

TECHNICAL MANUAL

UNIT MAINTENANCE MANUAL

FOR

**CARRIER, PERSONNEL, FULL TRACKED, ARMORED M113A3
2350-01-219-7577 (EIC AEY)**

**CARRIER, COMMAND POST, LIGHT TRACKED M577A3
2350-01-369-6085 (EIC AE7)**

**CARRIER, SMOKE GENERATOR, FULL TRACKED M1059A3
2350-01-369-6083 (EIC AFA)**

**CARRIER, MORTAR, 120-MM M121, SELF-PROPELLED M1064A3
2350-01-369-6082 (EIC AE8)**

**CARRIER, STANDARDIZED INTEGRATED COMMAND POST SYSTEM
(SICPS) M1068A3
2350-01-369-6086 (EIC AFC)**

**CARRIER, MECHANIZED SMOKE OBSCURANT M58
2350-01-418-6654 (EIC 5CG)**

***SUPERSEDURE NOTICE** — Supersedes TM 9-2350-277-20, 24 July 1994, including all changes.

DISTRIBUTION STATEMENT A — Approved for public release; distribution is unlimited.

HEADQUARTERS, DEPARTMENT OF THE ARMY

January 2001

CHANGE
NO. 5

HEADQUARTERS
DEPARTMENT OF THE ARMY
WASHINGTON, D.C., 01 JUNE 2009

TECHNICAL MANUAL

UNIT MAINTENANCE MANUAL

FOR

CARRIER, PERSONNEL, FULL TRACKED, ARMORED M113A3
2350-01-219-7577 (EIC AEY)

CARRIER, COMMAND POST, LIGHT TRACKED M577A3
2350-01-369-6085 (EIC AE7)

CARRIER, SMOKE GENERATOR, FULL TRACKED M1059A3
2350-01-369-6083 (EIC AFA)

CARRIER, MORTAR, 120-MM M121, SELF-PROPELLED M1064A3
2350-01-369-6082 (EIC AE8)

CARRIER, STANDARDIZED INTEGRATED COMMAND POST SYSTEM (SICPS) M1068A3
2350-01-369-6086 (EIC AFC)

CARRIER, MECHANIZED SMOKE OBSCURANT M58
2350-01-418-6654 (EIC 5CG)

DISTRIBUTION STATEMENT A – Approved for public release; distribution is unlimited.

TM 9-2350-277-20-2, 2 January 2001 is updated as follows:

1. File this change sheet in front of the publication for reference purposes.
2. New or updated text is indicated by a vertical bar in the outer margin of the page.
3. Revised illustrations are indicated by a miniature pointing hand adjacent to the updated area.
4. Remove old pages/Work Packages and insert new pages/Work Packages as indicated below.

Remove Pages/Work Packages

A/B blank
i – v/vi blank
WP 0155 00
WP 0161 00
Chapter 5 WP Index
WP 0166 00
WP 0169 00
None
WP 0170 00
WP 0172 00
WP 0175 00
WP 0213 00 – 0214 00
WP 0216 00 – 0220 00

Insert Pages/Work Packages

A/B blank
i – v/vi blank
WP 0155 00
WP 0161 00
Chapter 5 WP Index
WP 0166 00
WP 0169 00
WP 0169 01
WP 0170 00
WP 0172 00
WP 0175 00
WP 0213 00 – 0214 00
WP 0216 00 – 0220 00

Remove Pages/Work Packages (Continued)

WP 0221 00
WP 0223 00 – 0226 00
WP 0228 00
Index-1 – Index-99/100 blank
DA 2028

Insert Pages/Work Packages (Continued)

WP 0221 00
WP 0223 00 – 0226 00
WP 0228 00
Index-1 – Index 99/100 blank
DA 2028

By Order of the Secretary of the Army:

Official:



JOYCE E. MORROW
*Administrative Assistant to the
Secretary of the Army*
0913106

GEORGE W. CASEY, JR.
*General, United States Army
Chief of Staff*

DISTRIBUTION:

To be distributed in accordance with the initial distribution requirements for (IDN) 371205,
TM 9-2350-277-20-2.

CHANGE
NO. 4

HEADQUARTERS
DEPARTMENT OF THE ARMY
WASHINGTON, D.C., 31 DECEMBER 2006

TECHNICAL MANUAL

UNIT MAINTENANCE MANUAL

FOR

CARRIER, PERSONNEL, FULL TRACKED, ARMORED M113A3
2350-01-219-7577 (EIC AEY)

CARRIER, COMMAND POST, LIGHT TRACKED M577A3
2350-01-369-6085 (EIC AE7)

CARRIER, SMOKE GENERATOR, FULL TRACKED M1059A3
2350-01-369-6083 (EIC AFA)

CARRIER, MORTAR, 120-MM M121, SELF-PROPELLED M1064A3
2350-01-369-6082 (EIC AE8)

CARRIER, STANDARDIZED INTEGRATED COMMAND POST SYSTEM (SICPS) M1068A3
2350-01-369-6086 (EIC AFC)

CARRIER, MECHANIZED SMOKE OBSCURANT M58
2350-01-418-6654 (EIC 5CG)

DISTRIBUTION STATEMENT A – Approved for public release; distribution is unlimited.

TM 9-2350-277-20-2, 2 January 2001 is updated as follows:

1. File this change sheet in front of the publication for reference purposes.
2. New or updated text is indicated by a vertical bar in the outer margin of the page.
3. Revised illustrations are indicated by a miniature pointing hand adjacent to the updated area.
4. Remove old pages/Work Packages and insert new pages/Work Packages as indicated below.

Remove Pages/Work Packages

A/B blank
i – v/vi blank
WP 0155 00
Chapter 5 Index
WP 0169 00
None
WP 0172 00
WP 0220 00
WP 0239 00 – 0240 00
WP 0242 00
Index-1 – Index-103/104 blank
Metric Chart/Back Cover

Insert Pages/Work Packages

A/B blank
i – v/vi blank
WP 0155 00
Chapter 5 Index
WP 0169 00
WP 0169 01
WP 0172 00
WP 0220 00
WP 0239 00 – 0240 00
WP 0242 00
Index-1 – Index 98
Metric Chart/Back Cover

By Order of the Secretary of the Army:

PETER J. SCHOOMAKER
General, United States Army
Chief of Staff

Official:



JOYCE E. MORROW
Administrative Assistant to the
Secretary of the Army
0632404

DISTRIBUTION:

To be distributed in accordance with the initial distribution requirements for (IDN) 371205,
TM 9-2350-277-20-2.

CHANGE
NO. 3

HEADQUARTERS DEPARTMENT OF THE ARMY
WASHINGTON, D.C., 27 April 2004

TECHNICAL MANUAL

UNIT MAINTENANCE MANUAL

FOR

**CARRIER, PERSONNEL, FULL TRACKED, ARMORED M113A3
2350-01-219-7577 (EIC AEY)**

**CARRIER, COMMAND POST, LIGHT TRACKED M577A3
2350-01-369-6085 (EIC AE7)**

**CARRIER, SMOKE GENERATOR, FULL TRACKED M1059A3
2350-01-369-6083 (EIC AFA)**

**CARRIER, MORTAR, 120-MM M121, SELF-PROPELLED M1064A3
2350-01-369-6082 (EIC AE8)**

**CARRIER, STANDARDIZED INTEGRATED COMMAND POST SYSTEM (SICPS) M1068A3
2350-01-369-6086 (EIC AFC)**

**CARRIER, MECHANIZED SMOKE OBSCURANT M58
2350-01-418-6654 (EIC 5CG)**

DISTRIBUTION STATEMENT A – Approved for public release; distribution is unlimited.

TM 9-2350-277-20-2, 2 January 2001 is updated as follows:

1. File this change sheet in front of the publication for reference purposes.
2. New or updated text is indicated by a vertical bar in the outer margin of the page.
3. Revised illustrations are indicated by a miniature pointing hand adjacent to the updated area.
4. Remove old pages/Work Packages and insert new pages/Work Packages as indicated below.

Remove Pages/Work Packages

A/B blank
WP 0155 00
WP 0179 00
Index 17 – Index 28
Index 53 – Index 54
Index 93 – Index 94
Index 99 – Index 102

Insert Pages/Work Packages

A/B blank
WP 0155 00
WP 0179 00
Index 17 – Index 28
Index 53 – Index 54
Index 93 – Index 94
Index 99 – Index 102

By Order of the Secretary of the Army:

PETER J. SCHOOMAKER
General, United States Army
Chief of Staff

Official:

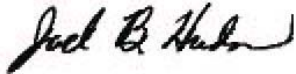

JOEL B. HUDSON
Administrative Assistant to the
Secretary of the Army
0405804

DISTRIBUTION:

To be distributed in accordance with the initial distribution number (IDN) 371205 requirements for TM 9-2350-277-20-2.

**TECHNICAL MANUAL
UNIT MAINTENANCE MANUAL
FOR**

**CARRIER, PERSONNEL, FULL TRACKED, ARMORED M113A3
2350-01-219-7577 (EIC AEY)**

**CARRIER, COMMAND POST, LIGHT TRACKED M577A3
2350-01-369-6085 (EIC AE7)**

**CARRIER, SMOKE GENERATOR, FULL TRACKED M1059A3
2350-01-369-6083 (EIC AFA)**

**CARRIER, MORTAR, 120-MM M121, SELF-PROPELLED M1064A3
2350-01-369-6082 (EIC AE8)**

**CARRIER, STANDARDIZED INTEGRATED COMMAND POST SYSTEM (SICPS) M1068A3
2350-01-369-6086 (EIC AFC)**

**CARRIER, MECHANIZED SMOKE OBSCURANT M58
2350-01-418-6654 (EIC 5CG)**

DISTRIBUTION STATEMENT A – Approved for public release; distribution is unlimited.

TM 9-2350-277-20-2, 2 January 2001 is updated as follows:

1. File this change sheet in front of the publication for reference purposes.
2. New or updated text is indicated by a vertical bar in the outer margin of the page.
3. Revised illustrations are indicated by a miniature pointing hand adjacent to the updated area.
4. Remove old pages/Work Packages and insert new pages/Work Packages as indicated below.

Remove Pages/Work Packages

Title
A/B
i-xxx
Chapter 3 WP Index
WP 0154 00
WP 0155 00
Chapter 4 WP Index
WP 0156 00
WP 0159 00
WP 0160 00
Chapter 5 WP Index
WP 0179 00
WP 0192 00
WP 0195 00
WP 0202 00
WP 0203 00
Chapter 7 WP Index
WP 0231 00
WP 0231 01
WP 0249 00
WP 0249 01
WP 0250 00
None
WP 0251 00
WP 0251 01
Index
Cover

Insert Pages/Work Packages

Title
A/B
i-v/vi blank
Chapter 3 WP Index
WP 0154 00
WP 0155 00
Chapter 4 WP Index
WP 0156 00
WP 0159 00
None
Chapter 5 WP Index
WP 0179 00
WP 0192 00
WP 0195 00
WP 0202 00
WP 0203 00
Chapter 7 WP Index
WP 0231 00
WP 0231 01
WP 0249 00
WP 0249 01
WP 0250 00
WP 0250 01
WP 0251 00
WP 0251 01
Index
Cover

By Order of the Secretary of the Army:

PETER J. SCHOOMAKER
*General, United States Army Official:
Chief of Staff*

Official:

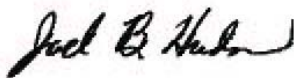

JOEL B. HUDSON
*Administrative Assistant to the
Secretary of the Army
0133205*

DISTRIBUTION:

To be distributed in accordance with the initial distribution number (IDN) 371205 requirements for TM 9-2350-277-20-2.

**TECHNICAL MANUAL
UNIT MAINTENANCE MANUAL
FOR**

**CARRIER, PERSONNEL, FULL TRACKED, ARMORED M113A3
2350-01-219-7577 (EIC AEY)**

**CARRIER, COMMAND POST, LIGHT TRACKED M577A3
2350-01-369-6085 (EIC AE7)**

**CARRIER, ANTI-TANK (TOW), FULL TRACKED, ARMORED M901A3
2350-01-369-7253 (EIC AFD)**

**CARRIER, FIRE SUPPORT PERSONNEL, FULL TRACKED, ARMORED M981A3
2350-01-369-6079 (EIC AFB)**

**CARRIER, SMOKE GENERATOR, FULL TRACKED M1059A3
2350-01-369-6083 (EIC AFA)**

**CARRIER, MORTAR, 120-MM M121, SELF-PROPELLED M1064A3
2350-01-369-6082 (EIC AE8)**

**CARRIER, STANDARDIZED INTEGRATED COMMAND POST SYSTEM (SICPS) M1068A3
2350-01-369-6086 (EIC AFC)**

**CARRIER, MECHANIZED SMOKE OBSCURANT M58
2350-01-418-6654 (EIC 5CG)**

DISTRIBUTION STATEMENT A – Approved for public release; distribution is unlimited.

TM 9-2350-277-20-2, 2 January 2001 is updated as follows:

1. File this change sheet in front of the publication for reference purposes.
2. New or updated text is indicated by a vertical bar in the outer margin of the page.
3. Revised illustrations are indicated by a miniature pointing hand adjacent to the updated area.
4. Remove old pages/Work Packages and insert new pages/Work Packages as indicated below.

Remove Pages/Work Packages

A/B
i-xxix/xxx blank
WP 0155 00
WP 0160 00
WP 0168 00
WP 0176 00
WP 0182 00
WP 0184 00
WP 0185 00
WP 0194 00
WP 0197 00
WP 0220 00
WP 0227 00
WP 0239 00
WP 0240 00
Index

Insert Pages/Work Packages

A/B blank
i-xxx
WP 0155 00
WP 0160 00
WP 0168 00
WP 0176 00
WP 0182 00
WP 0184 00
WP 0185 00
WP 0194 00
WP 0197 00
WP 0220 00
WP 0227 00
WP 0239 00
WP 0240 00
Index

Official:



JOEL B. HUDSON

*Administrative Assistant to the
Secretary of the Army*
0133206

PETER J. SCHOOMAKER
*General, United States Army
Chief of Staff*

DISTRIBUTION:

To be distributed in accordance with the initial distribution number (IDN) 371205 requirements for TM 9-2350-277-20-2.

INSERT LATEST UPDATED PAGES/WORK PACKAGES. DESTROY SUPERSEDED DATA.

LIST OF EFFECTIVE PAGES/WORK PACKAGES

Note: Updates to all portions of this TM are indicated by a vertical bar in the outer margin of the page.

Dates of issue for original and updated pages/work packages are:

Original 02 January 2001
 Change 1 05 September 2003
 Change 2 02 October 2003
 Change 3 27 April 2004
 Change 4 31 December 2006
 Change 5 01 June 2009

TOTAL NUMBER OF PAGES FOR FRONT AND REAR MATTER IS 130 AND TOTAL NUMBER OF WORK PACKAGES IS 103 CONSISTING OF THE FOLLOWING:

Page/WP No.	*Change No.	Page/WP No.	*Change No.	Page/WP No.	*Change No.
Cover	2	WP 0195 00	2		
Transmittal/Authentication	5	WP 0196 00	0		
A/B blank	5	WP 0197 00	1		
i – v/vi blank	5	WP 0198 00 – 0201 00	0		
Chapter 3 WP Index	2	WP 0202 00 – 0203 00	2		
WP 0154 00	2	WP 0204 00 – 0212 00	0		
WP 0155 00	5	WP 0213 00 – 0214 00	5		
Chapter 4 WP Index	2	WP 0215 00	0		
WP 0156 00	2	WP 0216 00 – 0220 00	5		
WP 0157 00 – 0158 00	0	Chapter 6 WP Index	0		
WP 0159 00	2	WP 0221 00	5		
WP 0160 00 (Deleted)	2	WP 0222 00	0		
WP 0161 00	5	WP 0223 00 – 0226 00	5		
WP 0162 00 – 0165 00	0	Chapter 7 WP Index	2		
Chapter 5 WP Index	5	WP 0227 00	1		
WP 0166 00	5	WP 0228 00	5		
WP 0167 00	0	WP 0229 00 – 0230 00	0		
WP 0168 00	1	WP 0231 00	2		
WP 0169 00	5	WP 0231 01 (Added)	2		
WP 0169 01 (Added)	5	WP 0232 00 – 0238 00	0		
WP 0170 00	5	WP 0239 00 – 0240 00	4		
WP 0171 00	0	WP 0241 00	0		
WP 0172 00	5	WP 0242 00	4		
WP 0173 00 – 0174 00	0	WP 0243 00 – 0248 00	0		
WP 0175 00	5	WP 0249 00	2		
WP 0176 00	1	WP 0249 01 (Added)	2		
WP 0177 00 – 0178 00	0	WP 0250 00	2		
WP 0179 00	3	WP 0250 01 (Added)	2		
WP 0180 00 – 0181 00	0	WP 0251 00	2		
WP 0182 00	1	WP 0251 01 (Added)	2		
WP 0183 00	0	Index-1 – Index-99/100 blank	5		
WP 0184 00 – 0185 00	1	DA 2028 Sample	5		
WP 0186 00 – 0191 00	0	DA 2028	5		
WP 0192 00	2	Authentication Page	0		
WP 0193 00	0	Back Cover	4		
WP 0194 00	1				

*Zero in this column indicates an original page

TECHNICAL MANUAL

UNIT MAINTENANCE MANUAL

CARRIER, PERSONNEL, FULL TRACKED, ARMORED M113A3
2350-01-219-7577
(EIC AEY)

CARRIER, COMMAND POST, LIGHT TRACKED M577A3
2350-01-369-6085
(EIC AE7)

CARRIER, SMOKE GENERATOR, FULL TRACKED M1059A3
2350-01-369-6083
(EIC AFA)

CARRIER, MORTAR, 120-MM M121, SELF-PROPELLED M1064A3
2350-01-369-6082
(EIC AE8)

CARRIER, STANDARDIZED INTEGRATED COMMAND POST SYSTEM (SICPS) M1068A3
2350-01-369-6086
(EIC AFC)

CARRIER, MECHANIZED SMOKE OBSCURANT M58
2350-01-418-6654
(EIC 5CG)

REPORTING ERRORS AND RECOMMENDING IMPROVEMENTS

You can help improve this publication. If you find any errors, or if you would like to recommend any improvements to the procedures in this publication, please let us know. The preferred method is to submit your DA Form 2028 (Recommended Changes to Publications and Blank Forms) through the Internet, on the Army Electronic Product Support (AEPS) website. The Internet address is <http://aeprs.ria.army.mil>. The DA Form 2028 is located under the Public Applications section in the AEPS Public Home Page. Fill out the form and click on SUBMIT. Using this form on the AEPS will enable us to respond quicker to your comments and better manage the DA Form 2028 program. You may also mail, e-mail, or fax your comments or DA Form 2028 directly to the U.S. Army TACOM Life Cycle Management Command. The postal mail address is U.S. Army TACOM Life Cycle Management Command, ATTN: AMSTA-LC-LMPP / TECH PUBS, 1 Rock Island Arsenal, Rock Island, IL 61299-7630. The email address is tacomlcmc.daform2028@us.army.mil. The fax number is DSN 793-0726 or Commercial (309) 782-0726.

CURRENT AS OF 30 April 2008

***SUPERSEDURE NOTICE** — Supersedes TM 9-2350-277-20 ,24 July 1994,including all changes.

DISTRIBUTION STATEMENT A — Approved for public release; distribution is unlimited.

TABLE OF CONTENTS

Volume 2

WP Sequence No.

CHAPTER 3 — UNIT MAINTENANCE INSTRUCTIONS FOR MAINTENANCE OF CARRIER

SERVICE UPON RECEIPT.....0154 00

PREVENTIVE MAINTENANCE CHECKS AND SERVICES (PMCS), INCLUDING LUBRICATION INSTRUCTIONS.....0155 00

CHAPTER 4 — UNIT MAINTENANCE INSTRUCTIONS FOR ENGINE

REMOVE/INSTALL POWER PLANT ASSEMBLY.....0156 00

BLOCK POWER PLANT.....0157 00

REPLACE ENGINE MOUNTS0158 00

REPLACE LEFT AND RIGHT AIR BOX DRAIN CHECK VALVE AND TUBES.....0159 00

DELETED.....0160 00

REPLACE ENGINE LIFTING BRACKET.....0161 00

REPLACE ENGINE OIL FILLER CAP.....0162 00

REPLACE ENGINE OIL SAMPLING VALVE AND HOSE.....0163 00

REPLACE OIL GAUGE ROD AND TUBE.....0164 00

REPLACE ENGINE OIL FILTER ELEMENT.....0165 00

CHAPTER 5 — UNIT MAINTENANCE INSTRUCTIONS FOR FUEL SYSTEM

REPLACE ENGINE FUEL PUMP.....0166 00

SERVICE AIR CLEANER FILTER ELEMENT.....0167 00

REPLACE AIR CLEANER AND ELBOW.....0168 00

REPLACE AIR CLEANER DOOR.....0169 00

REPAIR AIR CLEANER ASSEMBLY.....0169 01

REPAIR AIR CLEANER RETAINER.....0170 00

REPLACE AIR CLEANER RESTRICTION INDICATOR.....0171 00

REPLACE AIR CLEANER RESTRICTION INDICATOR HOSE.....0172 00

REMOVE/INSTALL AIR INTAKE ELBOW.....0173 00

REPLACE GRILL AIR INTAKE ELBOW AND HOSE.....0174 00

REPLACE EXHAUST EVACUATOR VALVE AND CONNECTOR.....0175 00

CLEAN FUEL CAP VENT AND FILTER SCREEN.....0176 00

DRAIN TANKS (ALL EXCEPT M577A3 AND M1068A3).....0177 00

DRAIN FUEL TANKS (M577A3 AND M1068A3 ONLY).....0178 00

REPLACE EXTERNAL FUEL TANKS (ALL EXCEPT M577A3 AND M1068A3).....0179 00

REPLACE FUEL TANKS (M577A3 AND M1068A3 ONLY).....0180 00

TEMPORARY FUEL TANK REPAIR (M577A3 AND M1068A3 ONLY).....0181 00

REPLACE FUEL TANK FILLER COVER AND LOCK (ALL EXCEPT M577A3 AND M1068A3).....0182 00

REPLACE FUEL TANK FILLER COVER AND LOCK (M577A3 AND M1068A3 ONLY).....0183 00

TABLE OF CONTENTS (cont)

WP Sequence No.

REPLACE FILLER CAP AND STRAINER PARTS (ALL EXCEPT M577A3 AND M1068A3).....0184 00

REPLACE FILLER CAP AND STRAINER PARTS (M577A3 AND M1068A3 ONLY).....0185 00

REPLACE FUEL FILLER AND STRAINER PARTS (M577A3 AND M1068A3 ONLY).....0186 00

REPLACE FUEL TANK ACCESS COVERS AND DRAIN PLUGS (ALL EXCEPT M577A3 AND M1068A3).....0187 00

REPLACE FUEL TANK ACCESS COVERS (M577A3 AND M1068A3 ONLY).....0188 00

REPLACE FUEL TANK FILLER FLANGE (M577A3 AND M1068A3 ONLY).....0189 00

REPLACE FUEL QUANTITY TRANSMITTER (ALL EXCEPT M577A3 AND M1068A3).....0190 00

REPLACE FUEL QUANTITY TRANSMITTER (M577A3 AND M1068A3 ONLY).....0191 00

REPLACE FUEL SUPPLY HOSES, TUBES, AND FITTINGS (M113A3, M1059A3, AND M58 ONLY).....0192 00

REPLACE FUEL SUPPLY HOSES, TUBES AND FITTINGS (M577A3 AND M1068A3 ONLY).....0193 00

REPLACE FUEL SUPPLY HOSES, TUBES, AND FITTINGS (M1064A3 ONLY).....0194 00

REPLACE FUEL RETURN HOSES, TUBES, AND FITTINGS (M113A3, M1059A3, AND M58 ONLY).....0195 00

REPLACE FUEL RETURN HOSES, TUBES, AND FITTINGS (M577A3 AND M1068A3 ONLY).....0196 00

REPLACE FUEL RETURN HOSES, TUBES, AND FITTINGS (M1064A3 ONLY).....0197 00

REPLACE FUEL VENT HOSES, TUBES, AND FITTINGS (M577A3 AND M1068A3 ONLY).....0198 00

REPLACE FUEL VALVE MOUNTING BLOCKS (ALL EXCEPT M577A3 AND M1068A3).....0199 00

REPLACE ENGINE FUEL SUPPLY HOSE.....0200 00

REPLACE ENGINE FUEL RETURN HOSE.....0201 00

REPLACE PRIMARY AND SECONDARY FUEL FILTER ELEMENTS.....0202 00

REPLACE PRIMARY AND SECONDARY FUEL FILTERS AND BRACKET.....0203 00

REPLACE AIR BOX HEATER IGNITION WIRE.....0204 00

REPLACE AIR BOX HEATER WIRING HARNESS.....0205 00

REPLACE AIR BOX HEATER LOWER FUEL LINE.....0206 00

REPLACE AIR HEATER ELECTRODE.....0207 00

REPLACE AIR BOX IGNITION COIL.....0208 00

REPLACE GLOW PLUG HARNESS AND GLOW PLUGS.....0209 00

REPLACE GLOW PLUG CONTROLLER.....0210 00

REPLACE GLOW PLUG POWER HARNESS.....0211 00

REPLACE GLOW PLUG CONTROLLER MOUNTING BRACKET.....0212 00

ADJUST THROTTLE VALVE (TV) MODULATOR.....0213 00

ADJUST ACCELERATOR LINKAGE.....0214 00

REPLACE LOWER ACCELERATOR PEDAL.....0215 00

REPLACE UPPER ACCELERATOR PEDAL ASSEMBLY.....0216 00

REPLACE FUEL CONTROL SHAFT AND LINKAGE.....0217 00

TABLE OF CONTENTS (cont)

WP Sequence No.

REPLACE THROTTLE VALVE (TV) MODULATOR AND LEVER.....	0218 00
REPLACE HAND THROTTLE CONTROL CABLE ASSEMBLY.....	0219 00
REPLACE FUEL CUTOFF CONTROL CABLE ASSEMBLY.....	0220 00
 CHAPTER 6 — UNIT MAINTENANCE INSTRUCTIONS FOR EXHAUST SYSTEM	
REPLACE ENGINE EXHAUST ELBOWS AND DOUBLE FLEX JOINT.....	0221 00
REPAIR DOUBLE FLEX EXHAUST JOINT.....	0222 00
REPLACE MUFFLER EXTENSION AND CAP.....	0223 00
REPLACE EXHAUST MUFFLER AND BRACKET.....	0224 00
REPLACE ENGINE LEFT/RIGHT EXHAUST ELBOWS.....	0225 00
REPLACE LEFT/RIGHT TURBO EXHAUST PIPE HEAT SHIELD.....	0226 00
 CHAPTER 7 — UNIT MAINTENANCE INSTRUCTIONS FOR COOLING SYSTEM	
DRAIN AND FILL COOLING SYSTEM.....	0227 00
CLEAN RADIATOR.....	0228 00
REPLACE RADIATOR AND PARTS.....	0229 00
REPLACE AUXILIARY TANK.....	0230 00
REPLACE THERMOSTATIC FAN SPEED SWITCH (OLD CONFIGURATION).....	0231 00
REPLACE VARIABLE SPEED FAN DRIVE VALVE AND OVERRIDE SWITCH (NEW CONFIGURATION).....	0231 01
REPLACE UPPER COOLANT HOSE AND TUBE.....	0232 00
REPLACE RADIATOR OUTLET TUBE AND HOSES.....	0233 00
REPLACE BALANCE HOSE.....	0234 00
REPLACE DRAIN COCK AND HOSE.....	0235 00
REPLACE COOLANT AIR SEPARATOR.....	0236 00
REPLACE THERMOSTAT/COVER.....	0237 00
REPLACE THERMOSTAT TUBE/HOSES.....	0238 00
ADJUST COOLANT PUMP BELTS.....	0239 00
REPLACE COOLANT PUMP IDLER PULLEY/BELTS.....	0240 00
REPLACE ENGINE COOLANT PUMP.....	0241 00
ADJUST VENTILATING FAN DRIVE BELT.....	0242 00
REPLACE VENTILATING FAN DRIVE BELT.....	0243 00
REPLACE VENTILATING FAN DRIVE PULLEY.....	0244 00
REPLACE FLAT PULLEYS AND BEARINGS.....	0245 00
REPLACE IDLER ARM AND SPRING TENSIONER.....	0246 00
REPLACE VENTILATING FAN ASSEMBLY.....	0247 00
REPLACE FAN DRIVE SHAFT AND BEARING HOUSING.....	0248 00
REPLACE FAN AND GENERATOR VARIABLE SPEED FAN DRIVE (OLD CONFIGURATION).....	0249 00
REPLACE VARIABLE SPEED FAN DRIVE ASSEMBLY (NEW CONFIGURATION).....	0249 01
REPLACE HOSES FROM THERMOSTAT SWITCH TO VARIABLE SPEED FAN DRIVE (OLD CONFIGURATION).....	0250 00

TABLE OF CONTENTS (cont)

WP Sequence No.

REPLACE VARIABLE SPEED FAN DRIVE CONTROLLER (NEW CONFIGURATION).....	0250 01
REPLACE TRANSMISSION OIL SUPPLY AND RETURN HOSES.....	0251 00
REPLACE HOSE FROM VARIABLE SPEED FAN DRIVE OVERRIDE SWITCH TO VSFD DRIVE (NEW CONFIGURATION).....	0251 01

CHAPTER 3
UNIT MAINTENANCE INSTRUCTIONS
FOR CARRIER

WORK PACKAGE INDEX

<u>Title</u>	<u>Sequence No.</u>
SERVICE UPON RECEIPT.....	0154 00
PREVENTIVE MAINTENANCE CHECKS AND SERVICES (PMCS), INCLUDING LUBRICATION INSTRUCTIONS.....	0155 00

SERVICE UPON RECEIPT

0154 00

THIS WORK PACKAGE COVERS:

This section contains information on how to check the M58, M113A3, M577A3, M1059A3, M1064A3, and M1068A3 carriers when received.

INITIAL SETUP:Maintenance LevelUnit

PRELIMINARY CHECKS AND ADJUSTMENTS**CHECKING UNPACKED EQUIPMENT**

1. Do the following steps to check carriers and parts upon receipt:
 - a. Inspect the equipment for possible damage incurred during shipment. If the equipment has been damaged, report the damage on DD Form 6, Packaging Improvement Report.
 - b. Check equipment against the packing slip and the BII in TM 9-2350-277-10 (All Carriers), to see if shipment is complete. Report all differences using the procedure given in DA Pamphlet 738-750.
 - c. Check to see whether the equipment has been modified. See DA Form 2408-9, Transfer, Gain, and Loss Report.

END OF TASK

**PREVENTIVE MAINTENANCE CHECKS AND SERVICES (PMCS),
INCLUDING LUBRICATION INSTRUCTIONS**

0155 00

THIS WORK PACKAGE COVERS:

Semi-Annual (page 0155 00-23).
Annual (page 0155 00-155).

INITIAL SETUP:

<u>Maintenance Level</u>	<u>References</u>
Unit	TM 9-2350-277-10
	DA Form 2026
<u>Tools and Special Tools</u>	DA Form 2402
Adapter (WP 0926 00, Item 4)	DA Form 2404
Socket Set (WP 0926 00, Item 71)	DA PAM 750-8
Socket Set (WP 0926 00, Item 72)	FM 9-207
Torque Wrench (WP 0926 00, Item 79)	FM 90-3
Torque Wrench (WP 0926 00, Item 80)	TB 43-0211
Torque Wrench (WP 0926 00, Item 82)	TM 3-4240-276-30&P
Torque Wrench (WP 0926 00, Item 85)	TM 3-6665-225-12
	TM-3-6680-316-10
<u>Materials/Parts</u>	TM 9-1220-248-23&P
Automotive grease (WP 0928 00, Item 12)	TM 9-214
Cleaning compound (WP 0928 00, Item 19)	TM 9-2350-277-24P
Crocus cloth (WP 0928 00, Item 1)	TM 9-2540-205-24&P
General purpose detergent (WP 0928 00, Item 35)	TM 9-2540-207-14&P
Insulating tape (WP 0928 00, Item 39)	TM 9-6140-200-14
Wiping rag (WP 0928 00, Item 65)	TM 9-6115-664-13&P
	TM 11-5855-249-23&P
<u>Personnel Required</u>	TM 11-5855-311-12&P-1 (to be released at a later date)
Mechanic	TM 43-0139
Helper	
	<u>Equipment Condition</u>
	Engine stopped (TM 9-2350-277-10)

SCOPE

This section details preventive maintenance checks and services (PMCS) and lubrication procedures required for the M113A3 FOV Carriers at the unit maintenance level. For crew level PMCS, see TM 9-2350-277-10.

MAINTENANCE FORMS AND RECORDS

The forms and records you fill out have many uses. They are a permanent record of the service, repairs, and changes made to your vehicle. They also tell you whether faults have been repaired. For information on forms and records, see DA Pamphlet 750-8.

WARNINGS AND CAUTIONS

Always observe the WARNINGS and CAUTIONS appearing in the PMCS tables BEFORE, DURING, and AFTER you operate the equipment. The WARNINGS and CAUTIONS appear before certain procedures. You must observe these WARNINGS and CAUTIONS to prevent serious injury to yourself and others or prevent your equipment from being damaged.

PMCS PROCEDURES

- (1) Obey all WARNINGS and CAUTIONS when you do PMCS.

- (2) Name, caution, and instruction plates should be easy to read. If they are dirty or corroded, clean them, and coat them with lacquer. See TM 43-0139 for instructions.
- (3) If something doesn't work, troubleshoot it using the troubleshooting procedures (WP 0006 00).
- (4) Do the semiannual PMCS every 1500 miles (2400 km) of operation or no later than 6 months after the last semiannual PMCS.
- (5) Always do your PMCS in the same order so it gets to be a habit. With practice, you'll spot anything that is wrong.
- (6) Keep your vehicle clean. Dirt, grease, oil, and debris only get in the way, and may cover up a serious problem. Clean your vehicle as you work and as needed.
- (7) Use cleaning compound on metal surfaces. Use general purpose detergent and water when you clean rubber or plastic parts.
- (8) You need to know how fluid leaks affect your vehicle. Definitions of the types and classes of leaks are given in General Maintenance Instructions below. You need to know them to determine the condition of your vehicle. Learn them. **REMEMBER: WHEN IN DOUBT, NOTIFY YOUR SUPERVISOR!**

GENERAL MAINTENANCE INSTRUCTIONS

SCOPE

This section contains safety warnings, guidelines, and general maintenance instructions. They should be followed when doing maintenance procedures authorized for unit maintenance level.

1. PREPARATION FOR MAINTENANCE

- a. *PERSONNEL SAFETY.* Practice all shop safety procedures and read all warnings in this manual.
- b. *PROPER EQUIPMENT.* Get tools and equipment before starting a maintenance task. See RPSTL (TM 9-2350-277-24P), and the maintenance task for tools, equipment, parts, and materials.
- c. *WHAT TO DISCARD.* Parts to discard, such as lockwashers, locknuts, and gaskets, are listed in the maintenance tasks. If the step does not say to discard a part, the part should be saved. It may be used later or may be repaired.
- d. *HANDLING TECHNIQUES.*
 - 1) Avoid damage to parts during removal, cleaning, inspection, repair, and installation procedures. Nicks, scratches, and dents caused by careless handling could result in equipment failure.
 - 2) Dirt can damage parts and cause malfunctions. Make sure all air and fluid openings, lines, and hoses are capped or plugged during maintenance procedures.
- e. *IDENTIFICATION.*
 - 1) During removal, tag parts to ensure proper installation.
 - 2) During removal, tag leads on electrical parts to ensure proper installation. Tag each lead as it is removed.

- f. *TORQUING*. Where needed, torque values are listed in the maintenance task. When torquing, use one of the star pattern sequences below unless otherwise stated in the maintenance task.

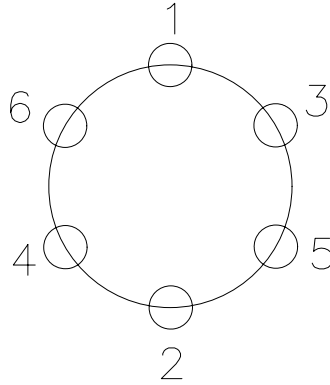

6-HOLE PATTERN

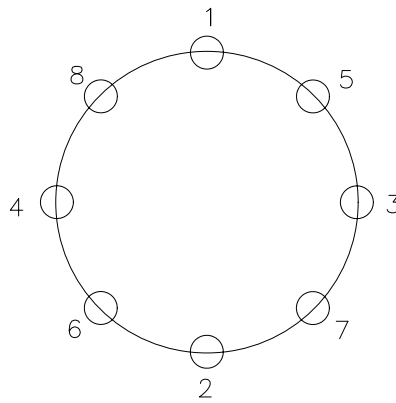

8-HOLE PATTERN

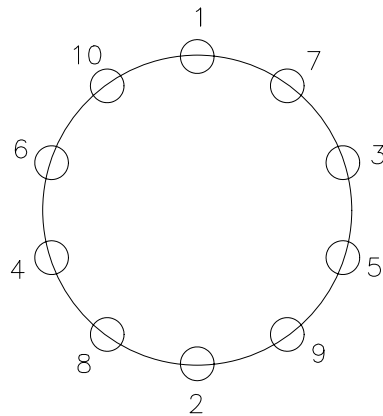

10-HOLE PATTERN

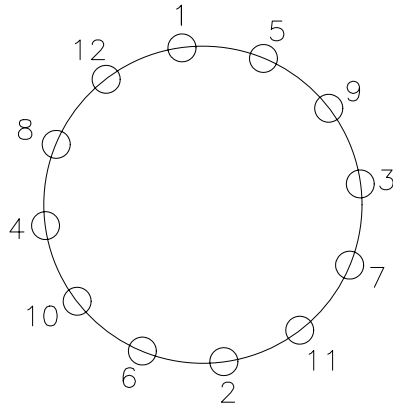

12-HOLE PATTERN

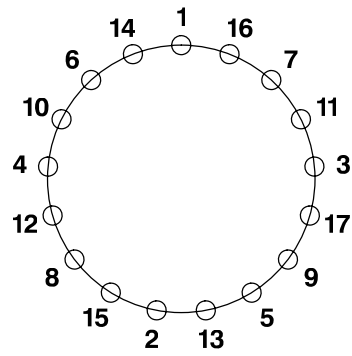

17-HOLE PATTERN

g. *USE OF TORQUE WRENCH ADAPTERS AND THE CONVERSION FORMULA.*

- 1) The torque values given in the text of this manual are the actual values that must be applied to the nut or screw for proper maintenance.
- 2) Some tasks require the use of a torque wrench adapter when the nut or screw cannot be reached with a regular socket on the end of the torque wrench. When an adapter is used on a torque wrench, definite rules must be followed or the nut or screw will be over- or under-torqued. The center line of the adapter should be used in one of two positions:
 - a) One position is to have the adapter center line at right angles to the center line of the torque wrench. In this position, the indicator reading does not have to be calculated and it may be read direct.

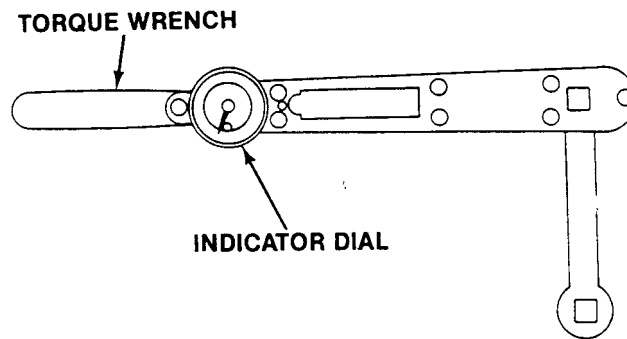

- b) The other position is to have the center line of the adapter in line with the center line of the torque wrench. In this case, the adapter adds to the overall length of the torque wrench and makes the dial or scale reading less than the actual torque applied to the nut or screw. To prevent overtorquing and damage to equipment, you must calculate a corrected dial or scale reading.

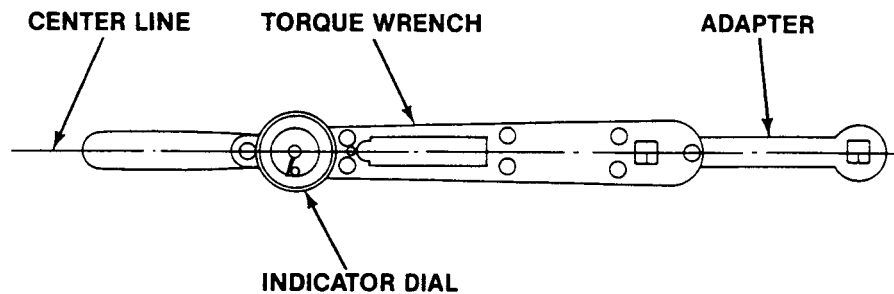

- 3) To determine the corrected scale or dial reading, use the following formula and refer to the example.

NOTE

The length of the torque wrench is measured from the center of the handle to the center of the drive. The length of the adapter is measured from the center of the drive to the center of the wrench.

$$\text{Corrected reading} = \text{Required torque value} \div \frac{\text{Length of torque wrench} + \text{length of adapter}}{\text{Length of torque wrench}}$$

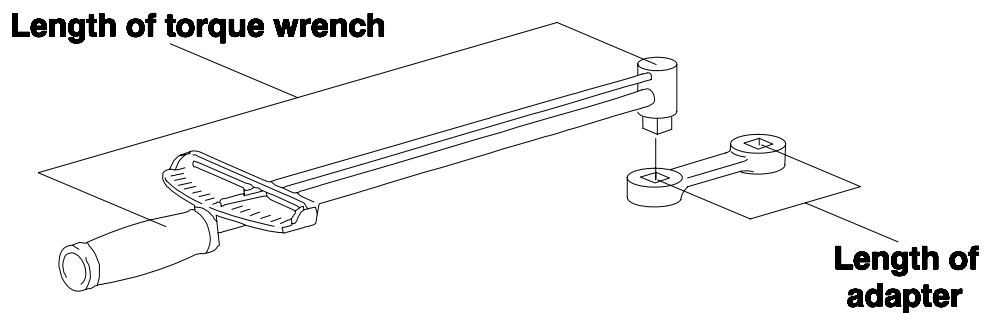

**PREVENTIVE MAINTENANCE CHECKS AND SERVICES (PMCS), INCLUDING
LUBRICATION INSTRUCTIONS — Continued**

0155 00

The following example has a torque wrench measuring 12 inches and an adapter measuring 3 inches. The required torque is 130-140 lb-ft and the corrected reading is 104-112 lb-ft.

EXAMPLE

Replace missing track tension adjuster screws. Tighten loose screws to 130-140 lb-ft (176-190 N·m) torque. Use adapter (WP 0926 00, Item 4) and torque wrench (WP 0926 00, Item 85). Adapter measures 3 inches from drive center to 12-point wrench center. 1/2-inch drive torque wrench measures 12 inches from handle center to drive center.

To determine the corrected reading for this task, use the formula as follows:

Corrected reading	=	Required torque value	÷	$\frac{\text{Length of torque wrench + length of adapter}}{\text{Length of torque wrench}}$
Corrected reading	=	130 lb-ft	÷	$\frac{12 \text{ inches} + 3 \text{ inches}}{12 \text{ inches}}$
Corrected reading	=	130 lb-ft	÷	$\frac{15 \text{ inches}}{12 \text{ inches}}$
Corrected reading	=	130 lb-ft	÷	1.25
Corrected reading	=	104 lb-ft		
		Repeat last step for other torque value.		
Corrected reading	=	140 lb-ft	÷	1.25 = 112 lb-ft

2. CLEANING

- a. *GENERAL.* Cleaning is very important. All parts must be cleaned well and kept clean during maintenance. Dirt or foreign matter can cause malfunctions and equipment failure. General cleaning procedures are detailed in steps b through m. Special cleaning procedures are covered in the task relating to the specific part. Clean after repair and before assembly.
- b. *CLEAN EVERY PART.* Clean every part well after removal and before installation. Clean parts such as housings, covers, and dipsticks before removal. Avoid getting dirt and foreign matter in a system. Inspect and cap all air and fluid openings, lines, and hoses.
- c. *HANDLE WITH CARE.* Use care when handling parts during cleaning and maintenance. Nicks, scratches, dents, or burrs can prevent proper assembly or cause malfunctions after assembly. Keep hands free of grease. Grease collects dirt. Cover or wrap parts to protect from dirt.
- d. *AVOID ABRASIVES.* Except where specially called for in a task, don't use abrasives, files, wire brushes, or sharp tools. On some surfaces, finish is important to the operation of close-fitting parts.
- e. *REMOVAL AGENTS.* Remove gum or old grease deposits by soaking parts in cleaning compound. Scrub with a brush. Use crocus cloth to remove minor surface defects.

WARNING

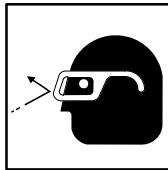

Air pressure in excess of 30 psi (207 kPa) can injure personnel. Do not direct pressurized air at yourself or others. Always wear goggles.

CAUTION

Lye or caustic mixtures will damage metal surfaces. Do not use lye or caustic mixtures to clean metal surfaces.

- f. *STEAM CLEANING.* If steam cleaning is used, dry clean parts at once with compressed air. Apply a thin film of clean oil to surfaces that are not painted to prevent rusting. Never use lye or caustic mixtures that will corrode or etch metal surfaces.
- g. *LUBRICATION OF NEW BEARINGS.* See TM 9-214 for cleaning and lubrication procedures. Bearings that have been in service should also be lubricated.

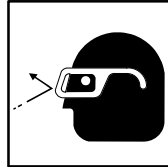
h. *CASTINGS.***WARNING**

Air pressure in excess of 30 psi (207 kPa) can injure personnel. Do not direct pressurized air at yourself or others. Always wear goggles.

- 1) Clean inner and outer surfaces of casting with cleaning compound. Dry casting with compressed air.
 - 2) Remove sludge and gum deposits with a brush.
 - 3) Blow out all tapped holes with compressed air.
- i. *BALL BEARINGS.* Bearings require special cleaning techniques. See TM 9-214 for cleaning and maintenance procedures for ball bearings.
- j. *OIL PASSAGES.*
- 1) Make sure oil passages are not clogged.
 - 2) Clean oil passages and break up any sludge or gum deposits.

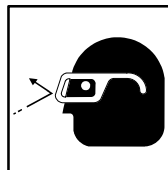
WARNING

Air pressure in excess of 30 psi (207 kPa) can injure personnel. Do not direct pressurized air at yourself or others. Always wear goggles.

- 3) Flush oil passages with cleaning compound. Dry parts with compressed air.
- k. *OIL SEALS, ELECTRIC CABLES, AND FLEXIBLE HOSES.*

CAUTION

Cleaning compound causes leather, rubber, and synthetic materials to become brittle. Do not use cleaning compound to clean seals, cables, and flexible hoses.

- 1) Clean seals, cables, and flexible hoses with general purpose detergent and water. Dry with wiping rag.

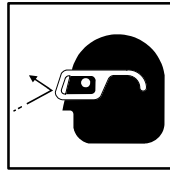
WARNING

Air pressurized in excess of 30 psi (207 kPa) can injure personnel. Do not direct pressurized air at yourself or others. Always wear goggles.

- l. *INSERTS*. Blow out insert holes with compressed air.
- m. *GASKETS*. If a gasket is being removed, scrape old gasket material and sealant off mating surface. Clean mating surface with cleaning compound. Dry with wiping rag.

3. INSPECTION

All removed parts must be inspected with care. Replace parts if damage or wear exceeds allowable limits.

- a. *GENERAL*. Procedures for inspection will be the same for most parts. General inspection procedures are given in steps b through p below. Special inspection procedures are covered in the task as needed.
- b. *CASTINGS*.
 - 1) Inspect all castings and forgings for breaks, cracks, and wear or scoring that would impair function.
 - 2) Inspect machined surfaces for nicks, burrs, and raised metal. Mark damaged areas for repair.
 - 3) Use straightedge to check all mounting flanges on housings and supports for bends. Inspect mating flanges for stains which would indicate oil leakage.
 - 4) Inspect all threaded parts for damaged or stripped threads.
- c. *NEEDLE ROLLER BEARINGS*. Inspect bearings for free and smooth rotation, and broken or missing rollers. Also look for tightness of fit in bearing bores. Inspect bearing races for wear and color changes due to heat. See TM 9-214 for inspection procedures.
- d. *STUDS*. Inspect all studs for stripped or damaged threads, bent or loose condition, and signs of stretching.
- e. *GEARS*. Inspect gears for burrs, wear, cracked or broken teeth, and pitting at tooth contact areas.
- f. *BUSHINGS AND BUSHING-TYPE BEARINGS*.
 - 1) Check all bushings and bushing-type bearings for secure fit in casting. Check for color changes which could mean overheating. Inspect for size, scoring, out-of-roundness, burrs, sharp edges, and signs of seizing.
 - 2) Check for dirt in oil holes and in bushing-type bearings. Oil holes and grooves must be clean and not damaged.
- g. *OIL SEALS*.
 - 1) Inspect feather edge of oil seals for tears, fraying, hardening, and cracking.
 - 2) Replace metal-covered oil seals when there are signs of damage or oil leakage.
- h. *CORE HOLE PLUGS*. Inspect core hole plugs for signs of leakage. Replace damaged core hole plugs.

- i. *INSERTS*.
 - 1) Inspect inserts for cracks and stripped or damaged threads.
 - 2) Check inserts for loose fit.
 - 3) Inspect armor mounting inserts and hull screw holes for loose or missing plugs and setscrews, as required.
 - j. *GREASE SEALS, PREFORMED PACKINGS, AND GASKETS*.
 - 1) Inspect composition seals, rings, and preformed packings for wear, brittleness, cracks, cuts, and damage.
 - 2) Inspect lip seals for cracks, wear, cuts, and brittleness. Inspect springs and seal shells for damage.
 - 3) Gaskets and seals on electrical parts may be reused. Inspect gaskets and seals for wear, nicks, cuts, and torn or missing gasket material. Replace gasket, if needed.
 - k. *SPLINED PARTS*. Inspect splined parts for burrs, wear, twisted, cracked, or broken splines.
 - l. *THREADED PARTS*. Inspect all threaded parts for burrs and stripped or damaged threads.
 - m. *RETAINING RINGS*. Inspect retaining rings for nicks, burrs, defects, loss of tension, and wear.
 - n. *SPRINGS*. Inspect springs for wear, defects, breaks, and loss of tension or compression. Inspect springs using a spring tester.
 - o. *SHAFTS AND SPINDLES*. Inspect shafts and spindles for excessive wear, binding, scores, cracks, burrs, and obstructed oil passages.
 - p. *ELECTRICAL PARTS*.
 - 1) Inspect electrical parts before you install them. Look for mildewed, corroded, or burned parts.
 - 2) Inspect electrical parts for pinched or loose wires and for cracked or broken wires, circuit cards, relays, and connectors.
 - 3) Inspect insulation and heatshrink tubing for cracks, tears, burns, or missing material.
4. **REPAIR**
- a. *GENERAL*. General repair procedures are given in Steps 4a - 4m below. Special repairs are covered in the task. After repair, clean all parts well.
 - b. *CASTINGS*.
 - 1) Replace all cracked or broken castings.
 - 2) Repair minor damage to machined surfaces of castings with crocus cloth. Replace any part with defects that cannot be corrected or which will impair function.
 - 3) Repair minor surface bends by working bent surface of casting across sheet of crocus cloth on surface plate. Replace bent castings which would impair assembly or function.
 - c. *BALL BEARINGS*. See TM 9-214 for inspection and maintenance for ball bearings.
 - d. *NEEDLE ROLLER BEARINGS*. See TM 9-214 for inspection and maintenance of needle roller bearings.
 - e. *BUSHINGS AND BUSHING-TYPE BEARINGS*. Replace bushings and bushing-type bearings if they are loose, scored, or have color change due to heat. When you replace bushings and bushing-type bearings, check nearby parts for damage or wear.

**PREVENTIVE MAINTENANCE CHECKS AND SERVICES (PMCS), INCLUDING
LUBRICATION INSTRUCTIONS — Continued**

0155 00

- f. *OIL SEALS*. Oil seals must be replaced when thin feather edge is damaged or when seal material is brittle.
 - 1) Press damaged oil seal from casting. Be careful not to damage bore.
 - 2) When oil seal bore is damaged so an oil-tight seal is impossible, replace casting or adapter. Remove slight nicks, burrs, and scratches with crocus cloth dipped in cleaning compound.
- g. *GREASE SEALS, PREFORMED PACKINGS, GROMMETS, AND GASKETS*. Seals, preformed packings, grommets, and gaskets should be replaced when removed unless otherwise stated in the maintenance task. They should not be reused.
- h. *THREADED PARTS*. Repair all parts that have stripped or damaged threads by chasing threads with a used tap or die. Replace parts that cannot be repaired.
- i. *RETAINING RINGS*.
 - 1) Retaining rings should be replaced when removed unless otherwise stated in the maintenance task. They should not be reused.
 - 2) Some retaining rings are beveled on one side. When installing this type of ring, the beveled side must face the part to be retained.
- j. *SPRINGS*. Discard springs that have defects. Load and height inspection data, where needed, are given in maintenance procedures.
- k. *SHAFTS AND SPINDLES*.
 - 1) Replace shafts and spindles that show signs of wear, binding, scores, cracks, burrs, or clogged oil passages.

WARNING

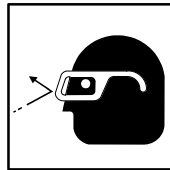

Air pressure in excess of 30 psi (207 kPa) can injure personnel. Do not direct pressurized air at yourself or others. Always wear goggles.

- 2) Remove obstructions with compressed air or by probing with soft wire.
- 3) Remove burrs and minor surface defects with a crocus cloth.
- l. *ELECTRICAL PARTS*.
 - 1) Replace corroded or burned parts and parts which show signs of mildew.
 - 2) Tighten loose connections.
 - 3) Replace cracked or broken wires, circuit cards, relays, and connectors.
 - 4) Replace cracked, torn, or burned insulation and heatshrink tubing.
- m. *INSERTS*. Replace insert when threads are stripped or when insert is cracked or loose.
 - 1) Drill and remove damaged insert from casting.
 - 2) Install new insert in casting using suitable replacement tool.
 - 3) Install plugs in armor mounting inserts, as required.

- 4) Install setscrews in hull armor mounting screw holes, as required.

5. FLUID LEAKS AND CHECKING FOR LEAKS

- a. *GENERAL.* Fluid leaks in hoses and fluid lines affect the carrier parts operation. The types and classes of leaks are given below.

CLASS I Fluid Seepage is not great enough to form drops, but it is shown by wetness or color changes.

CLASS II Fluid Leakage is great enough to form drops, but drops do not drip from the item being checked or inspected.

CLASS III Fluid Leakage is great enough to form drops that fall from the item being checked or inspected

NOTE

You are allowed to operate equipment with minor water or oil leaks (Class I or II). You must consider how much fluid the item or system being checked or inspected can hold. When in doubt, notify your supervisor. Any fuel or Class III leaks will make the vehicle NOT READY/AVAILABLE.

- b. *CHECKING FOR LEAKS AFTER A MAINTENANCE TASK.* After doing maintenance on a part which involves hoses or fluid lines, check for leaks. If leaks occur after you have done a replace or repair task, find the source of the leak. Correct the problem. Follow these procedures.
- 1) Do visual inspections to find the source of the leak.
 - a) Check for cracks on housing or cover.
 - b) Check that screws and any connections are not loose or overtight.
 - 2) If you cannot see the source of the leak, check the items listed below.
 - a) Check that preformed gasket is not bent, or pinched.
 - b) Check machined surfaces for fit and cleanliness.
 - c) If leak persists, notify supervisor.
- c. *CHECKING FOR LEAKS USING CHALK TEST.* Following replacement, repair, or adjustment of a ramp, door, hatch cover, access panel, or rubber seal, check for leaks by performing a chalk test. Use the following procedure:
- 1) Use chalk or chalk powder to coat area around seal.
 - 2) Close ramp, door, hatch cover, or panel.
 - 3) Open ramp, door, hatch cover, or panel.
 - 4) Check for unbroken chalk line on mating surface. Where chalk does not stick to mating surface, there is a leak in the seal surface.
 - 5) If a leak is found, perform adjustment to correct the problem.

6. WARM-UP ENGINE

To warm up the engine for a maintenance or troubleshooting task, do the following:

- a. Cover air inlet grill.
- b. Start engine. See TM 9-2350-277-10.
- c. Release parking brake and apply service brake.

WARNING



When shifting gear selector into PIVOT, vehicle can move if steering yoke is moved from centered position. Soldiers can be killed or injured. Hold brake pedal on. Clear all soldiers away from vehicle when shifting into PIVOT. Do not move yoke from centered position.

- d. Move gear selector to PIVOT. Do not turn steering yoke.
- e. Raise engine speed to 1500 RPM until normal operating temperature is reached.
- f. Lower engine RPM to idle.
- g. Move gear selector to SL.
- h. Stop engine. See TM 9-2350-277-10.
- i. Set parking brake.
- j. Uncover air inlet grille.
- k. Make sure MASTER SWITCH is OFF.

LUBRICATION TABLES

The following tables are used during PMCS lubrication checks.

Intervals (on-condition or hard time) and the related man-hour times are based on normal operation. The man-hour time specified is the time you need to do all the services prescribed for a particular interval. Hard time intervals will be indicated by one of the following symbols as appropriate: Daily (D), Weekly (W), Monthly (M), Semi-Annually (S), and Annually (A). On-condition (OC) oil sample intervals shall be applied unless changed by the Army Oil Analysis Program (AOAP) Laboratory. Change the hard time interval if lubricants are contaminated or if you are operating equipment under adverse operating conditions, including longer-than-usual operating hours. The hard time intervals may be extended during periods of low activity if adequate preservation precautions are taken. Hard time intervals will be applied to oil changes in the event AOAP Laboratory support is not available.

On-condition (OC) AOAP Laboratory determined oil change intervals shall be applied instead of hard time intervals such as hourly, calendar, or mileage, unless otherwise notified. The services will be required when directed by an Army Analysis Program (AOAP) Laboratory which has analyzed the oil for serviceability.

Clean fittings before lubricating. Clean parts with cleaning compound.

Unless specifically identified, all procedures apply to M58, M113A3, M577A3, M1059A3, M1064A3, and M1068A3 carriers.

NOTE

Park carrier on level ground to check oil levels. Check/lubricate all oil and grease fitting points after washing or fording.

ARMY OIL ANALYSIS PROGRAM (AOAP) — AOAP is an effective maintenance diagnostic tool and not a maintenance substitute. TB 43-0211 must not be interpreted to mean AOAP minimizes, in any way, the need to employ good maintenance practices and strong maintenance disciplines.

SAMPLING REQUIREMENTS — Samples may be taken without WARMING a component to operating temperature if the equipment has been operated within the last 30 days. If the equipment has not been operated within the last 30 days, the components must be brought to operating temperature. These requisites apply to both routine and special sampling. Oil samples must not be taken immediately after oil is added. When oil sampling valve is not available to take oil sample, use a vampire pump.

OIL CAN POINTS — Every 1500 miles, semi-annually or as required, lubricate fan tensioner, ramp hinges, ramp door hinges, power plant door hinges, driver's, commander's and cargo hatch hinges, control linkage pins and shafts and seat control. Use OE/HDO or OEA as appropriate.

**PREVENTIVE MAINTENANCE CHECKS AND SERVICES (PMCS), INCLUDING
LUBRICATION INSTRUCTIONS — Continued**

0155 00

Table 1. Engine

LUBRICANTS/ COMPONENTS Interval=OC Manhours=0.5	MAXIMUM CAPACITY	EXPECTED TEMPERATURE (For Arctic Operation, refer to FM 9-207)		
		Above +32°F (Above 0°C)	+40°F TO -10°F (+5°C to -23°C)	0°F to -65°F (-18°C to -54°C)
OE/HDO (MIL-PRF-2104) OR OEA (MIL-PRF-46167), LUBRICATING OIL, INTERNAL COMBUSTION ENGINE	18 qt.	OE/HDO-15/40	OE/HDO-15/40	OEA
(MIL-PRF-21260) PRESERVATION OIL		PE 30-1	PE 30-1	

Table 2. Fuel

LUBRICANTS/ COMPONENTS Interval=S Manhours=0.3	MAXIMUM CAPACITY	EXPECTED TEMPERATURE (For Arctic Operation, refer to FM 9-207)		
		Above +32°F (Above 0°C)	+40°F TO -10°F (+5°C to -23°C)	0°F to -65°F (-18°C to -54°C)
DIESEL FUEL A-A-52557A	95 gal. (All except M577A3 and M1068A3)	DF-2	DF-1	DF-A
	120 gal. (M577A3 and M1068A3)			
JP-8 MIL-DTL-83133	95 gal. (All except M577A3 and M1068A3)	JP-8	JP-8	JP-8
	120 gal. (M577A3 and M1068A3)			

**PREVENTIVE MAINTENANCE CHECKS AND SERVICES (PMCS), INCLUDING
LUBRICATION INSTRUCTIONS — Continued**

0155 00

Table 3. Transmission

LUBRICANTS/ COMPONENTS Interval=OC Manhours=0.5 Interval=S Manhours=0.2	MAXIMUM CAPACITY	EXPECTED TEMPERATURE (For Arctic Operation, refer to FM 9-207)		
		Above +32°F (Above 0°C)	+40°F TO -10°F (+5°C to -23°C)	0°F to -65°F (-18°C to -54°C)
OE/HDO (MIL-PRF-2104) OR OEA (MIL-PRF-46167), LUBRICATING OIL, INTERNAL COMBUSTION ENGINE	Initial fill - 14.25 gal. or 57 qt. Refill after oil change — approx. 36 qt.	OE/HDO-15/40	OE/HDO-15/40	OEA
(MIL-PRF-21260) PRESERVATION OIL		PE 10-1	PE 10-1	

Table 4. Final Drive

LUBRICANTS/ COMPONENTS Interval=S Manhours= 0.5	MAXIMUM CAPACITY	EXPECTED TEMPERATURE (For Arctic Operation, refer to FM 9-207)		
		Above +32°F (Above 0°C)	+40°F TO -10°F (+5°C to -23°C)	0°F to -65°F (-18°C to -54°C)
OE/HDO (MIL-PRF-2104) OR OEA (MIL-PRF-46167) LUBRICATING OIL, INTERNAL COMBUSTION ENGINE	3 1/2 qts or 7 pt. (FULL mark on gauge rod)	OE/HDO-15/40	OE/HDO-15/40	OEA

Table 5. Fan Gearbox

LUBRICANTS/ COMPONENTS Interval=S Manhours= 0.4	MAXIMUM CAPACITY	EXPECTED TEMPERATURE (For Arctic Operation, refer to FM 9-207)		
		Above +32°F (Above 0°C)	+40°F TO -10°F (+5°C to -23°C)	0°F to -65°F (-18°C to -54°C)
OE/HDO (MIL-PRF-2104) LUBRICATING OIL, INTERNAL COMBUSTION ENGINE	18 oz. or 1.125 pt.	OE/HDO-15/40	OE/HDO-15/40	OEA

**PREVENTIVE MAINTENANCE CHECKS AND SERVICES (PMCS), INCLUDING
LUBRICATION INSTRUCTIONS — Continued**

0155 00

Table 6. Pulley Support Arm

LUBRICANTS/ COMPONENTS Interval=S Manhours= 0.4	MAXIMUM CAPACITY	EXPECTED TEMPERATURE (For Arctic Operation, refer to FM 9-207)		
		Above +32°F (Above 0°C)	+40°F TO -10°F (+5°C to -23°C)	0°F to -65°F (-18°C to -54°C)
GAA (MIL-PRF-10924) GREASE, AUTOMOTIVE AND ARTILLERY	As required	ALL TEMPERATURES		

Table 7. Hydraulic System

LUBRICANTS/ COMPONENTS Interval=S Manhours= 1.0	MAXIMUM CAPACITY	EXPECTED TEMPERATURE (For Arctic Operation, refer to FM 9-207)		
		Above +32°F (Above 0°C)	+40°F TO -10°F (+5°C to -23°C)	0°F to -65°F (-18°C to -54°C)
FRH (MIL-PRF-46170) HYDRAULIC FLUID, RUST INHIBITED, FIRE RESISTANT (Ramp System)	3 1/2 qt. or 7 pt.	ALL TEMPERATURES		

Table 8. Steering Control and Foot Brake Cross-Shaft Bearings

LUBRICANTS/ COMPONENTS Interval=S Manhours=0.3	MAXIMUM CAPACITY	EXPECTED TEMPERATURE (For Arctic Operation, refer to FM 9-207)		
		Above +32°F (Above 0°C)	+40°F TO -10°F (+5°C to -23°C)	0°F to -65°F (-18°C to -54°C)
GAA (MIL-PRF-10924) GREASE, AUTOMOTIVE AND ARTILLERY (Steering Control Bearings, Foot Brake Cross-Shaft Bearings)	As Required	ALL TEMPERATURES		

PREVENTIVE MAINTENANCE CHECKS AND SERVICES (PMCS), INCLUDING LUBRICATION INSTRUCTIONS — Continued

0155 00

Table 9. Towing Pintle

LUBRICANTS/ COMPONENTS Interval=S Manhours=0.1	MAXIMUM CAPACITY	EXPECTED TEMPERATURE (For Arctic Operation, refer to FM 9-207)		
		Above +32°F (Above 0°C)	+40°F TO -10°F (+5°C to -23°C)	0°F to -65°F (-18°C to -54°C)
GAA (MIL-PRF-10924) GREASE AUTOMOTIVE AND ARTILLERY	As Required	ALL TEMPERATURES		

Table 10. Road and Idler Wheel Bearings, Road and Idler Wheel Support Arm Bearings

LUBRICANTS/ COMPONENTS Interval=S Manhours=1.4	MAXIMUM CAPACITY	EXPECTED TEMPERATURE (For Arctic Operation, refer to FM 9-207)		
		Above +32°F (Above 0°C)	+40°F TO -10°F (+5°C to -23°C)	0°F to -65°F (-18°C to -54°C)
GAA (MIL-PRF-10924) GREASE AUTOMOTIVE AND ARTILLERY (Road and Idler Wheel Bearings)	As Required	ALL TEMPERATURES		
GAA (MIL-PRF-10924) GREASE AUTOMOTIVE AND ARTILLERY (Road and Idler Wheel Support Arm Bearings)	As Required	ALL TEMPERATURES		

**PREVENTIVE MAINTENANCE CHECKS AND SERVICES (PMCS), INCLUDING
LUBRICATION INSTRUCTIONS — Continued**

0155 00

Table 11. Tachometer and Speedometer Shafts

LUBRICANTS/ COMPONENTS Interval=A Manhours=0.1	MAXIMUM CAPACITY	EXPECTED TEMPERATURE (For Arctic Operation, refer to FM 9-207)		
		Above +32°F (Above 0°C)	+40°F TO -10°F (+5°C to -23°C)	0°F to -65°F (-18°C to -54°C)
GIA (MIL-PRF-23827) GREASE, INSTRUMENT, AIRCRAFT	As Required	ALL TEMPERATURES		
GAA (MIL-PRF-10924) GREASE, AUTOMOTIVE AND ARTILLERY	As Required	ALL TEMPERATURES		
OE/HDO (MIL-PRF-2104) OR OEA (MIL-PRF-46167) LUBRICATING OIL, INTERNAL COMBUSTION ENGINE	As Required	ALL TEMPERATURES		

Table 12. Universal Joint

LUBRICANTS/ COMPONENTS Interval=S Manhours=0.5	MAXIMUM CAPACITY	EXPECTED TEMPERATURE (For Arctic Operation, refer to FM 9-207)		
		Above +32°F (Above 0°C)	+40°F TO -10°F (+5°C to -23°C)	0°F to -65°F (-18°C to -54°C)
GAA (MIL-PRF-10924) GREASE AUTOMOTIVE AND ARTILLERY	As Required	ALL TEMPERATURES		

PREVENTIVE MAINTENANCE CHECKS AND SERVICES (PMCS), INCLUDING LUBRICATION INSTRUCTIONS — Continued

0155 00

Lubrication Charts

Table 13. Lubricants For Engine Applications

LUBRICANT		EXPECTED TEMPERATURE
OE/HDO (MIL-PRF-2104) Lubricating Oil, ICE	OE/HDO-15/40 (O-1236)	0°F to 120°F (-18°C to 49°C)
	OE/HDO-30 (O-238)	10°F to 120°F (-12°C to 49°C)
	OE/HDO-40 (N/A)	20°F to 120°F (-7°C to 49°C)
OEA (MIL-PRF-46167) Lubricating Oil, ICE, Arctic (If OEA lubricant is required to met the low expected-temperature range, OEA lubricant is to be used in lieu of OE/HDO lubricant for all expected temperatures where OE/HDO is specified.)	OEA (O-183)	-65°F to 40°F (-54°C to 4°C)

Table 14. Lubricants For Transmission Applications

LUBRICANT		EXPECTED TEMPERATURE
OE/HDO (MIL-PRF-2104) Lubricating Oil, ICE, Tactical	OE/HDO-15/40 (O-1236)	0°F to 120°F (-18°C to 49°C)
OEA (MIL-PRF-46167) Lubricating Oil, ICE, Arctic (If OEA lubricant is required to met the low expected temperature range, OEA lubricant is to be used in lieu of OE/HDO lubricant for all expected temperatures where OE/HDO is specified.)	OEA (O-183)	-65°F to 40°F (-54°C to 4°C)

Table 15. Fluids For Hydraulic System Applications

LUBRICANT		EXPECTED TEMPERATURE
FRH (MIL-PRF-46170) Hydraulic Fluid, Rust Inhibited Fire Resistant, Synthetic Hydrocarbon Base	FRH	-40°F to 120°F (-40°C to 49°C)

**PREVENTIVE MAINTENANCE CHECKS AND SERVICES (PMCS), INCLUDING
LUBRICATION INSTRUCTIONS — Continued**

0155 00

Table 16. Lubricants For Exposed Gear, Chain and Wire Rope Applications

LUBRICANT		EXPECTED TEMPERATURE
CW-II (MIL-PRF-18458) Lubricating Oil, Chain, Wire Rope, and Exposed Gear	CW-IIC (O-203)	70°F to 120°F (21°C to 49°C)
	CW-IIB (N/A)	30°F to 90°F (-1°C to 32°C)
	CW-IIA (O-199)	-30°F to 50°F (-34°C to 10°C)
GO (MIL-PRF-2105) Lubricating Oil, Gear Multipurpose	GO-75 (O-186)	-70°F to -10°F (-57°C to 23°C)

Table 17. Fluids For General Purpose Applications

LUBRICANT		EXPECTED TEMPERATURE
PL-S (MIL-PRF-32033) Lubricating Oil, General Purpose, Preservative, Water Displacing, Low Temperature	PL-S (O-190)	-70°F to 120°F (-57°C to 49°C)
PL-M (MIL-PRF-3150) Lubricating Oil, Preservative, Medium	PL-M (O-192)	30°F to 120°F (-1°C to 49°C)

EXPLANATION OF PMCS TABLE ENTRIES

- (1) **Item Number Column** — Numbers in this column are for reference. When completing DA Form 2404 (Equipment Inspection and Maintenance Worksheet), include the item number for the check/service indicating a fault. Item numbers also appear in the order that you must do the checks and services for the intervals listed.
- (2) **Interval Column** — This column tells you how often you must perform the checks/services. Semi-Annual checks/services must be performed every six months or after 1500 (2400 km) of operation.
- (3) **Man-Hour Column** — This column gives the man-hours (to the nearest 10th of an hour) needed to complete the prescribed lubrication service. This column is used only for lubrication services.
- (4) **Item To Be Checked or Serviced Column** — This column lists the item to be checked or serviced.
- (5) **Crewmember/Procedure Column** — This column gives the procedure you must do to check or service the item listed in the *Item To Be Checked or Serviced* column to know if the equipment is ready or available for its intended mission or for operation. You must do the procedure at the time stated in the interval column.
- (6) **Equipment Not Ready/Available If: Column** — Information in this column tells you what faults will keep your equipment from being capable of performing its primary mission. If you perform check and service procedures that show faults as listed in this column, do not operate the equipment. Follow standard operating procedures for maintaining the equipment or reporting equipment failure.

PREVENTIVE MAINTENANCE CHECKS AND SERVICES (PMCS), INCLUDING
LUBRICATION INSTRUCTIONS — Continued

0155 00

Table 18. Semi-Annual Unit Level Preventive Maintenance Checks and Services for M113A3 FOV

ITEM NO.	INTERVAL	MAN-HOUR	ITEM TO BE CHECKED OR SERVICED	CREWMEMBER PROCEDURE	EQUIPMENT NOT READY/ AVAILABLE IF:
1	Semi-Annual		Road Test	<p style="text-align: center;">CAUTION</p> <p>Do not allow engine to operate for prolonged periods if outside air temperature is less than 85°F (29°C) and gauge is above 200°F (93°C) or outside air temperature is above 85°F (29°C) and gauge is above 225°F (100°C). Serious damage to engine may result.</p> <p style="text-align: center;">NOTE</p> <p>Be sure that all operator level PMCS in TM 9-2350-277-10 has been completed prior to performing this PMCS. Any non-mission capable faults must be corrected prior to road test.</p> <p style="text-align: center;">NOTE</p> <p>Check instruments, gauges, and warning lights for normal indications as outlined in TM 9-2350-277-10.</p> <p style="text-align: center;">NOTE</p> <p>Review all operator recorded problems prior to road test.</p> <p style="text-align: center;">NOTE</p> <p>When conditions prevent a road test, perform engine idle test (Step 3a) and governed no load test (Step 4a).</p>	

PREVENTIVE MAINTENANCE CHECKS AND SERVICES (PMCS), INCLUDING
LUBRICATION INSTRUCTIONS — Continued

0155 00

ITEM NO.	INTERVAL	MAN-HOUR	ITEM TO BE CHECKED OR SERVICED	CREWMEMBER PROCEDURE	EQUIPMENT NOT READY/AVAILABLE IF:
				<p>a. Start engine. See TM 9-2350-277-10. Perform a road test. Drive carrier at least 5 miles (8 km).</p> <p style="text-align: center;">CAUTION</p> <p>Power plant can be damaged. Do not pivot steer when carrier is moving except in a track failure emergency.</p>	<p>Any Class III leak or damage that would prevent operation of the carrier.</p>
a	Semi-Annual		Left and Right Steering	<p>a. Check steering wheel for left and right turns. If carrier does not turn left or right when wheel is turned, troubleshoot steering system (WP 0063 00).</p>	<p>Binding, grabbing, unusual noise, vibration, or carrier fails to turn.</p>
b	Semi-Annual		Steering in Forward and Reverse Range	<p>a. Check steering in forward range and in reverse angle. If carrier does not make a complete turn after steering wheel is turned to the left and right, troubleshoot steering system (WP 0063 00).</p>	
c	Semi-Annual		Carrier Braking	<p>a. Check carrier braking. If carrier does not stop when brakes are applied, troubleshoot brake adjustment (WP 0064 00).</p>	<p>Carrier fails to stop.</p>
d	Semi-Annual		Carrier Shifting in All Ranges	<p>a. Check shifting of carrier in all ranges. If carrier does not respond properly to selected driving range, troubleshoot gear selection system (WP 0065 00).</p>	<p>Carrier fails to shift into selected range.</p>
e	Semi-Annual		Speed	<p>a. When the vehicle is at normal temperature, it shall be capable of sustaining the speed of 40 mph.</p>	

PREVENTIVE MAINTENANCE CHECKS AND SERVICES (PMCS), INCLUDING LUBRICATION INSTRUCTIONS — Continued

0155 00

ITEM NO.	INTERVAL	MAN-HOUR	ITEM TO BE CHECKED OR SERVICED	CREWMEMBER PROCEDURE	EQUIPMENT NOT READY/AVAILABLE IF:
f	Semi-Annual		Drift	a. The vehicle's directional drift shall not exceed three feet in 100 feet of travel at 25 mph \pm 5 mph.	
g	Semi-Annual		Acceleration	a. At normal temperature, standing still, with the engine at idle RPM and the transmission in 1-4 range, the vehicle shall accelerate on a smooth, level, hard surface from zero to 20 mph in 11 seconds or less.	
h	Semi-Annual		Turning	a. Verify that the vehicle can make a 360° turn and pivot to the right and left. Pivot with the selector in PV. The vehicle should be brought to a full stop before reversing direction. b. Stop engine. See TM 9-2350-277-10.	
2	Semi-Annual		After Road Test	<div style="text-align: center;"> <p>WARNING</p>  <p>Failure to set the parking brake and block the road wheel can allow the carrier to move and result in injury or death. Always engage the parking brake and block the road wheels before working on the carrier.</p> </div>	

PREVENTIVE MAINTENANCE CHECKS AND SERVICES (PMCS), INCLUDING LUBRICATION INSTRUCTIONS — Continued

0155 00

ITEM NO.	INTERVAL	MAN-HOUR	ITEM TO BE CHECKED OR SERVICED	CREWMEMBER PROCEDURE	EQUIPMENT NOT READY/ AVAILABLE IF:
3	Semi-Annual		Idle Test	<p style="text-align: center;">WARNING</p> <div style="text-align: center;">  </div> <p>Never perform stall check. Transmission can be damaged. Personnel may be injured.</p> <ul style="list-style-type: none"> a. Immediately after road test cautiously feel all wheel and idler hubs for noticeable difference in temperature between hubs. An overheated hub indicates that bearing is out of adjustment, poorly lubricated, or unserviceable. b. Check temperature of shock absorbers. They should feel warm. A cold shock has failed. c. Visually check inside, outside, and underneath carrier for any fuel, oil, or hydraulic leaks. <p style="text-align: center;">CAUTION</p> <p>Avoid lengthy engine idling. This causes coolant temperature to drop below operating temperature and can shorten engine life.</p> <ul style="list-style-type: none"> a. Run engine at 800 RPM for 3-5 minutes with range selector in 2-3 range and brakes locked until operating temperature is reached. 	<p>A hub out of adjustment, poorly lubricated, or unserviceable.</p> <p>Any Class III leaks or cold shocks.</p> <p>Engine runs hot or rough.</p>

PREVENTIVE MAINTENANCE CHECKS AND SERVICES (PMCS), INCLUDING LUBRICATION INSTRUCTIONS — Continued

0155 00

ITEM NO.	INTERVAL	MAN-HOUR	ITEM TO BE CHECKED OR SERVICED	CREWMEMBER PROCEDURE	EQUIPMENT NOT READY/ AVAILABLE IF:
4	Semi-Annual		Governed No Load Test	<p>b. If outside temperature is less than 85°F (29°C), normal operating temperature should be 160° to 200°F (71° to 93° C). If outside air temperature is greater than 85°F (29°C), normal operating temperature should be 160° to 225°F (71° to 107°C)</p> <p>c. With range selector in SL, engine should idle smoothly at 650 to 700 RPM.</p> <p>d. High or low engine idle speed is usually caused by accelerator linkage being out of adjustment. Adjust linkage if necessary (WP 0214 00).</p> <p>e. Rough idling is usually caused by faulty injector timing and rack setting, faulty injectors or air in the injection system. Notify direct support maintenance.</p> <p>a. Run engine at 800 RPM for 3-5 minutes with range selector in 1 range and brakes locked until normal engine operating temperature is reached.</p> <p>b. If outside temperature is less than 85°F (29°C), normal operating temperature should be 160° to 200°F (71° to 93° C). If outside air temperature is greater than 85°F (29°C), normal operating temperature should be 160° to 225°F (71° to 107°C).</p> <p>c. With range selector in SL, slowly open throttle control until accelerator is fully depressed.</p> <p style="text-align: center;">CAUTION</p> <p>When you suspect a faulty governor, do not exceed 3,000 RPM engine speed for more than 2 or 3 seconds.</p>	<p>Tachometer above 700 or below 650 RPM.</p> <p>Engine runs hot or rough.</p>

PREVENTIVE MAINTENANCE CHECKS AND SERVICES (PMCS), INCLUDING LUBRICATION INSTRUCTIONS — Continued

0155 00

ITEM NO.	INTERVAL	MAN-HOUR	ITEM TO BE CHECKED OR SERVICED	CREWMEMBER PROCEDURE	EQUIPMENT NOT READY/ AVAILABLE IF:
5	Semi-Annual	1.2	Engine and Transmission Oil	<p>d. Engine speed may exceed 3,000 RPM momentarily, but should stabilize at 2,925 to 2,975 RPM.</p> <p>a. With engine at idle, sample engine and transmission oil.</p> <p style="text-align: center;">NOTE</p> <p>Do not sample new or overhauled engine until second oil change. Use hardtime requirement on new/overhauled engine.</p> <p style="text-align: center;">NOTE</p> <p>DO NOT ADD OIL immediately prior to taking oil samples. When operation checks and services indicate the need to replenish oil levels WAIT until after taking samples or before prolonged operation of components will adversely effect oil analysis results.</p> <ol style="list-style-type: none"> 1) Obtain two sample bottles from the unit AOAP monitor. 2) Start engine. See TM 9-2350-277-10. If required, operate carrier to bring engine and transmission up to normal operating temperatures. Refer to Sampling Requirements page 0155 00-15. 3) Stop carrier and set the brakes. See TM 9-2350-277-10. 4) Place range selector in SL position (steering lock) and keep engine running. 	<p>If governor cuts in and out, or surges at this speed, adjustments are needed.</p> <p>AOAP recommends oil change.</p>

PREVENTIVE MAINTENANCE CHECKS AND SERVICES (PMCS), INCLUDING LUBRICATION INSTRUCTIONS — Continued

0155 00

ITEM NO.	INTERVAL	MAN-HOUR	ITEM TO BE CHECKED OR SERVICED	CREWMEMBER PROCEDURE	EQUIPMENT NOT READY/AVAILABLE IF:
				<ol style="list-style-type: none"> 5) Remove driver's power plant access panel and open power plant access door. See TM 9-2350-277-10. 6) With engine running remove dust caps from engine and transmission oil sampling valves. 7) Open sample valve on engine oil filter and drain a small amount of oil into a container to clear valve of grit and contamination. (Properly dispose of container and oil upon completion of sample taking.) Fill sampling bottle to the neck shoulder and seal it. Attach DA Form 2026 to sample bottle. 	

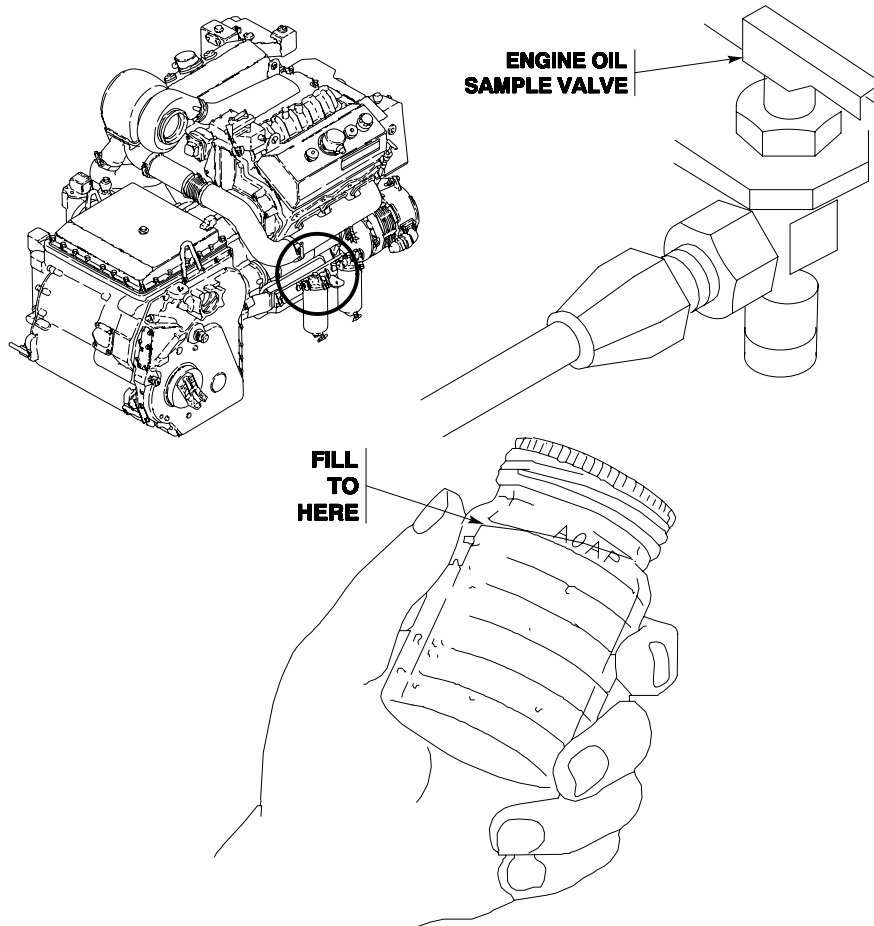

PREVENTIVE MAINTENANCE CHECKS AND SERVICES (PMCS), INCLUDING LUBRICATION INSTRUCTIONS — Continued

0155 00

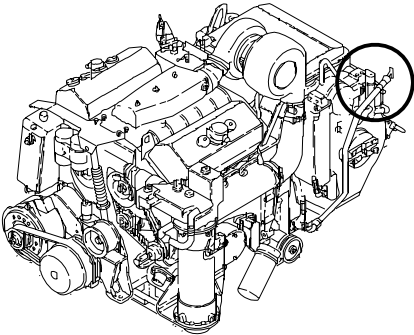
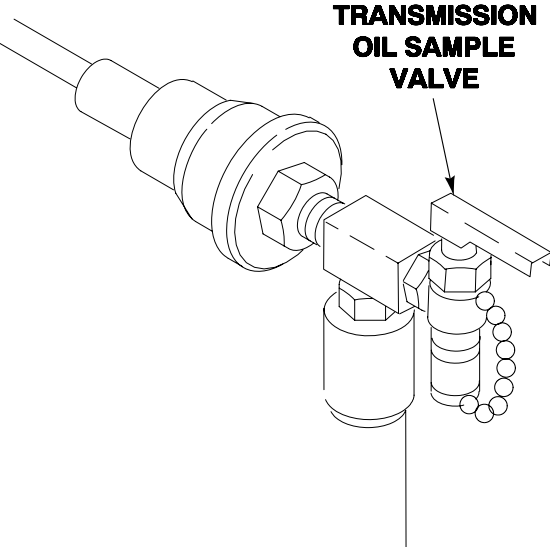
ITEM NO.	INTERVAL	MAN-HOUR	ITEM TO BE CHECKED OR SERVICED	CREWMEMBER PROCEDURE	EQUIPMENT NOT READY/AVAILABLE IF:
				<p>8) Close sample valve and install dust cap.</p> <p>9) Take oil sample from transmission in the same manner as in Steps a6 - a8.</p>  <p>10) Stop engine. See TM 9-2350-277-10.</p> <p>11) Install driver's compartment power plant access panel and secure carrier.</p> <p>12) Deliver sample bottles to the unit AOAP monitor.</p> <p style="text-align: center;">NOTE</p> <p>For location of nearest AOAP Laboratory and complete information about AOAP, refer to TB 43-0211.</p>	

PREVENTIVE MAINTENANCE CHECKS AND SERVICES (PMCS), INCLUDING LUBRICATION INSTRUCTIONS — Continued

0155 00

ITEM NO.	INTERVAL	MAN-HOUR	ITEM TO BE CHECKED OR SERVICED	CREWMEMBER PROCEDURE	EQUIPMENT NOT READY/ AVAILABLE IF:
				<p style="text-align: center;">NOTE</p> <p>If AOAP laboratory is not available, drain engine oil and change filter element/gasket every 150 hours/1500 miles or semi-annually. Transmission oil should be drained and filter element/gaskets changed every 150 hours/1500 miles or semi-annually. See AOAP TB 43-0211.</p> <p style="text-align: center;">NOTE</p> <p>Engine and transmission filters need to be replaced every 150 hours/1500 miles or semi-annually, even when following AOAP procedures.</p> <p>b. ON CONDITION — Drain engine oil.</p> <p style="text-align: center;">WARNING</p> <div style="text-align: center;">  </div> <p>Hot parts can burn you. Use care when you work near hot power unit.</p> <p style="text-align: center;">NOTE</p> <p>Drain oil only when hot after operation. Allow oil to drain thoroughly.</p> <ol style="list-style-type: none"> 1) Remove access cover from bottom of hull (WP 0450 00). 2) Place a suitable container under engine oil pan. 	

PREVENTIVE MAINTENANCE CHECKS AND SERVICES (PMCS), INCLUDING LUBRICATION INSTRUCTIONS — Continued

0155 00

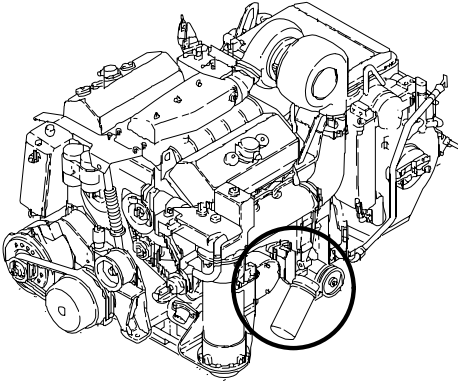
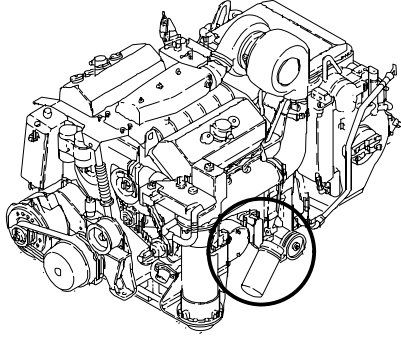
ITEM NO.	INTERVAL	MAN-HOUR	ITEM TO BE CHECKED OR SERVICED	CREWMEMBER PROCEDURE	EQUIPMENT NOT READY/AVAILABLE IF:
				<p>3) Remove plug from engine oil pan and drain oil into container.</p> <p>4) Inspect plug and oil for metallic particles. If metal chips are found, notify direct support maintenance.</p> <p>5) Clean and install drain plug in engine oil pan.</p>	
				<p>6) Install new oil filter element (WP 0165 00). Filter element will be replaced each time an engine oil change is required.</p>	

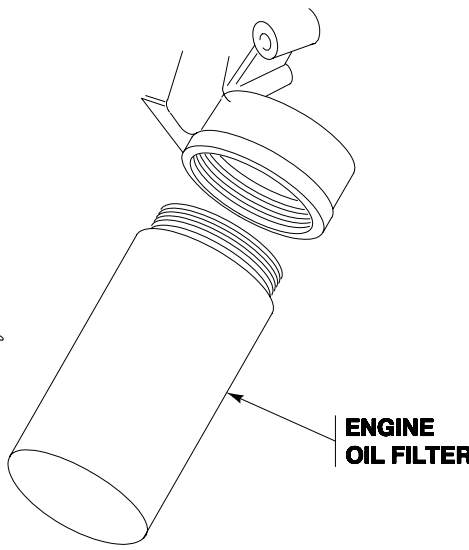
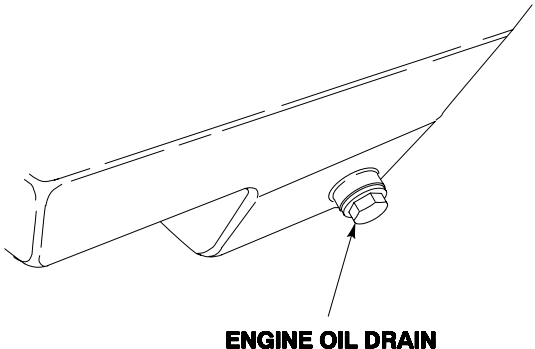

PREVENTIVE MAINTENANCE CHECKS AND SERVICES (PMCS), INCLUDING LUBRICATION INSTRUCTIONS — Continued

0155 00

ITEM NO.	INTERVAL	MAN-HOUR	ITEM TO BE CHECKED OR SERVICED	CREWMEMBER PROCEDURE	EQUIPMENT NOT READY/AVAILABLE IF:
				7) Fill engine with approximately 22 quarts of OE/HDO or OEA to bring level between F and L marks on gauge rod. See Engine Lubrication Table (Table 1, page 0155 00-16).	

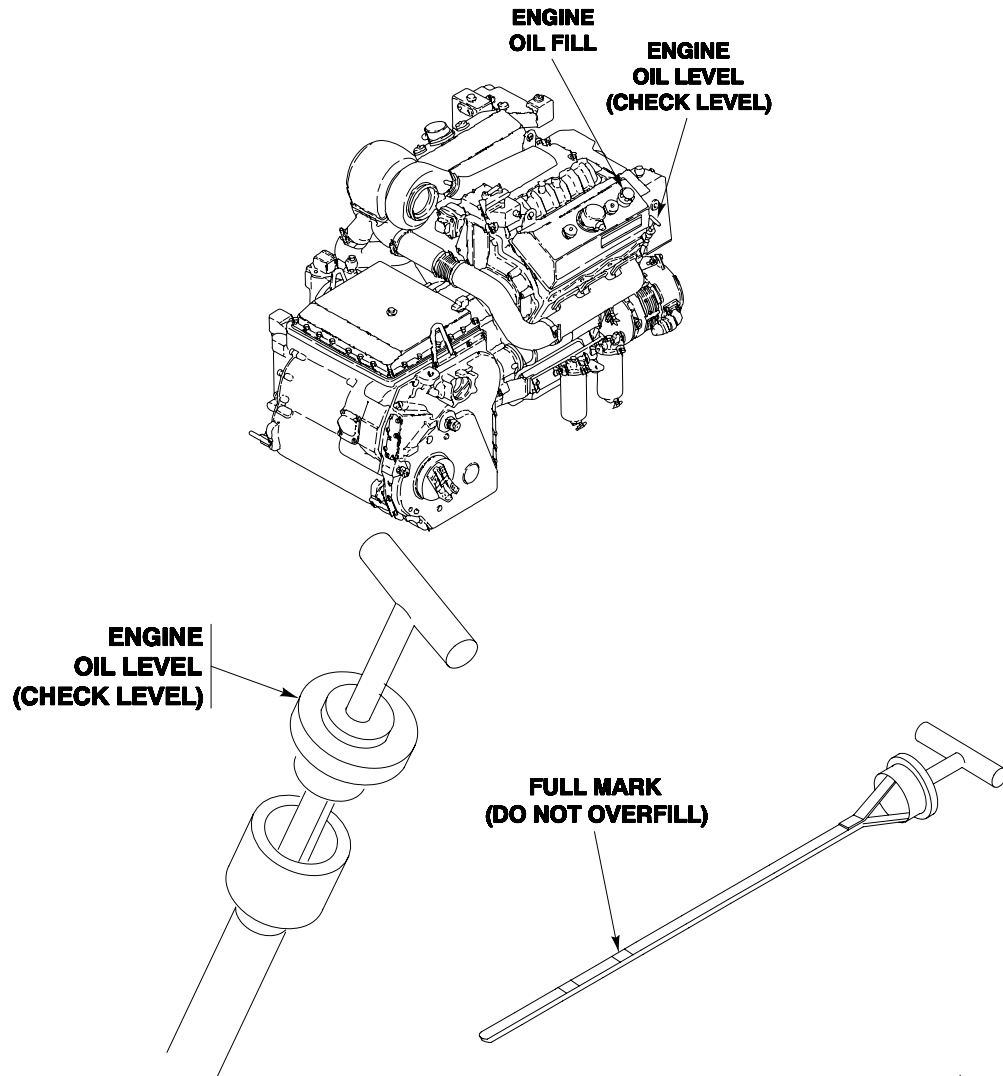

PREVENTIVE MAINTENANCE CHECKS AND SERVICES (PMCS), INCLUDING LUBRICATION INSTRUCTIONS — Continued

0155 00

ITEM NO.	INTERVAL	MAN-HOUR	ITEM TO BE CHECKED OR SERVICED	CREWMEMBER PROCEDURE	EQUIPMENT NOT READY/AVAILABLE IF:
				<p>c. If engine has been filled with preservation oil (MIL-PRF-21260, Grade PE 30-1), leave this oil in engine until first scheduled oil change. Maintain operating oil level by adding applicable grade oil (OE/HDO or OEA). When first scheduled oil change is made, refill engine oil with applicable grade of oil. See Engine Lubrication Table (Table 1, page 0155 00-16).</p> <p>d. Replace filter element each time an engine oil change is required (WP 0165 00).</p> <p>e. ON CONDITION — Drain transmission oil.</p> <p style="text-align: center;">WARNING</p> <div style="text-align: center;">  </div> <p>Hot parts can burn you. Use care when you work near hot power unit.</p> <p style="text-align: center;">NOTE</p> <p>Drain oil (36 quarts) only when hot after operation. Allow oil to drain for 1 hour if time permits.</p> <ol style="list-style-type: none"> 1) Remove access cover from bottom of hull (WP 0450 00). 2) Place a suitable container under transmission drain tube. 3) Remove plug from drain tube and drain oil into container. 4) Inspect plug and oil for metallic particles. If metal chips are found, notify direct support maintenance. 	

PREVENTIVE MAINTENANCE CHECKS AND SERVICES (PMCS), INCLUDING LUBRICATION INSTRUCTIONS — Continued

0155 00

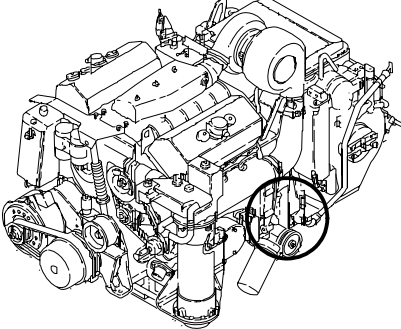
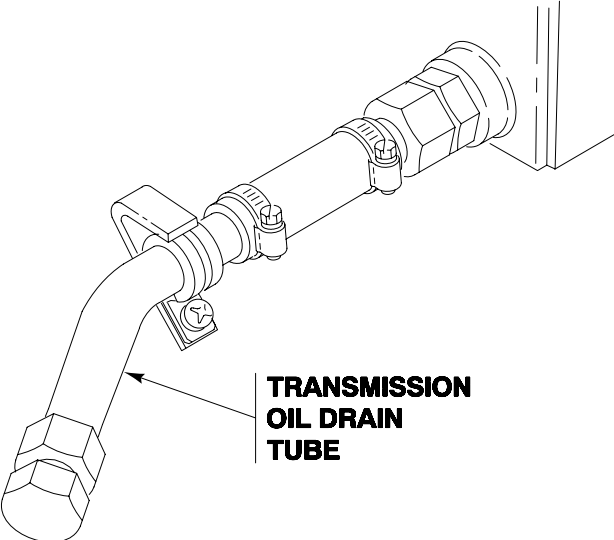
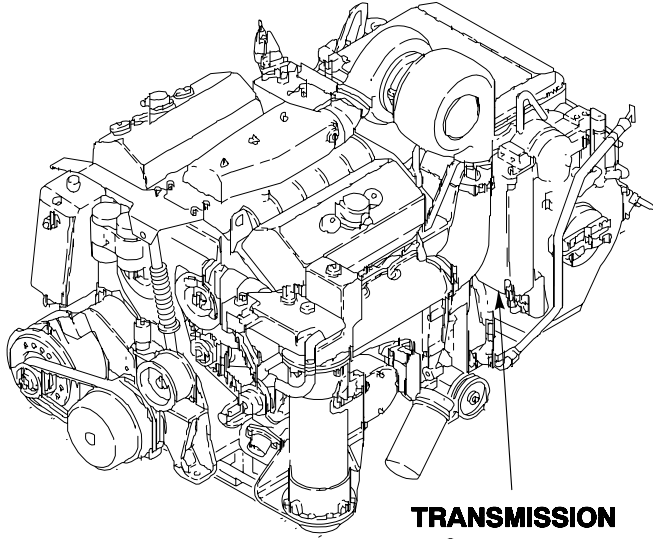
ITEM NO.	INTERVAL	MAN-HOUR	ITEM TO BE CHECKED OR SERVICED	CREWMEMBER PROCEDURE	EQUIPMENT NOT READY/AVAILABLE IF:
				<p>5) Clean and install drain plug in oil drain tube.</p> 	
				<p>6) Install new transmission oil filter element and gasket.</p>	

PREVENTIVE MAINTENANCE CHECKS AND SERVICES (PMCS), INCLUDING LUBRICATION INSTRUCTIONS — Continued

0155 00

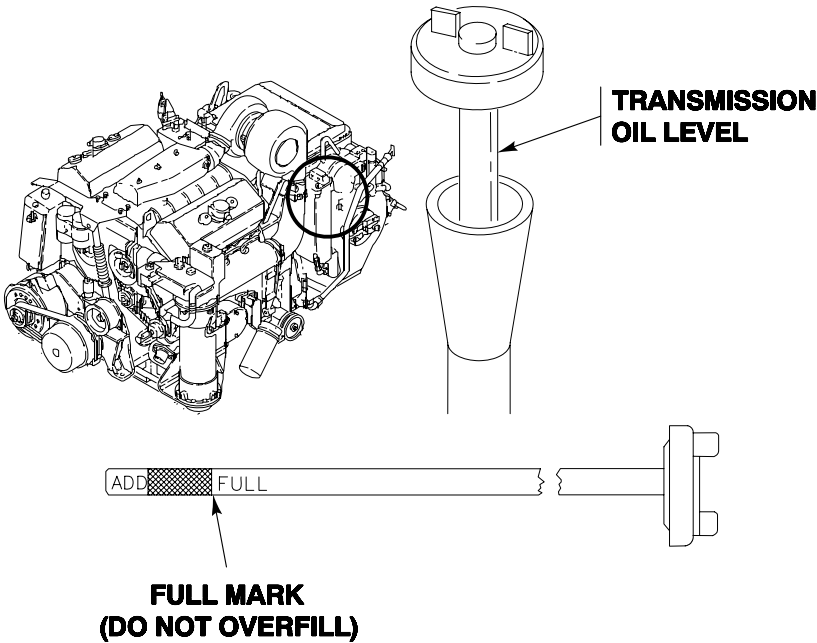
ITEM NO.	INTERVAL	MAN-HOUR	ITEM TO BE CHECKED OR SERVICED	CREWMEMBER PROCEDURE	EQUIPMENT NOT READY/AVAILABLE IF:
				<p>7) Fill transmission with approximately 36 quarts (refill capacity) or 57 quarts (initial fill) of OE/HDO or OEA, to bring level between FULL and ADD marks on gauge rod. See Transmission Lubrication Table (Table 3, page 0155 00-17).</p>  <p>TRANSMISSION OIL LEVEL</p> <p>FULL MARK (DO NOT OVERFILL)</p>	
				<p>f. If transmission has been filled with preservation oil (MIL-PRF-21260, Grade PE 10-1), leave this oil in transmission until first scheduled oil change. Maintain operating oil level by adding applicable grade oil (OE/HDO or OEA). When first scheduled oil change is made, refill transmission with applicable oil (OE/HDO or OEA).</p> <p>g. Replace filter element(WP 0398 00) each time a transmission oil change is required.</p> <p>h. Use the following procedure when changing oil grade or when oil is contaminated.</p>	

**PREVENTIVE MAINTENANCE CHECKS AND SERVICES (PMCS), INCLUDING
LUBRICATION INSTRUCTIONS — Continued**

0155 00

ITEM NO.	INTERVAL	MAN-HOUR	ITEM TO BE CHECKED OR SERVICED	CREWMEMBER PROCEDURE	EQUIPMENT NOT READY/ AVAILABLE IF:
				<p style="text-align: center;">NOTE</p> <p>Transmission oil must be flushed when changing oil grade or when oil is contaminated.</p> <ol style="list-style-type: none"> 1) Operate carrier until coolant reaches normal operating temperature. <p style="text-align: center;">NOTE</p> <p>Do not change transmission oil filter at this time.</p> <ol style="list-style-type: none"> 2) Drain transmission oil. 3) Fill transmission with new grade oil. 4) Operate transmission in 1-3 range with engine idling for 5-6 minutes. 5) Drain oil and change transmission oil filter. 6) Fill transmission with new grade oil. 7) Check oil level. <p style="text-align: center;">WARNING</p> <div style="text-align: center;">  </div> <p>Hot parts can burn you. Use care when working with them.</p>	

PREVENTIVE MAINTENANCE CHECKS AND SERVICES (PMCS), INCLUDING
LUBRICATION INSTRUCTIONS — Continued

0155 00

ITEM NO.	INTERVAL	MAN-HOUR	ITEM TO BE CHECKED OR SERVICED	CREWMEMBER PROCEDURE	EQUIPMENT NOT READY/ AVAILABLE IF:
				<p style="text-align: center;">NOTE</p> <p>Drain oil only when hot after operation. Allow oil to drain for one hour if time permits.</p> <p style="text-align: center;">NOTE</p> <p>If AOAP laboratory is not available, drain engine oil and change filter element/gaskets every 150 hours/1500 miles or annually. Transmission oil should be drained and filter element/gaskets changed every 150 hours/1500 miles or annually. Transmission oil should be drained and filter element/gaskets changed every 150 hours/1500 miles or semi-annually.</p> <p>i. HARDTIME — Hardtime interval can be shortened if equipment operates under adverse conditions. (For Arctic Operations, refer to FM 9-207. For Desert Operations, refer to FM 90-3.)</p> <p style="text-align: center;">CAUTION</p> <p>Engine and transmission can be damaged if filled above the full (F) mark on gauge rods.</p> <p style="text-align: center;">NOTE</p> <p>Do not mix OE/HDO-15/40 with single grade lubricants.</p> <p>j. Perform engine operational check.</p> <ol style="list-style-type: none"> 1) Start engine. See TM 9-2350-277-10. Check oil leaks at filter and drain plug. Stop engine. See TM 9-2350-277-10. 2) Inspect access cover on hull bottom and replace if damaged. 	<p>Any Class III leaks.</p>

**PREVENTIVE MAINTENANCE CHECKS AND SERVICES (PMCS), INCLUDING
LUBRICATION INSTRUCTIONS — Continued**

0155 00

ITEM NO.	INTERVAL	MAN-HOUR	ITEM TO BE CHECKED OR SERVICED	CREWMEMBER PROCEDURE	EQUIPMENT NOT READY/ AVAILABLE IF:
				<p>3) Install access cover on hull bottom (WP 0450 00).</p> <p>k. Perform transmission operational check.</p> <p>1) Start engine. See TM 9-2350-277-10. Check for oil leaks at transmission filter cover and drain plug. Recheck oil level.</p> <p>2) Inspect access cover on hull bottom and replace if damaged (WP 0450 00).</p> <p>3) Install access cover on hull bottom (WP 0450 00).</p> <p style="text-align: center;">NOTE</p> <p>Visual inspection of engine should not be justification for changing oil. Detergent oils may appear dark in color due to additives.</p> <p>l. Change oil and filters when converting from OE/HDO to OEA, PE 30-1 to OE/HDO, PE 10-1 to OE/HDO. See engine temperature key chart (Table 1, page 0155 00-16) and transmission temperature key chart (Table 3, page 0155 00-17). See Lubrication Charts.</p> <p>m. Every 150 hours/1500 miles or semiannually, remove and clean transmission breather using cleaning compound. Dry breather and install on transmission (WP 0399 00).</p>	<p>Any Class III leaks.</p>

PREVENTIVE MAINTENANCE CHECKS AND SERVICES (PMCS), INCLUDING
LUBRICATION INSTRUCTIONS — Continued

0155 00

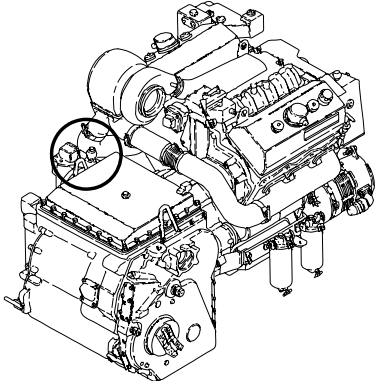
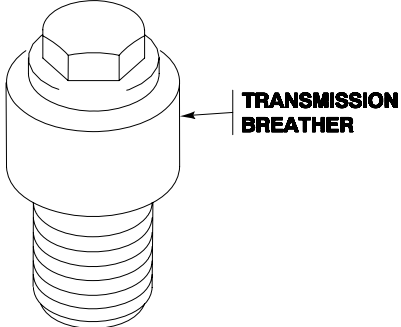
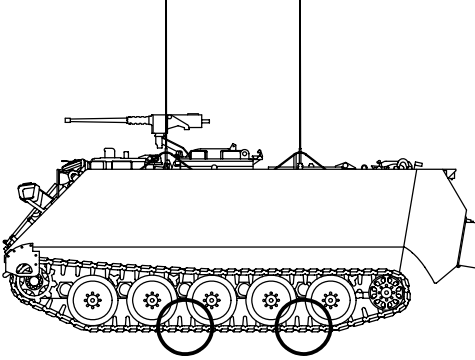
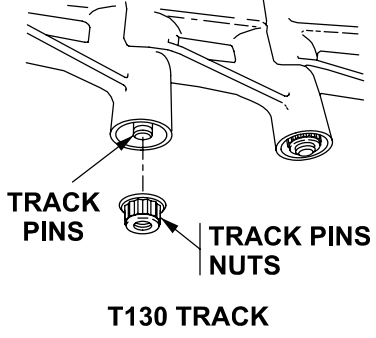
ITEM NO.	INTERVAL	MAN-HOUR	ITEM TO BE CHECKED OR SERVICED	CREWMEMBER PROCEDURE	EQUIPMENT NOT READY/AVAILABLE IF:
6	Semi-Annual		 <p>Track Pin/Nuts (T130 Track Only)</p>	 <p>a. Check track pin nuts for looseness or cracks. Replace cracked nuts. Check track pins for stripped threads. Replace stripped track pins. TIGHTEN LOOSE NUTS TO 115-135 LB-FT (156-183 N·M) TORQUE. Use torque wrench (WP 0926 00, Item 79).</p>	Any pins/nuts that are cracked, broken, bent, stripped, missing, or protruding.
					

PREVENTIVE MAINTENANCE CHECKS AND SERVICES (PMCS), INCLUDING LUBRICATION INSTRUCTIONS — Continued

0155 00

ITEM NO.	INTERVAL	MAN-HOUR	ITEM TO BE CHECKED OR SERVICED	CREWMEMBER PROCEDURE	EQUIPMENT NOT READY/ AVAILABLE IF:
7	Semi-annual		Track Assembly (T150 Track Only)	<p style="text-align: center;">NOTE</p> <p>The T150 track assembly is to be reversed semi-annually. It needs to be reversed to put wear on the end connectors and track shoe bushings in both directions.</p> <p>a. The T150 track assembly needs to be reversed to put wear on the end connectors and track shoe bushings in both directions (WP 0419 01). This will extend the life of the track. If it is not reversed the track will wear unevenly and the life of the track will be reduced.</p> <p style="text-align: center;">NOTE</p> <p>The end connector can only be checked with the track gauge when it is removed from the track shoe pins.</p> <p>b. Use the track gauge on the inside or facing side of the end connector toward the track shoe when it is removed. The track gauge slot is a no fit condition. If it does not fit, the end connector is still good for use. When the material on the end connector gets too thin and the track gauge fits, the end connector is bad and needs to be replaced with a new one.</p>	Any screws are missing, loose, or worn.

PREVENTIVE MAINTENANCE CHECKS AND SERVICES (PMCS), INCLUDING LUBRICATION INSTRUCTIONS — Continued

0155 00

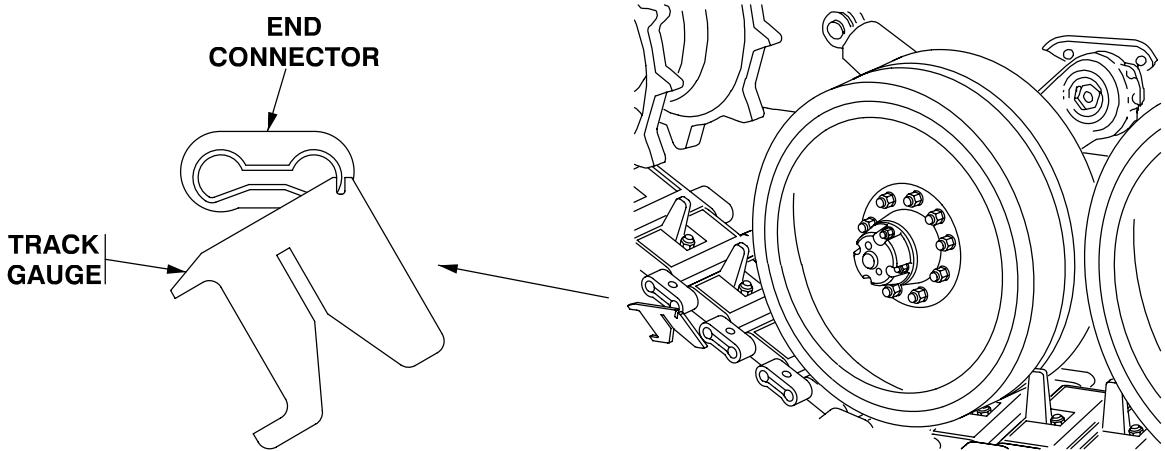
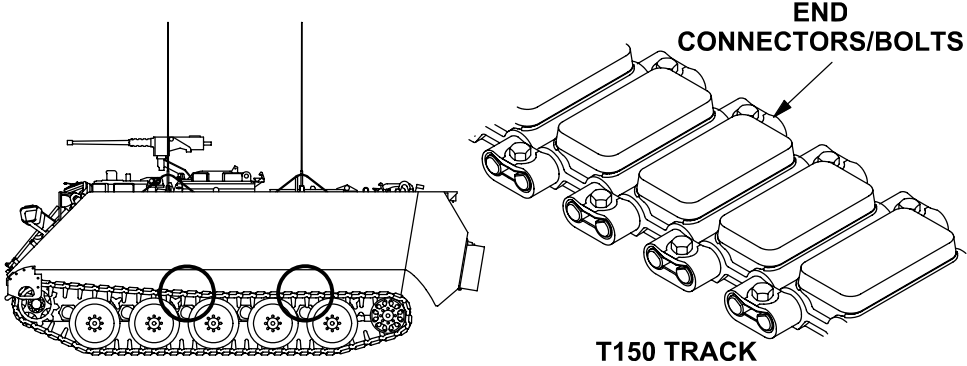
ITEM NO.	INTERVAL	MAN-HOUR	ITEM TO BE CHECKED OR SERVICED	CREWMEMBER PROCEDURE	EQUIPMENT NOT READY/AVAILABLE IF:
8	Semi-Annual		Track Shoe End Connectors/Bolts. (T150 Track Only)	 <p>a. Check all end connectors/bolts for cracks and looseness. Check bolts for stripped threads. TIGHTEN BOLTS TO 400-430 LB-FT (543-583 N·M) TORQUE. Use torque wrench (WP 0926 00, Item 79).</p> <p>b. New installed T150 track shoe end connector bolts require a check between 30-80 miles of operation. RETORQUE END CONNECTOR BOLTS TO 400-430 LB-FT (543-583 N·M). Use torque wrench (WP 0926 00, Item 79).</p> 	Any connectors that are cracked, broken, bent, stripped, or missing.

PREVENTIVE MAINTENANCE CHECKS AND SERVICES (PMCS), INCLUDING LUBRICATION INSTRUCTIONS — Continued

0155 00

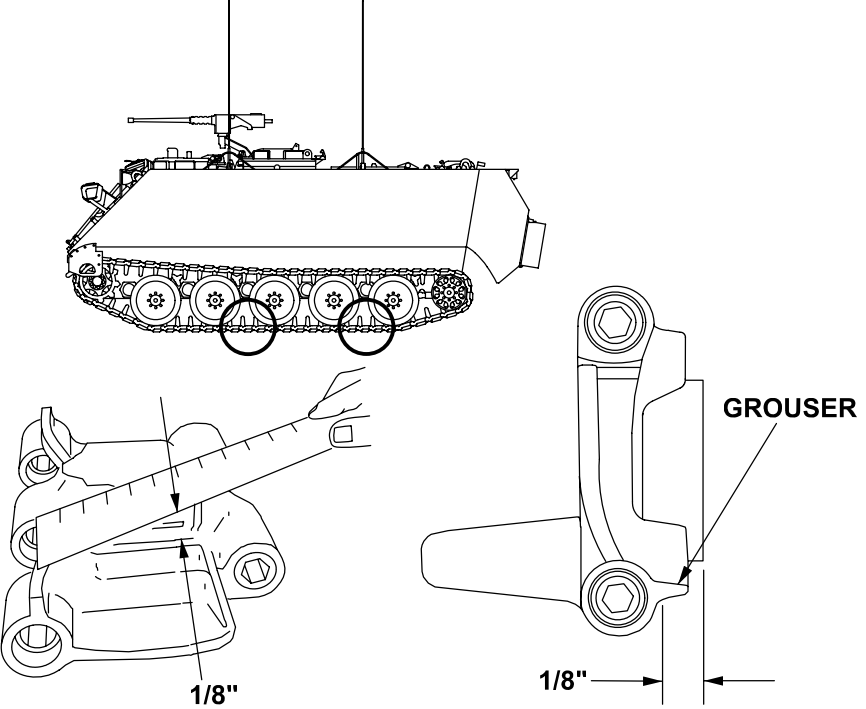
ITEM NO.	INTERVAL	MAN-HOUR	ITEM TO BE CHECKED OR SERVICED	CREWMEMBER PROCEDURE	EQUIPMENT NOT READY/ AVAILABLE IF:
9	Semi-Annual		Track Grouser (T130 Track Only)	a. Check grouser for wear or cracks on both tracks. Replace track shoe if grouser measures less than 1/8" (3 mm) in height or if grouser is cracked.	Grouser is worn below 1/8" or cracked.
					

PREVENTIVE MAINTENANCE CHECKS AND SERVICES (PMCS), INCLUDING LUBRICATION INSTRUCTIONS — Continued

0155 00

ITEM NO.	INTERVAL	MAN-HOUR	ITEM TO BE CHECKED OR SERVICED	CREWMEMBER PROCEDURE	EQUIPMENT NOT READY/ AVAILABLE IF:
10	Semi-Annual		Track Shoe Pads and Mounting Studs/Nuts	a. Check track shoes pads and mounting for looseness and stripped threads on both tracks. If mounting nuts are stripped, replace track shoe pad (T130) (WP 0424 00) or (T150) (WP 0424 01). TIGHTEN LOOSE NUTS TO 135-155 LB-FT (183-210 N·M). Use torque wrench (WP 0926 00, Item 80).	Studs/nuts are cracked, stripped, missing, or pad height is less than 1/16" above grouser (T130). Studs/nuts are cracked, stripped, missing, or pad height is less than 1/16" above track shoe (T150).

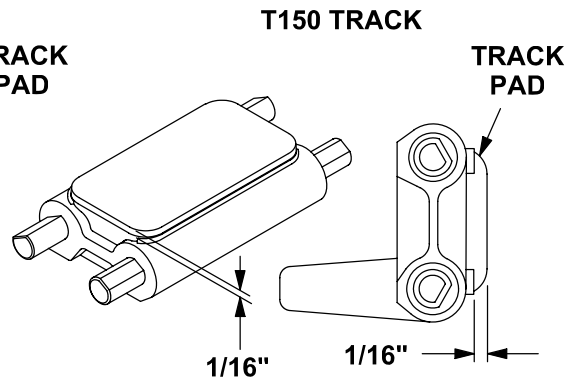
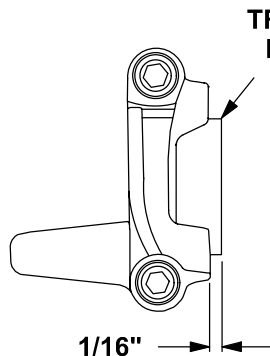
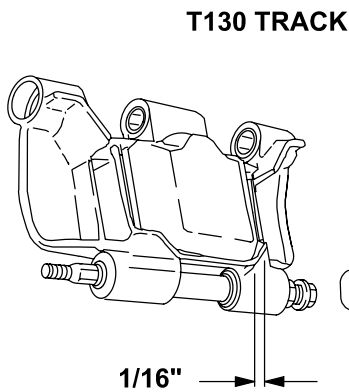
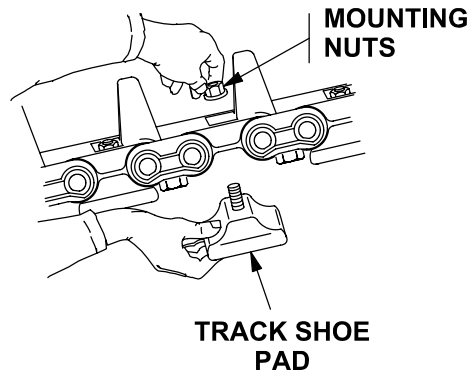
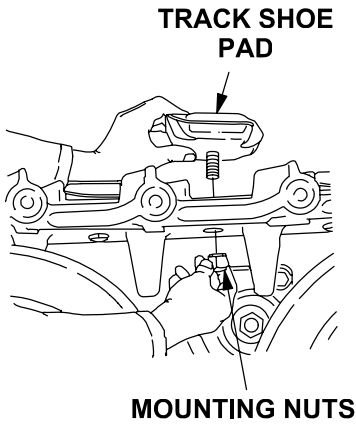

T130 TRACK

T150 TRACK

PREVENTIVE MAINTENANCE CHECKS AND SERVICES (PMCS), INCLUDING LUBRICATION INSTRUCTIONS — Continued

0155 00

ITEM NO.	INTERVAL	MAN-HOUR	ITEM TO BE CHECKED OR SERVICED	CREWMEMBER PROCEDURE	EQUIPMENT NOT READY/ AVAILABLE IF:
11	Semi-Annual		Track Tension Adjuster Mounting Hardware	<p>a. Check track tension adjuster for broken hardware or cracks on both sides of the carrier. Replace adjuster if either end is cracked or broken. Replace broken adjuster mount (WP 0419 00).</p> <p style="text-align: center;">NOTE</p> <p>See Step 1g under General Maintenance Instructions for proper use of torque wrench adapters.</p> <p>b. Replace missing track tension adjuster screws. TIGHTEN LOOSE SCREWS TO 130-140 LB-FT (176-190 N·M) TORQUE. Use adapter and torque wrench (WP 0926 00, Item 79).</p>	Hardware is broken, cracked, missing, or stripped.

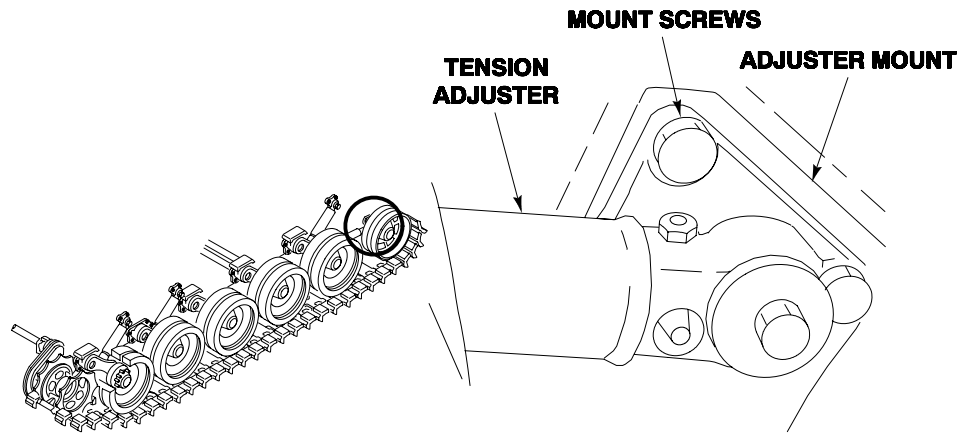

PREVENTIVE MAINTENANCE CHECKS AND SERVICES (PMCS), INCLUDING LUBRICATION INSTRUCTIONS — Continued

0155 00

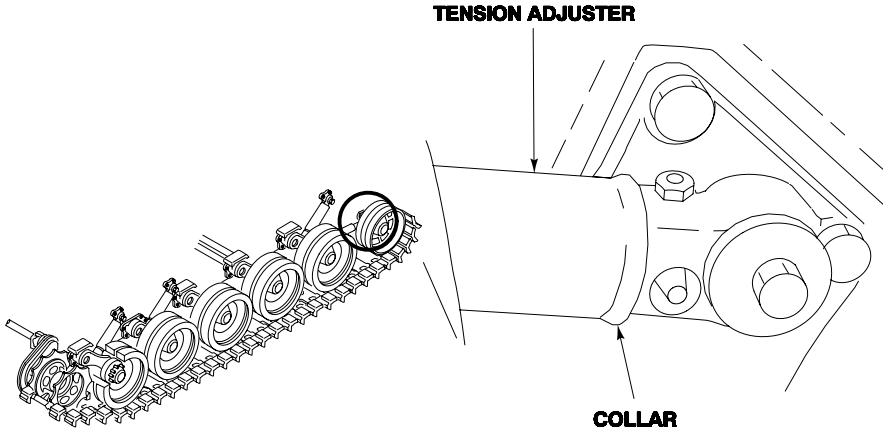
ITEM NO.	INTERVAL	MAN-HOUR	ITEM TO BE CHECKED OR SERVICED	CREWMEMBER PROCEDURE	EQUIPMENT NOT READY/ AVAILABLE IF:
12	Semi-Annual		Track Tension Adjuster Collar Leaks	a. Check for leaks around grease fittings, relief valve and collar of track tension adjuster. Replace leaking track adjuster (WP 0419 00).	Any leaks or fitting will not accept grease.
					
13	Semi-Annual		Sprocket Mounting Screws	a. Check sprockets on both tracks for wear indicating that mounting bolts have come loose. TIGHTEN LOOSE BOLTS TO 110-115 LB-FT (149-156 N·M) TORQUE. Use torque wrench (WP 0926 00, Item 79). b. Check sprocket cushions for wear. Replace cushions if gouges, chips, or cuts cause thumping (T130) (WP 0421 00) or (T150) (WP 0420 01).	Any bolts are missing, loose, or worn.

PREVENTIVE MAINTENANCE CHECKS AND SERVICES (PMCS), INCLUDING LUBRICATION INSTRUCTIONS — Continued

0155 00

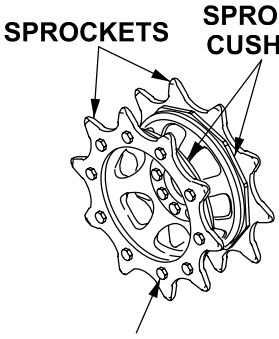
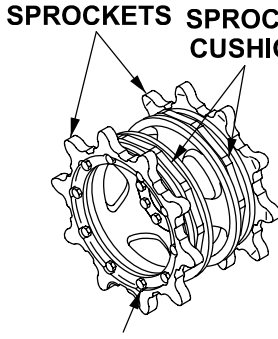
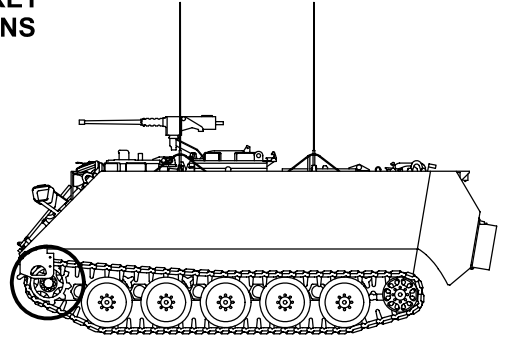
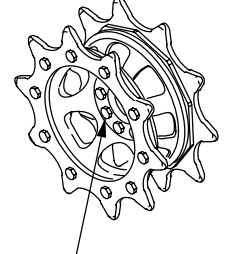
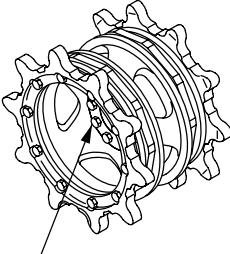
ITEM NO.	INTERVAL	MAN-HOUR	ITEM TO BE CHECKED OR SERVICED	CREWMEMBER PROCEDURE	EQUIPMENT NOT READY/AVAILABLE IF:	
14	Semi-Annual		 <p>SPROCKETS SPROCKET CUSHIONS MOUNTING BOLTS T130 TRACK</p>	 <p>SPROCKETS SPROCKET CUSHIONS MOUNTING BOLTS T150 TRACK</p>	 <p>a. Check sprocket hub bolts for looseness or missing bolts. TIGHTEN LOOSE BOLTS TO 170-190 LB-FT (231-258 N·M) TORQUE. Use torque wrench (WP 0926 00, Item 79). If bolts are missing, replace (T130) (WP 0420 00) or (T150) (WP 0420 01).</p>	Any bolts are missing, loose, or worn.
			Sprocket Hub Bolts			
			 <p>SPROCKET HUB BOLTS T130 TRACK</p>	 <p>SPROCKET HUB BOLTS T150 TRACK</p>		

PREVENTIVE MAINTENANCE CHECKS AND SERVICES (PMCS), INCLUDING LUBRICATION INSTRUCTIONS — Continued

0155 00

ITEM NO.	INTERVAL	MAN-HOUR	ITEM TO BE CHECKED OR SERVICED	CREWMEMBER PROCEDURE	EQUIPMENT NOT READY/ AVAILABLE IF:
15	Semi-Annual	0.5	Final Drive	<p>a. TIGHTEN LOOSE FINAL DRIVE-TO-HULL SCREWS TO 75-85 LB-FT (101-115 N·M) TORQUE. Use torque wrench (WP 0926 00, Item 79).</p> <p style="text-align: center;">NOTE</p> <p>Drain oil (3 1/2 qt.) only when hot after operation.</p> <p style="text-align: center;">NOTE</p> <p>Do not substitute hydraulic fluid for OE/HDO or OEA. Red dye has been added to some final drives to aid in detection of leaks.</p> <p>b. Drain final drives every 150 hours/1500 miles or semi-annually.</p> <ol style="list-style-type: none"> 1) Place a suitable container under final drive housing. 2) Remove drain plugs from final drive housing and drain oil into the container (WP 0452 00). 3) Inspect drain plugs and oil for metal particles. If metal chips are found, notify direct support maintenance. 4) Clean and install the drain plug (WP 0452 00). 	

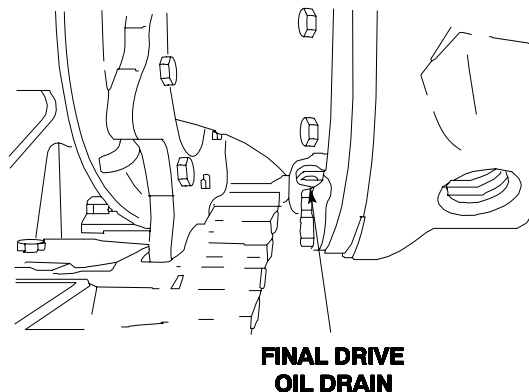
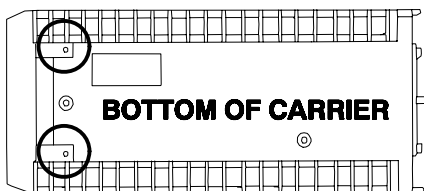

PREVENTIVE MAINTENANCE CHECKS AND SERVICES (PMCS), INCLUDING LUBRICATION INSTRUCTIONS — Continued

0155 00

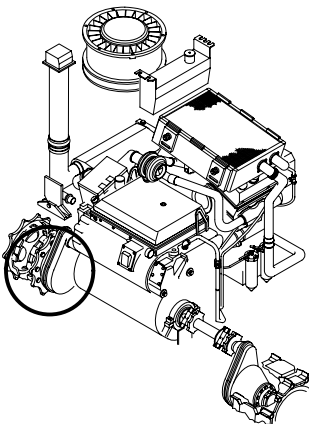
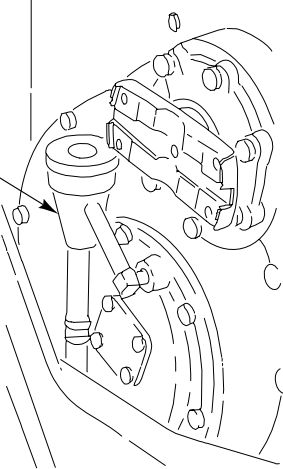
ITEM NO.	INTERVAL	MAN-HOUR	ITEM TO BE CHECKED OR SERVICED	CREWMEMBER PROCEDURE	EQUIPMENT NOT READY/AVAILABLE IF:
				<p>5) Fill each final drive with OE/HDO or OEA, as applicable, to bring oil level to a point between the FULL and ADD marks on gauge rod. Each final drive holds approximately 3 1/2 quarts. See Final Drive Lubrication Table (Table 4, page 0155 00-17).</p>  <p>FINAL DRIVE OIL LEVEL (CHECK AND FILL)</p> <p>RIGHT FINAL DRIVE FILLER TUBE</p>	<p>Oil is contaminated with metal chips or particles.</p>

PREVENTIVE MAINTENANCE CHECKS AND SERVICES (PMCS), INCLUDING
LUBRICATION INSTRUCTIONS — Continued

0155 00

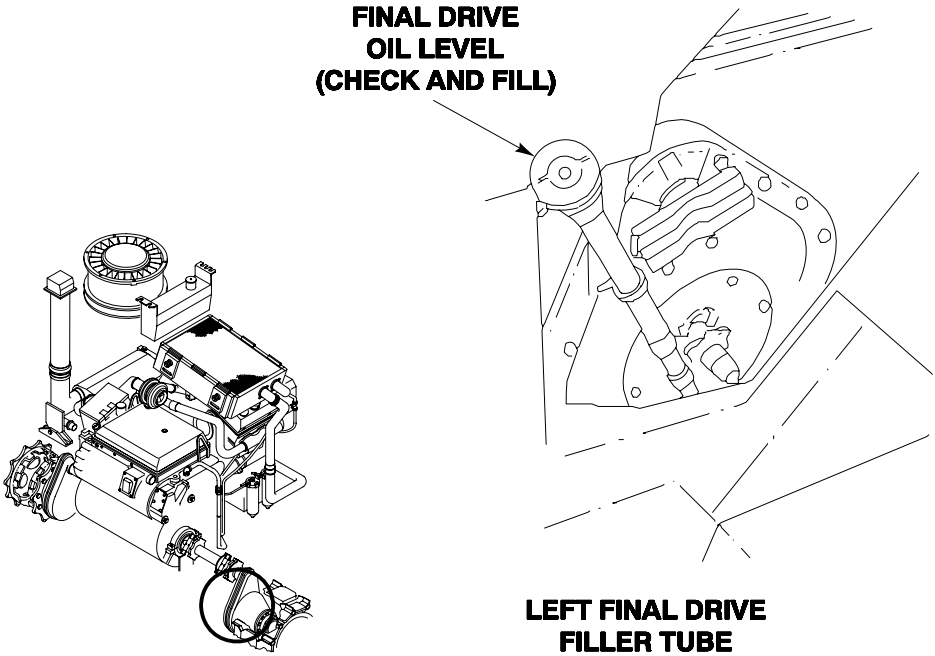
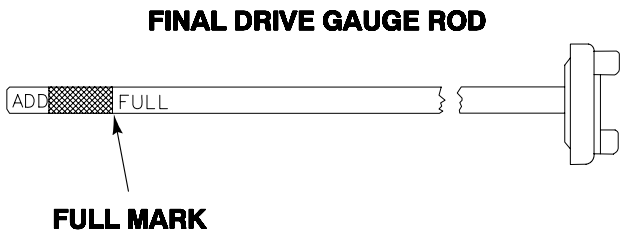
ITEM NO.	INTERVAL	MAN-HOUR	ITEM TO BE CHECKED OR SERVICED	CREWMEMBER PROCEDURE	EQUIPMENT NOT READY/AVAILABLE IF:
			 <p>FINAL DRIVE OIL LEVEL (CHECK AND FILL)</p> <p>LEFT FINAL DRIVE FILLER TUBE</p>	 <p>FINAL DRIVE GAUGE ROD</p> <p>FULL MARK</p>	

PREVENTIVE MAINTENANCE CHECKS AND SERVICES (PMCS), INCLUDING LUBRICATION INSTRUCTIONS — Continued

0155 00

ITEM NO.	INTERVAL	MAN-HOUR	ITEM TO BE CHECKED OR SERVICED	CREWMEMBER PROCEDURE	EQUIPMENT NOT READY/ AVAILABLE IF:
16	Semi-Annual		Idler and Road Wheel Arms	a. Replace cracked or bent idler or road wheel arms (WP 0415 00 or WP 0417 00). Replace idler or road wheel arm relief valves and grease fittings if leaking (WP 0415 00 or WP 0417 00). Replace leaking road wheel arms seals and gaskets (WP 0415 00).	Any bent, broken, or cracked arm, or leaking seal.
<p>The diagram shows a side view of a track assembly with idler and road wheels. A callout provides a detailed view of a road wheel hub and its mounting. Labels with arrows point to the 'IDLER ARM' at the top, 'RELIEF VALVES' on the right side of the hub, and 'GREASE FITTINGS' at the bottom of the hub.</p>					
17	Semi-Annual		Idler and Road Wheel Mounting Nuts	a. Check idler and road wheel mounting nuts for looseness. TIGHTEN LOOSE NUTS TO 150-170 LB-FT (203-230 N·M) TORQUE. Use torque wrench (WP 0926 00, Item 79).	Any missing or stripped nuts.
<p>The diagram shows a side view of a track assembly. A callout provides a detailed view of a road wheel hub. Labels with arrows point to the 'MOUNTING NUTS' at the top of the hub and the 'RIBBED BOLTS' at the bottom of the hub.</p>					

PREVENTIVE MAINTENANCE CHECKS AND SERVICES (PMCS), INCLUDING LUBRICATION INSTRUCTIONS — Continued

0155 00

ITEM NO.	INTERVAL	MAN-HOUR	ITEM TO BE CHECKED OR SERVICED	CREWMEMBER PROCEDURE	EQUIPMENT NOT READY/ AVAILABLE IF:
18	Semi-Annual	1.4	Idler, Road Wheels, and Idler/Road Wheel Hubs	<ul style="list-style-type: none"> a. Replace cracked, broken, or bent idler/road wheels and idler/road wheel hubs (WP 0415 00, WP 0416 00, WP 0417 00, and WP 0418 00). Refer to (WP 0155 00) for road wheel components. b. At each service, or wherever track is removed, adjust the wheel bearings if looseness or end play is observed (WP 0418 00). c. Replace leaking seals and gaskets (WP 0418 00). d. Replace grease fittings and relief valves if they are leaking (WP 0418 00). 	<p>Any broken, bent, or cracked idler/road wheels or leaking hub seals.</p> <p>Number one or number five wheel-bearing loose.</p> <p>Leaky grease fittings.</p>

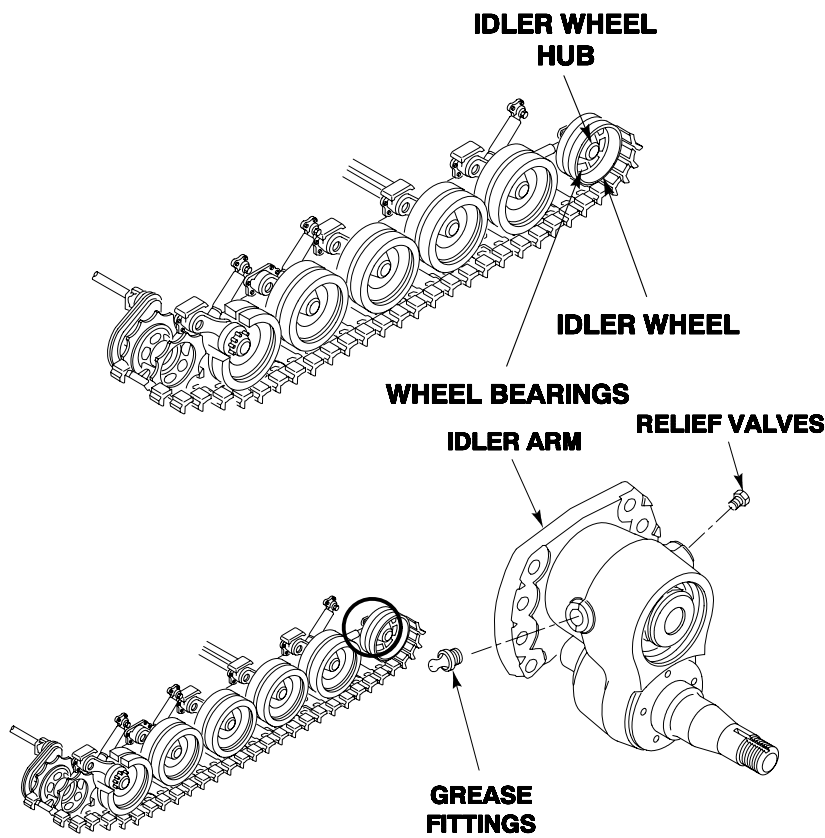

**PREVENTIVE MAINTENANCE CHECKS AND SERVICES (PMCS), INCLUDING
LUBRICATION INSTRUCTIONS — Continued**

0155 00

ITEM NO.	INTERVAL	MAN-HOUR	ITEM TO BE CHECKED OR SERVICED	CREWMEMBER PROCEDURE	EQUIPMENT NOT READY/ AVAILABLE IF:
				<p>e. Every 1500 miles or semi-annually, perform the following lubrication procedures. See Lubrication Table (Table 10, page 0155 00-19).</p> <p style="text-align: center;">NOTE</p> <p>When grease fitting will not accept GAA, notify your supervisor.</p> <ol style="list-style-type: none"> 1) Lubricate idler wheel support arm bearings through fittings. Use grease gun with GAA on fitting at rear of support arm until GAA appears at relief valve. 2) Lubricate road wheel and idler wheel hub bearings. Use GAA and grease gun with flexible adapter. Lubricate hub through fitting until grease appears at relief valve. 3) Lubricate all road wheel support arm bearings. Use GAA and grease gun with flexible adapter on fitting until GAA appears at relief valve. If support arm has plugs but no fittings, remove one plug and install fitting. Remove remaining plug and install relief valve. Perform lubrication. Remove fitting and relief valve. Clean and install two plugs. 4) Clean fittings with cleaning compound. Check/lubricate grease fitting points after washing or fording. 	

PREVENTIVE MAINTENANCE CHECKS AND SERVICES (PMCS), INCLUDING
LUBRICATION INSTRUCTIONS — Continued

0155 00

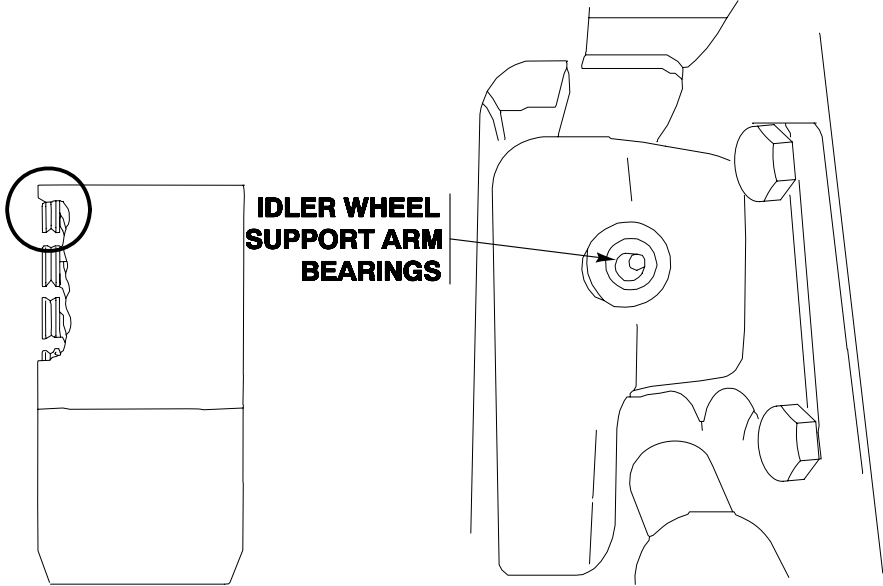
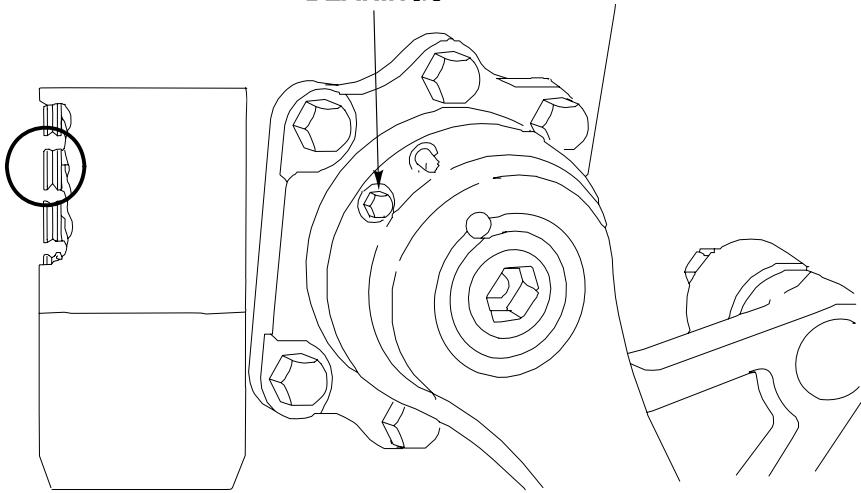
ITEM NO.	INTERVAL	MAN-HOUR	ITEM TO BE CHECKED OR SERVICED	CREWMEMBER PROCEDURE	EQUIPMENT NOT READY/AVAILABLE IF:
					
					

PREVENTIVE MAINTENANCE CHECKS AND SERVICES (PMCS), INCLUDING LUBRICATION INSTRUCTIONS — Continued

0155 00

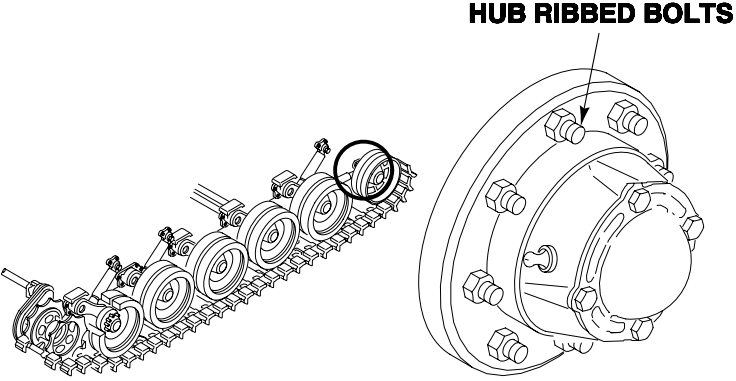
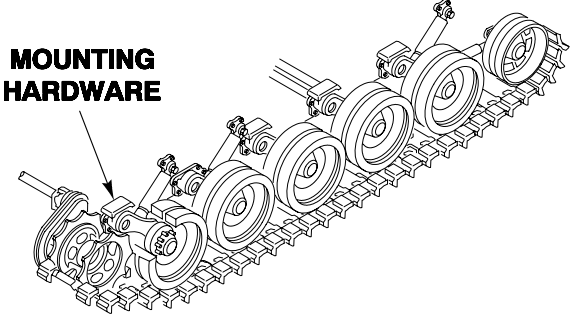
ITEM NO.	INTERVAL	MAN-HOUR	ITEM TO BE CHECKED OR SERVICED	CREWMEMBER PROCEDURE	EQUIPMENT NOT READY/ AVAILABLE IF:
19	Semi-Annual		Idler and Road Wheel Hub Ribbed Bolts	a. Replace bent, broken, or stripped idler or road wheel hub ribbed bolts (WP 0416 00 or WP 0418 00). Refer to WP 0417 00 for idler components.	Any broken, bent, or stripped bolts.
					
20	Semi-Annual		Road Wheel Arm Mounting Hardware	a. TIGHTEN LOOSE ROAD WHEEL ARM MOUNTING HARDWARE TO 130-140 LB-FT (176-190 N·M) TORQUE. Use torque wrench (WP 0926 00, Item 79).	Any loose mounting hardware.
					

PREVENTIVE MAINTENANCE CHECKS AND SERVICES (PMCS), INCLUDING LUBRICATION INSTRUCTIONS — Continued

0155 00

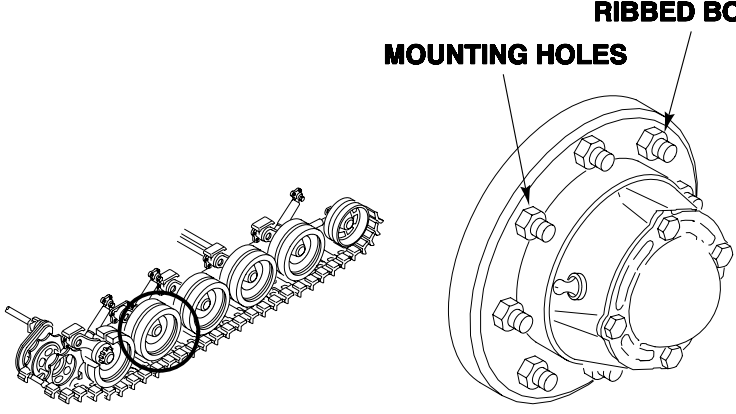
ITEM NO.	INTERVAL	MAN-HOUR	ITEM TO BE CHECKED OR SERVICED	CREWMEMBER PROCEDURE	EQUIPMENT NOT READY/AVAILABLE IF:
21	Semi-Annual		Road Wheel Mounting Holes	<p>a. If road wheel mounting holes extend beyond head of mounting nut, replace road wheel (WP 0426 00).</p> <div style="text-align: center;">  <p>The diagram consists of two parts. On the left is a perspective view of a road wheel assembly with a track. On the right is a top-down view of the wheel hub. Arrows point from the text 'MOUNTING HOLES' to the holes in the hub, and from 'RIBBED BOLTS' to the bolts around the perimeter of the hub.</p> </div>	Any elongated holes that extend beyond mounting nuts.
22	Semi-Annual		Torsion Bar Anchors/Splines/End Plugs	<p>a. Remove floor plates (WP 0539 00, WP 0542 00, WP 0543 00, WP 0544 00, and WP 0545 00).</p> <p>b. Check plugs. Be sure they are fully seated. TIGHTEN PLUGS TO 50-75 LB-FT (68-102 N·M). Use torque wrench (WP 0926 00, Item 79).</p> <p>c. Replace missing or damaged cotter pins and pins or bolts from torsion bar anchors (WP 0414 00).</p>	Any broken, bent, missing, stripped torsion bars or attaching hardware.

PREVENTIVE MAINTENANCE CHECKS AND SERVICES (PMCS), INCLUDING LUBRICATION INSTRUCTIONS — Continued

0155 00

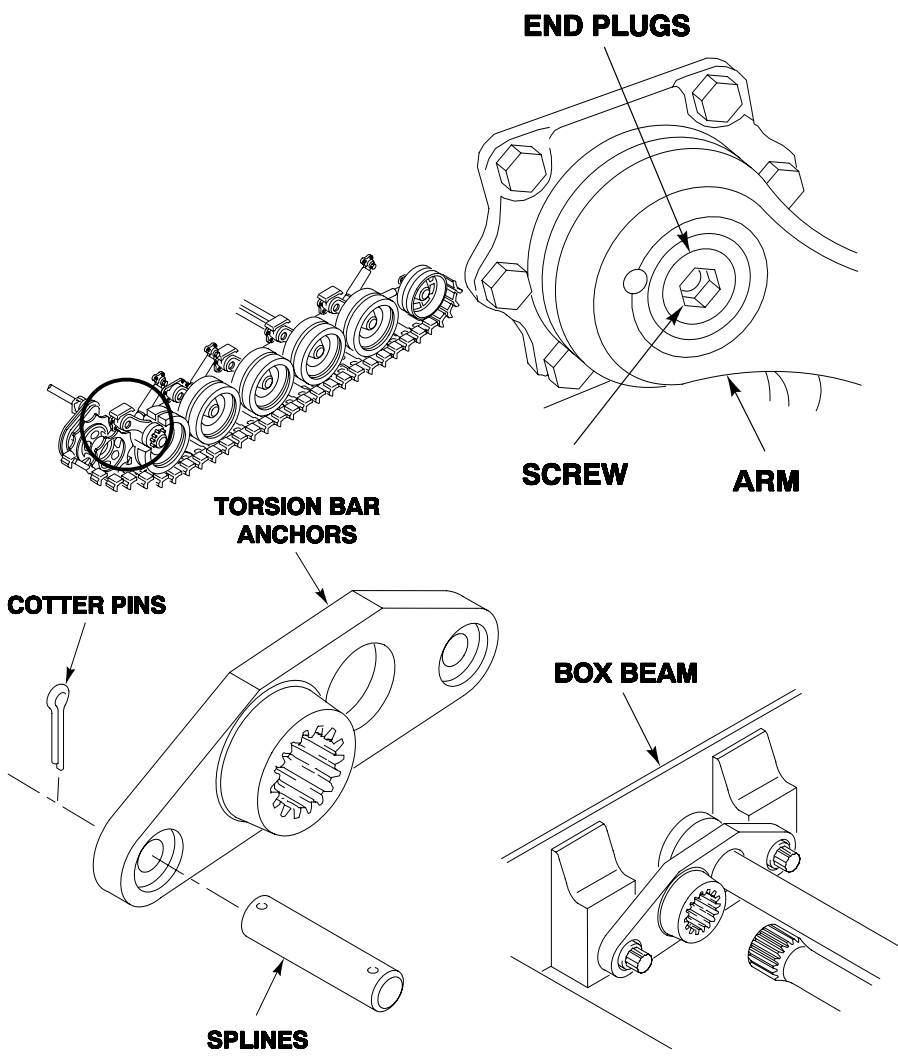
ITEM NO.	INTERVAL	MAN-HOUR	ITEM TO BE CHECKED OR SERVICED	CREWMEMBER PROCEDURE	EQUIPMENT NOT READY/AVAILABLE IF:
			 <p>The diagrams illustrate the following parts: <ul style="list-style-type: none"> END PLUGS: Two circular components with a central hole, used to seal the ends of a torsion bar. TORSION BAR ANCHORS: A U-shaped metal component with a circular end featuring splines. COTTER PINS: Small pins used to secure the anchor to the splines. SPLINES: A cylindrical shaft with a splined end. BOX BEAM: A structural component of the suspension system where the anchor is mounted. </p>	<p>d. Coat ends of suspension torsion bar with GAA. See Lubrication Table (Table 10, page 0155 00-19).</p>	

PREVENTIVE MAINTENANCE CHECKS AND SERVICES (PMCS), INCLUDING LUBRICATION INSTRUCTIONS — Continued

0155 00

ITEM NO.	INTERVAL	MAN-HOUR	ITEM TO BE CHECKED OR SERVICED	CREWMEMBER PROCEDURE	EQUIPMENT NOT READY/ AVAILABLE IF:
23	Semi-Annual		Shock Absorber	<p>a. Check shock absorber for dents or cracks. Replace shock absorber that is bent, broken, cracked, or dented enough to hinder operation (WP 0435 00).</p> <p>b. Replace shock absorbers if they have class III fluid leaks or loose fitting bearings (WP 0435 00).</p> <div data-bbox="743 884 1024 940" style="text-align: center;"> <p>BRACKET MOUNTING HARDWARE</p> </div> <div data-bbox="732 947 1036 1367" style="text-align: center;"> </div> <div data-bbox="927 1503 1016 1535" style="text-align: center;"> <p>NOTE</p> </div> <p>Remove and discard cotter pin, re-torque nut, if loose. Tighten to middle range of torque, check to see if nut and hole through mount are aligned, install new pin. If not aligned, tighten nut until alignment is first achieved and then install new cotter pin.</p>	Any cracked, broken, bent or missing shocks, dents that hinder shock operation or class III fluid leaks.

PREVENTIVE MAINTENANCE CHECKS AND SERVICES (PMCS), INCLUDING LUBRICATION INSTRUCTIONS — Continued

0155 00

ITEM NO.	INTERVAL	MAN-HOUR	ITEM TO BE CHECKED OR SERVICED	CREWMEMBER PROCEDURE	EQUIPMENT NOT READY/AVAILABLE IF:
24	Semi-Annual		Shock Absorber Mounting Hardware	a. Check shock absorber mounting hardware for looseness. TIGHTEN LOOSE HARDWARE TO 60-80 LB-FT (81-108 N·M) TORQUE. Use torque wrench (WP 0926 00, Item 79).	
25	Semi-Annual		Shock Absorber Bracket Mounting Hardware	a. Check shock absorber bracket mounting hardware for looseness. TIGHTEN LOOSE HARDWARE TO 130-140 LB-FT (176-190 N·M) TORQUE. Use torque wrench (WP 0926 00, Item 79).	
26	Semi-Annual		Fuel Filler Screen and Cap	<p>a. Check fuel filler screen for dirt buildup. If dirty, clean with cleaning compound. Replace any screen that is damaged (WP 0184 00 and WP 0186 00). Attach or replace loose, broken, or missing keeper chain on filler cap.</p> <p style="text-align: center;">NOTE</p> <p>Only M1068A3 and M577A3 have a single fuel cap and filler screen.</p>	

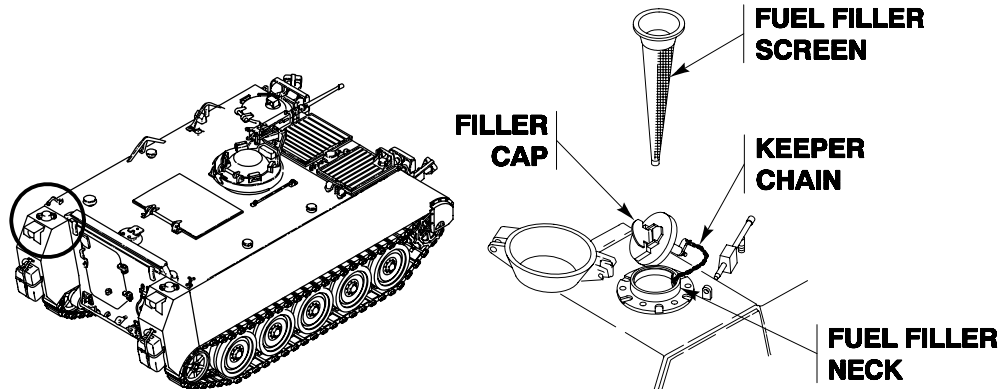

PREVENTIVE MAINTENANCE CHECKS AND SERVICES (PMCS), INCLUDING LUBRICATION INSTRUCTIONS — Continued

0155 00

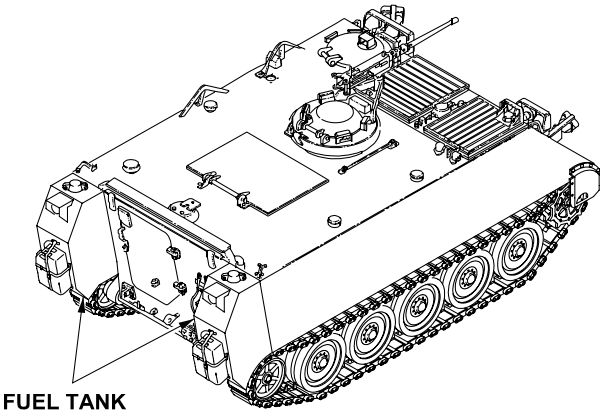
ITEM NO.	INTERVAL	MAN-HOUR	ITEM TO BE CHECKED OR SERVICED	CREWMEMBER PROCEDURE	EQUIPMENT NOT READY/AVAILABLE IF:
27	Semi-Annual		Fuel Tanks	<p style="text-align: center;">WARNING</p> <div style="text-align: center;">  </div> <p>Diesel fuel can catch fire and seriously injure or kill soldiers and damage or destroy vehicles. Wipe up fuel spills immediately. Do not smoke near fuel or when working on the fuel system.</p> <p>a. Disconnect battery ground lead (WP 0337 00 or WP 0338 00).</p> <p style="text-align: center;">CAUTION</p> <p>Don't expose sealed areas to steam for more than 15 minutes.</p> <p>b. Repair or replace any leaking tanks (WP 0179 00 or WP 0180 00).</p> <div style="text-align: center;">  </div>	Contaminated fuel tank or fuel leak.

PREVENTIVE MAINTENANCE CHECKS AND SERVICES (PMCS), INCLUDING LUBRICATION INSTRUCTIONS — Continued

0155 00

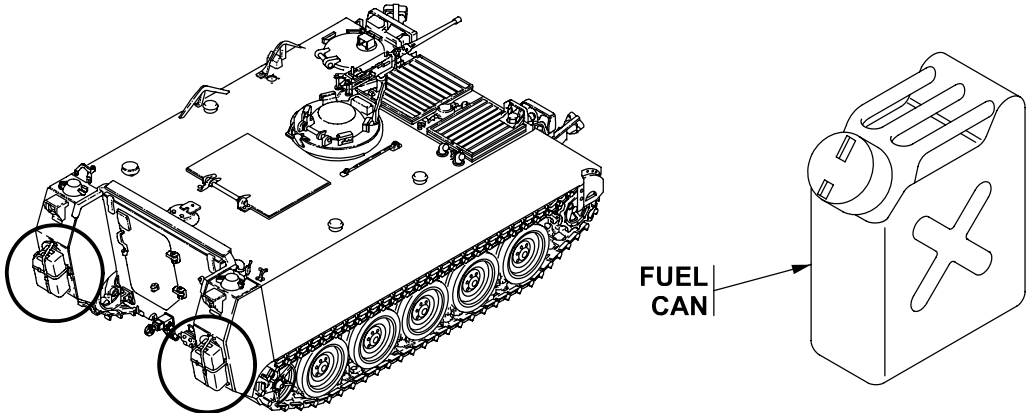
ITEM NO.	INTERVAL	MAN-HOUR	ITEM TO BE CHECKED OR SERVICED	CREWMEMBER PROCEDURE	EQUIPMENT NOT READY/AVAILABLE IF:
				<p>c. M1059A3 Only. Inspect tank and plug assembly for contamination. Clean as required. Check for leaks in fuel tank or fuel tank plug assembly. Repair leaky fuel tank plug (WP 0179 00) or replace leaky tank.</p>	
 <p>The diagram shows a top-down view of the M1059A3 vehicle chassis. A fuel tank is located on the top deck, and its location is highlighted with a circle. To the right of the chassis is a separate fuel can, also with a circle around its top. An arrow labeled 'FUEL CAN' points to the fuel can. The fuel can has a cross symbol on its side.</p>					

PREVENTIVE MAINTENANCE CHECKS AND SERVICES (PMCS), INCLUDING LUBRICATION INSTRUCTIONS — Continued

0155 00

ITEM NO.	INTERVAL	MAN-HOUR	ITEM TO BE CHECKED OR SERVICED	CREWMEMBER PROCEDURE	EQUIPMENT NOT READY/AVAILABLE IF:
28	Semi-Annual	0.1	Tow Hooks and Pintle	a. Check pintle for proper operation. See TM 9-2350-277-10.	

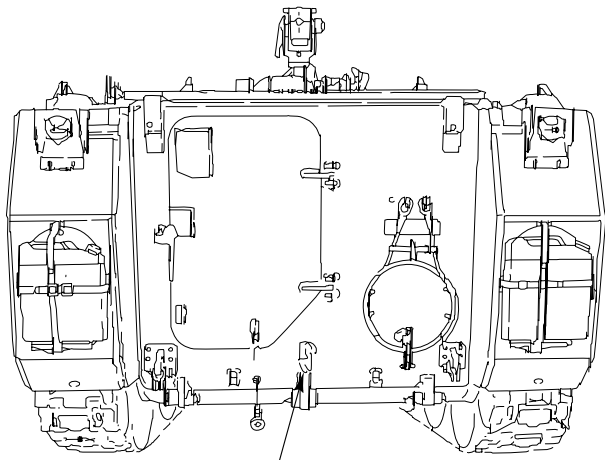

PINTLE

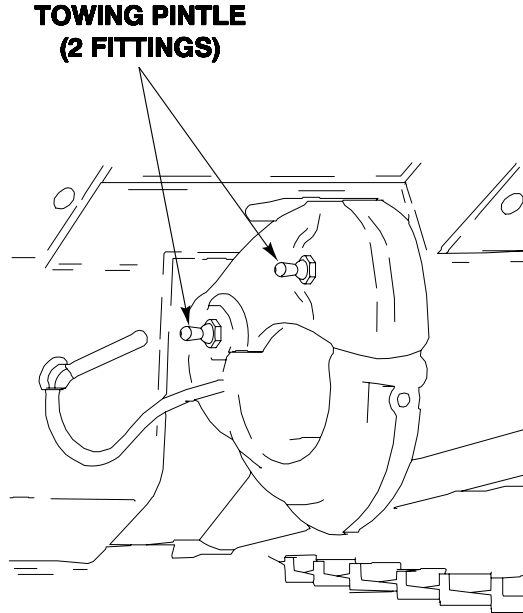

- b. Every 150 hours/1500 miles or semi-annually lubricate pintle. Late model pintles do not require lubrication.

NOTE

When grease fitting will not accept GAA, notify your supervisor.

- 1) Lubricate pintle through two fittings with GAA. See Towing Pintle Lubrication Table (Table 9, page 0155 00-19).
- 2) Clean fittings with cleaning compound prior to lubrication. Check/lubricate grease fitting points after washing or fording.

PREVENTIVE MAINTENANCE CHECKS AND SERVICES (PMCS), INCLUDING LUBRICATION INSTRUCTIONS — Continued

0155 00

ITEM NO.	INTERVAL	MAN-HOUR	ITEM TO BE CHECKED OR SERVICED	CREWMEMBER PROCEDURE	EQUIPMENT NOT READY/AVAILABLE IF:
				<p>c. Check tow hook mount for looseness. TIGHTEN LOOSE SCREWS TO 130-140 LB-FT (176-190 N·M). Use torque wrench (WP 0926 00, Item 79).</p> <p>d. Replace missing retaining pin or key (WP 0434 00).</p>	

PREVENTIVE MAINTENANCE CHECKS AND SERVICES (PMCS), INCLUDING LUBRICATION INSTRUCTIONS — Continued

0155 00

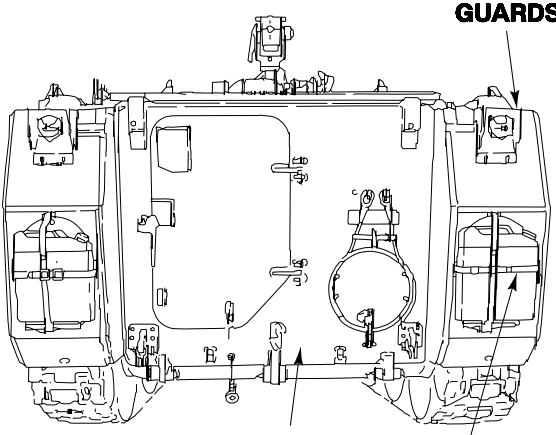
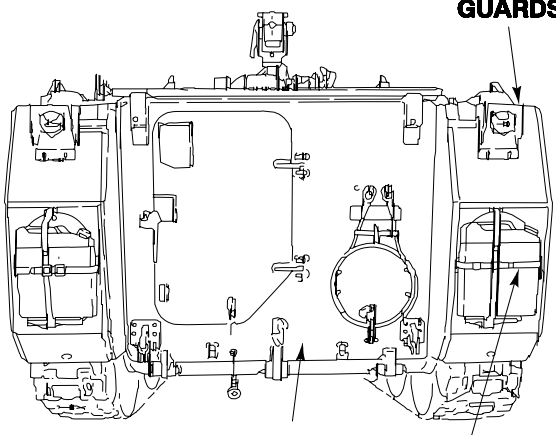
ITEM NO.	INTERVAL	MAN-HOUR	ITEM TO BE CHECKED OR SERVICED	CREWMEMBER PROCEDURE	EQUIPMENT NOT READY/ AVAILABLE IF:
29	Semi-Annual		Trailer Wiring Harness Receptacle Cover	a. Check cover for tight seal on wiring harness receptacle. Replace leaky cover (WP 0375 00).	
 <p style="text-align: center;">GUARDS</p> <p style="text-align: center;">COVER</p> <p style="text-align: center;">WEBBING STRAPS</p>					
30	Semi-Annual		Rubber Guards	a. Replace cracked, cut, or hard guards (WP 0375 00).	
31	Semi-Annual		Webbing Straps and Loops	a. Replace cracked, cut, or frayed webbing straps and loops, both external and internal (WP 0569 00).	
 <p style="text-align: center;">GUARDS</p> <p style="text-align: center;">COVER</p> <p style="text-align: center;">WEBBING STRAPS</p>					

PREVENTIVE MAINTENANCE CHECKS AND SERVICES (PMCS), INCLUDING LUBRICATION INSTRUCTIONS — Continued

0155 00

ITEM NO.	INTERVAL	MAN-HOUR	ITEM TO BE CHECKED OR SERVICED	CREWMEMBER PROCEDURE	EQUIPMENT NOT READY/AVAILABLE IF:
32	Semi-Annual		Taillights, Stoplights, and Blackout Lights	<p>a. Replace discolored and cracked taillight lens (WP 0300 00 or WP 0302 00).</p> <p>b. Have helper operate service taillight, service stoplight, and blackout stoplight. See TM 9-2350-277-10. Repair lights that do not work (WP 0305 00) or replace lights that do not work (WP 0306 00).</p>	

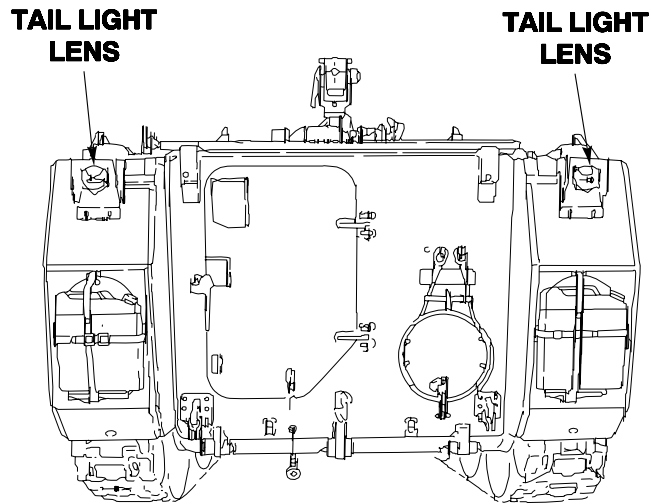

PREVENTIVE MAINTENANCE CHECKS AND SERVICES (PMCS), INCLUDING LUBRICATION INSTRUCTIONS — Continued

0155 00

ITEM NO.	INTERVAL	MAN-HOUR	ITEM TO BE CHECKED OR SERVICED	CREWMEMBER PROCEDURE	EQUIPMENT NOT READY/ AVAILABLE IF:
33	Semi-Annual		Ramp Door, Seal and Catch	<p style="text-align: center;">NOTE</p> <p>See (Step 5c) under General Maintenance Instructions to perform chalk test.</p> <ol style="list-style-type: none"> a. Perform chalk test. Replace leaky ramp door seal (WP 0520 00). b. Check door for smooth operation. If hinges bind, notify your supervisor. Repair catch if door does not lock in open position (WP 0524 00). c. Adjust handle if door does not seal tightly in closed position (WP 0519 00). 	Doors fail to lock in any position.

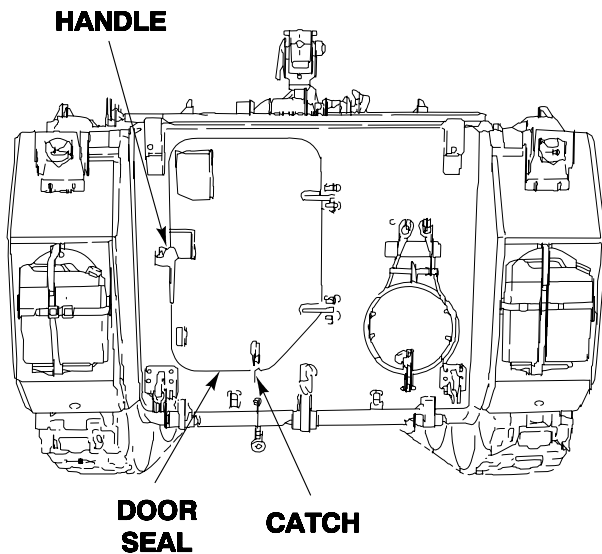

PREVENTIVE MAINTENANCE CHECKS AND SERVICES (PMCS), INCLUDING LUBRICATION INSTRUCTIONS — Continued

0155 00

ITEM NO.	INTERVAL	MAN-HOUR	ITEM TO BE CHECKED OR SERVICED	CREWMEMBER PROCEDURE	EQUIPMENT NOT READY/ AVAILABLE IF:
34	Semi-Annual		Ramp Latches and Seals	<p style="text-align: center;">WARNING</p>  <p>Lowering ramp could injure personnel. Make sure no one is in ramp zone before you lower ramp. Unlocked ramp can fall open suddenly. Personnel can be killed or injured. Ramp system and hull can get damaged if ramp unlocks when carrier is in operation. Do not operate carrier if locks do not secure ramp properly. Keep away from ramps that have come open during carrier operation.</p> <p>a. With ramp closed, check for tight fit on rear seal. Adjust ramp lock (WP 0521 00, WP 0522 00, or WP 0523 00) and linkage (WP 0526 00, WP 0527 00, or WP 0528 00), if needed.</p>	Ramp lock adjustment is loose.

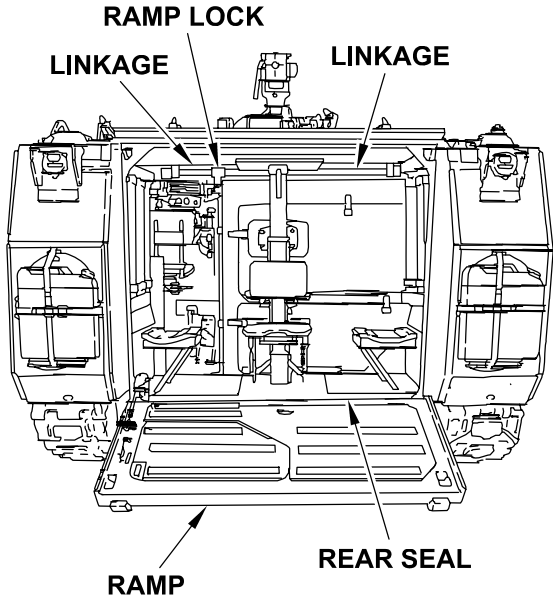

PREVENTIVE MAINTENANCE CHECKS AND SERVICES (PMCS), INCLUDING LUBRICATION INSTRUCTIONS — Continued

0155 00

ITEM NO.	INTERVAL	MAN-HOUR	ITEM TO BE CHECKED OR SERVICED	CREWMEMBER PROCEDURE	EQUIPMENT NOT READY/AVAILABLE IF:
				<p style="text-align: center;">NOTE</p> <p>Horn should be sounded before raising ramp, if tactical situation permits.</p> <p>b. Replace ramp seal that is cut, cracked, or hard (WP 0514 00).</p> <div style="text-align: center;">  </div>	

PREVENTIVE MAINTENANCE CHECKS AND SERVICES (PMCS), INCLUDING LUBRICATION INSTRUCTIONS — Continued

0155 00

ITEM NO.	INTERVAL	MAN-HOUR	ITEM TO BE CHECKED OR SERVICED	CREWMEMBER PROCEDURE	EQUIPMENT NOT READY/ AVAILABLE IF:
34.1	Semi-Annual		Ramp Wire Rope (Cable) Inspection	<p style="text-align: center;">WARNING</p>  <p>Lowering ramp could injure personnel. Make sure no one is in ramp zone before you lower ramp. Unlocked ramp can fall open suddenly. Personnel can be killed or injured. Ramp system and hull can get damaged if ramp unlocks when carrier is in operation. Do not operate carrier if locks do not secure ramp properly. Keep away from ramps that have come open during carrier operation.</p> <p style="text-align: center;">WARNING</p>  <p>Ramp wire rope (cable) failure may cause bodily injury or death to personnel or damage to equipment.</p> <p style="text-align: center;">CAUTION</p> <p>Be careful not to strike ramp wire rope (cable) with hard/sharp objects when loading/off-loading carrier or working around open ramp. Striking the ramp wire rope (cable) may cause permanent damage that will cause the ramp wire rope (cable) to fail.</p>	

**PREVENTIVE MAINTENANCE CHECKS AND SERVICES (PMCS), INCLUDING
LUBRICATION INSTRUCTIONS — Continued**

0155 00

ITEM NO.	INTERVAL	MAN-HOUR	ITEM TO BE CHECKED OR SERVICED	CREWMEMBER PROCEDURE	EQUIPMENT NOT READY/ AVAILABLE IF:
				<ul style="list-style-type: none"> a. Check ramp wire rope (cable) for dings, cuts, gouges, or other damages caused by foreign objects. See (WP 0656 01). b. Inspect ramp wire rope (cable) for defects, which include: bulges, pinching/dimpling, unraveling, separation, bends, kinks, bowing, flat spots, frayed or broken strands, and/or corrosion. See (WP 0656 01) c. Replace ramp wire rope (cable) if any defects exist. See (WP 0657 00 or WP 0658 00). 	<p>Any dings, cuts, gouges, or other objects are found on the ramp wire rope (cable).</p> <p>Any bulges, pinching/dimpling, unraveling, separation, bends, kinks, bowing, flat spots, frayed or broken strands, and/or corrosion are exhibited in the ramp wire rope (cable).</p>

PREVENTIVE MAINTENANCE CHECKS AND SERVICES (PMCS), INCLUDING LUBRICATION INSTRUCTIONS — Continued

0155 00

ITEM NO.	INTERVAL	MAN-HOUR	ITEM TO BE CHECKED OR SERVICED	CREWMEMBER PROCEDURE	EQUIPMENT NOT READY/AVAILABLE IF:
35	Semi-Annual		Headlights, Blackout Lights and Horn	a. Replace cracked or discolored lens in service headlights, blackout marker lights, or blackout headlight (WP 0303 00, WP 0304 00, WP 0305 00, or WP 0307 00). b. Have helper operate service headlights. Operate blackout marker lights, blackout headlight, and horn. Repair or replace lights or horn that do not work (WP 0303 00, WP 0304 00, WP 0305 00, WP 0307 00, or WP 0336 00).	

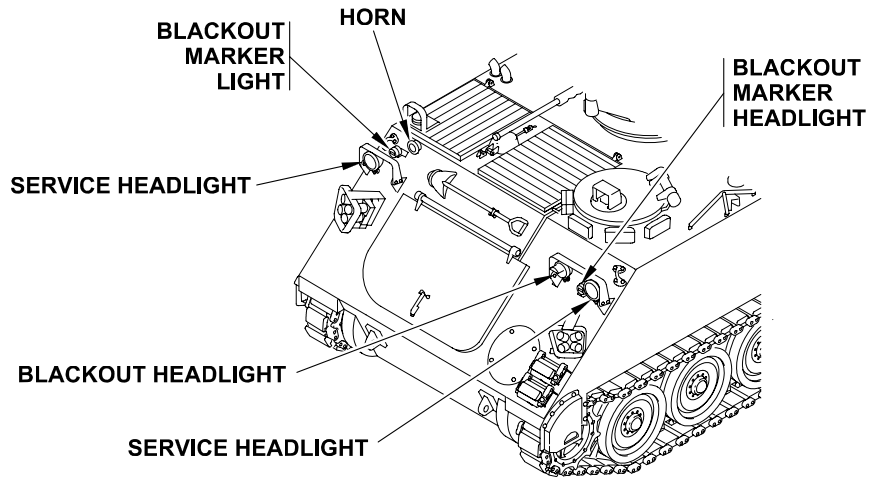

**PREVENTIVE MAINTENANCE CHECKS AND SERVICES (PMCS), INCLUDING
LUBRICATION INSTRUCTIONS — Continued**

0155 00

ITEM NO.	INTERVAL	MAN-HOUR	ITEM TO BE CHECKED OR SERVICED	CREWMEMBER PROCEDURE	EQUIPMENT NOT READY/AVAILABLE IF:
36	Semi-Annual		Smoke Grenade Discharger (if installed) (all except M577A3, M1068A3, and M1064A3)	<ul style="list-style-type: none"> a. Remove base from front hull plate (WP 0455 00). b. Check wiring harness. Replace cracked or broken leads and connectors (WP 0455 00). c. Check guard, plate, and base. Replace damaged parts. Tighten loose screws and nuts. d. Install base on front hull plate (WP 0455 00). e. Repeat Steps 36a-36d for opposite side of carrier. 	

PREVENTIVE MAINTENANCE CHECKS AND SERVICES (PMCS), INCLUDING LUBRICATION INSTRUCTIONS — Continued

0155 00

ITEM NO.	INTERVAL	MAN-HOUR	ITEM TO BE CHECKED OR SERVICED	CREWMEMBER PROCEDURE	EQUIPMENT NOT READY/ AVAILABLE IF:
37	Semi-Annual		Power Plant Grille and Power Plant Front Access Door	<p>a. Check screws on power plant grille for looseness. TIGHTEN LOOSE SCREWS TO 100-120 LB-FT (136-163 N·M) TORQUE. Use torque wrench (WP 0926 00, Item 79).</p> <p style="text-align: center;">WARNING</p>  <p>Power plant door may spring open. When opening door, stay out of door path. Soldiers can be injured.</p> <p>b. Check power plant front access door seal for cracks, cuts, stiffness, and looseness. If seal is loose, tighten. If seal is damaged, replace (WP 0472 00).</p> <p style="text-align: center;">NOTE</p> <p>See Step 5c under General Maintenance Instructions to perform chalk test.</p> <p>c. Check for tight seal on door in closed position. Perform chalk test.</p>	Damage prevents door from closing, sealing, and locking.

PREVENTIVE MAINTENANCE CHECKS AND SERVICES (PMCS), INCLUDING LUBRICATION INSTRUCTIONS — Continued

0155 00

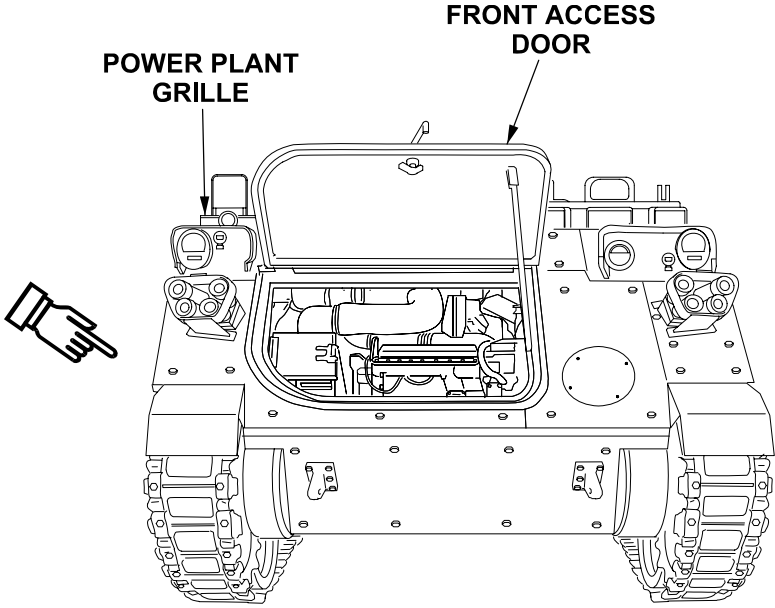
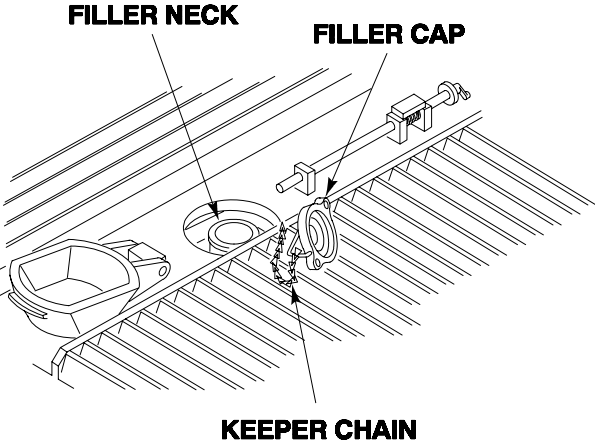
ITEM NO.	INTERVAL	MAN-HOUR	ITEM TO BE CHECKED OR SERVICED	CREWMEMBER PROCEDURE	EQUIPMENT NOT READY/AVAILABLE IF:
38	Semi-Annual		 <p>Radiator Auxiliary Tank Filler Cap</p>	<p>a. Replace filler cap that does not seal tightly on auxiliary tank filler neck (WP 0227 00).</p> <p>b. Attach or replace loose, broken, or missing keeper chain on filler cap (WP 0227 00).</p> 	Any class III coolant leaks.

PREVENTIVE MAINTENANCE CHECKS AND SERVICES (PMCS), INCLUDING LUBRICATION INSTRUCTIONS — Continued

0155 00

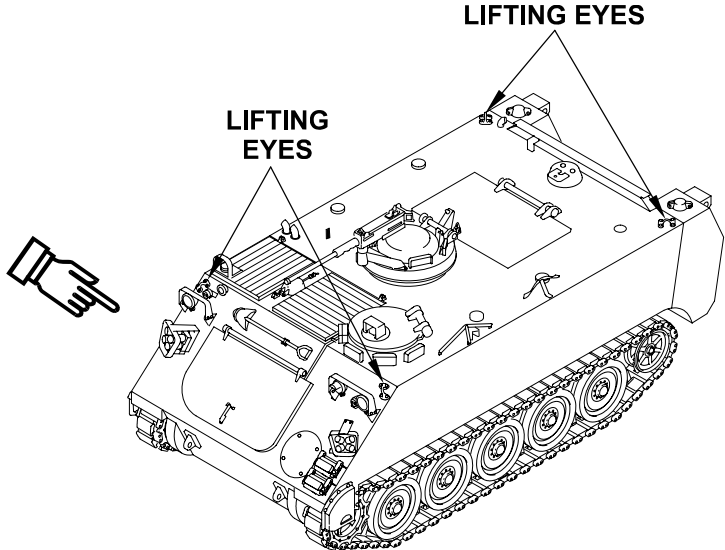
ITEM NO.	INTERVAL	MAN-HOUR	ITEM TO BE CHECKED OR SERVICED	CREWMEMBER PROCEDURE	EQUIPMENT NOT READY/ AVAILABLE IF:
39	Semi-Annual		Lifting Eyes	<p>a. Check for loose or missing screws on lifting eyes. Replace missing screws. TIGHTEN LOOSE SCREWS TO 175-200 LB-FT (237-271 N·M). Use torque wrench (WP 0926 00, Item 80).</p>  <p>The diagram shows a top-down view of a tracked vehicle's upper hull. Two callouts labeled 'LIFTING EYES' point to specific locations on the top deck. A hand icon with the index finger pointing is positioned to the left of the vehicle, indicating the inspection area.</p>	

PREVENTIVE MAINTENANCE CHECKS AND SERVICES (PMCS), INCLUDING LUBRICATION INSTRUCTIONS — Continued

0155 00

ITEM NO.	INTERVAL	MAN-HOUR	ITEM TO BE CHECKED OR SERVICED	CREWMEMBER PROCEDURE	EQUIPMENT NOT READY/AVAILABLE IF:
40	Semi-Annual		Hatch Covers, Latches and Seals	<ul style="list-style-type: none"> a. Replace cracked, cut, or hard seal (WP 0478 00). b. Check covers for smooth operation. Repair or lubricate cover that binds. Repair catch if cover doesn't lock in open position. c. Replace damaged or missing catch safety pins. d. Replace bumpers that are cut, gouged, or hard. e. Adjust bumpers that do not compress when covers are locked open. See TM 9-2350-277-10. 	Hatch fails to lock in any position or catch safety pin is missing.

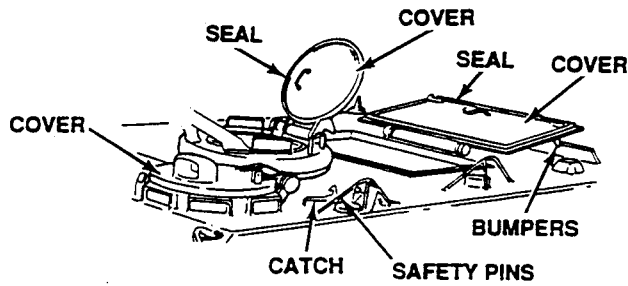

PREVENTIVE MAINTENANCE CHECKS AND SERVICES (PMCS), INCLUDING LUBRICATION INSTRUCTIONS — Continued

0155 00

ITEM NO.	INTERVAL	MAN-HOUR	ITEM TO BE CHECKED OR SERVICED	CREWMEMBER PROCEDURE	EQUIPMENT NOT READY/ AVAILABLE IF:
41	Semi-Annual		Machine Gun Mount	a. Check for loose or missing screws on machine gun mount. Replace missing screws.	Mount is cracked or broken.

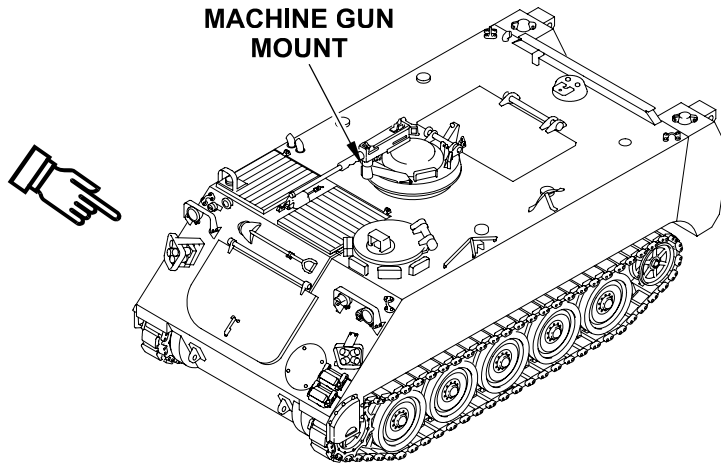

PREVENTIVE MAINTENANCE CHECKS AND SERVICES (PMCS), INCLUDING LUBRICATION INSTRUCTIONS — Continued

0155 00

ITEM NO.	INTERVAL	MAN-HOUR	ITEM TO BE CHECKED OR SERVICED	CREWMEMBER PROCEDURE	EQUIPMENT NOT READY/ AVAILABLE IF:
42	Semi-Annual		Power Plant Bottom Access Cover, Hull Drain Plugs, and Final Drive Drain Plugs	<p>a. Check final drive drain plugs for leaks. Tighten leaking plugs (WP 0452 00).</p> <p>b. Check for loose or missing hull drain plugs. If missing, replace hull drain plug. Tighten loose plugs (WP 0451 00).</p> <p>c. Remove power plant bottom access cover and check for missing or damaged seal. Replace missing or damaged seal. Install bottom access cover. TIGHTEN SCREWS TO 40-50 LB-FT (54-68 N·M) TORQUE. Use torque wrench (WP 0926 00, Item 79).</p> <p>d. Check for loose or missing screws in power plant bottom access cover. Replace screws if missing. TIGHTEN LOOSE SCREWS TO 40-50 LB-FT (54-68 N·M) TORQUE. Use torque wrench (WP 0926 00, Item 79).</p>	<p>Any Class III leaks or missing seals, covers, or plugs.</p> <p>Missing or loose seals, plugs, or covers.</p>

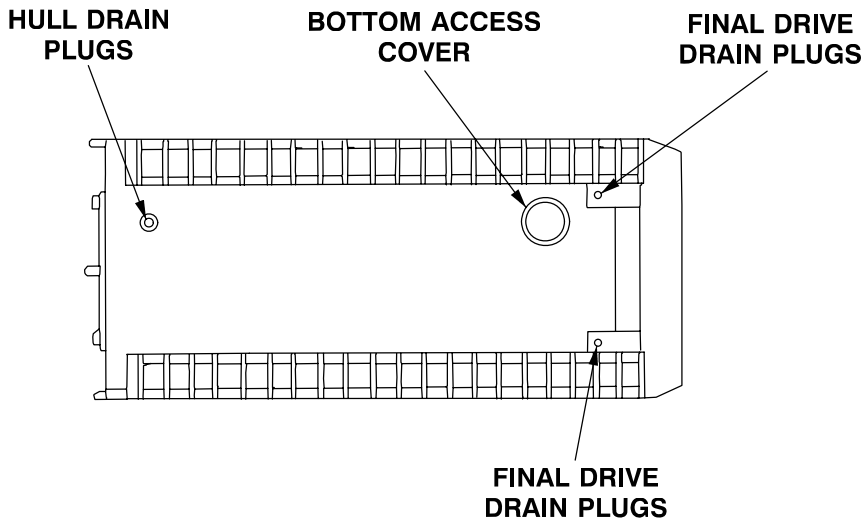

PREVENTIVE MAINTENANCE CHECKS AND SERVICES (PMCS), INCLUDING LUBRICATION INSTRUCTIONS — Continued

0155 00

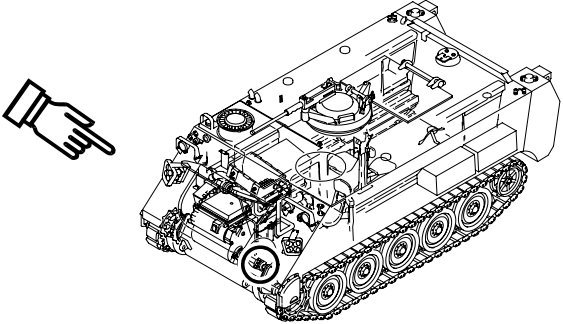
ITEM NO.	INTERVAL	MAN-HOUR	ITEM TO BE CHECKED OR SERVICED	CREWMEMBER PROCEDURE	EQUIPMENT NOT READY/ AVAILABLE IF:
43	Semi-Annual		Final Drive	a. Inspect final drive input shaft oil seals for evidence of leakage. Replace final drive seals that have leaks (WP 0404 00). Tighten screws to 21-25 lb-ft (28-34 N·m) torque. Use torque wrench (WP 0926 00, Item 79).	Any Class III leaks.
					
44	Semi-Annual		Power Plant Noises	a. Check power plant operation. If unusual noises are heard, repair suspect component or contact higher level of maintenance for assistance and repair.	
45	Semi-Annual		Exhaust System	<p style="text-align: center;">NOTE</p> <p>Carrier leaks exhaust when weather is cold. For this reason, carbon will be present around joints and exhaust pipe connecting clamps. This is normal. The exhaust system joints will seal after pipes heat up. Check for exhaust leaks only after engine reaches normal operating temperature of 180°-205° F (71°-93.3 °C).</p>	

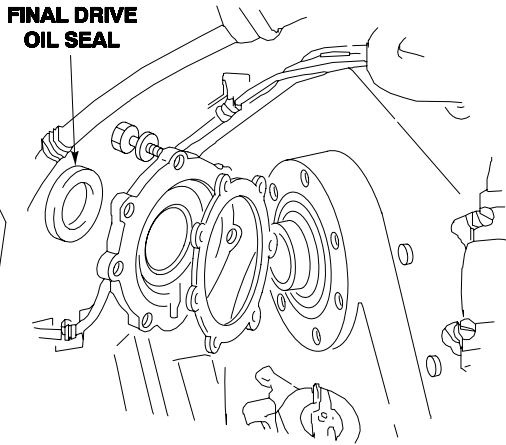

PREVENTIVE MAINTENANCE CHECKS AND SERVICES (PMCS), INCLUDING LUBRICATION INSTRUCTIONS — Continued

0155 00

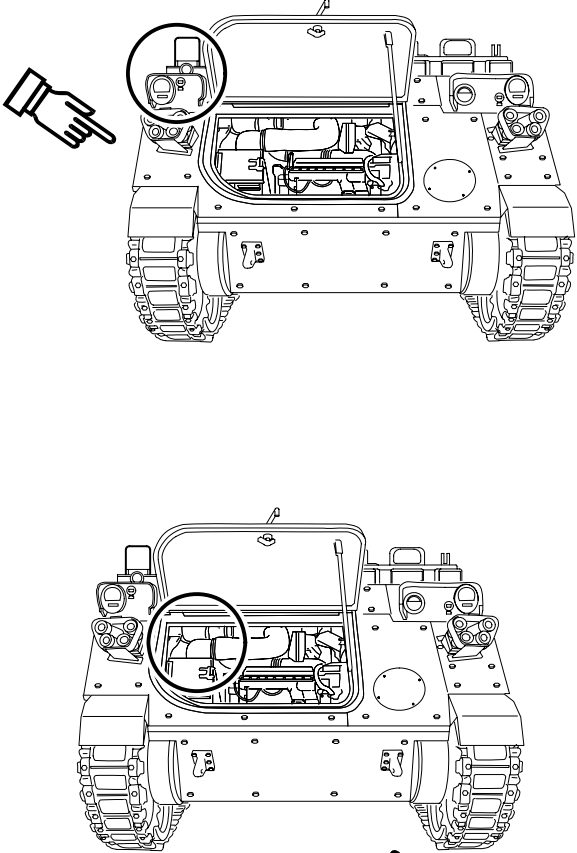
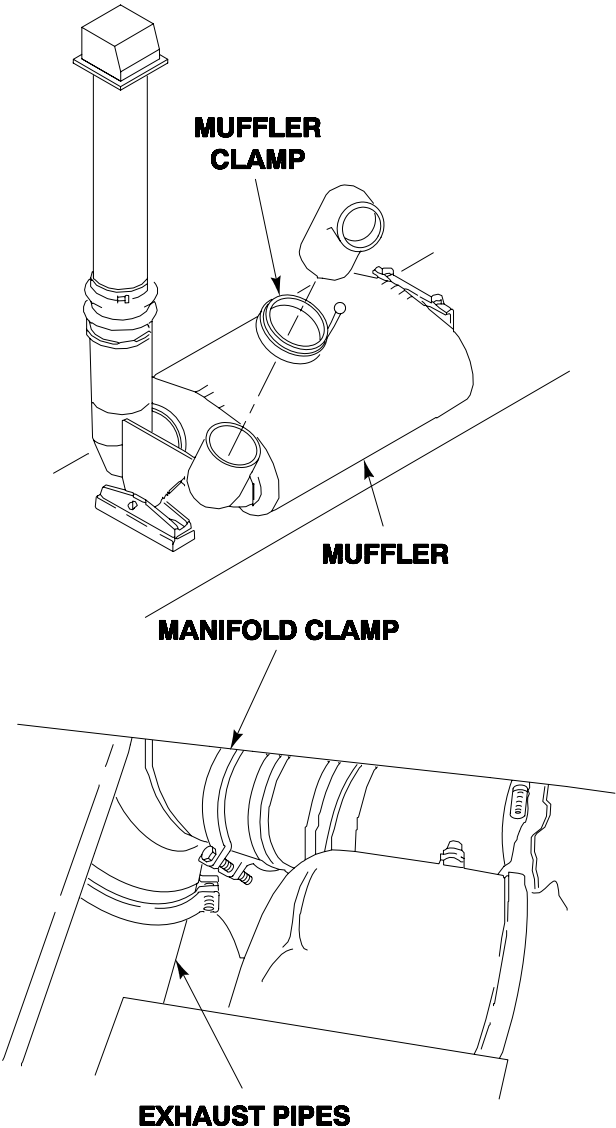
ITEM NO.	INTERVAL	MAN-HOUR	ITEM TO BE CHECKED OR SERVICED	CREWMEMBER PROCEDURE	EQUIPMENT NOT READY/AVAILABLE IF:
				<p>a. Check manifold, pipes, muffler, and clamps for looseness or damage. Replace damaged hardware. Tighten loose clamps.</p> 	<p>Missing or damaged hardware allowing exhaust leaks.</p>

PREVENTIVE MAINTENANCE CHECKS AND SERVICES (PMCS), INCLUDING LUBRICATION INSTRUCTIONS — Continued

0155 00

ITEM NO.	INTERVAL	MAN-HOUR	ITEM TO BE CHECKED OR SERVICED	CREWMEMBER PROCEDURE	EQUIPMENT NOT READY/ AVAILABLE IF:
46	Semi-Annual		Air Cleaner	a. Clean or replace air cleaner element (WP 0167 00). b. Clean drain hole on bottom of air cleaner container. Replace damaged container (WP 0167 00).	Latches or element is missing, damaged, or broken. Gasket is torn or separated from element.
47	Semi-Annual		Air Cleaner Hoses	a. Replace cracked, broken, or brittle hoses (WP 0172 00).	

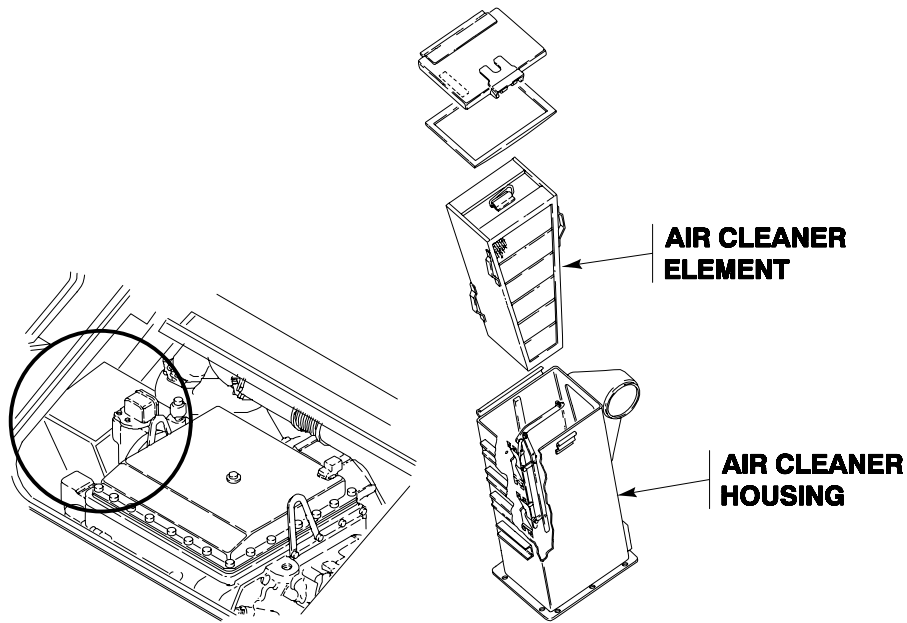

PREVENTIVE MAINTENANCE CHECKS AND SERVICES (PMCS), INCLUDING LUBRICATION INSTRUCTIONS — Continued

0155 00

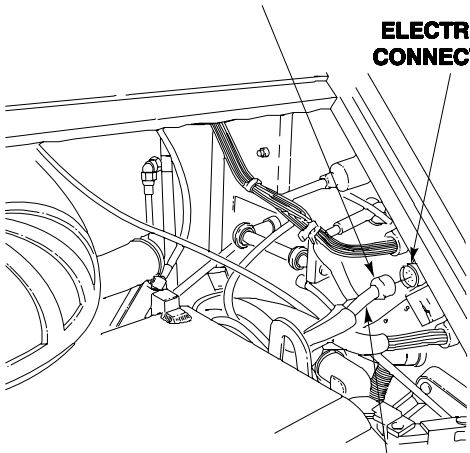
ITEM NO.	INTERVAL	MAN-HOUR	ITEM TO BE CHECKED OR SERVICED	CREWMEMBER PROCEDURE	EQUIPMENT NOT READY/AVAILABLE IF:
48	Semi-Annual		Electrical Connectors and Leads	<p>a. Check electrical connectors for looseness or broken contact. Replace broken connectors (WP 0382 00).</p> <p>b. Check that electrical leads in power plant compartment are not frayed, cut, or broken. If leads are damaged, identify damaged lead. Go to the Table of Contents for electrical lead/harness connectors repairs and locate the specific task to repair or replace the damaged lead or wiring harness.</p> <div style="text-align: center;"> <p>ELECTRICAL CONNECTORS</p>  <p>ELECTRICAL LEADS</p> </div>	
49	Semi-Annual	0.5	Drive Shafts and Universal Joints	<p style="text-align: center;">NOTE</p> <p>See Step 1g under General Maintenance Instructions for proper use of torque wrench adapter.</p> <p>a. Check for loose or missing screws and lockwashers on universal joints. TIGHTEN LOOSE SCREWS TO 86-92 LB-FT (117-127 N•M) TORQUE. Use torque wrench (WP 0926 00, Item 79) and adapter.</p>	Any hardware is loose, broken, or missing.

PREVENTIVE MAINTENANCE CHECKS AND SERVICES (PMCS), INCLUDING LUBRICATION INSTRUCTIONS — Continued

0155 00

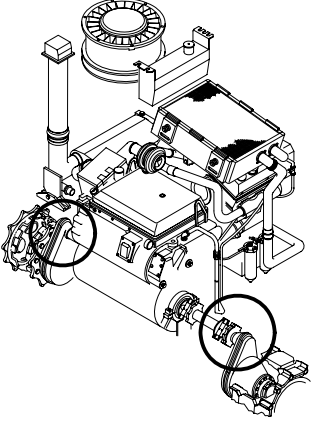
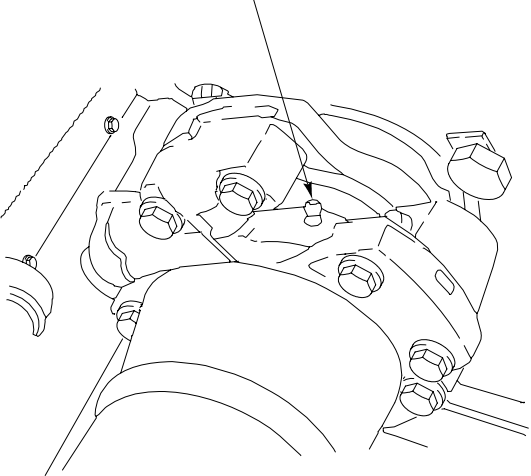
ITEM NO.	INTERVAL	MAN-HOUR	ITEM TO BE CHECKED OR SERVICED	CREWMEMBER PROCEDURE	EQUIPMENT NOT READY/AVAILABLE IF:
				<p>b. Every 1500 miles or semi-annually, lubricate U-joints.</p> <p style="text-align: center;">NOTE</p> <p>If universal joint does not have grease fittings, it is a permanently lubed universal joint and does not require lubrication.</p> <p style="text-align: center;">NOTE</p> <p>When grease fitting will not accept GAA, notify your supervisor.</p> <ol style="list-style-type: none"> 1) Lubricate four universal joints through fittings with GAA. Universal joints are on ends of propeller shafts. See Universal Joint Lubrication Table (Table 12, page 0155 00-20). 2) Clean fittings with cleaning compound prior to lubrication. Check/lubricate grease fitting points after washing or fording. 	
				<p style="text-align: center;">UNIVERSAL JOINT (4 FITTINGS)</p> 	

PREVENTIVE MAINTENANCE CHECKS AND SERVICES (PMCS), INCLUDING LUBRICATION INSTRUCTIONS — Continued

0155 00

ITEM NO.	INTERVAL	MAN-HOUR	ITEM TO BE CHECKED OR SERVICED	CREWMEMBER PROCEDURE	EQUIPMENT NOT READY/AVAILABLE IF:
50	Semi-Annual		Transmission Breather	a. Remove transmission breather and check for cracks, dents, or stripped threads. Replace damaged breather. b. Clean transmission breather with cleaning compound. Dry breather and install on transmission.	

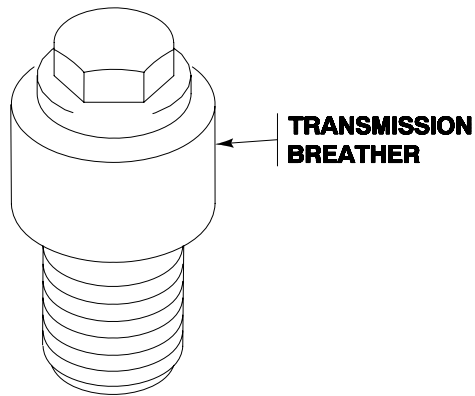
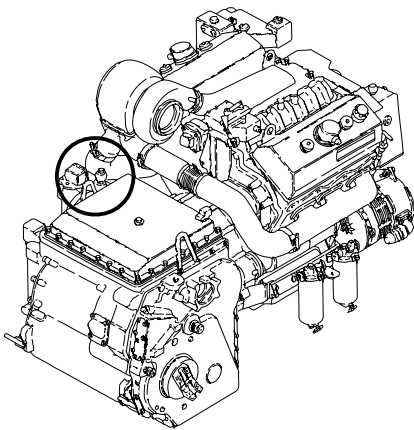

51	Semi-Annual		Transmission Rod and Connecting Link	a. Check steering rod and connecting link at lever on top of transmission for ease of movement from low to full position. If linkage doesn't move easily, troubleshoot steering system (WP 0071 00).	
----	-------------	--	--------------------------------------	--	--

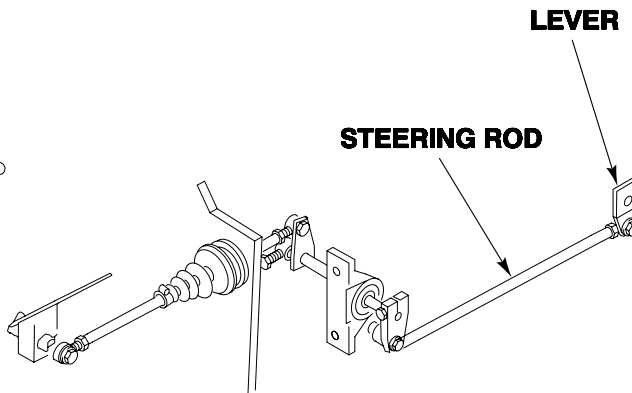
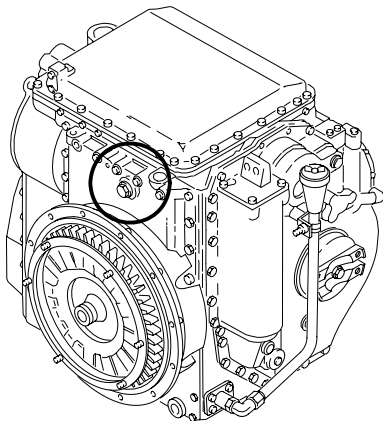

PREVENTIVE MAINTENANCE CHECKS AND SERVICES (PMCS), INCLUDING LUBRICATION INSTRUCTIONS — Continued

0155 00

ITEM NO.	INTERVAL	MAN-HOUR	ITEM TO BE CHECKED OR SERVICED	CREWMEMBER PROCEDURE	EQUIPMENT NOT READY/ AVAILABLE IF:
52	Semi-Annual		Power Plant Compartments	a. Open power plant front access door. See TM 9-2350-277-10. Remove hull access cover (WP 0449 00). b. Clean power plant compartment with cleaning compound. Remove debris and wipe up spilled oil and fuel.	
53	Semi-Annual		Power Plant Components	a. Check power plant components for looseness. Tighten any loose mounting components on the starter, generator, etc.	Any damage that would prevent operation of the vehicle.

MOUNTING COMPONENTS

MOUNTING COMPONENT

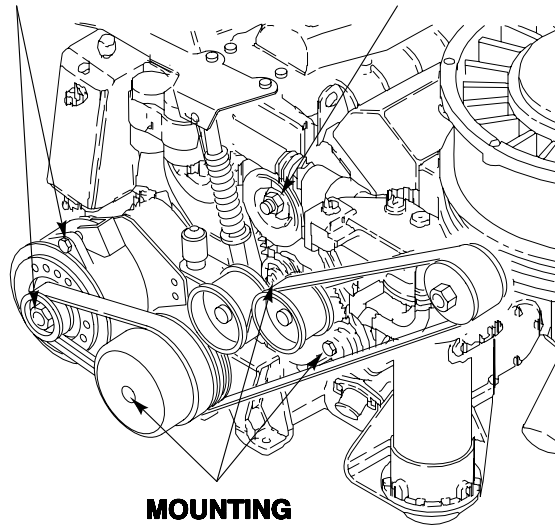

MOUNTING COMPONENTS

PREVENTIVE MAINTENANCE CHECKS AND SERVICES (PMCS), INCLUDING LUBRICATION INSTRUCTIONS — Continued

0155 00

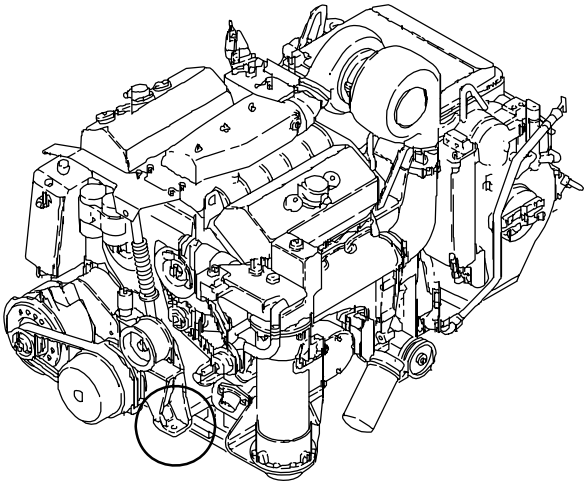
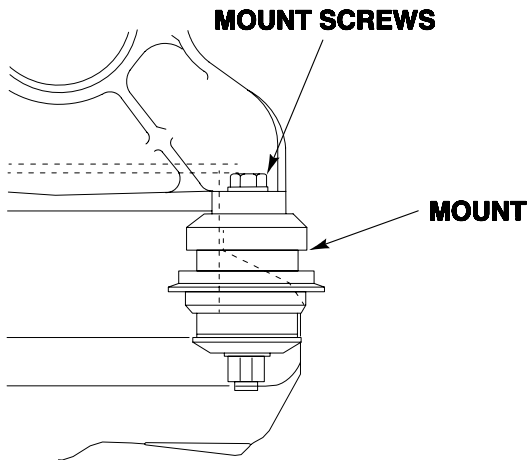
ITEM NO.	INTERVAL	MAN-HOUR	ITEM TO BE CHECKED OR SERVICED	CREWMEMBER PROCEDURE	EQUIPMENT NOT READY/AVAILABLE IF:
54	Semi-Annual		Power Plant Mount	a. TIGHTEN LOOSE MOUNT SCREWS (ON FORWARD ENGINE MOUNT) TO 100-120 LB-FT (136-163 N·M) TORQUE. Use torque wrench (WP 0926 00, Item 85) and socket set (WP 0926 00, Item 71).	Any cracked or broken nuts.
					

PREVENTIVE MAINTENANCE CHECKS AND SERVICES (PMCS), INCLUDING LUBRICATION INSTRUCTIONS — Continued

0155 00

ITEM NO.	INTERVAL	MAN-HOUR	ITEM TO BE CHECKED OR SERVICED	CREWMEMBER PROCEDURE	EQUIPMENT NOT READY/ AVAILABLE IF:
55	Semi-Annual		Drive Belts	a. Check fan belts for proper tension. Adjust if needed (WP 0242 00). b. Check generator drive belts for proper tension. Adjust if needed (WP 0252 00). c. Replace any frayed or cracked fan belts (WP 0243 00) and frayed or cracked generator drive belts (WP 0253 00).	Any belt that is missing, broken, frayed more than 2 inches, cracks 1/8 inch in depth or is 50% of belt thickness.

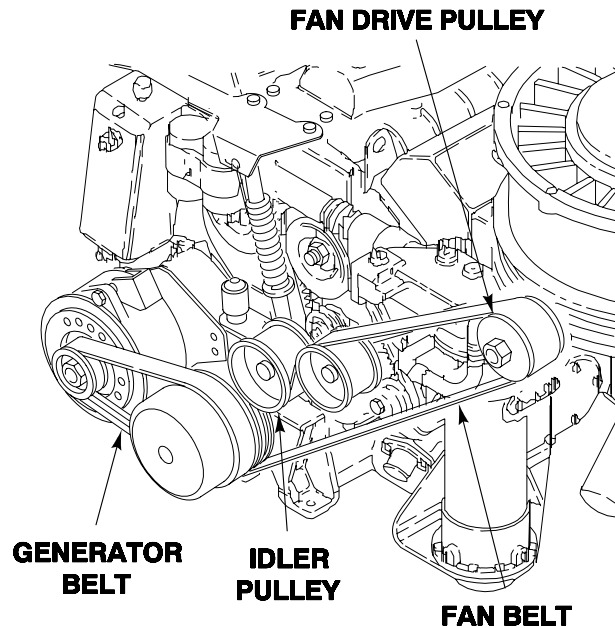

PREVENTIVE MAINTENANCE CHECKS AND SERVICES (PMCS), INCLUDING LUBRICATION INSTRUCTIONS — Continued

0155 00

ITEM NO.	INTERVAL	MAN-HOUR	ITEM TO BE CHECKED OR SERVICED	CREWMEMBER PROCEDURE	EQUIPMENT NOT READY/AVAILABLE IF:
56	Semi-Annual	0.4	Cooling Fan	<p>a. Replace cracked or bent drive pulley (WP 0244 00) and idler pulley (WP 0240 00).</p> <div data-bbox="519 604 1055 1155" data-label="Diagram"> </div> <p>b. Every 1500 miles or semi-annually, lubricate pulley support arm with GAA. Use grease gun with flexible adapter on fitting. See Pulley Support Arm Lubrication Table (Table 6, page 0155 00-18).</p> <div data-bbox="243 1407 1266 1911" data-label="Diagram"> </div>	Any cracked, broken, loose or missing hardware.

PREVENTIVE MAINTENANCE CHECKS AND SERVICES (PMCS), INCLUDING LUBRICATION INSTRUCTIONS — Continued

0155 00

ITEM NO.	INTERVAL	MAN-HOUR	ITEM TO BE CHECKED OR SERVICED	CREWMEMBER PROCEDURE	EQUIPMENT NOT READY/AVAILABLE IF:
57	Semi-Annual		Cooling System: Hoses, Coolant, Pump, and Drive Belt	<p>a. Replace cracked or broken hoses (WP 0233 00).</p> <p>b. Tighten loose clamps. Replace leaking coolant pump (WP 0241 00).</p> <p>c. Check engine coolant pump belt tension. Adjust, if necessary (WP 0239 00).</p> <p>d. Replace cracked or frayed engine water pump belts (WP 0240 00).</p>	Any missing, cracked, broken hardware or Class III leaks. Drive belt frays more than 2 inches, cracks 1/8 inch in depth or 50% of the belt thickness.

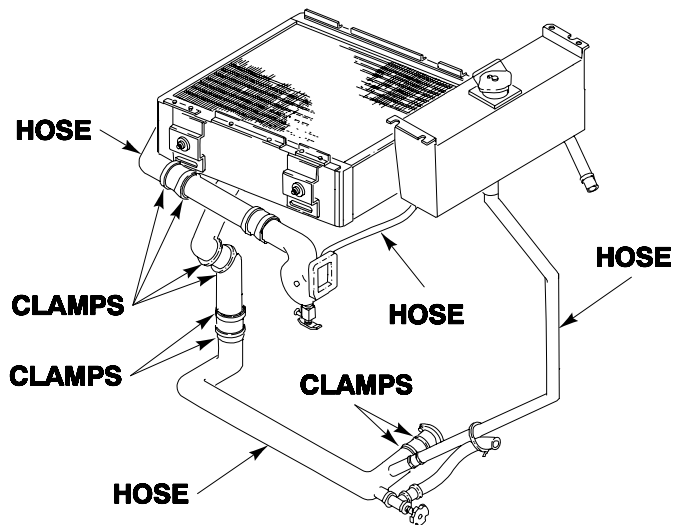

PREVENTIVE MAINTENANCE CHECKS AND SERVICES (PMCS), INCLUDING LUBRICATION INSTRUCTIONS — Continued

0155 00

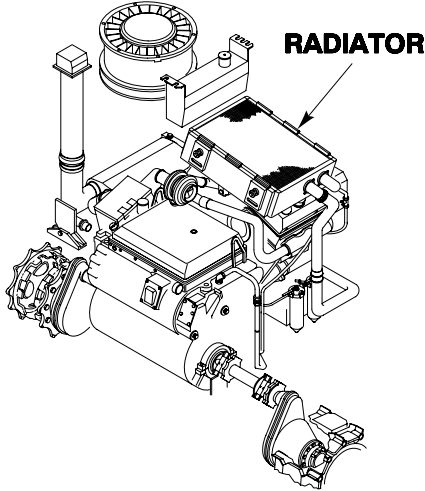
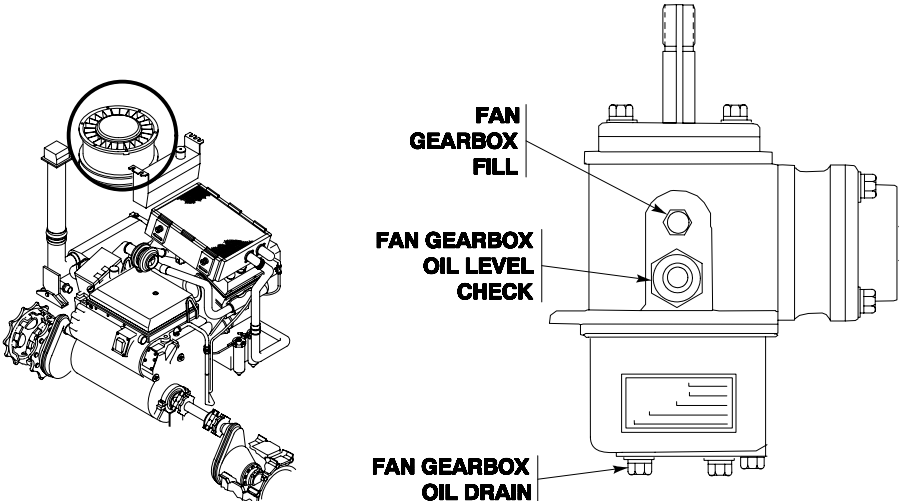
ITEM NO.	INTERVAL	MAN-HOUR	ITEM TO BE CHECKED OR SERVICED	CREWMEMBER PROCEDURE	EQUIPMENT NOT READY/AVAILABLE IF:
58	Semi-Annual		Radiator	a. Clean radiator (WP 0228 00). b. Replace leaking radiator (WP 0229 00). 	Any Class II leak.
59	Semi-Annual	0.4	Fan Gearbox	a. Check fan gearbox oil level. Add OE/HDO or OEA, as needed, to bring oil level to center of sight glass. 	No oil in sight glass. Any Class II leak or greater oil leak.

PREVENTIVE MAINTENANCE CHECKS AND SERVICES (PMCS), INCLUDING LUBRICATION INSTRUCTIONS — Continued

0155 00

ITEM NO.	INTERVAL	MAN-HOUR	ITEM TO BE CHECKED OR SERVICED	CREWMEMBER PROCEDURE	EQUIPMENT NOT READY/ AVAILABLE IF:
60	Semi-Annual		Operate Air Box Heater Air Pump	<p style="text-align: center;">NOTE</p> <p>Drain oil only when hot after operation.</p> <p>b. Drain gearbox every 150 hours/1500 miles or semiannually.</p> <ol style="list-style-type: none"> 1) Place a suitable container under fan gearbox drain. 2) Remove screw and washer from gearbox housing and drain oil into container (WP 0248 00). Discard packing. 3) Inspect screw, washer, and oil for metallic particles and foreign matter. If metal chips are found, notify your supervisor. 4) Lubricate new performed packing with OE/HDO prior to installing. 5) Install screw and washer in gearbox housing (WP 0248 00). Tighten screw. Do NOT over tighten. 6) Fill gearbox with enough OE/HDO oil to bring the level to center of sight glass. See Fan Gearbox Lubrication Table (Table 5, page 0155 00-17). <p style="text-align: center;">NOTE</p> <p>The purpose of the item is to exercise the vanes in the air box heater air pump.</p> <p>a. Disconnect lead from fuel shutoff solenoid (WP 0206 00).</p>	

PREVENTIVE MAINTENANCE CHECKS AND SERVICES (PMCS), INCLUDING LUBRICATION INSTRUCTIONS — Continued

0155 00

ITEM NO.	INTERVAL	MAN-HOUR	ITEM TO BE CHECKED OR SERVICED	CREWMEMBER PROCEDURE	EQUIPMENT NOT READY/ AVAILABLE IF:
61	Semi-Annual		Throttle Controls and Transmission	<p>b. To prevent engine from starting, pull fuel cutoff out. See TM 9-2350-277-10.</p> <p style="text-align: center;">CAUTION</p> <p>Air pump can be damaged if switch is held too long. Do not exceed a total of 20 seconds of operation.</p> <p>c. Have helper crank engine and run air pump at the same time intermittently for a total of 20 seconds. Listen for air pump operation. See TM 9-2350-277-10.</p> <p>d. Connect lead to fuel shutoff solenoid.</p> <p>e. Lubricate air motor with OE/HDO every 150 hours/1500 miles, semiannually, or as required.</p> <p>a. Check hand throttle for ease of movement from low to full position. If throttle doesn't move easily, adjust (WP 0213 00, WP 0214 00, or WP 0219 00).</p>	Any binding, broken, cracked, missing, or loose hardware.

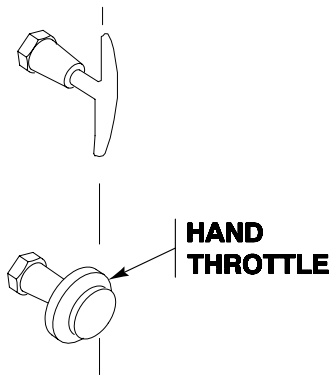
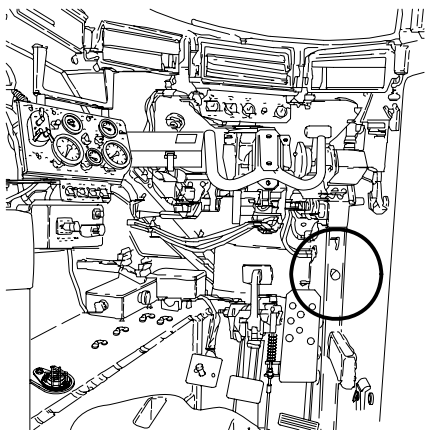

PREVENTIVE MAINTENANCE CHECKS AND SERVICES (PMCS), INCLUDING LUBRICATION INSTRUCTIONS — Continued

0155 00

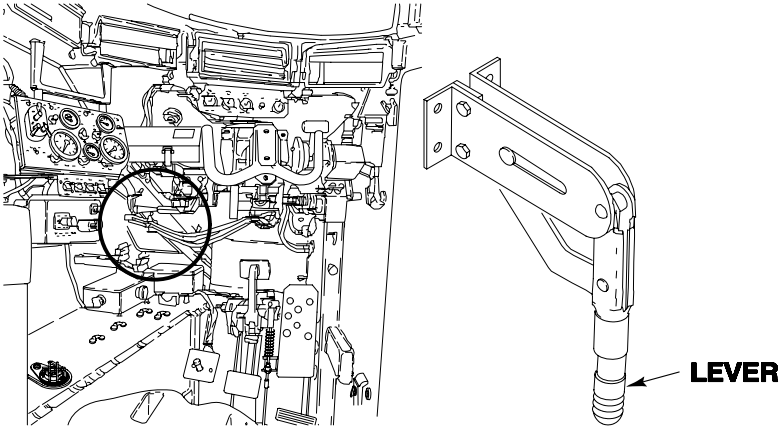
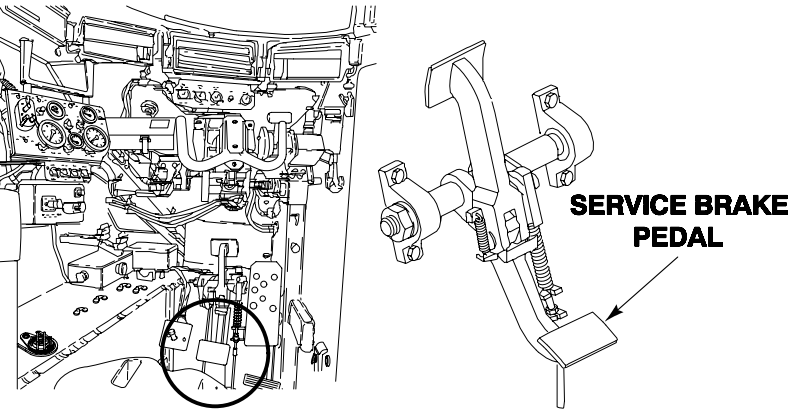
ITEM NO.	INTERVAL	MAN-HOUR	ITEM TO BE CHECKED OR SERVICED	CREWMEMBER PROCEDURE	EQUIPMENT NOT READY/AVAILABLE IF:
62	Semi-Annual		Parking Brake Linkage	a. Check parking brake linkage for proper adjustment. If lever doesn't move easily, adjust parking brake (WP 0408 00).	
					
63	Semi-Annual	0.3	Service Brake Linkage	a. Check service brake pedal and linkage for proper adjustment (WP 0407 00).	
					

PREVENTIVE MAINTENANCE CHECKS AND SERVICES (PMCS), INCLUDING LUBRICATION INSTRUCTIONS — Continued

0155 00

ITEM NO.	INTERVAL	MAN-HOUR	ITEM TO BE CHECKED OR SERVICED	CREWMEMBER PROCEDURE	EQUIPMENT NOT READY/AVAILABLE IF:
				<p style="text-align: center;">NOTE</p> <p>When grease fittings will not accept GAA, notify your supervisor.</p> <p>b. Lubricate foot brake cross-shaft bearings.</p> <ol style="list-style-type: none"> 1) Every 1500 miles or semi-annually, lubricate foot brake cross-shaft bearings with GAA through fitting. 2) Clean fittings with cleaning compound prior to lubrication. 3) Check/lubricate grease fitting points after washing or fording. See Foot Brake Cross-Shaft Lubrication Table (Table 8, page 0155 00-18). 	
			<p>FOOT BRAKE CROSS-SHAFT BEARINGS</p>		

PREVENTIVE MAINTENANCE CHECKS AND SERVICES (PMCS), INCLUDING LUBRICATION INSTRUCTIONS — Continued

0155 00

ITEM NO.	INTERVAL	MAN-HOUR	ITEM TO BE CHECKED OR SERVICED	CREWMEMBER PROCEDURE	EQUIPMENT NOT READY/ AVAILABLE IF:
64	Semi-Annual		Fuel System	<p style="text-align: center;">WARNING</p> <div style="text-align: center;">  </div> <p>Diesel fuel can catch fire and seriously injure or kill soldiers and damage or destroy vehicles. Wipe up fuel spills immediately. Do not smoke near fuel or when working on the fuel system.</p> <ol style="list-style-type: none"> a. Disconnect battery ground lead (WP 0337 00 or WP 0338 00). b. Check fuel tanks for leaks. Repair or replace fuel tanks that leak (WP 0179 00 or WP 0180 00). c. Replace fuel hoses and tubes that are cracked, crimped, or worn (WP 0192 00, WP 0193 00, or WP 0194 00). d. Replace cracked or stripped fittings (WP 0192 00 or WP 0195 00). 	Any fuel leaks. Cracked, broken, stripped, or crimped hardware.

PREVENTIVE MAINTENANCE CHECKS AND SERVICES (PMCS), INCLUDING LUBRICATION INSTRUCTIONS — Continued

0155 00

ITEM NO.	INTERVAL	MAN-HOUR	ITEM TO BE CHECKED OR SERVICED	CREWMEMBER PROCEDURE	EQUIPMENT NOT READY/AVAILABLE IF:
65	Semi-Annual		Fuel Cutoff	<p>a. Operate fuel cutoff to check for binding. If binding occurs, adjust (WP 0220 00).</p> <p>b. Operate accelerator to check for binding linkage. If binding occurs, adjust (WP 0214 00).</p> <p>c. Move transmission range controller through all gears to check for binding. If binding occurs, adjust (WP 0386 00 or WP 0387 00).</p>	Any binding, broken, cracked, missing, or loose hardware.

RANGE CONTROLLER

FUEL CUTOFF

ACCELERATOR

PREVENTIVE MAINTENANCE CHECKS AND SERVICES (PMCS), INCLUDING LUBRICATION INSTRUCTIONS — Continued

0155 00

ITEM NO.	INTERVAL	MAN-HOUR	ITEM TO BE CHECKED OR SERVICED	CREWMEMBER PROCEDURE	EQUIPMENT NOT READY/ AVAILABLE IF:
66	Semi-Annual	0.3	Fuel Filters	<p style="text-align: center;">WARNING</p> <div style="text-align: center;">  </div> <p>Fuel can catch fire and burn you. Do not smoke. Disconnect battery ground cables before you work on fuel system. Wipe up spilled fuel.</p> <p style="text-align: center;">NOTE</p> <p>Large amounts of sediment or debris may indicate contamination of fuel tanks.</p> <ol style="list-style-type: none"> a. Every 150 hours/1500 miles or semi-annually, inspect primary and secondary filter shells. Replace primary and secondary fuel filter elements (WP 0202 00). See Fuel Filter Lubrication Table (Table 2, page 0155 00-16). b. If engine will not start or hesitates, check for trapped air and drain fuel filter. 	Any fuel leaks.

PREVENTIVE MAINTENANCE CHECKS AND SERVICES (PMCS), INCLUDING LUBRICATION INSTRUCTIONS — Continued

0155 00

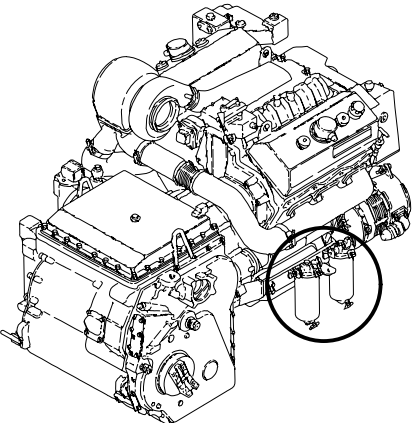
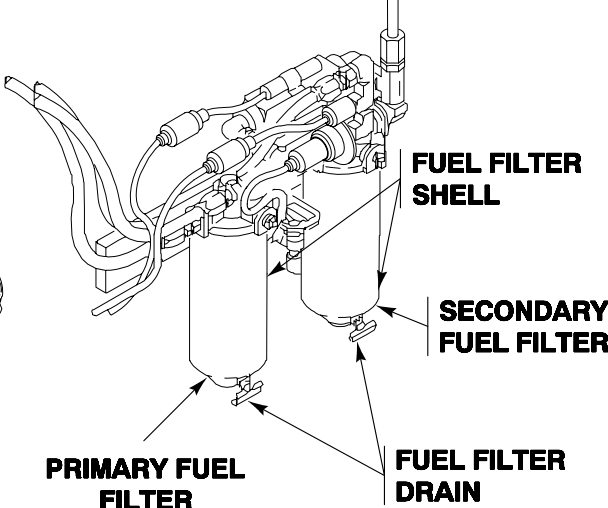
ITEM NO.	INTERVAL	MAN-HOUR	ITEM TO BE CHECKED OR SERVICED	CREWMEMBER PROCEDURE	EQUIPMENT NOT READY/AVAILABLE IF:
				<ol style="list-style-type: none"> 1) Remove driver's power plant access panel. See TM 9-2350-277-10. 2) Place suitable container under primary fuel filter. Open drain cock and drain water and sediment from primary fuel filter. When clean fuel starts to drain out, close drain cock. 3) Repeat Step a63 for secondary fuel filter. 4) Check for fuel leaks at primary and secondary fuel filters while engine is running. If leak is found, remove and install primary and secondary fuel filter elements and check for proper fit and seal (WP 0202 00). 	
					

PREVENTIVE MAINTENANCE CHECKS AND SERVICES (PMCS), INCLUDING LUBRICATION INSTRUCTIONS — Continued

0155 00

ITEM NO.	INTERVAL	MAN-HOUR	ITEM TO BE CHECKED OR SERVICED	CREWMEMBER PROCEDURE	EQUIPMENT NOT READY/ AVAILABLE IF:
67	Semi-Annual	1.0	Hydraulic System	<p style="text-align: center;">WARNING</p>  <p>Hydraulic fluid is poison and can be absorbed through your skin. Wash off hydraulic fluid that contacts your skin. Fire resistant hydraulic (FRH) fluid may contain Tricresyl Phosphate which, if taken internally, can produce paralysis. Wear long sleeves, gloves, goggles, and face shield. If FRH gets in eyes, wash them immediately and get medical aid immediately. If FRH gets on skin, thoroughly wash with soap and water. Wash hands thoroughly prior to eating or smoking.</p> <ol style="list-style-type: none"> a. Tighten or replace cracked or leaking fittings on hydraulic reservoir or pump (WP 0655 00, WP 0671 00, or WP 0672 00). b. Replace leaky pump (WP 0655 00). c. Tighten tubes or hoses that leak. 	Any hydraulic leaks, fluid not visible on sight gauge, cracked, broken, crimped, missing, or loose hardware.

PREVENTIVE MAINTENANCE CHECKS AND SERVICES (PMCS), INCLUDING LUBRICATION INSTRUCTIONS — Continued

0155 00

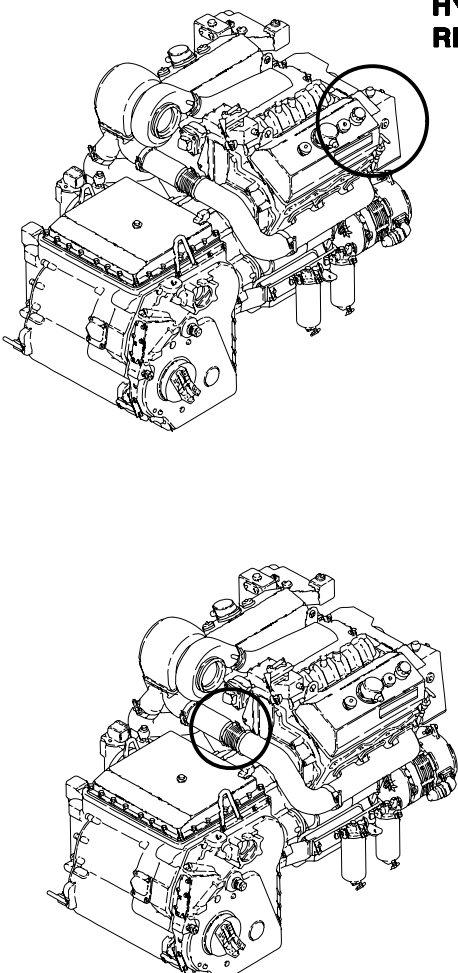
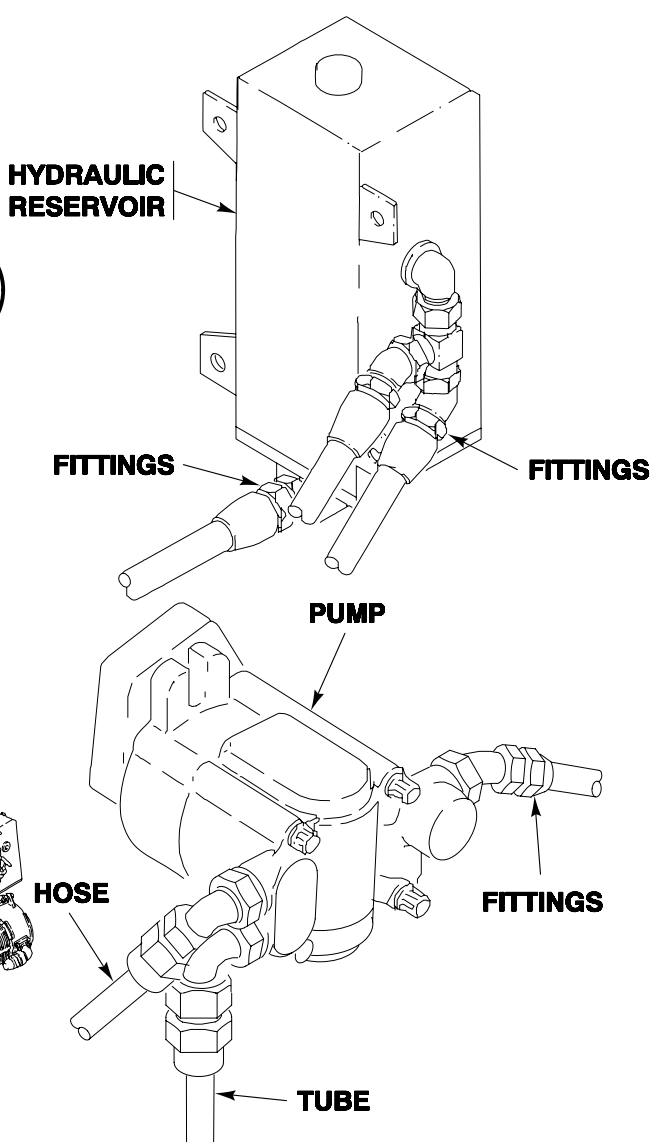
ITEM NO.	INTERVAL	MAN-HOUR	ITEM TO BE CHECKED OR SERVICED	CREWMEMBER PROCEDURE	EQUIPMENT NOT READY/AVAILABLE IF:
					

PREVENTIVE MAINTENANCE CHECKS AND SERVICES (PMCS), INCLUDING LUBRICATION INSTRUCTIONS — Continued

0155 00

ITEM NO.	INTERVAL	MAN-HOUR	ITEM TO BE CHECKED OR SERVICED	CREWMEMBER PROCEDURE	EQUIPMENT NOT READY/ AVAILABLE IF:
				<p style="text-align: center;">WARNING</p> <div style="text-align: center;">  </div> <p>Lowering ramp could injure personnel. Make sure no one is in ramp zone before you lower the ramp. Unlocked ramp can fall open suddenly. Personnel can be killed or injured. Ramp system and hull can get damaged if ramp unlocks when carrier is in operation. Do not operate carrier if locks do not secure ramp properly. Keep away from ramps that have come open during carrier operation.</p> <p>d. Tighten or replace cracked or leaky fitting on ramp cylinder and ramp control.</p> <p>e. Replace leaky ramp cylinder (WP 0656 00).</p> <p>f. Replace tubes or hoses that are cracked, crimped, or worn (WP 0660 00).</p> <p>g. Drain hydraulic system tank and service strainer every 1500 miles, semi-annually, or when hydraulic fluid is changed to FRH.</p> <ol style="list-style-type: none"> 1) Lower ramp. See TM 9-2350-277-10. 2) Place a suitable container under drain elbow on bottom of tank. 3) Remove drain cap and preformed packing from drain elbow. Discard packing. 4) Service hydraulic system tank breather (WP 0670 00) and strainer (WP 0669 00). 5) Install drain cap with new preformed packing on drain elbow. 	<p>Pumps fail to operate or raise ramp.</p>

PREVENTIVE MAINTENANCE CHECKS AND SERVICES (PMCS), INCLUDING LUBRICATION INSTRUCTIONS — Continued

0155 00

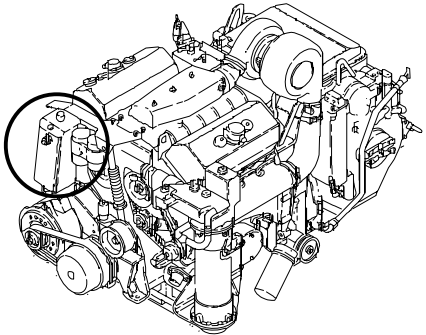
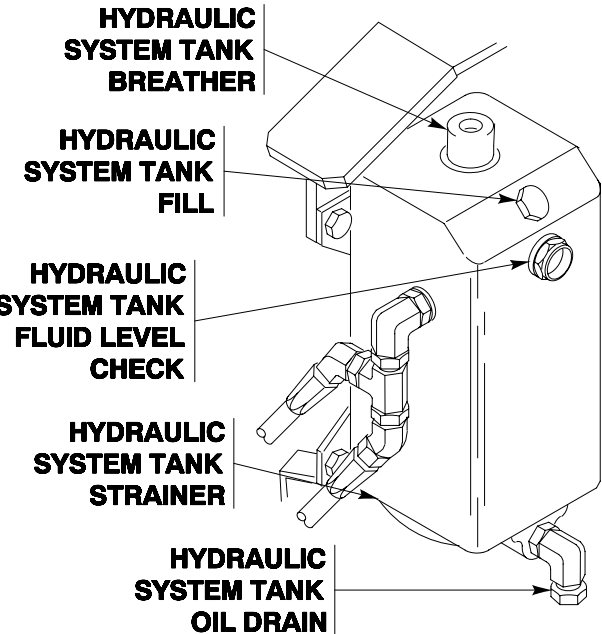
ITEM NO.	INTERVAL	MAN-HOUR	ITEM TO BE CHECKED OR SERVICED	CREWMEMBER PROCEDURE	EQUIPMENT NOT READY/ AVAILABLE IF:
				<p>6) Remove fill plug and preformed packing from top of tank.</p> <p>7) Fill hydraulic tank with FRH to bring level halfway in sight glass. Hydraulic tank takes approximately 3 1/2 quarts. See Hydraulic System Lubrication Table (Table 7, page 0155 00-18).</p> <p>8) Install fill plug with new preformed packing in top of tank.</p> <p>h. When changing from OHA to FRH hydraulic fluid, flush tank as follows.</p> <ol style="list-style-type: none"> 1) Drain and fill tank. See Step 68g. 2) Raise and lower ramp several times. See TM 9-2350-277-10. 3) Drain and fill tank again (Step 68g). 4) Test hydraulic ramp system. 	
					

PREVENTIVE MAINTENANCE CHECKS AND SERVICES (PMCS), INCLUDING LUBRICATION INSTRUCTIONS — Continued

0155 00

ITEM NO.	INTERVAL	MAN-HOUR	ITEM TO BE CHECKED OR SERVICED	CREWMEMBER PROCEDURE	EQUIPMENT NOT READY/AVAILABLE IF:
				<ul style="list-style-type: none"> i. Tighten tubes and hoses that leak. j. Replace tubes or hoses that are cracked, crimped, or worn (WP 0660 00 or WP 0668 00). k. Replace ramp cylinder that leaks (WP 0656 00). 	

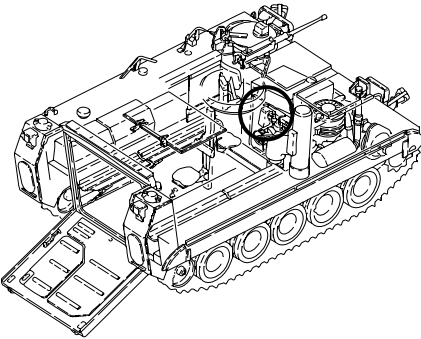

RAMP CONTROL

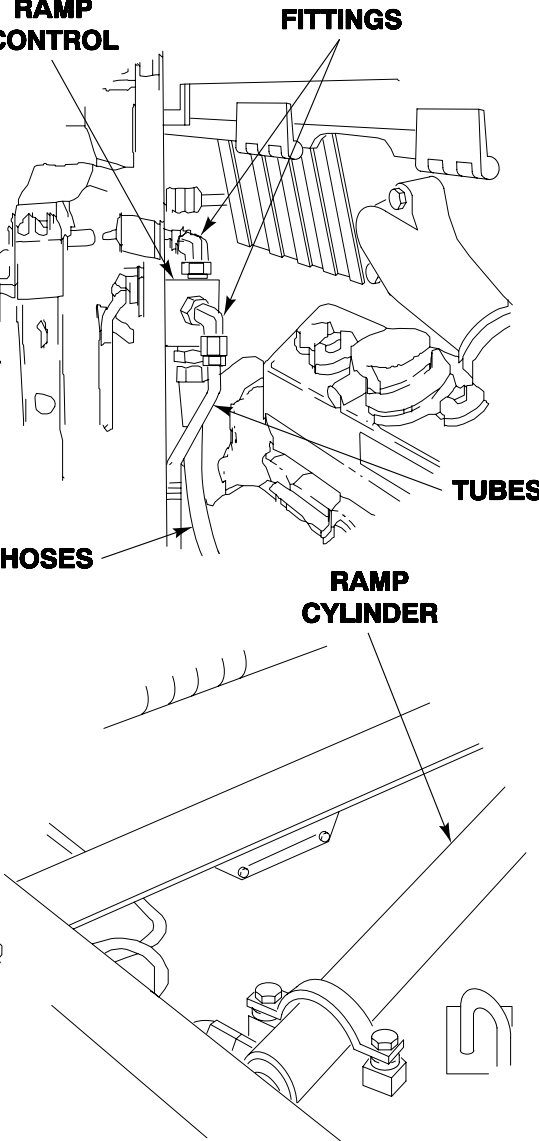

FITTINGS

TUBES

HOSES

RAMP CYLINDER

PREVENTIVE MAINTENANCE CHECKS AND SERVICES (PMCS), INCLUDING LUBRICATION INSTRUCTIONS — Continued

0155 00

ITEM NO.	INTERVAL	MAN-HOUR	ITEM TO BE CHECKED OR SERVICED	CREWMEMBER PROCEDURE	EQUIPMENT NOT READY/ AVAILABLE IF:
68	Semi-Annual		Portable and Fixed Fire Extinguisher	<p style="text-align: center;">WARNING</p>  <p>You could be injured if cylinder discharges when it is out of its mounting brackets or is dropped. Handle with great care.</p> <ol style="list-style-type: none"> a. Weigh portable fire extinguishers. Recharge or exchange fire extinguisher if weight loss is more than 10 percent of charged weight stamped on bottle. Fill out DA Form 2402 to exchange cylinders. b. Check wire seal. Replace broken or damaged seal. 	Extinguisher is missing or seal/hardware is missing or broken.

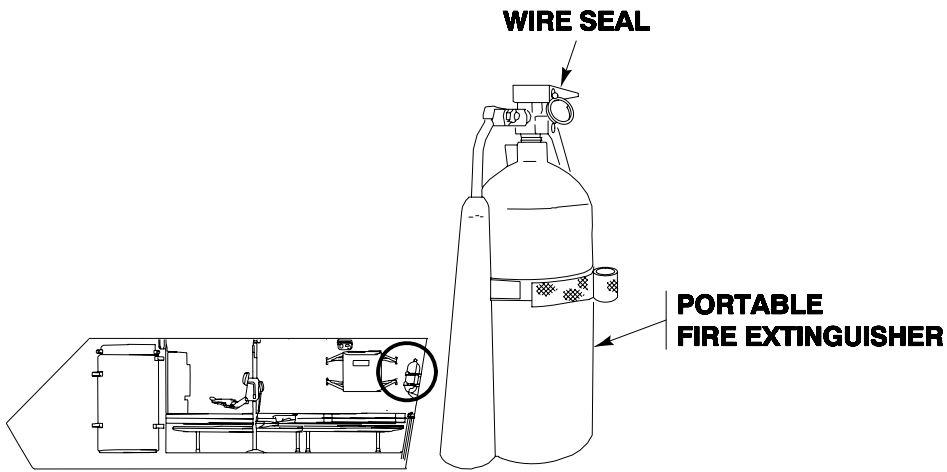



PREVENTIVE MAINTENANCE CHECKS AND SERVICES (PMCS), INCLUDING LUBRICATION INSTRUCTIONS — Continued

0155 00

ITEM NO.	INTERVAL	MAN-HOUR	ITEM TO BE CHECKED OR SERVICED	CREWMEMBER PROCEDURE	EQUIPMENT NOT READY/ AVAILABLE IF:
69	Semi-Annual		Fixed Fire Extinguisher	<p style="text-align: center;"><u>CAUTION</u></p> <p>Fire extinguisher control valve sealed with steel wire will not work. Make sure seal wire is made out of .020 light copper.</p> <ul style="list-style-type: none"> a. Remove and weigh fixed fire extinguisher cylinder (WP 0898 00). b. Recharge or exchange fire extinguisher if weight loss is more than 10 percent of charged weight stamped on bottle. c. Inspect fire extinguisher cylinder data plate to ensure that a hydrostatic test has been performed within the past 5 years. Faulty extinguishers, or those beyond the test time limit (5 years), shall be declared unserviceable and replaced. <p style="text-align: center;"><u>CAUTION</u></p> <p>Fire extinguisher control valve sealed with steel wire WILL NOT work. Use .020 thin copper wire.</p> <ul style="list-style-type: none"> d. Before reconnecting cylinder, operate discharge handles to be sure cables and controls work properly. e. Install cylinder and replace copper seal wires (WP 0898 00). f. Replace discharge tubes that are crimped, plugged, or cracked (WP 0899 00). 	Extinguisher is missing or seal/lockwire missing or broken, bottles are overdue for hydrostatic test. Lock wire is not .020 light copper.

PREVENTIVE MAINTENANCE CHECKS AND SERVICES (PMCS), INCLUDING
LUBRICATION INSTRUCTIONS — Continued

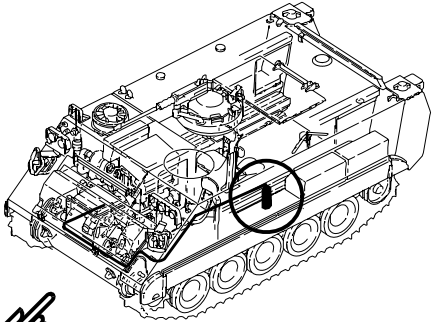
0155 00

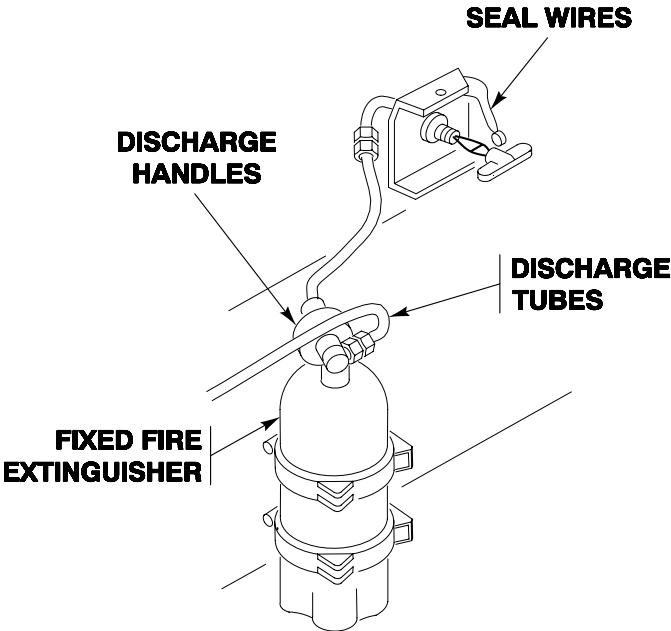
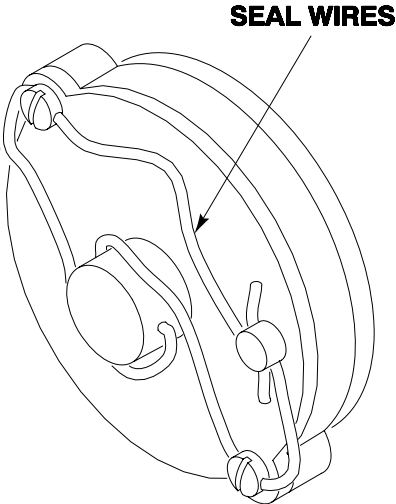
ITEM NO.	INTERVAL	MAN-HOUR	ITEM TO BE CHECKED OR SERVICED	CREWMEMBER PROCEDURE	EQUIPMENT NOT READY/AVAILABLE IF:
					
					
					
					

PREVENTIVE MAINTENANCE CHECKS AND SERVICES (PMCS), INCLUDING LUBRICATION INSTRUCTIONS — Continued

0155 00

ITEM NO.	INTERVAL	MAN-HOUR	ITEM TO BE CHECKED OR SERVICED	CREWMEMBER PROCEDURE	EQUIPMENT NOT READY/ AVAILABLE IF:
70	Semi-Annual		Batteries	<p style="text-align: center;">WARNING</p>  <p>Battery posts and cables touched by metal objects can short circuit and burn you or injure you. Use caution when you work with tools or other metal objects. Do not wear jewelry when you work on electrical system. Electrical current can burn you.</p> <p style="text-align: center;">NOTE</p> <p>Location of batteries and connection of battery leads varies by model. Model M1064A3 has two ground (negative) leads that need to be disconnected when performing any maintenance. All other models have one ground (negative) lead to be disconnected.</p> <ol style="list-style-type: none"> a. Remove battery ground lead before you start task (WP 0338 00, WP 0340 00, or WP 0345 00). b. Check battery posts and cables (WP 0095 00). 	Any leaks, loose, damaged, cracked, broken, or missing battery or hardware.

PREVENTIVE MAINTENANCE CHECKS AND SERVICES (PMCS), INCLUDING LUBRICATION INSTRUCTIONS — Continued

0155 00

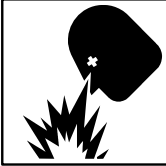
ITEM NO.	INTERVAL	MAN-HOUR	ITEM TO BE CHECKED OR SERVICED	CREWMEMBER PROCEDURE	EQUIPMENT NOT READY/ AVAILABLE IF:
				<p>c. Check specific gravity of batteries. See TM 9-6140-200-14.</p> <p style="text-align: center;">WARNING</p>  <p>Gas from batteries can explode and injure you. Do not allow sparks near batteries. Battery acid can blind or burn you. Do not get acid on your skin or eyes.</p> <p>d. Check electrolyte level in all cell batteries. Add distilled water as needed. See TM 9-6140-200-14.</p> <p>e. Test specific gravity of batteries. See TM 9-6140-200-14.</p>	<p>Specific gravity is not within set standards.</p> <p>One or more batteries unserviceable, missing, cables frayed, or broken.</p>

PREVENTIVE MAINTENANCE CHECKS AND SERVICES (PMCS), INCLUDING LUBRICATION INSTRUCTIONS — Continued

0155 00

ITEM NO.	INTERVAL	MAN-HOUR	ITEM TO BE CHECKED OR SERVICED	CREWMEMBER PROCEDURE	EQUIPMENT NOT READY/ AVAILABLE IF:
				<p>f. Clean vent holes in cell caps. Replace missing or damaged caps.</p> <p>g. Clean terminals, posts, and bolts (WP 0340 00).</p> <p>h. Tighten terminals and bolts with care to avoid damage to batteries. Apply light coat of automotive grease to terminals.</p>	
71	Semi-Annual	.3	Driver's Hatch	<p>a. Replace hard, cracked, or cut cushioning pad (WP 0530 00).</p> <p>b. Check driver's night vision quick release for smooth operation.</p> <p>c. Check vision blocks for cracks and chips.</p> <p>d. Replace vision blocks that have more than 50 percent impairment.</p>	Any missing lock pins or latches that fail to secure hatch in any position.

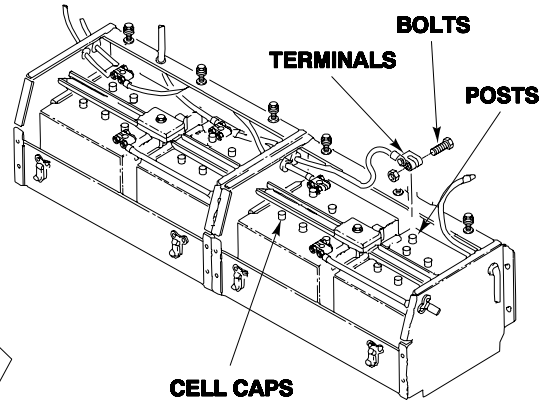
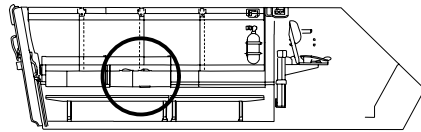

PREVENTIVE MAINTENANCE CHECKS AND SERVICES (PMCS), INCLUDING LUBRICATION INSTRUCTIONS — Continued

0155 00

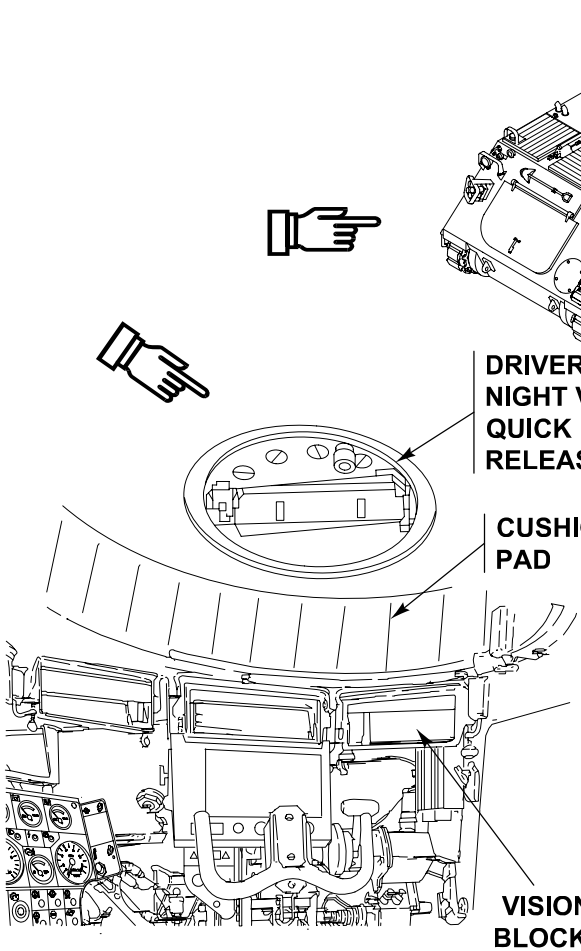
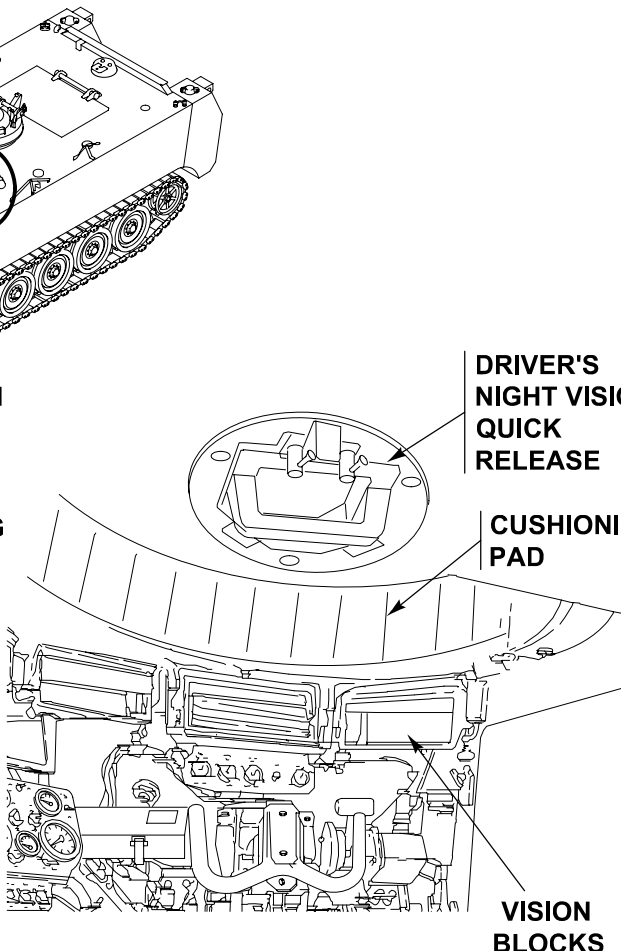
ITEM NO.	INTERVAL	MAN-HOUR	ITEM TO BE CHECKED OR SERVICED	CREWMEMBER PROCEDURE	EQUIPMENT NOT READY/AVAILABLE IF:
72	Semi-Annual	.3	 <p>DRIVER'S NIGHT VISION QUICK RELEASE</p> <p>CUSHIONING PAD</p> <p>VISION BLOCKS</p> <p>(NEW CONFIGURATION)</p>	 <p>DRIVER'S NIGHT VISION QUICK RELEASE</p> <p>CUSHIONING PAD</p> <p>VISION BLOCKS</p> <p>(OLD CONFIGURATION)</p>	<p>e. Push driver's release handle up and measure between hatch release handle and washer. Make sure gap is 0.06 to 0.09 inch (1.5 to 2.3 mm). If clearance is not within limits, loosen or tighten nut on cable end, as required.</p> <p>a. Inspect driver's night vision (viewer) AN/VVS-2(v) per TM 11-5855-249-23&P or DVE per TM 11-5855-311-12&P-1 (to be released at a later date).</p>
			<p>Driver's Night Viewer/Driver's Night Viewer Enhancer (DVE)</p>	<p>Per TM 11-5855-249-23&P or TM 11-5855-311-12&P-1.</p>	

PREVENTIVE MAINTENANCE CHECKS AND SERVICES (PMCS), INCLUDING LUBRICATION INSTRUCTIONS — Continued

0155 00

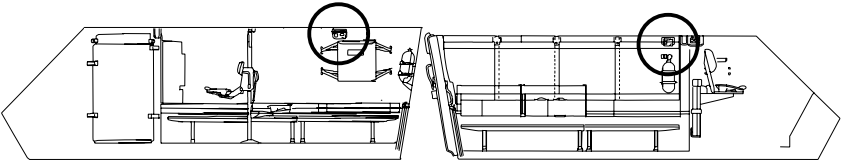
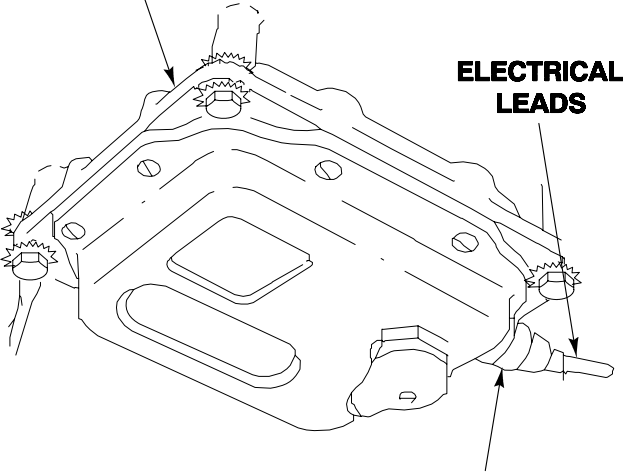
ITEM NO.	INTERVAL	MAN-HOUR	ITEM TO BE CHECKED OR SERVICED	CREWMEMBER PROCEDURE	EQUIPMENT NOT READY/ AVAILABLE IF:
73	Semi-Annual	.1	Dome Lights	a. Check that all dome lights work correctly. Troubleshoot faulty lights (WP 0039 00). b. Tape frayed electrical leads and replace damaged connectors (WP 0382 00).	
					
<p>DOME LIGHT</p>					
					
<p>ELECTRICAL LEADS</p>					
<p>CONNECTORS</p>					
74	Semi-Annual	.1	Dome Lights, Fluorescent Light, and Switches (M577A3 and M1068A3 Only)	a. Check that dome lights, blackout lights and fluorescent light work right. See TM 9-2350-277-10. Troubleshoot faulty lights (WP 0039 00, WP 0040 00, WP 0041 00, or WP 0102 00).	

PREVENTIVE MAINTENANCE CHECKS AND SERVICES (PMCS), INCLUDING
LUBRICATION INSTRUCTIONS — Continued

0155 00

ITEM NO.	INTERVAL	MAN-HOUR	ITEM TO BE CHECKED OR SERVICED	CREWMEMBER PROCEDURE	EQUIPMENT NOT READY/ AVAILABLE IF:
				<ul style="list-style-type: none"> b. Check dome light switches, blackout bypass switch, and fluorescent light switch for proper operation. See TM 9-2350-277-10. Troubleshoot faulty switches (WP 0048 00). c. Check that ramp door switch operates properly. See TM 9-2350-277-10. Troubleshoot faulty switch (WP 0040 00). d. Check that admittance buzzer operates properly. See TM 9-2350-277-10. Troubleshoot faulty buzzer. Replace unrepairable buzzer (WP 0042 00). e. Check that blower operates properly. See TM 9-2350-277-10. Troubleshoot faulty blower (WP 0043 00). f. Tape frayed electrical leads. g. Replace damaged connectors (WP 0382 00). 	

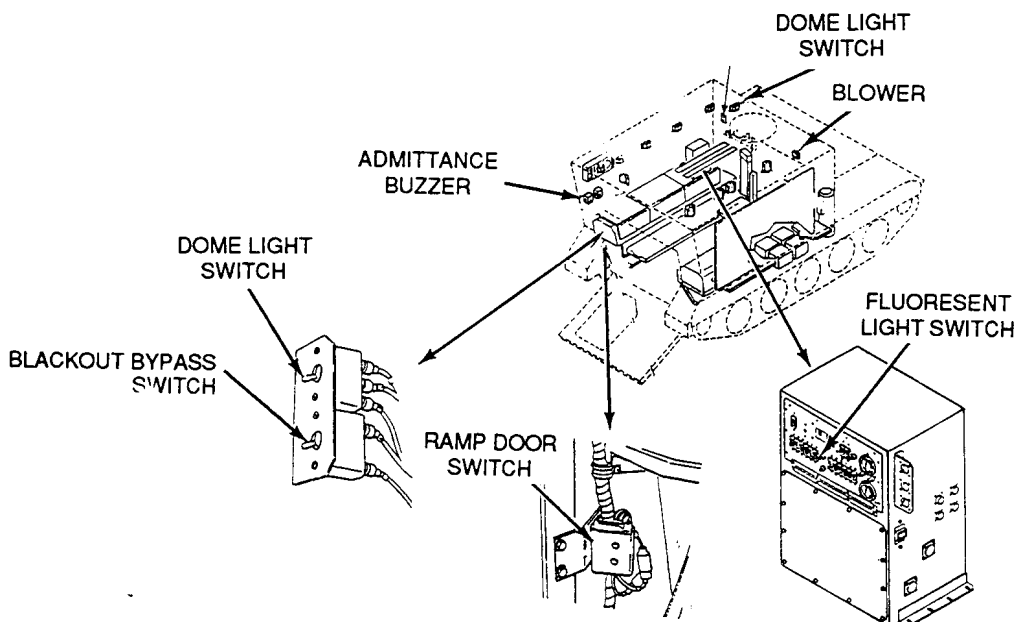

PREVENTIVE MAINTENANCE CHECKS AND SERVICES (PMCS), INCLUDING
LUBRICATION INSTRUCTIONS — Continued

0155 00

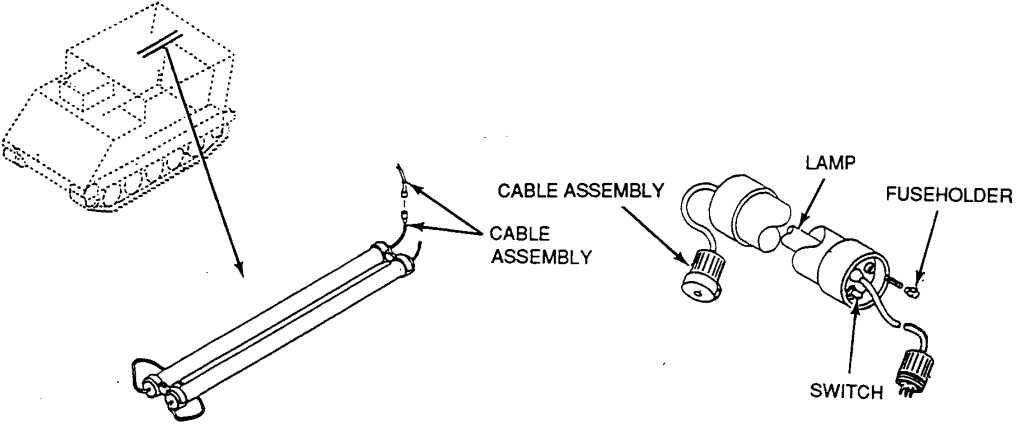
ITEM NO.	INTERVAL	MAN-HOUR	ITEM TO BE CHECKED OR SERVICED	CREWMEMBER PROCEDURE	EQUIPMENT NOT READY/ AVAILABLE IF:
				<p style="text-align: center;">WARNING</p> <div style="text-align: center;">  </div> <p>Lethal voltage is present when light set is connected to power source. Disconnect from power source before inspecting or repairing any electrical component. Be careful not to contact electrical connections. Electrical shock and death may result from failure to heed this warning.</p> <ul style="list-style-type: none"> h. Check cable assembly and their insulations for physical damage. If cable assemblies are damaged, it is necessary to go to a higher level of maintenance. i. Check for security and proper functioning of ON/OFF switch, fuseholder, and lamp. Troubleshoot any faulty elements (WP 0040 00, WP 0041 00, or WP 0102 00). 	
					

PREVENTIVE MAINTENANCE CHECKS AND SERVICES (PMCS), INCLUDING LUBRICATION INSTRUCTIONS — Continued

0155 00

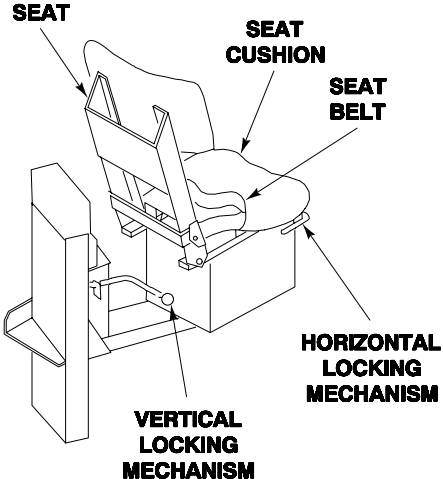
ITEM NO.	INTERVAL	MAN-HOUR	ITEM TO BE CHECKED OR SERVICED	CREWMEMBER PROCEDURE	EQUIPMENT NOT READY/ AVAILABLE IF:
75	Semi-Annual		Driver's Seat	<p>a. Replaced damaged seat components (WP 0551 00).</p> <p>b. Replace seat belts with cuts, frayed, or broken buckle (WP 0552 00).</p> <p style="text-align: center;">WARNING</p> <div style="text-align: center;">  </div> <p>Seat can spring up and hit you when vertical control handle is released. Make sure you are sitting in the seat before releasing vertical control handle.</p> <p>c. See that seat vertical locking mechanism and horizontal locking mechanism work properly (WP 0552 00 or (WP 0557 00). Lubricate locking mechanism as needed with OE/HDO.</p> <div style="text-align: center;">  </div>	<p>Any missing, broken, or cracked seat hardware, less seat cushions.</p> <p>Locking mechanism fails to lock in any position.</p>

PREVENTIVE MAINTENANCE CHECKS AND SERVICES (PMCS), INCLUDING LUBRICATION INSTRUCTIONS — Continued

0155 00

ITEM NO.	INTERVAL	MAN-HOUR	ITEM TO BE CHECKED OR SERVICED	CREWMEMBER PROCEDURE	EQUIPMENT NOT READY/AVAILABLE IF:
76	Semi-Annual		Personnel Seats	<p>a. Repair or replace damaged seat cushions (WP 0546 00, WP 0547 00, or WP 0548 00).</p> <p>b. Repair or replace cut, broken, or frayed seat belts (WP 0546 00, WP 0547 00, WP 0548 00, WP 0549 00, or WP 0550 00).</p>	Any missing, broken, or cracked seat hardware, less seat cushions or cut, frayed seat belts.

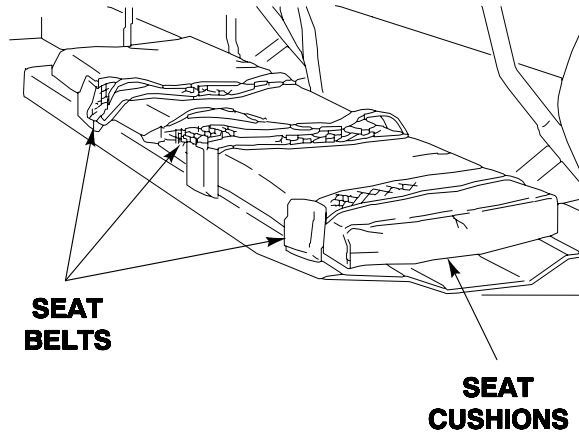

PREVENTIVE MAINTENANCE CHECKS AND SERVICES (PMCS), INCLUDING LUBRICATION INSTRUCTIONS — Continued

0155 00

ITEM NO.	INTERVAL	MAN-HOUR	ITEM TO BE CHECKED OR SERVICED	CREWMEMBER PROCEDURE	EQUIPMENT NOT READY/AVAILABLE IF:
77	Semi-Annual	.1	Commander's Seat (All Except M577A3 and M1068A3)	<p>a. Replaced damaged seat cushions (WP 0561 00). Replace cut, broken, or frayed seat belts (WP 0562 00).</p> <p>b. Check for smooth operation of seat and vertical locking mechanism. Lubricate as needed with OE/HDO.</p>	<p>Any missing, broken, or cracked seat hardware, less seat cushions or cut, broken, or frayed seat belts.</p> <p>Any broken or missing seat and post assembly.</p>

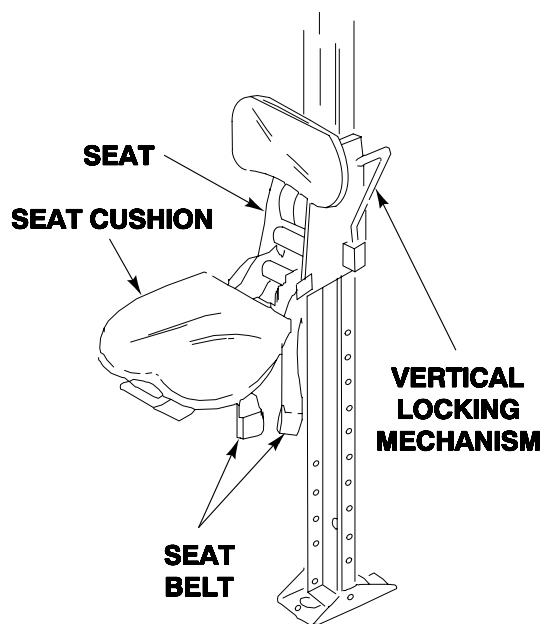

PREVENTIVE MAINTENANCE CHECKS AND SERVICES (PMCS), INCLUDING LUBRICATION INSTRUCTIONS — Continued

0155 00

ITEM NO.	INTERVAL	MAN-HOUR	ITEM TO BE CHECKED OR SERVICED	CREWMEMBER PROCEDURE	EQUIPMENT NOT READY/AVAILABLE IF:
78	Semi-Annual	.1	Commander's Platform (All Except M1059A3)	a. Check platform lock to make sure the platform locks securely in various vertical positions. See TM 9-2350-277-10. b. Check that platform securing catch and stowing catch work properly. See TM 9-2350-277-10.	Any missing, broken, or cracked platform hardware, or vertical locking mechanism failing to lock in any position.
79	Semi-Annual	.1	Operator's Seat (M1059A3 and M1068A3)	a. Lubricate locking mechanism and catch as needed with OE/HDO.	
80	Semi-Annual		Commander's Cupola (M113A3, M1064A3, and M1059A3)	a. Replace cut, cracked, or hard cushioning pad. Replace vision blocks that have more than 50 percent impairment. See TM 9-2350-277-10. b. Replace cracked or chipped vision blocks (WP 0490 00 or WP 0491 00). c. Check for smooth rotation of commander's cupola. Replace bearings as required. Notify your supervisor. d. For the M1059A3, check bracket and stop. Replace missing or broken parts (WP 0499 00).	

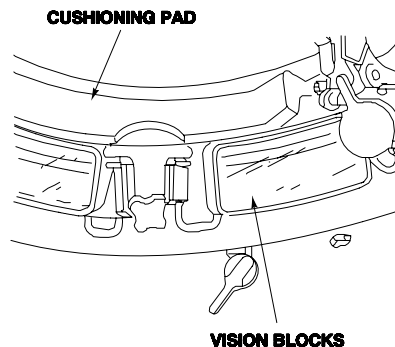

PREVENTIVE MAINTENANCE CHECKS AND SERVICES (PMCS), INCLUDING LUBRICATION INSTRUCTIONS — Continued

0155 00

ITEM NO.	INTERVAL	MAN-HOUR	ITEM TO BE CHECKED OR SERVICED	CREWMEMBER PROCEDURE	EQUIPMENT NOT READY/AVAILABLE IF:
81	Semi-Annual		Data Plates, Decals, Stencils, and Markers	a. Replace missing or damaged data plates, decals, stencils, and markers (WP 0654 00).	
82	Semi-Annual		Black-Out Curtain (M577A3 and M1068A3)	a. Repair or replace blackout curtain that is torn or worn thin (WP 0629 00). b. Replace blackout curtain that has torn or missing straps (WP 0629 00). c. Replace broken or missing fasteners (WP 0629 00).	

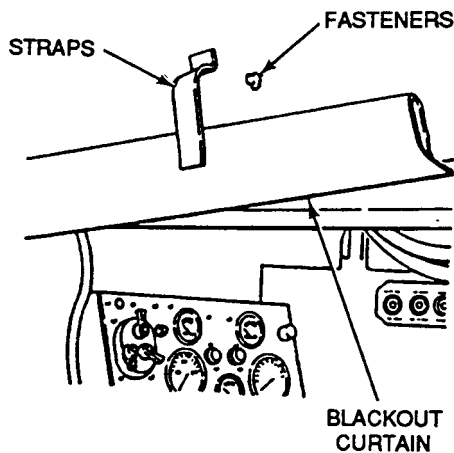

PREVENTIVE MAINTENANCE CHECKS AND SERVICES (PMCS), INCLUDING LUBRICATION INSTRUCTIONS — Continued

0155 00

ITEM NO.	INTERVAL	MAN-HOUR	ITEM TO BE CHECKED OR SERVICED	CREWMEMBER PROCEDURE	EQUIPMENT NOT READY/ AVAILABLE IF:
83	Semi-Annual		Map Tables and Map Board (M577A3 Only)	a. Tighten or replace loose or missing screws on map tables and supports. b. Replace map table or map board that is badly damaged or warped (WP 0578 00, WP 0580 00, WP 0581 00, or WP 0582 00).	
<p>The diagram shows a perspective view of a map table assembly. A dashed outline represents the main structure. A solid line indicates the 'BLACKOUT CURTAIN' at the top. Below it, a 'MAP BOARD' is mounted on 'SUPPORTS'. A 'SHELF' is positioned below the map board. At the bottom, a 'WORK SURFACE' is shown. Arrows point from each label to the corresponding part of the assembly.</p>					
84	Semi-Annual		Map Board, Rack Bases, Shelf Assembly, and Work Surfaces (M1068A3 Only)	a. Tighten or replace loose or missing screws on work surface, supports, map board, and shelf assembly. b. Replace badly damaged map boards and work surfaces (WP 0618 00).	

PREVENTIVE MAINTENANCE CHECKS AND SERVICES (PMCS), INCLUDING LUBRICATION INSTRUCTIONS — Continued

0155 00

ITEM NO.	INTERVAL	MAN-HOUR	ITEM TO BE CHECKED OR SERVICED	CREWMEMBER PROCEDURE	EQUIPMENT NOT READY/ AVAILABLE IF:
85	Semi-Annual		Tents and Stowage Brackets (M577A3 and M1068A3)	a. Replace tent that has tears, breaks, fraying, or other damage (WP 0627 00, WP 0628 00, or see TM 10-8340-243-13&P). b. Tighten screws on mounting clamps and strip.	
86	Semi-Annual		4.2 KW Generator Set Enclosure (M577A3 and M1068A3)	a. TIGHTEN OR REPLACE LOOSE OR MISSING SCREWS ON ENCLOSURE TO 55-60 LB-FT (75-81 N·M) TORQUE. Use torque wrench (WP 0926 00, Item 82). b. Replace damaged enclosure (WP 0674 00).	

PREVENTIVE MAINTENANCE CHECKS AND SERVICES (PMCS), INCLUDING LUBRICATION INSTRUCTIONS — Continued

0155 00

ITEM NO.	INTERVAL	MAN-HOUR	ITEM TO BE CHECKED OR SERVICED	CREWMEMBER PROCEDURE	EQUIPMENT NOT READY/ AVAILABLE IF:
87	Semi-Annual		5.0 KW Auxiliary Power Unit (APU) (M577A3 and M1068A3)	a. See TM 9-6115-664-13&P for PMCS procedures. b. Replace damaged APU (WP 0675 00).	

AUXILIARY POWER UNIT (5.0 KW APU) (M1068A3 & M577A3 ONLY)

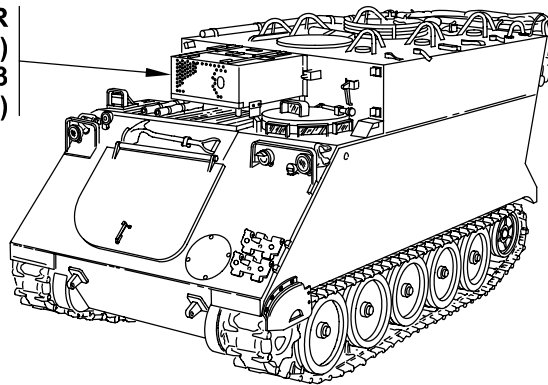

PREVENTIVE MAINTENANCE CHECKS AND SERVICES (PMCS), INCLUDING LUBRICATION INSTRUCTIONS — Continued

0155 00

ITEM NO.	INTERVAL	MAN-HOUR	ITEM TO BE CHECKED OR SERVICED	CREWMEMBER PROCEDURE	EQUIPMENT NOT READY/AVAILABLE IF:
88	Semi-Annual		Capstan Drum and Adapter (M113A3 and M1059A3)	<p>a. Check capstan drum and adapter. Replace cracked or damaged drum or adapter. Tighten loose screws or retainer.</p> <p>b. If retainer can be unscrewed from drum, replace spring pin.</p>	

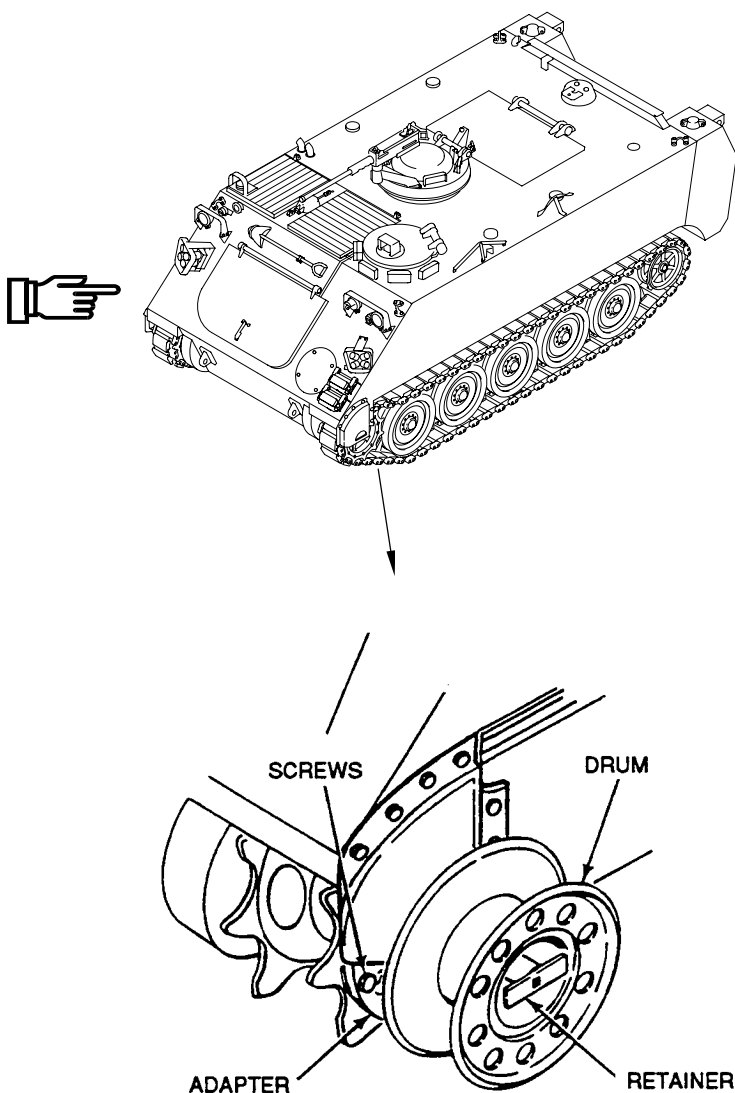

PREVENTIVE MAINTENANCE CHECKS AND SERVICES (PMCS), INCLUDING LUBRICATION INSTRUCTIONS — Continued

0155 00

ITEM NO.	INTERVAL	MAN-HOUR	ITEM TO BE CHECKED OR SERVICED	CREWMEMBER PROCEDURE	EQUIPMENT NOT READY/ AVAILABLE IF:
89	Semi-Annual		Litter Kit	<ul style="list-style-type: none"> a. Perform preventive maintenance checks and services every 750 miles (1207 km), 75 hours, semiannually, or whichever comes first. b. Check hanger. Replace hanger if cracked or if threads are stripped (WP 0744 00). c. Check three repair links. Replace cracked links (WP 0745 00). d. Check chain. Replace chain if links are broken (WP 0744 00). e. Check two litter straps. Replace straps if torn or if buckles are damaged (WP 0743 00). f. Check two litter hooks. Replace hooks if cracked or if they can't be recurved to hold litters (WP 0745 00). g. Check repair links. Replace links if they are broken (WP 0745 00). h. Check S hooks. Replace damaged S hooks (WP 0745 00). i. Check helical spring. Replace cracked spring (WP 0745 00). j. Check chain hook. Replace hook if cracked or if they can't be recurved (WP 0745 00). 	

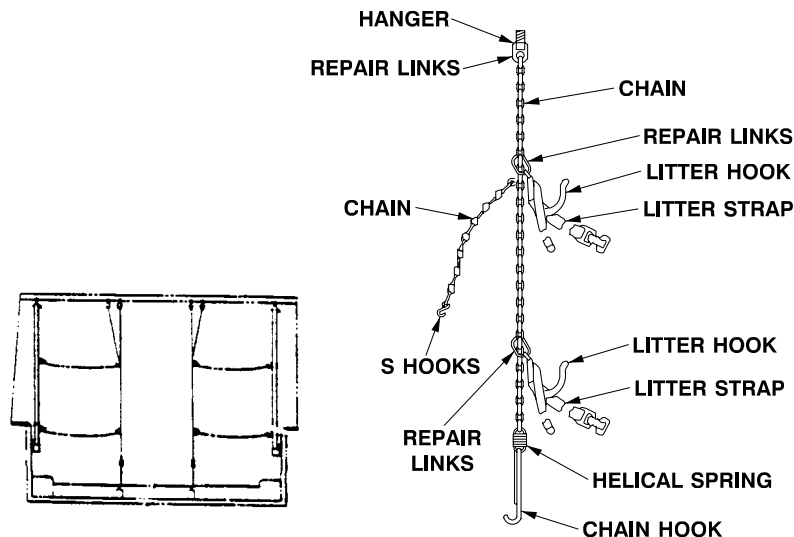

PREVENTIVE MAINTENANCE CHECKS AND SERVICES (PMCS), INCLUDING LUBRICATION INSTRUCTIONS — Continued

0155 00

ITEM NO.	INTERVAL	MAN-HOUR	ITEM TO BE CHECKED OR SERVICED	CREWMEMBER PROCEDURE	EQUIPMENT NOT READY/AVAILABLE IF:
				<p>k. Check posts. Straighten bent posts. Replace cracked posts (WP 0742 00).</p> <p>l. Check drive screw. Make sure it holds bead chain securely. Replace loose screw (WP 0745 00).</p> <p>m. Check bead chain. Replace broken chain (WP 0745 00).</p> <p>n. Check spring pin. Replace loose pin (WP 0742 00).</p> <p>o. Check litter support. Replace post if support is cracked (WP 0742 00).</p> <p>p. Check strap. Replace strap if torn or if buckles are damaged (WP 0743 00).</p> <p>q. Check bracket, screws, and washers. Replace loose or missing parts (WP 0741 00).</p>	

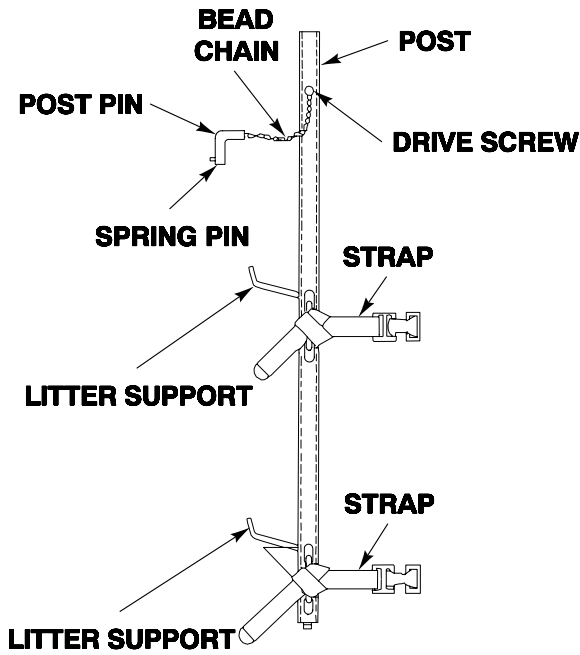



PREVENTIVE MAINTENANCE CHECKS AND SERVICES (PMCS), INCLUDING LUBRICATION INSTRUCTIONS — Continued

0155 00

ITEM NO.	INTERVAL	MAN-HOUR	ITEM TO BE CHECKED OR SERVICED	CREWMEMBER PROCEDURE	EQUIPMENT NOT READY/ AVAILABLE IF:
90	Semi-Annual	0.4	Carrier	<p>a. Lubricate steering control lever and shaft bearings.</p> <p style="text-align: center;">NOTE</p> <p>When grease fittings will not accept GAA, notify your supervisor.</p> <ol style="list-style-type: none"> 1) Every 150 hours/1500 miles or semi-annually, lubricate bearings with GAA through fitting at each end of steering support and power plant bulkhead. Use grease gun with flexible adapter. See Steering Control Bearing Lubrication Table (Table 8, page 0155 00-18). 2) Clean fittings with cleaning compound prior to lubrication. Check/lubricate grease fitting points after washing or fording. 	

PREVENTIVE MAINTENANCE CHECKS AND SERVICES (PMCS), INCLUDING
LUBRICATION INSTRUCTIONS — Continued

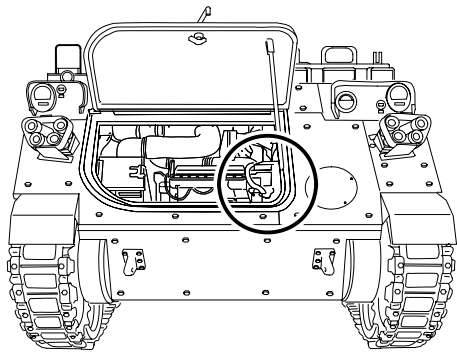
0155 00

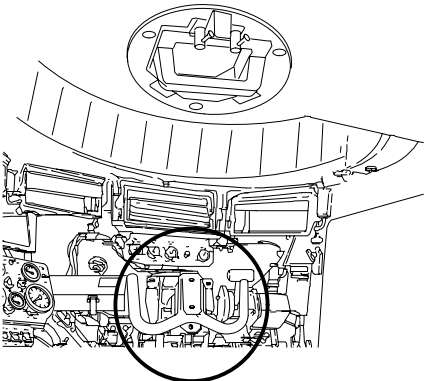
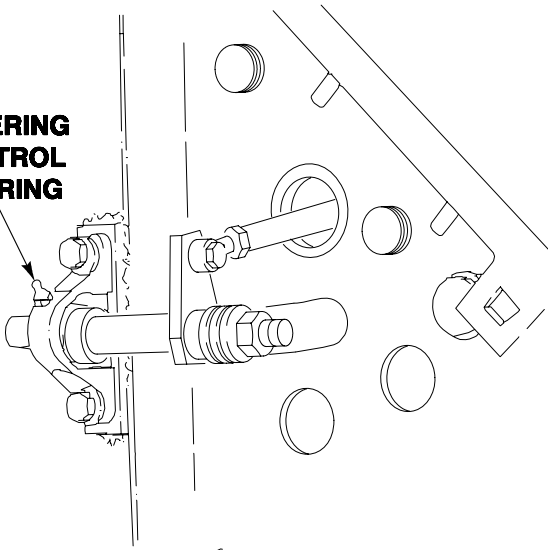
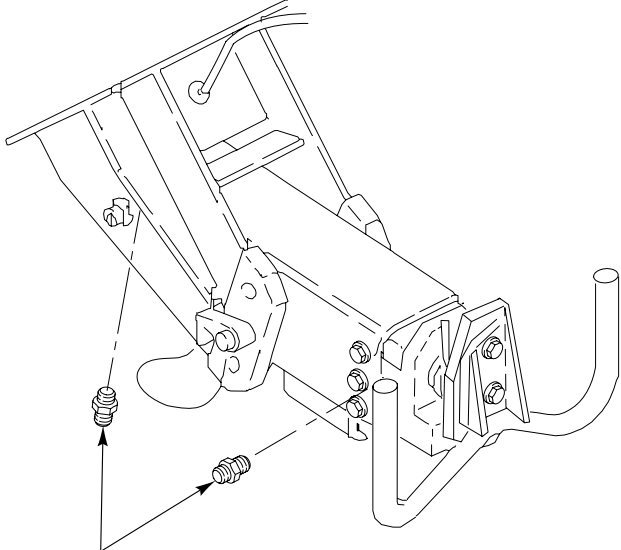
ITEM NO.	INTERVAL	MAN-HOUR	ITEM TO BE CHECKED OR SERVICED	CREWMEMBER PROCEDURE	EQUIPMENT NOT READY/AVAILABLE IF:
			  	<p>STEERING CONTROL BEARING</p>   <p>STEERING CONTROL BEARINGS (3 FITTINGS)</p>	

PREVENTIVE MAINTENANCE CHECKS AND SERVICES (PMCS), INCLUDING LUBRICATION INSTRUCTIONS — Continued

0155 00

ITEM NO.	INTERVAL	MAN-HOUR	ITEM TO BE CHECKED OR SERVICED	CREWMEMBER PROCEDURE	EQUIPMENT NOT READY/AVAILABLE IF:
91	Semi-Annual		NBC Mounting Hardware Kit	<ul style="list-style-type: none"> a. Check mounts. Replace worn, weak, or cracked mounts. b. Tighten loose mounting screws and nuts. c. Check webstraps securing NBC hoses properly. 	

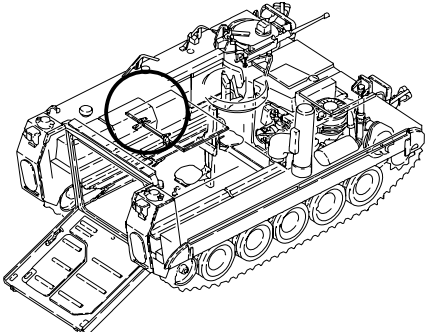

MOUNTING SCREWS/NUTS

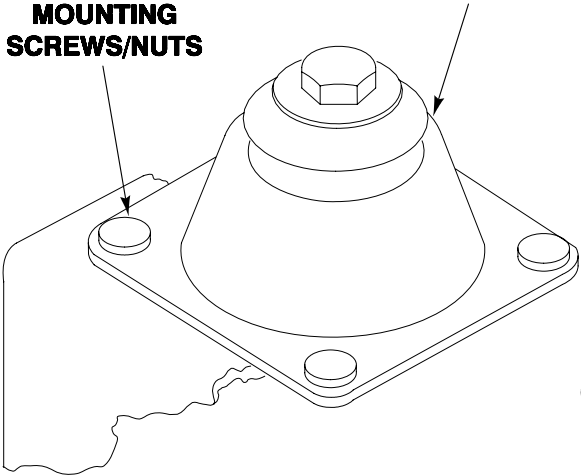

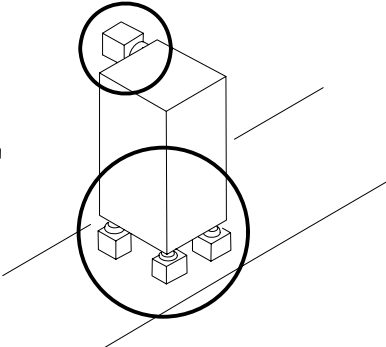

MOUNTS

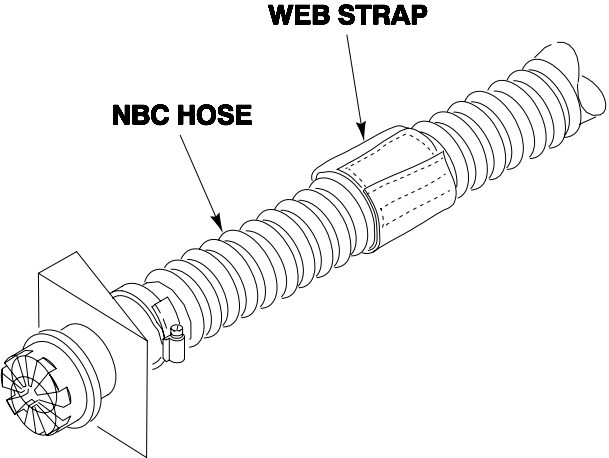

WEB STRAP

NBC HOSE

PREVENTIVE MAINTENANCE CHECKS AND SERVICES (PMCS), INCLUDING LUBRICATION INSTRUCTIONS — Continued

0155 00

ITEM NO.	INTERVAL	MAN-HOUR	ITEM TO BE CHECKED OR SERVICED	CREWMEMBER PROCEDURE	EQUIPMENT NOT READY/AVAILABLE IF:
92	Semi-Annual		Gas Particulate Filter	<p style="text-align: center;">NOTE</p> <p>Refer to TM 3-6680-316-10 for use of the M39 tester.</p> <ol style="list-style-type: none"> a. Slide spring clip away from slotted openings of precleaner (blower) assembly and set MASTER switch and NBC POWER switch to ON (blower must function). b. Remove calibrated orifice assembly from airflow tester (6650-00-436-4212) and zero magnetic gauge. c. Disconnect crew member hose (for station being tested) from container in vehicle and attach connector to calibrated orifice assembly connector of airflow tester. <p style="text-align: center;">NOTE</p> <p>An acceptable gauge reading is between 2.6 and 4.3 inches of water.</p> <ol style="list-style-type: none"> d. If reading is not within limits, note reading. See TM 3-6680-316-10. e. Connect crew member hose to vehicle connection. Set MASTER switch and NBC POWER switch to OFF and recover slotted holes in precleaner (blower) assembly with spring clip. <p style="text-align: center;">NOTE</p> <p>Refer repair of particulate filter to direct maintenance personnel per TM 3-4240-276-30&P.</p>	

PREVENTIVE MAINTENANCE CHECKS AND SERVICES (PMCS), INCLUDING LUBRICATION INSTRUCTIONS — Continued

0155 00

ITEM NO.	INTERVAL	MAN-HOUR	ITEM TO BE CHECKED OR SERVICED	CREWMEMBER PROCEDURE	EQUIPMENT NOT READY/ AVAILABLE IF:
93	Semi-Annual		Chemical Agent Automatic Alarm Kit (M113A3 Only)	<ul style="list-style-type: none"> a. Perform preventive maintenance checks and services every 750 miles (1,207 km), 75 hours, or semiannually, whichever comes first. b. Cable maintenance is limited to replacement of terminals (WP 0919 00). c. Remove distribution box from hull (WP 0269 00). Check terminal board and circuit breaker. Tighten loose connection. Install distribution box on hull (WP 0269 00). 	

CIRCUIT BREAKER

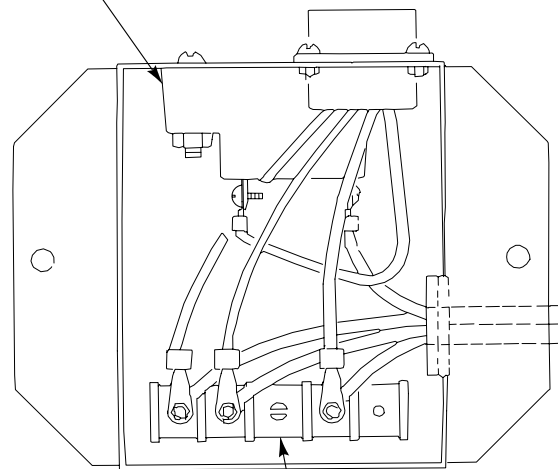
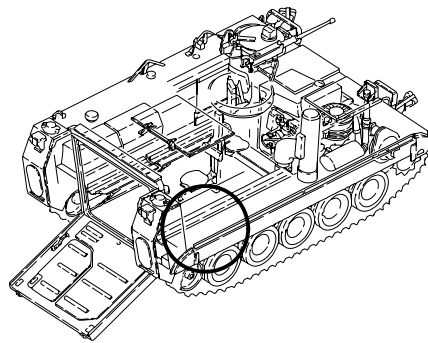

TERMINAL BOARD

PREVENTIVE MAINTENANCE CHECKS AND SERVICES (PMCS), INCLUDING
LUBRICATION INSTRUCTIONS — Continued

0155 00

ITEM NO.	INTERVAL	MAN-HOUR	ITEM TO BE CHECKED OR SERVICED	CREWMEMBER PROCEDURE	EQUIPMENT NOT READY/ AVAILABLE IF:
<p style="text-align: center;">NOTE</p> <p>Additional data on Chemical Agent Automatic Alarm Kit for the M113 FOV can be found in: Operator's and Unit Maintenance Manual, TM 3-6665-225-12. Repair Parts and Special Tools List, TM 9-2350-277-24P.</p> <p>d. Check mounting screws on junction box. Tighten loose screws in junction box. TIGHTEN LOOSE SCREWS TO 72 LB-IN (8 N·M) TORQUE. Use torque wrench (WP 0926 00, Item 79) and socket set (WP 0926 00, Item 72).</p> <p>e. Check grommet. Replace cracked or worn grommet.</p> <p>f. Check cable and circuit breaker terminal. Tighten loose connections. Replace damaged terminals.</p> <p>g. Check cables. Replace frayed or cracked cables (WP 0919 00).</p>					

CIRCUIT BREAKER TERMINALS

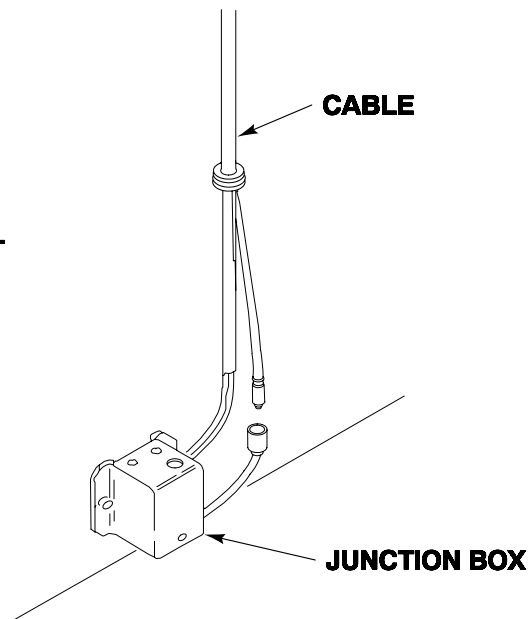
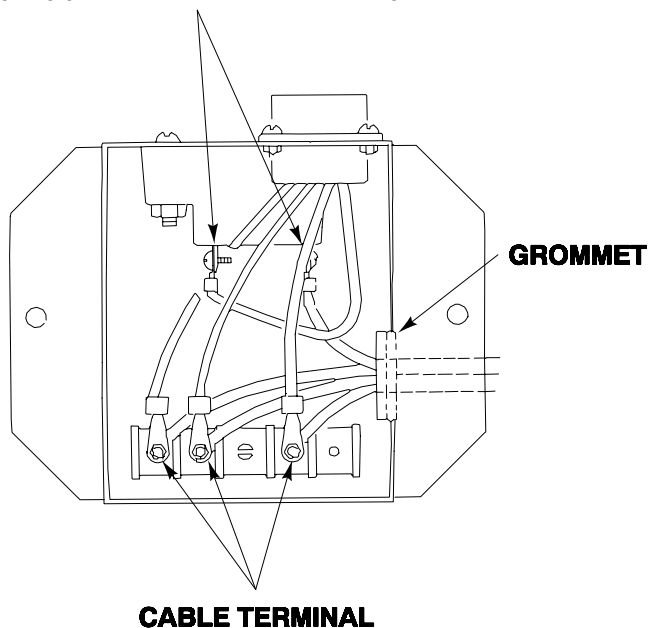

PREVENTIVE MAINTENANCE CHECKS AND SERVICES (PMCS), INCLUDING LUBRICATION INSTRUCTIONS — Continued

0155 00

ITEM NO.	INTERVAL	MAN-HOUR	ITEM TO BE CHECKED OR SERVICED	CREWMEMBER PROCEDURE	EQUIPMENT NOT READY/ AVAILABLE IF:
				<p>h. Check brackets. Replace cracked or broken brackets.</p> <p>i. Check mounting screws. TIGHTEN LOOSE SCREWS TO 264-285 LB-IN (30-32 N·M) TORQUE. Use torque wrench (WP 0926 00, Item 81) and socket set (WP 0926 00, Item 72).</p> <p>j. Check straps. Replace worn straps.</p>	

PREVENTIVE MAINTENANCE CHECKS AND SERVICES (PMCS), INCLUDING LUBRICATION INSTRUCTIONS — Continued

0155 00

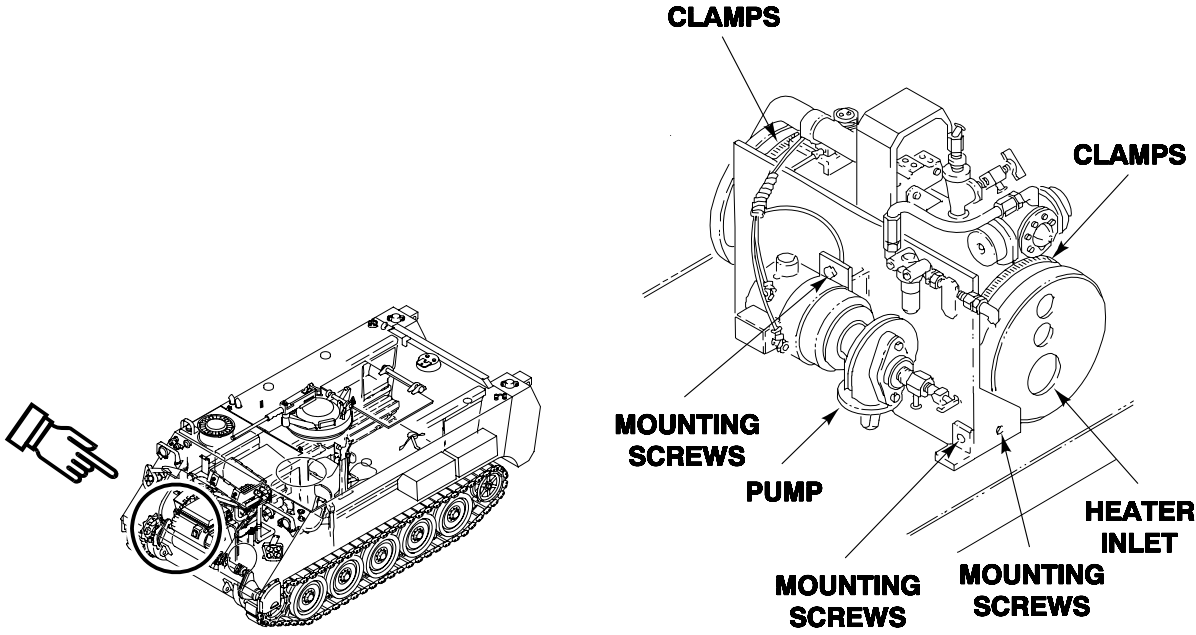
ITEM NO.	INTERVAL	MAN-HOUR	ITEM TO BE CHECKED OR SERVICED	CREWMEMBER PROCEDURE	EQUIPMENT NOT READY/AVAILABLE IF:
94	Semi-Annual		Engine Coolant Heater Kit	<ol style="list-style-type: none"> a. Perform preventive maintenance checks every 750 miles (1,207 km), 75 hours, or semiannually whichever comes first. b. Tighten mounting screws and clamps. c. Check heater inlet for debris. d. Check pump for leaks. Tighten connections that leak. 	Any fuel, coolant, or exhaust leaks.
 <p>The diagram shows the engine coolant heater kit installed on a vehicle chassis. A hand icon points to the kit. A detailed view of the heater kit shows the following components labeled: CLAMPS, CLAMPS, MOUNTING SCREWS, PUMP, HEATER INLET, MOUNTING SCREWS, and MOUNTING SCREWS.</p>					

PREVENTIVE MAINTENANCE CHECKS AND SERVICES (PMCS), INCLUDING LUBRICATION INSTRUCTIONS — Continued

0155 00

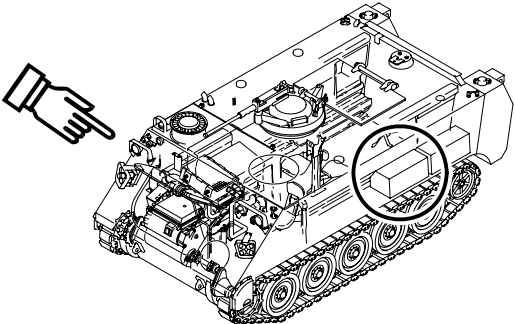
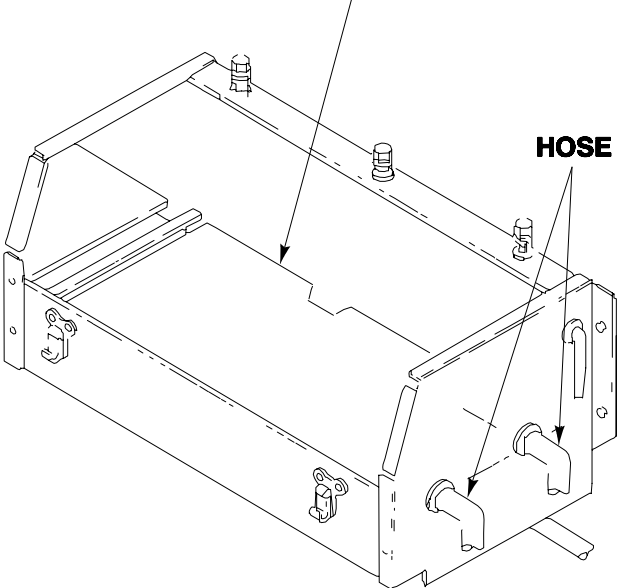
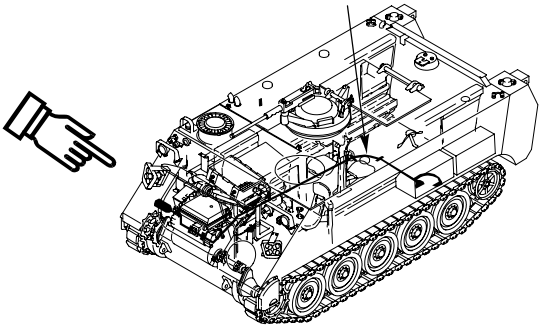
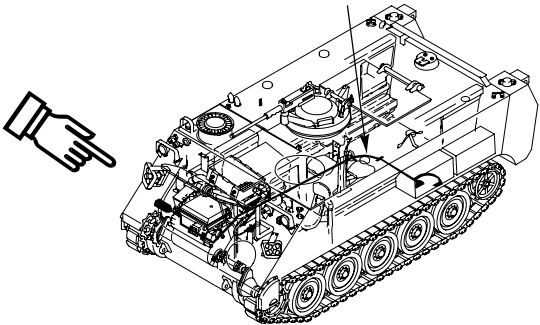
ITEM NO.	INTERVAL	MAN-HOUR	ITEM TO BE CHECKED OR SERVICED	CREWMEMBER PROCEDURE	EQUIPMENT NOT READY/AVAILABLE IF:
				<p>e. Check heat exchanger and hose connections for leaks. Tighten connections that leak. Replace connections that continue to leak.</p>	
				<p>HEAT EXCHANGER</p>  <p>HOSE</p>	
				<p>f. Check hose. Replace damaged hose (WP 0725 00).</p>	
				<p>HOSE</p> 	

PREVENTIVE MAINTENANCE CHECKS AND SERVICES (PMCS), INCLUDING LUBRICATION INSTRUCTIONS — Continued

0155 00

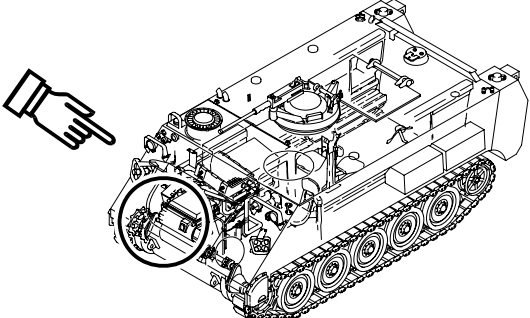
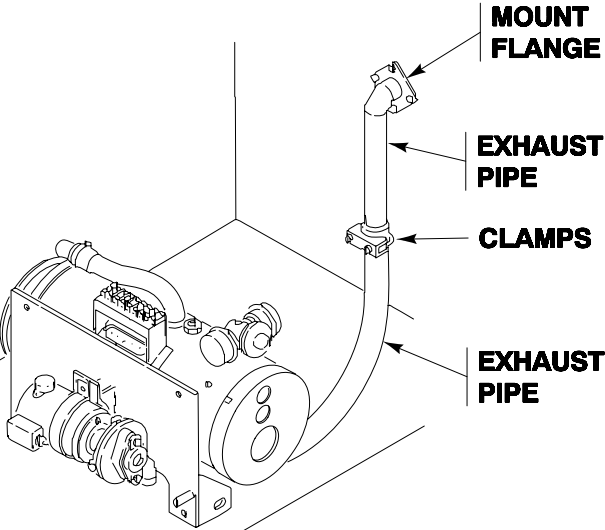
ITEM NO.	INTERVAL	MAN-HOUR	ITEM TO BE CHECKED OR SERVICED	CREWMEMBER PROCEDURE	EQUIPMENT NOT READY/AVAILABLE IF:
				<p>g. Check clamps and mount flange for exhaust leaks. Tighten clamp. Replace bad flange gaskets (WP 0724 00).</p> <p>h. Check exhaust pipe. Replace cracked or damaged pipe.</p> 	

PREVENTIVE MAINTENANCE CHECKS AND SERVICES (PMCS), INCLUDING LUBRICATION INSTRUCTIONS — Continued

0155 00

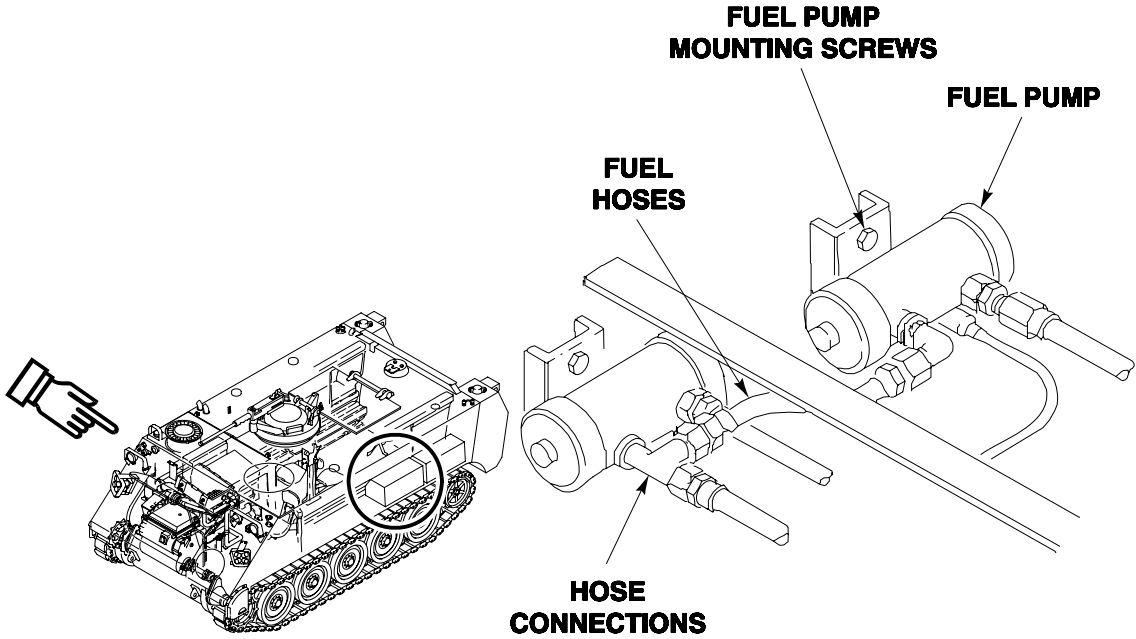
ITEM NO.	INTERVAL	MAN-HOUR	ITEM TO BE CHECKED OR SERVICED	CREWMEMBER PROCEDURE	EQUIPMENT NOT READY/AVAILABLE IF:
				i. Check fuel hoses, other hose connections and fuel pump for leaks. Tighten connections that leak. Replace connections that continue to leak. j. Service fuel pump (WP 0709 00). k. Tighten fuel pump mounting screws.	
					
				l. Check electrical leads and connectors at heater, at control box, and at fuel pump. Tape frayed leads. Replace damaged connectors (WP 0382 00). m. Check heater control box, switches, and light bulbs. Tighten or replace bad switches and bulbs (WP 0702 00). n. Start, run and stop heater. See TM 9-2350-277-10. During start cycle, verify that switches and lights work properly. o. During operation, check for unusual noises. Check for increase in coolant temperature.	Heater fails to cycle for proper shutdown.

PREVENTIVE MAINTENANCE CHECKS AND SERVICES (PMCS), INCLUDING LUBRICATION INSTRUCTIONS — Continued

0155 00

ITEM NO.	INTERVAL	MAN-HOUR	ITEM TO BE CHECKED OR SERVICED	CREWMEMBER PROCEDURE	EQUIPMENT NOT READY/AVAILABLE IF:
				<p>p. When stopping heater, check for correct purge cycle. Verify that indicator lights work properly. If heater does not operate as specified above, perform troubleshooting (WP 0089 00).</p>	

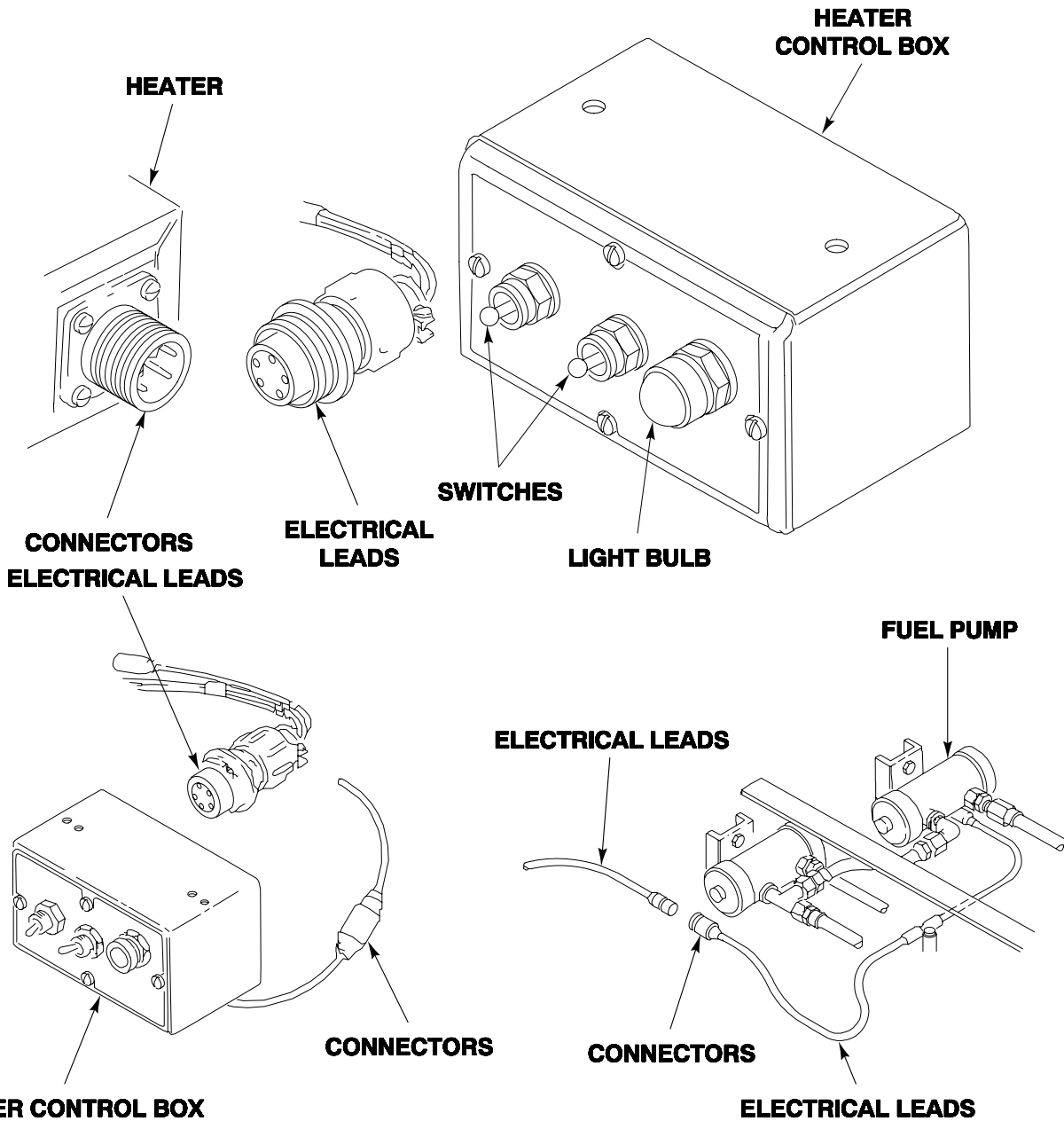

PREVENTIVE MAINTENANCE CHECKS AND SERVICES (PMCS), INCLUDING LUBRICATION INSTRUCTIONS — Continued

0155 00

ITEM NO.	INTERVAL	MAN-HOUR	ITEM TO BE CHECKED OR SERVICED	CREWMEMBER PROCEDURE	EQUIPMENT NOT READY/AVAILABLE IF:
95	Semi-Annual		Commander's Cupola Armor Shield Kit (M113A3 and M1064A3)	<p>a. Check left and right armor shield. Repair or replace cracked shield. If welds are cracked, notify supervisor (WP 0747 00).</p> <p>b. Check doors and clips. Straighten dents and bends. Replace cracked door or clip.</p> <p>c. Replace stowage strap or clamp if damaged (WP 0747 00).</p>	

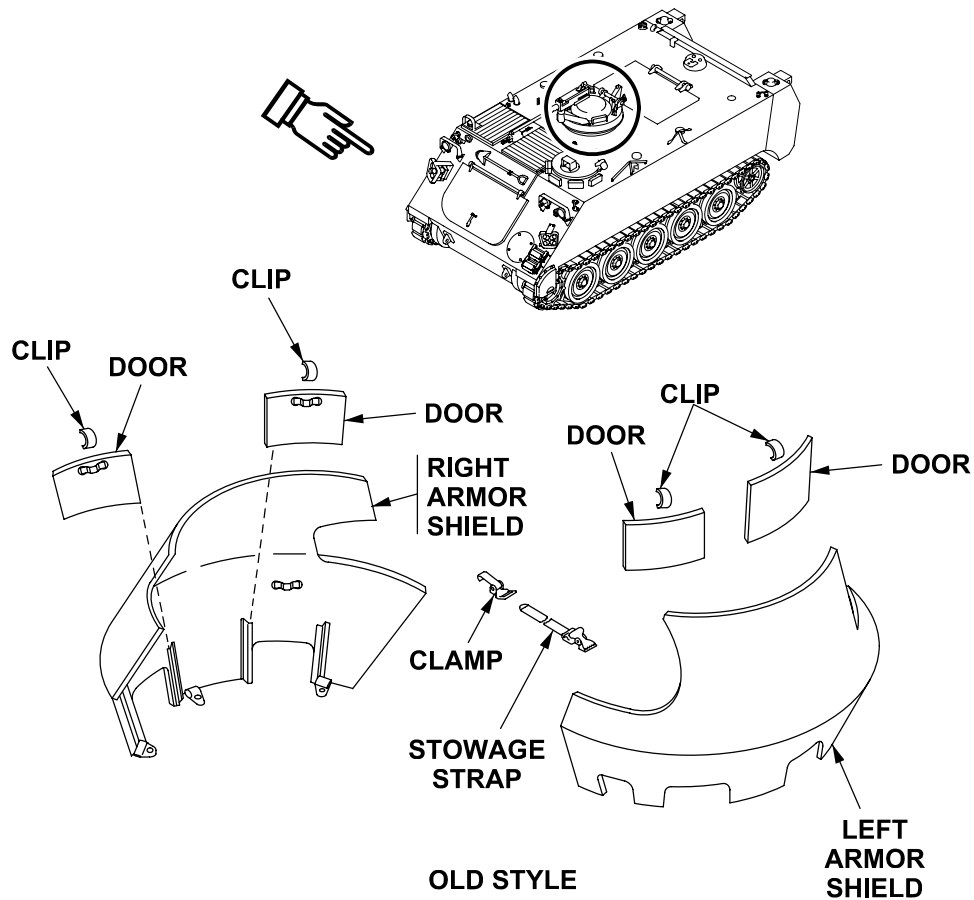

PREVENTIVE MAINTENANCE CHECKS AND SERVICES (PMCS), INCLUDING LUBRICATION INSTRUCTIONS — Continued

0155 00

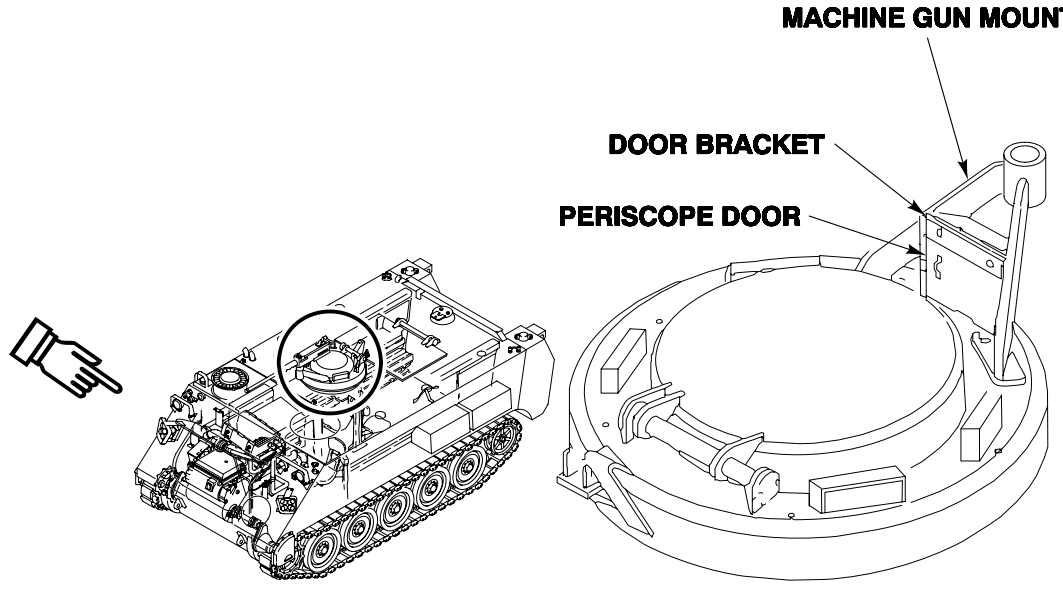
ITEM NO.	INTERVAL	MAN-HOUR	ITEM TO BE CHECKED OR SERVICED	CREWMEMBER PROCEDURE	EQUIPMENT NOT READY/AVAILABLE IF:
				<p>d. Check periscope door and door bracket on machine gun mount.</p> <p>e. Straighten dents and bends. Replace cracked parts.</p>	
<div style="display: flex; justify-content: space-around; align-items: center;">  </div>					

PREVENTIVE MAINTENANCE CHECKS AND SERVICES (PMCS), INCLUDING LUBRICATION INSTRUCTIONS — Continued

0155 00

ITEM NO.	INTERVAL	MAN-HOUR	ITEM TO BE CHECKED OR SERVICED	CREWMEMBER PROCEDURE	EQUIPMENT NOT READY/AVAILABLE IF:
96	Semi-Annual		Personnel Heater	<p>a. Tighten loose mounting screws and clamps.</p> <p>b. Check personnel heater for signs of fuel leaks. Check body of heater for signs of leaks or stains from prior leaking.</p> <p style="text-align: center;">NOTE</p> <p>For Models 10560M24B1 and D55350-G1 perform Steps c and d, then go to Step j. For Model 5000-30178 go to Step d.</p> <p>c. Remove control cover by turning two screws to the left.</p>	Any fuel, coolant, or exhaust leaks.

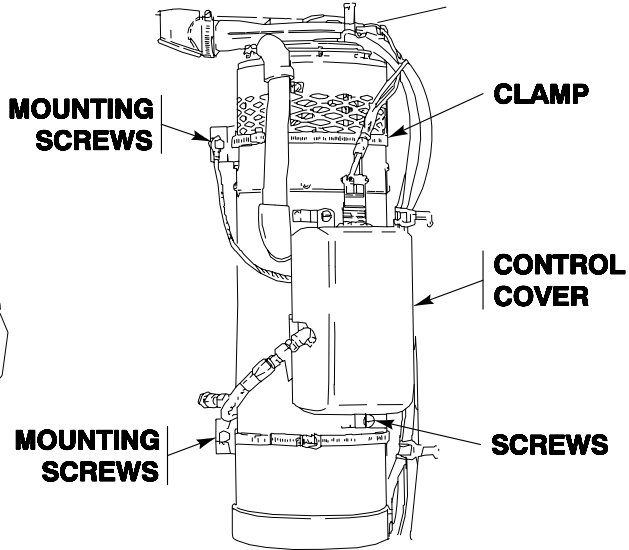
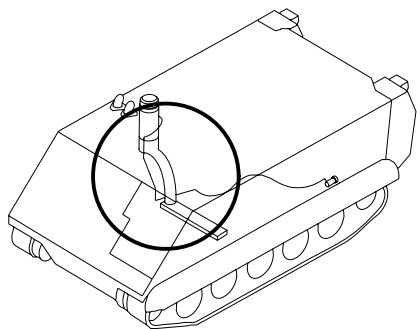

PREVENTIVE MAINTENANCE CHECKS AND SERVICES (PMCS), INCLUDING LUBRICATION INSTRUCTIONS — Continued

0155 00

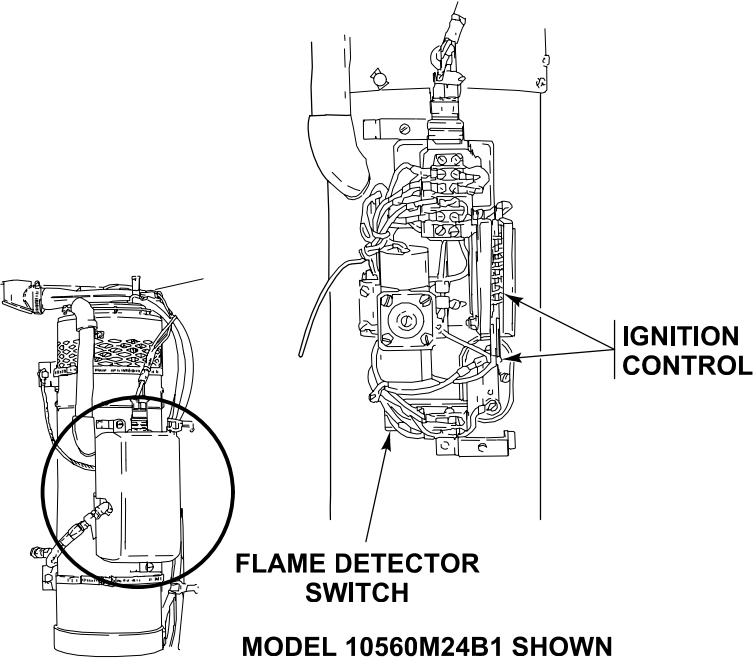
ITEM NO.	INTERVAL	MAN-HOUR	ITEM TO BE CHECKED OR SERVICED	CREWMEMBER PROCEDURE	EQUIPMENT NOT READY/AVAILABLE IF:
				<p>d. Check flame detector switch and ignition control. See TM 9-2540-205-24&P for Models 10560M24B1 and D55350-G1. See TM 9-2540-207-14&P for model 5000-30178.</p>	
 <p data-bbox="618 1199 862 1255">FLAME DETECTOR SWITCH</p> <p data-bbox="623 1283 997 1312">MODEL 10560M24B1 SHOWN</p>					

PREVENTIVE MAINTENANCE CHECKS AND SERVICES (PMCS), INCLUDING LUBRICATION INSTRUCTIONS — Continued

0155 00

ITEM NO.	INTERVAL	MAN-HOUR	ITEM TO BE CHECKED OR SERVICED	CREWMEMBER PROCEDURE	EQUIPMENT NOT READY/AVAILABLE IF:
				<p>e. Remove heater top housing cover.</p> <ol style="list-style-type: none"> 1) Remove four screws (3) and washers (2) from top cover(1). 2) Gently remove heater cover (1) from heater body. 	

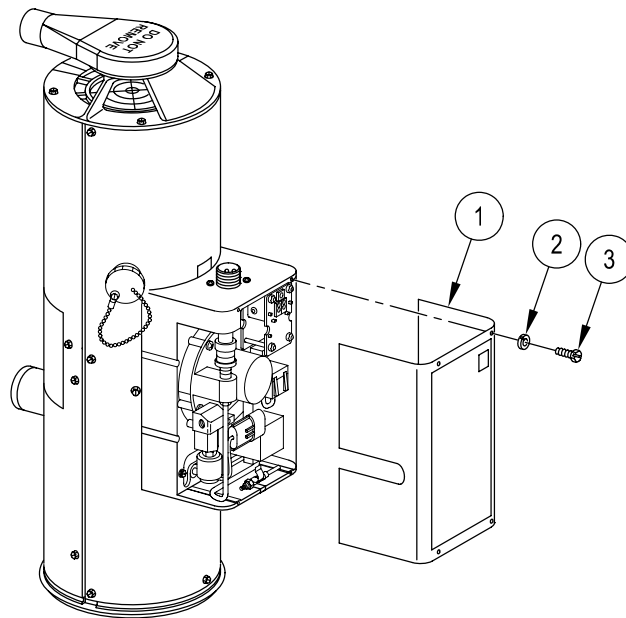

PREVENTIVE MAINTENANCE CHECKS AND SERVICES (PMCS), INCLUDING LUBRICATION INSTRUCTIONS — Continued

0155 00

ITEM NO.	INTERVAL	MAN-HOUR	ITEM TO BE CHECKED OR SERVICED	CREWMEMBER PROCEDURE	EQUIPMENT NOT READY/AVAILABLE IF:
				f. Inspect heater components for fuel leaks. 1) Check fuel injector, fuel pressure sensor, and fuel pump connections for leaking fuel. 2) Check all flexible hoses, fittings, and connections for leaking fuel.	Any fuel leaks.
				g. (H) Start personnel heater. See TM 9-2350-277-10. h. Reinspect heater components for fuel leaks. 1) Check all hoses, fittings, and connections for leaking fuel. 2) Check fuel injector, fuel pressure sensor, and fuel pump connections for leaking fuel. i. Observe the heater for excessive smoke for approximately 20 minutes. 1) Look for smoke around and under heater. 2) Look for smoke in heated air stream.	Any fuel leaks.

PREVENTIVE MAINTENANCE CHECKS AND SERVICES (PMCS), INCLUDING LUBRICATION INSTRUCTIONS — Continued

0155 00

ITEM NO.	INTERVAL	MAN-HOUR	ITEM TO BE CHECKED OR SERVICED	CREWMEMBER PROCEDURE	EQUIPMENT NOT READY/AVAILABLE IF:
				<p>j. Check heater fuel filter, fuel pump, fuel lines, and connections for leaks. Replace connections that continue to leak.</p>	
<p>The diagrams illustrate the heater fuel system components. The top-left diagram shows a heater unit with a fuel line connected to its side. The top-right diagram shows a fuel pump assembly with a fuel line and a connection point. The bottom-left diagram shows the heater unit with a circled connection point. The bottom-right diagram shows the heater fuel pump with a fuel line and a connection point.</p>					

PREVENTIVE MAINTENANCE CHECKS AND SERVICES (PMCS), INCLUDING LUBRICATION INSTRUCTIONS — Continued

0155 00

ITEM NO.	INTERVAL	MAN-HOUR	ITEM TO BE CHECKED OR SERVICED	CREWMEMBER PROCEDURE	EQUIPMENT NOT READY/AVAILABLE IF:
				1. Check electrical leads and connectors at heater, at heater control box, and at fuel pump. Tape leads if frayed. Replace damaged connectors (WP 0701 00).	

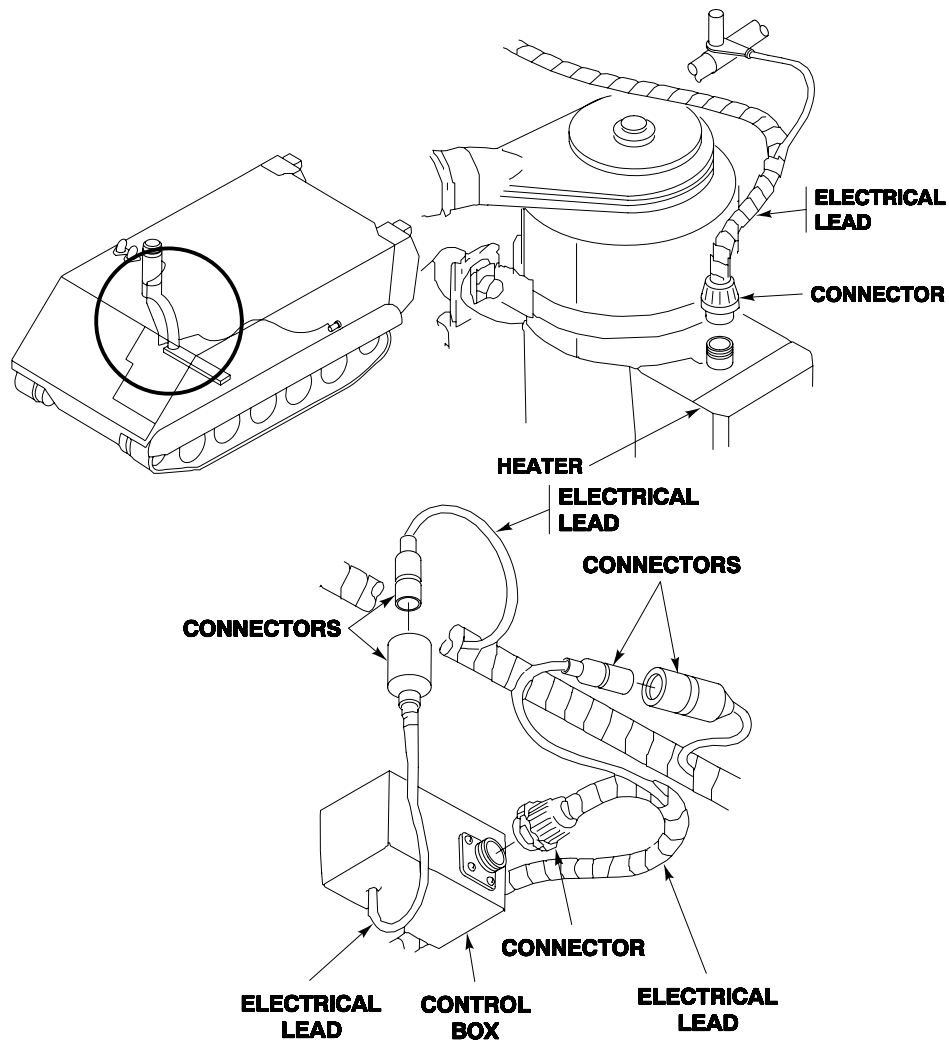

PREVENTIVE MAINTENANCE CHECKS AND SERVICES (PMCS), INCLUDING LUBRICATION INSTRUCTIONS — Continued

0155 00

ITEM NO.	INTERVAL	MAN-HOUR	ITEM TO BE CHECKED OR SERVICED	CREWMEMBER PROCEDURE	EQUIPMENT NOT READY/AVAILABLE IF:
----------	----------	----------	--------------------------------	----------------------	-----------------------------------

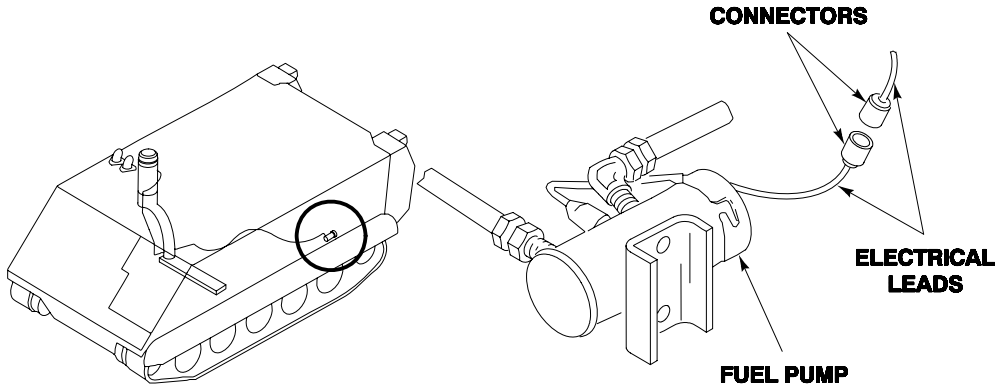

- m. Check heater control box, switches, and light bulb. Tighten or replace bad switches and bulbs (WP 0702 00).
- n. Start, run, and stop heater. See TM 9-2350-277-10. During start cycle, check that switches and light work properly. Check for increase in blower speed after ignition.
- o. During operation, check for unusual noises. Check for differences between high and low heat levels.
- p. When stopping heater, check for correct purge cycle. Verify that indicator light operates properly. If heater does not operate as specified above, perform troubleshooting (WP 0086 00).

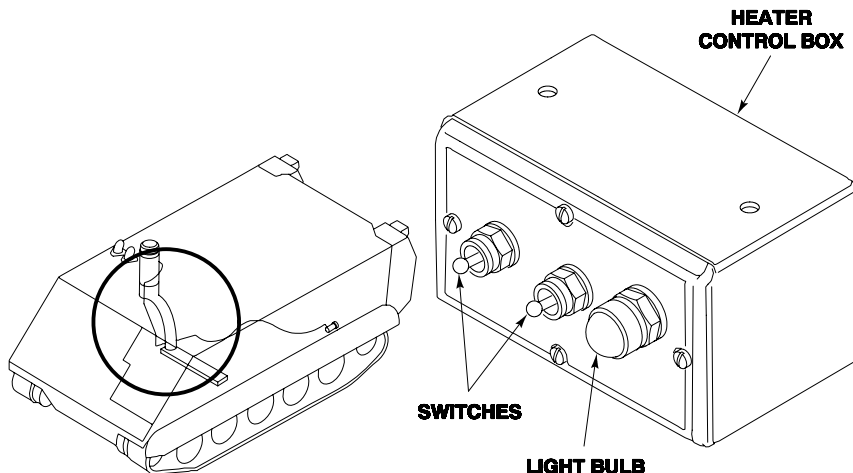

PREVENTIVE MAINTENANCE CHECKS AND SERVICES (PMCS), INCLUDING LUBRICATION INSTRUCTIONS — Continued

0155 00

ITEM NO.	INTERVAL	MAN-HOUR	ITEM TO BE CHECKED OR SERVICED	CREWMEMBER PROCEDURE	EQUIPMENT NOT READY/AVAILABLE IF:
97	Semi-Annual		Driver's Windshield Kit	<ul style="list-style-type: none"> a. Clean windshield with clean water. Check windows. Replace cracked or chipped windshield (WP 0739 00). b. Check windshield. Replace windshield that has broken or missing legs. c. Check mounting bracket and plates. Replace damaged brackets and plates. d. Check windshield canvas. Repair tears with sealing tape or replace windshield. 	
98	Semi-Annual		M1064A3/ M577A3 MFCS	<ul style="list-style-type: none"> a. See TM 9-1220-248-23&P for PMCS procedures. 	

PREVENTIVE MAINTENANCE CHECKS AND SERVICES (PMCS), INCLUDING LUBRICATION INSTRUCTIONS — Continued

0155 00

ITEM NO.	INTERVAL	MAN-HOUR	ITEM TO BE CHECKED OR SERVICED	CREWMEMBER PROCEDURE	EQUIPMENT NOT READY/ AVAILABLE IF:
99	Semi-Annual		Turn Signal Lights, Stoplights, Blackout Stoplights, Dome Lights, Fluorescent Lights, and Switches	a. Test operation of lights with signal control in all four operating positions. Repair or replace damaged or discolored lenses. Repair or replace defective lights, control, flasher, and lights.	
100	Semi-Annual		Reflectors	a. Check reflectors lens. Replace damaged or missing lens.	
101	Semi-Annual		Electrical Wiring	a. Tighten electrical connections and mounting brackets. Tape frayed harness. Replace missing or damaged connectors.	
102	Semi-Annual		Slave Cable	<p style="text-align: center;">NOTE</p> <p>Location varies by model.</p> <p>a. Check the slave cable receptacle and cap for damage, burnt condition, and corrosion.</p>	
103	Semi-Annual		Transmission/ Engine Spline Drive	<p>a. Perform M113A3 detection procedures for wear signs on the transmission/engine spline drive coupling as follows:</p> <p style="text-align: center;">NOTE</p> <p>Spline drive coupling wear can be detected in its early stages using any of the following three inspection procedures. For best results, use all three.</p>	

PREVENTIVE MAINTENANCE CHECKS AND SERVICES (PMCS), INCLUDING LUBRICATION INSTRUCTIONS — Continued

0155 00

ITEM NO.	INTERVAL	MAN-HOUR	ITEM TO BE CHECKED OR SERVICED	CREWMEMBER PROCEDURE	EQUIPMENT NOT READY/ AVAILABLE IF:
a	Semi-Annual		Transmission/ Engine Spline Drive (first check)	<p>a. The first type of inspection is the power method. This method is strictly audio based.</p> <p>b. To check the spline drive coupling, fully pull out the fuel cut-off control from the driver's position, so fuel can not get to the engine and it will not start. Dry start the engine for 4-6 seconds.</p> <p>c. The sound produced from a good spline drive coupling is muffled, and can be heard as the engine is cranking. The sound is muffled because the external spline on the spline drive ring is nylon coated. When the nylon coating, which is only 13 to 20 thousandths of an inch thick, on the spline drive ring is good, it will mate tightly with the engine's internal spline teeth and produce a muffled sound. The sound produced from a worn-out spline drive coupling is a very distinct metallic clanking sound that can be easily heard as the engine is cranking. When the nylon coating on the spline drive ring is worn-out, it engages in a metal to metal backlashing with the flywheel's internal spline teeth which are uncoated. This causes the metallic clanking sound.</p>	Metallic clanking sound is heard.
b	Semi-Annual		Transmission/ Engine Spline Drive (second check)	<p>a. The second type of inspection is the manual audio method.</p>	Metallic clanking sound is heard.

PREVENTIVE MAINTENANCE CHECKS AND SERVICES (PMCS), INCLUDING LUBRICATION INSTRUCTIONS — Continued

0155 00

ITEM NO.	INTERVAL	MAN-HOUR	ITEM TO BE CHECKED OR SERVICED	CREWMEMBER PROCEDURE	EQUIPMENT NOT READY/ AVAILABLE IF:
				<p style="text-align: center;">WARNING</p> <div style="text-align: center;">  </div> <p>Fuel cut-off control at driver's position must be pulled all the way out to prevent engine from starting. Personnel could be injured or killed if engine starts during this PMCS check.</p> <ul style="list-style-type: none"> b. Loosen the three wing nuts and clamps to remove the engine's rear access panel from the crew compartment. This will access the engine's variable drive assembly pulley. c. The pulley has three jacking bolt holes with 3/8" course thread. Hand tighten two 3/8" by 3" long bolts into the jacking holes. d. Place a small breaker bar, about 2 or 3 feet long, across the two bolts to check backlash on the spline drive coupling. <p style="text-align: center;">NOTE</p> <p>Although you can turn the engine by applying constant pressure, the idea is to detect any backlash generated between the engine and transmission mating splines.</p> <ul style="list-style-type: none"> e. As with the power method, a good spline drive coupling will produce a muffled sound, while a bad spline drive coupling will produce a distinctive metallic clanking sound. 	

PREVENTIVE MAINTENANCE CHECKS AND SERVICES (PMCS), INCLUDING LUBRICATION INSTRUCTIONS — Continued

0155 00

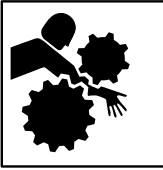
ITEM NO.	INTERVAL	MAN-HOUR	ITEM TO BE CHECKED OR SERVICED	CREWMEMBER PROCEDURE	EQUIPMENT NOT READY/ AVAILABLE IF:
c	Semi-Annual		Transmission/ Engine Spline Drive (third check)	<p>a. The third type of inspection is the visual method.</p> <p style="text-align: center;">WARNING</p>  <p>Fuel cut-off control at driver's position must be pulled all the way out to prevent engine from starting. Personnel could be injured or killed if engine starts during this PMCS check.</p> <p>b. Two people are required to perform the visual method. One will be inside the vehicle manually jerking the engine. Meanwhile the second will be under the vehicle observing the relative motion between the flywheel's clearance holes and the spline drive ring's studs and nuts.</p> <p>c. Remove the four bolts, washers, and gasket from the access cover under the vehicle directly under the powerpack.</p> <p>d. Push the hydraulic hoses to the side and look into the access opening. You will see the rear bottom side of the engine's flywheel cover as well as a 2'' by 3'' opening on the flywheel cover in the six o'clock location.</p>	Studs and nuts are not centered (approximately 1/4 inch) in flywheel clearance holes.

**PREVENTIVE MAINTENANCE CHECKS AND SERVICES (PMCS), INCLUDING
LUBRICATION INSTRUCTIONS — Continued**

0155 00

ITEM NO.	INTERVAL	MAN-HOUR	ITEM TO BE CHECKED OR SERVICED	CREWMEMBER PROCEDURE	EQUIPMENT NOT READY/ AVAILABLE IF:
				<ul style="list-style-type: none"> e. On a sharp angle through this opening, you will see the back side of the flywheel, as well as the clearance holes on the flywheel but through the opening you can only see one hole at a time. f. Looking at the clearance holes, you can also see the studs and locking nuts that hold the spline drive ring in place. The spline drive ring studs and nuts are designed to protrude into the flywheel's clearance holes and clear the flywheel's holes by approximately 1/4". g. As in the audio method, use the 3/8" bolts and the breaker bar to detect any backlash. Turn the engine manually to position one of the flywheel's clearance holes in the center of the flywheel's cover opening for visual accessibility. h. As the person in the crew compartment moves the engine, the person under the vehicle looking into the access hole will be able to detect one of the following two relative movements on the spline drive coupling. <ul style="list-style-type: none"> 1) When the spline drive coupling is in good condition, you can only detect unit movements because the clearance between the mating spline teeth is just a few thousandths of an inch. 	

**PREVENTIVE MAINTENANCE CHECKS AND SERVICES (PMCS), INCLUDING
LUBRICATION INSTRUCTIONS — Continued**

0155 00

ITEM NO.	INTERVAL	MAN-HOUR	ITEM TO BE CHECKED OR SERVICED	CREWMEMBER PROCEDURE	EQUIPMENT NOT READY/ AVAILABLE IF:
				<p style="text-align: center;">NOTE</p> <p>Remember that when the nylon coating on the spline drive ring teeth is new or in good condition, the clearance between the spline drive ring and the flywheel internal spline is only a few thousandths of an inch.</p> <p>2) When the spline drive coupling is worn-out, you will be able to detect the individual movement between the spline drive ring studs and nuts and flywheels's clearance holes. This movement is due to the actual wear of the spline teeth. The more wear, the more movement.</p> <p>i. If you should hear the metallic clanking sound, as mentioned in any one of the above inspection procedures, immediately notify your direct support maintenance or supervisor</p> <p>j. Using these three methods, you will easily be able to tell the difference between the muffled sound of a good spline drive coupling and the metallic clanking of a bad spline drive coupling. Detecting wear of this kind in its early stages will reduce down time and keep your M113A3 ready for action.</p>	

PREVENTIVE MAINTENANCE CHECKS AND SERVICES (PMCS), INCLUDING LUBRICATION INSTRUCTIONS — Continued

0155 00

ITEM NO.	INTERVAL	MAN-HOUR	ITEM TO BE CHECKED OR SERVICED	CREWMEMBER PROCEDURE	EQUIPMENT NOT READY/AVAILABLE IF:
104	Semi-Annual		Final Road Test	a. Perform final carrier road test. Drive carrier at least 5 miles (8 km). b. Ensure correction of operational faults. Pay close attention to those items that were faulty to begin with.	Any Class III leaks or operational faults.
a	Semi-Annual		Left and Right Steering	<p style="text-align: center;">CAUTION</p> <p>Power plant can be damaged. Do not pivot steer when carrier is moving except on a track failure emergency.</p> a. Check steering in left or right turns. If carrier doesn't finish a complete turn when wheel is turned right or left, troubleshoot steering system (WP 0076 00 or WP 0077 00).	
b	Semi-Annual		Steering in Forward and Reverse	a. Check steering in forward and reverse. If carrier doesn't finish a complete turn when wheel is turned right or left, troubleshoot steering system (WP 0076 00 or WP 0077 00).	
c	Semi-Annual		Carrier Braking	a. If carrier doesn't slow down with brake pedal slightly pressed or stop when pedal is fully depressed, troubleshoot brake selection system (WP 0064 00).	
d	Semi-Annual		Carrier Shifting in All Ranges	a. Check shifting of carrier in all ranges. If carrier doesn't respond properly to selected driving range, troubleshoot gear system (WP 0065 00).	

PREVENTIVE MAINTENANCE CHECKS AND SERVICES (PMCS), INCLUDING LUBRICATION INSTRUCTIONS — Continued

0155 00

Table 19. Annual Unit Level Preventive Maintenance Checks and Services for M113A3 FOV

ITEM NO.	INTERVAL	MAN-HOUR	ITEM TO BE CHECKED OR SERVICED	CREWMEMBER PROCEDURE	EQUIPMENT NOT READY/AVAILABLE IF:
105	Annual	0.1	Carrier	<p>a. Lubricate tachometer and speedometer shafts annually with GIA. See Tachometer and Speedometer Shaft Lubrication Table (Table 11, page 0155 00-20).</p> <p>1) Disconnect shafts at both ends (WP 0432 00), remove slotted washers from drive ends of cores, and remove cores from instrument panel end of shafts. Clean and lubricate cores with GIA, insert cores in shafts. Install slotted washers, and connect both end of shafts. If tachometer adapter has a grease fitting, lubricate sparingly with lubricant GIA.</p> <p>b. Clean, inspect, and lubricate cores. Insert cores in shafts. Install slotted washers and connect both ends of shafts. If tachometer adapter has a grease fitting, lubricate sparingly with GIA.</p>	

PREVENTIVE MAINTENANCE CHECKS AND SERVICES (PMCS), INCLUDING
LUBRICATION INSTRUCTIONS — Continued

0155 00

ITEM NO.	INTERVAL	MAN-HOUR	ITEM TO BE CHECKED OR SERVICED	CREWMEMBER PROCEDURE	EQUIPMENT NOT READY/AVAILABLE IF:
<p>The diagrams illustrate the installation and connection of the tachometer and speedometer shafts. The top-left diagram shows a tachometer shaft connected to a speedometer gauge. The top-right diagram shows the engine compartment with labels for the 'SPEEDOMETER SHAFT' and 'TACHOMETER SHAFT'. The bottom-left diagram shows a close-up of a tachometer shaft being inserted into a gauge. The bottom-right diagram shows a close-up of a speedometer shaft being inserted into an engine component.</p>					

**PREVENTIVE MAINTENANCE CHECKS AND SERVICES (PMCS), INCLUDING
LUBRICATION INSTRUCTIONS — Continued**

0155 00

The following list of parts are required when performing semi-annual, annual, or on-condition PMCS. The semiannual parts list contains the mandatory replacement parts for one semi-annual PMCS. The annual parts list contains the mandatory replacement parts for one semi-annual PMCS combined with the mandatory replacement parts for one (1) annual PMCS. The on-condition parts list contains replacement parts that are required when engine and transmission oil changes are directed by the Army Oil Analysis Program (AOAP) Laboratory. If AOAP Laboratory support is not available, change oil and filter elements/gasket every 150 hours/1500 miles or annually.

Table 20. SEMIANNUAL (1500 MILES)

Item No.	Part Number	NSN	Nomenclature	Qty
1	MS28778-12	5330-00-251-8839	PACKING	1

Table 21. ANNUAL (1500 MILES)

Item No.	Part Number	NSN	Nomenclature	Qty
1	MS28778-12	5330-00-251-8839	PACKING	1
2	10874832	4730-00-766-4714	FILTER	1
3	MS28775-231	5330-00-527-7025	PACKING	1
4	5574161	5330-00-846-9841	GASKET	1
5	CW226MP	2910-00-287-1912	FILTER, ELEMENT	1
6	5574126	5330-00-612-3123	GASKET	1
7	1503536	5330-00-551-0433	GASKET	1
8	T552	2940-00-745-7730	FILTER, ELEMENT	1
9	5703232	2940-01-214-9303	PARTS KIT, FLUID PRE	1

Table 22. ON-CONDITION (1500 MILES)

Item No.	Part Number	NSN	Nomenclature	Qty
1	5703089	2940-00-678-0641	PARTS KIT	1
2	FL804FP	2940-01-197-7106	FILTER ELEMENT, FLUID	1
3	5703232	2940-01-214-9303	PARTS KIT, FLUID PRE	1
4	MS28775-231	5330-00-527-7025	PACKING	1
5	10874832	4730-00-766-4714	FILTER	1
6	MS35338-45	5310-00-407-9566	WASHER , LOCK	1

CHAPTER 4
UNIT MAINTENANCE INSTRUCTIONS
FOR ENGINE

WORK PACKAGE INDEX

<u>Title</u>	<u>Sequence No.</u>
REMOVE/INSTALL POWER PLANT ASSEMBLY.....	0156 00
BLOCK POWER PLANT.....	0157 00
REPLACE ENGINE MOUNTS	0158 00
REPLACE LEFT AND RIGHT AIR BOX DRAIN CHECK VALVE AND TUBES.....	0159 00
DELETED.....	0160 00
REPLACE ENGINE LIFTING BRACKET.....	0161 00
REPLACE ENGINE OIL FILLER CAP.....	0162 00
REPLACE ENGINE OIL SAMPLING VALVE AND HOSE.....	0163 00
REPLACE OIL GAUGE ROD AND TUBE.....	0164 00
REPLACE OIL FILTER ELEMENT.....	0165 00

REMOVE/INSTALL POWER PLANT ASSEMBLY

0156 00

THIS WORK PACKAGE COVERS:

Removal (page 0156 00-1).
 Installation (page 0156 00-13).

INITIAL SETUP:

Maintenance Level

Unit

References

See your -10

Tools and Special Tools

General Mechanic's Tool Kit (WP 0926 00, Item 65)
 Power Plant Sling (WP 0926 00, Item 48)
 Torque Wrench (WP 0926 00, Item 85)

Equipment Condition

Engine stopped (see your -10)
 Carrier blocked (see your -10)
 Driver's power plant access panel removed (see your -10)
 Power plant rear access panel removed (see your -10)
 Propeller shafts and U-joints removed (WP 0405 00)
 Cooling system drained (WP 0227 00)
 Battery ground strap disconnected (WP 0337 00) or (WP 0338 00)
 Power plant grill raised (WP 0464 00)
 Power plant sling preoperative check performed (WP 0673 00)

Materials/Parts

Cotter pin (5)
 Locknut (8)
 Lockwasher (2)
 Propeller shaft screw (4)
 Spring tension washer
 Strap

Personnel Required

Unit Mechanic
 Helper (H)

REMOVAL

NOTE

Install covers on disconnected air cleaner lines and components during maintenance. Use tape, cloth, cardboard, or any appropriate material to prevent damage to components.

1. Disconnect air supply hose (1) from elbow (2) on air cleaner (3).
2. Disconnect air restriction indicator hose (4) from bulkhead adapter (5) and reducer (6).
3. Remove strap (7) from hose (4) and air intake elbow (8). Discard strap.

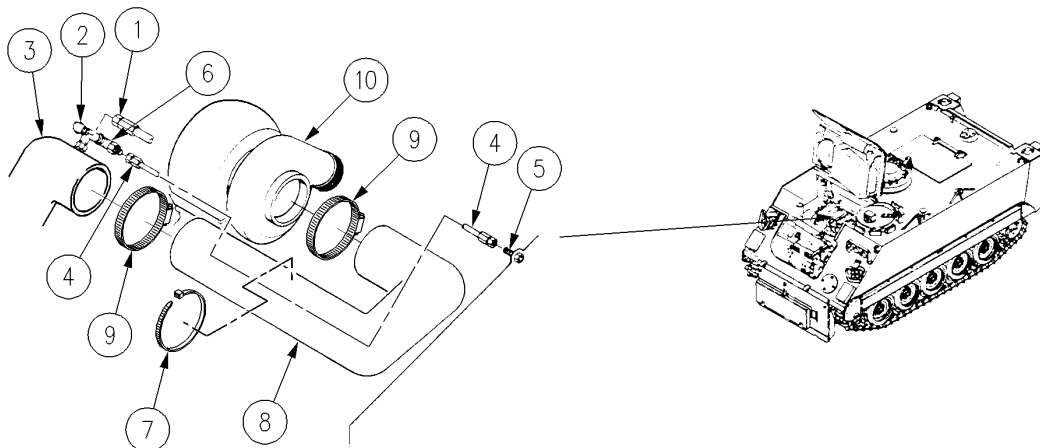

4. Loosen two clamps (9) and remove air intake elbow (8) from turbocharger inlet (10) and air cleaner (3).

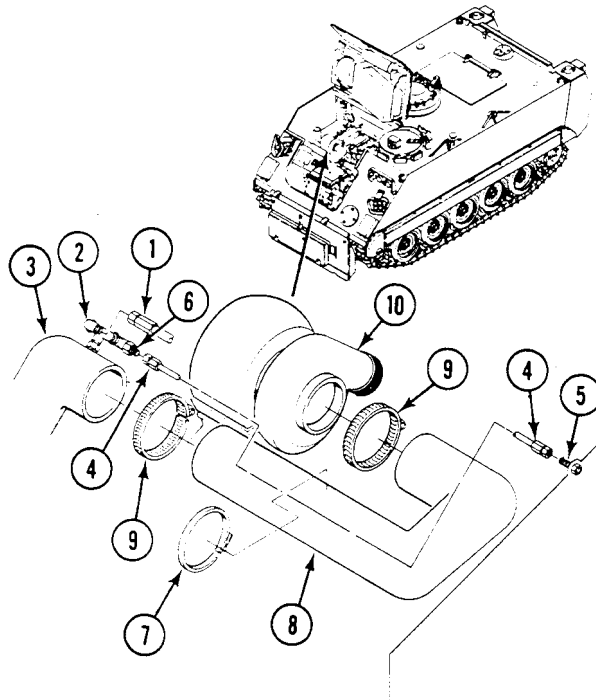

5. Disconnect return and supply fuel hoses (1) and (2) at quick disconnect (3) and (4).

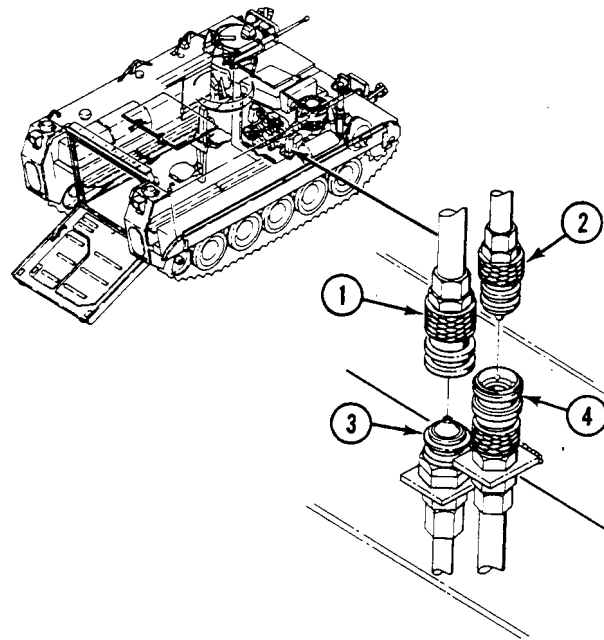

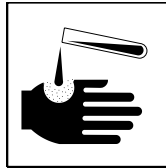
WARNING

Hydraulic fluid is poisonous and can be absorbed through your skin. Wash off any hydraulic fluid which contacts your skin. Read the hydraulic fluid warning in the front of this manual.

6. Disconnect ramp hydraulic hoses (5) and (6) at quick disconnects (7) and (8).

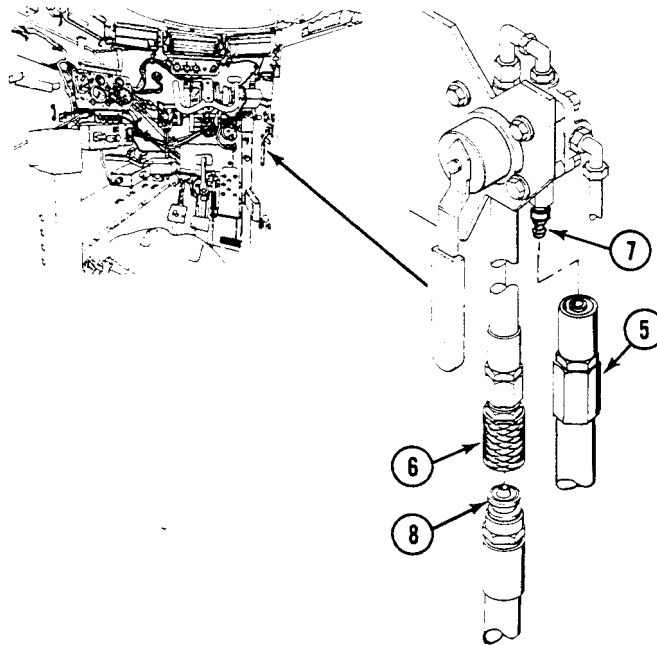

7. If engine coolant heater kit is installed, loosen clamp (9) at coolant pump shutoff valve (10) and remove hose (11).

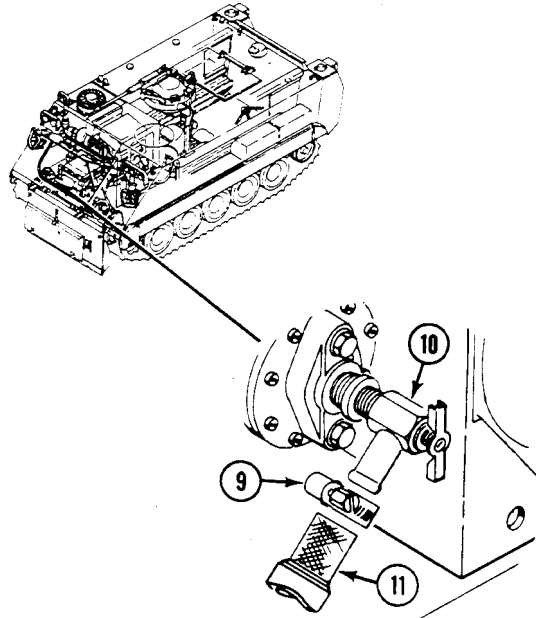

8. If engine coolant heater kit is installed, loosen clamp (12) on engine coolant elbow (13) located on bottom left side of engine manifold and remove hose (14).

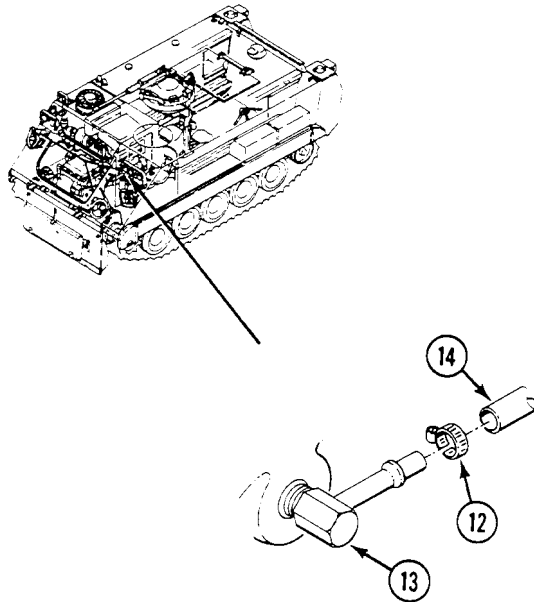

9. Remove locknut (1), screw (2), two washers (3), and spring tension washer (4) from hull ground lug (5). Disconnect ground leads (6) and (7) from hull ground lug. Discard spring tension washer and locknut.

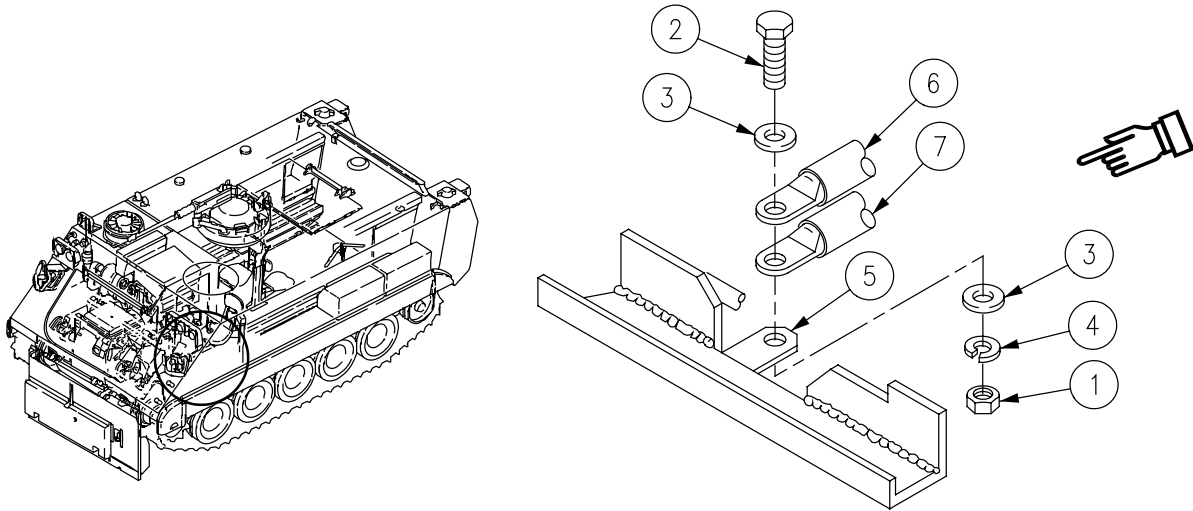

NOTE

New and Old Configuration refer to Variable Speed Fan Drive configurations.

10. Disconnect five cannon plugs (8) (Old Configuration) and seven cannon plugs (8) (New Configuration) at driver's compartment bulkhead.

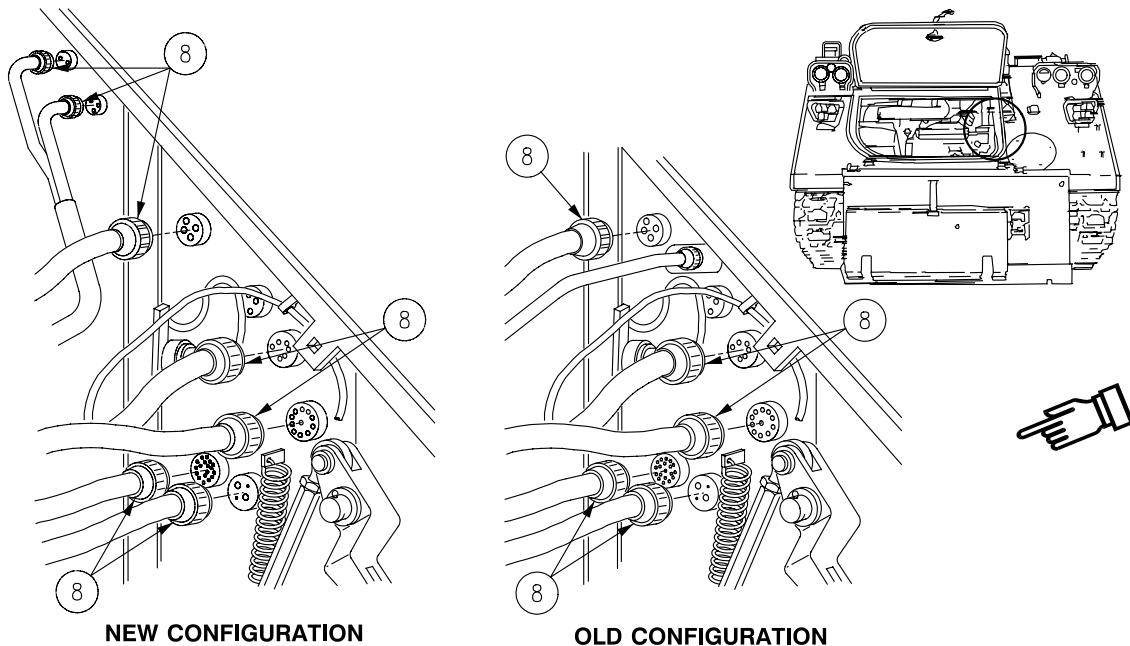

11. Remove cotter pin (9), straight pin (10), washer (11), and shutoff cable (12) from governor arm (13). Discard cotter pin.
12. Remove screw (14), washer (15), and clamp (16) with shutoff cable (12) from governor housing (17).

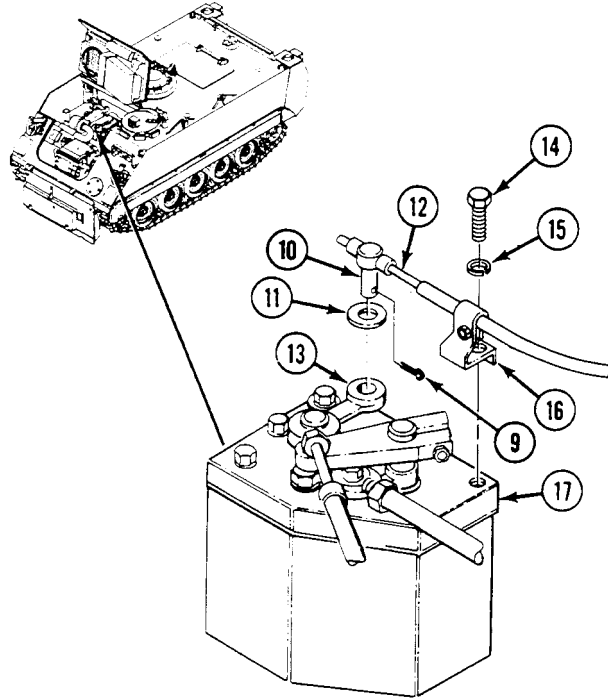

13. Remove locknut (18), washer (19), and bolt (20) from throttle link (21). Disconnect throttle link from throttle arm (22). Discard locknut.

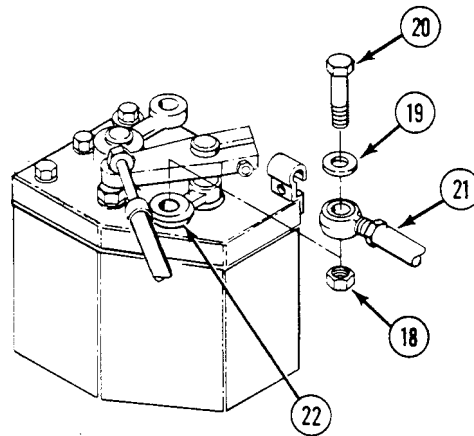

14. Remove two locknuts (10), screws (3), washers (2), two straps (5), and tow start cable (4) from bracket (1). Remove cotter pin (12), two washers (11), and pin (6) from control arm (13). Loosen set screw (9) and remove collar (8) and cable from arm. Discard cotter pin and locknut.

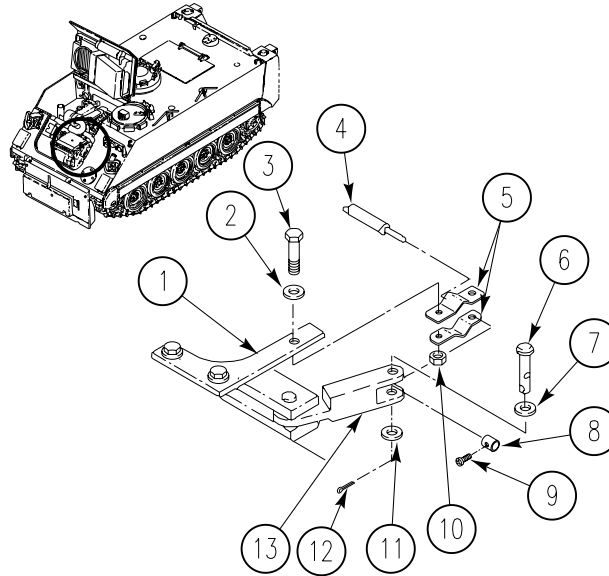

15. Remove two screws (13), washers (14), locknuts (15), and link (16) from link (17) and pivot shaft arm (18). Discard locknuts.

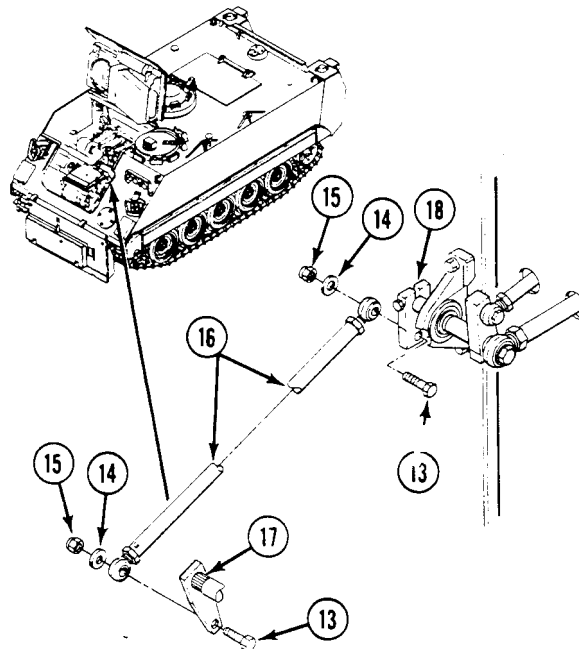

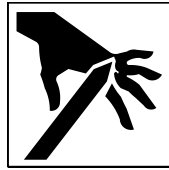
WARNING

Removing lower brake bearing from brake pivot shaft link while parking brake is on can cause shaft link to spring up and injure personnel. Disengage parking brake when doing this task.

16. Remove cotter pin (19), two washers (20), pin (21), and lower brake bearing (22) from brake pivot shaft link (23). Discard cotter pin.
17. Remove two screws (24), washers (25), lockwashers (26), and brake arms (27) and (28) from transmission. Discard lockwashers.
18. Remove cotter pin (29), two washers (30), pin (31), and link (32) from link (23). Discard cotter pin.
19. Remove cotter pin (33), washer (34), link (23) and assembly from shaft (35). Discard cotter pin.

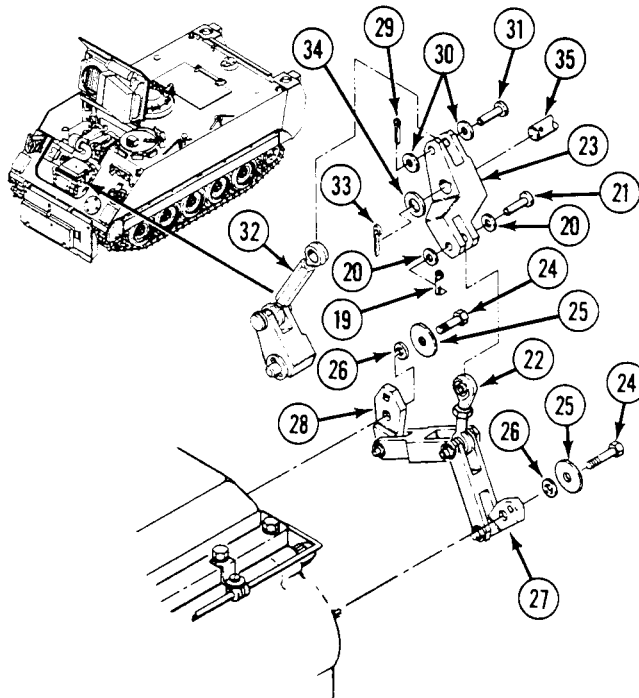

20. Remove two clamps (1) from elbow (2) and remove elbow from exhaust manifold (3) and turbo inlet (4).

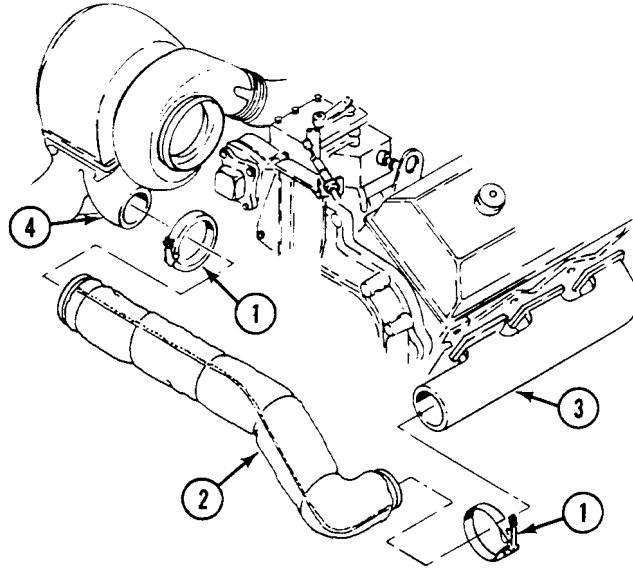

21. Disconnect tachometer cable (5) from adapter (6).

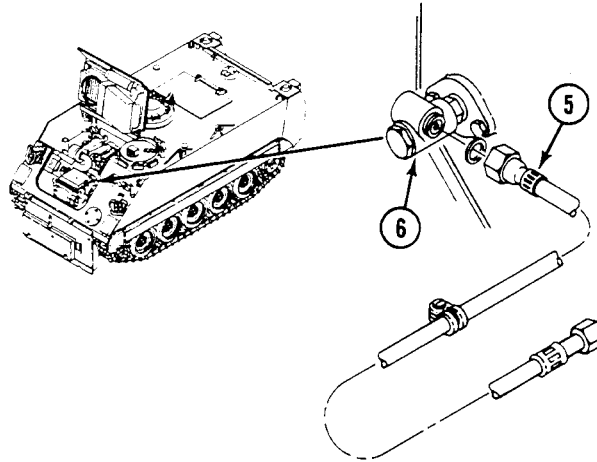

22. Remove air cleaner cover (7).

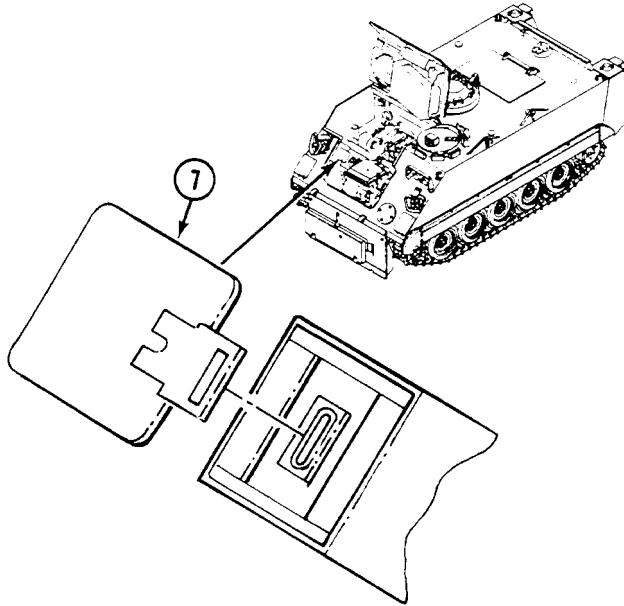

23. Remove four screws (8) and washers (9) from caps (10) and transmission mounts (11). Remove caps.

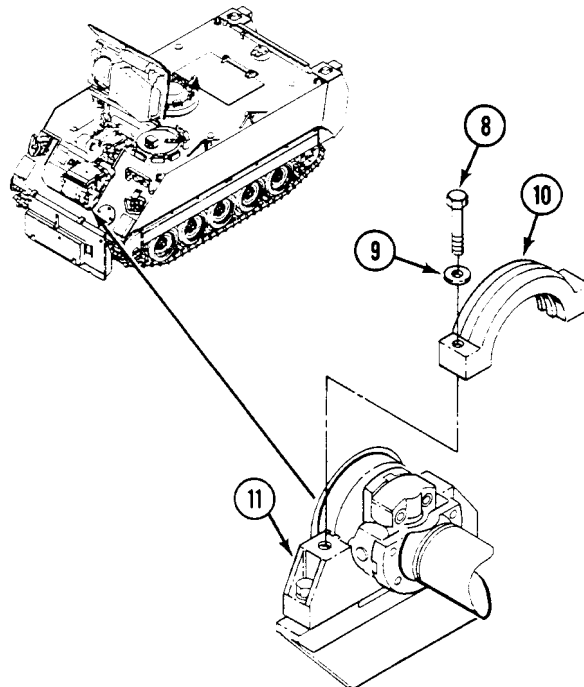

24. Disconnect engine coupling clamps (1) from rear power plant mount (2).

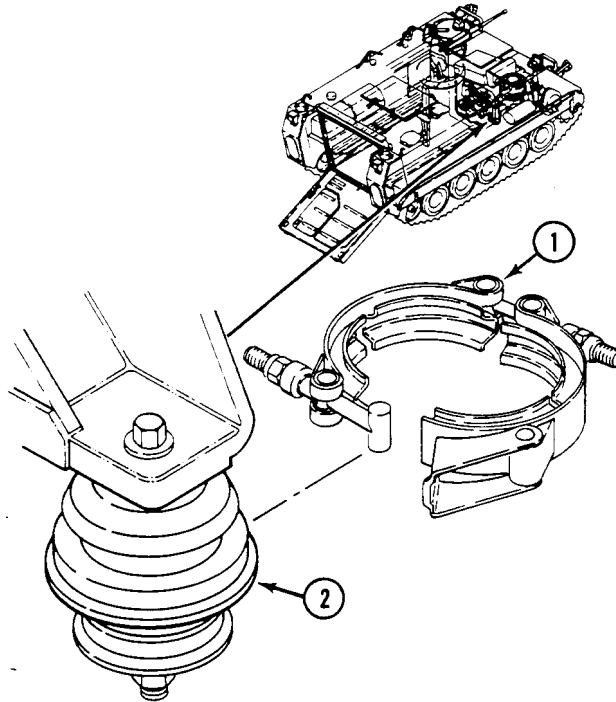

WARNING

Damaged lifting slings can fail with load. Soldiers can be killed or injured. Inspect all slings (WP 0673 00) before use. Do not use damaged slings.

WARNING

Hanging loads can kill or injure you. Keep away from hanging loads and overhead equipment. Keep hands out of compartment while power plant is being lifted for removal or lowered for installation.

25. Attach power plant sling (3) to lifting brackets (4) and lift power plant assembly. Have helper assist.

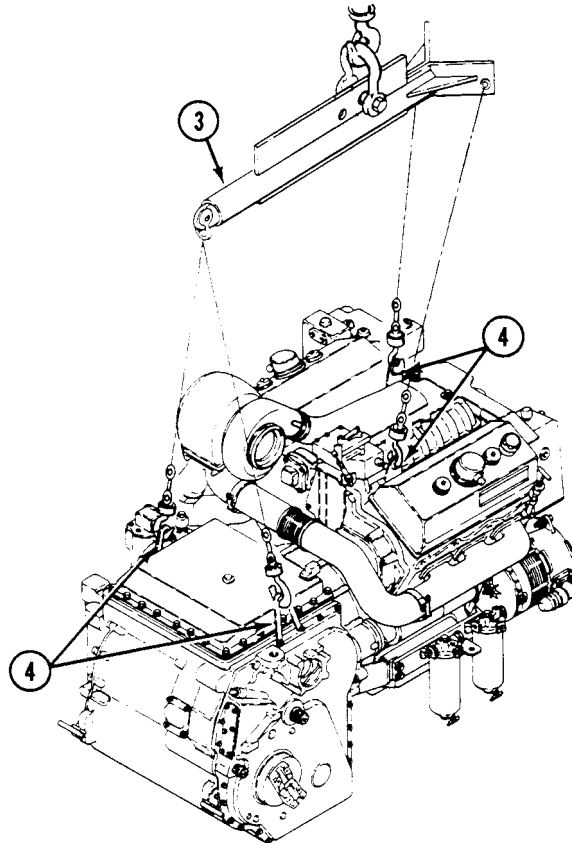

NOTE

Make sure spacer plate (half ring) stays in right side of transmission mount when power plant assembly is removed.

26. Remove power plant assembly from carrier and place on blocks (WP 0157 00). Have helper assist.

INSTALLATION**WARNING**

Damaged lifting slings can fail with load. Soldiers can be killed or injured. Inspect all slings (WP 0673 00) before use. Do not use damaged slings.

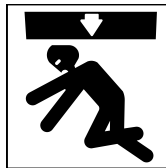
WARNING

Hanging loads can kill or injure you. Keep away from hanging loads and overhead equipment. Keep hands out of compartment while power plant is being lifted for removal or lowered for installation.

1. Attach power plant lifting sling (3) to power plant. Have helper assist.

NOTE

If engine mounts have been replaced, make sure mounts are aligned with hull mounts and nuts are torqued (WP 0158 00) before detaching sling.

Make sure spacer plate (half ring) is in the right side transmission mount slot before lowering power plant.

2. Lower power plant into carrier. Detach sling. Have helper assist.

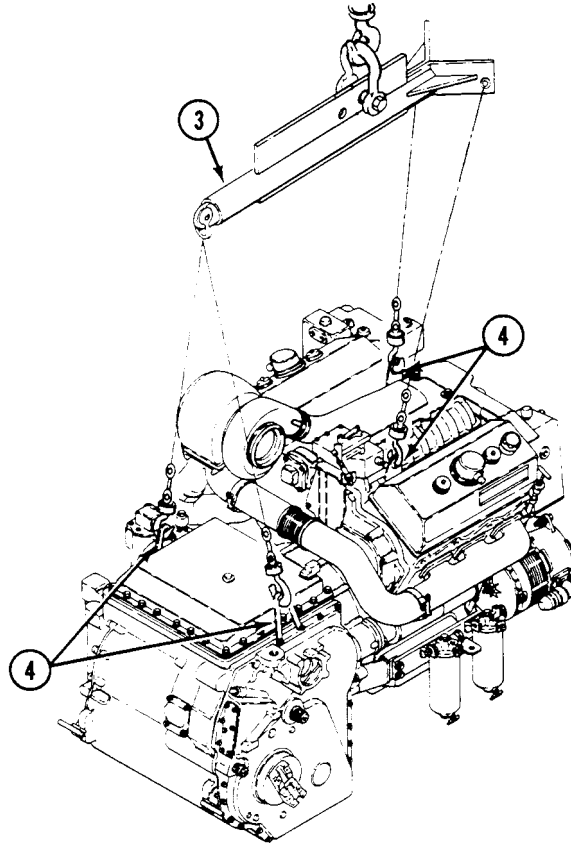

3. Install engine coupling clamps (1) on power plant mounts (2).

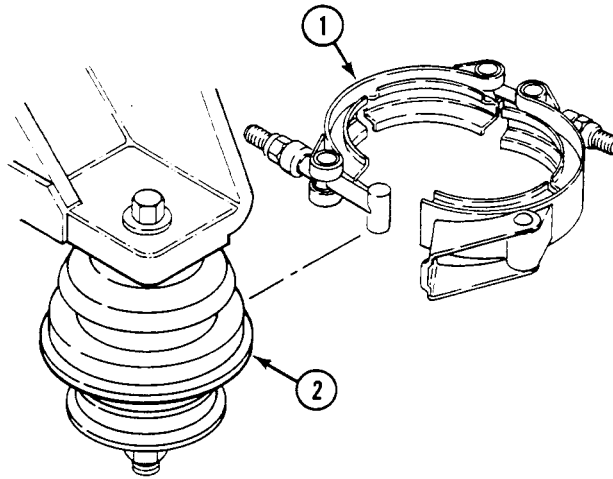

4. Install caps (3) on transmission mounts (4). Secure with four screws (5) and washers (6). Tighten screws to 86-94 lb-ft (107-126 N·m) torque.

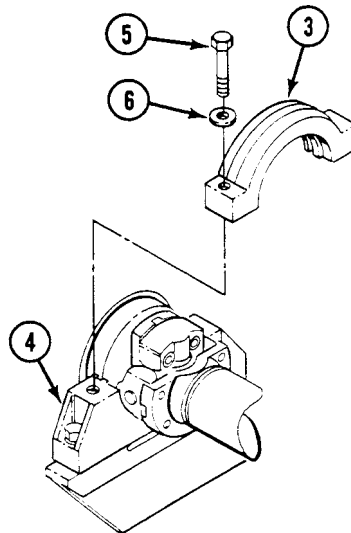

5. Install air cleaner cover (7).

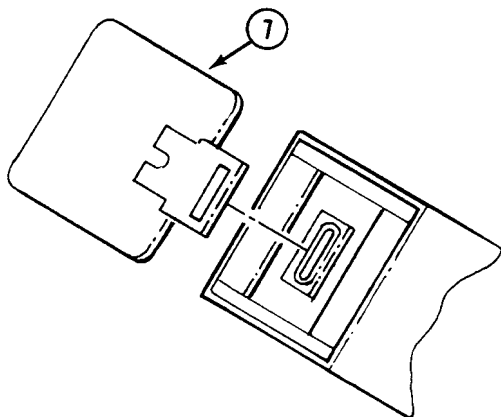

6. Install tachometer cable (8) on tachometer adapter (9).

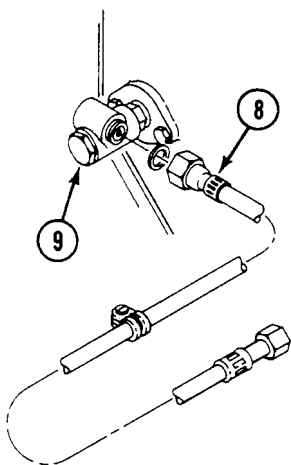

7. Install elbow (1) on turbo inlet (2) and exhaust manifold (3). Secure with two clamps (4).

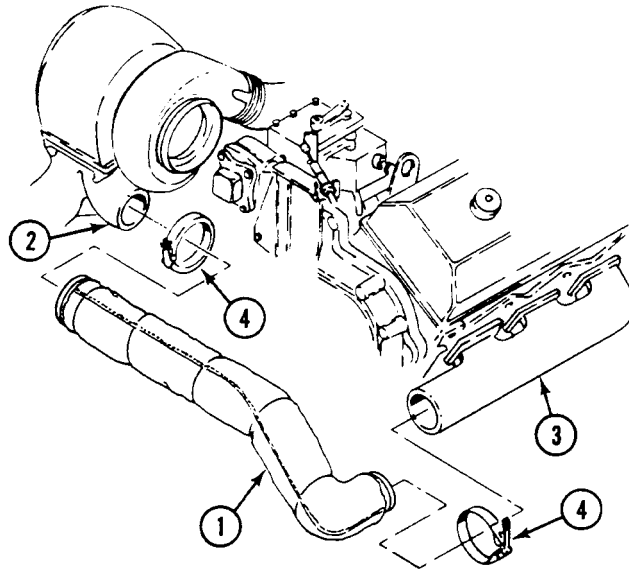

8. Install pivot shaft link (5) on pivot shaft (6). Secure with flat washer (7) and new cotter pin (8).
9. Install brake arms (9) and (10), links (11), and bearing (12) on transmission. Secure with two flat washers (13), new lockwashers (14), and screws (15).
10. Install lower bearing (12) on shaft link (5). Secure with pin (16), two washers (17), and new cotter pin (18).
11. Install link (19) on link (5). Secure with pin (20), two washers (21), and new cotter pin (22).

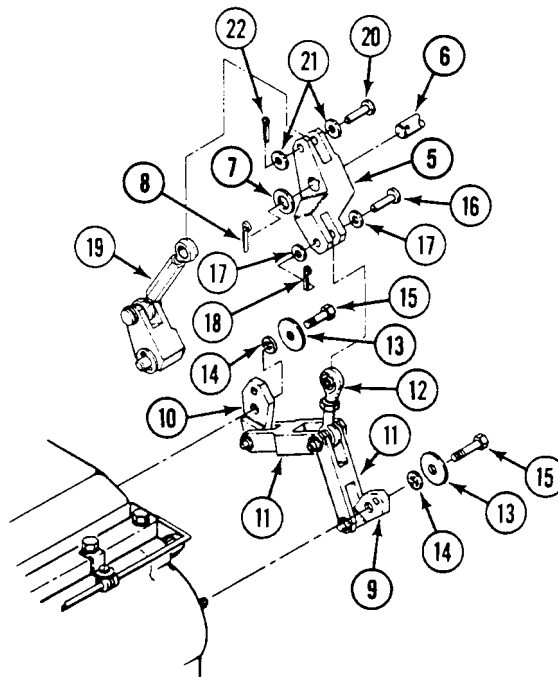

12. Install link (23) on link (24) and pivot shaft arm (25). Secure with two screws (26), washers (27), and new locknuts (28).

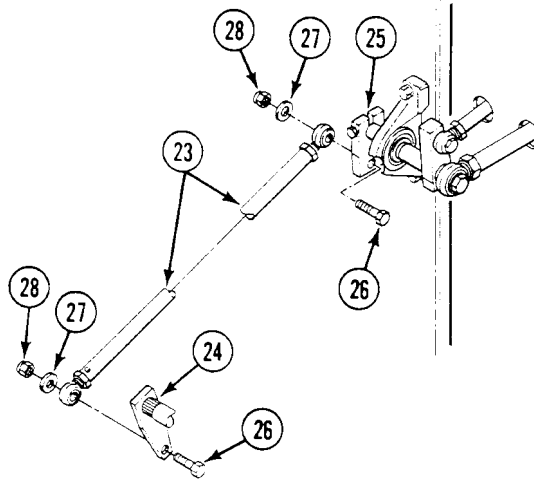

13. Install tow start cable (4) and two straps (5) on bracket (1). Secure with two locknuts (10), screws (3), and washers (2). Install control arm pin (6) and washer (7) in bracket (13). Install tow start cable in pin. Secure with collar (8). Secure pin to bracket with washer (11) and new cotter pin (12). Tighten set screw (9).

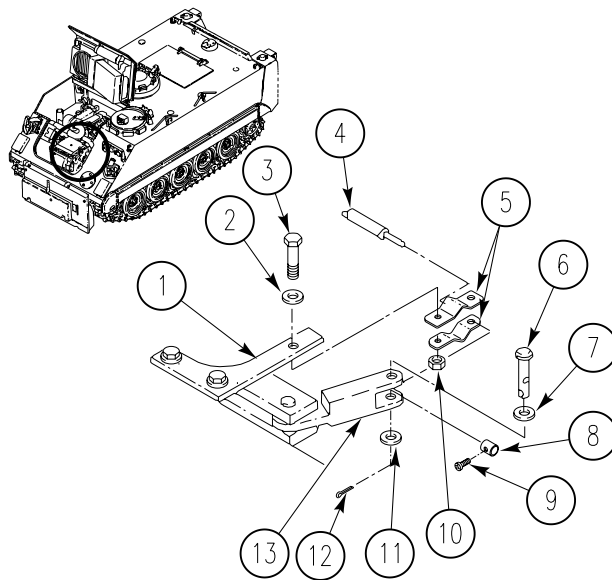

14. Install throttle link (14) on throttle arm (15). Secure with bolt (16), washer (17), and new locknut (18).

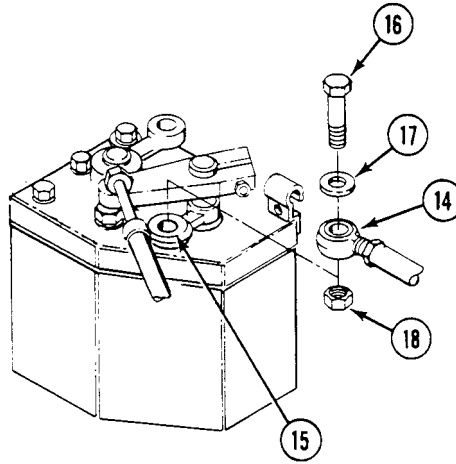

15. Install straight pin (19) with shutoff cable (20) on governor arm (21). Secure with washer (22) and new cotter pin (23).

16. Install clamp (24) with shutoff cable (20) on governor housing (25). Secure with washer (26) and screw (27).

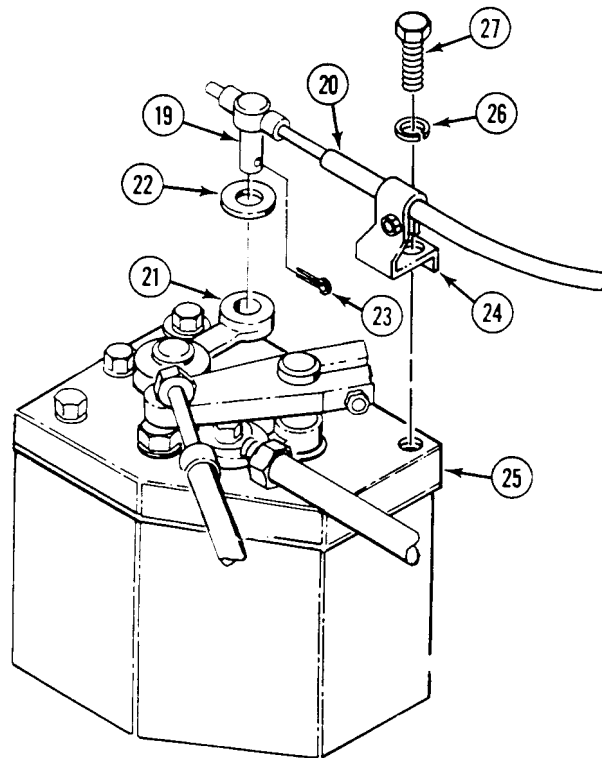

17. Install five cannon plugs (1) (Old Configuration) and seven cannon plugs (1) (New Configuration) on driver's compartment bulkhead.

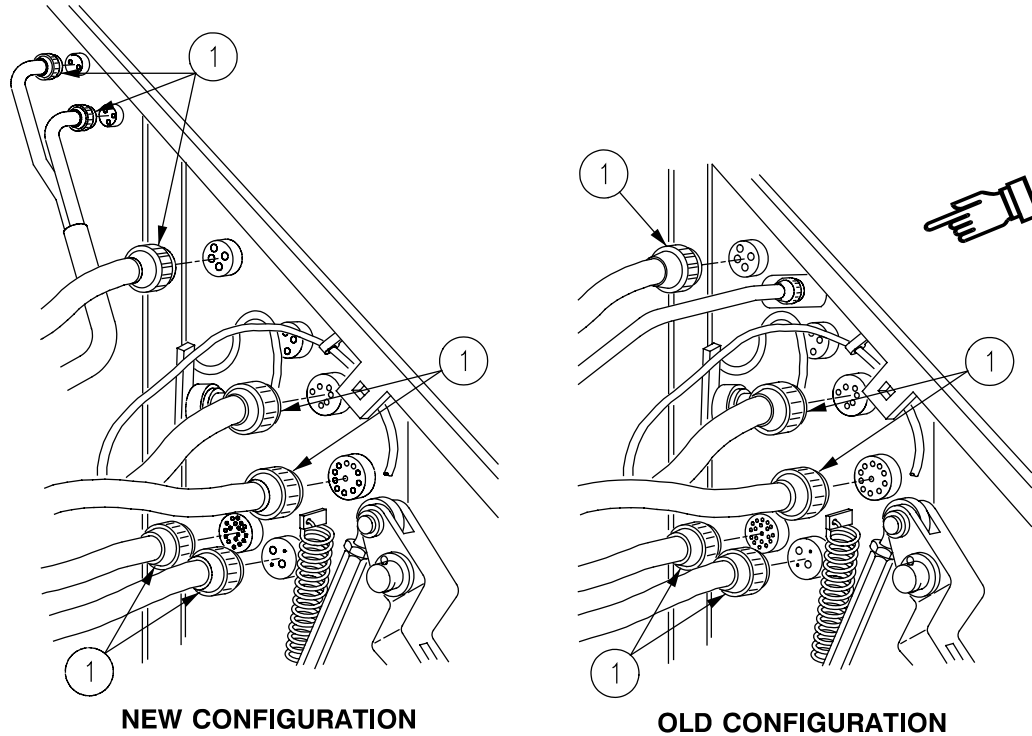

18. Install two ground leads (2) and (3) on hull ground lug (4). Secure with bolt (5), two flat washers (6), new spring washer (7), and new locknut (8).

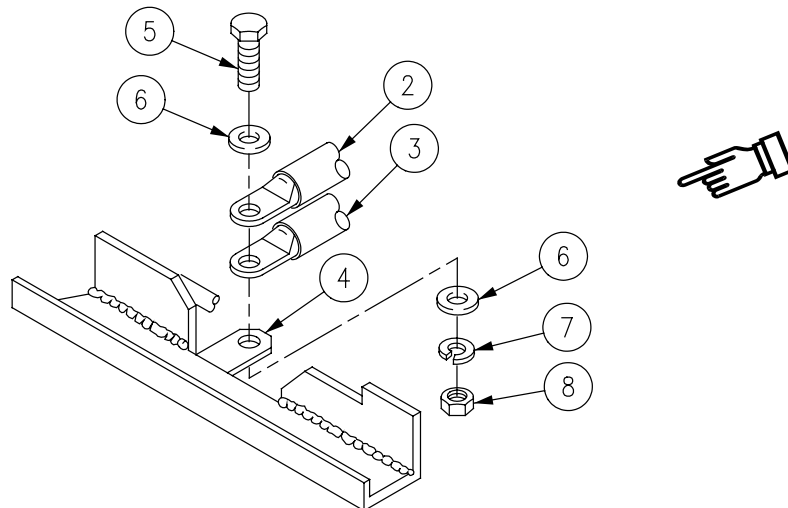

19. If engine coolant heater kit is installed, install hose (9) on coolant pump shutoff valve (10). Secure with clamp (11).

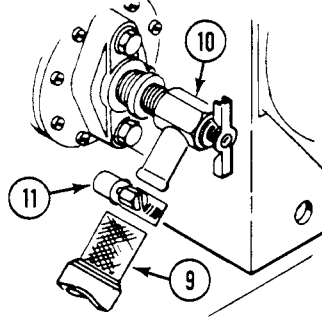

20. If engine coolant heater kit is installed, install hose (12) on engine coolant elbow (13) located on bottom left side of engine manifold. Secure with clamp (14).

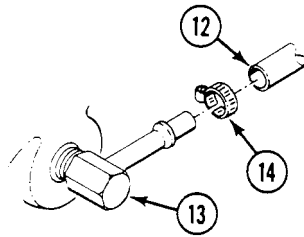

WARNING

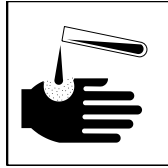

Hydraulic fluid is poisonous and can be absorbed through your skin. Wash off any hydraulic fluid which contacts your skin. Read the hydraulic fluid warning in the front of this manual.

21. Install two ramp hydraulic hoses (1) and (2) on quick disconnects (3) and (4).

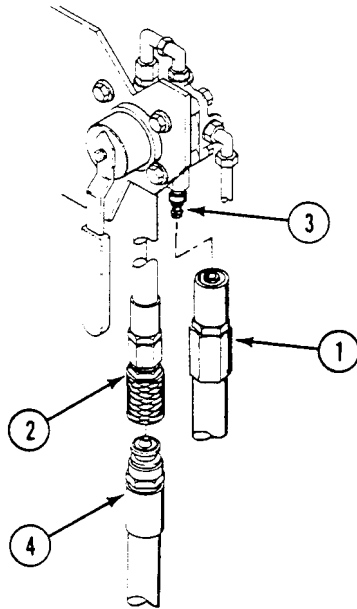

22. Install two fuel supply and return hoses (5) and (6) on quick disconnects (7) and (8).

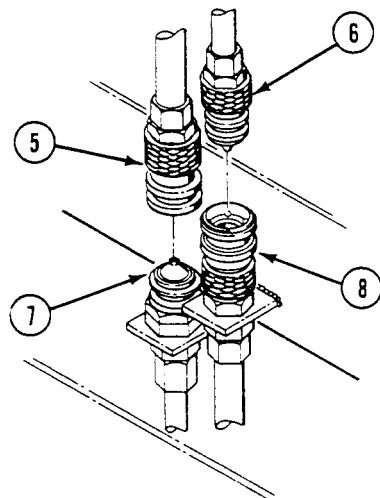

23. Install air intake elbow (9) on turbocharger inlet (10) and air cleaner (11). Secure with two clamps (12).
24. Install air restriction indicator hose (13) on bulkhead adapter (14) and reducer (15).
25. Install new strap (16) on hose (13) and air intake elbow (9).
26. Install air supply hose (17) on elbow (18) on air cleaner (11).

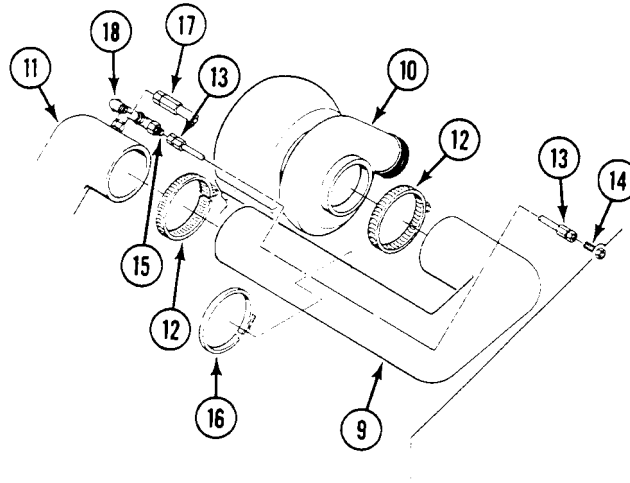

FOLLOW-THROUGH STEPS

1. Lower power plant grill (WP 0464 00).
2. Fill cooling system (WP 0227 00).
3. Connect battery ground strap (WP 0337 00) or (WP 0338 00).
4. Install propeller shafts and U-joints (WP 0405 00).
5. Perform brake adjustment check (WP 0406 00).
6. Start engine (see your -10). Check for leaks.
7. Stop engine. Turn MASTER SWITCH OFF (see your -10).
8. Install power plant rear access panel (see your -10).
9. Install driver's power plant access panel (see your -10).

END OF TASK

BLOCK POWER PLANT

0157 00

THIS WORK PACKAGE COVERS:

Jacking (page 0157 00-1).

INITIAL SETUP:

Maintenance Level

Unit

Personnel Required

Unit Mechanic
Helper (H)

Tools and Special Tools

General Mechanic's Tool Kit (WP 0926 00, Item 65)
Power Plant Sling (WP 0926 00, Item 48)

References

See your -10

Materials/Parts

Lumber, 4 x 6 x 40 inch (10 x 15 x 102 cm)
Lumber, 4 x 6 x 20 inch (10 x 15 x 51 cm) (2)

Equipment Condition

Engine stopped (see your -10)
Carrier blocked (see your -10)
Power plant removed (WP 0156 00)

PARKING

BLOCK POWER PLANT

WARNING

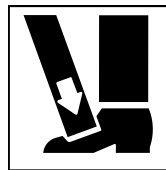

Blocking power plant on unlevel, soft ground can cause power plant to sink and tip over. Personnel can be injured and power plant can be damaged. Make sure to block power plant on flat, hard ground.

1. Use a lifting device of at least 3,000 pounds (1,362 kg) capacity and sling to lift power plant.
2. On level ground, place a 4 x 6 x 40 inch (10 x 15 x 102 cm) block (1) under motor mounts of the engine (2).
3. On level ground, place two 4 x 6 x 20 inch (10 x 15 x 52 cm) blocks (3) and (4) under transmission (5).
4. Lower power plant down slowly onto blocks. Have helper assist.

5. Check that power plant is firmly supported by the blocks.

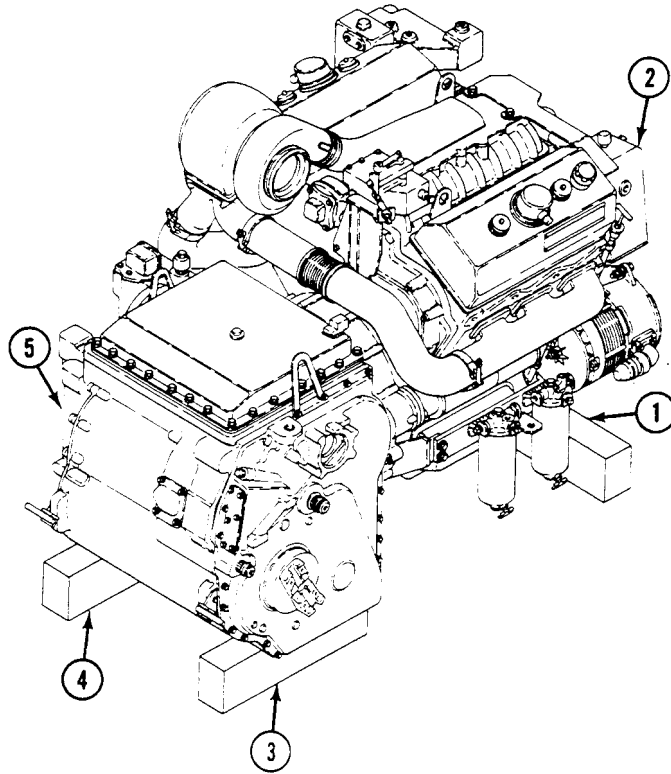

END OF TASK

REPLACE ENGINE MOUNTS

0158 00

THIS WORK PACKAGE COVERS:

Removal (page 0158 00-1).
 Installation (page 0158 00-2).

INITIAL SETUP:

Maintenance Level

Unit

References

See your -10

Tools and Special Tools

General mechanic's tool kit (WP 0926 00, Item 65)
 Torque wrench (WP 0926 00, Item 85)

Equipment Condition

Engine stopped (see your -10)
 Carrier blocked (see your -10)
 Battery ground strap disconnected (WP 0337 00) ,
 (WP 0338 00) , or (WP 0339 00) .
 Power plant removed (WP 0156 00)

Materials/Parts

Locknut

Personnel Required

Unit Mechanic

REMOVAL

NOTE

Right and left engine mounts are replaced in the same way.

1. Remove screw (1) , two washers (2) , two washers (3) , two mounts (4) , block (5) , and locknut (6) from engine. Discard locknut.

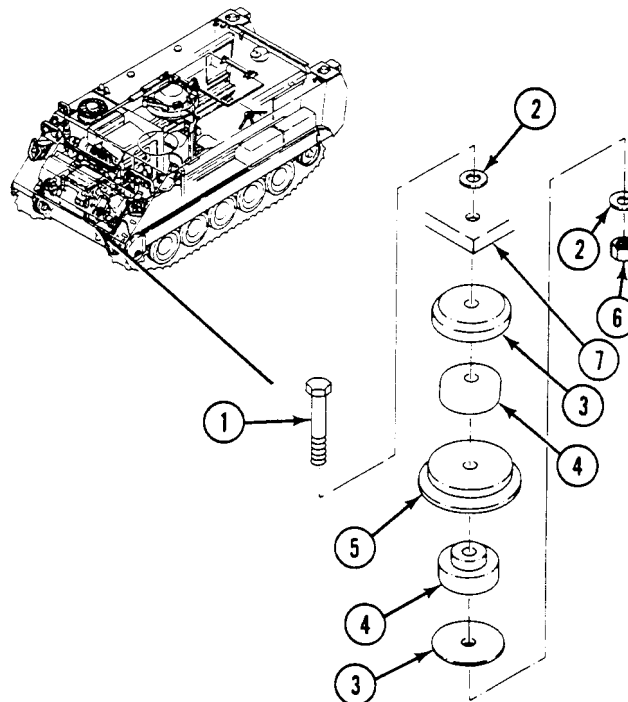

INSTALLATION

1. Install screw (1) and washer (2) in engine mount base (7).

NOTE

Do not torque nuts until engine mounts are properly aligned on hull mounts.

2. Lightly lubricate two mounts (4) with water. Install washer (3), mount (4), block (5), mount (4), and two washers (2) and washer (3) on engine. Secure with new locknut (6). Tighten nut to 100-120 lb-ft (136-163 N·m) torque.

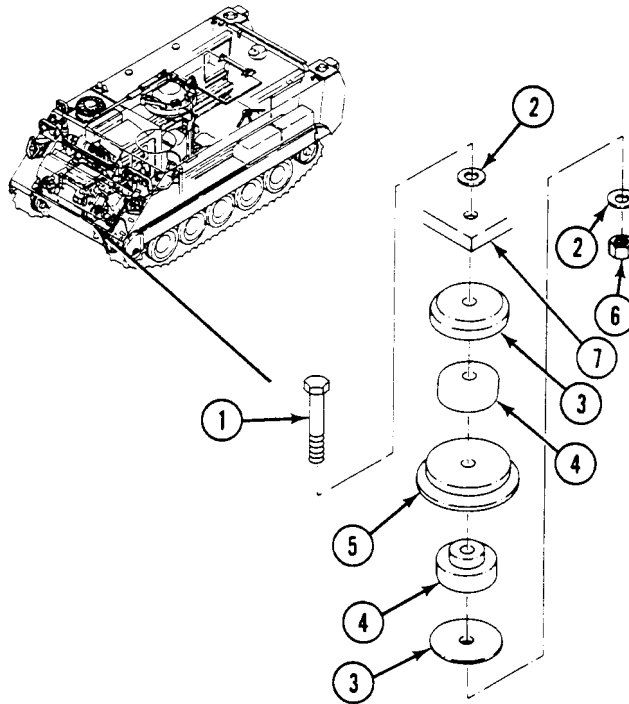
**FOLLOW-THROUGH STEPS**

1. Install power plant (WP 0156 00).
2. Connect battery ground strap (WP 0337 00), (WP 0338 00), or (WP 0339 00).

END OF TASK

REPLACE LEFT AND RIGHT AIR BOX DRAIN CHECK VALVES AND TUBES

0159 00

THIS WORK PACKAGE COVERS:

- Removal (page 0159 00-1).
- Installation (page 0159 00-13).

INITIAL SETUP:

Maintenance Level

Unit

Personnel Required

Unit Mechanic

Tools and Special Tools

- General Mechanic's Tool Kit (WP 0926 00, Item 65)
- Torque Wrench (WP 0926 00, Item 85)

References

See your -10

Materials/Parts

- Sealing compound (WP 0928 00, Item 56)
- Locknuts (2)
- Lockwashers (3)
- Washers, copper (2)

Equipment Condition

- Engine stopped (see your -10)
- Carrier blocked (see your -10)
- Driver's power plant access panel removed (see your -10 (right side only))
- Starter removed (WP 0259 00 (right side only))
- Power plant removed (WP 0156 00 (left side only))

REMOVAL

1. Remove two screws (1), four washers (2), two locknuts (3), and bracket (4) from engine. Discard locknuts.

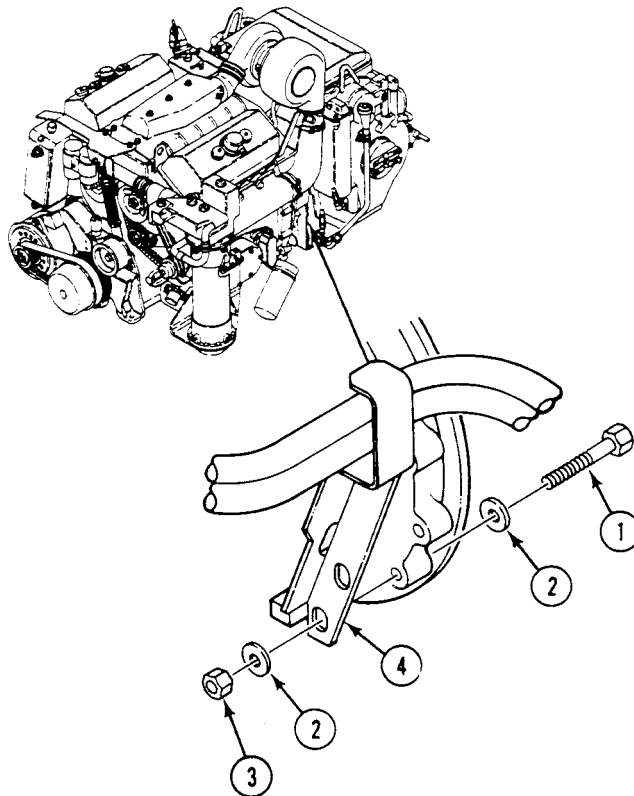

REPLACE LEFT AND RIGHT AIR BOX DRAIN CHECK VALVES AND TUBES — Continued

0159 00

2. Remove upper hose assembly (5) from elbow (6) in check valve (7) and elbow (8) on rear left cylinder block.
3. Remove lower hose assembly (9) from check valve (7) and elbow (10) on rear left oil pan.
4. If oil cooler has not been removed, remove screw (11), lockwasher (12), and flat washer (13) from clip (14) on oil cooler (15). Discard lockwasher.
5. Remove elbow (6) from check valve (7), elbow (8) from left side of cylinder block, and elbow (10) from left side of oil pan. If necessary, remove clip (14) from check valve.

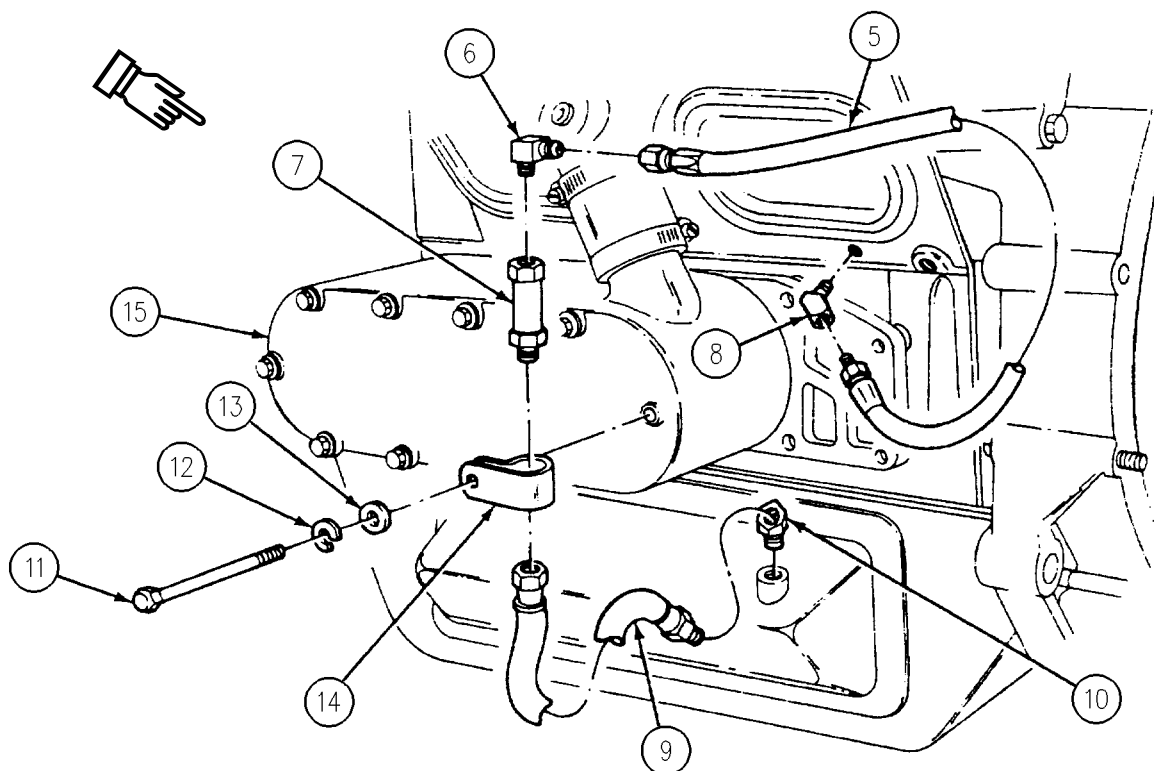

REPLACE LEFT AND RIGHT AIR BOX DRAIN CHECK VALVES AND TUBES — Continued

0159 00

6. Remove bolt (16) and lockwasher (17) from clip (18) on upper tube assembly (19). Discard lockwasher.
7. Remove upper tube assembly (19) from elbow (20) in check valve (21) and elbow (22) in rear right cylinder block. If necessary, remove clip (18) from tube assembly.
8. Disconnect lower tube assembly (23) from check valve (21). Remove check valve.
9. Remove elbow (20) from check valve (21) and elbow (22) from cylinder block.

NOTE**For model 5063-6392, do Step 10.**

10. Remove bolt (24), lockwasher (25), and spacer (26) from clip (27) on lower tube assembly (23). Discard lockwasher.
11. Remove adapter (28), two copper washers (29), and lower tube assembly (23) from cylinder block. If necessary, remove clip (27) from tube assembly. Discard flat washers.

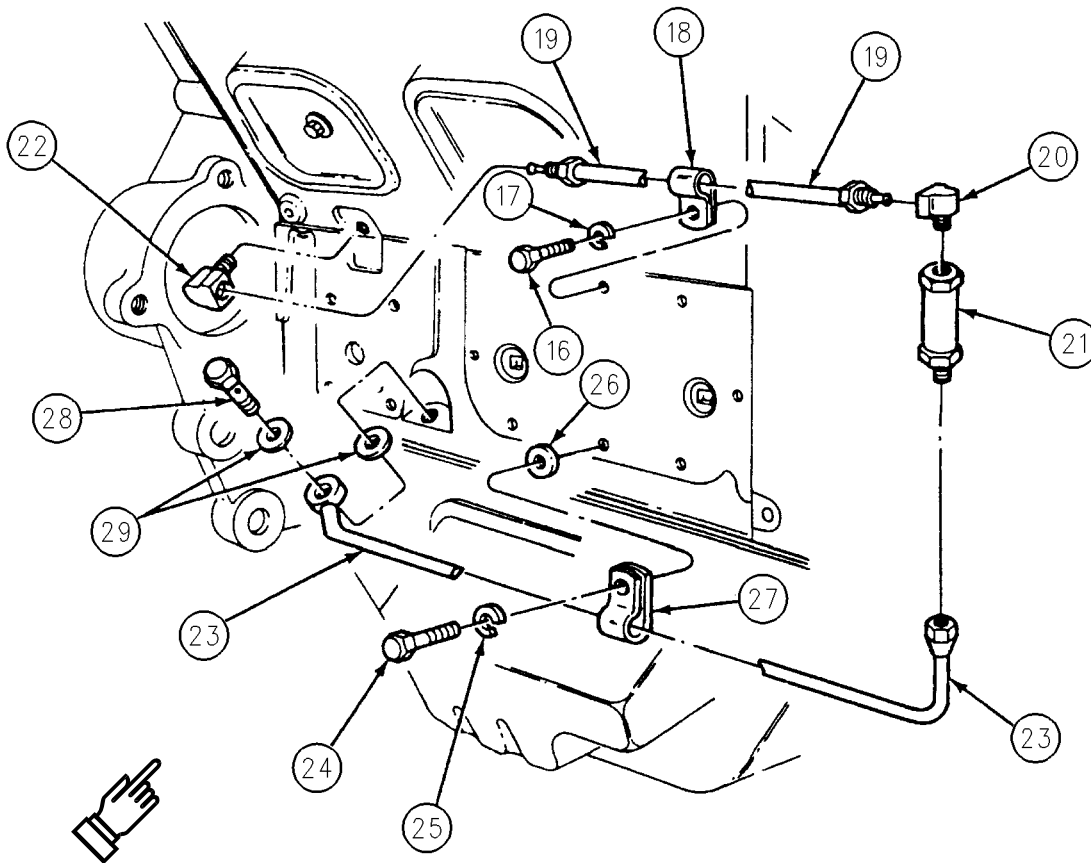

INSTALLATION

1. Loosely install lower tube assembly (23), adapter (28), and two copper washers (29) on right side of cylinder block.
2. Coat threads on elbow (22) with a pipe sealing compound and install elbow into cylinder block with port facing toward front of engine.
3. Install elbow (20) in top of check valve (21) and tighten securely.
4. Loosely connect lower tube assembly (23) to bottom of check valve (21). If removed, install clip (27) on lower tube assembly.
5. Loosely install upper tube assembly (19) in elbow (22) and elbow (20) in check valve (21). If removed, install clip (18) on upper tube assembly.
6. Install lockwasher (17) and bolt (16) through clip (18) into cylinder block.

NOTE

For model 5063-6392, do Step 7.

7. Install spacer (26), lockwasher (25), and bolt (24) through clip (27) into cylinder block.
8. Securely tighten tube assembly (19) and tube assembly (23). Torque adapter (28) to 14-16 lb-ft (19-22 N•m). Torque bolt (16) and bolt (24) to 13-17 lb-ft (18-23 N•m).

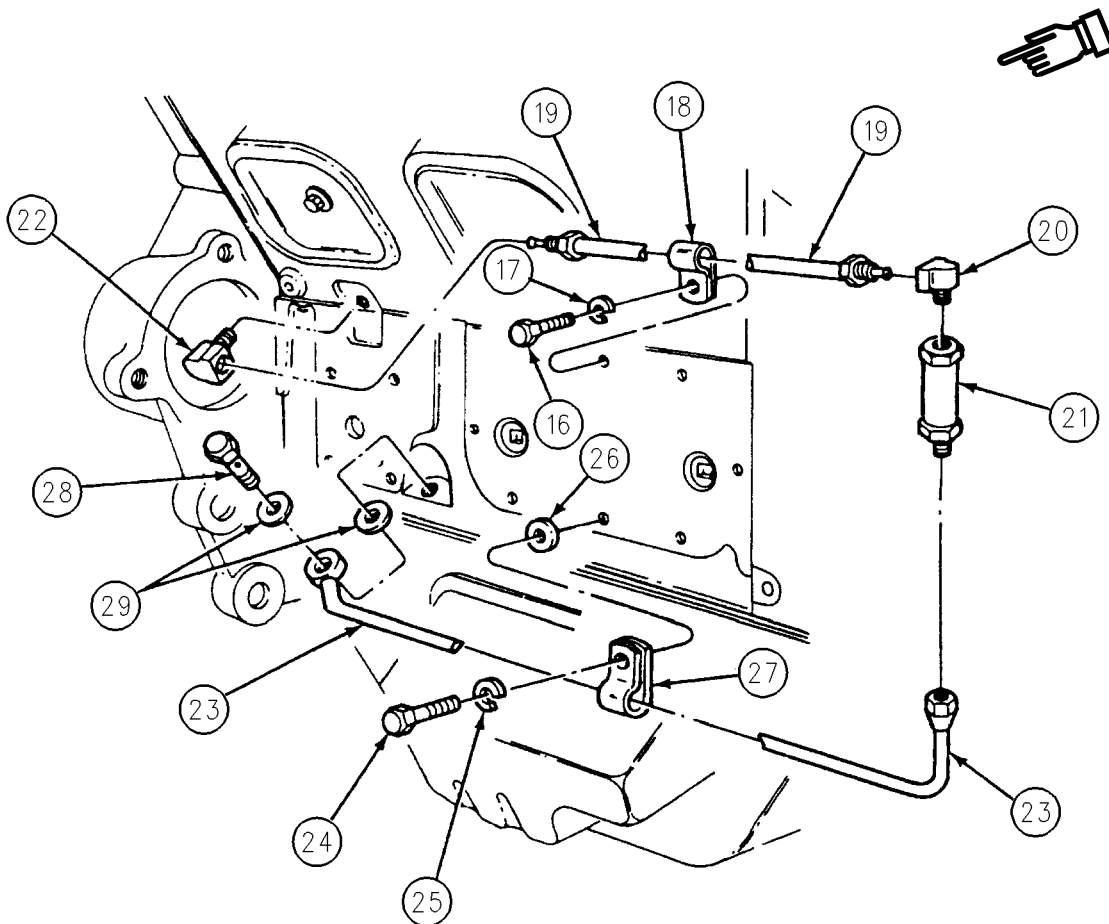

REPLACE LEFT AND RIGHT AIR BOX DRAIN CHECK VALVES AND TUBES — Continued**0159 00**

9. Coat threads on elbow (8) with a pipe sealing compound and install in left side of cylinder block. Tighten securely with port facing rear and downward at a 45 degree angle.
10. Install elbow (10) in oil pan and tighten securely with port facing outward from engine.
11. Install elbow (6) in top of check valve (7) and tighten securely. If removed, install clip (14) on check valve.
12. Connect upper hose assembly (5) to elbow (8) in cylinder block. Tighten securely.
13. Connect lower hose assembly (9) to elbow (10) in oil pan. Tighten securely.
14. If oil cooler is installed, install screw (11) through clip (14), new lockwasher (12), and flat washer (13) in oil cooler. Torque screw to 13-17 lb-ft (18-23 N•m).
15. Connect hose assembly (5) to elbow (6) in check valve (7) and hose assembly (9) to bottom of check valve. Tighten securely.

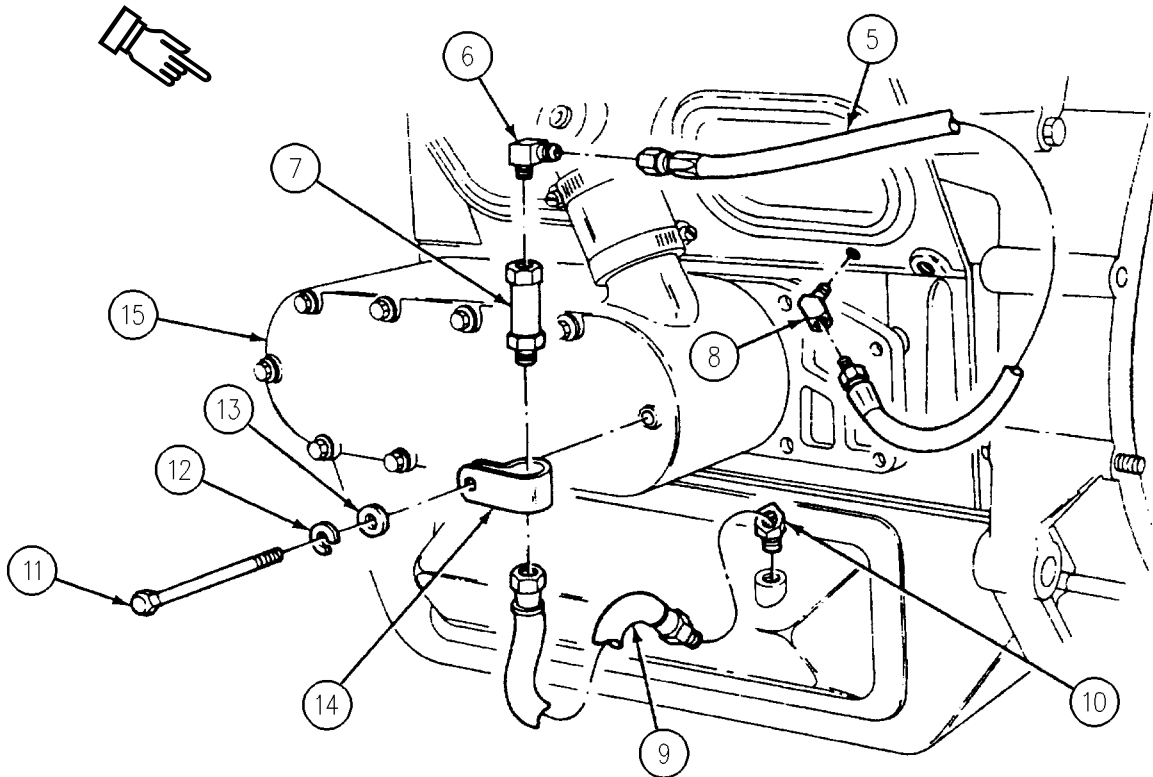

16. Install bracket (4) on engine. Secure with two screws (1), four washers (2), and two new locknuts (3).

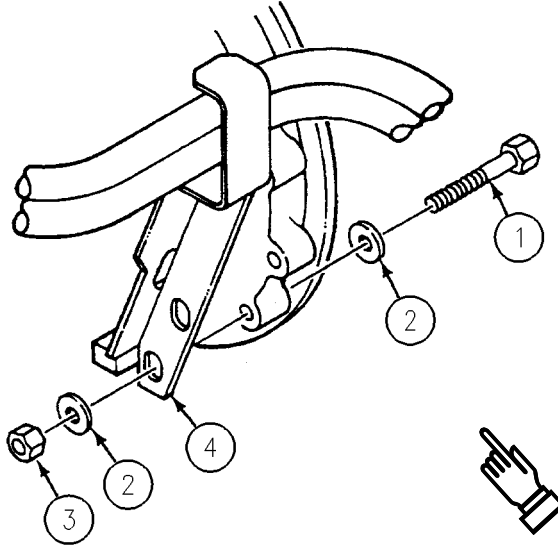

INSTALLATION

1. Install power pack (WP 0156 00 (left side only)).
2. Install driver's power plant access panel (see your -10 (right side only)).
3. Install starter (WP 0259 00 (right side only)).

END OF TASK

REPLACE ENGINE LIFTING BRACKET

0161 00

THIS WORK PACKAGE COVERS:

Removal (page 0161 00-1).
 Installation (page 0161 00-2).

INITIAL SETUP:

Maintenance Level

Unit

References

TM 9-2350-277-10
 WP 0464 00

Tools and Special Tools

General Mechanic's Tool Kit (WP 0926 00, Item 65)

Equipment Condition

Engine stopped (TM 9-2350-277-10)
 Carrier blocked (TM 9-2350-277-10)
 Power plant access door open (TM 9-2350-277-10)
 Power plant grill raised (WP 0464 00)

Materials/Parts

Lockwasher (2)

Personnel Required

Mechanic

REMOVAL

NOTE

Both brackets are removed and installed the same way.

1. Remove two screws (1), lockwashers (2), and lifting bracket (3) from power plant. Discard lockwashers.

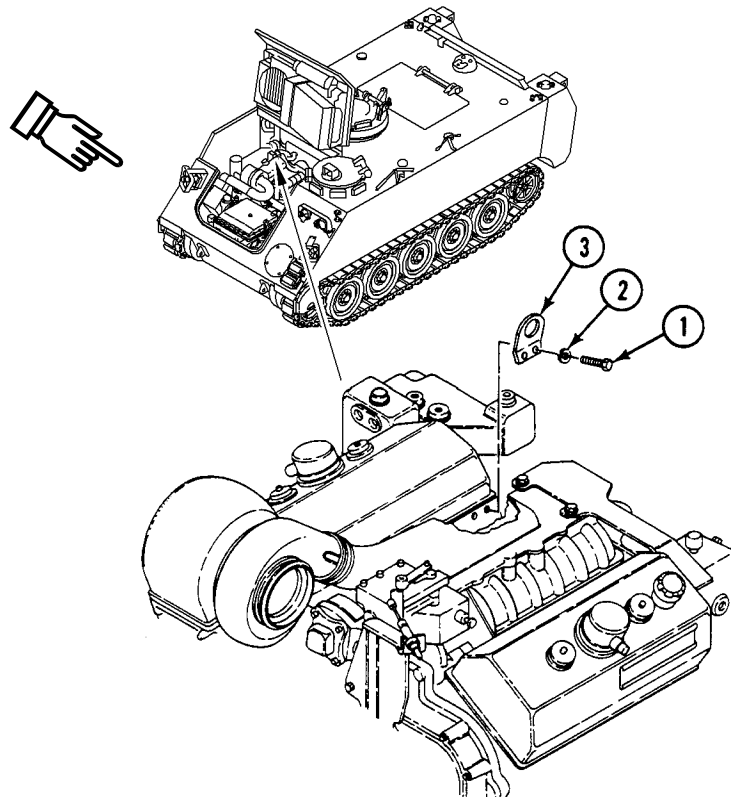

INSTALLATION

1. Install bracket (3) with two screws (1) and new lockwashers (2) on power plant.

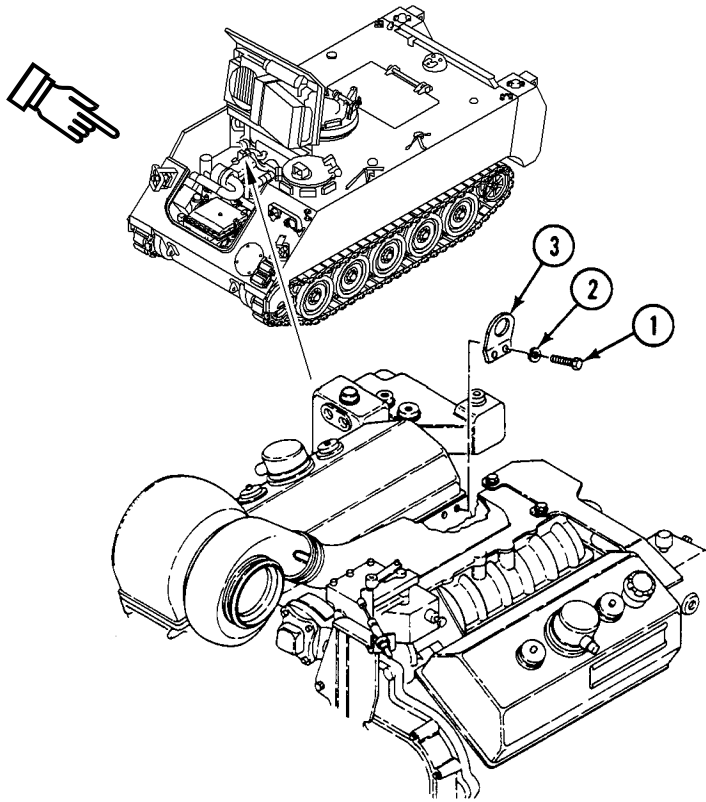
**FOLLOW-THROUGH STEPS**

1. Lower power plant grill (WP 0464 00).
2. Close power plant access door. See TM 9-2350-277-10.

END OF TASK

REPLACE ENGINE OIL FILLER CAP

0162 00

THIS WORK PACKAGE COVERS:

Removal (page 0162 00-1).
 Installation (page 0162 00-2).

INITIAL SETUP:

Maintenance Level

Unit

References

See your -10

Tools and Special Tools

General Mechanic's Tool Kit (WP 0926 00, Item 65)

Equipment Condition

Engine stopped (see your -10)

Carrier blocked (see your -10)

Materials/Parts

Filler cap

Hook (2)

Driver's power plant access panel removed
 (see your -10)

Personnel Required

Unit Mechanic

REMOVAL

1. Unscrew T-handle (1) on oil filler cap (2) and remove cap from filler hole (3).
2. Open hook (4) in filler hole (3) to remove cap (2) and chain (5). Discard hook.

3. Open hook (6) on filler cap (2) to remove hook and chain (5) from cap. Discard hook and cap.

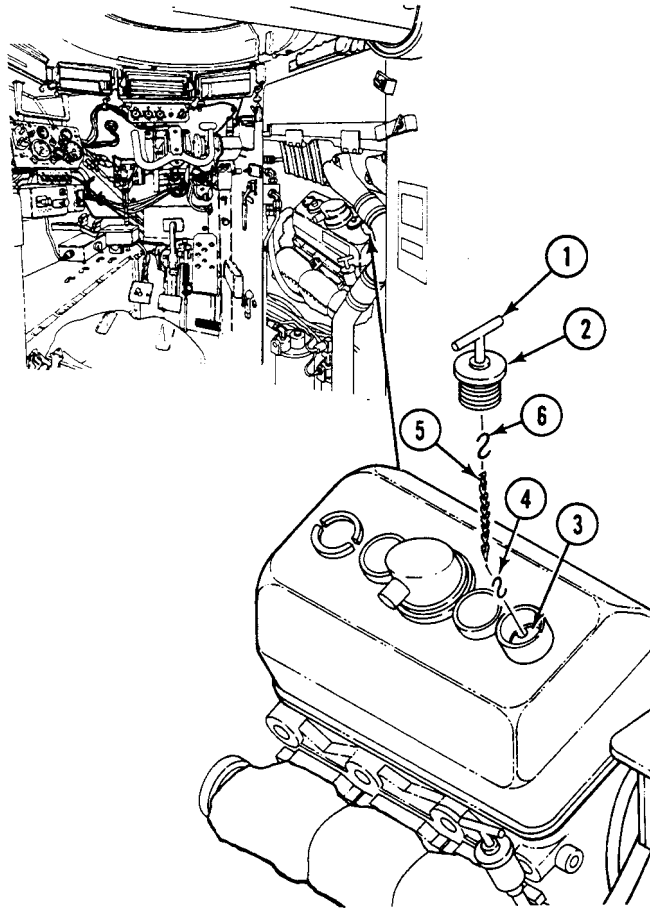

INSTALLATION

1. Secure chain (5) to new filler cap (2) with new hook (6).
2. Secure other end of chain (5) to filler hole (3) with new hook (4).
3. Install cap (2) in filler hole (3) and secure by turning T-handle (1) clockwise.

FOLLOW-THROUGH STEPS

1. Install driver's power plant access panel (see your -10).

END OF TASK

REPLACE ENGINE OIL SAMPLING VALVE AND HOSE

0163 00

THIS WORK PACKAGE COVERS:

Removal (page 0163 00-1).
 Installation (page 0163 00-2).

INITIAL SETUP:

Maintenance Level

Unit

References

See your -10

Tools and Special Tools

General Mechanic's Tool Kit (WP 0926 00, Item 65)

Equipment Condition

Engine stopped (see your -10)

Carrier blocked (see your -10)

Materials/Parts

Sealing compound (WP 0928 00, Item 56)

Personnel Required

Unit Mechanic

Driver's power plant access panel removed
 (see your -10)

REMOVAL

1. Remove hose (1) from adapter (2).
2. Remove hose (1) from elbow (3).
3. Loosen jam nut (4) on valve (5) and slide valve out of bracket (6).
4. Remove elbow (3) from bushing (7).
5. Remove bushing (7) from valve (5).

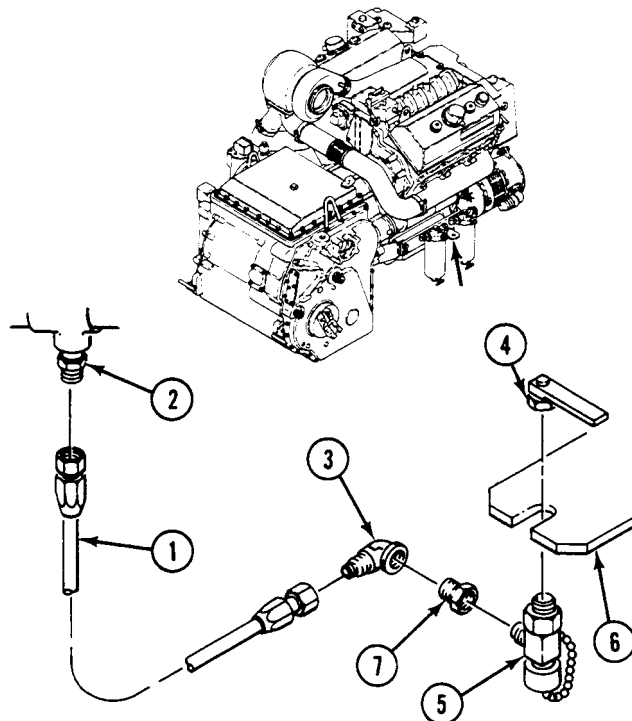

INSTALLATION

1. Apply sealing compound to all male tapered threads. Do not apply sealing compound beyond small end of tapered threads.
2. Install bushing (7) in valve (5).
3. Install elbow (3) in bushing (7).
4. Install valve (5) on bracket (6) and secure with jam nut (4).
5. Install hose (1) on elbow (3).
6. Route hose behind fuel filter and connect hose (1) to adapter (2).

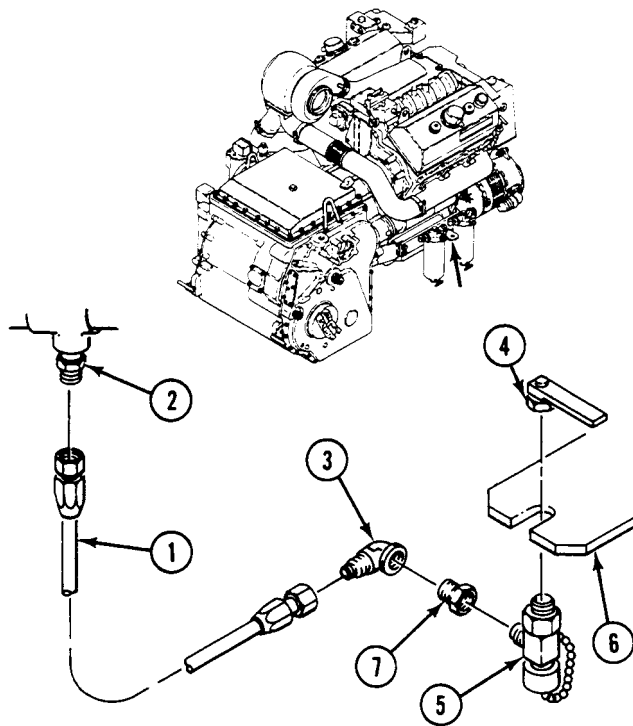
**FOLLOW-THROUGH STEPS**

1. Start engine (see your -10).
2. Check for leaks.
3. Stop engine (see your -10).
4. Install driver's power plant access panel (see your -10).

END OF TASK

REPLACE OIL GAUGE ROD AND TUBE

0164 00

THIS WORK PACKAGE COVERS:

Removal (page 0164 00-1).
 Installation (page 0164 00-2).

INITIAL SETUP:

Maintenance Level

Unit

References

See your -10

Tools and Special Tools

General Mechanic's Tool Kit (WP 0926 00, Item 65)

Equipment Condition

Materials/Parts

Adhesive (WP 0928 00, Item 4)

Locknut

Engine stopped (see your -10)

Carrier blocked (see your -10)

Personnel Required

Unit Mechanic

Driver's power plant access panel removed
 (see your -10)

REMOVAL

1. Loosen oil gauge rod tee handle (1). Remove oil gauge rod (2) from tube (3).
2. Remove locknut (4), clamp (5), and washer (6) from engine. Discard locknut.
3. Loosen nut (7). Remove tube (3) and clamp (5) from oil pan adapter (8).

REPLACE OIL GAUGE ROD AND TUBE — Continued

0164 00

4. Remove adapter (8) from oil pan (9).

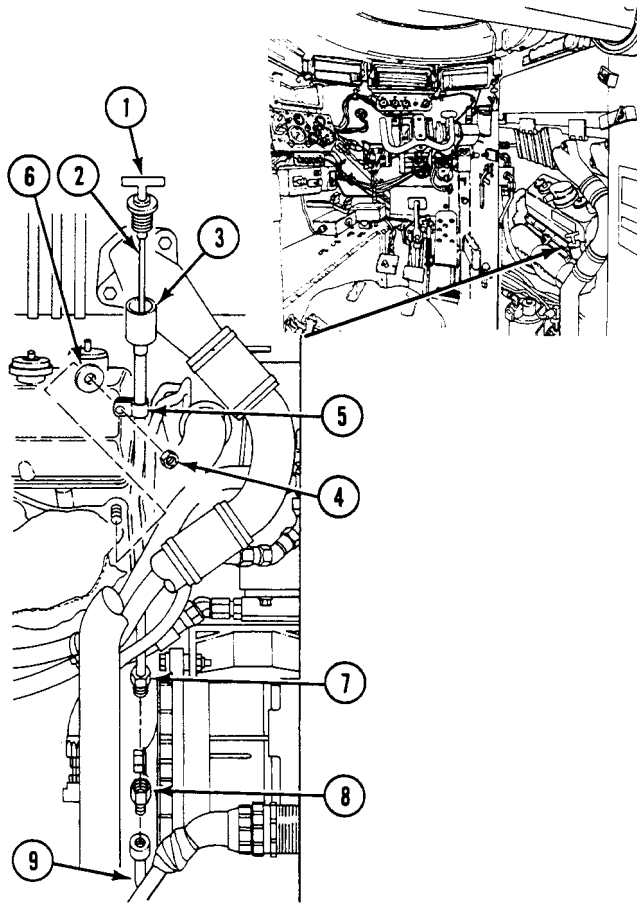
**INSTALLATION**

1. Apply a thin coat of adhesive to external threads of nut (7) and adapter (8).
2. Install adapter (8) on oil pan (9).
3. Install tube (3) and clamp (5) on oil pan adapter (8). Tighten nut (7).
4. Install washer (6), clamp (5) and tube (3) on engine. Secure with new locknut (4).
5. Install oil gauge rod (2) in tube (3). Tighten oil gauge rod tee handle (1).

FOLLOW-THROUGH STEPS

1. Install driver's power plant access panel (see your -10).

END OF TASK

REPLACE OIL FILTER ELEMENT

0165 00

THIS WORK PACKAGE COVERS:

- Removal (page 0165 00-1).
 - Cleaning (page 0165 00-1).
 - Installation (page 0165 00-2).
-

INITIAL SETUP:

Maintenance Level

Unit

References

See your -10

Tools and Special Tools

- General Mechanic's Tool Kit (WP 0926 00, Item 65)
- Oil filter wrench (WP 0926 00, Item 76)

Materials/Parts

- Cleaning compound (WP 0928 00, Item 19)
- Wiping rag (WP 0928 00, Item 65)

Equipment Condition

- Engine stopped (see your -10)
- Carrier blocked (see your -10)

Personnel Required

Unit Mechanic

Power plant bottom access cover removed (WP 0450 00)

REMOVAL

1. Remove engine oil filter element (1) from adapter (2) and bracket (3). Discard filter element per Unit SOP.

CLEANING

1. Clean surface of filter housing (4) with cleaning compound and wiping rags.

INSTALLATION

1. Install engine oil filter element (1) on adapter (2) and bracket (3).

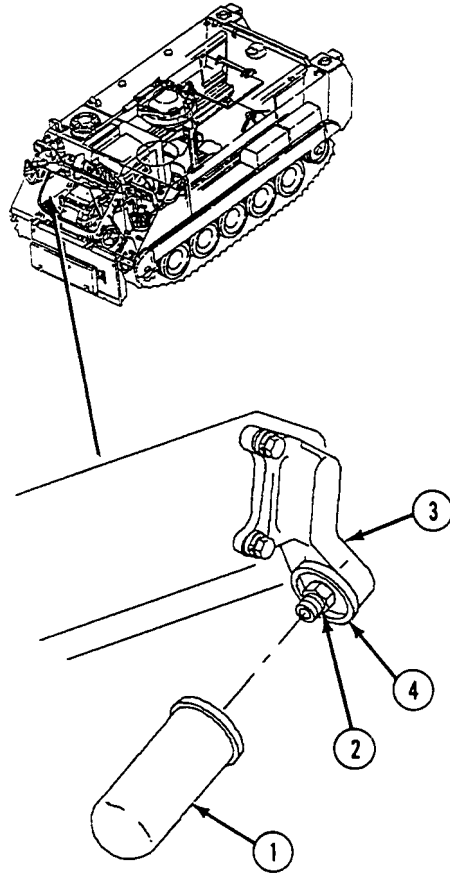
**FOLLOW-THROUGH STEPS**

1. Start engine (see your -10). Check for leaks.
2. Stop engine (see your -10).
3. Install power plant bottom access cover (WP 0450 00).

END OF TASK

CHAPTER 5
UNIT MAINTENANCE INSTRUCTIONS
FOR FUEL SYSTEM

WORK PACKAGE INDEX

<u>Title</u>	<u>Sequence No.</u>
REPLACE ENGINE FUEL PUMP.....	.0166 00
SERVICE AIR CLEANER FILTER ELEMENT.....	.0167 00
REPLACE AIR CLEANER AND ELBOW.....	.0168 00
REPLACE AIR CLEANER DOOR.....	.0169 00
REPAIR AIR CLEANER ASSEMBLY.....	.0169 01
REPAIR AIR CLEANER RETAINER.....	.0170 00
REPLACE AIR CLEANER RESTRICTION INDICATOR.....	.0171 00
REPLACE AIR CLEANER RESTRICTION INDICATOR HOSE.....	.0172 00
REMOVE/INSTALL AIR INTAKE ELBOW.....	.0173 00
REPLACE GRILL AIR INTAKE ELBOW AND HOSE.....	.0174 00
REPLACE EXHAUST EVACUATOR VALVE AND CONNECTOR.....	.0175 00
CLEAN FUEL CAP VENT AND FILTER SCREEN.....	.0176 00
DRAIN TANKS (ALL EXCEPT M577A3 AND M1068A3).....	.0177 00
DRAIN FUEL TANKS (M577A3 AND M1068A3 ONLY).....	.0178 00
REPLACE EXTERNAL FUEL TANKS (ALL EXCEPT M577A3 AND M1068A3).....	.0179 00
REPLACE FUEL TANKS (M577A3 AND M1068A3 ONLY).....	.0180 00
TEMPORARY FUEL TANK REPAIR (M577A3 AND M1068A3 ONLY).....	.0181 00
REPLACE FUEL TANK FILLER COVER AND LOCK (ALL EXCEPT M577A3 AND M1068A3).....	.0182 00
REPLACE FUEL TANK FILLER COVER AND LOCK (M577A3 AND M1068A3 ONLY).....	.0183 00
REPLACE FILLER CAP AND STRAINER PARTS (ALL EXCEPT M577A3 AND M1068A3).....	.0184 00
REPLACE FILLER CAP AND STRAINER PARTS (M577A3 AND M1068A3 ONLY).....	.0185 00
REPLACE FUEL FILLER AND STRAINER PARTS (M577A3 AND M1068A3 ONLY).....	.0186 00
REPLACE FUEL TANK ACCESS COVERS AND DRAIN PLUGS (ALL EXCEPT M577A3 AND M1068A3).....	.0187 00
REPLACE FUEL TANK ACCESS COVERS (M577A3 AND M1068A3 ONLY).....	.0188 00
REPLACE FUEL TANK FILLER FLANGE (M577A3 AND M1068A3 ONLY).....	.0189 00
REPLACE FUEL QUANTITY TRANSMITTER (ALL EXCEPT M577A3 AND M1068A3).....	.0190 00
REPLACE FUEL QUANTITY TRANSMITTER (M577A3 AND M1068A3 ONLY).....	.0191 00
REPLACE FUEL SUPPLY HOSES, TUBES, AND FITTINGS (M113A3, M1059A3, AND M58 ONLY).....	.0192 00
REPLACE FUEL SUPPLY HOSES, TUBES AND FITTINGS (M577A3 AND M1068A3 ONLY).....	.0193 00
REPLACE FUEL SUPPLY HOSES, TUBES, AND FITTINGS (M1064A3 ONLY).....	.0194 00
REPLACE FUEL RETURN HOSES, TUBES, AND FITTINGS (M113A3, M1059A3, AND M58 ONLY).....	.0195 00
REPLACE FUEL RETURN HOSES, TUBES, AND FITTINGS (M577A3 AND M1068A3 ONLY).....	.0196 00

CHAPTER 5
UNIT MAINTENANCE INSTRUCTIONS
FOR FUEL SYSTEM

WORK PACKAGE INDEX (Continued)

<u>Title</u>	<u>Sequence No.</u>
REPLACE FUEL RETURN HOSES, TUBES, AND FITTINGS (M1064A3 ONLY).....	0197 00
REPLACE FUEL VENT HOSES, TUBES, AND FITTINGS (M577A3 AND M1068A3 ONLY).....	0198 00
REPLACE FUEL VALVE MOUNTING BLOCKS (ALL EXCEPT M577A3 AND M1068A3).....	0199 00
REPLACE ENGINE FUEL SUPPLY HOSE.....	0200 00
REPLACE ENGINE FUEL RETURN HOSE.....	0201 00
REPLACE PRIMARY AND SECONDARY FUEL FILTER ELEMENTS.....	0202 00
REPLACE PRIMARY AND SECONDARY FUEL FILTERS AND BRACKET.....	0203 00
REPLACE AIR BOX HEATER IGNITION WIRE.....	0204 00
REPLACE AIR BOX HEATER WIRING HARNESS.....	0205 00
REPLACE AIR BOX HEATER LOWER FUEL LINE.....	0206 00
REPLACE AIR HEATER ELECTRODE.....	0207 00
REPLACE AIR BOX IGNITION COIL.....	0208 00
REPLACE GLOW PLUG HARNESS AND GLOW PLUGS.....	0209 00
REPLACE GLOW PLUG CONTROLLER.....	0210 00
REPLACE GLOW PLUG POWER HARNESS.....	0211 00
REPLACE GLOW PLUG CONTROLLER MOUNTING BRACKET.....	0212 00
ADJUST THROTTLE VALVE (TV) MODULATOR.....	0213 00
ADJUST ACCELERATOR LINKAGE.....	0214 00
REPLACE LOWER ACCELERATOR PEDAL.....	0215 00
REPLACE UPPER ACCELERATOR PEDAL ASSEMBLY.....	0216 00
REPLACE FUEL CONTROL SHAFT AND LINKAGE.....	0217 00
REPLACE THROTTLE VALVE (TV) MODULATOR AND LEVER.....	0218 00
REPLACE HAND THROTTLE CONTROL CABLE ASSEMBLY.....	0219 00
REPLACE FUEL CUTOFF CONTROL CABLE ASSEMBLY.....	0220 00

REPLACE ENGINE FUEL PUMP

0166 00

THIS WORK PACKAGE COVERS:

- Removal (page 0166 00-1).
 - Clean (page 0166 00-3).
 - Inspect (page 0166 00-3).
 - Repair (page 0166 00-3).
 - Installation (page 0166 00-4).
-

INITIAL SETUP:

Maintenance Level

Unit

References

TM 9-2350-277-10

WP 0439 00

Tools and Special Tools

General Mechanic's Tool Kit (WP 0926 00, Item 65)

Equipment Condition

Engine stopped (TM 9-2350-277-10)

Carrier blocked (TM 9-2350-277-10)

Power plant rear access panels removed (WP 0439 00)

Power plant access door open (TM 9-2350-277-10)

Battery ground strap disconnected (WP 0337 00 or
WP 0338 00)

Left exhaust elbow removed (WP 0225 00)

Materials/Parts

Adhesive (WP 0928 00, Item 4)

Cleaning compound (WP 0928 00, Item 19)

Gasket

Personnel Required

Mechanic

REMOVAL

CAUTION

Install covers on disconnected fuel lines, tubes, valves and components during maintenance. Use tape, cloth, cardboard, or any appropriate material to prevent damage to components or accidental fuel spills.

REPLACE ENGINE FUEL PUMP — Continued

0166 00

1. Remove fuel supply hose (1) at quick disconnect (2).
2. Remove fuel return hose (3) at quick disconnect (4).
3. Remove fuel supply hose (5) from elbow (6).
4. Remove elbow (6) from fuel pump (7).
5. Remove fuel supply hose (8) from elbow (9).
6. Remove elbow (9) from fuel pump (7).
7. Remove three screws (10), fuel pump (7), gasket (11), and fork (12) from engine block. Discard gasket.

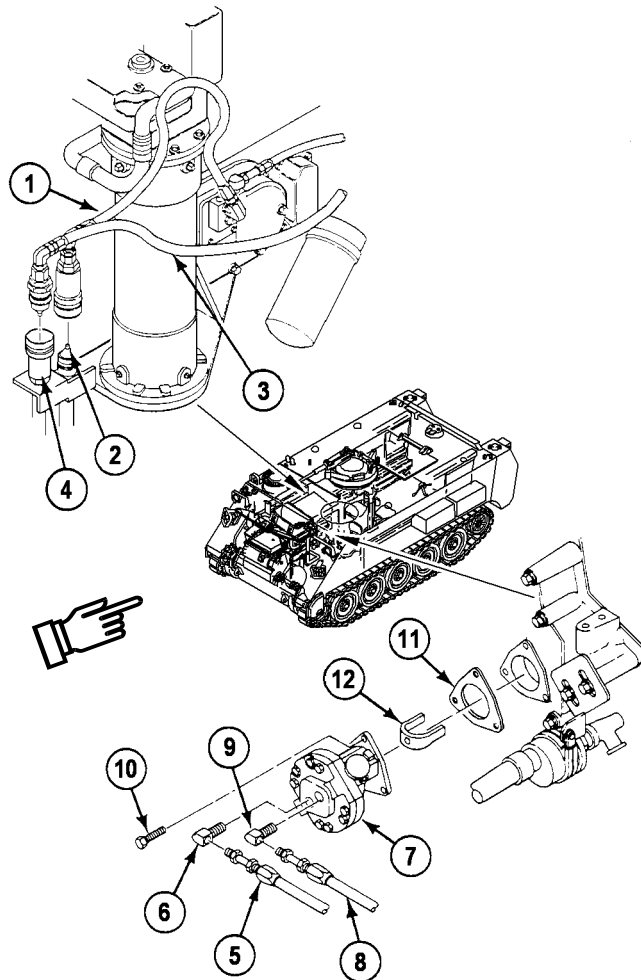

CLEANING

1. Clean fuel pump body (1) and fittings with cleaning compound.

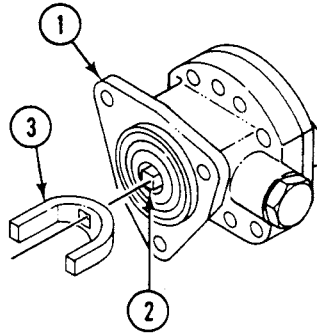
**INSPECTION-ACCEPTANCE AND REJECTION CRITERIA**

1. Check fuel pump body (1).
2. Check end of shaft (2)
3. Check fork (3).

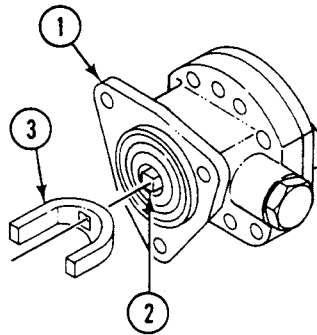
**REPAIR**

1. Replace fuel pump body (1) if damaged.
2. Replace shaft (2) that is worn or does not rotate smoothly.
3. Replace fork (3) if worn or damaged.

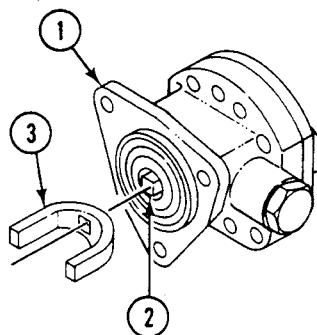

INSTALLATION

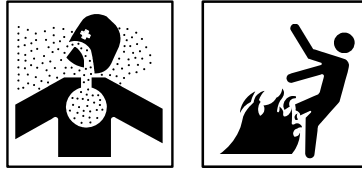
WARNING

Adhesive, primer, sealant compounds, and isopropyl alcohol are toxic and flammable. These compounds are toxic to eyes, skin, and respiratory tract. Continued exposure can make you dizzy and irritate your eyes and throat.

Always use in well ventilated areas, away from heat, sparks, and flames. Do not breathe fumes. Do not allow into contact with skin and eyes. Use goggles or face shield and protective gloves.

1. Apply adhesive to external threads of hoses (4) and (5) and elbows (6) and (7).
2. Install fork (3), new gasket (8), fuel pump (1) and three screws (9) on engine block.
3. Install elbow (7) in fuel pump (1).
4. Install fuel supply hose (5) on elbow (7).
5. Install elbow (6) in fuel pump (1).
6. Install fuel supply hose (4) on elbow (6).
7. Install fuel supply hose (10) at quick disconnect (11).
8. Install fuel return hose (12) at quick disconnect (13).

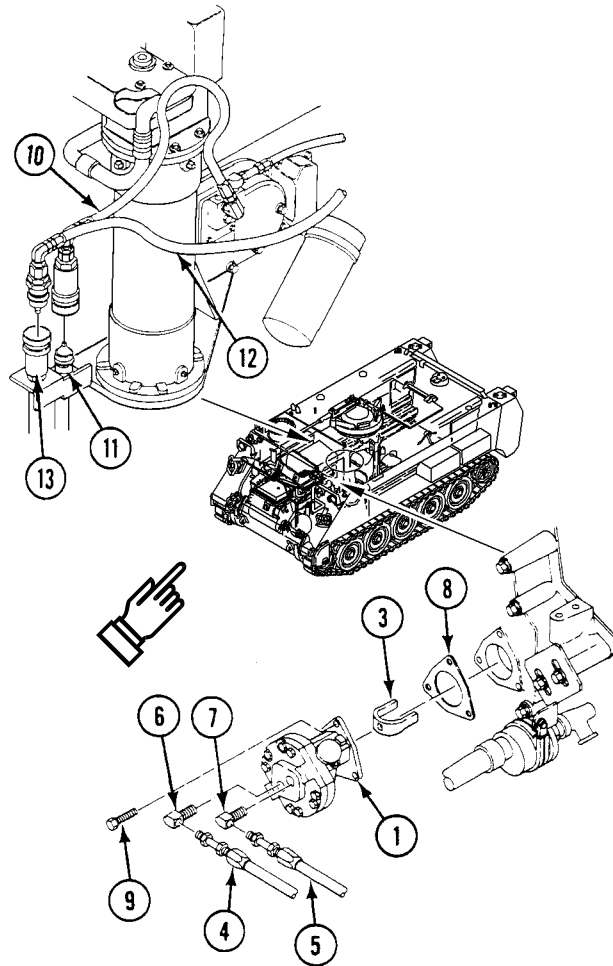

FOLLOW-THROUGH STEPS

1. Install left exhaust elbow (WP 0225 00).
2. Connect battery ground strap (WP 0337 00 or WP 0338 00).

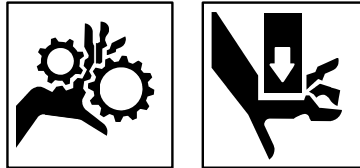
WARNING

Moving parts of power unit can seriously injure you.

Clear personnel away from power unit before startup. Stay clear of moving parts when power unit is running.

3. Start engine. See TM 9-2350-277-10. Check for leaks. Check for correct fuel pump operation.
4. Stop engine. See TM 9-2350-277-10.
5. Install power plant rear access panels (WP 0439 00).
6. Close power plant access door. See TM 9-2350-277-10.

END OF TASK

SERVICE AIR CLEANER FILTER ELEMENT

0167 00

THIS WORK PACKAGE COVERS:

Servicing (page 0167 00-1).

INITIAL SETUP:

Maintenance Level

Unit

References

See your -10

Tools and Special Tools

General Mechanic's Tool Kit (WP 0926 00, Item 65)
 Suitable Container

Equipment Condition

Engine stopped (see your -10)

Materials/Parts

Detergent (WP 0928 00, Item 35)

Carrier blocked (see your -10)

Personnel Required

Unit Mechanic

Air cleaner element removed (see your -10)

SERVICING

WARNING

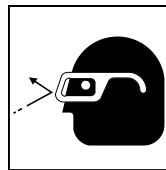

Air pressure in excess of 30 psi (207 kpa) can injure personnel. Do not direct pressurized air at yourself or others. Always wear goggles.

NOTE

Cleaning air filter element may be cleaned by either or both of the following methods.

1. Using air gun, blow out element with 30 psi (206 kpa) maximum compressed air from inside to outside of element (in direction opposite to normal air flow).

2. Wash element in solution of nonsudsing or low sudsing detergent and water or soap and water. Do not use gasoline or solvents for cleaning.
 - a. Prepare solution of 1 cup of dry detergent to 5 gallons of water in a container large enough to completely submerge the element. The temperature of the solution should not exceed 190°F (88°C). Make solution stronger if element is extremely dirty.
 - b. Immerse element completely in the washing solution. Agitate element gently for 2 minutes.
 - c. Allow element to soak in solution for a minimum of 15 minutes. Agitate element gently for an additional 3 to 5 minutes.
 - d. Remove element from solution and allow to drain.
 - e. Rinse element with cold water from a hose with a maximum 45 psi (310 kpa) water pressure from inside to outside of element. Continue rinsing until water runs clear and detergent or soap residue is removed from element.
 - f. Allow element to air dry thoroughly.

FOLLOW-THROUGH STEPS

1. Install air cleaner element (see your -10).

END OF TASK

REPLACE AIR CLEANER AND ELBOW

0168 00

THIS WORK PACKAGE COVERS:

Removal (page 0168 00-2).
 Installation (page 0168 00-7).

INITIAL SETUP:

Maintenance Level

Unit

Personnel Required

Unit Mechanic

Tools and Special Tools

General Mechanic's Tool Kit (WP 0926 00, Item 65)
 Torque Adapter (WP 0926 00, Item 1)
 Torque Wrench (WP 0926 00, Item 85)
 Torque Wrench (WP 0926 00, Item 86)

References

TM 9-2350-277-10

Materials/Parts

Lockwasher (2)
 Lockwasher (3)
 Locknut (10)
 Resilient mount (2)
 Tie strap
 Decal

Equipment Condition

Engine stopped (see your —10)
 Carrier blocked (see your —10)
 Power plant grill raised (WP 0464 00)

REMOVAL

1. Disconnect two hoses (1) from elbows (2) on air cleaner elbow (3). Remove two elbows (2) from tee (4).
2. Remove tee (4) from air cleaner elbow (3).
3. Remove tie strap (5) securing two hoses (1) to air duct (6). Discard tie strap.

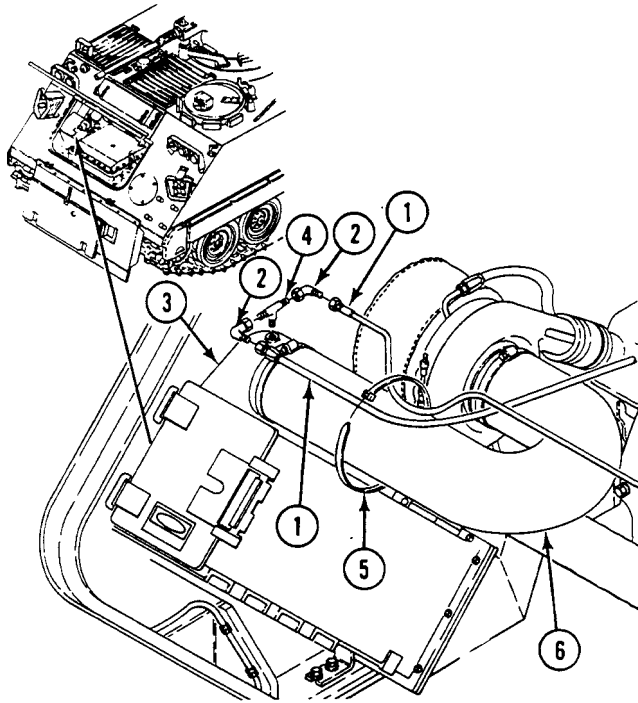

4. Loosen two clamps (1) securing air duct (2) to air cleaner elbow (3) and turbocharger (4).
5. Remove air duct (2) from air cleaner elbow (3) and turbocharger (4).

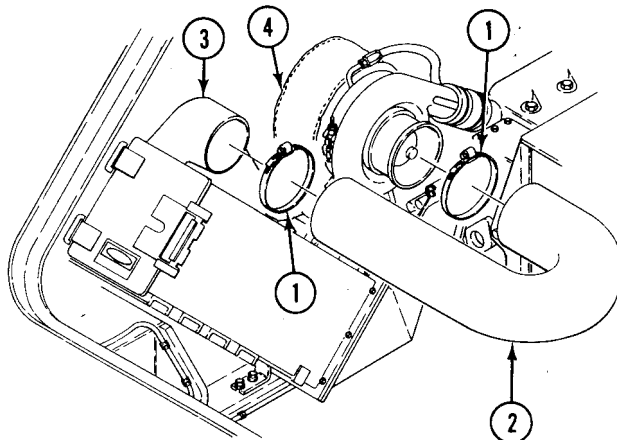

6. Remove two clamps (5) from right exhaust elbow (6). Remove exhaust elbow from exhaust manifold (7) and turbocharger inlet (8).

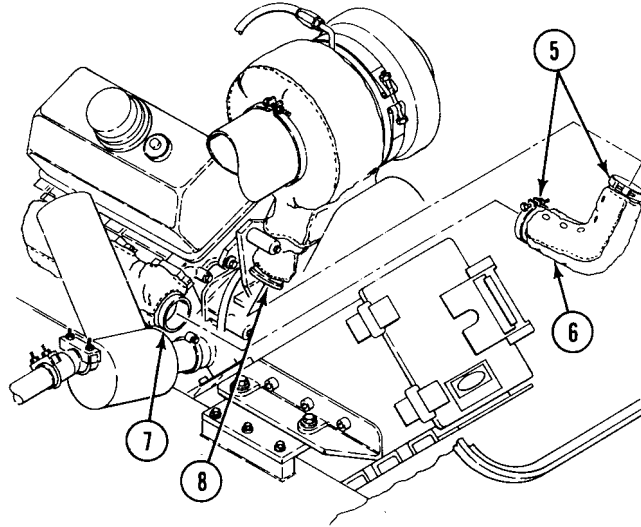

7. Loosen two clamps (9) securing hose (10) to air cleaner lower elbow (11) and exhaust evacuator valve (12).
8. Loosen clamp (13) securing evacuator valve (12) to connector (14). Move valve towards air cleaner elbow and remove valve.
9. Remove clamp (15) and duct (16) from air cleaner elbow (17).

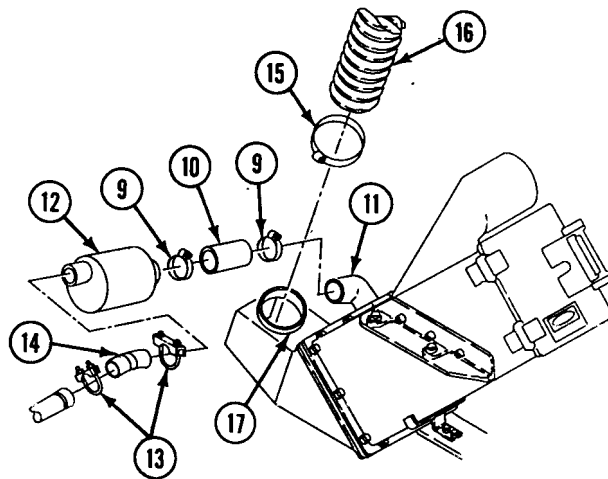

REPLACE AIR CLEANER AND ELBOW — Continued

0168 00

10. Open and remove air cleaner door (18).
11. Release air cleaner element retainer (19) and remove air cleaner element (20).

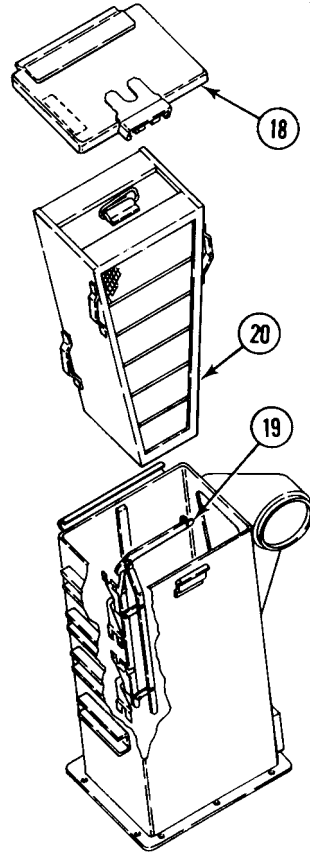

12. Remove three screws (1) and washers (2) securing bracket (3) to air cleaner (4).
13. Remove three screws (5), washers (6), and bracket (3) and (7) from sponson (8).

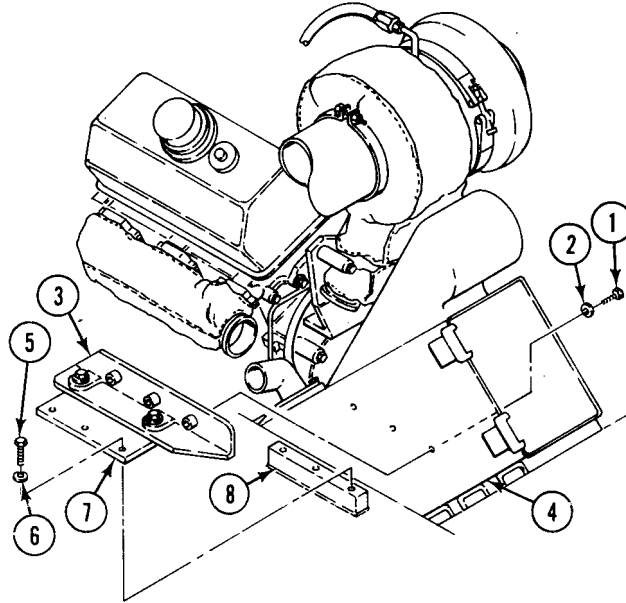

14. Remove two screws (9), lockwashers (10), washers (11), and air cleaner support (12) from box beam. Discard lockwashers.
15. Remove air cleaner (4) from carrier.

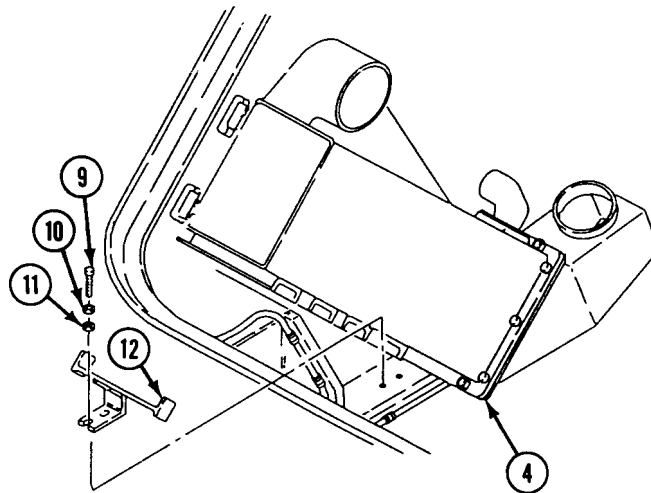

16. Remove three screws (13), lockwashers (14), washers (15), and adapter (16) from air cleaner (4). Discard lockwashers.

NOTE

The four screws at the top and bottom edges of the air cleaner flange are installed with heads down and nuts at top.

17. Remove 10 screws (17), 20 washers (18), 10 locknuts (19), and elbow (20) from air cleaner (4). Discard locknuts.

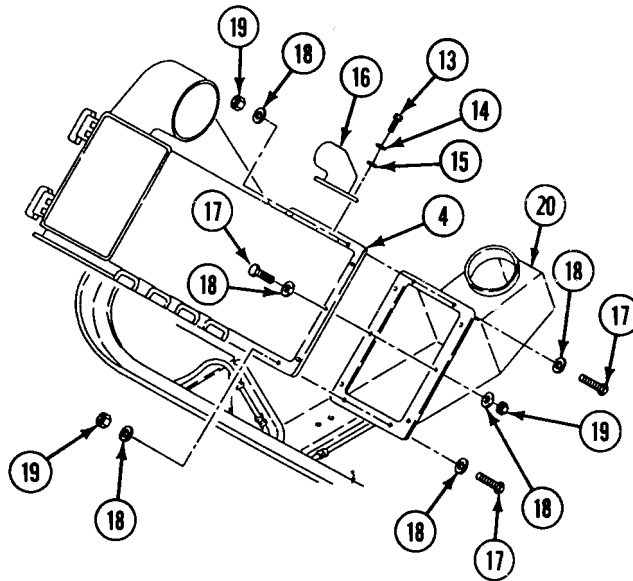

NOTE

Separate brackets only if damaged.

18. Remove two screws (21), washers (22), and resilient mounts (23) from air cleaner bracket (3) and sponson bracket (7). Discard damaged bracket and resilient mounts.

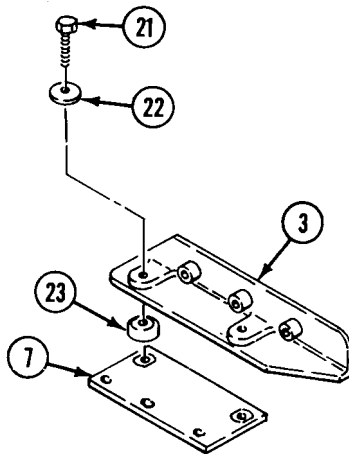

INSTALLATION

NOTE

If separated, reassemble brackets.

1. Lubricate two new resilient mounts (1) with water. Secure air cleaner bracket (2), sponson bracket (3), and two mounts (1) with two screws (4) and washers (5). Do not tighten screws.

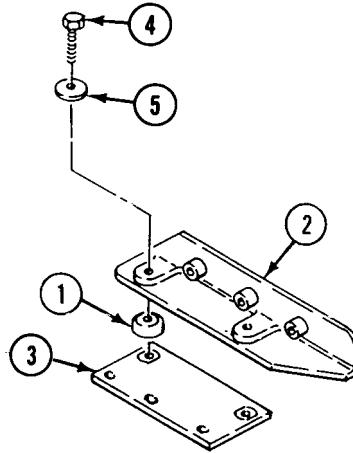

NOTE

The four screws at the top and bottom edges of the air cleaner flange must be installed with heads down and nuts at top.

2. Install elbow (6) on air cleaner (7) and secure with 10 screws (8), 20 washers (9), and 10 new locknuts (10).
3. Install adapter (11) on air cleaner (7) and secure with three screws (12), new lockwashers (13), and washers (14).

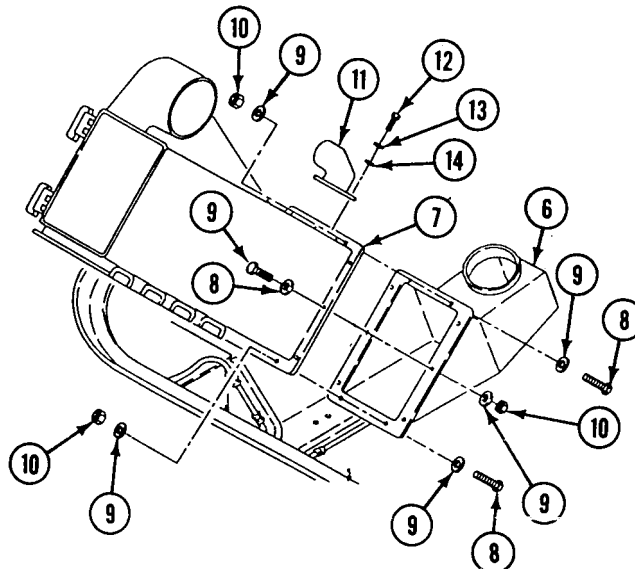

4. Position air cleaner (7) in engine compartment.
5. Position air cleaner support (15) on box beam and secure with two screws (16), new lockwashers (17), and washers (18).

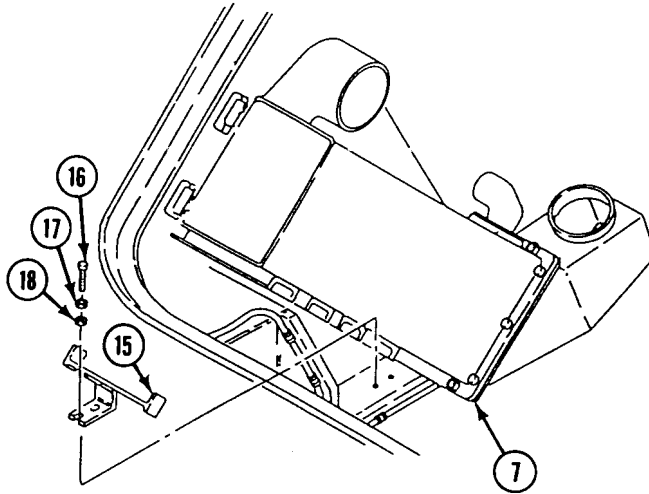

6. Install brackets (1) and (2) on sponson (3) and secure with three screws (4) and washers (5). **TIGHTEN THREE SCREWS TO 32-34 LB-FT (43-46 N·m) TORQUE.**
7. Position air cleaner (6) and air cleaner bracket (1). Secure bracket to air cleaner with three screws (7) and washers (8). **TIGHTEN THREE SCREWS TO 32-34 LB-FT (43-46 N·m) TORQUE.**
8. **TIGHTEN TWO SCREWS (9) TO 25-27 LB-FT (34-37 N·m) TORQUE.**

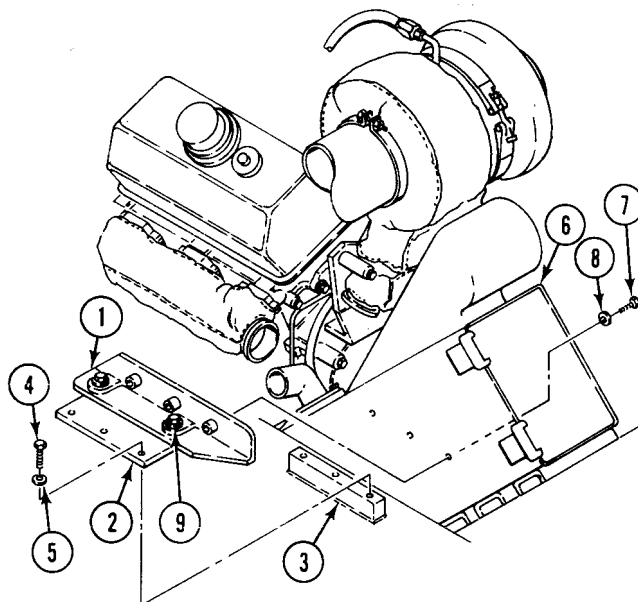

9. Install air cleaner element (10) and reset retainer (11).

NOTE

Install new decal (WP 0644 00) if door is to be replaced. ■

10. Install air cleaner door (12) on air cleaner.

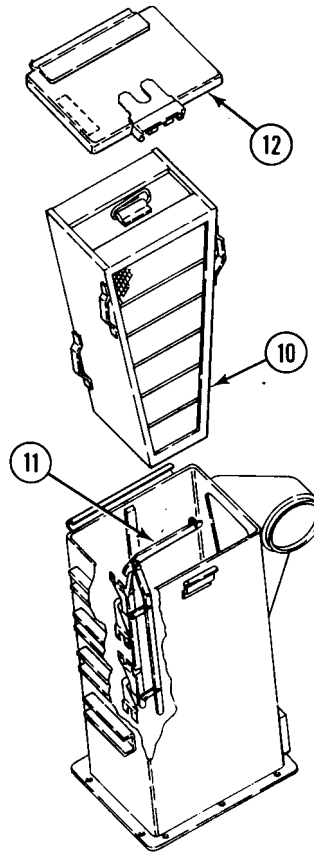

REPLACE AIR CLEANER AND ELBOW — Continued

0168 00

11. Install clamp (13) and duct (14) on air cleaner elbow (15).
12. Position exhaust evacuator valve (16) and hose (17) on elbow (18) and connector (19).
13. Align evacuator valve (16) as indicated on top of valve and tighten two clamps (20) on hose (17).
14. Install and tighten clamp (21) on connector (19).

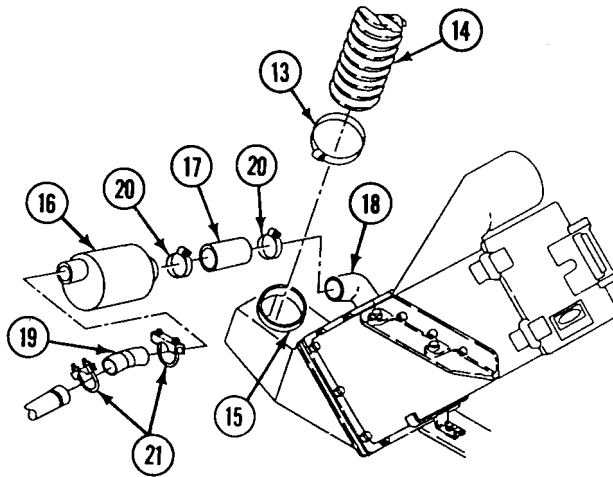

15. Install right exhaust elbow (1) on engine exhaust manifold (2) and turbocharger inlet (3). Secure with two clamps (4).

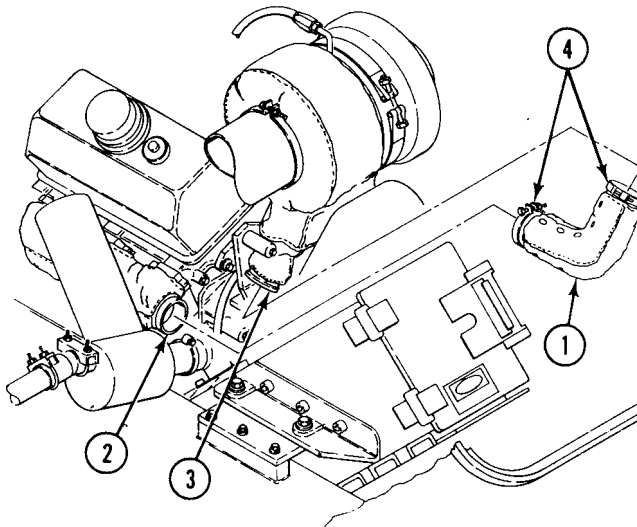

REPLACE AIR CLEANER AND ELBOW — Continued**0168 00**

16. Install air duct (5) between air cleaner elbow (6) and turbocharger (7). Secure air duct with two clamps (8).

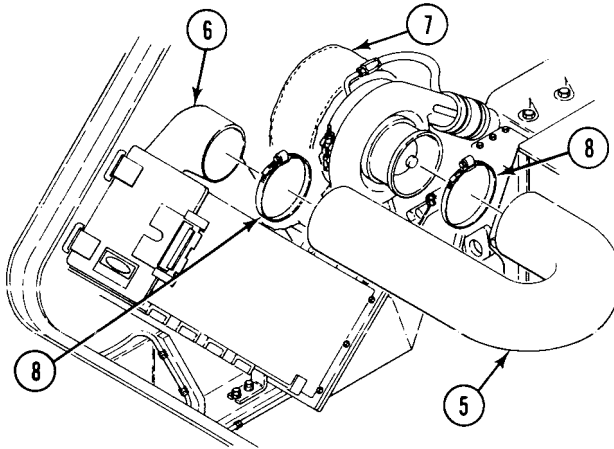

17. Install tee (9) in air cleaner elbow (6). Install two elbows (10) on tee and connect two hoses (11) to elbows. Secure two hoses to air duct (5) with new tie strap (12).

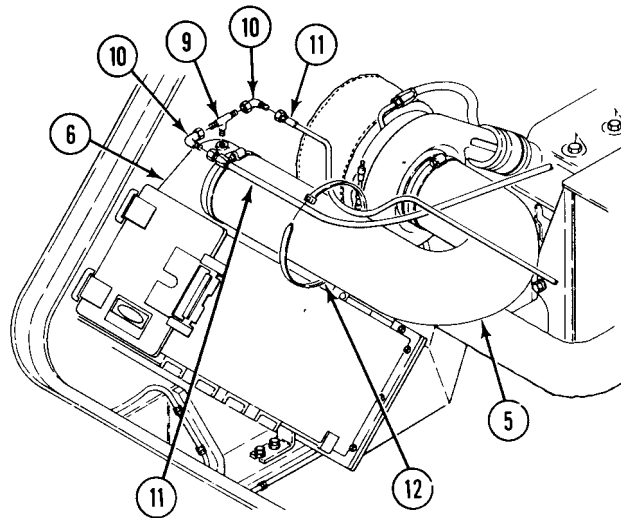
**FOLLOW-THROUGH STEPS**

1. Lower power plant grill (WP 0464 00).

END OF TASK

REPLACE AIR CLEANER DOOR

0169 00

THIS WORK PACKAGE COVERS:

Removal (page 0169 00-1).
 Installation (page 0169 00-2).

INITIAL SETUP:

Maintenance Level

Unit

References

TM 9-2350-277-10

Tools and Special Tools

General Mechanic's Tool Kit (WP 0926 00, Item 65)

Equipment Condition

Engine stopped (TM 9-2350-277-10)

Carrier blocked (TM 9-2350-277-10)

Power plant access door open (TM 9-2350-277-10)

Materials/Parts

Adhesive (WP 0928 00, Item 4)

Gasket

Personnel Required

Mechanic

REMOVAL

1. Remove door (1) from air cleaner (2).
2. Remove gasket (3) from door (1). Discard gasket.

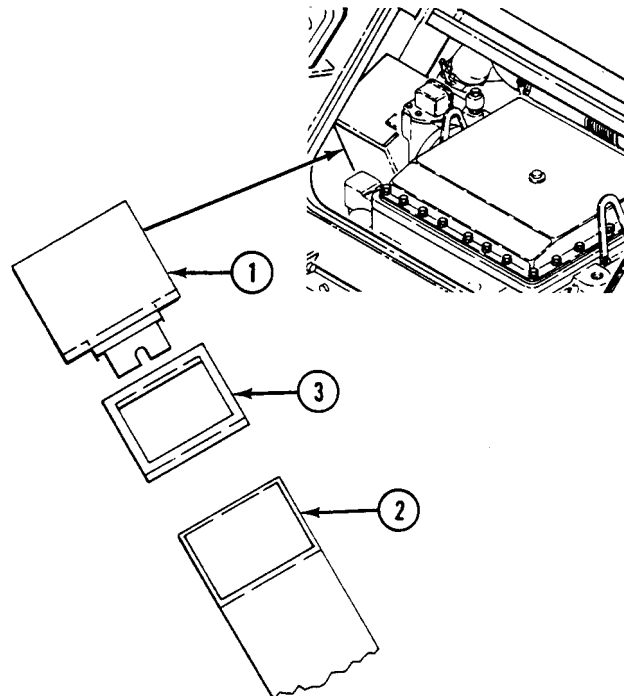

INSTALLATION

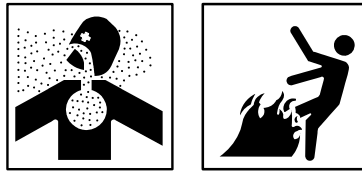
WARNING

Adhesive, primer, sealant compounds, and isopropyl alcohol are toxic and flammable. These compounds are toxic to eyes, skin, and respiratory tract. Continued exposure can make you dizzy and irritate your eyes and throat.

Always use in well ventilated areas, away from heat, sparks, and flames. Do not breathe fumes. Do not allow into contact with skin and eyes. Use goggles or face shield and protective gloves.

NOTE

Clean area on door before installing new gasket.

1. Apply adhesive to new gasket (3).
2. Install new gasket (3) on door (1).
3. Install door (1) on air cleaner (2).

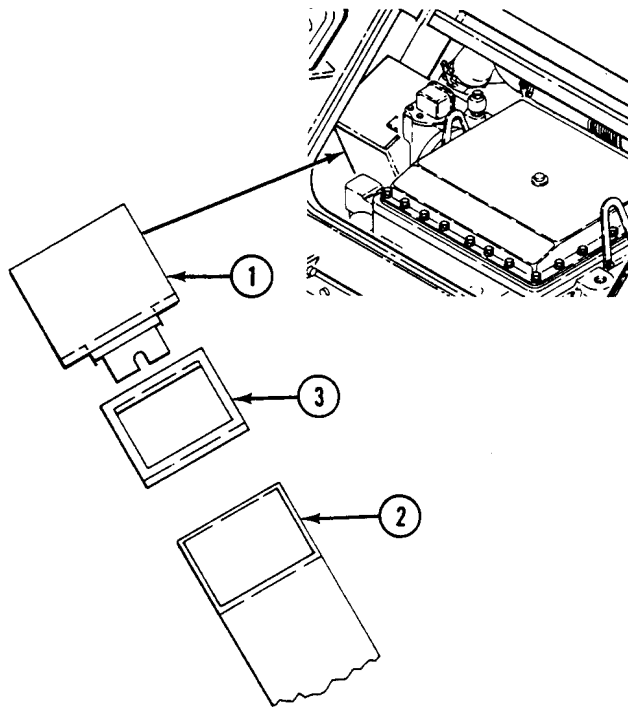
**FOLLOW-THROUGH STEPS**

1. Close power plant access door. See TM 9-2350-277-10.

END OF TASK

REPAIR AIR CLEANER ASSEMBLY

0169 01

THIS WORK PACKAGE COVERS:

Disassembly (page 0169 01-1).
 Assembly (page 0169 01-2).

INITIAL SETUP:

Maintenance Level

Unit

References

TM 9-2350-277-10
 WP 0168 00

Tools and Special Tools

General Mechanic's Tool Kit (WP 0926 00, Item 65)

Equipment Condition

Engine stopped (TM 9-2350-277-10)
 Carrier blocked (TM 9-2350-277-10)
 Power plant access door open (TM 9-2350-277-10)
 Air cleaner removed from carrier (WP 0168 00)

Materials/Parts

Adhesive (WP 0928 00, Item 5)

Personnel Required

Mechanic

DISASSEMBLY

1. Open and remove air cleaner door (1).
2. Release air cleaner element retainer (3) and remove air cleaner element (2).

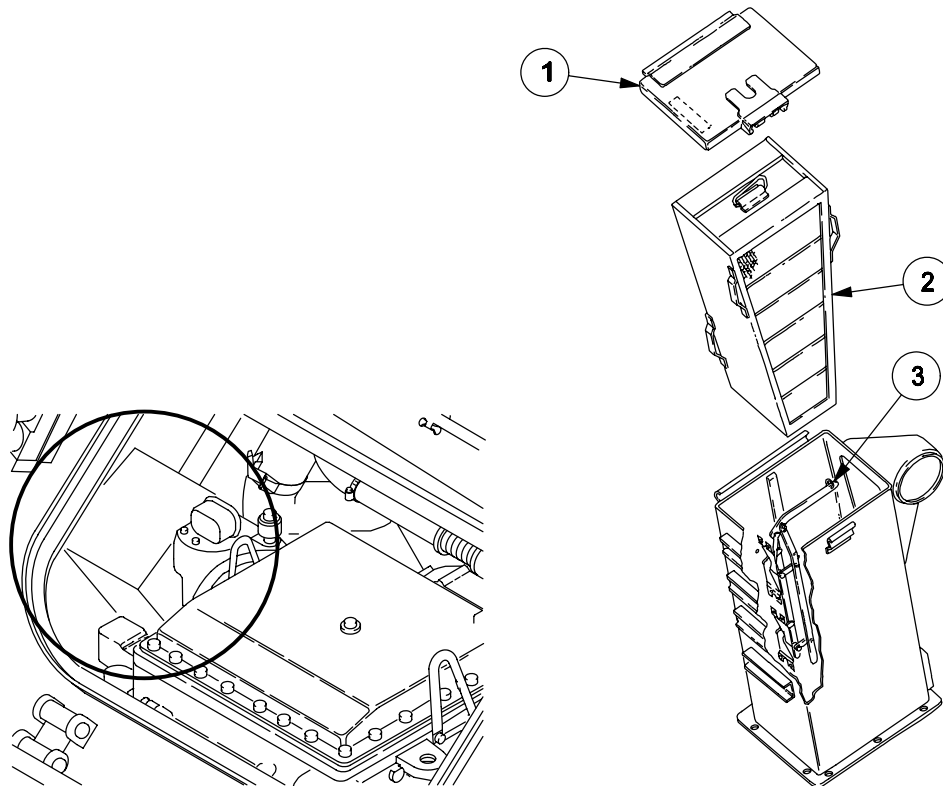

3. Remove intake (1) from bottom end of the air cleaner housing (2). Discard intake.
4. Remove old adhesive from air cleaner housing using a scraper. Clean up any debris from the interior of the air cleaner housing.

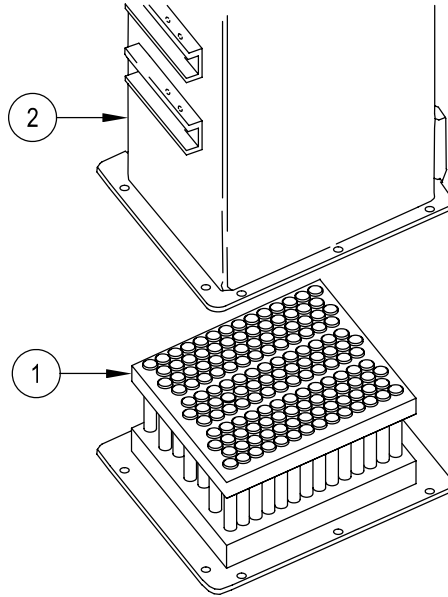

ASSEMBLY

1. Identify the location of the “T” marking (3) on the flange of the intake (4).
2. Identify the location of the “T” marking (1) on the flange of the air cleaner housing (2).
3. Position the “T” on the intake (4) so that it lines up with the “T” on the air cleaner housing (2).

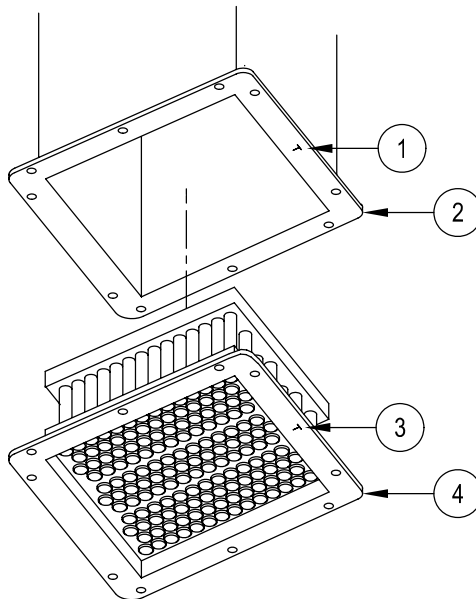

WARNING

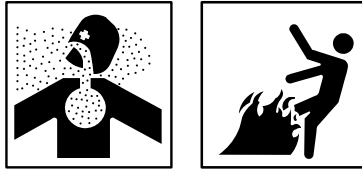

Adhesive, primer, sealant compounds, and isopropyl alcohol are toxic and flammable. These compounds are toxic to eyes, skin, and respiratory tract. Continued exposure can make you dizzy and irritate your eyes and throat.

Always use in well ventilated areas, away from heat, sparks, and flames. Do not breathe fumes. Do not allow into contact with skin and eyes. Use goggles or face shield and protective gloves.

4. Apply a bead of adhesive on the inside flange of the intake (1) (or on the flange of the air cleaner housing).

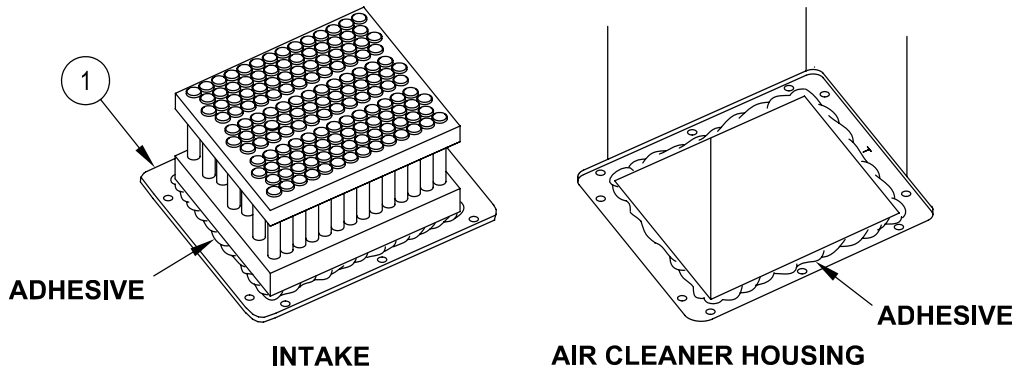

5. Insert the intake (1) into the air cleaner housing (2) by pushing it gently by hand until the intake flange (4) contacts the flange (3) on the air cleaner housing. Wipe off any excess adhesive.
6. Reaching from the top opening of the air cleaner housing (2), apply a bead of adhesive around the outer edges of the intake (1) where it contacts the air cleaner housing (2). The bead of adhesive should be approximately 1/4 in. (6 mm) wide, and it should flow into the joint and adhere to the metal to provide an "airtight seal."

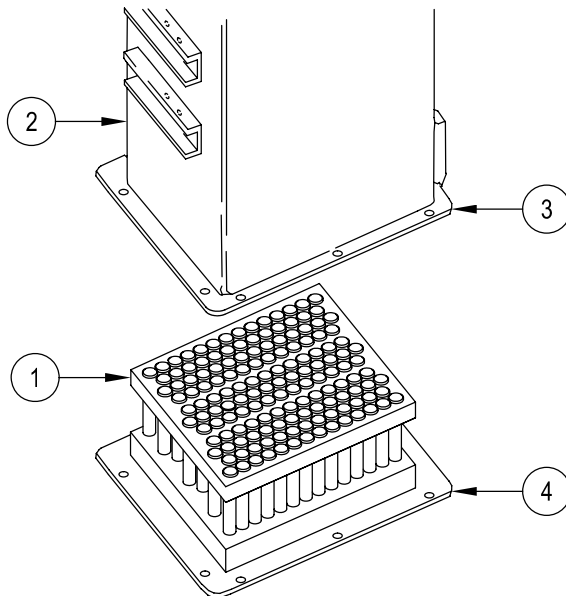

REPAIR AIR CLEANER ASSEMBLY — Continued**0169 01**

7. Open air cleaner element retainer (3) and install air cleaner element (2) into housing.
8. Install air cleaner door (1) and secure with latch.
9. Let adhesive dry for eight hours before operating.

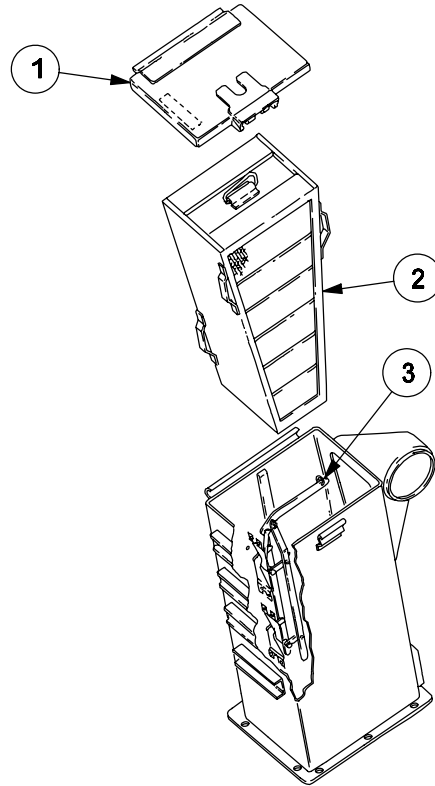
**FOLLOW-THROUGH STEPS**

1. Install air cleaner (WP 0168 00).
2. Close power plant access door. See TM 9-2350-277-10.

END OF TASK

REPAIR AIR CLEANER RETAINER

0170 00

THIS WORK PACKAGE COVERS:

Removal (page 0170 00-1).
 Installation (page 0170 00-2).

INITIAL SETUP:

Maintenance Level

Unit

References

TM 9-2350-277-10

Tools and Special Tools

General Mechanic's Tool Kit (WP 0926 00, Item 65)

Equipment Condition

Engine stopped (TM 9-2350-277-10)
 Carrier blocked (TM 9-2350-277-10)
 Power plant access door open (TM 9-2350-277-10)
 Air cleaner door removed (TM 9-2350-277-10)

Materials/Parts

Lockwasher (8)

Personnel Required

Mechanic

REMOVAL

1. Release retainer handle (1) and slide out filter element (2).
2. Remove eight nuts (3), lockwashers (4), and screws (5) from retainer (6) and housing (7). Remove retainer from housing. Discard lockwashers.

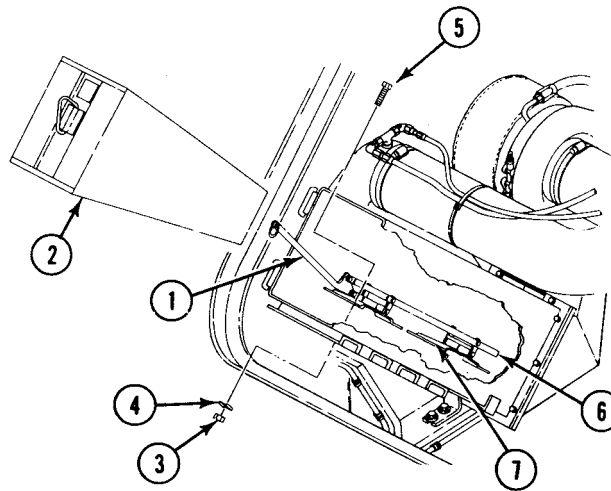

INSTALLATION

1. Position new retainer (6) into housing (7). Secure with eight screws (5), new lockwashers (4), and nuts (3). Tighten all nuts at this time.

NOTE

Check operation of retainer to make sure there is no binding during operation. If binding occurs, loosen screws and repeat Step 1.

2. Install filter element (2) and reset retainer handle (1).

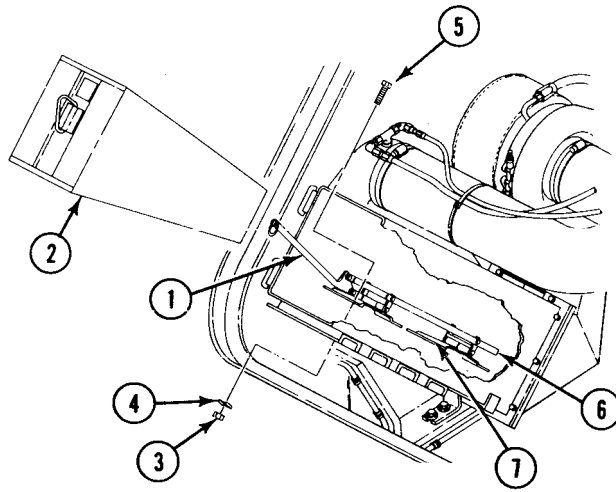
**FOLLOW-THROUGH STEPS**

1. Install air cleaner door. See TM 9-2350-277-10.
2. Close power front access door. See TM 9-2350-277-10.

END OF TASK

REPLACE AIR CLEANER RESTRICTION INDICATOR

0171 00

THIS WORK PACKAGE COVERS:

Removal (page 0171 00-1).
 Installation (page 0171 00-2).

INITIAL SETUP:

Maintenance Level

Unit

References

See your -10

Tools and Special Tools

General mechanic's tool kit (WP 0926 00, Item 65)

Equipment Condition

Engine stopped (see your -10)

Carrier blocked (see your -10)

Driver's power plant access panel removed
 (see your -10)

Materials/Parts

Locknut (2)

Personnel Required

Unit Mechanic

REMOVAL

1. Remove air cleaner restriction indicator hose (1) from indicator adapter (2). Tape end of hose.
2. Remove two screws (3), four washers (4), and two locknuts (5) from indicator (6). Remove indicator. Discard locknuts. Remove adapter (2) from indicator (6).

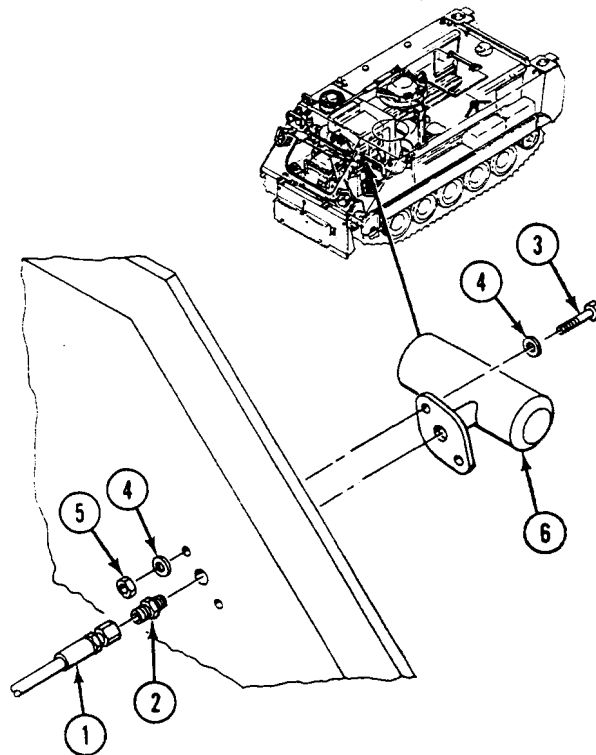

INSTALLATION

1. Remove and reuse the modified adapter (2) with a filter disc. Install adapter (2) in indicator (6).
2. Install restriction indicator (6), two screws (3), four washers (4), and two new locknuts (5).
3. Install hose (1) on indicator adapter (2).

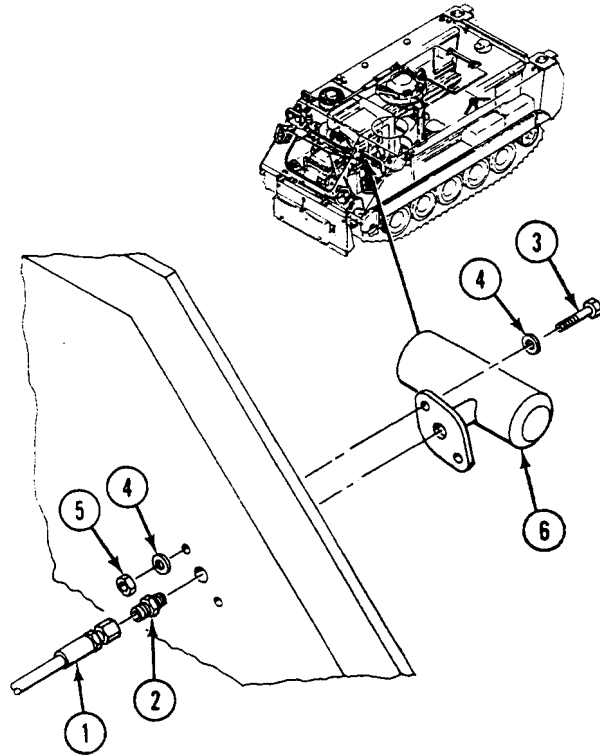
**FOLLOW-THROUGH STEPS**

1. Install driver's power plant access panel (see your -10).

END OF TASK

REPLACE AIR CLEANER RESTRICTION INDICATOR HOSE

0172 00

THIS WORK PACKAGE COVERS:

Removal (page 0172 00-1).
 Installation (page 0172 00-3).

INITIAL SETUP:

Maintenance Level

Unit

References

TM 9-2350-277-10

Tools and Special Tools

General Mechanic's Tool Kit (WP 0926 00, Item 65)

Equipment Condition

Engine stopped (TM 9-2350-277-10)

Carrier blocked (TM 9-2350-277-10)

Power plant access door open (TM 9-2350-277-10)

Materials/Parts

Sealing compound (WP 0928 00, Item 56)

Tie strap

Personnel Required

Mechanic

REMOVAL

NOTE

For removal with air box heater engine, perform REMOVAL Steps 1 - 7.

For removal with a glow plug engine, perform REMOVAL Steps 8 - 11.

1. Disconnect air cleaner restrictor indicator hose (1) from indicator adapter (2).
2. Remove tie strap (3) from hose (1) and air intake elbow (4). Discard tie strap.

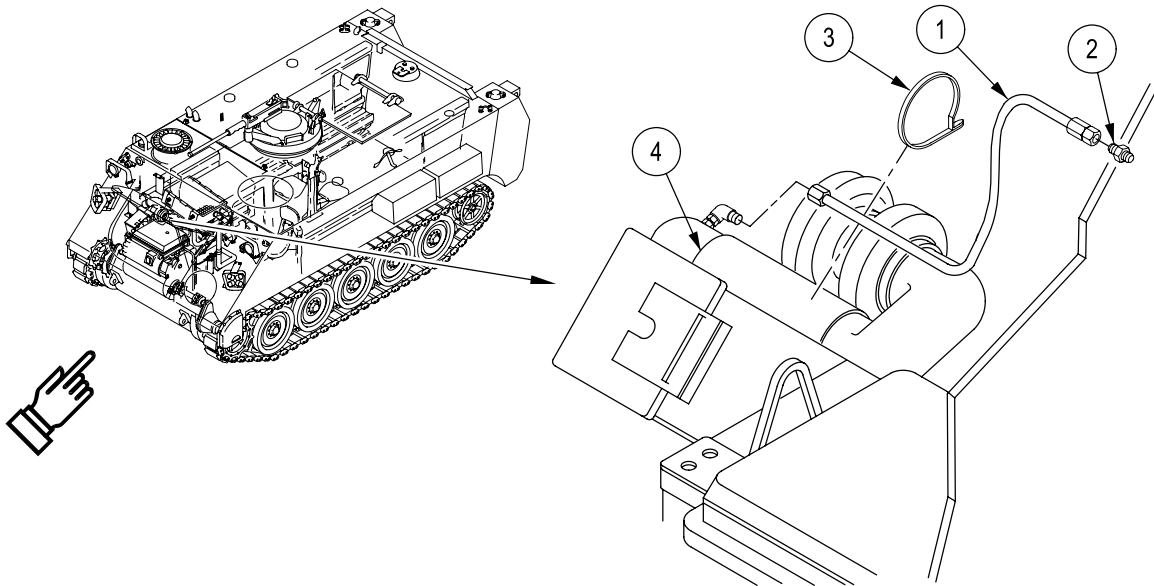

3. Remove hose (1) from reducer (5).
4. Remove nut (6) and reducer (5) from elbow (7).
5. Remove elbow (7) from indicator side of tee (8).
6. Remove hose (9) from elbow (10).
7. Remove tee (8) from reducer (11) and elbow (10).

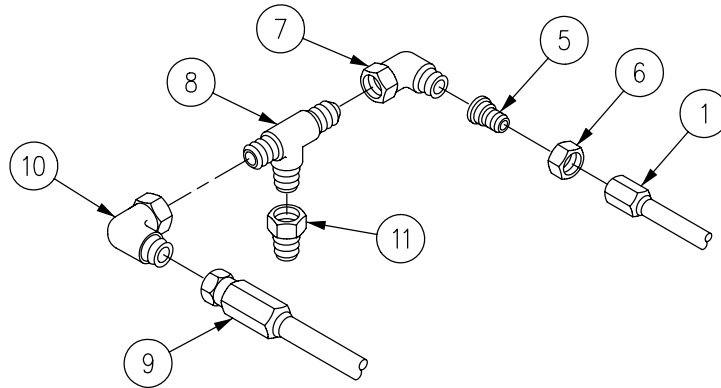

8. Remove indicator hose (3) from elbow (2).
9. Remove elbow (2) and adapter (1).
10. Remove indicator hose (3) from indicator adapter (4).
11. Remove tie strap (5) from hose (3) and remove hose from vehicle. Discard tie strap.

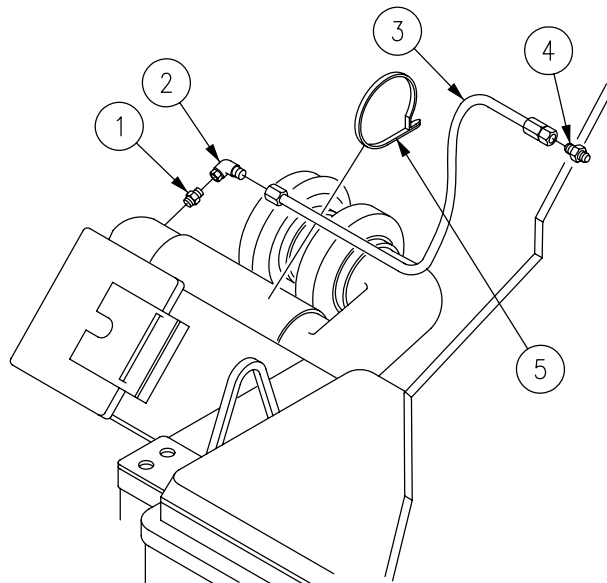

INSTALLATION

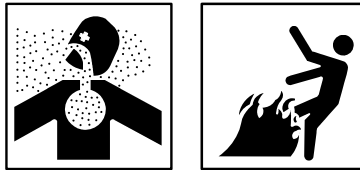
WARNING

Adhesive, primer, sealant compounds, and isopropyl alcohol are toxic and flammable. These compounds are toxic to eyes, skin, and respiratory tract. Continued exposure can make you dizzy and irritate your eyes and throat.

Always use in well ventilated areas, away from heat, sparks, and flames. Do not breathe fumes. Do not allow into contact with skin and eyes. Use goggles or face shield and protective gloves.

NOTE

For installation with air box heater engine, perform INSTALLATION Steps 1 - 8.

For installation with a glow plug engine, perform INSTALLATION Steps 9 - 12.

1. Apply light coat of sealing compound to pipe threads of tee (1). Install tee on reducer (2).
2. Install elbow (3) on tee (1).
3. Install hose (4) on elbow (3).
4. Install elbow (5) on tee (1).
5. Install reducer (6) and nut (7) on elbow (5).
6. Install hose (8) on reducer (6).
7. Install new tie strap (9) on hose (8) and elbow (10).
8. Connect hose (8) to indicator adapter (11).

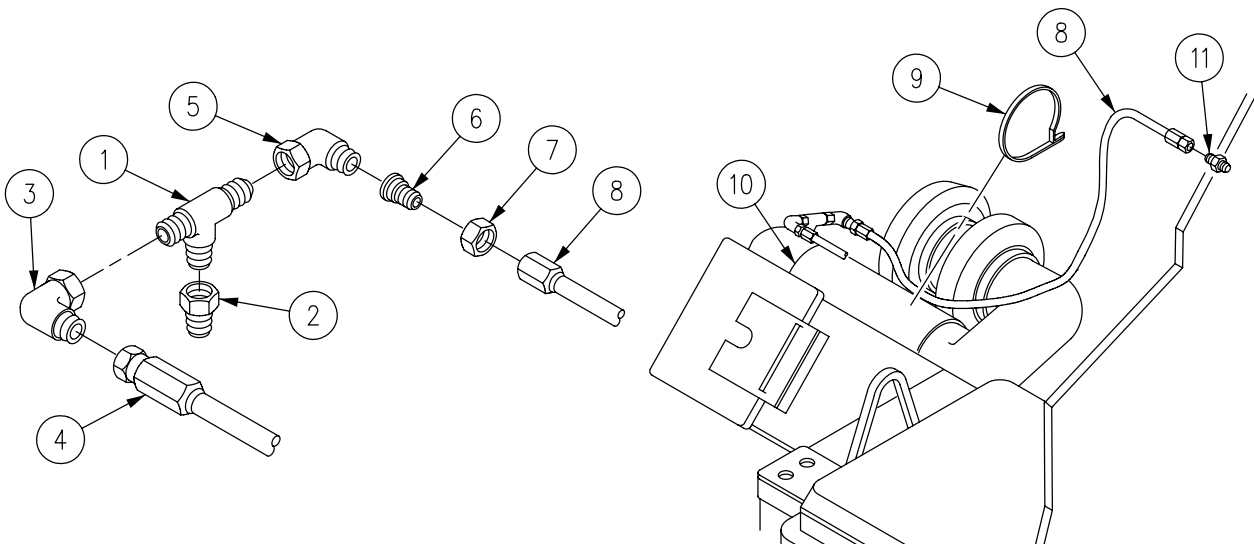

REPLACE AIR CLEANER RESTRICTION INDICATOR HOSE — Continued**0172 00**

9. Install adapter (2) and elbow (3) on air cleaner (1).
10. Install hose (4) on elbow (3).
11. Install hose (4) on indicator adapter (5).
12. Secure hose (4) on air cleaner duct (6) with a new tie strap (7).

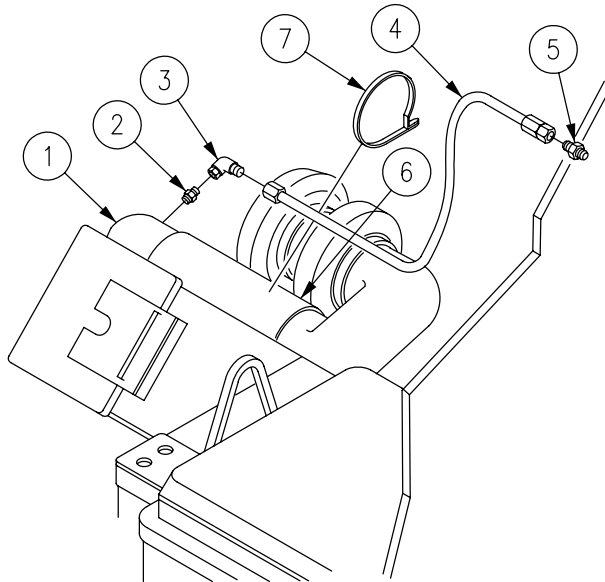
**FOLLOW-THROUGH STEPS**

1. Close power plant access door. See TM 9-2350-277-10.

END OF TASK

REMOVE/INSTALL AIR INTAKE ELBOW

0173 00

THIS WORK PACKAGE COVERS:

Removal (page 0173 00-1).
 Installation (page 0173 00-2).

INITIAL SETUP:

Maintenance Level
 Unit

References
 See your -10

Tools and Special Tools
 General mechanic's tool kit (WP 0926 00, Item 65)

Equipment Condition
 Engine stopped (see your -10)
 Carrier blocked (see your -10)
 Power plant grill raised (WP 0464 00)

Materials/Parts
 Strap

Personnel Required
 Unit Mechanic

REMOVAL

1. Remove strap (1), from air intake elbow (2) and air restriction indicator hose (3). Discard strap.
2. Loosen two clamps (4) and remove air intake elbow (2) from turbocharger inlet (5) and air cleaner (6).

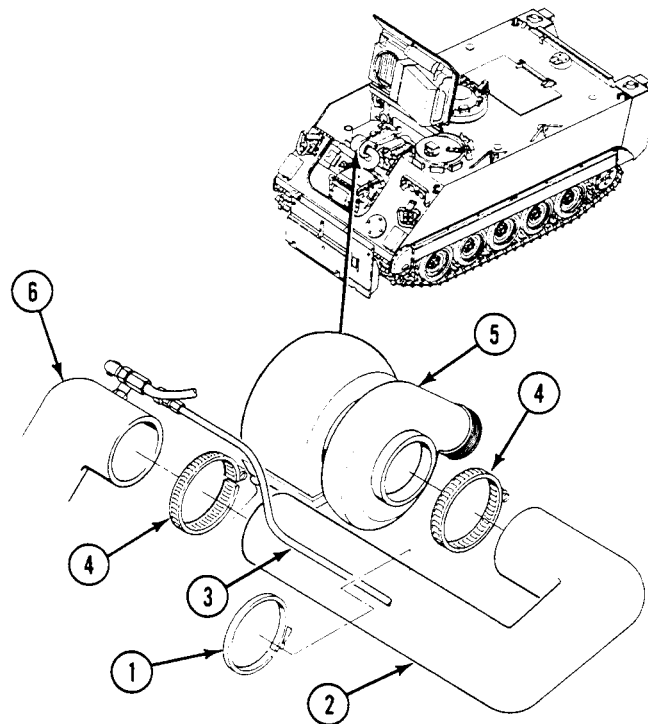

INSTALLATION

1. Install air intake elbow (2) on turbocharger inlet (5) and air cleaner (6). Secure with two clamps (4).
2. Install new strap (1) to secure air restriction hose (3) to air intake elbow (2).

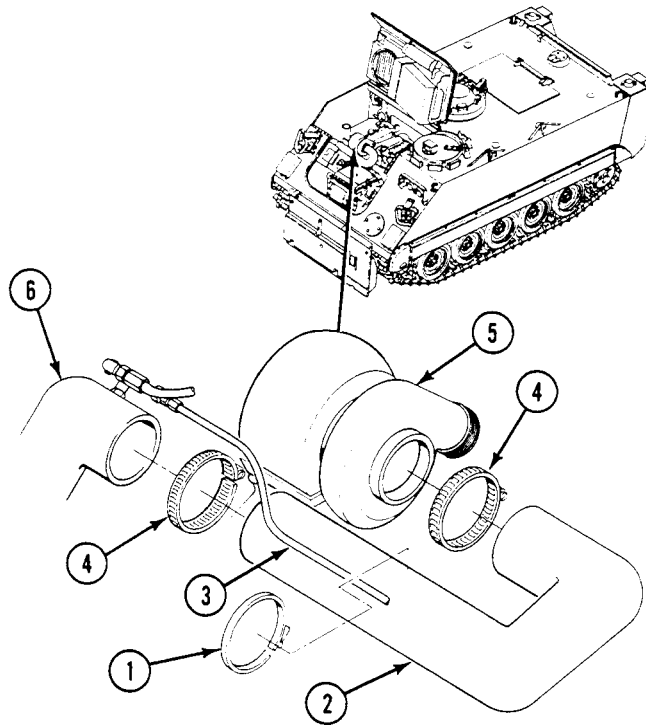
**FOLLOW-THROUGH STEPS**

1. Lower power plant grill (WP 0464 00).

END OF TASK

REPLACE GRILL AIR INTAKE ELBOW AND HOSE

0174 00

THIS WORK PACKAGE COVERS:

Removal (page 0174 00-1).
 Installation (page 0174 00-2).

INITIAL SETUP:

Maintenance Level

Unit

References

See your -10

Tools and Special Tools

General mechanic's tool kit (WP 0926 00, Item 65)

Equipment Condition

Engine stopped (see your -10)
 Carrier blocked (see your -10)
 Power plant grill raised (WP 0464 00)

Personnel Required

Unit Mechanic

REMOVAL

1. Remove two clamps in tandem (1), from elbow (2) and bracket (3) on power plant grill (4).
2. Remove clamp (5) from intake hose (6) and plenum (7).
3. Remove clamp (8) from intake hose (6) and elbow (2).

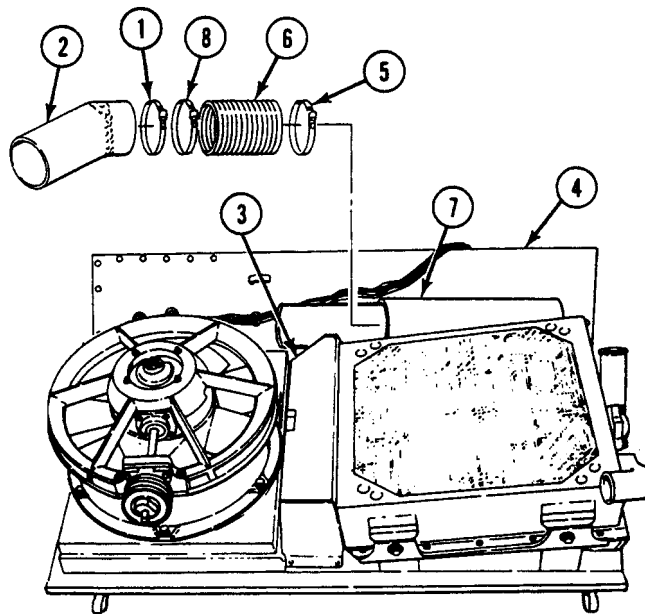

INSTALLATION

1. Install air intake hose (6) on elbow (2). Secure with clamp (8).
2. Install hose (6) on plenum (7). Secure with clamp (5).
3. Secure elbow (2) to bracket (3) on grill (4) with two clamps in tandem (1).

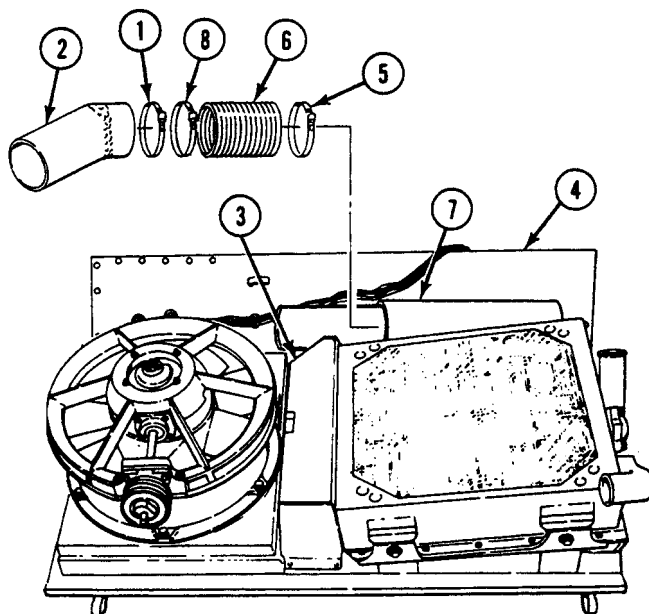
**FOLLOW-THROUGH STEPS**

1. Lower power plant grill (WP 0464 00).

END OF TASK

REPLACE EXHAUST EVACUATOR VALVE AND CONNECTOR

0175 00

THIS WORK PACKAGE COVERS:

Removal (page 0175 00-1).
 Installation (page 0175 00-2).

INITIAL SETUP:

Maintenance Level

Unit

References

TM 9-2350-277-10
 WP 0464 00

Tools and Special Tools

General Mechanic's Tool Kit (WP 0926 00, Item 65)
 Torque Wrench (WP 0926 00, Item 85)

Equipment Condition

Engine stopped (TM 9-2350-277-10)
 Carrier blocked (TM 9-2350-277-10)
 Power plant access door open (TM 9-2350-277-10)
 Power plant grill raised (WP 0464 00)

Materials/Parts

Clamp (2)
 Lockwasher (2)

Personnel Required

Mechanic

REMOVAL

1. Remove three screws (1) and washers (2) holding air cleaner support (3) to sponson.
2. Remove two screws (4), lockwashers (5), washers (6), and air cleaner support (7). Discard lockwashers.

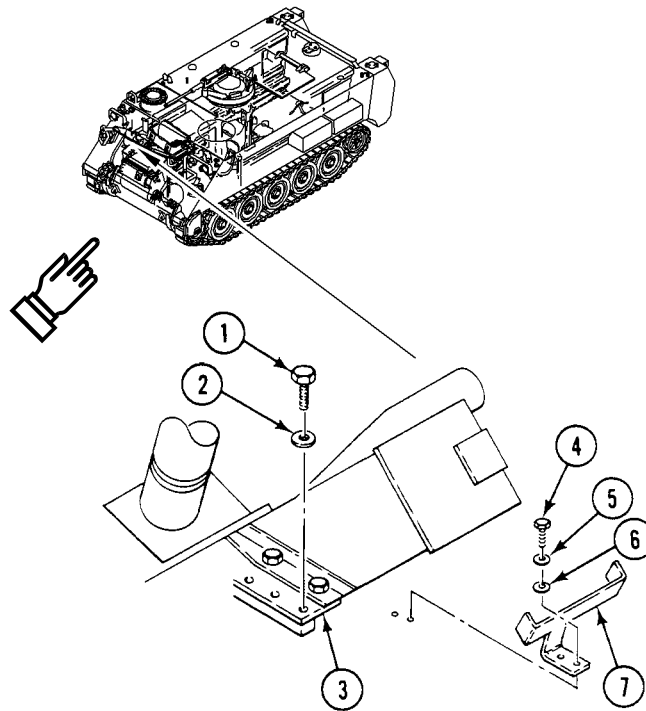

3. Loosen two clamps (8) securing hose (9) to evacuator valve (10) and air cleaner adapter (11). Slide hose (9) onto evacuator (10).
4. Remove two clamps (12) securing connector (13) to muffler (14) and evacuator valve (10). Discard clamps.
5. Move air cleaner against power plant. Remove connector (13) and valve (10) from muffler (14). Separate connector and valve. Remove clamps (8) and hose (9) from valve.

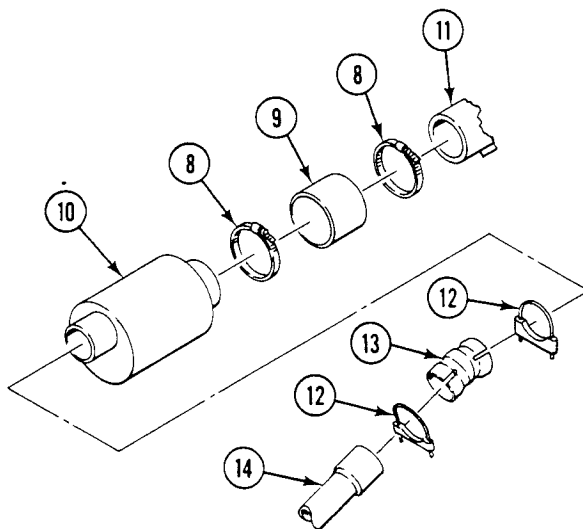

INSTALLATION

1. Join valve (1) and connector (2). Install hose (3) on valve (1). Install clamps (4) and valve (1).
2. Move air cleaner (5) against power plant. Install connector (2) and valve (1) on muffler (6).

NOTE

The position of the lettering may be within ± 1.5 inch (3.81 cm) of the top.

3. Rotate valve (1) and connector (2) until the lettering is on the top and the drain is on the bottom.
4. Secure connector (2) to muffler (6) and valve (1) with two new clamps (7).

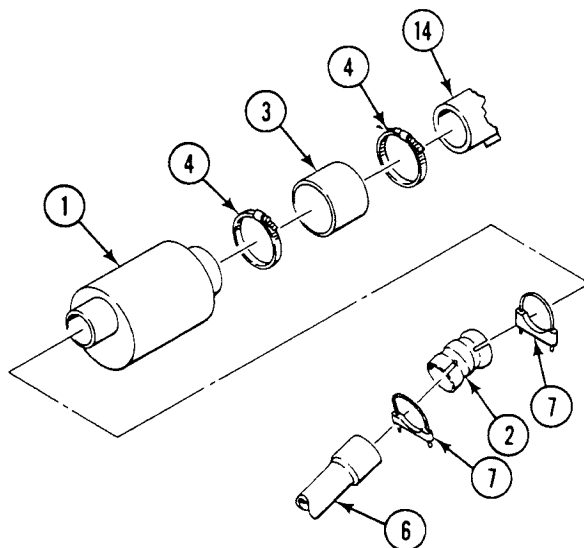

REPLACE EXHAUST EVACUATOR VALVE AND CONNECTOR — Continued**0175 00**

5. Move air cleaner (5) in position. Secure air cleaner to sponson with three screws (8) and washers (9). TORQUE SCREWS TO 32-34 LB-FT (43-46 N·M). USE TORQUE WRENCH.
6. Install support (10), two screws (11), new lockwashers (12), and flat washers (13).
7. Slide hose (3) on valve onto air cleaner adapter (14). Secure hose with two clamps (4).

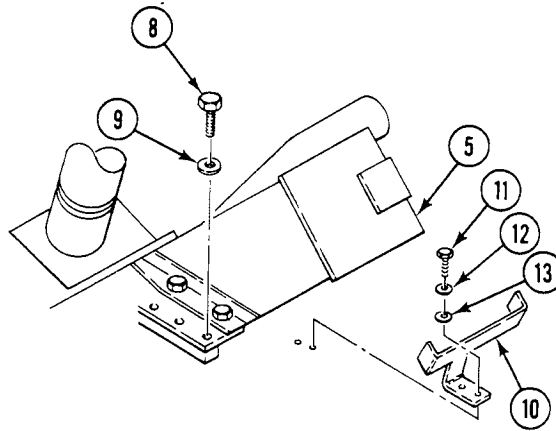
**FOLLOW-THROUGH STEPS**

1. Lower power plant grill (WP 0464 00).
2. Close power plant access door. See TM 9-2350-277-10.

END OF TASK

CLEAN FUEL CAP VENT AND FILTER SCREEN

0176 00

THIS WORK PACKAGE COVERS:

Cleaning (page 0176 00-1).

INITIAL SETUP:

Maintenance Level

Unit

References

See your -10

Tools and Special Tools

General Mechanic's Tool Kit (WP 0926 00, Item 65)

Equipment Condition

Engine stopped (see your -10)

Carrier blocked (see your -10)

Materials/Parts

Cleaning cloth (WP 0928 00, Item 15)

Cleaning compound (WP 0928 00, Item 19)

Personnel Required

Unit Mechanic

CLEANING

WARNING



Fuel fumes can explode and burn you. Do not smoke or allow open flame near carrier when removing and cleaning fuel cap(s).

NOTE

Carrier may have optional cap with pressure relief valve.
If fuel cap has pressure relief valve, do not perform this task.

1. Open ballistic cover (1), and remove fuel cap (2) from filler neck (3).
2. Squeeze spring plate (4), and remove fuel cap (2), with attached chain (5), from filler neck (3).
3. Clean vent grommet (6) and screen cap (7) in fuel cap (2) as follows:
 - a. Using pliers, pull on the tang in the center of screen cap (7), and remove screen cap from fuel cap (2).

NOTE

Do not remove internal filter screen from screen cap.

- b. Check vent grommet (6) to make sure it is clean, free from damage, and secure.
- c. If vent grommet (6) is damaged, replace entire fuel cap (WP 0184 00 or WP 0185 00).

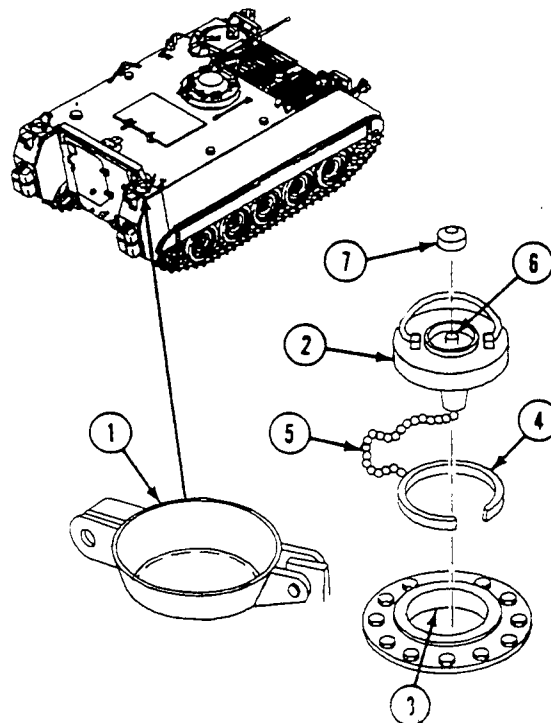

- d. If grommet (1) is clogged or dirty, remove and clean with cleaning compound and clean cloth.
- e. Reinstall grommet (1) in fuel cap (2). Make sure it is properly seated.

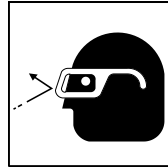
WARNING

Air pressure in excess of 30 psi (207 kPa) can injure personnel. Do not direct pressurized air at yourself or others. Always wear goggles.

- f. Clean screen cap (3) with cleaning compound. Dry with compressed air.
 - g. Reinstall screen cap (3) in fuel cap (2).
4. Squeeze spring plate (4), and install in filler neck (5).
 5. Install fuel cap (2), with attached chain (6) in filler neck (5).
 6. Close ballistic cover (7).

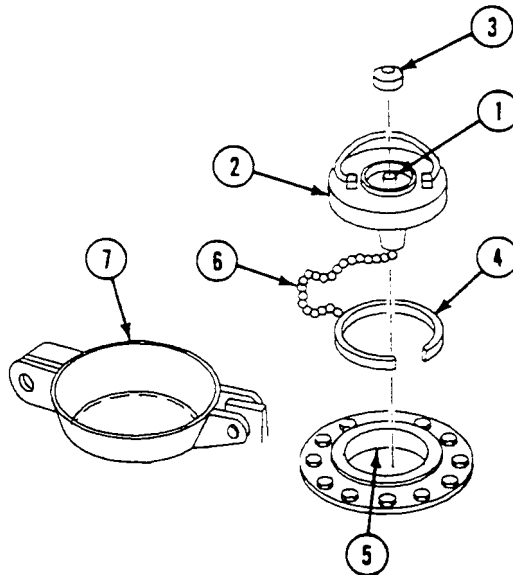

END OF TASK

DRAIN TANKS (ALL EXCEPT M577A3 AND M1068A3)

0177 00

THIS WORK PACKAGE COVERS:

Servicing (page 0177 00-1).

INITIAL SETUP:

Maintenance Level

Unit

References

See your -10

Tools and Special Tools

General Mechanic's Tool Kit (WP 0926 00, Item 65)

Equipment Condition

Materials/Parts

30 Gallon (114 liter) container (2)

Engine stopped (see your -10)

Carrier blocked (see your -10)

Personnel Required

Unit Mechanic

Battery ground strap disconnected (WP 0337 00) or
(WP 0339 00)

SERVICING

1. Open fuel filler combat cover (1). Remove fuel filler cap (see your -10).
2. Place a container (2), with at least 30 gallon (114 liters) capacity, directly beneath the fuel tank (3).

WARNING



Fuel flowing over a metal surface causes static electricity. This will cause a spark unless the surface is grounded.

3. Ground container (2) to carrier.
4. Shut off both fuel tank (3) shutoff valves. Drain fuel.
5. Install plug (4) in fuel tank (3) after the tank has been drained.

6. Install fuel filler cap. Close filler combat cover (1) to keep dirt out of tanks.

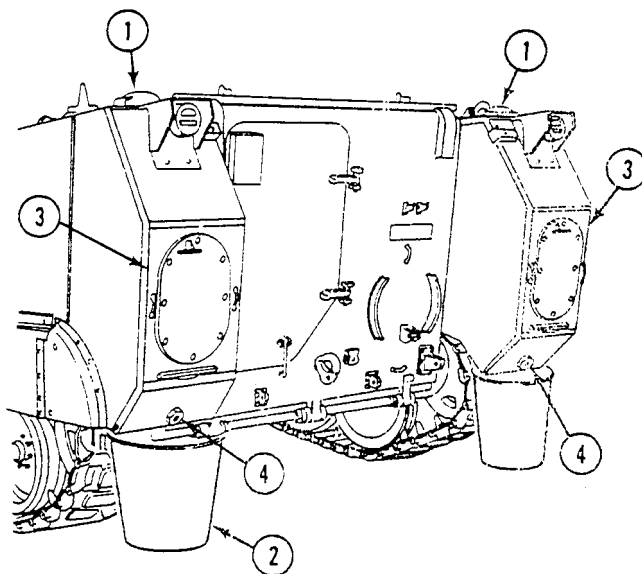
**FOLLOW-THROUGH STEPS**

1. Connect battery ground strap (WP 0337 00) or (WP 0339 00).
2. After maintenance has been performed, fill fuel tanks (see your -10).

END OF TASK

DRAIN FUEL TANKS (M577A3 AND M1068A3 ONLY)

0178 00

THIS WORK PACKAGE COVERS:

Drain (page 0178 00-1).

INITIAL SETUP:

Maintenance Level

Unit

References

See your -10

Tools and Special Tools

General Mechanic's Tool Kit (WP 0926 00, Item 65)
Hose Assembly (WP 0926 00, Item 26)

Equipment Condition

Engine stopped (see your -10)
Carrier blocked (see your -10)
Battery ground lead disconnected (WP 0338 00).
Rear compartment floor plates removed (WP 0539 00) or
(WP 0544 00)

Materials/Parts

Sealing compound (WP 0928 00, Item 56)
Wiping rag (WP 0928 00, Item 65)
Suitable container

Personnel Required

Unit Mechanic

SERVICING

1. Open fuel filler combat cover (1) and remove filler cap.
2. Loosen drain plug retaining screw (2) from under carrier. Remove drain plug (3).
3. Place container (4) under hull drain opening.

WARNING



Fuel flowing over a metal surface causes static electricity. This will cause a spark unless the surface is grounded.

NOTE

Use wiping rag to wipe up any spilled fuel.

4. Attach a ground strap (5) between hull and container (4).

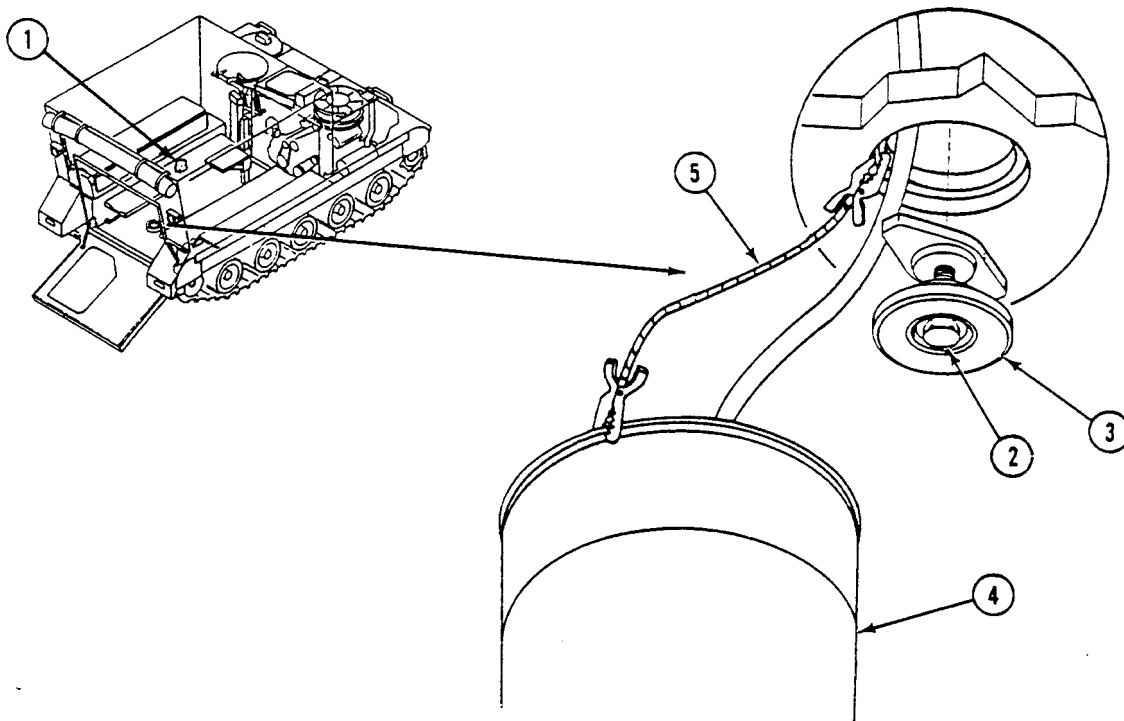

5. Remove pipe plug (1) from drain cock (2).
6. Install fuel drain hose (3) on drain cock (2). Insert drain hose through hull opening into container (4).
7. Open valve (5) and drain fuel from tanks.
8. Close valve (5) and remove hose (3) from drain cock (2).
9. Apply sealing compound to threads of pipe plug (1) and install plug in drain cock (2).
10. Remove ground strap (6) from hull and container (4).
11. Install drain plug (7) in hull and secure with retaining screw (8).
12. Install fuel filler cap. Close combat cover (9).

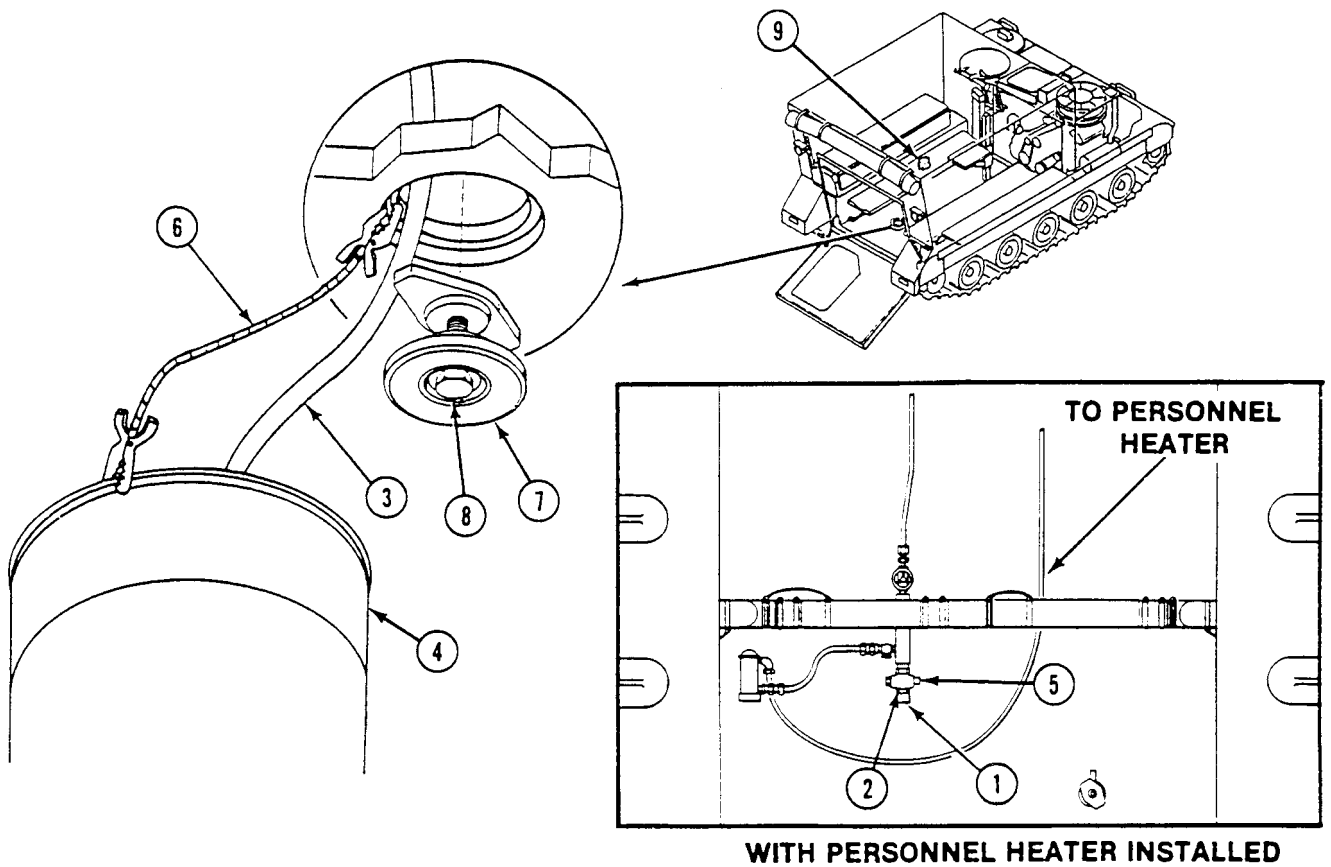

FOLLOW-THROUGH STEPS

1. Fill fuel tanks (see your -10).
2. Install rear compartment floor plates (WP 0539 00) or (WP 0544 00).
3. Connect battery ground lead (WP 0338 00).
4. Start engine (see your -10).
5. Raise and lock ramp (see your -10).
6. Stop engine (see your -10).

END OF TASK

REPLACE EXTERNAL FUEL TANKS (ALL EXCEPT M577A3 AND M1068A3)

0179 00

THIS WORK PACKAGE COVERS:

Removal (page 0179 00-2).
 Installation (page 0179 00-5).

INITIAL SETUP:

Maintenance Level

Unit

Tools and Special Tools

General Mechanic's Tool Kit (WP 0926 00, Item 65)
 Lifting Bracket (WP 0926 00, Item 9)
 Socket Wrench Set (WP 0926 00, Item 73)
 Torque Wrench (WP 0926 00, Item 86)
 Suitable Lifting Device

Materials/Parts

Adhesive (WP 0928 00, Item 4)
 Caulking compound (WP 0928 00, Item 14)
 Grease GMD (WP 0928 00, Item 41)
 Sealing compound (WP 0928 00, Item 54)
 Sealing compound (WP 0928 00, Item 56)
 Sealing compound primer (WP 0928 00, Item 57)
 Gasket
 Lockwasher (5)
 Setscrew (4)

Personnel Required

Unit Mechanic
 Helper (H)

References

See your -10

Equipment Condition

Engine stopped (see your -10)
 Carrier blocked (see your -10)
 Ramp lowered (see your -10)
 Battery ground strap disconnected (WP 0337 00)
 Fuel tanks drained (WP 0177 00)
 Filler covers and locks removed (WP 0182 00)
 Filler caps and strainers removed (WP 0184 00)
 Fuel tank access covers removed (WP 0187 00)
 Cable reel holders removed (M1064A3)
 (WP 0603 00)
 Tail lights and guards removed (WP 0298 00)
 Fuel quantity transmitter removed (WP 0190 00)

REMOVAL

NOTE

Two pipes are removed from both fuel tanks in the same way.

1. Unthread pipe (1) from fuel tank (2).

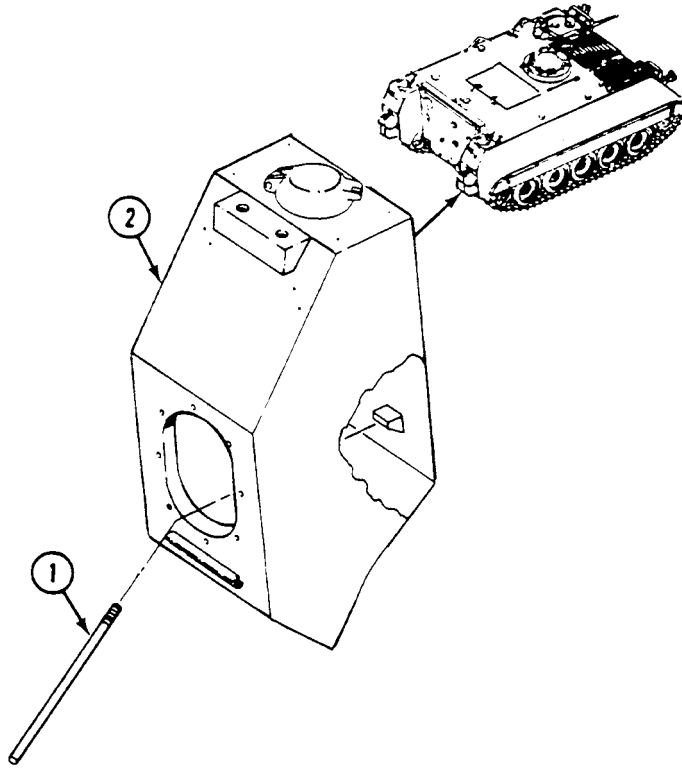

2. On M113A3 only, slide spall liners to access fuel fittings (see your -10).

NOTE

Fuel hoses are removed from both fuel tanks in the same way. Right side fuel tank shown.

3. On M113A3 only, remove five screws (1), lockwashers (2), washers (3), and guard (4) from bulkhead. Discard lockwashers.
4. Remove two elbows (5) with fuel hoses from two adapters (6).
5. Remove two adapters (6) from fuel tank (7).

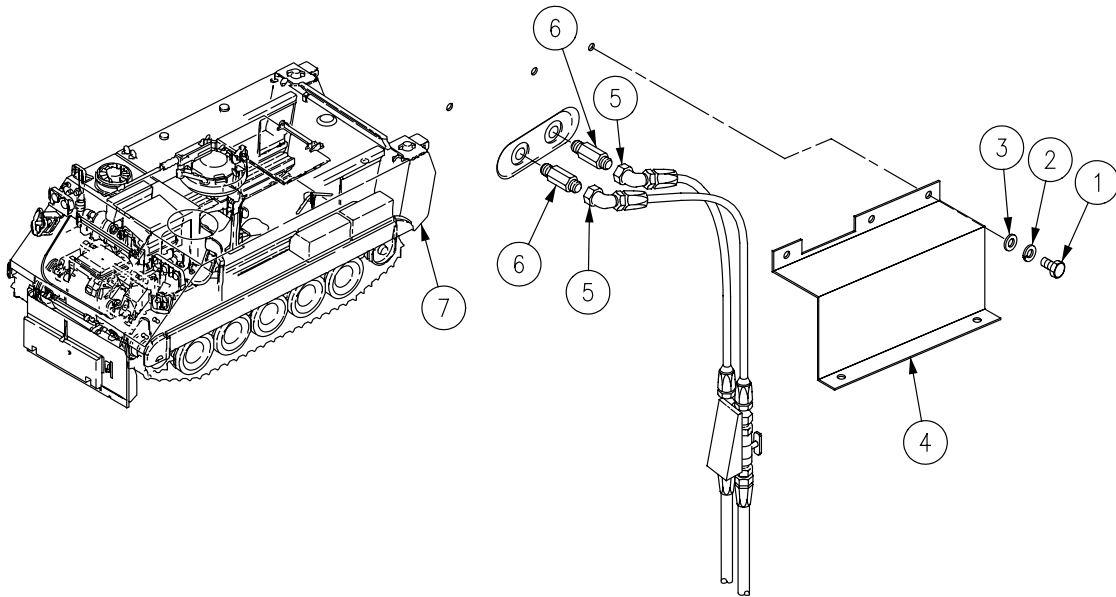

NOTE

Both fuel tanks are removed from carrier in the same way. Left side fuel tank shown.

Use tail light bracket screws to secure lifting bracket to fuel tank.

6. Install lifting bracket (8) on tail light bracket mounting holes (9). Secure with two screws (10). Attach lifting device to lifting bracket.

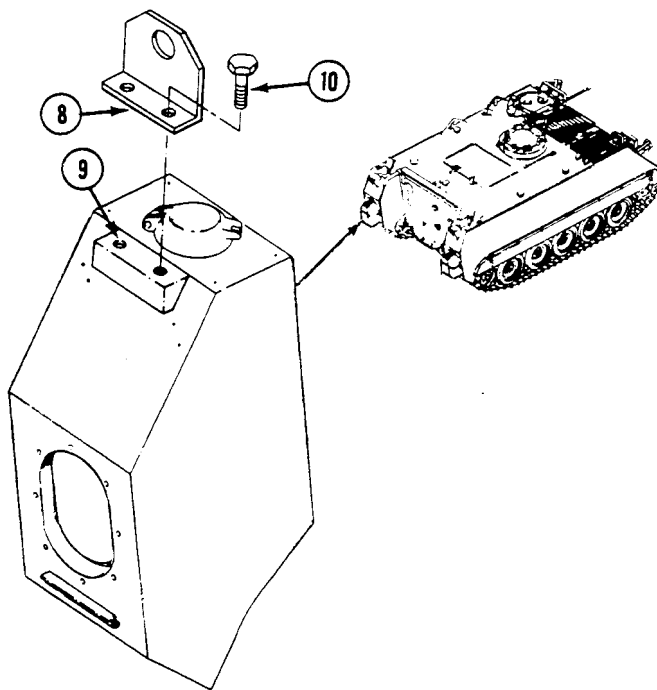

7. Remove fuel cap locking thumbscrew (11) from inside carrier.

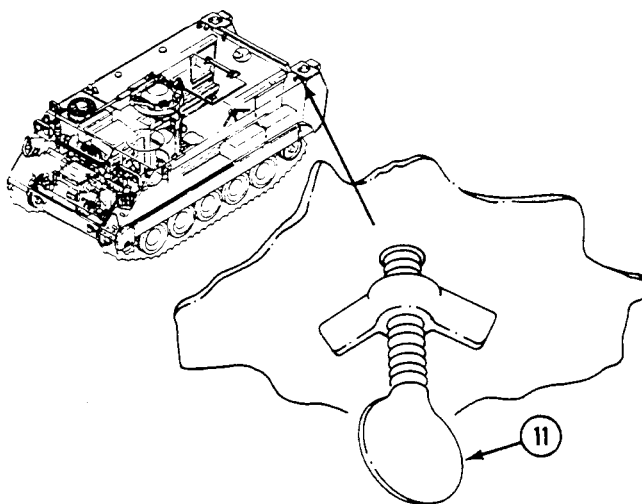

WARNING



Damaged lifting slings can fail with load. Soldiers can be killed or injured. Inspect all slings (WP 0673 00) before use. Do not use damaged slings.

WARNING



Hanging loads can kill or injure you. Keep away from hanging loads and overhead equipment. Keep hands out of compartment while power plant is being lifted for removal or lowered for installation.

8. Remove five screws (1), washers (2), and fuel tank (3) from carrier. Remove gasket (4) from fuel tank. Discard gasket.

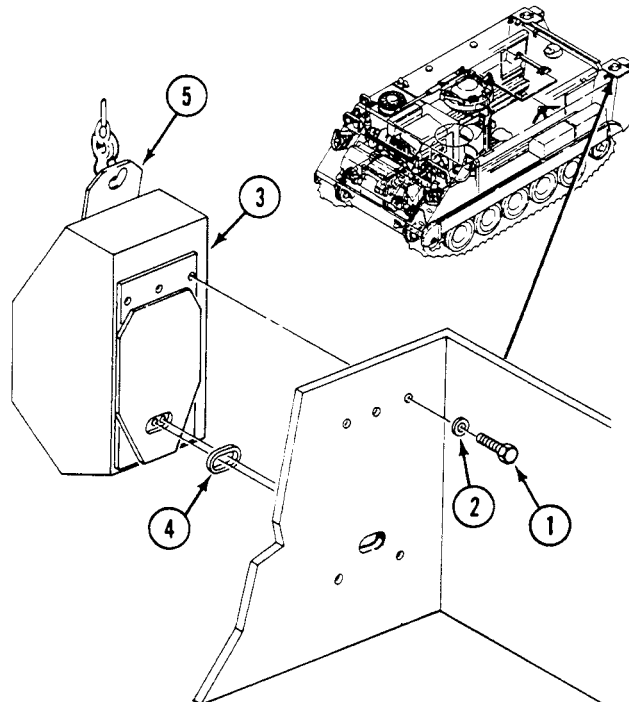

INSTALLATION

NOTE

Both fuel tanks are installed on carrier in the same way. Left side fuel tank shown.

1. Apply thin coat of adhesive to gasket surface of fuel tank (3) and new gasket (4). When adhesive has become tacky, install gasket on tank.

WARNING



Damaged lifting slings can fail with load. Soldiers can be killed or injured. Inspect all slings (WP 0673 00) before use. Do not use damaged slings.

WARNING



Hanging loads can kill or injure you. Keep away from hanging loads and overhead equipment. Keep hands out of compartment while power plant is being lifted for removal or lowered for installation.

2. Attach lifting device to lifting bracket (5). Position fuel tank (3) against rear hull plate. Have helper assist.
3. Apply grease GMD to threads of five screws (1).

NOTE

Inside of mounting holes and full diameter area under each washer must be free of paint to ensure good electrical ground.

4. Check that mounting holes and surfaces are free of paint. Secure fuel tank (3) to rear hull plate with five screws (1) and washers (2). TIGHTEN SCREWS TO 270-295 LB-FT (366-400 N·m) TORQUE. Remove lifting device. Have helper assist.
5. Apply caulking compound to space around installed screw heads (1) and washers (2) on rear hull plate. Do not apply compound to screw threads which engage with fuel tank (3).

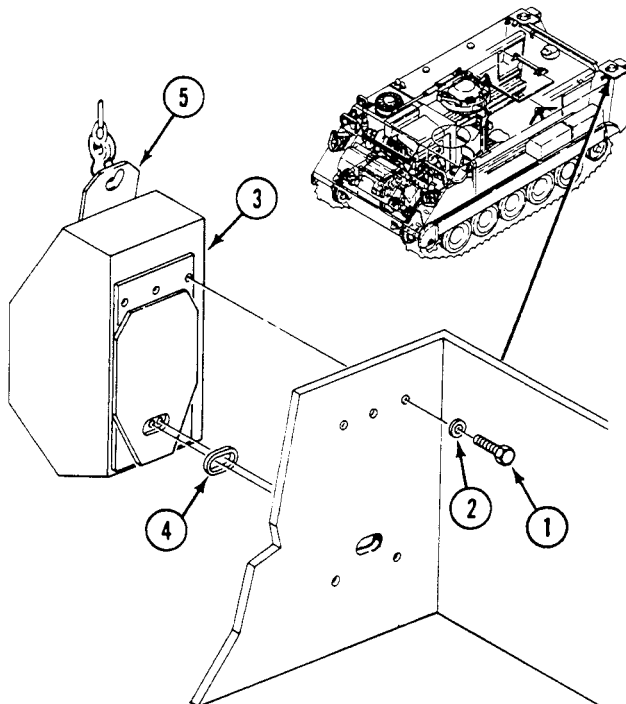

6. Install fuel cap locking thumbscrew (6) in carrier bulkhead.

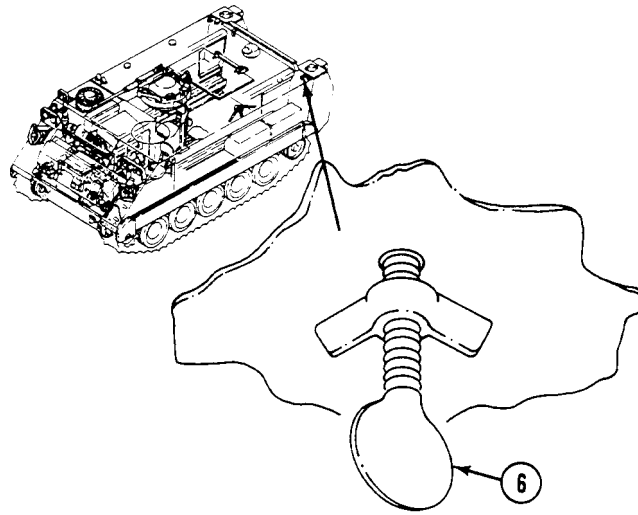

NOTE

Save lifting bracket screws for installation of tail light bracket.

7. Remove two screws (1) and lifting bracket (2) from fuel tank (3).

NOTE

Two pipes are installed in both fuel tanks in the same way.

8. Apply sealing compound primer to threads of pipe (4). Then coat threads with sealing compound.
9. Install pipe (4) in fuel tank (3).

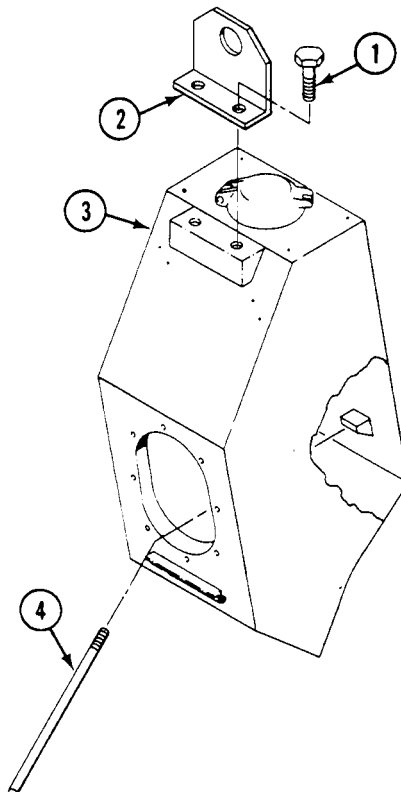

NOTE

Fuel hoses are installed on both fuel tanks the same way. Right side fuel tank shown.

10. Apply sealing compound to threads of adapters (5). Install adapters in fuel tank.
11. Apply caulking compound to space around adapters on fuel tank (6).
12. Install two elbows (7) with hoses on adapters (5).
13. On M113A3 only, install guard (8) on bulkhead. Secure with five screws (9), new lockwashers (10), and washers (11).

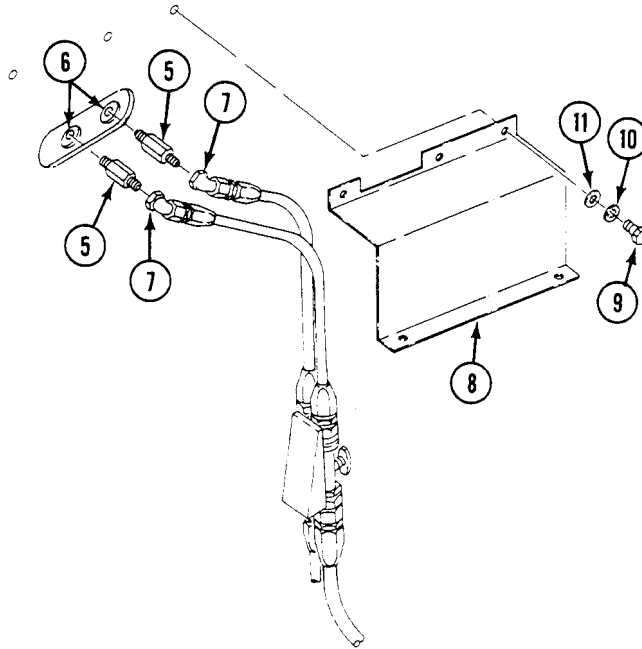

NOTE

The four spare electrical mounting holes are always the holes located on the outer edge of each fuel tank. The electrical guards are always mounted on the inner edge of each fuel tank.

14. Install four setscrews (12) in spare holes provided for electrical mounting.

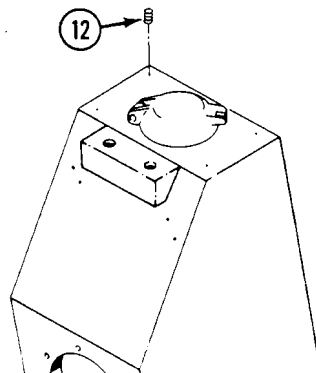

FOLLOW-THROUGH STEPS

1. Deleted
2. Install fuel quantity transmitter (WP 0190 00).
3. Install guards and tail lights (WP 0298 00).
4. Install cable reel holders (M1064A3) (WP 0603 00).
5. Install fuel tank access covers (WP 0187 00).
6. Install filler caps and strainers (WP 0184 00).
7. Install filler covers and locks (WP 0182 00).
8. Fill fuel tanks (see your -10).
9. Connect battery ground strap (WP 0337 00).
10. Start engine (see your -10). Check for leaks.
11. Raise and lock ramp (see your -10).
12. Stop engine (see your -10).
13. Close spill liners (M113A3) (see your -10).

END OF TASK

REPLACE FUEL TANKS (M577A3 AND M1068A3 ONLY)

0180 00

THIS WORK PACKAGE COVERS:

Removal (page 0180 00-1).
 Installation (page 0180 00-4).

INITIAL SETUP:

Maintenance Level

Unit

Tools and Special Tools

General Mechanic's Tool Kit (WP 0926 00, Item 65)

Materials/Parts

Sealing compound (WP 0928 00, Item 56)

Key washers (6)

Locknut (4)

Personnel Required

Unit Mechanic

References

See your -10

Equipment Condition

Engine stopped (see your -10)

Carrier blocked (see your -10)

Ramp lowered (see your -10)

Battery ground lead disconnected (WP 0338 00)

Map board removed (see your -10)

Work tables removed (WP 0578 00) or (WP 0581 00)
 and (WP 0582 00)

Fuel tanks drained (WP 0178 00)

Rear bilge pump discharge tube removed (WP 0634 00)

Fuel quantity transmitter removed (WP 0191 00)

Fuel tank access cover removed (WP 0188 00)

Fuel tank filler flange removed (WP 0189 00)

REMOVAL

1. Disconnect four supply hoses (1) and four adapters (2) from fuel tanks (3) and (4).
2. Loosen two clamps (5) and remove two supply hoses (6) from fuel tanks (3) and (4).
3. Disconnect vent hose (7) from elbow (8).
4. Disconnect vent hose (9) from elbow (10).

5. Remove six screws (11), key washers (12), two plates (13), and two brackets (14) that secure front of fuel tanks (3) and (4) on sponson. Discard key washers.

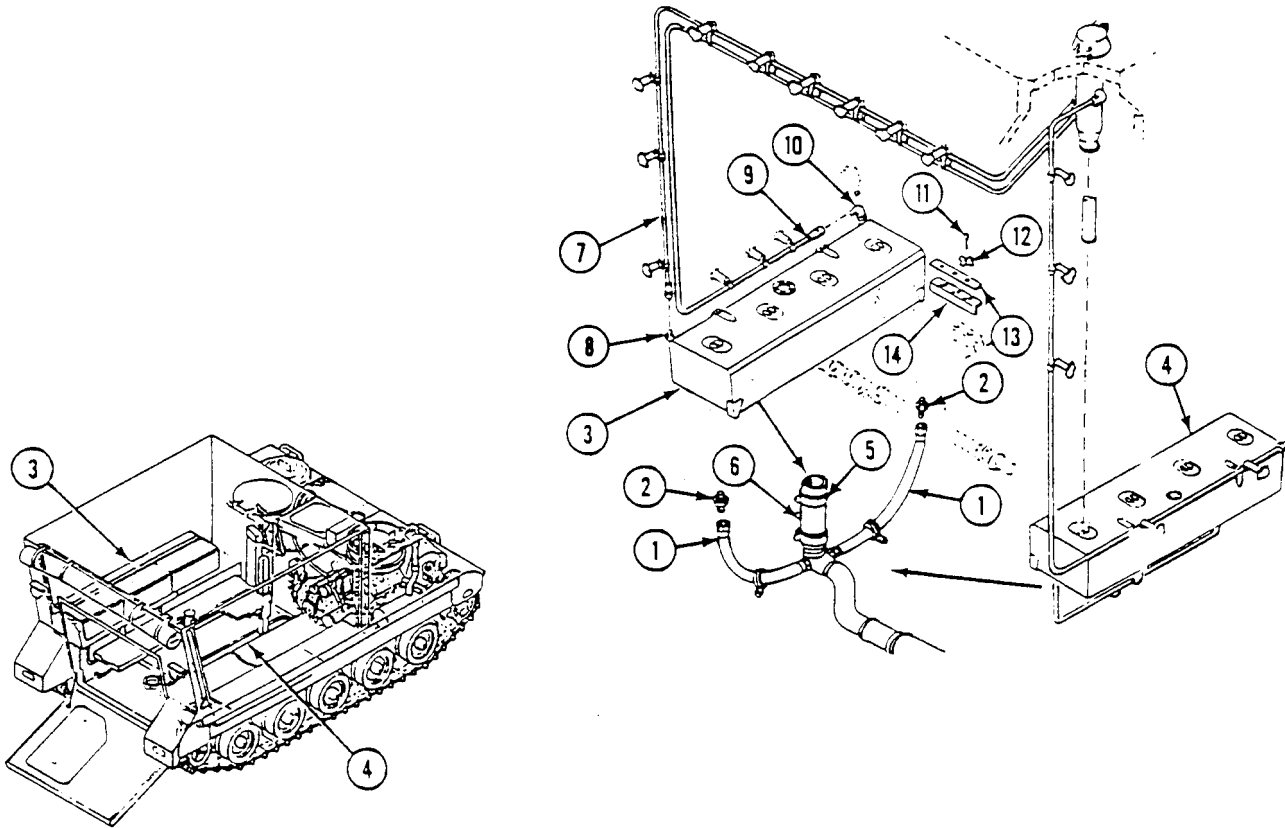

REPLACE FUEL TANKS (M577A3 AND M1068A3 ONLY) — Continued

0180 00

6. Remove four locknuts (1), screws (2), 12 washers (3), and 4 mounts (4) that secure bottom of fuel tanks (5) and (6) to sponson. Discard locknuts.
7. Disconnect vent tube (7) from elbow (8).
8. Remove four screws (9), plates (10), eight washers (11), and four mounts (12) that secure bottom of fuel tanks (5) and (6) to sponson.
9. Remove two fuel tanks (5) and (6) from carrier.
10. Remove elbow (13) from left fuel tank (5).
11. Remove elbow (14) from nipple (15).
12. Remove nipple (15) and elbow (16) from left fuel tank (5).
13. Remove elbow (8) and bushing (17) from right fuel tank (6).
14. Remove plug (18) from right fuel tank (6).

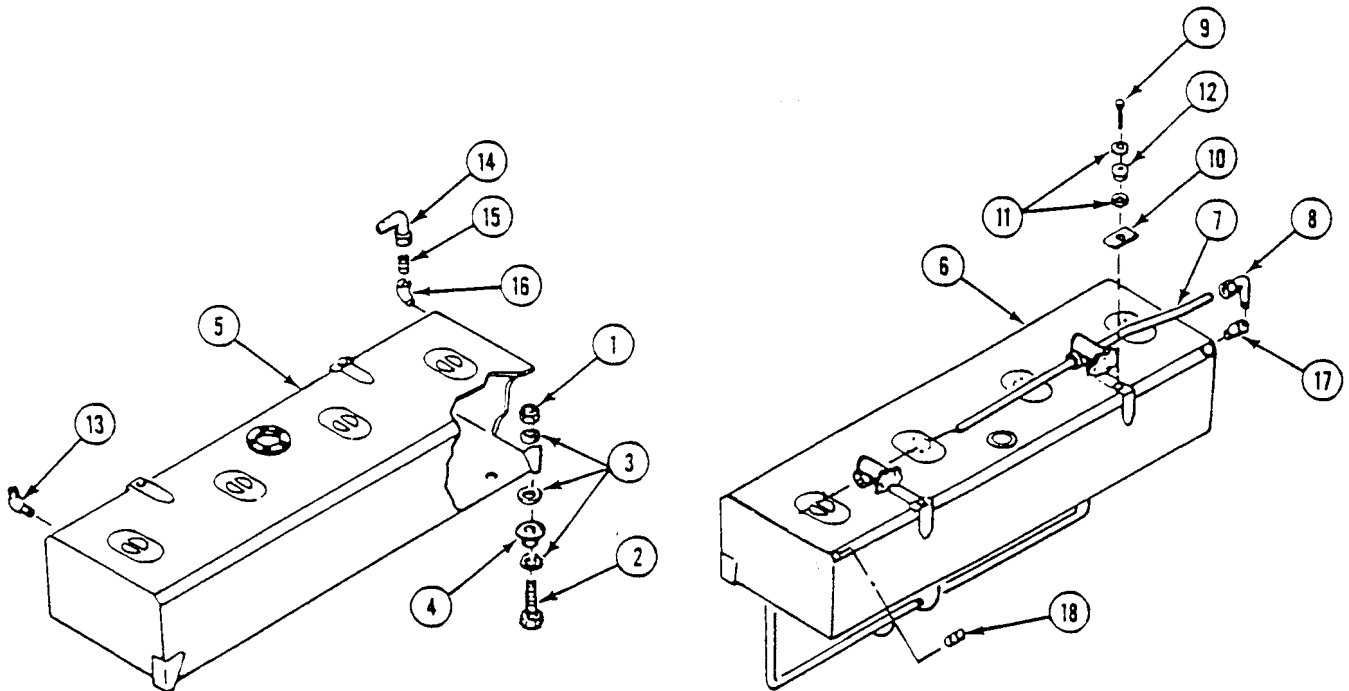

INSTALLATION

1. Apply a thin, even coat of sealing compound to cleaned external threads of fittings.
2. Install plug (18) in right fuel tank (6).
3. Install bushing (17) in fuel tank (6).
4. Install elbow (8) in bushing (17).
5. Install elbow (13) in left fuel tank (5).
6. Install elbow (16) in left fuel tank (5).
7. Install nipple (15) in elbow (16).
8. Install elbow (14) on nipple (15).
9. Place fuel tanks (5) and (6) on left and right sponsons.
10. Secure top of two fuel tanks (5) and (6) to hull with four screws (9), plates (10), eight washers (11), and four mounts (12).
11. Secure bottom of two fuel tanks (5) and (6) to sponson with four mounts (4), new locknuts (1), screws (2), and 12 washers (3).

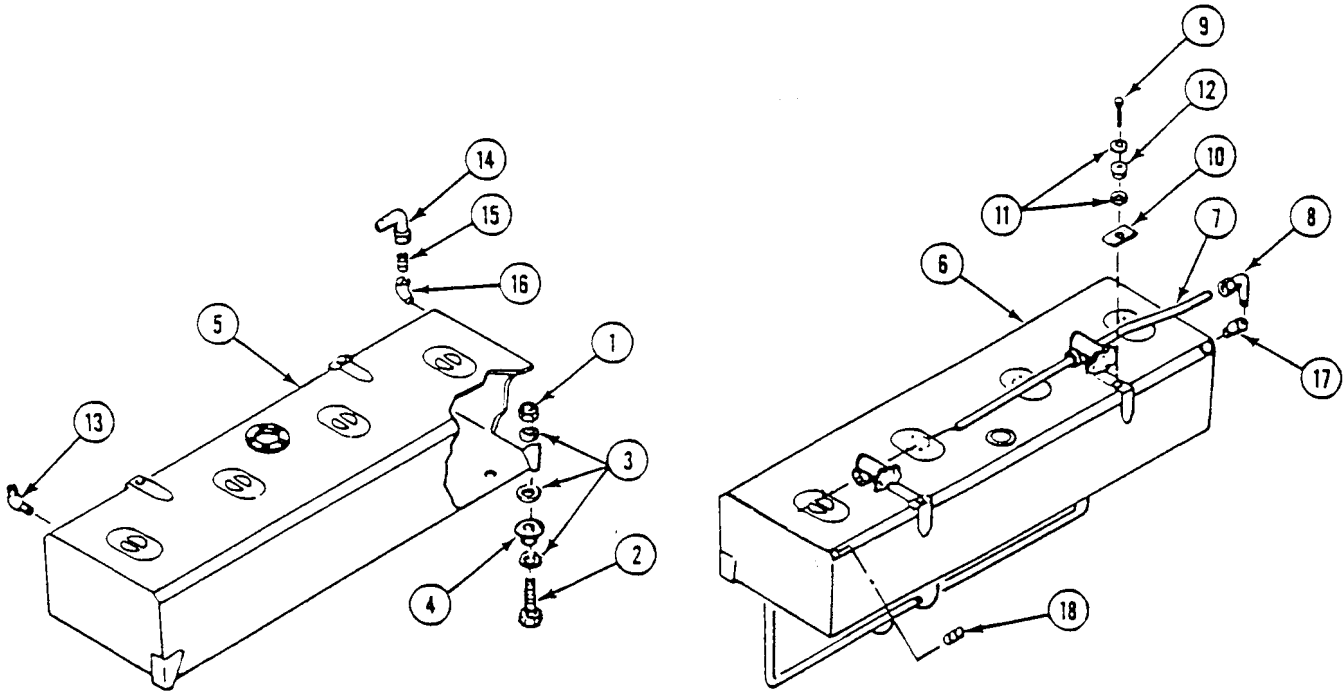

12. Secure front of two fuel tanks (3) and (4) to sponson with six screws (11), new key washers (12), two plates (13), and bracket (14).
13. Connect vent hose (9) to elbow (10).
14. Connect vent hose (7) to elbow (8).
15. Install two supply hoses (6) on fuel tanks (3) and (4). Secure with two clamps (5).

16. Connect four supply hoses (1) with four adapters (2) on fuel tanks (3) and (4).

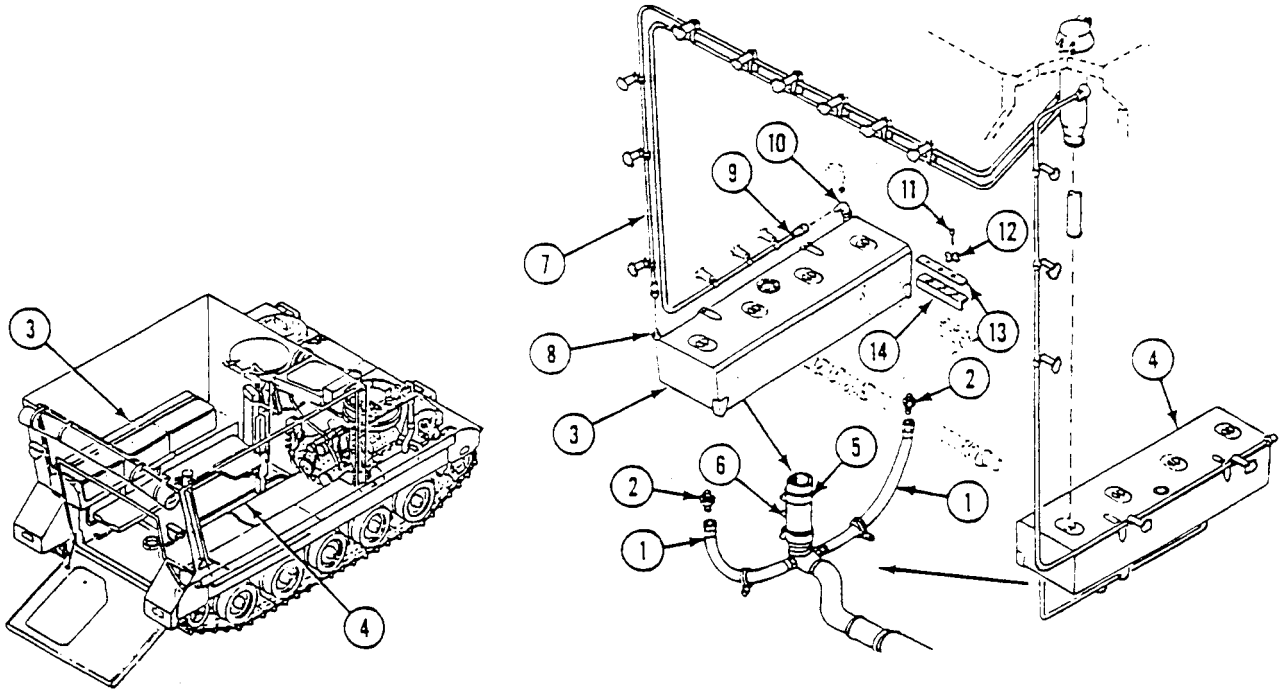

FOLLOW-THROUGH STEPS

1. Install fuel tank filler flange (WP 0189 00).
2. Install fuel tank access covers (WP 0188 00).
3. Install fuel quantity transmitter (WP 0191 00).
4. Install rear bilge pump discharge tube (WP 0634 00).
5. Fill fuel tanks (see your -10). Check for leaks.
6. Connect battery ground lead (WP 0338 00).
7. Start engine (see your -10). Check for leaks.
8. Raise and lock ramp (see your -10).
9. Stop engine (see your -10).
10. Install work tables (WP 0578 00) or (WP 0581 00) and (WP 0582 00).
11. Install map board (see your -10).

END OF TASK

TEMPORARY FUEL TANK REPAIR (M577A3 AND M1068A3 ONLY)

0181 00

THIS WORK PACKAGE COVERS:

Repair (page 0181 00-1).

INITIAL SETUP:

Maintenance Level

Unit

References

See your -10

Tools and Special Tools

General Mechanic's Tool Kit (WP 0926 00, Item 65)

Equipment Condition

Engine stopped (see your -10)

Carrier blocked (see your -10)

Ramp lowered (see your -10)

Battery ground lead disconnected (WP 0338 00)

Fuel tank removed (optional), (WP 0180 00) or

Fuel drained below area of repair (WP 0178 00)

Materials/Parts

Cleaning compound (WP 0928 00, Item 19)

Rubber adhesive tape (WP 0928 00, Item 46)

Sealing compound (WP 0928 00, Item 56)

Personnel Required

Unit Mechanic

REPAIR OR REPLACEMENT

CAUTION

Be sure fuel level in tank is below area to be repaired.

NOTE

This task is for fuel tank temporary repair only. Repair is not feasible in temperatures below +40°F (+4°C). Best results are obtained if temperature is between 75° and 90°F (24° and 32°C).

1. Clean 3 to 4 inches (8 to 10 cm) around repair area. Use a wire brush, steel wool, or emery cloth.
2. Clean area with cleaning compound. Dry area with a clean cloth.
3. Reinforce small repair area with clean cloth or rubber adhesive tape.
4. Reinforce large repair area with sheet metal (aluminum), cut to fit.

NOTE

Sealing compound is usable for two hours after mixing. Use mixed sealing compound within this time.

5. Apply mixed sealing compound 3/16-1/4 inch (4-6 mm) thick over repair area.
6. Apply 1/16 inch (2 mm) minimum of sealing compound over reinforcement. Sealing compound must extend at least two inches (5 cm) beyond reinforcement on all sides.
7. Allow sealing compound to cure before filling fuel tank. Sealing compound will be tack-free in 40 hours and cured in 72 hours.

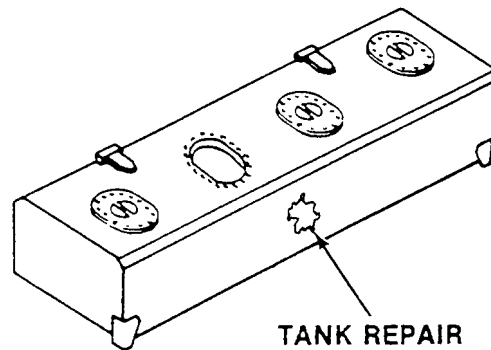
**FOLLOW-THROUGH STEPS**

1. Install fuel tank (WP 0180 00), (optional).
2. Fill fuel tank (see your -10). Check tank for leaks.
3. Connect battery ground lead (WP 0338 00).
4. Start engine (see your -10).
5. Raise and lock ramp (see your -10).
6. Stop engine (see your -10).

END OF TASK

REPLACE FUEL TANK FILLER COVER AND LOCK (ALL EXCEPT M577A3 AND M1068A3)

0182 00

THIS WORK PACKAGE COVERS:

Removal (page 0182 00-1).
 Installation (page 0182 00-2).

INITIAL SETUP:

Maintenance Level

Unit

References

TM 9-2350-277-10

Tools and Special Tools

General Mechanic's Tool Kit (WP 0926 00, Item 65)

Equipment Condition

Engine stopped (see your -10)

Carrier blocked (see your -10)

Battery ground strap disconnected (WP 0337 00) or (WP 0339 00)

Materials/Parts

Spring pin (3)

Personnel Required

Unit Mechanic

Ramp lowered (see your-10)

REMOVAL

1. Loosen wing nut (7) and thumbscrew (6) from inside carrier.
2. Remove spring pin (1), pin (2), washer (4), and spring (5) from support (3). Discard spring pin.

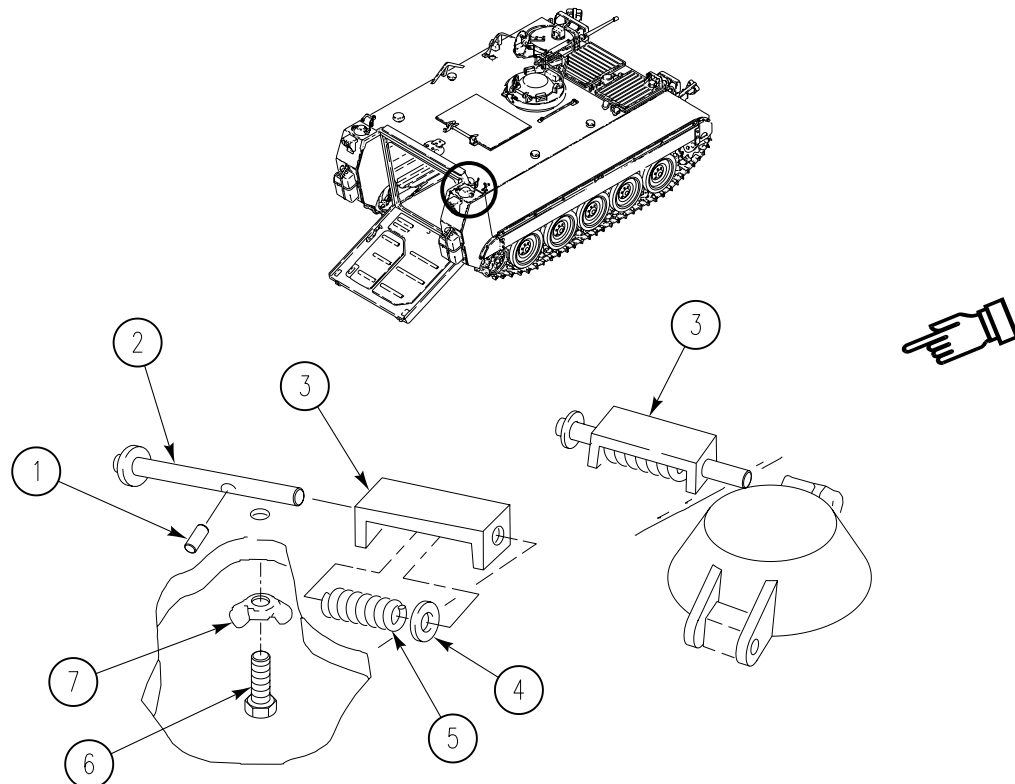

REPLACE FUEL TANK FILLER COVER AND LOCK (ALL EXCEPT M577A3 AND M1068A3) — Continued

0182 00

3. Remove spring pin (8), washer (9), pin (10), and spring (11) from cover (12). Discard spring pin.
4. Remove spring pin (13) and cover (12) from top of hull. Discard spring pin.

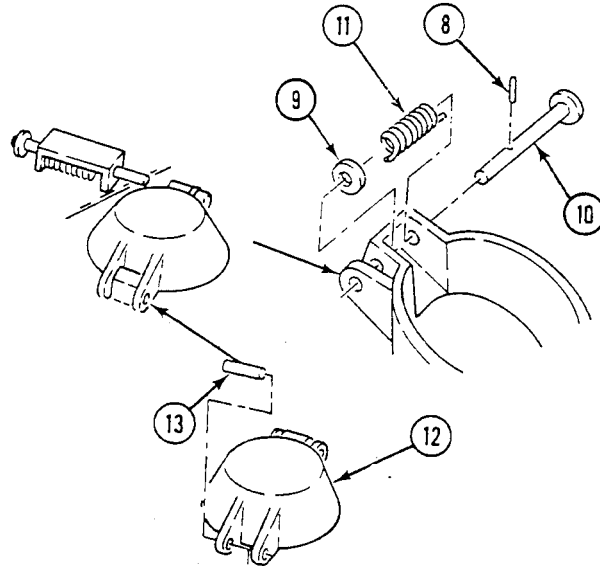

INSTALLATION

1. Secure spring (1), pin (2), and washer (3) to cover (4) with new spring pin (5).
2. Secure spring (6), washer (7), and pin (8) to support (9) with new spring pin (10).
3. Secure cover (4) to hull with new spring pin (11).
4. Turn thumbscrew (12) into lock position. Secure with wing nut (13).

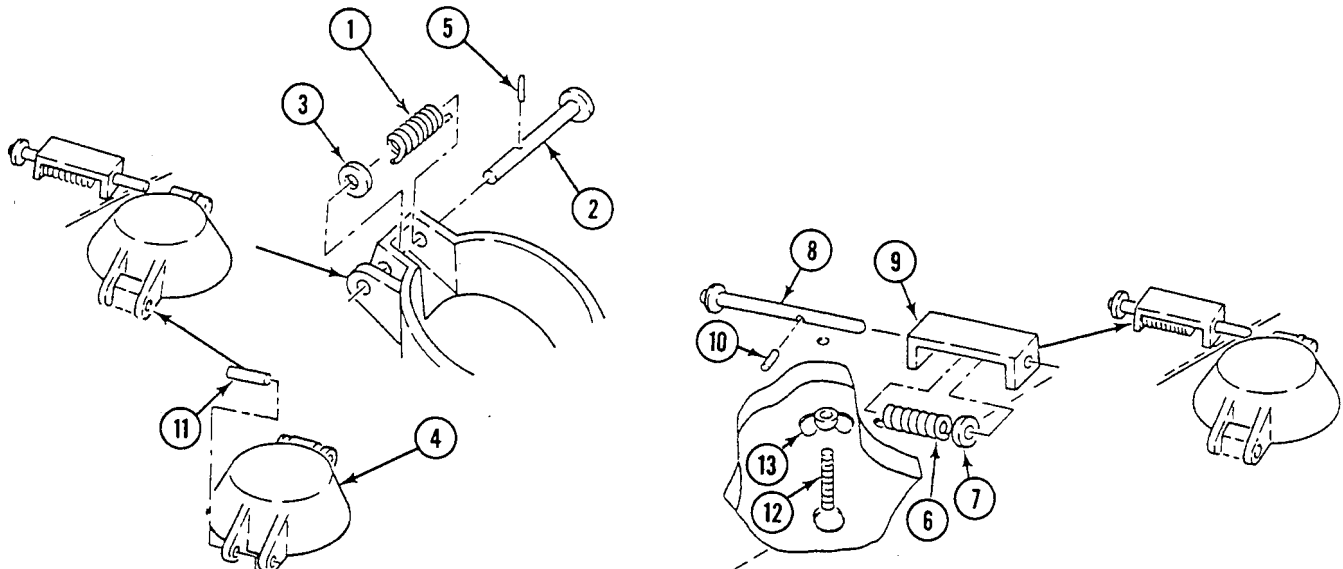

**REPLACE FUEL TANK FILLER COVER AND LOCK (ALL EXCEPT M577A3 AND
M1068A3) — Continued**

0182 00

FOLLOW-THROUGH STEPS

1. Connect battery ground strap (WP 0337 00) or (WP 0339 00).

END OF TASK

REPLACE FUEL TANK FILLER COVER AND LOCK (M577A3 AND M1068A3 ONLY)

0183 00

THIS WORK PACKAGE COVERS:

Removal (page 0183 00-1).
 Installation (page 0183 00-2).

INITIAL SETUP:

Maintenance Level

Unit

References

See your -10

Tools and Special Tools

General Mechanic's Tool Kit (WP 0926 00, Item 65)

Materials/Parts

Spring pin
 Spring pin

Equipment Condition

Engine stopped (see your -10)

Personnel Required

Unit Mechanic

Carrier blocked (see your -10)

Ramp lowered (see your -10)

REMOVAL

NOTE

If threads on thumbscrew were previously deformed, do Step 1.

1. Grind away deformed threads on thumbscrew (1). Remove wing nut (2) and thumbscrew (1).
2. Loosen wing nut (2) and thumbscrew (1) above fuel tank inside carrier.
3. Remove spring pin (3) and cover (4) from top of hull. Discard spring pin.

REPLACE FUEL TANK FILLER COVER AND LOCK (M577A3 AND M1068A3 ONLY) —
Continued

0183 00

4. Remove spring pin (5), washer (6), pin (7), and spring (8) from cover (4). Discard spring pin.

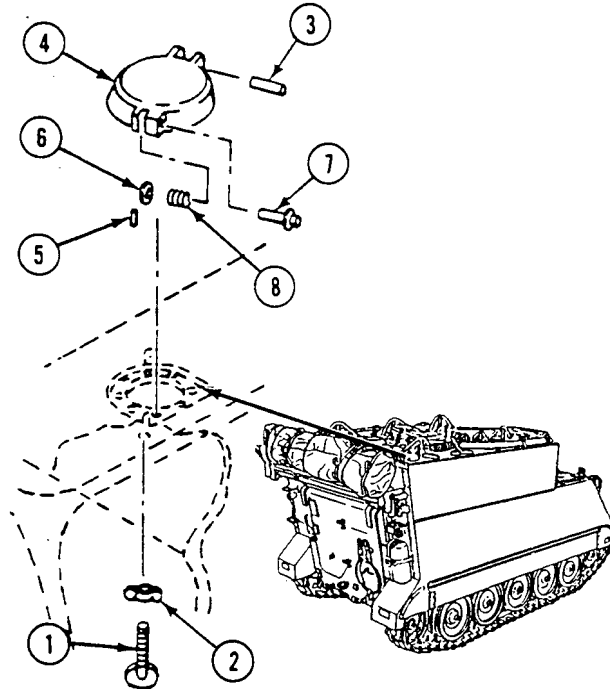
**INSTALLATION****NOTE**

If thumbscrew and wing nut were removed, do Step 1.

1. Screw wing nut (2) on thumbscrew (1) and install thumbscrew inside carrier above fuel tank. Deform threads on thumbscrew (1). Tighten wing nut (2).
2. Secure spring (8), pin (7), and washer (6) to cover (4) with new spring pin (5).
3. Secure cover (4) to hull with new spring pin (3).
4. Turn thumbscrew (1) into lock position. Tighten wing nut (2).

FOLLOW-THROUGH STEPS

1. Start engine (see your -10).
2. Raise and lock ramp (see your -10).
3. Stop engine (see your -10).

END OF TASK

REPLACE FILLER CAP AND STRAINER PARTS (ALL EXCEPT M577A3 AND M1068A3)

0184 00

THIS WORK PACKAGE COVERS:

- Removal (page 0184 00-2)
 - Installation (page 0184 00-3)
-

INITIAL SETUP:

Maintenance Level

Unit

References

TM 9-2350-277-10

Tools and Special Tools

General Mechanic's Tool Kit (WP 0926 00, Item 65)

Equipment Condition

Engine stopped (see your —10)

Materials/Parts

Lockwire (WP 0928 00, Item 42)

Gasket

Carrier blocked (see your —10)

Personnel Required

Unit Mechanic

Battery ground strap disconnected (WP 0339 00) or (WP 0337 00)

— Continued

REMOVAL

NOTE

Carrier may have optional cap with pressure relief valve.

If fuel cap has pressure relief valve, cap is removed by lifting pressure relief valve handle, then turning cap counterclockwise.

1. Unfasten fuel filler cap and chain assembly (1) from filler neck (2).
2. Remove lockwire (3), 12 screws (4), filler neck (2), strainer (5), and filler cap and chain assembly (1) from hull top. Discard lockwire.
3. Pull filler cap and chain assembly (1) through opening in filler neck (2).
4. Remove gasket (6). Discard gasket.

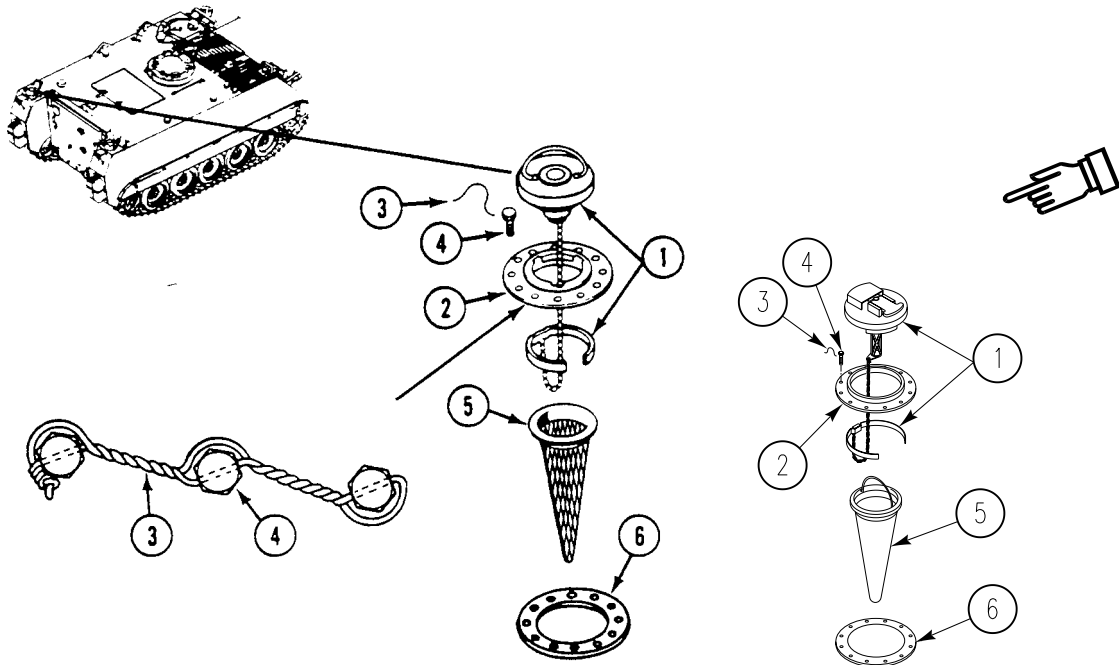

REPLACE FILLER CAP AND STRAINER PARTS (ALL EXCEPT M577A3 AND M1068A3)

0184 00

— Continued

INSTALLATION

1. Install new gasket (6).
2. Install filler cap and chain assembly (1) through filler neck (2).
3. Secure filler neck (2), strainer (5), and filler cap and chain assembly (1) to hull top with 12 screws (4).
4. Install new lockwire (3) thru heads of 12 screws (4). Secure with double twist method.
5. Fasten filler cap and chain assembly (1) in filler neck (2).

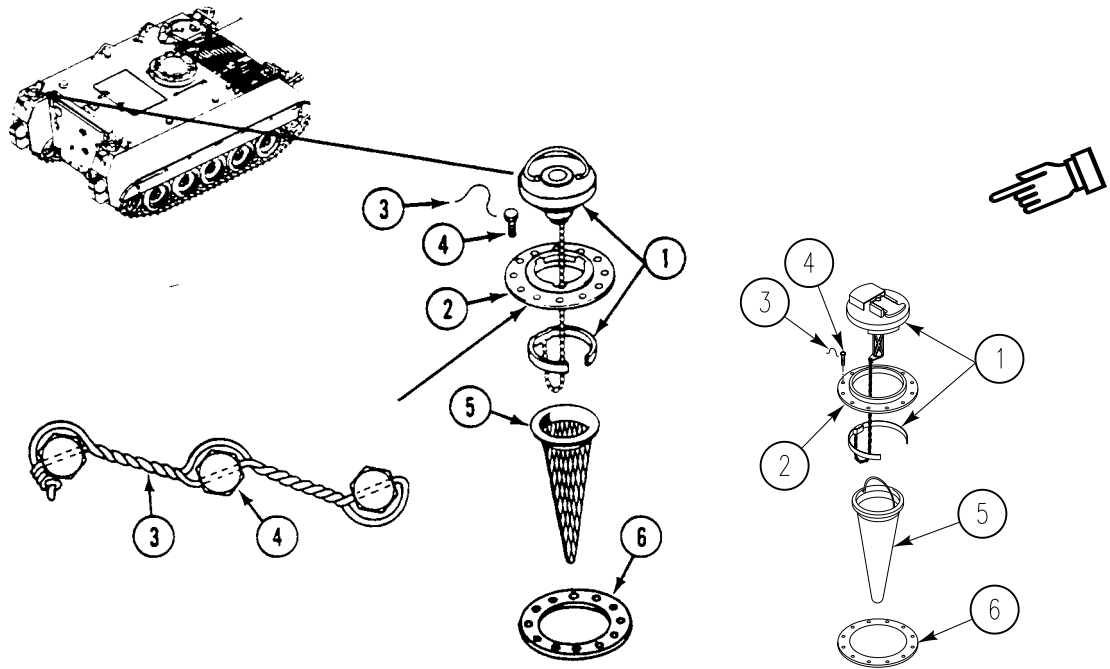

FOLLOW-THROUGH STEPS

1. Connect battery ground strap (WP 0339 00) or (WP 0337 00).

END OF TASK

REPLACE FILLER CAP AND STRAINER PARTS (M577A3 AND M1068A3 ONLY)

0185 00

THIS WORK PACKAGE COVERS:

Removal (page 0185 00-1).
Installation (page 0185 00-2).

INITIAL SETUP:

Maintenance Level

Unit

References

TM 9-2350-277-10

Tools and Special Tools

General Mechanic's Tool Kit (WP 0926 00, Item 65)

Equipment Condition

Engine stopped (see your -10)

Materials/Parts

Nonelectrical wire (WP 0928 00, Item 42)

Carrier blocked (see your -10)

Personnel Required

Unit Mechanic

Battery ground lead disconnected (WP 0338 00)

Combat filler cover and lock open (see your -10)

REMOVAL

NOTE

Carrier may have optional cap with pressure relief valve.

If fuel cap has pressure relief valve, remove cap by lifting pressure relief handle and turning cap counterclockwise.

1. Unfasten fuel filler cap and chain assembly (1) from filler neck.
2. Compress C ring (3) and remove from filler neck (2).
3. Remove lockwire (4), twelve screws (5), filler neck (2), retainer (7), and filler cap and chain assembly (1) from hull top. Discard lockwire.
4. Loosen clamp (8) that secures boot (9) to inside fuel tank. Remove boot through top of hull.

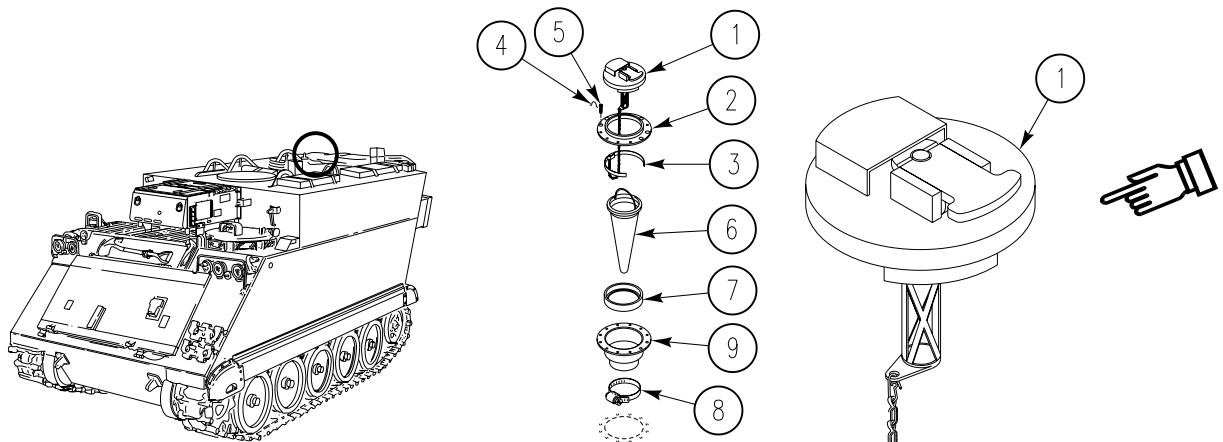

REPLACE FILLER CAP AND STRAINER PARTS (M577A3 AND M1068A3 ONLY) —
Continued

0185 00

INSTALLATION

1. Align mounting holes in boot (9) with mounting holes in hull top. Secure boot (9) to inside fuel tank neck with clamp (8).
2. Secure filler neck (2), retainer (7), strainer (6), and filler cap and chain assembly (1) to hull top with twelve screws (5).
3. Install new lockwire (4) through heads of twelve screws (5). Secure with double twist method.
4. Compress C ring (3) and install through filler neck (2).

NOTE

If fuel cap has pressure relief valve, cap is installed by turning cap clockwise until tight, then push pressure relief handle down.

5. Fasten filler cap and chain assembly (1) in filler neck.

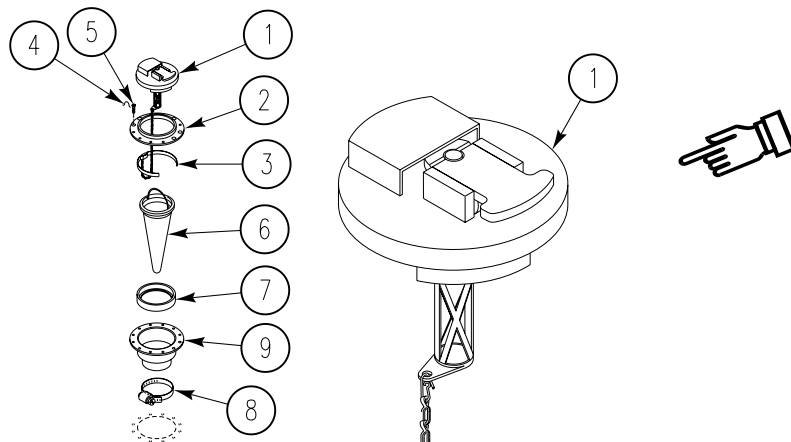

FOLLOW-THROUGH STEPS

1. Connect battery ground lead (WP 0338 00).
2. Close and lock combat filler cover (see your -10).

END OF TASK

REPLACE FUEL FILLER AND STRAINER PARTS (M577A3 AND M1068A3 ONLY)

0186 00

THIS WORK PACKAGE COVERS:

- Removal (page 0186 00-1).
- Cleaning (page 0186 00-2).
- Repair (page 0186 00-2).
- Installation (page 0186 00-2).

INITIAL SETUP:

Maintenance Level

Unit

References

See your -10

Tools and Special Tools

General Mechanic's Tool Kit (WP 0926 00, Item 65)

Equipment Condition

- Engine stopped (see your -10)
- Carrier blocked (see your -10)
- Ramp lowered (see your -10)
- Battery ground lead disconnected (WP 0338 00)
- Filler cover and lock removed (WP 0183 00)
- Filler cap removed (WP 0185 00)
- Fuel tanks drained below filler flange level (WP 0178 00)

Materials/Parts

Sealing compound (WP 0928 00, Item 56)
Gasket (2)

Personnel Required

Unit Mechanic

REMOVAL

1. Disconnect two fuel tank vent hoses (2) from two elbows (3) and remove elbows from filler neck (4).
2. Disconnect APU fuel return tube (5) from tee (6).
3. Disconnect engine fuel return hose (7) from elbow (8).
4. Disconnect fuel tank vent tube (9) from elbow (10) and remove elbow from filler neck (4).
5. Remove elbow (8) from tee (6) and tee from filler neck (4).
6. Remove 12 screws (11) and nuts (12) that secure flange (13), filler neck (4), and two gaskets (14) and (15) to hull top opening. Discard gaskets.
7. Remove strainer element (16), strainer assembly (17), and bushing (18) from hull.
8. Remove screw (19), nut (20), washer (21), clamp (22), and ground lead (23) from filler tube (24).

REPLACE FUEL FILLER AND STRAINER PARTS (M577A3 AND M1068A3 ONLY) —
Continued

0186 00

9. Remove four clamps (25), filler tube (24), filler neck (4), and two hoses (26) from fuel tank flange (1).

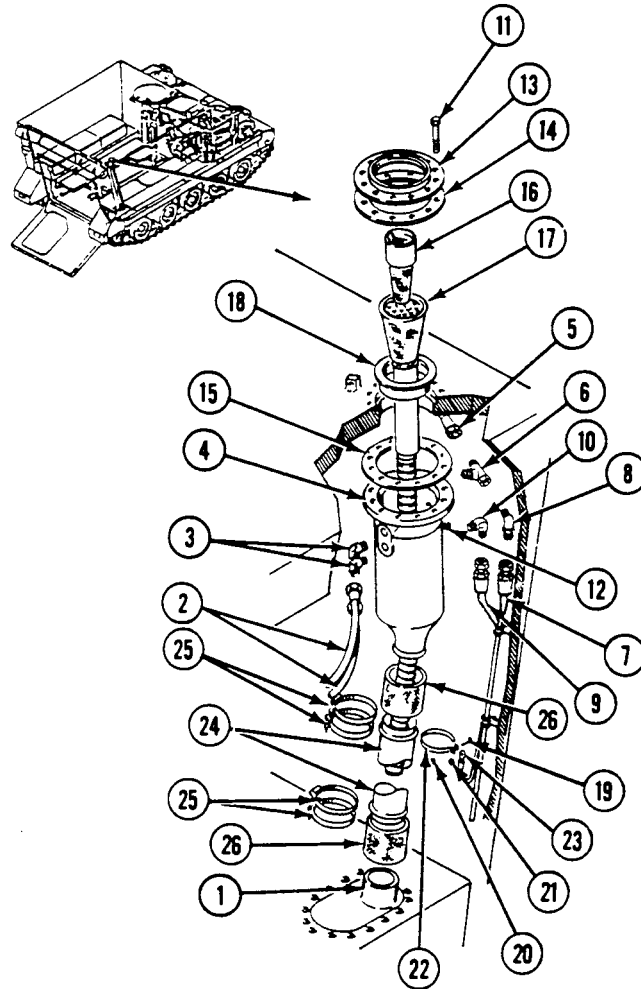
**CLEANING**

1. Clean and check hoses and tubes.
2. Clean and check machined surfaces of parts.

REPAIR OR REPLACEMENT

1. Replace worn, crimped, or cracked hoses and tubes.
2. Repair or replace nicked or dented machined surfaces of parts.

INSTALLATION

1. Apply a thin even coat of sealing compound to clean external threads of fittings before installation.
2. Install two hoses (1), and filler neck (2) with a new gasket (3) and filler tube (4) on filler flange (5). Secure with four clamps (6).
3. Install clamp (7) and ground lead (8) on filler tube (4). Secure with screw (9), washer (10), and nut (11).

REPLACE FUEL FILLER AND STRAINER PARTS (M577A3 AND M1068A3 ONLY) —
Continued

0186 00

4. Install bushing (12), strainer assembly (13), and strainer element (14) into hull top opening and filler neck (2).
5. Install flange (15) and new gasket (16) on hull top opening. Secure flange to filler neck (2) with 12 screws (17) and nuts (18).
6. Install two elbows (19) in filler neck (2) and connect two fuel tank vent hoses (20) to elbows.
7. Install tee (21) on filler neck (2) and install elbow (22) on tee.
8. Install elbow (23) in filler neck (2) and connect fuel tank vent tube (24) to elbow.
9. Connect engine fuel return hose (25) to elbow (22) and APU fuel return tube (26) to tee (21).

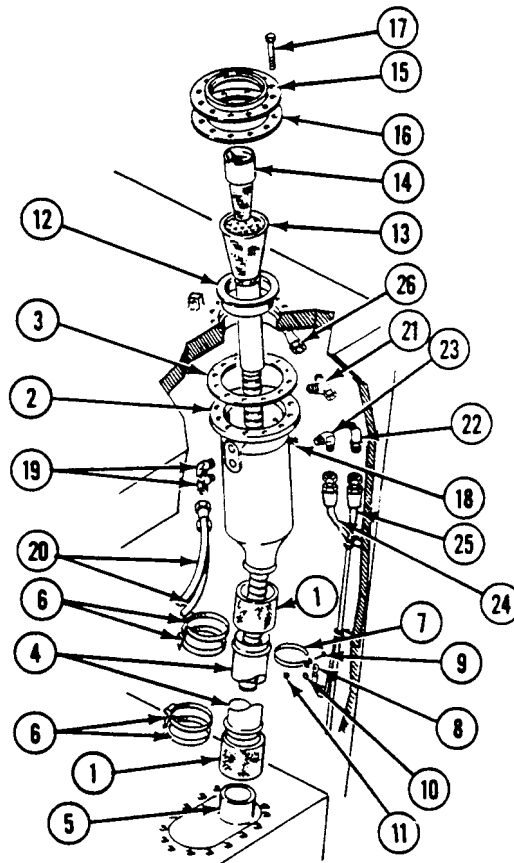
**FOLLOW-THROUGH STEPS**

1. Fill fuel tank (see your -10).
2. Check filler tube and hoses for leaks.
3. Install filler cap (WP 0185 00).
4. Install filler cover and lock (WP 0183 00).
5. Connect battery ground lead (WP 0338 00).
6. Start engine (see your -10).
7. Raise and lock ramp (see your -10).
8. Stop engine (see your -10).

END OF TASK

REPLACE FUEL TANK ACCESS COVERS AND DRAIN PLUGS (ALL EXCEPT M577A3 AND M1068A3)

0187 00

THIS WORK PACKAGE COVERS:

Removal (page 0187 00-1).
 Installation (page 0187 00-2).

INITIAL SETUP:

Maintenance Level

Unit

References

See your -10

Tools and Special Tools

General Mechanic's Tool Kit (WP 0926 00, Item 65)
 Torque Wrench (WP 0926 00, Item 85)

Equipment Condition

Engine stopped (see your -10)
 Carrier blocked (see your -10)
 Battery ground strap disconnected (WP 0337 00) or
 (WP 0339 00)
 Fuel tanks drained (WP 0177 00)

Materials/Parts

Sealing compound (WP 0928 00, Item 56)
 Gasket
 Lockwasher (10)

Personnel Required

Unit Mechanic

REMOVAL

NOTE

Right and left access covers are the same. The following steps apply to one cover.

1. Remove two screws (1), lockwashers (2), flat washers (3), and bracket (4) from cover (5). Discard lockwashers.
2. Remove eight screws (6), lockwashers (7), flat washers (8), cover (5), and gasket (9) from fuel tank (10). Discard gasket and lockwashers.

REPLACE FUEL TANK ACCESS COVERS AND DRAIN PLUGS (ALL EXCEPT M577A3 AND M1068A3) — Continued

0187 00

3. Remove drain plug (11) and bushing (12) from fuel tank (10).

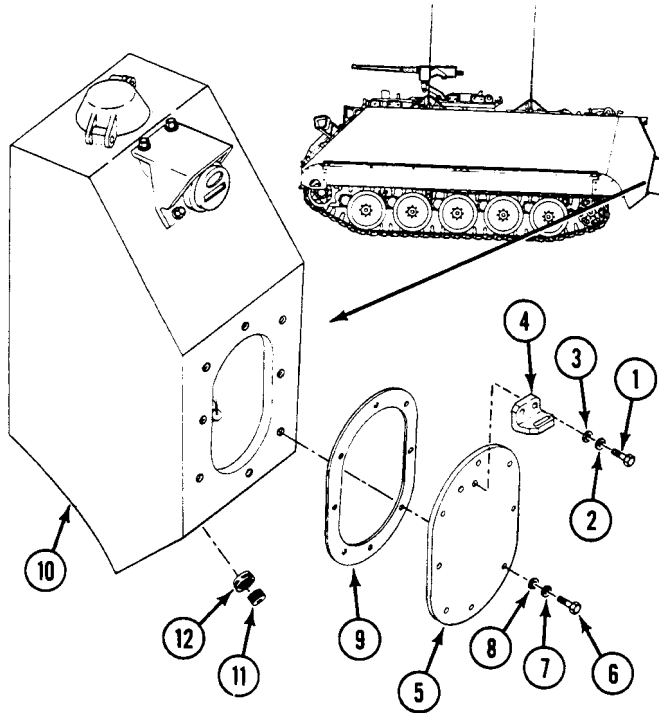
**INSTALLATION**

1. Install cover (5) and new gasket (9) on fuel tank (10). Secure with eight screws (6), new lockwashers (7), and flat washers (8). **TIGHTEN SCREWS TO 45-50 LB-FT (61-68 N·m) TORQUE.**
2. Install bracket (4) on cover (5). Secure with two screws (1), new lockwashers (2), and flat washers (3).
3. Apply a coat of sealing compound to cleaned threads of bushing (12) and drain plug (11).
4. Install bushing (12) in fuel tank (10).

REPLACE FUEL TANK ACCESS COVERS AND DRAIN PLUGS (ALL EXCEPT M577A3 AND M1068A3) — Continued

0187 00

5. Install drain plug (11) in bushing (12).

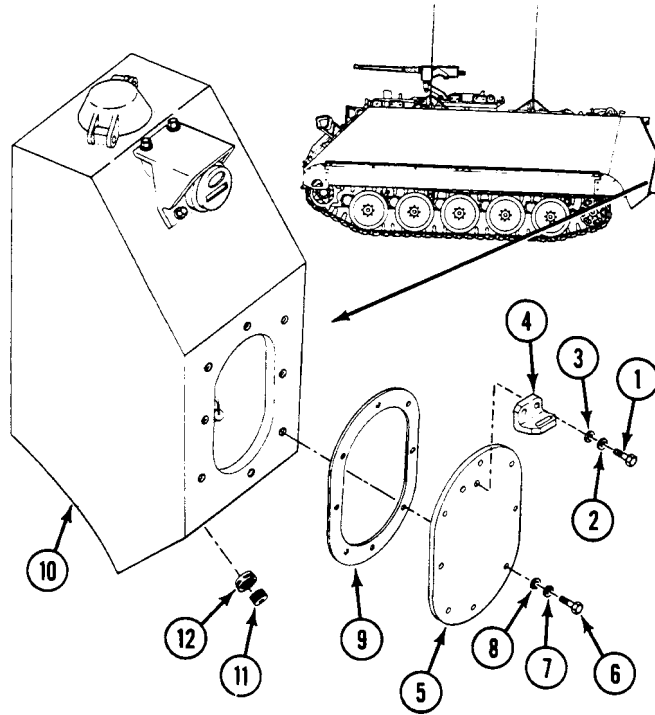
**FOLLOW-THROUGH STEPS**

1. Fill fuel tanks (see your -10).
2. Check for fuel leaks.
3. Connect battery ground strap (WP 0337 00) or (WP 0339 00).

END OF TASK

REPLACE FUEL TANK ACCESS COVERS (M577A3 AND M1068A3 ONLY)

0188 00

THIS WORK PACKAGE COVERS:

- Removal (page 0188 00-1).
- Installation (page 0188 00-2).

INITIAL SETUP:

Maintenance Level

Unit

References

See your -10

Tools and Special Tools

- General Mechanic's Tool Kit (WP 0926 00, Item 65)
- Socket Wrench Set (WP 0926 00, Item 73)
- Torque Wrench (WP 0926 00, Item 85)

Equipment Condition

- Engine stopped (see your -10)
- Carrier blocked (see your -10)
- Ramp lowered (see your -10)
- Battery access cover removed (see your -10)
- Battery ground lead disconnected (WP 0338 00)
- Map board removed (see your -10)
- Work tables removed (WP 0578 00) or (WP 0581 00) and (WP 0582 00)

Materials/Parts

- Gasket
- Locking plate bolt (8)

Personnel Required

Unit Mechanic

REMOVAL

NOTE

Left and right fuel tank access covers are the same. The following steps apply to one cover.

1. Drain fuel tank below filler flange (WP 0178 00).
2. Remove 16 screws (1) and eight locking plate bolts (2) securing fuel tank access cover (3) and gasket (4) to fuel tank. Discard locking plate bolts.

3. Remove fuel tank access cover (3) and gasket (4) from fuel tank. Discard gasket.

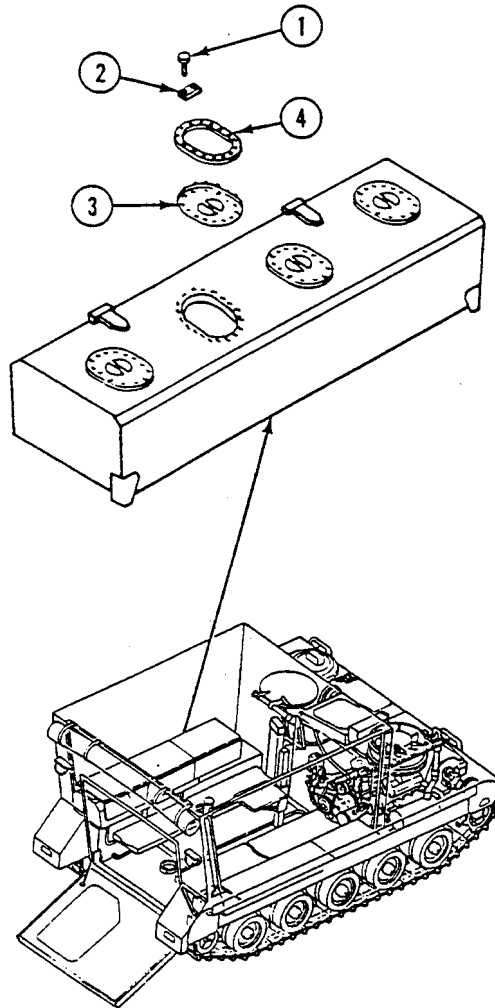

INSTALLATION

1. Place new gasket (4) on access cover (3).
2. Place cover (3) and new gasket (4) inside fuel tank opening. Secure with eight new locking plate bolts (2) and sixteen screws (1).

3. TIGHTEN SIXTEEN SCREWS (1) TO 36-48 LB-IN (4-6 N·m).

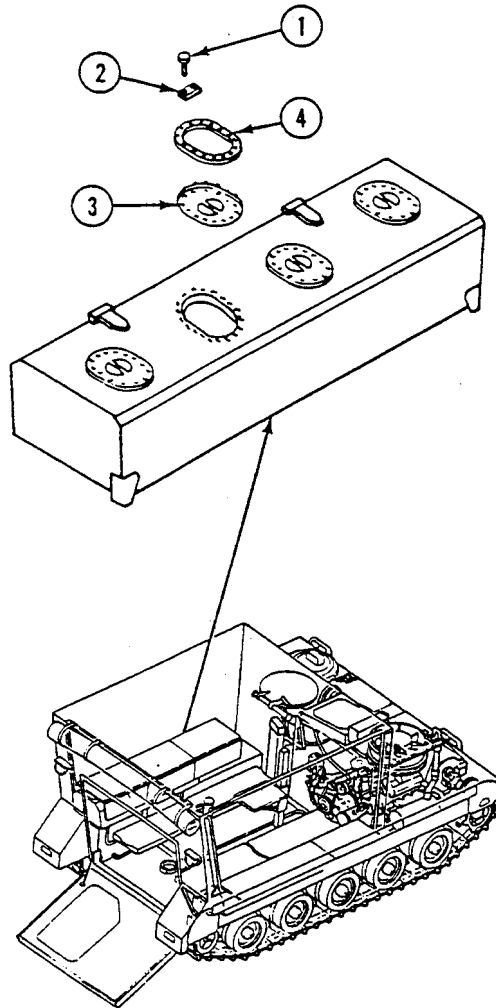

FOLLOW-THROUGH STEPS

1. Fill fuel tank (see your -10). Check tank for leaks.
2. Install work tables (WP 0578 00) or (WP 0581 00) and (WP 0582 00).
3. Install map board (see your -10).
4. Connect battery ground lead (WP 0338 00).
5. Install battery access cover (see your -10).
6. Start engine (see your -10).
7. Raise and lock ramp (see your -10).
8. Stop engine (see your -10).

END OF TASK

REPLACE FUEL TANK FILLER FLANGE (M577A3 AND M1068A3 ONLY)

0189 00

THIS WORK PACKAGE COVERS:

Removal (page 0189 00-1).
 Installation (page 0189 00-2).

INITIAL SETUP:

Maintenance Level

Unit

References

See your -10

Tools and Special Tools

General Mechanic's Tool Kit (WP 0926 00, Item 65)
 Socket Wrench Set (WP 0926 00, Item 73)
 Torque Wrench (WP 0926 00, Item 85)

Equipment Condition

Engine stopped (see your -10)
 Carrier blocked (see your -10)
 Ramp lowered (see your -10)
 Battery access cover removed (see your -10)
 Battery ground lead disconnected (WP 0338 00)
 Map board removed (see your -10)
 Work tables removed (WP 0578 00) or (WP 0581 00)
 and (WP 0582 00)
 Fuel tanks drained below filler flange level (WP 0178 00)

Materials/Parts

Gasket
 Locking plate bolt (8)

Personnel Required

Unit Mechanic

REMOVAL

1. Remove two clamps (1) and filler hose (2) from filler tube (3) and filler flange (4).
2. Remove 16 screws (5), 8 locking plate bolts (6), filler flange (4), and gasket (7) from fuel tank. Discard gasket and locking plate bolts.

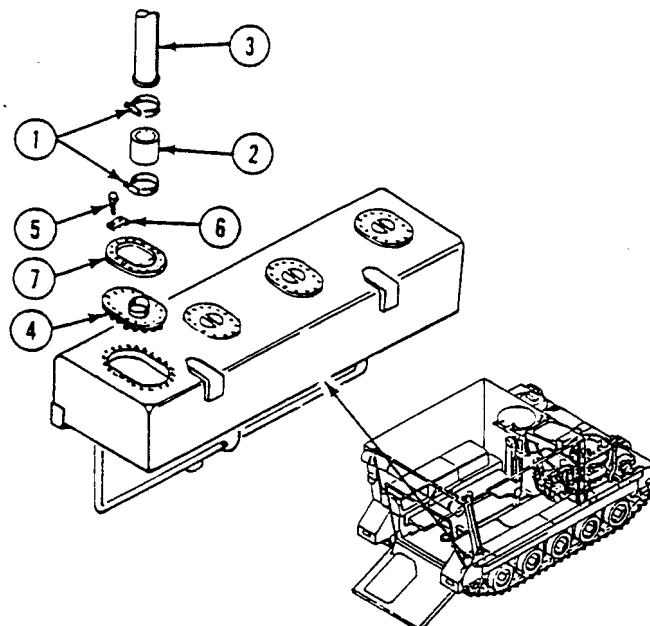

INSTALLATION

1. Place new gasket (7) on filler flange (4).
2. Place filler flange (4) and new gasket (7) inside fuel tank opening. Secure with 8 new locking plate bolts (6) and 16 screws (5).
3. TIGHTEN 16 SCREWS (5) TO 36-48 LB-IN (4-6 N·m) TORQUE.
4. Secure filler hose (2) to filler flange (4) and filler tube (3) with two clamps (1).

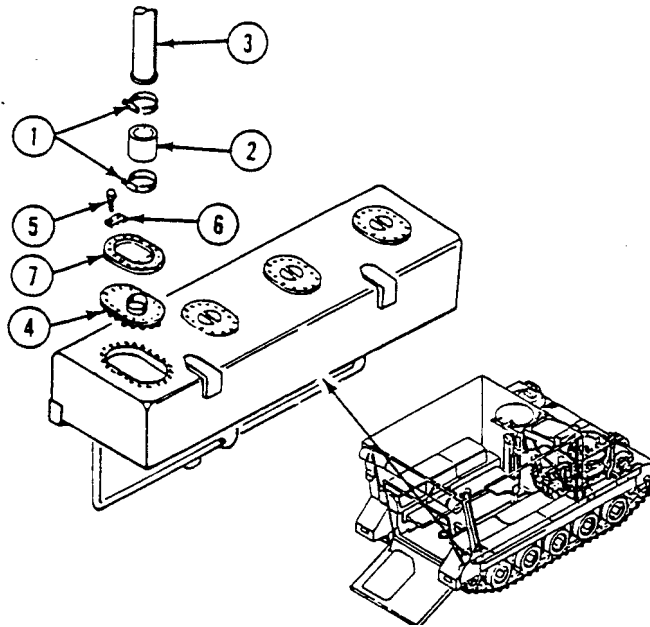
**FOLLOW-THROUGH STEPS**

1. Fill fuel tank (see your -10). Check tank for leaks.
2. Install work tables (WP 0578 00) or (WP 0581 00) and (WP 0582 00).
3. Install map board (see your -10).
4. Connect battery ground lead (WP 0338 00).
5. Install battery access cover (see your -10).
6. Start engine (see your -10).
7. Raise and lock ramp (see your -10)
8. Stop engine (see your -10).

END OF TASK

REPLACE FUEL QUANTITY TRANSMITTER (ALL EXCEPT M577A3 AND M1068A3)

0190 00

THIS WORK PACKAGE COVERS:

- Removal (page 0190 00-1).
- Inspection (page 0190 00-2).
- Repair (page 0190 00-2).
- Installation (page 0190 00-3).

INITIAL SETUP:

Maintenance Level

Unit

Tools and Special Tools

General Mechanic's Tool Kit (WP 0926 00, Item 65)

Materials/Parts

Sealing compound (WP 0928 00, Item 56)

Personnel Required

Unit Mechanic

References

See your -10

Equipment Condition

- Engine stopped (see your -10)
- Carrier blocked (see your -10)
- Battery ground strap disconnected (WP 0337 00) or (WP 0339 00)
- Fuel tanks drained (WP 0177 00)
- Fuel tank access covers removed (WP 0187 00)
- Tail lights and guards removed (WP 0298 00)

REMOVAL

NOTE

Right and left fuel quantity transmitters are replaced the same. The following steps apply to one unit.

1. Disconnect lead (1) from transmitter (2). Circuit 30A is left tank transmitter lead. Circuit 31A is right tank transmitter lead.
2. Remove two screws (3), washers (4), bracket (5), and transmitter (2) from fuel tank (6).
3. Remove screw (7), washer (8), and clamp (9) that secures lead (1) to fuel tank (6).
4. Remove connector (10) and lead (1) from fuel tank (6).

REPLACE FUEL QUANTITY TRANSMITTER (ALL EXCEPT M577A3 AND M1068A3) —
Continued

0190 00

5. Remove five screws (11) and nuts (12). Separate transmitter (2) from bracket (5).

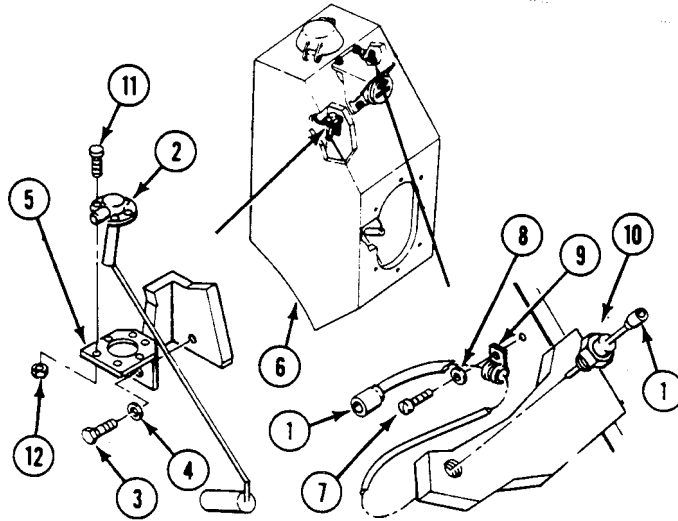
**INSPECTION-ACCEPTANCE AND REJECTION CRITERIA**

1. Inspect bracket.
2. Inspect connector.

REPAIR OR REPLACEMENT

1. Replace bracket if cracked.
2. Replace connector that is cracked or has stripped threads (WP 0382 00).

REPLACE FUEL QUANTITY TRANSMITTER (ALL EXCEPT M577A3 AND M1068A3) —
Continued

0190 00

INSTALLATION

1. Apply a thin coat of sealing compound to cleaned external threads of connector (1) before installation.
2. Secure transmitter (2) to bracket (3) with five screws (4) and nuts (5).
3. Install bracket (3) and transmitter (2) on fuel tank (6). Secure with two screws (7) and washers (8).
4. Install lead (9) and connector (1) in tank (6).
5. Connect lead (9) to transmitter (2). Circuit 30A is left tank transmitter lead. Circuit 31A is right tank transmitter lead.
6. Secure lead (9) to tank (6) with clamp (10), washer (11), and screw (12).

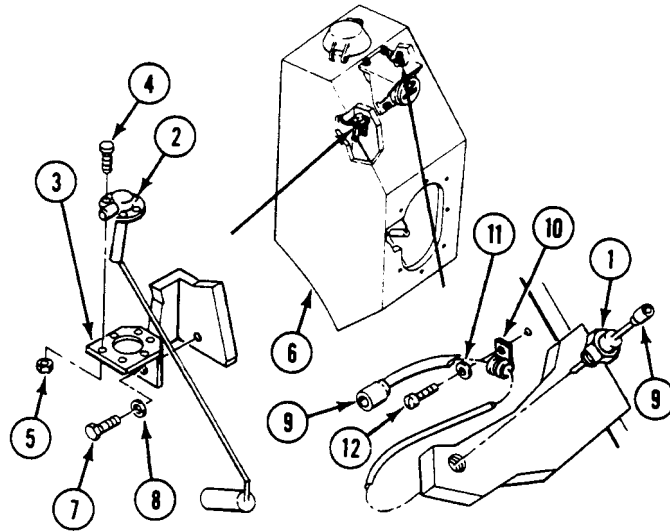
**FOLLOW-THROUGH STEPS**

1. Install tail lights and guards (WP 0298 00).
2. Install fuel tank access covers (WP 0187 00).
3. Fill fuel tanks (see your -10).
4. Connect battery ground strap (WP 0337 00) or (WP 0339 00).
5. Check that fuel quantity transmitter works properly (see your -10).

END OF TASK

REPLACE FUEL QUANTITY TRANSMITTER (M577A3 AND M1068A3 ONLY)

0191 00

THIS WORK PACKAGE COVERS:

- Removal (page 0191 00-1).
 - Cleaning (page 0191 00-2).
 - Installation (page 0191 00-2).
-

INITIAL SETUP:

Maintenance Level

Unit

References

See your -10

Tools and Special Tools

General Mechanic's Tool Kit (WP 0926 00, Item 65)

Equipment Condition

- Engine stopped (see your -10)
- Carrier blocked (see your -10)
- Ramp lowered (see your -10)
- Battery ground lead disconnected (WP 0338 00)
- Map board removed (see your -10)
- Work tables removed (WP 0578 00) or (WP 0581 00) and (WP 0582 00)
- Fuel tanks drained to less than 3/4 full (WP 0178 00)

Materials/Parts

- Cleaning Compound (WP 0928 00, Item 19)
- Nonelectrical Wire (WP 0928 00, Item 42)
- Gasket

Personnel Required

Unit Mechanic

REMOVAL

NOTE

Right and left fuel quantity transmitter are the same. The following steps apply to only one transmitter.

1. Disconnect lead (1) from transmitter (2). Circuit 29 lead is for right transmitter. Circuit 30 lead is for left transmitter.
2. Remove lockwire (3) from five screws (4). Discard lockwire.

3. Remove five screws (4), ground lead (5), transmitter (2), and gasket (6) from fuel tank. Discard gasket.

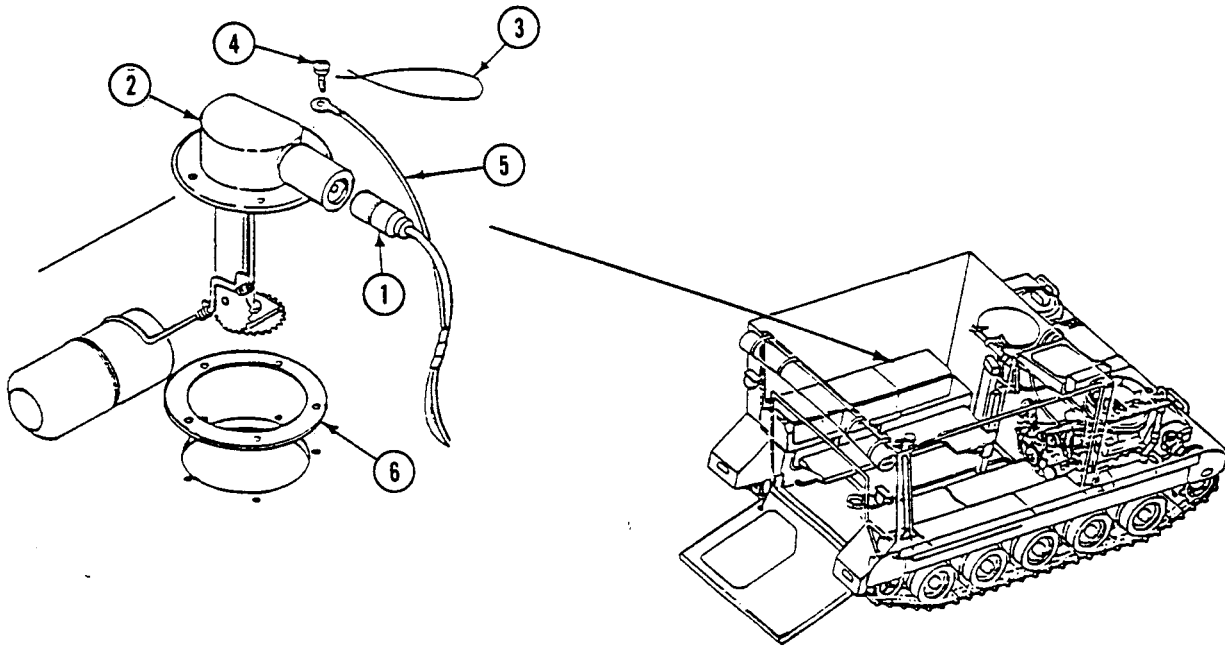

CLEANING

1. Clean gasket mating surface on top of fuel tank with cleaning compound.

INSTALLATION

1. Install new gasket (1), transmitter (2), and ground lead (3) on fuel tank. Secure with five screws (4).

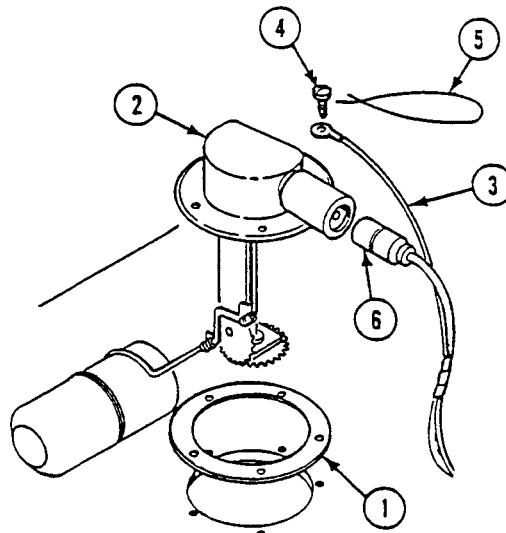

2. Install new lockwire (5) through heads of five screws (4). Secure with double twist method.

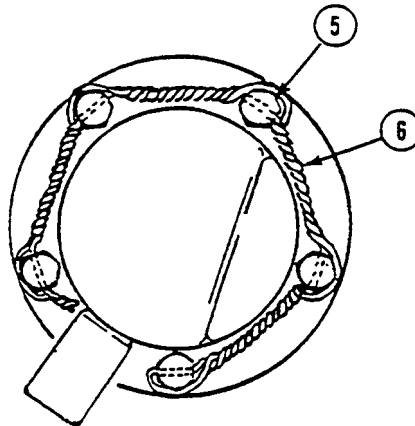

3. Connect lead (6) to transmitter (2). Circuit 29 is lead for right transmitter. Circuit 30 is lead for left transmitter.

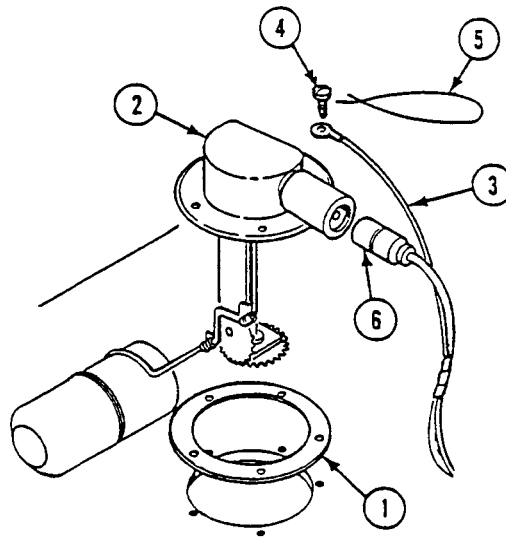

FOLLOW-THROUGH STEPS

1. Fill fuel tank. Check for leaks (see your -10).
2. Connect battery ground lead (WP 0338 00).
3. Check that fuel quantity transmitter operates properly (see your -10).
4. Install work tables (WP 0578 00) or (WP 0581 00) and (WP 0582 00).
5. Install map board (see your -10).
6. Start engine (see your -10).
7. Raise and lock ramp (see your -10).
8. Stop engine (see your -10).

END OF TASK

REPLACE FUEL SUPPLY HOSES, TUBES, AND FITTINGS (M113A3, M1059A3, AND M58 ONLY)

0192 00

THIS WORK PACKAGE COVERS:

Removal (page 0192 00-1).
 Installation (page 0192 00-8).

INITIAL SETUP:

Maintenance Level

Unit

Tools and Special Tools

General Mechanic's Tool Kit (WP 0926 00, Item 65)

Materials/Parts

Caulking compound (WP 0928 00, Item 14)

Sealing compound (WP 0928 00, Item 53)

Grommet

Lockwasher (6)

Personnel Required

Unit Mechanic

References

See your -10

TM 3-1040-285-20

Equipment Condition

Engine stopped (see your -10)

Carrier blocked (see your -10)

Ramp lowered

Power plant lower rear access panel removed
 (see your -10)

Floor plates removed (WP 0539 00), (WP 0542 00) and
 (WP 0545 00)

Battery ground strap disconnected (WP 0337 00)

Fuel tanks drained (WP 0177 00)

Smoke generator fog oil tank module removed
 (M1059A3 only) (WP 0753 00)

Smoke generator system removed (M58 only)
 (TM 3-1040-285-20)

**REPLACE FUEL SUPPLY HOSES, TUBES, AND FITTINGS (M113A3,
M1059A3, AND M58 ONLY) — Continued**

0192 00

REMOVAL

1. Remove quick disconnect (1) from coupler body (2).
2. Remove hose (3) from elbow (4).
3. Remove grommet (5) and hose (3) from bulkhead. Discard grommet.

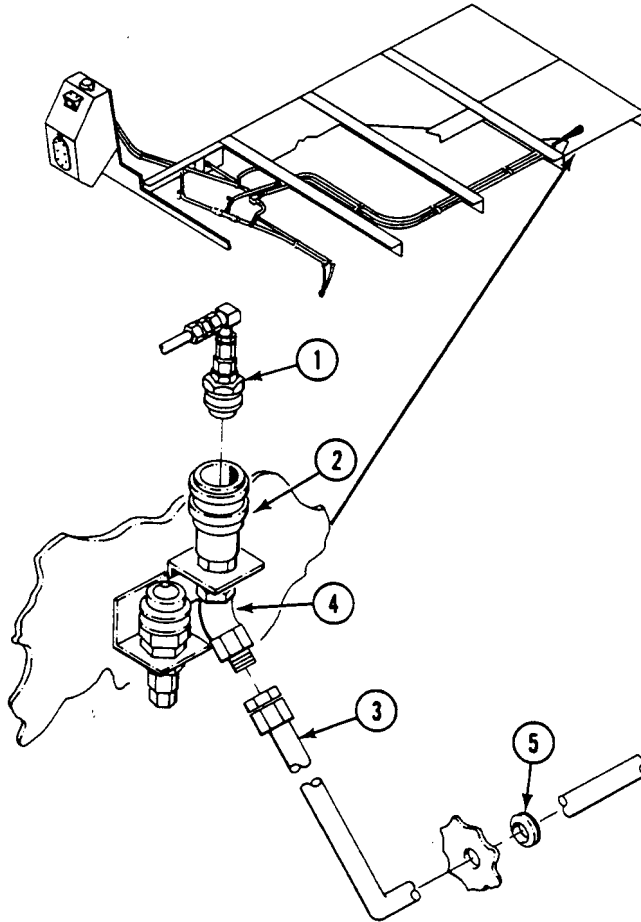

NOTE

Step 4, Step 5, and Step 6 refer to M58 only.

4. Remove hose (1) from tube cross (2).
5. Remove five screws (3), lockwashers (4), clamps (5), and hose (1) from carrier. Discard lockwashers.
6. Remove hoses (6 and 6.1) from tube cross (2). Remove tube cross from carrier.

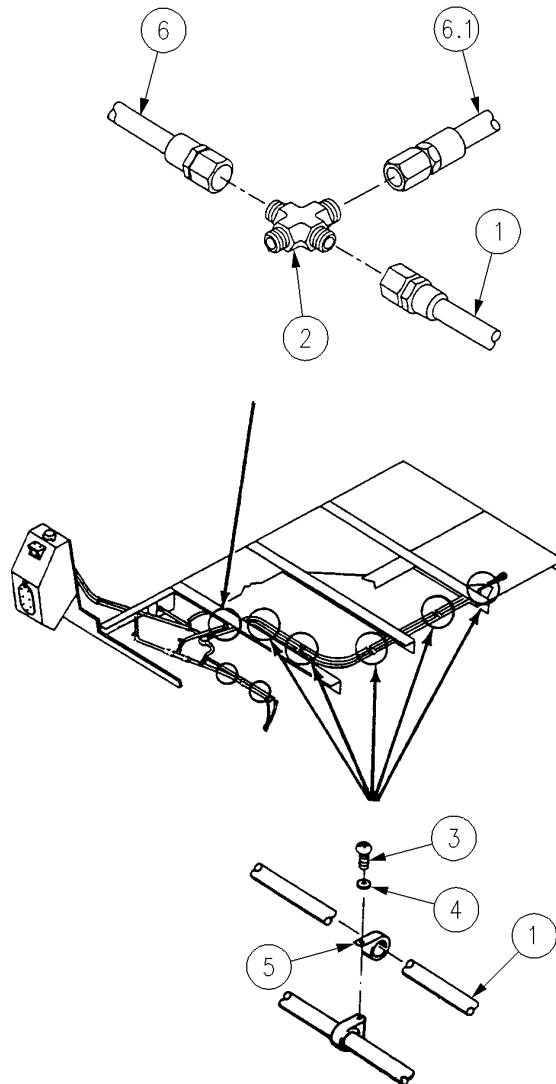

**REPLACE FUEL SUPPLY HOSES, TUBES, AND FITTINGS (M113A3,
M1059A3, AND M58 ONLY) — Continued**

0192 00

7. Remove screw (7), lockwasher (8), and clamp (9) from hose (6) and carrier. Discard lockwasher.
8. Remove hose (6) from adapter (10). Remove hose from carrier.
9. Remove adapter (10) from tee (11).

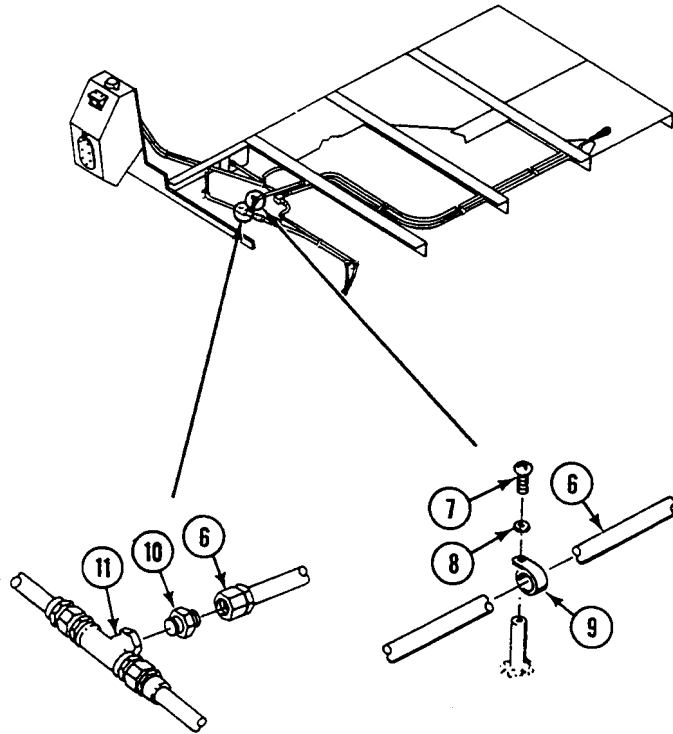

**REPLACE FUEL SUPPLY HOSES, TUBES, AND FITTINGS (M113A3,
M1059A3, AND M58 ONLY) — Continued**

0192 00

NOTE

Do Steps 10 - 24 for removing left side fuel tank supply hoses and fittings. Do Steps 25 - 38 for removing right side fuel tank supply hoses and fittings.

10. Remove hose (12) from adapter (20).
11. Remove adapter (20) from tee (11).
12. Remove three screws (21), lockwashers (22), and clamps (23) from hose (12) and carrier. Discard lockwashers.
13. Remove tiedown strap (14) from two hoses (12) and (13).
14. Remove locknut (18) and screw (17) from guard (16). Discard locknut.
15. Remove screw (19), washer (15), and guard (16) from ramp pulley mount.

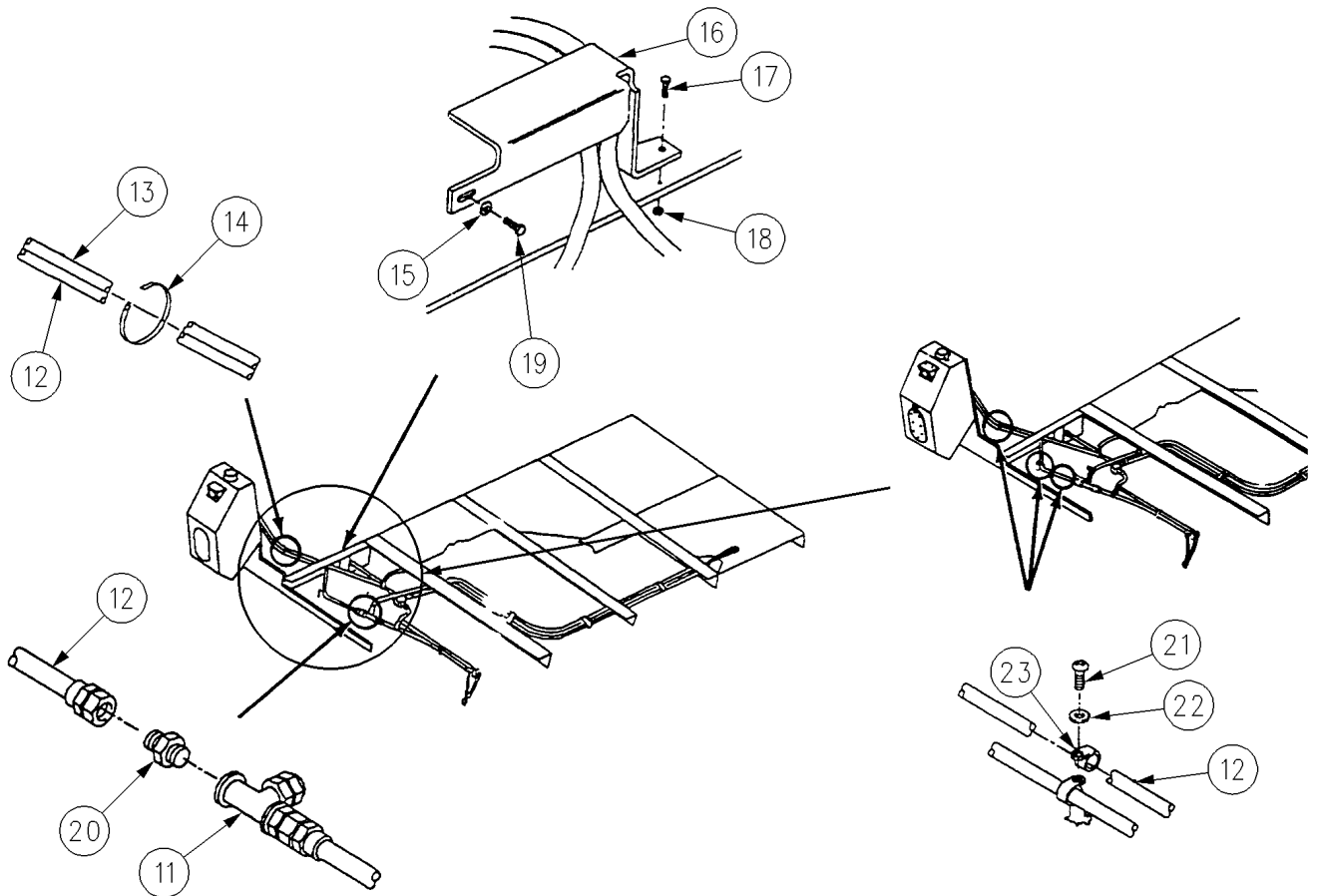

**REPLACE FUEL SUPPLY HOSES, TUBES, AND FITTINGS (M113A3,
M1059A3, AND M58 ONLY) — Continued**

0192 00

16. Remove two screws (24), washers (25), and clamps (26) securing valve (28) to mounting block (29).
17. Remove hose (12) from adapter (30). Remove hose from carrier.
18. Remove adapter (30) from adapter (31).
19. Remove adapter (31) from valve (28).
20. Remove hose (32) from adapter (33).
21. Remove adapter (33) from valve (28).
22. Remove hose (32) from elbow (34).
23. Remove elbow (34) from adapter (35).
24. Remove adapter (35) from fuel tank (36).

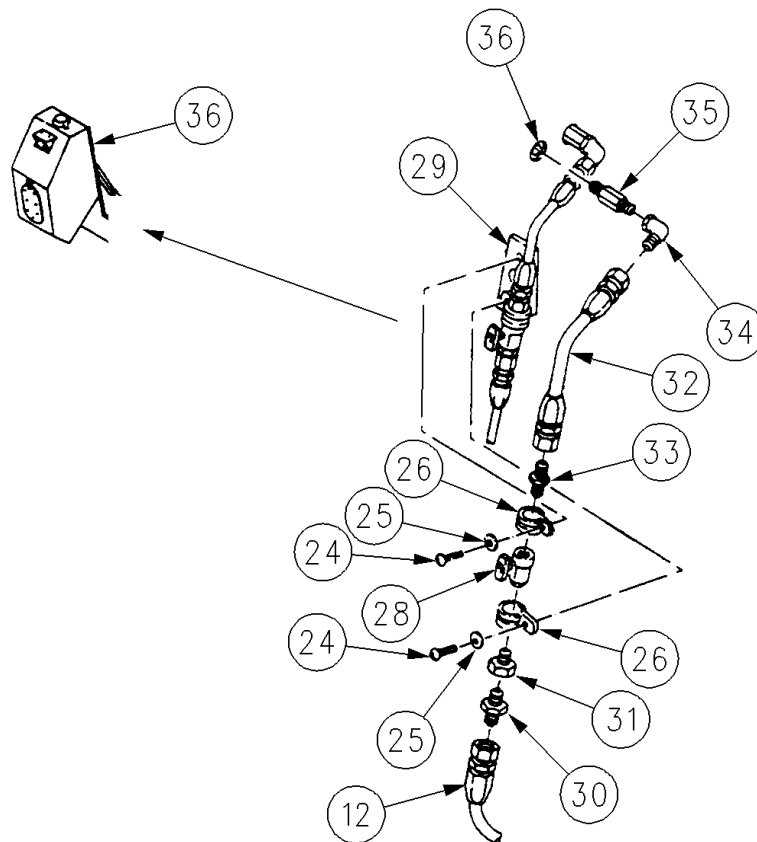

**REPLACE FUEL SUPPLY HOSES, TUBES, AND FITTINGS (M113A3,
M1059A3, AND M58 ONLY) — Continued**

0192 00

25. Remove hose (37) from adapter (38).
26. Remove adapter (38) from tee (11).
27. Remove two screws (39), lockwashers (40), and clamps (41) from hose (37) and carrier. Discard lockwashers.
28. Remove two tiedown straps (14) from two hoses (37) and (37.1).

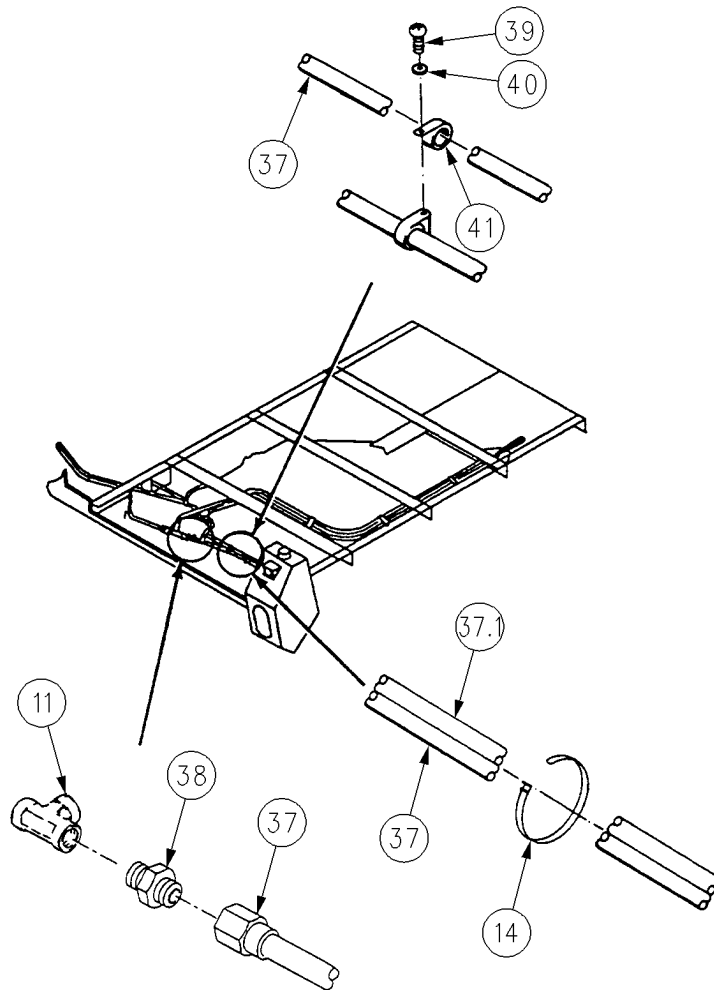

**REPLACE FUEL SUPPLY HOSES, TUBES, AND FITTINGS (M113A3,
M1059A3, AND M58 ONLY) — Continued**

0192 00

29. Remove screw (42), washer (43), and clamp (44) securing valve (45) to mounting block (46).
30. Remove hose (37) from adapter (47). Remove hose from carrier.
31. Remove adapter (47) from adapter (48).
32. Remove adapter (48) from valve (45).
33. Remove hose (49) from adapter (50).
34. Remove adapter (50) from valve (45).
35. Remove five screws (51), washers (52), lockwashers (53), and guard (54) from rear plate and sponson. Discard lockwashers.
36. Remove hose (49) from elbow (55). Remove hose from carrier.
37. Remove elbow (55) from adapter (56).
38. Remove adapter (56) from fuel tank (57).

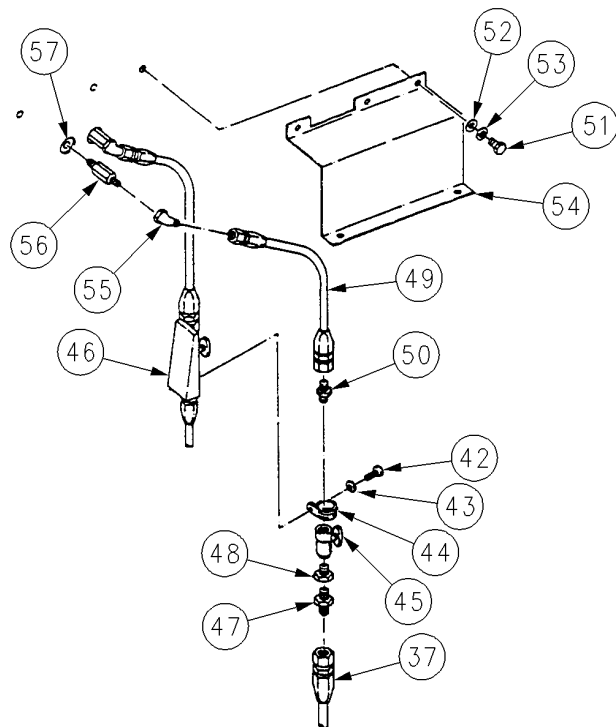
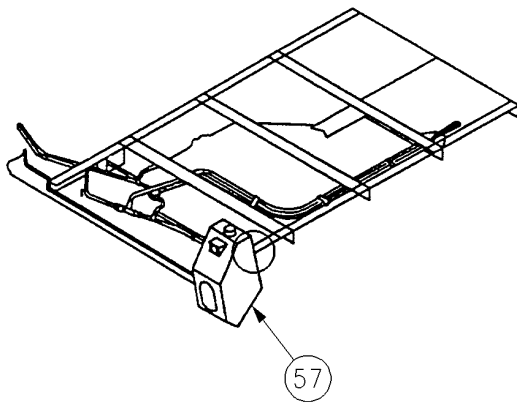

INSTALLATION

NOTE

Do Steps 1 - 15 for installing right side fuel tank supply hoses and fittings. Do Steps 16 - 30 for installing left side fuel tank supply hoses and fittings.

1. Apply sealing compound to external threads of adapter (1). Install adapter (1) on fuel tank (2).
2. Apply sealing compound to external threads of elbow (3). Install elbow (3) on adapter (1).
3. Apply caulking compound to space around adapter (1) on rear hull plate.
4. Install hose (4) on elbow (3).
5. Install guard (5) on rear plate and sponson and secure with five washers (6), lockwashers (7), and screws (8).
6. Apply sealing compound to external threads of adapter (9). Install adapter in valve (10).
7. Install hose (4) on adapter (9).
8. Apply sealing compound to external threads of adapter (11). Install adapter in valve (10).
9. Apply sealing compound to external threads of adapter (12). Install adapter on adapter (11).
10. Install hose (13) on adapter (12).
11. Secure valve (10) to mounting block (14) with clamp (15), washer (16), and screw (17).

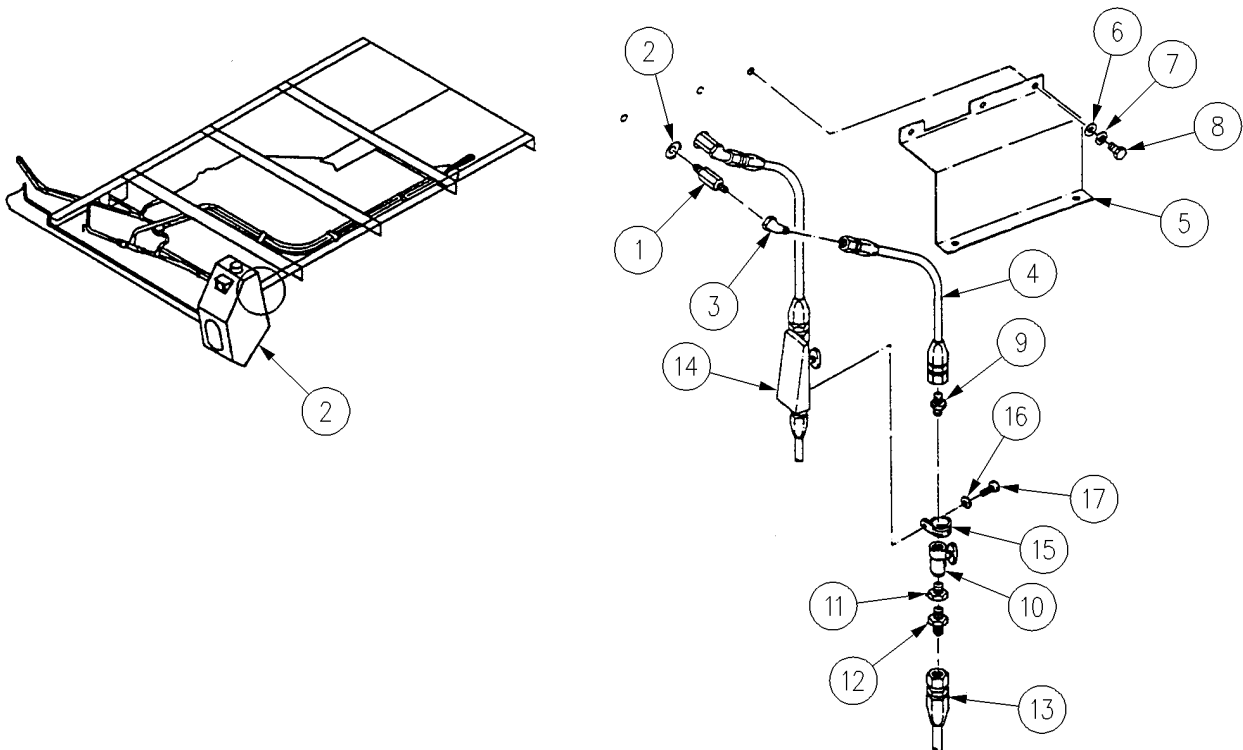

**REPLACE FUEL SUPPLY HOSES, TUBES, AND FITTINGS (M113A3,
M1059A3, AND M58 ONLY) — Continued**

0192 00

12. Apply sealing compound to external threads of adapter (18). Install adapter on tee (19).
13. Install hose (13) on adapter (18).
14. Install two clamps (20) on hose (13). Secure clamps to carrier with two screws (21) and new lockwashers (22).
15. Install two tiedown straps (23) on hoses (13) and (24).

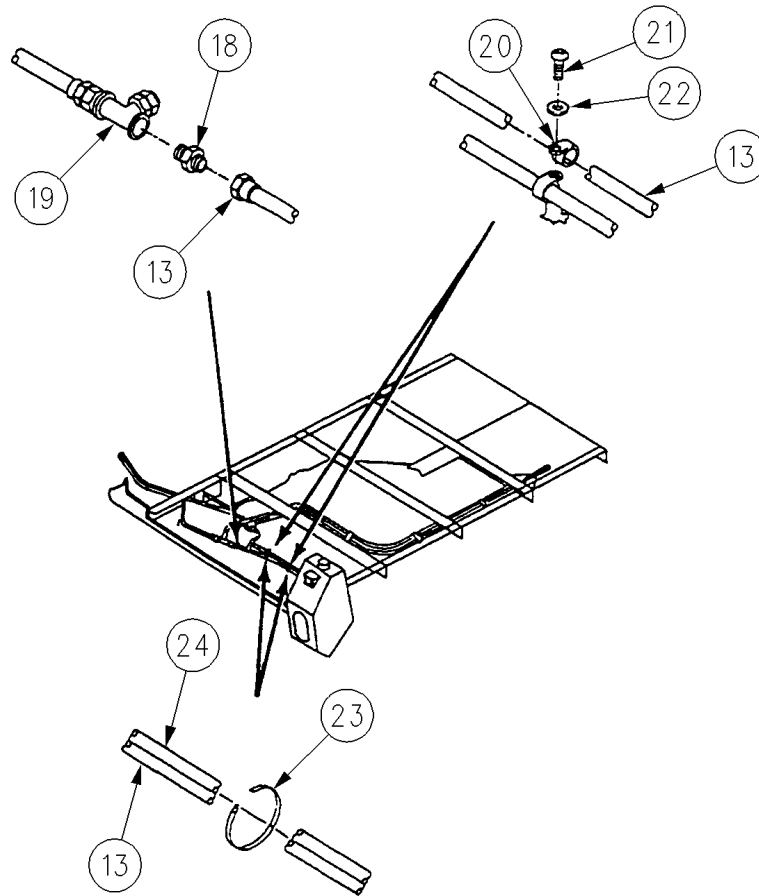

REPLACE FUEL SUPPLY HOSES, TUBES, AND FITTINGS (M113A3, M1059A3, AND M58 ONLY) — Continued

16. Apply sealing compound to external threads of adapter (25). Install adapter on fuel tank (26).
17. Apply sealing compound to external threads of elbow (27). Install elbow on adapter (25).
18. Apply caulking compound to space around adapter (25) on rear hull plate.
19. Install hose (28) on elbow (27).
20. Apply sealing compound to external threads of adapter (29). Install adapter on valve (30).
21. Install hose (28) on adapter (29).
22. Apply sealing compound to external threads of adapter (31). Install adapter on valve (30).
23. Apply sealing compound to external threads of adapter (32). Install adapter on adapter (31).
24. Install hose (33) on adapter (32).
25. Secure valve (30) to mounting block (34) with two clamps (35), washers (36), and screws (37).

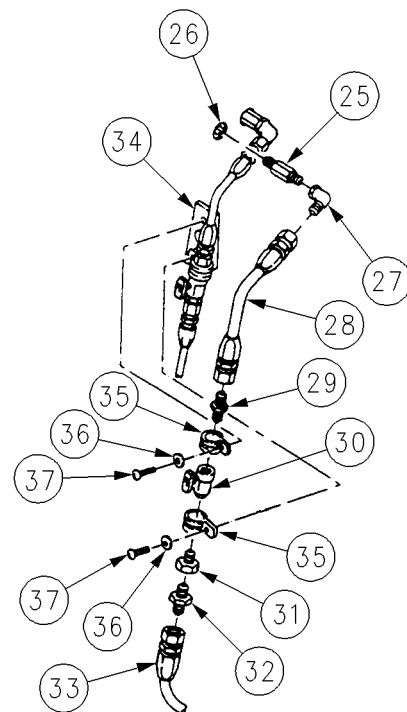
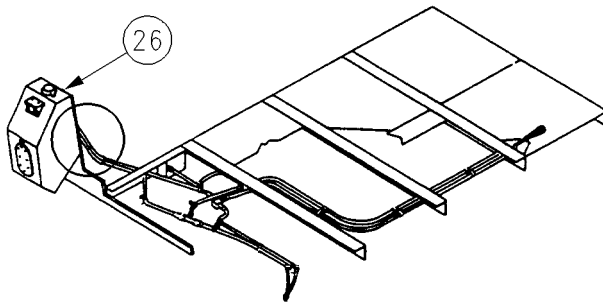

**REPLACE FUEL SUPPLY HOSES, TUBES, AND FITTINGS (M113A3,
M1059A3, AND M58 ONLY) — Continued**

0192 00

26. Apply sealing compound to external threads of adapter (38). Install adapter on tee (39).
27. Install hose (40) on adapter (38).
28. Apply sealing compound to external threads of adapter (41). Install adapter on tee (39).

NOTE**Step 29 is for M58 only.**

29. Install hose (42) on adapter (41) and tube cross (43).
30. Install clamp (44) on hose (42). Secure clamp to carrier with screw (45) and new lockwasher (46).

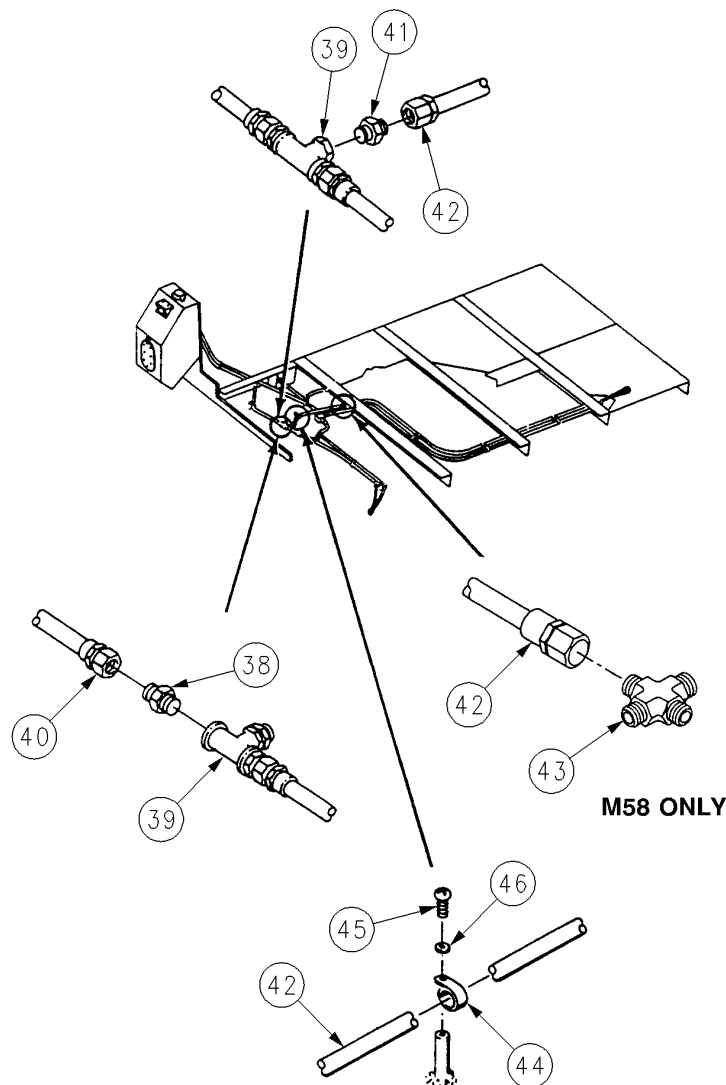

REPLACE FUEL SUPPLY HOSES, TUBES, AND FITTINGS (M113A3, M1059A3, AND M58 ONLY) — Continued

0192 00

31. Install three clamps (47) on hose (40). Secure clamps to carrier with three screws (48) and new lockwashers (49).
32. Place guard (50) over hoses (40) and (51). Secure guard with screw (52), new locknut (53), washer (54), and screw (55).
33. Install tiedown strap (56) on hoses (40) and (51).

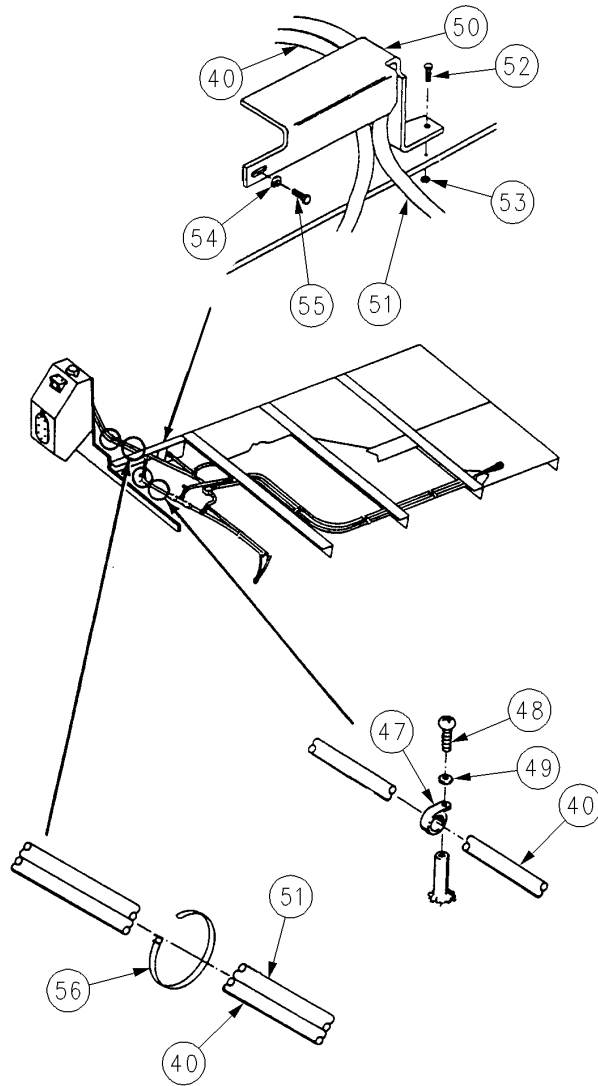

NOTE

Step 34 is for M58 only.

34. Install hoses (57 and 57.1) on tube cross (43).
35. Install five clamps (58) on hose (57). Secure clamps to carrier with five screws (59) and new lockwashers (60).

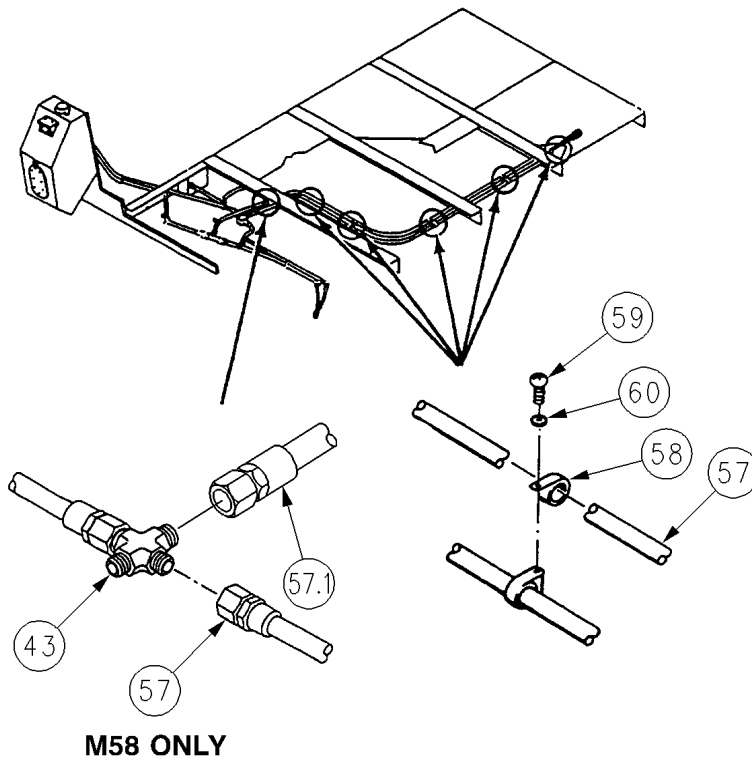

**REPLACE FUEL SUPPLY HOSES, TUBES, AND FITTINGS (M113A3,
M1059A3, AND M58 ONLY) — Continued**

0192 00

36. Install grommet (61) on hose (57). Route hose through hole in bulkhead and install grommet in bulkhead.
37. Install hose (57) on elbow (62). Hold elbow when tightening hose.
38. Install quick disconnect (63) on coupler body (64).

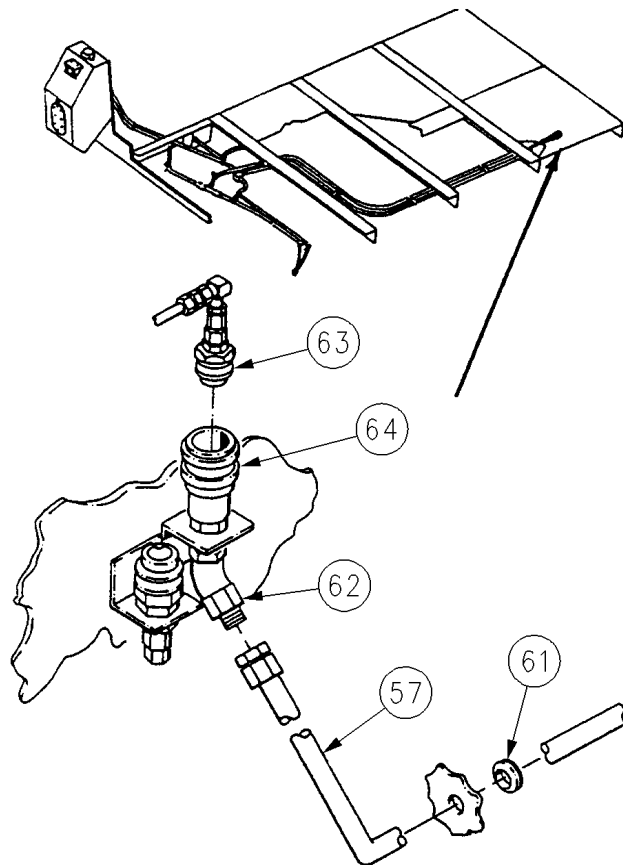

**REPLACE FUEL SUPPLY HOSES, TUBES, AND FITTINGS (M113A3,
M1059A3, AND M58 ONLY) — Continued**

0192 00

FOLLOW-THROUGH STEPS

1. Fill fuel tanks (see your -10).
2. Connect battery ground strap (WP 0337 00).
3. Start engine (see your -10). Check for leaks.
4. Stop engine (see your -10).
5. Install floor plates (see Table of Contents).
6. Install power plant lower rear access panel (see your -10).

NOTE

Do Step 7, Step 8, and Step 10 for M1059A3 only.

7. Disconnect battery ground strap (WP 0337 00).
8. Install smoke generator fog oil tank module (M1059A3 only) (WP 0753 00).
9. Install smoke generator system (M58 only) (TM 3-1040-285-20).
10. Connect battery ground strap (WP 0337 00).
11. Start engine (see your -10).
12. Raise and lock ramp (see your -10).
13. Stop engine (see your -10).

END OF TASK

REPLACE FUEL SUPPLY HOSES, TUBES AND FITTINGS (M577A3 AND M1068A3 ONLY)

0193 00

THIS WORK PACKAGE COVERS:

Removal (page 0193 00-1).
 Installation (page 0193 00-5).

INITIAL SETUP:

Maintenance Level

Unit

References

See your -10

Tools and Special Tools

General Mechanic's Tool Kit (WP 0926 00, Item 65)

Equipment Condition

Engine stopped (see your -10)

Carrier blocked (see your -10)

Ramp lowered (see your -10)

Battery ground lead disconnected (WP 0338 00)

Fuel tanks drained (WP 0178 00)

Power plant rear access panel removed (WP 0439 00)

Rear compartment floor plates removed (WP 0539 00) or
 (WP 0544 00)

Materials/Parts

Sealing compound (WP 0928 00, Item 56)

Wiping rag (WP 0928 00, Item 65)

Grommet

Locknut (4)

Lockwasher (14)

Personnel Required

Unit Mechanic

REMOVAL

WARNING



Fuel flowing over a metal surface causes static electricity. This will cause a spark unless the surface is grounded.

NOTE

Use wiping rag to wipe up any spilled fuel.

1. Disconnect personnel heater fuel hose (1) from shutoff valve (2), if installed.
2. Remove shutoff valve (2) and nipple (3) from tube (4).
3. Remove four screws (5) and lockwashers (6) that secure four ground leads (7), clamps (8), and two elbows (9) to four weldnuts (10). Discard lockwashers.

REPLACE FUEL SUPPLY HOSES, TUBES AND FITTINGS (M577A3 AND M1068A3 ONLY)

0193 00

— Continued

4. Remove four locknuts (11), lockwashers (12), and screws (13) that secure four leads (7) and clamps (14) to elbows (9) and tubes (4) and (15). Discard locknuts and lockwashers.

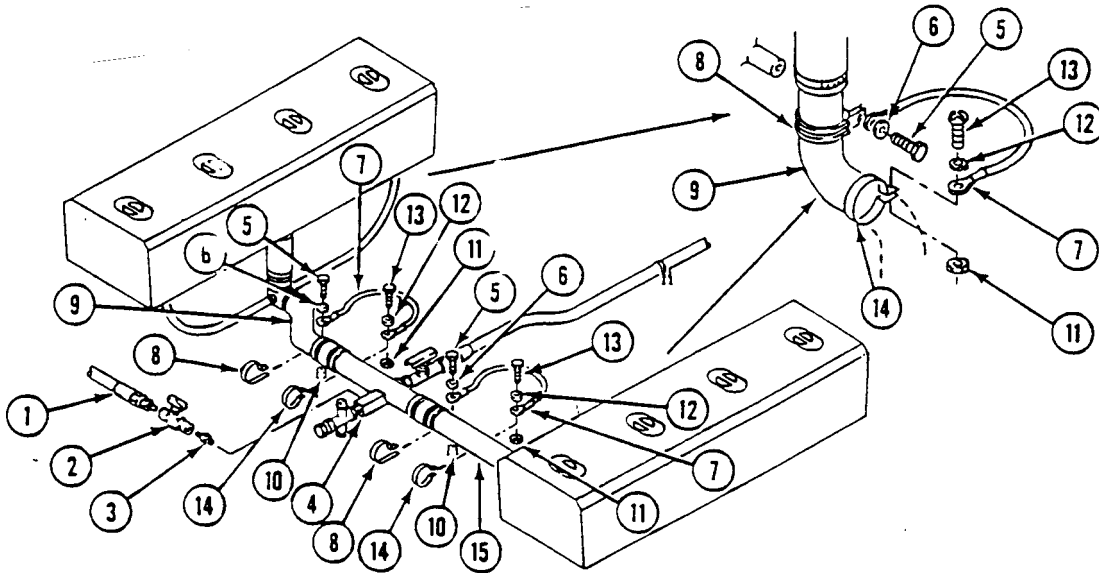

5. Remove plug (1) draincock (2), nipple (3), and bushing (4) from tube (5). Separate plug from draincock, draincock from nipple, and nipple from bushing.
6. Remove four screws (6), lockwashers (7), and clamps (8) that secure four hose assemblies (9) to weldnuts (10). Discard lockwashers.

REPLACE FUEL SUPPLY HOSES, TUBES AND FITTINGS (M577A3 AND M1068A3 ONLY)

0193 00

— Continued

7. Disconnect four hose assemblies (9) from nipples (11).
8. Remove four nipples (11) from two fuel tanks (12).
9. Disconnect four hose assemblies (9) from two elbows (13).
10. Remove two clamps (14) and hose (15) from elbow (13) and tube (5).
11. Remove two clamps (16) and hose (17) from elbow (13) and tube (18).
12. Remove screw (19), lockwasher (20), and clamp (21) that secure elbow (13) to weldnut (22). Discard lockwasher.
13. Remove two clamps (23) and hose (24) from two tubes (5) and (18).
14. Remove four clamps (25) that secure two hoses (26) to two elbows (13) and fuel tanks (12). Remove hoses.

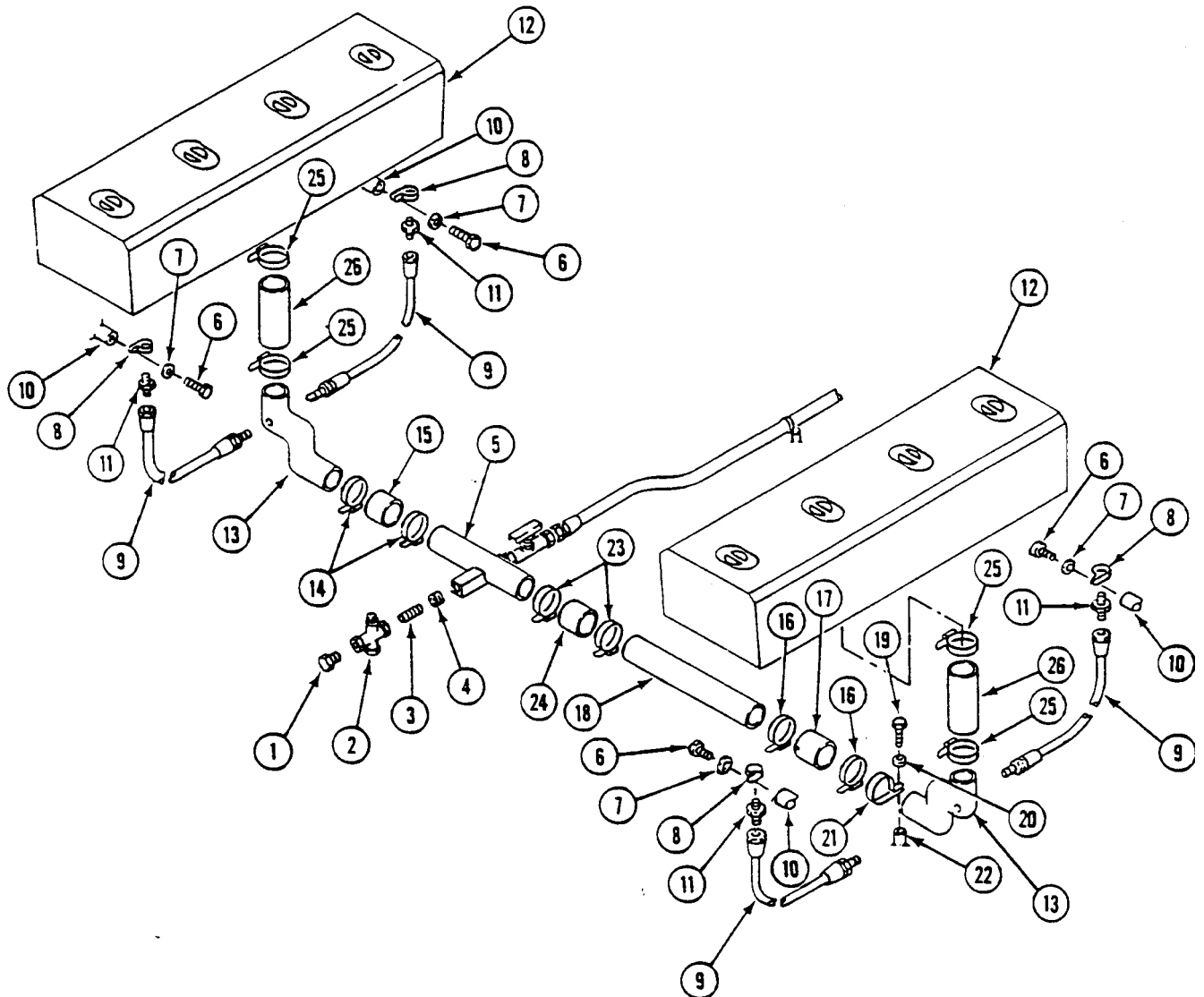

REPLACE FUEL SUPPLY HOSES, TUBES AND FITTINGS (M577A3 AND M1068A3 ONLY)**0193 00****— Continued**

15. Disconnect hose (1) from adapter (2).
16. Remove adapter (2), shutoff valve (3), and nipple (4) from tube (5).

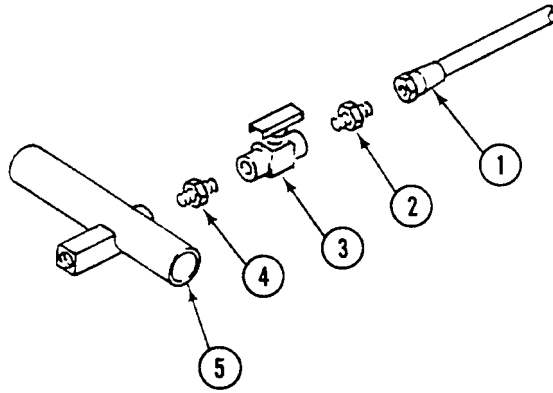

17. Remove quick disconnect (6) from coupler (7).
18. Remove hose (1) from elbow (8).
19. Remove grommet (9) and hose (1) from bulkhead. Discard grommet.

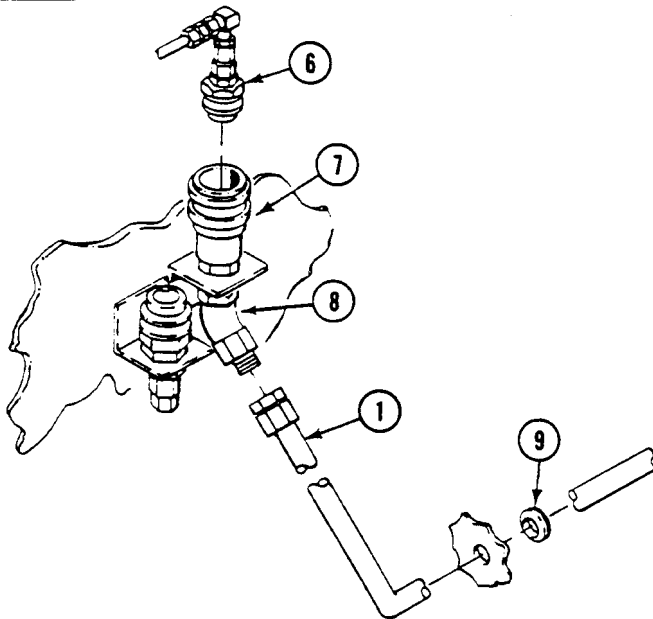

REPLACE FUEL SUPPLY HOSES, TUBES AND FITTINGS (M577A3 AND M1068A3 ONLY)
— Continued

0193 00

20. Remove five screws (10) and clamps (11) that secure hose (1) to weldnuts (12).

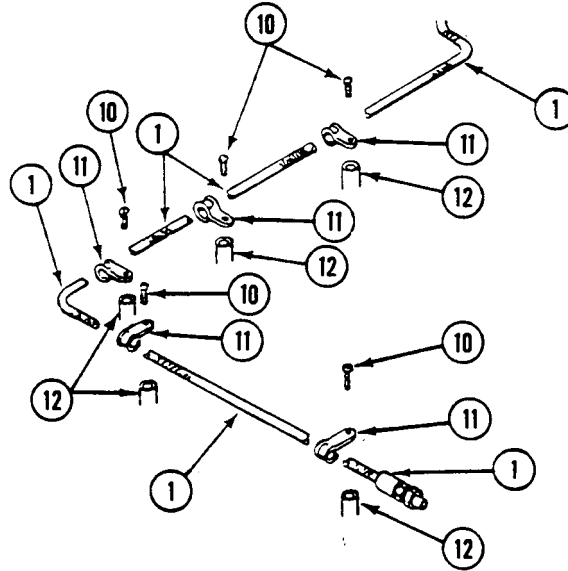

INSTALLATION

1. Apply a thin, even coat of sealing compound to cleaned external pipe threads on fittings.
2. Install new grommet (1) on hose (2). Route hose through hole in bulkhead and install grommet in bulkhead.
3. Install hose (2) on elbow (3). Hold elbow when tightening hose.
4. Install quick disconnect (4) on coupler body (5).

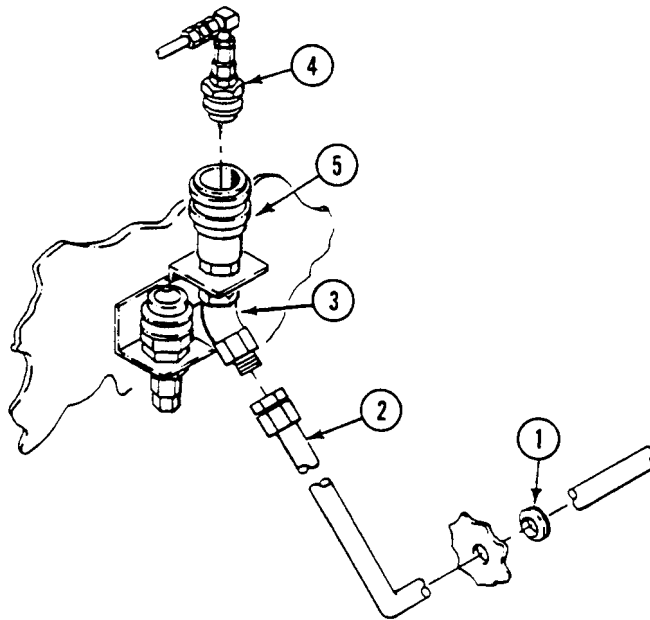

REPLACE FUEL SUPPLY HOSES, TUBES AND FITTINGS (M577A3 AND M1068A3 ONLY)

0193 00

— Continued

5. Install five clamps (6) on hose (2) and secure to weldnuts (7) with screws (8).

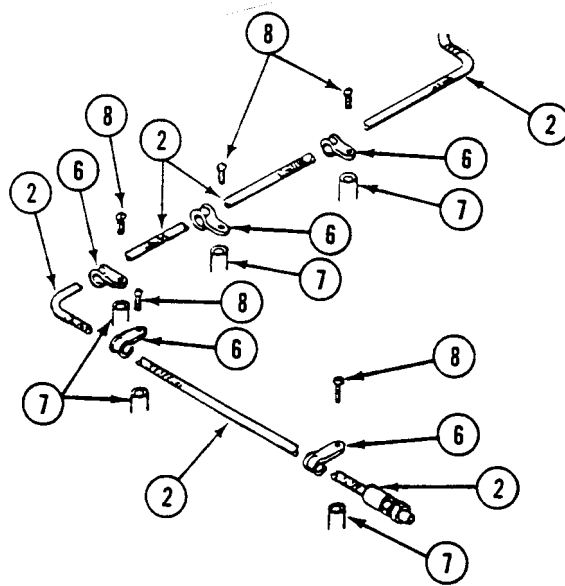

6. Install nipple (9) in tube (10).
7. Install shutoff valve (11) on nipple (9) with arrow pointing toward front of carrier.
8. Install adapter (12) in shutoff valve (11).
9. Connect hose (2) to adapter (12).

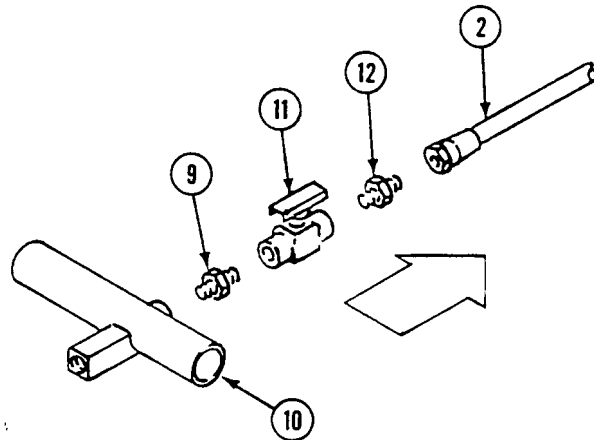

10. Connect two hoses (1) to two fuel tanks (2) and elbows (3) with four clamps (4).
11. Connect hose (5) to tubes (6) and (7) with two clamps (8).
12. Secure elbow (3) to weldnut (9) with clamp (10), new lockwasher (11), and screw (12).
13. Connect hose (13) to elbow (3) and tube (7) with two clamps (14).

REPLACE FUEL SUPPLY HOSES, TUBES AND FITTINGS (M577A3 AND M1068A3 ONLY)

0193 00

— Continued

14. Connect hose (15) to elbow (3) and tube (6) with two clamps (16).
15. Connect four hose assemblies (17) to two elbows (3).
16. Install four nipples (18) in two fuel tanks (2).
17. Connect four hose assemblies (17) to four nipples (18).
18. Install four hose assemblies (17) on four weldnuts (19). Secure with four clamps (20), new lockwashers (21), and screws (22).
19. Install bushing (23), nipple (24), draincock (25), and plug (26) on tube (6).

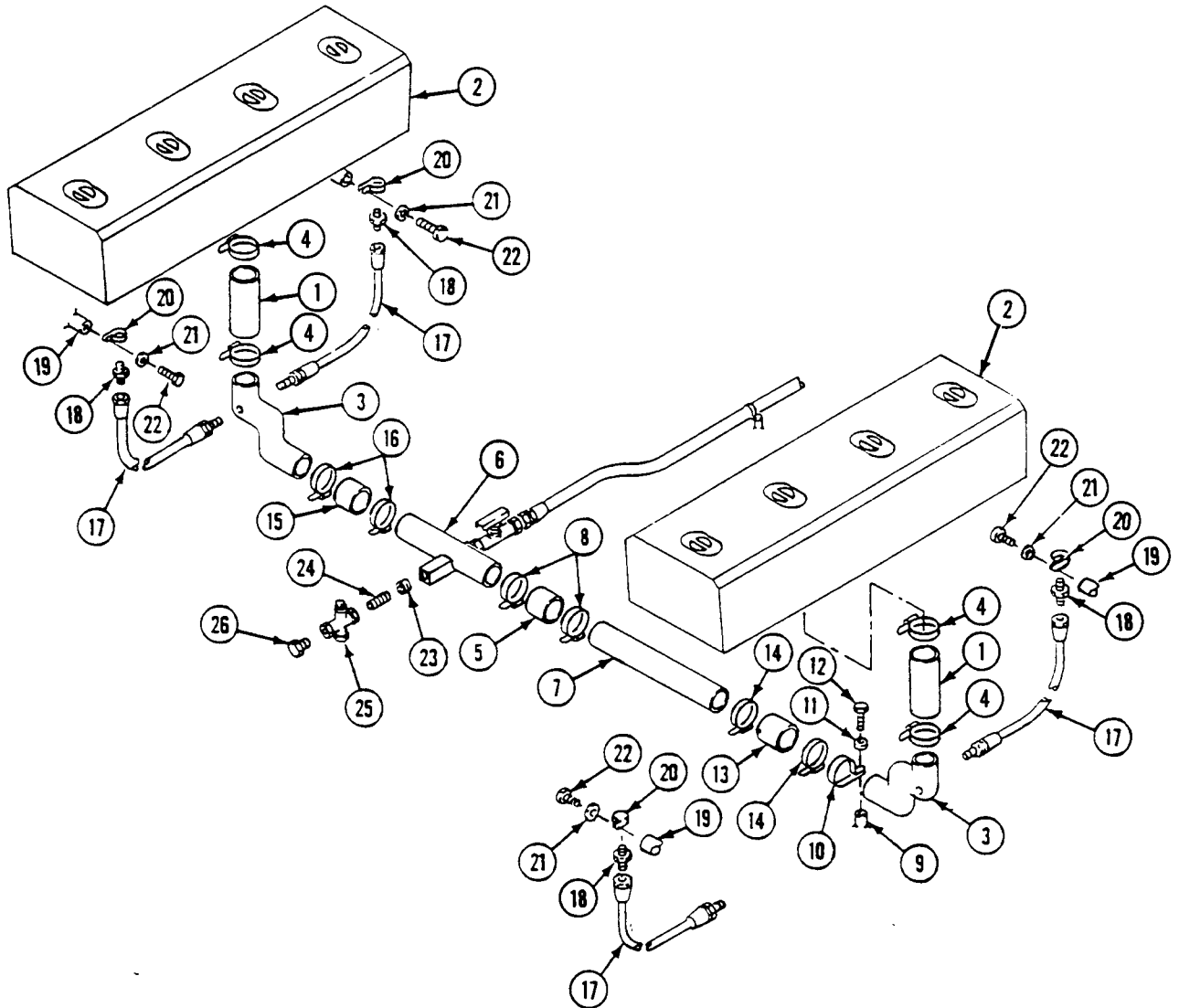

20. Install shutoff valve (1) on nipple (2).
21. Install nipple (2) in tube (3).
22. Install four clamps (4) on two elbows (5) and tubes (3) and (6). Secure four ground leads (7) to clamps (4) with four screws (8), new lockwashers (9), and new locknuts (10).

REPLACE FUEL SUPPLY HOSES, TUBES AND FITTINGS (M577A3 AND M1068A3 ONLY)**0193 00****— Continued**

23. Install leads (7), two elbows (5), and two tubes (3) and (6) on four weldnuts (11). Secure with four clamps (12), new lockwashers (13), and screws (14).
24. Connect personnel heater fuel hose (15) to shutoff valve (1).

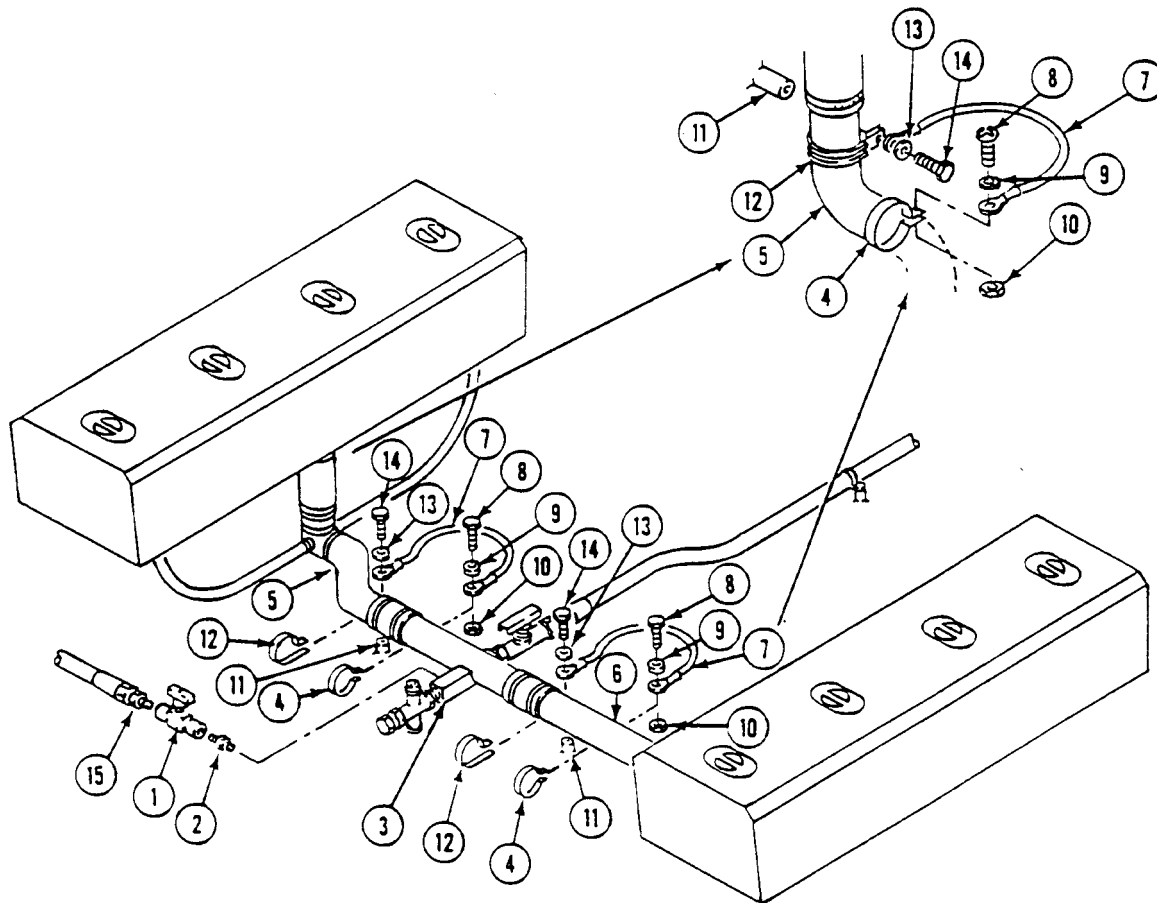
**FOLLOW-THROUGH STEPS**

1. Fill fuel tank (see your -10).
2. Connect battery ground lead (WP 0338 00).
3. Start engine (see your -10). Check for leaks.
4. Stop engine (see your -10).
5. Install power plant rear access panel (WP 0439 00).
6. Install rear compartment floor plates (WP 0539 00) or (WP 0544 00).
7. Start engine (see your -10).
8. Raise and lock ramp (see your -10).
9. Stop engine (see your -10).

END OF TASK

REPLACE FUEL SUPPLY HOSES, TUBES, AND FITTINGS (M1064A3 ONLY)

0194 00

THIS WORK PACKAGE COVERS:

Removal (page 0194 00-2).
 Installation (page 0194 00-9).

INITIAL SETUP:

Maintenance Level

Unit

References

See your -10

Tools and Special Tools

General Mechanic's Tool Kit (WP 0926 00, Item 65)

Equipment Condition

Ramp lowered (see your -10)
 Engine stopped (see your -10)
 Carrier blocked (see your -10)
 Power plant rear access panels removed (see your -10)
 Battery ground strap disconnected (WP 0337 00)
 Fuel tanks drained (WP 0177 00)
 Heater duct removed (WP 0706 00)
 Rear floor plates removed (WP 0543 00)

Materials/Parts

Calking compound (WP 0928 00, Item 14)
 Sealing compound (WP 0928 00, Item 54)
 Grommet
 Lockwasher (6)
 ■ Strap (2)

Personnel Required

Unit Mechanic

REMOVAL

1. Locate quick disconnect (1) on rear bulkhead inside power plant.
2. Separate quick disconnect nose (1) from quick disconnect body (2).
3. Remove fuel supply hose (6) from elbow (5).
4. Remove fuel supply hose (6) and grommet (7) from bulkhead. Discard grommet.
5. Remove elbow (5) from coupler body (2).
6. Remove nut (4) and coupler body (2) from bracket (3).

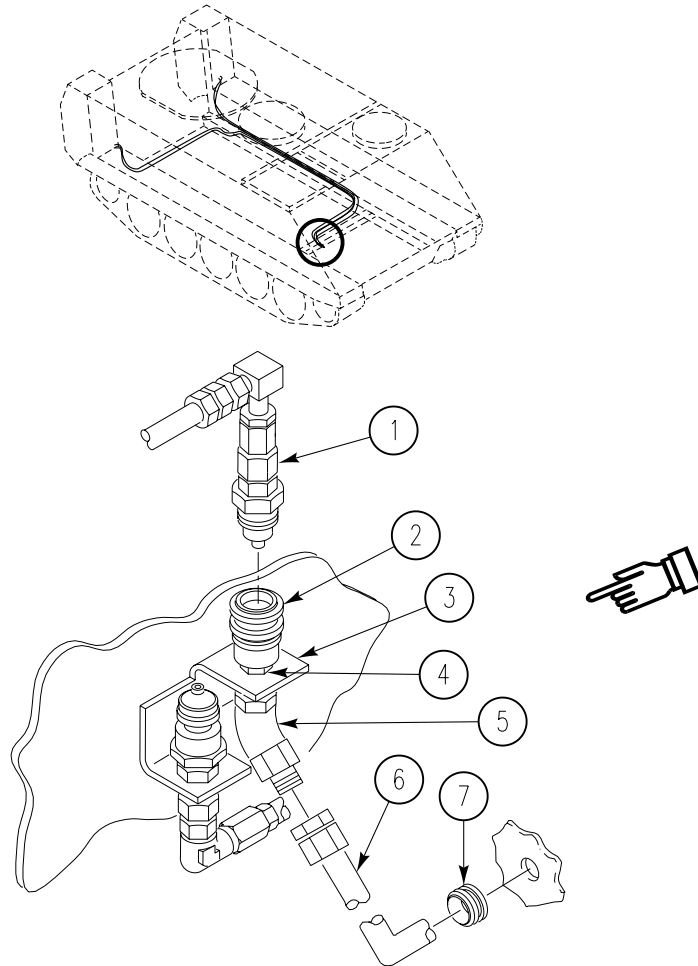

7. Remove four screws (19), lockwashers (18), and eight clamps (17) from weldnuts. Discard lockwashers.
8. Remove four hose clamps (17) from fuel supply hose (16).
9. Remove floor plate screw (14) and washer (15) from guard (12).
10. Remove screw (21), washer (20), nut (13), and guard (12).
11. Disconnect fuel supply hose (16) from adapter (8).
12. Remove adapter (8) from tee (7).

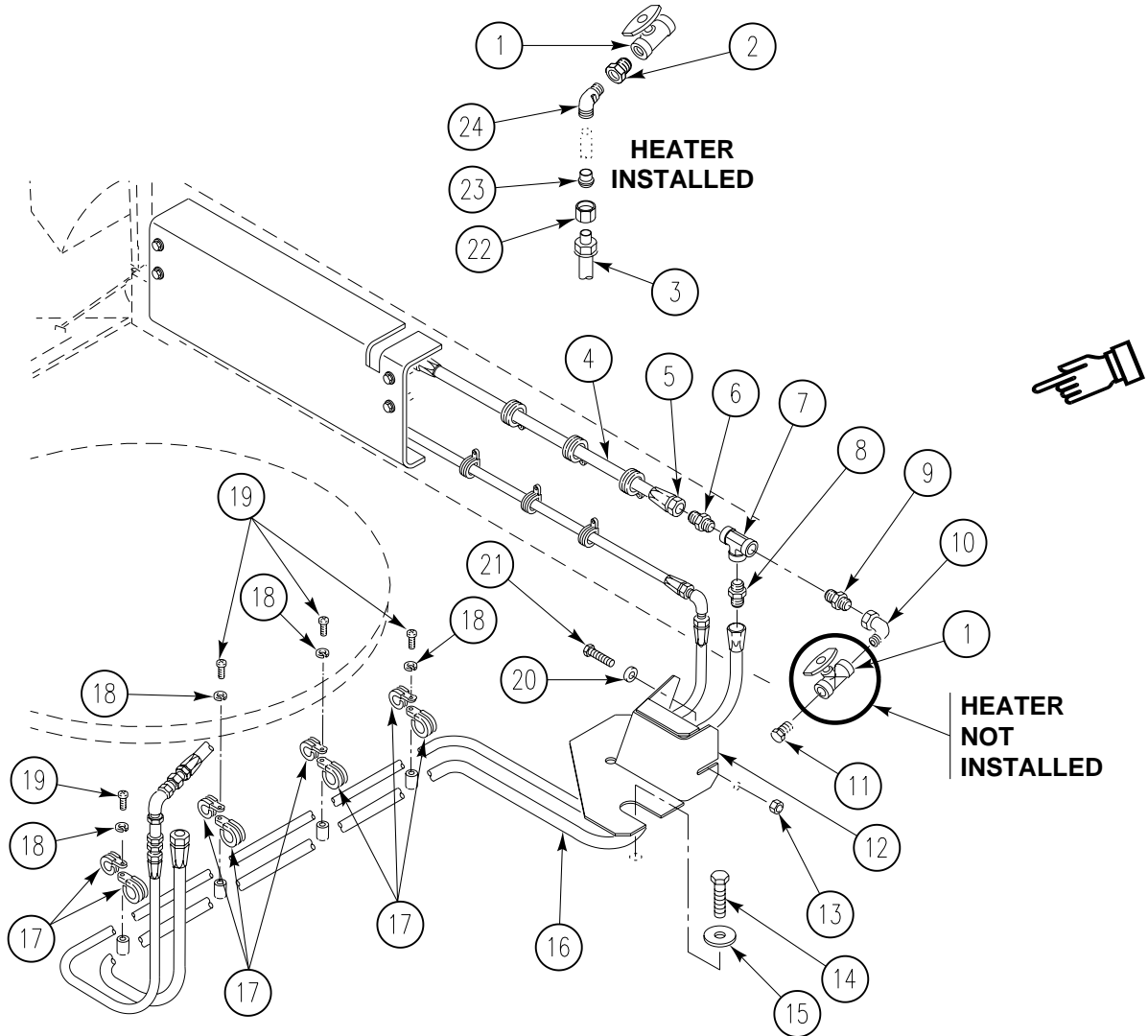

NOTE

If crew compartment heater is installed, complete Steps 13 - 15 to remove heater fuel supply hose. Skip Step 16.

If heater is not installed, do Step 16. Skip Steps 13 - 15.

13. Disconnect crew compartment heater hose (3) from elbow (24) with sleeve (23) and nut (22) attached.
14. Remove elbow (24) from bushing (2).
15. Remove bushing (2) from valve (1).
16. Remove plug (11) from valve (1).
17. Remove valve (1) from elbow (10).
18. Remove elbow (10) from nipple (9).
19. Remove nipple (9) from tee (7).
20. Remove fuel supply tube (4) from adapter (5).
21. Remove adapter (5) and nipple (6) from tee (7).

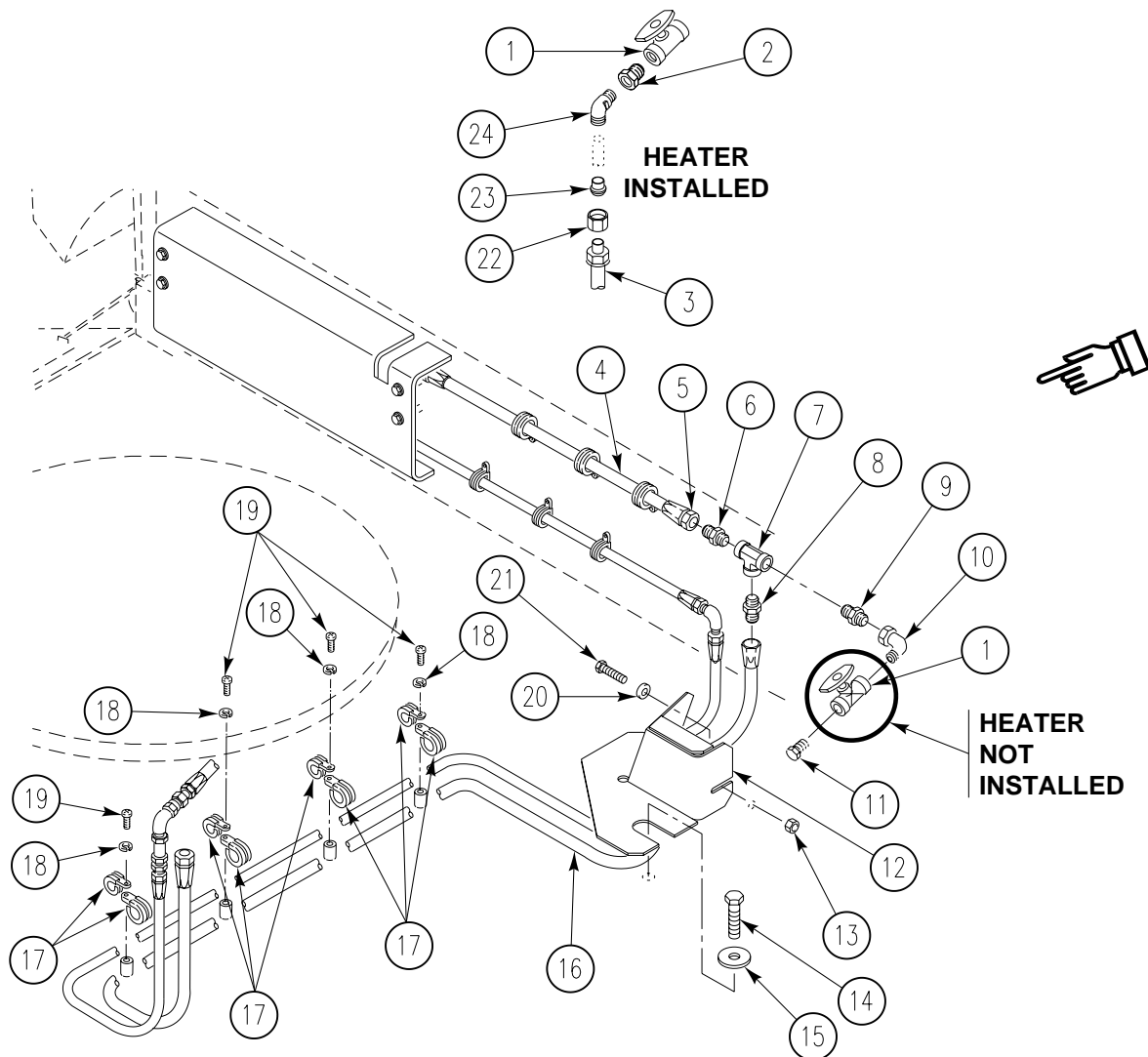

22. Remove three screws (1), lockwashers (2), and six clamps (3) from weldnuts. Discard lockwashers.
23. Remove clamps (3) from fuel supply tube (4).
24. Remove four screws (5), lockwashers (6), and guard (7) from sponson. Discard lockwashers.
25. Disconnect fuel supply tube (4) from adapter (8).
26. Remove adapter (8) from fuel supply hose (9).
27. Remove fuel supply hose (9) from adapter (10).
28. Remove adapter (10) from tee (11).

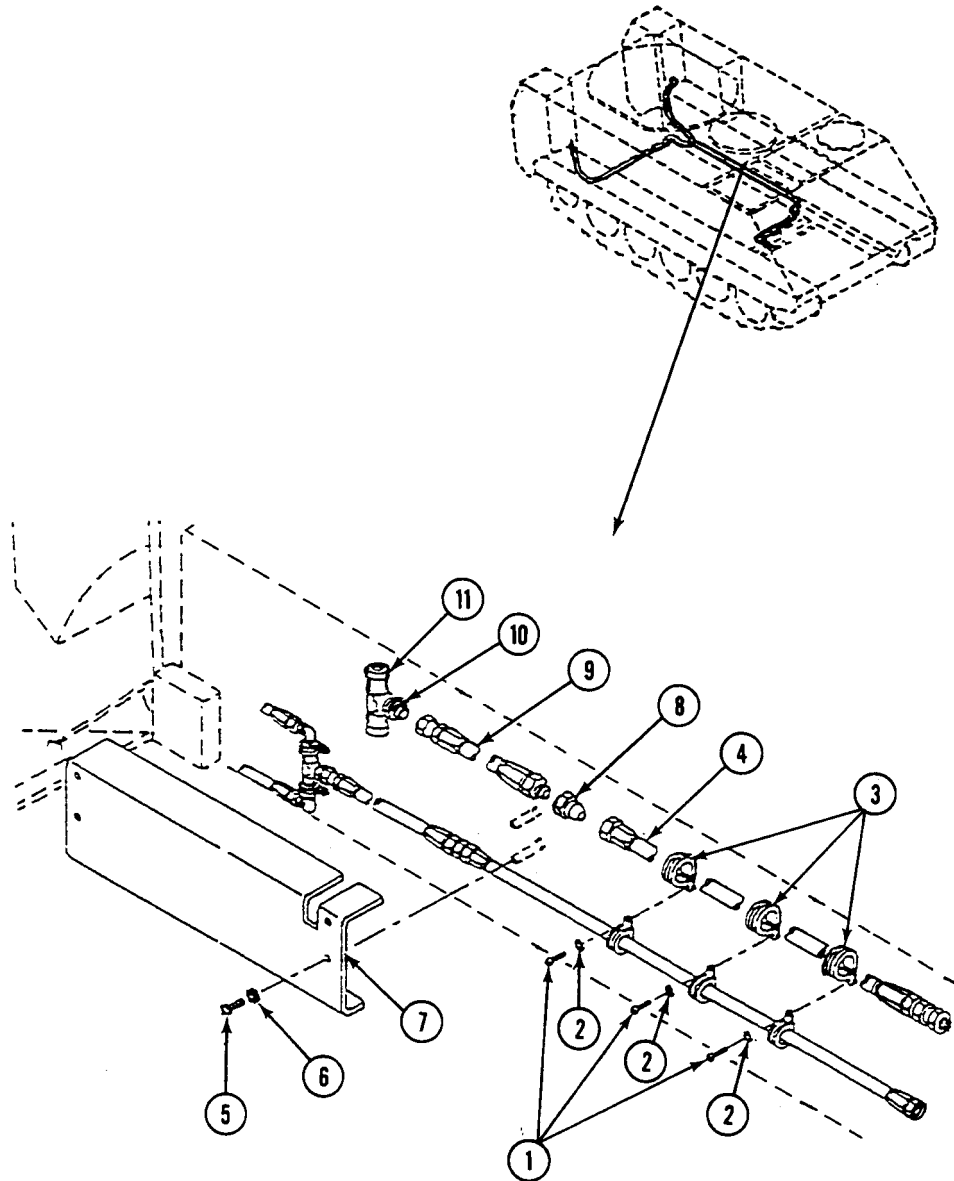

29. Disconnect two fuel supply hoses (11) and (17) from two elbows (12).
30. Remove two screws (16) and lockwashers (15) from clamps (13). Discard lockwashers.
31. Remove two clamps (13) and two elbows (12) from tee (14).

NOTE

The left external fuel tank outlet valve is secured to its mounting block by TWO clamps, washers, and screws. The right external fuel tank outlet valve is secured with two straps to bilge tube and return hose.

32. Remove two screws (26), washers (27), clamps (7), and left external fuel tank outlet valve (8) from mounting block (6).
- 33. Remove two straps (22) securing both fuel hoses to bilge tube (21). Discard straps.
34. Remove hoses (11) and (17) from adapters (10).
35. Remove adapters (10) from adapters (9).
36. Remove adapters (9) from valves (8) and (23).

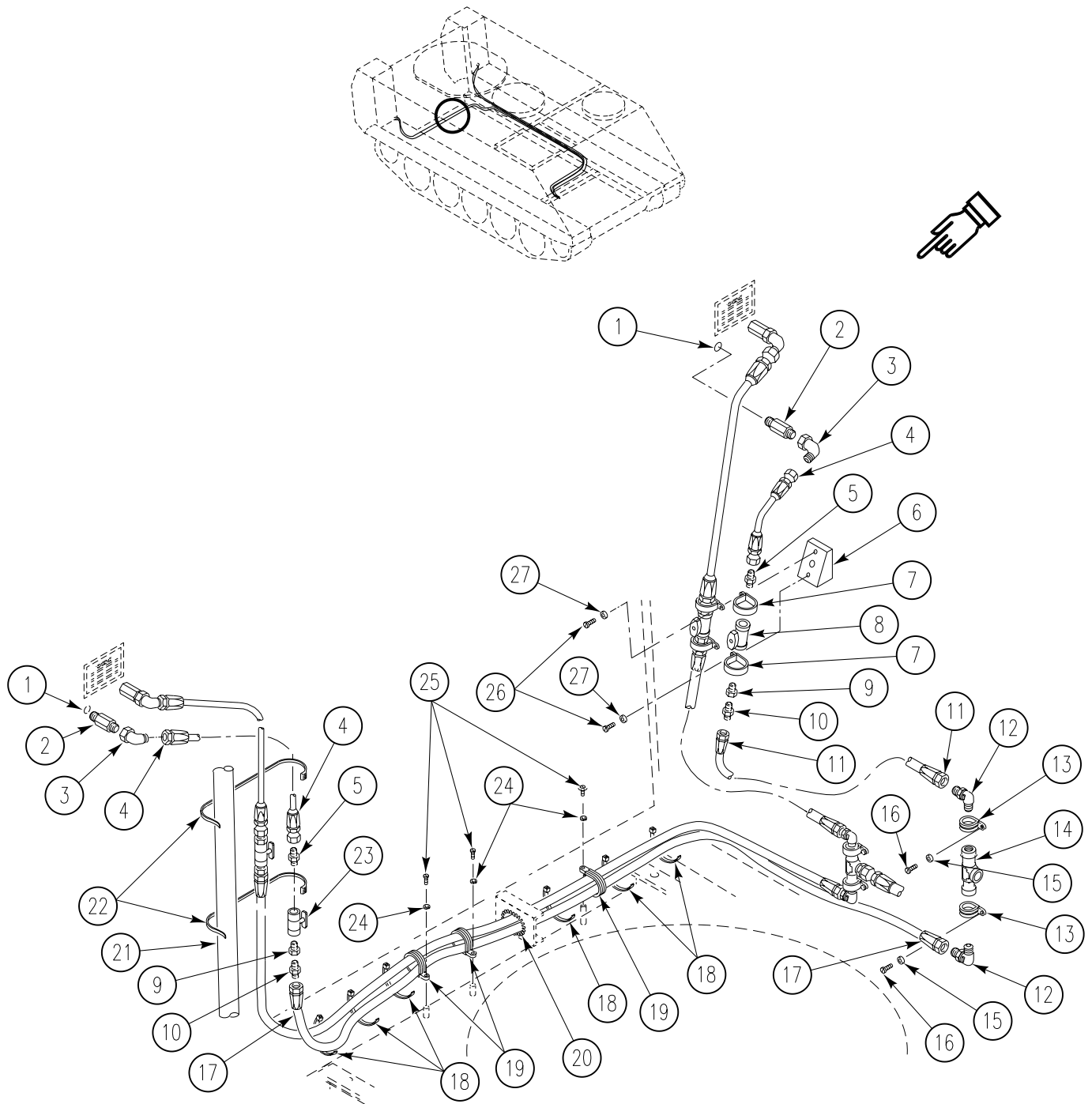

37. Remove hoses (4) from adapters (5).
38. Remove adapters (5) from valves (8) and (23).
39. Remove hoses (4) from elbows (3).
40. Remove elbows (3) from adapters (2).
41. Remove adapters (2) from fuel tanks (1).
42. Remove three screws (25), lockwashers (24), and clamps (19) securing right external fuel tank hose to weldnuts. Discard lockwashers.
43. Remove three clamps (19) and straps (18) from right external fuel tank hose, wiring harness, and bilge pump tube.

NOTE

Replace grommet only if necessary.

44. Remove fuel supply hose (17) from grommet (20).

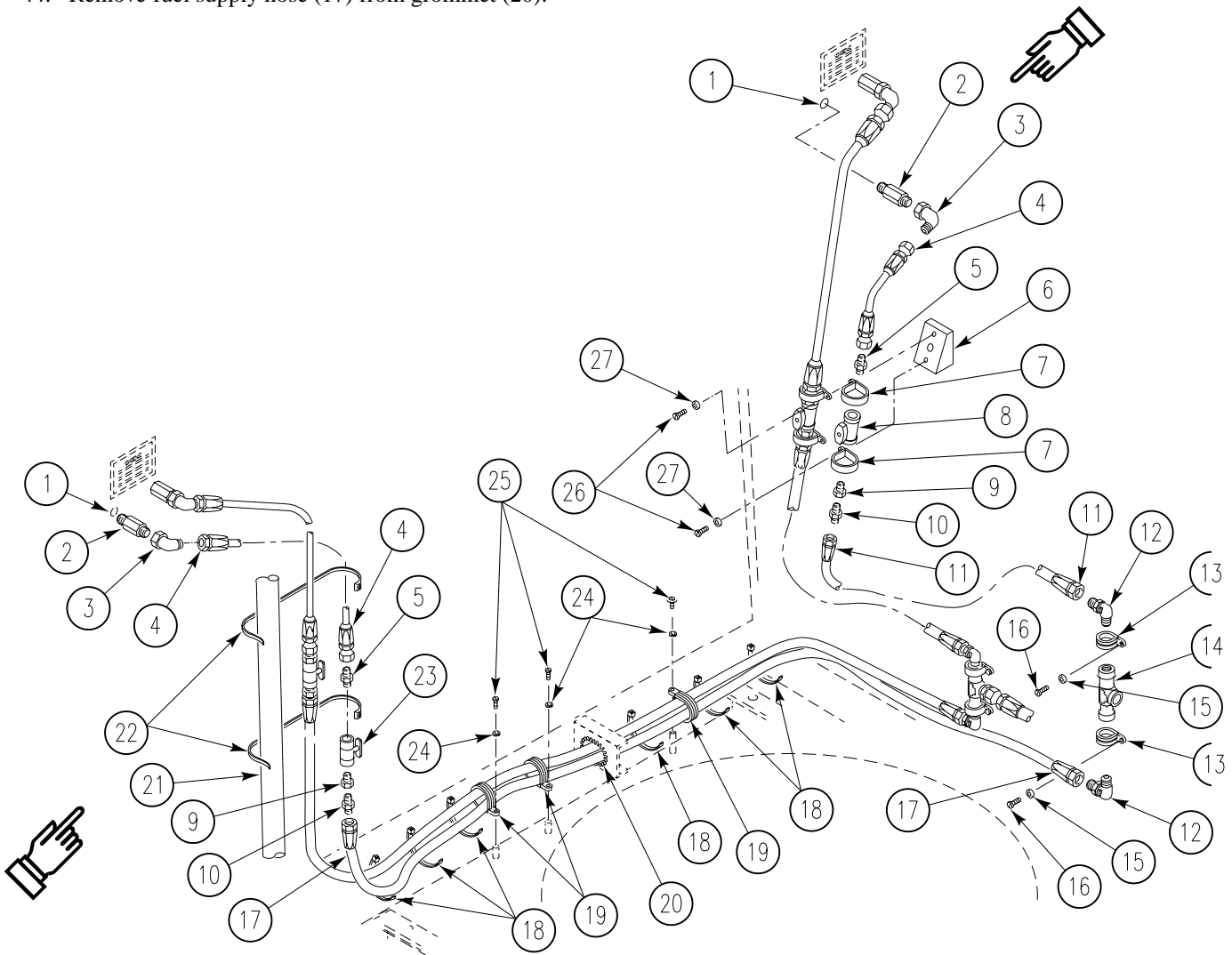

INSTALLATION

NOTE

To install left external fuel tank fuel supply hoses and fittings, do Steps 1 - 10. To install right external fuel tank fuel supply hoses and fittings, do Steps 11 - 23.

The left external fuel tank outlet valve is secured to its mounting block by TWO clamps, washers, and screws. The right external fuel tank outlet valve is secured to the bilge tube and fuel return hose with two straps.

1. Apply sealing compound to external threads of adapter (1) and elbow (2).
2. Install adapter (1) on left external fuel tank (3). Install elbow (2) on adapter (1).
3. Apply calking compound to space around adapter (1) on rear hull plate.
4. Install hose (4) on elbow (2).

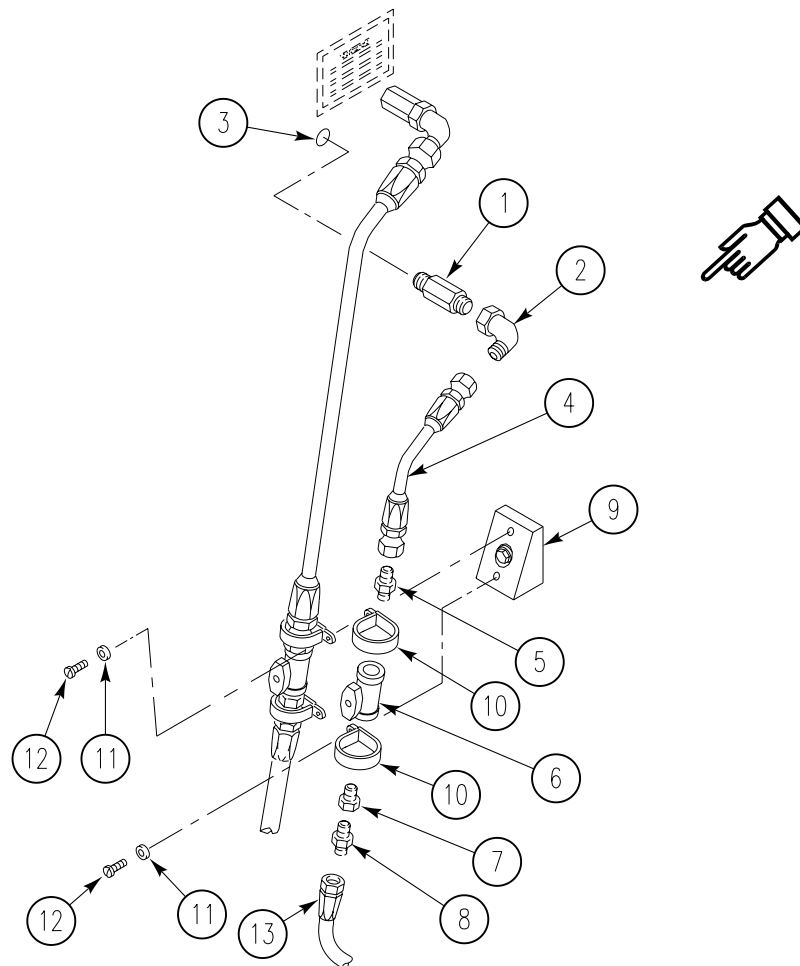

5. Apply sealing compound to external threads of adapter (5). Install adapter (5) on valve (6).
6. Install hose (4) on adapter (5).
7. Apply sealing compound on external threads of adapters (7) and (8).
8. Install adapter (7) on valve (6). Install adapter (8) on adapter (7).
9. Secure valve (6) to mounting block (9) with two clamps (10), washers (11), and screws (12).
10. Connect fuel supply hose (13) to adapter (8).

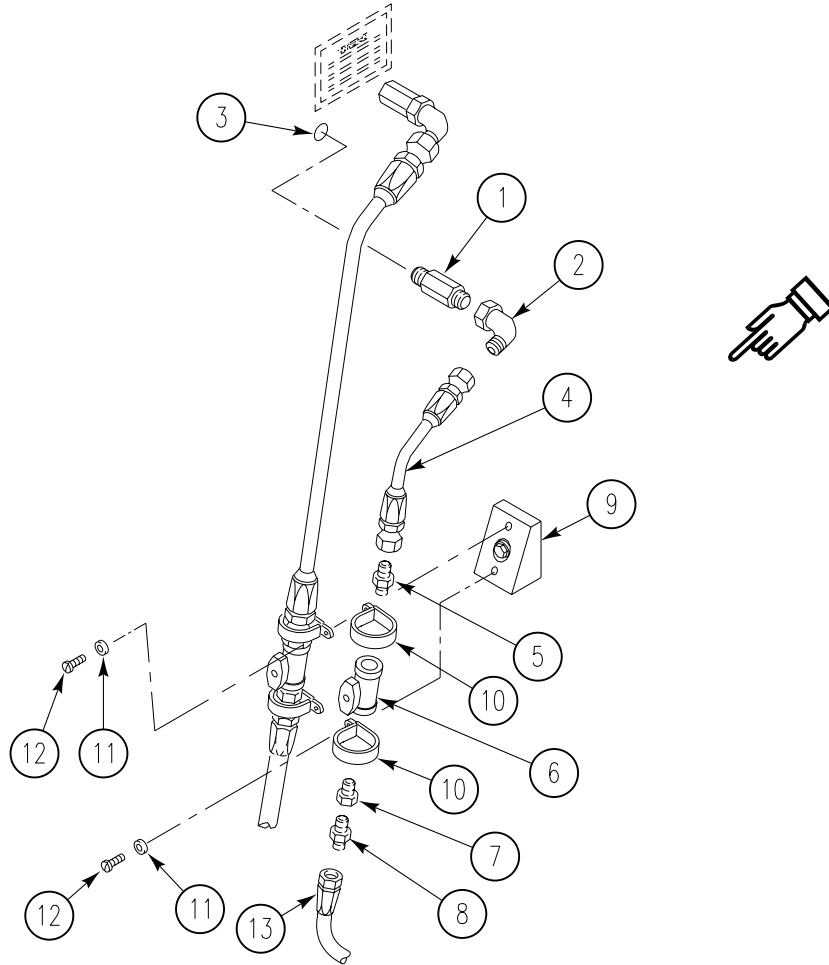

NOTE

Apply adhesive to new grommet before installing.

11. Install fuel supply hose (15) through grommet (18).
12. Install three clamps (17) and straps (16) as required on fuel hoses, wiring harness, and bilge pump tube.
13. Install three screws (7), new lockwashers (6), and clamps (17) on weldnuts.
14. Apply sealing compound to external threads of adapter (23) and elbow (22).
15. Install adapter (23) on right external fuel tank (1).
16. Install elbow (22) on adapter (23).
17. Apply calking compound to space around adapter (23) on rear hull plate.
18. Install hose (21) on elbow (22).
19. Apply sealing compound to external threads of adapter (2). Install adapter (2) on valve (3).
20. Install hose (21) on adapter (2).

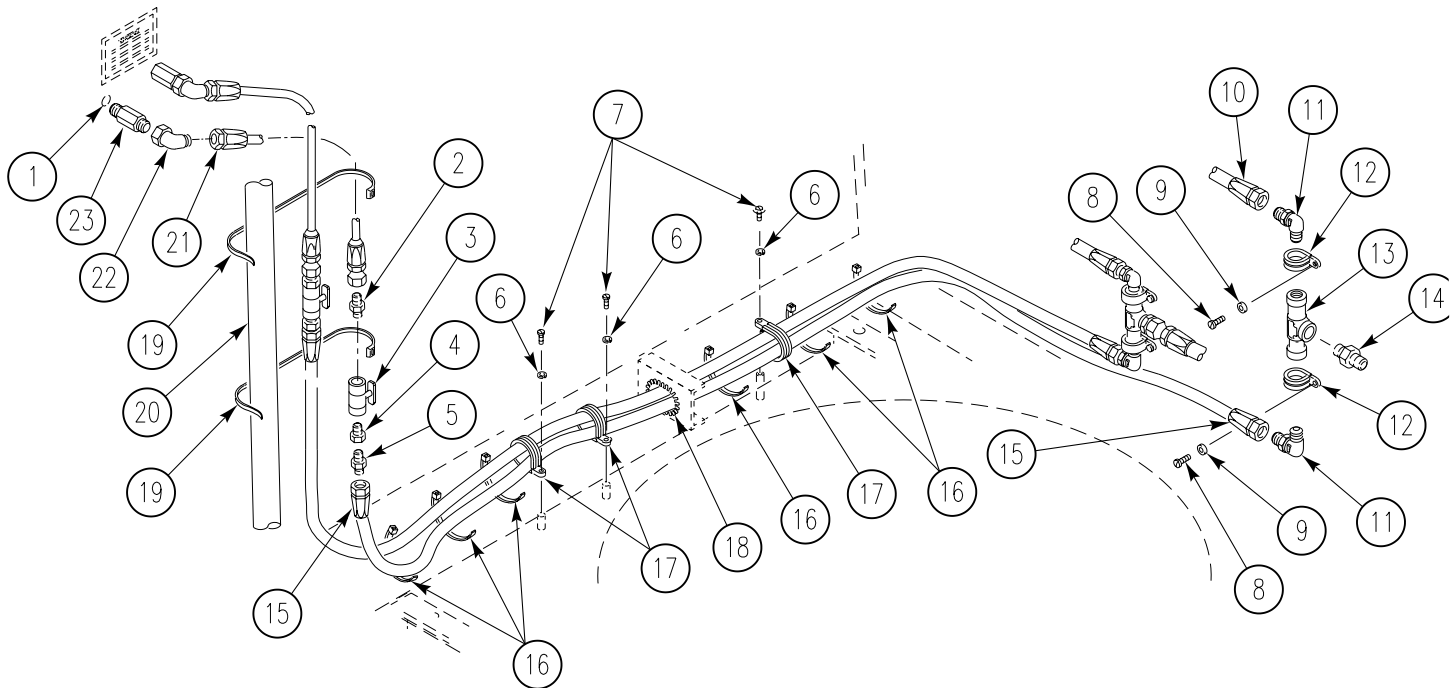

21. Apply sealing compound to external threads of adapters (4) and (5). Install adapter (4) on valve (3) and adapter (5) on adapter (4).
22. Install hose (15) on adapter (5).
23. Secure valve (3) with two new straps (19) to return fuel hose and bilge tube (20).
24. Apply sealing compound to external threads of two elbows (11). Install two elbows (11) and clamps (12) on tee (13).
25. Install two screws (8), new lockwashers (9), clamps (12), and tee (13) on weldnuts.
26. Connect two fuel supply hoses (10) and (15) to two elbows (11).
27. Apply sealing compound to external threads of adapter (14). Install adapter on tee (13).

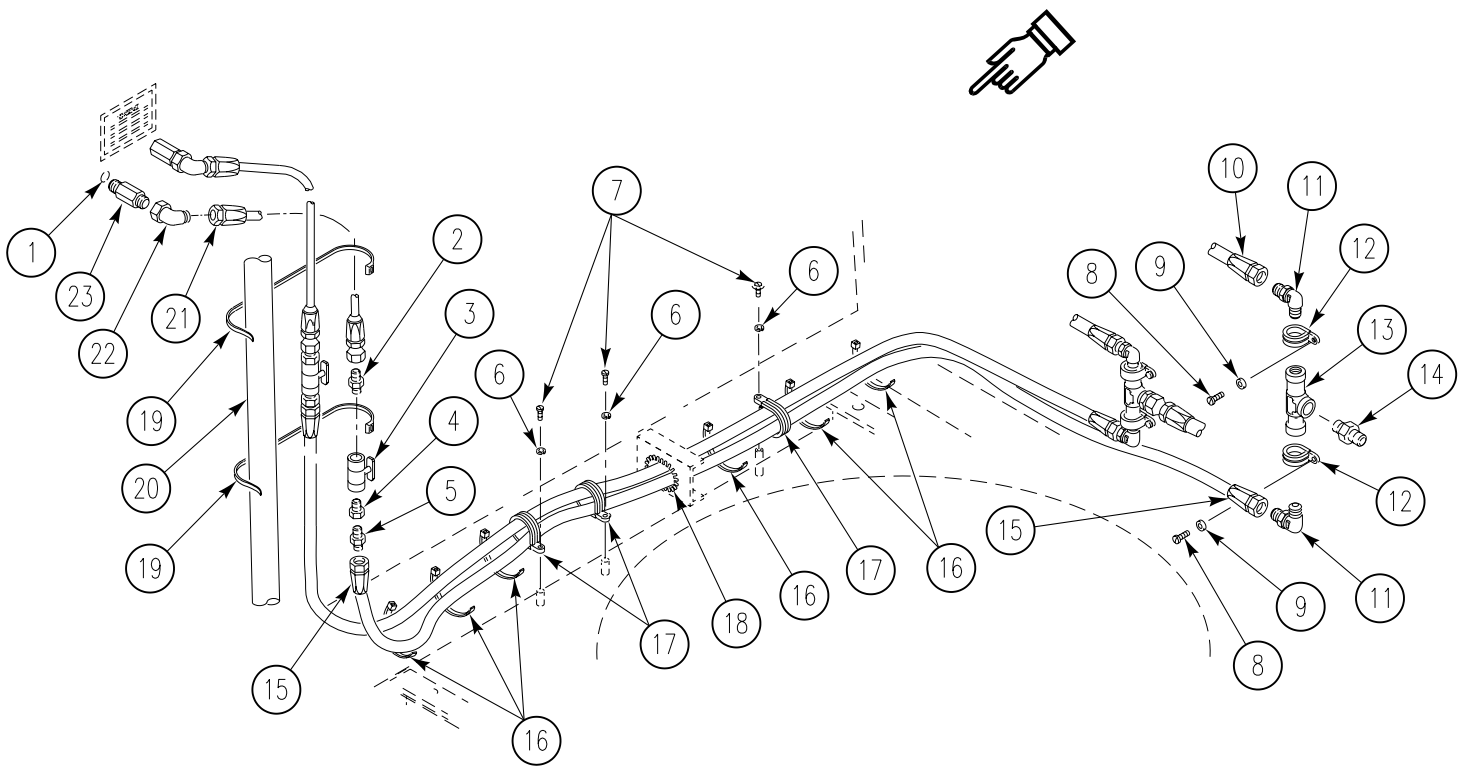

28. Connect fuel supply hose (1) to adapter (2).
29. Apply sealing compound to external threads of adapter (3). Install adapter (3) on fuel supply hose (1).
30. Connect fuel supply tube (4) to adapter (3).
31. Install guard (5), four new lockwashers (6) and screws (7) on sponson.
32. Install three clamps (8) on fuel supply tube (4).

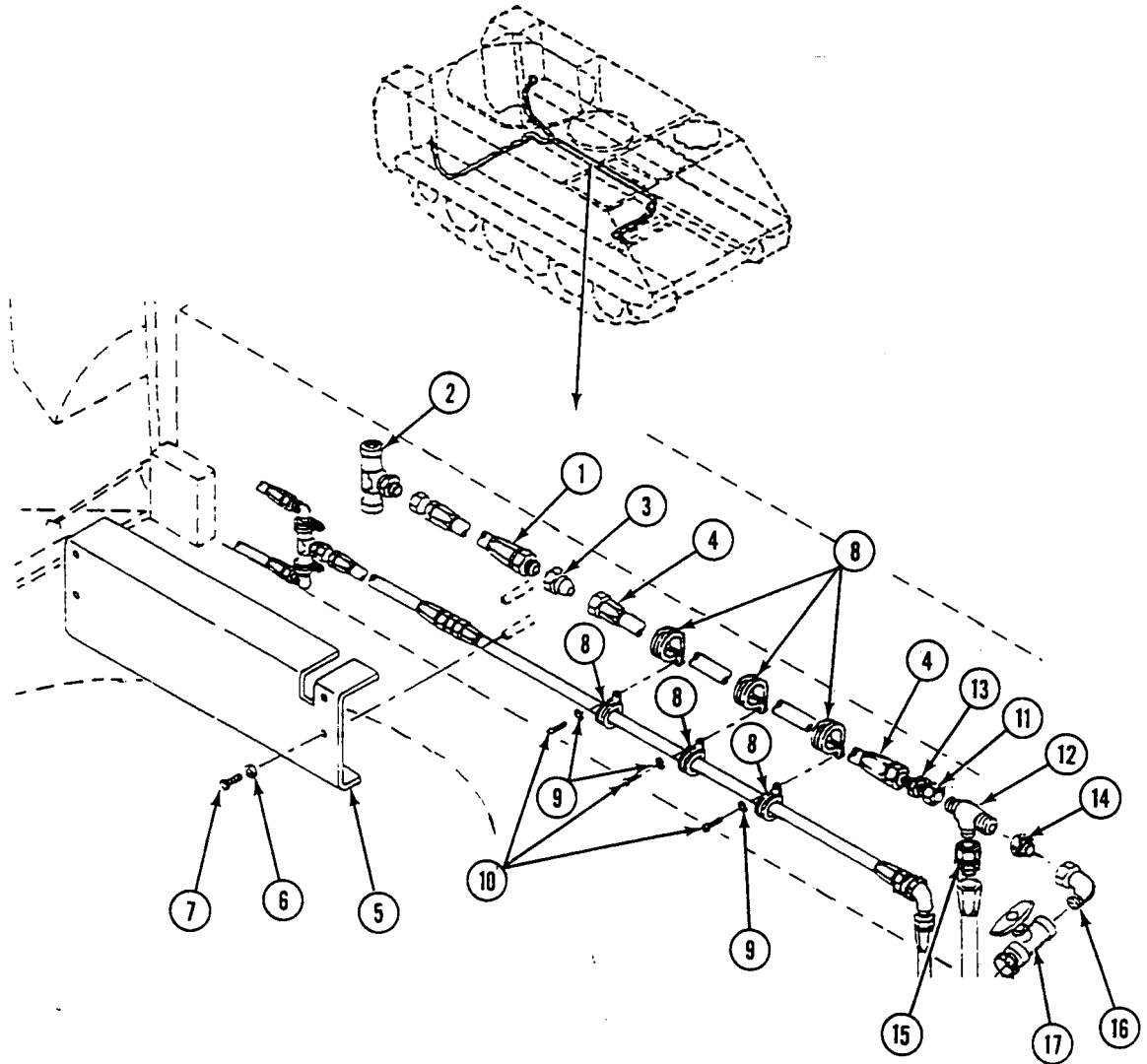

33. Install six clamps (8), fuel supply tube (4), three new lockwashers (9) and screws (10) on weldnuts.
34. Apply sealing compound to external threads of nipple (11) and tee (12). Install nipple (11) on tee (12).
35. Apply sealing compound to external threads on adapter (13). Install adapter (13) on nipple (11).
36. Connect fuel supply tube (4) to adapter (13).
37. Install nipple (14) and adapter (15) on tee (12).
38. Install elbow (16) on nipple (14).
39. Install valve (17) on elbow (16).

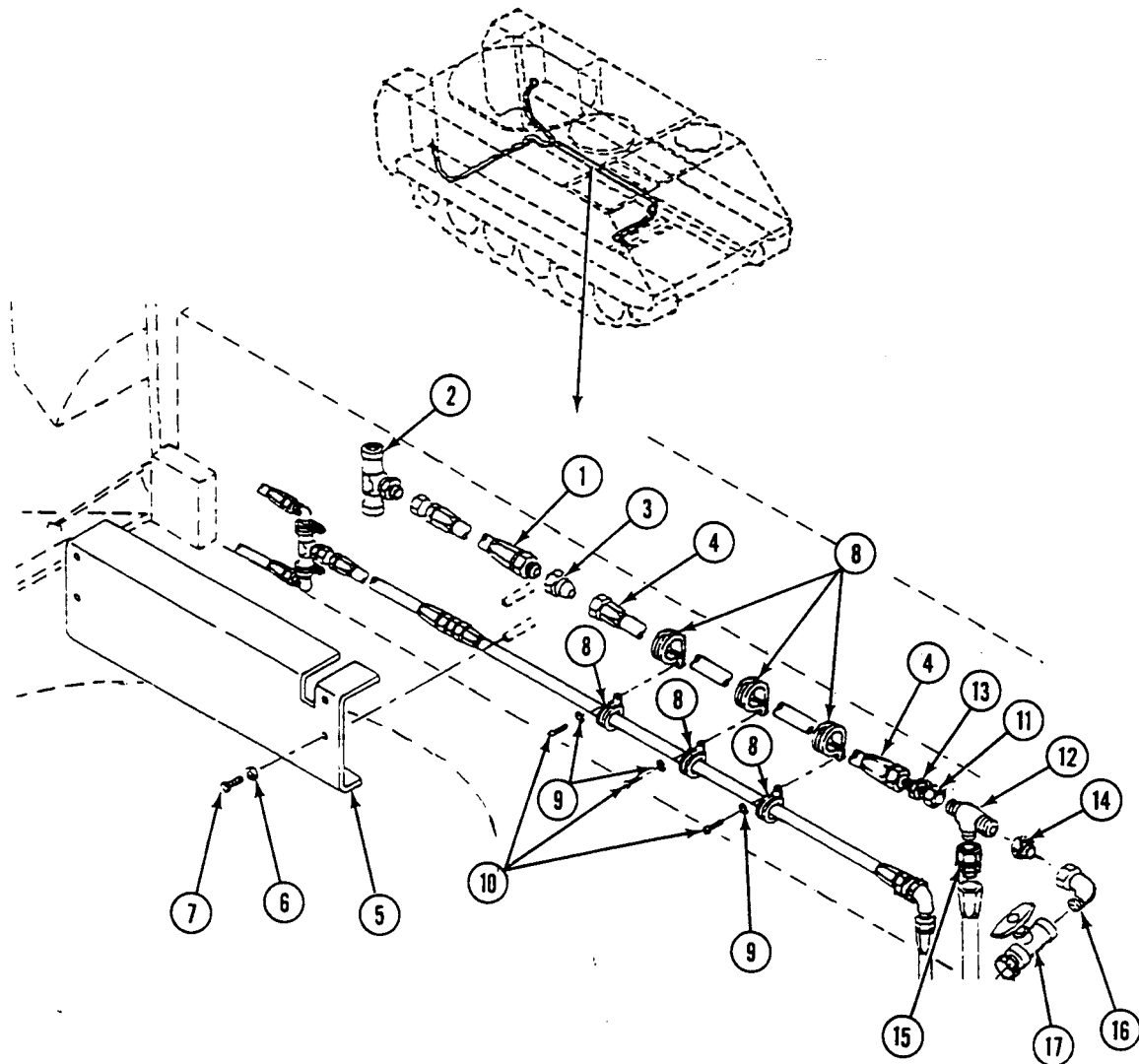

NOTE

If crew compartment heater is installed, do Steps 40 - 42. Skip Step 43. If heater is not installed, do Step 43. Skip Steps 40 - 42.

40. Install bushing (2) in valve (1).
41. Install elbow (3) in bushing (2).
42. Install crew compartment heater fuel supply hose (6) on elbow (3). Secure with sleeve (4) and nut (5).
43. Install plug (7) on valve (1).
44. Install fuel supply hose (8) on adapter (18).
45. Install four clamps (12) on fuel supply hose (8).
46. Install eight clamps (12), four new lockwashers (13), screws (14), and fuel supply hose (8) on weldnuts.

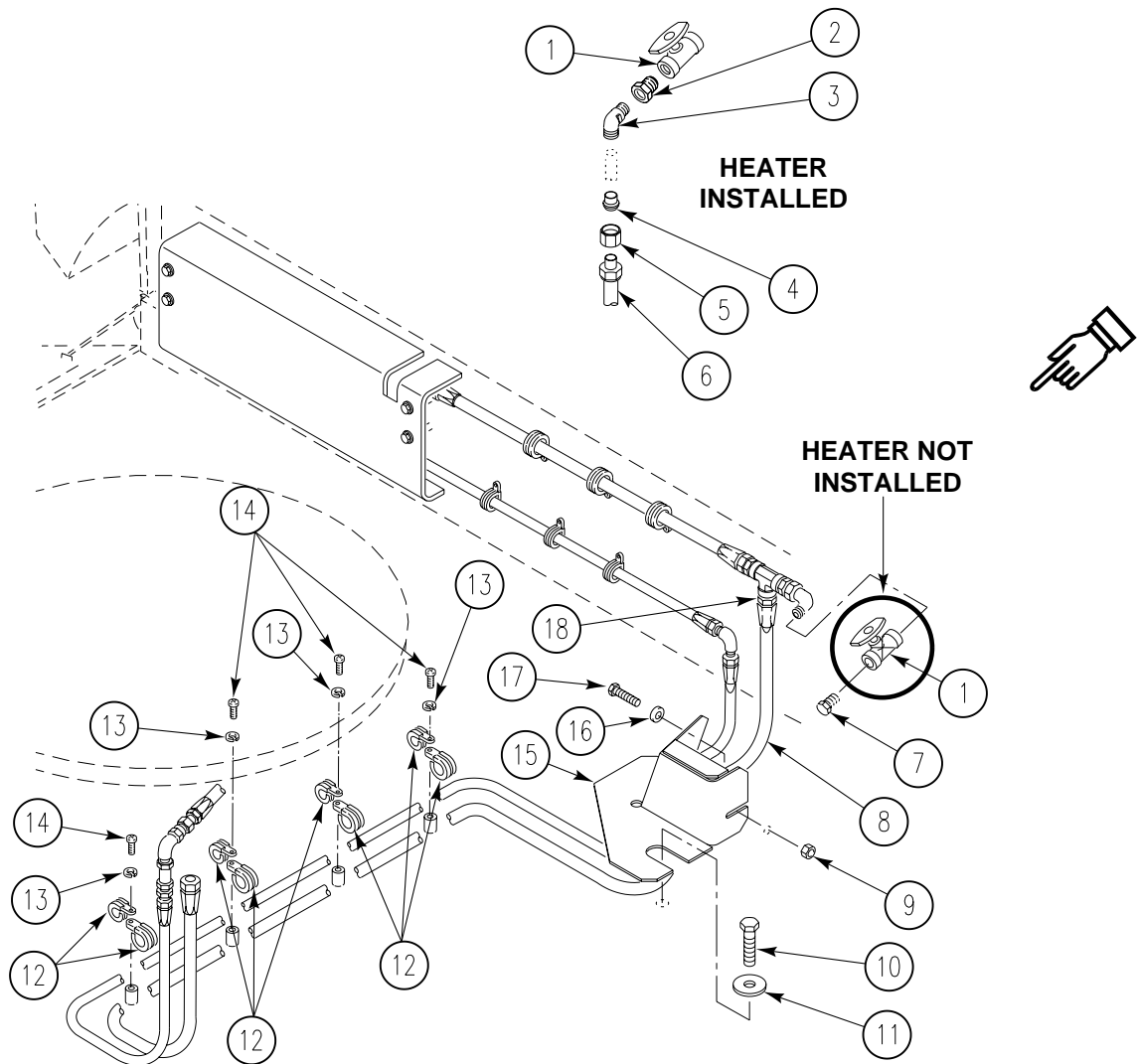

47. Install guard (15), washer (16), screw (17) and nut(9) .
48. Install floor plate screw (10) and washer (11) to secure guard (15).

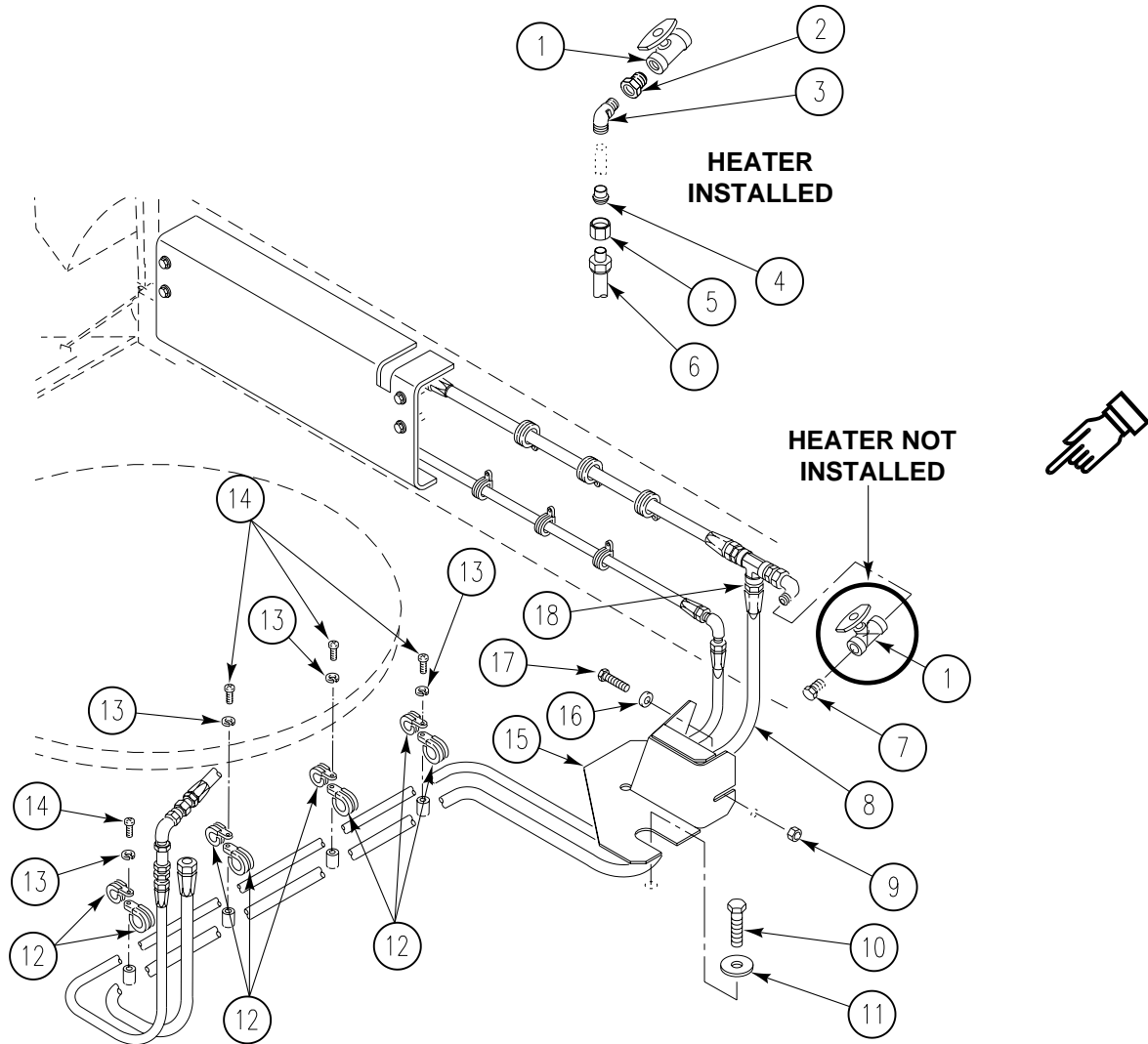

49. Install quick disconnect coupler body (2) and nut (4) in bracket (3).
50. Install elbow (5) on quick disconnect coupler body (2).
51. Install new grommet (7) on fuel supply hose (6). Route hose through hole in bulkhead and fit grommet into bulkhead.
52. Connect fuel supply hose (6) to elbow (5). Hold elbow when tightening hose.
53. Connect quick disconnect nose (1) to quick disconnect coupler body (2).

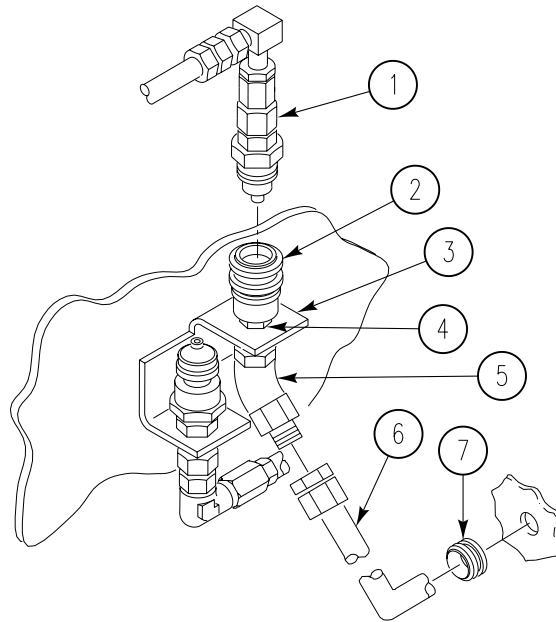

FOLLOW-THROUGH STEPS

1. Fill fuel tanks (see your -10).
2. Connect battery ground strap (WP 0337 00).
3. Start engine (see your -10).
4. Check for leaks in fuel lines.
5. Stop engine (see your -10).
6. Install power plant rear access panels (see your -10).
7. Install rear floor plates (WP 0543 00).
8. Install heater duct (WP 0706 00).
9. Start engine (see your -10).
10. Raise and lock ramp (see your -10).
11. Stop engine (see your -10).

END OF TASK

REPLACE FUEL RETURN HOSES, TUBES, AND FITTINGS (M113A3, M1059A3, AND M58 ONLY)

0195 00

THIS WORK PACKAGE COVERS:

Removal (page 0195 00-1).
 Installation (page 0195 00-8).

INITIAL SETUP:

Maintenance Level

Unit

Tools and Special Tools

General Mechanic's Tool Kit (WP 0926 00, Item 65)

Materials/Parts

Caulking compound (WP 0928 00, Item 14)

Sealing compound (WP 0928 00, Item 56)

Grommet

Locknut

Lockwasher (15)

Strap

Personnel Required

Unit Mechanic

References

See your -10
 TM 3-1040-285-20

Equipment Condition

Engine stopped (see your -10)

Carrier blocked (see your -10)

Ramp lowered (see your -10)

Power plant lower rear access panel removed (see your -10)

Floor plates removed (WP 0539 00), (WP 0542 00), or (WP 0545 00)

Battery ground strap disconnected (WP 0337 00)

Fuel tanks drained (WP 0177 00)

Smoke generator fog oil tank module removed (M1059A3 only) (WP 0753 00)

Smoke generator system removed (M58 only) (TM 3-1040-285-20)

**REPLACE FUEL RETURN HOSES, TUBES, AND FITTINGS (M113A3,
M1059A3, AND M58 ONLY) — Continued**

0195 00

REMOVAL

1. Remove quick disconnect coupler body (1) from quick disconnect coupler nose (2).
2. Remove hose (3) from elbow (4).
3. Remove hose (3) and grommet (5) from bulkhead. Discard grommet.

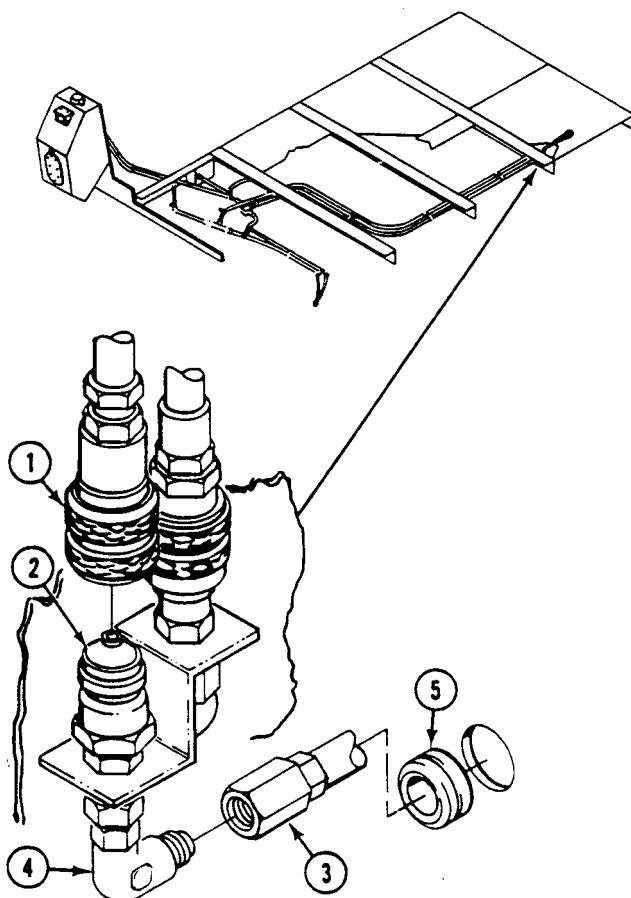

**REPLACE FUEL RETURN HOSES, TUBES, AND FITTINGS (M113A3,
M1059A3, AND M58 ONLY) — Continued**

0195 00

4. Remove five screws (1), lockwashers (2), and clamps (3) from hose (4) and carrier. Discard lockwashers.
5. Remove hose (4) from tee connector (5).

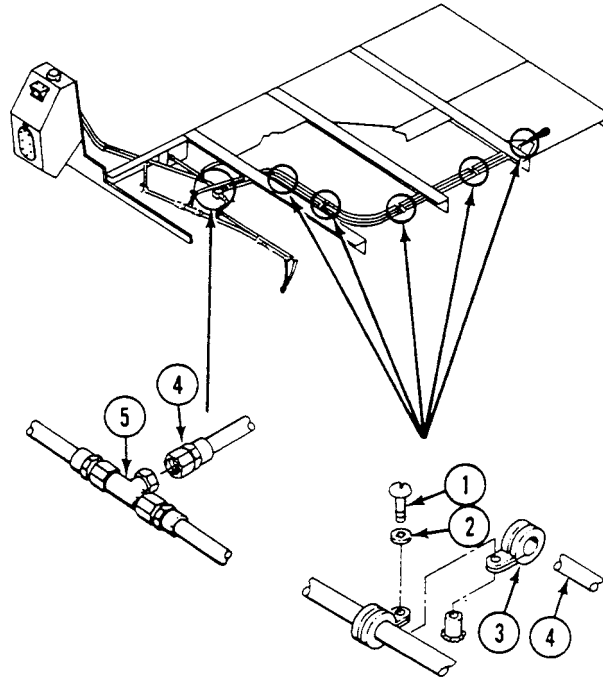

**REPLACE FUEL RETURN HOSES, TUBES, AND FITTINGS (M113A3,
M1059A3, AND M58 ONLY) — Continued**

0195 00

NOTE

Do Steps 6 - 18 for removing left side fuel tank return hoses and fittings. Do Steps 19 - 30 for removing right side fuel tank return hoses and fittings.

6. Remove screw (6), lockwasher (7), and clamp (8) from hose (9) and carrier. Discard lockwasher.
7. Remove tie down strap (10) from two hoses (9) and (11). Discard strap.
8. Remove locknut (12) and screw (13) from guard (14). Discard locknut.
9. Remove screw (15), washer (16), and guard (14) from bulkhead.
10. Remove hose (9) from tee (5).

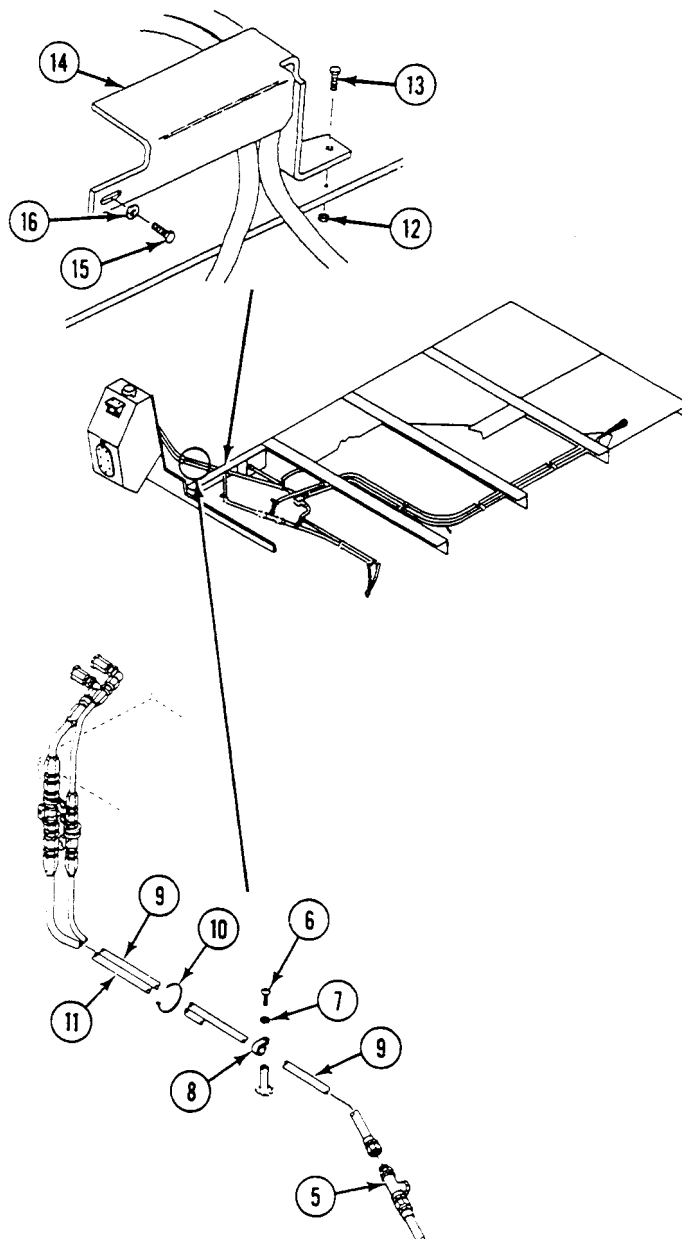

**REPLACE FUEL RETURN HOSES, TUBES, AND FITTINGS (M113A3,
M1059A3, AND M58 ONLY) — Continued**

0195 00

11. Remove screw (1), washer (2), and clamp (3) securing valve (4) to mounting block (5).
12. Remove hose (6) from adapter (7).
13. Remove adapter (7) from valve (4).
14. Remove hose (8) from adapter (9).
15. Remove adapter (9) from valve (4).
16. Remove hose (8) from elbow (10).
17. Remove elbow (10) from adapter (11).
18. Remove adapter (11) from fuel tank (12).

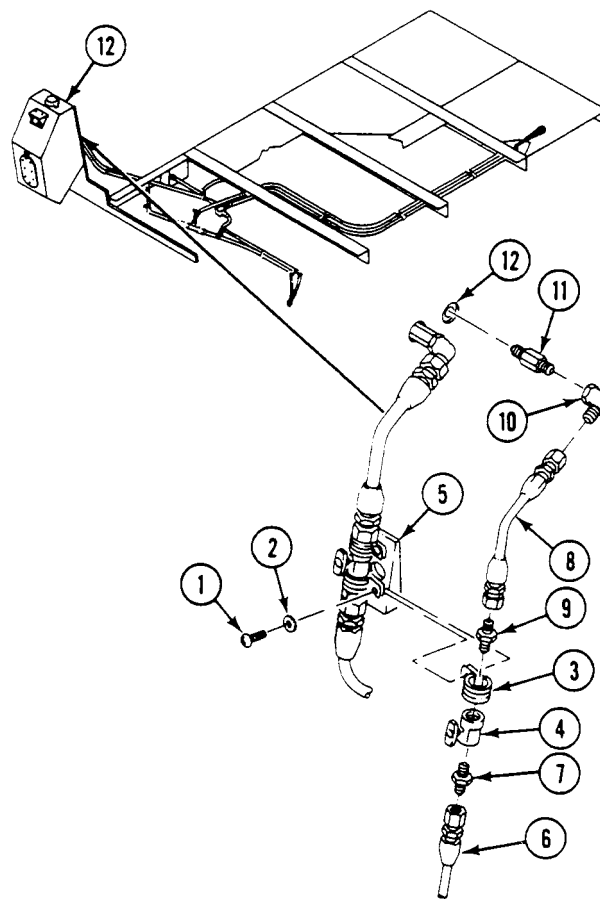

**REPLACE FUEL RETURN HOSES, TUBES, AND FITTINGS (M113A3,
M1059A3, AND M58 ONLY) — Continued**

0195 00

19. Remove three screws (13), lockwashers (14), and clamps (15) from hose (16) and carrier. Discard lockwashers.
20. Remove two tie down straps (17) from two hoses (16) and (18). Discard straps.
21. Remove hose (16) from tee (19).

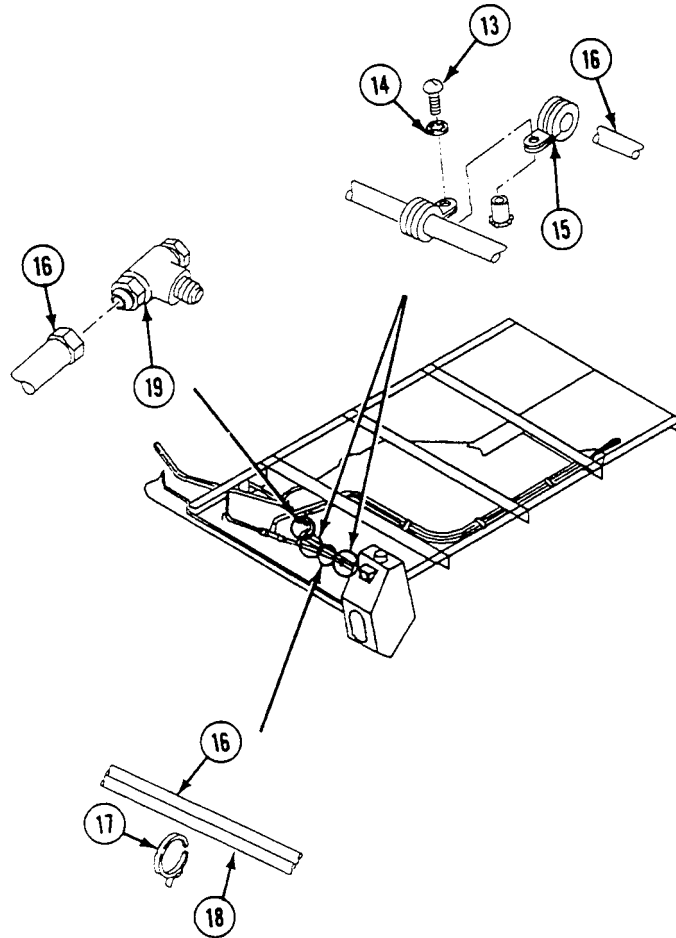

**REPLACE FUEL RETURN HOSES, TUBES, AND FITTINGS (M113A3,
M1059A3, AND M58 ONLY) — Continued**

0195 00

22. Remove two screws (1), washers (2), and clamps (3) securing valve (4) to mounting block (5).
23. Remove hose (6) from adapter (7).
24. Remove adapter (7) from valve (4).
25. Remove hose (8) from adapter (9).
26. Remove adapter (9) from valve (4).
27. Remove five screws (10), washers (11), lockwashers (12), and guard (13) from bulkhead. Discard lockwashers.
28. Remove hose (8) from elbow (14).
29. Remove elbow (14) from adapter (15).
30. Remove adapter (15) from fuel tank (16).

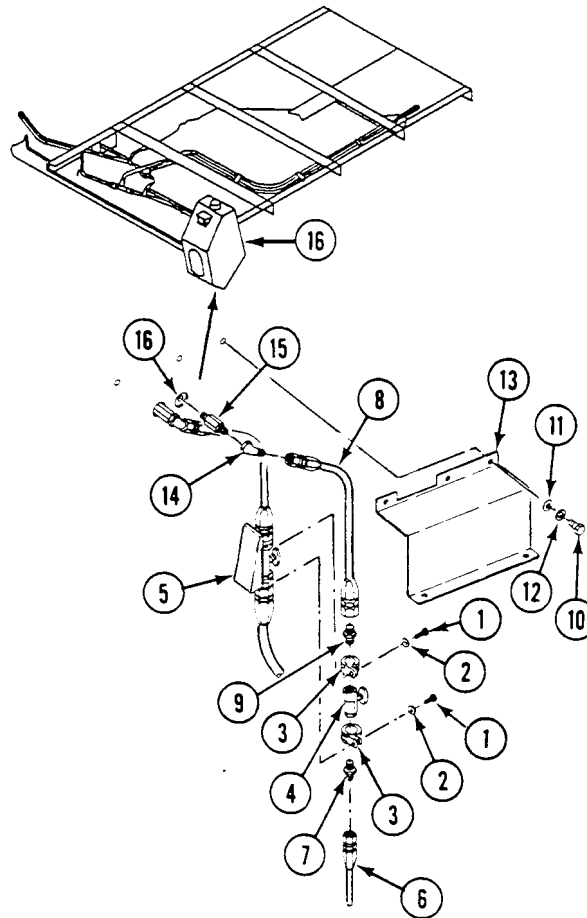

INSTALLATION

NOTE

Do Steps 1 - 13 for installing right side fuel tank return hoses and fittings. Do Steps 14 - 26 for installing left side fuel tank return hoses and fittings.

1. Apply sealing compound to external threads of adapter (15). Install adapter on fuel tank (16).
2. Apply sealing compound to external threads of elbow (14). Install elbow on adapter (15).
3. Apply caulking compound to space around adapter (15) on rear hull plate.
4. Install hose (8) on elbow (14).
5. Install guard (13) on bulkhead and secure with five washers (11), new lockwashers (12), and screws (10).
6. Apply sealing compound to external threads of adapter (9). Install adapter in valve (4).
7. Install hose (8) on adapter (9).
8. Apply sealing compound to external threads of adapter (7). Install adapter in valve (4).
9. Install hose (6) on adapter (7).
10. Secure valve (4) to mounting block (5) with two clamps (3), washers (2), and screws (1).

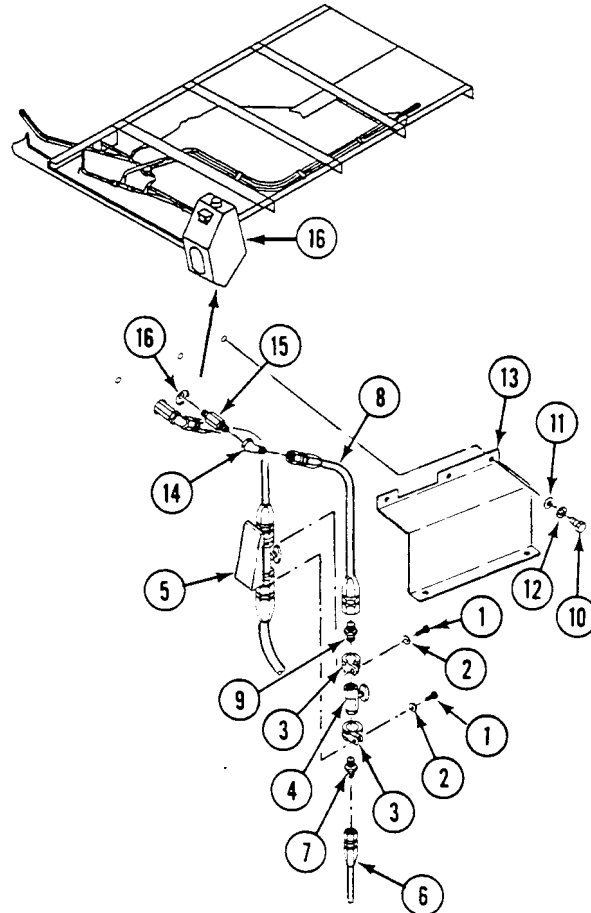

**REPLACE FUEL RETURN HOSES, TUBES, AND FITTINGS (M113A3,
M1059A3, AND M58 ONLY) — Continued**

0195 00

11. Install hose (1) on tee (2).
12. Install three clamps (3) on hose (1). Secure clamps to carrier with two screws (4) and new lockwashers (5).
13. Install two new tie down straps (6) on two hoses (1) and (7).

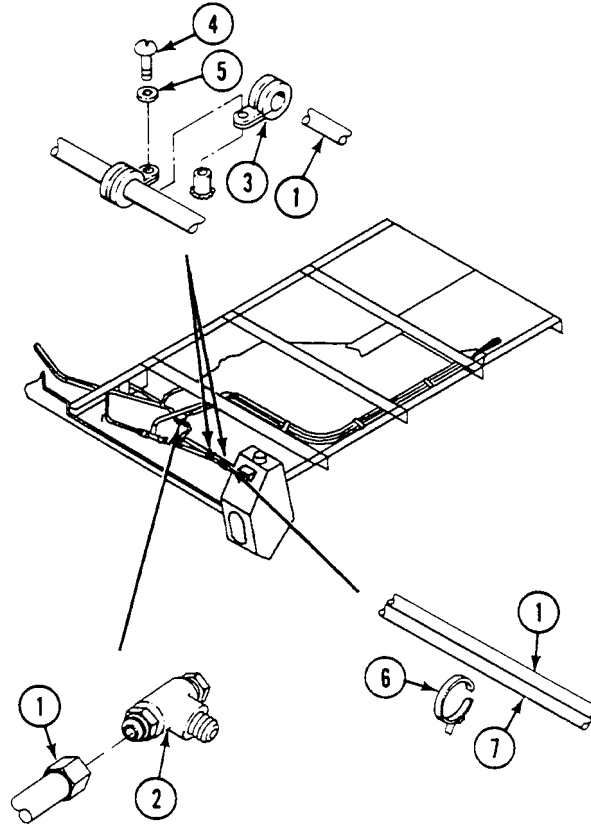

REPLACE FUEL RETURN HOSES, TUBES, AND FITTINGS (M113A3, M1059A3, AND M58 ONLY) — Continued

0195 00

14. Apply sealing compound to external threads of adapter (8). Install adapter on fuel tank (9).
15. Apply sealing compound to external threads of elbow (10). Install elbow on adapter (8).
16. Apply caulking compound to space around adapter (8) on rear hull plate.
17. Install hose (11) on elbow (10).
18. Apply sealing compound to external threads of adapter (12). Install adapter on valve (13).
19. Install hose (11) on adapter (12).
20. Apply sealing compound to external threads of adapter (14). Install adapter on valve (13).
21. Install hose (15) on adapter (14).
22. Secure valve (13) to mounting block (16) with clamp (17), new lockwasher (18), and screw (19).

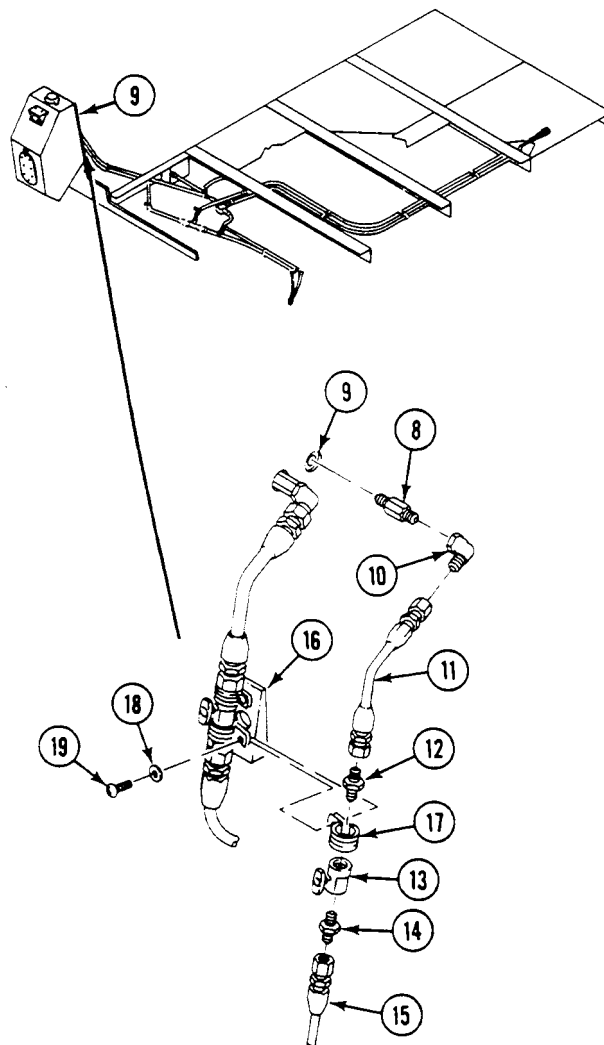

REPLACE FUEL RETURN HOSES, TUBES, AND FITTINGS (M113A3, M1059A3, AND M58 ONLY) — Continued

0195 00

23. Install hose (1) on tee (2).
24. Install clamp (3) on hose (1). Secure hose to carrier with screw (4) and new lockwasher (5).
25. Install new tiedown strap (6) on two hoses (1) and (7).

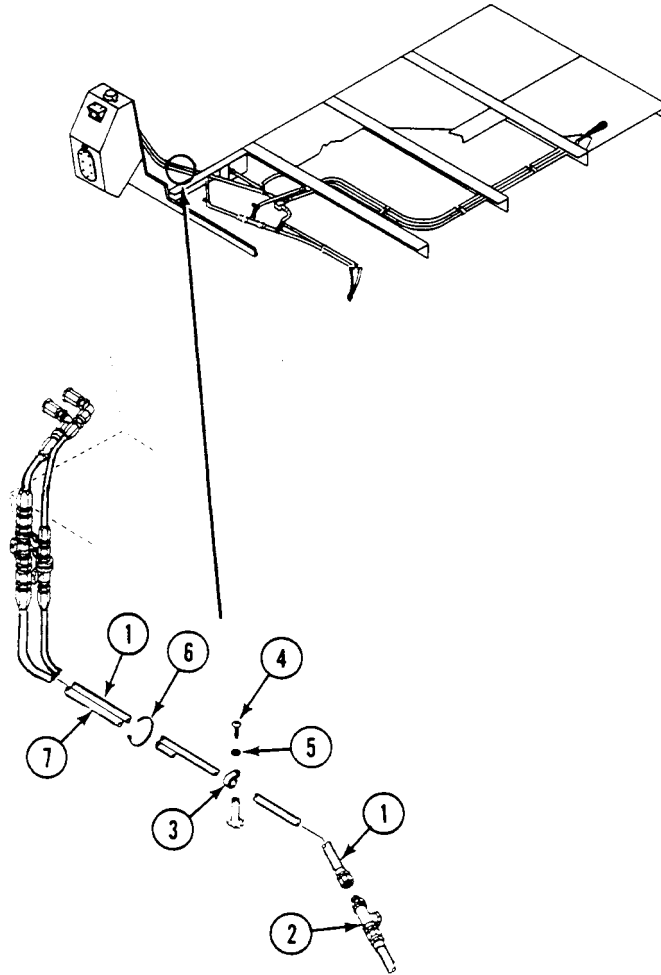

**REPLACE FUEL RETURN HOSES, TUBES, AND FITTINGS (M113A3,
M1059A3, AND M58 ONLY) — Continued**

0195 00

26. Install guard (8) on bulkhead. Secure side of guard with washer (9) and screw (10). Secure top of guard with screw (11) and new locknut (12).
27. Install hose (13) on tee (2).
28. Install five clamps (14) on hose (13). Secure hose to carrier with five screws (15) and new lockwashers (16).

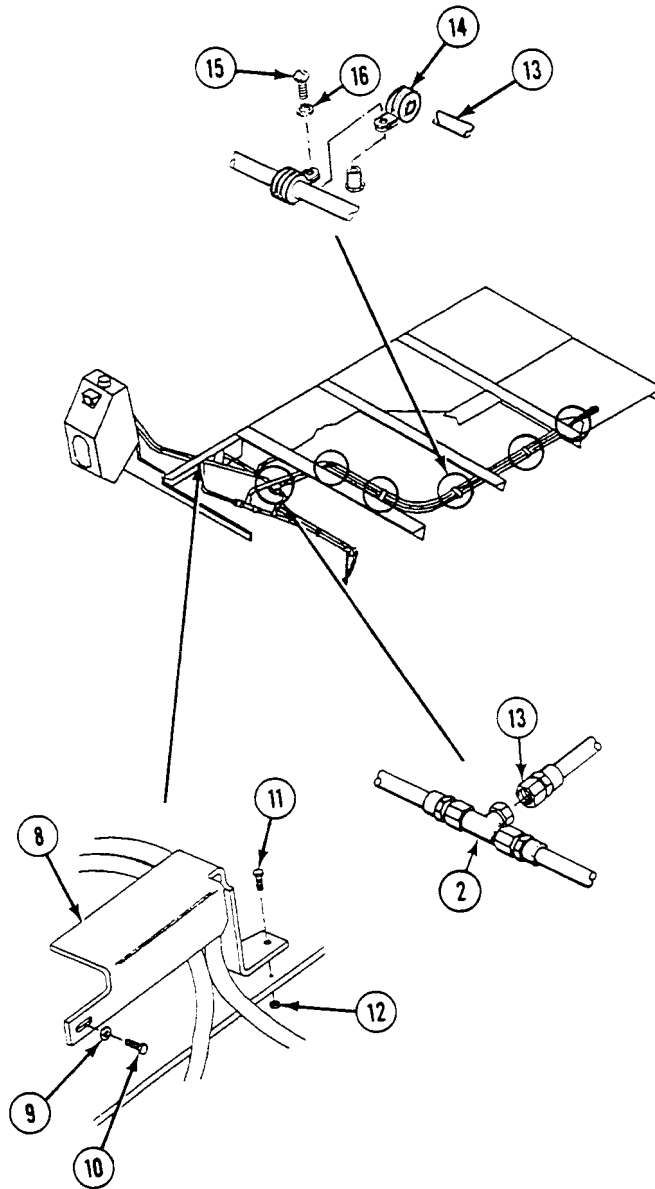

29. Install grommet (1) on hose (2). Route hose through hole in bulkhead and install grommet in bulkhead.
30. Install hose (2) on elbow (3). Hold elbow when tightening hose.

REPLACE FUEL RETURN HOSES, TUBES, AND FITTINGS (M113A3, M1059A3, AND M58 ONLY) — Continued

0195 00

31. Install quick disconnect coupler body (4) on quick disconnect coupler nose (5).

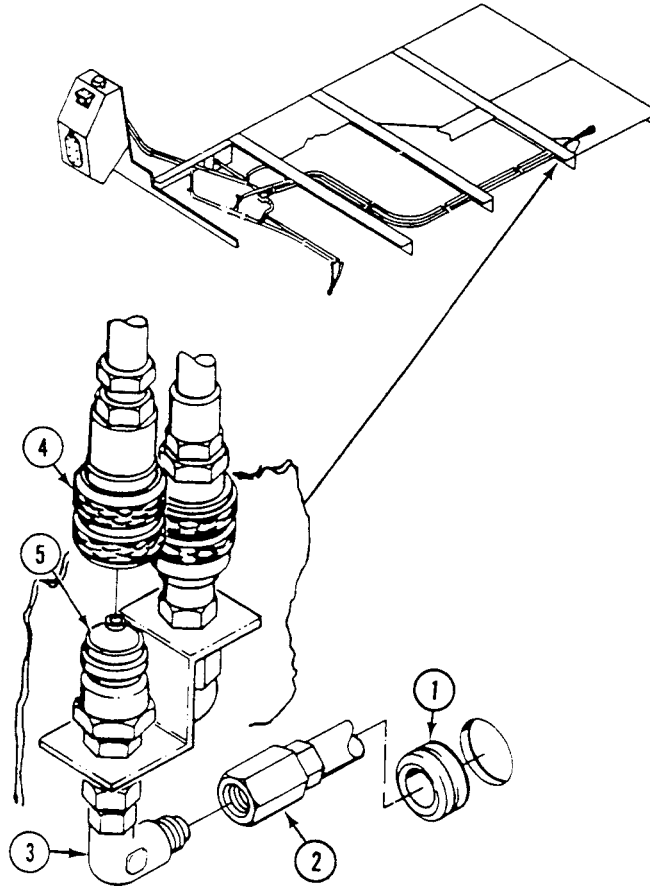
FOLLOW-THROUGH STEPS

1. Fill fuel tanks (WP 0177 00).
2. Connect battery ground strap (WP 0337 00).
3. Start engine (see your -10). Check for leaks.
4. Stop engine (see your -10).
5. Install floor plates (WP 0539 00), (WP 0542 00), or (WP 0545 00).
6. Install power plant lower rear access panel (see your -10).
7. Install smoke generator fog oil tank module (M1059A3 only) (WP 0753 00).
8. Install smoke generator system (M58 only) TM 3-1040-285-20
9. Start engine (see your -10).
10. Raise and lock ramp (see your -10).
11. Stop engine (see your -10).

END OF TASK

REPLACE FUEL RETURN HOSES, TUBES, AND FITTINGS (M577A3 AND M1068A3 ONLY)

0196 00

THIS WORK PACKAGE COVERS:

Removal (page 0196 00-1).
 Installation (page 0196 00-4).

INITIAL SETUP:

Maintenance Level

Unit

Tools and Special Tools

General Mechanic's Tool Kit (WP 0926 00, Item 65)

Materials/Parts

Sealing compound (WP 0928 00, Item 56)

Wiping rag (WP 0928 00, Item 65)

Grommet

Lockwasher (13)

Personnel Required

Unit Mechanic

References

See your -10

Equipment Condition

Engine stopped (see your -10)

Carrier blocked (see your -10)

Ramp lowered (see your -10)

Battery ground lead disconnected (WP 0338 00)

Map board removed (see your -10)

Work tables removed (WP 0578 00)

or (WP 0581 00 and WP 0582 00)

Power plant lower rear access panel removed
 (WP 0439 00)

Rear floor plates removed (WP 0539 00) or
 (WP 0544 00)

REMOVAL

NOTE

Use wiping rag to wipe up any spilled fuel.

1. Disconnect auxiliary generator return hose (1) from tee (2).
2. Remove return tube (3) from elbow (4).
3. Remove cap (5) and elbow (4) from tee (2).
4. Remove three screws (6), lockwashers (7), and clamps (8) from weldnuts on right hull plate. Discard lockwashers.
5. Disconnect return tube (3) from tee (9) on fuel filler tube (10).

REPLACE FUEL RETURN HOSES, TUBES, AND FITTINGS (M577A3 AND M1068A3 ONLY) — Continued

0196 00

6. Remove clamps (8) from return tube (3).

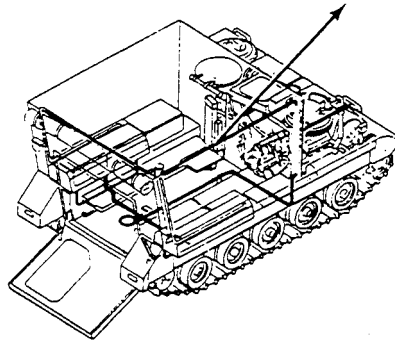
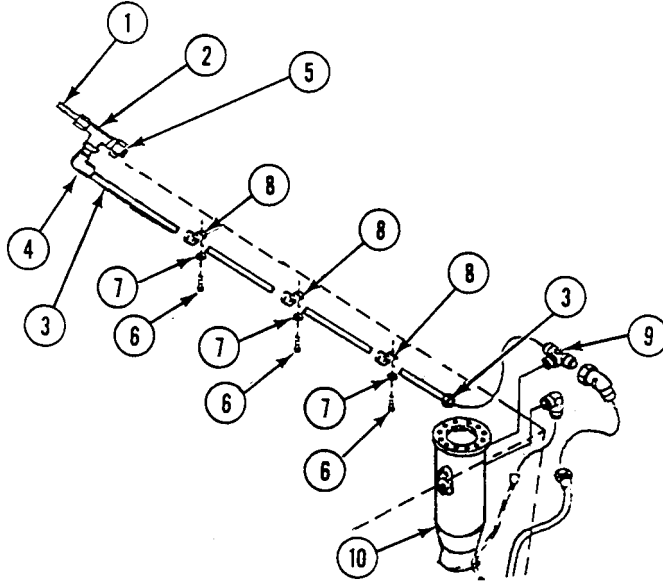

7. Remove fuel return hose (1) from elbow (2).
8. Remove elbow (2) from tee (3).
9. Remove tee (3) from fuel filler tube (4).

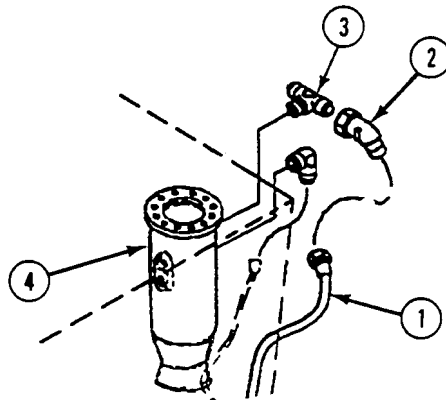

REPLACE FUEL RETURN HOSES, TUBES, AND FITTINGS (M577A3 AND M1068A3 ONLY) — Continued

0196 00

10. Remove two screws (5), lockwashers (6), and clamps (7) from weldnuts on rear hull plate. Discard lockwashers.
11. Remove clamps (7) from fuel return hose (8).
12. Remove eight screws (9), lockwashers (10) and clamps (11) from weldnuts on right box beam and bottom hull plate. Discard lockwashers.
13. Remove eight clamps (11) from fuel return hose (8).

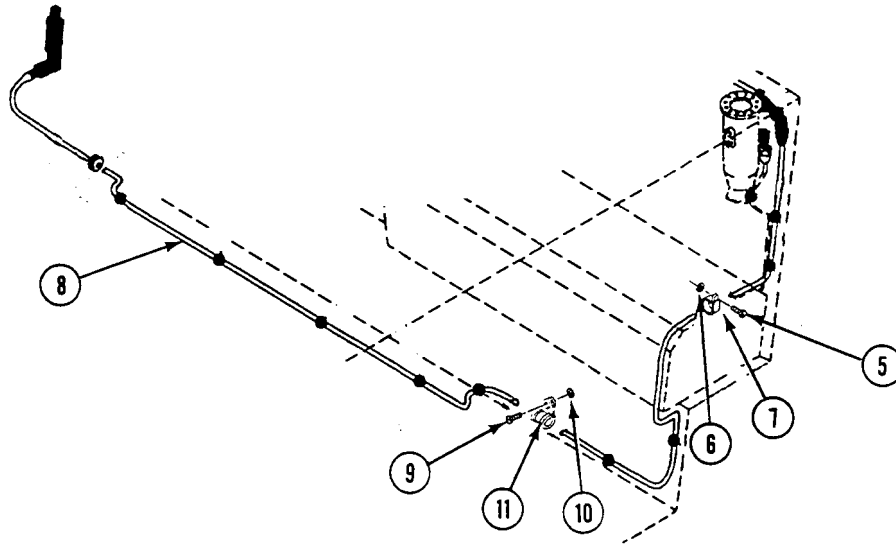

14. Separate quick-disconnect coupler (12) from coupler nose (13) inside power plant rear bulkhead.
15. Remove fuel return hose (14) from elbow (15).
16. Remove fuel return hose (14) and grommet (16) from bulkhead. Discard grommet.
17. Remove elbow (15) from reducer (17).
18. Remove nut (18) and reducer (17) from coupler nose (13).

REPLACE FUEL RETURN HOSES, TUBES, AND FITTINGS (M577A3 AND M1068A3 ONLY) — Continued

0196 00

19. Remove nut (19) and coupler nose (13) from bracket.

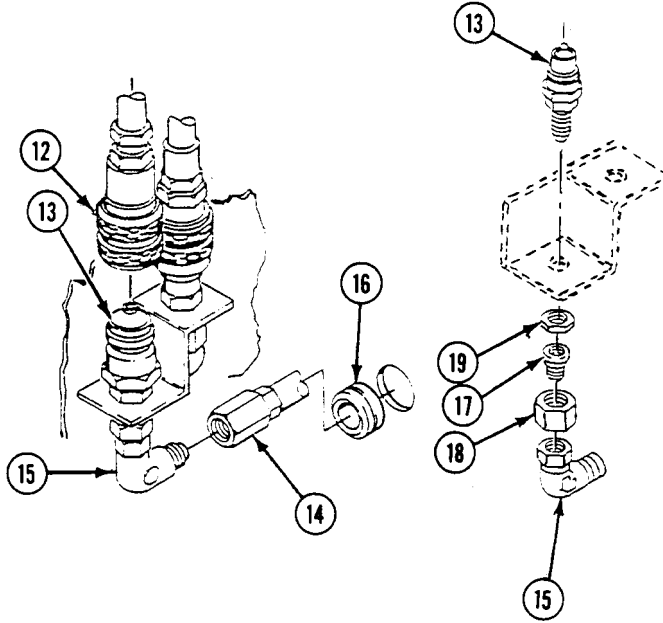

INSTALLATION

1. Apply thin even coat of sealing compound to cleaned external threads of fittings before installation.
2. Install coupler nose (1) in bracket and secure with nut (2).
3. Install reducer (3) and nut (4) on coupler nose (1).
4. Install elbow (5) on reducer (3).

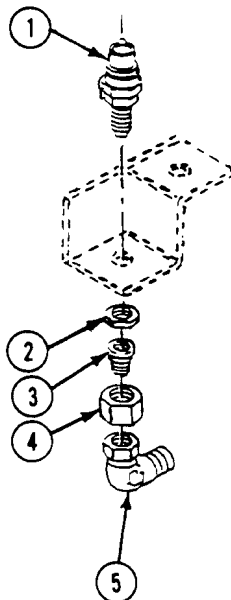

REPLACE FUEL RETURN HOSES, TUBES, AND FITTINGS (M577A3 AND M1068A3 ONLY) — Continued

0196 00

5. Install new grommet (6) on fuel return hose (7) and secure through bulkhead.
6. Connect fuel return hose (7) to elbow (5).
7. Connect quick-disconnect (8) to coupler nose (1).

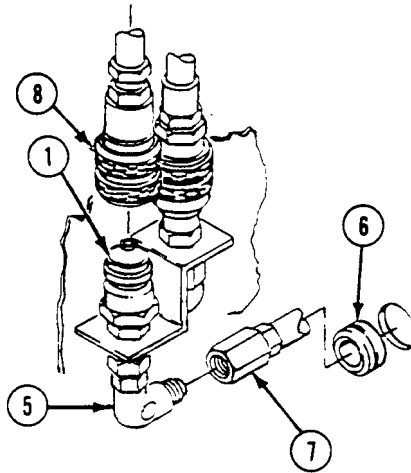

8. Install eight clamps (9) on fuel return hose (10) and secure to bottom hull plate and right box beam with new lockwashers (11), and screws (12).
9. Install two clamps (13) on fuel return hose (10) and secure to rear hull plate with new lockwashers (14), and screws (15).

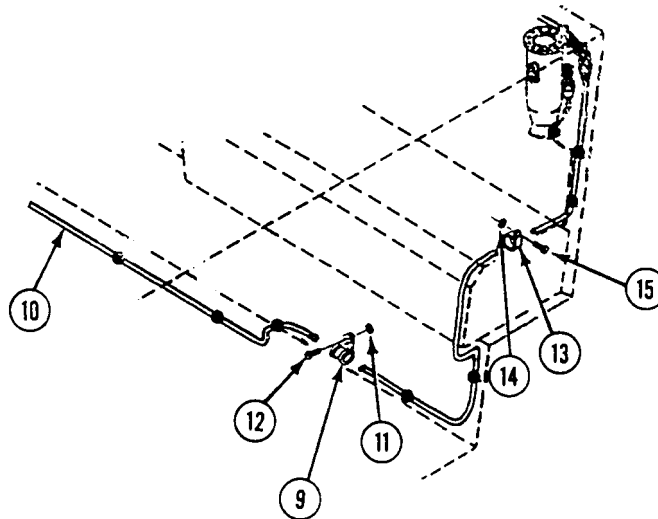

REPLACE FUEL RETURN HOSES, TUBES, AND FITTINGS (M577A3 AND M1068A3 ONLY) — Continued

0196 00

10. Install tee (16) in fuel filler tube (17).
11. Install elbow (18) on tee (16).
12. Connect fuel return hose (10) to elbow (18).

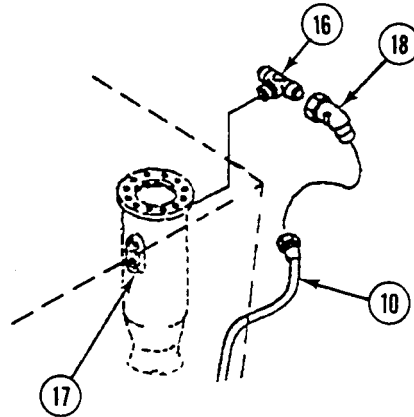

13. Connect auxiliary generator fuel return tube (1) to tee (2).
14. Install three clamps (3) on fuel return tube (1). Secure with new lockwashers (4) and screws (5) to weldnuts on right hull plate.
15. Install auxiliary generator fuel return hose (6) on tee (7).
16. Install cap (8) and elbow (9) on tee (7).
17. Connect auxiliary generator fuel return tube (1) to tee (7).

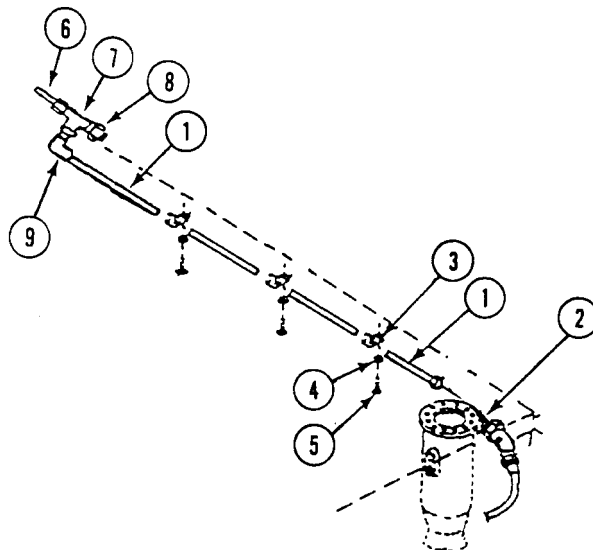

REPLACE FUEL RETURN HOSES, TUBES, AND FITTINGS (M577A3 AND M1068A3 ONLY) — Continued

0196 00

FOLLOW-THROUGH STEPS

1. Fill fuel tanks (see your -10).
2. Connect battery ground leads (WP 0338 00).
3. Start engine (see your -10).
4. Check all fittings and hoses for leaks.
5. Stop engine (see your -10).
6. Install power plant rear access panel (WP 0439 00).
7. Install rear floor plates (WP 0539 00) or (WP 0544 00).
8. Install work tables (WP 0578 00) or (WP 0581 00 and WP 0582 00).
9. Install map table (see your -10).
10. Start engine (see your -10).
11. Raise and lock ramp (see your -10).
12. Stop engine (see your -10).

END OF TASK

REPLACE FUEL RETURN HOSES, TUBES, AND FITTINGS (M1064A3 ONLY)

0197 00

THIS WORK PACKAGE COVERS:

Remove (page 0197 00-1).
 Installation (page 0197 00-9).

INITIAL SETUP:

Maintenance Level

Unit

References

TM 9-2350-277-10

Tools and Special Tools

General Mechanic's Tool Kit (WP 0926 00, Item 65)

Equipment Condition

Engine stopped (see your -10)
 Carrier blocked (see your -10)
 Ramp lowered (see your -10)
 Power plant lower rear access panel removed (see your -10)
 Battery ground strap disconnected (WP 0337 00)
 Fuel tanks drained (see your -10)
 Heater duct removed (WP 0706 00)
 Rear floor plates removed (WP 0543 00)

Materials/Parts

Calking compound (WP 0928 00, Item 14)
 Sealing compound (WP 0928 00, Item 56)
 Grommet
 Lockwasher (5)
 Strap (2)

Personnel Required

Unit Mechanic

REMOVAL

1. Separate quick-disconnect coupler (1) from coupler nose (5) inside power plant rear bulkhead.
2. Remove fuel return hose (3) from elbow (4).
3. Remove fuel return hose (3) and grommet (2) from bulkhead. Discard grommet.

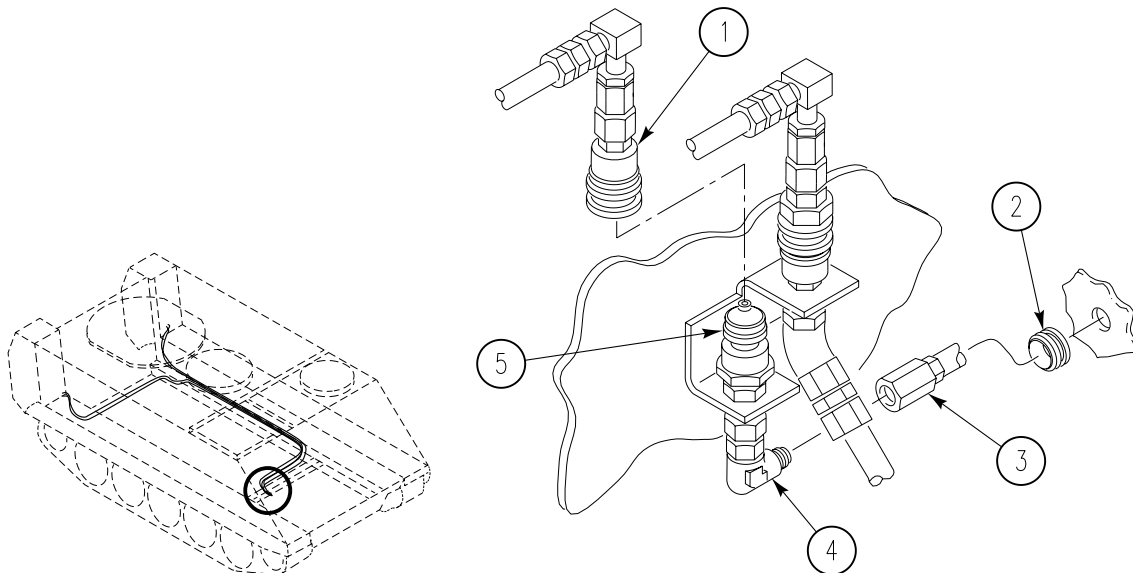

REPLACE FUEL RETURN HOSES, TUBES, AND FITTINGS (M1064A3 ONLY) —**0197 00**

Continued

4. Remove elbow (4) from reducer (6).
5. Remove nut (7) and reducer (6) from coupler nose (2).
6. Remove nut (8) and coupler nose (2) from bracket.

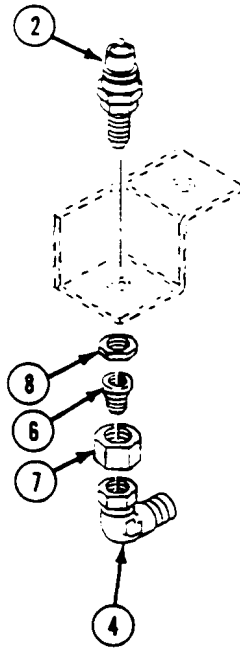

7. Remove four screws (12), lockwashers (11), and eight clamps (10) from weldnuts. Discard lockwashers.
8. Remove clamps (10) from fuel return hose (13).
9. Remove floor plate screw (8) and washer (9) from guard (6).
10. Remove screw (14), washer (15), nut (7), and guard (6).
11. Disconnect fuel return hose (13) from adapter (5).
12. Remove adapter (5) from elbow (4).
13. Remove elbow (4) and adapter (16) from fuel return tube (17).
14. Remove adapter (16) from elbow (4).

**REPLACE FUEL RETURN HOSES, TUBES, AND FITTINGS (M1064A3 ONLY) —
Continued**

0197 00

15. Remove two screws (18), lockwashers (19) and four clamps (3) from weldnuts. Discard lockwashers.
16. Remove clamps from fuel return tube (17).
17. Remove four screws (22), lockwashers (21), and guard (23) from sponson. Discard lockwashers.
18. Disconnect fuel return tube (17) from adapter (20).
19. Remove adapter (20) from fuel return hose (24).
20. Remove fuel return hose (24) from adapter (2).
21. Remove adapter (2) from tee (1).

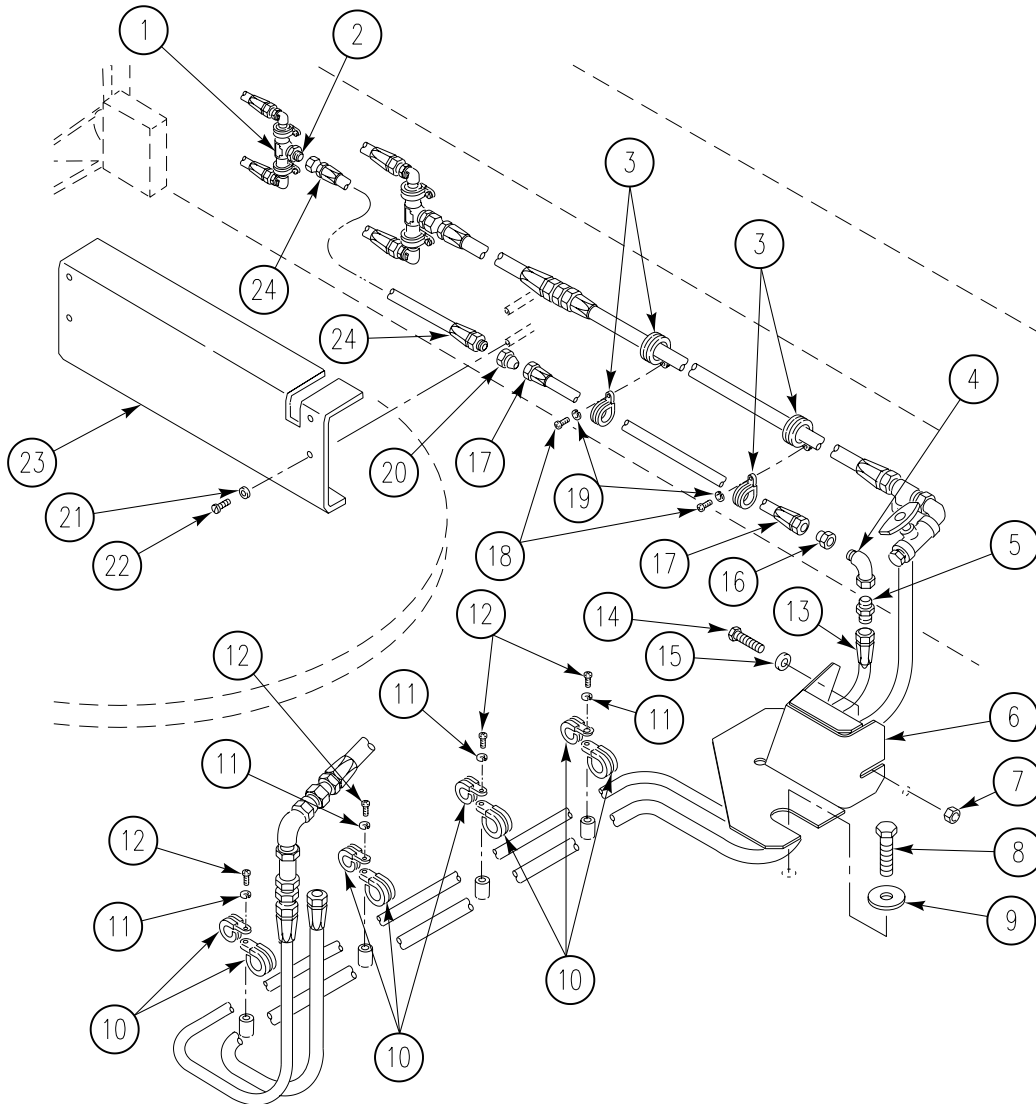

REPLACE FUEL RETURN HOSES, TUBES, AND FITTINGS (M1064A3 ONLY) —
Continued

0197 00

22. Disconnect two fuel return hoses (1) and (2) from two elbows (3).
23. Remove two screws (4), lockwashers (5) and clamps (6) from weldnuts. Discard lockwashers.
24. Remove two clamps (6) and elbows (3) from tee (7).

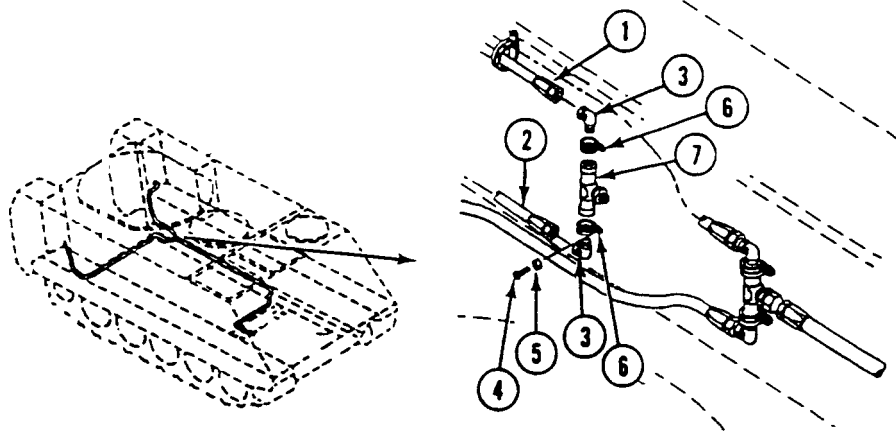

Continued

NOTE

Do Steps 23 - 30 for removing left side fuel tank return hoses and fittings. Do Steps 33 - 42 for removing right side fuel tank return hoses and fittings.

25. Remove two screws (8), washers (9), and clamps (10) securing valve (11) to mounting block (12).
26. Remove hose (1) from adapter (13).
27. Remove adapter (13) from valve (11).
28. Remove hose (14) from adapter (15).
29. Remove adapter (15) from valve (11).
30. Remove hose (14) from elbow (16).
31. Remove elbow (16) from adapter (17).
32. Remove adapter (17) from fuel tank (18).

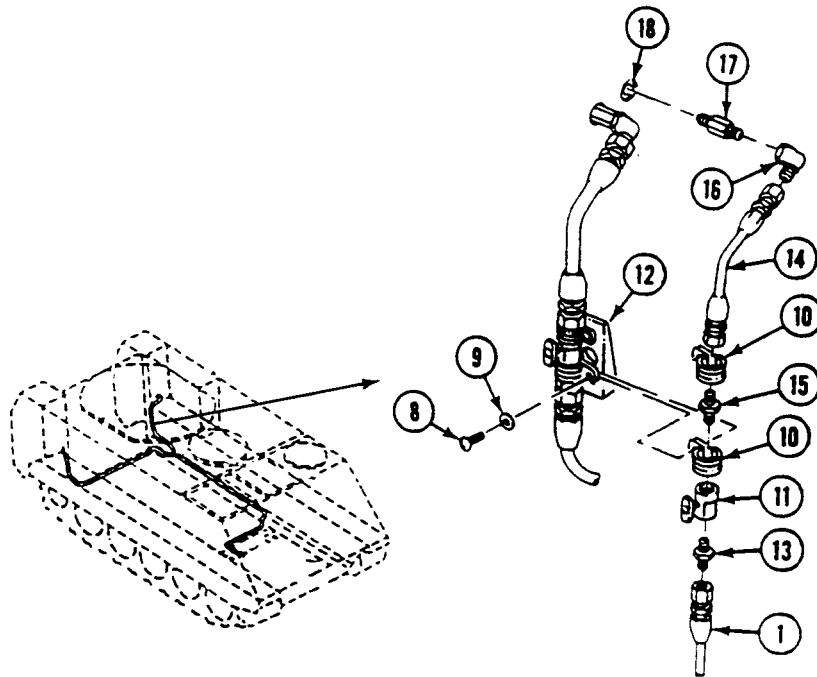

REPLACE FUEL RETURN HOSES, TUBES, AND FITTINGS (M1064A3 ONLY) —
Continued

0197 00

33. Remove three screws (19), lockwashers (20), and clamps (21) from weldnuts. Discard lockwashers.
34. Remove clamps (21) and straps (22) from fuel return hose (2), wiring harness, and bilge pump tube.

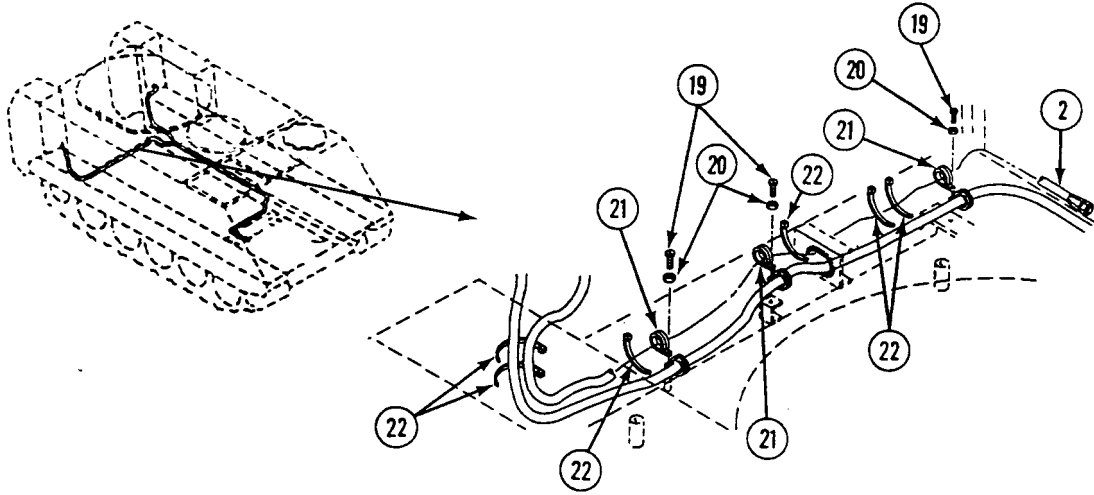

**REPLACE FUEL RETURN HOSES, TUBES, AND FITTINGS (M1064A3 ONLY) —
Continued**

0197 00

35. Remove two straps (10) securing valve (6) to fuel supply hoses and bilge tube (11). Discard straps.

NOTE

Replace grommet only if necessary.

36. Remove hose (8) and grommet (9) from adapter (7).
 37. Remove adapter (7) from valve (6).
 38. Remove fuel return hose (4) from adapter (5).
 39. Remove adapter (5) from valve (6).
 40. Remove fuel return hose (4) from elbow (3).
 41. Remove elbow (3) from adapter (2).
 42. Remove adapter (2) from fuel tank (1).

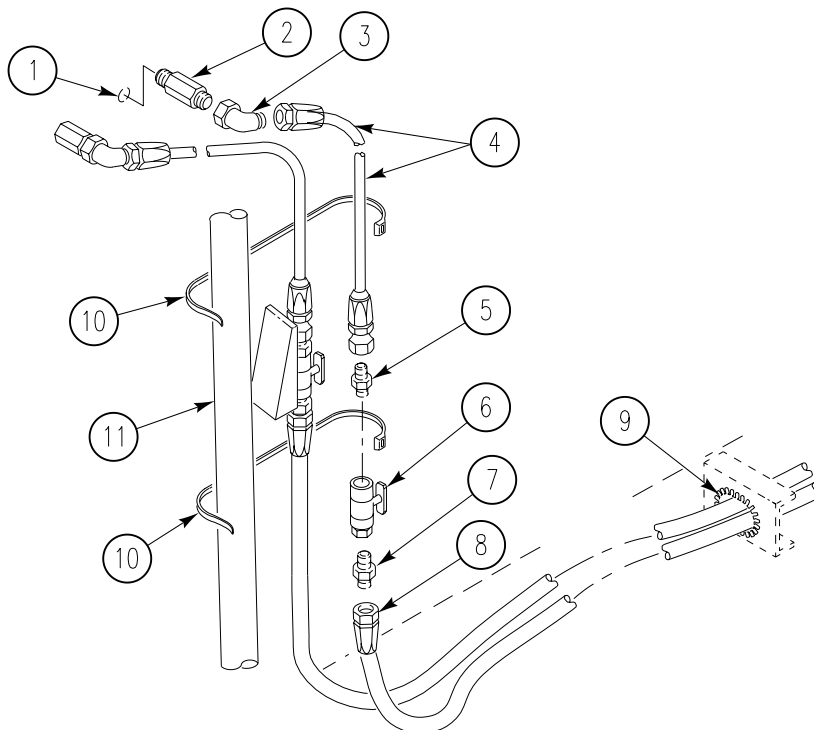
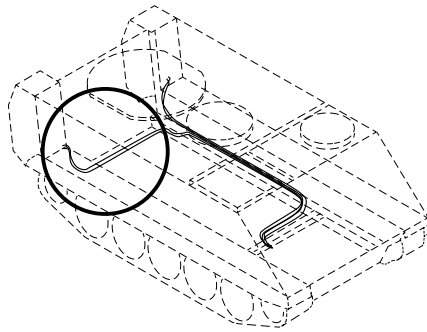

REPLACE FUEL RETURN HOSES, TUBES, AND FITTINGS (M1064A3 ONLY) —
Continued

0197 00

INSTALLATION**NOTE**

Do Steps 1 - 9 for installing right side fuel tank return hoses and fittings. Do Steps 20 - 29 for installing left side fuel return hoses and fittings.

1. Apply sealing compound to external threads of adapter (2) and install on fuel tank (1).
2. Apply sealing compound to external threads of elbow (3) and install on adapter (2).
3. Apply calking compound to space around adapter (2) on rear hull plate.
4. Install fuel return hose (4) on elbow (3).
5. Apply sealing compound to external threads of adapter (5) and install in valve (6).

NOTE

Apply adhesive to new grommet before installing.

6. Install fuel return hose (4) through grommet (9) and on adapter (5).
7. Apply sealing compound to external threads of adapter (7) and install in valve (6).
8. Connect fuel return hose (8) to adapter (7).
9. Secure valve (6) to fuel supply hoses and bilge tube (11) with two new straps. (10).

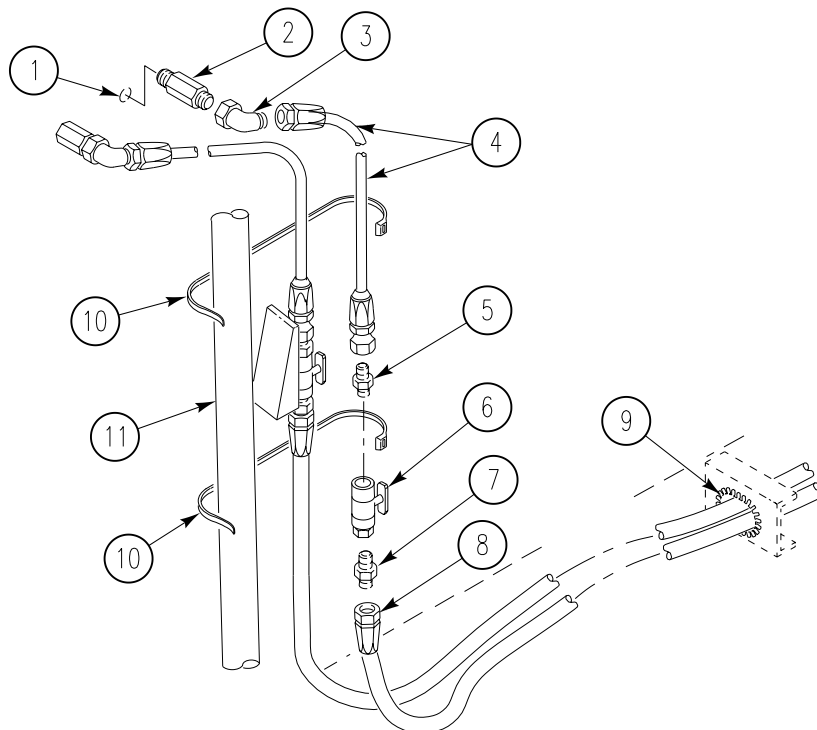

**REPLACE FUEL RETURN HOSES, TUBES, AND FITTINGS (M1064A3 ONLY) —
Continued**

0197 00

10. Install three clamps (14) and straps (15) on fuel return hose (6), wiring harness, and bilge pump tube.
11. Install three screws (16), new lockwashers (17), and clamps (14) on weldnuts.

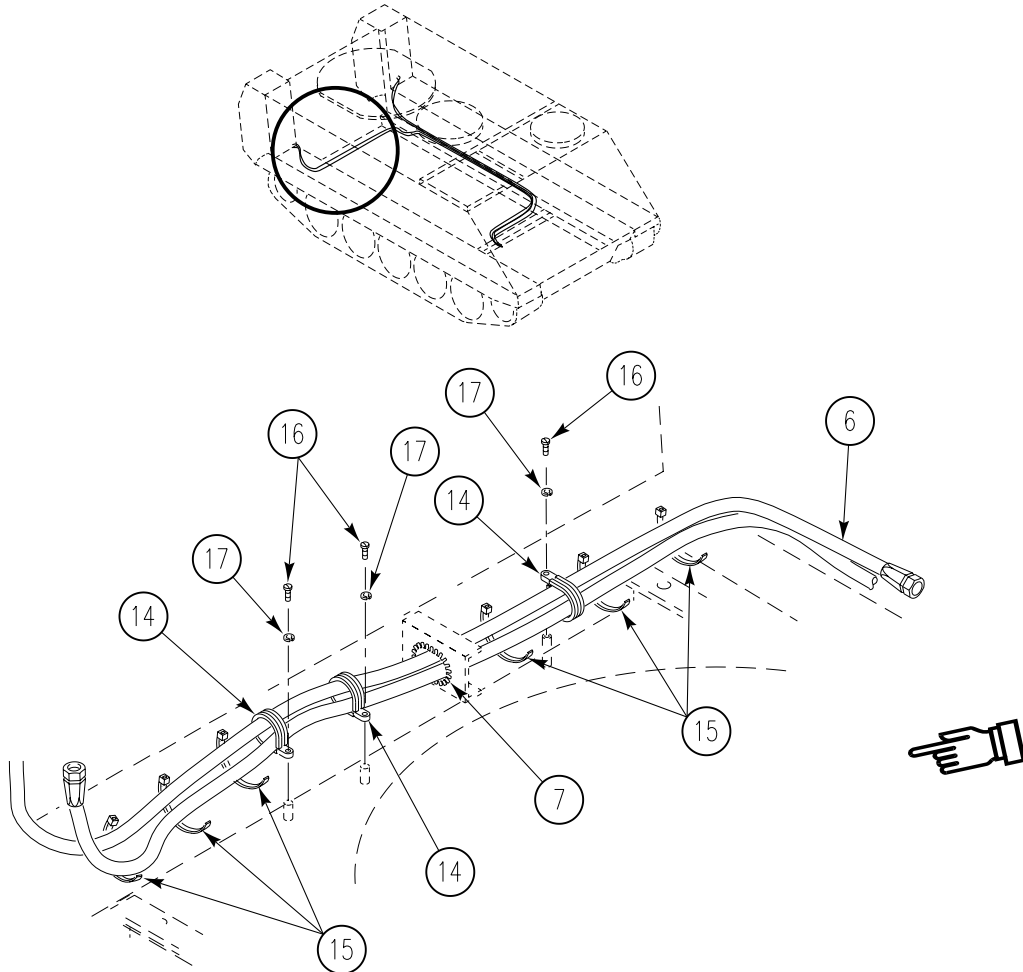

**REPLACE FUEL RETURN HOSES, TUBES, AND FITTINGS (M1064A3 ONLY) —
Continued**

0197 00

12. Apply sealing compound to external threads of adapter (1) and install on fuel tank (2).
13. Apply sealing compound on internal threads of elbow (3) and install on adapter (1).
14. Apply calking compound to space around adapter (1) on rear of hull plate.
15. Install fuel return hose (4) on elbow (3).
16. Apply sealing compound to external threads of adapter (5) and install on valve (6).
17. Install fuel return hose (4) on adapter (5).
18. Apply sealing compound to external threads of adapter (7) and install on valve (6).

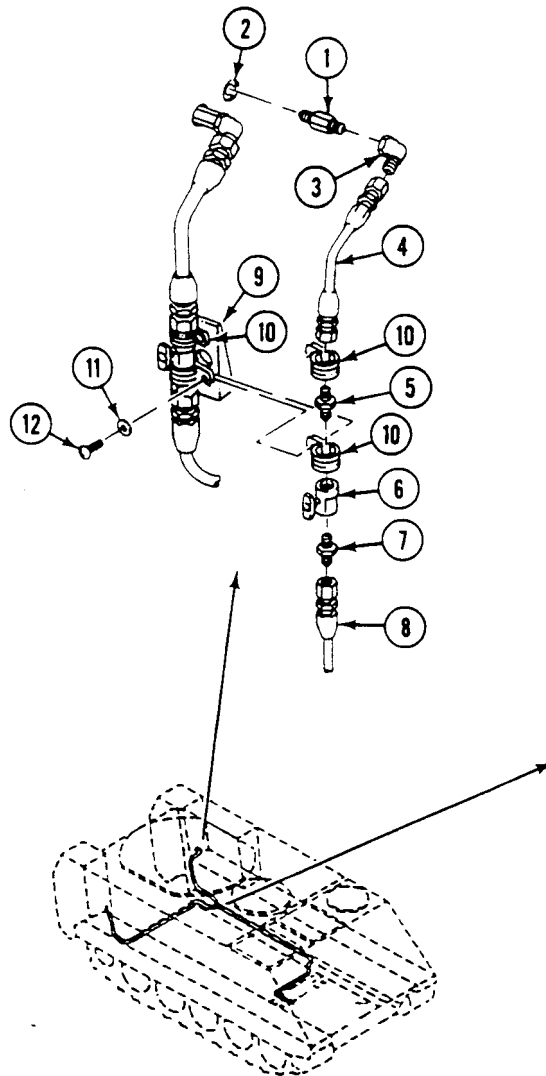

REPLACE FUEL RETURN HOSES, TUBES, AND FITTINGS (M1064A3 ONLY) —
Continued

0197 00

19. Install fuel return hose (8) on adapter (7).
20. Align valve (6) on mounting block (9) and secure with two clamps (10), washers (11), and screws (12).
21. Apply sealing compound to external threads of two elbows (13) and tee (14). Install two elbows (13) and clamps (15) on tee (14).
22. Install two new lockwashers (16), screws (17), and clamps (10) on weldnuts.
23. Connect left fuel return hose (8) and right fuel return hose (18) to elbows (13).
24. Install adapter (19) on tee (14).

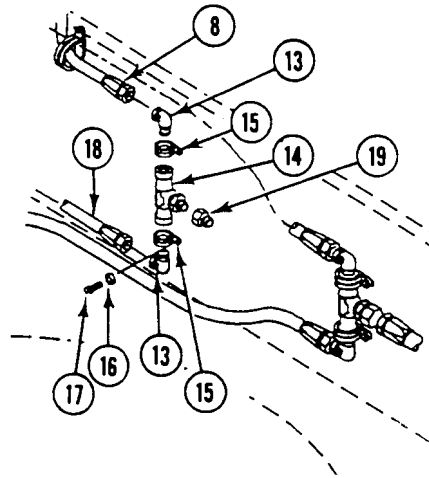

REPLACE FUEL RETURN HOSES, TUBES, AND FITTINGS (M1064A3 ONLY) —
Continued

0197 00

25. Connect fuel return hose (24) to adapter (2) and tee (1).
26. Apply sealing compound to external threads of adapter (20) and install on fuel return hose (24).
27. Connect fuel return tube (17) to adapter (20).
28. Install guard (23), four new lockwashers (21), and screws (22) on sponson.
29. Install two clamps (3) on fuel return tube (17).
30. Install four clamps (3), two new lockwashers (19), and screws (18) on weldnuts.

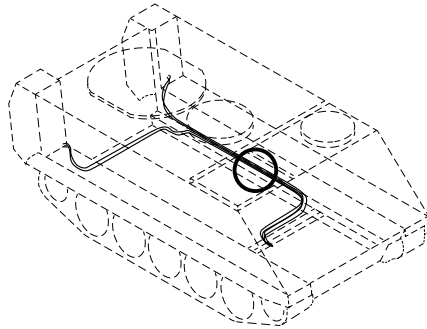

REPLACE FUEL RETURN HOSES, TUBES, AND FITTINGS (M1064A3 ONLY) —

0197 00

Continued

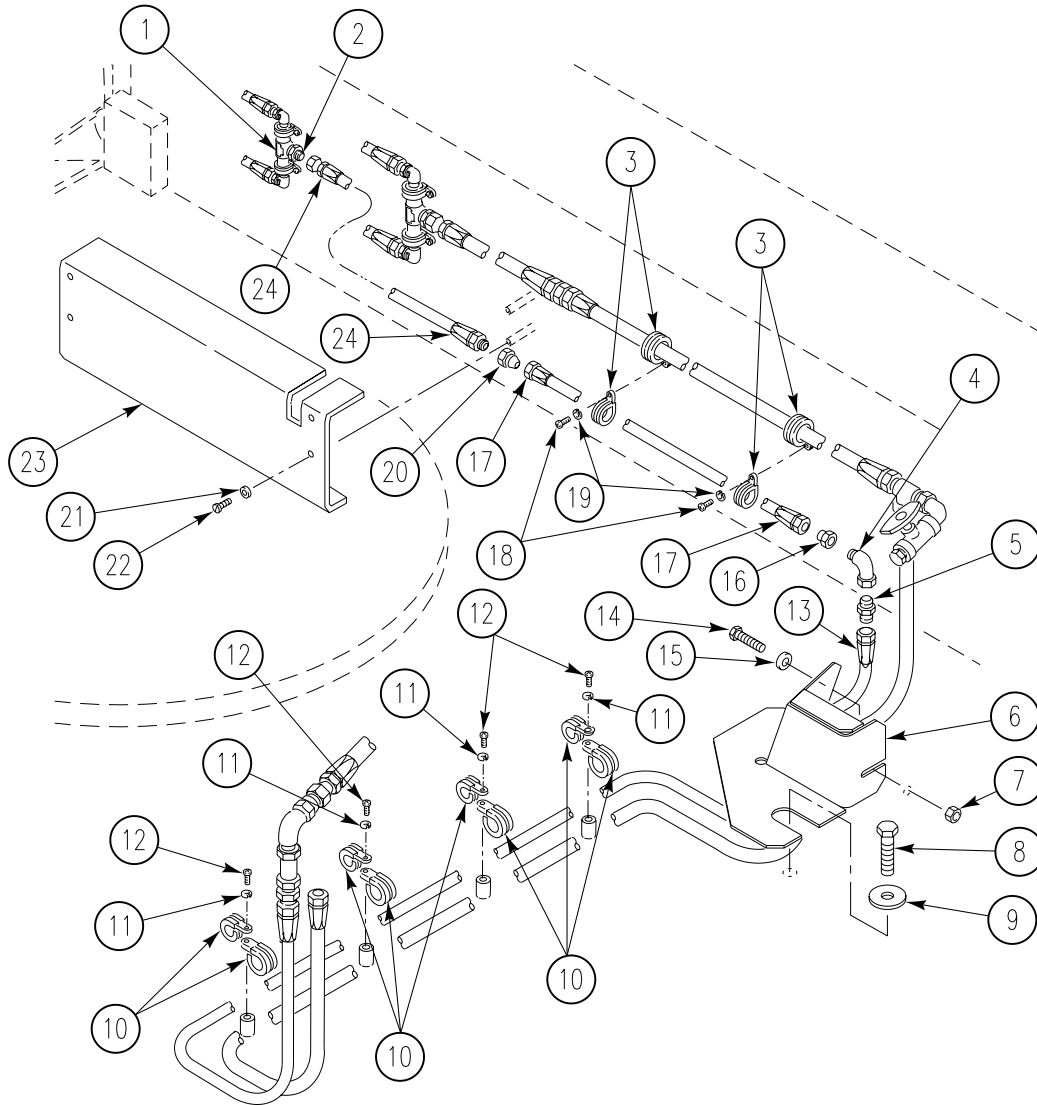

**REPLACE FUEL RETURN HOSES, TUBES, AND FITTINGS (M1064A3 ONLY) —
Continued**

0197 00

31. Apply sealing compound to external threads of elbow (4). Install adapter (16) and adapter (5) on elbow (4).
32. Connect fuel return tube (17) to adapter (16).
33. Connect fuel return hose (13) to adapter (5).
34. Install four clamps (10) on fuel return hose (13).
35. Install four screws (12), new lockwashers (11), and eight clamps (10) on weldnuts.
36. Install guard (6), two washers (15), screws (14), and nut(7) .
37. Install floor plate screw (8) and washer (9) to secure guard (6).

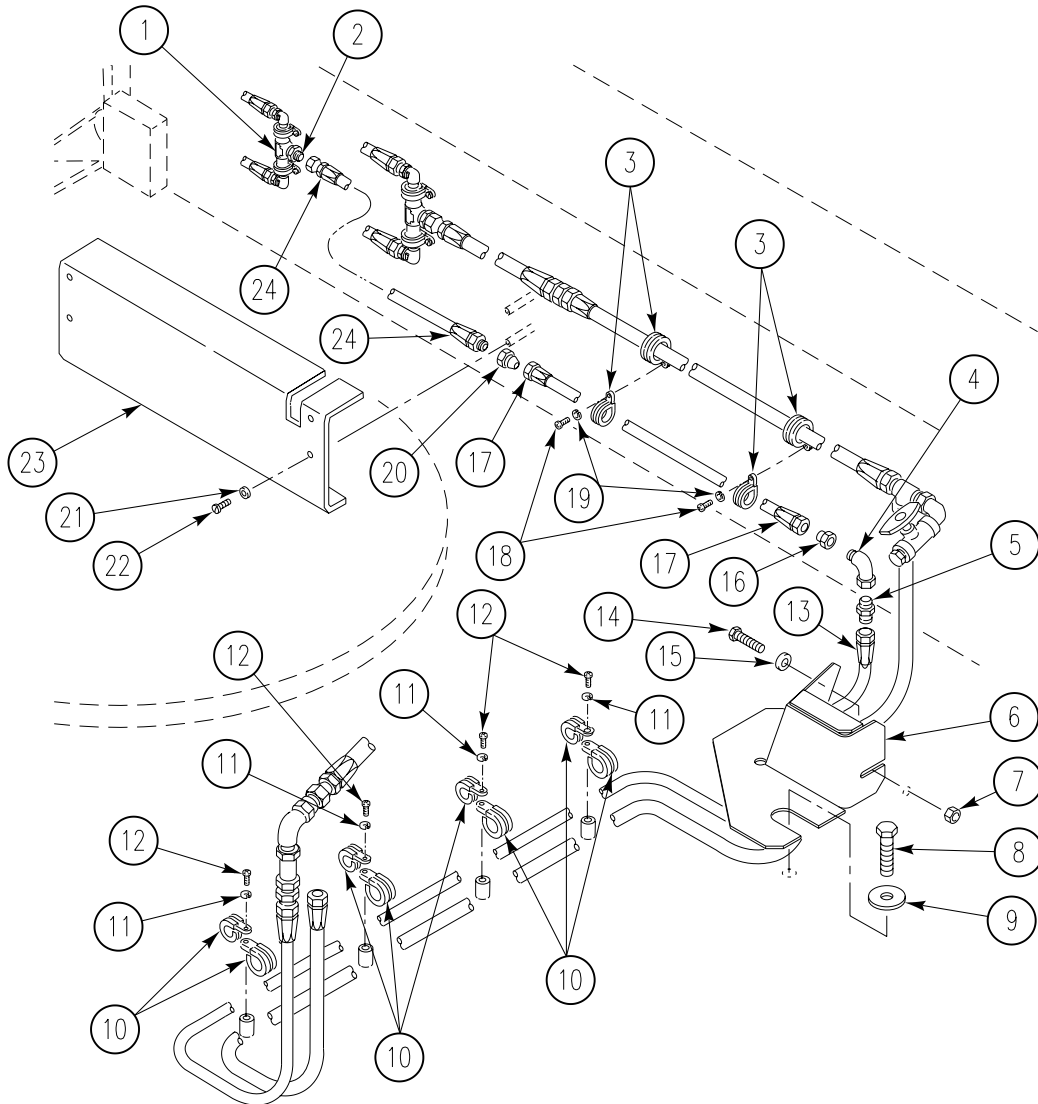

REPLACE FUEL RETURN HOSES, TUBES, AND FITTINGS (M1064A3 ONLY) —**0197 00****Continued**

38. Install coupler nose (1) in bracket and secure with nut (2).
39. Install reducer (3) and nut (4) on coupler nose (1).
40. Install elbow (5) on coupler nose (1).

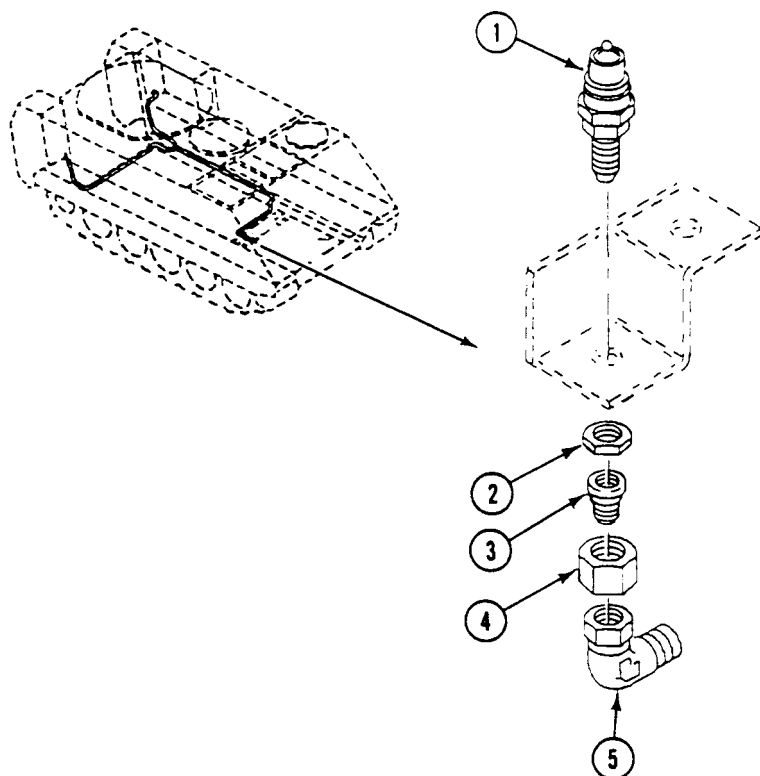

REPLACE FUEL RETURN HOSES, TUBES, AND FITTINGS (M1064A3 ONLY) —
Continued

0197 00

41. Install new grommet (2) on fuel return hose (3) and secure through bulkhead.
42. Connect fuel return hose (3) to elbow (4).
43. Connect quick-disconnect (1) to coupler nose (5).

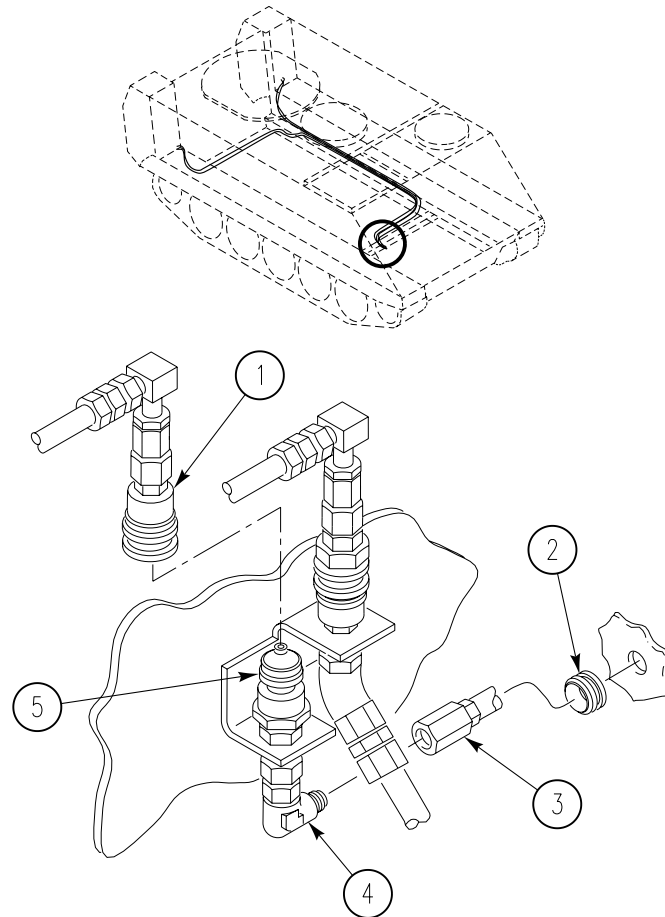
**FOLLOW-THROUGH STEPS**

1. Fill fuel tanks (see your -10).
2. Connect battery ground strap (see your -10).
3. Start engine (see your -10). Check for leaks.
4. Check for leaks in fuel lines.
5. Stop engine (see your -10).
6. Install power plant rear access panel (see your -10).
7. Install rear floor plates (WP 0543 00).
8. Install heater duct (WP 0706 00).
9. Start engine (see your -10).
10. Raise and lock ramp (see your -10).
11. Stop engine (see your -10).

END OF TASK

REPLACE FUEL VENT HOSES, TUBES, AND FITTINGS (M577A3 AND M1068A3 ONLY)

0198 00

THIS WORK PACKAGE COVERS:

Removal (page 0198 00-1).
 Installation (page 0198 00-4).

INITIAL SETUP:

Maintenance Level

Unit

References

See your -10

Tools and Special Tools

General Mechanic's Tool Kit (WP 0926 00, Item 65)

Equipment Condition

Engine stopped (see your -10)
 Carrier blocked (see your -10)
 Ramp lowered (see your -10)
 Battery ground lead disconnected (WP 0338 00)
 Map board removed (see your -10)
 Work tables removed (WP 0578 00)
 or (WP 0581 00 and WP 0582 00)

Materials/Parts

Sealing compound (WP 0928 00, Item 56)
 Lockwasher (17)
 Suitable container

Personnel Required

Unit Mechanic

REMOVAL

1. Drain fuel tanks below level of vent hoses (WP 0178 00).
2. Disconnect vent hose (1) from elbow (2).
3. Disconnect vent hose (3) from elbow (4).

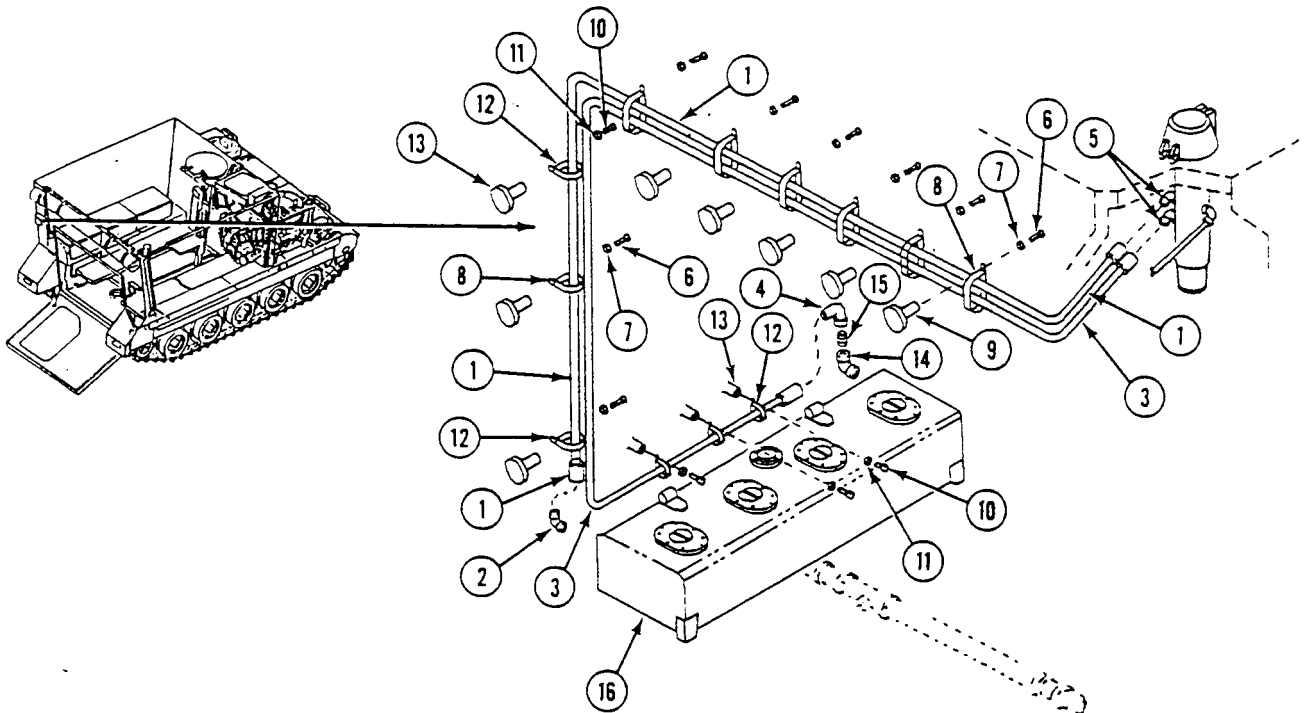

REPLACE FUEL VENT HOSES, TUBES, AND FITTINGS (M577A3 AND M1068A3 ONLY)

0198 00

— Continued

4. Disconnect vent hoses (1) and (3) from two elbows (5).
5. Remove seven screws (6), lockwashers (7), clamps (8), and vent hoses (1) and (3) from seven weldnuts (9). Discard lockwashers.
6. Remove five screws (10), lockwashers (11), clamps (12), and vent hoses (1) and (3) from five weldnuts (13). Discard lockwashers.
7. Remove three elbows (2), (4), and (14) and nipple (15) from left fuel tank (16).

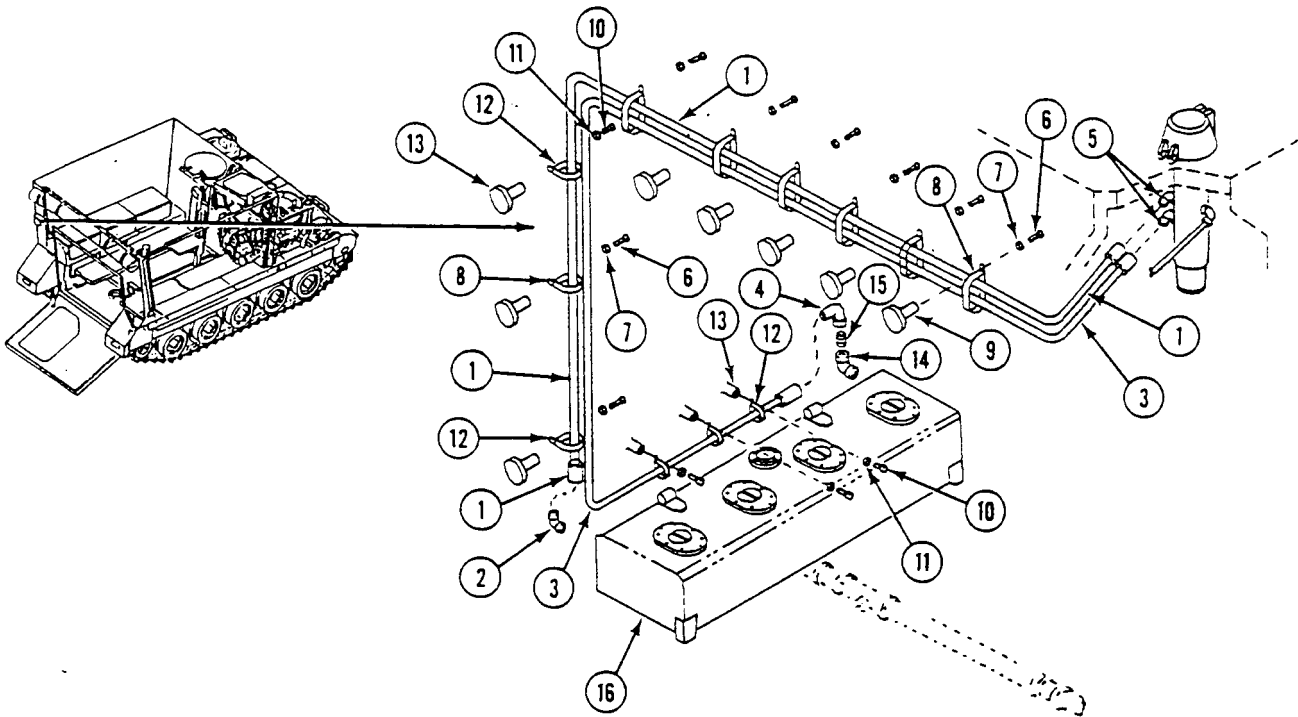

REPLACE FUEL VENT HOSES, TUBES, AND FITTINGS (M577A3 AND M1068A3 ONLY)
— Continued

0198 00

8. Disconnect vent tube (1) from two elbows (2) and (3).
9. Remove five screws (4), lockwashers (5), clamps (6), and vent tube (1) from five weldnuts (7). Discard lockwashers.
10. Remove two elbows (8) and elbow (2) from filler neck (9).
11. Remove elbow (3) and bushing (10) from right fuel tank (11).

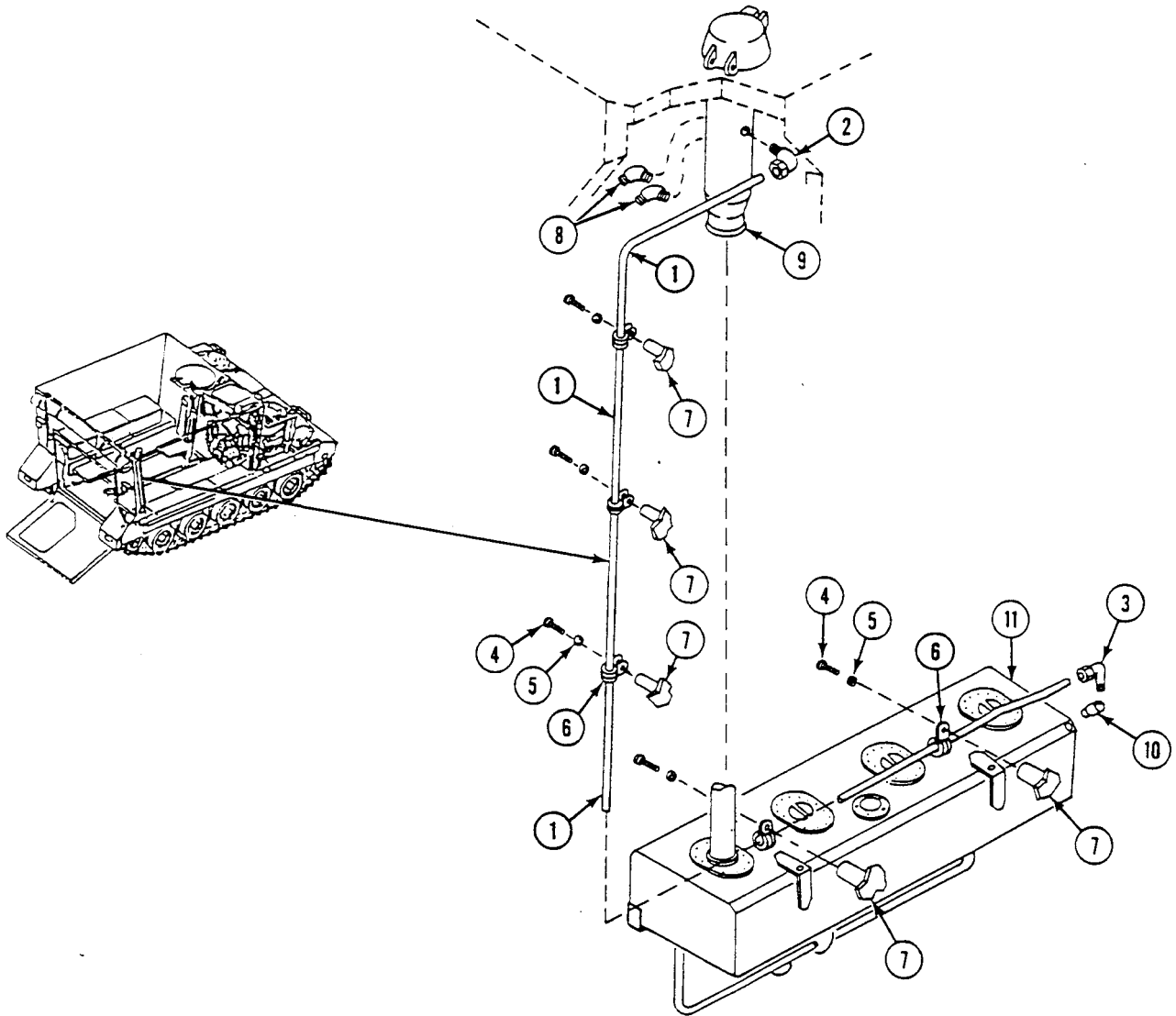

REPLACE FUEL VENT HOSES, TUBES, AND FITTINGS (M577A3 AND M1068A3 ONLY)

0198 00

— Continued

INSTALLATION

1. Apply a thin, even coat of sealing compound to cleaned external threads of fittings.
2. Install bushing (10) in right fuel tank (11).
3. Install elbow (3) on bushing (10).
4. Install two elbows (8) and elbow (2) in filler neck (9).
5. Connect vent tube (1) to two elbows (2) and (3).
6. Install vent tube (1) on five weldnuts (7). Secure with five clamps (6), new lockwashers (5), and screws (4).

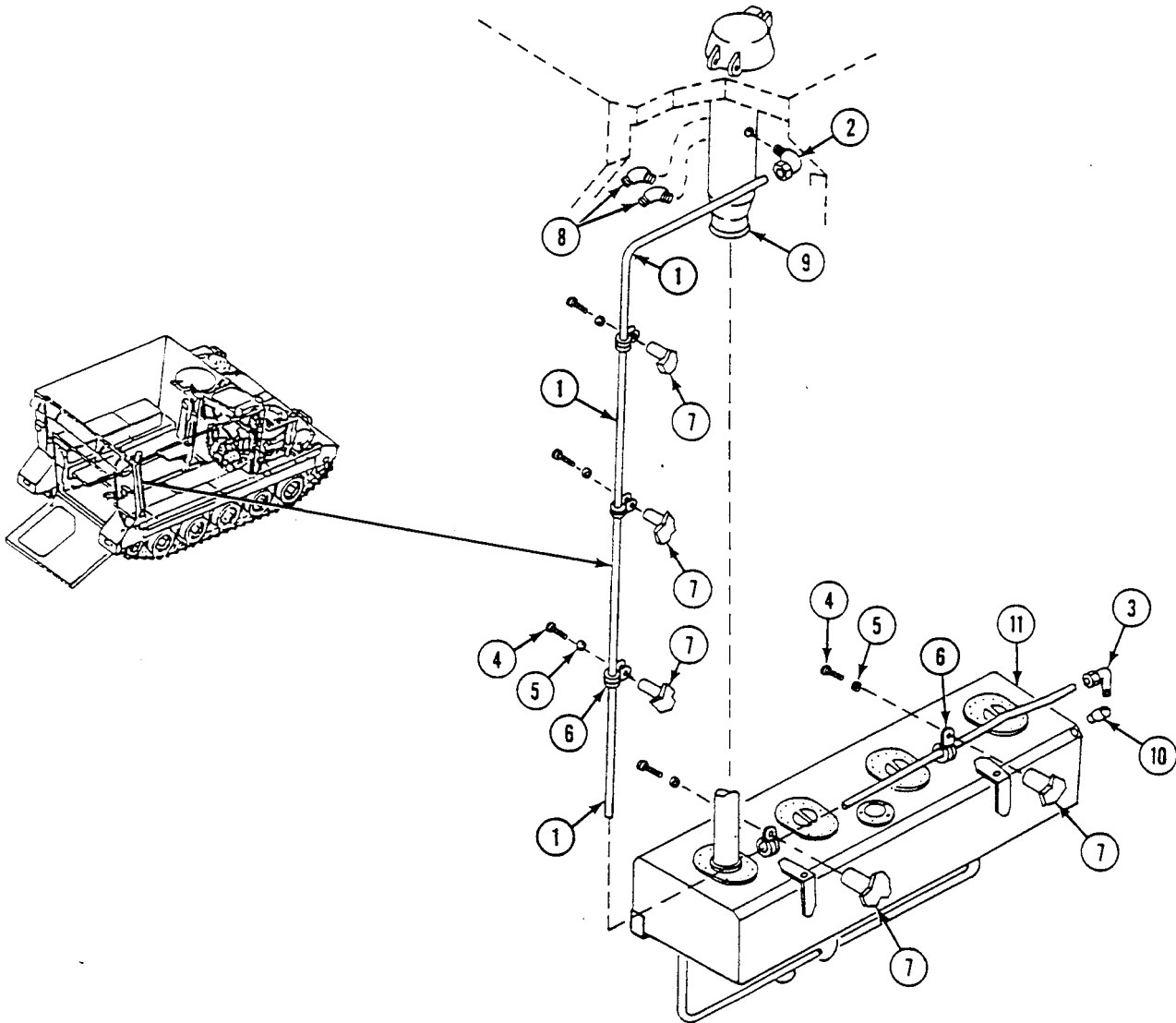

REPLACE FUEL VENT HOSES, TUBES, AND FITTINGS (M577A3 AND M1068A3 ONLY)

0198 00

— Continued

7. Install two elbows (1) and (2) in left fuel tank (3).
8. Install nipple (4) in elbow (2).
9. Install elbow (5) on nipple (4).
10. Connect vent hose (6) to elbow (1) at left fuel tank (3).
11. Connect vent hose (7) to elbow (5) at left fuel tank (3).
12. Connect two vent hoses (6) and (7) to two elbows (8) at filler neck (9).
13. Install two vent hoses (6) and (7) on seven weldnuts (10). Secure with seven clamps (11), new lockwashers (12), and screws (13).
14. Secure vent hose (7) to five weldnuts (14) with five clamps (15), new lockwashers (16), and screws (17).

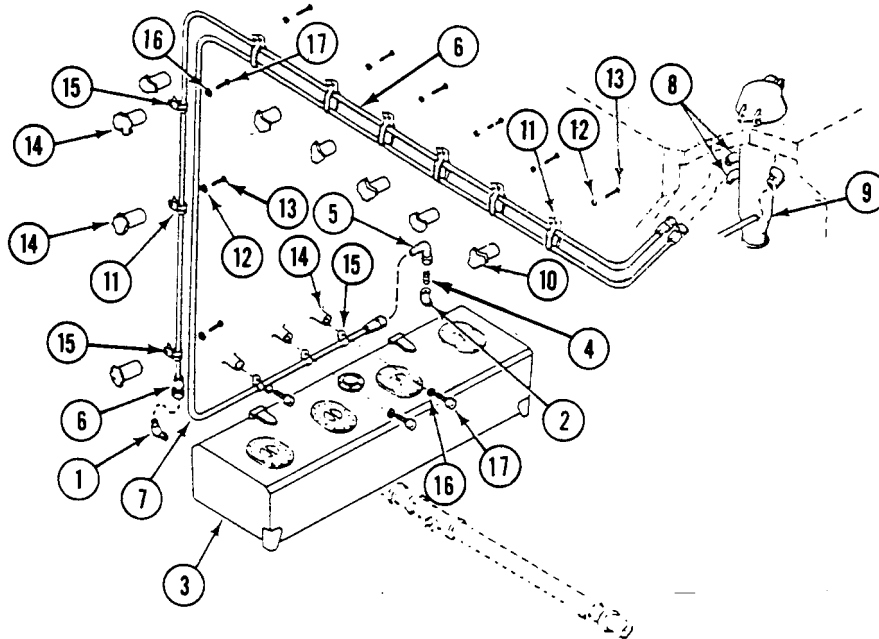

FOLLOW-THROUGH STEPS

1. Fill fuel tanks (see your -10). Check for leaks.
2. Install map board (see your -10).
3. Install work tables (WP 0578 00) or (WP 0581 00 and WP 0582 00).
4. Connect battery ground lead (WP 0338 00).
5. Start engine (see your -10).
6. Raise and lock ramp (see your -10).
7. Stop engine (see your -10).

END OF TASK

REPLACE FUEL VALVE MOUNTING BLOCKS (ALL EXCEPT M577A3 AND M1068A3)

0199 00

THIS WORK PACKAGE COVERS:

Removal (page 0199 00-1).
 Installation (page 0199 00-3).

INITIAL SETUP:

Maintenance Level

Unit

References

See your -10

Tools and Special Tools

General Mechanic's Tool Kit (WP 0926 00, Item 65)

Equipment Condition

Engine stopped (see your -10)
 Carrier blocked (see your -10)
 Ramp lowered (see your -10)

Personnel Required

Unit Mechanic

REMOVAL

NOTE

Right and left side mounting blocks are replaced the same way. Left side is shown.

1. Remove two screws (1) and washers (2) securing three clamps and fuel shutoff valves (3) and (4) to mounting block (5).

REPLACE FUEL VALVE MOUNTING BLOCKS (ALL EXCEPT M577A3 AND M1068A3) —
Continued

0199 00

2. Remove screw (6), washer (7), and mounting block (5) from side of sponson.

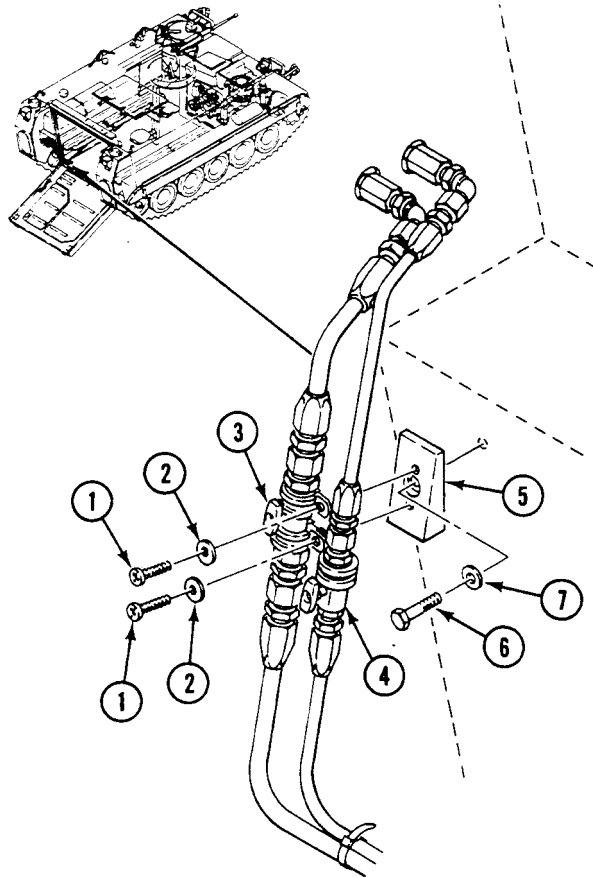

REPLACE FUEL VALVE MOUNTING BLOCKS (ALL EXCEPT M577A3 AND M1068A3) —
Continued

0199 00

INSTALLATION

1. Install mounting block (5) on side of sponson and secure with washer (7) and screw (6).
2. Secure three clamps and fuel shutoff valves (4) and (3) to mounting block (5) with two washers (2) and screws (1).

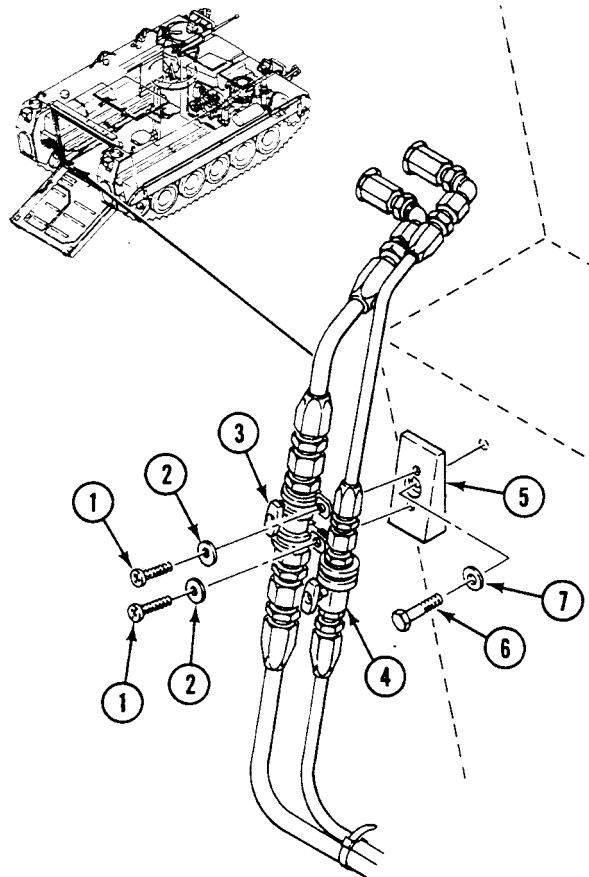
**FOLLOW-THROUGH STEPS**

1. Start engine (see your -10).
2. Raise and lock ramp (see your -10)
3. Stop engine (see your -10).

END OF TASK

REPLACE ENGINE FUEL SUPPLY HOSE

0200 00

THIS WORK PACKAGE COVERS:

Removal (page 0200 00-1).
 Installation (page 0200 00-3).

INITIAL SETUP:

Maintenance Level

Unit

Tools and Special Tools

General Mechanic's Tool Kit (WP 0926 00, Item 65)

Materials/Parts

Sealing compound (WP 0928 00, Item 56)
 Suitable container
 Tie strap

Personnel Required

Unit Mechanic
 Helper (H)

References

See your -10

Equipment Condition

Engine stopped (see your -10)
 Carrier blocked (see your -10)
 Power plant rear access panels removed (see your -10)
 Driver's compartment access panel removed
 (see your -10)
 Power plant access door open (see your -10)
 Battery ground strap disconnected (WP 0337 00),
 (WP 0338 00), or (WP 0339 00)
 Air intake elbow removed (WP 0173 00)
 Exhaust elbow removed (WP 0221 00)

REMOVAL

1. Disconnect coupler nose (1) from coupler body (2).

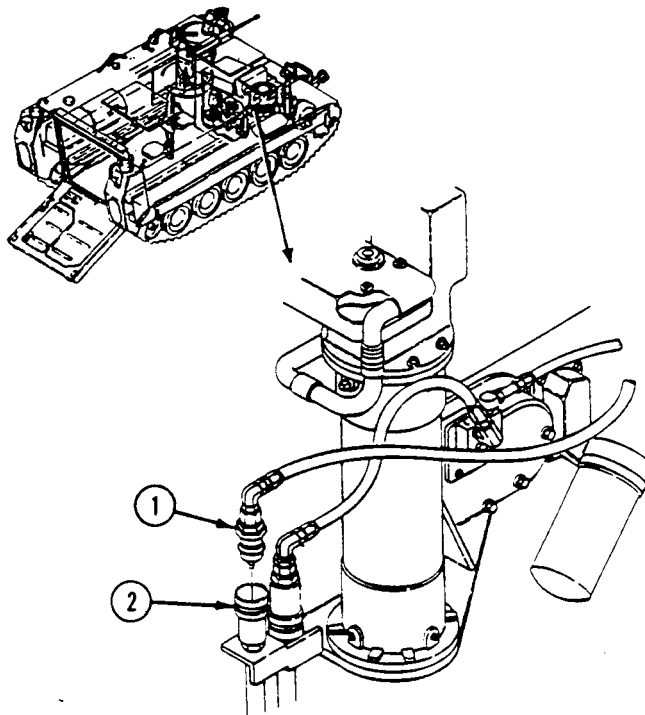

- Remove tie strap (3) from fuel hoses (4) and (5). Discard strap.

NOTE

Use suitable container to catch fuel leakage.

- Disconnect fuel supply hose (4) from elbow (6) on primary fuel filter.

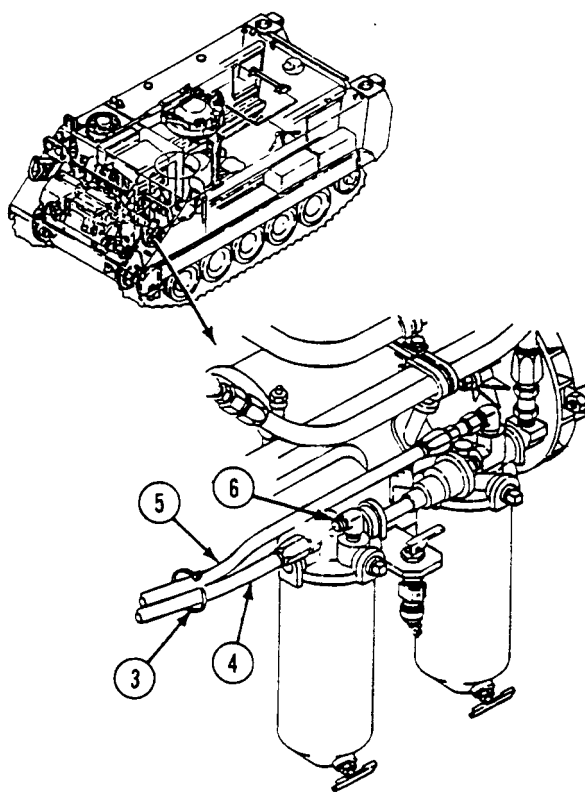
**NOTE**

Note position of fuel supply hose in relation to power plant before removing hose.

- Remove fuel supply hose (1) from carrier. Have helper assist.

5. Disassemble fuel supply hose (1) from elbow (2) on coupler nose (8).

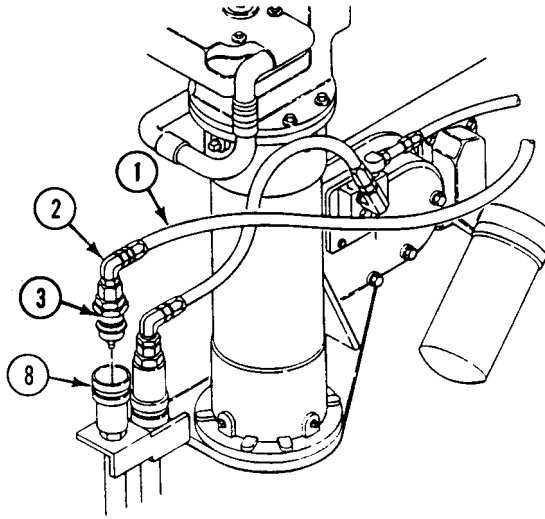

INSTALLATION

NOTE

Do Step 1 before installing fuel supply hose in carrier.

1. Assemble fuel supply hose (1) to elbow (2) on coupler nose (8).

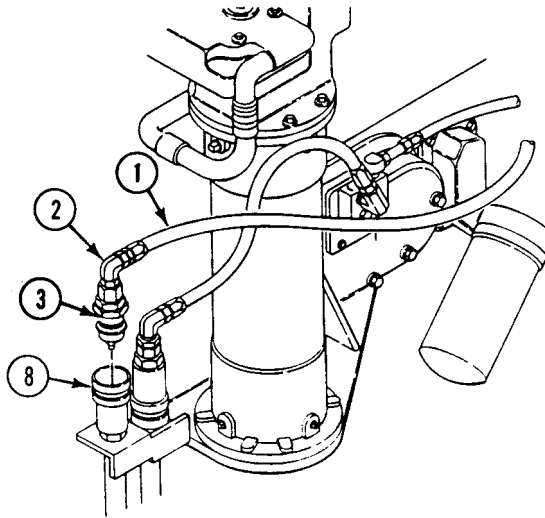

NOTE

Make sure routing of fuel supply hose is the same as it was before removal.

2. Install fuel supply hose (1) in carrier. Have helper assist.
3. Apply sealing compound to threads of elbow (4) on primary fuel filter (5).
4. Connect fuel supply hose (1) to elbow (4).
5. Secure fuel lines (1)(6) with new tie strap (7).
6. Connect coupler nose (1) to coupler body (2).

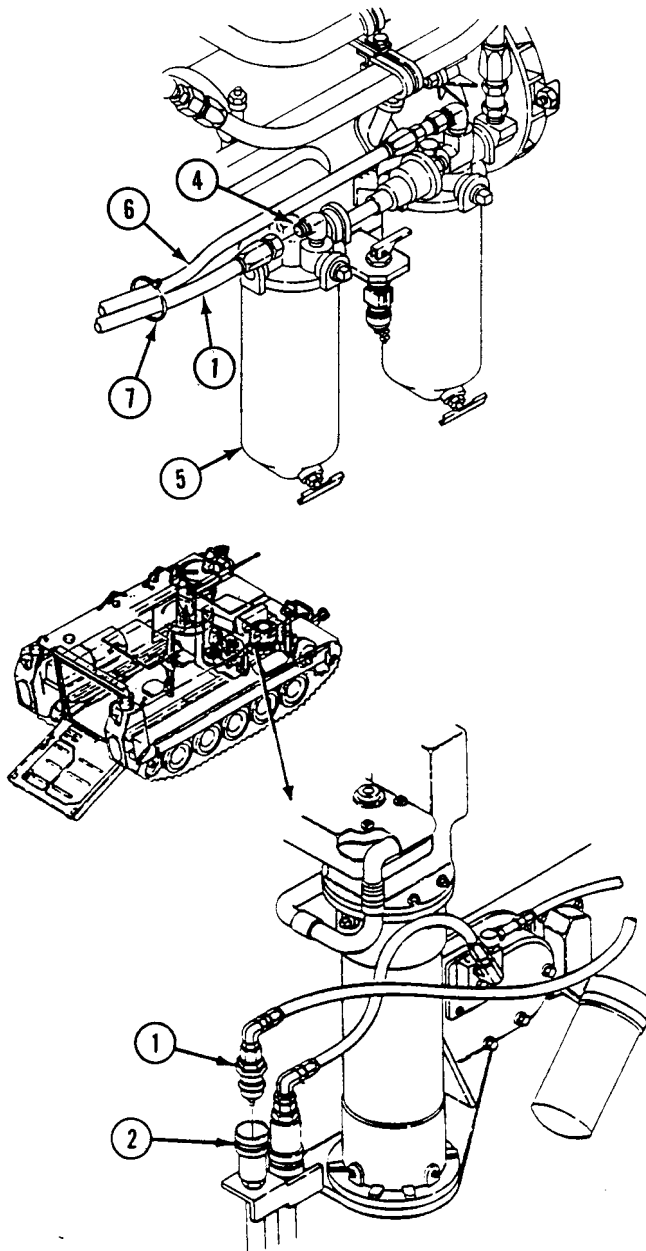

FOLLOW-THROUGH STEPS

1. Install exhaust elbow (WP 0221 00).
2. Install air intake elbow (WP 0173 00).
3. Connect battery ground strap (WP 0337 00), (WP 0338 00), or (WP 0339 00).
4. Start engine (see your -10). Check for leaks.
5. Stop engine (see your -10).
6. Install driver's compartment access panel (see your -10).
7. Install power plant rear access panels (see your -10).
8. Close power plant access door (see your -10).

END OF TASK

REPLACE ENGINE FUEL RETURN HOSE

0201 00**THIS WORK PACKAGE COVERS:**

Removal (page 0201 00-1).
Installation (page 0201 00-3).

INITIAL SETUP:Maintenance Level

Unit

Tools and Special Tools

General Mechanic's Tool Kit (WP 0926 00, Item 65)

Personnel Required

Unit Mechanic

References

See your -10

Equipment Condition

Engine stopped (see your -10)

Carrier blocked (see your -10)

Power plant rear access panels removed (see your -10)

Battery ground strap disconnected (WP 0337 00),
(WP 0338 00), or (WP 0339 00)

REMOVAL

1. Disconnect coupler body (1) from coupler nose (2).
2. Disconnect fuel return hose (3) from elbow (4) on fuel manifold.

3. Disconnect fuel return hose (3) from elbow (5) on coupler body (1).

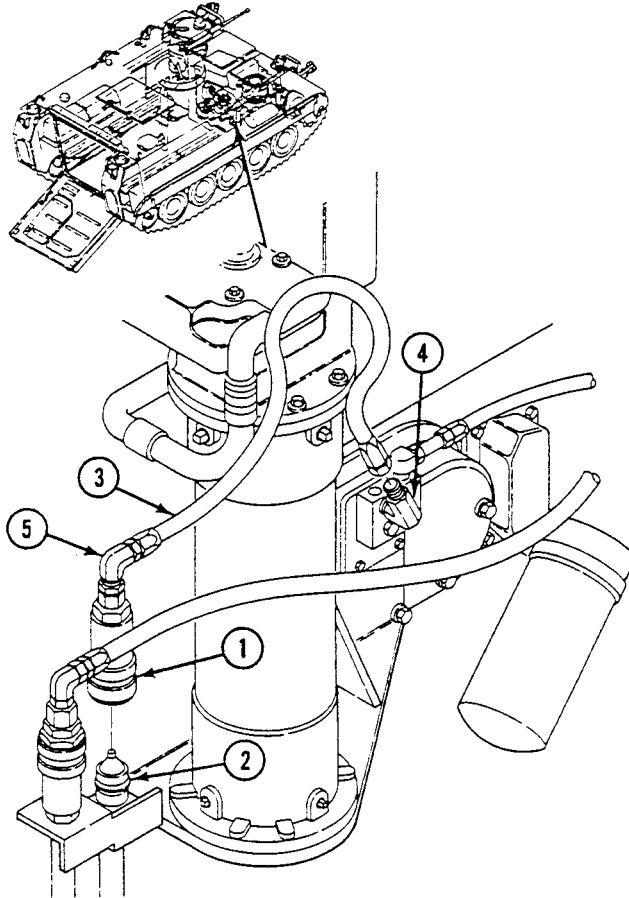

INSTALLATION

1. Connect fuel return hose (3) to elbow (5) on coupler body (1).
2. Connect fuel return hose (3) to elbow (4) on fuel manifold.
3. Connect coupler body (1) to coupler nose (2).

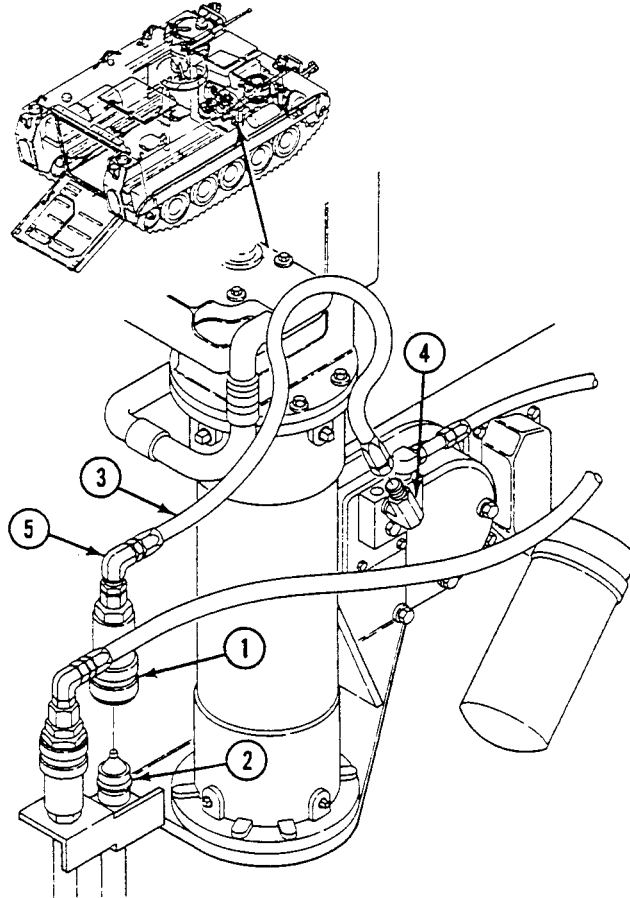
**FOLLOW-THROUGH STEPS**

1. Connect battery ground strap (WP 0337 00), (WP 0338 00), or (WP 0339 00).
2. Start engine (see your -10). Check for leaks. Stop engine.
3. Install power plant rear access panels (see your -10).

END OF TASK

REPLACE PRIMARY AND SECONDARY FUEL FILTER ELEMENTS

0202 00

THIS WORK PACKAGE COVERS:

Removal (page 0202 00-2).
 Installation (page 0202 00-5).

INITIAL SETUP:

Maintenance Level

Unit

Personnel Required

Unit Mechanic

Tools and Special Tools

General Mechanic's Tool Kit (WP 0926 00, Item 65)
 Crowfoot attachment, socket wrench, 3/4 inch
 (WP 0926 00, Item 16)

References

See your -10

Materials/Parts

Gasket (2)
 Container (quart)
 Primary filter kit
 Secondary filter kit
 Wiping rag (WP 0928 00, Item 65)

Equipment Condition

Engine stopped (see your -10)
 Carrier blocked (see your -10)
 Driver's power plant access panel
 removed (see your -10)
 Fuel supply and return valves turned off (see your -10)

REMOVAL

1. Place container under drain cock (1). Open drain cock and drain fuel from fuel filter. Close drain cock. Repeat procedures on drain cock (10) of secondary fuel filter, if replacing both filters.

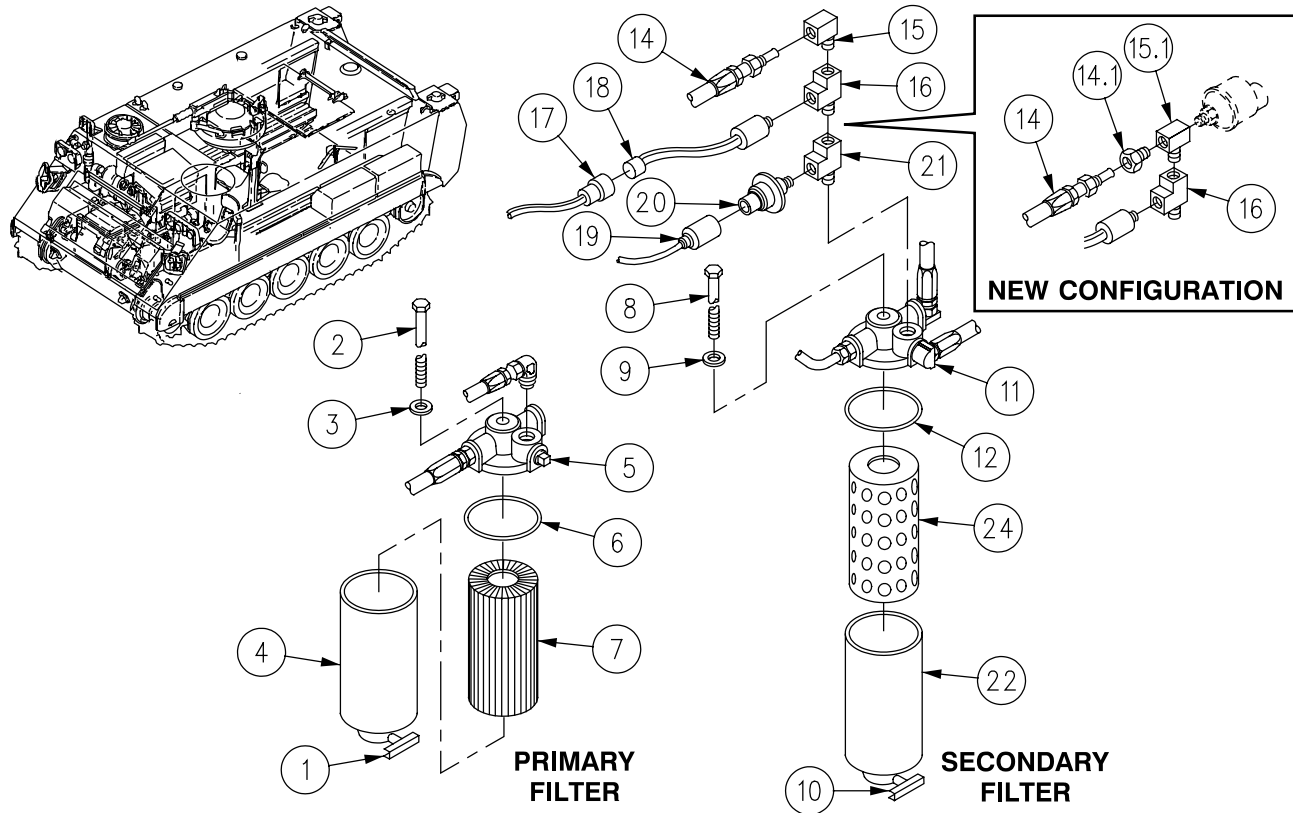

NOTE

Install covers on disconnected fuel lines, tubes, valves, and components during maintenance. Use tape, cloth, cardboard, or any appropriate material to prevent damage to components or accidental fuel spills.

If primary fuel filter element is being removed, skip Steps 4 - 10. If secondary fuel filter element is being removed, skip Step 2 and Step 3.

2. Hold primary filter canister (4) and remove screw (2) and washer (3) securing canister to fuel filter head (5).
3. Remove filter canister (4), gasket (6), and primary fuel filter element (7) from filter head (5). Discard filter element and gasket per local SOP. Use rags and wipe canister (4) clean. Discard rags per local SOP.

7. Remove elbow (15) from inlet tee (16) (Old Configuration).
- 7.1 Remove tee (15.1) from inlet tee (16) (New Configuration).
- 7.2 Remove adapter (14.1) from tee (15.1) (New Configuration).
8. Disconnect lead (17) from fuel pressure transmitter (18).
9. Remove fuel pressure transmitter (18) from inlet tee (16).
10. Disconnect lead (19) from generator field switch (20).
11. Remove generator field switch (20) from inlet tee (21).

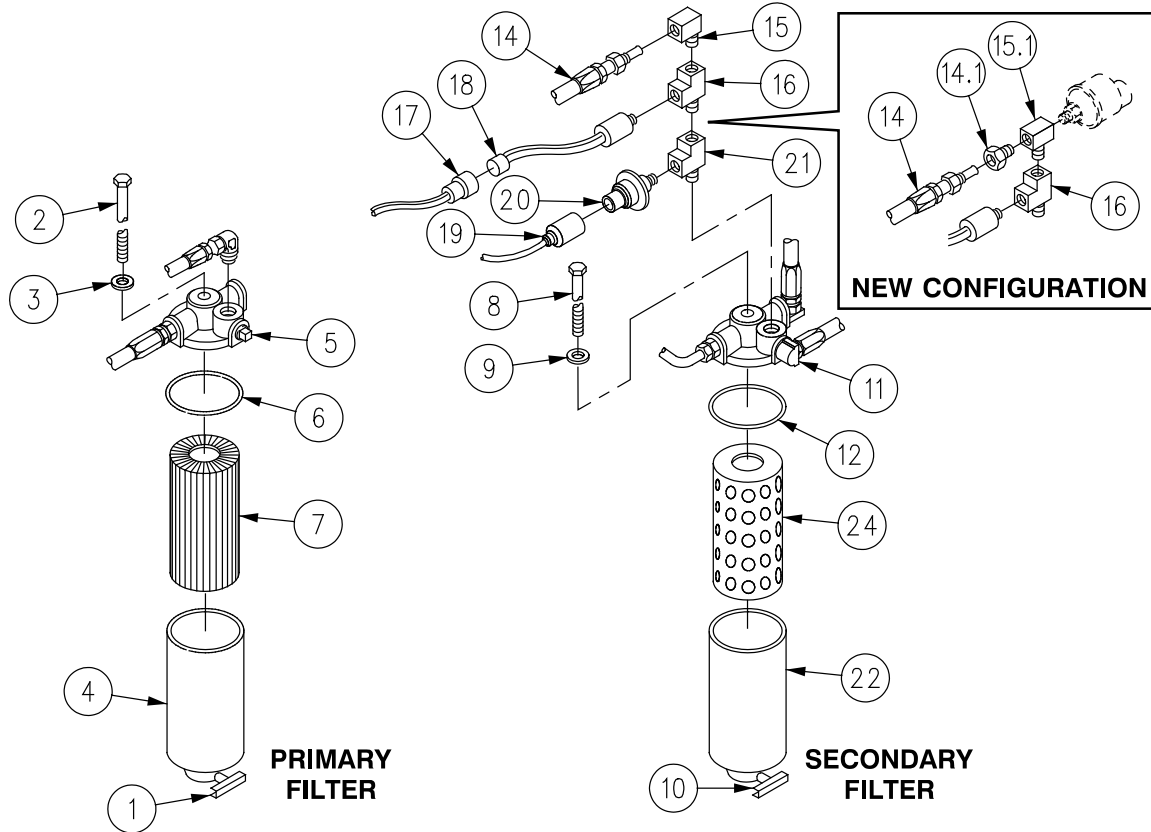

CAUTION

The two tees (16) and (21) and elbow (15) are made of brass and will damage easily if, during removal, the switch, transmitter, or hose are removed. Put a bolt or switch back in the tee when turning it. This will prevent it from collapsing.

12. If required to gain access, remove two inlet tees (16) and (21) from secondary fuel filter head (11).
13. Hold filter canister (22) and remove screw (8) and washer (9) securing canister to fuel filter head (11).
14. Remove filter canister (22), gasket (12), and filter element (24) from filter head (11). Discard filter element. Wipe canister (22) clean. Use rags. Discard filter, gasket, and rags per local SOP.

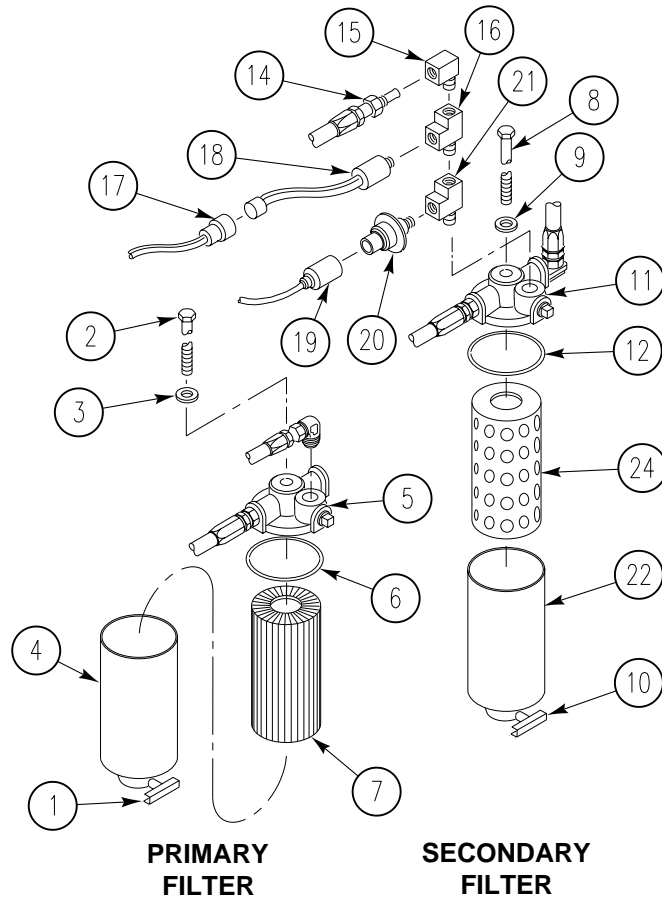

INSTALLATION**NOTE**

If secondary fuel filter element is being installed do Steps 1 - 10.

If primary fuel filter element is being installed do Steps 11 - 13.

1. Install new gasket (12) in filter head (11).
2. Install new filter element (24) in canister (22). Fill canister with fuel.

NOTE

Do not allow canister to turn when tightening screw. Damage to gasket can result.

3. Install canister (22) with filter element (24) on filter head (11). Secure with washer (9) and screw (8).
4. Install two inlet tees (16) and (21) on secondary fuel filter head (11).
5. Install generator field switch (20) on inlet tee (21).
6. Install fuel pressure transmitter (18) on inlet tee (16).
7. Connect lead (19) to generator field switch (20).
8. Connect lead (17) to fuel pressure transmitter (18).

REPLACE PRIMARY AND SECONDARY FUEL FILTER ELEMENTS — Continued

0202 00

9. Install elbow (15) on inlet tee (16) (Old Configuration).
- 9.1 Apply thin coat of sealing compound to male threads on tee (15.1). Install tee (15.1) on inlet tee (16) (New Configuration).
10. Connect hose (14) to elbow (15) on secondary fuel filter head (11) (Old Configuration).
- 10.1 Apply thin coat of sealing compound to male threads on adapter (14.1). Install adapter (14.1) on tee (15.1) (New Configuration).
- 10.2 Install hose (14) on adapter (14.1) (New Configuration).
11. Install new gasket (6) in filter head (5).
12. Install new primary fuel filter element (7) in canister (4). Fill canister with fuel.
13. Install canister (4) with filter element (7) on filter head (5). Secure with washer (3) and screw (2). Hold the canister (4) to prevent pushing the gasket out of place.

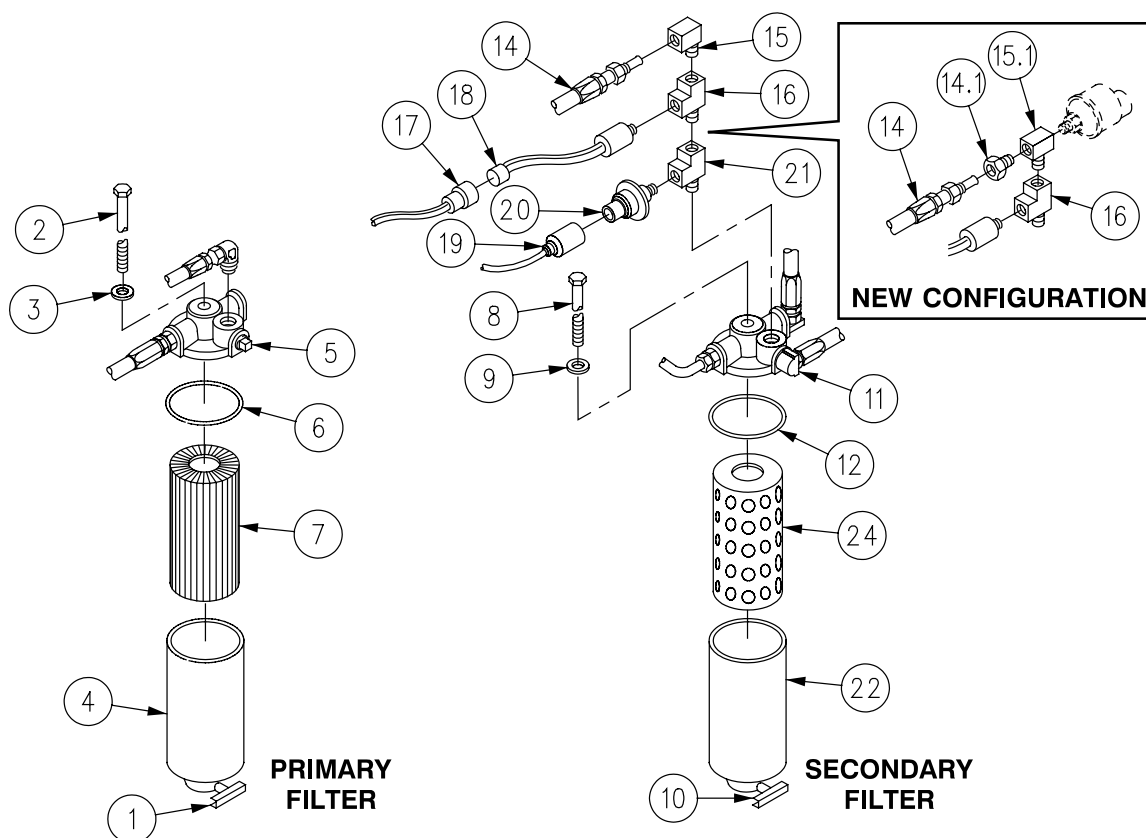

FOLLOW-THROUGH STEPS

1. Turn fuel supply and return valves on (see your -10).
2. Start engine (see your -10). Check for leaks. Stop engine (see your -10).
3. Install driver's compartment power plant access panel (see your -10).

END OF TASK

REPLACE PRIMARY AND SECONDARY FUEL FILTERS AND BRACKET

0203 00

THIS WORK PACKAGE COVERS:

Removal (page 0203 00-2).
 Installation (page 0203 00-3).

INITIAL SETUP:

Maintenance Level

Unit

References

See your -10

Tools and Special Tools

General Mechanic's Tool Kit (WP 0926 00, Item 65)

Equipment Condition

Carrier blocked (see your -10)
 Engine stopped (see your -10)
 Ramp lowered (see your -10)
 Master switch OFF (see your -10)
 Driver's power plant access panel
 removed (see your -10)
 Fuel tank shutoff valves closed (see your -10)
 Engine AOAP valve removed (WP 0163 00)
 Starter relay switch removed (WP 0258 00)

Materials/Parts

Locknut (4)
 Locknut (4)
 Sealing compound
 Wiping rag (WP 0928 00, Item 65)

Personnel Required

Unit Mechanic

REMOVAL

NOTE

New and Old Configuration refers to Variable Speed Fan Drive Configuration.

Install covers on disconnected fuel lines, tubes, valves, and components during maintenance. Use tape, cloth, cardboard, or any appropriate material to prevent damage to components or accidental fuel spills.

1. Remove hoses (1) from elbows (2). (New Configuration is a tee with adapter (7) instead of elbow (2).)
2. Remove hoses (6) and (3) from two adaptaters (5) and (4).

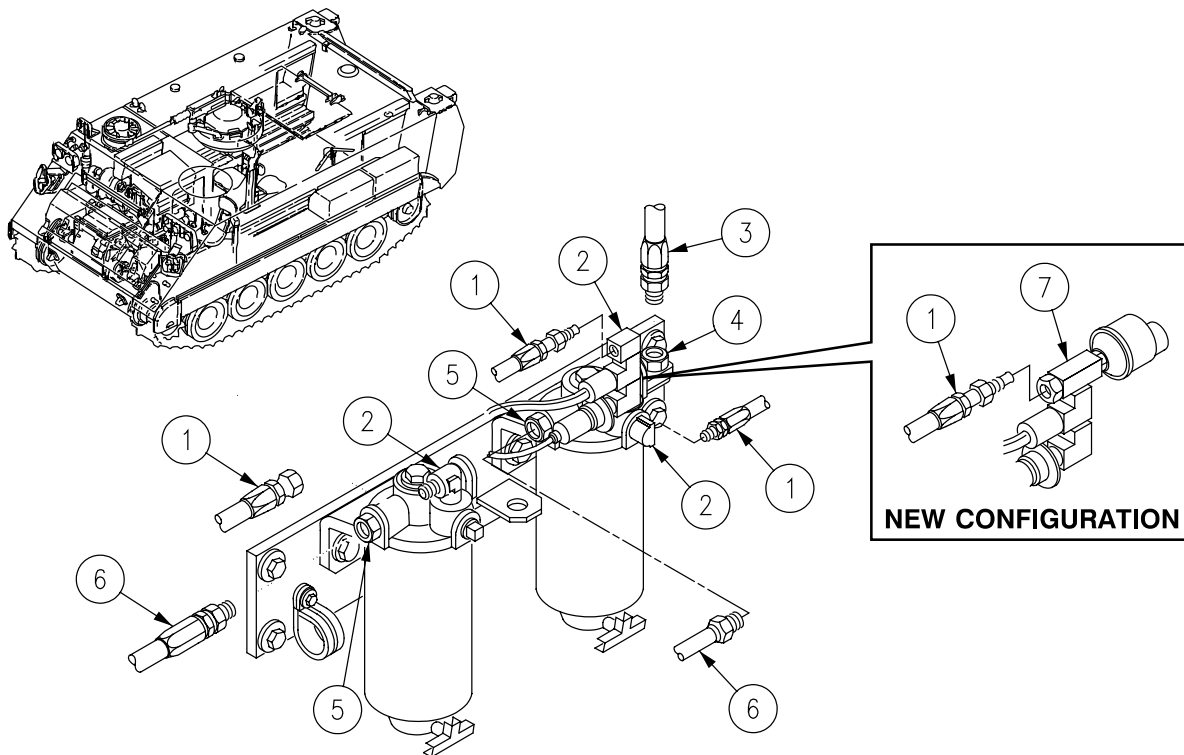

3. Remove screw (5), two washers (3), and clamp (4) from bracket (2).
4. Remove four screws (6), washers (7), locknuts (1), and bracket (2) from engine. Discard locknuts.

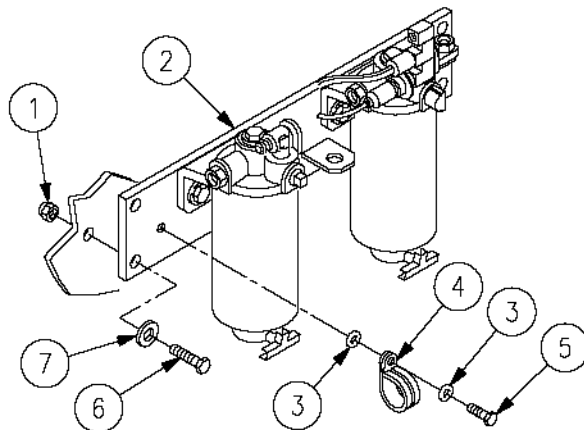

5. Remove four screws (9), washers (8), locknuts (1), and filters (10) from bracket (2). Discard locknuts.
6. Remove elbow (3) and adapters (11) from filter housings (6) and (7).
7. Remove elbows (5) and adapter (4) from filter housing (6).
8. Remove elbow (12), tee (13), and tee (14) from filter housing (6) (Old Configuration).
9. Remove tee with adapter and switch (15) (New Configuration).

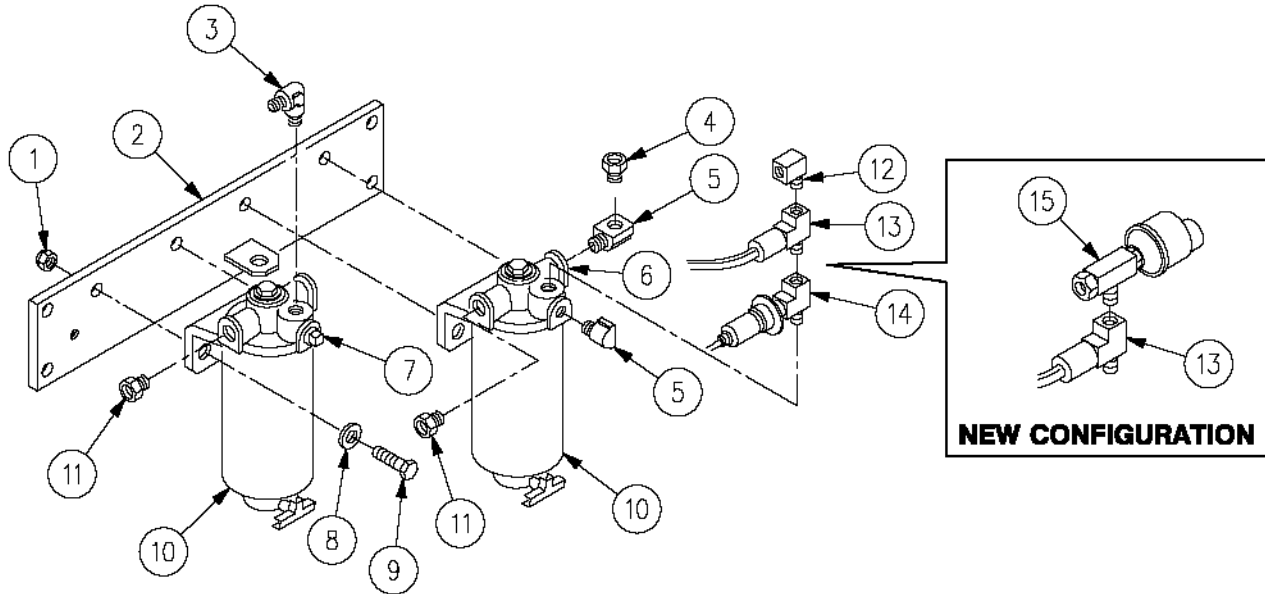

INSTALLATION

1. Install filters (3) on bracket (1). Secure with four screws (5), washers (4), and new locknuts (2).
2. Install clamp (8) on bracket (1) on engine. Secure with screw (6) and two washers (7).

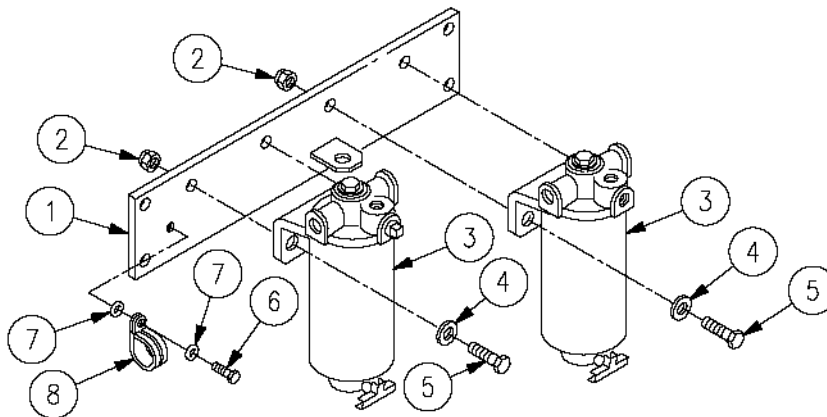

3. Install bracket (3) on engine (2). Secure with four screws (4), washers (5), and new locknuts (1).

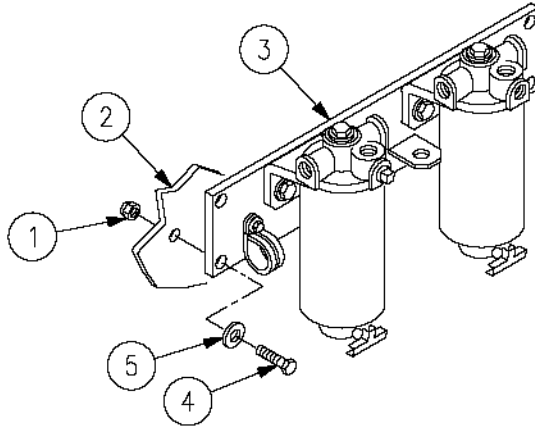

4. Apply thin coat of sealing compound to male tapered threads.
5. Install elbows (3) and adapter (2) on secondary filter housing (4).
- 5.1 Install elbow (7), tee (8) and tee (9) on secondary housing (4) (Old Configuration). Install tee with adapter and switch (10) to tee (8) (New Configuration).
6. Install elbow (1) and adapter (5) on primary filter housing (6).

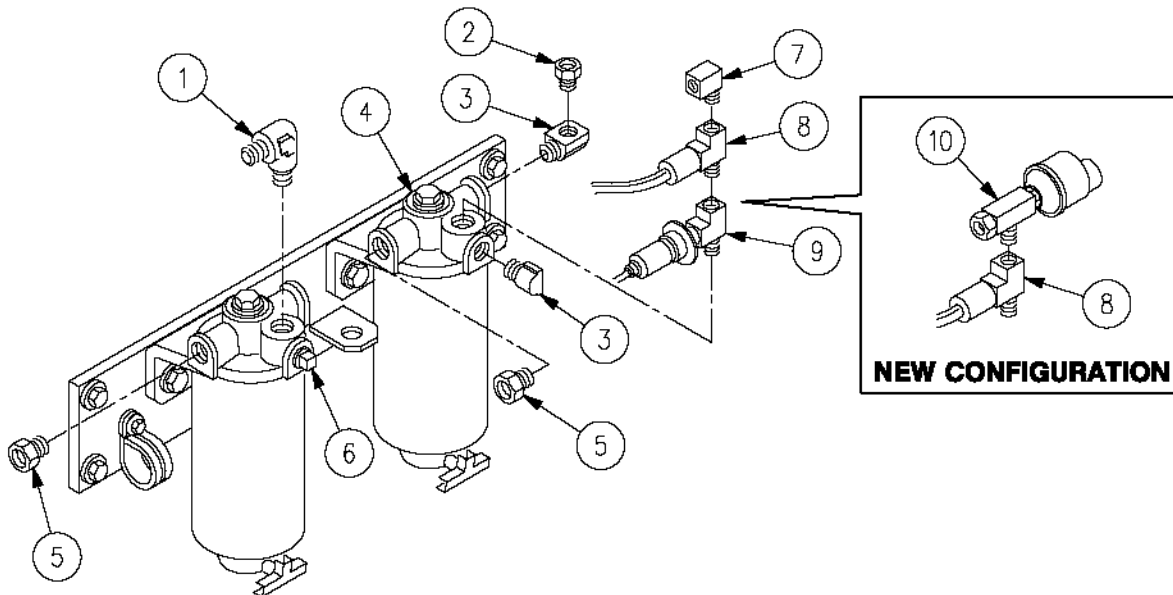

7. Install hoses (6) and (3) on two adapters (5) and adapter (4).
8. Install hose (1) on elbow (2) (Old Configuration).
9. Install hose (7) on tee (8). (New Configuration is a tee with adapter (8) instead of elbow (2).)

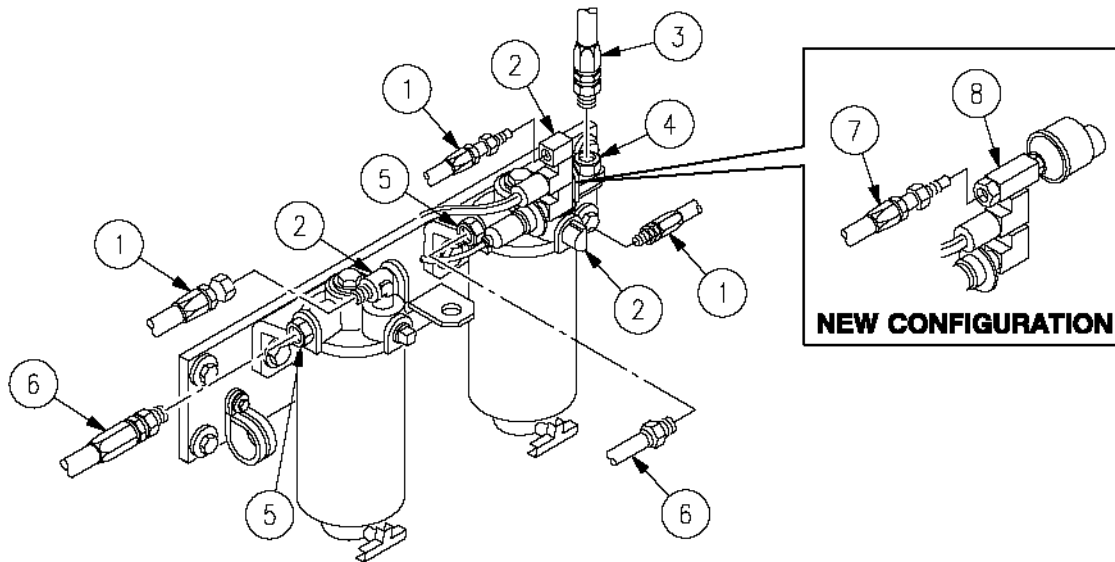

FOLLOW-THROUGH STEPS

1. Install engine AOAP valve (WP 0163 00).
2. Install starter relay switch (WP 0258 00).
3. Open fuel tank shutoff valves (see your -10).
4. Raise and lock ramp (see your -10).
5. Stop engine (see your -10).
6. Install driver's power plant access panel (see your -10).
7. Turn master switch OFF (see your -10).

END OF TASK

REPLACE AIR BOX HEATER IGNITION WIRE

0204 00

THIS WORK PACKAGE COVERS:

Removal (page 0204 00-1).
 Installation (page 0204 00-2).

INITIAL SETUP:

Maintenance Level

Unit

References

See your -10

Tools and Special Tools

General Mechanic's Tool Kit (WP 0926 00, Item 65)

Equipment Condition

Engine stopped (see your -10)

Carrier blocked (see your -10)

Materials/Parts

Tie strap (2)

Power plant upper and lower rear access panels and support removed (see your -10)

Personnel Required

Unit Mechanic

REMOVAL

1. Disconnect ignition wire (1) from air box igniter (2).
2. Remove two tie straps (3) from air pump wiring harness (4). Discard tie straps.
3. Disconnect other end of ignition wire (1) from ignition unit (5).
4. Loosen nut (6) and rotate solenoid receptacle (7) toward rear of carrier. Remove ignition wire (1).

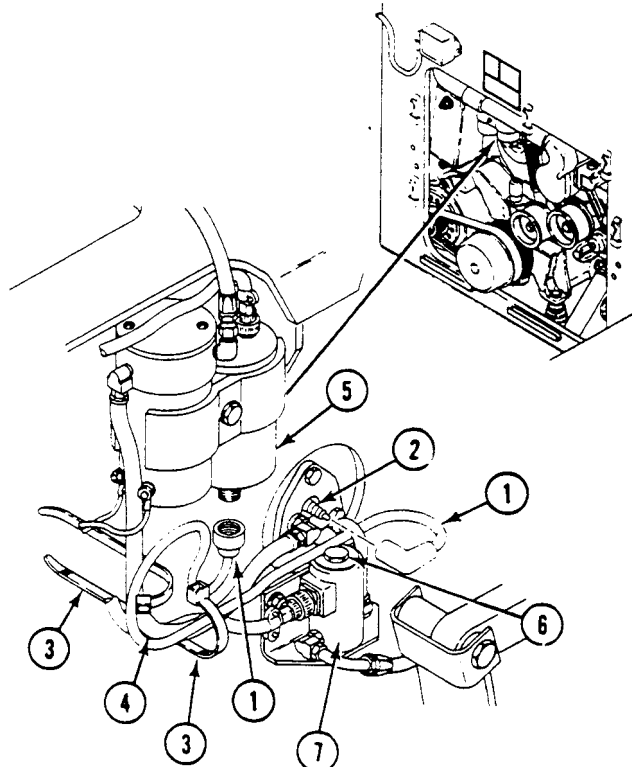

INSTALLATION

1. Connect ignition wire (1) to ignition unit (5).
2. Connect other end of ignition wire (1) to air box igniter (2).
3. Secure ignition wire (1) to air pump wiring harness (4) with two new tie straps (3).
4. Rotate solenoid receptacle (7) to original position. Tighten nut (6) 1/2 turn after contact.

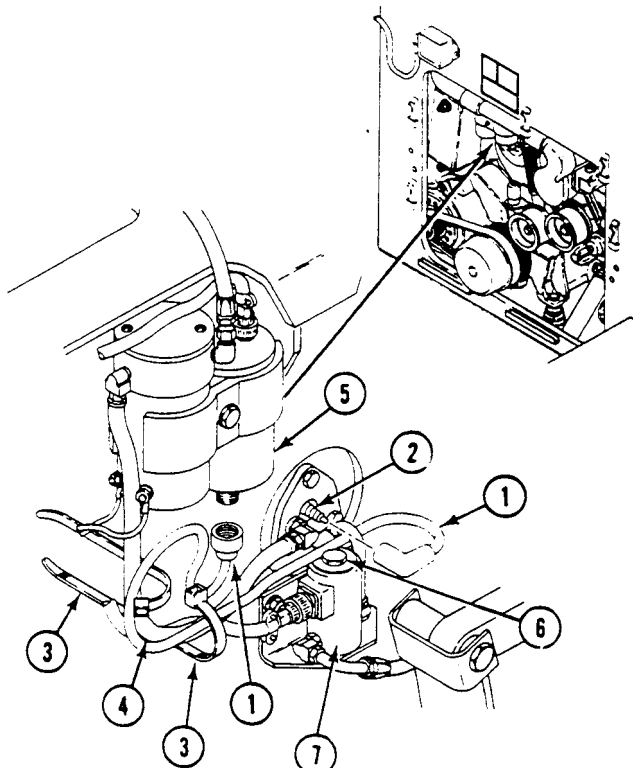
**FOLLOW-THROUGH STEPS**

1. Install power plant upper and lower rear access panels and support (see your -10).

END OF TASK

REPLACE AIR BOX HEATER WIRING HARNESS

0205 00

THIS WORK PACKAGE COVERS:

Removal (page 0205 00-1).
 Installation (page 0205 00-5).

INITIAL SETUP:

Maintenance Level

Unit

Personnel Required

Unit Mechanic

Tools and Special Tools

General Mechanic's Tool Kit (WP 0926 00, Item 65)

References

See your -10

Materials/Parts

Copper washer
 Lockwasher
 Tie strap (3)

Equipment Condition

Engine stopped (see your -10)
 Carrier blocked (see your -10)
 Power plant rear access panels
 and support removed (see your -10)

REMOVAL

NOTE

Hydraulic fluid reservoir is removed for clarity.

1. Loosen screw (1) and remove ignition coil (2). Disconnect lead (3) and lead (4) from ignition coil.

2. Remove screw (1), washer (5), two clamps (6) and three hoses (7) from engine.

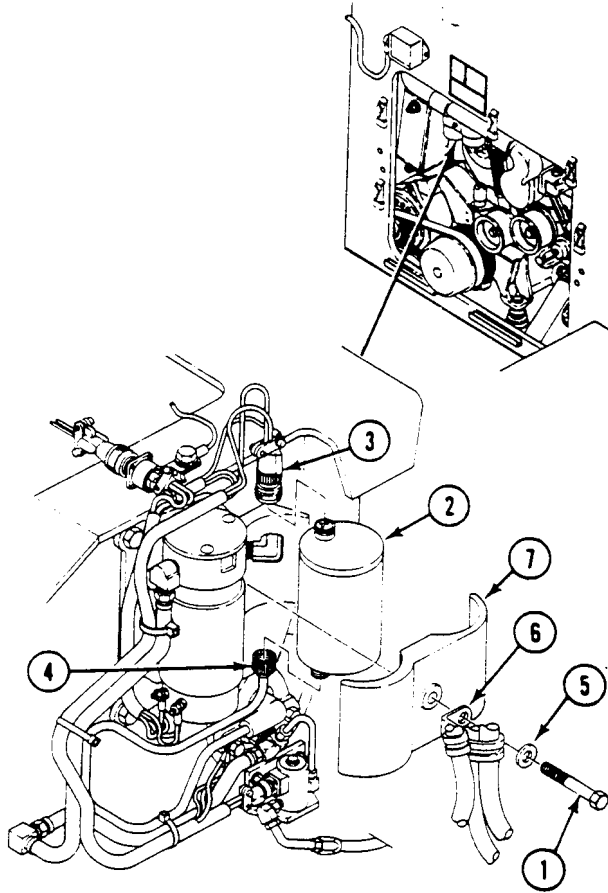

3. Disconnect engine wiring harness connector (1) from air box receptacle (2).
4. Remove screw (3), two washers (4), lockwasher (5), nut (6), ground lead (7), and clamp (8) from bracket (9). Discard lockwasher.

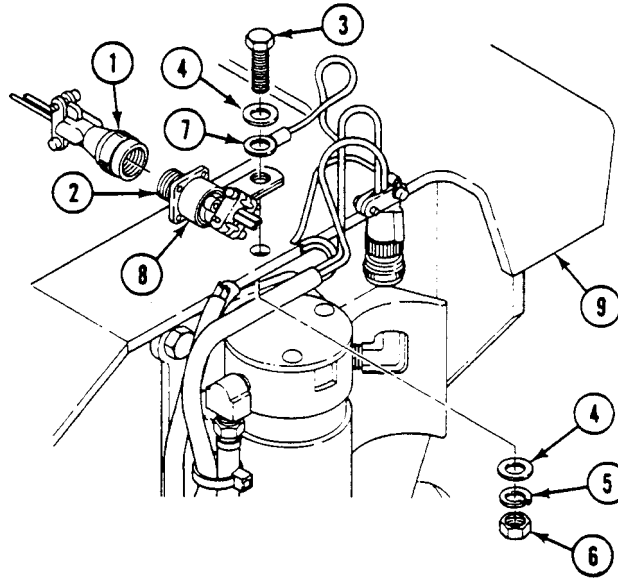

5. Remove three tie straps (10) from wiring harness (11) and air pump hose (12).

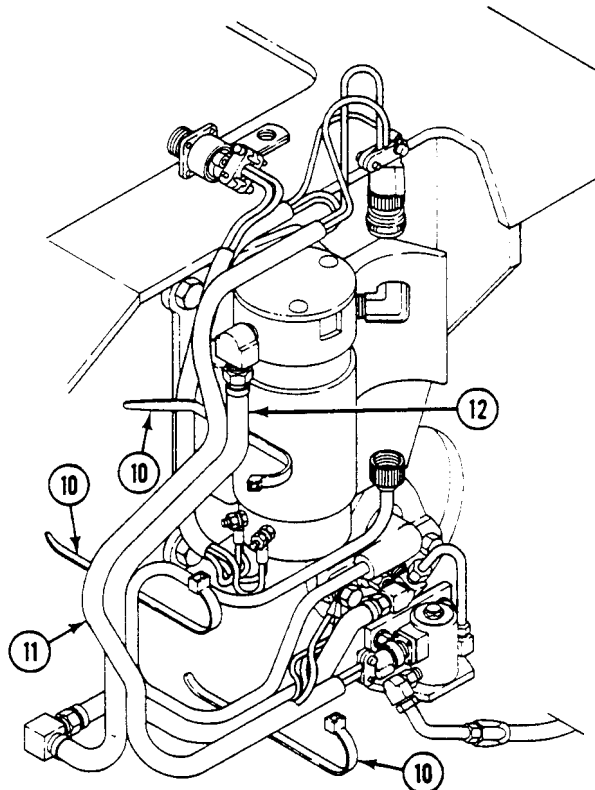

REPLACE AIR BOX HEATER WIRING HARNESS — Continued**0205 00**

6. Remove nut (13) and lead (14) from air pump positive (+) terminal (15).
7. Remove nut (16) and lead (17) from air pump negative (-) terminal (18).

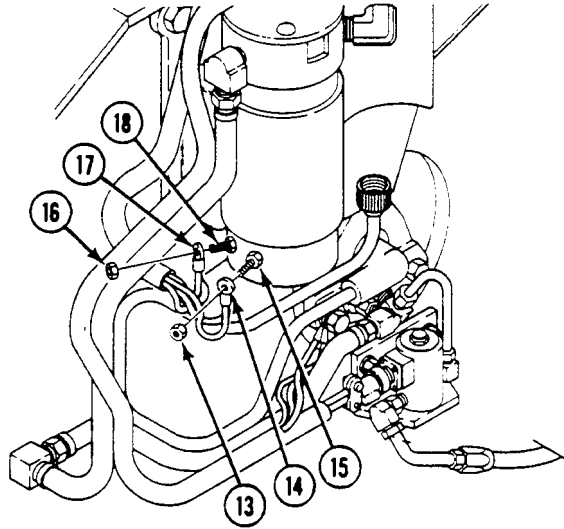

8. Disconnect wiring harness connector (19) from air box fuel solenoid (20).
9. Remove hose (21) from air box heater elbow (22).
10. Remove screw (23), copper washer (24) and three ground leads (25) from air box heater (26). Discard copper washer.

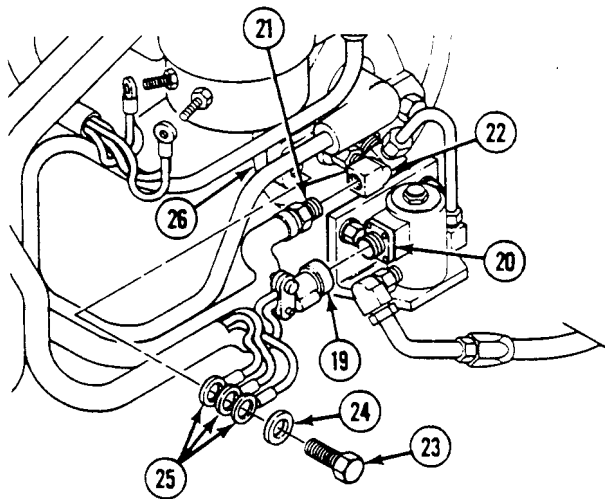

INSTALLATION

1. Install three ground leads (1) on air box heater (2). Secure with new copper washer (3) and screw (4).
2. Install hose (5) on air box heater elbow (6).
3. Connect wiring harness connector (7) to air box fuel solenoid (8).

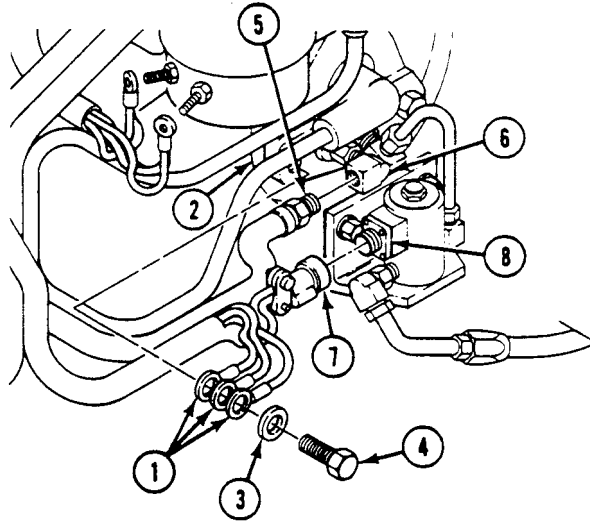

4. Install lead (9) on air pump negative (-) terminal (10). Secure with nut (11).
5. Install lead (12) on air pump positive (+) terminal (13). Secure with nut (14).

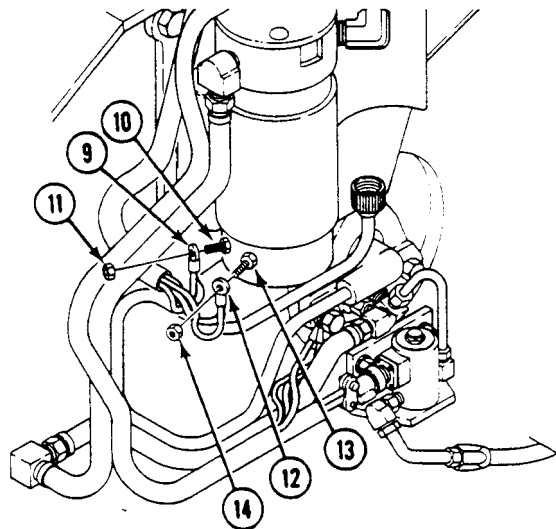

6. Fasten three new straps (15) to wiring harness (16) and air pump hose (17).

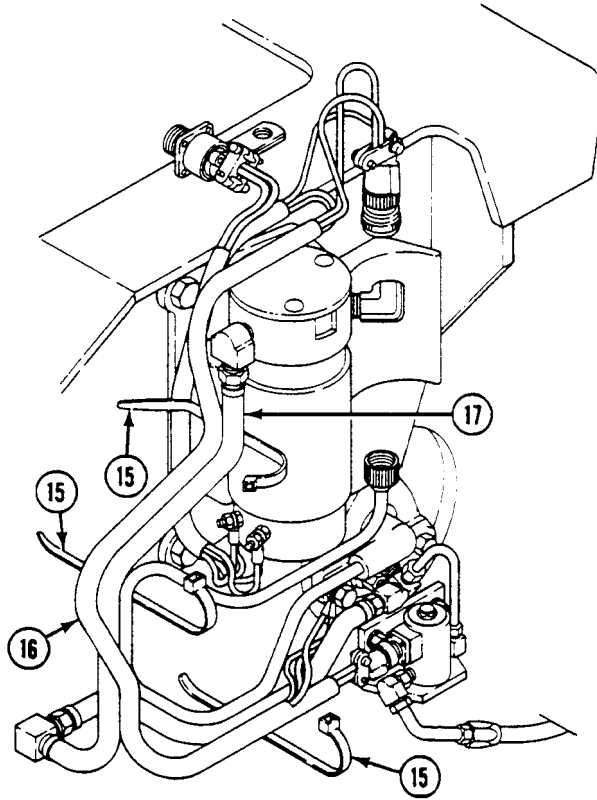

7. Install ground lead (18) and clamp (19) on bracket (20). Secure with screw (21), two washers (22), new lockwasher (23), and nut (24).
8. Connect engine wiring harness connector (25) to air box receptacle (26).

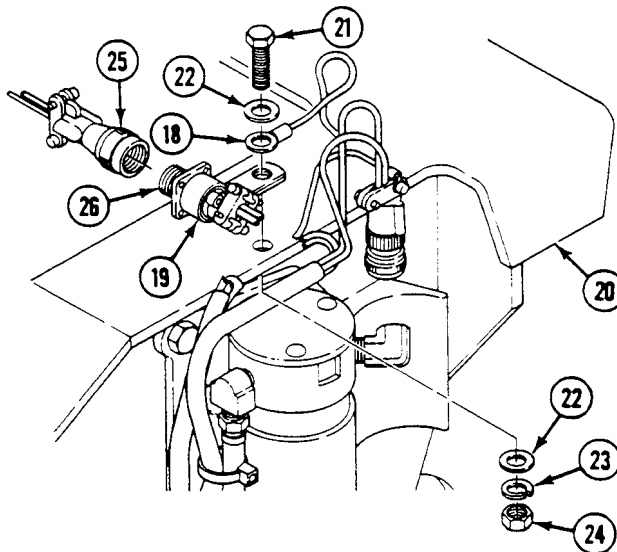

REPLACE AIR BOX HEATER WIRING HARNESS — Continued

0205 00

9. Install bracket (1) and two clamps with three hoses (2) on ignition coil (3). Secure with screw (4) and washer (5). Do not tighten screw.
10. Connect lead (6) and lead (7) to ignition coil (3). Install ignition coil on bracket (1). Tighten screw.

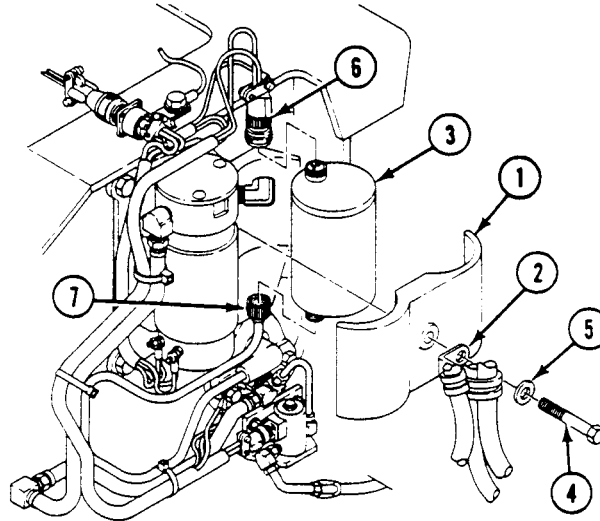
**FOLLOW-THROUGH STEPS**

1. Install power plant rear access panels and support (see your -10).

END OF TASK

REPLACE AIR BOX HEATER LOWER FUEL LINE

0206 00

THIS WORK PACKAGE COVERS:

Removal (page 0206 00-2).
 Installation (page 0206 00-3).

INITIAL SETUP:

Maintenance Level

Unit

References

See your -10

Tools and Special Tools

General Mechanic's Tool Kit (WP 0926 00, Item 65)

Equipment Condition

Engine stopped (see your -10)

Materials/Parts

Lockwasher

Carrier blocked (see your -10)

Personnel Required

Unit Mechanic

Power plant removed (WP 0156 00)

REMOVAL

NOTE

Coolant pump pulley bracket is not shown.

1. Remove hose (1) from elbow (2).
2. Remove screw (3), lockwasher (4), washer (5) and clamp (6) from coolant pump. Discard lockwasher.
3. Remove hose (1) from elbow (7).

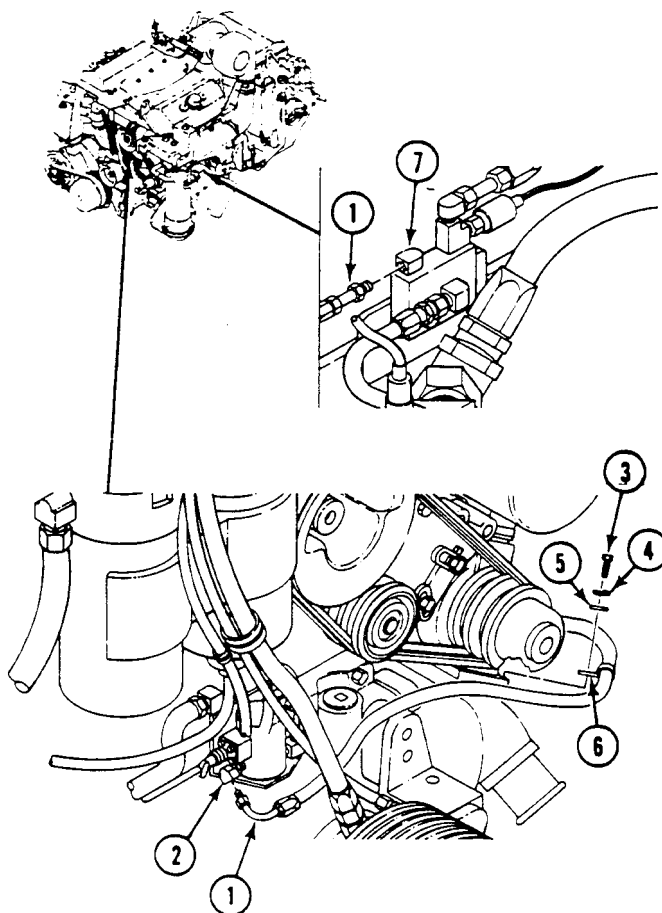

INSTALLATION

1. Install hose (1) on elbow (7).
2. Install screw (3), new lockwasher (4), washer (5) and clamp (6) on coolant pump.
3. Install hose (1) on elbow (2).

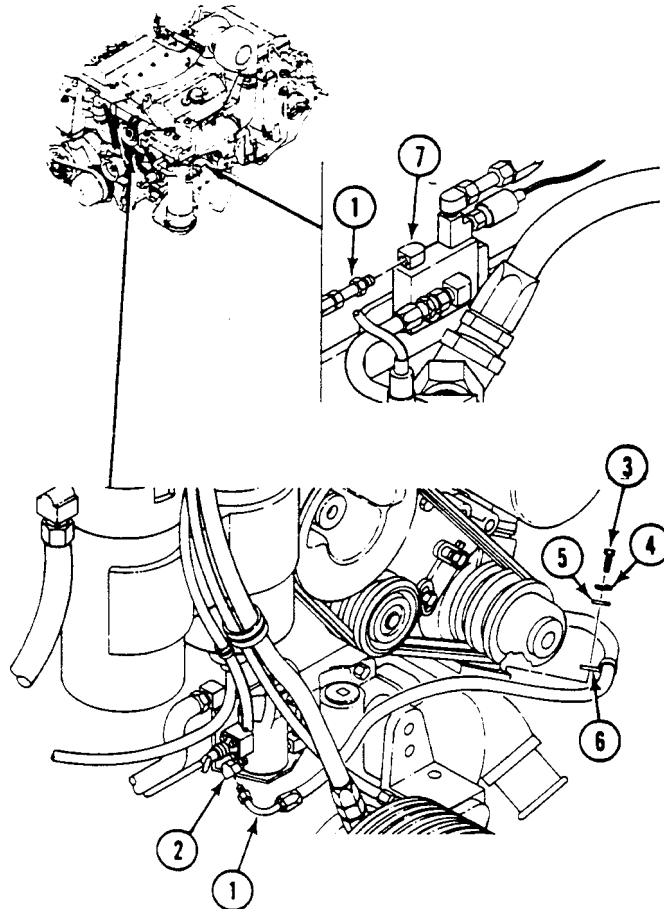
**FOLLOW-THROUGH STEPS**

1. Install power plant (WP 0156 00).

END OF TASK

REPLACE AIR HEATER IGNITER

0207 00

THIS WORK PACKAGE COVERS:

Removal (page 0207 00-1).
 Installation (page 0207 00-2).

INITIAL SETUP:

Maintenance Level

Unit

References

See your -10

Tools and Special Tools

General Mechanic's Tool Kit (WP 0926 00, Item 65)
 Socket wrench set (WP 0926 00, Item 72)
 Torque wrench (WP 0926 00, Item 81)

Equipment Condition

Engine stopped (see your -10)
 Carrier blocked (see your -10)
 Power plant upper rear access panel removed (see your -10)

Personnel Required

Unit Mechanic

REMOVAL

1. Remove harness boot end (1) from air heater electrode (2).
2. Remove electrode (2) from air box heater assembly (3). Use torque wrench with 5/8 inch deep well socket.

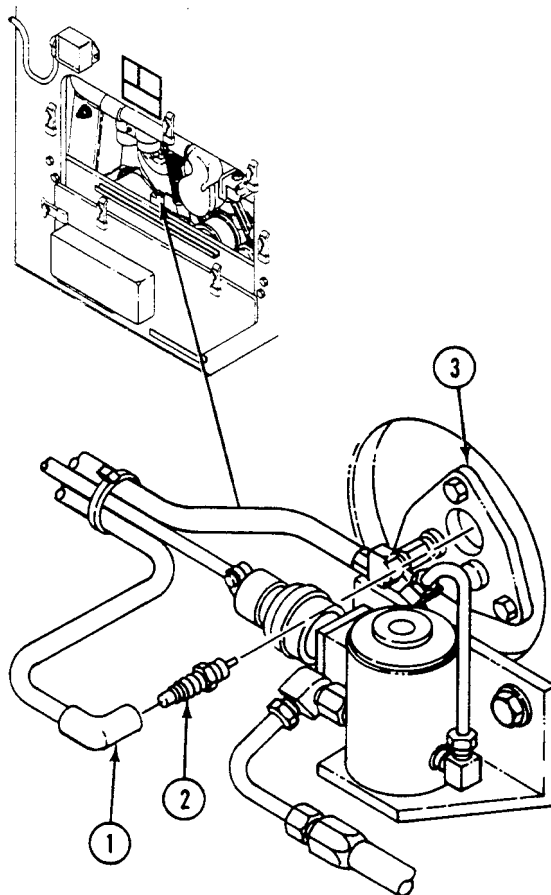

INSTALLATION

1. Thread new electrode (2) into heater box assembly (3). TIGHTEN ELECTRODE TO 180 LB-IN (20 N·m) TORQUE. Use torque wrench with 5/8 inch deep well socket.
2. Install harness boot end (1) on electrode (2) until positive engagement is felt.

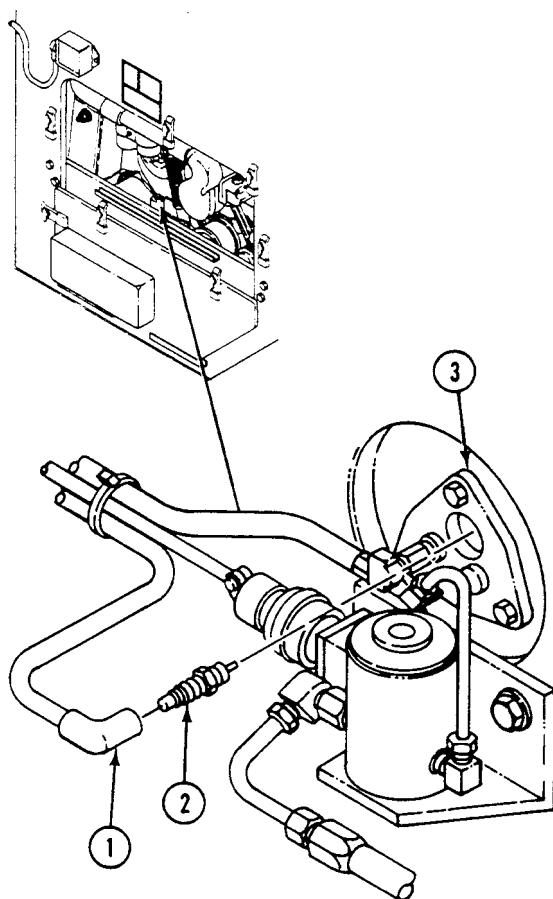
**FOLLOW-THROUGH STEPS**

1. Install power plant upper rear access panel (see your -10).

END OF TASK

REPLACE AIR BOX IGNITION COIL

0208 00

THIS WORK PACKAGE COVERS:

Removal (page 0208 00-1).
 Installation (page 0208 00-3).

INITIAL SETUP:

Maintenance Level

Unit

Equipment Condition

Engine stopped (see your -10)
 Carrier blocked (see your -10)
 Power plant upper rear access panel
 removed (see your -10)

Tools and Special Tools

General Mechanic's Tool Kit (WP 0926 00, Item 65)

Personnel Required

Unit Mechanic

References

See your -10

REMOVAL

1. Loosen screw (1). Remove air box ignition coil (2) and pad (3) from bracket (4).
2. Disconnect lead (5) from air box ignition coil (2).

3. Disconnect igniter lead (6) from air box ignition coil (2). Inspect pad (3). Replace if necessary.

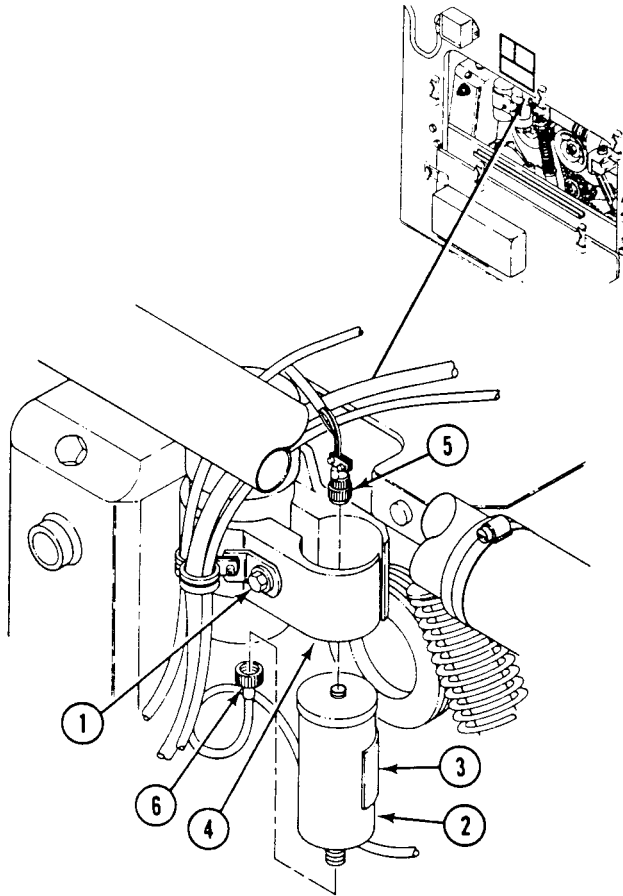

INSTALLATION

1. Connect igniter lead (6) to air box ignition coil (2).
2. Connect lead (5) to air box ignition coil (2).
3. Install air box ignition coil (2) and pad (3) on bracket (4). Tighten screw (1).

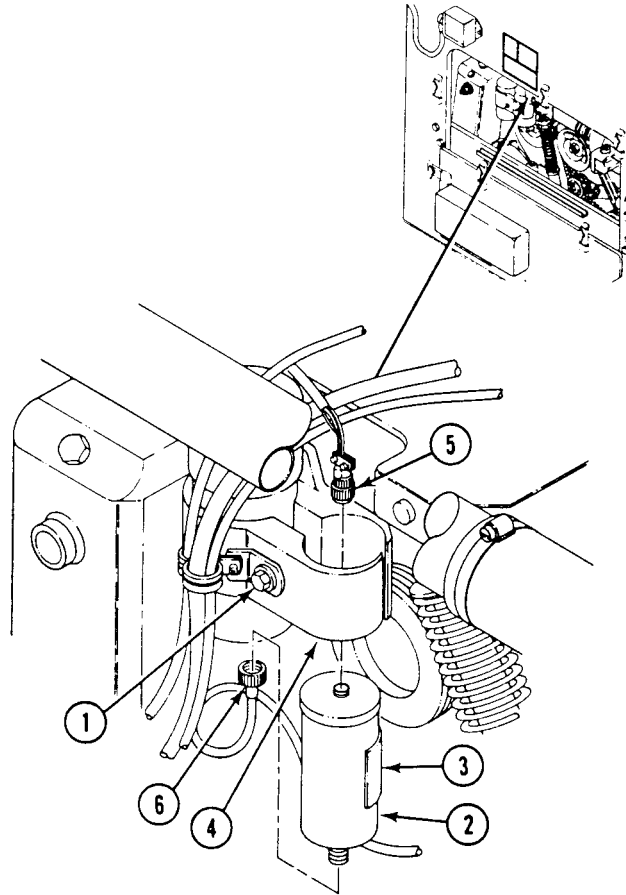
**FOLLOW-THROUGH STEPS**

1. Install power plant upper rear access panel (see your -10).

END OF TASK

REPLACE GLOW PLUG HARNESS AND GLOW PLUGS

0209 00

THIS WORK PACKAGE COVERS:

Removal (page 0209 00-1).
 Installation (page 0209 00-3).

INITIAL SETUP:

Maintenance Level

Unit

Equipment Condition

Engine stopped (see your -10)
 Carrier blocked (see your -10)
 Rear power plant access panel removed (see your -10)
 Battery ground strap disconnected (WP 0337 00),
 (WP 0338 00), or (WP 0339 00)

Tools and Special Tools

General Mechanic's Tool Kit (WP 0926 00, Item 65)
 Torque wrench (WP 0926 00, Item 81)

Personnel Required

Unit Mechanic

References

See your -10

REMOVAL

1. Remove two bolts (1) and nuts (2) securing two clips (3) on glow plug harness (4) to two brackets (5) on left cylinder head (6).
2. Disconnect three plug ends (7) of glow plug harness (4) from glow plugs (8).
3. Remove three glow plugs (8) from left cylinder head (6).
4. Repeat Steps 1 - 3 for opposite side.
5. Disconnect and remove glow plug harness (4) from right side (9) of controller (10).

INSTALLATION

1. If removed, install two clips (1) on each side of glow plug harness (2).
2. Connect glow plug harness (2) to right side (3) of glow plug controller (4).
3. Install three glow plugs (5) in left cylinder head (6). TIGHTEN GLOW PLUGS TO 132-156 LB-IN (15-18 N·m) TORQUE.

CAUTION

Glow plug harness leads are identified with location as to right or left bank. Correct installation of wires is necessary for proper diagnostics to aid in locating a failed glow plug.

4. Connect three plug ends (7) of glow plug harness (2) to glow plugs (5) in left cylinder head (6).
5. Secure glow plug harness (2) to two brackets (8) on left side cylinder (6) with two clips (1), bolts (9), and nuts (10). TORQUE BOLTS TO 360-420 LB-IN (41-47 N·m).
6. Repeat Steps 2 - 5 for opposite side.

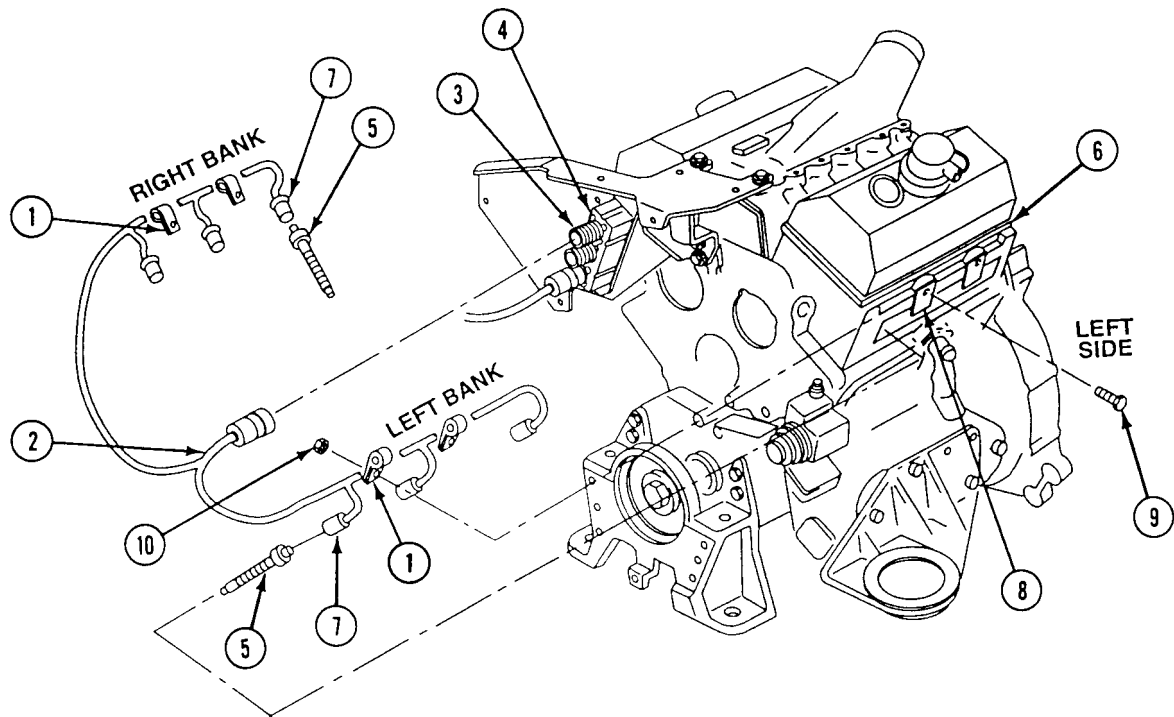
**FOLLOW-THROUGH STEPS**

1. Connect battery ground strap (WP 0337 00), (WP 0338 00), or (WP 0339 00).
2. Install rear power plant access panel (see your -10).

END OF TASK

REPLACE GLOW PLUG CONTROLLER

0210 00

THIS WORK PACKAGE COVERS:

Removal (page 0210 00-1).
 Installation (page 0210 00-3).

INITIAL SETUP:

Maintenance Level

Unit

References

See your -10

Tools and Special Tools

General Mechanic's Tool Kit (WP 0926 00, Item 65)
 Torque wrench (WP 0926 00, Item 83)

Equipment Condition

Engine stopped (see your -10)
 Carrier blocked (see your -10)
 Rear power plant access panel removed (see your -10)
 Battery ground strap disconnected (WP 0337 00),
 (WP 0338 00), or (WP 0339 00)

Materials/Parts

Lockwasher (2)

Personnel Required

Unit Mechanic

REMOVAL

1. Disconnect and remove glow plug power harness (1) from left side (2) of glow plug controller (3).
2. Disconnect and remove glow plug harness (4) from right side (5) of glow controller (3).

3. Remove two bolts (6), lockwashers (7), nuts (8), four washers (9), and glow plug controller (3) from mounting bracket (10) in front of engine. Discard lockwashers.

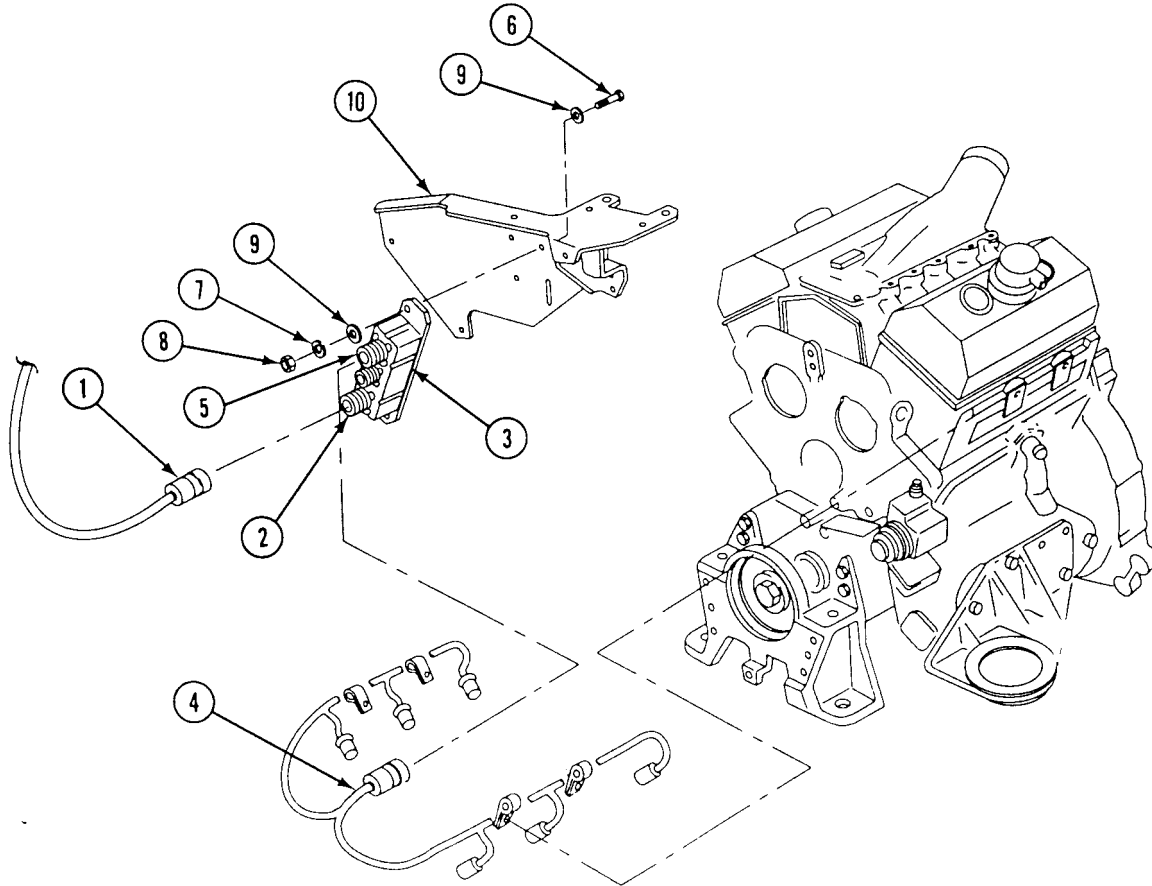

INSTALLATION

1. Install glow plug controller (1), two bolts (2), new lockwashers (3), nuts (4), and four washers (5) on mounting bracket (6). **TIGHTEN BOLTS TO 156-204 LB-IN (18-23 N·m) TORQUE.**
2. Connect glow plug harness (7) to right side (8) of glow plug controller (1).
3. Connect glow plug power harness (9) to left side (10) of glow plug controller (1).

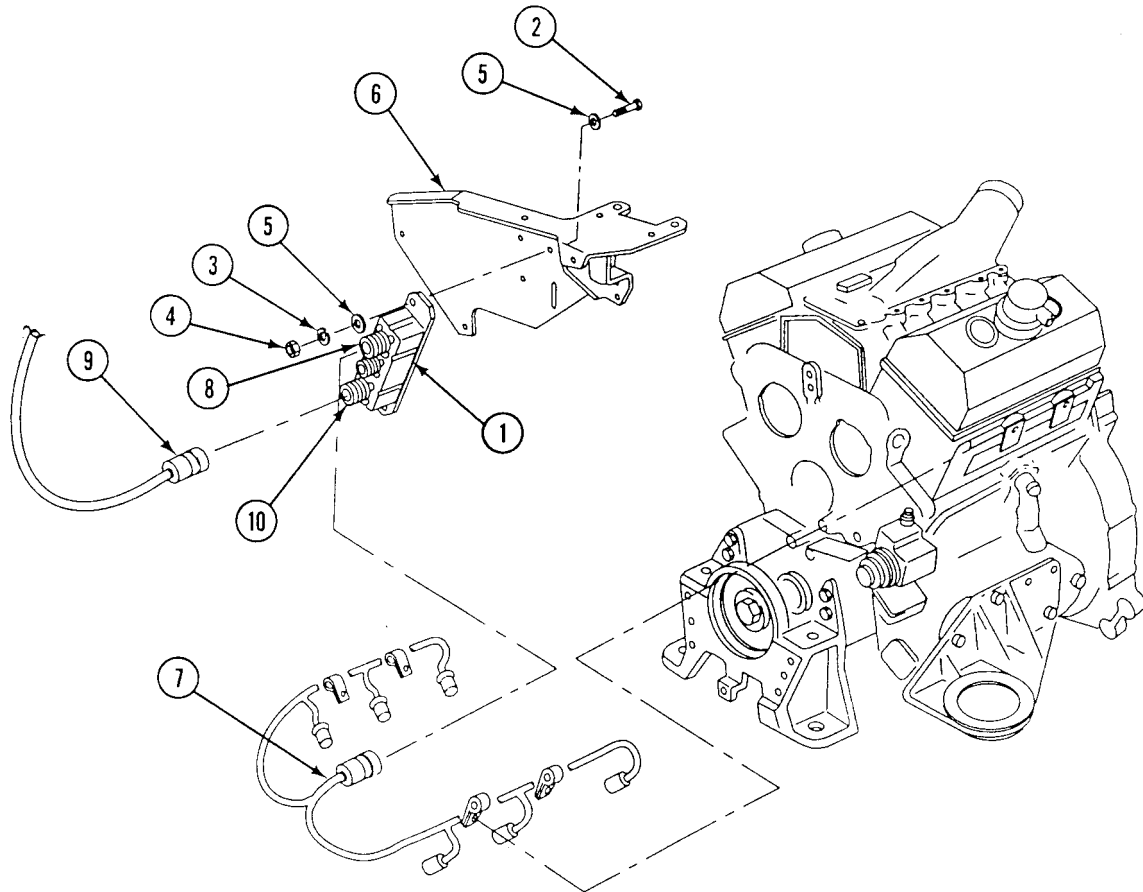
**FOLLOW-THROUGH STEPS**

1. Connect battery ground strap (WP 0337 00), (WP 0338 00), or (WP 0339 00).
2. Install power plant access panel (see your -10).

END OF TASK

REPLACE GLOW PLUG POWER HARNESS

0211 00

THIS WORK PACKAGE COVERS:

Removal (page 0211 00-1).
 Installation (page 0211 00-2).

INITIAL SETUP:

Maintenance Level

Unit

References

See your -10

Tools and Special Tools

General Mechanic's Tool Kit (WP 0926 00, Item 65)

Equipment Condition

Engine stopped (see your -10)
 Carrier blocked (see your -10)
 Driver's power plant access panel removed (see your -10)
 Rear power plant access panel removed (see your -10)
 Battery ground strap disconnected (WP 0337 00), (WP 0338 00), or (WP 0339 00)

Materials/Parts

Lockwasher (3)
 Tie straps (as required)

Personnel Required

Unit Mechanic

REMOVAL

1. Remove nut (1), lockwasher (2), and red double lead (3) from battery terminal (4) on solenoid (5). Do not remove other leads. Reinstall nut on battery terminal. Discard lockwasher.
2. Remove nut (6), lockwasher (7), and orange switch lead (8), from switch terminal (9) on solenoid (5). Do not remove other leads. Reinstall nut on switch terminal. Discard lockwasher.
3. Remove nut (10), lockwasher (11), and blue ground lead (12) from ground terminal (13) on solenoid (5). Do not remove other leads. Reinstall nut on ground terminal. Discard lockwasher.

REPLACE GLOW PLUG POWER HARNESS — Continued**0211 00**

4. Disconnect and remove glow plug power harness (14) from left side (15) of glow plug controller (16).
5. Remove clamp (17), two tie straps (18), and glow plug power harness (14) from engine. Discard tie straps.

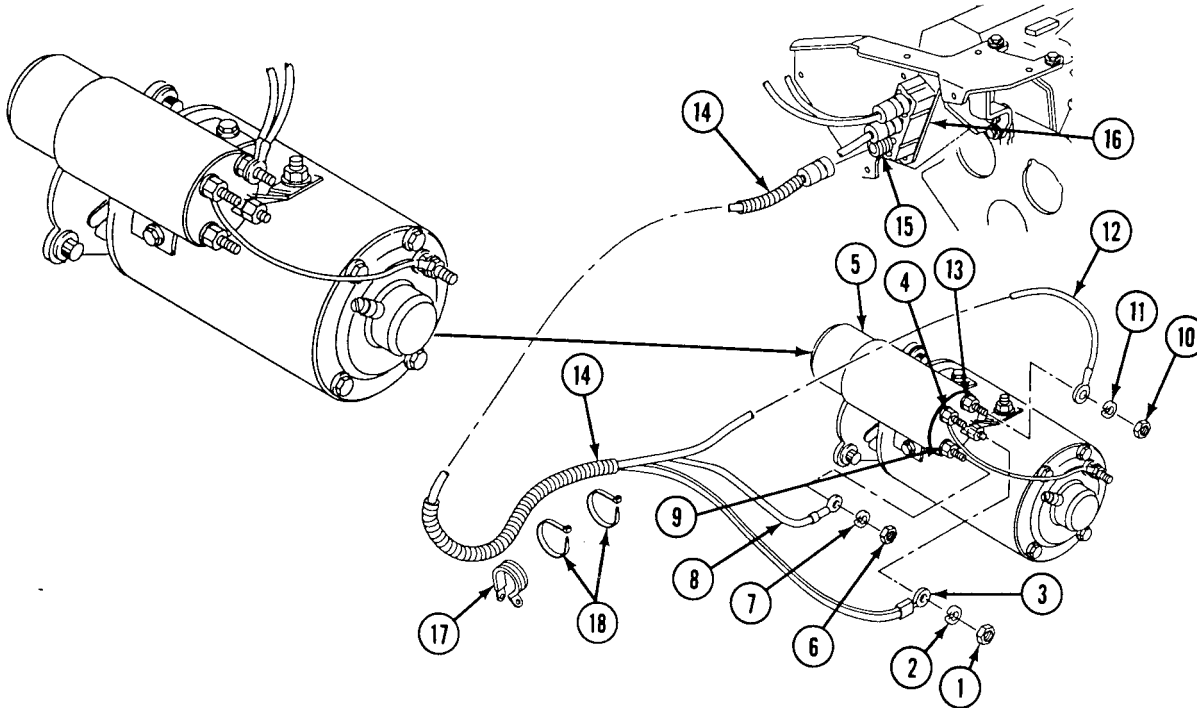
**INSTALLATION**

1. Install glow plug power harness (1), two tie straps (2), and clamp (3) on engine.

REPLACE GLOW PLUG POWER HARNESS — Continued

0211 00

2. Connect glow plug power harness (1) on left side (4) of glow plug controller (5).
3. Remove nut (6) from ground terminal (7). Install blue ground lead (8), new lockwasher (9), and nut on ground terminal.
4. Remove nut (10) from switch terminal (11). Install orange switch lead (12), new lockwasher (13), and nut on switch terminal.
5. Remove nut (14) from battery terminal (15). Install red double lead (16), new lockwasher (17), and nut on battery terminal.

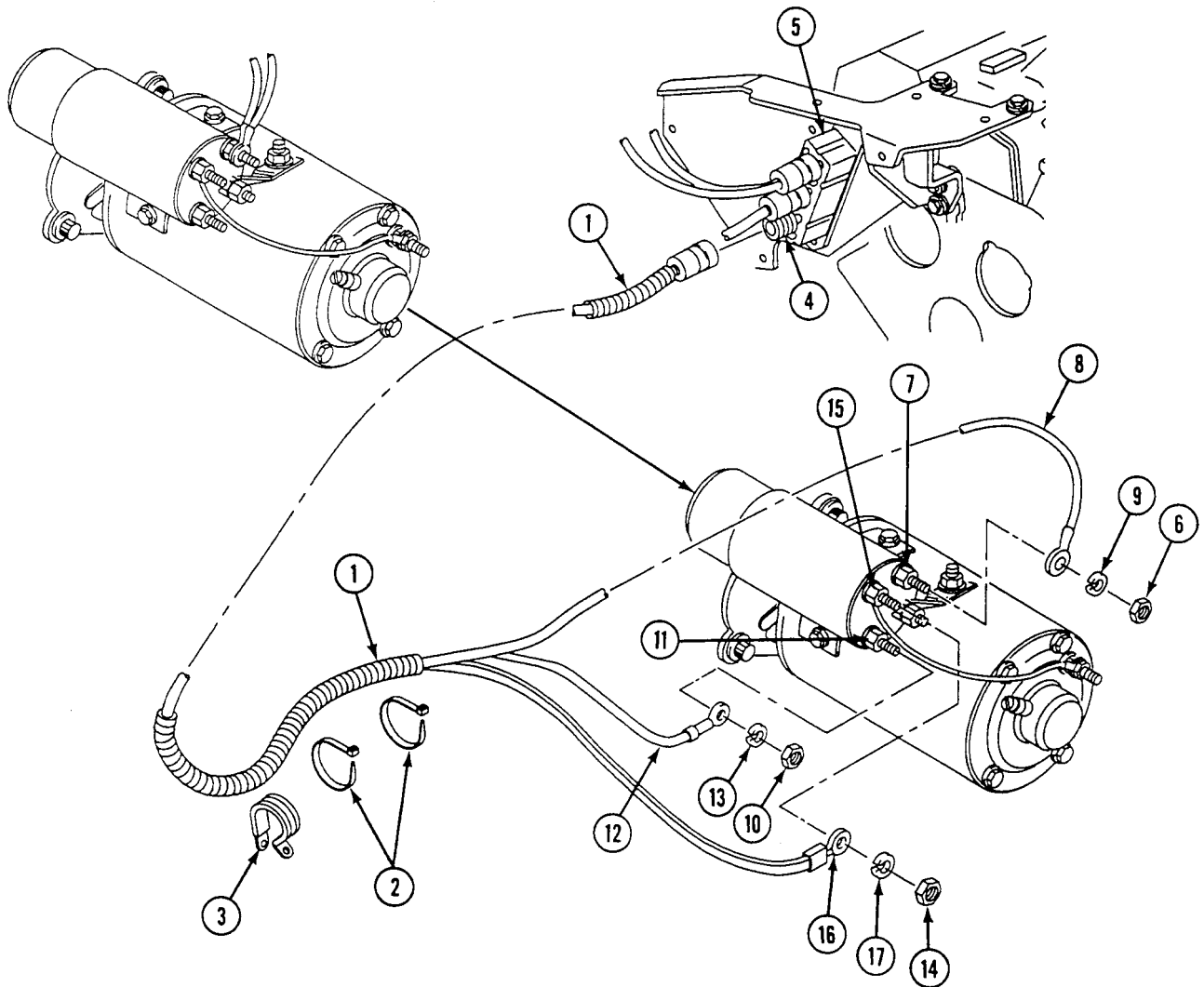

FOLLOW-THROUGH STEPS

1. Connect battery ground strap (WP 0337 00), (WP 0338 00), or (WP 0339 00).
2. Install power plant access panel (see your -10).
3. Install driver's power plant access panel (see your -10).

END OF TASK

REPLACE GLOW PLUG CONTROLLER MOUNTING BRACKET

0212 00

THIS WORK PACKAGE COVERS:

Removal (page 0212 00-1).
 Installation (page 0212 00-2).

INITIAL SETUP:

Maintenance Level

Unit

References

See your -10

Tools and Special Tools

General Mechanic's Tool Kit (WP 0926 00, Item 65)
 Torque wrench (WP 0926 00, Item 81)
 Torque wrench (WP 0926 00, Item 82)

Equipment Condition

Engine stopped (see your -10)
 Carrier blocked (see your -10)
 Rear power plant access panel removed (see your -10)
 Battery ground strap disconnected (WP 0337 00),
 (WP 0338 00), or (WP 0339 00)

Materials/Parts

Lockwasher (4)
 Lockwasher (2)

Personnel Required

Unit Mechanic

REMOVAL

1. Remove two bolts (1), lockwashers (2), nuts (3), four washers (4), and glow plug controller (5) from mounting bracket (6) on front of engine. Discard lockwashers.
2. Remove two short screws (7), lockwashers (8), and washers (9) from front of mounting bracket (6).
3. Remove two long screws (10), lockwashers (11), washers (12), spacers (13), and mounting bracket (6) from engine. Discard lockwashers.

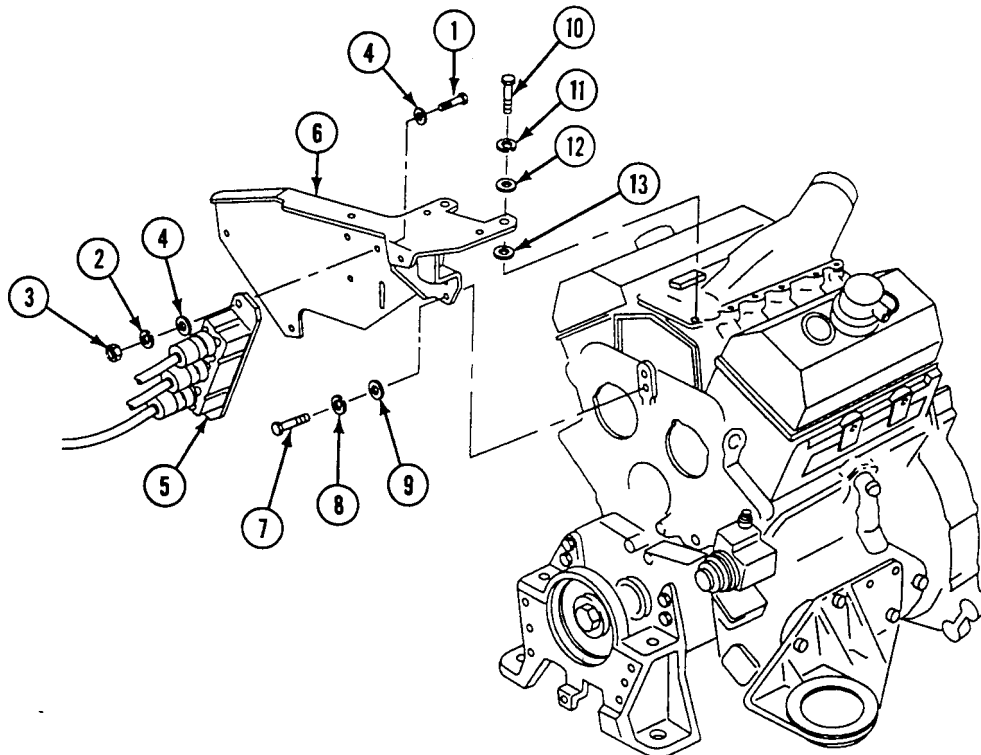

INSTALLATION

1. Install mounting bracket (1), two spacers (2), washers (3), new lockwashers (4), and long screws (5) on front of engine. TIGHTEN SCREWS TO 192-240 LB-IN (22-27 N·m) TORQUE. USE TORQUE WRENCH.
2. Install two washers (6), new lockwashers (7), and short screws (8) into front of mounting bracket (1). TIGHTEN SCREWS TO 46-50 LB-FT (62-68 N·m) TORQUE. USE TORQUE WRENCH.
3. Install glow plug controller (9), four washers (10), two new lockwashers (11), bolts (12), and nuts (13) on mounting bracket (1).

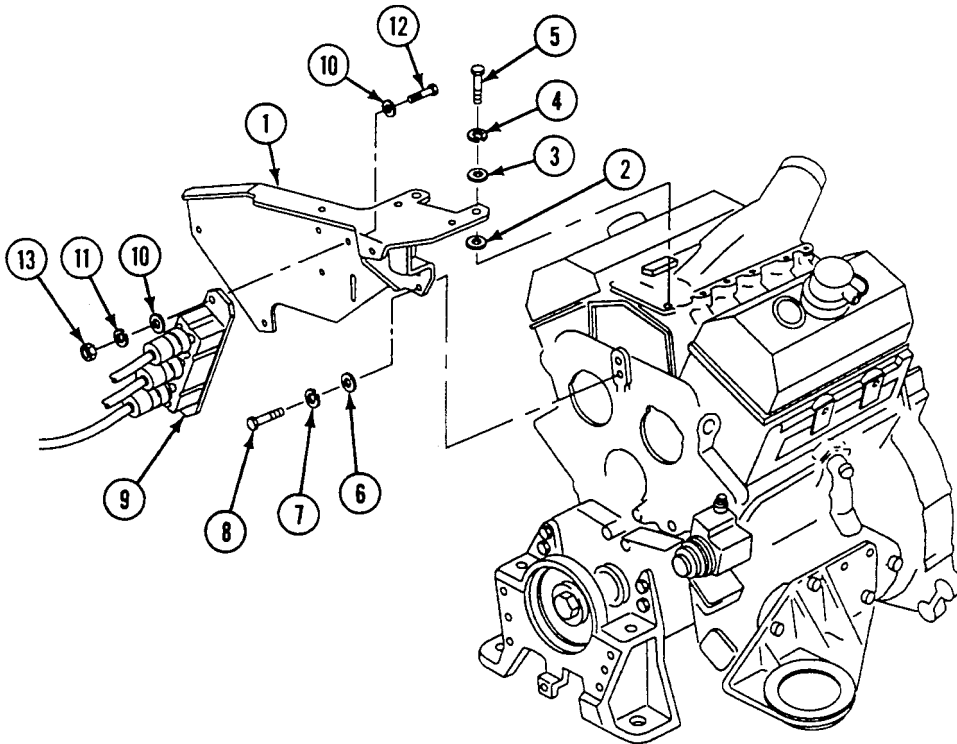
**FOLLOW-THROUGH STEPS**

1. Connect battery ground strap (WP 0337 00), (WP 0338 00), or (WP 0339 00).
2. Install engine access panel (see your -10).

END OF TASK

ADJUST THROTTLE VALVE (TV) MODULATOR

0213 00

THIS WORK PACKAGE COVERS:

- Adjustment (page 0213 00-1).
 - Field Operational Test (page 0213 00-5).
-

INITIAL SETUP:

Maintenance Level

Unit

References

- TM 9-2350-277-10
- WP 0441 00

Tools and Special Tools

- General Mechanic's Tool Kit (WP 0926 00, Item 65)
- Pressure Gauge Kit (WP 0926 00, Item 35)

Equipment Condition

- Engine warm
- Parking brake set (TM 9-2350-277-10)
- Engine stopped (TM 9-2350-277-10)
- Carrier blocked (TM 9-2350-277-10)
- Power plant access door open (TM 9-2350-277-10)
- Driver's power plant access panel removed (WP 0441 00)

Materials/Parts

- Sealing compound (WP 0928 00, Item 56)

Personnel Required

Mechanic

ADJUSTMENT

1. Check to make sure throttle valve modulator lever (1) is in idle position.
2. Adjust two hex nuts (2) so cable modulator bracket (3) is located near mid-range of threaded portion of cable housing (4). Tighten nuts.

NOTE

Steps 3 - 15 are an initial adjustment prior to FIELD OPERATIONAL TEST.

3. Check to make sure anchor (5) is 4-7/16 to 4-9/16 inches (11.3 to 11.5 cm) from bracket (3). If adjustment is needed, loosen hex nut (6) and reposition lever (1) by adjusting two nuts (7) and (8) so anchor (5) is located near mid-range of threaded portion of cable end (9). Tighten nuts (6), (7), and (8).

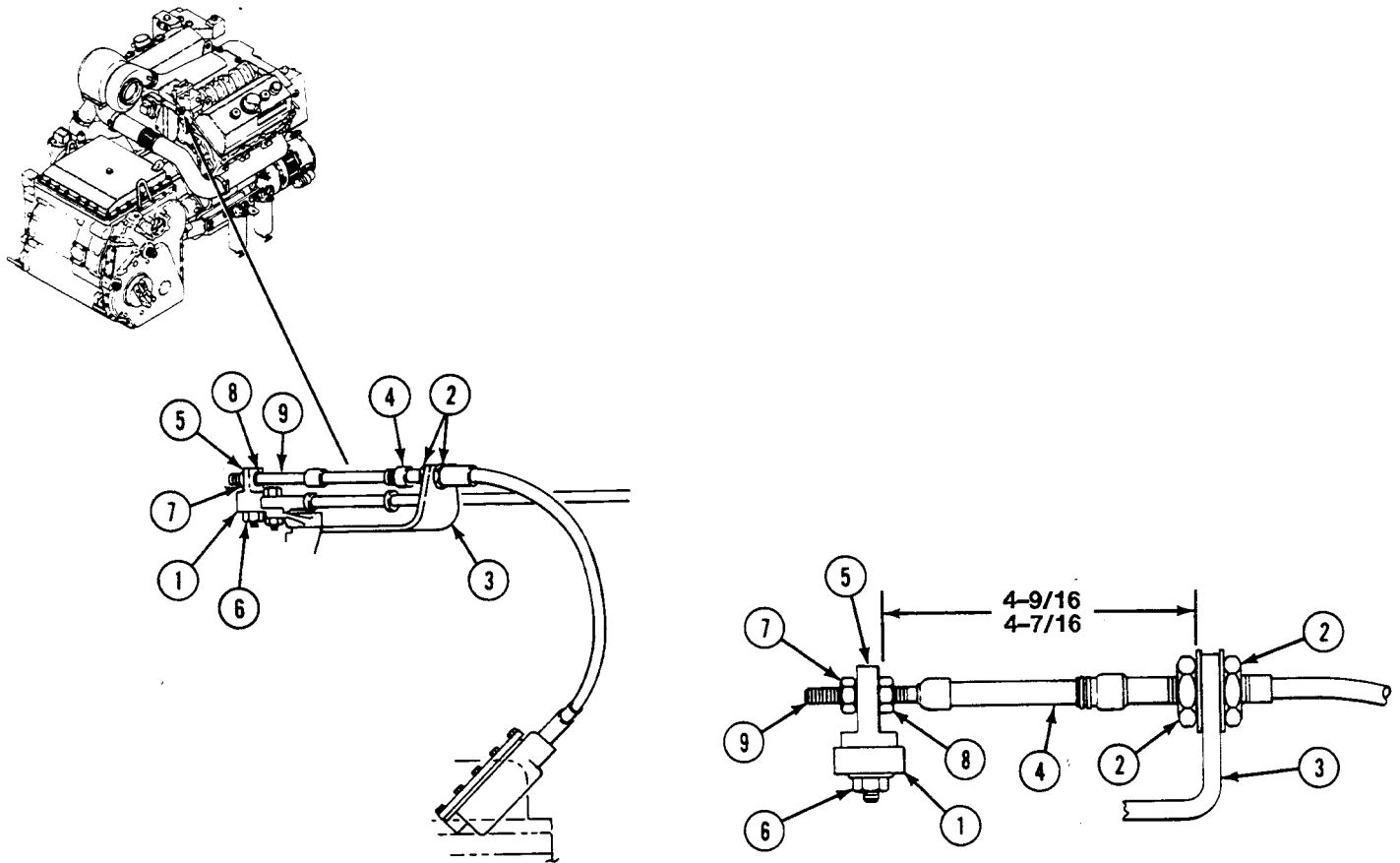

4. Open pressure gauge kit (1), and remove 0 to 160 psi (0 to 7607 kPa) pressure gauge (2), hose (3), and quick-disconnect fitting (4).

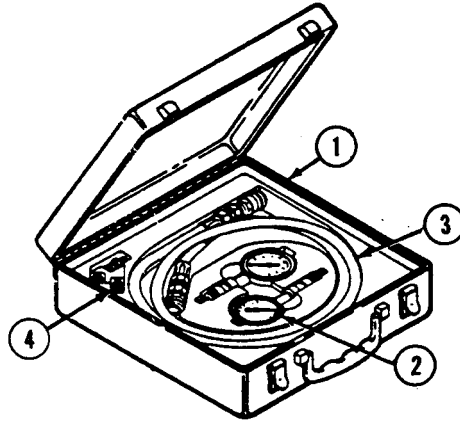

5. Remove pipe plug (5) from elbow (6) in throttle valve test port on transmission. Retain pipe plug.
6. Install quick-disconnect fitting (4) on elbow (6).
7. Install hose (3) on quick-disconnect fitting (4).
8. Install pressure gauge (2) on hose (3).

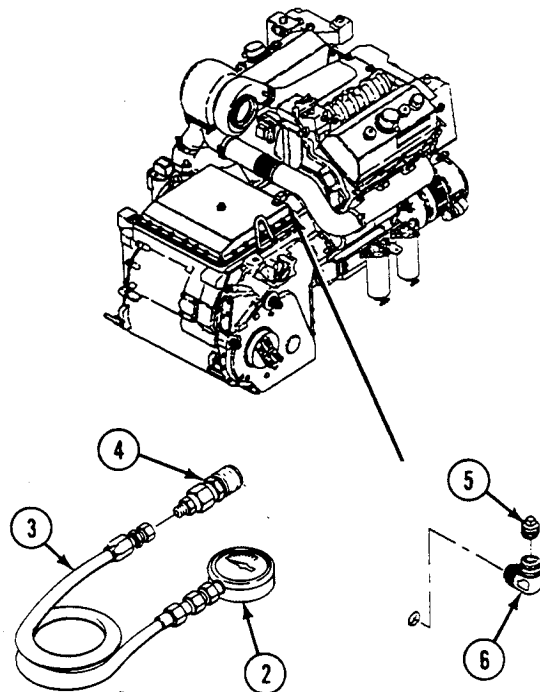

WARNING

Make sure parking brake is set before you start engine. Carrier could lurch and injure you.

9. Start engine and let idle with shift lever in the STEER LOCK (SL) position for 10 minutes or until engine reaches operating temperature. See TM 9-2350-277-10.
10. Depress accelerator fully to increase engine speed to full governed RPM. Pressure gauge should read from 94 to 98 psi (648 to 676 kPa).
11. If the pressure reading is below 94 psi (648 kPa), COURSE adjust throttle valve modulator linkage first by turning two adjusting nuts (7), one turn at a time, to the left, and then FINE adjust throttle valve modulator linkage by turning two adjusting nuts (8), one turn at a time, to the right.

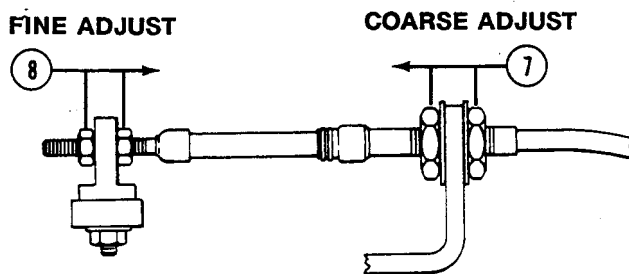

12. If the pressure gauge reading is above 98 psi (676 kPa), COURSE adjust throttle valve modulator linkage first by turning two adjusting nuts (7), one turn at a time to the right, and then FINE adjust throttle valve modulator linkage by turning two adjusting nuts (8), one turn at a time, to the left.

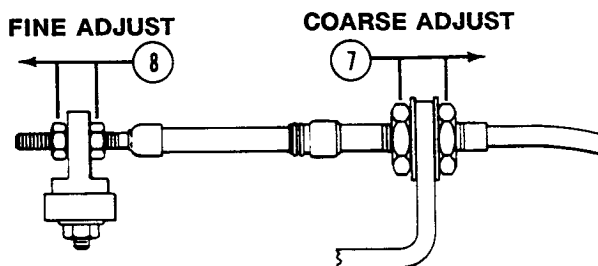

13. Stop engine. See TM 9-2350-277-10.
14. Remove quick-disconnect fitting (1) from elbow (2), hose (3) from quick-disconnect fitting (1), and pressure gauge (4) from hose (3). Stow in kit.
15. Apply a light coat of sealing compound to male threads of pipe plug (5), and install pipe plug in elbow (2).

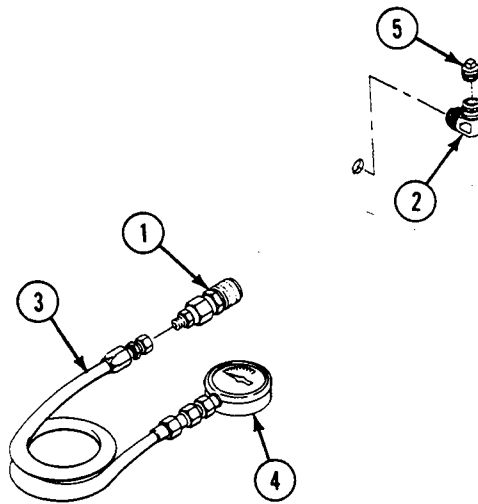

FIELD OPERATIONAL TEST

NOTE

Use judgment in evaluating speedometer readings by considering the variables that may effect the speedometer.

A cable driven speedometer can be affected by temperature and moisture, amount of bend in the cable, age, number of miles on the carrier, amount of lubricant used, and manufacturing tolerance error of ± 5 percent. All of these possibilities can result in speedometer lag (a reading slower than actual speed during acceleration).

The angle in which the driver looks at the speedometer can cause a 1 to 2 mile per hour error/difference. The height of an individual, seat height, or angle could account for inconsistency in speedometer readings. The higher the driver's vantage point, the more he tends to read below the actual speed.

If the transmission shifts smoothly and reaches top speed (30 to 39 mph (48 to 63 kph)) without lagging during wide open throttle tests, consider the adjustment complete even if the speedometer reading is somewhat outside the limits shown in the following steps.

1. Operate the carrier. See TM 9-2350-277-10. Drive the carrier on straight, level terrain with shift lever in the 1-4 position. Accelerate carrier with accelerator pedal fully depressed (wide open throttle). Verify that the following transmission shifts occur at the speeds shown:

Upshift 1 to 2	7 mph (11 km/h) min
Upshift 2 to 3	18 mph (29 km/h) max

NOTE

If shifts are within ranges, adjustment is complete. If not, do Step 2 and Step 3.

2. If the upshift 1 to 2 is below 7 mph (11 km/h), do ADJUST Step 11 again.
3. If upshift 2 to 3 is above 18 mph (29 km/h), do ADJUST Step 12 again.

NOTE

Do Step 4 only if the minimum/maximum shift points in Step 1 have not been obtained.

4. If more adjustment is needed, reposition throttle valve modulator lever (1) as follows:
 - a. Loosen hex nuts (2), (3), and (4).
 - b. Adjust lever (1) away from modulator bracket (5) if upshift 1 to 2 is below 7 mph (11 km/h).
 - c. Adjust lever (1) toward modulator bracket (5) if upshift 2 to 3 is above 18 mph (29 km/h).
 - d. Tighten hex nuts (2), (3), and (4).
5. Repeat Steps 1 - 4 until shift ranges are met.

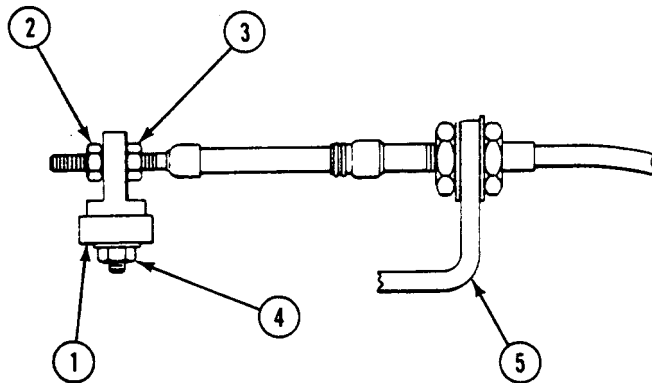
**FOLLOW-THROUGH STEPS**

1. Install driver's power plant access panel (WP 0441 00).
2. Close power plant access door. See TM 9-2350-277-10.

END OF TASK

ADJUST ACCELERATOR LINKAGE

0214 00

THIS WORK PACKAGE COVERS:

Adjustment (page 0214 00-1).

INITIAL SETUP:

Maintenance Level

Unit

Tools and Special Tools

General Mechanic's Tool Kit (WP 0926 00, Item 65)

Materials/Parts

Locknut

Locknut

Personnel Required

Mechanic

Helper (H)

References

TM 9-2350-277-10

WP 0441 00

WP 0449 00

Equipment Condition

Engine stopped (TM 9-2350-277-10)

Carrier blocked (TM 9-2350-277-10)

Power plant access door open (TM 9-2350-277-10)

Driver's power plant access panel removed (WP 0441 00)

Hull front access cover removed (WP 0449 00)

ADJUSTMENT

1. Remove screw (1), locknut (2), washer (3), and governor connecting link (4) from governor throttle arm (5). Discard locknut.

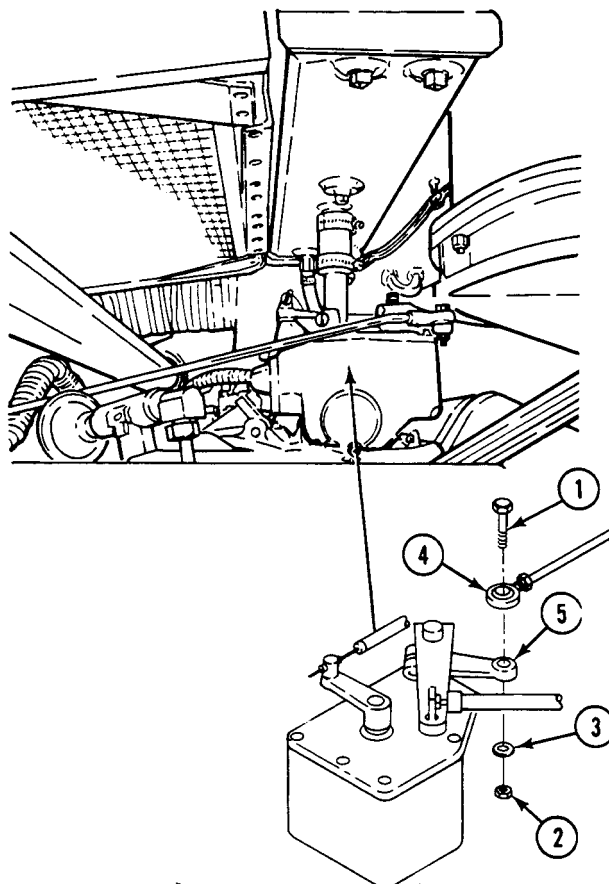

ADJUST ACCELERATOR LINKAGE — Continued**0214 00**

2. Remove screw (6), locknut (7), two washers (8), and throttle drag link (9) from accelerator arm (10). Discard locknut. Have helper assist.

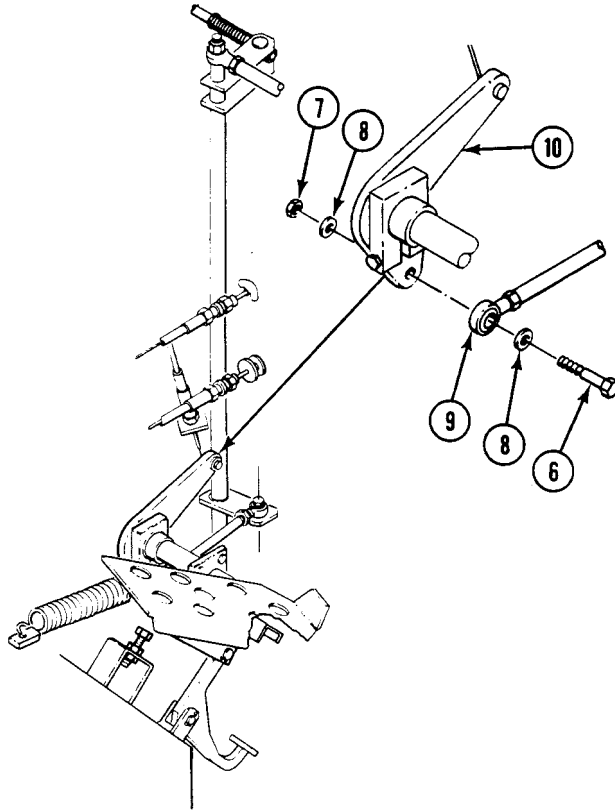

3. Position upper accelerator pedal (1) against heel stop (2). Have helper assist.
4. Loosen jamnut (3) on throttle drag link (4).

NOTE

Turn rod end bearing to the left to lengthen throttle drag link, or to the right to shorten link during adjustment.

5. Turn fuel control shaft (5) to the right until center of connecting pin (6) is 1-1/16 to 1-1/8 inches (27 to 29 mm) from power plant bulkhead. (H) Hold functional shaft in position.

NOTE

Make sure free pin fit is made during adjustment.

6. Install throttle drag link (4), two washers (7), screw (8), and new locknut (9) on accelerator arm (10). Tighten jamnut (3).

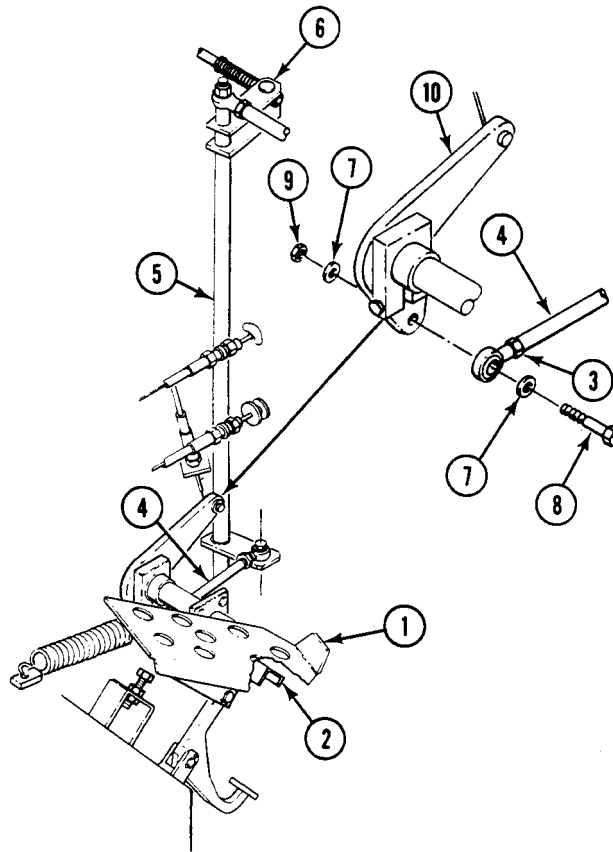

7. Loosen jamnut (11) on governor connecting link (12).
8. Position upper accelerator pedal (1) against heel stop (2). Have helper assist.

NOTE

Make sure governor throttle arm is in idle position.

9. Adjust length of governor connecting link (12) to allow a free pin fit when screw (13) is inserted in bearing (14) and governor throttle arm (15).

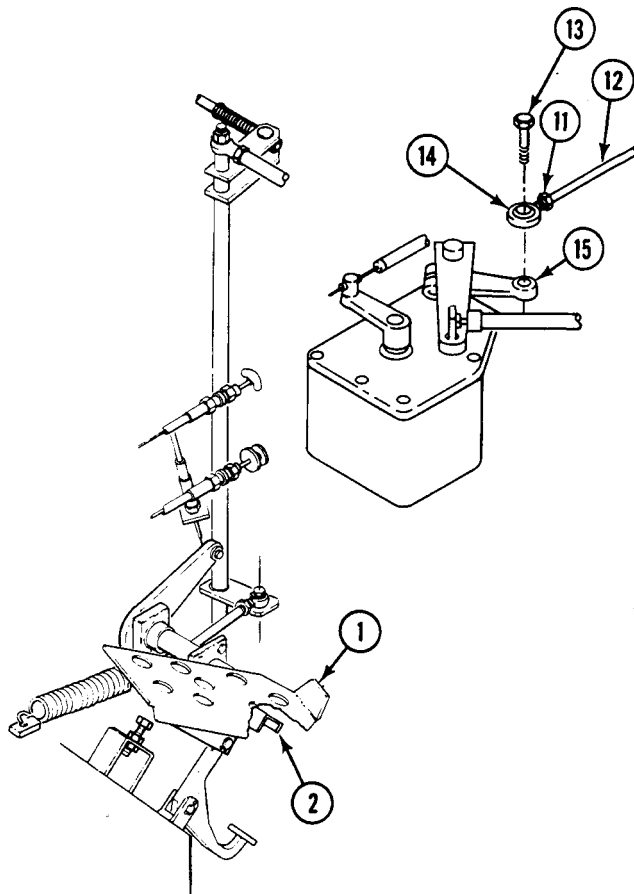

10. Install governor connecting link (1), washer (2), screw (3), and new locknut (4) on governor throttle arm (5). Tighten jamnut (6).

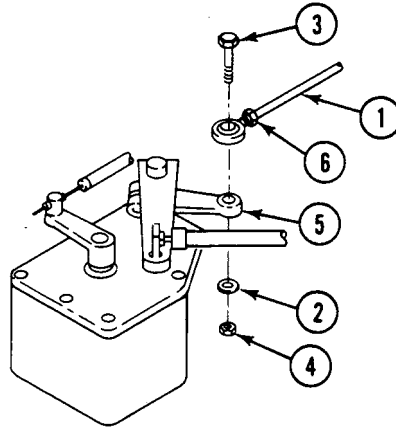

11. Loosen pedal toe stop screw (7) and jamnut (8).
12. Depress accelerator pedal (9) until edge of connecting pin (10) is 1/32 to 1/16 inch (1 to 1.5 mm) away from washer (11). Adjust pedal toe stop screw (7) and tighten jamnut (8). Have helper assist.

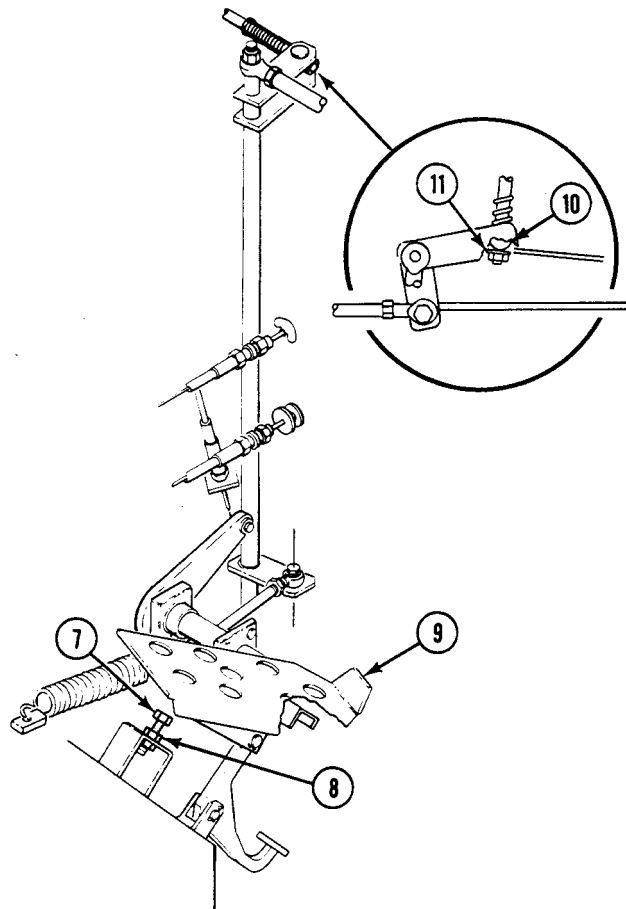

FOLLOW-THROUGH STEPS

1. Install hull front access cover (WP 0449 00).
2. Install driver's power plant access panel (WP 0441 00).
3. Close power plant access door. See TM 9-2350-277-10.

END OF TASK

REPLACE LOWER ACCELERATOR PEDAL

0215 00

THIS WORK PACKAGE COVERS:

Removal (page 0215 00-1).
 Installation (page 0215 00-3).

INITIAL SETUP:

Maintenance Level

Unit

References

See your -10

Tools and Special Tools

General Mechanic's Tool Kit (WP 0926 00, Item 65)

Equipment Condition

Engine stopped (see your -10)

Materials/Parts

Cotter pin

Carrier blocked (see your -10)

Cotter pin

Ramp lowered (see your -10)

Personnel Required

Unit Mechanic

Driver's seat removed (WP 0551 00)

REMOVAL

1. Remove cotter pin (1) and washer (2) from connecting pin (3) securing lower pedal (4) and connecting link (5) to upper pedal assembly (6).
2. Remove connecting pin (3) from pedal (4) and connecting link (5). Discard cotter pin.
3. Remove cotter pin (7) and washer (8) from connecting pin (9) securing lower pedal (4) to bracket (10).

4. Remove connecting pin (9), and lower pedal (4) from bracket (10). Discard cotter pin.

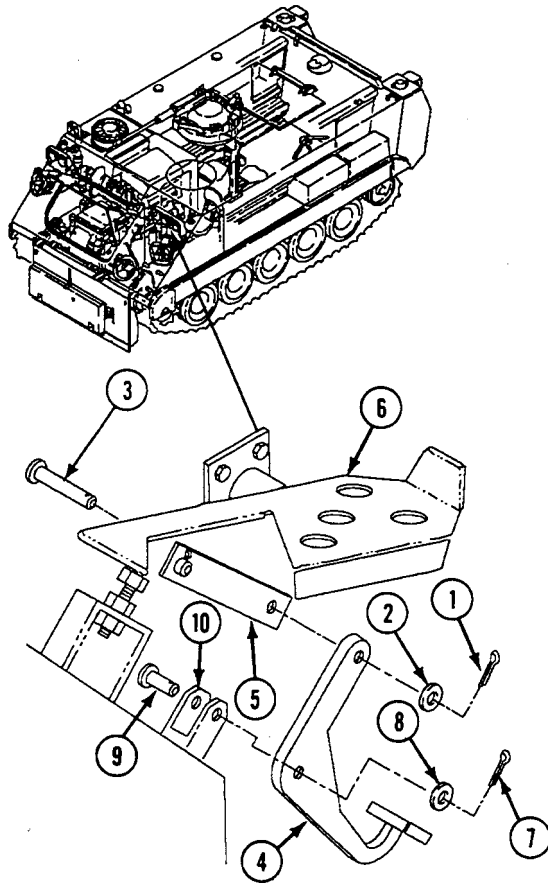

INSTALLATION

1. Place lower pedal (4) on bracket (10). Align holes in bracket and pedal. Install connecting pin (9) through bracket (10) and pedal (4).
2. Install washer (8) on connecting pin (9) and secure with new cotter pin (7).
3. Align holes in connecting link (5) and pedal (4). Install connecting pin (3) through connecting link (5) and pedal (4).
4. Install washer (2) on connecting pin (3) and secure with new cotter pin (1).

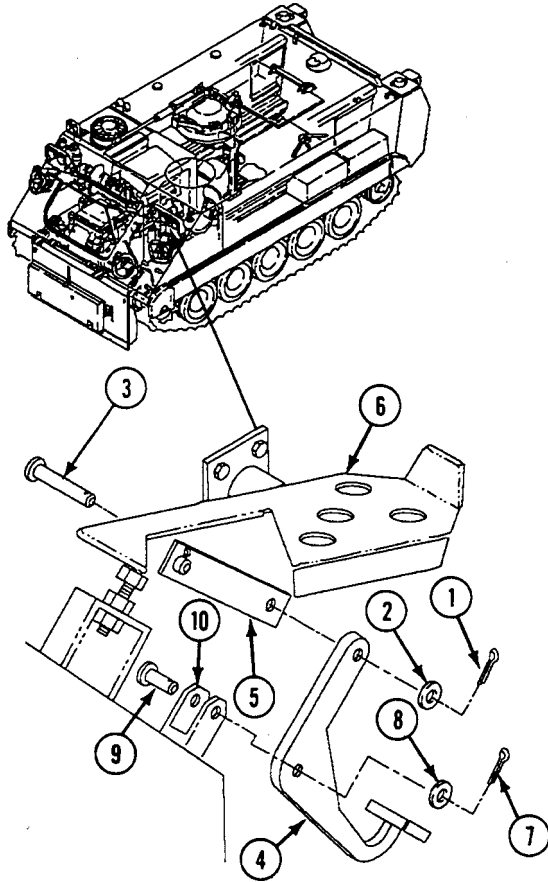
**FOLLOW-THROUGH STEPS**

1. Install driver's seat (WP 0551 00).
2. Start engine (see your -10). Check that accelerator pedal works right.
3. Raise and lock ramp (see your -10).

END OF TASK

REPLACE UPPER ACCELERATOR PEDAL ASSEMBLY

0216 00

THIS WORK PACKAGE COVERS:

Removal (page 0216 00-2).
 Installation (page 0216 00-4).

INITIAL SETUP:

Maintenance Level

Unit

References

TM 9-2350-277-10
 WP 0214 00
 WP 0441 00
 WP 0449 00

Tools and Special Tools

General Mechanic's Tool Kit (WP 0926 00, Item 65)

Equipment Condition

Engine stopped (TM 9-2350-277-10)
 Carrier blocked (TM 9-2350-277-10)
 Power plant access door open (TM 9-2350-277-10)
 Driver's power plant access panel removed
 (WP 0441 00)
 Hull front access cover removed (WP 0449 00)

Materials/Parts

Cotter pin
 Cotter pin
 Cotter pin
 Locknut

Personnel Required

Mechanic
 Helper

REMOVAL

1. Remove spring (1) from throttle control arm (2) and bracket (3) on power plant bulkhead.

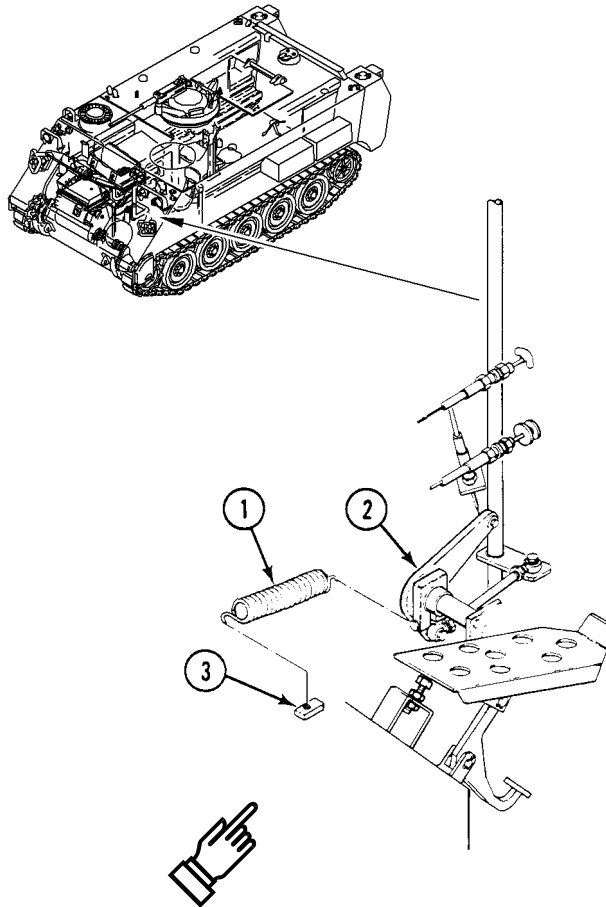

REPLACE UPPER ACCELERATOR PEDAL ASSEMBLY — Continued

0216 00

2. Remove locknut (1), washer (2) and screw (3) securing drag link (4) to fuel control shaft plate (5). Discard locknut.
3. Loosen locknut (6) on throttle control arm (7). Remove throttle control arm (7) with drag link (4) from shaft (8). Remove locknut (6), washer (9) and screw (10) from throttle control arm. Discard locknut. Have helper assist.
4. Remove cotter pin (11), and washer (12) securing hand throttle pin (13) to throttle control arm (7). Remove hand throttle pin (13) with cable (14). Discard cotter pin.
5. Remove locknut (15), two washers (16) and screw (17) securing drag link (4) to throttle control arm (7). Discard locknut.

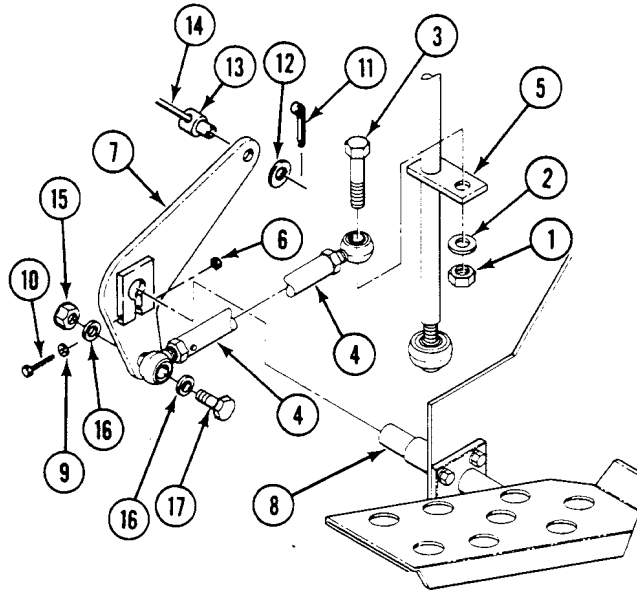

6. Remove cotter pin (18), washer (19), pin (20), and link (21) from lower accelerator pedal (22). Discard cotter pin.
7. Remove four screws (23) and washers (24) securing pedal guide (25) to bulkhead.

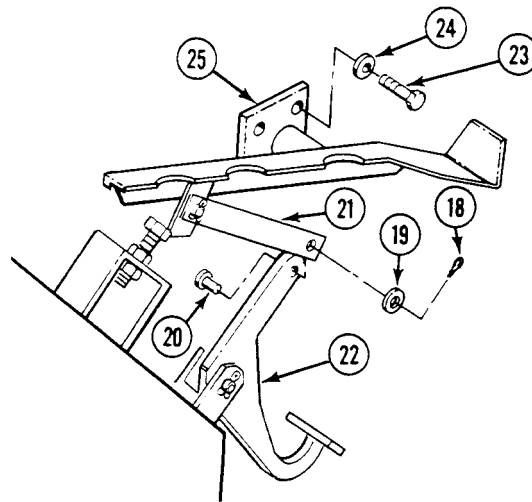

8. Remove upper accelerator pedal (26) with pedal guide (25) and link (21) from bulkhead.
9. Remove cotter pin (27), washer (28) and pin (29) securing link (21) to upper accelerator pedal (26). Remove link. Discard cotter pin.
10. Remove woodruff key (30) and pedal guide (25) from shaft (8).

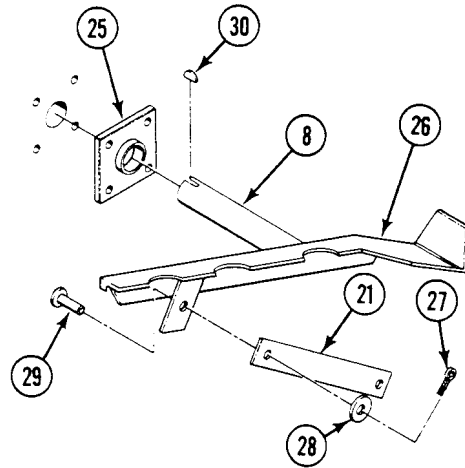

INSTALLATION

1. Install link (21) on upper accelerator pedal (26) and secure with pin (29), washer (28) and new cotter pin (27).
2. Install pedal guide (25) and woodruff key (30) on shaft (8).
3. Install upper accelerator pedal (26) with link (21) and pedal guide (25) in driver's right side bulkhead.

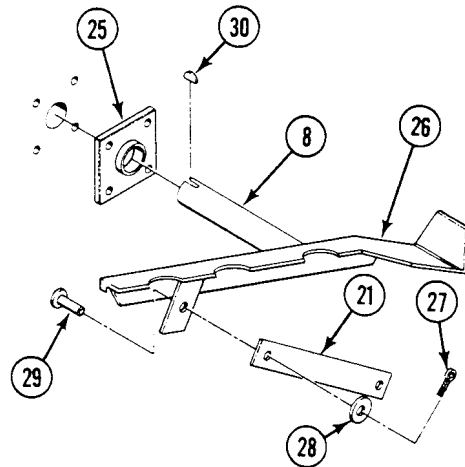

4. Secure pedal guide (1) to bulkhead with four washers (2) and screws (3).
5. Install link (4) on lower accelerator pedal (5) and secure with pin (6), washer (7) and new cotter pin (8).

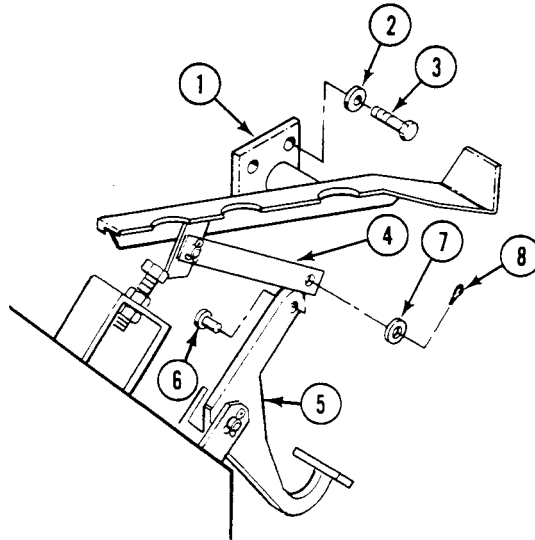

6. Install screw (9), washer (10) and new locknut (11) on new throttle control arm (12). Do not tighten at this time.
7. Install hand throttle pin (13) with cable (14) on throttle control arm (12) and secure with washer (15) and new cotter pin (16).
8. Install drag link (17) on throttle control arm (12) and secure with screw (18), two washers (19) and new locknut (20).
9. Install throttle control arm (12) on shaft (21). Align arm with woodruff key. Hold nut (11) and tighten screw (9).
10. Install drag link (17) on fuel control shaft plate (22) and secure with screw (23), washer (24) and new locknut (25).

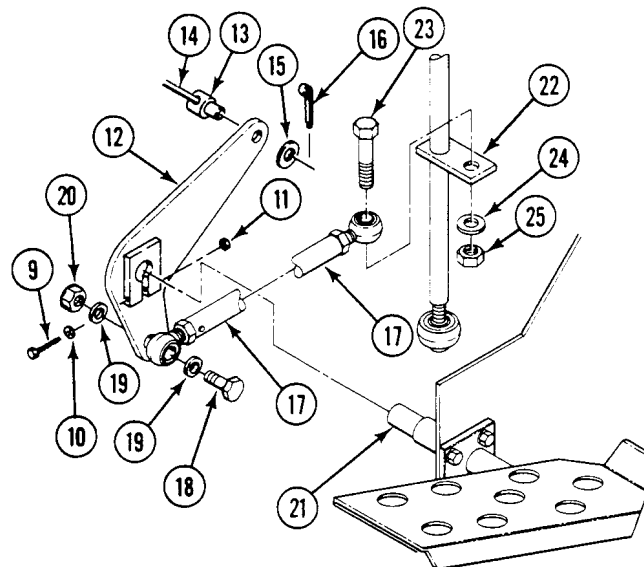

11. Install spring (26) in bracket (27) on power plant bulkhead and throttle control arm (12).

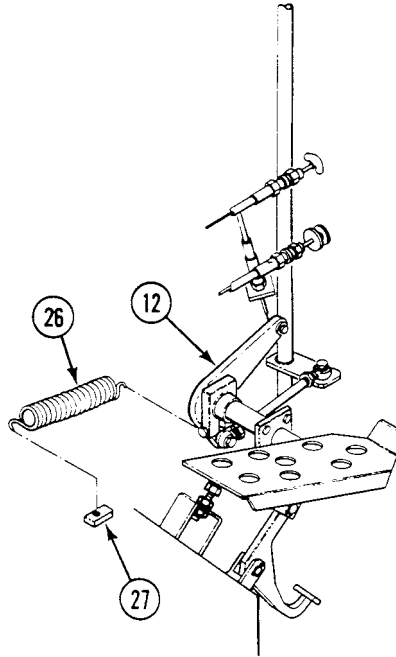

FOLLOW-THROUGH STEPS

1. Adjust accelerator linkage (WP 0214 00).
2. Install hull front access cover (WP 0449 00).
3. Install driver's power plant access panel (WP 0441 00).
4. Close power plant access door. See TM 9-2350-277-10.

END OF TASK

REPLACE FUEL CONTROL SHAFT AND LINKAGE

0217 00

THIS WORK PACKAGE COVERS:

Removal (page 0217 00-1).
 Installation (page 0217 00-4).

INITIAL SETUP:

Maintenance Level

Unit

References

TM 9-2350-277-10
 WP 0173 00
 WP 0214 00
 WP 0441 00
 WP 0441 00

Tools and Special Tools

General Mechanic's Tool Kit (WP 0926 00, Item 65)

Materials/Parts

Cotter pin
 Locknut (7)
 Lockwasher (2)

Equipment Condition

Engine stopped (TM 9-2350-277-10)
 Carrier blocked (TM 9-2350-277-10)
 Power plant access door open (TM 9-2350-277-10)
 Driver's power plant access panel removed
 (WP 0441 00)
 Hull front access cover removed (WP 0449 00)
 Air intake elbow removed (WP 0173 00)

Personnel Required

Mechanic

REMOVAL

REPLACE FUEL CONTROL SHAFT AND LINKAGE — Continued

0217 00

1. Remove spring (1) from bulkhead.
2. Remove locknut (2), two washers (3) and screw (4) securing drag link (5) to throttle control arm (6). Discard locknut.
3. Remove locknut (7), washer (8) and screw (9) securing drag link (5) to shaft (10). Remove drag link.
4. Remove locknut (11), washer (12) and screw (13) securing linkage (14) to arm (15).

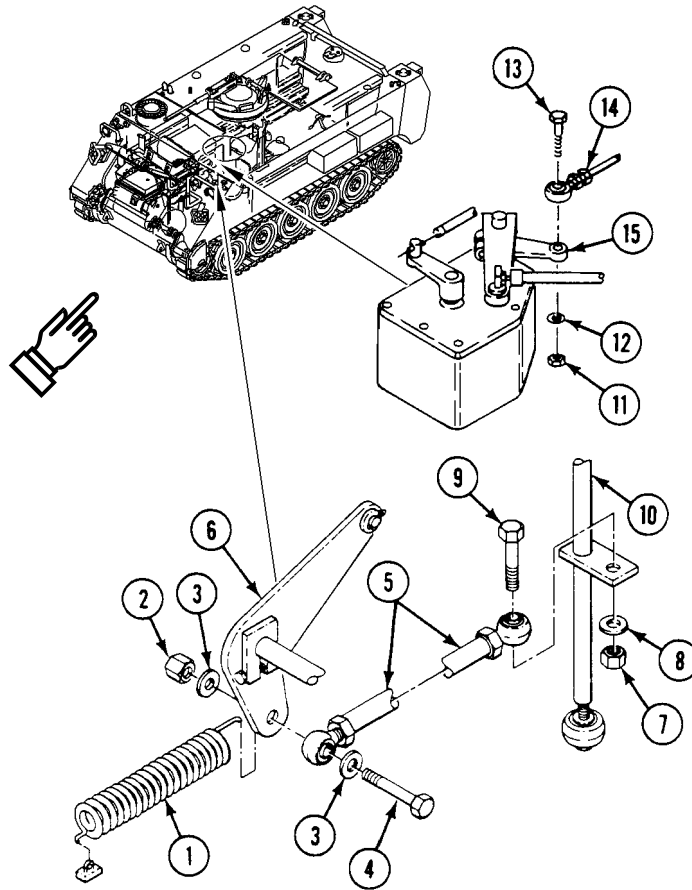

CAUTION

Use caution when removing linkage from pin due to spring on linkage.

5. Remove nut (1) and washer (2) from linkage (3). Remove linkage (3) from pin (4).
6. Remove locknut (5) and washer (6) holding bearing (7) to shaft (8). Discard locknut.
7. Hold bearing (7) and remove screw (9) from bearing. Remove washer (10), lockwasher (11) and screw (9) from bulkhead. Remove bearing (7) from shaft (8).
8. Remove shaft (8) from bearing (12).
9. Remove screw (13) from bearing (12). Remove bearing (12) from bulkhead. Remove washer (14), lockwasher (15) and screw (13) from bulkhead.
10. Remove cotter pin (16), washer (17), and pin (4) from lever (18). Discard cotter pin.

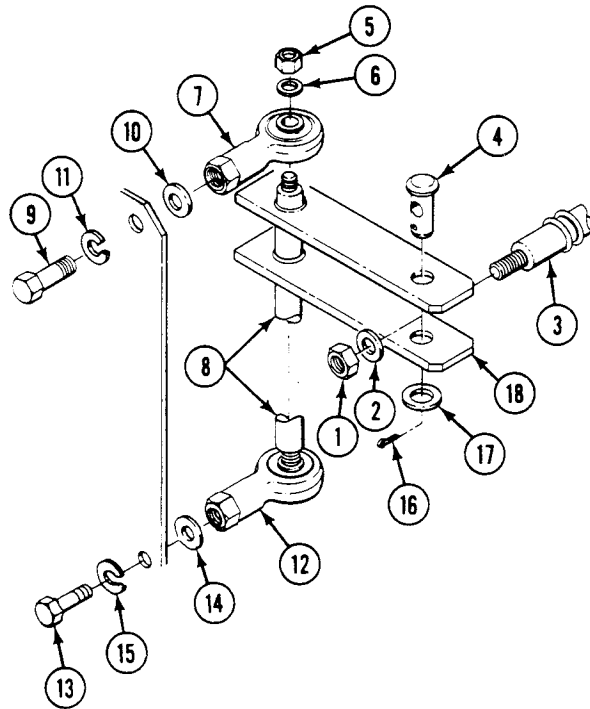

INSTALLATION

1. Install pin (4) on lever (18). Secure with washer (17) and new cotter pin (16).
2. Install bearing (7) on shaft (8). Secure with washer (6) and new locknut (5).
3. Position bearing (12) on bulkhead. Secure with washer (14), new lockwasher (15) and screw (13). Do not tighten screw at this time.
4. Install shaft (8) with bearing (7) on bearing (12). Secure bearing (7) to bulkhead with washer (10), new lockwasher (11) and screw (9).
5. Position bearing (12) for free movement of shaft (8) and tighten screw (13) on bearing (8).
6. Install link (3) through pin (4) and secure with washer (2) and nut (1). Do not tighten nut at this time.

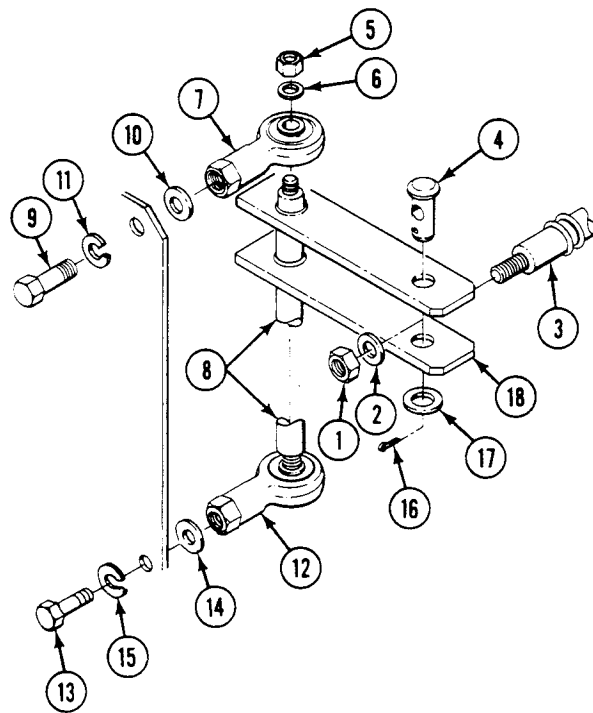

REPLACE FUEL CONTROL SHAFT AND LINKAGE — Continued

0217 00

7. Install screw (1) through linkage (2) and arm (3).

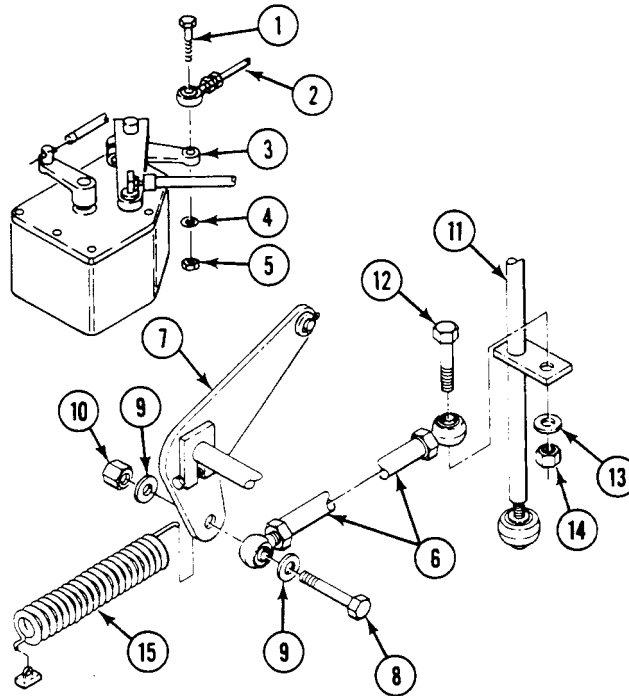

8. Tighten nut (1) at this time.

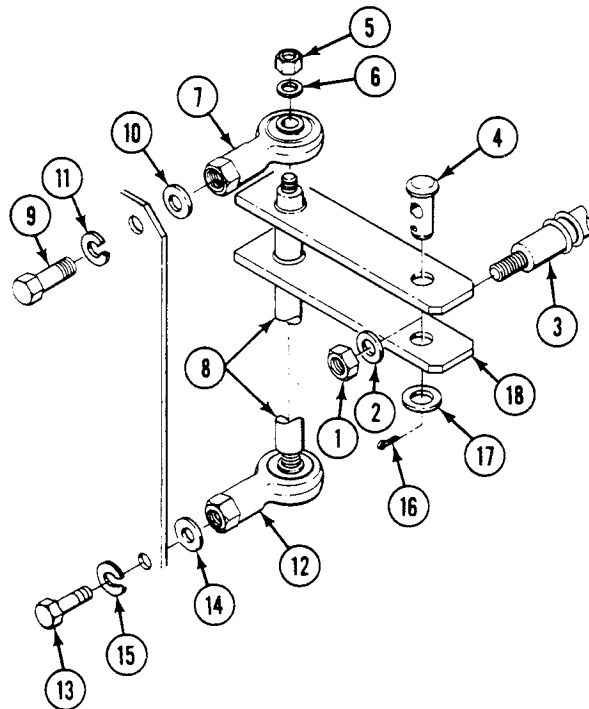

REPLACE FUEL CONTROL SHAFT AND LINKAGE — Continued**0217 00**

9. Install washer (4) and new locknut (5) on screw (1) and tighten.
10. Install link (6) on arm (7). Secure with screw (8), two washers (9) and new locknut (10).
11. Install link (6) on shaft (11). Secure with screw (12), washer (13) and new locknut (14).
12. Install spring (15) on arm (7) and bulkhead.

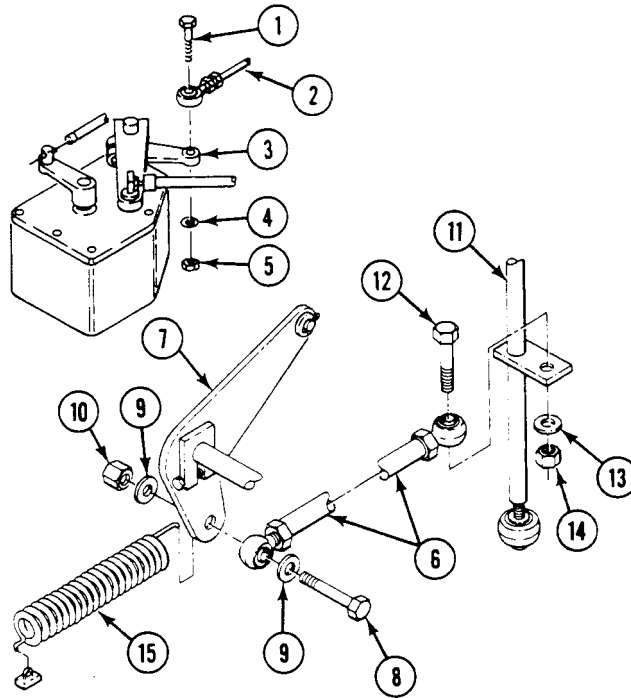
**FOLLOW-THROUGH STEPS**

1. Adjust accelerator linkage (WP 0214 00).
2. Install air intake elbow (WP 0173 00).
3. Install hull front access cover (WP 0449 00).
4. Install driver's power plant access panel (WP 0441 00).
5. Close power plant access door. See TM 9-2350-277-10.

END OF TASK

REPLACE THROTTLE VALVE (TV) MODULATOR AND LEVER

0218 00

THIS WORK PACKAGE COVERS:

Removal (page 0218 00-1).
 Installation (page 0218 00-4).

INITIAL SETUP:

Maintenance Level

Unit

References

TM 9-2350-277-10
 WP 0173 00
 WP 0221 00
 WP 0441 00

Tools and Special Tools

General Mechanic's Tool Kit (WP 0926 00, Item 65)

Materials/Parts

Locknut
 Locknut
 Sealing compound (WP 0928 00, Item 54)
 Self-locking bolt

Equipment Condition

Engine stopped (TM 9-2350-277-10)
 Carrier blocked (TM 9-2350-277-10)
 Power plant access door open (TM 9-2350-277-10)
 Driver's power plant access panel removed
 (WP 0441 00)
 Air intake elbow removed (WP 0173 00)
 Exhaust elbow removed (WP 0221 00)

Personnel Required

Mechanic

REMOVAL

REPLACE THROTTLE VALVE (TV) MODULATOR AND LEVER — Continued**0218 00**

1. Remove nut (1) from cable (2).
2. Loosen jamnut (3) on cable (2). Remove locknut (4) and washer (5) from anchor (6). Remove cable and anchor from lever (7). Discard locknut.
3. Remove anchor (6) and nut (8) from cable (2).
4. Remove locknut (9), screw (10), and two washers (11) from lever (7) and throttle shaft (12). Remove lever from throttle shaft. Discard locknut.

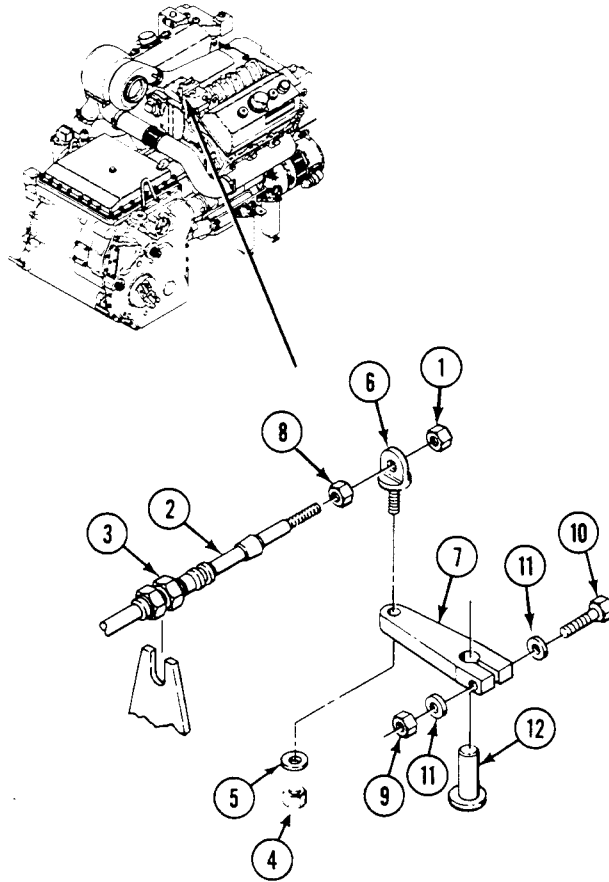

NOTE

Make sure throttle valve modulator is in idle position before removing modulator from transmission.

5. Remove self-locking bolt (1), modulator retainer (2), and throttle valve modulator (3) from transmission (4). Discard self-locking bolt.
6. Remove pipe plug (5) from pipe elbow (6), and remove pipe elbow from throttle valve pressure test port on transmission (4).

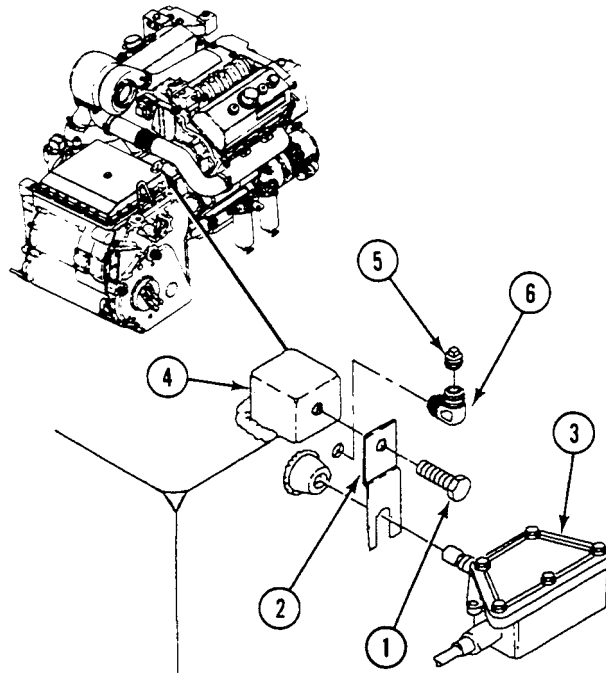

INSTALLATION**NOTE**

Apply a light coat of sealing compound to male pipe threads before installation. Do not coat leading thread.

1. Install elbow (6) in throttle valve pressure test port on transmission (4) in the 1:00 to 2:00 o'clock position.
2. Install pipe plug (5) in pipe elbow (6).

CAUTION

If preformed packing comes with throttle valve modulator, discard packing. The packing is not required because there is an oil seal already installed inside the transmission, and the packing does not allow for proper fit of the modulator into the transmission.

NOTE

Make sure modulator is in idle position before installing modulator on transmission.

3. Install modulator (3) in transmission (4). Secure with retainer (2) and new self-locking bolt (1).

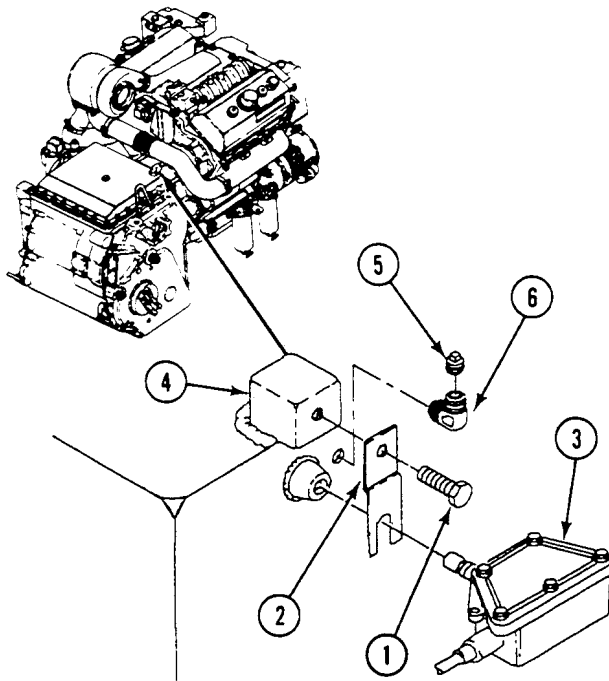

REPLACE THROTTLE VALVE (TV) MODULATOR AND LEVER — Continued

0218 00

4. Install lever (7) in throttle shaft (8). Secure with screw (9), two washers (10), and new locknut (11).
5. Install nut (12) and anchor (13) on cable (14).
6. Install anchor (13) with cable (14) in lever (7). Secure with washer (15) and new locknut (16).
7. Install nut (17) on cable (14).

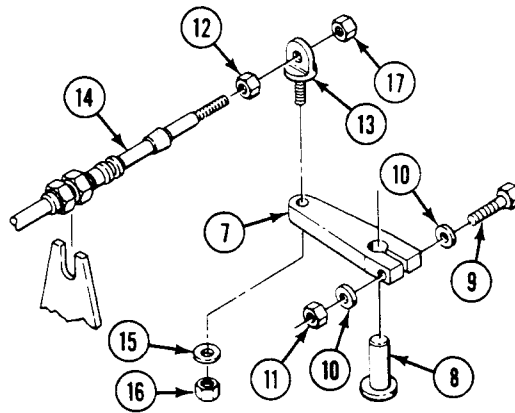

8. Tighten jamnut (1) on cable (2) 4-7/16 to 4-9/16 inch (11.27 to 11.58 cm) from bracket (3) to end of shield covering inner cable.
9. Adjust throttle valve modulator (WP 0213 00).

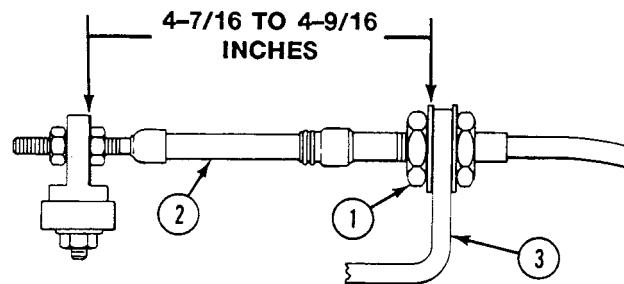

FOLLOW-THROUGH STEPS

1. Install exhaust elbow (WP 0221 00).
2. Install air intake elbow (WP 0173 00).
3. Install driver's power plant access panel (WP 0441 00).
4. Close power plant access door. See TM 9-2350-277-10.

END OF TASK

REPLACE HAND THROTTLE CONTROL CABLE ASSEMBLY

0219 00

THIS WORK PACKAGE COVERS:

- Removal (page 0219 00-1).
 - Installation (page 0219 00-4).
 - Adjustment (page 0219 00-7).
-

INITIAL SETUP:

Maintenance Level

Unit

References

- TM 9-2350-277-10
- WP 0441 00
- WP 0449 00

Tools and Special Tools

General Mechanic's Tool Kit (WP 0926 00, Item 65)

Equipment Condition

- Engine stopped (TM 9-2350-277-10)
- Carrier blocked (TM 9-2350-277-10)
- Power plant access door open (TM 9-2350-277-10)
- Driver's power plant access panel removed (WP 0441 00)
- Hull front access cover removed (WP 0449 00)

Materials/Parts

- Locknut
- Lockwasher
- Tie strap

Personnel Required

Mechanic

REMOVAL

REPLACE HAND THROTTLE CONTROL CABLE ASSEMBLY — Continued

0219 00

1. Remove screw (1), lockwasher (2), and clamp (3) from throttle control cable (4) and weldnut (5) on upper front plate. Discard lockwasher.
2. Remove strap (6) that secures cables together. Discard strap.

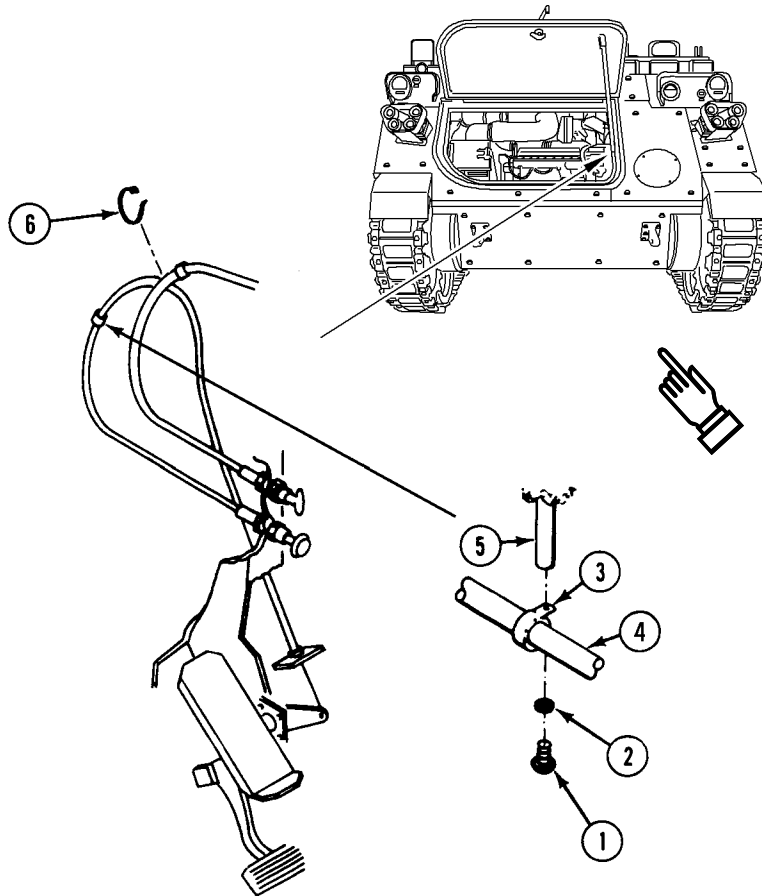

REPLACE HAND THROTTLE CONTROL CABLE ASSEMBLY — Continued

0219 00

3. Loosen set screw (1). Remove cable (2) from collar (3).
4. Remove locknut (4), washer (5), and control cable (2) from bracket (6). Discard locknut.
5. Remove washer (7) and nut (8) from control cable (2).

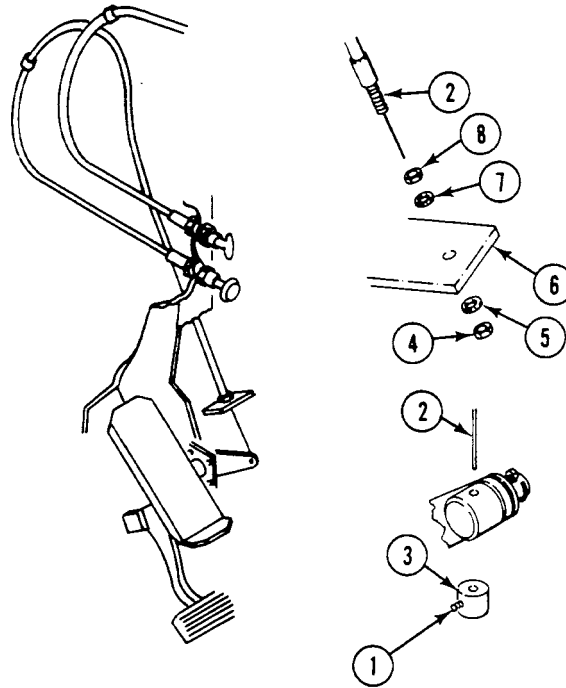

6. Remove nut (9) and washer (10) from control cable handle (11) on driver's compartment bulkhead.
7. Remove control cable (2) from driver's compartment bulkhead.

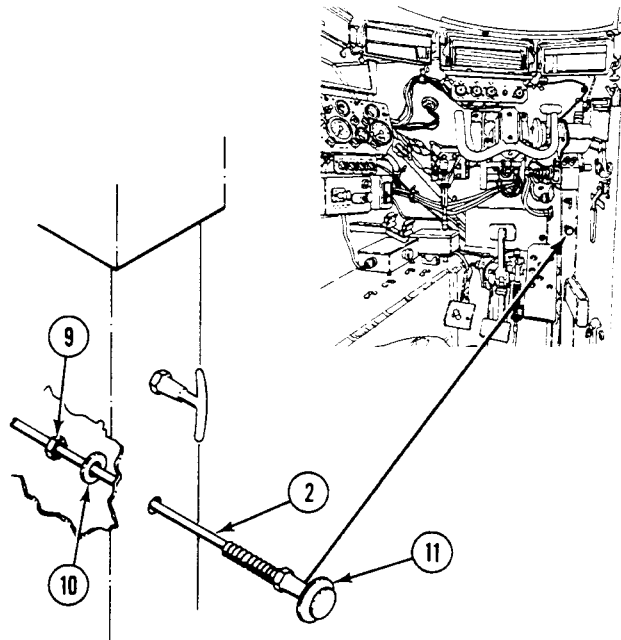

INSTALLATION

1. From driver's compartment, feed control cable (2) through mounting hole in driver's compartment bulkhead to power plant compartment.
2. Install washer (10) and nut (9) on control cable handle (11), and secure control cable (2) to driver's compartment bulkhead.

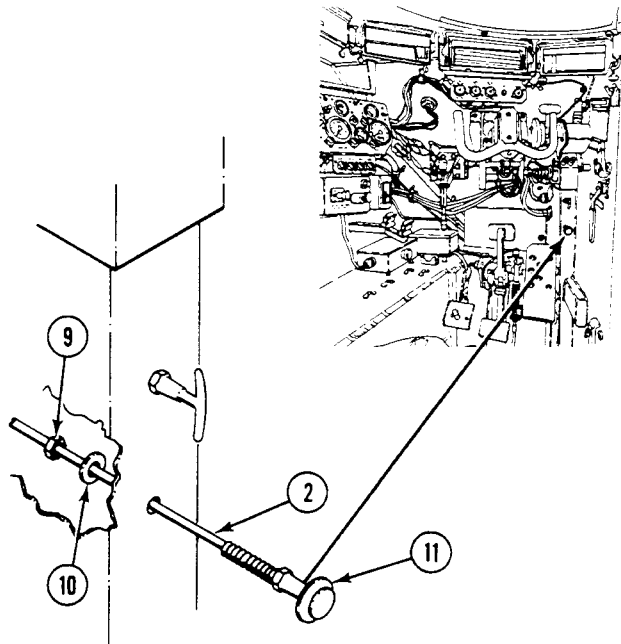

REPLACE HAND THROTTLE CONTROL CABLE ASSEMBLY — Continued**0219 00**

3. Install nut (12) and washer (13) on control cable (2).
4. Feed lower end of control cable (2) through mounting hole in bracket (14) at power plant compartment.
5. Install washer (15) and new locknut (16) on lower end of control cable (2). Secure cable to bracket (14).

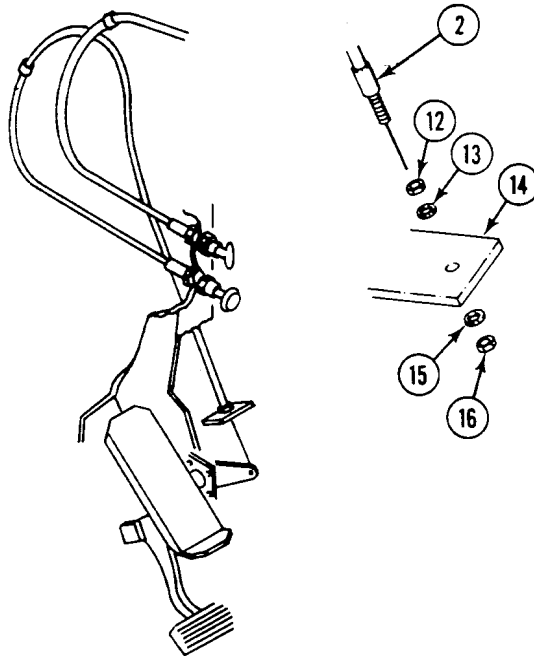

6. Install control cable (1) on collar (2). Tighten set screw (3).
7. Install clamp (4) on control cable (1) and install new lockwasher (5) and screw (6) on weldnut (7).
8. Install new strap (10) securing cables together.

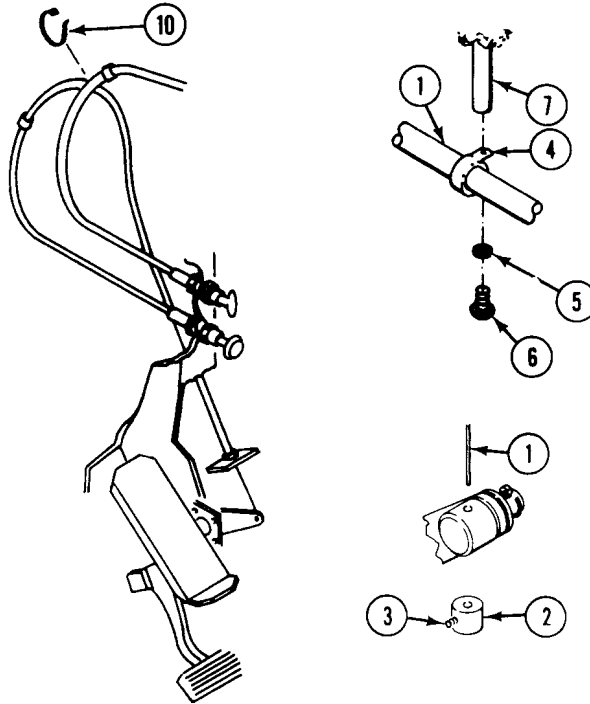

ADJUSTMENT

1. Loosen set screw (3). Push control cable handle (8) full forward.
2. Place accelerator pedal (9) in full closed throttle position. Tighten set screw (3) in collar (2).
3. Operate hand throttle control cable (1) and accelerator pedal. Check that control cable does not bind.

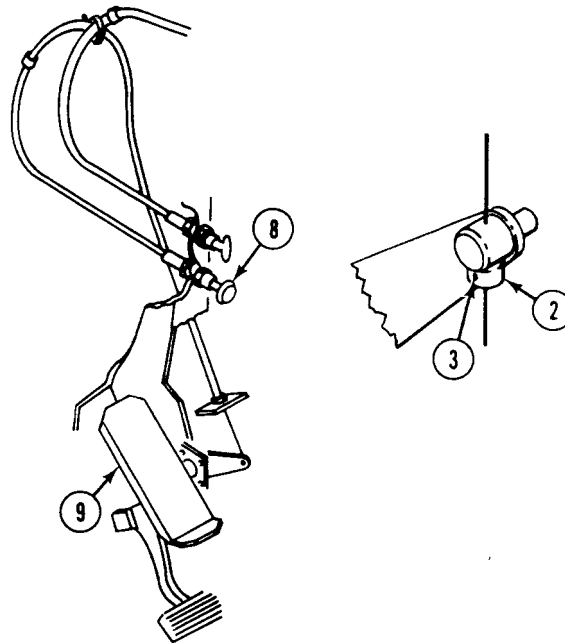
**FOLLOW-THROUGH STEPS**

1. Install hull front access cover (WP 0449 00).
2. Install driver's power plant access panel (WP 0441 00).
3. Close power plant access door. See TM 9-2350-277-10.

END OF TASK

REPLACE FUEL CUTOFF CONTROL CABLE ASSEMBLY

0220 00

THIS WORK PACKAGE COVERS:

- Removal (page 0220 00-1).
 - Installation (page 0220 00-5).
 - Adjustment (page 0220 00-8).
-

INITIAL SETUP:

Maintenance Level

Unit

Tools and Special Tools

General Mechanic's Tool Kit (WP 0926 00, Item 65)

Materials/Parts

- Cotter pin
- Lockwasher
- Tie strap

Personnel Required

- Mechanic
- Helper (H)

References

- TM 9-2350-277-10
- WP 0173 00
- WP 0441 00

Equipment Condition

- Engine stopped (TM 9-2350-277-10)
 - Carrier blocked (TM 9-2350-277-10)
 - Power plant access door open (TM 9-2350-277-10)
 - Driver's power plant access panel removed (WP 0441 00)
 - Air intake elbow removed (WP 0173 00)
-

REMOVAL

REPLACE FUEL CUTOFF CONTROL CABLE ASSEMBLY — Continued

0220 00

1. Remove screw (2), lockwasher (3), clamp (4), and fuel cutoff control cable (5) from weldnut (1) at upper front plate. Discard lockwasher.
2. Remove strap (6) that secures cables together. Discard strap.

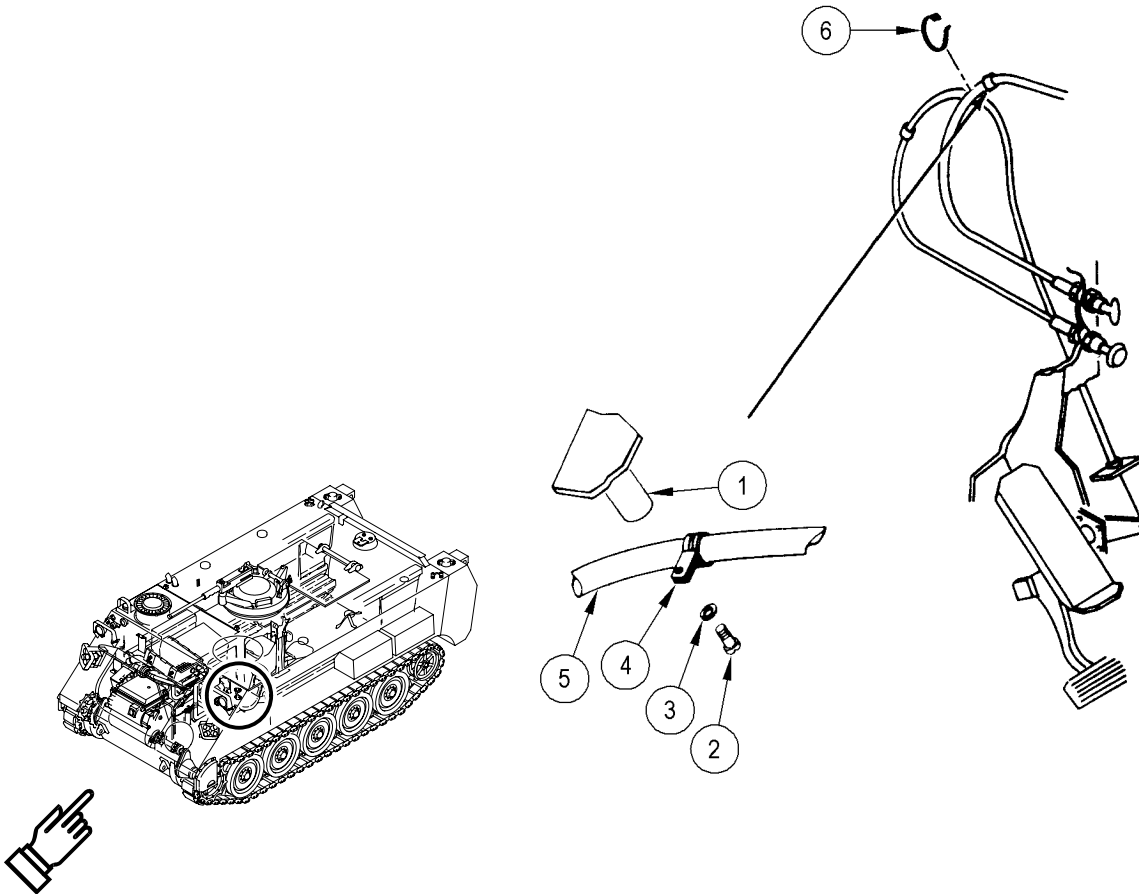

REPLACE FUEL CUTOFF CONTROL CABLE ASSEMBLY — Continued

0220 00

3. Remove cotter pin (1), washer (2), and headless shoulder pin (3) from engine governor fuel control arm (4). Discard cotter pin.
4. Loosen two setscrews (5). Remove two collars (6) and headless shoulder pin (3) from fuel cutoff control cable (7).
5. Remove nut (8), two washers (9), and screw (10), from clamp (11). Pull fuel cutoff control cable (7) from engine governor control housing (12).

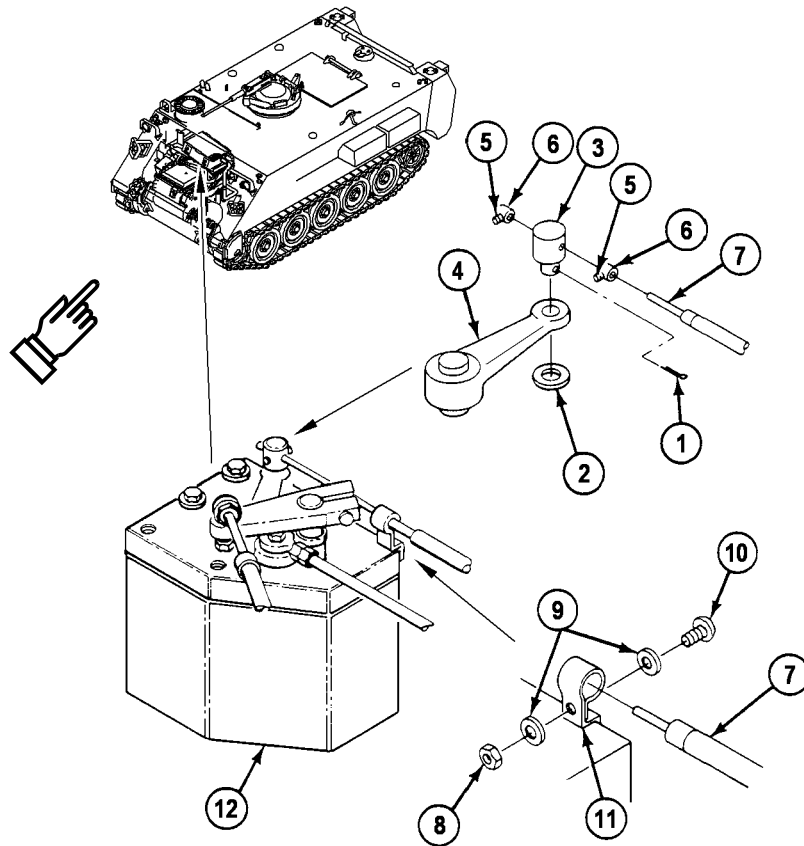

REPLACE FUEL CUTOFF CONTROL CABLE ASSEMBLY — Continued

0220 00

6. From power plant compartment, remove nut (13) and washer (14) from fuel cutoff control cable handle (15).
7. Remove fuel cutoff control cable (7) from driver's compartment bulkhead.

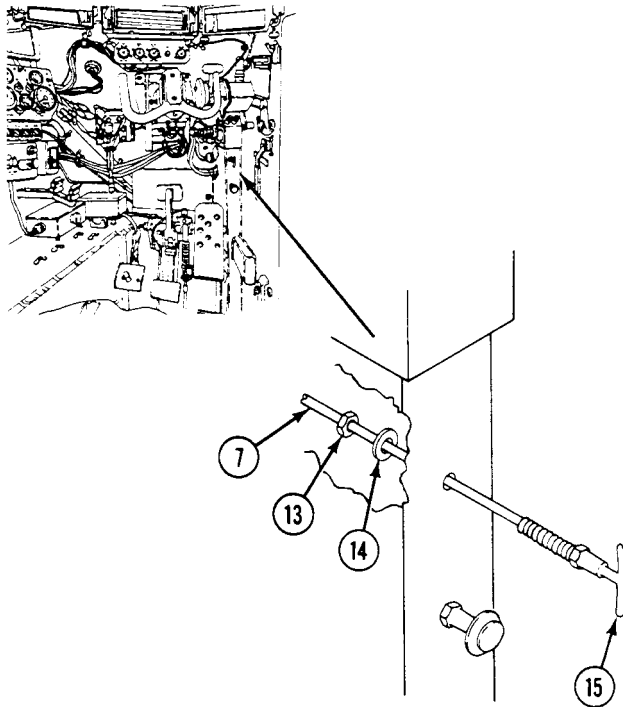

INSTALLATION

1. From driver's compartment, feed fuel cutoff control cable (7) through mounting hole in driver's compartment bulkhead to power plant compartment.
2. Install washer (14) and nut (13) on fuel cutoff control cable handle (15), and secure control cable (7) to driver's compartment bulkhead.

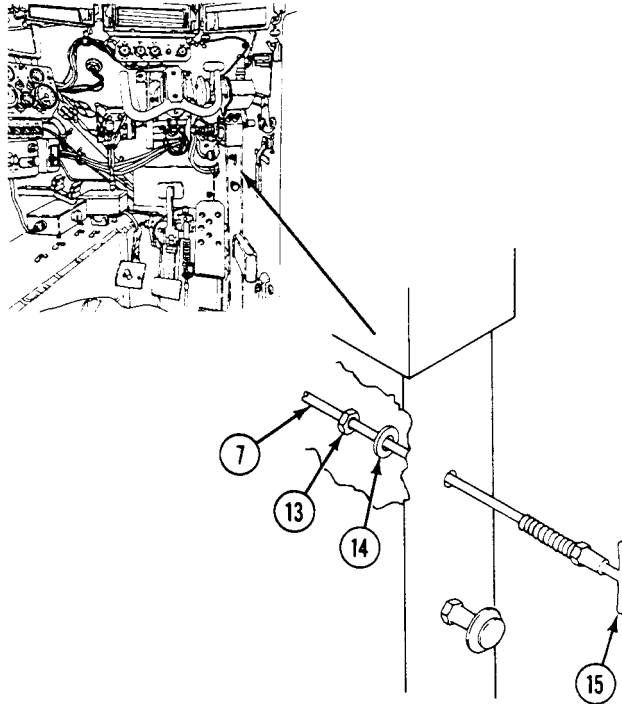

REPLACE FUEL CUTOFF CONTROL CABLE ASSEMBLY — Continued

0220 00

3. Feed fuel cutoff control cable (1) through clamp (2) on engine governor housing (3). Secure with screw (4), two washers (5), and nut (6). Do not tighten at this time.
4. Install headless shoulder pin (7) on fuel control arm (8). Install washer (9) on pin and secure with cotter pin (10).
5. Install one headless collar (11) onto cable (1), and install cable through headless shoulder pin (7). Install second collar (11) onto cable and tighten both collars with setscrew (12).
6. Position cable (1) in clamp (2). With cable pulled out, hold fuel control arm (8) in shut off position and tighten screw (4) and nut (6). Have helper assist.

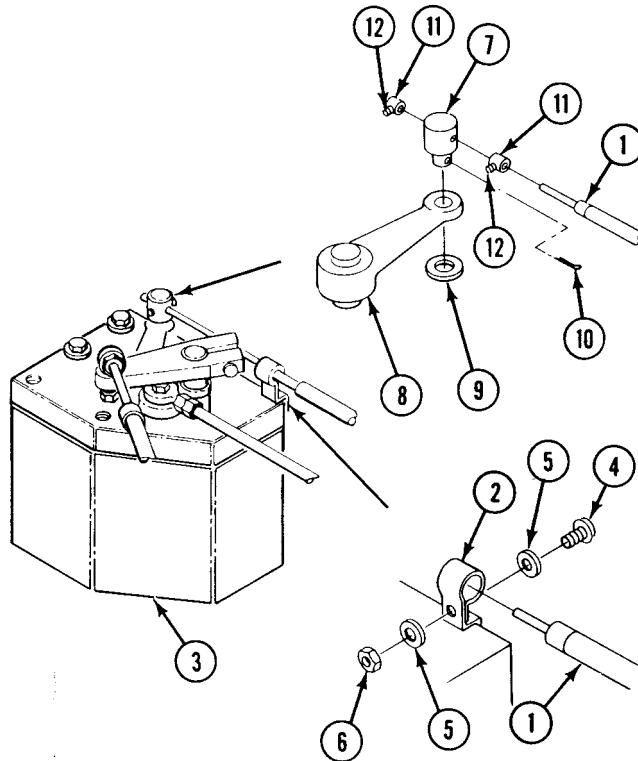

REPLACE FUEL CUTOFF CONTROL CABLE ASSEMBLY — Continued**0220 00**

7. Install clamp (13), control cable (1), new lockwasher (14), and screw (15) on weldnut (16).
8. Install new strap (17) securing cables together.

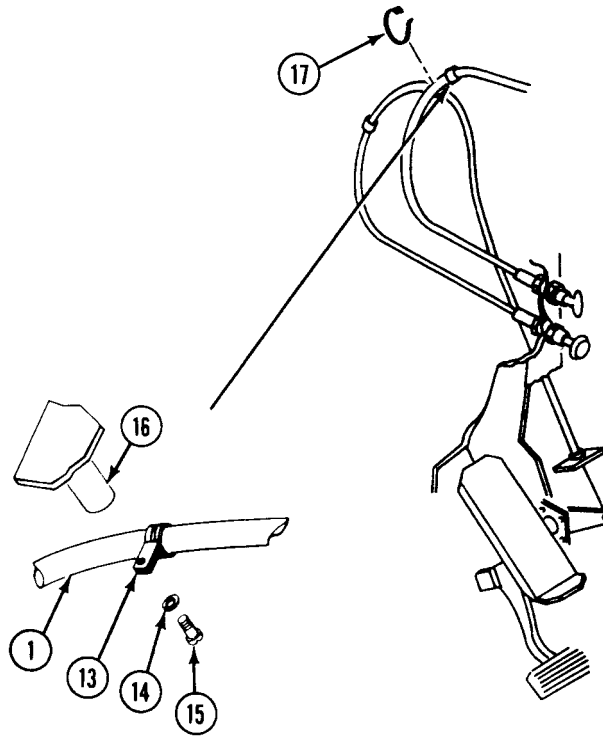

ADJUSTMENT

1. Pull fuel cutoff control cable handle (1) to full out position.

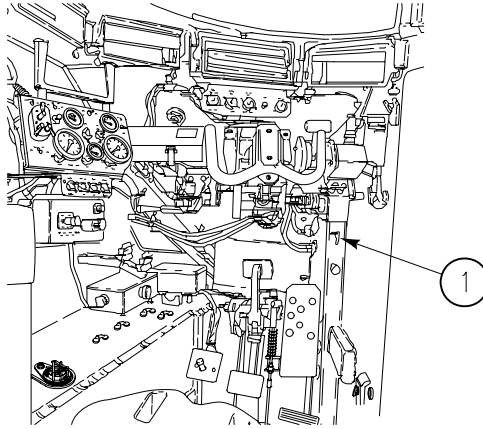

2. Rotate fuel control arm (2) to full clockwise position.
3. Reset two collars (3). Place collars (3) on each side of pin (4) and secure with two setscrews (5).

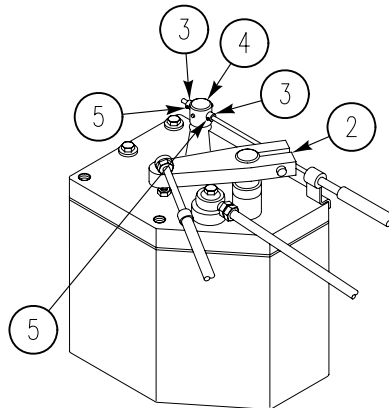
**FOLLOW-THROUGH STEPS**

1. Install air intake elbow (WP 0173 00).
2. Install driver's power plant access panel (WP 0441 00).
3. Close power plant access door. See TM 9-2350-277-10.

END OF TASK

CHAPTER 6

UNIT MAINTENANCE INSTRUCTIONS
FOR EXHAUST SYSTEM

WORK PACKAGE INDEX

<u>Title</u>	<u>Sequence No.</u>
REPLACE ENGINE EXHAUST ELBOWS AND DOUBLE FLEX JOINT.....	0221 00
REPAIR DOUBLE FLEX EXHAUST JOINT.....	0222 00
REPLACE MUFFLER EXTENSION AND CAP.....	0223 00
REPLACE EXHAUST MUFFLER AND BRACKET.....	0224 00
REPLACE ENGINE LEFT/RIGHT EXHAUST ELBOWS.....	0225 00
REPLACE LEFT/RIGHT TURBO EXHAUST PIPE HEAT SHIELD.....	0226 00

REPLACE ENGINE EXHAUST ELBOWS AND DOUBLE FLEX JOINT

0221 00

THIS WORK PACKAGE COVERS:

Removal (page 0221 00-1).
 Installation (page 0221 00-3).

INITIAL SETUP:

Maintenance Level

Unit

References

TM 9-2350-277-10
 WP 0464 00

Tools and Special Tools

General Mechanic's Tool Kit (WP 0926 00, Item 65)
 Torque Wrench (WP 0926 00, Item 79)

Equipment Condition

Engine stopped (TM 9-2350-277-10)
 Carrier blocked (TM 9-2350-277-10)
 Power plant access door open (TM 9-2350-277-10)
 Power plant grill raised (WP 0464 00)

Materials/Parts

Gasket (2)

Personnel Required

Mechanic

REMOVAL

WARNING



Hot exhaust pipes can burn you. Let power unit cool before you start work.

1. Loosen two V-clamps (1) that secure double flex joint (2) to two exhaust elbows (3) and (4).
2. Remove clamp (5) from elbow (3) and engine turbocharger. Remove elbow from turbocharger.
3. Remove clamp (6) from elbow (4) and muffler (7). Remove elbow from muffler.
4. Remove two V-clamps (1) and double flex joint (2) from elbows (3) and (4).
5. Remove two V-clamps (1), gaskets (8), and retainers (9) from double flex joint (2). Discard gaskets.

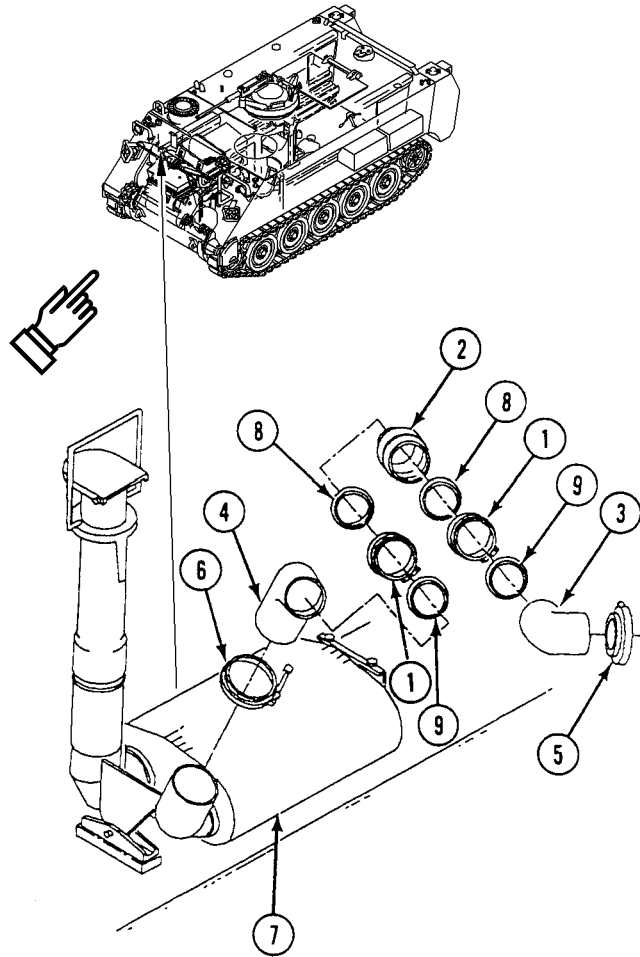

INSTALLATION

1. Install elbow (1) and clamp (2) on muffler (3).
2. Install two V-clamps (4), new gaskets (5), and retainers (6) on double flex joint (7).
3. Install double flex joint (7) and two clamps (4) on elbows (1) and (8).
4. Install elbow (8) and clamp (9) on turbocharger. Tighten clamps (2) and (9).
5. Rap clamp firmly with mallet while tightening nut and bolt on two clamps (4). TORQUE NUT TO 36-53 LB-IN (4-6 N·M). Use torque wrench.

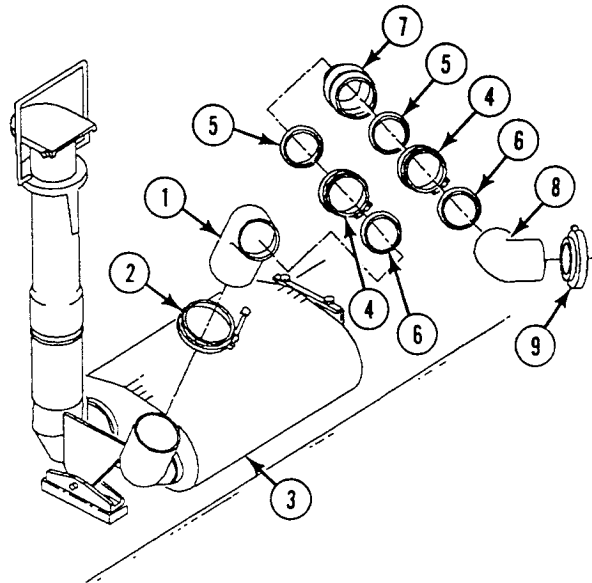
**FOLLOW-THROUGH STEPS**

1. Lower power plant grill (WP 0464 00).
2. Close power plant access door. See TM 9-2350-277-10.

END OF TASK

REPAIR DOUBLE FLEX EXHAUST JOINT

0222 00

THIS WORK PACKAGE COVERS:

Removal (page 0222 00-1).
 Installation (page 0222 00-2).

INITIAL SETUP:

Maintenance Level

Unit

References

See your -10

Tools and Special Tools

General Mechanic's Tool Kit (WP 0926 00, Item 65)

Equipment Condition

Engine stopped (see your -10)

Materials/Parts

Gasket (2)

Carrier blocked (see your -10)

Personnel Required

Unit Mechanic

Double flex joint removed (WP 0221 00)

REMOVAL

NOTE

The double flex exhaust joint can be repaired by replacing the clamp, gasket, or retainer.

1. Remove two clamps (1), gasket retainers (2), and gaskets (3) from double flex joint (4). Discard gaskets.

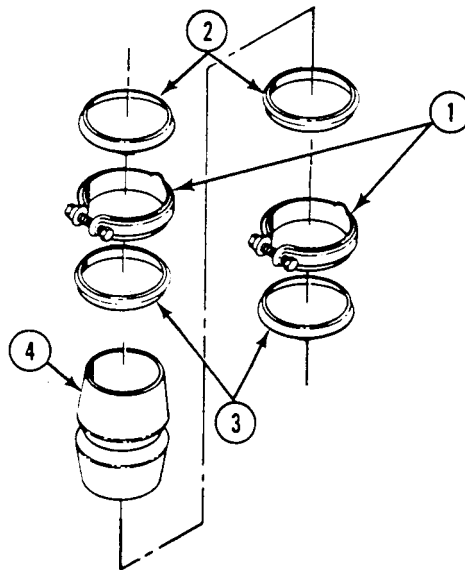

INSTALLATION

1. Install two clamps (1), gasket retainers (2), and new gaskets (3) on double flex joint (4).

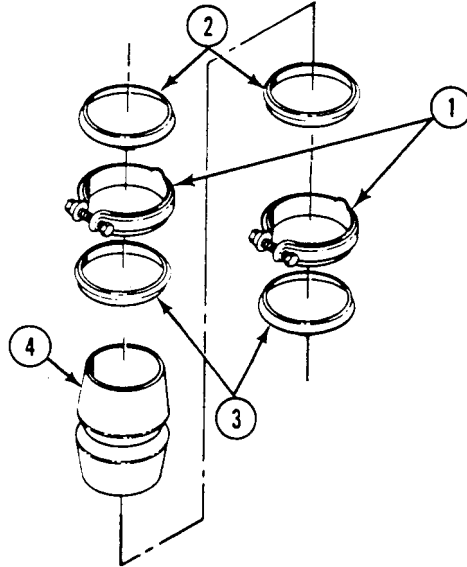
**FOLLOW-THROUGH STEPS**

1. Install double flex joint (WP 0221 00).

END OF TASK

REPLACE MUFFLER EXTENSION AND CAP

0223 00

THIS WORK PACKAGE COVERS:

Removal (page 0223 00-1).
Installation (page 0223 00-3).

INITIAL SETUP:

Maintenance Level

Unit

References

TM 9-2350-277-10

Tools and Special Tools

General Mechanic's Tool Kit (WP 0926 00, Item 65)

Equipment Condition

Engine stopped (TM 9-2350-277-10)

Carrier blocked (TM 9-2350-277-10)

Power plant access door open (TM 9-2350-277-10)

Materials/Parts

Cotter pin

Lockwasher (4)

Personnel Required

Mechanic

REMOVAL

WARNING



Hot exhaust pipes can burn you. Let power unit cool before you start work.

REPLACE MUFFLER EXTENSION AND CAP — Continued**0223 00**

1. Remove four screws (1), lockwashers (2) and washers (3) that secure exhaust extension pipe (4) to power plant grill. Remove pipe from grill and muffler (5). Discard lockwashers.
2. Remove cotter pin (6), pin (7), and cap (8) from exhaust extension pipe (4). Discard cotter pin.

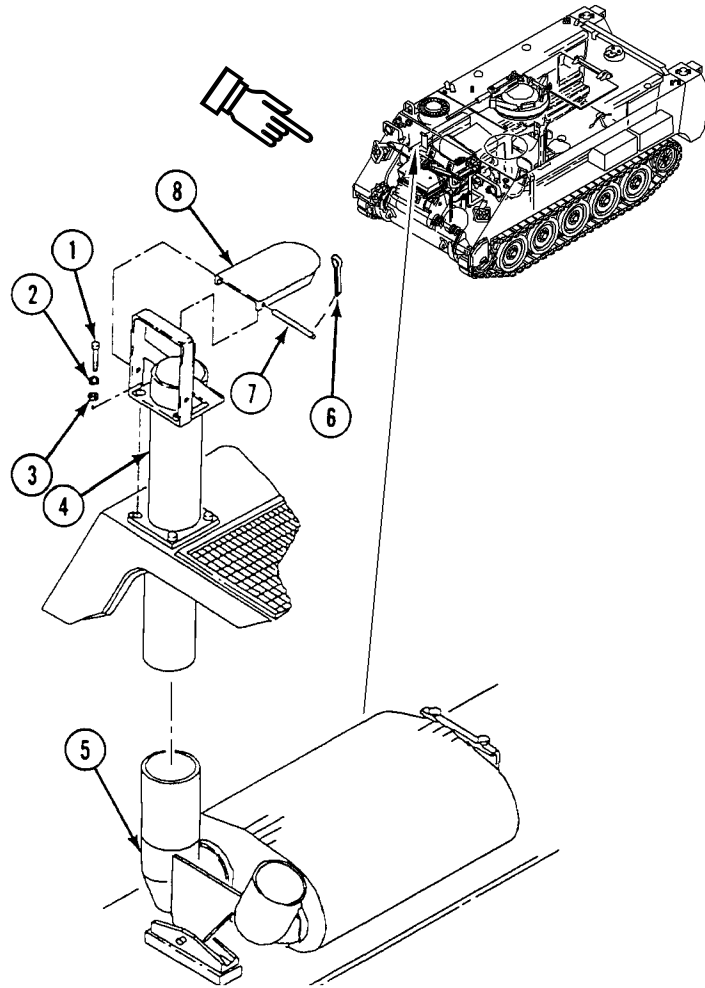

INSTALLATION

1. Install cap (8) on exhaust extension pipe (4). Secure with pin (7) and new cotter pin (6).
2. Install extension pipe (4) on muffler (5) and grill. Secure with four washers (3), lockwashers (2), and screws (1).

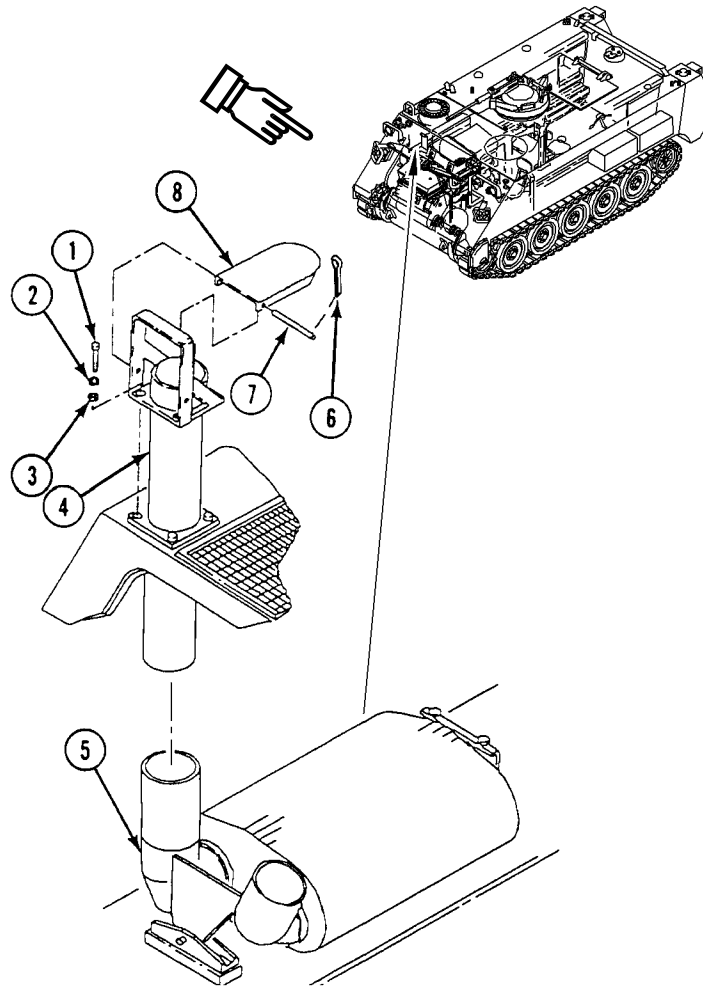
**FOLLOW-THROUGH STEPS**

1. Start engine. See TM 9-2350-277-10.
2. Check for leaks.
3. Stop engine. See TM 9-2350-277-10.
4. Close power plant access door. See TM 9-2350-277-10.

END OF TASK

REPLACE EXHAUST MUFFLER AND BRACKET

0224 00

THIS WORK PACKAGE COVERS:

Removal (page 0224 00-1).
 Installation (page 0224 00-2).

INITIAL SETUP:

Maintenance Level

Unit

Tools and Special Tools

General Mechanic's Tool Kit (WP 0926 00, Item 65)

Materials/Parts

Cotter pin
 Locknut (2)
 Lockwasher (2)

Personnel Required

Mechanic

References

TM 9-2350-277-10
 WP 0221 00
 WP 0223 00
 WP 0464 00

Equipment Condition

Engine stopped (TM 9-2350-277-10)
 Carrier blocked (TM 9-2350-277-10)
 Power plant access door open (TM 9-2350-277-10)
 Power plant grill raised (WP 0464 00)
 Exhaust elbows removed (WP 0221 00)
 Muffler extension and cap removed (WP 0223 00)

REMOVAL

1. Remove two screws (1), four washers (2), and two locknuts (3) that secure muffler (4) to bracket on hull. Discard locknuts.
2. Loosen clamp (5) securing muffler (4) to connector on air cleaner.
3. Remove two screws (6), lockwashers (7), and washers (8) that secure bracket (9) to sponson. Remove muffler (4) from carrier. Discard lockwashers.
4. Remove cotter pin (10) and straight headed pin (11) from muffler (4) and bracket (9). Remove bracket. Discard cotter pin.

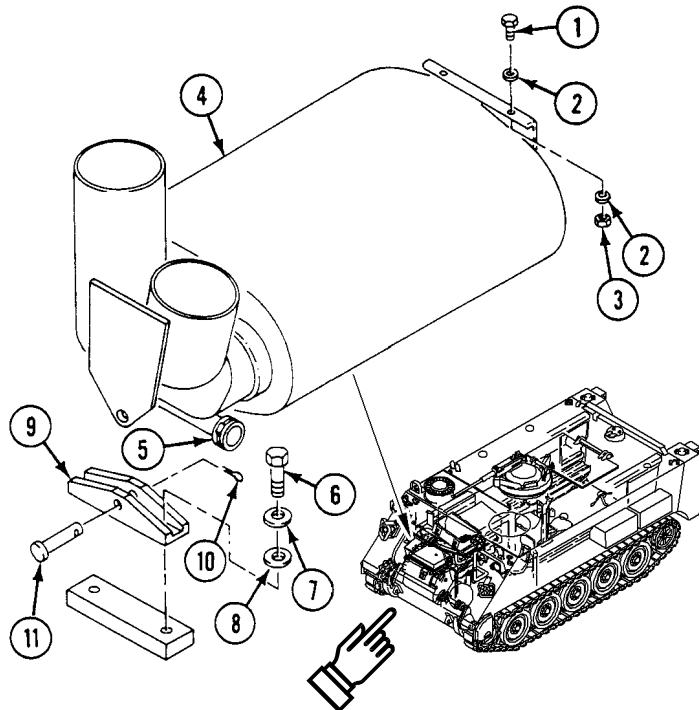

0224 00-1

INSTALLATION

1. Install bracket (9) on muffler (4) with pin (11) and new cotter pin (10).
2. Install muffler (4) in carrier. Secure muffler and bracket (9) to sponson with two screws (6), new lockwashers (7), and washers (8).
3. Tighten clamp (5) securing muffler (4) to connector on air cleaner.
4. Secure muffler (4) to hull bracket with two screws (1), four washers (2), and two new locknuts (3).

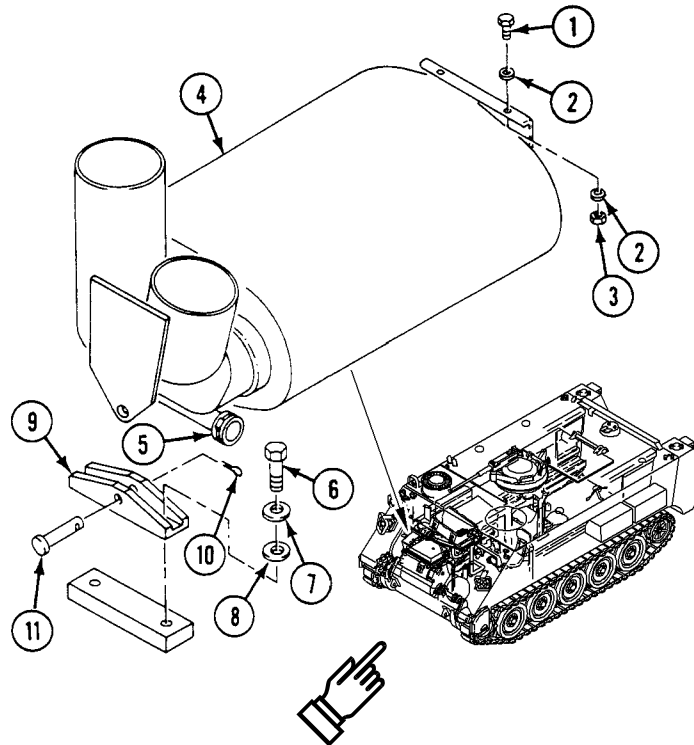
**FOLLOW-THROUGH STEPS**

1. Install muffler extension and cap (WP 0223 00).
2. Install exhaust elbows (WP 0221 00).
3. Lower power plant grill (WP 0464 00).
4. Close power plant access door. See TM 9-2350-277-10.

END OF TASK

REPLACE ENGINE LEFT/RIGHT EXHAUST ELBOWS

0225 00

THIS WORK PACKAGE COVERS:

Removal (page 0225 00-1).
 Installation (page 0225 00-2).

INITIAL SETUP:

Maintenance Level

Unit

Tools and Special Tools

General Mechanic's Tool Kit (WP 0926 00, Item 65)

Personnel Required

Mechanic

References

TM 9-2350-277-10
 WP 0226 00

Equipment Condition

Engine stopped (TM 9-2350-277-10)
 Carrier blocked (TM 9-2350-277-10)
 Power plant access door open (TM 9-2350-277-10)
 Air cleaner removed to access right elbow (WP 0168 00)
 Driver's power plant access panel removed to access left elbow (WP 0441 00)

REMOVAL

NOTE

Left elbow is shown only.

1. Loosen two clamps (1) and remove elbow hose (2) from air cleaner (3) and turbo (4).

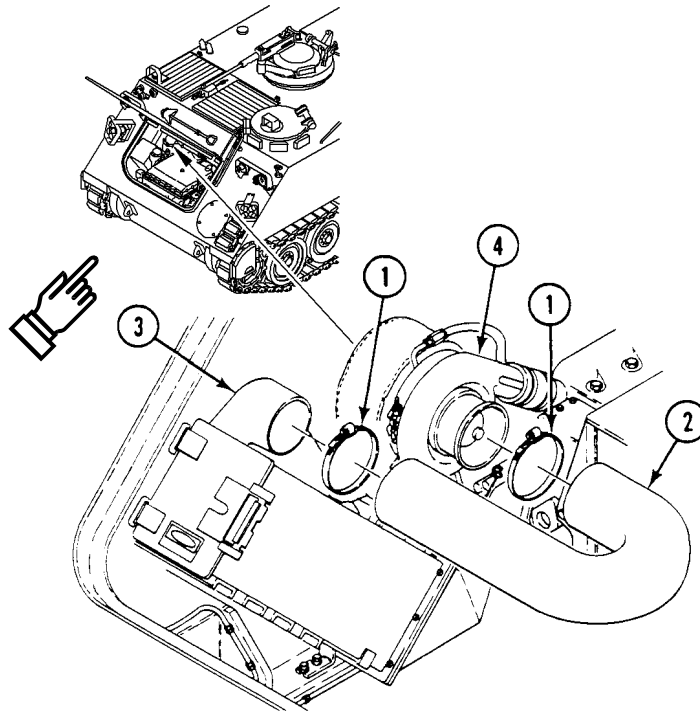

2. Remove two clamps (5) from exhaust inlet tube (6).
3. Remove exhaust inlet tube (6) from inlet tee (7) and exhaust manifold (8).
4. Remove turbo exhaust pipe heat shield (WP 0226 00).

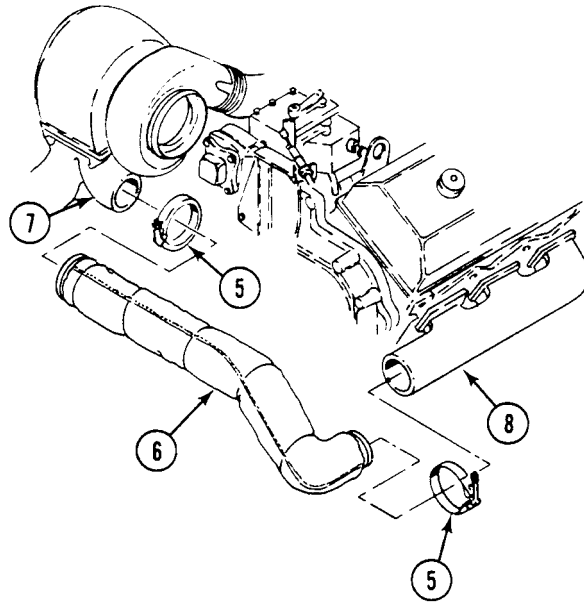

INSTALLATION

NOTE

Left elbow is shown only.

1. Install turbo exhaust pipe heat shield (WP 0226 00).
2. Install exhaust inlet tube (1) on inlet tee (2) and exhaust manifold (3).
3. Install and tighten two clamps (4) on exhaust inlet tube (1).

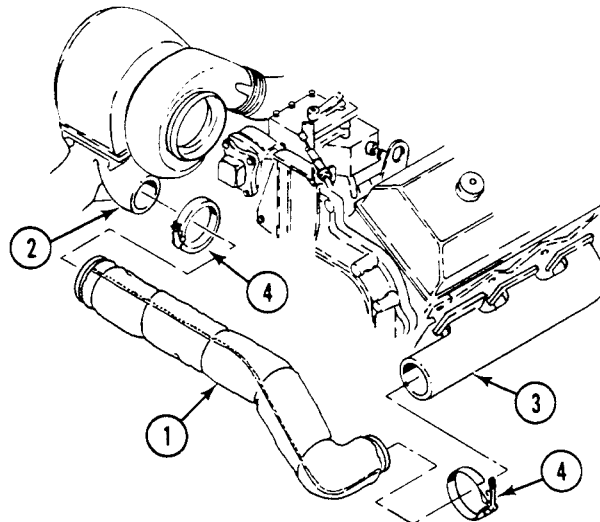

4. Install elbow hose (5) on turbo (6) and air cleaner (7). Secure with two clamps (8).

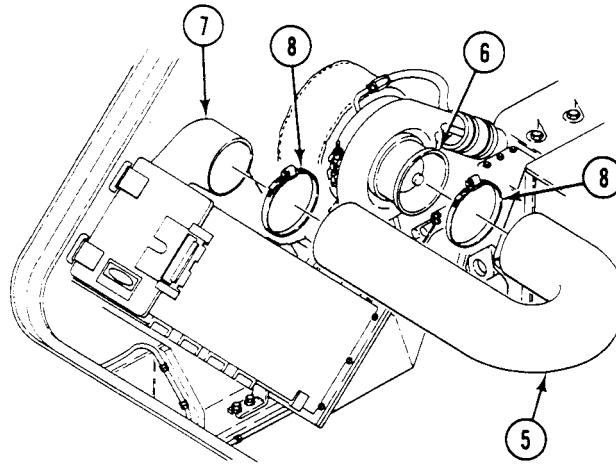
**FOLLOW-THROUGH STEPS**

1. Install driver's power plant access panel, if necessary (WP 0441 00).
2. Install air cleaner, if necessary (WP 0168 00).
3. Close power plant access door. See TM 9-2350-277-10.

END OF TASK

REPLACE LEFT/RIGHT TURBO EXHAUST PIPE HEAT SHIELD

0226 00

THIS WORK PACKAGE COVERS:

Removal (page 0226 00-1).
 Installation (page 0226 00-3).

INITIAL SETUP:

Maintenance Level

Unit

Equipment Condition

Engine stopped (TM 9-2350-277-10)
 Carrier blocked (TM 9-2350-277-10)
 Power plant access door open (TM 9-2350-277-10)
 Air cleaner removed to work on right shield
 (WP 0168 00)
 Driver's power plant access panel removed to work on
 left shield (WP 0441 00)

Tools and Special Tools

General Mechanic's Tool Kit (WP 0926 00, Item 65)

Materials/Parts

Nonelectrical wire (WP 0928 00, Item 42)

Personnel Required

Mechanic

References

TM 9-2350-277-10

REMOVAL

WARNING



Sharp edge safety wire can cut your fingers. Make sure to twist end of wire and bend back close to the attaching hole.

NOTE

Left and right insulation covers are removed and installed the same way. Left insulation cover is shown only.

REPLACE LEFT/RIGHT TURBO EXHAUST PIPE HEAT SHIELD — Continued**0226 00**

1. Cut and remove wire (1) connecting capstans (2) on insulation cover (3). Discard wire.
2. Remove insulation cover (3) from exhaust tube (4).

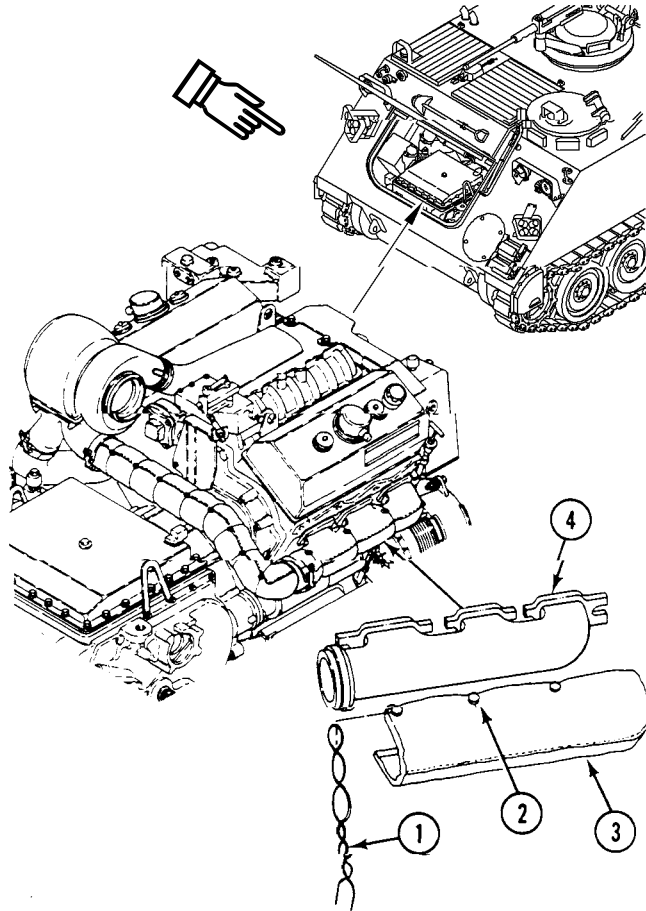

INSTALLATION

1. Wrap new insulation cover (1) around exhaust tube (2).
2. Cut new wire (3) to appropriate length and make two loops at the middle of length around capstan (4) on one half of insulation cover (1).
3. Pull wire ends (3) toward corresponding capstan (4) on other half of cover (1). Twist one wire around other to form a figure eight.
4. Cross ends of wire (3) behind second capstan (4).
5. Wind wire ends (3) to approximately 3/4 inch (19 mm) and cut off.
6. Bend wound ends back around capstan (4) hole.
7. Repeat Steps 4 - 7 to tie remaining sets of capstans (4) together. Check to make sure that seams are firmly pulled together.

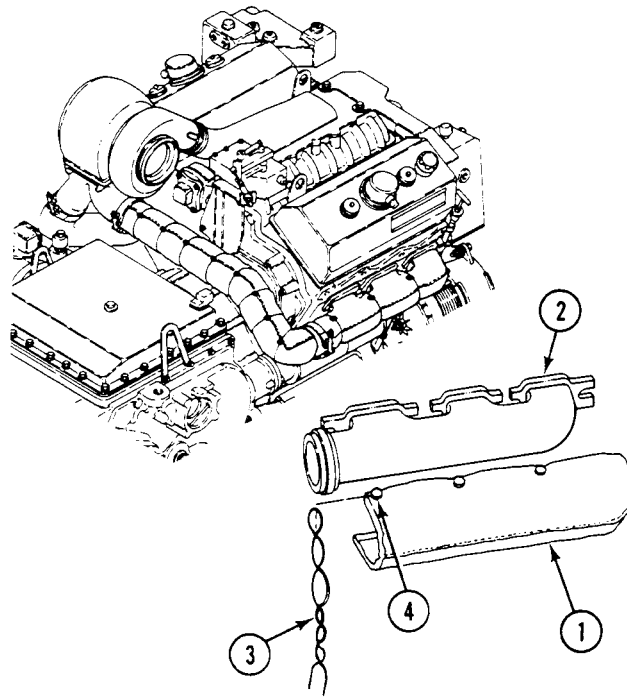
**FOLLOW-THROUGH STEPS**

1. Install driver's power plant access panel, if necessary (WP 0441 00).
2. Install air cleaner, if necessary (WP 0168 00).
3. Close power plant access door. See TM 9-2350-277-10.

END OF TASK

CHAPTER 7

UNIT MAINTENANCE INSTRUCTIONS
FOR COOLING SYSTEM

WORK PACKAGE INDEX

<u>Title</u>	<u>Sequence No.</u>
DRAIN AND FILL COOLING SYSTEM.....	0227 00
CLEAN RADIATOR.....	0228 00
REPLACE RADIATOR AND PARTS.....	0229 00
REPLACE AUXILIARY TANK.....	0230 00
REPLACE THERMOSTATIC FAN SPEED SWITCH (OLD CONFIGURATION).....	0231 00
REPLACE VARIABLE SPEED FAN DRIVE VALVE AND OVERRIDE SWITCH (NEW CONFIGURATION).....	0231 01
REPLACE UPPER COOLANT HOSE AND TUBE.....	0232 00
REPLACE RADIATOR OUTLET TUBE AND HOSES.....	0233 00
REPLACE BALANCE HOSE.....	0234 00
REPLACE DRAIN COCK AND HOSE.....	0235 00
REPLACE COOLANT AIR SEPARATOR.....	0236 00
REPLACE THERMOSTAT/COVER.....	0237 00
REPLACE THERMOSTAT TUBE/HOSES.....	0238 00
ADJUST COOLANT PUMP BELTS.....	0239 00
REPLACE COOLANT PUMP IDLER PULLEY/BELTS.....	0240 00
REPLACE ENGINE COOLANT PUMP.....	0241 00
ADJUST VENTILATING FAN DRIVE BELT.....	0242 00
REPLACE VENTILATING FAN DRIVE BELT.....	0243 00
REPLACE VENTILATING FAN DRIVE PULLEY.....	0244 00
REPLACE FLAT PULLEYS AND BEARINGS.....	0245 00
REPLACE IDLER ARM AND SPRING TENSIONER.....	0246 00
REPLACE VENTILATING FAN ASSEMBLY.....	0247 00
REPLACE FAN DRIVE SHAFT AND BEARING HOUSING.....	0248 00
REPLACE FAN AND GENERATOR VARIABLE SPEED DRIVE (OLD CONFIGURATION).....	0249 00
REPLACE VARIABLE SPEED FAN DRIVE ASSEMBLY (NEW CONFIGURATION).....	0249 01
REPLACE HOSES FROM THERMOSTAT TO VARIABLE SPEED DRIVE (OLD CONFIGURATION).....	0250 00
REPLACE VARIABLE SPEED FAN DRIVE CONTROLLER (NEW CONFIGURATION).....	0250 01
REPLACE TRANSMISSION OIL SUPPLY AND RETURN HOSES (OLD CONFIGURATION).....	0251 00
REPLACE HOSE FROM VARIABLE SPEED FAN DRIVE OVERRIDE SWITCH TO VSFD DRIVE (NEW CONFIGURATION).....	0251 01

DRAIN AND FILL COOLING SYSTEM

0227 00

THIS WORK PACKAGE COVERS:

Service (page 0227 00-2).

INITIAL SETUP:

Maintenance Level

Unit

Tools and Special Tools

- General Mechanic's Tool Kit (WP 0926 00, Item 65)
- Radiator filling can (WP 0926 00, Item 12)
- Suitable Container (14 gallon)
- Antifreeze and battery tester (WP 0926 00, Item 8.1)

Materials/Parts

- Antifreeze (WP 0928 00, Item 10)

Personnel Required

- Unit Mechanic

References

- See your -10
- See your PMCS
- TB 750-651

Equipment Condition

- Engine stopped (see your -10) ■
 - Carrier blocked (see your -10)
 - Power plant bottom access cover removed (WP 0450 00)
 - Power plant lower rear access panel removed (see your -10)
-

SERVICING

COMPLETE DRAIN

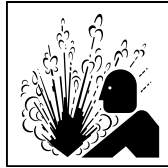
WARNING

Hot radiator coolant can burn you. Use hand to remove cap **ONLY** if cool to touch. Turn cap slowly to release pressure. Replace cap by pressing down and turning until tight.

CAUTION

Coolant in the cooling system must flow freely. If rust, scale, or sediment prevent the free flow of coolant, flush system per TB 750-651. This is to be done only as necessary.

1. Open coolant filler cap cover (1) on power plant grill (2).
2. Remove coolant filler cap (3) from auxiliary tank (4).

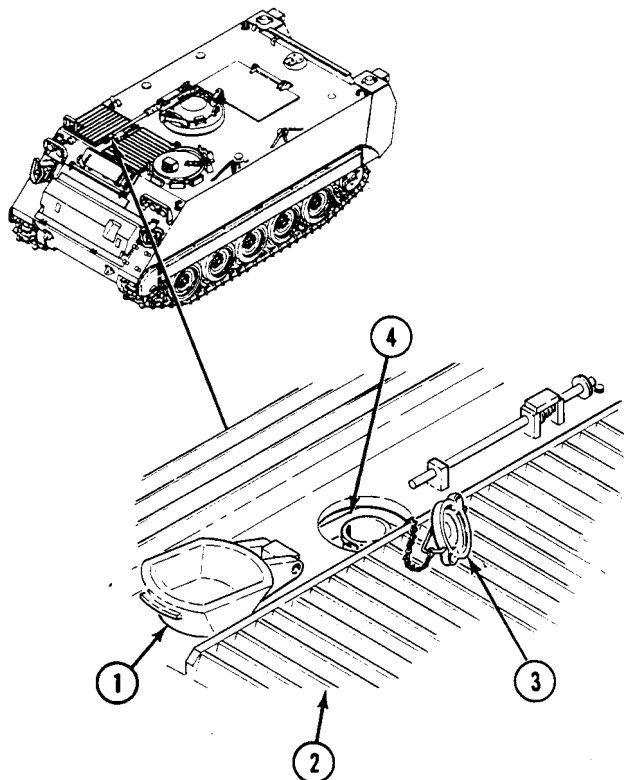

3. Place clean container under engine compartment bottom access opening.
4. Route end of drain hose (1) out through engine compartment bottom access opening.
5. Open drain cock (2) at radiator outlet tube (3) and drain hose (1).
6. After system is drained, close drain cock (2) and install engine compartment bottom access opening. Save coolant for reuse, unless check shows coolant should be changed.

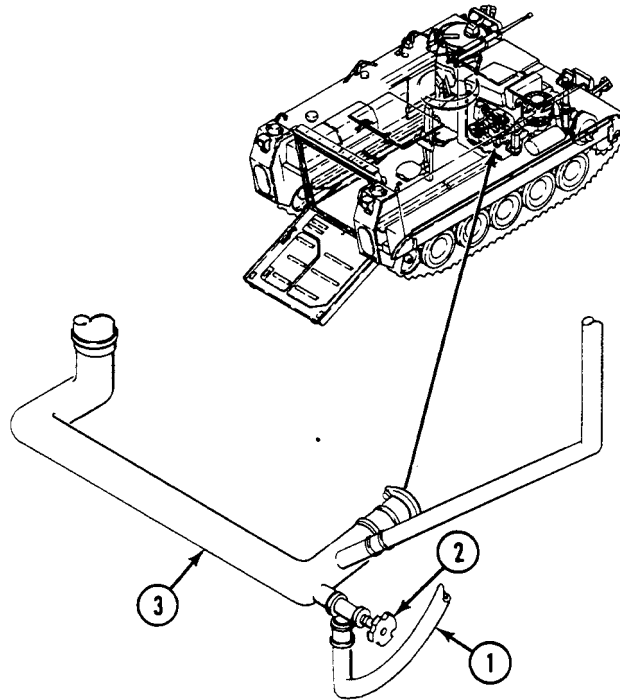

FILL COOLING SYSTEM

CAUTION

If not filling coolant system immediately, tag master switch to warn others that engine coolant has been drained.

NOTE

Use coolant in system at all times. It will reduce corrosion in engine block and cooling system parts. Ethylene glycol coolant will provide low temperature protection. Mix coolant and clean water based on protection label on container.

When filling the auxiliary tank, add coolant slowly to allow trapped air to escape.

1. Fill system with coolant. Bring coolant level to COLD mark of filler neck.
2. Install coolant filler cap (4) on auxiliary tank (5).
3. Close coolant filler cap cover (6) on power plant grill (7).

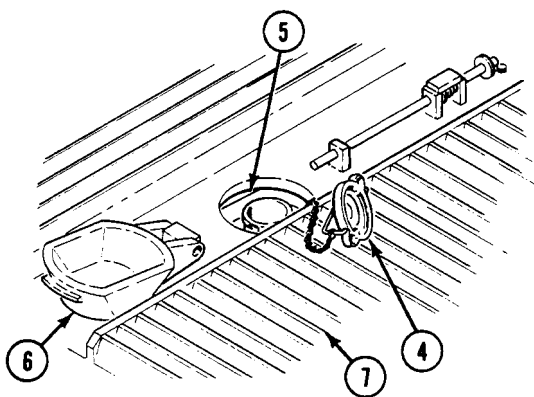
**CAUTION**

Do not operate engine if temperature is 230°F (110°C) or above. Serious engine damage will occur.

4. Start and run engine until operating temperature of 180° to 230°F (82° to 110°C) is reached.

CAUTION

If engine coolant temperature gage reading is above 230°F (110°C), stop engine (see you -10) and allow it to cool.

Check the following for cause of engine overheat:

Make sure air cleaner element is clean and installed right (see your -10).

Check fan belts (WP 0242 00) for correct adjustment.

Check radiator and air intake grill air passages. Clean and remove debris preventing free movement of air (see your -10).

Check engine oil level. Check for right grade of oil (WP 0155 00).

5. Stop engine and allow it to cool (see your -10).

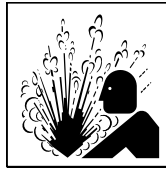
WARNING

Hot radiator coolant can burn you. Use hand to remove cap ONLY if cool to touch. Turn cap slowly to release pressure. Replace cap by pressing down and turning until tight.

6. Add coolant as necessary to bring level to COLD mark of filler neck (1). Check for leaks.

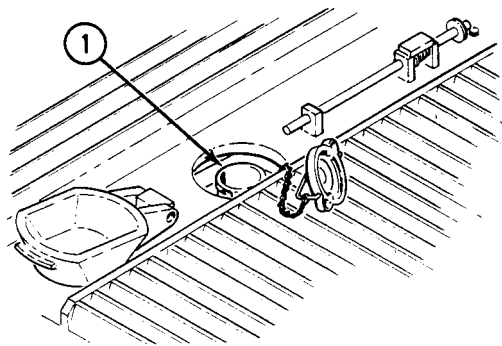
**FOLLOW-THROUGH STEPS**

1. Install power plant bottom access cover (WP 0450 00).
2. Install power plant lower rear access panel (see your -10).

END OF TASK

CLEAN RADIATOR

0228 00

THIS WORK PACKAGE COVERS:

Cleaning (page 0228 00-1).

INITIAL SETUP:

Maintenance Level

Unit

Tools and Special Tools

- General Mechanic's Tool Kit (WP 0926 00, Item 65)
- Radiator Cleaning Tool (WP 0926 00, Item 13)
- Suitable Container

Materials/Parts

- General purpose detergent (WP 0928 00, Item 35)

Personnel Required

Mechanic

References

- TM 9-2350-277-10
- WP 0439 00
- WP 0441 00
- WP 0450 00

Equipment Condition

- Engine stopped (TM 9-2350-277-10)
- Carrier blocked (TM 9-2350-277-10)
- Power plant access door open (TM 9-2350-277-10)
- Power plant rear access panels removed (WP 0439 00)
- Driver's power plant access panel removed (WP 0441 00)
- Power plant bottom access cover removed (WP 0450 00)

CLEANING

1. Loosen two bolts (1) and clamps (2). Remove radiator access panel (3) from power plant compartment bulkhead.

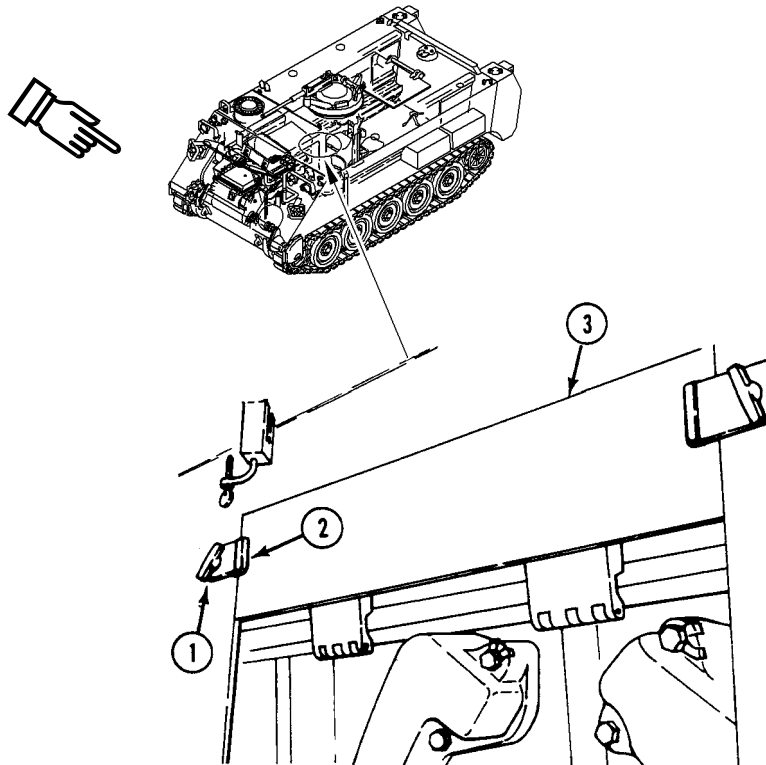

2. Release two fasteners (4) securing radiator access door (5) to radiator opening. Open door.
3. Cover exposed engine openings.
4. Mix one part detergent to five parts water in a clean container.
5. Submerge end of radiator cleaner siphon tube in detergent solution.

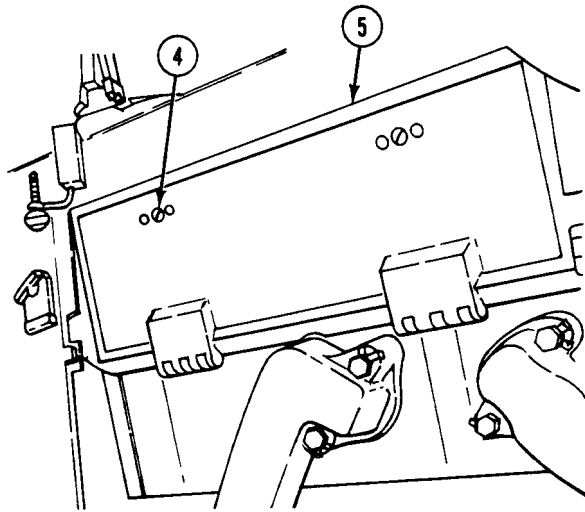

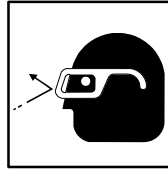
WARNING

Air pressure in excess of 30 psi (207 kpa) can injure personnel. Do not direct pressurized air at yourself or others. Always wear goggles.

6. Attach radiator cleaning tool to available air supply.
7. Clean sand, oil, and debris from radiator.
8. Rinse radiator with clear water.
9. Remove siphon hose from detergent solution.
10. Remove excess water with available air supply.
11. Uncover exposed engine openings.

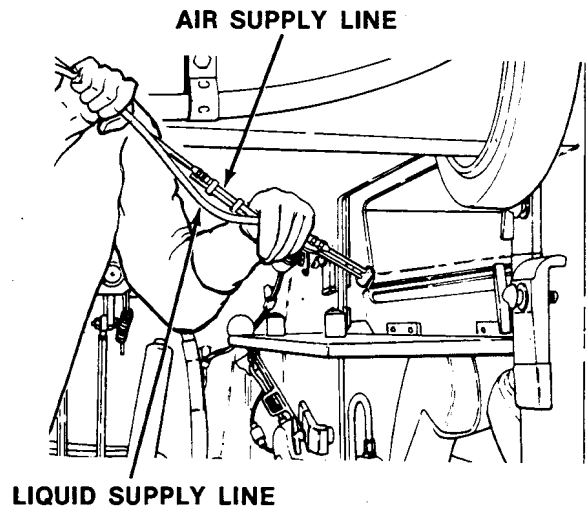

12. Secure radiator access door (1) to radiator opening with two fasteners (2).

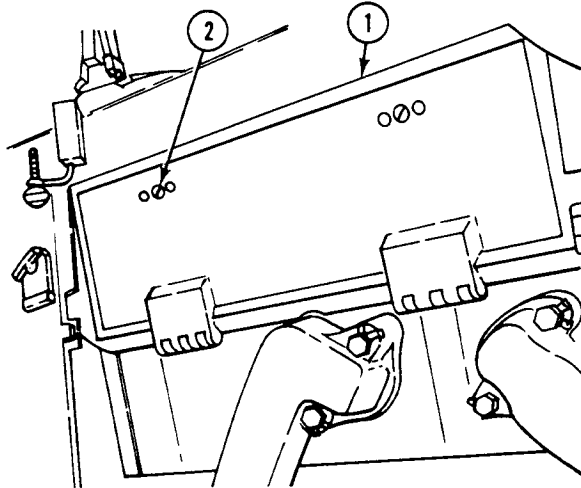

13. Secure radiator access panel (3) to power plant compartment bulkhead with two clamps (4) and bolts (5).

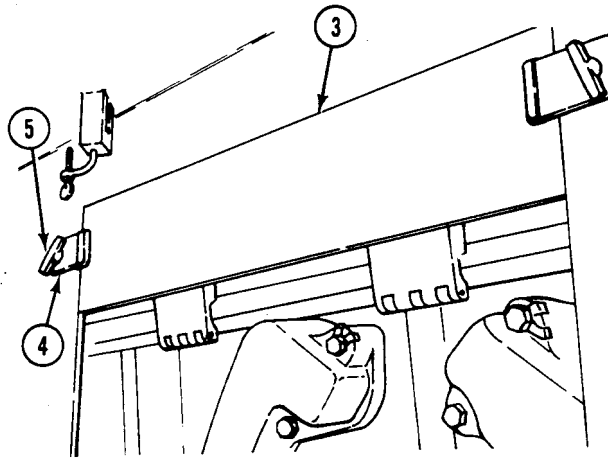

FOLLOW-THROUGH STEPS

1. Install power plant bottom access cover (WP 0450 00).
2. Install driver's power plant access pane (WP 0441 00).
3. Install power plant rear access panels (WP 0439 00).
4. Close power plant access door. See TM 9-2350-277-10.

END OF TASK

REPLACE RADIATOR AND PARTS

0229 00

THIS WORK PACKAGE COVERS:

Removal (page 0229 00-2).
 Installation (page 0229 00-4).

INITIAL SETUP:

Maintenance Level

Unit

References

See your -10

Tools and Special Tools

General Mechanic's Tool Kit (WP 0926 00, Item 65)
 Sling (WP 0926 00, Item 47)
 Socket Wrench Set (WP 0926 00, Item 72)
 Torque Wrench (WP 0926 00, Item 81)

Equipment Condition

Engine stopped (see your -10)
 Carrier blocked (see your -10)
 Driver's power plant access panel removed (see your -10)
 Power plant rear upper access panel removed (see your -10)
 Power plant grill raised (WP 0464 00)
 Grill intake elbow and hose removed (WP 0174 00)
 Balance hose removed (WP 0234 00)

Materials/Parts

Adhesive (WP 0928 00, Item 4)
 Sealing compound (WP 0928 00, Item 56)
 Gasket (2)
 Mount (4)
 Key washer (4)

Personnel Required

Unit Mechanic
 Helper (H)

REMOVAL

WARNING

Radiator is heavy and can cause back injury if handled improperly. Be sure to use a hoist and helper to remove radiator.

1. Attach sling to lifting device of at least 150 lb (68 kg) capacity to radiator support lifting eyes (1). Remove 6 nuts (2), 16 washers (3), and 10 screws (4) that secure radiator supports (5) to 2 plates (6) and to power plant grill (7). Lift radiator supports and radiator (8) from power plant grill. Lower radiator to a work table or flat wooden plate and detach lifting device. Have helper assist.

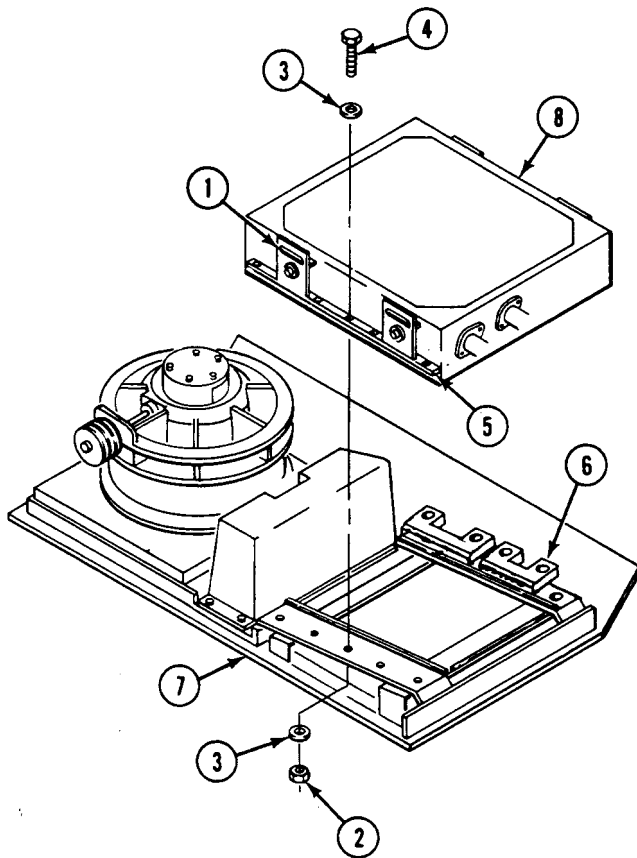

2. Remove two end seals (1) from power plant grill (2).
3. Remove two side seals (3) from power plant grill (2).

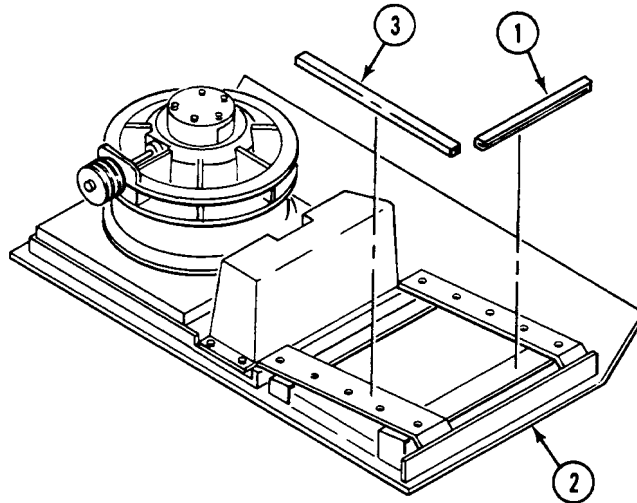

4. Remove balance hose adapter (4) from radiator (5).
5. Remove two screws (6), key washers (7), radiator outlet elbow (8), and gasket (9) from radiator (5). Discard gasket and washers.
6. Remove two screws (10), key washers (11), radiator inlet elbow (12), and gasket (13) from radiator (5). Discard gasket and washers.

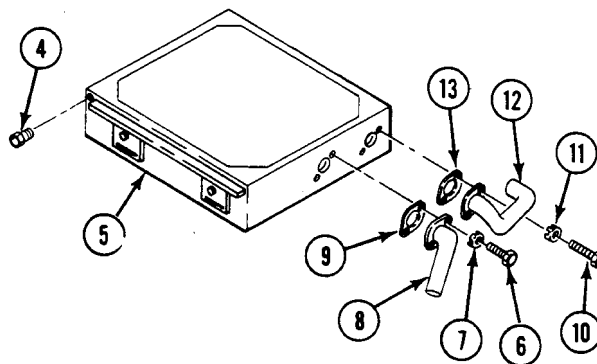

7. Remove four screws (14), washers (15), radiator supports (16), and mounts (17) from radiator (18). Discard mounts.

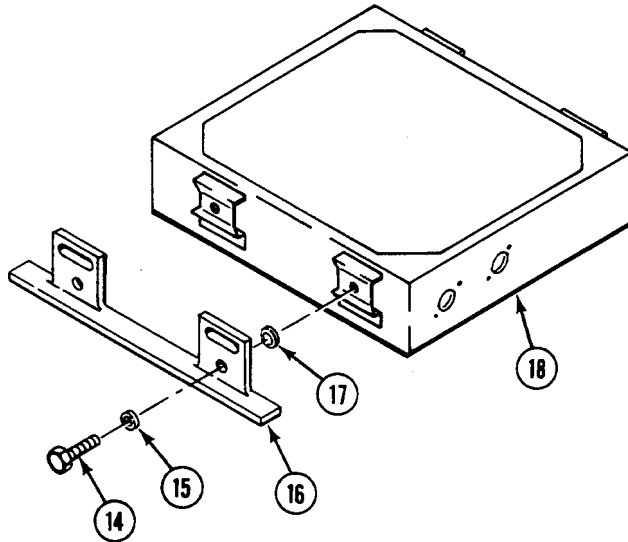

INSTALLATION

CAUTION

If installing a new radiator, make sure shipping plugs are removed.

1. Lubricate four new mounts (17) with water. Install mounts on two radiator supports (16).
2. Install two radiator supports (16) on radiator (18). Secure with four screws (14) and washers (15). **TIGHTEN SCREWS TO 360-420 LB-IN (41-48 N·m) TORQUE.**

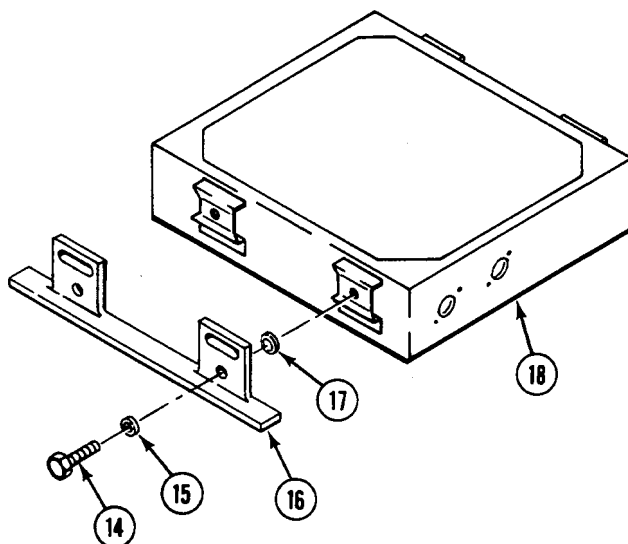

3. Apply a thin coat of sealing compound to both sides of new gaskets (1) and (8) and external threads of adapter (2).
4. Install radiator inlet elbow (3) and new gasket (1) on radiator (4). Secure with two screws (5) and new key washers (6).
5. Install radiator outlet elbow (7) and new gasket (8) on radiator (4). Secure with two screws (9) and new key washers (10).
6. Install balance hose adapter (2) on radiator (4).

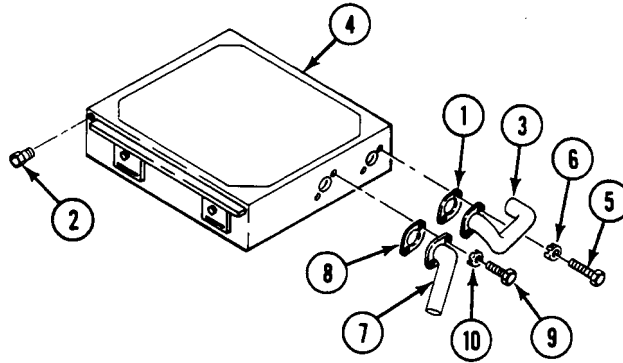

7. Apply thin coat of adhesive sealant to mounting surfaces of seals (11) and (13).
8. Install two side seals (11) on power plant grill (12).
9. Install two end seals (13) on power plant grill (12).

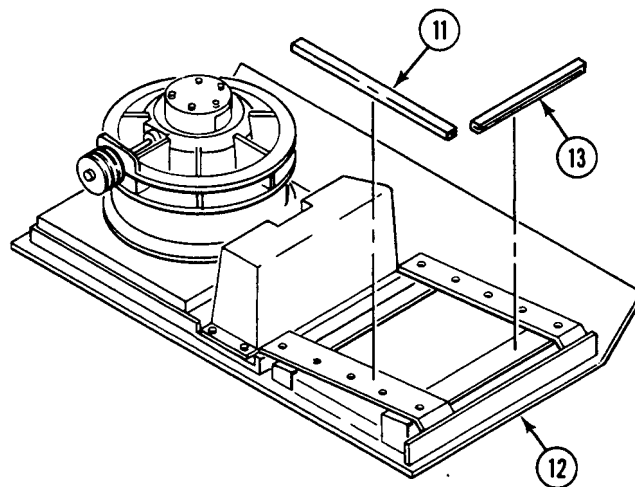

REPLACE RADIATOR AND PARTS — Continued**0229 00**

10. Attach a lifting device of at least 150 lb (68 kg) capacity to radiator support eyes (14). Lift and place radiator on power plant grill (15) between two end seals (13) and side seals (11).
11. Align mounting holes (16) of two radiator supports (17) to two plates (18) and power plant grill (15). Secure radiator (19) on plates (18) with four screws (20) and washers (21). Secure radiator on power plant grill with 6 screws (20), 12 washers (21), and 6 nuts (22).

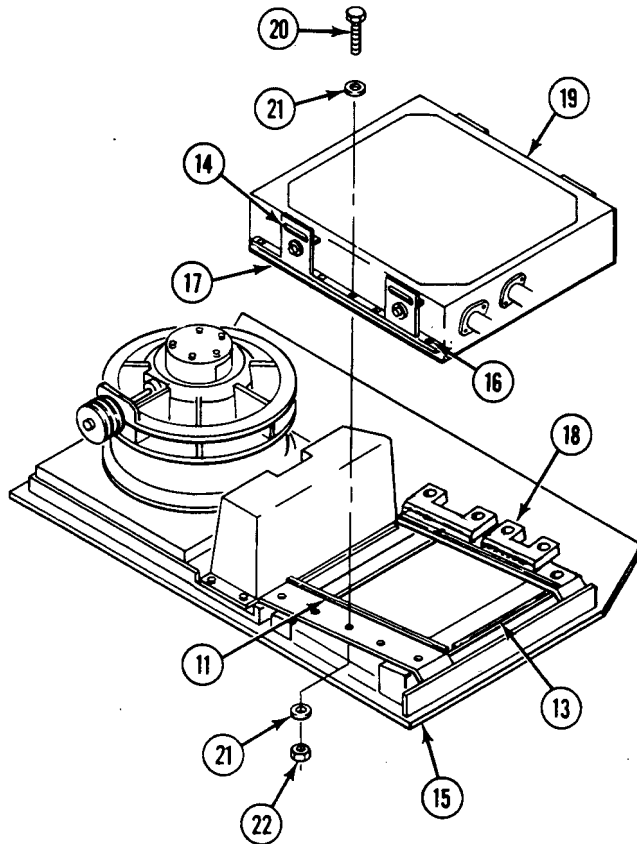
**FOLLOW-THROUGH STEPS**

1. Install balance hose (WP 0234 00).
2. Install grill intake elbow and hose (WP 0174 00).
3. Lower power plant grill (WP 0464 00).
4. Install power plant rear access panel (see your -10).
5. Install driver's power plant access panel (see your -10).

END OF TASK

REPLACE AUXILIARY TANK

0230 00

THIS WORK PACKAGE COVERS:

Removal (page 0230 00-1).
 Installation (page 0230 00-2).

INITIAL SETUP:

Maintenance Level

Unit

References

See your -10

Tools and Special Tools

General Mechanic's Tool Kit (WP 0926 00, Item 65)
 Torque wrench (WP 0926 00, Item 83)

Equipment Condition

Engine stopped (see your -10)
 Carrier blocked (see your -10)
 Power plant grill raised (WP 0464 00)
 Intake grill elbow and hose removed (WP 0174 00)
 Balance hose removed (WP 0234 00)

Materials/Parts

Sealing compound (WP 0928 00, Item 56)
 Gasket
 Lockwasher (4)

Personnel Required

Unit Mechanic

REMOVAL

1. Remove four screws (1), washers (2), and auxiliary tank (3) from power plant grill (4).
2. Remove three elbows (5), (6) and (7) from auxiliary tank (3).

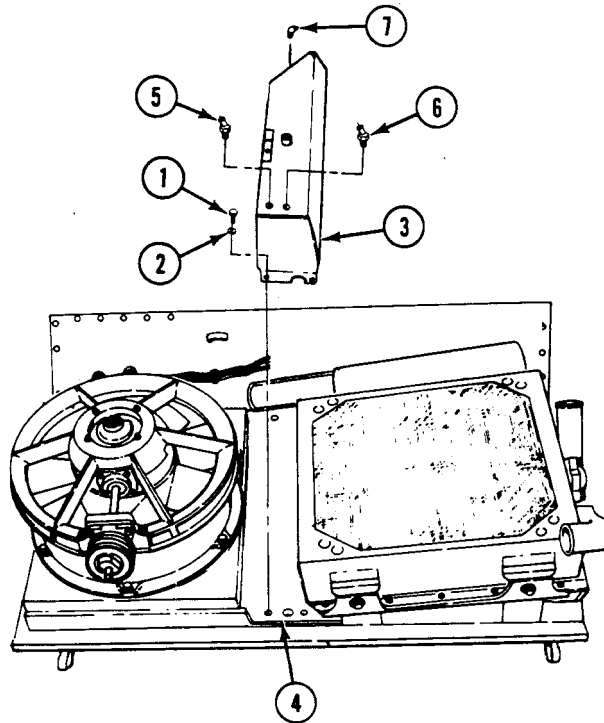

REPLACE AUXILIARY TANK — Continued**0230 00**

3. Remove screw (8), washer (9), lockwasher (10), bracket (11), two hooks (12), and filler cap (13) from filler neck (14). Discard lockwasher.
4. Remove three screws (15), washers (16), lockwashers (17), filler neck (14), and gasket (18) from auxiliary tank (3). Discard gasket and lockwashers.

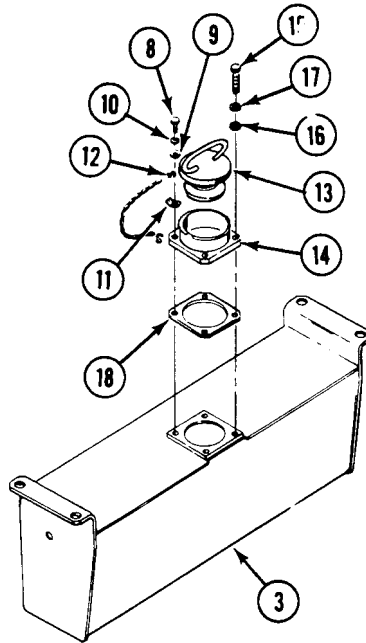
**INSTALLATION**

1. Apply thin coat of sealing compound to both sides of new gasket (1).
2. Install gasket (1) and filler neck (2) on auxiliary tank (3). Secure with three screws (4), washers (5), and new lockwashers (6).

3. Install bracket (7), two hooks (8), chain (9), and filler cap (10) on filler neck (2). Secure with screw (11), washer (12), and new lockwasher (13).

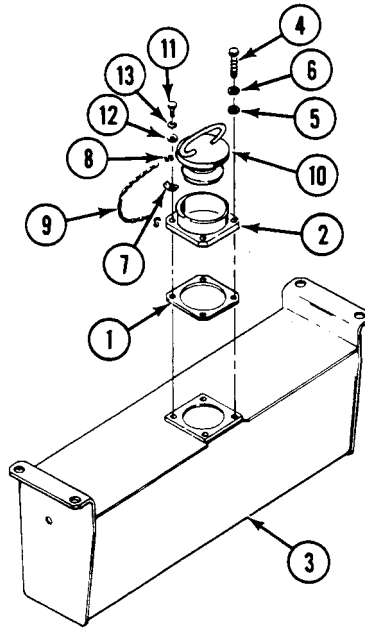

4. Apply thin coat of sealing compound to external threads of three elbows (14), (15), and (17).
5. Secure three elbows (14), (15), and (17) to auxiliary tank (3).
6. Install auxiliary tank (3) on power plant grill (17). Secure with four screws (18) and washers (19). **TIGHTEN SCREWS TO 264-288 LB-IN (30-32 N·m) TORQUE.**

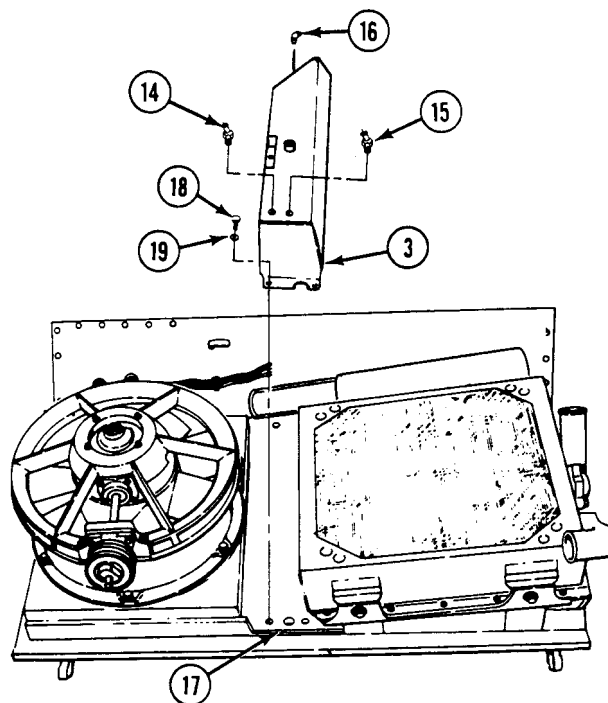

FOLLOW-THROUGH STEPS

1. Install balance hose (WP 0234 00).
2. Install grill intake elbow and hose (WP 0174 00).
3. Lower power plant grill (WP 0464 00).

END OF TASK

REPLACE THERMOSTATIC FAN SPEED SWITCH (OLD CONFIGURATION)

0231 00

THIS WORK PACKAGE COVERS:

Removal (page 0231 00-1).
 Installation (page 0231 00-3).

INITIAL SETUP:

Maintenance Level

Unit

Personnel Required

Unit Mechanic

Tools and Special Tools

General Mechanic's Tool Kit (WP 0926 00, Item 65)

References

See your -10

Materials/Parts

Sealing compound (WP 0928 00, Item 56)

Packing

Packing

Packing

Packing

Equipment Condition

Engine stopped (see your -10)

Carrier blocked (see your -10)

Power plant upper rear access panel removed (see your -10)

REMOVAL

1. Remove oil supply hose (1) from elbow (2) on thermostatic switch (3).
2. Remove elbow (2) and packing (4) from switch (3). Discard packing.

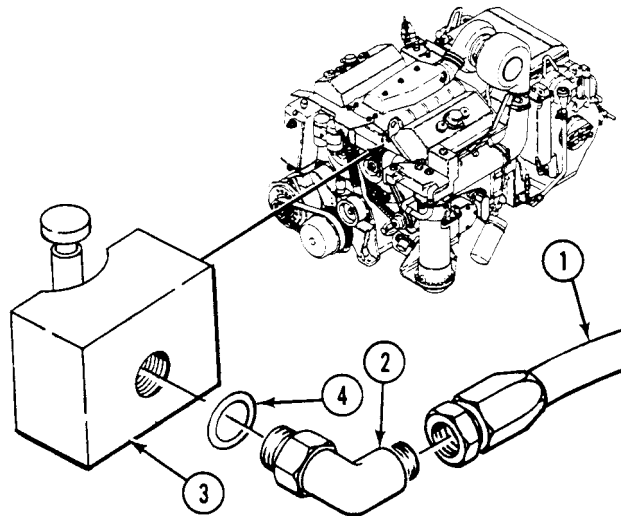

3. Remove two hoses (5) and (6) from adapters (7) and (8).
4. Remove adapters (7) and (8) and two packings (9) and (10) from switch (3). Discard packings.
5. Remove switch (3) and packing (11) from power plant (12). Discard packing.

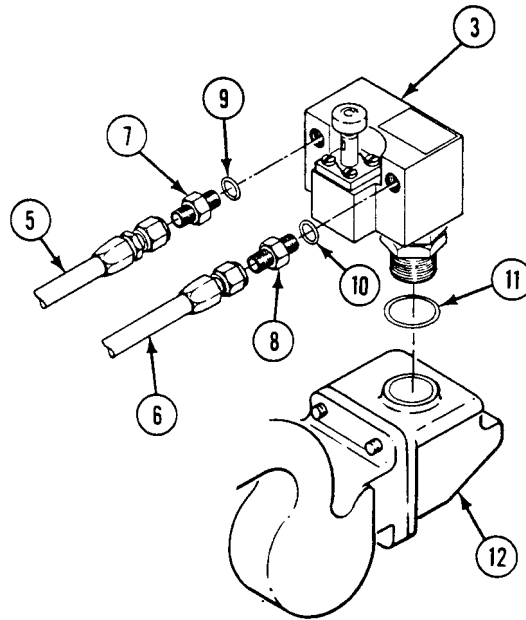

INSTALLATION

1. Apply thin coating of sealing compound to threads of switch (3).
2. Install switch (3) and new packing (11) on power plant (12).
3. Install adapters (7) and (8) and two new packings (9) and (10) on switch (3).
4. Install two hoses (5) and (6) on adapters (7) and (8).

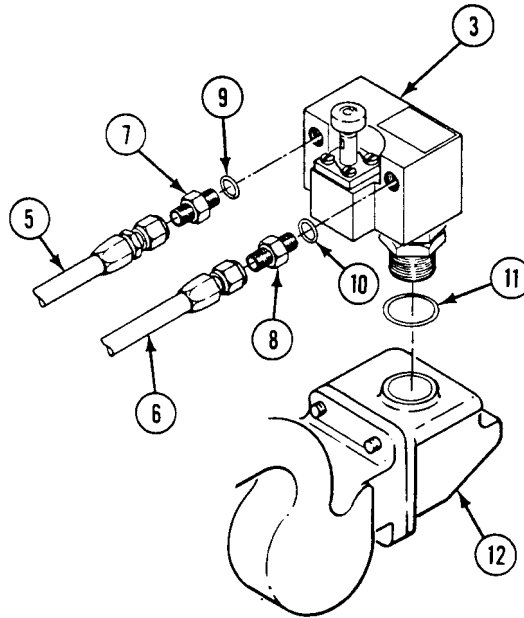

5. Install new packing (1) and elbow (2) on switch (3).
6. Install oil supply hose (4) on elbow (2).

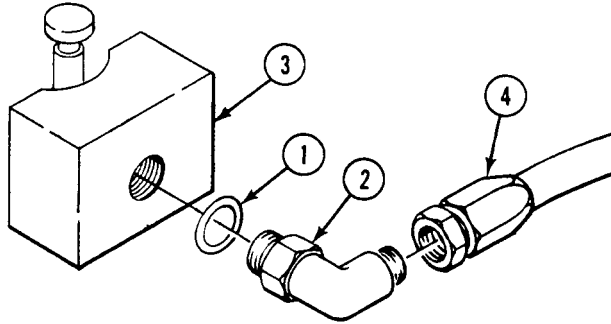
**FOLLOW-THROUGH STEPS**

1. Install power plant upper rear access panel (see your -10).

END OF TASK

**REPLACE VARIABLE SPEED FAN DRIVE VALVE AND OVERRIDE SWITCH
(NEW CONFIGURATION)**

0231 01**THIS WORK PACKAGE COVERS:**

Removal (page 0231 01-1)

Installation (page 0231 01-2)

INITIAL SETUP:Maintenance Level

Unit

Tools and Special Tools

General Mechanic's Tool Kit (WP 0926, Item 65)

Materials/Parts

Packing, preformed

Packing, preformed

Packing, preformed

Lockwashers (2)

Lockwashers (2)

Wiping rag (WP 0928 00, Item 65)

Personnel Required

Unit Mechanic

References

See your -10

Drawing 12474780

Drawing 12474790

Drawing 12474797

Equipment Conditions

Engine stopped (see your -10)

Carrier blocked (see your -10)

Power plant rear access panel removed

Battery ground strap disconnected (WP 0337 00 or WP 0338 00)

REPLACE VARIABLE SPEED FAN DRIVE VALVE AND OVERRIDE SWITCH (NEW CONFIGURATION) - Continued

0231 01

REMOVAL

1. Remove two screws (1), lockwashers (2), and bracket (3) (with valve and switch) from power plant (4). Discard lockwashers.
2. Remove two screws (5), lockwashers (6), and valve (7) from bracket (3). Discard lockwashers.
3. Remove oil supply hose (8) from elbow (9) on valve (7). Cover hose end with any appropriate material to prevent oil leaking from hose.
4. Remove elbow (9) and packing (10) from valve (7). Discard packing.
5. Remove lube hose (11) from elbow (12). Cover hose end with any appropriate material to prevent oil from leaking from hose.
6. Remove elbow (12) and packing (13) from valve (7). Discard packing.
7. Remove nut (14), lockwashers (15), and override switch (16) from bracket (3).
8. Tag and disconnect two leads (17) and (18) from override switch (16).

NOTE

Perform step 9 only if fitting and packing are leaking and tightening the fitting does not work.

9. Remove fitting (19) and packing (20) from power plant (4). Discard packing.

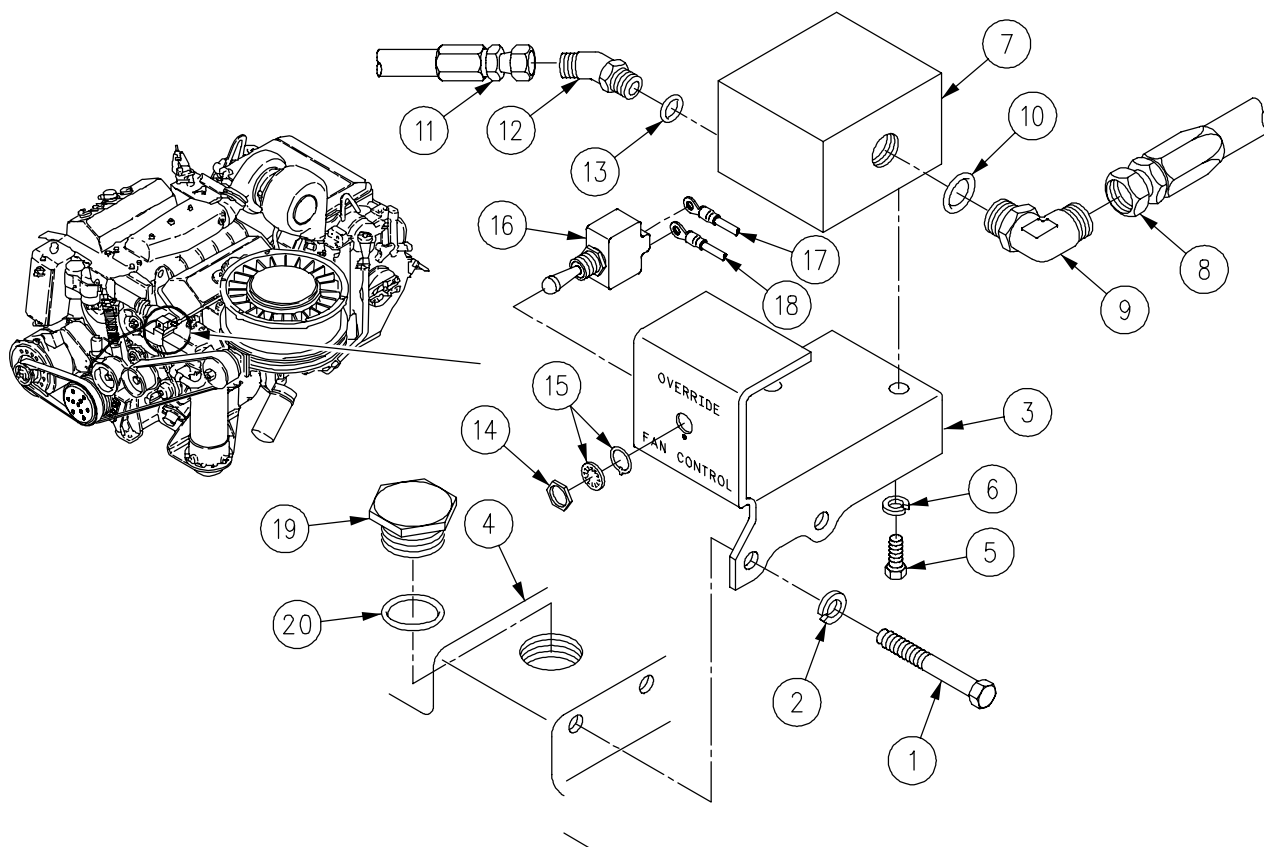

REPLACE VARIABLE SPEED FAN DRIVE VALVE AND OVERRIDE SWITCH (NEW CONFIGURATION) - Continued

0231 01

INSTALLATION

NOTE

Perform step 1 only if fitting and packing were removed in step 9.

1. Install new packing (20) and fitting (19) on power plant (4).
2. Connect two leads (17) and (18) to override switch (16). Remove tags on leads.
3. Install override switch (16), lockwashers (15), and nut (14) on bracket (3).
4. Install new packing (13) and elbow (12) on valve (7).
5. Remove cover from hose end. Install lube hose (11) on elbow (12).
6. Install new packing (10) and elbow (9) on valve (7).
7. Remove cover from hose end. Install oil supply hose (8) on elbow (9) on valve (7).
8. Install valve (7), two new lockwashers (6), and screws (5) on bracket (3).
9. Install bracket (3) (with valve and switch), two lockwashers (2), and screws (1) on power plant (4).

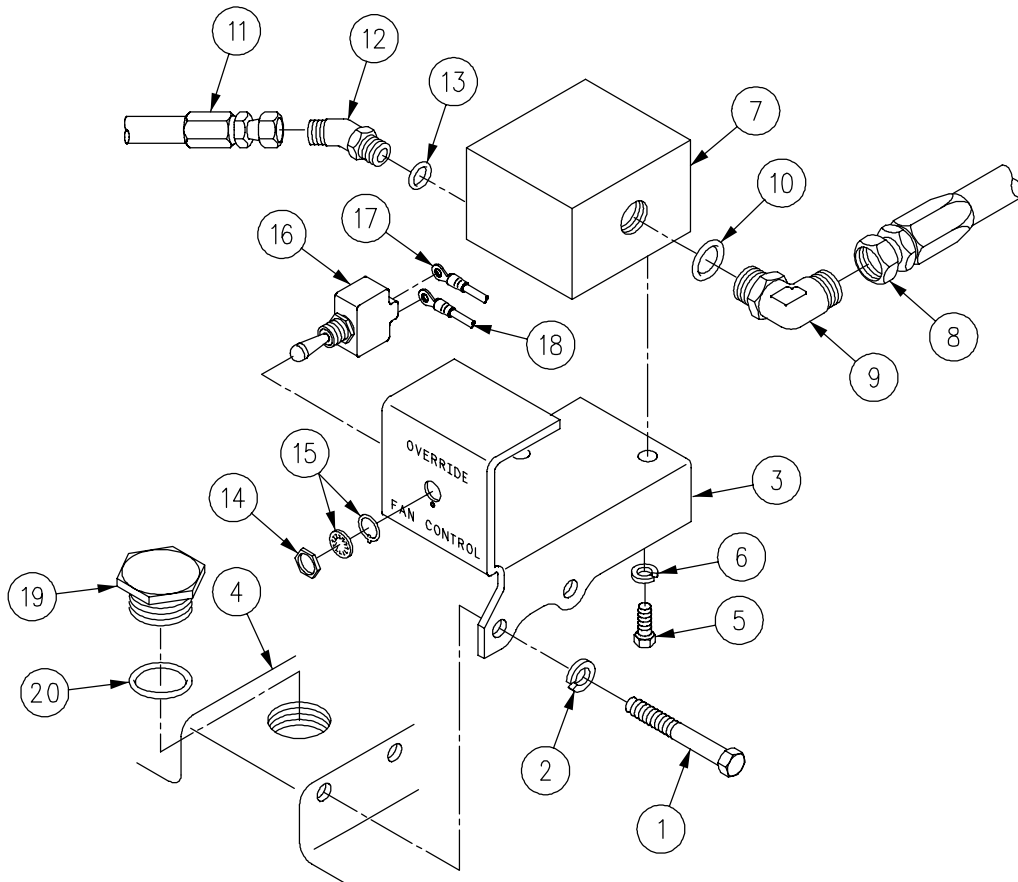

REPLACE VARIABLE SPEED FAN DRIVE VALVE AND OVERRIDE SWITCH (NEW CONFIGURATION) - Continued

0231 01

FOLLOW-THROUGH STEPS

1. Connect battery ground strap (WP 0337 00 or WP 0338 00).
2. Install driver's power plant access panel (see your-10).
3. Install power plant rear access panels (see your -10).

END OF TASK

REPLACE UPPER COOLANT HOSE AND TUBE

0232 00

THIS WORK PACKAGE COVERS:

Removal (page 0232 00-2).
 Installation (page 0232 00-4).

INITIAL SETUP:

Maintenance Level

Unit

References

See your -10

Tools and Special Tools

General Mechanic's Tool Kit (WP 0926 00, Item 65)

Equipment Condition

Engine stopped (see your -10)
 Carrier blocked (see your -10)
 Driver's power plant access panel
 removed (see your -10)
 Power plant upper rear access panel
 removed (see your -10)
 Cooling system drained (WP 0227 00)

Materials/Parts

Sealing compound (WP 0928 00, Item 56)
 Gasket
 Key washer (2)

Personnel Required

Unit Mechanic

REMOVAL

1. Loosen four clamps (1) on two hoses (2). Remove radiator inlet tube (3), hoses, and clamps.
2. Remove two screws (4), key washers (5), radiator inlet elbow (6), and gasket (7) from radiator (8). Discard gasket and key washers.

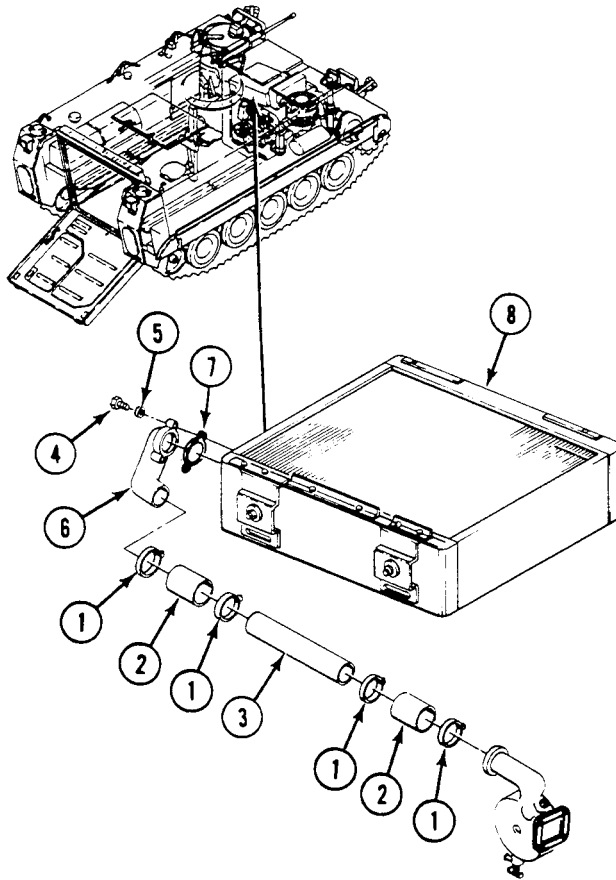

REPLACE UPPER COOLANT HOSE AND TUBE — Continued

0232 00

3. Loosen two clamps (1) and (2) on auxiliary tank outlet hose (3). Remove hose and clamps from auxiliary tank (4) and radiator outlet tube (5).
4. Loosen four clamps (6) and (7) on two vent hoses (8) and (9). Remove hoses and clamps.

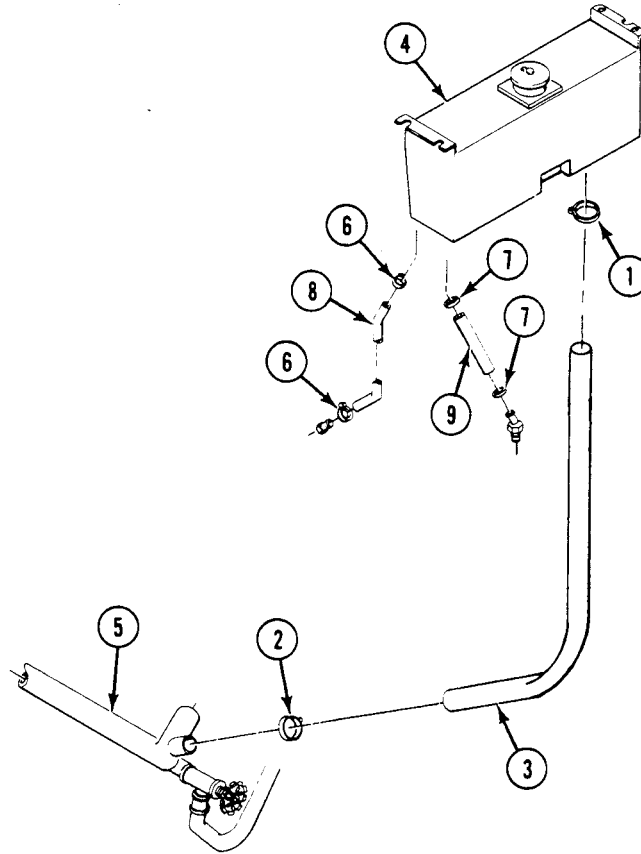

INSTALLATION

1. Install vent hose (10) on auxiliary tank (11) and air separator (12). Secure with two clamps (13).
2. Install vent hose (14) on auxiliary tank (11) and thermostat housing (15). Secure with two clamps (16).
3. Install hose (17) on auxiliary tank (11). Secure with clamp (18).

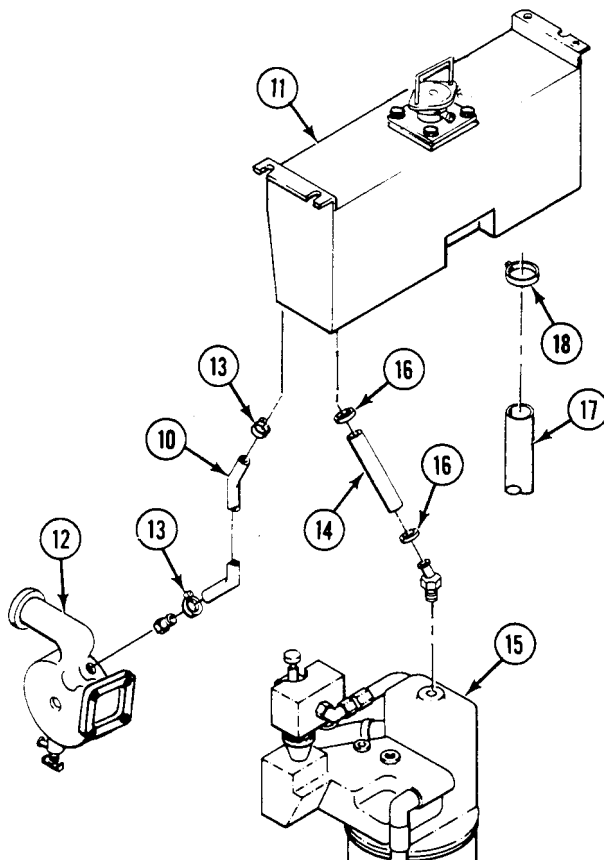

4. Install hose (19) on radiator outlet tube (20). Secure with clamp (21).

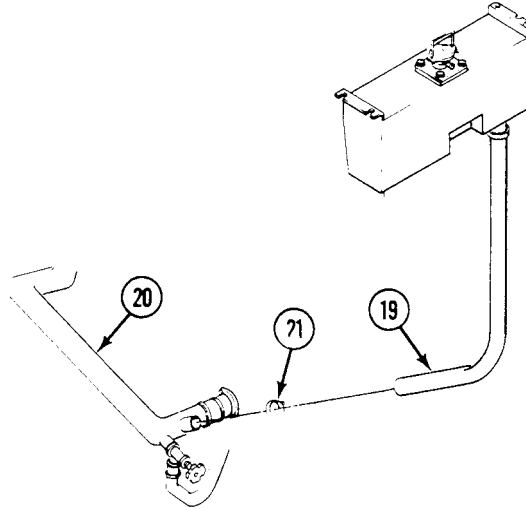

5. Apply a thin coat of sealing compound to both sides of new gasket (1) and tube elbow (2).
6. Install new gasket (1) on radiator inlet elbow (2). Secure elbow to radiator (3) with two screws (4) and new key washers (5).
7. Install two hoses (6) on radiator inlet tube (7). Secure hoses to tube, radiator inlet elbow (2), and air separator (8) with four clamps (9).

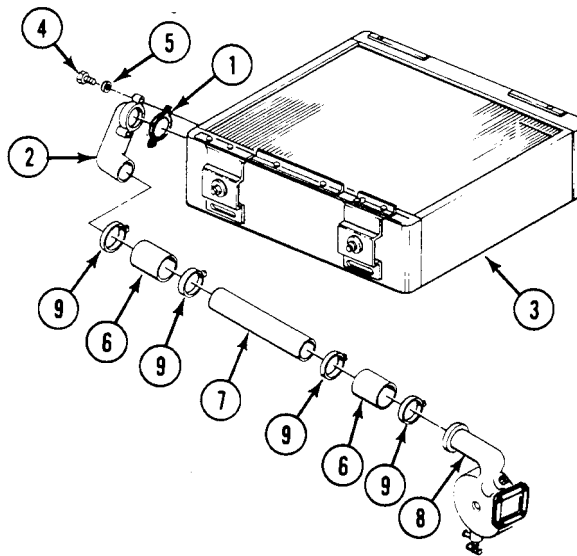

FOLLOW-THROUGH STEPS

1. Fill cooling system (WP 0227 00).
2. Install power plant upper rear access panel (see your -10).
3. Install driver's power plant access panel (see your -10).

END OF TASK

REPLACE RADIATOR OUTLET TUBE AND HOSES

0233 00

THIS WORK PACKAGE COVERS:

Removal (page 0233 00-1).
 Installation (page 0233 00-2).

INITIAL SETUP:

Maintenance Level

Unit

References

See your -10

Tools and Special Tools

General Mechanic's Tool Kit (WP 0926 00, Item 65)

Equipment Condition

Materials/Parts

Sealing compound (WP 0928 00, Item 56)

Gasket

Gasket

Key washer (2)

Lockwasher (2)

Engine stopped (see your -10)

Carrier blocked (see your -10)

Master switch OFF (see your -10)

Driver's power plant access panel
 removed (see your -10)

Personnel Required

Unit Mechanic

Power plant rear access panels removed (see your -10)

Power plant removed (WP 0156 00)

REMOVAL

1. Loosen clamp (1) securing drain hose (2) to drain cock (3). Remove hose and clamp.
2. Remove drain cock (3) from elbow (4). Remove elbow (4) from radiator outlet tube (5).
3. Loosen clamp (6) securing auxiliary tank outlet hose (7) to radiator outlet tube (5). Remove clamp and hose.
4. Remove two clamps (8) securing radiator outlet tube (5) to tube support bracket (9).
5. Loosen four clamps (10) securing two hoses (11) and radiator outlet tube (5) to adapter (12) and tube (13). Remove clamps, hoses, and tube.
6. Loosen two clamps (14) securing tube (13) and hose (15) to radiator outlet elbow. Remove clamps, hose, and tube.

- Remove two screws (16), lockwashers (17), washers (18), adapter (12), and gasket (19) from engine. Discard gasket and lockwashers.

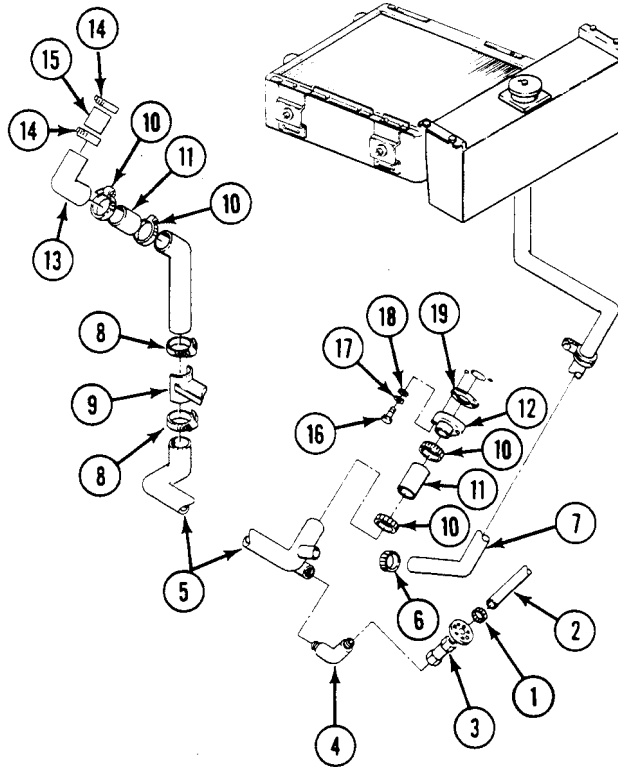

- Remove two screws (1), key washers (2), radiator outlet elbow (3), and gasket (4) from radiator (5). Discard gasket and key washers.

INSTALLATION

- Apply sealing compound to mounting surfaces of new gasket (4).
- Install radiator outlet elbow (3) with new gasket (4) on radiator (5). Secure with two screws (1) and new key washers (2).

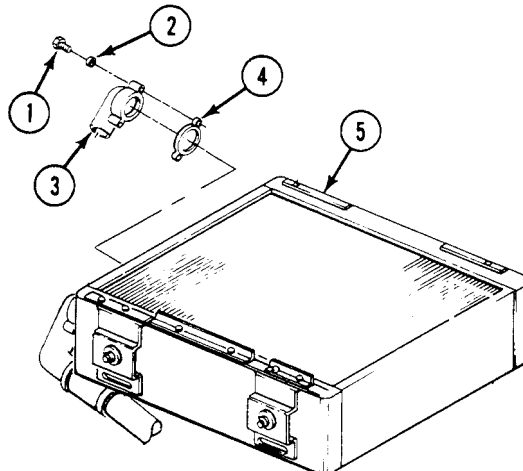

REPLACE RADIATOR OUTLET TUBE AND HOSES — Continued**0233 00**

3. Apply sealing compound to mounting surfaces of new gasket (6).
4. Install adapter (7) with new gasket (6) on engine. Secure with two screws (8), washers (9), and new lockwashers (10).
5. Install hose (11) and tube (12) on radiator outlet elbow (3). Secure with two clamps (13).
6. Install radiator outlet tube (14) and two hoses (15) on tube (12) and adapter (7). Secure with four clamps (16).
7. Secure radiator outlet tube (14) to support bracket (17) with two clamps (18).
8. Install auxiliary tank outlet hose (19) on radiator outlet tube (14). Secure with clamp (20).
9. Install elbow (21) on radiator outlet tube (14). Install drain cock (22) on elbow (21).
10. Install drain hose (23) on drain cock (22). Secure with clamp (24).

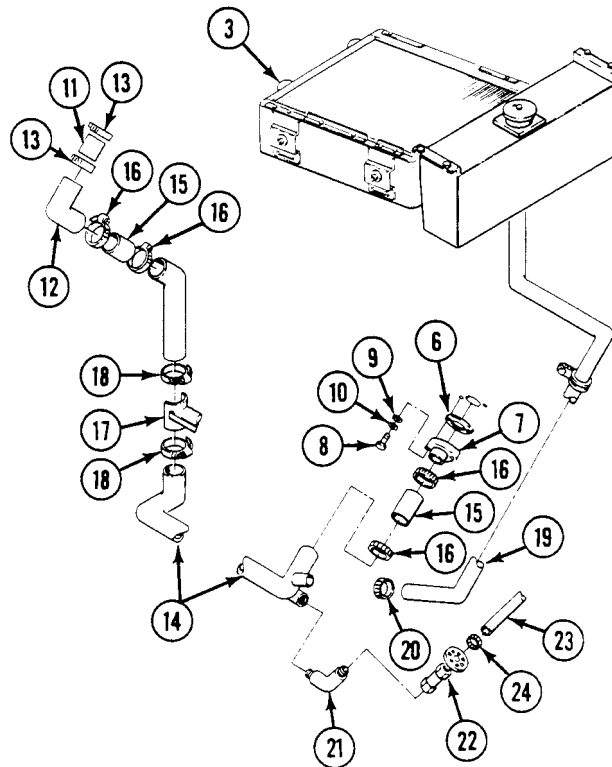
**FOLLOW-THROUGH STEPS**

1. Install power plant (WP 0156 00).
2. Install power plant rear access panels (see your -10).
3. Install driver's power plant access panel (see your -10).

END OF TASK

REPLACE BALANCE HOSE

0234 00

THIS WORK PACKAGE COVERS:

Removal (page 0234 00-1).
 Installation (page 0234 00-1).

INITIAL SETUP:

Maintenance Level

Unit

Equipment Condition

Engine stopped (see your -10)
 Carrier blocked (see your -10)
 Power plant grill raised (WP 0464 00)
 Grill air intake elbow and hose removed (WP 0174 00)

Tools and Special Tools

General Mechanic's Tool Kit (WP 0926 00, Item 65)

Personnel Required

Unit Mechanic

References

See your -10

REMOVAL

1. Loosen two clamps (1) on balance hose (2). Remove hose and clamps.

INSTALLATION

1. Slide two clamps (1) on balance hose (2).
2. Install balance hose (2) on auxiliary tank (3) and radiator (4). Tighten two clamps (1).

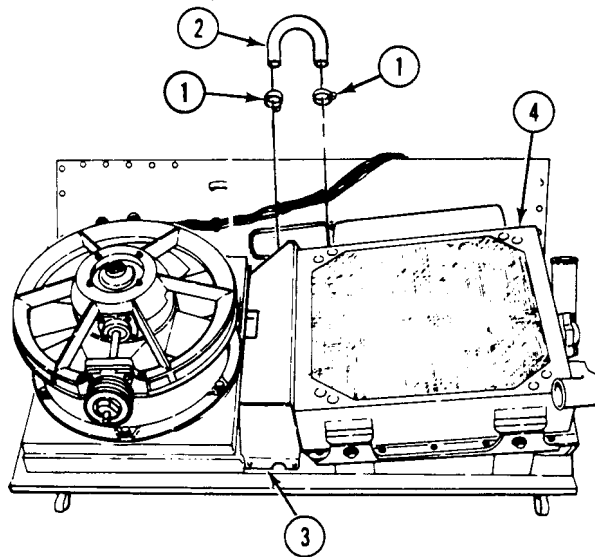

FOLLOW-THROUGH STEPS

1. Install grill air intake elbow and hose (WP 0174 00).
2. Lower power plant grill (WP 0464 00).

END OF TASK

REPLACE DRAIN COCK AND HOSE

0235 00

THIS WORK PACKAGE COVERS:

Removal (page 0235 00-1).
 Installation (page 0235 00-1).

INITIAL SETUP:

Maintenance Level

Unit

References

See your -10

Tools and Special Tools

General Mechanic's Tool Kit (WP 0926 00, Item 65)

Equipment Condition

Engine stopped (see your -10)

Carrier blocked (see your -10)

Power plant lower rear access panel removed (see your -10)

Power plant bottom access cover removed (WP 0450 00)

Cooling system drained (WP 0227 00)

Materials/Parts

Sealing compound (WP 0928 00, Item 56)

Personnel Required

Unit Mechanic

REMOVAL

1. Loosen clamp (1) on drain hose (2). Remove hose (2) from drain cock (3).
2. Remove cock (3) from radiator outlet tube (4).

INSTALLATION

1. Apply light coat of sealing compound to external tapered threads of cock (3).
2. Install cock (3) on radiator outlet tube (4).
3. Install hose (2) on cock (3). Secure with clamp (1).

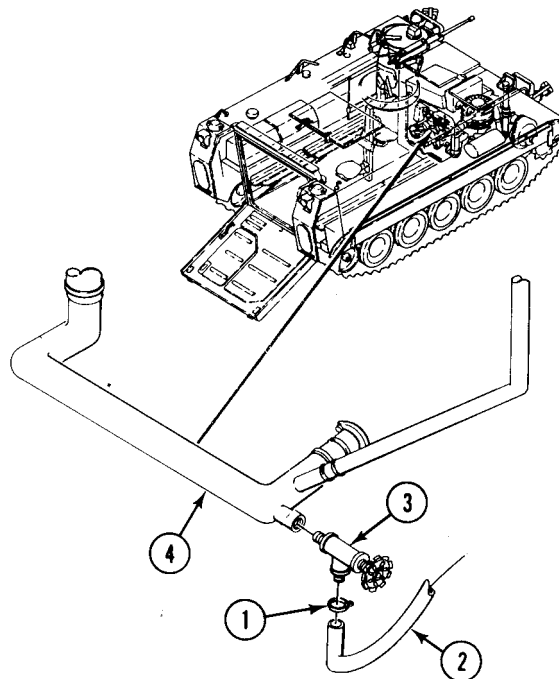

FOLLOW-THROUGH STEPS

1. Fill cooling system (WP 0227 00).
2. Install power plant bottom access cover (WP 0450 00).
3. Install power plant lower rear access panel (see your -10).

END OF TASK

REPLACE COOLANT AIR SEPARATOR

0236 00

THIS WORK PACKAGE COVERS:

Removal (page 0236 00-1).
 Installation (page 0236 00-3).

INITIAL SETUP:

Maintenance Level

Unit

References

See your -10

Tools and Special Tools

General Mechanic's Tool Kit (WP 0926 00, Item 65)

Equipment Condition

Materials/Parts

Sealing compound (WP 0928 00, Item 56)

Gasket

Key washer (4)

Engine stopped (see your -10)

Carrier blocked (see your -10)

Power plant rear upper access panel
 removed (see your -10)

Personnel Required

Unit Mechanic

Cooling system drained (WP 0227 00)

REMOVAL

1. Loosen two clamps (1) on hose (2). Remove hose from air separator (3).
2. Loosen clamp (4) on vent hose (5). Remove hose from air separator (3).

3. Remove drain cock (6) from air separator (3).

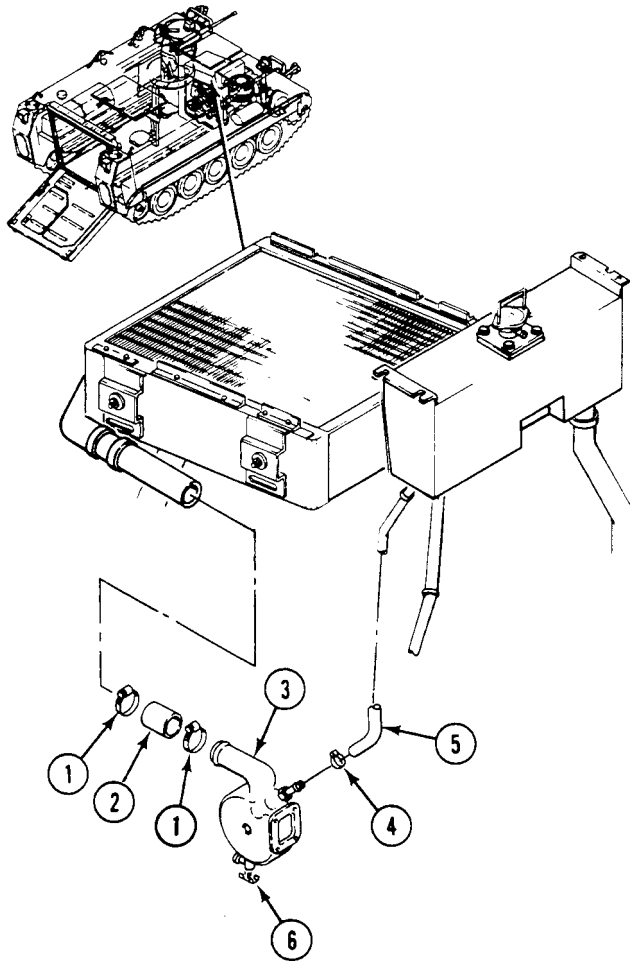

4. Remove four screws (1), key washers (2), air separator (3), and gasket (4) from thermostat housing (5). Discard gasket and key washers.

5. Remove adapter (6) from air separator (3).

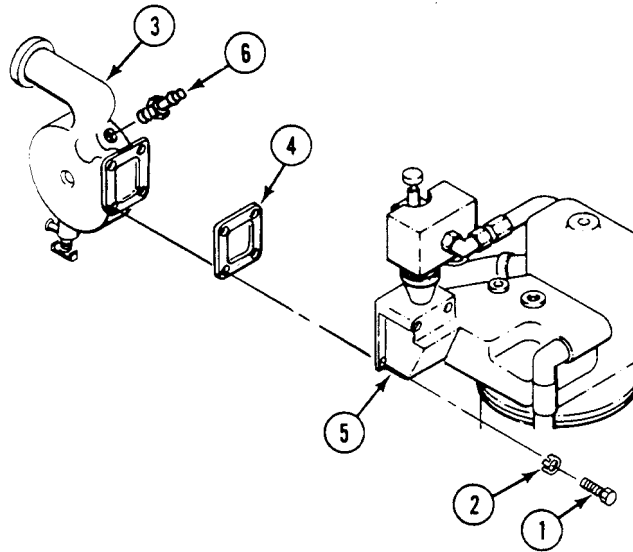

INSTALLATION

1. Install adapter (6) on air separator (3).
2. Install air separator (3) and new gasket (4) on thermostat housing (5). Secure with four screws (1) and new key washers (2).

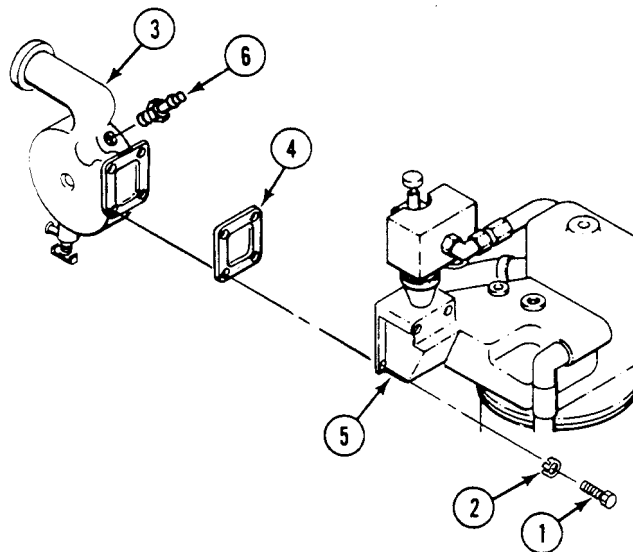

REPLACE COOLANT AIR SEPARATOR — Continued

0236 00

3. Install drain cock (7) on air separator (3).
4. Install vent hose (8) on adapter (6). Tighten clamp (9).
5. Install hose (10) on air separator (3). Tighten two clamps (11).

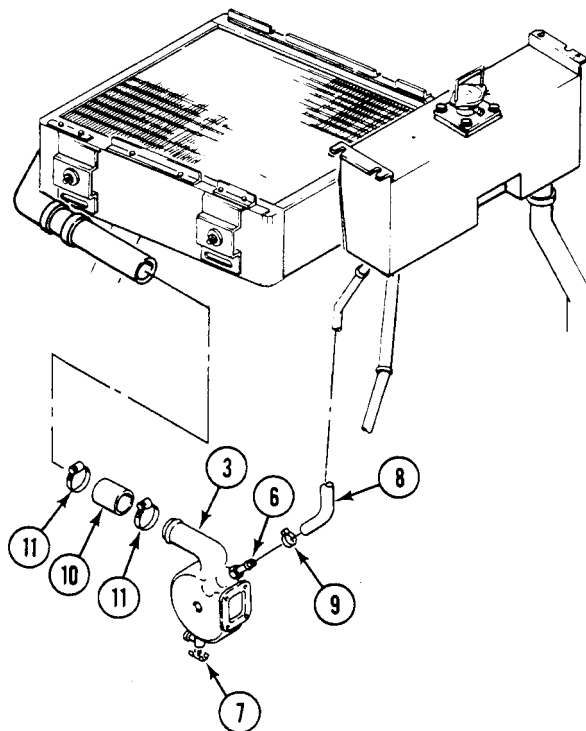
**FOLLOW-THROUGH STEPS**

1. Fill cooling system (WP 0227 00).
2. Install power plant rear upper access panel (see your -10).

END OF TASK

REPLACE THERMOSTAT/COVER

0237 00

THIS WORK PACKAGE COVERS:

Removal (page 0237 00-1).
 Installation (page 0237 00-4).

INITIAL SETUP:

Maintenance Level

Unit

References

See your -10

Tools and Special Tools

General Mechanic's Tool Kit (WP 0926 00, Item 65)

Equipment Condition

Materials/Parts

Adhesive (WP 0928 00, Item 4)

Gasket

Lockwasher (4)

Engine stopped (see your -10)

Carrier blocked (see your -10)

Cooling system drained (WP 0227 00)

Power plant upper rear access panel

removed (see your -10)

Personnel Required

Unit Mechanic

Coolant air separator removed (WP 0236 00)

REMOVAL

1. Remove oil supply hose (1) from elbow (2) on thermostat switch (3).
2. Remove two hoses (4) and (5) from adapters (6) and (7).

3. Loosen two clamps (8) and slide hose (9) down on bypass tube (10).

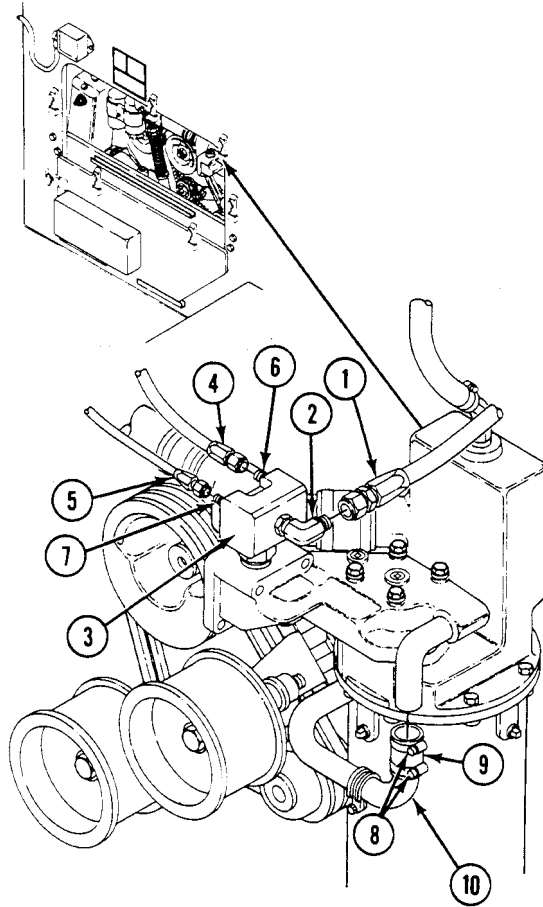

4. Remove four screws (1), lockwashers (2), washers (3), thermostat cover (4), and gasket (5) from thermostat housing (6). Discard lockwashers and gasket.

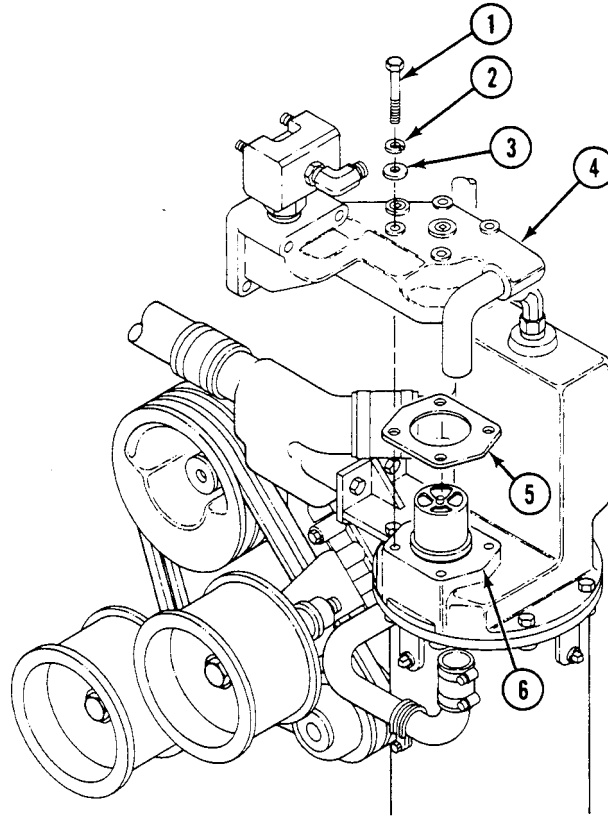

5. Remove thermostat (7) from thermostat housing (6).

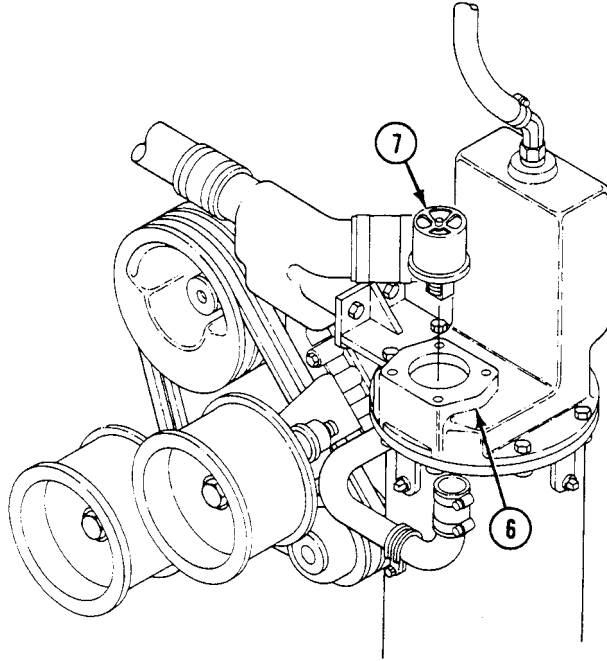

INSTALLATION

1. Install thermostat (7) on thermostat housing (6).

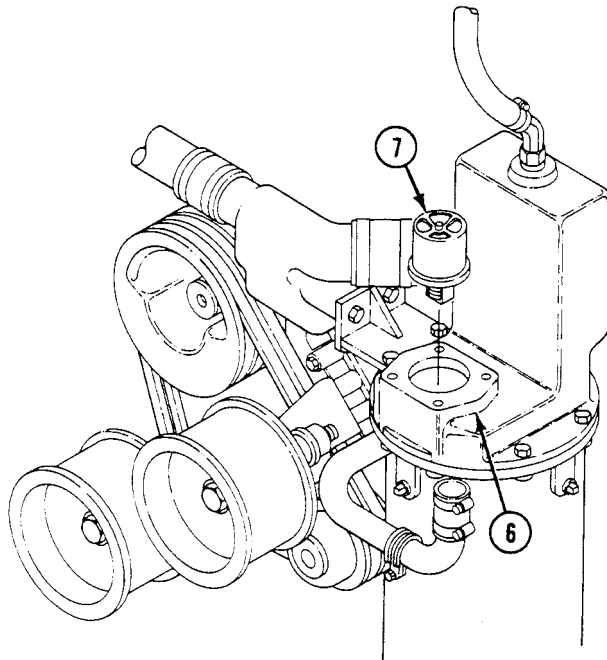

2. Apply a thin coat of adhesive to both sides of new gasket (8).
3. Install gasket (8), thermostat cover (9), four washers (10), new lockwashers (11), and screws (12) on thermostat housing (6).

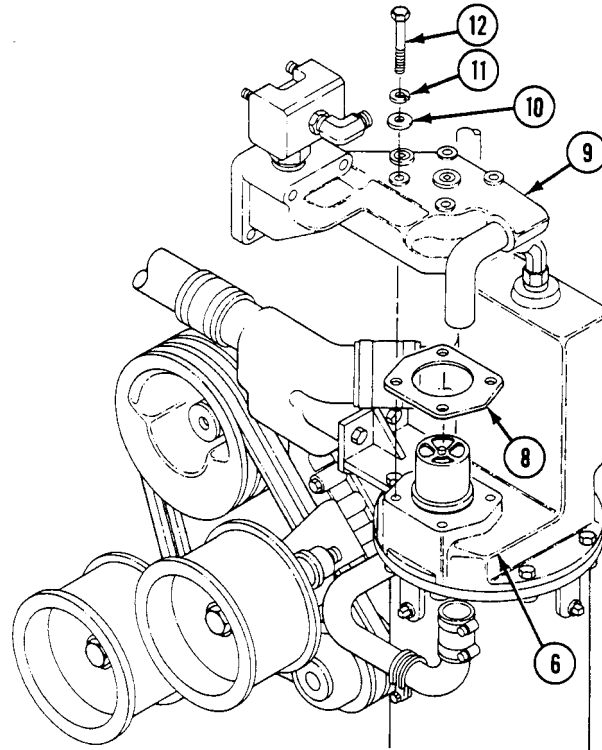

REPLACE THERMOSTAT/COVER — Continued

0237 00

4. Install hose (1) on thermostat cover (2) and bypass tube (3). Secure with two clamps (4).
5. Install two hoses (5) and (6) on adapters (7) and (8).
6. Install oil supply hose (9) on elbow (10) on thermostat switch (11).

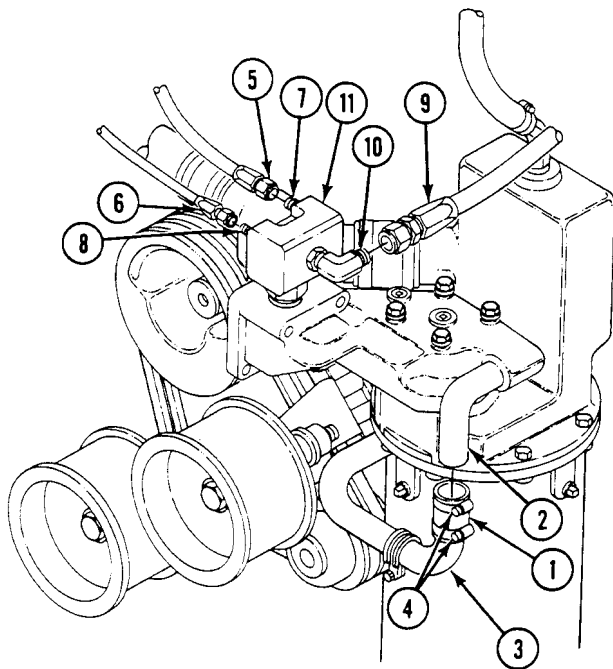
**FOLLOW-THROUGH STEPS**

1. Install coolant air separator (WP 0236 00).
2. Fill cooling system (WP 0227 00).
3. Install power plant upper rear access panel (see your -10).

END OF TASK

REPLACE THERMOSTAT TUBE/HOSES

0238 00

THIS WORK PACKAGE COVERS:

Removal (page 0238 00-1).
 Installation (page 0238 00-2).

INITIAL SETUP:

Maintenance Level

Unit

Equipment Condition

Engine stopped (see your -10)
 Carrier blocked (see your -10)
 Power plant upper and lower rear access panels and support removed (see your -10)

Tools and Special Tools

General Mechanic's Tool Kit (WP 0926 00, Item 65)

Personnel Required

Unit Mechanic

References

See your -10

REMOVAL

1. Loosen two upper clamps (1) and slide hose (2) down on bypass tube (3).
2. Disconnect two hose clamps (4) that support coolant hose (5).

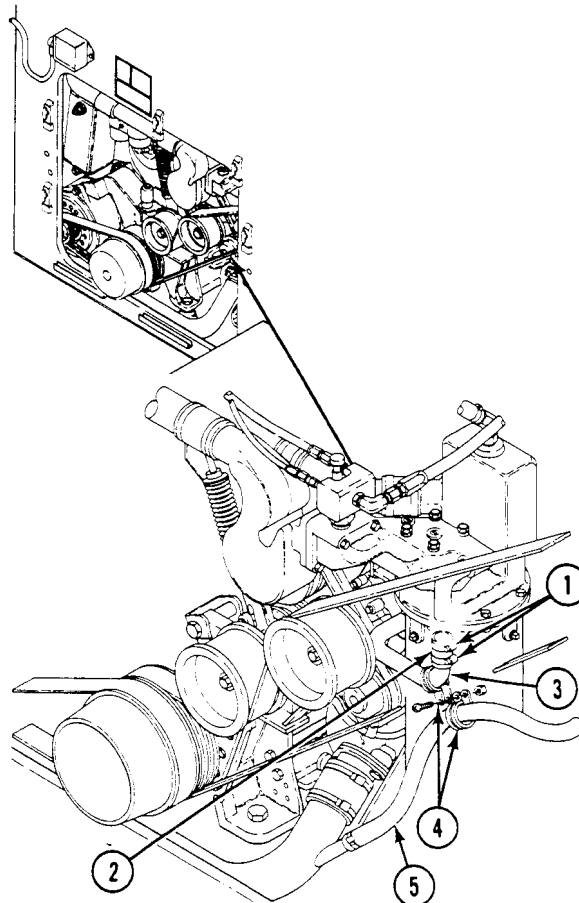

3. Loosen two lower hose clamps (6) on water pump housing (7) and slide hose (8) up on tube (3).
4. Remove tube (3), hoses (2) and (8) and clamps (1) and (6) as a unit.
5. Remove four clamps (1) and (6) and two hoses (2) and (8) from tube (3).
6. Inspect two hoses (2) and (8) for cracks or deterioration. Replace if necessary.

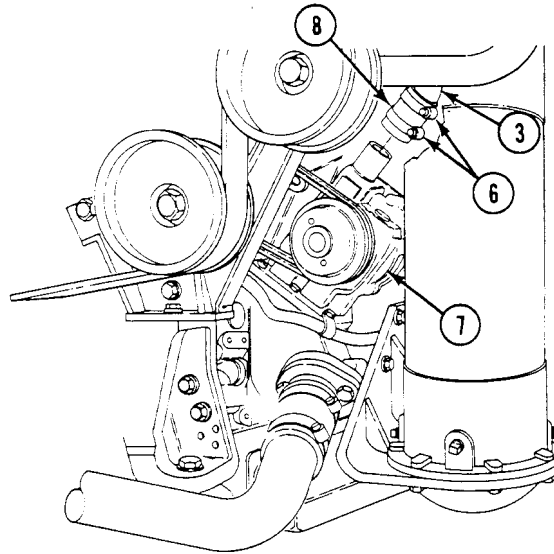

INSTALLATION

1. Install hose (1) and two clamps (2) on lower end of new tube (3).
2. Install hose (4) and two clamps (5) on upper end of tube (3).
3. Place tube (3) with two hoses (1) and (4) and four clamps (2) and (5) in position on engine. Slide upper hose (4) onto thermostat housing (6) and tighten with two clamps (5).

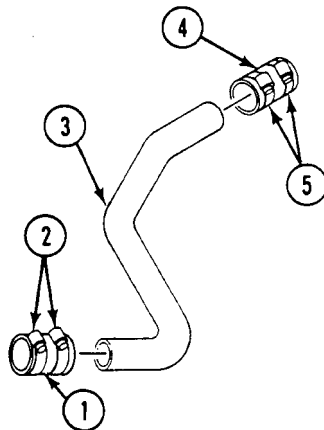

4. Connect the two hose clamps (7) that support the coolant hose (8).

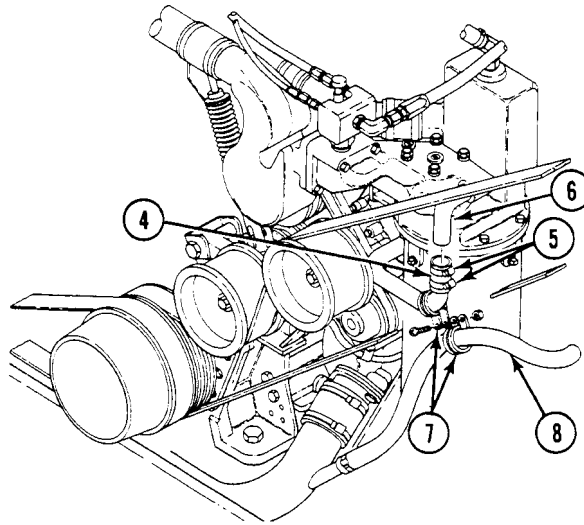

5. Slide lower hose (1) onto water pump housing (9). Position two clamps (2) and tighten.

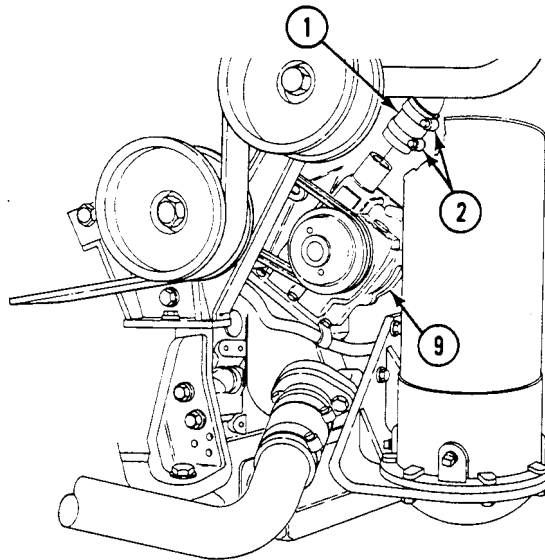

FOLLOW-THROUGH STEPS

1. Install power plant upper and lower rear access panels and support (see your -10).

END OF TASK

ADJUST COOLANT PUMP BELTS

0239 00

THIS WORK PACKAGE COVERS:

Adjustment (page 0239 00-1).

INITIAL SETUP:

Maintenance Level

Unit

Personnel Required

Unit Mechanic

Tools and Special Tools

General Mechanic's Tool Kit (WP 0926 00, Item 65)

Torque Wrench (WP 0926 00, Item 81)

Socket Set (WP 0926 00, Item 72)

Equipment Condition

Engine stopped (see your -10)

Carrier blocked (see your -10)

Power plant rear access panels removed (see your -10)

ADJUSTMENT

NOTE

Idler arm, pulleys, and belts are removed from art for clarity only. Physical removal of these items is not required to access coolant pump belts for adjustment.

1. Loosen two screws (2) securing idler adjusting bracket (1) to engine.

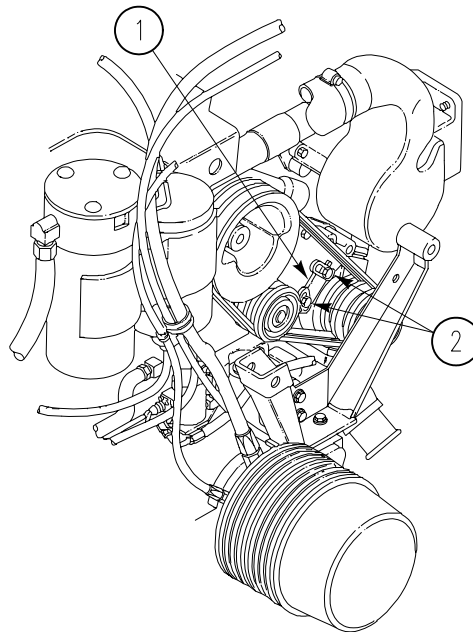

ADJUST COOLANT PUMP BELTS — Continued**0239 00**

2. Pry upward on tang of idler pulley assembly (5) to get 1/4 to 3/8 inch deflection on drive belts (6) midway between pulleys (1) and (3) while applying a firm push with thumb. Tighten two screws (4).
3. Check for proper tension by using straight edge (2) to measure deflection across drive belts at pulleys (1) and (3). If tension meter is available, check 40-50 lbs (173–217 N) tension. If necessary, readjust tension. **TORQUE TWO SCREWS (4) TO 360-420 LB-IN (41-47 N·M).** Use torque wrench and socket set.

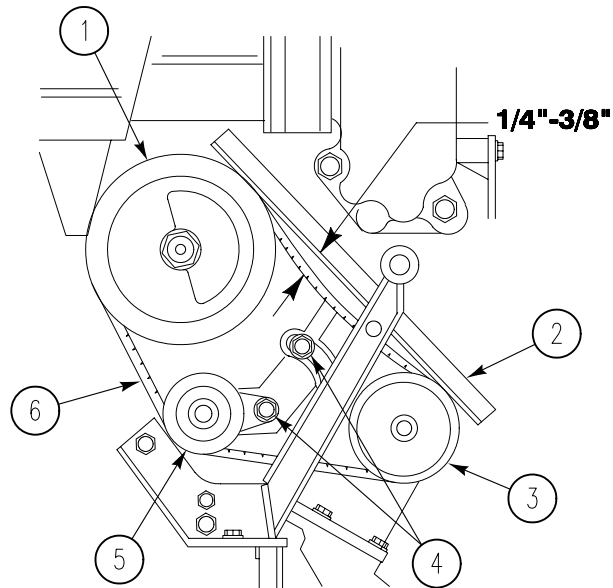
**FOLLOW-THROUGH STEPS**

1. Install power plant rear access panels (see your -10).

END OF TASK

REPLACE COOLANT PUMP IDLER PULLEY/BELTS

0240 00

THIS WORK PACKAGE COVERS:

Removal (page 0240 00-1).
 Installation (page 0240 00-2).

INITIAL SETUP:

Maintenance Level

Unit

Personnel Required

Unit Mechanic

Tools and Special Tools

General Mechanic's Tool Kit (WP 0926 00, Item 65)
 Torque Wrench (WP 0926 00, Item 81)
 Socket Set (WP 0926 00, Item 72)

Equipment Condition

Engine stopped (see your -10)
 Carrier blocked (see your -10)
 Power plant rear access panels removed (see your -10)

Materials/Parts

Lockwasher (2)

REMOVAL

NOTE

Idler arm, pulleys, and belts are removed from art for clarity only. Physical removal of these items is not required to access coolant pump belts for adjustment.

1. Loosen two screws (4) securing idler adjusting bracket (2) to engine.
2. Remove two drive belts (5) from three pulleys (1), (6), and (7).
3. If damaged, remove two screws (4), washers (3), idler adjusting bracket (2), and idler pulley (7) from engine.

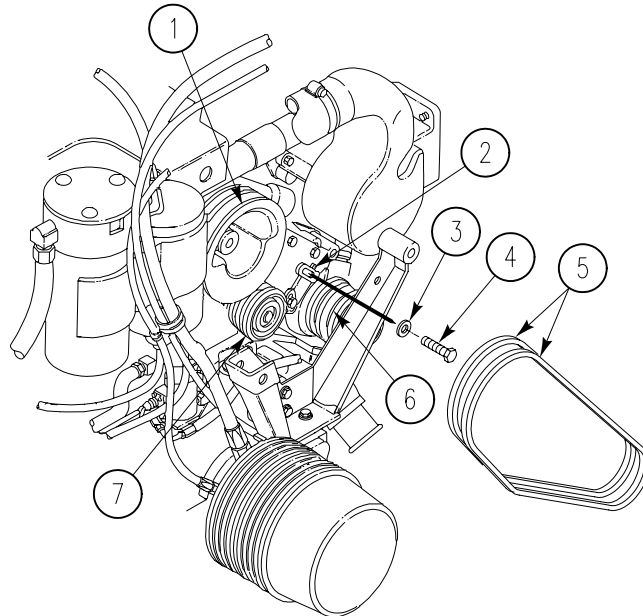

INSTALLATION

1. If removed, install idler pulley (7) and idler adjusting bracket (2) on engine. Secure with two washers (3) and screws (4). Do not tighten screws.

NOTE

Drive belts must be replaced in matched sets.

2. Position two drive belts (5) on three pulleys (1), (6), and (7).
3. Pry upward on tang of idler pulley assembly (2) to get 1/4 to 3/8 inch deflection on drive belts (5) midway between pulleys (1) and (6) while applying a firm push with thumb. Tighten two screws (4).

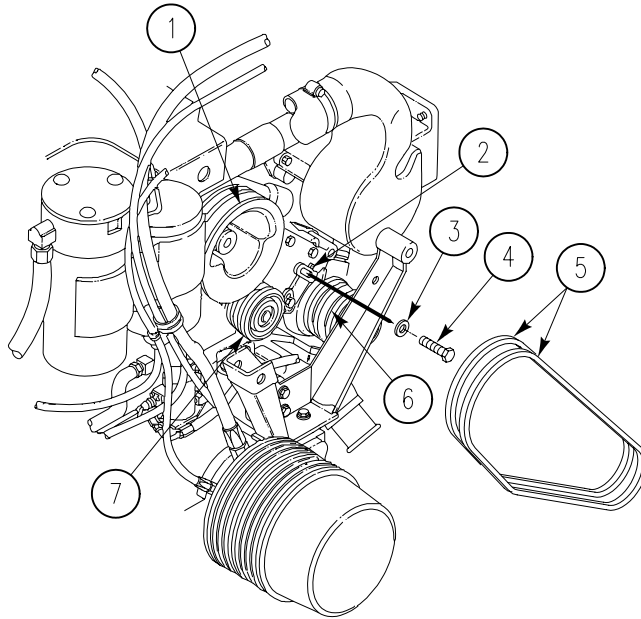

4. Check for proper tension by using straight edge (2) to measure deflection across drive belts at pulleys (1) and (3). If tension meter is available, check 40-50 lbs (173–217 N) tension. If necessary, readjust tension. TORQUE TWO SCREWS (4) TO 360-420 LB-IN (41-47 N.M). Use torque wrench and socket set.

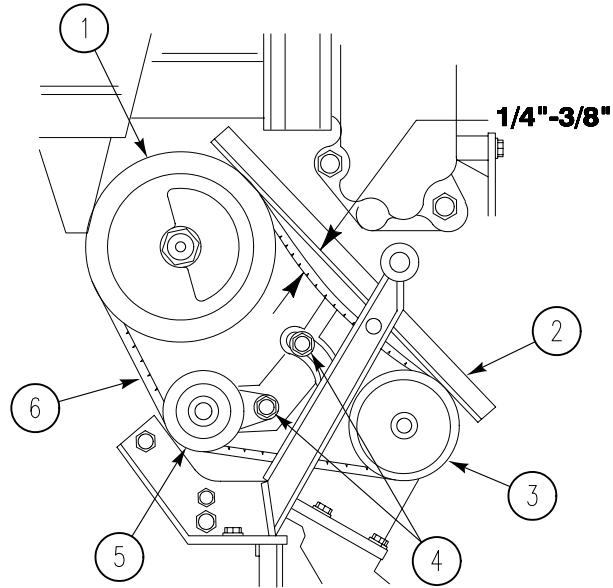

FOLLOW-THROUGH STEPS

1. Install power plant rear access panels (see your -10).

END OF TASK

REPLACE ENGINE COOLANT PUMP

0241 00

THIS WORK PACKAGE COVERS:

- Removal (page 0241 00-1).
- Installation (page 0241 00-4).

INITIAL SETUP:

Maintenance Level
Unit

Personnel Required
Unit Mechanic

Tools and Special Tools
General Mechanic's Tool Kit (WP 0926 00, Item 65)

References
See your -10

Materials/Parts
Cotter pin
Gasket
Locknut
Lockwasher
Lockwasher
Lockwasher (2)
Lockwasher (4)

Equipment Condition
Power plant removed from carrier (WP 0156 00)
Ventilating fan drive belt removed (WP 0243 00)

REMOVAL

1. Remove cotter pin (1), pin (2) and spring tensioner (3) from bracket (4). Discard cotter pin.

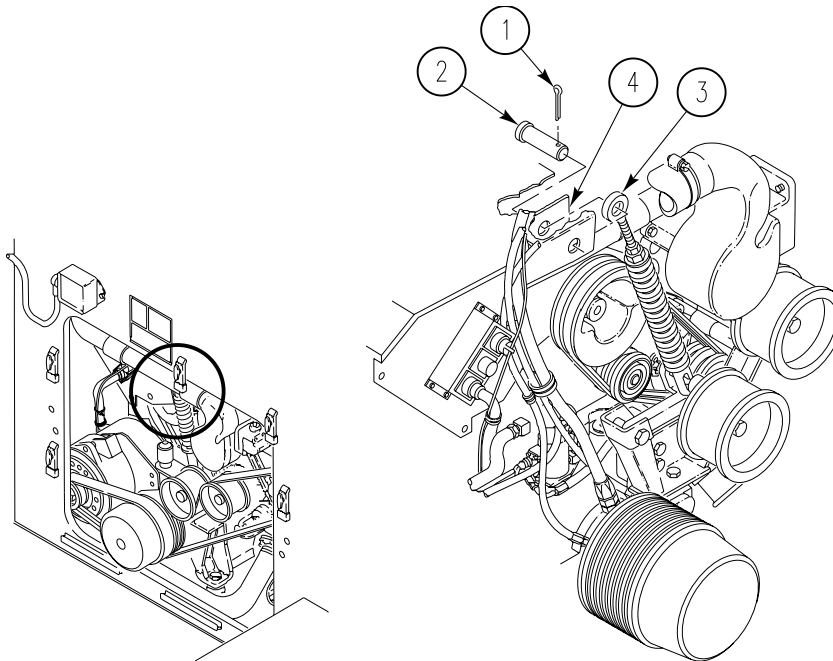

2. Remove locknut (5), two washers (3)(6), screw (1), and pulley (2) from bracket (4). Discard locknut.

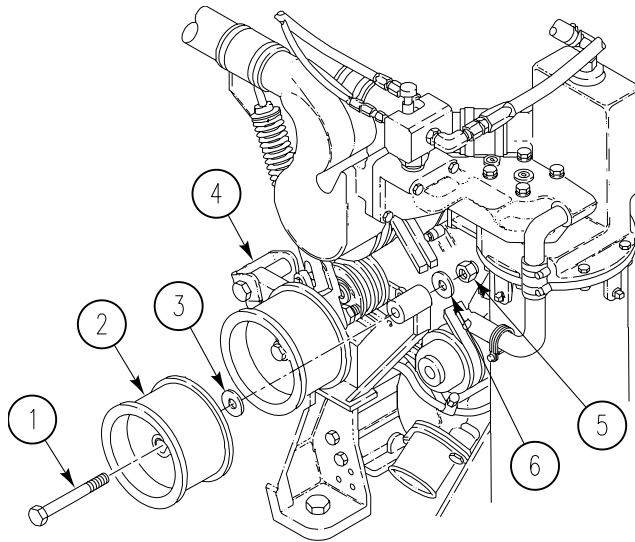

3. Remove screw (1), lockwasher (2), washer (3), and two spacers (5) from bracket (4). Discard lockwasher.

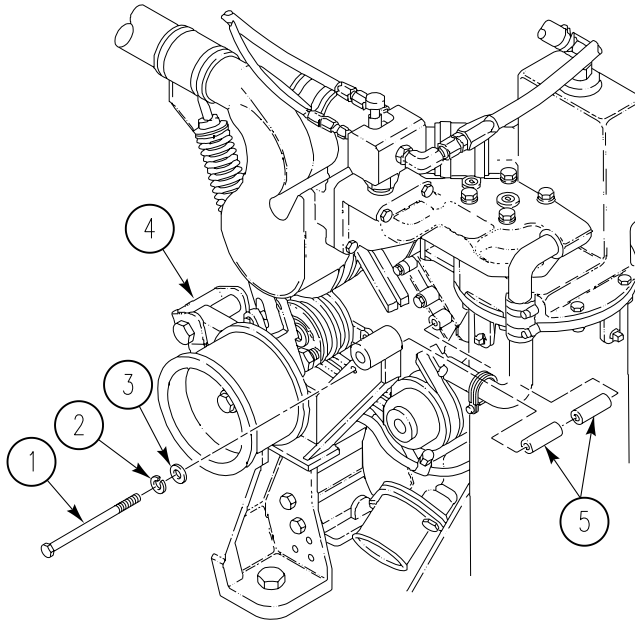

4. Remove screw (2), washer (3), locknut (4), and idler arm bracket (1) from engine. Discard locknut.

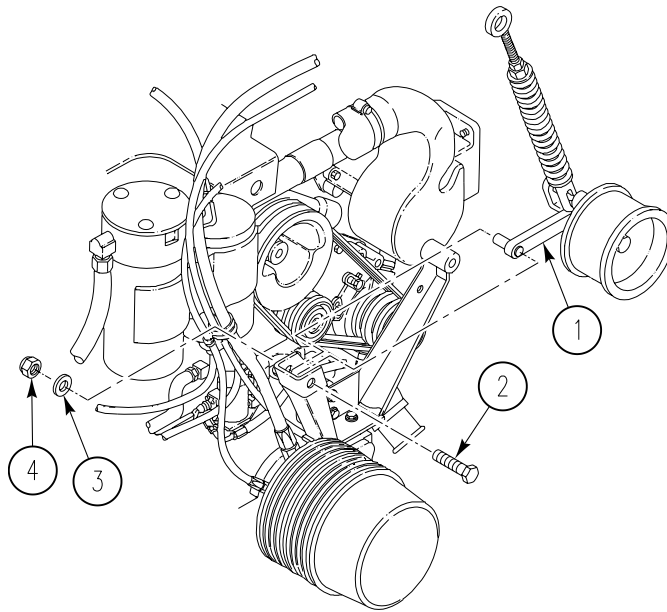

5. Loosen two screws (5) securing idler adjusting bracket (2) to engine.
6. Remove two drive belts (4) from three pulleys (1)(3)(6).

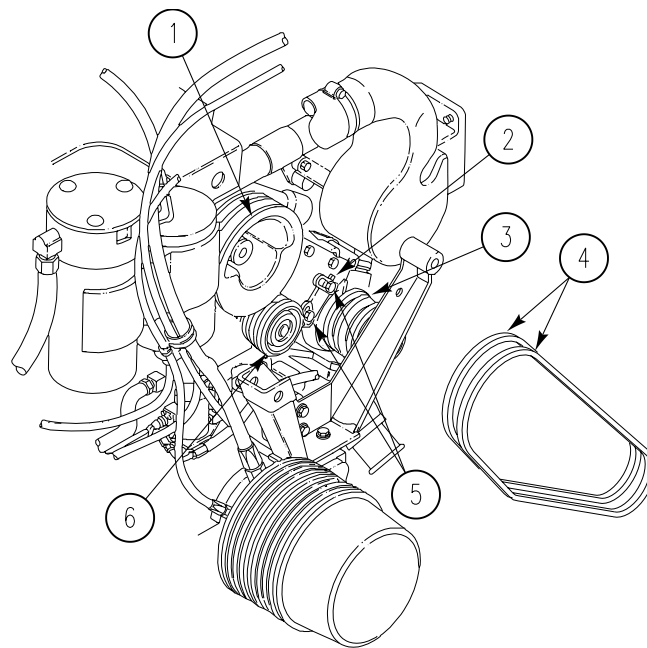

- Remove two screws (4), washers (3), idler adjusting bracket (2) and idler pulley (7) from engine.

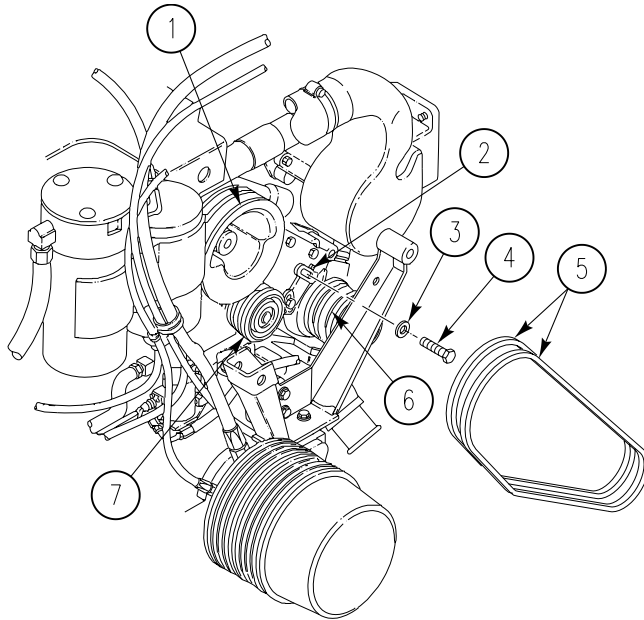

- Loosen two clamps (5) and slide bypass hose (6) up on thermostat tube (7).
- Remove four cap screws (8), lockwashers (9), washers (10), one socket head screw (11), hose bracket (12), coolant pump (13), and gasket (14) from oil cooler housing. Discard lockwashers and gasket.

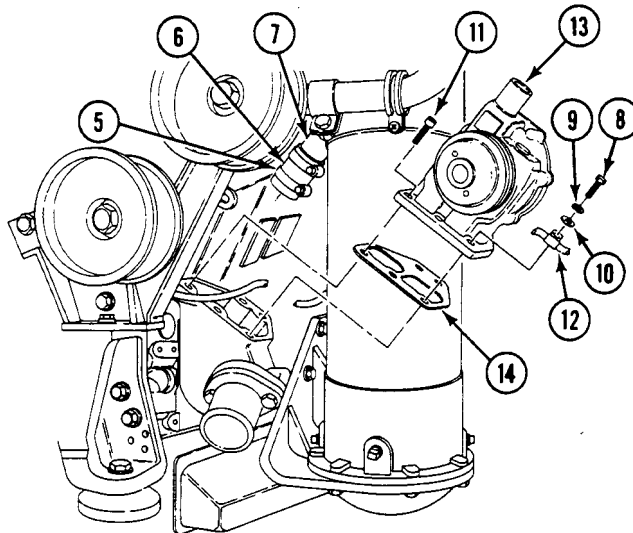

INSTALLATION

- Secure new gasket (14), coolant pump (13), and hose bracket (12) to oil cooler housing with one socket head screw (11), four washers (10), new lockwashers (9) and cap screws (8).

- Secure bypass hose (6) to thermostat tube (7) and coolant pump (13) with two clamps (5).

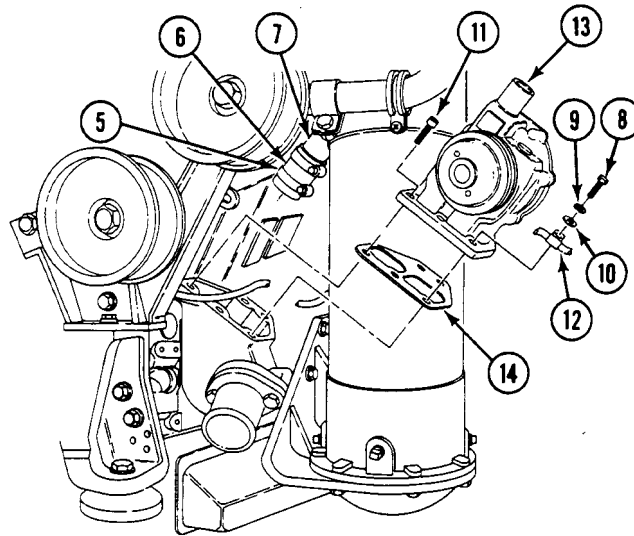

- Install idler pulley (7) and idler adjusting bracket (2) on engine. Secure with two washers (3) and screws (4). Do not tighten screws.

NOTE

Drive belts must be replaced in matched sets.

- Position two drive belts (5) on three pulleys (1)(6)(7).
- Move idler adjusting bracket (2) to obtain a 3/8 inch (10mm) deflection when two drive belts (5) are depressed midway between pulleys (1) and (6).
- Tighten two screws (4) to 30-35 lb-ft (41-47 N.m) torque.

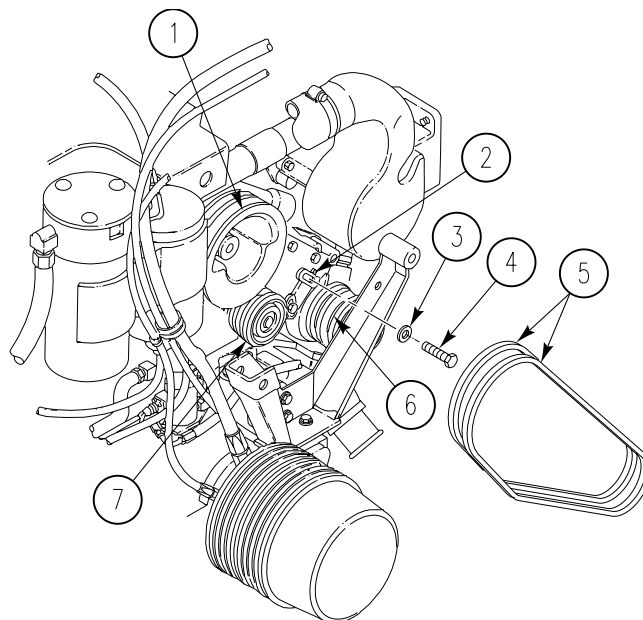

7. Install idler arm bracket (1) on engine. Secure with screw (2), washer (3), and new locknut (4).

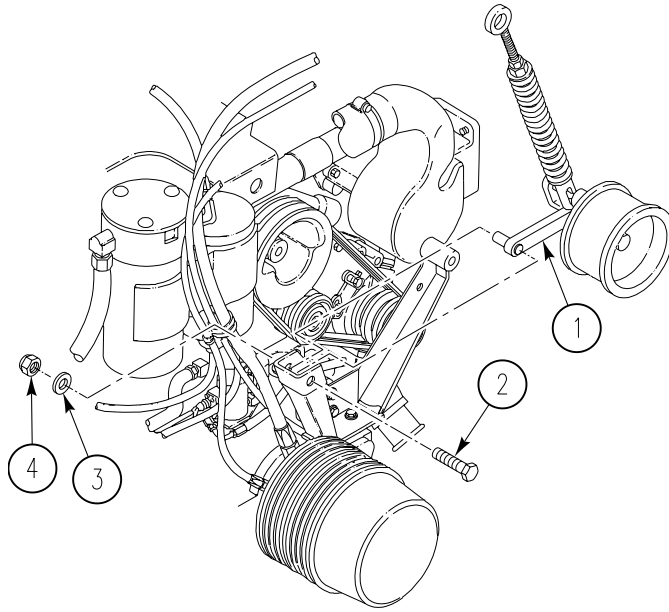

8. Install two screws (3), new lockwashers (2), and washers (1) on bracket (4).

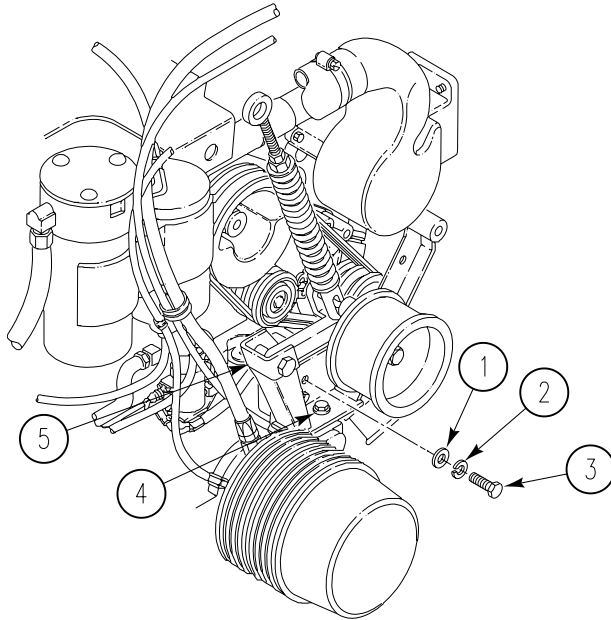

9. Install screw (1), new lockwasher (2), washer (3), and two spacers (5) on bracket (4).

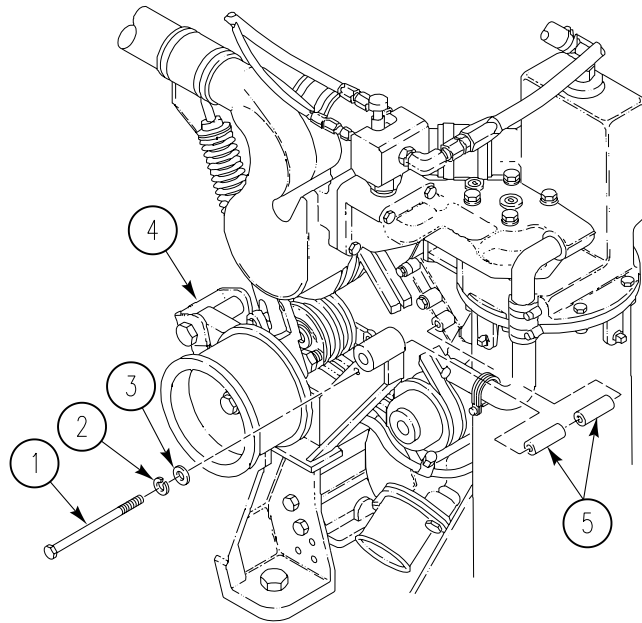

10. Install pulley (2), screw (1), two washers (3)(6), and new locknut (5) on bracket (4).

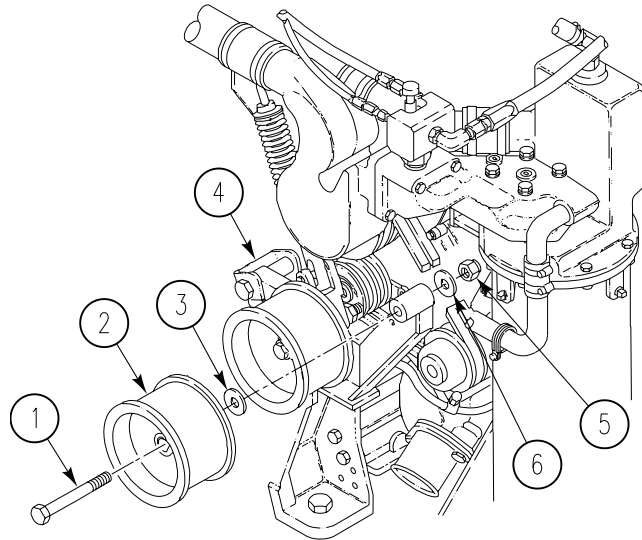

11. Install pin (2), spring tensioner (3), and new cotter pin (1) on bracket (4).

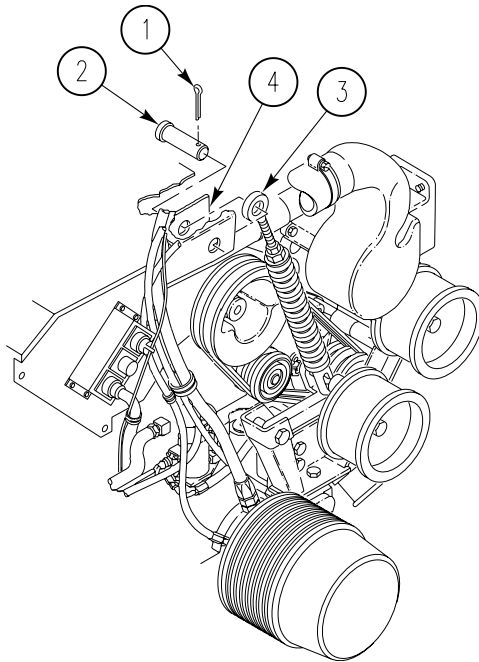
**FOLLOW-THROUGH STEPS**

1. Install ventilating fan drive belt (WP 0243 00).
2. Install power plant in carrier (WP 0156 00).

END OF TASK

ADJUST VENTILATING FAN DRIVE BELT

0242 00

THIS WORK PACKAGE COVERS:

Adjustment (page 0242 00-1).

INITIAL SETUP:

Maintenance Level

Unit

References

See your -10

Tools and Special Tools

- General Mechanic's Tool Kit (WP 0926 00, Item 65)
- V-Belt Tensiometer (WP 0926 00, Item 59)
- Yardstick (WP 0926 00, Item 87)

Equipment Condition

- Engine stopped (see your -10)
- Carrier blocked (see your -10)
- Rear power plant access panels removed (see your -10)
- Power plant access panels removed (WP 0439 00)

Personnel Required

Unit Mechanic

ADJUSTMENT

1. Check ventilating fan drive belt for damage. If damaged, replace drive belt (WP 0243 00).
2. Position lower o-ring (2) on tensiometer (3) at maximum allowable belt deflection of 5/8 inch (1.6 cm).
3. Position upper o-ring (4) on tensiometer at zero.

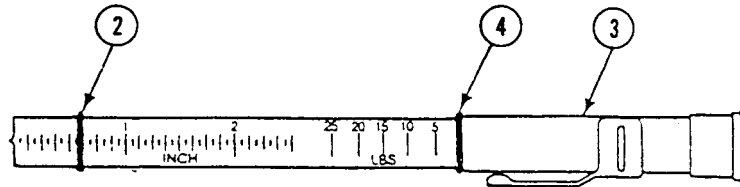

ADJUST VENTILATING FAN DRIVE BELT — Continued

0242 00

4. Place yardstick (5) on pulleys (6) and (7).
5. Place tensiometer (3) on belt (1) at midspan and at right angle to belt.
6. Press on top of tensiometer (3) until lower o-ring (2) aligns with yardstick (5). Remove tensiometer.
7. Take tensiometer reading at point where upper o-ring (4) stopped. Reading must be 12-15 lbs (5-7 kg).
8. To change belt tension, loosen locknut (8) and adjust fan idler adjusting nut (9) to obtain tension required. Tighten locknut.

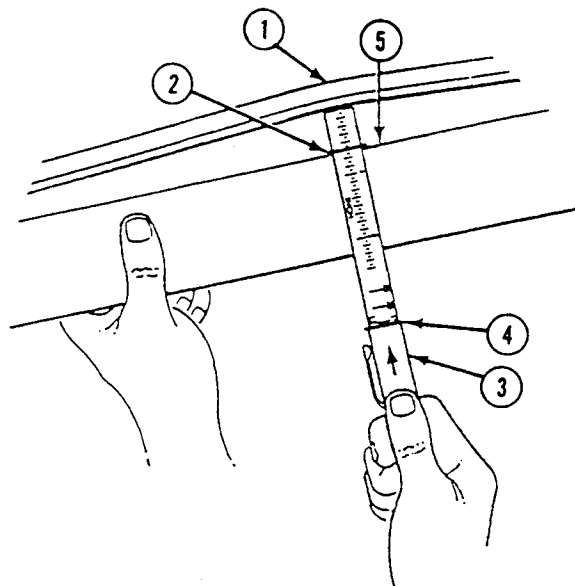
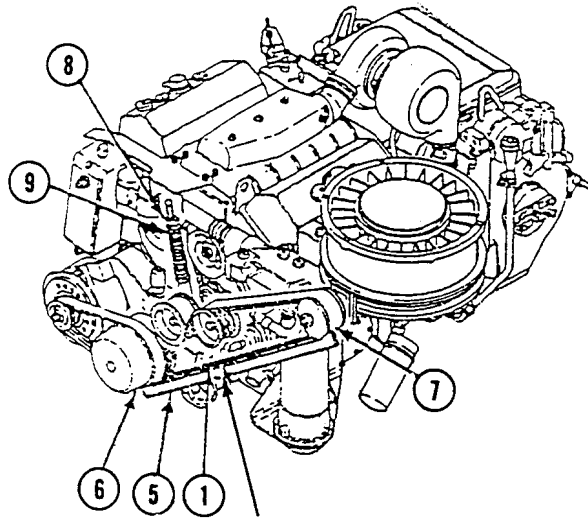

FOLLOW-THROUGH STEPS

1. Turn thermostatic fan speed switch bypass button ON (see your -10).
2. Start engine (see your -10).
3. Run in cooling fan belt for 10 minutes with engine at 2000 RPM.
4. Stop engine (see your -10).
5. Check belt tension. Adjust as needed.
6. Turn thermostatic fan speed switch bypass button OFF (see your -10).
7. Install power plant access panels (WP 0439 00).
8. Install rear power plant access panels (see your -10).

END OF TASK

REPLACE VENTILATING FAN DRIVE BELT

0243 00

THIS WORK PACKAGE COVERS:

Removal (page 0243 00-1).
 Installation (page 0243 00-2).

INITIAL SETUP:

Maintenance Level

Unit

References

See your -10

Tools and Special Tools

General Mechanic's Tool Kit (WP 0926 00, Item 65)
 Adjustable Wrench (WP 0926 00, Item 75)

Equipment Condition

Engine stopped (see your -10)
 Carrier blocked (see your -10)
 Power plant rear access panels removed (see your -10)
 Generator belt removed (WP 0253 00)
 Fan drive pulley access cover removed (WP 0440 00)

Materials/Parts

Fan drive belt

Personnel Required

Unit Mechanic

REMOVAL

1. Loosen locknut (1) that secures adjusting nut (2).
2. Rotate adjusting nut (2) to loosen fan drive belt (3). Discard fan drive belt (3). Use adjustable wrench.

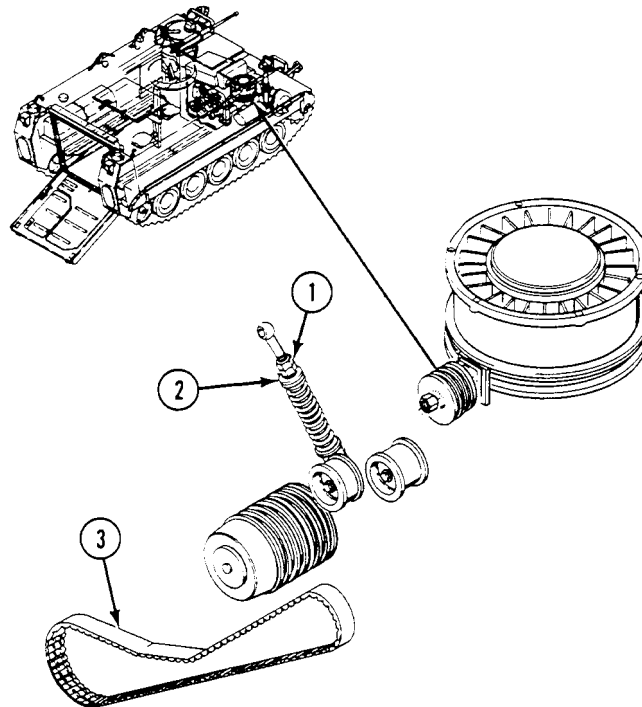

INSTALLATION**NOTE**

All pulleys should rotate freely before installing new fan drive belt.

Readjust new drive belt after 25-50 miles (40.23–80.45 Km) of carrier operation.

1. Position new fan drive belt (3) on pulleys.
2. Adjust fan drive belt (WP 0242 00).

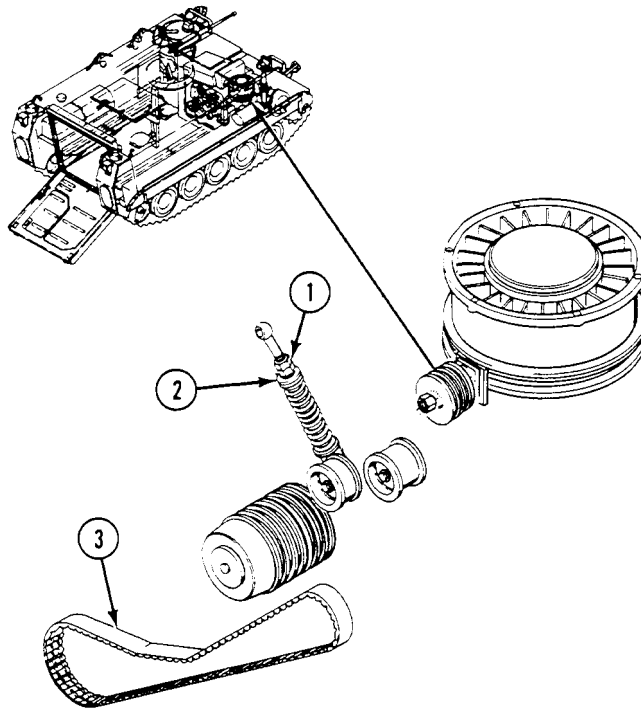
**FOLLOW-THROUGH STEPS**

1. Start engine (see your -10).
2. Check fan drive belt for proper operation.
3. Stop engine (see your -10).
4. Install generator belt (WP 0253 00).
5. Adjust generator belt (WP 0252 00).
6. Install fan drive pulley access cover (WP 0440 00).
7. Install power plant rear access panels (see your -10).

END OF TASK

REPLACE VENTILATING FAN DRIVE PULLEY

0244 00

THIS WORK PACKAGE COVERS:

- Removal (page 0244 00-1).
- Installation (page 0244 00-1).

INITIAL SETUP:

Maintenance Level

Unit

Personnel Required

Unit Mechanic

Tools and Special Tools

- General Mechanic's Tool Kit (WP 0926 00, Item 65)
- Mechanical Puller (WP 0926 00, Item 38)
- Torque Wrench (WP 0926 00, Item 80)

References

See your -10

Materials/Parts

- Key
- Locknut

Equipment Condition

- Engine stopped (see your -10)
- Carrier blocked (see your -10)
- Power plant grill raised (WP 0464 00)

REMOVAL

1. Remove locknut (1) and washer (2) from shaft of drive pulley (3). Discard locknut.
2. Remove pulley (3) and key (4) from shaft. Discard key. Use mechanical puller.

INSTALLATION

1. Install new key (4) in groove on fan drive shaft. Place pulley (3) on shaft and align groove in pulley with key on shaft. Tap pulley on shaft until pulley is seated on shaft.
2. Install washer (2) and new locknut (1) on shaft. **TIGHTEN LOCKNUT TO 75-81 LB-FT (102-111 N·M) TORQUE.**

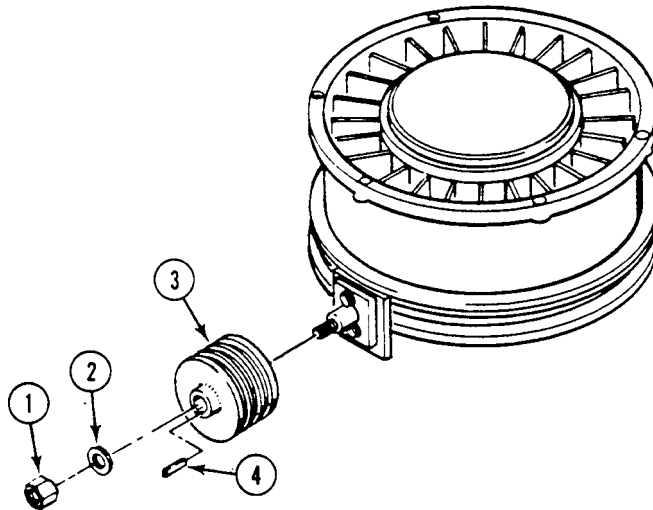

FOLLOW-THROUGH STEPS

1. Lower power plant grill (WP 0464 00).
2. Adjust ventilating fan drive belt (WP 0242 00).

END OF TASK

REPLACE FLAT PULLEYS AND BEARINGS

0245 00

THIS WORK PACKAGE COVERS:

Removal (page 0245 00-1).
 Installation (page 0245 00-3).

INITIAL SETUP:

Maintenance Level

Unit

References

See your -10

Tools and Special Tools

General Mechanic's Tool Kit (WP 0926 00, Item 65)
 Retaining Ring Pliers Set (WP 0926 00, Item 32)
 Torque Wrench (WP 0926 00, Item 82)

Equipment Condition

Engine stopped (see your -10)
 Carrier blocked (see your -10)
 Power plant rear access panels removed (see your -10)
 Ventilating fan drive belt removed (WP 0243 00)

Materials/Parts

Locknut
 Locknut (4)

Personnel Required

Unit Mechanic

REMOVAL

1. Remove four screws (1), locknuts (2), and panel support (3) from hull. Discard locknuts.

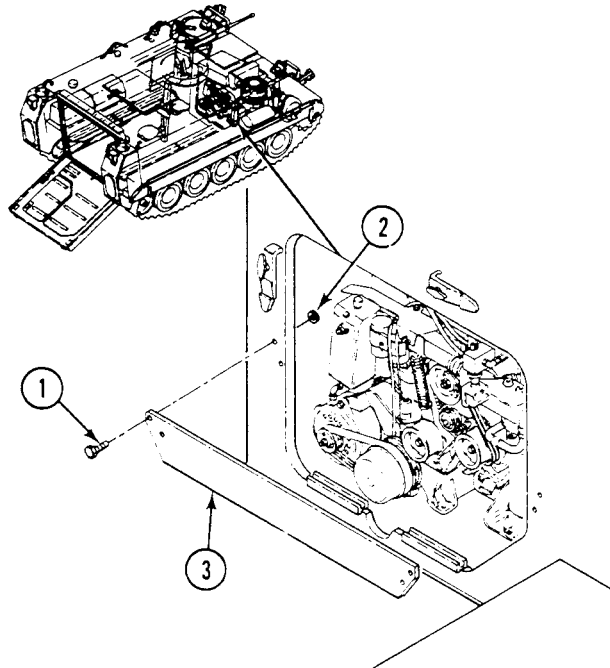

NOTE

Two pulleys are removed in the same way.

2. Remove locknut (4) and washer (5) from bolt (6). Discard locknut.
3. Remove bolt (6) and pulley (7) from bracket (8).

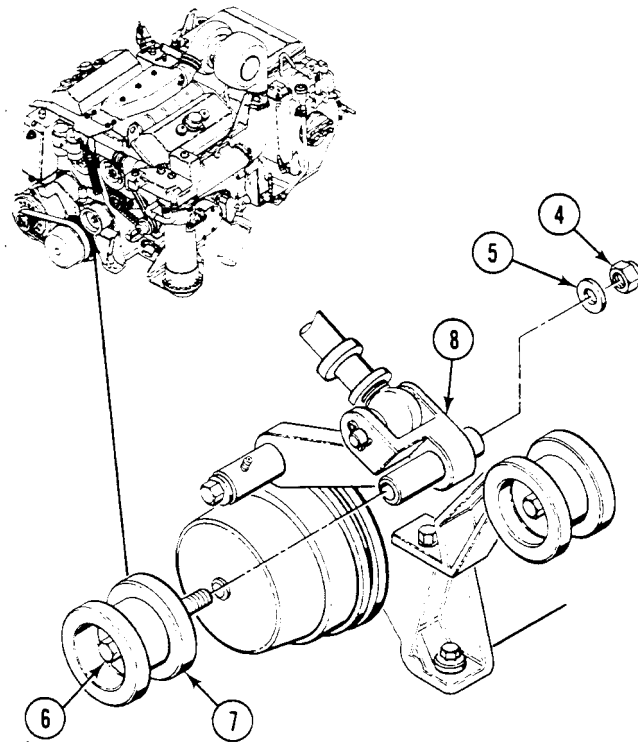

4. Remove bolt (1), ring (2), two bearings (3), and spacer (4) from pulley (5).

- Remove washer (6) and other ring (2) from pulley (5).

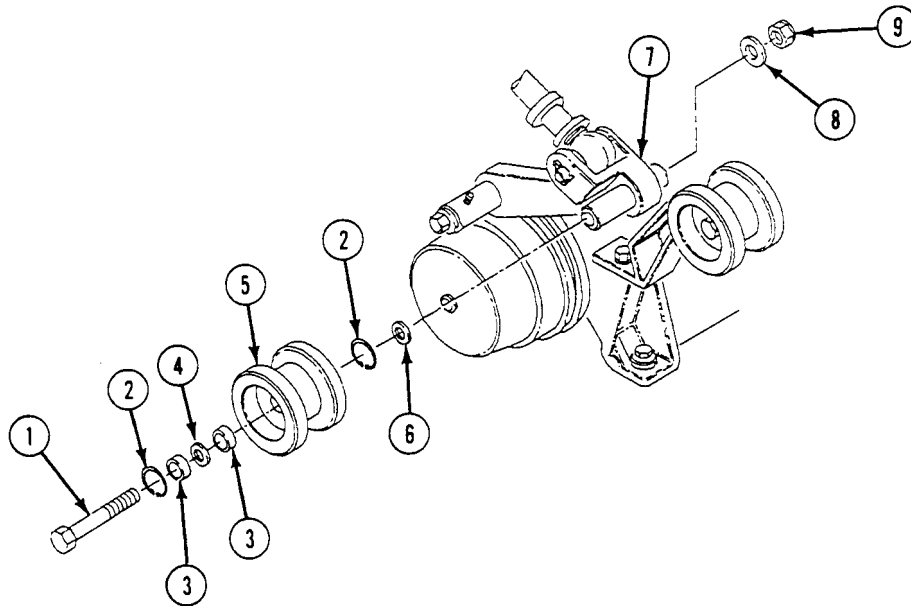

INSTALLATION

- Install ring (2) and washer (6) on pulley (5).
- Install bearing (3), spacer (4), second bearing (3) and other ring (2) on pulley (5).
- Install bolt (1) through two bearings (3) and bracket (7). Secure with washer (8) and new locknut (9). **TIGHTEN BOLT TO 50-55 LB-FT (68-75 N·M) TORQUE.**

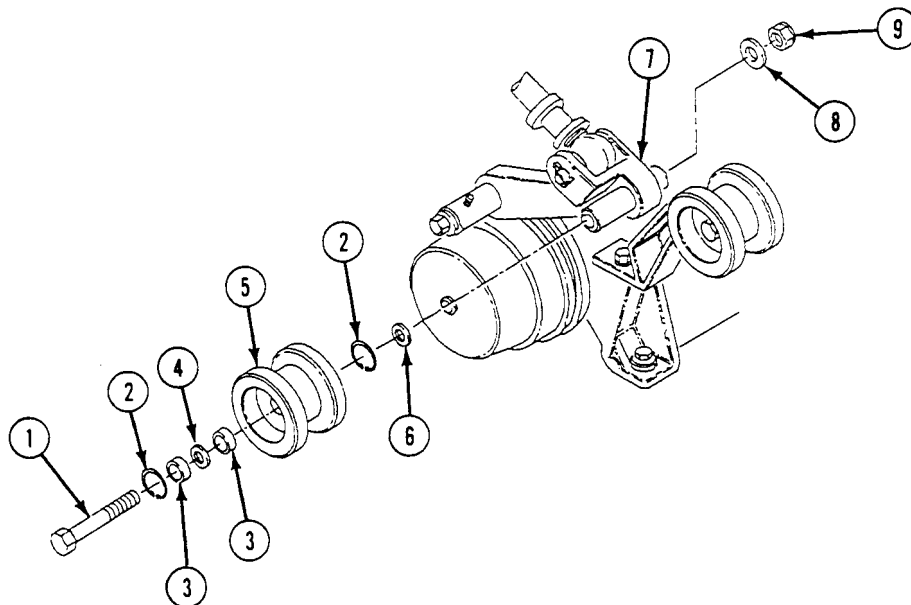

4. Install panel support (10) on hull. Secure with four screws (11) and new locknuts (12).

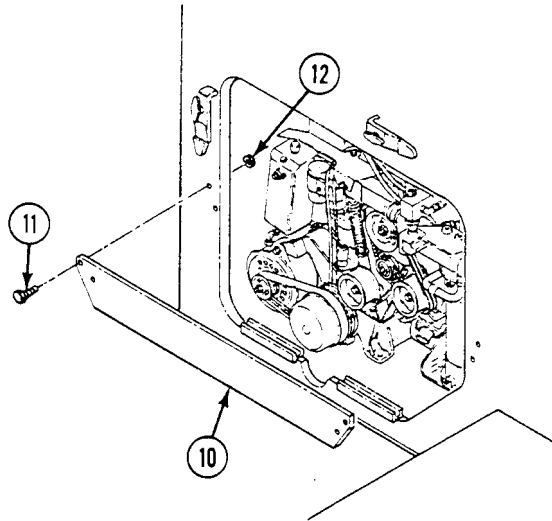
**FOLLOW-THROUGH STEPS**

1. Install power plant rear access panels (see your -10).
2. Install ventilating fan drive belt (WP 0243 00).

END OF TASK

REPLACE IDLER ARM AND SPRING TENSIONER

0246 00

THIS WORK PACKAGE COVERS:

Removal (page 0246 00-1).
 Installation (page 0246 00-2).

INITIAL SETUP:

Maintenance Level

Unit

References

See your -10

Tools and Special Tools

General Mechanic's Tool Kit (WP 0926 00, Item 65)

Equipment Condition

Engine stopped (see your -10)

Carrier blocked (see your -10)

Power plant lower rear access panel removed (see your -10)

Materials/Parts

Cotter pin (2)

Locknut

Flat pulley removed (WP 0245 00)

Personnel Required

Unit Mechanic

REMOVAL

1. Remove cotter pin (1) and pin (2) from bracket (3). Discard cotter pin.
2. Remove cotter pin (4) and pin (5) from idler arm (6). Remove spring tensioner (7). Discard cotter pin.

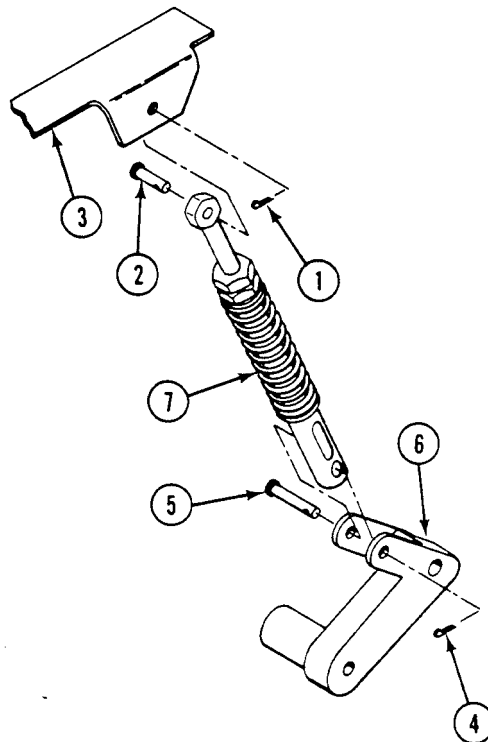

- Remove screw (8), washer (9), and locknut (10) from idler arm (6) and bracket (11). Remove idler arm. Discard locknut.

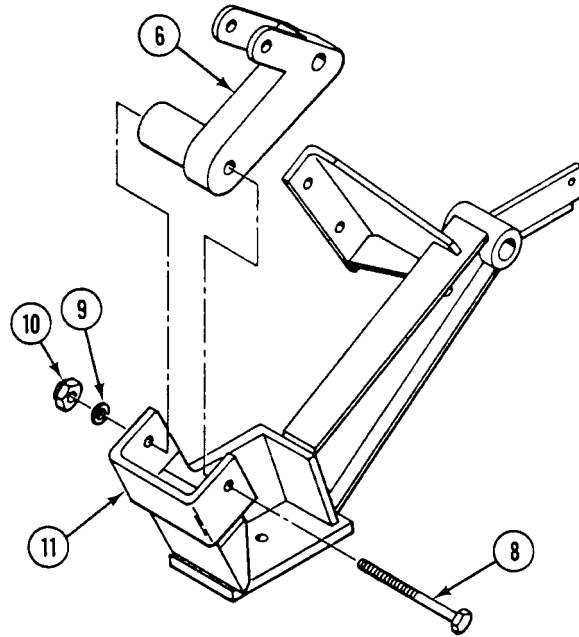

INSTALLATION

- Install idler arm (1) on bracket (2) and secure with screw (3), washer (4), and new locknut (5).

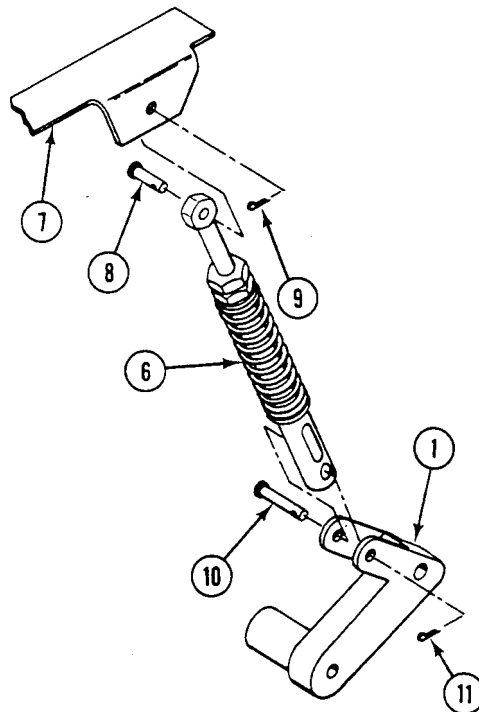

REPLACE IDLER ARM AND SPRING TENSIONER — Continued

0246 00

2. Install spring tensioner (6) on bracket (7). Secure with pin (8) and new cotter pin (9).
3. Install spring tensioner (6) on idler arm (1). Secure with pin (10) and new cotter pin (11).

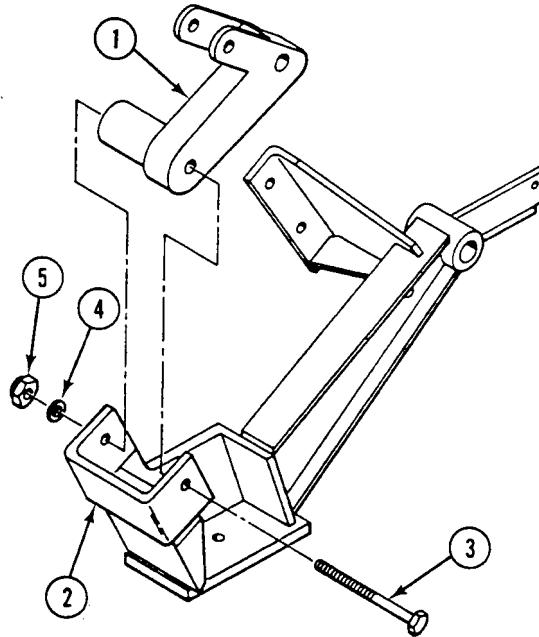
**FOLLOW-THROUGH STEPS**

1. Install flat pulley (WP 0245 00).
2. Install power plant lower rear access panel (see your -10).

END OF TASK

REPLACE VENTILATING FAN ASSEMBLY

0247 00

THIS WORK PACKAGE COVERS:

Removal (page 0247 00-2).
 Installation (page 0247 00-3).

INITIAL SETUP:

Maintenance Level

Unit

Personnel Required

Unit Mechanic

Tools and Special Tools

General Mechanic's Tool Kit (WP 0926 00, Item 65)
 Sling (WP 0926 00, Item 47)
 Torque Wrench (WP 0926 00, Item 82)
 Lifting Device

References

See your -10

Equipment Condition

Engine stopped (see your -10)
 Carrier blocked (see your -10)
 Power plant grill raised (WP 0464 00)

REMOVAL

1. Attach sling and suitable lifting device of at least 150 lbs (68 kg) capacity to fan assembly.
2. Remove six screws (1) and washers (2) that secure fan assembly (3) to power plant grill (4).
3. Lift fan assembly (3) from power plant grill (4) and place fan assembly on work bench or a flat wooden board.
4. Remove fan drive pulley (5) from fan assembly (3) (WP 0244 00).
5. Drain fan drive right angle gearbox (6) (WP 0155 00-0 106) .

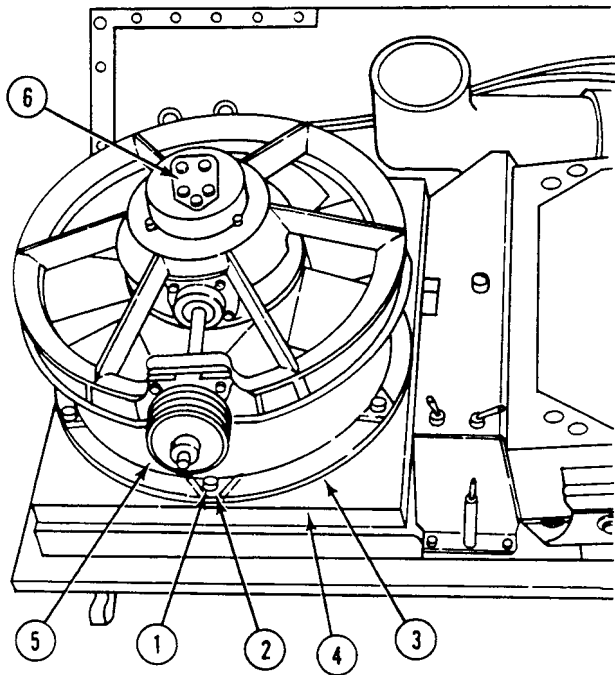

INSTALLATION**NOTE**

Fill on level ground.

1. Fill fan drive right angle gearbox (6) (WP 0155 00).
2. Install fan drive pulley (1) on fan assembly (2) (WP 0244 00).
3. Attach sling and suitable lifting device of at least 150 lbs (68 kg) capacity to fan assembly (2). Lift fan assembly and install on power plant grill (3).
4. Install six screws (4) and washers (5). **TIGHTEN SCREWS TO 24-28 LB-FT (33-38 N·M) TORQUE.**

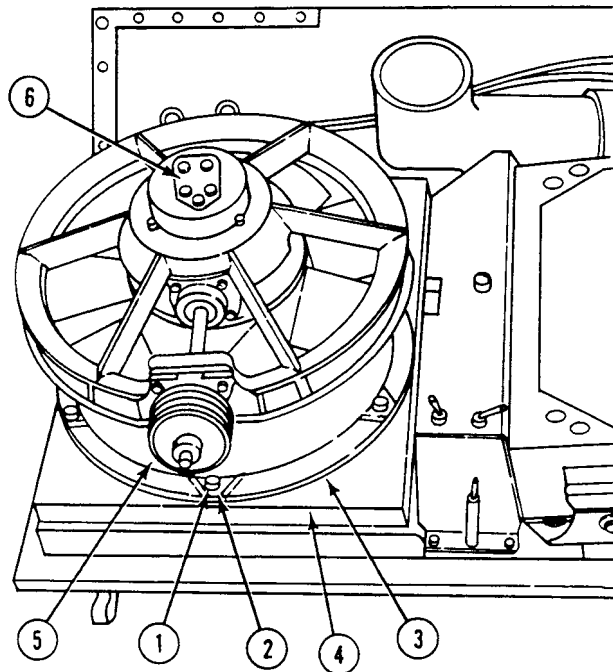
**FOLLOW-THROUGH STEPS**

1. Lower power plant grill (WP 0464 00).

END OF TASK

REPLACE FAN DRIVE SHAFT AND BEARING HOUSING

0248 00

THIS WORK PACKAGE COVERS:

Removal (page 0248 00-1).
 Installation (page 0248 00-3).

INITIAL SETUP:

Maintenance Level

Unit

References

See your -10

Tools and Special Tools

General Mechanic's Tool Kit (WP 0926 00, Item 65)
 Torque Wrench (WP 0926 00, Item 85)

Equipment Condition

Engine stopped (see your -10)
 Carrier blocked (see your -10)
 Battery ground strap removed (WP 0337 00),
 (WP 0338 00), or (WP 0339 00)
 Power plant rear access panel removed (see your -10)
 Fan drive gear box drained (WP 0155 00)
 Power plant grill raised (WP 0464 00)
 Fan drive pulley removed (WP 0244 00)

Materials/Parts

Antiseize compound (WP 0928 00, Item 11)
 Packing
 Washer (3)

Personnel Required

Unit Mechanic

REMOVAL

WARNING



Failure to set the parking brake and block the road wheels can allow the carrier to move and could result in injury or death. Always set the parking brake and block road wheels before working on the carrier.

1. Remove two pins (1) from bearing housing (2) and bearing support (3). Tap pins in toward center of fan.

- Remove three screws (4), washers (5), bearing housing (2), and drive shaft (6) from bearing support (3). Discard washers.

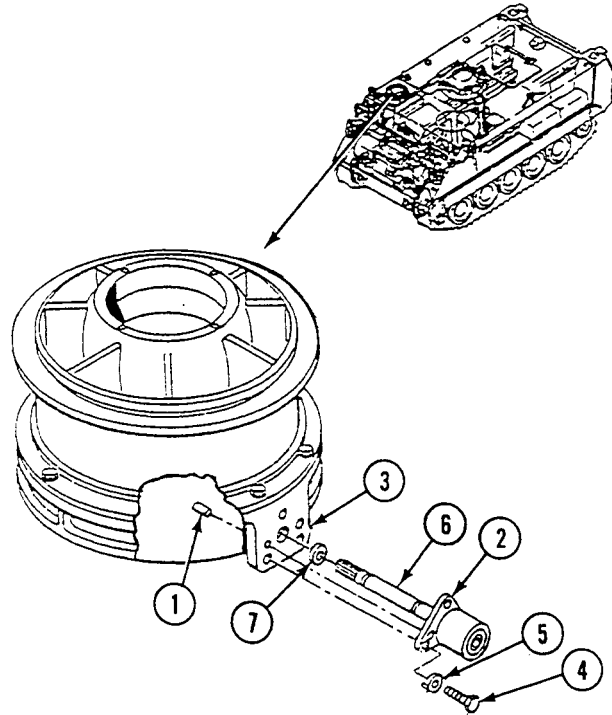

- Remove packing (7) from drive shaft (6). Discard packing.

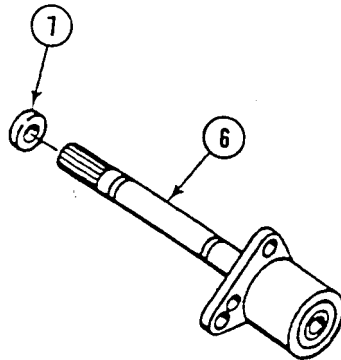

INSTALLATION

1. Install new packing (1) on drive shaft (2).

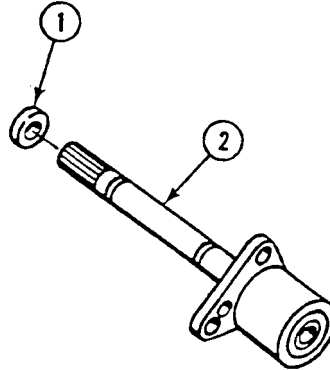

2. Align splines of drive shaft (2) with fan gear box splines (3). Install drive shaft in bearing support (4) and gear box (3).
3. Install two pins (5) in bearing housing (6) and bearing support (4). Tap pins in toward center of fan.
4. Apply antiseize compound to threads of screws (7).
5. Install three new washers (8) and screws (7) in bearing housing (6). **TIGHTEN SCREWS (7) TO 21-25 LB-FT (28-34 N·m) TORQUE.**

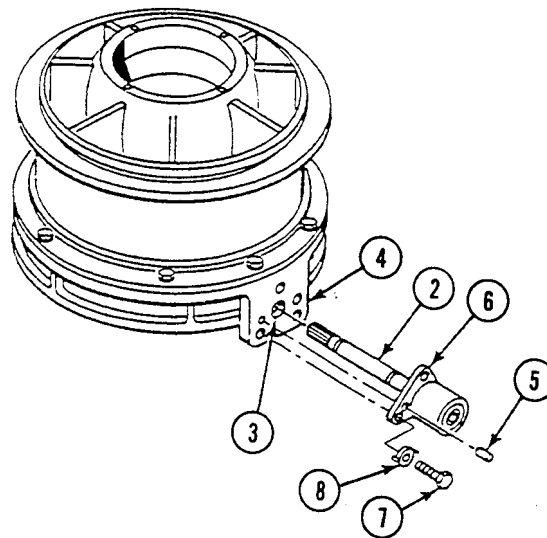

FOLLOW-THROUGH STEPS

1. Install fan drive pulley (WP 0244 00).
2. Lower power plant grill (WP 0464 00).
3. Fill fan drive gear box (WP 0155 00).
4. Install power plant rear access panel (see your -10).
5. Connect battery ground strap (WP 0337 00), (WP 0338 00), or (WP 0339 00).

END OF TASK

REPLACE FAN AND GENERATOR VARIABLE SPEED FAN DRIVE (OLD CONFIGURATION)

0249 00

THIS WORK PACKAGE COVERS:

- Removal (page 0249 00-1).
 - Installation (page 0249 00-3).
-

INITIAL SETUP:

Maintenance Level

Unit

References

See your -10

Tools and Special Tools

- General Mechanic's Tool Kit (WP 0926 00, Item 65)
- Torque Wrench (WP 0926 00, Item 85)

Equipment Condition

- Engine stopped (see your -10)
 - Carrier blocked (see your -10)
 - Power plant rear access panels removed (see your -10)
 - Fan drive belt removed (WP 0243 00)
 - Generator drive belt removed (WP 0253 00)
-

Materials/Parts

- Packing
- Packing
- Packing

Personnel Required

Unit Mechanic

REMOVAL**NOTE**

Of the three hoses removed, left hose is the lube port hose, center hose is the return hose, and right hose is the pressure hose.

1. Disconnect three hoses (1), (2), and (3) from drive assembly (4).
2. Remove six screws (5), washers (6), and drive assembly (4).
3. Remove three elbows (7), (8), and (9) and packings (10), (11), and (12) from drive assembly (4). Discard packings.

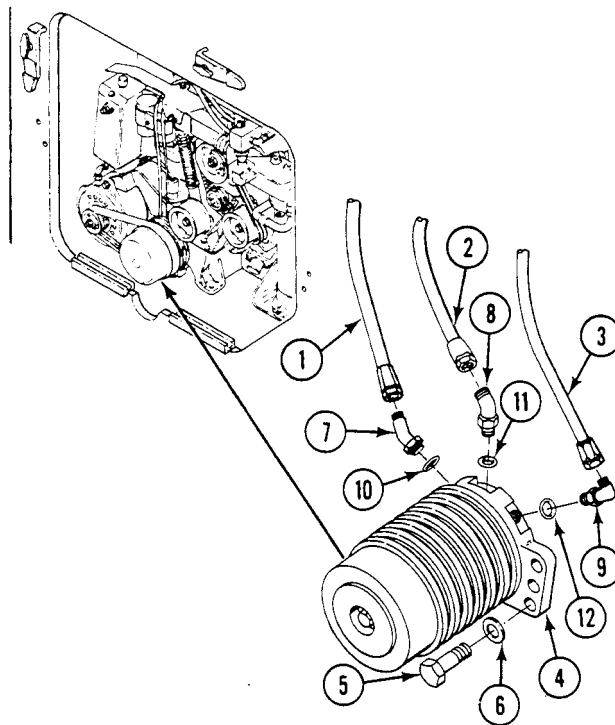

REPLACE FAN AND GENERATOR VARIABLE SPEED FAN DRIVE (OLD CONFIGURATION)
 — Continued

0249 00

INSTALLATION

1. Install three elbows (7), (8), and (9) and new packings (10), (11), and (12) on drive assembly (4).
2. Install drive assembly (4) on engine. Secure with six screws (5) and washers (6). **TIGHTEN SCREWS TO 32-34 LB-FT (43-46 N·M) TORQUE.**
3. Connect three hoses (1), (2), and (3) to drive assembly (4).

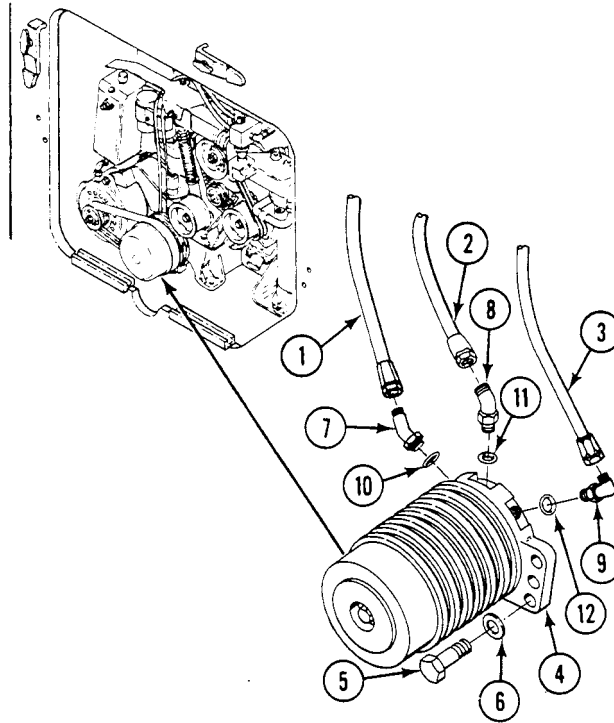
**FOLLOW-THROUGH STEPS**

1. Install fan drive belt (WP 0243 00).
2. Adjust fan drive belt (WP 0242 00).
3. Install generator drive belt (WP 0253 00).
4. Adjust generator drive belt (WP 0252 00).
5. Install power plant rear access panels (see your -10).

END OF TASK

REPLACE VARIABLE SPEED FAN DRIVE ASSEMBLY (NEW CONFIGURATION)

0249 01**THIS WORK PACKAGE COVERS:**

- Removal (page 0231 01-1).
 - Installation (page 0231 01-2).
 - Adjustment (page 0231 01-2).
-

INITIAL SETUP:Maintenance Level

Unit

Tools and Special Tools

- General Mechanic's Tool Kit (WP 0926, Item 65)
- Torque Wrench (WP 0926, Item 85)

Materials/Parts

- Molybdenum grease (WP 0928, Item 41)
- Sealing compound (WP 0928, Item 52)
- Packing, preformed
- Packing, preformed

Personnel Required

Unit Mechanic

References

- See your -10
- Drawing 12474790

Equipment Conditions

- Engine stopped (see your -10)
 - Carrier blocked (see your -10)
 - Power plant rear access panels removed (see your -10)
 - Driver's power plant access panel removed (see your-10)
 - Battery ground strap disconnected (WP 0337 00 or WP 0338 00)
 - Fan drive belt removed (WP 0243 00)
 - Generator drive belt removed (WP 0253 00)
-

REMOVAL

1. Disconnect plugs (1) from drive assembly (2).
2. Remove sensor (3) from drive assembly (2).

NOTE

Of the two hoses removed, the left hose is the lube port and the right hose is the return hose.

3. Disconnect two hoses (4) and (5) from elbows (6) and (7) on drive assembly (2).
4. Remove six screws (8), washers (9), and drive assembly (2).
5. Remove two elbows (6) and (7), packings (10) and (11), and one adapter (12) from drive assembly (2). Discard packing.

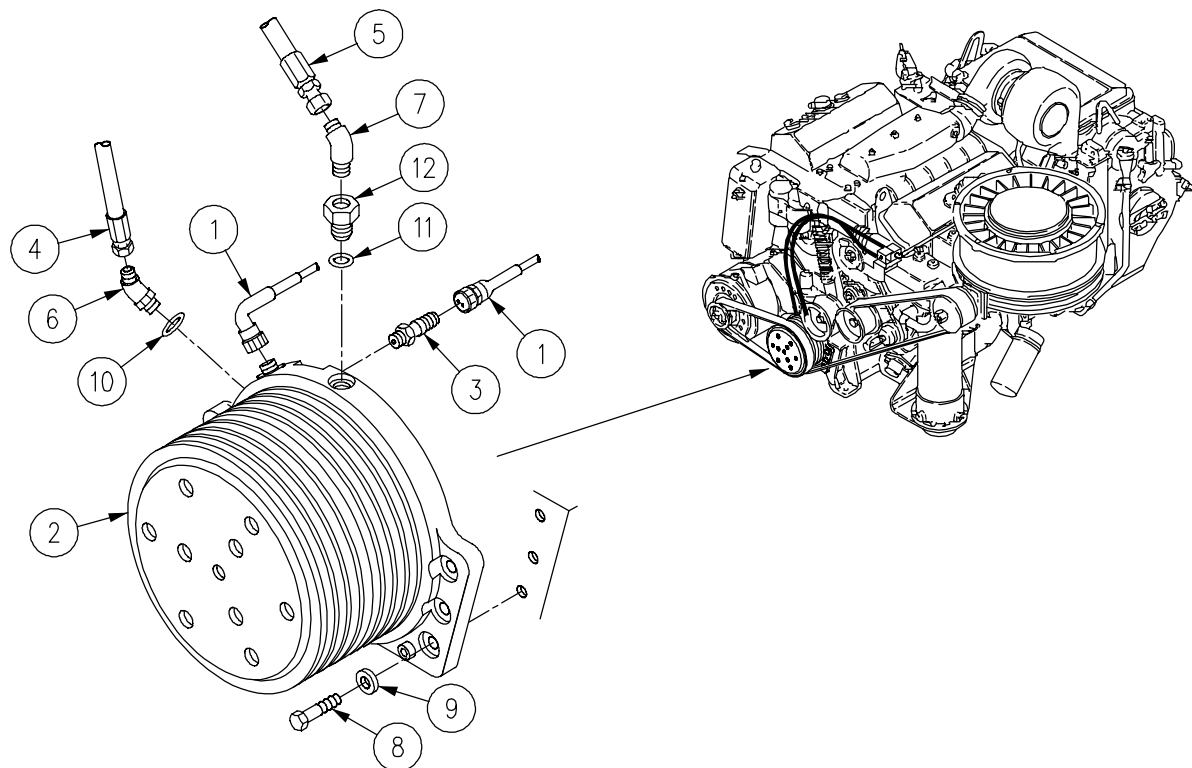

INSTALLATION

1. Apply thin layer of sealing compound to male threads on return hose elbow (7). Install adapter (12), two new packings (10) and (11), and elbows (6) and (7) on drive assembly (2).
2. Apply molybdenum grease to splines of drive assembly (2). Install drive assembly (2), six washers (9), and screws (8). TORQUE SCREWS TO 32-34 LB-FT (43-46 N·M) TORQUE.
3. Connect two hoses (4) and (5) to elbows (6) and (7) on drive assembly (2).
4. Install sensor (3) on drive assembly (2).
5. Connect plugs (1) on drive assembly (2).

ADJUST

1. Adjust sensor (3) so sensor tip is .030-.040 inch (8-11 mm) from drive pulley (2).

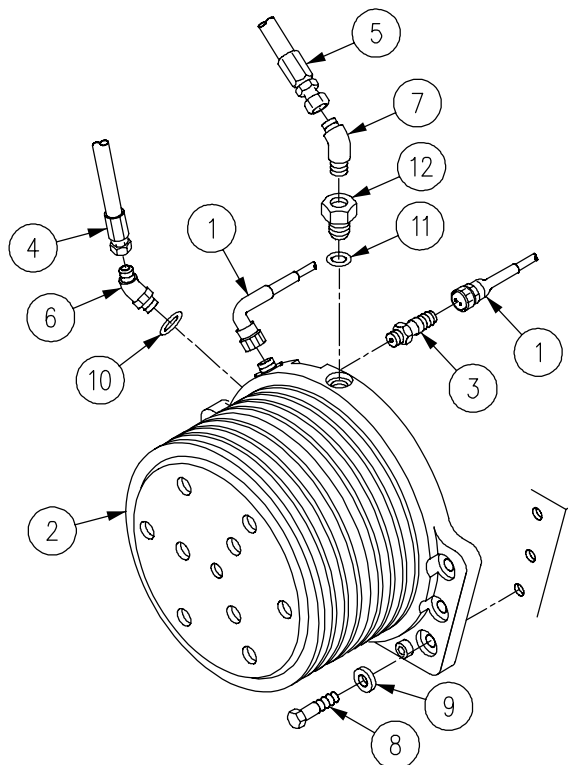

FOLLOW-THROUGH STEPS

1. Install generator drive belt (WP 0253 00).
2. Install fan drive belt (WP 0243 00).
3. Connect battery ground strap (WP 0337 00 or WP 0338 00).
4. Install driver's power plant access panel (see your-10).
5. Install power plant rear access panels (see your -10).

END OF TASK

**REPLACE HOSES FROM THERMOSTAT TO VARIABLE SPEED FAN DRIVE
(OLD CONFIGURATION)**

0250 00

THIS WORK PACKAGE COVERS:

Removal (page 0250 00-1).
Installation (page 0250 00-4).

INITIAL SETUP:

Maintenance Level

Unit

References

See your -10

Tools and Special Tools

General Mechanic's Tool Kit (WP 0926 00, Item 65)

Equipment Condition

Engine stopped (see your -10)
Carrier blocked (see your -10)
Power plant rear access panels removed (see your -10)
Power plant rear access panel support removed
(WP 0439 00)
Ventilating fan drive belt removed (WP 0243 00)

Materials/Parts

Locknut
Packing (2)
Packing (2)
Strap (1)

Personnel Required

Unit Mechanic

REPLACE HOSES FROM THERMOSTAT TO VARIABLE SPEED FAN DRIVE (OLD CONFIGURATION) — Continued

0250 00

REMOVAL

1. Remove strap (1) securing hoses (2) and (3) from variable speed fan drive (4). Discard strap.

NOTE

Install covers on disconnected hydraulic lines, tubes, valves and components during maintenance. Use tape, cloth, cardboard, or any appropriate material to prevent damage to components or accidental hydraulic fluid spills.

2. Remove lube port hose (2) from elbow (5) on variable speed fan drive (4).
3. Remove pressure hose (3) from elbow (6) on variable speed fan drive (4).
4. Remove elbow (5) and packing (7) from variable speed fan drive (4). Discard packing.
5. Remove elbow (6) and packing (8) from variable speed fan drive (4). Discard packing.

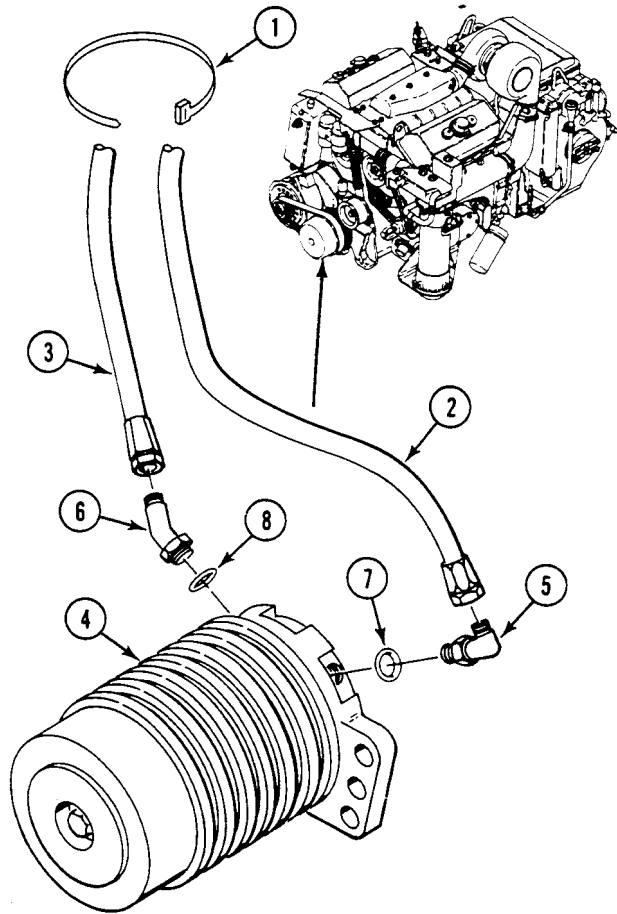

REPLACE HOSES FROM THERMOSTAT TO VARIABLE SPEED FAN DRIVE (OLD CONFIGURATION) — Continued

0250 00

6. Remove hose (1) from adapter (2).
7. Remove hose (3) from adapter (4).
8. Remove adapter (2) and packing (5) from thermostat housing (6). Discard packing.
9. Remove adapter (4) and packing (7) from thermostat housing (6). Discard packing.

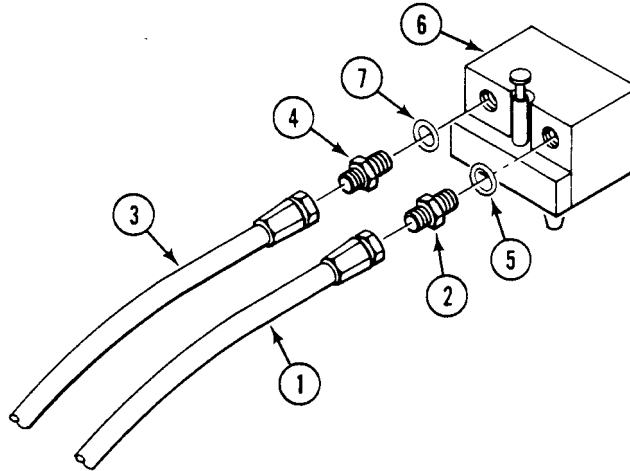

10. Remove screw (8), two washers (9), locknut (10) and two clamps (11) and (12) from bracket (13). Remove two clamps from hoses (3) and (1). Discard locknut.

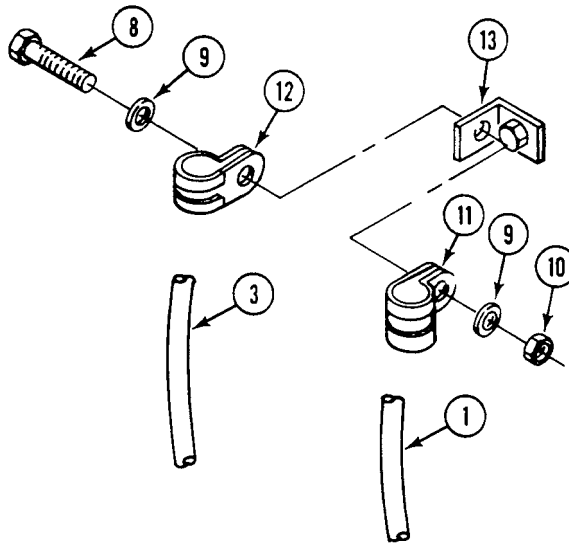

REPLACE HOSES FROM THERMOSTAT TO VARIABLE SPEED FAN DRIVE (OLD CONFIGURATION) — Continued

0250 00

INSTALLATION

1. Install elbow (14) and new packing (15) on variable speed fan drive (16).
2. Install elbow (17) and new packing (18) on variable speed fan drive (16).

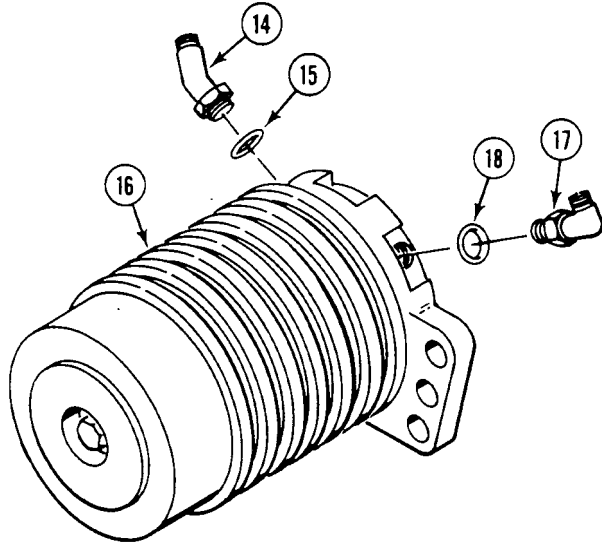

3. Install adapter (19) and new packing (20) on thermostat housing (21).
4. Install adapter (22) and new packing (23) on thermostat housing (21).
5. Install hose (24) on adapter (19).
6. Install hose (25) on adapter (22).

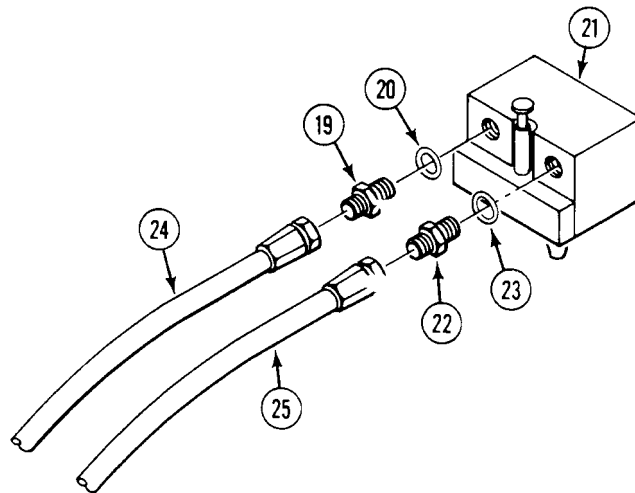

REPLACE HOSES FROM THERMOSTAT TO VARIABLE SPEED FAN DRIVE (OLD CONFIGURATION) — Continued

0250 00

7. Install two clamps (1) and (2) on two hoses (3) and (4). Secure clamps to bracket (5) with screw (6), two washers (7) and locknut (8).

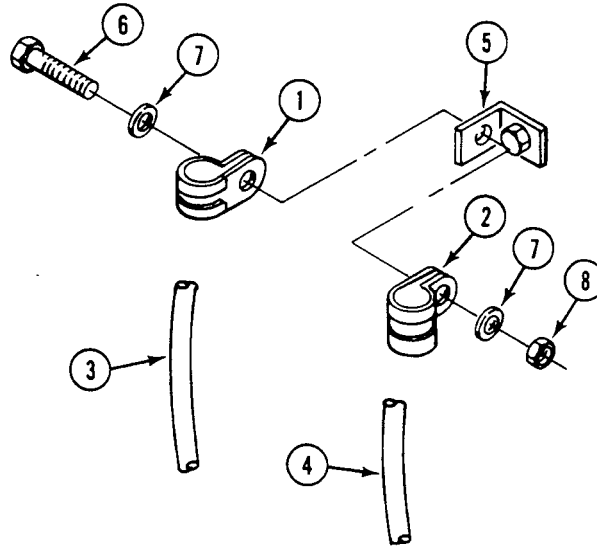

8. Install hose (3) on elbow (9).
9. Install hose (4) on elbow (10).
10. Secure hoses (3) and (4) together to variable speed fan drive with new strap (11).

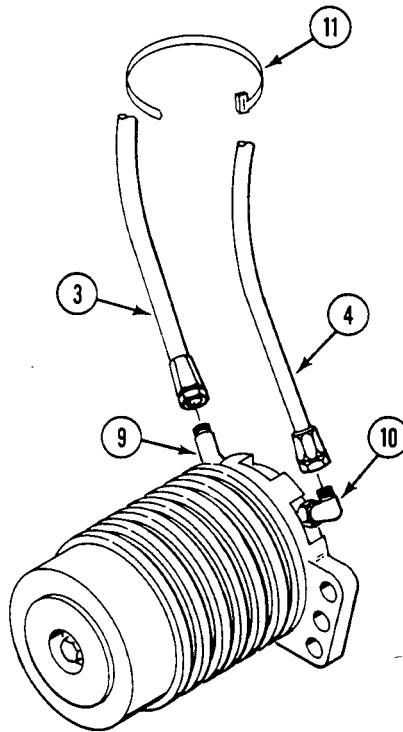

REPLACE HOSES FROM THERMOSTAT TO VARIABLE SPEED FAN DRIVE (OLD CONFIGURATION) — Continued

0250 00

FOLLOW-THROUGH STEPS

1. Install ventilating fan drive belt (WP 0243 00).
2. Adjust ventilating fan drive belt (WP 0242 00).
3. Install power plant rear access panel support (WP 0439 00).
4. Install power plant rear access panels (see your -10).

END OF TASK

REPLACE VARIABLE SPEED FAN DRIVE CONTROLLER (NEW CONFIGURATION)

0250 01

THIS WORK PACKAGE COVERS:

Removal (page 0250 01-1)

Installation (page 0250 01-2)

INITIAL SETUP:

Maintenance Level

Unit

Tools and Special Tools

General Mechanic's Tool Kit (WP 0926 00, Item 65)

Materials/Parts

Gasket

Lockwasher (2)

Lockwasher (2)

Lockwasher (4)

Personnel Required

Unit Mechanic

References

See your -10

Equipment Conditions

Engine stopped (see your -10)

Carrier blocked (see your -10)

Driver's power plant access panel removed (see your-10)

Battery ground strap disconnected (WP 0337 00 or WP 0338 00)

REMOVAL

1. Disconnect two wiring harnesses (1) and (2) from controller (3) on driver's compartment engine bulkhead.
2. Remove nut (4), screw (5), lockwasher (6), and controller jumper wire (7) from vehicle. Discard lockwasher.
3. Remove two lockwashers (8), flat washers (9), screws (10), bracket (11), and gasket (12) from driver's compartment engine bulkhead. Discard lockwashers and gasket.
4. Remove four nuts (13), jumper wire (7), lockwasher (14), four lockwashers (15), seven flat washers (16), four screws (17), and controller (3) from bracket (11). Discard lockwashers.

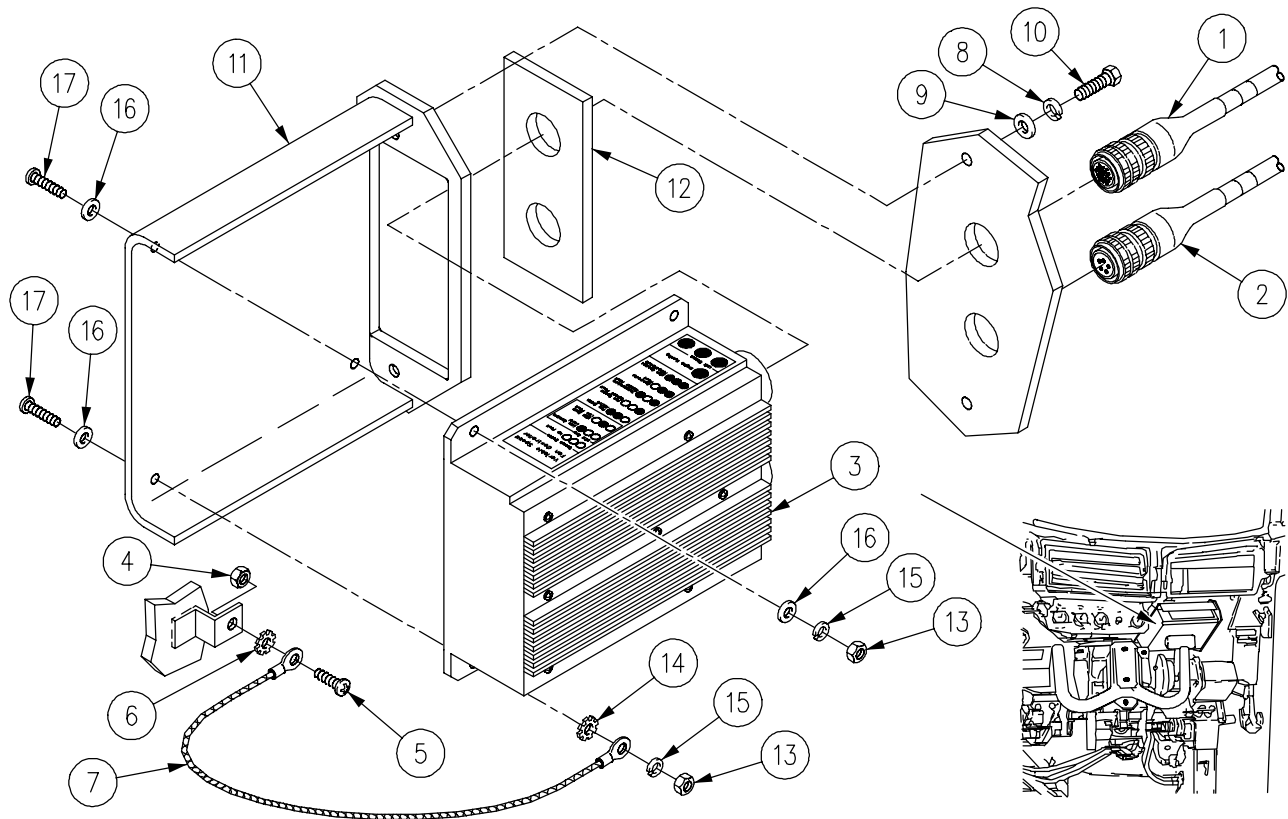

**REPLACE VARIABLE SPEED FAN DRIVE CONTROLLER
(NEW CONFIGURATION) - Continued**

0250 01

INSTALLATION

1. Install controller (3), four screws (17), seven flat washers (16), four new lockwashers (15), new lockwasher (14), jumper wire (7), and four nuts (13) on bracket (11).
2. Install new gasket (12), bracket (11), two screws (10), flat washers (9), and new lockwashers (8) on driver's compartment engine bulkhead.
3. Install nut (4), screw (5), new lockwasher (6), and controller jumper wire (7) on vehicle.
4. Connect two wiring harnesses (1) and (2) on controller (3) on driver's compartment engine bulkhead.

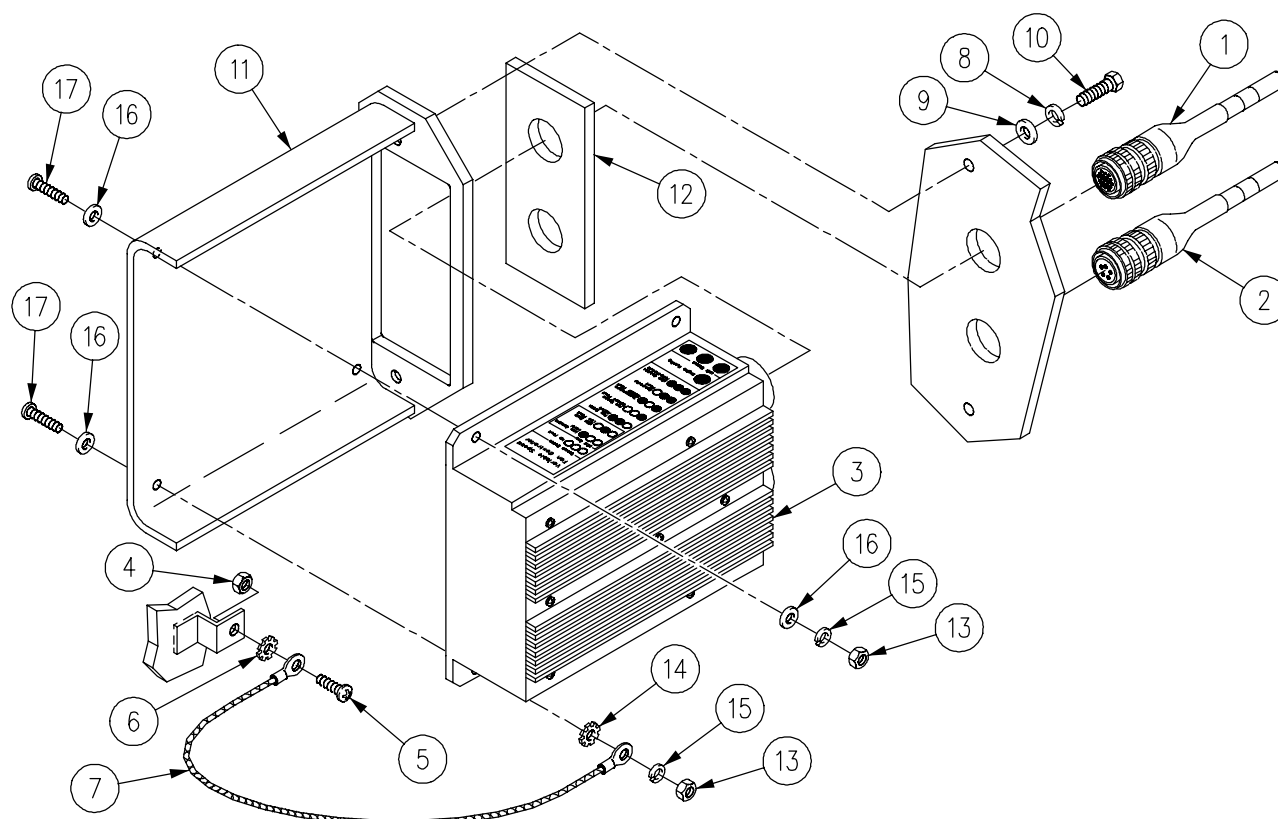
FOLLOW-THROUGH STEPS

1. Connect battery ground strap (WP 0337 00 or WP 0338 00).
2. Install driver's power plant access panel (see your-10).

END OF TASK

REPLACE TRANSMISSION OIL SUPPLY AND RETURN HOSES

0251 00

THIS WORK PACKAGE COVERS:

Removal (page 0251 00-1).
 Installation (page 0251 00-5).

INITIAL SETUP:

Maintenance Level

Unit

Personnel Required

Unit Mechanic

Tools and Special Tools

General Mechanic's Tool Kit (WP 0926 00, Item 65)

References

See your -10

Materials/Parts

Packing
 Locknut
 Transmission oil (WP 0928 00, Item 28)

Equipment Condition

Engine stopped (see your -10)
 Carrier blocked (see your -10)
 Power plant removed (WP 0156 00)
 Transmission oil drained (WP 0398 00)

REMOVAL

CAUTION

Cap or cover openings where oil lines or fittings have been removed.

NOTE

Old and New Configuration refers to variable speed fan drive configuration.

1. Remove return hose (1) from elbow (2).
2. Remove elbow (2) from transmission.

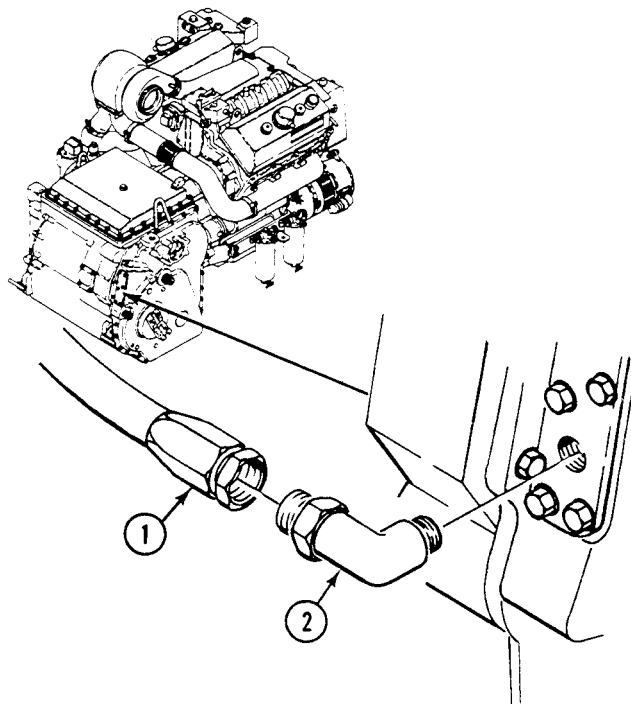

3. Remove two nuts (3), screws (4), four washers (5), and two clamps (6) that secure hose (1) to two brackets (7) on transmission.

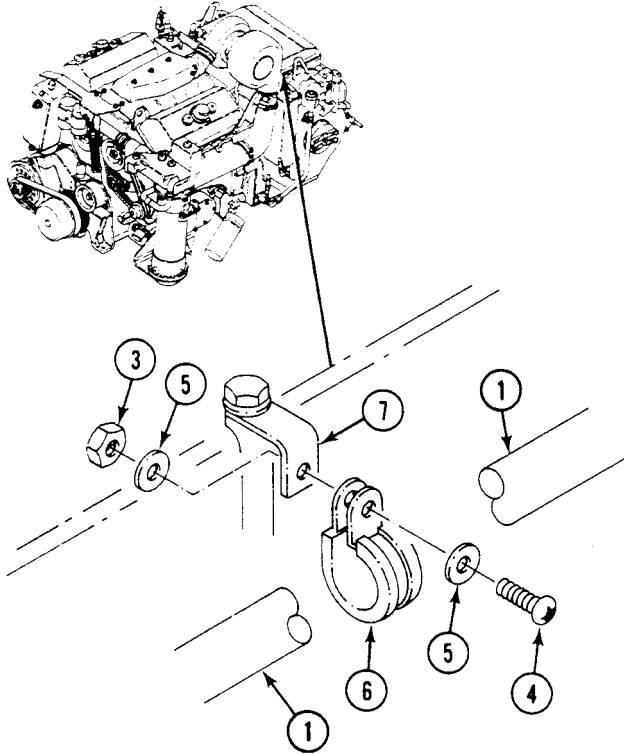

REPLACE TRANSMISSION OIL SUPPLY AND RETURN HOSES — Continued

0251 00

4. Remove supply hose (1) from elbow (2).
5. Remove elbow (2) from transmission.

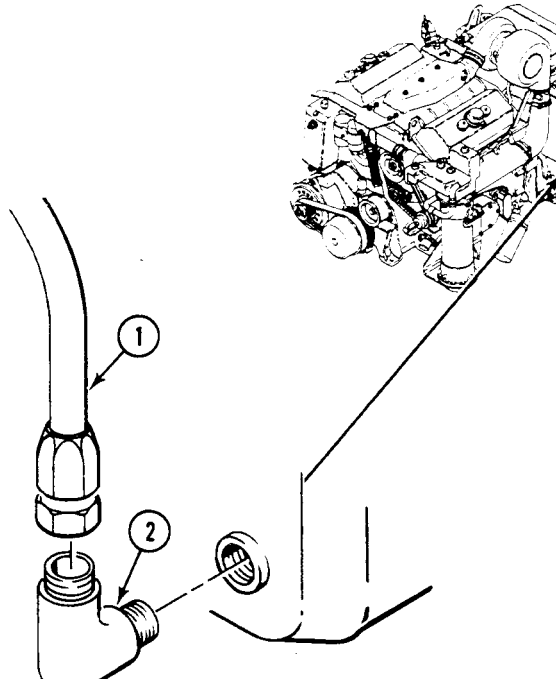

6. Remove supply hose (1) from elbow (3). Remove hose.
7. Remove elbow (3) and preformed packing (4) from thermostat housing (4.1) (Old Configuration), or valve (4.2) (New Configuration). Discard packing.

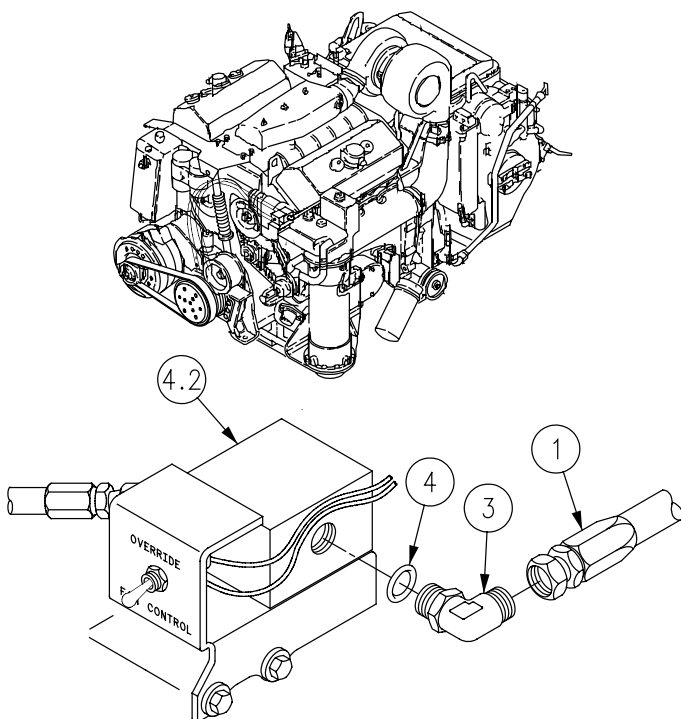

NEW CONFIGURATION

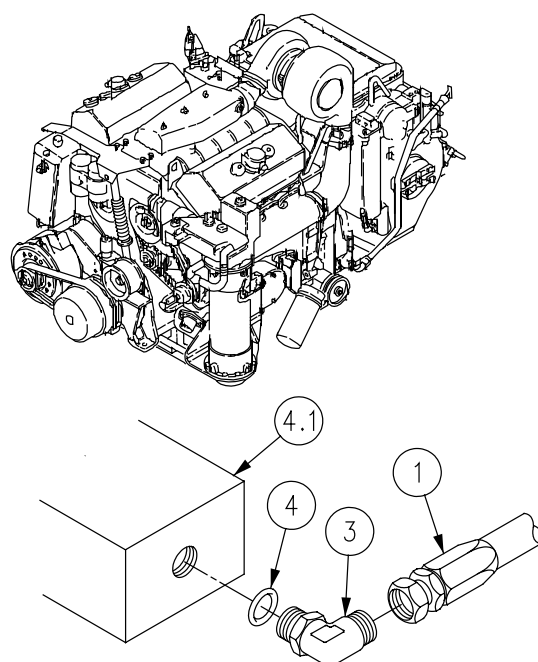

OLD CONFIGURATION

8. Remove hose (5) from elbow (6).
9. Remove elbow (6) from adapter (7).
10. Remove adapter (7) and packing (7.1) from variable speed fan drive (8). Discard packing.

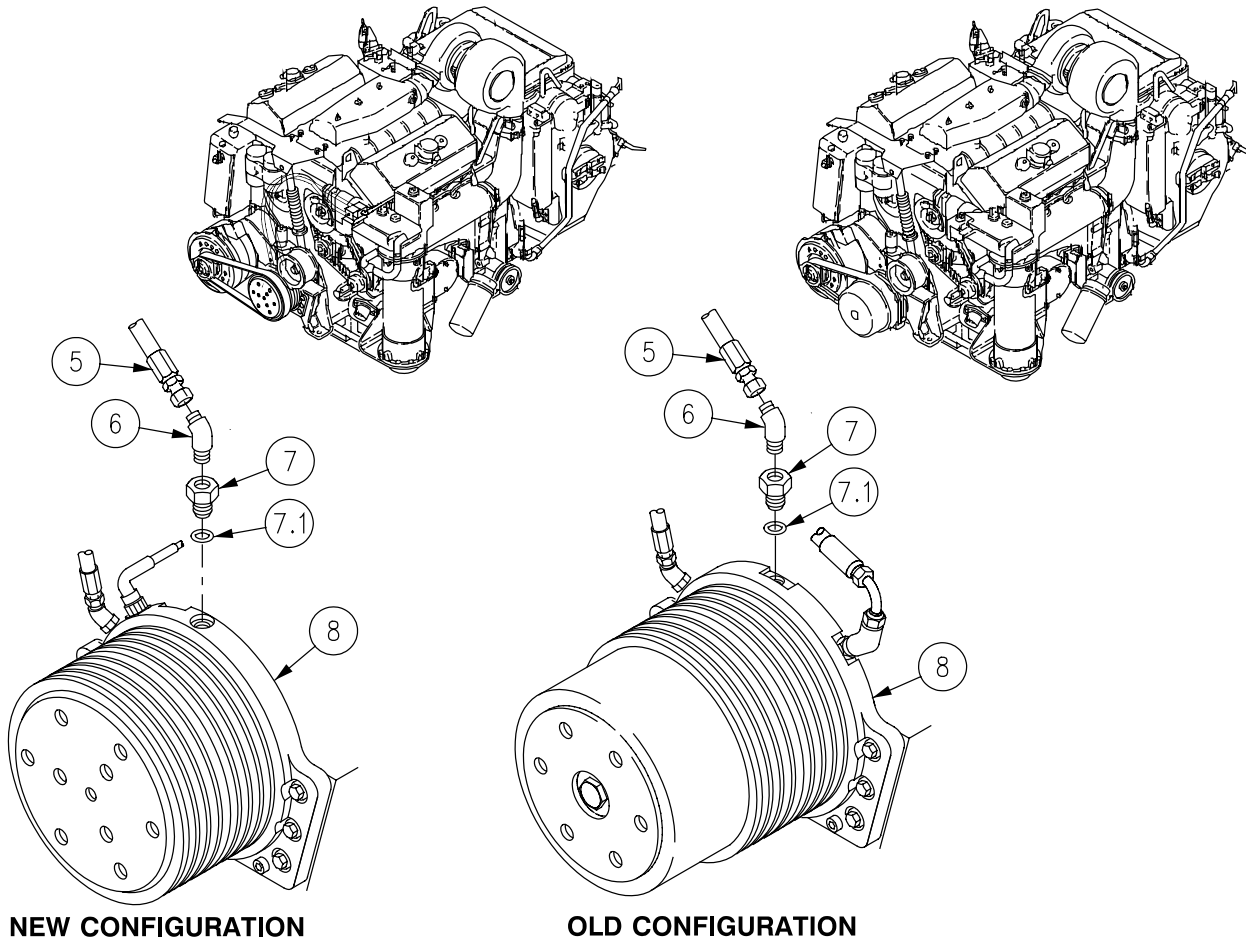

- Remove screw (1), two washers (2), locknut (3), and clamp (4) from hose (5). Discard locknut. Remove hose.

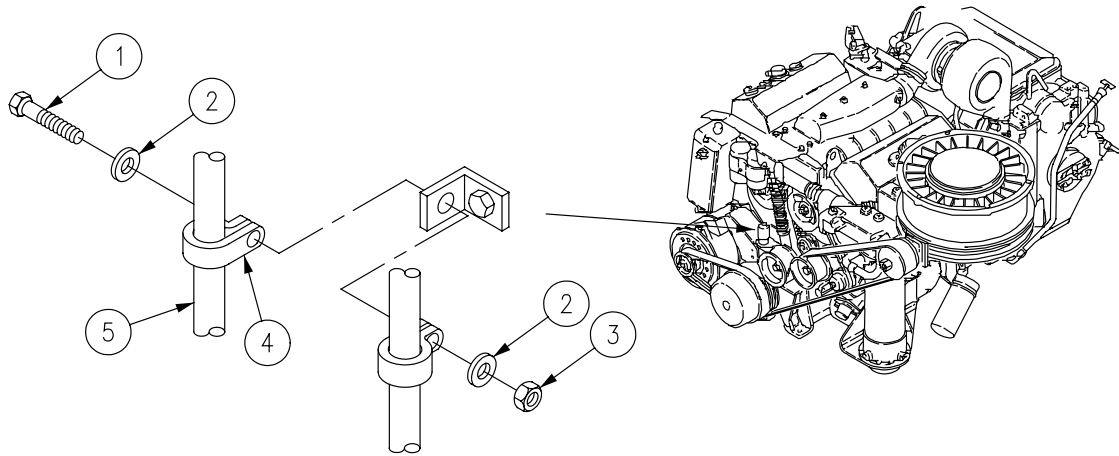

INSTALLATION

- Install adapter (6) and new packing (7.1) on variable speed fan drive (7).
- Install elbow (8) on adapter (6).

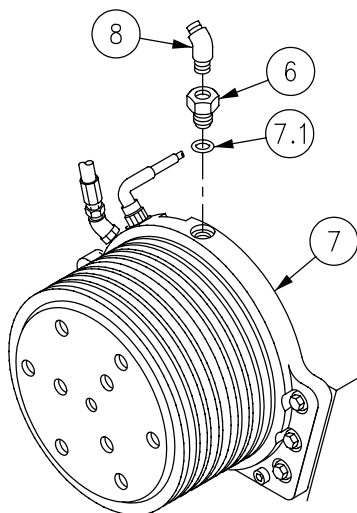

NEW CONFIGURATION

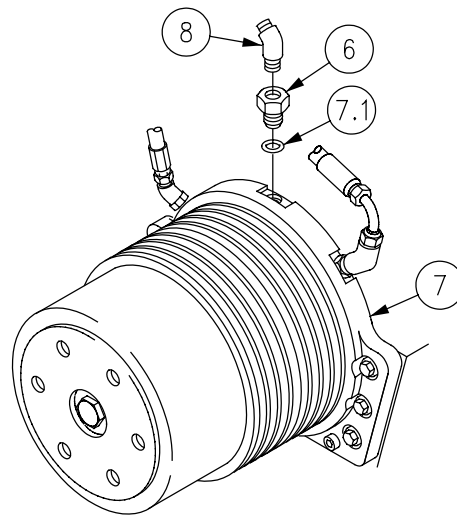

OLD CONFIGURATION

3. Install elbow (9) and new packing (10) on thermostat housing (11) (Old Configuration) or valve (11.1) (New Configuration).

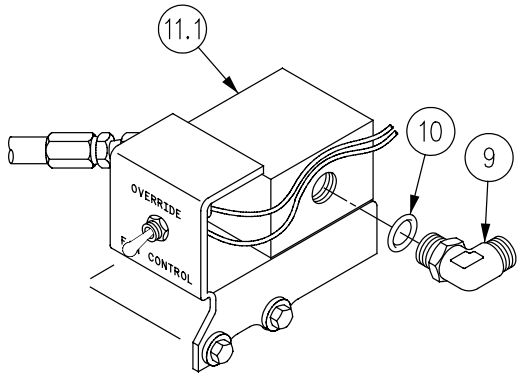

NEW CONFIGURATION

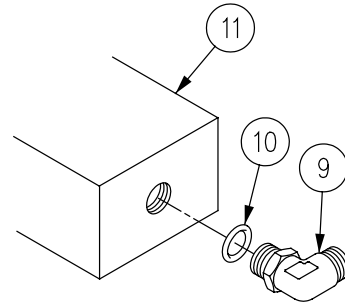

OLD CONFIGURATION

4. Install elbow (12) on transmission.

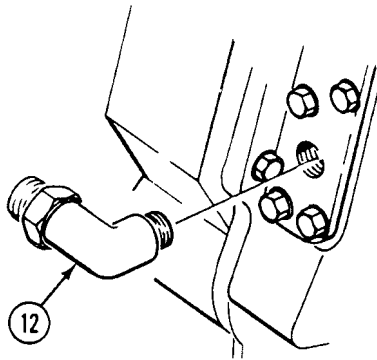

5. Install elbow (13) on transmission.

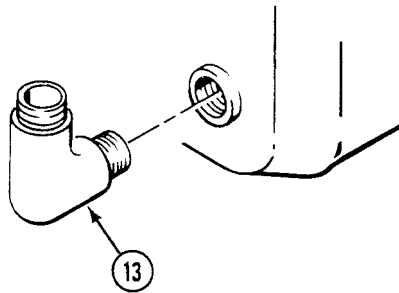

6. Install hose (1) on elbow (2).

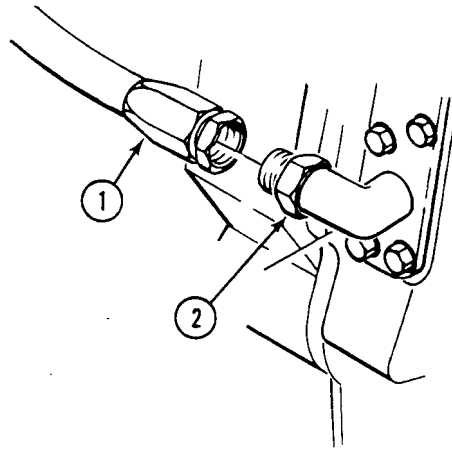

7. Install hose (3) on elbow (4).

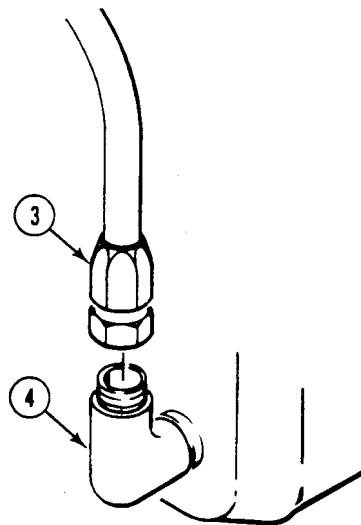

8. Install hose (3) on elbow (5).

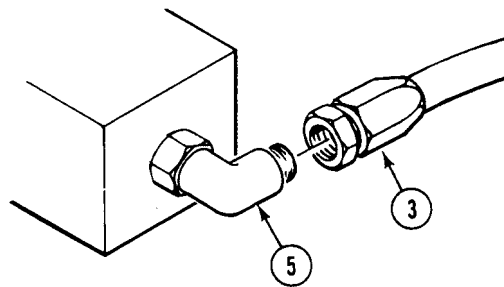

9. Install return hose (1) on elbow (6).

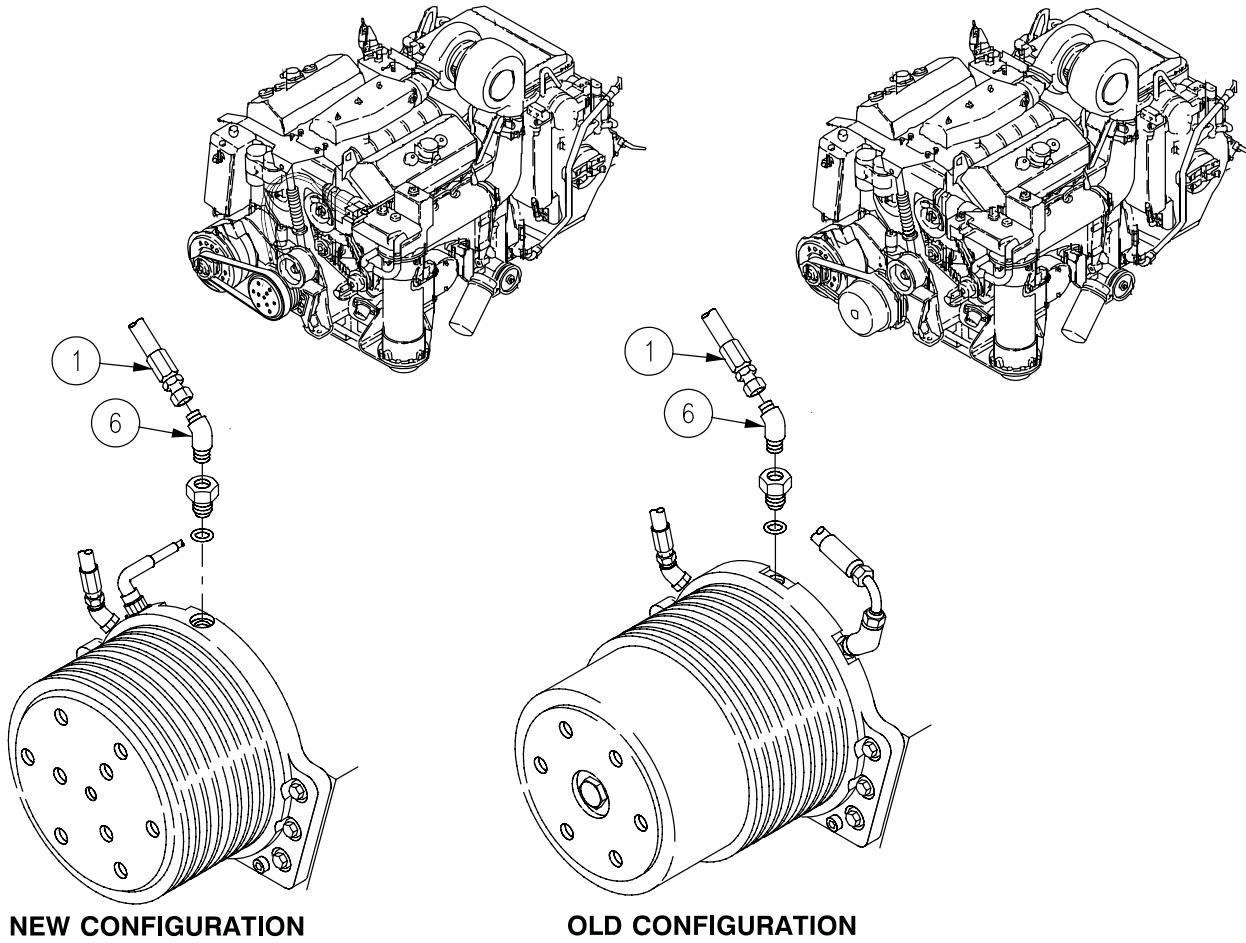

10. Install hose (1) on engine. Secure with screw (7), two washers (8), new locknut (9) and clamp (10).

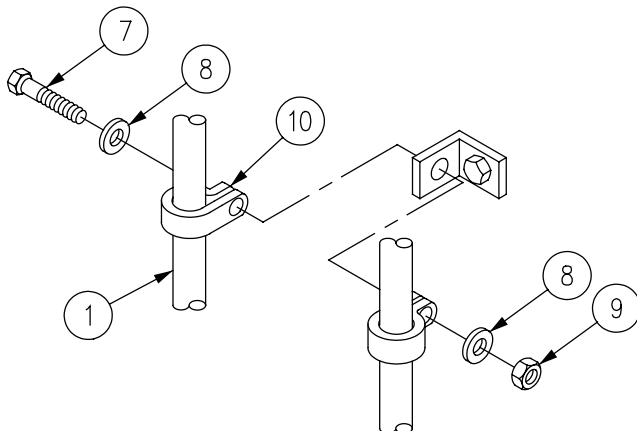

11. Secure hose (1) to two brackets (2) on transmission using two clamps (3), screws (4), four washers (5), and two nuts (6).

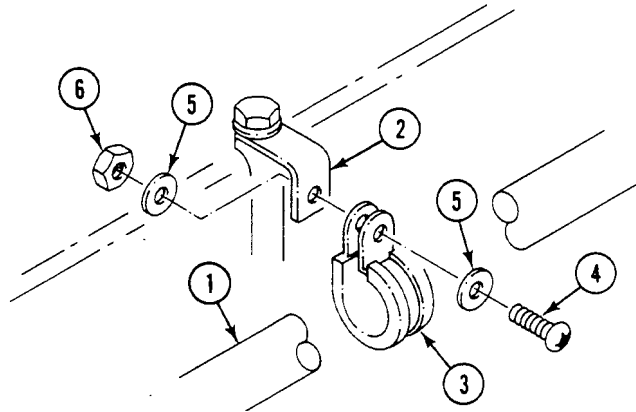
**FOLLOW-THROUGH STEPS**

1. Install power plant (WP 0156 00).
2. Fill transmission with oil (WP 0398 00).
3. Start engine and check for leaks (see your -10).
4. Stop engine (see your -10).

END OF TASK

REPLACE HOSE FROM VARIABLE SPEED FAN DRIVE OVERRIDE SWITCH TO VSFD DRIVE (NEW CONFIGURATION)

0251 01

THIS WORK PACKAGE COVERS:

Removal (page 0251 01-1).
 Installation (page 0251 01-5).

INITIAL SETUP:

Maintenance Level

Unit

Tools and Special Tools

General Mechanic's Tool Kit (WP 0926 00, Item 65)

Materials/Parts

Packing, preformed (2)
 Straps (2)

Personnel Required

Unit Mechanic

References

See your -10
 Drawing 12474790

Equipment Condition

Engine stopped (see your -10)
 Carrier blocked (see your -10)
 Transmission oil supply and return hoses disconnected (WP 0251 00)

REMOVAL

1. Remove straps (1) securing variable speed fan drive hoses together.
2. Remove hose (2) from elbow (3) on drive assembly (4).
3. Remove elbow (3) and packing (5) from drive assembly (4). Discard packing.
4. Remove hose (2) from elbow (6) on valve (7).
5. Remove elbow (6) and packing (8) from valve (7). Discard packing.

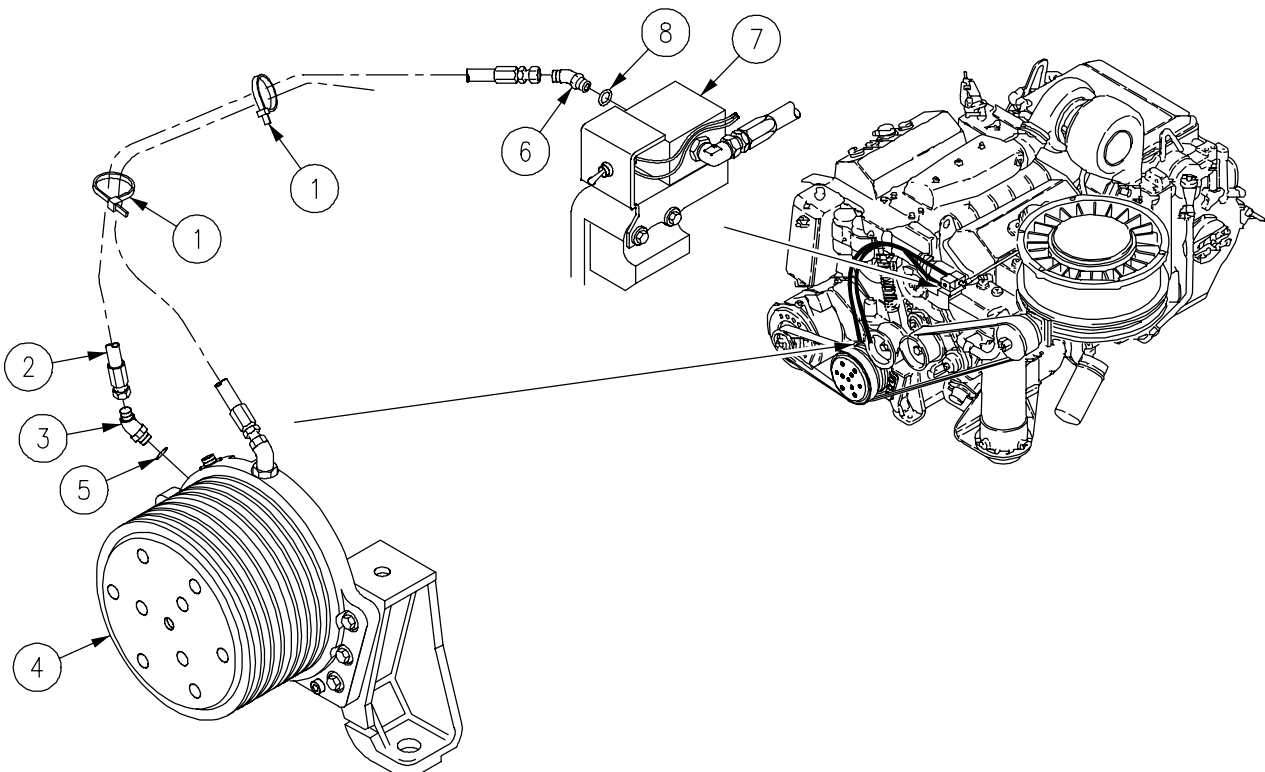

**REPLACE HOSE FROM VARIABLE SPEED FAN DRIVE OVERRIDE SWITCH
TO VSFD DRIVE (NEW CONFIGURATION) - Continued**

0251 01

INSTALLATION

1. Install new packing (8) and elbow (6) on valve (7).
2. Connect hose (2) to elbow (6) on valve (7).
3. Install new packing (5) and elbow (3) on drive assembly (4).
4. Connect hose (2) to elbow (3) on drive assembly (4).
5. Install straps (1) securing variable speed fan drive hoses together.

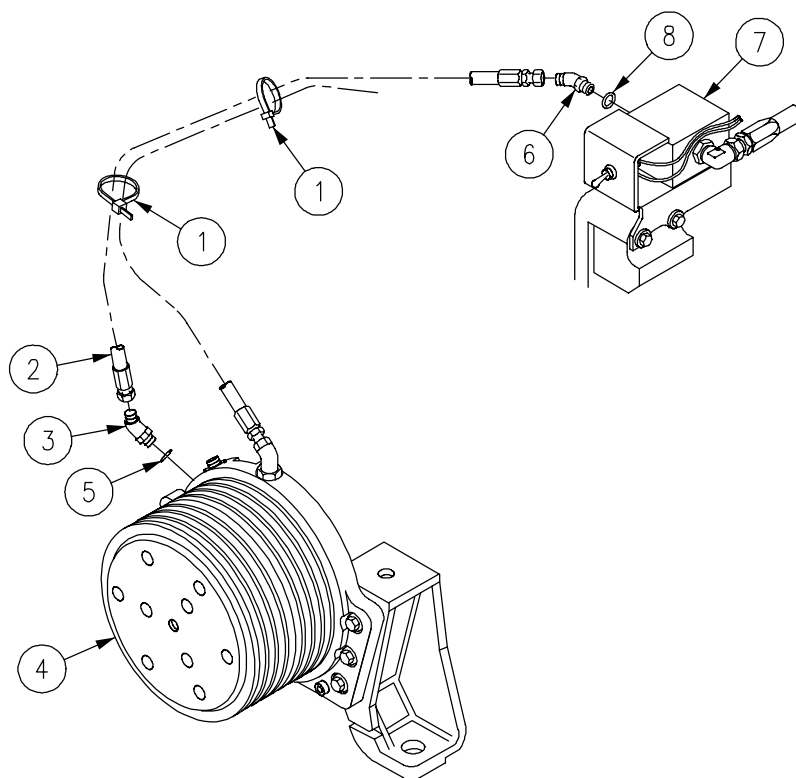
**FOLLOW-THROUGH STEPS**

1. Connect transmission oil supply and return hoses (WP 0251 00-1).
2. Start engine and check for leaks (see your-10).
3. Stop engine (see your-10).

END OF TASK

INDEX

<u>Subject</u>	<u>WP Sequence No.-Page No.</u>
5.0 kW Auxiliary Power Unit	
Installation	0675 01-4
Removal	0675 01-2
5.0 kW Auxiliary Power Unit	
Repair	0675 00-1
A	
AC Cable Assembly, W252	
Installation	0857 00-3
Removal	0857 00-1
AC Light Cable, W11	
Installation	0845 00-2
Removal	0845 00-2
AC Power Extension Box	
A19	
Installation	0822 00-2
Removal	0822 00-1
A6	
Installation	0834 00-3
Removal	0834 00-1
A7	
Installation	0815 00-2
Removal	0815 00-1
AC Power Extension Cable	
W7	
Installation	0842 00-3
Removal	0842 00-1
W8	
Installation	0843 00-2
Removal	0843 00-1
Accelerator	
Linkage	
Adjustment	0214 00-1
Pedal	
Lower	
Installation	0215 00-3
Removal	0215 00-1
Upper	
Installation	0216 00-3
Removal	0216 00-1
Access Cover	
Battery Box	
Installation	0352 00-2
Removal	0352 00-1

INDEX, cont'd

<u>Subject</u>	<u>WP Sequence No.-Page No.</u>
Fuel Tank	
All Except M577A3 and M1068A3	
Installation	0187 00-2
Removal	0187 00-1
M577A3 and M1068A3	
Installation	0188 00-2
Removal	0188 00-1
Hull Front	
Installation	0449 00-2
Removal	0449 00-1
Power Plant Bottom	
Cleaning	0450 00-2
Installation	0450 00-3
Removal	0450 00-1
Access Door, Turbine	
Gasket	
Installation	0486 00-1
Removal	0486 00-1
Hinges	
Installation	0487 00-3
Removal	0487 00-2
Installation	0485 00-2
Removal	0485 00-2
Access Panel, Driver's Power Plant	
Installation	0441 00-3
Removal	0441 00-1
Access Plate, Adapter, Smoke Generator	
Installation	0766 00-3
Removal	0766 00-1
Adapter	
■ AN/VAS-5 Driver's Vision Enhancer (DVE) Sensor Set Assembly	
Installation	0866 05-2
Removal	0866 05-1
Speedometer	
Installation	0860 00-3
Removal	0860 00-1
Tachometer	
Installation	0863 00-3
Removal	0863 00-1
Adjuster, Track Tension	
Installation	0419 00-2
Removal	0419 00-1
Air Box Drain, Left and Right, Check Valve and Tubes	
Installation	0159 00-4
Removal	0159 00-1

INDEX, cont'd

<u>Subject</u>	<u>WP Sequence No.-Page No.</u>
Air Box Heater	
Ignition Coil	
Installation	0208 00-3
Removal	0208 00-1
Ignition Wire	
Installation	0204 00-2
Removal	0204 00-1
Lower Fuel Line	
Installation	0206 00-3
Removal	0206 00-2
Wiring Harness	
Installation	0205 00-5
Removal	0205 00-1
Air Box Pressure Transducer	
Installation	0327 00-2
Removal	0327 00-1
Air Cleaner	
Air Intake Elbow	
Installation	0173 00-2
Removal	0173 00-1
Assembly	
Assembly	0169 01-2
Disassembly	0169 01-1
Door	
Installation	0169 00-2
Removal	0169 00-1
Elbow	
Installation	0168 00-7
Removal	0168 00-2
Filter Element	
Servicing	0167 00-1
Grill Air Intake Elbow and Hose	
Installation	0174 00-2
Removal	0174 00-1
Restriction Indicator	
Installation	0171 00-2
Removal	0171 00-1
Restriction Indicator Hose	
Installation	0172 00-3
Removal	0172 00-1
Retainer	
Installation	0170 00-2
Removal	0170 00-1
Air Compressor	
Assembly	
Installation	0762 00-3
Removal	0762 00-1
Electrical Cable Assembly	
Installation	0758 00-4
Removal	0758 00-2

INDEX, cont'd

<u>Subject</u>	<u>WP Sequence No.-Page No.</u>
Air Hose	
Adapter Access Plate to Cover Assembly, Smoke Generator	
Installation	0768 00-2
Removal	0768 00-1
Compressor Reservoir to Access Plate, Smoke Generator	
Installation	0767 00-3
Removal	0767 00-1
Air Purifier and Frame	
M13	
Installation	0779 00-3
Removal	0779 00-1
NBC	
Installation	0914 00-2
Removal	0914 00-1
Air Ventilator, Rear Compartment	
Installation	0454 00-2
Removal	0454 00-1
Alarm	
Chemical Agent Automatic Alarm Kit	
Installation	0918 00-1
Removal	0918 00-8
Chemical Alarm Junction Box	
Installation	0920 00-3
Removal	0920 00-1
Chemical Alarm Junction Box/Power Cable/Alarm Cable	
Inspection-Acceptance and Rejection Criteria	0919 00-6
Installation	0919 00-8
Removal	0919 00-2
Repair or Replacement	0919 00-7
M43 Unit Interface Wiring Harness	
Inspection-Acceptance and Rejection Criteria	0923 00-4
Installation	0923 00-4
Removal	0923 00-1
Repair or Replacement	0923 00-4
Refill Tray Bracket	
Installation	0922 00-2
Removal	0922 00-1
Spare Battery Bracket	
Installation	0921 00-3
Removal	0921 00-1
Repair or Replacement	0921 00-2
Ammunition Rack	
Horizontal	
Assembly	0607 00-4
Cleaning	0607 00-4

INDEX, cont'd

<u>Subject</u>	<u>WP Sequence No.-Page No.</u>
Disassembly	0607 00-1
Inspection-Acceptance and Rejection Criteria	0607 00-4
Installation	0606 00-2
Removal	0606 00-1
Vertical	
Installation	0608 00-3
Removal	0608 00-1
Amplifier, Intercom	
Installation	0888 00-2
Removal	0888 00-1
Anchor, Torsion Bar	
Installation	0414 00-3
Removal	0414 00-1
Antenna	
AS3916/VRC	
Installation	0887 00-2
Removal	0887 00-1
Cover	
Installation	0576 00-2
Removal	0576 00-1
Guard	
Installation	0575 00-2
Removal	0575 00-1
Mast Bracket Assembly, Taillight Wiring Harness, and Bracket	
Installation	0625 00-7
Removal	0625 00-1
Support	
Installation	0602 00-2
Removal	0602 00-2
APIU Rack, Mount and Bracket	
Installation	0813 00-2
Removal	0813 00-1
Arm	
Idler Wheel	
Bearings and Seals	
Cleaning	0418 00-2
Installation	0418 00-2
Removal	0418 00-1
Installation	0417 00-2
Removal	0417 00-1
Road Wheel Support	
Installation	0415 00-4
Removal	0415 00-2

INDEX, cont'd

<u>Subject</u>	<u>WP Sequence No.-Page No.</u>
Armor	
Plate	
Left Front	
Installation	0447 00-2
Removal	0447 00-1
Right Front	
Installation	0448 00-3
Removal	0448 00-1
Shields, Commander's Cupola	
Installation	0747 00-3
Removal	0747 00-1
Smoke Generator	
Installation	0771 00-2
Removal	0771 00-1
Armor Kit	
Installation	0751 01-1
Removal	0751 01-3
Auxiliary Power (Slave) Receptacle	
Ground Lead	
Installation	0379 00-3
Removal	0379 00-1
Lead (Circuit 50) to Master Switch	
Inspection-Acceptance and Rejection Criteria	0268 00-2
Installation	0268 00-3
Removal	0268 00-1
M113A3, M1059A3, M1064A3, and M58	
Installation	0263 00-2
Removal	0263 00-1
M577A3 and M1068A3	
Installation	0264 00-3
Removal	0264 00-2
Auxiliary Power Unit	
Fuel Shutoff Valve	
Installation	0676 00-3
Removal	0676 00-2
Installation	0675 01-4
Removal	0675 01-2
Repair	0675 00-1
Valve-to-Bulkhead Fuel Supply Hoses	
Installation	0677 00-4
Removal	0677 00-2
Auxiliary Tank	
Fluid Level Detector	
Installation	0329 00-2
Removal	0329 00-1
Installation	0230 00-2
Removal	0230 00-1

INDEX, cont'd

<u>Subject</u>	<u>WP Sequence No.-Page No.</u>
Azimuth Lock, Commander's Cupola	
Installation	0489 00-2
Removal	0489 00-1
B	
Backrest	
Personnel Seat	
M1059A3 Only	
Installation	0549 00-3
Removal	0549 00-1
M1064A3 Only	
Installation	0550 00-3
Removal	0550 00-1
Balance Hose	
Installation	0234 00-1
Removal	0234 00-1
Base Extension, Right Side	
Adjustment	0623 00-4
Installation	0623 00-3
Removal	0623 00-1
Supports	
Installation	0624 00-3
Removal	0624 00-1
Batteries	
M1064A3 Only	
Clean and Inspect	0349 00-2
Installation	0349 00-3
Removal	0349 00-1
M113A3 and M1059A3	
Clean and Inspect	0346 00-3
Installation	0346 00-4
Removal	0346 00-1
M577A3 and M1068A3	
Clean and Inspect	0347 00-3
Installation	0347 00-3
Removal	0347 00-1
M58 Only	
Assembly	0348 00-7
Cleaning	0348 00-6
Disassembly	0348 00-5
Installation	0348 00-8
Removal	0348 00-1
Battery	
Drawer	
Clean and Inspect	0353 00-3
Installation	0353 00-4

INDEX, cont'd

<u>Subject</u>	<u>WP Sequence No.-Page No.</u>
Insulation and Heat Exchanger	
Cleaning	0719 00-2
Inspection-Acceptance and Rejection Criteria	0719 00-2
Installation	0719 00-2
Removal	0719 00-1
Removal	0353 00-1
Ground Strap	
M113A3, M1059A3, M1064A3, and M58	
Connect	0337 00-2
Disconnect	0337 00-1
M577A3 and M1068A3	
Connect	0338 00-3
Disconnect	0338 00-1
Leads and Terminals	
M1064A3 Only (Left Side)	
Cleaning	0343 00-5
Installation	0343 00-5
Removal	0343 00-1
M1064A3 Only (Right Side)	
Cleaning	0344 00-3
Installation	0344 00-4
Removal	0344 00-1
M113A3 and M1059A3	
Clean and Inspect	0340 00-3
Installation	0340 00-4
Removal	0340 00-1
M577A3 and M1068A3	
Clean and Inspect	0341 00-3
Installation	0341 00-4
Removal	0341 00-1
M58 Only	
Cleaning	0345 00-3
Installation	0345 00-4
Removal	0345 00-1
Battery Box	
Access Cover	
Installation	0352 00-2
Removal	0352 00-1
Insulation and Heat Exchanger	
Installation	0718 00-2
Removal	0718 00-1
M1064A3 Only (Right Side)	
Clean and Inspect	0354 00-2
Installation	0354 00-3
Removal	0354 00-1
M113A3 and M1059A3	
Clean and Inspect	0350 00-3
Installation	0350 00-4
Removal	0350 00-1
M577A3 and M1068A3	
Clean and Inspect	0351 00-2
Installation	0351 00-2
Removal	0351 00-2

INDEX, cont'd

<u>Subject</u>	<u>WP Sequence No.-Page No.</u>
M58 Only	
Assembly	0348 00-7
Cleaning	0348 00-6
Disassembly	0348 00-5
Installation	0348 00-8
Removal	0348 00-1
Vent Fitting	
Installation	0355 00-3
Removal	0355 00-1
Bearing Housing	
Fan Drive Shaft	
Installation	0248 00-3
Removal	0248 00-1
Bearings	
Idler Wheel Arm	
Cleaning	0418 00-2
Installation	0418 00-2
Removal	0418 00-1
Road Wheel Support	
Installation	0415 00-4
Removal	0415 00-2
Tow Start Control Assembly	
Installation	0391 00-5
Removal	0391 00-2
Belt	
Coolant Pump	
Adjustment	0239 00-1
Generator Drive	
Adjustment	0252 00-2
Installation	0253 00-1
Removal	0253 00-1
Personnel	
M1059A3 Only	
Installation	0549 00-3
Removal	0549 00-1
M1064A3 Only	
Installation	0550 00-3
Removal	0550 00-1
M113A3 Only	
Installation	0546 00-2
Removal	0546 00-1
M577A3 Only	
Installation	0547 00-3
Removal	0547 00-1
Bilge Pump	
Circuit Breakers	
Installation	0275 00-2
Removal	0275 00-1

INDEX, cont'd

<u>Subject</u>	<u>WP Sequence No.-Page No.</u>
Front	
Installation	0632 00-3
Removal	0632 00-1
Pipes	
Front	
Installation	0631 00-3
Removal	0631 00-1
Rear	
Installation	0634 00-2
Removal	0634 00-1
Rear	
Installation	0635 00-3
Removal	0635 00-1
Schematic	0078 00-1
 Blackout Curtain	
Installation	0629 00-2
Removal	0629 00-1
 Blackout Headlight	
Assembly	0306 00-2
Disassembly	0306 00-1
Installation	0305 00-2
Removal	0305 00-1
 Blackout Marker Light	
Assembly	0308 00-2
Disassembly	0308 00-1
Installation	0307 00-2
Removal	0307 00-1
 Blower Switch	
Installation	0278 00-3
Removal	0278 00-1
 Box Assembly A5, Tent Interface Panel	
Installation	0833 00-3
Removal	0833 00-1
 Bracket	
Antenna Mast	
Installation	0625 00-7
Removal	0625 00-1
Chemical Alarm Refill Tray	
Installation	0922 00-2
Removal	0922 00-1
Chemical Alarm Spare Battery	
Installation	0921 00-3
Removal	0921 00-1
Repair or Replacement	0921 00-2

INDEX, cont'd

<u>Subject</u>	<u>WP Sequence No.-Page No.</u>
Coolant Heater and Pump	
Installation	0732 00-1
Removal	0732 00-1
Forward Spall Liner	
Installation	0507 00-3
Removal	0507 00-1
Fuel Filter, Primary and Secondary	
Installation	0203 00-3
Removal	0203 00-2
Generator	
Installation	0255 00-4
Removal	0255 00-1
Glow Plug Controller Mounting	
Installation	0212 00-2
Removal	0212 00-1
M13 Orifice	
Installation	0781 00-2
Removal	0781 00-1
Mortar Base Stowage	
Installation	0615 00-3
Removal	0615 00-1
Muffler	
Installation	0224 00-2
Removal	0224 00-1
Oil Can	
Installation	0574 00-1
Removal	0574 00-1
Parking Brake	
Clean and Inspect	0331 00-3
Installation	0331 00-3
Removal	0331 00-1
Personnel Heater Control Box and Intercom Box	
Installation	0617 00-2
Removal	0617 00-1
Power Extension Box A18	
Installation	0836 00-2
Removal	0836 00-1
Ramp	
Installation	0516 00-1
Removal	0516 00-1
Ramp Door Stop	
Installation	0517 00-1
Removal	0517 00-1
Rifle	
Installation	0573 00-2
Removal	0573 00-1
Roadside Data Panel Assembly A13	
Installation	0835 00-2
Removal	0835 00-1
Steering	
Installation	0432 00-5
Removal	0432 00-1

INDEX, cont'd

<u>Subject</u>	<u>WP Sequence No.-Page No.</u>
Transmission Oil Drain Tubes	
Installation	0384 00-2
Removal	0384 00-1
Transmission Range Controller	
Cable-Activated Steering Lock	
Installation	0387 00-3
Removal	0387 00-1
Solenoid-Activated Steering Lock	
Installation	0386 00-3
Removal	0386 00-1
Windshield Stowage	
Installation	0614 00-2
Removal	0614 00-1
Brackets and Mounts, Right Equipment Rack	
Installation	0814 00-2
Removal	0814 00-1
Brake	
Commander's Cupola	
Installation	0492 00-1
Removal	0492 00-1
Parking	
Adjustment	0408 00-1
Cable Control Assembly	
Installation	0411 00-4
Removal	0411 00-1
Control Lever Assembly	
Installation	0412 00-3
Removal	0412 00-1
Service	
Control Linkage	
Adjustment	0407 00-1
Installation	0410 00-7
Removal	0410 00-2
Pedal, Upper and Lower	
Installation	0409 00-6
Removal	0409 00-1
Transmission	
Adjust Left-Hand Brake	0394 00-1
Adjust Right-Hand Brake	0394 00-5
Check Adjustment	0406 00-1
Breather Hose, Ramp Cylinder	
All Except M1064A3	
Installation	0666 00-3
Removal	0666 00-1
M1064A3 Only	
Installation	0667 00-3
Removal	0667 00-2

INDEX, cont'd

<u>Subject</u>	<u>WP Sequence No.-Page No.</u>
Bulkhead Connection Hose to Fuel Pump	
Installation	0691 00-2
Removal	0691 00-1
Bumper, Driver's Hatch	
M113A3, M1059A3, M1064A3, and M58	
Installation	0532 00-2
Removal	0532 00-1
M577A3 and M1068A3	
Cleaning	0533 00-2
Installation	0533 00-3
Removal	0533 00-1
Repair or Replacement	0533 00-2
Buzzer and Switch, Admittance	
Inspection-Acceptance and Rejection Criteria	0334 00-2
Installation	0334 00-2
Removal	0334 00-1
Bypass Plug, Pressure Switch and Differential	
Installation	0401 00-2
Removal	0401 00-1
C	
Cable	
Artillery Communication, Inside	
Installation	0746 00-2
Removal	0746 00-1
Commander's Intercommunication Set	
Installation	0893 00-2
Removal	0893 00-1
Driver's Intercommunication Set	
Installation	0892 00-2
Removal	0892 00-1
Driver's Night Vision (DNV) AN/VVS-2 Power Supply	
Installation	0368 00-3
Removal	0368 00-1
Driver's Vision Enhancer (DVE) Power Supply	
Installation	0866 04-2
Removal	0866 04-1
Driver's Vision Enhancer (DVE) Sensor Set Assembly Power	
Installation	0866 01-2
Removal	0866 01-1
Test and Inspection	0866 01-1
Hand Throttle Control	
Installation	0219 00-4
Removal	0219 00-1
Intervehicle Power	
Assembly	0381 00-2
Disassembly	0381 00-1

INDEX, cont'd

<u>Subject</u>	<u>WP Sequence No.-Page No.</u>
Operator's Intercommunication Set	
Installation	0894 00-2
Removal	0894 00-1
Reel Holder Assembly	
Assembly	0604 00-2
Disassembly	0604 00-1
Installation	0603 00-2
Removal	0603 00-1
Smoke Generator, Internal	
Installation	0760 00-3
Removal	0760 00-1
Speedometer	
Assembly	0861 00-1
Disassembly	0861 00-1
Inspection	0861 00-1
Installation	0860 00-3
Removal	0860 00-1
Speedometer/Tachometer Flexible Core	
Installation	0858 00-5
Removal	0858 00-1
Tachometer	
Assembly	0865 00-2
Disassembly	0865 00-1
Inspection	0865 00-1
Installation	0864 00-4
Removal	0864 00-1
Tow Start Control	
Adjustment	0390 00-1
W10, DC Power Extension	
Installation	0844 00-3
Removal	0844 00-1
W103/W104, LAN A or B	
Installation	0854 00-3
Removal	0854 00-1
W11, AC Light	
Installation	0845 00-2
Removal	0845 00-2
W124	
Installation	0855 00-3
Removal	0855 00-1
W126	
Installation	0856 00-3
Removal	0856 00-1
W251	
Installation	0852 00-3
Removal	0852 00-1
W252	
Installation	0857 00-3
Removal	0857 00-1
W28	
Installation	0849 00-3
Removal	0849 00-1

INDEX, cont'd

<u>Subject</u>	<u>WP Sequence No.-Page No.</u>
W29	
Installation	0850 00-3
Removal	0850 00-1
W3, Power Distribution	
Installation	0837 00-3
Removal	0837 00-1
W35	
Installation	0849 00-3
Removal	0849 00-1
W38	
Installation	0850 00-3
Removal	0850 00-1
W4, DC Battery	
Installation	0838 00-3
Removal	0838 00-1
W4/W6	
Assembly	0841 00-2
Disassembly	0841 00-1
W40, Single Point LAN	
Installation	0851 00-3
Removal	0851 00-1
W42	
Installation	0852 00-3
Removal	0852 00-1
W43	
Installation	0852 00-3
Removal	0852 00-1
W45	
Installation	0853 00-3
Removal	0853 00-1
W5, Inverter AC	
Installation	0839 00-3
Removal	0839 00-1
W6, Inverter DC	
Installation	0840 00-3
Removal	0840 00-1
W7, AC Power Extension	
Installation	0842 00-3
Removal	0842 00-1
W8, AC Power Extension	
Installation	0843 00-2
Removal	0843 00-1
Cable Assembly, Remote (Outback Only)	
Installation	0847 01-8
Removal	0847 01-1
Cables and Switch Assembly, M14	
Installation	0799 00-3
Removal	0799 00-1

INDEX, cont'd

<u>Subject</u>	<u>WP Sequence No.-Page No.</u>
Cargo Hatch	
Cover	
Installation	0479 00-3
Removal	0479 00-2
Hold-Open Hook and Bumpers	
Installation	0474 00-3
Removal	0474 00-2
Interior Latch	
Adjustment	0475 00-5
Installation	0475 00-3
Removal	0475 00-1
Seals	
Installation	0478 00-1
Removal	0478 00-1
Cascade Remote Harness	
Installation	0847 00-3
Removal	0847 00-1
Chain Assembly, Litter Kit	
Assembly	0745 00-4
Disassembly	0745 00-1
Installation	0744 00-2
Removal	0744 00-1
Chemical Alarm	
Automatic Alarm Kit	
Installation	0918 00-1
Removal	0918 00-8
Junction Box	
Installation	0920 00-3
Removal	0920 00-1
Junction Box/Power Cable/Alarm Cable	
Inspection-Acceptance and Rejection Criteria	0919 00-6
Installation	0919 00-8
Removal	0919 00-2
Repair or Replacement	0919 00-7
M43 Unit Interface Wiring Harness	
Inspection-Acceptance and Rejection Criteria	0923 00-4
Installation	0923 00-4
Removal	0923 00-1
Repair or Replacement	0923 00-4
Refill Tray Bracket	
Installation	0922 00-2
Removal	0922 00-1
Spare Battery Bracket	
Installation	0921 00-3
Removal	0921 00-1
Repair or Replacement	0921 00-2

INDEX, cont'd

<u>Subject</u>	<u>WP Sequence No.-Page No.</u>
Circuit Breaker	
Bilge Pump	
Installation	0275 00-2
Removal	0275 00-1
Dome Light	
Installation	0316 00-3
Removal	0316 00-1
Installation	0280 00-2
Rear Utility Receptacle	
Inspection-Acceptance and Rejection Criteria	0276 00-2
Installation	0276 00-3
Removal	0276 00-1
Removal	0280 00-1
Clamps, Tent	
Installation	0627 00-2
Removal	0627 00-1
Combat Lock, Power Plant Door	
Installation	0473 00-3
Removal	0473 00-1
Commander's Cupola	
Armor Shields	
Installation	0747 00-3
Removal	0747 00-1
Azimuth Lock	
Installation	0489 00-2
Removal	0489 00-1
Brake Assembly	
Installation	0492 00-1
Removal	0492 00-1
Cover	
Installation	0493 00-3
Removal	0493 00-2
Cushioning Pad and Handle	
Installation	0488 00-2
Removal	0488 00-1
Hold-Open Hook and Bumper	
Installation	0494 00-2
Removal	0494 00-1
Interior Latch	
Installation	0496 00-2
Removal	0496 00-1
Machine Gun Mount	
Assembly	0498 00-2
Disassembly	0498 00-1
Installation	0497 00-1
Removal	0497 00-1
Machine Gun Mount Stops	
Installation	0499 00-3
Removal	0499 00-1

INDEX, cont'd

<u>Subject</u>	<u>WP Sequence No.-Page No.</u>
Vision Block Locks and Seals	
M1064A3 Only	
Installation	0491 00-3
Removal	0491 00-1
M113A3, M1059A3, and M58	
Installation	0490 00-3
Removal	0490 00-1
Commander's Hatch	
Cover	
Installation	0503 00-3
Removal	0503 00-2
Cushioning Pad and Handle	
Clean, Inspect, and Repair	0500 00-2
Installation	0500 00-2
Removal	0500 00-1
Hook and Bumper	
Installation	0501 00-4
Removal	0501 00-2
Interior Latch	
Adjustment	0502 00-2
Installation	0502 00-2
Removal	0502 00-1
Commander's Intercommunication Set Cable	
Installation	0893 00-2
Removal	0893 00-1
Commander's Interface Bracket Assembly	
M1064A3 Only	
Installation	0812 03-3
Removal	0812 03-2
Repair	0812 03-3
M577A3 Only	
Installation	0812 02-3
Removal	0812 02-1
Repair	0812 02-3
Commander's Jump Seat	
Installation	0563 00-3
Removal	0563 00-1
Commander's Platform	
M113A3, M1059A3, M1064A3, and M58	
Assembly	0559 00-4
Disassembly	0559 00-2
Installation	0559 00-6
Removal	0559 00-1

INDEX, cont'd

<u>Subject</u>	<u>WP Sequence No.-Page No.</u>
M577A3 and M1068A3	
Assembly	0564 00-3
Disassembly	0564 00-2
Inspection-Acceptance and Rejection Criteria	0564 00-3
Installation	0564 00-4
Removal	0564 00-1
Commander's Post	
M1064A3 Only	
Installation	0561 00-2
Removal	0561 00-1
M113A3, M1059A3, and M58	
Installation	0560 00-3
Removal	0560 00-1
Commander's Seat	
M1064A3 Only	
Installation	0561 00-2
Removal	0561 00-1
M1068A3 Only	
Assembly	0566 00-3
Disassembly	0566 00-2
Installation	0566 00-6
Removal	0566 00-1
M113A3, M1059A3, and M58	
Installation	0560 00-3
Removal	0560 00-1
M113A3, M1059A3, M1064A3, and M58	
Assembly	0562 00-4
Cleaning	0562 00-4
Disassembly	0562 00-1
Common Tools and Supplements and SpecialTools/Fixtures List	0926 00-1
Communication Box A11, External	
Installation	0817 00-4
Lid and Latches	
Installation	0818 00-2
Removal	0818 00-1
Removal	0817 00-1
Communication Cabling Diagram	0884 00-1
Control Assembly	
Push-Pull	
Installation	0429 00-7
Removal	0429 00-1
Tow Start	
Installation	0391 00-5
Removal	0391 00-2

INDEX, cont'd

<u>Subject</u>	<u>WP Sequence No.-Page No.</u>
Control Box	
Coolant Heater	
Assembly	0737 00-6
Disassembly	0737 00-1
Inspection and Repair	0737 00-5
Inspection-Acceptance and Rejection Criteria	0736 00-2
Installation	0736 00-2
Removal	0736 00-1
Personnel Heater	
Assembly	0702 00-5
Disassembly	0702 00-1
Installation	0701 00-3
Removal	0701 00-1
Repair or Replacement	0702 00-4
Control Cable Assembly, Fuel Cutoff	
Adjustment	0220 00-7
Installation	0220 00-4
Removal	0220 00-1
Control Valve	
Fire Extinguisher	
Installation	0904 00-3
Removal	0904 00-1
Ramp	
External to Internal Relief	
Installation	0660 00-6
Removal	0660 00-1
With External Relief Valve	
Repair or Replacement	0659 00-1
With Internal Relief Valve	
Installation	0661 00-4
Removal	0661 00-1
Control, Intercommunications Set	
Installation	0885 00-2
Removal	0885 00-1
Coolant Air Separator	
Installation	0236 00-3
Removal	0236 00-1
Coolant Heater	
Control Box	
Assembly	0737 00-6
Disassembly	0737 00-1
Inspection and Repair	0737 00-5
Inspection-Acceptance and Rejection Criteria	0736 00-2
Installation	0736 00-2
Removal	0736 00-1
Exhaust Elbow and Pipes	
Installation	0724 00-2
Removal	0724 00-1

INDEX, cont'd

<u>Subject</u>	<u>WP Sequence No.-Page No.</u>
Flame Detector Switch	
Adjustment	0727 00-1
Inspection-Acceptance and Rejection Criteria	0734 00-1
Installation	0734 00-2
Removal	0734 00-1
Fuel Filter	
Cleaning	0708 00-1
Installation	0708 00-2
Removal	0708 00-1
Fuel Inlet Hose and Fittings	
Installation	0712 00-3
Removal	0712 00-1
Fuel Pump	
Assembly	0709 00-2
Cleaning	0709 00-2
Disassembly	0709 00-1
Installation	0723 00-3
Removal	0723 00-1
Fuel Shutoff Valve	
Installation	0720 00-3
Removal	0720 00-1
Heater and Pump Bracket	
Installation	0732 00-1
Removal	0732 00-1
Heater to Engine Elbow Hose	
Installation	0715 00-2
Removal	0715 00-1
Hose	
Engine to Battery Box	
Installation	0714 00-4
Removal	0714 00-2
Filter Valve	
Installation	0716 00-2
Removal	0716 00-1
Fuel Pump	
Installation	0711 00-2
Removal	0711 00-1
Heater to Surge Tank	
Installation	0725 00-1
Removal	0725 00-1
Pump to Battery Box	
Installation	0713 00-3
Removal	0713 00-1
Inspection-Acceptance and Rejection Criteria	0729 00-1
Installation	0729 00-2
Pump	
Installation	0731 00-2
Removal	0731 00-1
Pump Unit	
Inspection-Acceptance and Rejection Criteria	0728 00-5
Installation	0728 00-5
Removal	0728 00-1
Removal	0729 00-1

INDEX, cont'd

<u>Subject</u>	<u>WP Sequence No.-Page No.</u>
Wiring Harness	
Installation	0735 00-4
Removal	0735 00-1
Coolant Heater Schematic	0087 00-1
Coolant Hose and Tube, Upper	
Installation	0232 00-4
Removal	0232 00-2
Coolant Pump	
Belts	
Adjustment	0239 00-1
Engine	
Installation	0241 00-4
Removal	0241 00-1
Idle Pulley/Belts	
Installation	0240 00-2
Removal	0240 00-1
Cooling System, Drain and Fill	
Complete Drain	0227 00-2
Fill Cooling System	0227 00-4
Cover	
Antenna	
Installation	0576 00-2
Removal	0576 00-1
Cargo Hatch	
Installation	0479 00-3
Removal	0479 00-2
Commander's Cupola	
Installation	0493 00-3
Removal	0493 00-2
Commander's Hatch	
Installation	0503 00-3
Removal	0503 00-2
Driver's Hatch	
Installation	0531 00-3
Removal	0531 00-1
Mortar Hatch	
Installation	0482 00-3
Removal	0482 00-2
Teleposts	
Installation	0296 00-3
Removal	0296 00-1
Thermostat	
Installation	0237 00-4
Removal	0237 00-1

INDEX, cont'd

<u>Subject</u>	<u>WP Sequence No.-Page No.</u>
Tow Start Control Assembly	
Installation	0392 00-2
Removal	0392 00-1
Curbside Data Panel A12	
Installation	0819 00-2
Removal	0819 00-1
Cushioning Pad	
Commander's Cupola	
Installation	0488 00-2
Removal	0488 00-1
Driver's Hatch	
Installation	0530 00-1
Removal	0530 00-1
Cushions	
Personnel	
M1059A3 Only	
Installation	0549 00-3
Removal	0549 00-1
M1064A3 Only	
Installation	0550 00-3
Removal	0550 00-1
M113A3 Only	
Installation	0546 00-2
Removal	0546 00-1
M577A3 Only	
Installation	0547 00-3
Removal	0547 00-1
Cylinder	
Discharge Tubes	
Installation	0899 00-3
Removal	0899 00-1
Discharge Tubes, Turbine	
Installation	0900 00-3
Removal	0900 00-1
Fixed Fire Extinguisher	
Installation	0898 00-4
Removal	0898 00-2

D

Data Panel Assembly	
A12, Curbside	
Installation	0819 00-2
Removal	0819 00-1
A13, Roadside	
Installation	0835 00-2
Removal	0835 00-1

INDEX, cont'd

<u>Subject</u>	<u>WP Sequence No.-Page No.</u>
Data Plates, Stencils, Markers, and Decals	
Cleaning	0654 00-2
Installation	0654 00-3
Removal	0654 00-2
Dataplates, Decals, and Markers	
All Models	0644 00-1
M1059A3 Only	0651 00-1
M1064A3 Only	0652 00-1
M113A3 and M1059A3	0645 00-1, 0647 00-1
M113A3, M1059A3, and M58	0646 00-1
M577A3 and M1068A3	0648 00-1
M58 Only	0653 00-1
DC Battery Cable (W4)	
Installation	0838 00-3
Removal	0838 00-1
DC Power Extension	
Box A9	
Installation	0834 00-3
Removal	0834 00-1
W10 Cable	
Installation	0844 00-3
Removal	0844 00-1
Diagram, Communication Cabling	0884 00-1
Differential Pressure Switch	
Bypass Plug	
Installation	0401 00-2
Removal	0401 00-1
Fuel Filter	
Installation	0328 00-5
Removal	0328 00-1
Dipstick	
Final Drive	
Installation	0402 00-3
Removal	0402 00-1
Transmission Oil Level	
X200-4 Only	
Installation	0395 00-3
Removal	0395 00-1
X200-4A Only	
Installation	0396 00-4
Removal	0396 00-1

INDEX, cont'd

<u>Subject</u>	<u>WP Sequence No.-Page No.</u>
Distribution Box	
M113A3, M1059A3, M1064A3, and M58	
Installation	0269 00-4, 0270 00-5
Removal	0269 00-2, 0270 00-2
M577A3 and M1068A3	
Installation	0271 00-3
Removal	0271 00-1
MSD/ICE	
M1064A3 Only	
Installation	0877 00-3
Removal	0877 00-1
M113A3 and M1059A3	
Installation	0874 00-3
Removal	0874 00-1
M577A3 and M1068A3	
Installation	0875 00-2
Removal	0875 00-1
Dome Light	
All Except M577A3 and M1068A3	
Assembly	0310 00-3
Disassembly	0310 00-1
Installation	0309 00-2
Removal	0309 00-1
Circuit Breaker	
Installation	0316 00-3
Removal	0316 00-1
Lens	
Installation	0313 00-3
Removal	0313 00-1
M577A3 and M1068A3	
Assembly	0312 00-3
Disassembly	0312 00-1
Installation	0311 00-3
Removal	0311 00-1
Switch	
Front	
Installation	0314 00-3
Removal	0314 00-1
Rear	
Installation	0315 00-2
Removal	0315 00-1
Door	
Power Plant	
Adjustment	0472 00-2
All Except M113A3	
Installation	0471 00-2
Removal	0471 00-1
Assembly	0472 00-2
Disassembly	0472 00-1

INDEX, cont'd

<u>Subject</u>	<u>WP Sequence No.-Page No.</u>
M113A3 Only	
Installation	0470 00-3
Removal	0470 00-1
Turbine Access	
Installation	0485 00-2
Removal	0485 00-2
Drain Check Valve and Tubes, Left and Right Air Box	
Installation	0159 00-4
Removal	0159 00-1
Drain Cock and Hose	
Installation	0235 00-1
Removal	0235 00-1
Drain Plug	
Final Drive Hull	
Installation	0452 00-2
Removal	0452 00-1
Fuel Tank	
Installation	0187 00-2
Removal	0187 00-1
Hull	
Installation	0451 00-2
Removal	0451 00-1
Ramp	
Installation	0515 00-1
Removal	0515 00-1
Drive Belt	
Generator	
Adjustment	0252 00-2
Installation	0253 00-1
Removal	0253 00-1
Ventilating Fan	
Adjustment	0242 00-1
Installation	0243 00-2
Removal	0243 00-1
Drive Pulley, Ventilating Fan	
Installation	0244 00-1
Removal	0244 00-1
Drive Sprocket Wheel Assembly	
T130 Track	
Assembly	0421 00-1
Disassembly	0421 00-1
Installation	0420 00-2
Removal	0420 00-1
T150 Track	
Installation	0420 01-2
Removal	0420 01-1

INDEX, cont'd

<u>Subject</u>	<u>WP Sequence No.-Page No.</u>
Driver's Compartment Floor Plates	
Cleaning	0453 00-2
Installation	0453 00-2
Removal	0453 00-1
Driver's Footrest	
Installation	0558 00-1
Removal	0558 00-1
Driver's Hatch	
Cover	
Installation	0531 00-3
Removal	0531 00-1
Cushioning Pad	
Installation	0530 00-1
Removal	0530 00-1
Exterior Lock	
Installation	0531 00-3
Removal	0531 00-1
Hold-Open Hook and Bumper	
M113A3, M1059A3, M1064A3, and M58	
Installation	0532 00-2
Removal	0532 00-1
M577A3 and M1068A3	
Cleaning	0533 00-2
Installation	0533 00-3
Removal	0533 00-1
Repair or Replacement	0533 00-2
Interior Lock and Latch	
Adjustment	0534 00-3
Installation	0534 00-2
Removal	0534 00-1
Night Vision Guard	
All Except M58	
Installation	0536 00-1
Removal	0536 00-1
M58 Only	
Installation	0536 01-2
Removal	0536 01-1
Night Vision Mount	
Installation	0537 01-3
Removal	0537 01-2
Vision Block Locks and Seals	
Clean, Inspect, and Repair	0535 00-3
Installation	0535 00-3
Removal	0535 00-1
Driver's Intercommunication Set Cable	
Installation	0892 00-2
Removal	0892 00-1

INDEX, cont'd

<u>Subject</u>	<u>WP Sequence No.-Page No.</u>
Driver's Night Vision	
AN/VVS-2 Power Supply Cable Assembly	
Installation	0368 00-3
Removal	0368 00-1
Mount	
Installation	0537 00-2
Removal	0537 00-1
Stowage	
Installation	0572 00-2
Removal	0572 00-1
Driver's Seat	
Assembly	0552 00-2
Back Assembly	
Assembly	0554 00-1
Disassembly	0554 00-1
Installation	0553 00-2
Removal	0553 00-1
Disassembly	0552 00-1
Impact Absorber	
Installation	0555 00-1
Removal	0555 00-1
Installation	0551 00-2
Post Assembly	
Assembly	0557 00-4
Disassembly	0557 00-1
Installation	0556 00-2
Removal	0556 00-1
Removal	0551 00-1
■ Driver's Vision Enhancer (DVE)	
Commander's Display Mounting Bracket	
Installation	0866 06-5
Removal	0866 06-1
Driver's Display Mounting Bracket	
Installation	0866 02-5
Removal	0866 02-1
Power Supply Cable	
Installation	0866 04-2
Removal	0866 04-1
Sensor Set Assembly	
Installation	0866 05-2
Removal	0866 05-1
Sensor Set Assembly Power Cable	
Installation	0866 01-2
Removal	0866 01-1
Test and Inspection	0866 01-1
Stowage Bracket	
Installation	0866 03-3
Removal	0866 03-1

INDEX, cont'd

<u>Subject</u>	<u>WP Sequence No.-Page No.</u>
Driver's Windshield	
Installation	0739 00-2
Removal	0739 00-1
Stowage Bag, Straps, and Decal	
Installation	0740 00-2
Removal	0740 00-1
Repair or Replacement	0740 00-2
E	
Elbow	
Air Cleaner	
Installation	0168 00-7
Removal	0168 00-2
Air Cleaner Air Intake	
Installation	0173 00-2
Removal	0173 00-1
Coolant Heater Exhaust	
Installation	0724 00-2
Removal	0724 00-1
Engine Exhaust, Left/Right	
Installation	0225 00-2
Removal	0225 00-1
Grill Air Intake	
Installation	0174 00-2
Removal	0174 00-1
Electrical Cable Assembly	
Air Compressor	
Installation	0758 00-4
Removal	0758 00-2
Fog Oil Pump	
Installation	0759 00-3
Removal	0759 00-1
Smoke Generator, Adapter Access Plate to Generator	
Installation	0761 00-3
Removal	0761 00-1
Electrical Schematic	0027 00-1
Electrode, Air Heater	
Installation	0207 00-2
Removal	0207 00-1
Element	
Air Cleaner Filter	
Servicing	0167 00-1
Fuel Filter, Primary and Secondary	
Installation	0202 00-6
Removal	0202 00-2

INDEX, cont'd

<u>Subject</u>	<u>WP Sequence No.-Page No.</u>
Transmission Oil and Filter	
Installation	0398 00-3
Removal	0398 00-1
Enclosure, Generator Set	
Installation	0674 00-3
Removal	0674 00-2
Engine	
Air Box Heater Schematic	0013 00-1
Block Fitting and Hardware	
Installation	0717 00-3
Removal	0717 00-1
Charging System Schematic	0007 00-1
Coolant Heater System	
Drain	0710 00-1
Fill	0710 00-3
Coolant Pump	
Installation	0241 00-4
Removal	0241 00-1
Exhaust Elbows and Double Flex Joint	
Installation	0221 00-3
Removal	0221 00-1
Exhaust Elbows, Left/Right	
Installation	0225 00-2
Removal	0225 00-1
Fuel Pump	
Cleaning	0166 00-3
Inspection-Acceptance and Rejection Criteria	0166 00-3
Installation	0166 00-4
Removal	0166 00-1
Repair or Replacement	0166 00-3
Fuel Return Hose	
Installation	0201 00-3
Removal	0201 00-1
Fuel Supply Hose	
Installation	0200 00-3
Removal	0200 00-1
Fuel System Schematic	
All Except M577A3 and M1068A3	0009 00-1
M577A3 and M1068A3	0010 00-1
Lifting Bracket	
Installation	0161 00-2
Removal	0161 00-1
Mounts	
Installation	0158 00-2
Removal	0158 00-1
Oil Filler Cap	
Installation	0162 00-2
Removal	0162 00-1
Oil Low Pressure Transmitter and Hardware	
Installation	0320 00-3
Removal	0320 00-1

INDEX, cont'd

<u>Subject</u>	<u>WP Sequence No.-Page No.</u>
Oil Sampling Valve and Hose	
Installation	0163 00-2
Removal	0163 00-1
Start Switch	
Installation	0284 00-2
Removal	0284 00-1
Starter Circuit Schematic	0011 00-1
Tachometer Adapter	
Installation	0863 00-3
Removal	0863 00-1
Wiring Harness	
Clean, Inspect, and Repair	0359 00-8
Installation	0359 00-8
Removal	0359 00-2
Equipment Description	
Capabilities and Features	0002 00-1
Differences Between Carriers	0002 00-5
Equipment Data	0002 00-6
Exhaust Joint, Double Flex	
Installation	0222 00-1
Removal	0222 00-1
Exhaust Muffler and Bracket	
Installation	0224 00-2
Removal	0224 00-1
Exhaust Pipe Heat Shield, Turbo, Left/Right	
Installation	0226 00-3
Removal	0226 00-1
Exhaust, Evacuator Valve and Connector	
Installation	0175 00-2
Removal	0175 00-1
Expendable/Durable Supplies and Materials List	0928 00-1
Extender Assembly, Tow Pintle	
Adjustment	0811 02-6
Assembly	0811 02-4
Disassembly	0811 02-3
Installation	0811 02-5
Removal	0811 02-1
Stow	0811 02-6
Extender Kit, Tow Pintle	
Adjustment	0811 01-3
Installation	0811 01-1
Stow	0811 01-3

INDEX, cont'd

<u>Subject</u>	<u>WP Sequence No.-Page No.</u>
Extension Box, AC Power	
A19	
Installation	0822 00-2
Removal	0822 00-1
A6	
Installation	0834 00-3
Removal	0834 00-1
A7	
Installation	0815 00-2
Removal	0815 00-1
External Cable Tube	
Installation	0905 00-5
Removal	0905 00-2
External Communication Box A11	
Installation	0817 00-4
Removal	0817 00-1
External Handle	
Fire Extinguisher Control Valve	
Installation	0904 00-3
Removal	0904 00-1
Shield	
M1064A3 Only	
Inspection-Acceptance and Rejection Criteria	0903 00-3
Installation	0903 00-3
Removal	0903 00-1
M113A3 and M1059A3	
Installation	0901 00-2
Removal	0901 00-1
M577A3 and M1068A3	
Installation	0902 00-1
Removal	0902 00-1
F	
Fabricated Tools	0927 00-1
Fan	
Drive Pulley Access Cover	
Installation	0440 00-2
Removal	0440 00-1
Drive Shaft	
Installation	0248 00-3
Removal	0248 00-1
Flat Pulleys and Bearings	
Installation	0245 00-3
Removal	0245 00-1

INDEX, cont'd

<u>Subject</u>	<u>WP Sequence No.-Page No.</u>
Variable Speed Drive	
Controller	
Installation	0250 01-1
Removal	0250 01-1
Fan Drive Assembly	
Adjustment	0249 01-3
Installation	0249 01-3
Removal	0249 01-2
Installation	0249 00-3
Removal	0249 00-2
Ventilation	
Installation	0383 00-3
Removal	0383 00-1
Filler Cap, Strainer Parts	
All Except M577A3 and M1068A3	
Installation	0184 00-3
Removal	0184 00-2
M577A3 and M1068A3	
Installation	0185 00-2
Removal	0185 00-1
Filler Cover and Lock	
Combat	
Installation	0466 00-2
Removal	0466 00-1
Fuel Tank	
All Except M577A3 and M1068A3	
Installation	0182 00-2
Removal	0182 00-1
M577A3 and M1068A3	
Installation	0183 00-2
Removal	0183 00-1
Filler Flange, Fuel Tank	
Installation	0189 00-2
Removal	0189 00-1
Filler Tube	
Final Drive	
Installation	0402 00-3
Removal	0402 00-1
Transmission Oil Lever	
X200-4 Only	
Installation	0395 00-3
Removal	0395 00-1
X200-4A Only	
Installation	0396 00-4
Removal	0396 00-1

INDEX, cont'd

<u>Subject</u>	<u>WP Sequence No.-Page No.</u>
Filter Element, Transmission Oil	
Installation	0398 00-3
Removal	0398 00-1
Filter, Fuel	
Installation	0726 00-2
Removal	0726 00-1
Final Drive	
Clean, Inspect, and Repair	0403 00-2
Differential Oil Seal	
Installation	0404 00-2
Removal	0404 00-1
Filler Tube and Dipstick	
Installation	0402 00-3
Removal	0402 00-1
Hull Drain Plugs	
Installation	0452 00-2
Removal	0452 00-1
Installation	0403 00-3
Removal	0403 00-1
Fire Extinguisher	
Control Valve and External Handle	
Installation	0904 00-3
Removal	0904 00-1
Fixed	
Cylinder and Mount	
Installation	0898 00-4
Removal	0898 00-2
Cylinder Discharge Tubes	
Installation	0899 00-3
Removal	0899 00-1
Turbine Cylinder Discharge Tubes	
Installation	0900 00-3
Removal	0900 00-1
Portable	
Inspection-Acceptance and Rejection Criteria	0896 00-3
Installation	0896 00-3
Mount (All Except M1068A3)	
Installation	0895 00-3
Removal	0895 00-1
Mount (M1068A3 Only)	
Assembly	0897 00-4
Disassembly	0897 00-3
Installation	0897 00-5
Removal	0897 00-1
Removal	0896 00-1
Fittings	
Coolant Heater Fuel Inlet	
Installation	0712 00-3
Removal	0712 00-1

INDEX, cont'd

<u>Subject</u>	<u>WP Sequence No.-Page No.</u>
Fuel Return	
M1064A3 Only	
Installation	0197 00-9
Removal	0197 00-1
M113A3, M1059A3, and M58	
Installation	0195 00-8
Removal	0195 00-2
M577A3 and M1068A3	
Installation	0196 00-4
Removal	0196 00-1
Fuel Vent	
Installation	0198 00-4
Removal	0198 00-1
Personnel Heater	
M1064A3 Only	
Installation	0688 00-5
Removal	0688 00-1
M577A3 and M1068A3	
Installation	0700 00-3
Removal	0700 00-2
Ramp Control Valve	
External to Internal Relief	
Installation	0660 00-6
Removal	0660 00-1
With External Relief Valve	
Repair or Replacement	0659 00-1
With Internal Relief Valve	
Installation	0661 00-4
Removal	0661 00-1
Flame Detector Switch, Coolant Heater	
Adjustment	0727 00-1
Inspection-Acceptance and Rejection Criteria	0734 00-1
Installation	0734 00-2
Removal	0734 00-1
Floor Plates	
Driver's Compartment	
Cleaning	0453 00-2
Installation	0453 00-2
Removal	0453 00-1
M1059A3 Only	
Installation	0542 00-2
Removal	0542 00-1
M1064A3 Only	
Installation	0543 00-2
Removal	0543 00-1
M1068A3 Only	
Installation	0544 00-3
Removal	0544 00-1

INDEX, cont'd

<u>Subject</u>	<u>WP Sequence No.-Page No.</u>
M113A3 and M577A3	
Installation	0539 00-2
Removal	0539 00-1
M58 Only	
Installation	0545 00-2
Removal	0545 00-1
Fluorescent Light Assemblies	
Installation	0825 00-2
Removal	0825 00-1
Fog Oil	
Pump Assembly	
Installation	0763 00-2
Removal	0763 00-1
Pump, Electrical Cable Assembly	
Installation	0759 00-3
Removal	0759 00-1
Quick Disconnect to Adapter Access Plate Hose	
Installation	0769 00-2
Removal	0769 00-1
Quick Disconnect to Adapter Access Plate Hose, Cover Assembly	
Installation	0770 00-2
Removal	0770 00-1
Tank Module	
Installation	0753 00-4
Removal	0753 00-1
Footrest, Driver's	
Installation	0558 00-1
Removal	0558 00-1
Forward Table, Right	
Installation	0581 00-3
Removal	0581 00-1
Frame, Blackout Curtain	
Installation	0629 00-2
Removal	0629 00-1
Front Bilge Valve	
Installation	0633 00-2
Removal	0633 00-1
Fuel Can Lid Assembly, Smoke Generator	
Installation	0764 00-2
Removal	0764 00-1
Fuel Cap Vent and Filter Screen	
Cleaning	0176 00-1

INDEX, cont'd

<u>Subject</u>	<u>WP Sequence No.-Page No.</u>
Fuel Control Shaft and Linkage	
Installation	0217 00-4
Removal	0217 00-1
Fuel Cutoff Control Cable Assembly	
Adjustment	0220 00-7
Installation	0220 00-4
Removal	0220 00-1
Fuel Filler and Strainer Parts	
Cleaning	0186 00-2
Installation	0186 00-2
Removal	0186 00-1
Repair or Replacement	0186 00-2
Fuel Filter	
Coolant Heater	
Cleaning	0708 00-1
Installation	0708 00-2
Removal	0708 00-1
Differential Pressure Switch	
Installation	0328 00-5
Removal	0328 00-1
Installation	0726 00-2
Personnel Heater	
M1064A3 Only	
Installation	0688 00-5
Removal	0688 00-1
M577A3 and M1068A3	
Installation	0700 00-3
Removal	0700 00-2
Primary and Secondary	
Installation	0203 00-3
Removal	0203 00-2
Primary and Secondary Elements	
Installation	0202 00-6
Removal	0202 00-2
Removal	0726 00-1
Fuel Line	
Lower, Air Box Heater	
Installation	0206 00-3
Removal	0206 00-2
Personnel Heater	
Bleed Air From System	0679 00-1
Smoke Generator	
Installation	0765 00-4
Removal	0765 00-1

INDEX, cont'd

<u>Subject</u>	<u>WP Sequence No.-Page No.</u>
Fuel Pump	
Coolant Heater	
Assembly	0709 00-2
Cleaning	0709 00-2
Disassembly	0709 00-1
Installation	0723 00-3
Removal	0723 00-1
Engine	
Cleaning	0166 00-3
Inspection-Acceptance and Rejection Criteria	0166 00-3
Installation	0166 00-4
Removal	0166 00-1
Repair or Replacement	0166 00-3
Hose	
Coolant Heater	
Installation	0711 00-2
Removal	0711 00-1
Personnel Heater	
Installation	0689 00-3
Removal	0689 00-2
Fuel Quantity Transmitter	
All Except M577A3 and M1068A3	
Inspection-Acceptance and Rejection Criteria	0190 00-2
Installation	0190 00-3
Removal	0190 00-1
Repair or Replacement	0190 00-2
M577A3 and M1068A3	
Cleaning	0191 00-1
Installation	0191 00-1
Removal	0191 00-1
Fuel Return Hoses	
Engine	
Installation	0201 00-3
Removal	0201 00-1
M1064A3 Only	
Installation	0197 00-9
Removal	0197 00-1
M113A3, M1059A3, and M58	
Installation	0195 00-8
Removal	0195 00-2
M577A3 and M1068A3	
Installation	0196 00-4
Removal	0196 00-1
Fuel Return Pressure Transducer	
Installation	0325 00-2
Removal	0325 00-1

INDEX, cont'd

<u>Subject</u>	<u>WP Sequence No.-Page No.</u>
Fuel Select Switch to Gauge Lead	
Inspection-Acceptance and Rejection Criteria	0281 00-2
Installation	0281 00-2
Removal	0281 00-1
Fuel Selector Switch	
Installation	0277 00-3
Removal	0277 00-1
Fuel Shutoff Valve	
Auxiliary Power Unit	
Installation	0676 00-3
Removal	0676 00-2
Coolant Heater	
Installation	0720 00-3
Removal	0720 00-1
Personnel Heater	
Installation	0684 00-3
Removal	0684 00-2
Fuel Supply	
Hoses, Tubes, and Fittings	
M1064A3 Only	
Installation	0194 00-9
Removal	0194 00-2
M113A3, M1059A3, and M58	
Installation	0192 00-9
Removal	0192 00-2
M577A3 and M1068A3	
Installation	0193 00-5
Removal	0193 00-1
Pressure Transducer	
Installation	0324 00-2
Removal	0324 00-1
Fuel Supply Hoses	
Auxiliary Power Unit Bulkhead-to-Hull	
Installation	0678 00-4
Removal	0678 00-1
Auxiliary Power Unit Valve-to-Bulkhead	
Installation	0677 00-4
Removal	0677 00-2
Engine	
Installation	0200 00-3
Removal	0200 00-1
Fuel Tank	
Access Covers	
All Except M577A3 and M1068A3	
Installation	0187 00-2
Removal	0187 00-1
M577A3 and M1068A3	
Installation	0188 00-2
Removal	0188 00-1

INDEX, cont'd

<u>Subject</u>	<u>WP Sequence No.-Page No.</u>
All Except M577A3 and M1068A3	
Installation	0179 00-5
Removal	0179 00-2
Servicing	0177 00-1
Drain Plugs	
Installation	0187 00-2
Removal	0187 00-1
Filler Cover and Lock	
All Except M577A3 and M1068A3	
Installation	0182 00-2
Removal	0182 00-1
M577A3 and M1068A3	
Installation	0183 00-2
Removal	0183 00-1
Filler Flange	
Installation	0189 00-2
Removal	0189 00-1
M577A3 and M1068A3	
Installation	0180 00-4
Removal	0180 00-1
Servicing	0178 00-1
Repair or Replacement	0181 00-1
Fuel Tube, Personnel Heater	
Installation	0686 00-2
Removal	0686 00-1
Fuel Valve, Mounting Blocks	
Installation	0199 00-3
Removal	0199 00-1
Fuel Vent Hoses, Tubes, and Fittings	
Installation	0198 00-4
Removal	0198 00-1
G	
Gasket	
Adapter Access Plate, Smoke Generator	
Installation	0766 00-3
Removal	0766 00-1
Turbine Access Door	
Installation	0486 00-1
Removal	0486 00-1
Gauges, Instrument Panel	
Installation	0285 00-2
Removal	0285 00-1
General Information	
Destruction of Army Materiel to Prevent Enemy Use	0001 00-5

INDEX, cont'd

<u>Subject</u>	<u>WP Sequence No.-Page No.</u>
List of Abbreviations/Acronyms	0001 00-7
Maintenance Forms, Records, and Reports	0001 00-5
Metric Equivalents	0001 00-8
Nomenclature Cross-Reference	0001 00-5
Preparation for Storage or Shipment	0001 00-5
Reporting Equipment Improvement Recommendations (EIR)	0001 00-5
Safety, Care, and Handling	0001 00-9
Scope	0001 00-1
 Generator	
Drive Belt	
Adjustment	0252 00-2
Installation	0253 00-1
Removal	0253 00-1
Field Pressure Switch	
Inspection-Acceptance and Rejection Criteria	0323 00-1
Installation	0323 00-2
Removal	0323 00-1
Installation	0255 00-4
Removal	0255 00-1
Turnbuckle Parts	
Installation	0254 00-2
Removal	0254 00-1
Variable Speed Drive	
Installation	0249 00-3
Removal	0249 00-2
 Generator Set, Enclosure	
Installation	0674 00-3
Removal	0674 00-2
 Glow Plug	
Cable Assembly, Smoke Generator	
Installation	0772 00-4
Removal	0772 00-2
Controller	
Installation	0210 00-3
Removal	0210 00-1
Controller Mounting Bracket	
Installation	0212 00-2
Removal	0212 00-1
Harness and Glow Plugs	
Installation	0209 00-3
Removal	0209 00-1
Power Harness	
Installation	0211 00-2
Removal	0211 00-1
 Governor Assembly	
Installation	0397 00-2
Removal	0397 00-1

INDEX, cont'd

<u>Subject</u>	<u>WP Sequence No.-Page No.</u>
Grenade Stowage Box	
Installation	0610 00-1
Removal	0610 00-1
Grill	
Air Intake Elbow and Hose	
Installation	0174 00-2
Removal	0174 00-1
Power Plant	
Installation	0465 00-3
Lower	0464 00-9
Raise	0464 00-2
Removal	0465 00-1
Support Arm	
Installation	0467 00-2
Removal	0467 00-1
Ground Lead	
Auxiliary Power (Slave) Receptacle	
Installation	0379 00-3
Removal	0379 00-1
Horn	
Installation	0336 00-3
Removal	0336 00-1
Ground Strap, W12	
Installation	0846 00-2
Removal	0846 00-1
Guard	
Antenna	
Installation	0575 00-2
Removal	0575 00-1
Driver's Hatch Night Vision	
All Except M58	
Installation	0536 00-1
Removal	0536 00-1
M58 Only	
Installation	0536 01-2
Removal	0536 01-1
Headlight	
Installation	0446 00-2
Removal	0446 00-1
Stoplight-Taillight	
Installation	0298 00-4
Removal	0298 00-1

INDEX, cont'd

<u>Subject</u>	<u>WP Sequence No.-Page No.</u>
H	
Hand Throttle Control Cable	
Installation	0219 00-4
Removal	0219 00-1
Handle and Arms, Ramp Lock	
Installation	0524 00-2
Removal	0524 00-1
Harness	
Cascade Remote	
Installation	0847 00-3
Removal	0847 00-1
W32	
Installation	0848 00-4
Removal	0848 00-1
Hatch, Mortar, Interior Release Mechanism	
Installation	0481 00-3
Removal	0481 00-1
Headlight	
Blackout	
Assembly	0306 00-2
Disassembly	0306 00-1
Installation	0305 00-2
Removal	0305 00-1
Guard	
Installation	0446 00-2
Removal	0446 00-1
High Beam Selector Switch	
Installation	0333 00-2
Removal	0333 00-1
Service	
Assembly	0304 00-3
Disassembly	0304 00-2
Inspection	0304 00-1
Installation	0303 00-2
Removal	0303 00-1
Wiring Harness, Right	
Inspect and Repair	0373 00-3
Installation	0373 00-3
Removal	0373 00-1
Heat Exchanger	
Battery Box	
Installation	0718 00-2
Removal	0718 00-1
Battery Drawer	
Cleaning	0719 00-2
Inspection-Acceptance and Rejection Criteria	0719 00-2
Installation	0719 00-2
Removal	0719 00-1

INDEX, cont'd

<u>Subject</u>	<u>WP Sequence No.-Page No.</u>
Heat Shield, Turbo Exhaust Pipe, Left/Right	
Installation	0226 00-3
Removal	0226 00-1
Heater, Water/Ration Mount Bracket	
Installation	0811 00-2
Removal	0811 00-1
Hinges, Turbine Access Door	
Installation	0487 00-3
Removal	0487 00-2
Hold-Open Hook and Bumper	
Cargo Hatch	
Installation	0474 00-3
Removal	0474 00-2
Commander's Cupola	
Installation	0494 00-2
Removal	0494 00-1
Driver's Hatch	
M113A3, M1059A3, M1064A3, and M58	
Installation	0532 00-2
Removal	0532 00-1
M577A3 and M1068A3	
Cleaning	0533 00-2
Installation	0533 00-3
Removal	0533 00-1
Repair or Replacement	0533 00-2
Hook and Bumper, Commander's Hatch	
Installation	0501 00-4
Removal	0501 00-2
Hopper Hatch	
Adjustment	0484 00-4
Installation	0484 00-3
Lock Assembly	
Adjustment	0483 00-2
Assembly	0483 00-2
Disassembly	0483 00-1
Removal	0484 00-1
Horizontal Ammunition Rack	
Assembly	0607 00-4
Cleaning	0607 00-4
Disassembly	0607 00-1
Inspection-Acceptance and Rejection Criteria	0607 00-4
Installation	0606 00-2
Removal	0606 00-1

INDEX, cont'd

<u>Subject</u>	<u>WP Sequence No.-Page No.</u>
Horn	
Ground Lead	
Installation	0336 00-3
Removal	0336 00-1
Switch	
All Except M58	
Installation	0293 00-2
Removal	0293 00-1
M58 Only	
Installation	0293 01-2
Removal	0293 01-1
Hose	
Auxiliary Power Unit Bulkhead-to-Hull Fuel Supply	
Installation	0678 00-4
Removal	0678 00-1
Battery Plate to Battery Plate	
Installation	0722 00-2
Removal	0722 00-1
Bulkhead to Ramp Cylinder	
Installation	0665 00-2
Removal	0665 00-1
Coolant Heater	
Engine to Battery Box	
Installation	0714 00-4
Removal	0714 00-2
Filter Valve	
Installation	0716 00-2
Removal	0716 00-1
Fuel Inlet	
Installation	0712 00-3
Removal	0712 00-1
Fuel Pump	
Installation	0711 00-2
Removal	0711 00-1
Pump to Battery Box	
Installation	0713 00-3
Removal	0713 00-1
Coolant Heater to Engine Elbow	
Installation	0715 00-2
Removal	0715 00-1
Coolant Heater to Surge Tank	
Installation	0725 00-1
Removal	0725 00-1
Engine	
Fuel Return	
Installation	0201 00-3
Removal	0201 00-1
Fuel Supply	
Installation	0200 00-3
Removal	0200 00-1

INDEX, cont'd

<u>Subject</u>	<u>WP Sequence No.-Page No.</u>
Fuel Pump Tee to Elbow	
Installation	0721 00-3
Removal	0721 00-1
Fuel Pump to Bulkhead Connection	
Installation	0691 00-2
Removal	0691 00-1
Fuel Vent	
Installation	0198 00-4
Removal	0198 00-1
Personnel Heater	
M1064A3 Only	
Installation	0688 00-5
Removal	0688 00-1
M577A3 and M1068A3	
Installation	0700 00-3
Removal	0700 00-2
Personnel Heater Fuel Pump	
Installation	0689 00-3
Removal	0689 00-2
Quick Disconnect to Adapter Access Plate, Fog Oil Tank	
Installation	0769 00-2
Removal	0769 00-1
Thermostat to Variable Speed Fan Drive	
Installation	0250 00-4
Removal	0250 00-2
Upper Coolant and Tube	
Installation	0232 00-4
Removal	0232 00-2
Variable Speed Drive Override Switch	
Installation	0251 01-2
Removal	0251 01-1
Hose Assemblies, NBC	
Installation	0915 00-3
Removal	0915 00-1
Hoses, Tubes, and Fittings	
Fuel Supply	
M1064A3 Only	
Installation	0194 00-9
Removal	0194 00-2
M113A3, M1059A3, and M58	
Installation	0192 00-9
Removal	0192 00-2
M577A3 and M1068A3	
Installation	0193 00-5
Removal	0193 00-1
Hull, Welding	
Aluminum Castings	0529 00-1
Fuel Tanks	0529 00-3

INDEX, cont'd

<u>Subject</u>	<u>WP Sequence No.-Page No.</u>
General Welding Instructions	0529 00-4
Magnesium Castings	0529 00-2
MIG Welding Method	0529 00-5
Plastic Molding Material	0529 00-3
Safety Precautions	0529 00-1
Welding Near Mortar Ring (M1064A3 Only)	0529 00-4
 Hydraulic Hoses, Power Plant	
Installation	0668 00-3
Removal	0668 00-1
 Hydraulic Pump, Ramp	
Installation	0655 00-3
Removal	0655 00-2
 Hydraulic Reservoir	
Assembly	0672 00-3
Breather	
Cleaning	0670 00-2
Installation	0670 00-2
Removal	0670 00-1
Clean, Inspect, and Repair	0669 00-2
Disassembly	0672 00-1
Installation	0669 00-3, 0671 00-3
Removal	0669 00-1, 0671 00-1
 I 	
Idler	
Arm	
Installation	0246 00-2
Removal	0246 00-1
Pulley/Belts, Coolant Pump	
Installation	0240 00-2
Removal	0240 00-1
Wheel	
Installation	0425 00-2
Removal	0425 00-1
Wheel Arm Assembly	
Installation	0417 00-2
Removal	0417 00-1
Wheel Arm Bearings and Seals	
Cleaning	0418 00-2
Installation	0418 00-2
Removal	0418 00-1
 Igniter	
Inspection-Acceptance and Rejection Criteria	0730 00-2
Installation	0730 00-2
Removal	0730 00-1

INDEX, cont'd

<u>Subject</u>	<u>WP Sequence No.-Page No.</u>
Ignition Coil, Air Box Heater	
Installation	0208 00-3
Removal	0208 00-1
Indicator Lights	
Installation	0286 00-3
Removal	0286 00-1
Indicators Schematic	0046 00-1
Instrument Panel	
Gauges	
Installation	0285 00-2
Removal	0285 00-1
■ Mounts and Ground Lead (New Configuration)	
Installation	0295 01-2
Removal	0295 01-1
■ Mounts and Ground Lead (Old Configuration)	
Installation	0295 00-4
Removal	0295 00-2
■ New Configuration	
Installation	0279 01-6
Removal	0279 01-1
■ Old Configuration	
Installation	0279 00-5
Removal	0279 00-2
On-Off Switches	
Installation	0282 00-3
Removal	0282 00-1
Special Purpose Cable	
Installation	0290 00-5
Removal	0290 00-1
Warning Lights	
Inspection-Acceptance and Rejection Criteria	0287 00-3
Installation	0287 00-4
Removal	0287 00-2
Instrument Warning Light Panel	
All Except M58	
Installation	0292 00-2
Removal	0292 00-1
M58 Only	
Installation	0288 00-2
Removal	0288 00-1
Intercom Amplifier	
Installation	0888 00-2
Removal	0888 00-1
Intercommunications Set Control	
Installation	0885 00-2
Removal	0885 00-1

INDEX, cont'd

<u>Subject</u>	<u>WP Sequence No.-Page No.</u>
Interior Latch	
Cargo Hatch	
Adjustment	0475 00-5
Installation	0475 00-3
Removal	0475 00-1
Commander's Cupola	
Installation	0496 00-2
Removal	0496 00-1
Commander's Hatch	
Adjustment	0502 00-2
Installation	0502 00-2
Removal	0502 00-1
Driver's Hatch	
Installation	0534 00-2
Removal	0534 00-1
Inverter	
AC Cable (W5)	
Installation	0839 00-3
Removal	0839 00-1
Convert Primary to Slave	0830 01-1
DC Cable (W6)	
Installation	0840 00-3
Removal	0840 00-1
Housing A2 Terminal Blocks TB1 and TB2	
Installation	0830 00-4
Removal	0830 00-1
J	
Jump Seat, Commander's	
Installation	0563 00-3
Removal	0563 00-1
K	
Kits	
Armor (M1064A3 Only)	
Installation	0751 01-1
Removal	0751 01-3
Litter	
Installation	0741 00-1
Mine Armor	
Cover Armor Plate	
Install	0752 00-4
Remove	0752 00-6
Mine Armor Plate	
Install	0752 00-1
Remove	0752 00-6

INDEX, cont'd

<u>Subject</u>	<u>WP Sequence No.-Page No.</u>
Sponson Armor Plate	
Install	0752 00-5
L	
Lamp, Transmission Range Controller	
Installation	0388 00-2
Removal	0388 00-1
LAN	
Cable (W40) Single Point	
Installation	0851 00-3
Removal	0851 00-1
Cable, A or B (W103/W104)	
Installation	0854 00-3
Removal	0854 00-1
Ground Box Assembly A15	
Assembly	0821 00-2
Disassembly	0821 00-1
Installation	0820 00-2
Removal	0820 00-1
Lanyard and Pin, Quick Release, Steering Wheel	
Installation	0431 00-2
Removal	0431 00-1
Lead	
Circuit 44A, Power Control Enclosure	
Installation	0829 00-3
Removal	0829 00-1
Circuit 49, Master Switch to Distribution Box	
M113A3, M1059A3, M1064A3, and M58	
Inspection-Acceptance and Rejection Criteria	0266 00-2
Installation	0266 00-3
Removal	0266 00-1
M577A3 and M1068A3	
Inspection-Acceptance and Rejection Criteria	0267 00-2
Installation	0267 00-3
Removal	0267 00-1
Circuit 50, Master Switch to Auxiliary Power Receptacle	
Inspection-Acceptance and Rejection Criteria	0268 00-2
Installation	0268 00-3
Removal	0268 00-1
Circuit 6, Battery to Master Switch	
M1064A3 Only	
Installation	0358 00-5
Removal	0358 00-1
M113A3 and M1059A3	
Installation	0356 00-4
Removal	0356 00-1

INDEX, cont'd

<u>Subject</u>	<u>WP Sequence No.-Page No.</u>
M577A3 and M1068A3	
Installation	0357 00-4
Removal	0357 00-1
Utility Outlet Assembly	
Inspect and Repair	0377 00-2
Installation	0377 00-2
Removal	0377 00-1
Lead Assembly, Master Switch Panel Dome Lights	
Installation	0380 00-3
Removal	0380 00-1
Leads and Terminals, Battery	
M1064A3 Only (Left Side)	
Cleaning	0343 00-5
Installation	0343 00-5
Removal	0343 00-1
M1064A3 Only (Right Side)	
Cleaning	0344 00-3
Installation	0344 00-4
Removal	0344 00-1
M113A3 and M1059A3	
Clean and Inspect	0340 00-3
Installation	0340 00-4
Removal	0340 00-1
M577A3 and M1068A3	
Clean and Inspect	0341 00-3
Installation	0341 00-4
Removal	0341 00-1
M58 Only	
Cleaning	0345 00-3
Installation	0345 00-4
Removal	0345 00-1
Left Side Rack Base	
Installation	0616 00-3
Removal	0616 00-1
Lens, Dome Light	
Installation	0313 00-3
Removal	0313 00-1
Lever and Cable, Ramp Lock	
Cleaning, Inspect, and Repair	0525 00-3
Installation	0525 00-3
Removal	0525 00-1
Lid and Latches, External Communication Box A11	
Installation	0818 00-2
Removal	0818 00-1

INDEX, cont'd

<u>Subject</u>	<u>WP Sequence No.-Page No.</u>
Lifting Eye	
Installation	0444 00-1
Removal	0444 00-1
Light	
Blackout Marker	
Assembly	0308 00-2
Disassembly	0308 00-1
Installation	0307 00-2
Removal	0307 00-1
Dome	
All Except M577A3 and M1068A3	
Assembly	0310 00-3
Disassembly	0310 00-1
Installation	0309 00-2
Removal	0309 00-1
M577A3 and M1068A3	
Assembly	0312 00-3
Disassembly	0312 00-1
Installation	0311 00-3
Removal	0311 00-1
Instrument Panel Warning	
Inspection-Acceptance and Rejection Criteria	0287 00-3
Installation	0287 00-4
Removal	0287 00-2
Left Stoplight-Taillight	
Assembly	0300 00-2
Disassembly	0300 00-1
Installation	0299 00-2
Removal	0299 00-1
Right Stoplight-Taillight	
Assembly	0302 00-2
Disassembly	0302 00-1
Installation	0301 00-2
Removal	0301 00-1
Switch, Main	
Installation	0283 00-2
Removal	0283 00-1
Warning Panel	
All Except M58	
Installation	0294 00-3
Removal	0294 00-1
M58 Only	
Inspection-Acceptance and Rejection Criteria	0294 01-2
Installation	0294 01-3
Removal	0294 01-2
Linkage	
Accelerator	
Adjustment	0214 00-1
Fuel Control	
Installation	0217 00-4
Removal	0217 00-1

INDEX, cont'd

<u>Subject</u>	<u>WP Sequence No.-Page No.</u>
Ramp	
M1064A3 Only	
Inspect and Repair	0528 00-3
Installation	0528 00-3
Removal	0528 00-1
M113A3 and M1059A3	
Installation	0526 00-3
Removal	0526 00-1
M577A3 and M1068A3	
Clean, Inspect, and Repair	0527 00-3
Installation	0527 00-3
Removal	0527 00-1
Service Brake Control	
Adjustment	0407 00-1
Installation	0410 00-7
Removal	0410 00-2
Steering Wheel	
Adjustment	0427 00-1
Installation	0430 00-6
Removal	0430 00-1
Litter Kit	
Chain Assembly	
Assembly	0745 00-4
Disassembly	0745 00-1
Installation	0744 00-2
Removal	0744 00-1
Installation	0741 00-1
Lock, Ramp	
M1064A3 Only	
Adjust Ramp Lock	0523 00-1
M113A3 and M1059A3	
Ramp Lock Adjustment	0521 00-2
Ramp Lock Test	0521 00-1
Ramp Seal Test	0521 00-1
M577A3 and M1068A3	
Adjust Ramp Lock	0522 00-1
M	
M13	
Air Purifier and Frame	
Installation	0779 00-3
Removal	0779 00-1
Filter Switch	
Installation	0805 00-2
Removal	0805 00-1

INDEX, cont'd

<u>Subject</u>	<u>WP Sequence No.-Page No.</u>
Filters and Hoses	
M1068A3 Only	
Installation	0789 00-4
Removal	0789 00-1
M577A3 Only	
Installation	0786 00-8
Removal	0786 00-2
Heater	
Installation	0798 00-4
Removal	0798 00-1
Hoses	
Installation	0790 00-6
Removal	0790 00-2
Orifice Connector Assembly, Bracket, and Quick Coupling Half	
Installation	0781 00-2
Removal	0781 00-1
Wiring Harness	
M1068A3 Only	
Installation	0809 00-6
Removal	0809 00-2
M577A3 Only	
Installation	0808 00-4
Removal	0808 00-2
M14	
Cables and Switch Assembly	
Installation	0799 00-3
Removal	0799 00-1
Hoses and Brackets	
Installation	0783 00-4
Removal	0783 00-1
Wiring Harness	
Installation	0807 00-4
Removal	0807 00-1
M3	
Control Box	
M1068A3 Only	
Installation	0793 00-3
Removal	0793 00-1
Control Box, Regulator, and Bracket	
M113A3 Only	
Installation	0791 00-4
Removal	0791 00-1
Heaters and Controllers	
M1059A3 Only	
Installation	0797 00-6
Removal	0797 00-1
M113A3 Ambulance Only	
Installation	0795 00-4
Removal	0795 00-1
M113A3 Only	
Installation	0794 00-4
Removal	0794 00-2

INDEX, cont'd

<u>Subject</u>	<u>WP Sequence No.-Page No.</u>
Hoses and Fittings	
M1059A3 Only	
Installation	0788 00-5
Removal	0788 00-1
M113A3 Ambulance Only	
Installation	0784 00-4
Removal	0784 00-1
M113A3 Only	
Installation	0782 00-4
Removal	0782 00-1
Wiring Harness	
Installation	0806 00-3
Removal	0806 00-1
M8A3	
Hoses and Brackets	
Installation	0787 00-4
Removal	0787 00-1
M8A3/M14 Orifice Connector Assembly, Support, and Quick Coupling Half	
Installation	0780 00-4
Removal	0780 00-1
M8A3/M3	
Filter Switch	
Installation	0804 00-3
Removal	0804 00-1
Machine Gun Mount	
Commander's Cupola	
Assembly	0498 00-2
Disassembly	0498 00-1
Installation	0497 00-1
Removal	0497 00-1
Stops	
Installation	0499 00-3
Removal	0499 00-1
Maintenance Allocation Chart (MAC)	
	0925 00-1
Map Board	
M1068A3 Only	
Installation	0618 00-3
Removal	0618 00-1
M577A3 Only	
Installation	0580 00-2
Removal	0580 00-1
Map Storage Box	
Assembly	0620 00-2

INDEX, cont'd

<u>Subject</u>	<u>WP Sequence No.-Page No.</u>
Disassembly	0620 00-1
Installation	0619 00-2
Removal	0619 00-1
 Master Switch	
Installation	0262 00-3
Removal	0262 00-1
 Master Switch Panel Assembly	
M113A3, M1059A3, M1064A3, and M58	
Installation	0260 00-4
Removal	0260 00-1
M577A3 and M1068A3	
Installation	0261 00-4
Removal	0261 00-1
 Master Switch Panel, Dome Lights Lead Assembly	
Installation	0380 00-3
Removal	0380 00-1
 Master Switch to Auxiliary Power Receptacle Lead, Circuit 50	
Inspection-Acceptance and Rejection Criteria	0268 00-2
Installation	0268 00-3
Removal	0268 00-1
 Master Switch to Distribution Box Lead, Circuit 49	
M113A3, M1059A3, M1064A3, and M58	
Inspection-Acceptance and Rejection Criteria	0266 00-2
Installation	0266 00-3
Removal	0266 00-1
M577A3 and M1068A3	
Inspection-Acceptance and Rejection Criteria	0267 00-2
Installation	0267 00-3
Removal	0267 00-1
 Mine Armor Kit	
Cover Armor Plate	
Install	0752 00-4
Remove	0752 00-6
Mine Armor Plate	
Install	0752 00-1
Remove	0752 00-6
Sponson Armor Plate	
Install	0752 00-5
 Mortar Base Stowage Bracket	
Installation	0615 00-3
Removal	0615 00-1

INDEX, cont'd

<u>Subject</u>	<u>WP Sequence No.-Page No.</u>
Mortar Fire Control System	
Commander's Interface Bracket Assembly	
M1064A3 Only	
Installation	0812 03-3
Removal	0812 03-2
Repair	0812 03-3
M577A3 Only	
Installation	0812 02-3
Removal	0812 02-1
Repair	0812 02-3
DAGR Holder Mounting Bracket and Shock Isolator	
Installation	0812 16-2
Removal	0812 16-1
General Maintenance	
.	0812 01-1
Gunner's Display, Alternate Location	
Installation	0812 15-2
Removal	0812 15-1
M1064A3 Only	
Cables	
Installation	0812 14-14
Removal	0812 14-1
Repair	0812 14-13
Driver's Display Assembly (M1064 Only)	
Disassembly	0812 10-2
Installation	0812 10-6
Removal	0812 10-1
Repair or Replacement	0812 10-3
Driver's Display Exterior Mounting Ball	
Installation	0812 11-2
Removal	0812 11-1
Repair	0812 11-1
Power Distribution Assembly	
Installation	0812 05-3
Removal	0812 05-2
Repair	0812 05-2
Precision Lightweight GPS Receiver (PLGR) and Bracket	
Installation	0812 08-3
Removal	0812 08-1
Repair	0812 08-2
Precision Lightweight GPS Receiver (PLGR) Antenna and Antenna Bracket	
Installation	0812 09-2
Removal	0812 09-1
Repair	0812 09-2
Travel Lock Adapter	
Installation	0812 13-2
Removal	0812 13-1
Repair	0812 13-2
Vehicle Motion Sensor Assembly	
Installation	0812 12-3
Removal	0812 12-1
Repair	0812 12-2

INDEX, cont'd

<u>Subject</u>	<u>WP Sequence No.-Page No.</u>
M577A3	
Cable Hanger	
Installation	0812 06-2
Removal	0812 06-1
Repair	0812 06-1
M577A3 Only	
Installation	0812 07-6
Power Distribution Assembly	
Installation	0812 04-3
Removal	0812 04-2
Repair	0812 04-3
Removal	0812 07-1
Repair	0812 07-5
Mortar Hatch	
Cover	
Installation	0482 00-3
Removal	0482 00-2
Exterior Catches and Bumpers	
Adjustment	0480 00-5
Installation	0480 00-4
Removal	0480 00-1
Interior Release Mechanisms	
Installation	0481 00-3
Removal	0481 00-1
Mount	
AC and DC Power Extension Boxes A6 and A9	
Installation	0834 00-3
Removal	0834 00-1
Commander's Cupola Machine Gun	
Installation	0497 00-1
Removal	0497 00-1
Dome Light	
Assembly	0312 00-3
Disassembly	0312 00-1
Installation	0311 00-3
Removal	0311 00-1
Driver's Hatch Night Vision	
Installation	0537 01-3
Removal	0537 01-2
Driver's Night Vision	
Installation	0537 00-2
Removal	0537 00-1
Engine	
Installation	0158 00-2
Removal	0158 00-1
Fixed Fire Extinguisher	
Installation	0898 00-4
Removal	0898 00-2
Portable Fire Extinguisher	
All Except M1068A3	
Installation	0895 00-3
Removal	0895 00-1

INDEX, cont'd

<u>Subject</u>	<u>WP Sequence No.-Page No.</u>
M1059A3 Only	
Inspection-Acceptance and Rejection Criteria	0896 00-3
Installation	0896 00-3
Removal	0896 00-1
M1068A3 Only	
Assembly	0897 00-4
Disassembly	0897 00-3
Installation	0897 00-5
Removal	0897 00-1
Printer	
Installation	0823 00-3
Removal	0823 00-1
Ramp Door Switch	
Adjustment	0335 00-4
Inspection-Acceptance and Rejection Criteria	0335 00-2
Installation	0335 00-3
Removal	0335 00-1
Shock Absorber	
Installation	0436 00-2
Removal	0436 00-1
Transmission	
Installation	0385 00-3
Removal	0385 00-1
Mount and Bracket, APIU Rack	
Installation	0813 00-2
Removal	0813 00-1
Mounting Blocks, Fuel Valve	
Installation	0199 00-3
Removal	0199 00-1
Mounting Bracket	
Commander's Display (DVE)	
Installation	0866 06-5
Removal	0866 06-1
Driver's Display (DVE)	
Installation	0866 02-5
Removal	0866 02-1
NBC Filter	
Installation	0803 00-3
Removal	0803 00-2
NBC Orifice Connector Assembly	
Installation	0916 00-5
Removal	0916 00-1
Water/Ration Heater	
Installation	0811 00-2
Removal	0811 00-1
Mounts and Ground Lead, Instrument Panel	
New Configuration	
Installation	0295 01-2
Removal	0295 01-1

INDEX, cont'd

<u>Subject</u>	<u>WP Sequence No.-Page No.</u>
Old Configuration	
Installation	0295 00-4
Removal	0295 00-2
MSD/ICE	
Crew Wiring Harness	
M1064A3 Only	
Inspection-Acceptance and Rejection Criteria	0881 00-4
Installation	0881 00-4
Removal	0881 00-1
Repair or Replacement	0881 00-4
M113A3 and M1059A3	
Inspection-Acceptance and Rejection Criteria	0878 00-4
Installation	0878 00-4
Removal	0878 00-1
Repair or Replacement	0878 00-4
M577A3 and M1068A3	
Inspection-Acceptance and Rejection Criteria	0879 00-4
Installation	0879 00-5
Removal	0879 00-1
Repair or Replacement	0879 00-5
Distribution Box	
M1064A3 Only	
Installation	0877 00-3
Removal	0877 00-1
M113A3 and M1059A3	
Installation	0874 00-3
Removal	0874 00-1
M577A3 and M1068A3	
Installation	0875 00-2
Removal	0875 00-1
Engine Wiring Harness	
Inspection-Acceptance and Rejection Criteria	0882 00-4
Installation	0882 00-5
Removal	0882 00-1
Repair or Replacement	0882 00-5
Pulse Tachometer	
Installation	0867 00-3
Removal	0867 00-1
Schematic	0136 00-1
Shunt	
M1064A3 Only	
Installation	0873 00-3
Removal	0873 00-1
M113A3 and M1059A3	
Installation	0870 00-4
Removal	0870 00-1
M577A3 and M1068A3	
Installation	0871 00-3
Removal	0871 00-2

INDEX, cont'd

<u>Subject</u>	<u>WP Sequence No.-Page No.</u>
Shunt Guard	
Cleaning	0868 00-3
Installation	0868 00-3
Removal	0868 00-1
Muffler	
Exhaust and Bracket	
Installation	0224 00-2
Removal	0224 00-1
Extension and Cap	
Installation	0223 00-3
Removal	0223 00-1
N	
NBC	
Air Purifier and Frame	
M1059A3 Only	
Installation	0777 00-2
Removal	0777 00-1
M1059A3 Only with M3 Heater	
Installation	0778 00-3
Removal	0778 00-1
M113A3 Only	
Installation	0775 00-2
Removal	0775 00-1
M577A3 Only	
Installation	0776 00-2
Removal	0776 00-1
M58 Only	
Installation	0914 00-2
Removal	0914 00-1
Cable Assembly	
M113A3 Only	
Installation	0800 00-3
Removal	0800 00-1
M58 Only	
Installation	0917 00-3
Removal	0917 00-1
Filter Switch	
M1059A3 Only	
Installation	0804 00-3
Removal	0804 00-1
M1068A3 Only	
Installation	0805 00-2
Removal	0805 00-1
M113A3 Only	
Installation	0802 00-3
Removal	0802 00-1
M577A3 Only	
Installation	0803 00-3
Removal	0803 00-2

INDEX, cont'd

<u>Subject</u>	<u>WP Sequence No.-Page No.</u>
Heaters and Controllers	
M1059A3 Only	
Installation	0797 00-6
Removal	0797 00-1
M113A3 Ambulance Only	
Installation	0795 00-4
Removal	0795 00-1
M113A3 Only	
Installation	0794 00-4
Removal	0794 00-2
Heaters and Mounts	
M577A3 Only	
Installation	0796 00-4
Removal	0796 00-2
Hoses	
M1068A3 Only	
Installation	0790 00-6
Removal	0790 00-2
M113A3 Ambulance Only	
Installation	0783 00-4
Removal	0783 00-1
M58 Only	
Installation	0915 00-3
Removal	0915 00-1
M13 Filters and Hoses	
M1068A3 Only	
Installation	0789 00-4
Removal	0789 00-1
M577A3 Only	
Installation	0786 00-8
Removal	0786 00-2
M13 Heater	
Installation	0798 00-4
Removal	0798 00-1
M14 Air Purifier and Frame	
M113A3 Only	
Installation	0774 00-2
Removal	0774 00-1
M3 Control Box, Regulator, and Bracket	
Installation	0791 00-4
Removal	0791 00-1
M3 Heater Control Box	
M1068A3 Only	
Installation	0793 00-3
Removal	0793 00-1
M3 Hoses and Fittings	
M1059A3 Only	
Installation	0788 00-5
Removal	0788 00-1
M113A3 Ambulance Only	
Installation	0784 00-4
Removal	0784 00-1

INDEX, cont'd

<u>Subject</u>	<u>WP Sequence No.-Page No.</u>
M113A3 Only	
Installation	0782 00-4
Removal	0782 00-1
M8A3 Hoses and Brackets	
Installation	0787 00-4
Removal	0787 00-1
Orifice Connector Assembly, Mounting Bracket, and Switch	
Installation	0916 00-5
Removal	0916 00-1
Wiring Harness	
M1059A3 Only	
Installation	0806 00-3
Removal	0806 00-1
M1068A3 Only	
Installation	0809 00-6
Removal	0809 00-2
M113A3 Ambulance Only	
Installation	0807 00-4
Removal	0807 00-1
M577A3 Only	
Installation	0808 00-4
Removal	0808 00-2
Night Vision Guard, Driver's Hatch	
All Except M58	
Installation	0536 00-1
Removal	0536 00-1
M58 Only	
Installation	0536 01-2
Removal	0536 01-1
Non-Skid Plates	
Installation	0738 00-2
Removal	0738 00-1
O	
Oil Can Bracket	
Installation	0574 00-1
Removal	0574 00-1
Oil Cooler Hoses, Fittings, and Mounting (Transmission)	
Installation	0399 00-8
Removal	0399 00-1
Oil Filter Element	
Cleaning	0165 00-1
Installation	0165 00-2
Removal	0165 00-1

INDEX, cont'd

<u>Subject</u>	<u>WP Sequence No.-Page No.</u>
Oil Gauge Rod/Tube	
Installation	0164 00-2
Removal	0164 00-1
On-Off Switches, Instrument Panel	
Installation	0282 00-3
Removal	0282 00-1
Operator's Intercommunication Set Cable	
Installation	0894 00-2
Removal	0894 00-1
Operator's Seat	
Assembly	0567 00-3
Disassembly	0567 00-2
Installation	0567 00-4
Removal	0567 00-1
Orifice Connector Assembly, Support, and Quick Coupling Half, M8A3/M14	
Installation	0780 00-4
Removal	0780 00-1
Outlet	
Rear Utility Receptacle	
Inspect and Repair	0378 00-2
Installation	0378 00-2
Removal	0378 00-1
P	
Pad	
Cushioning	
Installation	0570 00-1
Removal	0570 00-1
Track Shoe	
T130	
Installation	0424 00-2
Removal	0424 00-1
T150	
Installation	0424 01-2
Removal	0424 01-1
Pamphlet Bag Mounting	
Installation	0442 00-2
Removal	0442 00-1
Panel	
Driver's Power Plant Access	
Installation	0441 00-3
Removal	0441 00-1
Lights	
Installation	0286 00-3
Removal	0286 00-1

INDEX, cont'd

<u>Subject</u>	<u>WP Sequence No.-Page No.</u>
Panel Assembly	
Instrument (New Configuration)	
Installation	0279 01-6
Removal	0279 01-1
Instrument (Old Configuration)	
Installation	0279 00-5
Removal	0279 00-2
Parking Brake	
Adjustment	0408 00-1
Control Cable Assembly	
Installation	0411 00-4
Removal	0411 00-1
Control Lever Assembly	
Installation	0412 00-3
Removal	0412 00-1
Switch/Bracket	
Clean and Inspect	0331 00-3
Installation	0331 00-3
Removal	0331 00-1
Periscope Stowage Box	
Installation	0611 00-2
Removal	0611 00-1
Personnel Heater	
Air Intake and Exhaust Pipes	
All Except M1064A3	
Installation	0682 00-3
Removal	0682 00-1
M1064A3 Only	
Installation	0683 00-3
Removal	0683 00-1
All Except M1064A3	
Installation	0703 00-4
Removal	0703 00-1
Control Box	
Assembly	0702 00-5
Disassembly	0702 00-1
Installation	0701 00-3
Removal	0701 00-1
Repair or Replacement	0702 00-4
Control Box and Intercom Box Bracket	
Installation	0617 00-2
Removal	0617 00-1
Duct	
Installation	0706 00-3, 0707 00-2
Removal	0706 00-2, 0707 00-1
Fuel Filter	
Clean, Inspection, and Repair	0680 00-3

INDEX, cont'd

<u>Subject</u>	<u>WP Sequence No.-Page No.</u>
Installation	0680 00-3
Removal	0680 00-2
Fuel Filter/Bracket	
Installation	0698 00-2
Removal	0698 00-1
Fuel Line	
Bleed Air From System	0679 00-1
Fuel Pump	
Assembly	0681 00-2
Cleaning	0681 00-2
Disassembly	0681 00-2
M1064A3 Only	
Installation	0697 00-3
Removal	0697 00-1
M113A3, M1059A3, and M58	
Installation	0695 00-2
Removal	0695 00-1
M577A3 and M1068A3	
Installation	0696 00-4
Removal	0696 00-1
Fuel Pump Hose	
Installation	0689 00-3
Removal	0689 00-2
Fuel Supply Hoses	
Installation	0685 00-3
Removal	0685 00-2
Fuel Tube	
Installation	0686 00-2
Removal	0686 00-1
Heater Assembly	
Repair or Replacement	0705 00-1
Hose	
Fuel Pump to Bulkhead Connection	
Installation	0692 00-3
Removal	0692 00-2
Fuel Pump to Fuel Shutoff Valve	
Installation	0694 00-3
Removal	0694 00-1
Fuel Tank to Fuel Pump	
Installation	0690 00-3
Removal	0690 00-2
M1064A3 Only	
Installation	0704 00-5
Removal	0704 00-2
Schematic	0085 00-1
Tube, Bulkhead Connection to Heater	
Installation	0687 00-3
Removal	0687 00-1
Wiring Harness Guide	
Installation	0707 01-3
Removal	0707 01-1

INDEX, cont'd

<u>Subject</u>	<u>WP Sequence No.-Page No.</u>
Personnel Seats, Backrests, Cushions, and Belts	
M1059A3 Only	
Installation	0549 00-3
Removal	0549 00-1
M1064A3 Only	
Installation	0550 00-3
Removal	0550 00-1
Personnel Seats, Cushions, and Belts	
M113A3 Only	
Installation	0546 00-2
Removal	0546 00-1
M577A3 Only	
Installation	0547 00-3
Removal	0547 00-1
Pin	
Shock Absorber	
Installation	0437 00-2
Removal	0437 00-1
Spall Liner Quick Release	
Installation	0506 00-3
Removal	0506 00-1
Steering Wheel Quick Release	
Installation	0431 00-2
Removal	0431 00-1
Pintle, Towing	
Assembly	0434 00-2
Disassembly	0434 00-1
Installation	0433 00-2
Removal	0433 00-1
Pipes	
Coolant Heater Exhaust	
Installation	0724 00-2
Removal	0724 00-1
Front Bilge Pump	
Installation	0631 00-3
Removal	0631 00-1
Rear Bilge Pump	
Installation	0634 00-2
Removal	0634 00-1
Plates	
Driver's Compartment Floor	
Cleaning	0453 00-2
Installation	0453 00-2
Removal	0453 00-1
Non-Skid	
Installation	0738 00-2
Removal	0738 00-1

INDEX, cont'd

<u>Subject</u>	<u>WP Sequence No.-Page No.</u>
Rear Tiedown	
Installation	0445 00-2
Removal	0445 00-1
Spall Liner	
Installation	0506 00-3
Removal	0506 00-1
Platform, Commander's	
M113A3, M1059A3, M1064A3, and M58	
Assembly	0559 00-4
Disassembly	0559 00-2
Installation	0559 00-6
Removal	0559 00-1
M577A3 and M1068A3	
Assembly	0564 00-3
Disassembly	0564 00-2
Inspection-Acceptance and Rejection Criteria	0564 00-3
Installation	0564 00-4
Removal	0564 00-1
Plug	
Final Drive Hull Drain	
Installation	0452 00-2
Removal	0452 00-1
Hull Drain	
Installation	0451 00-2
Removal	0451 00-1
Post	
Commander's	
Assembly	0564 00-3
Disassembly	0564 00-2
Inspection-Acceptance and Rejection Criteria	0564 00-3
Installation	0564 00-4
M1064A3 Only	
Installation	0561 00-2
Removal	0561 00-1
M113A3, M1059A3, and M58	
Installation	0560 00-3
Removal	0560 00-1
Removal	0564 00-1
Driver's Seat	
Assembly	0557 00-4
Disassembly	0557 00-1
Installation	0556 00-2
Removal	0556 00-1
Post Assembly	
Assembly	0743 00-2
Disassembly	0743 00-1

INDEX, cont'd

<u>Subject</u>	<u>WP Sequence No.-Page No.</u>
Installation	0742 00-3
Removal	0742 00-1
Power Cable	
Driver's Vision Enhancer (DVE) Sensor Set Assembly	
Installation	0866 01-2
Removal	0866 01-1
Test and Inspection	0866 01-1
Intervehicle	
Assembly	0381 00-2
Disassembly	0381 00-1
Water/Ration Heater	
Installation	0810 00-3
Removal	0810 00-1
Power Control Enclosure	
AC and DC Meters and Light Indicators	
Installation	0827 00-4
Removal	0827 00-1
Circuit 44A Lead	
Installation	0829 00-3
Removal	0829 00-1
Faceplate and Bracket	
Assembly	0828 00-7
Disassembly	0828 00-1
Power Control Enclosure Assembly, A1	
Installation	0826 00-3
Removal	0826 00-1
Power Distribution	
Box A3	
Assembly	0831 00-3
Disassembly	0831 00-3
Installation	0831 00-4
Removal	0831 00-1
Cable (W3)	
Installation	0837 00-3
Removal	0837 00-1
Power Entry Box Assembly A4	
Installation	0832 00-3
Removal	0832 00-1
Power Extension Box A18 and Bracket	
Installation	0836 00-2
Removal	0836 00-1

INDEX, cont'd

<u>Subject</u>	<u>WP Sequence No.-Page No.</u>
Power Plant	
Block	
Jacking	0157 00-1
Bottom Access Cover	
Cleaning	0450 00-2
Installation	0450 00-3
Removal	0450 00-1
Door	
Adjustment	0472 00-2
All Except M113A3	
Installation	0471 00-2
Removal	0471 00-1
Assembly	0472 00-2
Disassembly	0472 00-1
M113A3 Only	
Installation	0470 00-3
Removal	0470 00-1
Door Combat Lock	
Installation	0473 00-3
Removal	0473 00-1
Grill	
Installation	0465 00-3
Lower	0464 00-9
Raise	0464 00-2
Removal	0465 00-1
Grill Screen	
Installation	0468 00-1
Removal	0468 00-1
Grill Support Arm	
Installation	0467 00-2
Removal	0467 00-1
Rear Access Panels	
Installation	0439 00-2
Removal	0439 00-1
Sling	
Periodic Check	0673 00-2
Preoperative Check	0673 00-8
Power Plant Assembly	
Installation	0156 00-13
Removal	0156 00-1
Power Supply	
Cable, Driver's Vision Enhancer (DVE) AN/VAS-5	
Installation	0866 04-2
Removal	0866 04-1
Storage Box Assembly	
Assembly	0824 00-5
Disassembly	0824 00-3
Installation	0824 00-7
Removal	0824 00-2

INDEX, cont'd

<u>Subject</u>	<u>WP Sequence No.-Page No.</u>
Pressure Switch	
Differential, Bypass Plug	
Installation	0401 00-2
Removal	0401 00-1
Transmission Oil Sampling Valve	
Installation	0400 00-2
Removal	0400 00-1
Preventive Maintenance Checks and Services (PMCS), Including Lubrication Instructions	
Annual	0155 00-1
Semi-Annual	0155 00-1
Printer Mount	
Installation	0823 00-3
Removal	0823 00-1
Propeller Shaft and Universal Joints	
Installation	0405 00-3
Removal	0405 00-1
Pulse Tachometer, MSD/ICE	
Installation	0867 00-3
Removal	0867 00-1
Pump	
Coolant Heater	
Installation	0731 00-2
Removal	0731 00-1
Engine Coolant	
Installation	0241 00-4
Removal	0241 00-1
Hydraulic, Ramp	
Installation	0655 00-3
Removal	0655 00-2
Pump Assembly, Fog Oil	
Installation	0763 00-2
Removal	0763 00-1
Pump Unit, Coolant Heater	
Inspection-Acceptance and Rejection Criteria	0728 00-5
Installation	0728 00-5
Removal	0728 00-1
Push-Pull Control Assembly, Bracket, Links, and Pins	
Installation	0429 00-7
Removal	0429 00-1

INDEX, cont'd

Subject WP Sequence No.-Page No.

Q

Quick Coupling Half	
M13 Orifice	
Installation	0781 00-2
Removal	0781 00-1
M8A3/M14 Orifice Support	
Installation	0780 00-4
Removal	0780 00-1
Quick Release	
Pin and Lanyard, Steering Wheel	
Installation	0431 00-2
Removal	0431 00-1
Pins, Spall Liner	
Installation	0506 00-3
Removal	0506 00-1

R

Rack	
Radio	
M58 Only	
Installation	0891 00-3
Removal	0891 00-1
Radio Stowage	
Left Bulkhead	
Installation	0577 00-2
Removal	0577 00-1
M1064A3 Only	
Installation	0609 00-1
Removal	0609 00-1
Right Front	
Installation	0579 00-1
Removal	0579 00-1
Right Side Base	
Installation	0622 00-3
Removal	0622 00-1
Radiator	
Access Door	
Installation	0469 00-1
Removal	0469 00-1
Cleaning	0228 00-1
Installation	0229 00-4
Outlet Tube and Hoses	
Installation	0233 00-2
Removal	0233 00-1
Removal	0229 00-2
Radio Operator's Seat	
Assembly	0568 00-5
Disassembly	0568 00-3
Installation	0568 00-7
Removal	0568 00-2

INDEX, cont'd

<u>Subject</u>	<u>WP Sequence No.-Page No.</u>
Radio Rack (M58 Only)	
Installation	0891 00-3
Removal	0891 00-1
Radio Stowage Rack	
Left Bulkhead	
Installation	0577 00-2
Removal	0577 00-1
M1064A3 Only	
Installation	0609 00-1
Removal	0609 00-1
Right Front	
Installation	0579 00-1
Removal	0579 00-1
Ramp	
Bracket	
Installation	0516 00-1
Removal	0516 00-1
Control Valve	
External to Internal Relief	
Installation	0660 00-6
Removal	0660 00-1
Hose and Elbow	
Installation	0663 00-3
Removal	0663 00-1
With External Relief Valve	
Repair or Replacement	0659 00-1
With Internal Relief Valve	
Installation	0661 00-4
Removal	0661 00-1
Cylinder	
Cleaning	0656 00-2
Installation	0656 00-3
Removal	0656 00-2
Cylinder Breather Hose	
All Except M1064A3	
Installation	0666 00-3
Removal	0666 00-1
M1064A3 Only	
Installation	0667 00-3
Removal	0667 00-2
Door	
Handles and Shaft	
Adjustment	0519 00-3
Installation	0519 00-2
Removal	0519 00-1
Hook and Spring	
Installation	0518 00-2
Removal	0518 00-1

INDEX, cont'd

<u>Subject</u>	<u>WP Sequence No.-Page No.</u>
Seal	
Installation	0520 00-2
Removal	0520 00-1
Stop Bracket	
Installation	0517 00-1
Removal	0517 00-1
Switch and Mount	
Adjustment	0335 00-4
Inspection-Acceptance and Rejection Criteria	0335 00-2
Installation	0335 00-3
Removal	0335 00-1
Drain Plugs	
Installation	0515 00-1
Removal	0515 00-1
Hydraulic Pump	
Installation	0655 00-3
Removal	0655 00-2
Linkage	
M1064A3 Only	
Inspect and Repair	0528 00-3
Installation	0528 00-3
Removal	0528 00-1
M113A3 and M1059A3	
Installation	0526 00-3
Removal	0526 00-1
M577A3 and M1068A3	
Clean, Inspect, and Repair	0527 00-3
Installation	0527 00-3
Removal	0527 00-1
Lock	
M1064A3 Only	
Adjust Ramp Lock	0523 00-1
M113A3 and M1059A3	
Ramp Lock Adjustment	0521 00-2
Ramp Lock Test	0521 00-1
Ramp Seal Test	0521 00-1
M577A3 and M1068A3	
Adjust Ramp Lock	0522 00-1
Lock Handle and Arms	
Installation	0524 00-2
Removal	0524 00-1
Lock Lever and Cable	
Cleaning, Inspect, and Repair	0525 00-3
Installation	0525 00-3
Removal	0525 00-1
Lower Inoperable/Unsafe Ramp	0513 00-7
Raise Inoperable/Unsafe Ramp	0513 00-2
Schematic	0081 00-1
Seal	
Installation	0514 00-2
Removal	0514 00-1

INDEX, cont'd

<u>Subject</u>	<u>WP Sequence No.-Page No.</u>
Vision Port and Shield	
Cleaning	0586 00-2
Installation	0586 00-3
Removal	0586 00-2
Ramp Wire Rope	
Cleaning	0656 01-1
Inspection	0656 01-2
Lubrication	0656 01-7
Rear Access Panels, Power Plant	
Installation	0439 00-2
Removal	0439 00-1
Rear Compartment Air Ventilator	
Installation	0454 00-2
Removal	0454 00-1
Rear External Stowage Frame	
Installation	0626 00-2
Removal	0626 00-1
Rear Main Wiring Harness	
M1064A3 Only	
Inspect and Repair	0364 00-13
Installation	0364 00-13
Removal	0364 00-1
M1068A3 Only	
Inspect and Repair	0365 00-14
Installation	0365 00-15
Removal	0365 00-2
M113A3, M1059A3, and M58	
Inspect and Repair	0362 00-21
Installation	0362 00-21
Removal	0362 00-2
M577A3 Only	
Inspect and Repair	0363 00-15
Installation	0363 00-15
Removal	0363 00-2
Rear Tiedown Plates	
Installation	0445 00-2
Removal	0445 00-1
Receptacle	
Auxiliary Power (Slave)	
Ground Lead	
Installation	0379 00-3
Removal	0379 00-1

INDEX, cont'd

<u>Subject</u>	<u>WP Sequence No.-Page No.</u>
M113A3, M1059A3, M1064A3, and M58	
Installation	0263 00-2
Removal	0263 00-1
M577A3 and M1068A3	
Installation	0264 00-3
Removal	0264 00-2
Rear Utility Circuit Breakers	
Inspection-Acceptance and Rejection Criteria	0276 00-2
Installation	0276 00-3
Removal	0276 00-1
Rear Utility Outlet	
Inspect and Repair	0378 00-2
Installation	0378 00-2
Removal	0378 00-1
Utility Outlet	
Inspection-Acceptance and Rejection Criteria	0265 00-2
Installation	0265 00-2
Removal	0265 00-1
Reel Holder Assembly, Cable	
Assembly	0604 00-2
Disassembly	0604 00-1
Installation	0603 00-2
Removal	0603 00-1
References	
Forms	0924 00-4
Lubrication Orders	0924 00-4
Other Publications	0924 00-4
Technical Manuals	0924 00-1
Regulator Assembly	
Inspection-Acceptance and Rejection Criteria	0257 00-2
Installation	0257 00-3
Removal	0257 00-1
Regulator, Voltage	
Adjustment	0256 00-1
Remote Cable Assembly (Outback Only)	
Installation	0847 01-8
Removal	0847 01-1
Repair Parts, Special Tools, TMDE, and Support Equipment	
Common Tools and Equipment	0004 00-1
Repair Parts	0004 00-1
Special Tools, TMDE, and Support Equipment	0004 00-1

INDEX, cont'd

<u>Subject</u>	<u>WP Sequence No.-Page No.</u>
Restriction Indicator	
Hose	
Installation	0172 00-3
Removal	0172 00-1
Installation	0171 00-2
Removal	0171 00-1
Retainer	
Air Cleaner	
Installation	0170 00-2
Removal	0170 00-1
Batteries	
M1064A3 Only	
Clean and Inspect	0349 00-2
Installation	0349 00-3
Removal	0349 00-1
M113A3 and M1059A3	
Clean and Inspect	0346 00-3
Installation	0346 00-4
Removal	0346 00-1
M577A3 and M1068A3	
Clean and Inspect	0347 00-3
Installation	0347 00-3
Removal	0347 00-1
Rifle Brackets	
Installation	0573 00-2
Removal	0573 00-1
Rifle Rack	
Installation	0612 00-2
Removal	0612 00-1
Right Equipment Rack, Brackets and Mounts	
Installation	0814 00-2
Removal	0814 00-1
Road Wheel	
Hub	
Cleaning	0416 00-2
Installation	0416 00-3
Removal	0416 00-2
Support Arm, Bearings, and Seals	
Installation	0415 00-4
Removal	0415 00-2
T130 Track	
Inspection and Repair	0426 00-2
Installation	0426 00-3
Removal	0426 00-1
T150 Track	
Inspection	0426 01-1
Installation	0426 01-3
Removal	0426 01-1

INDEX, cont'd

<u>Subject</u>	<u>WP Sequence No.-Page No.</u>
Roadside Data Panel A13	
Installation	0835 00-2
Removal	0835 00-1
S	
Safety Pin Stowage Block, Commander's Cupola	
Installation	0495 00-1
Removal	0495 00-1
Safety Relief Valve	
Tube, Hose, and Fittings	
Repair or Replacement	0662 00-1
Sampling Valve, Transmission Oil	
Installation	0400 00-2
Removal	0400 00-1
Schematic	
Bilge Pump	0078 00-1
Coolant Heater	0087 00-1
Electrical	0027 00-1
Engine Air Box Heater	0013 00-1
Engine Charging System	0007 00-1
Engine Fuel System	
All Except M577A3 and M1068A3	0009 00-1
M577A3 and M1068A3	0010 00-1
Engine Starter Circuit	0011 00-1
Indicators	0046 00-1
MSD/ICE	0136 00-1
Personnel Heater	0085 00-1
Ramp	0081 00-1
Steering Lock	
Cable-Activated Lock	0075 00-1
Solenoid-Activated Lock	0074 00-1
Transmission System	0060 00-1
Seal	
Cargo Hatch	
Installation	0478 00-1
Removal	0478 00-1
Idle Wheel Arm	
Cleaning	0418 00-2
Installation	0418 00-2
Removal	0418 00-1
Oil, Final Drive Differential	
Installation	0404 00-2
Removal	0404 00-1
Ramp	
Installation	0514 00-2
Removal	0514 00-1

INDEX, cont'd

<u>Subject</u>	<u>WP Sequence No.-Page No.</u>
Ramp Door	
Installation	0520 00-2
Removal	0520 00-1
Road Wheel Support	
Installation	0415 00-4
Removal	0415 00-2
Seat	
Commander's	
M1064A3 Only	
Installation	0561 00-2
Removal	0561 00-1
M1068A3 Only	
Assembly	0566 00-3
Disassembly	0566 00-2
Installation	0566 00-6
Removal	0566 00-1
M113A3, M1059A3, and M58	
Installation	0560 00-3
Removal	0560 00-1
M113A3, M1059A3, M1064A3, and M58	
Assembly	0562 00-4
Cleaning	0562 00-4
Disassembly	0562 00-1
Commander's Jump	
Installation	0563 00-3
Removal	0563 00-1
Driver's	
Assembly	0552 00-2
Back Assembly	
Assembly	0554 00-1
Disassembly	0554 00-1
Installation	0553 00-2
Removal	0553 00-1
Disassembly	0552 00-1
Impact Absorber	
Installation	0555 00-1
Removal	0555 00-1
Installation	0551 00-2
Removal	0551 00-1
Personnel	
M1059A3 Only	
Installation	0549 00-3
Removal	0549 00-1
M1064A3 Only	
Installation	0550 00-3
Removal	0550 00-1
M113A3 Only	
Installation	0546 00-2
Removal	0546 00-1

INDEX, cont'd

<u>Subject</u>	<u>WP Sequence No.-Page No.</u>
M577A3 Only	
Installation	0547 00-3
Removal	0547 00-1
Radio Operator's	
Assembly	0568 00-5
Disassembly	0568 00-3
Installation	0568 00-7
Removal	0568 00-2
Sensors and Switches	
Variable Speed Drive	
Installation	0321 01-2
Removal	0321 01-1
Service Brake	
Control Linkage	
Adjustment	0407 00-1
Installation	0410 00-7
Removal	0410 00-2
Pedal, Upper and Lower	
Installation	0409 00-6
Removal	0409 00-1
■ Service Headlight	
Assembly	0304 00-3
Disassembly	0304 00-2
Inspection	0304 00-1
Installation	0303 00-2
Removal	0303 00-1
Service Upon Receipt	0154 00-1
Shaft, Fuel Control	
Installation	0217 00-4
Removal	0217 00-1
Shelf Assembly	
Alternate Right Side	
Installation	0621 01-3
Removal	0621 01-2
Right Side	
Installation	0621 00-3
Removal	0621 00-1
Shield	
Armor, Commander's Cupola	
Installation	0747 00-3
Removal	0747 00-1
External Handle	
M1064A3 Only	
Inspection-Acceptance and Rejection Criteria	0903 00-3
Installation	0903 00-3
Removal	0903 00-1

INDEX, cont'd

<u>Subject</u>	<u>WP Sequence No.-Page No.</u>
M113A3 and M1059A3	
Installation	0901 00-2
Removal	0901 00-1
M577A3 and M1068A3	
Installation	0902 00-1
Removal	0902 00-1
Ramp Vision Port	
Cleaning	0586 00-2
Installation	0586 00-3
Removal	0586 00-2
Shock Absorber	
Installation	0435 00-4
Mount	
Installation	0436 00-2
Removal	0436 00-1
Pin	
Installation	0437 00-2
Removal	0437 00-1
Removal	0435 00-1
Signal Patch Panel Box A10	
Installation	0816 00-2
Removal	0816 00-1
Sling, Power Plant	
Periodic Check	0673 00-2
Preoperative Check	0673 00-8
Smoke Generator	
Adapter Access Plate and Gasket	
Installation	0766 00-3
Removal	0766 00-1
Adapter Access Plate to Cover Assembly Air Hose	
Installation	0768 00-2
Removal	0768 00-1
Armor	
Installation	0771 00-2
Removal	0771 00-1
Breather Hose Assembly	
Installation	0754 00-3
Removal	0754 00-1
Compressor Reservoir to Access Plate Air Hose	
Installation	0767 00-3
Removal	0767 00-1
Control Panel Assembly	
Installation	0756 00-2
Removal	0756 00-1
Electrical Cable Assembly, Adapter Access Plate to Generator	
Installation	0761 00-3
Removal	0761 00-1

INDEX, cont'd

<u>Subject</u>	<u>WP Sequence No.-Page No.</u>
Fuel Can Lid Assembly	
Installation	0764 00-2
Removal	0764 00-1
Fuel Filter/Water Separator	
Installation	0773 00-3
Removal	0773 00-1
Repair or Replacement	0773 00-2
Fuel Lines and Guards	
Installation	0765 00-4
Removal	0765 00-1
Glow Plug Cable Assembly	
Installation	0772 00-4
Removal	0772 00-2
Installation	0755 00-3
Internal Cable Assembly	
Installation	0760 00-3
Removal	0760 00-1
Power Supply Cable Assembly	
Installation	0757 00-2
Removal	0757 00-1
Removal	0755 00-1
Smoke Grenade Launcher	
Guard, Plate, and Base	
Installation	0455 00-3
Removal	0455 00-1
Wiring Harness	
Inspect and Repair	0366 00-7
Installation	0366 00-8
Removal	0366 00-1
Spall Liner	
Cargo Hatch Cover	
Installation	0509 00-2
Removal	0509 00-1
Forward and Bracket	
Installation	0507 00-3
Removal	0507 00-1
Forward Upper Right and Left Side	
Installation	0508 00-2
Removal	0508 00-1
Left Side	
Installation	0505 00-4
Removal	0505 00-1
On Ramp	
Installation	0512 00-2
Removal	0512 00-1
On Ramp Door	
Installation	0511 00-2
Removal	0511 00-1
Rear Upper Hull	
Installation	0510 00-2
Removal	0510 00-1

INDEX, cont'd

<u>Subject</u>	<u>WP Sequence No.-Page No.</u>
Right Side	
Installation	0504 00-4
Removal	0504 00-1
Spare Battery Bracket, Chemical Alarm	
Installation	0921 00-3
Removal	0921 00-1
Repair or Replacement	0921 00-2
Speedometer	
Cable	
Assembly	0861 00-2
Disassembly	0861 00-1
Inspection	0861 00-1
Cable and Adapter	
Installation	0860 00-4
Removal	0860 00-2
Flexible Cable Core	
Installation	0858 00-5
Removal	0858 00-1
Installation	0859 00-2
Removal	0859 00-1
Spring Tensioner	
Idler Arm	
Installation	0246 00-2
Removal	0246 00-1
Starter	
Installation	0259 00-2
Relay Switch	
Installation	0258 00-5
Removal	0258 00-2
Removal	0259 00-1
Steering Lock	
Schematic	
Cable-Activated Lock	0075 00-1
Solenoid-Activated Lock	0074 00-1
Solenoid, Bracket, Links, and Pins (Solenoid-Activated Lock)	
Adjustment	0428 00-7
Installation	0428 00-5
Removal	0428 00-1
Switch	
Installation	0330 00-3
Removal	0330 00-2
Switch Wiring Harness	
All Except M58	
Inspect and Repair	0367 00-5
Installation	0367 00-6
Removal	0367 00-2

INDEX, cont'd

<u>Subject</u>	<u>WP Sequence No.-Page No.</u>
M58 Only	
Inspect and Repair	0367 01-2
Installation	0367 01-2
Removal	0367 01-1
Steering Support, Brackets, and Shaft	
Installation	0432 00-5
Removal	0432 00-1
Steering Wheel	
Linkage	
Adjustment	0427 00-1
Installation	0430 00-6
Removal	0430 00-1
Steering, Transmission	
Adjustment	0393 00-3
Check Adjustment	0393 00-1
Stencils	
M1059A3	0640 00-1
M1064A3	0641 00-1
M1068A3 Only	0642 00-1
M113A3	0636 00-1
M577A3	0637 00-1
M58	0643 00-1
Stop Switch	
Clean and Inspect	0332 00-1
Installation	0332 00-2
Removal	0332 00-1
Stoplight-Taillight and Guards	
Installation	0298 00-4
Removal	0298 00-1
Storage Box Assembly, Power Supply	
Assembly	0824 00-5
Disassembly	0824 00-3
Installation	0824 00-7
Removal	0824 00-2
Stowage Box	
Grenade	
Installation	0610 00-1
Removal	0610 00-1
Periscope	
Installation	0611 00-2
Removal	0611 00-1

INDEX, cont'd

<u>Subject</u>	<u>WP Sequence No.-Page No.</u>
Stowage Bracket	
AN/VAS-5 Driver's Vision Enhancer	
Installation	0866 03-3
Removal	0866 03-1
Sight Extension Arm	
Installation	0613 00-1
Removal	0613 00-1
W1, W2, and NATO Slave Cables	
Installation	0626 01-2
Removal	0626 01-1
Stowage Frame, Rear External	
Installation	0626 00-2
Removal	0626 00-1
Stowage Rack	
Radio	
Left Bulkhead	
Installation	0577 00-2
Removal	0577 00-1
M1064A3 Only	
Installation	0609 00-1
Removal	0609 00-1
Right Front	
Installation	0579 00-1
Removal	0579 00-1
Strainer	
Front Bilge Pump	
Installation	0632 00-3
Removal	0632 00-1
Rear Bilge Pump	
Installation	0635 00-3
Removal	0635 00-1
Strainer Parts, Filler Cap	
All Except M577A3 and M1068A3	
Installation	0184 00-3
Removal	0184 00-2
M577A3 and M1068A3	
Installation	0185 00-2
Removal	0185 00-1
Straps, Webbing	
Installation	0569 00-1
Removal	0569 00-1
Support Arm, Power Plant Grill	
Installation	0467 00-2
Removal	0467 00-1

INDEX, cont'd

<u>Subject</u>	<u>WP Sequence No.-Page No.</u>
Support, Antenna	
Installation	0602 00-2
Removal	0602 00-2
Switch	
Blower	
Installation	0278 00-3
Removal	0278 00-1
Differential Pressure, Fuel Filter	
Installation	0328 00-5
Removal	0328 00-1
Dome Blackout Light Bypass	
Installation	0317 00-2
Removal	0317 00-1
Dome Light	
Front	
Installation	0314 00-3
Removal	0314 00-1
Rear	
Installation	0315 00-2
Removal	0315 00-1
Engine Start	
Installation	0284 00-2
Removal	0284 00-1
Flame Detector, Coolant Heater	
Adjustment	0727 00-1
Inspection-Acceptance and Rejection Criteria	0734 00-1
Installation	0734 00-2
Removal	0734 00-1
Fuel Selector	
Installation	0277 00-3
Removal	0277 00-1
Generator Field Pressure	
Inspection-Acceptance and Rejection Criteria	0323 00-1
Installation	0323 00-2
Removal	0323 00-1
Headlight, High Beam Selector	
Installation	0333 00-2
Removal	0333 00-1
Horn	
All Except M58	
Installation	0293 00-2
Removal	0293 00-1
M58 Only	
Installation	0293 01-2
Removal	0293 01-1
Main Light	
Installation	0283 00-2
Removal	0283 00-1
NBC Orifice Connector Assembly	
Installation	0916 00-5
Removal	0916 00-1

INDEX, cont'd

<u>Subject</u>	<u>WP Sequence No.-Page No.</u>
Parking Brake	
Clean and Inspect	0331 00-3
Installation	0331 00-3
Removal	0331 00-1
Starter Relay	
Installation	0258 00-5
Removal	0258 00-2
Steering Lock	
Installation	0330 00-3
Removal	0330 00-2
Stop	
Clean and Inspect	0332 00-1
Installation	0332 00-2
Removal	0332 00-1
Transmission Oil High Temperature	
Installation	0322 00-2
Removal	0322 00-1
Transmission Range Controller	
Cleaning	0389 00-1
Installation	0389 00-2
Removal	0389 00-1
Switch and Buzzer, Admittance	
Inspection-Acceptance and Rejection Criteria	0334 00-2
Installation	0334 00-2
Removal	0334 00-1
Switch and Mount, Ramp Door	
Adjustment	0335 00-4
Inspection-Acceptance and Rejection Criteria	0335 00-2
Installation	0335 00-3
Removal	0335 00-1
Switch Assembly, NBC Filter	
Installation	0802 00-3
Removal	0802 00-1
T	
Table	
Left	
Installation	0578 00-3
Removal	0578 00-1
Right Forward	
Installation	0581 00-3
Removal	0581 00-1
Right Rearward	
Installation	0582 00-1
Removal	0582 00-1

INDEX, cont'd

<u>Subject</u>	<u>WP Sequence No.-Page No.</u>
Tachometer	
Cable	
Assembly	0865 00-2
Disassembly	0865 00-1
Inspection	0865 00-1
Installation	0864 00-4
Removal	0864 00-2
Engine Adapter	
Installation	0863 00-3
Removal	0863 00-1
Flexible Cable Core	
Installation	0858 00-5
Removal	0858 00-1
Installation	0862 00-2
MSD/ICE Pulse	
Installation	0867 00-3
Removal	0867 00-1
Removal	0862 00-1
Tank	
Auxiliary	
Installation	0230 00-2
Removal	0230 00-1
Module, Fog Oil	
Installation	0753 00-4
Removal	0753 00-1
Teleposts and Cover	
Installation	0296 00-3
Removal	0296 00-1
Tent	
Frame Mounts	
Installation	0628 00-3
Removal	0628 00-1
Installation	0627 00-2
Interface Panel Box Assembly A5	
Installation	0833 00-3
Removal	0833 00-1
Light Assembly	
Installation	0318 00-3
Removal	0318 00-1
Removal	0627 00-1
Terminal Blocks TB1 and TB2, Inverter Housing A2	
Installation	0830 00-4
Removal	0830 00-1
Terminals and Leads, Battery	
M1064A3 Only (Left Side)	
Cleaning	0343 00-5
Installation	0343 00-5
Removal	0343 00-1

INDEX, cont'd

<u>Subject</u>	<u>WP Sequence No.-Page No.</u>
M1064A3 Only (Right Side)	
Cleaning	0344 00-3
Installation	0344 00-4
Removal	0344 00-1
M113A3 and M1059A3	
Clean and Inspect	0340 00-3
Installation	0340 00-4
Removal	0340 00-1
M577A3 and M1068A3	
Clean and Inspect	0341 00-3
Installation	0341 00-4
Removal	0341 00-1
M58 Only	
Cleaning	0345 00-3
Installation	0345 00-4
Removal	0345 00-1
Theory of Operation	
Auxiliary Automotive System	0003 00-2
Power Plant	0003 00-1
Scope	0003 00-1
Special Equipment	0003 00-3
Winterization Equipment	0003 00-3
Thermostat	
Installation	0237 00-4
Removal	0237 00-1
Tube/Hoses	
Installation	0238 00-2
Removal	0238 00-1
Thermostatic Fan Speed Switch	
Installation	0231 00-3
Removal	0231 00-1
Throttle Valve (TV)	
Modulator	
Adjustment	0213 00-1
Field Operational Test	0213 00-5
Modulator and Lever	
Installation	0218 00-4
Removal	0218 00-1
Tool Box Loops	
Installation	0571 00-2
Removal	0571 00-1
Torsion Bar	
Anchor	
Installation	0414 00-3
Removal	0414 00-1
Installation	0413 00-4
Removal	0413 00-1

INDEX, cont'd

<u>Subject</u>	<u>WP Sequence No.-Page No.</u>
Tow Pintle	
Assembly	0434 00-2
Disassembly	0434 00-1
Extender Assembly	
Adjustment	0811 02-6
Assembly	0811 02-4
Disassembly	0811 02-3
Installation	0811 02-5
Removal	0811 02-1
Stow	0811 02-6
Extender Kit	
Adjustment	0811 01-3
Installation	0811 01-1
Stow	0811 01-3
Installation	0433 00-2
Removal	0433 00-1
Tow Start Control	
Assembly and Bearing	
Installation	0391 00-5
Removal	0391 00-2
Cable Assembly	
Adjustment	0390 00-1
Cover	
Installation	0392 00-2
Removal	0392 00-1
Towing Hook and Eye	
Installation	0443 00-2
Removal	0443 00-1
Track	
Cover	
Installation	0438 00-2
Removal	0438 00-1
T130	
Clean, Inspect, and Repair	0422 00-2
Drive Sprocket Wheel Assembly	
Assembly	0421 00-1
Disassembly	0421 00-1
Installation	0420 00-2
Removal	0420 00-1
Installation	0422 00-3
Removal	0422 00-1
T150	
Drive Sprocket Wheel Assembly	
Installation	0420 01-2
Removal	0420 01-1
Installation	0422 01-2
Removal	0422 01-1
Reverse Drive Sprocket and Track Assemblies	
Installation	0419 01-2
Removal	0419 01-1

INDEX, cont'd

<u>Subject</u>	<u>WP Sequence No.-Page No.</u>
Tension Adjuster and Mount	
Installation	0419 00-2
Removal	0419 00-1
Track Shoe	
Pad	
T130	
Installation	0424 00-2
Removal	0424 00-1
T150	
Installation	0424 01-2
Removal	0424 01-1
Stowage Bracket	
Installation	0575 01-2
Removal	0575 01-1
T130	
Repair or Replacement	0423 00-1
T150	
Installation	0423 01-2
Removal	0423 01-1
Trailer Harness	
Inspection-Acceptance and Rejection Criteria	0375 00-2
Installation	0375 00-3
Removal	0375 00-1
Transducer	
Air Box Pressure	
Installation	0327 00-2
Removal	0327 00-1
Fuel Return Pressure	
Installation	0325 00-2
Removal	0325 00-1
Fuel Supply Pressure	
Installation	0324 00-2
Removal	0324 00-1
Turbo Outlet Pressure	
Installation	0326 00-2
Removal	0326 00-1
Transmission	
Brake	
Adjust Left-Hand Brake	0394 00-1
Adjust Right-Hand Brake	0394 00-5
Check Brake Adjustment	0406 00-1
Controller Wiring Harness	
Inspect and Repair	0361 00-4
Installation	0361 00-5
Removal	0361 00-1

INDEX, cont'd

<u>Subject</u>	<u>WP Sequence No.-Page No.</u>
Mounts	
Installation	0385 00-3
Removal	0385 00-1
Oil and Filter Element	
Installation	0398 00-3
Removal	0398 00-1
Oil Cooler Hoses, Fittings, and Mounting	
Installation	0399 00-8
Removal	0399 00-1
Oil Drain Tubes and Bracket	
Installation	0384 00-2
Removal	0384 00-1
Oil High Temperature Switch	
Installation	0322 00-2
Removal	0322 00-1
Oil Level Dipstick, Filler Tube, and Adapter	
X200-4 Only	
Installation	0395 00-3
Removal	0395 00-1
X200-4A Only	
Installation	0396 00-4
Removal	0396 00-1
Oil Sampling Valve and Pressure Switch	
Installation	0400 00-2
Removal	0400 00-1
Oil Supply and Return Hoses	
Installation	0251 00-5
Removal	0251 00-1
Range Controller Lamp	
Installation	0388 00-2
Removal	0388 00-1
Range Controller Switch	
Cleaning	0389 00-1
Installation	0389 00-2
Removal	0389 00-1
Range Controller/Bracket	
Cable-Activated Steering Lock	
Installation	0387 00-3
Removal	0387 00-1
Solenoid-Activated Steering Lock	
Installation	0386 00-3
Removal	0386 00-1
Schematic	0060 00-1
Steering	
Adjustment	0393 00-3
Check Adjustment	0393 00-1
Wiring Harness	
Inspect and Repair	0360 00-2
Installation	0360 00-2
Removal	0360 00-1

INDEX, cont'd

<u>Subject</u>	<u>WP Sequence No.-Page No.</u>
Transmitter	
Coolant Temperature	
Installation	0321 00-2
Removal	0321 00-1
Fuel Quantity	
All Except M577A3 and M1068A3	
Inspection-Acceptance and Rejection Criteria	0190 00-2
Installation	0190 00-3
Removal	0190 00-1
Repair or Replacement	0190 00-2
M577A3 and M1068A3	
Cleaning	0191 00-1
Installation	0191 00-1
Removal	0191 00-1
Troubleshooting	
Introduction How to Use Troubleshooting	0005 00-1
Malfunction/Symptom Index WP	0006 00-1
Tube	
Cylinder Discharge	
Installation	0899 00-4
Removal	0899 00-2
Fuel Return	
M1064A3 Only	
Installation	0197 00-9
Removal	0197 00-1
M113A3, M1059A3, and M58	
Installation	0195 00-8
Removal	0195 00-2
M577A3 and M1068A3	
Installation	0196 00-4
Removal	0196 00-1
Fuel Vent	
Installation	0198 00-4
Removal	0198 00-1
Personnel Heater	
Installation	0700 00-3
Removal	0700 00-2
Ramp Control Valve to Bulkhead	
Installation	0664 00-3
Removal	0664 00-1
Transmission Oil Drain	
Installation	0384 00-2
Removal	0384 00-1
Turbine Cylinder Discharge	
Installation	0900 00-3
Removal	0900 00-1

INDEX, cont'd

<u>Subject</u>	<u>WP Sequence No.-Page No.</u>
Turbine	
Access Door	
Installation	0485 00-2
Removal	0485 00-2
Access Door Hinges	
Installation	0487 00-3
Removal	0487 00-2
Turbo Outlet Pressure Transducer	
Installation	0326 00-2
Removal	0326 00-1
U	
Universal Joints	
Installation	0405 00-3
Removal	0405 00-1
Utility Outlet	
Lead Assembly	
Inspect and Repair	0377 00-2
Installation	0377 00-2
Removal	0377 00-1
Rear Receptacle	
Inspect and Repair	0378 00-2
Installation	0378 00-2
Removal	0378 00-1
Receptacle	
Inspection-Acceptance and Rejection Criteria	0265 00-2
Installation	0265 00-2
Removal	0265 00-1
V	
Valve	
Front Bilge	
Installation	0633 00-2
Removal	0633 00-1
Fuel Shutoff, Coolant Heater	
Installation	0720 00-3
Removal	0720 00-1
Fuel Shutoff, Personnel Heater	
Installation	0684 00-3
Removal	0684 00-2
Variable Speed Fan Drive	
Adjustment	0249 01-3
Controller	
Installation	0250 01-1
Removal	0250 01-1

INDEX, cont'd

<u>Subject</u>	<u>WP Sequence No.-Page No.</u>
Fan and Generator	
Installation	0249 00-3
Removal	0249 00-2
Installation	0249 01-3
Removal	0249 01-2
Sensors and Switches	
Installation	0321 01-2
Removal	0321 01-1
Valve and Override Switch	
Installation	0231 01-3
Removal	0231 01-2
Ventilating Fan	
Drive Belt	
Adjustment	0242 00-1
Installation	0243 00-2
Removal	0243 00-1
Drive Pulley	
Installation	0244 00-1
Removal	0244 00-1
Installation	0383 00-3
Removal	0383 00-1
Ventilating Fan Assembly	
Installation	0247 00-3
Removal	0247 00-2
Vertical Ammunition Rack	
Installation	0608 00-3
Removal	0608 00-1
Vision Block Locks and Seals	
Commander's Cupola	
M1064A3 Only	
Installation	0491 00-3
Removal	0491 00-1
M113A3, M1059A3, and M58	
Installation	0490 00-3
Removal	0490 00-1
Driver's Hatch	
Clean, Inspect, and Repair	0535 00-3
Installation	0535 00-3
Removal	0535 00-1
Voltage Regulator	
Adjustment	0256 00-1

INDEX, cont'd

<u>Subject</u>	<u>WP Sequence No.-Page No.</u>
W	
Warning Light Panel	
Instrument	
All Except M58	
Installation	0292 00-2
Removal	0292 00-1
M58 Only	
Installation	0288 00-2
Removal	0288 00-1
Warning Light Panel Assembly	
Installation	0291 00-2
Removal	0291 00-1
Warning Panel Lights	
All Except M58	
Installation	0294 00-3
Removal	0294 00-1
M58 Only	
Inspection-Acceptance and Rejection Criteria	0294 01-2
Installation	0294 01-3
Removal	0294 01-2
Water/Ration Heater	
Mount Bracket	
Installation	0811 00-2
Removal	0811 00-1
Power Cable	
Installation	0810 00-3
Removal	0810 00-1
Webbing Straps	
Installation	0569 00-1
Removal	0569 00-1
Welding, Hull Repair	
Aluminum Castings	0529 00-1
Fuel Tanks	0529 00-3
General Welding Instructions	0529 00-4
Magnesium Castings	0529 00-2
MIG Welding Method	0529 00-5
Plastic Molding Material	0529 00-3
Safety Precautions	0529 00-1
Welding Near Mortar Ring (M1064A3 Only)	0529 00-4
Windshield	
Driver's	
Installation	0739 00-2
Removal	0739 00-1
Stowage Bag, Straps, and Decal	
Installation	0740 00-2
Removal	0740 00-1
Repair or Replacement	0740 00-2

INDEX, cont'd

<u>Subject</u>	<u>WP Sequence No.-Page No.</u>
Stowage Bracket	
Installation	0614 00-2
Removal	0614 00-1
Wire Rope and Pulleys	
All Except M1064A3	
Installation	0657 00-2
Removal	0657 00-1
M1064A3 Only	
Installation	0658 00-2
Removal	0658 00-1
Wiring Harness	
3W1, Variable Speed Drive	
Installation	0359 01-3
Removal	0359 01-1
Assembly	0382 00-4
Battery-to-Radio (Left Side)	
Inspect and Repair	0369 00-4
Installation	0369 00-5
Removal	0369 00-2
Battery-to-Radio (Right Side)	
Inspect and Repair	0370 00-5
Installation	0370 00-6
Removal	0370 00-2
Chemical Alarm M43 Unit Interface	
Inspection-Acceptance and Rejection Criteria	0923 00-4
Installation	0923 00-4
Removal	0923 00-1
Repair or Replacement	0923 00-4
Coolant Heater	
Installation	0735 00-6
Removal	0735 00-2
Coolant Pump to Heater	
Inspection-Acceptance and Rejection Criteria	0733 00-3
Installation	0733 00-4
Removal	0733 00-2
Disassembly	0382 00-1
Engine	
Clean, Inspect, and Repair	0359 00-8
Installation	0359 00-8
Removal	0359 00-2
Guide, Personnel Heater	
Installation	0707 01-3
Removal	0707 01-1
Instrument Panel Battery-Generator Gauge	
Installation	0289 00-4
Removal	0289 00-2
M13 NBC Heater	
M1068A3 Only	
Installation	0809 00-6
Removal	0809 00-2

INDEX, cont'd

<u>Subject</u>	<u>WP Sequence No.-Page No.</u>
M577A3 Only	
Installation	0808 00-4
Removal	0808 00-2
M14 NBC Heater	
Installation	0807 00-4
Removal	0807 00-1
M3 NBC Heater	
Installation	0806 00-3
Removal	0806 00-1
MSD/ICE Crew	
M1064A3 Only	
Inspection-Acceptance and Rejection Criteria	0881 00-4
Installation	0881 00-4
Removal	0881 00-1
Repair or Replacement	0881 00-4
M113A3 and M1059A3	
Inspection-Acceptance and Rejection Criteria	0878 00-4
Installation	0878 00-4
Removal	0878 00-1
Repair or Replacement	0878 00-4
M577A3 and M1068A3	
Inspection-Acceptance and Rejection Criteria	0879 00-4
Installation	0879 00-5
Removal	0879 00-1
Repair or Replacement	0879 00-5
MSD/ICE Engine	
Inspection-Acceptance and Rejection Criteria	0882 00-4
Installation	0882 00-5
Removal	0882 00-1
Repair or Replacement	0882 00-5
Radiac	
Installation	0376 00-2
Removal	0376 00-1
Rear Main	
M1064A3 Only	
Inspect and Repair	0364 00-13
Installation	0364 00-13
Removal	0364 00-1
M1068A3 Only	
Inspect and Repair	0365 00-14
Installation	0365 00-15
Removal	0365 00-2
M113A3, M1059A3, and M58	
Inspect and Repair	0362 00-21
Installation	0362 00-21
Removal	0362 00-2
M577A3 Only	
Inspect and Repair	0363 00-15
Installation	0363 00-15
Removal	0363 00-2

INDEX, cont'd

<u>Subject</u>	<u>WP Sequence No.-Page No.</u>
Right Headlight	
Inspect and Repair	0373 00-3
Installation	0373 00-3
Removal	0373 00-1
Smoke Grenade Launcher	
Inspect and Repair	0366 00-7
Installation	0366 00-8
Removal	0366 00-1
Steering Lock Switch	
All Except M58	
Inspect and Repair	0367 00-5
Installation	0367 00-6
Removal	0367 00-2
M58 Only	
Inspect and Repair	0367 01-2
Installation	0367 01-2
Removal	0367 01-1
Trailer	
Inspection-Acceptance and Rejection Criteria	0375 00-2
Installation	0375 00-3
Removal	0375 00-1
Transmission	
Inspect and Repair	0360 00-2
Installation	0360 00-2
Removal	0360 00-1
Transmission Controller	
Inspect and Repair	0361 00-4
Installation	0361 00-5
Removal	0361 00-1
Warning Panel	
Inspect and Repair	0374 00-3
Installation	0374 00-4
Removal	0374 00-1

RECOMMENDED CHANGES TO PUBLICATIONS AND BLANK FORMS For use of this form, see AR 25-30; the proponent agency is ODISC4.						Use Part II (reverse) for Repair Parts and Special Tool Lists (RPSTL) and Supply Catalogs/Supply Manuals (SC/SM).	DATE Date you filled out this form.
TO: (Forward to proponent of publication or form) (Include ZIP Code) U.S. Army TACOM Life Cycle Management Command ATTN: AMSTA-LC-LMP/TECH PUBS 1 Rock Island Arsenal, Rock Island, IL 61299-7630						FROM: (Activity and location) (Include ZIP Code) Your mailing address	
PART I – ALL PUBLICATIONS (EXCEPT RPSTL AND SC/SM) AND BLANK FORMS							
PUBLICATION/FORM NUMBER TM 9-2350-277-20-2						DATE 02 Jan 01	Title Unit Maintenance Manual for M113A3 FOV
ITEM NO.	PAGE NO.	PARA-GRAPH	LINE NO. *	FIGURE NO.	TABLE NO.	RECOMMENDED CHANGES AND REASON (Provide exact wording of recommended changes, if possible).	
	0014 00-2					STEP b. The screws (4) on Bracket (2) must be Torqued. Please add Torque information.	
	0023 00-34			5 (SH15)		There are four clamps (144) on Wiring Harness (217), Not three as shown. Please correct.	
SAMPLE							
<i>*Reference to line numbers within the paragraph or subparagraph.</i>							
TYPED NAME, GRADE OR TITLE Your Name				TELEPHONE EXCHANGE/AUTOVON, PLUS EXTENSION		Signature Your Signature	

TO: (Forward direct to addressee listed in publication) U. S. Army TACOM Life Cycle Management Command ATTN: AMSTA-LC-LMPP/TECH PUBS 1 Rock Island Arsenal, Rock Island, IL 61299-7630	FROM: (Activity and location) (Include ZIP Code) Your address	DATE Date you filled out this form
--	---	--

PART II – REPAIR PARTS AND SPECIAL TOOL LISTS AND SUPPLY CATALOGS/SUPPLY MANUALS

PUBLICATION NUMBER TM 9-2350-277-20-2	DATE 02 Jan 01	TITLE Unit Maintenance Manual for M113A3 FOV
--	-------------------	---

PAGE NO.	COLM NO.	LINE NO.	NATIONAL STOCK NUMBER	REFERENCE NO.	FIGURE NO.	ITEM NO.	TOTAL NO. OF MAJOR ITEMS SUPPORTED	RECOMMENDED ACTION
<h1>SAMPLE</h1>								

PART III – REMARKS (Any general remarks or recommendations, or suggestions for improvement of publications and blank forms. Additional blank sheets may be used if more space is needed.)

TYPED NAME, GRADE OR TITLE Your Name	TELEPHONE EXCHANGE/AUTOVON, PLUS EXTENSION	SIGNATURE Your Signature
---	--	-----------------------------

TO: (Forward direct to addressee listed in publication) U. S. Army TACOM Life Cycle Management Command ATTN: AMSTA-LC-LMPP/TECH PUBS 1 Rock Island Arsenal, Rock Island, IL 61299-7630	FROM: (Activity and location) (Include ZIP Code)	DATE
--	---	-------------

PART II – REPAIR PARTS AND SPECIAL TOOL LISTS AND SUPPLY CATALOGS/SUPPLY MANUALS

PUBLICATION NUMBER TM 9-2350-277-20-2			DATE 02 Jan 01			TITLE Unit Maintenance Manual for M113A3 FOV		
PAGE NO.	COLM NO.	LINE NO.	NATIONAL STOCK NUMBER	REFERENCE NO.	FIGURE NO.	ITEM NO.	TOTAL NO. OF MAJOR ITEMS SUPPORTED	RECOMMENDED ACTION

PART III – REMARKS (Any general remarks or recommendations, or suggestions for improvement of publications and blank forms. Additional blank sheets may be used if more space is needed.)

TYPED NAME, GRADE OR TITLE	TELEPHONE EXCHANGE/AUTOVON, PLUS EXTENSION	SIGNATURE
----------------------------	--	-----------

RECOMMENDED CHANGES TO PUBLICATIONS AND BLANK FORMS						Use Part II (reverse) for Repair Parts and Special Tool Lists (RPSTL) and Supply Catalogs/Supply Manuals (SC/SM).	DATE
For use of this form, see AR 25-30; the proponent agency is ODISC4.							
TO: (Forward to proponent of publication or form) (Include ZIP Code) U. S. Army TACOM Life Cycle Management Command ATTN: AMSTA-LC-LMPP/TECH PUBS 1 Rock Island Arsenal, Rock Island, IL 61299-7630				FROM: (Activity and location) (Include ZIP Code)			
PUBLICATION/FORM NUMBER TM 9-2350-277-20-3						DATE 02 Jan 01	TITLE Unit Maintenance Manual for M112A3 FOV
ITEM NO.	PAGE NO.	PARA-GRAPH	LINE NO. *	FIGURE NO.	TABLE NO.	RECOMMENDED CHANGES AND REASON (Provide exact wording of recommended changes, if possible).	
<i>*Reference to line numbers within the paragraph or subparagraph.</i>							
TYPED NAME, GRADE OR TITLE				TELEPHONE EXCHANGE/AUTOVON, PLUS EXTENSION		SIGNATURE	

TO: (Forward direct to addressee listed in publication) U. S. Army TACOM Life Cycle Management Command ATTN: AMSTA-LC-LMPP/TECH PUBS 1 Rock Island Arsenal, Rock Island, IL 61299-7630	FROM: (Activity and location) (Include ZIP Code)	DATE
--	---	-------------

PART II – REPAIR PARTS AND SPECIAL TOOL LISTS AND SUPPLY CATALOGS/SUPPLY MANUALS

PUBLICATION NUMBER TM 9-2350-277-20-2				DATE 02 Jan 01			TITLE Unit Maintenance Manual for M113A3 FOV	
PAGE NO.	COLM NO.	LINE NO.	NATIONAL STOCK NUMBER	REFERENCE NO.	FIGURE NO.	ITEM NO.	TOTAL NO. OF MAJOR ITEMS SUPPORTED	RECOMMENDED ACTION

PART III – REMARKS *(Any general remarks or recommendations, or suggestions for improvement of publications and blank forms. Additional blank sheets may be used if more space is needed.)*

--

TYPED NAME, GRADE OR TITLE	TELEPHONE EXCHANGE/AUTOVON, PLUS EXTENSION	SIGNATURE
----------------------------	--	-----------

By Order of the Secretary of the Army:

Official:



JOEL B. HUDSON

*Administrative Assistant to the
Secretary of the Army*

9913203

ERIC K. SHINSEKI
*General, United States Army
Chief of Staff*

DISTRIBUTION: To be distributed in accordance with the initial distribution requirements for IDN: 371205, requirements for TM 9-2350-277-20-2.

THE METRIC SYSTEM AND EQUIVALENTS

LINEAR MEASURE

1 Centimeter = 10 Millimeters = 0.01 Meters = 0.3937 Inches
 1 Meter = 100 Centimeters = 1000 Millimeters = 39.37 Inches
 1 Kilometer = 1000 Meters = 0.621 Miles

WEIGHTS

1 Gram = 0.001 Kilograms = 1000 Milligrams = 0.035 Ounces
 1 Kilogram = 1000 Grams = 2.2 Lb.
 1 Metric Ton = 1000 Kilograms = 1 Megagram = 1.1 Short Tons

LIQUID MEASURE

1 Milliliter = 0.001 Liters = 0.0338 Fluid Ounces
 1 Liter = 1000 Milliliters = 33.82 Fluid Ounces

SQUARE MEASURE

1 Sq. Centimeter = 100 Sq. Millimeters = 0.155 Sq. Inches
 1 Sq. Meter = 10,000 Sq. Centimeters = 10.76 Sq. Feet
 1 Sq. Kilometer = 1,000 Sq. Meters = 0.386 Sq. Miles

CUBIC MEASURE

1 Cu. Centimeter = 1000 Cu. Millimeters = 0.06 Cu. Inches
 1 Cu. Meter = 1,000,000 Cu. Centimeters = 35.31 Cu. Feet

TEMPERATURE

$5/9 (^{\circ}\text{F} - 32) = ^{\circ}\text{C}$
 212^o Fahrenheit is equivalent to 100^o Celsius
 90^o Fahrenheit is equivalent to 32.2^o Celsius
 32^o Fahrenheit is equivalent to 0^o Celsius
 $(9/5 \times ^{\circ}\text{C}) + 32 = ^{\circ}\text{F}$

TO CHANGE	TO	MULTIPLY BY
Inches	Centimeters	2.540
Feet	Meters	0.305
Yards	Meters	0.914
Miles	Kilometers	1.609
Square Inches	Square Centimeters	6.451
Square Feet	Square Meters	0.093
Square Yards	Square Meters	0.836
Square Miles	Square Kilometers	2.590
Acres	Square Hectometers	0.405
Cubic Feet	Cubic Meters	0.028
Cubic Yards	Cubic Meters	0.765
Fluid Ounces	Milliliters	29.573
Pints	Liters	0.473
Quarts	Liters	0.946
Gallons	Liters	3.785
Ounces	Grams	28.349
Pounds	Kilograms	0.454
Short Tons	Metric Tons	0.907
Pound-Feet	Newton-Meters	1.356
Pounds per Square Inch	Kilopascals	6.895
Miles per Gallon	Kilometers per Liter	0.425
Miles per Hour	Kilometers per Hour	1.609

TO CHANGE	TO	MULTIPLY BY
Centimeters	Inches	0.394
Meters	Feet	3.280
Meters	Yards	1.094
Kilometers	Miles	0.621
Square Centimeters	Square Inches	0.155
Square Meters	Square Feet	10.764
Square Meters	Square Yards	1.196
Square Kilometers	Square Miles	0.386
Square Hectometers	Acres	2.471
Cubic Meters	Cubic Feet	35.315
Cubic Meters	Cubic Yards	1.308
Milliliters	Fluid Ounces	0.034
Liters	Pints	2.113
Liters	Quarts	1.057
Liters	Gallons	0.264
Grams	Ounces	0.035
Kilograms	Pounds	2.205
Metric Tons	Short Tons	1.102
Newton-Meters	Pound-Feet	0.738
Kilopascals	Pounds per Square Inch	0.145
Kilometers per Liter	Miles per Gallon	2.354
Kilometers per Hour	Miles per Hour	0.621

