

***TM 9-2815-205-24P**

**TECHNICAL MANUAL
FIELD AND SUSTAINMENT MAINTENANCE
REPAIR PARTS AND SPECIAL TOOLS LIST (RPSTL)
FOR**

6V53/6V53T ENGINES, DIESEL WITH CONTAINERS

MODEL 5063-5299

NSN 2815-00-124-5390

NSN 2815-01-295-7458

MODEL 5063-5392

NSN 2815-01-246-0903

MODEL 5063-5393

NSN 2815-01-248-7644

MODEL 5063-539L

NSN 2815-01-412-2715

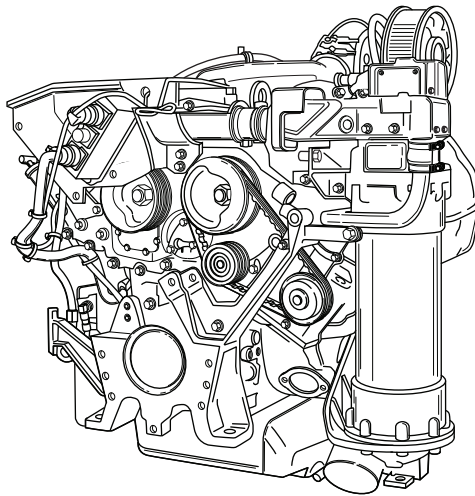

***SUPERSEDURE NOTICE** - This Technical Manual supersedes TM 9-2815-205-34P dated 10 October 2005, including all changes.

DISTRIBUTION STATEMENT A - Approved for public release; distribution is unlimited.

**HEADQUARTERS, DEPARTMENT OF THE ARMY
25 FEBRUARY 2013**

LIST OF EFFECTIVE PAGES/WORK PACKAGES

NOTE: This Technical Manual supersedes TM 9-2815-205-34P dated 10 October 2005, including all changes. Zero in the "Change No." column indicates an original page or work package.

Date of issue for the original manual is:

Original 25 February 2013

TOTAL NUMBER OF PAGES FOR FRONT AND REAR MATTER IS 24 AND TOTAL NUMBER OF WORK PACKAGES IS 64, CONSISTING OF THE FOLLOWING:

Page/WP No.	Change No.	Page/WP No.	Change No.
Front cover	0	WP 0030 (4 pgs)	0
Blank	0	WP 0031 (4 pgs)	0
Title block page (i/ii blank)	0	WP 0032 (4 pgs)	0
Table of contents (iii – v/vi blank)	0	WP 0033 (6 pgs)	0
Chapter title page	0	WP 0034 (4 pgs)	0
Blank	0	WP 0035 (4 pgs)	0
WP 0001 (8 pgs)	0	WP 0036 (4 pgs)	0
WP 0002 (4 pgs)	0	WP 0037 (4 pgs)	0
WP 0003 (6 pgs)	0	WP 0038 (4 pgs)	0
WP 0004 (4 pgs)	0	WP 0039 (4 pgs)	0
WP 0005 (4 pgs)	0	WP 0040 (4 pgs)	0
WP 0004 (4 pgs)	0	WP 0041 (4 pgs)	0
WP 0005 (4 pgs)	0	WP 0042 (4 pgs)	0
WP 0006 (4 pgs)	0	WP 0043 (4 pgs)	0
WP 0007 (4 pgs)	0	WP 0044 (4 pgs)	0
WP 0008 (4 pgs)	0	WP 0045 (4 pgs)	0
WP 0009 (4 pgs)	0	WP 0046 (4 pgs)	0
WP 0010 (4 pgs)	0	WP 0047 (4 pgs)	0
WP 0011 (4 pgs)	0	WP 0048 (4 pgs)	0
WP 0012 (4 pgs)	0	WP 0049 (4 pgs)	0
WP 0013 (4 pgs)	0	WP 0050 (4 pgs)	0
WP 0014 (4 pgs)	0	WP 0051 (4 pgs)	0
WP 0015 (4 pgs)	0	WP 0052 (4 pgs)	0
WP 0016 (4 pgs)	0	WP 0053 (4 pgs)	0
WP 0017 (4 pgs)	0	WP 0054 (4 pgs)	0
WP 0018 (4 pgs)	0	WP 0055 (4 pgs)	0
WP 0019 (4 pgs)	0	WP 0056 (4 pgs)	0
WP 0020 (6 pgs)	0	WP 0057 (6 pgs)	0
WP 0021 (4 pgs)	0	WP 0058 (10 pgs)	0
WP 0022 (4 pgs)	0	WP 0059 (6 pgs)	0
WP 0023 (4 pgs)	0	WP 0060 (4 pgs)	0
WP 0024 (4 pgs)	0	WP 0061 (10 pgs)	0
WP 0025 (4 pgs)	0	WP 0062 (4 pgs)	0
WP 0026 (4 pgs)	0	WP 0063 (16 pgs)	0
WP 0027 (4 pgs)	0	WP 0064 (16 pgs)	0
WP 0028 (4 pgs)	0	Inside back cover	0
WP 0029 (4 pgs)	0	Back cover	0

HEADQUARTERS, DEPARTMENT OF THE ARMY
Washington, D.C., 25 FEBRUARY 2013

TECHNICAL MANUAL
FIELD AND SUSTAINMENT MAINTENANCE
REPAIR PARTS AND SPECIAL TOOLS LIST (RPSTL)
FOR

6V53/6V53T ENGINES, DIESEL WITH CONTAINERS
MODEL 5063-5299
NSN 2815-00-124-5390
NSN 2815-01-295-7458
MODEL 5063-5392
NSN 2815-01-246-0903
MODEL 5063-5393
NSN 2815-01-248-7644
MODEL 5063-539L
NSN 2815-01-412-2715

REPORTING ERRORS AND RECOMMENDING IMPROVEMENTS

You can help improve this publication. If you find any errors, or if you would like to recommend any improvements to the procedures in this publication, please let us know. The preferred method is to submit your DA Form 2028 (Recommended Changes to Publications and Blank Forms) through the Internet on the TACOM Unique Logistics Support Applications (TULSA) Web site. The Internet address is <https://tulsa.tacom.army.mil>. Access to all applications requires CAC authentication, and you must complete the Access Request form the first time you use it. The DA Form 2028 is located under the TULSA Applications on the left-hand navigation bar. Fill out the form and click on SUBMIT. Using this form on the TULSA Web site will enable us to respond more quickly to your comments and to better manage the DA Form 2028 program.

You may also mail, e-mail, or fax your comments or DA Form 2028 directly to the U.S. Army TACOM Life Cycle Management Command. The postal mail address is U.S. Army TACOM Life Cycle Management Command, ATTN: AMSTA-LCL-MPP/ TECH PUBS, MS 727, 6501 E. 11 Mile Road, Warren, MI 48397-5000. The e-mail address is tacomlcmc.daform2028@us.army.mil. The fax number is DSN 786-1856 or Commercial (586) 282-1856. A reply will be furnished to you.

Current as of 31 JANUARY 2013

***SUPERSEDURE NOTICE** - This Technical Manual supersedes TM 9-2815-205-34P dated 10 October 2005, including all changes.

DISTRIBUTION STATEMENT A - Approved for public release; distribution is unlimited.

i/blank

TABLE OF CONTENTS

	Page No.
	<u>WP Sequence No.</u>
REPAIR PARTS AND SPECIAL TOOLS LIST (RPSTL) INTRODUCTION.....	WP 0001
Table 1. SMR Code Explanation.....	0001-1
GROUP 0100 ENGINE AND CONTAINER ASSEMBLY.....	WP 0002
GROUP 0101 CYLINDER BLOCK ASSEMBLY, END PLATE, AND RELATED PARTS.....	WP 0003
GROUP 0101 AIR BOX DRAINS AND RELATED PARTS.....	WP 0004
GROUP 0101 ENGINE FRONT SUPPORT (TRUNNION).....	WP 0005
GROUP 0101 CYLINDER HEAD ASSEMBLY AND LIFTING BRACKET.....	WP 0006
GROUP 0102 CRANKSHAFT, MAIN BEARINGS, AND TIMING GEAR.....	WP 0007
GROUP 0103 DRIVE PLATE, FLYWHEEL, AND HOUSING.....	WP 0008
GROUP 0104 PISTON AND ROD ASSEMBLY (TRUNK TYPE) WITH LINER (MODEL 5063-5299).....	WP 0009
GROUP 0104 PISTONS AND ROD ASSEMBLY (CROSSHEAD TYPE) WITH LINER.....	WP 0010
GROUP 0105 ROCKER ARM COVERS (MODEL 5063-5299).....	WP 0011
GROUP 0105 ROCKER ARM COVERS (MODELS 5063-5392, 5063-5393, AND 5063-539L).....	WP 0012
GROUP 0105 CAMSHAFTS, IDLER GEAR, AND BALANCE GEAR.....	WP 0013
GROUP 0105 ROCKER ARM ASSEMBLIES, VALVES, AND CAM FOLLOWERS.....	WP 0014
GROUP 0105 UPPER FRONT COVER.....	WP 0015
GROUP 0106 OIL COOLER ASSEMBLY (MODEL 5063-5299).....	WP 0016
GROUP 0106 OIL COOLER ASSEMBLY (MODEL 5063-5392).....	WP 0017
GROUP 0106 OIL COOLER ASSEMBLY (MODEL 5063-5393 AND 5063-539L).....	WP 0018
GROUP 0106 OIL INLET PIPE, SCREEN, AND SUPPORTS.....	WP 0019
GROUP 0106 OIL PAN AND OIL GAGE ASSEMBLY.....	WP 0020
GROUP 0106 OIL FILTER ASSEMBLY AND ADAPTER (MODEL 5063-5299).....	WP 0021
GROUP 0106 OIL FILTER ASSEMBLY, ADAPTER, AND RELATED PARTS (MODEL 5063-5392).....	WP 0022
GROUP 0106 OIL FILTER ASSEMBLY, ADAPTER, AND RELATED PARTS (MODELS 5063-5393 AND 5063-539L).....	WP 0023
GROUP 0106 LOWER FRONT COVER, OIL PRESSURE REGULATOR, AND OIL PUMP ASSEMBLY.....	WP 0024
GROUP 0108 EXHAUST MANIFOLDS.....	WP 0025

TABLE OF CONTENTS - Continued

	Page No.
	<u>WP Sequence No.</u>
GROUP 0109 TACHOMETER DRIVE ASSEMBLY.....	WP 0026
GROUP 0109 HYDRAULIC PUMP DRIVE (MODELS 5063-5393 AND 5063-539L).....	WP 0027
GROUP 0301 FUEL INJECTOR AND RELATED PARTS.....	WP 0028
GROUP 0302 FUEL PUMP ASSEMBLY AND DRIVE.....	WP 0029
GROUP 0302 FUEL LINES AND FITTINGS (MODEL 5063-5299).....	WP 0030
GROUP 0302 FUEL LINES AND FITTINGS (MODEL 5063-5392).....	WP 0031
GROUP 0302 FUEL LINES AND FITTINGS (MODELS 5063-5393 AND 5063-539L).....	WP 0032
GROUP 0305 BLOWER ASSEMBLY.....	WP 0033
GROUP 0305 TURBOCHARGER AND RELATED PARTS (MODEL 5063-5392).....	WP 0034
GROUP 0305 TURBOCHARGER AND RELATED PARTS (MODELS 5063-5393 AND 5063-539L).....	WP 0035
GROUP 0305 TURBOCHARGER (MODELS 5063-5392, 5063-5393 AND 5063-539L).....	WP 0036
GROUP 0305 BLOWER DRIVE GEAR AND RELATED PARTS.....	WP 0037
GROUP 0305 AIR INLET HOUSING AND RELATED PARTS.....	WP 0038
GROUP 0308 GOVERNOR AND COVER ASSEMBLY.....	WP 0039
GROUP 0308 GOVERNOR HOUSING ASSEMBLY AND COMPONENTS.....	WP 0040
GROUP 0308 GOVERNOR SHAFT AND LOWER BEARING.....	WP 0041
GROUP 0308 GOVERNOR HIGH SPEED SPRING PACK AND RELATED PARTS.....	WP 0042
GROUP 0308 FUEL INJECTOR CONTROL TUBES AND LINKAGE.....	WP 0043
GROUP 0308 THROTTLE DELAY, CHECK VALVE, AND LINKAGE (MODELS 5063-5392, 5063-5393 AND 5063-539L).....	WP 0044
GROUP 0309 FUEL FILTER AND STRAINER ASSEMBLIES (MODELS 5063-5299 AND 5063-5392)....	WP 0045
GROUP 0309 FUEL FILTER AND STRAINER ASSEMBLIES (MODELS 5063-5393 AND 5063-539L)....	WP 0046
GROUP 0311 AIR BOX HEATER AND RELATED PARTS (MODELS 5063-5299).....	WP 0047
GROUP 0311 AIR BOX HEATER AND RELATED PARTS (MODEL 5063-5392).....	WP 0048
GROUP 0311 AIR BOX HEATER AND RELATED PARTS (MODEL 5063-5393).....	WP 0049
GROUP 0311 GLOW PLUG CONTROLLER AND RELATED PARTS (MODEL 5063-539L).....	WP 0050
GROUP 0311 AIR BOX HEATER.....	WP 0051
GROUP 0311 AIR PUMP AND IGNITION COIL ASSEMBLY.....	WP 0052

TABLE OF CONTENTS - Continued

	Page No. <u>WP Sequence No.</u>
GROUP 0503 THERMOSTAT, HOUSING, LINES, AND FITTINGS (MODELS 5063-5299 and 5063-5392).....	WP 0053
GROUP 0503 THERMOSTAT, HOUSING, LINES, AND FITTINGS (MODELS 5063-5393 AND 5063-539L).....	WP 0054
GROUP 0504 COOLANT PUMP ASSEMBLY, IDLER PULLEY, AND BELT SET.....	WP 0055
GROUP 0603 STARTER MOTOR AND MOUNTING HARDWARE.....	WP 0056
GROUP 2604 SPECIAL TOOLS FIELD MAINTENANCE LEVEL (FML).....	WP 0057
GROUP 2604 SPECIAL TOOLS FOR SUSTAINMENT LEVEL MAINTENANCE-BELOW DEPOT (SML-BD).....	WP 0058
GROUP 3301 SHIPPING AND STORAGE CONTAINER ASSEMBLY (MODELS 5063-5299, 5063-5392, 5063-5393, AND 5063-539L).....	WP 0059
GROUP 3301 SHIPPING AND STORAGE CONTAINER ASSEMBLY (MODEL 5063-5299).....	WP 0060
GROUP 9401 REPAIR PARTS KITS.....	WP 0061
GROUP 9501 HARDWARE SUPPLIES AND BULK MATERIEL, COMMON.....	WP 0062
NATIONAL STOCK NUMBER INDEX.....	WP 0063
PART NUMBER INDEX.....	WP 0064

**FIELD AND SUSTAINMENT MAINTENANCE
REPAIR PARTS AND SPECIAL TOOLS LIST (RPSTL)
FOR
6V53/6V53T DIESEL ENGINES**

**FIELD MAINTENANCE
REPAIR PARTS AND SPECIAL TOOLS LIST (RPSTL) INTRODUCTION**

INTRODUCTION

SCOPE

This RPSTL lists and authorizes spares and repair parts, special tools, special tests, measurement, and diagnostic equipment (TMDE), and other special support equipment required for performance of Field and Sustainment Maintenance of the 6V53/6V53T Diesel Engine with container. It authorizes the requisitioning, issue, and disposition of spares, repair parts, and special tools as indicated by the source, maintenance, and recoverability (SMR) codes.

GENERAL

In addition to the Introduction work package, this RPSTL is divided into the following work packages:

1. Repair Parts List Work Packages. Work packages containing lists of spares and repair parts authorized by this RPSTL for use in the performance of maintenance. These work packages also include parts which must be removed for replacement of the authorized parts. Parts lists are composed of functional groups in ascending alphanumeric sequence, with the parts in each group listed in ascending figure and item number sequence. Sending units, brackets, filters, and bolts are listed with the component they mount on. Bulk materials are listed by item name in FIG. BULK at the end of the work packages. Repair parts kits are listed separately in their own functional group and work package. Repair parts for reparable special tools are also listed in a separate work package. Items listed are shown on the associated illustrations.
2. Special Tools List Work Packages. Work packages containing lists of special tools, special TMDE, and special support equipment authorized by this RPSTL (as indicated by Basis of Issue (BOI) information in the DESCRIPTION AND USABLE ON CODE (UOC) column). Tools that are components of common tool sets and/or Class VII are not listed.
3. Cross-Reference Indexes Work Packages. There are two cross-reference indexes work packages in this RPSTL: the National Stock Number (NSN) Index work package, and the Part Number (P/N) Index work package. The National Stock Number Index work package refers you to the figure and item number. The Part Number Index work package refers you to the figure and item number.

EXPLANATION OF COLUMNS IN THE REPAIR PARTS LIST AND SPECIAL TOOLS LIST WORK PACKAGES

ITEM NO. (Column (1)). Indicates the number used to identify items called out in the illustration.

SMR CODE (Column (2)). The SMR code containing supply/requisitioning information, maintenance level authorization criteria, and disposition instruction, as shown in the following breakout. This entry may be subdivided into four subentries, one for each service.

Table 1. SMR Code Explanation.

<u>Source Code</u>	<u>Maintenance Code</u>		<u>Recoverability Code</u>
XX	XX		X
1st two positions: How to get an item.	3rd position: Who can install, replace, or use the item.	4th position: Who can do complete repair* on the item.	5th position: Who determines disposition action on unserviceable items.

*Complete Repair: Maintenance capacity, capability, and authority to perform all corrective maintenance tasks of the "Repair" function in a use/user environment in order to restore serviceability to a failed item.

Source Code. The source code tells you how you get an item needed for maintenance, repair, or overhaul of an end item/equipment. Explanations of source codes follow:

Source Code	Application/Explanation
PA	<p style="text-align: center;">NOTE</p> <p style="text-align: center;">Items coded PC are subject to deterioration.</p> <p>Stock items; use the applicable NSN to requisition/request items with these source codes. They are authorized to the level indicated by the code entered in the third position of the SMR code.</p>
PB	
PC	
PD	
PE	
PF	
PG	
PH	
PR	
PZ	
KD	<p>Items with these codes are not to be requested/requisitioned individually. They are part of a kit which is authorized to the maintenance level indicated in the third position of the SMR code. The complete kit must be requisitioned and applied.</p>
KF	
KB	
MF-Made at field	<p>Items with these codes are not to be requisitioned/requested individually. They must be made from bulk material which is identified by the part number in the DESCRIPTION AND USABLE ON CODE (UOC) column and listed in the bulk material group work package of the RPSTL. If the item is authorized to you by the third position code of the SMR code, but the source code indicates it is made at higher level, order the item from the higher level of maintenance.</p>
MH-Made at below depot/sustainment level	
ML-Made at SRA	
MD-Made at depot	
MG-Navy only	

Source Code	Application/Explanation
AF-Assembled by field	Items with these codes are not to be requested/requisitioned individually. The parts that make up the assembled item must be requisitioned or fabricated and assembled at the level of maintenance indicated by the source code. If the third position of the SMR code authorizes you to replace the item, but the source code indicates the item is assembled at a higher level, order the item from the higher level of maintenance.
AH-Assembled by below depot sustainment level	
AL-Assembled by SRA	
AD-Assembled by depot	
AG-Navy only	
XA	Do not requisition an "XA" coded item. Order the next higher assembly. (Refer to NOTE below.)
XB	If an item is not available from salvage, order it using the CAGEC and part number.
XC	Installation drawings, diagrams, instruction sheets, field service drawings; identified by manufacturer's part number.
XD	Item is not stocked. Order an XD-coded item through local purchase or normal supply channels using the CAGEC and part number given, if no NSN is available.

NOTE

Cannibalization or controlled exchange, when authorized, may be used as a source of supply for items with the above source codes except for those items source coded "XA" or those aircraft support items restricted by requirements of AR 750-1.

Maintenance Code. Maintenance codes tell you the level(s) of maintenance authorized to use and repair support items. The maintenance codes are entered in the third and fourth positions of the SMR code as follows:

Third Position. The maintenance code entered in the third position tells you the lowest maintenance level authorized to remove, replace, and use an item. The maintenance code entered in the third position will indicate authorization to the following levels of maintenance:

Maintenance Code	Application/Explanation
F -	Field maintenance can remove, replace, and use the item.
H -	Below Depot Sustainment maintenance can remove, replace, and use the item.

Maintenance Code	Application/Explanation
L -	Specialized repair activity can remove, replace, and use the item.
G-	Afloat and ashore intermediate maintenance can remove, replace, and use the item. (Navy only)
K -	Contractor facility can remove, replace, and use the item.
Z -	Item is not authorized to be removed, replaced, or used at any maintenance level.
D -	Depot can remove, replace, and use the item.
*NOTE - Army may use C in the third position. However, for joint service publications, Army will Use O.	

Fourth Position. The maintenance code entered in the fourth position tells you whether or not the item is to be repaired and identifies the lowest maintenance level with the capability to do complete repair (perform all authorized repair functions).

NOTE

Some limited repair may be done on the item at a lower level of maintenance, if authorized by the Maintenance Allocation Chart (MAC) and SMR codes.

Maintenance Code	Application/Explanation
F-	Field is the lowest level that can do complete repair of the item.
H -	Below Depot Sustainment is the lowest level that can do complete repair of the item.
L-	Specialized repair activity (enter specialized repair activity or TASMG designator) is the lowest level that can do complete repair of the item.
D-	Depot is the lowest level that can do complete repair of the item.
G-	Both afloat and ashore intermediate levels are capable of complete repair of item. (Navy only)
K-	Complete repair is done at contractor facility.
Z-	Nonreparable. No repair is authorized.
B-	No repair is authorized. No parts or special tools are authorized for maintenance of "B" coded item. However, the item may be reconditioned by adjusting, lubricating, etc., at the user level.

Recoverability Code. Recoverability codes are assigned to items to indicate the disposition action on unserviceable items. The recoverability code is shown in the fifth position of the SMR code as follows:

<u>Recoverability Code</u>	<u>Application/Explanation</u>
Z -	Nonreparable item. When unserviceable, condemn and dispose of the item at the level of maintenance shown in the third position of the SMR code.
F -	Reparable item. When uneconomically repairable, condemn and dispose of the item at the field level.
H -	Reparable item. When uneconomically repairable, condemn and dispose of the item at the below depot sustainment level.
D -	Reparable item. When beyond lower level repair capability, return to depot. Condemnation and disposal of item are not authorized below depot level.
L -	Repairable Item. Condemnation and disposal not authorized below Specialized Repair Activity (SRA).
A -	Item requires special handling or condemnation procedures because of specific reasons (such as precious metal content, high dollar value, critical material, or hazardous material). Refer to appropriate manuals/directives for specific instructions.
G-	Field level repairable item. Condemn and dispose at either afloat or ashore intermediate levels. (Navy only)
K-	Reparable item. Condemnation and disposal to be performed at contractor facility.

NSN (Column (3)). The NSN for the item is listed in this column.

CAGEC (Column (4)). The Commercial and Government Entity Code (CAGEC) is a five-digit code which is used to identify the manufacturer, distributor, or Government agency/activity that supplies the item.

PART NUMBER (Column (5)). Indicates the primary number used by the manufacturer (individual, company, firm, corporation, or Government activity), which controls the design and characteristics of the item by means of its engineering drawings, specifications, standards, and inspection requirements to identify an item or range of items.

NOTE

When you use an NSN to requisition an item, the item you receive may have a different part number from the number listed.

DESCRIPTION AND USABLE ON CODE (UOC) (Column (6)). This column includes the following information:

1. The federal item name, and when required, a minimum description to identify the item.
2. Part numbers of bulk materials are referenced in this column in the line entry to be manufactured or fabricated.
3. Hardness Critical Item (HCI). A support item that provides the equipment with special protection from electromagnetic pulse (EMP) damage during a nuclear attack.
4. The statement END OF FIGURE appears just below the last item description in column (6) for a given figure in both the repair parts list and special tools list work packages.

QTY (Column (7)). The QTY (quantity per figure) column indicates the quantity of the item used in the breakout shown on the illustration/figure, which is prepared for a functional group, subfunctional group, or an assembly. A "V" appearing in this column instead of a quantity indicates that the quantity is variable and quantity may change from application to application.

EXPLANATION OF CROSS-REFERENCE INDEXES WORK PACKAGES FORMAT AND COLUMNS

1. National Stock Number (NSN) Index Work Package. NSN's in this index are listed in National Item Identification Number (NIIN) sequence.
STOCK NUMBER Column. This column lists the NSN in NIIN sequence. The NIIN consists of the last nine digits of the NSN. When using this column to locate an item, ignore the first four digits of the NSN. However, the complete NSN should be used when ordering items by stock number.
 For example, if the NSN is 5385-01-574-1476, the NIIN is 01-574-1476.
FIG. Column. This column lists the number of the figure where the item is identified/located. The figures are in numerical order in the repair parts list and special tools list work packages.
ITEM Column. The item number identifies the item associated with the figure listed in the adjacent FIG. column. This item is also identified by the NSN listed on the same line.

2. Part Number (P/N) Index Work Package. Part numbers in this index are listed in ascending alphanumeric sequence (vertical arrangement of letter and number combinations which places the first letter or digit of each group in order A through Z, followed by the numbers 0 through 9 and each following letter or digit in like order).
PART NUMBER Column. Indicates the part number assigned to the item.
FIG. Column. This column lists the number of the figure where the item is identified/located in the repair parts list and special tools list work packages.
ITEM Column. The item number is the number assigned to the item as it appears in the figure referenced in the adjacent figure number column.

SPECIAL INFORMATION

UOC. The UOC appears in the lower left corner of the Description Column heading. Usable on codes are shown as "UOC:..." in the Description Column (justified left) on the first line under the applicable item/nomenclature. Uncoded items are applicable to all models. Identification of the UOCs used in the RPSTL are:

Code	Used On
A6V	Model 5063-5299, M113 FOV
C6V	Model 5063-5392, M548A3
D6V	Model 5063-5393, M113A3 FOV
F6V	Model 5063-5299, M113 FOV
L6V	Model 5063-539L, M113A3 FOV

Fabrication Instructions. Bulk materials required to manufacture items are listed in the bulk material functional group of this RPSTL. Part numbers for bulk material are also referenced in the Description Column of the line item entry for the item to be manufactured/fabricated. Detailed fabrication instructions for items source coded to be manufactured or fabricated are found in (TM 9-2815-205-24P).

Index Numbers. Items which have the word BULK in the figure column will have an index number shown in the item number column. This index number is a cross-reference between the NSN / Part Number (P/N) Index work packages and the bulk material list in the repair parts list work package.

Associated Publications. The publication(s) listed below pertains to the 6V53/6V53T Diesel Engine with container:

<u>Publication</u>	<u>Short Title</u>
TM 9-2815-205-24	Field and Sustainment Maintenance for 6V53/6V53T Engines, Diesel with Containers
DMWR 9-2815-205	Depot Maintenance Work Requirement containing National Maintenance Repair Standards for 6V53/6V53T Engines, Diesel with Containers

HOW TO LOCATE REPAIR PARTS

1. When NSNs or Part Numbers Are Not Known.

First. Using the table of contents, determine the assembly group to which the item belongs. This is necessary since figures are prepared for assembly groups and subassembly groups, and lists are divided into the same groups.

Second. Find the figure covering the functional group or the subfunctional group to which the item belongs.

Third. Identify the item on the figure and note the number(s).

Fourth. Look in the repair parts list work packages for the figure and item numbers. The NSNs and part numbers are on the same line as the associated item numbers.

2. When NSN Is Known.

First. If you have the NSN, look in the STOCK NUMBER column of the NSN index work package. The NSN is arranged in NIIN sequence. Note the figure and item number next to the NSN.

Second. Turn to the figure and locate the item number. Verify that the item is the one you are looking for.

3. When Part Number Is Known.

First. If you have the part number and not the NSN, look in the PART NUMBER column of the part number index work package. Identify the figure and item number.

Second. Look up the item on the figure in the applicable repair parts list work package.

HOW TO ORDER ASSEMBLIES

Numbers for individual assemblies are designated at the top of a page or figure. When ordering parts, selecting the assembly number at the top of the bracket will order the entire series of part numbers within that particular bracket.

END OF WORK PACKAGE

**FIELD MAINTENANCE
ENGINE AND CONTAINER ASSEMBLY**

1
2 AND 3

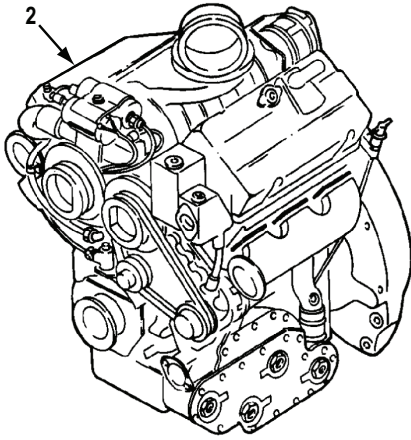

MODEL 5063-5299

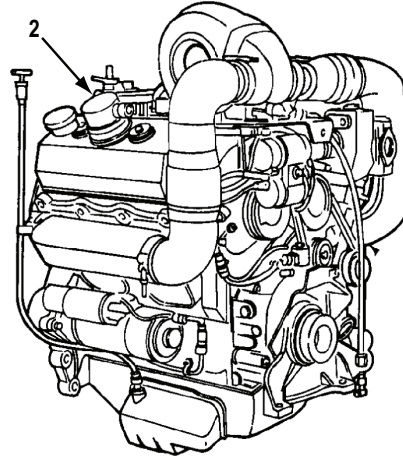

MODEL 5063-5392

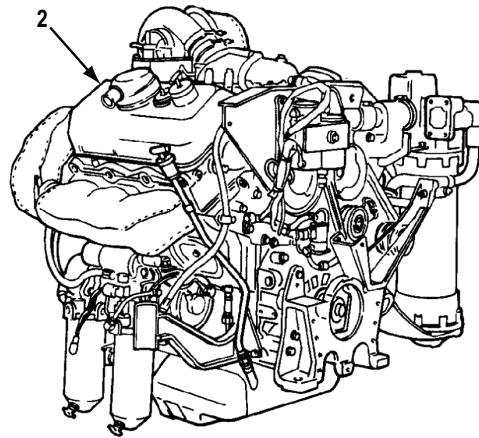
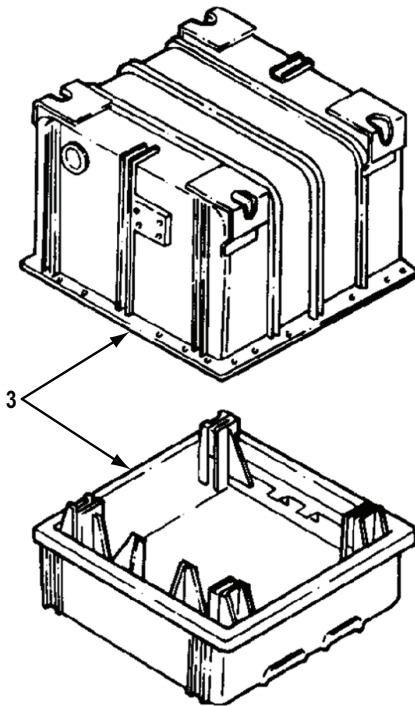

MODELS
5063-5393
5063-539L

R001

Figure 1. Engine and Container Assembly.

(1) ITEM NO.	(2) SMR CODE	(3) NSN	(4) CAGEC	(5) PART NUMBER	(6) DESCRIPTION AND USABLE ON CODE (UOC)	(7) QTY
GROUP 0100 ENGINE AND CONTAINER ASSEMBLY						
FIG. 1. ENGINE AND CONTAINER ASSEMBLY.						
1	PAFDD	2815-00-124-5390	19207	5703812	ENGINE WITH CONTAINER UOC: A6V	1
1	PAFDD	2815-01-246-0903	19207	5705596	ENGINE, W CONTAINER UOC: C6V	1
1	PAFDD	2815-01-248-7644	19207	5705597	ENGINE, W CONTAINER UOC: D6V	1
1	PAFDD	2815-01-295-7458	19207	57K1000	ENGINE,DIESEL UOC: F6V	1
1	PAFDD	2815-01-412-2715	19207	57K1006	ENGINE,DIESEL UOC: L6V	1
2	XAFDD		19207	8738127	. ENGINE DIESEL UOC: A6V,F6V	1
2	XAFDD		19207	11650200-1	. ENGINE,DIESEL UOC: C6V	1
2	XAFDD		19207	11650249-1	. ENGINE,DIESEL UOC: D6V	1
2	XAFDD		19207	11650241	. ENGINE,DIESEL UOC: L6V	1
3	PAFHH	8145-01-232-9447	19207	11650202	. SHIPPING AND STORAG SEE FIGURE 58 FOR COMPONENT PARTS UOC: C6V,D6V,F6V,L6V	1
3	PAFHH	8145-00-138-7809	19207	11678210	. SHIPPING AND STORAG SEE FIGURE 59 FOR COMPONENT PARTS UOC: A6V	1

END OF FIGURE

**SUSTAINMENT MAINTENANCE
CYLINDER BLOCK ASSEMBLY, END PLATE, AND RELATED PARTS**

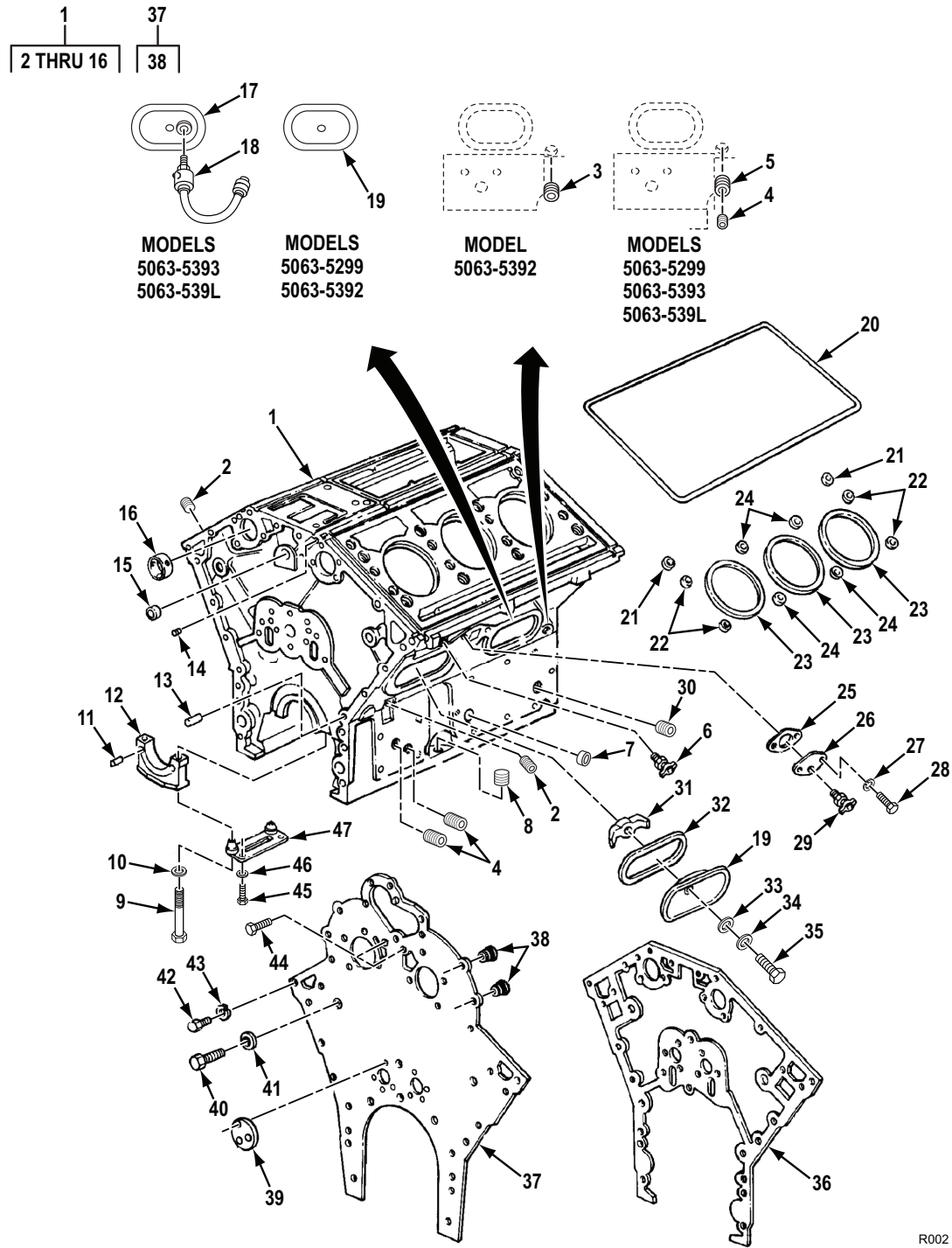

R002

Figure 2. Cylinder Block Assembly, End Plate, and Related Parts.

(1) ITEM NO.	(2) SMR CODE	(3) NSN	(4) CAGEC	(5) PART NUMBER	(6) DESCRIPTION AND USABLE ON CODE (UOC)	(7) QTY
GROUP 0101 CYLINDER BLOCK ASSEMBLY, END PLATE, AND RELATED PARTS						
FIG. 2. CYLINDER BLOCK ASSEMBLY, END PLATE, AND RELATED PARTS.						
1	PFHHH	2815-01-248-2554	72582	8926997	ENGINE BLOCK ASSEMB UOC: A6V,D6V,F6V,L6V	1
1	PFHHH	2815-01-246-0960	72582	8927003	ENGINE BLOCK ASSEMB UOC: C6V	1
2	PAHZZ	4730-00-371-5337	72582	08924380	. PLUG,PIPE RIGHT SIDE REAR 2PCS, LEFT SIDE REAR,1PC, LEFT SIDE REAR TOP OF BLOCK 1.....	4
3	PAHZZ	4730-01-188-3492	72582	8923313	. PLUG,PIPE RIGHT SIDE FRONT OIL GALLERY UOC: C6V	1
4	PAHZZ	4730-01-210-4252	72582	5146648	. PLUG,PIPE UOC: A6V,D6V,F6V,L6V	3
4	PAHZZ	4730-01-210-4252	72582	5146648	. PLUG,PIPE UOC: C6V	2
5	PAHZZ	4730-01-257-3799	72582	8928531	. BUSHING,PIPE RIGHT SIDE FRONT OIL GALLERY UOC: A6V,D6V,F6V,L6V	1
6	PAFZZ	4820-00-752-9040	58536	AA59440/1-004	. COCK,DRAIN RIGHT SIDE-2 PC'S,LEFT SIDE-1 PC. UOC: A6V,D6V,F6V,L6V	3
6	PAFZZ	4820-00-752-9040	58536	AA59440/1-004	. COCK,DRAIN RIGHT & LEFT SIDE REAR UOC: C6V	2
7	PAHZZ	2815-00-921-5348	72582	5119218	. PLUG OIL COOLER HOLE, RIGHT SIDE	1
8	PAHZZ	4730-01-398-7635	72582	8923847	. PLUG,PIPE RIGHT & LEFT SIDES OIL DIPSTICK HOLE UOC: A6V,F6V	2
8	PAHZZ	4730-01-398-7635	72582	8923847	. PLUG,PIPE LEFT SIDE OIL DIPSTICK HOLE UOC: C6V,D6V,L6V	1
9	PAHZZ	5306-00-933-0994	72582	5141701	. BOLT,EXTERNALLY REL 9/16-12UNC-3AX6.24 GR8 MAIN BEARING CAP.....	8
10	PAHZZ	5310-01-132-0830	72582	8921876	. WASHER MAIN BEARING CAP.....	8
11	PAHZZ	5315-00-014-1346	89926	0040398	. PIN,STRAIGHT,HEADLE.....	4
12	PBHZZ	3130-01-157-8861	72582	5132479	. CAP,PILLOW BLOCK MAIN BEARING....	4
13	PAHZZ	5315-01-042-8362	72582	5146900	. PIN,STRAIGHT,HEADLE.....	4
14	PAHZZ	5340-00-237-8324	72582	5150130	. PLUG,EXPANSION REAR OF BLOCK AT UPR RIGHT SIDE OIL GALLERY.....	1

(1) ITEM NO.	(2) SMR CODE	(3) NSN	(4) CAGEC	(5) PART NUMBER	(6) DESCRIPTION AND USABLE ON CODE (UOC)	(7) QTY
15	PAHZZ	5340-00-919-2876	72582	5109157	. PLUG,EXPANSION MAIN OIL GALLERY	2
16	PAHZZ	3120-00-921-5389	72582	5197945	. BEARING SET,SLEEVE CAMSHAFT.0.010 U.S. I.D., STD O.D.....	1
16	PAHZZ	3120-01-127-6531	72582	5198983	. BEARING SET,SLEEVE CAMSHAFT,STD I.D., 0.010 OVS 0.D.....	1
16	PAHZZ	3120-00-921-5390	72582	5197946	. BEARING CAMSHAFT.0.020 U.S. I.D., STD. O.D.....	1
16	PAHZZ	3120-00-089-3536	72582	5197944	. BEARING SET,SLEEVE CAMSHAFT, STD. SIZE.....	1
17	PAFZZ	2815-01-354-8172	72582	23501681	COVER,ENGINE POPPET RIGHT FRONT SIDE UOC: D6V,L6V	1
18	PAFZZ	6620-01-501-8648	19207	12258932-9	TRANSMITTER,PRESSUR UOC: D6V,L6V	1
19	PAFZZ	5340-00-921-5386	72582	8921313	COVER,ACCESS UOC: D6V,L6V	3
19	PAFZZ	5340-00-921-5386	72582	8921313	COVER,ACCESS UOC: A6V,C6V,F6V	4
20	KFFZZ	5330-00-921-5344	72582	5116292	PACKING,PREFORMED PART OF KIT P/N 5199811, PART OF KIT P/N 8928522, PART OF KIT P/N 8927743.....	2
21	KFFZZ	5310-00-774-9545	72582	5116122	WASHER,FLAT PART OF KIT P/N 5199811, PART OF KIT P/N 8928522, PART OF KIT P/N 8927743.....	4
22	KFFZZ	5310-00-880-1264	72582	5116290	WASHER,FLAT WATER SEAL,FRONT & REAR HOLES PART OF KIT P/N 5199811, PART OF KIT P/N 8928522, PART OF KIT P/N 8927743.....	8
23	KFFZZ	5330-00-780-5243	72582	5121254	GASKET PART OF KIT P/N 5199811, PART OF KIT P/N 8928522, PART OF KIT P/N 8927743.....	6
24	KFFZZ	5330-00-880-1263	72582	5121207	RETAINER,PACKING WATER SEALS, INTERMEDIATE HOLES PART OF KIT P/N 5199811, PART OF KIT P/N 8928522, PART OF KIT P/N 8927743.....	8
25	KFFZZ	5330-00-613-9397	72582	5116357	GASKET WATER COVER, RIGHT SIDE PART OF KIT P/N 8928522, PART OF KIT P/N 8927743.....	1
26	PAFZZ	5340-00-921-5355	72582	5123918	COVER,ACCESS WATER HOLE COVER, RIGHT SIDE UOC: C6V	1
27	PAFZZ	5310-00-407-9566	80205	MS35338-45	WASHER,LOCK UOC: C6V	2
28	PAFZZ	5306-00-226-4825	80204	B1821BH031C075N	BOLT,MACHINE 5/16-18UNC-2AX3/4 GR8 UOC: C6V	4

(1) ITEM NO.	(2) SMR CODE	(3) NSN	(4) CAGEC	(5) PART NUMBER	(6) DESCRIPTION AND USABLE ON CODE (UOC)	(7) QTY
29	PAFZZ	4820-00-752-9040	58536	AA59440/1-004	COCK,DRAIN RIGHT SIDE WATER HOLE COVER UOC: C6V	1
30	PAFZZ	4730-01-188-3492	72582	8923313	PLUG,PIPE RIGHT SIDE FRONT,OIL COOLER HOLE.....	1
31	PAFZZ	5340-01-108-2417	72582	5107440	CLAMP,BRIDGE.....	4
32	KFFZZ	5330-00-012-9514	72582	5132117	GASKET PART OF KIT P/N 8927743.....	4
33	PAFZZ	5325-00-921-6413	96906	MS35769-7	GASKET.....	4
34	PAFZZ	5310-00-080-6004	96906	MS27183-14	WASHER,FLAT.....	4
35	PAFZZ	5305-00-269-3237	80204	B1821BH038F113N	SCREW,CAP,HEXAGON H 3/8-24UNF-2AX1-1/8 GR8.....	4
36	KFHZZ	5330-00-789-4846	72582	5133397	GASKET PART OF KIT P/N 8928522, PART OF KIT P/N 8927743.....	1
37	PAHZZ	2815-00-999-2348	16236	CS815-SVS-0704	COVER,TIMING GEAR,I.....	1
38	PAHZZ	5325-00-921-6413	72582	5121459	. INSERT,SCREW,THREAD UOC: C6V,D6V,L6V	2
39	KFHZZ	5365-00-901-1032	72582	5123802	SHIM LEFT SIDE PART OF KIT P/N 8928522, PART OF KIT P/N 8927743.....	1
40	PAHZZ	5305-00-071-2069	80204	B1821BH050C150N	SCREW,CAP,HEXAGON H 1/2-13UNC-2AX1-1/2 GR 8 LEFT SIDE UOC: A6V,C6V,F6V	1
41	PAHZZ	5310-00-807-1367	72582	5188274	WASHER,SPECIAL LEFT SIDE UOC: A6V,C6V,F6V	1
42	PAHZZ	5305-00-942-2196	80204	B1821BH038C100D	SCREW,CAP,HEXAGON H 3/8-16UNC-2AX1 GR 8.....	2
43	PAHZZ	5310-00-637-9541	59556	019-00004-42	WASHER,LOCK.....	2
44	PAHZZ	5306-01-133-0812	72582	5101779	BOLT.....	2
45	PAHZZ	5305-00-921-5364	72582	9414523	SCREW,CAP,HEXAGON H 7/16-14UNC-2AX1 GR8.....	8
46	PAHZZ	5310-01-209-7979	72582	5125608	WASHER,FLAT.....	8
47	PAHZZ	2815-00-010-0297	72582	5132695	STABILIZER,MAIN BEA.....	4

END OF FIGURE

**FIELD MAINTENANCE
AIR BOX DRAINS AND RELATED PARTS**

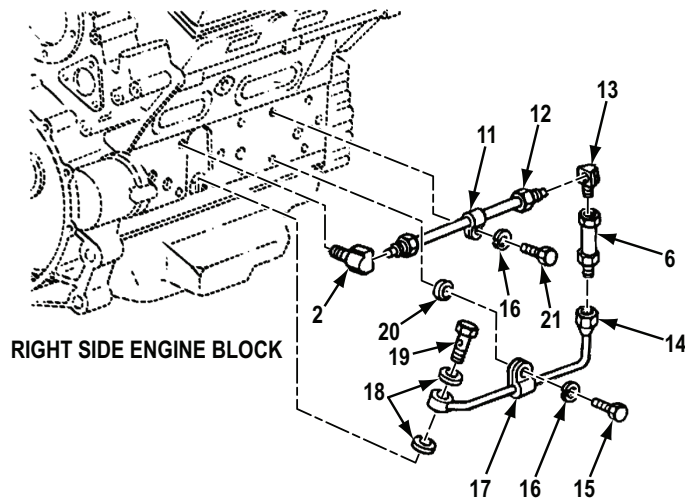
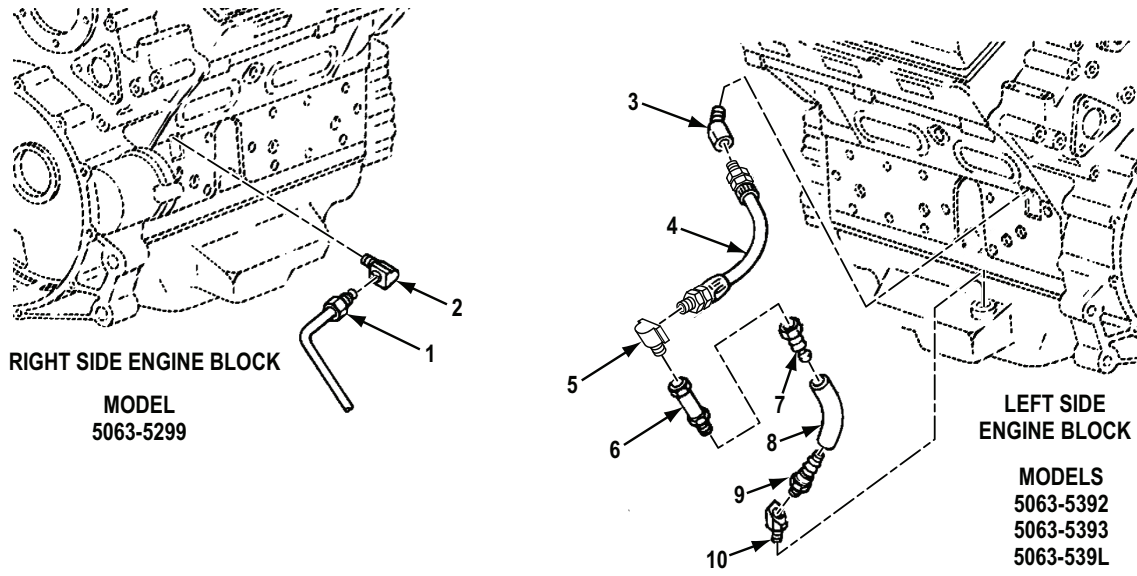

R003

Figure 3. Air Box Drains and Related Parts.

(1) ITEM NO.	(2) SMR CODE	(3) NSN	(4) CAGEC	(5) PART NUMBER	(6) DESCRIPTION AND USABLE ON CODE (UOC)	(7) QTY
GROUP 0101 AIR BOX DRAINS AND RELATED PARTS						
FIG. 3. AIR BOX DRAINS AND RELATED PARTS.						
1	PAFZZ	4710-00-701-3875	72582	5134195	TUBE ASSEMBLY,METAL UOC: A6V,F6V	2
2	PAFZZ	4730-01-187-6671	72582	8925032	ELBOW,PIPE TO TUBE UOC: A6V,F6V	2
2	PAFZZ	4730-01-187-6671	72582	8925032	ELBOW,PIPE TO TUBE UOC: C6V,D6V,L6V	2
3	PAFZZ	4730-00-277-5683	96906	MS14307-1	ELBOW,PIPE UOC: C6V,D6V,L6V	1
4	PAFZZ	4720-01-475-9707	72582	23504151	HOSE,NONMETALLIC UOC: C6V,D6V,L6V	1
5	PAFZZ	4730-00-366-3011	81343	SAE J513 4-4 010202B	ELBOW,PIPE TO TUBE UOC: C6V,D6V,L6V	1
6	PAFZZ	4820-01-160-8172	72582	8996207	VALVE,CHECK UOC: C6V,D6V,L6V	2
7	PAFZZ	4730-01-247-2463	72582	5113191	ADAPTER,STRAIGHT,PI UOC: C6V,D6V,L6V	1
8	MFFZZ	4720-01-462-8831	72582	8927796	HOSE,NONMETALLIC 8.0 IN. LG, MAKE FROM HOSE, P/N 2565-6,AIR BOX DRAIN LEFT SIDE UOC: C6V,D6V,L6V	1
9	PAFZZ	4730-00-849-2737	72582	5114049	FITTING UOC: C6V,D6V,L6V	1
10	PAFZZ	4730-01-157-6224	72582	8924161	ELBOW,HOSE UOC: C6V,D6V,L6V	1
11	PAFZZ	5340-00-235-2278	72582	5124802	CLIP,SPRING TENSION UOC: C6V,D6V,L6V	1
12	PAFZZ	4710-01-221-2216	72582	8926596	TUBE ASSEMBLY,METAL UOC: C6V,D6V,L6V	1
13	PAFZZ	4730-00-277-8643	81343	SAE J512 4-4 040202B	ELBOW,PIPE TO TUBE UOC: C6V,D6V,L6V	1
14	PAFZZ	4710-01-221-1492	72582	8926290	TUBE ASSEMBLY,METAL UOC: C6V,D6V,L6V	1
15	PAFZZ	5306-00-226-4827	80204	B1821BH031C100N	BOLT,MACHINE UOC: C6V,D6V,L6V	4
16	PAFZZ	5310-00-407-9566	80205	MS35338-45	WASHER,LOCK UOC: C6V,D6V,L6V	2
17	PAFZZ	5340-00-853-3467	72582	5151883	CLAMP,LOOP UOC: C6V,D6V,L6V	1
18	PAFZZ	5310-00-532-8136	72582	5151921	WASHER,FLAT UOC: C6V,D6V,L6V	2
19	PAFZZ	2815-01-210-6950	72582	5104370	ADAPTER,OIL GAGE GU UOC: C6V,D6V,L6V	1

(1) ITEM NO.	(2) SMR CODE	(3) NSN	(4) CAGEC	(5) PART NUMBER	(6) DESCRIPTION AND USABLE ON CODE (UOC)	(7) QTY
20	PAFZZ	2530-00-080-7024	72582	5196119	SPACER,TRANSMISSION UOC: C6V,D6V,L6V	1
21	PAFZZ	5306-00-226-4825	80204	B1821BH031C075N	BOLT,MACHINE 5/16-18UNC-2AX3/4 GR8 UOC: C6V,D6V,L6V	1

END OF FIGURE

**FIELD MAINTENANCE
ENGINE FRONT SUPPORT (TRUNNION)**

1
2 AND 3

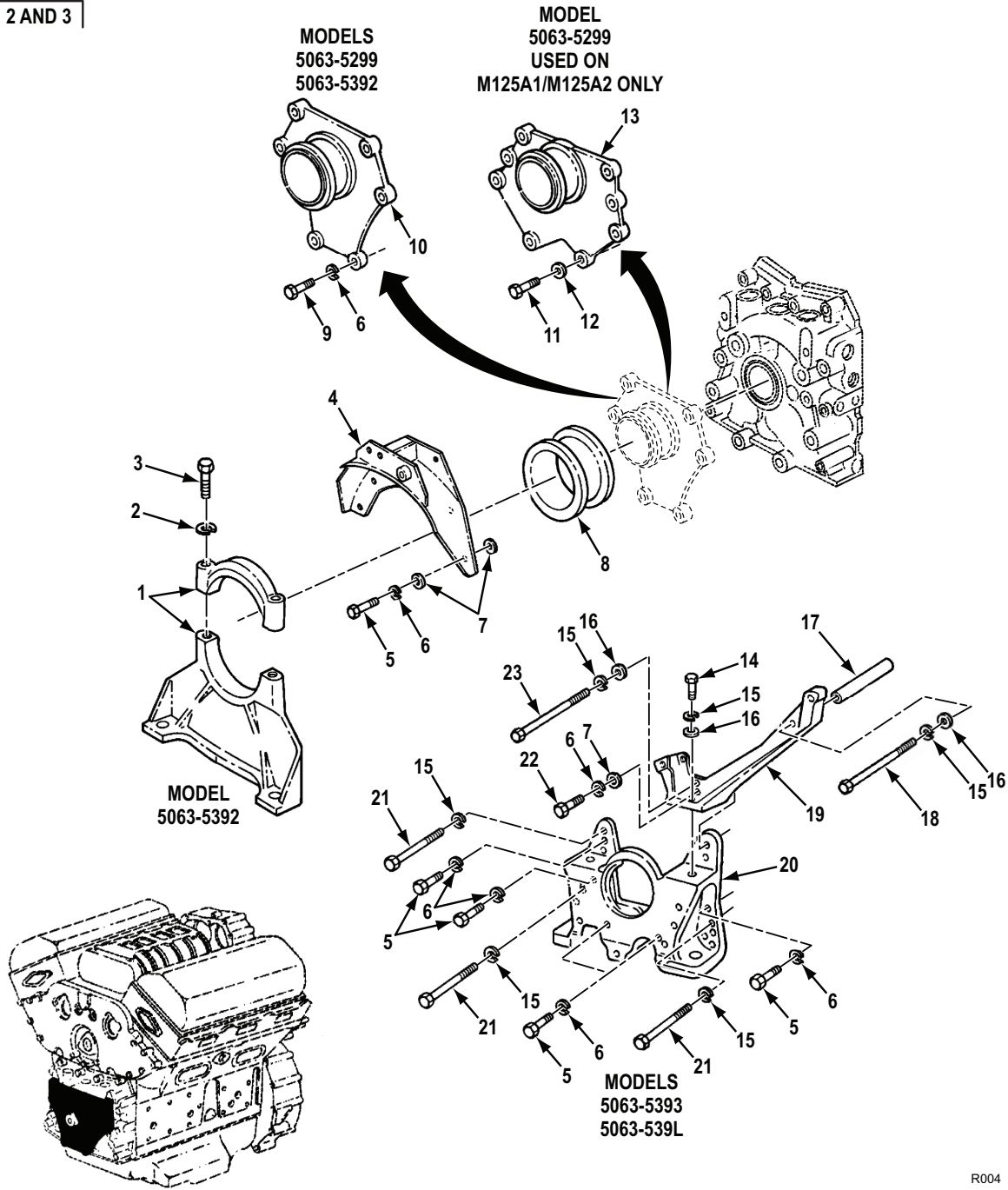

R004

Figure 4. Engine Front Support (Trunnion).

(1) ITEM NO.	(2) SMR CODE	(3) NSN	(4) CAGEC	(5) PART NUMBER	(6) DESCRIPTION AND USABLE ON CODE (UOC)	(7) QTY
GROUP 0101 ENGINE FRONT SUPPORT (TRUNNION)						
FIG. 4. ENGINE FRONT SUPPORT (TRUNNION).						
1	PAFZZ	2510-00-314-3585	72582	5186647	BRACKET,ENGINE MOUNT UOC: C6V	1
2	PAFZZ	5310-00-209-0965	80205	MS35338-47	. WASHER,LOCK UOC: C6V	2
3	PAFZZ	5305-00-071-2058	80204	B1821BH044C225N	. SCREW,CAP,HEXAGON H 7/16-14UNC-2AX2-1/4 GR8 UOC: C6V	2
4	PAFZZ	5340-01-210-4648	19207	12313367	BRACKET,ENGINE ACCESSORY UOC: C6V	1
5	PAFZZ	5305-00-071-2055	80204	B1821BH044C150N	SCREW,CAP,HEXAGON H 7/16-14UNC-2AX1-1/2 GR8 UOC: C6V	4
5	PAFZZ	5305-00-071-2055	80204	B1821BH044C150N	SCREW,CAP,HEXAGON H 7/16-14UNC-2AX1-1/2 GR8 UOC: D6V,L6V	5
6	PAFZZ	5310-00-209-0965	80205	MS35338-47	WASHER,LOCK UOC: AV6,C6V,F6V	6
7	PAFZZ	5310-00-809-4085	96906	MS27183-16	WASHER,FLAT UOC: C6V	1
7	PAFZZ	5310-00-809-4085	96906	MS27183-16	WASHER,FLAT UOC: D6V,L6V	8
8	KFFZZ	5330-00-599-6624	72582	5166864	PACKING,PREFORMED PART OF KIT P/N 8928522, PART OF KIT P/N 8927743 UOC: A6V,C6V,F6V	1
9	PAFZZ	5305-00-071-1788	80204	B1821BH044C125N	SCREW,CAP,HEXAGON H 7/16-14UNC-2AX1-1/4 GR8 UOC: A6V, F6V	6
9	PAFZZ	5305-00-071-1788	80204	B1821BH044C125N	SCREW,CAP,HEXAGON H 7/16-14UNC-2AX1-1/4 GR8 UOC: C6V	2
10	PAFZZ	2815-00-921-5358	72582	5124762	SUPPORT,FRONT MOUNT UOC: A6V,C6V,F6V	1
11	PAFZZ	5306-01-039-9718	96906	MS35764-250	BOLT,MACHINE 7/16-14UNC-2AX1-1/4 GR8,USED ON M125 & M125A2 ONLY UOC: A6V,F6V	8
12	PAFZZ	5310-01-086-3233	19207	11589292	WASHER,FLAT USED ON M125A1& M125A2 ONLY UOC: A6V,F6V	8
13	PAFZZ	2815-00-910-3720	19207	11589281	TRUNNION,ENGINE MOUNT USED ON M125A1& M125A2 ONLY UOC: A6V,F6V	1

(1) ITEM NO.	(2) SMR CODE	(3) NSN	(4) CAGEC	(5) PART NUMBER	(6) DESCRIPTION AND USABLE ON CODE (UOC)	(7) QTY
14	PAFZZ	5305-00-068-0510	80204	B1821BH038C100N	SCREW,CAP,HEXAGON H 3/8-16UNC-2AX1 GR8 UOC: D6V,L6V	1
15	PAFZZ	5310-00-637-9541	59556	019-00004-42	WASHER,LOCK UOC: D6V,L6V	6
16	PAFZZ	5310-00-080-6004	96906	MS27183-14	WASHER,FLAT UOC: D6V,L6V	3
17	PBFZZ	5365-01-255-5047	72582	23501135	SPACER,SLEEVE UOC: D6V,L6V	1
18	PAFZZ	5305-00-165-8037	21450	192884	SCREW,CAP,HEXAGON H 3/8-16UNC-2AX6-3/4 GR5 UOC: D6V,L6V	1
19	PBFZZ	5342-01-252-9503	72582	23501125	BRACKET,ENGINE ACCESSORY UOC: D6V,L6V	1
20	PBFZZ	2510-01-251-4465	72582	8928723	BRACKET,ENGINE MOUNT UOC: D6V,L6V	1
21	PAFZZ	5305-00-857-6886	80204	B1821BH038C450N	SCREW,CAP,HEXAGON H 3/8-16UNC-2AX4-1/2 GR8 UOC: D6V,L6V	3
22	PAFZZ	5305-00-071-2056	80204	B1821BH044C175N	SCREW,CAP,HEXAGON H 7/16-14UNC-2AX1-3/4 GR8 UOC: D6V,L6V	1
23	PAFZZ	5305-00-964-0503	80204	B1821BH038C500N	SCREW,CAP,HEXAGON H 3/8-16UNC-2AX5 GR8 UOC: D6V,L6V	1

END OF FIGURE

**FIELD MAINTENANCE
CYLINDER HEAD ASSEMBLY AND LIFTING BRACKET**

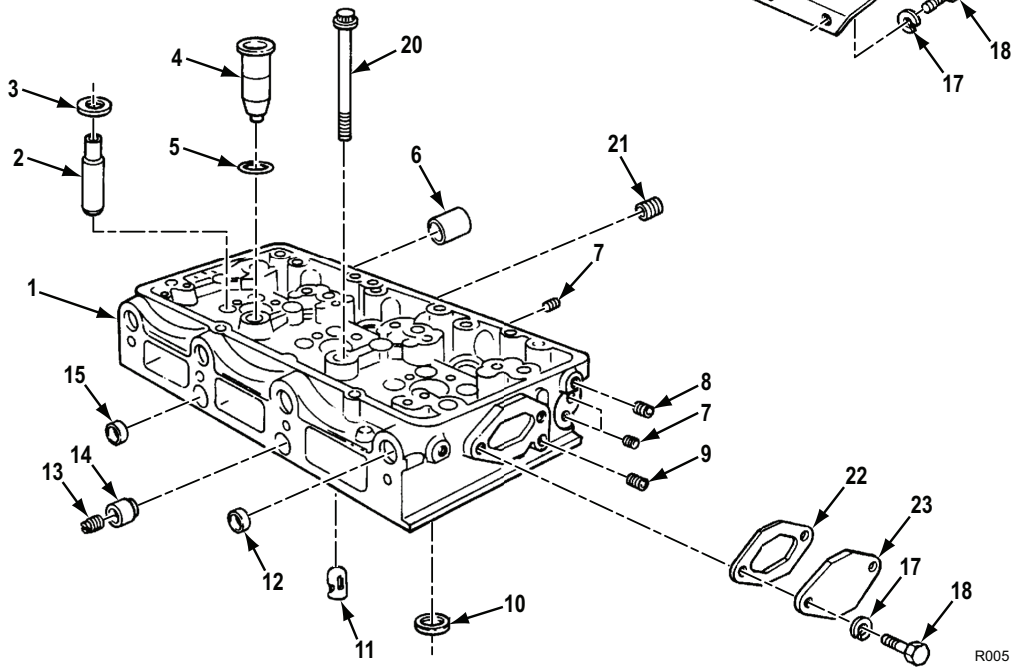
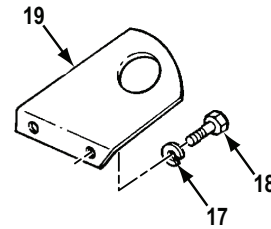
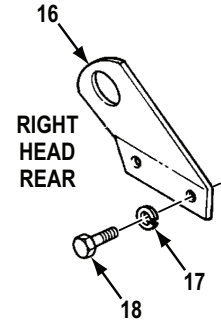
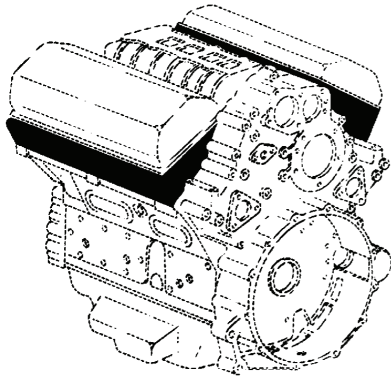
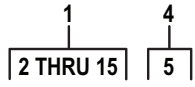

Figure 5. Cylinder Head Assembly and Lifting Bracket.

(1) ITEM NO.	(2) SMR CODE	(3) NSN	(4) CAGEC	(5) PART NUMBER	(6) DESCRIPTION AND USABLE ON CODE (UOC)	(7) QTY
GROUP 0101 CYLINDER HEAD ASSEMBLY AND LIFTING BRACKET						
FIG. 5. CYLINDER HEAD ASSEMBLY AND LIFTING BRACKET.						
1	PAFHH	2815-01-446-5425	72582	23516454	CYLINDER HEAD, DIESE UOC: L6V	2
1	PAFHH	2815-00-789-1006	72582	5198203	CYLINDER HEAD, DIESE UOC: A6V, C6V, D6V, F6V	2
2	PAHZZ	2815-00-159-3528	72582	5131961	. GUIDE, VALVE STEM.....	12
3	PAFZZ	5310-00-053-8377	72582	5111467	. WASHER, FLAT VALVE SPRING SEAT.	12
4	PAHZZ	2910-00-004-3443	72582	8925981	. PARTS KIT, FUEL INJE NEW STYLE TUBE U/W INSTALLER P/N J5286-20.....	3
5	PAHZZ	5331-00-599-0505	72582	5104701	. . O-RING.....	1
6	PAHZZ	3120-00-921-5342	72582	5116262	. BUSHING, SLEEVE GOVERNOR LINKAGE HOLE, REAR.....	1
7	PAHZZ	4730-01-398-7635	72582	8923847	. PLUG, PIPE 5 PC'S IN LEFT SIDE & 6 PC'S IN RIGHT SIDE.....	6
8	PAHZZ	5365-00-142-1775	72915	5154453	PLUG, MACHINE THREAD 4 PC'S USED PER HEAD UOC: A6V, C6V, F6V	8
8	PAHZZ	5365-00-142-1775	72915	5154453	PLUG, MACHINE THREAD 4 PC'S USED ON RIGHT SIDE HEAD, 3 PC'S USED ON LEFT SIDE HEAD UOC: D6V	7
9	PAHZZ	4730-00-371-5337	72582	08924380	. PLUG, PIPE.....	4
10	PAHZZ	2815-01-199-7910	72582	8921501	. INSERT, ENGINE VALVE UOC: A6V, C6V, D6V, F6V	12
10	PAHZZ	2815-00-953-1401	72582	8921502	. INSERT, ENGINE VALVE UOC: L6V	12
11	PAHZZ	2930-00-074-1922	72582	5119293	. NOZZLE, WATER, CYLIND.....	4
12	PAHZZ	5340-00-921-5380	72582	5151449	. PLUG, EXPANSION TWO ON OUTBOARD SIDE, ONE ON INBOARD SIDE.....	3
13	PAFZZ	5340-01-363-7839	72582	5198655	. PLUG, PROTECTIVE, DUS.....	1
14	PAFZZ	3805-00-332-5547	72582	5144425	. ADAPTER CYLINDER HE.....	1
15	PAHZZ	5340-00-202-0765	72582	5139997	. PLUG, EXPANSION WATER GALLERY, OUTBOARD SIDE.....	3
16	PAFZZ	5342-00-435-2347	72582	5127949	BRACKET.....	1
17	PAFZZ	5310-00-637-9541	59556	019-00004-42	WASHER, LOCK.....	8
18	PAFZZ	5305-00-068-0510	80204	B1821BH038C100N	SCREW, CAP, HEXAGON H.....	10
19	PAFZZ	2590-00-999-2340	72582	5125488	BRACKET, EYE, NONROTA.....	2

(1) ITEM NO.	(2) SMR CODE	(3) NSN	(4) CAGEC	(5) PART NUMBER	(6) DESCRIPTION AND USABLE ON CODE (UOC)	(7) QTY
20	PAFZZ	5306-00-792-8248	72582	5121263	BOLT, SHOULDER 5/8-11UNC-3AX6-1/8 GR8.....	1
21	PAFZZ	5365-00-142-1775	72915	5154453	PLUG, MACHINE THREAD INBOARD SIDE, TOP RAIL-4 PC'S IN EACH HEAD.....	8
22	KFFZZ	5330-00-055-1584	72582	5116242	GASKET PART OF KIT P/N 5199811, PART OF KIT P/N 8928522.....	2
23	PAFZZ	2815-00-921-5378	72582	5136610	COVER.....	2

END OF FIGURE

**SUSTAINMENT MAINTENANCE
CRANKSHAFT, MAIN BEARINGS, AND TIMING GEAR**

8
9

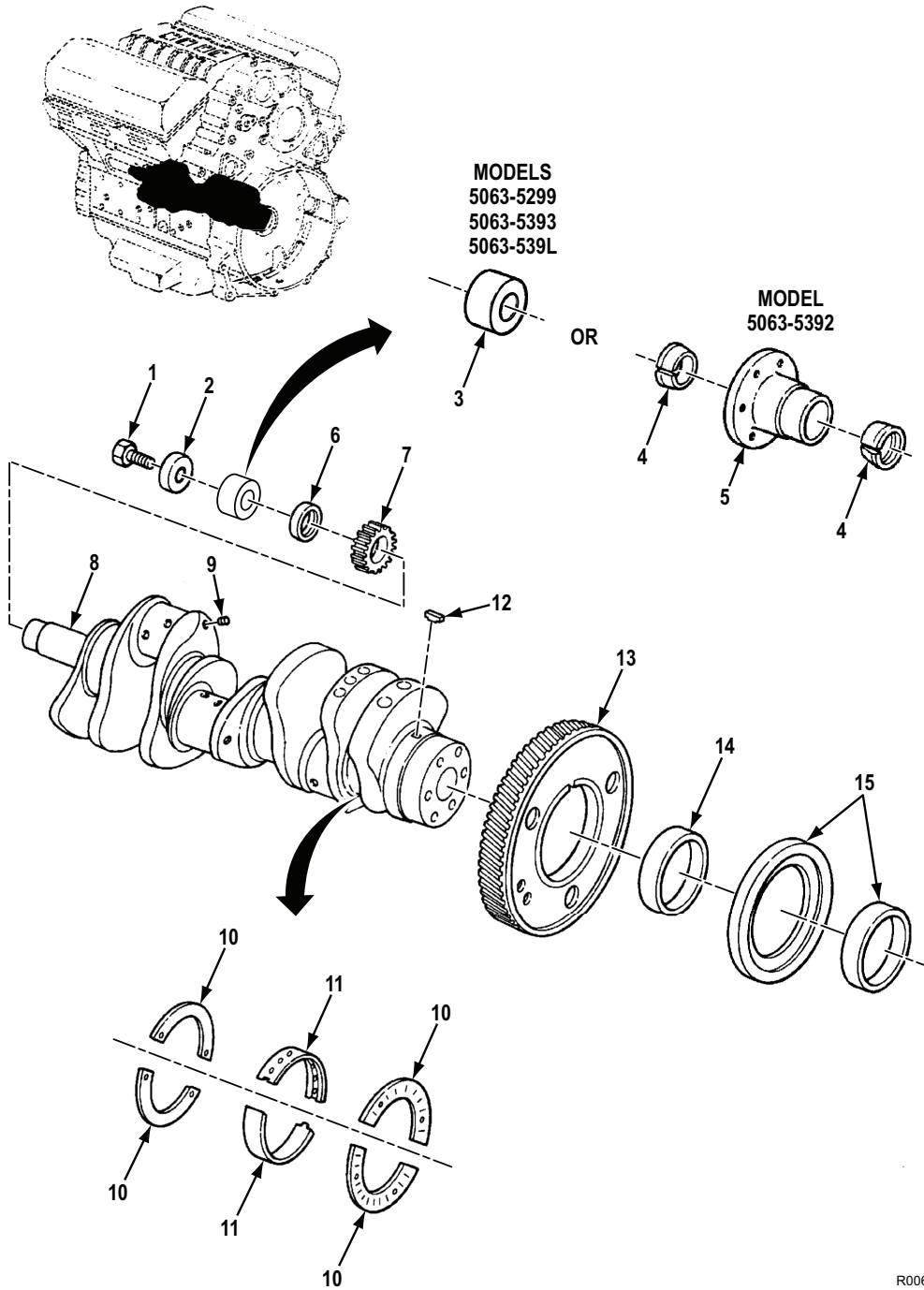

R006

Figure 6. Crankshaft, Main Bearings, and Timing Gear.

(1) ITEM NO.	(2) SMR CODE	(3) NSN	(4) CAGEC	(5) PART NUMBER	(6) DESCRIPTION AND USABLE ON CODE (UOC)	(7) QTY
GROUP 0102 CRANKSHAFT, MAIN BEARINGS, AND TIMING GEAR						
FIG. 6. CRANKSHAFT, MAIN BEARINGS, AND TIMING GEAR.						
1	PAHZZ	5305-00-082-6821	80204	B1821BH075F175N	SCREW,CAP,HEXAGON H 3/4-16UNF-2AX1-3/4 GR8 UOC: A6V,D6V,F6V,L6V	1
1	PAHZZ	5305-00-916-2345	80204	B1821BH075F200N	SCREW,CAP,HEXAGON H 3/4-16UNF-2AX2 GR8 UOC: C6V	1
2	PAHZZ	5365-00-932-4869	72582	5180291	SPACER,RING.....	1
3	PAHZZ	4810-01-209-3412	72582	5138945	SLEEVE,DIRECTIONAL UOC: A6V,D6V,F6V,L6V	1
4	PAHZZ	3020-00-947-2143	51071	11594036	CONE,CRANKSHAFT PUL UOC: C6V,D6V,L6V	2
5	PAHZZ	3040-01-239-7679	19207	12313344	HUB,BODY UOC: C6V	1
6	PAHZZ	3120-00-113-0612	72582	5198502	BUSHING,SLEEVE U/W SEAL, PLAIN ENCASED NSN 5330-00-112-0144 UOC: A6V,F6V	1
6	PAHZZ	5365-00-930-3266	3B518	5138786	SPACER,RING UOC: C6V,D6V,F6V,L6V	1
7	PAHZZ	3020-00-234-2991	72582	8921172	GEAR,SPUR.....	1
8	PAHZZ	2815-01-367-2053	72582	23504732	CRANKSHAFT,ENGINE.....	1
9	PAHZZ	4730-00-005-7376	00501	87708-S	. PLUG,PIPE.....	3
10	PAHZZ	3120-00-367-7235	72582	5192111	BEARING,WASHER,THRU 0.010 IN. US...	4
10	PAHZZ	3120-00-362-9301	72582	5160542	WASHER HALF,THRUST 0.005 IN. US.....	4
10	PAHZZ	3120-00-511-2336	72582	5159353	WASHER HALF,THRUST STD SIZE.....	4
11	PAHZZ	3120-00-169-0043	72582	5198413	BEARING HALF SET,SL 0.020 IN. US.....	1
11	PAHZZ	3120-01-038-8401	72582	5198411	BEARING SET,SLEEVE 0.002 IN. US.....	1
11	PAHZZ	3120-01-038-8402	72582	5198414	BEARING SET,SLEEVE 0.030 IN. US.....	1
11	PAHZZ	3120-00-169-0044	72582	5198412	BEARING HALF SET,SL 0.010 IN. US.....	1
11	PAHZZ	3120-00-922-6487	72582	5198410	BEARING HALF SET,SL STD SIZE.....	1
12	PAHZZ	5315-01-214-1876	72582	8926247	KEY,WOODRUFF.....	1
13	PAHZZ	3020-01-122-8276	72582	5107071	GEAR,HELICAL.....	1
14	PAHZZ	3120-00-781-7773	72582	23516636	BEARING,WASHER,THRU SLEEVE U/W SEAL NSN 5330-00-471-9287.....	1
15	PAHZZ	5330-01-176-7872	72582	8926902	SEAL,PLAIN ENCASED W/ INSTALLATION SLEEVE. UOC: C6V,D6V,L6V	1

(1) ITEM NO.	(2) SMR CODE	(3) NSN	(4) CAGEC	(5) PART NUMBER	(6) DESCRIPTION AND USABLE ON CODE (UOC)	(7) QTY
15	PAHZZ	5330-00-471-9287	72582	5196852	SEAL (OVS) U/W SLEEVE NSN 3120-00-781-7773.....	1

END OF FIGURE

**FIELD MAINTENANCE
DRIVE PLATE, FLYWHEEL, AND HOUSING**

15
16

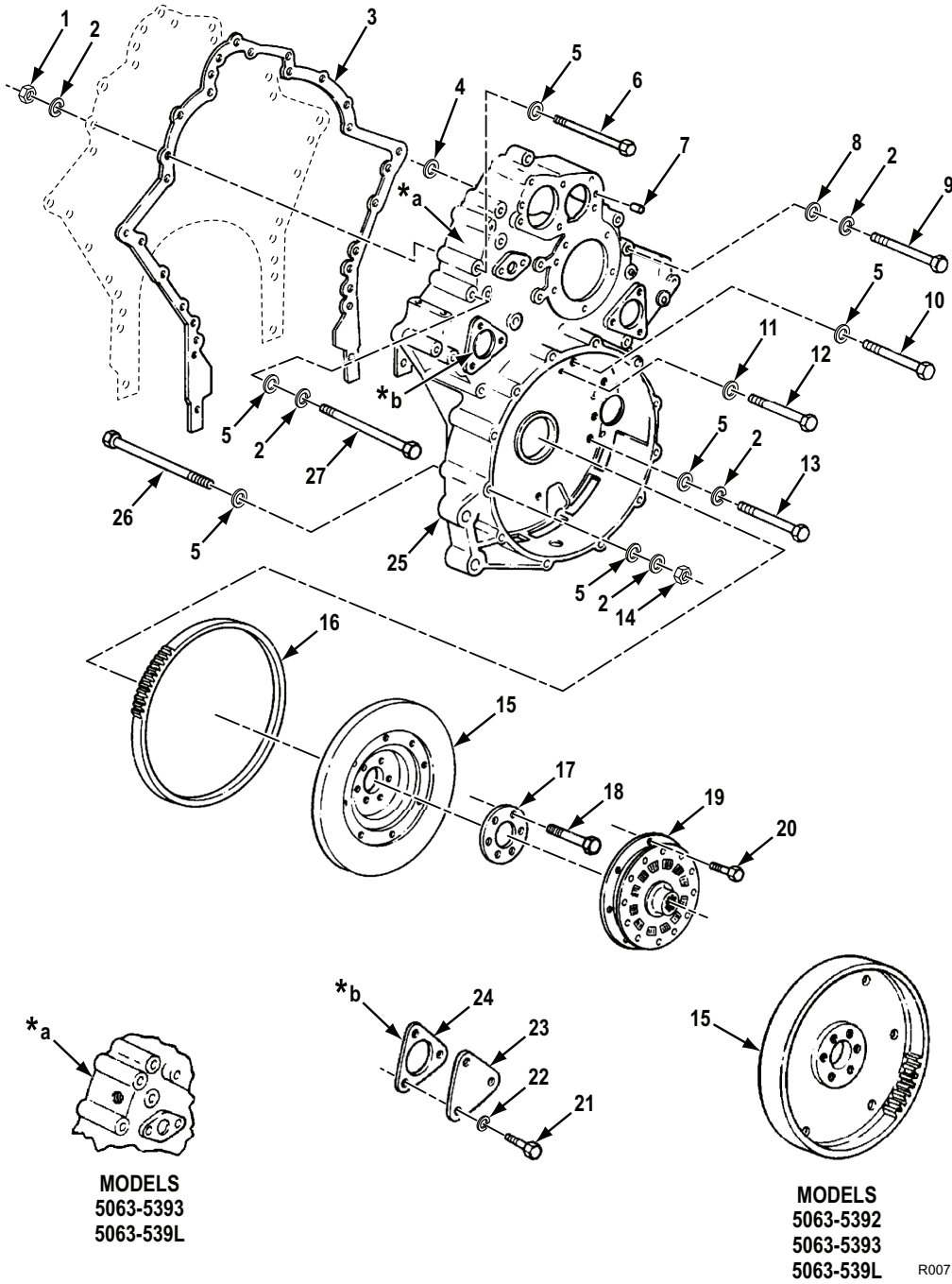

Figure 7. Drive Plate, Flywheel, and Housing.

(1) ITEM NO.	(2) SMR CODE	(3) NSN	(4) CAGEC	(5) PART NUMBER	(6) DESCRIPTION AND USABLE ON CODE (UOC)	(7) QTY
GROUP 0103 DRIVE PLATE, FLYWHEEL, AND HOUSING						
FIG. 7. DRIVE PLATE, FLYWHEEL, AND HOUSING.						
1	PAFZZ	5310-00-732-0559	96906	MS51968-8	NUT,PLAIN,HEXAGON.....	2
2	PAFZZ	5310-00-637-9541	59556	019-00004-42	WASHER,LOCK.....	21
3	KFHZZ	5330-00-944-4148	72582	5137470	GASKET FLYWHEEL HSG TO END PLATE PART OF KIT P/N 8927743, PART OF KIT P/N 8928522.....	1
4	KFHZZ	5330-01-109-6608	72582	5175882	GASKET FLYWHEEL HSG TO END PLATE PART OF KIT P/N 8927743, PART OF KIT P/N 8928522.....	1
5	PAFZZ	5310-00-080-6004	96906	MS27183-14	WASHER,FLAT.....	21
6	PAFZZ	5305-00-269-3248	80204	B1821BH038F350N	SCREW,CAP,HEXAGON H.....	2
7	PAFZZ	5315-00-014-1195	50024	25N450PC49	PIN,STRAIGHT,HEADL.....	1
8	PAFZZ	5310-01-177-5910	75160	24H1682	WASHER,FLAT.....	2
9	PAFZZ	5305-00-269-3247	6W728	4397001-071	SCREW,CAP,HEXAGON H 3/8-24UNF-2AX3-1/4 GR8.....	2
10	PAHZZ	5306-00-053-8378	24617	9414215	BOLT,MACHINE 3/8-16UNC-2AX2-1/2 GR8.....	4
11	PAHZZ	5310-00-081-4219	96906	MS27183-12	WASHER,FLAT.....	2
12	PAHZZ	5306-00-543-5696	19207	8350641	BOLT,MACHINE 5/16-18UNC-2AX2-1/2 GR8.....	2
13	PAHZZ	5305-00-543-2866	80204	B1821BH038C250N	SCREW,CAP,HEXAGON H 3/8-16UNC-2AX2-1/2 GR8.....	8
14	PAFZZ	5310-00-732-0558	96906	MS51967-8	NUT,PLAIN,HEXAGON.....	1
15	PAFZZ	2815-01-285-5068	19207	11650253	FLYWHEEL,ENGINE UOC: C6V,D6V,L6V	1
15	PAFZZ	2815-00-074-1938	72582	5133512	FLYWHEEL,ENGINE UOC: A6V,F6V	1
16	PAFZZ	3020-00-780-5222	72582	5116301	. GEAR,SPUR.....	1
17	PAFZZ	2815-00-074-1932	72582	5126671	PLATE,SCUFF,FLYWHEE.....	1
18	PAFZZ	5306-00-057-8494	72582	9409129	BOLT,MACHINE 1/2-20UNF-2AX1-3/4 GR8.....	6
19	PAFZZ	2520-00-789-4847	72582	5133530	CLUTCH PLATE ASSEMB FLYWHEEL UOC: A6V,F6V	1
20	PAFZZ	5306-01-193-9291	72582	8927580	BOLT,MACHINE 3/8-16UNC-2AX1.015 GR8 UOC: A6V,F6V	8
21	PAFZZ	5306-00-226-4826	72582	186625	BOLT,MACHINE.....	3
22	PAFZZ	5310-00-407-9566	80205	MS35338-45	WASHER,LOCK.....	3
23	PAFZZ	5340-00-148-0886	72582	5152716	COVER,ACCESS.....	1

(1) ITEM NO.	(2) SMR CODE	(3) NSN	(4) CAGEC	(5) PART NUMBER	(6) DESCRIPTION AND USABLE ON CODE (UOC)	(7) QTY
24	PAFZZ	5330-01-392-3715	70177	K 5150193 NON- ASBESTOS	GASKET PART OF KIT P/N 8927743, PART OF KIT P/N 8928522.....	1
25	PAHDD	2815-01-248-2560	72582	8928647	HOUSING,FLYWHEEL UOC: D6V,L6V	1
25	PAHDD	2805-01-218-4524	72582	8926085	HOUSING,FLYWHEEL UOC: A6V,C6V,F6V	1
26	PAFZZ	5305-00-857-6886	80204	B1821BH038C450N	SCREW,CAP,HEXAGON H 3/8-16UNC-2AX4-1/2 GR8 UOC: D6V,L6V	1
26	PAFZZ	5305-00-781-3928	80204	B1821BH038C400N	SCREW,CAP,HEXAGON H 3/8-16UNC-2AX4 GR8 UOC: A6V,C6V,F6V	1
27	PAFZZ	5305-00-990-8632	80204	B1821BH038C375N	SCREW,CAP,HEXAGON H 3/8-16UNC-2AX3-3/4 GR8.....	8

END OF FIGURE

**SUSTAINMENT MAINTENANCE
PISTON AND ROD ASSEMBLY (TRUNK TYPE) WITH LINER (MODEL 5063-5299)**

5	9
6	10 AND 11

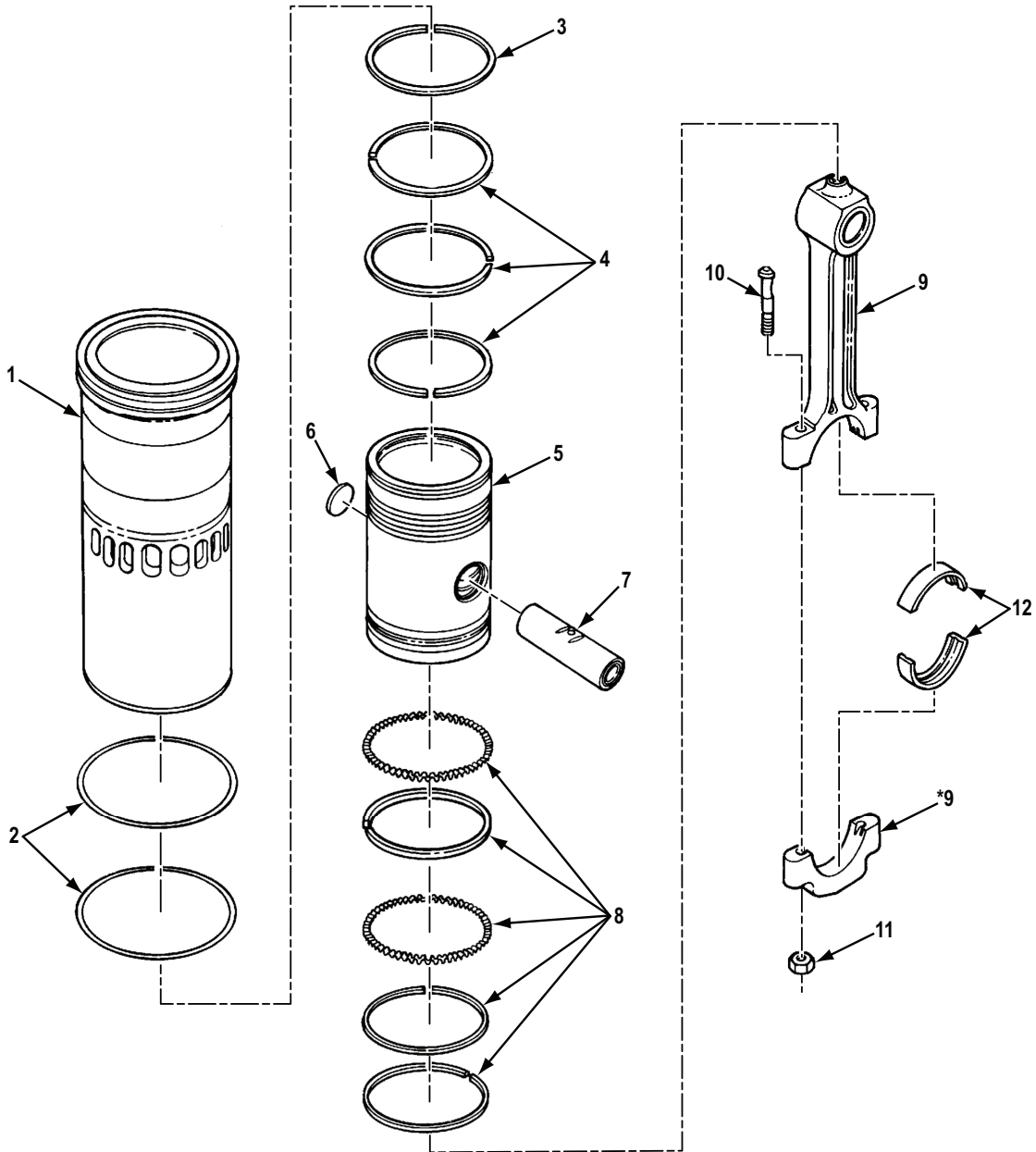

*9 PART OF ITEM 9

R008

Figure 8. Piston and Rod Assembly (Trunk Type) with Liner (Model 5063-5299).

(1) ITEM NO.	(2) SMR CODE	(3) NSN	(4) CAGEC	(5) PART NUMBER	(6) DESCRIPTION AND USABLE ON CODE (UOC)	(7) QTY
GROUP 0104 PISTON AND ROD ASSEMBLY (TRUNK TYPE) WITH LINER (MODEL 5063-5299)						
FIG. 8. PISTON AND ROD ASSEMBLY (TRUNK TYPE) WITH LINER (MODEL 5063-5299).						
1	PAHZZ	2815-01-211-8632	72582	5149944	CYLINDER SLEEVE (8632, 0.20) UOC: A6V,F6V	6
1	PAHZZ	2815-00-866-9402	72582	5132803	CYLINDER SLEEVE (9402, STD SIZE) UOC: A6V,F6V	6
1	PAHZZ	2815-01-119-4960	72582	5101016	CYLINDER SLEEVE (4960, 0.10) UOC: A6V,F6V	6
2	PAHZZ	5330-00-179-6227	72582	5121256	PACKING,PREFORMED UOC: A6V,F6V	12
2	PAHZZ	5330-01-226-9241	72582	5149945	SEAL UOC: A6V,F6V	12
3	KFHZZ	2815-01-187-4704	72582	8923328	RING,PISTON TOP GROOVE PART OF KIT P/N 5199116, PART OF KIT P/N 5198901 UOC: A6V,F6V	6
4	KFHZZ	2815-00-883-5593	72582	5116184	RING,PISTON SECOND, THIRD, & FOURTH GROOVE PART OF KIT P/N 5199116, PART OF KIT P/N 5198901 UOC: A6V,F6V	18
5	PAHZZ	2815-00-922-8355	72582	5198877	PARTS KIT,PISTON ASSEMBLY,ENGINE PART OF KIT P/N 5199116 UOC: A6V,F6V	6
6	PAHZZ	2815-01-075-7813	72582	5108131	. RETAINER,PISTON PIN UOC: A6V,F6V	12
7	PAHZZ	2815-00-820-7455	72582	5116189	PIN,PISTON PART OF KIT P/N 5199116 UOC: A6V,F6V	6
8	KFHZZ	2815-00-112-4606	72582	5198092	RING SET,PISTON PART OF KIT P/N 5199116, PART OF KIT P/N 5198901 UOC: A6V,F6V	6
9	PAHZZ	2815-00-451-6672	72582	5140949	CONNECTING ROD PIST UOC: A6V,F6V	6
10	PAHZZ	5306-00-789-4849	72582	5197852	. BOLT,CONNECTING ROD UOC: A6V,F6V	2
11	PAHZZ	5310-00-282-5658	7X677	839103	. NUT,PLAIN,HEXAGON UOC: A6V,F6V	2
12	PAHZZ	3120-00-921-5397	72582	5197977	BEARING,SLEEVE 0.010 IN UOC: A6V,F6V	6
12	PAHZZ	3120-00-089-6425	72582	5197979	BEARING,SLEEVE 0.030 IN UOC: A6V,F6V	6

(1) ITEM NO.	(2) SMR CODE	(3) NSN	(4) CAGEC	(5) PART NUMBER	(6) DESCRIPTION AND USABLE ON CODE (UOC)	(7) QTY
12	PAHZZ	3120-00-921-5398	72582	5197978	BEARING HALF SET,SLEEVE 0.020 IN UOC: A6V,F6V	6
12	PAHZZ	3120-00-921-5396	72582	5197976	BEARING HALF SET,SLEEVE 0.002 IN UOC: A6V,F6V	6
12	PAHZZ	3120-00-789-4851	72582	5197975	BEARING HALF SET,SLEEVE STD SIZE UOC: A6V,F6V	6

END OF FIGURE

**SUSTAINMENT MAINTENANCE
PISTONS AND ROD ASSEMBLY (CROSSHEAD TYPE) WITH LINER**

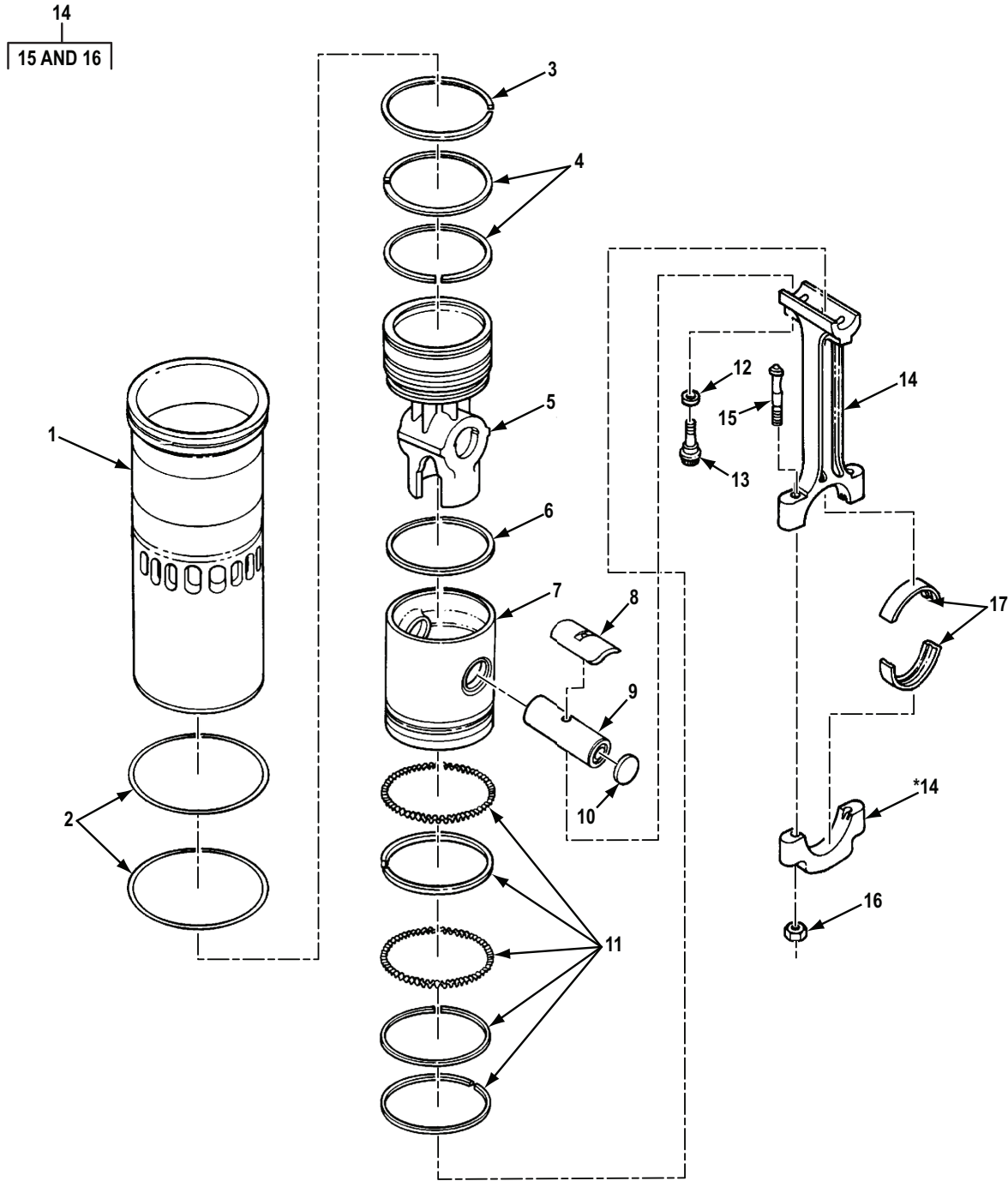

*14 PART OF ITEM 14

R009

Figure 9. Pistons and Rod Assembly (Crosshead Type) With Liner.

(1) ITEM NO.	(2) SMR CODE	(3) NSN	(4) CAGEC	(5) PART NUMBER	(6) DESCRIPTION AND USABLE ON CODE (UOC)	(7) QTY
GROUP 0104 PISTONS AND ROD ASSEMBLY (CROSSHEAD TYPE) WITH LINER						
FIG. 9. PISTONS AND ROD ASSEMBLY (CROSSHEAD TYPE) WITH LINER.						
1	PAHZZ	2815-01-119-4960	72582	5101016	CYLINDER SLEEVE 0.010 IN. OVS UOC: C6V,D6V,L6V	6
1	PAHZZ	2815-01-211-8632	72582	5149944	CYLINDER SLEEVE 0.020 IN. OVS UOC: C6V,D6V,L6V	6
1	PAHZZ	2815-00-866-9402	72582	5132803	CYLINDER SLEEVE STD SIZE UOC: C6V,D6V,L6V	6
2	PAHZZ	5330-01-226-9241	72582	5149945	SEAL USE WITH 0.020 IN. OVS LINER UOC: C6V,D6V,L6V	6
2	KFHZZ	5330-00-179-6227	72582	5121256	PACKING,PREFORMED STD SIZE PART OF KIT P/N 8928522, PART OF KIT P/N 23503811 UOC: C6V,D6V,L6V	12
3	KFHZZ	2815-01-220-9169	72582	8925780	RING,PISTON TOP GROOVE PART OF KIT P/N 8927223, PART OF KIT P/N 23503811 UOC: C6V,D6V,L6V	6
4	KFHZZ	2815-01-220-6659	72582	8925779	RING,PISTON SECOND & THIRD GROOVE PART OF KIT P/N 8927223, PART OF KIT P/N 23503811 UOC: C6V,D6V,L6V	12
5	KFHZZ	2815-01-442-3405	72582	23503948	PISTON, INTERNAL COM PART OF KIT P/N 23503779 UOC: C6V,D6V,L6V	6
6	KFHZZ	5330-01-224-1474	72582	8924733	GASKET PART OF KIT P/N 23503779, PART OF KIT P/N 23503811 UOC: C6V,D6V,L6V	6
7	PAHZZ	2815-01-230-0204	72582	8924002	SKIRT,PISTON UOC: C6V,D6V,L6V	6
8	KFHZZ	3120-01-227-5718	72582	23504946	BEARING,HALF SLEEVE PART OF KIT P/N 23503811, PART OF KIT P/N 23503779 UOC: C6V,D6V,L6V	6
9	PAHZZ	2815-01-220-9175	72582	8924735	PIN,PISTON PART OF KIT P/N 23503811, PART OF KIT P/N 23503779 UOC: C6V,D6V,L6V	6
10	KFHZZ	5340-01-224-1560	72582	8924731	DISK,SOLID,PLAIN PART OF KIT P/N 23503779, PART OF KIT P/N 23503811 UOC: C6V,D6V,L6V	12

(1) ITEM NO.	(2) SMR CODE	(3) NSN	(4) CAGEC	(5) PART NUMBER	(6) DESCRIPTION AND USABLE ON CODE (UOC)	(7) QTY
11	KFHZZ	2815-01-230-0207	72582	8927224	RING SET,OIL TWO PC OIL RING IN LWR GROOVE, ONE PC OIL RING IN UGROOVE PART OF KIT P/N 8927223, PART OF KIT P/N 23503811 UOC: C6V,D6V,L6V	6
12	PAHZZ	5365-01-223-7179	72582	8924732	SPACER,SLEEVE UOC: C6V,D6V,L6V	12
13	PAHZZ	5306-01-254-6351	72582	8924734	BOLT,MACHINE 3/8-24UNJF-3AX1-7/8 GR8,12 PT HEAD-SPECIAL UOC: C6V,D6V,L6V	12
14	PAHZZ	2815-01-220-9380	72582	8924003	CONNECTING ROD,PIST UOC: C6V,D6V,L6V	6
15	PAHZZ	5306-00-789-4849	72582	5197852	. BOLT,CONNECTING ROD 3/8-24UNF-3AX2.76 GR8 UOC: C6V,D6V,L6V	2
16	PAHZZ	5310-00-282-5658	72582	839103	. NUT,PLAIN,HEXAGON CONNECTING ROD UOC: C6V,D6V,L6V	2
17	PAHZZ	3120-00-921-5398	72582	5197978	BEARING HALF SET,SL 0.020 IN. US UOC: C6V,D6V,L6V	6
17	PAHZZ	3120-00-089-6425	72582	5197979	BEARING,SLEEVE 0.030 IN. US UOC: C6V,D6V,L6V	6
17	PAHZZ	3120-00-789-4851	72582	5197975	BEARING HALF SET,SL STD SIZE UOC: C6V,D6V,L6V	6
17	PAHZZ	3120-00-921-5396	72582	5197976	BEARING HALF SET,SL 0.002 IN. US UOC: C6V,D6V,L6V	6
17	PAHZZ	3120-00-921-5397	72582	5197977	BEARING,SLEEVE 0.010 IN. US UOC: C6V,D6V,L6V	6

END OF FIGURE

**FIELD MAINTENANCE
ROCKER ARM COVERS (MODEL 5063-5299)**

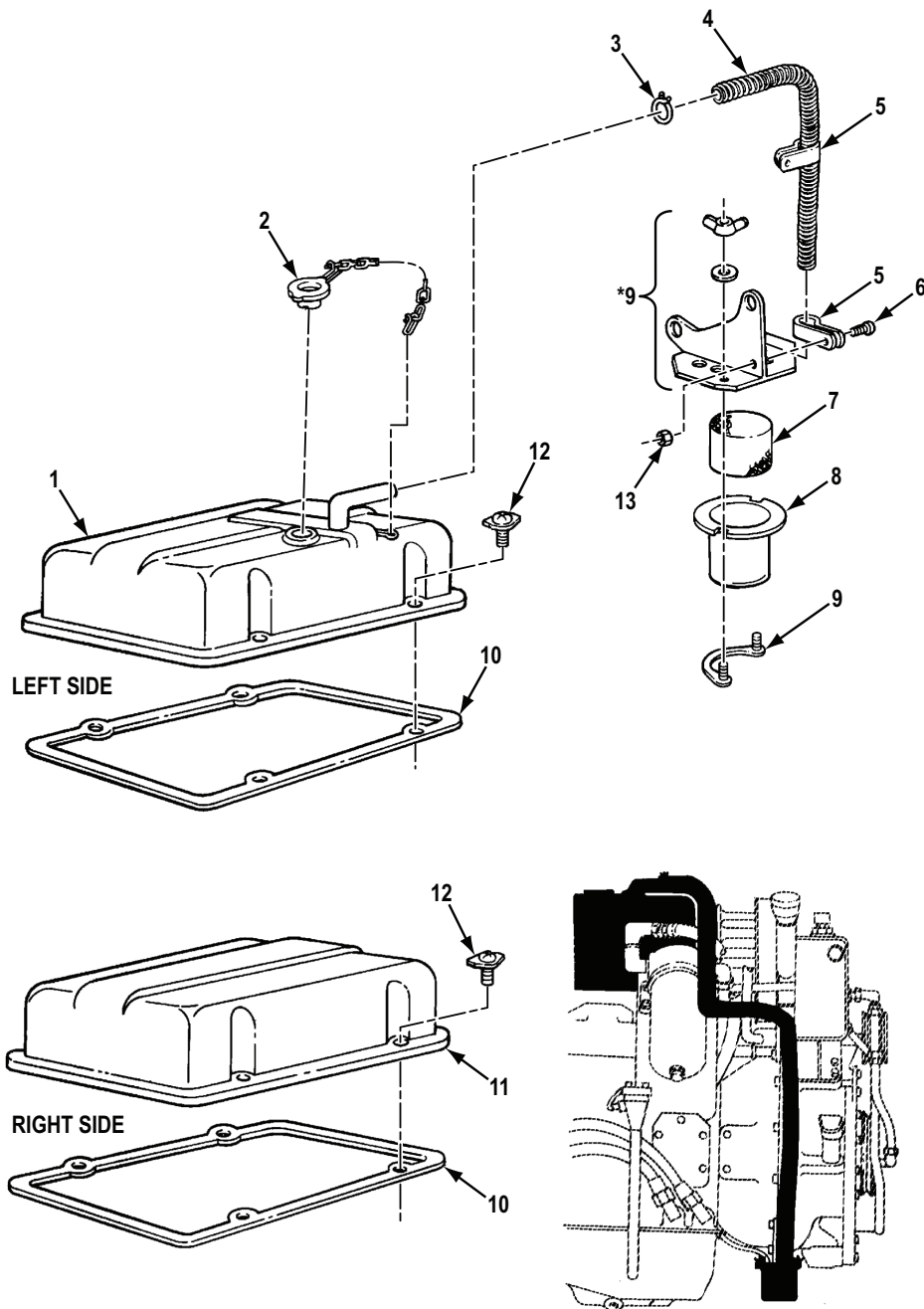

*9 PART OF ITEM 9

R010

Figure 10. Rocker Arm Covers (Model 5063-5299).

(1) ITEM NO.	(2) SMR CODE	(3) NSN	(4) CAGEC	(5) PART NUMBER	(6) DESCRIPTION AND USABLE ON CODE (UOC)	(7) QTY
GROUP 0105 ROCKER ARM COVERS (MODEL 5063-5299)						
FIG. 10. ROCKER ARM COVERS (MODEL 5063-5299).						
1	PAFZZ	2815-01-289-3771	72582	5135046	COVER,ENGINE POPPET LEFT SIDE ON MODEL 5063-5299 UOC: A6V,F6V	1
2	PAFZZ	2590-00-758-9043	72582	5140259	CAP,FILLER OPENING UOC: A6V,F6V	1
3	PAFZZ	4730-00-071-7890	81343	J1508	CLAMP,HOSE TYPE E, SIZE-18 UOC: A6V,F6V	1
4	PAFZZ	4720-01-157-3800	72582	5145678	HOSE,NONMETALLIC UOC: A6V,F6V	1
5	PAFZZ	5340-00-125-3204	72582	5181415	CLAMP,LOOP UOC: A6V,F6V	2
6	PAFZZ	5305-00-984-6211	05047	ASME B18.6.3	SCREW,MACHINE UOC: A6V,F6V	1
7	PAFZZ	2940-00-057-1582	16236	CS-2940-SV-0706	FILTER ELEMENT,INTA UOC: A6V,F6V	1
8	PBFZZ	2990-00-890-0697	72582	5134825	RECEPTACLE,DRAINBOX UOC: A6V,F6V	1
9	PAFZZ	5340-01-132-5145	19207	12269598	BRACKET,MOUNTING UOC: A6V,F6V	1
10	PAFZZ	5330-00-792-9026	72582	5119457	GASKET UOC: A6V,F6V	2
11	PAFZZ	5340-00-089-6430	72582	5121044	COVER,ACCESS RIGHT SIDE ON MODEL 5063-5299 UOC: A6V,F6V	1
12	PAFZZ	2815-00-074-1929	72582	5100104	CLAMP AND SCREW,ROC UOC: A6V,F6V	8
13	PAFZZ	5310-00-934-9764	80205	MS35649-205B	NUT,PLAIN,HEXAGON UOC: A6V,F6V	1

END OF FIGURE

FIELD MAINTENANCE
ROCKER ARM COVERS (MODELS 5063-5392, 5063-5393, AND 5063-539L)

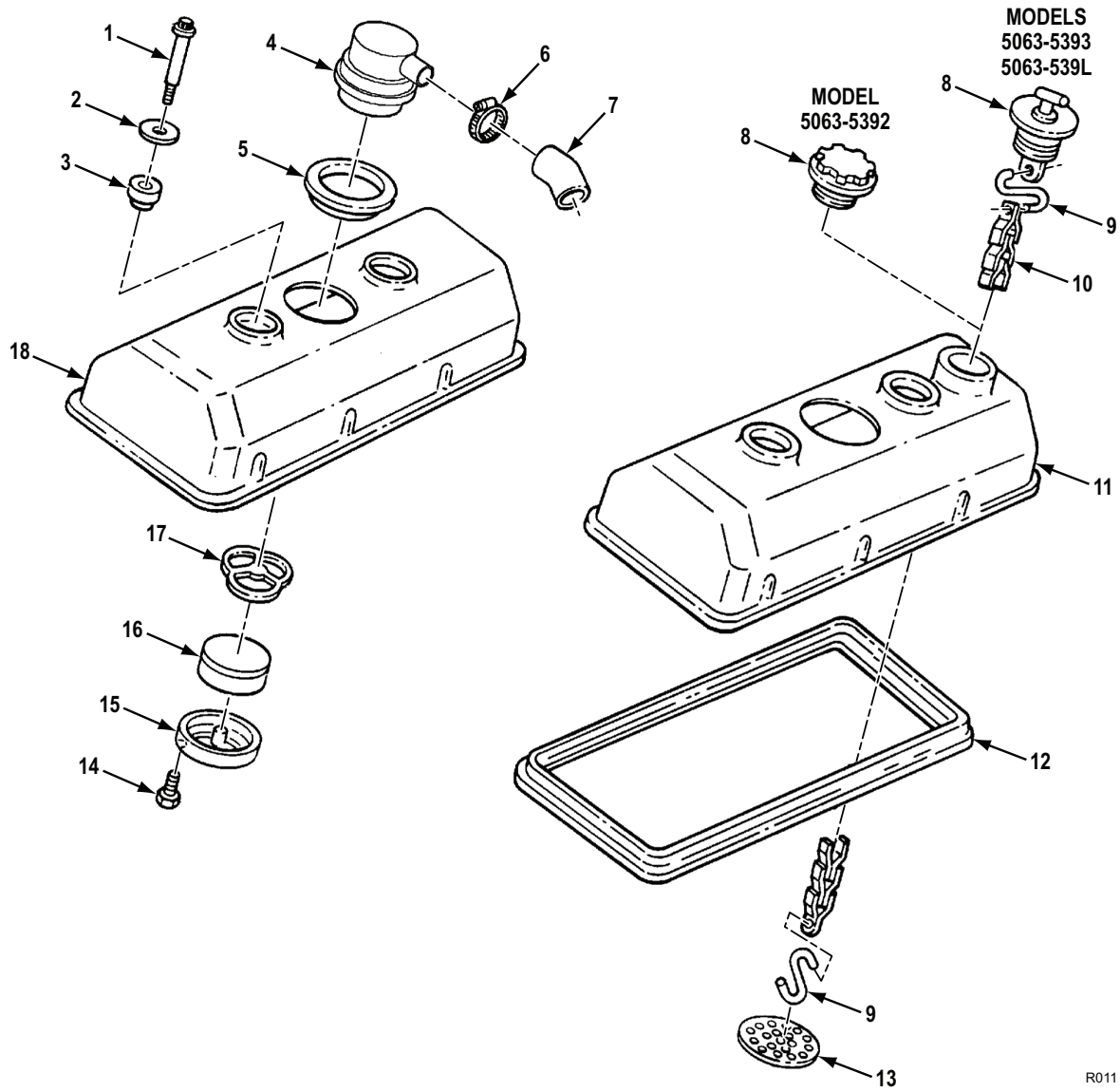

R011

Figure 11. Rocker Arm Covers (Models 5063-5392, 5063-5393, and 5063-539L).

(1) ITEM NO.	(2) SMR CODE	(3) NSN	(4) CAGEC	(5) PART NUMBER	(6) DESCRIPTION AND USABLE ON CODE (UOC)	(7) QTY
<p>GROUP 0105 ROCKER ARM COVERS (MODELS 5063-5392, 5063-5393, AND 5063-539L)</p> <p>FIG. 11. ROCKER ARM COVERS (MODELS 5063-5392, 5063-5393, AND 5063-539L).</p>						
1	PAFZZ	5306-01-078-4969	72582	5103635	BOLT UOC: C6V,D6V,L6V	4
2	PAFZZ	5310-01-055-4420	72582	5104514	WASHER,FLAT UOC: C6V,D6V,L6V	4
3	PAFZZ	5340-01-057-4230	72582	5104515	MOUNT,RESILIENT,GENERAL PURPOSE UOC: C6V,D6V,L6V	4
4	PAFZZ	2815-01-078-1333	72582	23515215	BREATHER UOC: C6V,D6V,L6V	2
5	PAFZZ	5330-01-088-2740	72582	5103646	SEAL,PLAIN UOC: C6V,D6V,L6V	2
6	PAFZZ	4730-00-908-3193	58536	A-A-52506-F-24	CLAMP,HOSE UOC: D6V,L6V	2
7	PAFZZ	4720-01-251-3203	72582	23501683	HOSE,PREFORMED UOC: D6V,L6V	2
8	PAFZZ	5340-01-419-5059	72582	23502458	PLUG SET,PROTECTIVE UOC: D6V,L6V	1
8	PAFZZ	2590-01-235-5017	78225	A0-3364	CAP,FILLER OPENING UOC: C6V	1
9	PAFZZ	4030-01-163-2286	45152	2AG452	HOOK,CHAIN,S UOC: D6V,L6V	2
10	MFFZZ	3805-00-340-7047	72582	05113825	CHAIN,CAP 6.50 IN. LG, MAKE FROM CHAIN,P/N 5113825 UOC: D6V,L6V	1
11	PAFZZ	2815-01-235-5044	72582	8925269	COVER,ENGINE POPPET RIGHT SIDE; MODEL 5063-5392, OIL FILL TO REAR, MODE5063-5393 AND 5063-539L, OIL FILL TO FRONT. UOC: C6V,D6V,L6V	1
12	PAFZZ	5330-01-242-0467	72582	8925273	GASKET UOC: C6V,D6V,L6V	2
13	PAFZZ	4730-01-267-2654	72582	23501682	STRAINER ELEMENT,SE UOC: C6V,D6V,L6V	1
14	PAFZZ	5305-01-078-1999	72582	5103642	SCREW,CAP,HEXAGON H #10-24UNC-2AX3/8 GR5 UOC: C6V,D6V,L6V	6
15	PAFZZ	2815-01-078-2724	72582	5103647	RETAINER,ROCKER UOC: C6V,D6V,L6V	2
16	PAFZZ	2940-00-089-2520	72582	5101760	FILTERING DISK,FLUI UOC: C6V	2

(1) ITEM NO.	(2) SMR CODE	(3) NSN	(4) CAGEC	(5) PART NUMBER	(6) DESCRIPTION AND USABLE ON CODE (UOC)	(7) QTY
16	PAFZZ	2940-01-251-0666	72582	8927797	FILTER ELEMENT,FLUI UOC: D6V,L6V	2
17	PAFZZ	2815-01-078-2723	72582	5103636	RETAINER,BREATHER UOC: C6V,D6V,L6V	2
18	PAFZZ	2815-01-235-5043	72582	8925270	COVER,ENGINE POPPET LEFT SIDE; MODELS 5063-5392,5063-5393 AND 5063-539. UOC: C6V,D6V,L6V	1

END OF FIGURE

**SUSTAINMENT MAINTENANCE
CAMSHAFTS, IDLER GEAR, AND BALANCE GEAR**

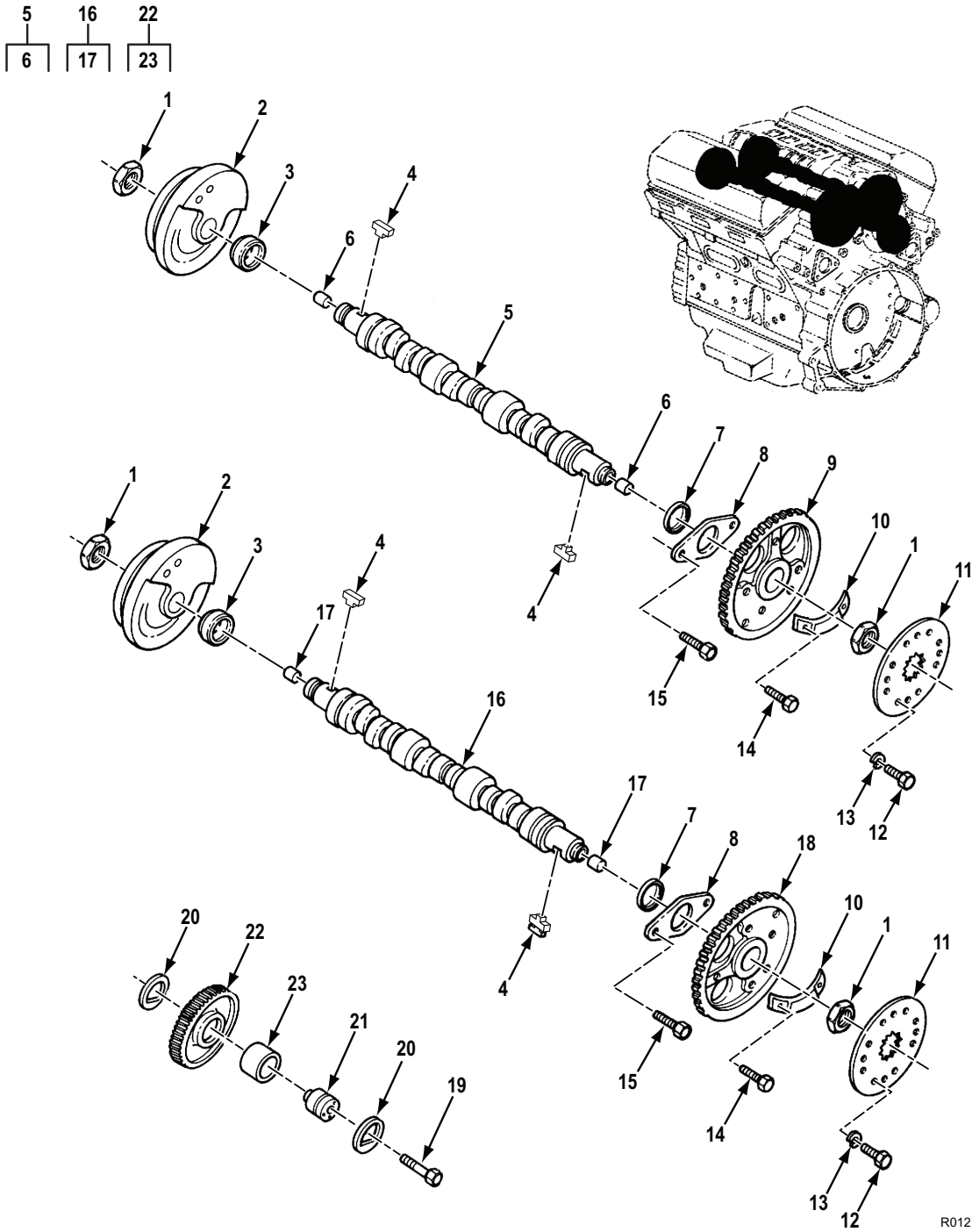

Figure 12. Camshafts, Idler Gear, and Balance Gear.

(1) ITEM NO.	(2) SMR CODE	(3) NSN	(4) CAGEC	(5) PART NUMBER	(6) DESCRIPTION AND USABLE ON CODE (UOC)	(7) QTY
GROUP 0105 CAMSHAFTS, IDLER GEAR, AND BALANCE GEAR						
FIG. 12. CAMSHAFTS, IDLER GEAR, AND BALANCE GEAR.						
1	PAHZZ	5310-00-274-4658	72582	5150087	NUT,PLAIN,HEXAGON.....	4
2	PAHZZ	3020-00-921-6994	72582	8925945	PULLEY,GROOVE UOC: A6V,F6V	2
2	PAHZZ	3020-01-236-6082	72582	8925942	PULLEY,GROOVE UOC: C6V,D6V,L6V	2
3	PAHZZ	5365-01-133-9149	72582	5106360	SPACER.....	2
4	PAHZZ	5315-01-205-3204	72582	8926248	KEY.....	4
5	PAHZZ	2815-01-028-8647	72582	5199397	CAMSHAFT ASSEMBLY RIGHT SIDE UOC: C6V,D6V,L6V	1
5	PAHZZ	2815-00-074-1934	72582	5126934	CAMSHAFT,ENGINE RIGHT SIDE UOC: A6V,F6V	1
6	PAHZZ	5315-00-276-4818	72582	5151277	. PIN,STRAIGHT,HEADLE.....	2
7	PAHZZ	5365-00-761-1985	72582	5121077	SPACER,SLEEVE.....	2
8	PAHZZ	5365-00-792-9028	72582	5116198	SPACER,PLATE.....	2
9	PAHZZ	3020-01-122-7790	72582	5107072	GEAR,HELICAL RIGHT SIDE.....	1
10	PBHZZ	3040-01-235-5038	72582	8926005	WEIGHT,COUNTERBALAN UOC: C6V,D6V,L6V	2
11	PAHZZ	3040-00-692-4152	72582	5172734	PLATE,RETAINING,SHA UOC: C6V,D6V,L6V	2
12	PAHZZ	5305-00-269-3234	80204	B1821BH038F075N	SCREW,CAP,HEXAGON H 3/8-24UNF-2AX3/4 GR8.....	4
13	PAHZZ	5310-00-637-9541	59556	019-00004-42	WASHER,LOCK.....	4
14	PAHZZ	5306-01-133-0812	72582	5101779	BOLT.....	4
15	PAHZZ	5306-01-421-9946	72582	9409029	BOLT,SELF-LOCKING 3/8-16UNC-2AX1.125 GR8	4
16	PAHZZ	2815-00-074-1933	72582	5126933	CAMSHAFT,ENGINE LEFT SIDE UOC: A6V,F6V	1
16	PAHZZ	2815-01-053-1377	72582	5199396	CAMSHAFT,ENGINE LEFT SIDE UOC: C6V,D6V,L6V	1
17	PAHZZ	5315-00-276-4818	72582	5151277	. PIN,STRAIGHT,HEADLE.....	2
18	PAHZZ	3020-01-123-0303	72582	5107073	CAM AND BALANCE GEA LEFT SIDE.....	1
19	PAHZZ	5305-00-821-3869	80204	B1821BH038C175N	SCREW,CAP,HEXAGON H 3/8-16UNC-2AX1-3/4 GR8.....	1
20	PAHZZ	3120-00-074-1911	72582	5132504	BEARING,WASHER,THRU.....	2
21	PAHZZ	3040-00-921-5357	72582	5124458	HUB,BODY.....	1
22	PAHZZ	3020-01-123-8875	72582	05107075	GEAR,HELICAL.....	1

(1) ITEM NO.	(2) SMR CODE	(3) NSN	(4) CAGEC	(5) PART NUMBER	(6) DESCRIPTION AND USABLE ON CODE (UOC)	(7) QTY
23	PAHZZ	3120-00-830-0246	72582	5196793	. BEARING,SLEEVE.....	1

END OF FIGURE

**SUSTAINMENT MAINTENANCE
ROCKER ARM ASSEMBLIES, VALVES, AND CAM FOLLOWERS**

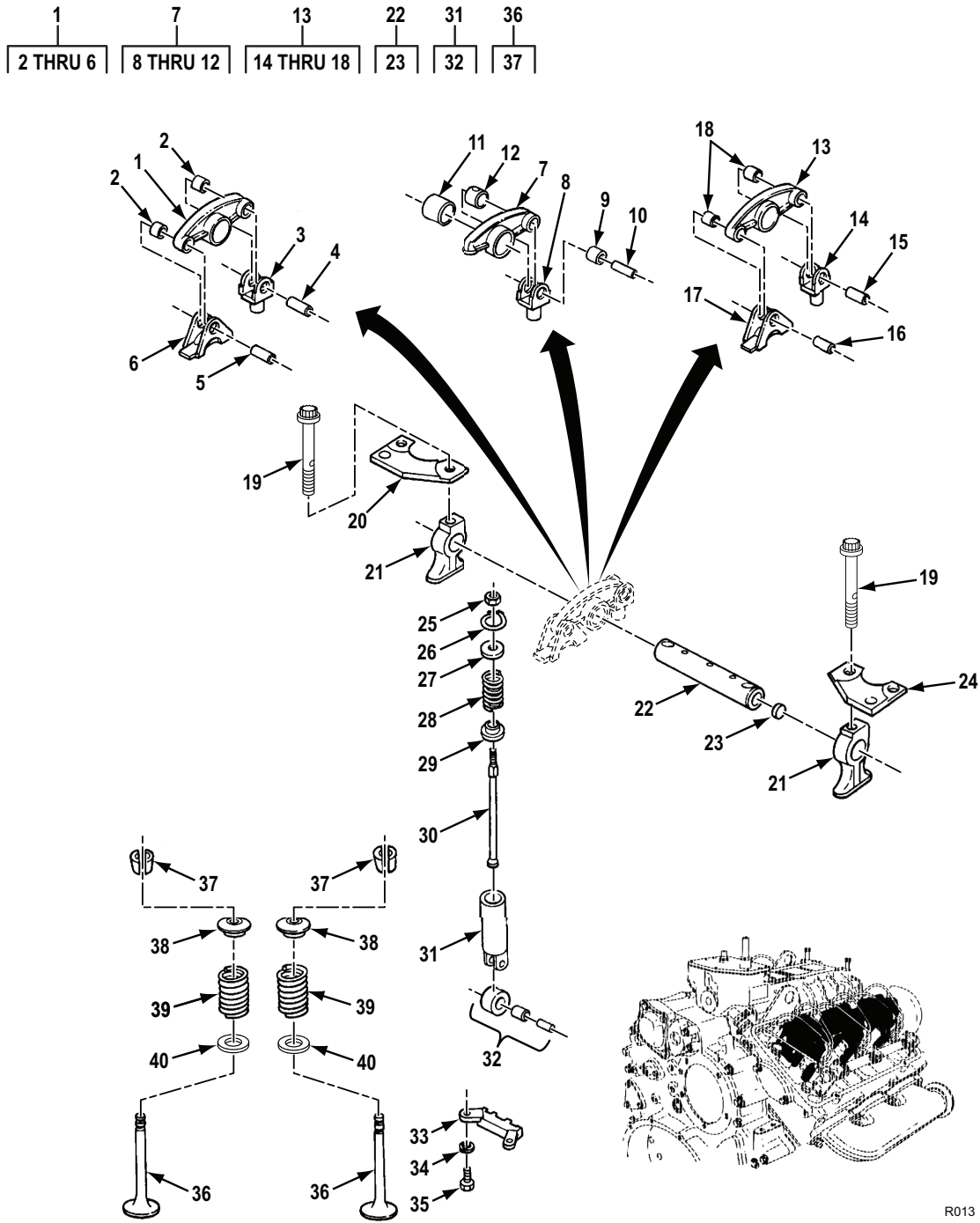

Figure 13. Rocker Arm Assemblies, Valves, and Cam Followers.

(1) ITEM NO.	(2) SMR CODE	(3) NSN	(4) CAGEC	(5) PART NUMBER	(6) DESCRIPTION AND USABLE ON CODE (UOC)	(7) QTY
GROUP 0105 ROCKER ARM ASSEMBLIES, VALVES, AND CAM FOLLOWERS						
FIG. 13. ROCKER ARM ASSEMBLIES, VALVES, AND CAM FOLLOWERS.						
1	PAHZZ	2815-00-966-9104	72582	5135267	ROCKER ARM,ENGINE P LEFT EXHAUST VALVE.....	6
2	PAHZZ	3120-00-662-1651	72582	5123700	. BUSHING,SLEEVE.....	2
3	PAHZZ	5340-00-662-9735	72582	5150312	. CLEVIS,ROD END.....	1
4	PAHZZ	5315-00-662-9093	72582	5150314	. PIN,HOLLOW.....	1
5	PAHZZ	5315-00-780-8097	72582	5123711	. PIN,HOLLOW.....	1
6	PAHZZ	5342-00-572-8726	72582	5135262	. BRACKET,ENGINE POPP.....	1
7	PAHZZ	2815-01-160-8289	72582	8923554	ROCKER ARM,ENGINE P INJECTOR.....	6
8	PAHZZ	5340-00-662-9735	72582	5150312	. CLEVIS,ROD END.....	1
9	PAHZZ	3120-00-662-1651	72582	5123700	. BUSHING,SLEEVE.....	1
10	PAHZZ	5315-00-662-9093	72582	5150314	. PIN,HOLLOW.....	1
11	PAHZZ	3120-00-661-7640	72582	5150318	. BEARING,SLEEVE.....	1
12	PAHZZ	3120-00-661-7616	72582	5150311	. BEARING,SLEEVE.....	1
13	PAHZZ	2815-00-966-9103	72582	05135268	ARM ASSEMBLY RIGHT EXHAUST VALVE.....	6
14	PAHZZ	5340-00-662-9735	72582	5150312	. CLEVIS,ROD END.....	1
15	PAHZZ	5315-00-662-9093	72582	5150314	. PIN,HOLLOW.....	1
16	PAHZZ	5315-00-780-8097	72582	5123711	. PIN,HOLLOW.....	1
17	PAHZZ	5342-00-572-8726	72582	5135262	. BRACKET,ENGINE POPP.....	1
18	PAHZZ	3120-00-662-1651	72582	5123700	. BUSHING,SLEEVE.....	2
19	PAHZZ	5306-00-780-5241	72582	5119198	BOLT,MACHINE 7/16-14UNC-2A GR7 OR OPT GR8.....	12
20	PAHZZ	3040-01-255-0950	72582	23501136	BRACKET,EYE,ROTATIN FRONT ON LEFT SIDE,REAR ON RIGHT SIDE UOC: C6V,D6V,L6V	2
21	PAHZZ	3040-00-921-5339	72582	5116128	BRACKET,EYE,NONROTA UOC: C6V,D6V,L6V	11
21	PAHZZ	3040-00-921-5339	72582	5116128	BRACKET,EYE,NONROTA UOC: A6V,F6V	11
22	PAHZZ	3040-00-055-1583	72582	5116072	SHAFT,STRAIGHT.....	6
23	PAHZZ	5340-00-841-9141	72582	5151272	. PLUG,PROTECTIVE,DUS.....	1
24	PAHZZ	5340-01-239-8166	72582	23500799	RETAINER,NUT AND BO REAR ON LEFT SIDE,FRONT ON RIGHT SIDE UOC: C6V,D6V,L6V	2

(1) ITEM NO.	(2) SMR CODE	(3) NSN	(4) CAGEC	(5) PART NUMBER	(6) DESCRIPTION AND USABLE ON CODE (UOC)	(7) QTY
25	PAHZZ	5310-00-270-7111	45152	1DD486	NUT,PLAIN,HEXAGON.....	18
26	PAHZZ	5325-00-282-5031	72582	5150303	RING,RETAINING.....	18
27	PAHZZ	2815-00-053-8992	72582	5108919	RETAINER,HELICAL CO.....	18
28	PAHZZ	5360-00-689-8264	72582	23524662	SPRING,HELICAL,COMP.....	18
29	PAHZZ	5340-00-885-5731	72582	5123250	SEAT,HELICAL COMPRE.....	18
30	PAHZZ	2815-00-345-6073	72582	5128640	PUSH ROD,ENGINE POP.....	18
31	PAHHH	3120-01-063-9810	7U177	FP8924439	BEARING, PLAIN, CAM, FOLLOWER.....	18
32	PAHZZ	3120-00-620-4779	72582	8923814	. ROLLER,LINEAR-ROTAR.....	1
33	PAHZZ	3040-00-055-1564	72582	5116125	CAM,CONTROL.....	6
34	PAHZZ	5310-00-582-5965	80205	MS35338-44	WASHER,LOCK.....	12
35	PAHZZ	5305-00-068-0508	07482	1C817P63	SCREW,CAP,HEXAGON H 1/4-20UNC-2AX3/4 GR8.....	12
36	PAHZZ	2815-00-074-1939	72582	5197176	PARTS KIT,ENGINE PO.....	24
37	PAHZZ	2815-00-055-1565	72582	5116341	. LOCK,VALVE SPRING R.....	2
38	PAHZZ	5340-00-055-0831	72582	5123330	SEAT,HELICAL COMPRE.....	24
39	PAHZZ	5360-00-236-3149	72582	5144019	SPRING,HELICAL,COMP.....	24
40	PAFZZ	5310-00-053-8377	72582	5111467	WASHER, FLAT VALVE SPRING SEAT....	12

END OF FIGURE

**SUSTAINMENT MAINTENANCE
UPPER FRONT COVER**

4
5 AND 6

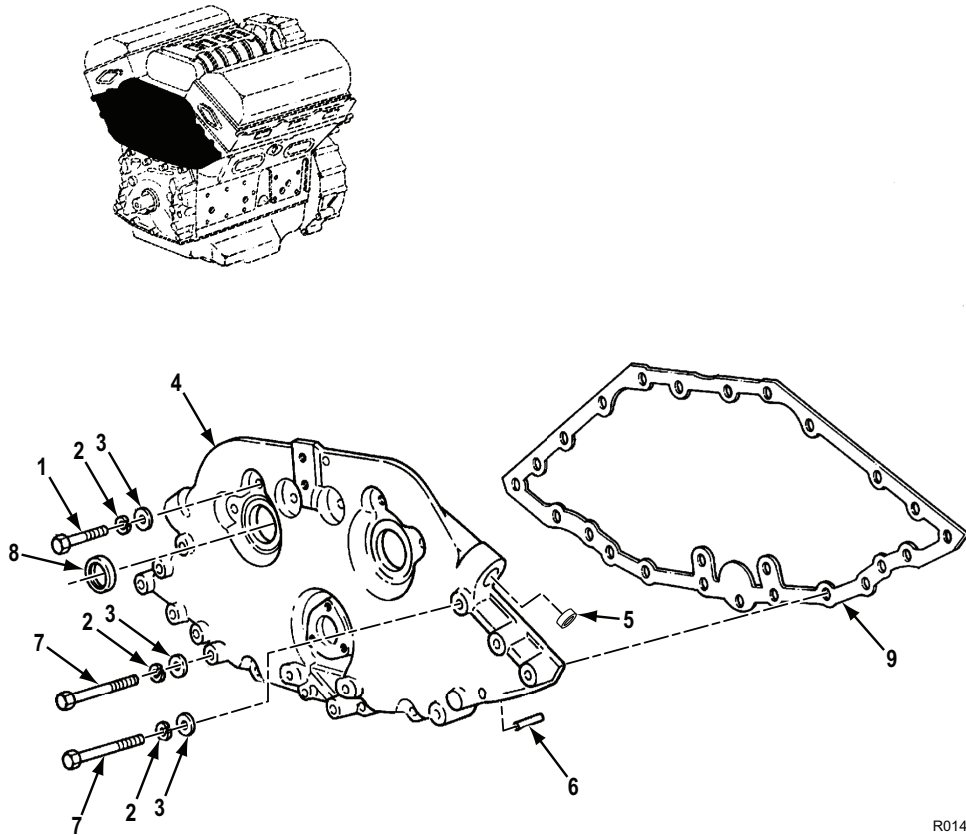

R014

Figure 14. Upper Front Cover.

(1) ITEM NO.	(2) SMR CODE	(3) NSN	(4) CAGEC	(5) PART NUMBER	(6) DESCRIPTION AND USABLE ON CODE (UOC)	(7) QTY
GROUP 0105 UPPER FRONT COVER						
FIG. 14. UPPER FRONT COVER.						
1	PAHZZ	5305-00-725-2317	80204	B1821BH038C150N	SCREW,CAP,HEXAGON H 3/8-16UNC-2AX1-1/2 GR8.....	11
2	PAHZZ	5310-00-637-9541	59556	019-00004-42	WASHER,LOCK UOC: A6V,F6V	18
2	PAHZZ	5310-00-637-9541	59556	019-00004-42	WASHER,LOCK UOC: C6V	21
2	PAHZZ	5310-00-637-9541	59556	019-00004-42	WASHER,LOCK UOC: D6V,L6V	18
3	PAHZZ	5310-00-080-6004	96906	MS27183-14	WASHER,FLAT UOC: A6V,F6V	19
3	PAHZZ	5310-00-080-6004	96906	MS27183-14	WASHER,FLAT UOC: C6V	21
3	PAHZZ	5310-00-080-6004	96906	MS27183-14	WASHER,FLAT UOC: D6V,L6V	18
4	PAHZZ	2815-00-921-5334	72582	5109807	COVER UPPER FRONT.....	1
5	PAHZZ	5340-00-921-5379	72582	5150829	. PLUG,EXPANSION.....	2
6	PAHZZ	5315-00-238-0838	72582	5157933	. PIN,STRAIGHT,HEADLE.....	2
7	PAHZZ	5305-00-638-8920	05047	AE501C375B25WA9 A91	SCREW,CAP,HEXAGON H 3/8-16UNC-2AX2-1/4 GR8 UOC: C6V	10
7	PAHZZ	5305-00-638-8920	05047	AE501C375B25WA9 A91	SCREW,CAP,HEXAGON H 3/8-16UNC-2AX2-1/4 GR8 UOC: A6V,F6V	8
7	PAHZZ	5305-00-638-8920	05047	AE501C375B25WA9 A91	SCREW,CAP,HEXAGON H 3/8-16UNC-2AX2-1/4 GR8 UOC: D6V,L6V	7
8	KFFZZ	5330-01-449-2376	72582	23516871	SEAL,PLAIN CAMSHAFT FRONT, PART OF KIT P/N 8927743, PART OF KIT P/N 8928522.....	2
9	KFHZZ	5330-00-074-1931	72582	5124055	GASKET UPPER FRONT COVER, PART OF KIT P/N 8927743, PART OF KIT P/N 8928522.....	1

END OF FIGURE

**FIELD MAINTENANCE
OIL COOLER ASSEMBLY (MODEL 5063-5299)**

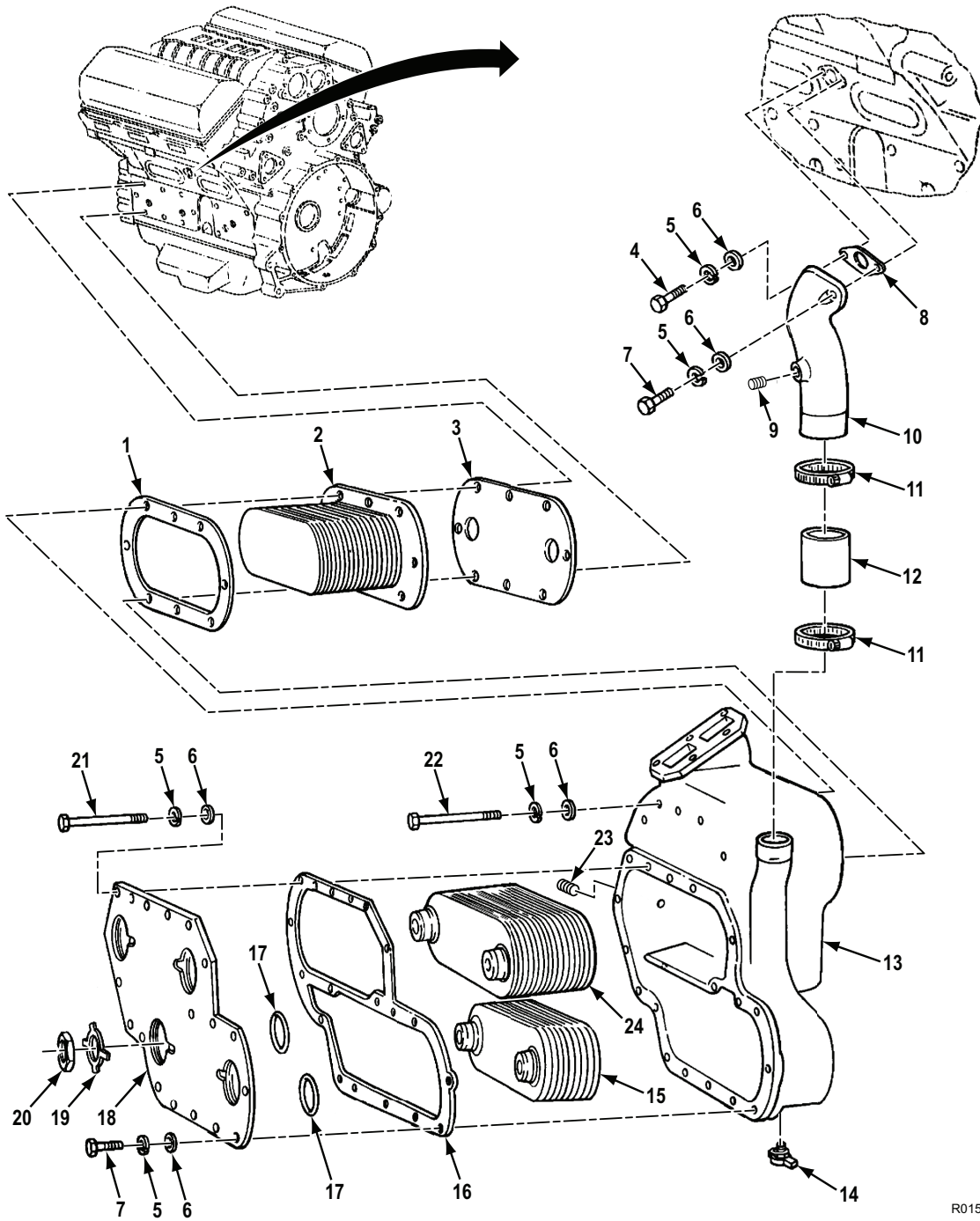

Figure 15. Oil Cooler Assembly (Model 5063-5299).

R015

(1) ITEM NO.	(2) SMR CODE	(3) NSN	(4) CAGEC	(5) PART NUMBER	(6) DESCRIPTION AND USABLE ON CODE (UOC)	(7) QTY
GROUP 0106 OIL COOLER ASSEMBLY (MODEL 5063-5299)						
FIG. 15. OIL COOLER ASSEMBLY (MODEL 5063-5299).						
1	PAFZZ	5330-01-299-3160	72582	23501591	GASKET BETWEEN CORE & OIL CLR HSG, PART OF KIT P/N 8927743 UOC: A6V,F6V	1
2	PAFZZ	2930-01-290-4054	72582	8547195	OIL COOLER ASSEMBLY ENGINE OIL-18 PLATES UOC: A6V,F6V	1
3	PAFZZ	5330-01-196-2504	72582	8923223	GASKET BETWEEN CORE & CYL BLK PART OF KIT P/N 8927743 UOC: A6V,F6V	1
4	PAFZZ	5306-00-226-4829	80204	B1821BH031C125N	BOLT,MACHINE 5/16-18UNC-2AX1-1/4 GR8 UOC: A6V,F6V	1
5	PAFZZ	5310-00-407-9566	80205	MS35338-45	WASHER,LOCK UOC: A6V,F6V	27
6	PAFZZ	5310-00-081-4219	96906	MS27183-12	WASHER,FLAT UOC: A6V,F6V	27
7	PAFZZ	5306-00-226-4828	80204	B1821BH031C113N	BOLT,MACHINE 5/16-18UNC-2AX1-1/8GR8 UOC: A6V,F6V	18
8	PAFZZ	5330-00-613-9397	72582	5116357	GASKET WATER OUTLET ELBOW PART OF KIT P/N 8927743 UOC: A6V,F6V	1
9	PAFZZ	4730-00-010-3885	72582	8924517	PLUG,PIPE UOC: A6V,F6V	1
10	PAFZZ	4730-00-074-1946	72582	5133535	ELBOW,FLANGE TO HOS UOC: A6V,F6V	1
11	PAFZZ	4730-01-125-9989	80204	23505048	CLAMP,HOSE UOC: A6V	2
12	MFFZZ		72582	8921826	HOSE 2.75 IN. LG, MAKE FROM HOSE,P/N 11662997. WATER OUT UOC: A6V,F6V	1
13	PAFZZ	2815-00-921-5368	72582	5133532	HOUSING,OIL COOLER UOC: A6V,F6V	1
14	PAFZZ	4820-01-132-6317	3B518	8924140	COCK,DRAIN UOC: A6V,F6V	1
15	PAFZZ	2930-00-767-7882	19207	10875136	COOLER,LUBRICATING XMSN OIL-10 PLATES UOC: A6V,F6V	1
16	PAFZZ	5330-00-789-4871	72582	5133537	GASKET BETWEEN COVER & OIL CLR HSG PART OF KIT P/N 8927743 UOC: A6V,F6V	1

(1) ITEM NO.	(2) SMR CODE	(3) NSN	(4) CAGEC	(5) PART NUMBER	(6) DESCRIPTION AND USABLE ON CODE (UOC)	(7) QTY
17	PAFZZ	5330-00-789-4867	72582	5133619	GASKET COVER NUT PART OF KIT P/N 8927743 UOC: A6V,F6V	4
18	PAFZZ	5340-00-921-5369	72582	5133536	COVER,ACCESS UOC: A6V,F6V	1
19	PAFZZ	5310-00-789-4870	72582	5133539	WASHER,KEY UOC: A6V,F6V	4
20	PAFZZ	5310-00-780-8102	72582	5133538	NUT,PLAIN,HEXAGON UOC: A6V,F6V	4
21	PAFZZ	5306-00-057-8427	72582	446597	BOLT,MACHINE 5/16-18UNC-2AX6-1/2 GR8 UOC: A6V,F6V	3
22	PAFZZ	5306-01-039-9601	72582	215386	BOLT 5/16-18UNC-2AX6 GR5 UOC: A6V,F6V	5
23	PAFZZ	4730-00-152-6070	72582	5115214	PLUG,PIPE UOC: A6V,F6V	1
24	PAFZZ	2930-00-767-7881	72582	8547572	CORE ASSEMBLY,FLUID XMSN OIL-14 PLATES UOC: A6V,F6V	1

END OF FIGURE

**FIELD MAINTENANCE
OIL COOLER ASSEMBLY (MODEL 5063-5392)**

2
3

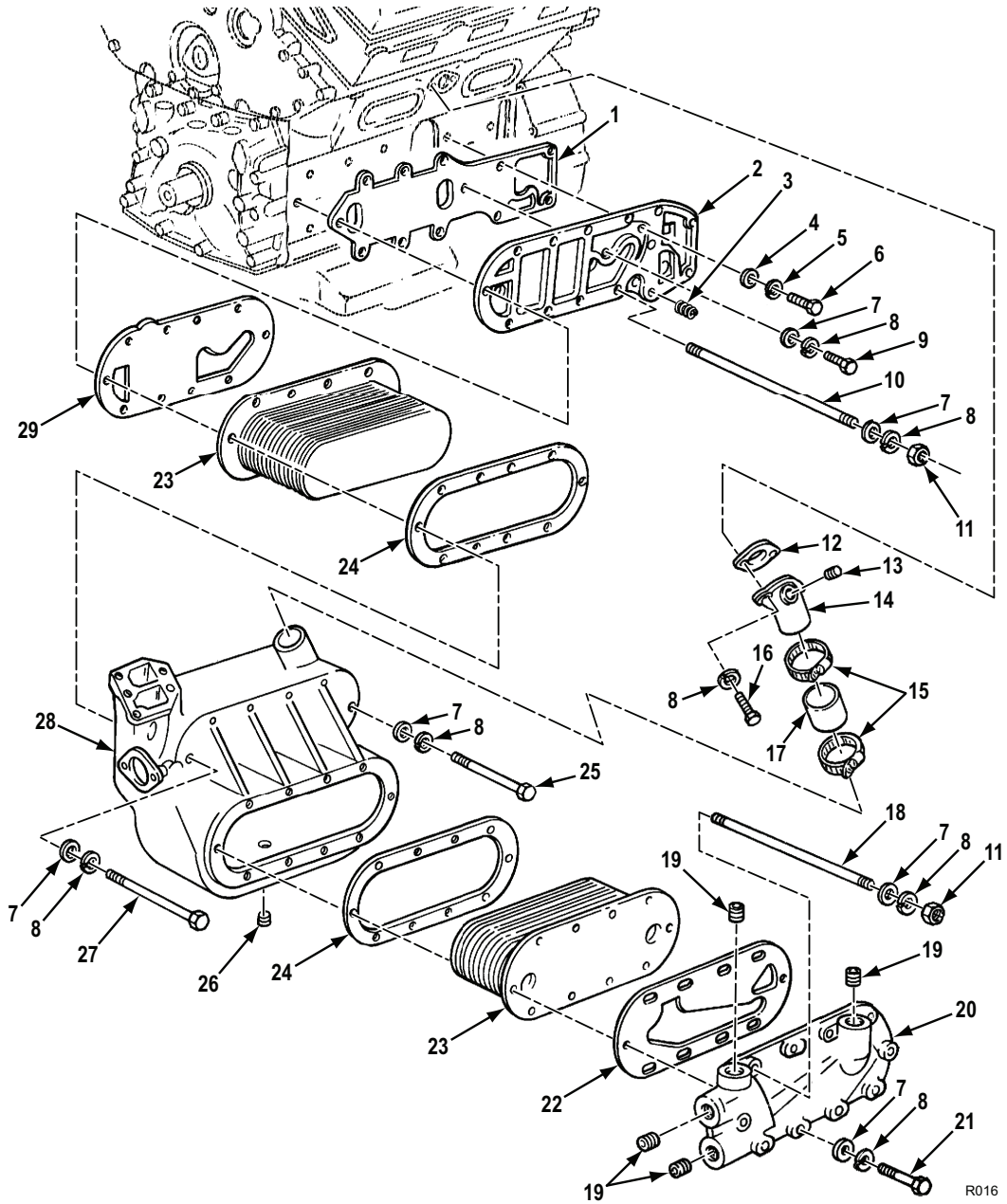

Figure 16. Oil Cooler Assembly (Model 5063-5392).

(1) ITEM NO.	(2) SMR CODE	(3) NSN	(4) CAGEC	(5) PART NUMBER	(6) DESCRIPTION AND USABLE ON CODE (UOC)	(7) QTY
GROUP 0106 OIL COOLER ASSEMBLY (MODEL 5063-5392)						
FIG. 16. OIL COOLER ASSEMBLY (MODEL 5063-5392).						
1	PAFZZ	5330-01-157-3771	72582	5104846	GASKET BLK TO ADAPTOR PLATE PART OF KIT P/N 8928522 UOC: C6V	1
2	PAFZZ	2815-01-234-7350	72582	8925675	ADAPTER,OIL COOLER UOC: C6V	1
3	PAFZZ	5325-00-290-4518	80205	MS122123	. INSERT,SCREW THREAD UOC: C6V	2
4	PAFZZ	5310-00-080-6004	96906	MS27183-14	WASHER,FLAT UOC: C6V	2
5	PAFZZ	5310-00-637-9541	59556	019-00004-42	WASHER,LOCK UOC: C6V	2
6	PAFZZ	5305-00-942-2196	80204	B1821BH038C100D	SCREW,CAP,HEXAGON H 3/8-16UNC-2AX1 GR8 UOC: C6V	2
7	PAFZZ	5310-00-081-4219	96906	MS27183-12	WASHER,FLAT UOC: C6V	17
8	PAFZZ	5310-00-407-9566	80205	MS35338-45	WASHER,LOCK UOC: C6V	19
9	PAFZZ	5306-00-226-4827	80204	B1821BH031C100N	BOLT,MACHINE 5/16-18UNC-2AX1 GR8 UOC: C6V	1
10	PAFZZ	5306-01-241-1599	72582	5107891	ROD,THREADED END UOC: C6V	1
11	PAFZZ	5310-00-136-5712	24617	114493	NUT,PLAIN,HEXAGON UOC: C6V	4
12	PAFZZ	5330-00-613-9397	72582	5116357	GASKET PART OF KIT P/N 8928522 UOC: C6V	1
13	PAFZZ	4730-00-010-3885	72582	8924517	PLUG,PIPE UOC: C6V	1
14	PAFZZ	4730-01-157-3763	72582	5142160	ELBOW,HOSE UOC: C6V	1
15	PAFZZ	4730-01-125-9989	72582	23505048	CLAMP,HOSE UOC: C6V	2
16	PAFZZ	5306-00-226-4828	80204	B1821BH031C113N	BOLT,MACHINE 5/16-18UNC-2AX1-1/8 GR8 UOC: C6V	2
17	MFFZZ		72582	8921826	HOSE 2.75 IN. LG,MAKE FROM HOSE,P/N 11662997. WATER OUTLET UOC: C6V	1
18	PAFZZ	5307-01-237-9273	72582	5107890	STUD,PLAIN UOC: C6V	3
19	PAFZZ	4730-01-210-4251	72582	8924750	PLUG,PIPE UOC: C6V	4

(1) ITEM NO.	(2) SMR CODE	(3) NSN	(4) CAGEC	(5) PART NUMBER	(6) DESCRIPTION AND USABLE ON CODE (UOC)	(7) QTY
20	PAFZZ	2815-01-231-0344	72582	5107930	HOUSING,OIL COOLER UOC: C6V	1
21	PAFZZ	5306-01-158-1154	80204	B1821BH031C275D	BOLT,MACHINE 5/16-18UNC-2AX2-3/4 GR8 UOC: C6V	6
22	KFFZZ	5330-01-241-5104	72582	23509198	GASKET BETWEEN CORE & OIL CLR COV PART OF KIT P/N 8928522 UOC: C6V	1
23	PAFZZ	2930-01-157-9016	72582	52456439	COOLER,LUBRICATING 20 PLATE UOC: C6V	2
24	KFFZZ	5330-01-157-3773	72582	5104881	GASKET BETWEEN CORE & OIL CLR HSG PART OF KIT P/N 8928522 UOC: C6V	2
25	PAFZZ	5306-00-057-8427	72582	446597	BOLT,MACHINE 5/16-18UNC-2AX6-1/2 GR8 UOC: C6V	2
26	PAFZZ	4730-01-398-7635	72582	8923847	PLUG,PIPE UOC: C6V	1
27	PAFZZ	5306-01-157-8906	72582	9437758	BOLT,MACHINE 5/16-18UNC-2AX7-1/4 GR5 UOC: C6V	4
28	PAFZZ	2815-01-234-7365	72582	5104801	HOUSING,OIL COOLER UOC: C6V	1
29	KFFZZ	5330-01-157-3772	72582	5104868	GASKET ADAPTOR PLATE TO CORE PART OF KIT P/N 8928522 UOC: C6V	1

END OF FIGURE

**FIELD MAINTENANCE
OIL COOLER ASSEMBLY (MODEL 5063-5393 AND 5063-539L)**

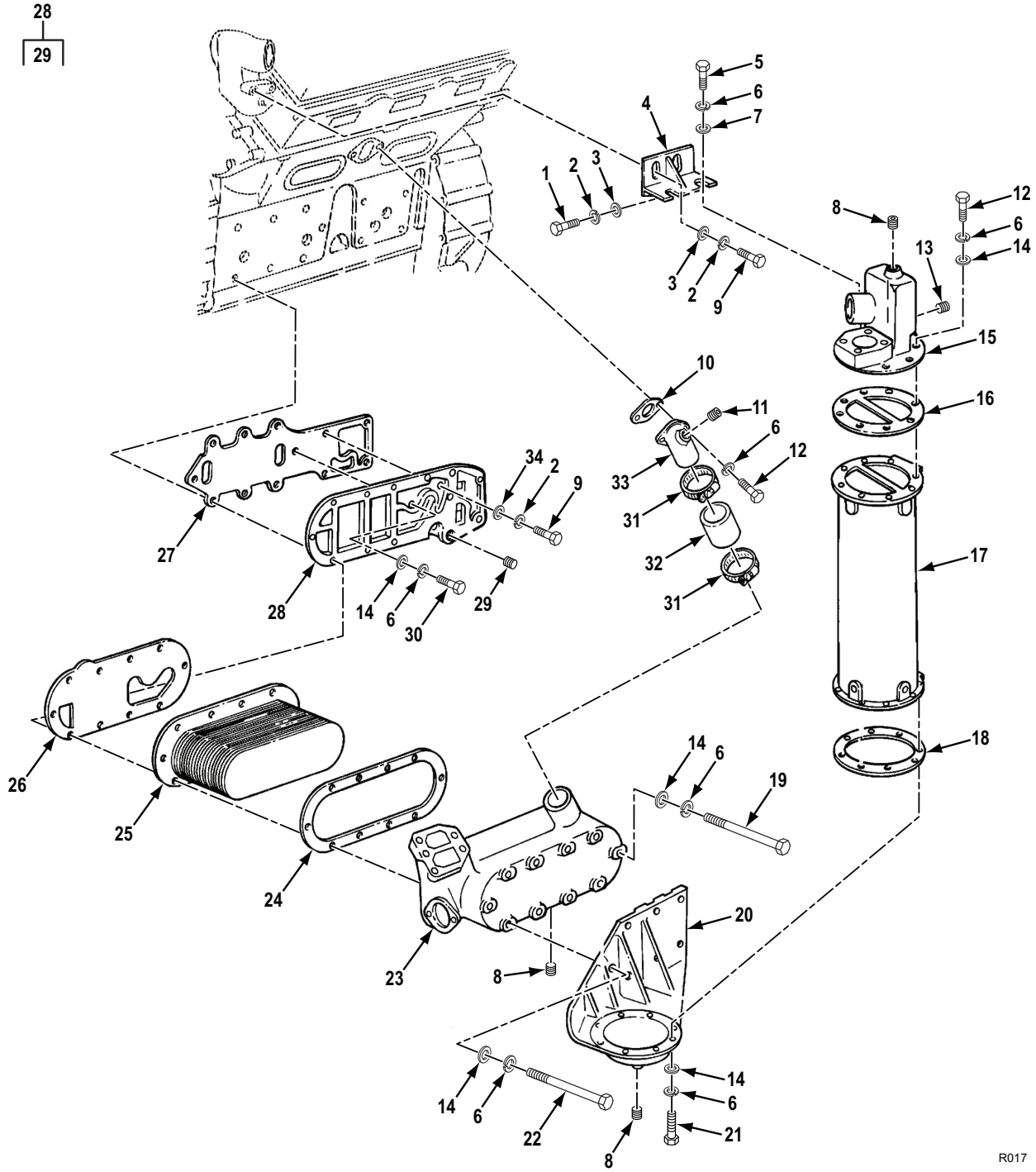

Figure 17. Oil Cooler Assembly (Model 5063-5393 and 5063-539L).

R017

(1) ITEM NO.	(2) SMR CODE	(3) NSN	(4) CAGEC	(5) PART NUMBER	(6) DESCRIPTION AND USABLE ON CODE (UOC)	(7) QTY
GROUP 0106 OIL COOLER ASSEMBLY (MODEL 5063-5393 AND 5063-539L)						
FIG. 17. OIL COOLER ASSEMBLY (MODEL 5063-5393 AND 5063-539L).						
1	PAFZZ	5305-00-543-4372	80204	B1821BH038C075N	SCREW,CAP,HEXAGON H UOC: D6V,L6V	1
2	PAFZZ	5310-00-637-9541	59556	019-00004-42	WASHER,LOCK UOC: D6V,L6V	2
3	PAFZZ	5310-00-023-4492	72582	5131433	WASHER,ENGINE UOC: D6V,L6V	3
4	PBFZZ	5342-01-251-4467	72582	8928722	BRACKET,ENGINE ACCE UOC: D6V,L6V	1
5	PAFZZ	5306-00-226-4830	80204	B1821BH031C138N	BOLT,MACHINE 5/16-18UNC-2AX1-3/8GR8 UOC: D6V,L6V	2
6	PAFZZ	5310-00-407-9566	80205	MS35338-45	WASHER,LOCK UOC: D6V,L6V	27
7	KFFZZ	5310-00-338-1088	72582	5121403	WASHER,FLAT PART OF KIT P/N 5198683 UOC: D6V,L6V	2
8	PAFZZ	4730-01-398-7635	72582	8923847	PLUG,PIPE UOC: D6V,L6V	3
9	PAFZZ	5305-00-068-0510	80204	B1821BH038C100N	SCREW,CAP,HEXAGON H 3/8-16UNC-2AX1GR8 UOC: D6V,L6V	4
10	KFFZZ	5330-00-613-9397	72582	5116357	GASKET PART OF KIT P/N 8928522 UOC: D6V,L6V	1
11	PAFZZ	4730-00-010-3885	72582	8924517	PLUG,PIPE UOC: D6V,L6V	1
12	PAFZZ	5306-00-226-4828	80204	B1821BH031C113N	BOLT,MACHINE 5/16-18UNC-2AX1-1/8GR8 UOC: D6V,L6V	4
13	PAFZZ	4730-01-210-4252	72582	8923916	PLUG,PIPE UOC: D6V,L6V	2
14	PAFZZ	5310-00-081-4219	96906	MS27183-12	WASHER,FLAT UOC: D6V,L6V	23
15	PAFZZ	2930-01-251-0655	72582	8928718	WATER OUTLET,ENGINE UOC: D6V,L6V	1
16	PAFZZ	5330-01-248-9559	72582	8928716	GASKET THERMOSTAT HSG TO CLR UOC: D6V,L6V	1
17	PAFZZ	2520-01-248-9566	72582	8928715	COOLER,FLUID,TRANSM UOC: D6V,L6V	1
18	PAFZZ	5330-01-252-0201	72582	8928812	GASKET COOLER TO LOWER BRACKET UOC: D6V,L6V	1
19	PAFZZ	5306-00-057-8427	72582	446597	BOLT,MACHINE 5/16-18UNC-2AX6-1/2 GR8 UOC: D6V,L6V	3

(1) ITEM NO.	(2) SMR CODE	(3) NSN	(4) CAGEC	(5) PART NUMBER	(6) DESCRIPTION AND USABLE ON CODE (UOC)	(7) QTY
20	PAFZZ	5342-01-251-5295	72582	8928717	BRACKET,ENGINE ACCE UOC: D6V,L6V	1
21	PAFZZ	5306-00-226-4829	80204	B1821BH031C125N	BOLT,MACHINE 5/16-18UNC-2AX1-1/4 GR8 UOC: D6V,L6V	8
22	PAFZZ	5306-01-543-3277	72582	23528796	BOLT,MACHINE 5/16-18UNC-2AX8 GR8 UOC: D6V,L6V	7
23	PBFZZ	2815-01-253-8646	72582	23501808	HOUSING,OIL COOLER UOC: D6V,L6V	1
24	KFFZZ	5330-01-157-3773	72582	5104881	GASKET CORE TO HOUSING PART OF KIT P/N 8928522 UOC: D6V,L6V	1
25	PAFZZ	2930-01-157-9016	72582	52456439	COOLER,LUBRICATING ENGINE OIL- 20 PLATE UOC: D6V,L6V	1
26	KFFZZ	5330-01-157-3772	72582	5104868	GASKET CORE TO ADAPTOR PLATE PART OF KIT P/N 8928522 UOC: D6V,L6V	1
27	PAFZZ	5330-01-157-3771	72582	5104846	GASKET ADAPTOR PLATE TO BLK PART OF KIT P/N 8928522 UOC: D6V,L6V	1
28	PAFZZ	2815-01-234-7350	72582	8925675	ADAPTER,OIL COOLER UOC: D6V,L6V	1
29	PAFZZ	5325-00-290-4518	80205	MS122123	. INSERT,SCREW THREAD UOC: D6V,L6V	2
30	PAFZZ	5306-00-226-4827	80204	B1821BH031C100N	BOLT,MACHINE UOC: D6V,L6V	1
31	PAFZZ	4730-01-125-9989	72582	23505048	CLAMP,HOSE UOC: D6V,L6V	2
32	MFFZZ	4720-01-418-6516	72582	8921826	HOSE 2.75 IN. LG, MAKE FROM HOSE, P/N 11662997. WATER OUTLET UOC: D6V,L6V	1
33	PAFZZ	4730-01-157-3763	72582	5142160	ELBOW,HOSE UOC: D6V,L6V	1
34	PAFZZ	5310-00-080-6004	96906	MS27183-14	WASHER,FLAT UOC: D6V,L6V	2

END OF FIGURE

**FIELD MAINTENANCE
OIL INLET PIPE, SCREEN, AND SUPPORTS**

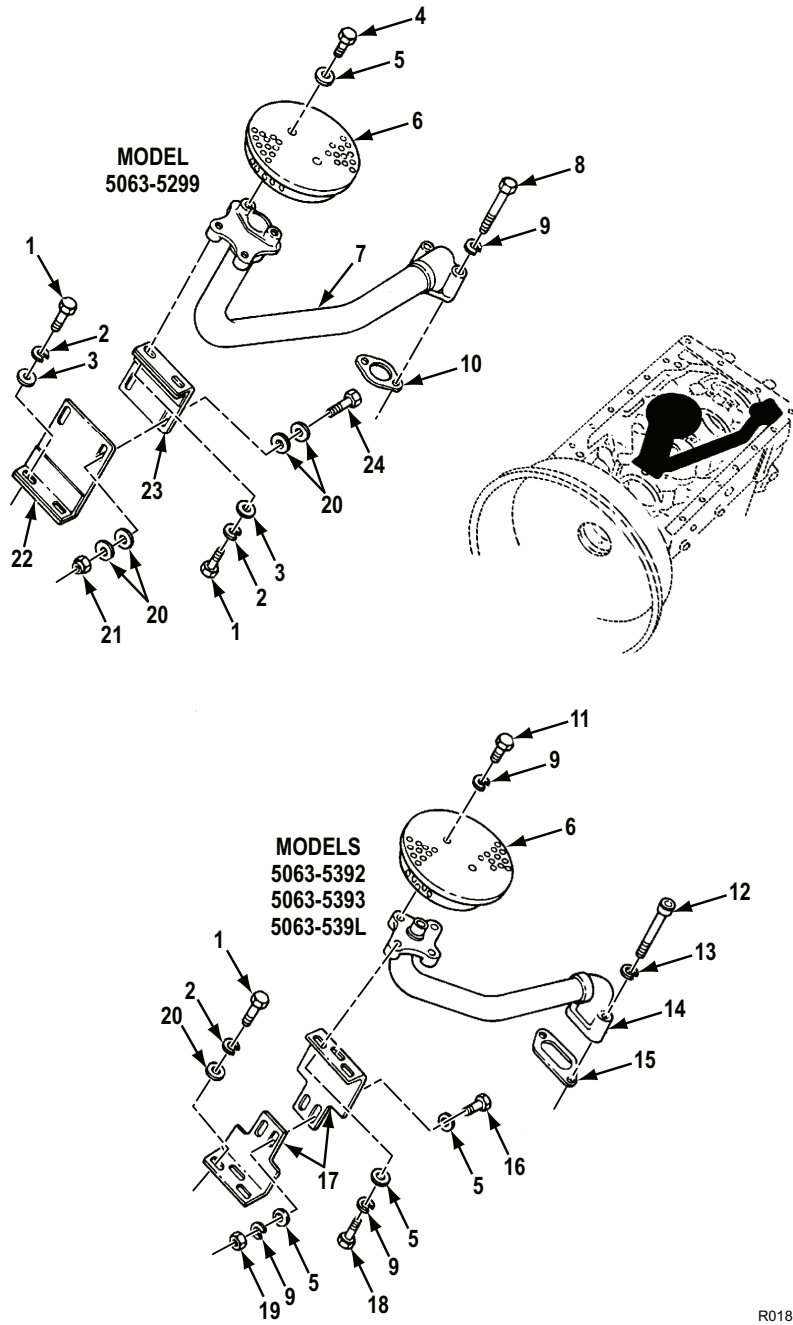

R018

Figure 18. Oil Inlet Pipe, Screen, and Supports.

(1) ITEM NO.	(2) SMR CODE	(3) NSN	(4) CAGEC	(5) PART NUMBER	(6) DESCRIPTION AND USABLE ON CODE (UOC)	(7) QTY
GROUP 0106 OIL INLET PIPE, SCREEN, AND SUPPORTS						
FIG. 18. OIL INLET PIPE, SCREEN, AND SUPPORTS.						
1	PAFZZ	5305-00-543-4372	80204	B1821BH038C075N	SCREW,CAP,HEXAGON H 3/8-16UNC-2AX3/4 GR8 UOC: C6V,D6V,L6V	2
1	PAFZZ	5305-00-543-4372	80204	B1821BH038C075N	SCREW,CAP,HEXAGON H 3/8-16UNC-2AX3/4 GR8 UOC: A6V,F6V	4
2	PAFZZ	5310-00-637-9541	59556	019-00004-42	WASHER,LOCK UOC: C6V,D6V,L6V	2
2	PAFZZ	5310-00-637-9541	59556	019-00004-42	WASHER,LOCK UOC: A6V,F6V	4
3	PAFZZ	5310-00-023-4457	72582	5138619	WASHER,FLAT UOC: A6V,F6V	4
4	PAFZZ	5306-00-940-9010	19207	9409010	BOLT,MACHINE 5/16-18UNC-2AX5/8 GR8 UOC: A6V,F6V	2
5	PAFZZ	5310-00-081-4219	96906	MS27183-12	WASHER,FLAT UOC: A6V,F6V	2
5	PAFZZ	5310-00-081-4219	96906	MS27183-12	WASHER,FLAT UOC: C6V,D6V,L6V	5
6	PAFZZ	4730-00-745-7741	72582	5126143	STRAINER ELEMENT,SE.....	1
7	PAFZZ	4710-00-921-6997	72582	5138240	TUBE ASSEMBLYXOIL P UOC: A6V,F6V	1
8	PAFZZ	5306-00-226-4834	80204	B1821BH031C225N	BOLT,MACHINE 5/16-18UNC-2AX2-1/4 GR8 UOC: A6V,F6V	2
9	PAFZZ	5310-00-407-9566	80205	MS35338-45	WASHER,LOCK UOC: C6V,D6V,L6V	5
9	PAFZZ	5310-00-407-9566	80205	MS35338-45	WASHER,LOCK UOC: A6V,F6V	2
10	PAFZZ	5330-00-682-7195	63005	5126473	GASKET UOC: A6V,F6V	1
11	PAFZZ	5306-00-226-4822	80204	B1821BH031C050N	BOLT,MACHINE 5/16-18UNC-2AX1/2 GR8 UOC: C6V,D6V,L6V	2
12	PAFZZ	5305-00-983-6625	96906	MS16997-84	SCREW,CAP,SOCKET HE 5/16-18UNC-3AX2 GR8 UOC: C6V,D6V,L6V	2
13	PAFZZ	5310-00-407-9566	80205	MS35338-45	WASHER,LOCK UOC: C6V,D6V,L6V	2
14	PAFZZ	4710-00-944-7066	72582	5136090	TUBE ASSEMBLY,METAL UOC: C6V,D6V,L6V	1
15	KFFZZ	5330-00-944-7073	72582	5135877	GASKET PART OF KIT P/N 8928522 UOC: C6V,D6V,L6V	1

(1) ITEM NO.	(2) SMR CODE	(3) NSN	(4) CAGEC	(5) PART NUMBER	(6) DESCRIPTION AND USABLE ON CODE (UOC)	(7) QTY
16	PAFZZ	5306-00-050-1238	80204	B1821BH031F075N	BOLT,MACHINE 5/16-24UNF-2AX3/4 GR8 UOC: C6V,D6V,L6V	2
17	PAFZZ	2815-01-035-1750	72582	5136225	SUPPORT,OILPUMP UOC: C6V,D6V,L6V	2
18	PAFZZ	5306-00-226-4824	80204	B1821BH031C063N	BOLT,MACHINE 5/16-18UNC-2AX1/2 GR8 UOC: C6V,D6V,L6V	1
19	PAFZZ	5310-00-880-7746	96906	MS51968-5	NUT,PLAIN,HEXAGON UOC: C6V,D6V,L6V	2
20	PAFZZ	5310-00-080-6004	96906	MS27183-14	WASHER,FLAT UOC: A6V,F6V	8
20	PAFZZ	5310-00-080-6004	96906	MS27183-14	WASHER,FLAT UOC: C6V,D6V,L6V	2
21	PAFZZ	5310-00-013-7718	18876	7613324	NUT,SELF-LOCKING,HE UOC: A6V,F6V	2
22	XDFZZ		72582	5138254	SUPPORT UOC: A6V,F6V	1
23	PBFZZ	5342-00-922-2026	72582	05138420	BRACKET,ENGINE,DIES UOC: A6V,F6V	1
24	PAFZZ	5305-00-269-3236	80204	B1821BH038F100N	SCREW,CAP,HEXAGON H 3/8-24UNF-2AX1 GR8 UOC: A6V,F6V	2

END OF FIGURE

**FIELD MAINTENANCE
OIL PAN AND OIL GAGE ASSEMBLY**

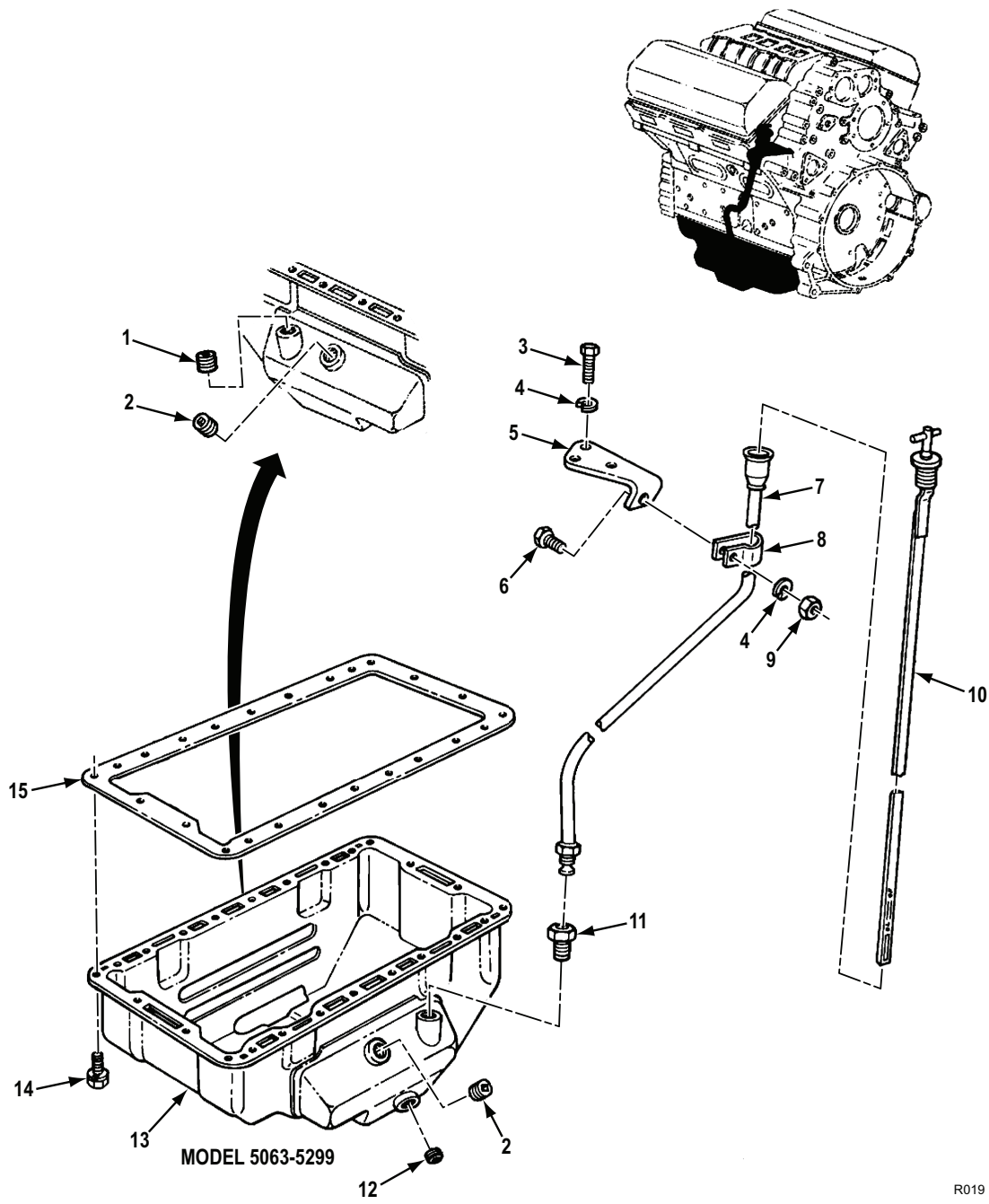

R019

Figure 19. Oil Pan and Oil Gage Assembly. (Sheet 1 of 3)

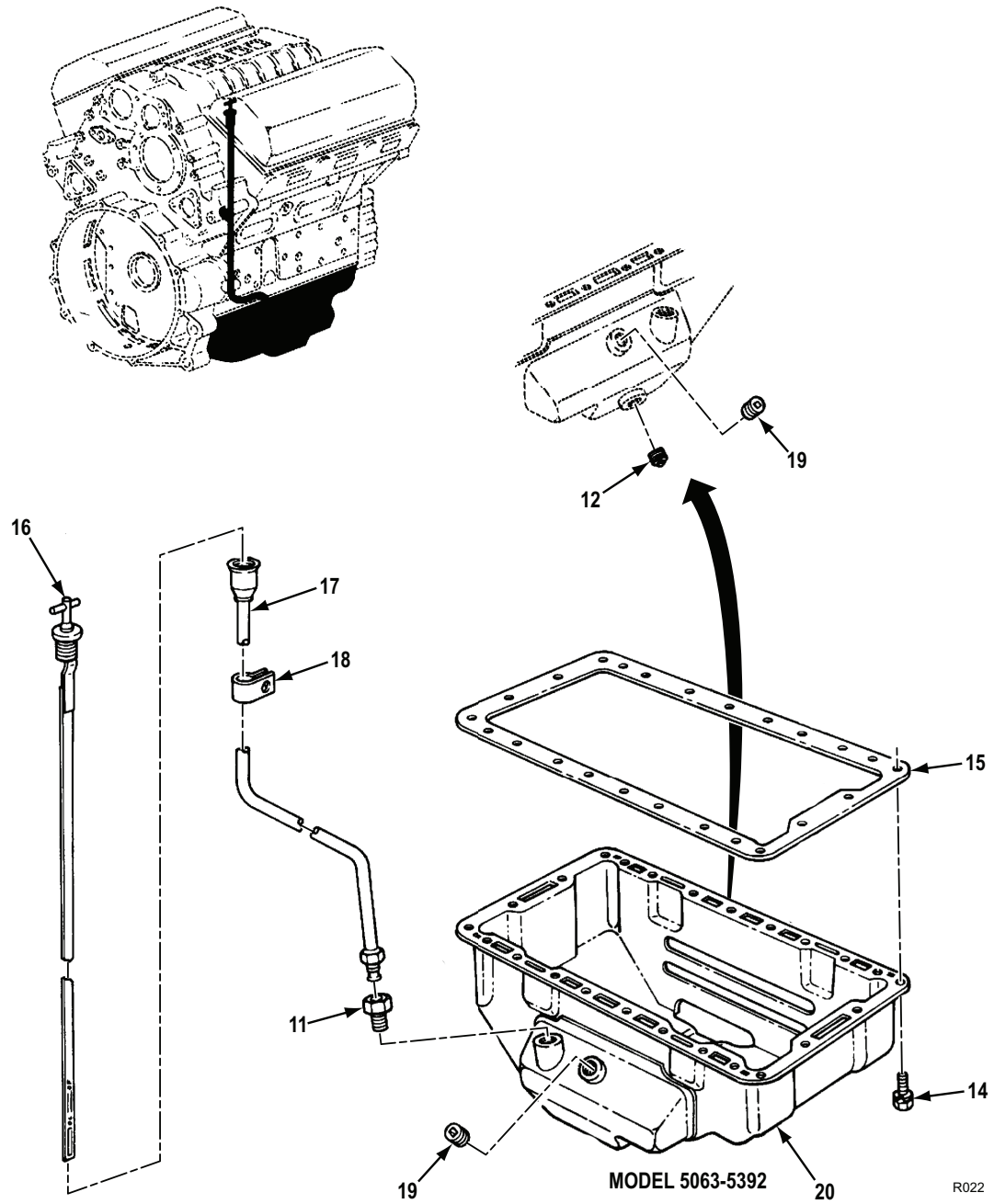

Figure 19. Oil Pan and Oil Gage Assembly. (Sheet 2 of 3)

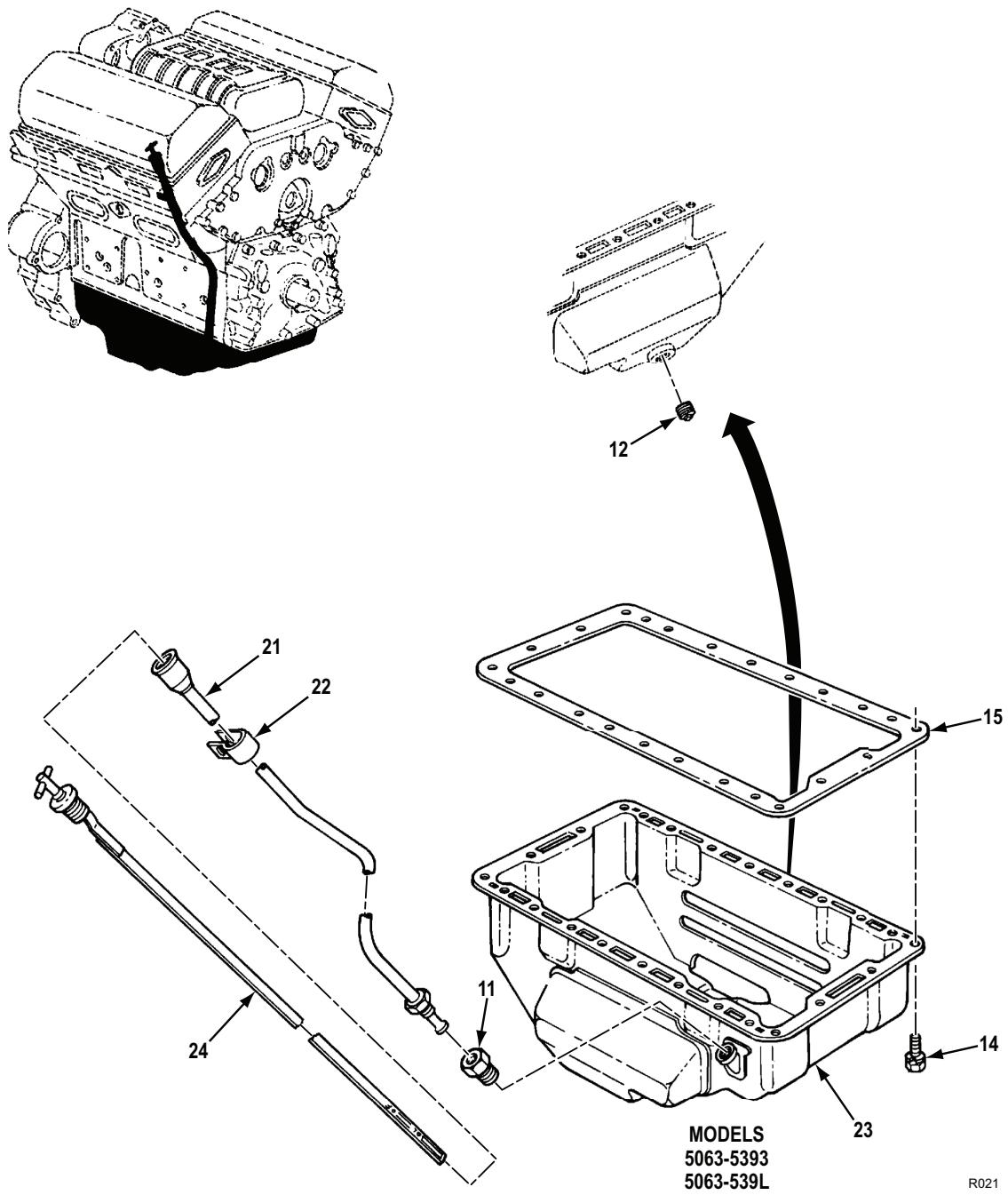

Figure 19. Oil Pan and Oil Gage Assembly. (Sheet 3 of 3)

(1) ITEM NO.	(2) SMR CODE	(3) NSN	(4) CAGEC	(5) PART NUMBER	(6) DESCRIPTION AND USABLE ON CODE (UOC)	(7) QTY
GROUP 0106 OIL PAN AND OIL GAGE ASSEMBLY						
FIG. 19. OIL PAN AND OIL GAGE ASSEMBLY.						
1	PAFZZ	4730-00-279-0985	58536	AA5616AASBCB	PLUG,PIPE UOC: A6V,F6V	1
2	PAFZZ	4730-00-152-6070	72582	5115214	PLUG,PIPE UOC: A6V,F6V	2
3	PAFZZ	5305-00-068-0510	80204	B1821BH038C100N	SCREW,CAP,HEXAGON H UOC: A6V,F6V	2
4	PAFZZ	5310-00-637-9541	59556	019-00004-42	WASHER,LOCK UOC: A6V,F6V	3
5	PAFZZ	5342-00-134-3182	72582	5134079	BRACKET UOC: A6V,F6V	1
6	PAFZZ	5305-00-543-4372	80204	B1821BH038C075N	SCREW,CAP,HEXAGON H 3/8-16UNC-2AX3/4 GR8 UOC: A6V,F6V	1
7	PAFZZ	4710-00-921-5373	72582	5134146	TUBE ASSEMBLY,METAL UOC: A6V,F6V	1
8	PAFZZ	5340-00-720-6213	96906	MS21333-59	CLAMP,LOOP UOC: A6V,F6V	1
9	PAFZZ	5310-00-732-0558	96906	MS51967-8	NUT,PLAIN,HEXAGON UOC: A6V,F6V	1
10	MOFZZ		72582	5133486	GAGE ROD-CAP,LIQUID /MAKE FROM BULK P/N 5146679 UOC: A6V,F6V	1
11	PAFZZ	4730-00-947-4290	72582	5151430	ADAPTER,STRAIGHT,PI.....	1
12	PAFZZ	4730-01-149-7156	72582	5102982	PLUG,PIPE.....	1
13	PAFZZ	2815-00-042-3865	72582	5145661	OIL PAN UOC: A6V,F6V	1
14	PAFZZ	5305-01-018-5215	72582	5148437	SCREW 5/16-18UNC-2AX1 GR5.....	22
15	KFFZZ	5330-00-999-7210	72582	5119266	GASKET PART OF KIT P/N 8928522, PART OF KIT P/N 8927743.....	1
16	PAFZZ	6680-01-232-1135	72582	8926489	GAGE ROD-CAP,LIQUID UOC: C6V	1
17	PAFZZ	4710-01-234-2824	72582	8926488	TUBE ASSEMBLY,METAL UOC: C6V	1
18	PAFZZ	5340-00-492-2722	72582	5131426	CLAMP,LOOP UOC: C6V	1
19	PAFZZ	4730-01-188-3492	72582	8923313	PLUG,PIPE UOC: C6V	2
20	PAFZZ	2815-01-040-2632	72582	5102567	OIL PAN UOC: C6V	1
21	PAFZZ	4710-01-251-6284	72582	8928640	TUBE ASSEMBLY,METAL UOC: D6V,L6V	1

(1) ITEM NO.	(2) SMR CODE	(3) NSN	(4) CAGEC	(5) PART NUMBER	(6) DESCRIPTION AND USABLE ON CODE (UOC)	(7) QTY
22	PAFZZ	2815-01-014-3142	72582	5136948	CLIP UOC: D6V,L6V	1
23	PAFZZ	2815-01-251-0653	72582	8928639	OIL PAN UOC: L6V	1
24	PAFZZ	6680-01-251-2640	72582	8928641	GAGE ROD-CAP,LIQUID UOC: D6V,L6V	1

END OF FIGURE

**FIELD MAINTENANCE
OIL FILTER ASSEMBLY AND ADAPTER (MODEL 5063-5299)**

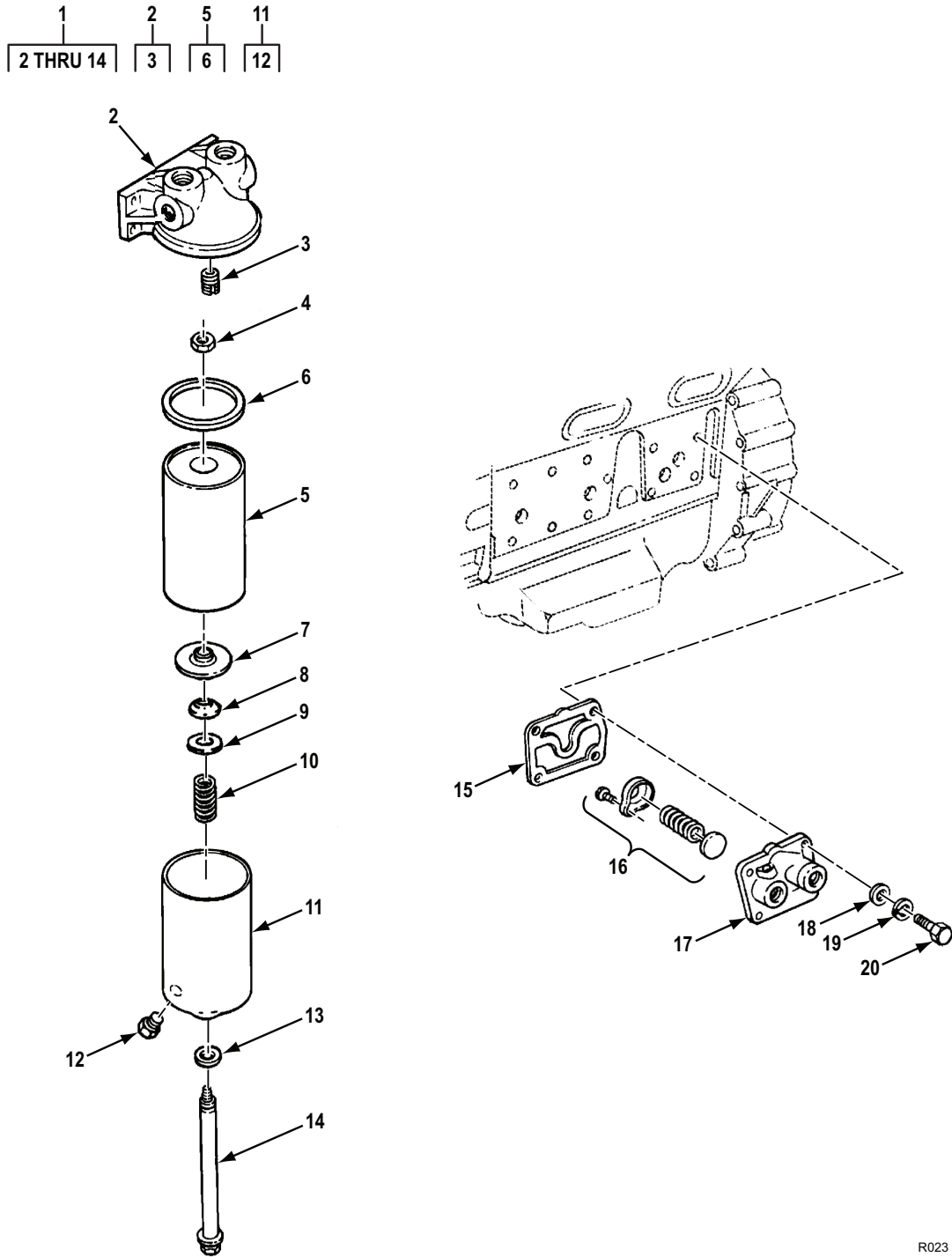

R023

Figure 20. Oil Filter Assembly and Adapter (Model 5063-5299).

(1) ITEM NO.	(2) SMR CODE	(3) NSN	(4) CAGEC	(5) PART NUMBER	(6) DESCRIPTION AND USABLE ON CODE (UOC)	(7) QTY
GROUP 0106 OIL FILTER ASSEMBLY AND ADAPTER (MODEL 5063-5299)						
FIG. 20. OIL FILTER ASSEMBLY AND ADAPTER (MODEL 5063-5299).						
1	AFFZZ	2940-00-789-4873	72582	5147683	FILTER,FLUID UOC: A6V,F6V	1
2	PAFZZ	2940-00-834-1157	72582	5147684	. HEAD,FLUID FILTER UOC: A6V,F6V	1
3	PAFZZ	5325-00-608-9214	73957	62518-12	. . INSERT,SCREW THREAD UOC: A6V,F6V	1
4	PAFZZ	5310-01-216-6636	96906	MS35691-1024	. NUT,PLAIN,HEXAGON UOC: A6V,F6V	1
5	PAFZZ	2940-00-580-6283	81348	F-F-351/7-3	. FILTER ELEMENT,FLUI UOC: A6V,F6V	1
6	PAFZZ	5330-01-383-3753	72582	1595620	. . GASKET UOC: A6V,F6V	1
7	PAFZZ	5330-00-629-6340	72582	5187309	. RETAINER,PACKING UOC: A6V,F6V	1
8	PAFZZ	5331-00-604-8094	72582	5187310	. O-RING UOC: A6V,F6V	1
9	PAFZZ	5365-00-262-4701	72582	5154538	. SPACER,RING UOC: A6V,F6V	1
10	PAFZZ	5360-00-801-8731	72582	5187308	. SPRING,HELICAL,COMP UOC: A6V,F6V	1
11	PAFFF	2940-00-019-4775	70040	OF203	. COVER,FLUID FILTER UOC: A6V,F6V	1
12	PAFZZ	4820-00-360-8299	72582	5570480	. . VALVE,PLUG UOC: A6V,F6V	1
13	PAFZZ	5330-00-833-0870	72582	6437298	. GASKET SET UOC: A6V,F6V	1
14	PAFZZ	5306-00-870-6222	72582	5120740	. BOLT,SHOULDER 5/8-18UNF-3AX11.96 GR1 UOC: A6V,F6V	1
15	PAFZZ	5330-00-074-1923	72582	5133263	GASKET PART OF KIT P/N 8927743 UOC: A6V,F6V	1
16	PAFZZ	2935-00-908-9733	72582	5198303	PARTS KIT,OIL COOLE UOC: A6V,F6V	1
17	PAFZZ	4330-00-921-5375	72582	5134304	HEAD,FLUID FILTER UOC: A6V,F6V	1
18	PAFZZ	5310-00-080-6004	72582	MS27183-14	WASHER,FLAT UOC: A6V,F6V	4
19	PAFZZ	5310-00-637-9541	59556	019-00004-42	WASHER,LOCK UOC: A6V,F6V	4

(1) ITEM NO.	(2) SMR CODE	(3) NSN	(4) CAGEC	(5) PART NUMBER	(6) DESCRIPTION AND USABLE ON CODE (UOC)	(7) QTY
20	PAFZZ	5305-00-068-0511	80204	B1821BH038C125N	SCREW,CAP,HEXAGON H 3/8-16UNC-2AX1-1/4 GR8 UOC: A6V,F6V	4

END OF FIGURE

**FIELD MAINTENANCE
OIL FILTER ASSEMBLY, ADAPTER, AND RELATED PARTS (MODEL 5063-5392)**

5	9	10	13	21
6	10 THRU 22	11	14	22

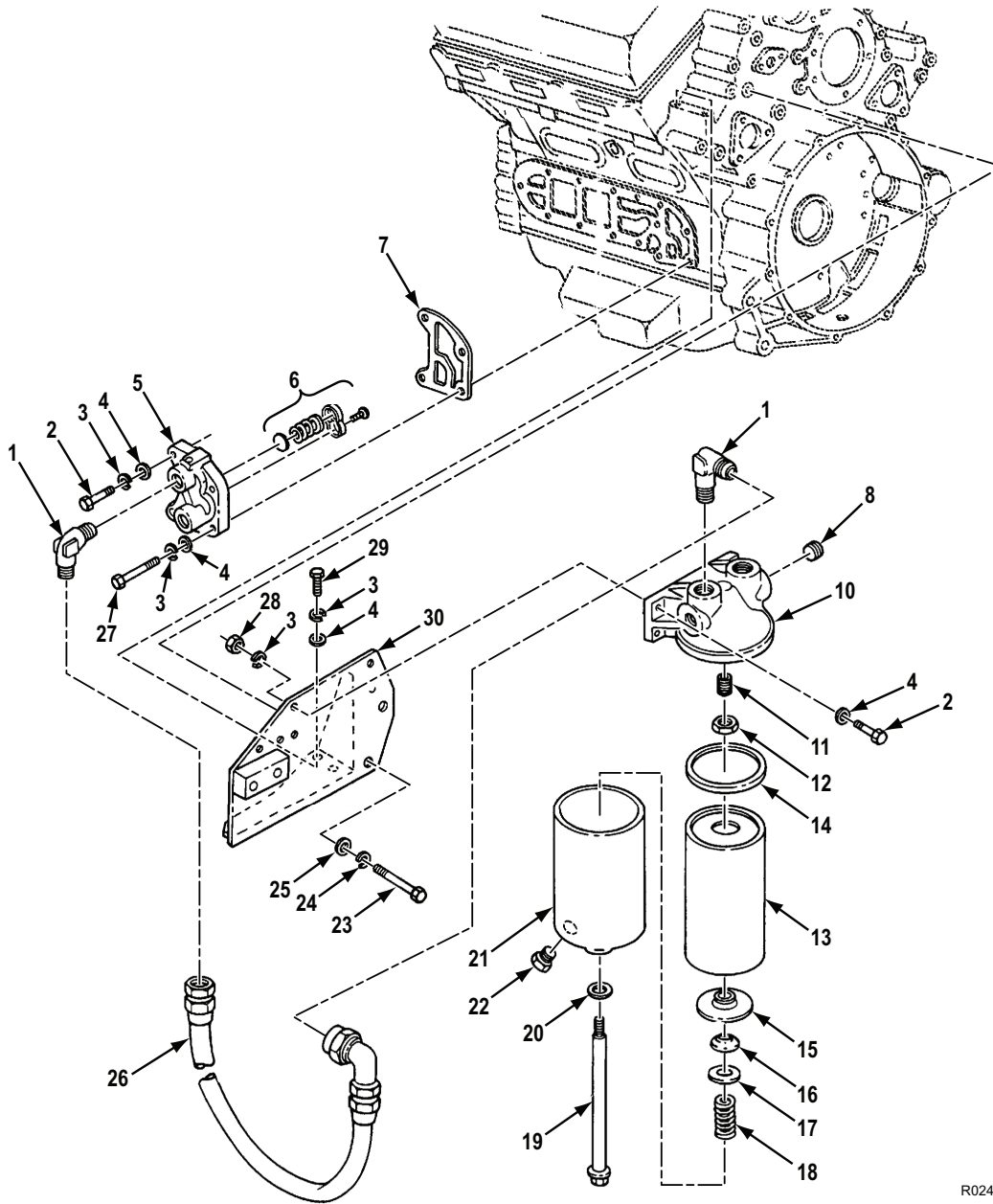

R024

Figure 21. Oil Filter Assembly, Adapter, and Related Parts (Model 5063-5392).

(1) ITEM NO.	(2) SMR CODE	(3) NSN	(4) CAGEC	(5) PART NUMBER	(6) DESCRIPTION AND USABLE ON CODE (UOC)	(7) QTY
GROUP 0106 OIL FILTER ASSEMBLY, ADAPTER, AND RELATED PARTS (MODEL 5063-5392)						
FIG. 21. OIL FILTER ASSEMBLY, ADAPTER, AND RELATED PARTS (MODEL 5063-5392).						
1	PAFZZ	4730-00-833-9315	96906	MS51504A16	ELBOW,PIPE TO TUBE UOC: C6V	4
2	PAFZZ	5305-00-725-2317	80204	B1821BH038C150N	SCREW,CAP,HEXAGON H UOC: C6V	6
3	PAFZZ	5310-00-637-9541	59556	019-00004-42	WASHER,LOCK UOC: C6V	10
4	PAFZZ	5310-00-080-6004	96906	MS27183-14	WASHER,FLAT UOC: C6V	10
5	PAFZZ	2940-01-157-8873	72582	5104771	ADAPTER,OIL FILTER UOC: C6V	1
6	PAFZZ	2935-00-908-9733	72582	5198303	. PARTS KIT,OIL COOLE UOC: C6V	1
7	KFFZZ	5330-01-157-3770	72582	5104866	GASKET PART OF KIT P/N 8928522 UOC: C6V	1
8	PAFZZ	4730-01-210-4251	81118	090321	PLUG,PIPE UOC: C6V	2
9	AFFZZ	2940-00-789-4873	72582	5147683	FILTER,FLUID UOC: C6V	1
10	PAFZZ	2940-00-834-1157	72582	5147684	. HEAD,FLUID FILTER UOC: C6V	1
11	PAFZZ	5325-00-608-9214	73957	6518-12	. . INSERT,SCREW THREAD UOC: C6V	1
12	PAFZZ	5310-01-216-6636	96906	MS35691-1024	. NUT,PLAIN,HEXAGON UOC: C6V	1
13	PAFFF	2940-00-580-6283	81348	F-F-351/7-3	. FILTER ELEMENT,FLUI UOC: C6V	1
14	PAFZZ	5330-01-383-3753	72582	1595620	. . GASKET UOC: C6V	1
15	PAFZZ	5330-00-629-6340	72582	5187309	. RETAINER,PACKING UOC: C6V	1
16	PAFZZ	5331-00-604-8094	72582	5187310	. O-RING UOC: C6V	1
17	PAFZZ	5365-00-262-4701	72582	5154538	. SPACER,RING UOC: C6V	1
18	PAFZZ	5360-00-801-8731	72582	5187308	. SPRING,HELICAL,COMP UOC: C6V	1
19	PAFZZ	5306-00-870-6222	72582	5120740	. BOLT,SHOULDER 5/8-18UNF-3AX11.96 UOC: C6V	1
20	PAFZZ	5330-00-833-0870	70040	6437298	. GASKET SET UOC: C6V	1

(1) ITEM NO.	(2) SMR CODE	(3) NSN	(4) CAGEC	(5) PART NUMBER	(6) DESCRIPTION AND USABLE ON CODE (UOC)	(7) QTY
21	PAFFF	2940-00-019-4775	70040	OF203	. COVER,FLUID FILTER UOC: C6V	1
22	PAFZZ	4820-00-360-8299	72582	5570480	. . VALVE,PLUG UOC: C6V	1
23	PAFZZ	5305-00-071-2073	80204	B1821BH050C250N	SCREW,CAP,HEXAGON H UOC: C6V	2
24	PAFZZ	5310-00-003-4094	96906	MS35338-48	WASHER,LOCK UOC: C6V	2
25	PAFZZ	5310-00-809-5997	96906	MS27183-17	WASHER,FLAT UOC: C6V	2
26	PAFZZ	4720-01-245-6607	72582	AEJH0350	HOSE ASSEMBLY,NONME UOC: C6V	2
27	PAFZZ	5305-00-018-7069	24617	187069	SCREW,CAP,HEXAGON H 3/8-16UNC-2AX2-1/8 GR2 UOC: C6V	2
28	PAFZZ	5310-01-156-7704	96906	MS16286-3	NUT,PLAIN,HEXAGON UOC: C6V	4
29	PAFZZ	5305-00-068-0510	80204	B1821BH038C100N	SCREW,CAP,HEXAGON H 3/8-16UNC-2AX1 GR8 UOC: C6V	2
30	PAFZZ	4330-01-210-4645	19207	12313567	BRACKET,FILTER MOUN UOC: C6V	1

END OF FIGURE

FIELD MAINTENANCE
OIL FILTER ASSEMBLY, ADAPTER, AND RELATED PARTS (MODELS 5063-5393 AND 5063-539L)

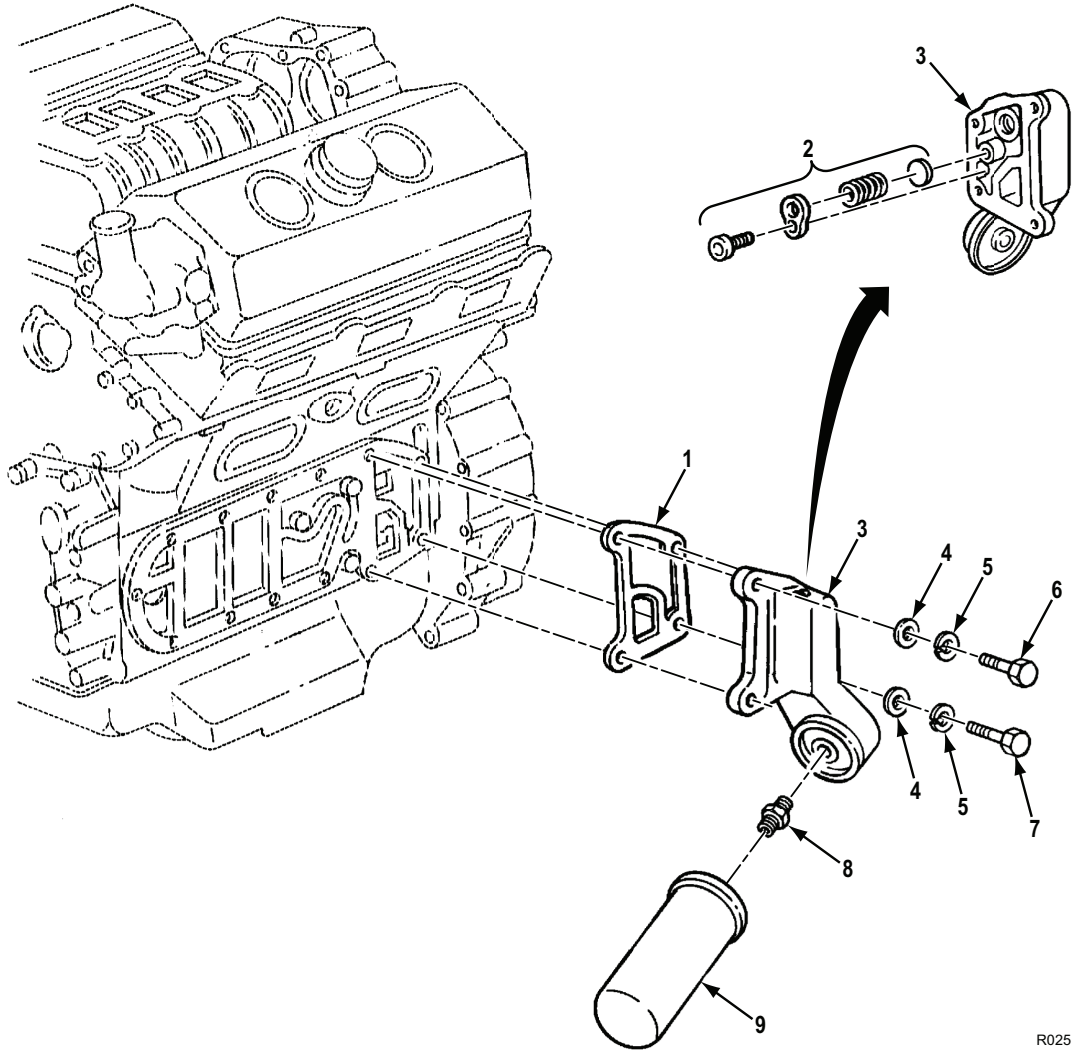

R025

Figure 22. Oil Filter Assembly, Adapter, and Related Parts (Models 5063-5393 and 5063-539L).

(1) ITEM NO.	(2) SMR CODE	(3) NSN	(4) CAGEC	(5) PART NUMBER	(6) DESCRIPTION AND USABLE ON CODE (UOC)	(7) QTY
<p>GROUP 0106 OIL FILTER ASSEMBLY, ADAPTER, AND RELATED PARTS (MODELS 5063-5393 AND 5063-539L)</p> <p>FIG. 22. OIL FILTER ASSEMBLY, ADAPTER, AND RELATED PARTS (MODELS 5063-5393 AND 5063-539L).</p>						
1	KFFZZ	5330-01-157-3770	72582	5104866	GASKET PART OF KIT P/N 8928522 UOC: D6V,L6V	1
2	PAFZZ	2935-00-908-9733	72582	5198303	PARTS KIT,OIL COOLE UOC: D6V,L6V	1
3	PAFZZ	2940-01-251-4472	72582	8928714	BRACKET,INTAKE AIR UOC: D6V,L6V	1
4	PAFZZ	5310-00-080-6004	96906	MS27183-14	WASHER,FLAT UOC: D6V,L6V	4
5	PAFZZ	5310-00-637-9541	59556	019-00004-42	WASHER,LOCK UOC: D6V,L6V	4
6	PAFZZ	5305-00-725-2317	80204	B1821BH038C150N	SCREW,CAP,HEXAGON H UOC: D6V,L6V	2
7	PAFZZ	5305-00-782-9489	80204	B1821BH038C200N	SCREW,CAP,HEXAGON H UOC: D6V,L6V	2
8	PAFZZ	4730-01-163-1085	72582	5103892	NIPPLE,TUBE UOC: D6V,L6V	1
9	PAFZZ	2940-01-197-7106	01637	FL804FP	FILTER ELEMENT,FLUI UOC: D6V,L6V	1

END OF FIGURE

**SUSTAINMENT MAINTENANCE
LOWER FRONT COVER, OIL PRESSURE REGULATOR, AND OIL PUMP ASSEMBLY**

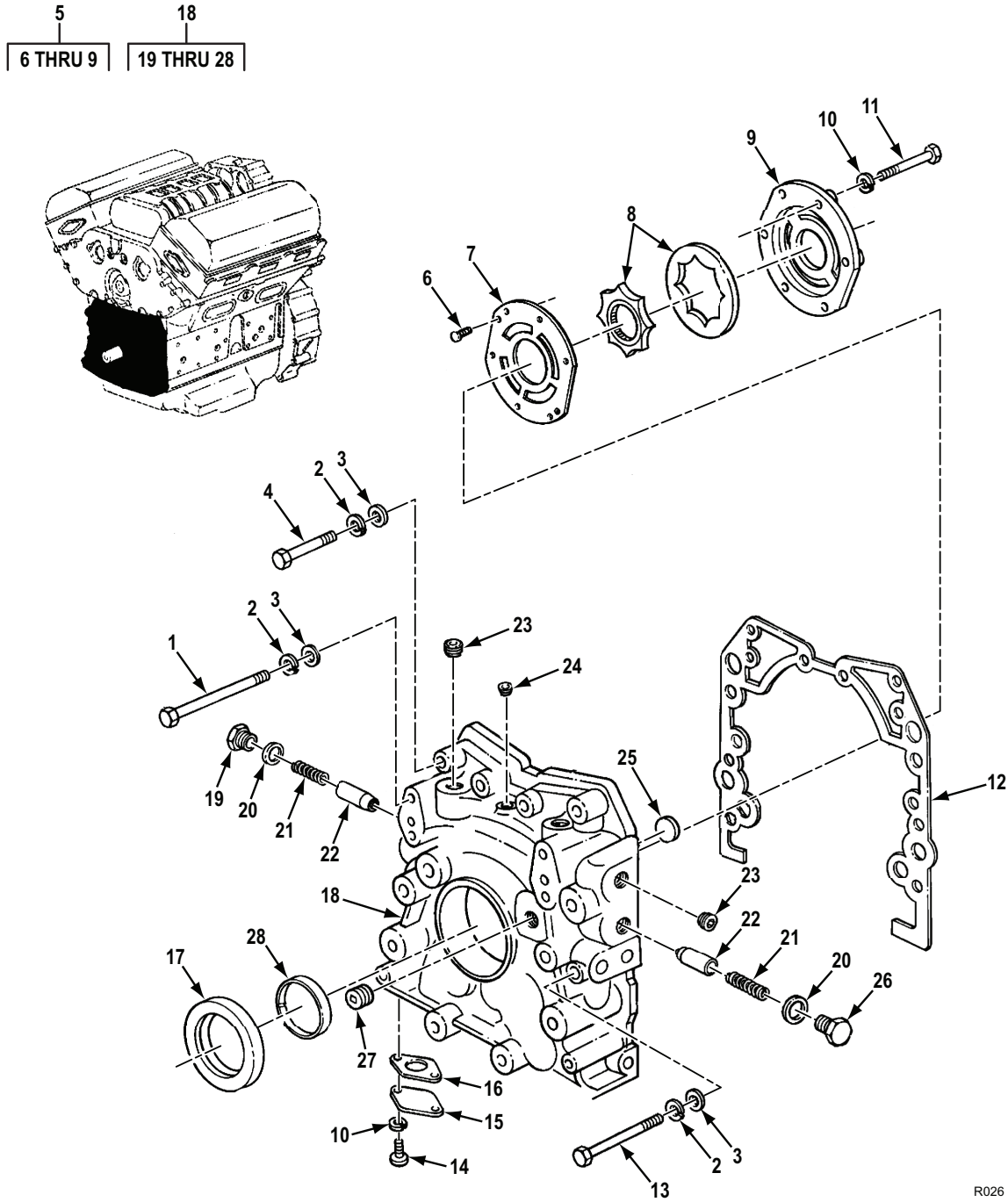

R026

Figure 23. Lower Front Cover, Oil Pressure Regulator, and Oil Pump Assembly.

(1) ITEM NO.	(2) SMR CODE	(3) NSN	(4) CAGEC	(5) PART NUMBER	(6) DESCRIPTION AND USABLE ON CODE (UOC)	(7) QTY
GROUP 0106 LOWER FRONT COVER, OIL PRESSURE REGULATOR, AND OIL PUMP ASSEMBLY						
FIG. 23. LOWER FRONT COVER, OIL PRESSURE REGULATOR, AND OIL PUMP ASSEMBLY.						
1	PAHZZ	5305-00-934-0279	1ML14	1000-16164	SCREW,CAP,HEXAGON H 3/8-16UNC-2AX4-1/8 GR5.....	4
2	PAHZZ	5310-00-637-9541	80045	23MS35338-46	WASHER,LOCK UOC: A6V,C6V,F6V	12
3	PAHZZ	5310-00-080-6004	96906	MS27183-14	WASHER,FLAT UOC: A6V,C6V,D6V,F6V	12
3	PAHZZ	5310-00-080-6004	96906	MS27183-14	WASHER,FLAT UOC: D6V,L6V	8
4	PAHZZ	5305-00-543-2866	80204	B1821BH038C250N	SCREW,CAP,HEXAGON H 3/8-16UNC-2AX2-1/2 GR8.....	4
5	PAHHH	2815-01-219-4102	72582	5104714	OIL PUMP ASSEMBLY,E UOC: C6V,D6V,L6V	1
5	PAHZZ	2815-00-780-5218	72582	5116070	PUMP,ENGINE OIL UOC: A6V,F6V	1
6	PAHZZ	5305-00-253-5620	80205	MS21318-29	. SCREW,DRIVE NO.6X3/8.....	2
7	PAHZZ	2815-00-921-5388	72582	5195685	. COVER.....	1
8	PAHZZ	4320-01-235-5731	19954	ER-431700	. GEAR ROTOR SET,ROTA UOC: C6V,D6V,L6V	1
8	PAHZZ	4320-00-789-4848	72582	5195687	. GEAR ROTOR SET,ROTA UOC: A6V,F6V	1
9	PAHZZ	2990-01-234-7368	72582	5104550	. HOUSING,OIL PUMP AS UOC: C6V,D6V,L6V	1
9	XAHZZ		72582	5195686	. HOUSING,OIL PUMP AS UOC: A6V,F6V	1
10	PAHZZ	5310-00-407-9566	80205	MS35338-45	WASHER,LOCK UOC: A6V,F6V,L6V	8
11	PAHZZ	5306-01-239-9393	72582	193268	BOLT,MACHINE.....	6
12	KFHZZ	5330-00-780-5242	72582	5119368	GASKET PART OF KIT P/N 8927743 PART OF KIT P/N 8928522.....	1
13	PAHZZ	5305-00-781-3927	80204	B1821BH038C350N	SCREW,CAP,HEXAGON H 3/8-16UNC-2AX3-1/2 GR8.....	4
14	PAHZZ	5305-01-071-8140	80205	NAS1352-5-16P	SCREW,CAP,SOCKET HE 5/16-18UNC-3AX1 GR8 UOC: A6V,F6V	2
14	PAHZZ	5305-01-289-9750	80205	NAS1352-5-14P	SCREW,CAP,SOCKET HE 5/16-18UNC-3AX7/8 GR8 UOC: C6V,D6V,L6V	2
15	PAHZZ	2930-01-051-7920	72582	5119426	FLANGE,THERMOSTAT.....	1

(1) ITEM NO.	(2) SMR CODE	(3) NSN	(4) CAGEC	(5) PART NUMBER	(6) DESCRIPTION AND USABLE ON CODE (UOC)	(7) QTY
16	KFHZZ	5330-00-682-7195	63005	5126473	GASKET PART OF KIT P/N 8927743 PART OF KIT P/N 8928522.....	1
17	PAHZZ	5330-00-112-0144	72582	5198503	SEAL,PLAIN ENCASED U/W BUSHING SLEEVE NSN 3120-00-113-0612. UOC: A6V,F6V	1
17	PAHZZ	5330-00-944-7065	72582	5138796	SEAL,PLAIN ENCASED UOC: C6V,D6V,L6V	1
17	PAHZZ	5330-00-792-9841	72582	5116224	SEAL,PLAIN ENCASED UOC: A6V,F6V	1
18	PAHZZ	2815-00-921-5337	72582	5109946	COVER LWR FRONT COVER UOC: A6V,F6V	1
18	PAHZZ	2815-01-016-0425	72582	5138830	COVER ASSEMBLY UOC: C6V,D6V,L6V	1
19	PAHZZ	5365-01-176-7441	72582	5109803	. PLUG,MACHINE THREAD.....	1
20	KFHZZ	5310-00-663-7617	15434	60598	. WASHER,FLAT PART OF KIT P/ N 8927743.....	1
21	PAHZZ	5360-00-682-7190	72582	5126436	. SPRING,HELICAL,COMP.....	1
22	PAHZZ	2815-00-903-0907	72582	5143021	. SLEEVE,OIL PRESSURE.....	1
23	PAHZZ	4730-00-959-2329	58536	AA59616ACAAAD	. PLUG,PIPE UOC: A6V,F6V	1
23	PAHZZ	4730-01-210-4252	72582	5146648	. PLUG,PIPE UOC: C6V,D6V,L6V	1
24	PAHZZ	4730-00-371-5337	72582	08924380	. PLUG,PIPE UOC: C6V,D6V,L6V	1
25	PAHZZ	5342-01-144-1937	72582	5139988	. PLUG UOC: C6V,D6V,L6V	1
26	PAHZZ	5365-00-903-0909	72582	5136227	. PLUG,MACHINE THREAD.....	1
27	PAHZZ	4730-00-010-3885	72582	8924517	. PLUG,PIPE UOC: C6V,D6V,L6V	1
28	PAHZZ	3120-00-930-3265	72582	5136097	. BEARING,SLEEVE UOC: C6V,D6V,L6V	1

END OF FIGURE

**FIELD MAINTENANCE
EXHAUST MANIFOLDS**

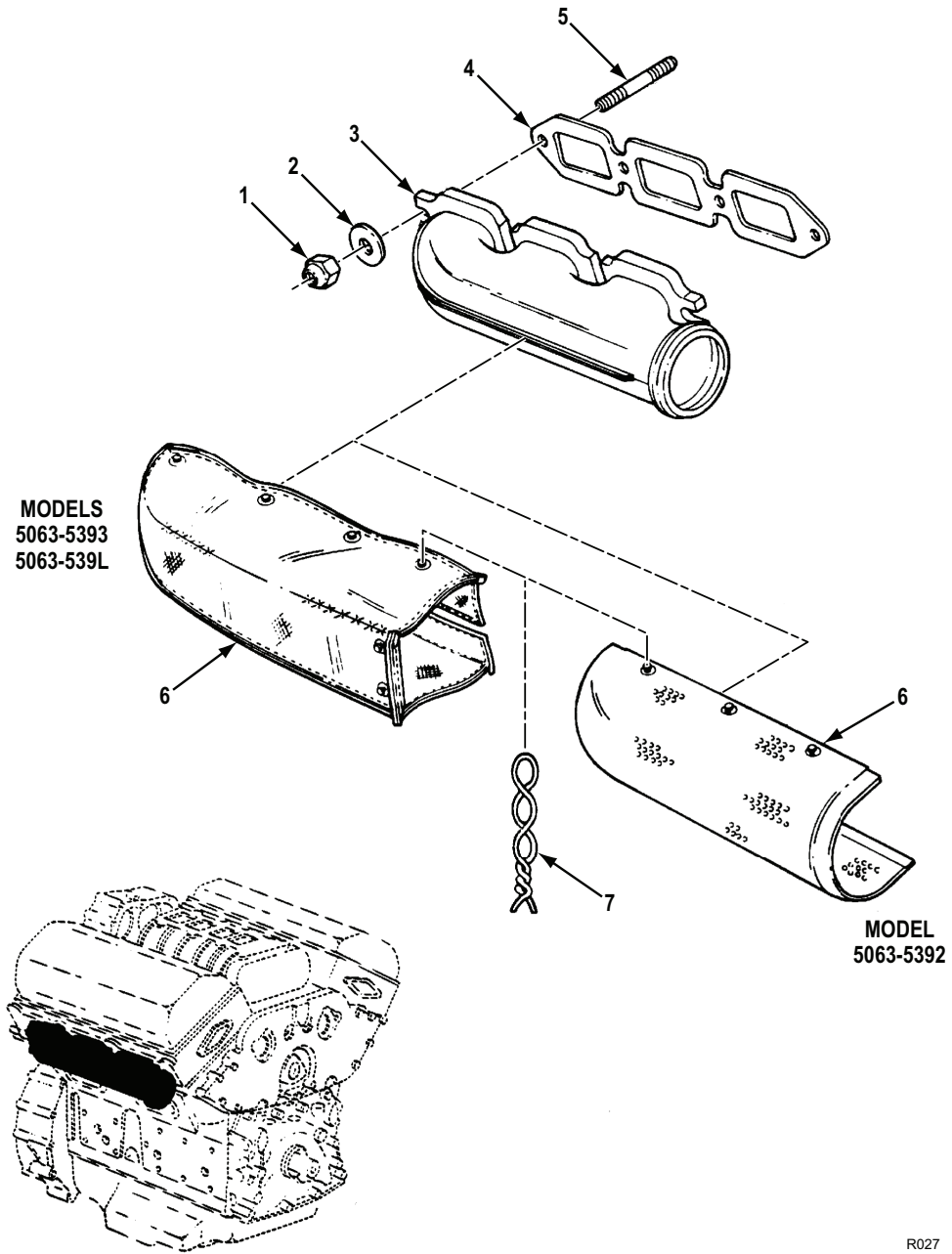

Figure 24. Exhaust Manifolds.

(1) ITEM NO.	(2) SMR CODE	(3) NSN	(4) CAGEC	(5) PART NUMBER	(6) DESCRIPTION AND USABLE ON CODE (UOC)	(7) QTY
GROUP 0108 EXHAUST MANIFOLDS						
FIG. 24. EXHAUST MANIFOLDS.						
1	PAFZZ	5310-00-274-9364	96906	MS21045-7	NUT, SELF-LOCKING, HE.....	8
2	PAFZZ	5310-00-595-8121	72582	5104439	WASHER, SPRING TENS.....	8
3	PAFZZ	2815-00-567-2502	72582	5135016	MANIFOLD, EXHAUST.....	2
4	KFFZZ	5330-01-467-2161	72582	5116205	GASKET PART OF KIT P/N 8927743, PART OF KIT P/N 8928522, PART OF KIT P/N 5199811.....	2
5	PAFZZ	5307-00-550-1879	72582	8925804	STUD, PLAIN.....	8
6	PAFZZ	2590-01-202-0960	19207	12313864	INSULATION, COVER UOC: C6V	2
6	PAFZZ	2990-01-291-1276	22013	298S30237	COVER, EXHAUST MANIF UOC: D6V, L6V	2
7	MFFZZ		72582	5101163	WIRE, NON-ELECTRICAL USE AS REQUIRED, MAKE FROM P/N MS2099NC20(96906) UOC: C6V, D6V, L6V	1

END OF FIGURE

**FIELD MAINTENANCE
TACHOMETER DRIVE ASSEMBLY**

1
2

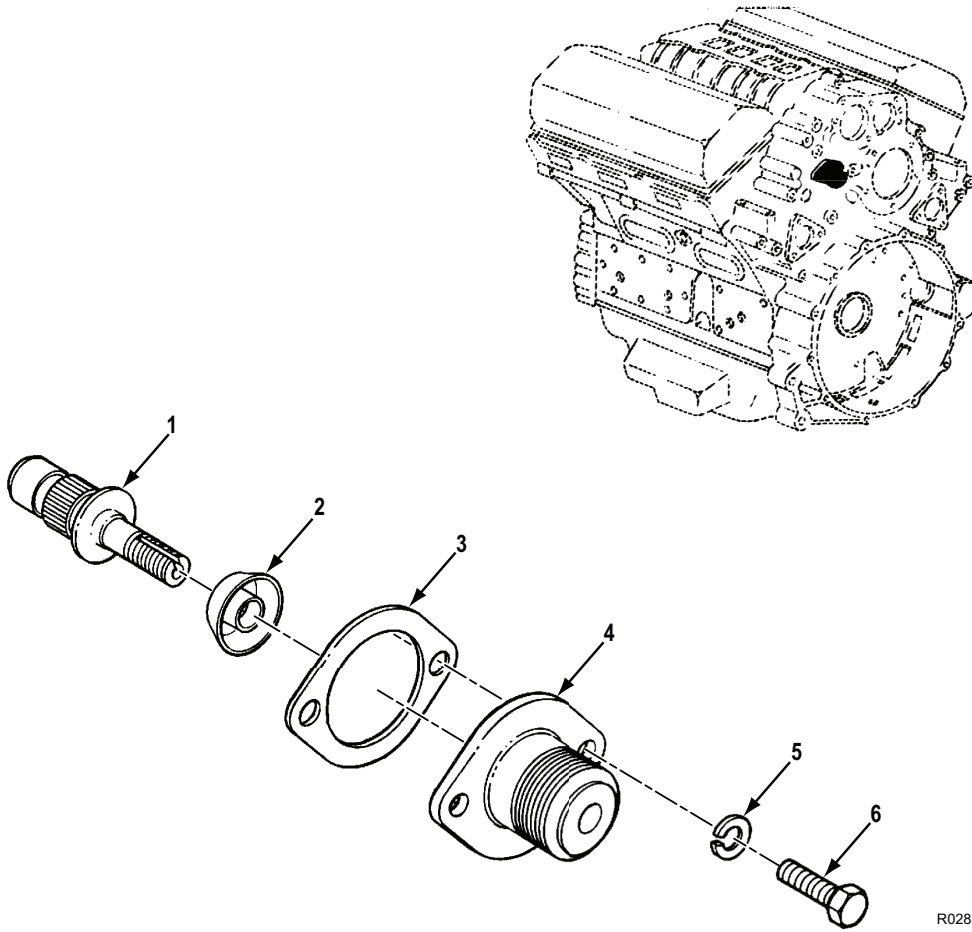

R028

Figure 25. Tachometer Drive Assembly.

(1) ITEM NO.	(2) SMR CODE	(3) NSN	(4) CAGEC	(5) PART NUMBER	(6) DESCRIPTION AND USABLE ON CODE (UOC)	(7) QTY
GROUP 0109 TACHOMETER DRIVE ASSEMBLY						
FIG. 25. TACHOMETER DRIVE ASSEMBLY.						
1	PAFZZ	2815-00-567-2501	72582	5134526	DRIVE ASSEMBLY, SHAF.....	1
2	PAFZZ	2815-00-540-0099	72582	5155818	. DEFLECTOR, DIRT AND.....	1
3	KFFZZ	5330-00-466-0467	72582	5135935	GASKET PART OF KIT P/N 8928522, PART OF KIT P/N 8927743.....	1
4	PAFZZ	6680-00-364-3506	72582	5155819	ADAPTOR, TACHOMETER.....	1
5	PAFZZ	5310-00-407-9566	80205	MS35338-45	WASHER, LOCK.....	2
6	PAFZZ	5306-00-226-4827	80204	B1821BH031C100N	BOLT, MACHINE 5/16-18UNC-2AX1 GR8..	2

END OF FIGURE

**SUSTAINMENT MAINTENANCE
HYDRAULIC PUMP DRIVE (MODELS 5063-5393 AND 5063-539L)**

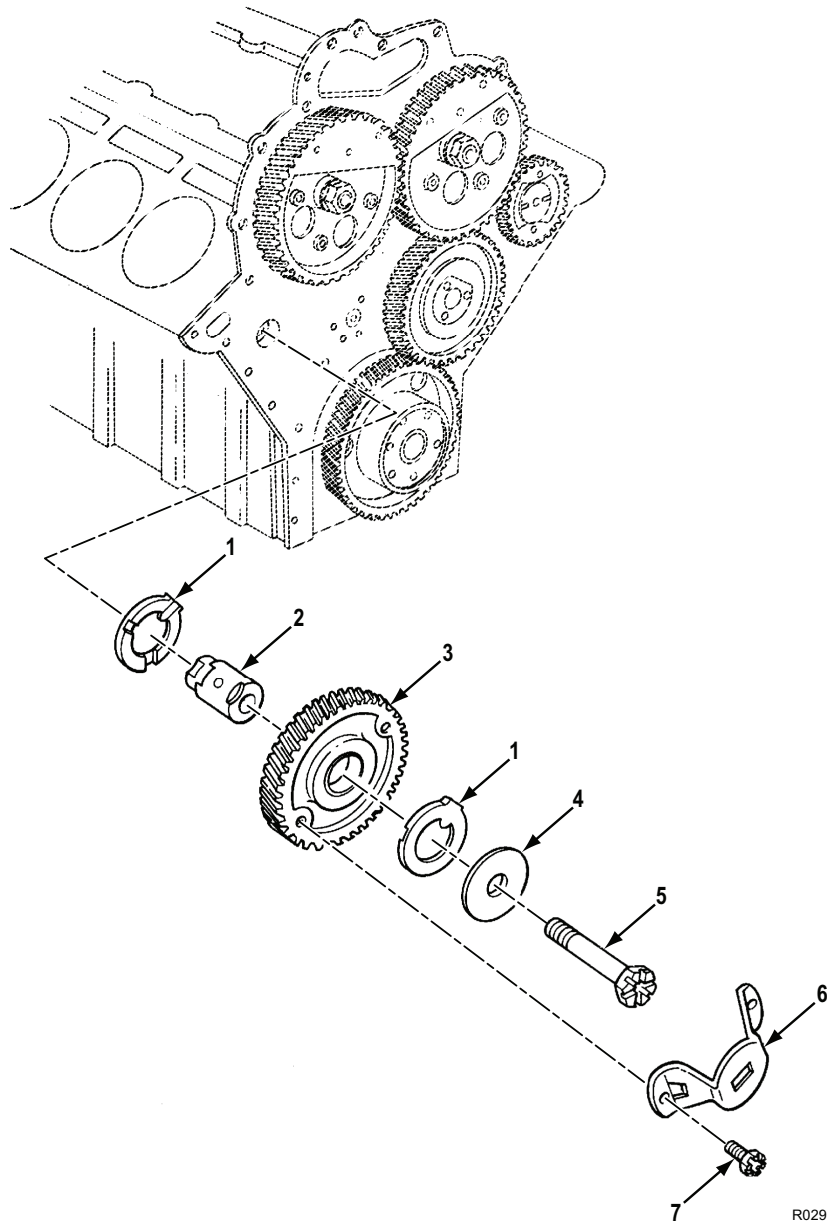

Figure 26. Hydraulic Pump Drive (Models 5063-5393 and 5063-539L).

(1) ITEM NO.	(2) SMR CODE	(3) NSN	(4) CAGEC	(5) PART NUMBER	(6) DESCRIPTION AND USABLE ON CODE (UOC)	(7) QTY
					GROUP 0109 HYDRAULIC PUMP DRIVE (MODELS 5063-5393 AND 5063-539L)	
					FIG. 26. HYDRAULIC PUMP DRIVE (MODELS 5063-5393 AND 5063-539L).	
1	PAHZZ	5310-00-999-2397	72582	5125771	WASHER,THRUST UOC: D6V,L6V	2
2	PAHZZ	3040-00-999-2352	72582	5125774	HUB,BODY UOC: D6V,L6V	1
3	PAHZZ	3020-00-089-7781	72582	5107088	GEAR,FUEL PUMP UOC: D6V,L6V	1
4	PAHZZ	2910-00-999-2396	72582	5126672	RETAINER,DRIVE GEAR UOC: D6V,L6V	1
5	PAHZZ	5306-00-846-3246	19207	8675776	BOLT,MACHINE UOC: D6V,L6V	1
6	PAHZZ	2910-00-999-2351	72582	23511479	ADAPTER HYDRAULIC PUMP DRIVE UOC: D6V,L6V	1
7	PAHZZ	5306-00-822-3685	24617	9409073	BOLT,SELF-LOCKING 1/4&20UNC-2AX5/8 GR8 UOC: D6V,L6V	2

END OF FIGURE

**SUSTAINMENT MAINTENANCE
FUEL INJECTOR AND RELATED PARTS**

7
8 THRU 28

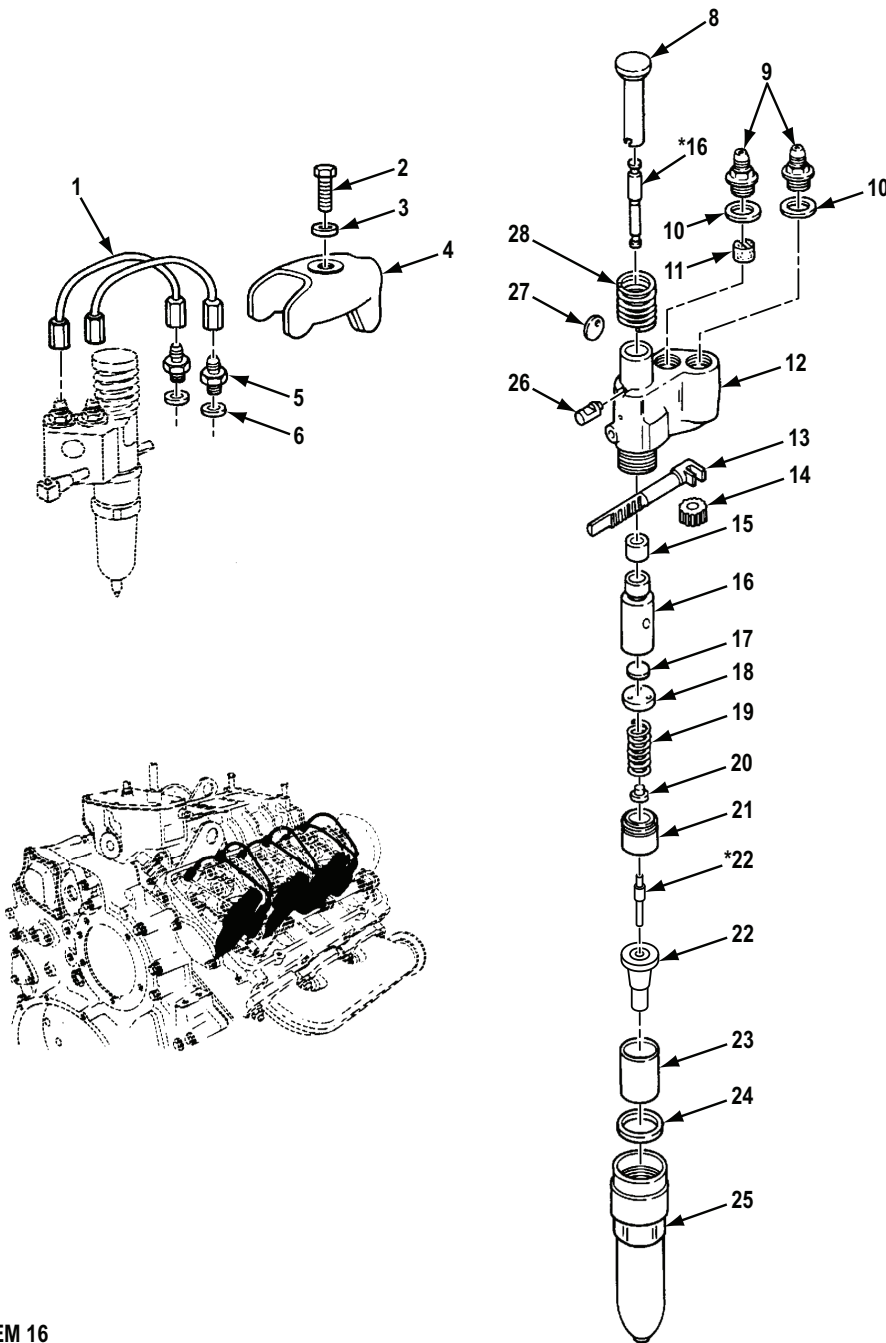

*16 PART OF ITEM 16
*22 PART OF ITEM 22

R030

Figure 27. Fuel Injector and Related Parts.

(1) ITEM NO.	(2) SMR CODE	(3) NSN	(4) CAGEC	(5) PART NUMBER	(6) DESCRIPTION AND USABLE ON CODE (UOC)	(7) QTY
GROUP 0301 FUEL INJECTOR AND RELATED PARTS						
FIG. 27. FUEL INJECTOR AND RELATED PARTS.						
1	PAFZZ	4710-01-446-3824	72582	23511852	TUBE ASSEMBLY,METAL FUEL INLET & OUTLET, INJECTOR TO CYL HD	12
2	PAFZZ	5305-00-782-9489	80204	B1821BH038C200N	SCREW,CAP,HEXAGON H 3/8-16UNC-2AX2 GR8.....	6
3	PAFZZ	5310-00-276-3015	72582	5150250	WASHER,CONVEX.....	6
4	PAFZZ	2910-00-735-6187	59556	002104T	CLAMP,FUEL INJECTOR.....	6
5	PAFZZ	4730-01-222-0914	72582	8926992	NIPPLE,TUBE CYL HEAD TO FUEL LINES.....	12
6	KFFZZ	5310-01-239-5071	72582	8925644	WASHER,FLAT PART OF KIT P/N 8928522, PART OF KIT P/N 5199811.....	12
7	PAFHH	2910-00-073-3011	72582	5228783	INJECTOR ASSEMBLY,F MODEL N50 UOC: A6V,F6V	6
7	PAFHH	2910-01-234-7373	77592	5226240	NOZZLE,FUEL INJECTI MODEL 5C55 UOC: C6V,D6V,L6V	6
8	PAHZZ	2910-00-126-9713	59556	002113T	. GUIDE,FOLLOWER UOC: C6V,D6V,L6V	1
9	PAHZZ	4730-00-937-0229	72582	5228588	. ADAPTER,STRAIGHT,TU INJECTOR BODY, FUEL INLET & OUTLET	2
10	KFHZZ	5365-00-255-0296	24617	5226186	. SPACER,RING PART OF KIT P/N 5229649, PART OF KIT P/N 5199811.....	2
11	KFHZZ	2910-00-374-4929	72582	5228587	. FILTER ELEMENT,FLUI PART OF KIT P/N 5229649, PART OF KIT P/N 5199811.....	1
12	PAHZZ	2910-00-833-1000	72582	5228584	. HOLDER,FUEL INJECTO.....	1
13	PAHZZ	2910-00-126-9712	72582	5226719	. RACK,INJECTOR.....	1
14	PAHZZ	3020-00-272-6038	72582	5226400	. GEAR,SPUR.....	1
15	PAHZZ	5365-00-849-2283	72582	5228586	. SPACER,SLEEVE.....	1
16	PAHZZ	2910-00-903-0910	72582	5228749	. PLUNGER AND BUSHING UOC: A6V,F6V	1
16	PAHZZ	2910-01-234-8566	77592	5226422	. PLUNGER AND BUSHING UOC: C6V,D6V,L6V	1
17	XDHZZ		72582	Q5228694	. VALVE CHECK MULT PK VALVE-INJECTOR CHECK--BUY AT 2000 PER PK. PACKAGE OF 2000.....	1
17	PAHZZ	5340-00-838-9696	71934	5228694	. DISK,SOLID,PLAIN.....	1
18	PAHZZ	6695-00-034-3918	54936	HN-5228696	. GAGE,VALVE INJECTOR.....	1
18	XDHZZ		72582	Q5228696	. CV CAGE MULTI PK CAGE-INJECTOR CHECK VALVE--BUY AT 2000 PER PACKAGE OF 2000.....	1

(1) ITEM NO.	(2) SMR CODE	(3) NSN	(4) CAGEC	(5) PART NUMBER	(6) DESCRIPTION AND USABLE ON CODE (UOC)	(7) QTY
19	PAHZZ	5360-00-986-7304	72582	5228596	. SPRING,HELICAL,COMP PART OF KIT P/N 5228769	1
19	XBHZZ		72582	Q5228596	. V SPRING MULTI PK SPRING- INJECTOR VALVE--BUY AT 2000 PER PK. PACKAGE OF 2000.....	1
20	KFHZZ	5340-00-837-8448	72582	5228766	. SEAT,HELICAL COMPRE PART OF KIT P/N 5228769 UOC: A6V,F6V	1
20	PAHZZ	5340-01-304-2471	72582	5226246	. SEAT,HELICAL COMPRE UOC: C6V,D6V,L6V	1
21	PAHZZ	5340-00-759-0542	72582	5228594	. SEAT,HELICAL COMPRE.....	1
21	XBHZZ		72582	Q5228594	. V SPR CAGE MULPICK CAGE- INJECTOR VALVE SPRING-BUY AT 2000 PER PACKAGE 2000.....	1
22	PAHZZ	2910-00-004-8422	72582	5229034	. SPRAY TIP,NOZZLE,FU UOC: A6V,F6V	1
22	PAHZZ	2910-01-234-6467	72582	5226404	. SPRAY TIP,FUEL INJE UOC: C6V,D6V,L6V	1
23	PAHZZ	5365-00-608-0486	72582	5228109	. SPACER,SLEEVE.....	1
24	KFHZZ	5330-00-364-3434	72582	5229167	. PACKING,PREFORMED BETWEEN INJECTOR BODY & NUT PART PART OF KIT P/N 5199811, PART OF KIT P/N 5229649.....	1
25	PAHZZ	5310-00-833-1013	72582	5228601	. NUT,INJECTOR,VALVE.....	1
26	PAHZZ	5315-00-707-1253	72582	5228608	. PIN,STOP,FUEL INJEC.....	1
27	PAHZZ	9905-01-023-9746	71934	5229191	. PLATE,MARKING,BLANK.....	1
28	PAHZZ	5360-00-792-9771	72582	5228739	. SPRING,HELICAL,COMP.....	1

END OF FIGURE

**FIELD MAINTENANCE
FUEL PUMP ASSEMBLY AND DRIVE**

9
|
10

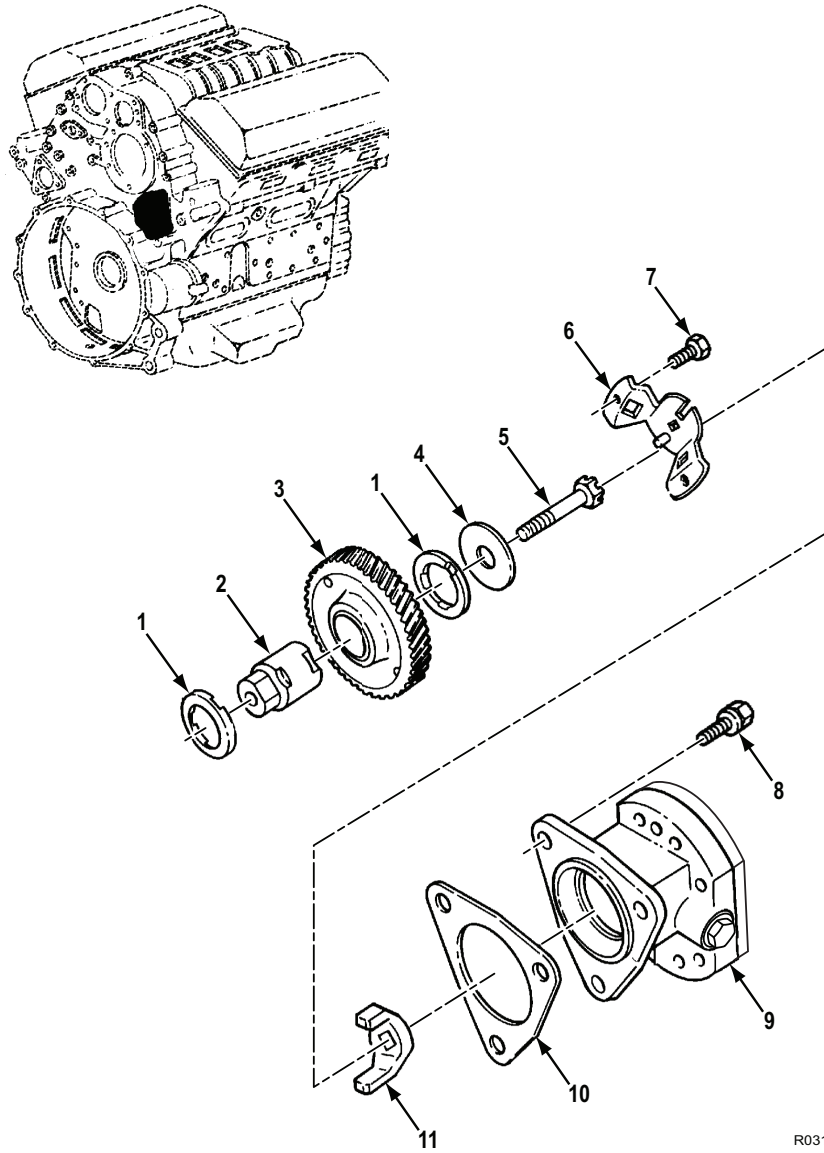

R031

Figure 28. Fuel Pump Assembly and Drive.

(1) ITEM NO.	(2) SMR CODE	(3) NSN	(4) CAGEC	(5) PART NUMBER	(6) DESCRIPTION AND USABLE ON CODE (UOC)	(7) QTY
GROUP 0302 FUEL PUMP ASSEMBLY AND DRIVE						
FIG. 28. FUEL PUMP ASSEMBLY AND DRIVE.						
1	PAHZZ	5310-00-999-2397	72582	5125771	WASHER, THRUST.....	2
2	PAHZZ	3040-00-999-2352	72582	5125774	HUB, BODY.....	1
3	PAHZZ	3020-01-122-8251	72582	5107087	GEAR ASSEMBLY, FUEL.....	1
4	PAHZZ	2910-00-999-2396	72582	5126672	RETAINER, DRIVE GEAR.....	1
5	PAHZZ	5306-00-846-3246	19207	8675776	BOLT, MACHINE 1/2-13UNC-2AX2-3/4 GR8.....	1
6	PAHZZ	2910-00-999-2351	72582	23511479	ADAPTER.....	1
7	PAHZZ	5306-00-822-3685	24617	9409073	BOLT, SELF-LOCKING 1/4-20UNC-2AX5/8 GR8.....	2
8	PAFZZ	5306-01-297-6987	72582	8926603	BOLT, MACHINE 5/16-18UNC-2AX3/4 GR2.....	3
9	PAFZZ	2910-00-355-7669	72582	5199734	PARTS KIT, ENGINE FU UOC: C6V, D6V, L6V	1
9	PAFZZ	2910-00-808-2655	72582	5199561	PUMP, FUEL, METERING UOC: A6V, F6V	1
10	PAFZZ	5310-01-392-3715	70177	K 5150193 NON- ASBESTOS	. GASKET PART OF KIT P/N , PART OF KIT P/N 8928522, PART OF KIT P/N , PART OF KIT P/N 8927743.....	1
11	PAFZZ	2910-01-127-6911	72582	8921934	FUEL PUMP DRIVE FOR.....	1

END OF FIGURE

**FIELD MAINTENANCE
FUEL LINES AND FITTINGS (MODEL 5063-5299)**

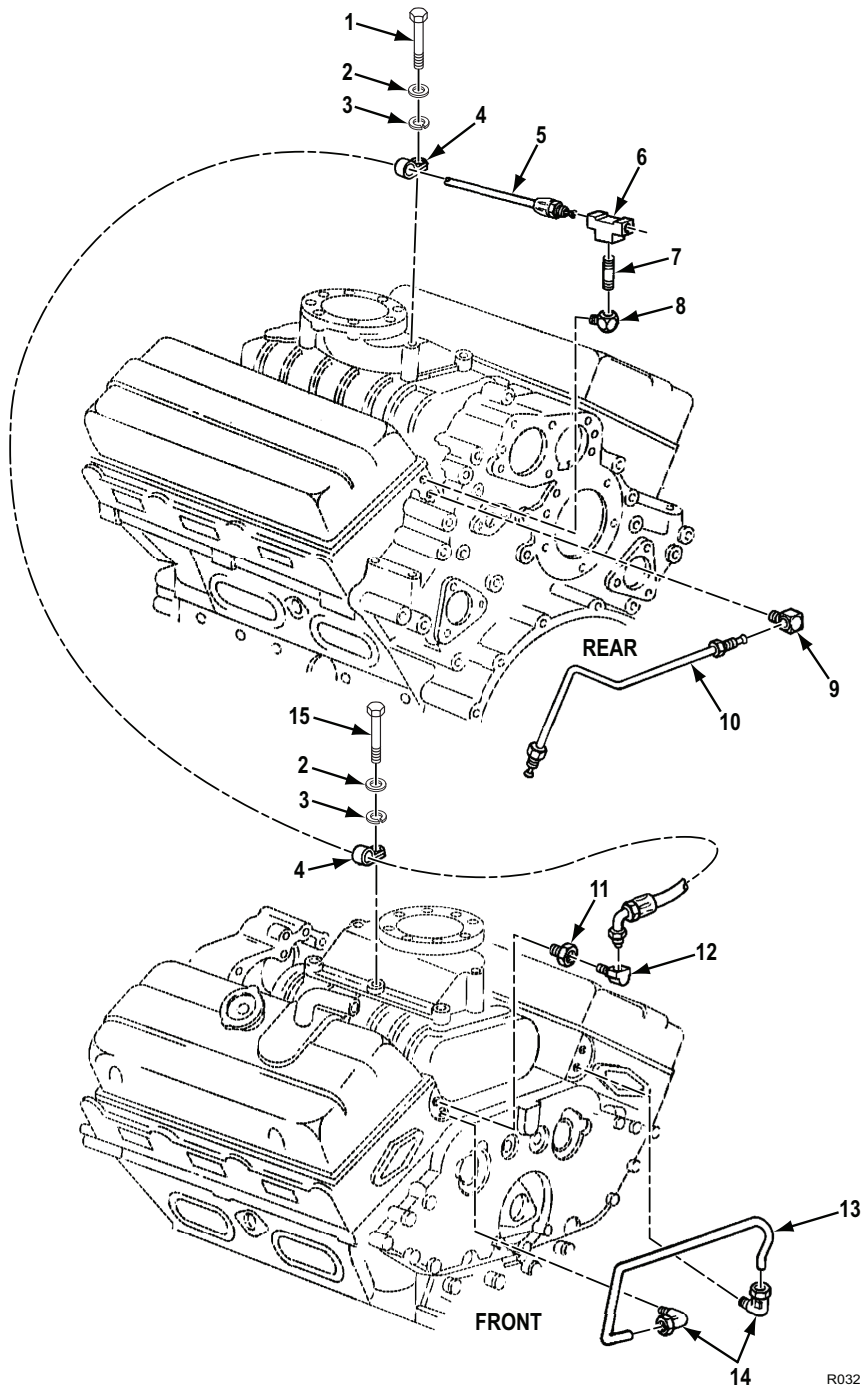
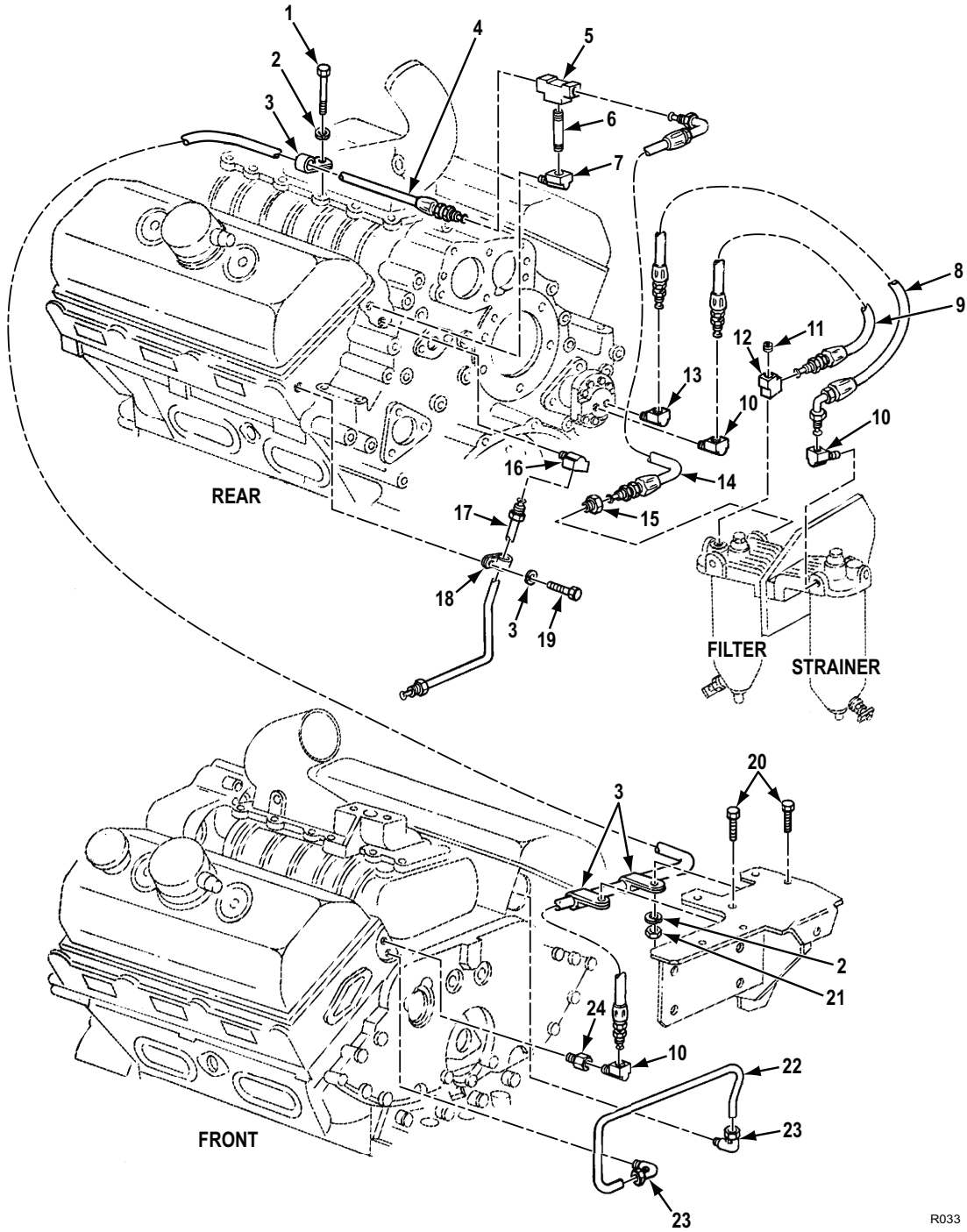

Figure 29. Fuel Lines and Fittings (Model 5063-5299).

(1) ITEM NO.	(2) SMR CODE	(3) NSN	(4) CAGEC	(5) PART NUMBER	(6) DESCRIPTION AND USABLE ON CODE (UOC)	(7) QTY
GROUP 0302 FUEL LINES AND FITTINGS (MODEL 5063-5299)						
FIG. 29. FUEL LINES AND FITTINGS (MODEL 5063-5299).						
1	PAFZZ	5305-00-990-8632	80204	B1821BH038C375N	SCREW,CAP,HEXAGON H UOC: A6V,F6V	1
2	PAFZZ	5310-00-637-9541	59556	019-00004-42	WASHER,LOCK UOC: A6V,F6V	2
3	PAFZZ	5310-00-080-6004	96906	MS27183-14	WASHER,FLAT UOC: D6V,L6V	2
4	PAFZZ	5340-00-499-3597	72582	5171509	CLAMP,LOOP UOC: A6V,F6V	2
5	PAFZZ	4720-00-994-5788	72582	5131375	HOSE ASSEMBLY,NONME UOC: A6V,F6V	1
6	PAFZZ	4730-01-075-7310	81343	6-6-4 040427B	TEE,PIPE TO TUBE UOC: A6V,F6V	1
7	PAFZZ	4730-00-196-1973	96906	MS51846-28	NIPPLE,PIPE UOC: A6V,F6V	1
8	PAFZZ	4730-00-595-4417	72582	8924168	ELBOW,PIPE UOC: A6V,F6V	1
9	PAFZZ	4730-00-780-5223	72582	8924185	ELBOW,PIPE TO TUBE UOC: A6V,F6V	1
10	PAFZZ	4710-01-118-5621	72582	5108025	TUBE ASSEMBLY,METAL UOC: A6V,F6V	1
11	PAFZZ	4730-01-157-8938	72582	8924172	COUPLING,PIPE UOC: A6V,F6V	1
12	PAFZZ	4730-00-277-8274	72582	137423	ELBOW,PIPE TO TUBE UOC: A6V,F6V	1
13	PAFZZ	4710-00-572-8603	72582	5135034	TUBE,BENT,METALLIC UOC: A6V,F6V	1
14	PAFZZ	4730-00-228-3302	72582	25101011	ELBOW,PIPE TO TUBE UOC: A6V,F6V	2
15	PAFZZ	5305-00-782-9489	80204	B1821BH038C200N	SCREW,CAP,HEXAGON H UOC: A6V,F6V	1

END OF FIGURE

**FIELD MAINTENANCE
FUEL LINES AND FITTINGS (MODEL 5063-5392)**



R033

Figure 30. Fuel Lines and Fittings (Model 5063-5392).

(1) ITEM NO.	(2) SMR CODE	(3) NSN	(4) CAGEC	(5) PART NUMBER	(6) DESCRIPTION AND USABLE ON CODE (UOC)	(7) QTY
GROUP 0302 FUEL LINES AND FITTINGS (MODEL 5063-5392)						
FIG. 30. FUEL LINES AND FITTINGS (MODEL 5063-5392).						
1	PAFZZ	5305-00-725-2317	80204	B1821BH038C150N	SCREW,CAP,HEXAGON H 3/8-16UNC-2AX1-1/2 GR8 UOC: C6V	1
2	PAFZZ	5310-00-637-9541	59556	019-00004-42	WASHER,LOCK UOC: C6V	8
3	PAFZZ	5340-00-161-5246	72582	2488022	CLAMP,LOOP UOC: C6V	3
4	PAFZZ	4720-01-238-5996	87373	2132828-6-6-6-35.25	HOSE ASSEMBLY,NONME UOC: C6V	1
5	PAFZZ	4730-01-075-7310	81343	6-6-4 040427B	TEE,PIPE TO TUBE UOC: C6V	1
6	PAFZZ	4730-00-196-1973	96906	MS51846-28	NIPPLE,PIPE UOC: C6V	1
7	PAFZZ	4730-00-595-4417	72582	8924168	ELBOW,PIPE UOC: C6V	1
8	PAFZZ	4720-00-994-5787	72582	5131575	HOSE ASSEMBLY,NONME UOC: C6V	1
9	PAFZZ	4720-00-010-0279	87373	2132828-6-6-6-32.00	HOSE ASSEMBLY,NONME UOC: C6V	1
10	PAFZZ	4730-01-204-4417	72582	8924154	ELBOW,PIPE HEAD UOC: C6V	3
11	PAFZZ	4730-01-398-7635	72582	8923847	PLUG,PIPE UOC: C6V	1
12	PAFZZ	4730-01-206-6146	72582	8924199	TEE,PIPE UOC: C6V	1
13	PAFZZ	4730-01-157-6223	72582	8924217	ELBOW,HOSE UOC: C6V	1
14	PAFZZ	4720-01-238-5995	87373	2132869-6-6-6-8.50	HOSE ASSEMBLY,NONME UOC: C6V	1
15	PAFZZ	4730-01-069-3216	72582	8924171	CONNECTOR UOC: C6V	1
16	PAFZZ	4730-01-210-6906	72582	8924183	ELBOW,TUBE UOC: C6V	1
17	PAFZZ	2835-01-015-5409	72582	5143774	TUBE UOC: C6V	1
18	PAFZZ	5342-01-134-5516	72582	140580	CLIP UOC: C6V	1
19	PAFZZ	5305-01-336-5925	4E670	8927579	SETSCREW UOC: C6V	1
20	PAFZZ	5305-00-543-4372	80204	B1821BH038C075N	SCREW,CAP,HEXAGON H UOC: C6V	2

(1) ITEM NO.	(2) SMR CODE	(3) NSN	(4) CAGEC	(5) PART NUMBER	(6) DESCRIPTION AND USABLE ON CODE (UOC)	(7) QTY
21	PAFZZ	5310-01-156-7704	96906	MS16286-3	NUT,PLAIN,HEXAGON UOC: C6V	2
22	PAFZZ	4710-00-572-8603	72582	5135034	TUBE,BENT,METALLIC UOC: C6V	1
23	PAFZZ	4730-00-228-3302	72582	25101011	ELBOW,PIPE TO TUBE UOC: C6V	2
24	PAFZZ	4730-01-157-8938	72582	8924172	COUPLING,PIPE UOC: C6V	1

END OF FIGURE

**FIELD MAINTENANCE
FUEL LINES AND FITTINGS (MODELS 5063-5393 AND 5063-539L)**

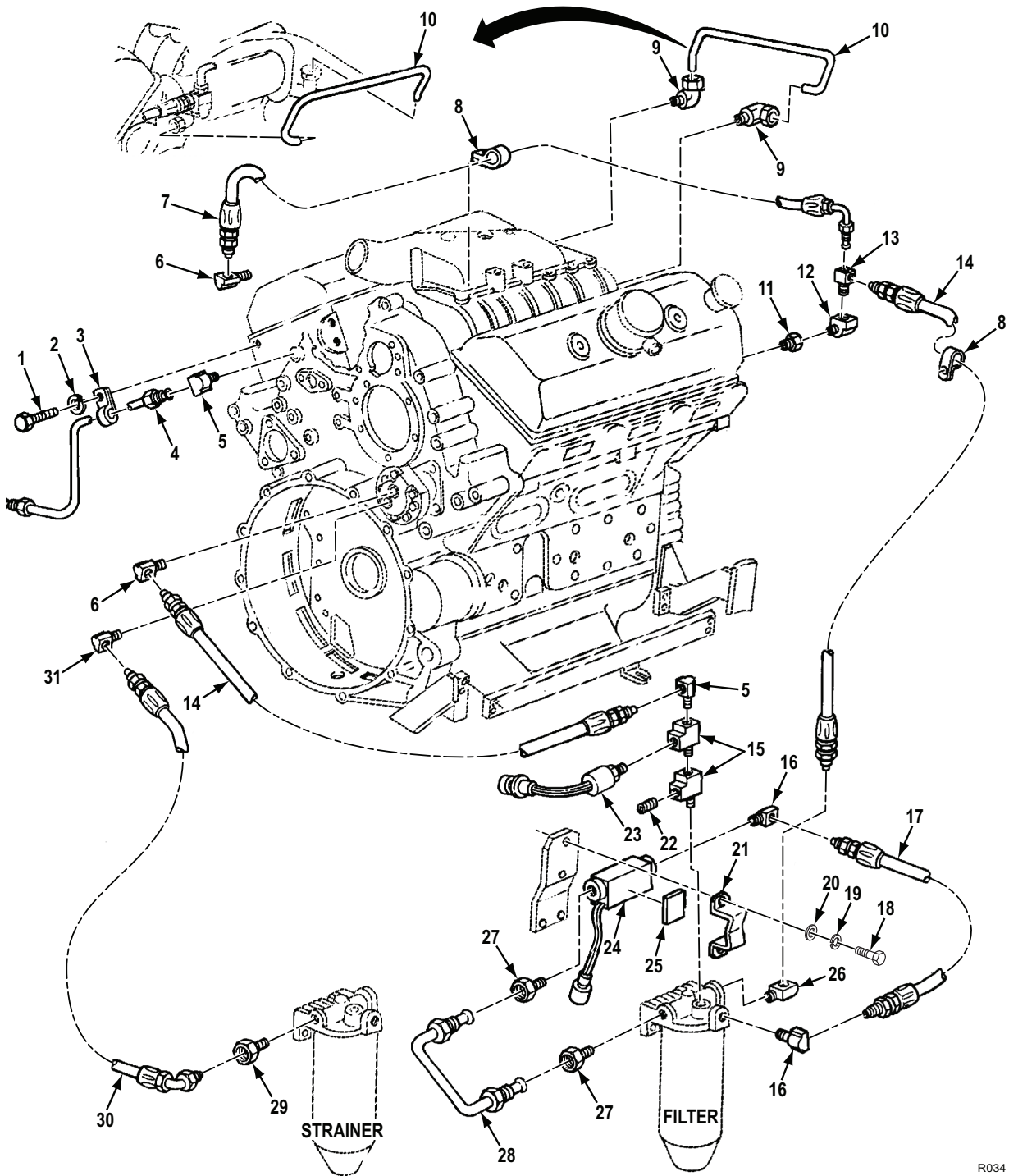

R034

Figure 31. Fuel Lines and Fittings (Models 5063-5393 and 5063-539L).

(1) ITEM NO.	(2) SMR CODE	(3) NSN	(4) CAGEC	(5) PART NUMBER	(6) DESCRIPTION AND USABLE ON CODE (UOC)	(7) QTY
GROUP 0302 FUEL LINES AND FITTINGS (MODELS 5063-5393 AND 5063-539L)						
FIG. 31. FUEL LINES AND FITTINGS (MODELS 5063-5393 AND 5063-539L).						
1	PAFZZ	5303-01-336-5925	4E670	8927579	BOLT 3/8-16 UNC-2AX3/4 GR5 UOC: D6V,L6V	1
2	PAFZZ	5310-00-637-9541	59556	019-00004-42	WASHER,LOCK UOC: D6V,L6V	4
3	PAFZZ	5342-01-134-5516	72582	140580	CLIP FUEL SPILL TUBE,LEFT SIDE REAR CYL HEAD UOC: D6V,L6V	1
4	PAFZZ	2835-01-015-5409	72582	5143774	TUBE UOC: D6V,L6V	1
5	PAFZZ	4730-01-204-4417	72582	8924154	ELBOW,PIPE UOC: D6V,L6V	2
6	PAFZZ	4730-00-014-3343	81343	5-4040202	ELBOW,PIPE TO TUBE UOC: D6V,L6V	1
7	PAFZZ	4720-00-994-5788	72582	5131375	HOSE ASSEMBLY,NONME UOC: D6V,L6V	1
8	PAFZZ	5340-00-161-5246	72582	2488022	CLAMP,LOOP UOC: D6V,L6V	2
9	PAFZZ	4730-00-228-3302	72582	25101011	ELBOW,PIPE TO TUBE UOC: D6V,L6V	2
10	PAFZZ	4710-00-572-8603	72582	5135034	TUBE,BENT,METALLIC FUEL SPILL CROSSOVER,FRONT UOC: D6V,L6V	1
11	PAFZZ	4730-01-157-8938	72582	8924172	COUPLING,PIPE UOC: D6V,L6V	1
12	PAFZZ	4730-00-595-4417	72582	8924168	ELBOW,PIPE UOC: D6V,L6V	2
13	PAFZZ	4730-00-862-4445	81343	6-4-6.040424B	TEE,PIPE TO TUBE UOC: D6V,L6V	1
14	PAFZZ	4720-01-016-0427	72582	5142005	HOSE ASSEMBLY,NONME UOC: D6V,L6V	2
15	PAFZZ	4730-01-005-3262	72582	8924178	TEE,PIPE UOC: D6V,L6V	2
16	PAFZZ	4730-00-366-3011	81343	SAEJ5134.4010202 B	ELBOW,PIPE TO TUBE 5/16-18UNC-2AX3/4 GR8 UOC: D6V,L6V	2
17	PAFZZ	4710-01-253-7058	72582	5133162	TUBE ASSEMBLY,METAL UOC: D6V,L6V	1
18	PAFZZ	5306-00-226-4825	80204	B1821BH031C075N	BOLT,MACHINE 5/16-18UNC-2AX3/4 GR8 UOC: D6V,L6V	2
19	PAFZZ	5310-00-407-9566	80205	MS35338-45	WASHER,LOCK UOC: D6V,L6V	2

(1) ITEM NO.	(2) SMR CODE	(3) NSN	(4) CAGEC	(5) PART NUMBER	(6) DESCRIPTION AND USABLE ON CODE (UOC)	(7) QTY
20	PAFZZ	5310-00-081-4219	96906	MS27183-12	WASHER,FLAT UOC: D6V,L6V	2
21	PBFZZ	5342-01-253-7396	72582	23501828	BRACKET,ENGINE ACCE UOC: D6V,L6V	1
22	PAFZZ	4730-01-398-7635	72582	8923847	PLUG,PIPE UOC: D6V,L6V	1
23	PAFZZ	6685-01-167-4298	19207	12258932-6	TRANSMITTER,PRESSUR UOC: D6V,L6V	1
24	PAFZZ	5930-01-148-8874	19207	12258938	SWITCH,PRESSURE UOC: D6V,L6V	1
25	PAFZZ	5999-01-254-4984	72582	23501826	MOUNTING PAD,ELECTR UOC: D6V,L6V	1
26	PAFZZ	4730-00-902-8991	96906	MS39162	ELBOW,PIPE TO TUBE UOC: D6V,L6V	1
27	PAFZZ	4730-01-242-9517	72582	8924218	COUPLING,TUBE UOC: D6V,L6V	2
28	PAFZZ	4710-01-253-7059	72582	23501830	TUBE ASSEMBLY,METAL UOC: D6V,L6V	1
29	PAFZZ	4730-00-266-0541	81343	J5138-6010102BA	ADAPTER,STRAIGHT,PI UOC: D6V,L6V	1
30	PAFZZ	4720-01-069-7708	01276	FA2408GGG0160AB	HOSE ASSEMBLY,NONME UOC: D6V,L6V	1
31	PAFZZ	4730-01-157-6223	72582	8924217	ELBOW,HOSE UOC: D6V,L6V	1

END OF FIGURE

**SUSTAINMENT MAINTENANCE
BLOWER ASSEMBLY**

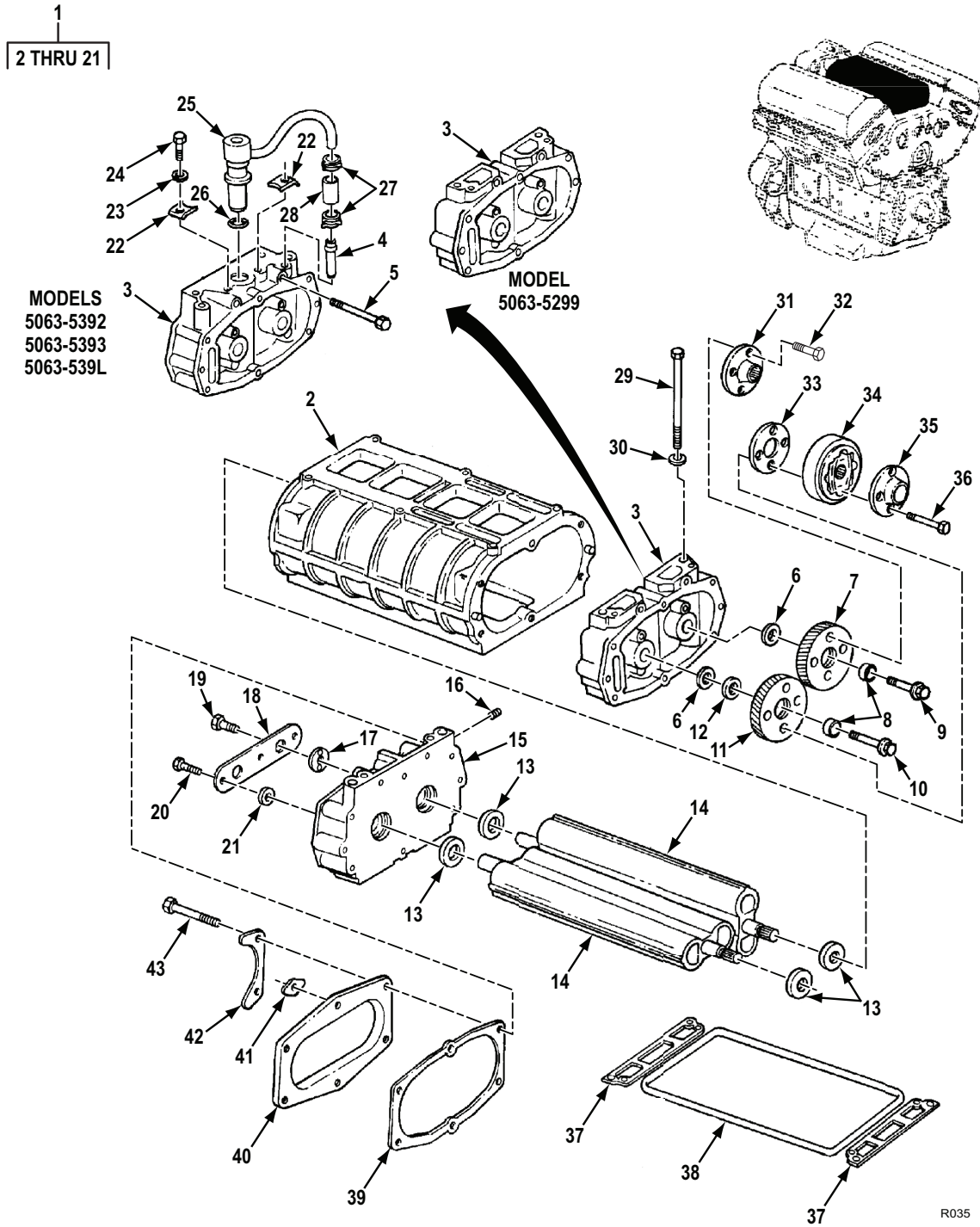

Figure 32. Blower Assembly.

(1) ITEM NO.	(2) SMR CODE	(3) NSN	(4) CAGEC	(5) PART NUMBER	(6) DESCRIPTION AND USABLE ON CODE (UOC)	(7) QTY
GROUP 0305 BLOWER ASSEMBLY						
FIG. 32. BLOWER ASSEMBLY.						
1	PAFHH	2930-01-448-7671	72582	23516738	BLOWER,ENGINE COOLI UOC: C6V,D6V,L6V	1
1	PAFHH	2990-01-122-7913	72582	23516736	SUPERCHARGER,ENGINE UOC: A6V,F6V	1
2	PAHZZ	2815-00-089-6439	72582	5119393	. HOUSING,BLOWER UOC: A6V,F6V	1
2	PAHZZ	2815-01-235-1507	72582	8924566	. HOUSING,SUPERCHARGE UOC: C6V,D6V,L6V	1
3	PAHZZ	2815-01-234-7352	72582	8924545	. PLATE,BLOWER HOUSIN UOC: C6V,D6V,L6V	1
3	PAHZZ	2815-00-888-2426	72582	5134915	. PLATE,BLOWER HOUSIN UOC: A6V,F6V	1
4	PAHZZ	5365-01-245-7257	72582	8924557	. SPACER,SLEEVE UOC: C6V,D6V,L6V	1
5	PAHZZ	5305-00-984-3021	80205	NAS1352-5-48P	. SCREW,CAP,SOCKET HE 5/16-18UNC-3AX3 GR8 UOC: C6V,D6V,L6V	2
6	PAHZZ	5310-01-254-1373	72582	8928695	. WASHER,FLAT PART OF KIT P/ N 5198683.....	2
7	PAHZZ	3020-01-122-5905	72582	5107084	. GEAR,HELICAL.....	1
8	KFHZZ	2815-00-089-6440	72582	5126236	. PILOT,BLOWER DRIVE PART OF KIT P/N 5198683.....	2
9	PAHZZ	5306-00-059-3529	24617	9420604	. BOLT,MACHINE 5/16-24UNF-2AX1-3/4 GR8, 12PT HEAD.....	1
10	PAHZZ	5306-01-020-6895	96906	MS35764-1277	. BOLT,SELF-LOCKING 5/16-24UNF-2AX1-3/4 GR8.....	1
11	PAHZZ	3020-01-122-5181	72582	5107083	. GEAR,HELICAL.....	1
12	KFHZZ	5365-00-819-4875	72582	5116164	. SHIM 0.002 IN. THK PART OF KIT P/N 5198683.....	1
12	KFHZZ	5365-00-816-9144	72582	5116165	. SHIM 0.003 IN. THK PART OF KIT P/N 5198683.....	1
12	KFHZZ	5365-00-902-7804	72582	5116167	. SHIM 0.005 IN. THK PART OF KIT P/N 5198683.....	1
12	KFHZZ	5365-00-902-7803	72582	5116166	. SHIM 0.004 IN. THK PART OF KIT P/N 5198683.....	1
13	PAHZZ	5330-00-079-8421	72582	5142266	. SEAL,PLAIN ENCASED STD.....	4
13	KFHZZ	5330 -01-359-0149	72582	5199366	SEAL,PLAIN ENCASED OSV SERVICE SEAL. U/W SLEEVE, P/N 5199368 PART OF KIT P/N 5198683.....	4
13	KFHZZ	2815-01-051-7917	72582	5199368	SLEEVE,BLOWER SEAL PART OF KIT P/N 5198683.....	4

(1) ITEM NO.	(2) SMR CODE	(3) NSN	(4) CAGEC	(5) PART NUMBER	(6) DESCRIPTION AND USABLE ON CODE (UOC)	(7) QTY
14	PAHZZ	6105-01-234-1037	72582	5104526ND	. ROTOR,MOTOR UOC: A6V,F6V	2
14	PAHZZ	6105-01-234-1037	72582	5104526ND	. ROTOR,MOTOR UOC: C6V,D6V,L6V	2
15	PAHZZ	2990-00-079-8611	72582	5134914	. PLATE,HOUSING COVER UOC: A6V,F6V	1
15	PAHZZ	2815-01-234-7351	72582	5104301	. PLATE,BLOWER UOC: C6V,D6V,L6V	1
16	PAHZZ	4730-00-371-5337	72582	08924380	. PLUG,PIPE.....	2
17	PAHZZ	5310-00-966-9141	72582	5127077	. WASHER,FLAT.....	2
18	PAHZZ	2815-00-103-2217	72582	5134179	. PLATE,BLOWER.....	1
19	PAHZZ	5305-00-940-9034	24617	9409034	. SCREW,CAP,HEXAGON H 3/8-24UNF-2AX7/8 GR8.....	2
20	PAHZZ	5306-00-940-9062	24617	9409062	. BOLT,SELF-LOCKING 1/4-20UNC-2AX1 GR8.....	3
21	PAHZZ	5365-00-921-5340	72582	5116170	. SPACER,SLEEVE.....	3
22	PAHZZ	2815-01-442-6636	72582	8927674	CLAMP,PRESSURE RELI UOC: C6V,D6V,L6V	2
23	PAHZZ	5310-00-582-5965	338X5	120380	WASHER,LOCK UOC: C6V,D6V,L6V	2
24	PAHZZ	5305-00-071-2505	80204	B1821BH025C088N	SCREW,CAP,HEXAGON H 1/4-20UNC-2AX7/8 GR8 UOC: C6V,D6V,L6V	2
25	PAHZZ	4820-01-342-6000	72582	23502801	VALVE,SAFETY RELIEF UOC: C6V,D6V,L6V	1
26	KFHZZ	5331-00-166-1020	81343	AS3085-024	O-RING PART OF KIT P/N 5198683 UOC: C6V,D6V,L6V	1
27	PAHZZ	4730-01-345-7333	72582	1622744	CLAMP,HOSE UOC: C6V,D6V,L6V	2
28	PAHZZ	4720-01-239-7960	72582	8926703	SPACER,SLEEVE UOC: C6V,D6V,L6V	1
29	PAFZZ	5306-00-947-7990	72582	5132923	BOLT,MACHINE 7/16-14UNC-2AX6-11/16 GR5,FRONT BLOWER HOLD DOWN BS IN FGC 0311 FOR MODEL 5063-5299 P/N 5136323 UOC: C6V,D6V,L6V	4
29	PAFZZ	5306-00-947-7990	72582	5132923	BOLT,MACHINE 7/16-14UNC-2AX6-11/16 GR5,FRONT BLOWER HOL D DOWN BS IN FGC 0311 FOR MODELS 5063-5 299, 5063-5395 &SEE P/N 5136323 UOC: A6V,F6V	2
30	PAFZZ	5310-00-780-8116	72582	5131913	WASHER,FLAT UOC: A6V,F6V	2

(1) ITEM NO.	(2) SMR CODE	(3) NSN	(4) CAGEC	(5) PART NUMBER	(6) DESCRIPTION AND USABLE ON CODE (UOC)	(7) QTY
30	PAFZZ	5310-00-780-8116	72582	5131913	WASHER,FLAT UOC: C6V,D6V,L6V	4
31	PAFZZ	3010-00-921-5352	72582	5121336	COUPLING HALF,SHAFT.....	1
32	PAFZZ	5306-00-781-7777	24617	9409219	BOLT,MACHINE 1/4-28UNF-2AX3/4 GR5..	4
33	KFHZZ	2910-00-999-2349	72582	5126237	SPACER,FUEL PUMP PART OF KIT P/N 5198683.....	1
34	PAFZZ	3010-00-055-0830	72582	8922969	COUPLING,SHAFT,FLEX.....	1
35	PAFZZ	2990-00-918-4206	72582	5119466	RETAINER,DRIVE COUP.....	1
36	PAFZZ	5306-00-780-8109	24617	9409221	BOLT,MACHINE 1/4-28UNF-2AX1-5/8 GR8.....	4
37	KFHZZ		72582	23520633	GASKET PART OF KIT P/N 5198043, PART OF KIT P/N 8928522, PART OF KIT P/N 8927743.....	2
38	KFFZZ	2990-00-780-5236	72582	5127963	SEAL,BLOWER PART OF KIT P/N 5198043, PART OF KIT P/N 8928522, PART OF KIT P/N 8927743.....	1
39	KFHZZ		72582	5119433 NON- ASBESTOS	GASKET PART OF KIT P/N 5198043, PART OF KIT P/N 8928522, PART OF KIT P/N 8927743 UOC: C6V,D6V,L6V	1
40	PAHZZ	5340-00-849-2111	72582	5119429	COVER,ACCESS UOC: C6V,D6V,L6V	1
41	PAHZZ	5365-00-849-2105	72582	5119395	SPACER,PLATE.....	2
42	PAHZZ	2950-00-849-2110	72582	5119394	PLATE,REINFORCEMENT.....	2
43	PAHZZ	5305-00-990-8632	80204	B1821BH038C375N	SCREW,CAP,HEXAGON H 3/8-16UNC-2AX3-3/4 GR8 UOC: C6V,D6V,L6V	6
43	PAHZZ	5305-00-543-2866	80204	B1821BH038C250N	SCREW,CAP,HEXAGON H 3/8-16UNC-2AX2-1/2 GR8 UOC: A6V,F6V	6

END OF FIGURE

**FIELD MAINTENANCE
TURBOCHARGER AND RELATED PARTS (MODEL 5063-5392)**

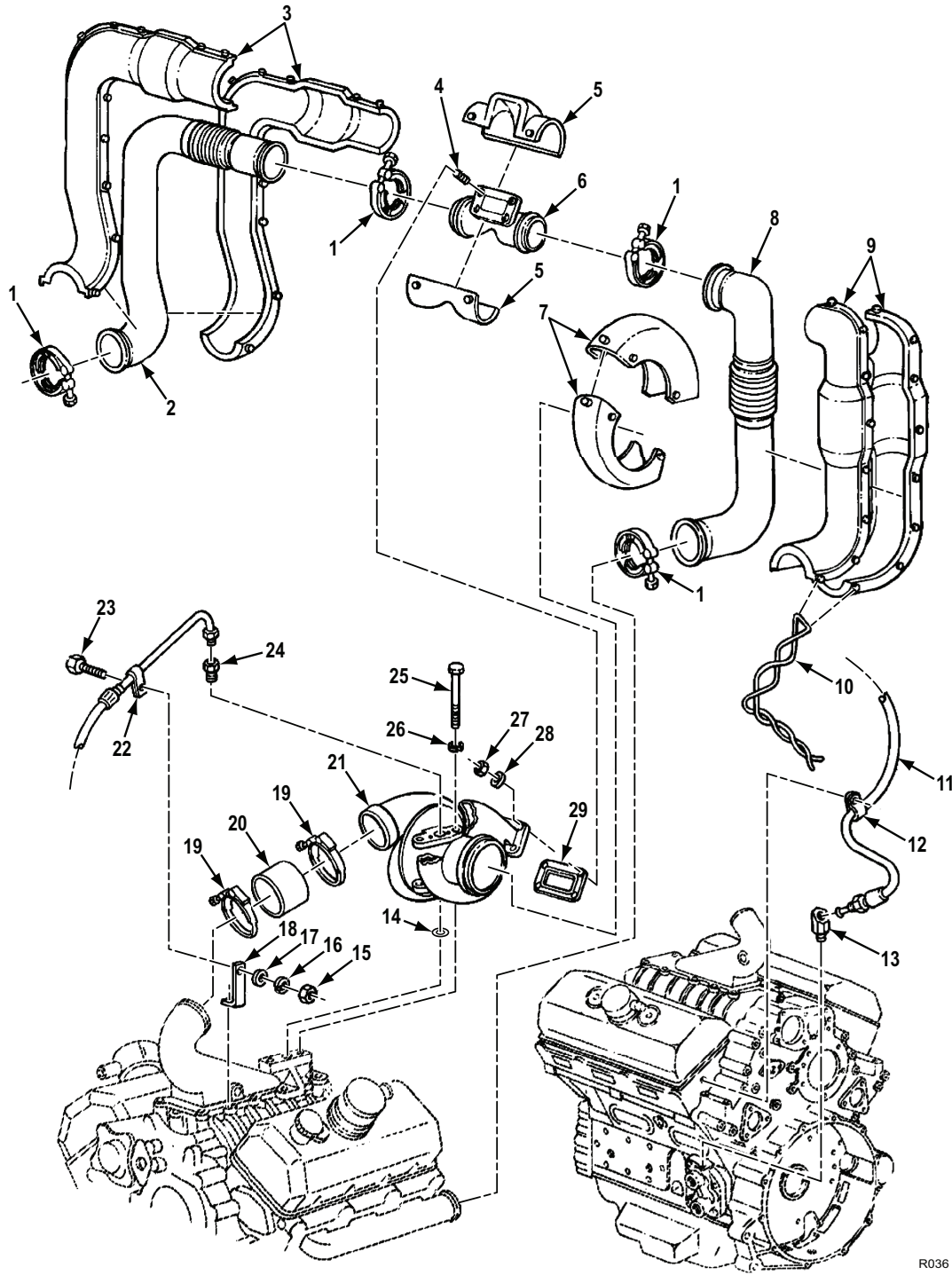

Figure 33. Turbocharger and Related Parts (Model 5063-5392).

(1) ITEM NO.	(2) SMR CODE	(3) NSN	(4) CAGEC	(5) PART NUMBER	(6) DESCRIPTION AND USABLE ON CODE (UOC)	(7) QTY
GROUP 0305 TURBOCHARGER AND RELATED PARTS (MODEL 5063-5392)						
FIG. 33. TURBOCHARGER AND RELATED PARTS (MODEL 5063-5392).						
1	PAFZZ	5342-00-092-6372	80205	AS5355/3-15B	COUPLING,CLAMP,GROO UOC: C6V	4
2	PAFZZ	4710-01-234-6525	72582	23500206	TUBE AND FITTINGS,M LEFT SIDE UOC: C6V	1
3	PAFZZ	5970-01-202-0962	19207	12313898	INSULATOR,SET UOC: C6V	1
4	PAFZZ	5307-01-044-7270	72582	5130488	STUD UOC: C6V	4
5	PAFZZ	5970-01-202-0964	19207	12313896	INSULATOR,SET UOC: C6V	1
6	PAFZZ	2990-01-234-7971	72582	5104083	CONNECTOR,EXHAUST P UOC: C6V	1
7	PAFZZ	5970-01-202-0963	61277	12313892-1 AND 12313892-2	INSULATOR,SET TURBINE HSG UOC: C6V	1
8	PAFZZ	4710-01-234-6524	72582	23500205	TUBE AND FITTINGS,M RIGHT SIDE UOC: C6V	1
9	PAFZZ	2990-01-202-0961	19207	12313895	GUARD,MUFFLER-EXHAU UOC: C6V	1
10	MFFZZ		72582	5101163	WIRE,NON-ELECTRICAL USE AS REQUIRED,MAKE FROM P/N MS2099NC20(96906) UOC: C6V	1
11	PAFZZ	4720-01-234-2800	01276	AAAZ0340	HOSE ASSEMBLY,NONME TURBO OIL FEED UOC: C6V	1
12	PAFZZ	5340-00-161-5246	72582	2488022	CLAMP,LOOP UOC: C6V	2
13	PAFZZ	4730-01-157-6224	72582	8924161	ELBOW,HOSE OIL FILTER ADAPTOR,OIL FEED UOC: C6V	1
14	PAFZZ	5330-01-163-8179	72582	5104978	GASKET AIR INLET HSG TO TURBO UOC: C6V	1
15	PAFZZ	5310-00-732-0559	96906	MS51968-8	NUT,PLAIN,HEXAGON UOC: C6V	1
16	PAFZZ	5310-00-379-9541	59556	019-00004-42	WASHER,LOCK UOC: C6V	1
17	PAFZZ	5310-00-080-6004	96906	MS27183-14	WASHER,FLAT UOC: C6V	1
18	PAFZZ	5340-01-240-4160	72582	5175606	BRACKET,ANGLE UOC: C6V	1
19	PAFZZ	5342-01-035-1755	72582	5147911	CLAMP UOC: C6V	2

(1) ITEM NO.	(2) SMR CODE	(3) NSN	(4) CAGEC	(5) PART NUMBER	(6) DESCRIPTION AND USABLE ON CODE (UOC)	(7) QTY
20	PAFZZ	4720-00-893-5429	72582	5162888	HOSE,PREFORMED AIR INLET HSG TO TURBO UOC: C6V	1
21	PAFHH	2950-01-220-3253	08179	466176-1	TURBOSUPERCHARGER,E SEE FIGURE 35 FOR COMPONENT PARTS. UOC: C6V	1
22	PAFZZ	5340-01-239-8038	72582	5131190	CLAMP,LOOP UOC: C6V	1
23	PAFZZ	5305-00-269-3234	80204	B1821BH038F075N	SCREW,CAP,HEXAGON H UOC: C6V	1
24	PAFZZ	4730-01-069-3216	72582	8924171	CONNECTOR UOC: C6V	1
25	PAFZZ	5305-01-156-5441	72582	187425	SCREW,CAP,HEXAGON H 7/16-14UNC-2AX5-1/4 GR5 UOC: C6V	2
26	PAFZZ	5310-00-209-0965	80205	MS35338-47	WASHER,LOCK 7/16-14UNC-2AX5-1/4 GR5 UOC: C6V	2
27	PAFZZ	5310-00-959-1488	81349	M45913/2-6FG5C	NUT,SELF-LOCKING,HE UOC: C6V	4
28	PAFZZ	5310-00-023-4492	72582	5131433	WASHER,ENGINE UOC: C6V	8
29	PAFZZ	5330-01-037-4129	72582	8929529	GASKET UOC: C6V	1

END OF FIGURE

**FIELD MAINTENANCE
TURBOCHARGER AND RELATED PARTS (MODELS 5063-5393 AND 5063-539L)**

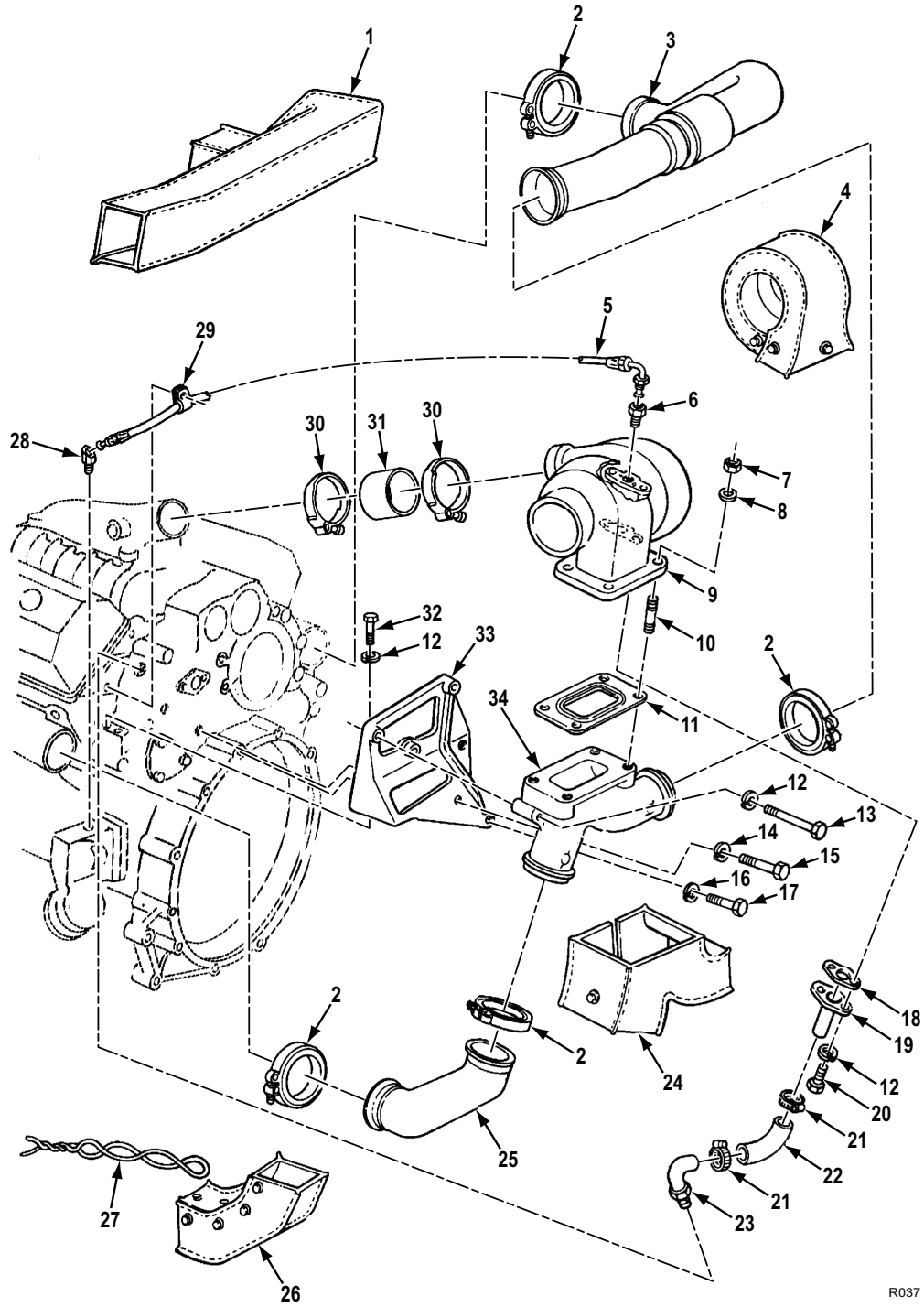

R037

Figure 34. Turbocharger and Related Parts (Models 5063-5393 and 5063-539L).

(1) ITEM NO.	(2) SMR CODE	(3) NSN	(4) CAGEC	(5) PART NUMBER	(6) DESCRIPTION AND USABLE ON CODE (UOC)	(7) QTY
GROUP 0305 TURBOCHARGER AND RELATED PARTS (MODELS 5063-5393 AND 5063-539L)						
FIG. 34. TURBOCHARGER AND RELATED PARTS (MODELS 5063-5393 AND 5063-539L).						
1	PAFZZ	2510-01-251-1796	22013	298S30235	INSULATION BLANKET, UOC: D6V,L6V	1
2	PAFZZ	5342-00-092-6372	81343	AS5355/3-15B	COUPLING,CLAMP,GROO UOC: D6V,L6V	4
3	PAFZZ	4710-01-251-6285	3B518	8928642	TUBE AND FITTINGS,M UOC: D6V,L6V	1
4	PAFZZ	5640-01-291-9010	22013	298S30233	INSULATION BLANKET, TURBOCHARGER UOC: D6V,L6V	1
5	PAFZZ	4720-00-994-5787	72582	5131575	HOSE ASSEMBLY,NONME TURBO OIL FEED UOC: D6V,L6V	1
6	PAFZZ	4730-01-069-3216	72582	8924171	CONNECTOR UOC: D6V,L6V	1
7	PAFZZ	5310-00-959-1488	81349	M45913/2-6FG5C	NUT,SELF-LOCKING,HE UOC: D6V,L6V	4
8	PAFZZ	5310-00-023-4492	72582	5131433	WASHER,ENGINE UOC: D6V,L6V	4
9	PAFHH	2950-01-220-3253	08179	466176-1	TURBOSUPERCHARGER,E SEE FIGURE 35 FOR COMPONENT PARTS. UOC: D6V,L6V	1
10	PAFZZ	5307-01-044-7270	72582	5130488	STUD UOC: D6V,L6V	4
11	KFFZZ	5330-01-037-4129	72582	8929529	GASKET PART OF KIT P/N 8928522 UOC: D6V,L6V	1
12	PAFZZ	5310-00-637-9541	59556	019-00004-42	WASHER,LOCK UOC: D6V,L6V	7
13	PAFZZ	5305-00-543-2866	80204	B1821BH038C250N	SCREW,CAP,HEXAGON H 3/8-16UNC-2AX2-1/2 GR8 UOC: D6V,L6V	3
14	PAFZZ	5310-00-584-5272	80205	MS35338-48	WASHER,LOCK UOC: D6V,L6V	2
15	PAFZZ	5305-00-071-2069	80204	B1821BH050C150N	SCREW,CAP,HEXAGON H 1/2-13UNC-2AX1-1/2 GR8 UOC: D6V,L6V	2
16	PAFZZ	5310-00-209-0965	80205	MS35338-47	WASHER,LOCK UOC: D6V,L6V	1
17	PAFZZ	5305-00-071-1788	80204	B1821BH044C125N	SCREW,CAP,HEXAGON H 7/16-14UNC-2AX1-1/4 GR8 UOC: D6V,L6V	1

(1) ITEM NO.	(2) SMR CODE	(3) NSN	(4) CAGEC	(5) PART NUMBER	(6) DESCRIPTION AND USABLE ON CODE (UOC)	(7) QTY
18	PAFZZ	5330-00-725-2388	72582	5170468	GASKET TURBO OIL DRAIN TUBE UOC: D6V,L6V	1
19	PAFZZ	4710-01-252-0828	72582	8928637	TUBE ASSEMBLY,METAL TURBO OIL DRAIN UOC: D6V,L6V	1
20	PAFZZ	5305-00-068-0510	80204	B1821BH038C100N	SCREW,CAP,HEXAGON H 3/8-16UNC-2AX1 GR8 UOC: D6V,L6V	2
21	PAFZZ	4730-00-908-3194	58536	A-A-52506-F-12	CLAMP,HOSE UOC: D6V,L6V	2
22	MFFZZ	5310-00-732-0558	72582	8927534	HOSE 5.00 IN. LG,MAKE FROM HOSE,P/N FC107-16 TURBO OIL DRAIN UOC: D6V,L6V	1
23	PAFZZ	4710-01-252-0829	72582	23500691	TUBE AND FITTINGS,M TURBO OIL DRAIN UOC: D6V,L6V	1
24	PAFZZ	2510-01-251-1794	22013	298S30234	INSULATION BLANKET, UOC: D6V,L6V	1
25	PAFZZ	4710-01-251-1825	72582	8928643	TUBE AND FITTINGS,M UOC: D6V,L6V	1
26	PAFZZ	2510-01-251-1795	22013	298S30236	INSULATION BLANKET, UOC: D6V,L6V	1
27	MFFZZ		72582	5101163	WIRE,NON-ELECTRICAL USE AS REQUIRED,MAKE FROM P/N MS2099NC20(96906) UOC: D6V,L6V	1
28	PAFZZ	4730-01-157-6224	72582	8924161	ELBOW,HOSE OIL FILTER ADAPTOR UOC: D6V,L6V	1
29	PAFZZ	5340-00-161-5246	72582	2488022	CLAMP,LOOP UOC: D6V,L6V	1
30	PAFZZ	4730-00-908-6292	58536	A-A-52506F-48	CLAMP,HOSE UOC: D6V,L6V	2
31	PAFZZ	4720-00-893-5429	72582	5162888	HOSE,PREFORMED AIR INLET HSG TO TURBO UOC: D6V,L6V	1
32	PAFZZ	5305-00-543-2419	80204	B1821BH038C113N	SCREW,CAP,HEXAGON H 3/8-16UNC-2AX1-1/8 GR8 UOC: D6V,L6V	2
33	PBFZZ	5342-01-251-1752	72582	8928644	BRACKET,ENGINE ACCE TURBO SUPPORT BRKT UOC: D6V,L6V	1
34	PAFZZ	2990-01-251-6229	72582	23522744	CONNECTOR,EXHAUST P UOC: D6V,L6V	1

END OF FIGURE

**SUSTAINMENT MAINTENANCE
TURBOCHARGER (MODELS 5063-5392, 5063-5393 AND 5063-539L)**

- 1
- 2
- 6
- 7 THRU 23

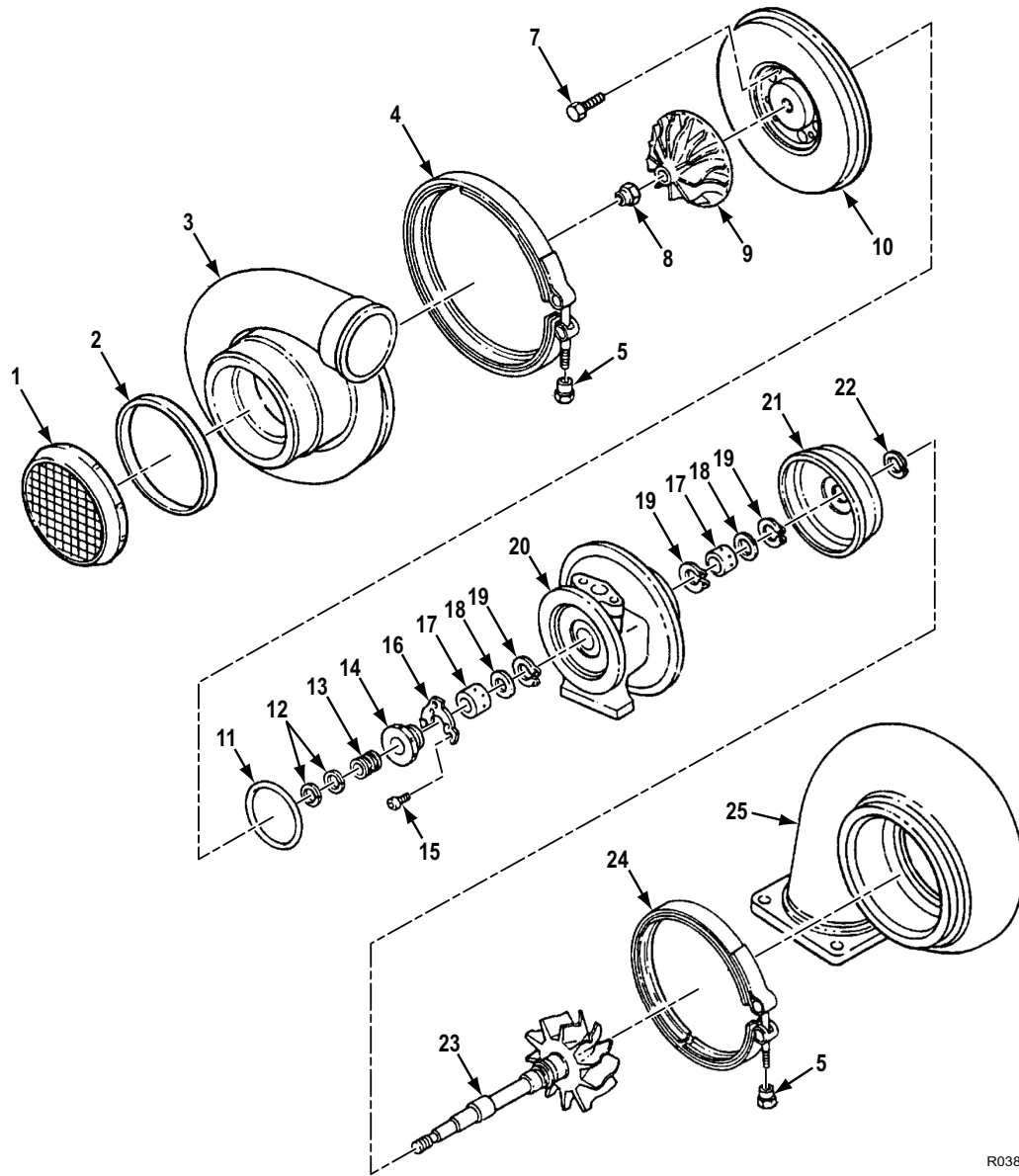

R038

Figure 35. Turbocharger (Models 5063-5392, 5063-5393 and 5063-539L).

(1) ITEM NO.	(2) SMR CODE	(3) NSN	(4) CAGEC	(5) PART NUMBER	(6) DESCRIPTION AND USABLE ON CODE (UOC)	(7) QTY
GROUP 0305 TURBOCHARGER (MODELS 5063-5392, 5063-5393 AND 5063-539L)						
FIG. 35. TURBOCHARGER (MODELS 5063-5392, 5063-5393 AND 5063-539L).						
1	PAHZZ	2815-01-281-4930	72582	23507978	GUARD,DIESEL ENGINE UOC: C6V,D6V,L6V	1
2	PAHZZ	5330-01-423-9503	72582	23515194	. SEAL,PLAIN UOC: C6V,D6V,L6V	1
3	PAHZZ	4310-01-235-5712	08179	441880-1	HOUSING,AIR COMPRES UOC: C6V,D6V,L6V	1
4	PAHZZ	5342-01-162-7865	72582	23505789	COUPLING,CLAMP,GROO UOC: C6V,D6V,L6V	1
5	PAHZZ	5310-01-015-5419	72582	5149163	LOCKNUT UOC: C6V,D6V,L6V	2
6	PAHHH	2950-01-241-2465	08179	442032-1	HOUSING AND ROTOR A UOC: C6V,D6V,L6V	1
7	PAHZZ	5306-01-238-6378	08179	400627-0620	. BOLT,MACHINE M6-1.00X20MM UOC: C6V,D6V,L6V	4
8	PAHZZ	5310-00-070-6870	27238	BH00163-6	. NUT,SELF-LOCKING,EX UOC: C6V,D6V,L6V	1
9	PAHZZ	2815-01-250-1861	08179	441829-2	. IMPELLER WHEEL,VEHI UOC: C6V,D6V,L6V	1
10	PAHZZ	2920-01-239-3362	72582	8925746	. BACKPLATE UOC: C6V,D6V,L6V	1
11	PAHZZ	5365-01-016-0443	72582	5198936	. RING,SEAL UOC: C6V,D6V,L6V	1
12	PAHZZ	5330-00-930-3254	80179	403818-0	. SEAL RING,METAL UOC: C6V,D6V,L6V	2
13	PAHZZ	5365-01-239-9477	72582	8925749	. SPACER,SLEEVE UOC: C6V,D6V,L6V	1
14	PAHZZ	3040-01-234-8467	72582	8925751	. COLLAR,SHAFT UOC: C6V,D6V,L6V	1
15	XDHZZ		08179	400960-0410	. SCREW,CAP,SOCKET HE M4-6GX10MM UOC: C6V,D6V,L6V	3
16	PAHZZ	3120-01-355-8844	08179	443686-1	. BEARING,WASHER,THRU UOC: C6V,D6V,L6V	1
17	PAHZZ	3120-01-239-1369	8179	441411-0001	. BEARING,SLEEVE UOC: C6V,D6V,L6V	2
18	PAHZZ	5310-00-153-2717	72582	5198988	. WASHER,FLAT UOC: C6V,D6V,L6V	2
19	PAHZZ	5325-00-930-3257	72582	5198049	. RING,RETAINING UOC: C6V,D6V,L6V	3
20	PAHZZ	4310-01-234-7948	08179	442028-1	. HOUSING,CENTER UOC: C6V,D6V,L6V	1

(1) ITEM NO.	(2) SMR CODE	(3) NSN	(4) CAGEC	(5) PART NUMBER	(6) DESCRIPTION AND USABLE ON CODE (UOC)	(7) QTY
21	PAHZZ	2950-01-205-3197	72582	5149173	. SHROUD WHEEL COMPRE UOC: C6V,D6V,L6V	1
22	PAHZZ	5325-01-015-5414	72582	5149154	. RING,RETAINING UOC: C6V,D6V,L6V	1
23	PAHZZ	2950-01-237-2943	08179	442029-3	. ROTOR,TURBINE,NONAI UOC: C6V,D6V,L6V	1
24	PAHZZ	4730-01-350-2088	08179	446397-5560	CLAMP,HOSE UOC: C6V,D6V,L6V	1
25	PAHZZ	2815-01-235-0841	5Z018	443110-0001	HOUSING,SUPERCHARGE UOC: C6V,D6V,L6V	1

END OF FIGURE

**FIELD MAINTENANCE
BLOWER DRIVE GEAR AND RELATED PARTS**

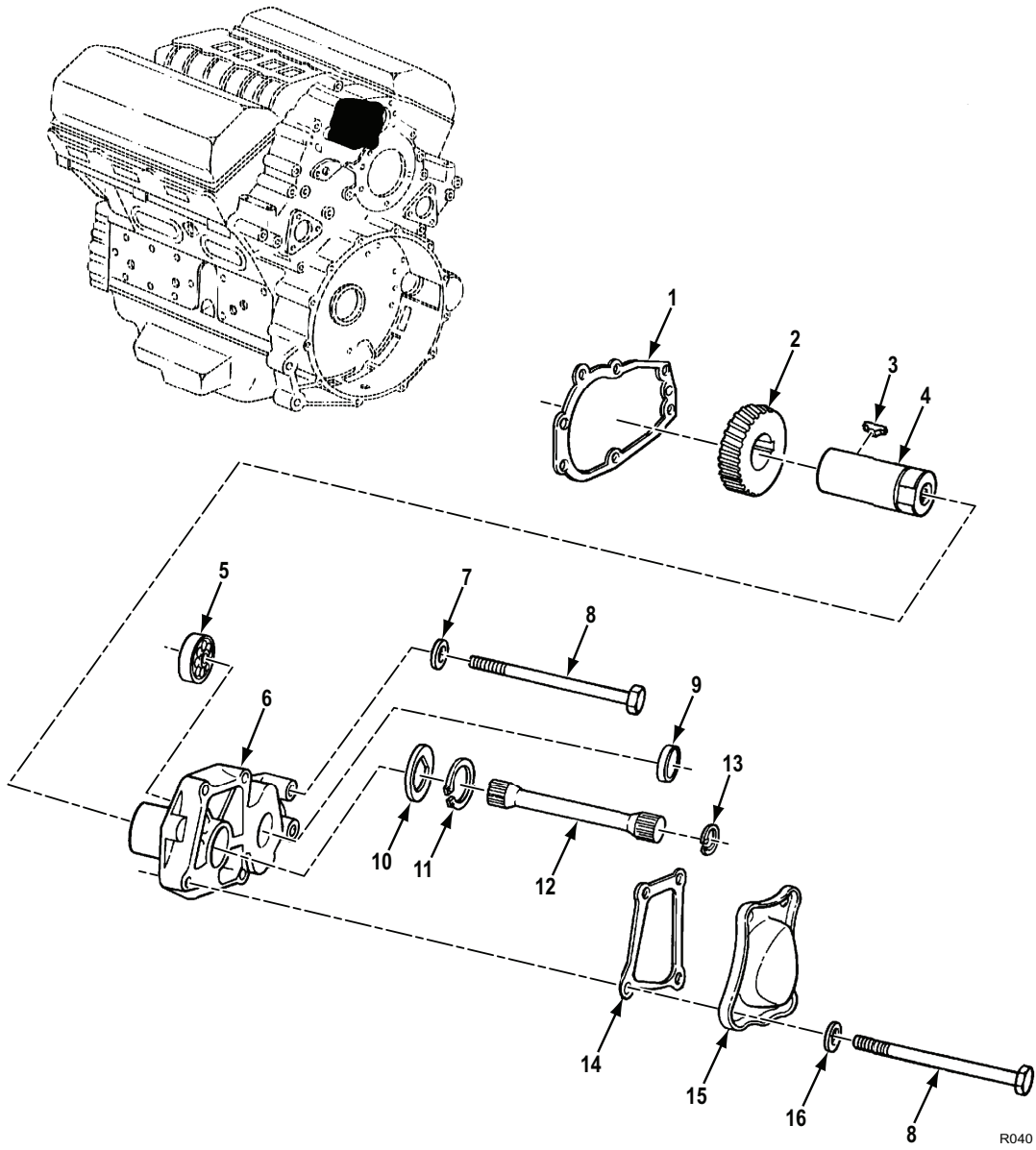

Figure 36. Blower Drive Gear and Related Parts.

(1) ITEM NO.	(2) SMR CODE	(3) NSN	(4) CAGEC	(5) PART NUMBER	(6) DESCRIPTION AND USABLE ON CODE (UOC)	(7) QTY
GROUP 0305 BLOWER DRIVE GEAR AND RELATED PARTS						
FIG. 36. BLOWER DRIVE GEAR AND RELATED PARTS.						
1	KFFZZ	5330-01-143-2300	72582	5103474	GASKET DRIVE SUPPORT TO FLYWHEEL HSG PART OF KIT P/N 8928522, PART OF KIT P/N 8927743, PART OF KIT P/N 5198043.....	1
2	PAFZZ	3020-01-122-7912	72582	5107079	GEAR,HELICAL.....	1
3	PAFZZ	5315-00-616-5525	77237	6J505	KEY,WOODRUFF BLOWER DRIVE GEAR TO SHAFT.....	1
4	PAFZZ	3040-00-921-5345	72582	5116418	SHAFT,STRAIGHT.....	1
5	PAHZZ	3110-00-554-2906	58536	AA59585-201JABT	BEARING,BALL,ANNULA.....	1
6	PAFZZ	2930-00-866-9382	72582	5129168	SUPPORT,BLOWER DRIVE.....	1
7	KFFZZ	5310-00-193-9753	72587	5226029	WASHER,FLAT PART OF KIT P/N 8927743, PART OF KIT P/N 5198043.....	2
8	PAFZZ	5305-00-964-0503	80204	B1821BH038C500N	SCREW,CAP,HEXAGON H UOC: C6V,D6V	6
9	PAFZZ	5342-01-157-8867	72582	9421753	PLUG,CUP.....	1
10	KFFZZ	5310-00-055-0829	72582	5119285	WASHER,FLAT PART OF KIT P/N 5198683.....	1
11	KFFZZ	5325-00-803-7316	96906	MS16624-1137	RING,RETAINING PART OF KIT P/N 5198683.....	1
12	PAFZZ	3040-00-903-0908	72582	5135876	SHAFT,BLOWER DRIVE.....	1
13	PAFZZ	5325-00-804-4997	96906	MS16625-2077	RING,RETAINING.....	1
14	KFFZZ	5330-00-074-1925	72582	5121344	GASKET PART OF KIT P/N 8928522, PART OF KIT P/N 8927743, PART OF KIT P/N 5198043.....	1
15	PBFZZ	5340-00-922-2018	72582	5121343	COVER,ACCESS UOC: C6V,D6V,L6V	1
16	PAFZZ	5310-01-177-5910	75160	24H1682	WASHER,FLAT UOC: C6V,D6V,L6V	4

END OF FIGURE

**FIELD MAINTENANCE
AIR INLET HOUSING AND RELATED PARTS**

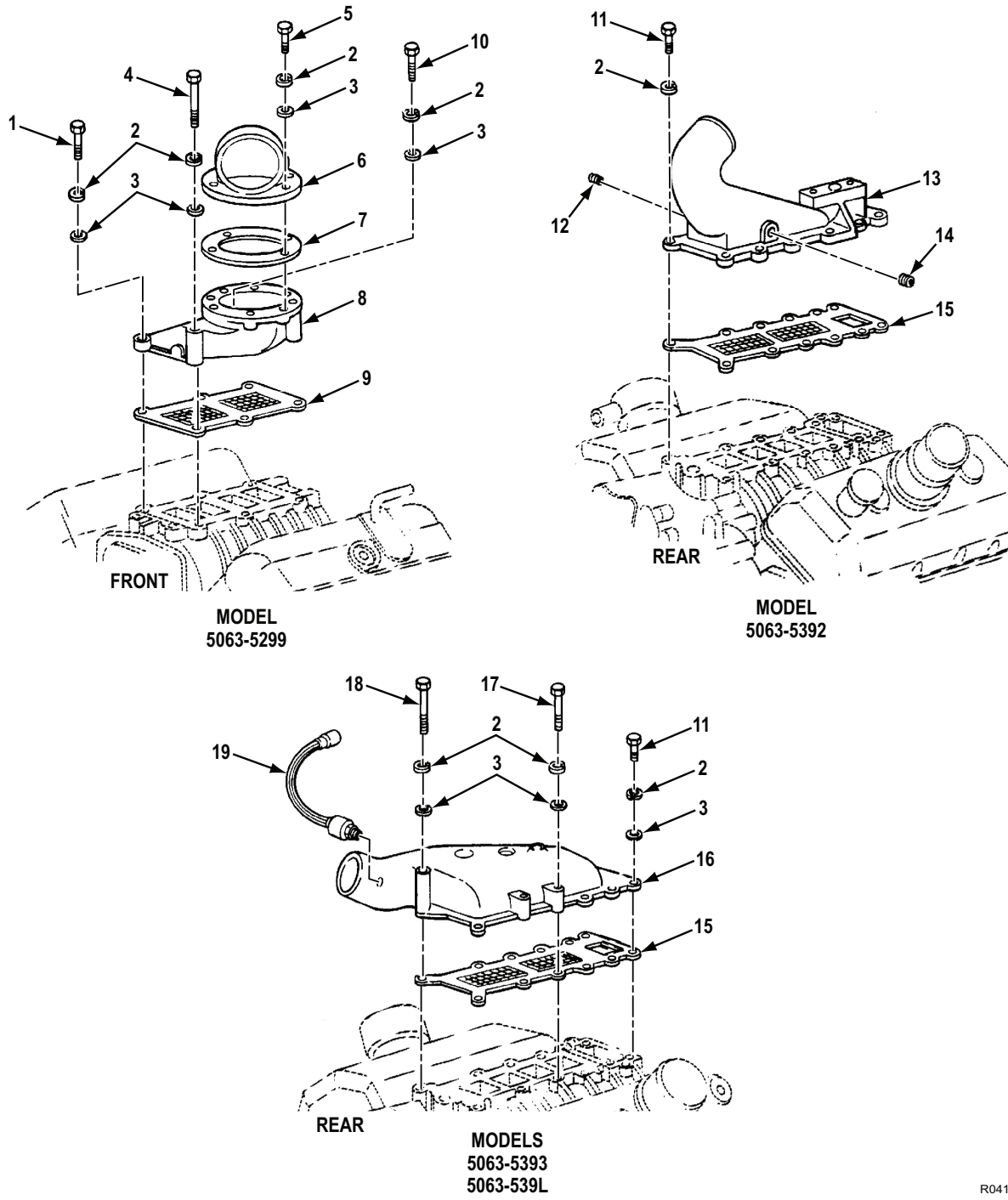

Figure 37. Air Inlet Housing and Related Parts.

R041

(1) ITEM NO.	(2) SMR CODE	(3) NSN	(4) CAGEC	(5) PART NUMBER	(6) DESCRIPTION AND USABLE ON CODE (UOC)	(7) QTY
GROUP 0305 AIR INLET HOUSING AND RELATED PARTS						
FIG. 37. AIR INLET HOUSING AND RELATED PARTS.						
1	PAFZZ	5305-00-018-0129	72582	180129	SCREW,CAP,HEXAGON H 3/8-16UNC-2AX1-7/8 GR5 UOC: A6V,F6V	3
2	PAFZZ	5310-00-637-9541	59556	019-00004-42	WASHER,LOCK UOC: A6V,F6V	8
2	PAFZZ	5310-00-637-9541	59556	019-00004-42	WASHER,LOCK UOC: C6V	9
2	PAFZZ	5310-00-637-9541	59556	019-00004-42	WASHER,LOCK UOC: D6V,L6V	10
3	PAFZZ	5310-00-080-6004	96906	MS27183-14	WASHER,FLAT UOC: A6V,F6V	8
3	PAFZZ	5310-00-080-6004	96906	MS27183-14	WASHER,FLAT UOC: D6V,L6V	10
4	PAFZZ	5305-00-781-3927	80204	B1821BH038C350N	SCREW,CAP,HEXAGON H 3/8-16UNC-2AX3-1/2 GR8 UOC: A6V,F6V	2
5	PAFZZ	5305-00-543-2419	80204	B1821BH038C113N	SCREW,CAP,HEXAGON H 3/8-16UNC-2AX1-1/8 GR8 UOC: A6V,F6V	4
6	PAFZZ	2940-00-999-2402	72582	5127238	ADAPTER AIR INLET HOUSING UOC: A6V,F6V	1
7	PAFZZ	5330-00-682-7197	72582	5127247	GASKET PART OF KIT P/N 8927743 UOC: A6V,F6V	1
8	PBFZZ	2815-00-921-5367	72582	5133296	HOUSING,DIESEL ENGI AIR INLET UOC: A6V,F6V	1
9	KFFZZ	2990-00-866-9378	72582	5122610	SCREEN,AIRINLETBLOW PART OF KIT P/N 8927743, PART OF KIT P/N 5198043 UOC: A6V,F6V	1
10	PAFZZ	5305-00-688-2111	80204	B1821BH038C138N	SCREW,CAP,HEXAGON H 3/8-16UNC-2AX1-3/8 GR8 UOC: A6V,F6V	1
11	PAFZZ	5305-00-068-0511	80204	B1821BH038C125N	SCREW,CAP,HEXAGON H 3/8-16UNC-2AX1-1/4 GR8 UOC: C6V	9
11	PAFZZ	5305-00-068-0511	80204	B1821BH038C125N	SCREW,CAP,HEXAGON H 3/8-16UNC-2AX1-1/4 GR8 UOC: D6V,L6V	4
12	PAFZZ	4730-00-148-4975	72582	5142549	PLUG,PIPE UOC: C6V	1
13	PBFZZ	2815-01-234-8565	72582	23500204	ADAPTOR,AIR INLET UOC: C6V	1

(1) ITEM NO.	(2) SMR CODE	(3) NSN	(4) CAGEC	(5) PART NUMBER	(6) DESCRIPTION AND USABLE ON CODE (UOC)	(7) QTY
14	PAFZZ	4730-01-398-7635	72582	8923847	PLUG,PIPE UOC: C6V	1
15	KFFZZ	2540-01-238-8792	72582	8927733	VENTILATOR,AIR CIRC PART OF KIT P/N 8928522 UOC: C6V,D6V,L6V	1
16	PBFZZ	2590-01-247-7926	72582	8928636	HOUSING,AIR INLET UOC: D6V,L6V	1
17	PAFZZ	5305-01-087-4489	72582	186277	SCREW,CAP,HEXAGON H 3/8-16UNC-2AX2-3/8 GR5 UOC: D6V,L6V	2
18	PAFZZ	5305-00-990-8632	80204	B1821BH038C375N	SCREW,CAP,HEXAGON H 3/8-16UNC-2AX3-3/4 GR8 UOC: D6V,L6V	4
19	PAFZZ	6620-01-501-8648	19207	12258932-9	TRANSMITTER,PRESSUR UOC: D6V,L6V	1

END OF FIGURE

**FIELD MAINTENANCE
GOVERNOR AND COVER ASSEMBLY**

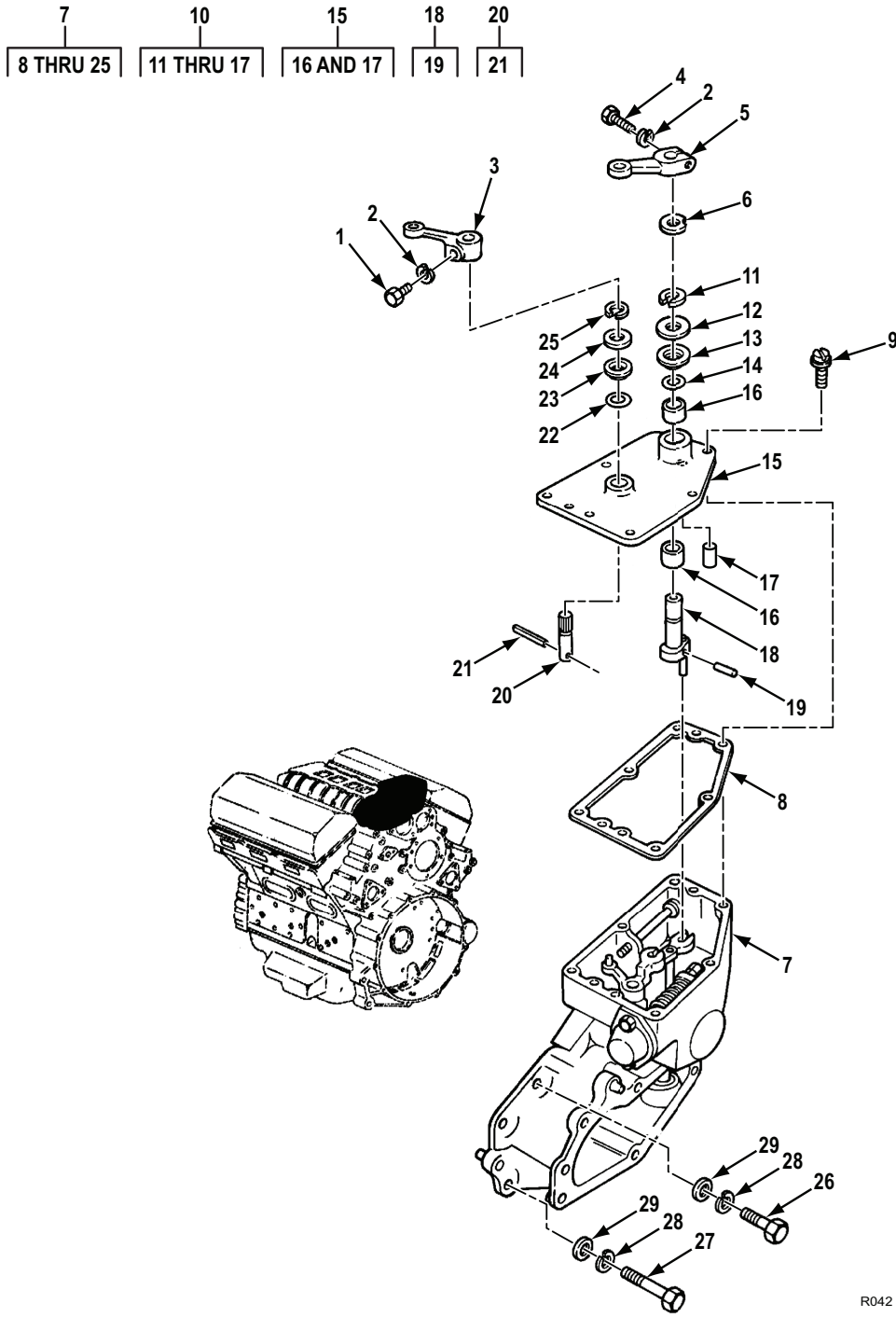

R042

Figure 38. Governor and Cover Assembly.

(1) ITEM NO.	(2) SMR CODE	(3) NSN	(4) CAGEC	(5) PART NUMBER	(6) DESCRIPTION AND USABLE ON CODE (UOC)	(7) QTY
GROUP 0308 GOVERNOR AND COVER ASSEMBLY						
FIG. 38. GOVERNOR AND COVER ASSEMBLY.						
1	PAFZZ	5305-00-068-0508	07482	1C817P63	SCREW,CAP,HEXAGON H 1/4-20UNC-2AX3/4 GR8.....	1
2	PAFZZ	5310-00-582-5965	338X5	120380	WASHER,LOCK.....	2
3	PAFZZ	3040-01-165-8316	45152	127259A	LEVER,REMOTE CONTRO STOP LEVER	1
4	PAFZZ	5305-00-225-3843	80204	B1821BH025C100N	SCREW,CAP,HEXAGON H 1/4-20UNC-2AX1 GR8.....	1
5	PAFZZ	2990-00-363-8093	72582	5151519	LEVER,REMOTE CONTRO SPEED CONTROL LEVER.....	1
6	PAFZZ	5310-00-550-3915	72582	5151249	WASHER,FLAT 0.078 IN. THICK.....	1
7	PAFHH	2910-01-016-5501	72582	5103786	GOVERNOR,DIESEL ENG SEE FIGURES 39, 40, & 41 FOR COMPONENT PARTS UOC: C6V,D6V,L6V	1
7	PAFHH	2990-00-944-2053	72582	5103782	GOVERNOR,DIESEL ENG SEE FIGURES 39, 40, & 41 FOR COMPONENT PARTS UOC: A6V,F6V	1
8	KFFZZ	5330-00-780-5232	18954	K-512342	. GASKET PART OF KIT P/N 8928522, PART OF KIT P/N 5198043, PART OF KIT P/N 5199811.....	1
9	PAFZZ	5305-00-135-5157	24617	271468	. SCREW,ASSEMBLED WAS.....	7
10	PAFZZ	2990-00-918-4210	72582	5103748	. COVER ASSEMBLY,GOVE.....	1
11	PAFZZ	5325-00-281-6660	72582	5174429	.. RING,RETAINING PART OF KIT P/N 8928522, PART OF KIT P/N 8927743...	1
12	PAFZZ	5310-00-262-3105	72582	5153060	.. WASHER,FLAT.....	1
13	PAFZZ	5310-00-231-0290	72582	5144177	.. WASHER,SHOULDERED A.....	1
14	PCFZZ	5331-00-599-2934	25184	112-7377	.. O-RING PART OF KIT P/N 8928522, PART OF KIT P/N 8927743.....	1
15	PAFZZ	2920-01-118-9826	72582	5103747	.. COVER ASSEMBLY.....	1
16	PAFZZ	3120-01-157-8946	72582	8921472	... BUSHING,SLEEVE.....	2
17	XDFZZ		1LW55	9417392	... PIN,SPRING.....	2
18	PAFZZ	2990-01-125-4812	72582	5106266	.. SHAFT ASSEMBLY,GOVE.....	1
19	PAFZZ	5315-00-051-9867	80205	MS24692-178	... PIN,TAPERED,PLAIN.....	1
20	PAFZZ	3040-00-089-6450	72582	5104516	.. SHAFT,STRAIGHT.....	1
21	PAFZZ	5315-01-159-8180	72582	457009	... PIN.....	1
22	PAFZZ	5330-01-105-6889	72582	5101691	.. SEAL SPECIAL PART OF KIT P/N 8928522, PART OF KIT P/N 8927743...	1

(1) ITEM NO.	(2) SMR CODE	(3) NSN	(4) CAGEC	(5) PART NUMBER	(6) DESCRIPTION AND USABLE ON CODE (UOC)	(7) QTY
23	PAFZZ	5310-00-409-9031	7U177	B5144178	.. WASHER, SHOULDERED A.....	1
24	PAFZZ	5310-00-262-2914	72582	5151487	.. WASHER, FLAT.....	1
25	PAFZZ	5325-00-205-5139	72582	5178581	.. RING, RETAINING.....	1
26	PAFZZ	5306-01-168-3796	72582	8921932	BOLT 3/8-16UNC-2AX1.25 GR8 UOC: C6V,D6V,L6V	1
27	PAFZZ	5305-00-990-8632	80204	B1821BH038C375N	SCREW,CAP,HEXAGON H 3/8-16UNC-2AX3-3/4 GR8 UOC: C6V,D6V,L6V	5
27	PAFZZ	5305-00-269-3219	25567	B-0611	SCREW,CAP,HEXAGON H UOC: A6V,F6V	6
28	PAFZZ	5310-00-637-9541	59556	019-00004-42	WASHER, LOCK.....	6
29	PAFZZ	5310-00-080-6004	96906	MS27183-14	WASHER, FLAT.....	6

END OF FIGURE

**SUSTAINMENT MAINTENANCE
GOVERNOR HOUSING ASSEMBLY AND COMPONENTS**

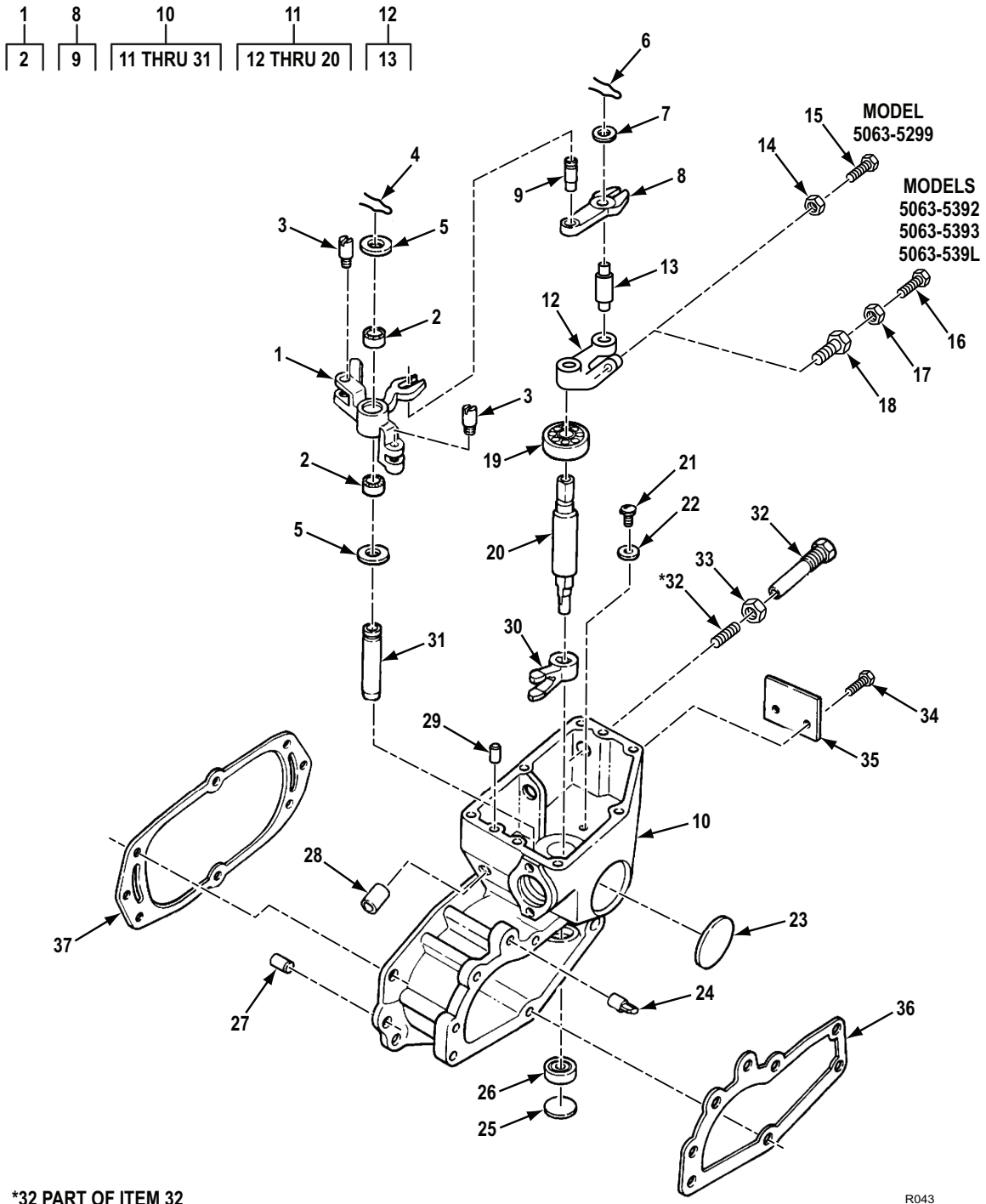

Figure 39. Governor Housing Assembly and Components.

(1) ITEM NO.	(2) SMR CODE	(3) NSN	(4) CAGEC	(5) PART NUMBER	(6) DESCRIPTION AND USABLE ON CODE (UOC)	(7) QTY
GROUP 0308 GOVERNOR HOUSING ASSEMBLY AND COMPONENTS						
FIG. 39. GOVERNOR HOUSING ASSEMBLY AND COMPONENTS.						
1	PAHHH	2815-00-921-5354	72582	5121490	LEVER ASSEMBLY UOC: A6V,F6V	1
1	PAHZZ	2815-01-016-0435	72582	5145820	LEVER ASSEMBLY INCLUDES YIELD LEVER FOR THROTTLE DELAY UOC: C6V,D6V,L6V	1
2	PAHZZ	3110-00-277-0337	81346	MS17131-9	. BEARING,ROLLER,NEED.....	2
3	PAHZZ	5315-00-921-5346	72582	5117693	PIN,SHOULDER,HEADLE.....	2
4	PAHZZ	5340-00-366-0618	72582	148148	CLIP,RETAINING.....	1
5	PAHZZ	5310-00-262-2914	72582	5151487	WASHER,FLAT UOC: C6V,D6V,L6V	3
5	PAHZZ	5310-00-262-2914	72582	5151487	WASHER,FLAT UOC: A6V,F6V	2
6	PAHZZ	5340-00-014-2583	72582	142583	CLIP,RETAINING.....	1
7	PAHZZ	5310-00-262-5429	72582	5150941	WASHER,FLAT.....	1
8	PAHZZ	2815-00-921-5356	72582	5124209	LEVER,REMOTE CONTRO.....	1
9	PAHZZ	5315-00-363-8100	72582	5150943	. PIN,SHOULDER,HEADLE.....	1
10	PAHHH	3040-00-097-7753	72582	5121001	HOUSING,MECHANICAL UOC: A6V,F6V	1
10	PAHZZ	2815-01-016-5458	72582	5100998	HOUSING ASSEMBLY UOC: C6V,D6V,L6V	1
11	PBHZZ	2990-00-812-0876	72582	5121458	. SHAFT ASSEMBLY UOC: A6V,F6V	1
11	PBHZZ	3040-01-305-5588	72582	5100999	. SHAFT,DRIVE,FLEXIBL UOC: C6V,D6V,L6V	1
12	PAHZZ	2815-00-921-5336	72582	5116011	.. BELL CRANK.....	1
13	PAHZZ	5315-00-363-8100	72582	5150943	... PIN,SHOULDER,HEADLE.....	1
14	PAHZZ	5310-00-971-7989	96906	MS35691-5	.. NUT,PLAIN,HEXAGON UOC: A6V,F6V	1
15	PAHZZ	5305-00-877-8051	72582	5132962	.. SCREW,SHAFT UOC: A6V,F6V	1
16	PAHZZ	5306-01-157-8904	72582	5106055	.. BOLT,MACHINE 5-40UNC-2BX.54 UOC: C6V,D6V,L6V	1
17	PAHZZ	5310-01-236-1685	80205	MS35649-265B	.. NUT,PLAIN,HEXAGON UOC: C6V,D6V,L6V	1
18	PAHZZ	5310-00-161-1604	72582	5145007	.. NUT,HEXAGON UOC: C6V,D6V,L6V	1
19	PAHZZ	3110-01-005-6623	72582	9431894	.. BEARING,GOVERNOR H.....	1
20	PBHZZ	3040-00-921-5353	72582	5121339	.. SHAFT,SHOULDERED.....	1

(1) ITEM NO.	(2) SMR CODE	(3) NSN	(4) CAGEC	(5) PART NUMBER	(6) DESCRIPTION AND USABLE ON CODE (UOC)	(7) QTY
21	PAHZZ	5305-00-899-2109	72582	9421917	. SCREW,SPECIAL 10-24UNRC-2AX7/16 SLOTTED HEAD SCREW AND LOCKWASHERSEMBLY.....	1
22	PAHZZ	5310-00-014-5850	96906	MS27183-42	. WASHER,FLAT.....	1
23	PAHZZ	4730-00-921-5736	72582	9417025	. PLUG,PIPE.....	1
24	PAHZZ	5315-00-921-5338	72582	5116071	. PIN.....	1
25	PAHZZ	5340-00-089-8037	72582	116337	. PLUG,EXPANSION.....	1
26	PAHZZ	3110-00-198-0576	58536	AA59583-400JBBT	. BEARING,BALL,ANNULA.....	1
27	PAHZZ	5315-00-480-4453	72582	141242	. PIN,STRAIGHT,HEADLE.....	2
28	PAHZZ	2910-00-999-2350	72582	5126069	. ADAPTER.....	2
29	PAHZZ	5315-00-597-4217	88044	AN150280	. PIN,STRAIGHT,HEADLE.....	2
30	PBHZZ	2520-00-833-1024	72582	5138335	. SHIFTER FORK,VEHICU.....	1
31	PAHZZ	5315-00-921-5349	72582	5119314	. PIN,GROOVED,HEADLESS UOC: A6V,F6V	1
31	PAHZZ	5315-01-016-0436	72582	5145823	. PIN UOC: C6V,D6V,L6V	1
32	PAFZZ	2990-00-918-4208	72582	5172383	SCREW ASSEMBLY,BUFF 3/8-24U NF-2AX4-1/2.....	1
33	KFFZZ	5310-01-067-8382	72582	5174286	NUT PART OF KIT P/N 8928522, PART OF KIT P/N 8927743.....	1
34	PAHZZ	5305-00-253-5614	80205	MS21318-20	SCREW,DRIVE NO.4X3/16.....	2
35	PAHZZ	2990-01-087-2751	72582	5122166	PLATE HOUSING.....	1
36	KFFZZ	5330-00-780-5233	72582	5121345	GASKET PART OF KIT P/N 5198043, PART OF KIT P/N 8928522, PART OF KIT P/N	1
37	KFFZZ	5330-00-780-5231	72582	5119438	GASKET PART OF KIT P/N 5198043, PART OF KIT P/N 8928522, PART OF KIT P/N 8927743.....	1

END OF FIGURE

**SUSTAINMENT MAINTENANCE
GOVERNOR SHAFT AND LOWER BEARING**

1
2 THRU 9

3
4

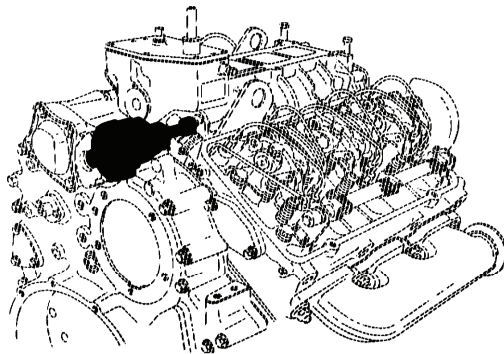
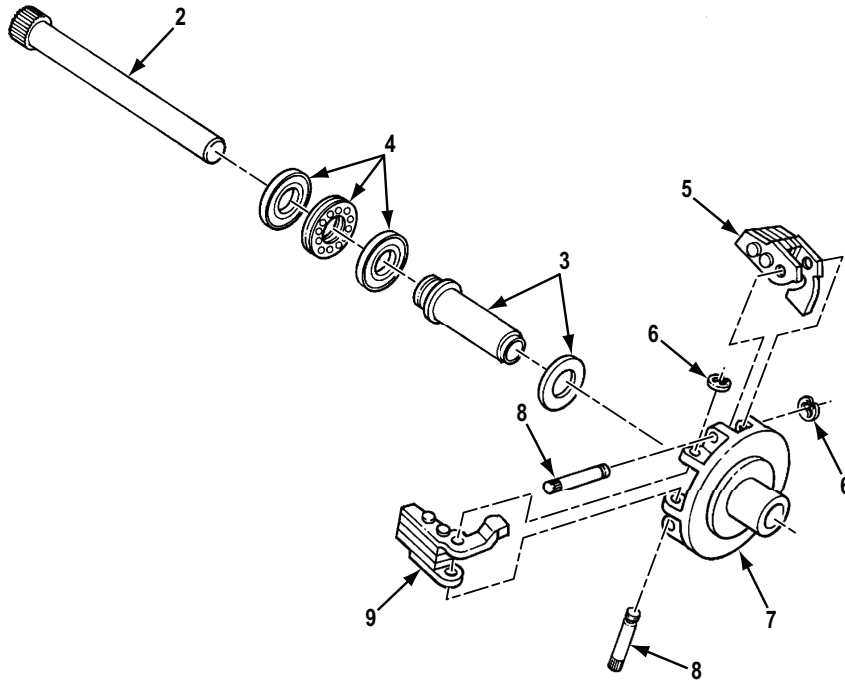

R044

Figure 40. Governor Shaft and Lower Bearing.

(1) ITEM NO.	(2) SMR CODE	(3) NSN	(4) CAGEC	(5) PART NUMBER	(6) DESCRIPTION AND USABLE ON CODE (UOC)	(7) QTY
GROUP 0308 GOVERNOR SHAFT AND LOWER BEARING						
FIG. 40. GOVERNOR SHAFT AND LOWER BEARING.						
1	PAHZZ	2990-00-921-5372	72582	5133819	SHAFT AND CARRIER A.....	1
2	PAHZZ	3040-00-089-7777	72582	5121337	. SHAFT, SHOULDERED.....	1
3	PAHZZ	2990-00-089-6453	72582	5125367	. RISER, GOVERNOR.....	1
4	PAHZZ	3120-01-117-6103	72582	9437108	. . BEARING, THRUST.....	1
5	PAHZZ	2990-00-089-6456	72582	5133662	. WEIGHT, GOVERNOR LOW SPEED WEIGHT.....	2
6	PAHZZ	5325-00-657-7565	72582	6525196	. RING, RETAINING.....	4
7	PAHZZ	2990-01-118-8187	72582	5133707	. CARRIER, WEIGHT.....	1
8	PAHZZ	5315-00-089-6457	72582	5122786	. PIN, GROOVED, HEADLES.....	4
9	PAHZZ	3040-00-089-6455	72582	5122771	. WEIGHT, COUNTERBALAN HIGH SPEED WEIGHT.....	2

END OF FIGURE

**SUSTAINMENT MAINTENANCE
GOVERNOR HIGH SPEED SPRING PACK AND RELATED PARTS**

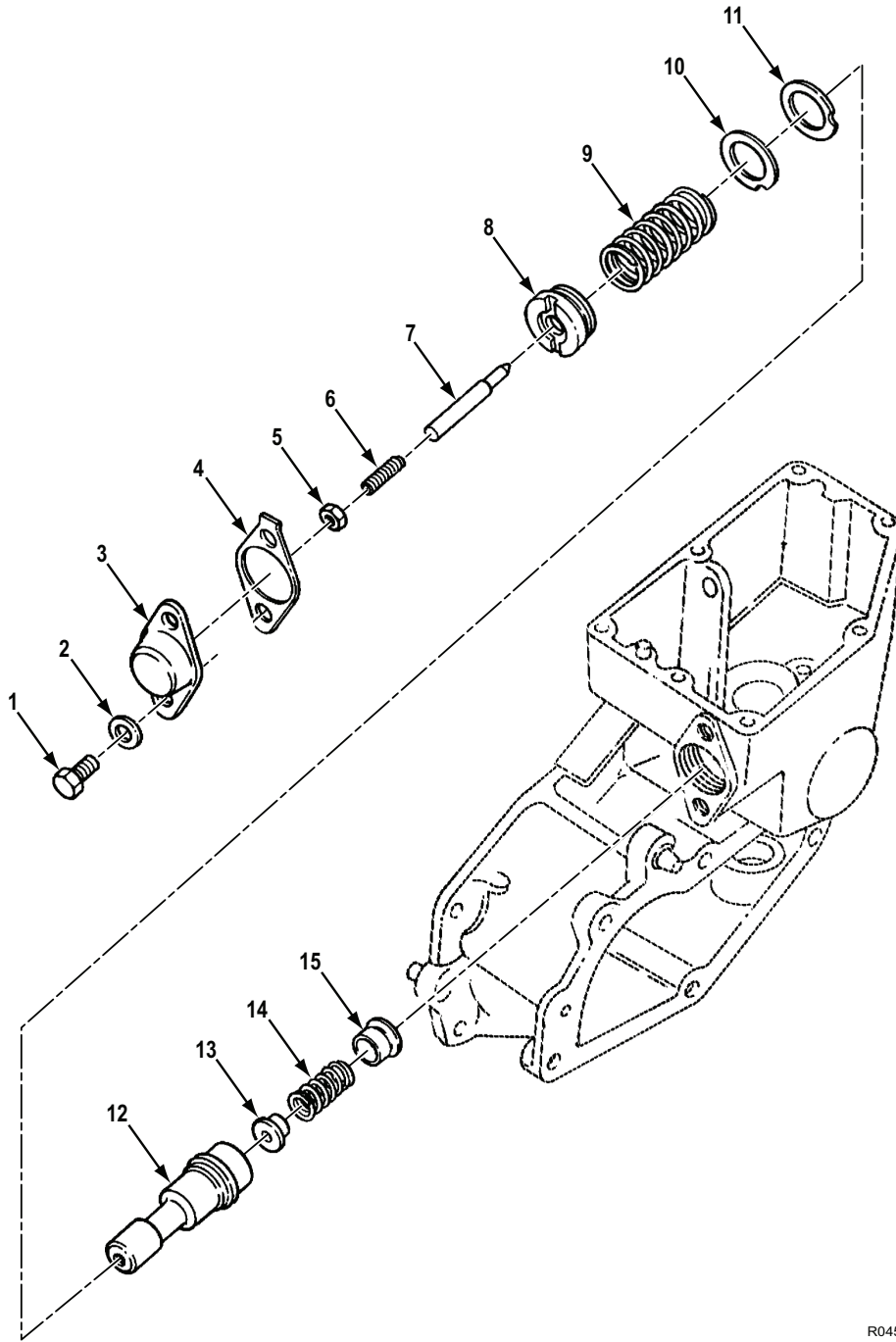

R045

Figure 41. Governor High Speed Spring Pack and Related Parts.

(1) ITEM NO.	(2) SMR CODE	(3) NSN	(4) CAGEC	(5) PART NUMBER	(6) DESCRIPTION AND USABLE ON CODE (UOC)	(7) QTY
GROUP 0308 GOVERNOR HIGH SPEED SPRING PACK AND RELATED PARTS						
FIG. 41. GOVERNOR HIGH SPEED SPRING PACK AND RELATED PARTS.						
1	PAHZZ	5306-00-226-4825	80204	B1821BH031C075N	BOLT,MACHINE 5/16-18UNC-2AX3/4 GR8.....	2
2	KFHZZ	5310-00-737-5429	19207	7375429	WASHER,FLAT PART OF KIT P/N 8928522, PART OF KIT P/N 8927743.....	2
3	PAHZZ	5340-00-462-2171	72582	5131132	COVER,ACCESS.....	1
4	KFHZZ	5330-01-392-3354	18954	K 5152944 NON- ASBESTOS	GASKET PART OF KIT P/N 5198043, PART OF KIT P/N 8928522, PART OF KIT P/N 8927743.....	1
5	PAHZZ	5310-00-971-7989	96906	MS35691-5	NUT,PLAIN,HEXAGON.....	1
6	PAHZZ	5305-01-039-9605	72582	5102270	SCREW 1/4-28UNF-2AX1,SPECIAL.....	1
7	PAHZZ	5315-01-157-8866	72582	5101798	PIN,CLEVIS.....	1
8	PAHZZ	4730-00-172-0528	72582	5174436	PACKING NUT.....	1
9	PAHZZ	5360-00-913-1199	72582	5131541	SPRING,HELICAL,COMP.....	1
10	PAHZZ	5310-00-550-3915	72582	5151249	WASHER,FLAT.....	5
11	PAHZZ	5365-00-262-4397	72582	5150947	SHIM.....	5
12	PAHZZ	5340-00-126-9665	72582	5126135	PLUNGER,DETENT.....	1
13	PAHZZ	5340-00-721-9658	14153	00513	SEAT,HELICAL COMPRE.....	1
14	PAHZZ	5360-00-930-3251	72582	5122165	SPRING,HELICAL,COMP.....	1
15	PAHZZ	2990-00-388-2670	72582	05103975	RETAINER,GOVERNOR S.....	1

END OF FIGURE

**FIELD MAINTENANCE
FUEL INJECTOR CONTROL TUBES AND LINKAGE**

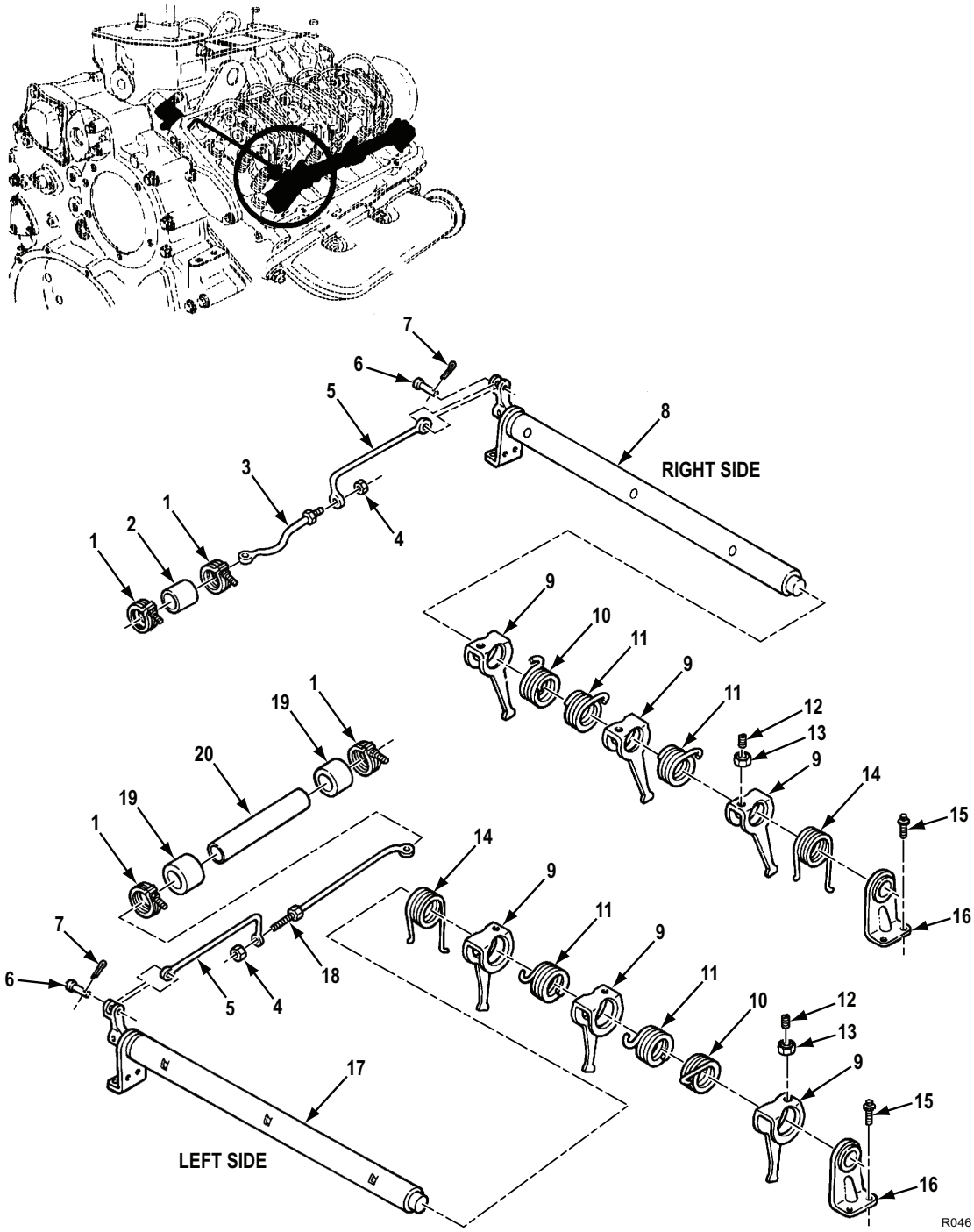

Figure 42. Fuel Injector Control Tubes and Linkage.

(1) ITEM NO.	(2) SMR CODE	(3) NSN	(4) CAGEC	(5) PART NUMBER	(6) DESCRIPTION AND USABLE ON CODE (UOC)	(7) QTY
GROUP 0308 FUEL INJECTOR CONTROL TUBES AND LINKAGE						
FIG. 42. FUEL INJECTOR CONTROL TUBES AND LINKAGE.						
1	KFFZZ	4730-00-289-3141	11083	1K6717	CLAMP,HOSE PART OF KIT P/N 5198043	4
2	KFFZZ	4720-00-789-4862	72582	5129706	HOSE,NONMETALLIC RIGHT SIDE PART OF KIT P/N 5198043.....	1
3	PAFZZ	3040-00-780-5252	72582	5121452	CONNECTING LINK,RIG RIGHT SIDE UPPER.....	1
4	PAFZZ	5310-00-483-8791	80205	MS17829-4F	NUT,SELF-LOCKING,HE.....	1
5	PAFZZ	3040-00-780-5251	72582	5121472	CONNECTING LINK,RIG LOWER.....	2
6	PAFZZ	5315-00-251-9989	72582	05147345	PIN,STRAIGHT,HEADLE.....	2
7	PAFZZ	5315-00-839-2325	15434	109155	PIN,COTTER.....	2
8	PAFFF	2910-01-182-4020	72582	5149965	PARTS KIT,FUEL INJE RIGHT SIDE.....	1
9	PAFZZ	2815-01-077-5096	72582	5101397	LEVER CONTROL INJEC UOC: A6V	6
10	PAFZZ	5360-01-089-7480	72582	5101258	SPRING INJECTOR RACK ARM, LEFT FRONT & RIGHT REAR.....	2
11	PAFZZ	5360-01-057-2935	72582	5101295	SPRING,HELICAL,TORS INJECTOR RACK ARM.....	4
12	PAFZZ	5305-01-078-4967	72582	5101392	SCREW 1/4-28UNF-2AX.90.....	6
13	PAFZZ	5310-00-297-8836	72915	120613	NUT,PLAIN,HEXAGON.....	6
14	PAFZZ	5360-00-055-2657	72582	5116265	SPRING,HELICAL,TORS INJECTOR CONTROL TUBE.....	2
15	PAFZZ	5306-01-015-5430	72582	9422203	BOLT,MACHINE 1/4-20UNRC-2AX5/8 GR5, 12PT HEAD.....	8
16	PAFZZ	5342-00-921-5343	72582	5116264	BRACKET,INJECTOR.....	2
17	PAFHH	2910-01-182-4019	72582	5149966	PARTS KIT,FUEL INJE LEFT SIDE.....	1
18	PAFZZ	2990-00-780-5237	72582	5121453	LINK,GOVERNOR CONTR LEFT SIDE UPPER.....	1
19	KFFZZ	4720-00-789-4863	72582	5129705	HOSE,PREFORMED LEFT SIDE PART OF KIT P/N 5198043.....	2
20	PAFZZ	2990-00-999-2528	72582	5126072	HOUSING,LINK,GOVERN LEFT SIDE.....	1

END OF FIGURE

**SUSTAINMENT MAINTENANCE
THROTTLE DELAY, CHECK VALVE, AND LINKAGE
(MODELS 5063-5392, 5063-5393 AND 5063-539L)**

2
3 AND 4

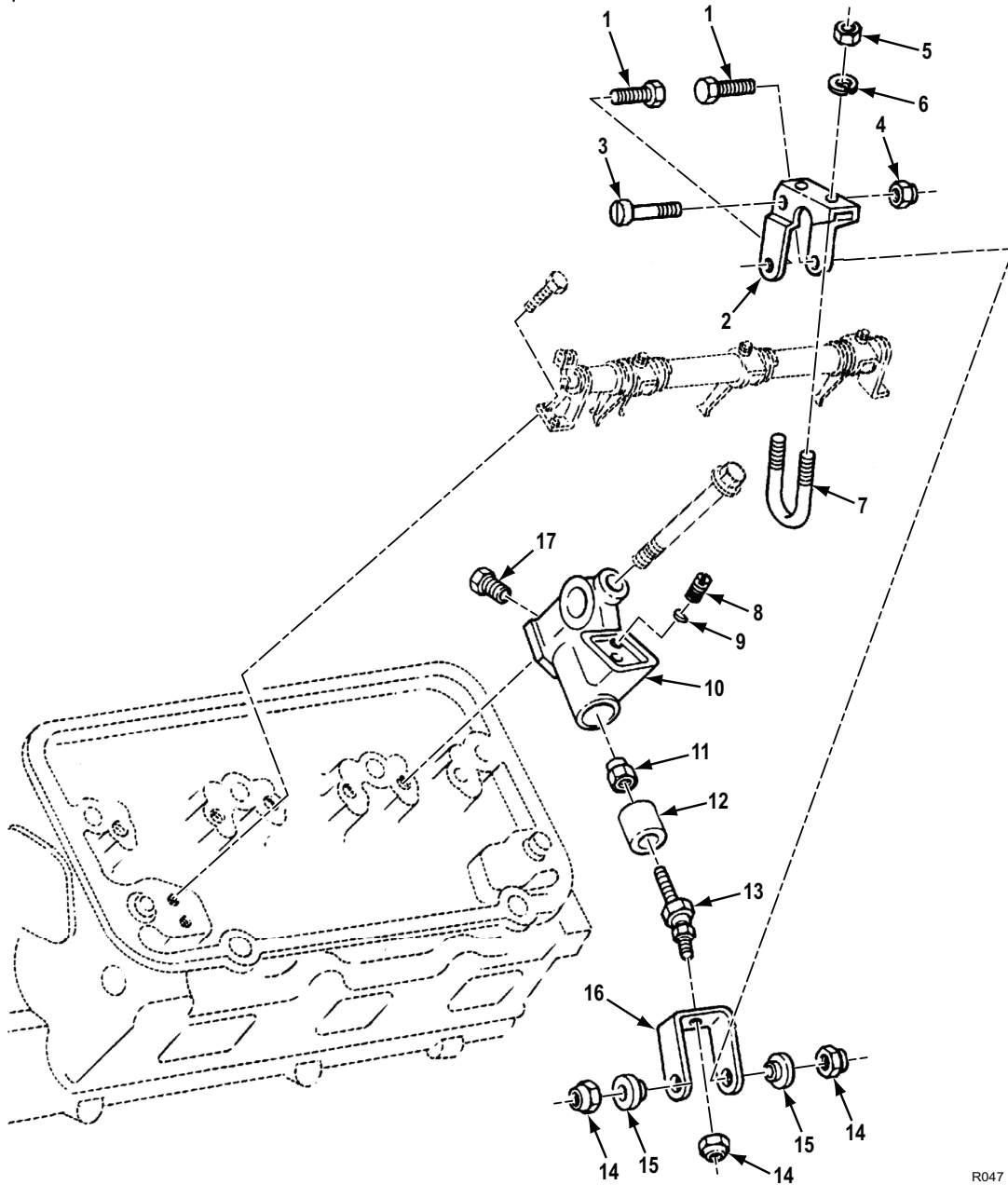

R047

Figure 43. Throttle Delay, Check Valve, and Linkage (Models 5063-5392, 5063-5393, and 5063-539L).

(1) ITEM NO.	(2) SMR CODE	(3) NSN	(4) CAGEC	(5) PART NUMBER	(6) DESCRIPTION AND USABLE ON CODE (UOC)	(7) QTY
<p>GROUP 0308 THROTTLE DELAY, CHECK VALVE, AND LINKAGE (MODELS 5063-5392, 5063-5393 AND 5063-539L)</p> <p>FIG. 43. THROTTLE DELAY, CHECK VALVE, AND LINKAGE (MODELS 5063-5392, 5063-5393, AND 5063-539L).</p>						
1	PAHZZ	5305-01-143-2328	72582	454065	SCREW,CAP,HEXAGON H 10-32UNRF-2AX3/4 UOC: C6V,D6V,L6V	2
2	PAHZZ	2910-01-025-3769	72582	5101402	LEVER ASSEMBLY,THRO UOC: C6V,D6V,L6V	1
3	PAHZZ	5305-00-455-7168	1LW55	274946	. SCREW,MACHINE 10-32UNF-2AX1-1/8 UOC: C6V,D6V,L6V	1
4	PAHZZ	5310-00-164-1790	72582	454749	. NUT,SELF-LOCKING,HE UOC: C6V,D6V,L6V	1
5	PAHZZ	5310-00-761-6882	96906	MS51967-2	NUT,PLAIN,HEXAGON UOC: C6V,D6V,L6V	2
6	PAFZZ	5310-00-582-5965	338X5	120380	WASHER,LOCK UOC: C6V,D6V,L6V	2
7	PAHZZ	5306-00-143-3217	72582	5180116	BOLT,U 1/4-20UNC-2A UOC: C6V,D6V,L6V	1
8	PAHZZ	4730-00-150-2042	72582	5189789	PLUG,PIPE UOC: C6V,D6V,L6V	1
9	PAHZZ	4730-01-312-1403	9005	143512	STRAINER ELEMENT,SE UOC: C6V,D6V,L6V	1
10	PAHZZ	5340-01-016-0437	72582	5145826	BRACKET,MOUNTING INSTALL BETWEEN #1 & #2 CYL ON RIGHT SIDE UOC: C6V,D6V,L6V	1
11	PAFZZ	5310-00-483-8791	80205	MS17829-4F	NUT,SELF-LOCKING,HE UOC: C6V,D6V,L6V	1
12	PAHZZ	2520-00-150-2037	72582	5145828	PISTON,INJECTOR CYL UOC: C6V,D6V,L6V	1
13	PAHZZ	4730-00-150-2038	72582	5146233	SWING JOINT,PIPE UOC: C6V,D6V,L6V	1
14	PAHZZ	5310-00-164-1790	72582	454749	NUT,SELF-LOCKING,HE UOC: C6V,D6V,L6V	3
15	PAHZZ	3120-01-016-0438	72582	5146039	BUSHING UOC: C6V,D6V,L6V	2
16	PAHZZ	2990-00-008-9360	72582	5145827	LINK,THROTTLE DELAY UOC: C6V,D6V,L6V	1
17	PAHZZ	4820-01-035-6082	01276	131-03008	VALVE,CHECK UOC: C6V,D6V,L6V	1

END OF FIGURE

**FIELD MAINTENANCE
FUEL FILTER AND STRAINER ASSEMBLIES (MODELS 5063-5299 AND 5063-5392)**

1	2	8	15
2 THRU 14	3 THRU 6	9 THRU 13	16 THRU 20

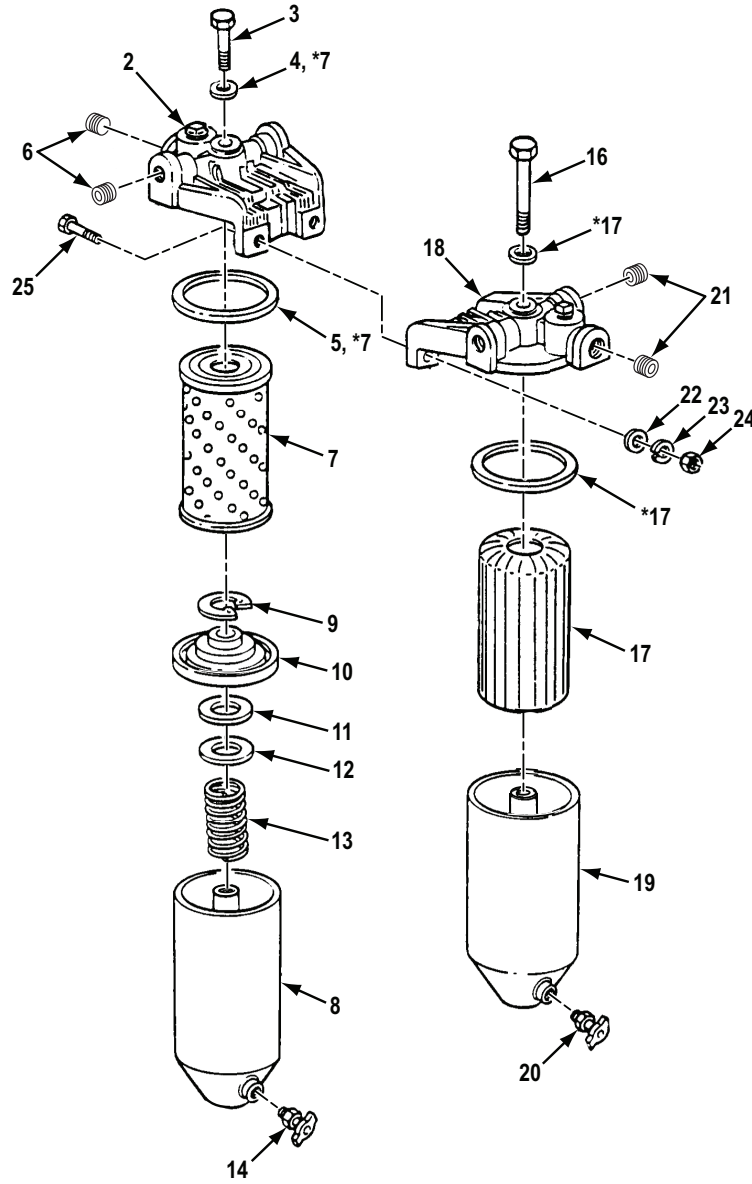

*7 PART OF ITEM 7
 *17 PART OF ITEM 17

R048

Figure 44. Fuel Filter and Strainer Assemblies (Models 5063-5299 and 5063-5392).

(1) ITEM NO.	(2) SMR CODE	(3) NSN	(4) CAGEC	(5) PART NUMBER	(6) DESCRIPTION AND USABLE ON CODE (UOC)	(7) QTY
GROUP 0309 FUEL FILTER AND STRAINER ASSEMBLIES (MODELS 5063-5299 AND 5063-5392)						
FIG. 44. FUEL FILTER AND STRAINER ASSEMBLIES (MODELS 5063-5299 AND 5063-5392).						
1	PAFFF	2910-00-781-1354	64829	6663085	FILTER,FLUID SECONDARY UOC: A6V,C6V,F6V	1
2	PAFZZ	2910-00-932-9634	72582	6436254	. HEAD,FLUID FILTER UOC: A6V,C6V,F6V	1
3	PAFZZ	5306-00-604-7961	72582	5574118	.. BOLT,SHOULDER UOC: A6V,C6V,F6V	1
4	PAFZZ	5330-00-551-0433	57526	GPW9184	.. GASKET UOC: A6V,C6V,F6V	1
5	PAFZZ	5330-00-846-9841	1LMS9	5133	.. GASKET UOC: A6V,C6V,F6V	1
6	PAFZZ	4730-00-279-0985	58536	AA5616AASBCB	.. PLUG,PIPE UOC: C6V	2
7	PAFZZ	2910-00-287-1912	81349	MIL-F-20627TYIICL2	. FILTER ELEMENT,FLUI FUEL FILTER UOC: A6V,C6V,F6V	1
8	PAFZZ	2940-00-015-3609	72582	5575169	. FILTER BODY,FLUID FUEL FILTER UOC: A6V,C6V,F6V	1
9	PAFZZ	5325-00-543-3615	70040	5574120	.. RING,RETAINING UOC: A6V,C6V,F6V	1
10	PAFZZ	5342-00-612-3134	70040	5574123	.. SEAT,FUEL FILTER EL UOC: A6V,C6V,F6V	1
11	PAFZZ	5330-00-612-3123	70040	5574126	.. GASKET UOC: A6V,C6V,F6V	1
12	PAFZZ	5340-01-024-6099	70040	0F209	.. SEAT,HELICAL COMPRE UOC: A6V,C6V,F6V	1
13	PAFZZ	5360-00-619-8198	70040	5573736	.. SPRING,HELICAL,COMP UOC: A6V,C6V,F6V	1
14	PAFZZ	4820-00-849-1220	58536	A-A-59440/1-005	. COCK,DRAIN UOC: A6V,C6V,F6V	1
15	PAFZZ	2910-00-884-1207	4V640	5575824	FILTER ASSEMBLY,FLU UOC: A6V,F6V	1
15	PAFZZ	2910-00-050-9838	4V640	11016	FILTER,FLUID UOC: C6V	1
16	PAFZZ	5306-00-080-7294	4V640	6435424	. BOLT,FUEL FILTER CO UOC: A6V,C6V,F6V	1
17	PAFZZ	2940-00-745-7730	01637	FD-156	. FILTER ELEMENT,FLUI UOC: A6V,C6V,F6V	1
18	PAFZZ	4330-00-849-2672	70040	0F594	. HEAD,FLUID FILTER UOC: A6V,F6V	1
18	PAFZZ	2910-00-050-9879	70040	6436746	. COVER,ASSEMBLY UOC: C6V	1

(1) ITEM NO.	(2) SMR CODE	(3) NSN	(4) CAGEC	(5) PART NUMBER	(6) DESCRIPTION AND USABLE ON CODE (UOC)	(7) QTY
19	PAFZZ	2910-00-922-2424	70040	5575893	. SHELL ASSEMBLY,FILT UOC: A6V,C6V,F6V	1
20	PAFZZ	4820-00-849-1220	58536	A-A-5944011-005	. COCK,DRAIN UOC: A6V,C6V,F6V	1
21	PAFZZ	4730-00-010-3885	72582	8924517	PLUG,PIPE UOC: C6V	1
22	PAFZZ	5310-00-080-6004	96906	MS27183-14	WASHER,FLAT UOC: C6V	2
23	PAFZZ	5310-00-637-9541	59556	019-00004-42	WASHER,LOCK UOC: C6V	2
24	PAFZZ	5310-01-156-7704	96906	MS16286-3	NUT,PLAIN,HEXAGON UOC: C6V	1
25	PAFZZ	5305-00-846-5703	80204	B1821BH038C300N	SCREW,CAP,HEXAGON H UOC: C6V	2

END OF FIGURE

**FIELD MAINTENANCE
FUEL FILTER AND STRAINER ASSEMBLIES (MODELS 5063-5393 AND 5063-539L)**

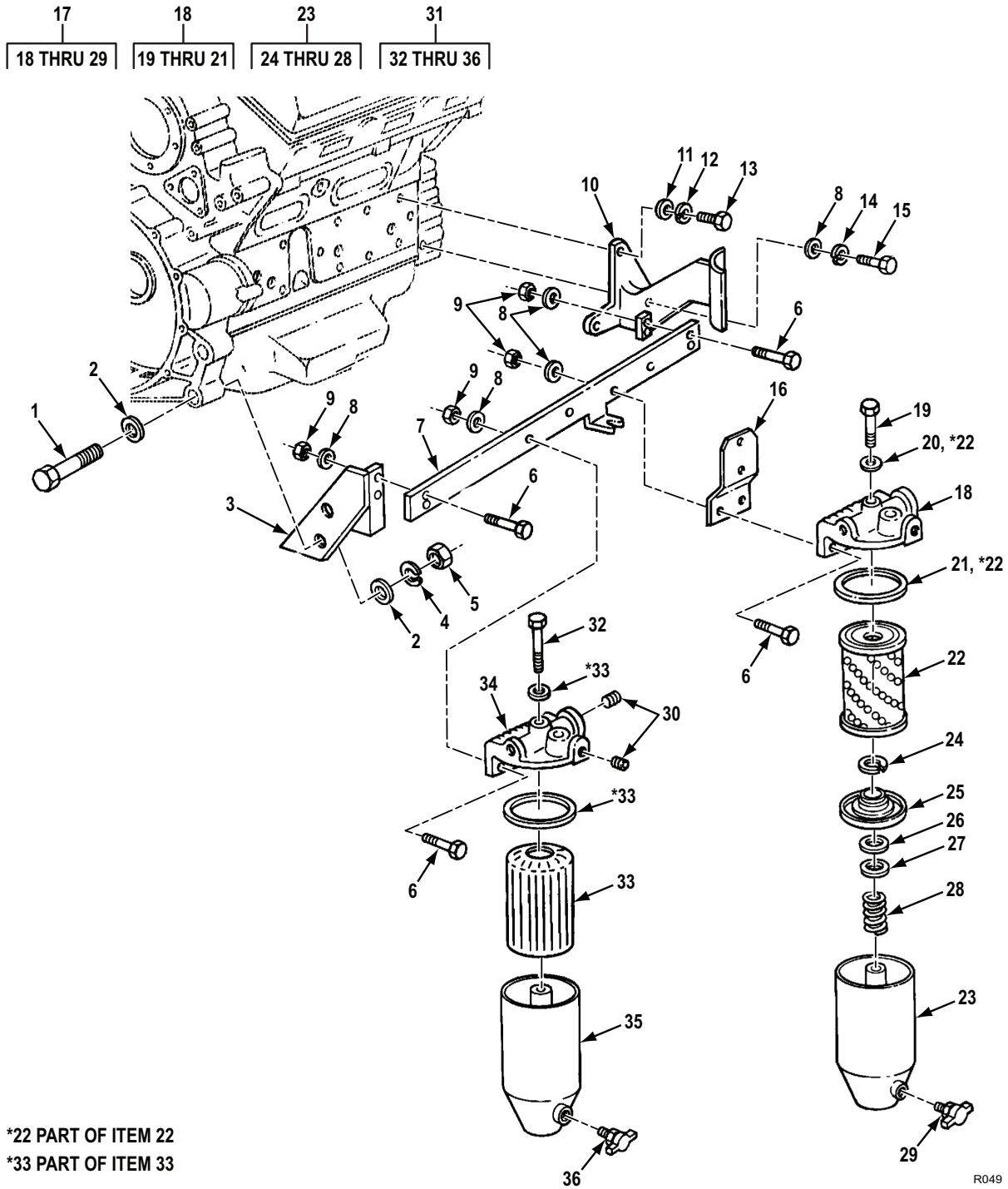

Figure 45. Fuel Filter and Strainer Assemblies (Models 5063-5393 and 5063-539L).

(1) ITEM NO.	(2) SMR CODE	(3) NSN	(4) CAGEC	(5) PART NUMBER	(6) DESCRIPTION AND USABLE ON CODE (UOC)	(7) QTY
GROUP 0309 FUEL FILTER AND STRAINER ASSEMBLIES (MODELS 5063-5393 AND 5063-539L)						
FIG. 45. FUEL FILTER AND STRAINER ASSEMBLIES (MODELS 5063-5393 AND 5063-539L).						
1	PAFZZ	5305-00-947-4355	80204	B1821BH075C325N	SCREW,CAP,HEXAGON H UOC: D6V,L6V	2
2	PAFZZ	5310-00-809-8533	96906	MS27183-23	WASHER,FLAT UOC: D6V,L6V	4
3	PBFZZ	5342-01-253-0547	72582	8928724	BRACKET,ENGINE ACCE UOC: D6V,L6V	1
4	PAFZZ	5310-00-584-7888	80205	NAMS35338	WASHER,LOCK UOC: D6V,L6V	2
5	PAFZZ	5310-00-763-8921	96906	MS51967-23	NUT,PLAIN,HEXAGON UOC: D6V,L6V	2
6	PAFZZ	5305-00-782-9489	80204	B1821BH038C200N	SCREW,CAP,HEXAGON H UOC: D6V,L6V	8
7	PBFZZ	5342-01-253-8652	72582	8928725	BRACKET,ENGINE ACCE UOC: D6V,L6V	1
8	PAFZZ	5310-00-080-6004	96906	MS27183-14	WASHER,FLAT UOC: D6V,L6V	8
9	PAFZZ	5310-00-087-4652	81349	M45913/1-6CG5C	NUT,SELF-LOCKING,HE UOC: D6V,L6V	8
10	PBFZZ	5342-01-253-8653	72582	8928726	BRACKET,ENGINE ACCE UOC: D6V,L6V	1
11	PAFZZ	5310-00-081-4219	96906	MS27183-12	WASHER,FLAT UOC: D6V,L6V	2
12	PAFZZ	5310-00-407-9566	80205	MS35338-45	WASHER,LOCK UOC: D6V,L6V	2
13	PAFZZ	5306-00-226-4827	80204	B1821BH031C100N	BOLT,MACHINE 5/16-18UNC-2AX1 GR8 UOC: D6V,L6V	2
14	PAFZZ	5310-00-637-9541	59556	019-00004-42	WASHER,LOCK UOC: D6V,L6V	1
15	PAFZZ	5305-00-068-0510	80204	B1821BH038C100N	SCREW,CAP,HEXAGON H UOC: D6V,L6V	1
16	PBFZZ	5342-01-254-1073	72582	23501827	BRACKET,ENGINE ACCE UOC: D6V,L6V	1
17	PAFFF	2910-00-781-1354	64829	663085	FILTER,FLUID UOC: D6V,L6V	1
18	PAFZZ	2910-00-932-9634	72582	6436254	. HEAD,FLUID FILTER UOC: D6V,L6V	1
19	PAFZZ	5306-00-604-7961	72582	5574118	. . BOLT,SHOULDER UOC: D6V,L6V	1
20	PAFZZ	2910-00-287-1912	81349	GPW9184	. GASKET UOC: D6V,L6V	1

(1) ITEM NO.	(2) SMR CODE	(3) NSN	(4) CAGEC	(5) PART NUMBER	(6) DESCRIPTION AND USABLE ON CODE (UOC)	(7) QTY
21	PAFZZ	5330-00-551-0433	57526	5574161	. . GASKET UOC: D6V,L6V	1
22	PAFZZ	5330-00-846-9841	ILMS9	MIL- F-200627TYIICL2	. . FILTER ELEMENT,FLUID UOC: D6V,L6V	1
23	PAFZZ	2940-00-015-3609	72582	5575169	. FILTER BODY,FLUID UOC: D6V,L6V	1
24	PAFZZ	5325-00-543-3615	70040	5574120	. . RING,RETAINING UOC: D6V,L6V	1
25	PAFZZ	5342-00-612-3134	70040	5574123	. . SEAT,FUEL FILTER EL UOC: D6V,L6V	1
26	PAFZZ	5330-00-612-3123	70040	5574126	. . GASKET UOC: D6V,L6V	1
27	PAFZZ	5340-01-024-6099	70040	0F209	. . SEAT,HELICAL COMPRE UOC: D6V,L6V	1
28	PAFZZ	5360-00-619-8198	70040	5573736	. . SPRING,HELICAL,COMP UOC: D6V,L6V	1
29	PAFZZ	4820-00-849-1220	58536	A-A-59440/1-005	. COCK,DRAIN UOC: D6V,L6V	1
30	PAFZZ	4730-00-010-3885	72582	8924517	PLUG,PIPE UOC: D6V,L6V	2
31	PAFZZ	2910-00-050-9838	4V640	11016	FILTER,FLUID UOC: D6V,L6V	1
32	PAFZZ	5306-00-080-7294	4V640	6435424	. BOLT,FUEL FILTER CO UOC: D6V,L6V	1
33	PAFZZ	2940-00-745-7730	01637	FD-156	. FILTER ELEMENT,FLUI UOC: D6V,L6V	1
34	PAFZZ	2910-00-050-9879	70040	6436746	. COVER,FILTER UOC: D6V,L6V	1
35	PAFZZ	2910-00-922-2424	70040	5575893	. SHELL ASSEMBLY,FILT UOC: D6V,L6V	1
36	PAFZZ	4820-00-849-1220	58536	A-A-59440/1-005	. COCK,DRAIN UOC: D6V,L6V	1

END OF FIGURE

**FIELD MAINTENANCE
AIR BOX HEATER AND RELATED PARTS (MODELS 5063-5299)**

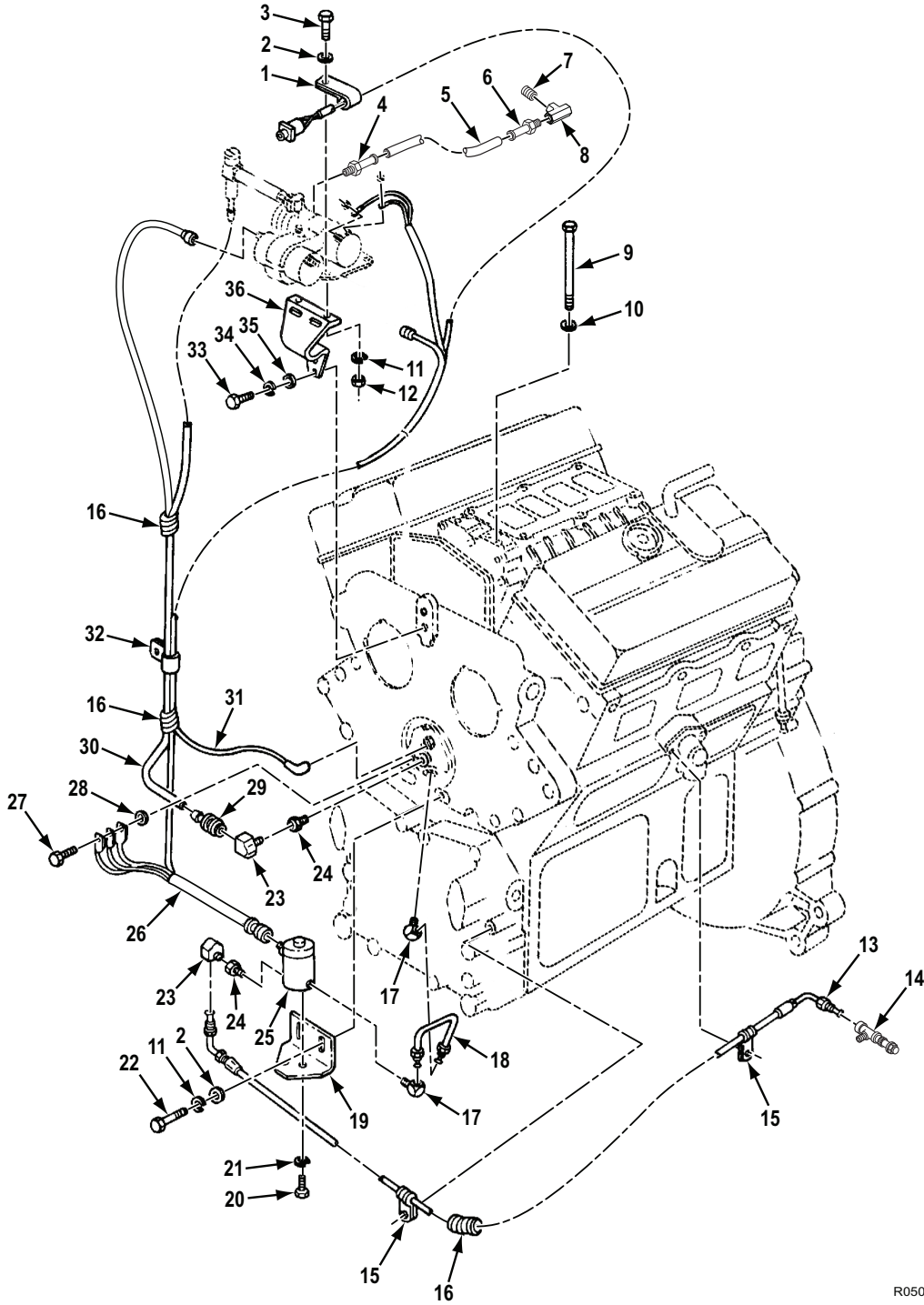

R050

Figure 46. Air Box Heater and Related Parts (Models 5063-5299).

(1) ITEM NO.	(2) SMR CODE	(3) NSN	(4) CAGEC	(5) PART NUMBER	(6) DESCRIPTION AND USABLE ON CODE (UOC)	(7) QTY
GROUP 0311 AIR BOX HEATER AND RELATED PARTS (MODELS 5063-5299)						
FIG. 46. AIR BOX HEATER AND RELATED PARTS (MODELS 5063-5299).						
1	PAFZZ	5342-01-016-0432	72582	5145429	CLIP UOC: A6V,F6V	1
2	PAFZZ	5310-00-080-6004	96906	MS27183-14	WASHER,FLAT UOC: A6V,F6V	4
3	PAFZZ	5305-00-068-0511	80204	B1821BH038C125N	SCREW,CAP,HEXAGON H UOC: A6V,F6V	2
4	PAFZZ	4730-00-849-2737	72582	5114049	FITTING UOC: A6V,F6V	1
5	MFFZZ		72582	5113687	HOSE,NONMETALLIC 20.00 IN. LG, MAKE FROM HOSE,P/N 2565-6, AIR PUMP AIR INLET UOC: A6V,F6V	1
6	PAFZZ	2815-00-841-9125	72582	5113214	FITTING,CYLINDER UOC: A6V,F6V	1
7	PAFZZ	4730-00-196-2055	96906	MS51953-25B	NIPPLE,PIPE UOC: A6V,F6V	1
8	PAFZZ	4730-00-249-2029	91340	D9484-5528	TEE,PIPE UOC: A6V,F6V	1
9	PAFZZ	5305-00-930-3253	72582	5136323	SCREW,CAP,HEXAGON H UOC: A6V,F6V	2
10	PAFZZ	5310-00-780-8116	72582	5131913	WASHER,FLAT UOC: A6V,F6V	2
11	PAFZZ	5310-00-637-9541	59556	019-00004-42	WASHER,LOCK UOC: A6V,F6V,	4
12	PAFZZ	5310-00-732-0558	96906	MS51967-8	NUT,PLAIN,HEXAGON UOC: A6V,F6V	2
13	PAFZZ	4720-01-039-6516	72582	5147883	HOSE ASSEMBLY,NONME UOC: A6V,F6V	1
14	PAFZZ	2990-01-039-6515	72582	5147858	FITTING UOC: A6V,F6V	1
15	PAFZZ	5340-00-158-0417	72582	5109020	CLAMP,LOOP UOC: A6V,F6V	2
16	PAFZZ	4720-01-127-6546	72582	5142470	TUBING,NONMETALLIC UOC: A6V,F6V	3
17	PAFZZ	4730-01-187-6671	72582	8925032	ELBOW,PIPE TO TUBE UOC: A6V,F6V	2
18	PAFZZ	4710-01-016-0433	72582	5145565	TUBE ASSEMBLY UOC: A6V,F6V	1
19	PBFZZ	5340-00-234-6028	72582	5132519	BRACKET,ANGLE UOC: A6V,F6V	1

(1) ITEM NO.	(2) SMR CODE	(3) NSN	(4) CAGEC	(5) PART NUMBER	(6) DESCRIPTION AND USABLE ON CODE (UOC)	(7) QTY
20	PAFZZ	5305-00-989-7435	80205	MS35207-264	SCREW,MACHINE UOC: A6V,F6V	2
21	PAFZZ	5310-00-045-3296	80205	MS35338-43	WASHER,LOCK UOC: A6V,F6V	2
22	PAFZZ	5305-00-543-2866	80204	B1821BH038C250N	SCREW,CAP,HEXAGON H UOC: A6V,F6V	2
23	PAFZZ	4730-00-640-1051	12204	137422	ELBOW,PIPE TO TUBE UOC: A6V,F6V	2
24	XBFZZ	4730-00-415-3172	81343	2-2130139B	COUPLING,PIPE UOC: A6V,F6V	2
25	PAFZZ	4810-00-974-7605	81978	V5J21735	VALVE,SOLENOID UOC: A6V,F6V	1
26	PAFZZ	6150-01-016-0434	72582	5145566	HARNESS UOC: A6V,F6V	1
27	PAFZZ	5306-00-226-4828	80204	B1821BH031C113N	BOLT,MACHINE 5/16-18UNC-2AX1-1/8 GR8 UOC: A6V,F6V	1
28	KFFZZ	5310-00-737-5429	19207	7375429	WASHER,FLAT PART OF KIT P/N 8927743 UOC: A6V,F6V	1
29	PAFZZ	4730-00-446-2584	01276	4740-5-4B	ADAPTER,STRAIGHT,TU UOC: A6V,F6V	1
30	MFFZZ	4720-01-111-2283	72582	5129627	HOSE ASSEMBLY,NONME 28.00 IN. LG, MAKE FROM HOSE,P/N 1525-4, CHECK VALVE TO AIRBOX HEATER ASSY UOC: A6V,F6V	1
31	PAFZZ	2920-01-016-0428	72582	5142056	WIRE UOC: A6V,F6V	1
32	PAFZZ	5340-00-720-6213	96906	MS21333-59	CLAMP,LOOP UOC: A6V,F6V	1
33	PAFZZ	5305-00-071-1787	05047	AES01C438A12AW9 A91	SCREW,CAP,HEXAGON H UOC: A6V,F6V	2
34	PAFZZ	5310-00-209-0965	80205	MS35338-47	WASHER,LOCK UOC: A6V,C6V,F6V,L6V	2
35	PAFZZ	5310-00-809-4085	96906	MS27183-16	WASHER,FLAT UOC: A6V,F6V	2
36	PAFZZ	5340-01-127-7904	72582	5136207	STRAP,RETAINING UOC: A6V,F6V	1

END OF FIGURE

**FIELD MAINTENANCE
AIR BOX HEATER AND RELATED PARTS (MODEL 5063-5392)**

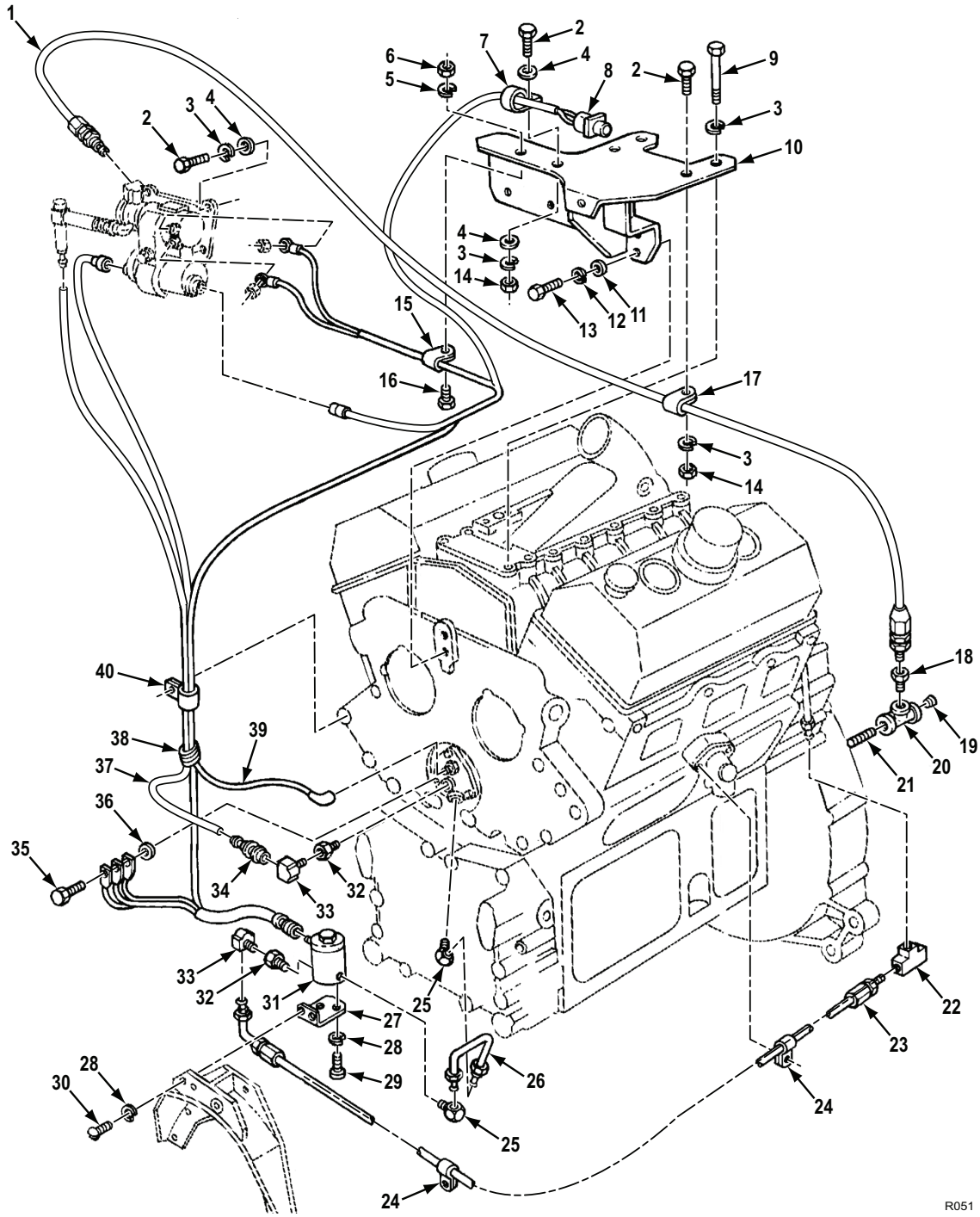

R051

Figure 47. Air Box Heater and Related Parts (Model 5063-5392).

(1) ITEM NO.	(2) SMR CODE	(3) NSN	(4) CAGEC	(5) PART NUMBER	(6) DESCRIPTION AND USABLE ON CODE (UOC)	(7) QTY
GROUP 0311 AIR BOX HEATER AND RELATED PARTS (MODEL 5063-5392)						
FIG. 47. AIR BOX HEATER AND RELATED PARTS (MODEL 5063-5392).						
1	PAFZZ	4720-00-230-3489	72582	5133829	HOSE ASSEMBLY, NONME UOC: C6V	1
2	PAFZZ	5305-00-543-4372	80204	B1821BH038C075N	SCREW, CAP, HEXAGON H UOC: C6V	6
3	PAFZZ	5310-00-637-9541	59556	019-00004-42	WASHER, LOCK UOC: C6V	8
4	PAFZZ	5310-00-080-6004	96906	MS27183-14	WASHER, FLAT UOC: C6V	6
5	PAFZZ	5310-00-582-5965	338X5	120380	WASHER, LOCK UOC: C6V	1
6	PAFZZ	5310-00-761-6882	96906	MS51967-2	NUT, PLAIN, HEXAGON UOC: C6V	1
7	PAFZZ	5342-01-016-0432	72582	5145429	CLIP UOC: C6V	1
8	PAFZZ	6150-01-016-0434	72582	5145566	HARNES UOC: C6V	1
9	PAFZZ	5305-00-725-2317	80204	B1821BH038C150N	SCREW, CAP, HEXAGON H UOC: C6V	2
10	PAFZZ	5340-01-239-0623	72582	8926597	BRACKET, ANGLE UOC: C6V	1
11	PAFZZ	5310-00-809-4085	96906	MS27183-16	WASHER, FLAT UOC: C6V	2
12	PAFZZ	5310-00-209-0965	80205	MS35338-47	WASHER, LOCK UOC: C6V	2
13	PAFZZ	5305-00-071-1787	05047	AES01C438A12AW9 891	SCREW, CAP, HEXAGON H UOC: C6V	2
14	PAFZZ	5310-00-732-0558	96906	MS51967-8	NUT, PLAIN, HEXAGON UOC: C6V	2
15	PAFZZ	5340-00-152-6428	72582	5134759	CLIP, RETAINING UOC: C6V	1
16	PAFZZ	5305-00-068-0508	07482	1C817P63	SCREW, CAP, HEXAGON H UOC: C6V	1
17	PAFZZ	5340-00-161-5246	72582	2488022	CLAMP, LOOP AIR INLET HOSE UOC: C6V	1
18	PAFZZ	4730-00-150-2043	72582	9432266	COUPLING, TUBE UOC: C6V	1
19	PAFZZ	4730-00-371-5337	72582	08924380	PLUG, PIPE UOC: C6V	1
20	PAFZZ	4730-00-249-2029	91340	D9484-5528	TEE, PIPE UOC: C6V	1

(1) ITEM NO.	(2) SMR CODE	(3) NSN	(4) CAGEC	(5) PART NUMBER	(6) DESCRIPTION AND USABLE ON CODE (UOC)	(7) QTY
21	PAFZZ	4730-01-055-4021	07421	425-100-004	NIPPLE,PIPE UOC: C6V	1
22	PAFZZ	4730-00-542-4402	93061	2441FHD-5	TEE,TUBE UOC: C6V	1
23	PAFZZ	4720-01-077-6453	72582	5140399	HOSE ASSEMBLY,NONME UOC: C6V	1
24	PAFZZ	5340-00-158-0417	72582	5109020	CLAMP,LOOP UOC: C6V	2
25	PAFZZ	4730-01-187-6671	72582	8925032	ELBOW,PIPE TO TUBE UOC: C6V	2
26	PAFZZ	4710-01-229-3422	19207	12313571	TUBE ASSEMBLY,METAL UOC: C6V	1
27	PAFZZ	5340-01-231-0345	19207	12313437	BRACKET,MOUNTING UOC: C6V	1
28	PAFZZ	5310-00-045-3296	80205	MS35338-43	WASHER,LOCK UOC: C6V	4
29	PAFZZ	5305-00-989-7435	80205	MS35207-264	SCREW,MACHINE UOC: C6V	2
30	PAFZZ	5305-00-989-7434	96906	MS35207-263	SCREW,MACHINE 10-32UNF-2AX1/2, SOLENOID BRKT UOC: C6V	2
31	PAFZZ	4810-00-974-7605	81978	V5521735	VALVE,SOLENOID UOC: C6V,D6V	1
32	PAFZZ	4730-00-415-3172	81343	2-2130139B	COUPLING,PIPE UOC: C6V	2
33	PAFZZ	4730-00-640-1051	12204	137422	ELBOW,PIPE TO TUBE UOC: C6V	2
34	PAFZZ	4730-00-446-2584	01276	4740-5-4B	ADAPTER,STRAIGHT,TU UOC: C6V	1
35	PAFZZ	5306-00-226-4828	80204	B1821BH031C113N	BOLT,MACHINE UOC: C6V	1
36	PAFZZ	5310-00-737-5429	19207	7375429	WASHER,FLAT PART OF KIT P/N 8928522 UOC: C6V	1
37	MFFZZ		72582	5129627	HOSE ASSEMBLY,NONME 28.00 IN. LG, MAKE FROM HOSE, P/N 1525-4, AIR HOSE, CHECK VALVE TO HEATER UOC: C6V	1
38	PAFZZ	4720-01-127-6546	72582	5142470	TUBING,NONMETALLIC UOC: C6V	1
39	PAFZZ	2920-01-016-0428	72582	5142056	WIRE UOC: C6V	1
40	PAFZZ	5340-00-720-6213	96906	MS21333-59	CLAMP,LOOP UOC: C6V	1

END OF FIGURE

**FIELD MAINTENANCE
AIR BOX HEATER AND RELATED PARTS (MODEL 5063-5393)**

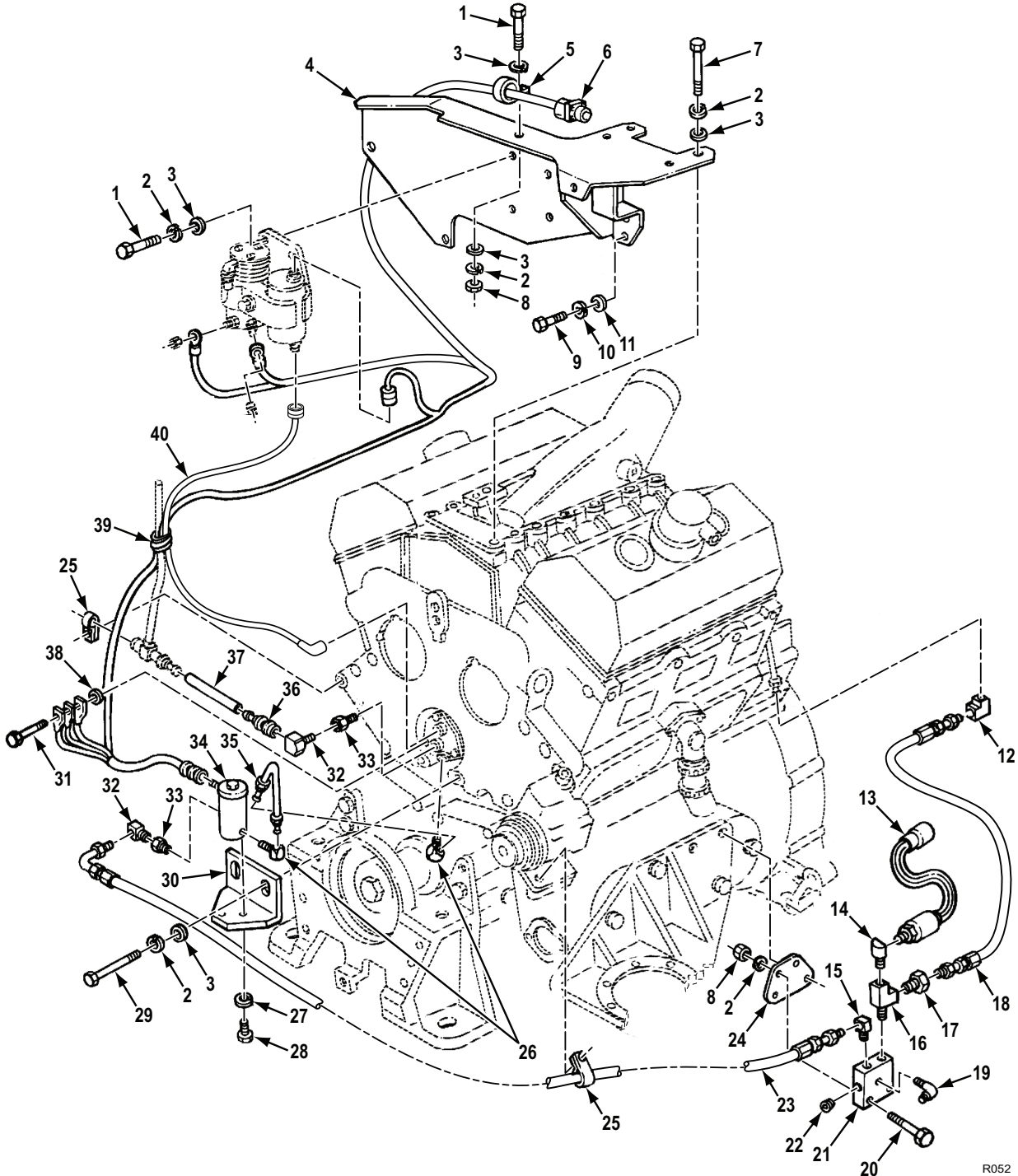

R052

Figure 48. Air Box Heater and Related Parts (Model 5063-5393).

(1) ITEM NO.	(2) SMR CODE	(3) NSN	(4) CAGEC	(5) PART NUMBER	(6) DESCRIPTION AND USABLE ON CODE (UOC)	(7) QTY
GROUP 0311 AIR BOX HEATER AND RELATED PARTS (MODEL 5063-5393)						
FIG. 48. AIR BOX HEATER AND RELATED PARTS (MODEL 5063-5393).						
1	PAFZZ	5305-00-068-0511	80204	B1821BH038C125N	SCREW,CAP,HEXAGON H UOC: D6V	5
2	PAFZZ	5310-00-637-9541	59556	019-00004-46	WASHER,LOCK UOC: D6V	11
3	PAFZZ	5310-00-080-6004	96906	MS27183-14	WASHER,FLAT UOC: D6V	10
4	PAFZZ	5340-01-247-7925	72582	8928727	BRACKET,MOUNTING UOC: D6V	1
5	PAFZZ	5342-01-016-0432	72582	5145429	CLIP UOC: D6V	1
6	PAFZZ	6150-01-016-0434	72582	5145566	HARNES UOC: D6V	1
7	PAFZZ	5305-00-725-2317	80204	B1821BH038C150N	SCREW,CAP,HEXAGON H UOC: D6V	2
8	PAFZZ	5310-00-732-0558	96906	MS51967-8	NUT,PLAIN,HEXAGON UOC: D6V	3
9	PAFZZ	5305-00-071-1787	05047	AES01C438A12AW9 A91	SCREW,CAP,HEXAGON H UOC: D6V	2
10	PAFZZ	5310-00-209-0965	80205	MS35338-47	WASHER,LOCK UOC: D6V	2
11	PAFZZ	5310-00-809-4085	96906	MS27183-16	WASHER,FLAT UOC: D6V	2
12	PAFZZ	4730-00-716-4928	81343	5-5040201B	ELBOW,TUBE UOC: D6V	1
13	PAFZZ	6685-01-167-4298	19207	12258932-6	TRANSMITTER,PRESSUR UOC: D6V	1
14	PAFZZ	4730-00-595-4417	72582	8924168	ELBOW,PIPE UOC: D6V	1
15	PAFZZ	4730-00-014-3343	81343	5-4040202	ELBOW,PIPE TO TUBE UOC: D6V	1
16	PAFZZ	4730-01-005-3262	72582	8924178	TEE,PIPE UOC: D6V	1
17	PAFZZ	4730-01-242-9517	72582	8924218	COUPLING,TUBE UOC: D6V	1
18	PAFZZ	4720-00-904-4566	72582	5132612	HOSE ASSEMBLY,NONME UOC: D6V	1
19	PAFZZ	4730-01-242-2825	7X677	9402839	ELBOW,PIPE TO TUBE UOC: D6V	1
20	PAFZZ	5305-00-782-9489	80204	B1821BH038C200N	SCREW,CAP,HEXAGON H UOC: D6V	2

(1) ITEM NO.	(2) SMR CODE	(3) NSN	(4) CAGEC	(5) PART NUMBER	(6) DESCRIPTION AND USABLE ON CODE (UOC)	(7) QTY
21	PAFZZ	2910-01-251-1719	72582	8928896	BLOCK,FUEL INJECTIO UOC: D6V	1
22	PAFZZ	4730-01-398-7635	72582	8923847	PLUG,PIPE UOC: D6V	1
23	PAFZZ	4720-00-904-8102	72582	5132599	HOSE ASSEMBLY,NONME UOC: D6V	1
24	PAFZZ	5342-01-251-3135	72582	8928897	BRACKET,BLOCK,FUEL UOC: D6V	1
25	PAFZZ	5340-00-161-5246	72582	2488022	CLAMP,LOOP UOC: D6V	2
26	PAFZZ	4730-01-187-6671	72582	8925032	ELBOW,PIPE TO TUBE UOC: D6V	2
27	PAFZZ	5310-00-045-3296	80205	MS35338-43	WASHER,LOCK UOC: D6V	2
28	PAFZZ	5305-00-989-7435	80205	MS35207-264	SCREW,MACHINE UOC: D6V	2
29	PAFZZ	5305-00-543-2866	80204	B1821BH038C250N	SCREW,CAP,HEXAGON H UOC: D6V	2
30	XBFZZ		72582	23502456	BRACKET,ANGLE UOC: D6V	1
31	PAFZZ	5306-00-226-4828	80204	B1821BH031C113N	BOLT,MACHINE UOC: D6V	1
32	PAFZZ	4730-00-640-1051	12204	137422	ELBOW,PIPE TO TUBE UOC: D6V	2
33	PAFZZ	4730-00-415-3172	81343	2-2130139B	COUPLING,PIPE UOC: D6V	2
34	PAFZZ	4810-00-974-7605	81978	V5121735	VALVE,SOLENOID UOC: D6V	1
35	PAFZZ	4710-01-287-4607	72582	23502455	TUBE ASSEMBLY,METAL UOC: D6V	1
36	PAFZZ	4730-00-446-2584	01276	4740-5-4B	ADAPTER,STRAIGHT,TU UOC: D6V	1
37	MFFZZ	4720-00-481-9390	14571	113-964ID1	HOSE,NONMETALLIC 6.50 IN. LG,MAKE FROM HOSE,P/N 1525-4. CHECK VALVE TO HEATER UOC: D6V	1
38	PAFZZ	5310-00-737-5429	19207	7375429	WASHER,FLAT PART OF KIT P/N 8928522 UOC: D6V	1
39	PAFZZ	4720-01-127-6546	72582	5142470	TUBING,NONMETALLIC UOC: D6V	1
40	PAFZZ	2920-01-016-0428	72582	5142056	WIRE UOC: D6V	1

END OF FIGURE

**FIELD MAINTENANCE
GLOW PLUG CONTROLLER AND RELATED PARTS (MODEL 5063-539L)**

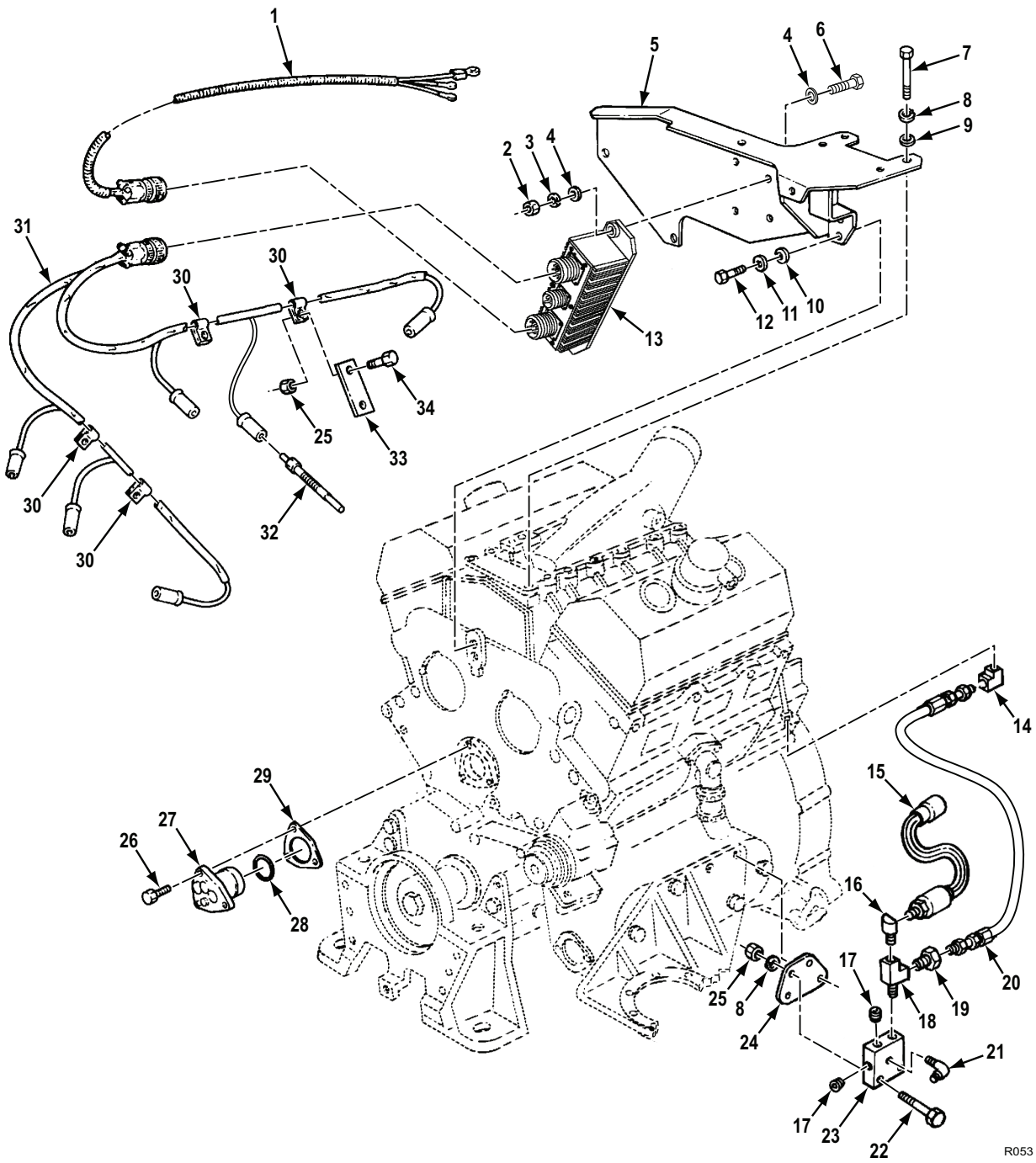

R053

Figure 49. Glow Plug Controller and Related Parts (Model 5063-539L).

(1) ITEM NO.	(2) SMR CODE	(3) NSN	(4) CAGEC	(5) PART NUMBER	(6) DESCRIPTION AND USABLE ON CODE (UOC)	(7) QTY
GROUP 0311 GLOW PLUG CONTROLLER AND RELATED PARTS (MODEL 5063-539L)						
FIG. 49. GLOW PLUG CONTROLLER AND RELATED PARTS (MODEL 5063-539L).						
1	PAFZZ	6150-01-371-0247	72582	23506389	CABLE ASSEMBLY,SPEC UOC: L6V	1
2	PAFZZ	5310-00-880-7744	80204	ANSI B18.2.2	NUT,PLAIN,HEXAGON UOC: L6V	2
3	PAFZZ	5310-00-407-9566	80205	MS35338-45	WASHER,LOCK UOC: L6V	2
4	PAFZZ	5310-00-081-4219	96906	MS27183-12	WASHER,FLAT UOC: L6V	4
5	PAFZZ	5340-01-499-1736	72582	23516121	BRACKET,MOUNTING UOC: L6V	1
6	PAFZZ	5306-00-122-9721	72582	186624	BOLT,MACHINE UOC: L6V	2
7	PAFZZ	5305-00-725-2317	80204	B1821BH038C150N	SCREW,CAP,HEXAGON H 3/8-16UNC-2AX1-1/2 GR8 UOC: L6V	2
8	PAFZZ	5310-00-637-9541	59556	019-00004-42	WASHER,LOCK UOC: L6V	4
9	PAFZZ	5310-00-080-6004	96906	MS27183-14	WASHER,FLAT UOC: L6V	10
10	PAFZZ	5310-00-809-4085	96906	MS27183-16	WASHER,FLAT UOC: L6V	2
11	PAFZZ	5310-00-209-0965	80205	MS35338-47	WASHER,LOCK UOC: L6V	2
12	PAFZZ	5305-00-071-1787	05047	AESC01C438A12A W9A91	SCREW,CAP,HEXAGON H 7/16-14UNC-2AX1-1/8 GR8 UOC: L6V	2
13	PAFZZ	6110-01-427-6395	19207	12368977	REGULATOR,CURRENT UOC: L6V	1
14	PAFZZ	4730-00-716-4928	81343	5-5040201B	ELBOW,TUBE LEFT SIDE HEAD- REAR,FUEL SPILL UOC: L6V	1
15	PAFZZ	6685-01-167-4298	19207	12258932-6	TRANSMITTER,PRESSUR JUNCTION BLOCK UOC: L6V	1
16	PAFZZ	4730-00-595-4417	72582	8924168	ELBOW,PIPE UOC: L6V	1
17	PAFZZ	4730-01-398-7635	72582	8923847	PLUG,PIPE JUNCTION BLOCK UOC: L6V	1
18	PAFZZ	4730-01-005-3262	72582	8924178	TEE,PIPE UOC: L6V	1

(1) ITEM NO.	(2) SMR CODE	(3) NSN	(4) CAGEC	(5) PART NUMBER	(6) DESCRIPTION AND USABLE ON CODE (UOC)	(7) QTY
19	PAFZZ	4730-00-288-9953	35301	182-15	COUPLING,TUBE UOC: L6V	1
20	PAFZZ	4720-00-904-4566	72582	5132612	HOSE ASSEMBLY,NONME LEFT SIDE REAR HEAD TO JUNCTION BLK UOC: L6V	1
21	PAFZZ	4730-01-242-2825	7X677	9402839	ELBOW,PIPE TO TUBE JUNCTION BLK,FUEL SPILL UOC: L6V	1
22	PAFZZ	5305-00-782-9489	80204	B1821BH038C200N	SCREW,CAP,HEXAGON H 3/8-16UNC-2AX2 GR8,JUNCTION BLK UOC: L6V	2
23	PAFZZ	2910-01-251-1719	72582	8928896	BLOCK,FUEL INJECTIO JUNCTION BLOCK WITH 0.106" RESTRICTOR UOC: L6V	1
24	PAFZZ	5342-01-251-3135	72582	8928897	BRACKET,BLOCK,FUEL JUNCTION BLOCK UOC: L6V	1
25	PAFZZ	5310-00-732-0558	96906	MS51967-8	NUT,PLAIN,HEXAGON UOC: L6V	4
26	PAHZZ	5306-01-169-5526	45152	2AG305	BOLT,MACHINE 5/16-18UNC-2AX1.00 LOCKING UOC: L6V	3
27	PAHZZ	5340-01-435-0416	72582	5101391	PLUG,LEAKPROOF SEAL UOC: L6V	1
28	PAHZZ	5331-00-403-0024	72582	5109517	O-RING UOC: L6V	1
29	PAHZZ	5330-00-689-8265	72582	5109496	GASKET UOC: L6V	1
30	PAFZZ	5340-01-130-6245	72582	5144934	CLAMP,LOOP UOC: L6V	4
31	PAFZZ	6150-01-439-9221	72582	23516122	WIRING HARNESS,BRAN UOC: L6V	1
32	PAFZZ	2920-01-434-7201	72582	23518271	GLOW PLUG UOC: L6V	6
33	PAFZZ	5340-01-104-8888	72582	5130913	BRACKET,MOUNTING UOC: L6V	4
34	PAFZZ	5305-01-242-1783	72582	8927581	SETSCREW 3/8-16UNC-2AX.755 GR8 UOC: L6V	4

END OF FIGURE

**FIELD MAINTENANCE
AIR BOX HEATER**

5
6 THRU 8

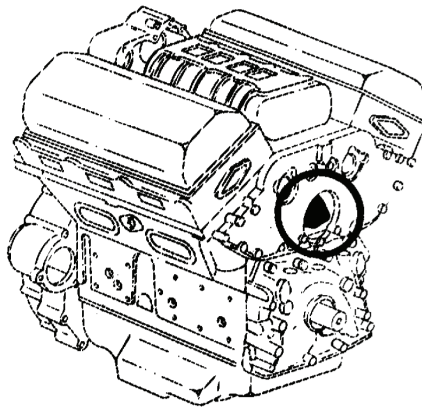
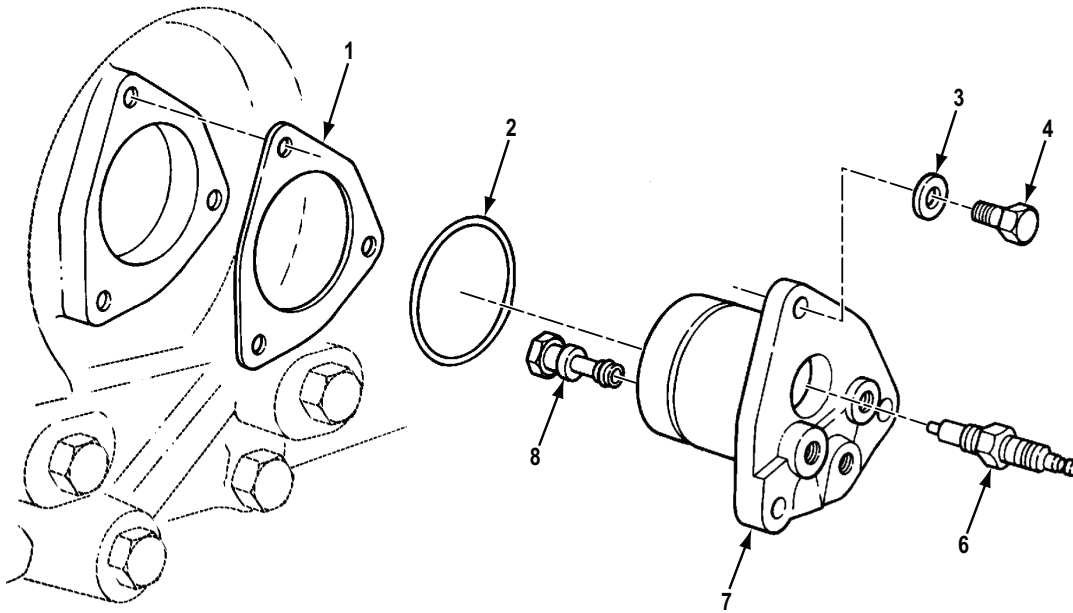

R054

Figure 50. Air Box Heater.

(1) ITEM NO.	(2) SMR CODE	(3) NSN	(4) CAGEC	(5) PART NUMBER	(6) DESCRIPTION AND USABLE ON CODE (UOC)	(7) QTY
GROUP 0311 AIR BOX HEATER						
FIG. 50. AIR BOX HEATER.						
1	KFFZZ	5330-00-689-8265	72582	5109496	GASKET PART OF KIT P/N 8928522, PART OF KIT P/N 8927743 UOC: A6V,C6V,D6V,F6V	1
2	KFFZZ	5331-00-403-0024	72582	5109517	O-RING PART OF KIT P/N 8928522, PART OF KIT P/N 8927743 UOC: A6V,C6V,D6V,F6V	1
3	KFFZZ	5310-00-737-5429	02978	520275	WASHER,FLAT PART OF KIT P/N 8928522, PART OF KIT P/N 8927743 UOC: A6V,C6V,D6V,F6V	2
4	PAFZZ	5306-00-226-4826	72582	186625	BOLT,MACHINE 5/16-18UNC-2AX7/8 GR8 UOC: A6V,C6V,D6V,F6V	2
5	PAFZZ	2910-00-169-2829	72582	5144367	HEATER ASSEMBLY UOC: A6V,C6V,D6V,F6V	1
6	PAFZZ	4520-00-164-1323	72582	5611416	. IGNITER,SPARK,FUEL UOC: A6V,C6V,D6V,F6V	1
7	PAFZZ	2815-00-462-3715	72582	5144325	. BODY,AIR HEATER UOC: A6V,C6V,D6V,F6V	1
8	PAFZZ	2910-00-423-0941	72582	5232650	. NOZZLE,FUEL INJECTI UOC: A6V,C6V,D6V,F6V	1

END OF FIGURE

**FIELD MAINTENANCE
AIR PUMP AND IGNITION COIL ASSEMBLY**

1
2 THRU 8

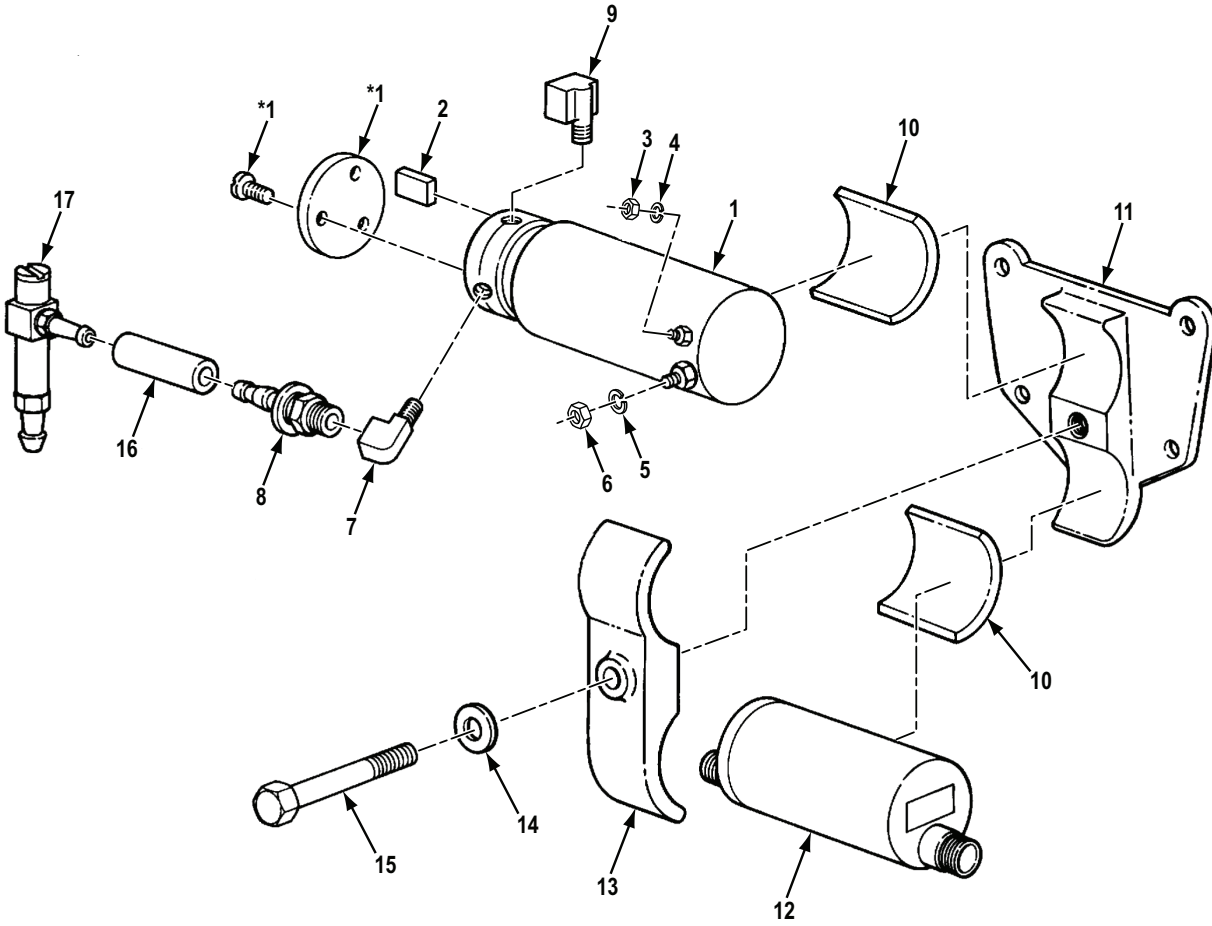

*1 PART OF ITEM 1

R055

Figure 51. Air Pump and Ignition Coil Assembly.

(1) ITEM NO.	(2) SMR CODE	(3) NSN	(4) CAGEC	(5) PART NUMBER	(6) DESCRIPTION AND USABLE ON CODE (UOC)	(7) QTY
GROUP 0311 AIR PUMP AND IGNITION COIL ASSEMBLY						
FIG. 51. AIR PUMP AND IGNITION COIL ASSEMBLY.						
1	PAFZZ	2910-00-103-4550	72582	5142748	PUMP,FUEL,ELECTRICA UOC: A6V,C6V,D6V,F6V	1
2	PAFZZ	2540-01-105-3037	72582	8921167	. VANE SET UOC: A6V,C6V,D6V,F6V	1
3	PAFZZ	5310-00-934-9757	80205	MS35649-282	. NUT,PLAIN,HEXAGON UOC: A6V,C6V,D6V,F6V	2
4	PAFZZ	5310-00-045-3299	80205	MS35338-42	. WASHER,LOCK UOC: A6V,C6V,D6V,F6V	1
5	PAFZZ	5310-00-045-3296	80205	MS35338-43	. WASHER,LOCK UOC: A6V,C6V,D6V,F6V	1
6	PAFZZ	5310-00-852-8593	96906	MS35649-103	. NUT,PLAIN,HEXAGON UOC: A6V,C6V,D6V,F6V	2
7	PAFZZ	4730-00-640-1051	12204	137422	. ELBOW,PIPE TO TUBE UOC: A6V,C6V,D6V,F6V	1
8	PAFZZ	4730-00-446-2584	01276	4740-5-4B	. ADAPTER,STRAIGHT,TU UOC: A6V,C6V,D6V,F6V	1
9	PAFZZ	4730-01-157-6224	72582	8924161	ELBOW,HOSE UOC: A6V,F6V	1
9	PAFZZ	4730-00-277-8274	72582	137423	ELBOW,PIPE TO TUBE UOC: C6V	1
10	PAFZZ	2590-01-016-0429	72582	5145223	PAD,CUSHIONING UOC: A6V,C6V,D6V,F6V	2
11	PAFZZ	2590-01-016-0430	72582	5145427	BRACKET,VEHICULAR C UOC: A6V,C6V,D6V,F6V	1
12	PAFZZ	2920-00-770-1641	OAFL4	305001	IGNITION UNIT, MANIF UOC: C6V,D6V	1
13	PAFZZ	5340-01-016-0431	72582	5145428	BRACKET,ANGLE UOC: A6V,C6V,D6V,F6V	1
14	PAFZZ	5310-00-809-4061	96906	MS27183-15	WASHER,FLAT UOC: A6V,C6V,D6V,F6V	1
15	PAFZZ	5306-01-015-5413	72582	5148932	BOLT 7/16-14UNC-2AX3-3/4 GR5 UOC: A6V,C6V,D6V,F6V	1
16	MFFZZ	4720-00-847-1710	72582	5145666	HOSE,NONMETALLIC 2.00 IN. LG,MAKE FROM HOSE,P/N 1525-4,AIR PUMP TO CHECK VALVE UOC: A6V,C6V,F6V	1
16	MFFZZ		81349	M6000-A	HOSE CHECK VALVE 10.50 IN. LG,MAKE FROMHOSE, P/N 1525-4, AIR PUMP TO CHECK VALVE UOC: D6V	1

(1) ITEM NO.	(2) SMR CODE	(3) NSN	(4) CAGEC	(5) PART NUMBER	(6) DESCRIPTION AND USABLE ON CODE (UOC)	(7) QTY
17	PAFZZ	4820-00-152-6195	72582	5145461	VALVE,CHECK UOC: A6V,C6V,D6V,F6V	1

END OF FIGURE

**FIELD MAINTENANCE
THERMOSTAT, HOUSING, LINES, AND FITTINGS (MODELS 5063-5299 AND 5063-5392)**

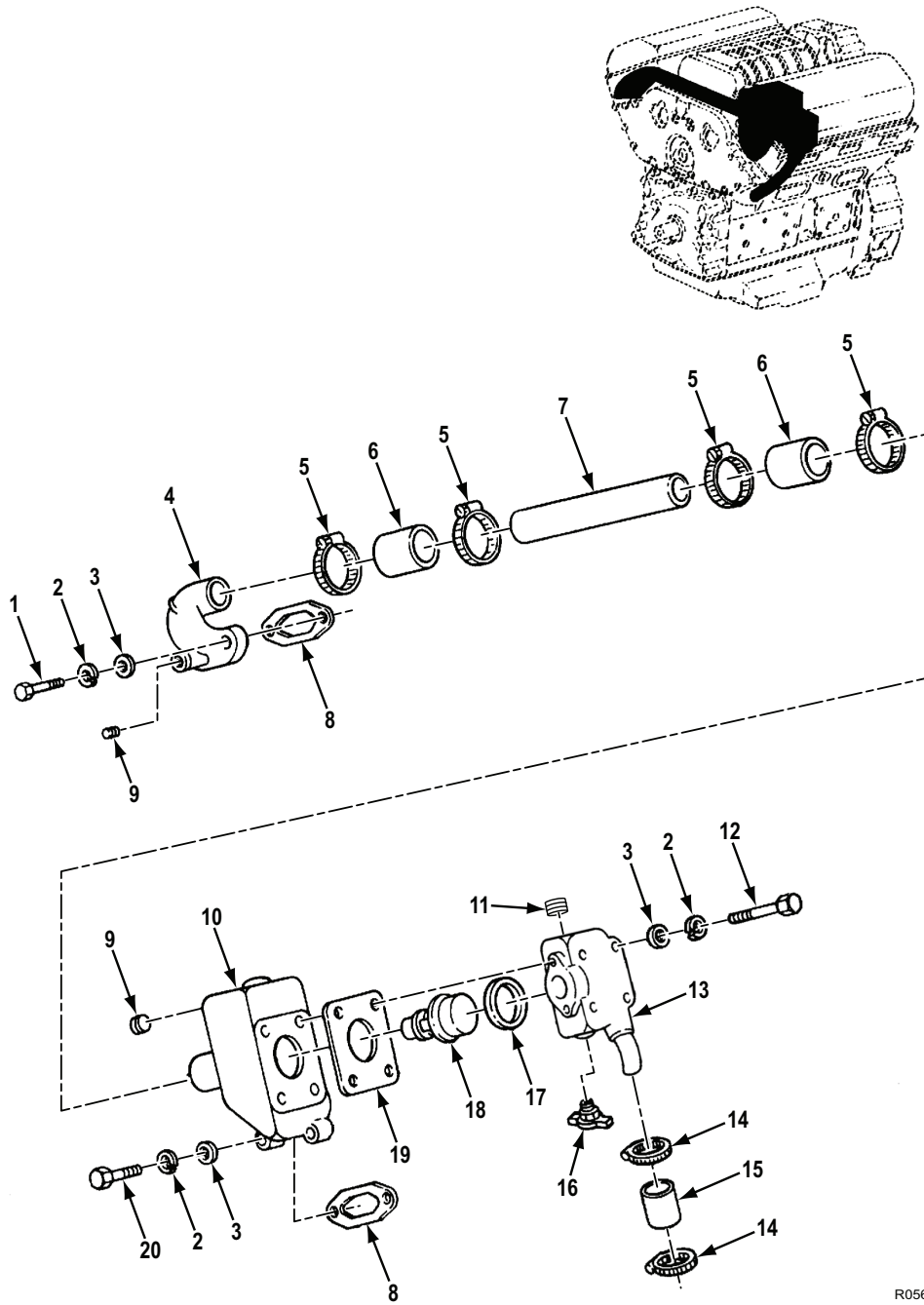

R056

Figure 52. Thermostat, Housing, Lines, and Fittings (Models 5063-5299 and 5063-5392).

(1) ITEM NO.	(2) SMR CODE	(3) NSN	(4) CAGEC	(5) PART NUMBER	(6) DESCRIPTION AND USABLE ON CODE (UOC)	(7) QTY
GROUP 0503 THERMOSTAT, HOUSING, LINES, AND FITTINGS (MODELS 5063-5299 and 5063-5392)						
FIG. 52. THERMOSTAT, HOUSING, LINES, AND FITTINGS (MODELS 5063-5299 AND 5063-5392).						
1	PAFZZ	5305-00-821-3869	80204	B1821BH038C175N	SCREW,CAP,HEXAGON H UOC: A6V,C6V,F6V	2
2	PAFZZ	5310-00-637-9541	59556	019-00004-42	WASHER,LOCK UOC: A6V,C6V,F6V	8
3	PAFZZ	5310-00-080-6004	96906	MS27183-14	WASHER,FLAT UOC: A6V,C6V,F6V	8
4	PBFZZ	4730-00-470-1791	72582	5109549	ELBOW,FLANGE TO HOS UOC: A6V,C6V,F6V	1
5	PAFZZ	4730-01-125-9989	72582	23505048	CLAMP,HOSE UOC: A6V,C6V,F6V	4
6	MFFZZ		72582	8921827	HOSE,NONMETALLIC 2.0 IN. LG,MAKE FROM HOSE,P/N 7F0368 WATER CROSSOVER TUBE UOC: A6V,C6V,F6V	2
7	PBFZZ	2930-00-909-5950	72582	5109680	TUBE,METAL PREFORME UOC: A6V,C6V,F6V	1
8	KFFZZ	5330-00-055-1584	72582	5116242	GASKET PART OF KIT P/N 5199811, PART OF KIT P/N 8928522, PART OF KIT P/N 8927743 UOC: A6V,C6V,F6V	2
9	PAFZZ	4730-01-210-4252	72582	5146648	PLUG,PIPE UOC: A6V,C6V,F6V	2
10	PBFZZ	2930-01-249-6859	72582	23501592	WATER OUTLET,ENGINE UOC: A6V,C6V,F6V	1
11	PAFZZ	4730-00-010-3885	72582	8924517	PLUG,PIPE UOC: A6V,C6V,F6V	1
12	PAFZZ	5305-00-990-8632	80204	B1821BH038C375N	SCREW,CAP,HEXAGON H 3/8-16UNC-2AX3-3/4 GR8 UOC: A6V,C6V,F6V	4
13	PAFZZ	2930-00-152-9855	72582	5135713	COVER ASSEMBLY UOC: A6V,C6V,F6V	1
14	KFFZZ	4730-00-289-3141	11083	1K6717	CLAMP,HOSE PART OF KIT P/N 5198043 UOC: A6V,C6V,F6V	2
15	PAFZZ	4720-01-056-0097	72582	5104839	HOSE,PREFORMED UOC: A6V,C6V,F6V	1
16	PAFZZ	4820-01-442-8109	72582	8926978	COCK,DRAIN UOC: A6V,C6V,F6V	1
17	KFFZZ	5330-00-246-6380	11083	3S9643	SEAL,PLAIN ENCASED PART OF KIT P/N 8928522 UOC: A6V,C6V,F6V	1

(1) ITEM NO.	(2) SMR CODE	(3) NSN	(4) CAGEC	(5) PART NUMBER	(6) DESCRIPTION AND USABLE ON CODE (UOC)	(7) QTY
18	PAFZZ	6620-01-339-1227	72582	23503825	THERMOSTAT, FLOW CON UOC: C6V	1
18	PAFZZ	6685 -01-334-8995	72582	23503828	THERMOSTAT, FLOW CON UOC: A6V, F6V	1
19	KFFZZ	5330-00-781-7117	72582	5117786	GASKET PART OF KIT P/N 8928522, PART OF KIT P/N 8927743 UOC: A6V, C6V, F6V	1
20	PAFZZ	5305-00-638-8920	05047	AES01C375B25AW9 A91	SCREW, CAP, HEXAGON H UOC: A6V, C6V, F6V	2

END OF FIGURE

**FIELD MAINTENANCE
THERMOSTAT, HOUSING, LINES, AND FITTINGS (MODELS 5063-5393 AND 5063-539L)**

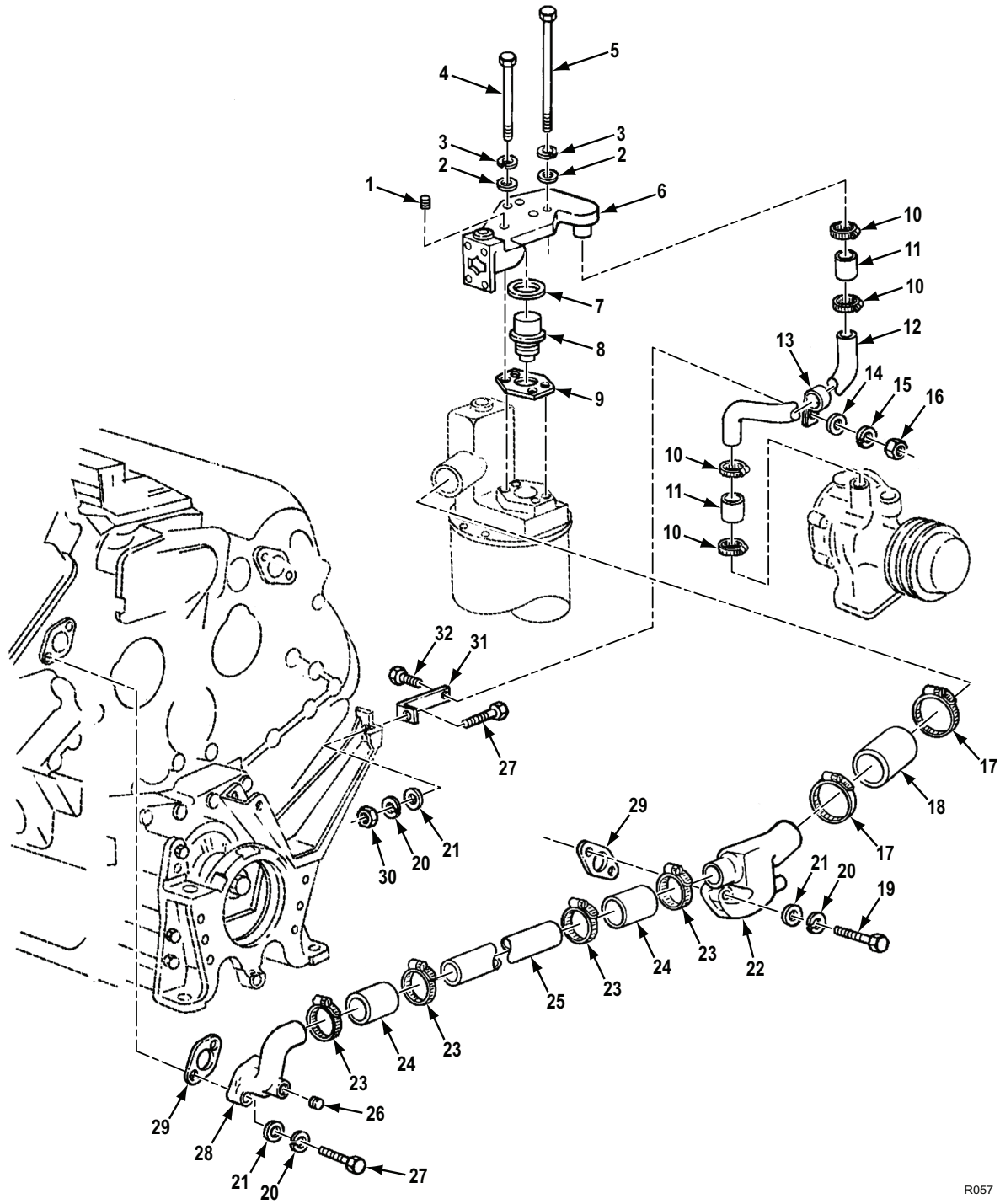

R057

Figure 53. Thermostat, Housing, Lines, and Fittings (Models 5063-5393 and 5063-539L).

(1) ITEM NO.	(2) SMR CODE	(3) NSN	(4) CAGEC	(5) PART NUMBER	(6) DESCRIPTION AND USABLE ON CODE (UOC)	(7) QTY
<p>GROUP 0503 THERMOSTAT, HOUSING, LINES, AND FITTINGS (MODELS 5063-5393 AND 5063-539L)</p> <p>FIG. 53. THERMOSTAT, HOUSING, LINES, AND FITTINGS (MODELS 5063-5393 AND 5063-539L).</p>						
1	PAFZZ	4730-00-010-3885	72582	8924517	PLUG,PIPE UOC: D6V,L6V	1
2	PAFZZ	5310-00-081-4219	96906	MS27183-12	WASHER,FLAT UOC: D6V,L6V	4
3	PAFZZ	5310-00-407-9566	80205	MS35338-45	WASHER,LOCK UOC: D6V,L6V	4
4	PAFZZ	5306-00-226-4839	80204	B1821BH031C350N	BOLT,MACHINE UOC: D6V,L6V	2
5	PAFZZ	5306-01-039-9601	72582	215386	BOLT UOC: D6V,L6V	2
6	PAFZZ	2930-01-251-0656	72582	8928771	WATER OUTLET,ENGINE UOC: D6V,L6V	1
7	KFFZZ	5330-00-246-6380	11083	3S9643	SEAL,PLAIN ENCASED PART OF KIT P/N 8928522 UOC: D6V,L6V	1
8	PAFZZ	6620-01-339-1227	72582	23503825	THERMOSTAT,FLOW CON UOC: D6V,L6V	1
9	PAFZZ	5330-01-254-1389	72582	8928720	GASKET UOC: D6V,L6V	1
10	PAFZZ	4730-00-289-3141	11083	1K6717	CLAMP,HOSE UOC: D6V,L6V	4
11	PAFZZ	4720-01-056-0097	72582	5104839	HOSE,PREFORMED UOC: D6V,L6V	2
12	PAFZZ	4710-01-251-3074	72582	8928768	TUBE,BENT,METALLIC UOC: D6V,L6V	1
13	PAFZZ	5340-00-125-3204	72582	5181415	CLAMP,LOOP UOC: D6V,L6V	1
14	PAFZZ	5310-00-809-4061	96906	MS27183-15	WASHER,FLAT UOC: D6V,L6V	1
15	PAFZZ	5310-00-209-0965	80205	MS35338-47	WASHER,LOCK UOC: D6V,L6V	1
16	PAFZZ	5310-00-880-8189	96906	MS51967-11	NUT,PLAIN,HEXAGON UOC: D6V,L6V	1
17	PAFZZ	4730-00-908-6292	58536	A-A-52506-F-48	CLAMP,HOSE UOC: D6V,L6V	2
18	MFFZZ		59556	019-00001-95	HOSE 2.26 IN. LG,MAKE FROMHOSE,P/ N 5199782, THERMOSTAT HSG UOC: D6V,L6V	1

(1) ITEM NO.	(2) SMR CODE	(3) NSN	(4) CAGEC	(5) PART NUMBER	(6) DESCRIPTION AND USABLE ON CODE (UOC)	(7) QTY
19	PAFZZ	5305-00-638-8920	05047	AES01C375B25AW9 A91	SCREW,CAP,HEXAGON H UOC: D6V,L6V	2
20	PAFZZ	5310-00-637-9541	59556	019-00004-42	WASHER,LOCK UOC: D6V,L6V	5
21	PAFZZ	5310-00-637-9511	59556	019-00004-42	WASHER,FLAT UOC: D6V,L6V	5
22	PBFZZ	2930-01-251-1100	72582	8928721	WATER OUTLET,ENGINE UOC: D6V,L6V	1
23	PAFZZ	4730-01-125-9989	72582	23505048	CLAMP,HOSE UOC: D6V,L6V	4
24	MFFZZ		72582	8921827	HOSE,NONMETALLIC 2.00 IN. LG,MAKE FROM HOSE,P/N 7F0368,WATER CROSSOVER TUBE UOC: D6V,L6V	2
25	PBFZZ	2930-00-909-5950	72582	5109680	TUBE,METAL PREFORME UOC: D6V,L6V	1
26	PAFZZ	4730-01-210-4252	72582	5146648	PLUG,PIPE UOC: D6V,L6V	1
27	PAFZZ	5305-00-821-3869	80204	B1821BH038C175N	SCREW,CAP,HEXAGON H UOC: D6V,L6V	3
28	PBFZZ	4730-00-470-1791	72582	5109549	ELBOW,FLANGE TO HOS UOC: D6V,L6V	1
29	KFFZZ	5330-00-055-1584	72582	5116242	GASKET PART OF KIT P/N 5199811, PART OF KIT P/N 8928522 UOC: D6V,L6V	2
30	PAFZZ	5310-00-732-0558	96906	MS51967-8	NUT,PLAIN,HEXAGON UOC: D6V,L6V	1
31	PBFZZ	5342-01-251-1103	72582	8928767	BRACKET,ENGINE ACCE UOC: D6V,L6V	1
32	PAFZZ	5305-00-071-1786	80204	B1821BH044C100N	SCREW,CAP,HEXAGON H UOC: D6V,L6V	1

END OF FIGURE

**FIELD MAINTENANCE
COOLANT PUMP ASSEMBLY, IDLER PULLEY, AND BELT SET**

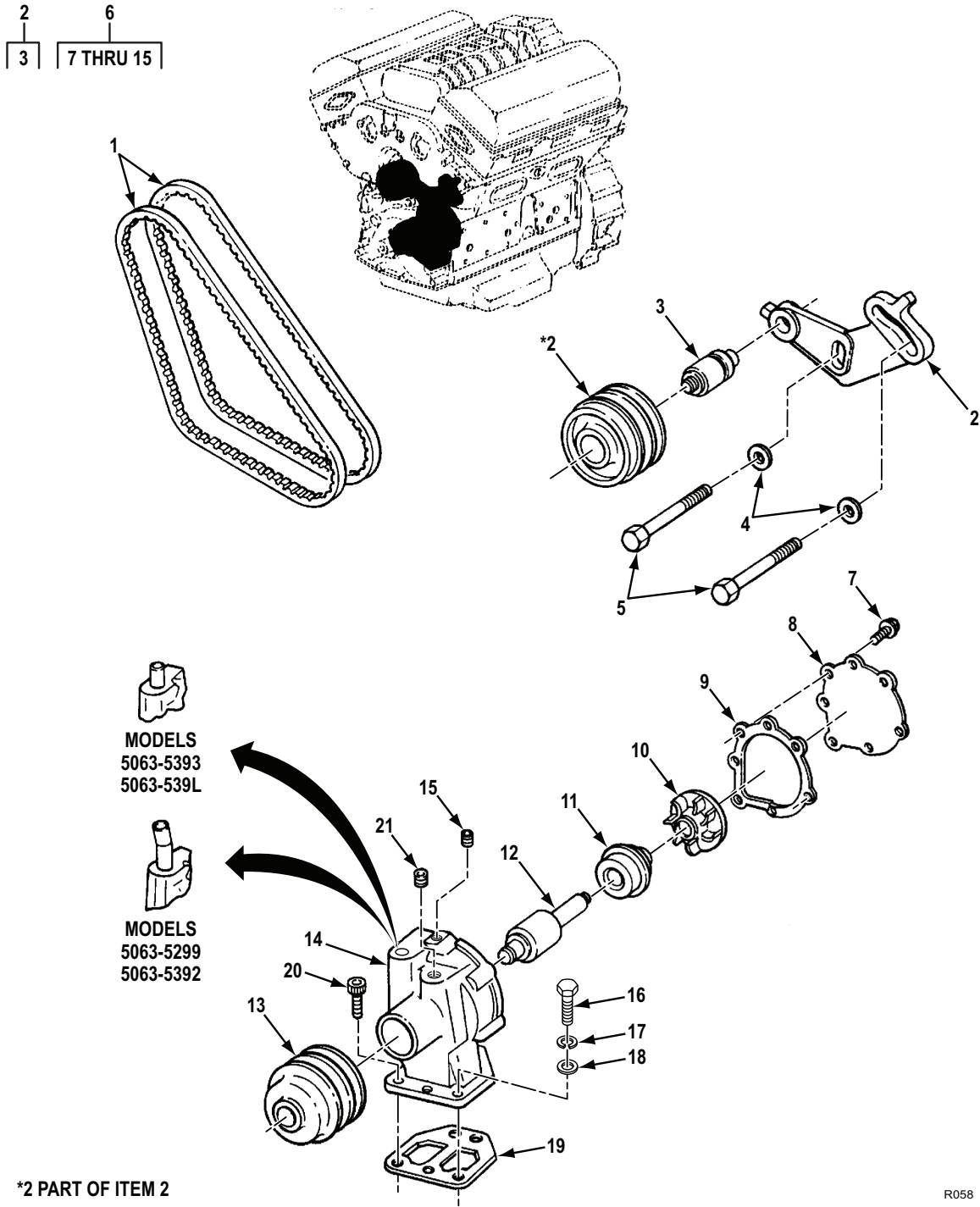

Figure 54. Coolant Pump Assembly, Idler Pulley, and Belt Set.

(1) ITEM NO.	(2) SMR CODE	(3) NSN	(4) CAGEC	(5) PART NUMBER	(6) DESCRIPTION AND USABLE ON CODE (UOC)	(7) QTY
GROUP 0504 COOLANT PUMP ASSEMBLY, IDLER PULLEY, AND BELT SET						
FIG. 54. COOLANT PUMP ASSEMBLY, IDLER PULLEY, AND BELT SET.						
1	PAFZZ	3030-01-301-8013	58536	A-A-52155-1P37B2R	BELTS,V,MATCHED SET NONARTIC.....	1
1	PAFZZ	3030-00-537-1531	96906	MS51065RP37-2	BELTS,V,MATCHED SET ARTIC	1
2	PAFZZ	3020-00-034-1874	72582	5139237	PULLEY ASSEMBLY,IDL.....	1
3	PAHZZ	3120-00-422-3968	72582	0907394	. BEARING,SLEEVE.....	1
4	PAFZZ	5310-00-080-6004	96906	MS27183-14	WASHER,FLAT.....	2
5	PAFZZ	5305-00-152-6326	80204	B1821BH038C275D	SCREW,CAP,HEXAGON H.....	2
6	PAFHH	2930-01-248-9579	72582	8928803	PUMP,COOLING SYSTEM UOC: D6V,L6V	1
6	PAFFF	2930-01-354-2064	72582	23506011	PUMP,COOLING SYSTEM UOC: A6V,C6V,F6V	1
7	PAHZZ	5306-01-188-0689	72582	5104293	. BOLT,MACHINE 5/16-18UNC-2AX3/4 GR5.1.....	7
8	PAHZZ	5340-00-880-0446	72582	5119283	. COVER,ACCESS.....	1
9	KFHZZ		72582	5119282 NON- ASBESTOS	. GASKET WATER PUMP COVER PART OF KIT P/N 23506869.....	1
10	KFHZZ	4320-00-240-2038	72582	5113800	. IMPELLER,PUMP,CENTR PART OF KIT P/N 23506869.....	1
11	KFHZZ	5330-00-866-9403	72582	8924297	. SEAL,WATERPUMP PART OF KIT P/N 23506869.....	1
12	KFHZZ	3110-00-792-8990	43334	885804X1C	. BEARING,FAN AND WAT PART OF KIT P/N 23506869.....	1
13	PAHZZ	3020-00-230-0066	72582	5144503	. PULLEY,GROOVE.....	1
14	PAHZZ	4320-01-251-0651	72582	8928769	. HOUSING,LIQUID PUMP UOC: D6V,L6V	1
14	PAFHH	2930-00-127-2517	72582	5104391	. HOUSING,COOLANT PUM UOC: A6V,C6V,F6V	1
15	PAHZZ	4730-00-371-5337	72582	08924380	. PLUG,PIPE.....	1
16	PAFZZ	5305-00-990-8632	80204	B1821BH038C375N	SCREW,CAP,HEXAGON H 3/8-16UNC-2AX3-3/4 GR8 UOC: A6V,C6V,F6V	4
17	PAFZZ	5310-00-407-9566	80205	MS35338-45	WASHER,LOCK.....	4
18	PAFZZ	5310-00-081-4219	96906	MS27183-12	WASHER,FLAT.....	4
19	KFFZZ	5330-00-235-4885	72582	5133107	GASKET PART OF KIT P/N 8928522, PART OF KIT P/N 23506869, PART OF KIT P/N 8927743.....	1
20	PAFZZ	5305-01-289-9750	80205	NAS1352-5-14P	. SCREW,CAP,SOCKET HE	1

(1) ITEM NO.	(2) SMR CODE	(3) NSN	(4) CAGEC	(5) PART NUMBER	(6) DESCRIPTION AND USABLE ON CODE (UOC)	(7) QTY
21	PAFZZ	4730-01-188-3492	72582	8923313	PLUG,PIPE UOC: C6V,D6V,L6V	1

END OF FIGURE

**FIELD MAINTENANCE
STARTER MOTOR AND MOUNTING HARDWARE**

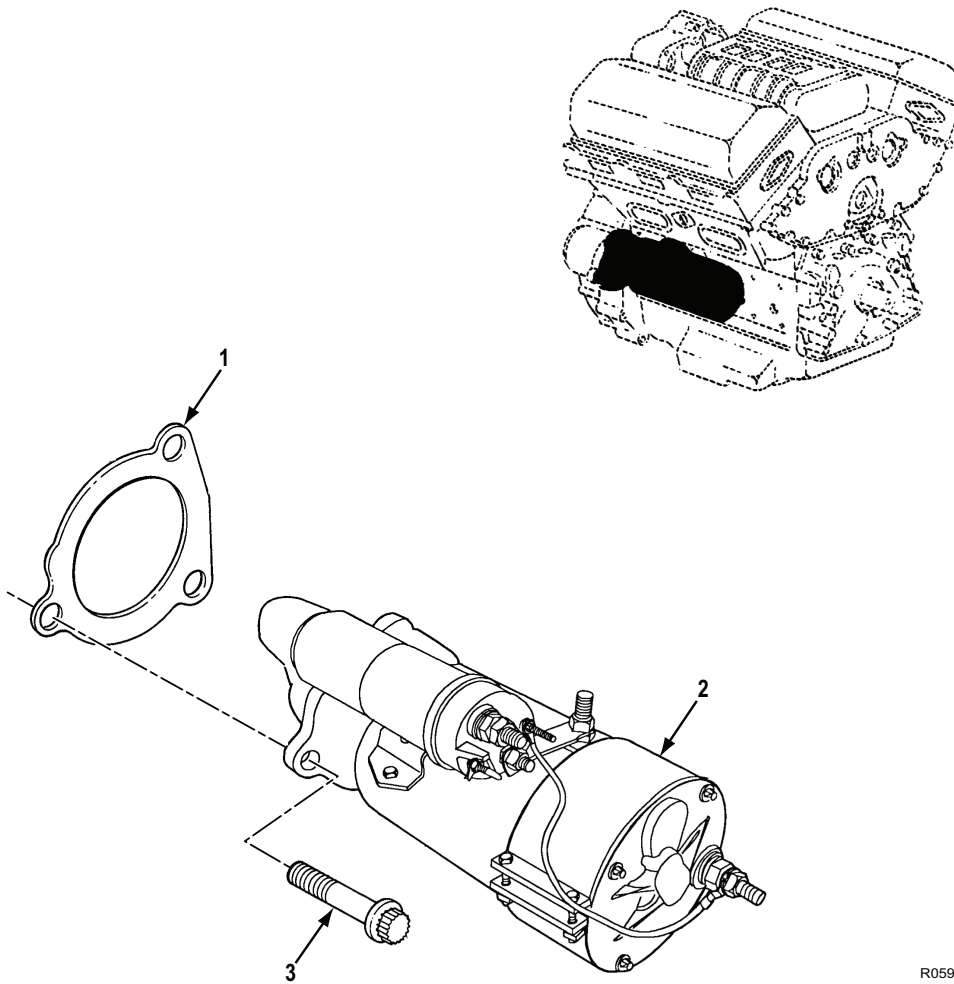
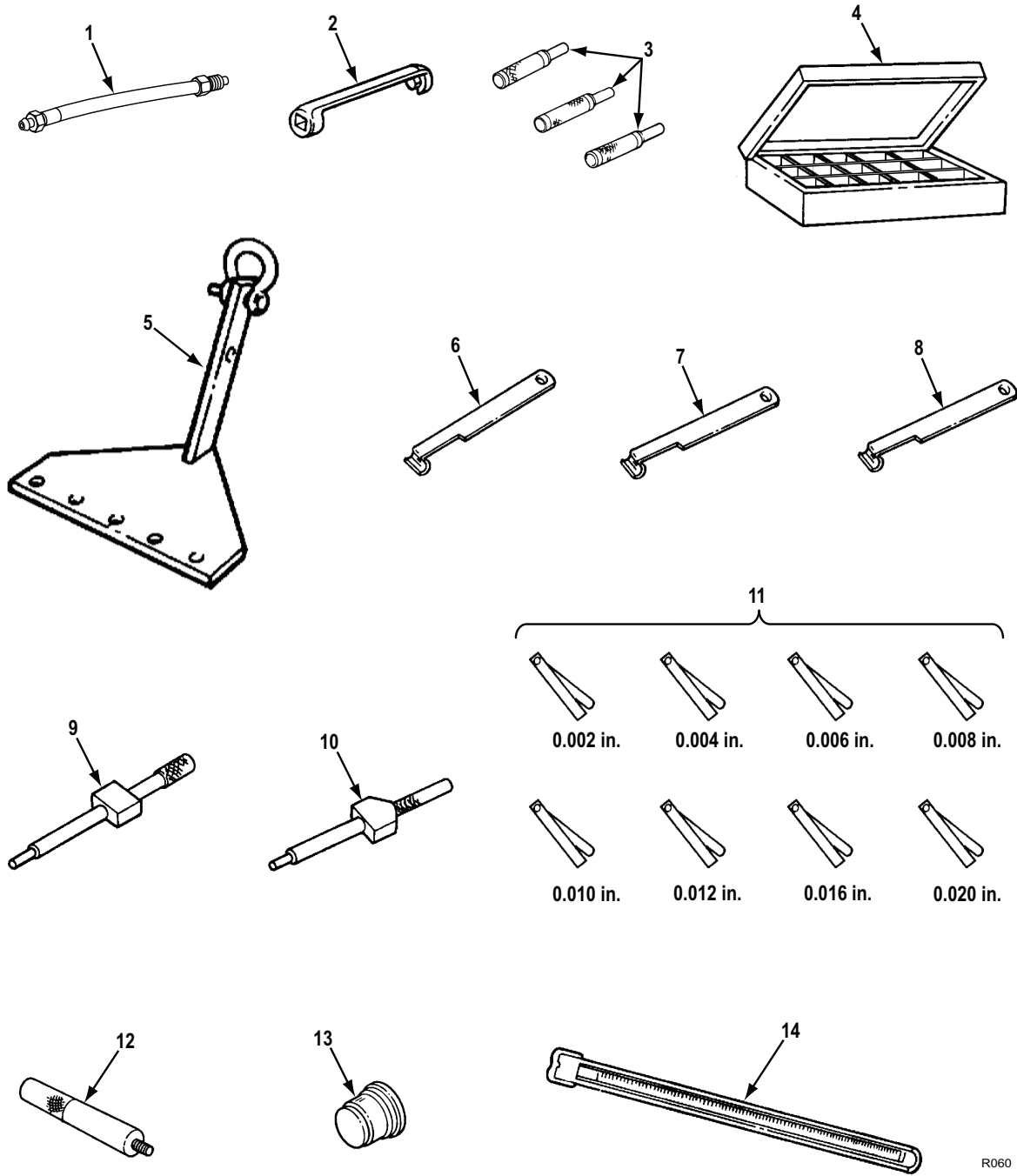

Figure 55. Starter Motor and Mounting Hardware.

(1) ITEM NO.	(2) SMR CODE	(3) NSN	(4) CAGEC	(5) PART NUMBER	(6) DESCRIPTION AND USABLE ON CODE (UOC)	(7) QTY
GROUP 0603 STARTER MOTOR AND MOUNTING HARDWARE						
FIG. 55. STARTER MOTOR AND MOUNTING HARDWARE.						
1	KFFZZ	5330-00-980-1546	72582	5130995	GASKET PART OF KIT P/N 8928522, PART OF KIT P/N 8927743 UOC: C6V,D6V,L6V	1
2	PAFHH	2920-01-187-3636	24975	M001729ME	STARTER,ENGINE,ELEC.....	1
3	PAFZZ	5306-00-064-5356	24617	9418228	BOLT,MACHINE.....	3

END OF FIGURE

**FIELD MAINTENANCE
SPECIAL TOOLS FIELD MAINTENANCE LEVEL (FML)**



R060

Figure 56. Special Tools For Field Maintenance Level (FML). (Sheet 1 of 3)

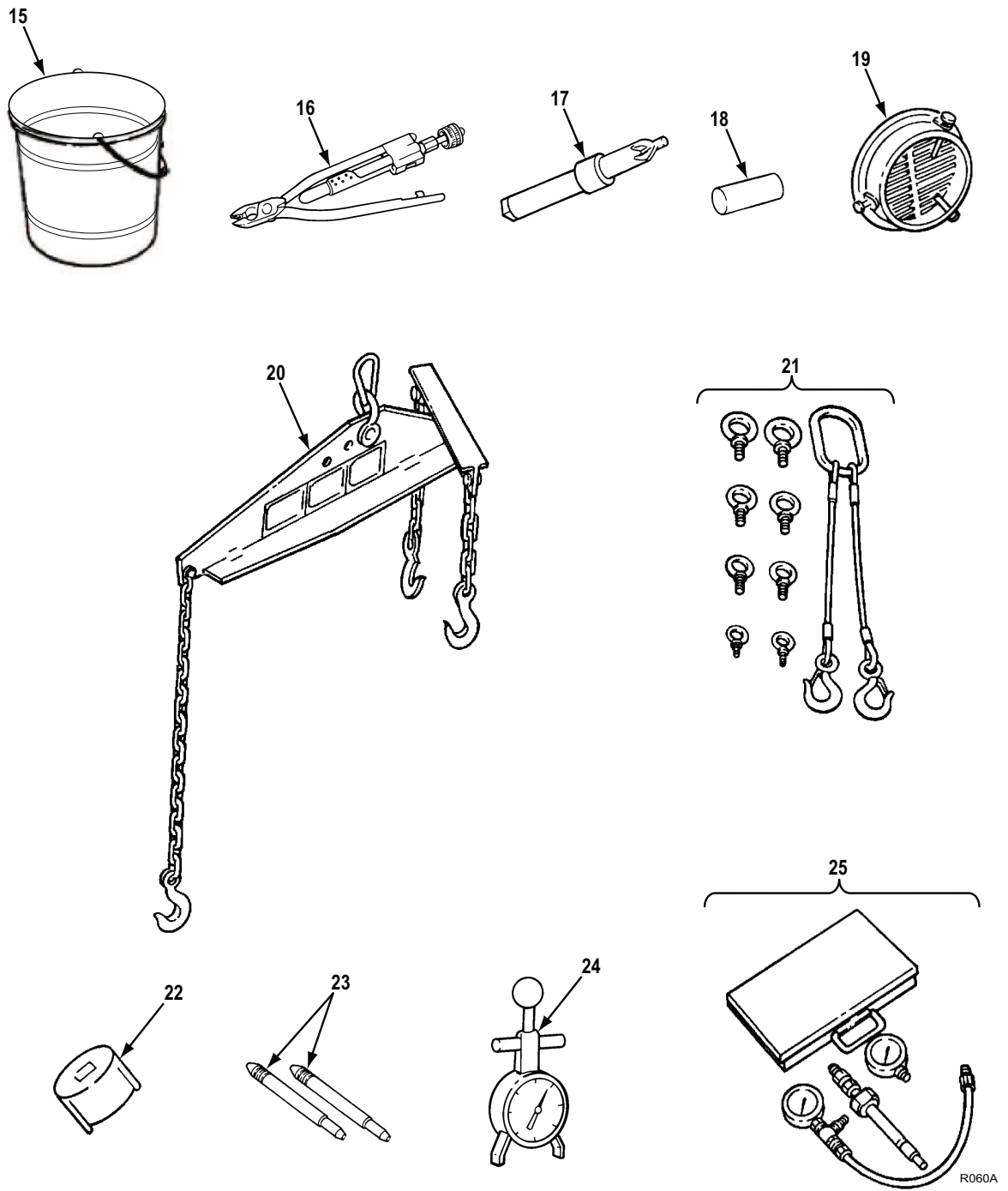
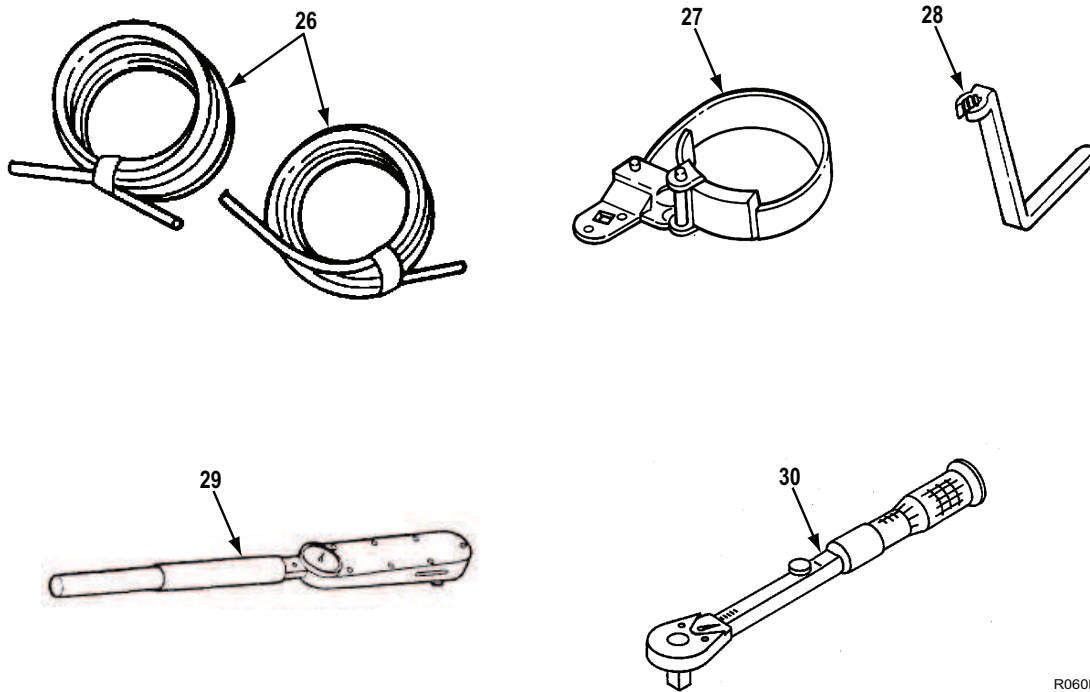

Figure 56. Special Tools For Field Maintenance Level (FML). (Sheet 2 of 3)



R060B

Figure 56. Special Tools For Field Maintenance Level (FML). (Sheet 3 of 3)

(1) ITEM NO.	(2) SMR CODE	(3) NSN	(4) CAGEC	(5) PART NUMBER	(6) DESCRIPTION AND USABLE ON CODE (UOC)	(7) QTY
GROUP 2604 SPECIAL TOOLS FIELD MAINTENANCE LEVEL (FML)						
FIG. 56. SPECIAL TOOLS FOR FIELD MAINTENANCE LEVEL (FML).						
1	PEFZZ	4910-01-240-3101	33287	J7915-3C	ADAPTER,CYLINDER CO.....	1
2	PEFZZ	5120-01-147-7923	19207	10881875	ADAPTER,TORQUE WREN.....	1
3	PEFZZ	5120-00-102-58062	33287	J-23068	ALIGNMENT TOOL SET,.....	1
4	PEFZZ	5340-00-450-5718	19207	10935405	CAP SET,PROTECTIVE,.....	1
5	PEFZZ	4910-00-456-7620	55683	304-J22062-01	FIXTURE,LIFTING,CYL.....	1
6	PEFZZ	5210-01-091-8354	33287	J-24889	GAGE,INJECTOR RACK UOC: C6V,D6V,L6V	1
7	PEFZZ	5210-01-373-9397	33287	J-28479	GAGE,INJECTOR RACK UOC: A6V,F6V	1
8	PEFZZ	5210-00-538-8465	33287	J23190	GAGE,INJECTOR RACK UOC: A6V,F6V	1
9	PEFZZ	5210-00-387-9581	33287	J-1853	GAGE,INJECTOR TIMIN UOC: A6V,F6V	1
10	PEFZZ	5210-01-242-4091	33287	J9595	GAGE,INJECTOR TIMIN UOC: C6V,D6V,L6V	1
11	PEFZZ	5210-01-245-9564	33287	J1698-02	GAGE SET,THICKNESS.....	1
12	PEFZZ	5210-00-977-5578	45152	2KM50	HANDLE,DRIVER (SEA.....	1
13	PEFZZ	5120-00-116-3652	33287	J-22091	INSERTER,SEAL UOC: A6V,D6V,L6V	1
14	PEFZZ	6685-00-857-4895	85274	1211-60	MANOMETER,U-TUBE.....	1
15	PEFZZ	7240-00-160-0455	80244	A-A-1273 TY2	PAIL,UTILITY.....	1
16	PEFZZ	5120-01-112-5031	55719	GA311B	PLIERS,WIRE TWISTER UOC: C6V,D6V,L6V	1
17	PEHZZ	5110-00-294-4606	19207	10881907	REAMER,HAND.....	1
18	PEFZZ	5120-00-363-7572	33287	J-1930	REMOVER,SEAL.....	1
19	PEFZZ	4910-01-127-7959	33287	J26554-A	SHIELD,TURBO PROTEC UOC: C6V,D6V,L6V	1
20	PEFZZ	3940-00-646-6893	19207	10942647	SLING,BEAM TYPE.....	1
21	PEFZZ	3940-00-977-7398	19207	10930560	SLING,MULTIPLE LEG UOC: A6V,C6V,D6V,F6V	1
22	PEFZZ	5120-00-808-5230	33287	J-5895	SOCKET,WRENCH,FACE.....	1
23	PEFZZ	4910-00-591-6634	33287	J9665	STUD,CYLINDER HEAD,.....	1
24	PEFZZ	6635-01-093-3710	33287	6673	TENSIOMETER,DIAL IN.....	1
25	PEFZZ	4910-00-870-6283	19207	10899180	TESTER,CYLINDER COM.....	1
26	PEFZZ	4720-00-271-9839	81349	M6855/4-10L089	TUBING,NONMETALLIC.....	1

(1) ITEM NO.	(2) SMR CODE	(3) NSN	(4) CAGEC	(5) PART NUMBER	(6) DESCRIPTION AND USABLE ON CODE (UOC)	(7) QTY
27	PEFZZ	5120-01-197-6720	55719	YA342C	WRENCH,OIL FILTER UOC: D6V,L6V	1
28	PEFZZ	5120-00-740-3347	19207	10949344	WRENCH,OPEN END BOX.....	1
29	PEFZZ	5120-00-640-6364	05047	B107.300	WRENCH,TORQUE.....	1
30	PEFZZ	5120-01-396-6072	81343	AS28431	WRENCH,TORQUE.....	1

END OF FIGURE

**SUSTAINMENT MAINTENANCE
SPECIAL TOOLS FOR SUSTAINMENT LEVEL MAINTENANCE-BELOW DEPOT (SML-BD)**

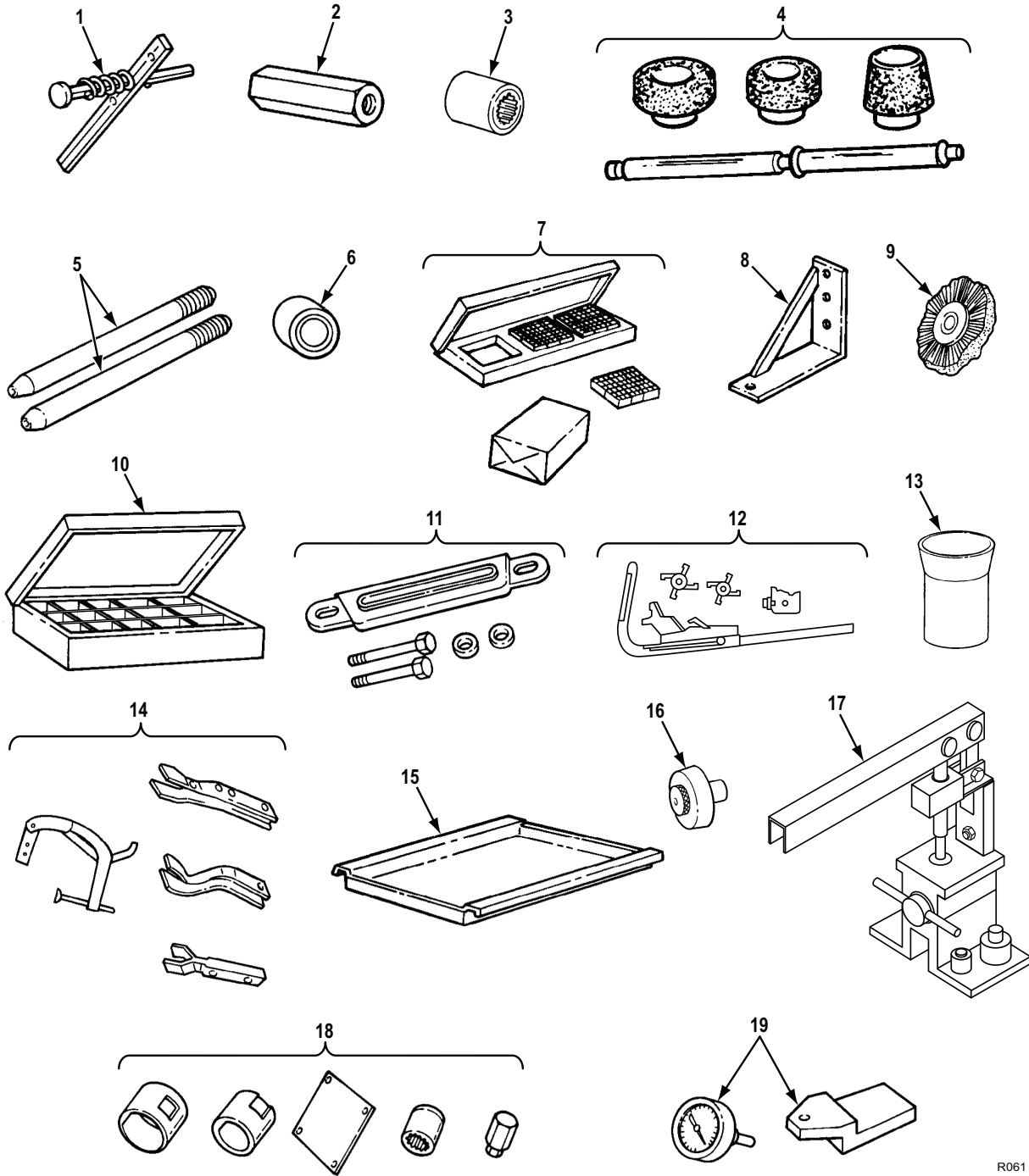

R061

Figure 57. Special Tools For Sustainment Level Maintenance-Below Depot (SML-BD). (Sheet 1 of 5)

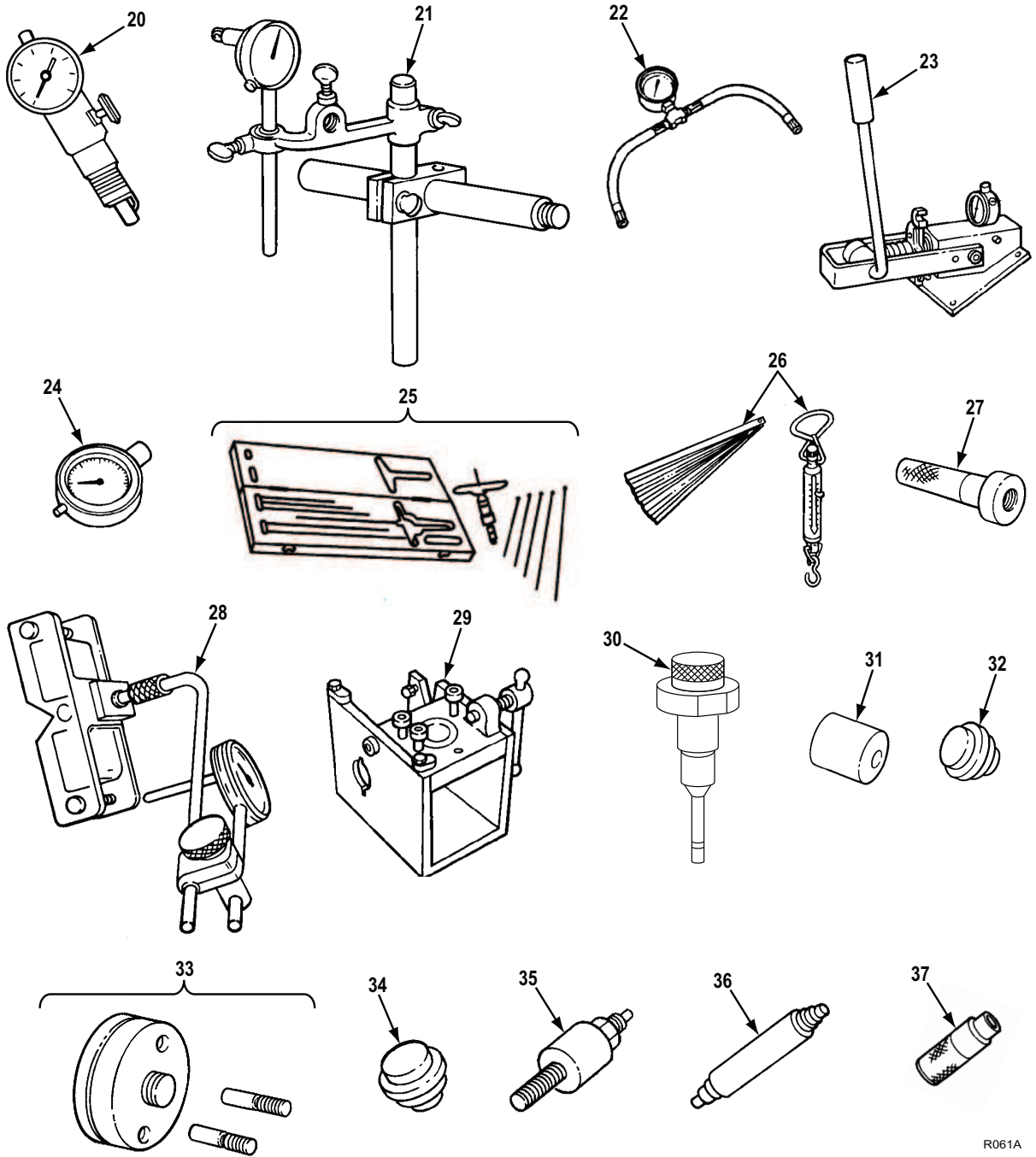

R061A

Figure 57. Special Tools For Sustainment Level Maintenance-Below Depot (SML-BD). (Sheet 2 of 5)

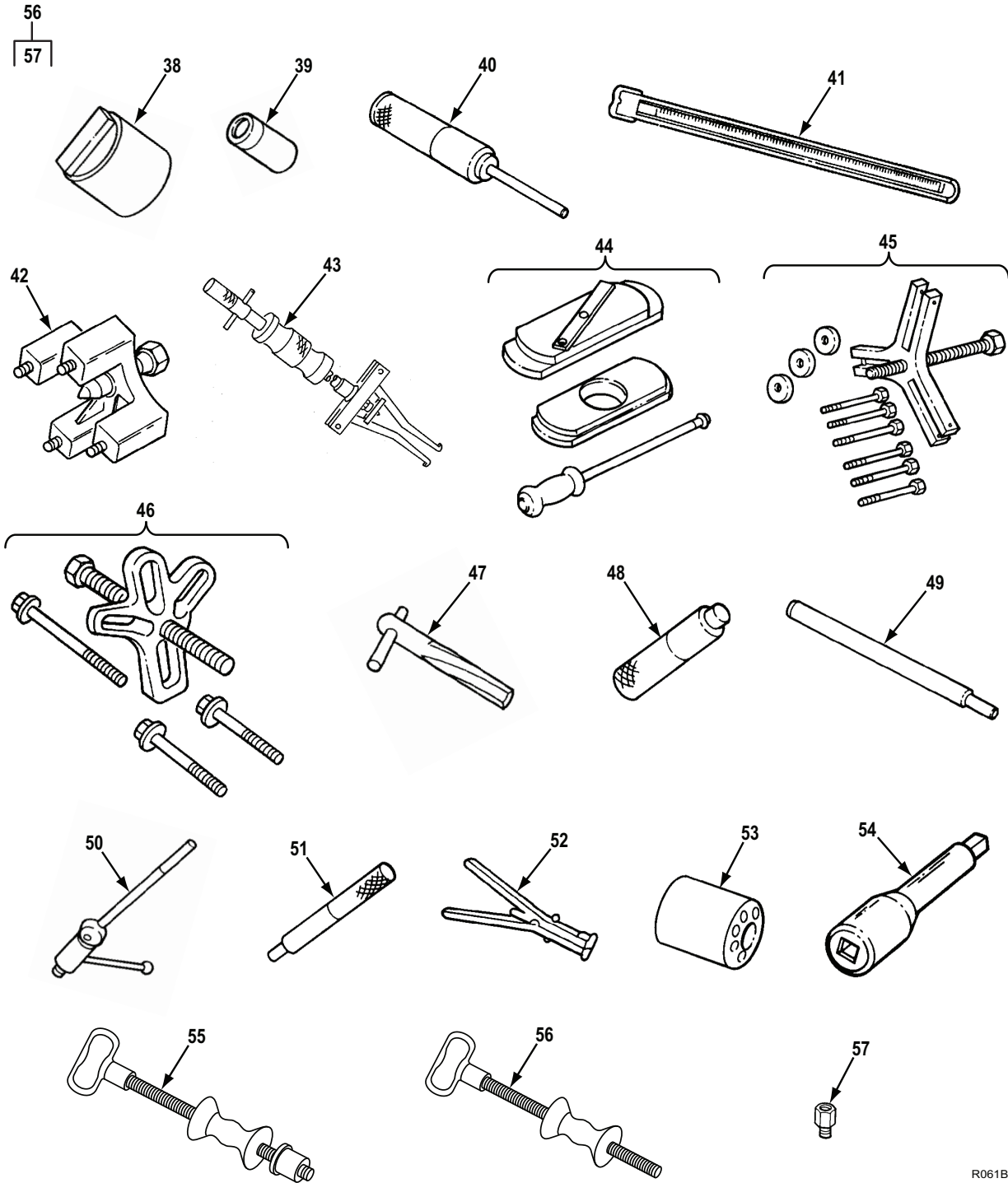

R061B

Figure 57. Special Tools For Sustainment Level Maintenance-Below Depot (SML-BD). (Sheet 3 of 5)

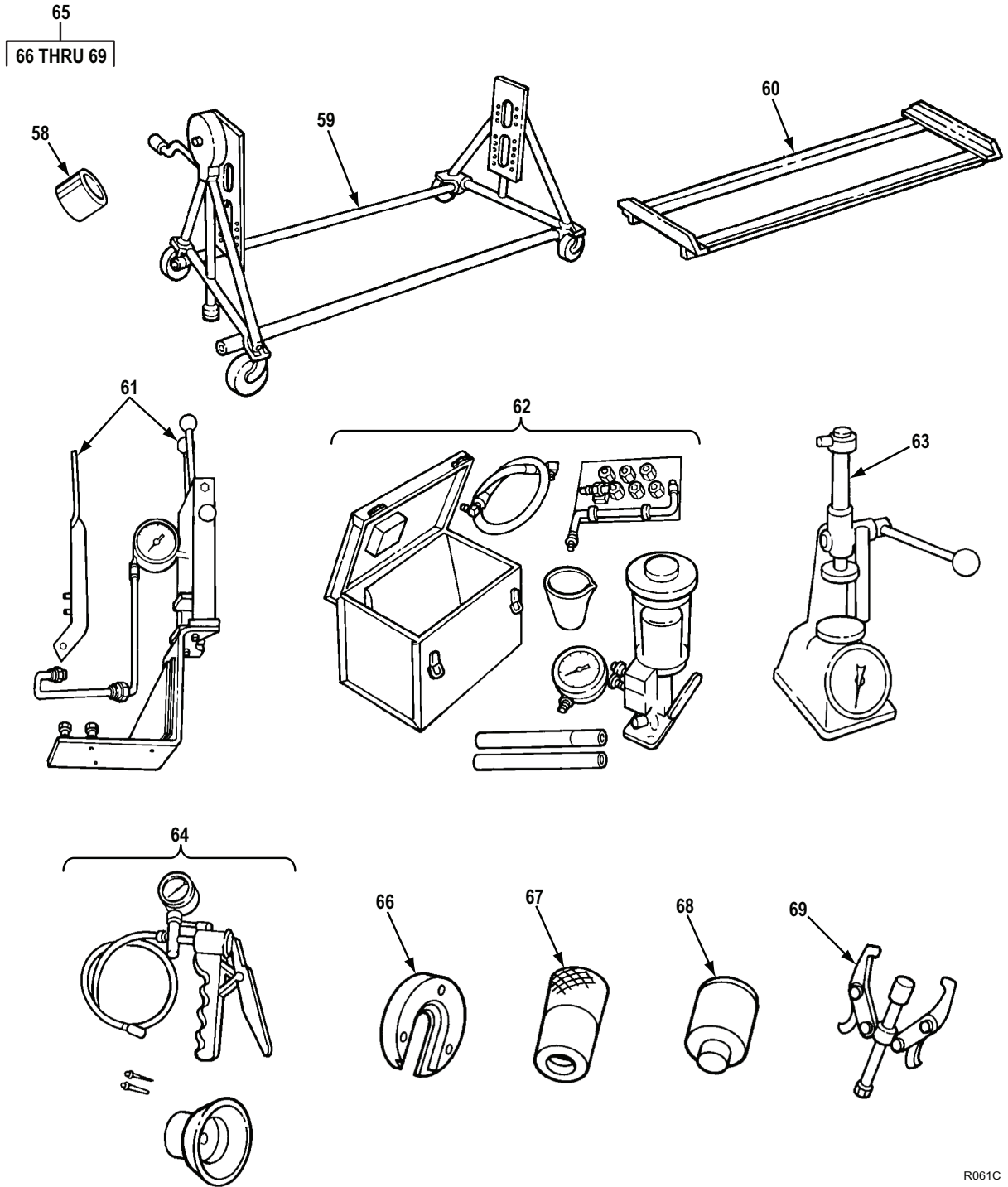

R061C

Figure 57. Special Tools For Sustainment Level Maintenance-Below Depot (SML-BD). (Sheet 4 of 5)

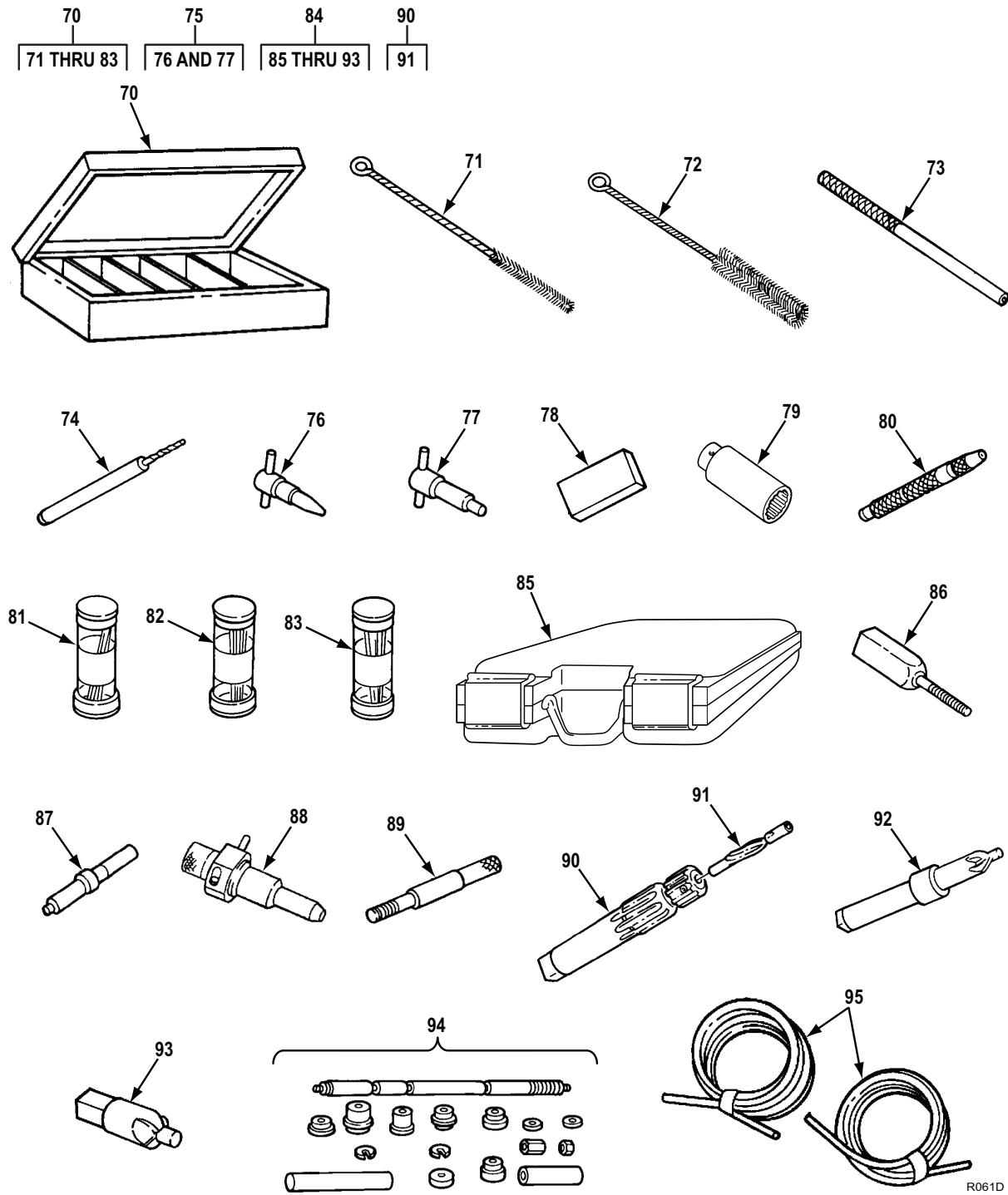

Figure 57. Special Tools For Sustainment Level Maintenance-Below Depot (SML-BD). (Sheet 5 of 5)

(1) ITEM NO.	(2) SMR CODE	(3) NSN	(4) CAGEC	(5) PART NUMBER	(6) DESCRIPTION AND USABLE ON CODE (UOC)	(7) QTY
<p>GROUP 2604 SPECIAL TOOLS FOR SUSTAINMENT LEVEL MAINTENANCE-BELOW DEPOT (SML-BD)</p> <p>FIG. 57. SPECIAL TOOLS FOR SUSTAINMENT LEVEL MAINTENANCE-BELOW DEPOT (SML-BD).</p>						
1	PEHZZ	4910-00-907-0713	33287	J21224	ADAPTER,DIAL INDICA UOC: C6V,D6V,L6V	1
2	PEFZZ	5120-00-127-7831	33287	J-5901-3	ADAPTER,TACHOMETER	1
3	PEHZZ	5120-01-169-5300	56161	10513891	ADAPTER,TORQUE WREN.....	1
4	PEHZZ	4910-00-254-5018	33287	J-7792-01	ADAPTER KIT,VALVE S.....	1
5	PEHZZ	5120-00-872-6015	33287	J7540	ALIGNMENT STUD,FLYW.....	1
6	PEHZZ	5210-00-494-1738	57163	247B	BALL ATTACHMENT,MIC.....	1
7	PEHZZ	3460-00-937-5521	33287	J22090-A	BLOCK SET,LAPPING.....	1
8	PEHZZ	5340-01-006-4589	19207	11678105	BRACKET,ENGINE MOUN.....	1
9	PEHZZ	5130-00-937-7281	33287	J7944	BRUSH,WIRE,ROTARY W.....	1
10	PEFZZ	5340-00-450-5718	19207	10935405	CAP SET,PROTECTIVE.....	1
11	PEHZZ	5120-00-999-8618	80244	5120-999-8618	CLAMP,HOLD DOWN,C.....	1
12	PEFZZ	5120-00-799-3398	33287	J-3936-C	CLEANER,PISTON RING	1
13	PEFZZ	5120-01-406-4702	33287	J-6883-B	COMPRESSOR,PISTON R	1
14	PEHZZ	5120-00-254-5049	33287	J8062	COMPRESSOR,VALVE SP.....	1
15	PEHZZ	4930-00-545-8639	19207	8708359	DRAIN UNIT,WASTE OI.....	1
16	PEHZZ	5120-00-918-0587	33287	J9769	EXPANDER,OIL SEAL.....	1
17	PEFZZ	4910-00-705-9278	33287	J-33421-A	FIXTURE,CAM FOLLOWE	1
18	PEHZZ	4910-01-170-4914	56161	10513844	FIXTURE SET,TURBO UOC: C6V,D6V,L6V	1
19	PEHZZ	5210-00-023-4798	33287	J-22273-A	GAGE,CYLINDER,DEPT.....	1
20	PEHZZ	4910-00-779-7103	00256	9320	GAGE,DIAL,VALVE SEA.....	1
21	PEHZZ	5210-00-937-7284	33287	J-9737-D	GAGE,FLYWHEEL HOUSI.....	1
22	PEFZZ	6620-00-671-4509	33287	J8151	GAGE,FUEL PRESSURE	1
23	PEHZZ	5210-00-990-3327	63704	21178	GAGE,INJECTOR (TIP &.....	1
24	PEHZZ	5210-00-937-7285	33287	J9462-02	GAGE,LIFT (NEEDLE VA.....	1
25	PEFZZ	5120-00-619-4045	1E258	52-225-015	GAGE SET,DEPTH,MICR.....	1
26	PEHZZ	5210-00-116-1631	33287	J-05438-A	GAGE SET,PISTON-LINE.....	1
27	PEHZZ	5120-00-808-5082	33287	J-3154-1A	HANDLE,DRIVER (SEAL.....	1

(1) ITEM NO.	(2) SMR CODE	(3) NSN	(4) CAGEC	(5) PART NUMBER	(6) DESCRIPTION AND USABLE ON CODE (UOC)	(7) QTY
28	PEHZZ	5210-00-402-9619	33287	J7872	INDICATOR,DIAL (W/M.....	1
29	PEHHH	5220-01-061-4248	33287	J22396-1	INJECTOR VISE (FIXT UOC: C6V,D6V,L6V	1
30	PEFZZ	5120-01-248-7737	33287	J5286-20	INSERTER,BEARING &	1
31	PEHZZ	5120-01-242-4092	33287	J35572	INSERTER,PISTON (PI UOC: C6V,D6V,L6V	1
32	PEHZZ	5120-00-936-4377	33287	J9783	INSERTER,SEAL (CRAN.....	1
33	PEHZZ	5120-00-169-5806	33287	J9479	INSERTER,SEAL (CRAN.....	1
34	PEHZZ	5120-00-937-6143	33287	J-9790	INSERTER,SEAL (FRON.....	1
35	PEHZZ	4910-00-779-6392	33287	J7773	INSTALLER,CRANKSHA.....	1
36	PEHZZ	4910-00-779-6078	33287	J21068	INSTALLER,GOVERNOR.....	1
37	PEHZZ	5120-01-166-5167	33287	J24519	INSTALLER,VALVE GUI.....	1
38	PEHZZ	4910-00-736-1371	19207	J7557	INSTALLING TOOL (CR UOC: C6V,D6V	1
39	PEHZZ	4910-00-169-5805	33287	J-08968-A	INSTALLING TOOL,DRIV.....	1
40	PEHZZ	4910-00-603-8925	19207	J7790	INSTALLING TOOL,VAL UOC: C6V,D6V	1
41	PEHZZ	6685-00-857-4895	85274	1211-60	MANOMETER,U-TUBE.....	1
42	PEHZZ	5120-00-219-8397	33287	J-1902-B	PULLER,MECHANICAL	1
43	PEHZZ	5120-00-293-1429	80244	PD5120-00-293-142 9	PULLER,MECHANICAL	1
44	PEHZZ	5120-00-937-6140	33287	J22490	PULLER,MECHANICAL,C.....	1
45	PEHZZ	5120-00-740-3345	33287	J-04871-A	PULLER,MECHANICAL,T.....	1
46	PEHZZ	5180-00-999-4053	33287	J-24420-C	PULLER KIT,UNIVERSA.....	1
47	PEHZZ	5110-00-937-7628	80244	J-21089	REAMER,HAND,INJECT	1
48	PEHZZ	5120-00-808-5078	33287	J- 21967-01	REMOVER,BEARING &.....	1
49	PEHZZ	4910-00-591-6632	33287	J-7775-A	REMOVER,VALVE GUID UOC: C6V,D6V	1
50	PEHZZ	5120-00-591-6631	33287	J-23479-453	REMOVER,VALVE SEAT	1
51	PEHZZ	4910-00-779-7315	33287	J8985	REMOVER & INSTALLER	1
52	PEHZZ	5120-00-494-1846	80244	5120-494-1846	REMOVER & REPLACE (.....	1
53	PEHZZ	5120-00-733-8874	19207	10881874	REPLACER,PISTON PIN UOC: A6V,C6V,F6V	1
54	PEHZZ	5120-01-297-2374	33287	J-34650	SCREWDR ATTCHMT,SC UOC: A6V,D6V,L6V	1
55	PEHZZ	5120-00-910-7868	33287	J-2619-01	SLIDE HAMMER SET	1
56	PEHZZ	5120-00-937-7266	33287	J-6471-02	SLIDE HAMMER SET (.....	1
57	PEHZZ	5120-01-130-8865	45225	8005	. ADAPTER,3/8-16 UNC	1

(1) ITEM NO.	(2) SMR CODE	(3) NSN	(4) CAGEC	(5) PART NUMBER	(6) DESCRIPTION AND USABLE ON CODE (UOC)	(7) QTY
58	PEFZZ	5365-00-779-7308	33287	J8984	SPACER,GOVERNOR WEI.....	1
59	PEHZZ	4910-00-795-0189	23569	7950189	STAND,MAINTENANCE.....	1
60	PEHZZ	4910-00-795-0198	19207	7950198	STAND,SUB-ASSY.,MAI .	1
61	PEHZZ	4910-00-355-6248	92372	65-0251	TEST FIXTURE,DIESEL.....	1
62	PEHZZ	4910-00-255-8641	05008	3YFL	TESTER,DIESEL FUEL.....	1
63	PEHZZ	4940-01-138-8259	33287	J-22738-02	TESTER,SPRING.....	1
64	PEHHH	6685-01-061-4253	33287	J-23987-B	TESTER,VACUUM GAGE.....	1
65	XDHZZ		33287	J23679-A	TOOL KIT,BLOWER & GO.....	1
66	XDFZZ		33287	J-23679-2	. BLOWER SLEEVE REMOV.....	1
67	PEFZZ	5120-01-170-4935	33287	J22576	. INSERTER,SEAL	1
68	PEFZZ	5120-01-493-2921	33287	J-23679-1	. INSTALLER,SLEEVE	1
69	PEFZZ	5120-01-166-5164	33287	J28483	. REMOVER BLOWER GEAR	1
70	PEHZZ	5180-01-038-0251	33287	J23435-C	TOOL KIT,DIESEL INJ.....	1
71	XDHZZ		33287	J-8150	. BRUSH,RACK HOLE.....	1
72	PEHZZ	7920-00-238-1906	55380	3223914	. BRUSH,INJECTOR CLEA.....	1
73	PEHZZ	5120-00-355-6167	33287	J1291-02	. DRIVER,INJECTOR SPR.....	1
74	PEFZZ	5120-01-170-4922	33287	J24838	. REMOVER,CARBON,INJE	1
75	PEHZZ	5110-00-084-0951	33287	J9418	. REMOVER SET,CARBON.....	1
76	PEHZZ	5110-00-937-7629	33287	J-9418-5	. . REMOVER,CARBON,INJE.....	1
77	PEHZZ	5110-00-937-7630	33287	J-9418-1	. . REMOVER,CARBON,INJE.....	1
78	XDHZZ		33287	J-8170	. SHARPENING STONE,IN.....	1
79	PEHZZ	5120-00-219-8409	33287	J-04983A	. SOCKET,SOCKET WRENC.....	1
80	XDHZZ		33287	J4298-1	. VISE,PIN.....	1
81	PEHZZ	5120-00-140-7547	33287	J-21461-A	. WIRE,SPRAY HOLE.....	1
82	PEHZZ	4910-01-163-7894	33287	J21462-A	. WIRE,SPRAY TIP.....	1
83	PEHZZ	4910-01-163-7893	33287	J-21460-A	. WIRE,SPRAY TIP.....	1
84	PEHZZ	5180-00-596-8541	33287	J-22525-B	TOOL KIT,DIESEL INJ.....	1
85	PEHZZ	8115-01-048-1386	33287	J22525-4	. BOX INSTRUCTION ASS.....	1
86	PEHZZ	5120-00-711-1920	19207	10881892	. FLARING TOOL,TUBE,H.....	1
87	PEHZZ	5220-01-167-4281	33287	J-25521	. GAGE,PROFILE.....	1
88	PEHZZ	4940-00-711-1918	19207	10881893	. INSTALLER,BODY,INJE.....	1
89	PEHZZ	4940-00-711-1919	19207	10881896	. INSTALLER,PILOT,INJ.....	1
90	PEHZZ	5110-00-785-1016	19207	10881897	. REAMER,HAND.....	1
91	PEHZZ	5110-01-048-2199	33287	J-22525-3	. . REAMER,HAND.....	1

(1) ITEM NO.	(2) SMR CODE	(3) NSN	(4) CAGEC	(5) PART NUMBER	(6) DESCRIPTION AND USABLE ON CODE (UOC)	(7) QTY
92	PEHZZ	5110-00-294-4606	56161	10514045	. REAMER,HAND (2ND OP	1
93	PEHZZ	5120-00-785-1017	19207	J-5286-8	. TUBE TIP REFINISHER.....	1
94	PEHZZ	5180-01-167-8073	33287	J-7593-03	TOOL KIT,INTERNAL C UOC: C6V,D6V	1
95	PEFZZ	4720-00-271-9839	81349	M6855/4-10L089	TUBING,NONMETALLIC.....	1

END OF FIGURE

**FIELD MAINTENANCE
SHIPPING AND STORAGE CONTAINER ASSEMBLY
(MODELS 5063-5299, 5063-5392, 5063-5393, AND 5063-539L)**

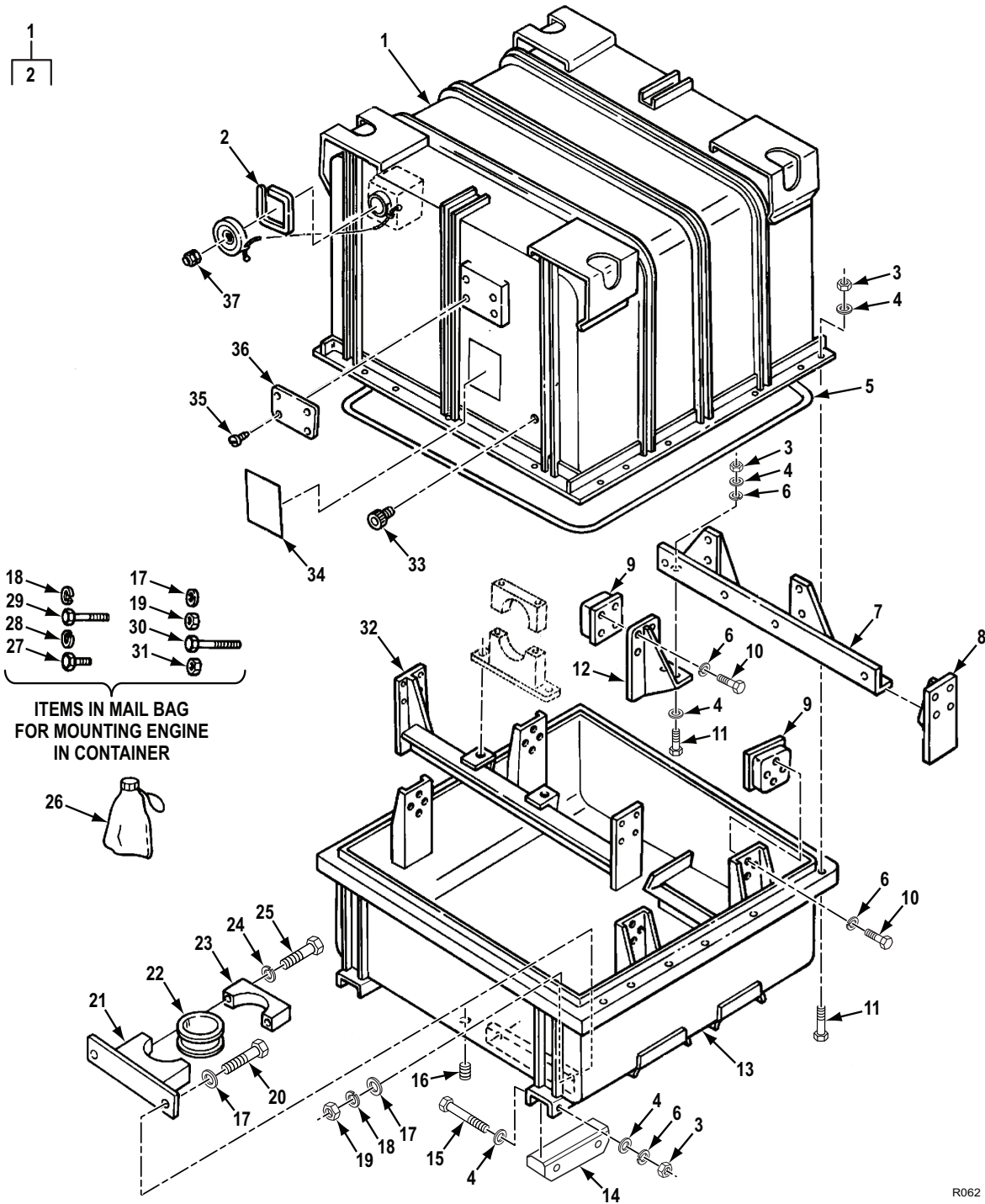

R062

Figure 58. Shipping and Storage Container Assembly (Models 5063-5299, 5063-5392, 5063-5393 and 5063-539L).

(1) ITEM NO.	(2) SMR CODE	(3) NSN	(4) CAGEC	(5) PART NUMBER	(6) DESCRIPTION AND USABLE ON CODE (UOC)	(7) QTY
GROUP 3301 SHIPPING AND STORAGE CONTAINER ASSEMBLY (MODELS 5063-5299, 5063-5392, 5063-5393, AND 5063-539L)						
FIG. 58. SHIPPING AND STORAGE CONTAINER ASSEMBLY (MODELS 5063-5299, 5063-5392, 5063-5393 AND 5063-539L).						
1	XDFHH		19207	11650211	SHIPPING AND STORAG CONTAINER UPPER UOC: C6V,D6V,F6V,L6V	1
2	MFFZZ		19207	11650211-11	. EDGE STRIP 30.50 IN. LG, MAKE FROM EDGE STRIP,P/N PN5PLA UOC: C6V,D6V,F6V,L6V	1
3	PAFZZ	5310-00-768-0318	96906	MS51967-14	NUT,PLAIN,HEXAGON UOC: C6V,D6V,F6V,L6V	36
4	PAFZZ	5310-00-809-5998	96906	MS27183-18	WASHER,FLAT UOC: C6V,D6V,F6V,L6V	44
5	PAFZZ	5330-01-241-2797	19207	11650220	SEAL,NONMETALLIC RO UOC: C6V,D6V,F6V,L6V	1
6	PAFZZ	5310-00-584-5272	80205	MS35338-48	WASHER,LOCK UOC: C6V,D6V,F6V,L6V	44
7	PAFZZ	2590-01-241-9137	19207	11650213	BRACKET,VEHICULAR C UOC: C6V,D6V,F6V,L6V	1
8	PAFZZ	5340-01-241-9136	19207	11650214	BRACKET,MOUNTING UOC: C6V,D6V,F6V,L6V	1
9	PCFZZ	5342-01-240-8299	19207	11650221	MOUNT,RESILIENT,WEA UOC: C6V,D6V,F6V,L6V	4
10	PAFZZ	5305-00-719-5143	80204	B1821BH050F075N	SCREW,CAP,HEXAGON H 1/2-20UNF-2AX3/4 GR8 UOC: C6V,D6V,F6V,L6V	32
11	PAFZZ	5305-00-071-2070	80204	B1821BH050C175N	SCREW,CAP,HEXAGON H 1/2-13UNC-2AX1-3/4 GR8 UOC: C6V,D6V,F6V,L6V	28
12	PAFZZ	5340-01-243-3724	19207	11650215	BRACKET,MOUNTING UOC: C6V,D6V,F6V,L6V	1
13	XDFHH		19207	11650210	SHIPPING AND STORAG CONTAINER, LOWER UOC: C6V,D6V,F6V,L6V	1
14	MFHZZ	3990-01-247-3626	19207	11650219	SKID,PLATFORM 3.5X3.5X13 IN.MAKE FROM LUMBER P/N MML736(OAK 4X4) UOC: C6V,D6V,F6V,L6V	4
15	PAFZZ	5305-00-071-2083	80204	B1821BH050C500N	SCREW,CAP,HEXAGON H 1/2-13UNC-2AX5 UOC: C6V,D6V,F6V,L6V	8

(1) ITEM NO.	(2) SMR CODE	(3) NSN	(4) CAGEC	(5) PART NUMBER	(6) DESCRIPTION AND USABLE ON CODE (UOC)	(7) QTY
16	PAFZZ	4730-00-221-2140	81343	AS4863	PLUG,PIPE UOC: C6V,D6V,F6V,L6V	1
17	PAFZZ	5310-00-823-8803	96906	MS27183-21	WASHER,FLAT QTY 4 IN MAIL BAG UOC: C6V,D6V,F6V,L6V	8
18	PAFZZ	5310-00-820-6653	92392	904209	WASHER,LOCK QTY 2 IN MAIL BOX UOC: C6V,D6V,F6V,L6V	4
19	PAFZZ	5310-00-763-8920	96906	MS51967-20	NUT,PLAIN,HEXAGON QTY 2 IN MAIL BAG UOC: C6V,D6V,F6V,L6V	4
20	PAFZZ	5305-00-724-7222	80204	B1821BH063C200N	SCREW,CAP,HEXAGON H 5/8-11UNC-2AX2 GR8 UOC: C6V,D6V,F6V,L6V	2
21	PBFZZ	3040-01-238-8823	19207	11650218	BRACKET,EYE,ROTATIN UOC: C6V,D6V,F6V,L6V	1
22	PAFZZ	5330-00-599-6624	72582	5166864	PACKING,PREFORMED U/W TRUNNION LWR P/N 11650218 & TRUNNION UPR P/N 11217 WHEN SHIPPING 5063-5299 ENGINE IN CONTAINER. UOC: C6V,D6V,F6V,L6V	1
23	PBFZZ	3040-01-238-8825	19207	11650217	BRACKET,EYE,ROTATIN UOC: C6V,D6V,F6V,L6V	1
24	PAFZZ	5310-00-209-0965	80205	MS35338-47	WASHER,LOCK UOC: C6V,D6V,F6V,L6V	2
25	PAFZZ	5305-00-182-9584	80204	B1821BH044C350D	SCREW,CAP,HEXAGON H UOC: C6V,D6V,F6V,L6V	2
26	PAFZZ	8105-00-477-3716	19207	10890481	BAG,MAIL UOC: C6V,D6V,F6V,L6V	1
27	PAFZZ	5305-00-724-7223	80204	B1821BH063C225N	SCREW,CAP,HEXAGON H 5/8-11UNC-2AX2-1/4 GR8 UOC: C6V,D6V,F6V,L6V	2
28	PAFZZ	5310-00-637-9541	59556	019-00004-42	WASHER,LOCK UOC: C6V,D6V,L6V	6
29	PAFZZ	5305-00-068-0510	80204	B1821BH038C100N	SCREW,CAP,HEXAGON H 3/8-16UNC-2AX1 GR8 UOC: C6V,D6V,F6V,L6V	4
30	PAFZZ	5305-00-781-3929	80204	B1821BH038C425N	SCREW,CAP,HEXAGON H 3/8-16UNC-2AX4-1/4 GR8 UOC: C6V,D6V,F6V,L6V	2
31	PAFZZ	5310-00-732-0558	96906	MS51967-8	NUT,PLAIN,HEXAGON UOC: C6V,D6V,F6V,L6V	1
32	PAFZZ	2815-01-232-9448	19207	11650212	SUPPORT,FORWARD UOC: C6V,D6V,F6V,L6V	1
33	PAFZZ	6685-00-618-1822	10001	2510127	INDICATOR,HUMIDITY, UOC: C6V,D6V,F6V,L6V	1
34	PCFZZ	7690-01-240-4617	19207	11650224	MARKER,IDENTIFICATI UOC: C6V,D6V,F6V,L6V	1

(1) ITEM NO.	(2) SMR CODE	(3) NSN	(4) CAGEC	(5) PART NUMBER	(6) DESCRIPTION AND USABLE ON CODE (UOC)	(7) QTY
35	PAFZZ	5305-00-253-5627	80205	MS21318-48	SCREW,DRIVE #10X3/4 UOC: C6V,D6V,F6V,L6V	4
36	PAFZZ	9905-00-901-2942	19207	7973326	PLATE,IDENTIFICATIO UOC: C6V,D6V,F6V,L6V	1
37	PAFZZ	4820-01-204-8364	08992	TA330-10-10-R	VALVE,PRESSURE EQUA UOC: C6V,D6V,F6V,L6V	1

END OF FIGURE

**FIELD MAINTENANCE
SHIPPING AND STORAGE CONTAINER ASSEMBLY (MODEL 5063-5299)**

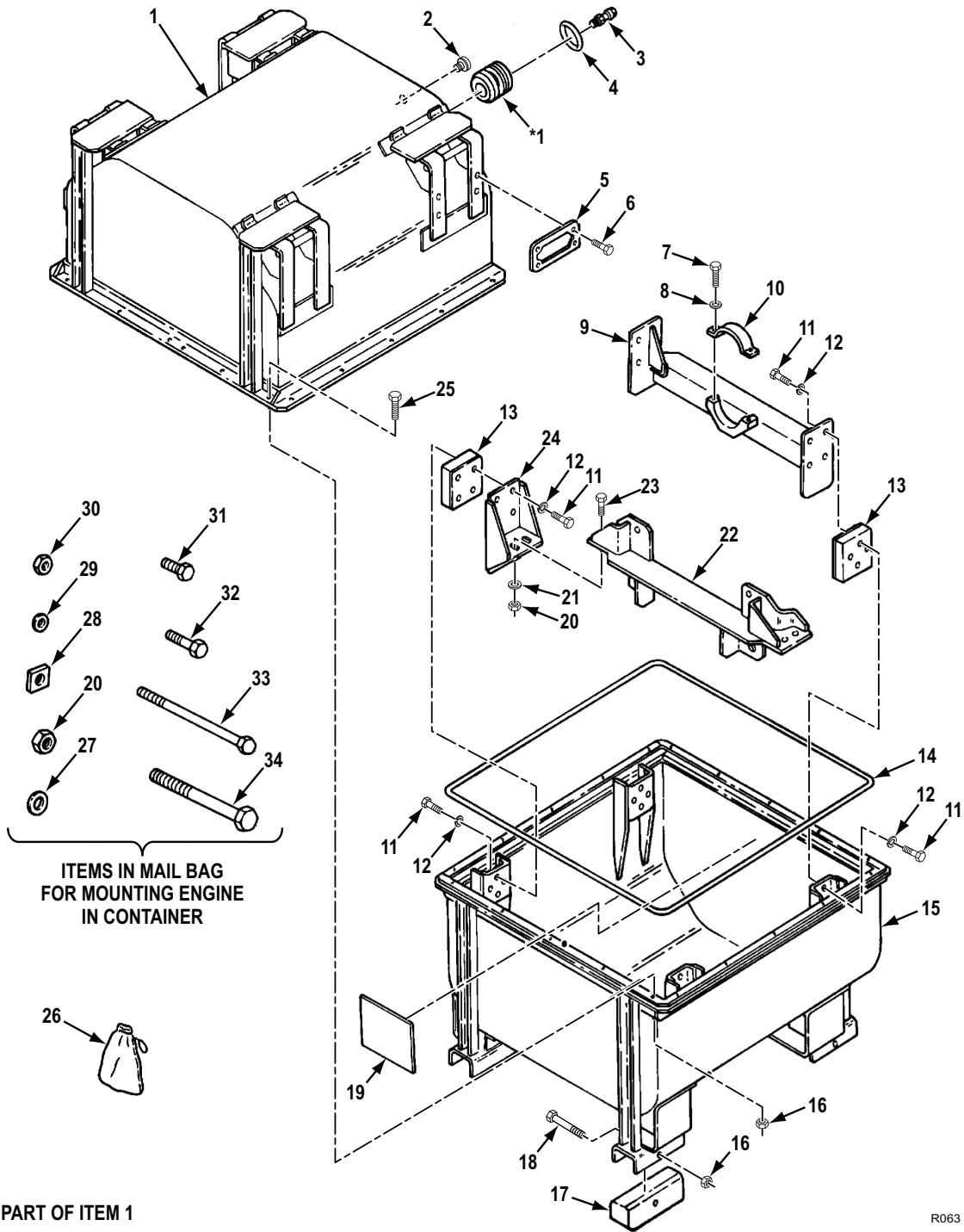

Figure 59. Shipping and Storage Container Assembly (Model 5063-5299).

(1) ITEM NO.	(2) SMR CODE	(3) NSN	(4) CAGEC	(5) PART NUMBER	(6) DESCRIPTION AND USABLE ON CODE (UOC)	(7) QTY
GROUP 3301 SHIPPING AND STORAGE CONTAINER ASSEMBLY (MODEL 5063-5299)						
FIG. 59. SHIPPING AND STORAGE CONTAINER ASSEMBLY (MODEL 5063-5299).						
1	XCFHH		19207	11678209	CONTAINER, TOP UOC: A6V	1
2	PAFZZ	6685-00-618-1822	10001	2510127	INDICATOR, HUMIDITY, UOC: A6V	1
3	PAFZZ	4820-01-204-8364	08992	TA330-10-10-R	VALVE, PRESSURE EQUA UOC: A6V	1
4	PAFZZ	5330-01-036-8535	08992	2856628-6	PACKING, PREFORMED UOC: A6V	1
5	PAFZZ	9905-00-901-2942	19207	7973326	PLATE, IDENTIFICATIO UOC: A6V	1
6	PAFZZ	5305-00-253-5625	80205	MS21318-46	SCREW, DRIVE #10 DRIVE SCREW 3/8 LG. UOC: A6V	4
7	PAFZZ	5305-00-071-2067	80204	B1821BH050C125N	SCREW, CAP, HEXAGON H 1/2-13UNC-2AX1-1/4 GR8 UOC: A6V	2
8	PAFZZ	5310-00-866-4417	19200	10910174-5	WASHER, FLAT UOC: A6V	2
9	PBFZZ	2510-01-122-8472	19207	11678206	BRACKET, ENGINE MOUN UOC: A6V	1
10	PBFZZ	5340-01-026-1261	19207	11678246	STRAP, RETAINING UOC: A6V	1
11	PAFZZ	5305-00-719-5143	80204	B1821BH050F075N	SCREW, CAP, HEXAGON H 1/2-20UNF-2AX3/4 GR8 UOC: A6V	32
12	PAFZZ	5310-00-194-1483	80205	MS35333-44	WASHER, LOCK UOC: A6V	32
13	PCFZZ	5342-00-597-6594	19207	8352283	MOUNT, RESILIENT, WEA UOC: A6V	4
14	PAFZZ	5330-01-052-7673	19207	11678205	SEAL, NONMETALLIC ST UOC: A6V	1
15	XCFHH		19207	11678211	CONTAINER, BOTTOM UOC: A6V	1
16	PAFZZ	5310-00-225-6993	81349	M45913/1-8CG5C	NUT, SELF-LOCKING, HE UOC: A6V	24
17	MFHZZ	3990-01-136-4894	19207	11678204	SKID, SHIPPING AND S 3.56 X 3.56 X 10.00 IN. REQD, MAKE FROM LUMBER, P/N736 (OAK 4 X 4) UOC: A6V	4

(1) ITEM NO.	(2) SMR CODE	(3) NSN	(4) CAGEC	(5) PART NUMBER	(6) DESCRIPTION AND USABLE ON CODE (UOC)	(7) QTY
18	PAFZZ	5305-00-071-2082	80204	B1821BH050C475N	SCREW,CAP,HEXAGON H 1/2-13UNC-2AX4-3/4 GR8 UOC: A6V	4
19	PCFZZ	7690-01-026-0458	19207	11678261	DECAL UOC: A6V	1
20	PAFZZ	5310-00-269-4040	81349	M45913/1-10CG5C	NUT,SELF-LOCKING,HE QTY 2 IN MAIL BAG UOC: A6V	6
21	PAFZZ	5310-00-866-4418	19200	10910174-7	WASHER,FLAT UOC: A6V	4
22	PBFZZ	2815-01-016-3734	19207	11678208	SUPPORT,ENGINE UOC: A6V	1
23	PAFZZ	5305-00-724-7222	80204	B1821BH063C200N	SCREW,CAP,HEXAGON H 5/8-11UNC-2AX2 GR8 UOC: A6V	4
24	PBFZZ	8145-01-021-5026	19207	11678207	SUPPORT,ENGINE UOC: A6V	2
25	PAFZZ	5305-00-071-2069	80204	B1821BH050C150N	SCREW,CAP,HEXAGON H 1/2-13UNC-2AX1-1/2 GR8 UOC: A6V	20
26	PAFZZ	8105-00-477-3716	19207	10890481	BAG,MAIL UOC: A6V	1
27	PAFZZ	5310-00-823-8803	96906	MS27183-21	WASHER,FLAT UOC: A6V	8
28	PAFZZ	5365-01-020-6348	19207	11678239	SPACER,PLATE UOC: A6V	1
29	PAFZZ	5310-00-080-6004	96906	MS27183-14	WASHER,FLAT UOC: A6V	8
30	PAFZZ	5310-00-087-4652	81349	M45913/1-6CG5C	NUT,SELF-LOCKING,HE UOC: A6V	2
31	PAFZZ	5305-00-543-4372	80204	B1821BH038C075N	SCREW,CAP,HEXAGON H 3/8-16UNC-2AX3/4 GR8 UOC: A6V	2
32	PAFZZ	5305-00-543-2419	80204	B1821BH038C113N	SCREW,CAP,HEXAGON H 3/8-16UNC-2AX1-1/8 GR8 UOC: A6V	2
33	PAFZZ	5305-00-857-6886	80204	B1821BH038C450N	SCREW,CAP,HEXAGON H 3/8-16UNC-2AX4-1/2 GR8 UOC: A6V	2
34	PAFZZ	5305-00-724-7264	80204	B1821BH063C450N	SCREW,CAP,HEXAGON H 5/8-11UNC-2AX4-1/2 GR8 UOC: A6V	2

END OF FIGURE

**SUSTAINMENT MAINTENANCE
REPAIR PARTS KITS**

(1) ITEM NO.	(2) SMR CODE	(3) NSN	(4) CAGEC	(5) PART NUMBER	(6) DESCRIPTION AND USABLE ON CODE (UOC)	(7) QTY
GROUP 9401 REPAIR PARTS KITS						
FIG. KITS. REPAIR PARTS KITS.						
1	PAHZZ	2990-00-074-1928	72582	5198043	PARTS KIT,BLOWER TU.....	1
					CLAMP,HOSE (4) 42-1	
					CLAMP,HOSE (2) 52-14	
					GASKET (1) 38-8	
					GASKET (1) 41-4	
					GASKET (1) 39-36	
					GASKET (1) 32-39	
					GASKET (1) 32-37	
					GASKET (1) 39-37	
					GASKET (1) 36-1	
					GASKET (1) 36-14	
					HOSE,NONMETALLIC(1) 42-2	
					HOSE,PREFORMED (2) 42-19	
					SCREEN,AIRINLETBL(1) 37-9	
					OW	
					SEAL,BLOWER (1) 32-38	
					WASHER,FLAT (2) 36-7	
2	PAHZZ	2990-00-234-3015	72582	5198683	PARTS KIT,BLOWER TU.....	1
					O-RING (1) 32-26	
					PILOT,BLOWER (2) 32-8	
					DRIVE	
					RING,RETAINING (1) 36-11	
					SEAL,PLAIN (4) 32-13	
					ENCASED	
					SHIM (1) 32-12	
					SHIM (1) 32-12	
					SHIM (1) 32-12	
					SHIM (1) 32-12	
					SLEEVE,BLOWER (4) 32-13	
					SEAL	
					SPACER,FUEL PUMP(1) 32-33	
					WASHER,FLAT (1) 36-10	
					WASHER,FLAT (2) 32-6	
					WASHER,FLAT (2) 17-7	
3	PAFZZ	2815-00-890-5019	72582	5198901	RING SET,PISTON PART OF KIT P/N 5199116 UOC: A6V,F6V	6
					RING SET,PISTON (6) 8-8	
					RING,PISTON (18) 8-4	
					RING,PISTON (6) 8-3	

(1) ITEM NO.	(2) SMR CODE	(3) NSN	(4) CAGEC	(5) PART NUMBER	(6) DESCRIPTION AND USABLE ON CODE (UOC)	(7) QTY
4	PAHZZ	2815-00-080-6540	72582	5199116	PARTS KIT,PISTON AS UOC: A6V,F6V	6
					PARTS KIT,PISTON (6) 8-5 AS	
					PIN,PISTON (6) 8-7	
					RING SET,PISTON (6) KITS-5	
					RING SET,PISTON (6) 8-8	
					RING,PISTON (6) 8-3	
					RING,PISTON (18) 8-4	
5	PAHZZ	2930-00-460-4504	72582	23506869	PARTS KIT,ENGINE WA.....	1
					BEARING,FAN AND (1) 54-12 WAT	
					GASKET (1) 54-9	
					GASKET (1) 54-19	
					IMPELLER,PUMP,CE (1) 54-10 NTR	
					SEAL,WATERPUMP (1) 54-11	
6	PAHZZ	5330-00-792-9839	72582	5199811	GASKET SET.....	2
					GASKET (6) 2-23	
					GASKET (2) 5-22	
					GASKET (1) 38-8	
					GASKET (2) 24-4	
					GASKET (2) 52-8	
					GASKET (2) 53-29	
					PACKING,PREFORM (2) 2-20 ED	
					RETAINER,PACKING (8) 2-24	
					WASHER,FLAT (8) 2-22	
					WASHER,FLAT (4) 2-21	
					WASHER,FLAT (12) 27-6	
					FILTER (1) 27-11 ELEMENT,FLUI	
					PACKING,PREFORM (1) 27-24 ED	
					SPACER,RING (2) 27-10	
7	XDHZZ	2910-00-920-7580	72582	5228769	PARTS KIT,FUEL INJE UOC: A6V,F6V	1
					SEAT,HELICAL (1) 27-20 COMPRE	
					SPRING,HELICAL,CO (1) 27-19 MP	

(1) ITEM NO.	(2) SMR CODE	(3) NSN	(4) CAGEC	(5) PART NUMBER	(6) DESCRIPTION AND USABLE ON CODE (UOC)	(7) QTY
8	XDHZZ	2910-00-073-3010	72582	5229649	PARTS KIT,FUEL INJE..... FILTER (1) 27-11 ELEMENT,FLUI PACKING,PREFORM (1) 27-24 ED SPACER,RING (2) 27-10	1
9	PAHZZ	2815-01-230-0206	72582	8927223	RING SET UOC: C6V,D6V,L6V RING SET,OIL (6) 9-11 RING,PISTON (6) 9-3 RING,PISTON (12) 9-4	1
10	PAHZZ	2815-01-370-3665	72582	23503779	PARTS KIT,PISTON AS UOC: C6V,D6V,L6V BEARING,PLAIN,SPH (6) 9-8 ER DISK,SOLID,PLAIN (12) 9-10 DOME,PISTON (6) 9-5 GASKET (6) 9-6 PIN,PISTON (6) 9-9	1
11	PAHZZ	2815-01-230-0203	72582	23503811	CYLINDER SLEEVE AND UOC: C6V,D6V,L6V BEARING,HALF (6) 9-8 SLEEVE DISK,SOLID,PLAIN (12) 9-10 GASKET (6) 9-6 PACKING,PREFORM (12) 9-2 ED RING SET,OIL (6) 9-11 RING,PISTON (6) 9-3 RING,PISTON (12) 9-4 PIN,PISTON (6) 9-9	6

(1) ITEM NO.	(2) SMR CODE	(3) NSN	(4) CAGEC	(5) PART NUMBER	(6) DESCRIPTION AND USABLE ON CODE (UOC)	(7) QTY
12	PAHZZ	2815-01-248-4992	72582	8927743	PARTS KIT,DIESEL EN UOC: A6V,F6V	1
					GASKET (1)	15-1
					GASKET (1)	15-17
					GASKET (1)	15-8
					GASKET (1)	15-3
					GASKET (1)	15-16
					GASKET (2)	20-15
					GASKET (1)	37-7
					GASKET (1)	2-36
					GASKET (4)	2-32
					GASKET (1)	2-25
					GASKET (6)	2-23
					GASKET (1)	7-3
					GASKET (1)	7-4
					GASKET (1)	7-24
					GASKET (1)	23-12
					GASKET (1)	23-16
					GASKET (1)	38-8
					GASKET (1)	41-4
					GASKET (1)	39-36
					GASKET (1)	54-19
					GASKET (1)	14-9
					GASKET (1)	25-3
					GASKET (2)	24-4
					GASKET (1)	50-1
					GASKET (2)	52-8
					GASKET (1)	52-19
					GASKET (1)	19-15
					GASKET (1)	55-1
					GASKET (1)	28-10
					GASKET (1)	32-39
					GASKET (2)	32-37
					GASKET (1)	39-37
					GASKET (1)	36-1
					GASKET (1)	36-14
					NUT (1)	39-33
					O-RING (1)	50-2
					O-RING (1)	38-14
					PACKING,PREFORM ED (2)	2-20

(1) ITEM NO.	(2) SMR CODE	(3) NSN	(4) CAGEC	(5) PART NUMBER	(6) DESCRIPTION AND USABLE ON CODE (UOC)	(7) QTY
					PACKING,PREFORM (1) ED	4-8
					RETAINER,PACKING (8)	2-24
					RING,RETAINING (1)	38-11
					SCREEN,AIRINLETBL(1) OW	37-9
					SEAL SPECIAL (1)	38-22
					SEAL,BLOWER (1)	32-38
					SEAL,PLAIN (2)	14-8
					SHIM (1)	2-39
					WASHER,FLAT (1)	46-28
					WASHER,FLAT (2)	41-2
					WASHER,FLAT (8)	2-22
					WASHER,FLAT (4)	2-21
					WASHER,FLAT (2)	23-20
					WASHER,FLAT (2)	50-3
					WASHER,FLAT (2)	36-7

(1) ITEM NO.	(2) SMR CODE	(3) NSN	(4) CAGEC	(5) PART NUMBER	(6) DESCRIPTION AND USABLE ON CODE (UOC)	(7) QTY
13	PAHZZ	5330-01-232-7724	72582	8928522	GASKET AND PREFORME UOC: C6V,D6V,L6V	1
					GASKET (1)	2-36
					GASKET (1)	2-25
					GASKET (6)	2-23
					GASKET (1)	7-3
					GASKET (1)	7-4
					GASKET (1)	7-24
					GASKET (1)	23-12
					GASKET (1)	23-16
					GASKET (1)	18-15
					GASKET (1)	5-22
					GASKET (1)	38-8
					GASKET (6)	41-4
					GASKET (1)	39-36
					GASKET (1)	16-1
					GASKET (1)	16-29
					GASKET (2)	16-24
					GASKET (1)	16-22
					GASKET (1)	16-12
					GASKET (1)	54-19
					GASKET (1)	21-7
					GASKET (1)	14-9
					GASKET (1)	25-3
					GASKET (2)	24-4
					GASKET (2)	50-1
					GASKET (2)	52-8
					GASKET (1)	52-19
					GASKET (1)	19-15
					GASKET (1)	55-1
					GASKET (1)	28-10
					GASKET (1)	32-39
					GASKET (1)	32-37
					GASKET (2)	39-37
					GASKET (1)	36-1
					GASKET (1)	36-14
					GASKET (1)	17-26
					GASKET (1)	17-24
					GASKET (1)	17-27
					GASKET (1)	17-10
					GASKET (1)	22-1
					GASKET (1)	34-11

(1) ITEM NO.	(2) SMR CODE	(3) NSN	(4) CAGEC	(5) PART NUMBER	(6) DESCRIPTION AND USABLE ON CODE (UOC)	(7) QTY
					GASKET	(2) 53-29
					NUT	(1) 39-33
					O-RING	(1) 50-2
					O-RING	(1) 38-14
					PACKING,PREFORM ED	(2) 2-20
					PACKING,PREFORM ED	(12) 9-2
					PACKING,PREFORM ED	(1) 4-8
					RETAINER,PACKING	(8) 2-24
					RING,RETAINING	(1) 38-11
					SEAL SPECIAL	(1) 38-22
					SEAL,BLOWER	(1) 32-38
					SEAL,PLAIN	(1) 14-8
					SEAL,PLAIN ENCASED	(1) 52-17
					SEAL,PLAIN ENCASED	(1) 53-7
					SHIM	(1) 2-39
					VENTILATOR,AIR CIRC	(1) 37-15
					WASHER,FLAT	(2) 41-2
					WASHER,FLAT	(8) 2-22
					WASHER,FLAT	(4) 2-21
					WASHER,FLAT	(12) 27-6
					WASHER,FLAT	(2) 50-3
					WASHER,FLAT	(1) 47-36
					WASHER,FLAT	(1) 48-38

END OF FIGURE

**FIELD MAINTENANCE
HARDWARE SUPPLIES AND BULK MATERIEL, COMMON**

(1) ITEM NO.	(2) SMR CODE	(3) NSN	(4) CAGEC	(5) PART NUMBER	(6) DESCRIPTION AND USABLE ON CODE (UOC)	(7) QTY
GROUP 9501 HARDWARE SUPPLIES AND BULK MATERIEL, COMMON						
FIG. BULK. HARDWARE SUPPLIES AND BULK MATERIEL, COMMON.						
1	PCFZZ	4720-00-278-4892	19207	10886344-5	HOSE, NONMETALLIC NO. 6 BULK, RUBBER	1
2	MFFZZ		72582	5121989	CHAIN, CAP UOC: D6V, L6V	1
3	PAFZZ	6680-00-975-8550	72582	5130678	GAGE ROD, LIQUID LEV BULK SERVICE DIPSTICK (61 " LG) UOC: A6V, F6V	1
4	PAFZZ	4720-00-481-9390	13174	C104	HOSE, NONMETALLIC.....	1
5	PAFZZ	4720-00-278-1109	11083	7F0368	HOSE, NONMETALLIC.....	1
6	PAFZZ	4720-00-150-5968	19207	11662997	HOSE, NONMETALLIC.....	1
7	PAFZZ	4720-01-018-6548	72582	5199782	HOSE, NONMETALLIC UOC: D6V, L6V	1
8	PAFZZ	4720-00-494-9340	01276	FC107-16	HOSE, NONMETALLIC UOC: D6V, L6V	1
9	PAHZZ	5510-00-274-4995	81348	MML736C TYPE 11	LUMBER, HARDWOOD.....	1
10	PAHZZ	5330-01-287-2379	19207	11650223	PLASTIC STRIP UOC: C6V, D6V, L6V	1
11	PAFZZ	9525-00-618-0257	80205	MS20995NC20	WIRE, NONELECTRICAL UOC: C6V, D6V, L6V	1

END OF FIGURE

**FIELD MAINTENANCE
NATIONAL STOCK NUMBER INDEX**

STOCK NUMBER	FIG.	ITEM	STOCK NUMBER	FIG.	ITEM
5310-00-003-4094	21	24	5310-00-053-8377	5	3
2910-00-004-3443	5	4		13	40
2910-00-004-8422	27	22	5306-00-053-8378	7	10
4730-00-005-7376	6	9	2815-00-053-8992	13	27
2990-00-008-9360	43	16	5310-00-055-0829	36	10
4720-00-010-0279	30	9	3010-00-055-0830	32	34
2815-00-010-0297	2	47	5340-00-055-0831	13	38
4730-00-010-3885	15	9	3040-00-055-1564	13	33
	16	13	2815-00-055-1565	13	37
	17	11	3040-00-055-1583	13	22
	23	27	5330-00-055-1584	5	22
	44	21		52	8
	45	30		53	29
	52	11	5360-00-055-2657	42	14
	53	1	2940-00-057-1582	10	7
5330-00-012-9514	2	32	5306-00-057-8427	15	21
5310-00-013-7718	18	21		16	25
5315-00-014-1195	7	7		17	19
5315-00-014-1346	2	11	5306-00-057-8494	7	18
5340-00-014-2583	39	6	5306-00-059-3529	32	9
4730-00-014-3343	31	6	5306-00-064-5356	55	3
	48	15	5305-00-068-0508	13	35
5310-00-014-5850	39	22		38	1
2940-00-015-3609	44	8		47	16
	45	23	5305-00-068-0510	4	14
5305-00-018-0129	37	1		5	18
5305-00-018-7069	21	27		17	9
2940-00-019-4775	20	11		19	3
	21	21		21	29
5310-00-023-4457	18	3		34	20
5310-00-023-4492	17	3		45	15
	33	28		58	29
	34	8	5305-00-068-0511	20	20
5210-00-023-4798	57	19		37	11
3020-00-034-1874	54	2		46	3
6695-00-034-3918	27	18		48	1
2815-00-042-3865	19	13	5310-00-070-6870	35	8
5310-00-045-3296	46	21	5305-00-071-1786	53	32
	47	28	5305-00-071-1787	46	33
	48	27		47	13
	51	5		48	9
5310-00-045-3299	51	4		49	12
5306-00-050-1238	18	16	5305-00-071-1788	4	9
2910-00-050-9838	44	15		34	17
	45	31	5305-00-071-2055	4	5
2910-00-050-9879	44	18	5305-00-071-2056	4	22
	45	34	5305-00-071-2058	4	3
5315-00-051-9867	38	19	5305-00-071-2067	59	7

STOCK NUMBER	FIG.	ITEM	STOCK NUMBER	FIG.	ITEM
5305-00-071-2069	2	40		45	32
	34	15	5310-00-081-4219	7	11
	59	25		15	6
5305-00-071-2070	58	11		16	7
5305-00-071-2073	21	23		17	14
5305-00-071-2082	59	18		18	5
5305-00-071-2083	58	15		31	20
5305-00-071-2505	32	24		45	11
4730-00-071-7890	10	3		49	4
2910-00-073-3010	KITS	8		53	2
2910-00-073-3011	27	7		54	18
3120-00-074-1911	12	20	5305-00-082-6821	6	1
2930-00-074-1922	5	11	5110-00-084-0951	57	75
5330-00-074-1923	20	15	5310-00-087-4652	45	9
5330-00-074-1925	36	14		59	30
2990-00-074-1928	KITS	1	2940-00-089-2520	11	16
2815-00-074-1929	10	12	3120-00-089-3536	2	16
5330-00-074-1931	14	9	3120-00-089-6425	8	12
2815-00-074-1932	7	17		9	17
2815-00-074-1933	12	16	5340-00-089-6430	10	11
2815-00-074-1934	12	5	2815-00-089-6439	32	2
2815-00-074-1938	7	15	2815-00-089-6440	32	8
2815-00-074-1939	13	36	3040-00-089-6450	38	20
4730-00-074-1946	15	10	2990-00-089-6453	40	3
5330-00-079-8421	32	13	3040-00-089-6455	40	9
2990-00-079-8611	32	15	2990-00-089-6456	40	5
5310-00-080-6004	2	34	5315-00-089-6457	40	8
	4	16	3040-00-089-7777	40	2
	7	5	3020-00-089-7781	26	3
	14	3	5340-00-089-8037	39	25
	16	4	5342-00-092-6372	33	1
	17	34		34	2
	18	20	3040-00-097-7753	39	10
	20	18	5120-00-102-58062	56	3
	21	4	2815-00-103-2217	32	18
	22	4	2910-00-103-4550	51	1
	23	3	5330-00-112-0144	23	17
	29	3	2815-00-112-4606	8	8
	33	17	3120-00-113-0612	6	6
	37	3	5210-00-116-1631	57	26
	38	29	5120-00-116-3652	56	13
	44	22	5306-00-122-9721	49	6
	45	8	2815-00-124-5390	1	1
	46	2	5340-00-125-3204	10	5
	47	4		53	13
	48	3	5340-00-126-9665	41	12
	49	9	2910-00-126-9712	27	13
	52	3	2910-00-126-9713	27	8
	54	4	2930-00-127-2517	54	14
	59	29	5120-00-127-7831	57	2
2815-00-080-6540	KITS	4	5342-00-134-3182	19	5
2530-00-080-7024	3	20	5305-00-135-5157	38	9
5306-00-080-7294	44	16	5310-00-136-5712	16	11

STOCK NUMBER	FIG.	ITEM	STOCK NUMBER	FIG.	ITEM
8145-00-138-7809	1	3		4	6
5120-00-140-7547	57	81		33	26
5365-00-142-1775	5	8		34	16
	5	21		46	34
5306-00-143-3217	43	7		47	12
5340-00-148-0886	7	23		48	10
4730-00-148-4975	37	12		49	11
2520-00-150-2037	43	12		53	15
4730-00-150-2038	43	13		58	24
4730-00-150-2042	43	8	5120-00-219-8397	57	42
4730-00-150-2043	47	18	5120-00-219-8409	57	79
4720-00-150-5968	BULK	6	4730-00-221-2140	58	16
4730-00-152-6070	15	23	5305-00-225-3843	38	4
	19	2	5310-00-225-6993	59	16
4820-00-152-6195	51	17	5306-00-226-4822	18	11
5305-00-152-6326	54	5	5306-00-226-4824	18	18
5340-00-152-6428	47	15	5306-00-226-4825	2	28
2930-00-152-9855	52	13		3	21
5310-00-153-2717	35	18		31	18
5340-00-158-0417	46	15		41	1
	47	24	5306-00-226-4826	7	21
2815-00-159-3528	5	2		50	4
7240-00-160-0455	56	15	5306-00-226-4827	3	15
5310-00-161-1604	39	18		16	9
5340-00-161-5246	30	3		17	30
	31	8		25	6
	33	12		45	13
	34	29	5306-00-226-4828	15	7
	47	17		16	16
	48	25		17	12
4520-00-164-1323	50	6		46	27
5310-00-164-1790	43	4		47	35
	43	14		48	31
5305-00-165-8037	4	18	5306-00-226-4829	15	4
5331-00-166-1020	32	26		17	21
3120-00-169-0043	6	11	5306-00-226-4830	17	5
3120-00-169-0044	6	11	5306-00-226-4834	18	8
2910-00-169-2829	50	5	5306-00-226-4839	53	4
4910-00-169-5805	57	39	4730-00-228-3302	29	14
5120-00-169-5806	57	33		30	23
4730-00-172-0528	41	8		31	9
5330-00-179-6227	8	2	3020-00-230-0066	54	13
	9	2	4720-00-230-3489	47	1
5305-00-182-9584	58	25	5310-00-231-0290	38	13
5310-00-193-9753	36	7	3020-00-234-2991	6	7
5310-00-194-1483	59	12	2990-00-234-3015	KITS	2
4730-00-196-1973	29	7	5340-00-234-6028	46	19
	30	6	5340-00-235-2278	3	11
4730-00-196-2055	46	7	5330-00-235-4885	54	19
3110-00-198-0576	39	26	5360-00-236-3149	13	39
5340-00-202-0765	5	15	5340-00-237-8324	2	14
5325-00-205-5139	38	25	5315-00-238-0838	14	6
5310-00-209-0965	4	2	7920-00-238-1906	57	72

STOCK NUMBER	FIG.	ITEM	STOCK NUMBER	FIG.	ITEM
4320-00-240-2038	54	10	2910-00-287-1912	44	7
5330-00-246-6380	52	17		45	20
	53	7	4730-00-288-9953	49	19
4730-00-249-2029	46	8	4730-00-289-3141	42	1
	47	20		52	14
5315-00-251-9989	42	6		53	10
5305-00-253-5614	39	34	5325-00-290-4518	16	3
5305-00-253-5620	23	6		17	29
5305-00-253-5625	59	6	5120-00-293-1429	57	43
5305-00-253-5627	58	35	5110-00-294-4606	56	17
4910-00-254-5018	57	4		57	92
5120-00-254-5049	57	14	5310-00-297-8836	42	13
5365-00-255-0296	27	10	2510-00-314-3585	4	1
4910-00-255-8641	57	62	3805-00-332-5547	5	14
5310-00-262-2914	38	24	5310-00-338-1088	17	7
	39	5	3805-00-340-7047	11	10
5310-00-262-3105	38	12	2815-00-345-6073	13	30
5365-00-262-4397	41	11	5120-00-355-6167	57	73
5365-00-262-4701	20	9	4910-00-355-6248	57	61
	21	17	2910-00-355-7669	28	9
5310-00-262-5429	39	7	4820-00-360-8299	20	12
4730-00-266-0541	31	29		21	22
5305-00-269-3219	38	27	3120-00-362-9301	6	10
5305-00-269-3234	12	12	5120-00-363-7572	56	18
	33	23	2990-00-363-8093	38	5
5305-00-269-3236	18	24	5315-00-363-8100	39	9
5305-00-269-3237	2	35		39	13
5305-00-269-3247	7	9	5330-00-364-3434	27	24
5305-00-269-3248	7	6	6680-00-364-3506	25	4
5310-00-269-4040	59	20	5340-00-366-0618	39	4
5310-00-270-7111	13	25	4730-00-366-3011	3	5
4720-00-271-9839	56	26		31	16
	57	95	3120-00-367-7235	6	10
3020-00-272-6038	27	14	4730-00-371-5337	2	2
5310-00-274-4658	12	1		5	9
5510-00-274-4995	BULK	9		23	24
5310-00-274-9364	24	1		32	16
5310-00-276-3015	27	3		47	19
5315-00-276-4818	12	6		54	15
	12	17	2910-00-374-4929	27	11
3110-00-277-0337	39	2	5310-00-379-9541	33	16
4730-00-277-5683	3	3	5210-00-387-9581	56	9
4730-00-277-8274	29	12	2990-00-388-2670	41	15
	51	9	5210-00-402-9619	57	28
4730-00-277-8643	3	13	5331-00-403-0024	49	28
4720-00-278-1109	BULK	5		50	2
4720-00-278-4892	BULK	1	5310-00-407-9566	2	27
4730-00-279-0985	19	1		3	16
	44	6		7	22
5325-00-281-6660	38	11		15	5
5325-00-282-5031	13	26		16	8
5310-00-282-5658	8	11		17	6
	9	16		18	9

STOCK NUMBER	FIG.	ITEM	STOCK NUMBER	FIG.	ITEM
	18	13		23	4
	23	10		32	43
	25	5		34	13
	31	19		46	22
	45	12		48	29
	49	3	5325-00-543-3615	44	9
	53	3		45	24
	54	17	5305-00-543-4372	17	1
5310-00-409-9031	38	23		18	1
4730-00-415-3172	46	24		19	6
	47	32		30	20
	48	33		47	2
3120-00-422-3968	54	3		59	31
2910-00-423-0941	50	8	5306-00-543-5696	7	12
5342-00-435-2347	5	16	4930-00-545-8639	57	15
4730-00-446-2584	46	29	5307-00-550-1879	24	5
	47	34	5310-00-550-3915	38	6
	48	36		41	10
	51	8	5330-00-551-0433	44	4
5340-00-450-5718	56	4		45	21
	57	10	3110-00-554-2906	36	5
2815-00-451-6672	8	9	2815-00-567-2501	25	1
5305-00-455-7168	43	3	2815-00-567-2502	24	3
4910-00-456-7620	56	5	4710-00-572-8603	29	13
2930-00-460-4504	KITS	5		30	22
5340-00-462-2171	41	3		31	10
2815-00-462-3715	50	7	5342-00-572-8726	13	6
5330-00-466-0467	25	3		13	17
4730-00-470-1791	52	4	2940-00-580-6283	20	5
	53	28		21	13
5330-00-471-9287	6	15	5310-00-582-5965	13	34
8105-00-477-3716	58	26		32	23
	59	26		38	2
5315-00-480-4453	39	27		43	6
4720-00-481-9390	48	37		47	5
	BULK	4	5310-00-584-5272	34	14
5310-00-483-8791	42	4		58	6
	43	11	5310-00-584-7888	45	4
5340-00-492-2722	19	18	5120-00-591-6631	57	50
5210-00-494-1738	57	6	4910-00-591-6632	57	49
5120-00-494-1846	57	52	4910-00-591-6634	56	23
4720-00-494-9340	BULK	8	4730-00-595-4417	29	8
5340-00-499-3597	29	4		30	7
3120-00-511-2336	6	10		31	12
5310-00-532-8136	3	18		48	14
3030-00-537-1531	54	1		49	16
5210-00-538-8465	56	8	5310-00-595-8121	24	2
2815-00-540-0099	25	2	5180-00-596-8541	57	84
4730-00-542-4402	47	22	5315-00-597-4217	39	29
5305-00-543-2419	34	32	5342-00-597-6594	59	13
	37	5	5331-00-599-0505	5	5
	59	32	5331-00-599-2934	38	14
5305-00-543-2866	7	13	5330-00-599-6624	4	8

STOCK NUMBER	FIG.	ITEM	STOCK NUMBER	FIG.	ITEM
	58	22		49	8
4910-00-603-8925	57	40		52	2
5306-00-604-7961	44	3		53	20
	45	19		58	28
5331-00-604-8094	20	8	5305-00-638-8920	14	7
	21	16		52	20
5365-00-608-0486	27	23		53	19
5325-00-608-9214	20	3	4730-00-640-1051	46	23
	21	11		47	33
5330-00-612-3123	44	11		48	32
	45	26		51	7
5342-00-612-3134	44	10	5120-00-640-6364	56	29
	45	25	3940-00-646-6893	56	20
5330-00-613-9397	2	25	5325-00-657-7565	40	6
	15	8	3120-00-661-7616	13	12
	16	12	3120-00-661-7640	13	11
	17	10	3120-00-662-1651	13	2
5315-00-616-5525	36	3		13	9
9525-00-618-0257	BULK	11		13	18
6685-00-618-1822	58	33	5315-00-662-9093	13	4
	59	2		13	10
5120-00-619-4045	57	25		13	15
5360-00-619-8198	44	13	5340-00-662-9735	13	3
	45	28		13	8
3120-00-620-4779	13	32		13	14
5330-00-629-6340	20	7	5310-00-663-7617	23	20
	21	15	6620-00-671-4509	57	22
5310-00-637-9511	53	21	5360-00-682-7190	23	21
5310-00-637-9541	31	2	5330-00-682-7195	18	10
5310-00-637-9541	2	43		23	16
	4	15	5330-00-682-7197	37	7
	5	17	5305-00-688-2111	37	10
	7	2	5360-00-689-8264	13	28
	12	13	5330-00-689-8265	49	29
	14	2		50	1
	16	5	3040-00-692-4152	12	11
	17	2	4710-00-701-3875	3	1
	18	2	4910-00-705-9278	57	17
	19	4	5315-00-707-1253	27	26
	20	19	4940-00-711-1918	57	88
	21	3	4940-00-711-1919	57	89
	22	5	5120-00-711-1920	57	86
	23	2	4730-00-716-4928	48	12
	29	2		49	14
	30	2	5305-00-719-5143	58	10
	34	12		59	11
	37	2	5340-00-720-6213	19	8
	38	28		46	32
	44	23		47	40
	45	14	5340-00-721-9658	41	13
	46	11	5305-00-724-7222	58	20
	47	3		59	23
	48	2	5305-00-724-7223	58	27

STOCK NUMBER	FIG.	ITEM	STOCK NUMBER	FIG.	ITEM
5305-00-724-7264	59	34	3020-00-780-5222	7	16
5305-00-725-2317	14	1	4730-00-780-5223	29	9
	21	2	5330-00-780-5231	39	37
	22	6	5330-00-780-5232	38	8
	30	1	5330-00-780-5233	39	36
	47	9	2990-00-780-5236	32	38
	48	7	2990-00-780-5237	42	18
	49	7	5306-00-780-5241	13	19
5330-00-725-2388	34	18	5330-00-780-5242	23	12
5310-00-732-0558	7	14	5330-00-780-5243	2	23
	19	9	3040-00-780-5251	42	5
	34	22	3040-00-780-5252	42	3
	46	12	5315-00-780-8097	13	5
	47	14		13	16
	48	8	5310-00-780-8102	15	20
	49	25	5306-00-780-8109	32	36
	53	30	5310-00-780-8116	32	30
	58	31		46	10
5310-00-732-0559	7	1	2910-00-781-1354	44	1
	33	15		45	17
5120-00-733-8874	57	53	5305-00-781-3927	23	13
2910-00-735-6187	27	4		37	4
4910-00-736-1371	57	38	5305-00-781-3928	7	26
5310-00-737-5429	41	2	5305-00-781-3929	58	30
	46	28	5330-00-781-7117	52	19
	47	36	3120-00-781-7773	6	14
	48	38	5306-00-781-7777	32	32
	50	3	5305-00-782-9489	22	7
5120-00-740-3345	57	45		27	2
5120-00-740-3347	56	28		29	15
2940-00-745-7730	44	17		45	6
	45	33		48	20
4730-00-745-7741	18	6		49	22
4820-00-752-9040	2	6	5110-00-785-1016	57	90
	2	29	5120-00-785-1017	57	93
2590-00-758-9043	10	2	2815-00-789-1006	5	1
5340-00-759-0542	27	21	5330-00-789-4846	2	36
5365-00-761-1985	12	7	2520-00-789-4847	7	19
5310-00-761-6882	43	5	4320-00-789-4848	23	8
	47	6	5306-00-789-4849	8	10
5310-00-763-8920	58	19		9	15
5310-00-763-8921	45	5	3120-00-789-4851	8	12
2930-00-767-7881	15	24		9	17
2930-00-767-7882	15	15	4720-00-789-4862	42	2
5310-00-768-0318	58	3	4720-00-789-4863	42	19
2920-00-770-1641	51	12	5330-00-789-4867	15	17
5310-00-774-9545	2	21	5310-00-789-4870	15	19
4910-00-779-6078	57	36	5330-00-789-4871	15	16
4910-00-779-6392	57	35	2940-00-789-4873	20	1
4910-00-779-7103	57	20		21	9
5365-00-779-7308	57	58	5306-00-792-8248	5	20
4910-00-779-7315	57	51	3110-00-792-8990	54	12
2815-00-780-5218	23	5	5330-00-792-9026	10	10

STOCK NUMBER	FIG.	ITEM	STOCK NUMBER	FIG.	ITEM
5365-00-792-9028	12	8		28	5
5360-00-792-9771	27	28	5305-00-846-5703	44	25
5330-00-792-9839	KITS	6	5330-00-846-9841	44	5
5330-00-792-9841	23	17		45	22
4910-00-795-0189	57	59	4720-00-847-1710	51	16
4910-00-795-0198	57	60	4820-00-849-1220	44	14
5120-00-799-3398	57	12		44	20
5360-00-801-8731	20	10		45	29
	21	18		45	36
5325-00-803-7316	36	11	5365-00-849-2105	32	41
5325-00-804-4997	36	13	2950-00-849-2110	32	42
5310-00-807-1367	2	41	5340-00-849-2111	32	40
2910-00-808-2655	28	9	5365-00-849-2283	27	15
5120-00-808-5078	57	48	4330-00-849-2672	44	18
5120-00-808-5082	57	27	4730-00-849-2737	3	9
5120-00-808-5230	56	22		46	4
5310-00-809-4061	51	14	5310-00-852-8593	51	6
	53	14	5340-00-853-3467	3	17
5310-00-809-4085	4	7	6685-00-857-4895	56	14
	46	35		57	41
	47	11	5305-00-857-6886	4	21
	48	11		7	26
	49	10		59	33
5310-00-809-5997	21	25	4730-00-862-4445	31	13
5310-00-809-5998	58	4	5310-00-866-4417	59	8
5310-00-809-8533	45	2	5310-00-866-4418	59	21
2990-00-812-0876	39	11	2990-00-866-9378	37	9
5365-00-816-9144	32	12	2930-00-866-9382	36	6
5365-00-819-4875	32	12	2815-00-866-9402	8	1
5310-00-820-6653	58	18		9	1
2815-00-820-7455	8	7	5330-00-866-9403	54	11
5305-00-821-3869	12	19	5306-00-870-6222	20	14
	52	1		21	19
	53	27	4910-00-870-6283	56	25
5306-00-822-3685	26	7	5120-00-872-6015	57	5
	28	7	5305-00-877-8051	39	15
5310-00-823-8803	58	17	5340-00-880-0446	54	8
	59	27	5330-00-880-1263	2	24
3120-00-830-0246	12	23	5310-00-880-1264	2	22
5330-00-833-0870	20	13	5310-00-880-7744	49	2
	21	20	5310-00-880-7746	18	19
2910-00-833-1000	27	12	5310-00-880-8189	53	16
5310-00-833-1013	27	25	2815-00-883-5593	8	4
2520-00-833-1024	39	30	2910-00-884-1207	44	15
4730-00-833-9315	21	1	5340-00-885-5731	13	29
2940-00-834-1157	20	2	2815-00-888-2426	32	3
	21	10	2990-00-890-0697	10	8
5340-00-837-8448	27	20	2815-00-890-5019	KITS	3
5340-00-838-9696	27	17	4720-00-893-5429	33	20
5315-00-839-2325	42	7		34	31
2815-00-841-9125	46	6	5305-00-899-2109	39	21
5340-00-841-9141	13	23	5365-00-901-1032	2	39
5306-00-846-3246	26	5	9905-00-901-2942	58	36

STOCK NUMBER	FIG.	ITEM	STOCK NUMBER	FIG.	ITEM
	59	5	2815-00-921-5368	15	13
5365-00-902-7803	32	12	5340-00-921-5369	15	18
5365-00-902-7804	32	12	2990-00-921-5372	40	1
4730-00-902-8991	31	26	4710-00-921-5373	19	7
2815-00-903-0907	23	22	4330-00-921-5375	20	17
3040-00-903-0908	36	12	2815-00-921-5378	5	23
5365-00-903-0909	23	26	5340-00-921-5379	14	5
2910-00-903-0910	27	16	5340-00-921-5380	5	12
4720-00-904-4566	48	18	5340-00-921-5386	2	19
	49	20	2815-00-921-5388	23	7
4720-00-904-8102	48	23	3120-00-921-5389	2	16
4910-00-907-0713	57	1	3120-00-921-5390	2	16
4730-00-908-3193	11	6	3120-00-921-5396	8	12
4730-00-908-3194	34	21		9	17
4730-00-908-6292	34	30	3120-00-921-5397	8	12
	53	17		9	17
2935-00-908-9733	20	16	3120-00-921-5398	8	12
	21	6		9	17
	22	2	4730-00-921-5736	39	23
2930-00-909-5950	52	7	5325-00-921-6413	2	33
	53	25		2	38
2815-00-910-3720	4	13	3020-00-921-6994	12	2
5120-00-910-7868	57	55	4710-00-921-6997	18	7
5360-00-913-1199	41	9	5340-00-922-2018	36	15
5305-00-916-2345	6	1	5342-00-922-2026	18	23
5120-00-918-0587	57	16	2910-00-922-2424	44	19
2990-00-918-4206	32	35		45	35
2990-00-918-4208	39	32	3120-00-922-6487	6	11
2990-00-918-4210	38	10	2815-00-922-8355	8	5
5340-00-919-2876	2	15	5360-00-930-3251	41	14
2910-00-920-7580	KITS	7	5305-00-930-3253	46	9
2815-00-921-5334	14	4	5330-00-930-3254	35	12
2815-00-921-5336	39	12	5325-00-930-3257	35	19
2815-00-921-5337	23	18	3120-00-930-3265	23	28
5315-00-921-5338	39	24	5365-00-930-3266	6	6
3040-00-921-5339	13	21	5365-00-932-4869	6	2
5365-00-921-5340	32	21	2910-00-932-9634	44	2
3120-00-921-5342	5	6		45	18
5342-00-921-5343	42	16	5306-00-933-0994	2	9
5330-00-921-5344	2	20	5305-00-934-0279	23	1
3040-00-921-5345	36	4	5310-00-934-9757	51	3
5315-00-921-5346	39	3	5310-00-934-9764	10	13
2815-00-921-5348	2	7	5120-00-936-4377	57	32
5315-00-921-5349	39	31	4730-00-937-0229	27	9
3010-00-921-5352	32	31	3460-00-937-5521	57	7
3040-00-921-5353	39	20	5120-00-937-6140	57	44
2815-00-921-5354	39	1	5120-00-937-6143	57	34
5340-00-921-5355	2	26	5120-00-937-7266	57	56
2815-00-921-5356	39	8	5130-00-937-7281	57	9
3040-00-921-5357	12	21	5210-00-937-7284	57	21
2815-00-921-5358	4	10	5210-00-937-7285	57	24
5305-00-921-5364	2	45	5110-00-937-7628	57	47
2815-00-921-5367	37	8	5110-00-937-7629	57	76

STOCK NUMBER	FIG.	ITEM	STOCK NUMBER	FIG.	ITEM
5110-00-937-7630	57	77	2590-00-999-2340	5	19
5306-00-940-9010	18	4	2815-00-999-2348	2	37
5305-00-940-9034	32	19	2910-00-999-2349	32	33
5306-00-940-9062	32	20	2910-00-999-2350	39	28
5305-00-942-2196	2	42	2910-00-999-2351	26	6
	16	6		28	6
2990-00-944-2053	38	7	3040-00-999-2352	26	2
5330-00-944-4148	7	3		28	2
5330-00-944-7065	23	17	2910-00-999-2396	26	4
4710-00-944-7066	18	14		28	4
5330-00-944-7073	18	15	5310-00-999-2397	26	1
3020-00-947-2143	6	4		28	1
4730-00-947-4290	19	11	2940-00-999-2402	37	6
5305-00-947-4355	45	1	2990-00-999-2528	42	20
5306-00-947-7990	32	29	5180-00-999-4053	57	46
2815-00-953-1401	5	10	5330-00-999-7210	19	15
5310-00-959-1488	33	27	5120-00-999-8618	57	11
	34	7	4730-01-005-3262	31	15
4730-00-959-2329	23	23		48	16
5305-00-964-0503	4	23		49	18
	36	8	3110-01-005-6623	39	19
2815-00-966-9103	13	13	5340-01-006-4589	57	8
2815-00-966-9104	13	1	2815-01-014-3142	19	22
5310-00-966-9141	32	17	2835-01-015-5409	30	17
5310-00-971-7989	39	14		31	4
	41	5	5306-01-015-5413	51	15
4810-00-974-7605	46	25	5325-01-015-5414	35	22
	47	31	5310-01-015-5419	35	5
	48	34	5306-01-015-5430	42	15
6680-00-975-8550	BULK	3	2815-01-016-0425	23	18
5210-00-977-5578	56	12	4720-01-016-0427	31	14
3940-00-977-7398	56	21	2920-01-016-0428	46	31
5330-00-980-1546	55	1		47	39
5305-00-983-6625	18	12		48	40
5305-00-984-3021	32	5	2590-01-016-0429	51	10
5305-00-984-6211	10	6	2590-01-016-0430	51	11
5360-00-986-7304	27	19	5340-01-016-0431	51	13
5305-00-989-7434	47	30	5342-01-016-0432	46	1
5305-00-989-7435	46	20		47	7
	47	29		48	5
	48	28	4710-01-016-0433	46	18
5210-00-990-3327	57	23	6150-01-016-0434	46	26
5305-00-990-8632	7	27		47	8
	29	1		48	6
	32	43	2815-01-016-0435	39	1
	37	18	5315-01-016-0436	39	31
	38	27	5340-01-016-0437	43	10
	52	12	3120-01-016-0438	43	15
	54	16	5365-01-016-0443	35	11
4720-00-994-5787	30	8	2815-01-016-3734	59	22
	34	5	2815-01-016-5458	39	10
4720-00-994-5788	29	5	2910-01-016-5501	38	7
	31	7	5305-01-018-5215	19	14

STOCK NUMBER	FIG.	ITEM	STOCK NUMBER	FIG.	ITEM
4720-01-018-6548	BULK	7	2815-01-075-7813	8	6
5365-01-020-6348	59	28	2815-01-077-5096	42	9
5306-01-020-6895	32	10	4720-01-077-6453	47	23
8145-01-021-5026	59	24	2815-01-078-1333	11	4
9905-01-023-9746	27	27	5305-01-078-1999	11	14
5340-01-024-6099	44	12	2815-01-078-2723	11	17
	45	27	2815-01-078-2724	11	15
2910-01-025-3769	43	2	5305-01-078-4967	42	12
7690-01-026-0458	59	19	5306-01-078-4969	11	1
5340-01-026-1261	59	10	5310-01-086-3233	4	12
2815-01-028-8647	12	5	2990-01-087-2751	39	35
2815-01-035-1750	18	17	5305-01-087-4489	37	17
5342-01-035-1755	33	19	5330-01-088-2740	11	5
4820-01-035-6082	43	17	5360-01-089-7480	42	10
5330-01-036-8535	59	4	5210-01-091-8354	56	6
5330-01-037-4129	33	29	6635-01-093-3710	56	24
	34	11	5340-01-104-8888	49	33
5180-01-038-0251	57	70	2540-01-105-3037	51	2
3120-01-038-8401	6	11	5330-01-105-6889	38	22
3120-01-038-8402	6	11	5340-01-108-2417	2	31
2990-01-039-6515	46	14	5330-01-109-6608	7	4
4720-01-039-6516	46	13	4720-01-111-2283	46	30
5306-01-039-9601	15	22	5120-01-112-5031	56	16
	53	5	3120-01-117-6103	40	4
5305-01-039-9605	41	6	4710-01-118-5621	29	10
5306-01-039-9718	4	11	2990-01-118-8187	40	7
2815-01-040-2632	19	20	2920-01-118-9826	38	15
5315-01-042-8362	2	13	2815-01-119-4960	8	1
5307-01-044-7270	33	4		9	1
	34	10	3020-01-122-5181	32	11
8115-01-048-1386	57	85	3020-01-122-5905	32	7
5110-01-048-2199	57	91	3020-01-122-7790	12	9
2815-01-051-7917	32	13	3020-01-122-7912	36	2
2930-01-051-7920	23	15	2990-01-122-7913	32	1
5330-01-052-7673	59	14	3020-01-122-8251	28	3
2815-01-053-1377	12	16	3020-01-122-8276	6	13
4730-01-055-4021	47	21	2510-01-122-8472	59	9
5310-01-055-4420	11	2	3020-01-123-0303	12	18
4720-01-056-0097	52	15	3020-01-123-8875	12	22
	53	11	2990-01-125-4812	38	18
5360-01-057-2935	42	11	4730-01-125-9989	15	11
5340-01-057-4230	11	3		16	15
5220-01-061-4248	57	29		17	31
6685-01-061-4253	57	64		52	5
3120-01-063-9810	13	31		53	23
5310-01-067-8382	39	33	3120-01-127-6531	2	16
4730-01-069-3216	30	15	4720-01-127-6546	46	16
	33	24		47	38
	34	6		48	39
4720-01-069-7708	31	30	2910-01-127-6911	28	11
5305-01-071-8140	23	14	5340-01-127-7904	46	36
4730-01-075-7310	29	6	4910-01-127-7959	56	19
	30	5	5340-01-130-6245	49	30

STOCK NUMBER	FIG.	ITEM	STOCK NUMBER	FIG.	ITEM
5120-01-130-8865	57	57	2815-01-160-8289	13	7
5310-01-132-0830	2	10	5342-01-162-7865	35	4
5340-01-132-5145	10	9	4730-01-163-1085	22	8
4820-01-132-6317	15	14	4030-01-163-2286	11	9
5306-01-133-0812	2	44	4910-01-163-7893	57	83
	12	14	4910-01-163-7894	57	82
5365-01-133-9149	12	3	5330-01-163-8179	33	14
5342-01-134-5516	30	18	3040-01-165-8316	38	3
	31	3	5120-01-166-5164	57	69
3990-01-136-4894	59	17	5120-01-166-5167	57	37
4940-01-138-8259	57	63	5220-01-167-4281	57	87
5330-01-143-2300	36	1	6685-01-167-4298	31	23
5305-01-143-2328	43	1		48	13
5342-01-144-1937	23	25		49	15
5120-01-147-7923	56	2	5180-01-167-8073	57	94
5930-01-148-8874	31	24	5306-01-168-3796	38	26
4730-01-149-7156	19	12	5120-01-169-5300	57	3
5305-01-156-5441	33	25	5306-01-169-5526	49	26
5310-01-156-7704	21	28	4910-01-170-4914	57	18
	30	21	5120-01-170-4922	57	74
	44	24	5120-01-170-4935	57	67
4730-01-157-3763	16	14	5365-01-176-7441	23	19
	17	33	5330-01-176-7872	6	15
5330-01-157-3770	21	7	5310-01-177-5910	7	8
	22	1		36	16
5330-01-157-3771	16	1	2910-01-182-4019	42	17
	17	27	2910-01-182-4020	42	8
5330-01-157-3772	16	29	2920-01-187-3636	55	2
	17	26	2815-01-187-4704	8	3
5330-01-157-3773	16	24	4730-01-187-6671	3	2
	17	24		46	17
4720-01-157-3800	10	4		47	25
4730-01-157-6223	30	13		48	26
	31	31	5306-01-188-0689	54	7
4730-01-157-6224	3	10	4730-01-188-3492	2	3
	33	13		2	30
	34	28		19	19
	51	9		54	21
3130-01-157-8861	2	12	5306-01-193-9291	7	20
5315-01-157-8866	41	7	5330-01-196-2504	15	3
5342-01-157-8867	36	9	5120-01-197-6720	56	27
2940-01-157-8873	21	5	2940-01-197-7106	22	9
5306-01-157-8904	39	16	2815-01-199-7910	5	10
5306-01-157-8906	16	27	2590-01-202-0960	24	6
4730-01-157-8938	29	11	2990-01-202-0961	33	9
	30	24	5970-01-202-0962	33	3
	31	11	5970-01-202-0963	33	7
3120-01-157-8946	38	16	5970-01-202-0964	33	5
2930-01-157-9016	16	23	4730-01-204-4417	30	10
	17	25		31	5
5306-01-158-1154	16	21	4820-01-204-8364	58	37
5315-01-159-8180	38	21		59	3
4820-01-160-8172	3	6	2950-01-205-3197	35	21

STOCK NUMBER	FIG.	ITEM	STOCK NUMBER	FIG.	ITEM
5315-01-205-3204	12	4	4710-01-234-6525	33	2
4730-01-206-6146	30	12	2815-01-234-7350	16	2
4810-01-209-3412	6	3		17	28
5310-01-209-7979	2	46	2815-01-234-7351	32	15
4730-01-210-4251	16	19	2815-01-234-7352	32	3
	21	8	2815-01-234-7365	16	28
4730-01-210-4252	2	4	2990-01-234-7368	23	9
	17	13	2910-01-234-7373	27	7
	23	23	4310-01-234-7948	35	20
	52	9	2990-01-234-7971	33	6
	53	26	3040-01-234-8467	35	14
4330-01-210-4645	21	30	2815-01-234-8565	37	13
5340-01-210-4648	4	4	2910-01-234-8566	27	16
4730-01-210-6906	30	16	2815-01-235-0841	35	25
2815-01-210-6950	3	19	2815-01-235-1507	32	2
2815-01-211-8632	8	1	2590-01-235-5017	11	8
	9	1	3040-01-235-5038	12	10
5315-01-214-1876	6	12	2815-01-235-5043	11	18
5310-01-216-6636	20	4	2815-01-235-5044	11	11
	21	12	4310-01-235-5712	35	3
2805-01-218-4524	7	25	4320-01-235-5731	23	8
2815-01-219-4102	23	5	5310-01-236-1685	39	17
2950-01-220-3253	33	21	3020-01-236-6082	12	2
	34	9	2950-01-237-2943	35	23
2815-01-220-6659	9	4	5307-01-237-9273	16	18
2815-01-220-9169	9	3	4720-01-238-5995	30	14
2815-01-220-9175	9	9	4720-01-238-5996	30	4
2815-01-220-9380	9	14	5306-01-238-6378	35	7
4710-01-221-1492	3	14	2540-01-238-8792	37	15
4710-01-221-2216	3	12	3040-01-238-8823	58	21
4730-01-222-0914	27	5	3040-01-238-8825	58	23
5365-01-223-7179	9	12	5340-01-239-0623	47	10
5330-01-224-1474	9	6	3120-01-239-1369	35	17
5340-01-224-1560	9	10	2920-01-239-3362	35	10
5330-01-226-9241	8	2	5310-01-239-5071	27	6
	9	2	3040-01-239-7679	6	5
3120-01-227-5718	9	8	4720-01-239-7960	32	28
4710-01-229-3422	47	26	5340-01-239-8038	33	22
2815-01-230-0203	KITS	11	5340-01-239-8166	13	24
2815-01-230-0204	9	7	5306-01-239-9393	23	11
2815-01-230-0206	KITS	9	5365-01-239-9477	35	13
2815-01-230-0207	9	11	4910-01-240-3101	56	1
2815-01-231-0344	16	20	5340-01-240-4160	33	18
5340-01-231-0345	47	27	7690-01-240-4617	58	34
6680-01-232-1135	19	16	5342-01-240-8299	58	9
5330-01-232-7724	KITS	13	5306-01-241-1599	16	10
8145-01-232-9447	1	3	2950-01-241-2465	35	6
2815-01-232-9448	58	32	5330-01-241-2797	58	5
6105-01-234-1037	32	14	5330-01-241-5104	16	22
4720-01-234-2800	33	11	5340-01-241-9136	58	8
4710-01-234-2824	19	17	2590-01-241-9137	58	7
2910-01-234-6467	27	22	5330-01-242-0467	11	12
4710-01-234-6524	33	8	5305-01-242-1783	49	34

STOCK NUMBER	FIG.	ITEM	STOCK NUMBER	FIG.	ITEM
4730-01-242-2825	48	19	4710-01-252-0828	34	19
	49	21	4710-01-252-0829	34	23
5210-01-242-4091	56	10	5342-01-252-9503	4	19
5120-01-242-4092	57	31	5342-01-253-0547	45	3
4730-01-242-9517	31	27	4710-01-253-7058	31	17
	48	17	4710-01-253-7059	31	28
5340-01-243-3724	58	12	5342-01-253-7396	31	21
4720-01-245-6607	21	26	2815-01-253-8646	17	23
5365-01-245-7257	32	4	5342-01-253-8652	45	7
5210-01-245-9564	56	11	5342-01-253-8653	45	10
2815-01-246-0903	1	1	5342-01-254-1073	45	16
2815-01-246-0960	2	1	5310-01-254-1373	32	6
4730-01-247-2463	3	7	5330-01-254-1389	53	9
3990-01-247-3626	58	14	5999-01-254-4984	31	25
5340-01-247-7925	48	4	5306-01-254-6351	9	13
2590-01-247-7926	37	16	3040-01-255-0950	13	20
2815-01-248-2554	2	1	5365-01-255-5047	4	17
2815-01-248-2560	7	25	4730-01-257-3799	2	5
2815-01-248-4992	KITS	12	4730-01-267-2654	11	13
2815-01-248-7644	1	1	2815-01-281-4930	35	1
5120-01-248-7737	57	30	2815-01-285-5068	7	15
5330-01-248-9559	17	16	5330-01-287-2379	BULK	10
2520-01-248-9566	17	17	4710-01-287-4607	48	35
2930-01-248-9579	54	6	2815-01-289-3771	10	1
2930-01-249-6859	52	10	5305-01-289-9750	23	14
2815-01-250-1861	35	9		54	20
4320-01-251-0651	54	14	2930-01-290-4054	15	2
2815-01-251-0653	19	23	2990-01-291-1276	24	6
2930-01-251-0655	17	15	5640-01-291-9010	34	4
2930-01-251-0656	53	6	2815-01-295-7458	1	1
2940-01-251-0666	11	16	5120-01-297-2374	57	54
2930-01-251-1100	53	22	5306-01-297-6987	28	8
5342-01-251-1103	53	31	5330-01-299-3160	15	1
2910-01-251-1719	48	21	3030-01-301-8013	54	1
	49	23	5340-01-304-2471	27	20
5342-01-251-1752	34	33	3040-01-305-5588	39	11
2510-01-251-1794	34	24	4730-01-312-1403	43	9
2510-01-251-1795	34	26	6685 -01-334-8995	52	18
2510-01-251-1796	34	1	5303-01-336-5925	31	1
4710-01-251-1825	34	25	5305-01-336-5925	30	19
6680-01-251-2640	19	24	6620-01-339-1227	52	18
4710-01-251-3074	53	12		53	8
5342-01-251-3135	48	24	4820-01-342-6000	32	25
	49	24	4730-01-345-7333	32	27
4720-01-251-3203	11	7	4730-01-350-2088	35	24
2510-01-251-4465	4	20	2930-01-354-2064	54	6
5342-01-251-4467	17	4	2815-01-354-8172	2	17
2940-01-251-4472	22	3	3120-01-355-8844	35	16
5342-01-251-5295	17	20	5330 -01-359-0149	32	13
2990-01-251-6229	34	34	5340-01-363-7839	5	13
4710-01-251-6284	19	21	2815-01-367-2053	6	8
4710-01-251-6285	34	3	2815-01-370-3665	KITS	10
5330-01-252-0201	17	18	6150-01-371-0247	49	1

STOCK NUMBER	FIG.	ITEM	STOCK NUMBER	FIG.	ITEM
5210-01-373-9397	56	7	5330-01-423-9503	35	2
5330-01-383-3753	20	6	6110-01-427-6395	49	13
	21	14	2920-01-434-7201	49	32
5330-01-392-3354	41	4	5340-01-435-0416	49	27
5310-01-392-3715	28	10	6150-01-439-9221	49	31
5330-01-392-3715	7	24	2815-01-442-3405	9	5
5120-01-396-6072	56	30	2815-01-442-6636	32	22
4730-01-398-7635	2	8	4820-01-442-8109	52	16
	5	7	4710-01-446-3824	27	1
	16	26	2815-01-446-5425	5	1
	17	8	2930-01-448-7671	32	1
	30	11	5330-01-449-2376	14	8
	31	22	4720-01-462-8831	3	8
	37	14	5330-01-467-2161	24	4
	48	22	4720-01-475-9707	3	4
	49	17	5120-01-493-2921	57	68
5120-01-406-4702	57	13	5340-01-499-1736	49	5
2815-01-412-2715	1	1	6620-01-501-8648	2	18
4720-01-418-6516	17	32		37	19
5340-01-419-5059	11	8	5306-01-543-3277	17	22
5306-01-421-9946	12	15			

END OF WORK PACKAGE

**FIELD MAINTENANCE
PART NUMBER INDEX**

PART NUMBER	FIG.	ITEM	PART NUMBER	FIG.	ITEM
				17	30
A-A-1273 TY2	56	15		25	6
A-A-52155-1P37B2R	54	1		45	13
A-A-52506-F-12	34	21	B1821BH031C113N	15	7
A-A-52506-F-24	11	6		16	16
A-A-52506-F-48	53	17		17	12
A-A-52506F-48	34	30		46	27
A-A-59440/1-005	44	14		47	35
	45	29		48	31
	45	36	B1821BH031C125N	15	4
A-A-5944011-005	44	20		17	21
A0-3364	11	8	B1821BH031C138N	17	5
AA5616AASBCB	19	1	B1821BH031C225N	18	8
	44	6	B1821BH031C275D	16	21
AA59440/1-004	2	6	B1821BH031C350N	53	4
	2	29	B1821BH031F075N	18	16
AA59583-400JBBT	39	26	B1821BH038C075N	17	1
AA59585-201JABT	36	5		18	1
AA59616ACAAAD	23	23		19	6
AAAZ0340	33	11		30	20
AE501C375B25WA9A91	14	7		47	2
AEJH0350	21	26		59	31
AES01C375B25AW9A91	52	20	B1821BH038C100D	2	42
	53	19		16	6
AES01C438A12AW9891	47	13	B1821BH038C100N	4	14
AES01C438A12AW9A91	46	33		5	18
	48	9		17	9
AESC01C438A12AW9A91	49	12		19	3
AN150280	39	29		21	29
ANSI B18.2.2	49	2		34	20
AS28431	56	30		45	15
AS3085-024	32	26		58	29
AS4863	58	16	B1821BH038C113N	34	32
AS5355/3-15B	33	1		37	5
	34	2		59	32
ASME B18.6.3	10	6	B1821BH038C125N	20	20
B-0611	38	27		37	11
B107.300	56	29		46	3
B1821BH025C088N	32	24		48	1
B1821BH025C100N	38	4	B1821BH038C138N	37	10
B1821BH031C050N	18	11	B1821BH038C150N	14	1
B1821BH031C063N	18	18		21	2
B1821BH031C075N	2	28		22	6
	3	21		30	1
	31	18		47	9
	41	1		48	7
B1821BH031C100N	3	15		49	7
	16	9	B1821BH038C175N	12	19

PART NUMBER	FIG.	ITEM	PART NUMBER	FIG.	ITEM
	52	1		59	11
	53	27	B1821BH063C200N	58	20
B1821BH038C200N	22	7		59	23
	27	2	B1821BH063C225N	58	27
	29	15	B1821BH063C450N	59	34
	45	6	B1821BH075C325N	45	1
	48	20	B1821BH075F175N	6	1
	49	22	B1821BH075F200N	6	1
B1821BH038C250N	7	13	B5144178	38	23
	23	4	BH00163-6	35	8
	32	43	C104	BULK	4
	34	13	CS-2940-SV-0706	10	7
	46	22	CS815-SVS-0704	2	37
	48	29	D9484-5528	46	8
B1821BH038C275D	54	5		47	20
B1821BH038C300N	44	25	ER-431700	23	8
B1821BH038C350N	23	13	F-F-351/7-3	20	5
	37	4		21	13
B1821BH038C375N	7	27	FA2408GGG0160AB	31	30
	29	1	FC107-16	BULK	8
	32	43	FD-156	44	17
	37	18		45	33
	38	27	FL804FP	22	9
	52	12	FP8924439	13	31
	54	16	GA311B	56	16
B1821BH038C400N	7	26	GPW9184	44	4
B1821BH038C425N	58	30		45	20
B1821BH038C450N	4	21	HN-5228696	27	18
	7	26	J- 21967-01	57	48
	59	33	J-04871-A	57	45
B1821BH038C500N	4	23	J-04983A	57	79
	36	8	J-05438-A	57	26
B1821BH038F075N	12	12	J-08968-A	57	39
	33	23	J-1853	56	9
B1821BH038F100N	18	24	J-1902-B	57	42
B1821BH038F113N	2	35	J-1930	56	18
B1821BH038F350N	7	6	J-21089	57	47
B1821BH044C100N	53	32	J-21460-A	57	83
B1821BH044C125N	4	9	J-21461-A	57	81
	34	17	J-22091	56	13
B1821BH044C150N	4	5	J-22273-A	57	19
B1821BH044C175N	4	22	J-22525-3	57	91
B1821BH044C225N	4	3	J-22525-B	57	84
B1821BH044C350D	58	25	J-22738-02	57	63
B1821BH050C125N	59	7	J-23068	56	3
B1821BH050C150N	2	40	J-23479-453	57	50
	34	15	J-23679-1	57	68
	59	25	J-23679-2	57	66
B1821BH050C175N	58	11	J-23987-B	57	64
B1821BH050C250N	21	23	J-24420-C	57	46
B1821BH050C475N	59	18	J-24889	56	6
B1821BH050C500N	58	15	J-25521	57	87
B1821BH050F075N	58	10	J-2619-01	57	55

PART NUMBER	FIG.	ITEM	PART NUMBER	FIG.	ITEM
J-28479	56	7	J9462-02	57	24
J-3154-1A	57	27	J9479	57	33
J-33421-A	57	17	J9595	56	10
J-34650	57	54	J9665	56	23
J-3936-C	57	12	J9769	57	16
J-5286-8	57	93	J9783	57	32
J-5895	56	22	K 5150193 NON-ASBESTOS	7	24
J-5901-3	57	2		28	10
J-6471-02	57	56	K 5152944 NON-ASBESTOS	41	4
J-6883-B	57	13	K-512342	38	8
J-7593-03	57	94	M001729ME	55	2
J-7775-A	57	49	M45913/1-10CG5C	59	20
J-7792-01	57	4	M45913/1-6CG5C	45	9
J-8150	57	71		59	30
J-8170	57	78	M45913/1-8CG5C	59	16
J-9418-1	57	77	M45913/2-6FG5C	33	27
J-9418-5	57	76		34	7
J-9737-D	57	21	M6000-A	51	16
J-9790	57	34	M6855/4-10L089	56	26
J1291-02	57	73		57	95
J1508	10	3	MIL-F-200627TYIICL2	45	22
J1698-02	56	11	MIL-F-20627TYIICL2	44	7
J21068	57	36	MML736C TYPE 11	BULK	9
J21224	57	1	MS122123	16	3
J21462-A	57	82		17	29
J22090-A	57	7	MS14307-1	3	3
J22396-1	57	29	MS16286-3	21	28
J22490	57	44		30	21
J22525-4	57	85		44	24
J22576	57	67	MS16624-1137	36	11
J23190	56	8	MS16625-2077	36	13
J23435-C	57	70	MS16997-84	18	12
J23679-A	57	65	MS17131-9	39	2
J24519	57	37	MS17829-4F	42	4
J24838	57	74		43	11
J26554-A	56	19	MS20995NC20	BULK	11
J28483	57	69	MS21045-7	24	1
J35572	57	31	MS21318-20	39	34
J4298-1	57	80	MS21318-29	23	6
J5138-6010102BA	31	29	MS21318-46	59	6
J5286-20	57	30	MS21318-48	58	35
J7540	57	5	MS21333-59	19	8
J7557	57	38		46	32
J7773	57	35		47	40
J7790	57	40	MS24692-178	38	19
J7872	57	28	MS27183-12	7	11
J7915-3C	56	1		15	6
J7944	57	9		16	7
J8062	57	14		17	14
J8151	57	22		18	5
J8984	57	58		31	20
J8985	57	51		45	11
J9418	57	75		49	4

PART NUMBER	FIG.	ITEM	PART NUMBER	FIG.	ITEM
MS27183-14	53	2		15	5
	54	18		16	8
	2	34		17	6
	4	16		18	9
	7	5		18	13
	14	3		23	10
	16	4		25	5
	17	34		31	19
	18	20		45	12
	20	18		49	3
	21	4		53	3
	22	4		54	17
	23	3	MS35338-47	4	2
	29	3		4	6
	33	17		33	26
	37	3		34	16
	38	29		46	34
	44	22		47	12
	45	8		48	10
	46	2		49	11
47	4		53	15	
48	3		58	24	
49	9	MS35338-48	21	24	
52	3		34	14	
54	4		58	6	
59	29	MS35649-103	51	6	
MS27183-15	51	14	MS35649-205B	10	13
	53	14	MS35649-265B	39	17
MS27183-16	4	7	MS35649-282	51	3
	46	35	MS35691-1024	20	4
	47	11		21	12
	48	11	MS35691-5	39	14
	49	10		41	5
MS27183-17	21	25	MS35764-1277	32	10
MS27183-18	58	4	MS35764-250	4	11
MS27183-21	58	17	MS35769-7	2	33
	59	27	MS39162	31	26
MS27183-23	45	2	MS51065RP37-2	54	1
MS27183-42	39	22	MS51504A16	21	1
MS35207-263	47	30	MS51846-28	29	7
MS35207-264	46	20		30	6
	47	29	MS51953-25B	46	7
MS35333-44	48	28	MS51967-11	53	16
	59	12	MS51967-14	58	3
	51	4	MS51967-2	43	5
MS35338-42	46	21		47	6
MS35338-43	47	28	MS51967-20	58	19
	48	27	MS51967-23	45	5
	51	5	MS51967-8	7	14
MS35338-44	13	34		19	9
MS35338-45	2	27		46	12
	3	16		47	14
	7	22		48	8

PART NUMBER	FIG.	ITEM	PART NUMBER	FIG.	ITEM
	49	25		44	23
	53	30		45	14
	58	31		46	11
MS51968-5	18	19		47	3
MS51968-8	7	1		49	8
	33	15		52	2
NAMS35338	45	4		53	20
NAS1352-5-14P	23	14		53	21
	54	20		58	28
NAS1352-5-16P	23	14	019-00004-46	48	2
NAS1352-5-48P	32	5	05103975	41	15
OF203	20	11	05107075	12	22
	21	21	05113825	11	10
OF594	44	18	05135268	13	13
PD5120-00-293-1429	57	43	05138420	18	23
Q5228594	27	21	05147345	42	6
Q5228596	27	19	08924380	2	2
Q5228694	27	17		5	9
Q5228696	27	18		23	24
SAE J512 4-4 040202B	3	13		32	16
SAE J513 4-4 010202B	3	5		47	19
SAEJ5134.4010202B	31	16		54	15
TA330-10-10-R	58	37	090321	21	8
	59	3	0907394	54	3
V5121735	48	34	0F209	44	12
V5521735	47	31		45	27
V5J21735	46	25	1000-16164	23	1
YA342C	56	27	10513844	57	18
002104T	27	4	10513891	57	3
002113T	27	8	10514045	57	92
0040398	2	11	10875136	15	15
00513	41	13	10881874	57	53
019-00001-95	53	18	10881875	56	2
019-00004-42	2	43	10881892	57	86
	4	15	10881893	57	88
	5	17	10881896	57	89
	7	2	10881897	57	90
	12	13	10881907	56	17
	14	2	10886344-5	BULK	1
	16	5	10890481	58	26
	17	2		59	26
	18	2	10899180	56	25
	19	4	10910174-5	59	8
	20	19	10910174-7	59	21
	21	3	109155	42	7
	22	5	10930560	56	21
	29	2	10935405	56	4
	30	2		57	10
	31	2	10942647	56	20
	33	16	10949344	56	28
	34	12	11016	44	15
	37	2		45	31
	38	28	112-7377	38	14

PART NUMBER	FIG.	ITEM	PART NUMBER	FIG.	ITEM
113-964ID1	48	37	12313367	4	4
114493	16	11	12313437	47	27
11589281	4	13	12313567	21	30
11589292	4	12	12313571	47	26
11594036	6	4	12313864	24	6
116337	39	25	12313892-1 AND 12313892-2	33	7
11650200-1	1	2	12313895	33	9
11650202	1	3	12313896	33	5
11650210	58	13	12313898	33	3
11650211	58	1	12368977	49	13
11650211-11	58	2	127259A	38	3
11650212	58	32	131-03008	43	17
11650213	58	7	137422	46	23
11650214	58	8		47	33
11650215	58	12		48	32
11650217	58	23		51	7
11650218	58	21	137423	29	12
11650219	58	14		51	9
11650220	58	5	140580	30	18
11650221	58	9		31	3
11650223	BULK	10	141242	39	27
11650224	58	34	142583	39	6
11650241	1	2	143512	43	9
11650249-1	1	2	148148	39	4
11650253	7	15	1595620	20	6
11662997	BULK	6		21	14
11678105	57	8	1622744	32	27
11678204	59	17	180129	37	1
11678205	59	14	182-15	49	19
11678206	59	9	186277	37	17
11678207	59	24	186624	49	6
11678208	59	22	186625	7	21
11678209	59	1		50	4
11678210	1	3	187069	21	27
11678211	59	15	187425	33	25
11678239	59	28	192884	4	18
11678246	59	10	193268	23	11
11678261	59	19	1C817P63	13	35
120380	32	23		38	1
	38	2		47	16
	43	6	1DD486	13	25
	47	5	1K6717	42	1
120613	42	13		52	14
1211-60	56	14		53	10
	57	41	2-2130139B	46	24
12258932-6	31	23		47	32
	48	13		48	33
	49	15	21178	57	23
12258932-9	2	18	2132828-6-6-6-32.00	30	9
	37	19	2132828-6-6-6-35.25	30	4
12258938	31	24	2132869-6-6-6-8.50	30	14
12269598	10	9	215386	15	22
12313344	6	5		53	5

PART NUMBER	FIG.	ITEM	PART NUMBER	FIG.	ITEM
23500204	37	13	23516871	14	8
23500205	33	8	23518271	49	32
23500206	33	2	23520633	32	37
23500691	34	23	23522744	34	34
23500799	13	24	23524662	13	28
23501125	4	19	23528796	17	22
23501135	4	17	23MS35338-46	23	2
23501136	13	20	2441FHD-5	47	22
23501591	15	1	247B	57	6
23501592	52	10	2488022	30	3
23501681	2	17		31	8
23501682	11	13		33	12
23501683	11	7		34	29
23501808	17	23		47	17
23501826	31	25		48	25
23501827	45	16	24H1682	7	8
23501828	31	21		36	16
23501830	31	28	25101011	29	14
23502455	48	35		30	23
23502456	48	30		31	9
23502458	11	8	2510127	58	33
23502801	32	25		59	2
23503779	KITS	10	25N450PC49	7	7
23503811	KITS	11	271468	38	9
23503825	52	18	274946	43	3
	53	8	2856628-6	59	4
23503828	52	18	298S30233	34	4
23503948	9	5	298S30234	34	24
23504151	3	4	298S30235	34	1
23504732	6	8	298S30236	34	26
23504946	9	8	298S30237	24	6
23505048	15	11	2AG305	49	26
	16	15	2AG452	11	9
	17	31	2KM50	56	12
	52	5	304-J22062-01	56	5
	53	23	305001	51	12
23505789	35	4	3223914	57	72
23506011	54	6	3S9643	52	17
23506389	49	1		53	7
23506869	KITS	5	3YFL	57	62
23507978	35	1	400627-0620	35	7
23509198	16	22	400960-0410	35	15
23511479	26	6	403818-0	35	12
	28	6	425-100-004	47	21
23511852	27	1	4397001-071	7	9
23515194	35	2	441411-0001	35	17
23515215	11	4	441829-2	35	9
23516121	49	5	441880-1	35	3
23516122	49	31	442028-1	35	20
23516454	5	1	442029-3	35	23
23516636	6	14	442032-1	35	6
23516736	32	1	443110-0001	35	25
23516738	32	1	443686-1	35	16

PART NUMBER	FIG.	ITEM	PART NUMBER	FIG.	ITEM
446397-5560	35	24	5104301	32	15
446597	15	21	5104370	3	19
	16	25	5104391	54	14
	17	19	5104439	24	2
454065	43	1	5104514	11	2
454749	43	4	5104515	11	3
	43	14	5104516	38	20
457009	38	21	5104526ND	32	14
466176-1	33	21	5104550	23	9
	34	9	5104701	5	5
4740-5-4B	46	29	5104714	23	5
	47	34	5104771	21	5
	48	36	5104801	16	28
	51	8	5104839	52	15
5-4040202	31	6		53	11
	48	15	5104846	16	1
5-5040201B	48	12		17	27
	49	14	5104866	21	7
5100104	10	12		22	1
5100998	39	10	5104868	16	29
5100999	39	11		17	26
5101016	8	1	5104881	16	24
	9	1		17	24
5101163	24	7	5104978	33	14
	33	10	5106055	39	16
	34	27	5106266	38	18
5101258	42	10	5106360	12	3
5101295	42	11	5107071	6	13
5101391	49	27	5107072	12	9
5101392	42	12	5107073	12	18
5101397	42	9	5107079	36	2
5101402	43	2	5107083	32	11
5101691	38	22	5107084	32	7
5101760	11	16	5107087	28	3
5101779	2	44	5107088	26	3
	12	14	5107440	2	31
5101798	41	7	5107890	16	18
5102270	41	6	5107891	16	10
5102567	19	20	5107930	16	20
5102982	19	12	5108025	29	10
5103474	36	1	5108131	8	6
5103635	11	1	5108919	13	27
5103636	11	17	5109020	46	15
5103642	11	14		47	24
5103646	11	5	5109157	2	15
5103647	11	15	5109496	49	29
5103747	38	15		50	1
5103748	38	10	5109517	49	28
5103782	38	7		50	2
5103786	38	7	5109549	52	4
5103892	22	8		53	28
5104083	33	6	5109680	52	7
5104293	54	7		53	25

PART NUMBER	FIG.	ITEM	PART NUMBER	FIG.	ITEM
5109803	23	19	5119293	5	11
5109807	14	4	5119314	39	31
5109946	23	18	5119368	23	12
5111467	5	3	5119393	32	2
	13	40	5119394	32	42
5113191	3	7	5119395	32	41
5113214	46	6	5119426	23	15
5113687	46	5	5119429	32	40
5113800	54	10	5119433 NON-ASBESTOS	32	39
5114049	3	9	5119438	39	37
	46	4	5119457	10	10
5115214	15	23	5119466	32	35
	19	2	5120-494-1846	57	52
5116011	39	12	5120-999-8618	57	11
5116070	23	5	5120740	20	14
5116071	39	24		21	19
5116072	13	22	5121001	39	10
5116122	2	21	5121044	10	11
5116125	13	33	5121077	12	7
5116128	13	21	5121207	2	24
5116164	32	12	5121254	2	23
5116165	32	12	5121256	8	2
5116166	32	12		9	2
5116167	32	12	5121263	5	20
5116170	32	21	5121336	32	31
5116184	8	4	5121337	40	2
5116189	8	7	5121339	39	20
5116198	12	8	5121343	36	15
5116205	24	4	5121344	36	14
5116224	23	17	5121345	39	36
5116242	5	22	5121403	17	7
	52	8	5121452	42	3
	53	29	5121453	42	18
5116262	5	6	5121458	39	11
5116264	42	16	5121459	2	38
5116265	42	14	5121472	42	5
5116290	2	22	5121490	39	1
5116292	2	20	5121989	BULK	2
5116301	7	16	5122165	41	14
5116341	13	37	5122166	39	35
5116357	2	25	5122610	37	9
	15	8	5122771	40	9
	16	12	5122786	40	8
	17	10	5123250	13	29
5116418	36	4	5123330	13	38
5117693	39	3	5123700	13	2
5117786	52	19		13	9
5119198	13	19		13	18
5119218	2	7	5123711	13	5
5119266	19	15		13	16
5119282 NON-ASBESTOS	54	9	5123802	2	39
5119283	54	8	5123918	2	26
5119285	36	10	5124055	14	9

PART NUMBER	FIG.	ITEM	PART NUMBER	FIG.	ITEM
5124209	39	8		46	10
5124458	12	21	5131961	5	2
5124762	4	10	5132117	2	32
5124802	3	11	5132479	2	12
5125367	40	3	5132504	12	20
5125488	5	19	5132519	46	19
5125608	2	46	5132599	48	23
5125771	26	1	5132612	48	18
	28	1		49	20
5125774	26	2	5132695	2	47
	28	2	5132803	8	1
5126069	39	28		9	1
5126072	42	20	5132923	32	29
5126135	41	12	5132962	39	15
5126143	18	6	5133	44	5
5126236	32	8	5133107	54	19
5126237	32	33	5133162	31	17
5126436	23	21	5133263	20	15
5126473	18	10	5133296	37	8
	23	16	5133397	2	36
5126671	7	17	5133486	19	10
5126672	26	4	5133512	7	15
	28	4	5133530	7	19
5126933	12	16	5133532	15	13
5126934	12	5	5133535	15	10
5127077	32	17	5133536	15	18
5127238	37	6	5133537	15	16
5127247	37	7	5133538	15	20
5127949	5	16	5133539	15	19
5127963	32	38	5133619	15	17
5128640	13	30	5133662	40	5
5129168	36	6	5133707	40	7
5129627	46	30	5133819	40	1
	47	37	5133829	47	1
5129705	42	19	5134079	19	5
5129706	42	2	5134146	19	7
5130488	33	4	5134179	32	18
	34	10	5134195	3	1
5130678	BULK	3	5134304	20	17
5130913	49	33	5134526	25	1
5130995	55	1	5134759	47	15
5131132	41	3	5134825	10	8
5131190	33	22	5134914	32	15
5131375	29	5	5134915	32	3
	31	7	5135016	24	3
5131426	19	18	5135034	29	13
5131433	17	3		30	22
	33	28		31	10
	34	8	5135046	10	1
5131541	41	9	5135262	13	6
5131575	30	8		13	17
	34	5	5135267	13	1
5131913	32	30	5135713	52	13

PART NUMBER	FIG.	ITEM	PART NUMBER	FIG.	ITEM
5135876	36	12	5145429	46	1
5135877	18	15		47	7
5135935	25	3		48	5
5136090	18	14	5145461	51	17
5136097	23	28	5145565	46	18
5136207	46	36	5145566	46	26
5136225	18	17		47	8
5136227	23	26		48	6
5136323	46	9	5145661	19	13
5136610	5	23	5145666	51	16
5136948	19	22	5145678	10	4
5137470	7	3	5145820	39	1
5138240	18	7	5145823	39	31
5138254	18	22	5145826	43	10
5138335	39	30	5145827	43	16
5138619	18	3	5145828	43	12
5138786	6	6	5146039	43	15
5138796	23	17	5146233	43	13
5138830	23	18	5146648	2	4
5138945	6	3		23	23
5139237	54	2		52	9
5139988	23	25		53	26
5139997	5	15	5146900	2	13
5140259	10	2	5147683	20	1
5140399	47	23		21	9
5140949	8	9	5147684	20	2
5141701	2	9		21	10
5142005	31	14	5147858	46	14
5142056	46	31	5147883	46	13
	47	39	5147911	33	19
	48	40	5148437	19	14
5142160	16	14	5148932	51	15
	17	33	5149154	35	22
5142266	32	13	5149163	35	5
5142470	46	16	5149173	35	21
	47	38	5149944	8	1
	48	39		9	1
5142549	37	12	5149945	8	2
5142748	51	1		9	2
5143021	23	22	5149965	42	8
5143774	30	17	5149966	42	17
	31	4	5150087	12	1
5144019	13	39	5150130	2	14
5144177	38	13	5150250	27	3
5144325	50	7	5150303	13	26
5144367	50	5	5150311	13	12
5144425	5	14	5150312	13	3
5144503	54	13		13	8
5144934	49	30		13	14
5145007	39	18	5150314	13	4
5145223	51	10		13	10
5145427	51	11		13	15
5145428	51	13	5150318	13	11

PART NUMBER	FIG.	ITEM	PART NUMBER	FIG.	ITEM
5150829	14	5	5188274	2	41
5150941	39	7	5189789	43	8
5150943	39	9	5192111	6	10
	39	13	5195685	23	7
5150947	41	11	5195686	23	9
5151249	38	6	5195687	23	8
	41	10	5196119	3	20
5151272	13	23	5196793	12	23
5151277	12	6	5196852	6	15
	12	17	5197176	13	36
5151430	19	11	5197852	8	10
5151449	5	12		9	15
5151487	38	24	5197944	2	16
	39	5	5197945	2	16
5151519	38	5	5197946	2	16
5151883	3	17	5197975	8	12
5151921	3	18		9	17
5152716	7	23	5197976	8	12
5153060	38	12		9	17
5154453	5	8	5197977	8	12
	5	21		9	17
5154538	20	9	5197978	8	12
	21	17		9	17
5155818	25	2	5197979	8	12
5155819	25	4		9	17
5157933	14	6	5198043	KITS	1
5159353	6	10	5198049	35	19
5160542	6	10	5198092	8	8
5162888	33	20	5198203	5	1
	34	31	5198303	20	16
5166864	4	8		21	6
	58	22		22	2
5170468	34	18	5198410	6	11
5171509	29	4	5198411	6	11
5172383	39	32	5198412	6	11
5172734	12	11	5198413	6	11
5174286	39	33	5198414	6	11
5174429	38	11	5198502	6	6
5174436	41	8	5198503	23	17
5175606	33	18	5198655	5	13
5175882	7	4	5198683	KITS	2
5178581	38	25	5198877	8	5
5180116	43	7	5198901	KITS	3
5180291	6	2	5198936	35	11
5181415	10	5	5198983	2	16
	53	13	5198988	35	18
5186647	4	1	5199116	KITS	4
5187308	20	10	5199366	32	13
	21	18	5199368	32	13
5187309	20	7	5199396	12	16
	21	15	5199397	12	5
5187310	20	8	5199561	28	9
	21	16	5199734	28	9

PART NUMBER	FIG.	ITEM	PART NUMBER	FIG.	ITEM
5199782	BULK	7	5703812	1	1
5199811	KITS	6	5705596	1	1
52-225-015	57	25	5705597	1	1
520275	50	3	57K1000	1	1
5226029	36	7	57K1006	1	1
5226186	27	10	6-4-6.040424B	31	13
5226240	27	7	6-6-4 040427B	29	6
5226246	27	20		30	5
5226400	27	14	60598	23	20
5226404	27	22	62518-12	20	3
5226422	27	16	6435424	44	16
5226719	27	13		45	32
5228109	27	23	6436254	44	2
5228584	27	12		45	18
5228586	27	15	6436746	44	18
5228587	27	11		45	34
5228588	27	9	6437298	20	13
5228594	27	21		21	20
5228596	27	19	65-0251	57	61
5228601	27	25	6518-12	21	11
5228608	27	26	6525196	40	6
5228694	27	17	663085	45	17
5228739	27	28	6663085	44	1
5228749	27	16	6673	56	24
5228766	27	20	6J505	36	3
5228769	KITS	7	7375429	41	2
5228783	27	7		46	28
5229034	27	22		47	36
5229167	27	24		48	38
5229191	27	27	7613324	18	21
5229649	KITS	8	7950189	57	59
5232650	50	8	7950198	57	60
52456439	16	23	7973326	58	36
	17	25		59	5
5570480	20	12	7F0368	BULK	5
	21	22	8005	57	57
5573736	44	13	8350641	7	12
	45	28	8352283	59	13
5574118	44	3	839103	8	11
	45	19		9	16
5574120	44	9	8547195	15	2
	45	24	8547572	15	24
5574123	44	10	8675776	28	5
	45	25	8675776	26	5
5574126	44	11	8708359	57	15
	45	26	8738127	1	2
5574161	45	21	87708-S	6	9
5575169	44	8	885804X1C	54	12
	45	23	8921167	51	2
5575824	44	15	8921172	6	7
5575893	44	19	8921313	2	19
	45	35	8921472	38	16
5611416	50	6	8921501	5	10

PART NUMBER	FIG.	ITEM	PART NUMBER	FIG.	ITEM
8921502	5	10	8924199	30	12
8921826	15	12	8924217	30	13
	16	17		31	31
	17	32	8924218	31	27
8921827	52	6		48	17
	53	24	8924297	54	11
8921876	2	10	8924517	15	9
8921932	38	26		16	13
8921934	28	11		17	11
8922969	32	34		23	27
8923223	15	3		44	21
8923313	2	3		45	30
	2	30		52	11
	19	19		53	1
	54	21	8924545	32	3
8923328	8	3	8924557	32	4
8923554	13	7	8924566	32	2
8923814	13	32	8924731	9	10
8923847	2	8	8924732	9	12
	5	7	8924733	9	6
	16	26	8924734	9	13
	17	8	8924735	9	9
	30	11	8924750	16	19
	31	22	8925032	3	2
	37	14		46	17
	48	22		47	25
	49	17		48	26
8923916	17	13	8925269	11	11
8924002	9	7	8925270	11	18
8924003	9	14	8925273	11	12
8924140	15	14	8925644	27	6
8924154	30	10	8925675	16	2
	31	5		17	28
8924161	3	10	8925746	35	10
	33	13	8925749	35	13
	34	28	8925751	35	14
	51	9	8925779	9	4
8924168	29	8	8925780	9	3
	30	7	8925804	24	5
	31	12	8925942	12	2
	48	14	8925945	12	2
	49	16	8925981	5	4
8924171	30	15	8926005	12	10
	33	24	8926085	7	25
	34	6	8926247	6	12
8924172	29	11	8926248	12	4
	30	24	8926290	3	14
	31	11	8926488	19	17
8924178	31	15	8926489	19	16
	48	16	8926596	3	12
	49	18	8926597	47	10
8924183	30	16	8926603	28	8
8924185	29	9	8926703	32	28

PART NUMBER	FIG.	ITEM	PART NUMBER	FIG.	ITEM
8926902	6	15	8928727	48	4
8926978	52	16	8928767	53	31
8926992	27	5	8928768	53	12
8926997	2	1	8928769	54	14
8927003	2	1	8928771	53	6
8927223	KITS	9	8928803	54	6
8927224	9	11	8928812	17	18
8927534	34	22	8928896	48	21
8927579	30	19		49	23
	31	1	8928897	48	24
8927580	7	20		49	24
8927581	49	34	8929529	33	29
8927674	32	22		34	11
8927733	37	15	8996207	3	6
8927743	KITS	12	904209	58	18
8927796	3	8	9320	57	20
8927797	11	16	9402839	48	19
8928522	KITS	13		49	21
8928531	2	5	9409010	18	4
8928636	37	16	9409029	12	15
8928637	34	19	9409034	32	19
8928639	19	23	9409062	32	20
8928640	19	21	9409073	26	7
8928641	19	24		28	7
8928642	34	3	9409129	7	18
8928643	34	25	9409219	32	32
8928644	34	33	9409221	32	36
8928647	7	25	9414215	7	10
8928695	32	6	9414523	2	45
8928714	22	3	9417025	39	23
8928715	17	17	9417392	38	17
8928716	17	16	9418228	55	3
8928717	17	20	9420604	32	9
8928718	17	15	9421753	36	9
8928720	53	9	9421917	39	21
8928721	53	22	9422203	42	15
8928722	17	4	9431894	39	19
8928723	4	20	9432266	47	18
8928724	45	3	9437108	40	4
8928725	45	7	9437758	16	27
8928726	45	10			

END OF WORK PACKAGE

RECOMMENDED CHANGES TO PUBLICATIONS AND BLANK FORMS For use of this form, see AR 25-30; the proponent agency is ODISC4.						Use Part II (reverse) for Repair Parts and Special Tool Lists (RPSTL) and Supply Catalogs/Supply Manuals (SC/SM).	DATE Date you filled out this form.
TO: (Forward to proponent of publication or form) (Include ZIP Code) U.S. Army TACOM Life Cycle Management Command ATTN: AMSTA-LCL-MPP/TECH PUBS 6501 E. 11 Mile Road Warren, MI 48397-5000						FROM: (Activity and location) (Include ZIP Code) Your mailing address	
PART I - ALL PUBLICATIONS (EXCEPT RPSTL AND SC/SM) AND BLANK FORMS							
PUBLICATION/FORM NUMBER TM 9-2815-205-24P						DATE 25 February 2013	TITLE; FIELD AND SUSTAINMENT MAINTENANCE REPAIR PARTS AND SPECIAL TOOLS LIST FOR 6V53/6V53T ENGINES, DIESEL
ITEM NO.	PAGE NO.	PARA-GRAPH	LINE NO.*	FIGURE NO.	TABLE NO.	RECOMMENDED CHANGES AND REASON (Provide exact wording of recommended changes, if possible).	
	9-5	9-7				Wrong POC is listed for small arms information.	
SAMPLE							
*Reference to line number within the paragraph or subparagraph.							
TYPED NAME, GRADE OR TITLE Your Name				TELEPHONE EXCHANGE/AUTOVON, PLUS EXTENSION Your DSN or Commercial Phone		SIGNATURE Your Signature	

TO: (Forward to proponent of publication or form) (Include ZIP Code) U.S. Army TACOM Life Cycle Management Command ATTN: AMSTA-LCL-MPP/TECH PUBS 6501 E. 11 Mile Road Warren, MI 48397-5000	FROM: (Activity and location) (Include ZIP Code) Your mailing address	DATE Date you filled out this form.
--	---	---

PART II - REPAIR PARTS AND SPECIAL TOOL LISTS AND SUPPLY CATALOGS/SUPPLY MANUALS

PUBLICATION/FORM NUMBER TM 9-2815-205-24P	DATE 25 February 2013	TITLE; FIELD AND SUSTAINMENT MAINTENANCE REPAIR PARTS AND SPECIAL TOOLS LIST FOR 6V53/6V53T ENGINES, DIESEL
--	--------------------------	---

PAGE NO.	COLM NO.	LINE NO.	FEDERAL STOCK NUMBER	REFERENCE NO.	FIGURE NO.	ITEM NO.	TOTAL NO. OF MAJOR ITEMS SUPPORTED	RECOMMENDED ACTION
SAMPLE								

PART III - REMARKS (Any general remarks or recommendations, or suggestions for improvement of publications and blank forms. Additional blank sheets may be used if more space is needed.)

TYPED NAME, GRADE OR TITLE Your Name	TELEPHONE EXCHANGE/AUTOVON, PLUS EXTENSION Your DSN or Commercial Phone	SIGNATURE Your Signature
---	--	-----------------------------

RECOMMENDED CHANGES TO PUBLICATIONS AND BLANK FORMS						Use Part II (reverse) for Repair Parts and Special Tool Lists (RPSTL) and Supply Catalogs/Supply Manuals (SC/SM).	DATE
For use of this form, see AR 25-30; the proponent agency is ODISC4.							
TO: (Forward to proponent of publication or form) (Include ZIP Code) U.S. Army TACOM Life Cycle Management Command ATTN: AMSTA-LCL-MPP/TECH PUBS 6501 E. 11 Mile Road Warren, MI 48397-5000						FROM: (Activity and location) (Include ZIP Code)	
PART I - ALL PUBLICATIONS (EXCEPT RPSTL AND SC/SM) AND BLANK FORMS							
PUBLICATION/FORM NUMBER TM 9-2815-205-24P					DATE 25 February 2013		TITLE; FIELD AND SUSTAINMENT MAINTENANCE REPAIR PARTS AND SPECIAL TOOLS LIST FOR 6V53/6V53T ENGINES, DIESEL
ITEM NO.	PAGE NO.	PARA-GRAPH	LINE NO.*	FIGURE NO.	TABLE NO.	RECOMMENDED CHANGES AND REASON (Provide exact wording of recommended changes, if possible).	
*Reference to line number within the paragraph or subparagraph.							
TYPED NAME, GRADE OR TITLE				TELEPHONE EXCHANGE/AUTOVON, PLUS EXTENSION		SIGNATURE	

TO: (Forward to proponent of publication or form) (Include ZIP Code) U.S. Army TACOM Life Cycle Management Command ATTN: AMSTA-LCL-MPP/TECH PUBS 6501 E. 11 Mile Road Warren, MI 48397-5000	FROM: (Activity and location) (Include ZIP Code)	DATE
--	---	-------------

PART II - REPAIR PARTS AND SPECIAL TOOL LISTS AND SUPPLY CATALOGS/SUPPLY MANUALS

PUBLICATION/FORM NUMBER TM 9-2815-205-24P	DATE 25 February 2013	TITLE; FIELD AND SUSTAINMENT MAINTENANCE REPAIR PARTS AND SPECIAL TOOLS LIST FOR 6V53/6V53T ENGINES, DIESEL
--	--------------------------	---

PAGE NO.	COLM NO.	LINE NO.	FEDERAL STOCK NUMBER	REFERENCE NO.	FIGURE NO.	ITEM NO.	TOTAL NO. OF MAJOR ITEMS SUPPORTED	RECOMMENDED ACTION

PART III - REMARKS (Any general remarks or recommendations, or suggestions for improvement of publications and blank forms. Additional blank sheets may be used if more space is needed.)

TYPED NAME, GRADE OR TITLE	TELEPHONE EXCHANGE/AUTOVON, PLUS EXTENSION	SIGNATURE
----------------------------	--	-----------

RECOMMENDED CHANGES TO PUBLICATIONS AND BLANK FORMS						Use Part II (reverse) for Repair Parts and Special Tool Lists (RPSTL) and Supply Catalogs/Supply Manuals (SC/SM).	DATE
For use of this form, see AR 25-30; the proponent agency is ODISC4.							
TO: (Forward to proponent of publication or form) (Include ZIP Code) U.S. Army TACOM Life Cycle Management Command ATTN: AMSTA-LCL-MPP/TECH PUBS 6501 E. 11 Mile Road Warren, MI 48397-5000						FROM: (Activity and location) (Include ZIP Code)	
PART I - ALL PUBLICATIONS (EXCEPT RPSTL AND SC/SM) AND BLANK FORMS							
PUBLICATION/FORM NUMBER TM 9-2815-205-24P					DATE 25 February 2013		TITLE; FIELD AND SUSTAINMENT MAINTENANCE REPAIR PARTS AND SPECIAL TOOLS LIST FOR 6V53/6V53T ENGINES, DIESEL
ITEM NO.	PAGE NO.	PARA-GRAPH	LINE NO.*	FIGURE NO.	TABLE NO.	RECOMMENDED CHANGES AND REASON (Provide exact wording of recommended changes, if possible).	
*Reference to line number within the paragraph or subparagraph.							
TYPED NAME, GRADE OR TITLE				TELEPHONE EXCHANGE/AUTOVON, PLUS EXTENSION		SIGNATURE	

TO: (Forward to proponent of publication or form) (Include ZIP Code) U.S. Army TACOM Life Cycle Management Command ATTN: AMSTA-LCL-MPP/TECH PUBS 6501 E. 11 Mile Road Warren, MI 48397-5000	FROM: (Activity and location) (Include ZIP Code)	DATE
--	---	-------------

PART II - REPAIR PARTS AND SPECIAL TOOL LISTS AND SUPPLY CATALOGS/SUPPLY MANUALS

PUBLICATION/FORM NUMBER TM 9-2815-205-24P	DATE 25 February 2013	TITLE; FIELD AND SUSTAINMENT MAINTENANCE REPAIR PARTS AND SPECIAL TOOLS LIST FOR 6V53/6V53T ENGINES, DIESEL
--	--------------------------	---

PAGE NO.	COLM NO.	LINE NO.	FEDERAL STOCK NUMBER	REFERENCE NO.	FIGURE NO.	ITEM NO.	TOTAL NO. OF MAJOR ITEMS SUPPORTED	RECOMMENDED ACTION

PART III - REMARKS (Any general remarks or recommendations, or suggestions for improvement of publications and blank forms. Additional blank sheets may be used if more space is needed.)

TYPED NAME, GRADE OR TITLE	TELEPHONE EXCHANGE/AUTOVON, PLUS EXTENSION	SIGNATURE
----------------------------	--	-----------

RECOMMENDED CHANGES TO PUBLICATIONS AND BLANK FORMS For use of this form, see AR 25-30; the proponent agency is ODISC4.						Use Part II (reverse) for Repair Parts and Special Tool Lists (RPSTL) and Supply Catalogs/Supply Manuals (SC/SM).	DATE
TO: (Forward to proponent of publication or form) (Include ZIP Code) U.S. Army TACOM Life Cycle Management Command ATTN: AMSTA-LCL-MPP/TECH PUBS 6501 E. 11 Mile Road Warren, MI 48397-5000						FROM: (Activity and location) (Include ZIP Code)	
PART I - ALL PUBLICATIONS (EXCEPT RPSTL AND SC/SM) AND BLANK FORMS							
PUBLICATION/FORM NUMBER TM 9-2815-205-24P						DATE 25 February 2013	TITLE; FIELD AND SUSTAINMENT MAINTENANCE REPAIR PARTS AND SPECIAL TOOLS LIST FOR 6V53/6V53T ENGINES, DIESEL
ITEM NO.	PAGE NO.	PARA-GRAPH	LINE NO.*	FIGURE NO.	TABLE NO.	RECOMMENDED CHANGES AND REASON (Provide exact wording of recommended changes, if possible).	
*Reference to line number within the paragraph or subparagraph.							
TYPED NAME, GRADE OR TITLE				TELEPHONE EXCHANGE/AUTOVON, PLUS EXTENSION		SIGNATURE	

TO: (Forward to proponent of publication or form) (Include ZIP Code) U.S. Army TACOM Life Cycle Management Command ATTN: AMSTA-LCL-MPP/TECH PUBS 6501 E. 11 Mile Road Warren, MI 48397-5000	FROM: (Activity and location) (Include ZIP Code)	DATE
--	---	-------------

PART II - REPAIR PARTS AND SPECIAL TOOL LISTS AND SUPPLY CATALOGS/SUPPLY MANUALS

PUBLICATION/FORM NUMBER TM 9-2815-205-24P	DATE 25 February 2013	TITLE; FIELD AND SUSTAINMENT MAINTENANCE REPAIR PARTS AND SPECIAL TOOLS LIST FOR 6V53/6V53T ENGINES, DIESEL
--	--------------------------	---

PAGE NO.	COLM NO.	LINE NO.	FEDERAL STOCK NUMBER	REFERENCE NO.	FIGURE NO.	ITEM NO.	TOTAL NO. OF MAJOR ITEMS SUPPORTED	RECOMMENDED ACTION

PART III - REMARKS (Any general remarks or recommendations, or suggestions for improvement of publications and blank forms. Additional blank sheets may be used if more space is needed.)

TYPED NAME, GRADE OR TITLE	TELEPHONE EXCHANGE/AUTOVON, PLUS EXTENSION	SIGNATURE
----------------------------	--	-----------

RECOMMENDED CHANGES TO PUBLICATIONS AND BLANK FORMS For use of this form, see AR 25-30; the proponent agency is ODISC4.						Use Part II (reverse) for Repair Parts and Special Tool Lists (RPSTL) and Supply Catalogs/Supply Manuals (SC/SM).	DATE
TO: (Forward to proponent of publication or form) (Include ZIP Code) U.S. Army TACOM Life Cycle Management Command ATTN: AMSTA-LCL-MPP/TECH PUBS 6501 E. 11 Mile Road Warren, MI 48397-5000						FROM: (Activity and location) (Include ZIP Code)	
PART I - ALL PUBLICATIONS (EXCEPT RPSTL AND SC/SM) AND BLANK FORMS							
PUBLICATION/FORM NUMBER TM 9-2815-205-24P						DATE 25 February 2013	TITLE; FIELD AND SUSTAINMENT MAINTENANCE REPAIR PARTS AND SPECIAL TOOLS LIST FOR 6V53/6V53T ENGINES, DIESEL
ITEM NO.	PAGE NO.	PARA-GRAPH	LINE NO.*	FIGURE NO.	TABLE NO.	RECOMMENDED CHANGES AND REASON (Provide exact wording of recommended changes, if possible).	
*Reference to line number within the paragraph or subparagraph.							
TYPED NAME, GRADE OR TITLE				TELEPHONE EXCHANGE/AUTOVON, PLUS EXTENSION		SIGNATURE	

TO: (Forward to proponent of publication or form) (Include ZIP Code) U.S. Army TACOM Life Cycle Management Command ATTN: AMSTA-LCL-MPP/TECH PUBS 6501 E. 11 Mile Road Warren, MI 48397-5000	FROM: (Activity and location) (Include ZIP Code)	DATE
--	---	-------------

PART II - REPAIR PARTS AND SPECIAL TOOL LISTS AND SUPPLY CATALOGS/SUPPLY MANUALS

PUBLICATION/FORM NUMBER TM 9-2815-205-24P	DATE 25 February 2013	TITLE; FIELD AND SUSTAINMENT MAINTENANCE REPAIR PARTS AND SPECIAL TOOLS LIST FOR 6V53/6V53T ENGINES, DIESEL
--	--------------------------	---

PAGE NO.	COLM NO.	LINE NO.	FEDERAL STOCK NUMBER	REFERENCE NO.	FIGURE NO.	ITEM NO.	TOTAL NO. OF MAJOR ITEMS SUPPORTED	RECOMMENDED ACTION

PART III - REMARKS (Any general remarks or recommendations, or suggestions for improvement of publications and blank forms. Additional blank sheets may be used if more space is needed.)

TYPED NAME, GRADE OR TITLE	TELEPHONE EXCHANGE/AUTOVON, PLUS EXTENSION	SIGNATURE
----------------------------	--	-----------

By Order of the Secretary of the Army:

Official:



JOYCE E. MORROW

*Administrative Assistant to the
Secretary of the Army*

1301704

RAYMOND T. ODIERNO
*General, United States Army
Chief of Staff*

Distribution:

To be distributed in accordance with the initial distribution number (IDN) 371407 requirements for TM 9-2815-205-24P.

THE METRIC SYSTEM AND EQUIVALENTS

Linear Measure

1 Centimeter = 10 Millimeters = 0.01 Meters = 0.3937 Inches
 1 Meter = 100 Centimeters = 1000 Millimeters = 39.37 Inches
 1 Kilometer = 1000 Meters = 0.621 Miles

Square Measure

1 Sq Centimeter = 100 Sq Millimeters = 0.155 Sq Inches
 1 Sq Meter = 10,000 Sq Centimeters = 10.76 Sq Feet
 1 Sq Kilometer = 1,000,000 Sq Meters = 0.386 Sq Miles

Weights

1 Gram = 0.001 Kilograms = 1000 Milligrams = 0.035 Ounces
 1 Kilogram = 1000 Grams = 2.2 Pounds
 1 Metric Ton = 1000 Kilograms = 1 Megagram = 1.1 Short Tons

Cubic Measure

1 Cu timeter = 1,000 Cu Millimeters = 0.06 Cu Inches
 1 Cu Meter = 1,000,000 Cu Centimeters = 35.31 Cu Feet

Liquid Measure

1 Milliliter = 0.001 Liters = 0.0338 Fluid Ounces
 1 Liter = 1000 Milliliters = 33.82 Fluid Ounces

Temperature

$5/9 (F - 32) = C$
 212 Fahrenheit is equivalent to 100 Celsius
 90 Fahrenheit is equivalent to 32.2 Celsius
 32 Fahrenheit is equivalent to 0 Celsius
 $9/5 C + 32 = F$

APPROXIMATE CONVERSION FACTORS

<u>TO CHANGE</u>	<u>TO</u>	<u>MULTIPLY BY</u>
Inches.....	Centimeters	2.540
Feet.....	Meters	0.305
Yards.....	Meters	0.914
Miles.....	Kilometers.....	1.609
Square Inches.....	Square Centimeters.....	6.451
Square Feet.....	Square Meters.....	0.093
Square Yards.....	Square Meters.....	0.836
Square Miles.....	Square Kilometers.....	2.590
Acres.....	Square Hectometers.....	0.405
Cubic Feet.....	Cubic Meters.....	0.028
Cubic Yards.....	Cubic Meters.....	0.765
Fluid Ounces.....	Milliliters.....	29.573
Pints.....	Liters.....	0.473
Quarts.....	Liters.....	0.946
Gallons.....	Liters.....	3.785
Ounces.....	Grams.....	28.349
Pounds.....	Kilograms.....	0.454
Short Tons.....	Metric Tons.....	0.907
Pound-Feet.....	Newton-Meters.....	1.356
Pounds/Sq Inch.....	Kilopascals.....	6.895
Miles per Gallon.....	Kilometers per Liter.....	0.425
Miles per Hour.....	Kilometers per Hour.....	1.609

<u>TO CHANGE</u>	<u>TO</u>	<u>MULTIPLY BY</u>
Centimeters.....	Inches.....	0.394
Meters.....	Feet.....	3.280
Meters.....	Yards.....	1.094
Kilometers.....	Miles.....	0.621
Sq Centimeters.....	Square Inches.....	0.155
Square Meters.....	Square Feet.....	10.764
Square Meters.....	Square Yards.....	1.196
Square Kilometers.....	Square Miles.....	0.386
Square Hectometers.....	Acres.....	2.471
Cubic Meters.....	Cubic Feet.....	35.315
Cubic Meters.....	Cubic Yards.....	1.308
Milliliters.....	Fluid Ounces.....	0.034
Liters.....	Pints.....	2.113
Liters.....	Quarts.....	1.057
Liters.....	Gallons.....	0.264
Grams.....	Ounces.....	0.035
Kilograms.....	Pounds.....	2.205
Metric Tons.....	Short Tons.....	1.102
Newton-Meters.....	Pound-Feet.....	0.738
Kilopascals.....	Pounds per Sq Inch.....	0.145
Km per Liter.....	Miles per Gallon.....	2.354
Km per Hour.....	Miles per Hour.....	0.621

