

TECHNICAL MANUAL

SCHEDULED MAINTENANCE

OPERATOR LEVEL

2½-TON 6X6, M44A1 AND M44A2 SERIES TRUCKS
(MULTIFUEL)

TRUCK, CARGO: M35A1,

M35A2, M35A2C, M36A2; TRUCK,

TANK, FUEL: M49A1C, M49A2C; TRUCK, TANK,

WATER: M50A1, M50A2, M50A3; TRUCK, VAN,

SHOP: M109A2, M109A3; TRUCK, REPAIR SHOP:

MW5A2, M185A3; TRUCK, TRACTOR: M275A1,

M275A2; TRUCK, DUMP: M342A2; TRUCK,

MAINTENANCE, PIPELINE CONSTRUCTION:

M756A2; TRUCK, MAINTENANCE,

EARTH BORING AND POLESETTING: M764

Chapter 1
Preventive
Maintenance

Chapter 2
Checkout,
Alinement, and
Adjustment

Chapter 3
Lubrication

Chapter 4
Scheduled
Maintenance of
Material Used
in Conjunction
with Major
Items

This copy is a reprint which includes current
pages from Change 1.

WARNING

EXHAUST GASES CAN BE DEADLY

Exposure to exhaust gases produces symptoms of headache, dizziness, loss of muscular control, apparent drowsiness, and coma. Permanent brain damage or death can result from severe exposure.

Carbon monoxide occurs in the exhaust fumes of fuel burning heaters and internal combustion engines, and becomes dangerously concentrated under conditions of inadequate ventilation. The following precautions must be observed to insure the safety of personnel whenever fuel burning heater(s) or engine of any vehicle is operated for maintenance purposes or tactical use.

Do not operate heater or engine of vehicle in an enclosed area unless it is adequately ventilated.

Do not idle engine for long periods without maintaining adequate ventilation in personnel compartments.

Do not drive any vehicle with inspection plates or cover plates removed unless necessary for maintenance purposes.

Be alert at all times during vehicle operation for exhaust odors and exposure symptoms. If either are present, immediately ventilate personnel compartments. If symptoms persist, remove affected personnel from vehicle and treat as follows: expose to fresh air; keep warm; do not permit physical exercise; if necessary, administer artificial respiration.

If exposed, seek prompt medical attention for possible delayed onset of acute lung congestion. Administer oxygen if available.

The best defense against exhaust gas poisoning is adequate ventilation.

WARNING

Serious or fatal injury to personnel may result if the following instructions are not complied with.

Use extreme care when removing radiator cap, especially when temperature gage shows above 180°F.

Always wear leather gloves when handling winch cable. Never allow cable to slip through hands. Do not operate winch with less than four turns of cable on drum.

Do not drive truck until the low air pressure warning buzzer is silent and the air pressure gage shows at least 65 PSI. This is the minimum pressure required for safe braking action.

Do not use hand throttle to drive the vehicle.

Do not park truck with front transmission gearshift lever in gear.

If your vehicle class number is greater than the bridge class number, do not cross.

CHANGE
NO.2

HEADQUARTERS
DEPARTMENT OF THE ARMY
Washington D. C., 30 March 1992

SCHEDULED MAINTENANCE

OPERATOR LEVEL

2 1/2-TON, 6X6, M44A1 , AND M44A2 SERIES TRUCKS (MULTIFUEL)

TRUCK, CARGO: M35A1, M35A2, M35A2C, M36A2;
TRUCK, TANK, FUEL: M49A1C, M49A2C;
TRUCK, TANK, WATER: M50A1, M50A2, M50A3;
TRUCK, VAN SHOP: M109A2, M109A3;
TRUCK, REPAIR SHOP: M185A2, M185A3;
TRUCK, TRACTOR: M275A1, M275A2;
TRUCK, DUMP: M342A2;
TRUCK, MAINTENANCE, PIPELINE CONSTRUCTION: M756A2;
TRUCK, MAINTENANCE, EARTH BORING AND POLESETTING: M764

TM 9-2320-209-10-2/TO 36A1 2-1B-1091-2, 26 September 1980, is changed as follows:

1. Remove old pages and insert new pages as indicated below.
2. New or changed information is indicated by a vertical bar in the margin of the page.

Remove Pages

a/(b blank)
1-5 through 1-12.2

Insert Pages

a and b
1-5 through 1-12.2

File this change sheet in front of the publication for reference purposes.

Approved for public release; distribution is unlimited.

By Order of the Secretary of the Army:

GORDON R. SULLIVAN
General, United States Army
Chief of Staff

Official:

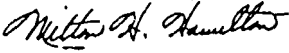
MILTON H. HAMILTON
Administrative Assistant to the
Secretary of the Army
00699

By Order of the Secretary of the Air Force:

MERRILL A. McPEAK
General, United States Air Force
Chief of Staff

CHARLES C. McDONALD
General, United States Air Force
Commander, Air Force Logistics Command

Distribution:

To be distributed in accordance with DA Form 12-38-E (Block 0185) Operator maintenance requirements for TM9-2320-209-10-2.

**CHANGE
NO. 1**

**DEPARTMENTS OF THE ARMY
AND THE AIR FORCE
WASHINGTON, DC , 17 December 1982**

**SCHEDULED MAINTENANCE
OPERATOR LEVEL
2½-TON, 6X6, M44A1, AND M44A2 SERIES TRUCKS
(MULTIFUEL)**

TRUCK, CARGO: M35A1, M35A2, M35A2C, M36A2;
TRUCK, TANK, FUEL: M49A1C, M49A2C;
TRUCK, TANK, WATER: M50A1, M50A2, M50A3;
TRUCK, VAN, SHOP: M109A2, M109A3;
TRUCK, REPAIR SHOP: M185A2, M185A3;
TRUCK, TRACTOR: M275A1, M275A2;
TRUCK, DUMP: M342A2;
TRUCK, MAINTENANCE, PIPELINE CONSTRUCTION: M756A2;
TRUCK, MAINTENANCE, EARTH BORING AND POLESETTING: M764

Current as of 15 September 1982

TM 9-2320-209-10-2/TO 36A12-1B-1091-2, 26 September 1980, is changed as follows:

1. Remove old pages and insert new pages as indicated below. New or changed material is indicated by a vertical bar in the margin of the page. Added or revised illustrations are indicated by a vertical bar adjacent to the illustration.

Remove Pages

Delete WARNING, page 2 of cover
1-1 through 1-12
None
1-13 through 1-18
2-1/3-1/4-1 through 4-7/(4-8 blank)

Insert Pages

a
1-1- through 1-12
1-12.1 and 1-12.2
1-13 through 1-18
2-1/3-1/4-1 through 4-7/(4-8 blank)

2. File this change sheet in front of the publication for reference purposes.

By Order of the Secretaries of the Army and the Air Force:

E.C. MEYER
General, United States Army
Chief of Staff

Official:

ROBERT M. JOYCE
Major General, United States Army
The Adjutant General

CHARLES A. GABRIEL, *General, USAF*
Chief of Staff

Official:

JAMES E. WYATT, JR., Colonel, USAF
Director of Administration

Distribution:

To be distributed in accordance with DA Form 12-38, Operator's Maintenance requirements for Truck, 2-1/2 Ton, 6X6, M44A1 and M44A2 Series.

WARNING**EXHAUST GASES CAN BE DEADLY**

Exposure to exhaust gases produces symptoms of headache, dizziness, loss of muscular control, apparent drowsiness, and coma. Permanent brain damage or death can result from severe exposure.

Carbon monoxide occurs in the exhaust fumes of fuel burning heaters and internal combustion engines, and becomes dangerously concentrated under conditions of inadequate ventilation. The following precautions must be observed to insure the safety of personnel whenever fuel burning heater(s) or engine of any vehicle is operated for maintenance purposes or tactical use.

Do not operate heater or engine of vehicle in an enclosed area unless it is adequately ventilated.

Do not idle engine for long periods without maintaining adequate ventilation in personnel compartments.

Do not drive any vehicle with inspection plates or cover plates removed unless necessary for maintenance purposes.

Be alert at all times during vehicle operation for exhaust odors and exposure symptoms. If either are present, immediately ventilate personnel compartments. If symptoms persist, remove affected personnel from vehicle and treat as follows: expose to fresh air; keep warm; do not permit physical exercise; if necessary, administer artificial respiration.

If exposed, seek prompt medical attention for possible delayed onset of acute lung congestion. Administer oxygen if available.

The best defense against exhaust gas poisoning is adequate ventilation.

WARNING

Serious or fatal injury to personnel may result if the following instructions are not complied with.

Use extreme care when removing radiator cap, especially when temperature gage shows above 1800 F (82.20°C).

Always wear leather gloves when handling winch cable. Never allow cable to slip through hands. Do not operate winch with less than four turns of cable on drum.

Do not drive truck until the low air pressure warning buzzer is silent and the air pressure gage shows at least 85 PSI (586.075 kPa). This is the minimum pressure required for safe braking action.

Do not use hand throttle to drive the vehicle.

Do not park truck with front transmission gearshift lever in gear.

If your vehicle class number is greater than the bridge class number, do not cross.

WARNING

Serious or fatal injury to personnel may result if the following instructions are not complied with.

Do not perform fuel filter checks, inspections, or draining, while smoking or near fire, flames, or sparks. Fuel may ignite, causing injury or death to personnel.

Wear safety glasses or goggles when checking batteries. Always check electrolyte level with engine stopped. Do not smoke or use exposed flame when checking battery; explosive gases are present and severe injury to personnel can result.

Remove all jewelry such as rings, dog tags, bracelets, etc. If jewelry contacts battery positive terminal and ground, a direct short will result in instant heating of tools, damage to equipment, and injury to personnel.

If NBC exposure is suspected, all air filter media should be handled by personnel wearing protective equipment. Consult your unit NBC Officer or NBC NCO for appropriate handling or disposal instructions.

Do not touch hot exhaust pipes with bare hands.

TECHNICAL MANUAL
NO. 9-2320-209-10-2
TECHNICAL ORDER
NO. 36A12-1B-1091-2

DEPARTMENTS OF THE ARMY
AND
THE AIR FORCE
Washington, DC, 26 September 1980

TECHNICAL MANUAL

SCHEDULED MAINTENANCE
OPERATOR LEVEL
2½-TON, 6X6, M44A1 AND M44A2 SERIES TRUCKS
(MULTIFUEL)

Model		NSN without Winch	NSN with Winch
Truck, Cargo	M35A1	2320-00-542-5633	2320-00-542-5634
	M35A2	2320-00-077-1616	2320-00-077-1617
	M35A2C	2320-00-926-0873	2320-00-926-0875
	M36A2	2320-00-077-1618	2320-00-077-1619
Truck, Tank, Fuel	M49A1C	2320-00-440-3349	2320-00-440-3346
	M49A2C	2320-00-077-1631	2320-00-077-1632
Truck, Tank, Water	M50A1	2320-00-440-8307	2320-00-440-8305
	M50A2	2320-00-077-1633	2320-00-077-1634
	M50A3	2320-00-937-4036	2320-00-937-5264
Truck, Van, Shop	M109A2	2320-00-440-8313	2320-00-440-8308
	M109A3	2320-00-077-1636	2320-00-077-1637
Truck, Repair Shop	M185A2	4940-40-987-8799	4940-00-987-8800
	M185A3	4940-00-077-1638	4940-00-077-1639
Truck, Tractor	M275A1	2320-00-446-2479	
	M275A2	2320-00-077-1640	2320-00-077-1641
Truck, Dump	M342A2	2320-00-077-1643	2320-00-077-1644
Truck, Maintenance, Pipeline Construction	M756A2		2320-00-904-3277
Truck, Maintenance, Earth Boring and Polesetting	M764		2320-00-937-5980

Current as of 15 February 1980

*This manual supersedes TM 9-2320-209-ESC, 12 April 1973, and together with TM 9-2320-209-10-1, 26 September 1980; TM 9-2320-209-10-3, 26 September 1980; and TM 9-2320-209-10-4, 26 September 1980, supersedes TM 9-2320-209-10/1, 29 October 1976.

REPORTING OF ERRORS AND RECOMMENDING IMPROVEMENTS

You can help improve this manual. If you find any mistakes or if you know of a way to improve the procedure, please let us know. Mail your letter, DA Form 2028 (Recommended Changes to Publication and Blank Forms), or DA Form 2028-2 located in the back of this manual direct to: Commander, U.S. Army Tank Automotive Materiel Readiness Command, ATTN: DRSTA-MB, Warren, Michigan 48090. A reply will be furnished to you.

	Paragraph	Page
CHAPTER 1. PREVENTIVE MAINTENANCE		
General	1-1	1-1
Maintenance Forms and Records.	1-1a	1-1
Preventive Maintenance Checks and Services	1-1b	1-1
General Maintenance Procedures	1-2	1-1
Cleanliness	1-2a	1-1
Bolts, Nuts, and Screws	1-2b	1-2
Welds	1-2c	1-2
Electric Wires and Connectors	1-2d	1-2
Hydraulic Lines and Fittings	1-2e	1-2
Fluid Leakage	1-3	1-2
2. CHECKOUT , ALINEMENT, AND ADJUSTMENT		
General	2-1	2-1
3. LUBRICATION		
General	3-1	3-1
Special Instructions	3-2	3-1
4. SCHEDULED MAINTENANCE OF MATERIAL USED IN CONJUNCTION WITH MAJOR ITEMS		
General	4-1	4-1
PMCS Procedures	4-2	4-1

LIST OF TABLES

		Page
1-1.	Operator /Crew Preventive Maintenance Checks and Services	1-3
1-2.	Operator /Crew Preventive Maintenance Checks and Services for M35A1, M35A2, M35A2C and M35A2 Cargo Trucks	1-15
1-3.	Operator /Crew Preventive Maintenance Checks and Services for M49A1C and M49A2C Fuel Tank Trucks	1-16
1-4.	Operator /Crew Preventive Maintenance Checks and Services for M50A1, M50A2, and M50A3 Water Tank Trucks	1-20
1-5.	Operator /Crew Preventive Maintenance Checks and Services for M109A2, M109A3, M185A2 and M185A3 Shop Van and Instrument Repair Trucks.	1-23
1-6.	Operator /Crew Preventive Maintenance Checks and Services for M275A1 and M275A2 Tractor Trucks	1-26
1-7.	Operator /Crew Preventive Maintenance Checks and Services for M342A2 Dump Truck...	1-28
1-8.	Operator /Crew Preventive Maintenance Checks and Services for M756A2 Pipeline Construction Truck	1-29
1-9.	Operator /Crew Preventive Maintenance Checks and Services for M764 Earth Boring Machine and Polesetting Truck	1-31
4-1.	Operator /Crew Preventive Maintenance Checks and Services for Special Purpose Kits	4-2

CHAPTER 1

PREVENTIVE MAINTENANCE

1-1. GENERAL .

a. Maintenance Forms and Records. Every mission begins and ends with the paperwork. There isn't much of it, but you have to keep it up. The forms and records you fill out have several uses; they are a permanent record of the services, repairs, and modifications made on your vehicle; they are reports to Organizational Maintenance and to your Commander; and they are a checklist for you when you want to know what is wrong with the vehicle after its last use, and whether those faults have been fixed. For the information you need on forms and records, see TM 38-750.

b. Preventive Maintenance Checks and Services. (Tables 1-1 to 1-9 and 4-1)

(1) Do your (B) PREVENTIVE MAINTENANCE just before you operate your vehicle. Pay attention to the CAUTIONS and WARNINGS.

(2) Do your during (D) PREVENTIVE MAINTENANCE while the vehicle and/or its component systems are in operation.

(3) Do your after (A) PREVENTIVE MAINTENANCE right after operating the vehicle. Pay attention to the CAUTIONS and WARNINGS.

(4) Do your (W) PREVENTIVE MAINTENANCE weekly.

(5) Do your (M) PREVENTIVE MAINTENANCE once a month.

(6) If something doesn't work, troubleshoot it with the instructions in TM 9-2320-209-10-3 and notify your supervisor.

(7) Always do your PREVENTIVE MAINTENANCE in the same order until it gets to be a habit. Once you've had some practice, you'll spot anything wrong in a hurry.

(8) If anything looks wrong and you can't fix it, write it on your DA Form 2404. If you find something seriously wrong, report it to Organizational Maintenance RIGHT NOW.

(9) When you do your PREVENTIVE MAINTENANCE, take along the tools you need to make all the checks. You always need a rag or two, also.

1-2. GENERAL MAINTENANCE PROCEDURES.

a. Cleanliness. Dirt, grease, oil, and debris only get in the way and may cover up a serious problem. Clean as you work and as needed. Use dry cleaning solvent Type II, Fed. Spec P-D-680, on all metal surfaces.

WARNING

Dry cleaning solvent, Type II, Fed. Spec P-D-680, is potentially dangerous to personnel and property. Do not use near open flame or excessive heat. Flash point of solvent is 139° F (59.4° C).

b. Bolts, Nuts, and Screws. Check them all for obvious looseness, missing, bent, or broken condition. You can't try them all with a tool, of course, but look for chipped paint, bare metal, or rust around bolt heads. If you find one you think is loose, tighten it, or report it to Organizational Maintenance.

c. Welds. Look for loose or chipped paint, rust, or gaps where parts are welded together. If you find a bad weld, report it to Organizational Maintenance.

d. Electric Wires and Connectors. Look for cracked or broken insulation, bare wires, and loose or broken connectors. Check for loose connectors and make sure the wires are in good shape. Report loose connectors and bad wires to organizational maintenance.

e. Hydraulic Lines and Fittings. Look for wear, damage, leaks, and make sure clamps and fittings are tight. Wet spots show leaks, of course, but a stain around a fitting or connector can mean a leak. If a leak comes from a loose fitting or connector, report it to Organizational Maintenance. If something is broken or worn out, report it to Organizational Maintenance.

1-3. FLUID LEAKAGE. It is necessary for you to know how fluid leakage affects the status of the fuel, lubricating, coolant and hydraulic systems. The following are definitions of the types/classes of leakage you need to know to be able to determine the status of your vehicle. Learn, then be familiar with them and REMEMBER -- WHEN IN DOUBT, NOTIFY YOUR SUPERVISOR!

CAUTION

Equipment operation is allowable with minor leakages (Class I or II). Of course, consideration must be given to the fluid capacity in the item/system being checked/inspected. When in doubt, notify your supervisor

When operating with Class I or II leaks, continue to check fluid levels as required in your PMCS.

Class III leaks should be reported to your supervisor or to Organizational Maintenance.

- a. Class I. Seepage of fluid (as indicated by wetness or discoloration) not great enough to form drops.
- b. Class II. Leakage of fluid great enough to form drops but not enough to cause drops to drip from item being checked/inspected.
- c. Class III. Leakage of fluid great enough to form drops that fall from the item being checked /inspected.

Table 1-1. Operator /Crew Preventive Maintenance Checks and Services

NOTE : These checks are to be made in the order listed, within designated interval.

B-Before operation
D-During operation

A-After operation
W-Weekly

M-Monthly

Item No.	Interval					Item to be Inspected Procedure: Check for and have repaired, filled, or adjusted as needed	Equipment is not ready/available if:
	B	D	A	W	M		
1						<p>NOTE</p> <p>Perform Weekly (W) as well as Before (B) PMCS's if:</p> <p>a. You are the assigned operator but have not operated the vehicle since the last weekly.</p> <p>b. You are operating the vehicle for the first time.</p> <p><u>MAKE THE FOLLOWING WALK AROUND CHECKS :</u></p> <p>EXTERIOR OF VEHICLE</p> <p>a. Visually check for obvious damage to body and cab that would impair operation.</p> <p>b. Check tires for cuts, gouges or cracks. Remove all penetrating objects.</p> <p>c. Look under vehicle for evidence of fluid leakage (fuel, oil, coolant).</p> <p>d. Check condition of:</p> <p>(1) Windshield and windows. (2) Windshield wiper arms anti blades. (3) Mirrors. (4) All locking and fastening devices.</p>	
	1						Tires have cuts, gouges, or cracks which would result in tire failure during operation. Three or more tires missing or flat.
	1						Class III leakage of oil or coolant is evident. Any class [1] fuel leak. Any gasoline leak.
	1		1				

Table 1-1. Operator/Crew Preventive Maintenance Checks and Services - Cont

NOTE: These checks are to be made in the order listed, within designated interval.

B-Before operation
D-During operation

A-After operation
W-Weekly

M-Monthly

Item No.	Interval					Item to be Inspected Procedure: Check for and have repaired, filled, or adjusted as needed	Equipment is not ready/available if:								
	B	D	A	W	M										
1 (cont)		•		•		(5) Spare tire mounting. (6) Operation of doors and windows. (7) Operation of headlights, taillights, stoplights, turn signals, and blackout lights. (8) Steering knuckle boots (1). Check for tears.									
2				•		 <p style="text-align: right;">TA 252430</p> <p>TIRES</p> <p>a. Gage tires for correct air pressure using tire inflation gage and hose assembly. Adjust as necessary: For normal operation of vehicle, tire pressure for 9:00 x 20 tires, should be as follows:</p> <table border="0" style="margin-left: 40px;"> <thead> <tr> <th style="text-align: left;">Road Cond</th> <th style="text-align: left;">Pressure (psi)</th> </tr> </thead> <tbody> <tr> <td>Highway</td> <td>50 (344.750 kPa)</td> </tr> <tr> <td>Crosscountry</td> <td>35 (241.325 kPa)</td> </tr> <tr> <td>Mud, snow and sand</td> <td>15 (103.425 kPa)</td> </tr> </tbody> </table> <p>b. Make sure that all wheel stud nuts are tight. If stud nuts are found loose, tighten and notify organizational maintenance.</p>	Road Cond	Pressure (psi)	Highway	50 (344.750 kPa)	Crosscountry	35 (241.325 kPa)	Mud, snow and sand	15 (103.425 kPa)	
Road Cond	Pressure (psi)														
Highway	50 (344.750 kPa)														
Crosscountry	35 (241.325 kPa)														
Mud, snow and sand	15 (103.425 kPa)														

Table 1-1. Operator/Crew Preventive Maintenance Checks and Services – Cont

NOTE: These checks are to be made in the order listed, within designated interval.

B-Before operation
D-During operation

A-After operation
W-Weekly

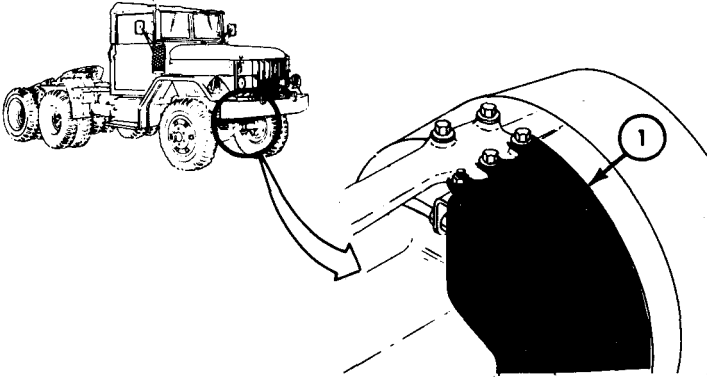
M-Monthly

Item No.	Interval					Item to be Inspected Procedure: Check for and have repaired, filled, or adjusted as needed	Equipment is not ready/available if:
	B	D	A	W	M		
3	●					<p>PRIMARY FUEL FILTER</p> <p>Check primary fuel filter (1) for water or dirt. If contaminated, notify organizational maintenance.</p> 	Any Class III fuel leaks. Any gasoline leak.

Table 1-1. Operator/Crew Preventive Maintenance Checks and Services – Cont

NOTE: These checks are to be made in the order listed, within designated interval.

B–Before operation
D–During operation

A–After operation
W–Weekly

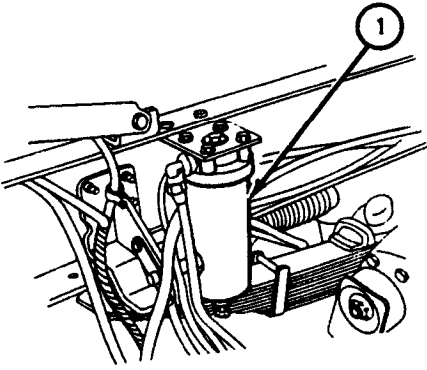
M–Monthly

Item No.	Interval					Item to be Inspected Procedure: Check for and have repaired, filled, or adjusted as needed	Equipment is not ready/available if:
	B	D	A	W	M		
3.1						<p>SECONDARY AND FINAL FUEL FILTERS</p> <p>WARNING</p> <p>Do not perform fuel filter checks, inspections, or draining, while smoking or near fire, flames, or sparks. Fuel may ignite, causing injury or death to personnel.</p> <p>CAUTION</p> <p>If one pint (0.473 L) of fuel is drained and fuel is still unclear, notify organizational maintenance.</p> <p>Open draincocks (1) and (2) at bottom of secondary fuel filter (3) and final fuel filter (4). Drain approximately one pint (0.473 L) of fuel from each into a container. If there are large amounts of water or impurities, notify your supervisor. Close draincocks (1) and (2). Check for fuel leaks.</p> 	
4						<p>FUEL SYSTEM</p> <p>a. Inspect fuel tank for leaks or broken supports.</p> <p>b. Check fuel lines and hoses for leakage and damage. Make sure all connections are secure.</p>	<p>Any Class III fuel leakage, any water or contaminants in final fuel filter.</p> <p>Fuel tank(s) or lines are damaged or any broken supports.</p>

Table 1-1. Operator/Crew Preventive Maintenance Checks and Services – Cent

NOTE: These checks are to be made in the order listed, within designated interval.

B–Before operation
D–During operation

A–After operation
W–Weekly

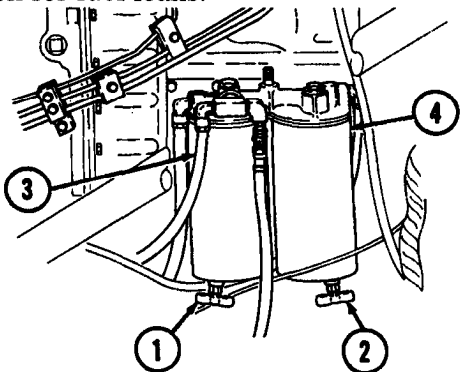
M–Monthly

Item No.	Interval					Item to be Inspected Procedure: Check for and have repaired, filled, or adjusted as needed	Equipment is not ready/available if:
	B	D	A	W	M		
5			●			<p>AIR RESERVOIR DRAIN COCK</p> <p>Drain air reservoirs as follows:</p> <ol style="list-style-type: none"> Turn petcocks (1) on bottom of tanks (2) to opened position. Let air and condensation drain off. Turn petcocks (1) to closed position. 	Any reservoir line or hose missing, leaking or damaged. Any broken supports.
6						<p>BATTERIES</p> <p><u>WARNING</u></p> <p>Wear safety glasses or goggles when checking batteries. Always check electrolyte level with engine stopped. Do not smoke or use exposed flame when checking battery; explosive gases are present and severe injury to personnel can result.</p> <p>Remove all jewelry such as rings, dog tags, bracelets, etc. If jewelry contacts battery positive terminal and ground, a direct short will result in instant heating of tools, damage to equipment, and injury to personnel.</p>	

Table 1-1. Operator/Crew Preventive Maintenance Checks and Services – Cont

NOTE: These checks are to be made in the order listed, within designated interval.

B-Before operation
D-During operation

A-After operation
W-Weekly

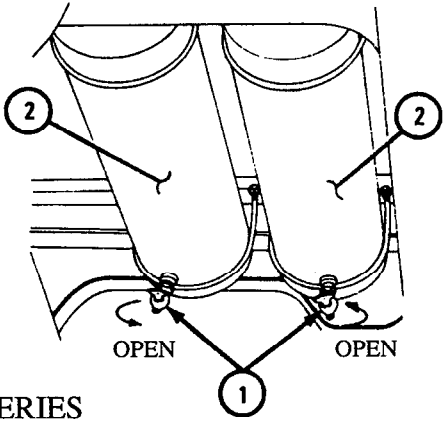
M-Monthly

Item No.	Interval					Item to be Inspected Procedure: Check for and have repaired, filled, or adjusted as needed	Equipment is not ready/ available if
	B	D	A	W	M		
6 (cont)						<p style="text-align: center;">NOTE</p> <p>Battery compartment is located on right side of truck between running board and cab door.</p> <p>a. Check that fluid level is to split-ring.</p> <p style="text-align: center;">NOTE</p> <p>If fluid fluid level is below split-rings repeatedly or is boiling, notify organizational maintenance. When temperature drops below 32°F (0°C), run the engine 15 minutes to allow distilled water added to battery by organizational maintenance to mix with electrolyte.</p> <p>b. Check terminals and posts for tightness, damage, and corrosion.</p> <p>c. Check batteries for cracked or leaking casing, broken, burnt, or loose battery terminal posts.</p> <p>d. Inspect battery compartment for corrosion. If excessively corroded, Notify Organizational Maintenance.</p>	One or more missing or unserviceable batteries or will not crank engine.
7						<p><u>UNDERBODY</u></p> <p>FRAME</p> <p style="text-align: center;">NOTE</p> <p>If any of the following conditions are found, notify your supervisor.</p> <p>• Visually check frame side rails, crossmembers and underbody supports for broken/loose bolts or rivets, obvious cracks, broken welds, and rusted-through conditions.</p>	Any obviously cracked, rusted-through, loose, or broken or missing side rails, crossmembers, welds, bolts or rivets.

Table 1-1. Operator/Crew Preventive Maintenance Checks and Services – Cont

NOTE: These checks are to be made in the order listed, within designated interval.

B-Before operation
D-During operation

A-After operation
W-Weekly

M-Monthly

Item No.	Interval					Item to be Inspected Procedure: Check for and have repaired, filled, or adjusted as needed	Equipment is not ready/available if:
	B	D	A	W	M		
7.1						<p><u>ENGINE COMPARTMENT</u></p> <p><u>AIR INTAKE SYSTEM</u></p> <p><u>WARNING</u> If NBC exposure is suspected, all air filter media should be handled by personnel wearing protective equipment. Consult your unit NBC Officer or NBC NCO for appropriate handling or disposal instructions.</p> <ul style="list-style-type: none"> Check clamps (1) for tightness and hump hose (2), tube (3), hose (4), and air cleaner assembly (5) for openings which would allow foreign materials to enter engine. 	Leaks or openings which will allow foreign material to enter engine are evident.
8						<p><u>RADIATOR</u></p> <p><u>WARNING</u> Use care when removing radiator filler cap. Coolant is under pressure, and can cause severe burns when cap is removed while engine is hot.</p> <ul style="list-style-type: none"> Check to see that radiator is full. If low, notify organizational maintenance. Check all hoses for deterioration, leakage and secure connections. 	Any Class III leaks.

Table 1-1. Operator/Crew Preventive Maintenance Checks and Services – Cont

NOTE: These checks are to be made in the order listed, within designated interval.

B–Before operation

A–After operation

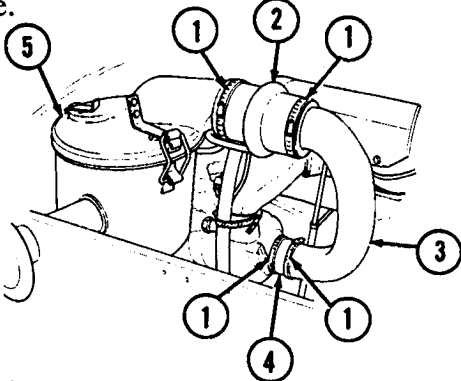
M–Monthly

D–During operation

W–Weekly

Item No.	Interval					Item to be Inspected Procedure: Check for and have repaired, filled, or adjusted as needed	Equipment is not ready/available if:
	B	D	A	W	M		
9	●					ENGINE OIL LEVEL a. Check engine oil level. When checking COLD, oil level should be approximately 1" - 1 1/2" (25.4 to 38.1 mm) above full mark. Add oil as necessary. Do not overfill. b. When checking HOT, oil level should be between the "ADD" and "FULL" marks. Add oil as necessary. Do not overfill.	
10						DRIVE BELTS ● Check for missing belts, broken, cracking, or fraying.	Any drivebelt is missing, broken, cracked to the belt fiber, has more than one crack (1/8 in. depth or 50% of belt thickness) within a 6 in. area, or has frays more than 2 in. long.
11						AIR COMPRESSOR  ● Check compressor (1) for loose bolts and air leaks.	

Table 1-1. Operator/Crew Preventive Maintenance Checks and Services – Cont

NOTE: These checks are to be made in the order listed, within designated interval.

B–Before operation
D–During operation

A–After operation
W–Weekly

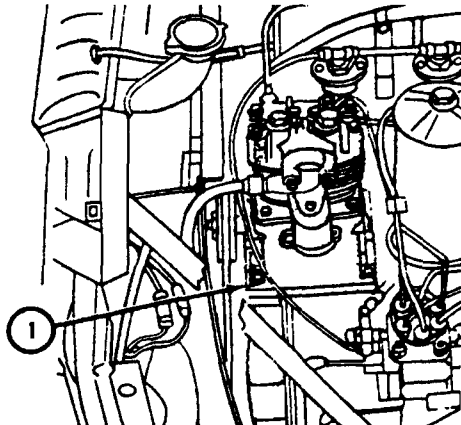
M–Monthly

Item No.	Interval					Item to be Inspected Procedure: Check for and have repaired, filled, or adjusted as needed	Equipment is not ready/available if:
	B	D	A	W	M		
12						<p>EXHAUST SYSTEM</p> <p style="text-align: center;"><u>WARNING</u></p> <ul style="list-style-type: none"> ● Exhaust gases can kill. Operate vehicle in a well-ventilated area. Failure to do this may result in injury or death to personnel. ● Do not touch hot exhaust pipes with bare hands. Injury to personnel may result. <p>Start engine, and after system has warmed up, check exhaust pipes (1) and couplings (2) for leaks and loose clamps.</p> 	Any cracked, broken, or missing parts, and obvious exhaust leaks are evident.

Table 1-1. Operator/Crew Preventive Maintenance Checks and Services-Cont

NOTE: These checks are to be made in the order listed, within designated interval.

B-Before operation
D-During operation

A-After operation
W-Weekly

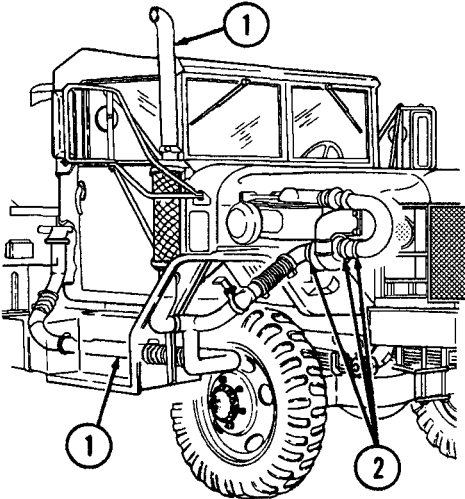
M-Monthly

Item No.	Interval					Item to be Inspected Procedure: Check for and have repaired, filled, or adjusted as needed	Equipment is not ready/ available if
	B	D	A	W	M		
13						<p><u>INTERIOR OF VEHICLE</u></p> <p>INSTRUMENTS</p> <p>If buzzer stops and air pressure reading is below 65 psi, there maybe no braking action. Shut down engine and check to see what is wrong. Failure to do so may result in injury or death to personnel.</p> <p>a. Start engine and run at idle speed (650 -850 RPM) to let it warm up. Listen for air buzzer.</p> <p>b. Listen for unusual noise or vibration.</p>	<p>Engine is inoperative. Air buzzer will not come on. Air buzzer will not shut off above 66 psi or will not come on at approximately 60 psi and remain on with decreasing air pressure. There is unusual noise or vibration.</p>

Table 1-1. Operator/Crew Preventive Maintenance Checks and Services – Cont

NOTE: These checks are to be made in the order listed, within designated interval.

B–Before operation
D–During operation

A–After operation
W–Weekly

M–Monthly

Item No.	Interval					Item to be Inspected Procedure: Check for and have repaired, filled, or adjusted as needed	Equipment is not ready/available if
	B	D	A	W	M		
13 (cont)						<p style="text-align: center;"><u>CAUTION</u></p> <p>If oil pressure reading is zero (0) or very low, or if temperature reading is over 210°F (98.8°C), shut down engine at once, or engine may be damaged.</p> <p style="text-align: center;">NOTE</p> <ul style="list-style-type: none"> ● Position of instruments shown is normal but some trucks may have instruments in different positions. ● Normal oil pressure with engine running at idle speed is about 10 psi (69 kPa). With engine running at road speeds, engine oil pressure should read about 45 to 60 psi (309.275 to 413.700 kPa). ● Some engines have normal oil pressure readings between 40 and 75 psi (275.800 and 517.125 kPa) at road speeds. If your oil pressure gage has a maximum reading of 60 psi (413.700 kPa) and the needle peaks at 60 psi (413.700 kPa), notify organizational maintenance. They will replace the gage and sending unit with one that can measure a higher range of oil pressure. 	

Table 1-1. Operator/Crew Preventive Maintenance Checks and Services - Cont

NOTE: These checks are to be made in the order listed, within designated interval.

B—Before operation
D—During operation

A—After operation
W—Weekly

M—Monthly

Item No.	Interval					Item to be Inspected Procedure: Check for and have repaired, filled, or adjusted as needed	Equipment is not ready/available if
	B	D	A	W	M		
13 (cont)						<p>c. Check engine instruments on instrument panel for steady, normal readings as follows:</p> <ul style="list-style-type: none"> ● Oil pressure — 10-75 psi (69 -517.125 kPa) ● Temperature — 180°- 200°F (82.3 - 93.3°C) ● Air Pressure — 85-120 psi (585.775 -827.586 kPa) ● Battery/ Generator — In green area ● Tachometer — Idle: 650-850 RPM — Max: 2600-2900 RPM ● F u e l — Shows fuel level <p style="text-align: center;">NOTE</p> <p style="text-align: center;">Inoperative fuel gage does not down vehicle.</p> <div style="text-align: center;"> </div> <p>d. Engine stop cable</p> <p style="text-align: center;">CAUTION</p> <p>Do not attempt to force cable handle inward while serrations are interlocked. This will strip the serrations on the cable and render the vehicle inoperative.</p>	<p>Gages do not read within limits given.</p> <p>Oil Pressure is less than 10 psi. Temp. more than 210°F</p> <p>Air pressure 60 psi or below. Gage needle reads in red area.</p> <p>Tach gage is not with in limits.</p> <p>Inoperative or will not lock in the out position</p>

Table 1-1. Operator/Crew Preventive Maintenance Checks and Services – Cont

NOTE: These checks are to be made in the order listed, within designated interval.

B-Before operation
D-During operation

A-After operation
W-Weekly

M-Monthly

Item No.	Interval					Item to be Inspected Procedure: Check for and have repaired, filled, or adjusted as needed	Equipment is not ready/available if:
	B	D	A	W	M		
14		●				<p>AIR FILTER INDICATOR</p> <p><u>WARNING</u></p> <p>If NBC exposure is suspected, all air filter media should be handled by personnel wearing protective equipment. Consult your unit NBC Officer or NBC NCO for appropriate handling or disposal instructions.</p> <p>Check air filter indicator (1) at bottom of instrument panel. A red band means filter element needs to be cleaned or replaced.</p> 	Red is seen on indicator with engine running.
15				●		<p>BRAKE SYSTEM</p> <ol style="list-style-type: none"> a. Check master cylinder fluid level. b. With engine running and parking brake engaged, walk around vehicle and visually check: <ul style="list-style-type: none"> ● (1) Air reservoirs for leaks. ● (2) All brake lines and hoses (air and hydraulic) for deterioration chafing, binding, and leaks. c. Operate service brakes to determine stopping ability. Check for any pulling to one side, grabbing or other abnormal operation. 	<p>Any reservoir, line, or hose missing, leaking, or damaged.</p> <p>Service brakes do not operate properly. Brake pedal goes to within 2 in. (51 mm) of floorboard.</p>

Table 1-1. Operator/Crew Preventive Maintenance Checks and Services – Cont

NOTE: These checks are to be made in the order listed, within designated interval.

B–Before operation
D–During operation

A–After operation
W–Weekly

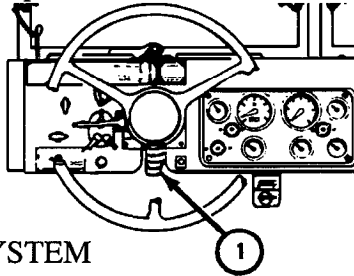
M–Monthly

Item No.	Interval					Item to be Inspected Procedure: Check for and have repaired, filled, or adjusted as needed	Equipment is not ready/available if:
	B	D	A	W	M		
	•					<p>d. Restart the vehicle and ensure that the air pressure is up to normal operating pressure. Determine the parking brake ability to hold the vehicle by first engaging the hand brake, then engage the transmission in 5th gear position. The vehicle should not move when clutch is slowly released</p>	Parking brake is inoperative or defective.
		•				<p>e. Adjust hand brake as required by moving knob on top of brake handle (1) clockwise to increase braking action, counterclockwise to decrease braking action.</p> 	Parking brake cannot be adjusted or does not hold properly after being adjusted.
	•					<p>f. Check seatbelts for proper operation and security of mounting.</p>	

Table 1-1. Operator/Crew Preventive Maintenance Checks and Services - Cont

NOTE : These checks are to be made in the order listed, within designated interval.

B-Before operation
D-During operation

A-After operation
W-Weekly

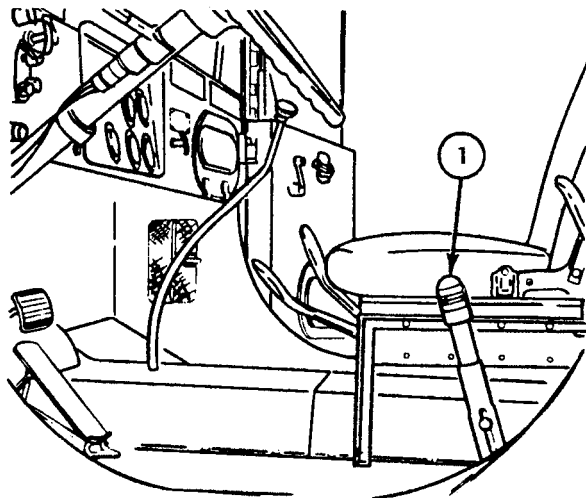
M-Monthly

Item No.	Interval					Item to be Inspected Procedure: Check for and have repaired, filled, or adjusted as needed	Equipment is not ready/available if
	B	D	A	w	M		
16		•				STEERING SYSTEM Check for unusual free play, binding, wander, or shimmy.	Loose or binding steering action, steering inoperative.
17		•				TRANSMISSION Shift transmission in all ranges observing any unusual stiffness or binding of shifting linkage.	Transmission is inoperative.
18		•				CLUTCH Check for drag, noise, chatter, grab, slippage, and clashing of gears.	Clutch is inoperative, slipping, or has definite grab or chatter.
19		•				TRANSFER Check shifting operation for unusual noises, stiffness, or jumping out of gear.	Transfer is inoperative.
20		•				HORNS Check for operation if tactical situation permits.	
21		•				FRONTAND REAR DRIVE AXLES AND PROPELLER SHAFTS Listen for unusual noises or vibrations. Vibrations, clicking, or clunking noises indicate worn U-joints or damaged propeller shafts.	Unusual noises or vibrations evident.

Table 1-1. Operator/Crew Preventive Maintenance Checks and Services - Cont

NOTE: These checks are to be made in the order listed, within designated interval.

B-Before operation
D-During operation

A-After operation
W-Weekly

M-Monthly

Item No.	Interval					Item to be Inspected Procedure: Check for and have repaired, filled, or adjusted as needed	Equipment is not ready/available if:
	B	D	A	W	M		
22						<p><u>SPECIAL BODY EQUIPMENT</u></p> <p>FRONT WINCH (For vehicles where winch is required for mission completion.)</p> <ul style="list-style-type: none"> a. Check all winch controls for operation. b. Check cable for kinks, frays, and breaks.  <p style="text-align: right;">TA 252436</p> <p>Continue checks of SPECIAL EQUIPMENT as listed in Tables 1-2 through 1-9.</p>	<p>No control response.</p> <p>Evidence of frays or breaks.</p>

Table 1-2. Operator/Crew Preventive Maintenance Checks and Services for M35A1, M35A2, M35A2C and M36A2 Cargo Trucks

NOTE: These checks are to be made in the order listed, within designated interval.

B-Before operation
D-During operation

A-After operation
W-Weekly

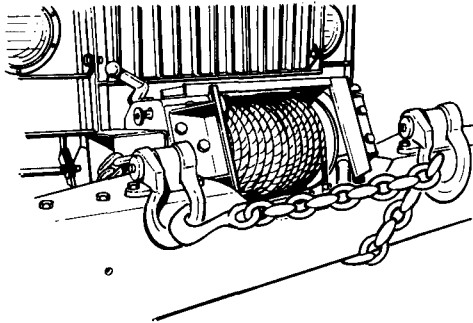
M-Monthly

Item No.	Interval					Item to be Inspected Procedure: Check for and have repaired, filled, or adjusted as needed	Equipment is not ready/available if:
	B	D	A	W	M		
1						<p>SIDE AND END PANELS, AND ACCESSORIES</p> <ul style="list-style-type: none"> Checks are to be made in the order that follows for breaks, tears, cracked or broken wood, missing or damaged parts: troop seats (1); side panels (2); end panels (3); bows (4); tarp (5); end curtains (6); tailgate (7); reflectors (8); and mud guards (9).  <p style="text-align: right;">TA 252433</p>	

Table 1-3. Operator/Crew preventive Maintenance Checks and Services for M49A1C and M49A2C Fuel Tank Trucks

NOTE: These checks are to be made in the order listed, within designated interval.

B-Before operation
D-During operation

A-After operation
W-Weekly

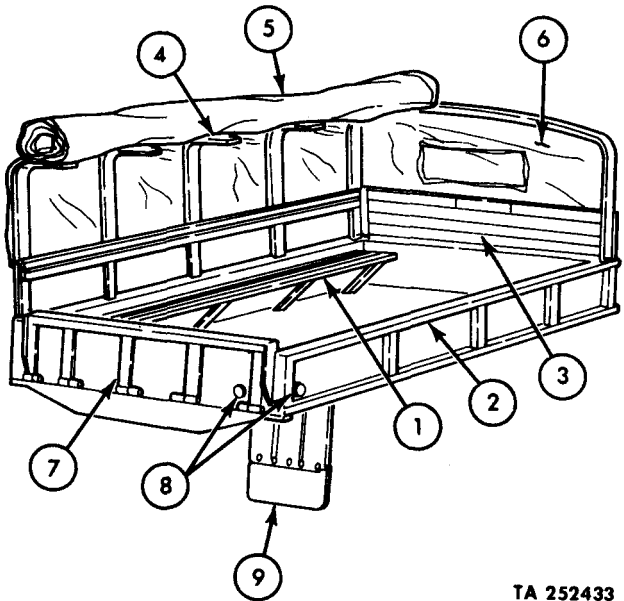
M-Monthly

Item No.	Interval					Item to be Inspected Procedure: Check for and have repaired, filled, or adjusted as needed	Equipment is not ready/available if:
	B	D	A	W	M		
1	•					<p>REAR COMPARTMENT</p> <p>Open rear doors and check that the following items are not loose or obviously damaged.</p> <p>Delivery pump (1) Strainer (2) Fuel lines (3) Controls (4) Ground wire reel (5)</p> <p>NOTE</p> <p>Controls for both fuel tank trucks are the same except as shown.</p>  <p>ON M49A1C TRUCK</p> <p>ON M49A2C TRUCK</p> <p>TA 045326</p>	Delivery pump, strainer, fuel lines, controls, or ground wire reel loose or unserviceable.

Table 1-3. Operator/Crew Preventive Maintenance Checks and Services for M49A1C and M49A2C Fuel Tank Trucks - Cont

NOTE: These checks are to be made in the order listed, within designated interval.

B-Before operation
D-During operation

A-After operation
W-Weekly

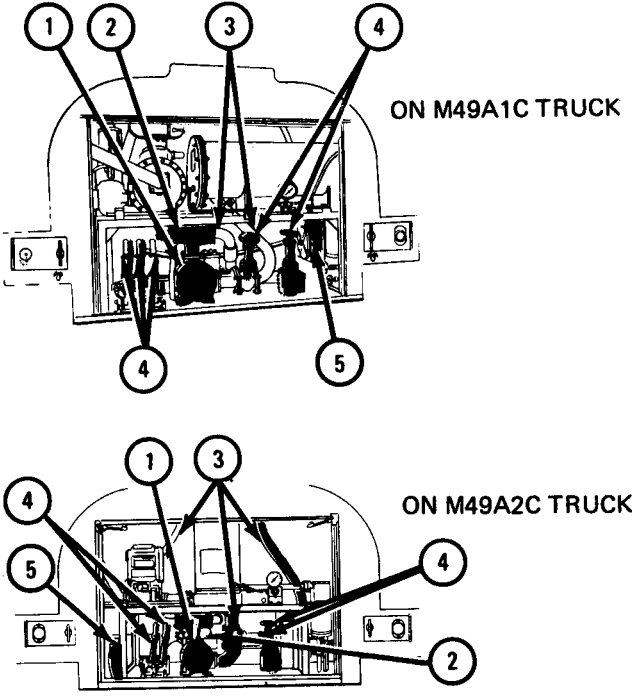
M-Monthly

Item No.	Interval					Item to be Inspected Procedure: Check for and have repaired, filled, or adjusted as needed	Equipment is not ready/available if:
	B	D	A	W	M		
2	•					<p>SUCTION HOSES</p> <p>Check both suction hoses in suction hose compartments (1) for damaged or missing parts.</p>  <p style="text-align: right;">TA 045327</p>	
3	•					<p>DISPENSER LINE ASSEMBLY</p> <p>Check the following for damaged or missing parts:</p> <ul style="list-style-type: none"> Dispenser line (1) Dispenser line nozzle (2) Bracket (3) Nozzle ground clip (4)  <p style="text-align: right;">TA 045328</p>	Dispenser line or nozzle missing or unserviceable.

Table 1-3. Operator/ Crew Preventive Maintenance Checks and Services for M49A1C and M49A2C Fuel Tank Trucks - Cont

NOTE: These checks are to be made in the order listed, within designated interval.

B-Before operation
D-During operation

A-After operation
W-Weekly

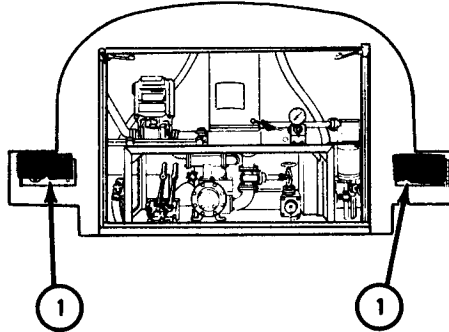
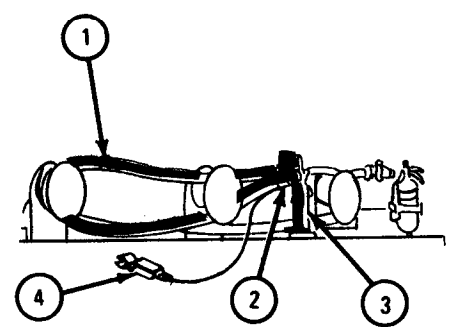
M-Monthly

Item No.	Interval					Item to be Inspected Procedure: Check for and have repaired, filled, or adjusted as needed	Equipment is not ready/ available if:
	B	D	A	W	M		
4	•				•	<p>TANK BODY</p> <p>a. Visually check that tank body is not leaking.</p> <p>b. Check that the tank body mounting bolts are not broken or missing. (See location illustrations below).</p>  <p style="text-align: right;">TA 045524-1</p> <p>Right side tank body front (1) and center (2) mounting bolts</p>	<p>Tank body leaks gasoline or has class III diesel fuel leak.</p> <p>Two or more mounting bolts broken or missing.</p>

Table 1-3. Operator/Crew Preventive Maintenance Checks and Services for M49A1C and M49A2C Fuel Tank Trucks - Cont

NOTE: These checks are to be made in the order listed, within designated interval.

B-Before operation
D-During operation

A-After operation
W-Weekly

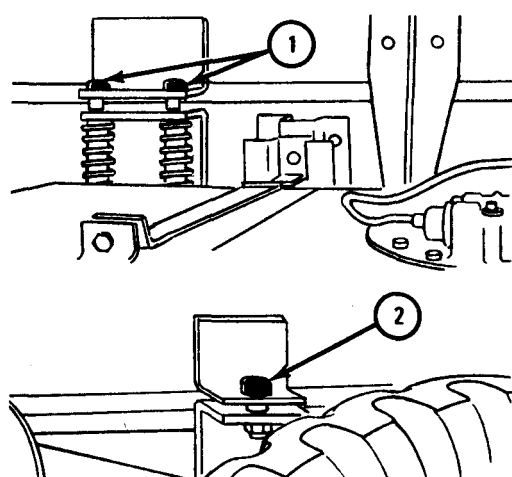
M-Monthly

Item No.	Interval					Item to be Inspected Procedure: Check for and have repaired, filled, or adjusted as needed	Equipment is not ready/ available if:
	B	D	A	W	M		
4 (cont)						 <p>TA 045524-2</p> <p>Right-side tank body center (2) and rear (3) mounting bolts</p>  <p>TA 045525</p> <p>Left-side tank body front (4), center (5), and rear (6) mounting bolts</p>	

Table 1-4. Operator/Crew Preventive Maintenance Checks and Services for M50A1, M50A2, and M50A3 Water Tank Trucks

NOTE: These checks are to be made in the order listed, within designated interval.

B-Before operation
D-During operation

A-After operation
W-Weekly

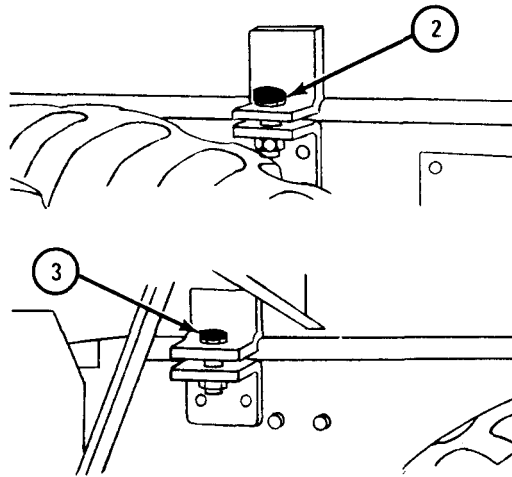
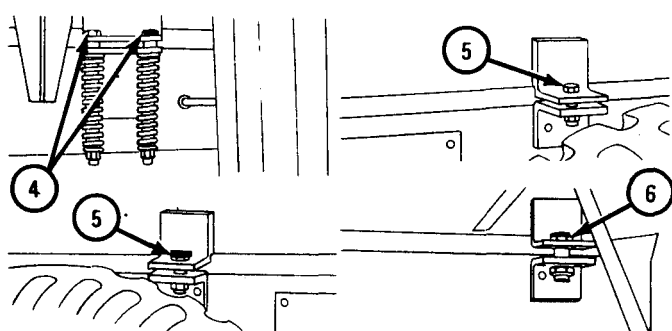
M-Monthly

Item No.	Interval					Item to be Inspected Procedure: Check for and have repaired, filled, or adjusted as needed	Equipment is not ready/available if:
	B	D	A	W	M		
1	•					<p>REAR COMPARTMENT</p> <p>a. Visually check that the following items are not damaged or missing:</p> <ul style="list-style-type: none"> Delivery pump (1) Delivery strainer (2) Water lines (3) Controls (4) Six suction hoses (5) Three discharge hoses (6) Dispenser nozzle (7) Water suction strainer (8) 	Items missing or unserviceable.

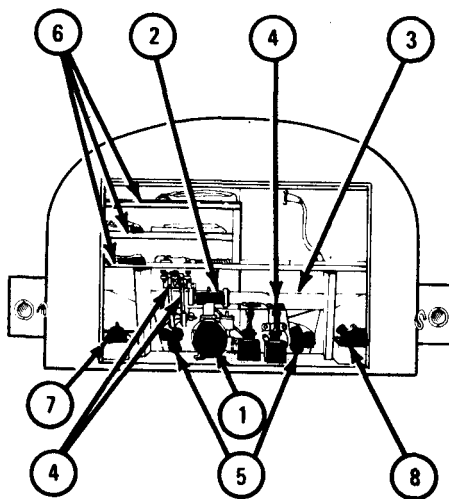

TA 045332

Table 1-4. Operator /Crew Preventive Maintenance Checks and Services for M50A1, M50A2, and M50A3 Water Tank Trucks - Cont

NOTE: These checks are to be made in the order listed, within designated interval.

B-Before operation
D-During operation

A-After operation
W-Weekly

M-Monthly

Item No.	Interval					Item to be Inspected Procedure: Check for and have repaired, filled, or adjusted as needed	Equipment is not ready/available if:
	B	D	A	W	M		
2	•			•		<p>TANK BODY</p> <p>a. Check that tank body is not leaking.</p> <p>b. Check that the body mounting bolts are not broken or missing (locations illustrated below).</p>  <p style="text-align: right;">TA 045312</p> <p>Right-side tank body front (1), center (2), and rear (3) mounting bolts.</p>	Two or more mounting bolts broken or missing.

Table 1-4. Operator/Crew Preventive Maintenance Checks and Services for M50A1, M50A2, and M50A3 Water Tank Trucks - Cont

NOTE: These checks are to be made in the order listed, within designated interval.

B-Before operation
D-During operation

A-After operation
W-Weekly

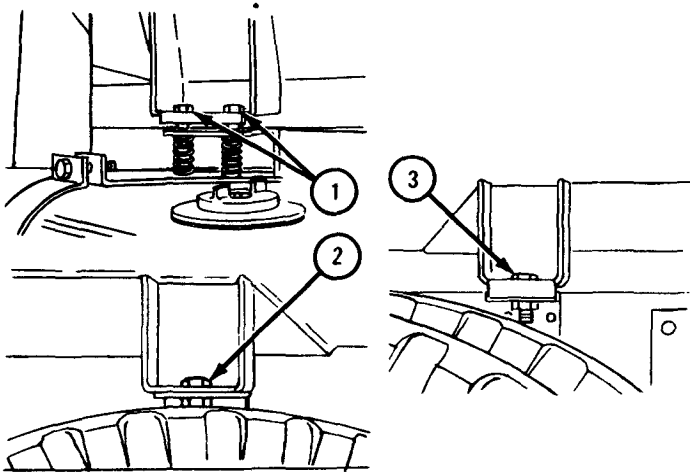
M-Monthly

Item No.	Interval					Item to be Inspected Procedure: Check for and have repaired, filled, or adjusted as needed	Equipment is not ready/available if:
	B	D	A	W	M		
2 (cont)						 <p style="text-align: right;">TA 045313</p> <p>Left-side tank body front (1), center (2) and rear (3) mounting bolts.</p>	
3		•				<p>CONTROLS AND RELATED EQUIPMENT</p> <p>Monitor controls and related equipment for proper operation. Listen for unusual noises.</p>	Improper operation or unusual noises.

Table 1-5. Operator/Crew Preventive Maintenance Checks and Services for M109A2, M109A3, M185A2 and M185A3 Shop Van and Instrument Repair Trucks

NOTE: These checks are to be made in the order listed, within designated interval.

B-Before operation
D-During operation

A-After operation
W-Weekly

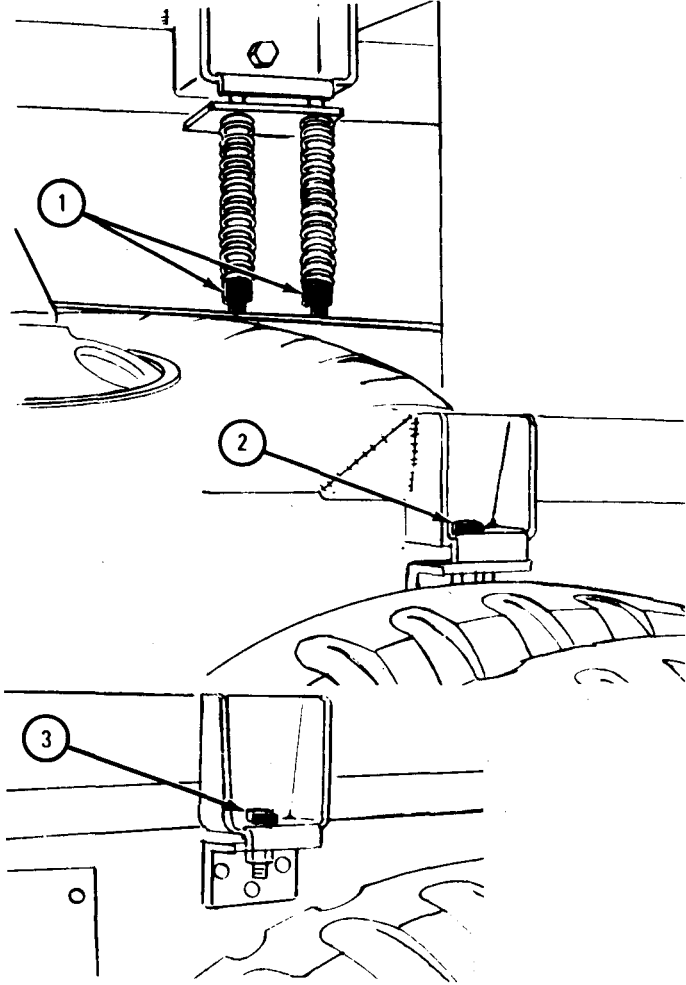
M-Monthly

Item No.	Interval					Item to be Inspected Procedure: Check for and have repaired, filled, or adjusted as needed	Equipment is not ready/ available if:
	B	D	A	W	M		
1		•				<p>INTERIOR LIGHTS, SWITCHES, AND ACCESSORIES</p> <p>a. Turn on the following switches, lights, and accessories to check that they operate properly:</p> <ul style="list-style-type: none"> Dome light toggle switch (1) and dome light Blackout dome light toggle switch (2) and dome light Rear door blackout switches (3 and 4) and dome lights Exhaust blower switch and exhaust blower. 	

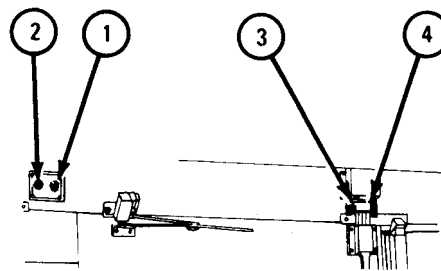

RIGHT REAR DOOR

TA 045335

Table 1-5. Operator/ Crew Preventive Maintenance Checks and Services for M109A2, M109A3, M185A2 and M185A3 Shop Van and Instrument Repair Trucks - Cont

NOTE : These checks are to be made in the order listed, within designated interval.

B-Before operation
D-During operation

A-After operation
W-Weekly

M-Monthly

Item No.	Interval					Item to be Inspected Procedure: Check for and have repaired, filled, or adjusted as needed	Equipment is not ready/available if:
	B	D	A	W	M		
1 (cont)				•		<p>b. Check that the following front panel items are not loose or damaged:</p> <ul style="list-style-type: none"> • Dome light switch (1) • Converter selector switch (2) • Exhaust blower switch (3) • Red light (4) • Power switch handle (5) • Circuit breaker box (6) 	

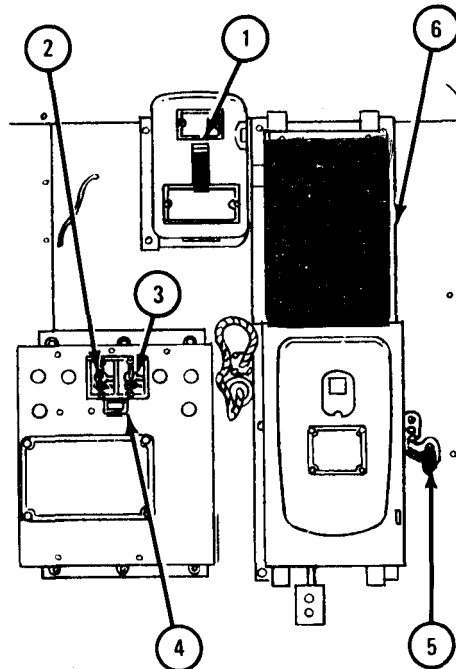

Table 1-5. Operator/Crew Preventive Maintenance Checks and Services for M109A2, M109A3, M185A2 and M185A3 Shop Van and Instrument Repair Trucks - Cont

NOTE: These checks are to be made in the order listed, within designated interval.

B-Before operation
D-During operation

A-After operation
W-Weekly

M-Monthly

Item No.	Interval					Item to be Inspected Procedure: Check for and have repaired, filled, or adjusted as needed	Equipment is not ready/available if:
	B	D	A	W	M		
2				●		<p>ELECTRICAL CONNECTORS</p> <p>Check that electrical connectors (1 and 2) are not loose or damaged.</p>  <p style="text-align: right;">TA 045337</p>	
3				●		<p>BODY MOUNTING BOLTS</p> <p>Check to see if body mounting bolts are broken or missing.</p>	Two or more body mounting bolts broken or missing.

Table 1-6. Operator/Crew Preventive Maintenance Checks and Services for M275A1 and M275A2 Tractor Trucks

NOTE : These checks are to be made in the order listed, within designated interval.

B-Before operation
D-During operation

A-After operation
W-Weekly

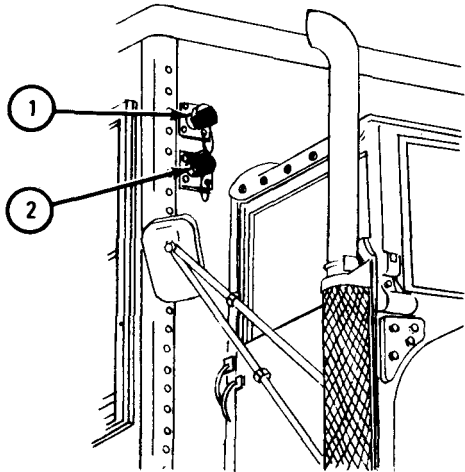
M-Monthly

Item No.	Interval					Item to be Inspected Procedure: Check for and have repaired, filled, or adjusted as needed	Equipment is not ready/available if:
	B	D	A	W	M		
1				●		<p>TRAILER AIR BRAKE HOSES AND ELECTRICAL CABLE</p> <p>Check trailer air brake hoses (1) and electrical cable (2) for missing or damaged parts.</p>  <p style="text-align: right;">TA 045339</p>	Brake hoses / electrical cable are missing or unserviceable.

Table 1-6. Operator /Crew Preventive Maintenance Checks and Services for M275A1 and M275A2 Tractor Trucks - Cont

NOTE: These checks are to be made in the order listed, within designated interval.

B-Before operation
D-During operation

A-After operation
W-Weekly

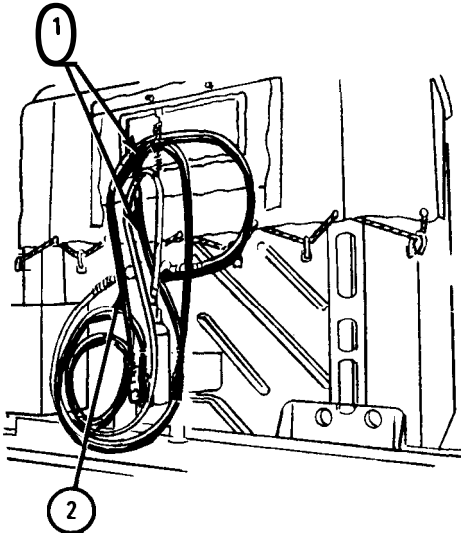
M-Monthly

em No.	Interval					Item to be Inspected Procedure: Check for and have repaired, filled, or adjusted as needed	Equipment is not ready/available if:
	B	D	A	W	M		
2		•				<p>FIFTH WHEEL ASSEMBLY</p> <p>a. Check operation of coupler jaws (1).</p> <p>b. Check that fifth wheel assembly mounting bolts (2) and locking plunger (3) are not missing or damaged.</p>	Coupler jaws do not operate.

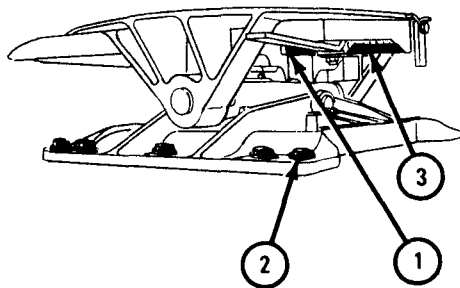

TA 045340

Table 1-7. Operator/Crew Preventive Maintenance Checks and Services for M342A2 Dump Truck

NOTE : These checks are to be made in the order listed, within designated interval.

B-Before operation
D-During operation

A-After operation
W-Weekly

M-Monthly

Item No.	Interval					Item to be Inspected Procedure: Check for and have repaired, filled, or adjusted as needed	Equipment is not ready/available if:
	B	D	A	W	M		
1		•				<p>HYDRAULIC HOIST SYSTEM</p> <p>a. Check that hydraulic hoist cylinder (1) is not leaking.</p>  <p>TA 052366</p> <p>b. Check oil level in hydraulic oil tank. If oil level is below top of red area on dipstick (1) , add oil until red area on dipstick is covered.</p>  <p>TA 080607</p> <p>c. Monitor controls and related equipment for proper operation. Listen for unusual noises.</p>	Class III leakage evident.
							Improper operation or unusual noises.

Table 1-8. Operator/Crew Preventive Maintenance Checks and Services for M756A2 Pipeline Construction Truck

NOTE : These checks are to be made in the order listed, within designated interval.

B-B efore operation
D-During operation

A-After operation
W-Weekly

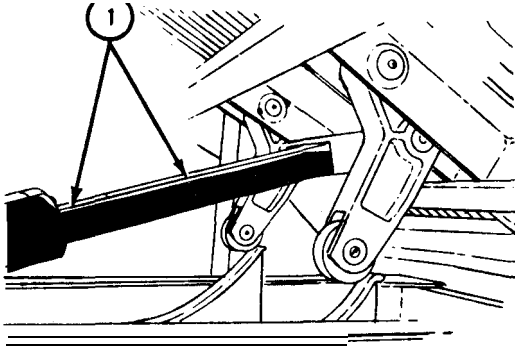
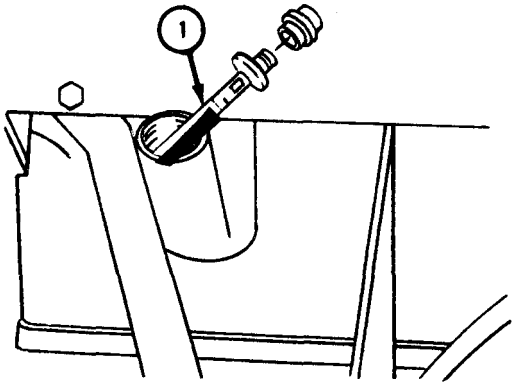
M-Monthly

em No.	Interval					Item to be Inspected Procedure: Check for and have repaired, filled, or adjusted as needed	Equipment is not ready/available if:
	B	D	A	W	M		
1						<p>BODY</p> <ul style="list-style-type: none"> Check that mounting bolts (1) are not broken or missing.  <p style="text-align: right;">TA 080612</p>	Two or more mounting bolts broken or missing.
2		•				<p>CONTROLS AND RELATED EQUIPMENT</p> <p>Monitor cent rols and related equipment for proper operation. Listen for unusual noises.</p>	Improper operation or unusual noises.

Table 1-8. Operator/Crew Preventive Maintenance Checks and Services for M756A2 Pipeline Construction Truck - Cent

NOTE : These checks are to be made in the order listed, within designated interval.

B-Before operation
D-During operation

A-After operation
W-Weekly

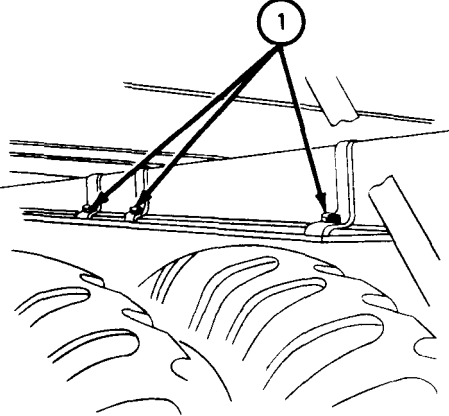
M-Monthly

Item No.	Interval					Item to be Inspected Procedure: Check for and have repaired, tilled, or adjusted as needed	Equipment is not ready/available if:
	B	D	A	W	M		
3				•		<p>REAR WINCH</p> <p>a. Visually check rear winch drive chain (1) for damage.</p>  <p>TA 045347</p> <p>b. Check that rear winch shear pin (2) is in place and serviceable (located on back side of sprocket).</p>	
4	•					<p>A FRAME</p> <p>Check that A-Frame parts are not missing, broken, or damaged.</p>	A-Frame cannot be used due to damaged or missing parts.

Table 1-9. Operator/ Crew Preventive Maintenance Checks and Services for M764 Earth Boring Machine and Pole setter Truck

NOTE : These checks are to be made in the order listed, within designated interval.

B-Before operation
D-During operation

A-After operation
W-Weekly

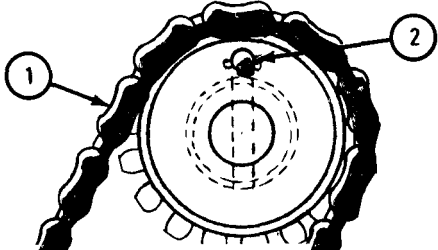
M-Monthly

em No.	Interval					Item to be Inspected Procedure: Check for and have repaired, filled, or adjusted as needed	Equipment is not ready/ available if:
	B	D	A	W	M		
1		•				<p>CONTROLS AND RELATED EQUIPMENT</p> <p>Monitor controls and related equipment for proper operation. Listen for unusual noises.</p>	Improper operation or unusual noises.
2	•			•		<p>REAR WINCH</p> <p>a. Push in on rear winch drive chain (1) at its midpoint and check that there is no slack.</p> <p>b. Check that rear winch shear pin (2) is in place and is not damaged.</p>  <p style="text-align: right;">TA 045349</p>	

Table 1-9. Operator/Crew Preventive Maintenance Checks and Services for M764 Earth Boring Machine and Polesetter Truck - Cent

NOTE: These checks are to be made in the order listed, within designated interval.

B-Before operation
D-During operation

A-After operation
W-Weekly

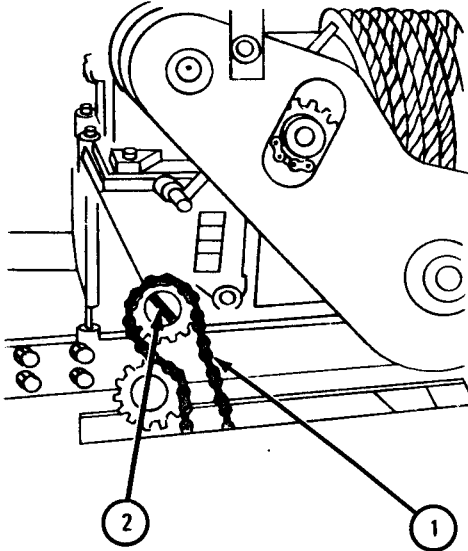
M-Monthly

Item No.	Interval					Item to be Inspected Procedure: Check for and have repaired, tilled, or adjusted as needed	Equipment is not ready/ available if:
	B	D	A	W	M		
3	•					<p>POLE LIFTING JACK</p> <p>Visually check pole lifting jack (1) for missing parts and damage.</p>  <p>TA 045350</p>	

Table 1-9. Operator/Crew Preventive Maintenance Checks and Services for M764 Earth Boring Machine and Polesetter Truck - Cent

NOTE : These checks are to be made in the order listed, within designated interval.

B-Before operation
D-During operation

A-After operation
W-Weekly

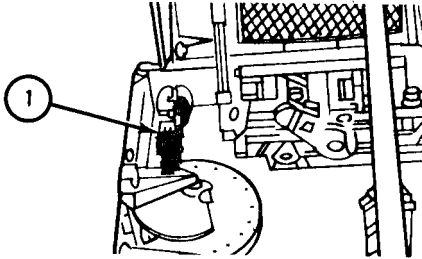
M-Monthly

Item No.	Interval					Item to be Inspected Procedure: Check for and have repaired, filled, or adjusted as needed	Equipment is not ready/available if:
	B	D	A	W	M		
4	•					<p>EARTH BORING MACHINE DERRICK</p> <p>Check earth boring machine derrick (1) for missing parts and damage.</p>  <p style="text-align: right;">TA 045351</p>	
5	•					<p>COLLAPSIBLE CABLE REEL</p> <p>Check that collapsible cable reel (2) is not damaged.</p>	

Table 1-9. Operator/Crew Preventive Maintenance Checks and Services for M764 Earth Boring Machines and Polesetter Truck - Cent

NOTE : These checks are to be made in the order listed, within designated interval.

B-Before operation
D-During operation

A-After operation
W-Weekly

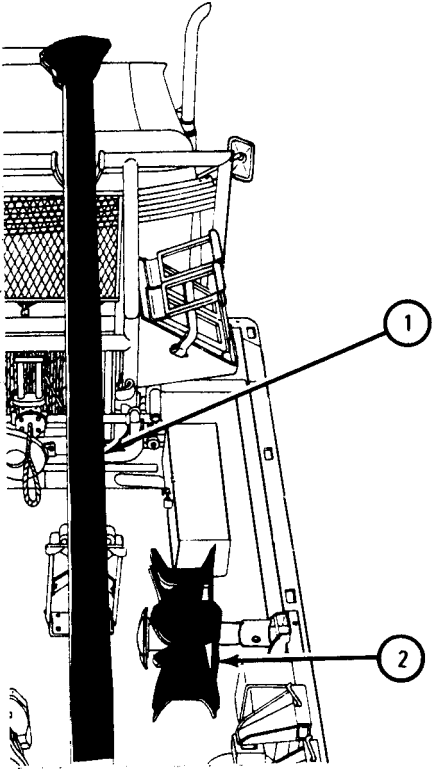
M-Monthly

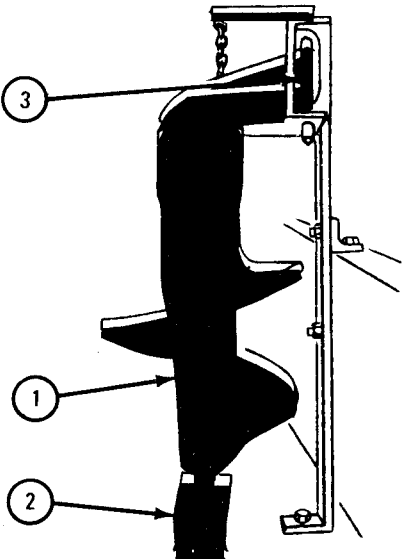
Item No.	Interval					Item to be Inspected Procedure: Check for and have repaired, filled, or adjusted as needed	Equipment is not ready/available if:
	B	D	A	W	M		
6	•					<p>EARTH AUGERS</p> <p>Check that earth augers (1) are not damaged. Auger tips should be seated in floor brackets (2) with locking pins (3) in place.</p>  <p style="text-align: right;">TA 045352</p>	

CHAPTER 2

CHECKOUT, **ALINEMENT**, AND ADJUSTMENT

2-1. There are no scheduled checkout, **alinement**, or adjustment procedures, to be done at the operator's level of maintenance.

CHAPTER 3

LUBRICATION

3-1. **GENERAL**. Refer to LO 9-2320-209-12/1 for lubrication of the vehicle.

3-2. **SPECIAL INSTRUCTIONS**. Special Instructions for lubrication of the vehicle by the operator are found in LO 9-2320-209-12/1, in instructions for service on receipt of equipment (Vol 1, para 3-1), and in instructions for operation of vehicle under unusual conditions (Vol 1, para 4-22 and 4-25e).

CHAPTER 4

SCHEDULED MAINTENANCE OF MATERIAL USED IN CONJUNCTION WITH MAJOR ITEMS

4-1. **GENERAL**. These preventive maintenance checks and services (**PMCS**) cover the special purpose kits supplies as part of the vehicle. The special purpose kits include the arctic **winterization** kit, deep water fording kit, and A-frame kit. Table 4-1 gives **PMCS** procedures and location of kit components.

4-2. **PMCS PROCEDURES**. Refer to chapter 1, **para** 1-1 for the purpose and use of the interval columns in the **PMCS** table.

Table 4-1. Operator/Crew Preventive Maintenance Checks and Services for Special Purpose Kits

NOTE : These checks are to be made in the order listed, within designated interval.

B-Before operation
D-During operation

A-After operation
W-Weekly

M-Monthly

Item No.	Interval					Item to be Inspected Procedure: Check for and have repaired, filled, or adjusted as needed	Equipment is not ready/available if:
	B	D	A	W	M		
1		•				<p>ARTIC WINTERIZATION KIT</p> <p>a. Check engine coolant heater assembly as follows:</p> <ul style="list-style-type: none"> • Check that heater fuel lines (1) and fittings are not leaking. • Check that exhaust tube (2) is not loose or damaged. • Check that coolant hose and fittings (3) are not leaking. 	<p>Any Class III leakage.</p> <p>Class III leakage</p>
 <p style="text-align: right;">TA 045360</p>							

Table 4-1. Operator/Crew Preventive Maintenance Checks and Services for Special Purpose Kits - Cent

NOTE: These checks are to be made in the order listed, within designated interval.

B-B efore operation
D-During operation

A-After operation
W-Weekly

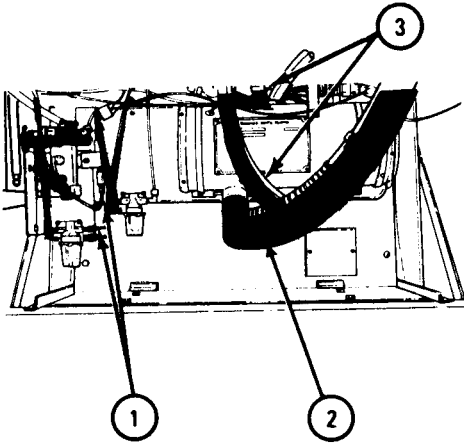
M-Monthly

Item No.	Interval					Item to be Inspected Procedure: Check for and have repaired, filled, or adjusted as needed	Equipment is not ready/available if:
	B	D	A	W	M		
1 ont)		•				<p>b. Check personnel heater as follows:</p> <p>NOTE</p> <p>Personnel heater is mounted on left side of engine compartment.</p> <p>Check that heater fuel line (1) and fittings are not leaking.</p> <div style="text-align: center;">  <p>TA 045362</p> </div>	Any Class III leakage.

Table 4-1. Operator/Crew Preventive Maintenance Checks and Services for Special Purpose Kits - Cent

NOTE: These checks are to be made in the order listed, within designated interval.

B-Before operation
D-During operation

A-After operation
W-Weekly

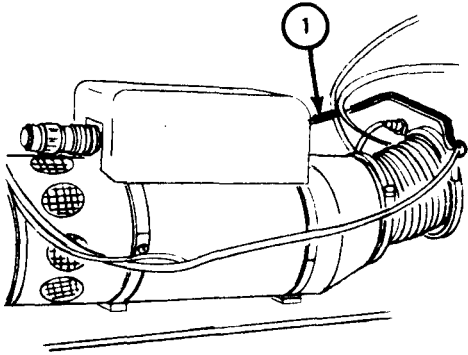
M-Monthly

Item No.	Interval					Item to be Inspected Procedure: Check for and have repaired, filled, or adjusted as needed	Equipment is not ready/available if:
	B	D	A	W	M		
1 cent)	•					<p>c. Check alcohol evaporator (cold weather only) as follows:</p> <p>NOTE</p> <p>Alcohol evaporator is mounted in left front area of engine compartment, near air compressor.</p> <p>Unscrew filler cap (1) and check alcohol level in alcohol evaporator (2). Evaporator should be full. Fill as necessary.</p>  <p>TA 045363</p>	

Table 4-1. Operator/Crew Preventive Maintenance Checks and Services for Special Purpose Kits - Cent

NOTE : These checks are to be made in the order listed, within designated interval.

B-B efore operation
D-During operation

A-After operation
W-Weekly

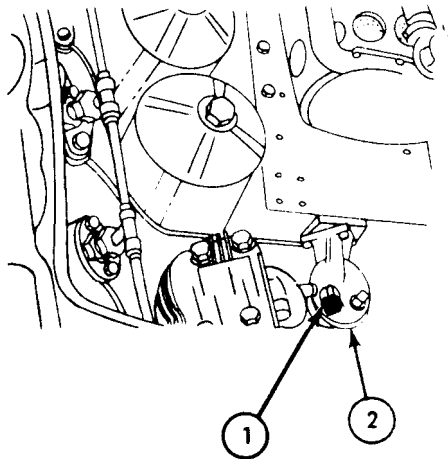
M-Monthly

Item No.	Interval					Item to be Inspected Procedure: Check for and have repaired, filled, or adjusted as needed	Equipment is not ready/ available if:
	B	D	A	W	M		
2	•					<p>DEEP WATER FORDING KIT</p> <p>a. Check that air intake system hoses (1) and cap (2) are not loose or damaged.</p> <p>b. Check that exhaust system pipe (3) is not loose or damaged.</p>	

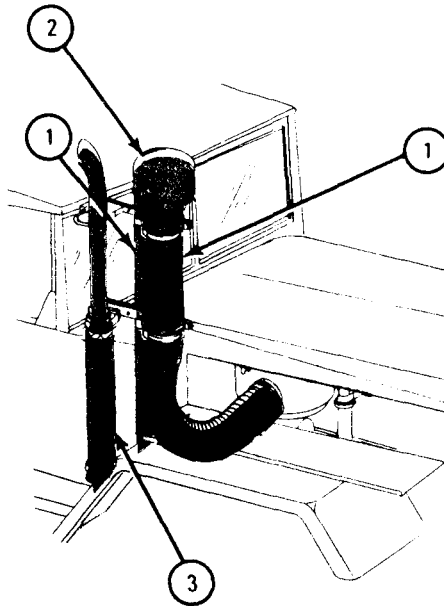

TA 045365

Table 4-1. Operator/Crew Preventive Maintenance Checks and Services for Special Purpose Kits - Cent

NOTE : These checks are to be made in the order listed, within designated interval.

B-B efore operation
D-During operation

A-After operation
W-Weekly

M-Monthly

Item No.	Interval					Item to be Inspected Procedure: Check for and have repaired, filled, or adjusted as needed	Equipment is not ready/available if:
	B	D	A	W	M		
2 cent)	•					<p>c. Check that flywheel housing drain plug (1) (mounted behind and below engine) is in place as shown.</p>  <p>TA 045366</p>	

Table 4-1. Operator/Crew Preventive Maintenance Checks and Services for Special Purpose Kits - Cent

NOTE: These checks are to be made in the order listed, within designated interval.

B-Before operation
D-During operation

A-After operation
W-Weekly

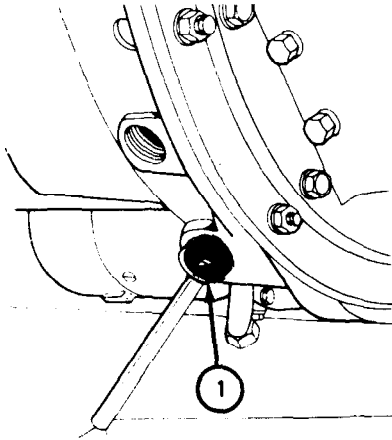
M-Monthly

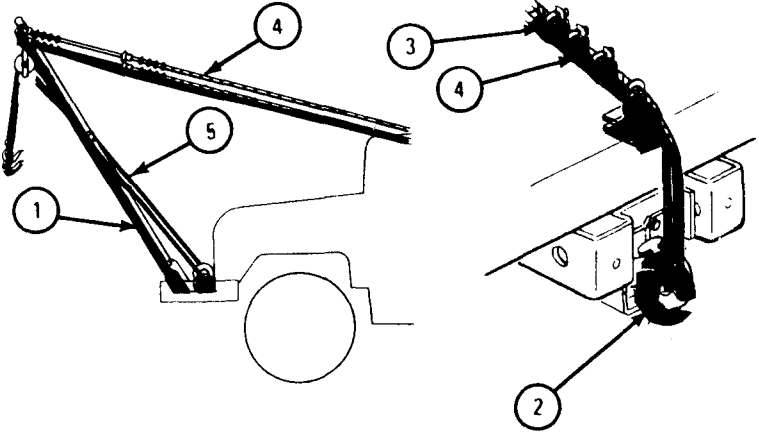
Item No.	Interval					Item to be Inspected Procedure: Check for and have repaired, filled, or adjusted as needed	Equipment is not ready/available if:
	B	D	A	w	M		
3		•				<p>A-FRAME KIT</p> <p>a. Before operating A-frame (1) , make sure it is positioned at about a 60° angle and is securely attached to the front bumper and the inverted pintle hook (2) . Also check that:</p> <p>Cable clamps (3) are not loose Cable assembly (4) is not frayed or broken</p>  <p style="text-align: right;">TA 045372</p> <p style="text-align: center;"><u>WARNING</u></p> <p>Use leather gloves when checking winch cable. Injury to hands may result if gloves are not worn.</p> <p>b. Inspect A-frame (1) for bends and winch cable (5) for kinks, frays, and breaks.</p>	Cable is frayed or broken.

By Order of the Secretaries of the Army and the Air Force:

Official:

E. C. MEYER
General, United States Army
Chief of Staff

J. C. PENNINGTON
Major General, United States Army
The **Adjutant** General

Official:

LEW ALLEN, JR., General, USAF
Chief of Staff

VAN L. CRAWFORD, JR., Colonel, USAF
Director of Administration

Distribution:

To be distributed in accordance with DA Form 12-38,
Operator **Maintenance** requirements for 2-1/2 Ton Truck
Cargo, and 2-1/2 Ton Truck **Cargo**.



THEN... JOT DOWN THE DOPE ABOUT IT ON THIS FORM, CAREFULLY TEAR IT OUT, FOLD IT AND DROP IT IN THE MAIL!

SOMETHING WRONG WITH THIS PUBLICATION?

FROM (PRINT YOUR UNIT'S COMPLETE ADDRESS)
 CDR, 1st Bn, 65th ADA
 Attn: SP4 Jane Idone
 Key West, FL 33040

DATE SENT
 Date sent in

PUBLICATION NUMBER
 TM 9-2320-209-10-2

PUBLICATION DATE
 26 Sep 80

PUBLICATION TITLE OPERATOR
 SCHEDULED MAINTENANCE MANUAL

BE EXACT PIN-POINT WHERE IT IS

PAGE NO	PARA-GRAPH	FIGURE NO	TABLE NO
1-2	1-2d		
1-4			1-1
1-17			1-3

IN THIS SPACE TELL WHAT IS WRONG AND WHAT SHOULD BE DONE ABOUT IT:

Subpara d. first sentence should be changed to read "broken connectors" instead of "connections."

Item 2 TIRES
 Cross country gives 25 psi; should be changed to 35 psi.

Item 3 DISPENSER LINE ASSEMBLY
 Change illustration callouts.
 Reason: callouts for dispenser line nozzle (2) and nozzle ground clip (4) are reversed.

SAMPLE

PRINTED NAME GRADE OR TITLE AND TELEPHONE NUMBER
 SP4 Jane Idone Autovon 222-2224

SIGN HERE
 Jane Idone

FILL IN YOUR
UNIT'S ADDRESS

FOLD BACK

DEPARTMENT OF THE ARMY

POSTAGE AND FEES PAID
DEPARTMENT OF THE ARMY
DOD 314



OFFICIAL BUSINESS
PENALTY FOR PRIVATE USE \$300

COMMANDER
U S ARMY TANK – AUTOMOTIVE
MATERIEL READINESS COMMAND
ATTN: DRSTA –MB
WARREN, MI 48090

TEAR ALONG PERFORATED LINE

RECOMMENDED CHANGES TO EQUIPMENT TECHNICAL PUBLICATIONS

SOMETHING WRONG WITH THIS PUBLICATION?



THEN . . . JOT DOWN THE DOPE ABOUT IT ON THIS FORM, CAREFULLY TEAR IT OUT, FOLD IT AND DROP IT IN THE MAIL!

FROM: (PRINT YOUR UNIT'S COMPLETE ADDRESS)

DATE SENT

PUBLICATION NUMBER

TM 9-2320-209-20-2

PUBLICATION DATE

26 Sep 80

PUBLICATION TITLE

Operator
Scheduled Maintenance Manual

BE EXACT . . . PIN-POINT WHERE IT IS

PAGE NO	PARA-GRAPH	FIGURE NO	TABLE NO

IN THIS SPACE TELL WHAT IS WRONG AND WHAT SHOULD BE DONE ABOUT IT:

TEAR ALONG PERFORATED LINE

PRINTED NAME, GRADE OR TITLE, AND TELEPHONE NUMBER

SIGN HERE

FILL IN YOUR
UNIT'S ADDRESS

FOLD BACK

DEPARTMENT OF THE ARMY

POSTAGE AND FEES PAID
DEPARTMENT OF THE ARMY
DOD 314



OFFICIAL BUSINESS
PENALTY FOR PRIVATE USE \$300

Commander
US Army Tank-Automotive Materiel Readiness Command
ATTN: DRSTA-MB
Warren, Michigan 48090

TEAR ALONG PERFORATED LINE

RECOMMENDED CHANGES TO EQUIPMENT TECHNICAL PUBLICATIONS



THEN . . . JOT DOWN THE DOPE ABOUT IT ON THIS FORM, CAREFULLY TEAR IT OUT, FOLD IT AND DROP IT IN THE MAIL!

SOMETHING WRONG WITH THIS PUBLICATION?

FROM: (PRINT YOUR UNIT'S COMPLETE ADDRESS)

DATE SENT

PUBLICATION NUMBER

TM 9-2320-209-20-2

PUBLICATION DATE

26 Sep 80

PUBLICATION TITLE Operator

Scheduled Maintenance Manual

BE EXACT . . . PIN-POINT WHERE IT IS

PAGE NO

PARA-GRAPH

FIGURE NO

TABLE NO

IN THIS SPACE TELL WHAT IS WRONG AND WHAT SHOULD BE DONE ABOUT IT:

TEAR ALONG PERFORATED LINE

PRINTED NAME, GRADE OR TITLE, AND TELEPHONE NUMBER

SIGN HERE:

DA FORM 2028-2
1 JUL 79

PREVIOUS EDITIONS ARE OBSOLETE.

P.S.--IF YOUR OUTFIT WANTS TO KNOW ABOUT YOUR RECOMMENDATION MAKE A CARBON COPY OF THIS AND GIVE IT TO YOUR HEADQUARTERS.

FILL IN YOUR
UNIT'S ADDRESS

FOLD BACK

DEPARTMENT OF THE ARMY

POSTAGE AND FEES PAID
DEPARTMENT OF THE ARMY
DOD 314



OFFICIAL BUSINESS
PENALTY FOR PRIVATE USE \$300

Commander
US Army Tank-Automotive Materiel Readiness Command
ATTN: DRSTA-MB
Warren, Michigan 48090

TEAR ALONG PERFORATED LINE

RECOMMENDED CHANGES TO EQUIPMENT TECHNICAL PUBLICATIONS



THEN... JOT DOWN THE DOPE ABOUT IT ON THIS FORM, CAREFULLY TEAR IT OUT, FOLD IT AND DROP IT IN THE MAIL!

SOMETHING WRONG WITH THIS PUBLICATION?

FROM: (PRINT YOUR UNIT'S COMPLETE ADDRESS)

DATE SENT

PUBLICATION NUMBER

TM 9-2320-209-20-2

PUBLICATION DATE

26 Sep 80

PUBLICATION TITLE

Operator
Scheduled Maintenance Manual

BE EXACT... PIN-POINT WHERE IT IS

PAGE NO

PARA-GRAPH

FIGURE NO

TABLE NO

IN THIS SPACE TELL WHAT IS WRONG AND WHAT SHOULD BE DONE ABOUT IT:

TEAR ALONG PERFORATED LINE

PRINTED NAME, GRADE OR TITLE, AND TELEPHONE NUMBER

SIGN HERE.

DA FORM 2028-2
1 JUL 79

PREVIOUS EDITIONS ARE OBSOLETE.

P.S.--IF YOUR OUTFIT WANTS TO KNOW ABOUT YOUR RECOMMENDATION MAKE A CARBON COPY OF THIS AND GIVE IT TO YOUR HEADQUARTERS.

FILL IN YOUR
UNIT'S ADDRESS

FOLD BACK

DEPARTMENT OF THE ARMY

POSTAGE AND FEES PAID
DEPARTMENT OF THE ARMY
DOD 314



OFFICIAL BUSINESS
PENALTY FOR PRIVATE USE \$300

Commander
US Army Tank-Automotive Materiel Readiness Command
ATTN: DRSTA-MB
Warren, Michigan 48090

TEAR ALONG PERFORATED LINE

THE METRIC SYSTEM AND EQUIVALENTS

LINEAR MEASURE

1 **Centimeter** = 10 **Millimeters** = 0.01 **Meters** = 0.3937 **Inches**
 1 **Meter** = 100 **Centimeters** = 1,000 **Millimeters** = 39.37 **Inches**
 1 **Kilo Meter** = 1,000 **Meters** = 0.621 **Miles**

WEIGHTS

1 **Gram** = 0.001 **Kilograms** = 1,000 **Milligrams** = 0.035 **Ounces**
 1 **Kilogram** = 1,000 **Grams** = 2.2 **Lb**
 1 **Metric Ton** = 1,000 **Kilograms** = 1 **Megagram** = 1.1 **Short Tons**

LIQUID MEASURE

1 **Milliliter** = 0.001 **Liters** = 0.0338 **Fluid Ounces**
 1 **Liter** = 1,000 **Milliliters** = 33.82 **Fluid Ounces**

SQUARE MEASURE

1 **Sq Centimeter** = 100 **Sq Millimeters** = 0.155 **Sq Inches**
 1 **Sq Meter** = 10,000 **Sq Centimeters** = 10.76 **Sq Feet**
 1 **Sq Kilometer** = 1,000,000 **Sq Meters** = 0.386 **Sq Miles**

CUBIC MEASURE

1 **Cu Centimeter** = 1,000 **Cu Millimeters** = 0.06 **Cu Inches**
 1 **Cu Meter** = 1,000,000 **Cu Centimeters** = 35.31 **Cu Feet**

TEMPERATURE

$5/9 (^{\circ}\text{F} - 32) = ^{\circ}\text{C}$
 2 12^o Fahrenheit is equivalent to 100^o Celsius
 90^o Fahrenheit is equivalent to 32.2^o Celsius
 32^o Fahrenheit is equivalent to 0^o Celsius
 $9/5 \text{ C} + 32 = \text{F}^{\circ}$

APPROXIMATE CONVERSION FACTORS

TO CHANGE	TO	MULTIPLY BY
Inches	Centimeters	2.540
Feet	Meters	0.305
Yards	Meters	0.914
Miles	Kilometers	1.609
Square Inches	Square Centimeters	6.451
Square Feet	Square Meters	0.093
Square Yards	Square Meters	0.836
Square Miles	Square Kilometers	2.590
Acres	Square Hectometers	0.405
Cubic Feet	Cubic Meters	0.028
Cubic Yards	Cubic Meters	0.765
Fluid Ounce	Milliliters	29.573
Pints	Liters	0.473
Quarts	Liters	0.946
Gallons	Liters	3.785
Ounces	Grams	28.349
Pounds	Kilograms	0.454
Short Tons	Metric Tons	0.907
Pound-Feet	Newton-Meters	1.356
Pounds Per Square Inch	Kilopascals	6.895
Miles Per Gallon	Kilometers Per Liter	0.425
Miles Per Hour	Kilometers Per Hour	1.609
TO CHANGE	TO	MULTIPLY BY
Centimeters	Inches	0.394
Meters	Feet	3.280
Meters	Yards	1.094
Kilometers	Miles	0.621
Square Centimeters	Square Inches	0.155
Square Meters	Square Feet	10.764
Square Meters	Square Yards	1.196
Square Kilometers	Square Miles	0.386
Square Hectometers	Acres	2.471
Cubic Meters	Cubic Feet	35.315
Cubic Meters	Cubic Yards	1.308
Millimeters	Fluid Ounces	0.034
Liters	Pints	2.113
Liters	Quarts	1.057
Liters	Gallons	0.264
Grams	Ounces	0.035
Kilograms	Pounds	2.205
Metric Tons	Short Tons	1.102
Newton-Meters	Pound-Feet	0.738
Kilopascals	Pounds Per Square Inch	0.145
Kilometers Per Liter	Miles Per Gallon	2.354
Kilometers Per Hour	Miles Per Hour	0.621

