

TM 9-2320-209-20-3-4

T.O. 36A12-1B-1092-1-3

TECHNICAL MANUAL

VOLUME 3 OF 3

PART 4 OF 4

MAINTENANCE

ORGANIZATIONAL LEVEL

2½-TON, 6X6, M44A1 AND M44A2 SERIES TRUCKS

(MULTIFUEL)

TRUCK, CARGO: N35A1,

M35A2, M35A2C, M36A2; TRUCK,

TANK, FUEL: M49A1C, M49A2C; TRUCK, TANK,

WATER: M50A1, M50A2, M50A3; TRUCK, VAN,

SHOP: M109A2, M109A3; TRUCK, REPAIR SHOP:

M185A2, M185A3; TRUCK, TRACTOR: M275A1,

M275A2; TRUCK, DUMP: M342A2; TRUCK,

MAINTENANCE, PIPELINE CONSTRUCTION:

M756A2; TRUCK, MAINTENANCE,

EARTH BORING AND POLESETTING: M764

Chapter 19
Winch and Hoist
Assemblies and
Power Takeoff
Controls and Linkage

Chapter 20
Bumper Guards

Chapter 21
Body Accessory
Items

Chapter 22
Nonelectrical
Gages

Chapter 23
Material Used in
Conjunction with
Major Items

Appendix A
References

NOTE:

THE STYLE OF THIS TM IS
EXPERIMENTAL. IT IS BEING TRIED
BY THE ARMY ONLY ON
A LIMITED BASIS

DEPARTMENTS OF THE ARMY AND THE AIR FORCE

MAY 1981

WARNING

EXHAUST GASES CAN BE DEADLY

Exposure to exhaust gases produces symptoms of headache, dizziness, loss of muscular control, apparent drowsiness, and coma. Permanent brain damage or death can result from severe exposure.

Carbon monoxide occurs in the exhaust fumes of fuel burning heaters and internal combustion engines, and becomes dangerously concentrated under conditions of inadequate ventilation. The following precautions must be observed to insure the safety of personnel whenever fuel burning heater(s) or engine of any vehicle is operated for maintenance purposes or tactical use.

Do not operate heater or engine of vehicle in an enclosed area unless it is adequately ventilated.

Do not idle engine for long periods without maintaining adequate ventilation in personnel compartments.

Do not drive any vehicle with inspection plates or cover plates removed unless necessary for maintenance purposes.

Be alert at all times during vehicle operation for exhaust odors and exposure symptoms. If either are present, immediately ventilate personnel compartments. If symptoms persist, remove affected personnel from vehicle and treat as follows: expose to fresh air; keep warm; do not permit physical exercise; if necessary, administer artificial respiration.

If exposed, seek prompt medical attention for possible delayed onset of acute lung congestion. Administer oxygen if available.

The best defense against exhaust gas poisoning is adequate ventilation.

WARNING

Serious or fatal injury to personnel may result if the following instructions are not complied with.

Always wear protective gloves when handling winch cable. Do not let winch cable slip through hands. Rusty or broken wires can cause serious injury.

Always use hand THROTTLE to control engine speed when operating winch. Avoid sudden changes in speed or high speed. Rough, jerky operation may cause broken shear pins and snapped cables, damage to vehicle or injury to personnel.

Dry cleaning solvent is flammable. Do not use near an open flame. Keep a fire extinguisher nearby when solvent is used. Use only in well-ventilated places. Failure to do this may result in injury to personnel and damage to equipment.

Eye shields must be worn when using grinder. Eye injury can occur if eye shields are not used.

Never work under dump body unless safety braces are in place. Dump body could drop and personnel could be seriously injured.

Do not work on hot heater exhaust tube. Let it cool before removing it. Hot exhaust tube can cause serious burns.

Eye shields must be worn when using compressed air. Eye injury can occur if eye shields are not used.

WARNING - Cont

Smoking, sparks or open flame are not allowed within 50 feet of work area during fuel filter service. Fuel may burn, causing explosion, injury to personnel, and damage to equipment.

Do not work on cooling system components until cool. Personnel can be badly burned by hot components.

***TM 9-2320-209-20-3-4
T.O. 36A12-1B-1092-1-3**

TECHNICAL MANUAL
NO. 9-2320-209-20-3-4
TECHNICAL ORDER
NO. 36A12-1B-1092-1-3

DEPARTMENTS OF THE ARMY
AND
THE AIR FORCE
Washington, D.C., 27 May 1981

**TECHNICAL MANUAL
VOLUME 3 OF 3
PART 4 OF 4
MAINTENANCE
ORGANIZATIONAL LEVEL
2½-TON 6X6, M44A1 AND M44A2 SERIES TRUCKS
(MULTIFUEL)**

Model		NSN without Winch	NSN with Winch
Truck, Cargo	M35A1	2320-00-542-5633	2320-00-542-5634
	M35A2	2320-00-077-1616	2320-00-077-1617
	M35A2C	2320-00-926-0873	2320-00-926-0875
	M36A2	2320-00-077-1618	2320-00-077-1619
Truck, Tank, Fuel	M49A1C	2320-00-440-3349	2320-00-440-3346
	M49A2C	2320-00-077-1631	2320-00-077-1632
Truck, Tank, Water	M50A1	2320-00-440-8307	2320-00-440-8305
	M50A2	2320-00-077-1633	2320-00-077-1634
	M50A3	2320-00-937-4036	2320-00-937-5264
Truck, Van, Shop	M109A2	2320-00-440-8313	2320-00-440-8308
	M109A3	2320-00-077-1636	2320-00-077-1637
Truck, Repair Shop	M185A2	4940-00-987-8799	4940-00-077-1639
	M185A3	4940-00-077-1638	
Truck, Tractor	M275A1	2320-00-446-2479	2320-00-077-1641
	M275A2	2320-00-077-1640	
Truck, Dump	M342A2	2320-00-077-1643	2320-00-077-1644
Truck, Maintenance, Pipeline Construction	M756A2		2320-00-904-3277
Truck, Maintenance, Earth Boring and Polesetting	M764		2320-00-937-5980

*This manual, together with TM 9-2320-209-20-1, 27 May 1981; TM 9-2320-209-20-2-1, 27 May 1981; TM 9-2320-209-20-2-2, 27 May 1981; TM 9-2320-209-20-3-1, 27 May 1981; TM 9-2320-209-20-3-2, 27 May 1981; and TM 9-2320-209-20-3-3, 27 May 1981 supersedes TM 9-2320-209-20-1, 31 August 1978.

REPORTING OF ERRORS AND RECOMMENDING IMPROVEMENTS

You can help improve this manual. If you find any mistakes or if you know of a way to improve the procedure, please let us know. Mail your letter, DA Form 2028 (Recommended Changes to Publication and Blank Forms), or DA Form 2028-2 located in the back of this manual direct to: Commander, U.S. Army Tank Automotive Materiel Readiness Command, ATTN: DRSTA-MB , Warren, Michigan 48090. A reply will be furnished to you.

TABLE OF CONTENTS

	Paragraph	Page
CHAPTER 19. WINCH AND HOIST ASSEMBLIES AND POWER TAKEOFF CONTROLS AND LINKAGE GROUP MAINTENANCE		
Section I. Scope		19-1
Equipment Items Covered	19-1	19-1
Equipment Items Not Covered	19-2	19-1
Section II. Winch and Hoist Assemblies		19-1
Front Winch Brake Test Adjustments	19-3	19-1
Preliminary Procedure	19-3a	19-1
Drag Brake Test and Adjustment	19-3b	19-2
Automatic Brake Test Adjustment	19-3c	19-4
Front Winch Removal and Replacement	19-4	19-14
Preliminary Procedures	19-4a	19-14
Removal	19-4b	19-14
Replacement	19-4c	19-15
Front Winch Propeller Shaft Removal and Replacement	19-5	19-16
Removal	19-5a	19-16
Replacement	19-5b	19-18
Rear Winch Control Lever Linkage Adjustment (Truck M764)	19-6	19-20
Winch Drum Lock Assembly Removal, Repair, and Replacement (Truck M756A2)	19-7	19-24
Removal	19-7a	19-24
Disassembly	19-7b	19-26
Cleaning	19-7c	19-27
Inspection and Repair	19-7d	19-27
Assembly	19-7e	19-28
Replacement	19-7f	19-29
Winch and Power Takeoff Sprockets Removal, Repair, and Replacement (Truck M756A2)	19-8	19-31
Preliminary Procedure	19-8a	19-31
Removal	19-8b	19-32
Disassembly of Winch Sprocket Assembly	19-8c	19-37
Cleaning	19-8d	19-38
Inspection and Repair	19-8e	19-38

TABLE OF CONTENTS-CONT

	Paragraph	Page
Assembly of Winch Sprocket Assembly	19-8f	19-38
Replacement	19-8g	19-39
Rear Winch Drum Clutch Lever and Guide Plate Removal, Repair, and Replacement (Truck M756A2)	19-9	19-43
Removal	19-9a	19-43
Disassembly	19-9b	19-44
Assembly	19-9c	19-46
Replacement	19-9d	19-47
Front, Mid, and Rear Winch Cable and Chain Assembly Removal, Repair, and Replacement . .	19-10	19-48
Preliminary Procedure	19-10a	19-48
Removal	19-10b	19-49
Disassembly (Early Model)	19-10c	19-50
Disassembly (Late Model)	19-10d	19-51
Cleaning	19-10e	19-53
Inspection and Repair	19-10f	19-53
Assembly (Early Model)	19-10g	19-54
Assembly (Late Model)	19-10h	19-55
Replacement	19-10i	19-59
Rear Winch Cable Removal and Replacement (Truck M764)	19-11	19-60
Preliminary Procedure	19-11a	19-60
Removal	19-11b	19-60
Replacement	19-11c	19-62
Rear Winch Assembly Worm Gear Housing Oil Drain Tube Removal Inspection, Repair, and Replacement (Truck M764)	19-12	19-64
Removal	19-12a	19-64
Cleaning	19-12b	19-66
Inspection and Repair	19-12c	19-66
Replacement	19-12d	19-66
Rear Winch Drive Chain Removal and Replacement (Truck M756A2)	19-13	19-68
Removal	19-13a	19-68
Cleaning	19-13b	19-69
Inspection and Repair	19-13c	19-69
Replacement	19-13d	19-69
Rear Winch Drive Chain Adjustment (Truck M756A2)	19-14	19-70
Preliminary Procedure	19-14a	19-70
Adjustment	19-14b	19-70
Carriage Cross Chain Removal and Replacement (Truck M764)	19-15	19-76
Preliminary Procedure	19-15a	19-76
Removal	19-15b	19-76
Replacement	19-15c	19-80

TABLE OF CONTENTS-CONT

	Paragraph	Page
Carriage Travel Adjustment (Truck M764)	19-16	19-83
Preliminary Procedure	19-16a	19-83
Carriage Travel Adjustment	19-16b	19-83
Reduction Drive Chains Removal and Replacement (Truck M764)	19-17	19-86
Removal	19-17a	19-86
Replacement	19-17b	19-91
Reduction Drive Chains Adjustment (Truck M764)	19-18	19-95
First Reduction Drive Chain	19-18a	19-95
Second Reduction Drive Chain	19-18b	19-98
Cable Level Winder Drive Chains Repair (Truck M764)	19-19	19-101
Preliminary Procedure	19-19a	19-101
Repair	19-19b	19-101
Outrigger Pump Drive Shaft Universal Joint Assembly Removal and Replacement (Truck M764)	19-20	19-102
Removal	19-20a	19-103
Replacement	19-20b	19-105
Hydraulic Hoist Pump Propeller Shaft Removal, Repair, and Replacement (Truck M342A2)	19-21	19-108
Removal	19-21a	19-108
Repair	19-21b	19-110
Replacement	19-21c	19-111
Flexible Hydraulic Lines Removal and Replace- ment (Truck M342A2)	19-22	19-113
Preliminary Procedure	19-22a	19-113
Removal	19-22b	19-114
Replacement	19-22c	19-117
Hydraulic Hoist Control Linkage Removal, Repair, and Replacement (Truck M342A2)	19-23	19-120
Removal	19-23a	19-120
Replacement and Adjustment	19-23b	19-123
Dump Body Safety Brace Locking and Unlocking (Truck M342A2)	19-24	19-127
Locking	19-24a	19-127
Unlocking	19-24b	19-128
Section III. Power Takeoff Controls and Linkage		19-129
Transmission Power Takeoff		
Shift Linkage Removal, Replacement, Checkout, and Adjustment	19-25	19-129
Preliminary Procedure	19-25a	19-129
Removal	19-25b	19-129
Replacement	19-25c	19-130
Checkout	19-25d	19-131
Adjustment	19-25e	19-132

TABLE OF CONTENTS -CONT

		Paragraph	Page
	Power Divider Controls and Linkage Removal, Replacement, and Adjustment (Truck M764)	19-26	19-133
	Preliminary Procedure.	19-26a	19-133
	Removal	19-26b	19-133
	Replacement	19-26c	19-136
	Adjustment	19-26d	19-140
	Power Divider Propeller Shaft Assembly Removal and Replacement (Truck M764)	19-27	19-143
	Removal	19-27a	19-143
	Repair	19-27b	19-145
	Replacement	19-27c	19-145
CHAPTER 20.	BUMPER GUARDS GROUP MAINTENANCE		
Section I.	Scope		20-1
	Equipment Items Covered	20-1	20-1
	Equipment Items Not Covered	20-2	20-1
Section II.	Bumper Brackets, Guards, and Protective Devices		20-1
	Headlight Guard Removal and Replacement	20-3	20-1
	Removal	20-3a	20-2
	Replacement	20-3b	20-3
CHAPTER 21.	BODY ACCESSORY ITEMS GROUP MAINTENANCE		
Section I.	Scope		21-1
	Equipment Items Covered	21-1	21-1
	Equipment Items Not Covered	21-2	21-1
Section II.	Canvas Accessory Items		21-1
	Bow Assembly Repair	21-3	21-1
	Disassembly	21-3a	21-2
	Cleaning	21-3b	21-3
	Inspection and Repair	21-3c	21-3
	Assembly	21-3d	21-3
Section III.	Cab Accessory Items		21-4
	Windshield Wiper Motor Removal and Replacement	21-4	21-4
	Removal	21-4a	21-4
	Replacement	21-4b	21-6
	Windshield Washer Repair	21-5	21-8
	Preliminary Procedure.	21-5a	21-8
	Removal	21-5b	21-8
	Repair	21-5c	21-11
	Replacement	21-5d	21-11
	Mirror and Bracket Assembly Removal, Repair, and Replacement	21-6	21-15
	Removal	21-6a	21-15
	Repair	21-6b	21-19
	Replacement	21-6c	21-19

TABLE OF CONTENTS-CONT

	Paragraph	Page
Section IV. Data Plates		21-24
Data Plates Removal and Replacement	21-7	21-24
Removal	21-7a	21-25
Replacement	21-7b	21-29
CHAPTER 22. NONELECTRICAL GAGES GROUP MAINTENANCE		
Section I. Scope		22-1
Equipment Items Covered	22-1	22-1
Equipment Items Not Covered	22-2	22-1
Section II. Nonelectrical Gages		22-1
Tachometer Assembly Removal, Repair, and Replacement	22-3	22-1
Preliminary Procedures	22-3a	22-1
Removal of Tachometer	22-3b	22-2
Removal of Flexible Shaft Assembly	22-3c	22-4
Removal of Right Angle Adapter.	22-3d	22-7
Removal of Flexible Shaft Core	22-3e	22-8
Repair of Flexible Shaft Assembly	22-3f	22-9
Replacement of Flexible Shaft Core	22-3g	22-9
Replacement of Right Angle Adapter.	22-3h	22-10
Replacement of Flexible Shaft Assembly	22-3i	22-11
Replacement of Tachometer	22-3j	22-13
Speedometer Assembly Removal Repair, and Replacement	22-4	22-16
Preliminary Procedures	22-4a	22-16
Removal of Speedometer.	22-4b	22-16
Removal of Flexible Shaft Assembly	22-4c	22-18
Removal of Right Angle Drive Adapter	22-4d	22-21
Removal of Flexible Shaft Core	22-4e	22-22
Repair of Flexible Shaft Assembly	22-4f	22-23
Replacement of Flexible Shaft Core	22-4g	22-23
Replacement of Right Angle Drive Adapter.	22-4h	22-24
Replacement of Flexible Shaft Assembly	22-4i	22-25
Replacement of Speedometer.	22-4j	22-30
CHAPTER 23. MAINTENANCE OF MATERIAL USED IN CONJUNCTION WITH MAJOR ITEMS		
Section I. Scope		23-1
Equipment Items Covered	23-1	23-1
Equipment Items Not Covered	23-2	23-1
Section II. Winterization Kits		23-1
Vehicular Compartment Heater Removal and Replacement	23-3	23-1
Preliminary Procedures	23-3a	23-1
Removal	23-3b	23-2
Replacement	23-3c	23-3

TABLE OF CONTENTS-CONT

	Paragraph	Page
Fuel Burning Personnel Heater Ducting		
Repair	23-4	23-4
Preliminary Procedure	23-4a	23-4
Removal	23-4b	23-4
Repair	23-4c	23-5
Replacement	23-4d	23-5
Fuel Burning Personnel Heater Air Diverter		
Repair	23-5	23-7
Preliminary Procedure	23-5a	23-7
Removal	23-5b	23-7
Replacement	23-5c	23-8
Fuel Burning Personnel Heater Air Inlet		
Adapter Repair	23-6	23-9
Preliminary Procedure	23-6a	23-9
Removal	23-6b	23-9
Replacement	23-6c	23-11
Fuel Burning Personnel Heater Exhaust Tube and Clamps Repair	23-7	23-13
Preliminary Procedure	23-7a	23-13
Removal	23-7b	23-13
Replacement	23-7c	23-15
Fuel Burning Personnel Heater Control Cables		
Repair and Adjustment	23-8	23-17
Removal	23-8a	23-17
Repair	23-8b	23-19
Replacement	23-8c	23-19
Adjustment	23-8d	23-21
Personnel and Engine Heater Control Box		
Indicator Lamp Removal and Replacement	23-9	23-22
Removal	23-9a	23-22
Replacement	23-9b	23-23
Winterization Kit Fuel Filters Repair	23-10	23-24
Preliminary Procedures	23-10a	23-24
Removal	23-10b	23-25
Cleaning and Inspection.	23-10c	23-26
Repair	23-10d	23-26
Replacement	23-10e	23-27
Oil Pan Shroud Repair	23-11	23-28
Removal	23-11a	23-28
Replacement	23-11b	23-29
Powerplant Heater Exhaust Tube Removal and Replacement	23-12	23-30
Preliminary Procedures	23-12a	23-30
Removal	23-12b	23-30
Replacement	23-12c	23-33

TABLE OF CONTENTS-CONT

	Paragraph	Page
Powerplant Coolant Heater Hoses and Clamps Removal and Replacement.	23-13	23-36
Preliminary Procedures	23-13a	23-36
Removal	23-13b	23-37
Replacement	23-13c	23-41
Hot Water Personnel Heater Ducting Repair . . .	23-14	23-45
Hot Water Personnel Heater Air Diverter Repair	23-15	23-45
Hot Water Personnel Heater Control Cables Repair and Adjustment.	23-16	23-45
Hot Water Personnel Heater Control Switch . . .		
Removal and Replacement	23-17	23-45
Removal	23-17a	23-46
Replacement	23-17b	23-48
Hot Water Personnel Heater Hoses and Clamps Removal and Replacement.	23-18	23-50
Preliminary Procedure	23-18a	23-50
Removal	23-18b	23-50
Replacement	23-18c	23-52
Hot Water Personnel Heater Motor Resistor Removal and Replacement	23-19	23-54
Preliminary Procedure	23-19a	23-54
Removal	23-19b	23-54
Replacement	23-19c	23-55
Hot Water Personnel Heater Blower Motor Repair	23-20	23-56
Preliminary Procedure	23-20a	23-56
Removal	23-20b	23-56
Replacement	23-20c	23-57
Winterization Kit Fuel Pump Repair	23-21	23-58
Preliminary Procedures	23-21a	23-58
Removal	23-21b	23-59
Cleaning, Inspection, and Repair	23-21c	23-61
Replacement	23-21d	23-62
Battery Box Heater Pad Repair	23-22	23-64
Preliminary Procedures	23-22a	23-64
Removal	23-22b	23-65
Replacement	23-22c	23-69
Hood, Side Panel, and Radiator Covers Removal and Replacement	23-23	23-73
Removal	23-23a	23-73
Replacement	23-23b	23-76
Slave Receptacle Assembly Repair	23-24	23-79
Preliminary Procedures	23-24a	23-79
Removal	23-24b	23-79
Disassembly	23-24c	23-82

TABLE OF CONTENTS-CONT

		Paragraph	Page
	Inspection and Repair	23-24d	23-83
	Assembly	23-24e	23-83
	Replacement	23-24f	23-84
	Van Body Personnel Heater Assembly Repair (Trucks M109A2 and M109A3)	23-25	23-87
	Preliminary Procedures	23-25a	23-87
	Removal	23-25b	23-87
	Replacement	23-25c	23-90
	Van Body Personnel Heater Duct Removal and Replacement (Trucks M109A2 and M109A3)	23-26	23-93
	Removal	23-26a	23-93
	Replacement	23-26b	23-94
	Van Body Personnel Heater Switches Repair (Trucks M109A2 and M109A3)	23-27	23-95
	Preliminary Procedures	23-27a	23-95
	Removal	23-27b	23-95
	Replacement	23-27c	23-99
Section III.	Deep Water Fording Kit		23-103
	Deep Water Fording Kit Exhaust Extension Removal, Repair, and Replacement	23-28	23-103
	Removal	23-28a	23-103
	Repair	23-28b	23-105
	Replacement	23-28c	23-106
	Deep Water Fording Kit Transmission Breather Removal, Repair, and Replacement	23-29	23-108
	Preliminary Procedure	23-29a	23-108
	Removal	23-29b	23-108
	Repair	23-29c	23-109
	Replacement	23-29d	23-110
	Deep Water Fording Kit Control Valve Removal, Repair, and Replacement	23-30	23-111
	Preliminary Procedure	23-30a	23-111
	Removal	23-30b	23-112
	Repair	23-30c	23-113
	Replacement	23-30d	23-115
	Deep Water Fording Kit Pressurization Valve Hand Control Assembly Removal and Replacement	23-31	23-116
	Preliminary Procedure	23-31a	23-116
	Removal	23-31b	23-116
	Replacement	23-31c	23-118
Section IV.	Special Purpose Kits		23-120
	Decontamination Apparatus Mounting Bracket Removal and Replacement	23-32	23-120
	Preliminary Procedure	23-32a	23-120
	Removal	23-32b	23-120
	Replacement	23-32c	23-123

TABLE OF CONTENTS-CONT

	Paragraph	Page
A-Frame Kit Spreader Tube Repair	23-33	23-126
Preliminary Procedure	23-33a	23-126
Removal	23-33b	23-126
Replacement	23-33c	23-129
APPENDIX A. REFERENCES		A-1
INDEX		Index 1

CHAPTER 19

WINCH AND HOIST ASSEMBLIES AND POWER TAKEOFF CONTROLS AND LINKAGE GROUP MAINTENANCE

Section I. SCOPE

19-1. EQUIPMENT ITEMS COVERED . This chapter gives equipment maintenance procedures for the winch and hoist assemblies and the power takeoff controls and linkage for which there are authorized corrective maintenance tasks at the organizational maintenance level.

19-2. EQUIPMENT ITEMS NOT COVERED. All equipment items for which corrective maintenance is authorized at the organizational maintenance level are covered in this chapter.

Section II. WINCH AND HOIST ASSEMBLIES

19-3. FRONT WINCH BRAKE TEST AND ADJUSTMENTS.

TOOLS: 9/16-inch wrench
Offset screwdriver
Leather gloves

SUPPLIES: None

PERSONNEL: Three

EQUIPMENT CONDITION: Truck parked, engine off, handbrake set.

a. Preliminary Procedures. Disengage winch clutch. Refer to TM 9-2320-209-10.

b. Drag Brake Test and Adjustment.

(1) Test.

FRAME 1

WARNING

Always wear protective gloves when handling winch cable. Do not let winch cable slip through hands. Rusty or broken wires can cause serious injury.

1. Grab winch cable (1) and pull out about six feet of cable, then let go of cable quickly. If drum (2) keeps turning, do drag brake adjustment. If drum (2) stops turning when cable (1) is let go, adjustment is correct.

END OF TASK

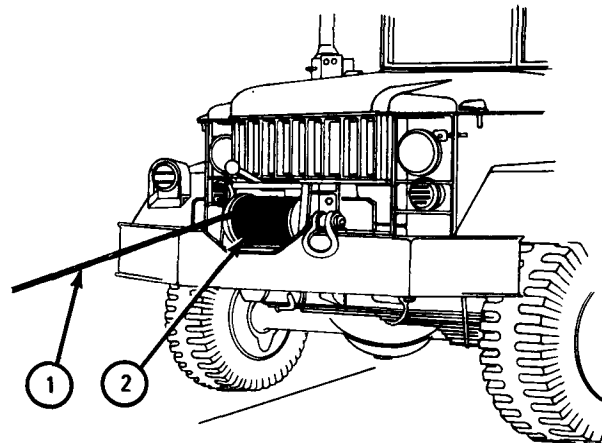
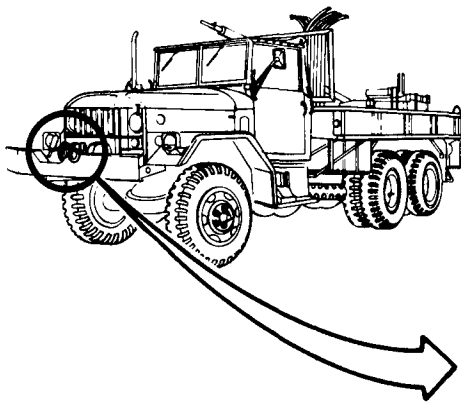

TA 080939

(2) Adjustment.

FRAME 1

1. Using offset screwdriver, screw in adjusting screw (1) 1/2 turn.
 2. Do test again.
- END OF TASK

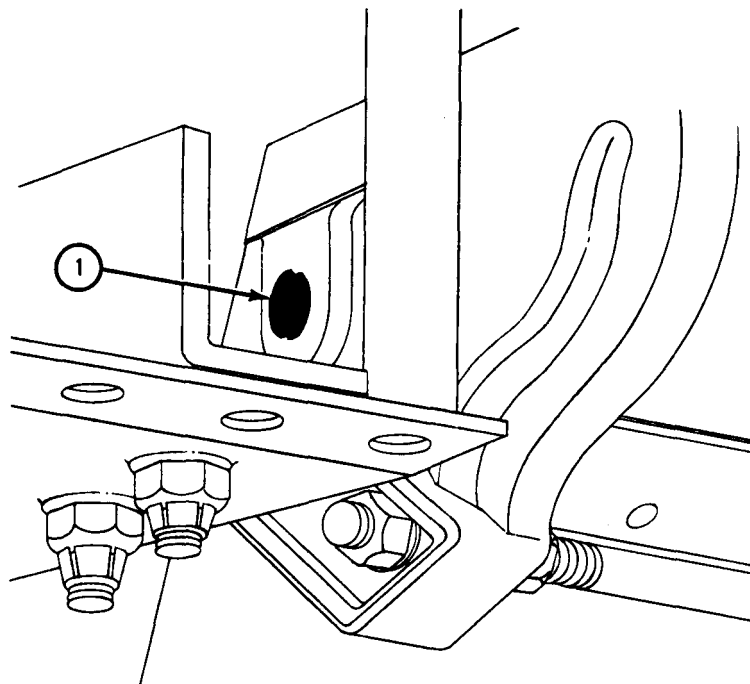

TA 080940

c. Automatic Brake Test and Adjustment.

FRAME 1

Soldier A 1. Park truck (1) with winch to be tested at top of steep grade as shown. Refer to TM 9-2320-209-10. Sit in cab throughout this task with engine running.

GO TO FRAME 2

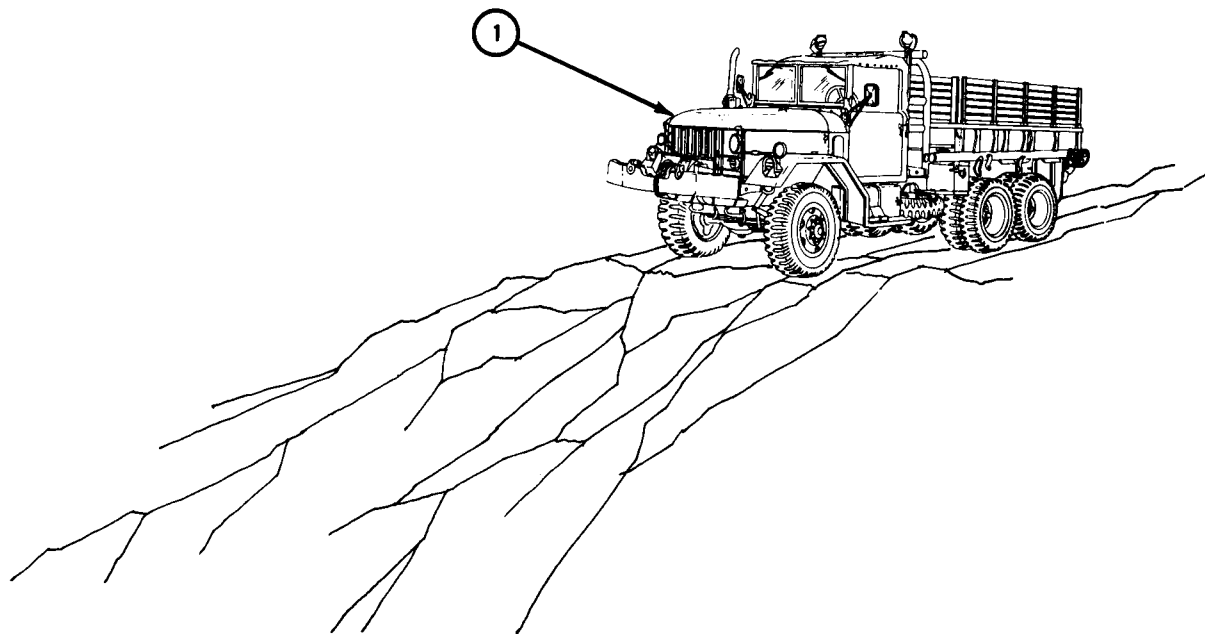

TA 080941

FRAME 2

1. Pull handbrake (1) up to brake on position.
2. Press clutch pedal (2) all the way down.
3. Place FRONT TRANSMISSION gearshift lever (3) in N (neutral) position.
4. Let clutch pedal (2) up.
5. Turn front winch control lever hinge lock (4) to unlock position.
6. Keep front winch control lever (5) in upper N (neutral) position.

GO TO FRAME 3

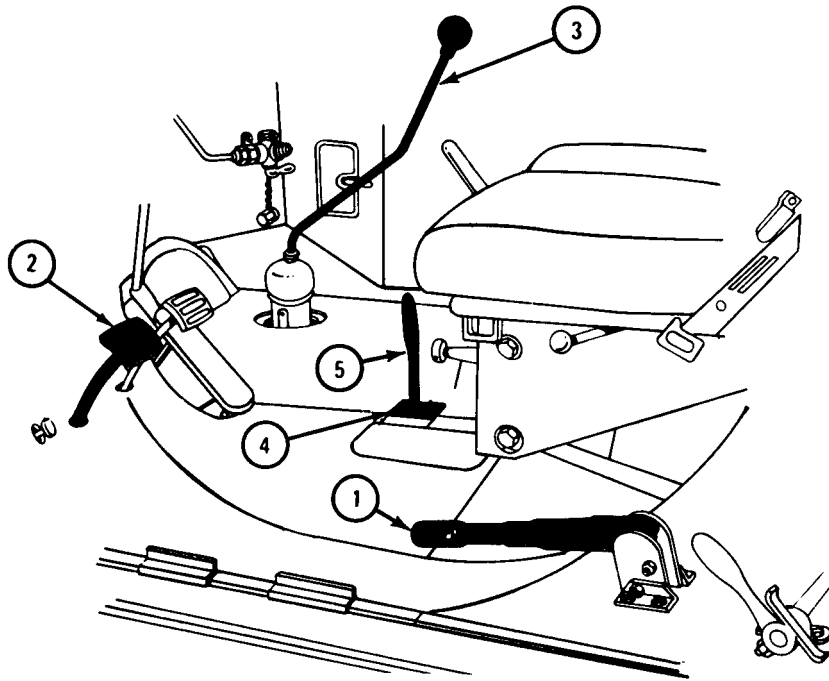

TA 080942

FRAME 3

Soldier B 1. Pullout front winch drum lock knob (1). Turn it 1/4-turn and let it go into unlocked position.

GO TO FRAME 4

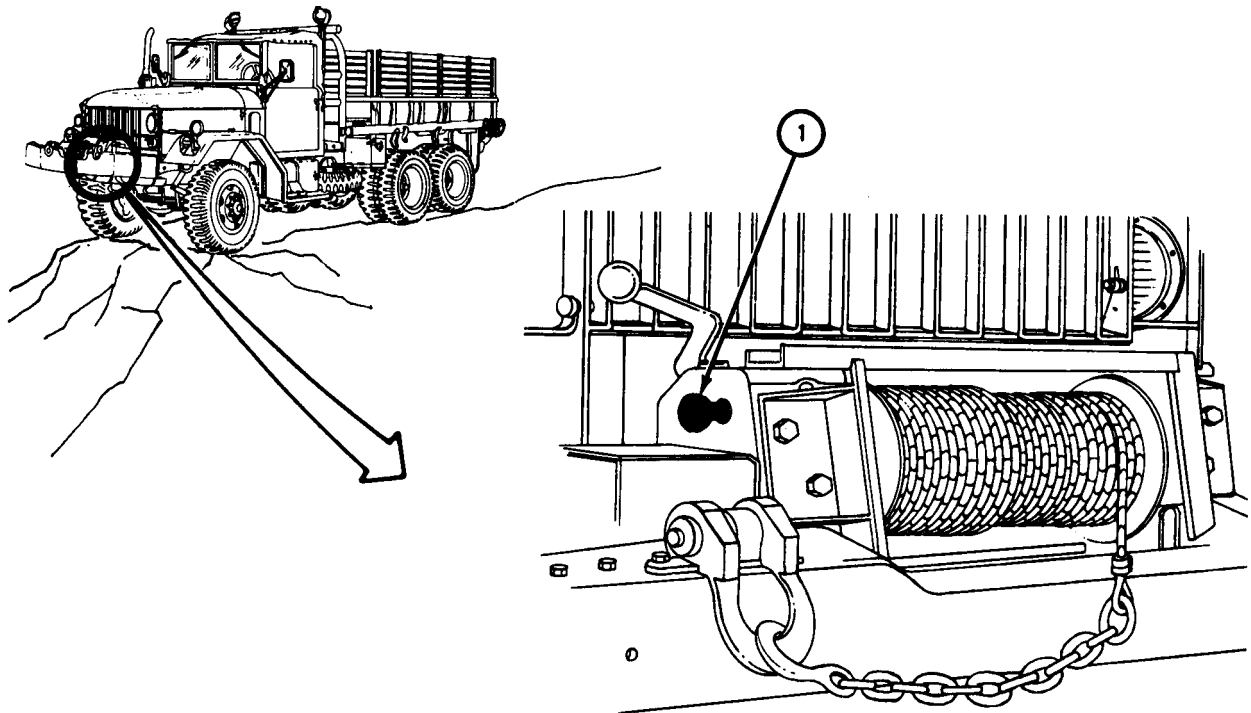

TA 080943

FRAME 4

- Soldier C
1. Park second truck (1) at bottom of steep grade in a direct line with winch (2) on first truck (3) as shown. Refer to TM 9-2320-209-10.
 2. Sit in cab during this task with engine running.

WARNING

Always wear protective gloves when handling winch cable. Do not let winch cable slip through hands. Rusty or broken wires can cause serious injury.

CAUTION

Do not operate winch with less than four turns of cable on drum. End of cable may pull free of drum.

NOTE

Do not kink winch cable.

- Soldier B
3. Pull winch cable (4) from winch (2) to reach second truck (1).
 4. Hook winch cable (4) on second truck (1).

GO TO FRAME 5

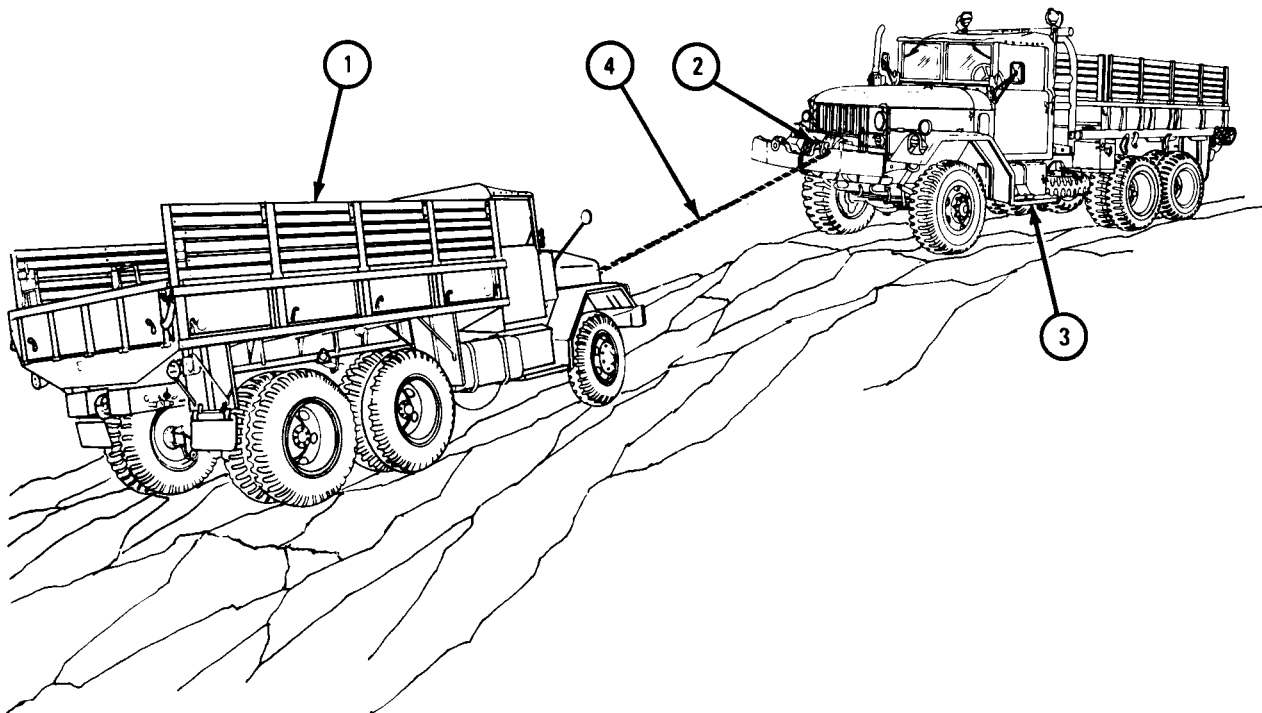

TA 080944

FRAME 5

Soldier B 1. Move front winch drum clutch lever (1) on upper truck as far as it will go from the drum (2) (engage position). Stand clear of trucks and cable (3).

GO TO FRAME 6

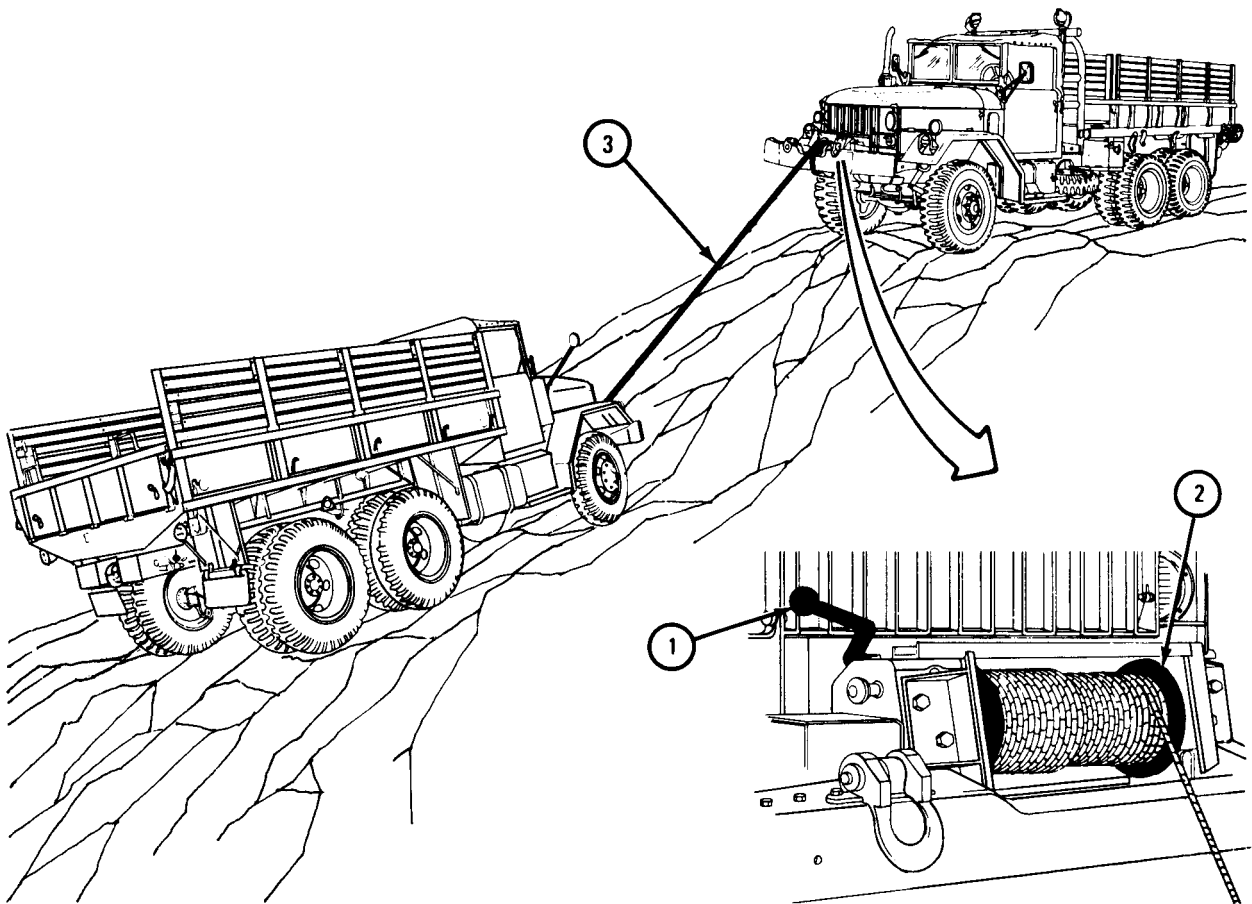

TA 080945

FRAME 6

- Soldier C 1. Sit in cab of lower truck, ready to step on brake pedal (1) to stop truck if it starts to roll down grade. Tell soldier A when ready.
- Soldier A 2. Sitting in cab of upper truck, with engine running, leave FRONT TRANSMISSION gearshift lever (2) in N (neutral) position.

WARNING

Always use hand THROTTLE to control engine speed when operating winch. Avoid sudden changes in speed or high speed. Rough, jerky operation may cause broken shear pins and snapped cables, damage to vehicle or injury to personnel.

3. Press down on clutch pedal (3).
4. Move front WINCH CONTROL lever (4) to L (low) position.

GO TO FRAME 7

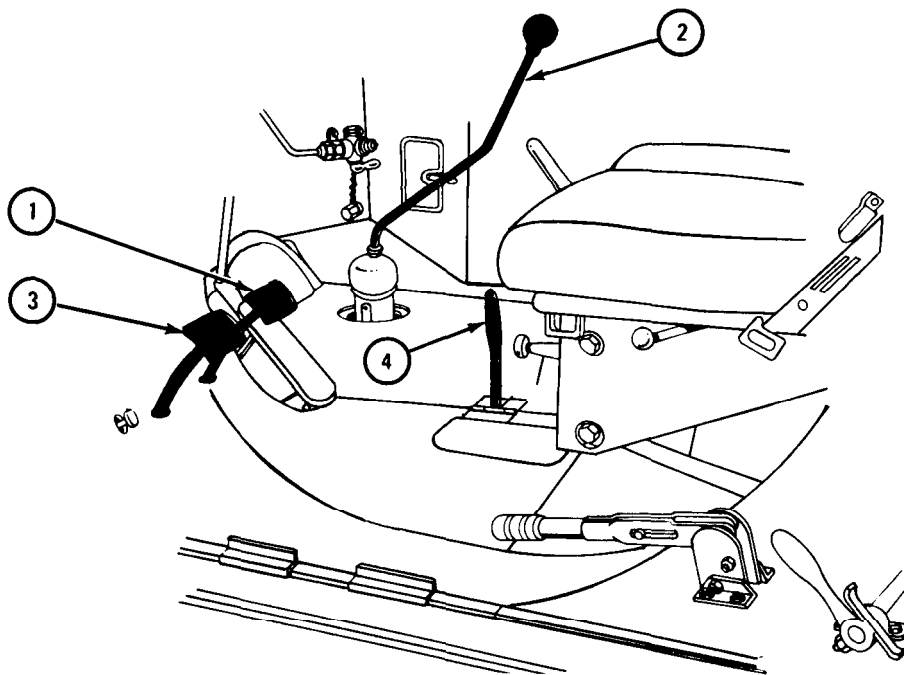

TA 080946

FRAME 7

- Soldier A
1. Sitting in cab of upper truck (1), let clutch pedal (2) come up slowly.
 2. Wind in winch cable (3) to take up slack.
 3. Use hand THROTTLE (4) to control speed and continue smooth operation. Pull lower truck (5) three-quarters of the way up grade.

GO TO FRAME 8

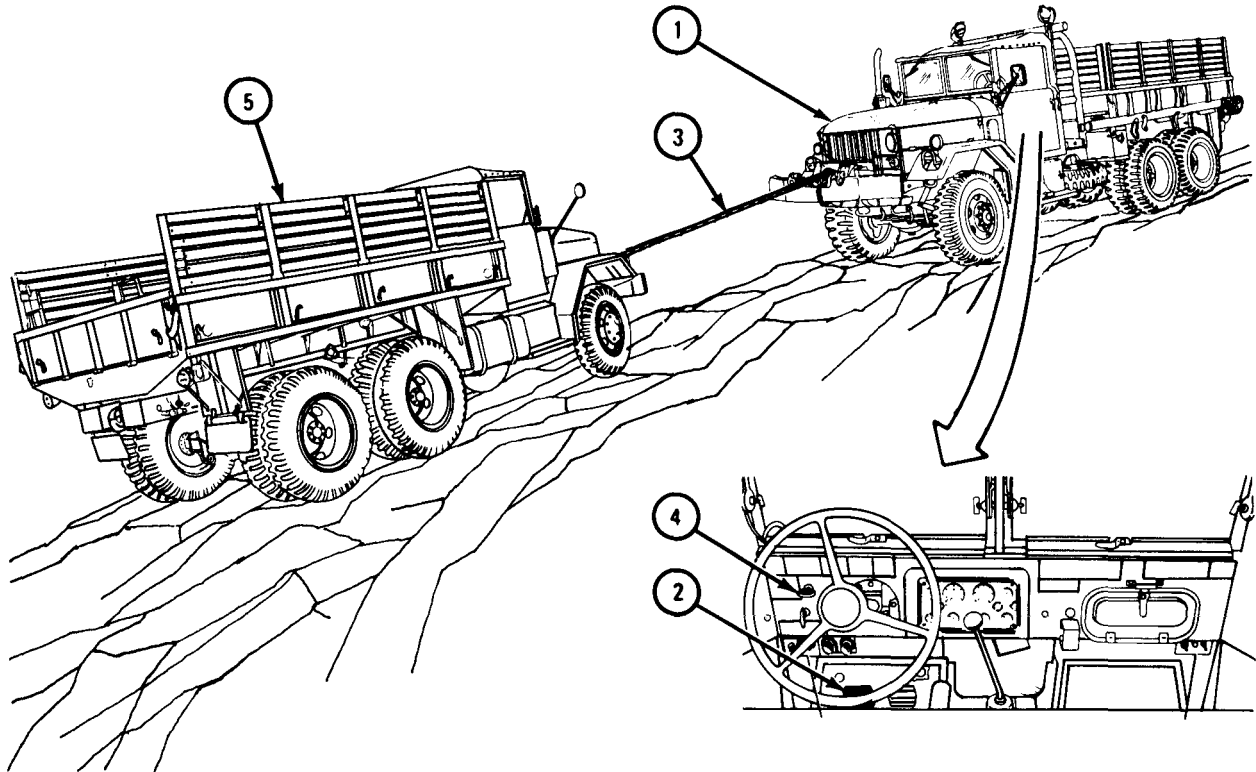

TA 080947

FRAME 8

- Soldier A
1. Sitting in cab of upper truck (1), press clutch pedal (2) all the way down.
 2. Place front WINCH CONTROL lever (3) in upper N (neutral) position.
 3. Let up on clutch pedal (2) slowly.

IF TRUCK (4) ROLLS DOWN GRADE, GO TO FRAME 9.

IF TRUCK (4) DOES NOT ROLL DOWN GRADE, GO TO FRAME 10

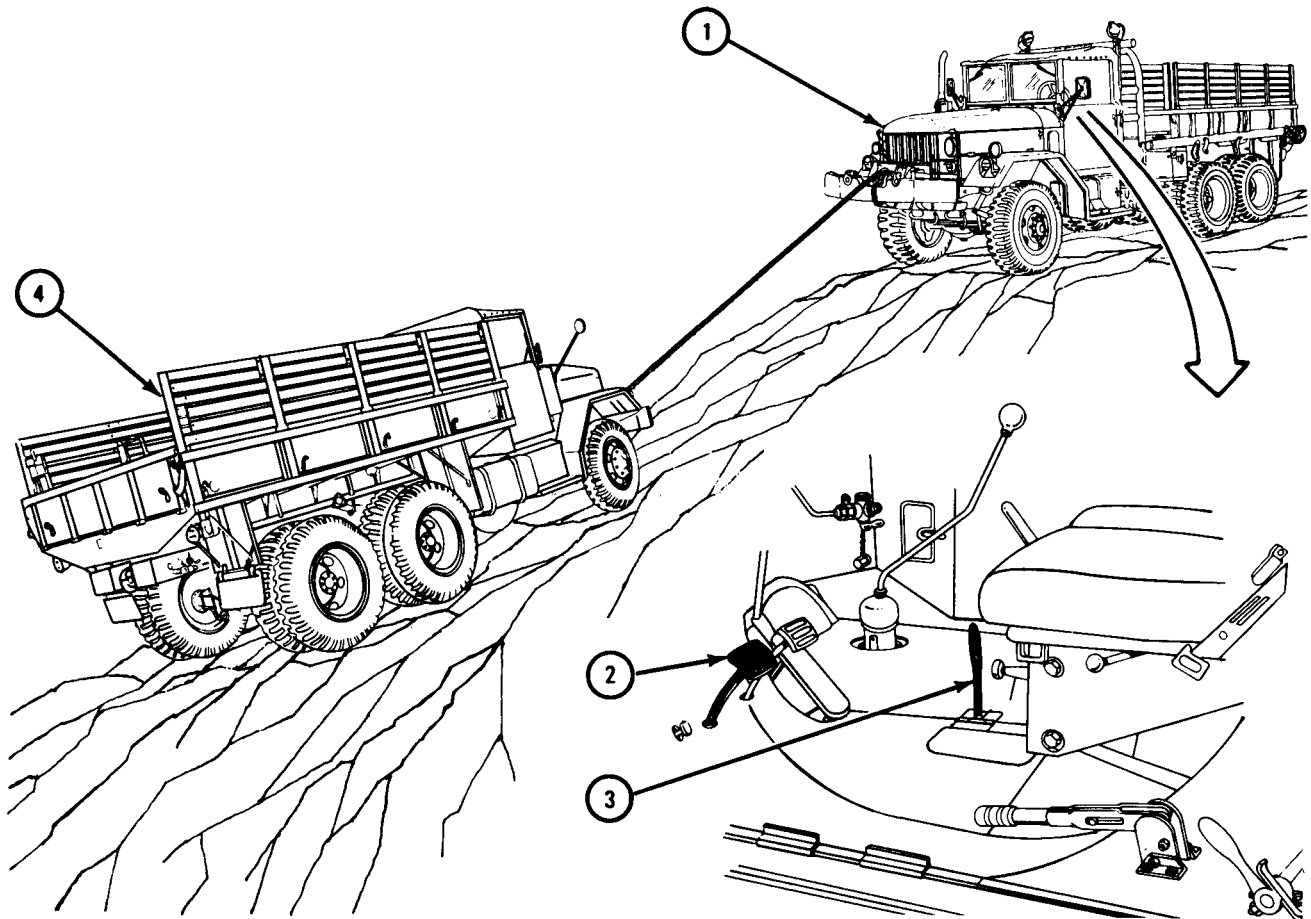

TA 080948

FRAME 9

Soldier C 1. Push down brake pedal (1). Pull up handbrake (2) to on position and let go of brake pedal. Tell soldier B when ready.

Soldier B 2. Using 9/16-inch wrench, turn screw (3) 1/2 turn to right.

NOTE

When correctly adjusted, the brake will become warm, but should not be too hot to hold brake cover with hand.

Soldier C 3. Push handbrake (2) down to off position.

IF TRUCK (4) ROLLS DOWN GRADE, DO FRAME 9 AGAIN.

IF TRUCK (4) DOES NOT ROLL DOWN GRADE, GO TO FRAME 10

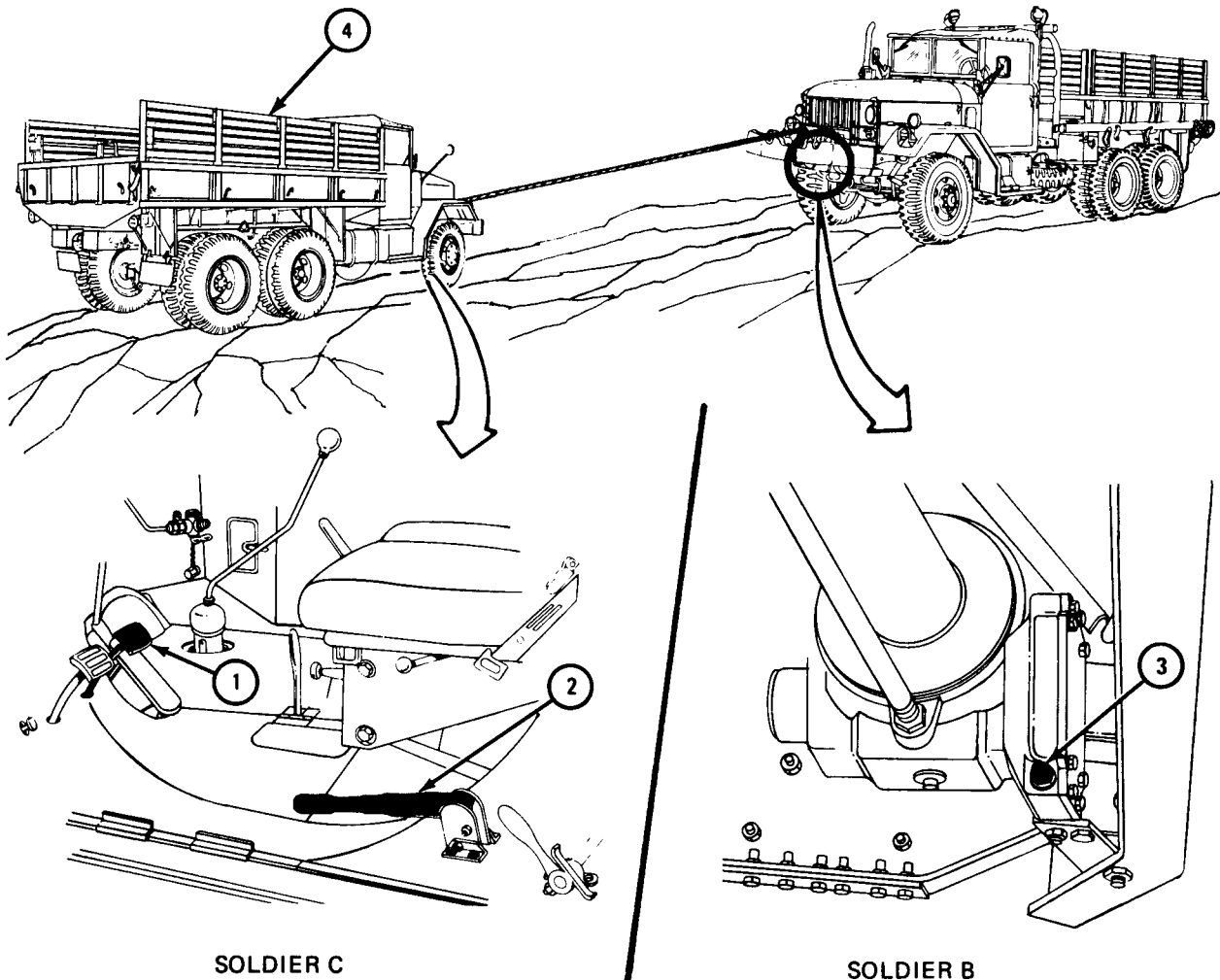

TA 080950

FRAME 10

- Soldier C 1. Pull up handbrake (1) to on position. Tell soldier A when ready.
- Soldier A 2. Press clutch pedal (2) all the way down.
3. Place front WINCH CONTROL lever (3) in R (reverse) position.
4. Let up clutch pedal (2) slowly until there is enough slack in cable (4) to unlock it from truck (5).
5. Press clutch pedal (2) all the way down.
6. Place front WINCH CONTROL lever (3) in N (neutral) position.
7. Let up clutch pedal (2).
- Soldier B 8. Unhook winch cable (4) from truck (5).
- Soldier A 9. Rewind winch cable (4). Refer to TM 9-2320-209-10.

NOTE

Follow-on Maintenance Action Required:

Engage winch clutch. Refer to TM 9-2320-209-10.

END OF TASK

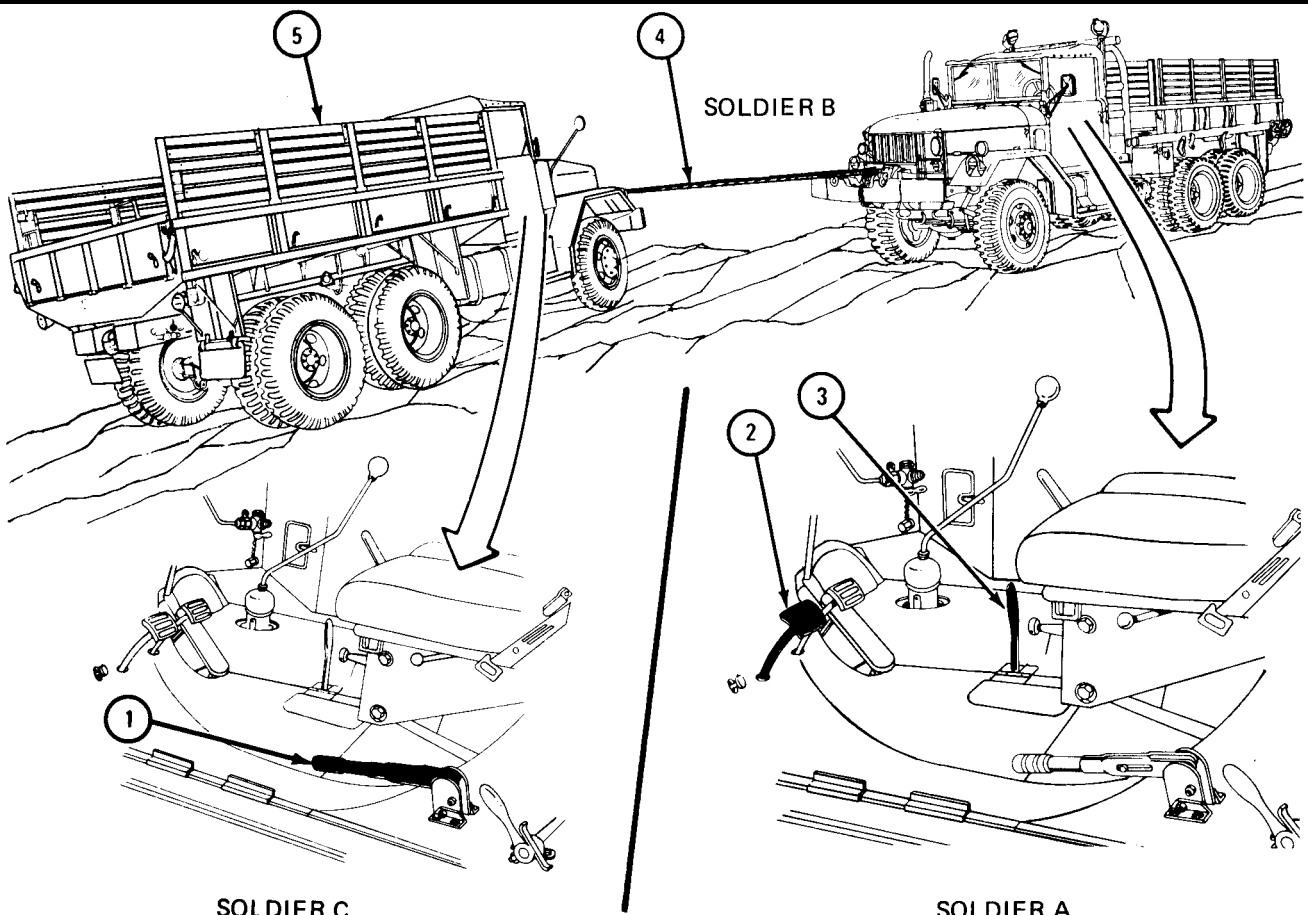

TA 080949

19-4. FRONT WINCH REMOVAL AND REPLACEMENT.

TOOLS: 3/4-inch wrench
Chain sling
Hoist

SUPPLIES: Wood blocks

PERSONNEL: Two

EQUIPMENT CONDITION: Truck parked, engine off, handbrake set.

a. Preliminary Procedures.

(1) Remove front winch propeller shaft. Refer to para 19-5.

(2) Remove front winch cable. Refer to para 19-10.

b. Removal.

FRAME 1

1. Put chain sling (1) around drum of winch (2) and join chain sling to hoist.

2. Raise hoist enough to hold weight of winch (2).

3. Using 3/4-inch wrench, unscrew and take out six screws (3), lockwashers (4), and flat washers (5).

4. Do step 3 again on other side of winch (2).

Soldier A 5. Guide winch (2) while soldier B lifts it off truck.

Soldier B 6. Using hoist, lift winch (2) off truck and set it down on wood blocks.

Soldier A 7. Unhook chain sling (1) from hoist and take it off drum of winch (2).

END OF TASK

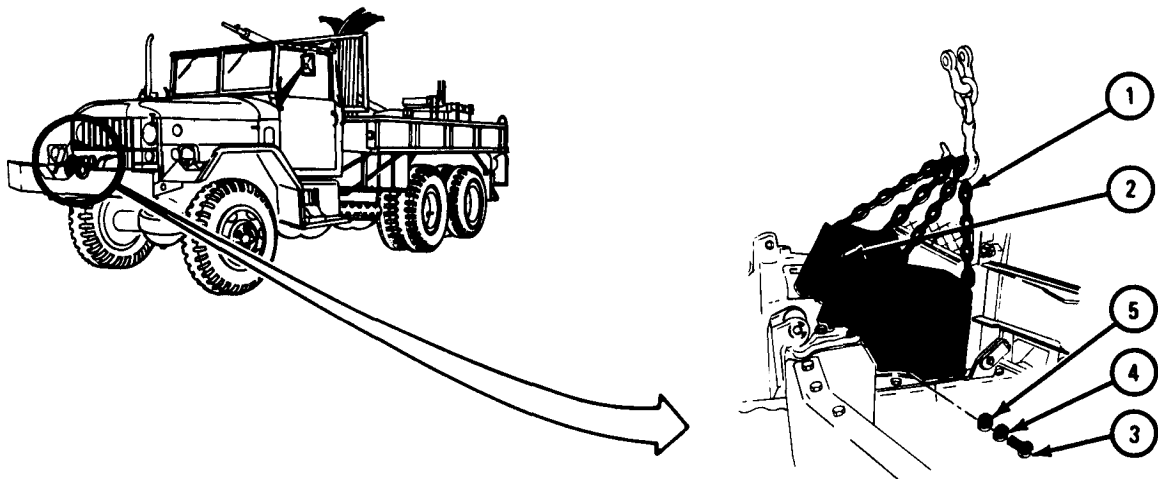

TA 080866

c. Replacement.

FRAME 1

1. Put chain sling (1) around drum of winch (2) and join chain sling to hoist.
- Soldier A 2. Guide winch (2) when soldier B lifts it off of ground onto truck.
- Soldier B 3. Using hoist, lift winch (2) off of ground into place on truck.
- Soldier A 4. Tell soldier B when mounting holes of winch (2) are alined.
5. Using 3/4-inch wrench, screw in and tighten six screws (3) with lockwashers (4) and flat washers (5).
6. Do step 5 again on other side of winch (2).
7. Unhook chain sling (1) from hoist and take it off drum on winch (2).

NOTE

Follow-on Maintenance Action Required:

1. Put front winch propeller shaft back in place. Refer to para 19-5.
2. Put cable back on front winch. Refer to para 19-10.

END OF TASK

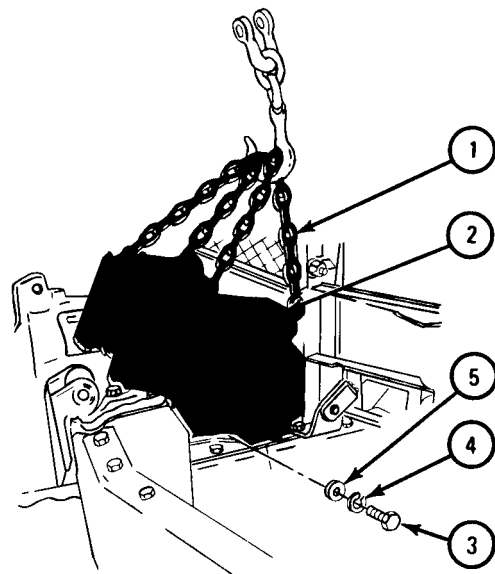
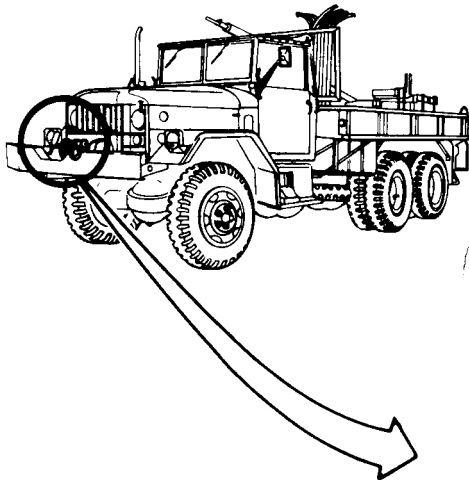

TA 080867

19-5. FRONT WINCH PROPELLER SHAFT REMOVAL AND REPLACEMENT.

TOOLS: Pliers
8-ounce ballpeen hammer
1/4-inch punch
9/16-inch wrench (2)

SUPPLIES: None

PERSONNEL: One

EQUIPMENT CONDITION: Truck parked, engine off, handbrake set.

a. Removal.

FRAME 1

1. Working under front of truck and using pliers, pull out one of two cotter pins (1) from shear pin (2) in front universal joint yoke (3).
2. Using hammer and punch, drive shear pin (2) out of universal joint yoke (3). Leave other cotter pin (1) in shear pin.

GO TO FRAME 2

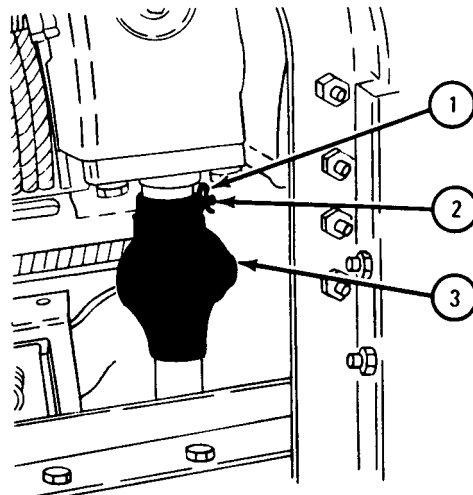
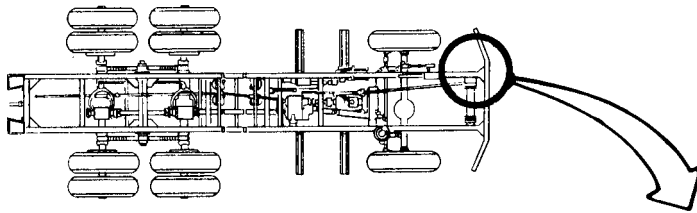

TA 080868

FRAME 2

1. Working under truck at rear of propeller shaft (1) and using 9/16-inch wrenches, unscrew and take out four screws (2) and four nuts (3). Pull universal joint (4) down and away from flange (5).
2. Take out propeller shaft (1) by dropping rear end down and sliding it toward rear of truck.

END OF TASK

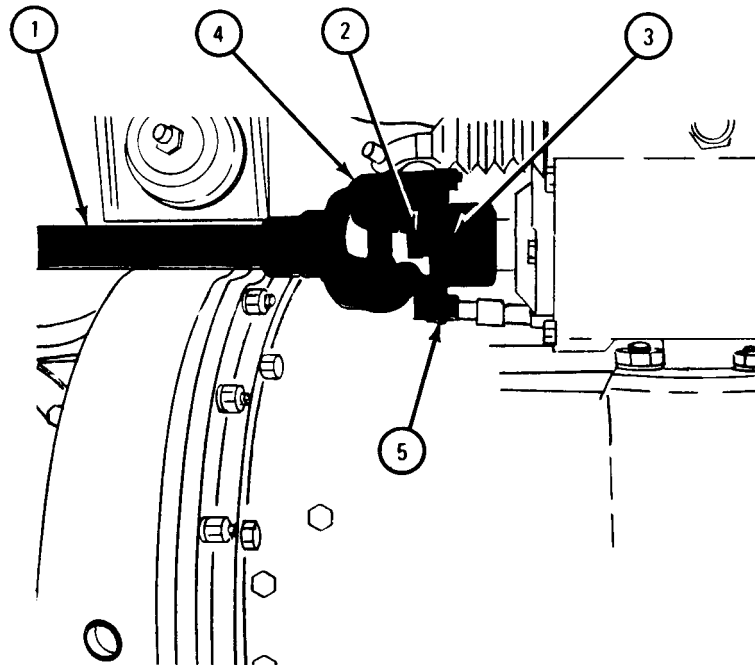

TA 080869

b. Replacement.

FRAME 1

1. Working under truck, put propeller shaft (1) in place as shown with front universal joint yoke (2) on winch input shaft (3).
2. Working at rear of propeller shaft (1), aline holes in universal joint yoke (4) with holes in flange (5).
3. Using 9/16-inch wrenches, screw in and tighten four screws (6) and four nuts (7).

GO TO FRAME 2

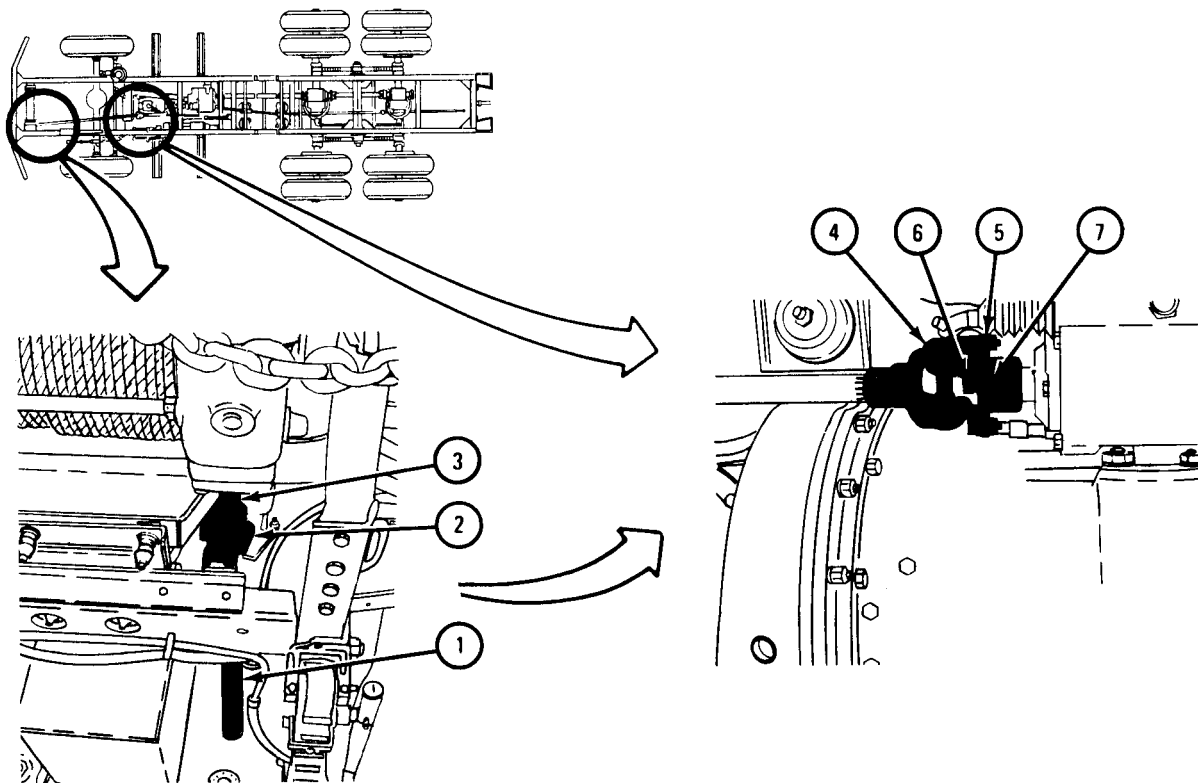

TA 080870

FRAME 2

1. Working at front of propeller shaft (1), aline shear pin hole in universal joint yoke (2) with hole in winch input shaft.
2. Using hammer, tap shear pin (3) through holes.
3. Using pliers, put in cotter pin (4) and bend open ends of cotter pin.

END OF TASK

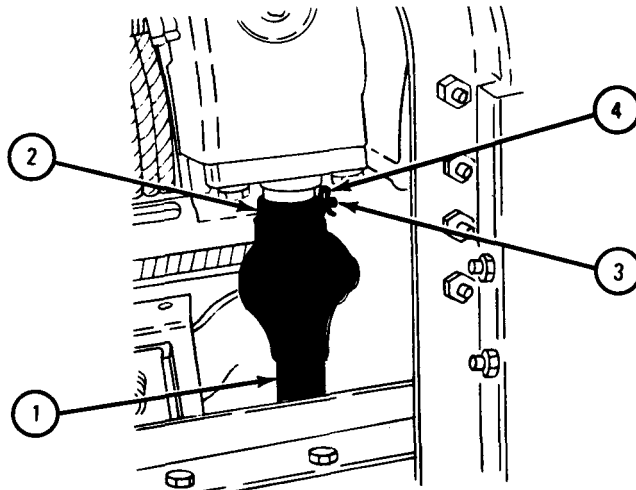

TA 080871

19-6. REAR WINCH CONTROL LEVER LINKAGE ADJUSTMENT (TRUCK M764).

TOOLS: Needle nose pliers
9/16-inch open end wrench
Adjustable wrench
Mirror

SUPPLIES: Cotter pin

PERSONNEL: Two

EQUIPMENT CONDITION: Truck parked, engine off, handbrake set.

FRAME 1

1. Turn locking latch (1) to unlocked position.
2. Move rear winch control lever (2) slightly to make sure that clutch and brake plate (3) snap into neutral detent.
3. Using mirror (4), check that clutch and brake plate (3) is just inside dogs (5) on drum assembly (6).

GO TO FRAME 2

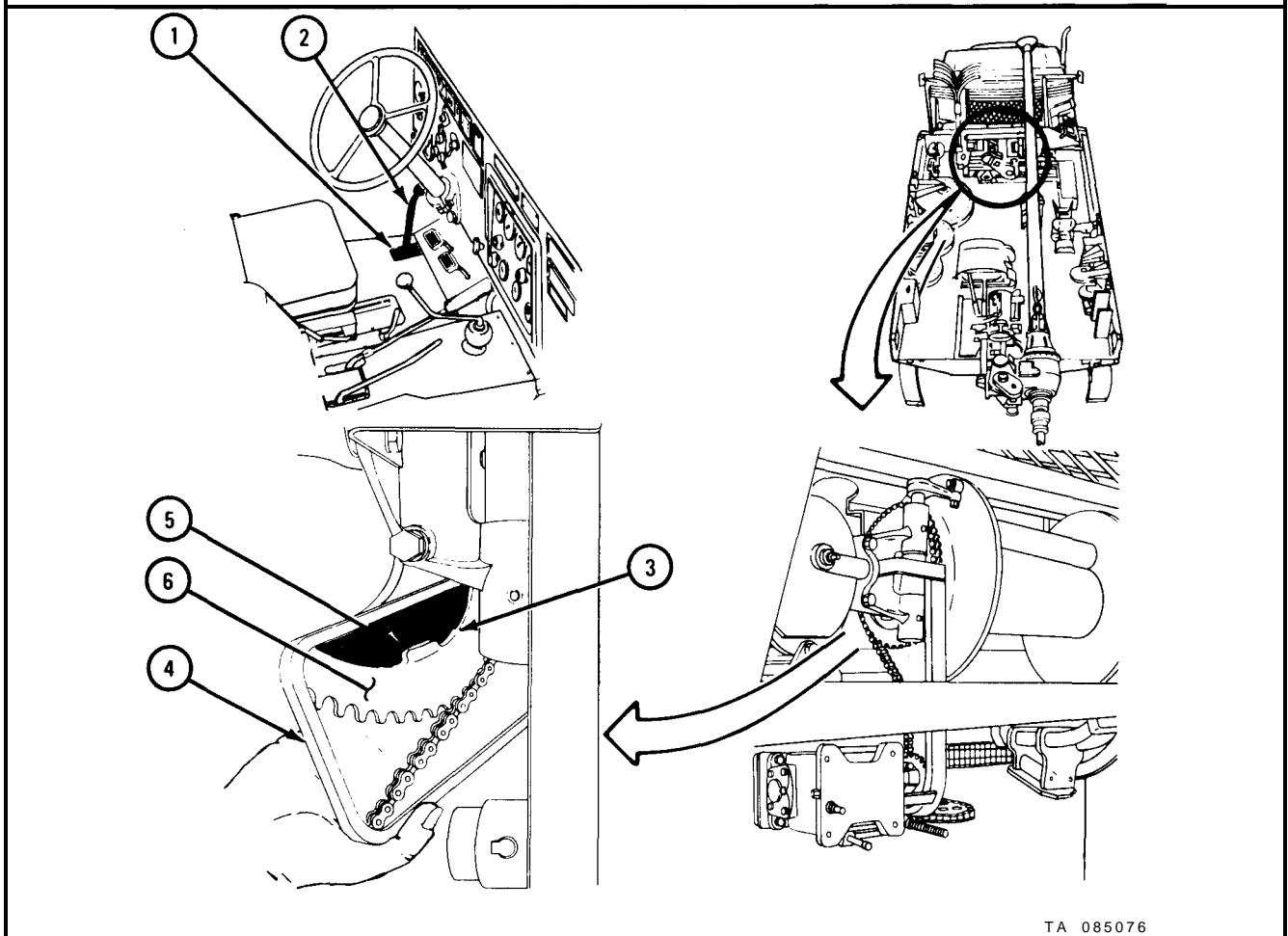

TA 085076

FRAME 2

1. Using pliers, pullout and throw away cotter pin (1).
2. Using 9/16-inch open end wrench, loosen locknut (2) from clevis (3).
3. Takeout clevis pin (4).

GO TO FRAME 3

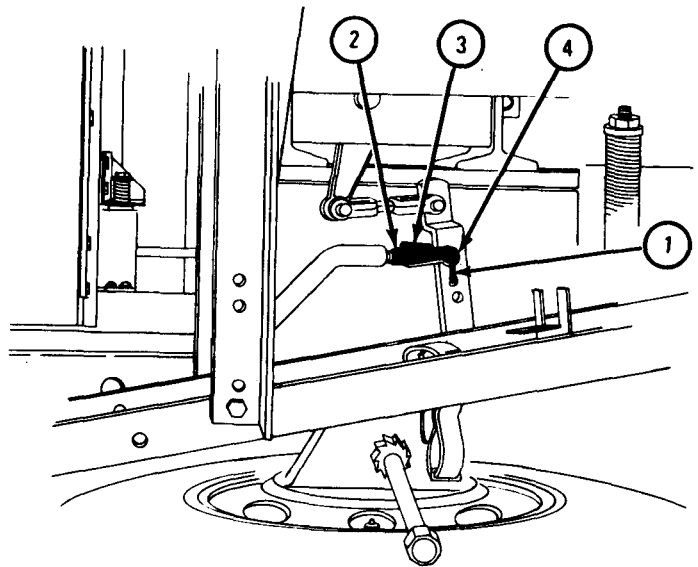
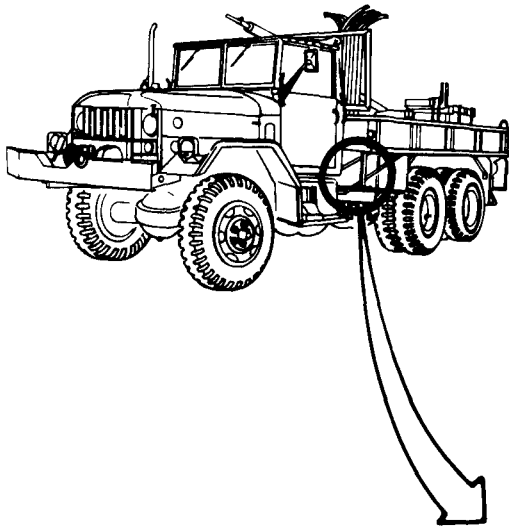

TA 080901

FRAME 3

- Soldier A 1. Turn locking latch (1) to lock position. Move and hold rear winch control lever (2) forward against edge of locking latch.
- Soldier B 2. Hold up control rod (3) and clevis (4) to check alinement of holes in clevis and pivot arm (5). Check how far clevis must be moved in or out for pin (6) to fit freely through holes.
- Soldier A 3. Turn locking latch (1) to unlock position. Move winch control lever (2) to the rear.
- Soldier B 4. Using adjustable wrench, turn clevis (4) in or out as needed to aline holes for pin (6).
- Soldier A 5. Slowly move winch control lever (2) forward until soldier B tells you to stop.
- Soldier B 6. When holes in clevis (4) and pivot arm (5) aline, tell soldier A to stop. Put in pin (6) and check for free fit. If pin fits freely, go to frame 4.
- Soldiers A and B 7. If pin (6) does not fit freely, do steps 3, 4, 5, and 6 again.
- GO TO FRAME 4

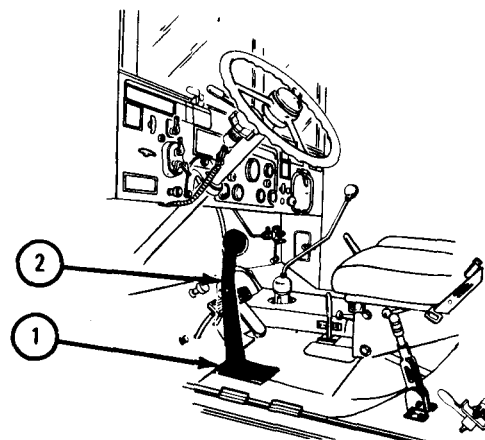
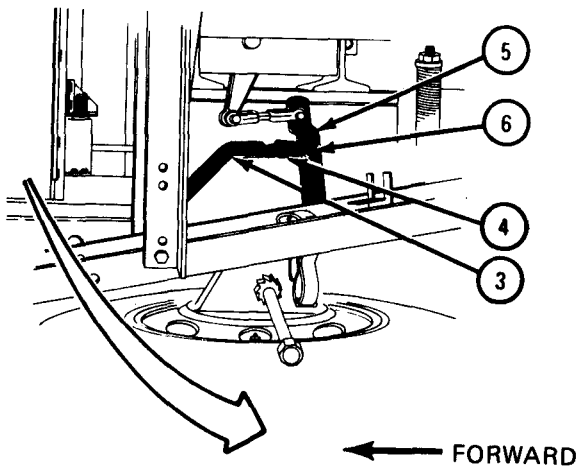

TA 080902

FRAME 4

1. Put cotter pin (1) through hole in pin (2). Using pliers, bend open ends of cotter pin.
2. Using 9/16-inch wrench, and adjustable wrench, tighten locknut (3).
3. Move rear winch control lever (4) through its three operation positions. Check that detents match positions of control lever and that winch operates correctly. Refer to TM 9-2320-209-10.

Soldiers
A and B

END OF TASK

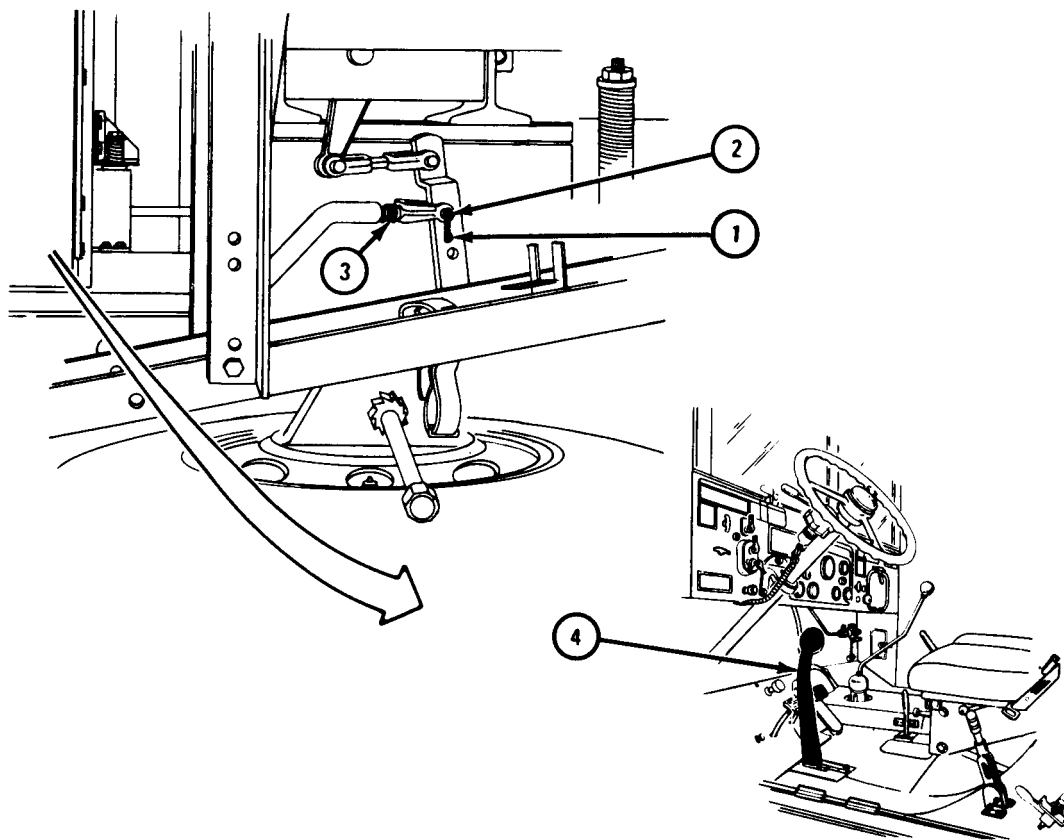

TA 085077

19-7. WINCH DRUM LOCK ASSEMBLY REMOVAL, REPAIR, AND REPLACEMENT
(TRUCK M756A2).

TOOLS: 1/2-inch wrench (2)
3/4-inch wrench

SUPPLIES: Solvent, dry cleaning, type II (SD-2), Fed. Spec P-D-680

PERSONNEL: One

EQUIPMENT CONDITION: Truck parked, engine off, handbrake set.

a. Removal.

FRAME 1

1. Using 1/2-inch wrenches, unscrew and take off locknut (1).
2. Using 1/2-inch wrench, unscrew and take off nut (2).
3. Take off drum lock latch (3).

GO TO FRAME 2

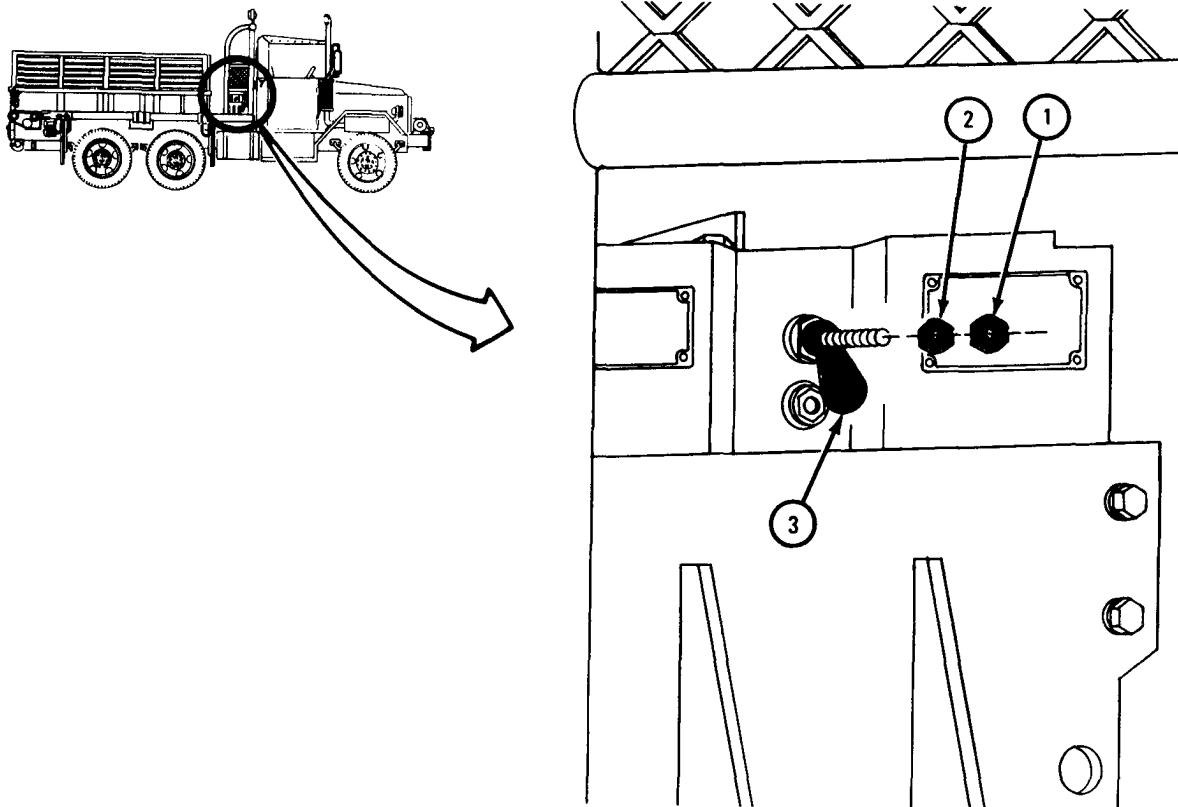

TA 080927

FRAME 2

1. Using 3/4-inch wrench, unscrew and takeout poppet assembly (1).
- END OF TASK

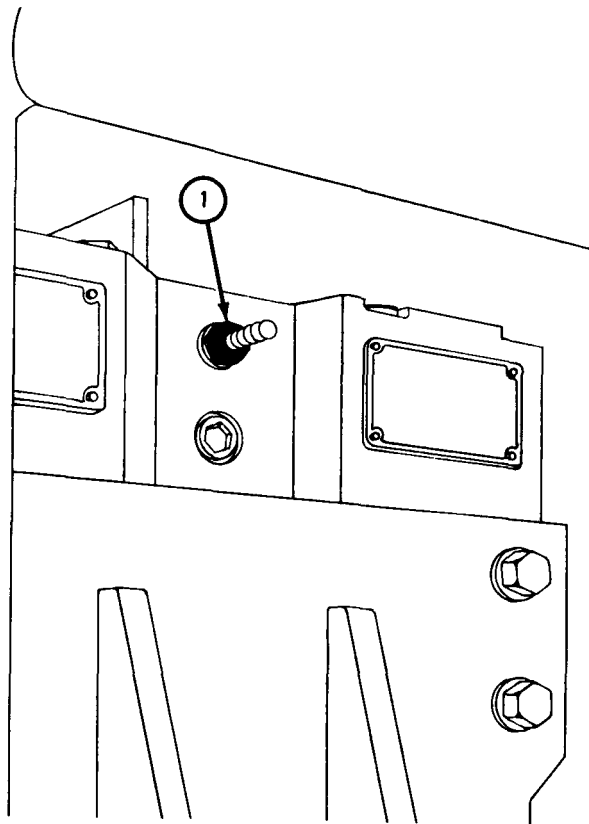

TA 080928

b. Disassembly.

FRAME 1

1. Slide off nut (1).
 2. Take off spacer (2) and spring (3).
- END OF TASK

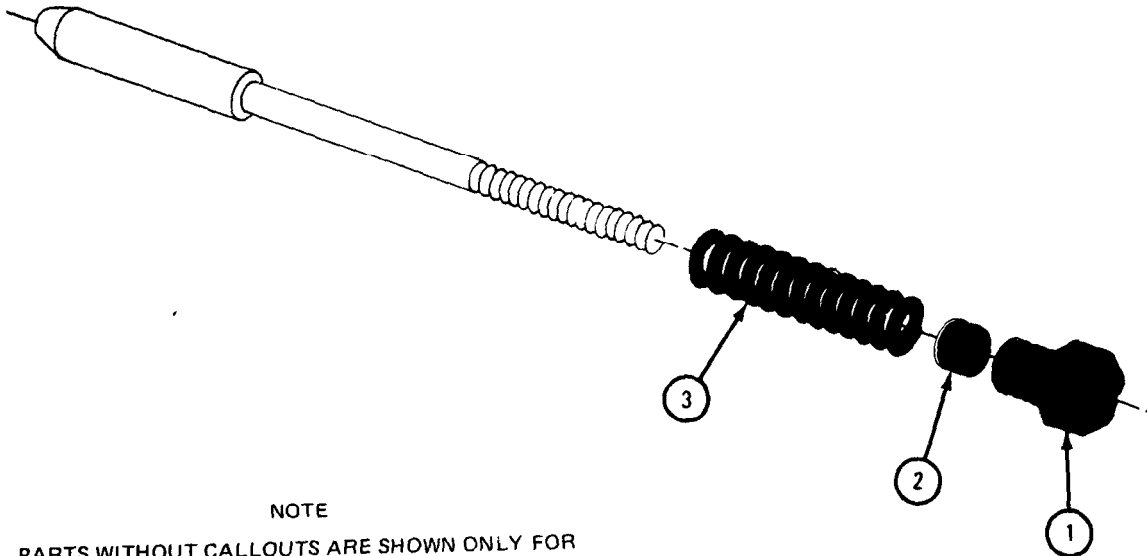

NOTE
PARTS WITHOUT CALLOUTS ARE SHOWN ONLY FOR
REFERENCE PURPOSES.

TA 080929

WARNING

Dry cleaning solvent is flammable. Do not use near an open flame. Keep a fire extinguisher nearby when solvent is used. Use only in well-ventilated places. Failure to do this may result in injury to personnel and damage to equipment.

- c. Cleaning. Clean all parts in solvent.
- d. Inspection and Repair.

FRAME 1

1. Check that poppet (1), poppet nut (2), spring (3), and spacer (4) are not worn, bent or damaged. If parts are damaged, get new ones in their place.

END OF TASK

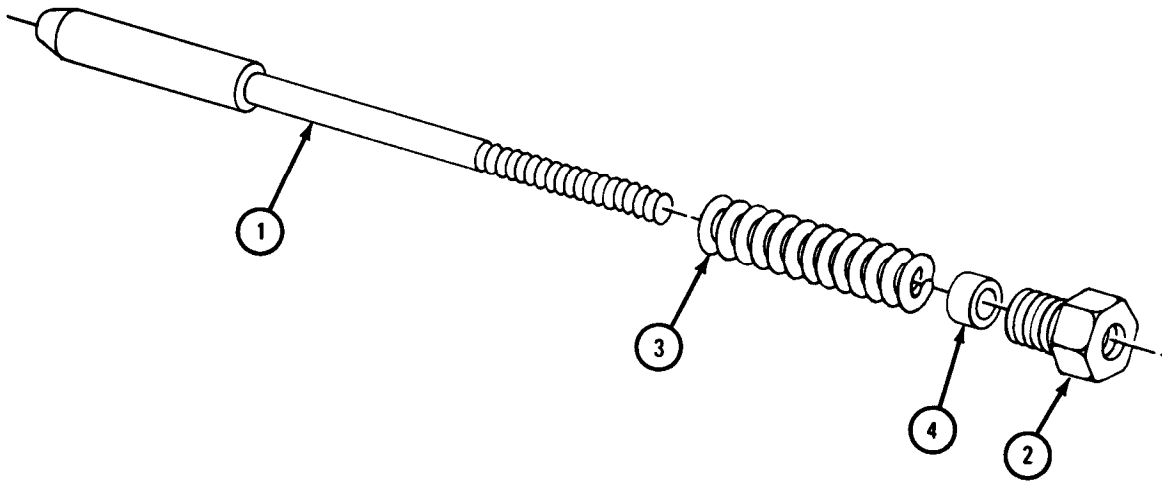

TA 080930

e. Assembly.

FRAME 1

1. Put spring (1) on poppet (2).
2. Put spacer (3) on poppet (2).
3. Slide nut (4) on poppet (2).

END OF TASK

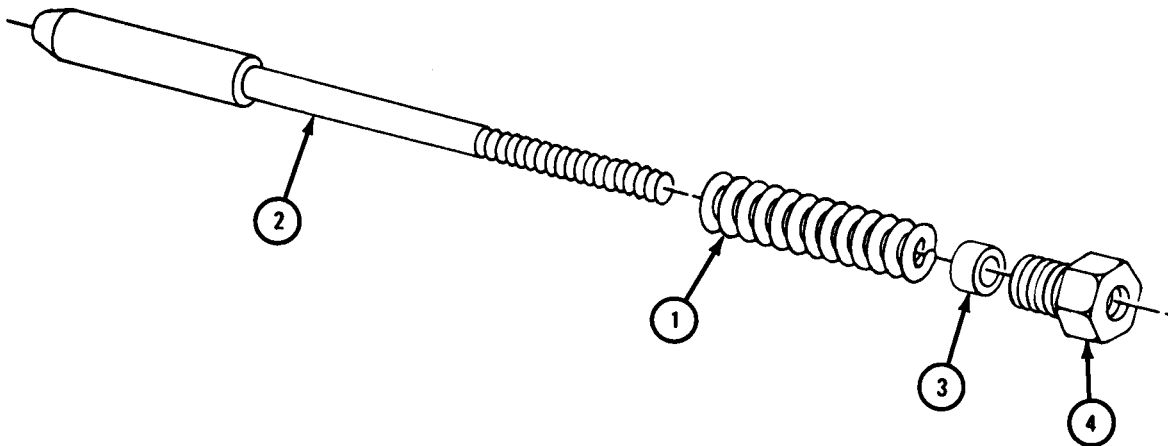

TA 080931

f. Replacement.

FRAME 1

1. Using 3/4-inch wrench, screw in and tighten poppet assembly (1).

GO TO FRAME 2

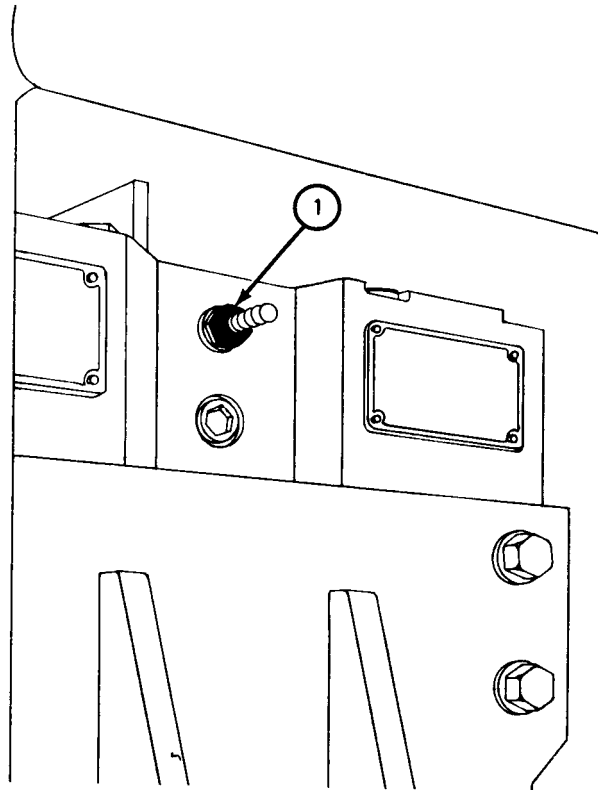
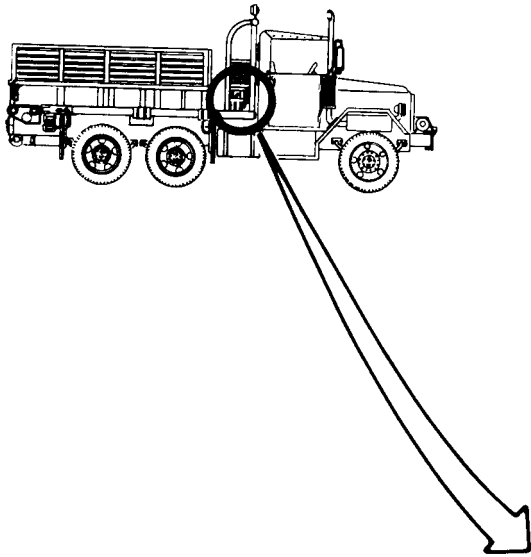

TA 080932

FRAME 2

1. Put drum lock latch (1) in place.
2. Using 1/2-inch wrench, screw on and tighten nut (2).
3. Using 1/2-inch wrenches, screw on and tighten locknut (3).

END OF TASK

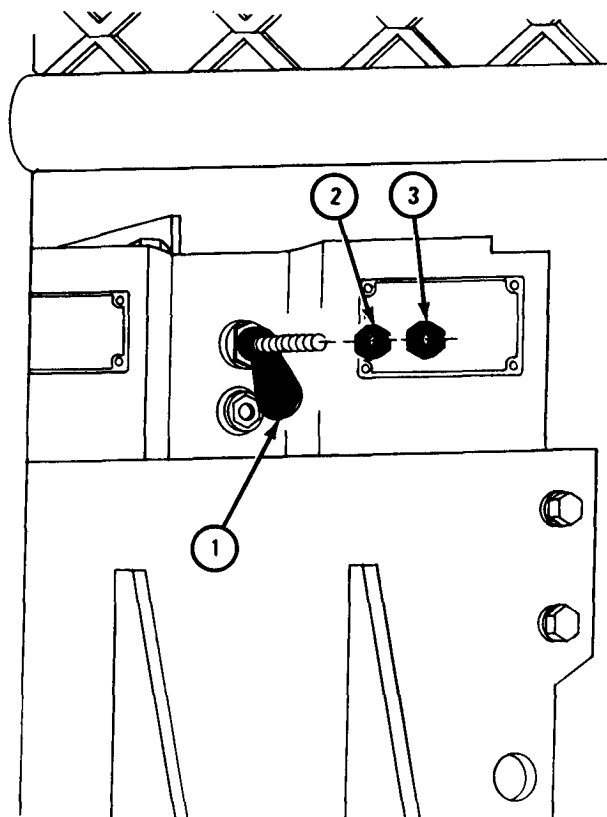

TA 080933

19-8. WINCH AND POWER TAKEOFF SPROCKETS REMOVAL, REPAIR, AND REPLACEMENT (TRUCK M756A2).

TOOLS: 3/4-inch drive ratchet
Short extension
1 1/2-inch socket
Medium ballpeen hammer
1/4-inch punch
Needle nose pliers
Snapping pliers
6-inch puller
5-foot prybar
Wood block, 2 x 4 x 15 1/2 inches
Wood block, 2 x 4 x 3 inches

SUPPLIES: Solvent, dry cleaning, type II (SD-2), Fed. Spec P-D-680
Cotter pin

PERSONNEL: Two

EQUIPMENT CONDITION: Truck parked, engine off, handbrake set.

- a. Preliminary Procedure. Remove winch drive chain. Refer to para 19-13.

b. Removal.

(1) Winch sprocket.

FRAME 1

1. Using needle nose pliers, pull out cotter pin (1) from shear pin (2). Throw away cotter pin.
 2. Take out shear pin (2).
- GO TO FRAME 2

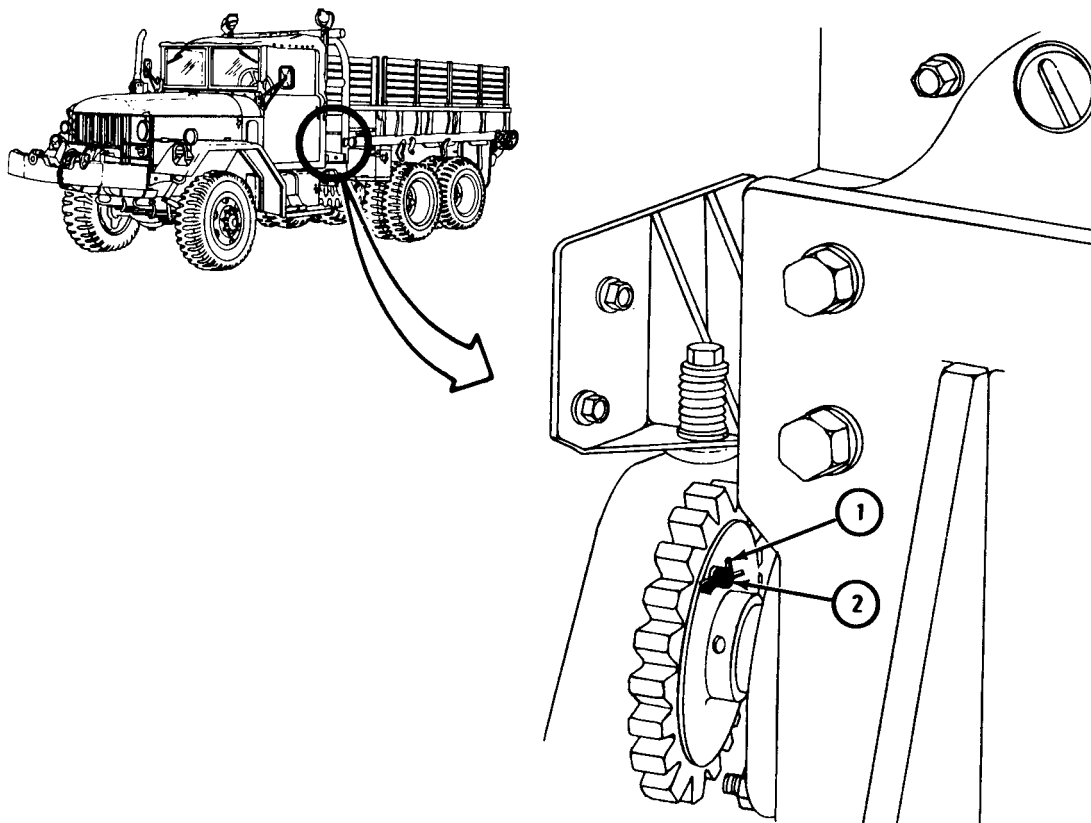

TA 080914

FRAME 2

1. Turn hub (1) one-quarter turn to line up hole in sprocket (2).
2. Using hammer and punch, drive out pin (3) from hub (1).
3. Take off hub (1) and sprocket (2) together.

END OF TASK

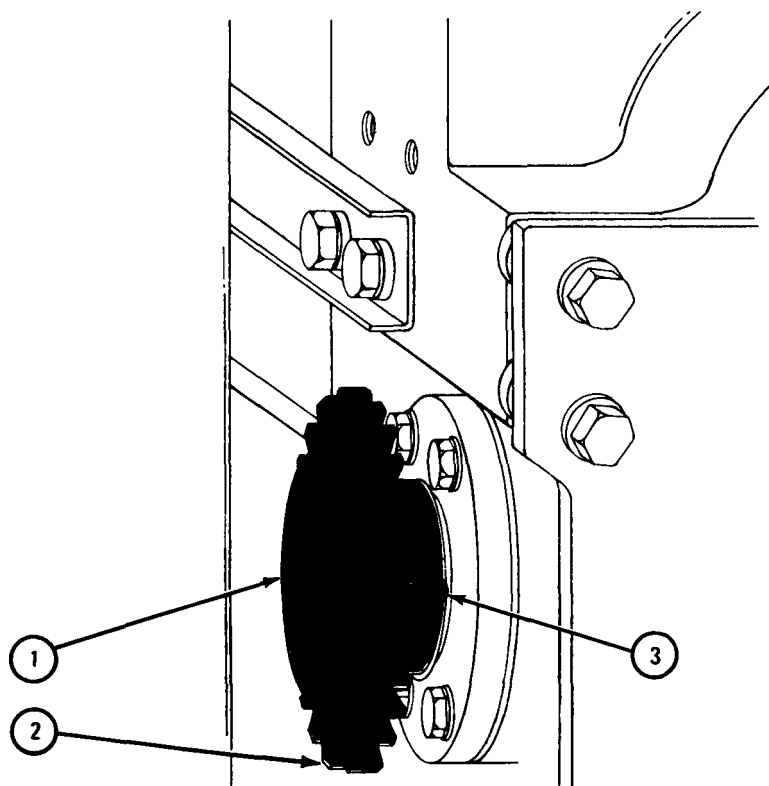

TA 080915

(2) Power takeoff sprocket.

FRAME 1

NOTE

To take off power take off sprocket, winch mounting frame must first be raised for clearance.

1. Using 1/2-inch wrench, unscrew and take out two screws (1).
2. Using 1/2-inch wrenches, unscrew and take out two screws (2) and two nuts (3).
3. Take off tread plate (4).

GO TO FRAME 2

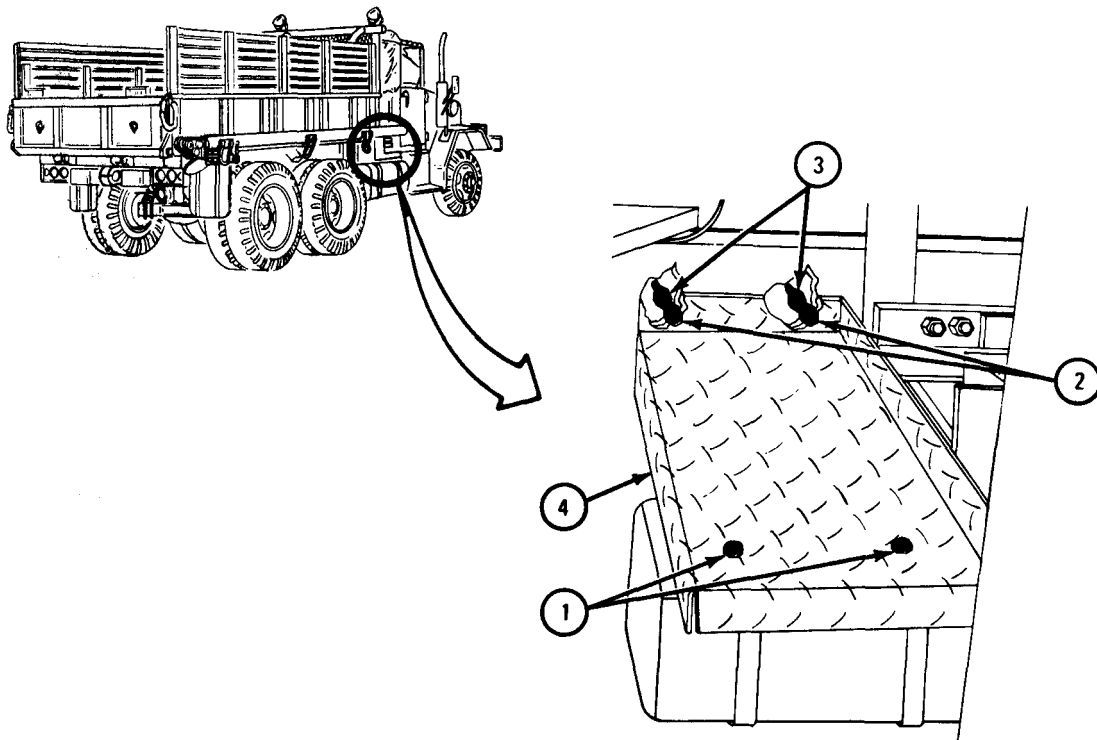

TA 085001

FRAME 2

1. Working on right side of winch, using 15/16-inch wrenches, unscrew and take out six nuts (1) and six screws (2).
2. Working on left side of winch, using 15/16-inch wrenches, unscrew and take out eight nuts (3) and eight screws (4).

Soldier A 3. Using prybar, raise left side of winch with mount (5) three inches.
 Soldier B 4. Place 2 x 4 x 3-inch wood block (6) under winch mount (5).
 GO TO FRAME 3

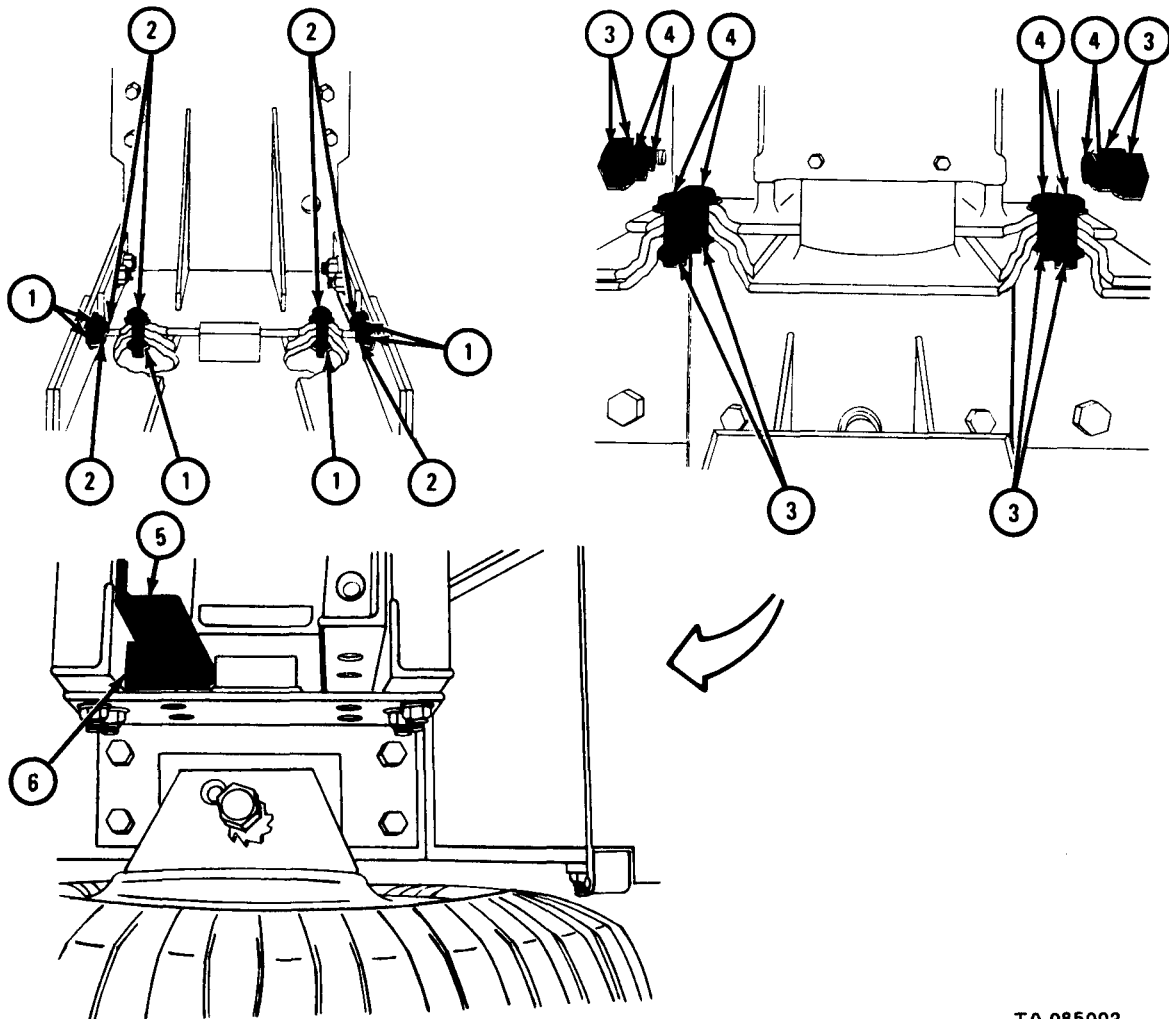

TA 085002

FRAME 3

1. Working under truck, using needle nose pliers, pull out cotter pin (1) from shaft nut (2). Throw away cotter pin.
2. Hold 2 x 4 x 15 1/2-inch wood block (3) between teeth of sprocket (4) and truck frame. Using 3/4-inch ratchet, short extension, and 1 1/2-inch socket, unscrew and take off shaft nut (2).
3. Using puller, take off sprocket (4).

NOTE

Do not lose key in sprocket shaft.

END OF TASK

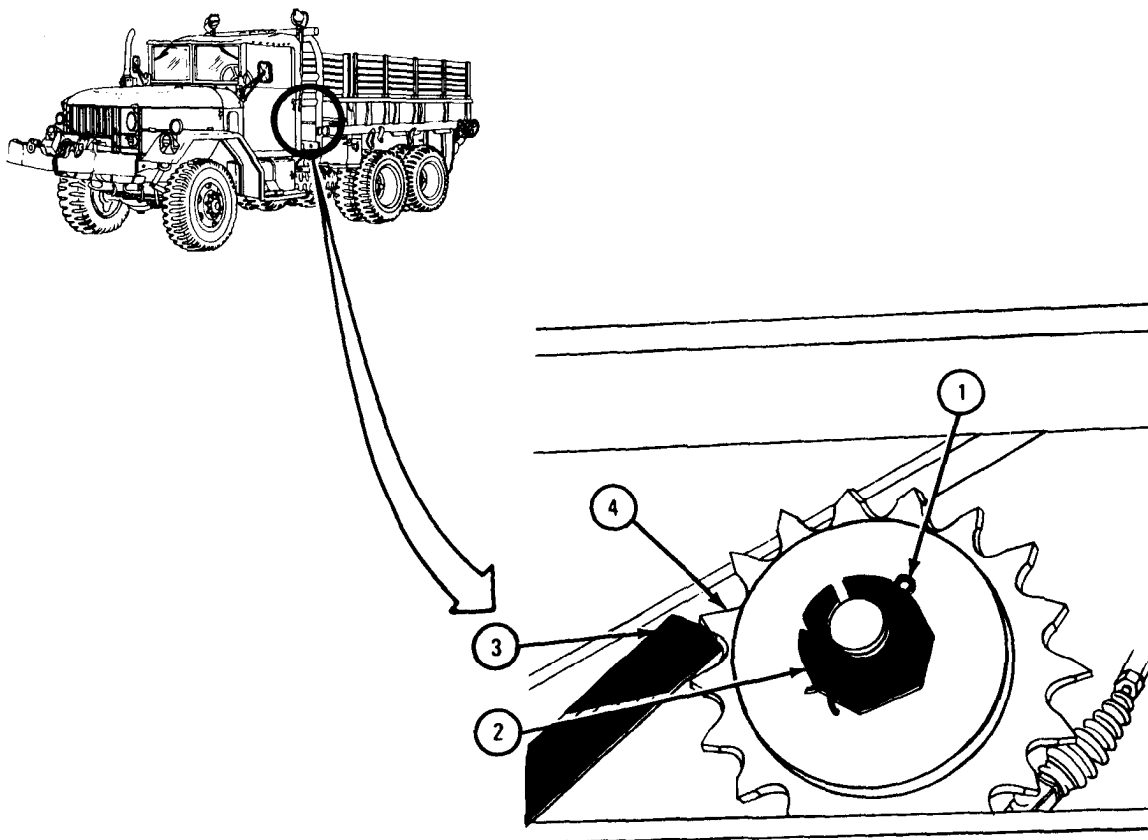

TA 080919

c. Disassembly of Winch Sprocket Assembly.

FRAME 1

1. Using snapping pliers, take off snapping (1).
2. Takeout washer (2).
3. Take hub (3) out of sprocket (4).

END OF TASK

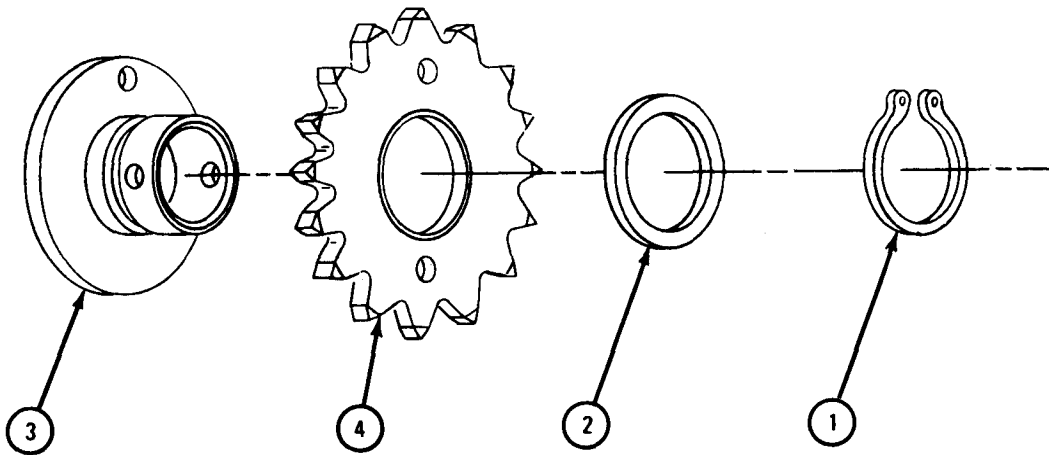

TA 080916

WARNING

Dry cleaning solvent is flammable. Do not use near an open flame. Keep a fire extinguisher nearby when solvent is used. Use only in well-ventilated places. Failure to do this may result in injury to personnel or damage to equipment.

- d. Cleaning. Clean sprockets in solvent.
- e. Inspection and Repair. Check that sprockets have no wear, cracks, breaks, chips or broken teeth. If sprockets are damaged, get new ones in their place.
- f. Assembly of Winch Sprocket Assembly.

FRAME 1

1. Put hub (1) in sprocket (2).
2. Put washer (3) in place.
3. Using snapping pliers, put on snapping (4).

END OF TASK

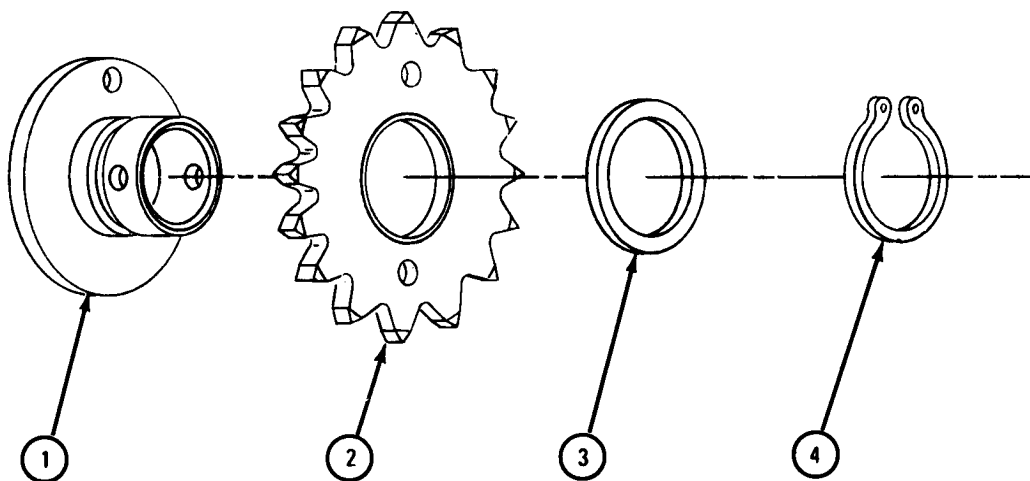

TA 080917

g. Replacement.

(1) Power takeoff sprocket.

FRAME 1

1. Put sprocket (1) in place.
2. Hold 2 x 4 x 15 1/2-inch wood block (2) between teeth of sprocket (1) and truck frame. Using 3/4-inch drive ratchet, short extension, and 1 1/2-inch socket, screw on and tighten shaft nut (3).
3. Using needle nose pliers, put cotter pin (4) through hole in shaft nut (3) and bend open ends of cotter pin.

GO TO FRAME 2

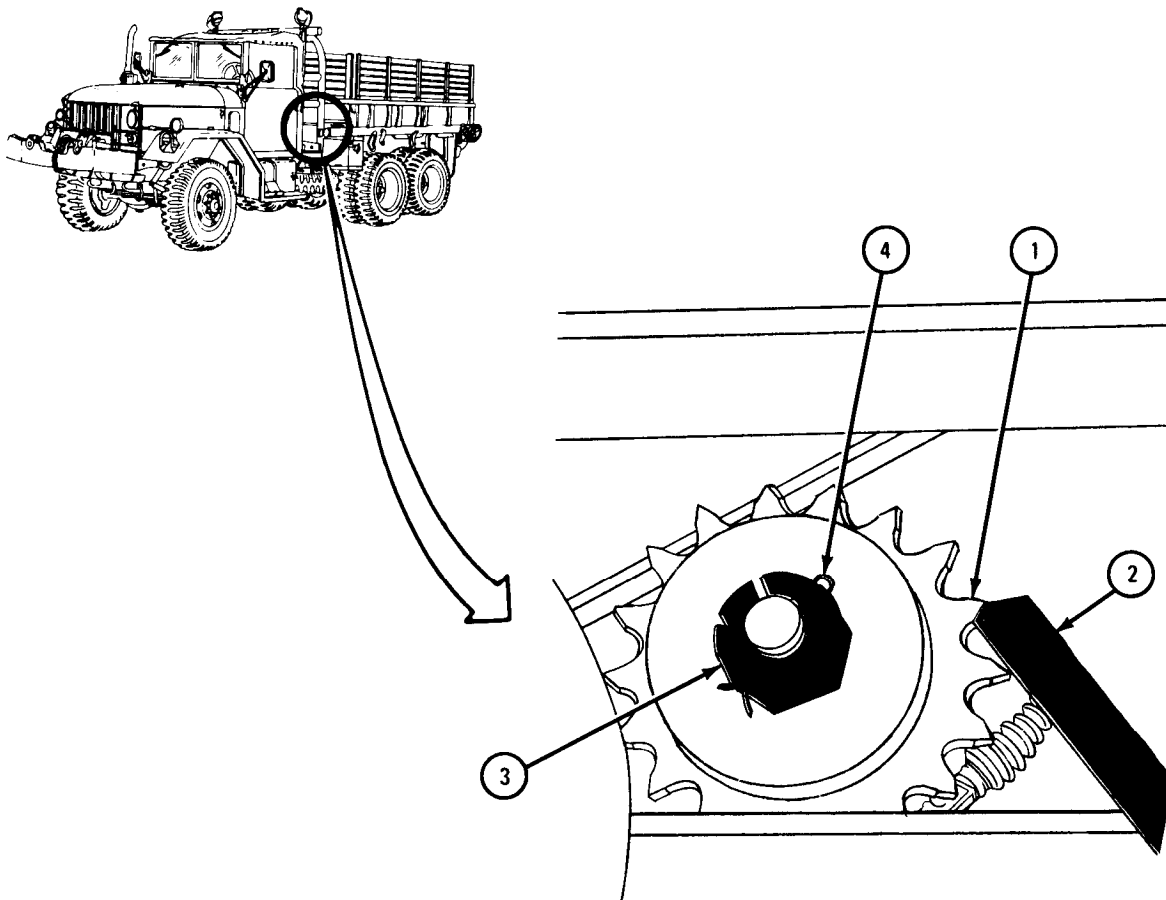

TA 080920

FRAME 2

- Soldier A 1. Using prybar, raise left side of winch with mount (1) off wood block (2).
- Soldier B 2. Take out wood block (2) .
- Soldier A 3. Using prybar, lower left side of winch with mount (1), alining mounting holes with holes in bracket (3).
- Soldier B 4. Place eight screws (4) in place. Screw on eight nuts (5).
- Soldier A 5. Working on right side of truck, put six screws (6) in place. Using 15/16-inch wrenches, screw on and tighten six nuts (7).
- Soldier B 6. Working on left side of truck, using 15/16-inch wrenches, tighten eight nuts (5).

GO TO FRAME 3

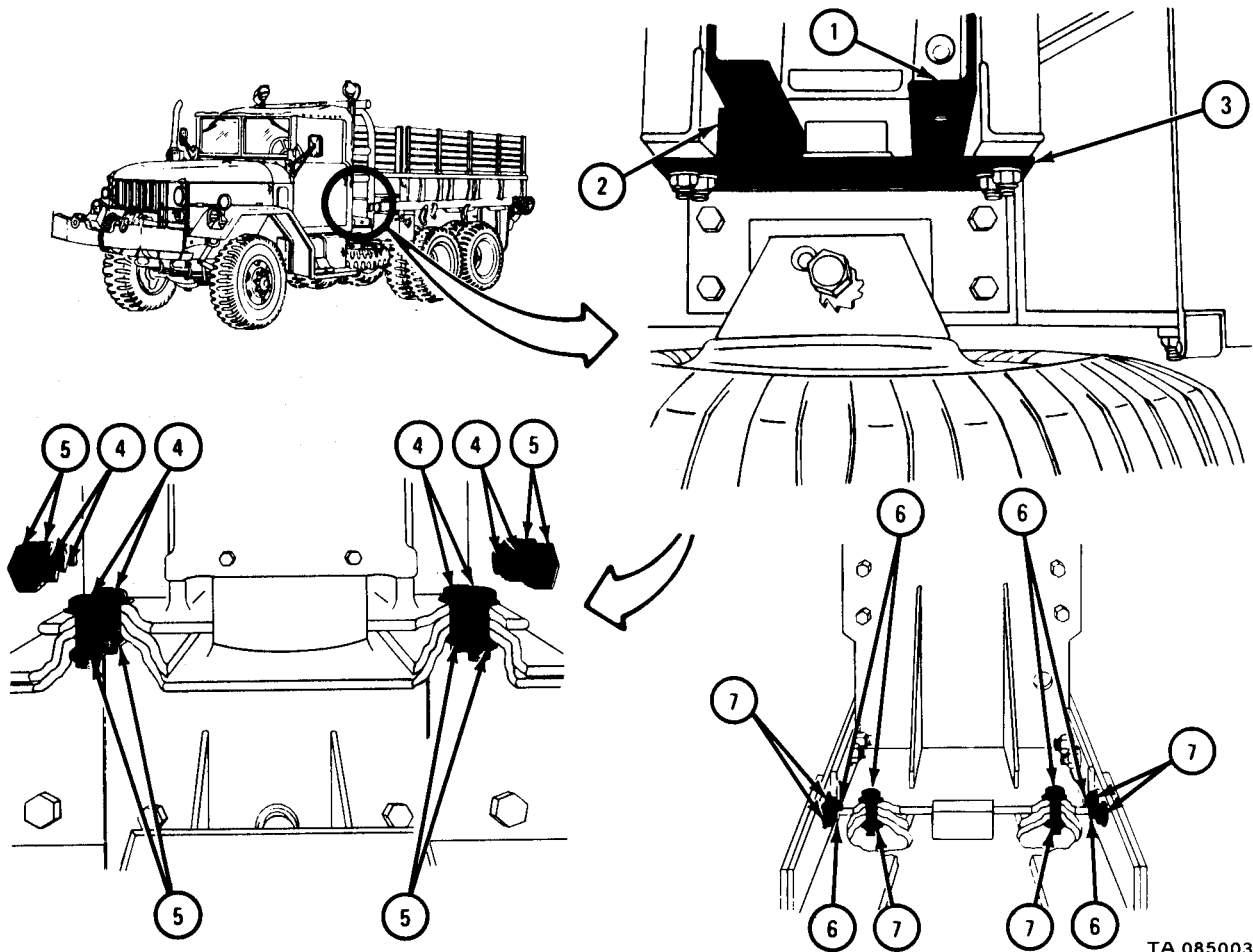

TA 085003

FRAME 3

1. Working on right side of truck, put tread plate (1) in place over fuel tank (2) and align holes.
2. Using 1/2-inch wrench, screw in, but do not tighten, two screws (3).
3. Put two screws (4) in place. Using 1/2-inch wrenches, screw on and tighten two nuts (5).
4. Using 1/2-inch wrench, tighten two screws (3).

END OF TASK

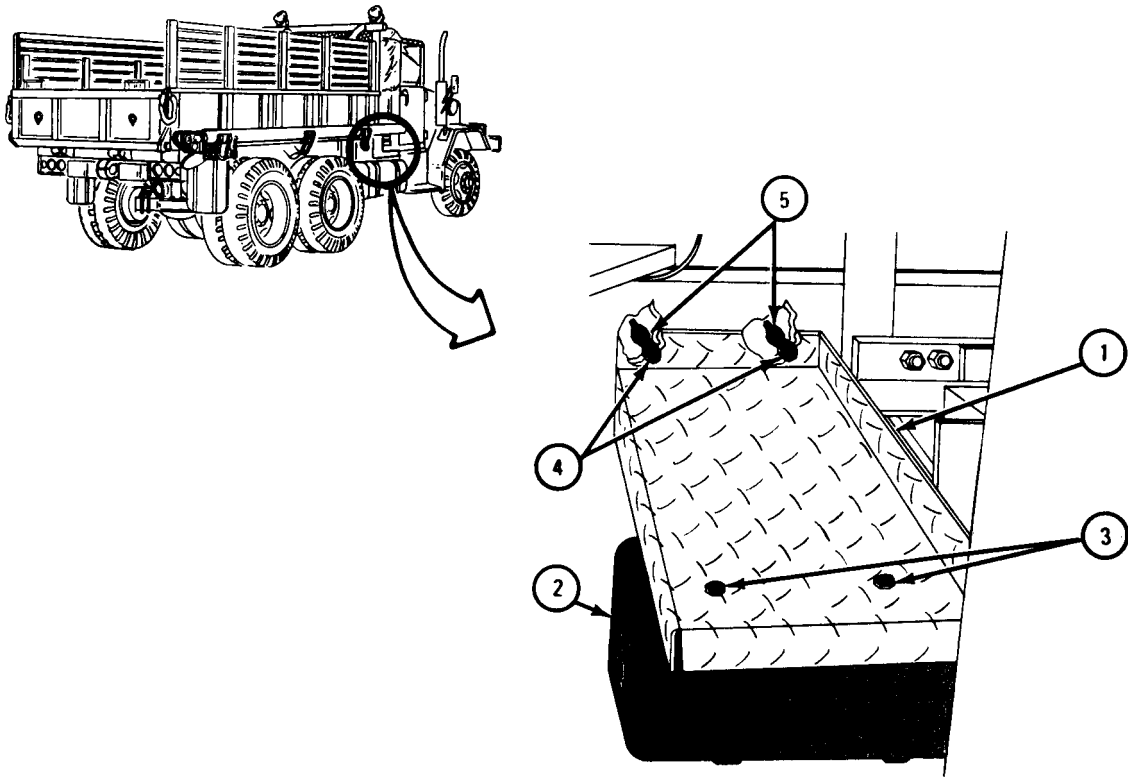

TA 085004

(2) Winch sprocket assembly.

FRAME 1

1. Put hub (1) and sprocket (2) on winch shaft (3) and line up hole in winch shaft with holes in hub and sprocket.
2. Using hammer and punch, drive pin (4) into winch shaft (3) and hub (1). Pin must be only in hub and shaft so sprocket will turn.
3. Turn sprocket (2) one-quarter turn and put shear pin (5) through holes in sprocket and hub (1).
4. Using needle nose pliers, put cotter pin (6) through hole in shear pin (5) and bend open ends of cotter pin.

NOTE

Follow-on Maintenance Action Required:

Replace winch drive chain. Refer to para 19-13.

END OF TASK

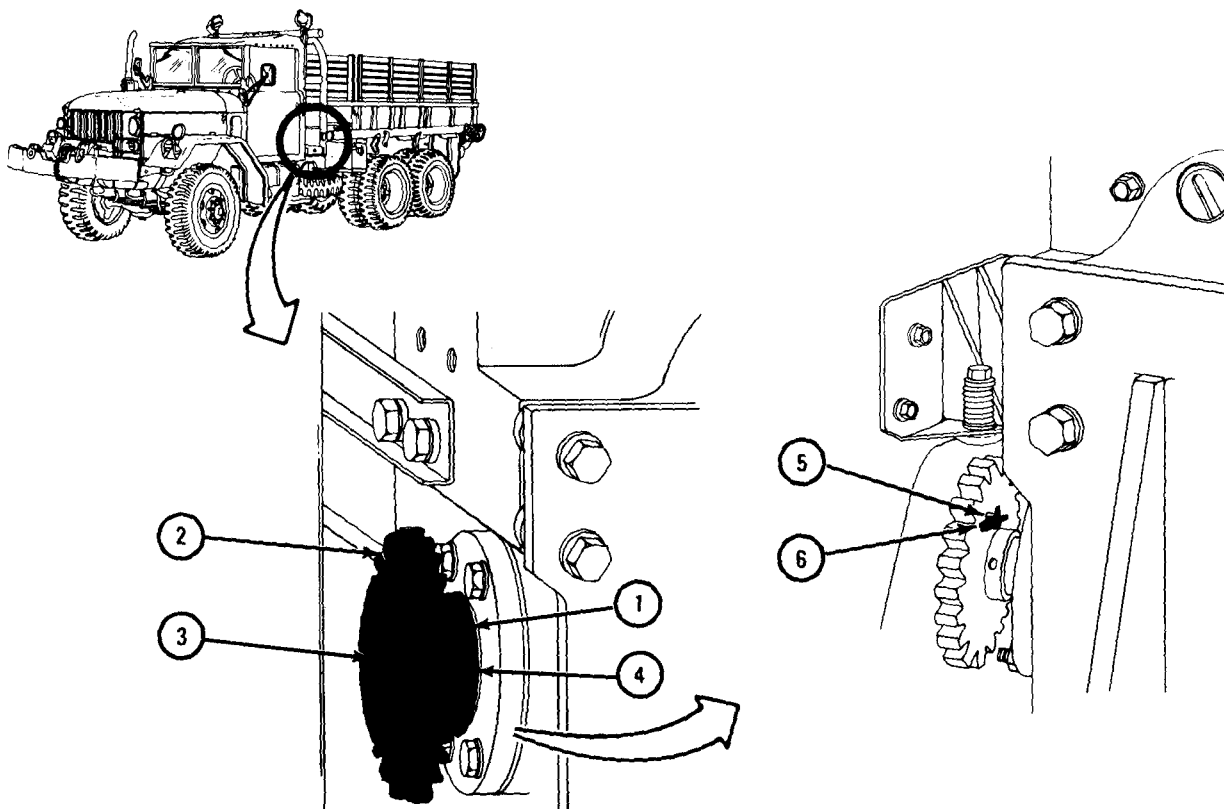

TA 080918

19-9. REAR WINCH DRUM CLUTCH LEVER AND GUIDE PLATE REMOVAL, REPAIR, AND REPLACEMENT (TRUCK M756A2).

TOOLS: Hammer
 1/8-inch punch
 9/16-inch wrench
 Flat-tip screwdriver
 Five-foot prybar
 Vise

SUPPLIES: Solvent, dry cleaning, type II (SD-2), Fed. Spec P-D-680

PERSONNEL: Two

EQUIPMENT CONDITION: Truck parked, engine off, handbrake set.

a. Removal.

FRAME 1

1. Working in between cab protector and cab and using hammer and punch, drive out pin (1) holding drum clutch lever (2) to clutch shaft (3).
2. Using 9/16-inch wrench, unscrew and take out two screws, lockwashers, and flat washers (4) from guide plate (5).
3. Take off data plate (6) and guide plate (5).
4. Using screwdriver, pry drum clutch lever (2) from clutch shaft (3). Take out drum clutch lever (2).

END OF TASK

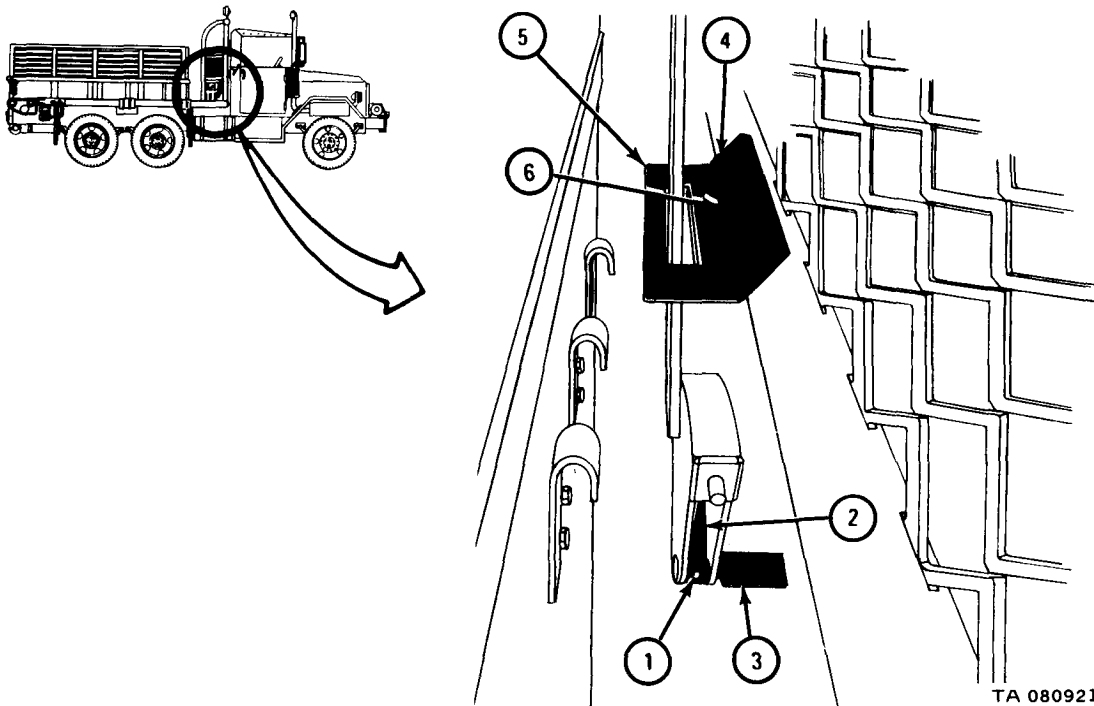

b . Disassembly.

FRAME 1

1. Put drum clutch lever (1) in vise as shown.
2. Using hammer and punch, drive out pin (2) from drum clutch lever (1).
3. Take drum clutch lever (1) out of vise and take out curved rod (3).

GO TO FRAME 2

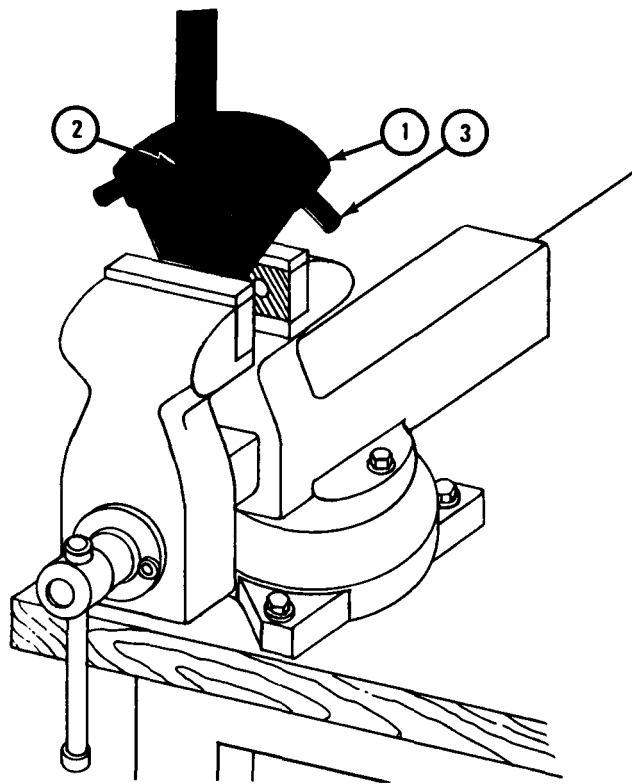

TA 080922

FRAME 2

1. Pull out center post (1) from drum clutch lever (2). Be careful two springs (3) do not pop out.
2. Take out two springs (3).

END OF TASK

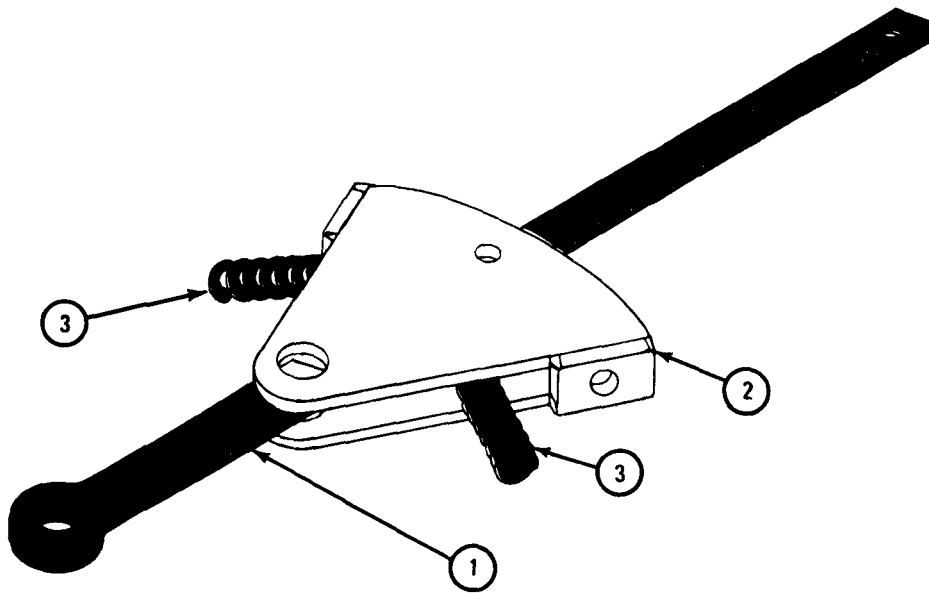

TA 080923

c. Assembly.

FRAME 1

- Soldier A 1. Hold two springs (1) in drum clutch lever (2).
- Soldier B 2. Put in center post (3) as soldier A holds in springs (1).
3. Push curved rod (4) through drum clutch lever (2), springs (1), and center post (3).
4. Using hammer and punch, drive in pin (5).

END OF TASK

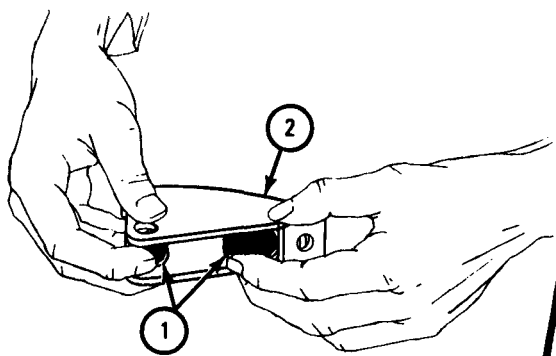

SOLDIER A

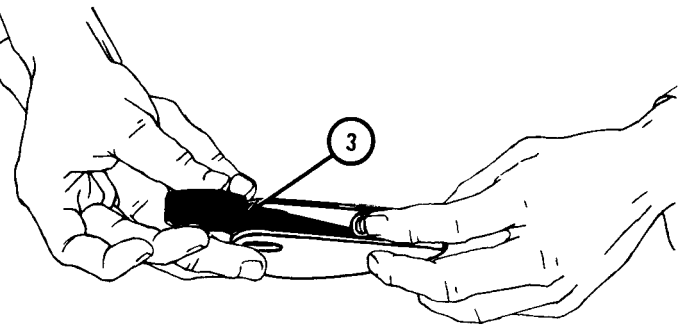

SOLDIER A AND B

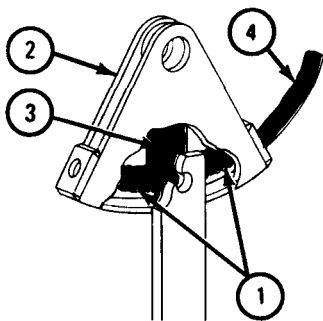

SOLDIER B

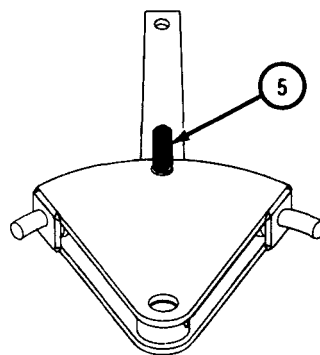

SOLDIER B

TA 080925

d. Replacement.

FRAME 1

1. Using prybar, push drum clutch lever (1) onto winch shaft (2).
2. Put guide plate (3) and data plate (4) in place.
3. Using 9/16-inch wrench, screw in and tighten two screws, lockwashers, and flat washers (5).
4. Using hammer and punch, drive in pin (6) to hold drum clutch lever (1) on winch shaft (2).

END OF TASK

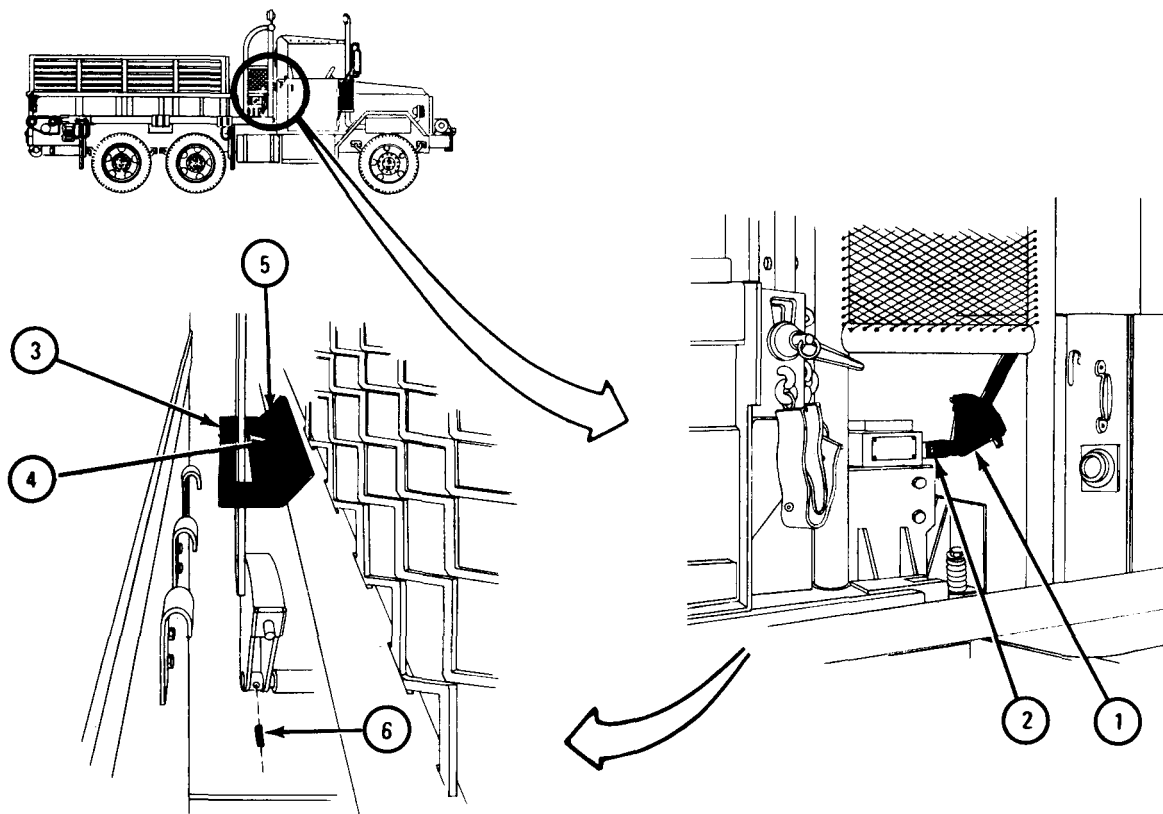

TA 080926

19-10. FRONT, MID, AND REAR WINCH CABLE AND CHAIN ASSEMBLY REMOVAL,
REPAIR, AND REPLACEMENT.

NOTE

This task shown is for the mid winch cable and chain assembly. This task is the same for the front and rear winch cable and chain assemblies.

TOOLS: 3/8-inch socket head screw key Wire cutters
 (Allen wrench or equivalent) Hammer
 12-inch ruller Soft-jawed vise
 Leather gloves Adjustable wrench (2)

SUPPLIES: Solvent, dry cleaning, type II (SD-2), Fed. Spec P-D-680
 Clean rags
 Clevis assembly
 Seizing

PERSONNEL: One

EQUIPMENT CONDITION: Truck parked, engine off, handbrake set.

WARNING

Always wear protective gloves when handling winch cable. Do not let winch cable slip through hands. Rusty or broken wires can cause serious injury.

a. Preliminary Procedure. Unwind winch cable to the end. Refer to TM 9-2320-209-10.

b. Removal.

FRAME 1

1. Using 3/8-inch allen wrench, loosen setscrew (1).
2. Pull winch cable (2) out of drum (3) and off truck.

END OF TASK

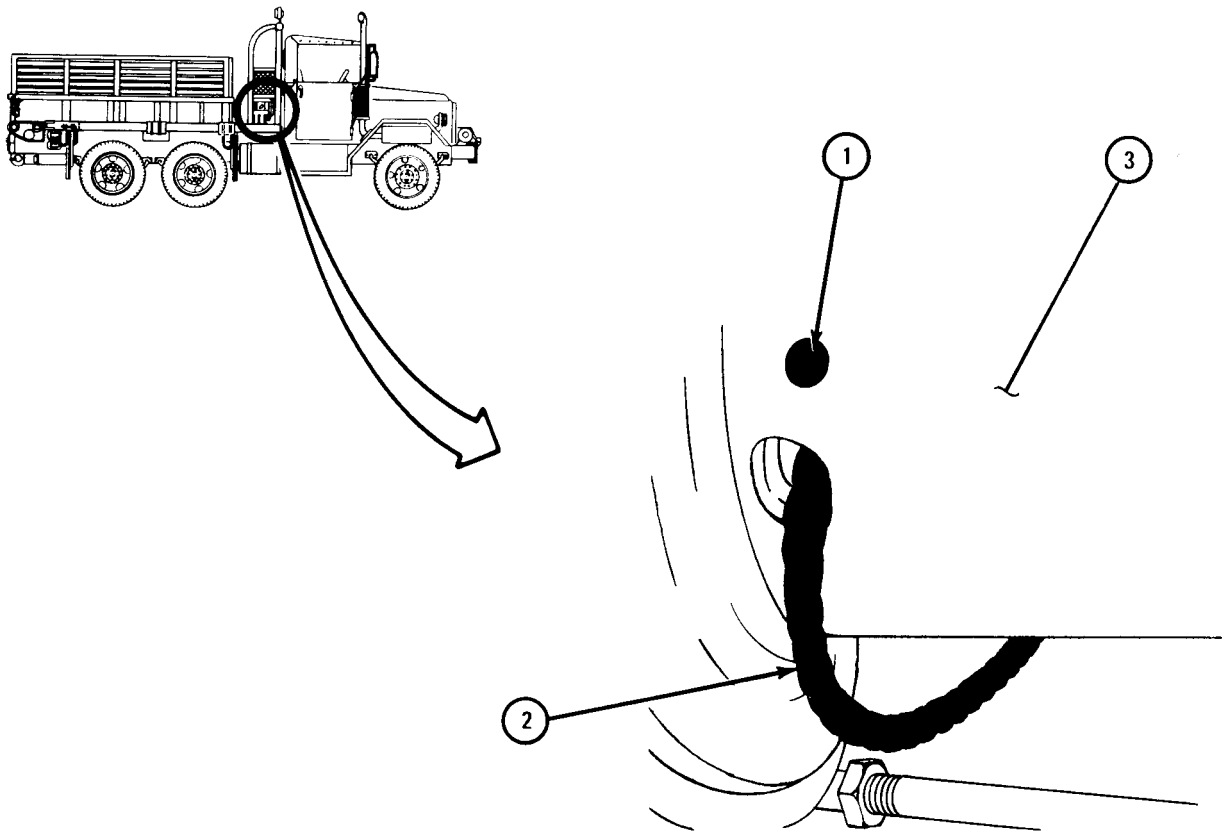

TA 084032

c. Disassembly (Early Model).

FRAME 1

1. Using vise, hold split nut (1).
2. Using adjustable wrench, unscrew and slide back nut (2).
3. Take off both halves of split nut (1).
4. Take off chain (3), thimble (4), and nut (2) from cable (5).

END OF TASK

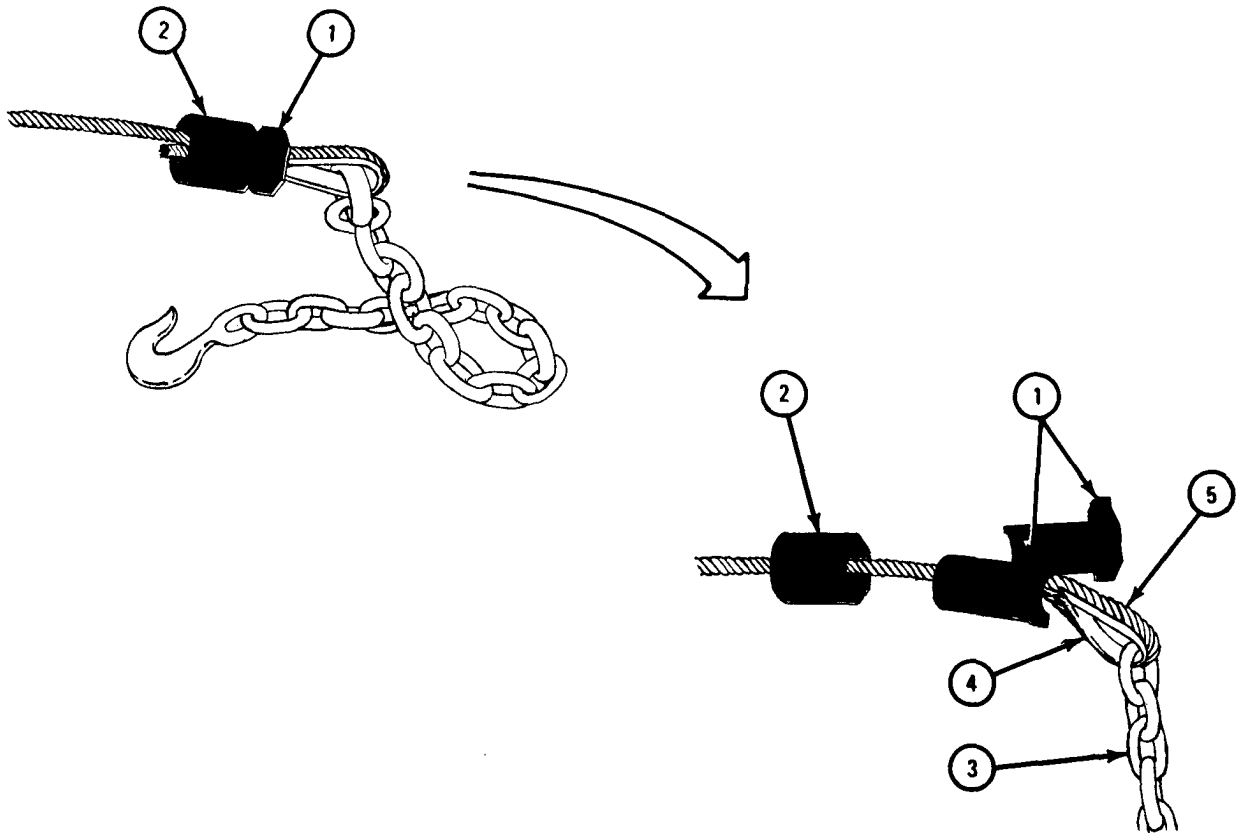

TA 084033

d. Disassembly (Late Model).

FRAME 1

1. Using adjustable wrenches, hold nut (1) and unscrew and take out bolt (2).
2. Take off chain (3).

GO TO FRAME 2

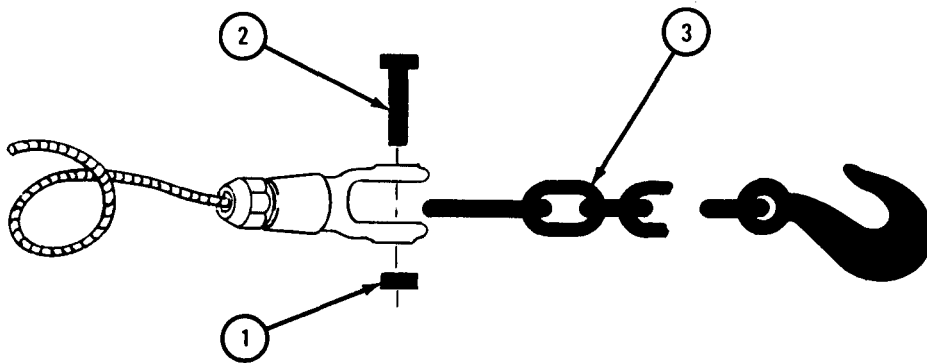

TA 101632

FRAME 2

1. Place cable (1) in vise (2), leaving enough space to cut cable.
2. Using wire cutters, cut cable (1) at base of clevis (3). Take out and throw away clevis. Take cable out of vise (2).

END OF TASK

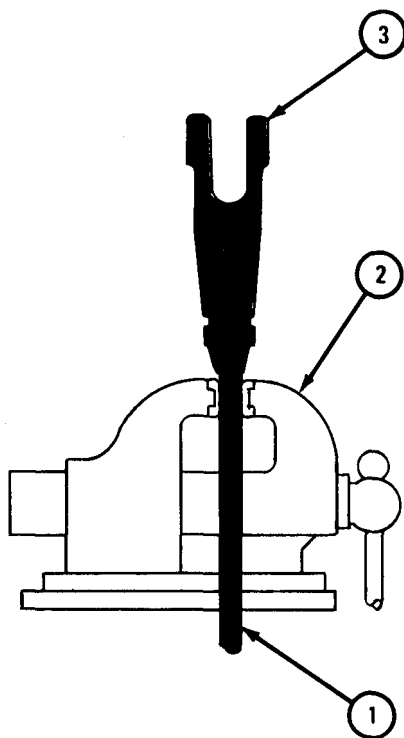

TA 101633

WARNING

Dry cleaning solvent is flammable. Do not use near an open flame. Keep a fire extinguisher nearby when solvent is used. Use only in well-ventilated places. Failure to do this may result in injury to personnel and damage to equipment.

e. Cleaning. Clean all parts in solvent. Dry with clean rags.

f. Inspection and Repair.

(1) Check that cable is not kinked, frayed or cut. If cable is damaged, cut off damaged part.

(2) Check that chain and thimble are not damaged. If parts are damaged, throw them away and get new ones.

g. Assembly (Early Model).

FRAME 1

1. Slide nut (1) on cable (2).
2. Put end of cable (2) around thimble (3) and through chain link (4).
3. Make sure that cable (2) is tight around thimble (3).
4. Place loop in vise as shown. Put both halves of split nut (5) in place so that 1/2 inch of cable (2) will stick out from nut (1).
5. Put split nut (5) in vise and press halves of split nut together.
6. Using adjustable wrenches, screw on and tighten nut (1).
7. Check to make sure 1/2 inch of cable is sticking out past nut (1).
8. Take cable (2) from vise.

END OF TASK

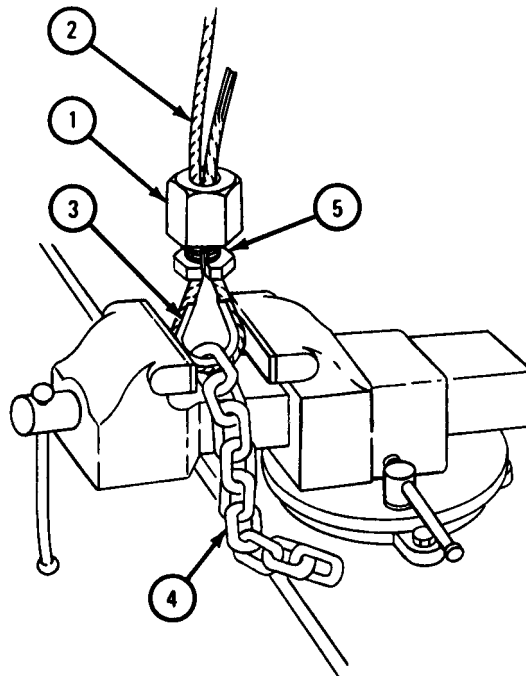

TA 084034

h. Assembly (Late Model).

FRAME 1

1. Clamp cable (1) in vise (2) about six inches from end.
2. Using ruler, measure 4 1/8 inches from cut end of cable (1). Wrap new seizing (3) tightly around cable for 3/4 inch. Tie ends of seizing.
3. Clamp cable (1) in vise (2) around seizing (3).
4. Take off any old seizing and spread cable strands (4).
5. Cut hemp core (5) as close as possible to seizing (3).

GO TO FRAME 2

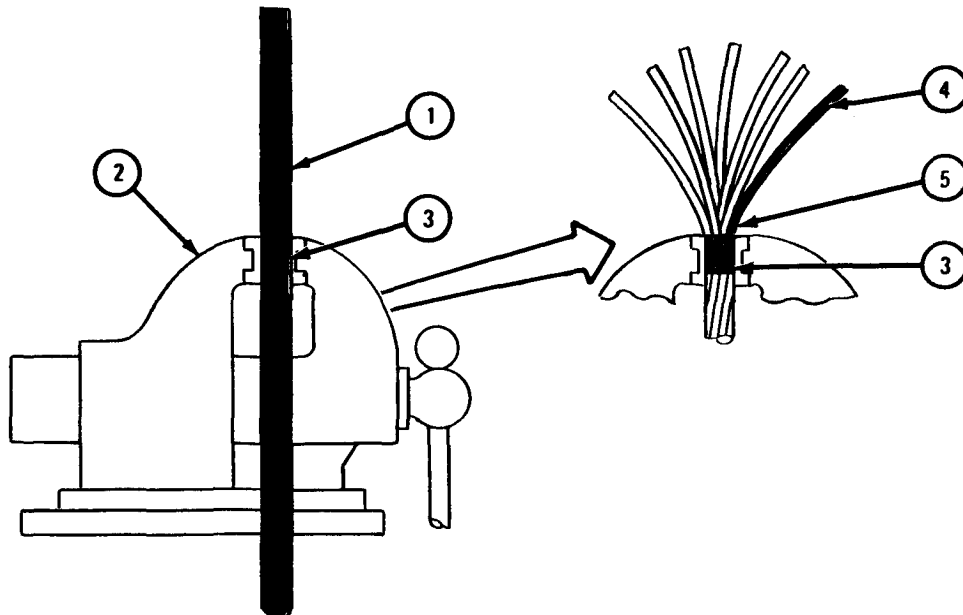

TA 101634

FRAME 2

1. Close strands (1) and slide on sleeve (2).

NOTE

Length of strands from end of sleeve (2) to cable end must be about 1 1/2 inches.

2. Spread strands (1) and bend ends inward.
3. Put plug (3) through center of strands (1) into sleeve (2). Using hammer, drive plug to solid seat and close strands over top of plug.
4. Take cable (4) out of vise.

GO TO FRAME 3

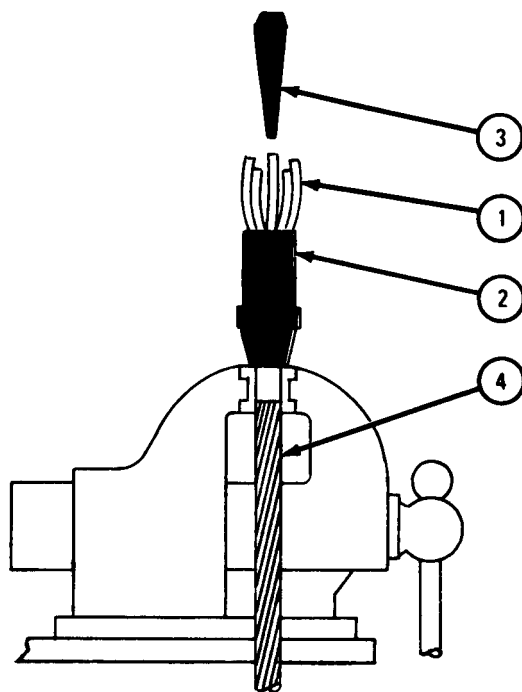

TA 101635

FRAME 3

1. Clamp lower end of sleeve (1) in vise (2).
2. Slide socket (3) over strands and sleeve (1). Using adjustable wrench, screw socket securely to sleeve. Socket will not screw all the way down.
3. Check inspection hole (4). Strands should be seen. If they are not seen, using adjustable wrench, unscrew socket (3), straighten strands, and do steps 1 and 2 again.
4. Take sleeve (1) out of vise (2).

GO TO FRAME 4

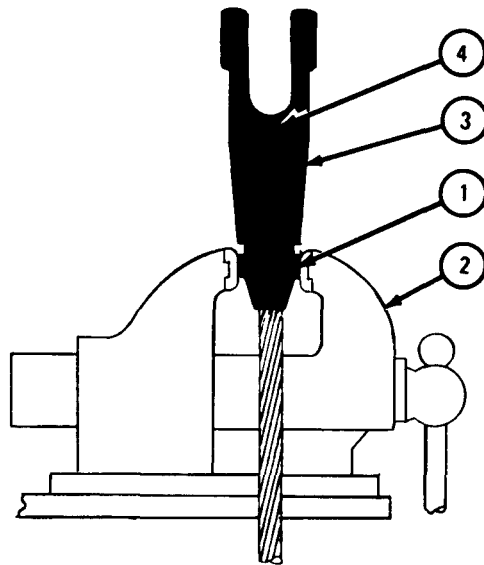

TA 101636

1. Put end link of chain (1) in clevis (2).
 2. Put bolt (3) through clevis (2) and end link of chain (1).
 3. Using adjustable wrenches, hold bolt (3) and screw on and tighten nut (4).
- END OF TASK

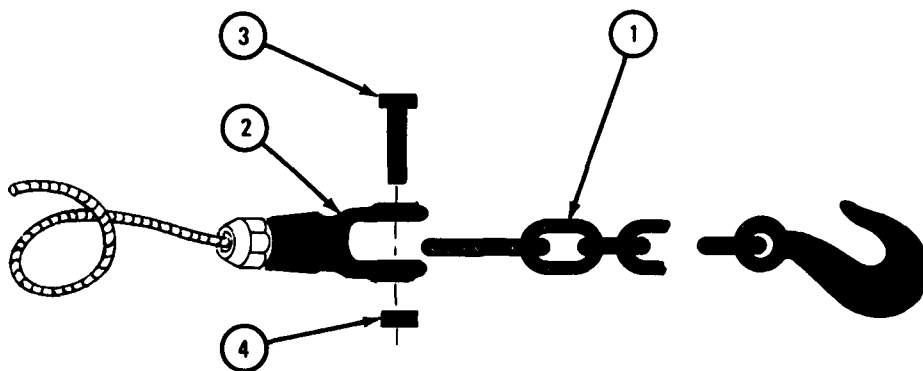

TA 101637

i. Replacement.

FRAME 1

1. Put end of cable (1) in hole in winch drum (2).
2. Using 3/8-inch allen wrench, screw in and tighten setscrew (3).

NOTE

Follow-on Maintenance Action Required:

1. Lubricate winch cable. Refer to LO 9-2320-209-12/1.
2. Wind winch cable on winch. Refer to TM 9-2320-209-10.

END OF TASK

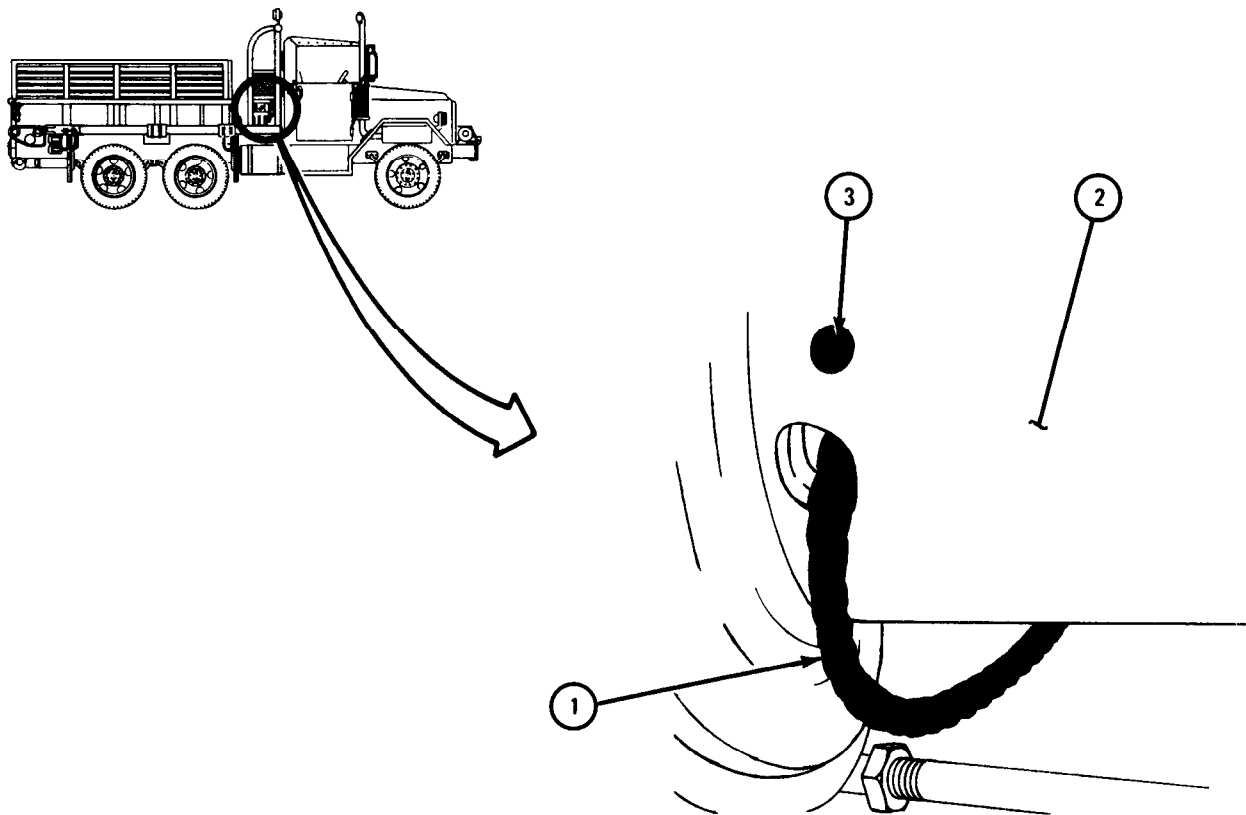

TA 084035

19-11. REAR WINCH CABLE REMOVAL AND REPLACEMENT (TRUCK M764).

TOOLS: Breaker bar
Extension
Screwdriver attachment
Wood block, 2 x 4 x 24 inches

SUPPLIES: None

PERSONNEL: Two

EQUIPMENT CONDITION: Truck parked, engine off, handbrake set.

a. Preliminary Procedure. Remove rear winch cable chain assembly. Refer to para 19-10.

WARNING

Always wear heavy leather gloves when handling cable. Do not let cable run through hands. Broken or rusty wire can cause serious injury to personnel.

b. Removal.

FRAME 1

Soldier A 1. Working in cab, start engine. Refer to TM 9-2320-209-10. Pull power divider lever (1) back to REAR WINCH REV position.

GO TO FRAME 2

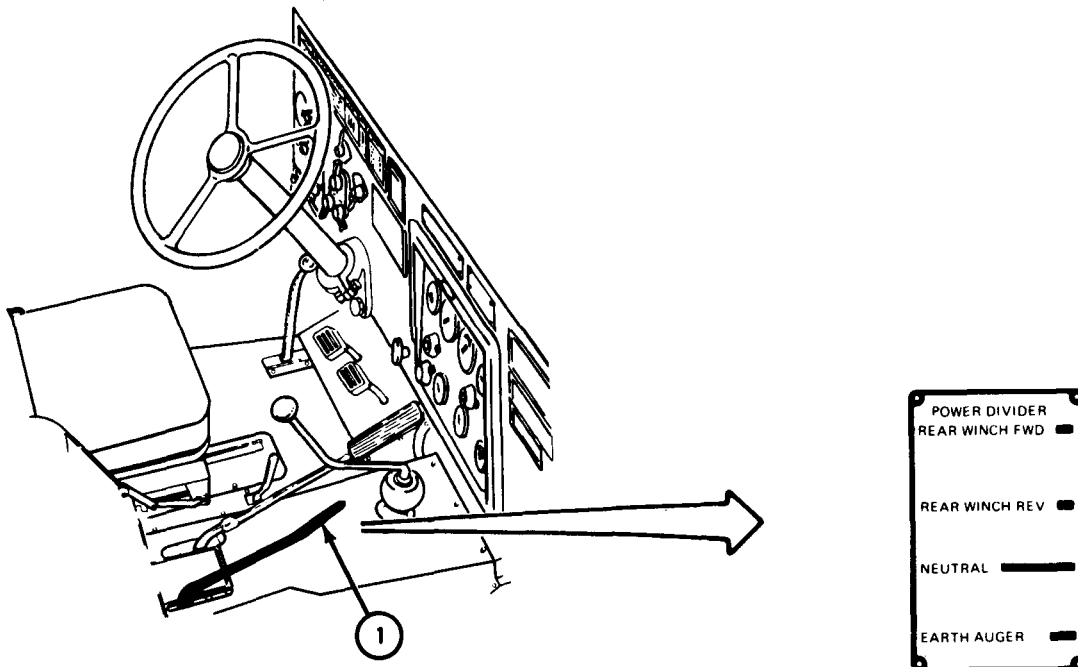

TA 083920

FRAME 2

Soldier B 1. Working in back of truck, pull winch cable (1) out all the way.

Soldier A 2. Stop engine. Refer to TM 9-2320-209-10.

Soldier B 3. Using breaker bar, extension, and screwdriver attachment, unscrew and take out screw (2) and clamp (3).

4. Pull winch cable (1) off drum (4) and through level winder (5).

END OF TASK

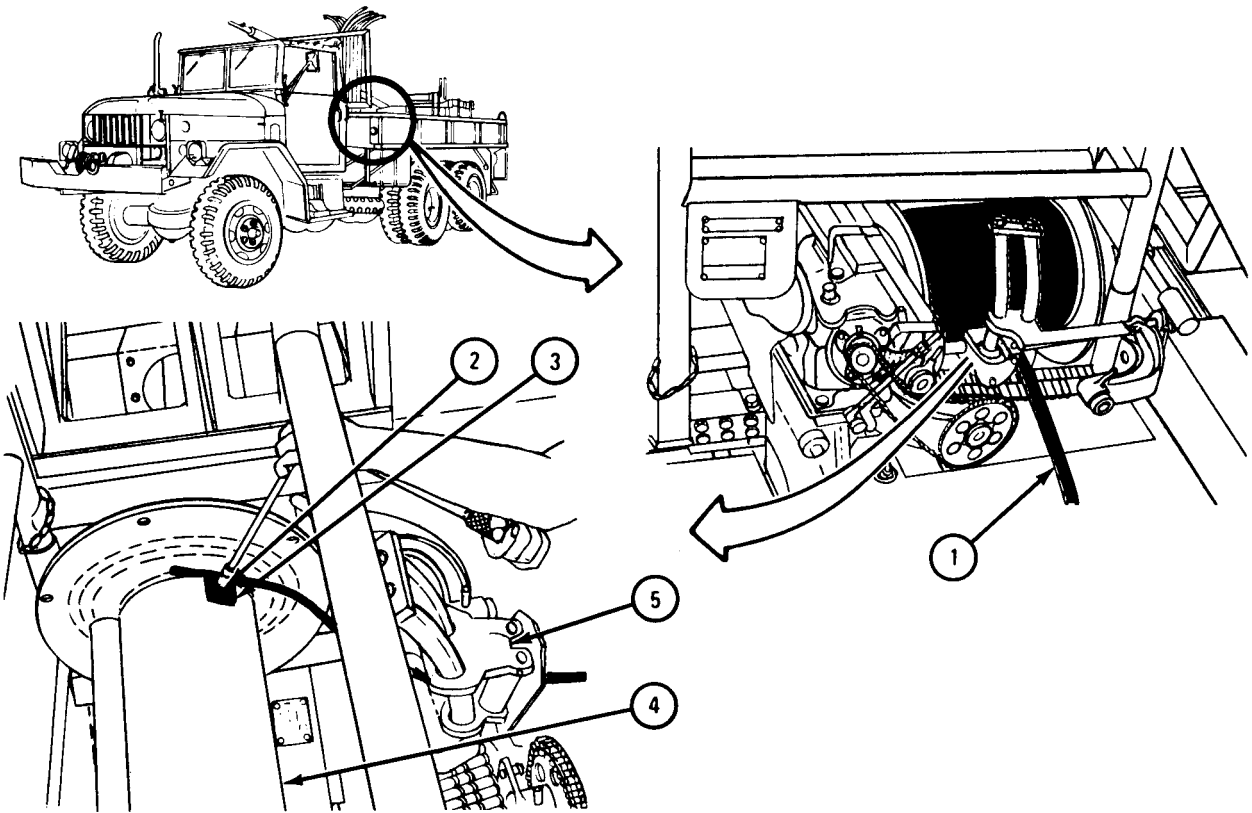

TA 083921

c. Replacement.

FRAME 1

NOTE

Before putting cable on drum, check that cable winder carriage has reached end of travel towards end of drum. End point of travel is when carriage guide pin in center of vertical slot in carriage is outside of cross chain sprocket.

1. Put end of cable (1) through level winder (2) and put it in place on drum (3).
2. Put clamp (4) on cable (1) and using breaker bar, extension, and screwdriver attachment, screw in and tighten screw (5).

GO TO FRAME 2

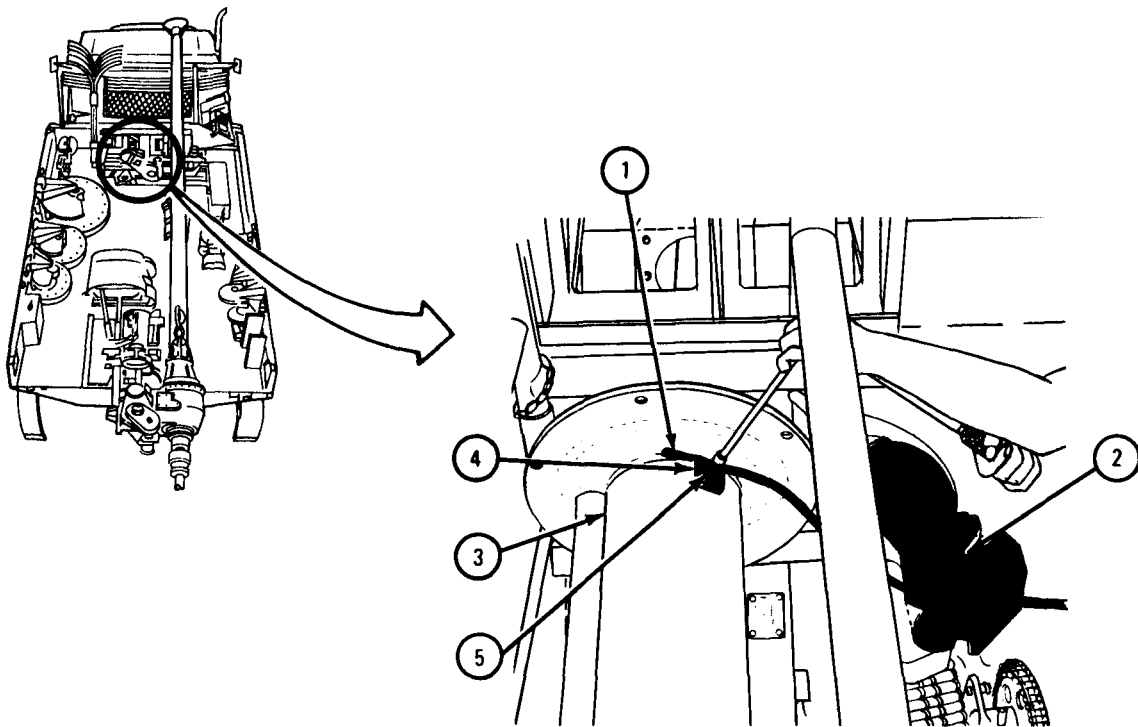

TA 083922

FRAME 2

NOTE

Check that first layer of cable coils are close together.
If needed, use a block of wood to hammer or push cable coils together.

Soldier A 1. Working in cab, start engine. Refer to TM 9-2320-209-10.
Put power divider lever (1) in REAR WINCH FWD position when soldier B is ready.

Soldier B 2. Working in back of truck, hold tension on winch cable (2). Tell soldier A to start winch. Wind up cable in drum (3).

Soldier A 3. Stop engine. Refer to TM 9-2320-209-10.

NOTE

Follow-on Maintenance Action Required:

Replace rear winch cable chain assembly. Refer to para 19-10.

END OF TASK

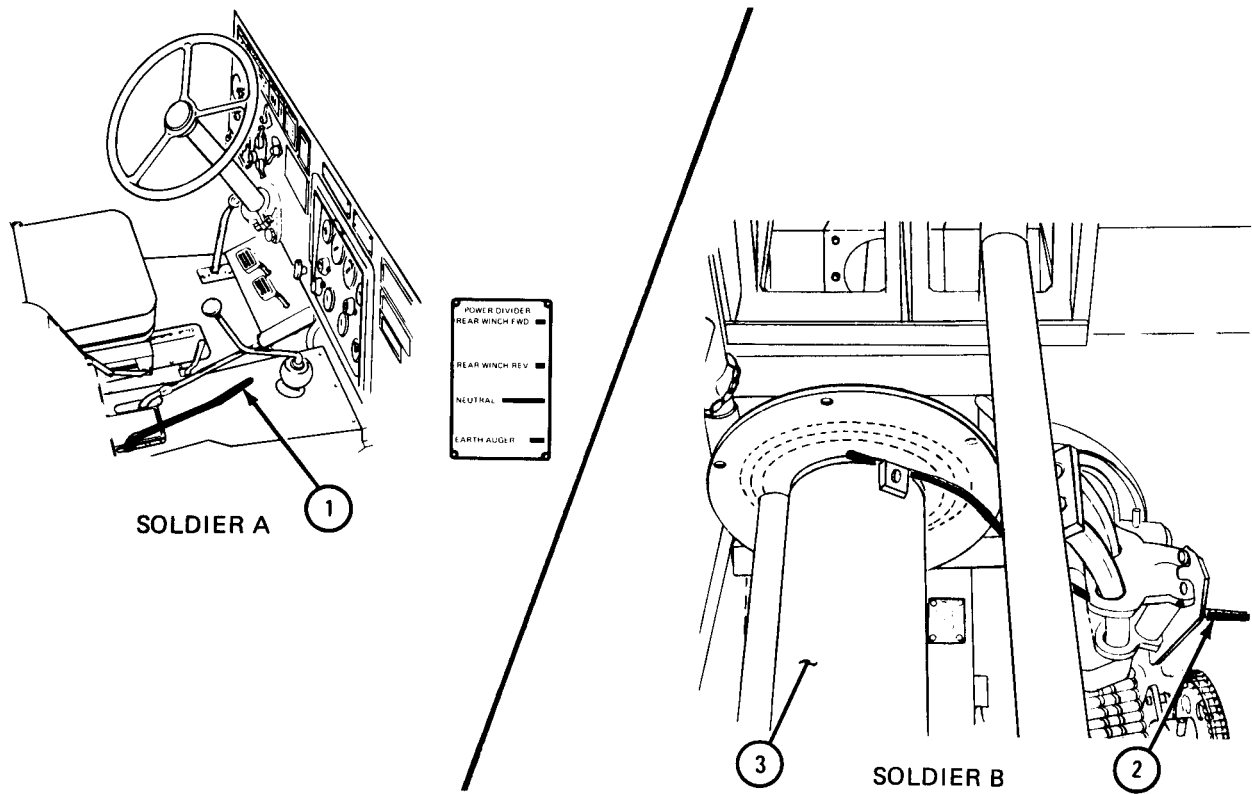

TA 083923

19-12. REAR WINCH ASSEMBLY WORM GEAR HOUSING OIL DRAIN TUBE REMOVAL, CLEANING, INSPECTION, REPAIR AND REPLACEMENT (TRUCK M764).

TOOLS: Open end wrench set, pn GGG-W-636
One-gallon drain pan

SUPPLIES: Lubricating oil, GO 80/90, MIL-L-2105
Solvent, dry cleaning, type II (SD-2), Fed. Spec P-D-680
Clean dry rags

PERSONNEL: One

EQUIPMENT CONDITION: Truck parked, engine off, handbrake set.

a. Removal.

FRAME 1

1. Put drain pan under elbow (1).
2. Using wrench, unscrew and take out pipe plug (2). Let oil drain into drain pan.
3. Using wrenches, unscrew and takeout screw (3), nut (4), clamp (5), and bracket (6).

GO TO FRAME 2

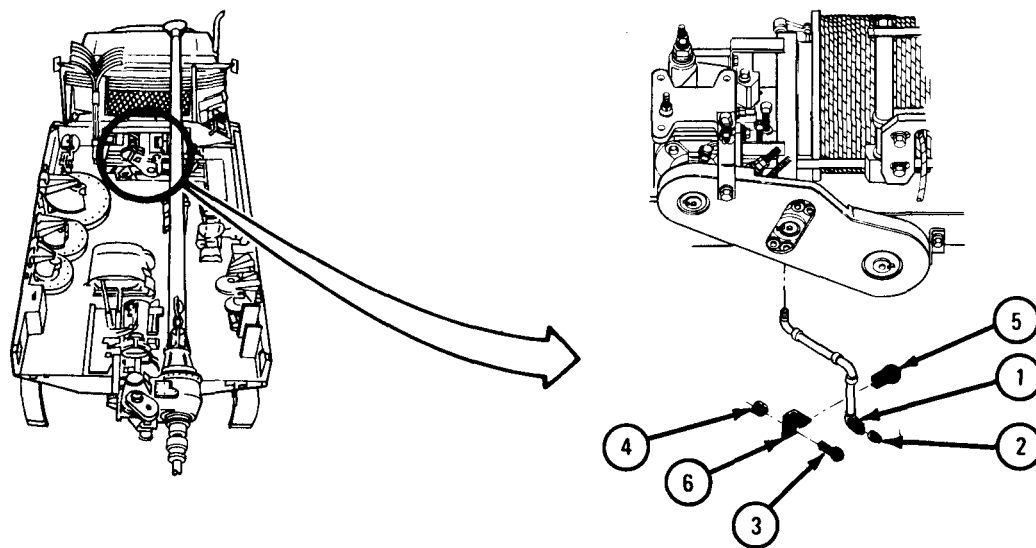

TA 104751

FRAME 2

1. Unscrew and take off elbow (1), pipe nipple (2), elbow (3), pipe nipple (4), and elbow (5).

END OF TASK

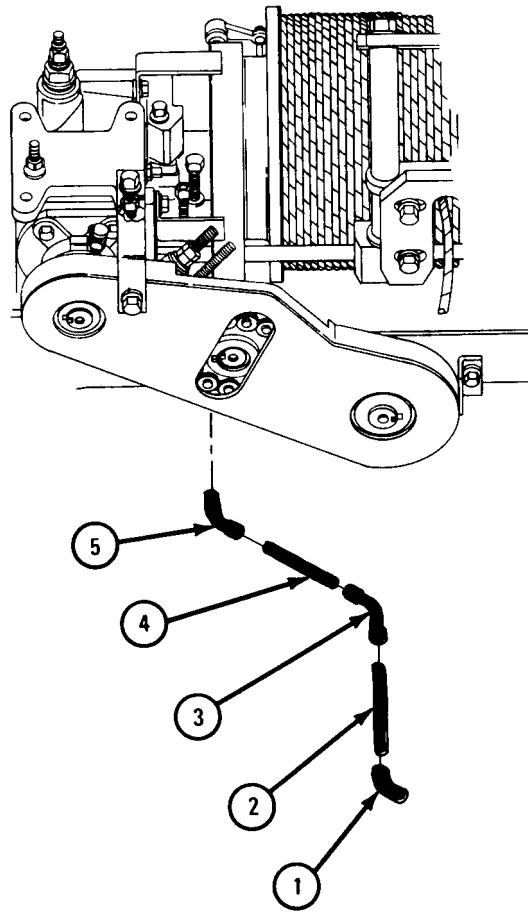

TA 104752

WARNING

Dry cleaning solvent is flammable. Do not use near an open flame. Keep a fire extinguisher nearby when solvent is used. Use only in well-ventilated places. Failure to do this may result in injury to personnel and damage to equipment.

b. Cleaning. Clean all parts with dry cleaning solvent. Dry parts using clean dry rags.

c. Inspection and Repair. Check that all parts are not cracked or broken and that threaded parts are not damaged. If parts are damaged, get new ones.

d. Replacement.

FRAME 1

1. Screw on elbow (1), pipe nipple (2), elbow (3), pipe nipple (4), and elbow (5).

GO TO FRAME 2

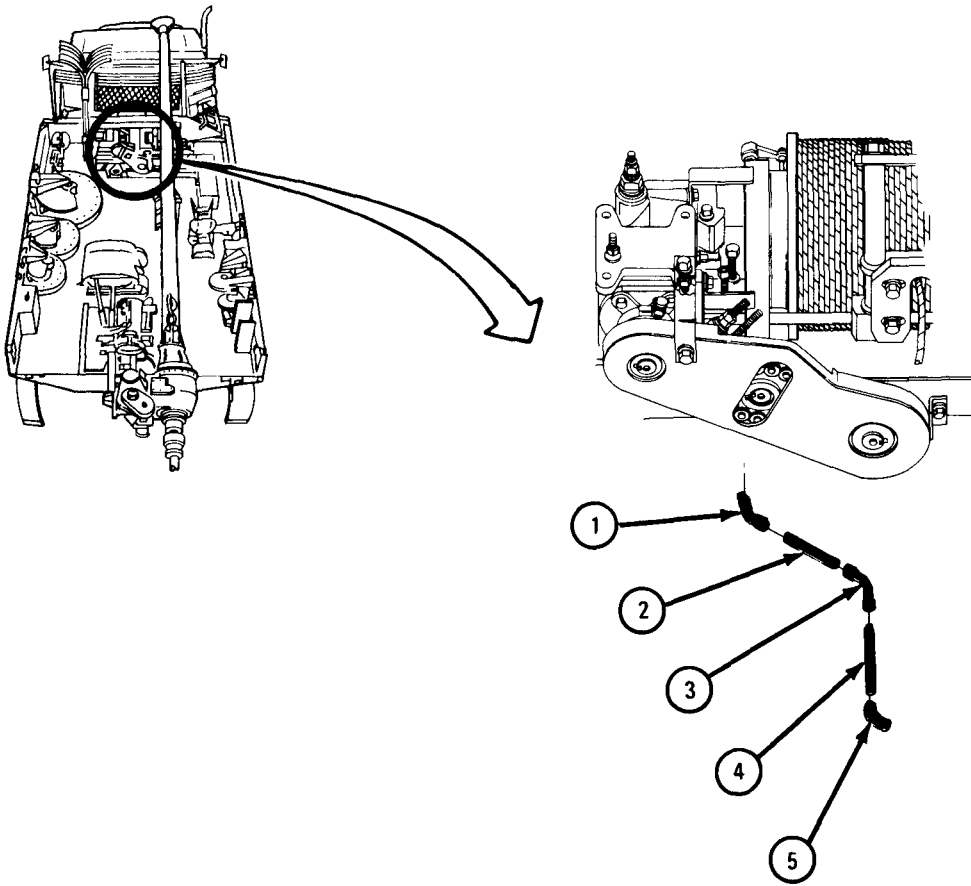

TA 104753

FRAME 2

1. Put clamp (1) and bracket (2) in place.
2. Using wrenches, screw on and tighten nut (3) and screw (4).
3. Using wrench, screw on and tighten pipe plug (5).

NOTE

Follow-on Maintenance Action Required:

Fill rear winch worm gear housing. Refer to LO 9-2320-209-12/1.

END OF TASK

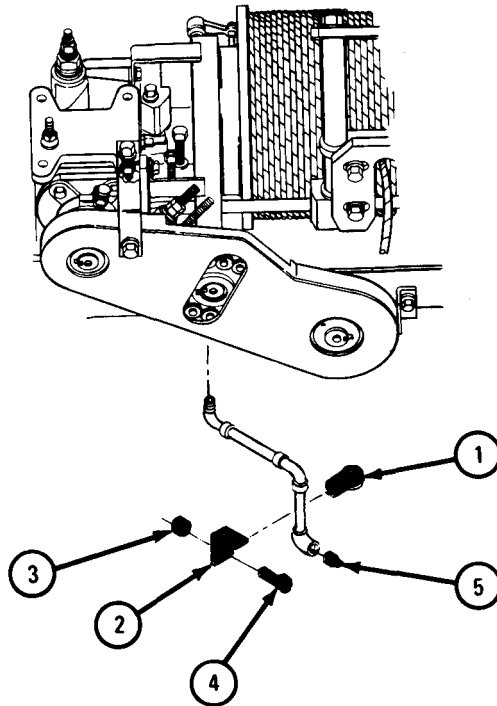

TA 104754

19-13. REAR WINCH DRIVE CHAIN REMOVAL, REPAIR AND REPLACEMENT
(TRUCK M756A2).

TOOLS: Needle nose pliers
Flat-tip screwdriver

SUPPLIES: Solvent, dry cleaning, type II (SD-2), Fed. Spec P-D-680

PERSONNEL: One

EQUIPMENT CONDITION: Truck parked, engine off, handbrake set.

a. Removal.

FRAME 1

1. Using pliers, pull out and throw away cotter pin (1) from each of two pins in master link (2).
2. Using screwdriver, take off master link cap (3) from master link (2).
3. Take out master link (2).
4. Take off drive chain (4).

END OF TASK

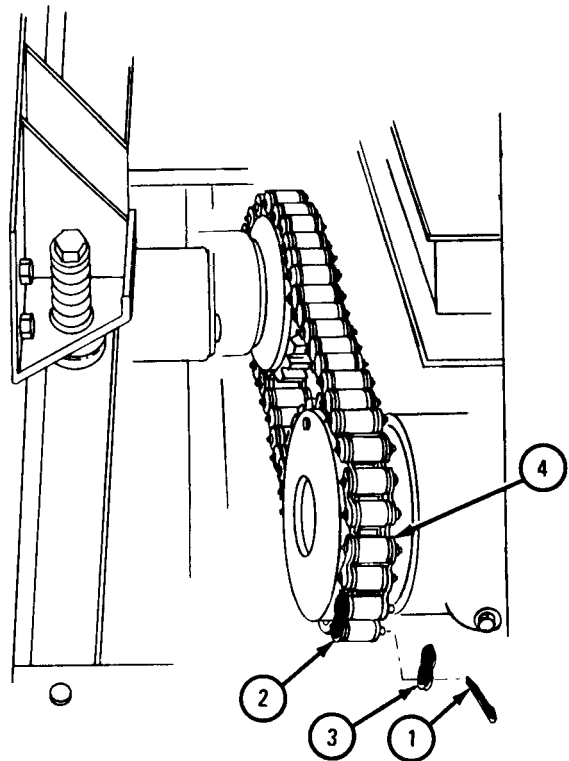
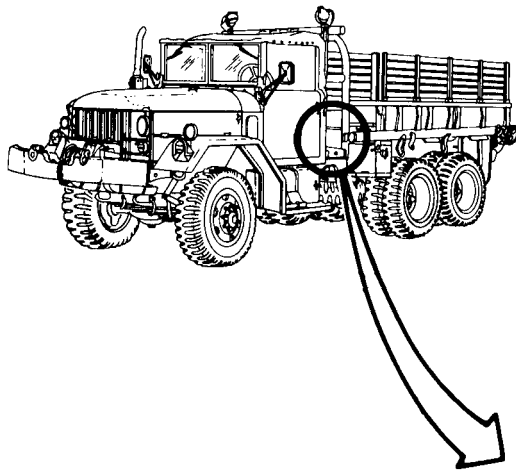

TA 080906

WARNING

Dry cleaning solvent inflammable. Do not use near an open flame. Keep a fire extinguisher nearby when solvent is used. Use only in well-ventilated places. Failure to do this may result in injury to personnel and damage to equipment.

- b. Cleaning. Clean chain in solvent.
- c. Inspection and Repair. Check that chain has no cracks or breaks and that it is not worn. If chain is damaged, get a new one.
- d. Replacement.

FRAME 1

1. Put drive chain (1) in place.
2. Put two pins on master link (2) through ends of chain (1).
3. Put on master link cap (3).
4. Using pliers, put cotter pin (4) in each pin in master link (2) and bend open ends of cotter pin.

NOTE

Follow-on Maintenance Action Required:
Adjust drive chain. Refer to para 19-14.

END OF TASK

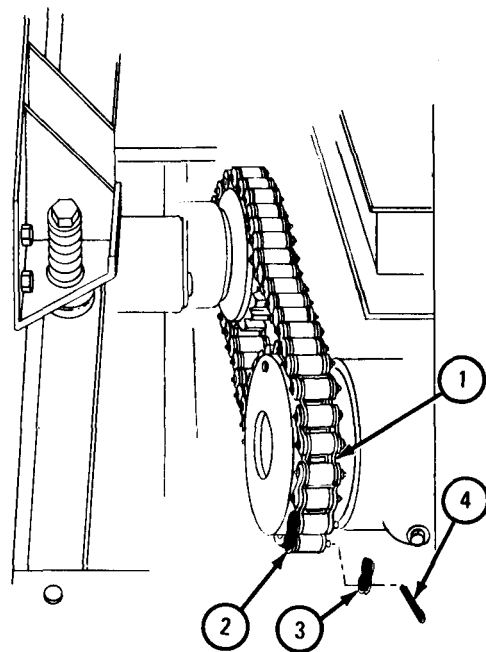
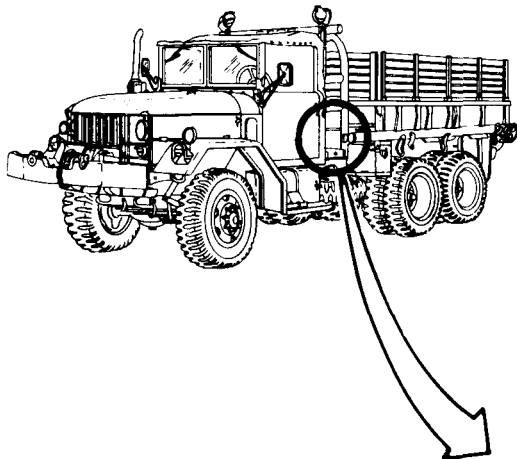

TA 080907

19-14. REAR WINCH DRIVE CHAIN ADJUSTMENT (TRUCK M756A2).

TOOLS: 1/2-inch wrench (2) 15/16-inch wrench
15/16-inch socket Breaker bar
6-inch ruler Prybar
Drill 6-inch extension

SUPPLIES: None

PERSONNEL: One

EQUIPMENT Condition: Truck parked, engine off, handbrake set.

a. Preliminary Procedure. Pull both gin poles away from truck. Refer to TM 9-230-209-10.

b. Adjustment.

FRAME 1

1. Using 1/2-inch wrenches, unscrew and take out four screws (1) and nuts (2).
2. Take off floor plate (3).
3. Using 15/16-inch wrench, breaker bar, and 15/16-inch socket, loosen six screws (4) and nuts (5).

GO TO FRAME 2

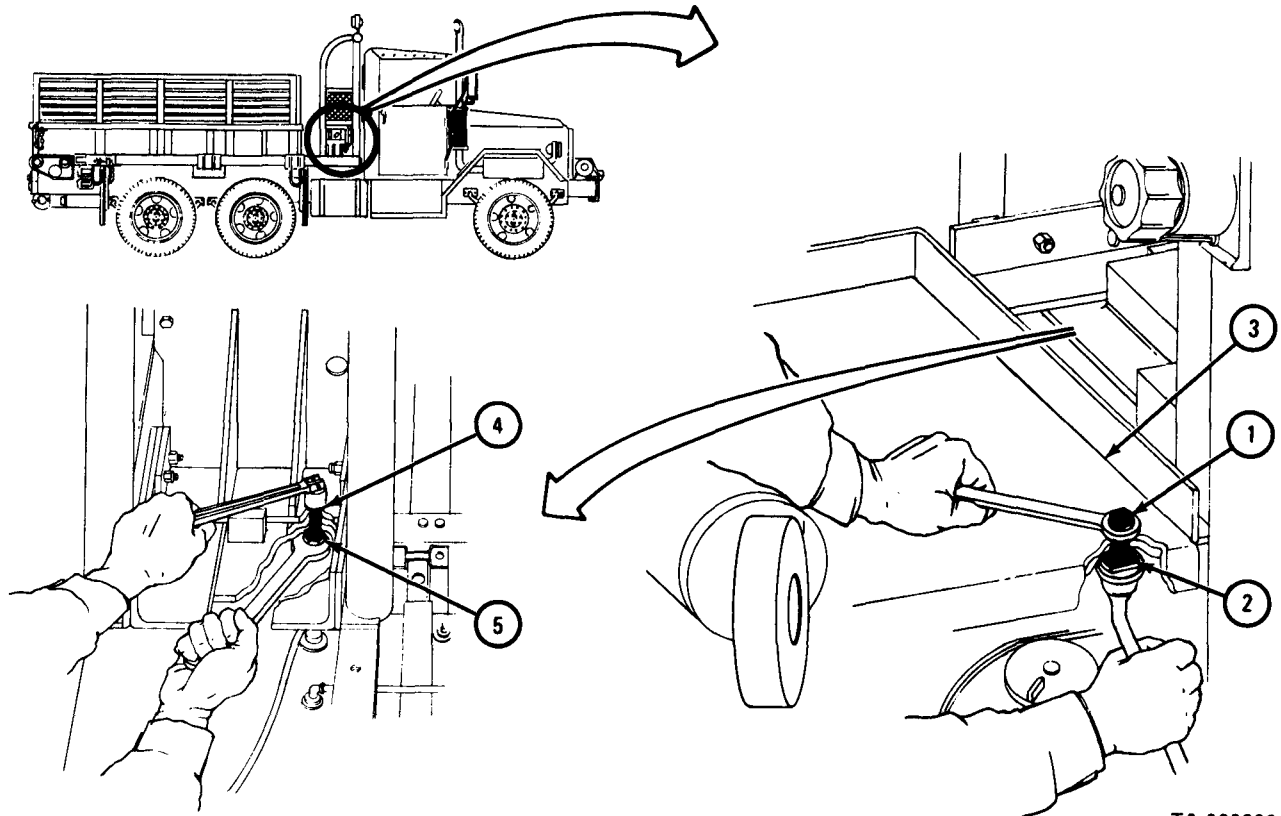

TA 080908

FRAME 2

1. Using 15/16-inch wrench, breaker bar, and 15/16-inch socket, loosen eight screws (1) and nuts (2).

GO TO FRAME 3

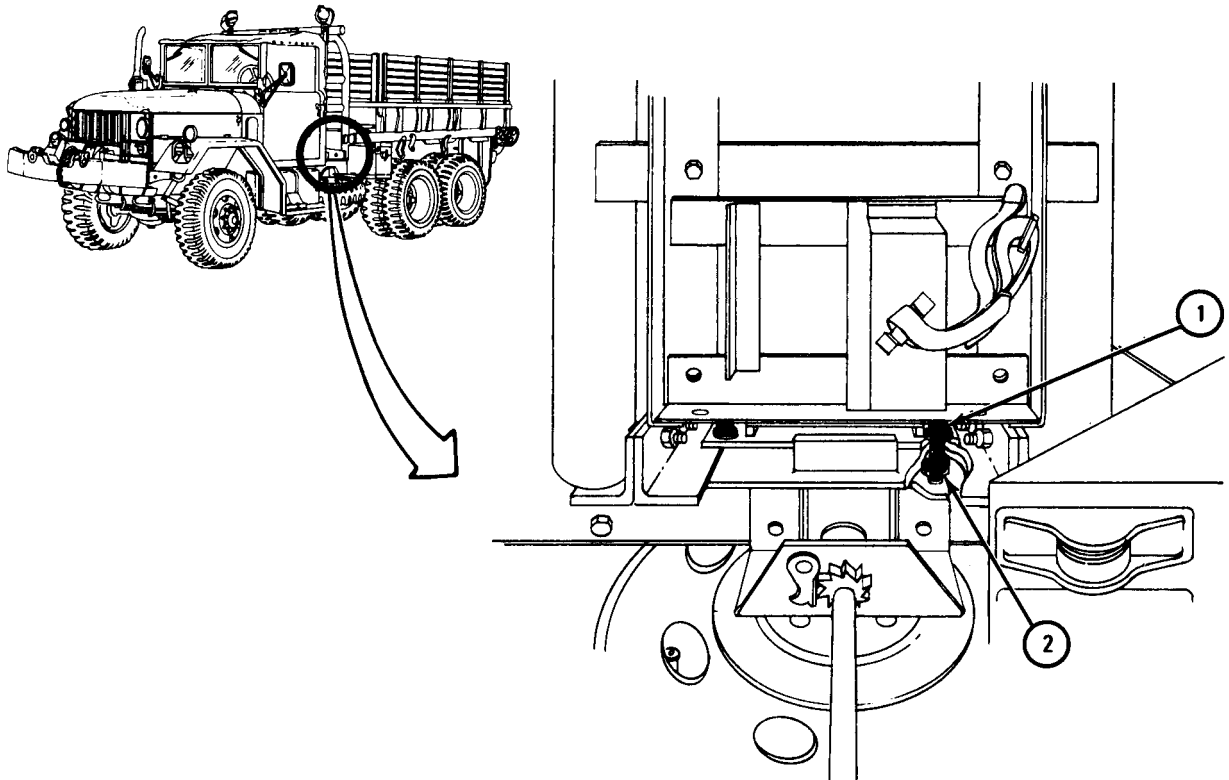

TA 080909

FRAME 3

1. Using 6-inch ruler, measure slack in drive chain (1) at midpoint between two sprockets (2 and 3). If slack is 1/2 inch, adjustment is correct.
2. If there is too much slack in drive chain (1), using prybar (4) as shown, push winch assembly (5) to the left. If there is not enough slack in drive chain, using prybar (6) as shown, push winch assembly (5) to the right.
3. After adjusting winch assembly (5), do step 1 again to check adjustment.

GO TO FRAME 4

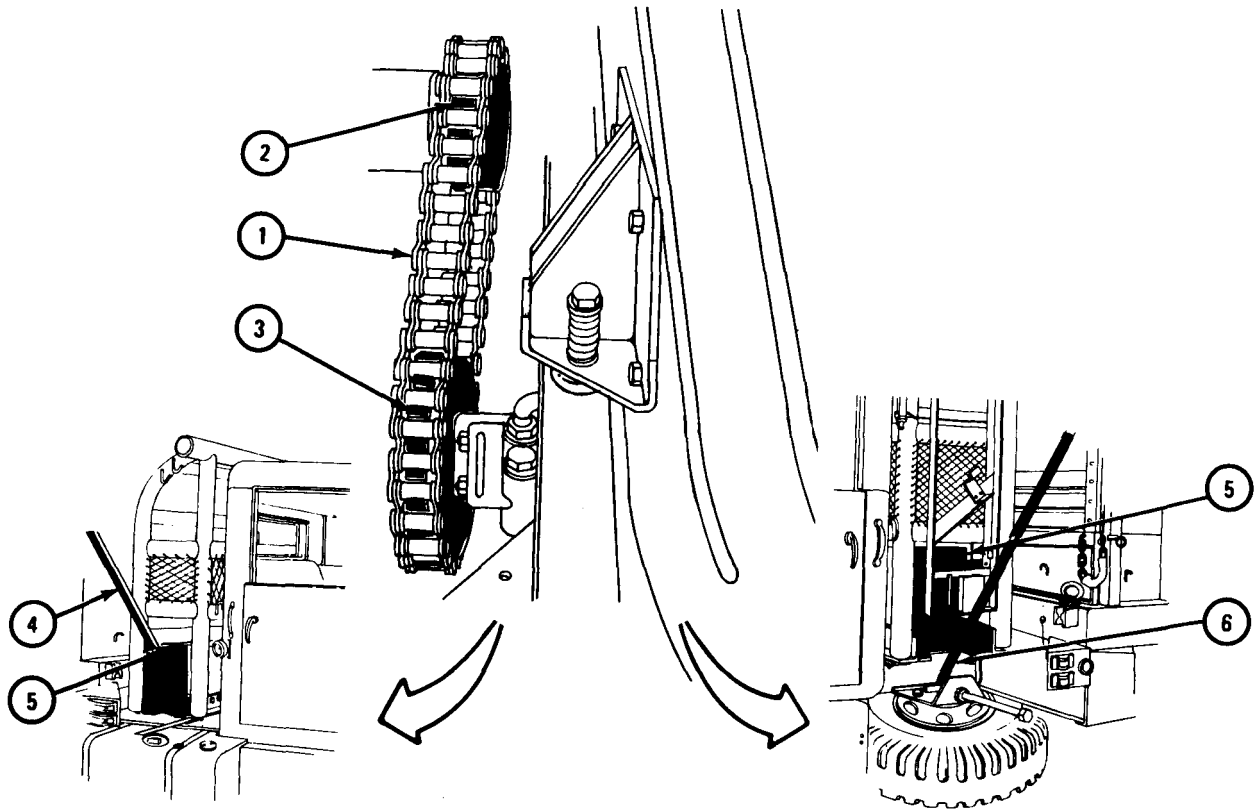

TA 080910

FRAME 4

1. Using 15/16-inch wrench, breaker bar, and 15/16-inch socket, tighten eight screws (1) and nuts (2).

GO TO FRAME 5

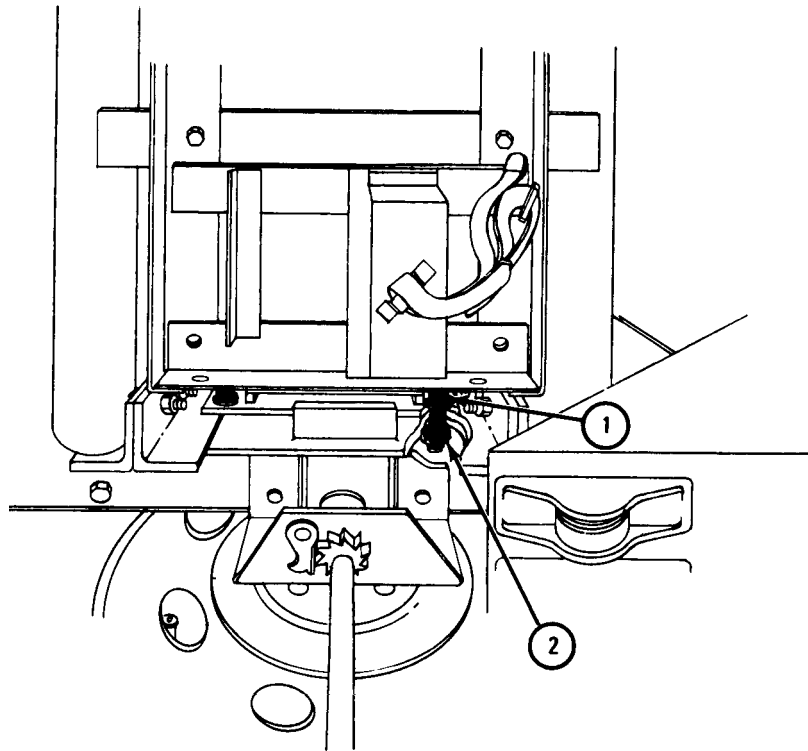

TA 080911

FRAME 5

1. If the winch drive chain has been adjusted, using drill, slot two screw holes (1) to the right or left as needed.

GO TO FRAME 6

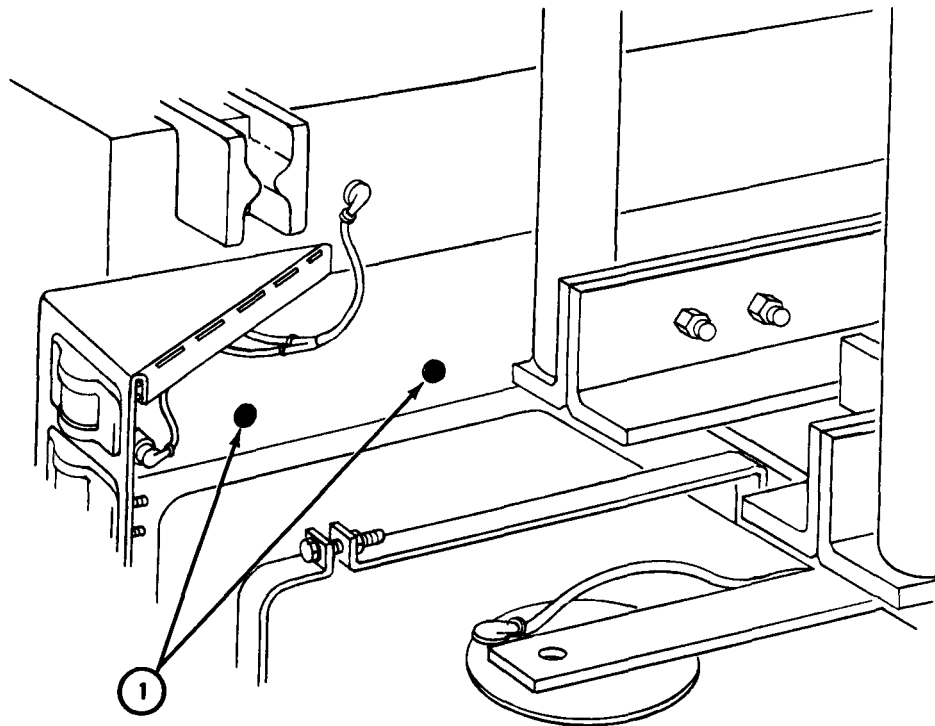

TA 080912

FRAME 6

1. Using 15/16-inch wrench, breaker bar, and 15/16-inch socket, tighten six screws (1) and nuts (2).
 2. Put floor plate (3) in place.
 3. Using 1/2-inch wrenches, screw in and tighten four screws (4) and nuts (5).
- END OF TASK

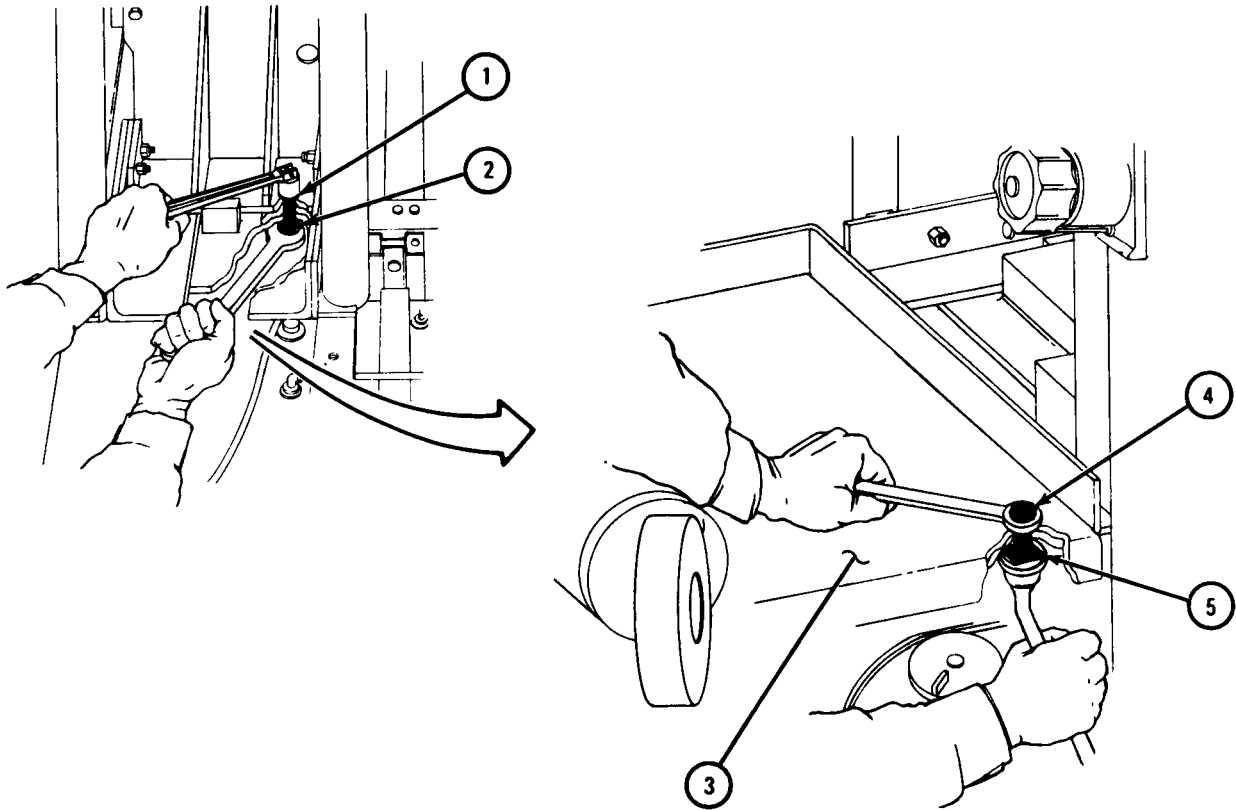

TA 080913

19-15. CARRIAGE CROSS CHAIN REMOVAL AND REPLACEMENT (TRUCK M764).

TOOLS: 1/2-inch wrench
Breaker bar
3/4-inch socket
Socket extension
3/4-inch wrench
15/16-inch wrench (2)
Hammer
Flat-tip screwdriver

SUPPLIES: None

PERSONNEL: One

EQUIPMENT CONDITION: Truck parked, engine off, handbrake set.

a. Preliminary Procedure. Remove secondary reduction drive chain. Refer to para 19-17.

b. Removal.

FRAME 1

1. Using 1/2-inch wrench, unscrew and take out four screws, washers, and lock-washers (1) from cross chain cover (2).
 2. Take off cross chain cover (2).
 3. Turn sprocket (3) until you find connecting link (4) in cross chain (5).
- GO TO FRAME 2

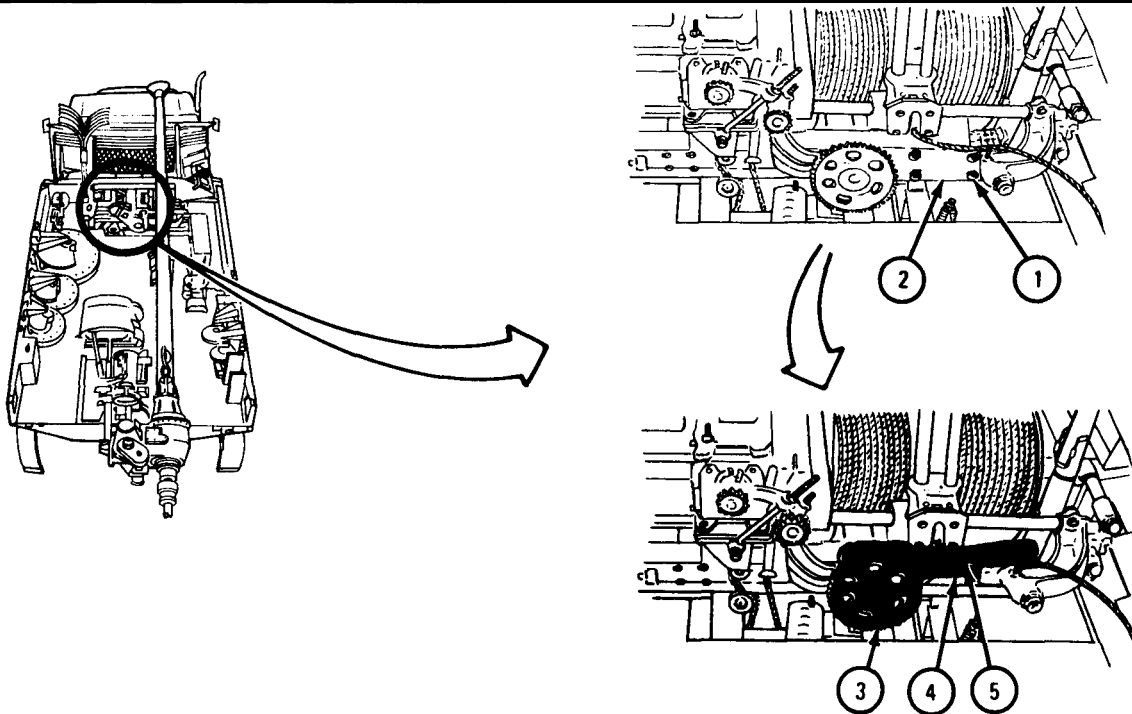

TA 080894

FRAME 2

1. Using breaker bar, 3/4-inch socket, extension, and 3/4-inch wrench, loosen two screws (1) and nuts (2) holding cross chain bracket (3) to tie rod (4).
2. Using 15/16-inch wrenches, loosen adjusting screw (5) and locknut (6) on right side of cross bracket (3).

GO TO FRAME 3

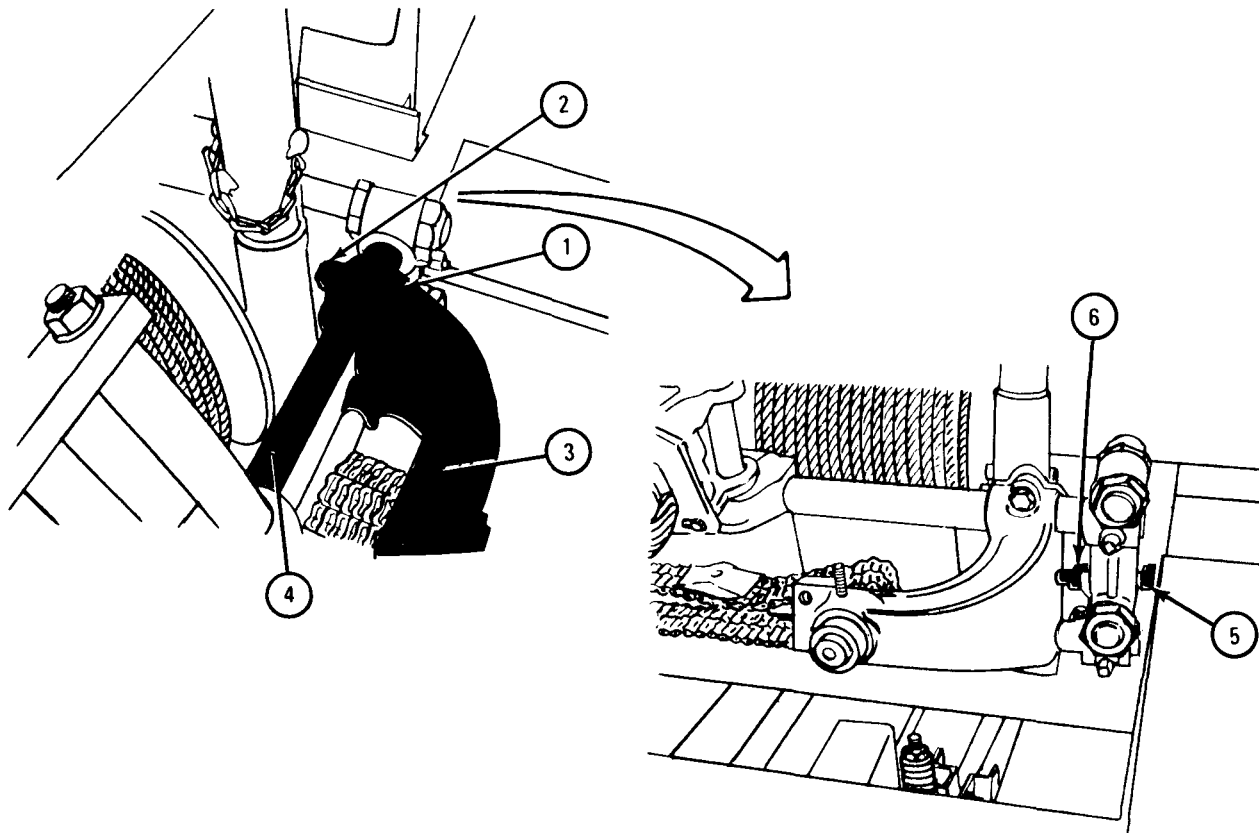

TA 080895

FRAME 3

1. Using hammer, tap cross chain bracket (1) toward chain (2) to take tension off chain.
2. Using screwdriver, pry off clip (3). Take off keeper (4).
3. Put hand under connecting link (5) to catch four spacers (6).
4. Take out connecting link (5) and four spacers (6).
5. Take out chain (2) with chain guide (7).

GO TO FRAME 4

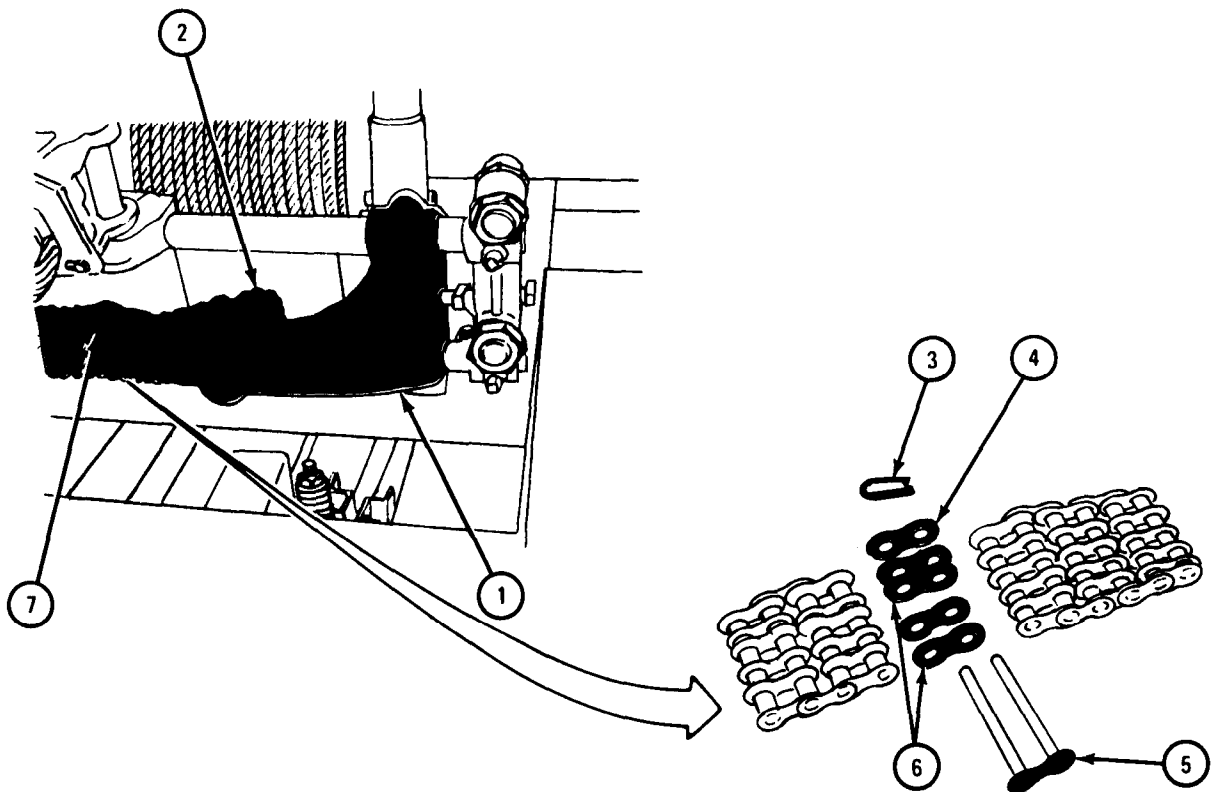

TA 080896

FRAME 4

1. Using screwdriver, pry off two clips (1).
2. Take out two pins (2).
3. Take ends of chain (3) out of chain guide (4).

END OF TASK

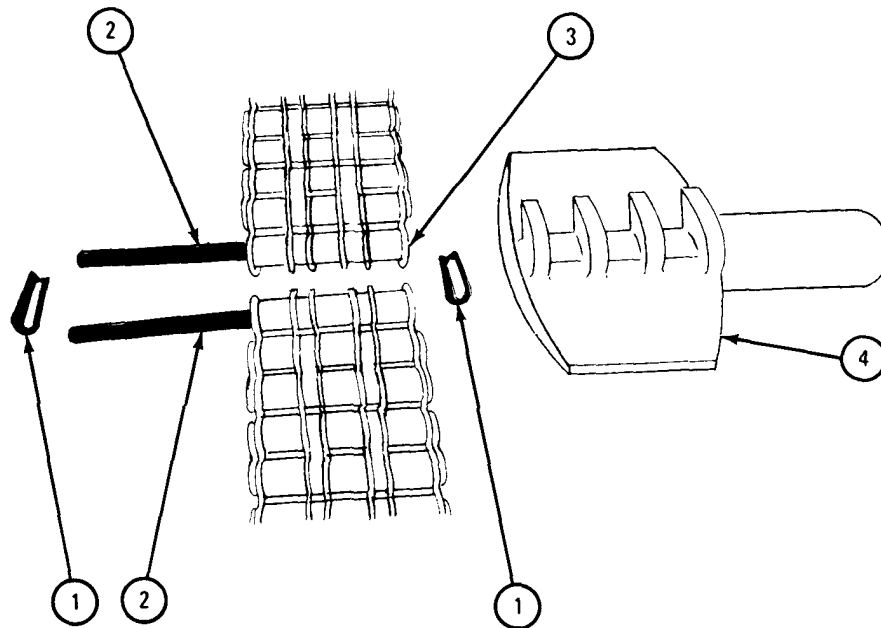

TA 080897

c. Replacement.

FRAME 1

1. Put ends of chain (1) in place in chain guide (2) and aline holes.
 2. Put two pins (3) through chain (1) and chain guide (2).
 3. Put on two clips (4).
- GO TO FRAME 2

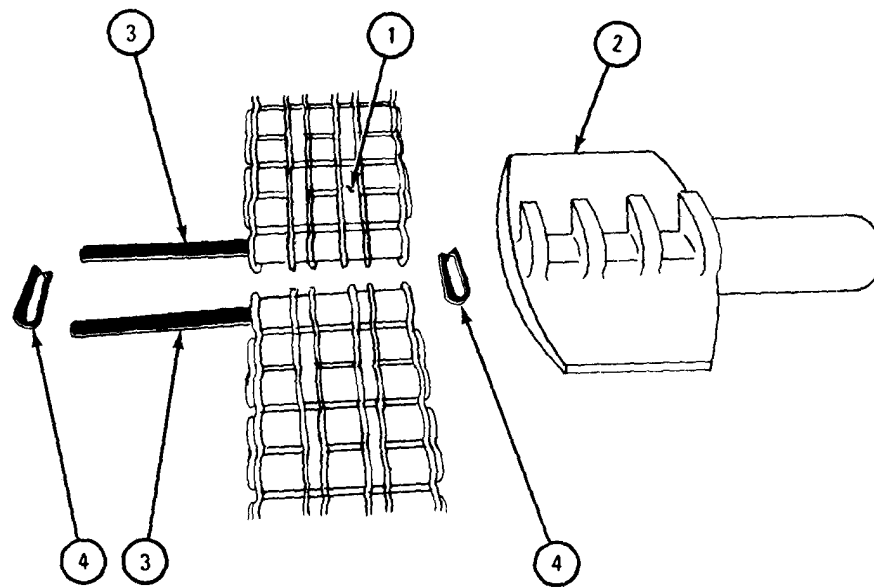

TA 080898

FRAME 2

1. Put chain (1) in place as shown.
2. Put four spacers (2) in place between two chain rollers (3) as shown.
3. Aline holes and put connecting link (4) in place.
4. Put on keeper (5) and clip (6).
5. Using 15/16-inch wrench, tighten screw (7) to put tension on chain (1).
6. Using 15/16-inch wrenches, hold screw (7) and tighten locknut (8).

GO TO FRAME 3

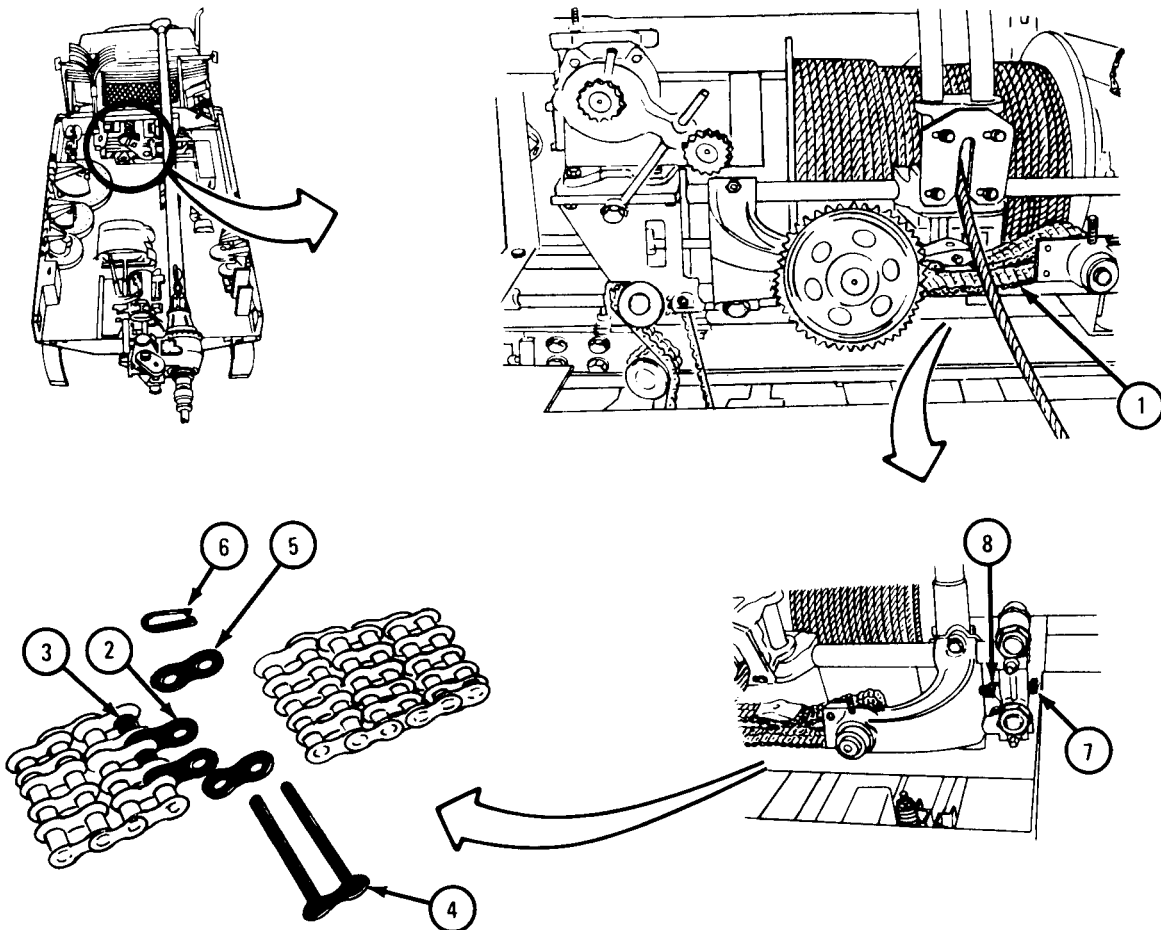

TA 080899

FRAME 3

1. Using 3/4-inch socket and wrench, tighten bolt (1) and nut (2).
2. Put cross chain cover (3) in place.
3. Using 1/2-inch wrench, screw in and tighten four screws, washers, and lock-washers (4).

NOTE

Follow-on Maintenance Action Required:

1. Adjust carriage travel. Refer to para 19-16.
2. Replace secondary reduction drive chain. Refer to para 19-17.

END OF TASK

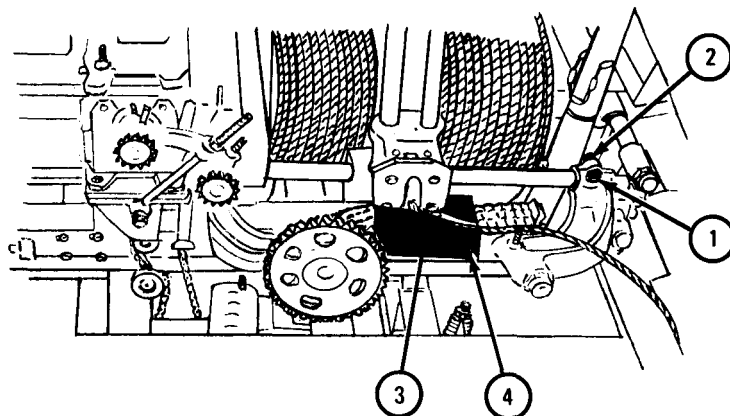

TA 080900

19-16. CARRIAGE TRAVEL ADJUSTMENT (TRUCK M764).

TOOLS: 3/4-inch wrench
 15/16-inch wrench (2)
 3/4-inch socket
 Breaker bar
 5-inch extension
 6-inch ruler

SUPPLIES: None

PERSONNEL: One

EQUIPMENT CONDITION: Truck parked, engine off, handbrake set.

a. Preliminary Procedure. Remove second reduction drive chain. Refer to para 19-17.

b. Carriage Travel Adjustment.

FRAME 1

- Using 3/4-inch wrench, breaker bar, extension, and 3/4-inch socket, loosen screw (1) and nut (2) on each cross chain bracket (3).
- Using 15/16-inch wrenches, loosen two adjusting screws (4).

GO TO FRAME 2

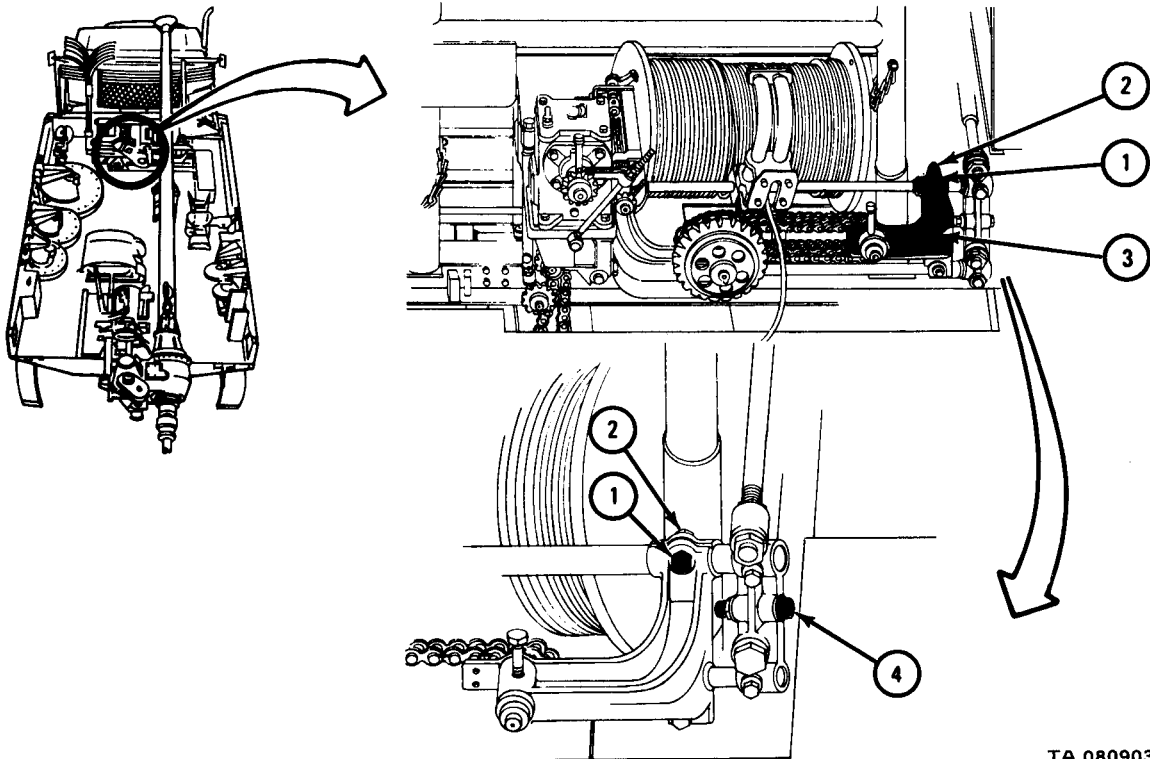

TA 080903

FRAME 2

1. Using 6-inch ruler, measure distance between drum flange (1) and cross chain bracket (2), and distance between drum flange (3) and cross chain bracket (4) as shown. Distances should be equal.
2. If distances measured in step 1 are not equal, using 15/16-inch wrenches, turn adjusting screws (5) on cross chain brackets (2 and 4) until distances are equal.

GO TO FRAME 3

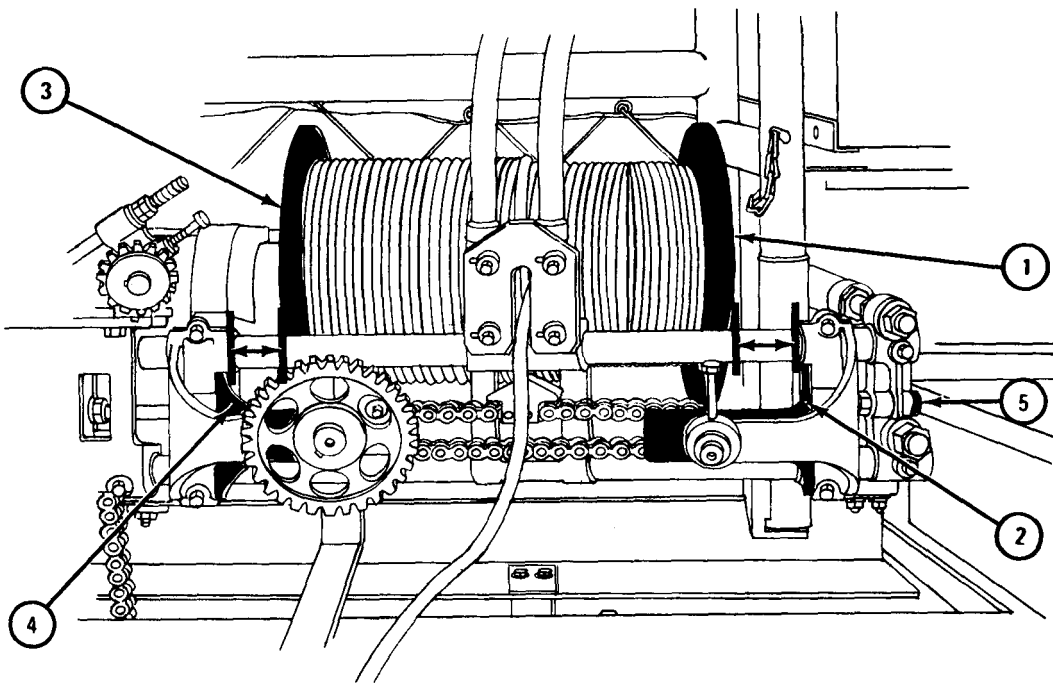

TA 080904

FRAME 3

1. Using 15/16-inch wrenches, tighten two locknuts (1).
2. Using 3/4-inch wrench, breaker bar, extension, and 3/4-inch socket, tighten two screws (2) and nuts (3) on each cross chain bracket (4).

NOTE

Follow-on Maintenance Action Required:

Replace second reduction drive chain. Refer to para 19-17.

END OF TASK

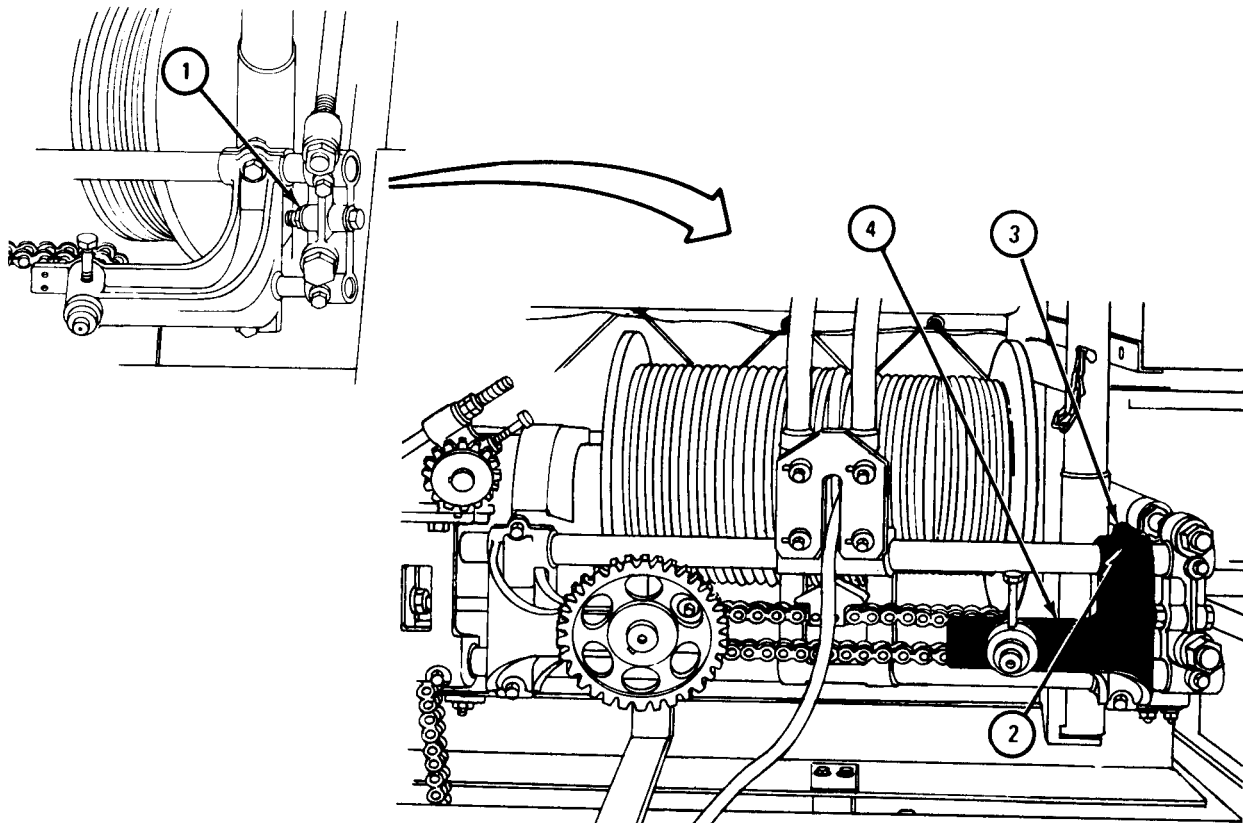

TA 080905

19-17. REDUCTION DRIVE CHAINS REMOVAL AND REPLACEMENT (TRUCK M764).

TOOLS: 9/16-inch wrench
1/2-inch wrench (2)
3/4-inch wrench
Flat-tip screwdriver

SUPPLIES: None

PERSONNEL: One

EQUIPMENT CONDITION: Truck parked, engine off, handbrake set.

a. Removal.

(1) First reduction drive chain.

FRAME 1

1. Using 9/16-inch wrench, unscrew and take out screw (1) and flat washers (2).
2. Using 1/2-inch wrench, unscrew and take out screw with flat washer (3).
3. Take off cover (4).

GO TO FRAME 2

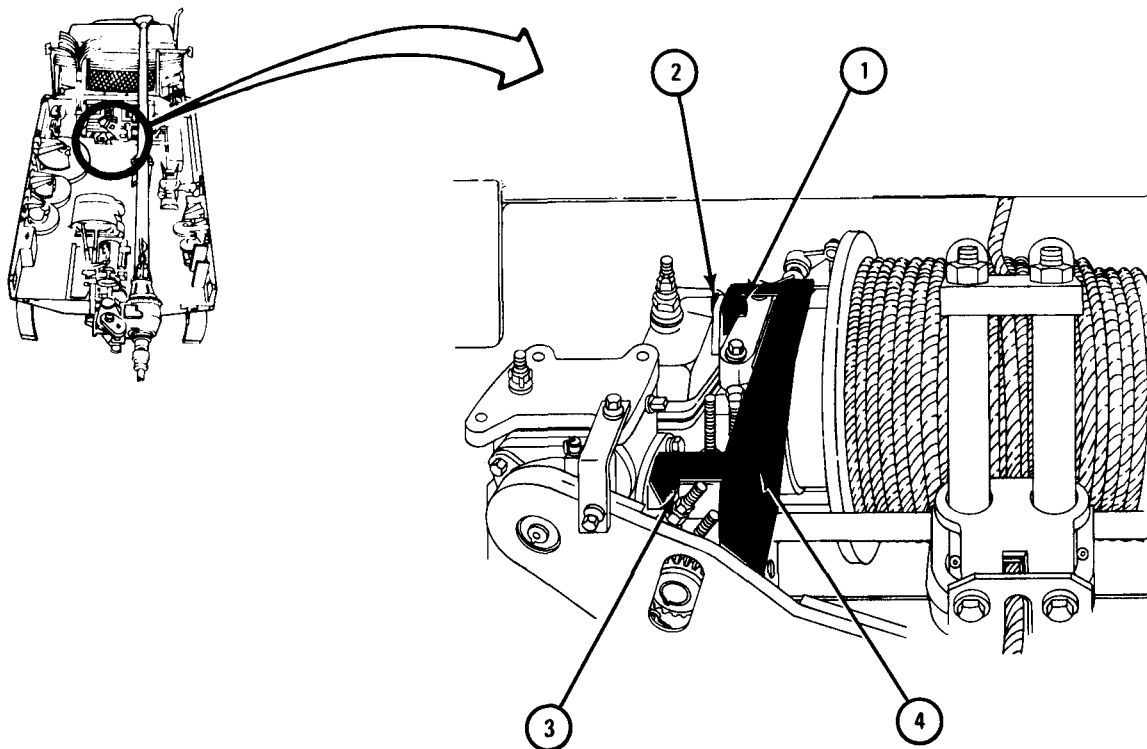

TA 080888

FRAME 2

1. Find detachable link (1) on chain (2).
2. Using screwdriver, push off clip (3).
3. Take off keeper (4) and detachable link (1).
4. Take off chain (2).

END OF TASK

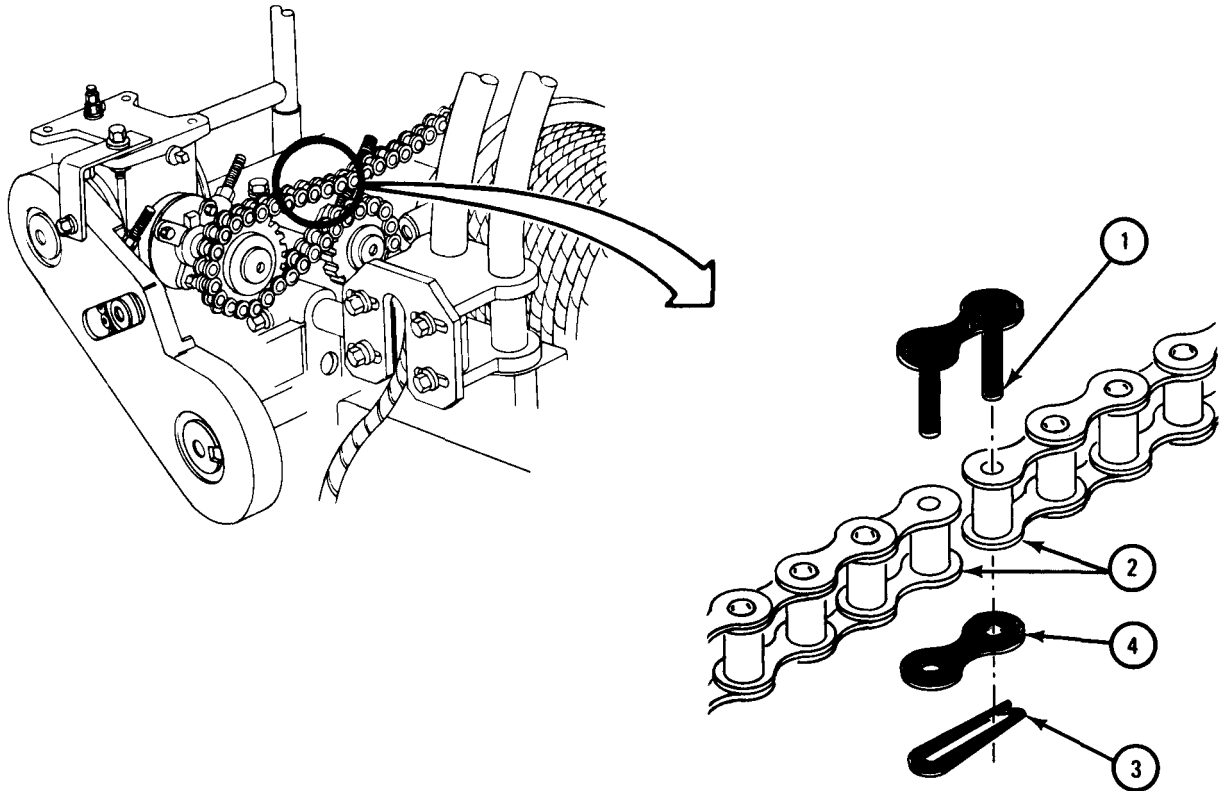

TA 080880

(2) Second reduction drive chain.

FRAME 1

1. Using 1/2-inch wrenches, unscrew and take out screw and washer (1) and nut (2).
2. Using 1/2-inch wrench, unscrew and take out screw and washer (3).
3. Take off cover (4).

GO TO FRAME 2

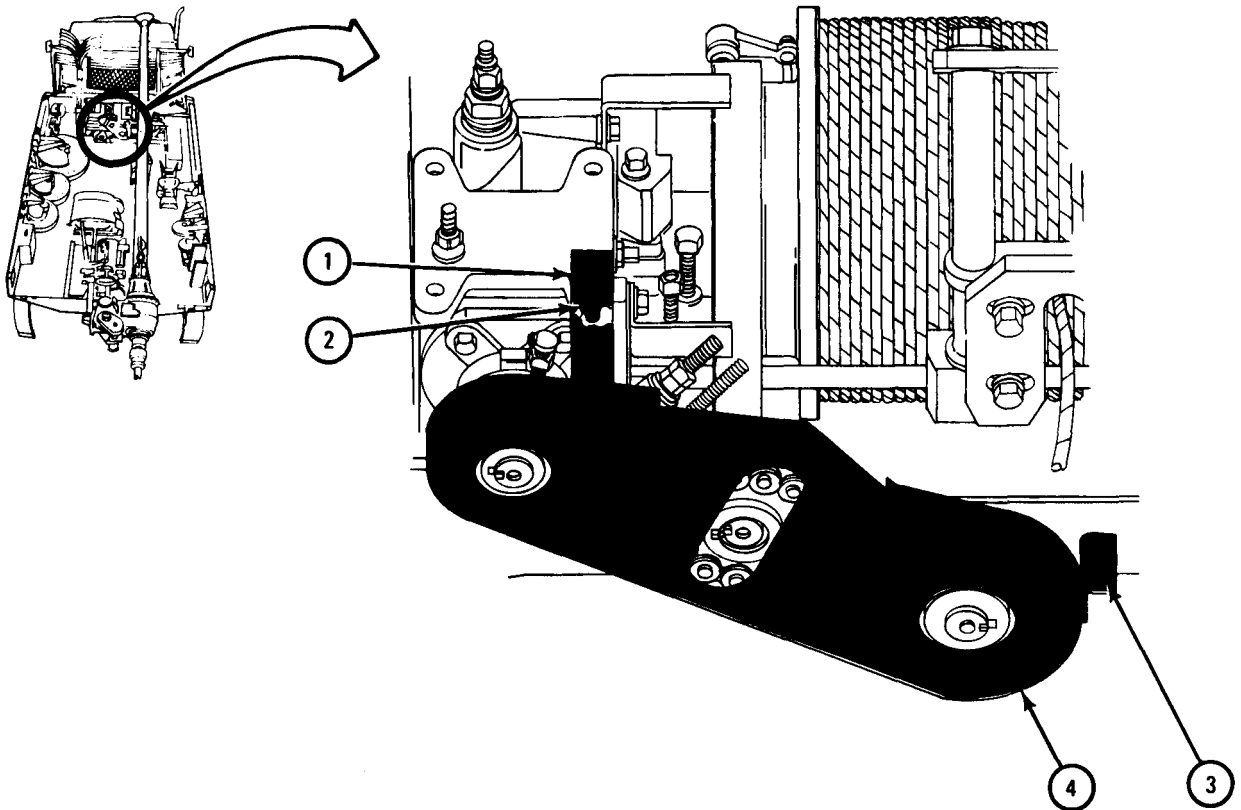

TA 080883

FRAME 2

1. Using 3/4-inch wrench, loosen locknut (1) five turns.
2. Using 3/4-inch wrench, loosen adjusting nut (2) until there is slack in chain (3).

GO TO FRAME 3

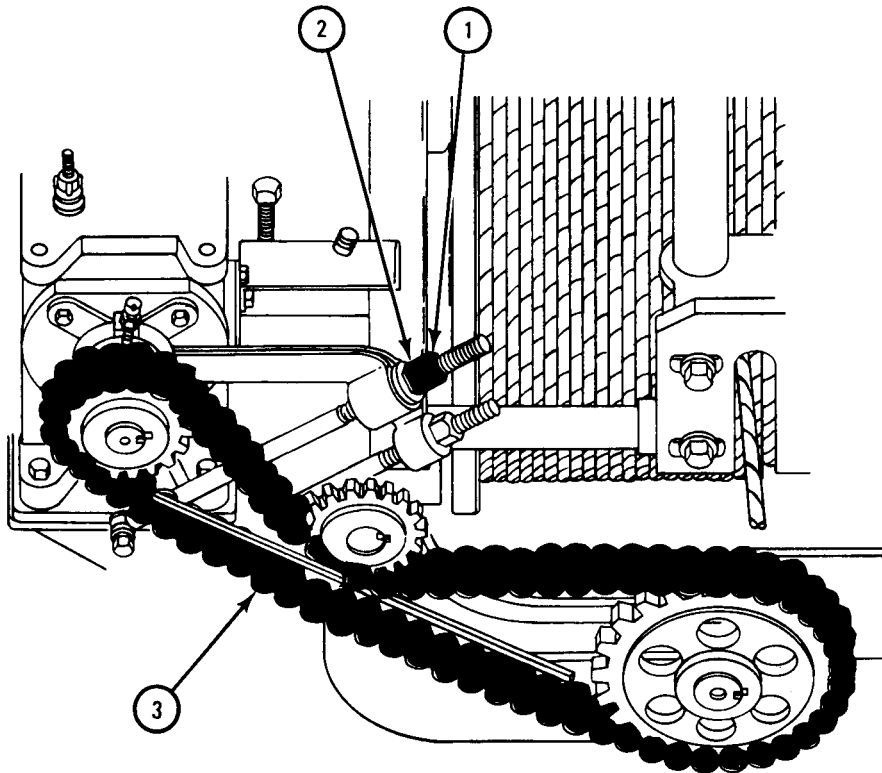

TA 080884

FRAME 3

1. Find detachable link (1) in chain (2).
2. Using screwdriver, push off clip (3).
3. Take off keeper (4) and detachable link (1).
4. Take off chain (2).

END OF TASK

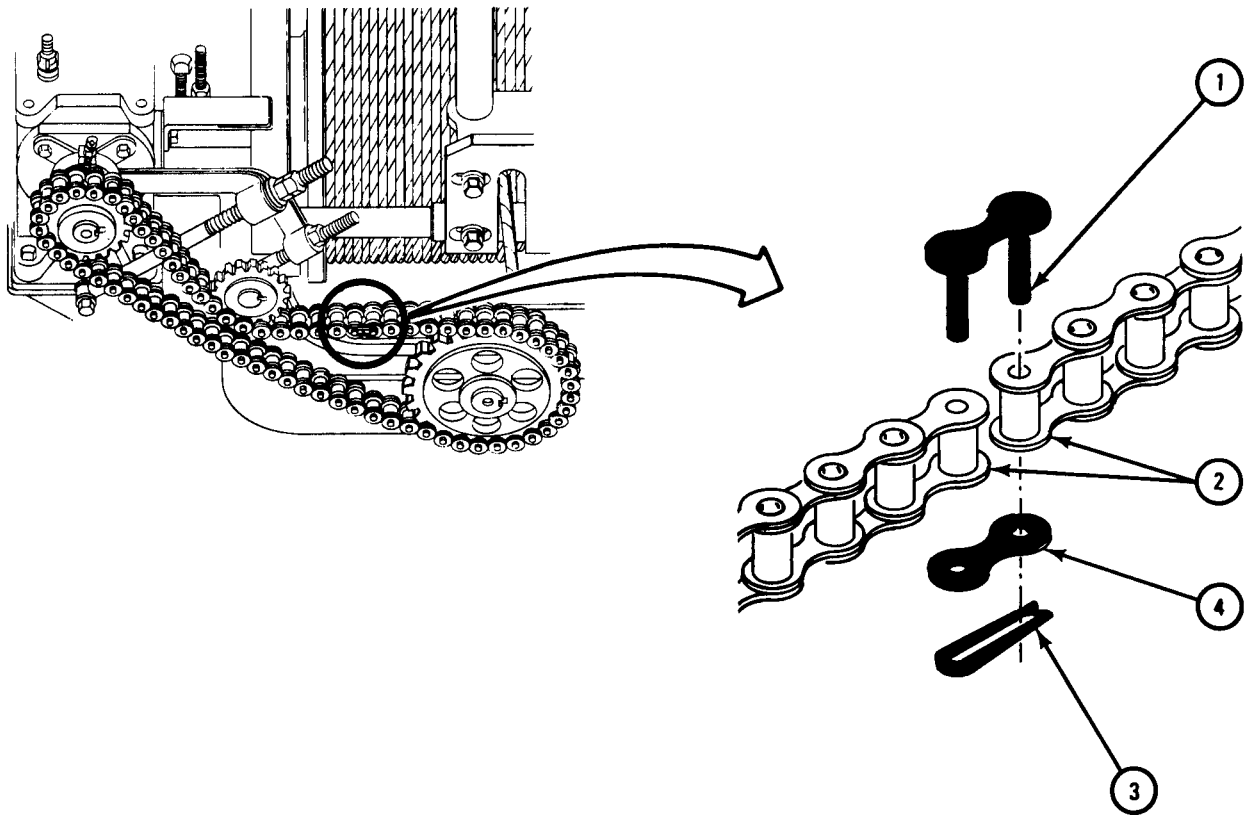

TA 080885

b. Replacement.

(1) First reduction drive chain.

FRAME 1

1. Put chain (1) in place and put detachable link (2) through ends of chain.
2. Put on keeper (3) and clip (4).
3. Adjust first reduction drive chain (1). Refer to para 19-18.

GO TO FRAME 2

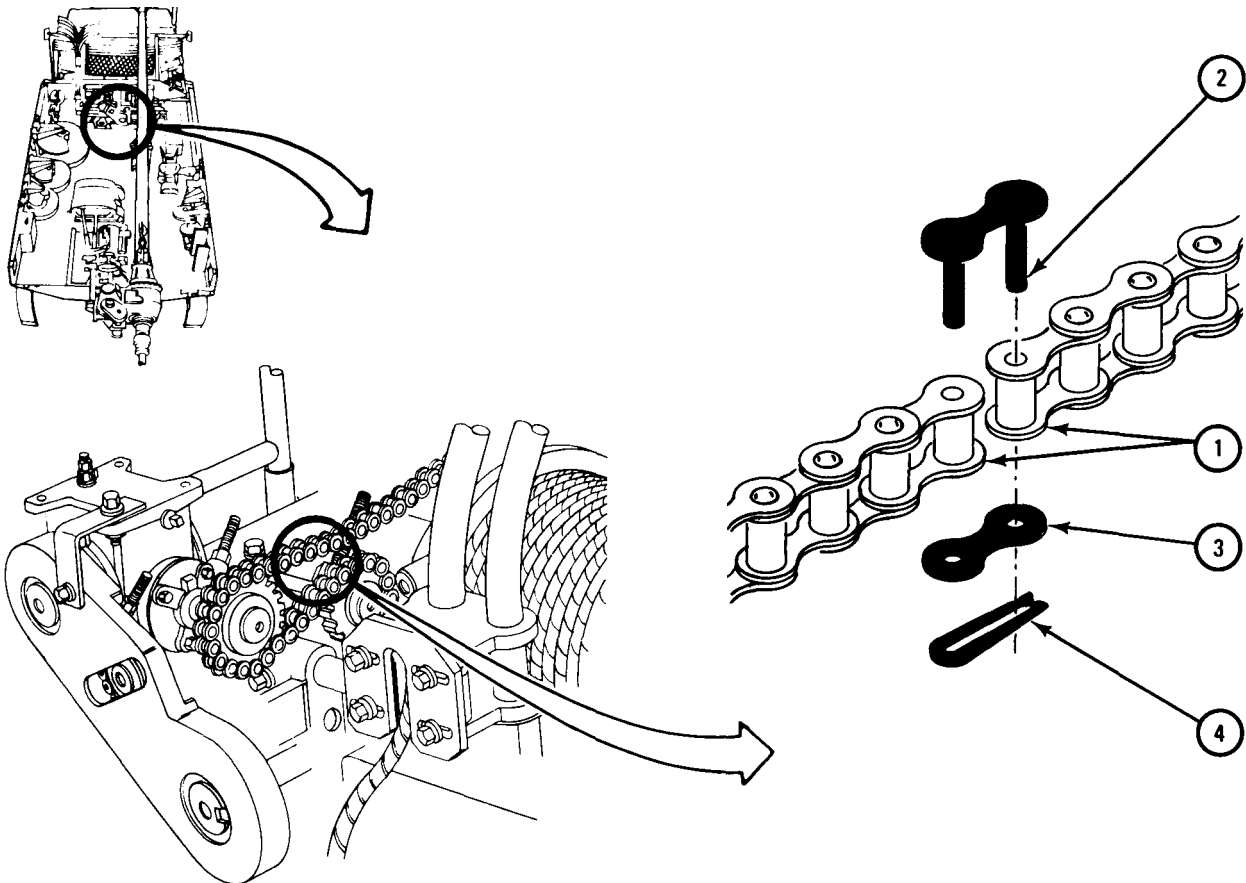

TA 080881

FRAME 2

1. Put cover (1) in place.
2. Using 1/2-inch wrench, screw in and tighten screw with flat washer (2).
3. Put flat washers (3) in place.
4. Using 9/16-inch wrench, screw in and tighten screw (4).

END OF TASK

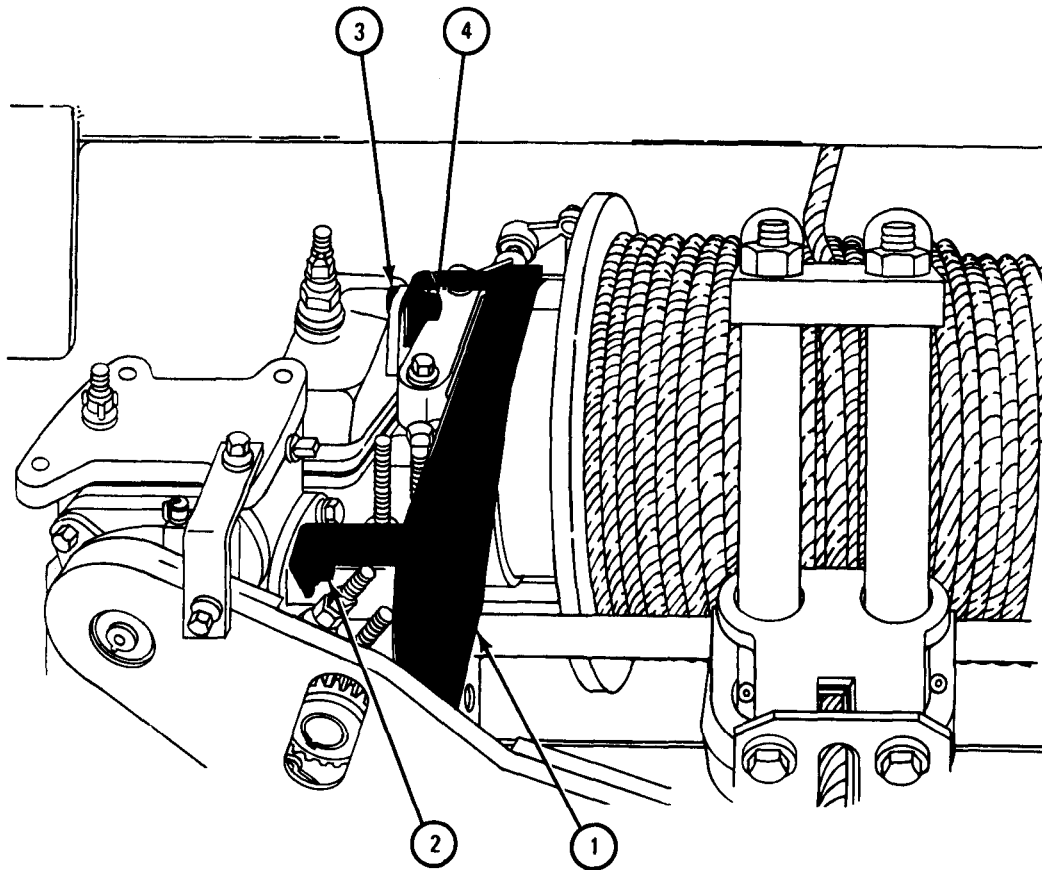

TA 080882

(2) Second reduction drive chain.

FRAME 1

1. Put chain (1) in place.
2. Put detachable link (2) through ends of chain (1).
3. Put keeper (3) in place and put on clip (4).
4. Adjust second reduction drive chain. Refer to para 19-18.

GO TO FRAME 2

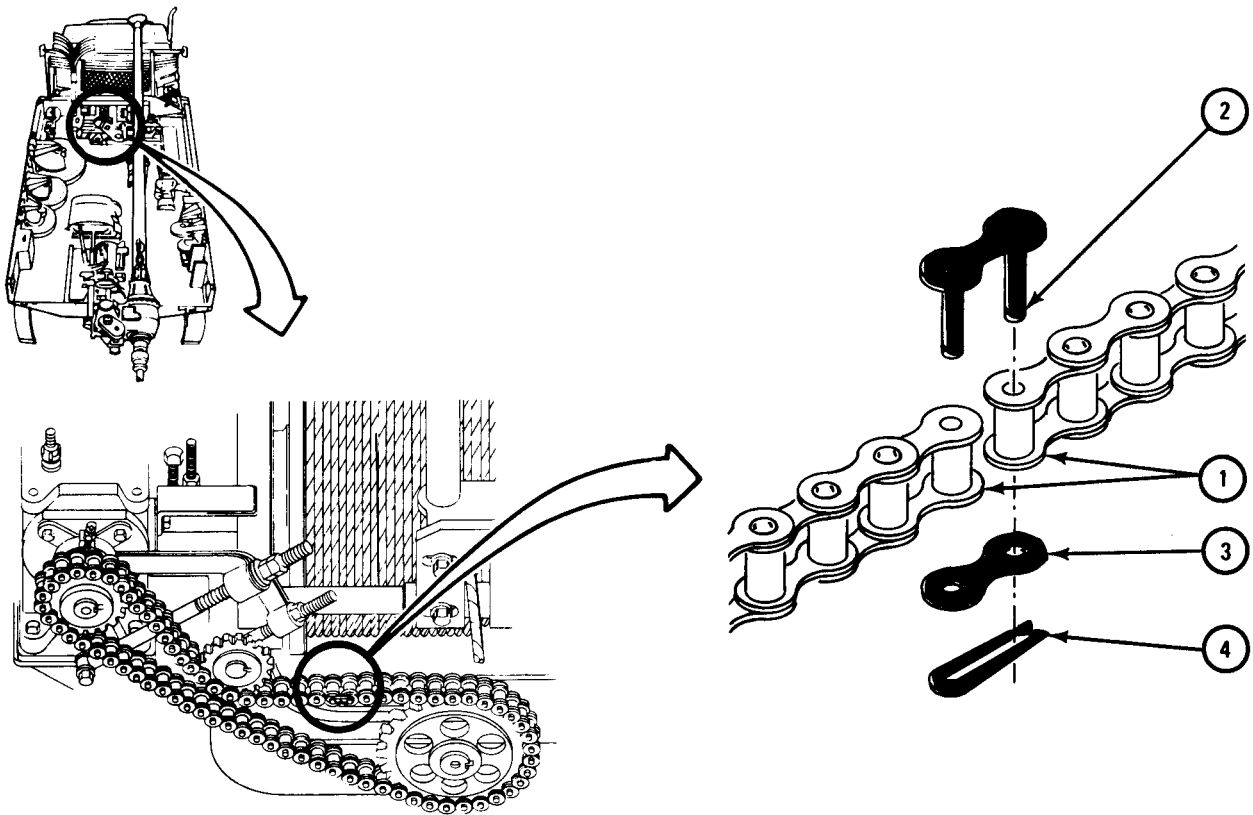

TA 080886

FRAME 2

1. Put cover (1) in place.
2. Using 1/2-inch wrench, screw in and tighten screw and washer (2).
3. Using 1/2-inch wrenches, screw in and tighten screw and washer (3) and nut (4).

END OF TASK

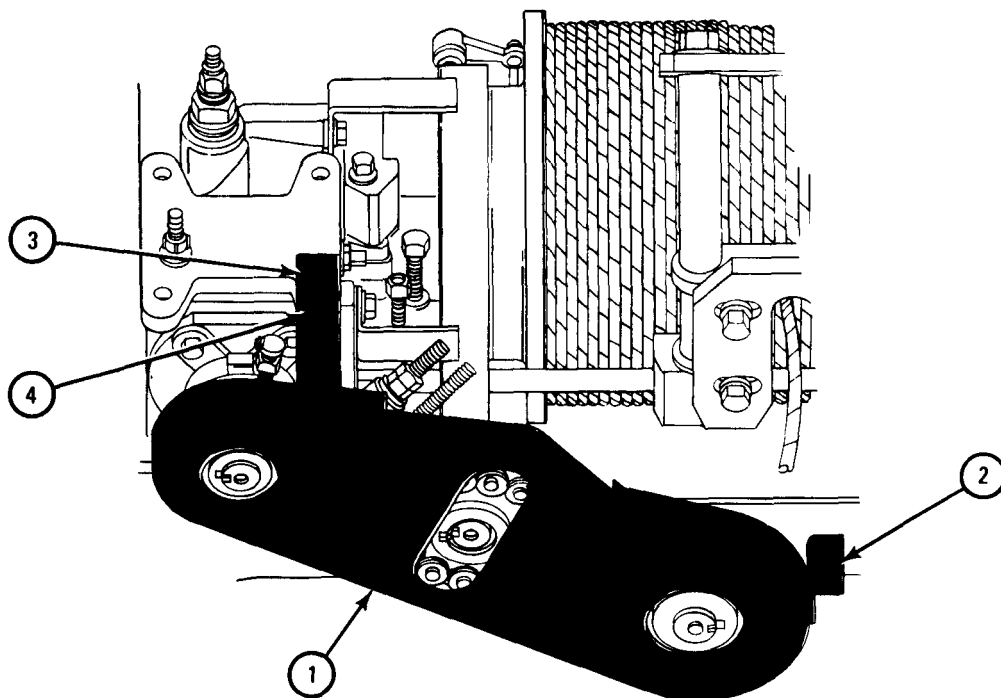

TA 080887

19-18. REDUCTION DRIVE CHAINS ADJUSTMENT (TRUCK M764).

TOOLS: 9/16-inch wrench
1/2-inch wrench (2)
3/4-inch wrench
6-inch ruler
18-inch straight edge

SUPPLIES: None

PERSONNEL: One

EQUIPMENT CONDITION: Truck parked, engine off, handbrake set.

a. First Reduction Drive Chain.

FRAME 1

1. Using 9/16-inch wrench, unscrew and take out screw (1) and flat washers (2).
2. Using 1/2-inch wrench, unscrew and take out screw with flat washer (3).
3. Take off cover (4).

GO TO FRAME 2

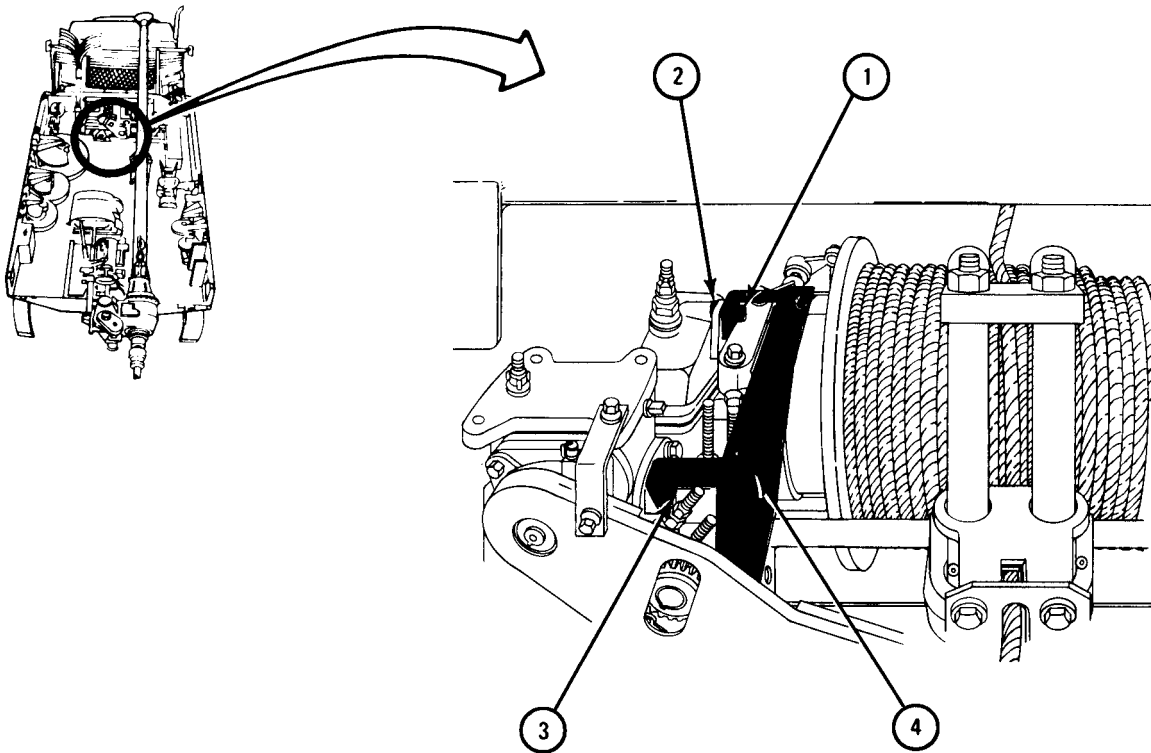

TA 080888

FRAME 2

1. Using 3/4-inch wrench, loosen locknut (1) on adjusting screw (2).
2. Hold straight edge along top of chain (3) as shown. Hold 6-inch ruler at midpoint of chain (3). Push down on top of chain and check that there is 1/2 inch of slack.
3. If there is less than 1/2 inch of slack, using 1/2-inch wrench, loosen adjusting screw (2). If there is more than 1/2 inch of slack, tighten adjusting screw.
4. When there is 1/2 inch of slack, using 1/2-inch wrench, hold adjusting screw (2). Using 3/4-inch wrench, tighten locknut (1).

GO TO FRAME 3

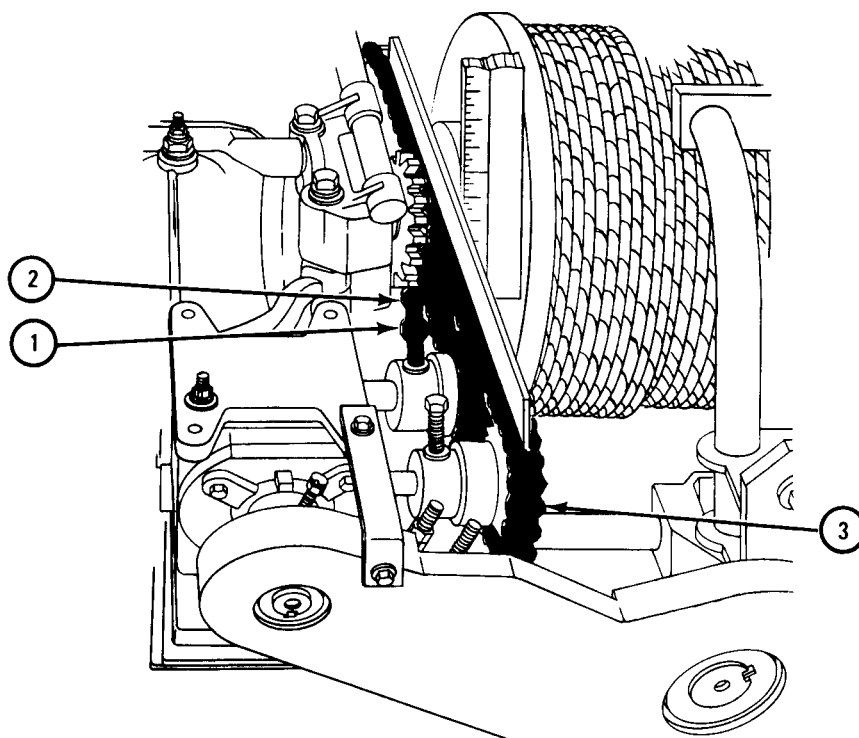

TA 080889

FRAME 3

1. Put cover (1) in place.
2. Using 1/2-inch wrench, screw in and tighten screw with flat washer (2).
3. Put flat washers (3) in place, and using 9/16-inch wrench, screw in and tighten screw (4).

END OF TASK

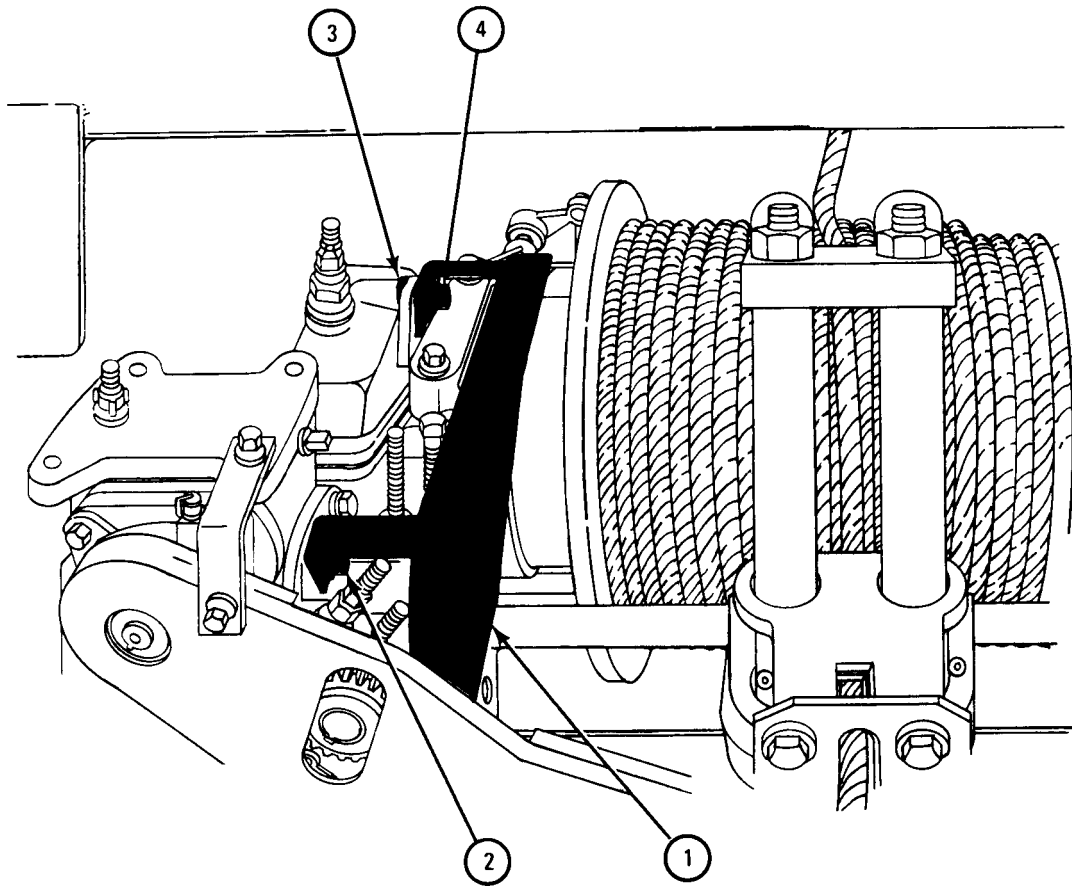

TA 080890

b. Second Reduction Drive Chain.

FRAME 1

1. Using 1/2-inch wrenches, unscrew and take out screw and washer (1) and nut (2).
2. Using 1/2-inch wrench, unscrew and take out screw and washer (3).
3. Take off cover (4).

GO TO FRAME 2

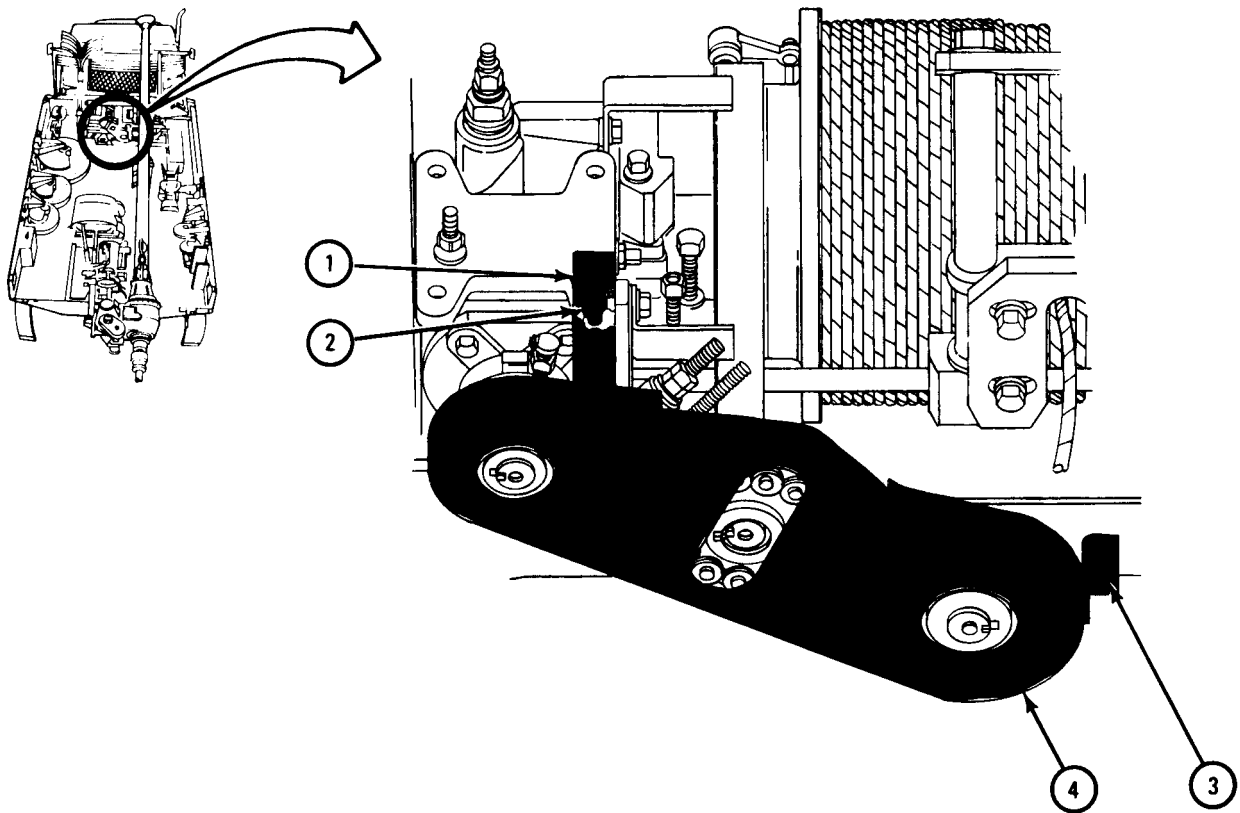

TA 080883

FRAME 2

1. Using 3/4-inch wrench, loosen locknut (1) on adjusting screw (2).
2. Hold straight edge along chain (3) as shown. Place 6-inch ruler at midpoint of chain (3) as shown. Push in bottom of chain and check that there is 1/2-inch of slack in chain.
3. If there is more than 1/2 inch of slack, tighten adjusting nut (4). If there is less than 1/2 inch of slack, loosen adjusting nut.
4. When there is 1/2 inch of slack, using 3/4-inch wrench, tighten locknut (1).

GO TO FRAME 3

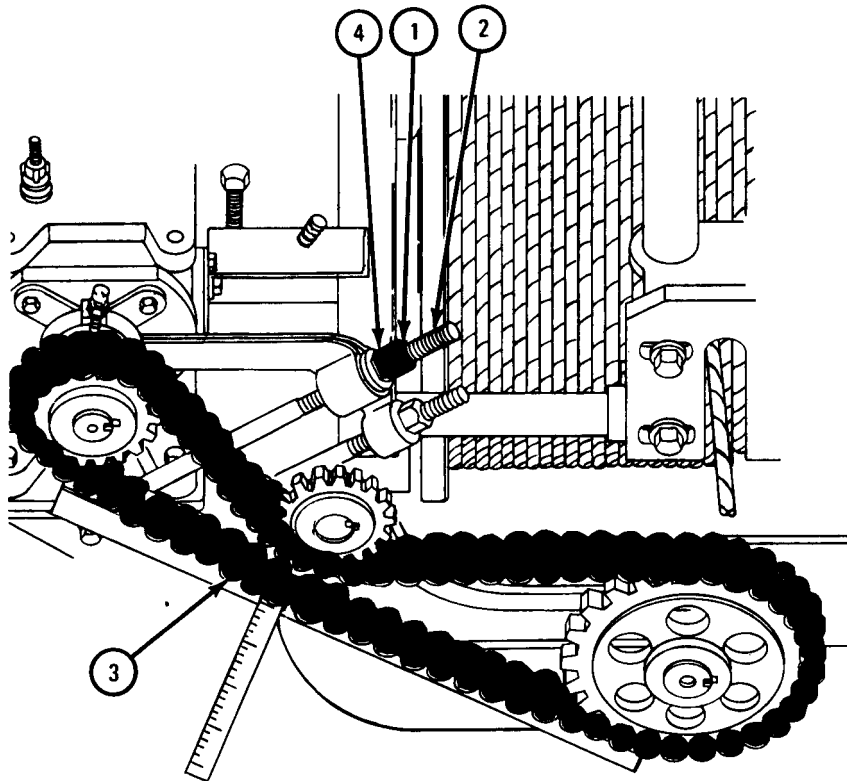

TA 080892

FRAME 3

1. Put cover (1) in place.
2. Using 1/2-inch wrench, screw in and tighten screw and washer (2).
3. Using 1/2-inch wrenches, screw in and tighten screw and washer (3) and nut (4).

END OF TASK

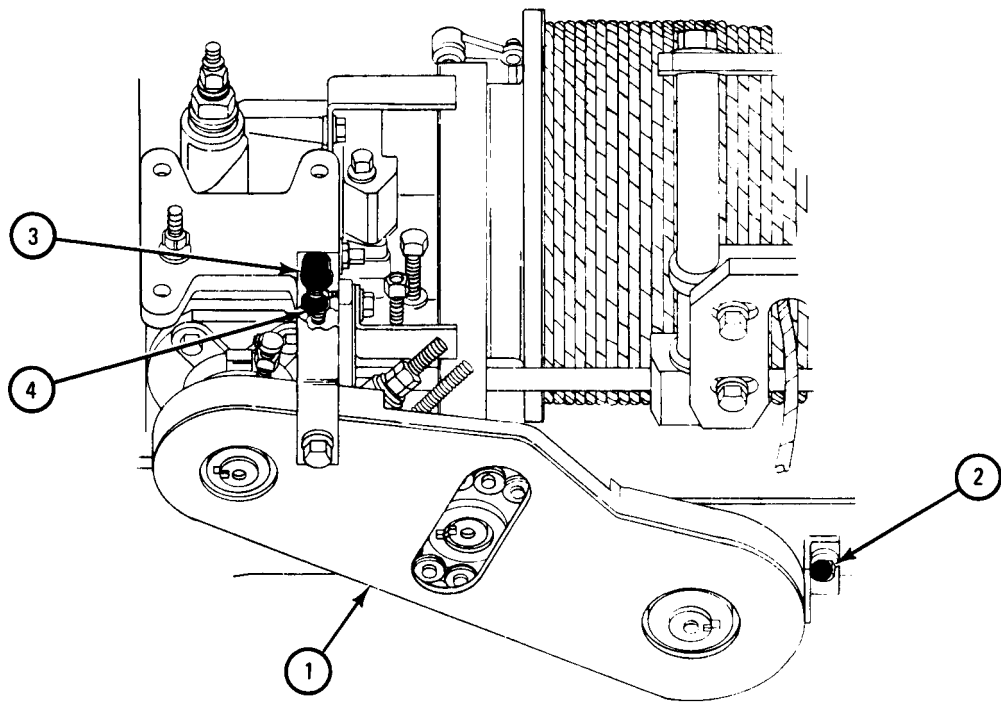

TA 080887

19-19. CABLE LEVEL WINDER DRIVE CHAINS REPAIR (TRUCK M764).

TOOLS: Grinder

SUPPLIES: Chain connecting link assembly

PERSONNEL: One

EQUIPMENT CONDITION: Truck parked, engine off, handbrake set.

a. Preliminary Procedure. Remove drive chain to be repaired. Refer to para 19-15.

b. Repair.

FRAME 1

WARNING

Eye shields must be worn when using grinder. Eye injury can occur if eye shields are not used.

1. Using grinder, grind off riveted ends of link pins (1) on any link found to be damaged. Take off keeper (2) and link (3).
2. Put connecting link (4) through both ends of chain (5).
3. Put on keeper (6) and clip (7).

NOTE

Follow-on Maintenance Action Required:
Replace drive chain. Refer to para 19-15.

END OF TASK

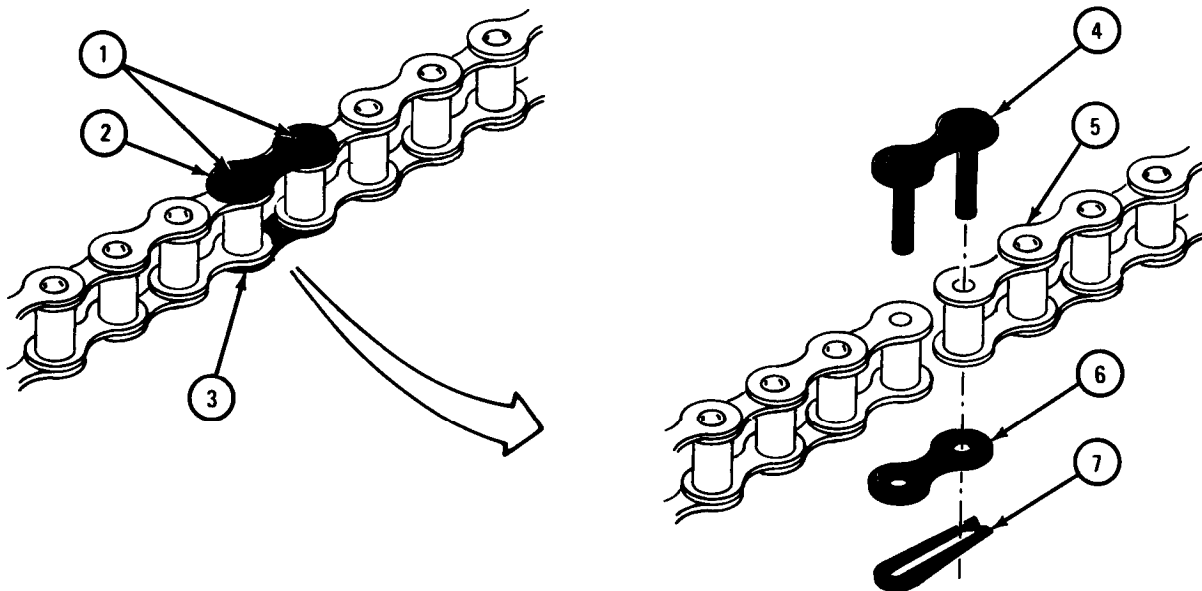

TA 080934

19-20 OUTRIGGER PUMP DRIVE SHAFT UNIVERSAL JOINT ASSEMBLY REMOVAL
AND REPLACEMENT (TRUCK M764).

TOOLS: 9/16-inch combination wrench (2)
3/32-inch sockethead screw key (Allen wrencher equivalent)
Snapping pliers
Ballpeen hammer

SUPPLIES: Artillery and automotive grease, type GAA, MIL-G-10924

PERSONNEL: Two

EQUIPMENT CONDITION: Truck parked, engine off, handbrake set, wheels
chocked.

a. Removal.

FRAME 1

- Soldier A 1. Using allen wrench, loosen two setscrews (1).
- Soldier B 2. Hold pump (2) so it will not fall when soldier A works on it.
- Soldier A 3. Using wrenches, unscrew and take out four screws (3) and nuts (4).
4. Hold universal joint (5).
- Soldier B 5. Pull pump (2) out of universal joint (5).
- Soldier A 6. Take universal joint (5) off shaft (6). Using ballpeen hammer and brass drift, tap out two keys (7).
- Soldier B 7. Put pump (2) back in place, alining hole for one screw (3).
- Soldier A 8. Using wrenches, screw in and tighten one screw (3) and nut (4) to hold pump (2).

GO TO FRAME 2

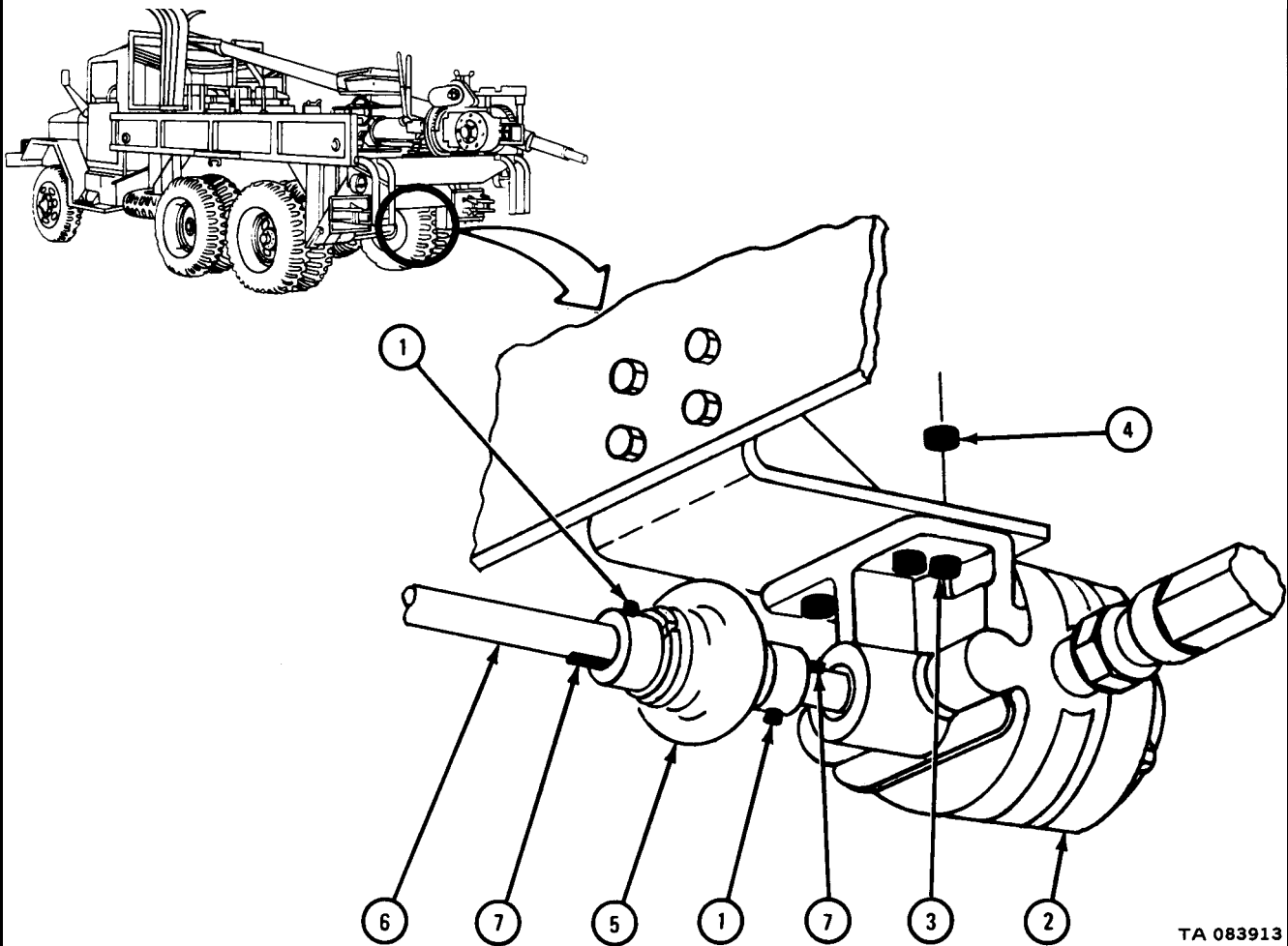

TA 083913

FRAME 2

1. Using allen wrench, loosen two setscrews (1).
2. Take shaft (2) out of universal joint (3). Take out universal joint. Using ballpeen hammer and brass drift, tap out two keys (4).

END OF TASK

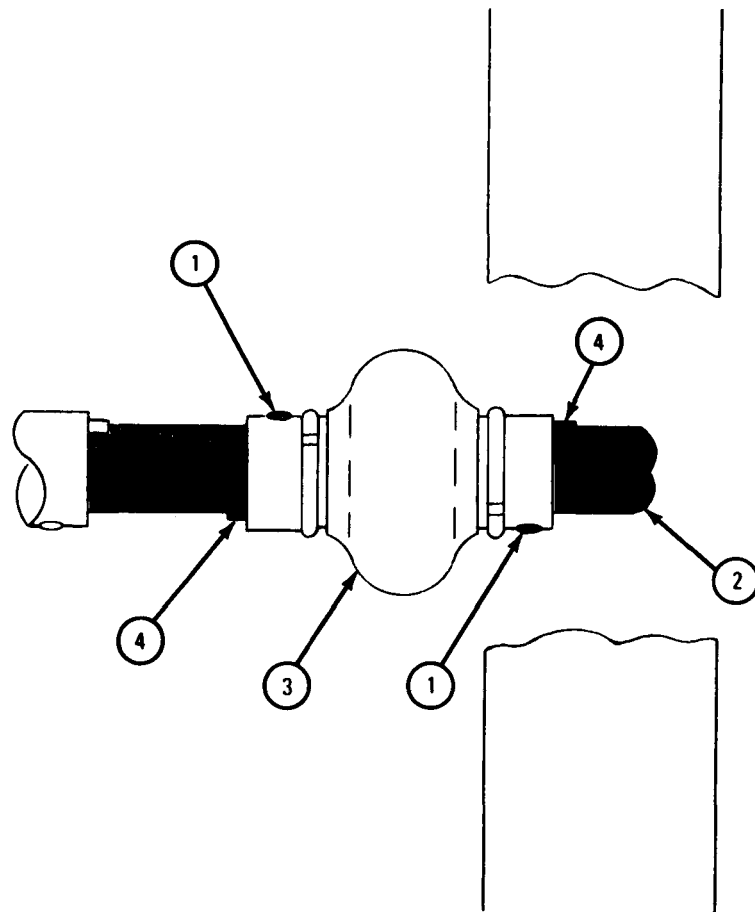

TA 083914

b. Replacement.

FRAME 1

1. Using snapping pliers, take off two snaprings (1). Take off boot (2).
2. Pack universal joint (3) with grease.
3. Put boot (2) onto universal joint (3).
4. Using snapping pliers, put on two snaprings (1).

GO TO FRAME 2

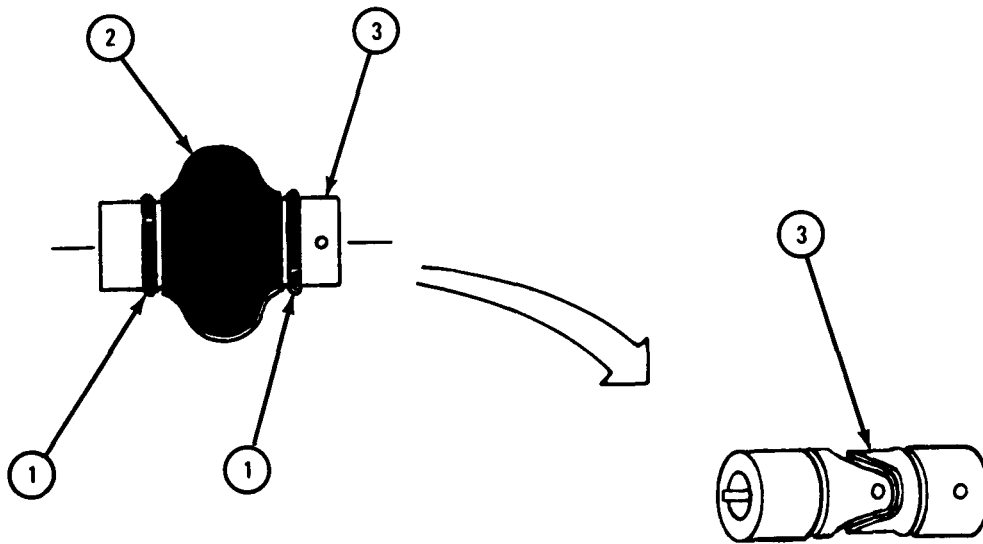

TA 083915

FRAME 2

1. Using ballpeen hammer and brass drift, tap key (1) in place. Put universal joint (2) onto shaft (3). Using allen wrench, tighten setscrew (4).
2. Using ballpeen hammer and brass drift, tap key (5) in place. Put shaft (6) into universal joint (2). Using allen wrench, tighten setscrew (7).

GO TO FRAME 3

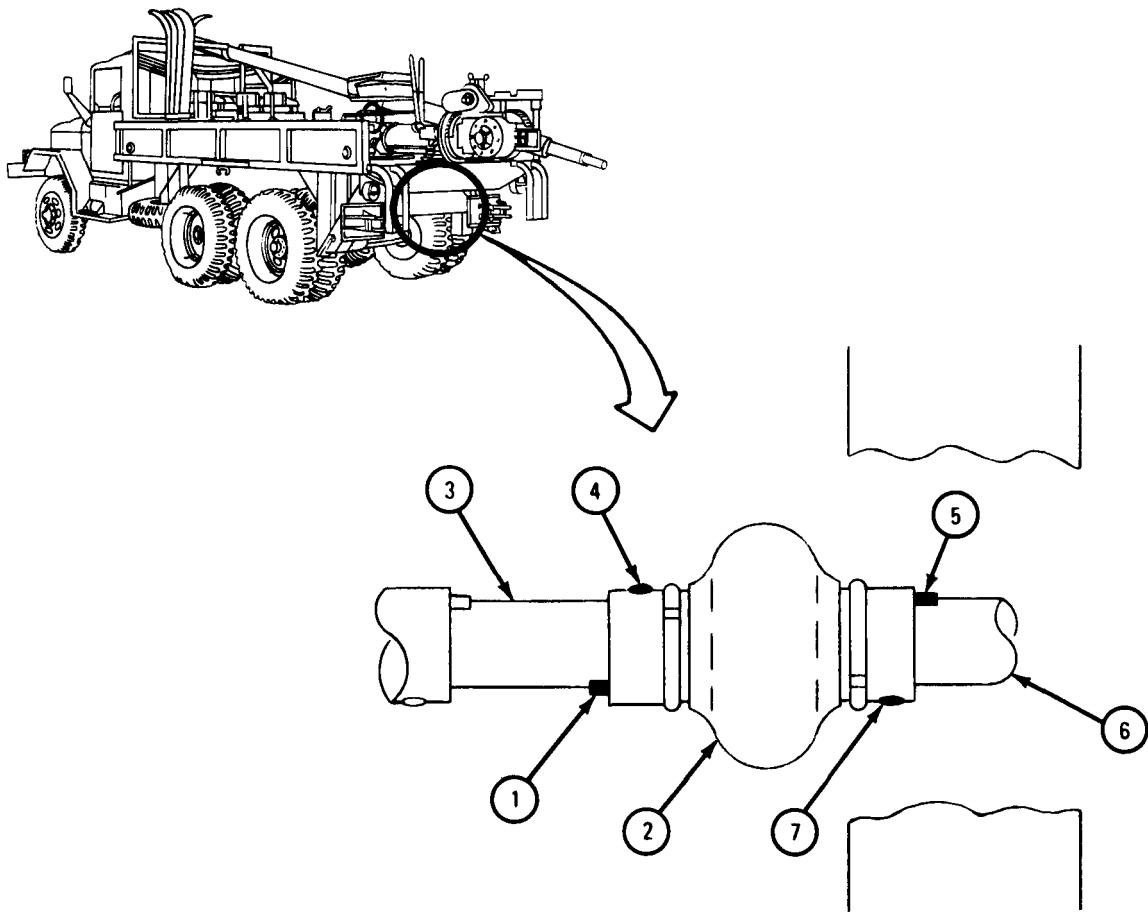

TA 083916

FRAME 3

- Soldier A 1. Using ballpeen hammer and brass drift, tap key (1) in place.
Put universal joint (2) onto shaft (3). Using allen wrench, tighten setscrew (4).
- Soldier B 2. Hold pump (5) so it will not fall down when soldier A works on it.
- Soldier A 3. Using wrenches, unscrew and take out screw (6) and nut (7).
4. Using ballpeen hammer and brass drift, tap in key (8).
- Soldier B 5. Put shaft of pump (5) into universal joint (2). Aline holes for four screws (6).
- Soldier A 6. Using wrenches, screw in and tighten four screws (6) and nuts (7).
7. Using allen wrench, tighten setscrew (9).

END OF TASK

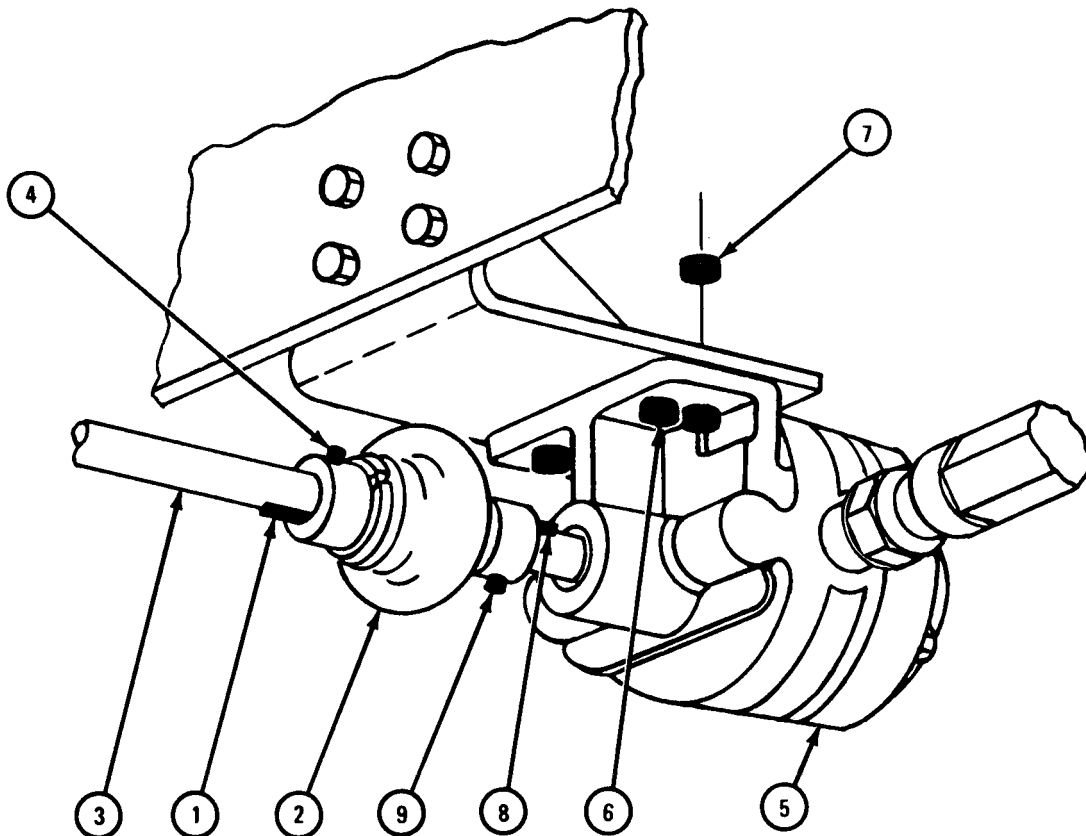

TA 083917

19-21. HYDRAULIC HOIST PUMP PROPELLER SHAFT REMOVAL, REPAIR, AND REPLACEMENT (TRUCK M342A2).

TOOLS: 3/8-inch open end wrench
Prybar
6-inch steel ruler

SUPPLIES: None

PERSONNEL: One

EQUIPMENT CONDITION: Truck parked, engine off, handbrake set.

a. Removal.

FRAME 1

1. Using 3/8-inch wrench, unscrew and take out setscrew (1).
2. Put prybar between yoke (2) and hydraulic hoist pump (3) as shown and pry yoke off hydraulic hoist pump. Pull propeller shaft (4) out of universal joint yoke (5).

GO TO FRAME 2

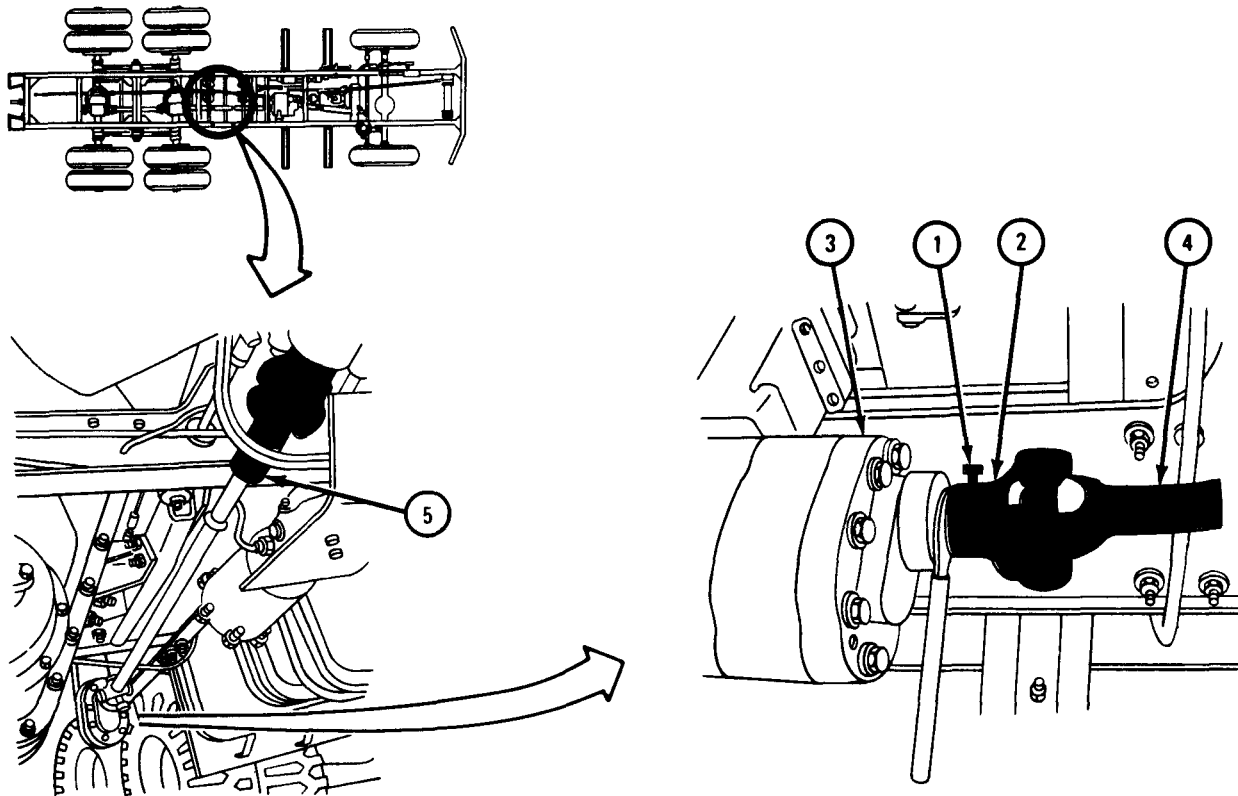

TA 084003

FRAME 2

1. Using 3/8-inch wrench, unscrew and take out setscrew (1).
2. Put prybar between universal joint yoke (2) and power takeoff (3) as shown and pry off universal joint yoke. Take universal joint yoke out from under truck.

END OF TASK

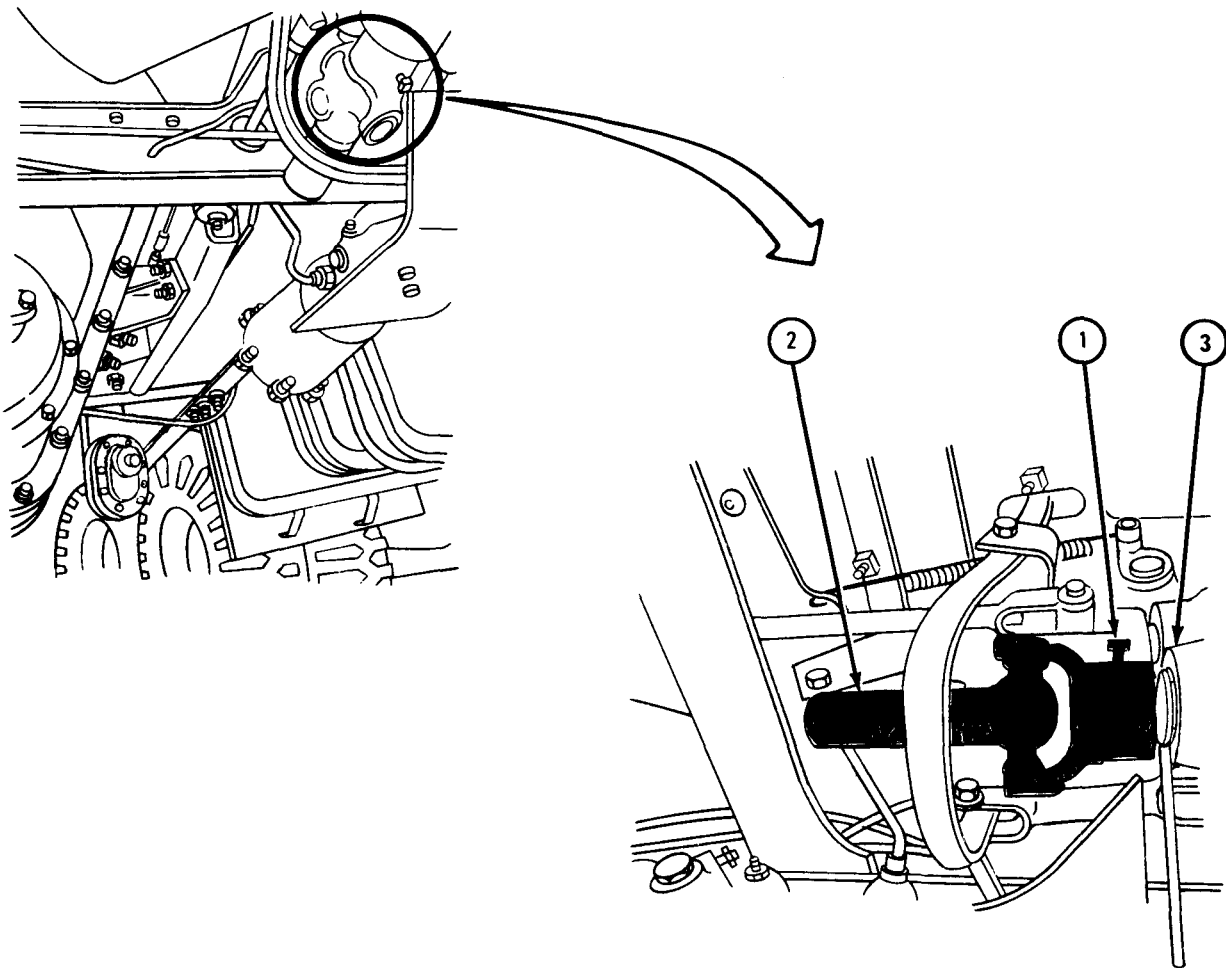

TA 084004

b. Repair

FRAME 1

1. Check that propeller shaft (1) and universal joint yokes (2, 3, 4, and 5) are not bent or cracked. If damaged, get new parts.
2. Check that universal joints (6 and 7) are not rusted, loose or broken. If damaged, do universal joint repair. Refer to Part 1, para 10-5.

END OF TASK

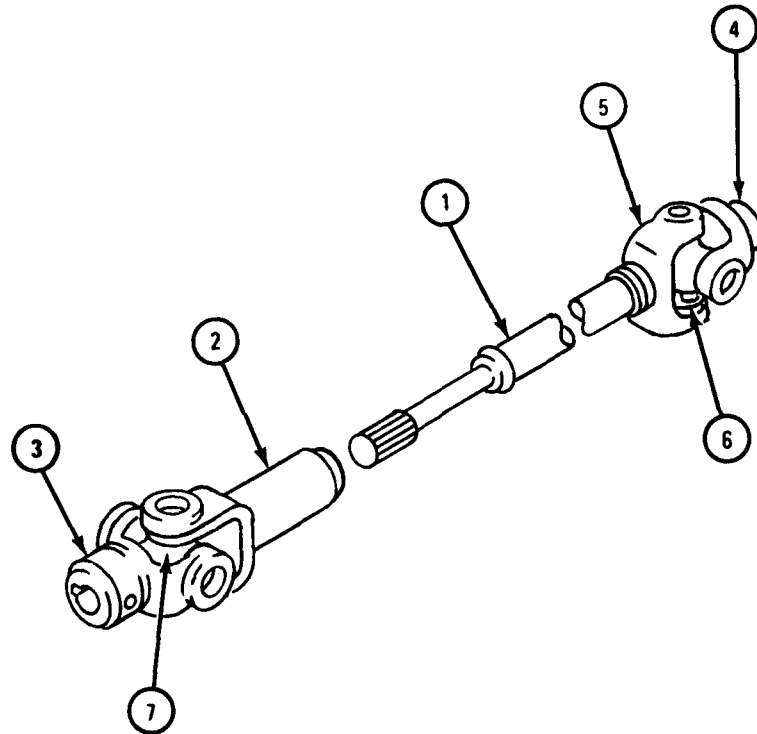

TA 084005

c. Replacement.

FRAME 1

1. Working under truck at power takeoff (1), align keyway in universal joint yoke (2) with woodruff key on power takeoff shaft (3).
2. Push universal joint yoke (2) on power takeoff shaft (3). Using ruler, leave 1/2 inch space between universal joint yoke and power takeoff (1).
3. Using 3/8-inch wrench, screw in and tighten setscrew (4).

GO TO FRAME 2

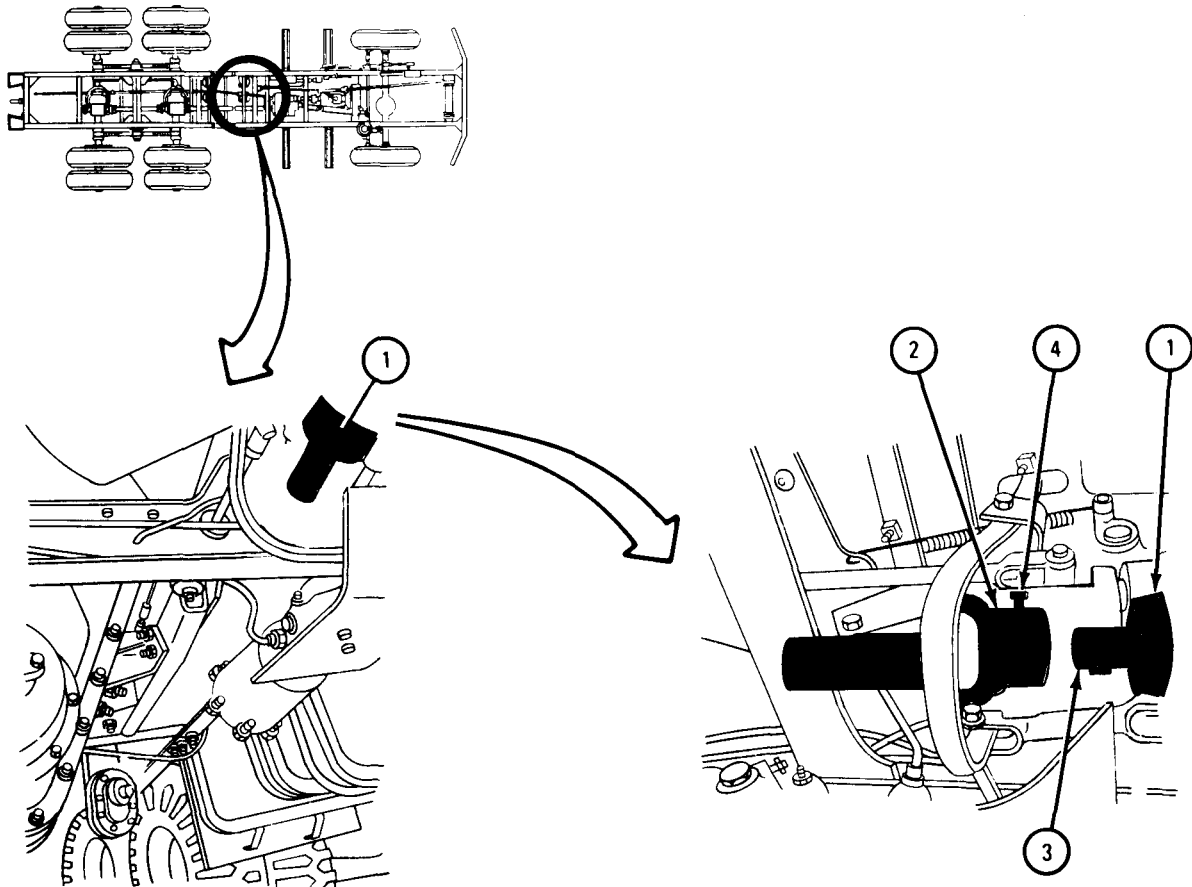

TA 084006

FRAME 2

1. Aline splines on driveshaft (1) with splines in universal joint yoke (2). Put propeller shaft into universal joint yoke.
2. Working at hydraulic hoist pump (3), aline keyway in universal joint yoke (4) with woodruff key on hydraulic hoist pump shaft (5).
3. Push universal joint yoke (4) on hydraulic hoist pump shaft (5). Using ruler, leave 1/2 inch space between universal joint yoke and hydraulic hoist pump (3).
4. Using 3/8-inch wrench, screw in and tighten setscrew (6).

NOTE

Follow-on Maintenance Action Required:

If universal joints were replaced, lubricate universal joints. Refer to LO 9-2320-209-12/1.

END OF TASK

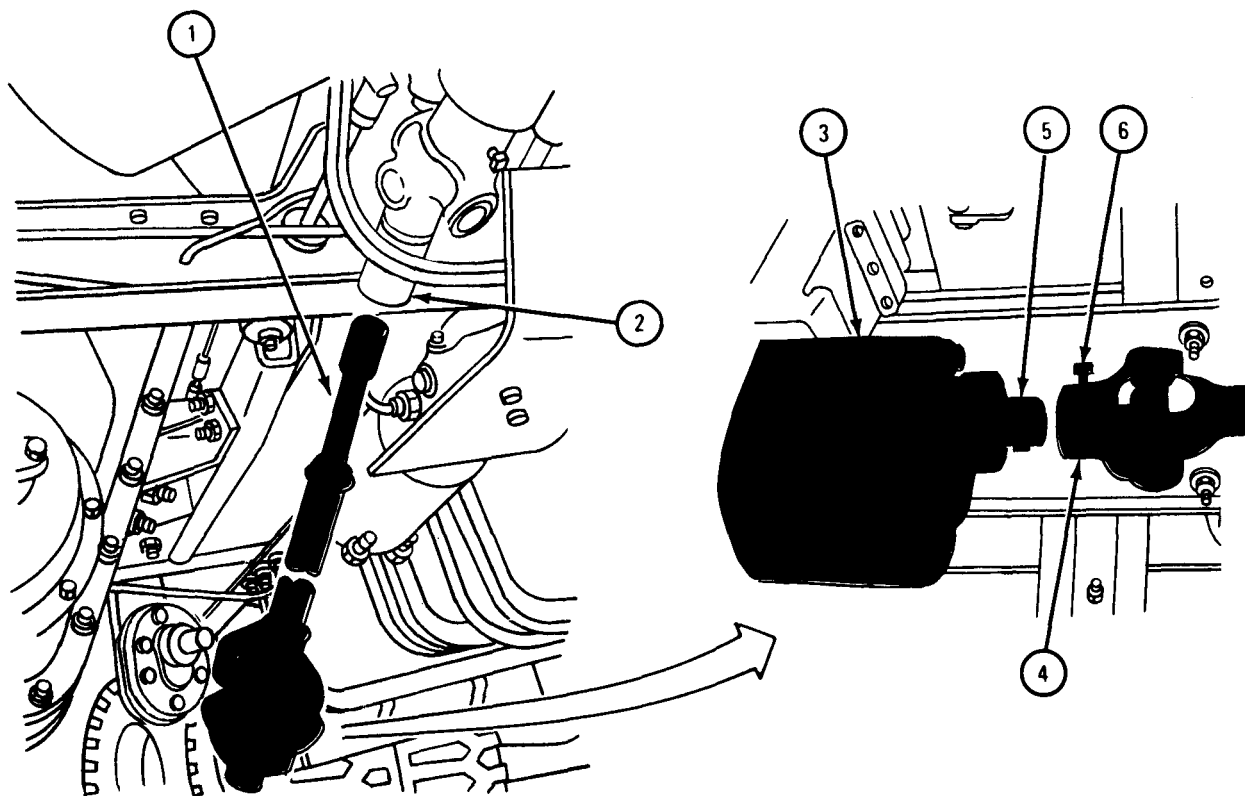

TA 084007

19-22. FLEXIBLE HYDRAULIC LINES REMOVAL AND REPLACEMENT (TRUCK M342A2).

TOOLS: 1 1/4-inch open end wrench
1 3/8-inch open end wrench (2)
One-gallon container

SUPPLIES: Tags

PERSONNEL: One

EQUIPMENT CONDITION: Truck parked, engine off, handbrake set.

WARNING

Never work under dump body unless safety braces are in place. Dump body could drop and personnel could be seriously injured.

a. Preliminary Procedure. Raise dump body and set safety braces. Refer to para 19-24.

b. Removal.

NOTE

Tag hydraulic lines and note the way they are routed so they can be put back in the right place.

FRAME 1

1. Start engine. Refer to TM 9-2320-209-10.

NOTE

When hoist control lever (1) is put into position B, dump body will stay up on safety braces.

2. Put safety lock (2) in OFF position.
3. Put hoist control lever (1) in position B and hold for at least one minute.
4. Put hoist control lever (1) in position A.
5. Stop engine. Refer to TM 9-2320-209-10.

GO TO FRAME 2

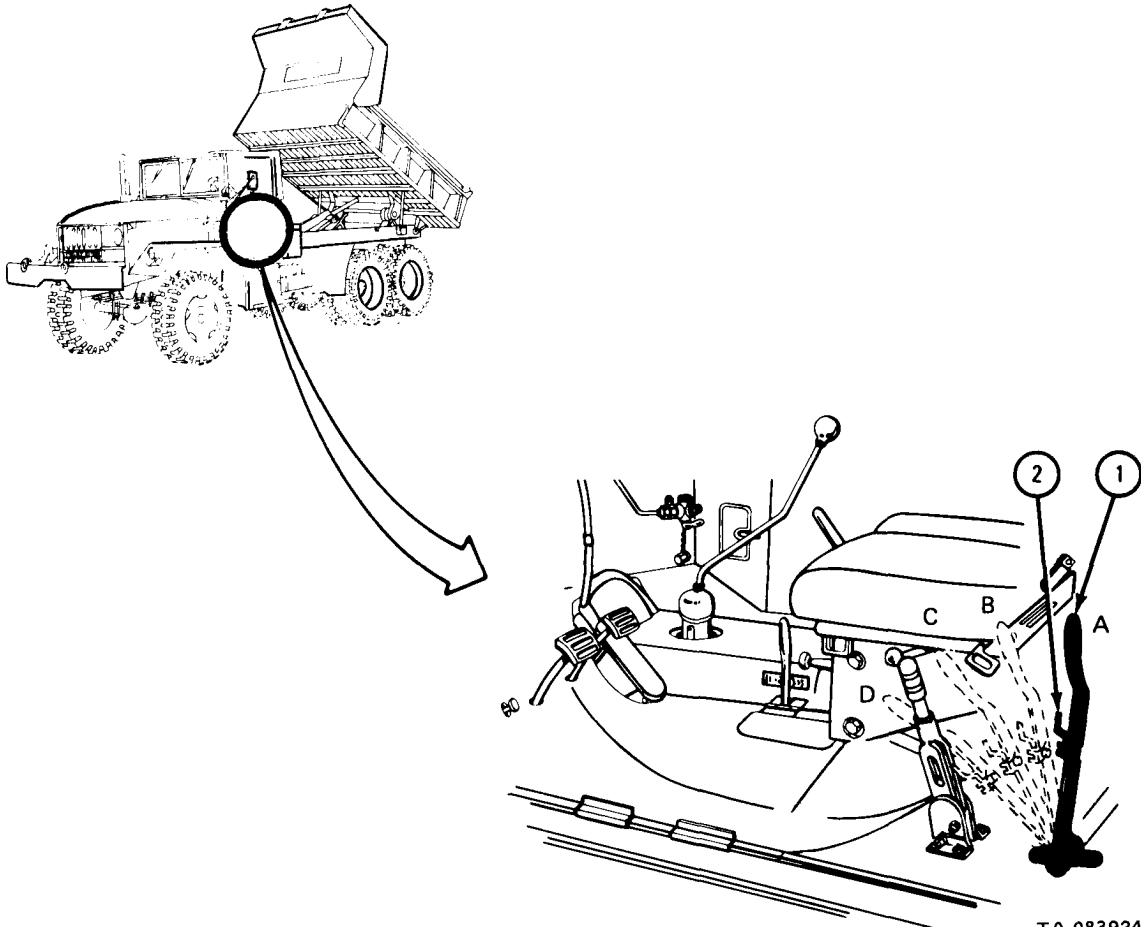

FRAME 2

1. Drain hydraulic oil reservoir. Refer to LO 9-2320-209-12/1.
2. Working under truck, put 1-gallon container under hose coupling nut (1).
3. Using 1 3/8-inch wrenches, hold four hose nuts (2). Using 1 1/4-inch wrench, unscrew four coupling nuts (1). Let hydraulic lines (3) drain into container.
4. Put hydraulic fluid in approved disposal area.

GO TO FRAME 3

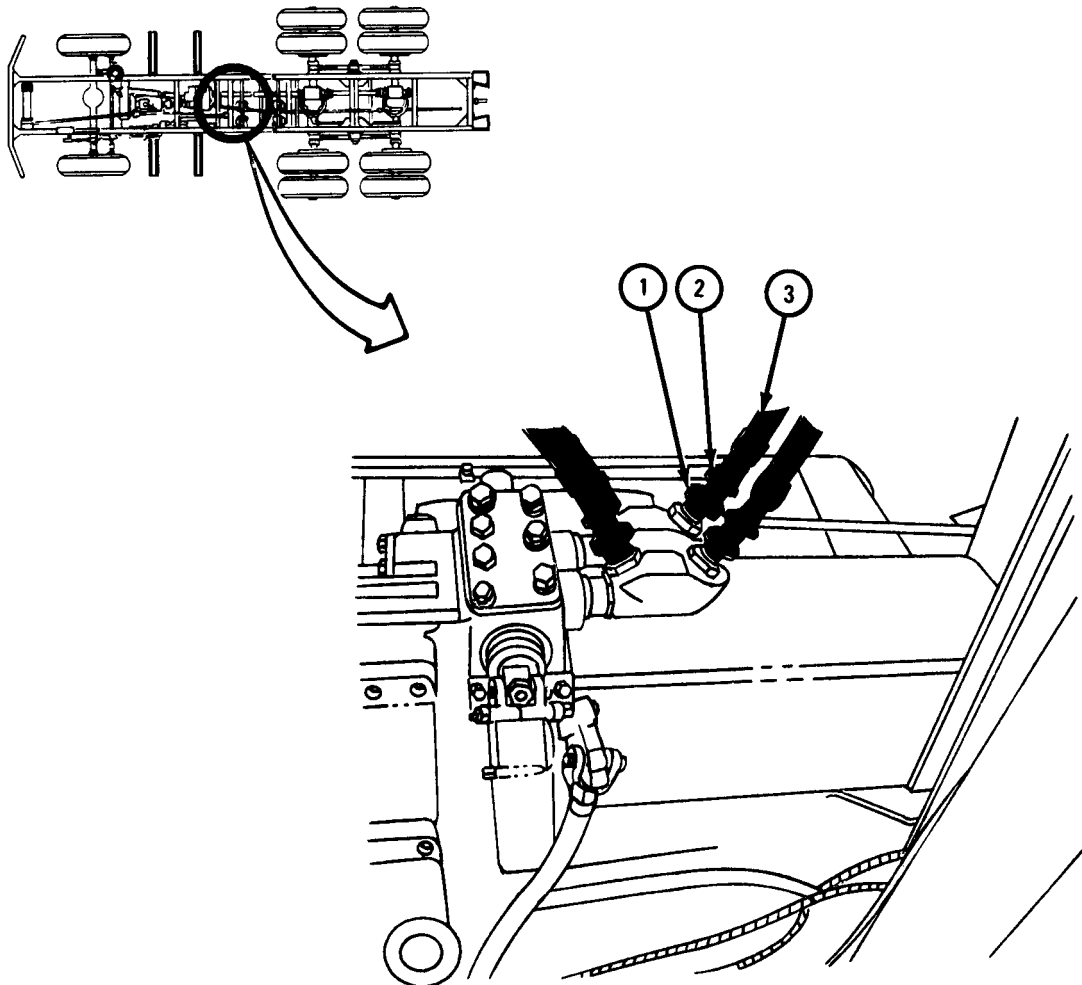

TA 083925

FRAME 3

NOTE

On some trucks there may be bushings instead of coupling nuts (1).

1. Working under truck and using 1 3/8-inch wrench, hold four hose nuts (2). Using 1 1/2-inch wrench, unscrew four coupling nuts (1). If truck has bushings, using 1 3/8-inch wrenches, hold bushings and unscrew four hose nuts.
2. Take off four hydraulic lines (3).

END OF TASK

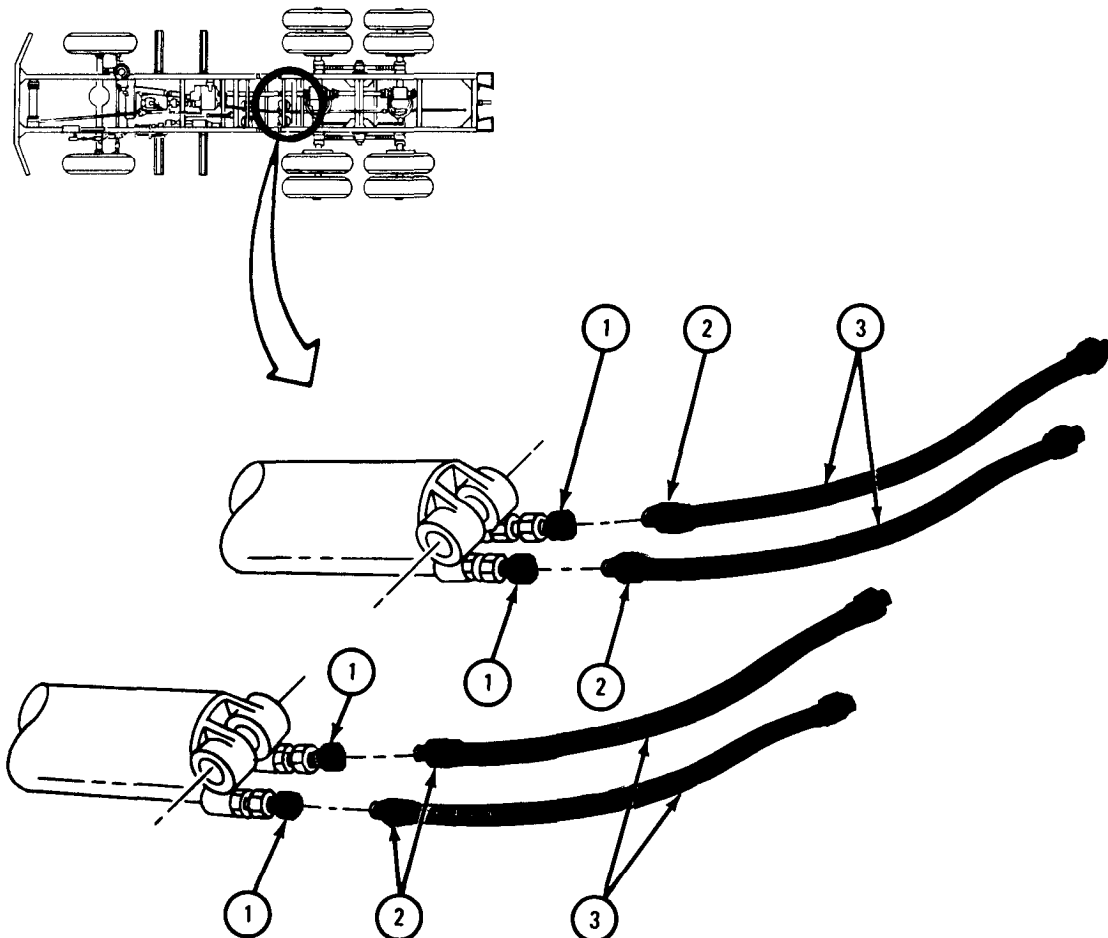

TA 083926

c. Replacement.

FRAME 1

NOTE

Bushings may be used instead of coupling nuts (1).

1. Screw on and finger tighten four coupling nuts (1) onto four hydraulic line hose nuts (2). If using bushings, finger tighten four hydraulic line hose nuts into bushings.

NOTE

If using old hydraulic lines (3), tighten coupling nuts (1) 1/8 turn.

If using new hydraulic lines, do not tighten coupling nuts more than two turns.

2. Using 1 3/8-inch wrenches, hold four hose nuts (2) and tighten four coupling nuts (1). If using bushings, using 1 3/8-inch wrenches, hold bushings and tighten four hose nuts into bushings.

GO TO FRAME 2

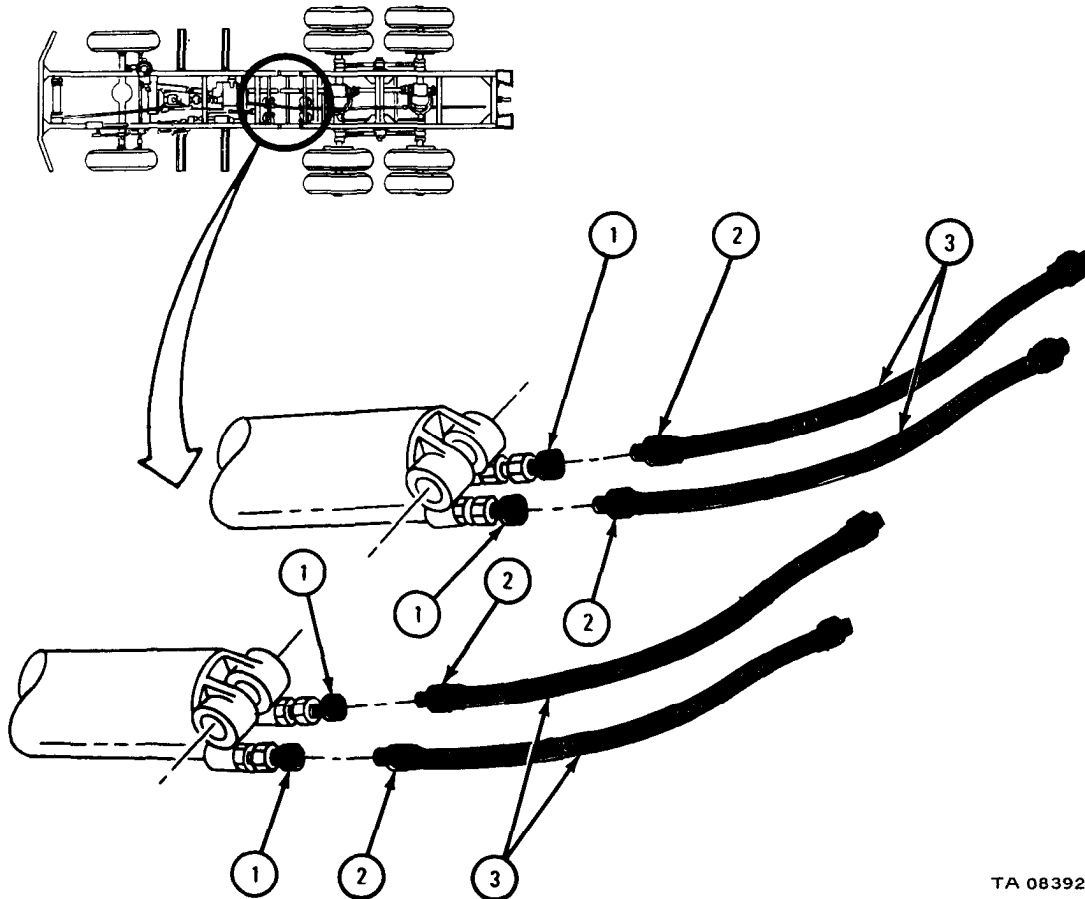

TA 083927

FRAME 2

1. Screw on and finger tighten four coupling nuts (1) onto four hydraulic line hose nuts (2) as tagged. Take off tags.

NOTE

If using old hydraulic lines (3), tighten coupling nuts (1) 1/8 turn.

If using new hydraulic lines, do not tighten coupling nuts more than two turns.

2. Using 1 3/8-inch wrenches, hold four hose nuts (2). Using 1 1/4-inch wrench, tighten four coupling nuts (1).

GO TO FRAME 3

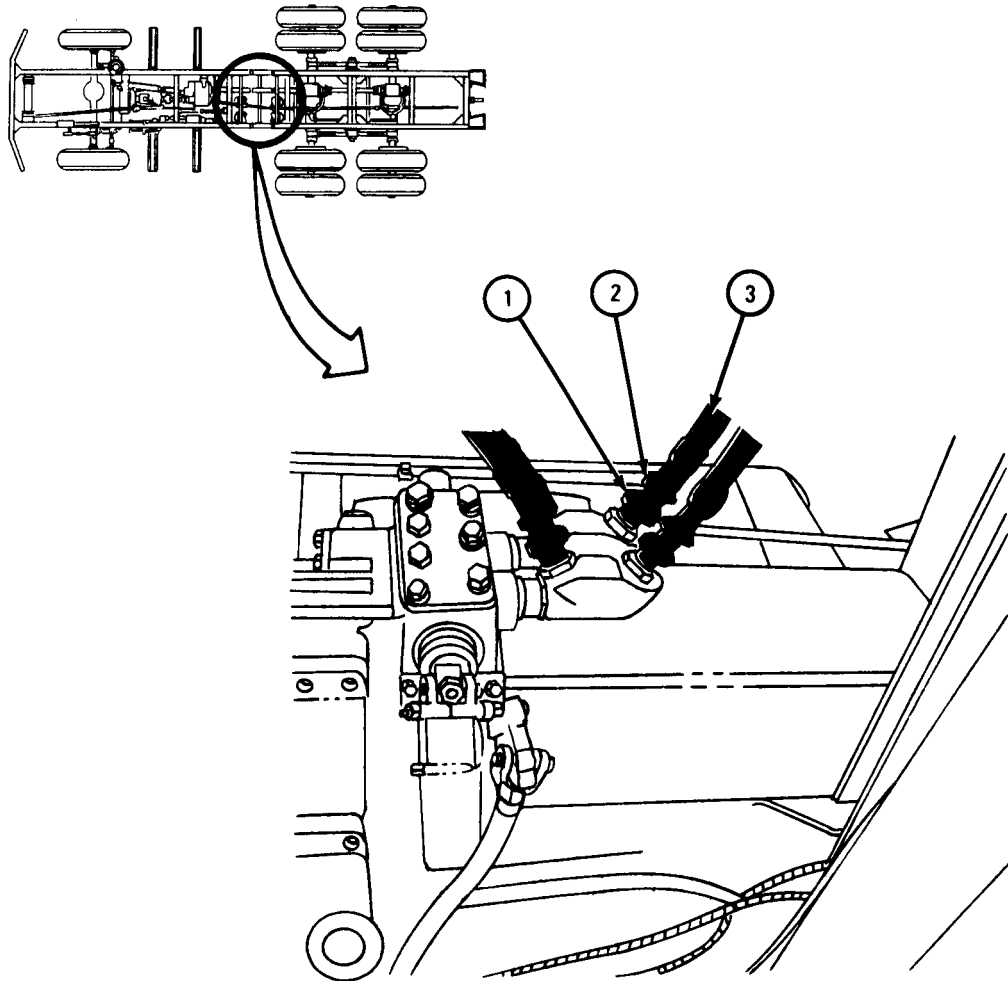

TA 083928

FRAME 3

1. Refill hydraulic oil reservoir. Refer to LO 9-2320-209-12/1.
2. Start engine. Refer to TM 9-2320-209-10.
3. Put hoist control lever (1) in position D to raise dump body. Lower safety braces. Refer to para 19-24.
4. Raise and lower dump body several times. Refer to TM 9-2320-209-10.
5. Check hydraulic lines for leaks. If hydraulic lines leak, tighten coupling nuts just enough to stop leaks. Refer to frames 1 and 2.
6. Do steps 4 and 5 again. If hydraulic lines still leak, tell direct support maintenance.

END OF TASK

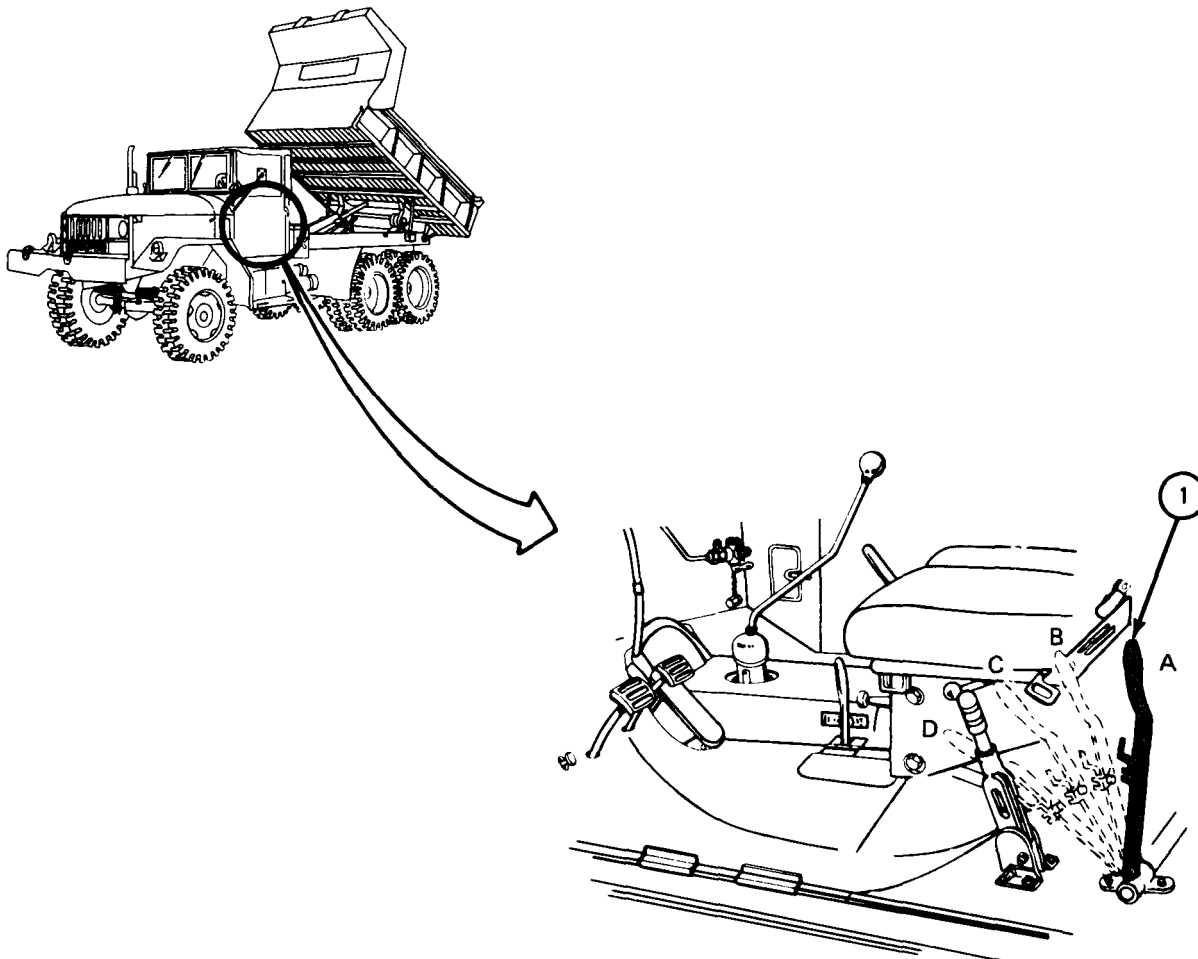

TA 083929

19-23. HYDRAULIC HOIST CONTROL LINKAGE REMOVAL, REPLACEMENT, AND ADJUSTMENT (TRUCK M342A2).

TOOLS: Pliers
9/16-inch wrench (2)
3/4-inch wrench
Adjustable wrench

SUPPLIES: None

PERSONNEL: Two

EQUIPMENT CONDITION: Truck parked, engine off, handbrake set.

a. Removal.

FRAME 1

1. Working under truck and using pliers, take out and throw away cotter pin (1). Take out clevis pin (2).
2. Take clevis (3) off lever (4). Pull out rod assembly (5).
3. Using pliers, take out cotter pin (6). Take out clevis pin (7).
4. Take clevis (8) off lever (9).

GO TO FRAME 2

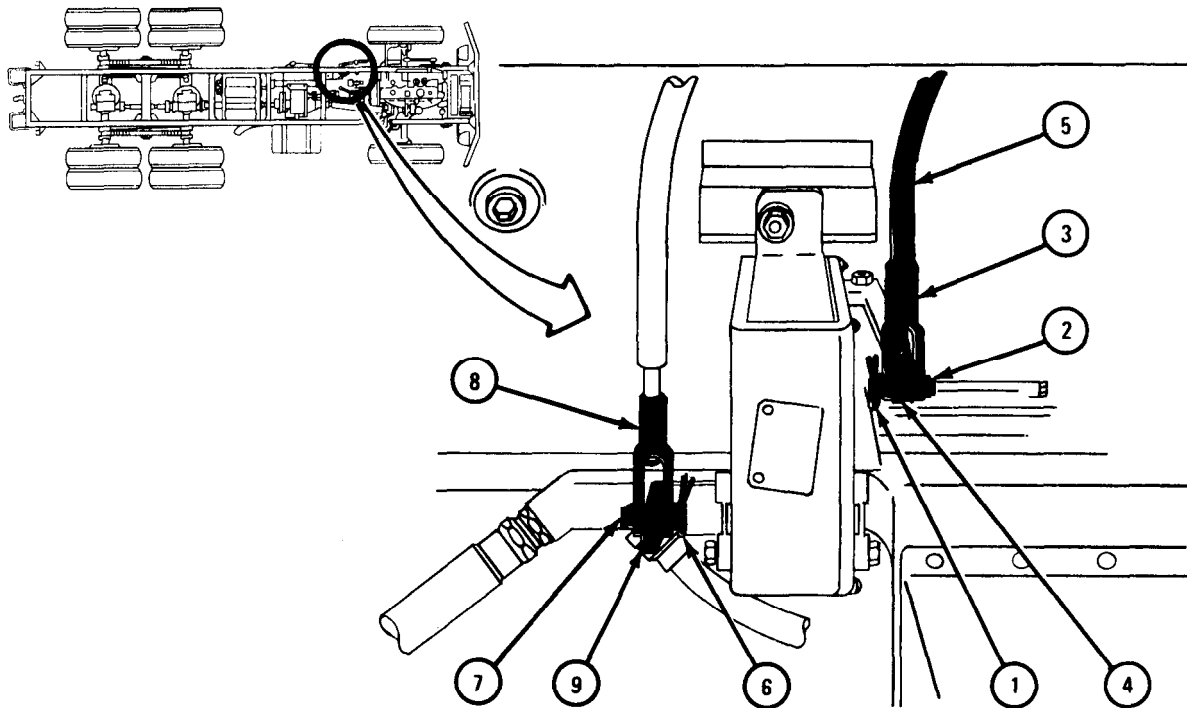

TA 083348

FRAME 2

1. Using pliers, take out and throw away cotter pin (1). Take out clevis pin (2) and take clevis (3) off power takeoff rod arm (4).
2. Using 3/4-inch wrench, loosen nut (5).
3. Using adjustable wrench, unscrew and take off clevis (3).
4. Using 3/4-inch wrench, if needed, unscrew and take off nut (5).

GO TO FRAME 3

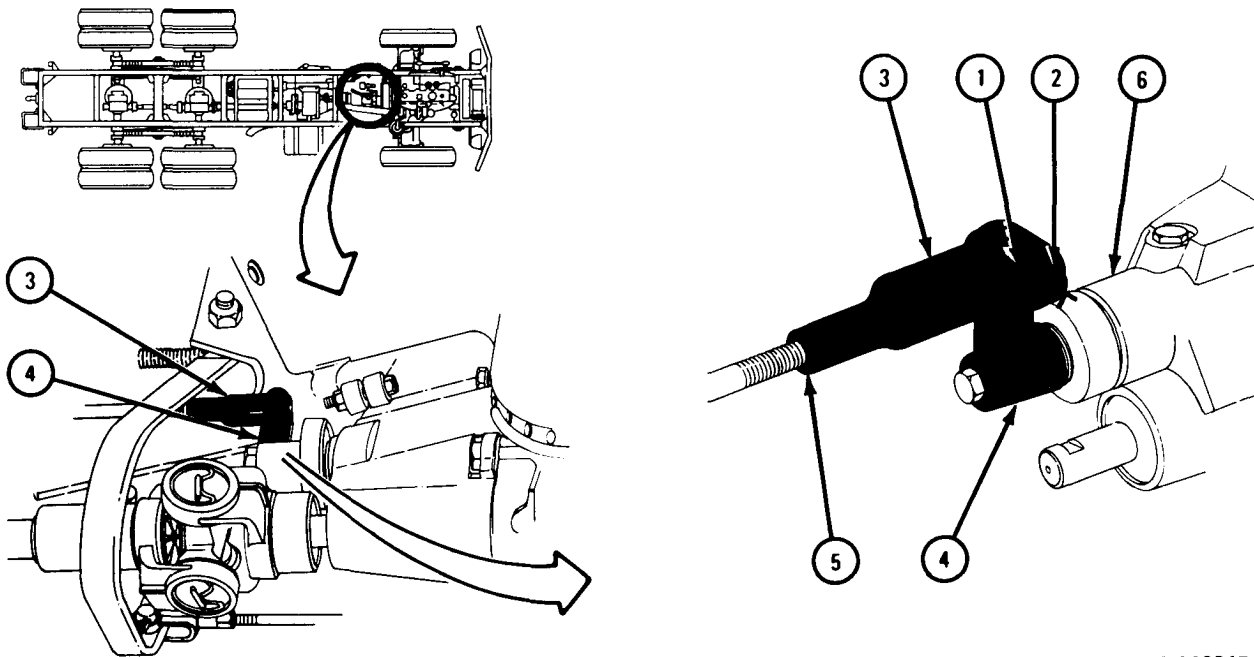

TA 083347

FRAME 3

- Soldier A 1. Working under truck and using pliers, take out and throw away cotter pin (1). Take out clevis pin (2).
2. Take clevis pin (3) off lever (4). Take rod (5) with clevis out of truck.
- Soldier B 3. Working in cab, put companion seat back (6) down.
4. Using 9/16-inch wrench, hold two screws (7) on each of two bearing brackets (8). Tell soldier A when ready.
- Soldier A 5. Using 9/16-inch wrench, unscrew and take off four nuts (9).
- Soldier B 6. Take out four screws (7). Take out control rod assembly (10) with lever (4) and two bearing brackets (8).

END OF TASK

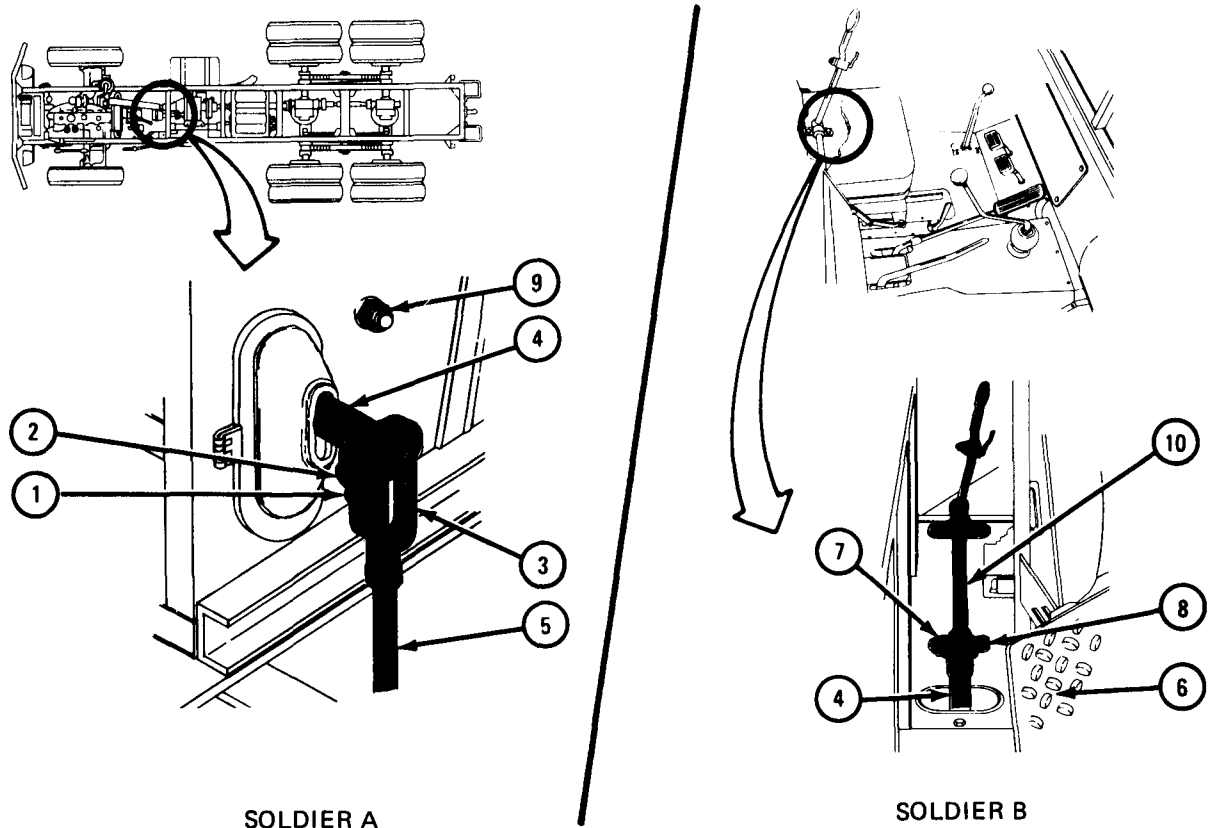

TA 083349

b. Replacement and Adjustment.

FRAME 1

1. Put clevis (1) on lever (2) and put clevis pin (3) through holes in clevis and lever.
2. Put cotter pin (4) through hole in clevis pin (3) and using pliers, bend open ends of cotter pin.
3. Put rod assembly (5) through hole in frame crossmember (6) as shown. Turn rod assembly so it is in position shown and put clevis (7) on lever (8).
4. Put clevis pin (9) through holes in clevis (7) and lever (8).
5. Put cotter pin (10) through hole in clevis pin (9) and using pliers, bend open ends of cotter pin.
6. Push lever (2) as far forward as it will go.

GO TO FRAME 2

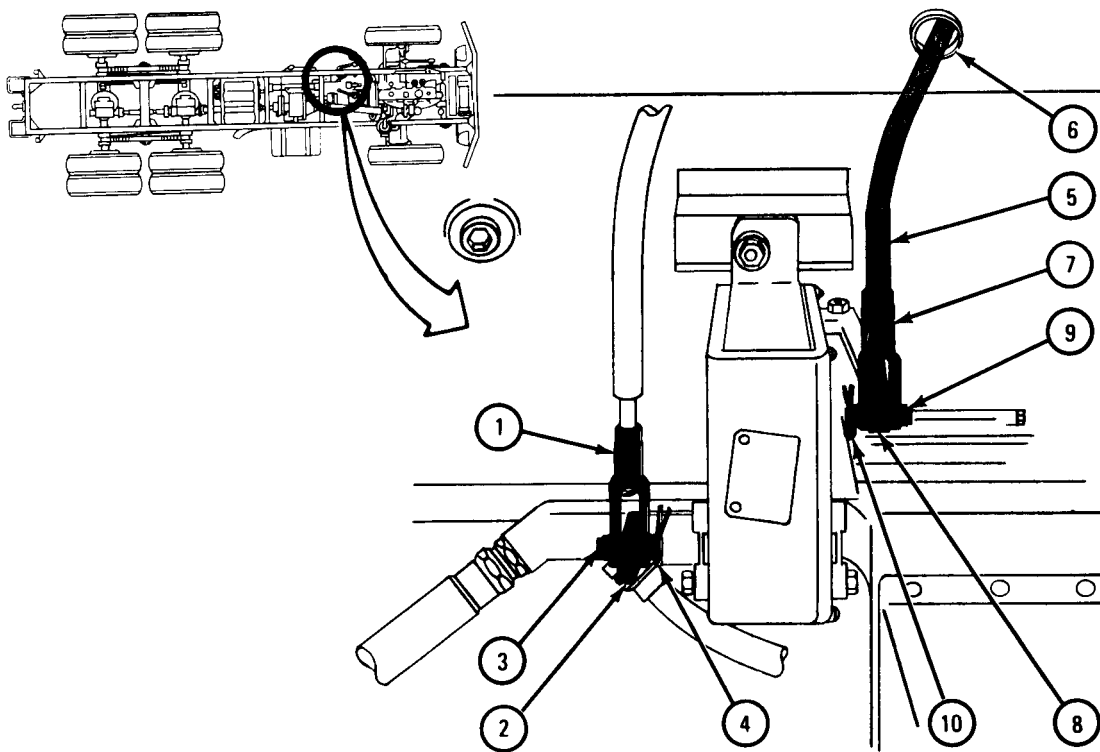

TA 083353

FRAME 2

1. Using 3/4-inch wrench, screw on nut (1) onto rod (2).
2. Using adjustable wrench, screw on clevis (3) until holes in clevis align with holes in arm (4). Using 3/4-inch wrench, tighten nut (1).
3. Put clevis pin (5) through holes in clevis (3) and arm (4). Using pliers, put cotter pin (6) through hole in clevis pin and bend open ends of cotter pin.

GO TO FRAME 3

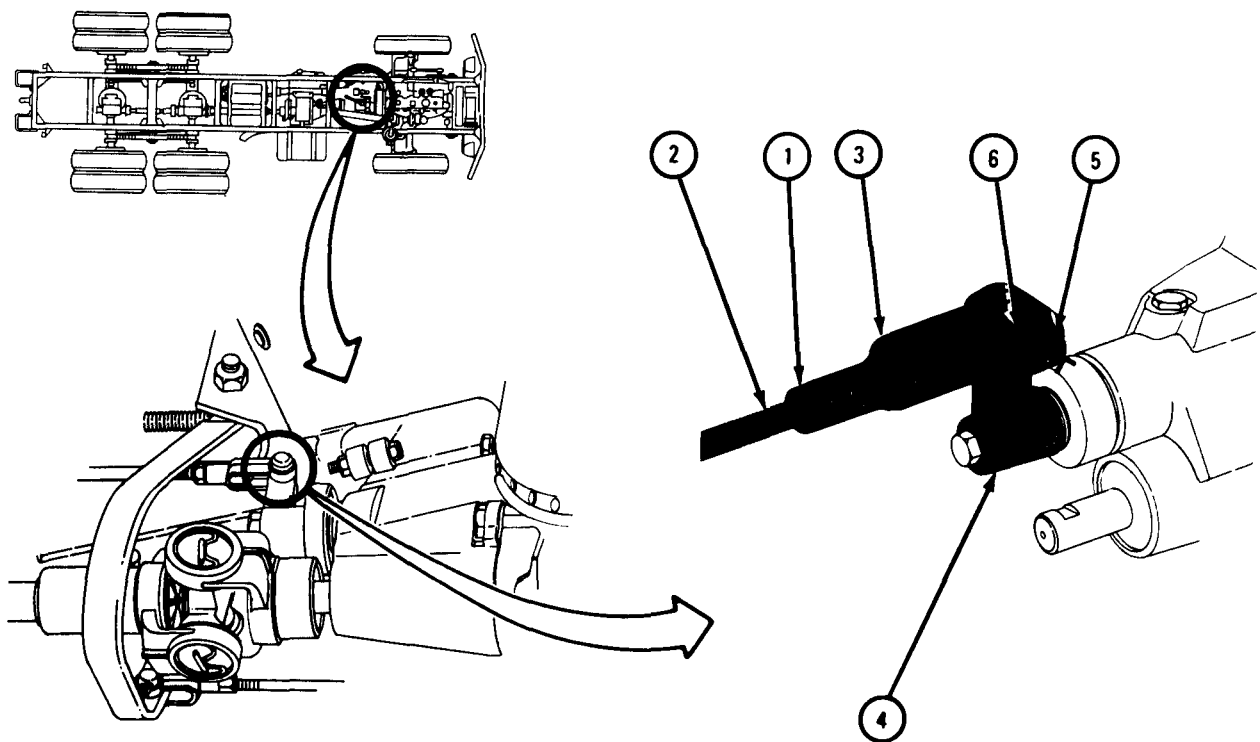

TA 083354

FRAME 4

- Soldier A
1. Put control rod assembly (1) with hoist control lever (2) through hole in cab floor. Put two bearing brackets (3) in place. Aline screw holes in bearing brackets with holes in cab floor (4).
 2. Put two screws (5) in each of two bearing brackets (3).
 3. Using 9/16-inch wrench, hold four screws (5). Tell soldier B when ready.
- Soldier B
4. Working under truck and using 9/16-inch wrench, screw on and tighten four nuts (6).
- Soldier A
5. Raise back of companion seat (7).
 6. Lock hoist control lever (2) in off position.

GO TO FRAME 4

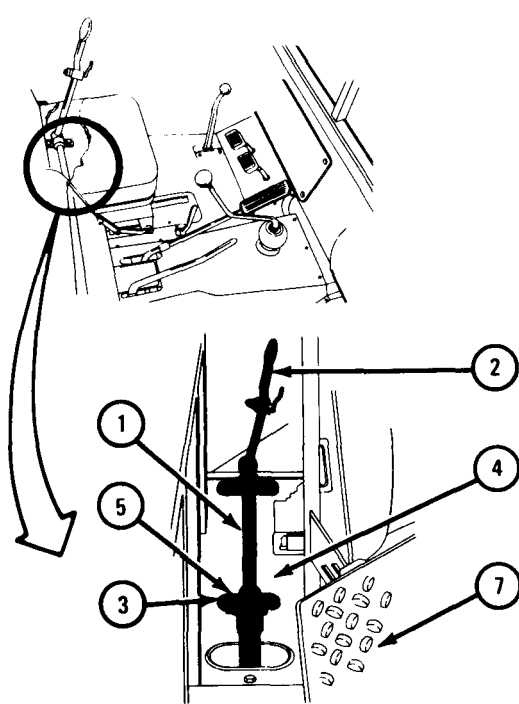

SOLDIER A

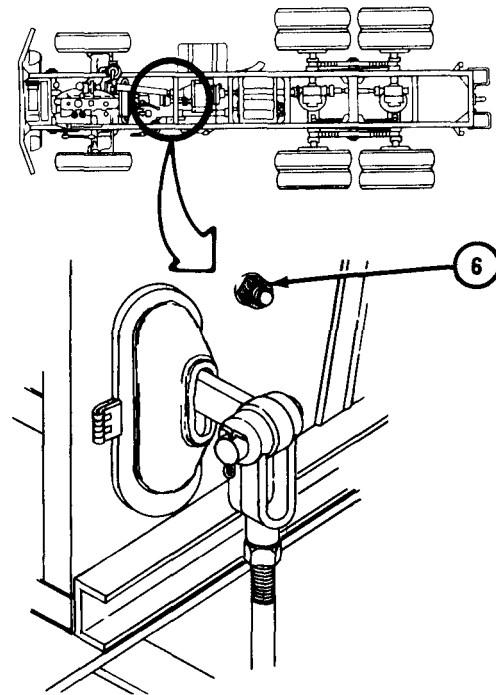

SOLDIER B

TA 083352

FRAME 4

1. Put rod (1) with clevis (2) in place under truck.
2. Using 3/4-inch wrench, loosen nut (3). Turn clevis (2) until holes align with holes in lever (4). Tighten nut (3).
3. Put clevis pin (5) through holes in clevis (2) and lever (4).
4. Put cotter pin (6) through hole in clevis pin (5) and using pliers, bend open ends of cotter pin.

END OF TASK

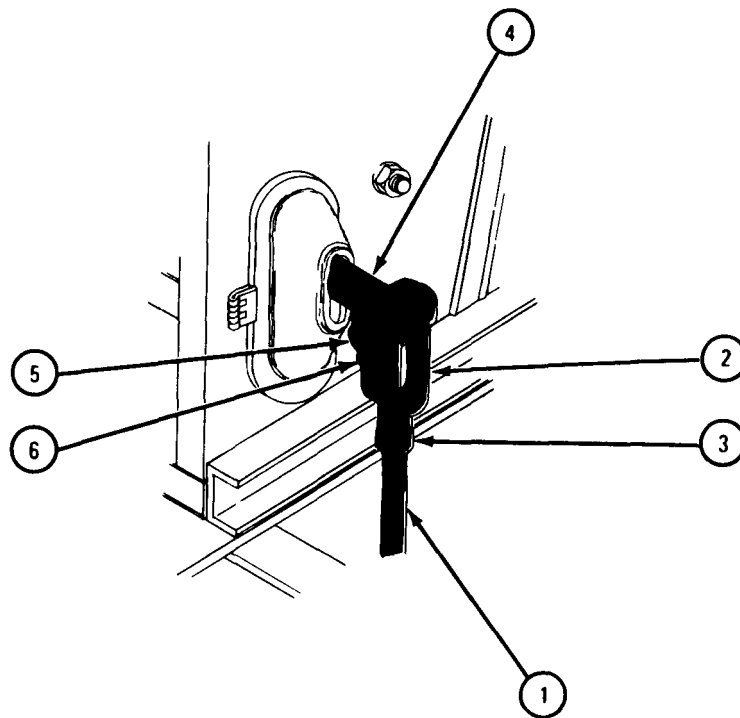

TA 083357

19-24. DUMP BODY SAFETY BRACE LOCKING AND UNLOCKING (TRUCK M342A2).

TOOLS: None

SUPPLIES: None

PERSONNEL: One

EQUIPMENT CONDITION: Truck parked, engine off, handbrake set.

a. Locking.

FRAME 1

1. Start engine and raise dump body (1). Refer to TM 9-2320-209-10.
2. Swing two hoist braces (2), one on each side, into upright position under dump body (1).
3. Lower dump body (1) onto hoist braces (2) and stop engine. Refer to TM 9-2320-209-10.

END OF TASK

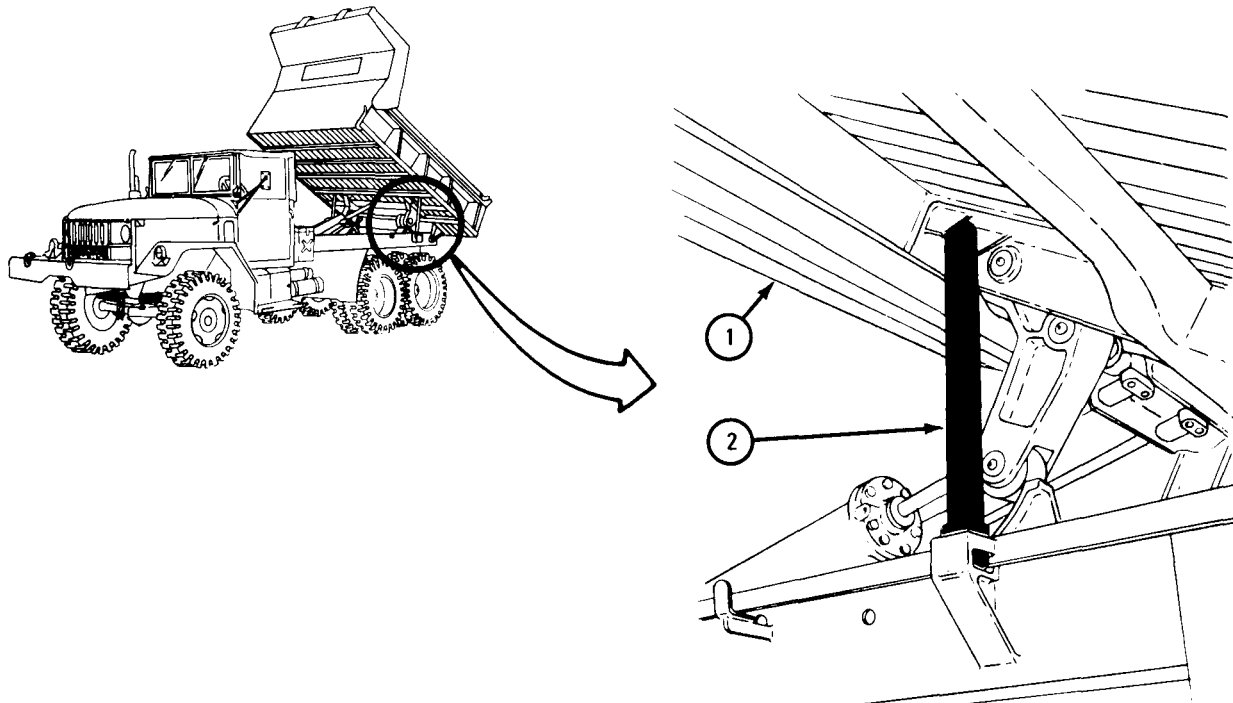

b. Unlocking.

FRAME 1

1. Start engine and raise dump body (1) to free two hoist braces (2). Refer to TM 9-2320-209-10.
2. Swing two hoist braces (2), one on each side, down to stowed position.
3. Lower dump body (1) and stop engine. Refer to TM 9-2320-209-10.

END OF TASK

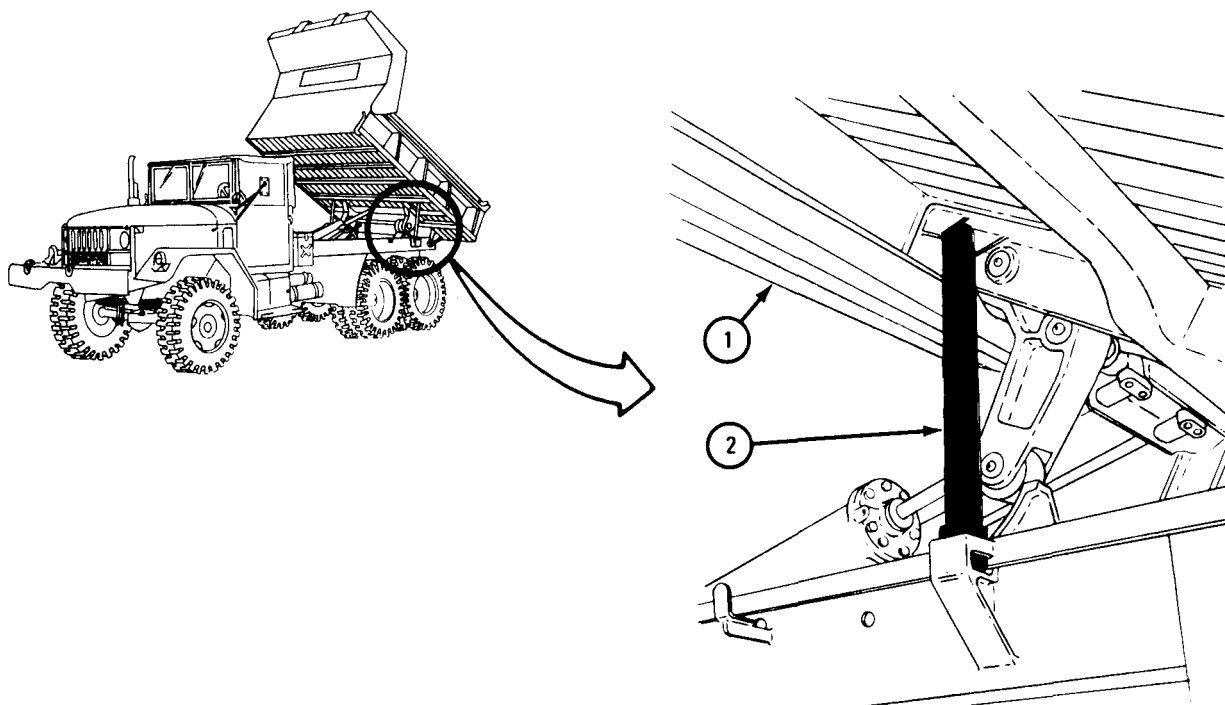

TA 083289

Section III. POWER TAKEOFF CONTROLS AND LINKAGE

19-25. TRANSMISSION POWER TAKEOFF SHIFT LINKAGE REMOVAL, REPLACEMENT, CHECKOUT AND ADJUSTMENT.

TOOLS: Pliers
 5/8-inch wrench
 3/4-inch wrench

SUPPLIES: None

PERSONNEL: One

EQUIPMENT CONDITION: Truck parked, engine off, handbrake set.

a. Preliminary Procedure. Remove air hydraulic shield. Refer to Part 2, para 13-14.

b. Removal.

FRAME 1

1. Pull and turn poppet (1) on yoke end (2) of clevis (3).
2. Take off yoke end (2) from transmission power takeoff shifter shaft (4).
3. Using 5/8-inch wrench, unscrew and take out two screws and lockwashers (5), holding power takeoff shifting lever support (6) to master cylinder (7).
4. Take off transmission power takeoff shift linkage.

END OF TASK

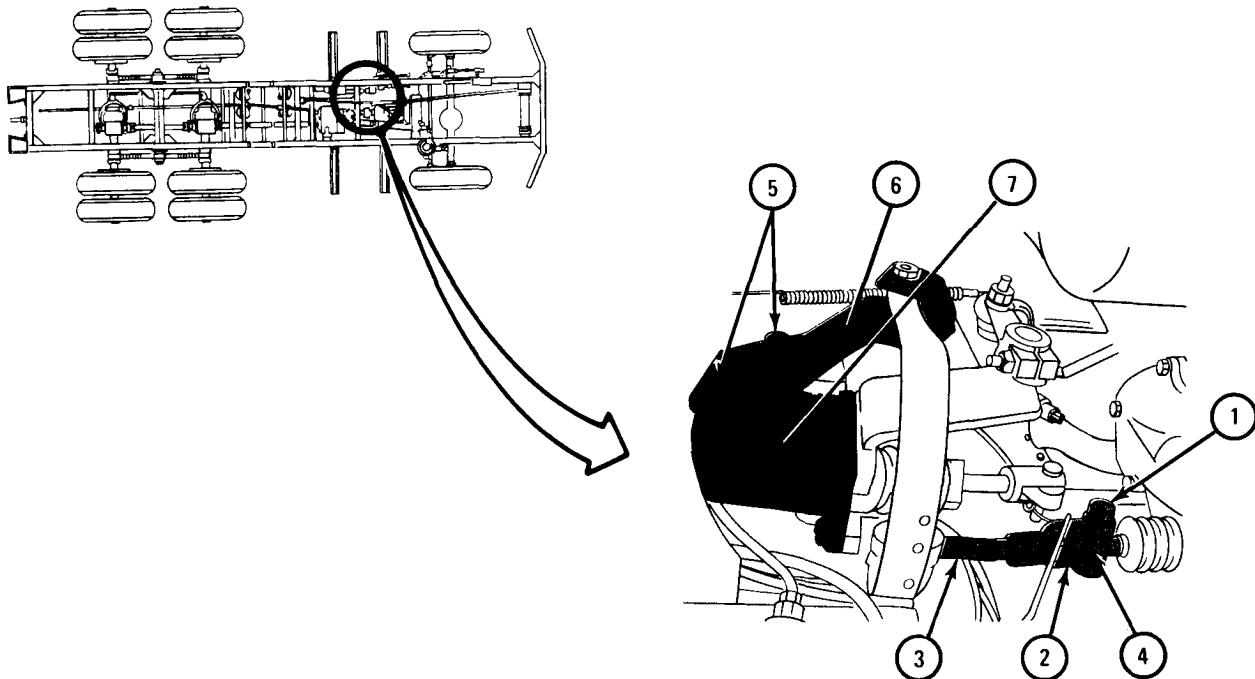

TA 047410

c. Replacement.

FRAME 1

1. Put transmission power takeoff shift linkage in place and aline holes in shifting lever support (1) with holes in master cylinder (2).
2. Put two screws and lockwashers (3) through holes in shifting lever support (1) and in holes in master cylinder (2).
3. Using 5/8-inch wrench, tighten screws (3).
4. Pull out poppet (4) on yoke end (5) of power takeoff shifting lever rod (6).
5. Aline yoke end (5) with hole in power takeoff shifter shaft (7). Turn poppet (4) and let it go in hole in shifter shaft (7).

END OF TASK

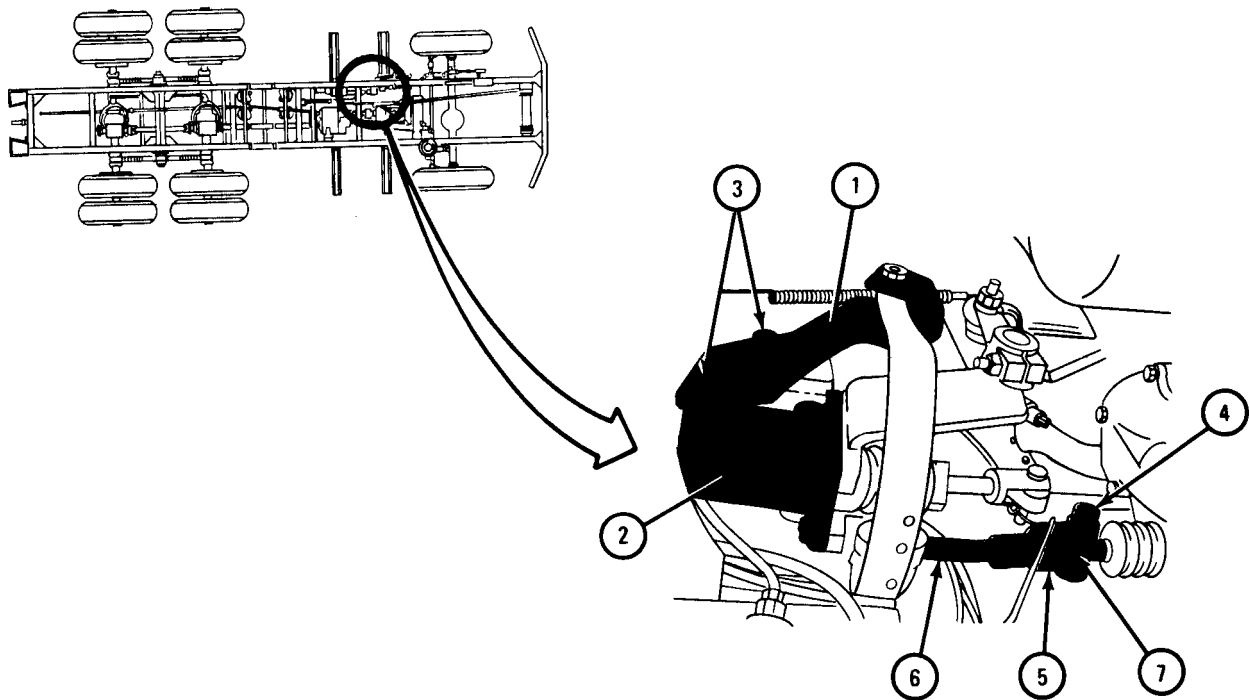

TA 047411

d. Checkout.

FRAME 1

1. Move transmission power takeoff shifting lever (1) to all positions shown on data plate (2).
2. Lever (1) should hold in each position. If it does not hold, adjust linkage. Refer to para 19-25e.

END OF TASK

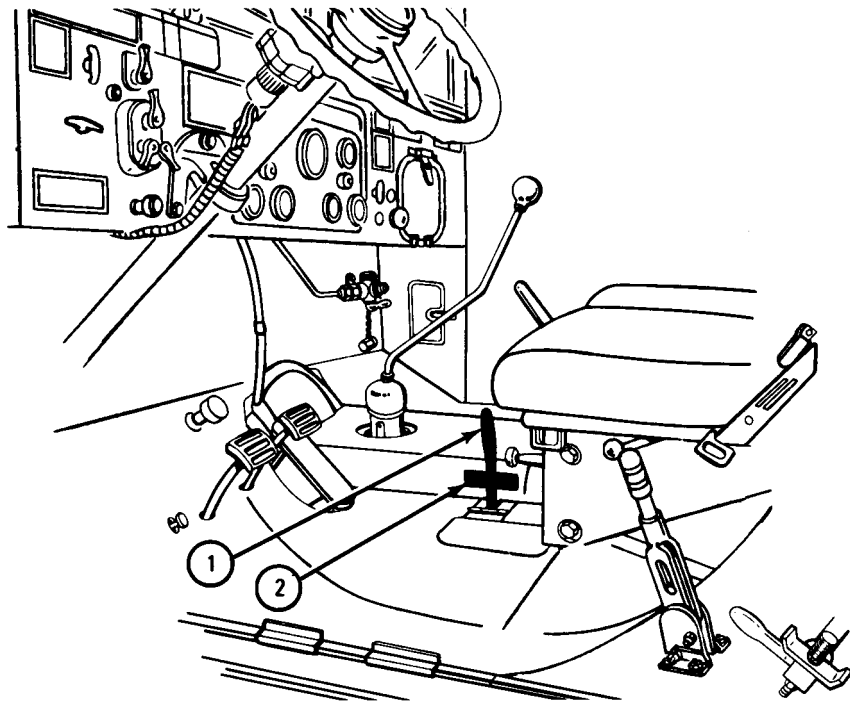

TA 047412

e. Adjustment.

FRAME 1

1. Using 3/4-inch wrench, loosen locknut (1).
2. Pull out poppet (2) on yoke end (3).
3. Take off yoke end (3) from shifter shaft (4).
4. Turn yoke end (3) in or out as necessary.
5. Pull poppet (2) out, align yoke end (3) with shifter shaft (4), and let poppet (2) go into hole in shifter shaft (4).
6. Tighten locknut (1).
7. Check shifting lever alignment. Refer to para 19-25d.

NOTE

Follow-on Maintenance Action Required:

Replace air hydraulic shield. Refer to Part 2, para 13-14.

END OF TASK

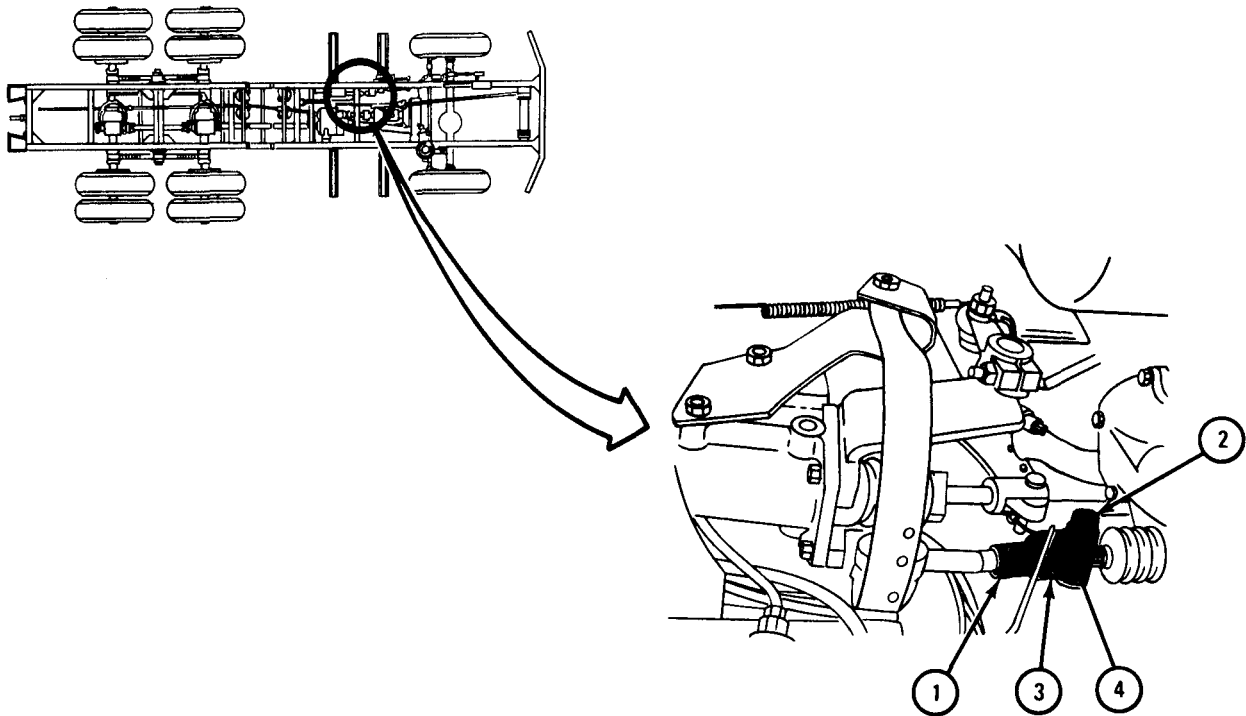

TA 047413

19-26. POWER DIVIDER CONTROLS AND LINKAGE REMOVAL, REPLACEMENT, AND ADJUSTMENT (TRUCK M764).

TOOLS: Pliers
5/8-inch wrench
11/16-inch wrench

SUPPLIES: None

PERSONNEL: Two

EQUIPMENT CONDITION: Truck parked, engine off, handbrake set.

a. Preliminary Procedure. Remove front and rear tunnel. Refer to Part 3, para 18-5.

b. Removal.

FRAME 1

1. Using pliers, pull out cotter pins (1) at both ends of control rod assembly (2).
2. Take pins (3) out of clevis rod ends (4).
3. Take control rod assembly (2) off of power divider control lever (5) and power divider shifter shaft (6).

GO TO FRAME 2

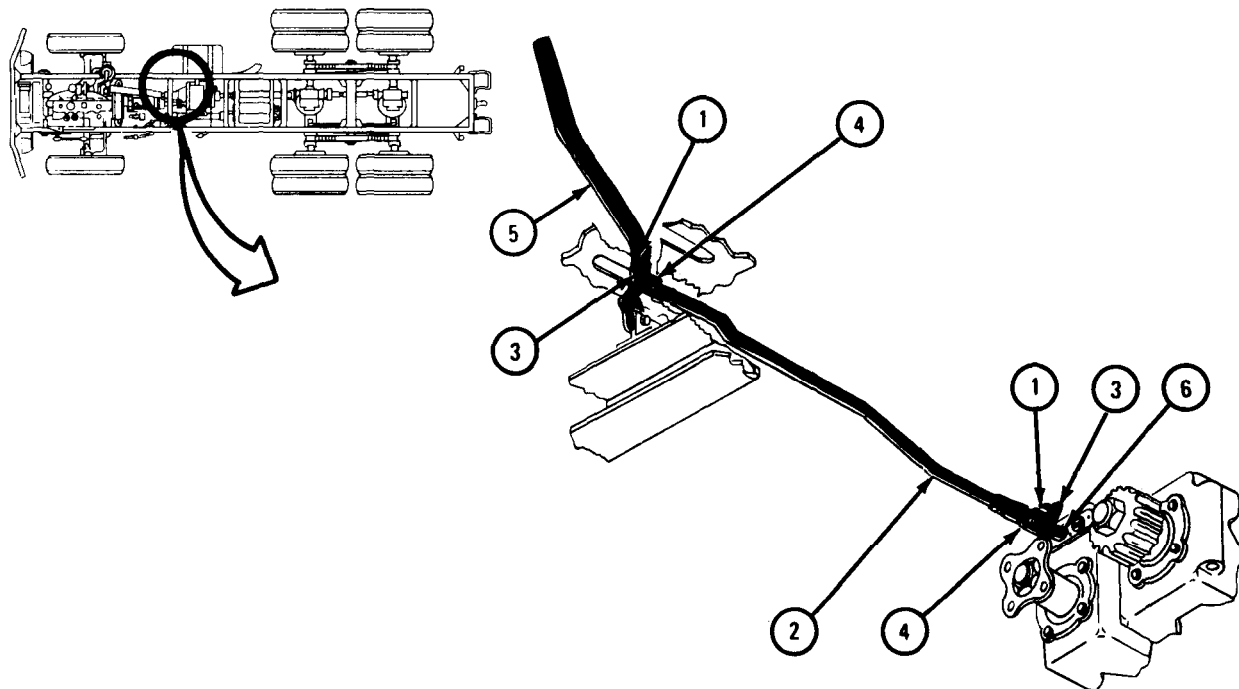

TA 047418

FRAME 2

1. Using 5/8-inch and 11/16-inch wrenches, hold screw (1) and unscrew and take off nut (2).
2. Take screw (1), lockwasher (3), and spacer (4) out of power divider control lever (5) and bracket (6).

GO TO FRAME 3

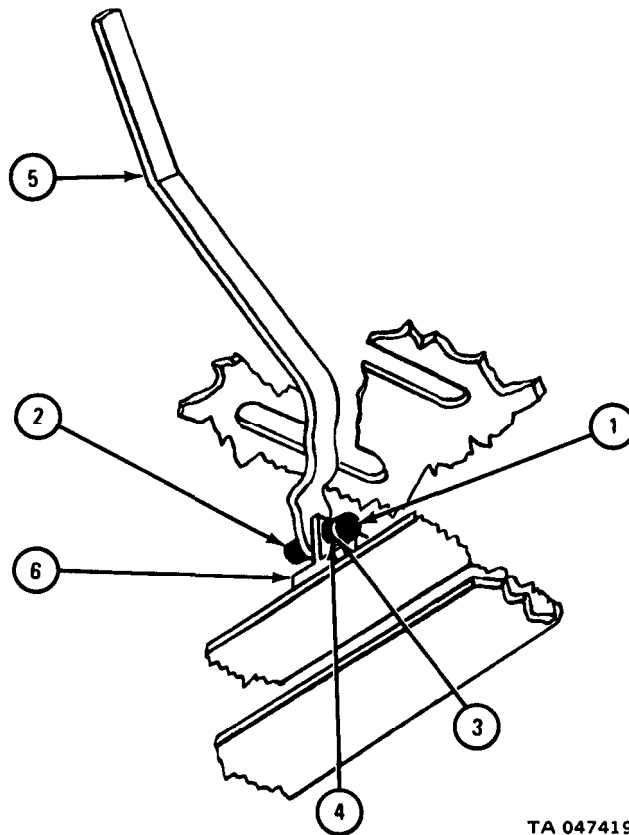

FRAME 3

1. From inside of driver's compartment, lift out power divider control lever (1).
- END OF TASK

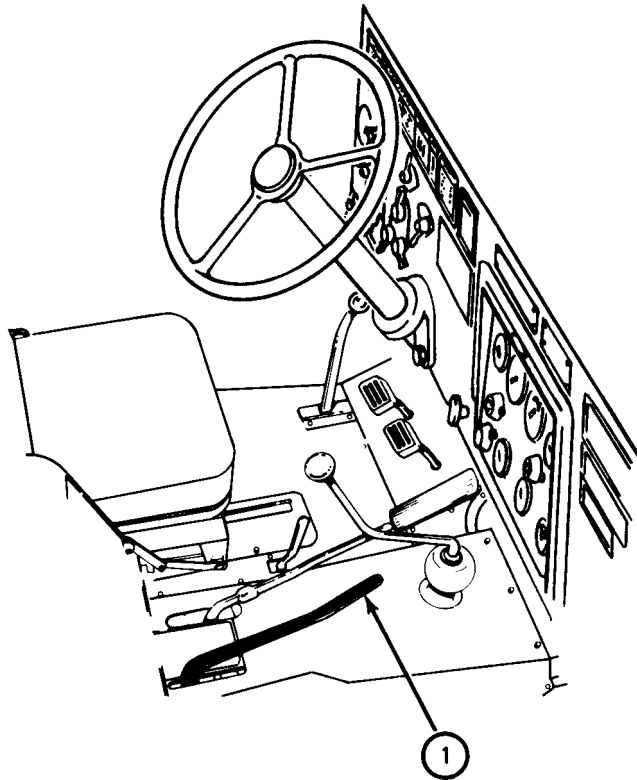

TA 047420

c. Replacement.

FRAME 1

1. Put power divider control lever (1) in place as shown.

GO TO FRAME 2

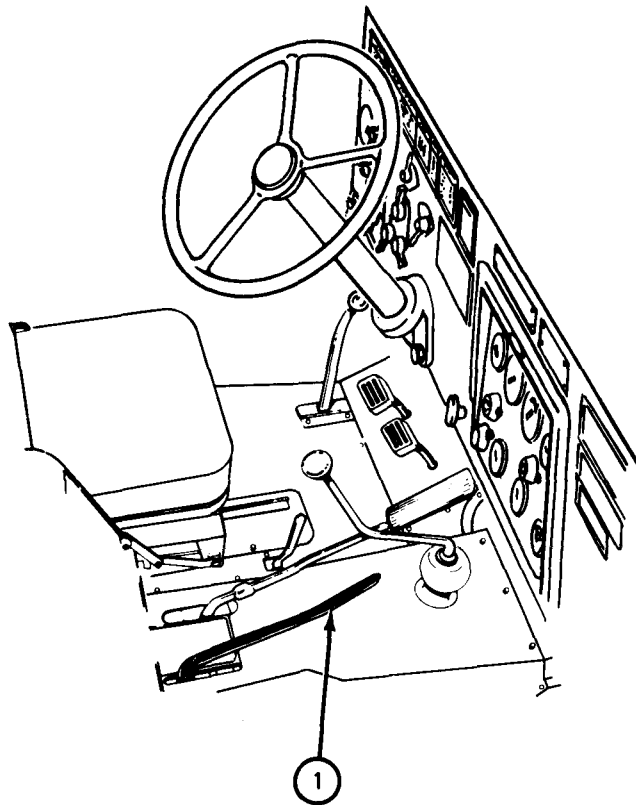

TA 047421

FRAME 2

1. Aline lower hole in power divider control lever (1) with hole in bracket (2).
2. Put spacer (3) into hole in control lever (1).
3. Put lockwasher (4) on screw (5) and put screw (5) through lower hole in control lever (1) and bracket (2).
4. Screw on nut (6).
5. Using 5/8-inch wrench, hold screw (5) and using 11/16-inch wrench, tighten nut (6).

GO TO FRAME 3

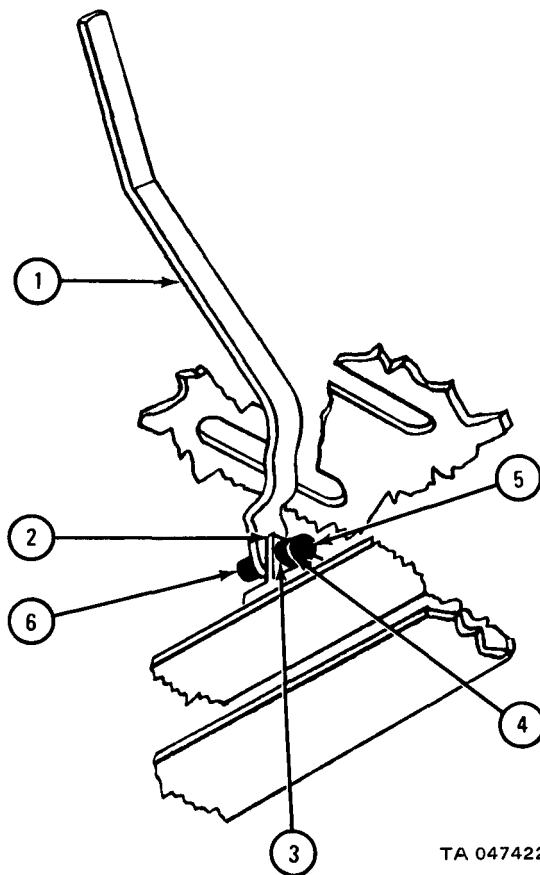

TA 047422

FRAME 3

1. Place clevis rod end (1) of control rod assembly (2) on control lever (3).
2. Aline holes on clevis rod end (1) with hole in control lever (3).
3. Put pin (4) through holes in clevis rod end (1) and control lever (3).
4. Put cotter pin (5) in hole at end of pin (4).
5. Using pliers, bend open ends of cotter pin (5).

GO TO FRAME 4

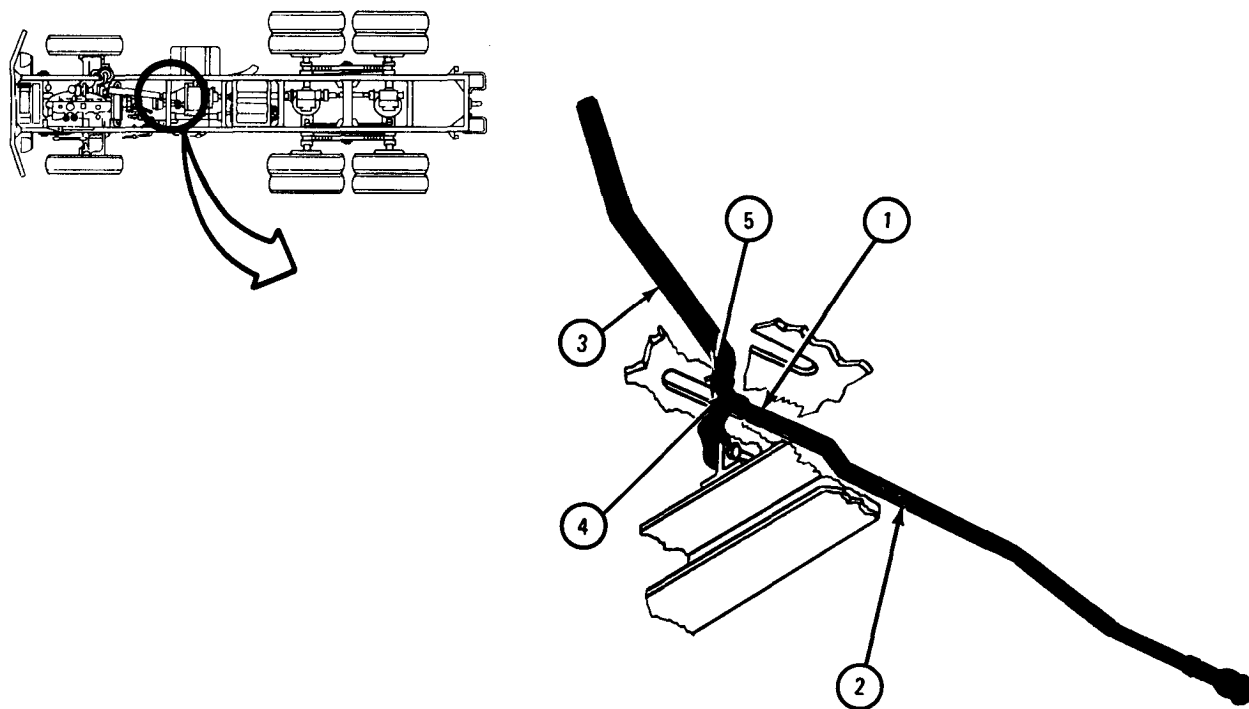

TA 047423

FRAME 4

1. Place clevis rod end (1) of control rod assembly (2) on shifter rod (3) coming out of power divider (4).
2. Aline holes in clevis rod end (1) with hole in shifter rod (3).
3. Put pin (5) through holes in clevis rod end (1) and shifter rod (3).
4. Put cotter pin (6) in hole in pin (5).
5. Using pliers, bend open ends of cotter pin (6).

NOTE

Follow-on Maintenance Action Required:

Adjust linkage. Refer to para 19-26d.

END OF TASK

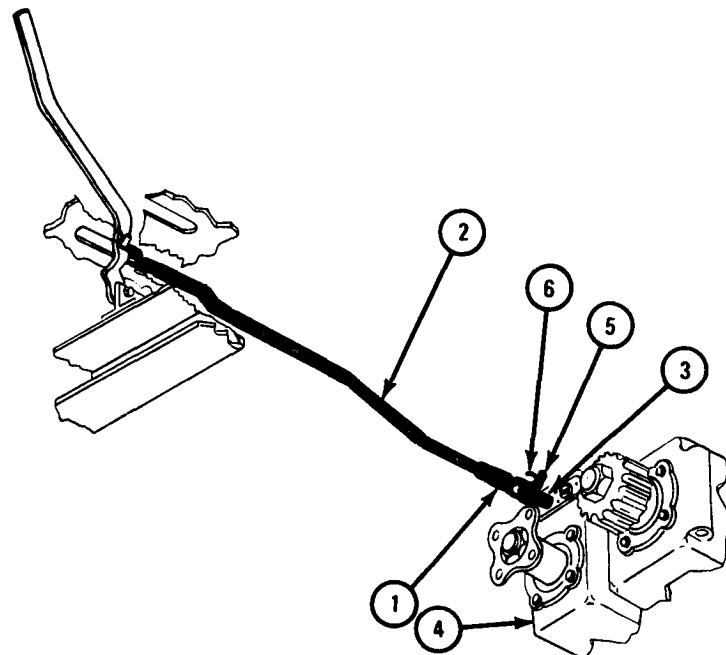

d. Adjustment.

FRAME 1

Soldier A 1. Standby at power divider linkage control rod (1) under truck.
GO TO FRAME 2

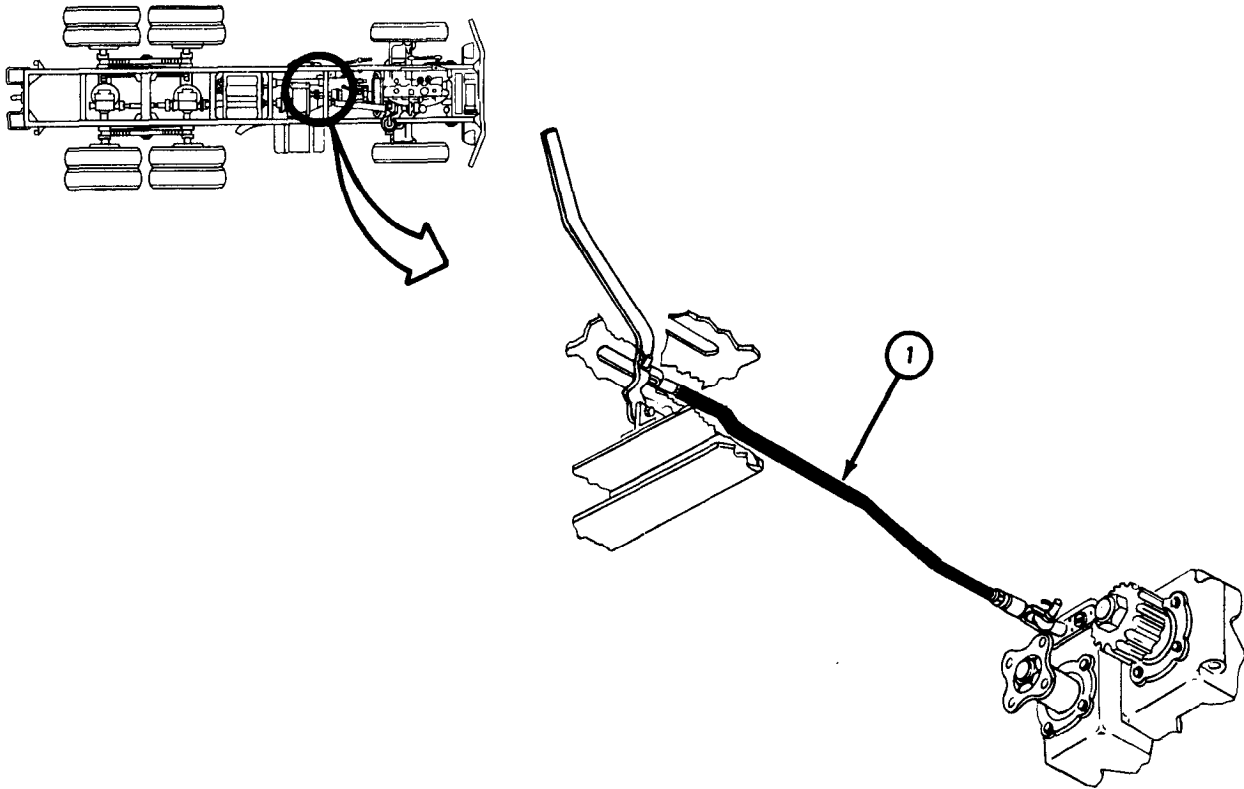

TA 047425

FRAME 2

Soldier B 1. Shift power divider control lever (1) through all four operating positions shown on data plate (2).

GO TO FRAME 3

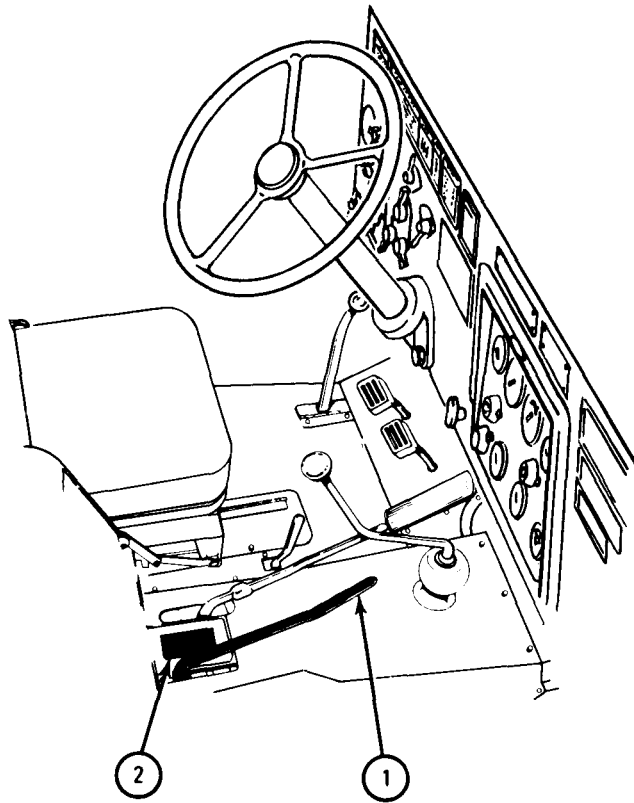

TA 047426

FRAME 3

- Soldier A
1. While soldier B is shifting power divider control lever (1), watch linkage control rod (2).
 2. If power divider control lever (1) goes into all four positions and linkage control rod (2) does not touch transfer transmission case (3), no adjustment is needed.
 3. If power divider control lever (1) does not go into all four positions or if linkage control rod (2) touches transfer transmission case (3) or flange (4), do steps 4 through 8.
 4. Using 5/8-inch wrench, loosen nuts (5) at each end of linkage control rod (2).
 5. Take off control rod assembly (2). Refer to para 19-26b.
 6. Using 5/8-inch wrench, turn clevis rod ends (6) in or out as needed and tighten nuts (5).
 7. Put back control rod assembly (2). Refer to para 19-26c.
 8. If needed, do steps 4 through 7 again.

NOTE

If adjustment cannot be made or if power divider shifter shaft (7) requires adjustment, tell direct support maintenance.

Follow-on Maintenance Action Required:

Replace front and rear tunnel. Refer to Part 3, para 18-5.

END OF TASK

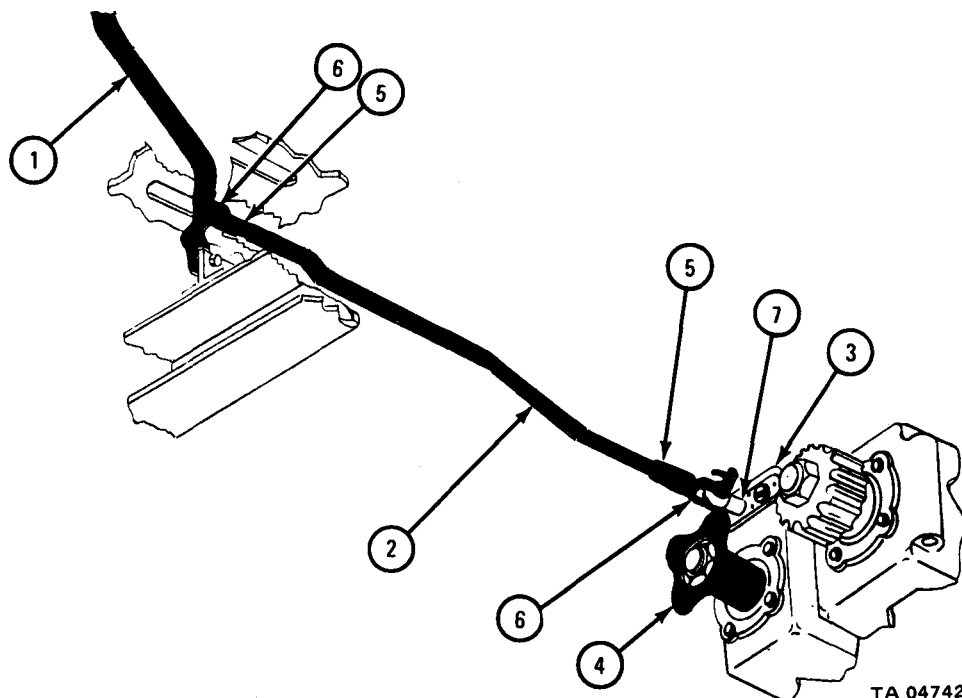

19-27. POWER DIVIDER PROPELLER SHAFT ASSEMBLY REMOVAL AND REPLACEMENT (TRUCK M764).

TOOLS: Prybar
9/16-inch wrench (2)
Torque wrench, 150 pound-feet capacity

SUPPLIES: None

PERSONNEL: One

EQUIPMENT CONDITION: Truck parked, engine off, handbrake set.

a. Removal.

FRAME 1

1. Using 9/16-inch wrench, hold four cap screws (1).
2. Using 9/16-inch wrench, unscrew and take off four self-locking nuts and lockwashers (2).
3. Take out four cap screws (1) holding flange yoke (3) to companion flange (4) on power divider (5).

GO TO FRAME 2

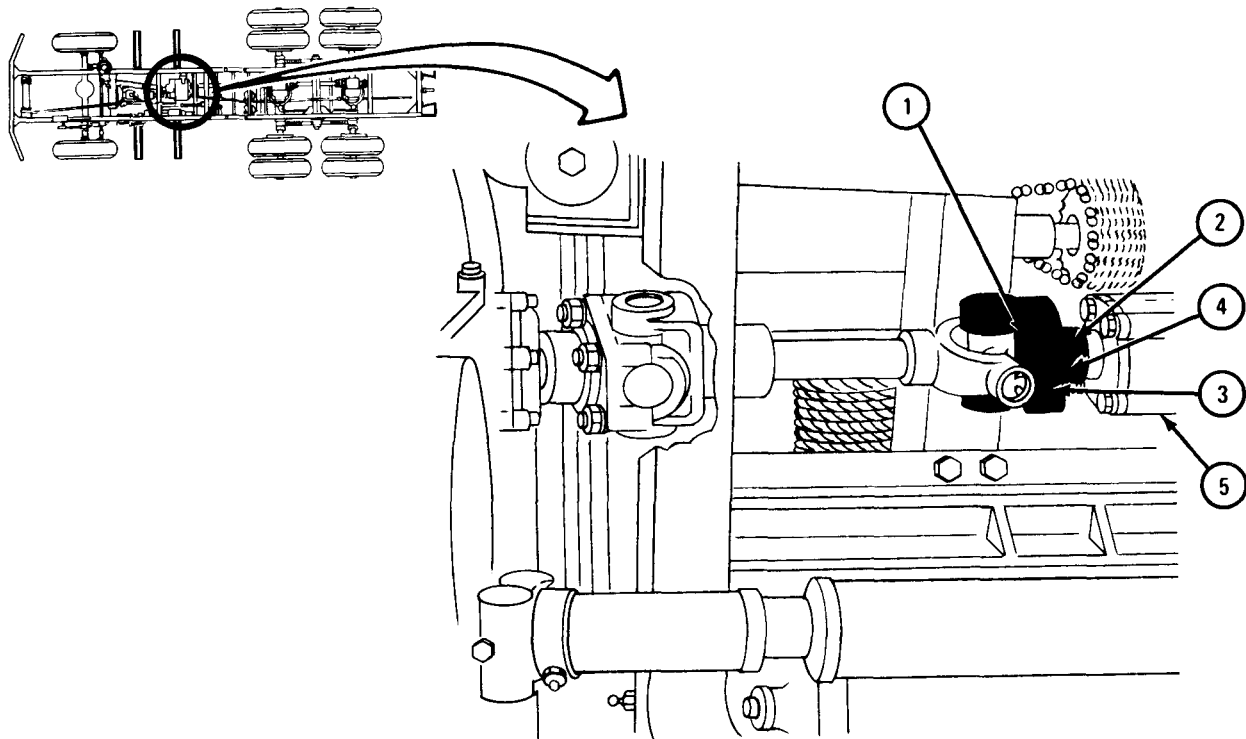

TA 047414

FRAME 2

1. Use prybar to keep propeller shaft assembly (1) from turning.
2. Using 9/16-inch wrench, unscrew and take off four nuts (2) and lockwashers (3) from two U-bolts (4).

NOTE

Be careful not to let bearing caps (5) slip off journal (6).

3. Take two U-bolts (4) out of end yoke (7) and off bearings (5).
4. Shorten propeller shaft assembly (1) by pushing ends together and take propeller shaft assembly out from under truck.

END OF TASK

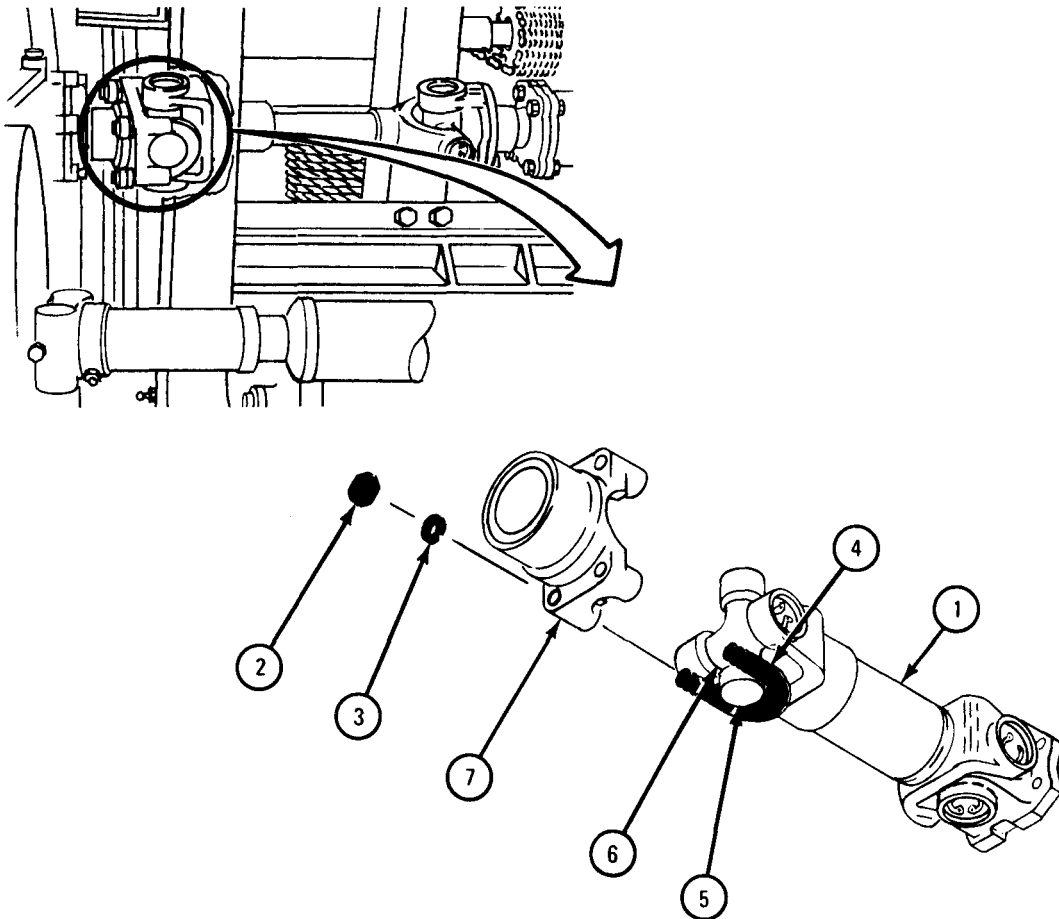

TA 047415

b. Repair. Repair is limited to removal and replacement of universal joints. Refer to Part 3, para 10-5.

c. Replacement.

FRAME 1

1. Put sleeve yoke end of propeller shaft (1) in place at power takeoff yoke end (2). Be careful not to let bearing caps (3) slip off.
 2. Put two U-bolts (4) over bearing caps (3) and into yoke end (2).
 3. Screw on and hand tighten four nuts (5) and lockwashers (6) onto U-bolts (4).
- GO TO FRAME 2

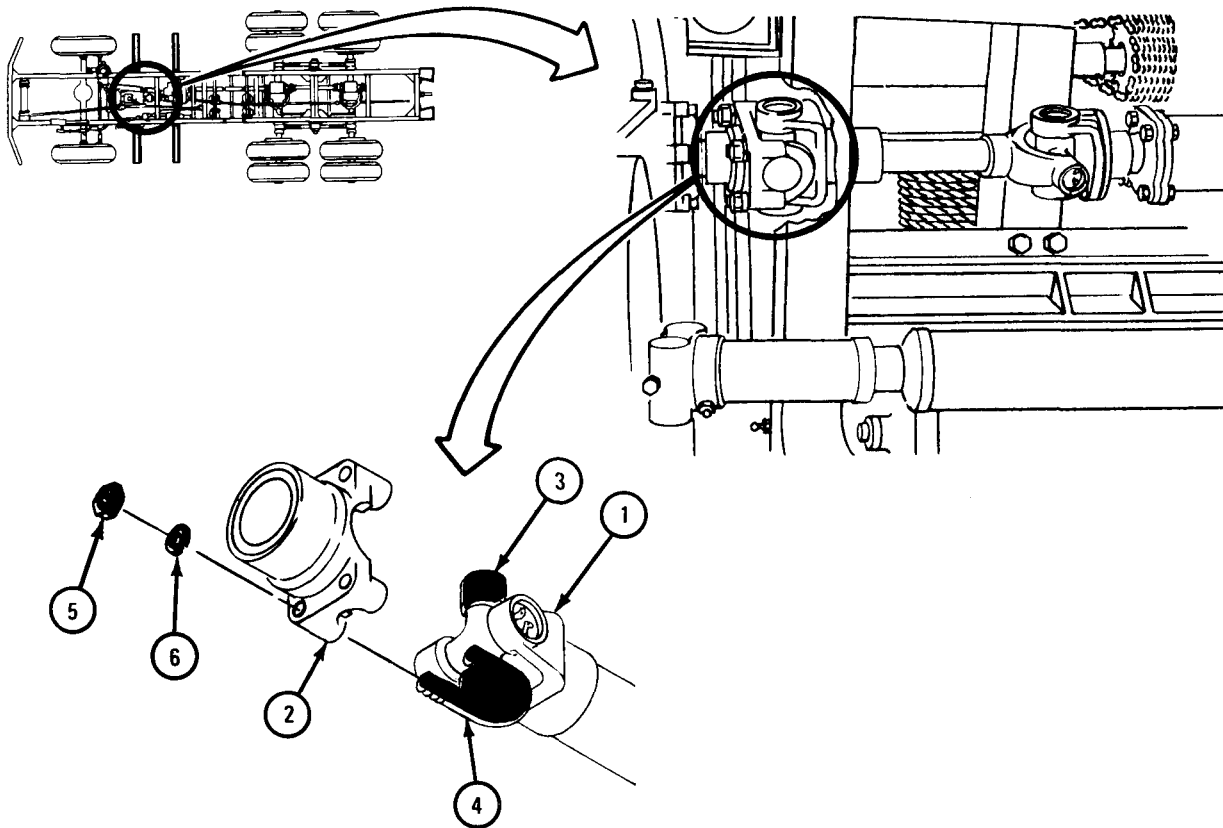

TA 047416

FRAME 2

1. Aline holes in flange yoke (1) with holes in companion yoke (2) and put in four capscrews (3).
2. Using 9/16-inch wrenches, screw on and tighten four capscrews (3) and four nuts and lockwashers (4).
3. Use prybar to keep propeller shaft assembly (5) from turning.
4. Using torque wrench, tighten locknuts (6) to 25 to 29 pound-feet.

END OF TASK

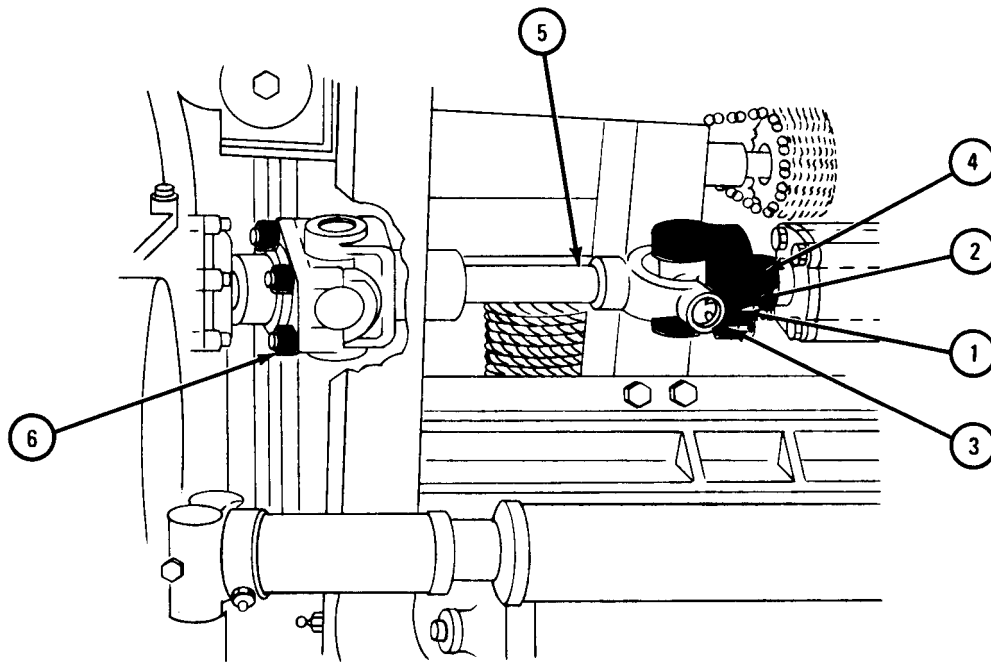

TA 047417

CHAPTER 20

BUMPER GUARDS GROUP MAINTENANCE

Section I. SCOPE

20-1. EQUIPMENT ITEMS COVERED. This chapter gives equipment maintenance procedures for bumper brackets, guards, and protective devices for which there are authorized corrective maintenance tasks at the organizational maintenance level.

20-2. EQUIPMENT ITEMS NOT COVERED . All equipment items for which corrective maintenance is authorized at the organizational maintenance level are covered in this chapter.

Section II. BUMPER BRACKETS , GUARDS, AND PROTECTIVE DEVICES

20-3. HEADLIGHT GUARD REMOVAL AND REPLACEMENT .

NOTE

This task is the same for the right and left headlight guards, This task is shown for the left headlight guard. On some trucks, the headlight is on the bottom and on other trucks the headlight is on the top. This task is the same for both.

TOOLS : 9/16-inch wrench (2)
3/4-inch wrench (2)

SUPPLIES : None

PERSONNEL : One

EQUIPMENT CONDITION : Truck parked, engine off, handbrake set.

a. Removal.

FRAME 1

1. Using 9/16-inch wrenches, hold two screws (1) and unscrew and take off two nuts (2). Take screws out of headlight guard (3).
2. Using 3/4-inch wrenches, hold screw (4) and unscrew and take off nut (5).
3. Take screw (4) out of headlight guard (3).
4. Take headlight guard (3) off screw (4) and out of brush guard (6).

END OF TASK

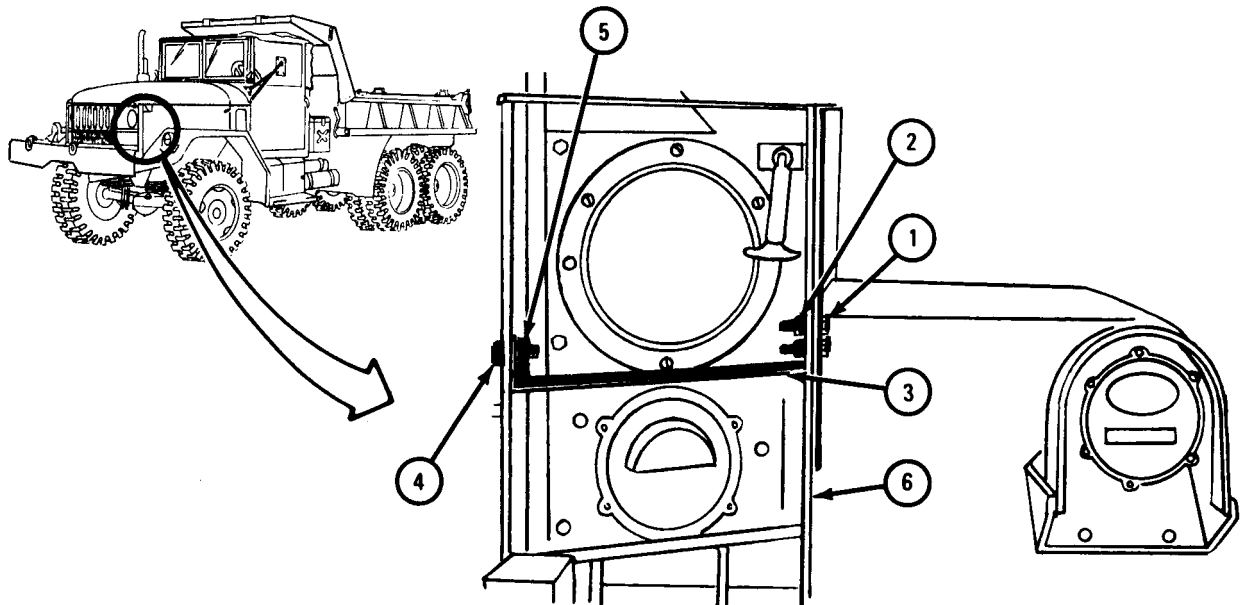

TA 047430

b. Replacement.

FRAME 1

1. Slide headlight guard (1) on screw (2).
2. Put headlight guard (1) in place in brush guard (3).
3. Aline holes in headlight guard (1) with holes in brush guard (3).
4. Put two screws (4) through holes in headlight guard (1) and brush guard (3).
5. Using 9/16-inch wrench, screw on two nuts (5).
6. Using 9/16-inch wrenches, hold two screws (4) and tighten two nuts (5).
7. Using 3/4-inch wrenches, hold screws (2) and screw on and tighten nut (6).

END OF TASK

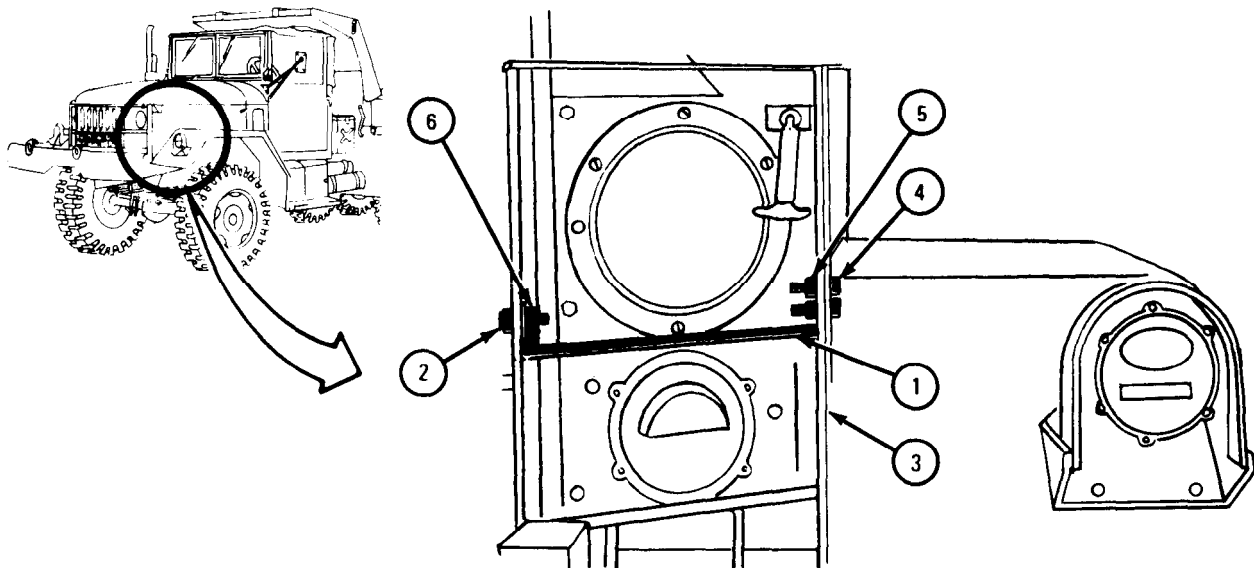

TA 047431

CHAPTER 21

BODY ACCESSORY ITEMS GROUP MAINTENANCE

Section I. SCOPE

21-1. EQUIPMENT ITEMS COVERED . This chapter gives equipment maintenance procedures for canvas and cab accessory items and data plates for which there are authorized corrective maintenance tasks at the organizational maintenance level.

21-2. EQUIPMENT ITEMS NOT COVERED . All equipment items for which corrective maintenance is authorized at the organizational maintenance level are covered in this chapter.

Section II. CANVAS ACCESSORY ITEMS

21-3. BOW ASSEMBLY REPAIR.

TOOLS : Cross-tip screwdriver (Phillips type)

SUPPLIES : Solvent, dry cleaning, type II (SD-2), Fed. Spec P-D-680
Rags

PERSONNEL: One

EQUIPMENT CONDITION : Bow assembly on workbench.

a. Disassembly.

FRAME 1

1. Using screwdriver, unscrew and take out screw (1). Take off strap (2).
2. Using screwdriver, unscrew and take out two screws (3). Pull bow stake (4) out of bow corner (5).
3. Using screwdriver, unscrew and take out two screws (6). Pull bow corner (5) out of bow top (7).
4. Do steps 1 through 3 again on other side of bow assembly.

END OF TASK

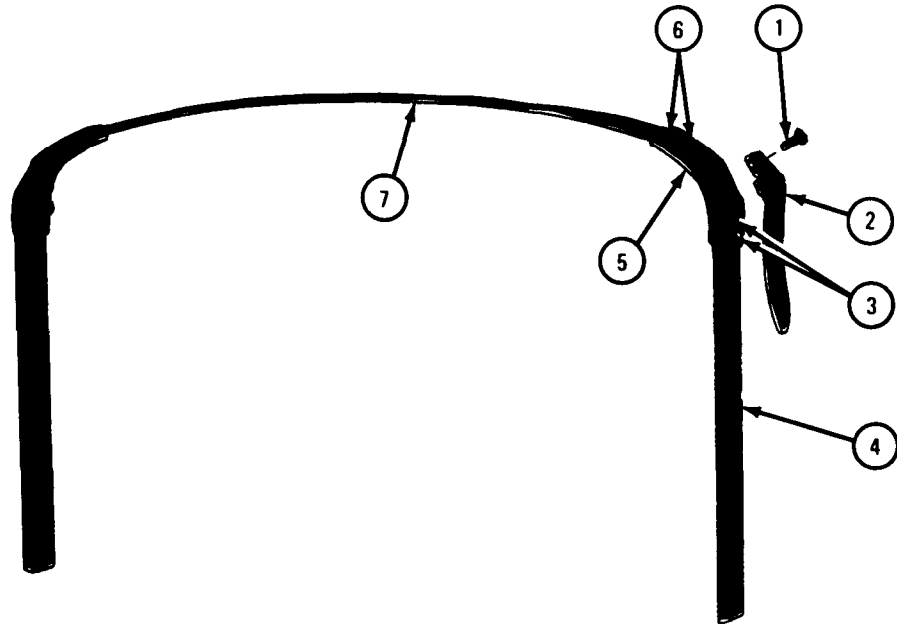

TA 048987

WARNING

Dry cleaning solvent is flammable. Do not use near an open flame. Keep a fire extinguisher nearby when solvent is used. Use only in well-ventilated places. Failure to do this may result in injury to personnel and damage to equipment.

- b. Cleaning. Using solvent, clean all metal parts.
- c. Inspection and Repair. Check all parts for damage. Throw away any bent, broken or damaged parts. Get new parts in their place.
- d. Assembly.

FRAME 1

1. Push bow top (1) into bow corner (2) and align holes.
2. Using screwdriver, screw in and tighten two screws (3).
3. Push bow stake (4) into bow corner (2) and align holes.
4. Using screwdriver, screw in and tighten two screws (5).
5. Put strap (6) against bow corner (2) as shown. Align holes and hold it in place.
6. Using screwdriver, screw in and tighten screw (7).
7. Do steps 1 through 6 again on other side of bow top (1).

END OF TASK

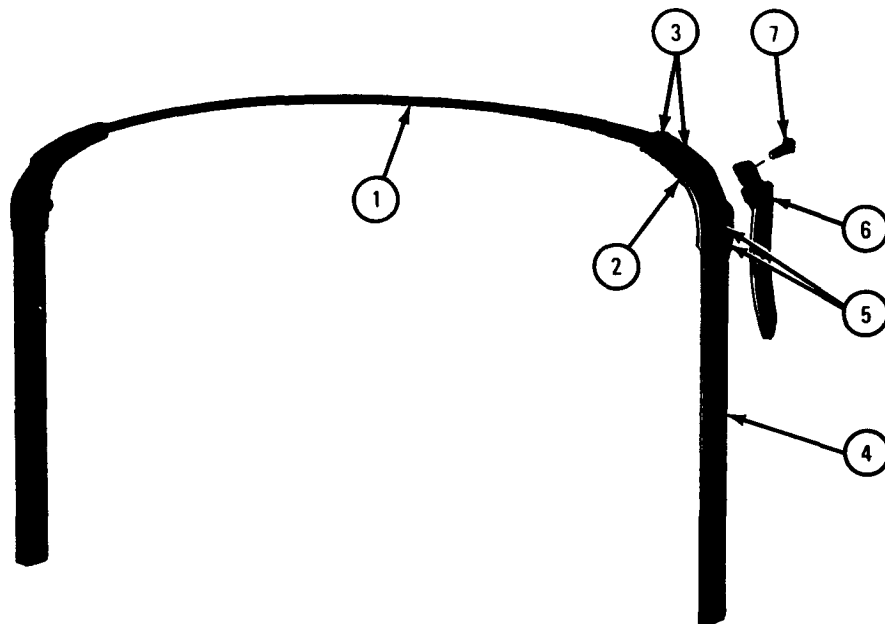

TA 048988

Section III. CAB ACCESSORY ITEMS

21-4. WINDSHIELD WIPER MOTOR REMOVAL AND REPLACEMENT.

NOTE

This task is the same for both windshield wiper motors.

TOOLS : Cross-tip screwdriver (Phillips type)
Hose clamp pliers
3/8-inch open end wrench

SUPPLIES: None

PERSONNEL: One

EQUIPMENT CONDITION: Truck parked, engine off, handbrake set.

a . Removal.

FRAME 1

1. Unclip wiper blade (1) from wiper arm (2) and takeoff blade.
2. Using 3/8-inch wrench, unscrew cap nut (3) and take off arm (2).
3. Using phillips screwdriver, unscrew two screws (4) letting wiper motor (5) hang on shaft (6).

GO TO FRAME 2

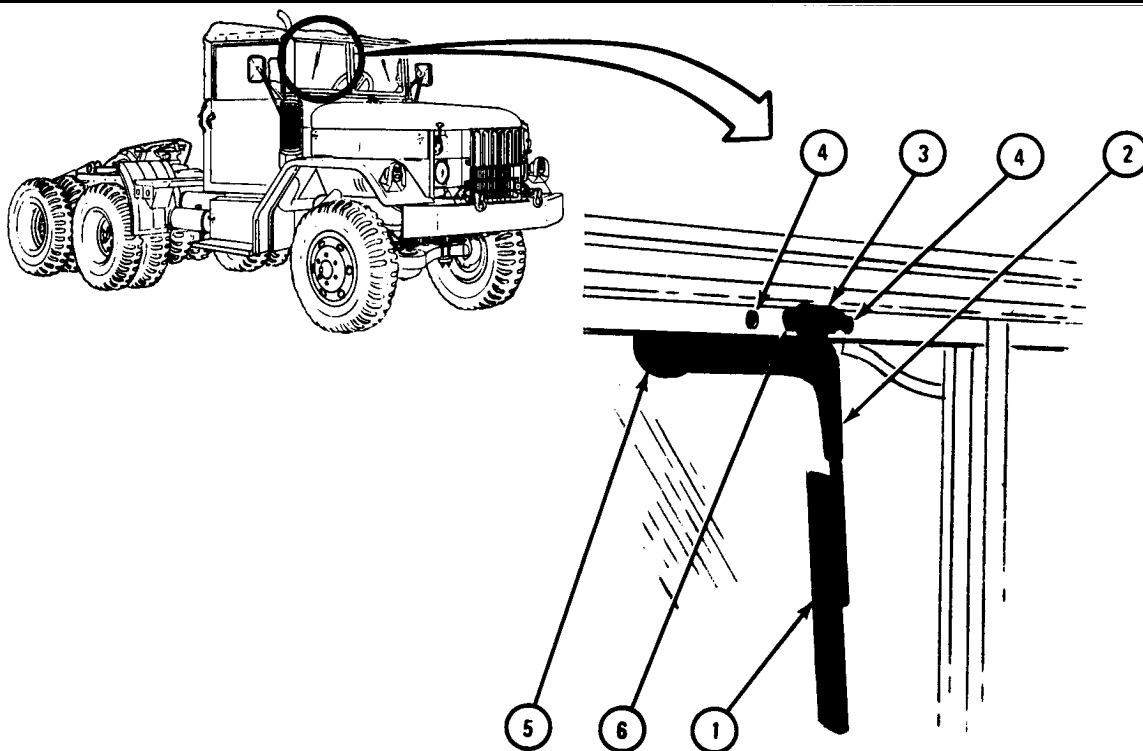

TA 047303

FRAME 2

1. Using pliers, spread hose clamp (1) and slide clamp back on hose (2).
2. Pull hose (2) off wiper motor (3) and lift wiper motor clear of windshield frame (4).

END OF TASK

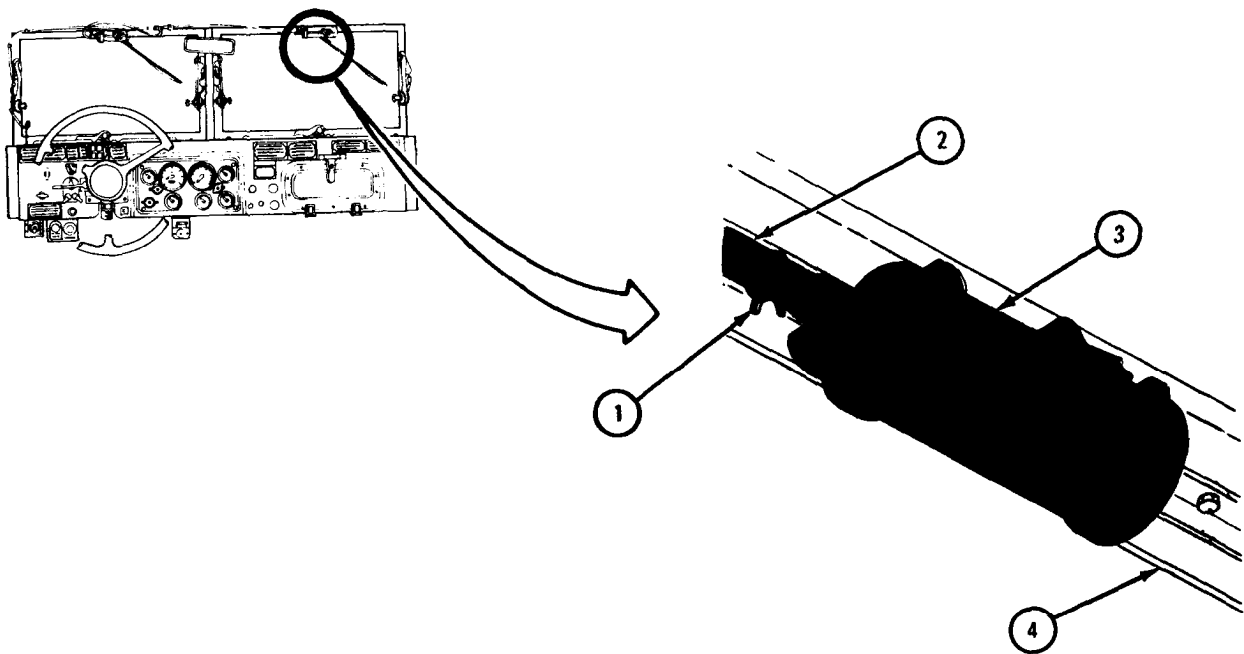

TA 047304

b. Replacement.

FRAME 1

1. Put end of hose (1) on wiper motor (2). Using pliers, spread hose clamp (3) and slide clamp down hose to wiper motor.
2. Put wiper motor shaft (4) through hole in windshield frame (5) as shown, and aline two mounting holes.
3. Turn manual control lever (6) to full right position.

GO TO FRAME 2

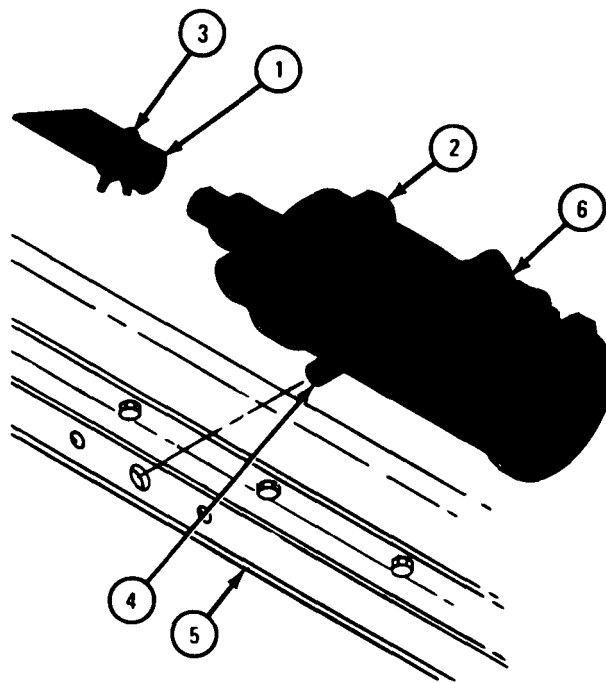
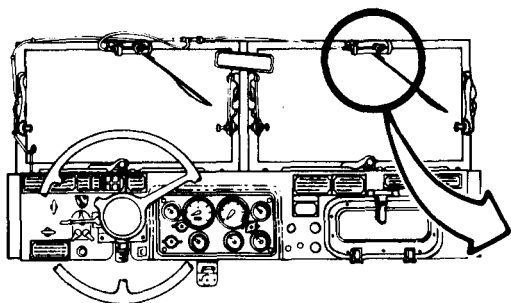

TA 047305

FRAME 2

1. Using phillips screwdriver, screw two screws (1) through windshield frame (2) into wiper motor (3). Tighten screws.
2. Clip wiper blade (4) to wiper arm (5).
3. Put wiper arm (5) on serrated shaft of wiper motor (3). Set arm so that blade clears windshield center post (6) and windshield frame (2) by turning manual control lever (7) to the right and left.
4. Using 3/8-inch wrench, screw on and tighten cap nut (8).

NOTE

Follow-on Maintenance Action Required:

Start engine and turn on windshield wiper control valve to check operation of wiper motor. Refer to TM 9-2320-209-10.

END OF TASK

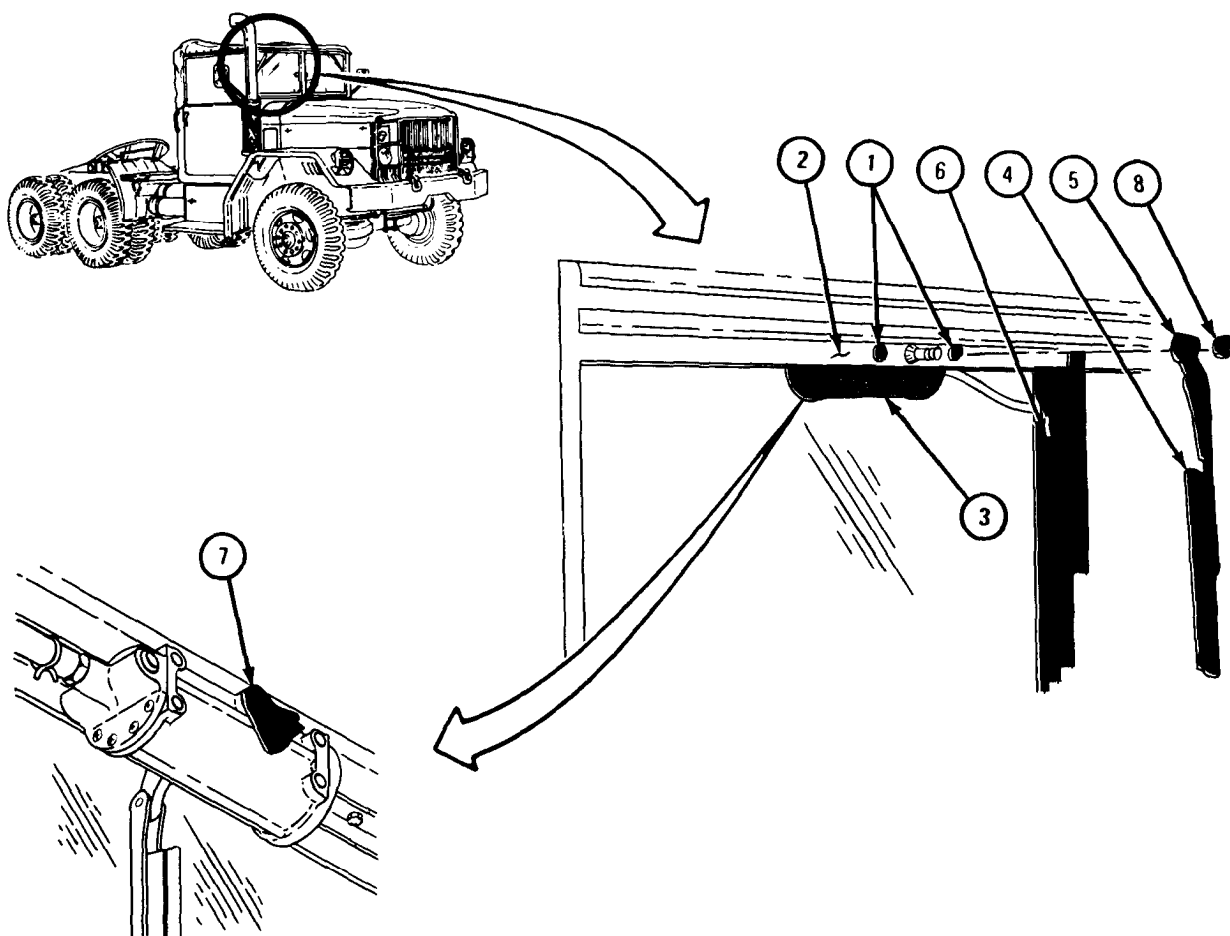

TA 047306

21-5. WINDSHIELD WASHER REPAIR.

TOOLS : 7/16-inch wrench (2)
9/16-inch wrench (2)
6-foot tape measure

SUPPLIES: None

PERSONNEL: Two

EQUIPMENT CONDITION: Truck parked, engine off, handbrake set.

Preliminary Procedure. Open hood and left side panel. Refer to TM 9-2320-209-10.

b. Removal.

FRAME 1

1. Take cap (1) off reservoir (2).
 2. Take strainer (3) off hose (4) and pull hose out of cap (1).
 3. Using 7/16-inch wrenches, unscrew and take off three capscrews (5), washers (6), and nuts (7). Take off reservoir (2) and plate (8).
 4. Spread open and take off two clamps (9).
- GO TO FRAME 2

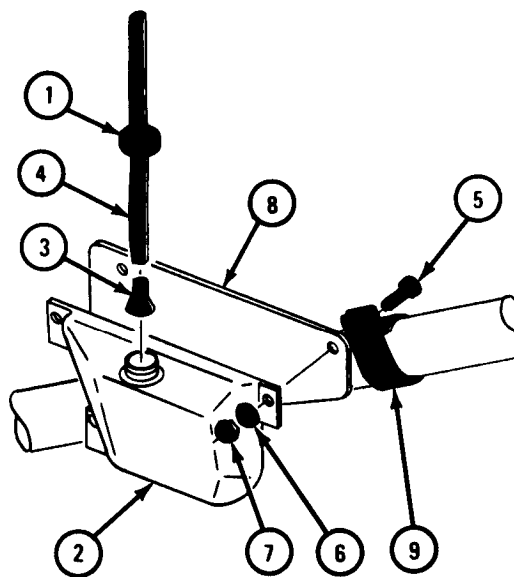
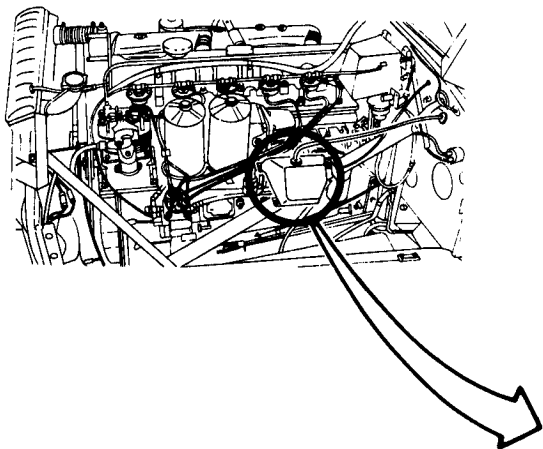

TA 084049

FRAME 2

1. Working behind instrument panel, pull two hoses (1) off pump (2) and pull hose (3).
2. Pull hose (4) through grommet (5) and take hoses (1, 3, and 4) out of truck.
3. Pull hoses (1, 3, and 4) off tee fitting (6) and valve (2).
4. Using 7/16-inch wrenches, unscrew and take off capscrew (8), two washers (9), and nut (10). Take off pump (2).

GO TO FRAME 3

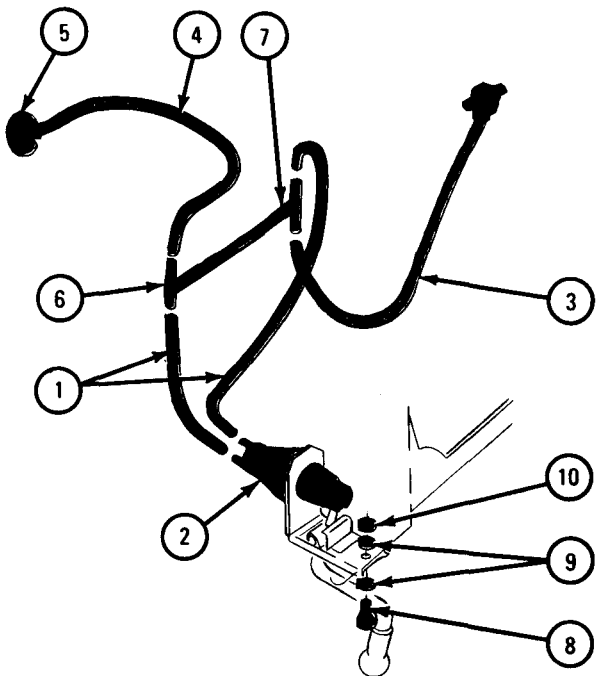
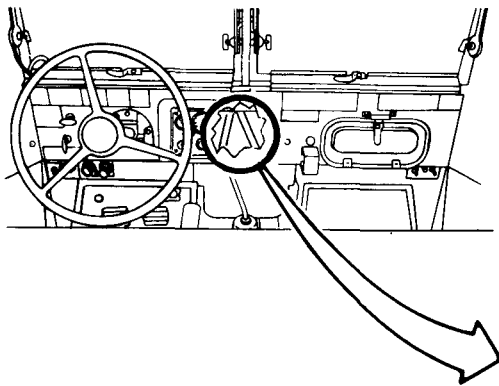

TA 084050

FRAME 3

Soldier A 1. Using 9/16-inch wrench, hold jet washer (1). Tell soldier B when ready.

Soldier B 2. Using 7/16-inch wrench, unscrew and take off nut (2) and two rubber washers (3).

NOTE

Note the way jet washer (1) is facing so it will be put back the same way.

Soldier A 3. Take jet washer (1) off truck.

END OF TASK

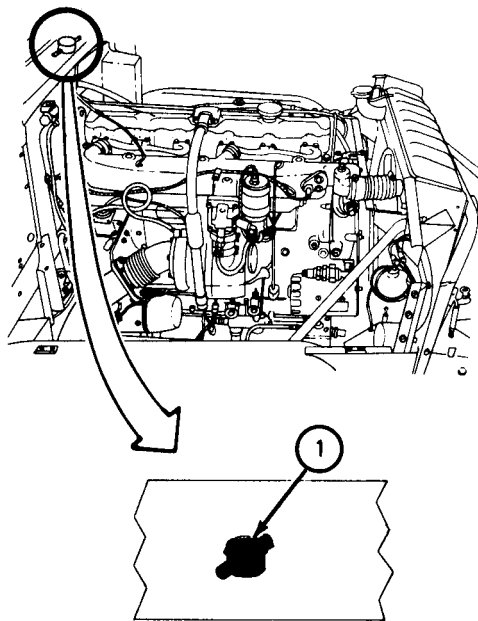

SOLDIER A

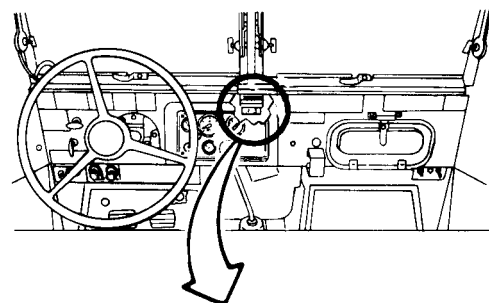

SOLDIER B

TA 084051

c. Repair. Check that all parts are not clogged, cracked or broken. If parts are damaged, get new ones.

d. Replacement.

FRAME 1

Soldier A 1. Put jet washer (1) on cowl of truck as shown. Using 9/16-inch wrench, hold jet washer and face it as noted. Tell soldier B when ready.

Soldier B 2. Put two rubber washers (2) and nut (3) on jet washer (1). Using 7/16-inch wrench, tighten nut (3).

GO TO FRAME 2

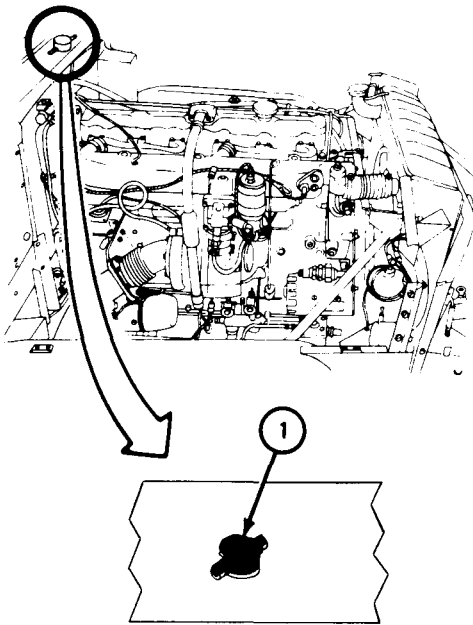

SOLDIER A

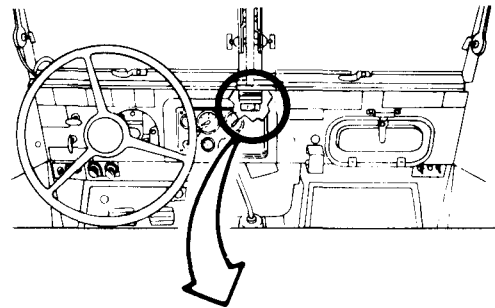

SOLDIER B

TA 084052

FRAME 2

1. Working behind instrument panel (1), put pump (2) in place under instrument panel. Using 7/16-inch wrenches, screw in and tighten capscrew (3), two washers (4), and nut (5).
2. Put 7-inch hose (6) and 9-inch hose (7) on pump (2).
3. Put tee fitting (8) on hose (6) and valve (9) on hose (7) as shown.
4. Put 3-inch hose (10) between tee fitting (8) and valve (9).

GO TO FRAME 3

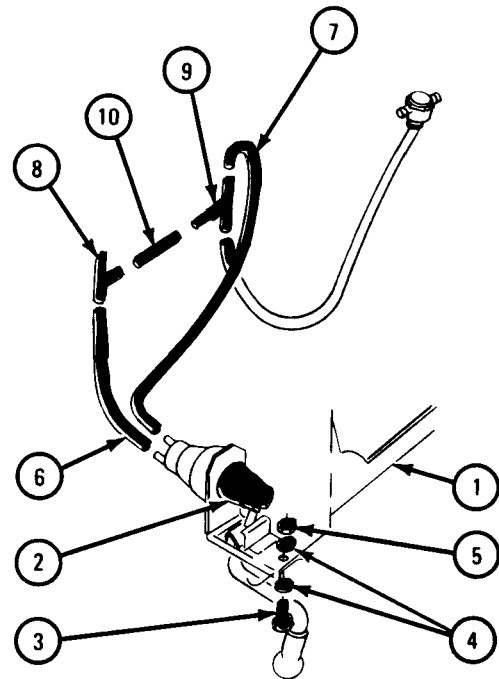
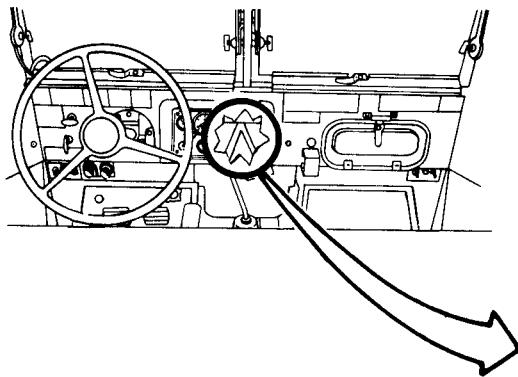

TA 084053

FRAME 3

1. Put one end of 11-inch hose (1) on jet washer (2) and other end of hose on valve (3).
2. Put 39-inch hose (4) through grommet (5) and put end of hose on tee fitting (6).

GO TO FRAME 4

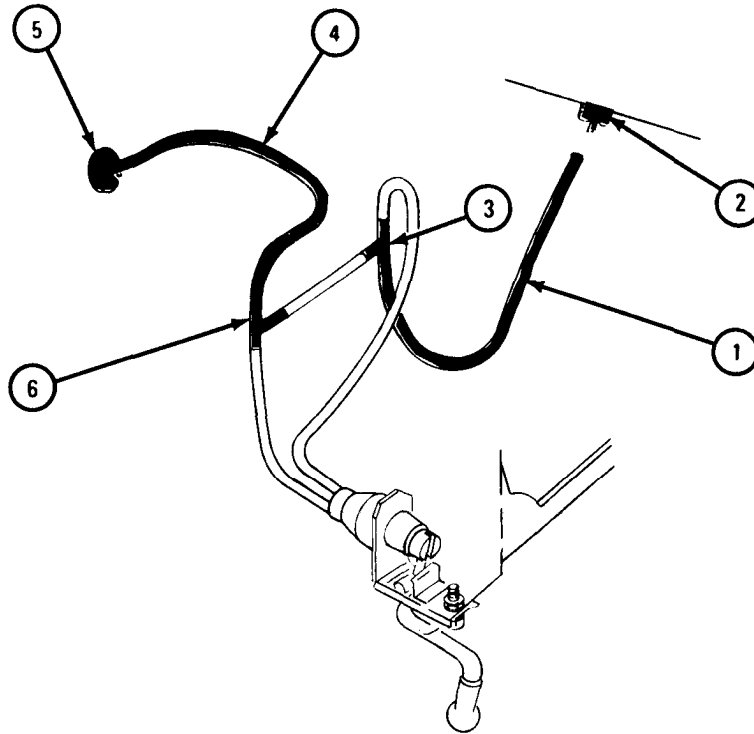

TA 084054

FRAME 4

1. Put two clamps (1) on steering column (2). Aline screw holes in plate (3) and reservoir (4) with screw holes in two clamps (1) and put through three cap-screws (5).
2. Using 7/16-inch wrenches, hold three capscrews (5) and screw on and tighten three washers (6) and nuts (7).
3. Put 39-inch hose (8) on cap (9) and put strainer (10) into hose. Put cap on reservoir (4).

NOTE

Follow-on Maintenance Action Required:

Close hood and left side panel. Refer to TM 9-2320-209-10.

END OF TASK

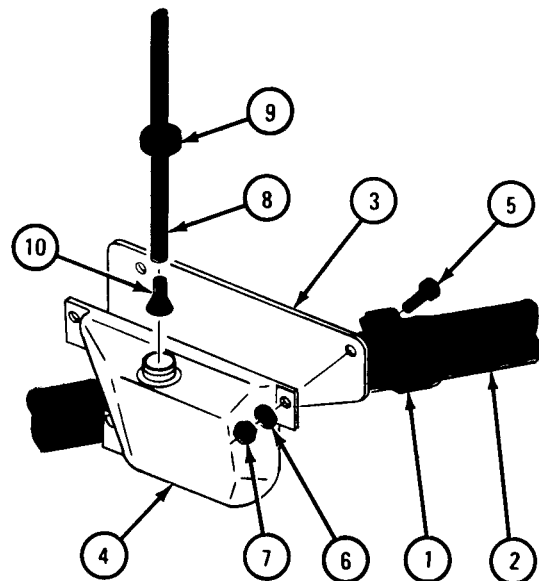
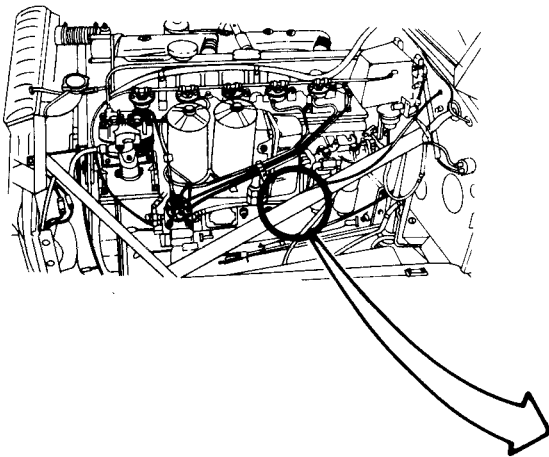

TA 084055

21-6. MIRROR AND BRACKET ASSEMBLY REMOVAL, REPAIR, AND REPLACEMENT.

NOTE

Procedure is the same for right mirror and bracket assembly.

TOOLS : 9/16-inch open end wrench
7/16-inch open end wrench
7/8-inch open end wrench
1/2-inch socket wrench

SUPPLIES : None

PERSONNEL: One

EQUIPMENT CONDITION: Truck parked, engine off, handbrake set.

a. Removal.

FRAME 1

1. Using 9/16-inch wrench, unscrew nut (1) from bolt (2).
2. Take out bolt (2), two lockwashers (3), and two flat washers (4).
3. Do steps 1 and 2 again at lower end of bracket (5) and take off mirror and arm assembly (6).

GO TO FRAME 2

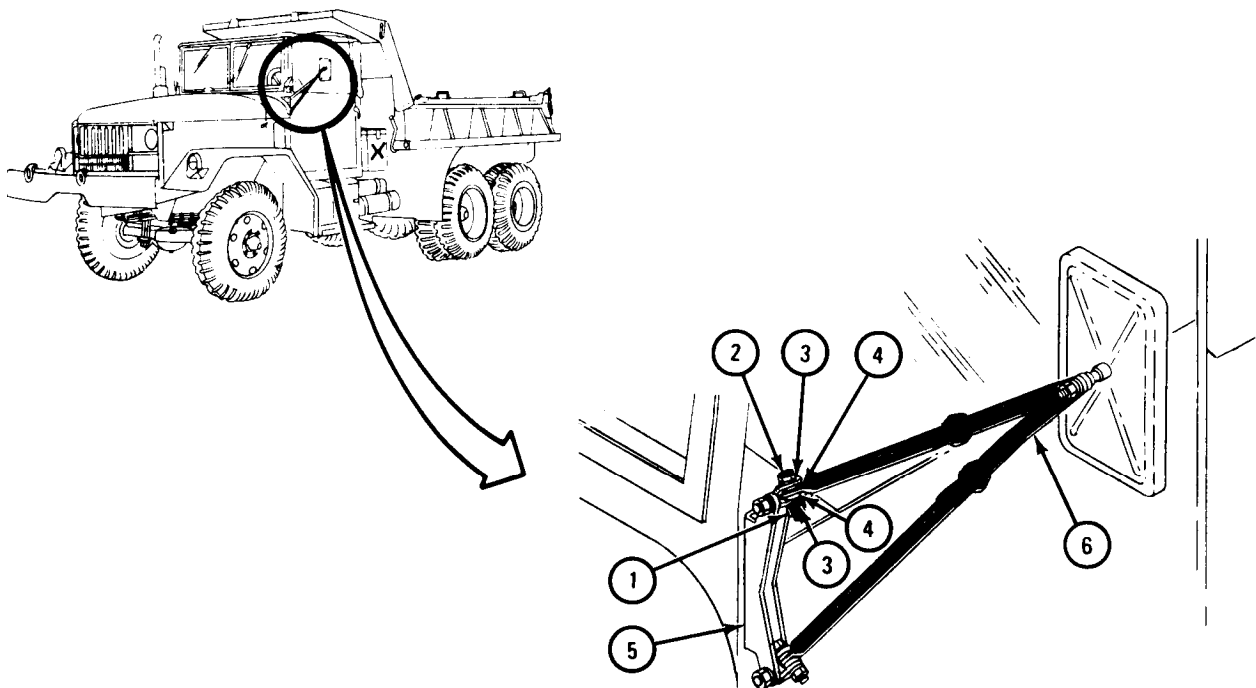

TA 047294

FRAME 2

1. Using 7/16-inch wrench, unscrew and take off nut (1) and lockwasher (2).
2. Pull mirror (3) out of upper arm (4) and lower arm (5).

GO TO FRAME 3

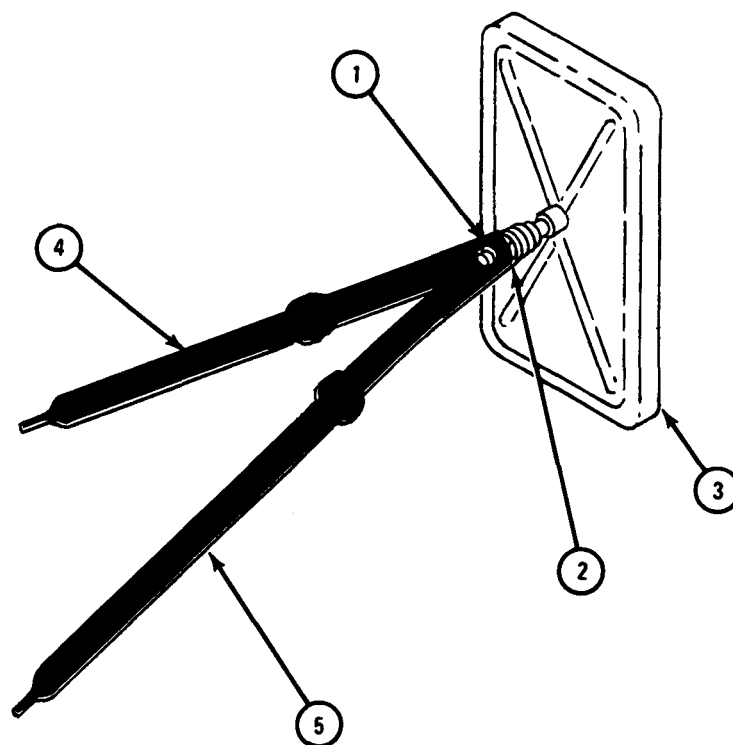

TA 047295

FRAME 3

1. Using 1/2-inch socket wrench, unscrew two lockwasher bolts (1) and take off bracket (2).

GO TO FRAME 4

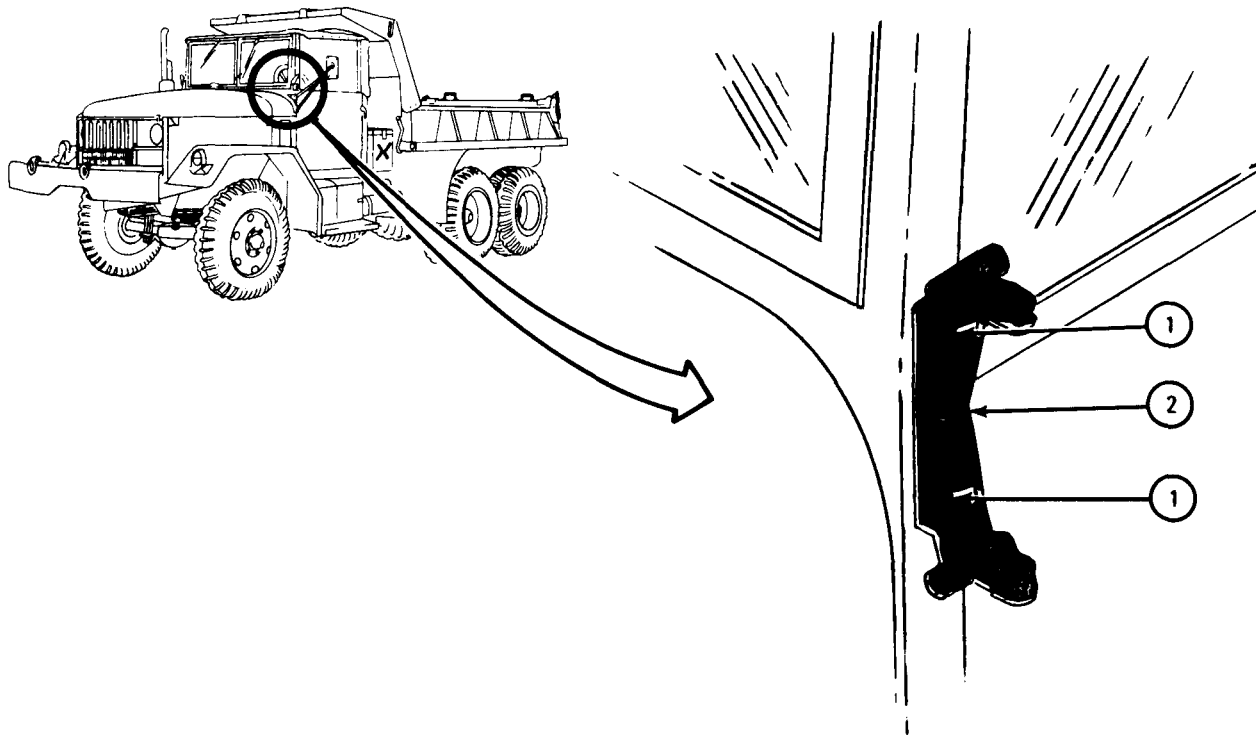

TA 047296

FRAME 4

1. Using 9/16-inch wrench, unscrew nut (1) from bolt (2). Take bolt out of bracket (3) and off two lockwashers (4).
2. Pull loop clamp (5) out of bracket (3) taking off two fiber washers (6) and two flat washers (7).
3. Do steps 1 and 2 again at bottom of bracket (5).

END OF TASK

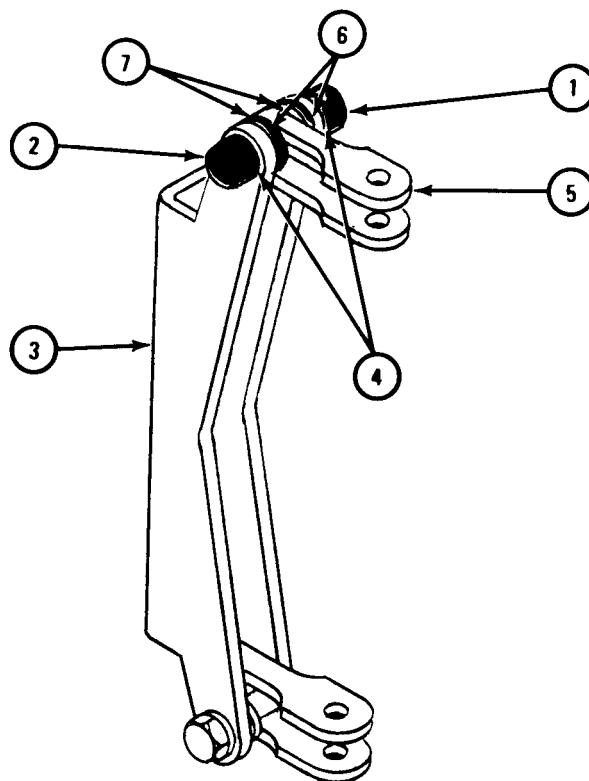

TA 047297

- b. Repair. Repair mirror and bracket assembly by replacing damaged parts.
- c. Replacement.

FRAME 1

1. Put threaded stud (1) through arms (2 and 3) as shown.
2. Screw on nut (4) with lockwasher (5). Snug up nut, but do not tighten at this time.

GO TO FRAME 2

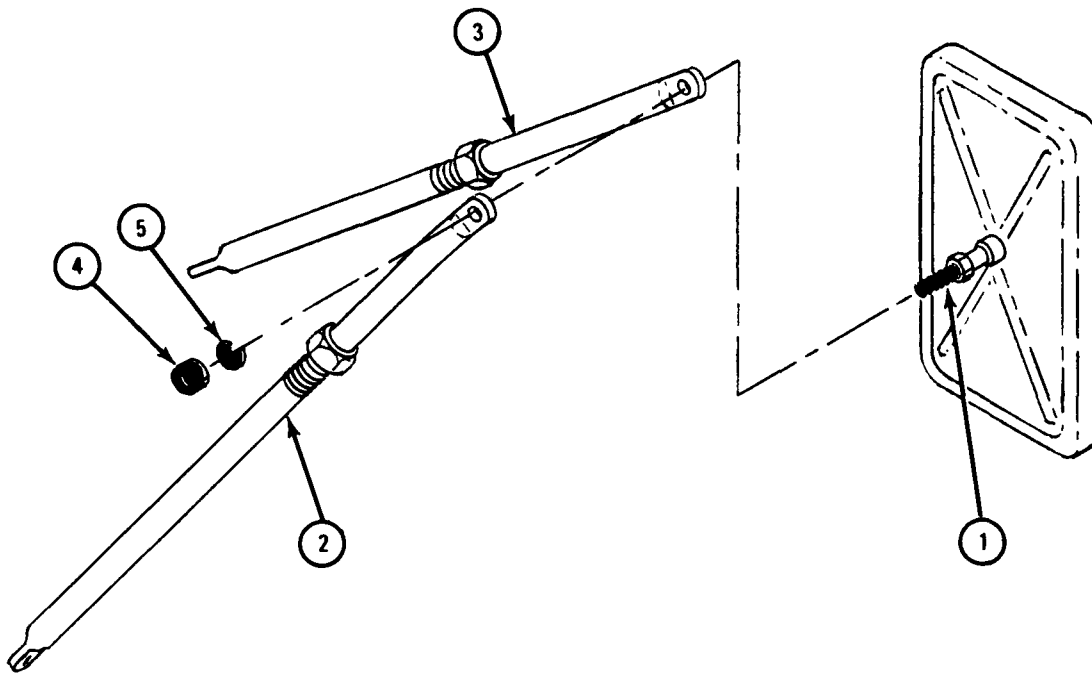

TA 047298

FRAME 2

1. Join loop clamp (1) to bracket (2) as shown.
 2. Use bolt (3), two lockwashers (4), two fiber washers (5), two flat washers (6), and nut (7). Put parts together as shown.
 3. Using 9/16-inch wrench, snug up nut (7), but do not tighten at this time.
 4. Do steps 2 and 3 again to join loop clamp at other end of bracket (2).
- GO TO FRAME 3

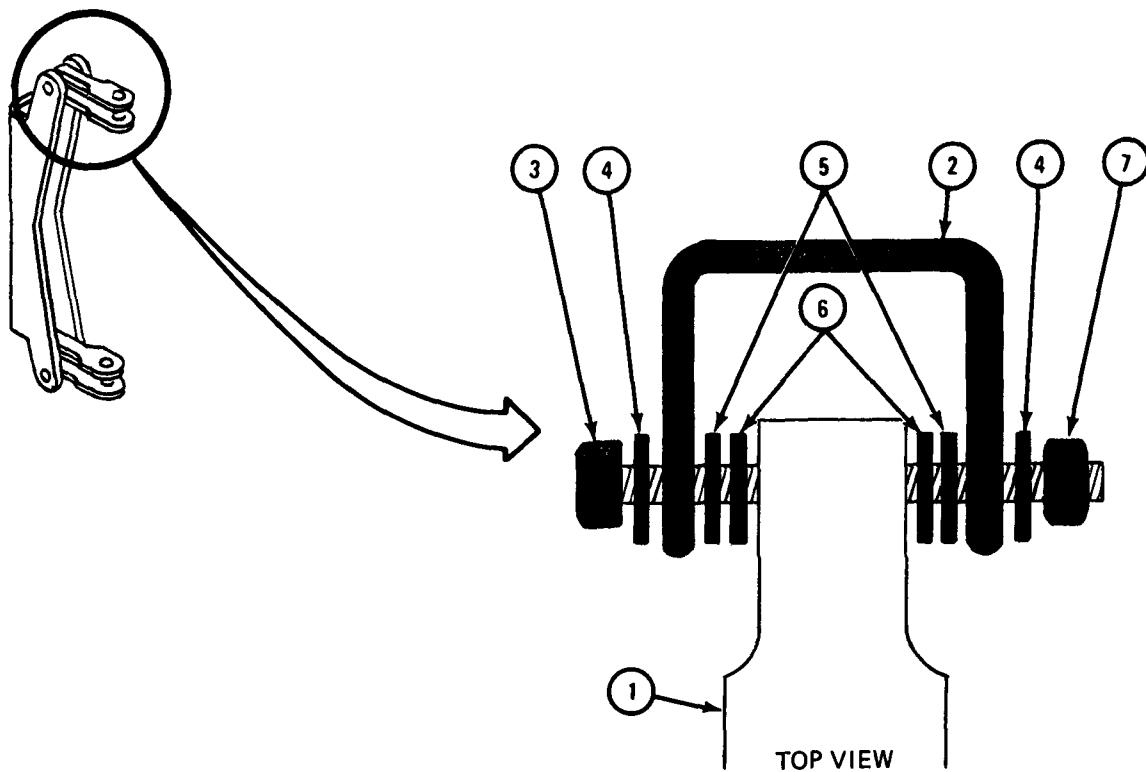

TA 047299

FRAME 3

1. Place bracket (1) so bracket holes align with two mounting holes in truck as shown.
2. Screw in two lockwasher bolts (2) as shown and tighten using 1/2-inch socket wrench.

GO TO FRAME 4

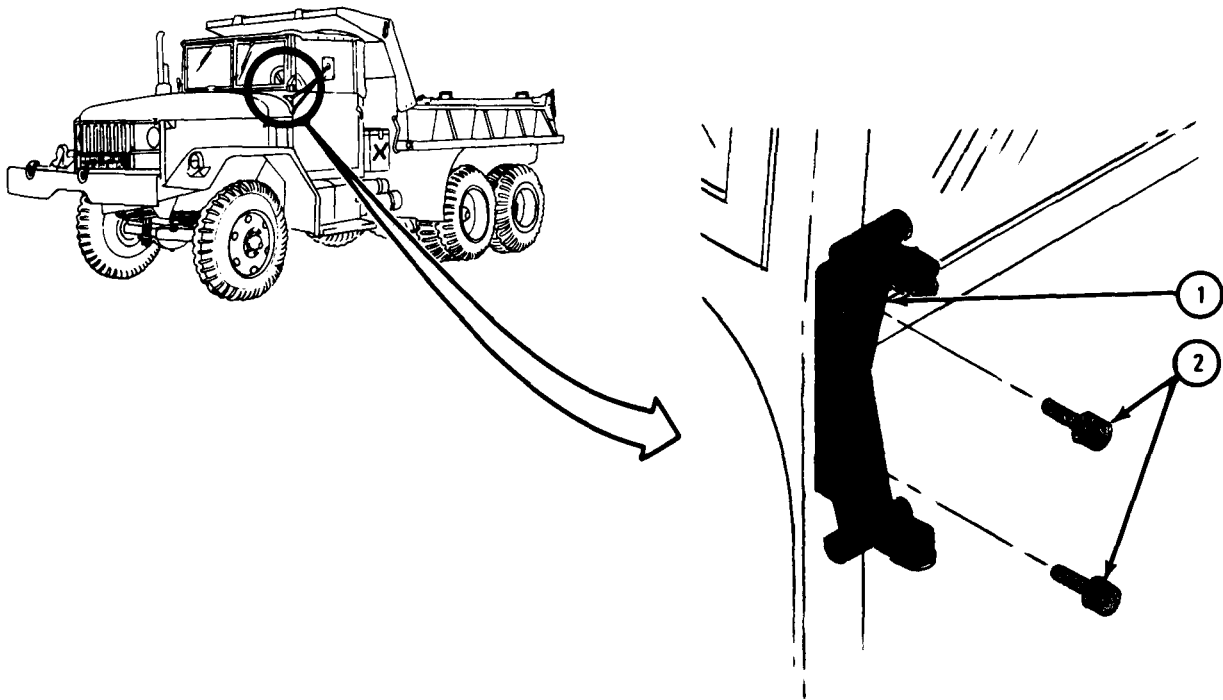

TA 047300

FRAME 4

1. Join upper arm (1) to loop clamp (2) as shown.
 2. Put bolt (3), two lockwashers (4), two flat washers (5), and nut (6) together as shown.
 3. Using 9/16-inch wrench, snug up nut (6), but do not tighten at this time.
 4. Do steps 1 through 3 again to join lower arm to other loop clamp.
- GO TO FRAME 5

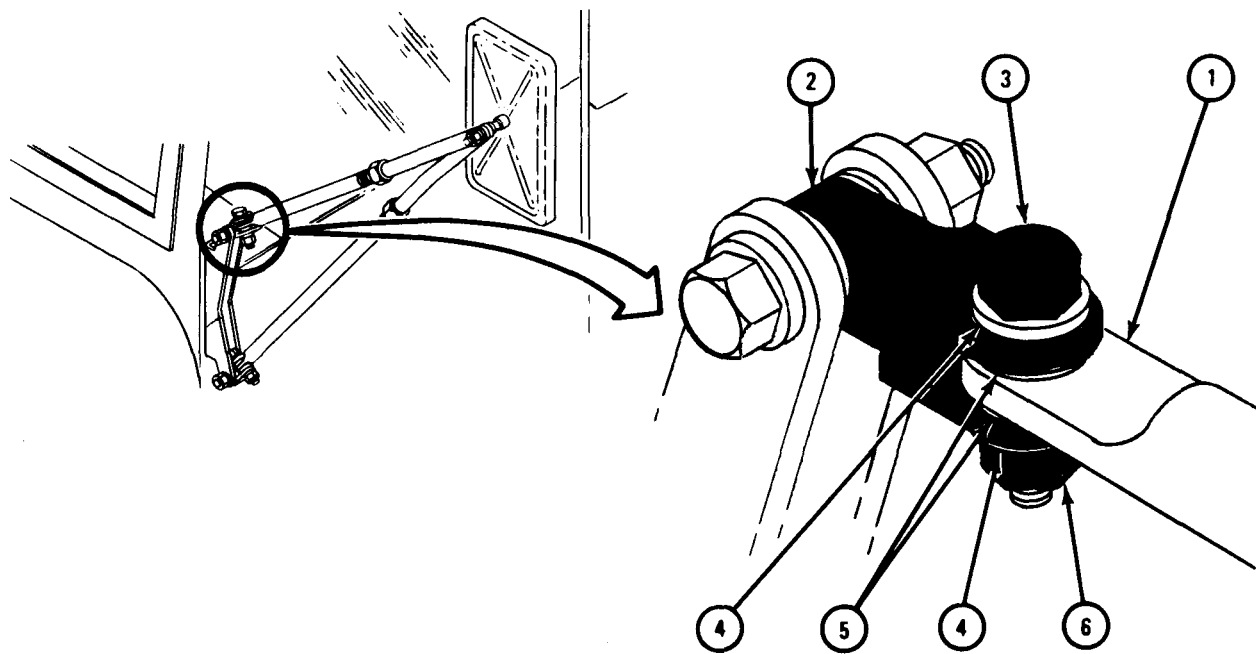

TA 047301

FRAME 5

1. Using 7/8-inch wrench, loosen two adjustment nuts (1) on arms (2). Set arm length for right mirror height and tighten nuts.
2. Using 7/16-inch wrench, tighten two nuts (3).
3. From driver's position, swing mirror assembly toward front or rear of truck. When rear view is right, tighten two nuts (4) using 9/16-inch wrench.
4. Using 7/16-inch wrench, tighten mirror nut (5).

END OF TASK

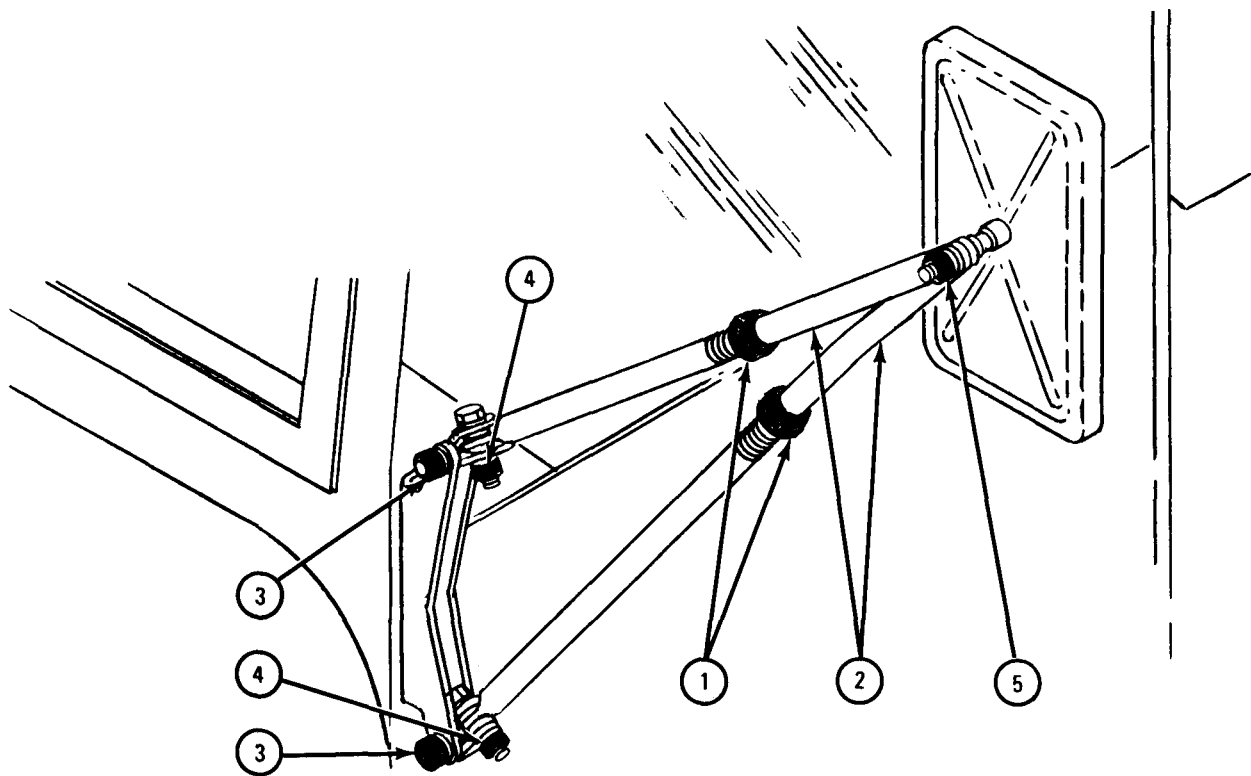

TA 047302

Section IV. DATA PLATES

21-7. DATA PLATES REMOVAL AND REPLACEMENT.

TOOLS : 1/2-inch cold cut chisel (data plates held with rivets or drive screws)
8-ounce hammer (data plates held with rivets or drive screws)
1/8-inch punch (data plates held with rivets or drive screws)
Blind hand riveter (data plates held with rivets)
Cross-tip screwdriver (Phillips type) (data plates held with screws)
Scraper (data plates held with adhesive)
6-inch pliers (data plates held with adhesive)

SUPPLIES : None

PERSONNEL: One

EQUIPMENT CONDITION: Truck parked, engine off, handbrake set.

a. Removal.

NOTE

Note which plates are taken off so they are put back in the same place.

(1) Riveted data plates.

FRAME 1

1. Using hammer and chisel, cut heads off each rivet (1) holding data plate (2) in place.

CAUTION

Before punching rivet ends through an item, make sure rivets (1) go through to other side. Do not punch rivets held in deep solid block or hollow bottomless assemblies. Damage to equipment could result.

2. Using hammer and punch, tap out the rest of each rivet (1) and take off data plate (2).

END OF TASK

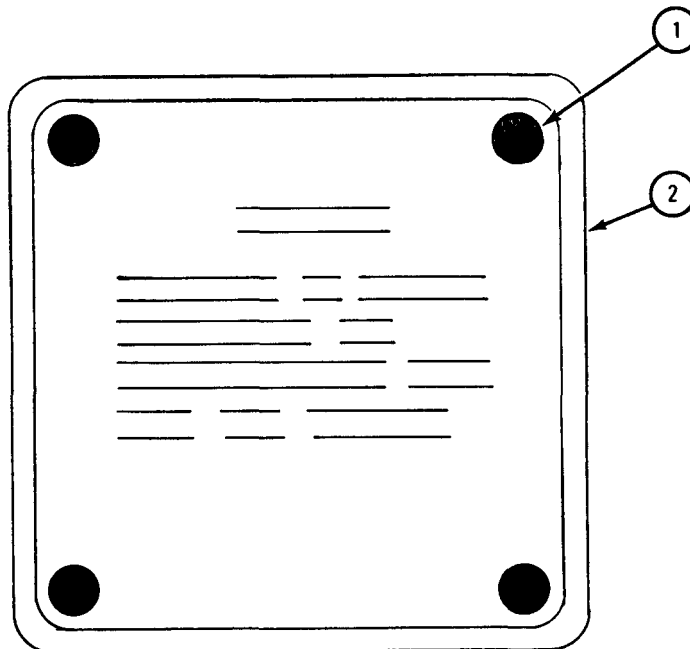

TA 080846

(2) Data plates held with screws.

FRAME 1

1. Using screwdriver, unscrew and take out screws (1) while holding data plate (2).
 2. Take off data plate.
- END OF TASK

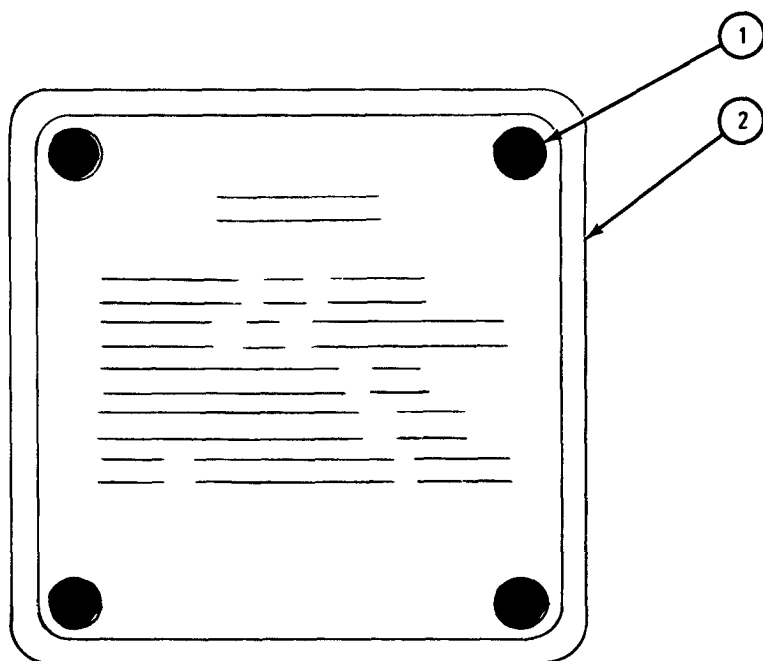

TA 080848

(3) Data plates held with drive screws.

FRAME 1

1. Using hammer and chisel, cut off head of each drive screw (1) holding data plate (2) in place.
2. Using hammer and center punch, center punch each drive screw (1).

CAUTION

Before punching drive screw ends through an item, make sure drive screws (1) go through to other side. Do not punch screws held in deep solid block or hollow bottomless assemblies. Damage to equipment could result.

3. Using 1/8-inch punch and hammer, drive out rest of drive screws (1) and take off data plate (2).

END OF TASK

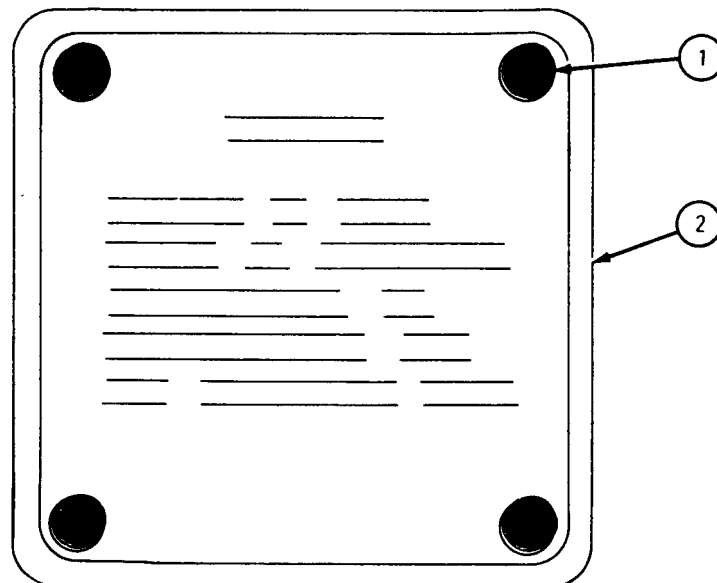

TA 080850

(4) Data plates held with adhesive.

FRAME 1

1. Using scraper, lift up one corner of data plate (1).
 2. Using pliers, take off data plate (1).
 3. Using scraper, takeoff adhesive from surface data plate (1) was held to.
- END OF TASK

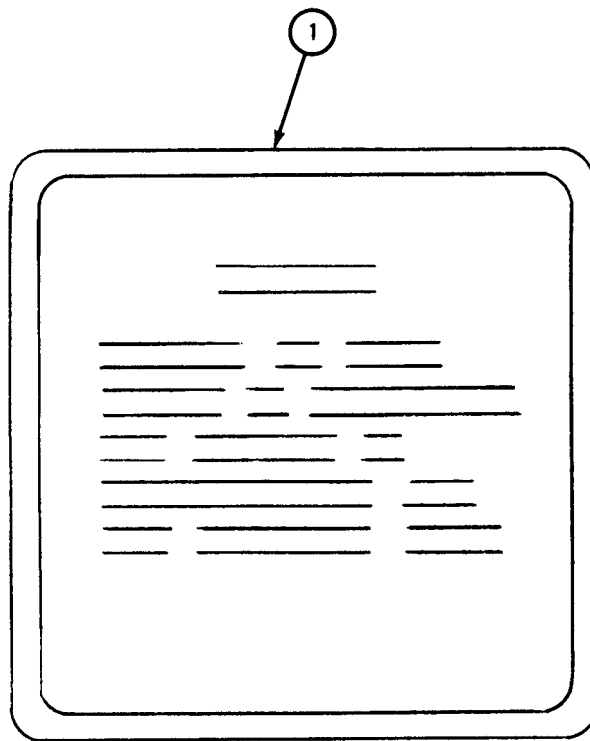

TA 080852

b. Replacement.

NOTE

Put back data plates as noted.

(1) Riveted data plates.

FRAME 1

1. Put data plate (1) in place and align rivet holes.
2. Put rivets (2) in blind riveter and through data plate (1) and part data plate is being riveted to.
3. Using blind riveter, rivet data plate (1) tightly in place.

END OF TASK

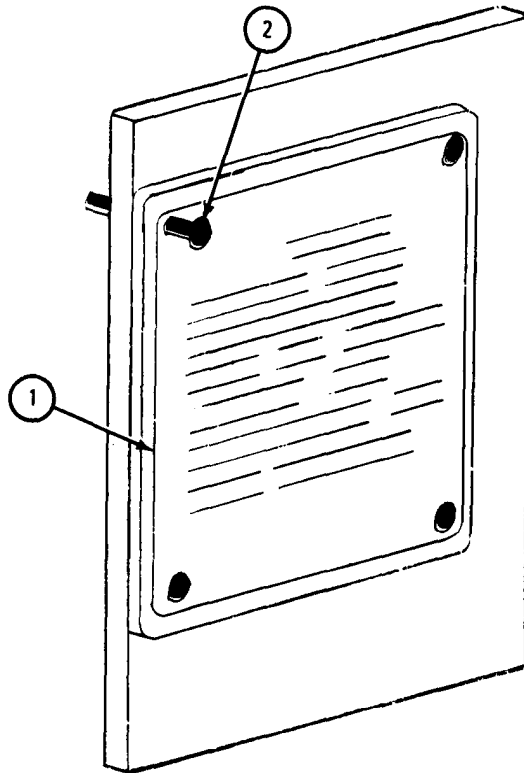

TA 080847

(2) Data plates held with screws.

FRAME 1

1. Put data plate (1) in place and aline holes.
 2. Using screwdriver, screw in and tighten screws (2).
- END OF TASK

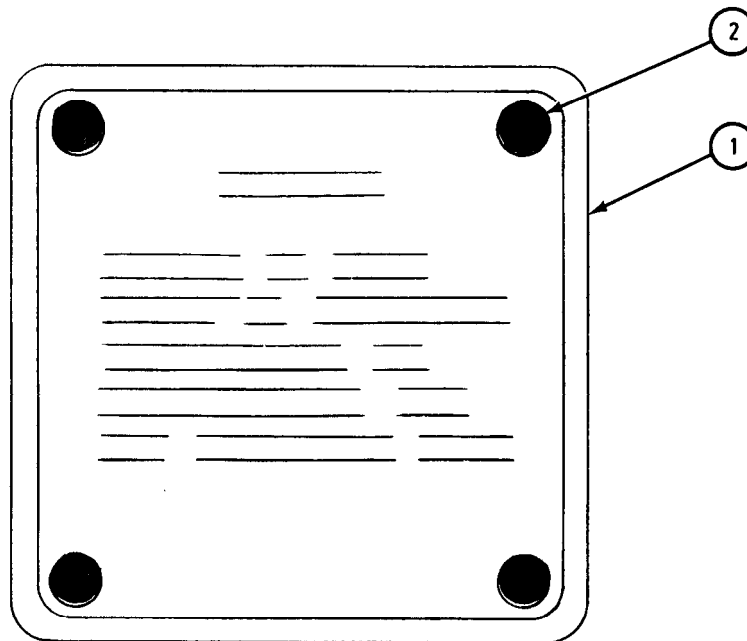

TA 080849

(3) Data plates held with drive screws.

FRAME 1

NOTE

Drive screws (1) used to put back data plate (2) must have a larger diameter than drive screw which were drilled out.

1. Put data plate (2) in place and aline holes.
2. Using hammer, tap in drive screws (1) until data plate (2) is tightly held in place.

END OF TASK

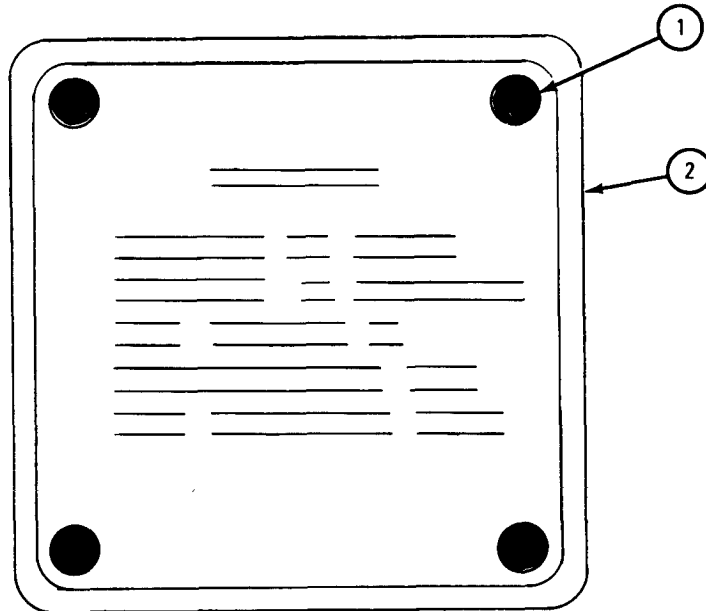

TA 080851

(4) Data plates held with adhesive.

FRAME 1

1. Peel off backing paper (1) from back of data plate (2).
2. Press data plate (2) in place. Rub data plate firmly to make sure it stays in place.

END OF TASK

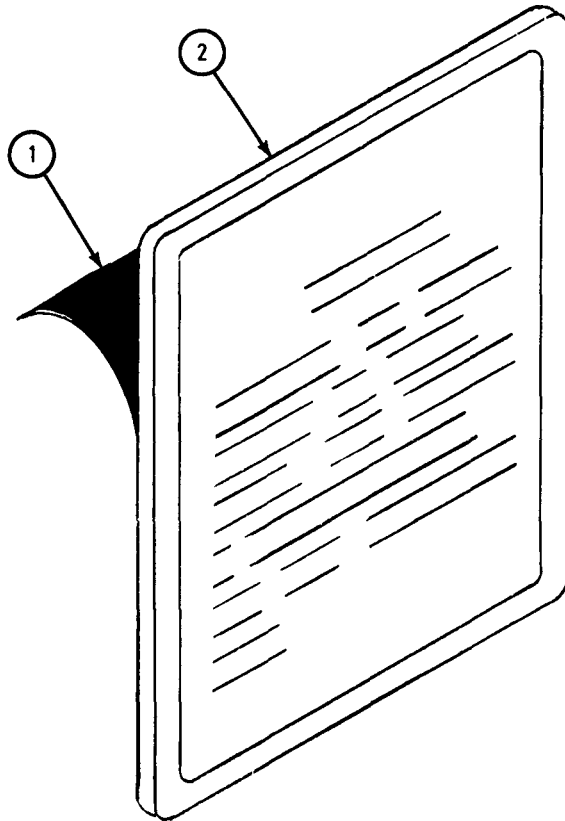

TA080853

CHAPTER 22

NONELECTRICAL GAGES GROUP MAINTENANCE

Section I. SCOPE

22-1. EQUIPMENT ITEMS COVERED. This chapter gives equipment maintenance procedures for nonelectrical gages for which there are authorized corrective maintenance tasks at the organizational maintenance level.

22-2. EQUIPMENT ITEMS NOT COVERED. All equipment items for which corrective maintenance is authorized at the organizational maintenance level are covered in this chapter.

Section II. NONELECTRICAL GAGES

22-3. TACHOMETER ASSEMBLY REMOVAL, REPAIR , AND REPLACEMENT.

TOOLS : Flat tip screwdriver 3/4-inch open end wrench
 7 /16-inch open end wrench 7/16-inch open end wrench
 1-inch open end wrench 3/8-inch open end wrench
 Slip joint pliers

SUPPLIES : Tachometer drive plug gasket
 Tachometer drive adapter gasket
 Rubber grommet

PERSONNEL : One

EQUIPMENT CONDITION : Truck parked, engine off, handbrake set.

a. Preliminary Procedures.

- (1) Disconnect battery ground cable. Refer to Part 1, para 7-58.
- (2) Open hood and left side panel. Refer to TM 9-2320-20%10.
- (3) Take off air compressor belt. Refer to Part 2, para 13-34.

b. Removal of Tachometer.

FRAME 1

1. Using screwdriver, turn mounting studs (1) one quarter turn to the left.
 2. Pull instrument cluster (2) away from instrument panel (3).
- GO TO FRAME 2

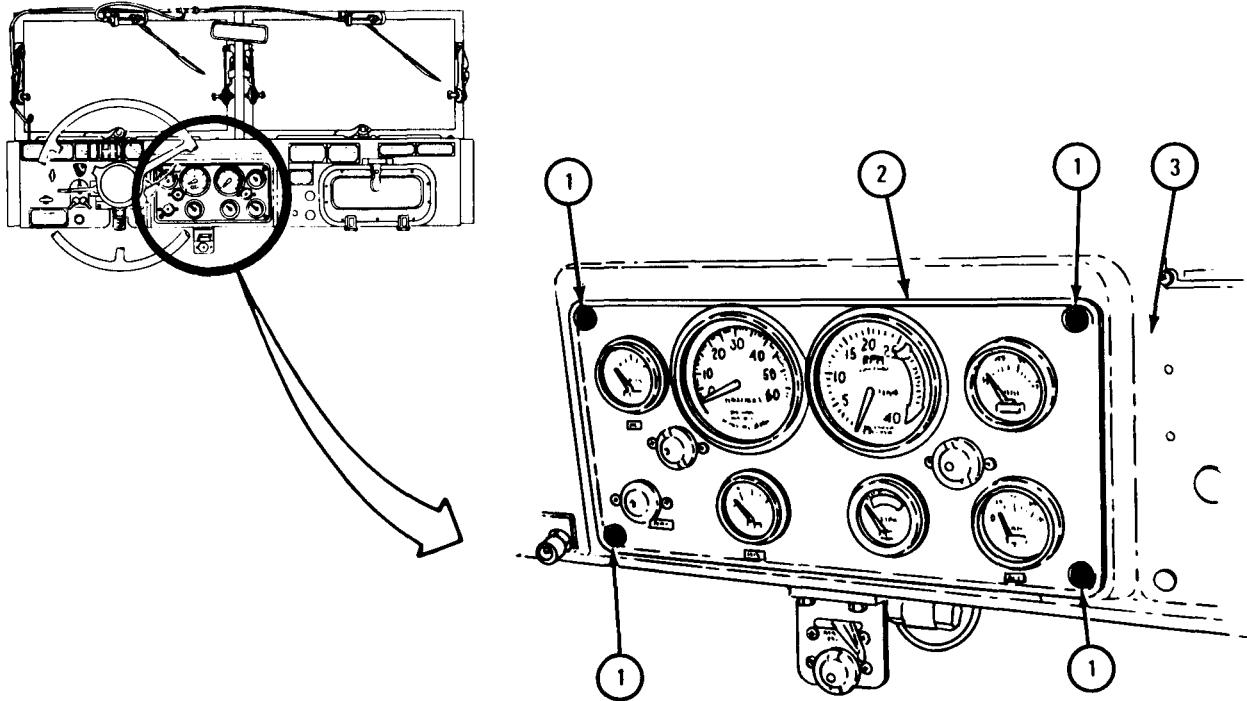

TA 101566

FRAME 2

1. Using 3/4-inch wrench, unscrew nut (1) and pull flexible shaft assembly (2) away from tachometer (3). Take off gasket (4).
2. Using 3/8-inch wrench, unscrew and take off two nuts and lockwashers (5). Pull clamp (6) off tachometer (3) and take tachometer out from front of panel (7).
3. Enter hours of operation, shown on tachometer (3), in vehicle equipment log if another tachometer is to be put in.

END OF TASK

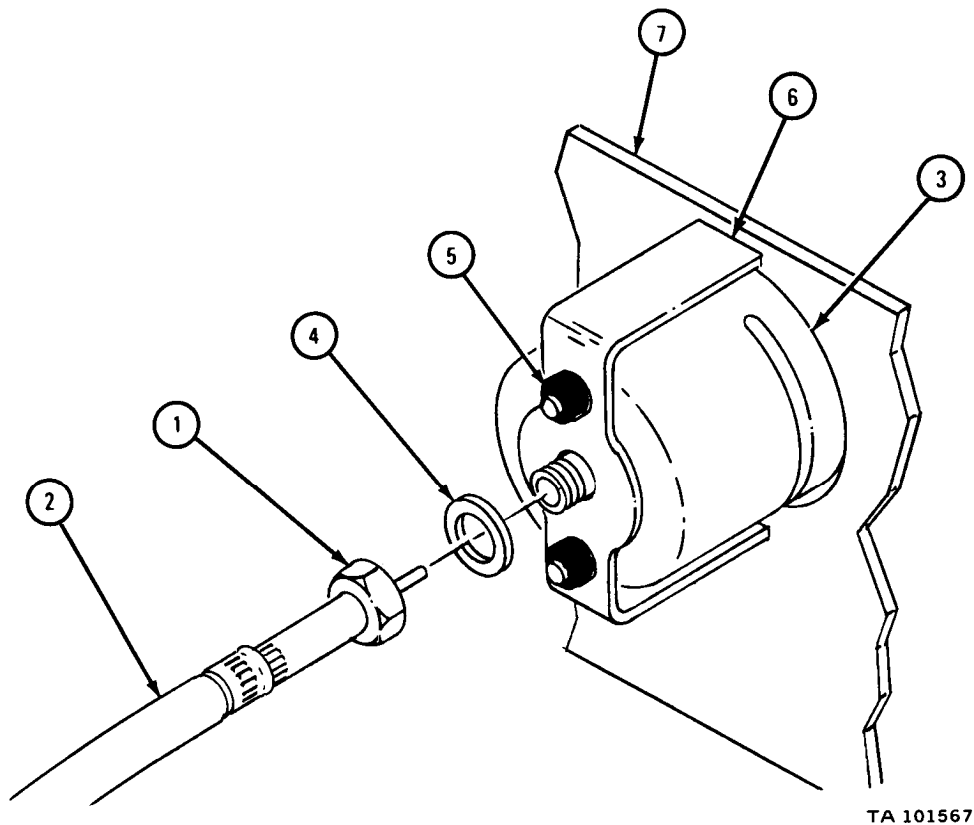

TA 101567

c. Removal of Flexible Shaft Assembly.

FRAME 1

1. Using 1-inch wrench, unscrew nut (1). Pull flexible shaft assembly (2) away from right angle adapter (3).
 2. Take off gasket (4). Throw away gasket.
- GO TO FRAME 2

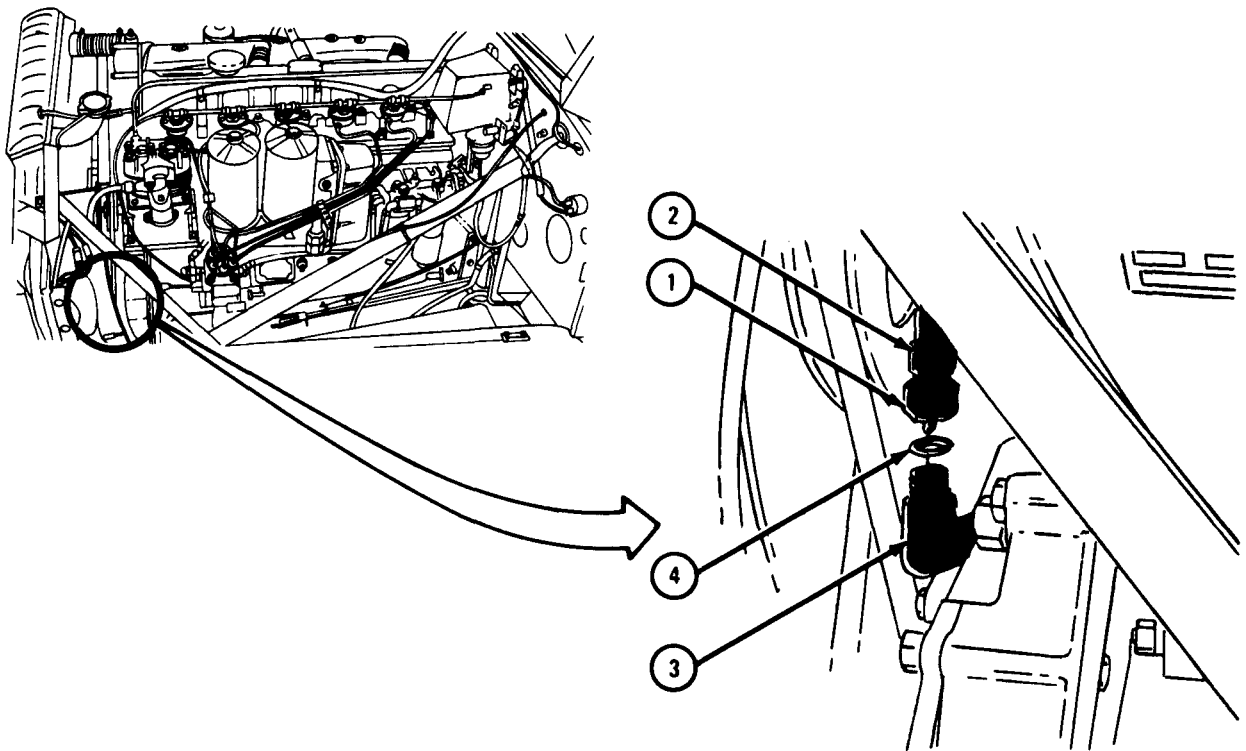

TA 047309

FRAME 2

1. Using 7/16-inch wrenches, unscrew and take off three locknuts (1) and bolts (2).
2. Take three clamps (3) off brackets (4). Take clamps off flexible shaft assembly (5) by spreading clamps.

GO TO FRAME 3

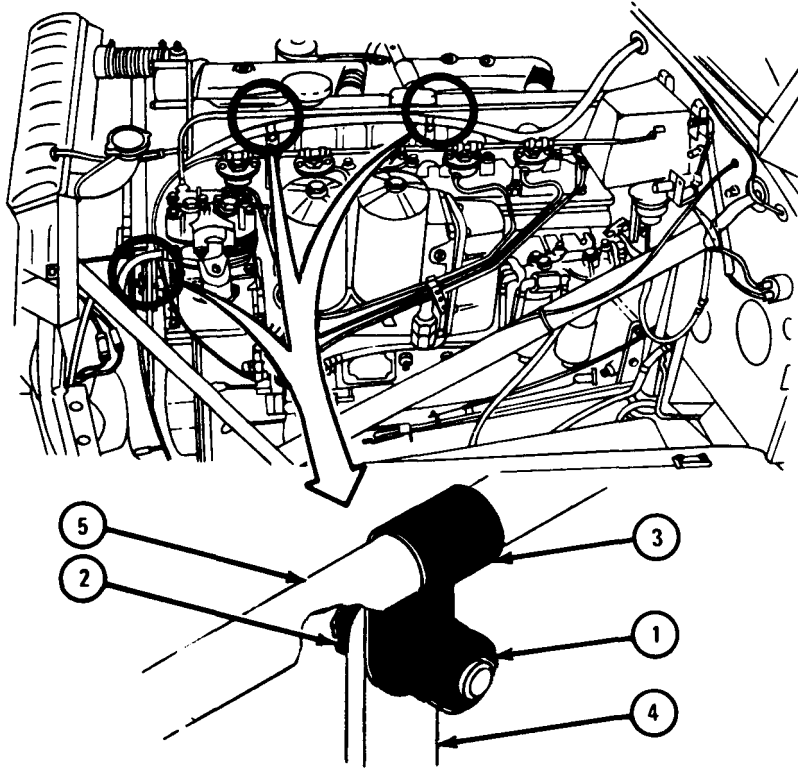

TA 047310

FRAME 3

1. Take grommet (1) out of hole in firewall (2).
2. Pull end of flexible shaft assembly (3) out through firewall (2).

END OF TASK

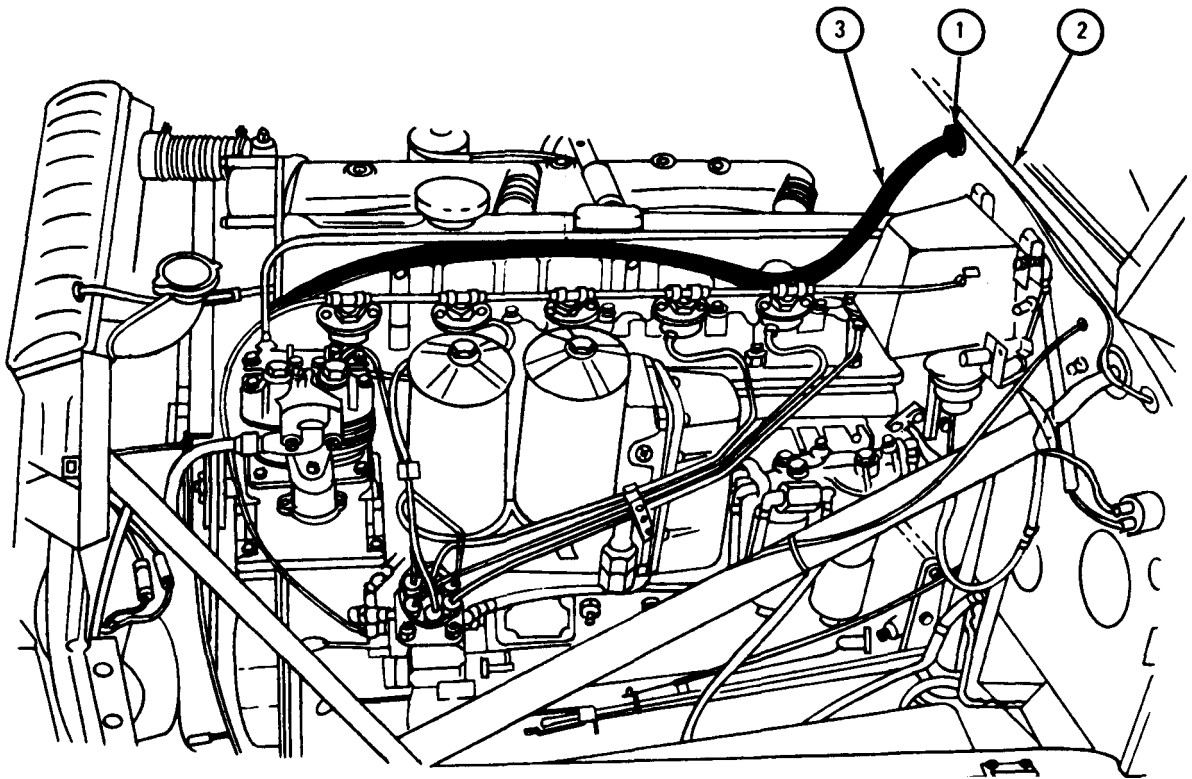

TA 047311

d. Removal of Right Angle Adapter.

FRAME 1

1. Using 1-inch wrench, unscrew tachometer angle drive adapter (1) and take out drive shaft (2).
2. Using 1-inch wrench, unscrew and take off adapter (3) and gasket (4).

END OF TASK

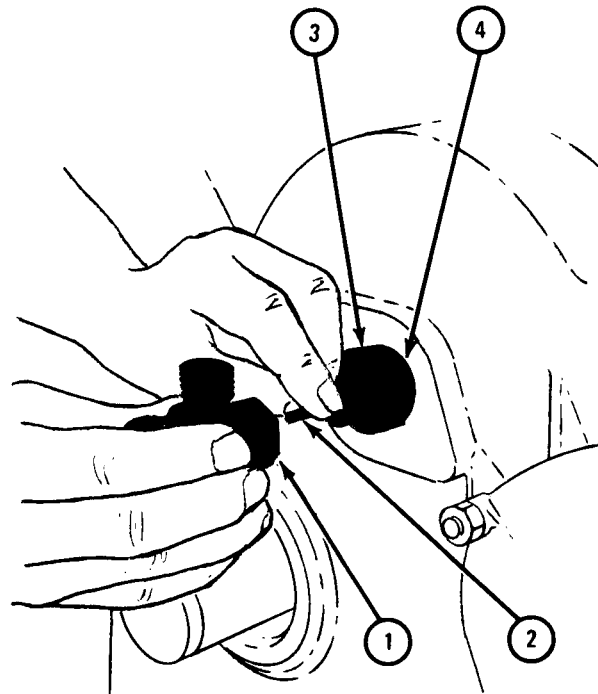
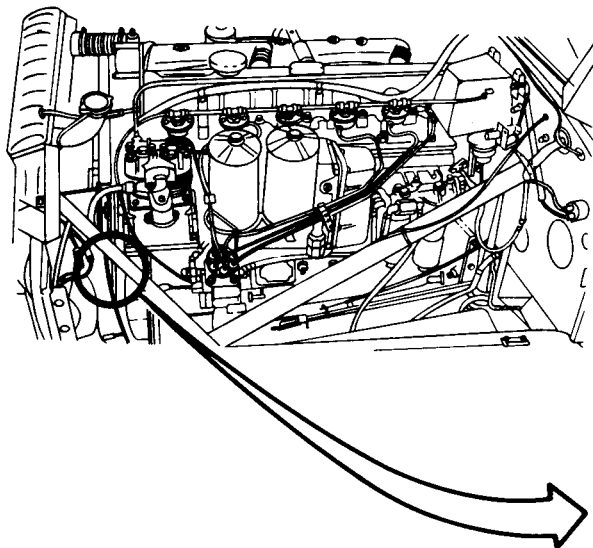

TA 047312

e. Removal of Flexible Shaft Core.

FRAME 1

NOTE

Flexible shaft assembly does not have to be taken out of truck to replace core. However, shaft assembly must be taken off at tachometer end and engine end.

1. Take off clip (1) from engine end of shaft core (2).
2. Take out shaft core (2) from casing (3) by pulling on tachometer end (4) of core, using pliers.
3. If shaft core (2) is broken, use pliers on engine end (5) to pull out other piece.

END OF TASK

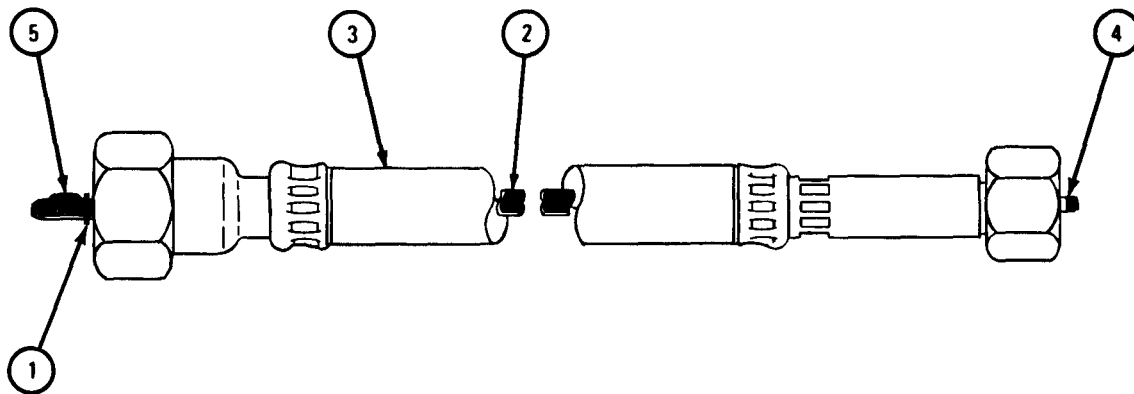

TA 101568

f. Repair of Flexible Shaft Assembly. Repair of the flexible shaft assembly is limited to replacement of the core. Refer to para 22-3e and 22-3g of this procedure.

g. Replacement of Flexible Shaft Core.

NOTE

Before putting back flexible shaft core, check that casing has no dents, sharp bends or other damage. If casing is damaged, do not put back core. Get a new complete flexible shaft assembly.

FRAME 1

1. Put keyed end (1) of core (2) into tachometer end of casing (3) that has the smaller coupling nut.
2. Carefully push core (2) through casing (4) until keyed end (5) seats in engine end of housing (5). Square end (6) should stick out of tachometer end of housing (3).
3. Put clip (7) in engine end of core (2).

END OF TASK

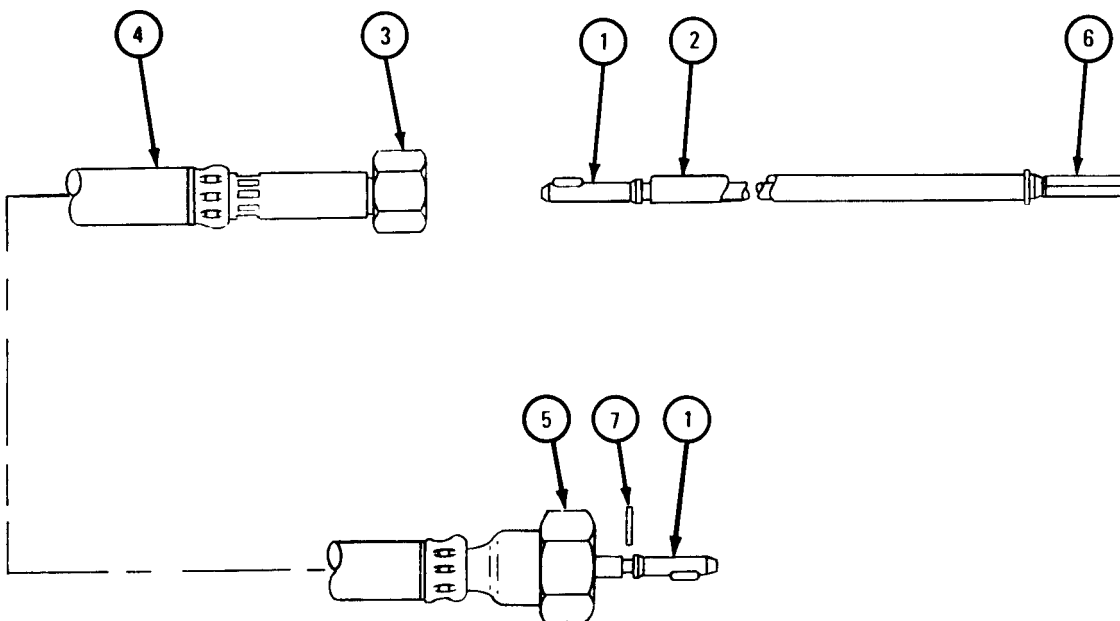

TA 101569

h. Replacement of Right Angle Adapter.

FRAME 1

1. Put gasket (1) on takeoff adapter (2) and screw adapter into mounting hole. Using 1-inch wrench, tighten adapter.
2. Put drive shaft (3) into takeoff adapter (2) and screw on angle drive adapter (4).
3. Using 1-inch wrench, tighten and position angle drive adapter (4). Face angle drive adapter so it will be in line with flexible cable assembly when put in.

END OF TASK

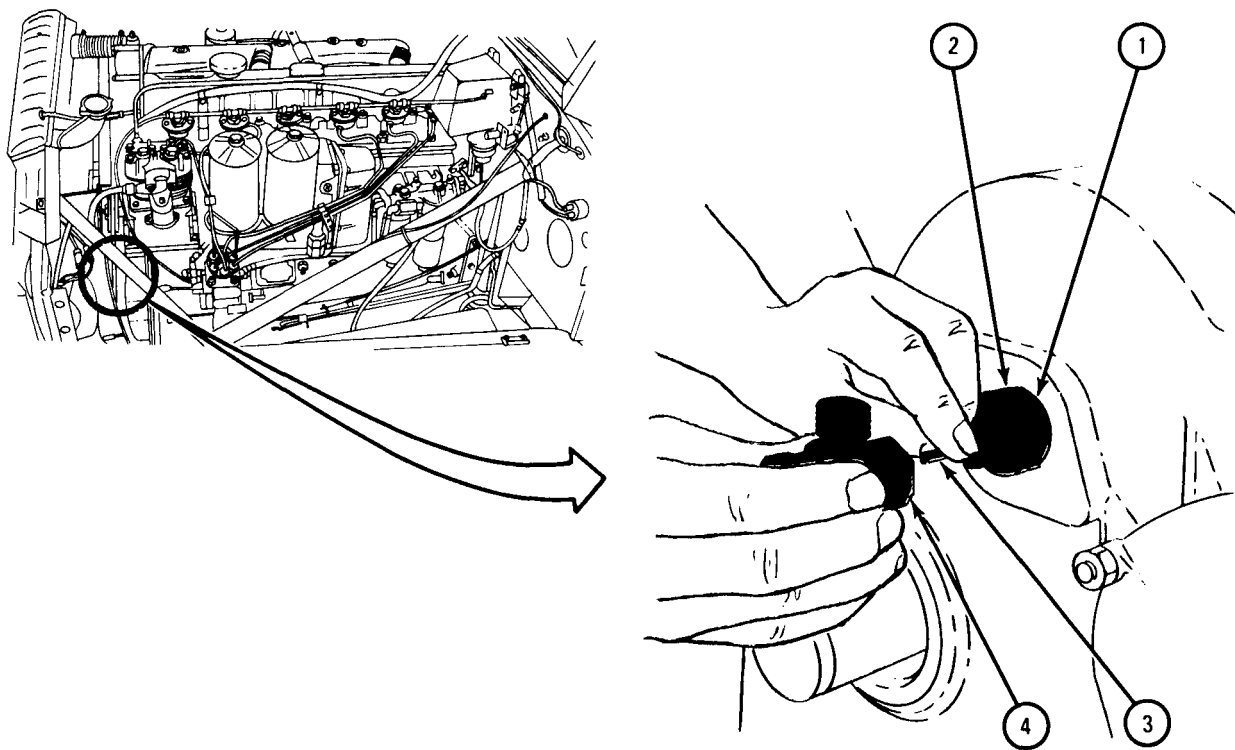

i. Replacement of Flexible Shaft Assembly.

FRAME 1

1. Place flexible shaft assembly (1) along top of engine as shown.
2. Put new grommet (2) in hole in firewall (3).

NOTE

Tachometer end (4) of flexible shaft assembly (1) has square shank.

3. Put tachometer end (4) of flexible shaft assembly (1) through grommet (2) as shown.

GO TO FRAME 2

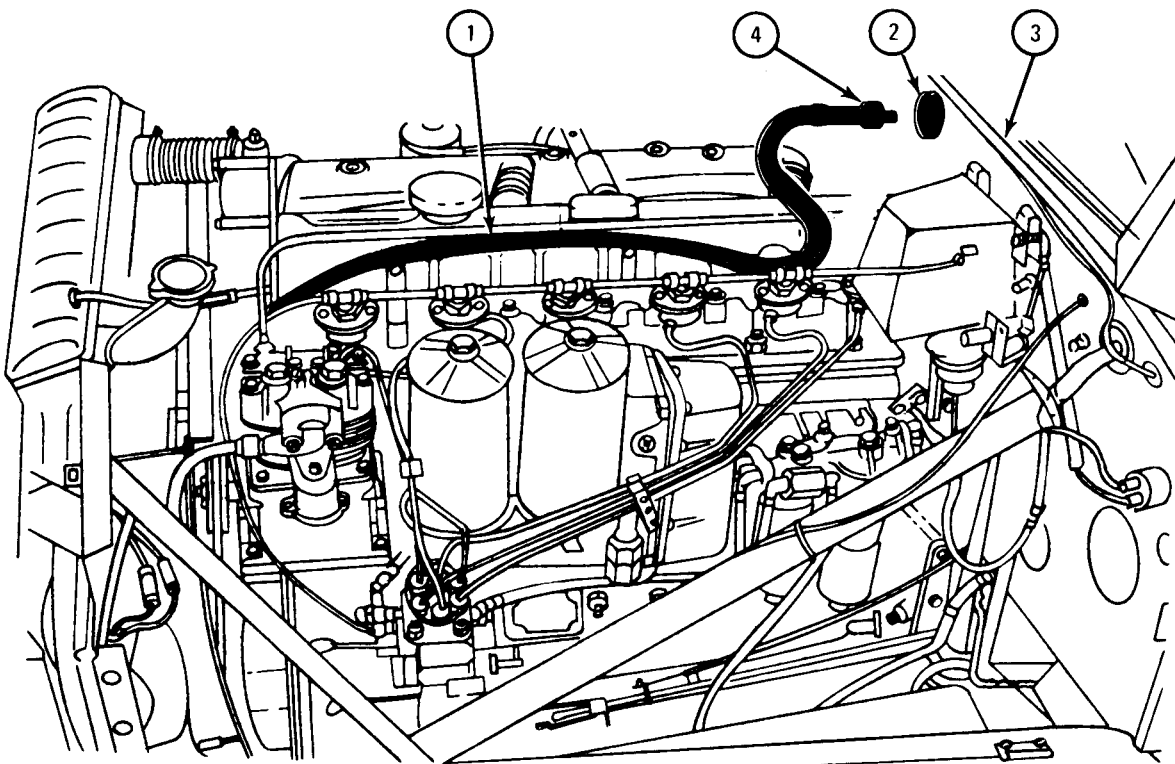

TA 047316

FRAME 2

1. Place gasket (1) on angle drive adapter (2). Aline key (3) with keyway in angle drive adapter and screw on coupling nut (4). Using 1-inch wrench, tighten coupling nut.
2. Put three clamps (5) on flexible shaft assembly (6). Aline holes in clamps with holes in three brackets (7).
3. Join three clamps (5) to brackets (7) using three bolts (8) and three locknuts (9). Using 7/16-inch wrenches, tighten locknuts.

END OF TASK

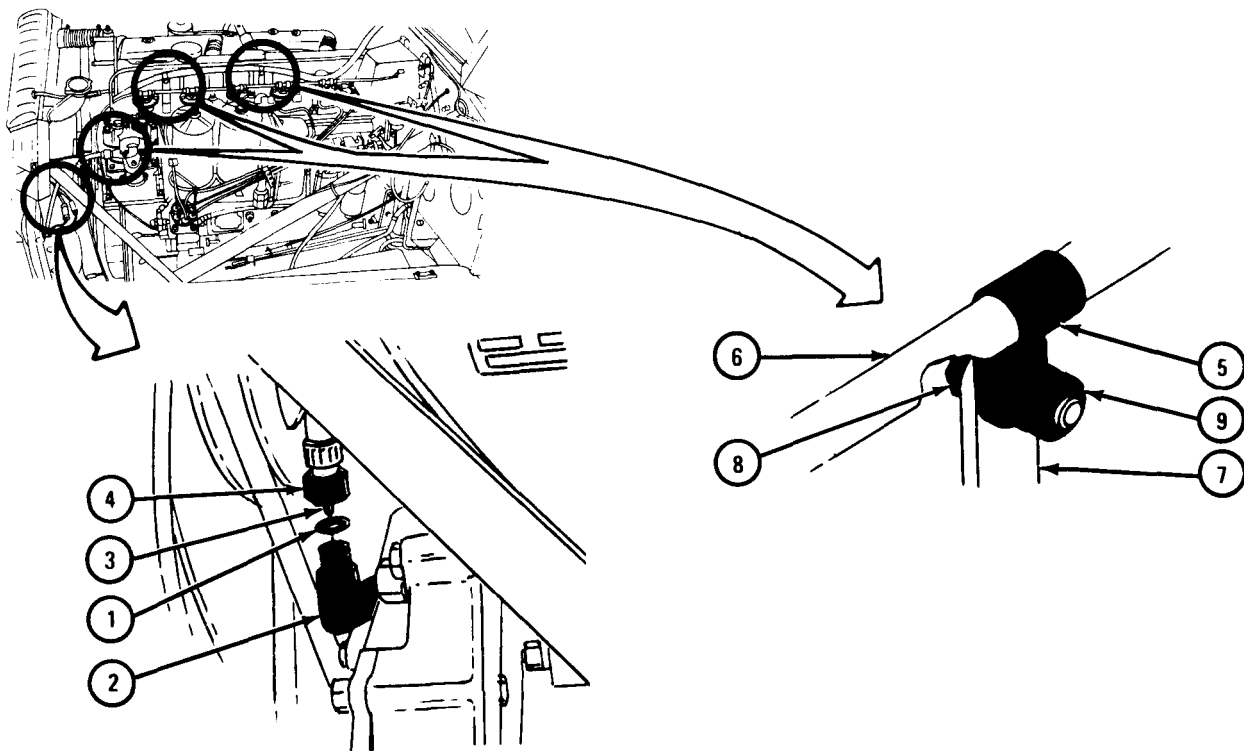

TA 047317

j. Replacement of Tachometer.

FRAME 1

1. Put tachometer (1) through hole in panel (2) from front of panel.
2. Place clamp (3) over studs (4) and screw on two nuts (5) with lockwashers (6).
3. Look at front of panel (2) and turn tachometer (1), if necessary, to make sure it is straight. Using 3/8-inch wrench, tighten two nuts (5).

GO TO FRAME 2

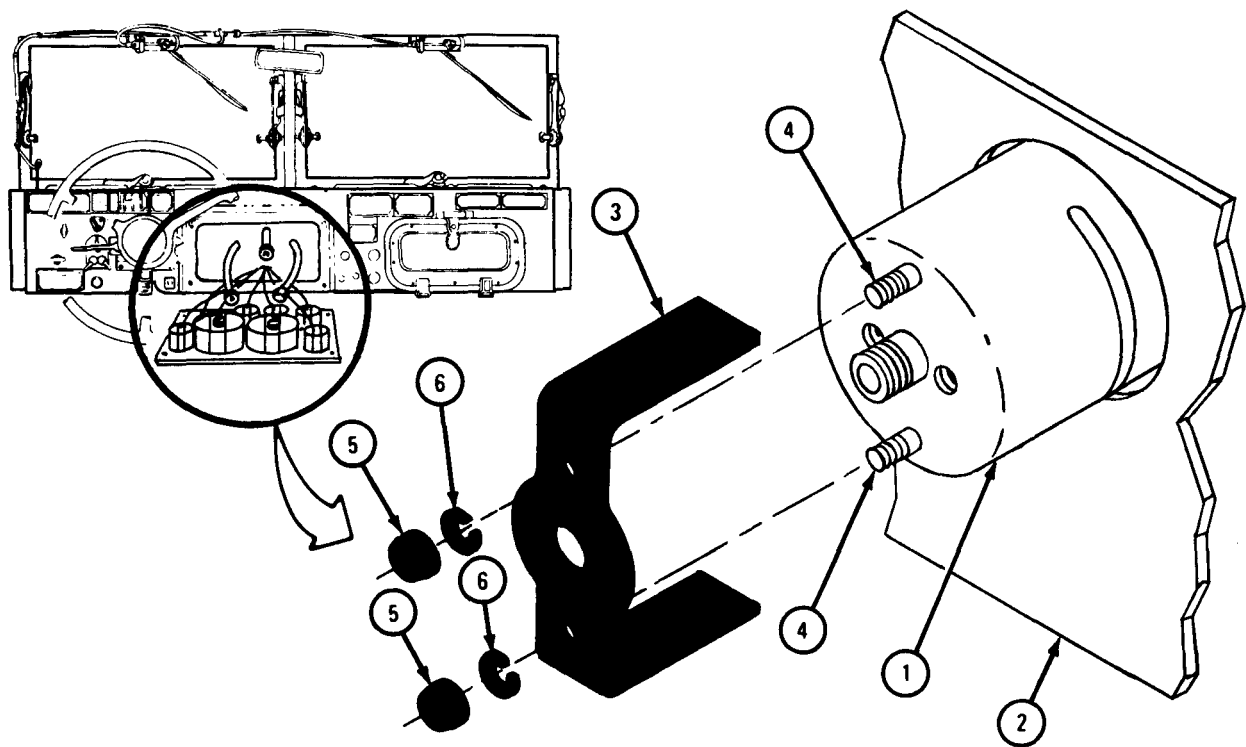

TA 101570

FRAME 2

1. Put gasket (1) over end of flexible shaft assembly (2) and press into coupling nut (3).
2. Put square end of flexible shaft assembly (2) into tachometer (4) and screw on coupling nut (3). Using $\frac{1}{4}$ -inch wrench, tighten nut.

GO TO FRAME 3

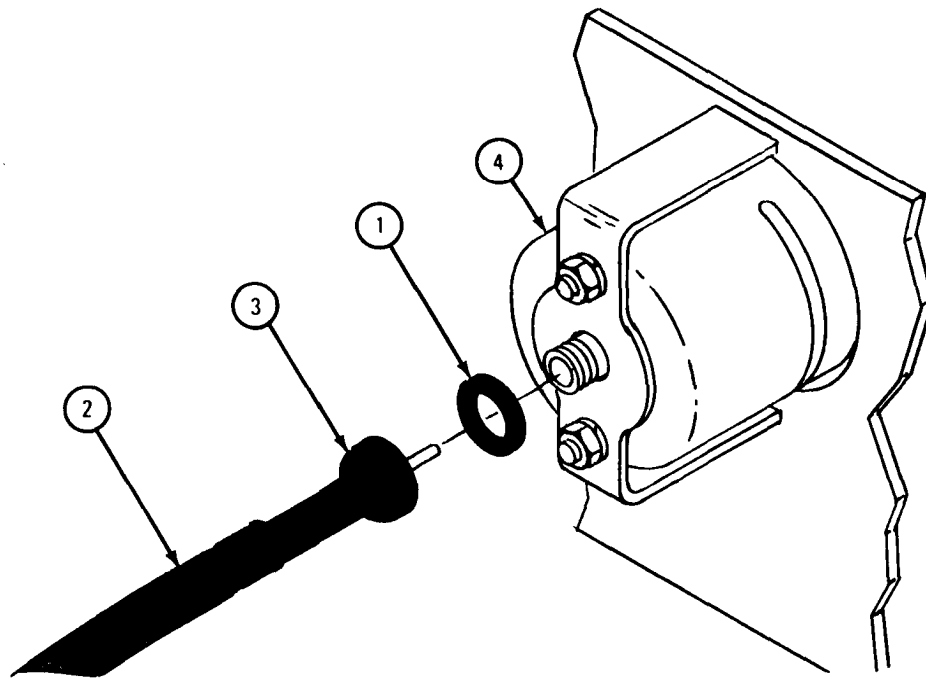

TA 101571

FRAME 3

1. Place instrument cluster (1) on instrument panel (2) as shown.
2. Using screwdriver, turn mounting studs (3) 1/4 turn to right.
3. Enter hours of operation shown on tachometer in vehicle equipment log if new one was put in.

NOTE

Follow-on Maintenance Action Required:

1. Put on air compressor belt. Refer to Part 2, para 13-34.
2. Reconnect battery ground cable. Refer to Part 1, para 7-58.
3. Close hood and left side panel. Refer to TM 9-2320-209-10.
4. Start engine and check tachometer operation. Refer to TM 9-2320-209-20.

END OF TASK

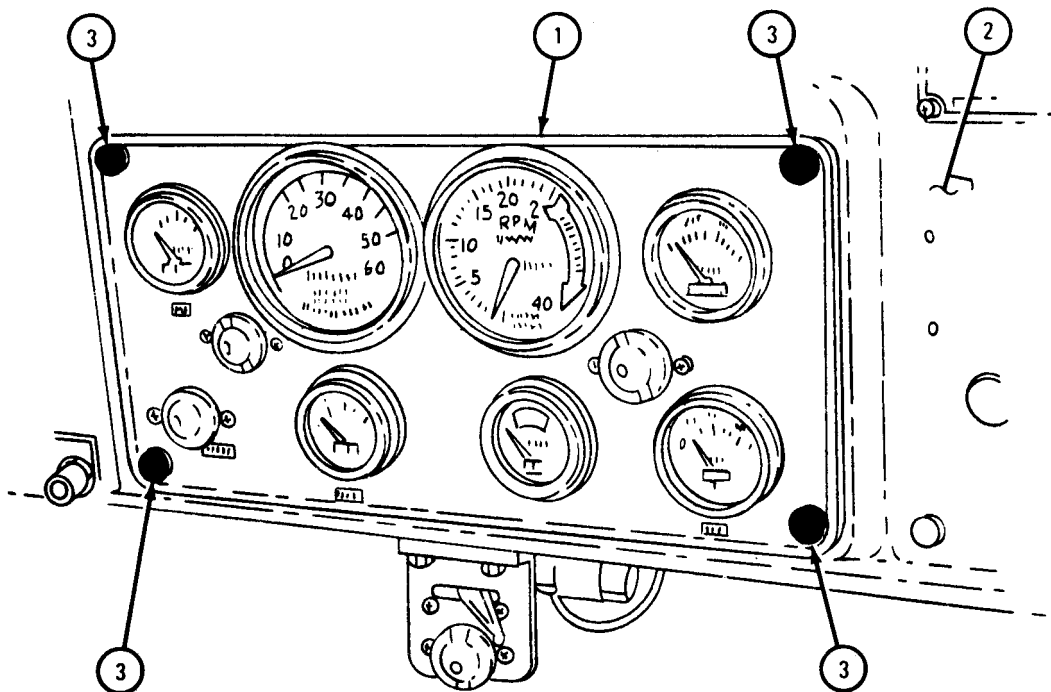

TA 101572

22-4. SPEEDOMETER ASSEMBLY REMOVAL, REPAIR, AND REPLACEMENT.

TOOLS: Flat-tip screwdriver 1-inch open end wrench
 3/4-inch open end wrench 9/16-inch open end wrench
 3/8-inch open end wrench 7/8-inch open end wrench
 Slip joint pliers

SUPPLIES: Cotter pin

PERSONNEL: Two

EQUIPMENT CONDITION: Truck parked, engine off, handbrake set.

a. Preliminary Procedures.

- (1) Disconnect battery ground cable. Refer to Part 1, para 7-58.
- (2) Open hood and left side panel. Refer to TM 9-2320-209-10.
- (3) Remove front tunnel. Refer to Part 3, para 18-5.

b. Removal of Speedometer.

FRAME 1

1. Using screwdriver, turn mounting studs (1) one quarter turn to the left.
2. Pull instrument cluster (2) away from instrument panel (3).

GO TO FRAME 2

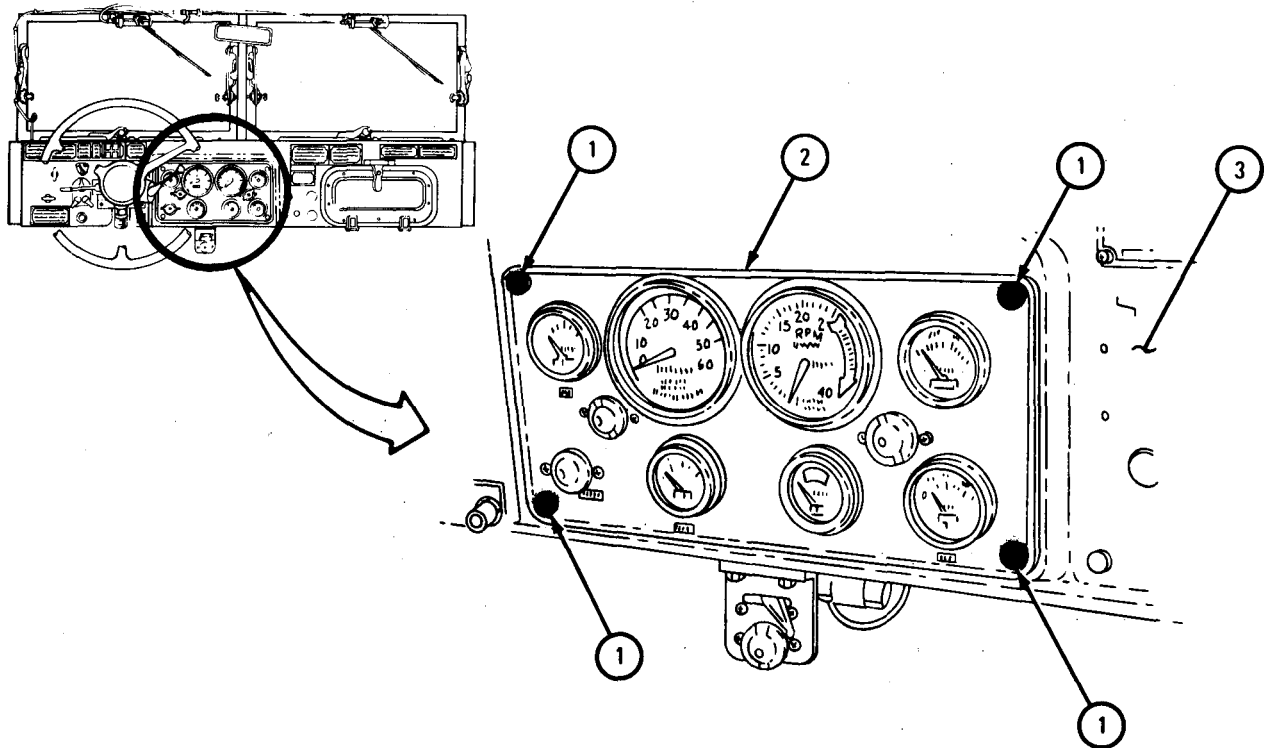

TA 101574

FRAME 2

1. Using 3/4-inch wrench, unscrew nut (1) and pull flexible shaft assembly (2) away from speedometer (3). Take off gasket (4).
2. Using 3/8-inch wrench, unscrew and take off two nuts and lockwashers (5). Pull clamp (6) off speedometer (3) and take speedometer out from front of panel (7).
3. Enter odometer mileage indication in vehicle equipment log if another speedometer (3) is to be put in.

END OF TASK

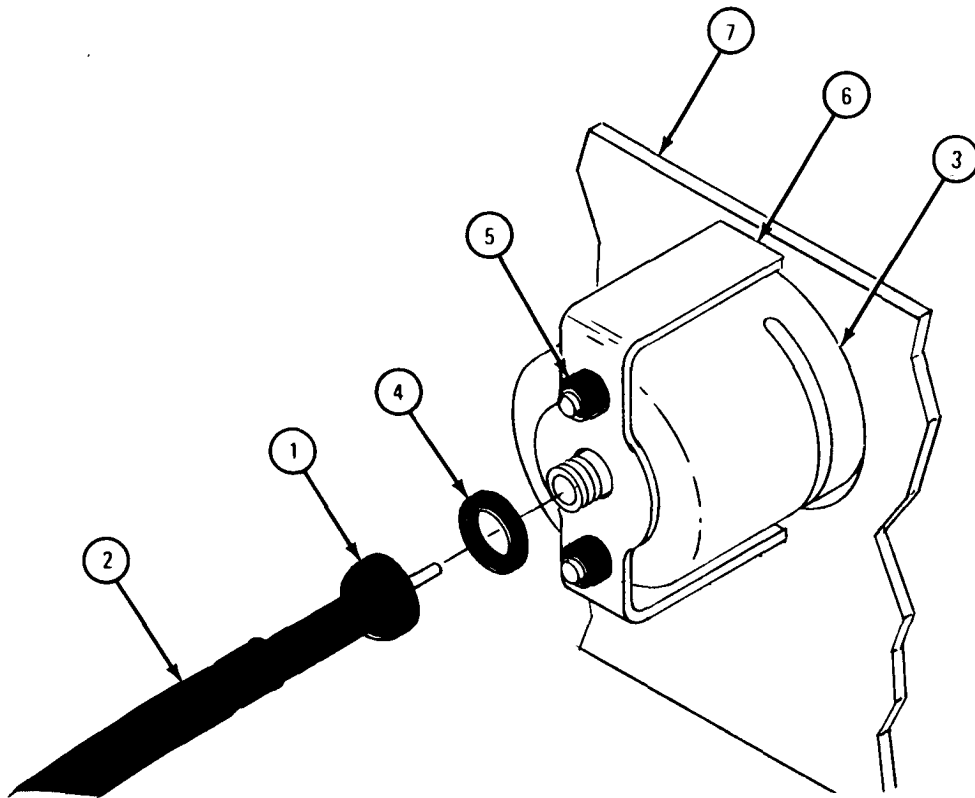

TA 101575

c. Removal of Flexible Shaft Assembly.

FRAME 1

1. Working under truck and using 1-inch wrench, unscrew coupling nut (1) from right angle adapter (2). Pull flexible shaft assembly (3) away from right angle adapter.
 2. Take gasket (4) out of coupling nut (1).
- GO TO FRAME 2

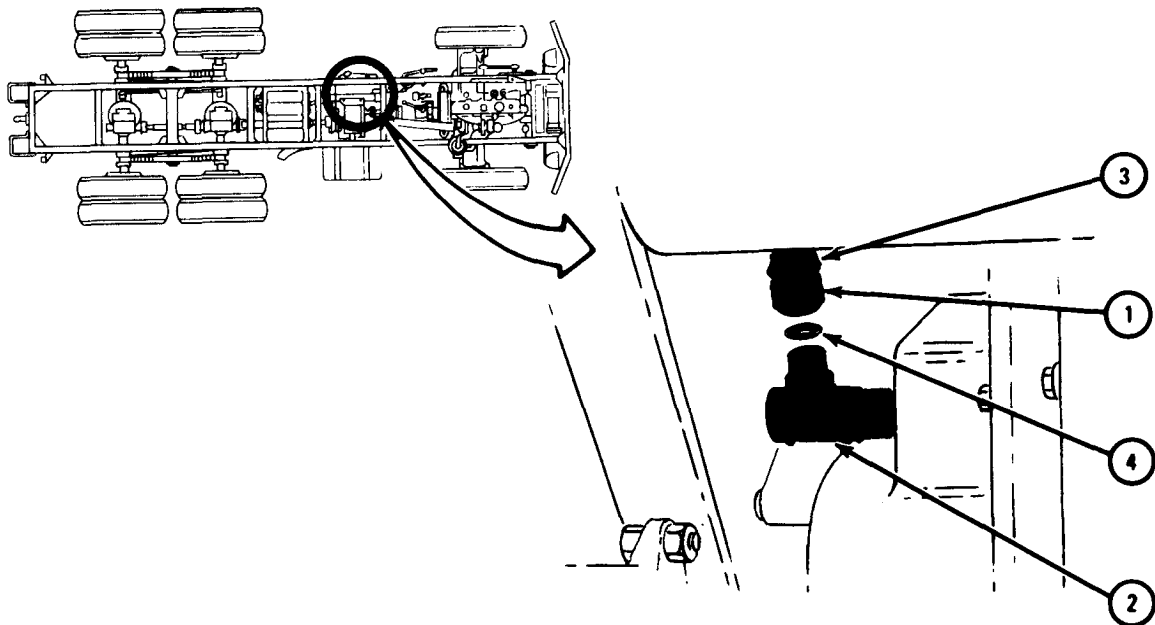

TA 047321

FRAME 2

- Soldier A 1. Put 9/16-inch wrench on locknut (1) that holds clamp (2) to firewall in cab. Tell soldier B when ready.
- Soldier B 2. Using 9/16-inch wrench, hold bolt (3).
- Soldier A 3. Unscrew locknut (1) and take off clamp (4). Leave clamp on cable (5).
- Soldier B 4. Take out bolt (3) and take clamp (2) off flexible shaft (6).
- GO TO FRAME 3

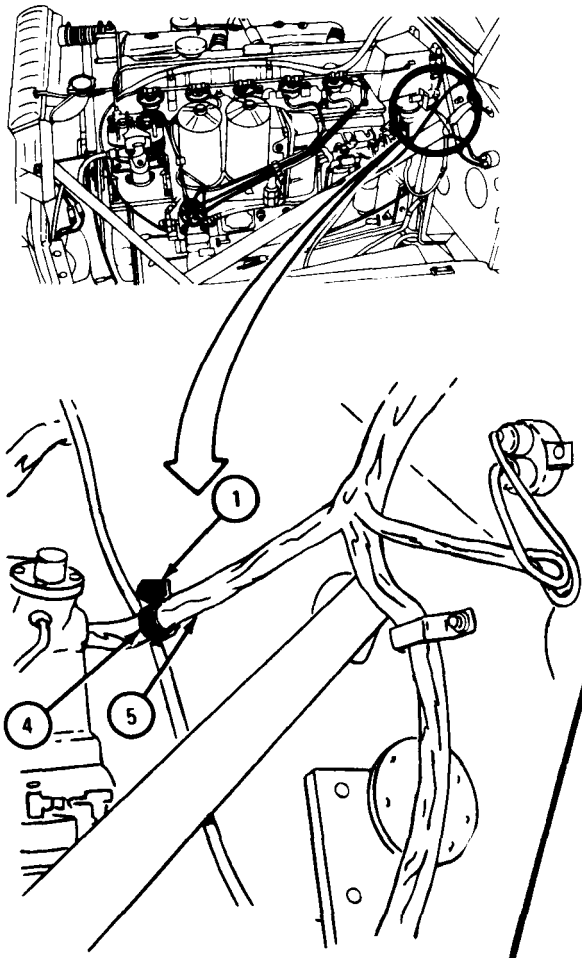

SOLDIER A

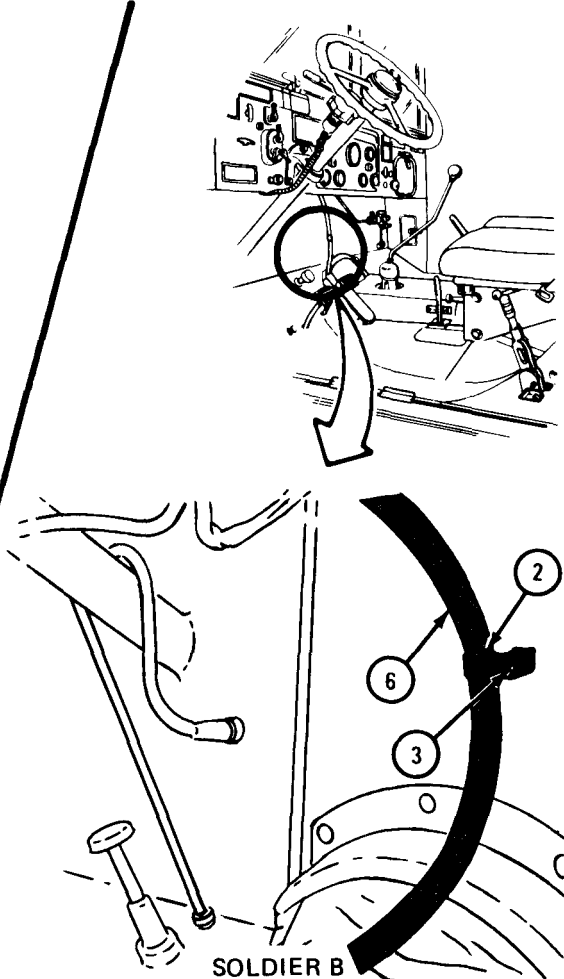

SOLDIER B

TA 047322

FRAME 3

NOTE

Some trucks may have speedometer flexible shaft clamped to floor boards instead of accelerator stop bolt.

Soldier A 1. Using pliers, take cotter pin (1) out of accelerator connecting link (2). Take connecting link out of pedal (3) and lift pedal clear of stop bolt (4).

2. Hold stop bolt (4) from turning.

Soldier B 3. Using 9/16-inch wrench, unscrew locknut (5) and lift clamp (6) off bolt (4). Take clamp off flexible cable (7).

NOTE

Before taking flexible shaft (7) out of truck, note the way it is routed. Shaft must be put back the same way.

4. Take flexible shaft (7) out of truck.

END OF TASK

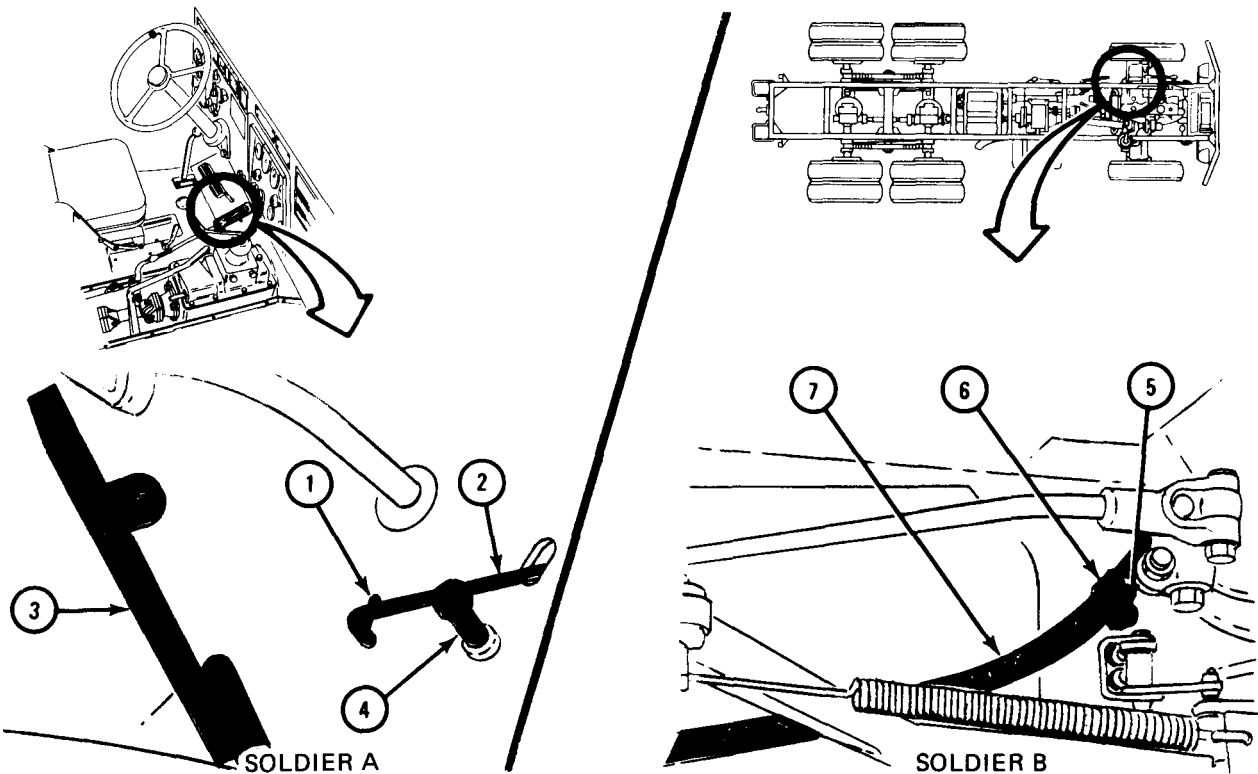

TA 047323

d. Removal of Right Angle Drive Adapter.

FRAME 1

1. Using 1-inch wrench, unscrew right angle drive adapter (1) with sleeve and seal (2) from transfer case (3).
2. Take drive adapter (4) out of sleeve and seal (2).
3. Using 7/8-inch wrench, unscrew sleeve and seal (2) from right angle drive adapter (1). Take out sliding drive shaft (5).

END OF TASK

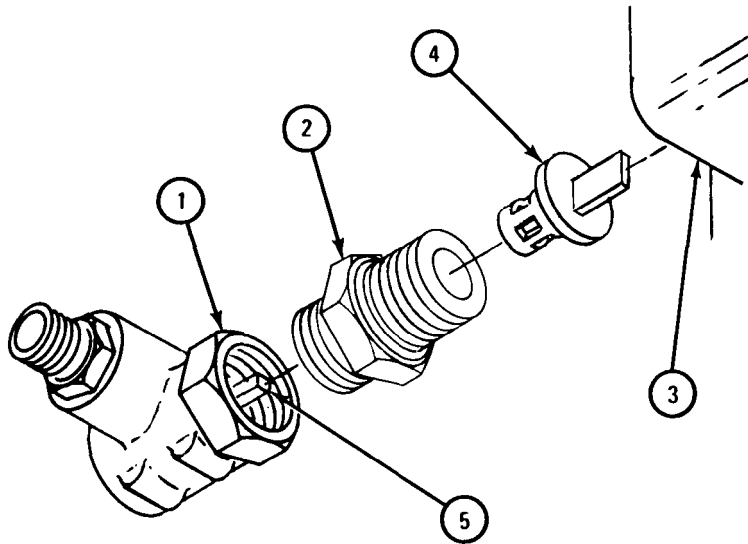

TA 047324

e. Removal of Flexible Shaft Core.

FRAME 1

NOTE

The flexible shaft assembly does not have to be taken out of truck to put back core (1), but it must be taken off at speedometer end (2) and transfer end (3).

1. Take retaining clip (4) from transfer end (3) of core (1).
2. Take flexible shaft core (1) out of casing (5) by pulling on transfer end (3) with pliers.
3. If flexible shaft core (1) is broken, use pliers on speedometer end (2) to pull out other piece.

END OF TASK

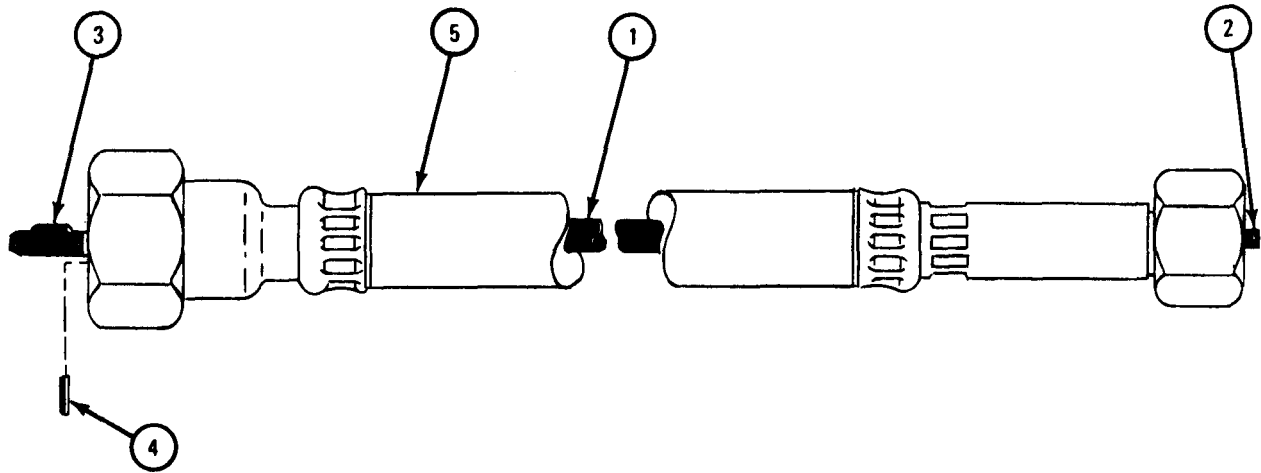

TA 047313

f. Repair of Flexible Shaft Assembly. The only repair that can be made to the flexible shaft assembly is to replace core. Refer to para 22-4e and 22-4g of this procedure.

g. Replacement of Flexible Shaft Core.

NOTE

Before putting back flexible shaft core, check that it has no dents, sharp bends or other damage. If casing is damaged, do not put back core. Get a new complete flexible shaft assembly.

FRAME 1

1. Put keyed end (1) of core (2) into speedometer end (3) of casing (4) that has the smaller coupling nut.
2. Carefully push core (2) through casing (4) until keyed end (1) seats in transfer end (5) of casing. Square end (6) should stick out of speedometer end (3) of casing as shown.
3. Put on retaining clip (7).

END OF TASK

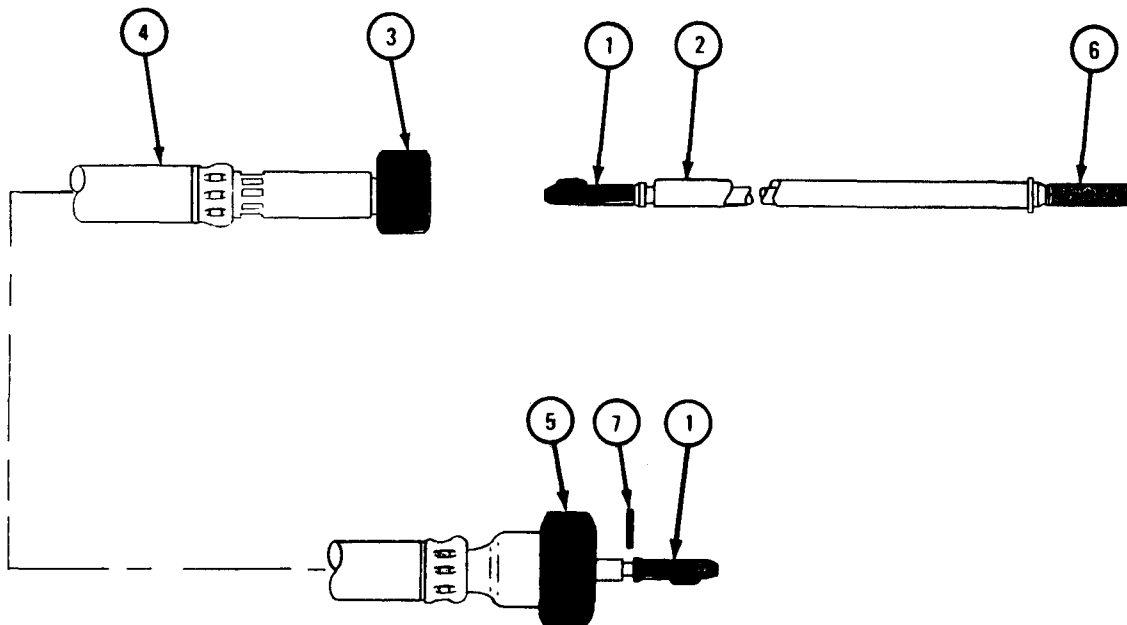

TA 101569

h. Replacement of Right Angle Drive Adapter.

FRAME 1

NOTE

Speedometer right angle drive adapters are supplied in two different gear ratios. Change parts (1 and 2) only with parts having same part numbers.

1. Put sliding drive shaft (1) into right angle drive adapter (2).
2. Screw sleeve (3) with seal (4) into right angle drive adapter (2) and tighten using 7/8-inch wrench.
3. Put drive adapter shaft (5) into hole in transfer case (6). Mesh flat end of shaft with slot in transfer case.

CAUTION

Make sure lip of rubber seal (4) faces transfer case (6) to keep oil from leaking.

4. Carefully screw assembled right angle drive adapter (2) into transfer case (6) and tighten using 1-inch wrench.
5. Face right angle drive adapter (2) to best position to take flexible shaft assembly without bending shaft.

END OF TASK

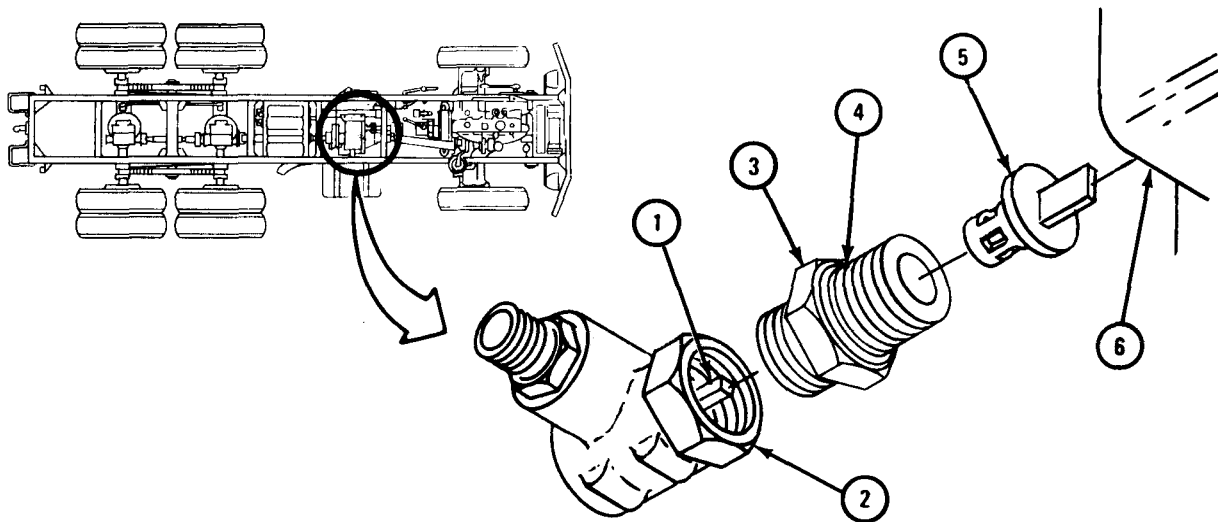

TA 047326

i. Replacement of Flexible Shaft Assembly.

FRAME 1

Soldier B 1. Stand by under truck.

Soldier A 2. Route keyed end of flexible shaft assembly (1) from inside of cab down firewall (2). Route it down left side of transmission (3) as shown to soldier B under truck.

GO TO FRAME 2

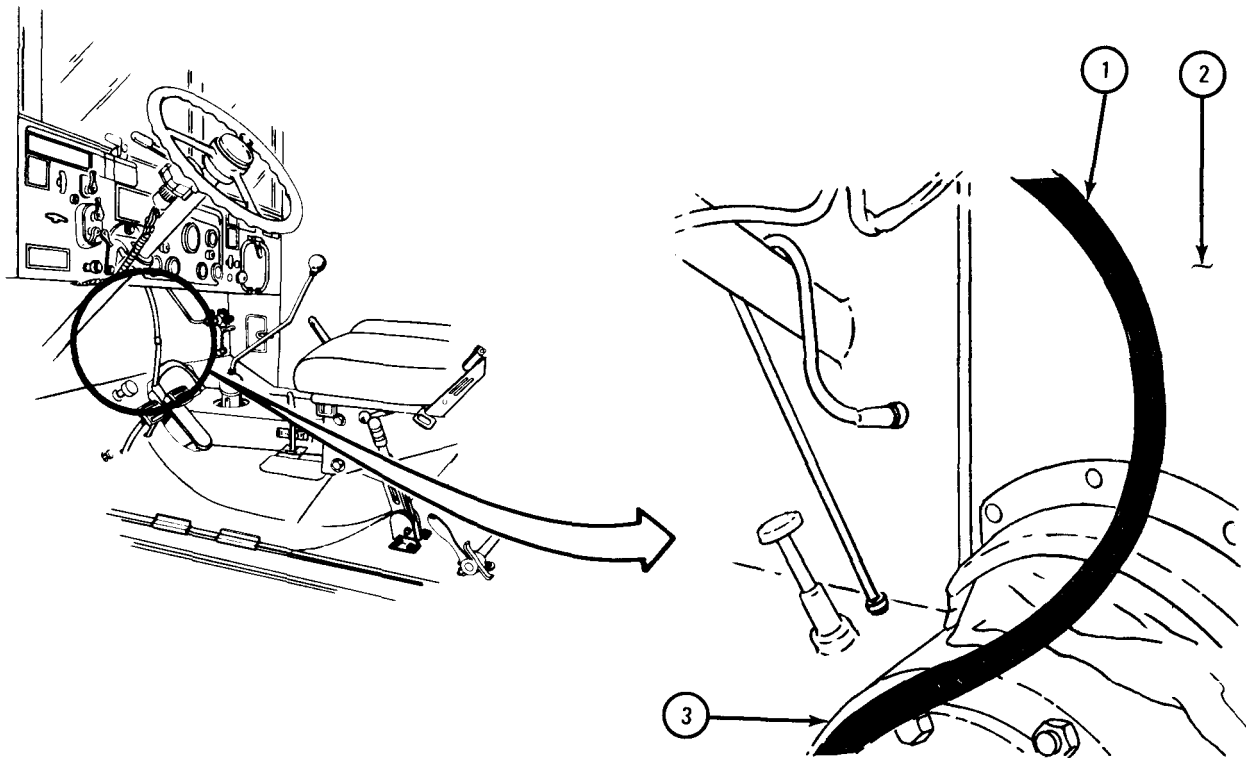

TA 047327

FRAME 2

NOTE

Speedometer flexible shaft (1) routing under cab may vary slightly on different trucks. Route replacement cable same way as noted.

Soldier B 1. Route flexible shaft assembly (1) over clutch linkage (2), brake lever (3), and brake cylinder (4). Route keyed end (5) back to transfer (6) as shown.

GO TO FRAME 3

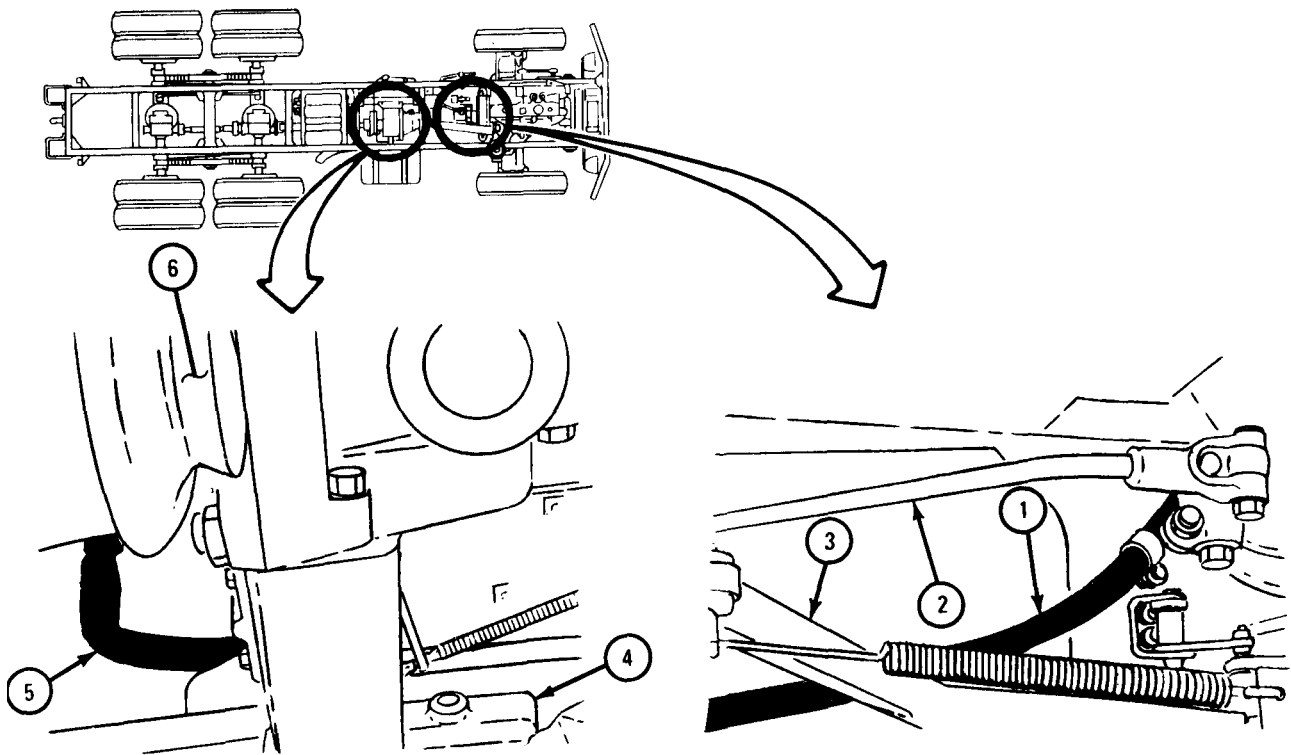

TA 047328

FRAME 3

1. Make sure gasket (1) is seated inside coupling nut (2).
2. Put keyed end of flexible shaft (3) in right angle adapter (4). Screw on coupling nut (2) and tighten using 1-inch wrench.

GO TO FRAME 4

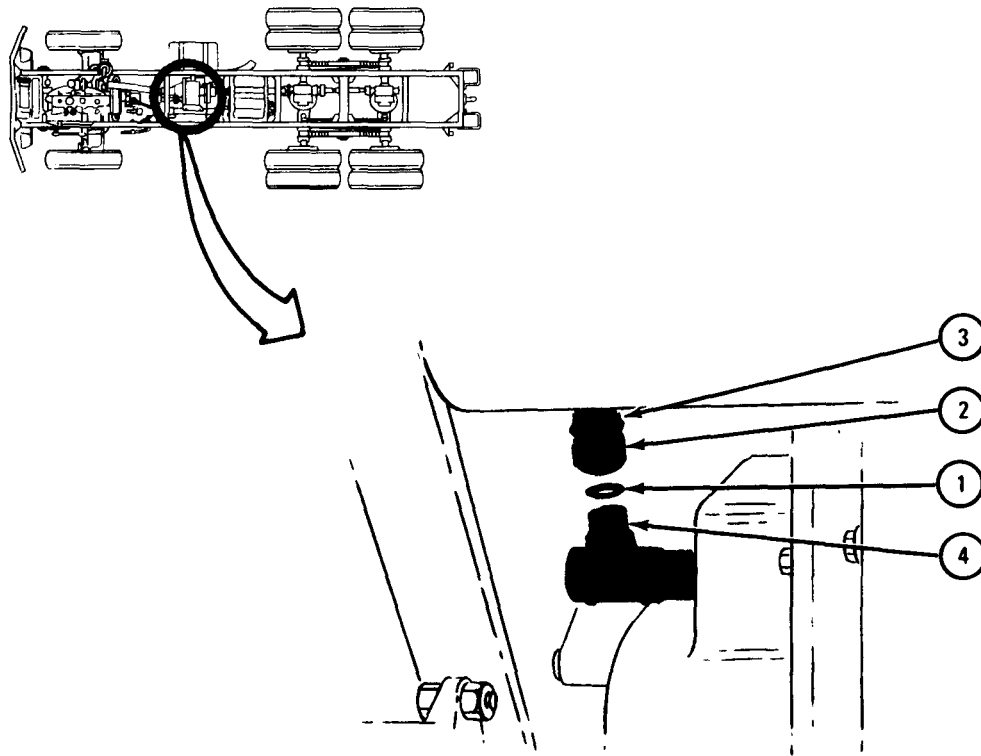

TA 047358

FRAME 4

NOTE

Some trucks may have speedometer flexible shaft clamped to floorboards instead of accelerator stop bolt.

- Soldier A 1. Stand by in cab with 9/16-inch wrench to hold accelerator stop bolt (1) when soldier B is ready under truck.
- Soldier B 2. Put clamp (2) on flexible shaft (3). Tell soldier A to press down on stop bolt (1) with fingers.
3. Put clamp (2) on bolt and screw on locknut (4) with fingers.

CAUTION

Check that flexible shaft (3) is clear of all moving linkages and free of sharp bends. Move shaft in clamp as necessary to feed extra slack through cab floor.

4. Tell soldier A to hold stop bolt (1) with 9/16-inch wrench. Using 9/16-inch wrench, tighten locknut (4).
- Soldier A 5. Lower pedal (5) and put connecting link (6) through hole in pedal. Using pliers, put cotter pin (7) through hole in end of connecting link and bend open ends of cotter pin.

GO TO FRAME 5

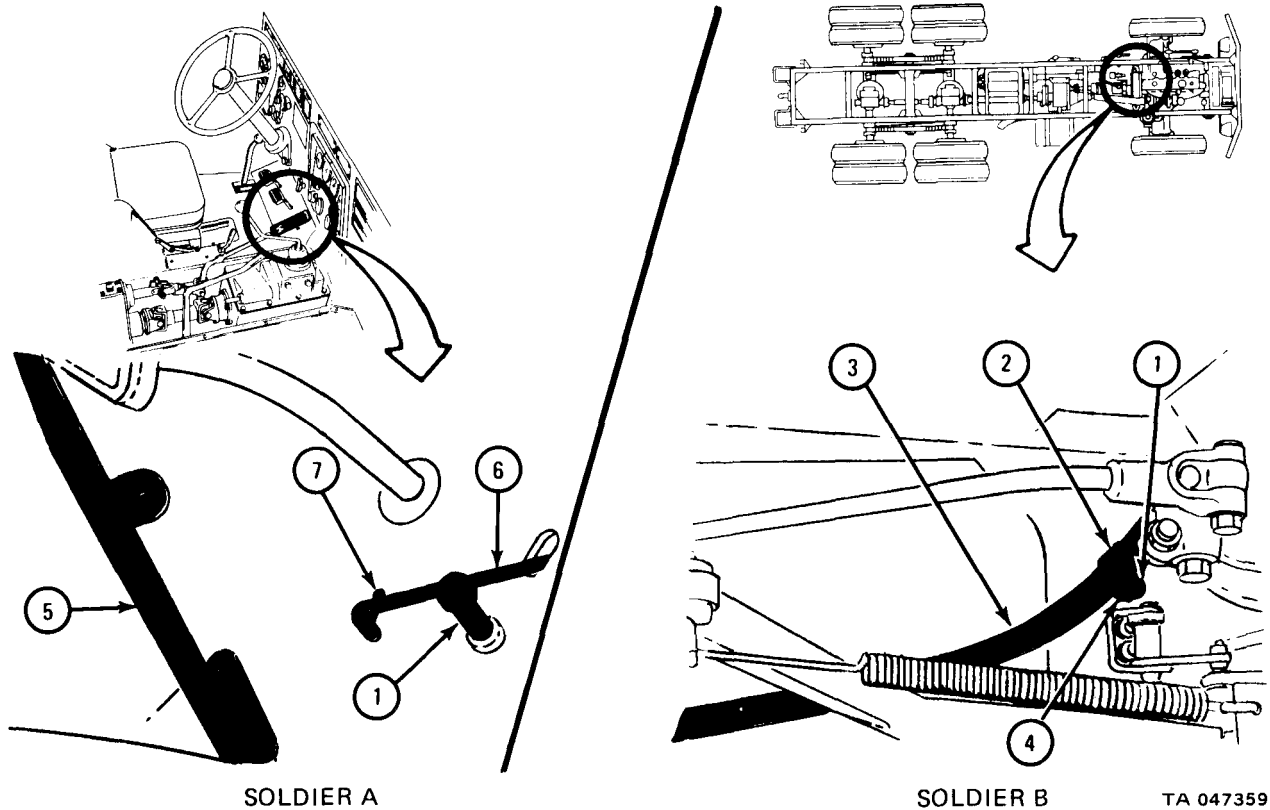

SOLDIER A

SOLDIER B

TA 047359

FRAME 5

- Soldier A 1. Stand by on engine side of firewall with 9/16-inch wrench.
- Soldier B 2. Put clamp (1) on flexible shaft (2) and put bolt (3) through clamp. Put bolt through hole in firewall (4). Put 9/16-inch wrench on bolt.
- Soldier A 3. Make sure clamp (5) is around cable (6) and then put clamp on bolt (3). Screw on locknut (7) and tighten using 9/16-inch wrench.
- END OF TASK

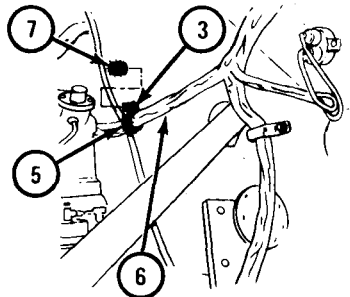
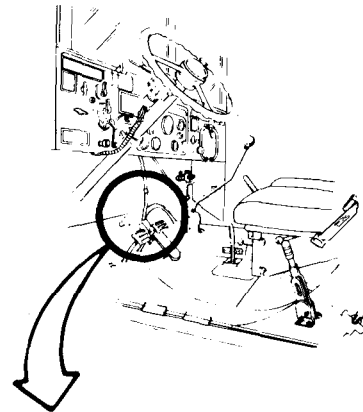
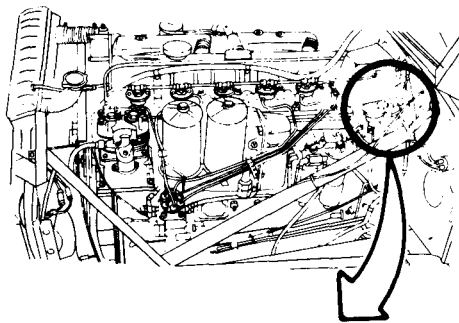

SOLDIER A

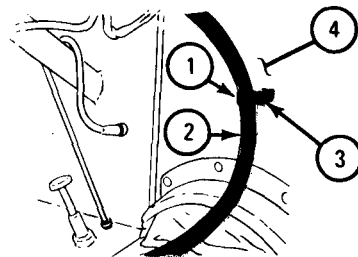

SOLDIER B

TA 047360

j. Replacement of Speedometer.

FRAME 1

1. Put speedometer (1) through hole in panel (2) from front of panel.
2. Place clamp (3) over studs (4) and screw on two nuts (5) with lockwashers (6).
3. Look at front of panel (2) and turn speedometer (1) if necessary to make sure it is straight. Using 3/8-inch wrench, tighten two nuts (5).

GO TO FRAME 2

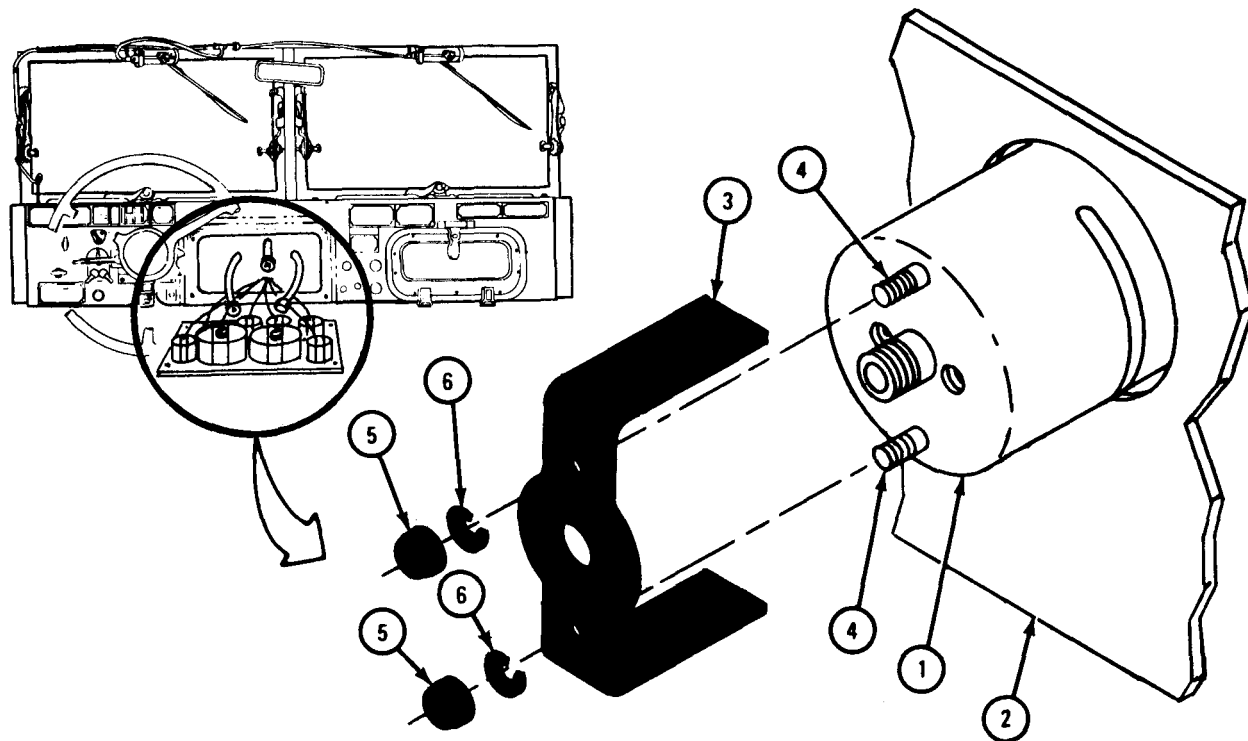

TA 047318

FRAME 2

1. Put gasket (1) over end of flexible shaft assembly (2) and press into coupling nut (3).
2. Put square end of flexible shaft assembly (2) into speedometer (4) and screw on coupling nut (3). Using 3/4-inch wrench, tighten nut.

GO TO FRAME 3

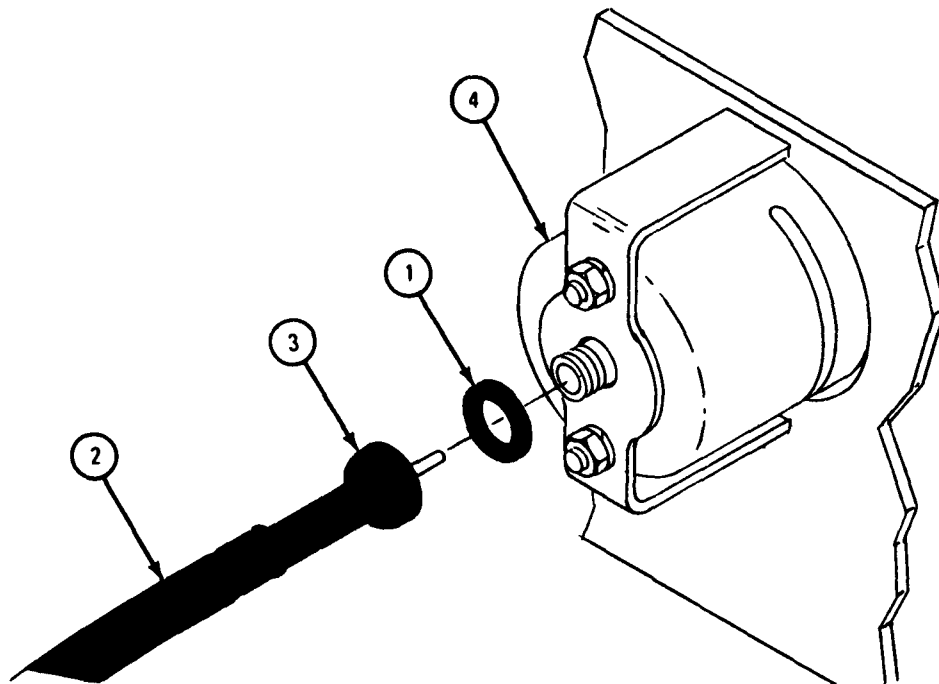

TA 101577

FRAME 3

1. Place instrument cluster (1) on instrument panel (2) as shown.
2. Using screwdriver, turn mounting studs (3) 1/4 turn to right.
3. Enter odometer mileage indication speedometer in vehicle equipment log if new one was put in.

NOTE

Follow-on Maintenance Action Required

1. Reconnect battery ground cable. Refer to Part 1, para 7-58.
2. Close hood and left side panel. Refer to TM 9-2320-209-10.
3. Replace front tunnel. Refer to Part 3, para 18-5.
4. Road test truck and check speedometer and odometer operation. Refer to TM 9-2320-209-10.

END OF TASK

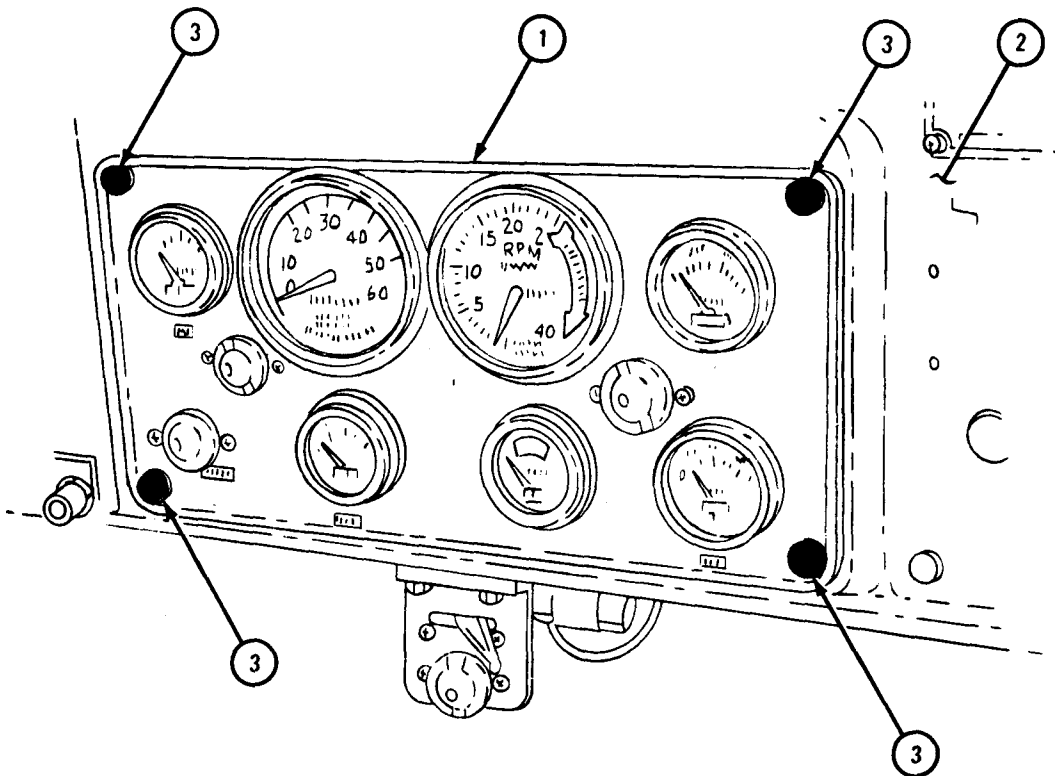

TA 101576

CHAPTER 23

MAINTENANCE OF MATERIAL USED IN CONJUNCTION WITH MAJOR ITEMS

Section I. SCOPE

23-1. EQUIPMENT ITEMS COVERED. This chapter gives equipment maintenance procedures for winterization kits, deep water fording kit, and special purpose kits for which there are authorized corrective maintenance tasks at the organizational maintenance level.

23-2. EQUIPMENT ITEMS NOT COVERED. All equipment items for which corrective maintenance is authorized at the organizational maintenance level are covered in this chapter.

Section II. WINTERIZATION KITS

23-3. VEHICULAR COMPARTMENT HEATER REMOVAL AND REPLACEMENT.

TOOLS: Flat-tip screwdriver
Open end wrench set, pn GGG-W-636

SUPPLIES: None

PERSONNEL: One

EQUIPMENT CONDITION: Truck parked, engine off, handbrake set.

a. Preliminary Procedures.

- (1) Open hood. Refer to TM 9-2320-209-10.
- (2) Remove two heater hoses. Refer to para 23-18.

b. Removal.

FRAME 1

1. Using screwdriver, loosen two screws in two clamps (1). Pull ram air duct (2) and heater outlet duct (3) from heater assembly (4).
2. Unplug heater motor electrical cable connector (5).
3. Using wrenches, unscrew and take off four screws and lockwashers (6) and nuts (7). Take heater assembly (4) from heater support (8).

END OF TASK

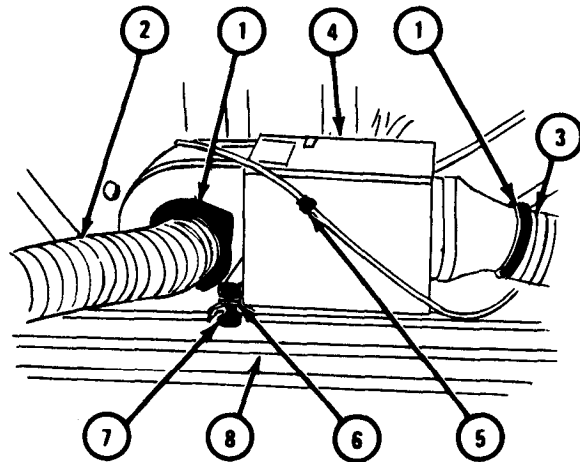
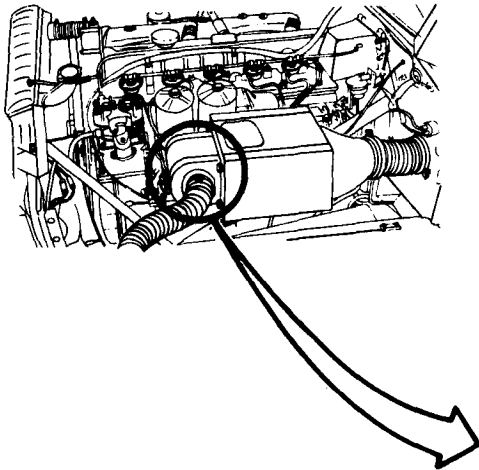

TA 047486

c. Replacement.

FRAME 1

1. Put heater assembly (1) in place on heater support (2) and line up holes.
2. Using wrenches, screw in and tighten four screws (3) and lockwashers and nuts (4).
3. Join two ends of heater motor cable (5) and plug together connector (6).
4. Put ram air duct (7) and heater outlet duct (8) onto heater assembly (1). Using screwdriver, screw in and tighten two screws in two clamps (9).

NOTE

Follow-on Maintenance Action Required:

1. Replace two heater hoses. Refer to para 23-18.
2. Close hood. Refer to TM 9-2320-209-10.

END OF TASK

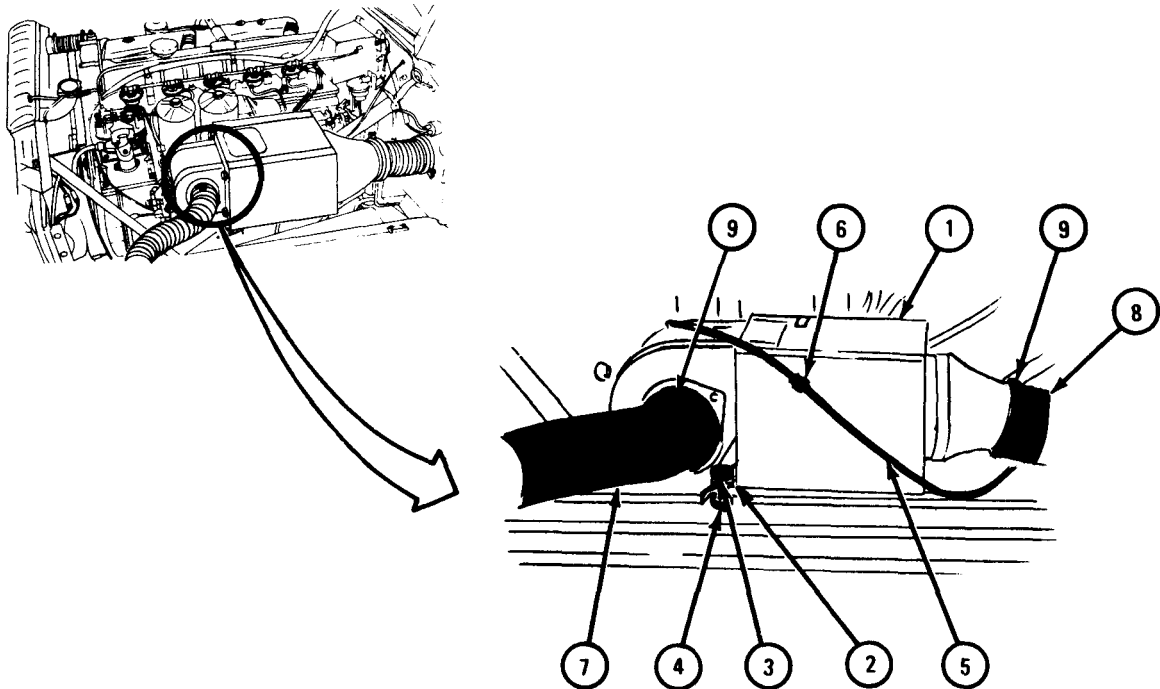

TA 047487

23-4. FUEL BURNING PERSONNEL HEATER DUCTING REPAIR.

TOOLS: Flat-tip screwdriver
3-foot tape measure

SUPPLIES: None

PERSONNEL: One

EQUIPMENT CONDITION: Truck parked, engine off, handbrake set.

a. Preliminary Procedure. Open hood and left side panel. Refer to TM 9-2320-209-10.

b. Removal.

FRAME 1

1. Working from inside cab and using screwdriver, loosen six duct clamps (1).
2. Turn and pull off three diverter ducts (2, 3, and 4) and take off six duct clamps (1).
3. Working in engine compartment and using screwdriver, loosen two heater duct clamps (5).
4. Turn and pull off heater duct (6) and take off two duct clamps (5).

END OF TASK

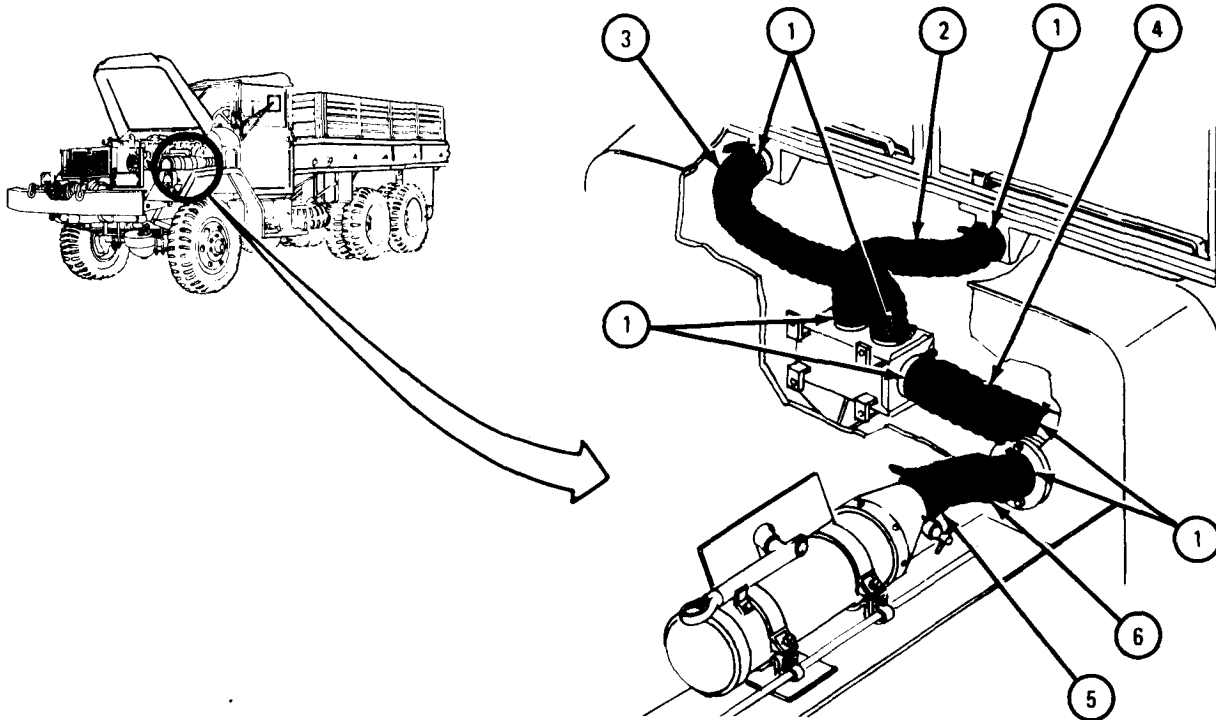

TA 080777

c. Repair. Repair is limited to throwing out damaged parts and getting new parts in their place.

d. Replacement.

FRAME 1

1. Working in engine compartment, put two duct clamps (1) on 3 1/2-inch heater duct (2). Put heater duct in place and slide duct clamps to each end of duct as shown. Using screwdriver, tighten two duct clamps.
2. Working from inside of cab, put two duct clamps (3) on 19 1/2-inch diverter duct (4). Put diverter duct in place and slide duct clamps to each end of duct as shown.
3. Using screwdriver, tighten two duct clamps (3).

GO TO FRAME 2

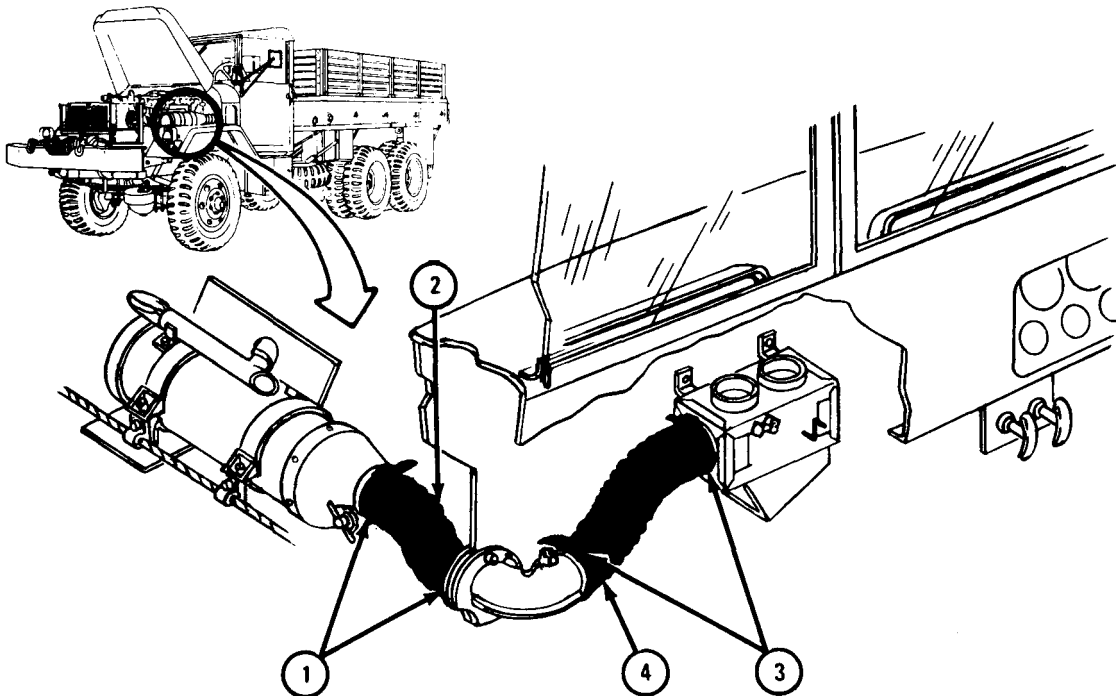

TA 080778

FRAME 2

1. Working from inside cab, put two duct clamps (1) on 29 1/2-inch diverter duct (2). Put one end of diverter duct on left port of diverter assembly (3) and put other end of left deflector (4). Slide duct clamps to each end of duct.
2. Using screwdriver, tighten two duct clamps (1).
3. Put two duct clamps (5) on 26 1/2-inch diverter duct (6). Put one end of diverter duct on right port of diverter assembly (3) and put other end on right deflector (7). Slide duct clamp to each end of duct.
4. Using screwdriver, tighten two duct clamps (5).

NOTE

Follow-on Maintenance Action Required:

Close hood and left side panel. Refer to TM 9-2320-209-10.

END OF TASK

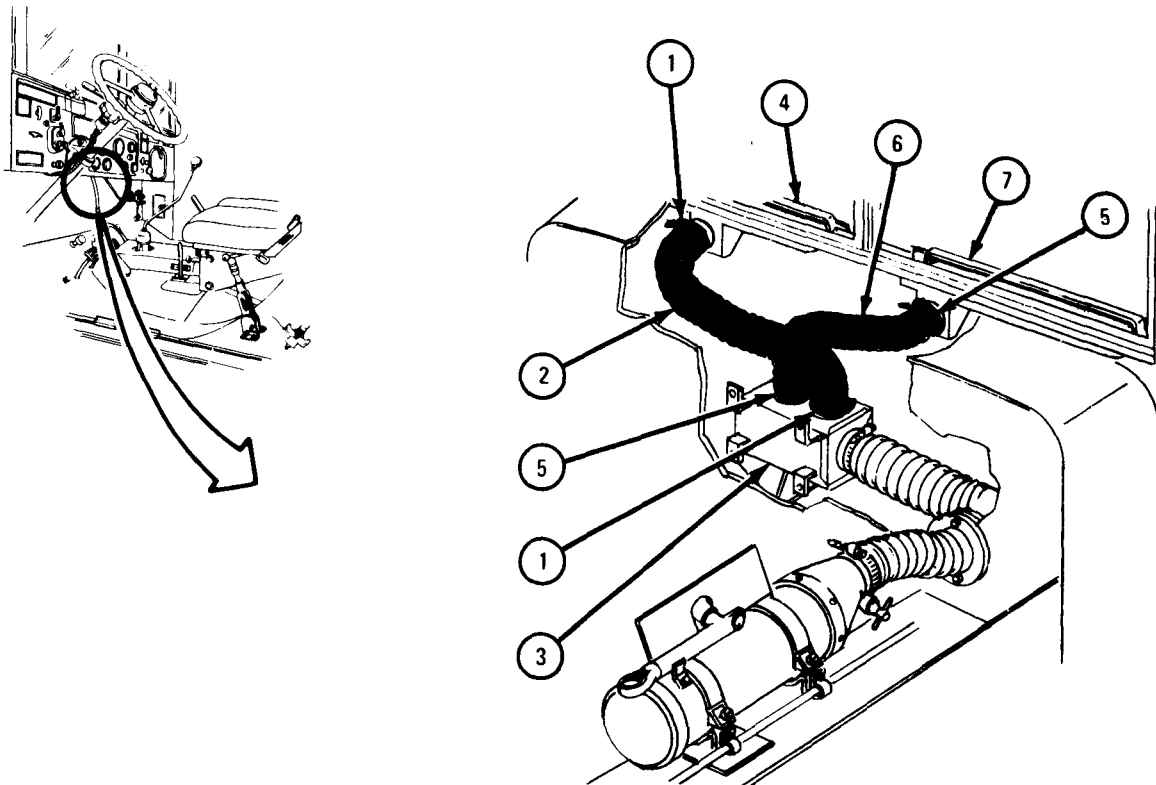

TA 080779

23-5. FUEL BURNING PERSONNEL HEATER AIR DIVERTER REPAIR.

TOOLS: Flat-tip screwdriver
7/16-inch wrench (2)

SUPPLIES: None

PERSONNEL: Two

EQUIPMENT CONDITION: Truck parked, engine off, handbrake set.

a. Preliminary Procedure. Open hood and right side panel. Refer to TM 9-2320-209-10.

b. Removal.

FRAME 1

- Soldier A 1. Working from inside of cab and using screwdriver, loosen three duct clamps (1).
2. Turn and pull off three diverter ducts (2).
3. Using screwdriver, loosen screw (3) and take end of control cable (4) off shaft (5). Pull control cable out of diverter clamp (6).
4. Using 7/16-inch wrench, hold four screws (7). Tell soldier B when ready.
- Soldier B 5. Working from under hood and using 7/16-inch wrench, unscrew and take off four nuts (8) and washers (9).
- Soldier A 6. Take out heater diverter assembly (10).

END OF TASK

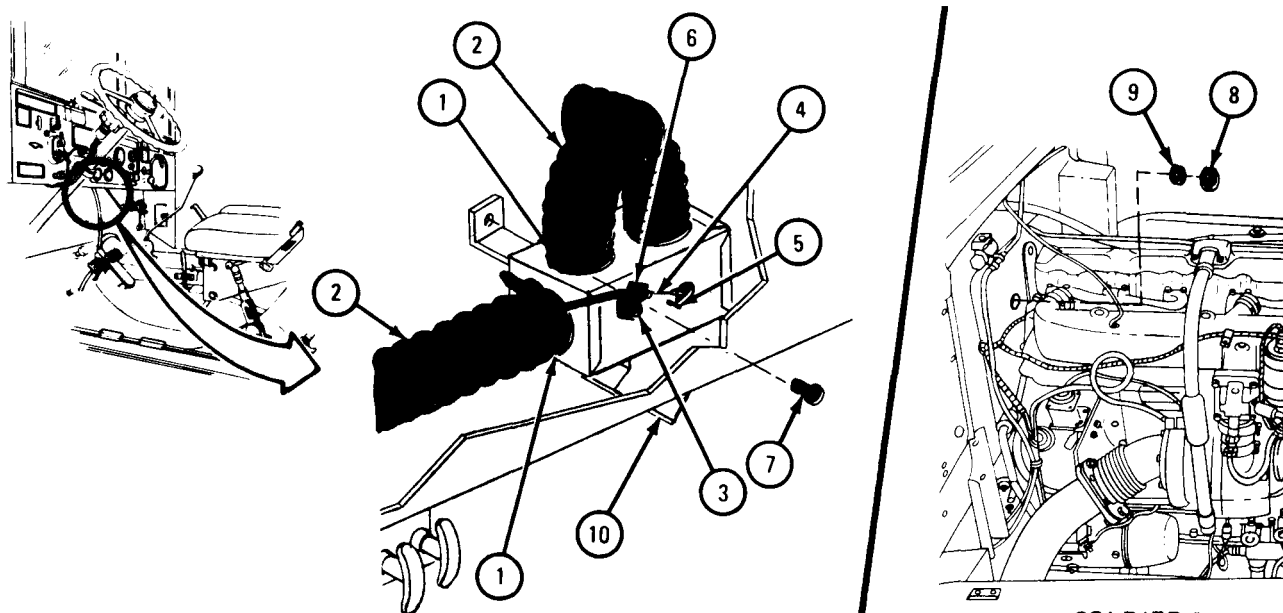

TA 080769

c. Replacement.

FRAME 1

- Soldier A 1. Working from inside of cab, put heater diverter assembly (1) in place and put through four screws (2). Using 7/16-inch wrench, hold four screws and tell soldier B when ready.
- Soldier B 2. Working from under hood and using 7/16-inch wrench, screw in and tighten four washers (3) and nuts (4).
- Soldier A 3. Put on three diverter ducts (5).
4. Using screwdriver, tighten three duct clamps (6).
5. Put cable (7) through diverter clamp (8). Put looped end of control cable on shaft (9).
6. Using screwdriver, tighten screw (10).

NOTE

Follow-on Maintenance Action Required:

1. Adjust control cable. Refer to para 23-8.
2. Close hood and right side panel. Refer to TM 9-2320-209-10.

END OF TASK

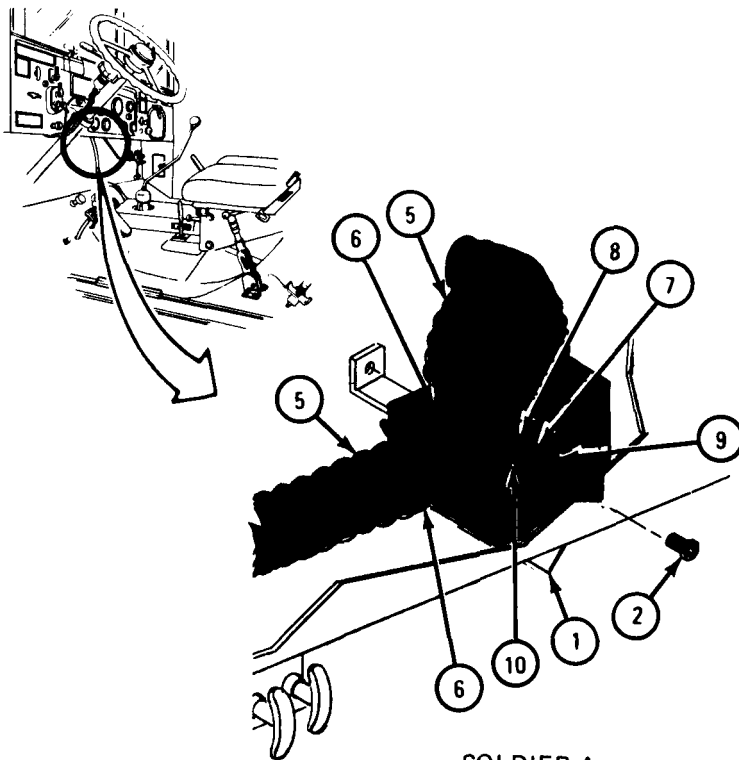

SOLDIER A

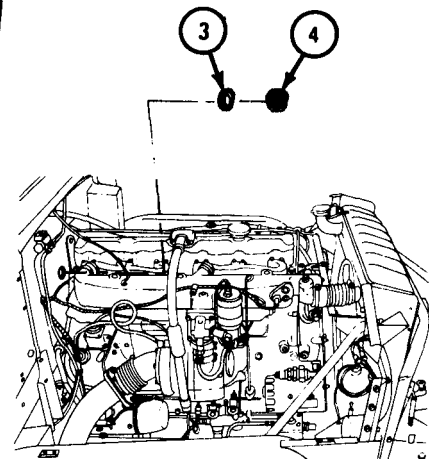

SOLDIER B

TA 080770

23-6. FUEL BURNING PERSONNEL HEATER AIR INLET ADAPTER REPAIR.

TOOLS: Flat-tip screwdriver
11/32-inch wrench (2)

SUPPLIES: None

PERSONNEL: Two

EQUIPMENT CONDITION: Truck parked, engine off, handbrake set.

a. Preliminary Procedure. Open hood and left side panel. Refer to TM 9-2320-209-10.

b. Removal.

FRAME 1

1. Using screwdriver, loosen screw (1) and take looped end of adapter cable assembly (2) off shaft (3). Pull adapter cable assembly out of cable clamp (4).
2. Using screwdriver, loosen duct clamp (5) and turn and take off diverter duct (6).
- Soldier A 3. Using screwdriver, hold two screws (7) and tell soldier B when ready.

GO TO FRAME 2

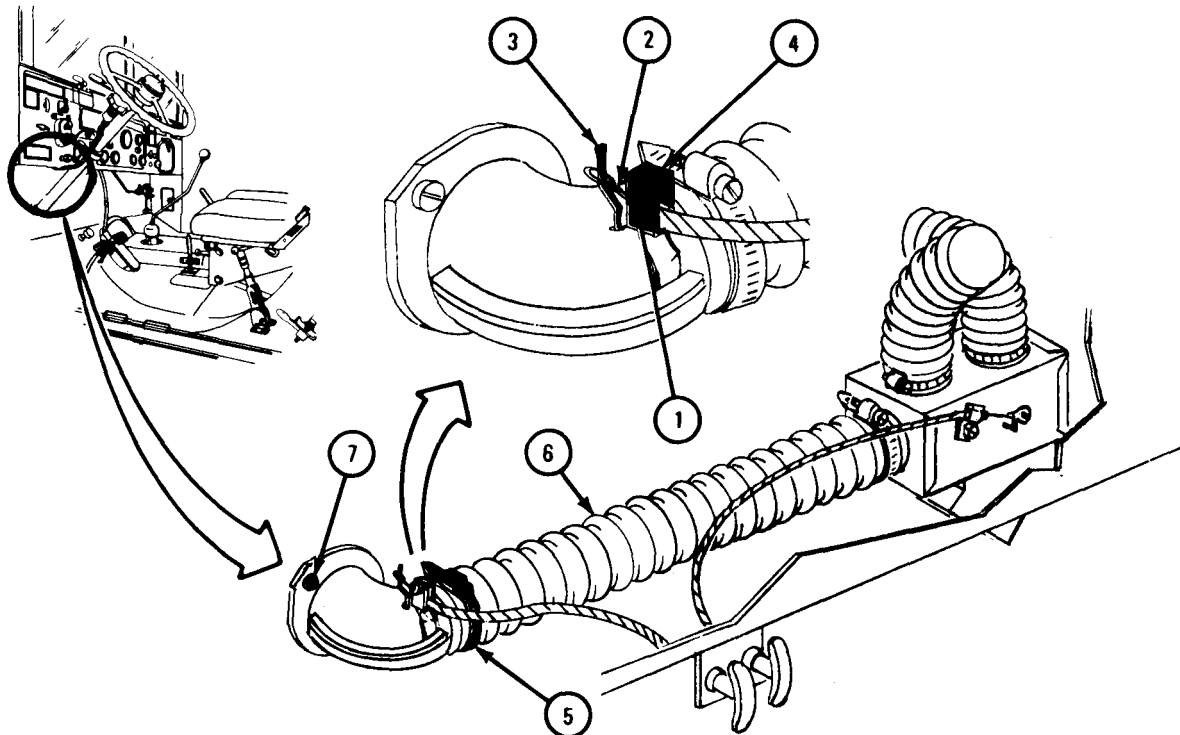

TA 080773

FRAME 2

- Soldier B 1. Using 11/32-inch wrench, unscrew and take off two nuts and washers (1).
2. Using screwdriver, loosen duct clamp (2). Turn and take off heater duct (3).
- Soldier A 3. Take out two screws (4) and take off air inlet adapter (5).
- END OF TASK

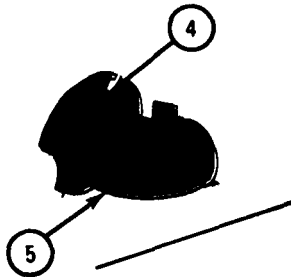

SOLDIER A

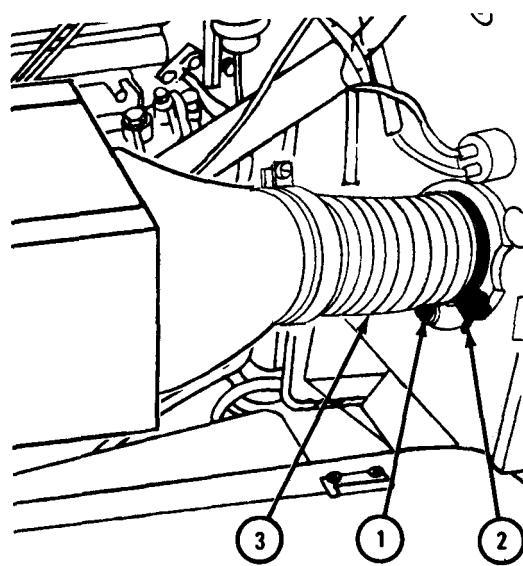

SOLDIER B

TA 080774

c. Replacement.

FRAME 1

Soldier A 1. Put air inlet adapter (1) in place on firewall (2) as shown. Align two screw holes and put in two screws (3). Using screwdriver, hold two screws and tell soldier B when ready.

Soldier B 2. Using 11/32-inch wrench, screw on and tighten two nuts and washers (4).

3. Put heater duct (5) on air inlet adapter (1). Using screwdriver, tighten duct clamp (6).

GO TO FRAME 2

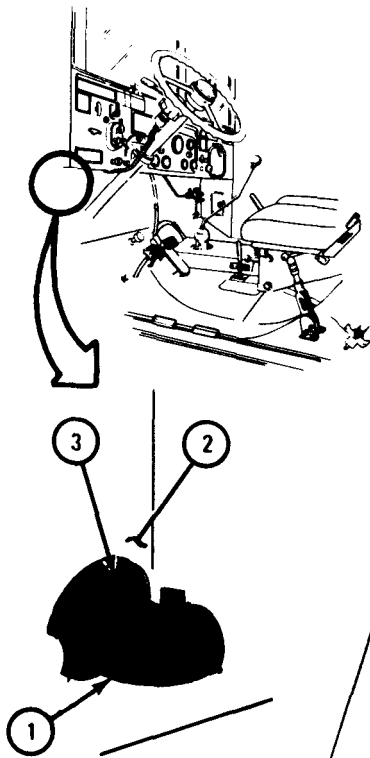

SOLDIER A

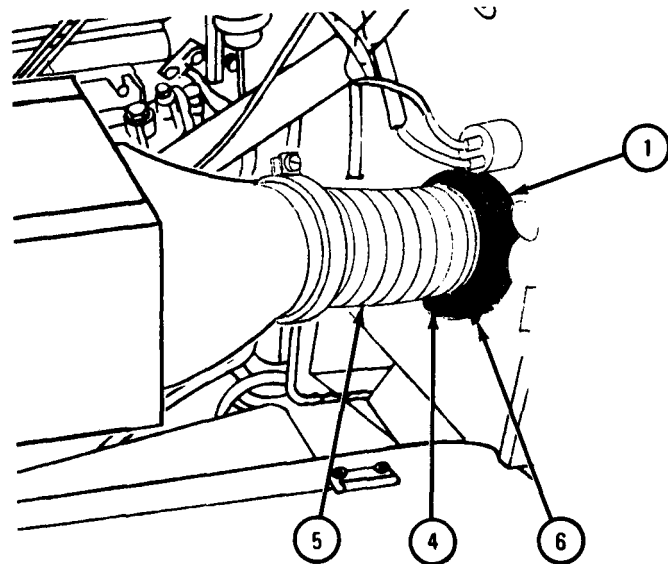

SOLDIER B

TA 080775

FRAME 2

1. Put diverter duct (1) on air inlet adapter (2). Using screwdriver, tighten duct clamp (3).
2. Put adapter cable assembly (4) through cable clamp (5) and put looped end of cable on shaft (6).
3. Using screwdriver, tighten screw (7).

NOTE

Follow-on Maintenance Action Required:

1. Adjust control cable. Refer to para 23-8.
2. Close hood and left side panel. Refer to TM 9-2320-209-10.

END OF TASK

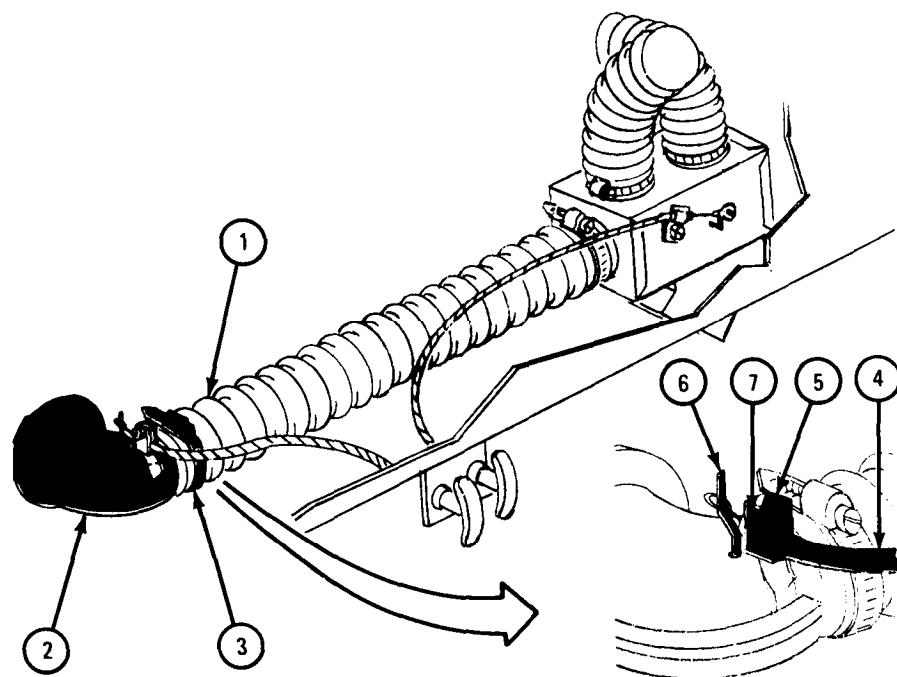

TA 080776

23-7. FUEL BURNING PERSONNEL HEATER EXHAUST TUBE AND CLAMPS REPAIR.

TOOLS: 1/2-inch wrench (2)
6-inch pliers.

SUPPLIES: None

PERSONNEL: One

EQUIPMENT CONDITION: Truck parked, engine off, handbrake set.

a. Preliminary Procedure. Open hood and left side panel. Refer to TM 9-2320-209-10.

b. Removal.

WARNING

Hot exhaust tube can cause serious burns. Let it cool before starting task.

FRAME 1

1. Using 1/2-inch wrenches, unscrew and take off three screws and nuts (1) from three clamps (2). Spread clamps open and take them off.

GO TO FRAME 2

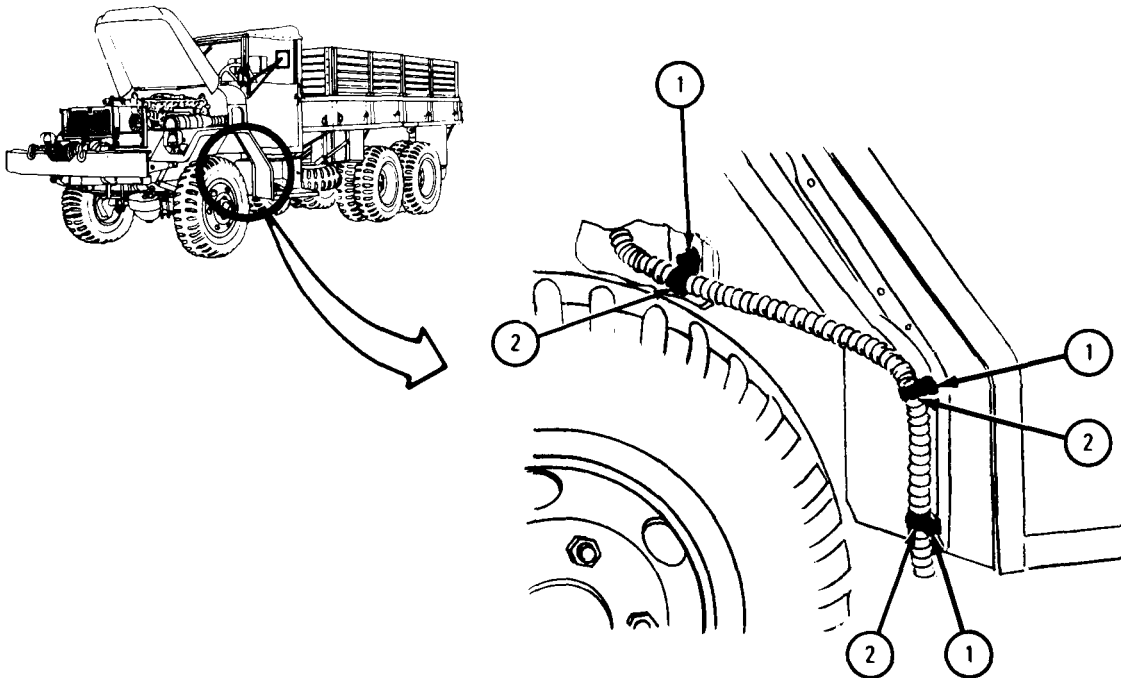

TA 080771

FRAME 2

1. Using pliers, take out cotter pin (1) and take off exhaust tube (2).

END OF TASK

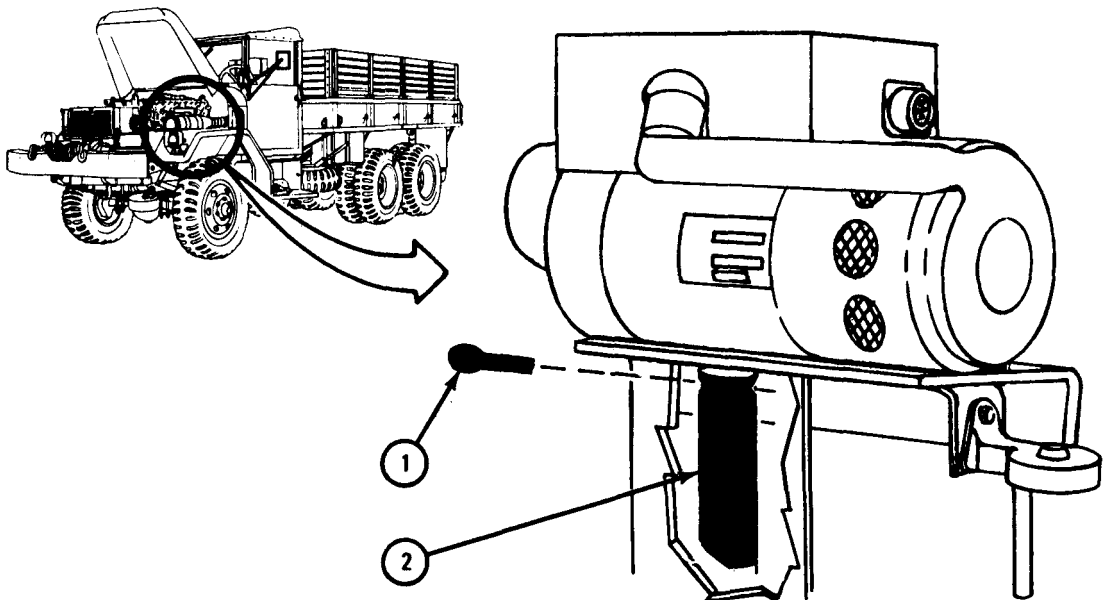

TA 083942

c. Replacement.

FRAME 1

1. Put exhaust tube (1) on fuel burning personnel heater (2) and align holes.
2. Put cotter pin (3) through exhaust tube (1).
3. Using pliers, bend open ends of cotter pin (3).

GO TO FRAME 2

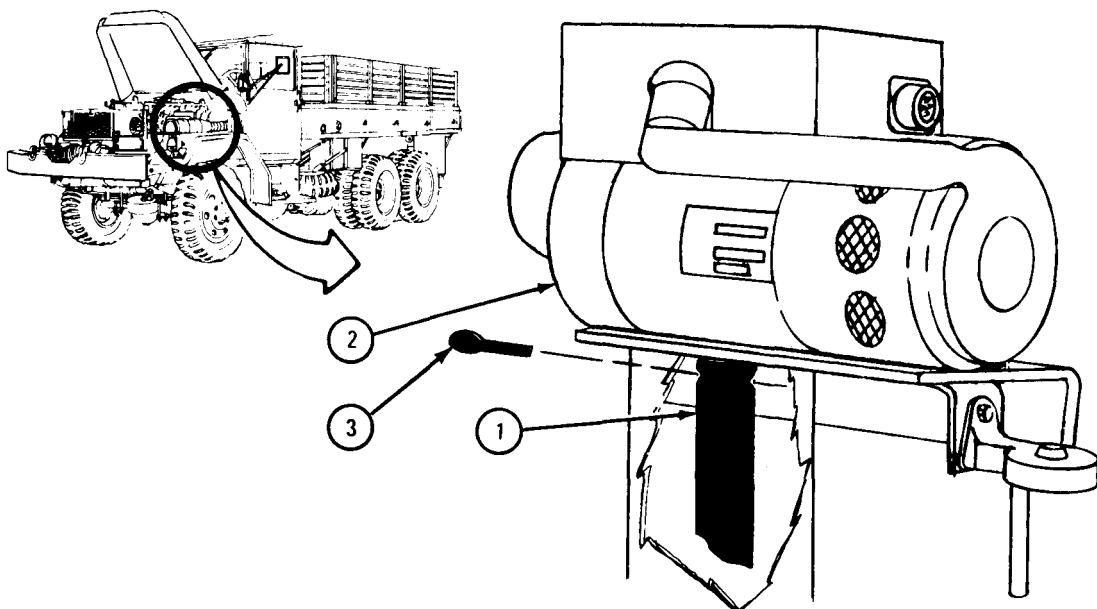

TA 083943

FRAME 2

1. Put three clamps (1) on exhaust tube (2) as shown and align screw holes.
2. Using 1/2-inch wrenches, screw in and tighten three screws and nuts (3).

NOTE

Follow-on Maintenance Action Required:
Close hood and left side panel. Refer to
TM 9-2320-209-10.

END OF TASK

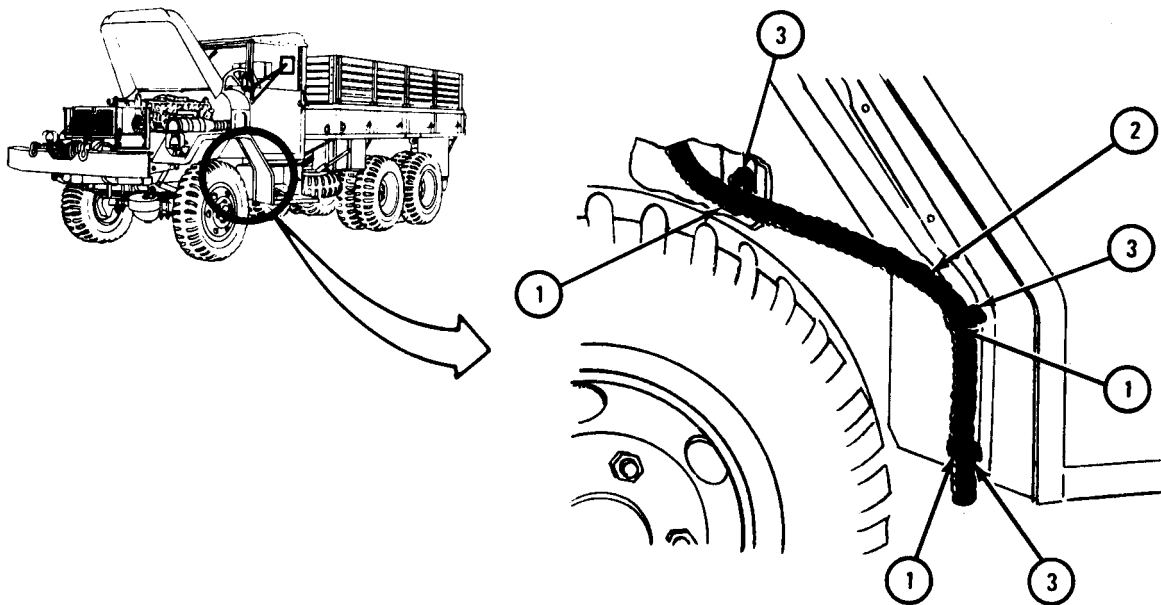

TA 080772

23-8. FUEL BURNING PERSONNEL HEATER CONTROL CABLES REPAIR AND ADJUSTMENT.

TOOLS: 9/16-inch wrench
Flat-tip screwdriver

SUPPLIES: None

PERSONNEL: One

EQUIPMENT CONDITION: Truck parked, engine off, and brake set.

a. Removal.

FRAME 1

1. Working from behind instrument panel and using screwdriver, loosen screw (1) on adapter clamp (2). Take looped end of diverter adapter cable assembly (3) off shaft (4) and take cable out of adapter clamp.
2. Using screwdriver, loosen screw (5) on diverter clamp (6). Take looped end of diverter cable (7) off shaft (8) and take cable out of diverter clamp.

GO TO FRAME 2

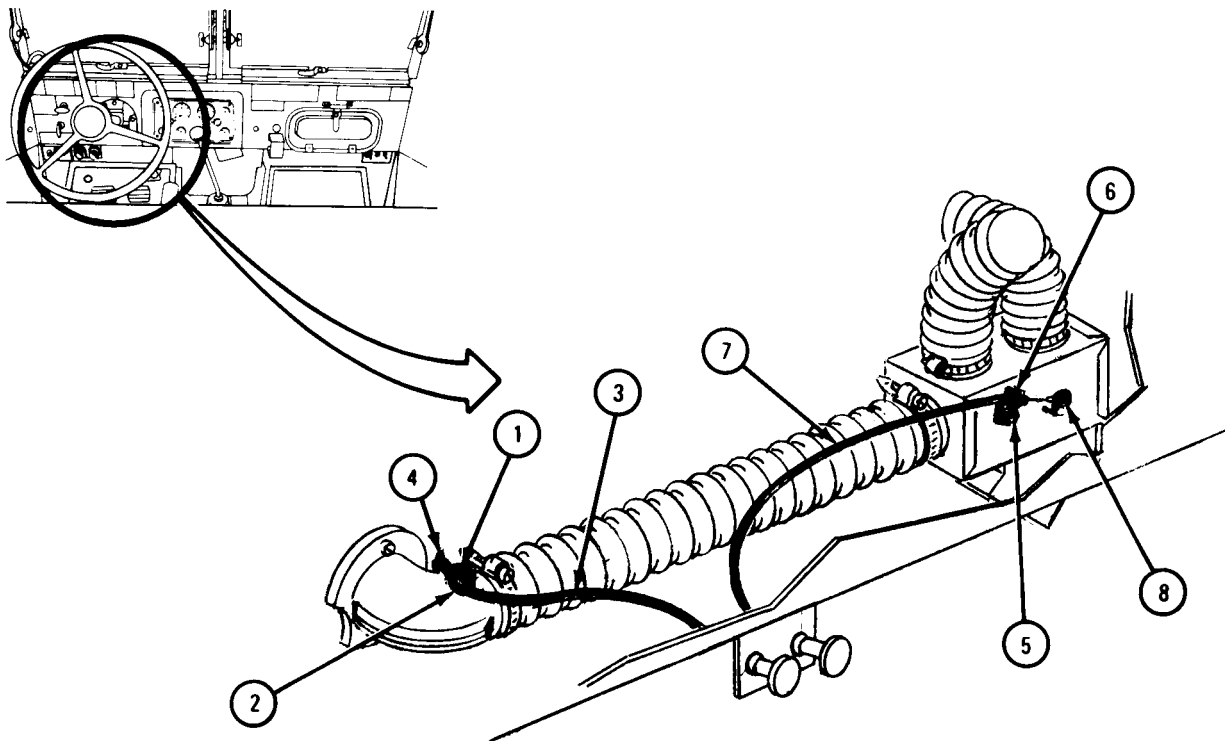

TA 080756

FRAME 2

1. Using 9/16-inch wrench, unscrew nut and washer (1) and slide them off of diverter adapter cable assembly (2).
2. Using 9/16-inch wrench, unscrew nut and washer (3) and slide them off diverter cable assembly (4).
3. Pull out diverter adapter cable assembly (2) and diverter cable assembly (4), AIR plate (5), and DEFROSTER plate (6) from front of bracket (7).

END OF TASK

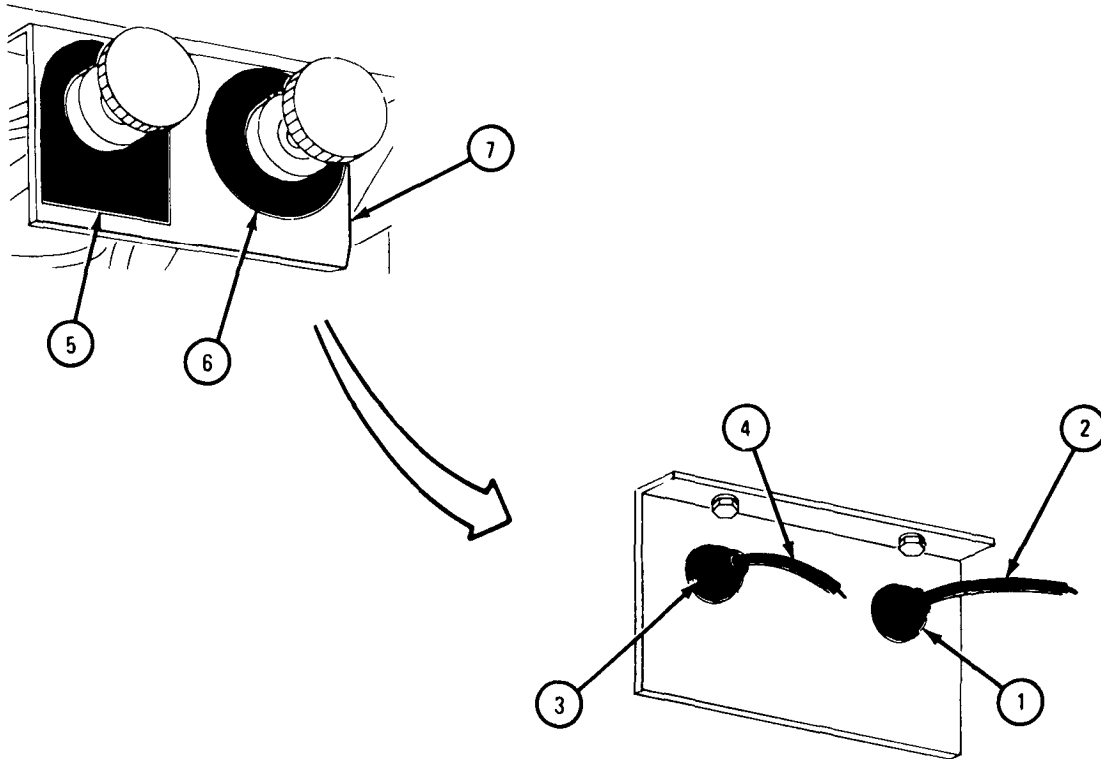

TA 080757

b. Repair. Repair is limited to throwing away damaged parts and getting new parts in their place.

c. Replacement.

FRAME 1

1. Put identification plate marked AIR (1) over left hole in bracket (2) and put diverter adapter cable assembly (3) through hole as shown.
2. Slide nut and washer (4) over diverter adapter cable (3) and using 9/16-inch wrench, screw on and tighten nut and washer.
3. Put identification plate marked DEFROSTER (5) over right hole in bracket (2) and put diverter cable assembly (6) through hole as shown.
4. Slide nut and washer (7) up over diverter cable (6) and using 9/16-inch wrench, screw on and tighten nut and washer.

GO TO FRAME 2

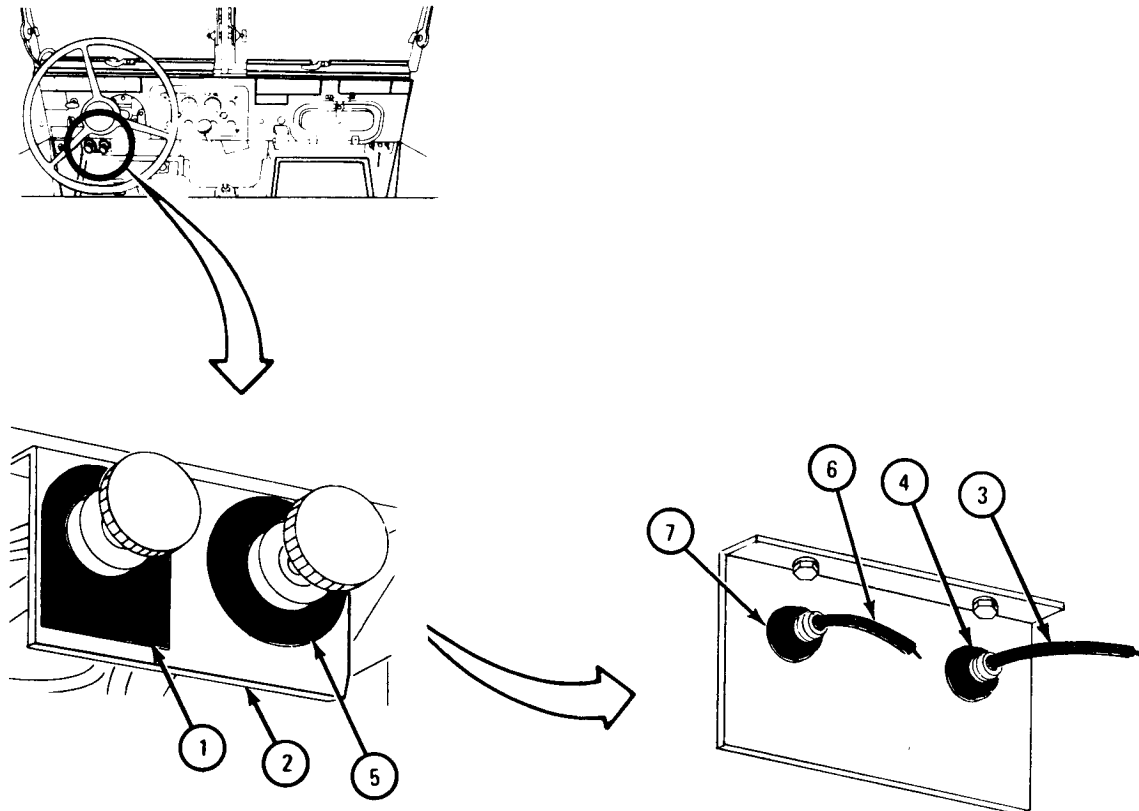

TA 080758

FRAME 2

1. Working from behind instrument panel, put diverter adapter cable assembly (1) through adapter clamp (2) and put looped end of cable over shaft (3).
2. Using screwdriver, tighten screw (4).
3. Put diverter cable assembly (5) through diverter clamp (6) and put looped end of cable over shaft (7).
4. Using screwdriver, tighten screw (8).

END OF TASK

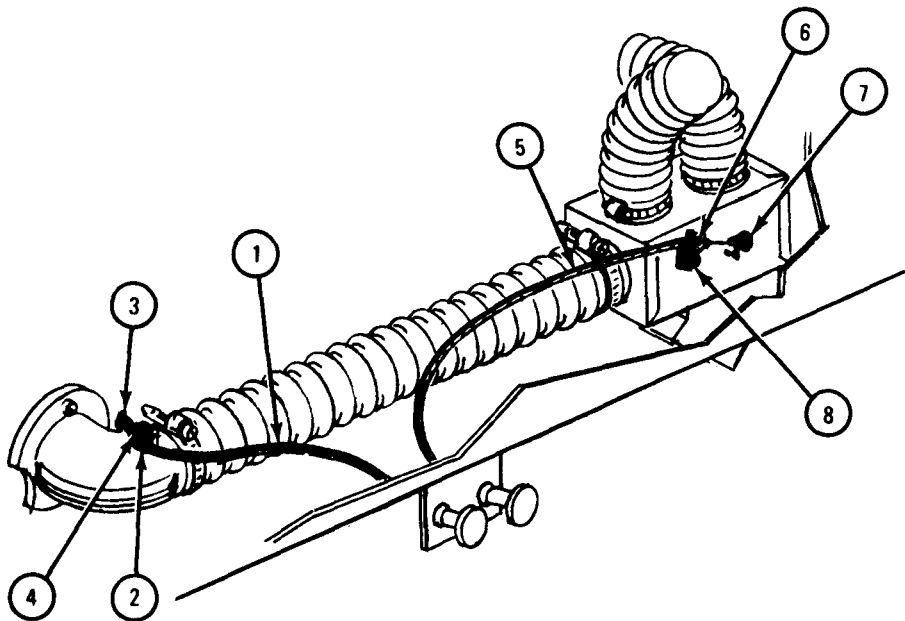

TA 080759

d. Adjustment.

FRAME 1

NOTE

This task is shown for one cable. It can be used for both cables.

1. Using screwdriver, loosen screw (1).
2. Pull knob (2) all the way out.
3. Pull shaft (3) all the way in towards cable clamp (4).
4. Using screwdriver, tighten screw (1). Do not let cable assembly (5) pull out of cable clamp (4).
5. Push knob (2) in and see if shaft (3) moves freely.

END OF TASK

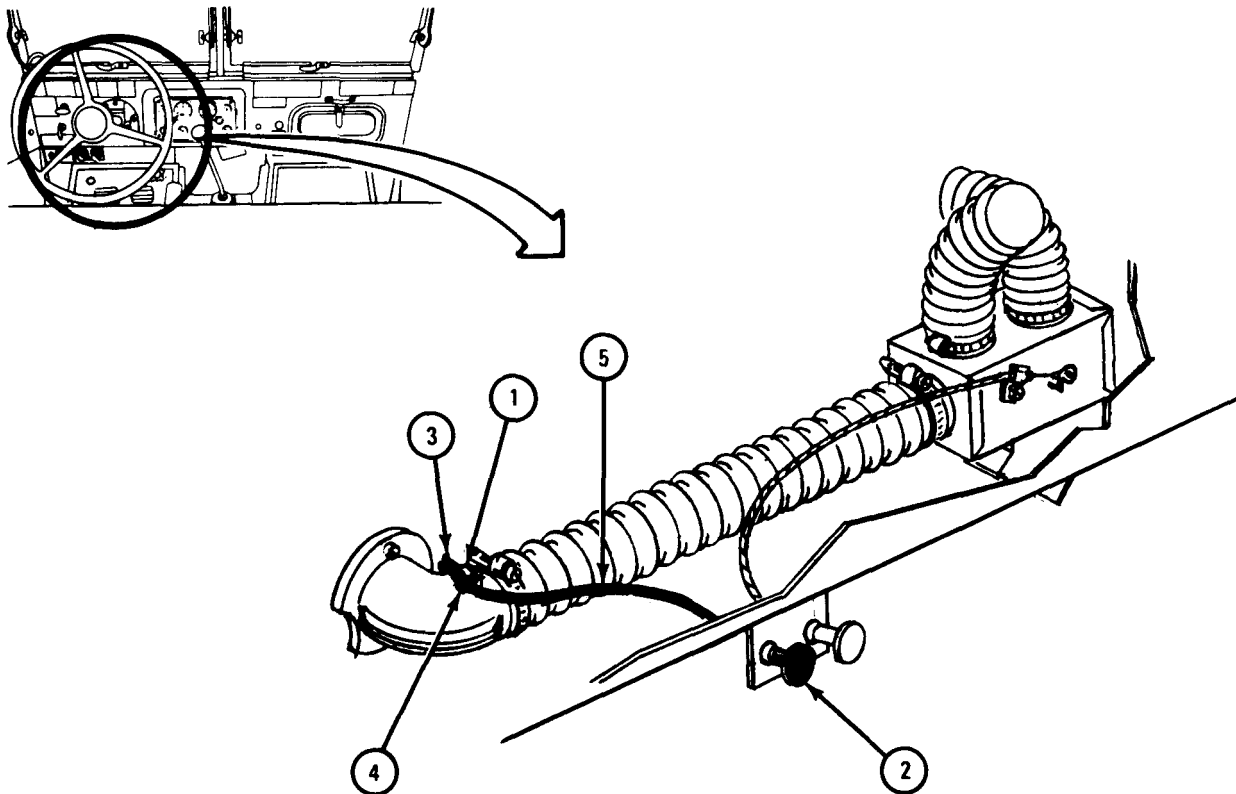

TA 080760

23-9. PERSONNEL AND ENGINE HEATER CONTROL BOX INDICATOR LAMP REMOVAL AND REPLACEMENT.

NOTE

This procedure is the same for the personnel and engine heater control boxes. This procedure is shown for the engine heater control box.

TOOLS: None

SUPPLIES: None

PERSONNEL: One

EQUIPMENT CONDITION: Truck parked, engine off, handbrake set.

a. Removal.

FRAME 1

1. Unscrew and take off lens cap (1).
 2. Take out indicator lamp (2) by pushing it in and turning it to left.
- END OF TASK

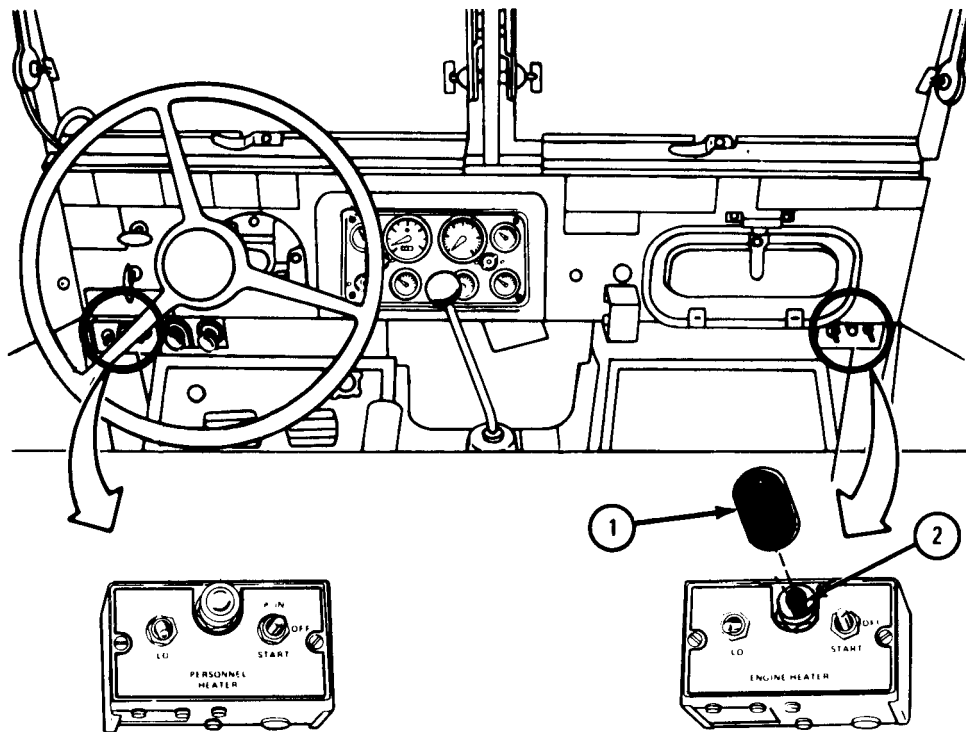

TA 080767

b. Replacement.

FRAME 1

1. Push in indicator lamp (1) and turn it to right.
 2. Screw on and tighten lens cap (2).
- END OF TASK

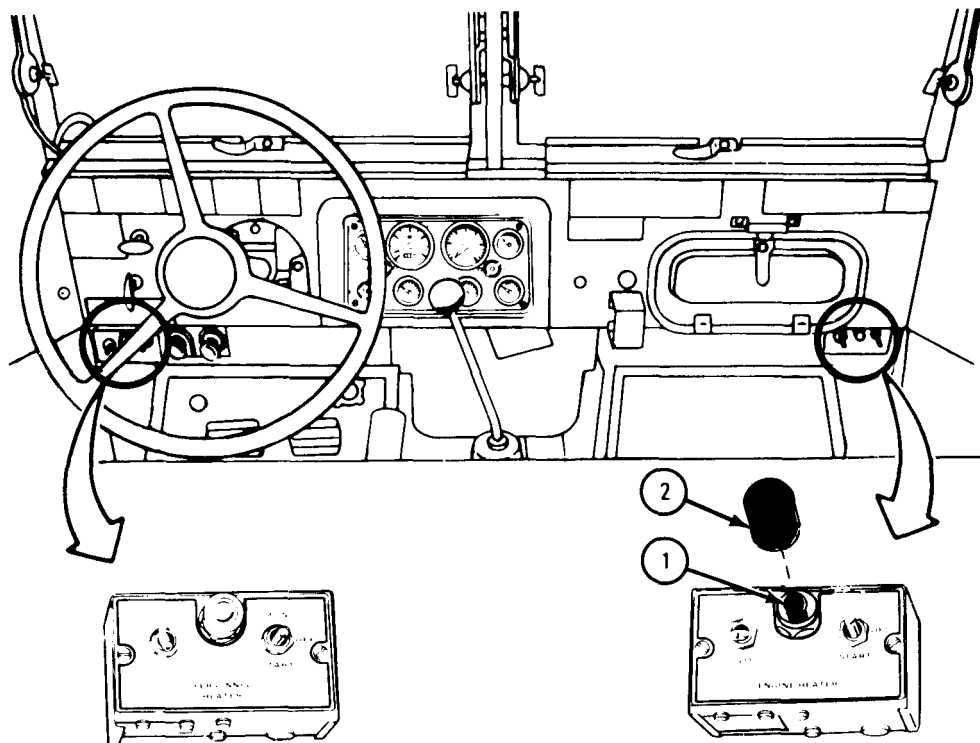

TA 080768

23-10. WINTERIZATION KIT FUEL FILTERS REPAIR.

NOTE

There are two fuel filters in the winterization kit. This task can be used for either one. Some trucks may have only one filter.

TOOLS: 1/2-gallon container

SUPPLIES: Solvent, dry cleaning, type II (SD-2), Fed. Spec P-D-680
Fuel filter gasket

PERSONNEL: One

EQUIPMENT CONDITION: Truck parked, engine off, handbrake set.

a. Preliminary Procedures.

(1) Disconnect battery ground cable. Refer to Part 1, para 7-58.

(2) Turn off personnel heater and powerplant heater. Refer to

TM 9-2320-209-10.

b. Removal.

FRAME 1

WARNING

Smoking, sparks or open flame are not allowed within 50 feet of work area during fuel filter service. Fuel may burn, causing explosion, injury to personnel, and damage to equipment.

1. Open battery box door (1).
2. Put container under fuel filter bowl (2). Unscrew filter bowl and take off helical compression spring (3), filter element (4), and gasket (5). Put fuel in filter bowl into container and put fuel in approved disposal area.
3. Throw away gasket (5).

END OF TASK

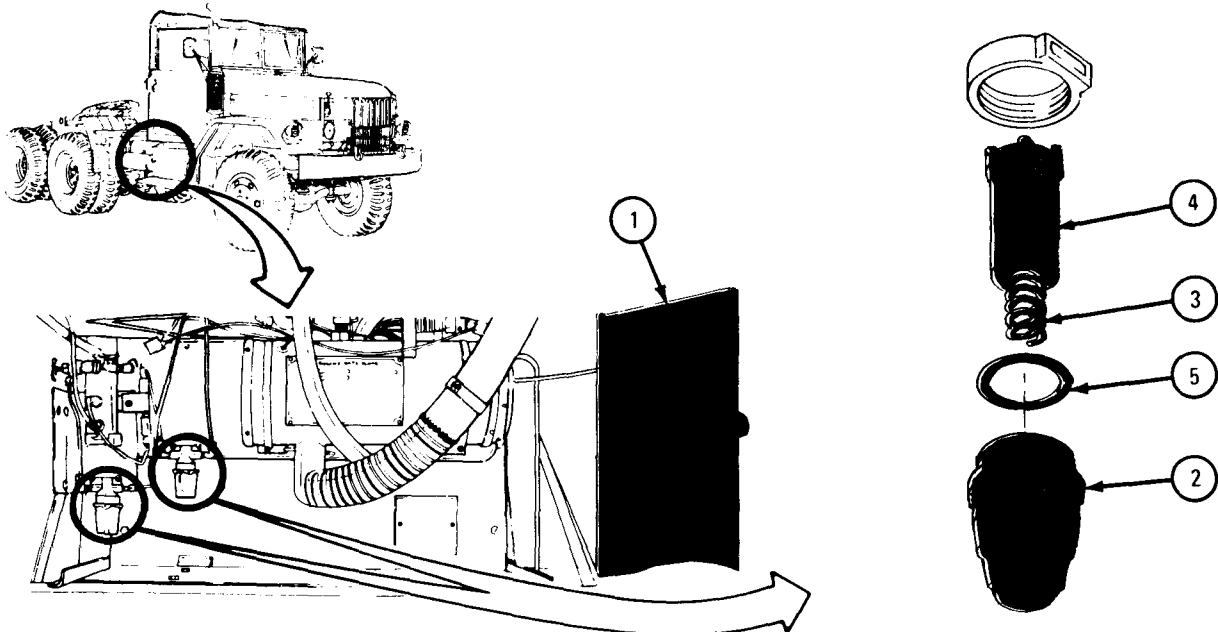

TA 080761

c. Cleaning and Inspection.

WARNING

Dry cleaning solvent is flammable. Do not use near an open flame. Keep a fire extinguisher nearby when solvent is used. Use only in well-ventilated places. Failure to do this may result in injury to personnel and damage to equipment.

(1) Wash all parts in solvent.

(2) Check that all parts are not cracked or damaged.

d. Repair. If any parts are damaged, throw them away and get new parts in their place.

e. Replacement.

FRAME 1

1. Put gasket (1) over threaded relief flange on filter bowl (2).
2. Put helical compression spring (3) and fuel filter element (4) into filter bowl (2).

CAUTION

Do not overtighten filter bowl (2) as gasket (1) may be damaged.

3. Screw in and hand tighten filter bowl (2) into head (5).
4. Reconnect battery ground cable. Refer to Part 1, para 7-58.
5. Start fuel burning personnel heater or powerplant heater. Refer to TM 9-2320-209-10. Check filter bowl (2) for leaks.
6. Turn off fuel burning personnel heater or powerplant heater. Refer to TM 9-2320-209-10.
7. Close battery box door (6).

END OF TASK

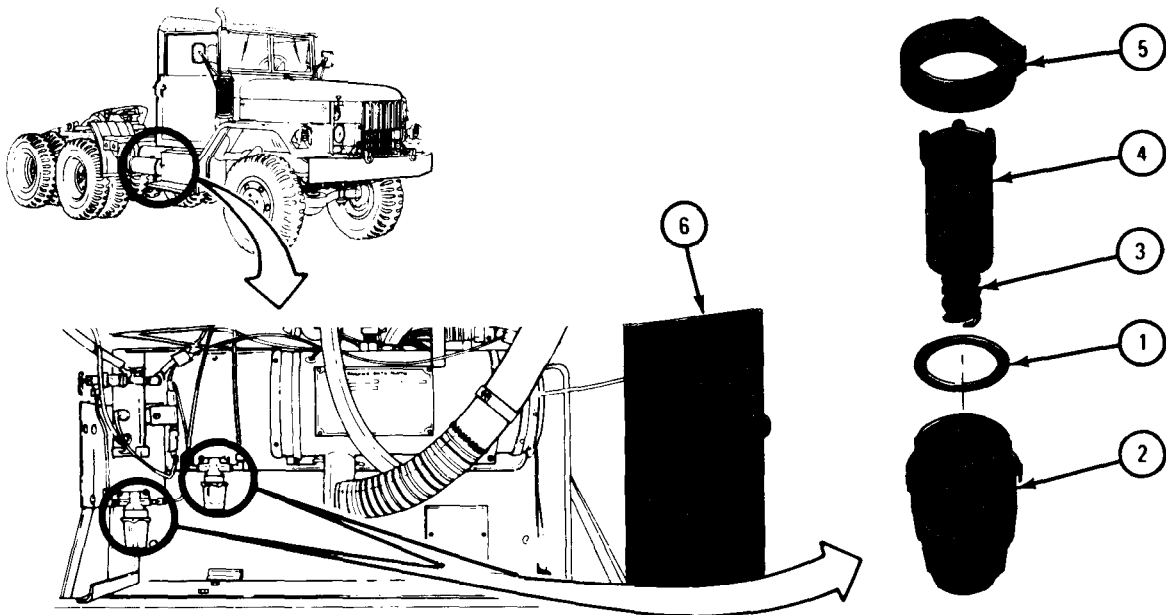

TA 080762

23-11. OIL PAN SHROUD REPAIR.

TOOLS: 6-inch pliers
9/16-inch wrench

SUPPLIES: None

PERSONNEL: One

EQUIPMENT CONDITION: Truck parked, engine off, handbrake set.

NOTE

Make sure powerplant heater is off and cool.

a. Removal.

FRAME 1

1. Using pliers, take out and throw away cotter pin (1).
2. Using 9/16-inch wrench, unscrew and take off four capscrews with washers (2), two on each side, while holding oil pan shroud (3) in place.
3. Take down oil pan shroud (3).

END OF TASK

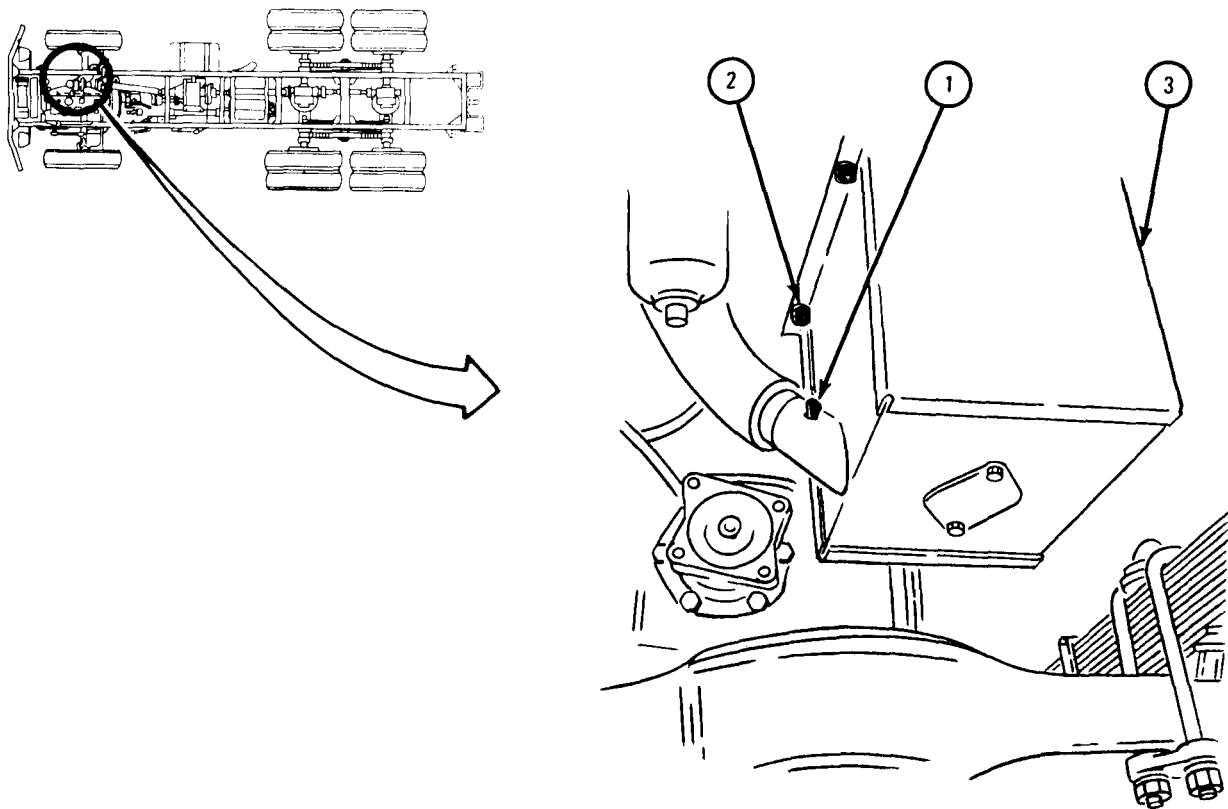

TA 080793

b. Replacement.

FRAME 1

1. Aline exhaust inlet on oil pan shroud (1) with exhaust tube (2). Push oil pan shroud up and hold it in place.
2. Aline four screw holes in oil pan (3) with screw holes in oil pan shroud (1). Using 9/16-inch wrench, screw in and tighten four capscrews with washers (4). two on each side of oil pan shroud.
3. Using pliers, put in cotter pin (5) and bend open ends of cotter pin.

END OF TASK

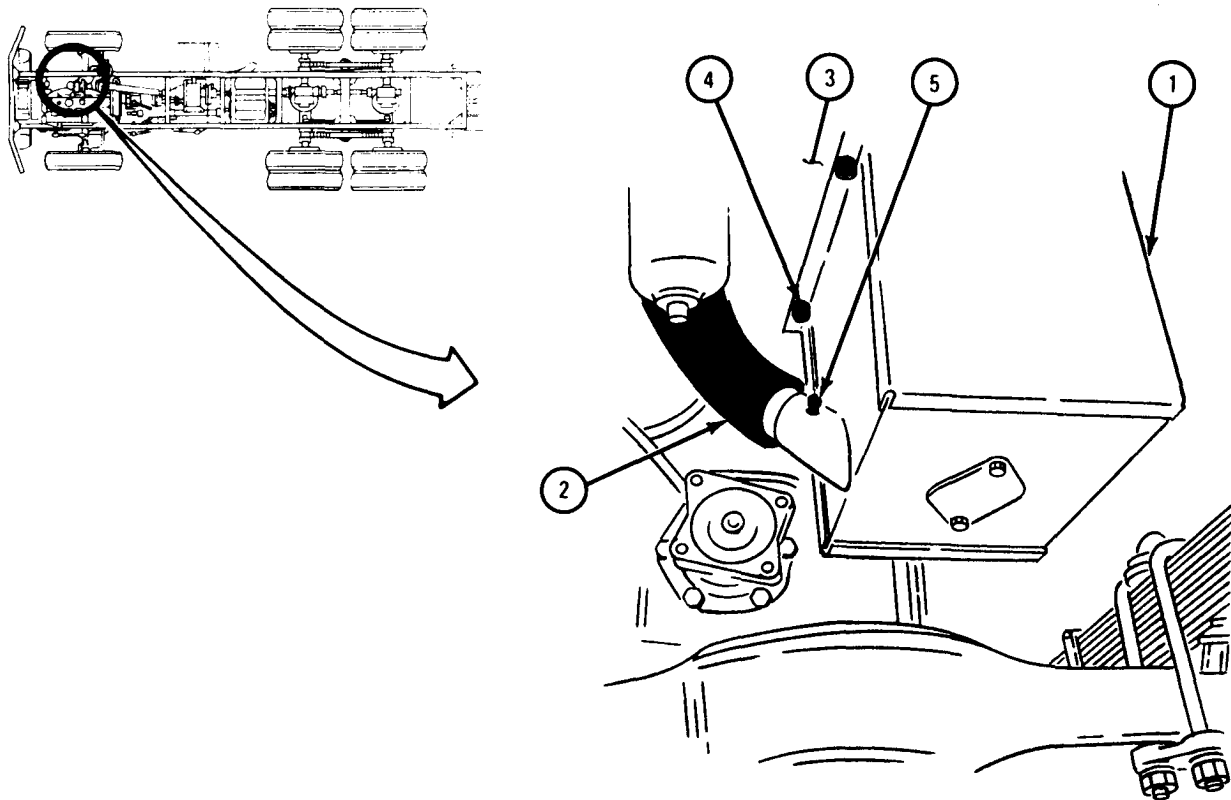

TA 080794

23-12. POWERPLANT HEATER EXHAUST TUBE REMOVAL AND REPLACEMENT.

TOOLS: 7/16-inch wrench (2)
6-inch pliers
1/8-inch punch

SUPPLIES: None

PERSONNEL: One

EQUIPMENT CONDITION: Truck parked, engine off and cool, handbrake set.

a. Preliminary Procedures.

- (1) Open hood and right side panel. Refer to TM 9-2320-209-10.
- (2) Open powerplant heater box door. Refer to para 23-22.

WARNING

Do not work on hot exhaust tube. Personnel can be badly burned.

b. Removal.

FRAME 1

1. Using pliers, take out and throw away cotter pin (1). Take exhaust tube (2) off elbow (3).

GO TO FRAME

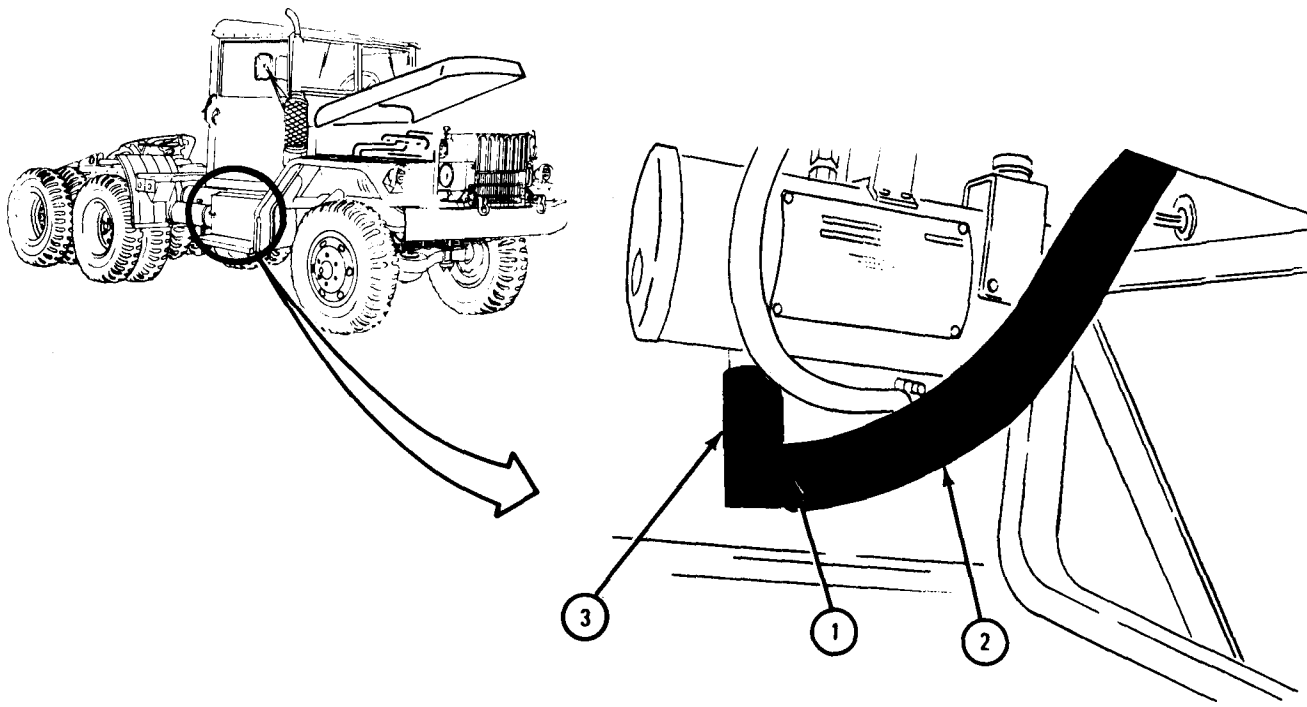

TA 080787

FRAME 2

1. Using pliers, take out and throw away cotter pin (1). Take exhaust tube (2) out of oil pan shroud exhaust inlet (3).

GO TO FRAME 3

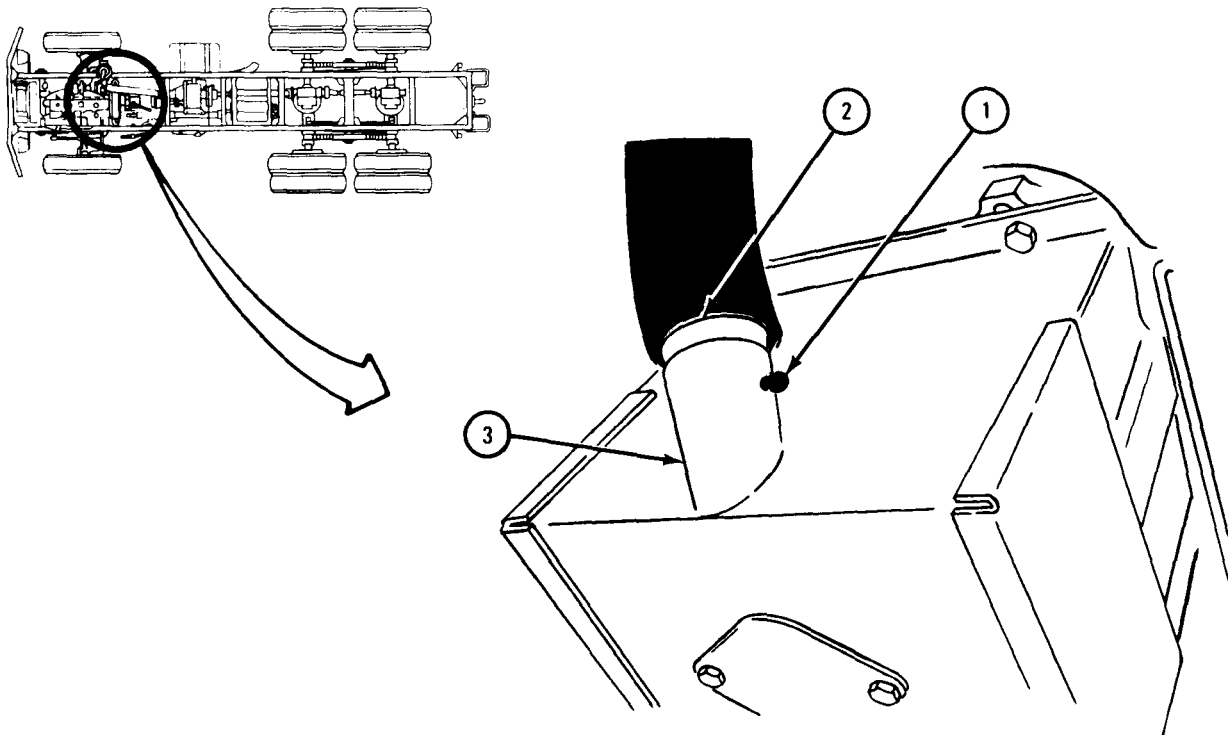

TA 080788

FRAME 3

NOTE

Note position of exhaust tube (1) so it can be put back in the same position.

1. Working from under right front fender and using 7/16-inch wrench, hold locknut (2).
2. Using 7/16-inch wrench, unscrew and take out screw (3).
3. Take exhaust tube (1) out of truck.
4. Spread open and take off clamp (4).

END OF TASK

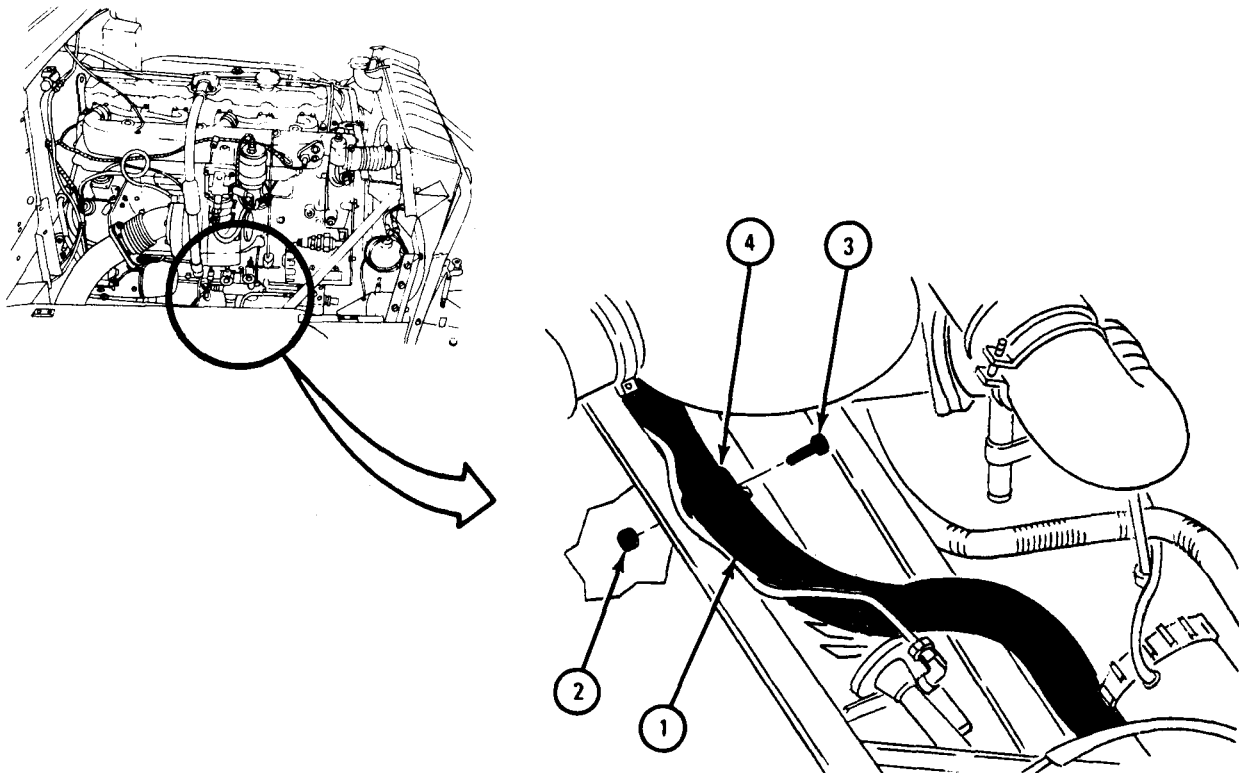

TA 080789

c. Replacement.

FRAME 1

1. Put exhaust tube (1) in place as noted.
 2. Put exhaust tube (1) on elbow (2) and aline holes.
 3. Using pliers, put in cotter pin (3) and bend open ends of cotter pin.
- GO TO FRAME 2

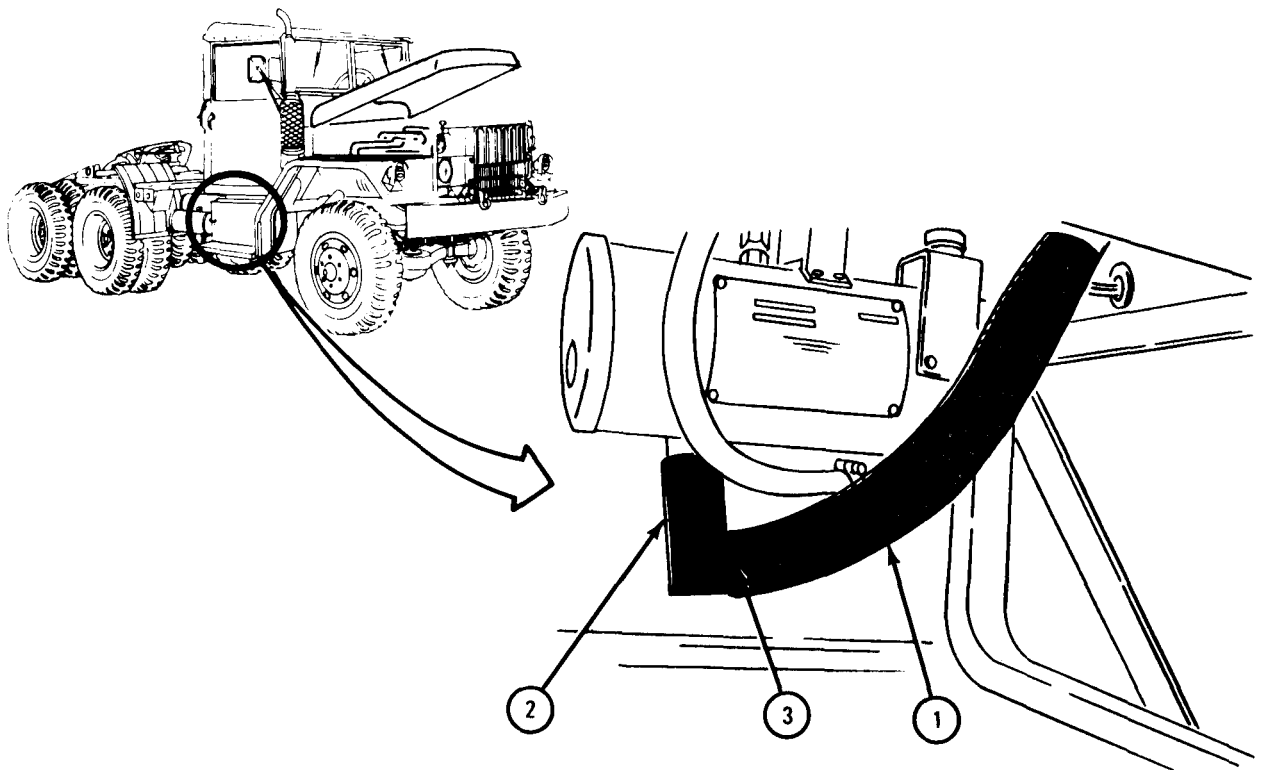

TA 080790

FRAME 2

1. Put exhaust tube (1) in oil pan shroud exhaust inlet (2). Using punch, aline holes.
 2. Using pliers, put in cotter pin (3) and bend open ends of cotter pin.
- GO TO FRAME 3

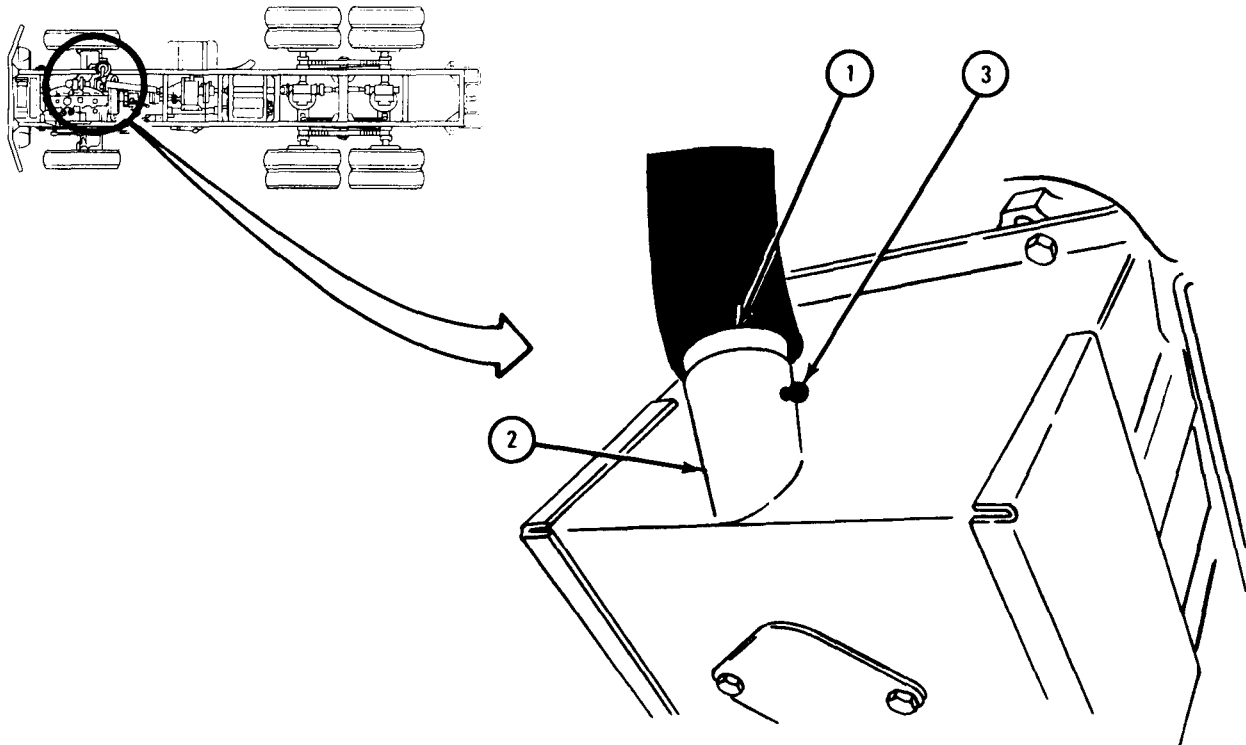

TA 080791

FRAME 3

1. Put clamp (1) over exhaust tube (2) and align screw holes. Put in screw (3) and using 7/16-inch wrench, hold capscrew.
2. Working from under right fender and using 7/16-inch wrench, screw on and tighten locknut (4).

NOTE

Follow-on Maintenance Action Required:

1. Close hood and right side panel. Refer to TM 9-2320-209-10.
2. Close power plant heater box door. Refer to para 23-22.

END OF TASK

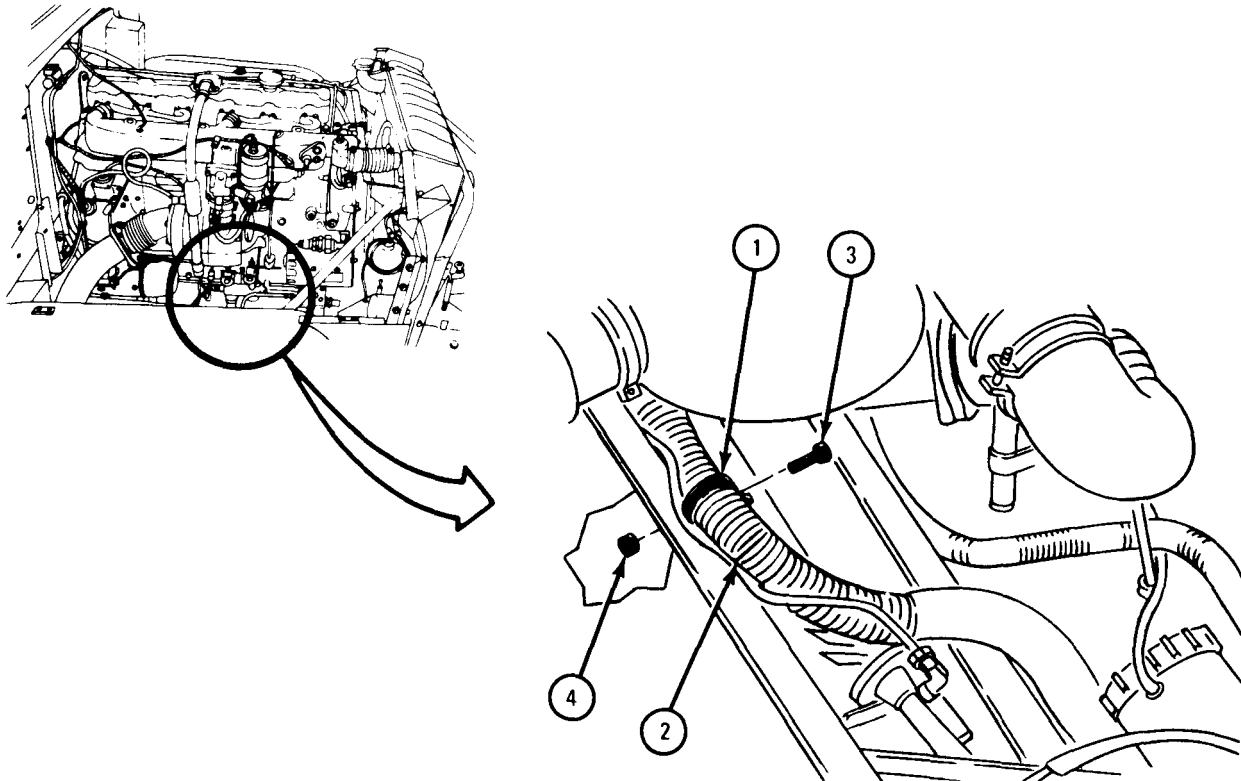

TA 080792

23-13. POWERPLANT COOLANT HEATER HOSES AND CLAMPS REMOVAL AND REPLACEMENT.

TOOLS: Flat-tip screwdriver
Coolant drain pan

SUPPLIES: Engine coolant (as needed)

PERSONNEL: One

EQUIPMENT CONDITION: Truck parked, engine off, handbrake set.

a. Preliminary Procedures.

(1) Remove air cleaner filter element. Refer to TM 9-2320-209-10.

(2) Open battery box door. Refer to TM 9-2320-209-10.

b. Removal.

FRAME 1

1. Close petcock (1) at right front of engine.
2. Close petcock (2) at right rear of engine.
3. Using screwdriver, unscrew and loosen clamp (3). Take off inlet hose (4) from connector (5). Take off clamp.
4. Using screwdriver, unscrew and loosen clamp (6). Take off outlet hose (7) from connector (8). Take off clamp.

GO TO FRAME 2

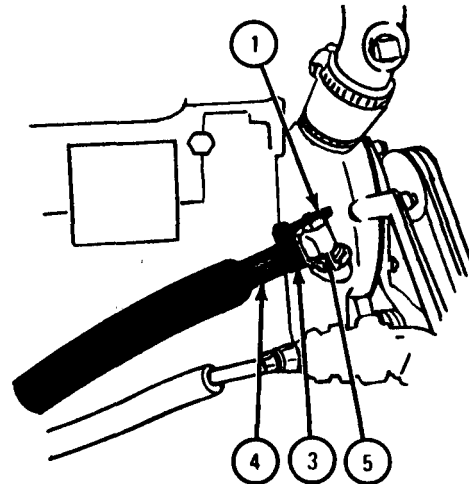
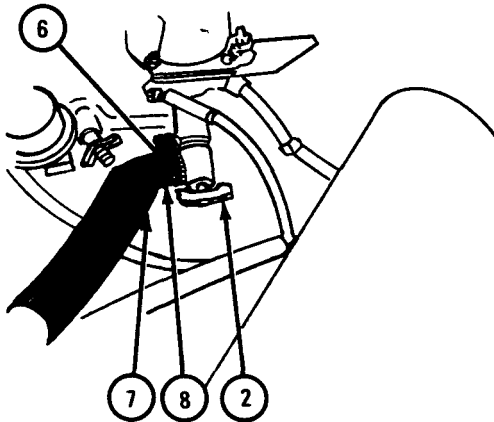
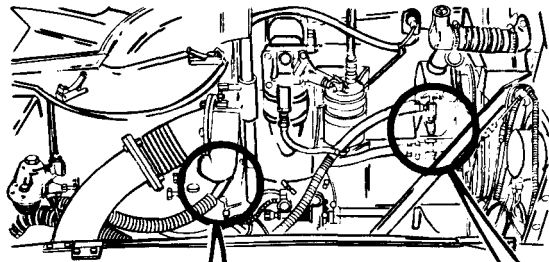

TA 104768

FRAME 2

NOTE

It is not needed to take off heater exhaust pipe.

1. Using screwdriver, unscrew and loosen clamp (1). Take off return hose (2) from elbow connector (3). Drain coolant from return hose. Take off clamp.
2. Using screwdriver, unscrew and loosen clamp (4). Take off return hose (2) from battery box heating pad connector (5). Take off clamp.
3. Using screwdriver, unscrew and loosen clamp (6). Take off inlet hose (7) from elbow connector (8). Take off clamp.

GO TO FRAME

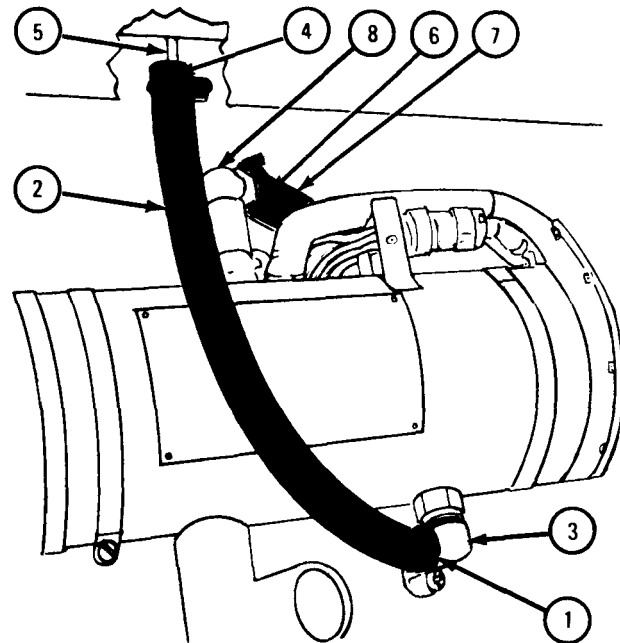
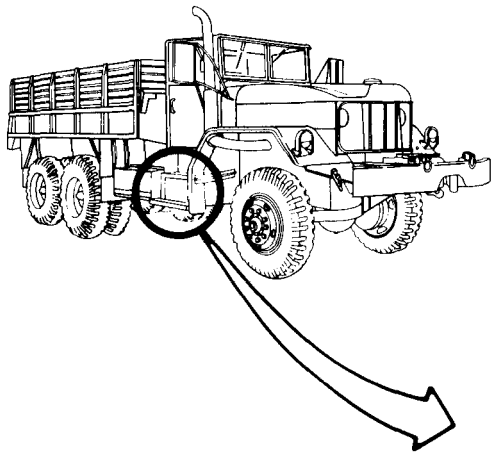

TA 104769

FRAME 3

1. Using screwdriver, unscrew and loosen clamp (1). Take off outlet hose (2) from battery box heating pad connector (3). Take off clamp.
2. Pull outlet hose (2) from over frame rail (4) to under side of truck. Drain coolant from hose.

GO TO FRAME 4

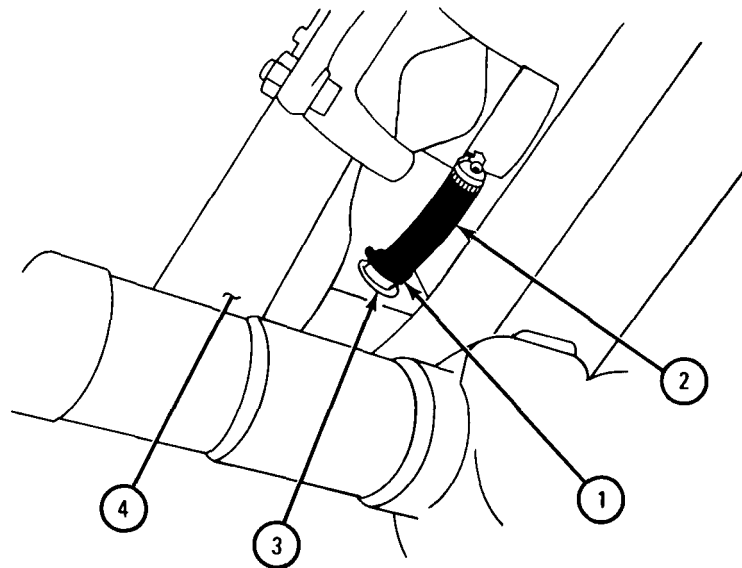
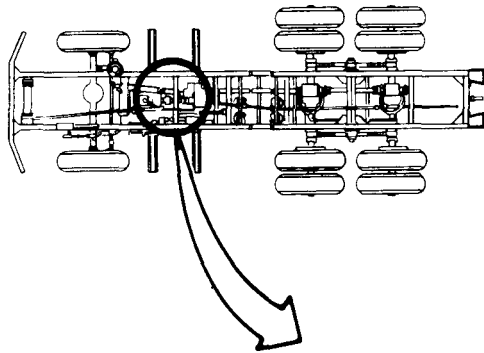

TA 104770

FRAME 4

1. Pull inlet hose and shield (1) through hole (2) in body to under side of truck. Drain coolant from inlet hose.
2. Pull inlet hose and shield (1) and outlet hose and shield (3) from over engine mount (4).
3. Take hoses and shields (1 and 2) off truck.

END OF TASK

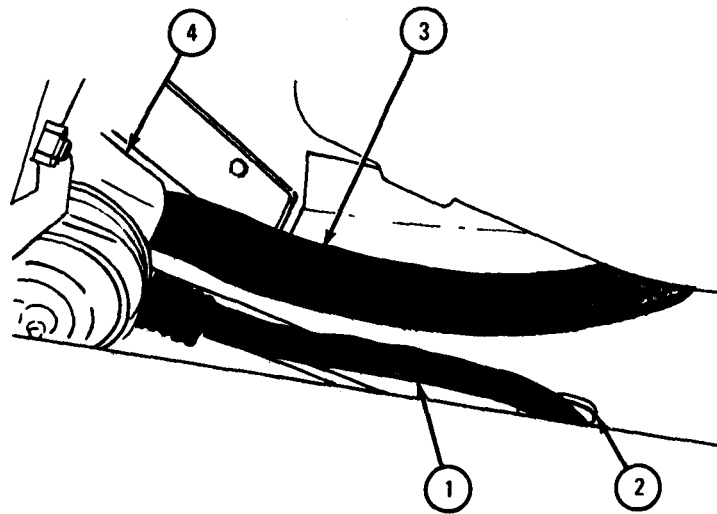

TA 104771

c. Replacement.

FRAME 1

CAUTION

When putting hoses together, be sure metal protective shield covering coolant inlet and outlet hoses is put on and placed properly, and that hoses are routed the same way they came off. Failure to do this could result in rubbing damage to hoses and loss of coolant.

1. Route inlet hose and shield (1) and outlet hose and shield (2) over engine mount (3).
2. Route end of inlet hose (1) through hole in body (4).

GO TO FRAME 2

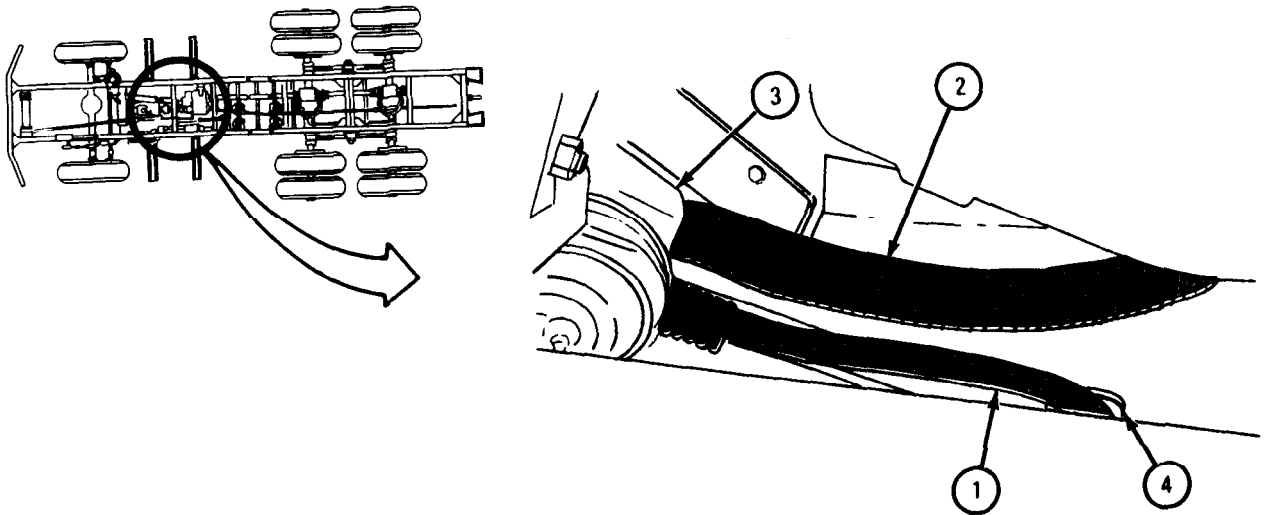

TA 104772

FRAME 2

1. Route end of outlet hose (1) over frame rail (2).
2. Put clamp (3) on end of outlet hose (1).
3. Put end of outlet hose (1) on battery box heating pad connector (4).
4. Using screwdriver, screw and tighten clamp (3).

GO TO FRAME 3

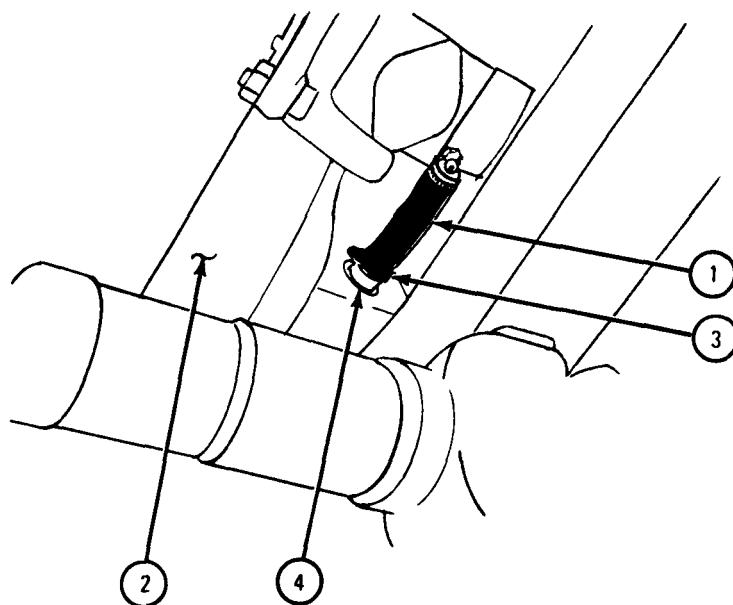

TA 104773

FRAME 3

1. Put clamp (1) on end of inlet hose (2). Put end of inlet hose (2) on elbow connector (3).
2. Using screwdriver, screw and tighten clamp (1).
3. Put clamp (4) on end of return hose (5).
4. Put end of return hose (5) on battery box heating pad connector (6).
5. Using screwdriver, screw and tighten clamp (4).
6. Put clamp (7) on other end of return hose (5).
7. Put end of return hose (5) on elbow connector (8).
8. Using screwdriver, screw and tighten clamp (7).

GO TO FRAME 4

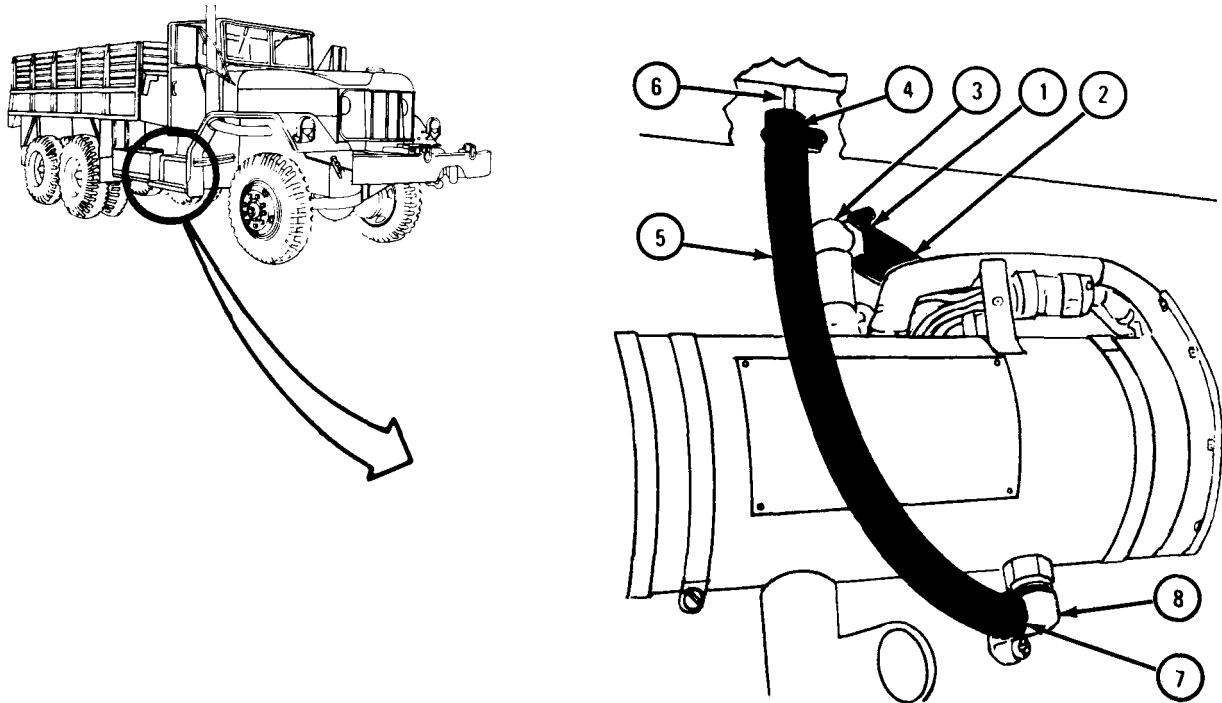

TA 104774

FRAME 4

1. Route inlet hose (1) in engine compartment.
2. Put clamp (2) on end of inlet hose (1). Put end of inlet hose (1) on connector (3).
3. Using screwdriver, screw and tighten clamp (2).
4. Route outlet hose (4) in engine compartment.
5. Put clamp (5) on end of outlet hose (4). Put end of outlet hose (4) on connector (6).
6. Using screwdriver, screw and tighten clamp (5).
7. Open petcocks (7 and 8) at front and rear of engine.

NOTE

Follow-on Maintenance Action Required:

1. Put on air cleaner filter element, but do not close hood. Refer to TM 9-2320-209-10.
2. Close battery box door. Refer to TM 9-2320-209-10.
3. Start engine. Check for coolant leaks. Refer to TM 9-2320-209-10.
4. Stop engine. Check coolant level. Refer to TM 9-2320-209-10.
5. Close hood. Refer to TM 9-2320-209-10.

END OF TASK

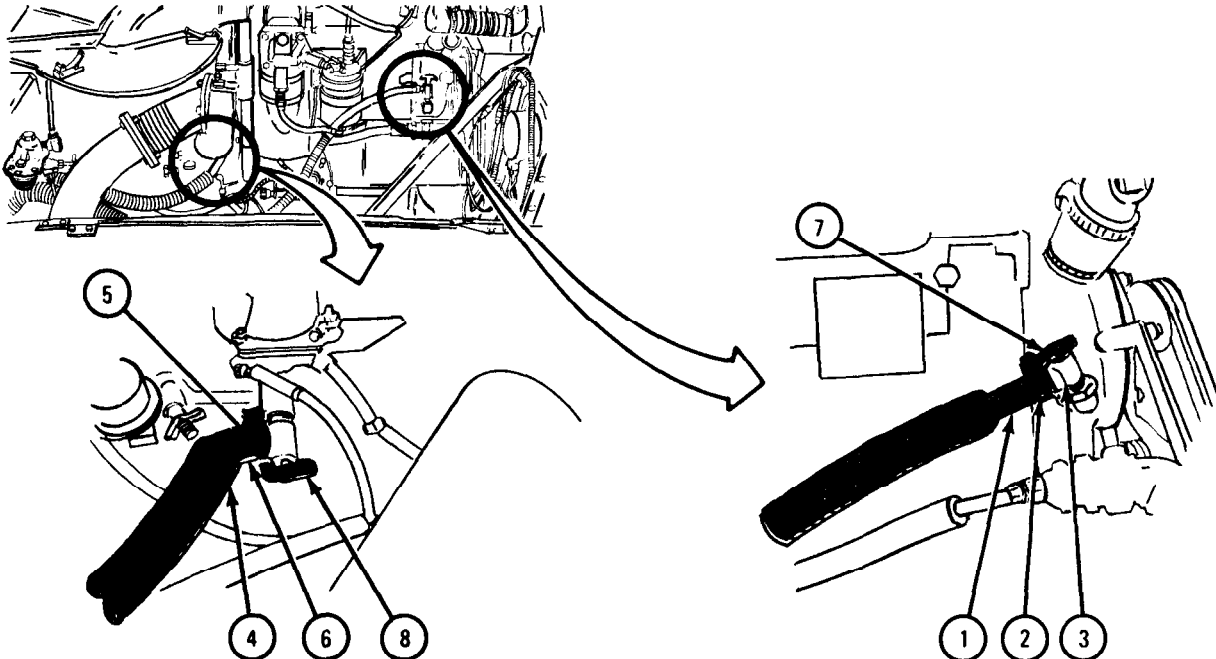

TA 104775

23-14. HOT WATER PERSONNEL HEATER DUCTING REPAIR. Refer to personnel fuel burning heater ducting repair, para 23-4, for procedures to repair the hot water heater ducting.

23-15. HOT WATER PERSONNEL HEATER AIR DIVERTER REPAIR. Refer to fuel burning personnel heater air diverter repair, para 23-5, for procedures to repair the hot water personnel heater air diverter.

23-16. HOT WATER PERSONNEL HEATER CONTROL CABLES REPAIR AND ADJUSTMENT. Refer to personnel fuel burning heater control cables repair and adjustment, para 23-8, for procedures to repair and adjust hot water personnel heater control cables.

23-17. HOT WATER PERSONNEL HEATER CONTROL SWITCH REMOVAL AND REPLACEMENT.

TOOLS: 1-inch wrench
Flat-tip screwdriver

SUPPLIES: None

PERSONNEL: One

EQUIPMENT CONDITION: Truck parked, engine off, handbrake set.

a. Removal.

FRAME 1

NOTE

Note position of heater control switch before taking it out so that it can be put back the same way.

1. Using 1-inch wrench, unscrew and take off locking nut (1). Take heater control switch (2) from switch mounting bracket (3) from back of instrument panel (4).

GO TO FRAME 2

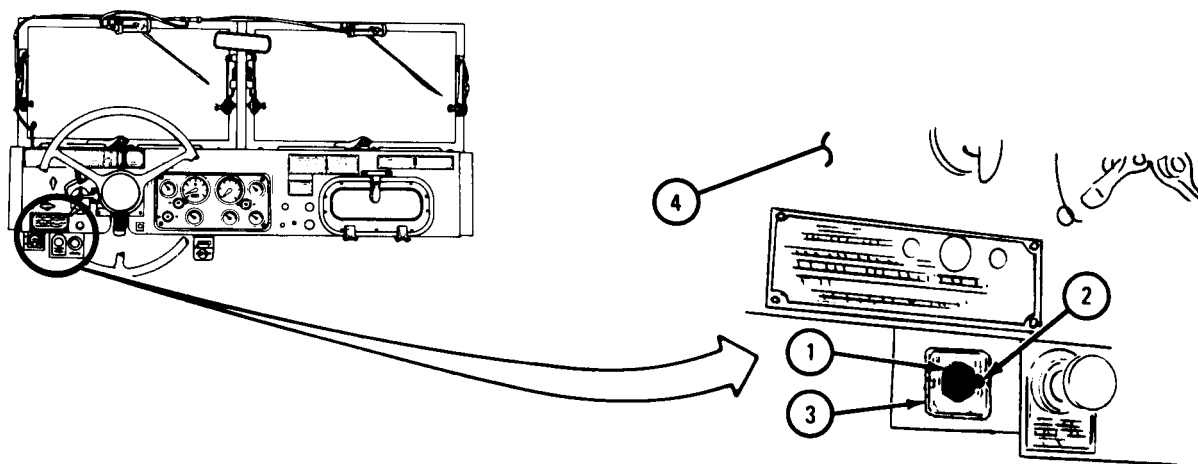

TA 047488

FRAME 2

NOTE

Tag all electrical connectors so they will be put back in the same place.

1. Using screwdriver, unscrew and take out three screws and lockwashers (1) from end of heater control switch (2). Take off four wires (3).

END OF TASK

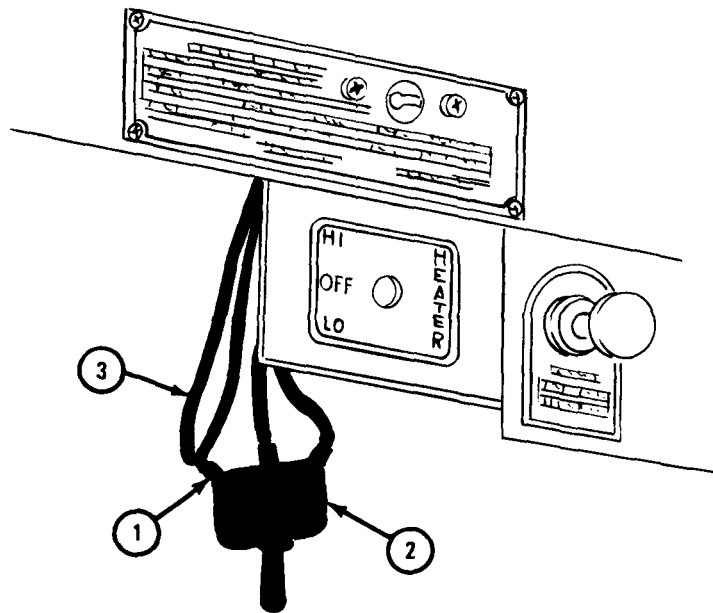

TA 047489

b. Replacement.

FRAME 1

1. Put four wires (1) on heater control switch (2) as tagged.
2. Using screwdriver, screw in and tighten three screws and lockwashers (3). Take off tags.

GO TO FRAME 2

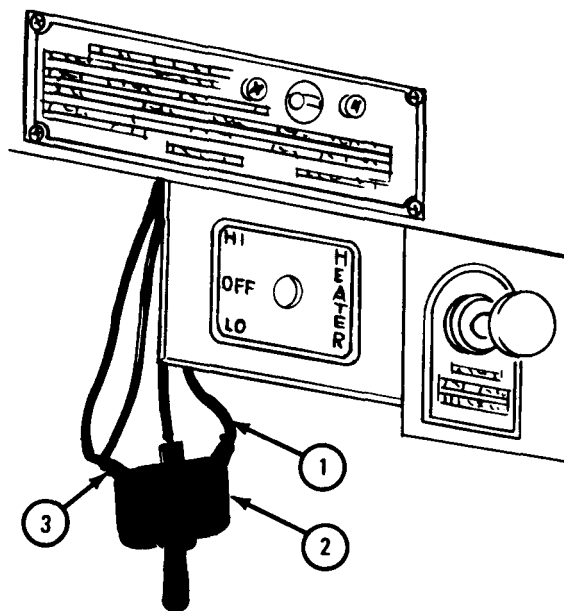
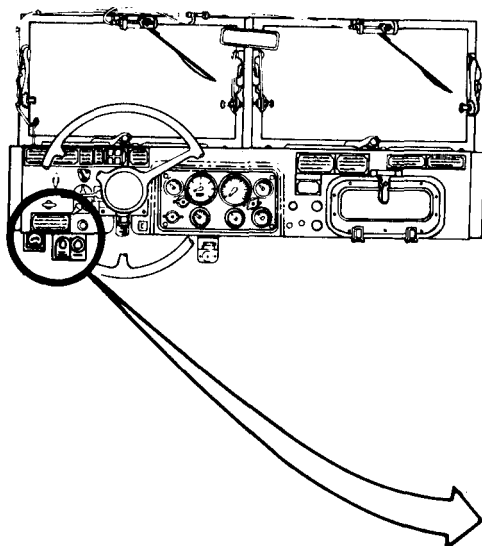

TA 047490

FRAME 2

1. Put heater control switch (1) into place on mounting bracket (2) from back of instrument panel (3) in position noted.
2. Using 1-inch wrench, screw on and tighten locking nut (4).

END OF TASK

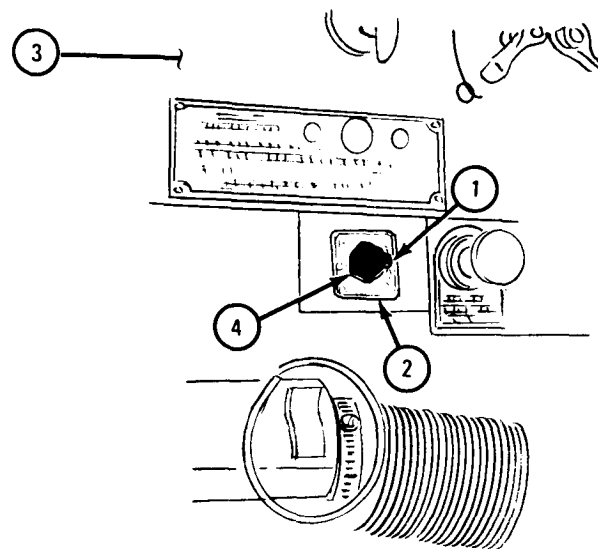

TA 047491

23-18. HOT WATER PERSONNEL HEATER HOSES AND CLAMPS REMOVAL AND REPLACEMENT.

TOOLS: Flat-tip screwdriver
1-gallon container

SUPPLIES: None

PERSONNEL: One

EQUIPMENT CONDITION: Truck parked, engine off and cool, handbrake set.

a. Preliminary Procedure. Open hood and left side panel. Refer to TM 9-2320-209-10.

b. Removal.

FRAME 1

1. Close return shutoff cock (1) and inlet shutoff cock (2) by turning them to the right.
2. Using screwdriver, loosen two hose clamps (3).

NOTE

Note position of hoses (4 and 5) so that they are put back in the same place.

3. One at a time, take off ends of return hose (4) and inlet hose (5) and catch coolant in container.

GO TO FRAME 2

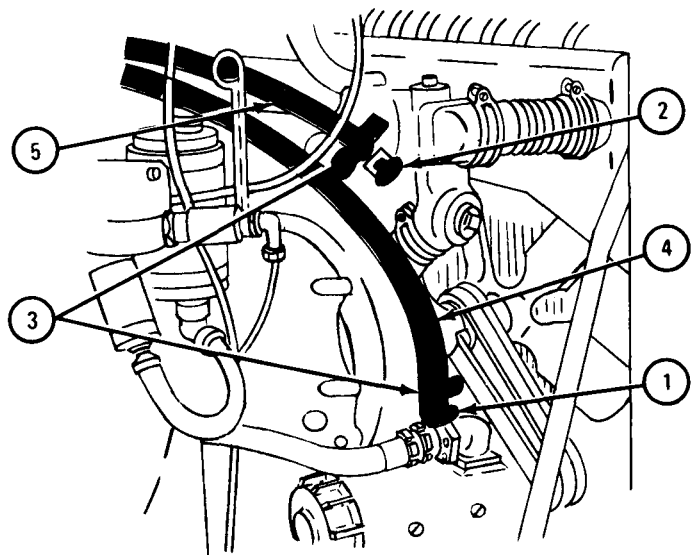
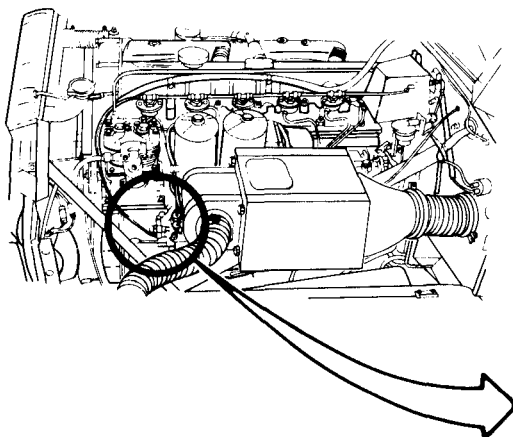

TA 102671

FRAME 2

1. Using screwdriver, loosen two hose clamps (1).
2. Take off two hoses (2).

END OF ASK

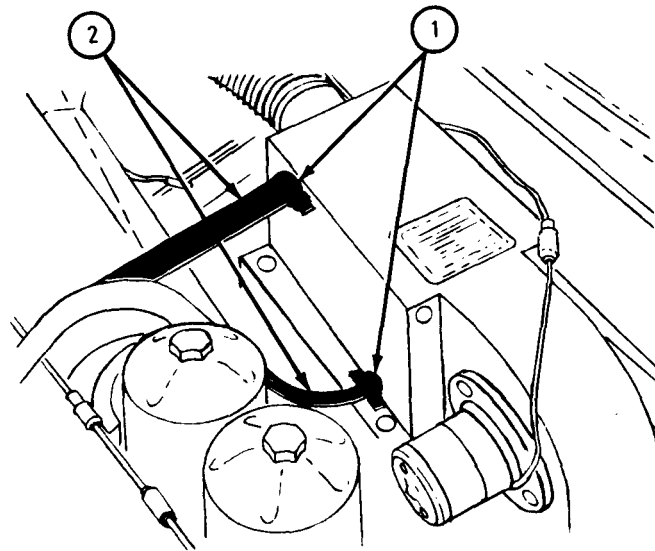

TA 102672

c. Replacement.

FRAME 1

1. Put two hoses (1) with clamps (2) on heater assembly (3) as noted.
 2. Using screwdriver, tighten two hose clamps (2).
- GO TO FRAME 2

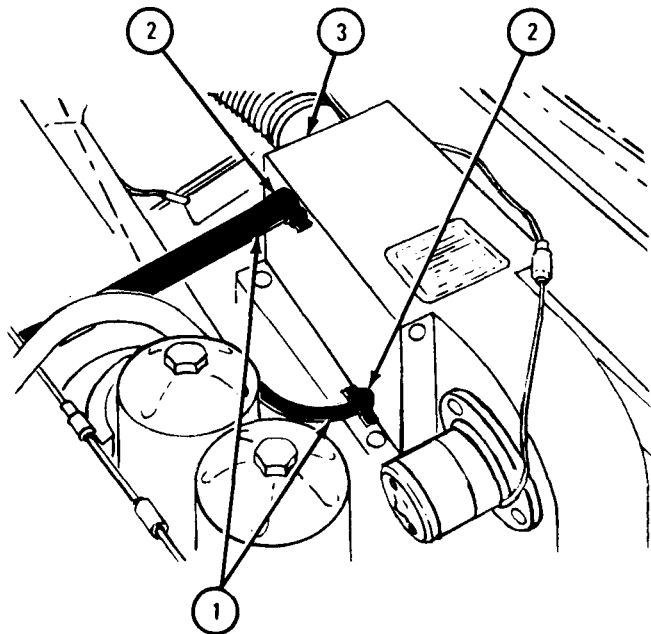
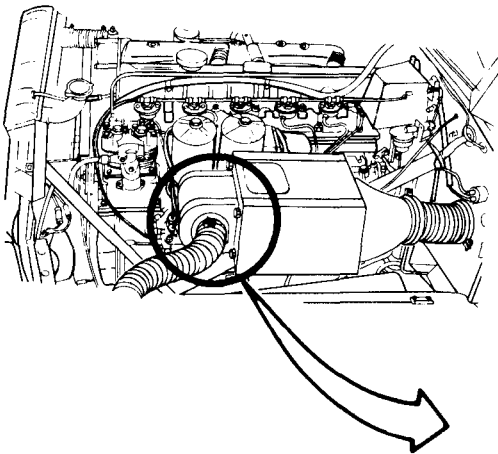

TA 102673

FRAME 2

1. Put two clamps (1) on inlet hose (2) and return hose (3).
2. Put inlet hose (2) in place. Put return hose (3) in place.
3. Using screwdriver, tighten two clamps (1).
4. Open inlet shutoff cock (4) and return shutoff cock (5) by turning them to the left.

NOTE

Follow-on Maintenance Action Required:

1. Fill cooling system. Refer to Part 1, para 6-10.
2. Close hood and left side panel. Refer to TM 9-2320-209-10.

END OF TASK

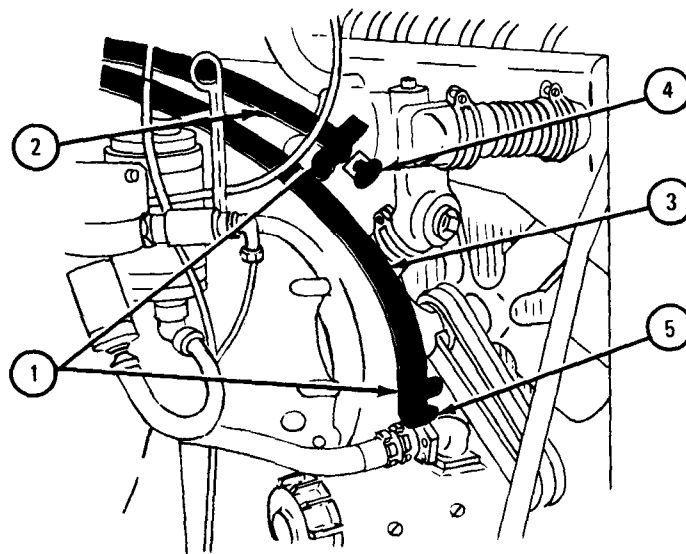

TA 102674

23-19. HOT WATER PERSONNEL HEATER MOTOR RESISTOR REMOVAL AND REPLACEMENT.

TOOLS: Flat-tip screwdriver

SUPPLIES: Tags

PERSONNEL: One

EQUIPMENT CONDITION: Truck parked, engine off, handbrake set.

a. Preliminary Procedure. Disconnect battery ground cable. Refer to Part 1, para 7-58.

b. Removal.

FRAME 1

1. Using screwdriver, unscrew and take off two screws (1). Let heater motor resistor (2) hang down.

NOTE

Tag wires (3) so they can be put back in the same places.

2. Using screwdriver, unscrew and take off two screws (4) and two wires (3).
3. Take out heater motor resistor (2).

END OF TASK

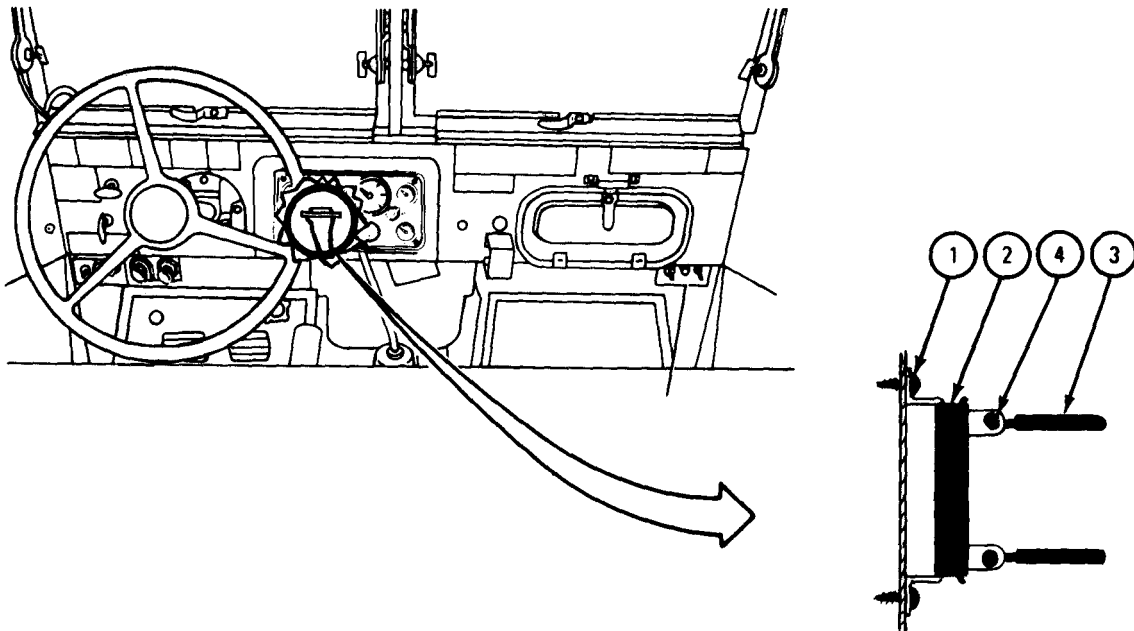

TA 080765

c. Replacement.

FRAME 1

1. Using screwdriver, screw in and tighten two screws (1) with two wires (2) as tagged on heater motor resistor (3). Take off tags.
2. Put heater motor resistor (3) on fire wall (4) and align screw holes.
3. Using screwdriver, screw in and tighten two screws (5).

NOTE

Follow-on Maintenance Action Required:

Reconnect battery ground cable. Refer to Part 1, para 7-58.

END OF TASK

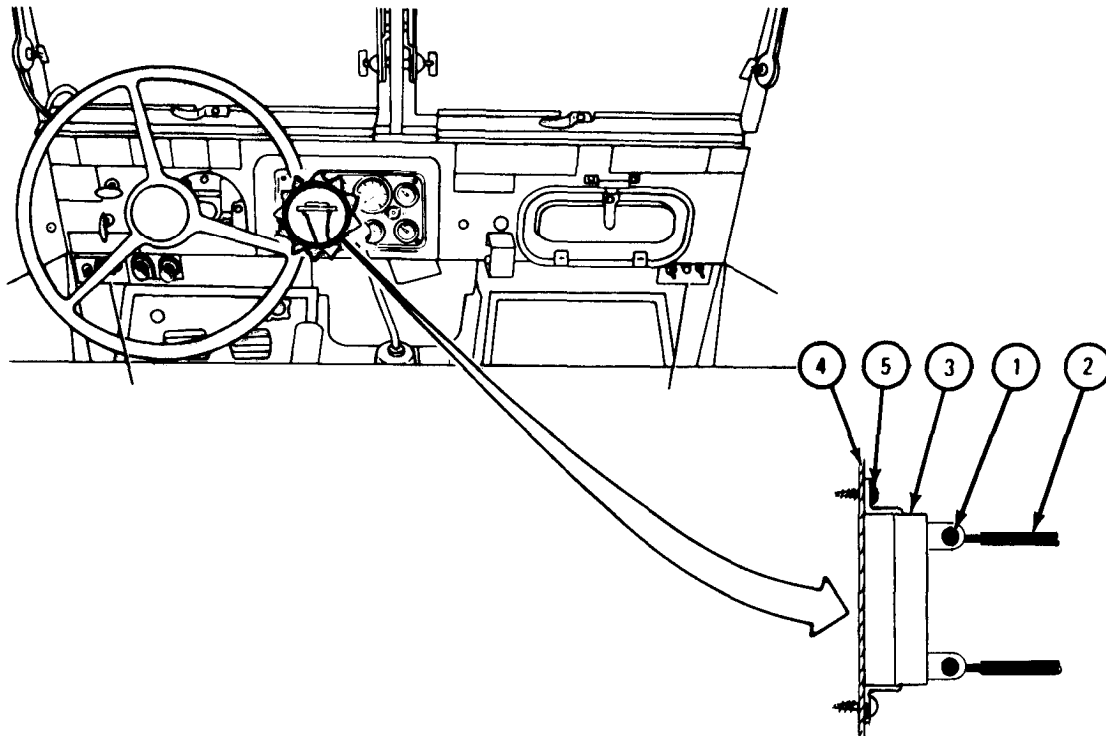

TA 080766

23-20. HOT WATER PERSONNEL HEATER BLOWER MOTOR REPAIR.

TOOLS: Flat-tip screwdriver

SUPPLIES: None

PERSONNEL: One

EQUIPMENT CONDITION: Truck parked, engine off, handbrake set.

a. Preliminary Procedure. Open hood and left side panel. Refer to TM 9-2920-209-10.

b. Removal.

FRAME 1

1. Unplug electrical lead connector (1).
 2. Using screwdriver, unscrew and take out four screws and lockwashers (2).
 3. Take blower motor (3) out of blower housing (4).
- END OF TASK

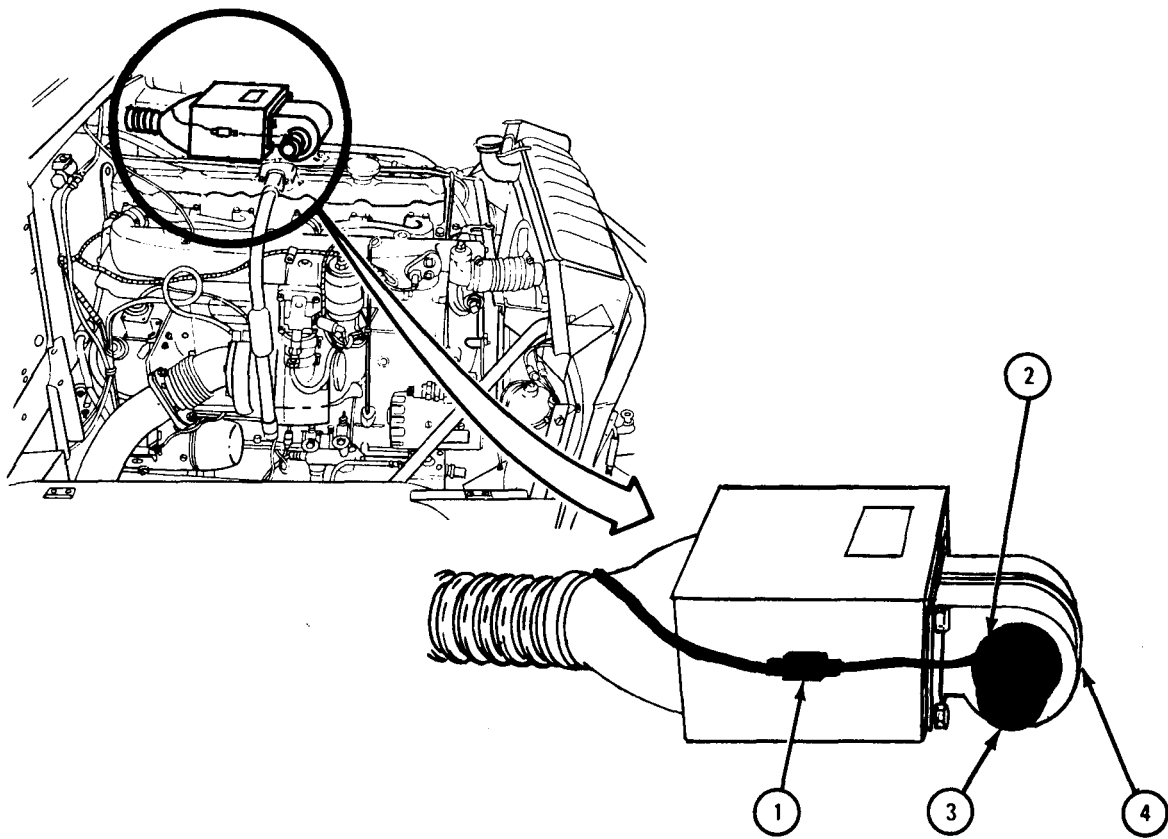

TA 080763

c. Replacement.

FRAME 2

1. Put blower motor (1) in blower housing (2) and align screw holes.
2. Using screwdriver, screw in and tighten four screws with lockwashers (3).
3. Plug in electrical lead connector (4).

NOTE

Follow -on Maintenance Action Required:
Close hood and left side panel. Refer to TM 9-2320-209-10.

END OF TASK

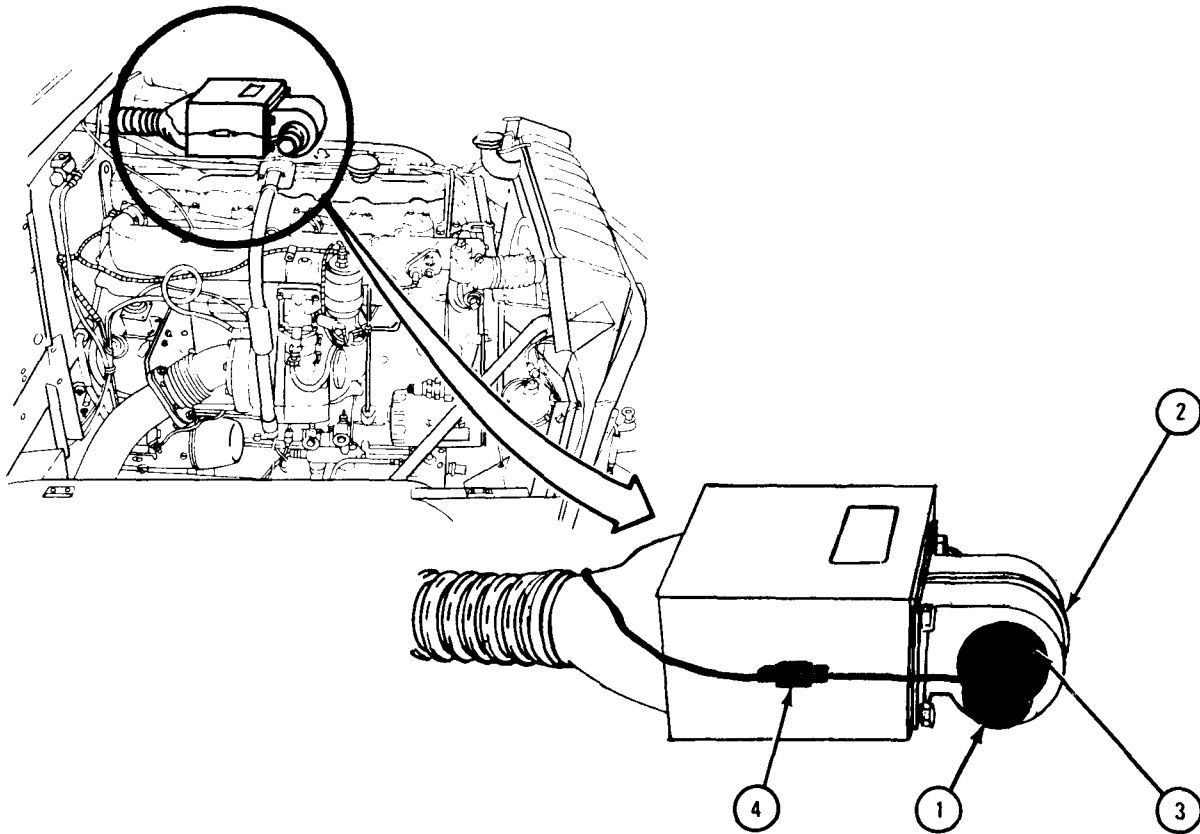

TA 080764

23-21. WINTERIZATION KIT FUEL PUMP REPAIR.

TOOLS: Open end wrench set, pn GGG-W-636
Flat-tip screwdriver
6-inch pliers
1/2-gallon container

SUPPLIES: Solvent, dry cleaning, type II (SD-2), Fed. Spec P-D-680
Fuel pump cover gasket
Fuel pump cup gasket
Rags

PERSONNEL: One

EQUIPMENT CONDITION: Truck parked, engine off, handbrake set.

a. Preliminary Procedures.

- (1) Disconnect battery ground cable. Refer to Part 1, para 7-58.
- (2) Turn off personnel heater and powerplant heater. Refer to TM 9-2320-209-10.

WARNING

Smoking, sparks, or open flame are not allowed within 50 feet of work area during this task. Fuel could catch fire or explode, causing serious injury to personnel and damage to equipment.

b. Removal.

FRAME 1

1. Using wrenches, hold tube fitting (1) and unscrew tube nut (2).
2. Pull tube (3) with tube nut (2) away from tube fitting (1).
3. Using rags, wipe up any fuel which drains from tube (3) and put rags in approved disposal area.

GO TO FRAME 2

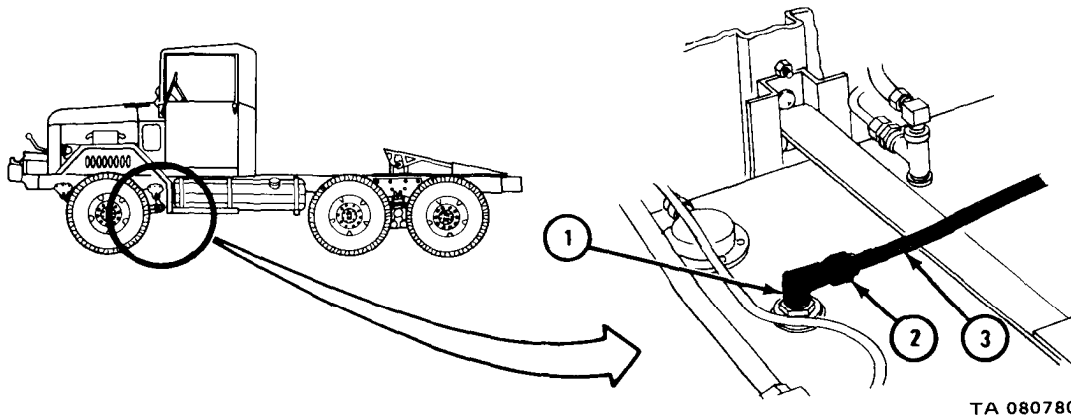

FRAME 2

NOTE

When taking off cover (1), drain fuel into container and put fuel in approved disposal area.

1. Open battery box door (2).
2. Turn cover (1) to left and take it off.
3. Take out sediment strainer (3) and gasket (4). Throw away gasket.

END OF TASK

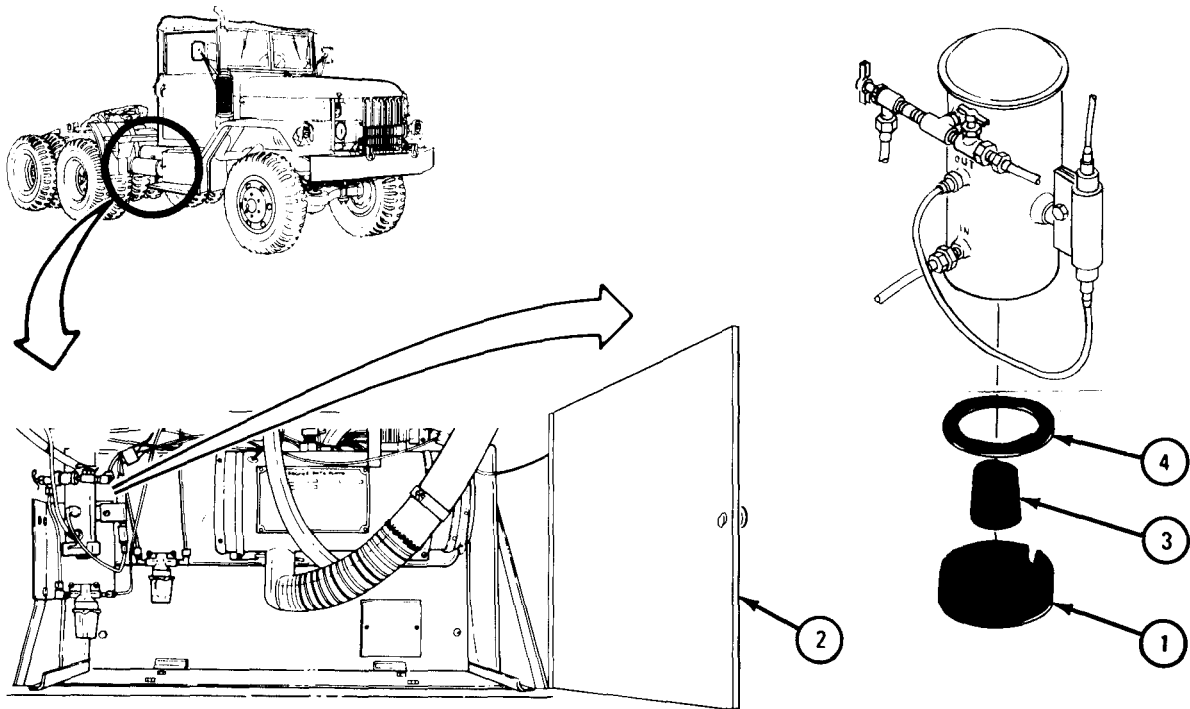

TA 080781

c. Cleaning, Inspection, and Repair.

FRAME 1

WARNING

Dry cleaning solvent is flammable. Do not use near an open flame. Keep a fire extinguisher nearby when solvent is used. Use only in well-ventilated places. Failure to do this may result in injury to personnel and damage to equipment.

Eye shields must be worn when using compressed air. Eye injury can occur if eye shields are not used.

1. Clean all parts with solvent.
2. Using compressed air, clean magnet inside of cover (1).
3. Check that cover (1) has no cracks or breaks. If cover is damaged, throw it away and get a new one.
4. Check that sediment strainer (2) has no cracks, breaks, tears or bends. If sediment strainer is damaged, throw it away and get a new one.

END OF TASK

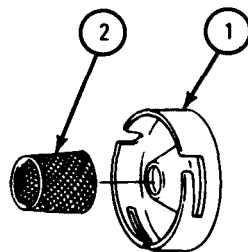

TA 080783

d. Replacement.

FRAME 1

1. Put gasket (1) in cover (2).
2. Put sediment strainer (3) on cone in cover (2).
3. Put cover (2) on fuel pump (4) and turn cover to right to lock.
4. Close battery box door (5).

GO TO FRAME 2

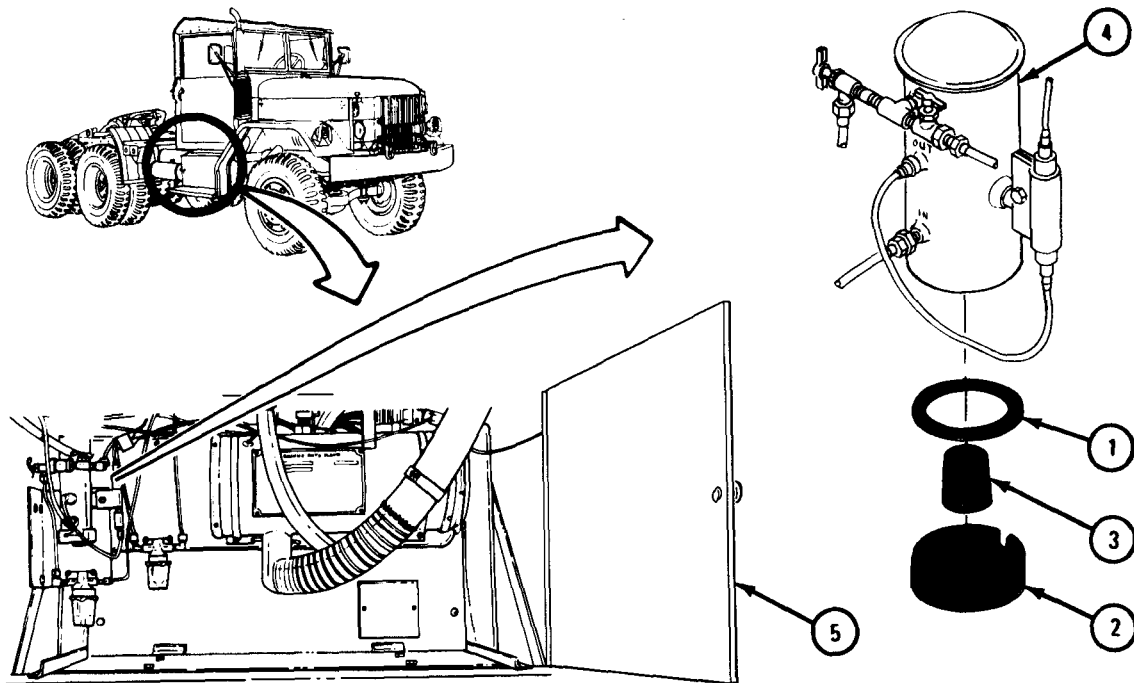

TA 080784

FRAME 2

1. Using wrenches, hold tube fitting (1) and screw on and tighten tube nut (2) with tube (3).

NOTE

Follow-on Maintenance Action Required:

Reconnect battery ground cable. Refer to Part 1, para 7-58.

END OF TASK

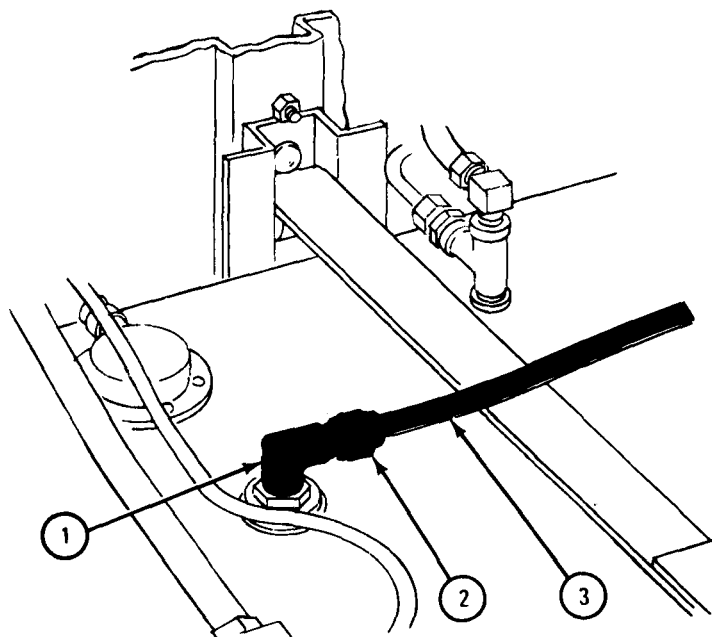
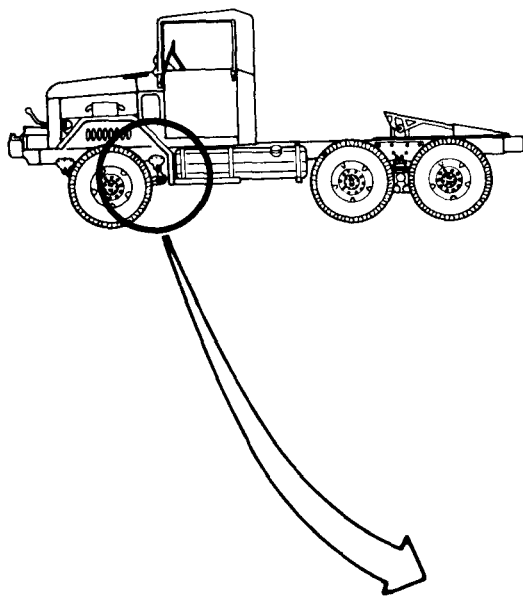

TA 080785

23-22. BATTERY BOX HEATER PAD REPAIR.

NOTE

Repair of battery box heater pad is limited to putting a new battery box heater pad in place of a damaged one.

TOOLS: Flat-tip screwdriver
1-gallon container

SUPPLIES: None

PERSONNEL: One

EQUIPMENT CONDITION: Truck parked, engine off and cool, handbrake set.

a. Preliminary Procedures.

- (1) Remove batteries. Refer to Part 1, para 7-56.
- (2) Open hood and right side panel. Refer to TM 9-2320-209-10.

WARNING

Do not work on cooling system components until cool. Personnel can be badly burned by hot components.

NOTE

Make sure powerplant heater is off and cool.

b. Removal.

FRAME 1

1. Turn two shutoff cocks (1) to right to stop coolant flow.
- GO TO FRAME 2

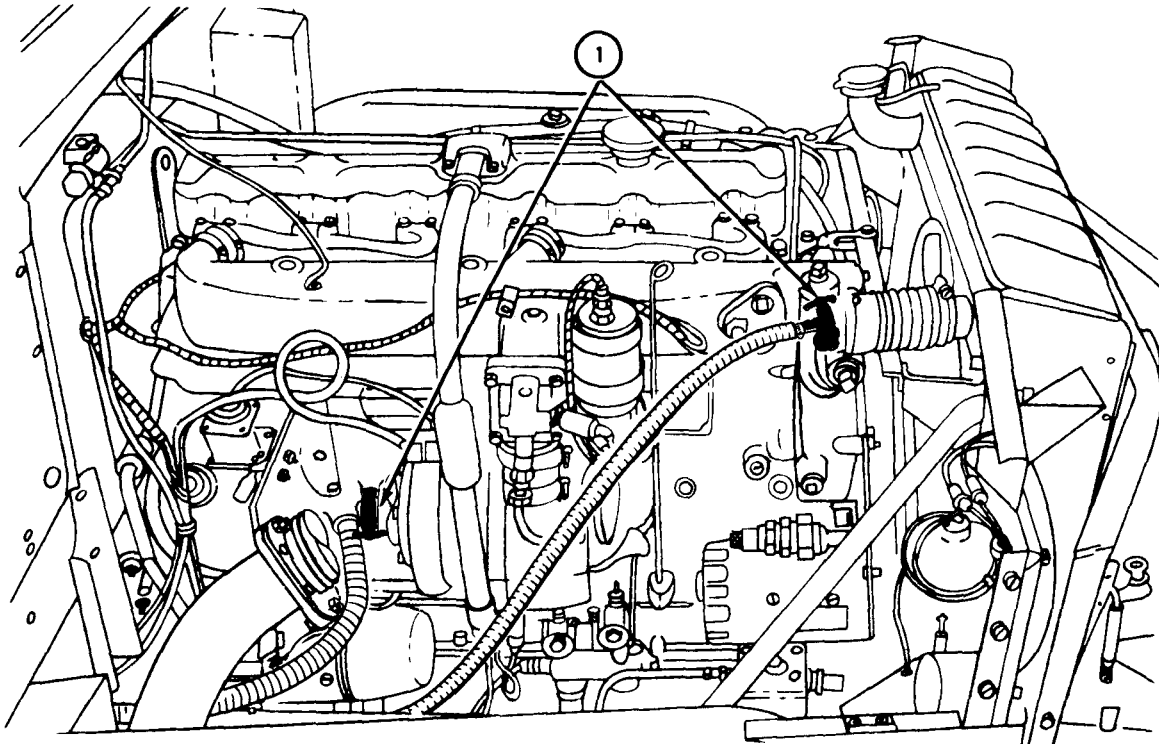

TA 080797

FRAME 2

1. Open powerplant heater box door (1).
2. Using screwdriver, loosen hose clamp (2).
3. Turn and pull off heater hose (3). Drain coolant from heater hose into container.

GO TO FRAME 3

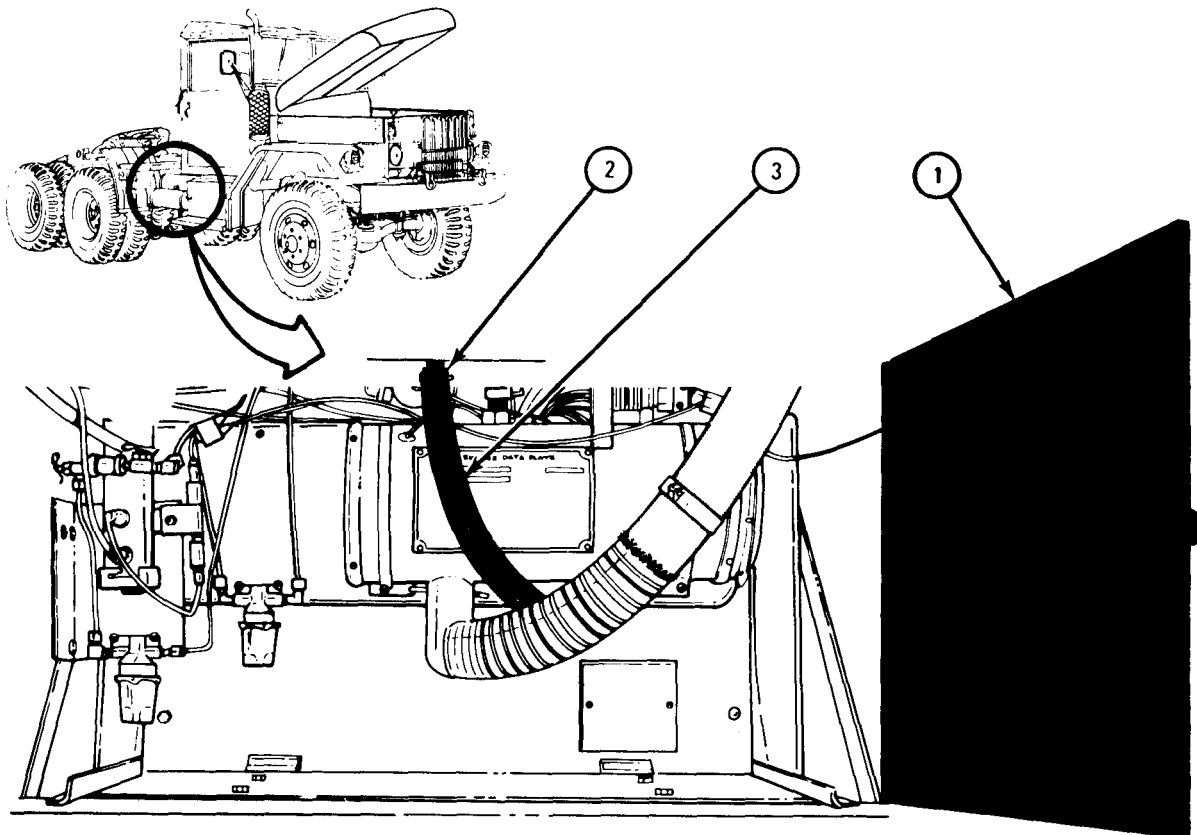

TA 080798

FRAME 3

1. Using screwdriver, loosen hose clamp (1).
2. Turn and pull off heater hose (2). Drain coolant from heater hose into container.
3. Put coolant in container in approved disposal area.

GO TO FRAME 4

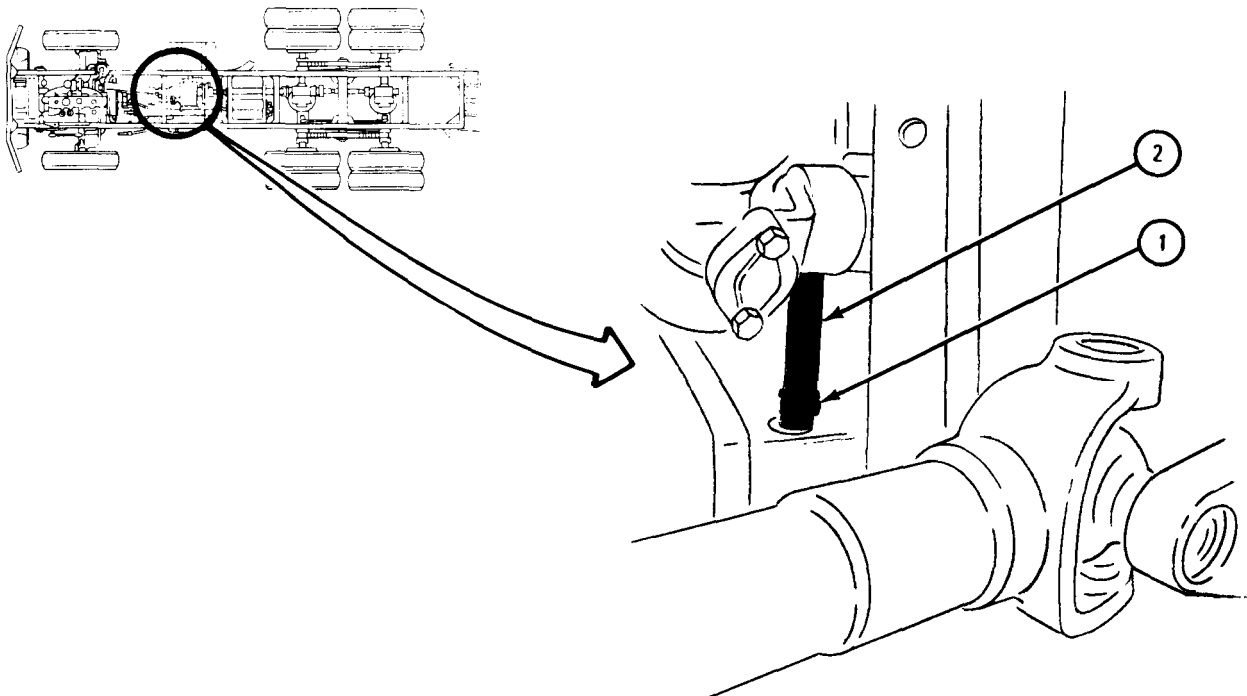

TA 080799

FRAME 4

1. Move battery cables (1) out of the way and lift out battery box heater pad (2).
END OF TASK

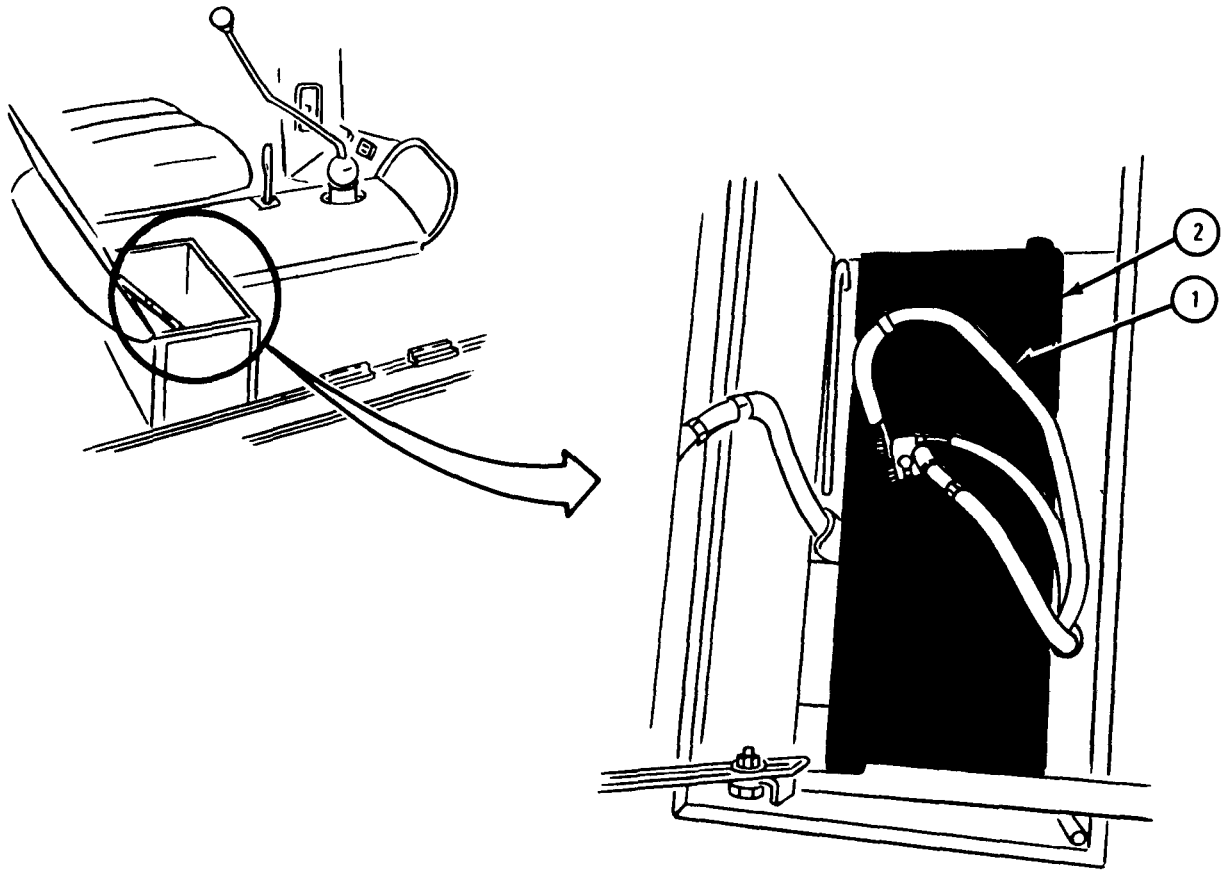

TA 080800

c. Replacement.

FRAME 1

1. Move battery cables (1) out of the way. Put battery box heater pad (2) into battery box (3) with straight hose connection (4) toward driver's seat.

GO TO FRAME 2

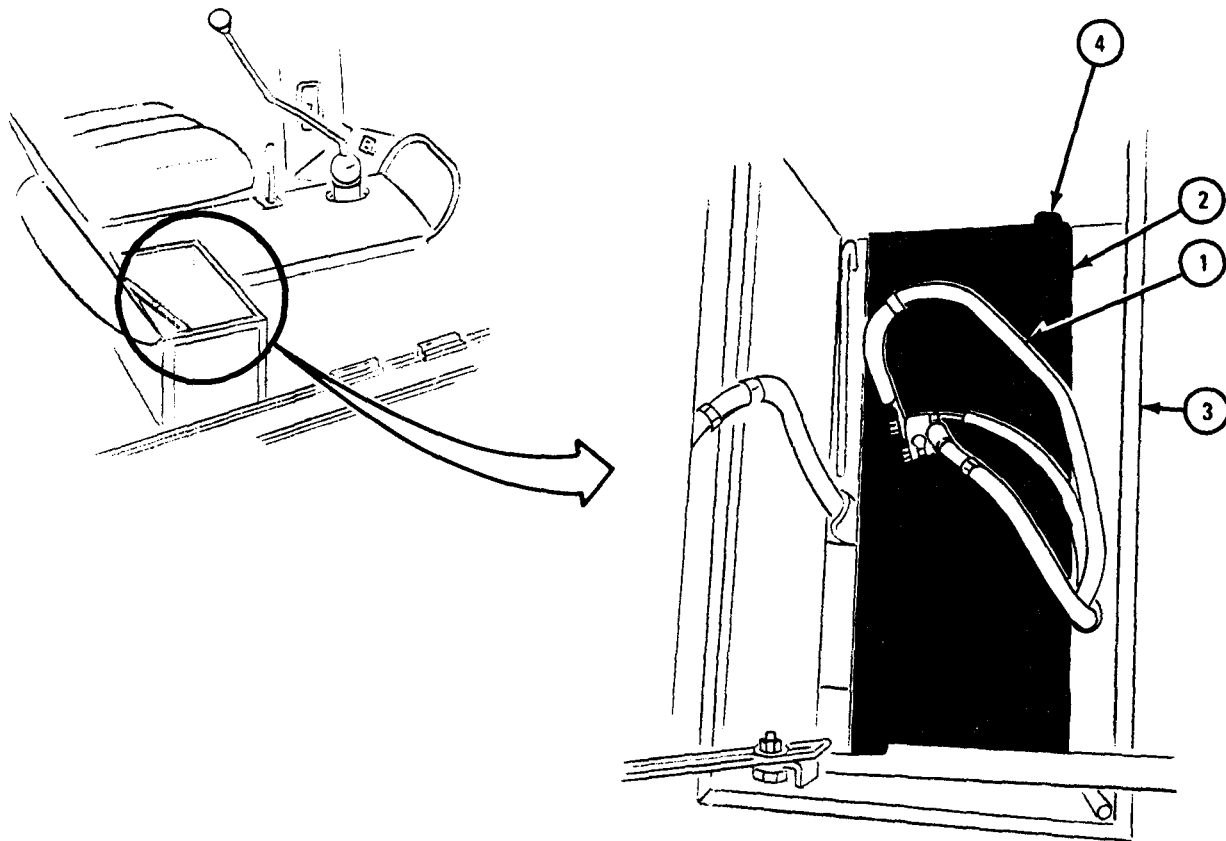

TA 080801

FRAME 2

1. Put heater hose (1) on hose connection (2).
 2. Using screwdriver, tighten hose clamp (3).
- GO TO FRAME 3

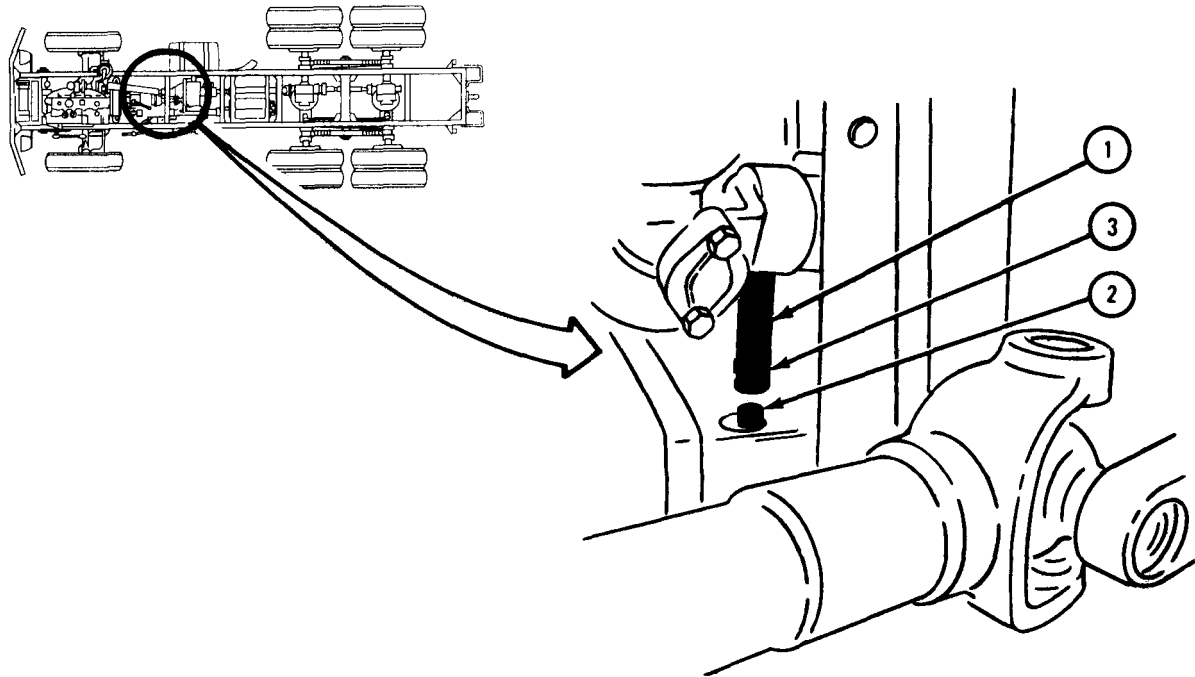

TA 080802

FRAME 3

1. Put heater hose (1) on hose connection (2).
2. Using screwdriver, tighten hose clamp (3).
3. Close powerplant heater box door (4).

GO TO FRAME 4

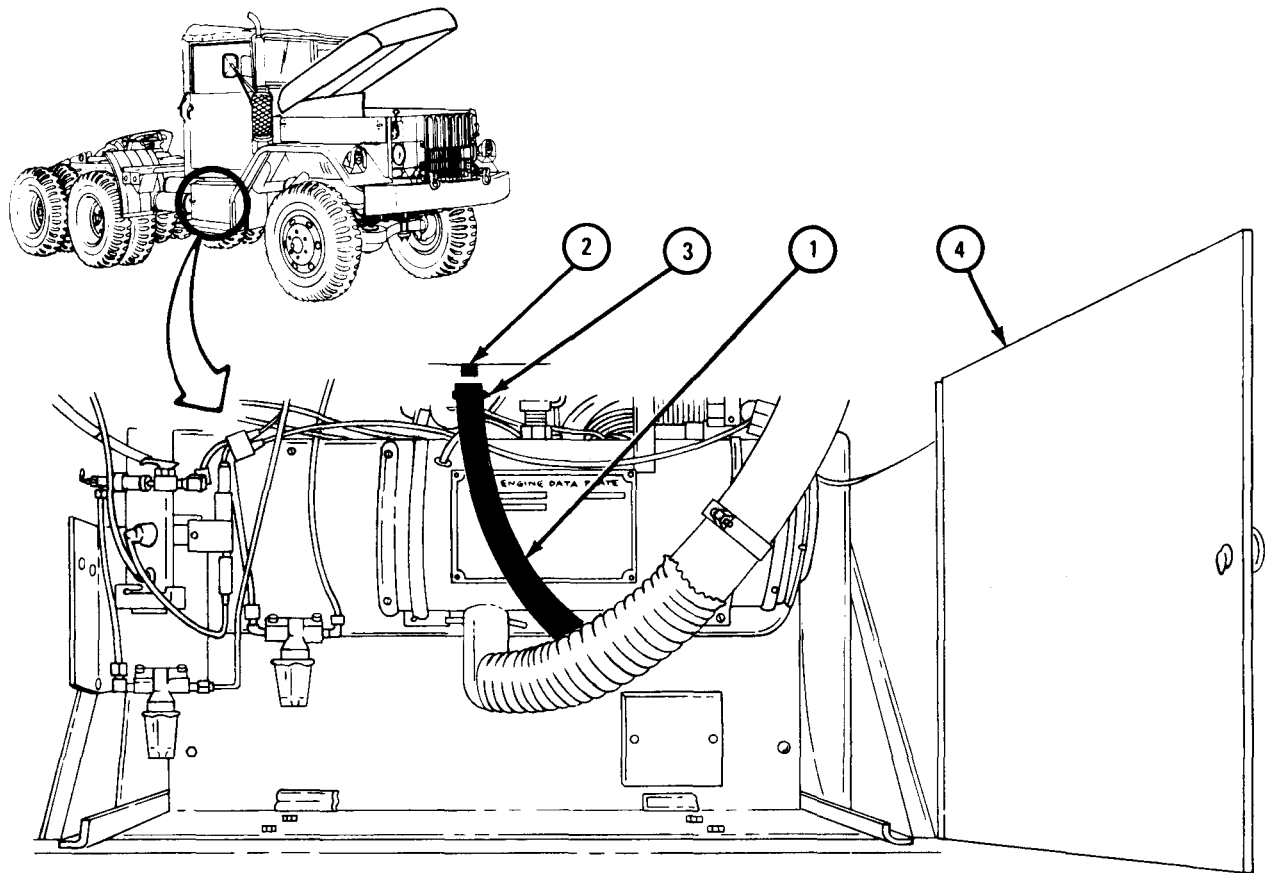

TA 080803

FRAME 4

1. Turn two shutoff cocks (1) to left to let coolant flow.

NOTE

Yellow-on Maintenance Action Required:

1. Put batteries in battery box. Refer to Part 1, para 7-56.
2. Refill cooling system. Refer to Part 1, para 6-10.
3. Close hood and right side panel. Refer to TM 9-2320-209-10.

END OF TASK

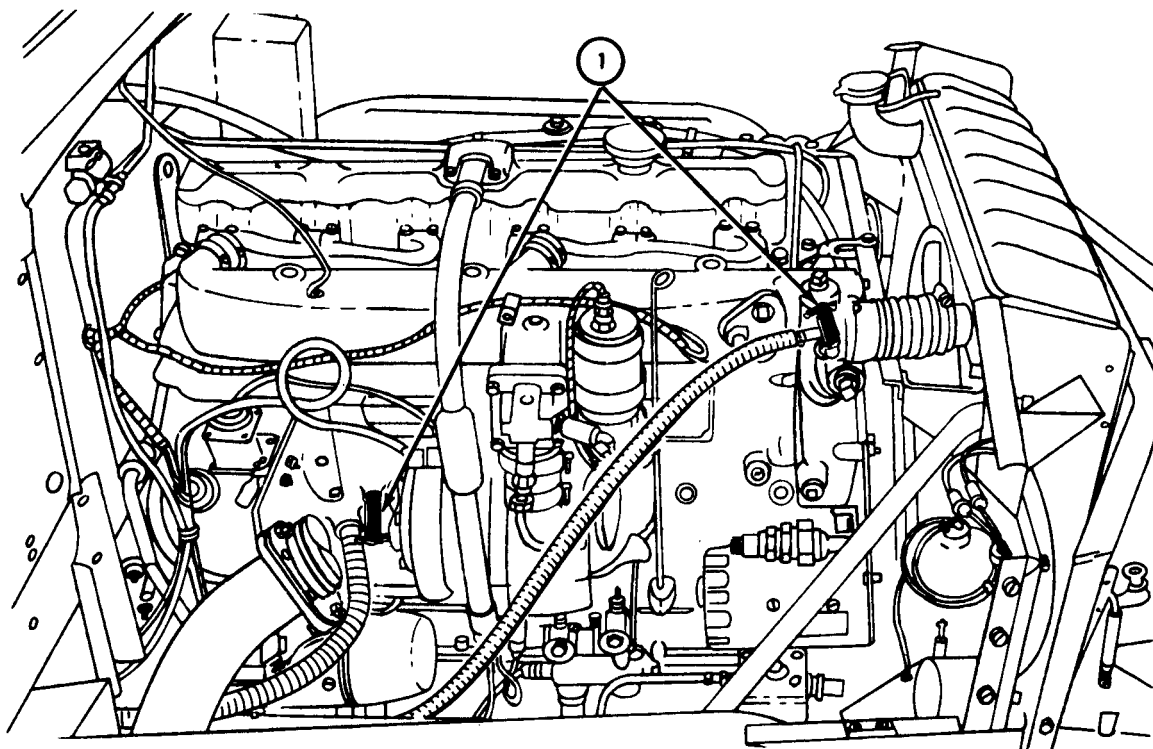

TA 080797

23-23. HOOD, SIDE PANEL, AND RADIATOR COVERS REMOVAL AND REPLACEMENT.

TOOLS: None

SUPPLIES: None

PERSONNEL: One

EQUIPMENT CONDITION: Truck parked, engine off, handbrake set.

a. Removal.

FRAME 1

1. Working at right side of truck, untie strap (1) at point (2) and pull strap through 16 loops (3).
2. Do step 1 again on left side of truck.
3. Take off hood cover (4).

GO TO FRAME 2

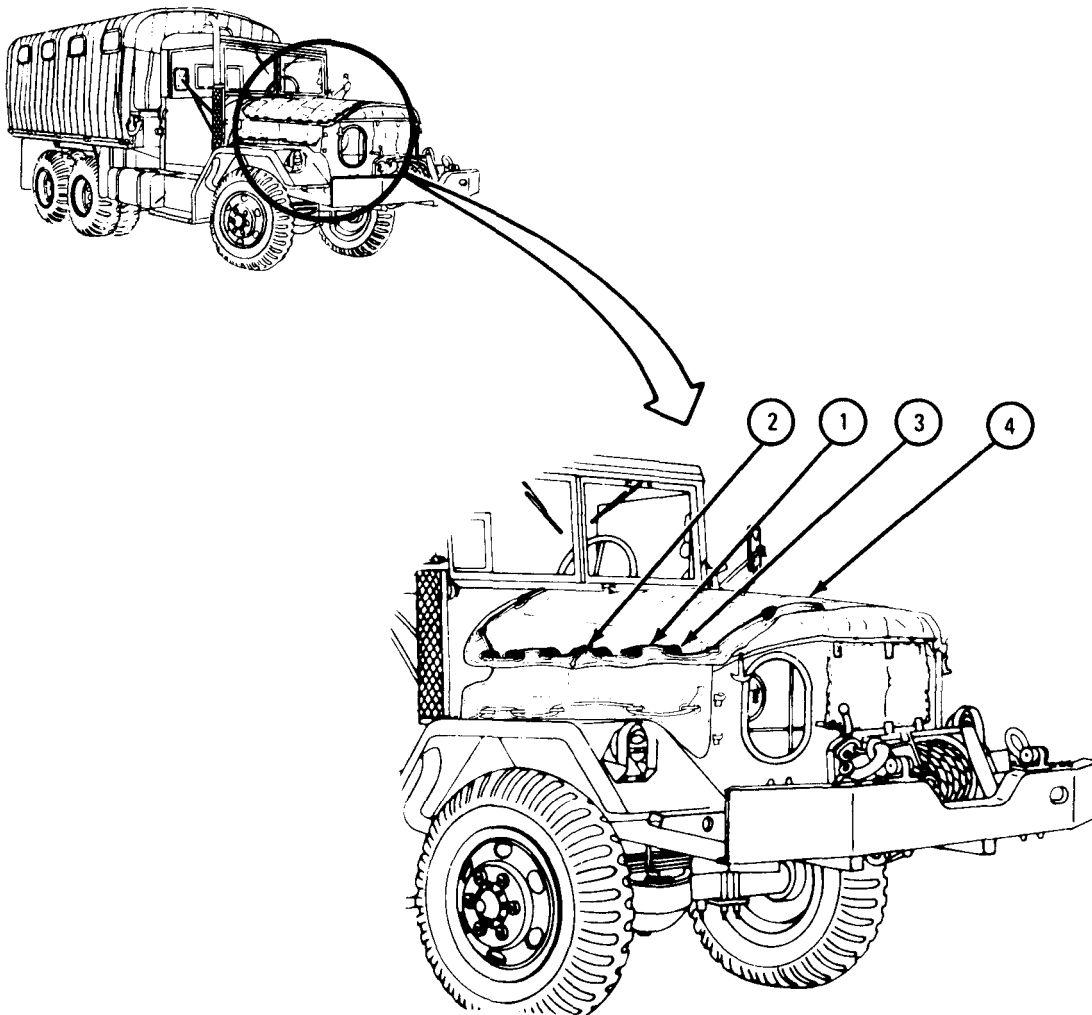

TA 083996

FRAME 2

1. Working at right side of truck, untie strap (1) at point (2) and pull strap through eight loops (3).
2. Take off side panel cover (4).
3. Do steps 1 and 2 again on left side of truck.

GO TO FRAME 3

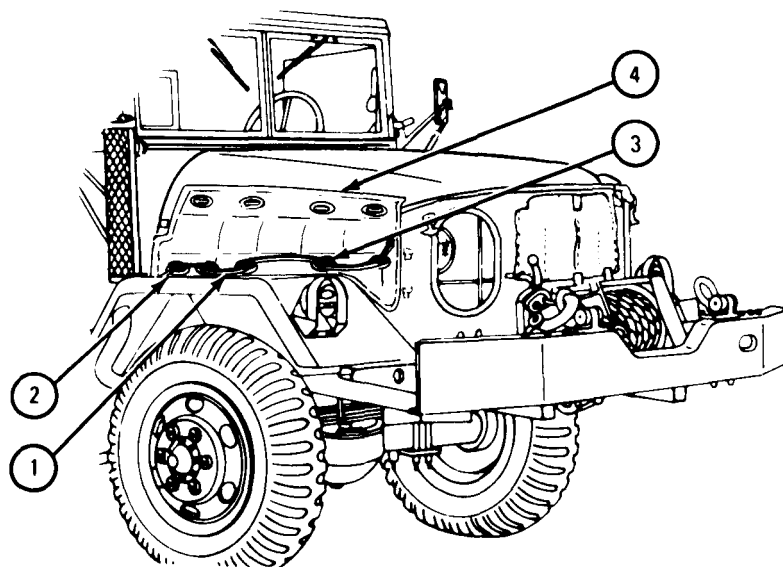

TA 083997

FRAME 3

- 1. Working at front of truck, unhook two springs (1).
- 2. Unbuckle straps (2) and pull them through loops (3).
- 3. Untie straps (4) and take off radiator cover (5).

END OF TASK

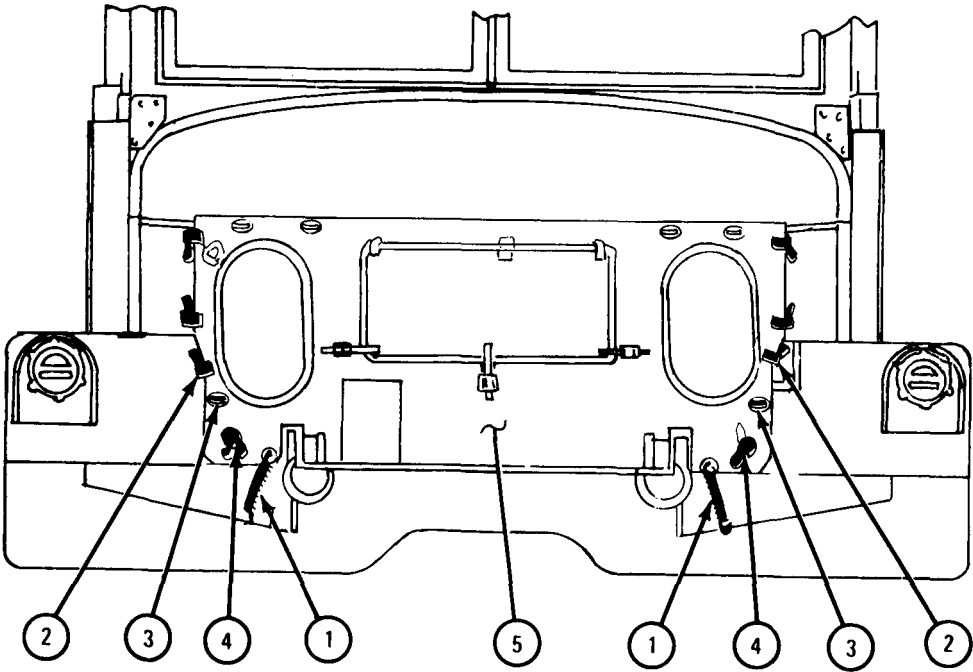

TA 083998

b. Replacement.

FRAME 1

1. Working at front of truck, hang radiator cover (1) over loops (2).
2. Put straps (3) through loops (2) and tie straps down.
3. Put straps (4) through loops (2) and buckle (5) and make straps fast to buckle.
4. Hook up two springs (6) as shown.

GO TO FRAME 2

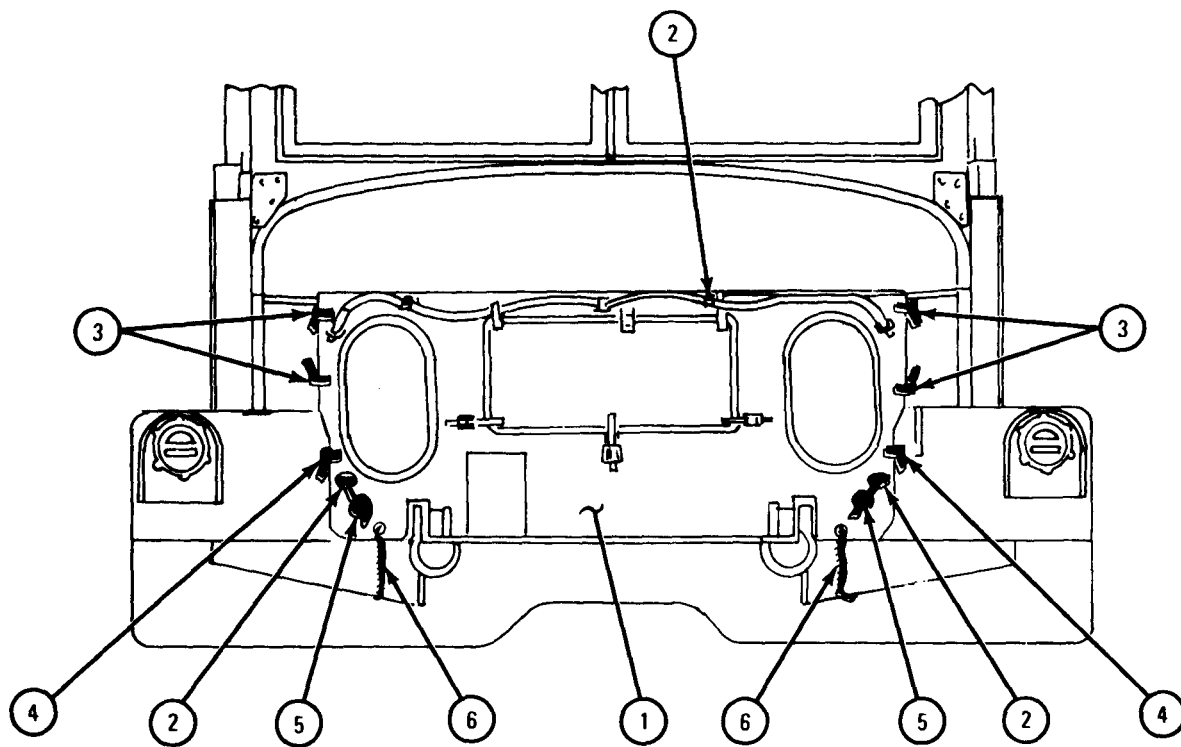

TA 083999

FRAME 2

1. Working at right side of truck, hang side panel cover (1) over loops (2) and loops (3).
 2. Push strap (4) through loops (3) and tie strap down at point (5).
 3. Do steps 1 and 2 again at left side of truck.
- GO TO FRAME 3

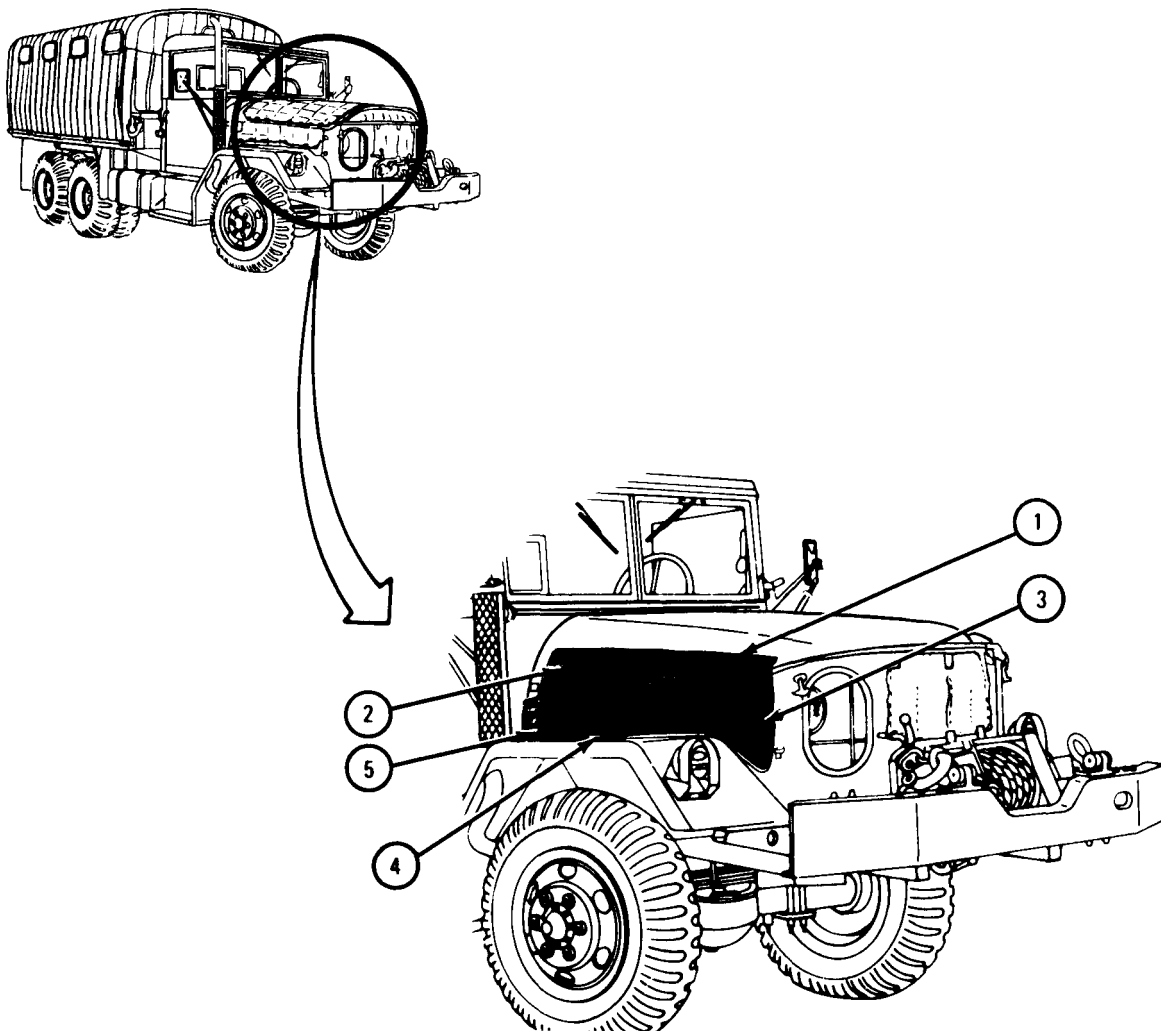

TA 084000

FRAME 3

1. Place hood cover (1) on hood and hook it on loops (2).
2. Working on right side of truck, push straps (3) through loops (2). Tie straps at point (4).
3. Do steps 1 and 2 again on left side of truck.

END OF TASK

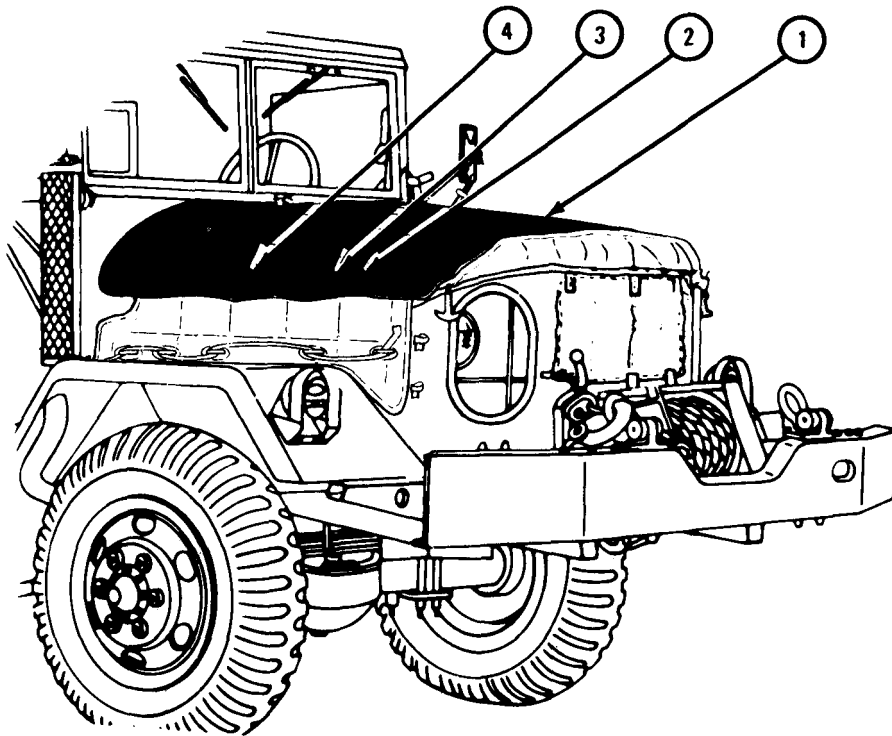

TA 084001

23-24. SLAVE RECEPTACLE ASSEMBLY REPAIR.

TOOLS: 9/16-inch wrench (2)
 7/16-inch wrench (2)
 Soldering iron
 Flat-tip screwdriver
 6-inch pliers
 Cross-tip screwdriver (Phillips type)

SUPPLIES: Solder

PERSONNEL: Two

EQUIPMENT CONDITION: Truck parked, engine off, handbrake set.

a. Preliminary Procedures.

(1) Open battery box cover.

(2) Disconnect battery ground cable. Refer to Part 1, para 7-58.

b. Removal.

FRAME 1

1. Using 9/16-inch wrenches, hold capscrew (1) and unscrew and take off nut (2).
2. Take off positive cable (3).

GO TO FRAME 2

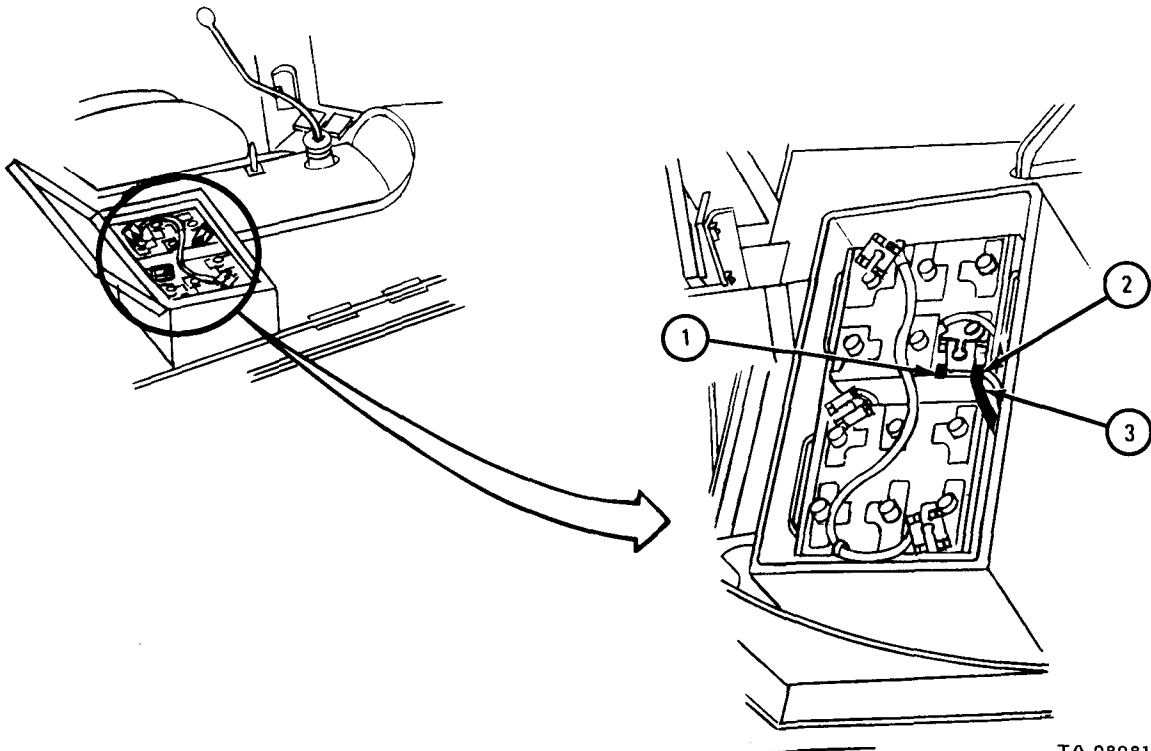

TA 080818

FRAME 2

1. Open powerplant heater box door (1).
 - Soldier A 2. Working under truck and using 9/16-inch wrench, hold capscrew (2).
 - Soldier B 3. Using 9/16-inch wrench, unscrew and take off nut (3), washer (4), and cable (5).
 4. Pull positive cable (6) out of grommet (7).
- GO TO FRAME 3

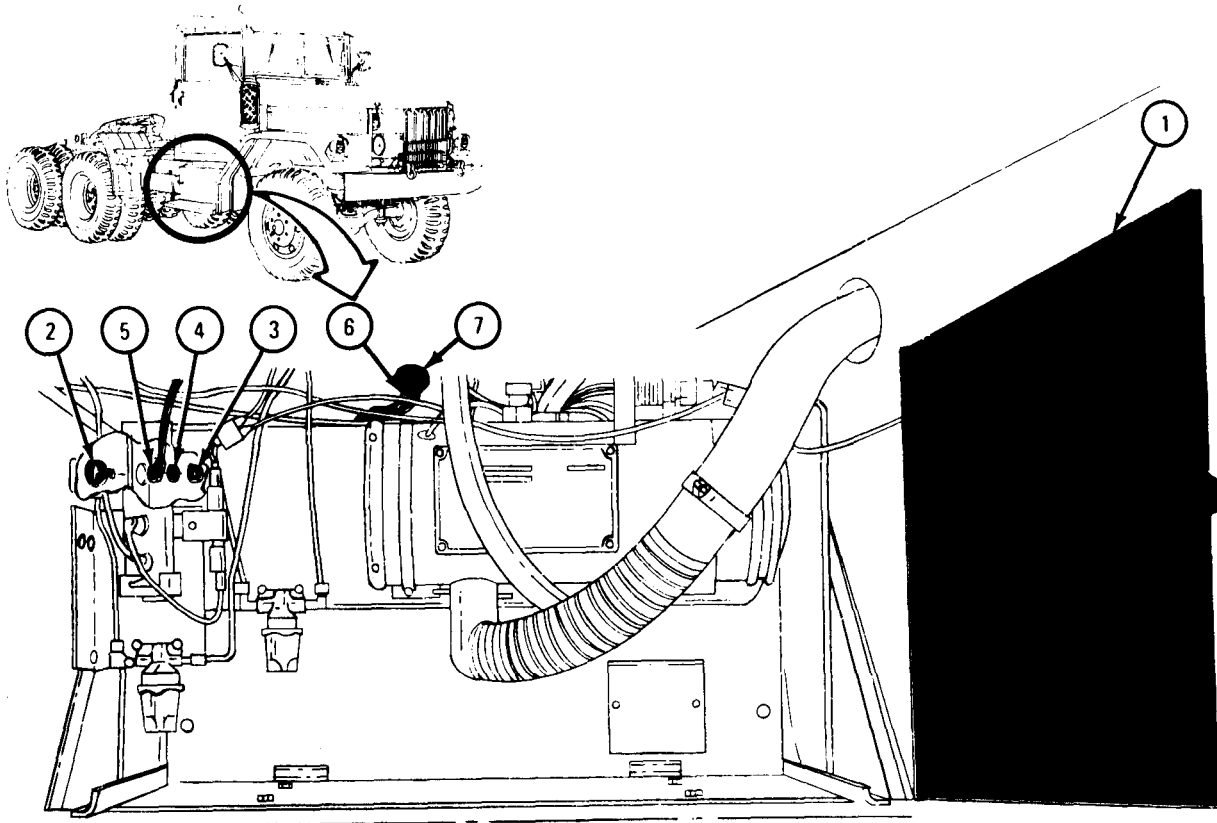

TA 080819

FRAME 3

1. Using phillips screwdriver, unscrew and take out two screws (1). Spread open and take off two clamps (2).
2. Pull two slave receptacle cables (3) out of two grommets (4). Using screwdriver, pry out two grommets.
3. Using 7/16-inch wrenches, unscrew and take out four capscrews (5), four lockwashers (6), and four nuts (7). Take out slave receptacle assembly (8).

END OF TASK

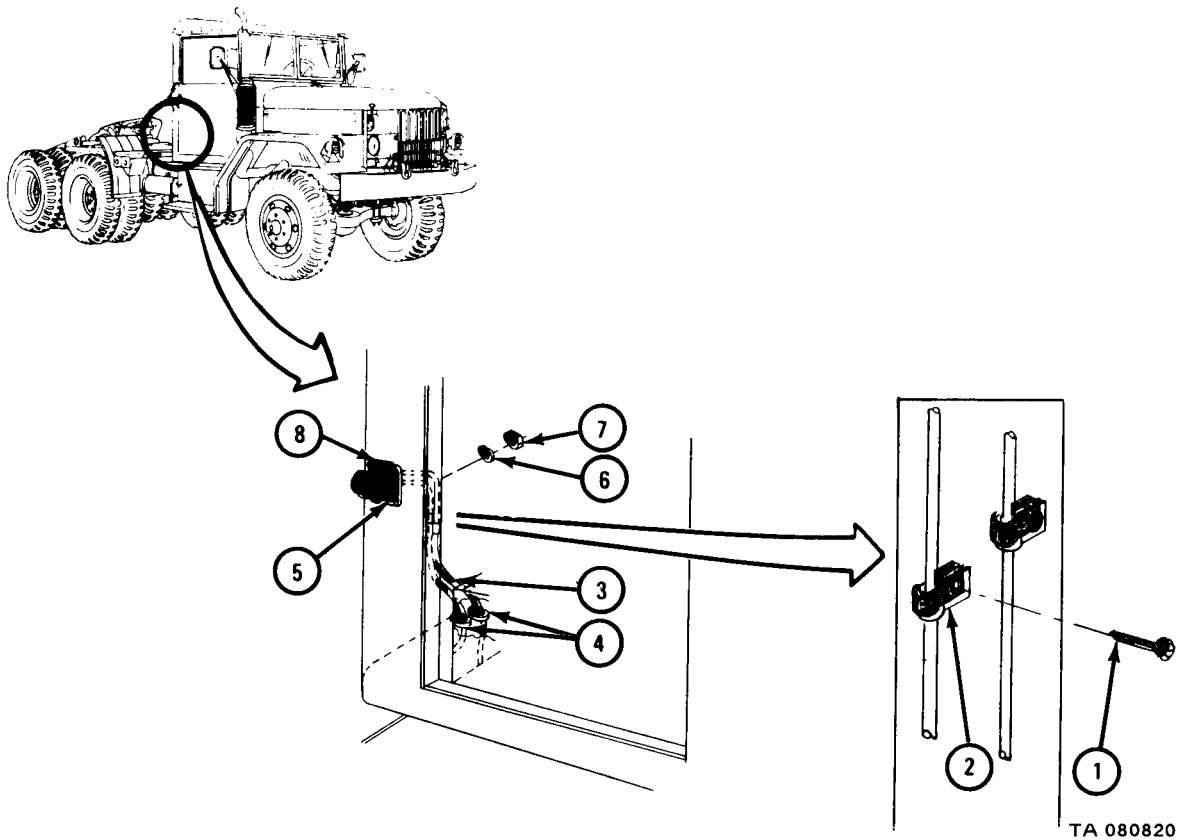

c. Disassembly.

FRAME 1

1. Using pliers, hold two terminal ends (1) and using soldering iron, unsolder and take off terminal ends.
2. Using soldering iron, unsolder and take off two cables (2) from slave receptacle (3).

END OF TASK

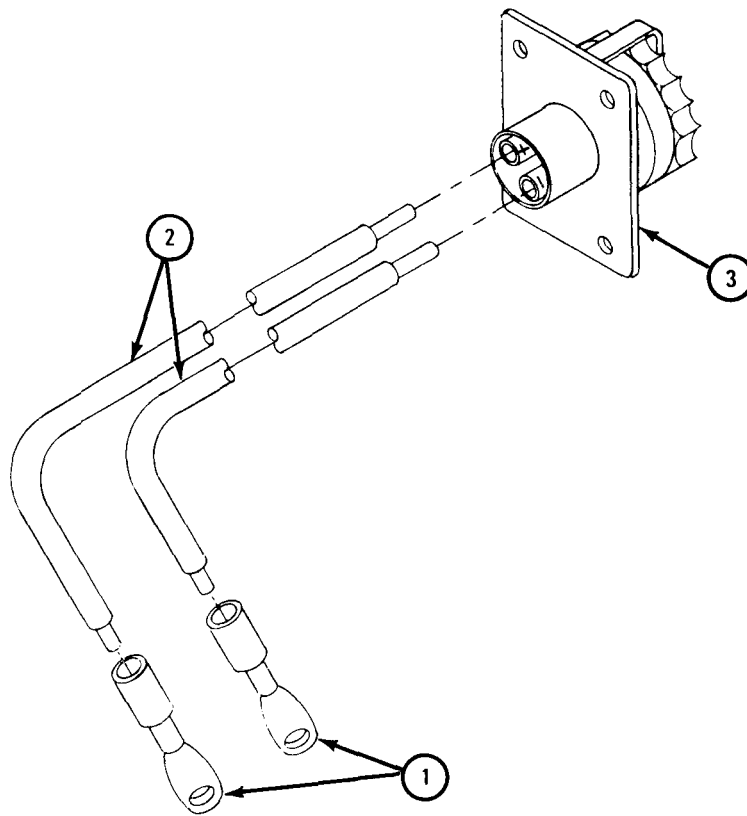

TA 080821

- d. Inspection and Repair. Check that all parts have no breaks, corrosion or wear. If parts are damaged, get new ones.
- e. Assembly.

FRAME 1

NOTE

Longer cable goes to terminal marked +.

1. Put two cables (1) into two lugs on slave receptacle (2). Using soldering iron, solder cables in place.
2. Put two terminal ends (3) on two cables (1). Using soldering iron, solder terminal ends in place.

END OF TASK

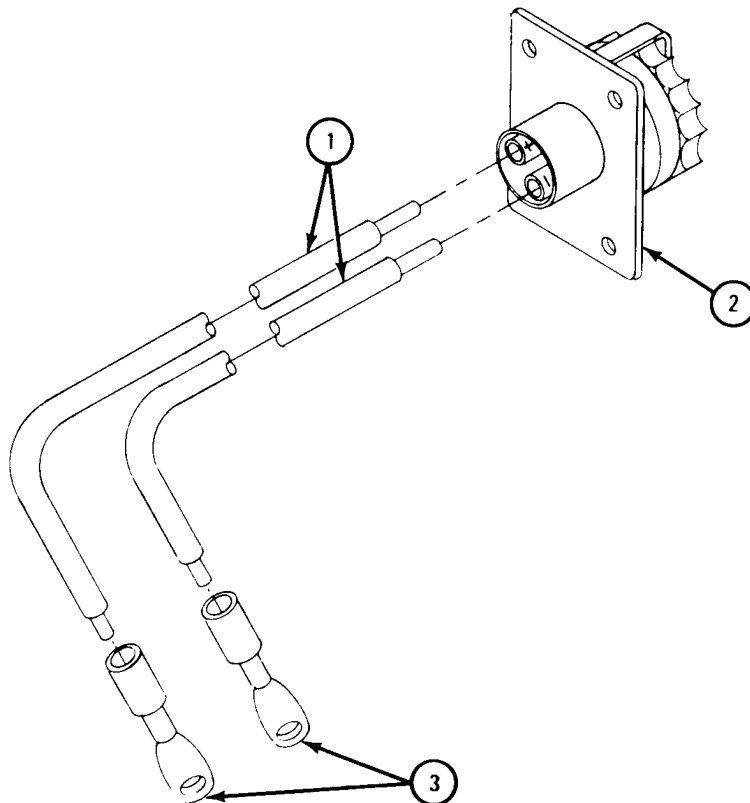

TA 080822

f. Replacement.

FRAME 1

1. Put two cables (1), joined to slave receptacle assembly (2), through hole in cab (3). Aline screw holes in slave receptacle assembly and cab. Using 7/16-inch wrenches, screw in and tighten four capscrews (4), four lockwashers (5), and four nuts (6).
2. Put two grommets (7) in holes on cab floor. Put longer of two cables (1) into grommet closest to door and shorter cable into other grommet.
3. Put two clamps (8) on two cables (1) and line screw holes in clamps with holes on U-channel (9). Using screwdriver, screw in and tighten two screws (10).

GO TO FRAME 2

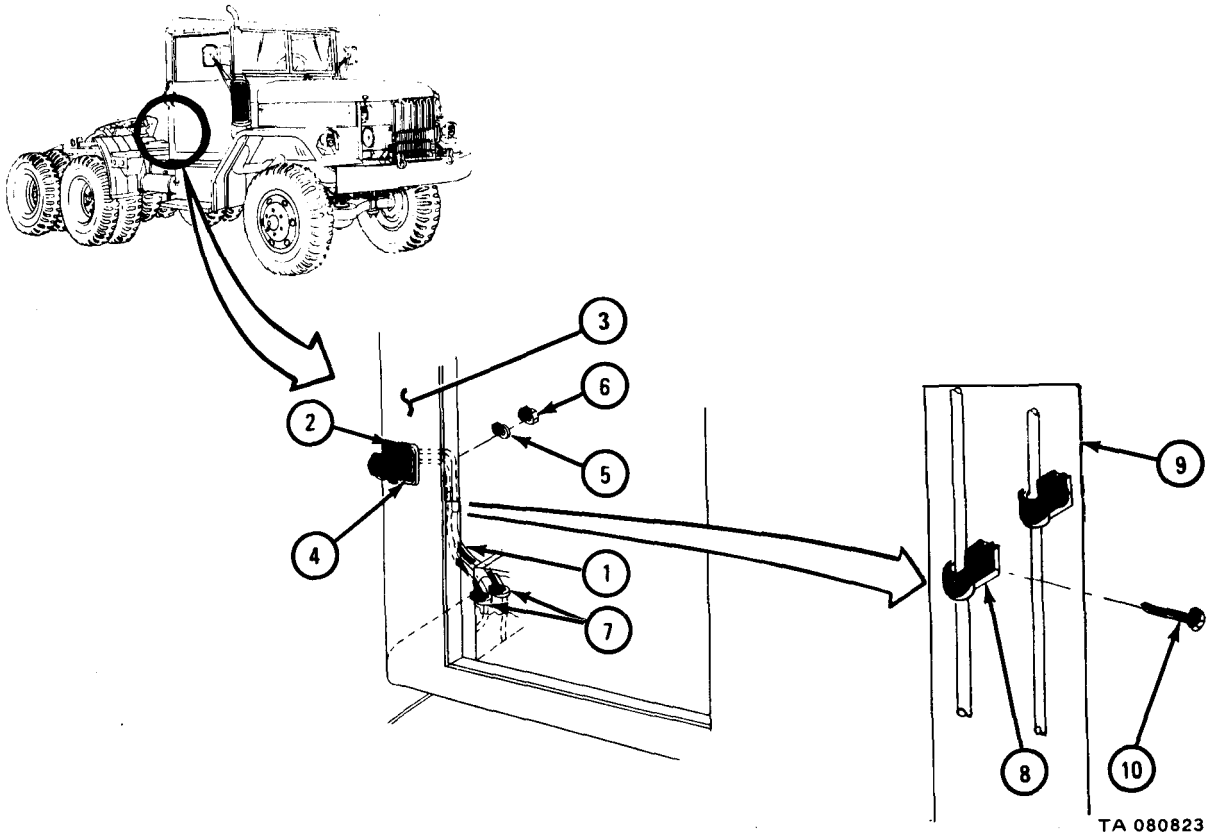

FRAME 2

- Soldier A 1. Working under truck and using 9/16-inch wrench, hold capscrew (1).
- Soldier B 2. Put cable (2) and washer (3) on cap screw (1). Using 9/16-inch wrench, screw on and tighten nut (4).
3. Put positive cable (5) up into grommet (6).
4. Close powerplant heater door (7).

GO TO FRAME 3

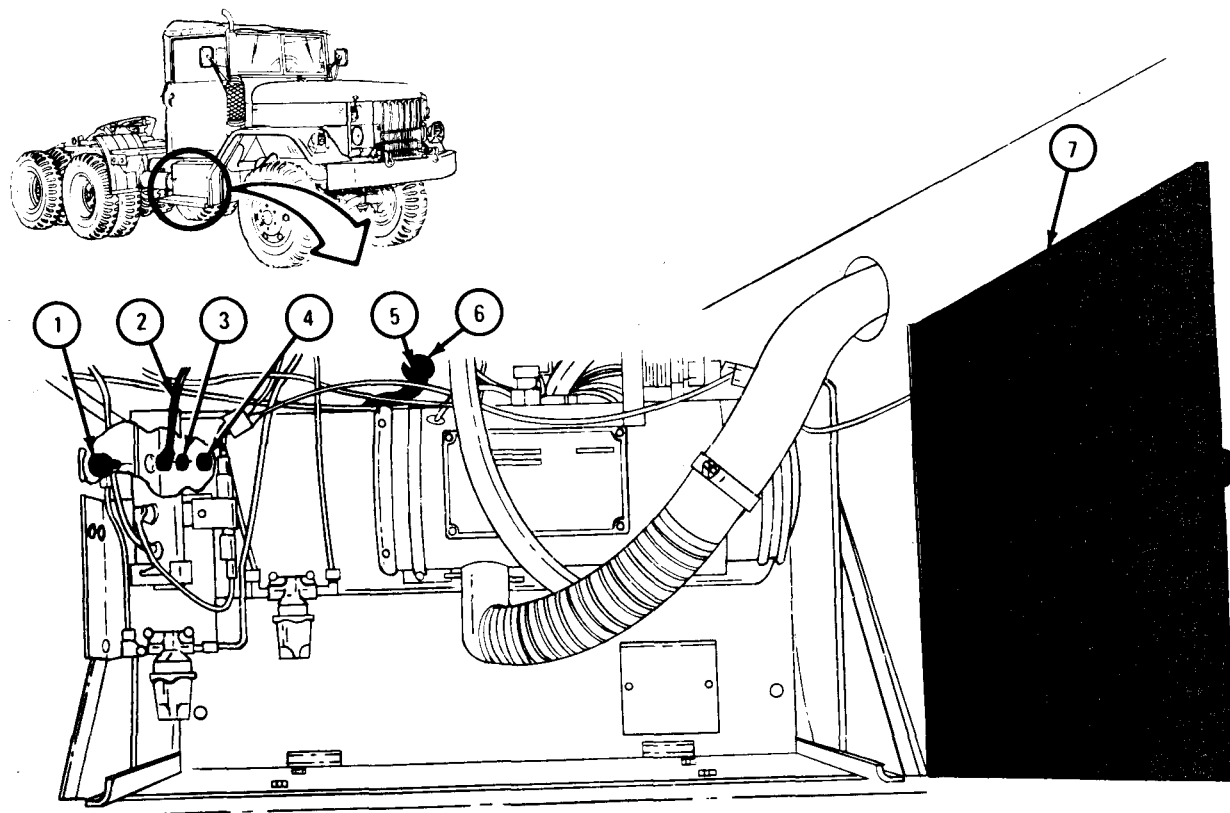

TA 080824

FRAME 3

1. Put positive cable (1) on end of capscrew (2).
2. Using 9/16-inch wrenches, hold capscrew (2) and screw on and tighten nut (3).

NOTE

Follow-on Maintenance Action Required:

1. Reconnect battery ground cable. Refer to Part 1, para 7-58.
2. Close battery box cover.

END OF TASK

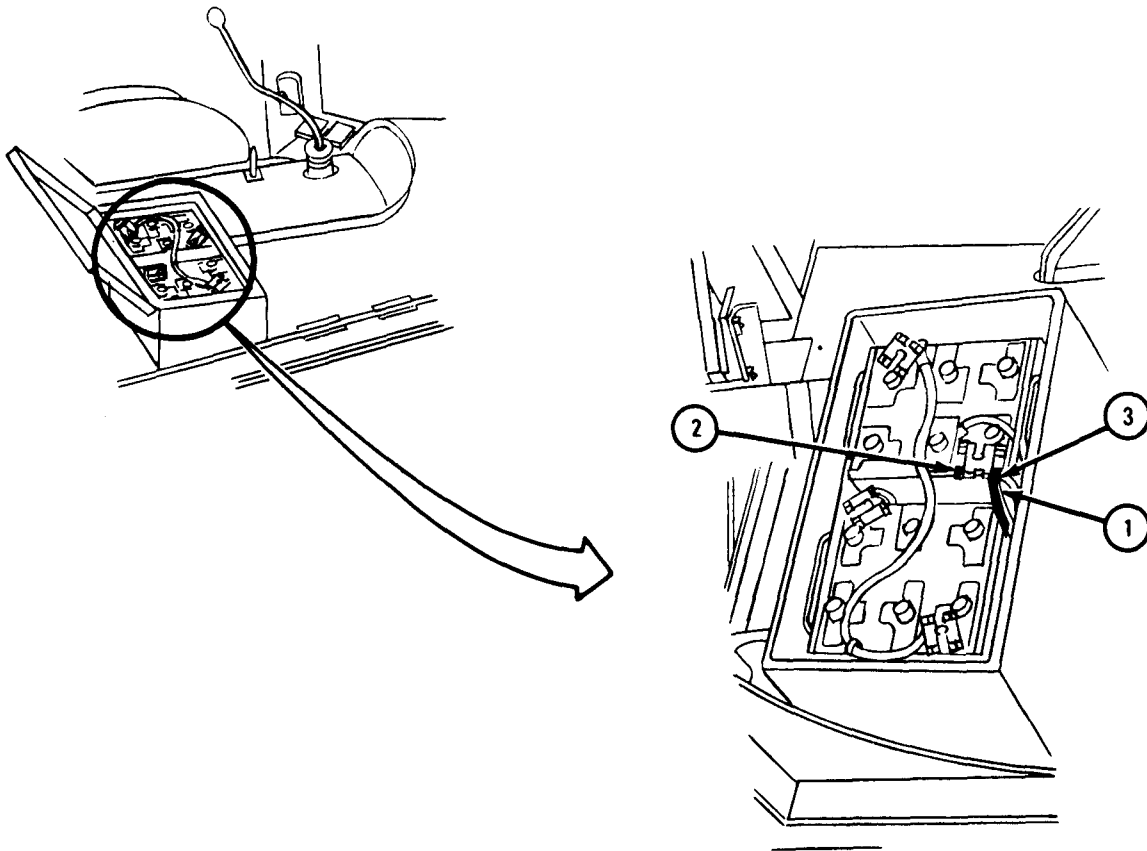

TA 080825

23-25. VAN BODY PERSONNEL HEATER ASSEMBLY REPAIR (TRUCKS M109A2 AND M109A3).

TOOLS: Flat-tip screwdriver
 Open end wrench set, pn GGG-W-636
 1/2-gallon container

SUPPLIES: None

PERSONNEL: One

EQUIPMENT CONDITION: Truck parked, engine off, handbrake set.

a. Preliminary Procedures.

- (1) Make sure van body personnel heater is off and cool.
- (2) Disconnect battery ground cable. Refer to Part 1, para 7-58.

b. Removal.

FRAME 1

1. Using wrench, unscrew and take off capscrew (1) and cover (2).

GO TO FRAME 2

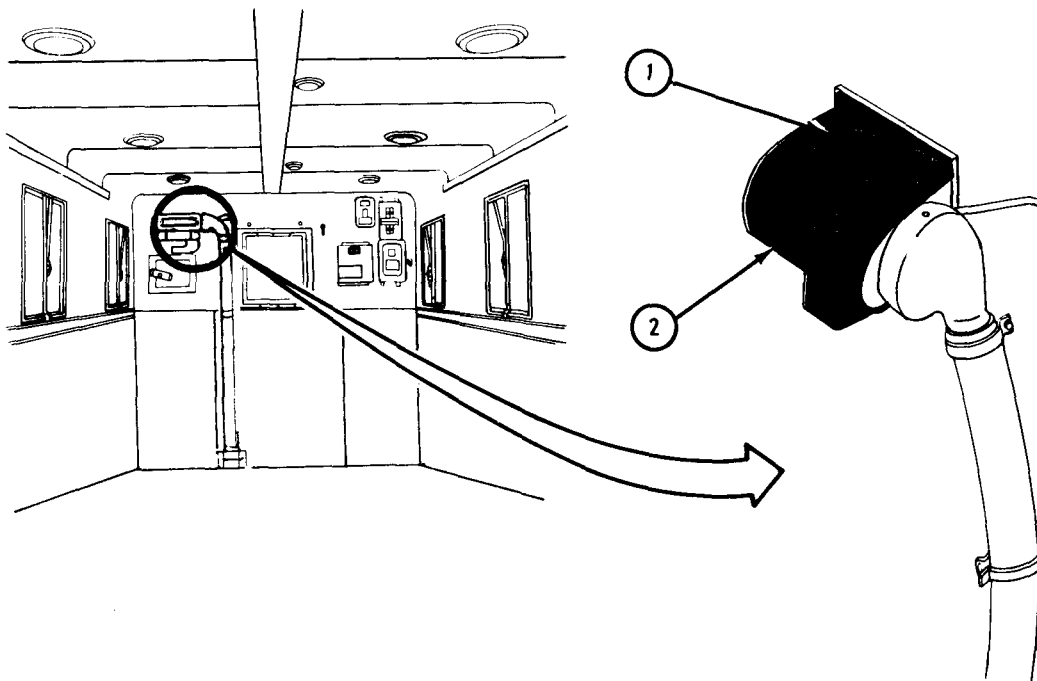

TA 080748

FRAME 2

1. Unplug electrical cable (1) from back of heater (2).
2. Using wrenches, unscrew and take off tube nut (3). Use container to catch fuel and put fuel in approved disposal area.
3. Using wrench, unscrew and take off capscrew (4). Take off guard (5).
4. Using wrench, unscrew and take off four capscrews (6). Take off exhaust pipe (7) and gaskets (8 and 9).

GO TO FRAME 3

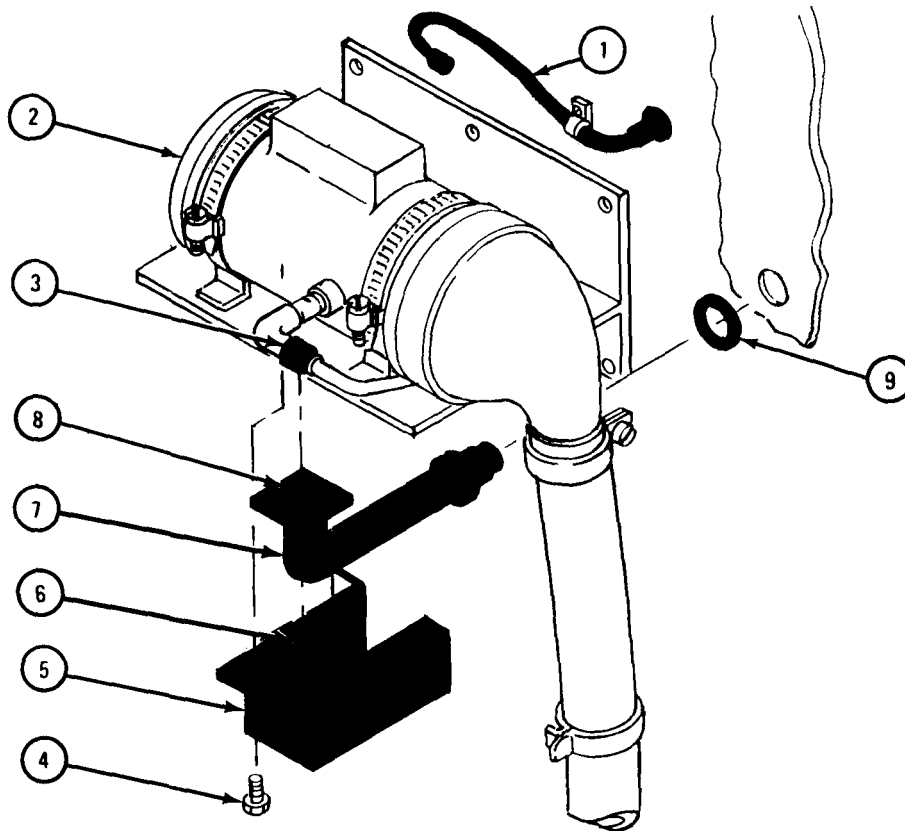

TA 080749

FRAME 3

1. Using screwdriver, unscrew and spread open two hose clamps (1).
2. Using wrench, unscrew and take off capscrew (2).
3. Move heater adapter (3) away from heater (4) and take heater off support (5).

END OF TASK

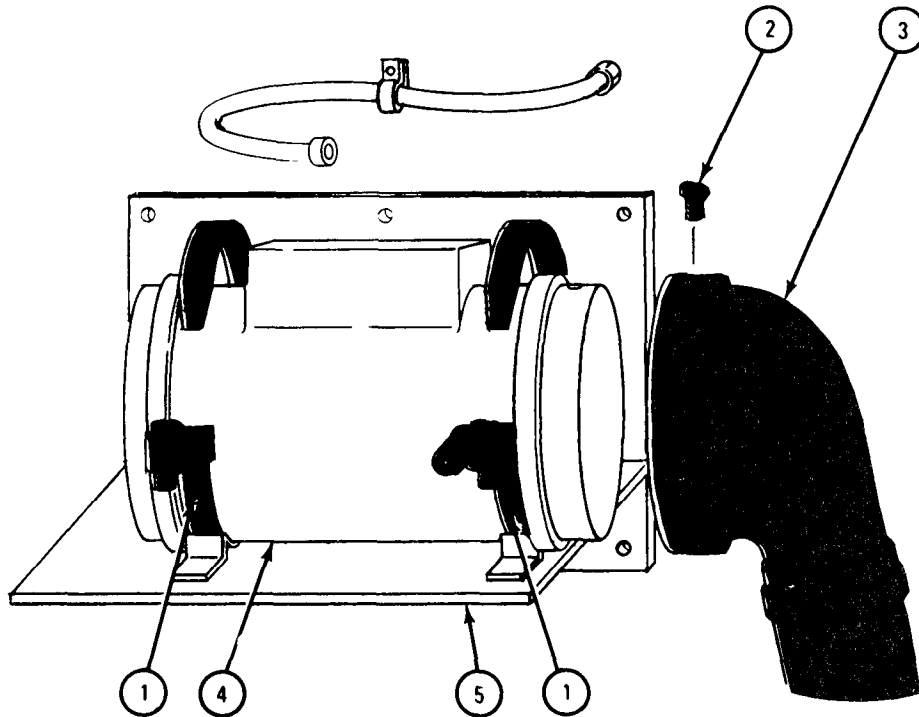

TA 080750

c. Replacement.

FRAME 1

1. Put heater (1) on support (2) between two hose clamps (3) as shown.
2. Put heater adapter (4) on heater (1) and align screw holes.
3. Using wrench, screw in and tighten cap screw (5).
4. Using screwdriver, screw in and tighten two hose clamps (3).

GO TO FRAME 2

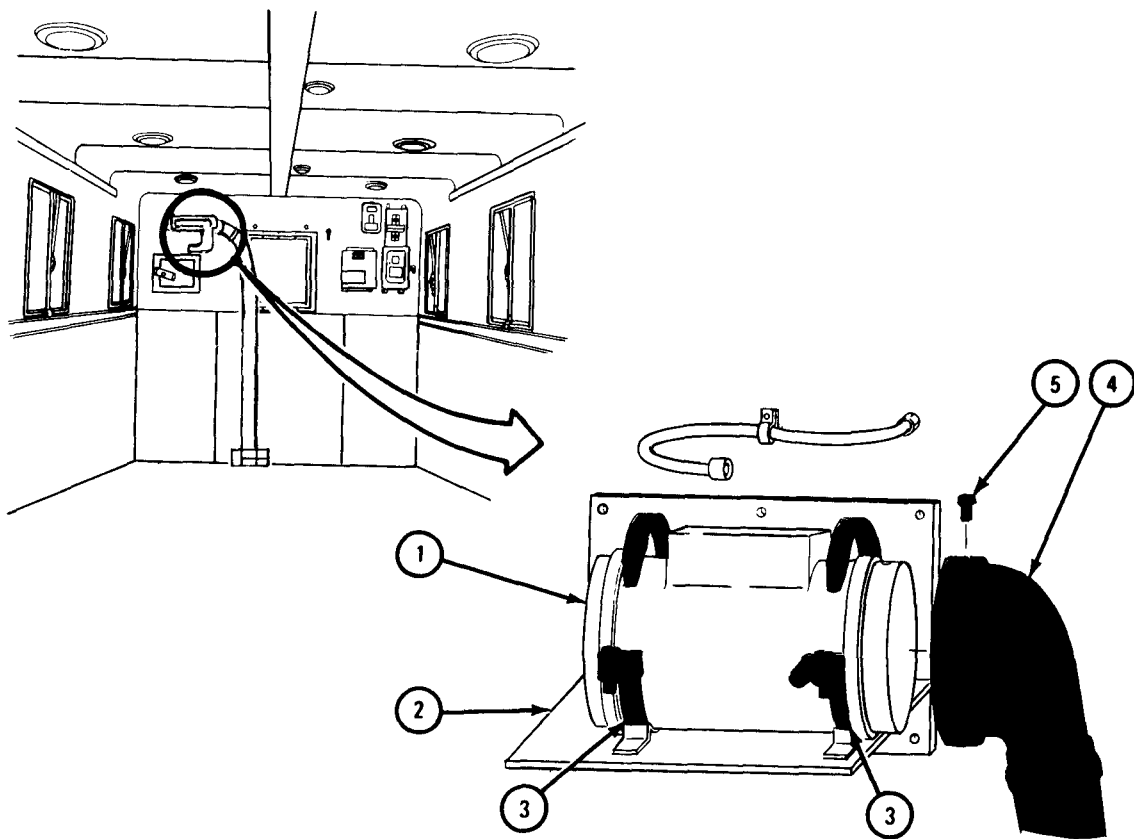

TA 080751

FRAME 2

1. Put gasket (1) on end of exhaust pipe (2) and put gasket (3) on top of exhaust pipe. Put one end of exhaust pipe in body (4) and other end in heater (5).
2. Using wrench, screw in and tighten four cap screws (6).
3. Put guard (7) over exhaust pipe (2) and using wrench, screw in and tighten capscrew (8).
4. Plug electrical cable (9) into back of heater (5).
5. Using wrenches, screw on and tighten tube nut (10).

GO TO FRAME 3

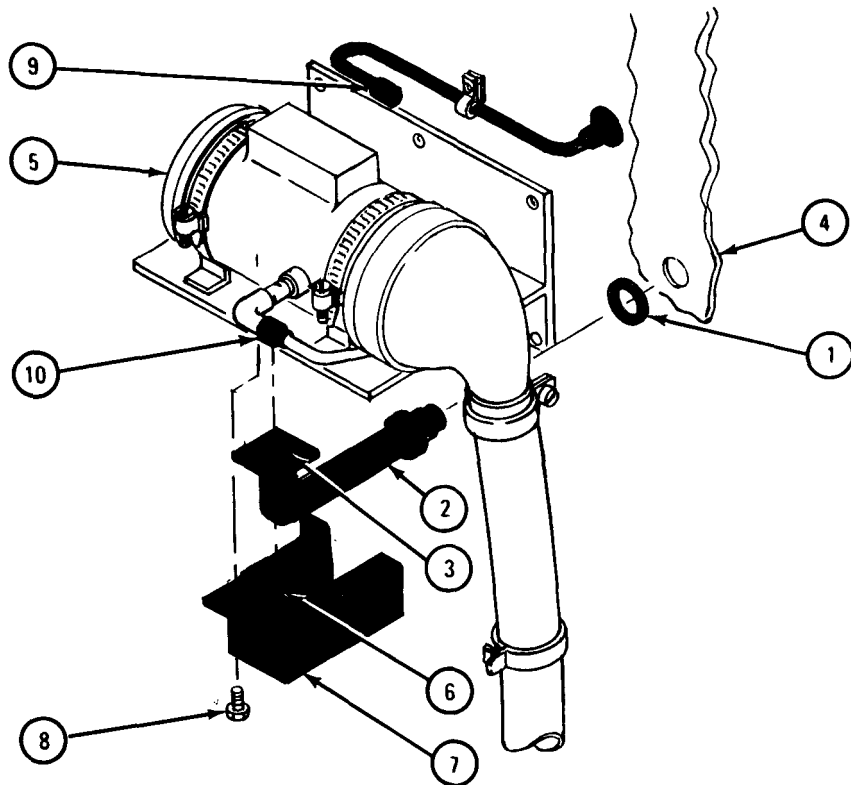

TA 080752

FRAME 3

1. Put cover (1) over heater (2) and align screw holes.
2. Using wrench, screw in and tighten capscrew (3).

NOTE

Follow-on Maintenance Action Required:

Reconnect battery ground cable. Refer to Part 1, para 7-58.

END OF TASK

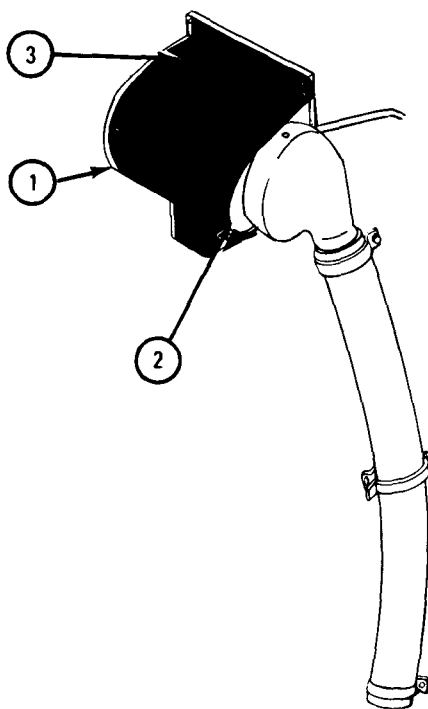

TA 080753

23-26. VAN BODY PERSONNEL HEATER DUCT REMOVAL AND REPLACEMENT (TRUCKS M109A2 and M109A3).

TOOLS: Open end wrench set, pn GGG-W-636

SUPPLIES: None

PERSONNEL: One

EQUIPMENT CONDITION: Truck parked, engine off, handbrake set.

a. Removal.

FRAME 1

1. Using wrenches, loosen two capscrews (1).
2. Using wrench, unscrew and take out capscrew (2). Spread open and take off strap (3).
3. Slide duct (4) off heater adapter (5) and adapter (6).

END OF TASK

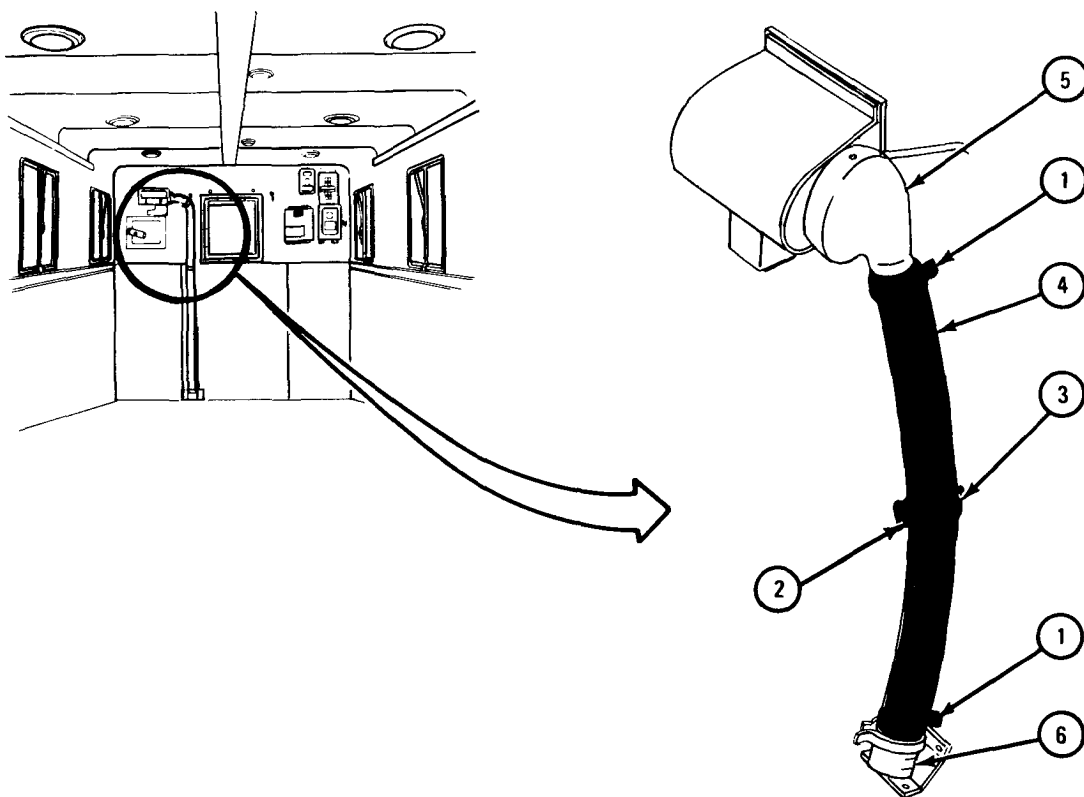

TA 080754

b. Replacement.

FRAME 1

1. Slide duct (1) on heater adapter (2) and adapter (3).
2. Using wrench, tighten two capscrews (4).
3. Put strap (5) over duct (1) and align screw holes.
4. Using wrench, screw in and tighten capscrew (6).

END OF TASK

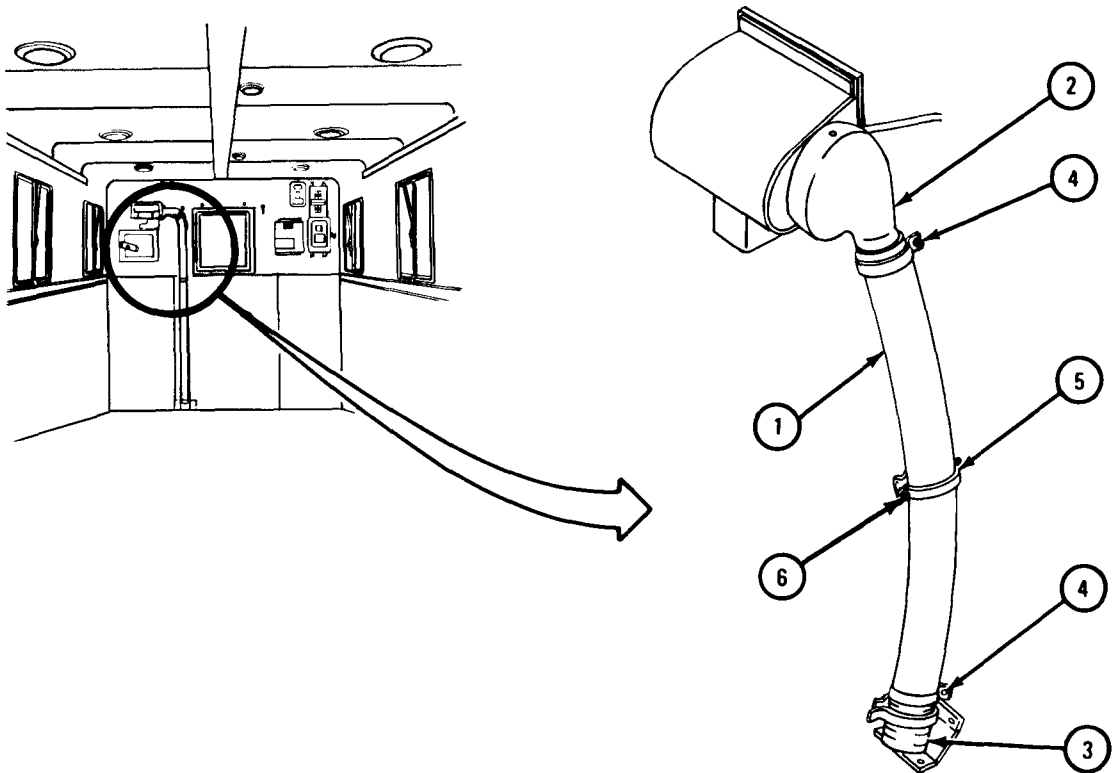

23-27. VAN BODY PERSONNEL HEATER SWITCHES REPAIR (TRUCKS M109A2 AND M109A3).

TOOLS: Flat-tip screwdriver

SUPPLIES: Tags

PERSONNEL: One

EQUIPMENT CONDITION: Truck parked, engine off, handbrake set.

a. Preliminary Procedures.

(1) Disconnect battery ground cable. Refer to Part 1, para 7-58.

(2) If connected, unplug 115-volt power line from entrance receptacle. Refer to TM 9-2320-209-10.

b. Removal.

FRAME 1

1. Unscrew and unplug electrical connector (1).
2. Unplug electrical plug (2).
3. Using screwdriver, turn screw (3) 1/4 turn to left and open door (4).
4. Using screwdriver, unscrew and take out eight screws (5).

GO TO FRAME 2

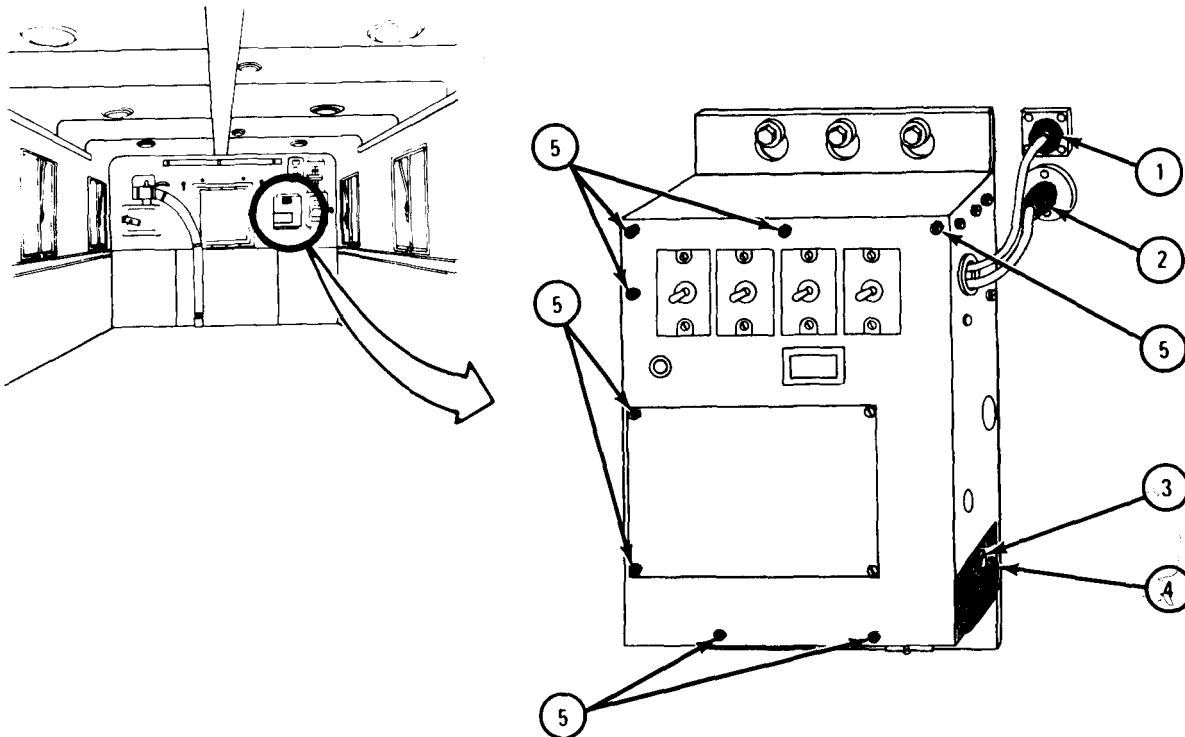

TA 083905

FRAME 2

1. Using screwdriver, unscrew and take out six screws (1).
2. Pull front cover (2) off switch box (3) and let front cover hang.
3. Using screwdriver, unscrew and take off four screws (4) and two data plates (5).

GO TO FRAME 3

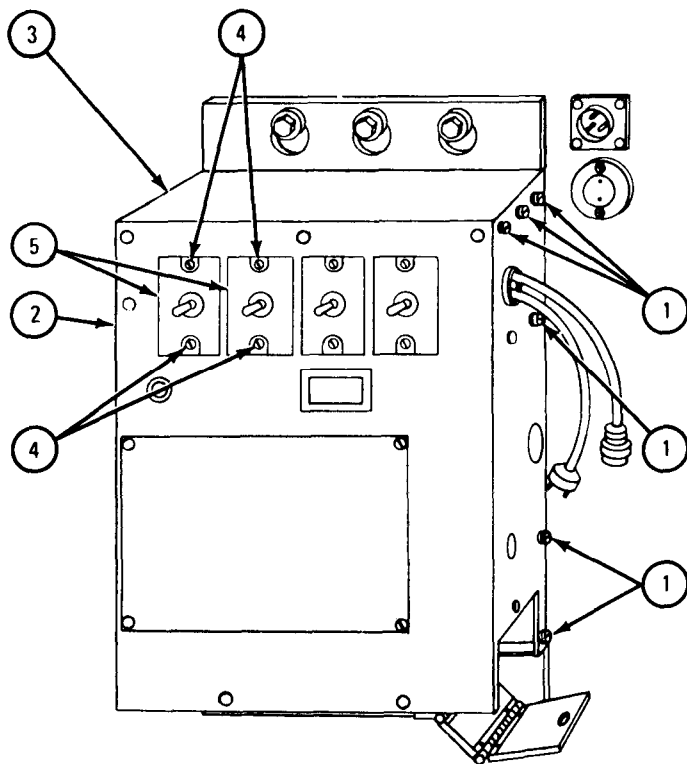

TA 083906

FRAME 3

1. Pull out and turn around HI-LO switch (1).

NOTE

Tag two wires (2) so they can be put back in the right place.

2. Using screwdriver, unscrew and take out two screws (3) and HI-LO switch (1).
GO TO FRAME 4

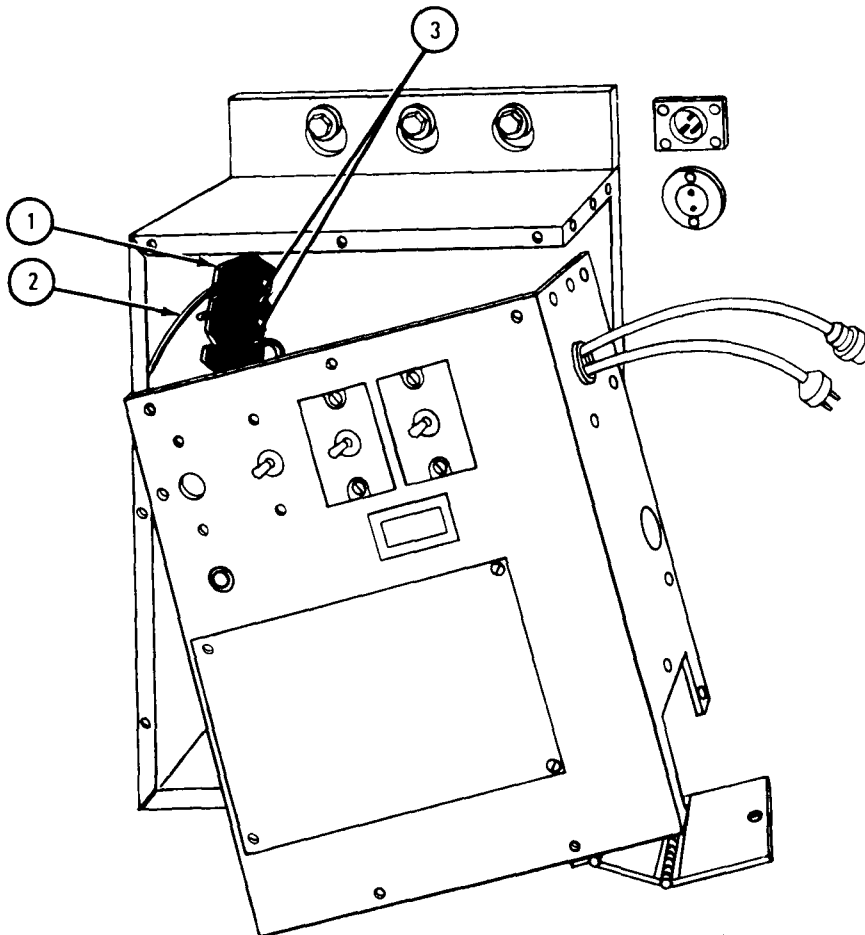

TA 083907

FRAME 4

1. Pull out and turn around HEATER switch (1).

NOTE

Tag five wires (2) so they can be put back in the right place.

2. Using screwdriver, unscrew and take out five screws (3) and HEATER switch (1).

END OF TASK

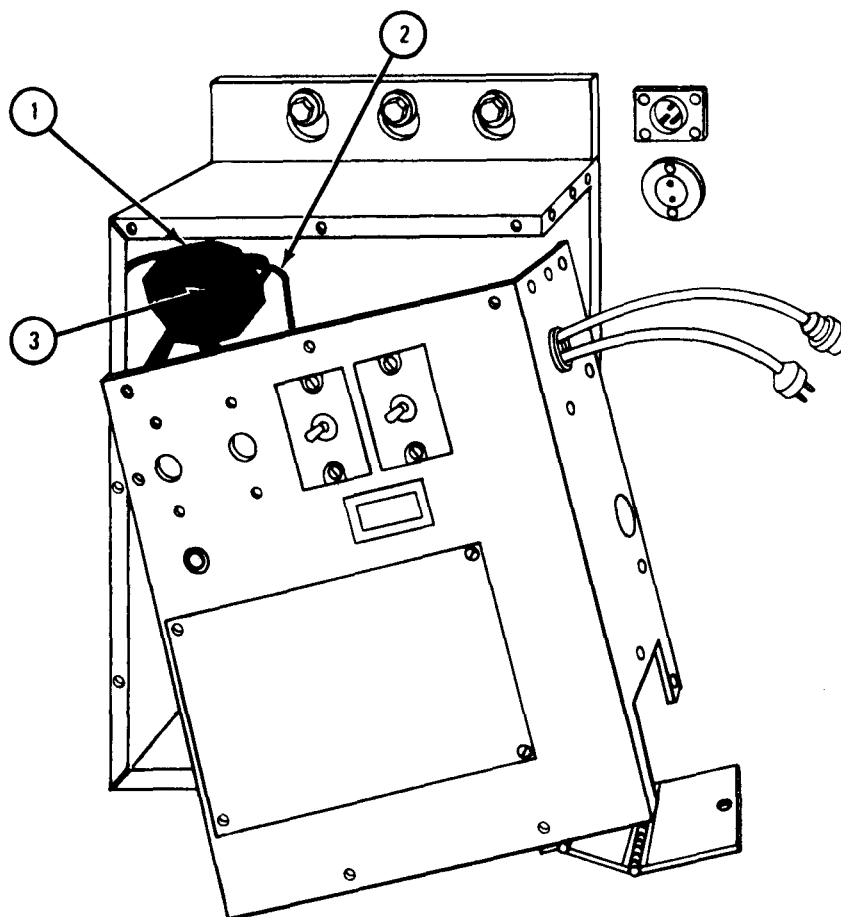

TA 083908

c. Replacement.

FRAME 1

1. Put five wires (1) on HEATER switch (2) as tagged.
2. Using screwdriver, screw in and tighten five screws (3). Take off tags.
3. Turn around HEATER switch (2) and put toggle on HEATER switch through hole (4) in front cover (5).

GO TO FRAME 2

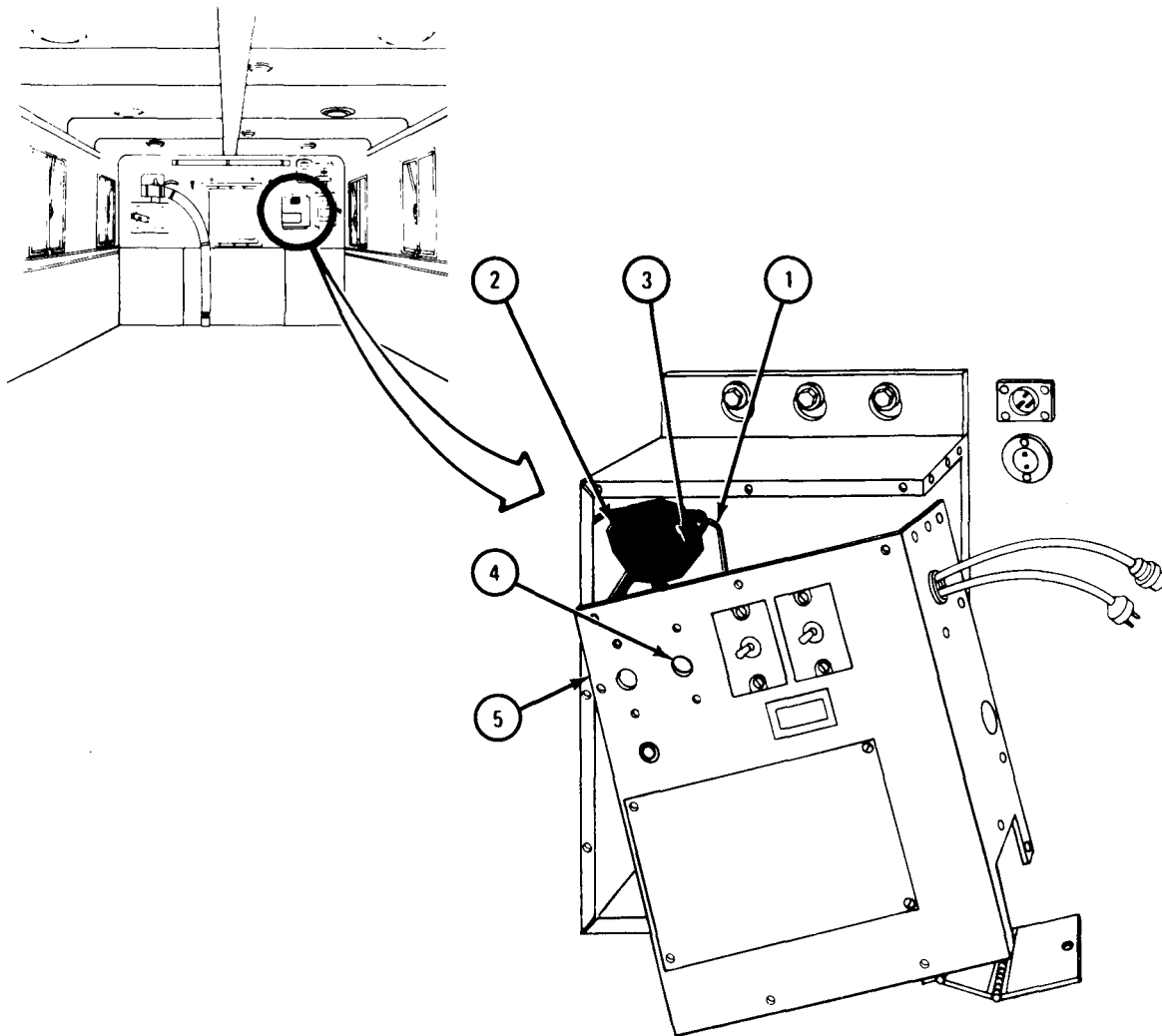

TA 083909

FRAME 2

1. Put two wires (1) on HI-LO switch (2) as tagged.
2. Using screwdriver, screw in and tighten two screws (3). Take off tags.
3. Turn around HI-LO switch (2) and put toggle on HI-LO switch through hole (4) in front cover (5).

GO TO FRAME 3

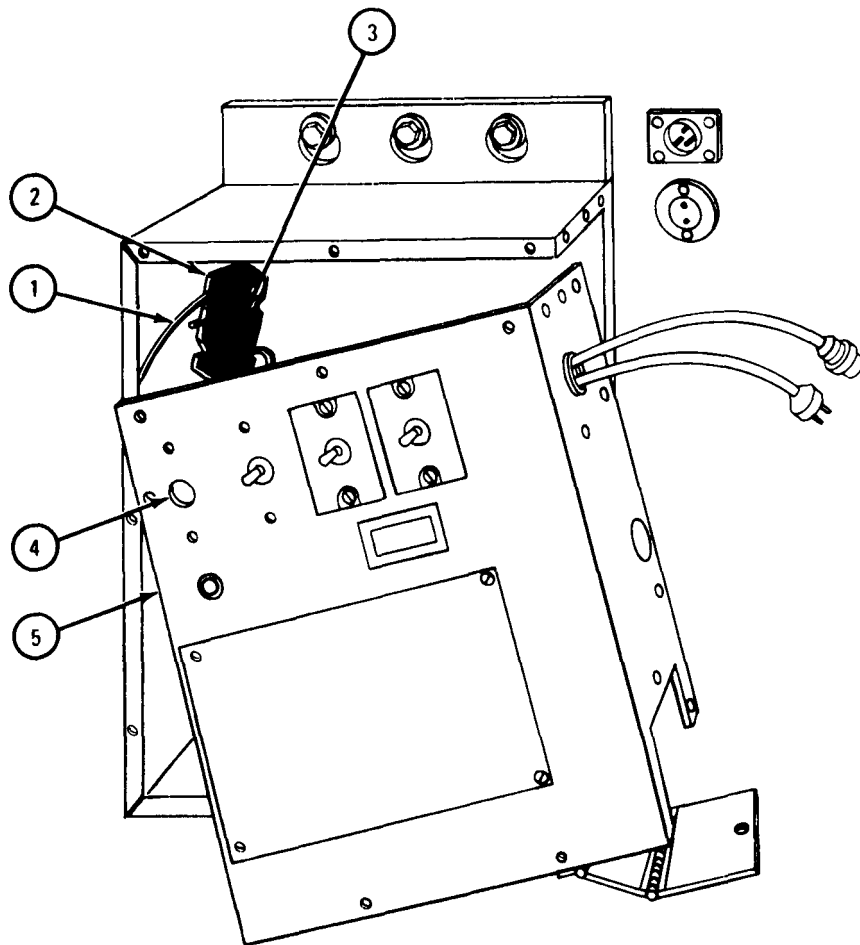

TA 083910

FRAME 3

1. Put HEATER data plate (1) over HEATER switch (2) and screw in two screws (3).
2. Put HI-LO data plate (4) over HI-LO switch (5) and screw in two screws (6).
3. Put front cover (7) in place and aline screw holes.
4. Using screwdriver, screw in and tighten six screws (8).
5. Using screwdriver, tighten two screws (3) and two screws (6).

Go TO FRAME 4

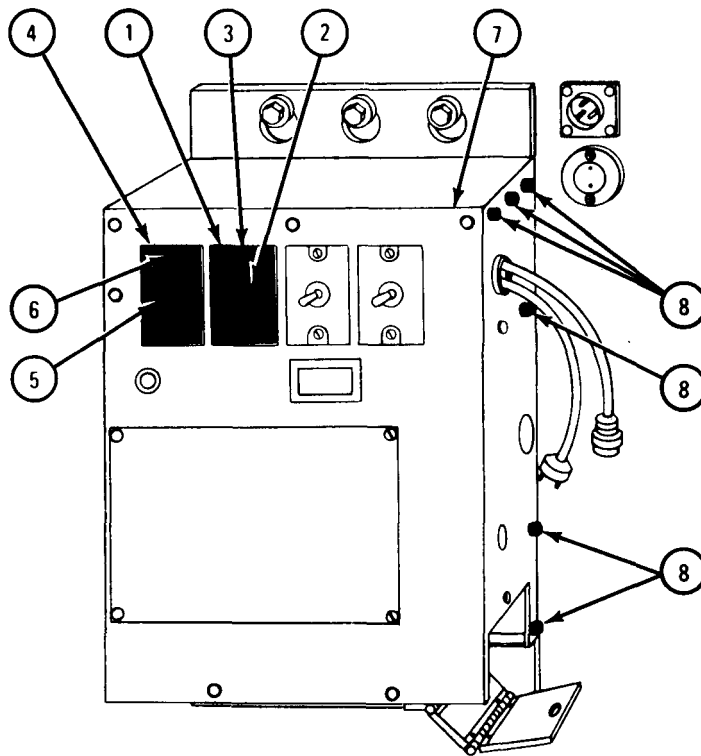

TA 083911

FRAME 4

1. Using screwdriver, screw in and tighten eight screws (1).
2. Close door (2). Using screwdriver, turn screw (3) 1/4 turn to right.
3. Plug in electrical plug (4).
4. Plug in and screw on and tighten electrical connector (5).

NOTE

Follow-on Maintenance Action Required:

1. If it was connected, plug in 115-volt power line to entrance receptacle. Refer to TM 9-2320-209-10.
2. Reconnect battery ground cable. Refer to Part 1, para 7-58.

END OF TASK

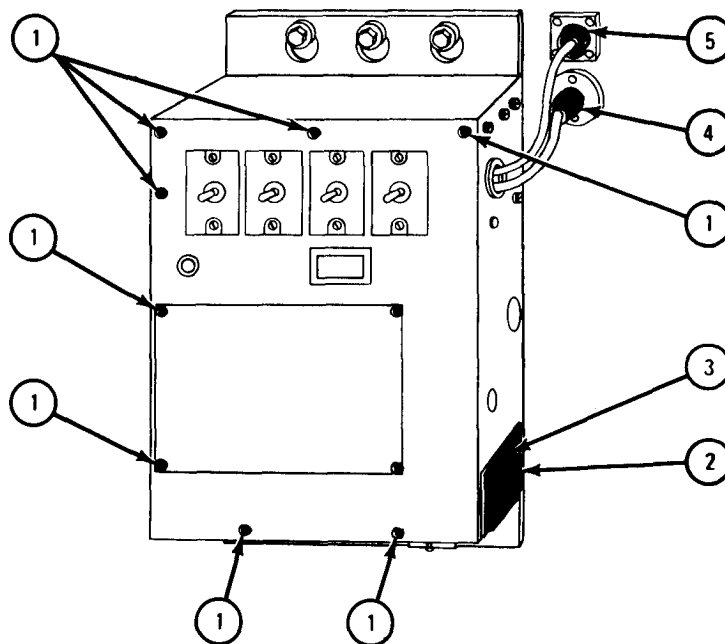

TA 083912

Section III. DEEP WATER FORDING KIT

23-28. DEEP WATER FORDING KIT EXHAUST EXTENSION REMOVAL, REPAIR, AND REPLACEMENT.

TOOLS: Open end wrench set, pn GGG-W-636

SUPPLIES: Lubricating oil, ICE, OE/HDO 30, MIL-L-2104

PERSONNEL: One

EQUIPMENT CONDITION: Truck parked, engine off, handbrake set.

a. Removal.

FRAME 1

1. Using wrenches, unscrew and take off three nuts (1). Take out screws (2).
2. Using wrenches, unscrew and take off two nuts (3) and flat washers (4). Take out screws (5) and lift off exhaust extension (6).
3. Take off and throw away gasket (7).

GO TO FRAME 2

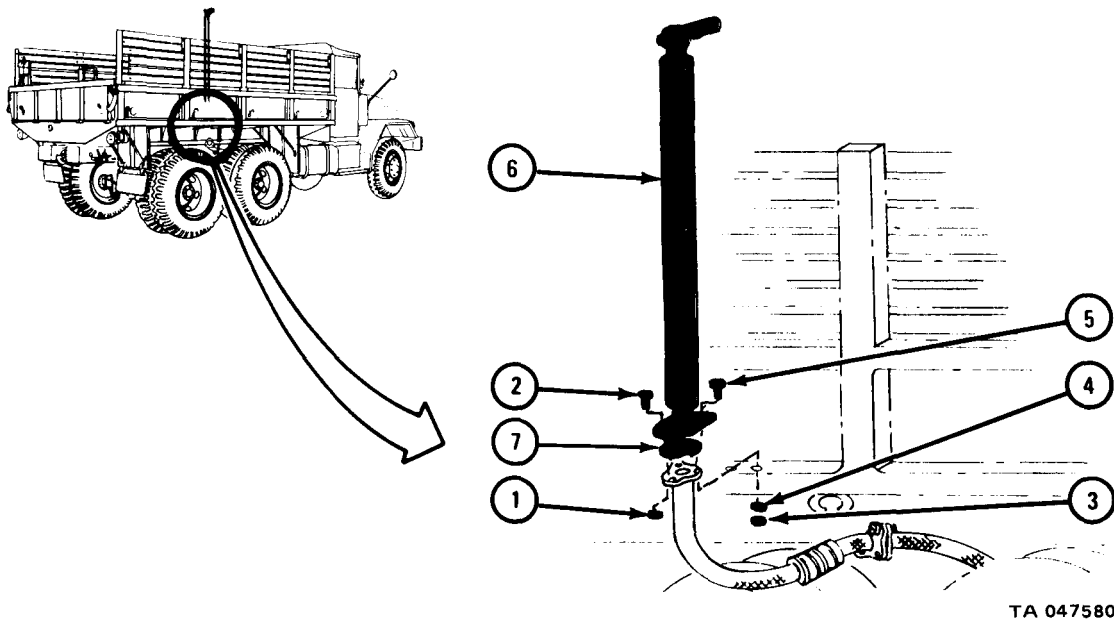

FRAME 2

1. Using wrenches, unscrew and take off three nuts (1).
2. Take out three screws (2) and take off lower exhaust extension (3).
3. Take off and throw away gasket (4).

END OF TASK

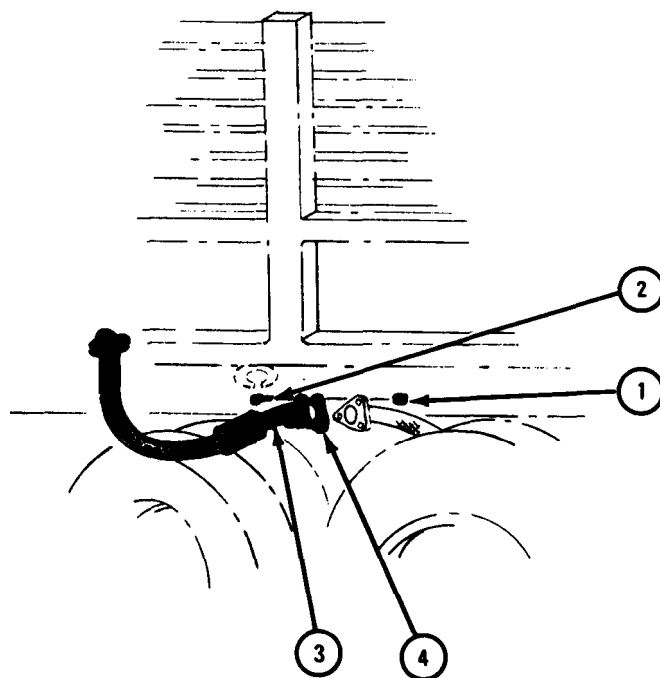

TA 047581

b. Repair.

FRAME 1

1. Check that upper exhaust extension (1) has no cracks, dents or holes. If upper exhaust extension is damaged, get a new one.
2. Check that weather cap (2) opens and closes freely. Put lubricating oil on hinge (3) if needed.
3. Check that lower exhaust extension (4) has no cracks, dents or holes. If lower exhaust extension is damaged, get a new one.

END OF TASK

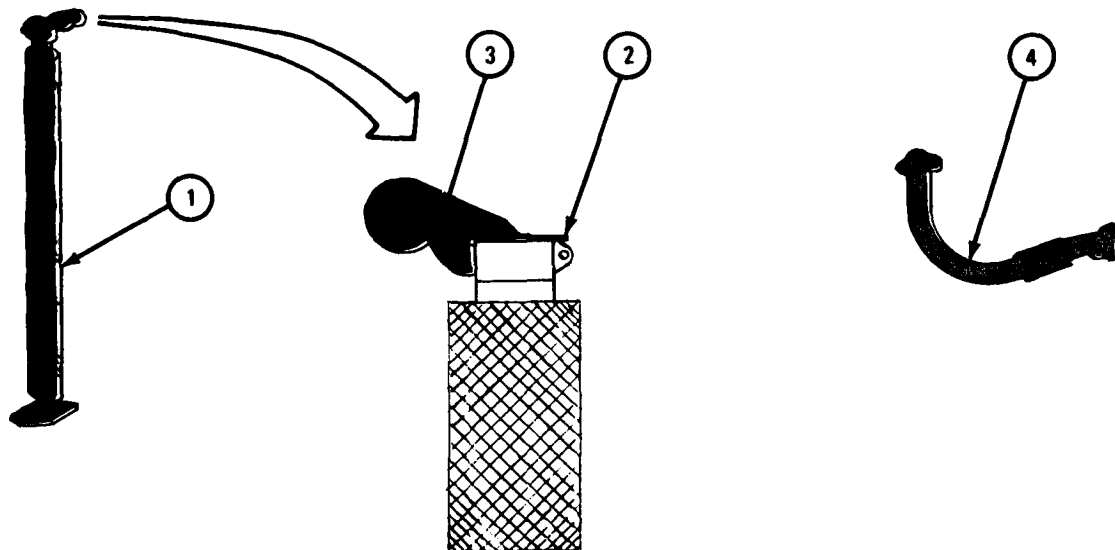

TA 047582

c. Replacement.

FRAME 1

1. Put three screws (1) through holes in flange (2), gasket (3), and flange (4) as shown.
 2. Using wrenches, screw on and tighten three nuts (5).
- GO TO FRAME 2

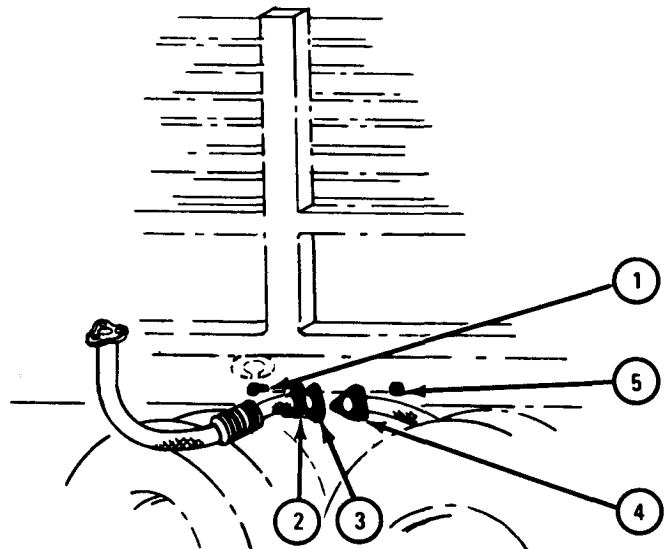
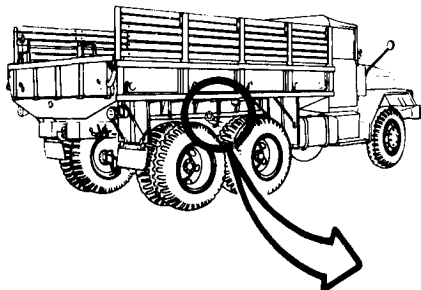

TA 047583

FRAME 2

1. Place gasket (1) on flange (2).
2. Place exhaust extension (3) on flange (2) so that holes in straight side of plate (4) aline with holes in truck body.
3. Put five screws (5) in place.
4. Put on washers (6). Using wrenches, screw on and tighten five nuts (7).

END OF TASK

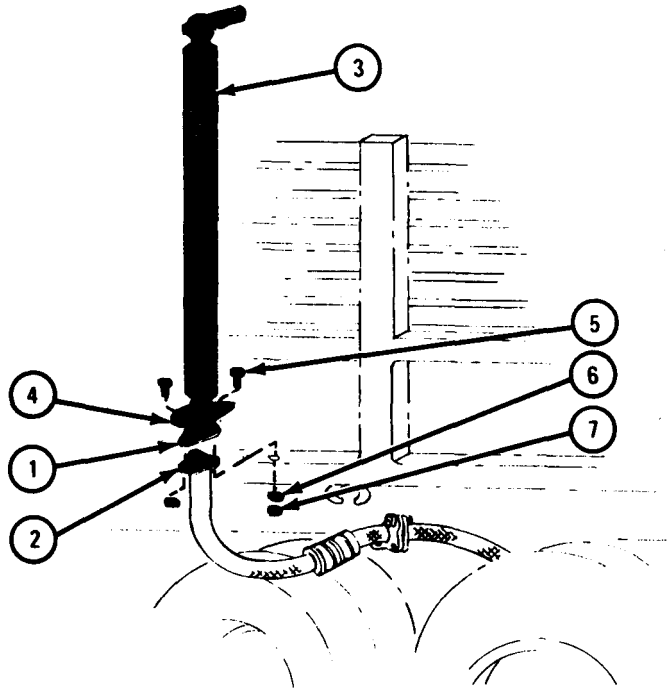

TA 047584

23-29. DEEP WATER FORDING KIT TRANSMISSION BREATHER REMOVAL, REPAIR, AND REPLACEMENT.

TOOLS: 7/16-inch open end wrench

SUPPLIES: Solvent, dry cleaning, type II (SD-2), Fed. Spec P-D-680
Rag
Lubricating oil, ICE, OE/HDO 10, MIL-L-2104

PERSONNEL: One

EQUIPMENT CONDITION: Truck parked, engine off, handbrake set.

- a. Preliminary Procedure. Remove intermediate tunnel. Refer to Part 3, para 18-5.
- b. Removal.

FRAME 1

1. Using 7/16-inch wrench, unscrew and take out transmission breather (1) from transmission housing cover (2).

END OF TASK

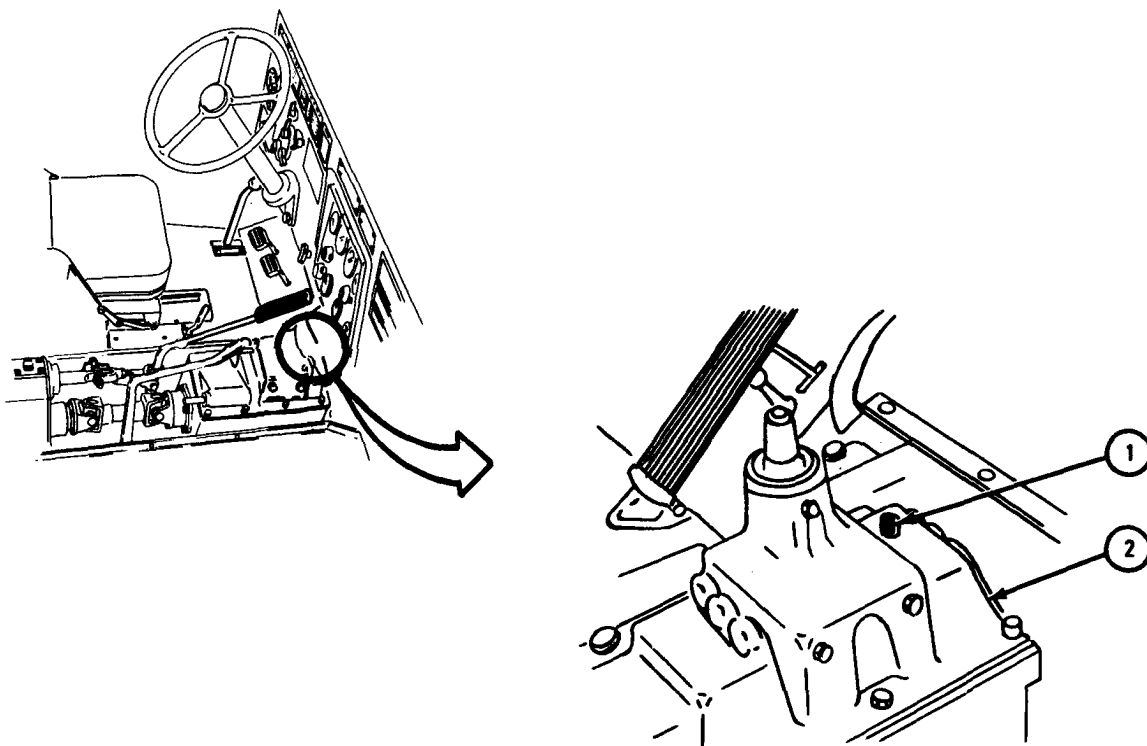

TA 047593

c. Repair.

FRAME 1

WARNING

Dry cleaning solvent is flammable. Do not use near an open flame. Keep a fire extinguisher nearby when solvent is used. Use only in well-ventilated places. Failure to do this may result in injury to personnel and damage to equipment.

1. Soak transmission breather (1) in solvent.
2. Using wire brush, brush all dirt from transmission breather (1).
3. Clean passage (2) and make sure valve cap (3) moves freely.
4. Use clean lubricating oil to lubricate transmission breather (1).

END OF TASK

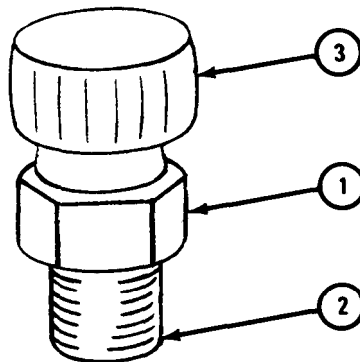

TA 047594

d. Replacement.

FRAME 1

1. Using rag, wipe surface clean around mounting hole for transmission breather (1) in transmission housing cover (2).
2. Using 7/16-inch wrench, screw in transmission breather (1).

NOTE

Follow-on Maintenance Action Required:

Replace intermediate tunnel. Refer to Part 3, para 18-5.

END OF TASK

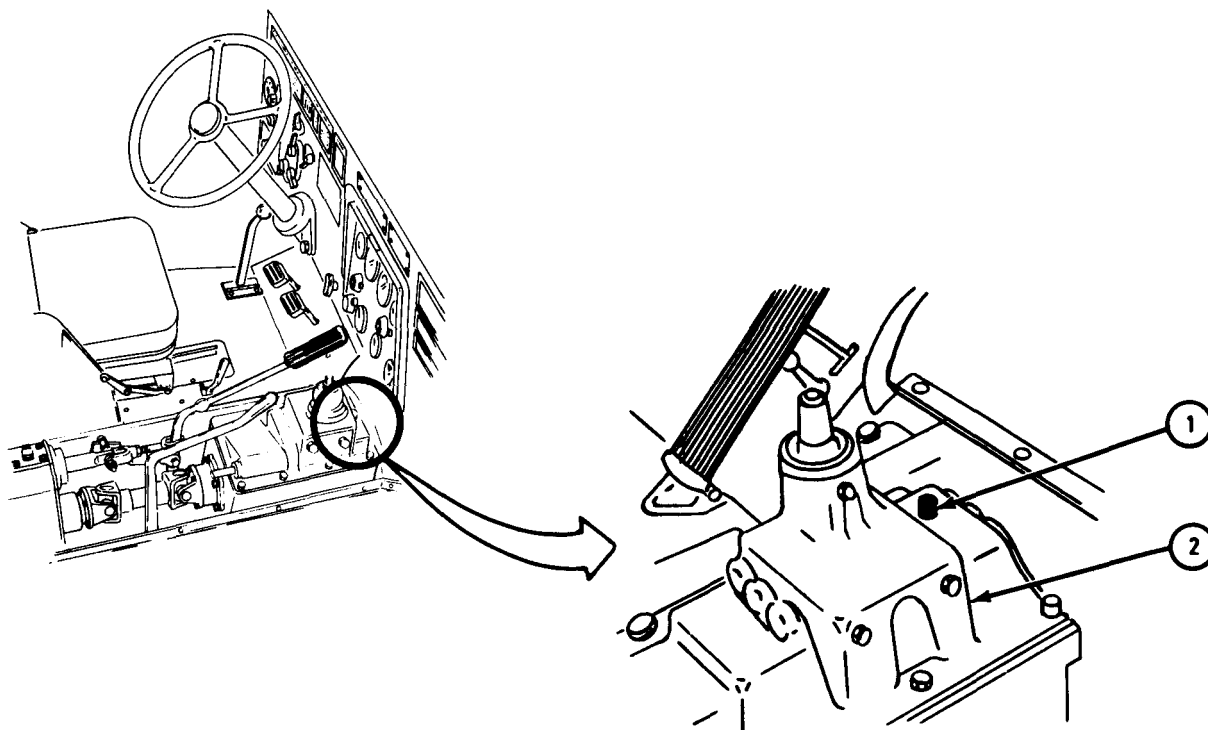

TA 047595

23-30. DEEP WATER FORDING KIT CONTROL VALVE REMOVAL, REPAIR, AND REPLACEMENT.

NOTE

There are two deep water fording kit control valves, one for trucks with front wheel drive lever, and the other for trucks without front wheel drive lever. This procedure shows both models.

TOOLS: Open end wrench set, pn GGG-W-636
Cross-tip screwdriver (Phillips type)
Sockethead screw key set, pn GGG-K-275 (Allen wrenches or equivalent)

SUPPLIES: Tags

PERSONNEL: One

EQUIPMENT CONDITION: Truck parked, engine off, handbrake set.

a. Preliminary Procedure. Vent air system pressure. Refer to Part 2, para 13-20.

b. Removal.

NOTE

Tag air lines before taking them off to be sure they are put back in the same place.

FRAME 1

1. Using wrench, unscrew and take off two coupling nuts (1).
2. Using screwdriver, unscrew and take out two screws (2).
3. Take out control valve (3).

END OF TASK

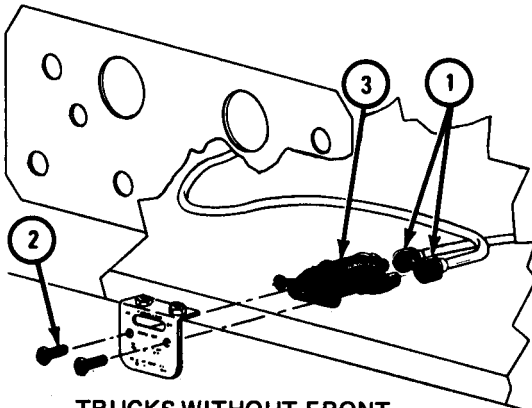
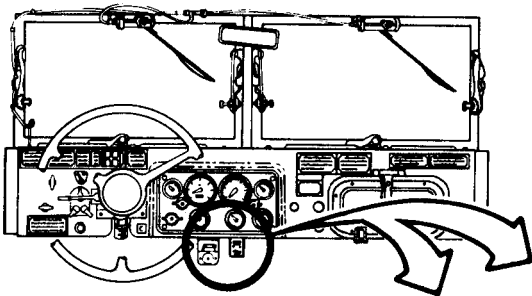

TRUCKS WITHOUT FRONT WHEEL DRIVE LEVER

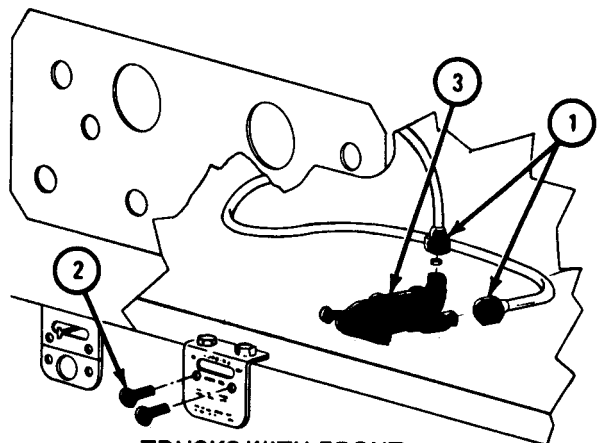

TRUCKS WITH FRONT WHEEL DRIVE LEVER

TA 047589

c. Repair.

FRAME 1

1. Using wrench, unscrew and take out elbow (1).
2. Using wrench, unscrew and take out reducer pipe (2) or elbow (3).
3. Using allen wrench, unscrew and take out pipe plug (4).
4. Check that all parts have no damage or wear. If part is damaged, get a new one.

GO TO FRAME 2

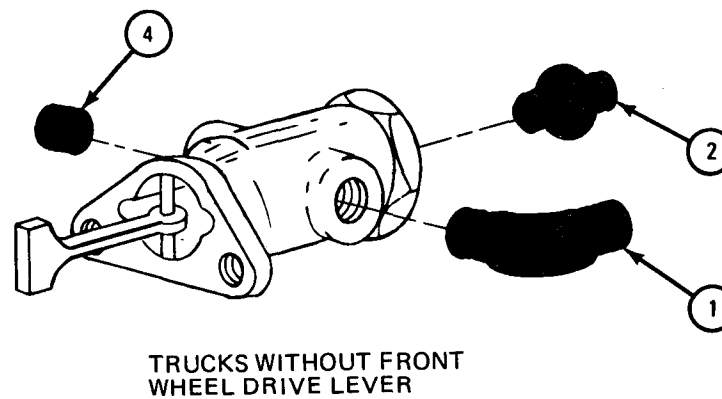
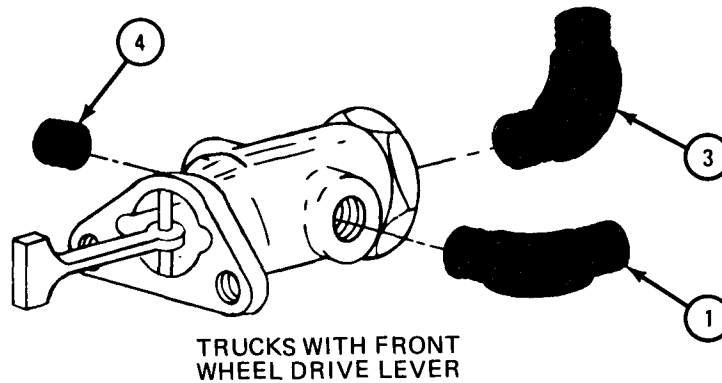

TA 047590

FRAME 2

1. Using allen wrench, screw in and tighten pipe plug (1) in control valve (2).
 2. Using wrench, screw in and tighten elbow (3) as shown.
 3. Using wrench, screw in and tighten reducer pipe (4) or elbow (5) as shown.
- END OF TASK

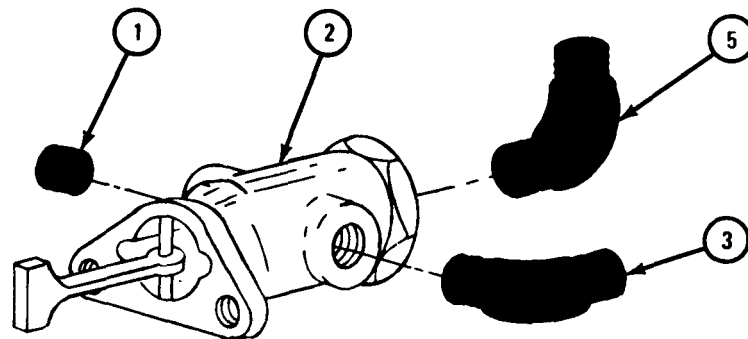

TRUCKS WITH FRONT
WHEEL DRIVE LEVER

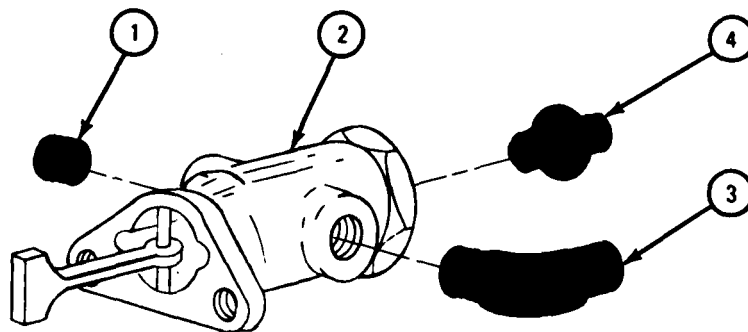

TRUCKS WITHOUT FRONT
WHEEL DRIVE LEVER

TA 047591

d. Replacement.

FRAME 1

1. Put control valve lever (1) through slot in bracket (2). Using screwdriver, screw in and tighten two screws (3).
2. Using wrench, screw in and tighten coupling nut (4) on hose (5) onto elbow or reducer (6) as tagged. Take off tag.
3. Using wrench, screw in and tighten coupling nut (7) on hose (8) onto elbow (9) as tagged. Take off tag.

END OF TASK

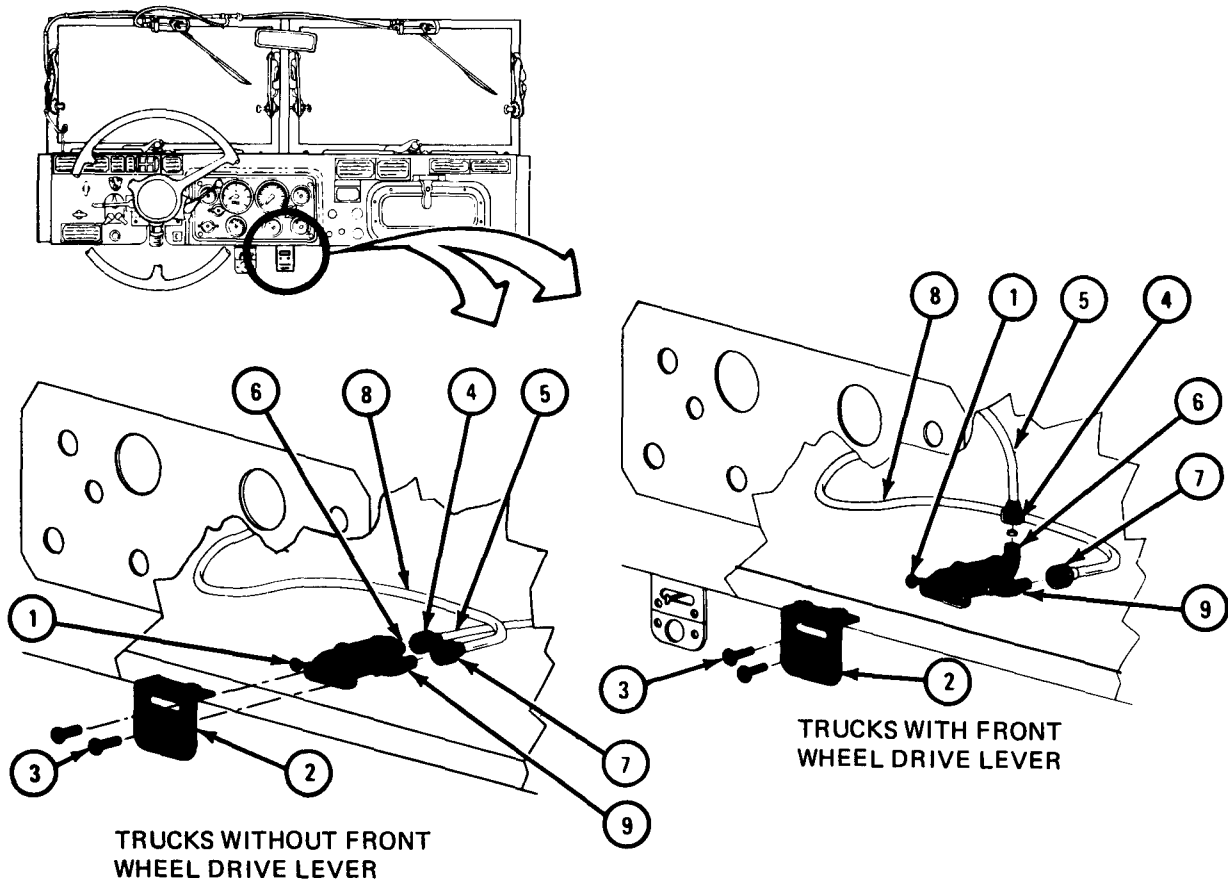

TA 047592

23-31. DEEP WATER FORDING KIT PRESSURIZATION VALVE HAND CONTROL ASSEMBLY REMOVAL AND REPLACEMENT.

TOOLS: Flat-tip screwdriver
Open end wrench set, pn GGG-W-636

SUPPLIES: None

PERSONNEL: One

EQUIPMENT CONDITION: Truck parked, engine off, handbrake set.

- a. Preliminary Procedure. Open hood. Refer to TM 9-2320-209-10.
- b. Removal.

FRAME 1

1. Using screwdriver, loosen two setscrews (1).
 2. Using wrenches, loosen capscrew and nut (2).
- GO TO FRAME 2

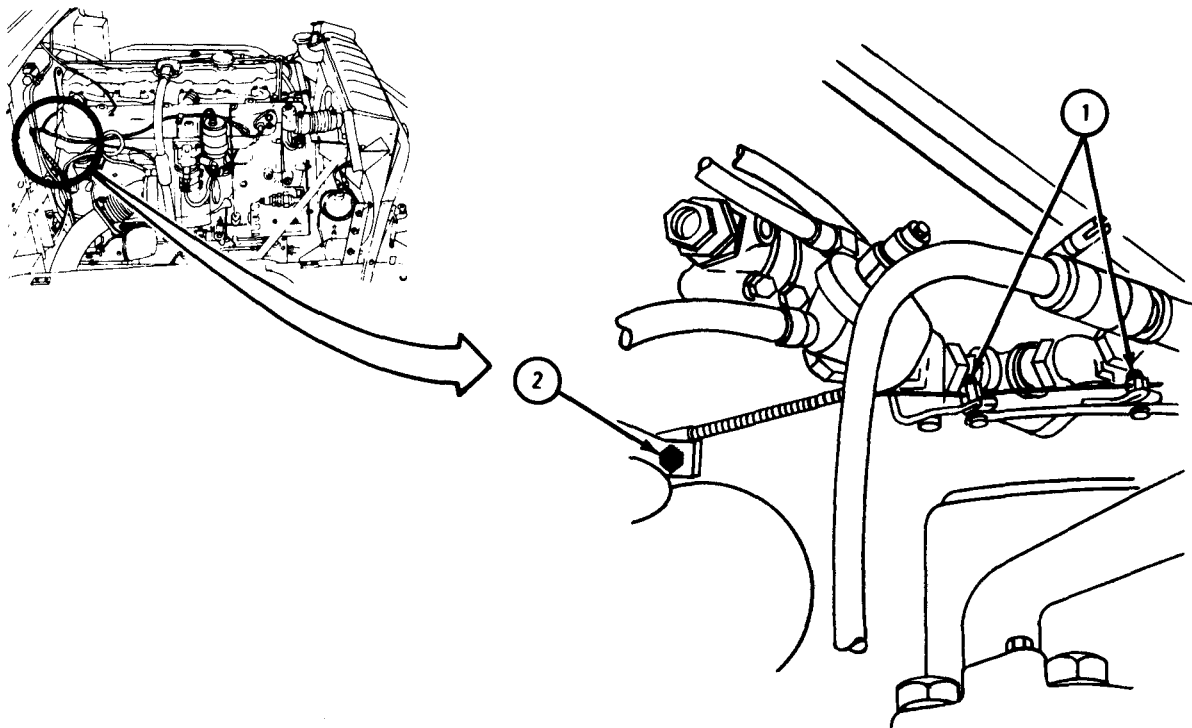

TA 085579

FRAME 2

1. Using wrench, unscrew nut (1).
2. Pull pressurization valve hand control assembly (2) out of instrument panel (3) and take off nut (1) and washer (4).

END OF TASK

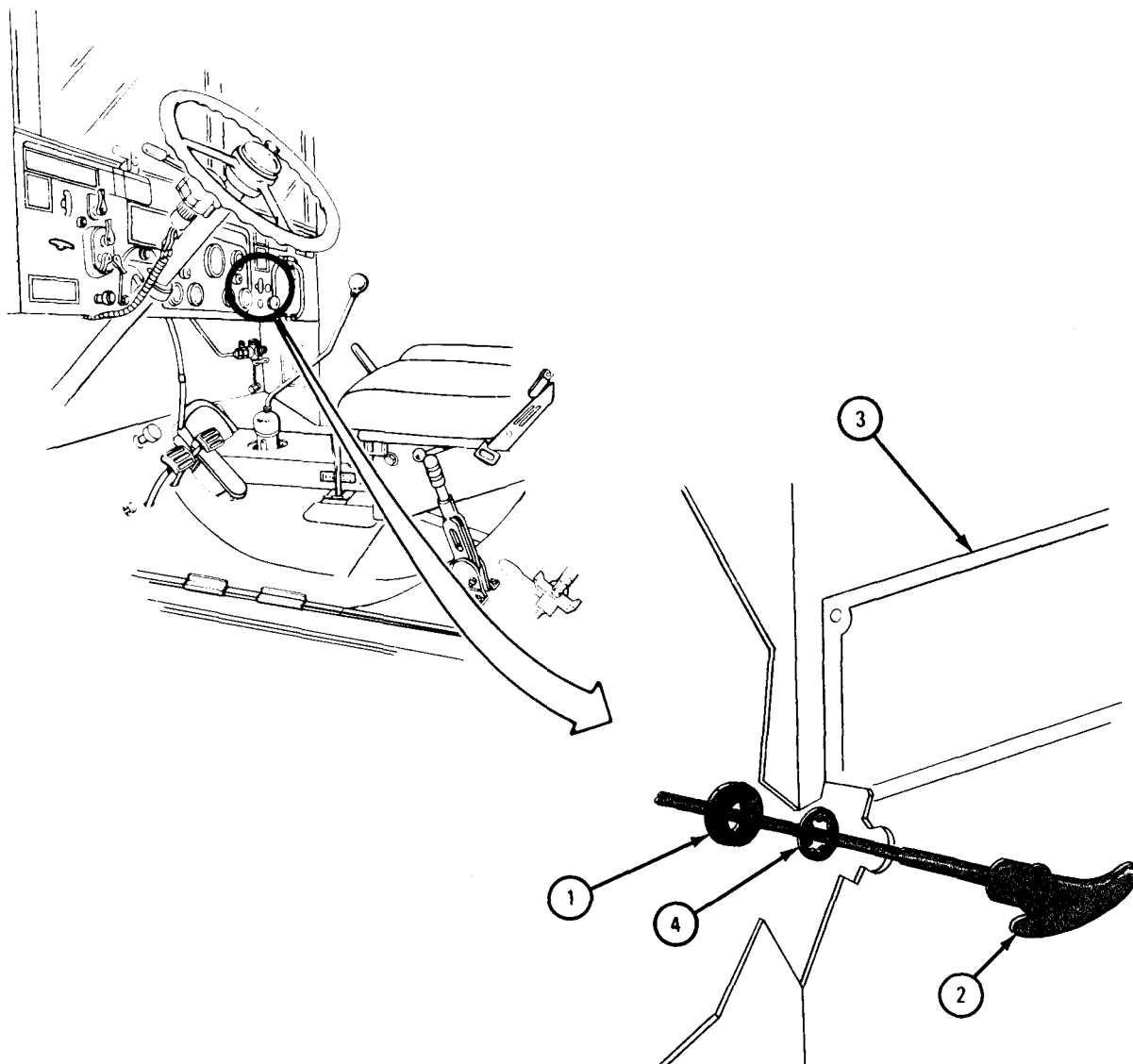

TA 085580

c. Replacement.

FRAME 1

1. Put pressurization valve hand control assembly (1) through hole in instrument panel (2), washer (3), nut (4), and grommet (5).
 2. Using wrench, screw on and tighten nut (4).
 3. Push knob (6) all the way in.
- GO TO FRAME 2

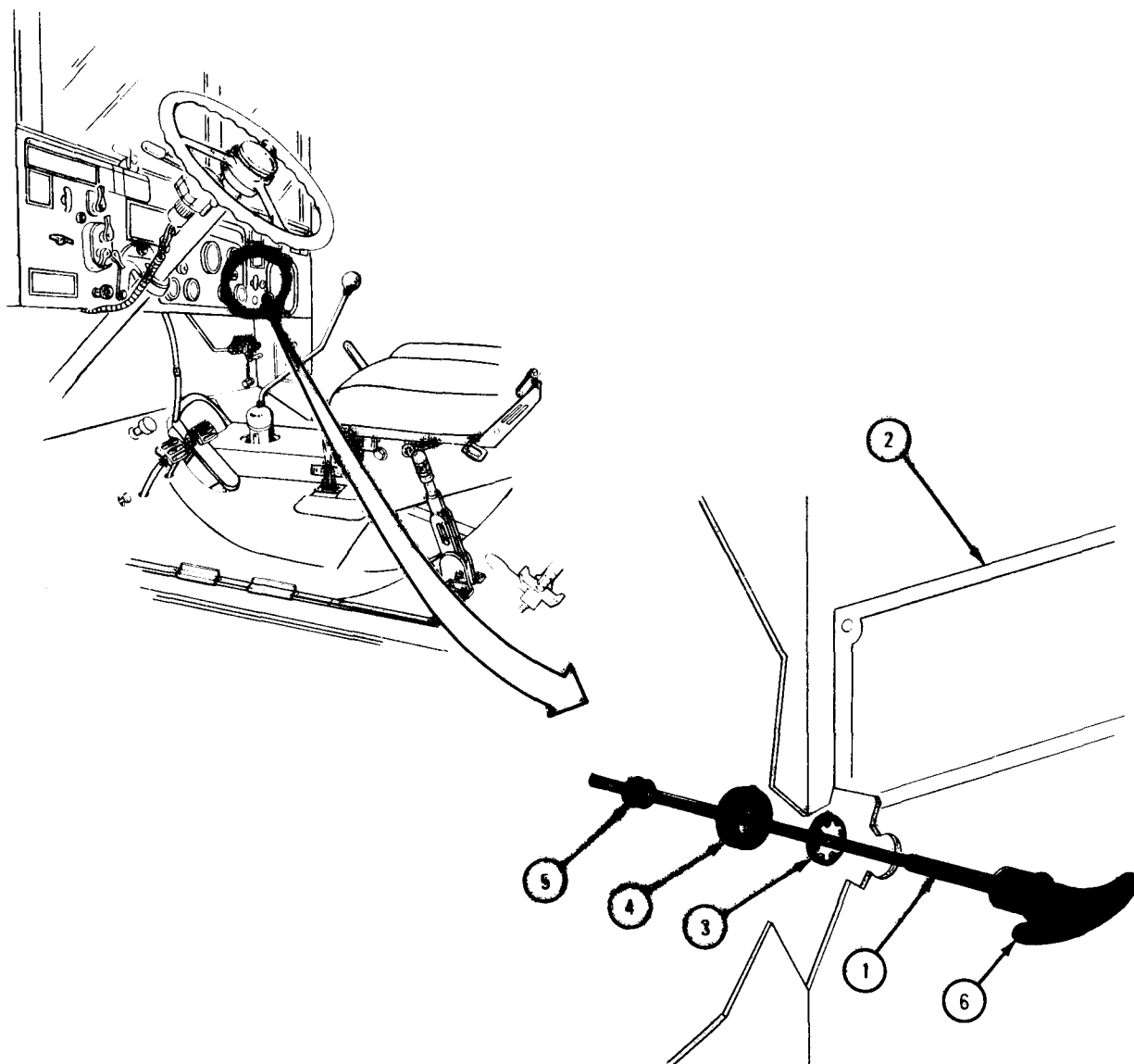

TA 085581

FRAME 2

1. Put pressurization valve hand control assembly cable housing (1) in clamp (2) and control cable (3) in two swivels (4).
2. Push swivels (4) all the way toward firewall (5).
3. Slide pressurization valve hand control assembly cable housing (1) in clamp (2) so there is no less than 1/2 inch between swivels (4) and pressurization valve hand control assembly cable housing (1).
4. Using wrenches, tighten capscrew and nut (6). Push swivels (4) all the way away from firewall (5).
5. Using screwdriver, tighten two setscrews (7).
6. From inside cab, move pressurization valve hand control knob (8) out and in several times to make sure all parts move smoothly without binding.

NOTE

Follow-on Maintenance Action Required:
Close hood. Refer to TM 9-2320-209-10.

END OF TASK

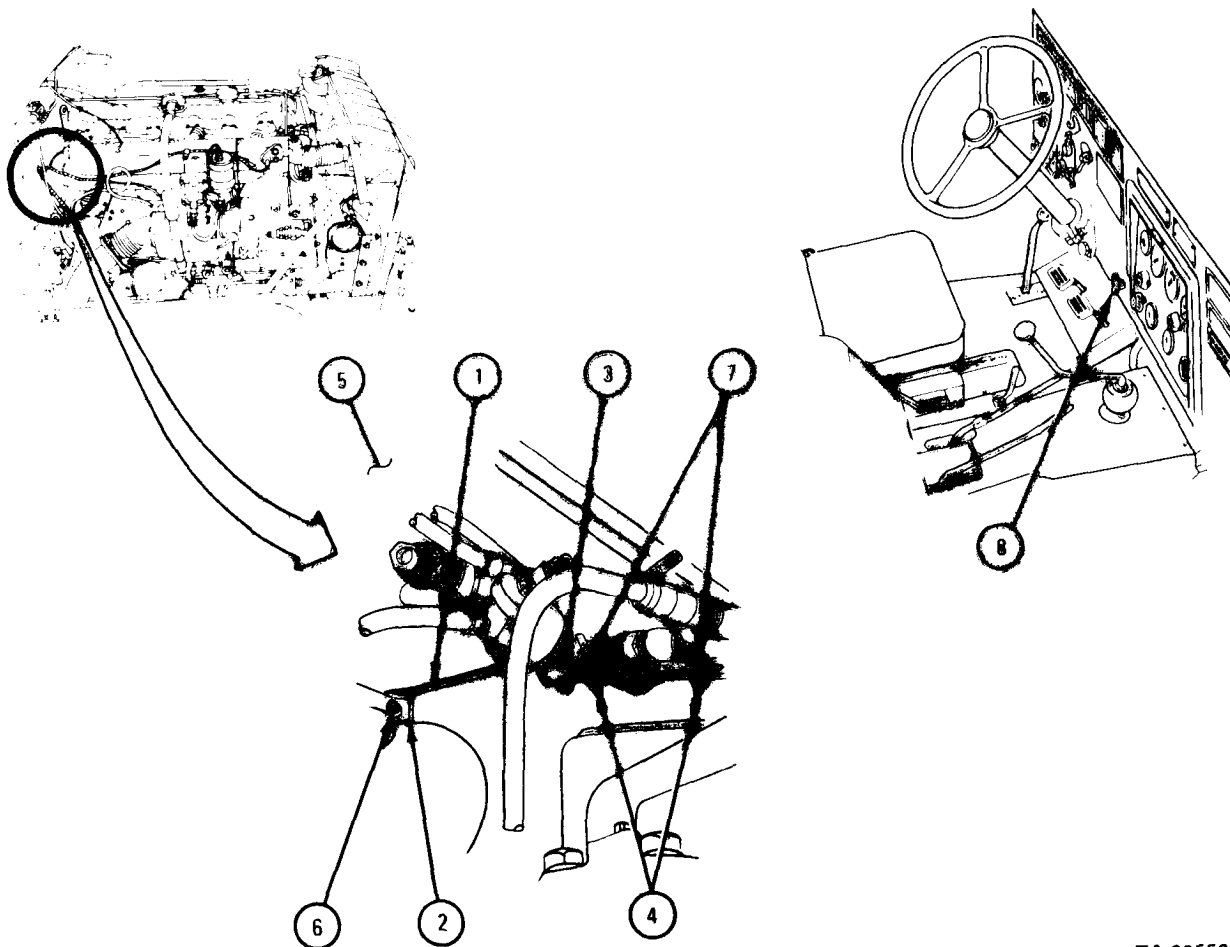

TA 085582

Section IV. SPECIAL PURPOSE KITS

23-32. DECONTAMINATION APPARATUS MOUNTING BRACKET REMOVAL AND REPLACEMENT.

TOOLS: 7/16-inch wrench
11/16-inch open end wrench
5/8-inch open end wrench
9/16-inch wrench (2)

SUPPLIES: None

PERSONNEL: One

EQUIPMENT CONDITION: Truck parked, engine off, handbrake set.

a. Preliminary Procedure. Remove decontamination apparatus bracket assembly. Refer to TM 3-4230-204-12&P.

b. Removal.

FRAME 1

1. Slide rubber boot (1) up gearshift lever (2) as shown.
2. Using 11/16-inch and 5/8-inch wrenches, unscrew and take off nut with flat washer (3) from bolt (4). Take out bolt and lift off gearshift lever (2).

GO TO FRAME 2

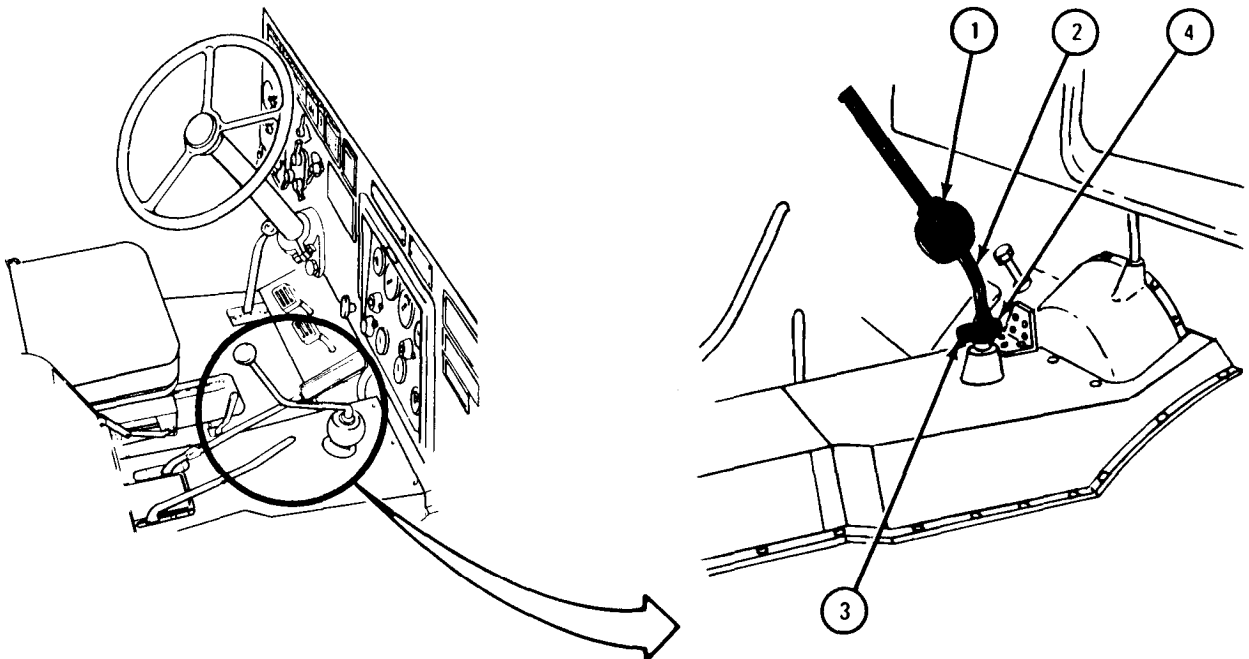

TA 103850

FRAME 2

1. Using 7/16-inch wrench, unscrew and take out 13 screws (1) holding intermediate tunnel (2) to front tunnel (3), cab floor (4), and rear tunnel (5).
2. Lift off intermediate tunnel (2) and take it out of cab.

GO TO FRAME 3

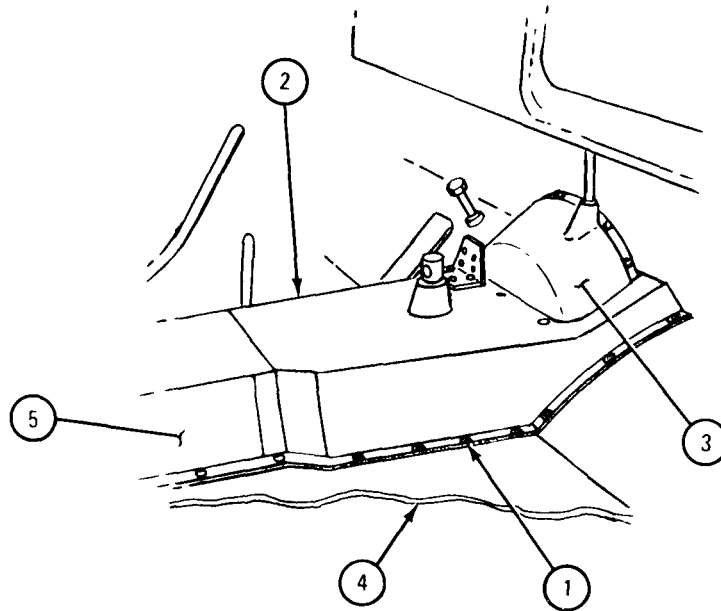

TA 103851

FRAME 3

1. Using 9/16-inch wrenches, unscrew and take out four screws (1) and nuts (2).
Take off bracket (3).

END OF TASK

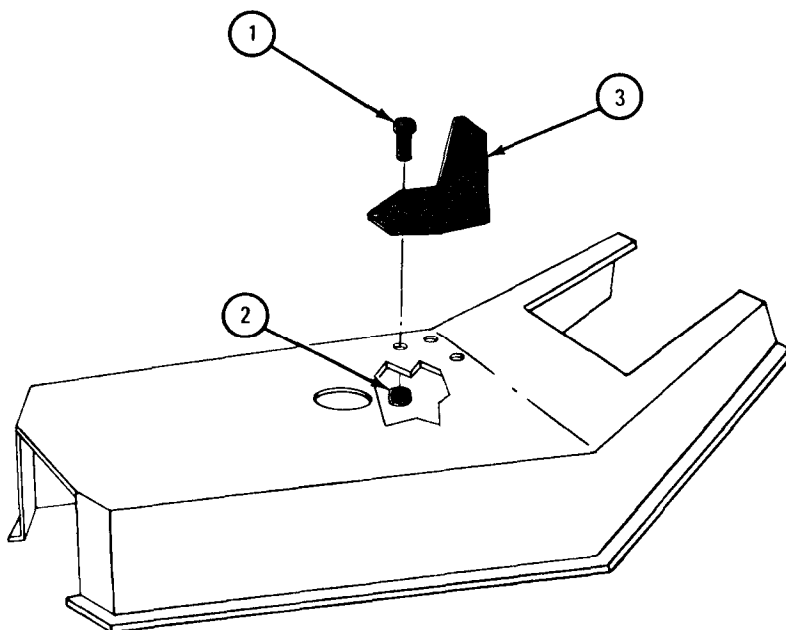

TA 103852

c. Replacement.

FRAME 1

1. Put decontamination apparatus bracket (1) on intermediate tunnel (2) and aline screw holes. Using 9/16-inch wrenches, screw in and tighten four screws (3) and nuts (4).

GO TO FRAME 2

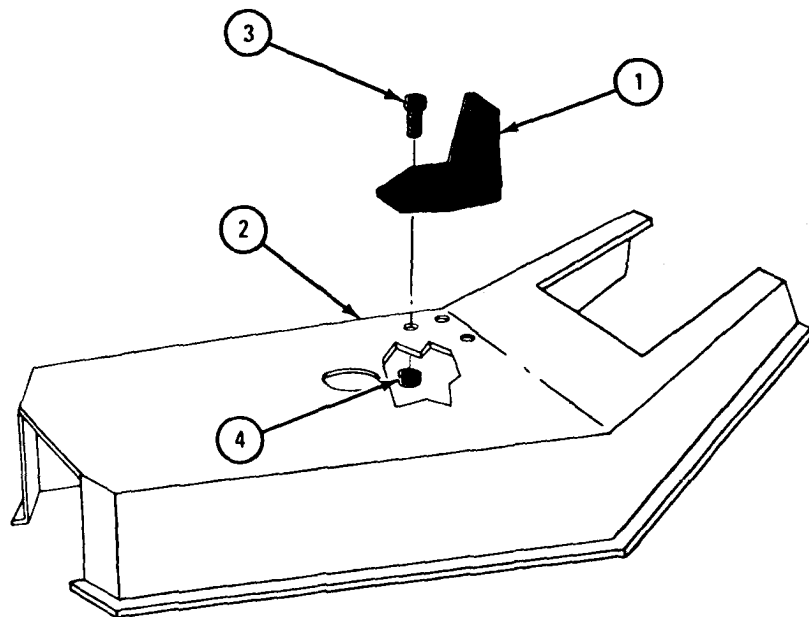

TA 103459

FRAME 2

1. Working inside cab, place intermediate tunnel (1) over front tunnel (2) and rear tunnel (3) as shown. Aline mounting holes and using 7/16-inch wrench, screw in and tighten 13 screws (4).

GO TO FRAME 3

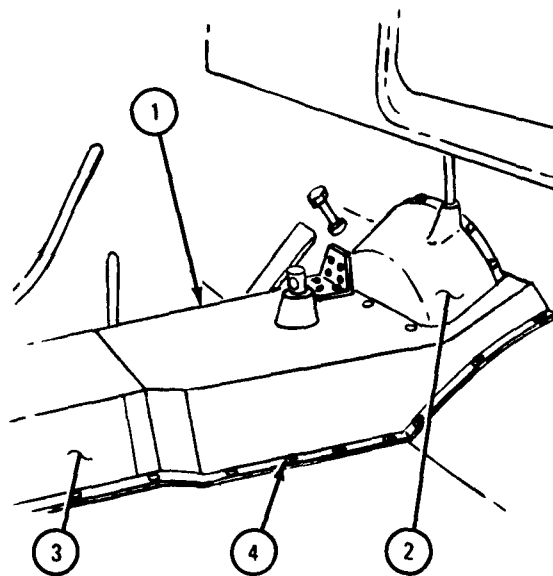
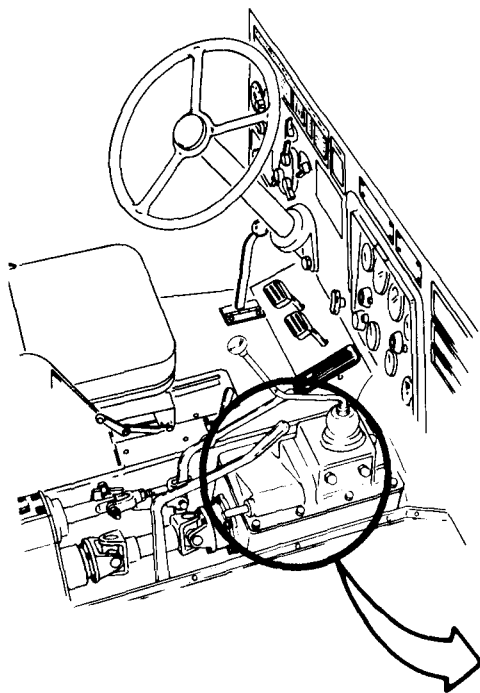

TA 103853

FRAME 3

1. Put gearshift lever (1) over stub shaft (2).
2. Put bolt (3) through split flange holes at bottom of gearshift lever (1).
3. Using 5/8-inch and 11/16-inch wrenches, screw on and tighten locknut and flat washer (4).
4. Slide rubber boot (5) down over end of gearshift lever (1).

NOTE

Follow-on Maintenance Action Required:

Replace decontamination apparatus bracket assembly.
Refer to TM 3-4230-204-12&P.

END OF TASK

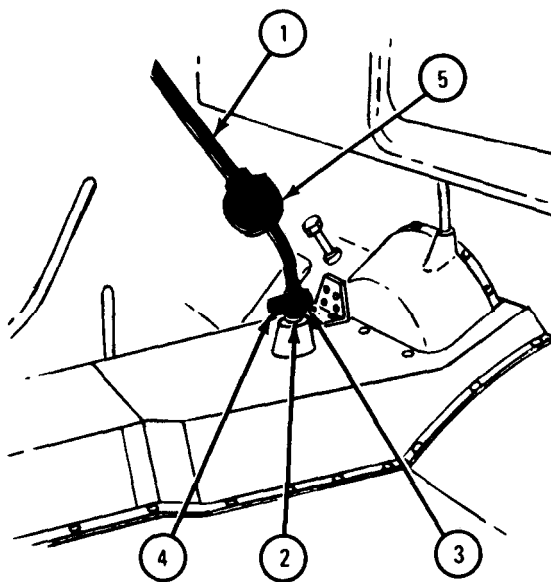

TA 103461

23-33. A-FRAME KIT SPREADER TUBE REPAIR.

TOOLS: Open end wrench set, pn GGG-W-636
6-inch pliers

SUPPLIES: None

PERSONNEL: Three

EQUIPMENT CONDITION: Truck parked, engine off, handbrake set.

a. Preliminary Procedure. Using front winch, lower cable hook to ground.
Refre to 9-2320-209-10

b. Removal.

FRAME 1

1. Using wrench, unscrew and take out two adjusting screws (1), one from each leg (2).
2. Using pliers and wrench, hold eyebolt (3) and unscrew and take off nut (4), lockwasher (5), and flat washer (6).

GO TO FRAME 2

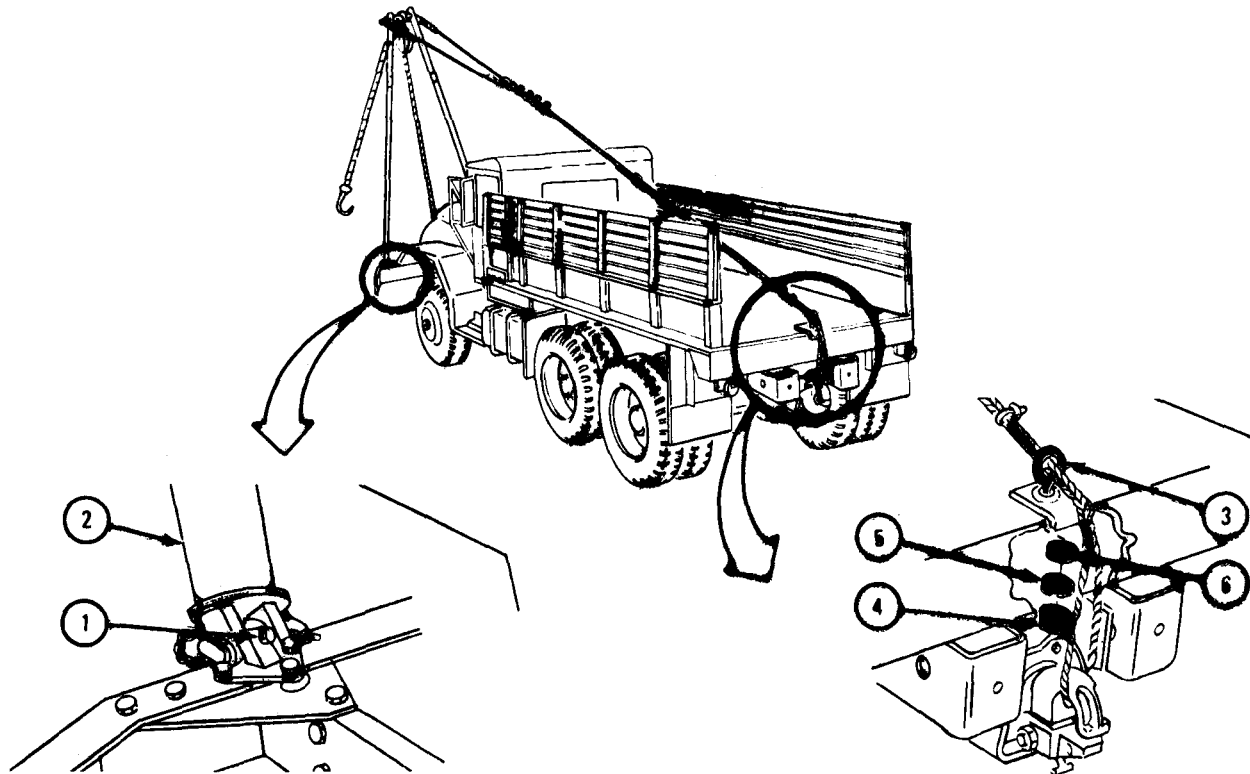

TA 080812

FRAME 2

Soldiers A and B 1. Push A-frame (1) toward cab until cable (2) goes slack and hold A-frame in place.

Soldier C 2. When there is enough slack in cable (2), open pintle hook (3) and take out cable. Put out eyebolt (4) and take off plate (5) and washer (6).

Soldiers A and B 3. Lower A-frame (1) down to ground. Take off snatch block (7).

GO TO FRAME 3

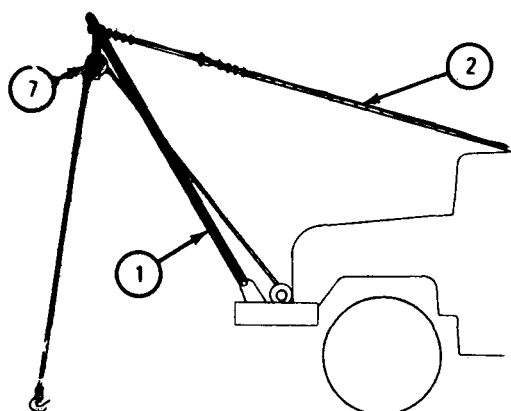

SOLDIERS A AND B

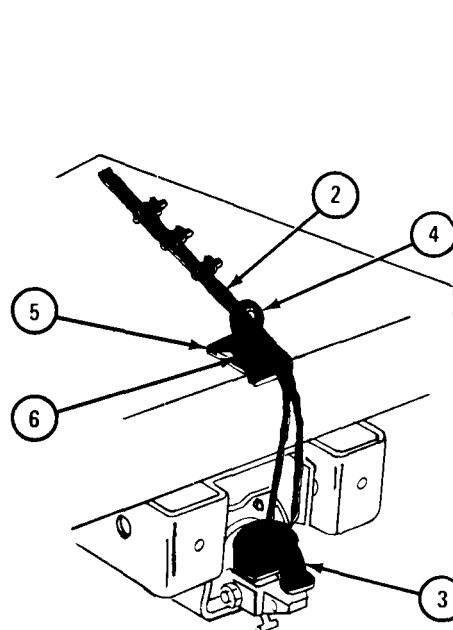

SOLDIER C

TA 080813

FRAME 3

1. Using wrench, unscrew and take off two locknuts (1).
2. Using wrench, unscrew and take off two adjusting nuts (2).
3. Take off two washers (3).
4. Take each end of harness assembly (4) off two spacers (5) and take off two spacers.
5. Take out spreader tube stud (6) and take off spreader tube (7).

END OF TASK

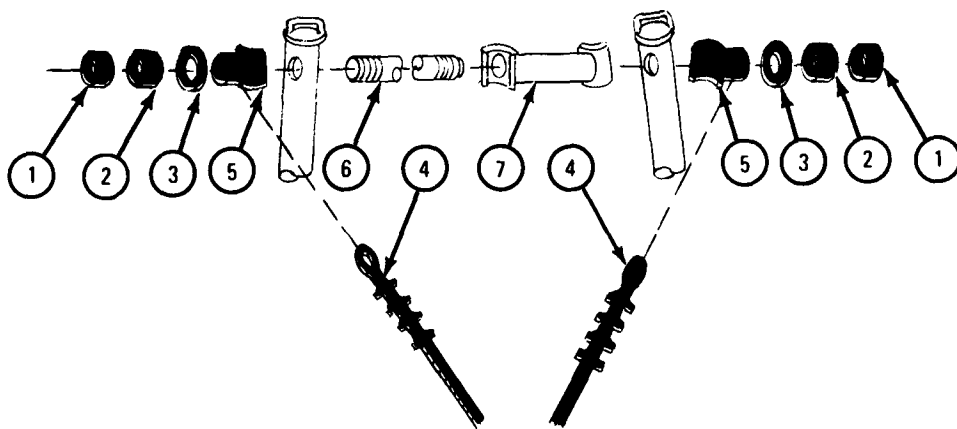

TA 080814

c. Replacement.

FRAME 1

1. Put spreader tube (1) in place between two upper leg tubes (2). Put in spreader stud (3) so that the same number of threads show on each side of upper leg tubes (2).
2. Put on two spacers (4), one on each end of spreader stud (3) as shown.
3. Put looped ends of harness assembly (5) over each spacer (4).
4. Put on two washers (6) and using wrench, screw on and tighten two adjusting nuts (7). Make sure the same number of threads show from each adjusting nut.
5. Using wrench, screw on and tighten two locknuts (8).

GO TO FRAME 2

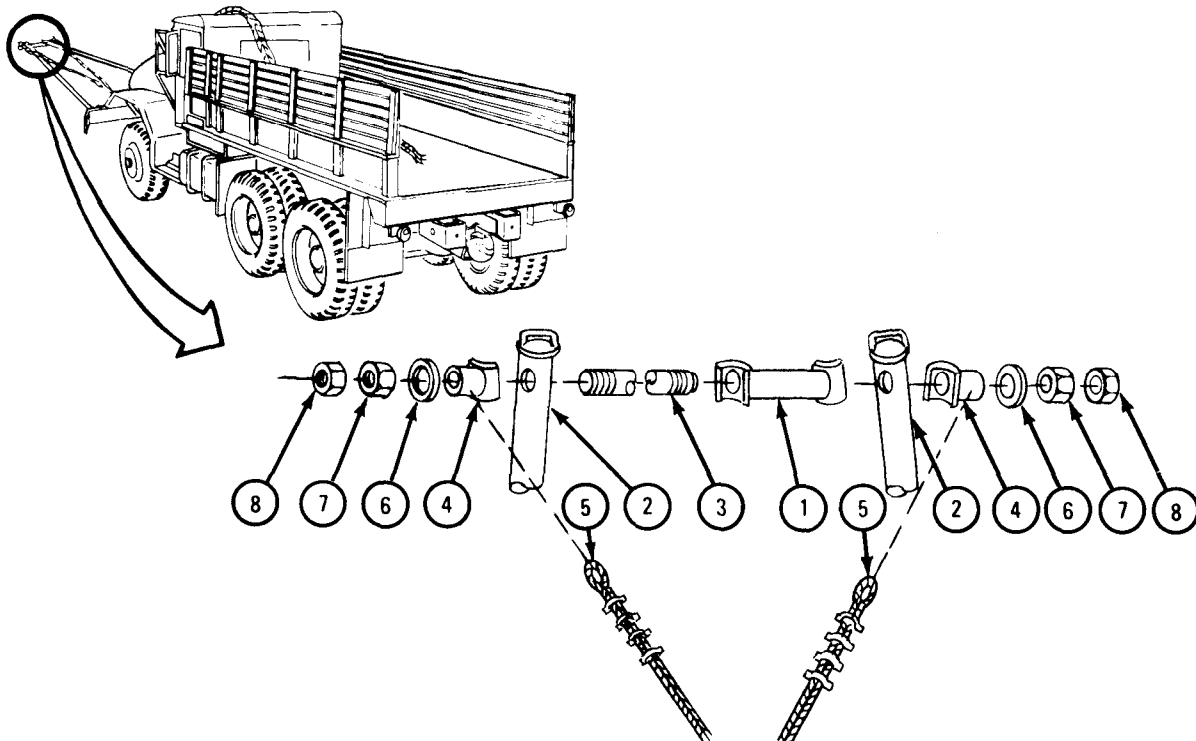

TA 080815

FRAME 2

- Soldier A 1. Hook snatch block (1) on center of spreader tube on A-frame (2).
- Soldiers A and B 2. Lift up A-frame (2) until soldier C has enough slack to put end loop of cable (3) on pintle hook (4) and hold A-frame in place.
- Soldier C 3. When there is enough slack in cable (3), put eyebolt (5) over loop end of cable. Open pintle hook (4) and put looped end of cable around pintle hook as shown.
4. Put washer (6) and plate (7) on back of truck and align screw hole. Put eyebolt (5) in place. Tell soldiers A and B when finished.
- Soldiers A and B 5. Lower A-frame (2) to position shown.
- GO TO FRAME 3

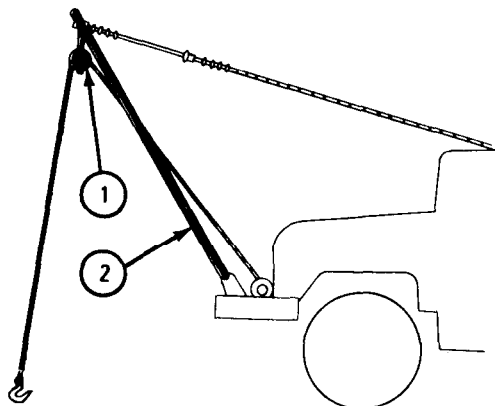

SOLDIERS A AND B

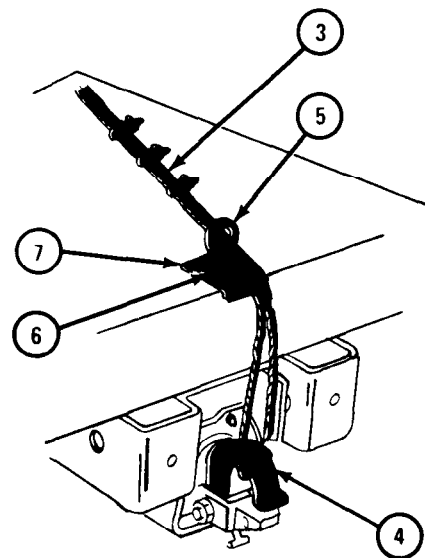

SOLDIER C

TA 080816

FRAME 3

1. Using wrench and pliers, hold eyebolt (1) and screw on and tighten flat washer (2), lockwasher (3), and nut (4).
2. Using wrench, screw in and tighten two adjusting screws (5), one in each leg (6).

NOTE

Follow-on Maintenance Action Required:

Using front winch, raise cable hook off ground. Refer to TM 9-2320-209-10.

END OF TASK

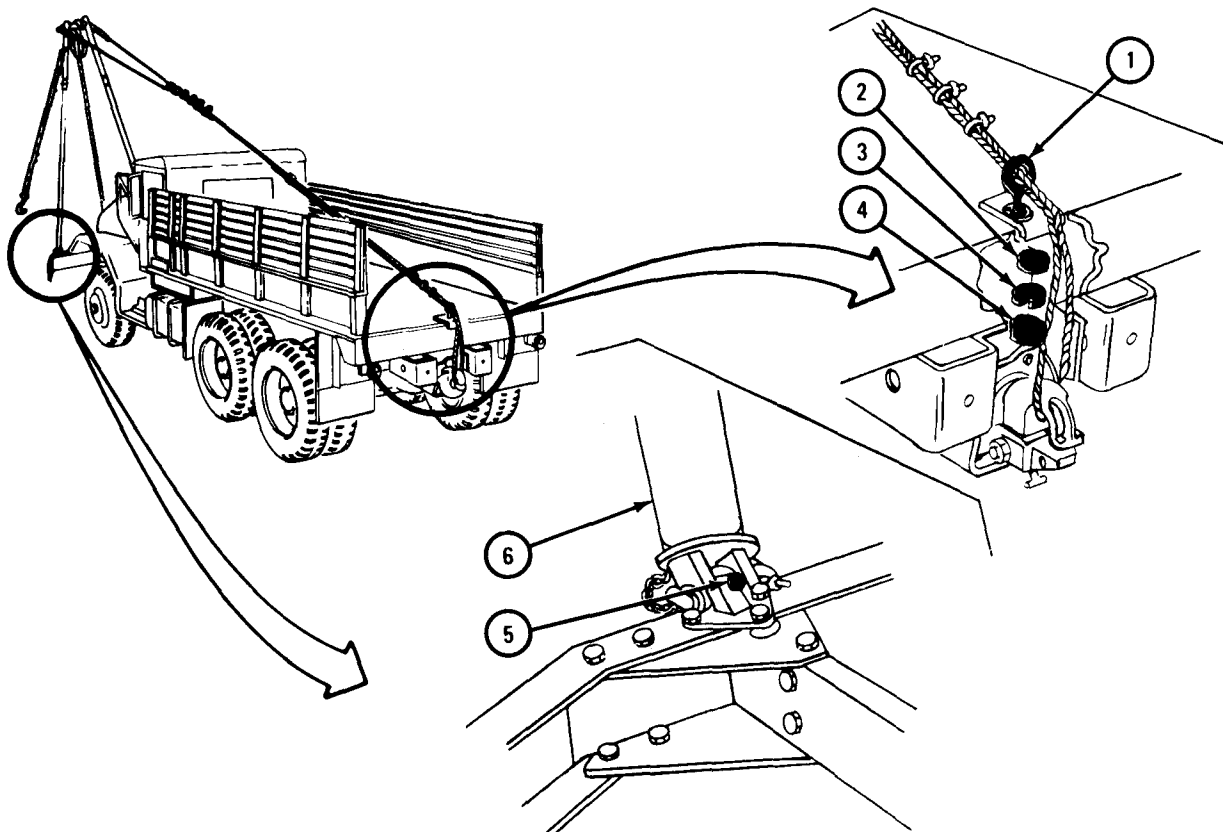

TA 080817

APPENDIX A

REFERENCES

A-1. PUBLICATION INDEXES AND GENERAL REFERENCE.

Indexes should be checked often for the latest changes or revisions of references given in this appendix and for new publications on materiel covered in this technical manual.

a. Military Publications Indexes.

- Index of Army Motion Pictures
and Related Audio-Visual Aids DA Pam 108-1
- Index of Administrative Publications DA Pam 310-1
- Index of Blank Forms DA Pam 310-2
- Index of Doctrinal Training and
Organizational Publications DA Pam 310-3

Military Publications:

- Index of Technical Manuals, Technical
Bulletins, Supply Bulletins, and
Lubrications Orders DA Pam 310-4
- Index of Supply Catalogs and
Supply Manuals (excluding types
7, 8, and 9) DA Pam 310-6
- Index of Modification Work Orders DA Pam 310-7
- Common Tools and Equipment
Supply Manuals DA Supply Manuals
SC-4910-95-CL-A01, A02,
A31, A32, A50, A63,
A64, A65, A67, A68, A72,
A73, and A74

b. General Reference.

- Authorization Abbreviations and Brevity
Codes AR 310-50
- Dictionary of United States Army Terms AR 310-25

A-2. FORMS.

The following forms are for this material. (Refer to DA pamphlet 310-2 for index of blank forms and to TM 38-750 for explanation of their use.)

Recommended Changes to Equipment Publications.....	DA Form 2028-2
Maintenance Request - Continuation Sheet	DA Form 2407-1
Equipment Log Assembly (Records).....	DA Form 2408

A-3. OTHER PUBLICATIONS.

a. Vehicle.

Lubrication Order	LO 9-2320-209-12/1
Operator's Manual	TM 9-2320-209-10-1
Direct Support and General Support Maintenance Manual	TM 9-2320-209-34
Organizational Maintenance Repair Parts and Special Tools List	TM 9-2320-209-20P
Direct Support and General Support Maintenance Repair Parts and Special Tools List	TM 9-2320-209-34P

b. General.

Camouflage of Vehicles	TB 43-0209
Chemical, Biological, and Radiological (CBR) Decontamination	TM 3-220
Chemical, Biological, Radiological, and Nuclear Defense	FM 21-40
Safety Inspection and Testing of Lifting Devices	TB 43-0142
Rigging.	TM 5-725
Accident Reporting and Records	AR 385-40
Basic Cold Weather Manual	FM 31-70
Cooling Systems: Tactical Vehicles	TM 750-254
Manual for the Wheeled Vehicle Driver	TM 21-305
Driver Selection and Training (Wheeled Vehicles)	FM 21-300
Deepwater Fording of Ordnance Materiel	TM 9-238

Fording Kits for Combat and Transport Vehicles MIL-F-3201

Maintenance Assistance and Instruction Team (MAIT) Program AR 750-51

Transportability Guidance, Trucks, 2 1/2 ton, 6x6 TM 55-2320-209-15-1

Army Motor Transport Operations FM 55-30

Mountain Operations FM 31-72

Northern Operations FM 31-71

Operation and Maintenance of Ordnance Materiel in Cold Weather (0°F to -65°F) TM 9-207

Painting Instructions for Field Use TM 43-0139

Petroleum Handling Equipment and Operation TM 10-1101

Preservation-Packaging, Methods of MIL-P-116

Principles of Automotive Vehicles TM 9-8000

Prevention of Motor Vehicle Accidents AR 385-55

Organizational Maintenance: Spark Plugs Used on Ordnance Materiel TM 9-8638

Functional Grouping Codes - Combat, Tactical, and Support Vehicles and Special Purpose Equipment TM 750-93-1

The Army Management System TM 38-750

Administrative Storage of Equipment TM 740-90-1

c. Maintenance and Repair.

Use of Antifreeze Solutions and Cleaning Compounds in Engine Cooling Systems TB 750-651

Organizational Care, Maintenance and Repair of Pneumatic Tires and Inner Tubes TM 9-2610-200-20

Combat Vehicles and Tactical Transport Vehicles: Procedure for Starting Engines With Slave Cable TB ORD 537

Description, Use, Bonding Techniques, and Properties of Adhesives TB ORD 1032

General Supply: Winterization Kits for Army Tank-Automotive Materiel SB 9-16

Inspection, Care and Maintenance of Antifriction Bearings TM 9-214

Operator and Organizational Maintenance Manual for Lead-Acid Storage Batteries	TM 9-6140-200-12
Army Materiel Maintenance Concepts and Policies	AR 750-1
Operator's Manual: Welding Theory and Application	TM 9-237
Operator's and Organizational Maintenance Manual (Including Repair Parts and Special Tools List) For Decontamination Apparatus	TM 3-4230-204-12&P
Materials Used for Cleaning, Preserving, Abrading and Cementing Ordnance Materiel and Related Materials Including Chemicals	TM 9-247

INDEX

Subject	Paragraph	Page
A		
Accelerator controls and linkages	4-29	4-166
Adjustment	4-29e	4-174
Preliminary procedure	4-29a	4-166
Removal	4-29b	4-166
Repair	4-29c	4-169
Replacement	4-29d	4-169
Air cleaner, intake	4-3	4-1
Preliminary procedures	4-3a	4-1
Removal	4-3b	4-2
Repair	4-3c	4-4
Replacement	4-3d	4-4
Air compressor	13-31	13-237
Preliminary procedures	13-31a	13-237
Removal	13-31b	13-238
Replacement	13-31c	13-242
Air compressor service	13-32	13-247
Assembly	13-32d	13-249
Disassembly and service	13-32c	13-248
Preliminary procedure	13-32a	13-247
Removal	13-32b	13-247
Replacement	13-32e	13-250
Air hydraulic cylinder	13-14	13-107
Preliminary procedure	13-14a	13-107
Removal	13-14b	13-107
Replacement	13-14c	13-112
Air reservoirs, truck M35A1	13-30	13-229
Preliminary procedures	13-30a	13-229
Removal	13-30b	13-229
Replacement	13-30c	13-233
Air reservoirs, truck M764	13-29	13-217
Preliminary procedures	13-29a	13-217
Removal	13-29b	13-217
Replacement	13-29c	13-223
Air reservoirs, trucks M275A1, M275A2, and M342A2	13-26	13-183
Preliminary procedures	13-26a	13-183
Removal	13-26b	13-183
Replacement	13-26c	13-187
Air reservoirs, trucks M35A2C, M50A2, M109A3, and M756A2	13-28	13-203
Preliminary procedures	13-28a	13-203
Removal	13-28b	13-203
Replacement	13-28c	13-210

INDEX - CONT

Subject	Paragraph	Page
A - Cont		
Air reservoirs, trucks M49A1C and M49A2C	13-27	13-191
Preliminary procedures	13-27a	13-191
Removal	13-27b	13-191
Replacement	13-27c	13-197
Air system leakage test	1-5	1-2
Alinement, front wheel	15-3	15-1
Preliminary procedures	15-3a	15-1
Toe-in check and adjustment	13-3b	15-2
Alternator and pulley	7-4	7-14
Preliminary procedures	7-4a	7-14
Removal	7-4b	7-14
Replacement	7-4c	7-20
Axle shaft assembly, front	11-5	11-12
Preliminary procedures	11-5a	11-12
Removal	11-5b	11-12
Replacement	11-5c	11-14
Axle shaft, rear	12-3	12-1
Removal	12-3a	12-1
Replacement	12-3b	12-3
B		
Batteries, servicing the	7-55	7-204
Cleaning the batteries	7-55c	7-207
Preliminary procedure	7-55a	7-204
Specific gravity check	7-55b	7-204
Batteries, storage	7-56	7-209
Removal	7-56a	7-209
Replacement	7-56b	7-212
Battery box heater pad repair	23-22	23-64
Preliminary procedures	23-22a	23-64
Removal	23-22b	23-65
Replacement	23-22c	23-69
Battery ground cable	7-58	7-223
Disconnect	7-58a	7-223
Reconnect	7-58b	7-225
Blackout drive light assembly repair	7-24	7-117
Preliminary procedures	7-24a	7-117
Cleaning, Inspection, and Repair	7-24b	7-118
Blower assembly, exhaust, trucks M109A2 and M109A3	18-74	18-393
Removal	18-74a	18-393
Replacement	18-74b	18-395
Blower motor, hot water personnel heater, repair	23-20	23-56
Preliminary procedure	23-20a	23-56
Removal	23-20b	23-56
Replacement	23-20c	23-57

INDEX -CONT

Sub ject	Paragraph	Page
B - Cont		
Bow assembly repair	21-3	21-1
Assembly	21-3d	21-3
Cleaning	21-3b	21-3
Disassembly	21-3a	21-2
Inspection and repair	21-3c	21-3
Brace, safety, dump body, truck, M342A2	19-24	19-127
Locking	19-24a	19-127
Unlocking	19-24b	19-128
Bracket, mounting, decontamination apparatus	23-32	23-120
Preliminary procedure	23-32a	23-120
Removal	23-32b	23-120
Replacement	23-32c	23-123
Brake pedal	13-17	13-134
Preliminary procedure	13-17a	13-134
Removal	13-17b	13-134
Replacement	13-17c	13-139
Brake pedal adjustment, service	13-19	13-146
Brake pedal pad	13-18	13-144
Removal	13-18a	13-144
Replacement	13-18b	13-145
Brake shoe assembly, service	13-8	13-49
Preliminary procedure	13-8a	13-49
Removal	13-8b	13-49
Replacement	13-8c	13-54
Brakes, major adjustment service	13-10	13-63
Brakes, minor adjustment, service	13-9	13-61
Brake system, service, bleeding, using bleeder tank	13-15	13-117
Bleeding air hydraulic cylinder	13-15b	13-120
Bleeding wheel cylinders	13-15c	13-122
Connecting bleeding tank	13-15a	13-117
Disconnecting bleeder tank	13-15d	13-124
Brake system, service, bleeding, without using bleeder tank	13-16	13-127
Bleeding air hydraulic cylinder	13-16b	13-128
Bleeding wheel cylinders	13-16c	13-131
Filling master cylinder	13-16a	13-127
Breather tube, crankcase	2-6	2-19
Preliminary procedure	2-6a	2-19
Removal	2-6b	2-19
Replacement	2-6c	2-24
Breather valve, axle, rear	12-4	12-4
Removal	12-4a	12-4
Replacement	12-4b	12-5
Buzzer, low air pressure	7-51	7-188
Removal	7-51a	7-188
Replacement	7-51b	7-189

INDEX - CONT

Subject	Paragraph	Page
C		
Cab door	18-3	18-1
Removal	18-3a	18-2
Replacement	18-3b	18-3
Cab door, repair	18-4	18-4
Assembly	18-4c	18-7
Disassembly	18-4a	18-4
Repair	18-4b	18-7
Cable and chain assembly, front, mid, and rear winch	19-10	19-48
Assembly (early models)	19-10g	19-54
Assembly (late models)	19-10h	19-55
Cleaning	19-10e	19-53
Inspection and repair	19-10f	19-53
Disassembly (early models)	19-10c	19-50
Disassembly (late models)	19-10d	19-51
Preliminary procedure	19-10a	19-48
Removal	19-10b	19-49
Replacement	19-10i	19-59
Cable, emergency release	18-24	18-94
Removal	18-24a	18-95
Replacement	18-24b	18-97
Cable, rear winch, truck M764	19-11	19-60
Preliminary procedure	19-11a	19-60
Removal	19-11b	19-60
Replacement	19-11c	19-62
Cab protector upper section, truck M764	18-83	18-441
Preliminary procedures	18-83a	18-441
Removal	18-83b	18-441
Replacement	18-83c	18-442
Cab tunnel	18-5	18-10
Removal, front intermediate, and rear tunnels	18-5a	18-10
Replacement, front, intermediate, and rear tunnels	18-5b	18-12
Carriage cross chain, truck M764	19-15	19-76
Preliminary procedure	19-15a	19-76
Removal	19-15b	19-76
Replacement	19-15c	19-80
Carriage travel adjustment, truck M764	19-16	19-83
Adjustment	19-16b	19-83
Preliminary procedure	19-16a	19-83
Circuit breaker	7-16	7-86
Preliminary procedures	7-16a	7-86
Removal	7-16b	7-86
Replacement	7-16c	7-87
Circuit breaker, 115-volt	18-70	18-371
Removal	18-70a	18-371
Replacement	18-70b	18-373

INDEX - CONT

Subject	Paragraph	Page
C - Cont		
Circuit breaker, 24-volt	18-69	18-369
Preliminary procedure	18-69a	18-369
Removal	18-69b	18-369
Replacement	18-69c	18-370
Cleaning	1-3	1-1
Clutch control and linkage	3-3	3-1
Adjustment	3-3e	3-15
Preliminary procedures	3-3a	3-1
Removal	3-3b	3-2
Repair	3-3c	3-7
Replacement	3-3d	3-7
Clutch lever and guide plate, rear winch drum, truck M756A2	19-9	19-43
Assembly	19-9c	19-46
Disassembly	19-9b	19-44
Removal	19-9a	19-43
Replacement	19-9d	19-47
Control cables, fuel burning personnel heater, repair and adjustment	23-8	23-17
Adjustment	23-8d	23-21
Removal	23-8a	23-17
Repair	23-8b	23-19
Replacement	23-8c	23-19
Control cables, hot water personnel heater, repair and adjustment	23-16	23-45
Control lever linkage, rear winch, adjustment, truck M764	19-6	19-20
Control linkage, hydraulic hoist, truck M342A2	19-23	19-120
Removal	19-23a	19-120
Replacement and adjustment	19-23b	19-123
Controls and linkage, power divider, truck M764	19-26	19-133
Adjustment	19-26d	19-140
Preliminary procedure	19-26a	19-133
Removal	19-26b	19-133
Replacement	19-26c	19-136
Control valve, deep water fording kit	23-30	23-111
Preliminary procedure	23-30a	23-111
Removal	23-30b	23-112
Repair	23-30c	23-113
Replacement	23-30d	23-115
Cooling system service	6-10	6-49
Cleaning	6-10c	6-51
Draining	6-10b	6-50
Filling	6-10f	6-73
Flushing	6-10d	6-54
Neutralization	6-10e	6-67
Preliminary procedure	6-10a	6-49

INDEX - CONT

Subject	Paragraph	Page
C - Cont		
Cover, hood, side panel, and radiator, winterization kit	23-23	23-73
Removal	23-23a	23-73
Replacement	23-23b	23-76
Cover, manhole, trucks M49A1C and M49A2C	18-51	18-259
Removal	18-51a	18-259
Replacement	18-51b	18-260
Cover, manhole, repair	18-52	18-261
Assembly	18-52d	18-262
Disassembly	18-52b	18-261
Inspection and repair	18-52c	18-262
Preliminary procedure	18-52a	18-261
Cover, manhole, truck M50A3	18-63	18-352
Removal	18-63a	18-352
Repair	18-63b	18-353
Replacement	18-63c	18-354
Cover, manhole, trucks M50A1 and M50A2	18-62	18-343
Removal, inner manhole cover	18-62b	18-344
Removal, outer manhole cover	18-62a	18-343
Repair, inner manhole cover	18-62c	18-345
Repair, outer manhole cover	18-62d	18-347
Replacement, inner manhole cover	18-62e	18-348
Replacement, outer manhole cover	18-62f	18-351
Cover seal and air vent, transmission transfer output	9-7	9-51
Preliminary procedure	9-7a	9-51
Removal	9-7b	9-51
Replacement	9-7c	9-52
Cover, water tank filler, trucks M50A1, M50A2, and M50A3	18-64	18-357
Cleaning	18-64b	18-358
Inspection and repair	18-64c	18-358
Removal	18-64a	18-357
Replacement	18-64d	18-358
Cutoff cocks and couplings, air brake, all trucks except M764	13-39	13-270
Preliminary procedures	13-39a	13-270
Removal	13-39b	13-271
Replacement	13-39c	13-273
Cutoff cocks and couplings, air brake, truck M764	13-40	13-275
Preliminary procedures	13-40a	13-275
Removal	13-40b	13-276
Replacement	13-40c	13-277

D

Data plates	21-7	21-24
Removal	21-7a	21-25
Replacement	21-7b	21-29
Destruction to prevent enemy use	1-14	1-5

INDEX - CONT

Subject	Paragraph	Page
D - Cont		
Directional signal and solid state flasher	7-63	7-242
Preliminary procedures	7-63a	7-242
Removal	7-63b	7-242
Repair	7-63c	7-244
Replacement	7-63d	7-246
Door assembly, van trucks M109A2, M109A3, M185A2, and M185A3	18-75	18-397
Preliminary Procedure	18-75a	18-397
Removal	18-75b	18-397
Replacement	18-75c	18-400
Door repair, van, trucks M109A2, M109A3, M185A2, and M185A3	18-77	18-406
Assembly	18-77e	18-416
Cleaning	18-77c	18-413
Disassembly	18-77b	18-407
Inspection and repair	18-77d	18-414
Preliminary procedure	18-77a	18-406
Door seals, trucks M109A2, M109A3, M185A2, and M185A3	18-76	18-403
Removal	18-76a	18-403
Replacement	18-76b	18-405
Drag link adjustment	15-9	15-30
Drag link assembly	15-7	15-22
Preliminary procedure	15-7a	15-22
Removal	15-7b	15-22
Replacement	15-7c	15-25
Drag link assembly repair	15-8	15-29
Drive belt, air compressor	13-34	13-258
Preliminary procedures	13-34a	13-258
Removal	13-34b	13-258
Replacement and adjustment	13-34c	13-259
Drive belt and pulley, air compressor	13-33	13-251
Preliminary procedures	13-33a	13-251
Removal	13-33b	13-252
Replacement	13-33c	13-254
Drive belts, fan	6-9	6-44
Preliminary procedure	6-9a	6-44
Removal	6-9b	6-44
Replacement and adjustment	6-9c	6-46
Drive chain, cable level winder, repair, truck M764	19-19	19-101
Preliminary procedure	19-19a	19-101
Repair	19-19b	19-101
Drive chain, horizontal leveling worm, truck M764	18-78	18-422
Removal	18-78a	18-422
Replacement	18-78b	18-425

INDEX - CONT

Subject	Paragraph	Page
D - Cont		
Drive chain, leveling worm, adjustment	18-80	18-434
Adjustment	18-80b	18-435
Preliminary procedure	18-80a	18-434
Drive chain, rear winch, truck M756A2	19-13	19-68
Cleaning	19-13b	19-69
Inspection and repair	19-13c	19-69
Removal	19-13a	19-68
Replacement	19-13d	19-69
Drive chain, rear winch, adjustment, truck M756A2	19-14	19-70
Adjustment	19-14b	19-70
Preliminary procedure	19-14a	19-70
Drive chain, roller, repair	18-81	18-436
Preliminary procedures	18-81a	18-436
Repair	18-81b	18-437
Drive chain, vertical leveling worm, truck M764	18-79	18-428
Removal	18-79a	18-428
Replacement	18-79b	18-431
Drive chains, reduction, truck M764	19-17	19-86
Removal	19-17a	19-86
Replacement	19-17b	19-91
Drive chains, reduction, adjustment, truck M764	19-18	19-95
First reduction drive chain	19-18a	19-95
Second reduction drive chain	19-18b	19-98
Drive shaft assembly, earth boring machine	18-82	18-438
Removal	18-82a	18-438
Replacement	18-82b	18-439
Drive shaft bearing and journal universal, pump	18-36	18-167
Preliminary procedure	18-36a	18-167
Removal	18-36b	18-167
Replacement	18-36c	18-170
Drive shaft, delivery pump	18-59	18-323
Removal	18-59a	18-323
Repair	18-59b	18-328
Replacement	18-59c	18-330
Ducting, fuel burning personnel heater, repair	23-4	23-4
Preliminary procedure	23-4a	23-4
Removal	23-4b	23-4
Repair	23-4c	23-5
Replacement	23-4d	23-5
Ducting, hot water personnel heater, repair	23-14	23-45

INDEX - CONT

Subject	Paragraph	Page
E		
Electrical cable, trailer connector	7-60	7-230
Removal	7-60a	7-230
Replacement	7-60b	7-231
Electric coupling receptacle, trailer	7-61	7-232
Removal	7-61a	7-232
Replacement	7-61b	7-234
Electrical coupling receptacle, trailer, trucks M275A1 and M275A2	7-62	7-236
Removal	7-62a	7-236
Replacement	7-62b	7-239
Engine mounts, rear	2-4	2-10
Preliminary procedure	2-4a	2-10
Removal	2-4b	2-10
Replacement	2-4c	2-12
Engine mounts, front	2-3	2-1
Identification of engine mounts	2-3b	2-2
Preliminary procedure	2-3a	2-1
Removal, basic type	2-3c	2-3
Removal, revised type	2-3e	2-6
Replacement, basic type	2-3d	2-5
Replacement, revised type	2-3f	2-8
Engine stop controls and linkages	4-30	4-175
Adjustment	4-30e	4-179
Preliminary procedure	4-30a	4-175
Removal	4-30b	4-175
Repair	4-30c	4-177
Replacement	4-30d	4-177
Equipment improvement report and maintenance digest (EIR MD) and equipment improvement report and maintenance summary (EIR MS)	1-11	1-2
Exhaust extension, deep water fording kit	23-28	23-103
Removal	23-28a	23-103
Repair	23-28b	23-105
Replacement	23-28c	23-106
Exhaust system, clean air	5-7	5-76
Preliminary procedure	5-7a	5-76
Removal	5-7b	5-76
Replacement	5-7c	5-83
Exhaust system, horizontal, engine LD-427	5-5	5-45
Preliminary procedures	5-5a	5-45
Removal	5-5b	5-45
Replacement	5-5c	5-50
Exhaust system, horizontal, engine LD-465	5-3	5-1
Preliminary procedure	5-3a	5-1
Removal	5-3b	5-2
Replacement	5-3c	5-10

INDEX - CONT

Subject	Paragraph	Page
E - Cont		
Exhaust system, horizontal, trucks M50A1, M50A2, and M50A3	5-4	5-17
Preliminary procedure	5-4a	5-17
Removal	5-4b	5-18
Replacement	5-4c	5-30
Exhaust system, vertical stack, engines LD-465-1, LD-465-1C, and LDT-465-1C except for trucks M50A2 and M50A3	5-6	5-55
Preliminary procedure	5-6a	5-55
Removal	5-6b	5-55
Replacement	5-6c	5-64
Exhaust tube and clamps, fuel burning personnel heater repair	23-7	23-13
Preliminary procedure	23-7a	23-13
Removal	23-7b	23-13
Replacement	23-7c	23-15
Exhaust tube, power plant heater	23-12	23-30
Preliminary procedures	23-12a	23-30
Removal	23-12b	23-30
Replacement	23-12c	23-33
F		
Fan, engine cooling	6-8	6-42
Preliminary procedures	6-8a	6-42
Removal	6-8b	6-42
Replacement	6-8c	6-43
Fifth wheel assembly	16-11	16-48
Removal	16-11a	16-48
Replacement	16-11b	16-50
Filter element, water segregator, truck M49A1C	18-41	18-198
Removal	18-41a	18-199
Replacement	18-41b	18-207
Filters, water segregator, and go/no-go fuses, truck M49A2C	18-42	18-215
Cleaning	18-42b	18-219
Removal	18-42a	18-215
Replacement	18-42c	18-219
Floodlight and bracket assembly, truck M756A2	7-37	7-149
Cleaning, inspection, and repair	7-37b	7-150
Removal	7-37a	7-149
Replacement	7-37c	7-150
Floodlight housing, truck M756A2	7-38	7-151
Cleaning, inspection, and repair	7-38c	7-152
Preliminary procedure	7-38a	7-151
Removal	7-38b	7-151
Replacement	7-38d	7-153

INDEX - CONT

Subject	Paragraph	Page
F - Cont		
Floodlight sealed beam	7-39	7-154
Cleaning, inspection, and repair	7-39b	7-156
Removal	7-39a	7-154
Replacement	7-39c	7-156
Forms and records	1-10	1-2
Front wheel and brake drum assembly	14-3	14-1
Preliminary procedure	14-3a	14-1
Removal	14-3b	14-1
Replacement	14-3c	14-6
Fuel filter assemblies	4-10	4-55
Air bleeding of low pressure fuel system	4-10f	4-61
Preliminary procedures	4-10a	4-55
Removal of primary fuel filter assembly	4-10b	4-55
Removal of secondary and final fuel filter assemblies	4-10c	4-57
Replacement of secondary and final fuel filter assemblies	4-10e	4-60
Fuel filter, manifold heater, side-mounted	4-15	4-77
Preliminary procedure	4-15a	4-77
Removal	4-15b	4-78
Replacement	4-15c	4-82
Fuel filter, manifold heater, top-mounted, covered	4-24	4-129
Preliminary procedure	4-24a	4-129
Removal	4-24b	4-129
Replacement	4-24c	4-130
Fuel filters repair	4-11	4-63
Assembly of primary fuel filter	4-11e	4-67
Assembly of secondary and final fuel filters	4-11f	4-69
Cleaning, inspection, and repair	4-11d	4-67
Disassembly of primary fuel filter	4-11b	4-63
Disassembly of secondary and final fuel filters	4-11c	4-65
Preliminary procedure	4-11a	4-63
Fuel filters, winterization kit, repair	23-10	23-24
Cleaning and inspection	23-10c	23-26
Preliminary procedures	23-10a	23-24
Removal	23-10b	23-25
Repair	23-10d	23-26
Replacement	23-10e	23-27
Fuel lines and fittings	4-5	4-8
Removal	4-5a	4-9
Replacement	4-5b	4-19
Fuel pump, in-tank	4-8	4-46
Preliminary procedures	4-8a	4-46
Removal	4-8b	4-46
Replacement	4-8c	4-48

INDEX - CONT

Subject	Paragraph	Page
F - Cont		
Fuse, fuel pump, in-tank	4-9	4-51
Removal	4-9a	4-51
Replacement	4-9b	4-53
Fuse, power switch, trucks M185A2 and M185A3	18-68	18-367
Preliminary procedures	18-68a	18-367
Removal	18-68b	18-367
Replacement	18-68c	18-368
Fusible link	18-30	18-125
Removal	18-30a	18-125
Replacement	18-30b	18-127
G		
Gasoline drum bracket	18-14	18-46
Removal	18-14a	18-46
Replacement	18-14b	18-47
Generator and pulley	7-3	7-1
Polarization	7-3d	7-11
Preliminary procedures	7-3a	7-1
Removal	7-3b	7-2
Replacement	7-3c	7-6
Generator-regulator	7-5	7-27
Preliminary procedures	7-5a	7-27
Removal	7-5b	7-27
Replacement	7-5c	7-28
Gin pole and clamp A-frame, truck M756A2	18-88	18-475
Preliminary procedure	18-88a	18-475
Removal	18-88b	18-476
Repair	18-88c	18-479
Replacement	18-88d	18-479
Governor, air compressor, pressure check and adjustment	13-36	13-264
Adjustment, air pressure less than 105 psi	13-36c	13-266
Adjustment, air pressure more than 105 psi	13-36b	13-265
Pressure check	13-36a	13-264
Governor assembly, air compressor	13-35	13-260
Preliminary procedures	13-35a	13-260
Removal	13-35b	13-260
Replacement	13-35c	13-262
Ground straps	7-57	7-217
Removal	7-57a	7-217
Replacement	7-57b	7-220
H		
Handbrake brake drum	13-3	13-1
Preliminary procedure	13-3a	13-1
Removal	13-3b	13-2

INDEX - CONT

Subject	Paragraph	Page
H - Cont		
Replacement	13-3c	13-6
Handbrake brakeshoes	13-4	13-10
Removal	13-4a	13-10
Replacement	13-4b	13-14
Handbrake cable and lever assembly adjustment	13-7	13-43
Handbrake cable assembly	13-5	13-18
Preliminary procedure	13-5a	13-18
Removal of overcenter locking handbrake lever cable	13-5b	13-18
Removal of ratchet and pawl handbrake lever cable	13-5c	13-23
Replacement of overcenter locking handbrake lever cable	13-5d	13-27
Replacement of ratchet and pawl handbrake lever cable	13-5e	13-32
Handbrake lever assembly	13-6	13-37
Removal	13-6a	13-37
Replacement	13-6b	13-40
Hand control assembly, pressurization valve, deep water fording kit	23-31	23-116
Preliminary procedure	23-31a	23-116
Removal	23-31b	23-116
Replacement	23-31c	23-118
Harness, generator-to-regulator, engines LDS 427-2, LD 465-1, and LDT 465- 1C	7-59	7-227
Preliminary procedure	7-59a	7-227
Removal	7-59b	7-227
Repair	7-59c	7-228
Replacement	7-59d	7-229
Headlight assembly, front service	7-17	7-88
Preliminary procedure	7-17a	7-88
Removal	7-17b	7-88
Replacement	7-17c	7-89
Headlight, assembly, front service, adjustment	7-19	7-95
Headlight, assembly, front service, repair	7-18	7-90
Assembly	7-18d	7-93
Cleaning, inspection, and repair	7-18c	7-92
Disassembly	7-18b	7-90
Preliminary procedures	7-18a	7-90
Headlight guard	20-3	20-1
Removal	20-3a	20-2
Replacement	20-3b	20-3
Heater air diverter repair, hot water personnel heater	23-15	23-45
Heater assembly, van body personnel, repair, trucks M109A2 and M109A3	23-25	23-87
Preliminary procedures	23-25a	23-87
Removal	23-25b	23-87
Replacement	23-25c	23-90
Heater duct, van body personnel, trucks M109A2 and M109A3	23-26	23-93
Removal	23-26a	23-93
Replacement	23-26b	23-94

INDEX - CONT

Subject	Paragraph	Page
H - Cont		
Heater, fuel burning personnel, air diverter repair	23-5	23-7
Preliminary procedure	23-5a	23-7
Removal	23-5b	23-7
Replacement	23-5c	23-8
Heater, fuel burning personnel, air inlet adapter repair	23-6	23-9
Preliminary procedure	23-6a	23-9
Removal	23-6b	23-9
Replacement	23-6c	23-11
Heater motor resistor, hot water personnel heater	23-19	23-54
Preliminary procedure	23-19a	23-54
Removal	23-19b	23-54
Replacement	23-19c	23-55
Heater, vehicular compartment	23-3	23-1
Preliminary procedures	23-3a	23-1
Removal	23-3b	23-2
Replacement	23-3c	23-3
Horn, air, and solenoid	7-53	7-197
Preliminary procedures	7-53a	7-197
Removal	7-53b	7-197
Replacement	7-53c	7-199
Horn button	7-52	7-190
Cleaning	7-52d	7-193
Preliminary procedure	7-52a	7-190
Removal	7-52b	7-190
Repair	7-52c	7-193
Replacement	7-52c	7-193
Horn electric	7-54	7-202
Preliminary procedure	7-54a	7-202
Removal	7-54b	7-202
Replacement	7-54c	7-203
Hose, air brake	13-41	13-278
Preliminary procedure	13-41a	13-278
Removal	13-41b	13-278
Replacement	13-41c	13-281
Hose, air brake, repair	13-42	13-283
Preliminary procedure	13-42a	13-283
Repair	13-42b	13-283
Hose and nozzle assembly	18-48	18-245
Removal	18-48a	18-245
Replacement	18-48b	18-248
Hose assembly, dispenser, trucks M50A1, M50A2, and M50A3	18-60	18-337
Removal	18-60a	18-337
Replacement	18-60b	18-338
Hose coupling gasket, truck M49A1C	18-49	18-251
Removal	18-49a	18-251
Replacement	18-49b	18-253

INDEX - CONT

Subject	Paragraph	Page
H - Cont		
Hose coupling gasket, truck M49A2C	18-50	18-255
Removal	18-50a	18-255
Replacement	18-50b	18-257
Hose, pump-to-manifold, trucks M49A1C and M49A2C	18-38	18-181
Removal	18-38a	18-181
Replacement	18-38b	18-184
Hoses and clamps	6-5	6-20
Cooling system hoses and clamps	6-5a	6-20
Turbocharger system hoses and clamps	6-5b	6-27
Hoses and clamps, personnel hot water heater	23-18	23-50
Preliminary procedure	23-18a	23-50
Removal	23-18b	23-50
Replacement	23-18c	23-52
Hoses and clamps, powerplant coolant heater	23-13	23-36
Preliminary procedures	23-13a	23-36
Removal	23-13b	23-37
Replacement	23-13c	23-41
Hoses and fittings, hydraulic, outrigger.	18-84	18-443
Preliminary procedure	18-84a	18-443
Removal	18-84b	18-444
Replacement	18-84c	18-451
Hoses, water discharge, dispenser nozzle, and suction strainer, trucks M50A1, M50A2, and M50A3	18-61	18-339
Preliminary procedure	18-61a	18-339
Removal	18-61b	18-339
Replacement	18-61c	18-341
Hub and brake drum assembly, front	14-4	14-11
Preliminary procedure	14-4a	14-11
Removal	14-4b	14-11
Replacement	14-4c	14-15
Hub and brake drum assembly, rear	14-9	14-55
Preliminary procedure	14-9a	14-55
Removal	14-9b	14-55
Replacement	14-9c	14-59
Hub and brake drum assembly, repair, front and rear	14-5	14-20
Front hub and drum	14-5b	14-20
Preliminary procedure	14-5a	14-20
Rear and hub and drum	14-5c	14-26
Hydraulic lines and fittings, outrigger, truck M764	18-84	18-443
Preliminary procedure	18-84a	18-443
Removal	18-84b	18-444
Replacement	18-84c	18-451
Hydraulic lines, flexible	19-22	19-113
Preliminary procedure	19-22a	19-113
Removal	19-22b	19-114
Replacement	19-22c	19-117

INDEX - CONT

Subject	Paragraph	Page
H - Cont		
Hydraulic lines, hoses, and fittings	13-13	13-87
Removal	13-13a	13-88
Replacement	13-13b	13-97

I

Ignition coil and fuel pump manifold heater, top-mounted, covered, engine LD 465-1C	4-27	4-150
Preliminary procedures	4-27a	4-150
Removal	4-27b	4-151
Replacement	4-27c	4-154
Ignition unit, manifold heater, engines LD 427-2 and LDS 465-1...	4-22	4-123
Preliminary procedure	4-22a	4-123
Removal	4-22b	4-123
Replacement	4-22c	4-125
Ignition unit, manifold heater, top-mounted, uncovered	4-13	4-73
Preliminary procedures	4-13a	4-73
Removal	4-13b	4-73
Replacement	4-13c	4-74
Indicator air cleaner	4-4	4-6
Removal	4-4a	4-6
Replacement	4-4b	4-7
Instrument cluster components, except speedometer and tachometer	7-13	7-74
Preliminary procedures	7-13a	7-74
Removal	7-13b	7-74
Replacement	7-13c	7-76
Instrument cluster	7-12	7-64
Preliminary procedure	7-12a	7-64
Removal	7-12b	7-64
Replacement	7-12c	7-69

J

Jack assembly, stiffleg, truck M756A2	18-94	18-517
Removal	18-94a	18-517
Repair	18-94b	18-519
Replacement	18-94c	18-519
Jacking and supporting axle housing	11-3	11-1
Jacking and supporting front axle housing	11-3a	11-2
Jacking and supporting rear axle housing	11-3c	11-4
Removal of front axle housing supports	11-3b	11-3
Removal of rear axle housing supports	11-3d	11-5
Jacking and supporting truck chassis	11-4	11-6
Lowering front chassis	11-4b	11-7
Raising front chassis	11-4a	11-6
Lowering rear of chassis, both sides	11-4f	11-11

INDEX - CONT

Subject	Paragraph	Page
J - Cont		
Raising rear of chassis, both sides	11-4e	11-10
Lowering rear of chassis, one side	11-4d	11-9
Raising rear of chassis, one side	11-4c	11-8
L		
Lamp, blackout stoplight, right side only, early model trucks with turn signals	7-32	7-135
Removal	7-32a	7-135
Replacement	7-32b	7-136
Lamp, dome light, 115-volt, trucks M109A2, M109A3, M185A2, and M185A3	18-67	18-365
Preliminary procedure	18-67a	18-365
Removal	18-67b	18-365
Replacement	18-67c	18-366
Lamp, dome light, 24-volt, trucks M109A2, M109A3, M185A2, and M185A3	18-66	18-363
Preliminary procedures	18-66a	18-363
Removal	18-66b	18-363
Replacement	18-66c	18-364
Lamp, indicator, heater control box, personnel and engine.	23-9	23-22
Removal	23-9a	23-22
Replacement	23-9b	23-23
Lamps, clearance, service and blackout	7-47	7-179
Removal	7-47a	7-179
Replacement	7-47b	7-180
Lamps, composite, front	7-41	7-163
Removal	7-41a	7-163
Replacement	7-41b	7-164
Lamps, composite, rear	7-45	7-173
Removal	7-45a	7-173
Replacement	7-45b	7-174
Lamps, front, marker	7-35	7-144
Removal	7-35a	7-144
Replacement	7-35b	7-145
Lamps, taillight and stoplight, left side only	7-29	7-128
Removal	7-29a	7-128
Replacement	7-29b	7-129
Lamps, taillight and stoplight, right side only	7-27	7-124
Removal	7-27a	7-124
Replacement	7-27b	7-125
Lifting devices, safety inspection and testing	1-9	1-2
Lifting shackle, front	16-3	16-1
Preliminary procedure	16-3a	16-1
Removal	16-3b	16-2
Replacement	16-3c	16-5

INDEX - CONT

Subject	Paragraph	Page
L - Cont		
Lifting shackle, rear	16-4	16-8
Removal	16-4a	16-8
Replacement	16-4b	16-9
Light and bracket assembly, front marker	7-34	7-139
Removal	7-34a	7-139
Replacement	7-34b	7-141
Light assembly and bracket, blackout drive, trucks without winch	7-22	7-109
Preliminary procedure	7-22a	7-109
Removal	7-22b	7-109
Replacement	7-22c	7-111
Light assembly and bracket, blackout drive, trucks with winch	7-21	7-104
Preliminary procedure	7-21a	7-104
Removal	7-21b	7-104
Replacement	7-21c	7-106
Light, front composite, and bracket assembly	7-40	7-158
Removal	7-40a	7-158
Replacement	7-40b	7-160
Light, front composite, repair	7-42	7-165
Preliminary procedures	7-42a	7-165
Cleaning, Inspection, and Repair	7-42b	7-166
Light, rear composite, and bracket assembly	7-43	7-167
Preliminary procedure	7-43a	7-167
Removal	7-43b	7-167
Replacement	7-43c	7-169
Light, rear composite, repair	7-44	7-171
Preliminary procedures	7-44a	7-171
Cleaning, Inspection, and Repair	7-44b	7-172
Light, dome, assemblies, 24-volt and 115-volt, trucks M109A2, M109A3, M185A2, and M185A3	18-65	18-359
Preliminary procedures	18-65a	18-359
Removal	18-65b	18-359
Replacement	18-65c	18-361
Light, front marker, repair	7-36	7-146
Assembly	7-36d	7-148
Cleaning, inspection, and repair	7-36c	7-147
Disassembly	7-36b	7-146
Preliminary procedures	7-36a	7-146
Lights, clearance, service and blackout, truck M756A2	7-46	7-175
Removal	7-46a	7-175
Replacement	7-46b	7-177
Lines and fittings, air system	13-21	13-149
Preliminary procedure	13-21a	13-149
Removal	13-21b	13-150
Replacement	13-21c	13-156

INDEX - CONT

Subject	Paragraph	Page
L - Cont		
Lines and fittings, pump, engine manifold heater, engines		
LDS 427-2 and LDS 465-1	4-20	4-102
Preliminary procedures	4-20a	4-102
Removal	4-20b	4-102
Replacement	4-20c	4-111
Lock assembly, winch drum, truck M756A2	19-7	19-24
Assembly	19-7e	19-28
Cleaning	19-7c	19-27
Disassembly	19-7b	19-26
Inspection and repair	19-7d	19-27
Removal	19-7a	19-24
Replacement	19-7f	19-29
Lubrication, general instructions	1-20	1-11
M		
Maintenance, general	1-2	1-1
Manifold, fuel drain	18-37	18-172
Cleaning and inspection	18-37c	18-176
Preliminary procedure	18-37a	18-172
Removal	18-37b	18-172
Replacement	18-37d	18-177
Manifold heater, engines LDS 427-2 and LDS 465-1	4-17	4-88
Preliminary procedure	4-17a	4-88
Removal	4-17b	4-89
Replacement	4-17c	4-91
Manifold flame heater, intake, and elbow top-mounted, covered, engines LD 465-1, LD 465-1C, and LDT 465-1C	4-25	4-131
Preliminary procedures	4-25a	4-131
Removal	4-25b	4-132
Replacement	4-25c	4-138
Master cylinder assembly	13-12	13-78
Removal	13-12a	13-78
Replacement	13-12b	13-83
Meter, gallon indicating, truck M49A1C	18-46	18-229
Preliminary procedure	18-46a	18-229
Removal	18-46b	18-229
Replacement	18-46c	18-233
Meter, gallon indicating, truck M49A2C	18-47	18-238
Removal	18-47a	18-238
Replacement	18-47b	18-242
Metric system	1-13	1-5
Mirror and bracket assembly	21-6	21-15
Removal	21-6a	21-15
Repair	21-6b	21-19
Replacement	21-6c	21-19

INDEX - CONT

Subject	Paragraph	Page
N		
Nozzle and valve assembly, manifold heater, top-mounted, uncovered, engines LDS 427-2 and LDS 465-1.	4-12	4-71
Preliminary procedure	4-12a	4-71
Removal	4-12b	4-71
Replacement	4-12c	4-72
Nozzle and valve manifold heater	4-21	4-121
Preliminary procedure	4-21a	4-121
Removal	4-21b	4-121
Replacement	4-21c	4-122
O		
Oil drain tube, worm gear housing, rear winch assembly, truck M764	19-12	19-64
Cleaning	19-12b	19-66
Inspection and repair	19-12c	19-66
Removal	19-12a	19-64
Replacement	19-12d	19-66
Oil filter element	2-5	2-13
Preliminary procedure	2-5a	2-13
Removal	2-5b	2-13
Replacement	2-5c	2-16
Oil pan shroud repair	23-11	23-28
Removal	23-11a	23-28
Replacement	23-11b	23-29
Oil pressure transmitter	7-49	7-183
Preliminary procedure	7-49a	7-183
Removal	7-49b	7-183
Replacement	7-49c	7-184
P		
Painting	1-4	1-2
Pintle hook	16-5	16-10
Removal	16-5a	16-10
Replacement	16-5b	16-11
Pintle hook repair	16-6	16-12
Assembly	16-6c	16-15
Disassembly	16-6b	16-12
Preliminary procedure	16-6a	16-12
Pipe, discharge, trucks M50A1, M50A2, and M50A3	18-57	18-289
Preliminary procedure	18-57a	18-289
Removal, M50A1 and M50A2	18-57b	18-290
Replacement, M50A1 and M50A2	18-57c	18-302

INDEX - CONT

Subject	Paragraph	Page
P - Cont		
Pipes, discharge, trucks M4A1C and M49A2C	18-21	18-77
Preliminary procedure	18-21a	18-77
Removal	18-21b	18-78
Replacement, Truck M49A1C	18-21c	18-84
Pitman arm	15-4	15-8
Removal	15-4a	15-8
Replacement	15-4b	15-10
Power leveler repair, truck M764	18-87	18-473
Cleaning	18-87b	18-474
Inspection and repair	18-87c	18-474
Replacement	18-87d	18-474
Removal	18-87a	18-473
Power takeoff, transmission, shift linkage	19-25	19-129
Adjustment	19-25e	19-132
Checkout	19-25d	19-131
Preliminary procedure	19-25a	19-129
Removal	19-25b	19-129
Replacement	19-25c	19-130
Propeller shaft assembly, power divider, truck M764	19-27	19-143
Removal	19-27a	19-143
Repair	19-27b	19-145
Replacement	19-27c	19-145
Propeller shaft and universal joint, intermediate propeller shaft, truck M36A2	10-3	10-1
Removal	10-3a	10-2
Replacement	10-3b	10-5
Propeller shaft, front winch	19-5	19-16
Removal	19-5a	19-16
Replacement	19-5b	19-18
Propeller shaft, hydraulic hoist pump, truck M543A2	19-21	19-108
Removal	19-21a	19-108
Repair	19-21b	19-110
Replacement	19-21c	19-111
Propeller shaft and universal joints, all except intermediate propeller shaft on truck M36A2	10-4	10-9
Removal	10-4a	10-9
Replacement	10-4b	10-10
Pump, centrifugal, trucks M49A1C and M49A2C	18-33	18-138
Removal	18-33a	18-138
Replacement	18-33b	18-143
Pump, delivery, propeller shafts, trucks M49A1C and M49A2C	18-35	18-152
Removal	18-35a	18-152
Repair	18-35b	18-160
Replacement	18-35c	18-160

INDEX - CONT

Subject	Paragraph	Page
P - Cont		
Pump delivery, trucks M50A1, M50A2, and M50A3	18-58	18-314
Removal	18-58a	18-314
Replacement	18-58b	18-318
Pump, delivery, strainer and gasket	18-34	18-149
Removal	18-34a	18-149
Replacement	18-34b	18-151
Pump, electric fuel supply, and fuel filter, manifold heater	4-19	4-98
Preliminary procedures	4-19a	4-98
Removal	4-19b	4-98
Replacement	4-19c	4-100
Pump, fuel and ignition unit, manifold flame heater, top-mounted, covered, engines LD 465-1, LD 465-1C, and LDT 465-1C	4-26	4-143
Preliminary procedures	4-26a	4-143
Removal	4-26b	4-144
Replacement	4-26c	4-147
Pump, fuel manifold heater, engines LDS 427-2 and LDS 465-1	4-18	4-94
Preliminary procedure	4-18a	4-94
Removal	4-18b	4-94
Replacement	4-18c	4-96
Pump, fuel winterization kit	23-21	23-58
Cleaning, inspection, and repair	23-21c	23-61
Preliminary procedures	23-21a	23-58
Removal	23-21b	23-59
Replacement	23-21d	23-62
Pump, outrigger hydraulic, truck M764	18-85	18-459
Removal	18-85a	18-459
Replacement	18-85b	18-463
Pump, water	6-7	6-39
Preliminary procedures	6-7a	6-39
Removal	6-7b	6-39
Replacement	6-7c	6-40
Q		
Quick disconnect coupling half	13-37	13-267
Preliminary procedures	13-37a	13-267
Removal	13-37b	13-267
Replacement	13-37c	13-268
Quick disconnect coupling half repair	13-38	13-269
R		
Radiator	6-3	6-1
Preliminary procedures	6-3a	6-1
Removal	6-3b	6-1
Replacement	6-3c	6-8
Receipt of materiel, service upon	1-17	1-10
Recommendations, improvement, reporting	1-12	1-5
Reel assembly, static, repair, trucks M49A1C and M49A2C	18-45	18-227
Assembly	18-45b	18-228
Disassembly	18-45a	18-227

INDEX - CONT

Subject	Paragraph	Page
R - Cont		
Reel assembly, static, truck M49A1C	18-43	18-223
Removal	18-43a	18-223
Replacement	18-43b	18-224
Reel assembly, static, truck M49A2C	18-44	18-225
Removal	18-44a	18-225
Replacement	18-44b	18-226
Repair parts, maintenance	1-19	1-11
Roller assembly, tailboard, truck M756A2	18-93	18-511
Preliminary procedures	18-93a	18-511
Removal	18-93b	18-512
Repair	18-93c	18-514
Replacement	18-93d	18-514
Roller bracket assembly auxiliary, truck M756A2	18-92	18-507
Removal	18-92a	18-507
Repair	18-92b	18-509
Replacement	18-92c	18-509
S		
Scope of manual	1-1	1-1
Sealed beam, front service	7-20	7-102
Removal	7-20a	7-102
Replacement	7-20b	7-103
Sealed beam unit, blackout drive	7-23	7-113
Removal	7-23a	7-113
Replacement	7-23b	7-115
Seat, companion, early model trucks	18-12	18-34
Removal	18-12a	18-34
Replacement	18-12b	18-36
Seat, companion, later model trucks	18-11	18-30
Removal	18-11a	18-30
Replacement	18-11b	18-32
Seat, companion, repair, early model trucks	18-13	18-38
Removal	18-13a	18-38
Replacement	18-13b	18-42
Seat, driver's early model trucks	18-7	18-18
Preliminary procedures	18-7a	18-18
Removal	18-7b	18-18
Replacement	18-7c	18-19
Seat, driver's, repair, trucks M35A1 and A49A2C	18-10	18-26
Removal	18-10a	18-26
Replacement	18-10b	18-28
Seat, floating driver's	18-8	18-20
Removal	18-8a	18-20
Replacement	18-8b	18-21
Seat, floating driver's, repair	18-9	18-22
Preliminary procedure	18-9a	18-22
Removal	18-9b	18-22
Replacement	18-9c	18-24

INDEX - CONT

Subject	Paragraph	Page
S - Cont		
Sending unit, fuel gage	7-50	7-185
Preliminary procedures	7-50a	7-185
Removal	7-50b	7-185
Replacement	7-50c	7-186
Sheave assembly, A-frame, truck M756A2	18-89	18-482
Assembly	18-89c	18-485
Disassembly	18-89b	18-483
Preliminary procedure	18-89a	18-482
Sheave, snatch, truck M764	18-95	18-521
Removal	18-95a	18-521
Replacement	18-95b	18-522
Shift linkage, reverse, transmission transfer, adjustment	9-6	9-46
Adjustment, forward speed	9-6b	9-46
Adjustment, reverse speed	9-6c	9-49
Preliminary procedure	9-6a	9-46
Shift linkage, reverse, transmission transfer, check	9-5	9-45
Preliminary procedure	9-5a	9-45
Check	9-5b	9-45
Shock absorber	17-11	17-57
Preliminary procedure	17-11a	17-57
Removal	17-11b	17-57
Replacement	17-11c	17-59
Slave receptacle assembly repair	23-24	23-79
Assembly	23-24e	23-83
Disassembly	23-24c	23-82
Inspection and repair	23-24d	23-83
Preliminary procedures	23-24a	23-79
Removal	23-24b	23-79
Replacement	23-24f	23-84
Spare wheel carrier, all trucks except M342A2	16-7	16-17
Preliminary procedures	16-7a	16-17
Removal	16-7b	16-18
Replacement	16-7c	16-19
Spare wheel carrier repair, all trucks except M342A2	16-8	16-20
Assembly	16-8c	16-23
Disassembly	16-8b	16-20
Preliminary procedure	16-8a	16-20
Spare wheel carrier, truck M342A2	16-9	16-25
Preliminary procedure	16-9a	16-25
Removal	16-9b	16-25
Replacement	16-9c	16-29
Spare wheel carrier repair, truck M342A2	16-10	16-34
Assembly	16-10d	16-41
Disassembly	16-10b	16-34
Preliminary procedure	16-10a	16-34
Repair	16-10c	16-41

INDEX - CONT

Subject	Paragraph	Page
S - Cont		
Spark plug and nozzle, manifold heater, side-mounted	4-16	4-86
Preliminary procedures	4-16a	4-86
Removal	4-16b	4-86
Replacement	4-16c	4-87
Spark plug, manifold heater, top-mounted, covered	4-23	4-127
Preliminary procedure	4-23a	4-127
Removal	4-23b	4-127
Replacement	4-23c	4-128
Spark plug, manifold heater, top-mounted, uncovered, engines LDS 427-2 and LDS 465-1	4-14	4-75
Preliminary procedure	4-14a	4-75
Removal	4-14b	4-75
Replacement	4-14c	4-76
Speedometer assembly	22-4	22-16
Preliminary procedures	22-4a	22-16
Removal of flexible shaft assembly	22-4c	22-18
Removal of flexible shaft core	22-4e	22-22
Removal of right angle drive adapter	22-4d	22-21
Removal of speedometer	22-4b	22-16
Repair of flexible shaft assembly	22-4f	22-23
Replacement of flexible shaft assembly.	22-4i	22-25
Replacement of flexible shaft core	22-4g	22-23
Replacement of right angle drive adapter	22-4h	22-24
Replacement of speedometer	22-4j	22-30
Splash guards, rear, truck M756A2	18-91	18-504
Removal	18-91a	18-504
Replacement	18-91b	18-505
Spreader tube repair, A-frame kit	23-33	23-126
Preliminary procedure	23-33a	23-126
Removal	23-33b	23-126
Replacement	23-33c	23-129
Spring assembly, front leaf	17-4	17-14
Assembly	17-4d	17-21
Cleaning, inspection, and repair	17-4c	17-20
Disassembly	17-4b	17-15
Preliminary procedure	17-4a	17-14
Spring assembly, rear leaf	17-7	17-33
Assembly	17-7d	17-36
Cleaning, inspection, and repair	17-7c	17-35
Disassembly	17-7b	17-33
Preliminary procedures	17-7a	17-33
Spring seat, front	17-5	17-25
Preliminary procedure	17-5a	17-25
Removal	17-5b	17-25
Replacement	17-5c	17-27

INDEX - CONT

Subject	Paragraph	Page
S - Cont		
Spring seat, rear	17-8	17-38
Preliminary procedures	17-8a	17-38
Removal	17-8b	17-38
Replacement	17-8c	17-41
Spring seat repair, rear	17-9	17-46
Assembly	17-9c	17-48
Disassembly	17-9b	17-47
Preliminary procedures	17-9a	17-46
Spring seat with bearings, rear	17-10	17-49
Preliminary procedures	17-10a	17-49
Removal	17-10b	17-49
Replacement	17-10c	17-52
Springs, front	17-3	17-1
Removal	17-3a	17-2
Replacement	17-3b	17-6
Springs, rear	17-6	17-29
Preliminary procedures	17-6a	17-29
Removal	17-6b	17-29
Replacement	17-6c	17-31
Sprockets, winch and power takeoff, truck M756A2	19-8	19-31
Assembly of winch sprocket assembly.	19-8f	19-38
Cleaning	19-8d	19-38
Disassembly of winch sprocket assembly	19-8c	19-37
Inspection and Repair	19-8e	19-38
Preliminary procedure	19-8a	19-31
Removal	19-8b	19-32
Replacement	19-8g	19-39
Starter button	7-9	7-46
Preliminary procedures	7-9a	7-46
Removal	7-9b	7-46
Replacement	7-9c	7-47
Starter, engine, trucks with floor pedal starter switch	7-10	7-48
Preliminary procedures	7-10a	7-48
Removal	7-10b	7-48
Replacement	7-10c	7-51
Starter, engine, trucks with pushbutton starter switch	7-11	7-54
Preliminary procedures	7-11a	7-54
Removal	7-11b	7-54
Replacement	7-11c	7-59
Starter pedal and linkage assembly	7-6	7-29
Preliminary procedures	7-6a	7-29
Removal	7-6b	7-29
Repair	7-6c	7-31
Replacement	7-6d	7-31
Steering gear	15-5	15-12
Adjustment	15-5b	15-12
Preliminary procedure	15-5a	15-12

INDEX - CONT

Subject	Paragraph	Page
S - Cont		
Steering knuckle boot.	11-6	11-18
Removal	11-6a	11-18
Replacement	11-6b	11-22
Steering wheel	15-10	15-31
Preliminary procedures	15-10a	15-31
Removal	15-10b	15-32
Replacement	15-10c	15-35
Stone shield, radiator	6-4	6-16
Preliminary procedure	6-4a	6-16
Removal	6-4b	6-16
Replacement	6-4c	6-18
Stoplight assembly, blackout, right side only, early model trucks with turn signals	7-31	7-133
Removal	7-31a	7-133
Replacement	7-31b	7-134
Stoplight assembly repair, blackout right side only	7-33	7-137
Assembly	7-33d	7-138
Disassembly	7-33b	7-137
Preliminary procedures	7-33a	7-137
Repair	7-33c	7-138
Storage, administrative	1-21	1-11
Switch, accessory	7-15	7-82
Preliminary procedure	7-15a	7-82
Removal	7-15b	7-82
Replacement	7-15c	7-84
Switch, air stoplight, trucks M275A1 and M275A2	7-68	7-263
Preliminary procedures	7-68a	7-263
Removal	7-68b	7-264
Replacement	7-68c	7-265
Switch, control, hot water personnel heater	23-17	23-45
Removal	23-17a	23-46
Replacement	23-17b	23-48
Switch, dome light, 115-volt	18-71	18-375
Preliminary procedures	18-71a	18-375
Removal	18-71b	18-375
Replacement	18-71c	18-377
Switches, blackout, 24-volt and 115-volt, van rear door.	18-73	18-389
Preliminary procedures	18-73a	18-389
Removal	17-73b	18-389
Replacement	18-73c	18-391
Switches, dome light and blackout dome light, 24-volt, toggle, trucks M109A2 and M109A3	18-72	18-380
Preliminary procedure	18-72a	18-380
Removal	18-72b	18-381
Replacement	18-72c	18-385

INDEX - CONT

Subject	Paragraph	Page
S - Cont		
Switches, van body personnel heater, trucks M109A2 and M109A3	23-27	23-95
Preliminary procedures	23-27a	23-95
Removal	23-27b	23-95
Replacement	23-27c	23-99
Switch, floodlight housing, trucks M756A2 and M764	7-66	7-254
Cleaning, inspection, and repair	7-66c	7-255
Preliminary procedure	7-66a	7-254
Removal	7-66b	7-254
Replacement	7-66d	7-256
Switch, headlight dimmer	7-65	7-250
Preliminary procedures	7-65a	7-250
Removal	7-65b	7-250
Replacement	7-65c	7-252
Switch, hydraulic stoplight, all trucks except models M275A1 and M275A2	7-67	7-257
Removal	7-67a	7-257
Replacement of switch pn 7064588	7-67b	7-260
Replacement of switch pn 7760414 with pn 7064588	7-67c	7-261
Switch, light	7-14	7-78
Preliminary procedure	7-14a	7-78
Removal	7-14b	7-78
Replacement	7-14c	7-80
Switch, low air pressure buzzer	7-69	7-266
Preliminary procedures	7-69a	7-266
Removal	7-69b	7-266
Type A replacement	7-69c	7-269
Type B replacement	7-69d	7-270
Switch, magnetic starter	7-7	7-35
Preliminary procedures	7-7a	7-35
Removal	7-7b	7-36
Replacement	7-7c	7-38
Switch, manifold heater	7-64	7-248
Preliminary procedure	7-64a	7-248
Removal	7-64b	7-248
Replacement	7-64c	7-249
Switch, starter, trucks with pedal starter	7-8	7-41
Adjustment	7-8d	7-44
Preliminary procedures	7-8a	7-41
Removal	7-8b	7-41
Replacement	7-8c	7-42

T

Tabulated data	1-16	1-5
Tachometer assembly	22-3	22-1
Preliminary procedures	22-3a	22-1

INDEX - CONT

Subject	Paragraph	Page
T - Cont		
Removal of flexible shaft assembly	22-3c	22-4
Removal of flexible shaft core	22-3e	22-8
Removal of right angle adapter	22-3d	22-7
Removal of tachometer	22-3b	22-2
Repair of flexible shaft assembly	22-3f	22-9
Replacement of flexible shaft assembly	22-3i	22-11
Replacement of flexible shaft core	22-3g	22-9
Replacement of right angle adapter	22-3h	22-10
Replacement of tachometer	22-3j	22-13
Tailgate assembly, all cargo trucks except M35A2C	18-16	18-48
Removal	18-16a	18-48
Replacement	18-16b	18-50
Tailgate assembly, truck M35A2C	18-17	18-52
Removal	18-17a	18-52
Replacement	18-17b	18-54
Taillight and stoplight assembly, left side only	7-28	7-126
Removal	7-28a	7-126
Replacement	7-28b	7-127
Taillight and stoplight assembly repair, left side only	7-30	7-130
Assembly	7-30d	7-132
Cleaning, inspection, and repair	7-30c	7-131
Disassembly	7-30b	7-130
Preliminary procedures	7-30a	7-130
Taillight and stoplight assembly, right side only, early model trucks with turn signals	7-25	7-119
Preliminary procedure	7-25a	7-119
Removal	7-25b	7-119
Replacement	7-25c	7-120
Taillight and stoplight assembly repair, right side only, truck M756A2	7-26	7-121
Assembly	7-26d	7-123
Cleaning, inspection, and repair	7-26c	7-122
Disassembly	7-26b	7-121
Preliminary procedures	7-26a	7-121
Tank, fuel, trucks M275A1 and M275A2	4-6	4-29
Preliminary procedures	4-6a	4-29
Removal	4-6b	4-29
Replacement	4-6c	4-31
Tank, fuel, trucks M275 and M275A2	4-7	4-33
Preliminary procedures	4-7a	4-33
Removal	4-7b	4-33
Replacement	4-7c	4-39
Thermostat	6-6	6-31
Preliminary procedure	6-6a	6-31
Removal	6-6b	6-31
Replacement	6-6c	6-34

INDEX - CONT

Subject	Paragraph	Page
T - Cont		
Throttle control and linkage	4-28	4-157
Adjustment	4-28e	4-163
Preliminary procedure	4-28a	4-157
Removal	4-28b	4-157
Repair	4-28c	4-160
Replacement	4-28d	4-160
Tie rod end	15-6	15-18
Preliminary procedure	15-6a	15-18
Removal	15-6b	15-18
Replacement	15-6c	15-20
Tire and tube	14-12	14-78
Preliminary procedure	14-12a	14-78
Removal	14-12b	14-78
Replacement	14-12c	14-83
Tool box, truck M756A2	18-90	18-487
Removal	18-90a	18-487
Replacement	18-90b	18-495
Tools and equipment	1-18	1-11
Tools, common	1-8	1-2
Tools, special, and equipment	1-7	1-2
Torque rods	17-12	17-61
Preliminary procedures	17-12a	17-61
Removal	17-12b	17-62
Replacement	17-12c	17-66
Transfer controls and linkage, with power takeoff, trucks M49A1C, M49A2C, M50A1, M50A2, M50A3, M756A2, and M764	9-3	9-1
Preliminary procedure	9-3a	9-1
Removal of power takeoff shift controls and linkage	9-3e	9-4
Removal of power takeoff shifting lever lockout linkage, trucks M49A1C, M49A2C, M50A1, M50A2, and M50A3	9-3f	9-5
Removal of transmission transfer reverse shift linkage, transfers without air actuated positive lockup	9-3d	9-4
Removal of transmission transfer shift lever and linkage, trucks M49A1C, M49A2C, M50A1, M50A2, and M50A3	9-3c	9-2
Removal of transmission transfer shift lever and linkage, trucks M756A2 and M764	9-3b	9-1
Repair of transmission transfer controls and linkages	9-3g	9-8
Replacement of transmission transfer power takeoff shift controls and linkage	9-3j	9-14
Replacement of transmission transfer power takeoff shifting lever lockout linkage, trucks M49A1C, M49A2C, M50A1, M50A2, and M50A3	9-3k	9-16
Replacement of transmission transfer shift lever and linkage (trucks M49A1C, M59A2C, M50A1, M50A2, and M50A3)	9-3h	9-8
Replacement of transmission transfer shift lever and linkage, trucks M756A2 and M764	9-3i	9-14

INDEX - CONT

Subject	Paragraph	Page
T - Cont		
Transmission transfer controls and linkage, without power takeoff	9-4	9-24
Assembly of transmission transfer reverse shift rod, transfers without air actuated positive lockup	9-4e	9-33
Disassembly of transmission transfer reverse shift rod, transfers without air actuated positive lockup	9-4d	9-31
Preliminary procedure	9-4a	9-24
Removal of transmission transfer shift lever and linkage ..	9-4b	9-25
Removal of transmission transfer reverse shift lever and linkage, transfer without air actuated positive lockup ..	9-4c	9-27
Repair of transmission transfer controls and linkage	9-4f	9-35
Replacement of transmission transfer reverse shift levers and linkage, transfer without air actuated positive lockup ..	9-4h	9-41
Replacement of transmission transfer shift lever and linkage ..	9-4g	9-35
Transmission breather, deep water fording kit	23-29	23-108
Preliminary procedure	23-29a	23-108
Removal	23-29b	23-108
Repair	23-29c	23-109
Replacement	23-29d	23-110
Transmission breather	8-3	8-1
Preliminary procedure	8-3a	8-1
Removal	8-3b	8-2
Replacement	8-3c	8-3
Transmitter, water temperature	7-48	7-181
Preliminary procedures	7-48a	7-181
Removal	7-48b	7-181
Replacement	7-48c	7-182
Troop seat rack assembly repair	18-18	18-56
Assembly of rack and seat assembly	18-18i	18-66
Assembly of rack assembly	18-18h	18-64
Assembly of seat assembly	18-18g	18-61
Cleaning	18-18e	18-60
Disassembly of rack and seat assembly	18-18b	18-56
Disassembly of rack assembly	18-18c	18-57
Disassembly of seat assembly	18-18d	18-58
Inspection and repair	18-18f	18-60
Preliminary procedure	18-18a	18-56
U		
Universal joint assembly, drive shaft, outrigger pump, truck M764	19-20	19-102
Removal	19-20a	19-103
Replacement	19-20b	19-105

INDEX - CONT

Subject	Paragraph	Page
U - Cont		
Universal joint, snapping, C-ring, and bearing cap type	10-5	10-12
Assembly, bearing cap type	10-5f	10-24
Assembly, snapping and C-ring type	10-5e	10-21
Cleaning, all types	10-5c	10-20
Disassembly, bearing cap type	10-5b	10-15
Disassembly, snapping and C-ring type	10-5a	10-12
Inspection and repair, all types	10-5d	10-20
V		
Values, torque	1-6	1-2
Valve, air brake	13-22	13-162
Preliminary procedure	13-22a	13-162
Removal	13-22b	13-162
Replacement	13-22c	13-164
Valve, air brake hand control	13-24	13-170
Removal	13-24a	13-170
Replacement	13-24b	13-174
Valve, air brake hand control, repair	13-23	13-166
Removal	13-23a	13-166
Replacement	13-23b	13-168
Valve assembly, discharge, trucks M49A1C and M49A2C	18-19	18-67
Preliminary procedure	18-19a	18-67
Removal	18-19b	18-67
Replacement	18-19c	18-70
Valve cable, front discharge, truck M49A1C	18-25	18-101
Removal	18-25a	18-101
Replacement	18-25b	18-103
Valve cable, front discharge, truck M49A2C	18-26	18-106
Removal	18-26a	18-106
Replacement	18-26b	18-108
Valve cable, intermediate discharge, truck M49A1C	18-27	18-111
Removal	18-27a	18-111
Replacement	18-27b	18-113
Valve cable, rear discharge, truck M49A1C	18-28	18-116
Removal	18-28a	18-116
Replacement	18-28b	18-118
Valve cable, rear discharge, truck M49A2C	18-29	18-120
Removal	18-29a	18-120
Replacement	18-29b	18-122
Valve cables, front and rear discharge, trucks M50A1, M50A2, and M50A3	18-56	18-280
Preliminary procedure	18-56a	18-280
Removal	18-56b	18-280
Replacement	18-56c	18-284

INDEX - CONT

Subject	Paragraph	Page
V - Cont		
Valve, discharge, control levers, trucks M50A1, M50A2 and M50A3	18-55	18-276
Preliminary procedure	18-55a	18-276
Removal	18-55b	18-276
Replacement	18-55c	18-278
Valve, discharge, packing, trucks M50A1, M50A2, and M50A3	18-54	18-272
Preliminary procedures	18-54a	18-272
Removal	18-54b	18-272
Replacement	18-54c	18-274
Valve, discharge, trucks M50A1, M50A2, and M50A3	18-53	18-263
Preliminary procedure	18-53a	18-263
Removal	18-53b	18-264
Replacement	18-53c	18-268
Valve, gate, trucks M49A1C and M49A2C	18-22	18-90
Removal	18-22a	18-90
Replacement	18-22b	18-91
Valve, globe	18-31	18-129
Removal	18-31a	18-129
Replacement	18-31b	18-132
Valve operating lever, discharge	18-32	18-134
Removal	18-32a	18-134
Replacement	18-32b	18-136
Valve, outrigger control, truck M764.	18-86	18-467
Preliminary procedure	18-86a	18-467
Removal	18-86b	18-467
Replacement	18-86c	18-470
Valve packing, discharge, trucks M49A1C and M49A2C	18-20	18-73
Removal	18-20a	18-73
Replacement	18-20b	18-75
Valve packing, gate, trucks M49A1C and M49A2C	18-23	18-92
Removal	18-23a	18-92
Replacement	18-23b	18-93
Valve, safety, air system	13-25	13-180
Preliminary procedures	13-25a	13-180
Removal	13-25b	13-181
Replacement	13-25c	13-182
Vehicle description	1-15	1-5
Venting, air system pressure	13-20	13-148

W

Water segregator unit, truck M49A1C	18-39	18-187
Removal	18-39a	18-188
Repair	18-39b	18-192
Replacement	18-39c	18-194

INDEX - CONT

Subject	Paragraph	Page
W - Cont		
Water, segregator unit service, truck M49A1C	18-40	18-197
Webbing strap repair	18-15	18-48
Wheel bearing cones and seals, front	14-6	14-32
Cleaning	14-6c	14-33
Inspection	14-6d	14-34
Lubrication	14-6e	14-35
Preliminary procedure	14-6a	14-32
Removal	14-6b	14-32
Replacement	14-6f	14-36
Wheel bearing cones and seals, rear	14-11	14-73
Cleaning	14-11c	14-74
Inspection	14-11d	14-75
Lubrication	14-11e	14-76
Preliminary procedure	14-11a	14-73
Removal	14-11b	14-73
Replacement	14-11f	14-77
Wheel bearings and seals, front inner and outer	14-7	14-37
Cleaning	14-7c	14-40
Inspection	14-7d	14-41
Lubrication	14-7e	14-42
Preliminary procedure	14-7a	14-37
Removal	14-7b	14-37
Replacement	14-7f	14-43
Wheel bearings and seals, rear inner and outer	14-10	14-64
Cleaning	14-10c	14-67
Inspection	14-10d	14-68
Lubrication	14-10e	14-69
Preliminary procedure	14-10a	14-64
Removal	14-10b	14-64
Replacement	14-10f	14-70
Wheel cylinder, hydraulic	13-11	13-73
Preliminary procedure	13-11a	13-73
Removal	13-11b	13-73
Replacement	13-11c	13-75
Wheels and brake drum assembly, rear	14-8	14-46
Preliminary procedure	14-8a	14-46
Removal	14-8b	14-46
Replacement	14-8c	14-50
Winch brake, front, test and adjustments	19-3	19-1
Automatic brake test and adjustment.	19-3c	19-4
Drag brake test and adjustment	19-3b	19-2
Preliminary procedure	19-3a	19-1
Winch, front	19-4	19-14
Preliminary procedures	19-4a	19-14
Removal	19-4b	19-14
Replacement	19-4c	19-15

INDEX - CONT

Subject	Paragraph	Page
W - Cont		
Windshield assembly	18-6	18-14
Preliminary procedure	18-6a	18-14
Removal	18-6b	18-14
Replacement	18-6c	18-16
Windshield washer repair	21-5	21-8
Preliminary procedure	21-5a	21-8
Removal	21-5b	21-8
Repair	21-5c	21-11
Replacement	21-5d	21-11
Windshield wiper motor	21-4	21-4
Removal	21-4a	21-4
Replacement	21-4b	21-6

Order of the Secretaries of the Army and the Air Force:

E. C. MEYER
General, United States Army
Chief of Staff

Official:

J. C. PENNINGTON
Major General, United States Army
The Adjutant General

LEW ALLEN, JR., General, USAF
Chief of Staff

Official:

VAN L. CRAWFORD, JR., Colonel, USAF
Director of Administration

Distribution:

To be distributed in accordance with DA Form 12-38, Organizational Maintenance requirements for 2-1/2-Ton Truck Cargo, 2-1/2-Ton Truck Van, etc.

RECOMMENDED CHANGES TO EQUIPMENT TECHNICAL PUBLICATIONS



THEN... JOT DOWN THE DOPE ABOUT IT ON THIS FORM, CAREFULLY TEAR IT OUT, FOLD IT AND DROP IT IN THE MAIL!

SOMETHING WRONG WITH THIS PUBLICATION?

FROM (PRINT YOUR UNIT'S COMPLETE ADDRESS)
 CDR, 1st Bn, 65th ADA
 Attn: SP4 Jane Idone
 Key West, FL 33040

DATE SENT _____ Date Sent In _____

PUBLICATION NUMBER: TM 9-2320-209-20-3-4
 PUBLICATION DATE: 27 May 81
 PUBLICATION TITLE: ORGANIZATIONAL MAINTENANCE MANUAL

BE EXACT... PIN-POINT WHERE IT IS

PAGE NO	PARA-GRAPH	FIGURE NO	TABLE NO
19-31	19-8		
19-73	19-14 b		
22-24	22-4 h		

IN THIS SPACE TELL WHAT IS WRONG AND WHAT SHOULD BE DONE ABOUT IT:

Subparagraph a refers to para 9-3.
 Should refer to para 19-13.

FRAME 4, step 1 reads "Using 15/16-inch wrench, breaker bar, and 15/16-inch socket, tighten six screws (1) and nuts (2)."
 Should read "Using 15/16-inch wrench, breaker bar, and 15/16-inch socket, tighten eight screws (1) and nuts (2)."

FRAME 1 - Change illustration callouts.
 Reason: callouts for sliding drive shaft (1) and drive adapter shaft (5) are reversed.

SAMPLE

PRINTED NAME GRADE OR TITLE AND TELEPHONE NUMBER

SP4 Jane Idone Autovon 222-2224

SIGN HERE

Jane Idone

FILL IN YOUR
UNIT'S ADDRESS

DEPARTMENT OF THE ARMY

OFFICIAL BUSINESS
PENALTY FOR PRIVATE USE \$.

SAMPLE

FOLY

POSTAGE AND FEES PAID
DEPARTMENT OF THE ARMY
DOD 314



TEAR ALONG
DASHED LINE

Commander
U.S. Army Tank-Automotive Command
ATTN: DRSTA-MB
Warren, MI 48090

FILL IN YOUR
UNIT'S ADDRESS

FOLD BACK

DEPARTMENT OF THE ARMY

OFFICIAL BUSINESS
PENALTY FOR PRIVATE USE \$300

POSTAGE AND FEES PAID
DEPARTMENT OF THE ARMY
DOD 314



TEAR ALONG
PERFORATED LINE

Commander
U.S. Army Tank-Automotive Command
ATTN: DRSTA-MB
Warren, MI 48090

RECOMMENDED CHANGES TO EQUIPMENT TECHNICAL PUBLICATIONS

SOMETHING WRONG WITH THIS PUBLICATION?



THEN... JOT DOWN THE DOPE ABOUT IT ON THIS FORM. CAREFULLY TEAR IT OUT, FOLD IT AND DROP IT IN THE MAIL.

FROM (PRINT YOUR UNIT'S COMPLETE ADDRESS)

DATE SENT

PUBLICATION NUMBER

TM 9-2320-209-20-3-4

PUBLICATION DATE

27 May 81

PUBLICATION TITLE

ORGANIZATIONAL MAINTENANCE MANUAL

BE EXACT PIN-POINT WHERE IT IS

PAGE NO

PARA-GRAPH

FIGURE NO

TABLE NO

IN THIS SPACE TELL WHAT IS WRONG AND WHAT SHOULD BE DONE ABOUT IT:

PRINTED NAME GRADE OR TITLE AND TELEPHONE NUMBER

SIGN HERE

FILL IN YOUR
UNIT'S ADDRESS

FOLD BACK

DEPARTMENT OF THE ARMY

OFFICIAL BUSINESS
PENALTY FOR PRIVATE USE \$300

POSTAGE AND FEES PAID
DEPARTMENT OF THE ARMY
DOD 314



TEAR ALONG
DASHED LINE

Commander
U.S. Army Tank-Automotive Command
ATTN: DRSTA-MB
Warren, MI 48090

RECOMMENDED CHANGES TO EQUIPMENT TECHNICAL PUBLICATIONS



THEN... JOT DOWN THE DOPE ABOUT IT ON THIS FORM, CAREFULLY TEAR IT OUT, FOLD IT AND DROP IT IN THE MAIL!

SOMETHING WRONG WITH THIS PUBLICATION?

FROM (PRINT YOUR UNIT'S COMPLETE ADDRESS)

DATE SENT

PUBLICATION NUMBER

TM 9-2320-209-20-3-4

PUBLICATION DATE

27 May 81

PUBLICATION TITLE

ORGANIZATIONAL MAINTENANCE MANUAL

BE EXACT... PIN-POINT WHERE IT IS

PAGE NO	PARA-GRAPH	FIGURE NO	TABLE NO

IN THIS SPACE TELL WHAT IS WRONG AND WHAT SHOULD BE DONE ABOUT IT:

PRINTED NAME GRADE OR TITLE AND TELEPHONE NUMBER

SIGN HERE

FILL IN YOUR
UNIT'S ADDRESS

FOLD BACK

DEPARTMENT OF THE ARMY

OFFICIAL BUSINESS
PENALTY FOR PRIVATE USE \$300

POSTAGE AND FEES PAID
DEPARTMENT OF THE ARMY
DOD 314



TEAR ALONG
PERFORATED LINE

Commander
U.S. Army Tank-Automotive Command
ATTN: DRSTA-MB
Warren, MI 48090

THE METRIC SYSTEM AND EQUIVALENTS

LINEAR MEASURE

1 Centimeter = 10 Millimeters = 0.01 Meters = 0.3937 Inches
 1 Meter = 100 Centimeters = 1000 Millimeters = 39.37 Inches
 1 Kilometer = 1000 Meters = 0.621 Miles

WEIGHTS

1 Gram = 0.001 Kilograms = 1000 Milligrams = 0.035 Ounces
 1 Kilogram = 1000 Grams = 2.2 Lb
 1 Metric Ton = 1000 Kilograms = 1 Megagram = 1.1 Short Tons

LIQUID MEASURE

1 Milliliter = 0.001 Liters = 0.0338 Fluid Ounces
 1 Liter = 1000 Milliliters = 33.82 Fluid Ounces

SQUARE MEASURE

1 Sq Centimeter = 100 Sq Millimeters = 0.155 Sq Inches
 1 Sq Meter = 10,000 Sq Centimeters = 10.76 Sq Feet
 1 Sq Kilometer = 1,000,000 Sq Meters = 0.386 Sq Miles

CUBIC MEASURE

1 Cu Centimeter = 1000 Cu Millimeters = 0.06 Cu Inches
 1 Cu Meter = 1,000,000 Cu Centimeters = 35.31 Cu Feet

TEMPERATURE

$5/9 (^{\circ}\text{F} - 32) = ^{\circ}\text{C}$
 212^o Fahrenheit is equivalent to 100^o Celsius
 90^o Fahrenheit is equivalent to 32.2^o Celsius
 32^o Fahrenheit is equivalent to 0^o Celsius
 $9/5 \text{ C}^{\circ} + 32 = \text{F}^{\circ}$

APPROXIMATE CONVERSION FACTORS

<u>TO CHANGE</u>	<u>TO</u>	<u>MULTIPLY BY</u>
Inches	Centimeters	2.540
Feet	Meters	0.305
Yards	Meters	0.914
Miles	Kilometers	1.609
Square Inches	Square Centimeters	6.451
Square Feet	Square Meters	0.093
Square Yards	Square Meters	0.836
Square Miles	Square Kilometers	2.590
Acres	Square Hectometers	0.405
Cubic Feet	Cubic Meters	0.028
Cubic Yards	Cubic Meters	0.765
Fluid Ounces	Milliliters	29.573
Pints	Liters	0.473
Quarts	Liters	0.946
Gallons	Liters	3.785
Ounces	Grams	28.349
Pounds	Kilograms	0.454
Short Tons	Metric Tons	0.907
Pound-Feet	Newton-Meters	1.356
Pounds per Square Inch	Kilopascals	6.895
Miles per Gallon	Kilometers per Liter	0.425
Miles per Hour	Kilometers per Hour	1.609

<u>TO CHANGE</u>	<u>TO</u>	<u>MULTIPLY BY</u>
Centimeters	Inches	0.394
Meters	Feet	3.280
Meters	Yards	1.094
Kilometers	Miles	0.621
Square Centimeters	Square Inches	0.155
Square Meters	Square Feet	10.764
Square Meters	Square Yards	1.196
Square Kilometers	Square Miles	0.386
Square Hectometers	Acres	2.471
Cubic Meters	Cubic Feet	35.315
Cubic Meters	Cubic Yards	1.308
Milliliters	Fluid Ounces	0.034
Liters	Pints	2.113
Liters	Quarts	1.057
Liters	Gallons	0.264
Grams	Ounces	0.035
Kilograms	Pounds	2.205
Metric Tons	Short Tons	1.102
Newton-Meters	Pound-Feet	0.738
Kilopascals	Pounds per Square Inch	0.145
Kilometers per Liter	Miles per Gallon	2.354
Kilometers per Hour	Miles per Hour	0.621

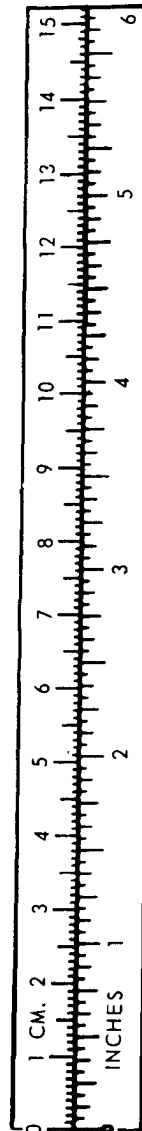

TAO89991