

TECHNICAL MANUAL
VOLUME 1 OF 2
TROUBLESHOOTING
DIRECT SUPPORT AND GENERAL SUPPORT LEVEL
2 1/2 TON, 6X6, M44A1 AND M44A2 SERIES TRUCKS

(MULTIFUEL)

TRUCK, CARGO: M35A1
M35A2, M35A2C, M36A2; TRUCK,
TANK, FUEL: M49A1C, M49A2C, TRUCK, TANK,
WATER: M50A1, M50A2, M50A3; TRUCK, VAN,
SHOP: M109A2, M109A3; TRUCK, REPAIR SHOP:
M185A2, M185A3; TRUCK, TRACTOR: M275A1,
M275A2; TRUCK, DUMP: M342A2; TRUCK,
MAINTENANCE, PIPELINE CONSTRUCTION:
M756A2; TRUCK, MAINTENANCE,
EARTH BORING AND POLESETTING: M764

NOTE:

THE STYLE OF THIS TM IS
EXPERIMENTAL. IT IS BEING TRIED
BY THE ARMY ONLY ON
A LIMITED BASIS

WARNING

EXHAUST GASES CAN BE DEADLY

Exposure to exhaust gases produces symptoms of headache, dizziness, loss of muscular control, apparent drowsiness, and coma. Permanent brain damage or death can result from severe exposure.

Carbon monoxide occurs in the exhaust fumes of fuel burning heaters and internal combustion engines, and becomes dangerously concentrated under conditions of inadequate ventilation. The following precautions must be observed to insure the safety of personnel whenever fuel burning heater(s) or engine of any vehicle is operated for maintenance purposes or tactical use.

Do not operate heater or engine of vehicle in an enclosed area unless it is adequately ventilated.

Do not idle engine for long periods without maintaining adequate ventilation in personnel compartments.

Do not drive any vehicle with inspection plates or cover plates removed unless necessary for maintenance purposes.

Be alert at all times during vehicle operation for exhaust odors and exposure symptoms. If either are present, immediately ventilate personnel compartments. If symptoms persist, remove affected personnel from vehicle and treat as follows: expose to fresh air; keep warm; do not permit physical exercise; if necessary, administer artificial respiration.

If exposed, seek prompt medical attention for possible delayed onset of acute lung congestion. Administer oxygen if available.

The best defense against exhaust gas poisoning is adequate ventilation.

WARNING

Serious or fatal injury to personnel may result if the following instructions are not complied with.

Diesel fuel is very flammable. Care must be used when choosing a place to work on fuel system. Keep truck about 50 feet away from an area where open flame, sparks, or smoking may cause a fire. Keep a fire extinguisher close by.

Fuel coming out of an injector nozzle under pressure can go through the skin. This can cause blood poisoning. Keep hands away from injector nozzle when doing test procedures.

Only properly trained personnel should perform test on 115 volt system. The voltage present in 115 volt system can cause severe or fatal electric shock.

***TM 9-2320-209-34-1**
T.O. 36A12-1B-1092-2-1

TECHNICAL MANUAL
NO. 9-2320-209-34-1
TECHNICAL ORDER
NO. 36A12-1B-1092-2-1

DEPARTMENTS OF THE ARMY
AND
THE AIR FORCE
Washington, DC, 20 May 1981

TECHNICAL MANUAL
VOLUME 1 OF 2
TROUBLESHOOTING
DIRECT SUPPORT AND GENERAL SUPPORT LEVEL
2 1/2-TON, 6X6, M44A1 AND M44A2 SERIES TRUCKS
(MULTIFUEL)

Model		NSN without Winch	NSN with Winch
Truck, Cargo	M135A1	2320-00-542-5633	2320-00-542-5634
	M35A2	2320-00-077-1616	2320-00-077-1617
	M35A2C	2320-00-926-0873	2320-00-926-0875
	M36A2	2320-00-077-1618	2320-00-077-1619
Truck, Tank, Fuel	M49A1C	2320-00-440-3349	2320-00-440-3346
	M49A2C	2320-00-077-1631	2320-00-077-1632
Truck, Tank, Water	M50A1	2320-00-440-8307	2320-00-440-8305
	M50A2	2320-00-077-1633	2320-00-077-1634
	M50A3	2320-00-937-4036	2320-00-937-5264
Truck, Van, Shop	M109A2	2320-00-440-8313	2320-00-440-8308
	M109A3	2320-00-077-1636	2320-00-077-1637
Truck, Repair Shop	M185A2	4940-00-987-8799	4940-00-987-8800
	M185A3	4940-00-077-1638	4940-00-077-1639
Truck, Tractor	M275A1	2320-00-446-2479	
	M275A2	2320-00-077-1640	2320-00-077-1641
Truck, Dump	M342A2	2320-00-077-1643	2320-00-077-1644
Truck, Maintenance, Pipeline Construction	M756A2		2320-00-904-3277
Truck, Maintenance, Earth Boring and Polesetter	M7 64		2320-00-937-5980

* This manual, together with TM 9-2320-209-34-2-1, 20 May 1981; TM 9-2320-209-34-2-2, 20 May 1981; and TM 9-2320-209-34-2-3, 20 May 1981, supersedes TM 9-2320-209-34, Dated 30 March 1979.

REPORTING OF ERRORS AND RECOMMENDING IMPROVEMENTS

You can help improve this manual. If you find any mistakes or if you know of a way to improve the procedure, please let us know. Mail your letter, DA Form 2028 (Recommended Changes to Publications and Blank Forms), or DA Form 2028-2 located in the back of this manual direct to: Commander, US Army Tank-Automotive Command, ATTN: DRSTA-MB, Warren, Michigan 48090. A reply will be furnished to you.

TABLE OF CONTENTS

	Paragraph	Page
CHAPTER 1. GENERAL INFORMATION		
Scope	1-1	1-1
Organization	1-2	1-1
Troubleshooting Approach	1-3	1-1
CHAPTER 2. TROUBLESHOOTING APPROACH		
General Approach	2-1	2-1
Troubleshooting Index	2-2	2-1
Test Equipment Procedures Index	2-3	2-1
Troubleshooting Roadmaps	2-4	2-1
Fault Symptom Index.	2-5	2-1
Sample Troubleshooting Procedure	2-6	2-1
CHAPTER 3. TROUBLESHOOTING INDEX		
General	3-1	3-1
Index	3-2	3-1
CHAPTER 4. TEST EQUIPMENT PROCEDURE INDEX		
General.	4-1	4-1
Index	4-2	4-1
CHAPTER 5. TROUBLESHOOTING ROADMAPS		
General	5-1	5-1
Roadmaps	5-2	5-1
CHAPTER 6. FAULT SYMPTOM INDEXES		
General	6-1	6-1
Indexes	6-2	6-1
CHAPTER 7. SAMPLE TROUBLESHOOTING PROCEDURES		
General	7-1	7-1
Sample Detailed Procedure	7-2	7-1
CHAPTER 8. ENGINE SYSTEM TROUBLESHOOTING		
Equipment Items Covered	8-1	8-1
Equipment Items Not Covered	8-2	8-1
CHAPTER 9. ENGINE SYSTEM TEST PROCEDURES		
General	9-1	9-1
Test Set-up	9-2	9-1
Test Procedure	9-3	9-1

TABLE OF CONTENTS-CONT

		Paragraph	Page
CHAPTER 10.	FUEL SYSTEM TROUBLESHOOTING		
	Equipment Items Covered	10-1	10-1
	Equipment Items Not Covered	10-2	10-1
CHAPTER 11.	FUEL SYSTEM SUPPORT DIAGRAMS		
	General	11-1	11-1
CHAPTER 12.	FUEL SYSTEM TEST PROCEDURES		
	General	12-1	12-1
	Test Set-up	12-2	12-1
	Test Procedures	12-3	12-1
CHAPTER 13.	ELECTRICAL SYSTEM TROUBLESHOOTING		
	Equipment Items Covered	13-1	13-1
	Equipment Items Not Covered	13-2	13-1
CHAPTER 14.	ELECTRICAL SYSTEM TEST PROCEDURES		
	Test Procedures	14-1	14-1
CHAPTER 15.	TRANSMISSION SYSTEM TROUBLESHOOTING		
	Equipment Items Covered	15-1	15-1
	Equipment Items Not Covered	15-2	15-1
CHAPTER 16.	EARTH BORING MACHINE SYSTEM TROUBLESHOOTING		
	Equipment Items Covered	16-1	16-1
	Equipment Items Not Covered	16-2	16-1
CHAPTER 17.	FRONT WINCH SYSTEM TROUBLESHOOTING		
	Equipment Items Covered	17-1	17-1
	Equipment Items Not Covered	17-2	17-1
CHAPTER 18.	DUMP SYSTEM TROUBLESHOOTING		
	Equipment Items Covered	18-1	18-1
	Equipment Items Not Covered	18-2	18-1
CHAPTER 19.	REAR WINCH (M764) SYSTEM TROUBLESHOOTING		
	Equipment Items Covered	19-1	19-1
	Equipment Items Not Covered	19-2	19-1
CHAPTER 20.	REAR WINCH (M756A2) SYSTEM TROUBLESHOOTING		
	Equipment Items Covered	20-1	20-1
	Equipment Items Not Covered	20-2	20-1

TABLE OF CONTENTS-CONT

VOLUME 2 OF 2

Part 1 of 3

(TM 9-2320-209-34-2-1)

	Page	
CHAPTER 1.	GENERAL MAINTENANCE INFORMATION	
CHAPTER 2.	ENGINE SYSTEM GROUP MAINTENANCE	
Section I.	Scope	2-1
Section II.	Engine Assembly	2-1
Section III.	Crankcase, Block, and Cylinder Head	2-42
Section IV.	Crankshaft	2-106
Section V.	Flywheel	2-123
Section VI.	Pistons and Connecting Rods	2-132
Section VII.	Valves, Camshaft, and Timing System	2-132
Section VIII.	Engine Lubricating System and Manifold	2-169
CHAPTER 3.	CLUTCH SYSTEM GROUP MAINTENANCE	
Section I.	Scope	3-1
Section II.	Clutch Assembly	3-1
Section III.	Clutch Release Mechanism	3-5
CHAPTER 4.	FUEL SYSTEM GROUP MAINTENANCE	
Section I.	Scope	4-1
Section II.	Fuel Injector	4-1
Section III.	Turbocharger	4-6
Section IV.	Fuel Tanks	4-6
CHAPTER 5.	EXHAUST SYSTEM GROUP MAINTENANCE	
Section I.	Scope	5-1
Section II.	Exhaust Pipes and Mufflers..	5-1
CHAPTER 6.	COOLING SYSTEM GROUP MAINTENANCE	
Section I.	Scope	6-1
Section II.	Radiator and Shrouds	6-1
CHAPTER 7.	ELECTRICAL SYSTEM GROUP MAINTENANCE	
Section I.	Scope	7-1
Section II.	Charging System	7-1
Section III.	Battery System	7-1
Section IV.	Chassis Wiring Harnesses	7-2
CHAPTER 8.	TRANSMISSION SYSTEM GROUP MAINTENANCE	
Section I.	Scope	8-1
Section II.	Transmission Assembly.....	8-1
CHAPTER 9.	TRANSMISSION TRANSFER SYSTEM GROUP MAINTENANCE	
Section I.	Scope	9-1
Section II.	Transmission Transfer Assembly	9-1
CHAPTER 10.	FRONT AXLE GROUP MAINTENANCE	
Section I.	Scope	10-1
Section II.	Front Axle Assembly	10-1
Section III.	Differential Carrier Assembly	10-41
Section IV.	Steering Mechanism	10-107

TABLE OF CONTENTS-CONT

	Page
CHAPTER 11. REAR AXLE GROUP MAINTENANCE	
Section I. Scope	11-1
Section II. Rear Axle Assembly	11-1
CHAPTER 12. BRAKE SYSTEM GROUP MAINTENANCE	
Section I. Scope	12-1
Section II. Handbrake and Service Brake Assemblies	12-1
Section III. Hydraulic Brake System	12-7
Section IV. Trailer Brake Connections and Controls	12-59
CHAPTER 13. WHEEL SYSTEM GROUP MAINTENANCE	
Section I. Scope	13-1
Section II. Wheel Assembly	13-1
CHAPTER 14. STEERING SYSTEM GROUP MAINTENANCE	
Section I. Scope	14-1
Section II. Mechanical Steering Gear Assembly	14-1
CHAPTER 15. FRAME AND TOWING ATTACHMENTS GROUP MAINTENANCE	
Section I. Scope	15-1
Section II. Frame Assembly	15-1
Section III. Fifth Wheel Assembly	15-57
CHAPTER 16. SPRINGS GROUP MAINTENANCE	
Section I. Scope	16-1
Section II. Springs	16-1

Part 2 of 3
(TM 9-2320 -209-34-2-2)

CHAPTER 17. BODY , CAB, HOOD, AND HULL GROUP MAINTENANCE	
Section I. Scope	17-1
Section II. Hood and Cab Components	17-1
Section III. Fenders, Running Boards, and Windshield Assembly	17-79
Section IV. Seats	17-122
Section V. Cargo Body Components	17-147
Section VI. Tank Body Components	17-165
Section VII. Special Purpose Body Components	17-376

Part 3 of 3
(TM 9-2320 -209-34-2-3)

CHAPTER 18. WINCH , HOIST, AND POWER TAKEOFF ASSEMBLIES GROUP MAINTENANCE	
Section I. Scope	18-1
Section II. Winch and Hoist Assemblies	18-1
Section III. Power Takeoff Assembly	18-274

TABLE OF CONTENTS-CONT

	Paragraph	Page
CHAPTER 19. BUMPER AND GUARDS GROUP MAINTENANCE		
Section I. Scope		19-1
Section II. Bumper, Brackets, Guards, and Protective Devices		19-1
CHAPTER 20. BODY ACCESSORY ITEMS GROUP MAINTENANCE		
Section I. Scope		20-1
Section II. Canvas and Rubber Items		20-1
CHAPTER 21. MAINTENANCE OF MATERIAL USED IN CONJUNCTION WITH MAJOR ITEMS		
Section I. Scope		21-1
Section II. Winterization Kits		21-1
Section III. Deep Water Fording Kit		21-140
Section IV. Special Purpose Kits		21-199
APPENDIX A. REFERENCES		A-1
INDEX		Index 1

CHAPTER 1

GENERAL INFORMATION

1-1. SCOPE. This volume shows you how to do troubleshooting at the direct and general support levels of maintenance. The amount of troubleshooting you can do is based on what the Maintenance Allocation Chart says you can fix. Because of this, the only trouble symptoms you will find here are those that could be caused by faulty things you can fix.

1-2. ORGANIZATION. This volume has the information you will need to troubleshoot the truck. Chapter 2 tells you how to use the information in the other chapters of this volume to find what is wrong with the truck, and what you must do to fix it. Chapter 7 has a procedure that takes you step-by-step through a sample troubleshooting procedure and shows you how to use the information to find the trouble and fix it.

1-3. TROUBLESHOOTING APPROACH. In order to find out what is causing the problem in the truck, you must use a good approach. A good approach just means a way of doing troubleshooting so you can find the problem and not get confused or lost. The following chapter describes how you can use the materials in this volume to troubleshoot with a good approach.

CHAPTER 2

TROUBLESHOOTING APPROACH

2-1. GENERAL APPROACH. This chapter gives you instructions on how to use the troubleshooting material to help you find and fix the trouble. In every system of the truck there can be faults or problems which will cause certain symptoms. Symptoms can be such things as unusual noise, vibration, or even complete failure of a system. This volume gives information for each system on which you can do troubleshooting to find faults and fix them. Before you troubleshoot a system, you should look at the troubleshooting indexes which will lead you to the information you need to help make your troubleshooting faster and easier. If you follow the instructions the right way, you will find those troubles you can fix. But, if you fix something and the trouble is still there, it means there is more than one trouble. If this happens, start all over again to find the other trouble.

2-2. TROUBLESHOOTING INDEX. The troubleshooting index, and instructions how to use it are in chapter 3. Go to this index first because it tells you where to find troubleshooting roadmaps, fault symptom indexes, summary troubleshooting charts and support diagrams for each system.

2-3. TEST EQUIPMENT PROCEDURES INDEX. The test equipment procedures index, and instructions on how to use it are in chapter 4. This index tells you where to find electrical and mechanical tests which you can use to do your troubleshooting. It also tells you what equipment you will need to do the tests. If you have a STE/ICE (Simplified Test Equipment/Internal Combustion Engine) Set (NSN 4910-00-124-2554), you may use it, where applicable, to do your troubleshooting. Refer to TM 9-4910-571-12&P.

2-4. TROUBLESHOOTING ROADMAPS. Troubleshooting roadmaps for each system are in chapter 5. If the system is made up of subsystems, these subsystems are also on the roadmap. Under the subsystem is a list of things which are the most likely causes of a fault symptom in that subsystem. If you have enough skill, you can troubleshoot these things on the truck without using the detailed troubleshooting procedures. So if you know enough about the truck to work on your own, use the roadmap for the system with the problem before you check the fault symptom index.

2-5. FAULT SYMPTOM INDEX. Fault symptom indexes and instructions on how to use them are in chapter 6. For each system of the truck, there is an index which gives you a list of the fault symptoms for that system. The index also tells you where to find the detailed troubleshooting procedures and what resources (tools/people) you need to do each procedure.

2-6. SAMPLE TROUBLESHOOTING PROCEDURE. A sample troubleshooting procedure is in chapter 7. This sample procedure will help you see the way detailed troubleshooting procedures are to be used.

CHAPTER 3

TROUBLESHOOTING INDEX

3-1. GENERAL. This chapter has a troubleshooting index which covers every system of the truck on which you can do troubleshooting. The index tells you where to find all the other information you need to do your troubleshooting procedures.

3-2. INDEX. The troubleshooting index. (figure 3-1) is divided into five columns that list systems, troubleshooting roadmaps, fault symptoms, summary troubleshooting procedures, and system support diagrams. The following breakdown tells you what is in each column.

a. System Column. This column gives a list of systems on the truck for which troubleshooting can be done at the direct support maintenance level.

b. Troubleshooting Roadmaps Column. This column tells you where to find the troubleshooting roadmap for each listed system. These roadmaps are given in chapter 5.

c. Fault Symptom Index Column. This column tells you where to find the troubleshooting fault symptom index for each listed system. Fault symptom indexes are given in chapter 6.

d. Summary troubleshooting Procedures Column. This column tells you where to find the summary troubleshooting procedure for each listed system. Some systems do not have summary trouble shooting procedures, so the column will be left blank for those systems.

e. System Support Diagrams Column. This column tells you where to find support diagrams for each listed system. Some systems do not have support diagrams, so the column will be left blank for those systems.

	SYSTEM	TROUBLE-SHOOTING ROADMAPS	FAULT SYMPTOM INDEXES	SUMMARY TROUBLE-SHOOTING PROCEDURES	SYSTEM SUPPORT DIAGRAMS
1	ENGINE	Figure 5-1	Table 6-1		Figure 9-1
2	FUEL	Figure 5-2	Table 6-2		Figure 11-1
3	ELECTRICAL	Figure 5-3	Table 6-3		
4	TRANSMISSION	Figure 5-4	Table 6-4		
5	EARTH BORING MACHINE	Figure 5-5	Table 6-5		
6	FRONT WINCH	Figure 5-6	Table 6-6		
7	DUMP	Figure 5-7	Table 6-7		
8	M764 REAR WINCH	Figure 5-8	Table 6-8		
9	M756A2 REAR WINCH	Figure 5-9	Table 6-9		

TA 120721

Figure 3-1. Troubleshooting Index

CHAPTER 4

TEST EQUIPMENT PROCEDURES INDEX

4-1. GENERAL. This chapter has a test equipment procedures index which tells you where to find the tests you need to do your troubleshooting.

4-2. INDEX. The test equipment procedures index is divided into three columns that list test equipment, tests, and figure numbers. The following breakdown tells you what is in each column.

a. Test Equipment Column. This column tells you what kind of equipment you need to do your troubleshooting tests.

b. Tests Column. This column tells you what tests are given in this manual. Next to each piece of test equipment are listed the tests that you can do with that equipment. This column also gives troubleshooting tests which can be done without using test equipment.

c. Figure Column. This column tells you where you can find the tests in this manual.

TEST EQUIPMENT		TESTS	FIGURE
1	COMPRESSION TESTER GAGE	Engine Cylinder Compression	9-1
2		Fuel Injector Nozzle	12-1
3	MULTIMETER TESTS	Refer to TM 9-2320-209-20	
4			
5			
6			
7			
8			

TA 120722

Figure 4-1. Test Equipment Procedures Index

CHAPTER 5

TROUBLESHOOTING ROADMAPS

5-1. GENERAL. This chapter gives troubleshooting roadmaps for every system of the truck for which you have detailed troubleshooting procedures. Figures 5-1 through 5-9 cover all the roadmaps for the detailed procedures.

5-2. ROADMAPS. Each roadmap gives a list of things which are most likely to cause a fault symptom in a system or sub-system. At least one of the items listed will be found to be bad when you do the detailed troubleshooting procedures for that system.

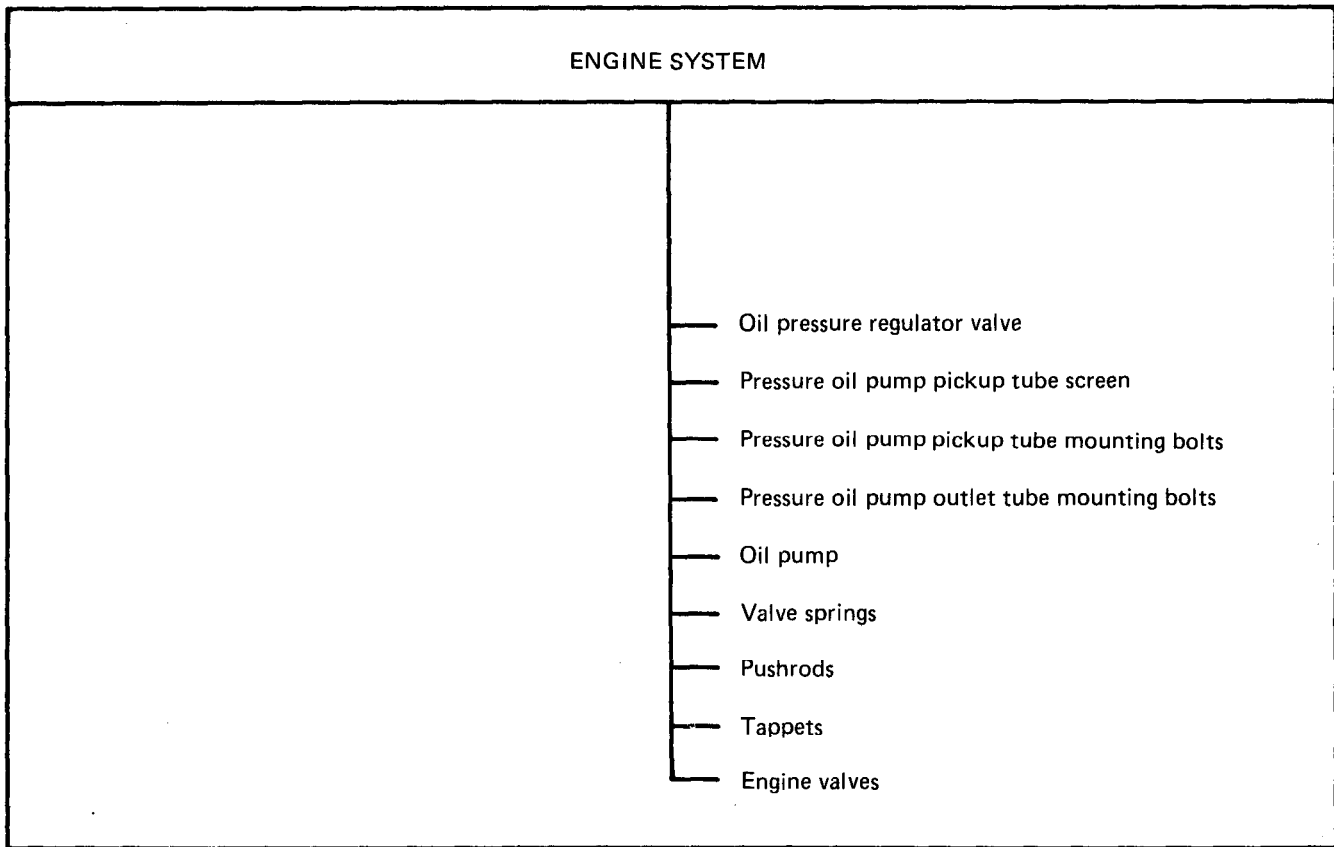
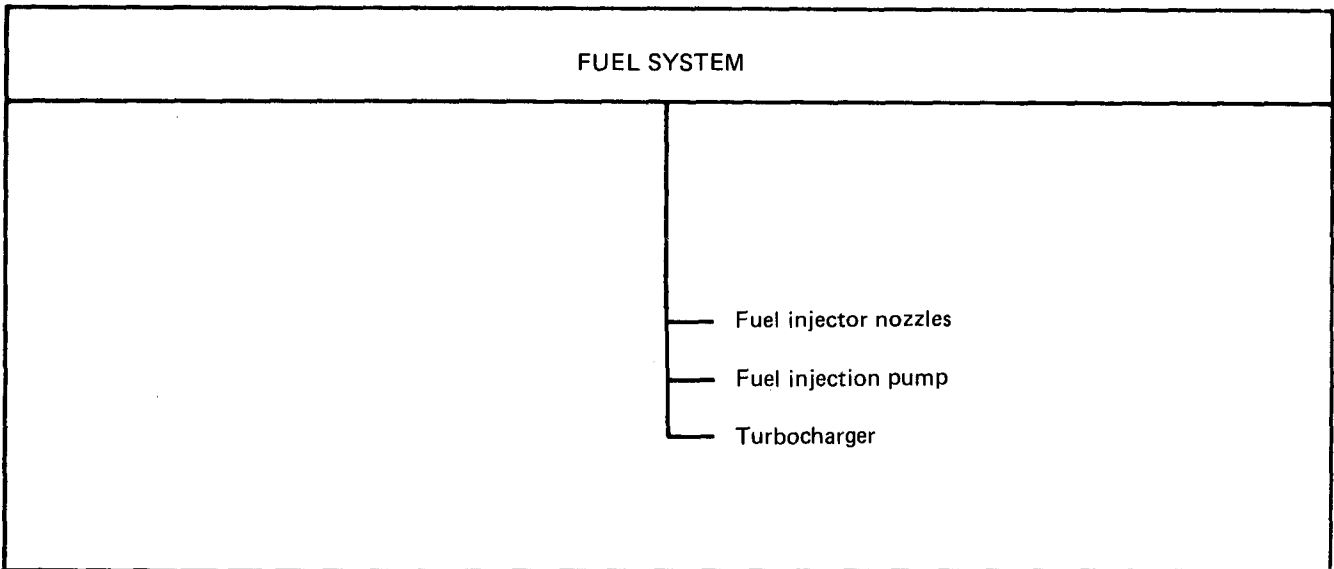
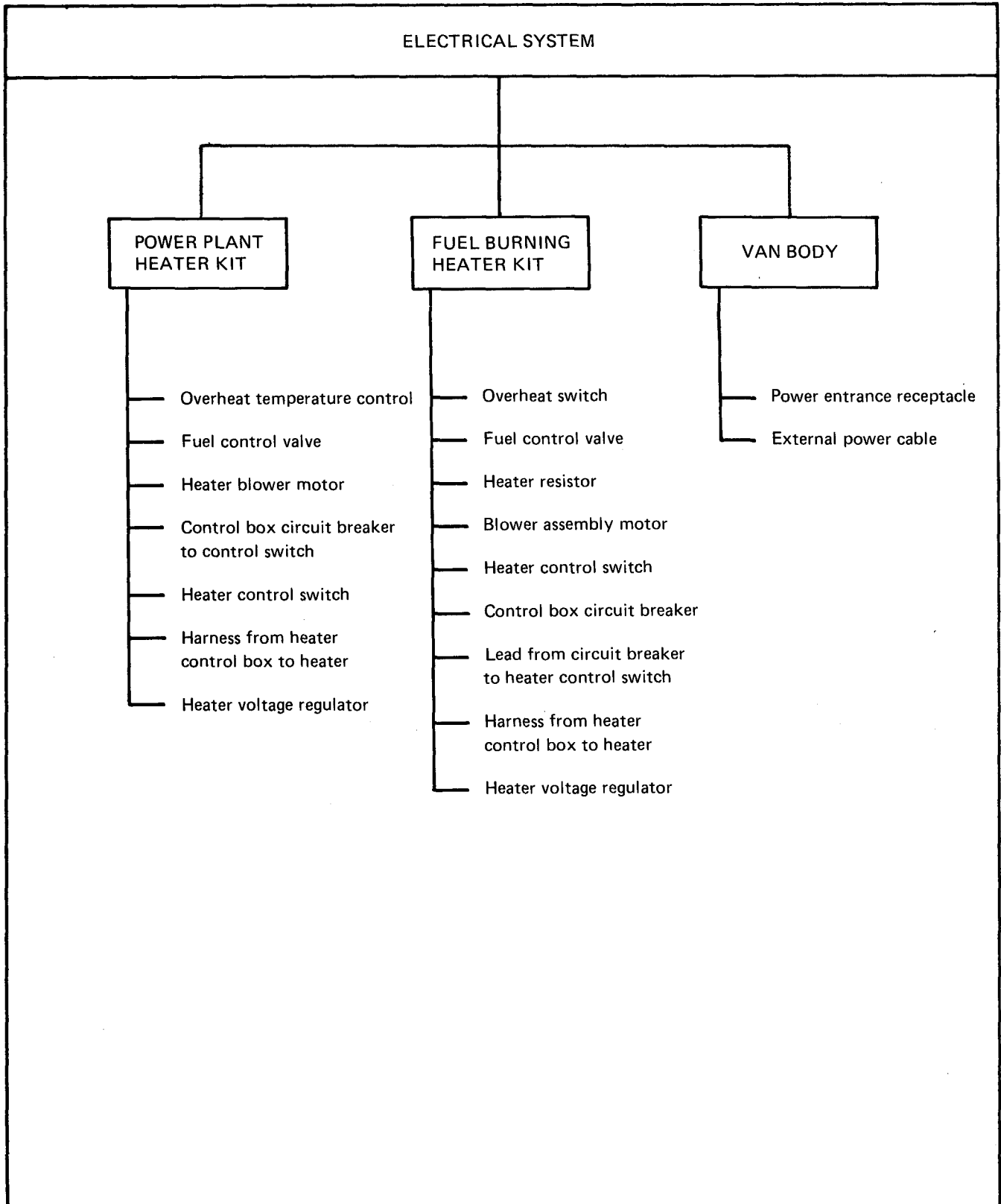

Figure 5-1. Troubleshooting Roadmap, Engine System



TA 120723

Figure 5-2. Troubleshooting Roadmap, Fuel System



TA 120724

Figure 5-3. Troubleshooting Roadmap, Electrical System

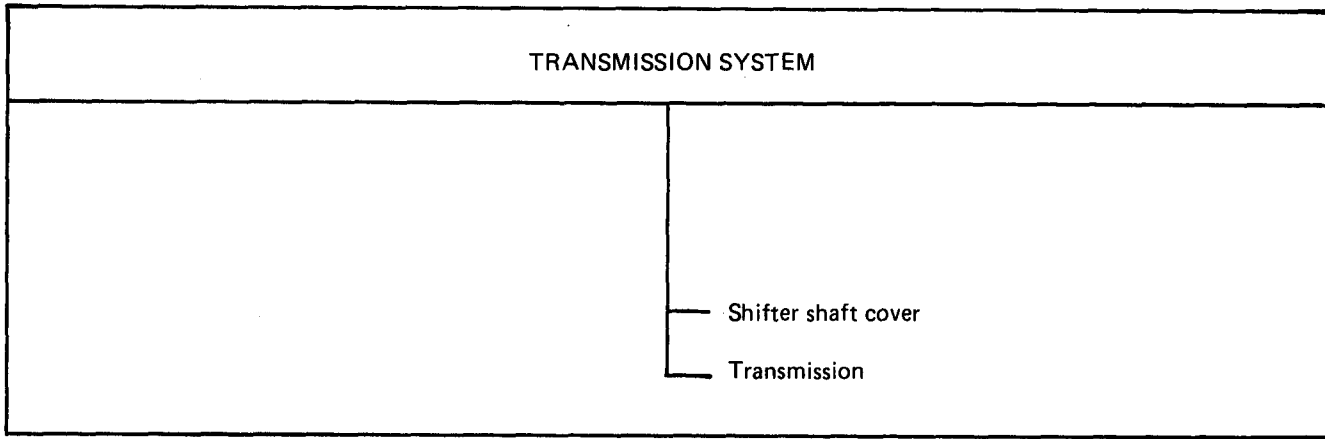

Figure 5-4. Troubleshooting Roadmap, Transmission System

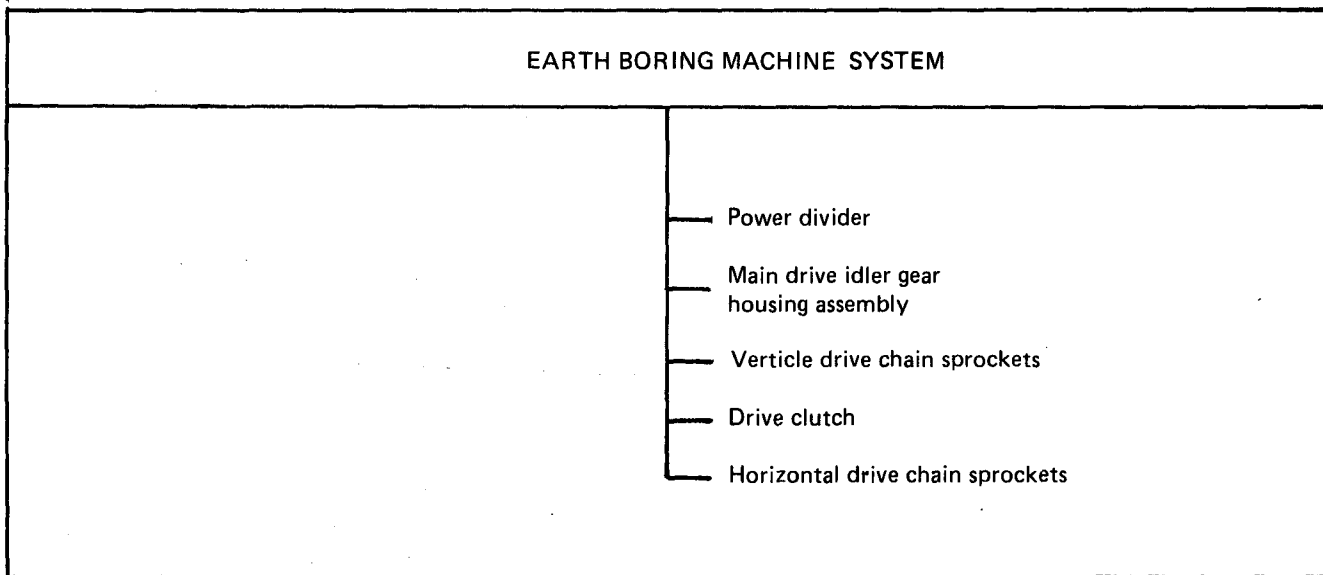
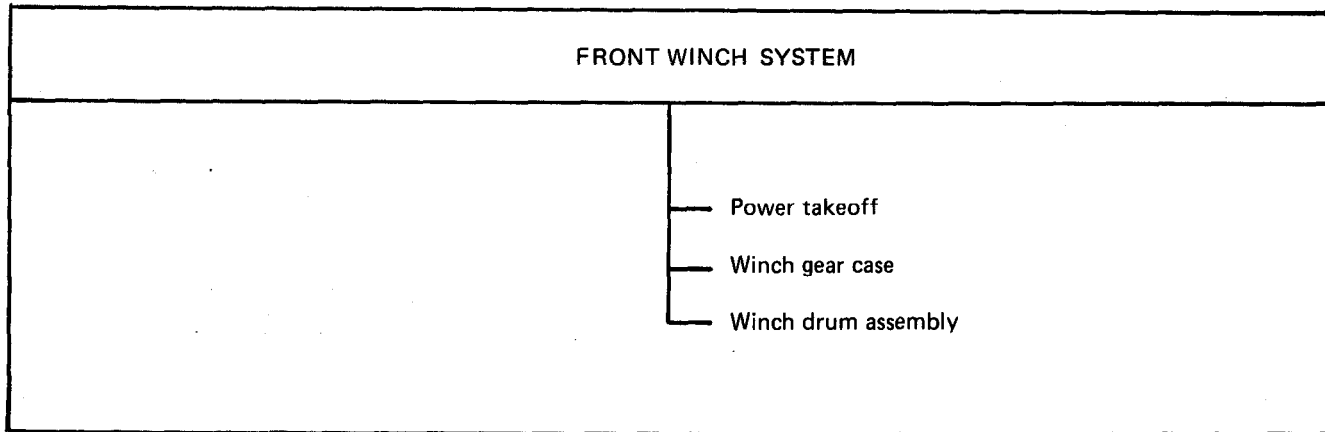

Figure 5-5. Troubleshooting Roadmap, Earth Boring Machine System



TA 120725

Figure 5-6. Troubleshooting Roadmap, Front Winch System

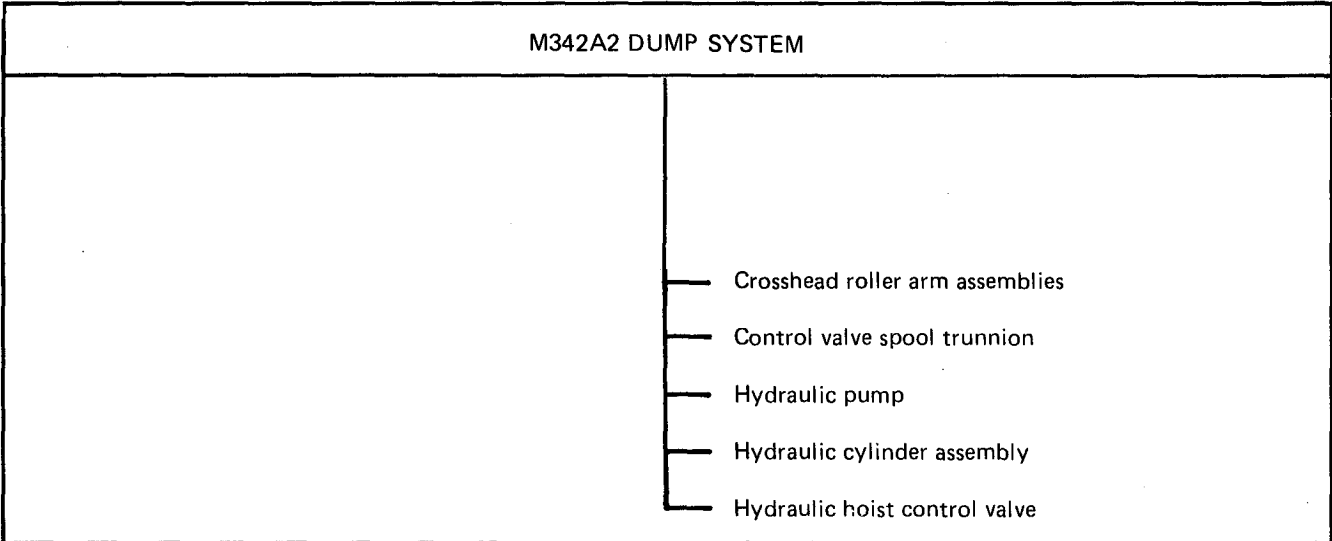

Figure 5-7. Troubleshooting Roadmap , M342A2 Dump System

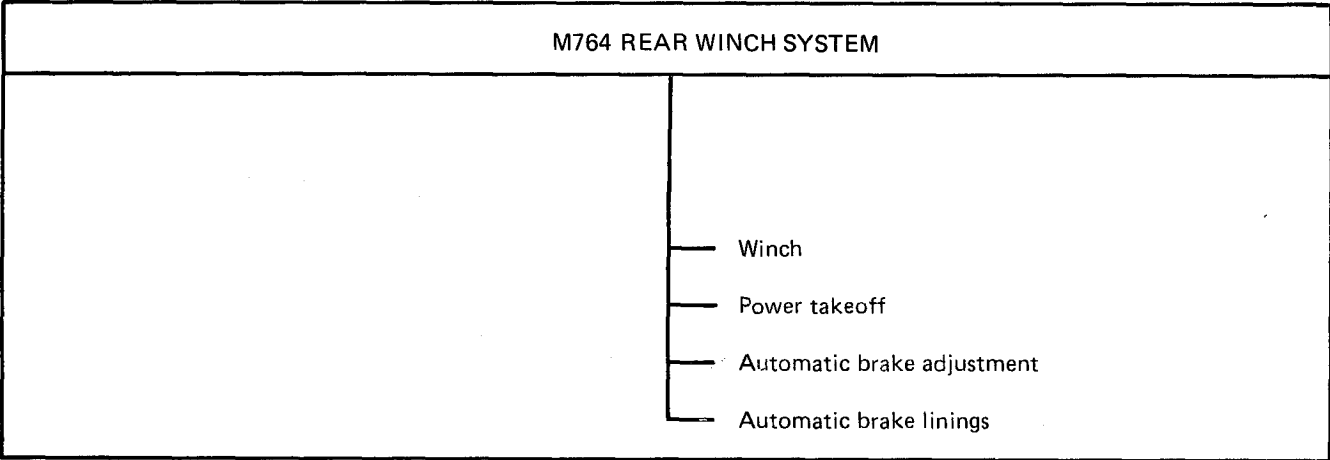
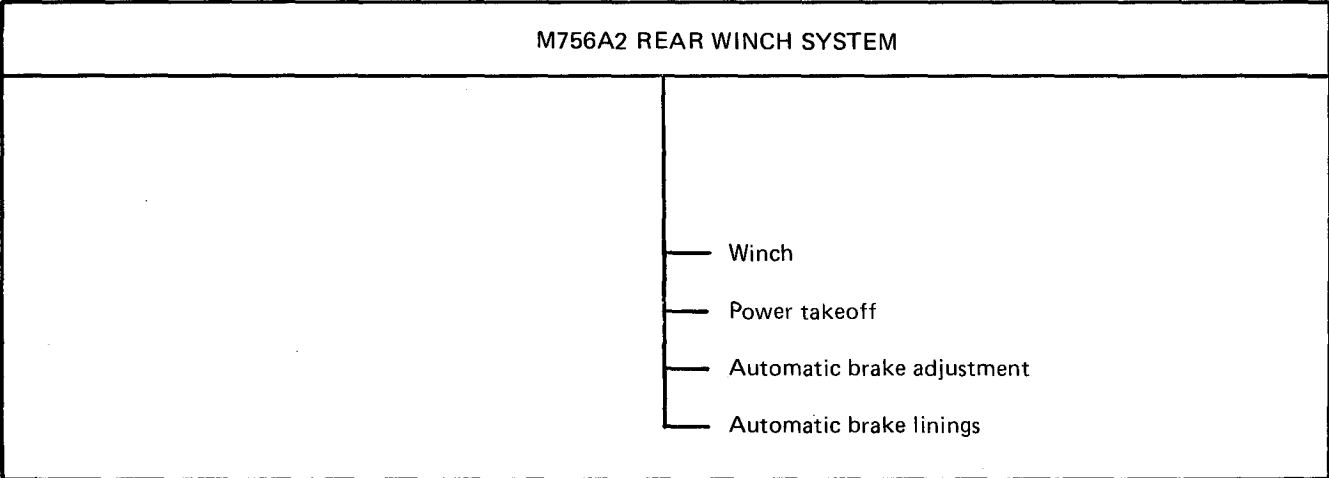

Figure 5-8. Troubleshooting Roadmap, M764 Rear Winch System



TA 120726

Figure 5-9. Troubleshooting Roadmap, M756A2 Rear Winch System

CHAPTER 6

FAULT SYMPTOM INDEXES

6-1. GENERAL. This chapter gives troubleshooting fault symptom indexes for every system of the truck for which you have detailed troubleshooting procedures. These indexes are in table form (tables 6-1 through 6- 9) which gives you a quick way to check what material you have to use to do your troubleshooting.

6-2. INDEXES. Each index is divided into columns which give you information you need to help you do troubleshooting procedures. The following breakdown tells you what is in each column.

- a. Subsystem Column. If the main system is divided into subsystems, the subsystems will be listed in this column.
- b. Symptom Column. This column lists the symptoms, or problems for which detailed troubleshooting procedures are given.
- c. Summary Column. This column tells you where to find the summary troubleshooting procedures for each symptom.
- d. Detailed Column. This column tells you where to find the detailed troubleshooting procedure for each symptom.
- e. Persons Column. This column tells you how many people are needed to do the troubleshooting procedure.
- f. Special Tools Column. Any tools needed to do the troubleshooting procedure which are not included in your common tool kit are listed in this column.
- g. Standard Tools Column. A dot in this column means that tools found in your common tool kit are needed to do the troubleshooting procedure.
- h. Materials Column. This column tells you what materials are needed to do the troubleshooting procedure. These materials and how they will be issued will be decided by your maintenance officer.
- i. Time Column. This column tells you how much time you will need to do the detailed troubleshooting procedure. The time will be decided by your maintenance officer.

FAULT SYMPTOM INDEX

TABLE 6-1. ENGINE SYSTEM								
SUBSYSTEM	SYMPTOM	TS PROCEDURE		RESOURCES REQ'D				
		SUMMARY	DETAILED	PERSONS	TEST EQUIPMENT		MATERIALS	TIME
					SPECIAL TOOLS	STANDARD TOOLS		
_____	1. Low oil pressure	_____	Figure 8-1	1	_____	•		
_____	2. Engine runs rough	_____	Figure 8-2	1	Checking cylinder compression gage assembly	•		
_____	3. Hard starting	_____	Figure 8-3	1	Checking cylinder compression gage assembly	•		

FAULT SYMPTOM INDEX

TABLE 6-2. FUEL SYSTEM								
SUBSYSTEM	SYMPTOM	TS PROCEDURE		RESOURCES REQ'D				
		SUMMARY	DETAILED	PERSONS	TEST EQUIPMENT		MATERIALS	TIME
					SPECIAL TOOLS	STANDARD TOOLS		
_____	1. Engine runs rough and lacks power	_____	Figure 10-1	1	_____	•		
_____	2. Engine cranks but does not start	_____	Figure 10-2	2	_____	•		
_____	3. Poor fuel mileage	_____	Figure 10-3	1	_____	•		

TA 120727

FAULT SYMPTOM INDEX

TABLE 6-3. ELECTRICAL SYSTEM									
SUBSYSTEM	SYMPTOM	TS PROCEDURE		RESOURCES REQ'D					
		SUMMARY	DETAILED	PERSONS	TEST EQUIPMENT			MATERIALS	TIME
					MULTIMETER	HYDROMETER	STANDARD TOOLS		
POWER PLANT HEATER KIT	1. Power plant heater overheats and continues burning	_____	Figure 13-1	1	•		•		
	2. Power plant heater does not give enough heat	_____	Figure 13-2	1	•		•		
	3. Power plant heater does not start	_____	Figure 13-3	1	•		•		
FUEL BURNING HEATER KIT	4. Fuel burning heater overheats and continues burning	_____	Figure 13-4	1	•		•		
	5. Fuel burning heater does not give enough heat	_____	Figure 13-5	1	•		•		
	6. Fuel burning heater does not start	_____	Figure 13-6	1	•		•		
VAN BODY	7. No van lights or equipment work	_____	Figure 13-7	1	•				

FAULT SYMPTOM INDEX

TABLE 6-4. TRANSMISSION SYSTEM								
SUBSYSTEM	SYMPTOM	TS PROCEDURE		RESOURCES REQ'D				
		SUMMARY	DETAILED	PERSONS	TEST EQUIPMENT		MATERIALS	TIME
					SPECIAL TOOLS	STANDARD TOOLS		
—	1. Transmission is hard to shift or pops out of gear	—	Figure 15-1	1	—	•		

FAULT SYMPTOM INDEX

TABLE 6-5. EARTH BORING MACHINE SYSTEM								
SUBSYSTEM	SYMPTOM	TS PROCEDURE		RESOURCES REQ'D				
		SUMMARY	DETAILED	PERSONS	TEST EQUIPMENT		MATERIALS	TIME
					SPECIAL TOOLS	STANDARD TOOLS		
—	1. Boring machine propeller shaft does not turn	—	Figure 16-1	2	—			
—	2. Boring machine does not move up or down	—	Figure 16-2	1	—	•		
—	3. Boring machine does not move left or right	—	Figure 16-3	1	—	•		

FAULT SYMPTOM INDEX

TABLE 6-6. FRONT WINCH SYSTEM								
SUBSYSTEM	SYMPTOM	TS PROCEDURE		RESOURCES REQ'D				
		SUMMARY	DETAILED	PERSONS	TEST EQUIPMENT		MATERIALS	TIME
					SPECIAL TOOLS	STANDARD TOOLS		
—	1. Winch does not pull load	—	Figure 17-1	1	—			

FAULT SYMPTOM INDEX

TABLE 6-7. M342A2 DUMP SYSTEM								
SUBSYSTEM	SYMPTOM	TS PROCEDURE		RESOURCES REQ'D				
		SUMMARY	DETAILED	PERSONS	TEST EQUIPMENT		MATERIALS	TIME
					SPECIAL TOOLS	STANDARD TOOLS		
—	1. Dump body does not rise	—	Figure 18-1	1	—	•		
—	2. Dump body rises slowly	—	Figure 18-2	1	—	•		

FAULT SYMPTOM INDEX

TABLE 6-8. M764 REAR WINCH SYSTEM								
SUBSYSTEM	SYMPTOM	TS PROCEDURE		RESOURCES REQ'D				
		SUMMARY	DETAILED	PERSONS	TEST EQUIPMENT		MATERIALS	TIME
					SPECIAL TOOLS	STANDARD TOOLS		
—	1. Winch does not pull load	—	Figure 19-1	1	—	•		
—	2. Winch does not hold load	—	Figure 19-2	1	—	•		
—	3. Winch drum spins too fast when unwinding cable	—	Figure 19-3	1	—	•		

FAULT SYMPTOM INDEX

TABLE 6-9. M756A2 REAR WINCH SYSTEM								
SUBSYSTEM	SYMPTOM	TS PROCEDURE		RESOURCES REQ'D				
		SUMMARY	DETAILED	PERSONS	TEST EQUIPMENT		MATERIALS	TIME
					SPECIAL TOOLS	STANDARD TOOLS		
—	1. Winch does not pull load	—	Figure 20-1	1	—	•		
—	2. Winch does not hold load	—	Figure 20-2	1	—	•		
—	3. Winch drum spins too fast when unwinding cable	—	Figure 20-3	1	—	•		

TA 120731

CHAPTER 7

SAMPLE TROUBLESHOOTING PROCEDURE

7-1. GENERAL. This chapter gives a sample troubleshooting procedure. The purpose of the sample procedure is to help you see how detailed troubleshooting procedures, test equipment procedures, and summary troubleshooting procedures are used to find faults in a system.

7.2. SAMPLE DETAILED PROCEDURE. (See figure 7-1.) The sample detailed procedure given is the fuel system troubleshooting procedure for the symptom, STARTER MOTOR WILL NOT CRANK ENGINE. This symptom is one you will have when you try to start your truck and certain parts on the truck are not working correctly. In each numbered box, instructions are given which tell you what to do, and how to do it. A large dot is placed next to the "what-to-do" instructions, and small dots next to the "how-to-do-it" instructions.

a. Box number ① gives general instructions on getting the truck ready before you start to troubleshoot.

b. Box number ② gives fault isolation test instructions. In this case you are told to check the starting system circuit for loose, burned, or broken leads and connections. These tests or checks, are often referred to in detailed troubleshooting procedures to help you find the problem and fix it. After you do the tests or checks you read the question at the bottom of box number ②. If the starter system is not okay, the answer to the question is NO so you go to the next box.

c. Box number ③ gives you a corrective action. In this case the fault is burned or broken leads or connectors. The corrective action is what you do to fix the fault, which is to replace any burned or broken leads or connectors. If the engine still doesn't start after you do this, it could mean that there are other faults in the system. When this happens, go back to the beginning of the procedure and do each step again until you find the other faults.

d. Sometimes the corrective actions given for a fault will tell you what to do to fix the fault, but will not give you detailed instructions on how to fix it. Instead, you will be told to refer to another volume in this manual for these instructions. Box number ④ is an example of this.

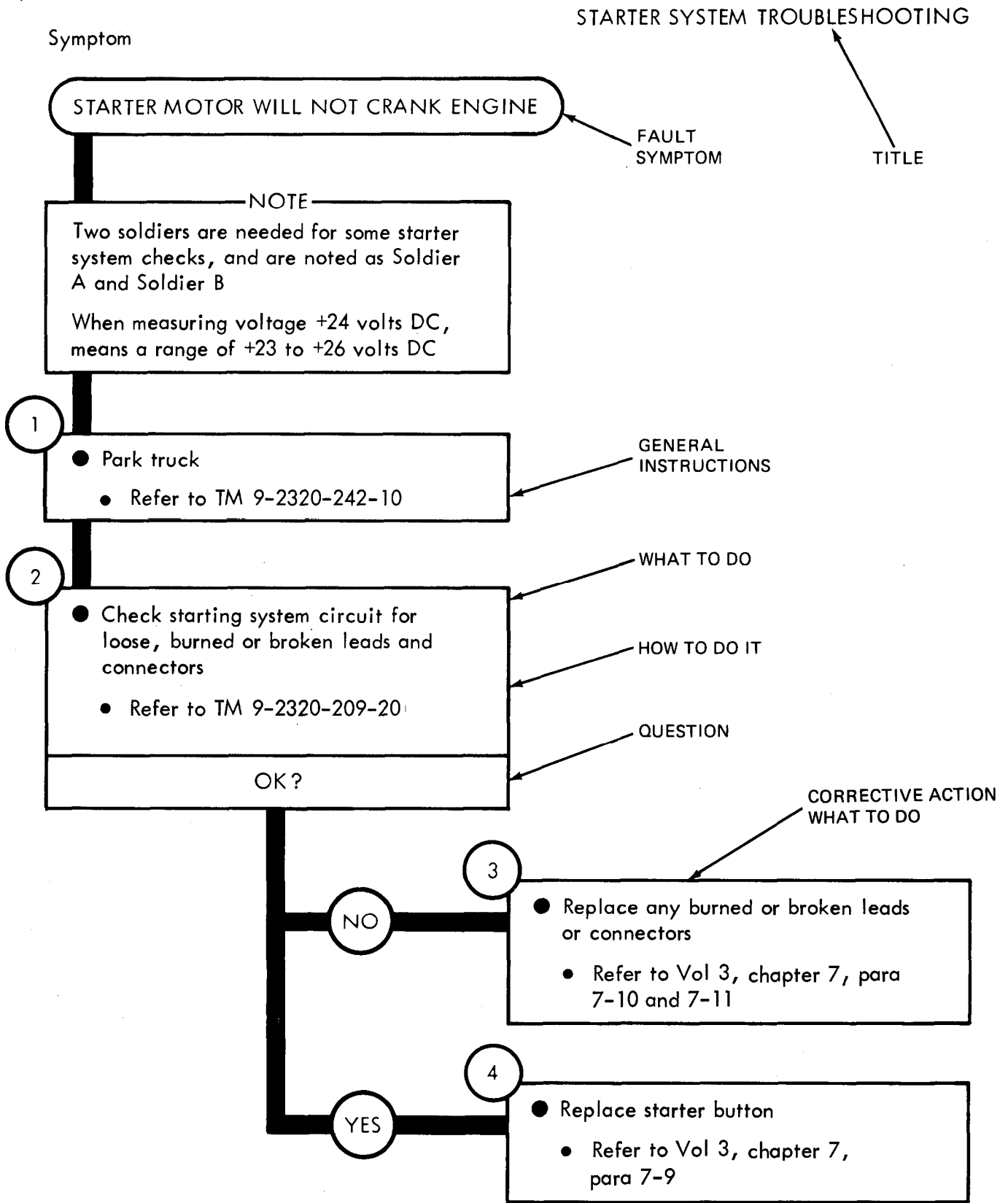

TA 120799

Figure 7-1. Sample Troubleshooting Procedure

CHAPTER 8

ENGINE SYSTEM TROUBLESHOOTING

8-1. EQUIPMENT ITEMS COVERED. This chapter gives equipment troubleshooting procedures for the engine system, for which there are authorized corrective maintenance tasks at the direct support and general support maintenance level.

8-2. EQUIPMENT ITEMS NOT COVERED. All equipment items for which corrective maintenance is authorized at the direct support and general support maintenance level are covered in this chapter.

ENGINE SYSTEM TROUBLESHOOTING

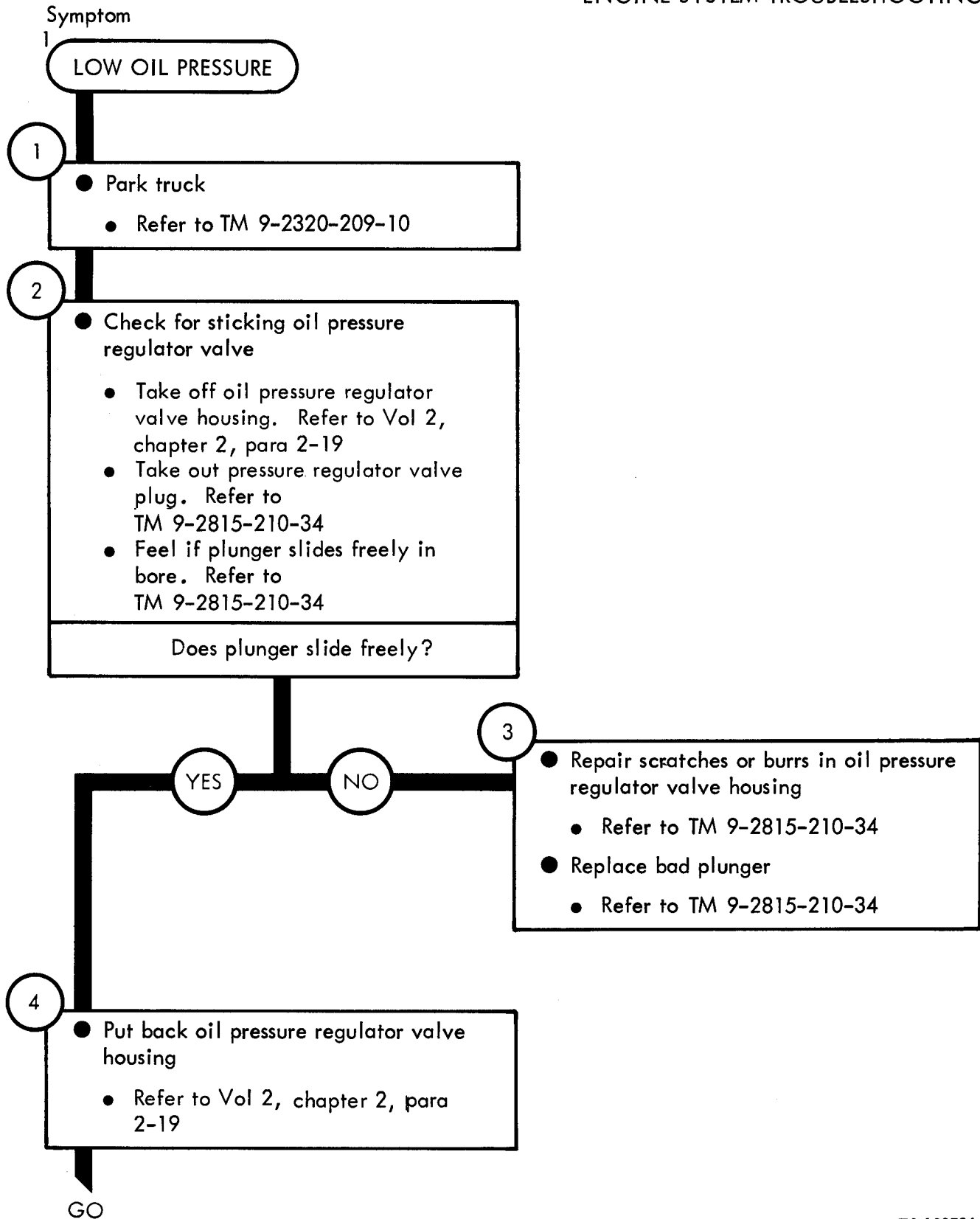

TA 120734

Figure 8-1 (Sheet 1 of 4)

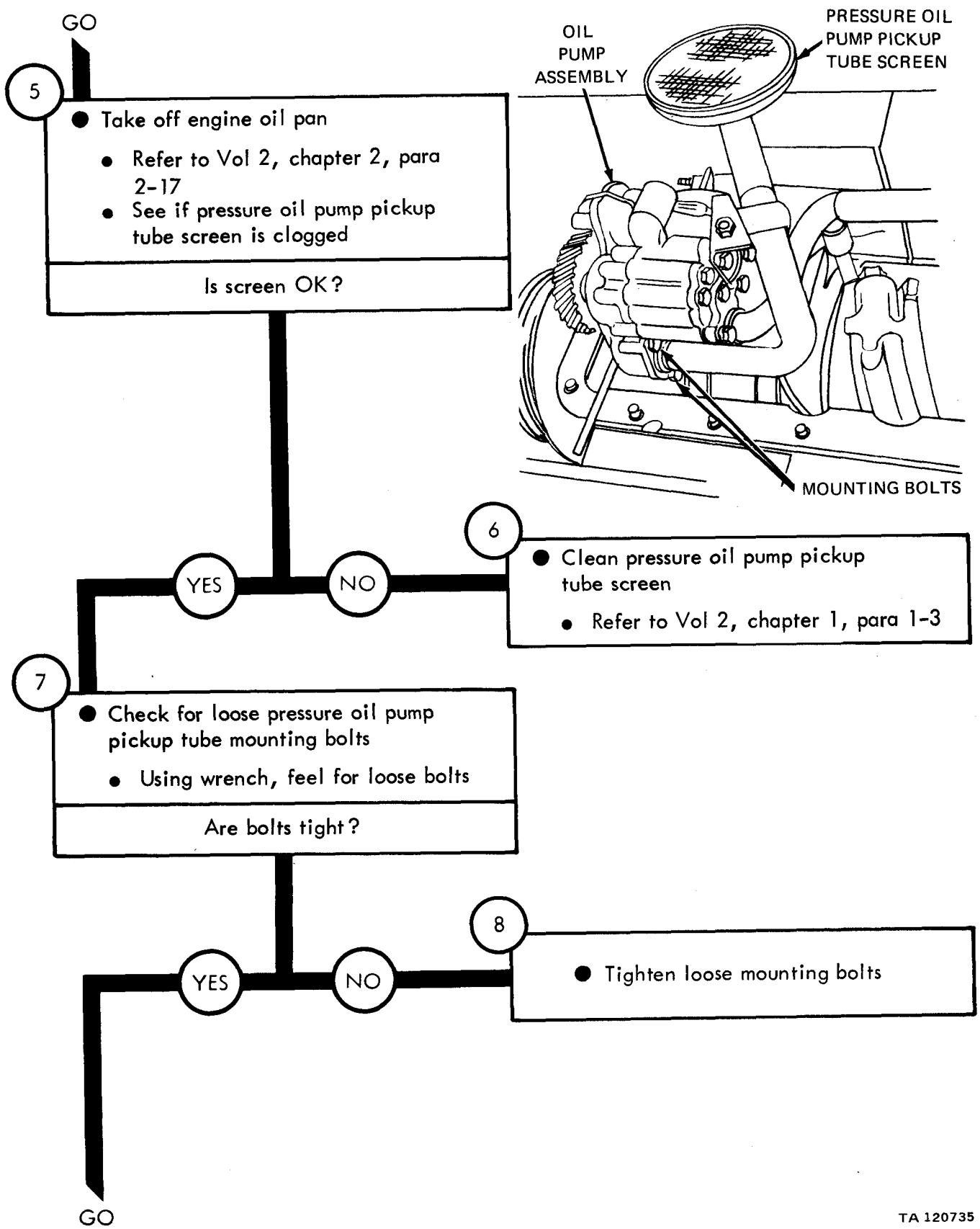

TA 120735

Figure 8-1 (Sheet 2 of 4)

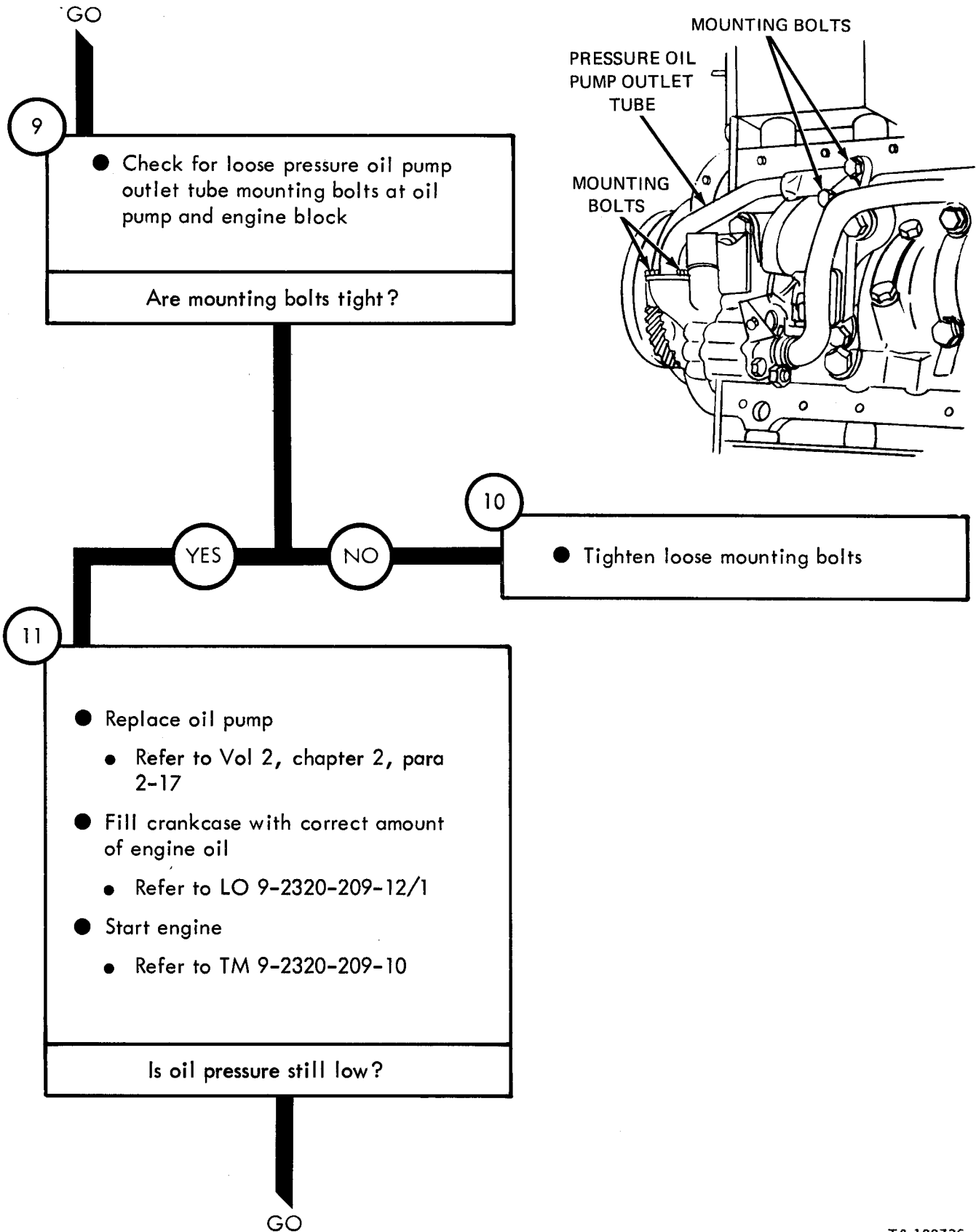

TA 120736

Figure 8-1 (Sheet 3 of 4)

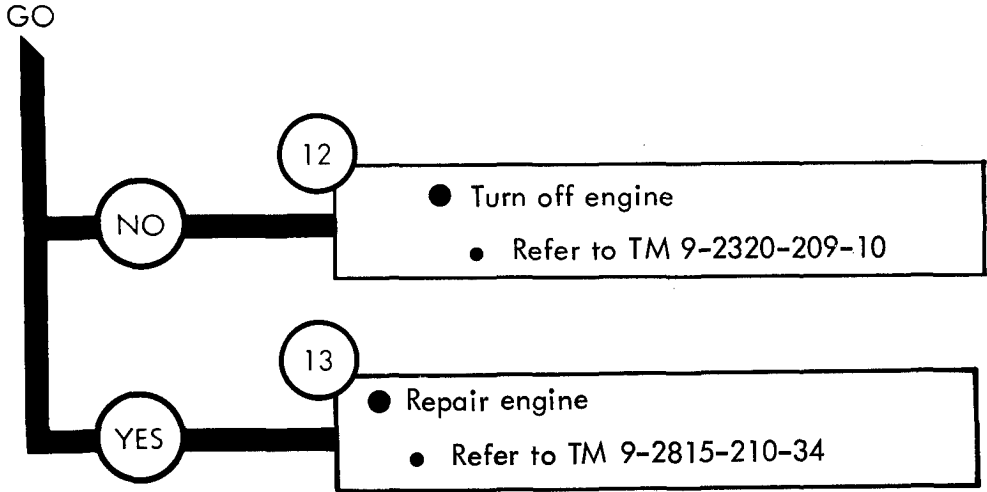

TA 120737

Figure 8-1 (Sheet 4 of 4)

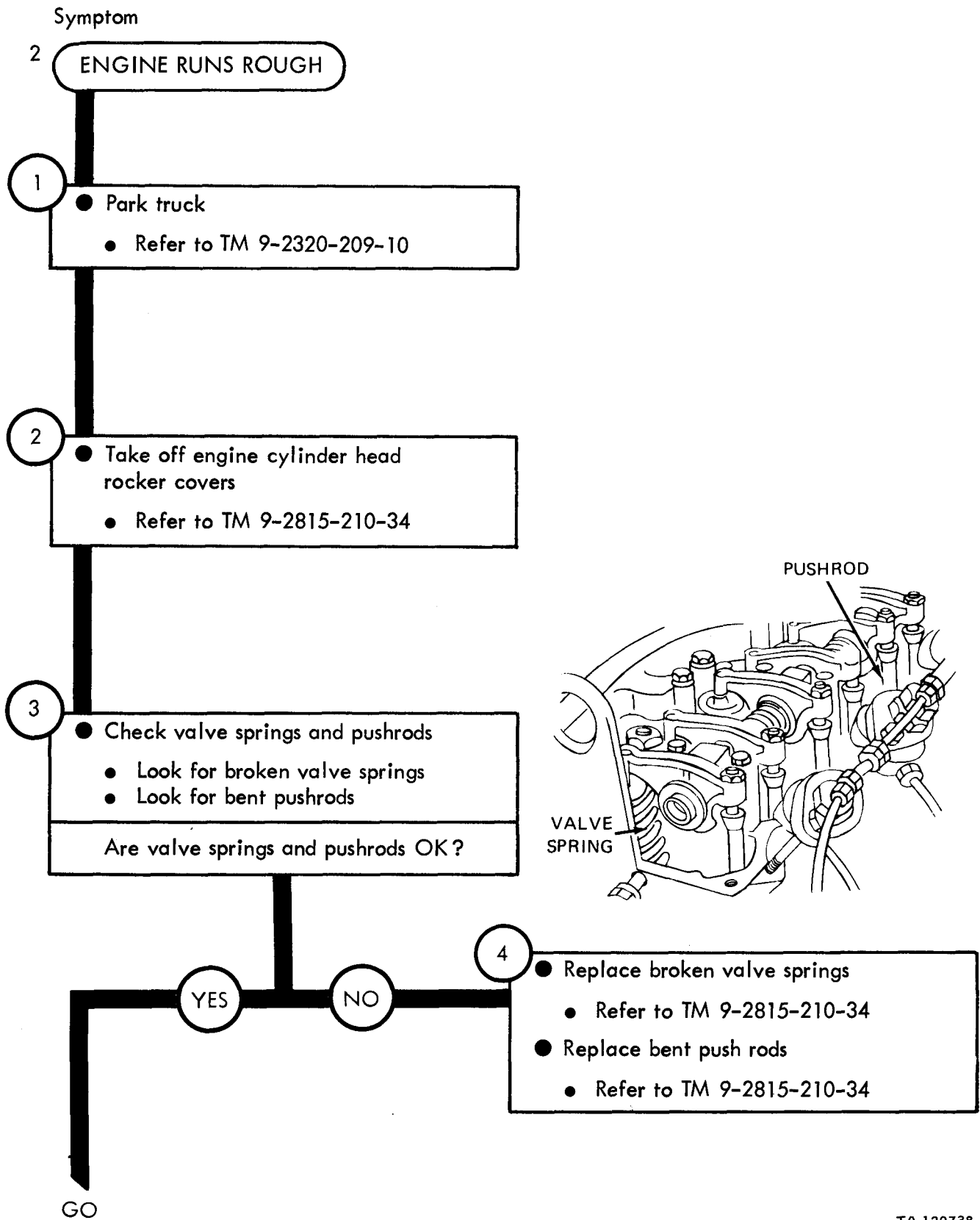

TA 120738

Figure 8-2 (Sheet 1 of 2)

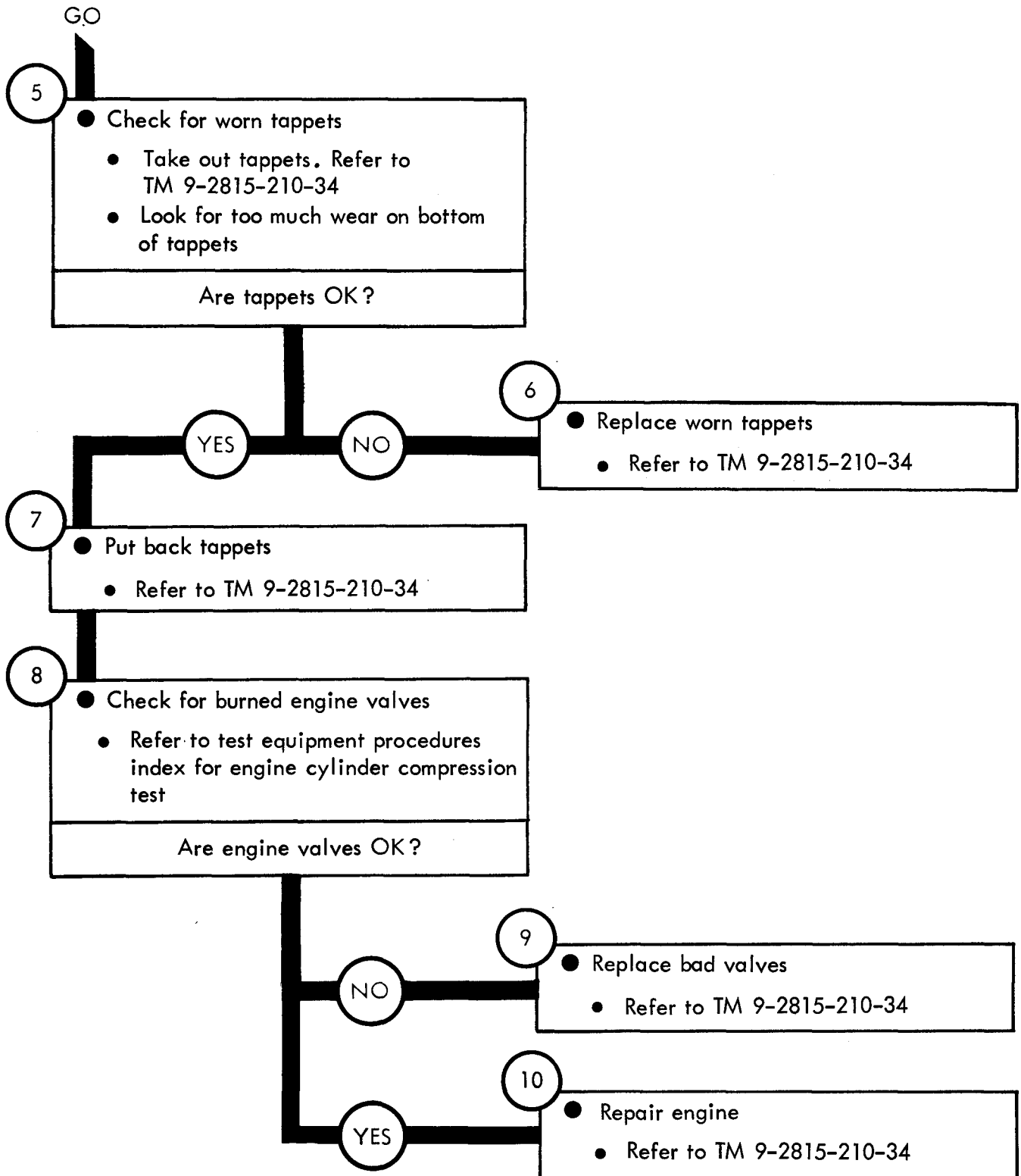

TA 120739

Figure 8-2 (Sheet 2 of 2)

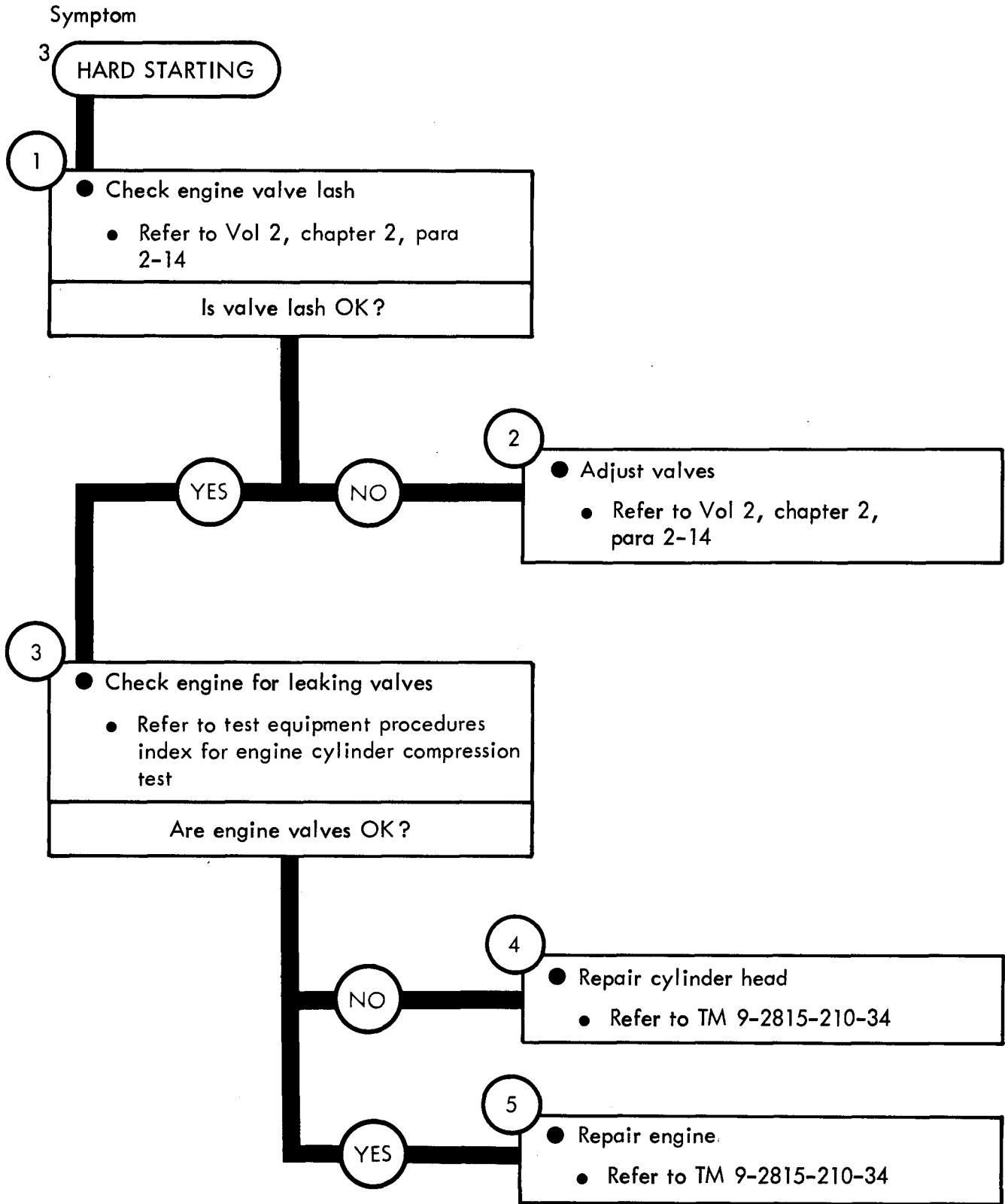

TA 120740

Figure 8-3

CHAPTER 9

ENGINE SYSTEM TEST PROCEDURES

9-1. GENERAL. This chapter gives test procedures for the tests given in chapter 8, for the **engine system**.

9-2. TEST SET-UP. Instructions for setup of test equipment and parts to be tested are given before the test procedures. Illustrations are used, when needed, to show you how to hook up the test equipment to the part to be tested.

9-3. TEST PROCEDURE. Detailed step-by-step instructions, in flow chart form, are given for each test. The procedure calls out the type of test and the condition of the truck system for each part of testing. The step-by-step test will lead you to the bad component or to a fault symptom within a related system. Reference is made to the fault symptom index, chapter 6, if the test shows a fault in another system.

ENGINE SYSTEM TEST PROCEDURES

ENGINE CYLINDER COMPRESSION TEST

- 1
 - Start engine and warm up to operating temperature
 - Refer to TM 9-2320-209-10
 - Turn off engine
 - Refer to TM 9-2320-209-10

- 2
 - Take out all 6 fuel injector nozzle and holder assemblies
 - Refer to Vol 2, chapter 4, para 4-3

- 3
 - Put compression gage onto number one fuel injector opening in cylinder head
 - Using new fuel injector nozzle to head gasket, put on adapter
 - Put compression gage onto adapter

- 4
 - Crank engine for 5 seconds
 - Refer to TM 9-2320-209-10
 - Note: Keep fuel shutoff in off position
 - Read compression from gage and write down reading

GO

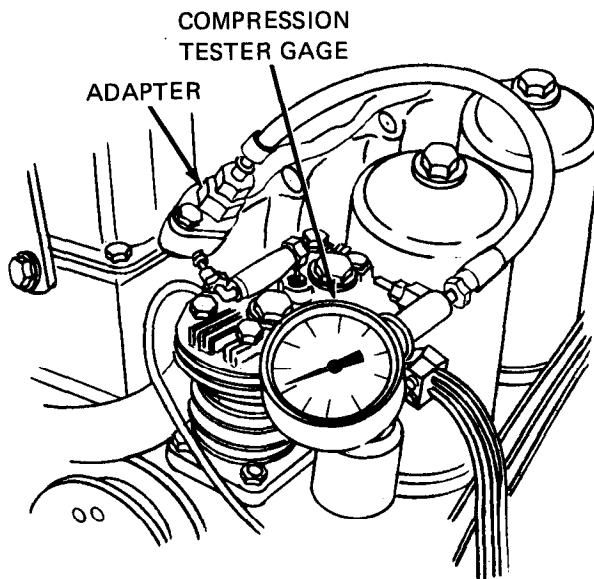
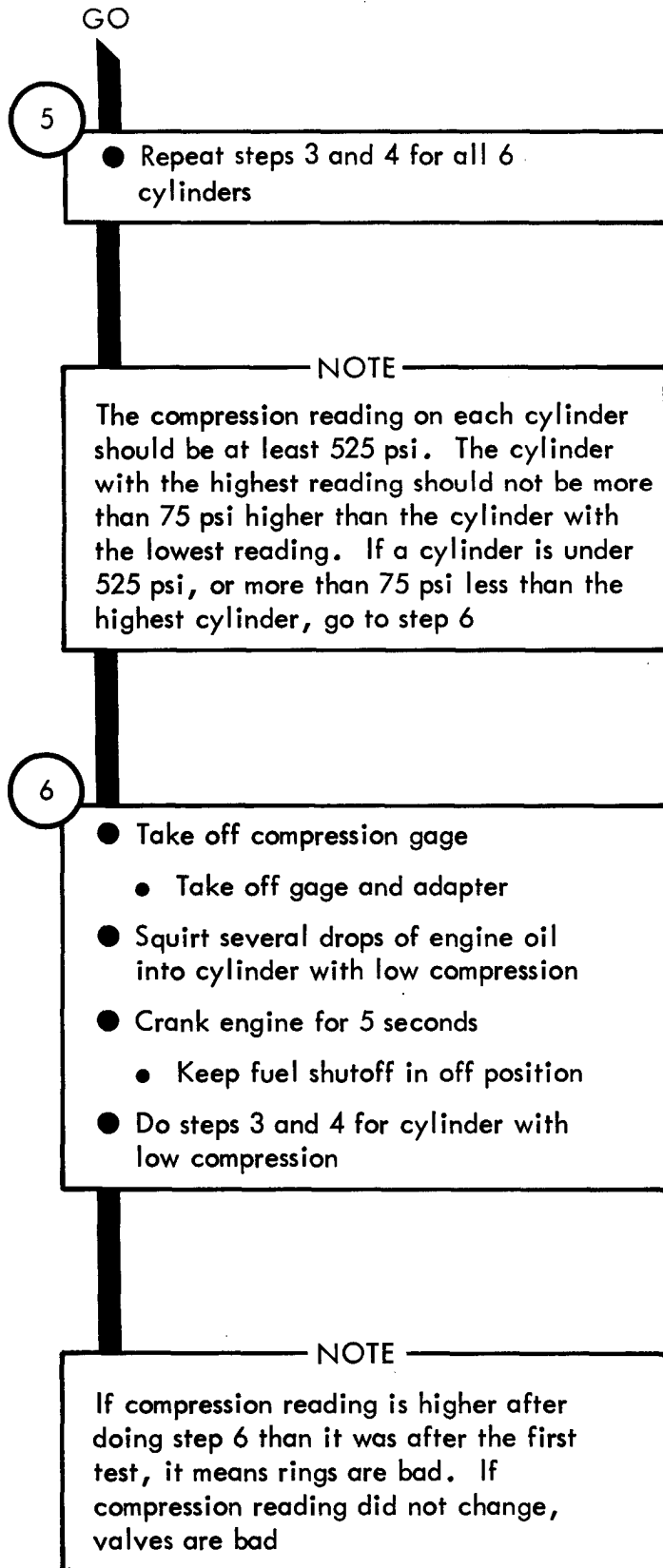

Figure 9-1 (Sheet 1 of 2)

TA 120741



TA 120742

Figure 9-1 (Sheet 2 of 2)

CHAPTER 10

FUEL SYSTEM TROUBLESHOOTING

10-1. EQUIPMENT ITEMS COVERED. This chapter gives equipment troubleshooting procedures for the fuel system, for which there are authorized corrective maintenance tasks at the direct support and general support maintenance level.

10-2. EQUIPMENT ITEMS NOT COVERED. All equipment items for which corrective maintenance is authorized at the direct support and general support maintenance level are covered in this chapter.

Symptom

1 ENGINE RUNS ROUGH AND LACKS POWER

- 1
- Park truck
 - Refer to TM 9-2320-209-10

WARNING

Diesel fuel is very flammable. Care must be used when choosing a place to work on fuel system. Keep truck about 50 feet away from an area where open flame, sparks, or smoking can cause a fire. Keep a fire extinguisher close by

- 2
- Check fuel injector nozzles
 - Refer to test equipment procedures index for fuel injector nozzle test
- Are fuel injector nozzles OK?

GO

Figure 10-1 (Sheet 1 of 2)

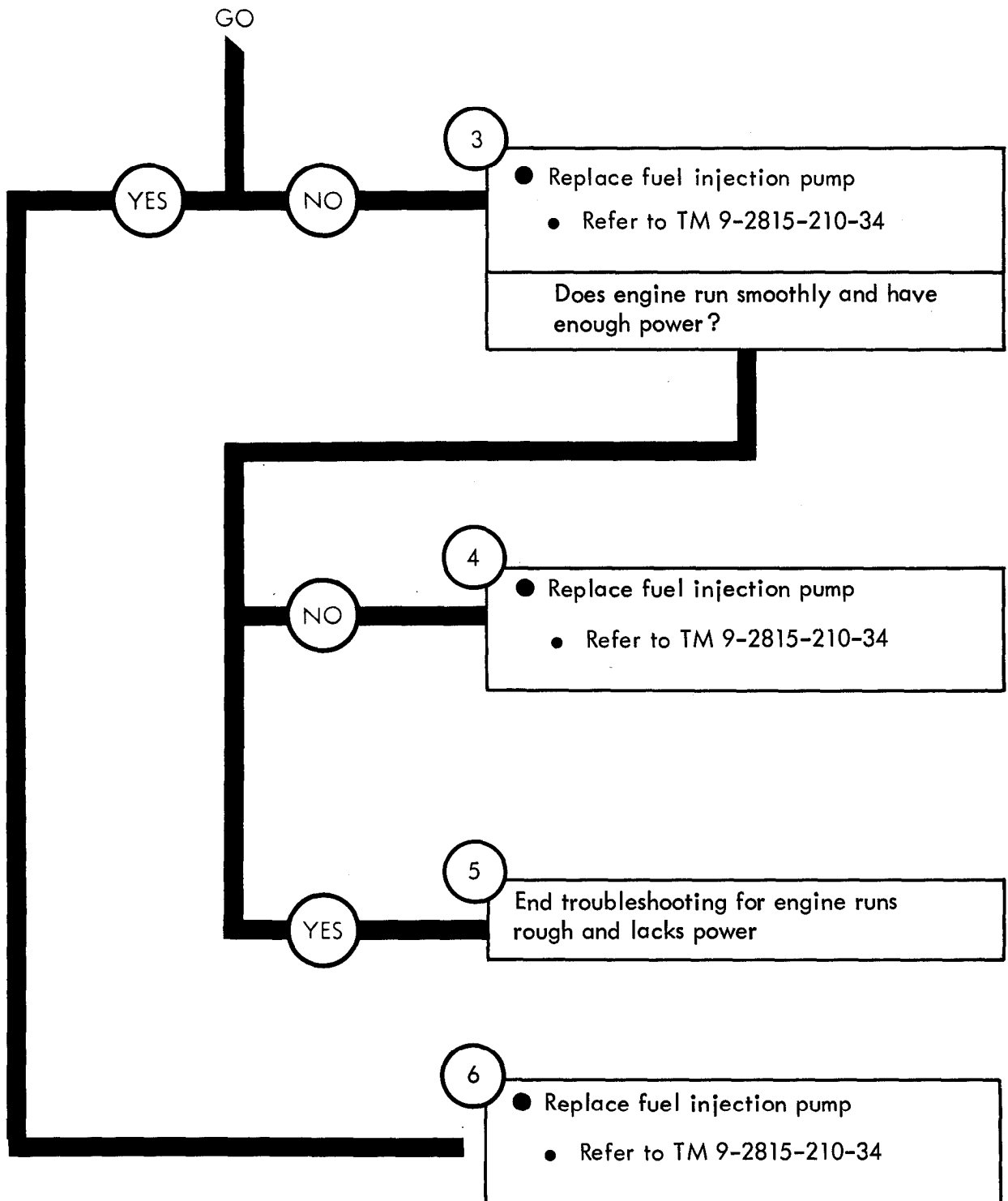

Figure 10-1 (Sheet 2 of 2)

Symptom

2

ENGINE CRANKS BUT DOES NOT START

WARNING

Diesel fuel is very flammable. Care must be used when choosing a place to work on fuel system. Keep truck about 50 feet away from an area where open flame, sparks, or smoking may cause a fire. Keep a fire extinguisher close by

NOTE

The following procedure will need the use of two soldiers. The lead soldier will be called soldier A. The helper will be called soldier B

1

● Check for fuel supply from fuel injection pump

SOLDIER A: Loosen one fuel injector nozzle fitting but do not take it off

SOLDIER B: Crank engine for 5 seconds. Refer to TM 9-2320-209-10

SOLDIER A: See if fuel comes out of fuel injector nozzle fitting

Does fuel come out of fitting?

GO

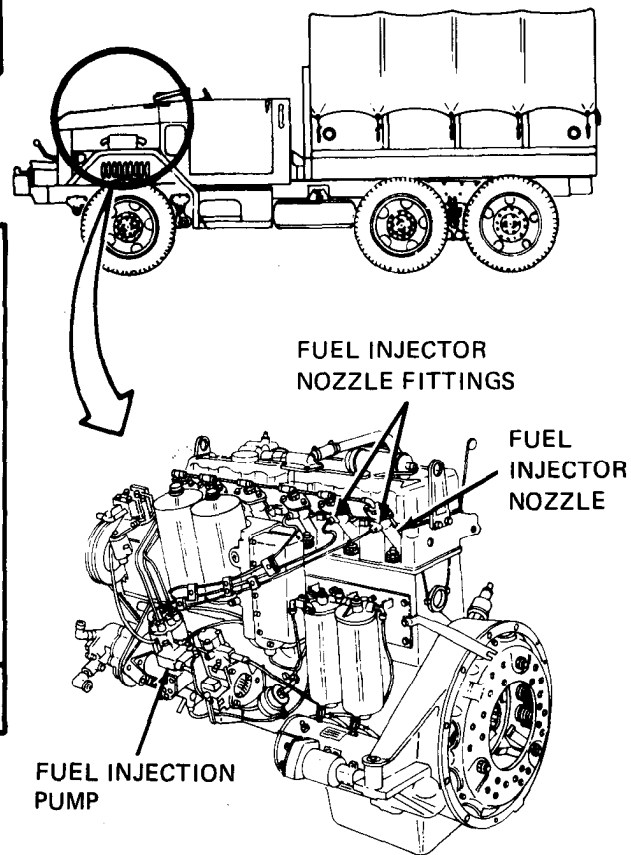

TA 120745

Figure 10-2 (Sheet 1 of 3)

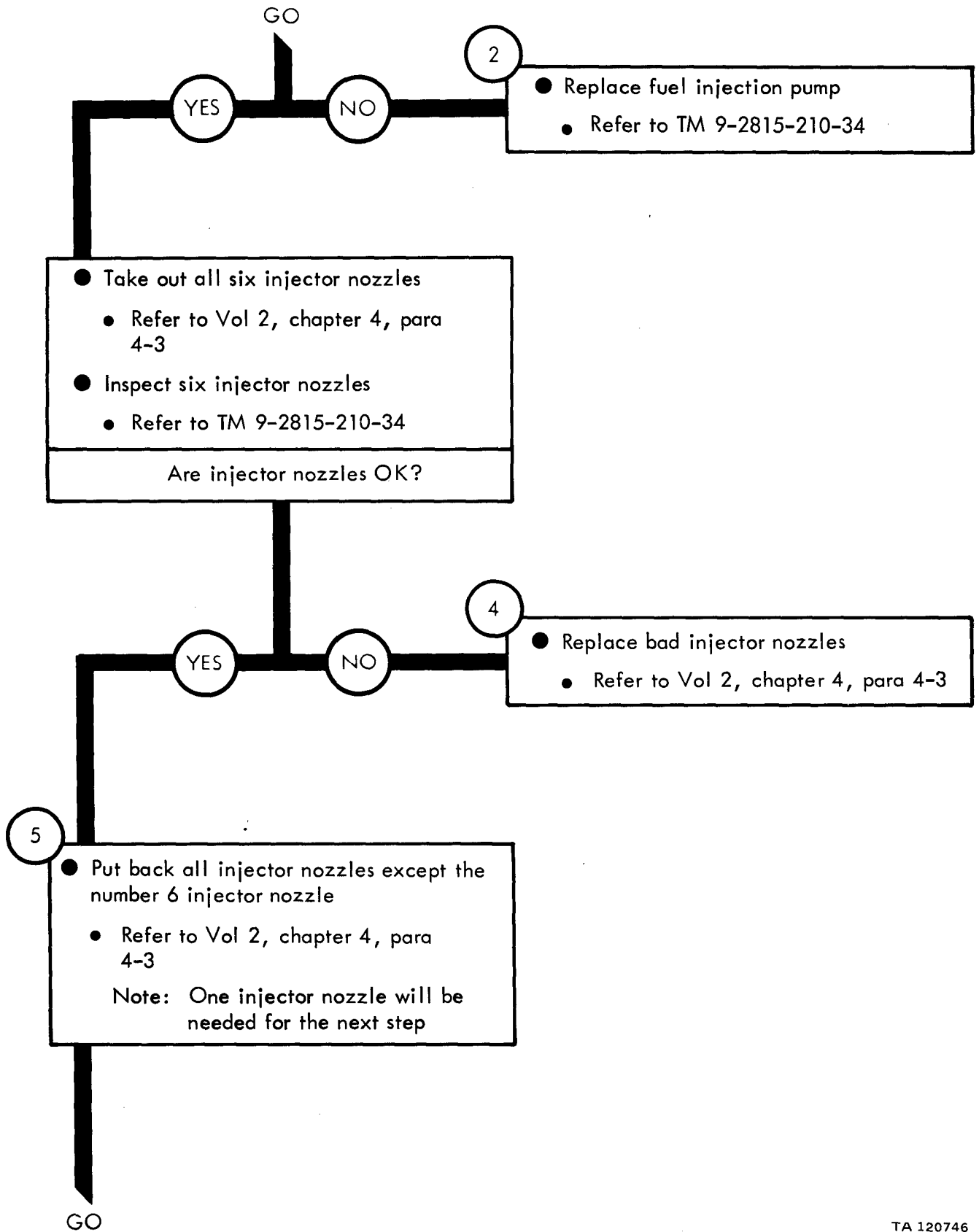

TA 120746

Figure 10-2 (Sheet 2 of 3)

GO

WARNING
Fuel coming out of an injector nozzle under pressure can go through the skin. This can cause blood poisoning. Keep hands away from injector nozzle when doing the next step

6

- Put number 6 fuel injector nozzle onto fuel supply tube

SOLDIER A: Connect injector nozzle to fuel supply tube. See figure 11-1

SOLDIER B: Crank engine for 5 seconds

SOLDIER A: See if correct fuel spray pattern comes from injector nozzle. Refer to figure 11-1

Is fuel spray pattern OK?

NO

7

- Replace fuel injection pump
- Refer to TM 9-2815-210-34

YES

8

- Adjust fuel injection pump timing
- Refer to TM 9-2815-210-34

TA 120747

Figure 10-2 (Sheet 3 of 3)

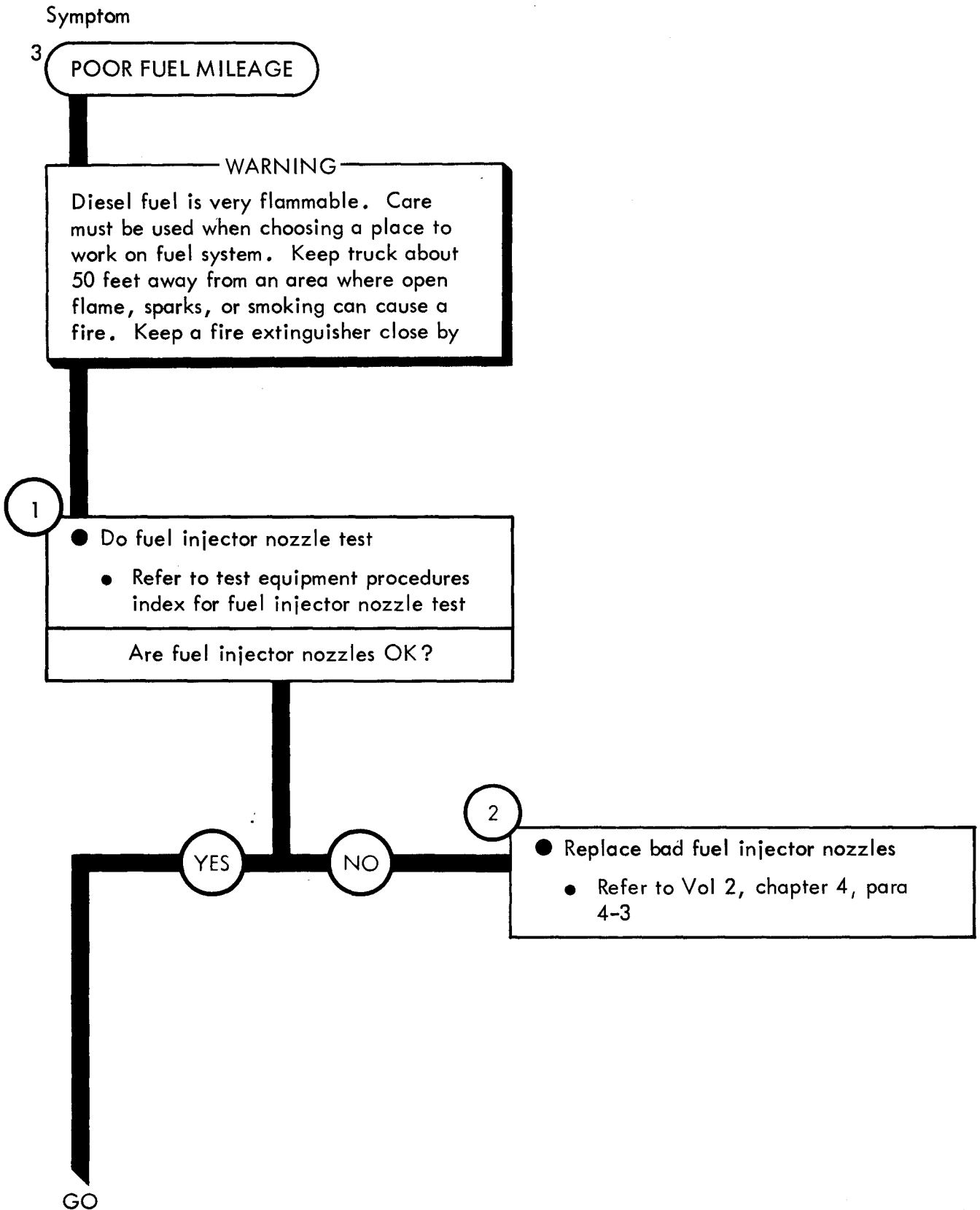

TA 120748

Figure 10-3 (Sheet 1 of 3)

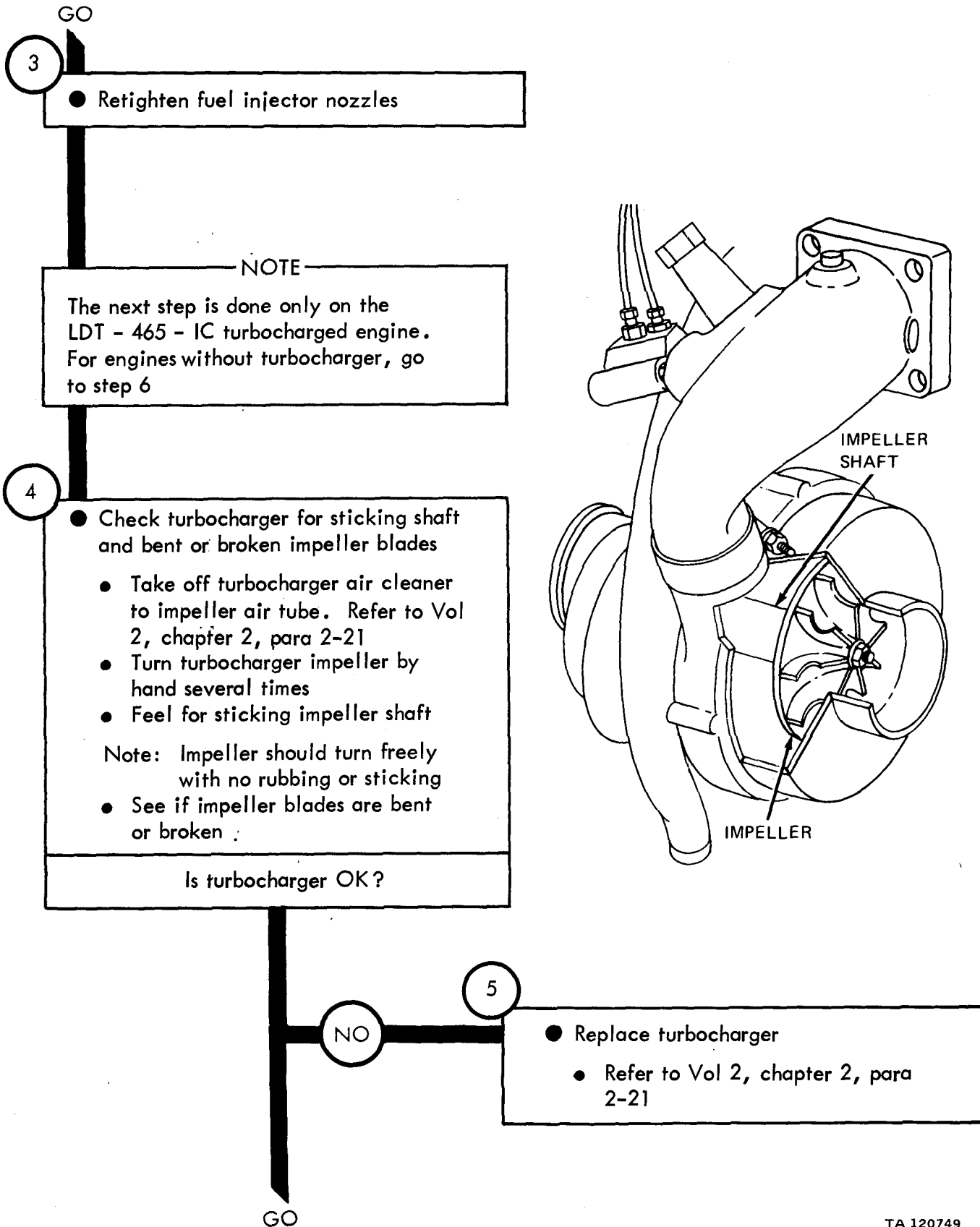

TA 120749

Figure 10-3 (Sheet 2 of 3)

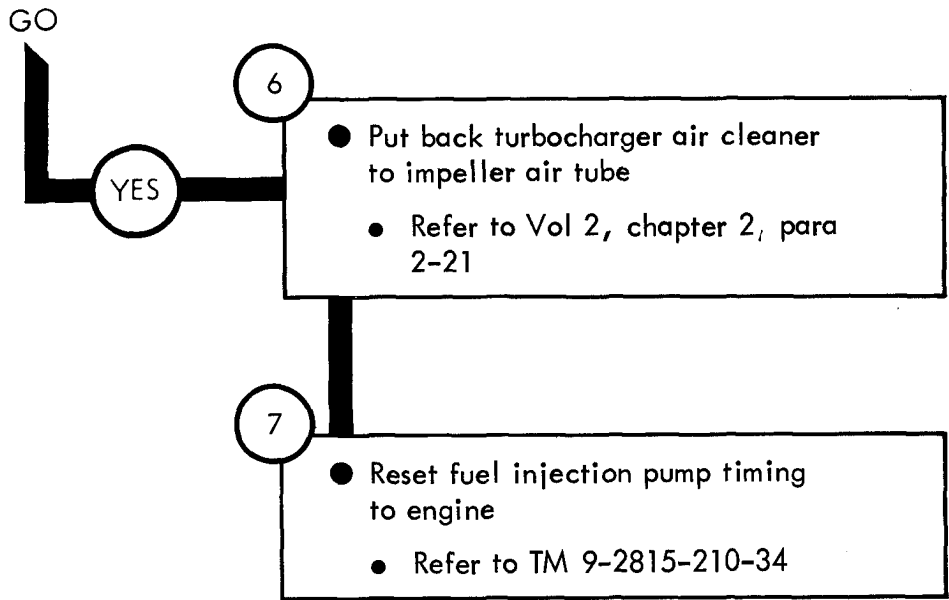

CHAPTER 11

FUEL SYSTEM SUPPORT DIAGRAMS

11-1. GENERAL This chapter gives the diagrams you need when doing troubleshooting procedures in chapter 10. Figure 3-1 is a complete listing of all support diagrams used in this manual.

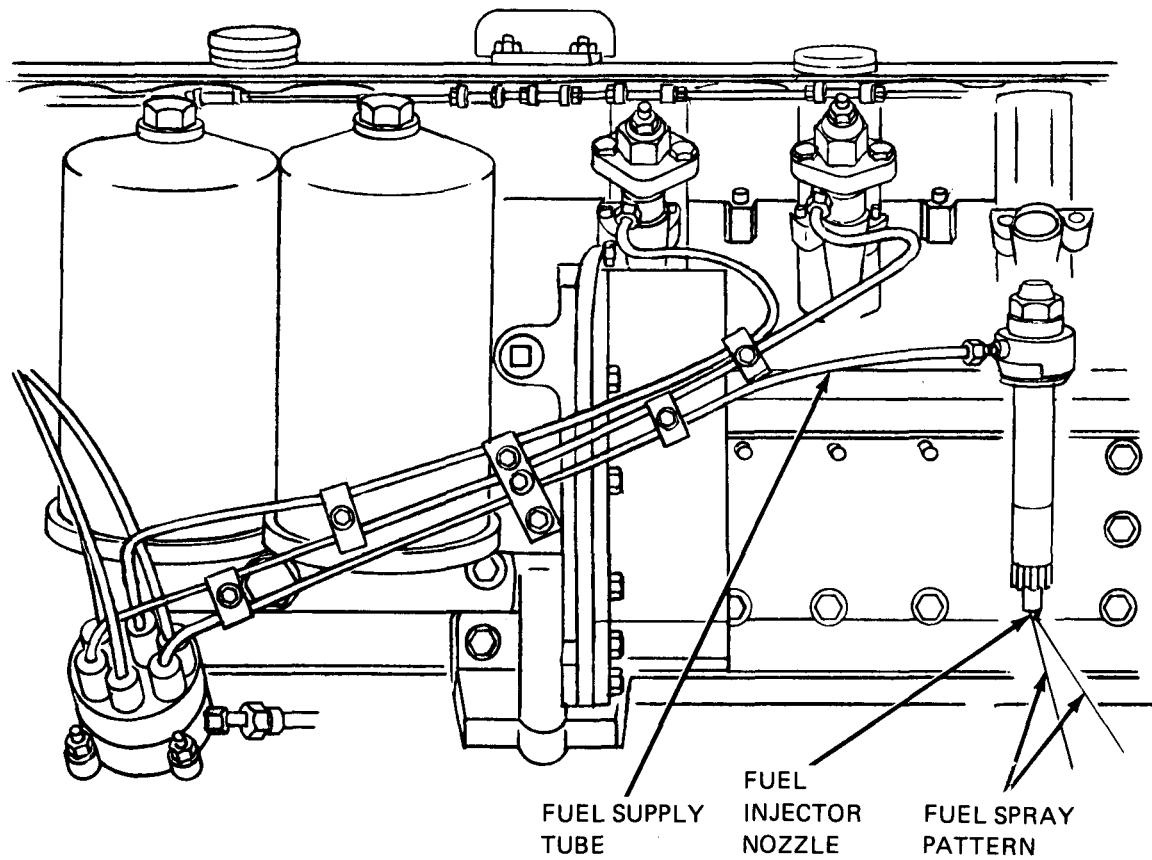

Figure 11-1. Fuel System Support Diagram

TA 120751

CHAPTER 12

FUEL SYSTEM TEST PROCEDURES

12-1. GENERAL. This chapter gives test procedures for the tests given in chapter 10, for the fuel system.

12-2. TEST SET-UP. Instructions for setup of test equipment and parts to be tested are given before the test procedures. Illustrations are used, when needed, to show you how to hook up the test equipment to the part to be tested.

12-3. TEST PROCEDURE. Detailed step-by-step instructions, in flow chart form, are given for each test. The procedure calls out the type of test and the condition of the truck system for each part of testing. The step-by-step test will lead you to the bad component or to a fault symptom within a related system. Reference is made to the fault symptom index, chapter 6, if the test shows a fault in another system.

FUEL SYSTEM TROUBLESHOOTING TESTS

FUEL INJECTOR NOZZLE TEST

1

- Start and warm up engine
 - Refer to TM 9-2320-209-10

WARNING

Diesel fuel is very flammable. Care must be used when choosing a place to work on fuel system. Keep truck about 50 feet away from an area where open flame, sparks, or smoking can cause a fire. Keep a fire extinguisher close by

NOTE

Put rag under line fittings before loosening to catch any fuel which drips out

2

- Loosen fuel injector nozzle fitting of one fuel injector nozzle and see if engine runs rougher
 - Note: If engine runs rougher the injector nozzle is OK
- Tighten fuel injector nozzle fitting
 - Note: Do procedure for all six fuel injector nozzle fittings

3

- Stop engine
 - Refer to TM 9-2320-209-10

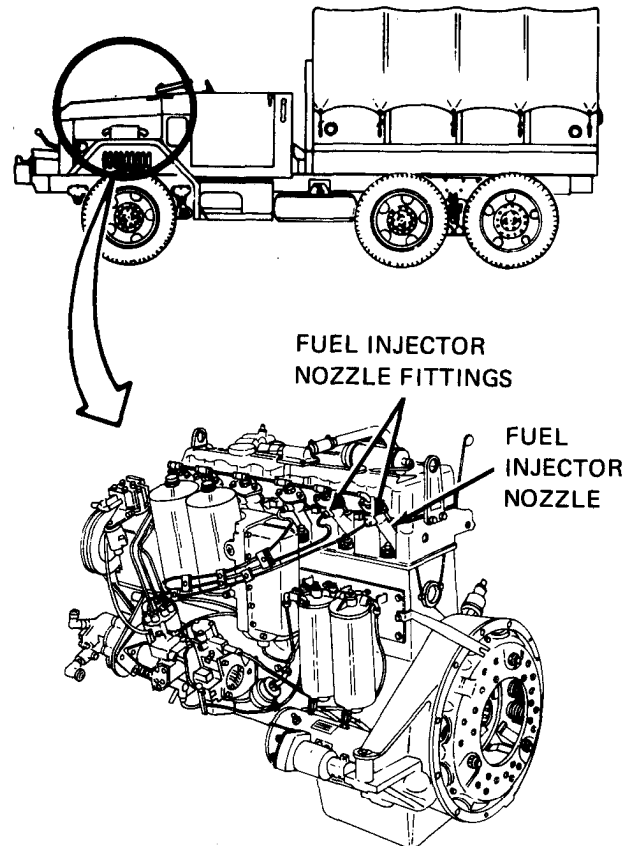

TA 120752

Figure 12-1

CHAPTER 13

ELECTRICAL SYSTEM TROUBLESHOOTING

13-1. EQUIPMENT ITEMS COVERED. This chapter gives equipment troubleshooting procedures for the electrical system, for which there are authorized corrective maintenance tasks at the direct support and general support maintenance level.

13-2. EQUIPMENT ITEMS NOT COVERED. All equipment items for which corrective maintenance is authorized at the direct support and general support maintenance level are covered in this chapter.

ELECTRICAL SYSTEM TROUBLESHOOTING

Symptom

1 POWER PLANT HEATER OVERHEATS AND CONTINUES BURNING

NOTE

When measuring voltage +24 volts DC means a range of +23 to +26 volts DC

1

- Park truck
- Refer to TM 9-2320-209-10

2

- Check overheat temperature control for continuity
 - Take out overheat switch. Refer to Vol 2, chapter 21, para 21-6
 - Set multimeter to check continuity
 - Put multimeter - lead on contact of overheat temperature control and + lead on other end of overheat temperature control
 - Read multimeter. Multimeter should measure zero ohms
- Does multimeter measure zero ohms?



GO

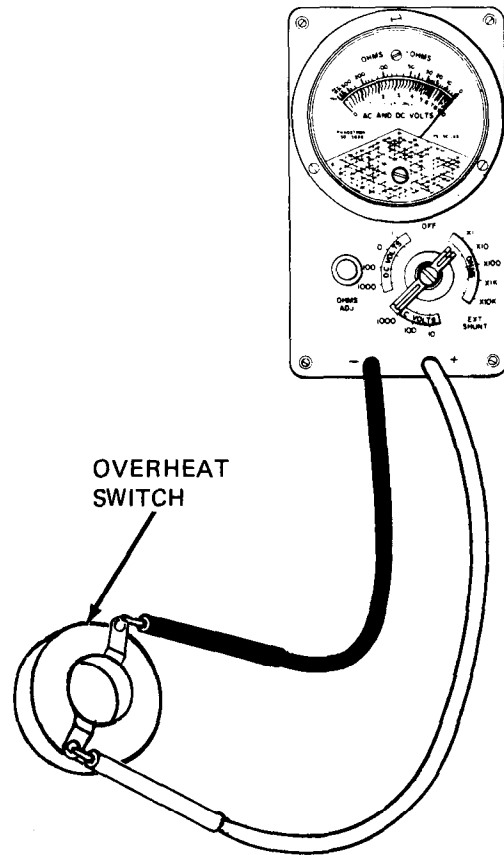

TA 120753

Figure 13-1 (Sheet 1 of 2)

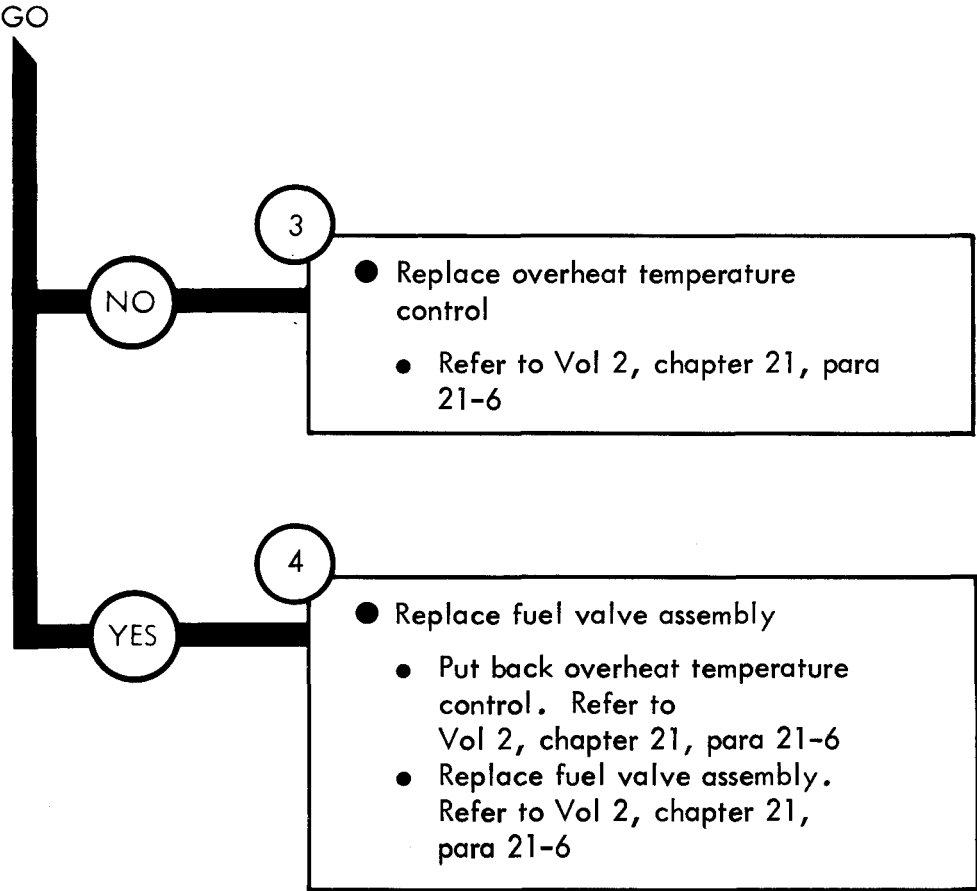

Figure 13-1 (Sheet 2 of 2)

Symptom

2 POWER PLANT HEATER DOES NOT GIVE OFF ENOUGH HEAT

NOTE

When measuring voltage +24 volts DC means a range of +23 to +26 volts DC

1

- Park truck
- Refer to TM 9-2320-209-10

2

- Check combustion blower for continuity
 - Disconnect combustion blower lead. Refer to Vol 2, chapter 21, para 21-6
 - Set multimeter to measure continuity
 - Put multimeter - lead on blower motor
 - Put multimeter + lead on blower motor lead
 - Read multimeter. Multimeter should measure zero ohms

Does multimeter measure zero ohms?

GO

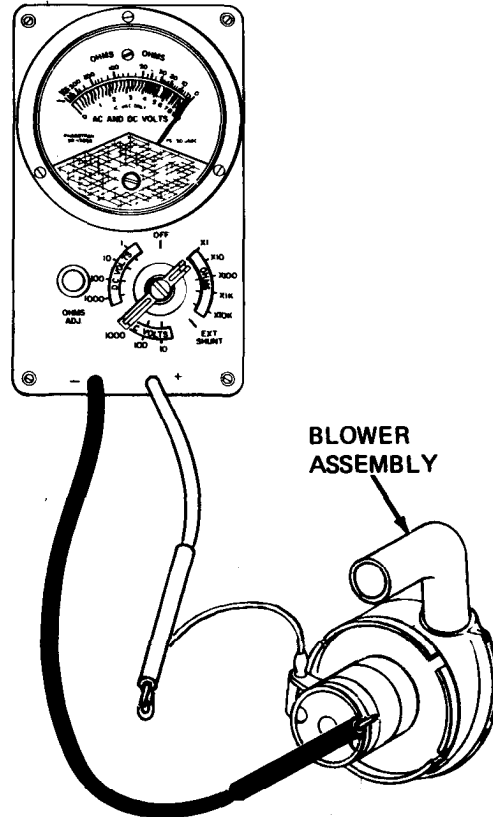

TA 120755

Figure 13-2 (Sheet 1 of 3)

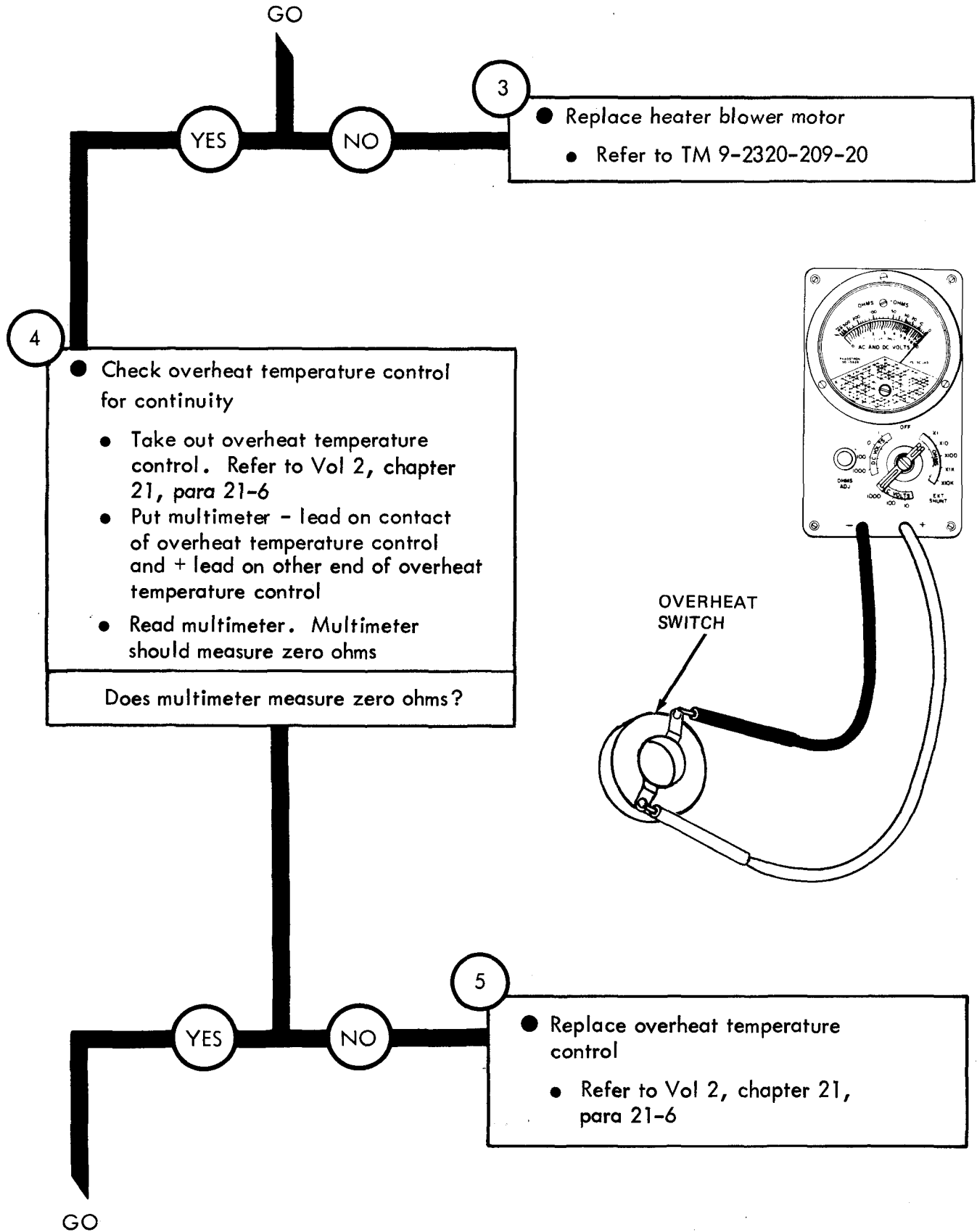

Figure 13-2 (Sheet 2 of 3)

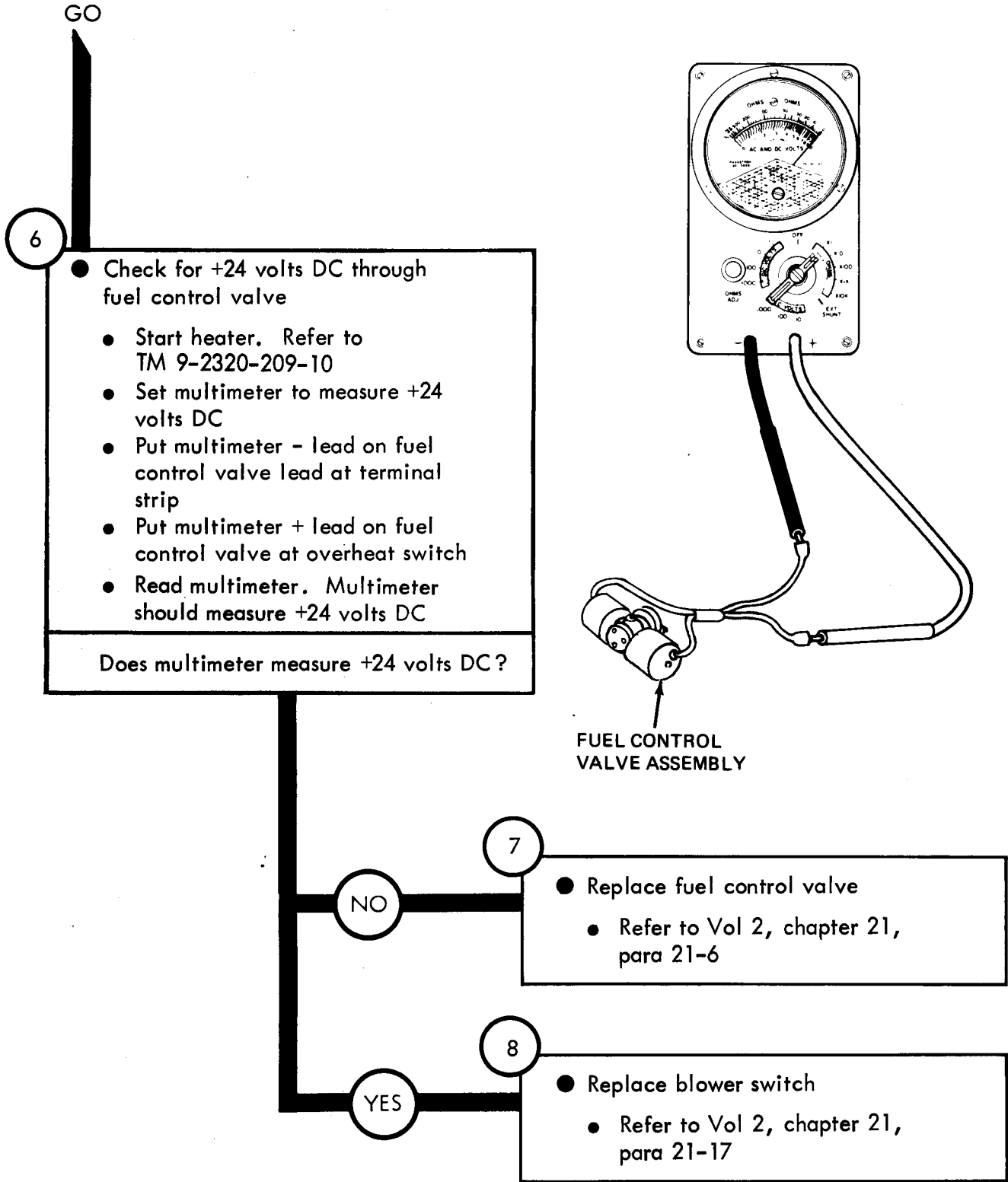

Figure 13-2 (Sheet 3 of 3)

TA 120757

Symptom

3

POWER PLANT HEATER DOES NOT START

NOTE

When measuring voltage +24 volts DC means a range of +23 to +26 volts DC.

1

- Park truck
- Refer to TM 9-2320-209-10

2

- Check for +24 volts DC through control box circuit breaker
 - Take cover off control box. Refer to Vol 2, chapter 21, para 21-17
 - Set multimeter to measure +24 volts DC
 - Put multimeter - lead on one contact of circuit breaker
 - Put multimeter + lead on other contact of circuit breaker
 - Read multimeter. Multimeter should measure +24 volts DC

Does multimeter measure +24 volts DC?

GO

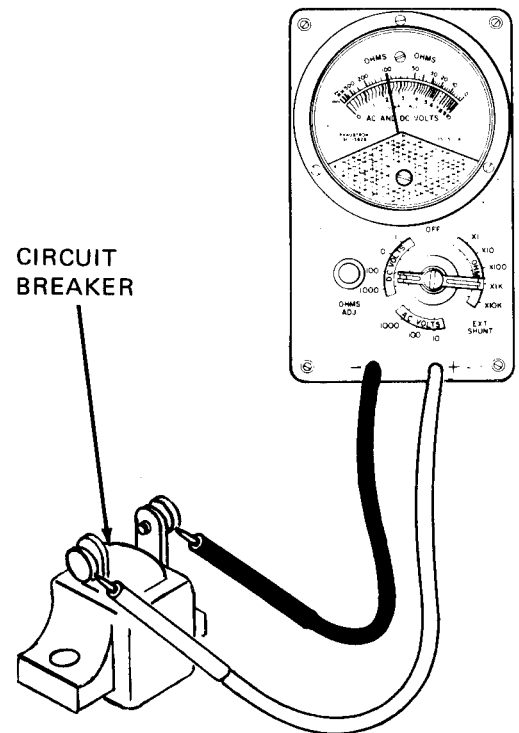

Figure 13-3 (Sheet 1 of 6)

TA 120758

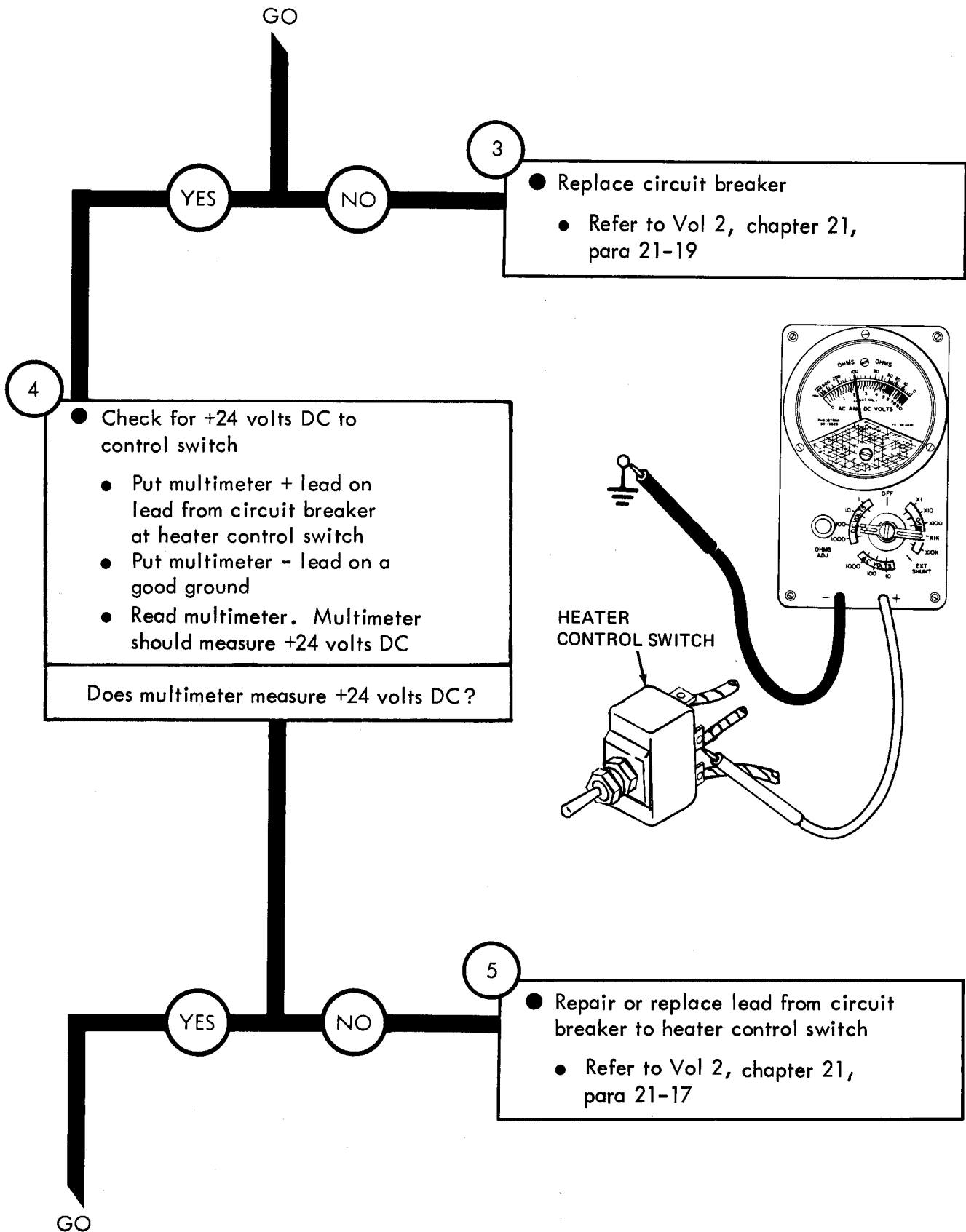

Figure 13-3 (Sheet 2 of 6)

TA 120759

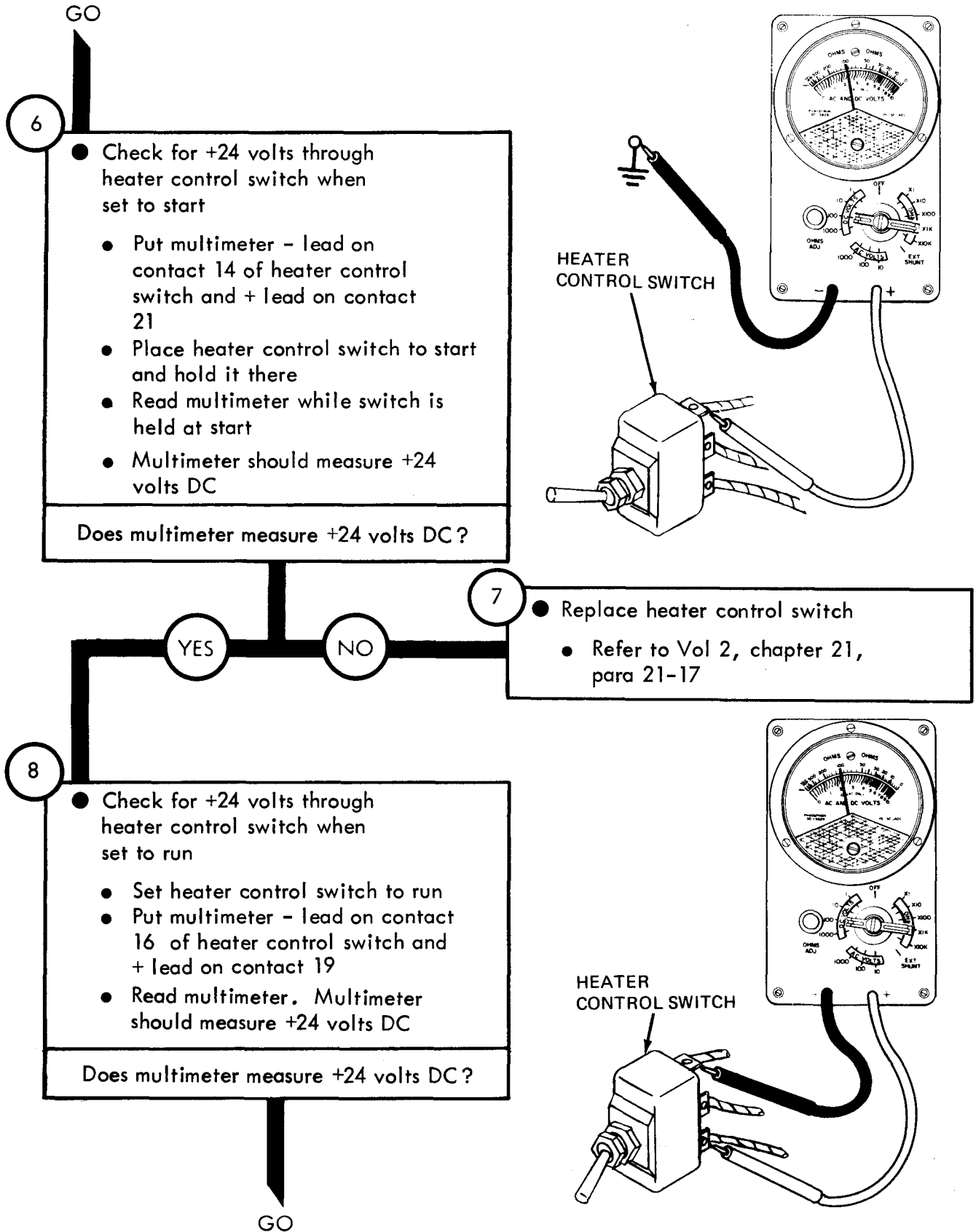

Figure 13-3 (Sheet 3 of 6)

TA 120760

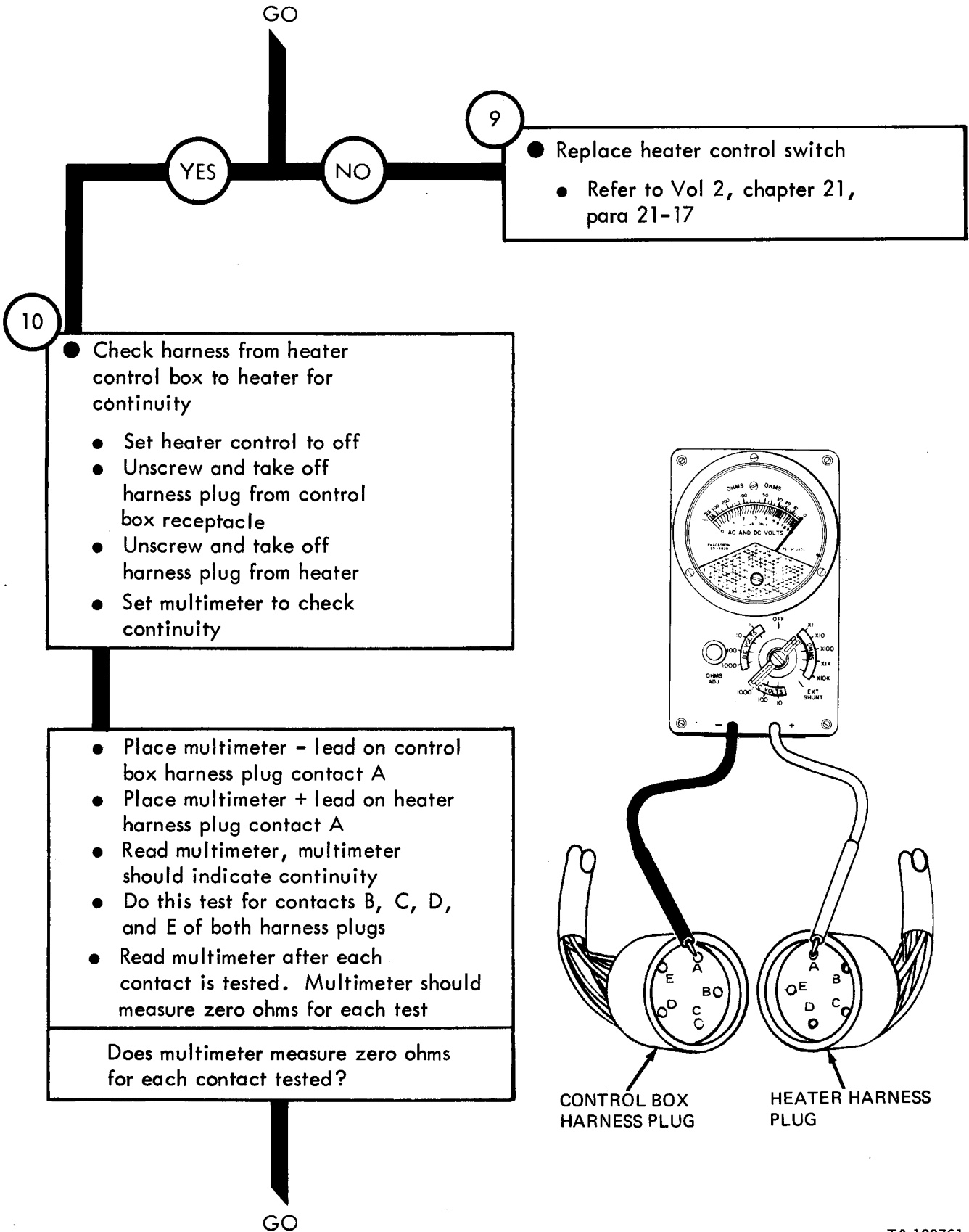

Figure 13-3 (Sheet 4 of 6)

TA 120761

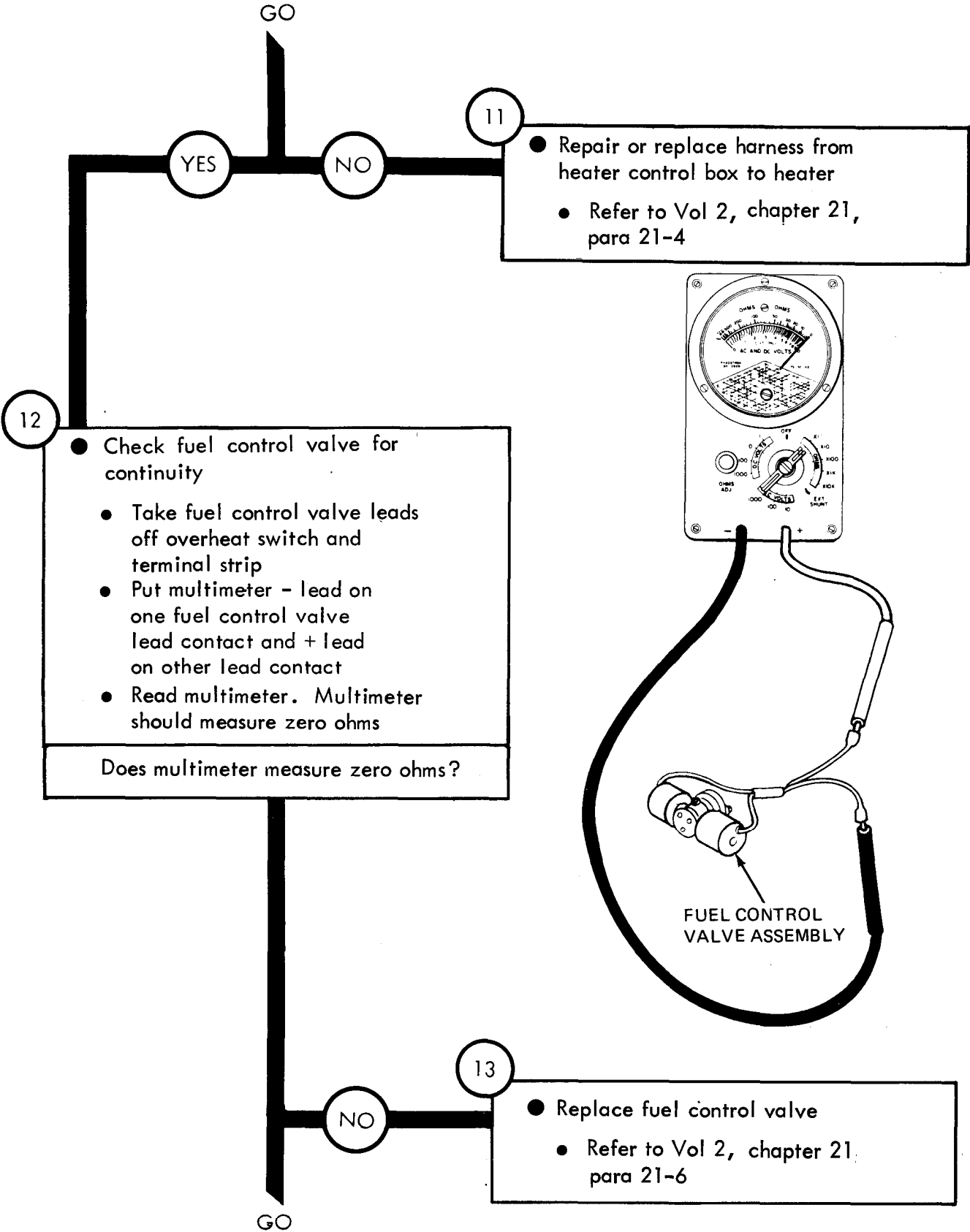

Figure 13-3 (Sheet 5 of 6)

TA 120762

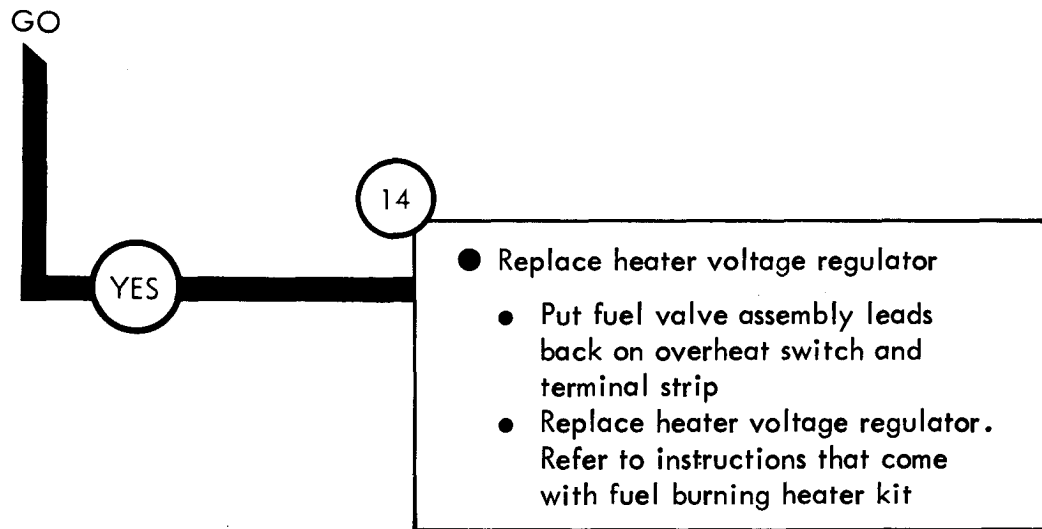

Figure 13-3 (Sheet 6 of 6)

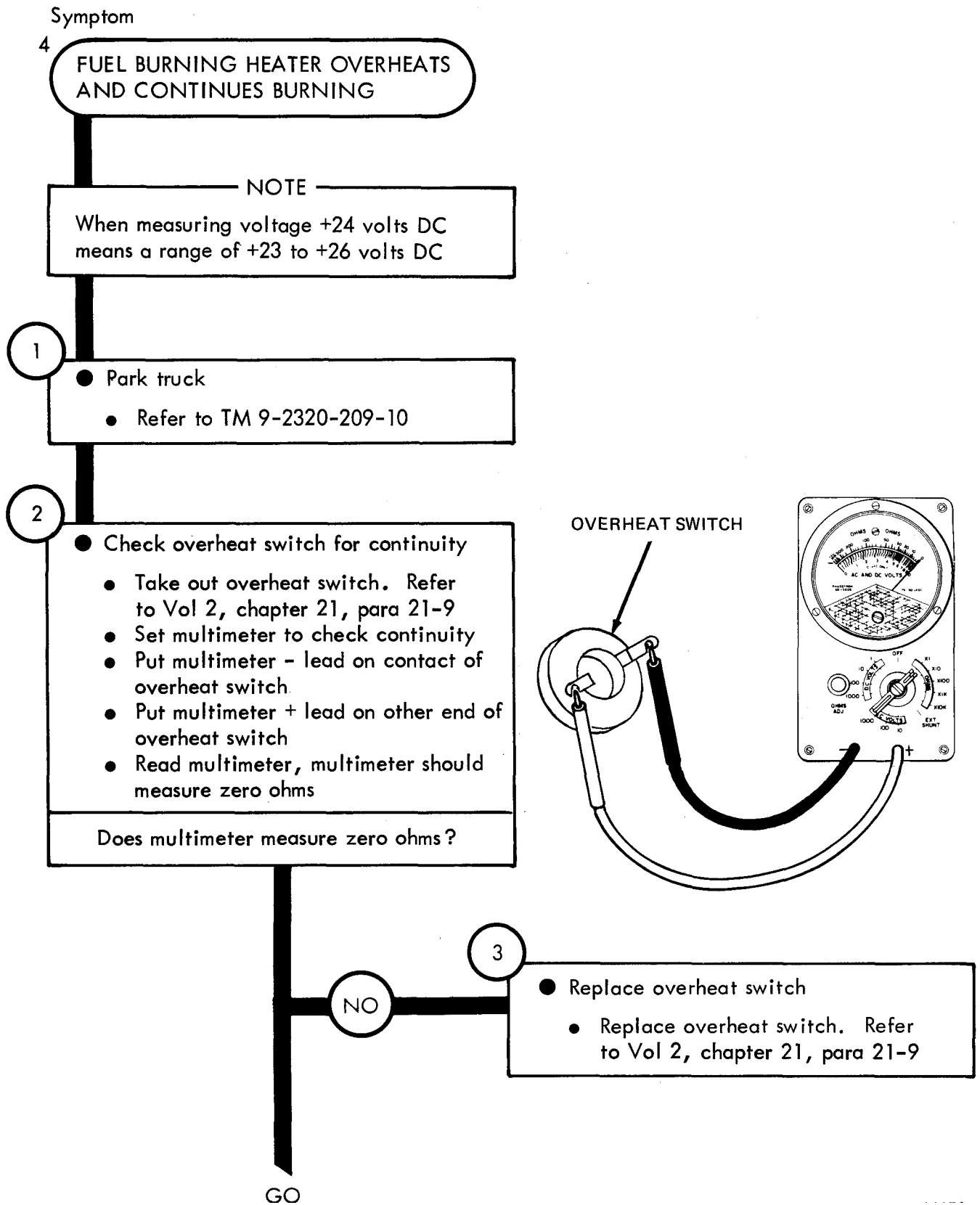

Figure 13-4 (Sheet 1 of 2)

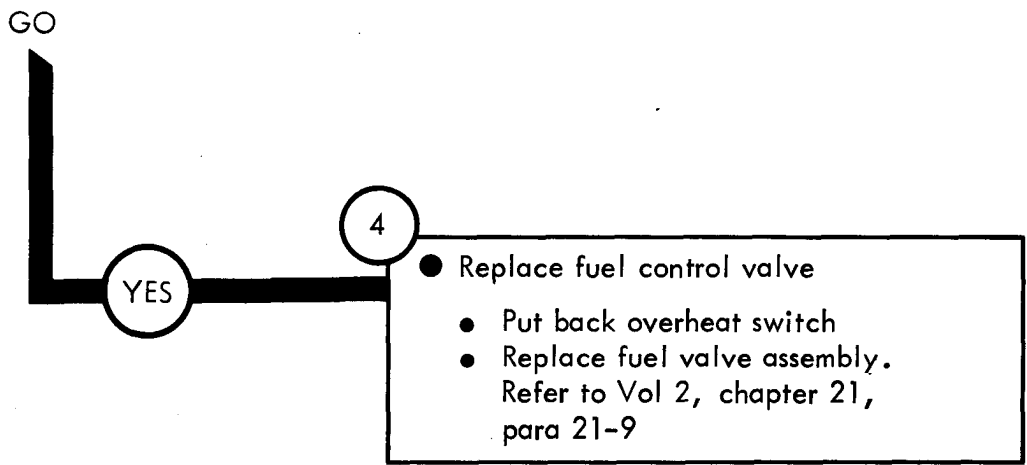

Figure 13-4 (Sheet 2 of 2)

Symptom

5 FUEL BURNING HEATER DOES NOT GIVE OFF ENOUGH HEAT

NOTE

When measuring voltage +24 volts DC means a range of +23 to +26 volts DC

1

- Park truck
- Refer to TM 9-2320-209-10

2

- Check resistance of heater resistor
 - Pull lead off both contacts of heater resistor
 - Set multimeter to measure resistance
 - Put multimeter - lead on one contact of resistor and + lead on other contact of heater resistor
 - Read multimeter, multimeter should measure resistance
 - Put multimeter - lead on contact where multimeter + lead was and + lead where - lead was for last test. Read multimeter. Multimeter should measure resistance

Did multimeter measure resistance for both tests?

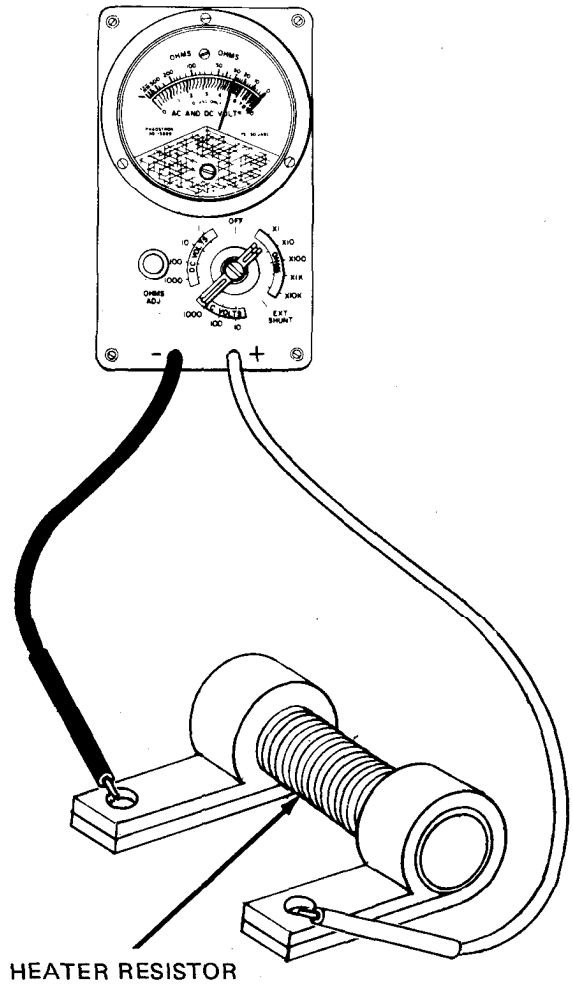

HEATER RESISTOR

YES NO

3

- Replace heater resistor
- Refer to Vol 2, chapter 21, para 21-9

GO

Figure 13-5 (Sheet 1 of 4)

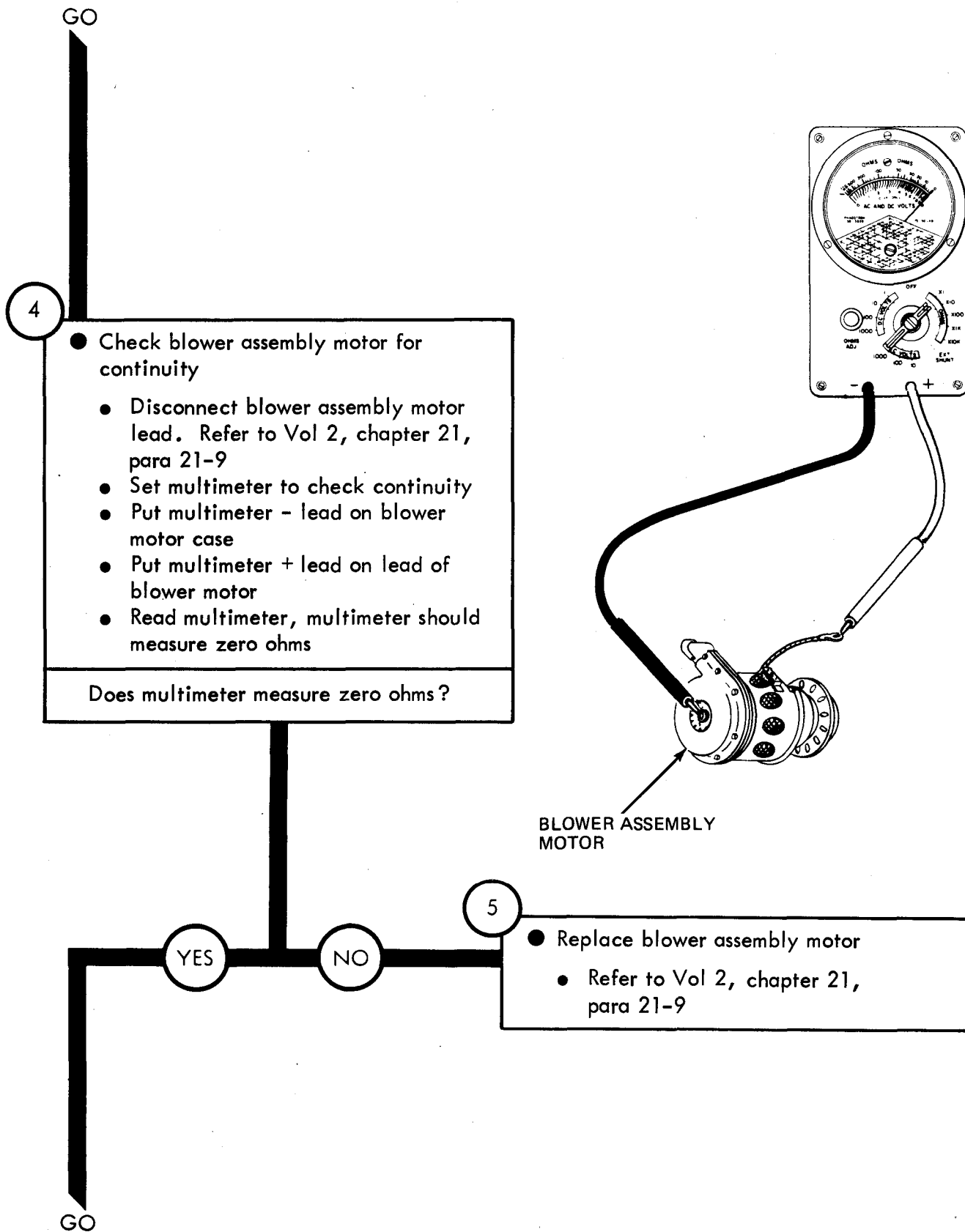

Figure 13-5 (Sheet 2 of 4)

TA 120767

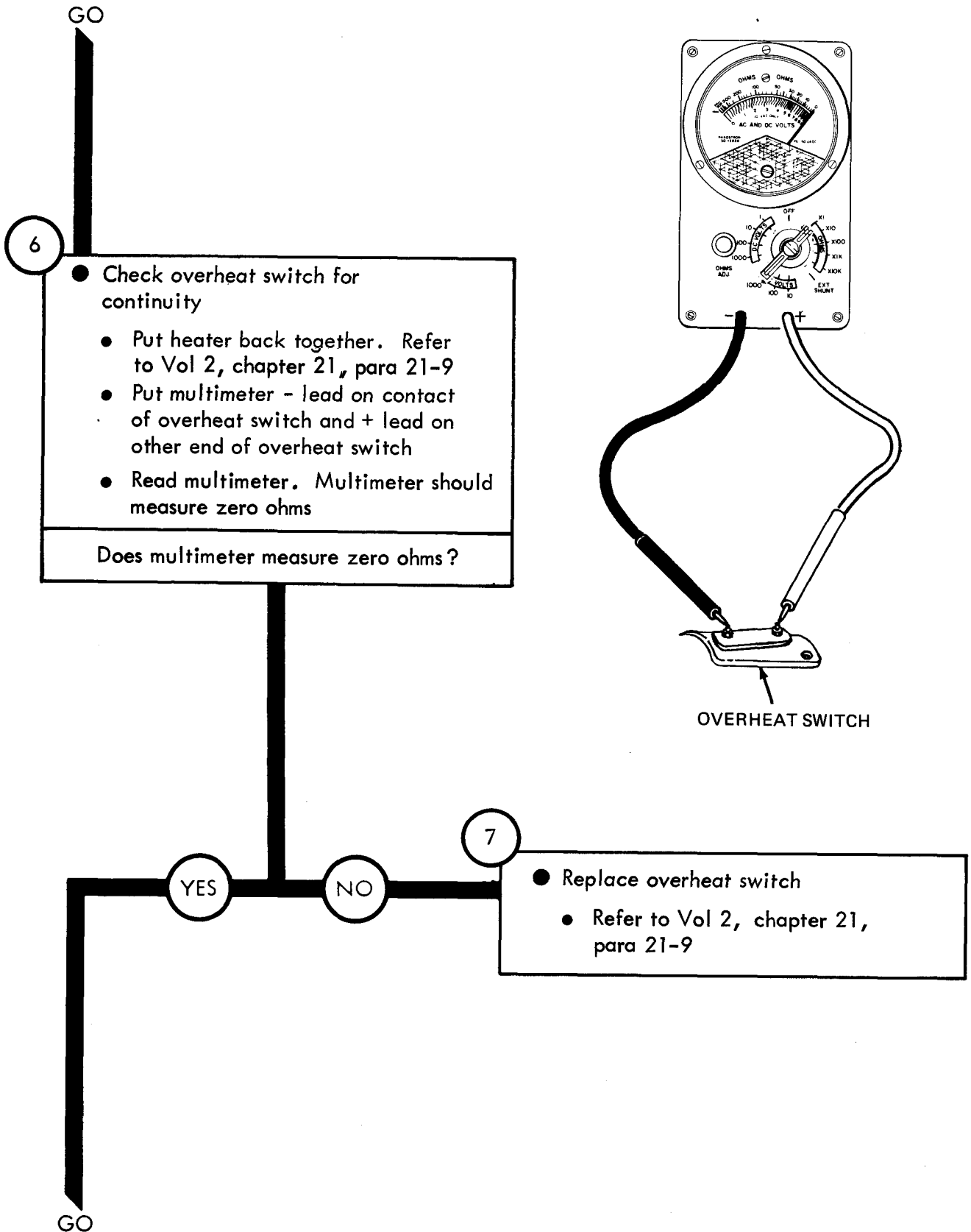

Figure 13-5 (Sheet 3 of 4)

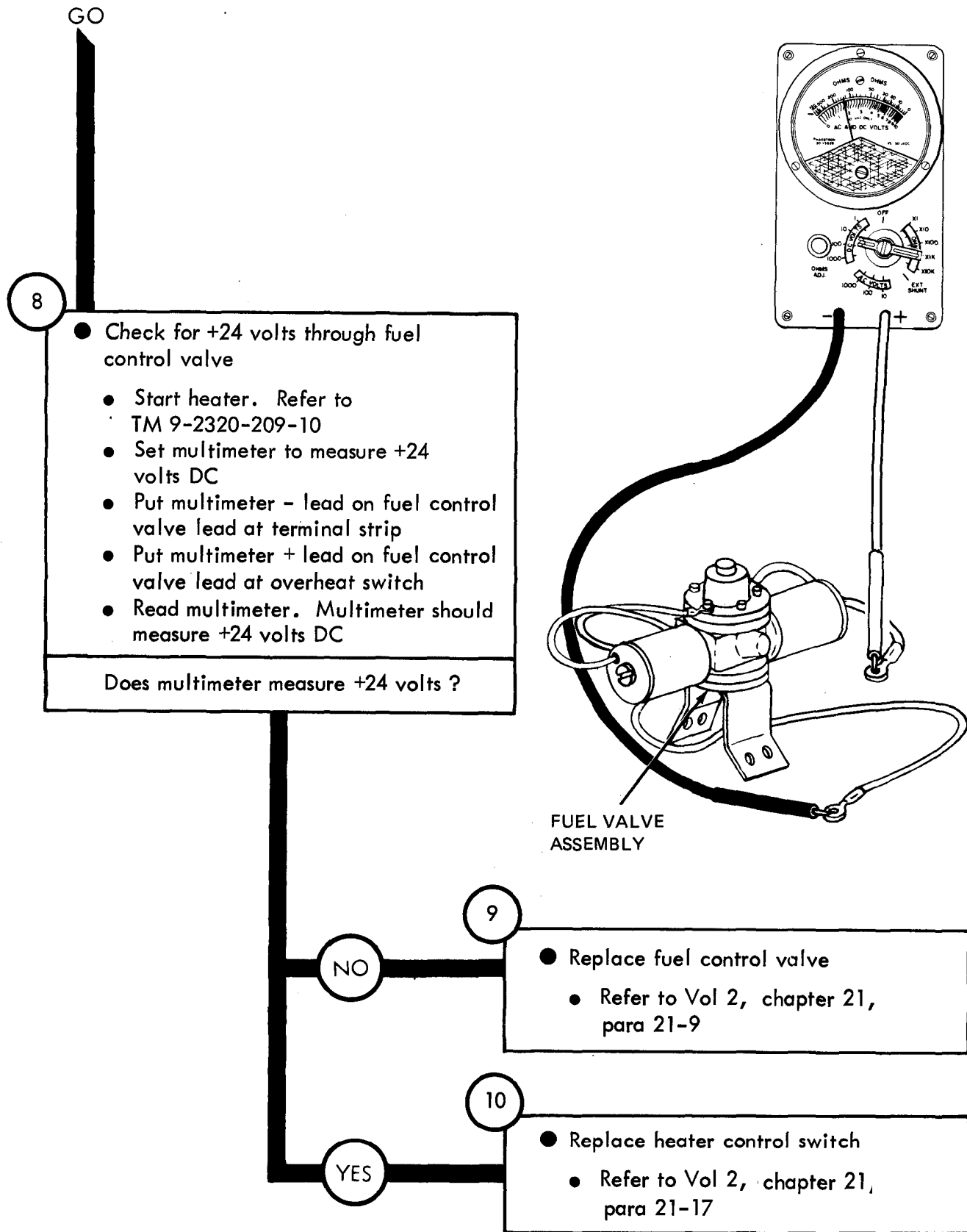

Figure 13-5 (Sheet 4 of 4)

TA 120769

Symptom

6 FUEL BURNING HEATER DOES NOT START

NOTE

When measuring voltage +24 volts DC means a range of +23 to +26 volts DC

1

- Park truck
- Refer to TM 9-2320-209-10

2

● Check for +24 volts DC through control box circuit breaker

- Take cover off control box. Refer to Vol 2, chapter 21, para 21-17
- Set multimeter to measure +24 volts DC
- Put multimeter - lead on one contact of circuit breaker
- Put multimeter + lead on other contact of circuit breaker
- Read multimeter. Multimeter should measure +24 volts DC

Does multimeter measure +24 volts DC?

YES

NO

3

- Replace circuit breaker
- Refer to Vol 2, chapter 21, para 21-17

GO

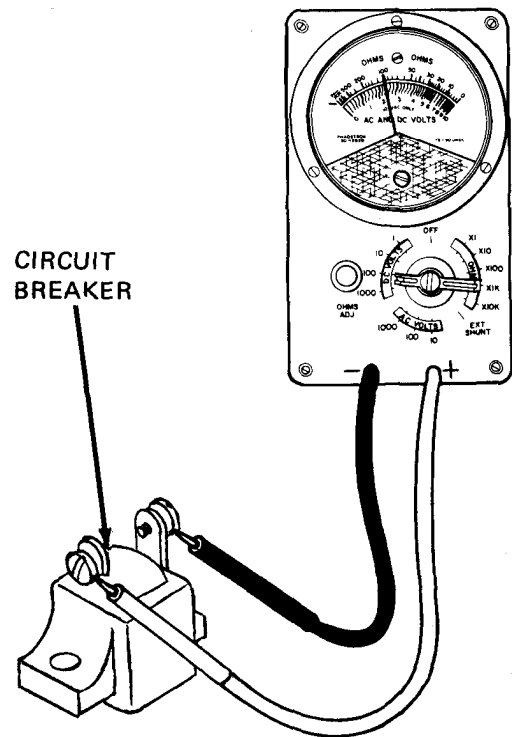

Figure 13-6 (Sheet 1 of 5)

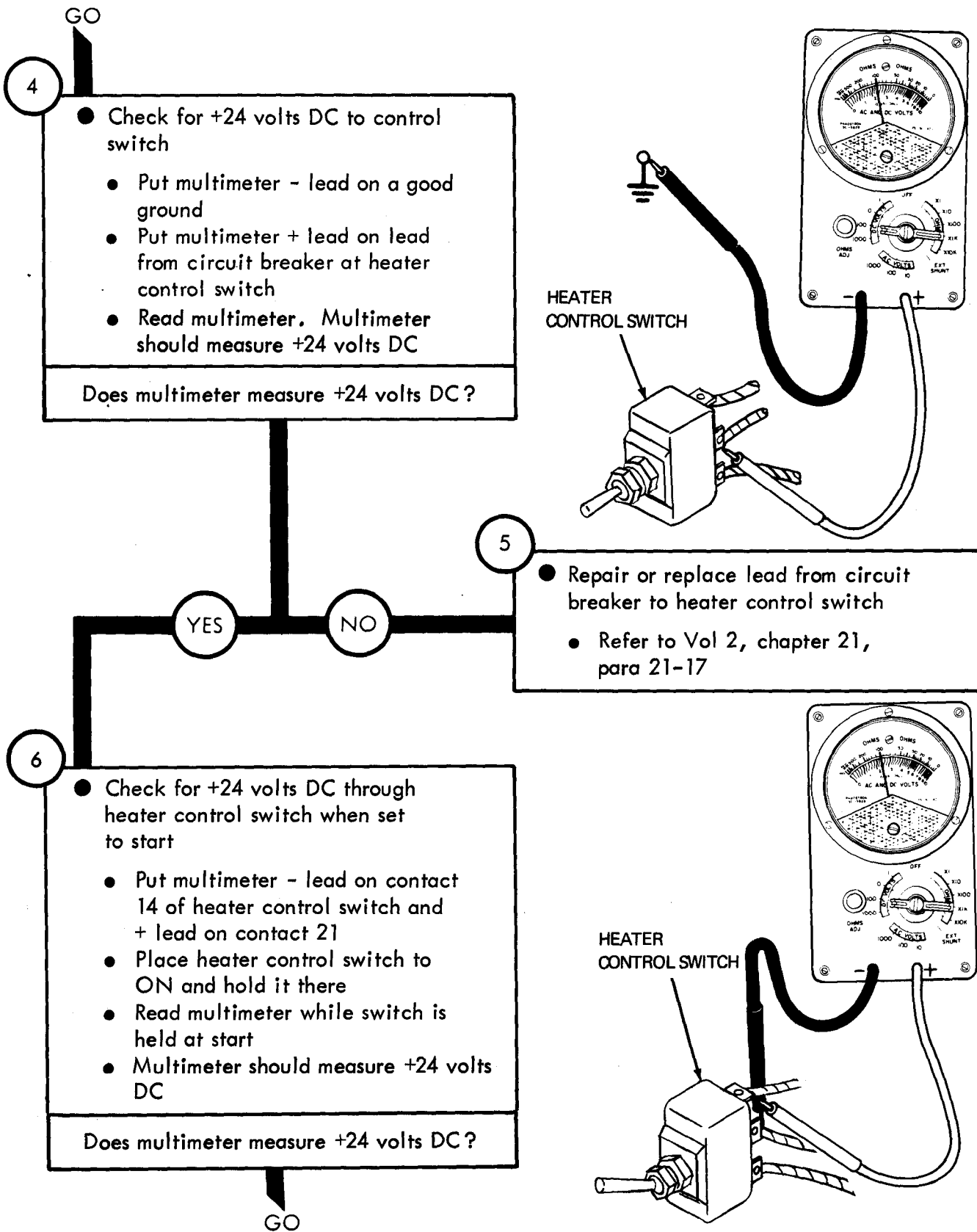

Figure 13-6 (Sheet 2 of 5)

TA 120771

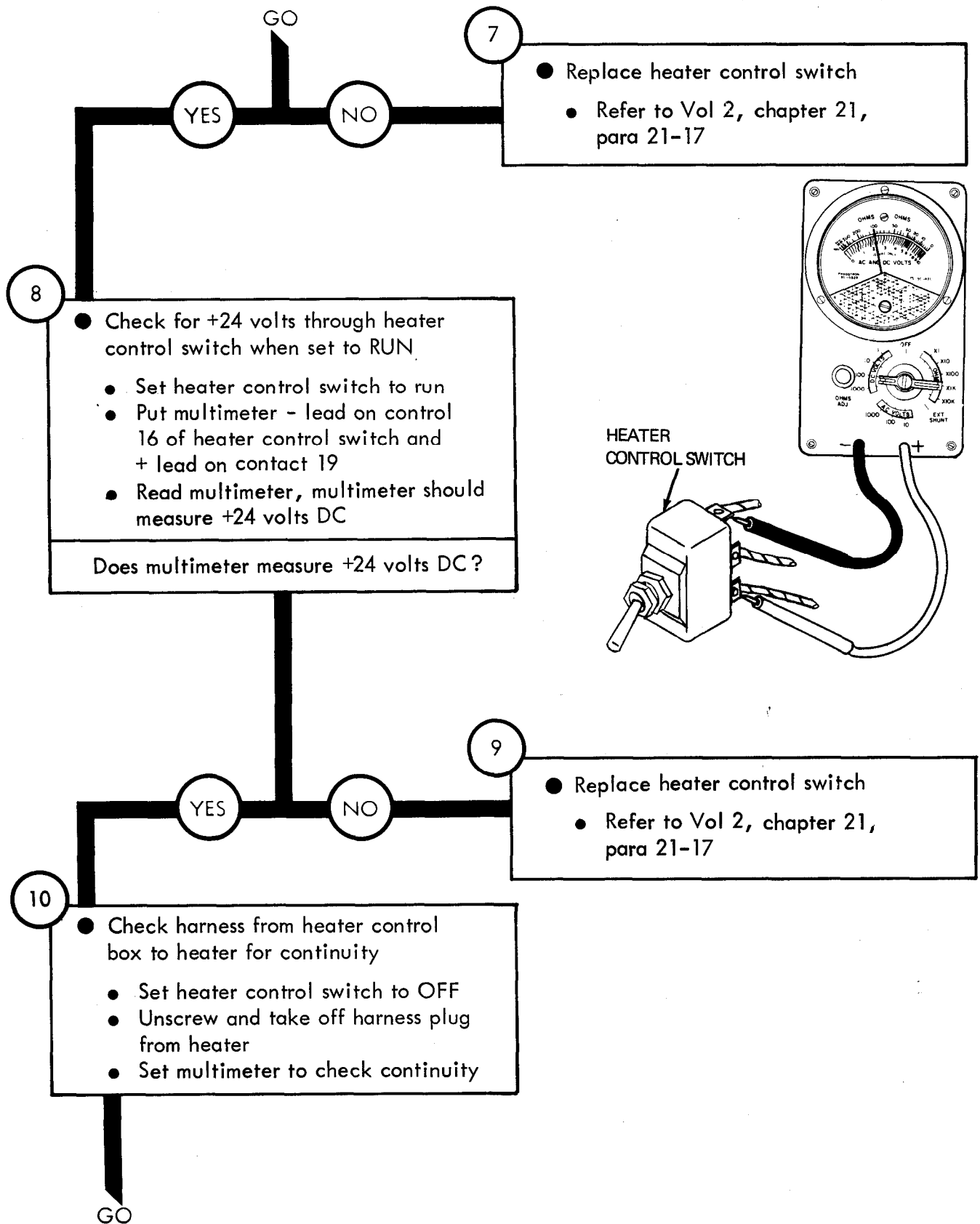

Figure 13-5 (Sheet 3 of 5)

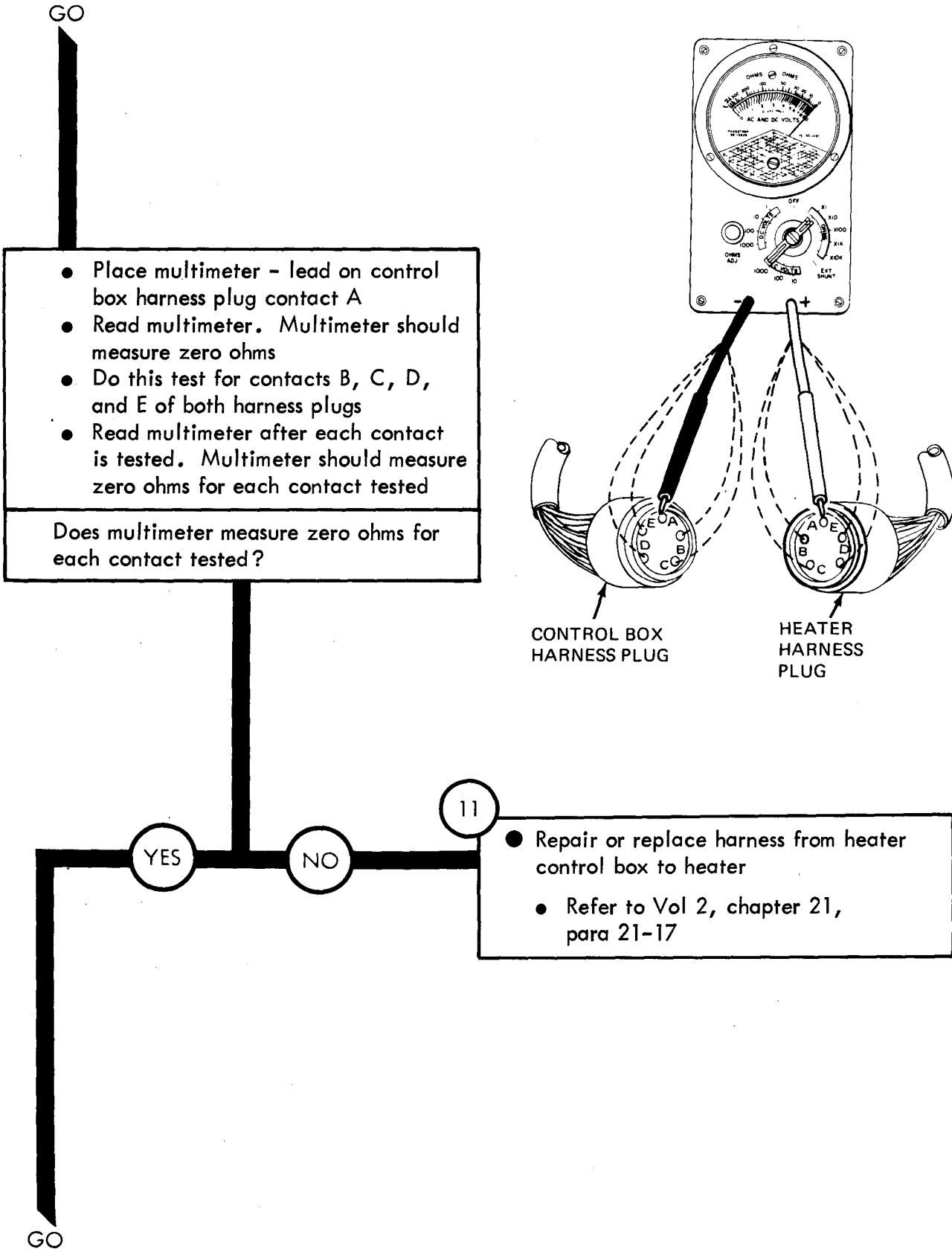

Figure 13-5 (Sheet 4 of 5)

TA 120773

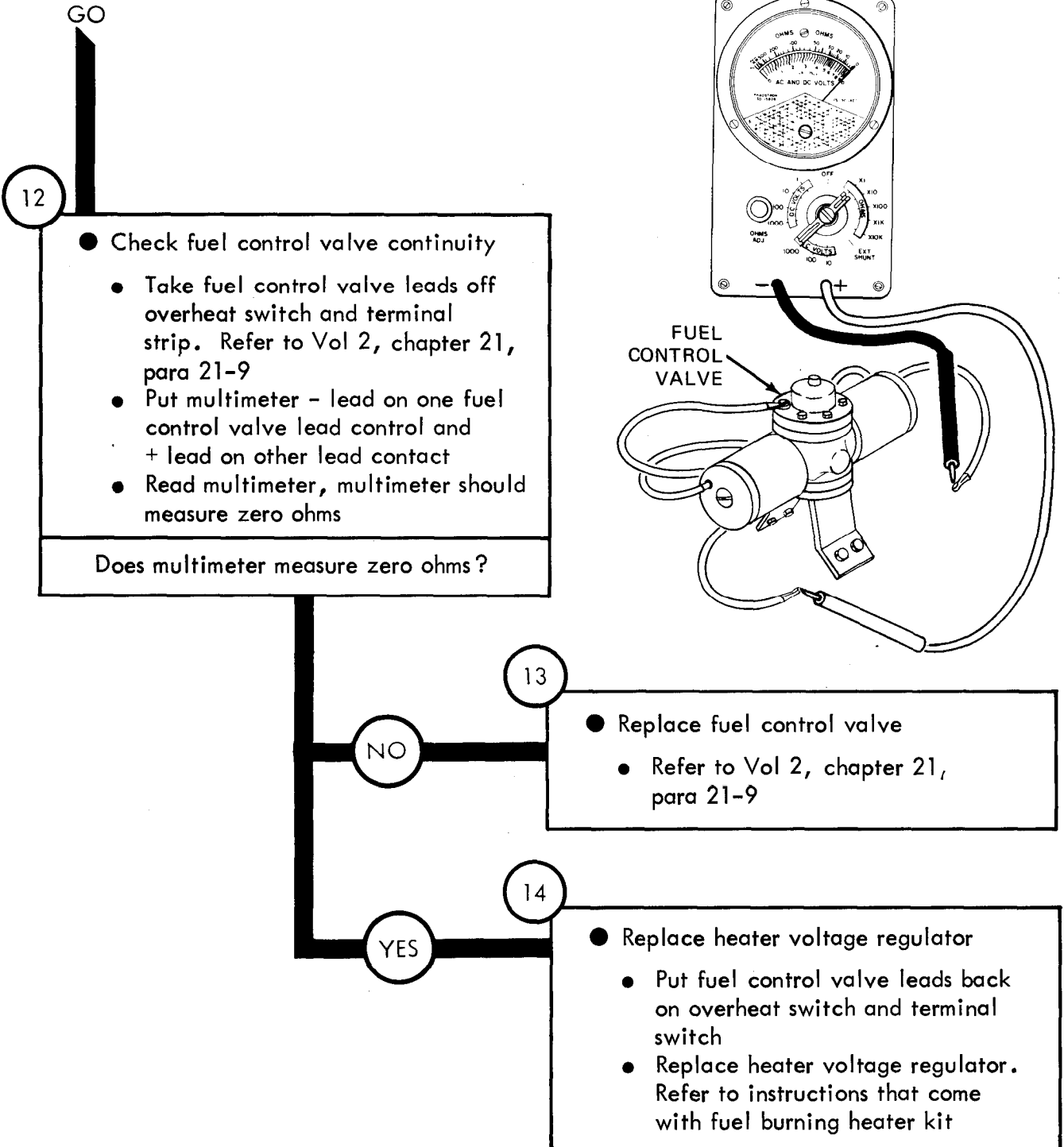

Figure 13-5 (Sheet 5 of 5)

VAN BODY TROUBLESHOOTING

Symptom

7 NO VAN LIGHTS OR EQUIPMENT WORK

WARNING

Only properly trained personnel should perform tests on van body 115 volt AC systems

The voltage present in 115 volt AC system can cause severe or fatal electric shock

- 1
 - Park truck
 - Refer to TM 9-2320-209-10

- 2
 - Check for 115 volt AC through external power cable
 - Pull external power cable plug from power entrance receptacle
 - Set multimeter to measure 115 volts AC
 - Put multimeter on large contact of power cable plug and keep it there
 - Put multimeter on each of the small contacts of power cable plug
 - Read multimeter for each contact tested. Multimeter should measure 115 volts AC
- Does multimeter measure less than 115 volts AC for any contact tested?

GO

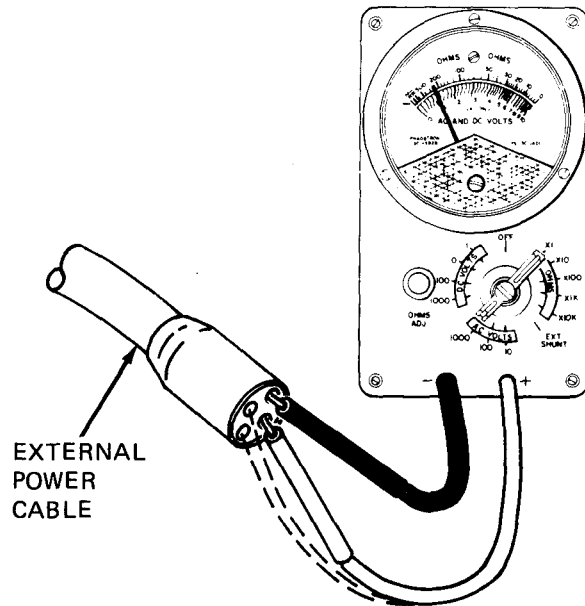
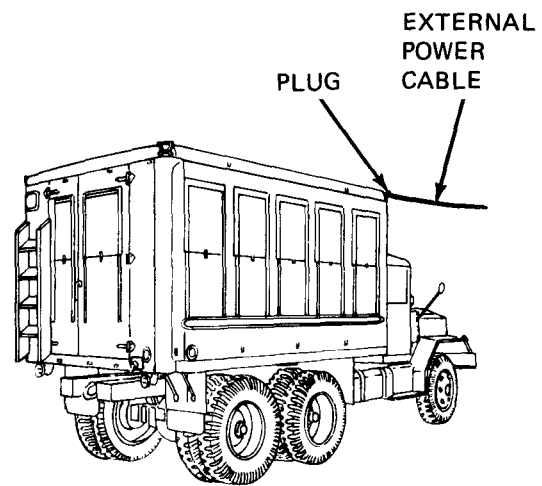

Figure 13-7 (Sheet 1 of 2)

TA 120775

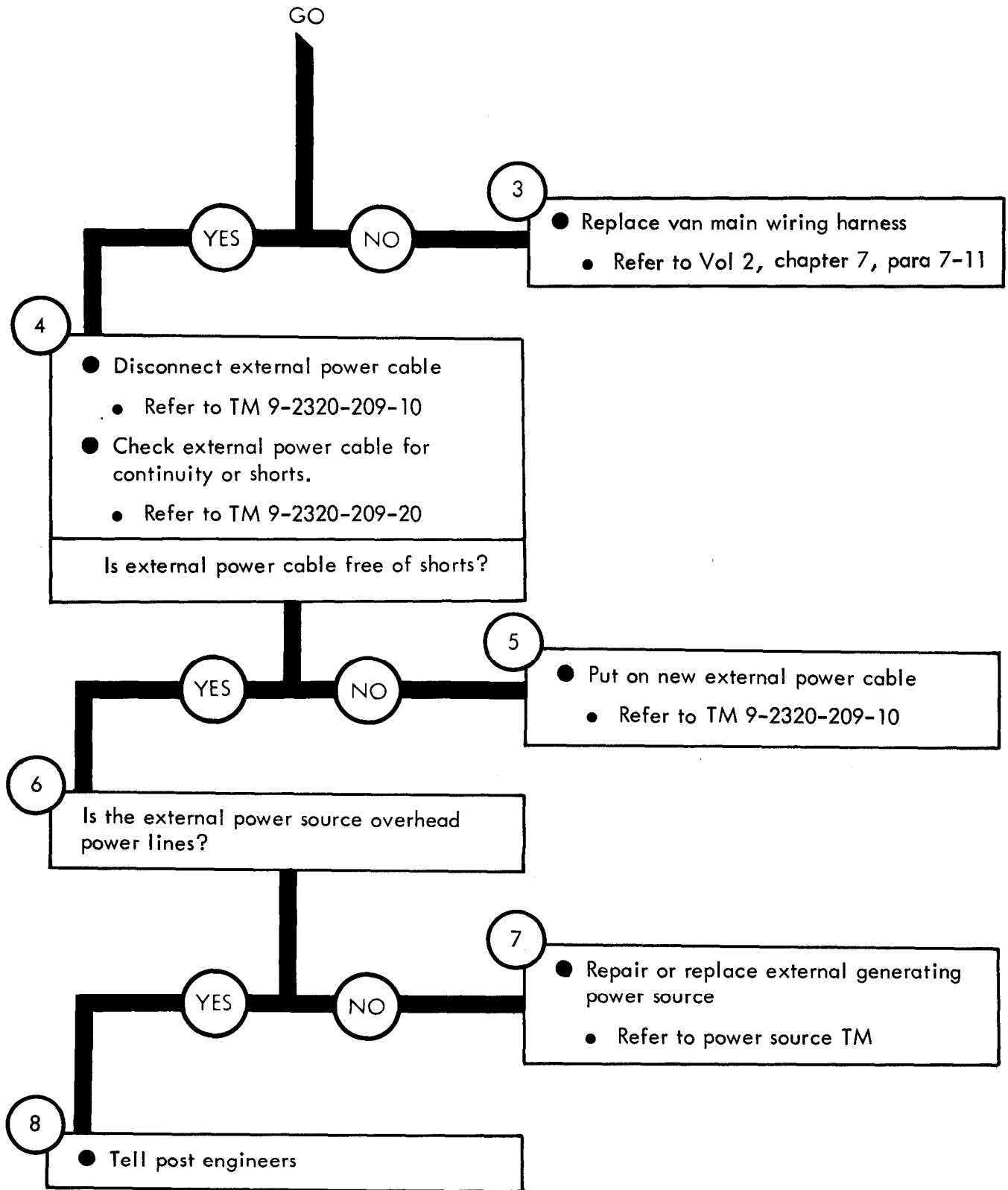

Figure 13-7 (Sheet 2 of 2)

TA 120776

CHAPTER 14

ELECTRICAL SYSTEM TEST PROCEDURES

14-1. TEST PROCEDURES. Test procedures for the electrical system consist of procedures for using multimeters. Refer to TM 9-2320-209-20-2 for these procedures.

CHAPTER 15

TRANSMISSION SYSTEM TROUBLESHOOTING

15-1. EQUIPMENT ITEMS COVERED. This chapter gives equipment troubleshooting procedures for the transmission system , for which there are authorized corrective maintenance tasks at the direct support and general support maintenance level.

15-2. EQUIPMENT ITEMS NOT COVERED. All equipment items for which corrective maintenance is authorized at the direct support and general support maintenance level are covered in this chapter.

TRANSMISSION SYSTEM TROUBLESHOOTING

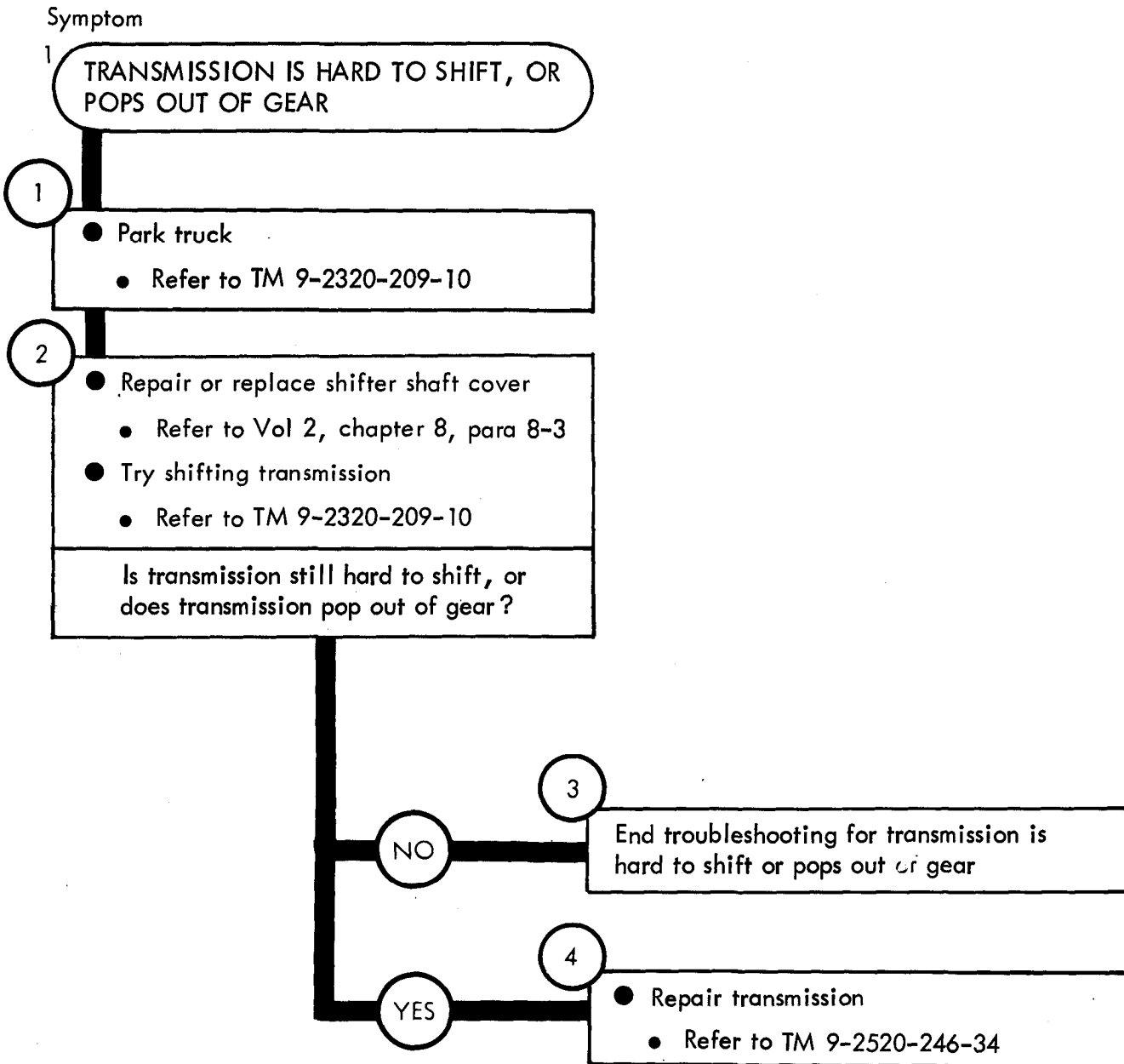

Figure 15-1

TA 120777

CHAPTER 16

EARTH BORING MACHINE SYSTEM TROUBLESHOOTING

16-1. EQUIPMENT ITEMS COVERED. This chapter gives equipment troubleshooting procedures for the earth boring machine system , for which there are authorized corrective maintenance tasks at the direct support and general support maintenance level.

16-2. EQUIPMENT ITEMS NOT COVERED. All equipment items for which corrective maintenance is authorized at the direct support and general support maintenance level are covered in this chapter.

EARTH BORING MACHINE TROUBLESHOOTING

Symptom

1 EARTH BORING MACHINE PROPELLER SHAFT DOES NOT TURN

- 1
- Park truck
 - Refer to TM 9-2320-209-10

NOTE

The following procedure will need the use of two soldiers. The lead soldier will be called Soldier A and the helper will be called Soldier B

- 2
- Check power divider
- SOLDIER B: ● Start engine. Refer to TM 9-2320-209-10
- Engage earth boring machine. Refer to TM 9-2320-209-10
- SOLDIER A: ● See if earth boring machine propeller shaft turns
- SOLDIER B: ● Shut down earth boring machine. Refer to TM 9-2320-209-10
- Turn off engine. Refer to TM 9-2320-209-10
- Does propeller shaft turn?

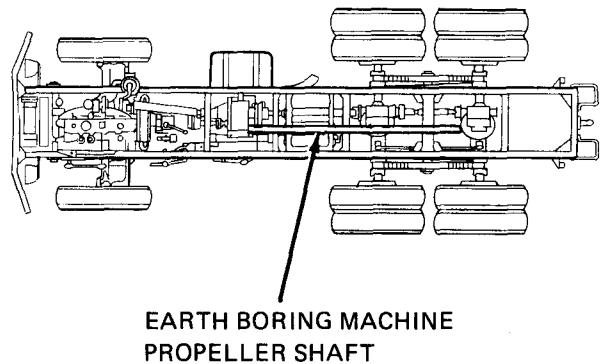

GO

TA 120778

Figure 16-1 (Sheet 1 of 2)

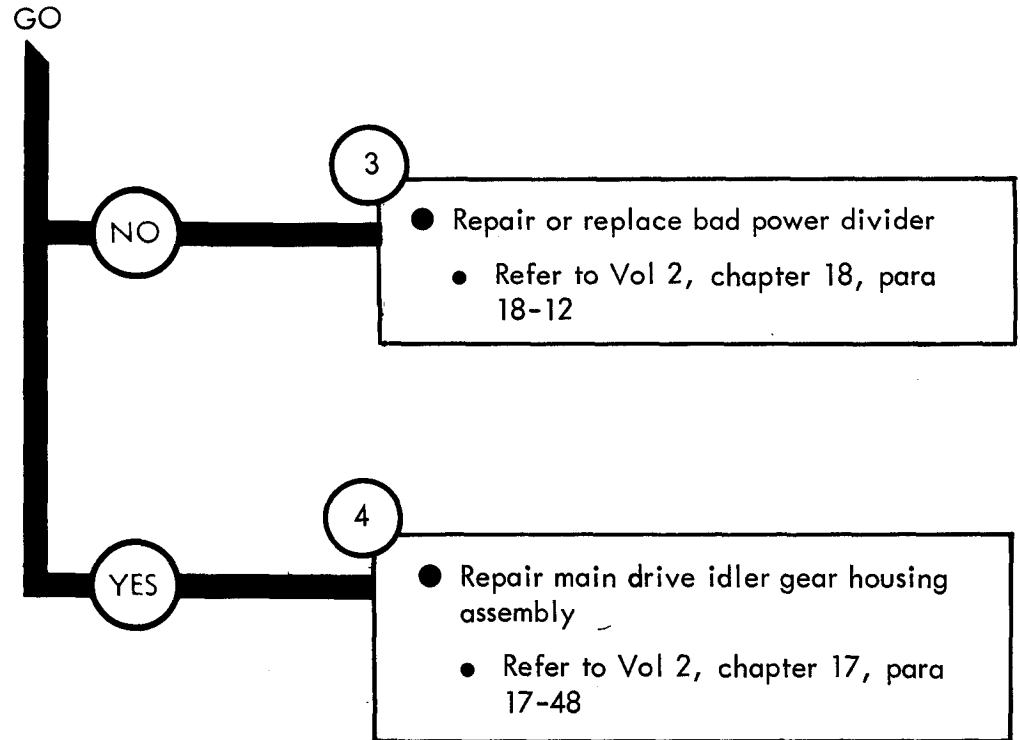

Figure 16-1 (Sheet 2 of 2)

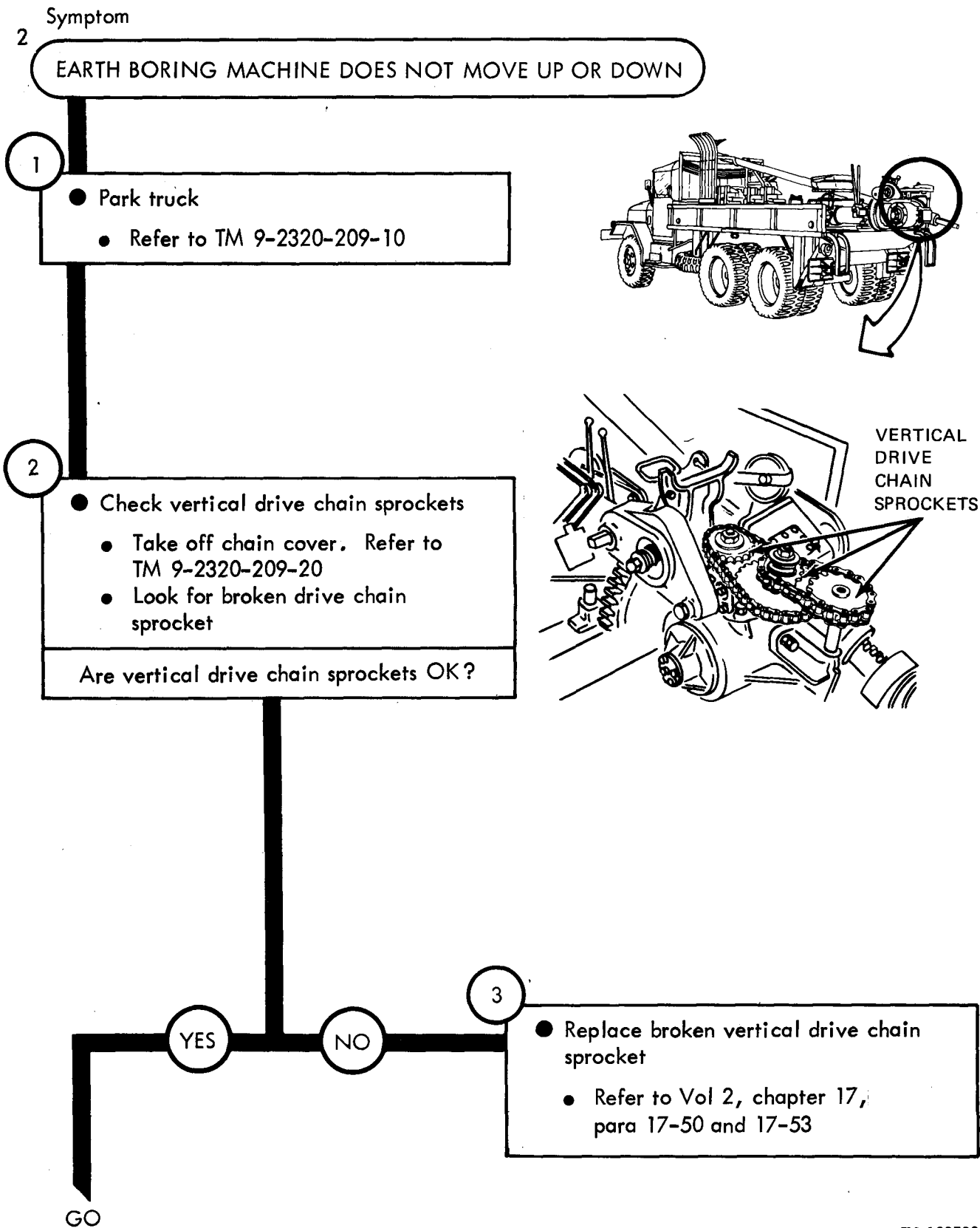

Figure 16-2 (Sheet 1 of 2)

TA 120780

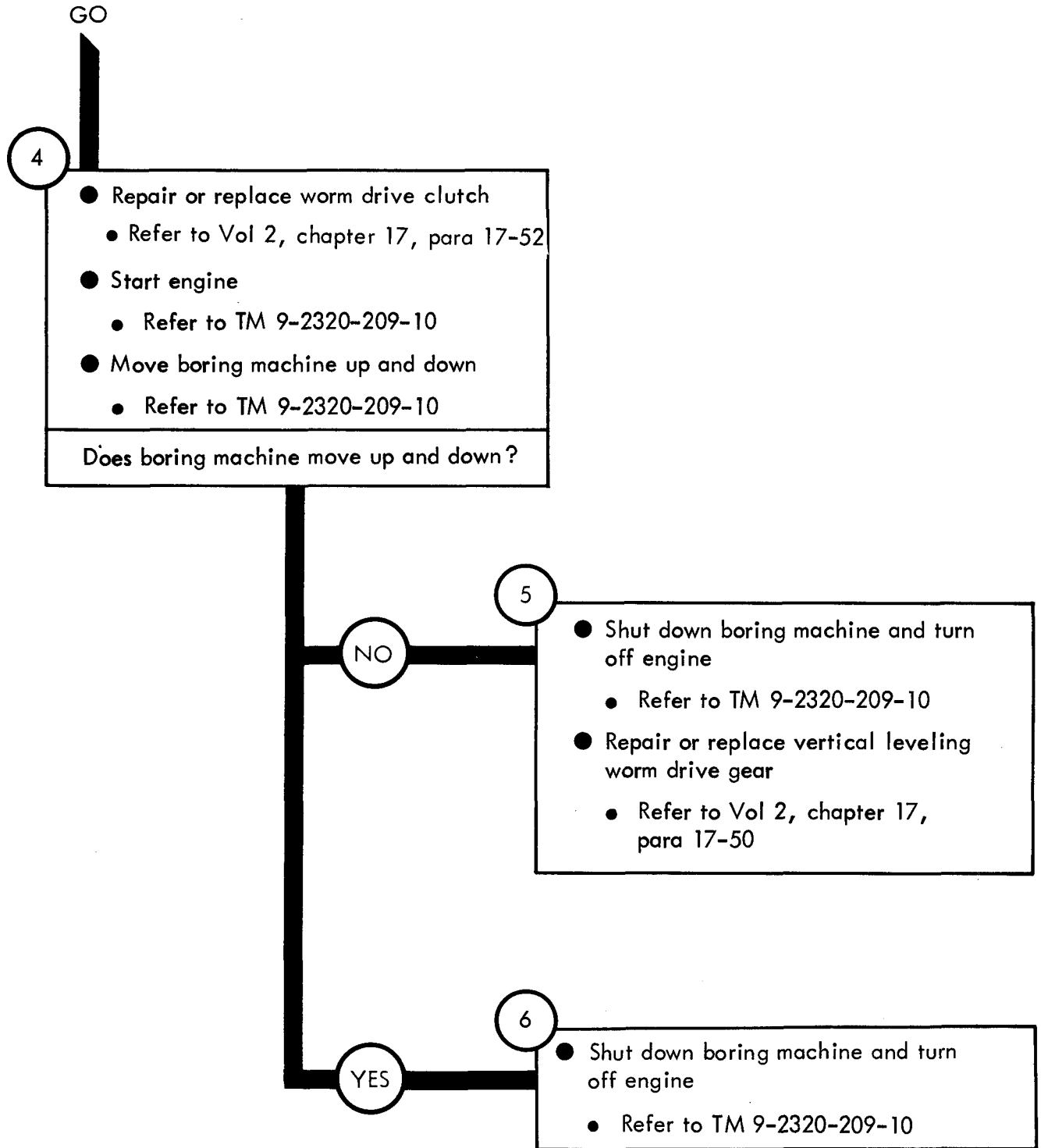

Figure 16-2 (Sheet 2 of 2)

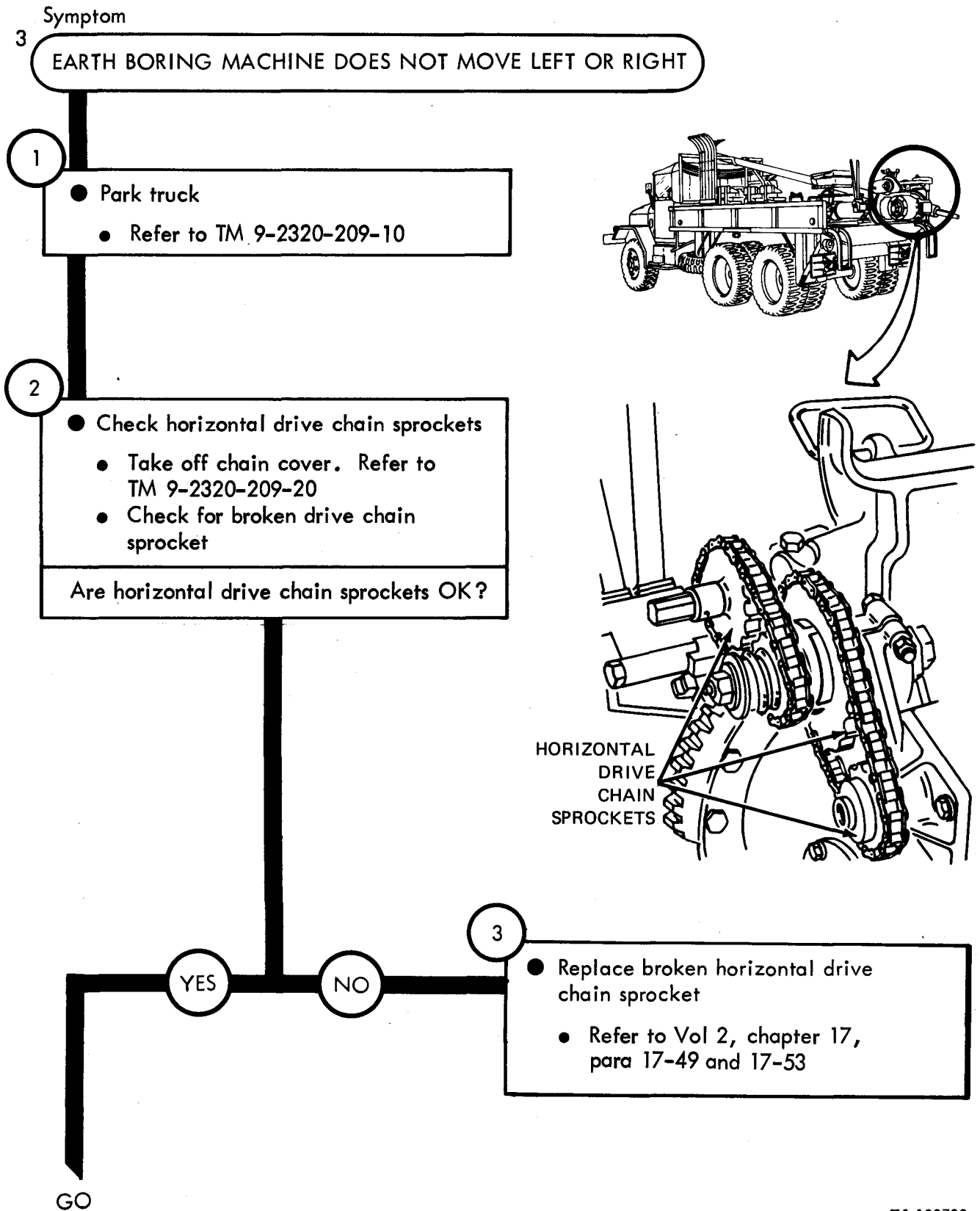

Figure 16-3 (Sheet 1 of 2)

TA 120782

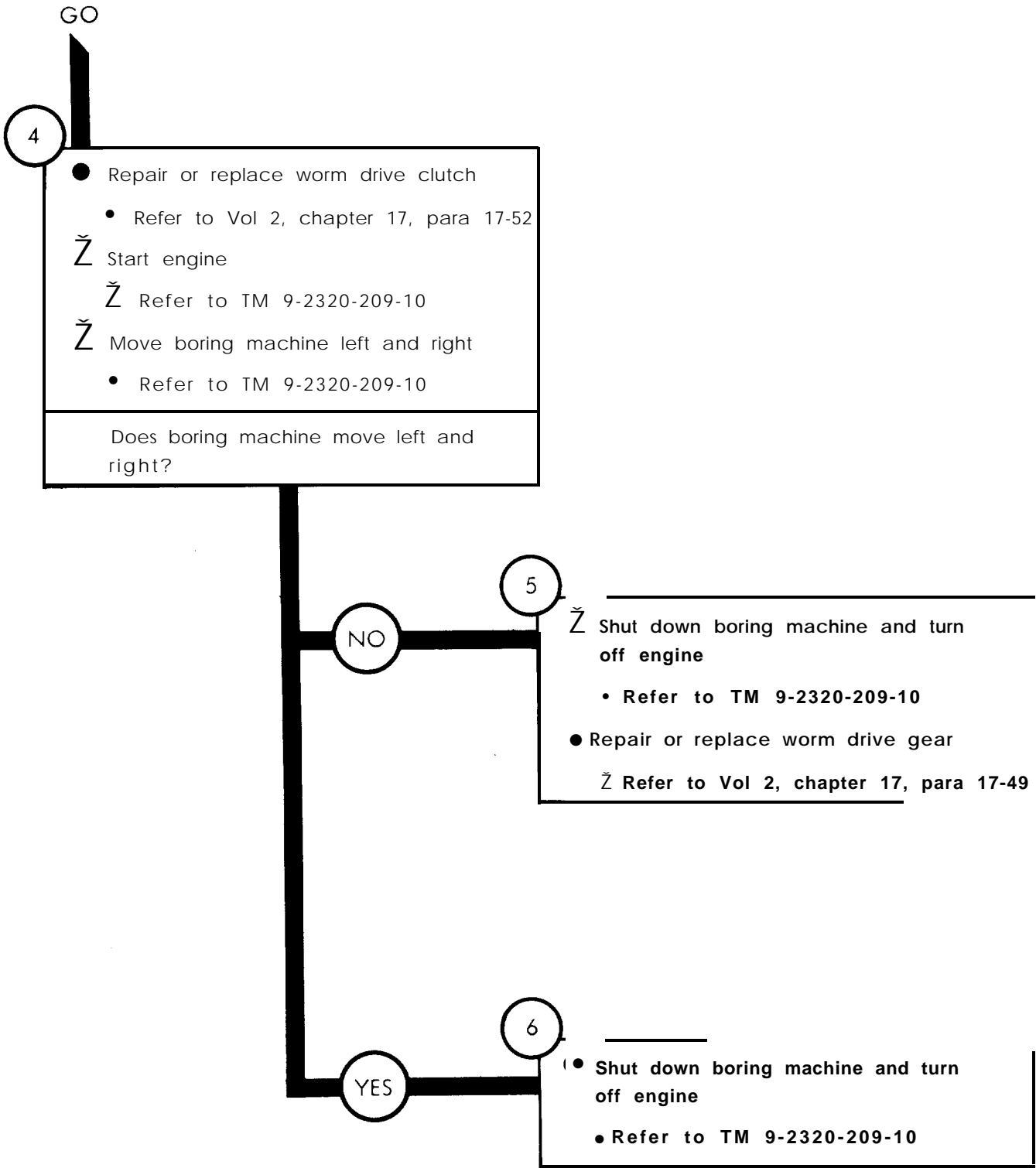

Figure 16-3 (Sheet 2 of 2)

CHAPTER 17

FRONT WINCH SYSTEM TROUBLESHOOTING

17-1. EQUIPMENT ITEMS COVERED. This chapter gives equipment troubleshooting procedures for the front winch system, for which there are authorized corrective maintenance tasks at the direct support and general support maintenance level.

17-2. EQUIPMENT ITEMS NOT COVERED. All equipment items for which corrective maintenance is authorized at the direct support and general support maintenance level are covered in this chapter.

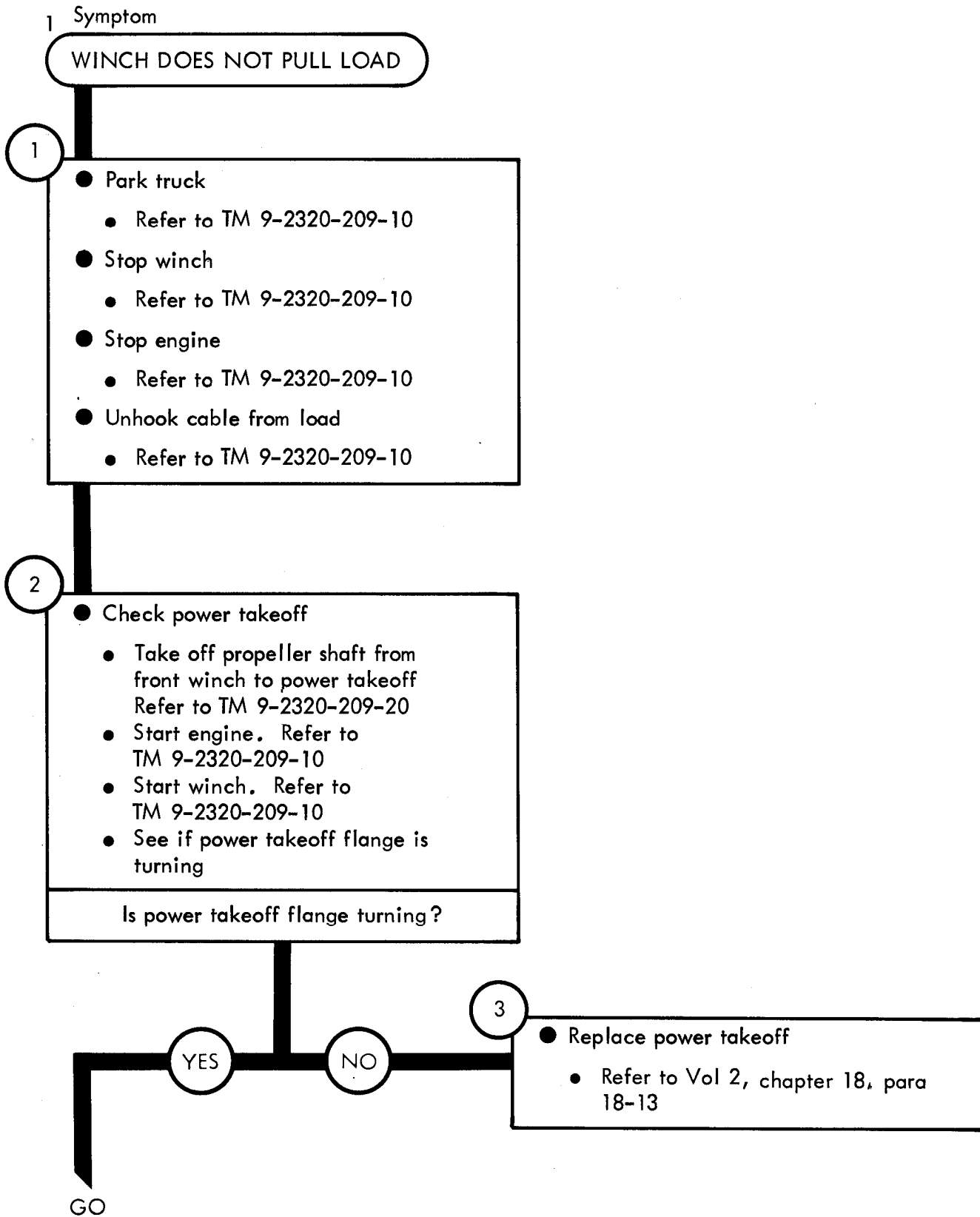

Figure 17-1 (Sheet 1 of 2)

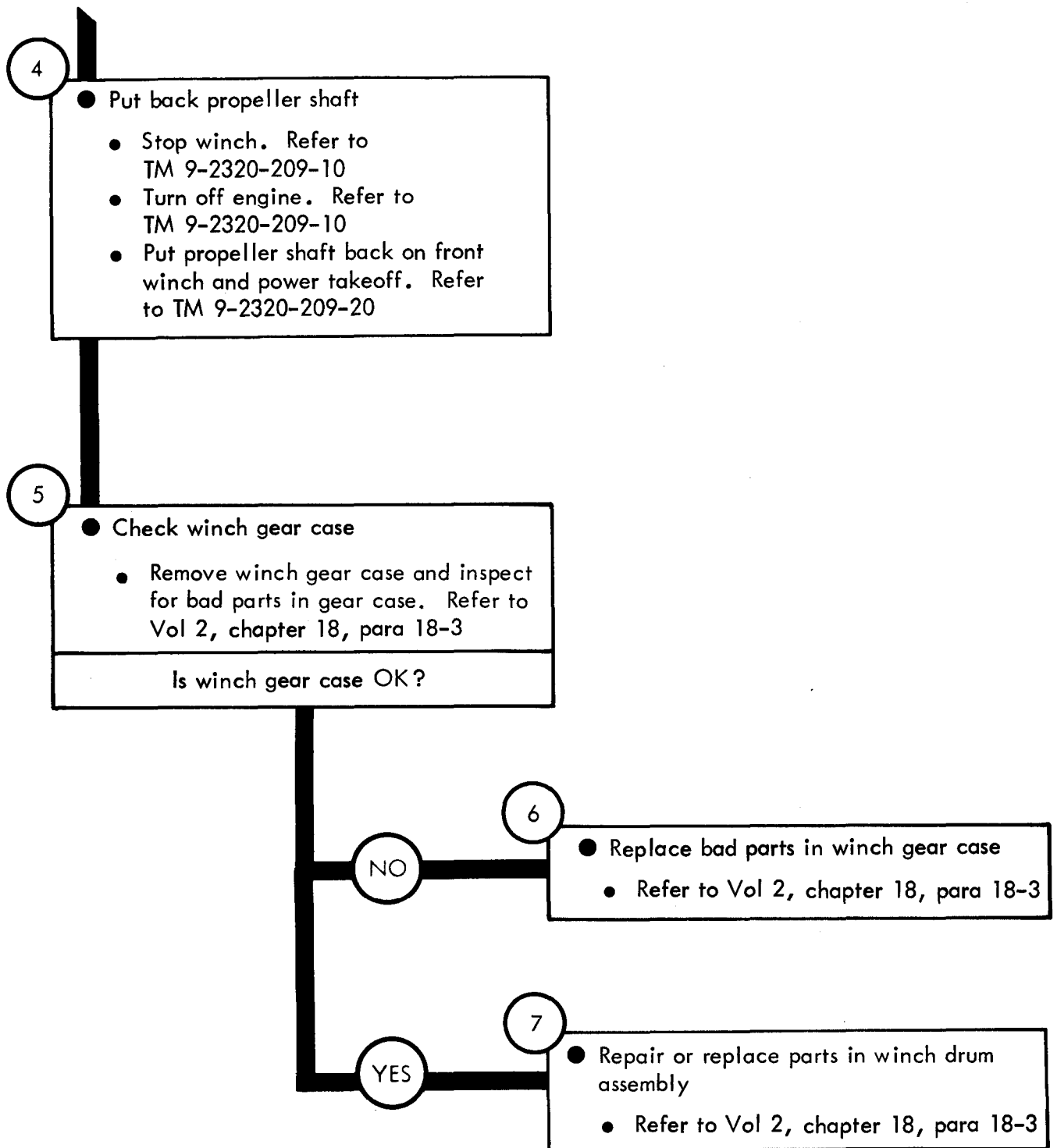

Figure 17-1 (Sheet 2 of 2)

CHAPTER 18

DUMP SYSTEM (M342A2) TROUBLESHOOTING

18-1. EQUIPMENT ITEMS COVERED. This chapter gives equipment troubleshooting procedures for the dump system, for which there are authorized corrective maintenance tasks at the direct support and general support maintenance level.

18-2. EQUIPMENT ITEMS NOT COVERED. All equipment items for which corrective maintenance is authorized at the direct support and general support maintenance level are covered in this chapter.

DUMP TROUBLESHOOTING

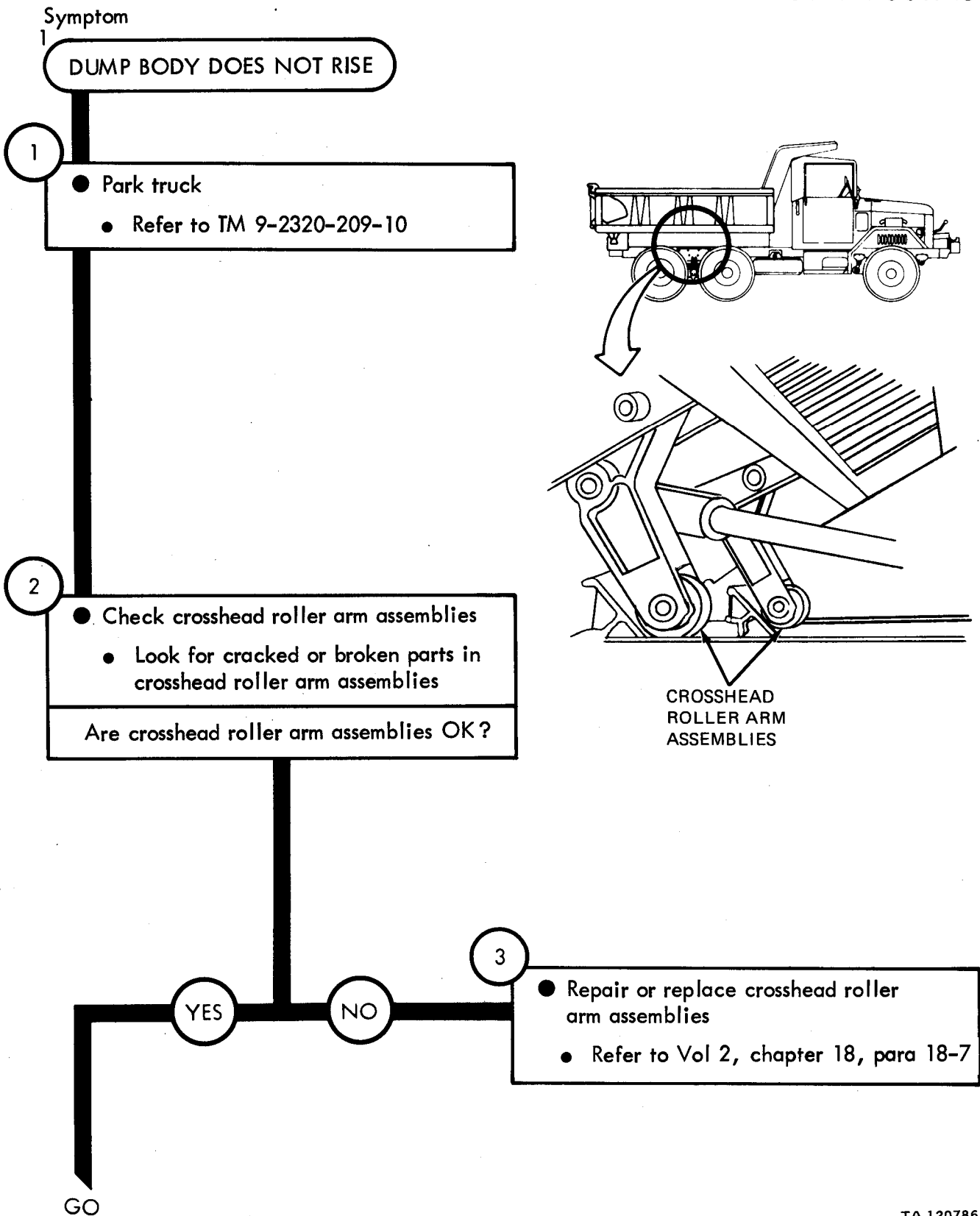

TA 120786

Figure 18-1 (Sheet 1 of 2)

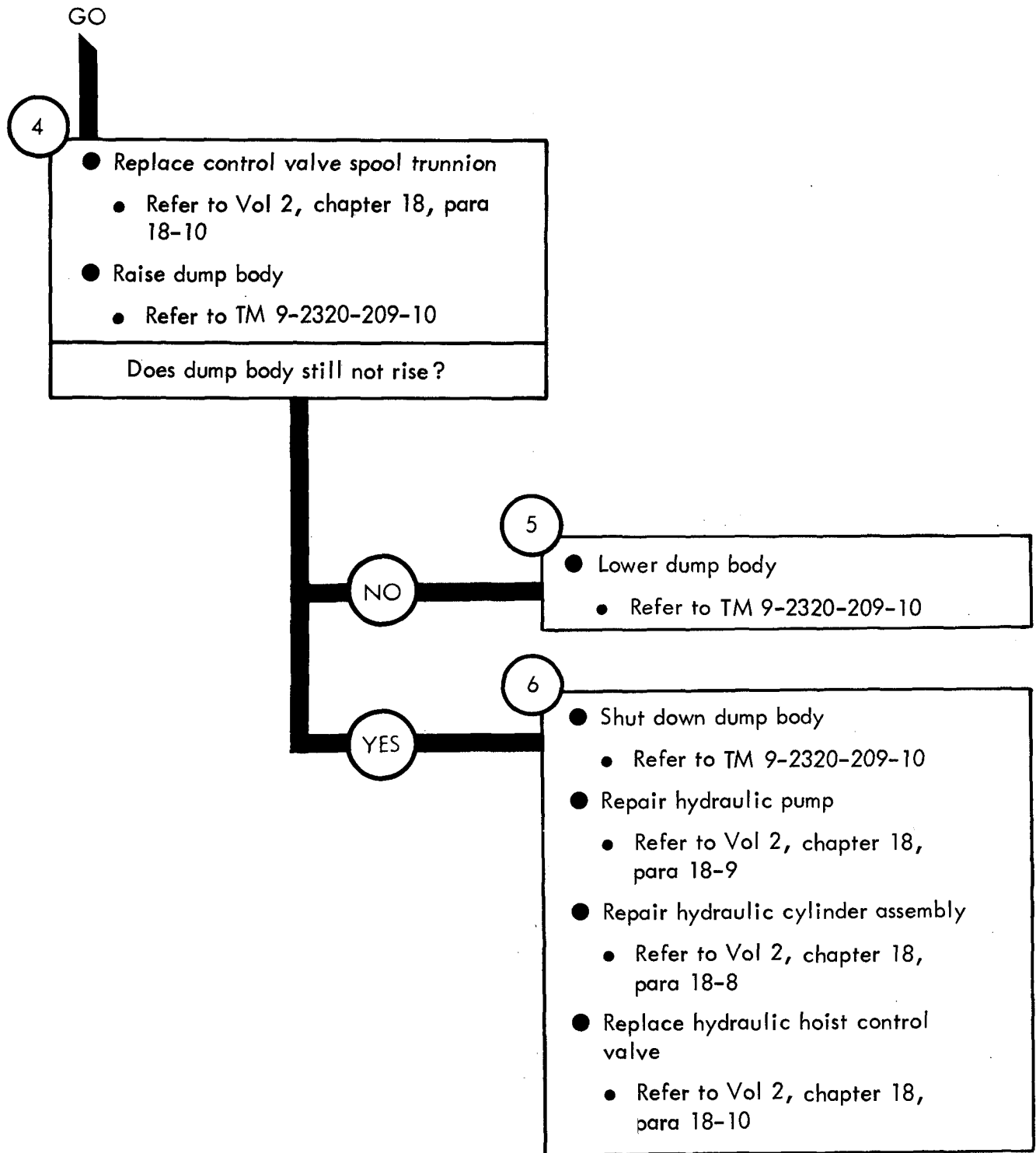

TA 120787

Figure 18-1 (Sheet 2 of 2)

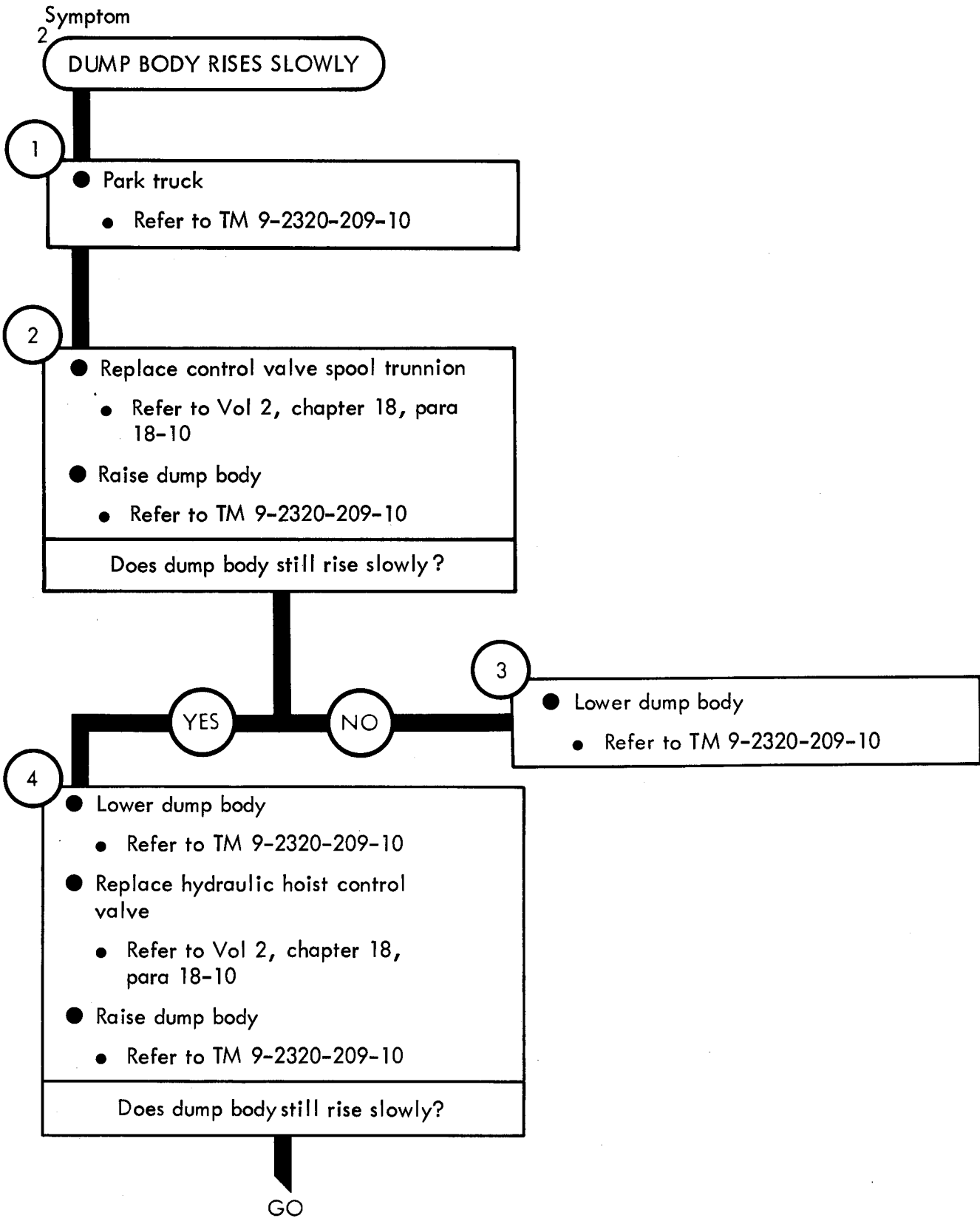

Figure 18-2 (Sheet 1 of 2)

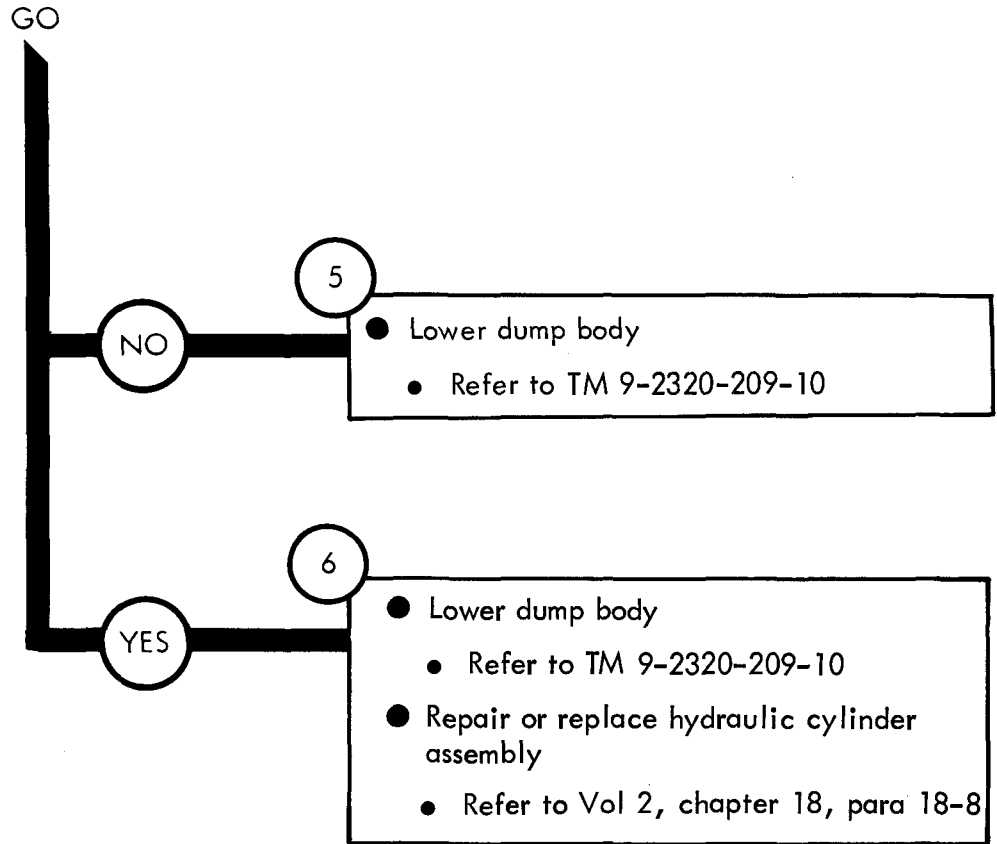

Figure 18-2 (Sheet 2 of 2)

CHAPTER 19

REAR WINCH (M764) SYSTEM TROUBLESHOOTING

19-1. EQUIPMENT ITEMS COVERED. This chapter gives equipment troubleshooting procedures for the M764 rear winch system, for which there are authorized corrective maintenance tasks at the direct support and general support maintenance level.

19-2. EQUIPMENT ITEMS NOT COVERED. All equipment items for which corrective maintenance is authorized at the direct support and general support maintenance level are covered in this chapter.

REAR WINCH TROUBLESHOOTING FOR M764

Symptom

WINCH DOES NOT PULL LOAD

1

- Park truck
 - Refer to TM 9-2320-209-10
 - Turn off winch. Refer to TM 9-2320-209-10
 - Turn off engine. Refer to TM 9-2320-209-10

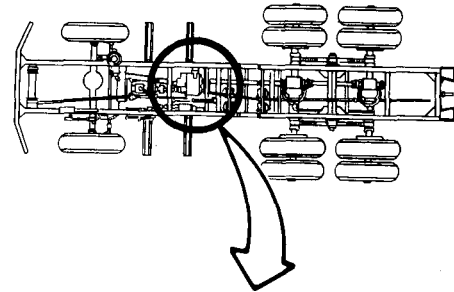

2

- Check power takeoff
 - Take out power divider driveshaft. Refer to TM 9-2320-209-20
 - Start engine. Refer to TM 9-2320-209-10
 - Turn on power takeoff. Refer to TM 9-2320-209-10

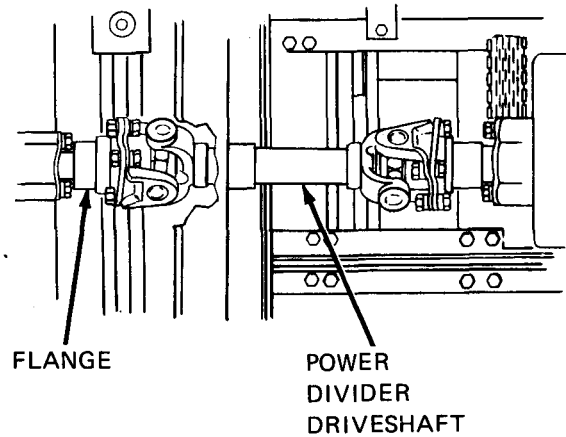

Does flange turn?

YES

NO

3

- Turn off power takeoff and turn off engine
 - Refer to TM 9-2320-209-10
- Replace broken power takeoff
 - Refer to Vol 2, chapter 18, para 18-16
- Put back power divider driveshaft
 - Refer to TM 9-2320-209-20

GO

TA 121183

Figure 19-1 (Sheet 1 of 2)

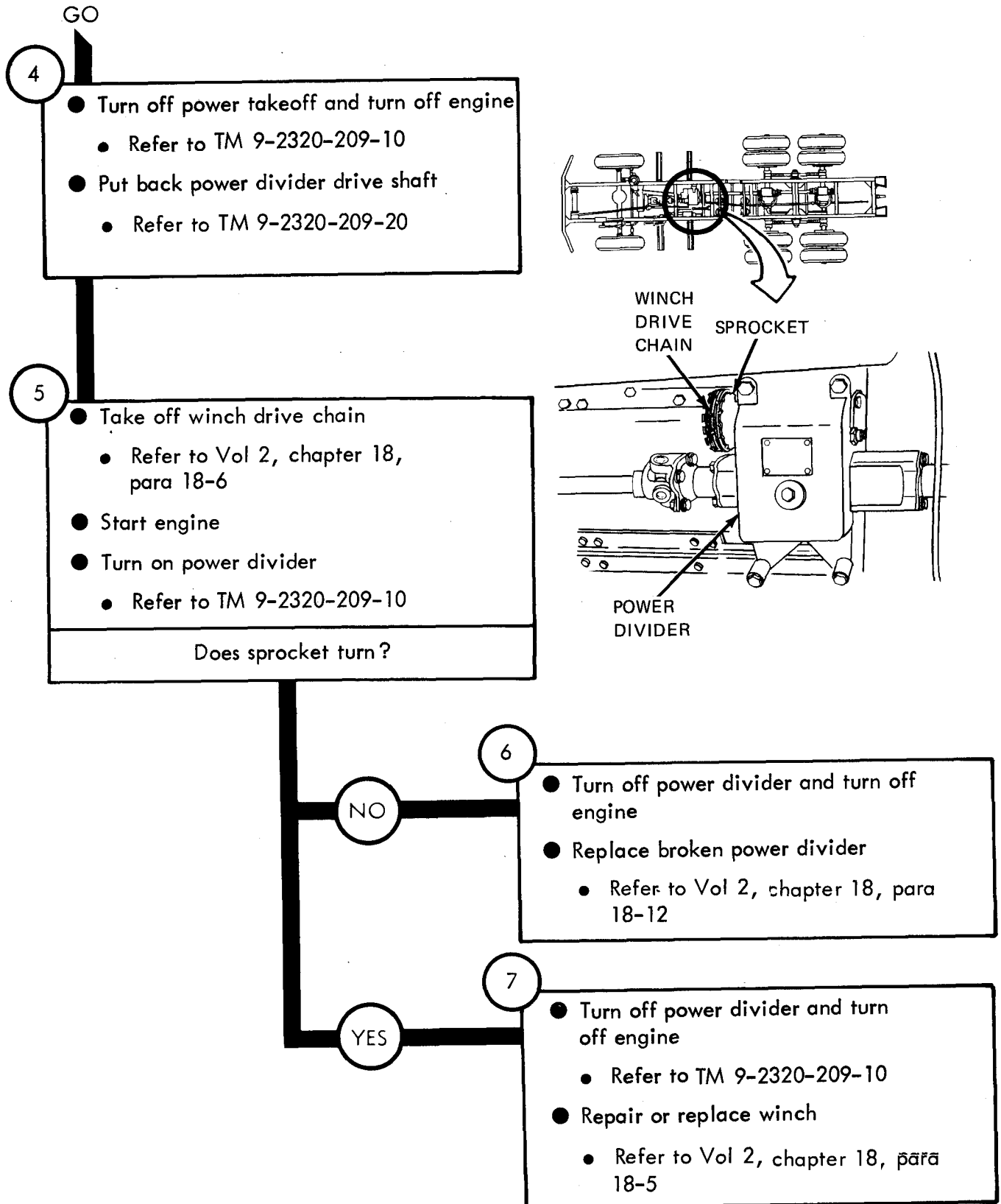

TA 121184

Figure 19-1 (Sheet 2 of 2)

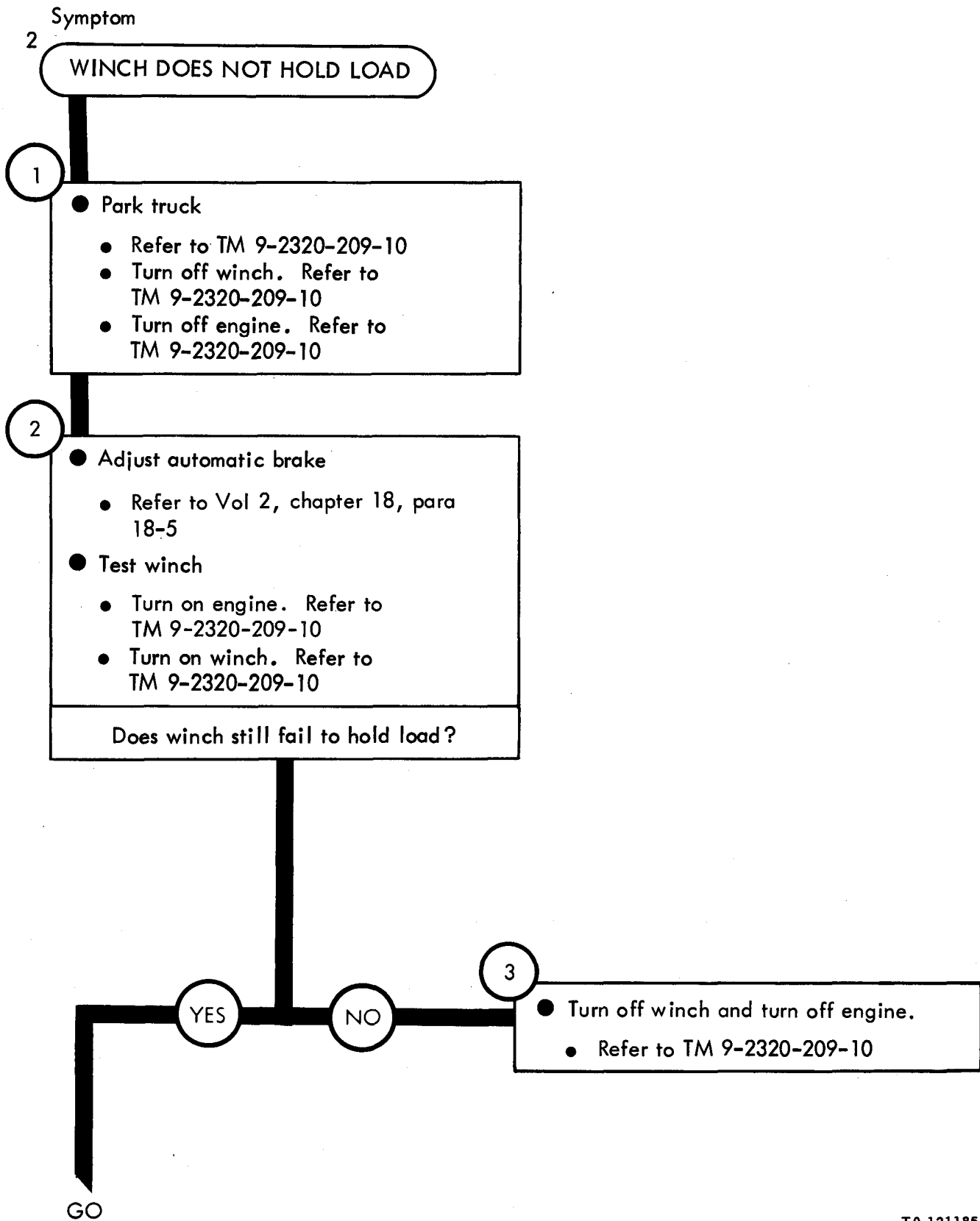

TA 121185

Figure 19-2 (Sheet 1 of 2)

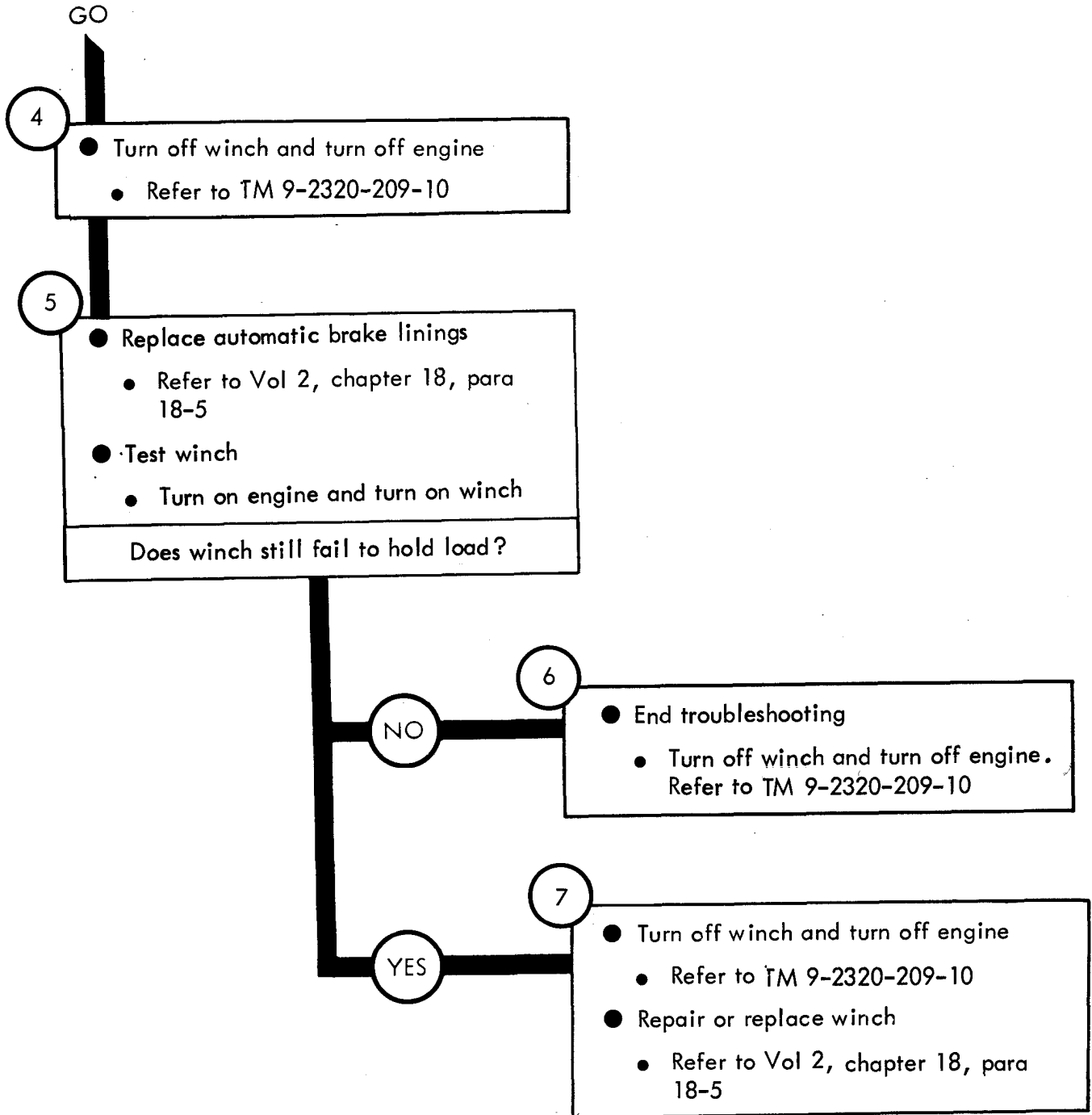

Figure 19-2 (Sheet 2 of 2)

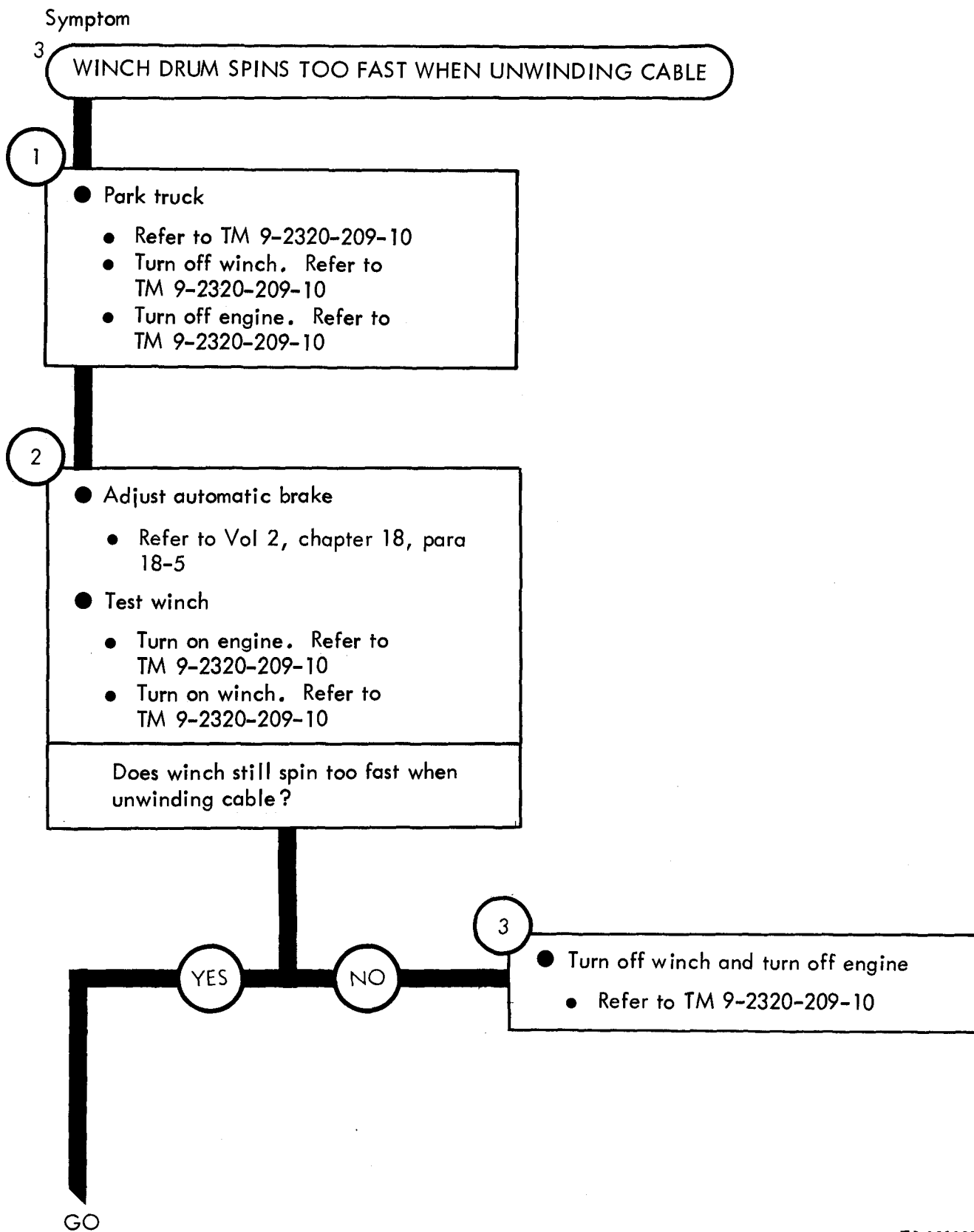

Figure 19-3 (Sheet 1 of 2)

TA 121187

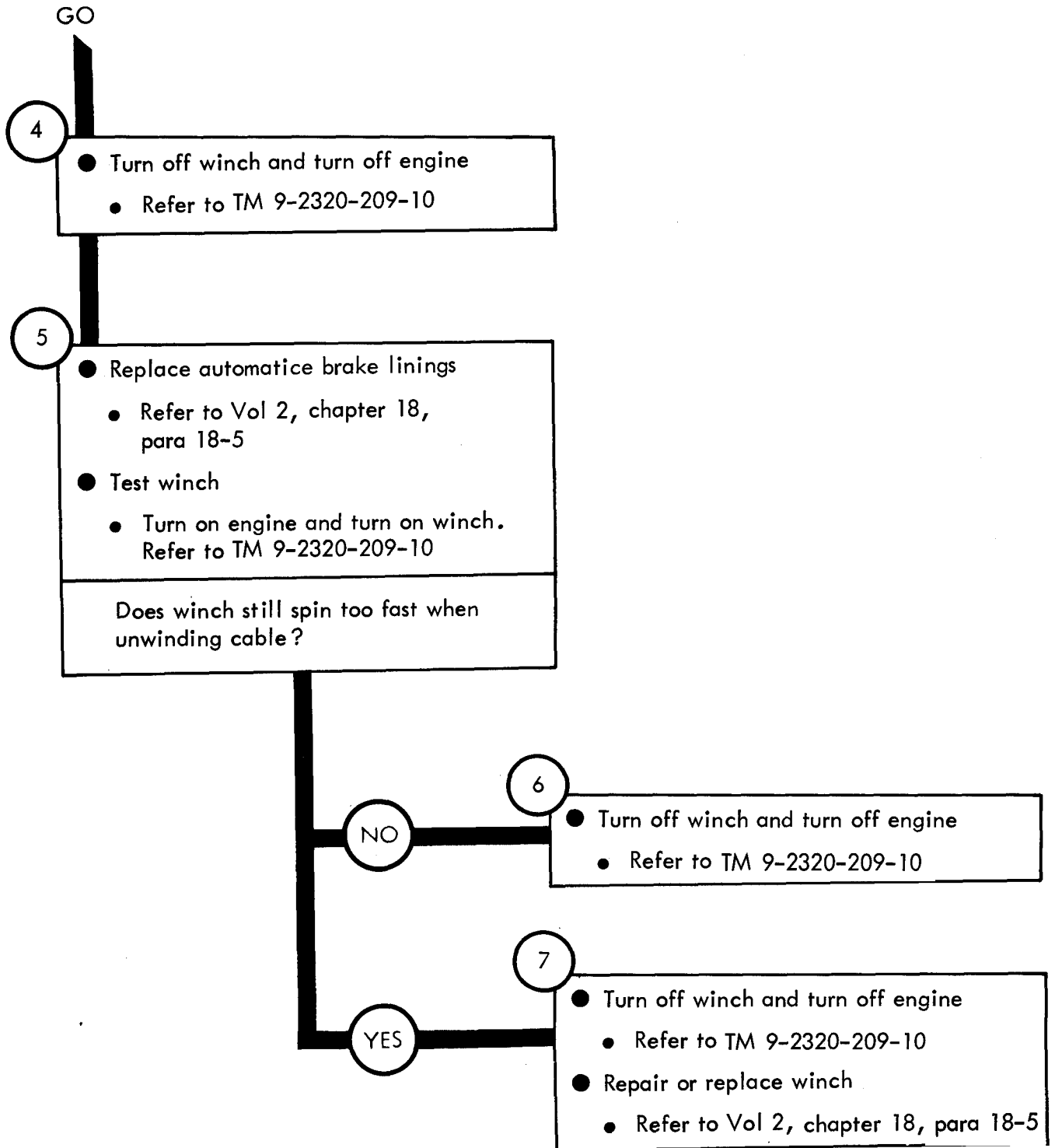

Figure 19-3 (Sheet 2 of 2)

CHAPTER 20

REAR WINCH (M756A2) SYSTEM TROUBLESHOOTING

20-1. EQUIPMENT ITEMS COVERED. This chapter gives equipment troubleshooting procedures for the M756A2 rear winch system, for which there are authorized corrective maintenance tasks at the direct support and general support maintenance level.

20-2. EQUIPMENT ITEMS NOT COVERED. All equipment items for which corrective maintenance is authorized at the direct support and general support maintenance level are covered in this chapter.

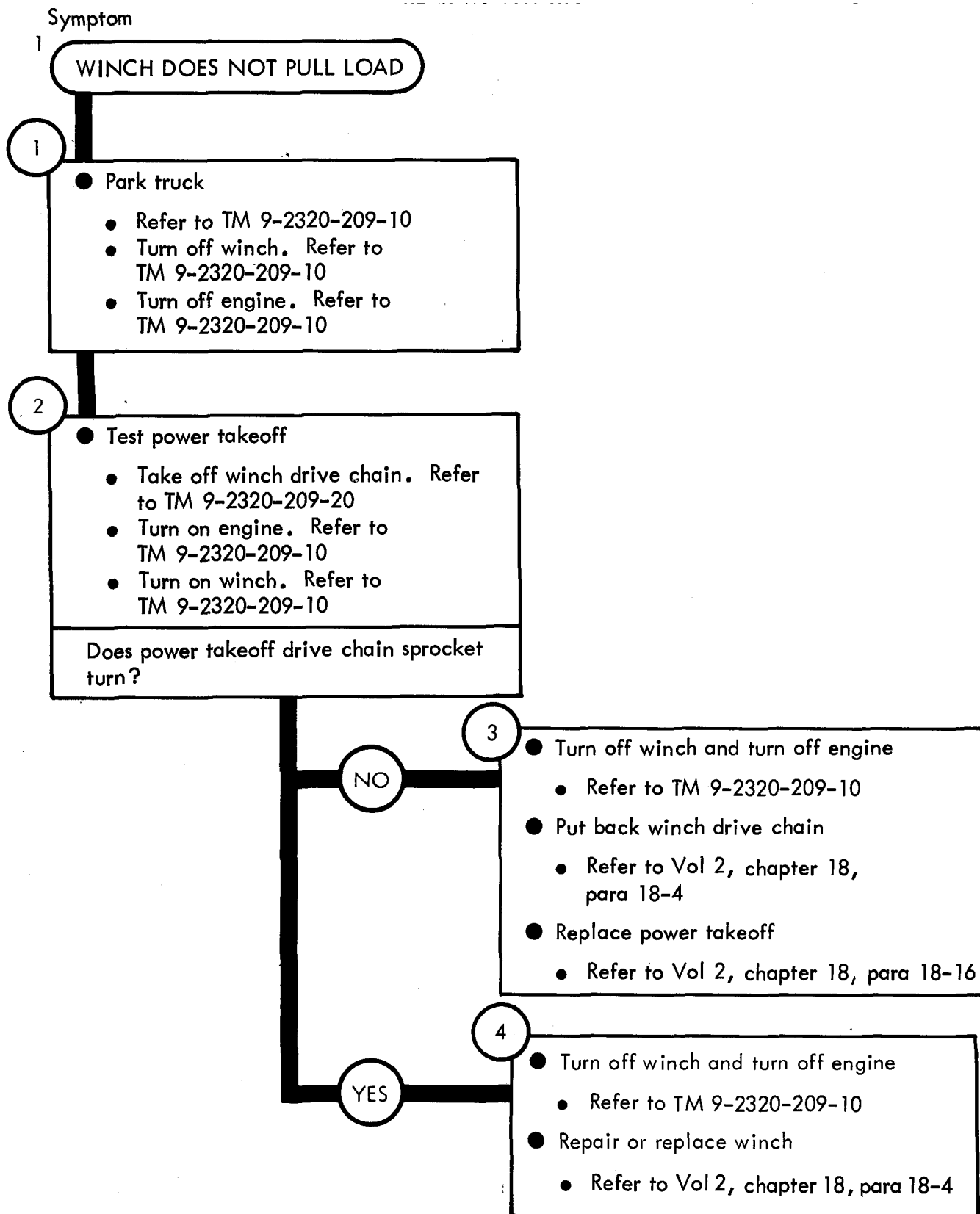

TA 121189

Figure 20-1

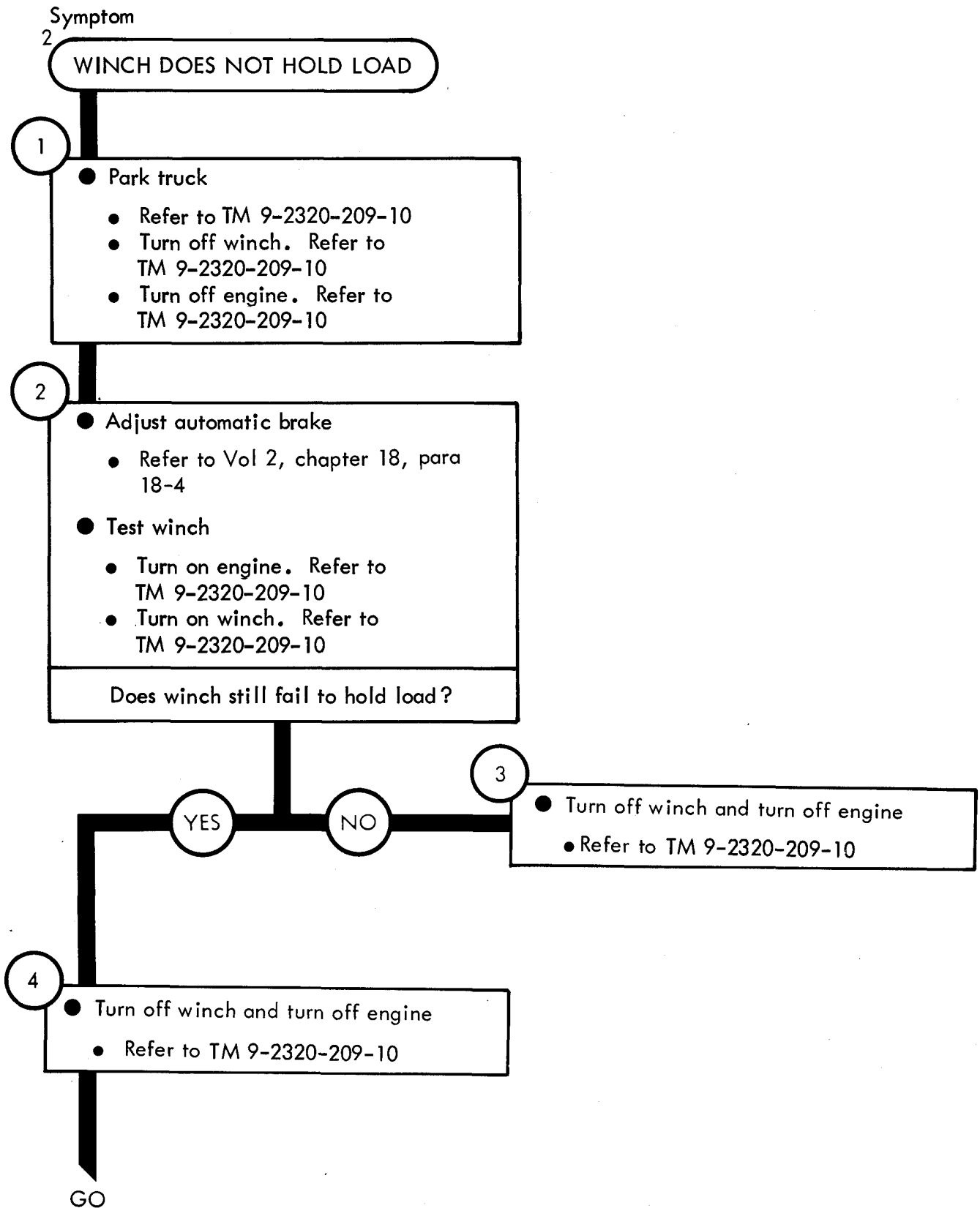

Figure 20-2 (Sheet 1 of 2)

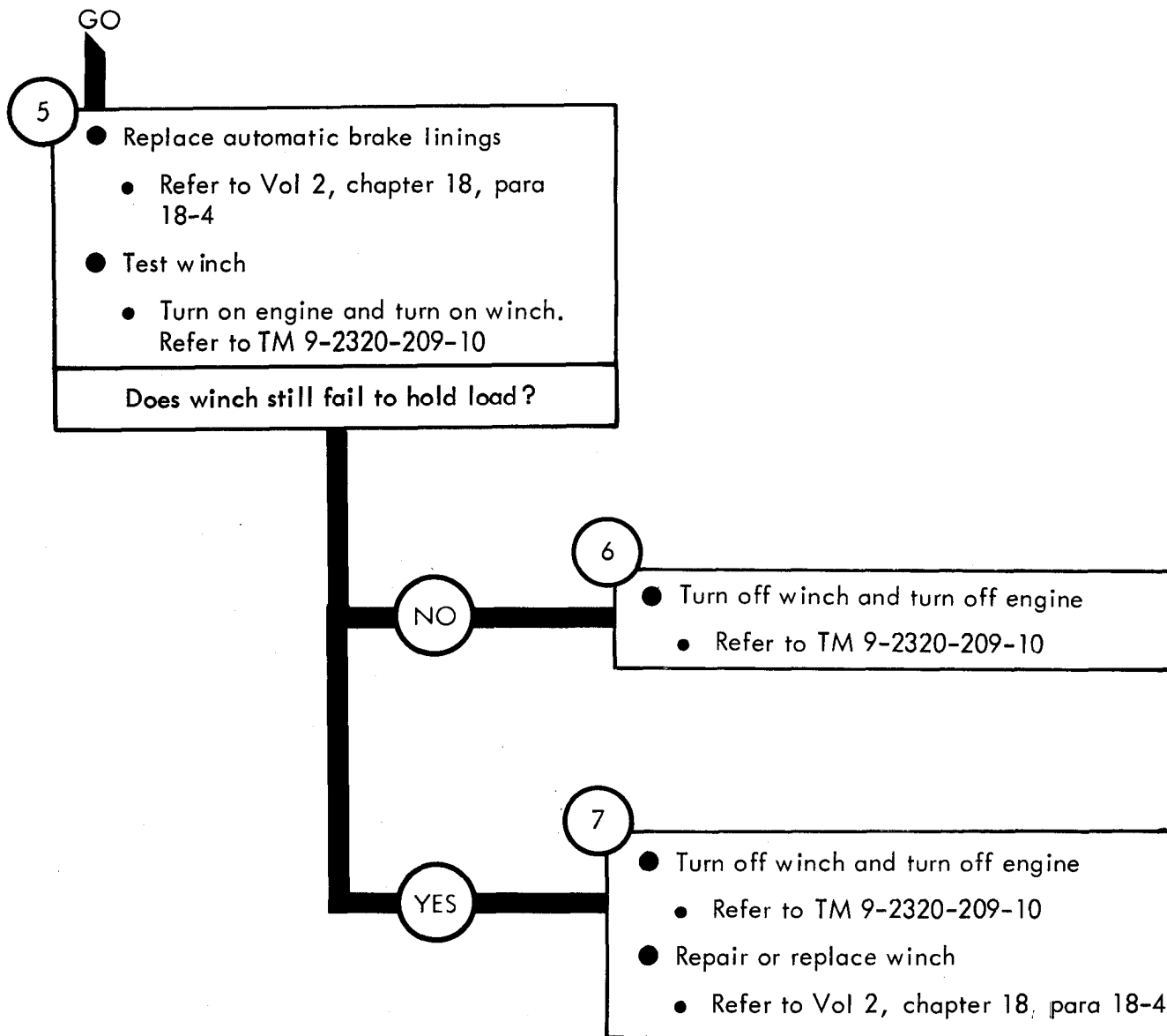

Figure 20-2 (Sheet 2 of 2)

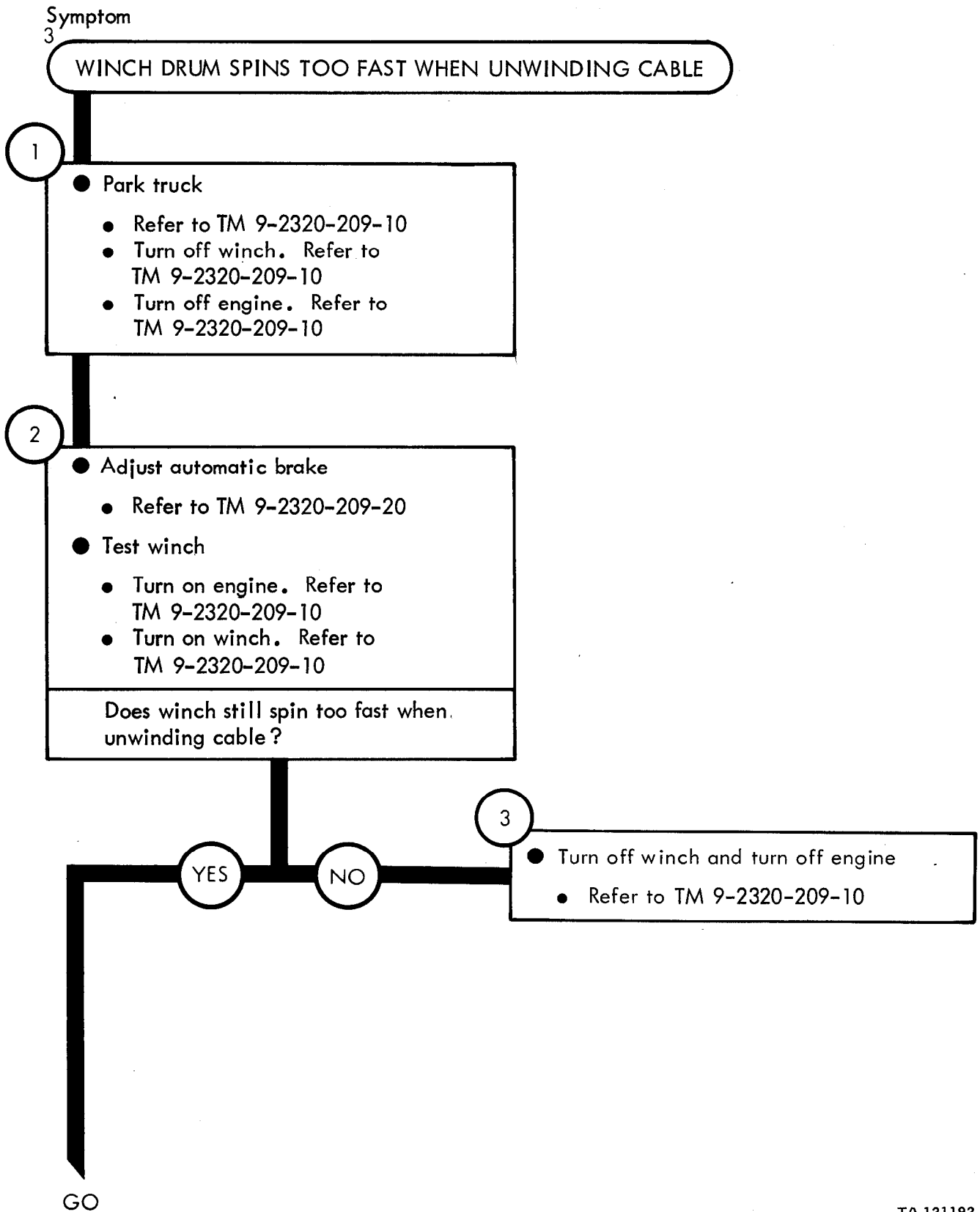

Figure 20-3 (Sheet 1 of 2)

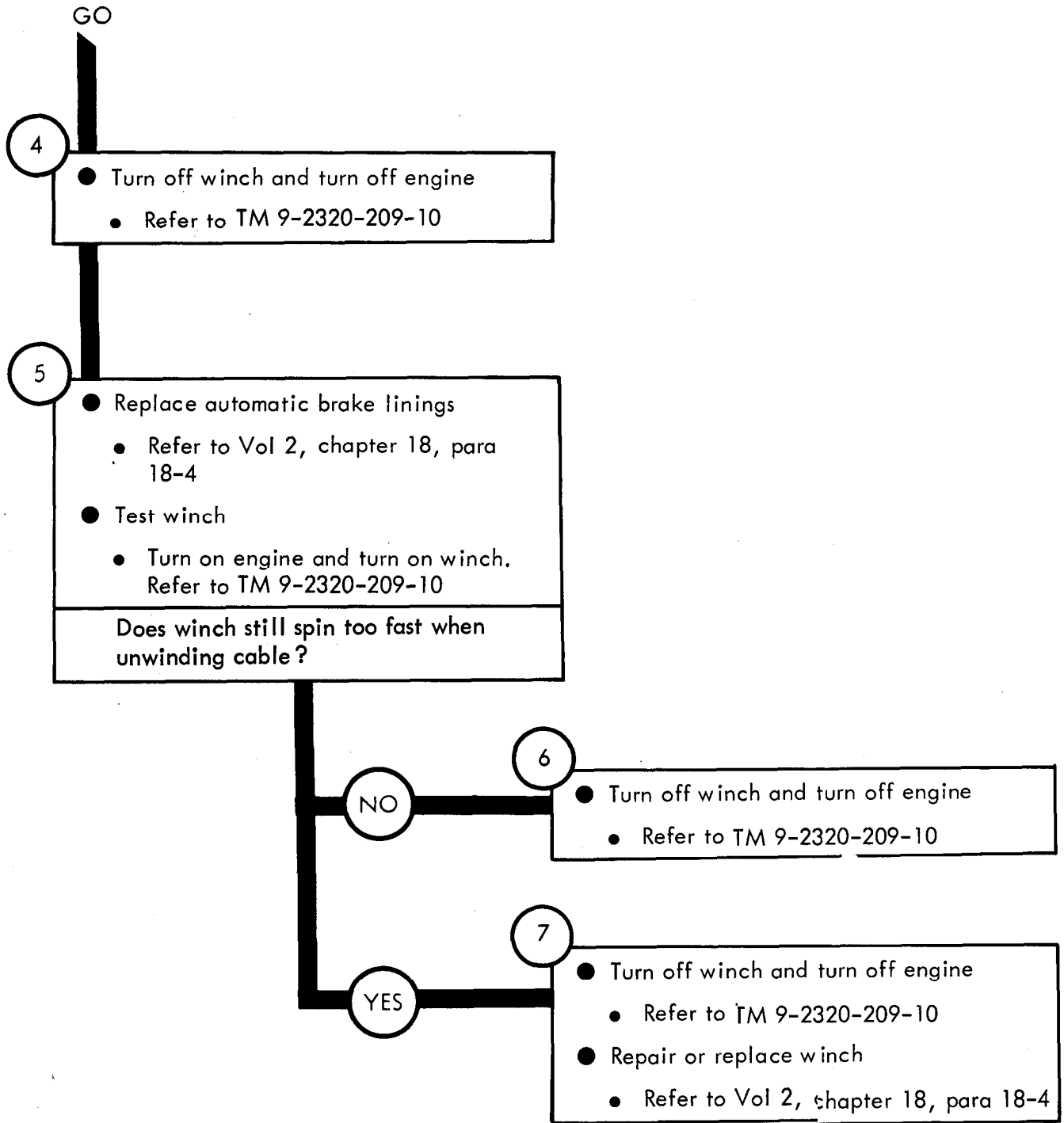

Figure 20-3 (Sheet 2 of 2)

By Order of the Secretaries of the Army and the Air Force:

E.C. MEYER
General, United States Army
Chief of Staff

Official:

J.C. PENNINGTON
Major General, United States Army
The Adjutant General

LEW ALLEN, JR., General, USAF
Chief of Staff

Official:

VAN L. CRAWFORD, JR., Colonel, USAF
Director of Administration

Distribution:

To be distributed in accordance with DA FORM 12-38, Direct Support and General Support Maintenance requirements for 2-1/2 Ton Truck Cargo, and 2-1/2 Ton Truck Van, etc.

RECOMMENDED CHANGES TO EQUIPMENT TECHNICAL PUBLICATIONS



THEN... JOT DOWN THE DOPE ABOUT IT ON THIS FORM, CAREFULLY TEAR IT OUT, FOLD IT AND DROP IT IN THE MAIL!

SOMETHING WRONG WITH THIS PUBLICATION?

FROM: (PRINT YOUR UNIT'S COMPLETE ADDRESS)

CDR, 1st Bn, 65th ADA
Attn: SP4 Jane Idone
Key West, FL 33040

DATE SENT

Date sent in

PUBLICATION NUMBER

TM 9-2320-209-34-1

PUBLICATION DATE

20 May 1981

PUBLICATION TITLE

DIR. & GEN. SUPPORT
TROUBLESHOOTING MANUAL

BE EXACT... PIN-POINT WHERE IT IS

PAGE NO	PARA-GRAPH	FIGURE NO	TABLE NO
6-3			6-3
13-4		13-2 (Sheet 1 of 3)	
19-2		19-1 (Sheet 1 of 2)	

IN THIS SPACE TELL WHAT IS WRONG AND WHAT SHOULD BE DONE ABOUT IT:

VAN BODY subsystem, symptom 7, detailed procedure refers to Figure 13. Should refer to Figure 13-7.

Box ②, sixth sentence reads "Put multimeter + lead on blower motor." Should read "Put multimeter + lead on blower motor lead"

Change illustration callouts.
Reason: callouts for FLANGE and POWER DIVIDER DRIVESHAFT are reversed.

SAMPLE

PRINTED NAME GRADE OR TITLE AND TELEPHONE NUMBER

SP4 Jane Idone

Autovon 222-2224

SIGN HERE

Jane Idone

FILL IN YOUR UNIT'S ADDRESS



FOLD

DEPARTMENT OF THE ARMY

OFFICIAL BUSINESS
PENALTY FOR PRIVATE USE \$.

SAMPLE

POSTAGE AND FEES PAID
DEPARTMENT OF THE ARMY
DOD 314



TEAR ALONG PERFORATED LINE

Commander
U.S. Army Tank-Automotive Command
ATTN: DRSTA-MB
Warren, MI 48090

FILL IN YOUR
UNIT'S ADDRESS

FOLD BACK

DEPARTMENT OF THE ARMY

OFFICIAL BUSINESS
PENALTY FOR PRIVATE USE \$300

POSTAGE AND FEES PAID
DEPARTMENT OF THE ARMY
DOD 314



TEAR ALONG PERFORATED LINE

Commander
U.S. Army Tank-Automotive Command
ATTN: DRSTA-MB
Warren, MI 48090

FILL IN YOUR
UNIT'S ADDRESS

FOLD BACK

TEAR ALONG PERFORATED LINE

DEPARTMENT OF THE ARMY

OFFICIAL BUSINESS
PENALTY FOR PRIVATE USE \$300

POSTAGE AND FEES PAID
DEPARTMENT OF THE ARMY
DOD 314



Commander
U.S. Army Tank-Automotive Command
ATTN: DRSTA-MB
Warren, MI 48090

RECOMMENDED CHANGES TO EQUIPMENT TECHNICAL PUBLICATIONS



THEN... JOT DOWN THE DOPE ABOUT IT ON THIS FORM, CAREFULLY TEAR IT OUT, FOLD IT AND DROP IT IN THE MAIL!

SOMETHING WRONG WITH THIS PUBLICATION?

FROM (PRINT YOUR UNIT'S COMPLETE ADDRESS)

DATE SENT

PUBLICATION NUMBER

TM 9-2320-209-34-1

PUBLICATION DATE

20 May 1981

PUBLICATION TITLE

DIR. & GEN. SUPPORT
TROUBLESHOOTING MANUAL

BE EXACT... PIN-POINT WHERE IT IS

PAGE
NO

PARA-
GRAPH

FIGURE
NO

TABLE
NO

IN THIS SPACE TELL WHAT IS WRONG
AND WHAT SHOULD BE DONE ABOUT IT:

PRINTED NAME GRADE OR TITLE AND TELEPHONE NUMBER

SIGN HERE

FILL IN YOUR
UNIT'S ADDRESS

FOLD BACK

DEPARTMENT OF THE ARMY

POSTAGE AND FEES PAID
DEPARTMENT OF THE ARMY
DOD 314



TEAR ALONG PERFORATED LINE

OFFICIAL BUSINESS
PENALTY FOR PRIVATE USE \$300

Commander
U.S. Army Tank-Automotive Command
ATTN: DRSTA-MB
Warren, MI 48090

THE METRIC SYSTEM AND EQUIVALENTS

LINEAR MEASURE

1 Centimeter = 10 Millimeters = 0.01 Meters = 0.3937 Inches
 1 Meter = 100 Centimeters = 1,000 Millimeters = 39.37 Inches
 1 Kilo Meter = 1,000 Meters = 0.621 Miles

WEIGHTS

1 Gram = 0.001 Kilograms = 1,000 Milligrams = 0.035 Ounces
 1 Kilogram = 1,000 Grams = 2.2 Lb
 1 Metric Ton = 1,000 Kilograms = 1 Megagram = 1.1 Short
 Tons

LIQUID MEASURE

1 Milliliter = 0.001 Liters = 0.0338 Fluid Ounces
 1 Liter = 1,000 Milliliters = 33.82 Fluid Ounces

SQUARE MEASURE

1 Sq Centimeter = 100 Sq Millimeters = 0.155 Sq Inches
 1 Sq Meter = 10,000 Sq Centimeters = 10.76 Sq Feet
 1 Sq Kilometer = 1,000,000 Sq Meters = 0.386 Sq Miles

CUBIC MEASURE

1 Cu Centimeter = 1,000 Cu Millimeters = 0.06 Cu Inches
 1 Cu Meter = 1,000,000 Cu Centimeters = 35.31 Cu Feet

TEMPERATURE

$5/9 (^{\circ}\text{F} - 32) = ^{\circ}\text{C}$
 $212^{\circ}\text{ Fahrenheit is equivalent to } 100^{\circ}\text{ Celsius}$
 $90^{\circ}\text{ Fahrenheit is equivalent to } 32.2^{\circ}\text{ Celsius}$
 $32^{\circ}\text{ Fahrenheit is equivalent to } 0^{\circ}\text{ Celsius}$
 $9/5 \text{ C}^{\circ} + 32 = \text{F}^{\circ}$

APPROXIMATE CONVERSION FACTORS

TO CHANGE	TO	MULTIPLY BY
Inches	Centimeters	2.540
Feet	Meters	0.305
Yards	Meters	0.914
Miles	Kilometers	1.609
Square Inches	Square Centimeters	6.451
Square Feet	Square Meters	0.093
Square Yards	Square Meters	0.836
Square Miles	Square Kilometers	2.590
Acres	Square Hectometers	0.405
Cubic Feet	Cubic Meters	0.028
Cubic Yards	Cubic Meters	0.765
Fluid Ounces	Milliliters	29.573
Pints	Liters	0.473
Quarts	Liters	0.946
Gallons	Liters	3.785
Ounces	Grams	28.349
Pounds	Kilograms	0.454
Short Tons	Metric Tons	0.907
Pound-Feet	Newton-Meters	1.356
Pounds Per Square Inch	Kilopascals	6.895
Miles Per Gallon	Kilometers Per Liter	0.425
Miles Per Hour	Kilometers Per Hour	1.609
TO CHANGE	TO	MULTIPLY BY
Centimeters	Inches	0.394
Meters	Feet	3.280
Meters	Yards	1.094
Kilometers	Miles	0.621
Square Centimeters	Square Inches	0.155
Square Meters	Square Feet	10.764
Square Meters	Square Yards	1.196
Square Kilometers	Square Miles	0.386
Square Hectometers	Acres	2.471
Cubic Meters	Cubic Feet	35.315
Cubic Meters	Cubic Yards	1.308
Millimeters	Fluid Ounces	0.034
Liters	Pints	2.113
Liters	Quarts	1.057
Liters	Gallons	0.264
Grams	Ounces	0.035
Kilograms	Pounds	2.205
Metric Tons	Short Tons	1.102
Newton-Meters	Pound-Feet	0.738
Kilopascals	Pounds Per Square Inch	0.145
Kilometers Per Liter	Miles Per Gallon	2.354
Kilometers Per Hour	Miles Per Hour	0.621