

TECHNICAL MANUAL

VOLUME 2 OF 2

PART 1 OF 3

MAINTENANCE

DIRECT SUPPORT AND GENERAL SUPPORT LEVEL

2½-TON 6X6, M44A1 AND M44A2 SERIES TRUCKS

(MULTIFUEL)

TRUCK, CARGO: M35A1,

M35A2, M35A2C, M36A2; TRUCK,

TANK, FUEL: M49A1C, M49A2C; TRUCK, TANK,

WATER: M50A1, M50A2, M50A3; TRUCK, VAN,

SHOP: M109A2, M109A3; TRUCK, REPAIR SHOP:

M185A2, M185A3; TRUCK, TRACTOR: M275A1,

M275A2; TRUCK, DUMP: M342A2; TRUCK,

MAINTENANCE, PIPELINE CONSTRUCTION:

M756A2; TRUCK, MAINTENANCE,

EARTH BORING AND POLESETTING: M764

Chapter 1
General
Maintenance
Information

Chapters 2, 3, 4
Engine, Clutch
and Fuel Systems

Chapters 5, 6
Exhaust and
Cooling Systems

Chapter 7
Electrical
System

Chapter 8
Transmission System

Chapter 9
Transmission
Transfer System

Chapters 10, 11
Front Axle and
Rear Axle

Chapters 12, 13, 14
Brake
Wheel, and
Steering Systems

Chapter 15, 16
Frame and
Towing Attachments,
and Springs

NOTE:

THE STYLE OF THIS TM IS
EXPERIMENTAL. IT IS BEING TRIED
BY THE ARMY ONLY ON
A LIMITED BASIS

TM 9-2320-209-34-2-1
T.O. 36A12-1B-1092-2-2

CHANGE }
NO. 1 }

HEADQUARTERS
DEPARTMENT OF THE ARMY
Washington, DC 10 Apr 87

TECHNICAL MANUAL
VOLUME 2 OF 2
PART 1 OF 3

MAINTENANCE

DIRECT SUPPORT AND GENERAL SUPPORT LEVEL
2½-TON, 6X6 M44A1 AND M44A2 SERIES TRUCKS
(MULTIFUEL)

TRUCK, CARGO: M35A1,
M35A2, M35A2C, M36A2; TRUCK,
TANK, FUEL: M49A1C, M49A2C; TRUCK, TANK,
WATER: M50A1, M50A2, M50A3; TRUCK, VAN,
SHOP: M109A2, M109A3; TRUCK, REPAIR SHOP:
M185A2, M185A3; TRUCK, TRACTOR: M275A1,
M275A2; TRUCK, DUMP: M342A2; TRUCK,
MAINTENANCE, PIPELINE CONSTRUCTION:
M756A2; TRUCK, MAINTENANCE,
EARTH BORING AND POLESETTING: M764

TM 9-2320-209-34-2-1, dated 20 May 1981 is changed as follows:

1. Remove old pages and insert new pages as indicated below.

Remove Pages	Insert Pages
12-7 and 12-8	12-7 and 12-8
12-27 and 12-28	12-27 and 12-28

File this change sheet in front of the publication for reference purposes.

By Order of the Secretaries of the Army and the Air Force:

JOHN A. WICKHAM, JR.
General, United States Army
Chief of Staff

Official:

R.L. DILWORTH
Brigadier General, United States Army
The Adjutant General

Official:

NORMAND G. LEZY, Colonel, USAF
Director of Administration

LARRY D. WELCH, General, USAF
Chief of Staff

Distribution:

To be distributed in accordance with DA Form 12-38, Direct and General Maintenance requirements for Truck, Multifuel, 2 1/2-ton, 6x6, M44A1 and M44A2-Series (TM 9-2320-209-series).

WARNING

EXHAUST GASES CAN BE DEADLY

Exposure to exhaust gases produces symptoms of headache, dizziness, loss of muscular control, apparent drowsiness, and coma. Permanent brain damage or death can result from severe exposure.

Carbon monoxide occurs in the exhaust fumes of fuel burning heaters and internal combustion engines, and becomes dangerously concentrated under conditions of inadequate ventilation. The following precautions must be observed to insure the safety of personnel whenever fuel burning heater(s) or engine of any vehicle is operated for maintenance purposes or tactical use.

Do not operate heater or engine of vehicle in an enclosed area unless it is adequately ventilated.

Do not idle engine for long periods without maintaining adequate ventilation in personnel compartments.

Do not drive any vehicle with inspection plates or cover plates removed unless necessary for maintenance purposes.

Be alert at all times during vehicle operation for exhaust odors and exposure symptoms. If either are present, immediately ventilate personnel compartments. If symptoms persist, remove affected personnel from vehicle and treat as follows: expose to fresh air; keep warm; do not permit physical exercise; if necessary, administer artificial respiration.

If exposed, seek prompt medical attention for possible delayed onset of acute lung congestion. Administer oxygen if available.

The best defense against exhaust gas poisoning is adequate ventilation.

WARNING

**SERIOUS OR FATAL INJURY TO PERSONNEL MAY RESULT
IF THE FOLLOWING INSTRUCTIONS ARE NOT COMPLIED WITH.**

The engine is heavy and bulky. Make sure there is enough clearance around and over truck before lifting unit. This will stop damage to equipment and injury to personnel.

Vibration damper must be heated to be replaced. Wear welder's gloves when handling damper to avoid injury to personnel.

Flywheel is very heavy and should be taken out and put into place by two people. Failure to do this may cause flywheel to fall, causing injury to personnel and damage to equipment.

Do not let tool touch positive terminal on battery and truck or there will be a direct short, arcing, and tool will heat. This could cause equipment damage and injury to personnel.

Do not touch any uninsulated or live connections working on ignition unit. Voltage output of ignition unit can cause dangerous electrical shock. Read warning notice on ignition unit.

Do not repair fuel tank unless tank has been cleaned and properly treated to get rid of all flammable or explosive fumes. Merely draining tank does not make it safe for welding. An "empty" tank can be more dangerous than a full one. Before repairing,

WARNING - Cont

thoroughly steam clean tank or use other approved method to completely take out all fumes.

Do not use a wire brush or compressed air to clean brake drums. There may be asbestos dust on brake drums which can be dangerous to your health if you breathe it in.

Do not dry bearing with compressed air. Spinning bearings may explode and cause serious injury to personnel.

Crossrod is heavy and may drop a few inches when 12 screws and nuts holding it in place are taken out. Keep all parts of body out from under crossrod when taking out screws and nuts.

Rear axle system is extremely heavy. Be careful when raising axles and putting in jack stands to avoid injury to personnel.

While working on spring, keep body clear of underside of spring. When parts are taken off, spring may come out and cause injury to personnel.

The fifth wheel is heavy and bulky. Make sure there is enough clearance around working area before lifting unit to avoid injury to personnel and damage to equipment.

***TM 9-2320-209-34-2-1
T.O. 36A12-1B-1092-2-2**

TECHNICAL MANUAL
NO. 9-2320-209 -34-2-1
TECHNICAL ORDER
NO. 36A12-1B-1092-2-2

DEPARTMENTS OF THE ARMY
AND
THE AIR FORCE
Washington, DC, 20 May 1981

TECHNICAL MANUAL

VOLUME 2 OF 2

PART 1 OF 3

MAINTENANCE

DIRECT SUPPORT AND GENERAL SUPPORT LEVEL

**2½-TON 6X6, M44A1 AND M44A2 SERIES TRUCKS
(MULTIFUEL)**

Model		NSN without Winch	NSN with Winch
Truck, Cargo	M35A1	2320-00-542-5633	2320-00-542-5634
	M35A2	2320-00-077-1616	2320-00-077-1617
	M35A2C	2320-00-926-0873	2320-00-926-0875
	M36A2	2320-00-077-1618	2320-00-077-1619
Truck, Tank, Fuel	M49A1C	2320-00-440-3349	2320-00-440-3346
	M49A2C	2320-00-077-1631	2320-00-077-1632
Truck, Tank, Water	M50A1	2320-00-440-8307	2320-00-440-8305
	M50A2	2320-00-077-1633	2320-00-077-1634
	M50A3	2320-00-937-4036	2320-00-937-5264
Truck, Van, Shop	M109A2	2320-00-440-8313	2320-00-440-8308
	M109A3	2320-00-077-1636	2320-00-077-1637
Truck, Repair Shop	M185A2	4940-00-987-8799	4940-00-987-8800
	M185A3	4940-00-077-1638	4940-00-077-1639
Truck, Tractor	M275A1	2320-00-446-2479	
	M275A2	2320-00-077-1640	2320-00-077-1641
Truck, Dump	M342A2	2320-00-077-1643	2320-00-077-1644
Truck, Maintenance, Pipeline Construction	M756A2		2320-00-904-3277
Truck, Maintenance, Earth Boring and Polesetter	M764		2320-00-937-5980

*This manual, together with TM 9-2320-209-34-1, 20 May 1981; TM 9-2320-209-34-2-2, 20 May 1981; and TM 9-2320-209-34-2-3, 20 May 1981, supersedes TM 9-2320-209-34, dated 30 March 1979.

REPORTING OF ERRORS AND RECOMMENDING IMPROVEMENTS

You can help improve this manual. If you find any mistakes or if you know of a way to improve the procedure, please let us know. Mail your letter, DA Form 2028 (Recommended Changes to Publication and Blank Forms), or DA Form 2028-2 located in the back of this manual direct to: Commander, U.S. Army Tank Automotive Materiel Readiness Command, ATTN: DRSTA-MB, Warren Michigan 48090. A reply will be furnished to you.

TABLE OF CONTENTS

	Paragraph	Page
CHAPTER 1. GENERAL MAINTENANCE INFORMATION		
Scope	1-1	1-1
General Maintenance	1-2	1-1
Cleaning	1-3	1-1
Painting	1-4	1-2
Torque Values	1-5	1-2
Special Tools and Equipment	1-6	1-2
Safety Inspection and Testing of Lifting Devices	1-7	1-2
Forms and Records	1-8	1-2
Equipment Improvement Report and Maintenance Digest (EIR MD) and Equipment Improvement Report and Maintenance Summary (EIR MS)	1-9	1-2
Reporting Improvement Recommendations	1-10	1-2
Metric System	1-11	1-2
Destruction to Prevent Enemy Use	1-12	1-2
Administrative Storage	1-13	1-3
Tabulated Data	1-14	1-3
Vehicle Description	1-15	1-3
General Shipping Instructions	1-16	1-3
Transportability Guidance	1-17	1-3
Maintenance Repair Parts	1-18	1-3
CHAPTER 2. ENGINE SYSTEM GROUP MAINTENANCE		
Section 1. Scope		2-1
Equipment Items Covered	2-1	2-1
Equipment Items Not Covered	2-2	2-1
Section II. Engine Assembly		2-1
Engine Removal and Replacement	2-3	2-1
Preliminary Procedures	2-3a	2-1
Removal	2-3b	2-2
Replacement	2-3C	2-22
Engine (LD 465-1, LD 465-1C, and LDT 465-1C) Repair	2-4	2-42
Engine (LDS 427-2) Repair	2-5	2-42

TABLE OF CONTENTS - CONT

		Paragraph	Page
Section III.	Crankcase, Block, and Cylinder Head		2-42
	Cylinder Head Removal, Repair, and		
	Replacement (Trucks with Engines		
	LD 465-1, LD 465-1C, and LDT 465-1C)	2-6	2-42
	Preliminary Procedures	2-6a	2-42
	Removal	2-6b	2-43
	Cleaning, Inspection, and Repair	2-6c	2-69
	Replacement	2-6d	2-69
	Cylinder Sleeve Removal and		
	Replacement	2-7	2-106
Section IV.	Crankshaft		2-106
	Vibration Damper Removal and		
	Replacement	2-8	2-106
	Preliminary Procedures	2-8a	2-106
	Removal	2-8b	2-106
	Replacement	2-8c	2-113
	Main Bearings Removal and		
	Replacement	2-9	2-120
	Crankshaft Front Oil Seal Removal and		
	Replacement	2-10	2-120
	Preliminary Procedures	2-10a	2-120
	Removal	2-10b	2-120
	Replacement	2-10c	2-121
Section V.	Flywheel.....		2-123
	Flywheel Removal, Repair, and		
	Replacement (Engines LD 465-1,		
	LD465-1C, and LDT465-1C)	2-11	2-123
	Preliminary Procedures	2-11a	2-123
	Removal	2-11b	2-123
	Cleaning	2-11c	2-126
	Inspection and Repair	2-11d	2-126
	Replacement	2-11e	2-126
	Test	2-11f	2-128
Section VI.	Pistons and Connecting Rods		2-132
	Connecting Rod Bearings Removal and		
	Replacement	2-12	2-132
	Piston and Connecting Rod Assembly		
	Removal, Repair, and Replacement	2-13	2-132
Section VII.	Valves, Camshaft, and Timing System		2-132
	Poppet Valve Pushrod Removal and		
	Replacement	2-14	2-132
	Preliminary Procedure	2-14a	2-132
	Removal	2-14b	2-133
	Replacement	2-14c	2-137

TABLE OF CONTENTS - CONT

	Paragraph	Page
Camshaft Assembly Removal and Replacement	2-15	2-148
Preliminary Procedures	2-15a	2-148
Removal	2-15b	2-149
Replacement	2-15c	2-153
Camshaft and Crankshaft Gears		
Removal and Replacement	2-16	2-157
Preliminary Procedures	2-16a	2-157
Removal	2-16b	2-158
Replacement	2-16c	2-163
Section VIII. Engine Lubricating System and Manifolds		2-169
Lubricating Oil Pump Assembly Removal, Repair, and Replacement	2-17	2-169
Preliminary Procedure	2-17a	2-169
Removal	2-17b	2-170
Disassembly	2-17c	2-175
Cleaning	2-17d	2-179
Inspection and Repair	2-17e	2-179
Assembly	2-17f	2-181
Replacement	2-17g	2-185
Oil Cooler Radiator Removal and Replacement	2-18	2-189
Preliminary Procedures	2-18a	2-189
Removal	2-18b	2-189
Replacement	2-18c	2-193
Oil Pressure Regulator Removal, Repair, and Replacement	2-19	2-197
Preliminary Procedures	2-19a	2-197
Removal	2-19b	2-198
Cleaning, Inspection, and Repair	2-19c	2-200
Replacement	2-19d	2-200
Oil Cooler Bypass Valve Removal, Repair and Replacement	2-20	2-203
Preliminary Procedure	2-20a	2-203
Removal	2-20b	2-203
Inspection and Repair	2-20c	2-204
Replacement	2-20d	2-204
Air Intake and Exhaust Manifolds		
Removal, Repair and Replacement	2-21	2-205
Preliminary Procedures	2-21a	2-205
Removal	2-21b	2-206
Repair	2-21c	2-231
Replacement	2-21d	2-231

TABLE OF CONTENTS - CONT

	Paragraph	Page
CHAPTER 3. CLUTCH SYSTEM GROUP MAINTENANCE		
Section I. Scope		3-1
Equipment Items Covered	3-1	3-1
Equipment Items Not Covered	3-2	3-1
Section II. Clutch Assembly		3-1
Clutch Assembly Removal and Replacement	3-3	3-1
Preliminary Procedure	3-3a	3-1
Removal	3-3b	3-2
Replacement	3-3c	3-3
Clutch Assembly Repair	3-4	3-5
Section III. Clutch Release Mechanism		3-5
Clutch Release Bearing and Throwout		
Shaft Yoke Removal and Replacement	3-5	3-5
Preliminary Procedure	3-5a	3-5
Removal	3-5b	3-5
Replacement	3-5c	3-7
CHAPTER 4. FUEL SYSTEM GROUP MAINTENANCE		
Section I. Scope		4-1
Equipment Items Covered	4-1	4-1
Equipment Items Not Covered	4-2	4-1
Section II. Fuel Injector		4-1
Fuel Injector Nozzle and Holder Assembly		
Removal and Replacement	4-3	4-1
Preliminary Procedure	4-3a	4-1
Removal	4-3b	4-2
Replacement	4-3c	4-4
Fuel Injector Nozzle and Holder Assembly		
Repair	4-4	4-6
Fuel Injector Pump Repair	4-5	4-6
Section III. Turbocharger		4-6
Turbocharger Repair	4-6	4-6
Section IV. Fuel Tanks		4-6
Fuel Tank Repair (All Except Trucks		
M275A1, M275A2, and M342A2)	4-7	4-6
Preliminary Procedures	4-7a	4-6
Disassembly	4-7b	4-7
Cleaning	4-7c	4-8
Inspection and Repair	4-7d	4-9
Assembly	4-7e	4-10
Fuel Tank Repair (Trucks M275A1,		
M275A2, and M342A2)	4-8	4-11
Preliminary Procedures	4-8a	4-11
Disassembly	4-8b	4-11
Cleaning, Inspection, and Repair	4-8c	4-12
Assembly	4-8d	4-13

TABLE OF CONTENTS - CONT

	Paragraph	Page
CHAPTER 5. EXHAUST SYSTEM GROUP MAINTENANCE		
Section I. Scope		5-1
Equipment Items Covered	5-1	5-1
Equipment Items Not Covered	5-2	5-1
Section II. Exhaust Pipes and Mufflers		5-1
Exhaust Bypass Fording Valve Removal, Repair, and Replacement (Trucks M50A1 and M50A2)	5-3	5-1
Preliminary Procedure	5-3a	5-1
Removal	5-3b	5-2
Disassembly	5-3c	5-3
Cleaning	5-3d	5-5
Inspection and Repair	5-3e	5-5
Assembly	5-3f	5-6
Replacement	5-3g	5-8
CHAPTER 6. COOLING SYSTEM GROUP MAINTENANCE		
Section I. Scope		6-1
Equipment Items Covered	6-1	6-1
Equipment Items Not Covered	6-2	6-1
Section II. Radiator and Shrouds		6-1
Radiator Repair and Test	6-3	6-1
Radiator Shroud Repair	6-4	6-1
CHAPTER 7. ELECTRICAL SYSTEM GROUP MAINTENANCE		
Section I. Scope		7-1
Equipment Items Covered	7-1	7-1
Equipment Items Not Covered	7-2	7-1
Section II. Charging System		7-1
Alternator and Regulator Repair	7-3	7-1
Section III. Battery System		7-1
Battery Inspection, Removal, Service, and Replacement	7-4	7-1
Section IV. Chassis Wiring Harness		7-2
Wiring Harness Clamps Removal and Replacement	7-5	7-2
Removal	7-5a	7-2
Replacement	7-5b	7-3
Front Wiring Harness Removal and Replacement (All Trucks Except M275A1 and M275A2)	7-6	7-4
Preliminary Procedures	7-6a	7-4
Removal	7-6b	7-5
Replacement	7-6c	7-9

TABLE OF CONTENTS - CONT

	Paragraph	Page
Rear Wiring Harness Removal and Replacement (All Trucks Except M275A1 and M275A2)	7-7	7-13
Preliminary Procedure	7-7a	7-13
Removal	7-7b	7-13
Replacement	7-7c	7-15
Chassis Wiring Harness Removal and Replacement (Trucks M275A1 and M275A2)	7-8	7-17
Preliminary Procedures	7-8a	7-17
Removal	7-8b	7-18
Replacement	7-8c	7-23
Clearance Light Wiring Harnesses Removal and Replacement (Truck M756A2)	7-9	7-28
Preliminary Procedure	7-9a	7-28
Removal	7-9b	7-29
Replacement	7-9c	7-31
Floodlight Harness Removal and Replacement (Truck M756A2)	7-10	7-33
Preliminary Procedure	7-10a	7-33
Removal	7-10b	7-33
Replacement	7-10c	7-34
Van Main Wiring Harness Removal and Replacement	7-11	7-36
Preliminary Procedures	7-11a	7-36
Removal	7-11b	7-36
Replacement	7-11c	7-38
Van 24-Volt Wiring Harness Removal and Replacement 1	7-12	7-40
Preliminary Procedure	7-12a	7-40
Removal	7-12b	7-40
Replacement	7-12c	7-41
CHAPTER 8. TRANSMISSION SYSTEM GROUP MAINTENANCE		
Section I. Scope		8-1
Equipment Items Covered	8-1	8-1
Equipment Items Not Covered	8-2	8-1
Section II. Transmission Assembly		8-1
Transmission Cover Removal and Replacement	8-3	8-1
Preliminary Procedure	8-3a	8-1
Removal	8-3b	8-2
Disassembly	8-3c	8-6
Cleaning	8-3d	8-12
Inspection and Repair	8-3e	8-12
Assembly	8-3f	8-14
Replacement	8-3g	8-20

TABLE OF CONTENTS - CONT

	Paragraph	Page
Transmission, Removal, Repair and Replacement	8-4	8-24
Preliminary Procedures	8-4a	8-24
Removal	8-4b	8-25
Repair	8-4c	8-27
Replacement	8-4d	8-27
CHAPTER 9. TRANSMISSION TRANSFER SYSTEM GROUP MAINTENANCE		
Section I. Scope		9-1
Equipment Items Covered	9-1	9-1
Equipment Items Not Covered	9-2	9-1
Section II. Transmission Transfer Assembly		9-1
Air Actuated Transmission Transfer Assembly Removal and Replacement	9-3	9-1
Preliminary Procedures	9-3a	9-1
Removal	9-3b	9-2
Replacement	9-3c	9-5
Air Actuated Transmission Transfer Assembly Repair	9-4	9-8
Double Sprag Transmission Transfer Removal, Repair, and Replacement	9-5	9-8
Preliminary Procedures	9-5a	9-8
Removal	9-5b	9-9
Repair	9-5c	9-11
Replacement	9-5d	9-11
CHAPTER 10. FRONT AXLE GROUP MAINTENANCE		
Section I. Scope		10-1
Equipment Items Covered	10-1	10-1
Equipment Items Not Covered	10-2	10-1
Section II. Front Axle Assembly		10-1
Front Axle Assembly Removal and Replacement	10-3	10-1
Preliminary Procedures	10-3a	10-1
Removal	10-3b	10-2
Replacement	10-3c	10-4
Front Axle Assembly Repair	10-4	10-8
Preliminary Procedures	10-4a	10-8
Disassembly	10-4b	10-9
Cleaning	10-4c	10-16
Inspection and Repair	10-4d	10-17
Assembly	10-4e	10-19
Front Axle Shaft And Universal Joint Repair	10-5	10-27
Preliminary Procedure	10-5a	10-27
Disassembly	10-5b	10-27
Cleaning	10-5c	10-31
Inspection and Repair	10-5d	10-31
Assembly	10-5e	10-35

TABLE OF CONTENTS-CONT

	Paragraph	Page
Front Axle Drive Flange Repair	10-6	10-38
Preliminary Procedure	10-6a	10-38
Cleaning	10-6b	10-38
Disassembly	10-6c	10-38
Inspection and Repair	10-6d	10-39
Assembly	10-6e	10-40
Section III. Differential Carrier Assembly		10-41
Differential Carrier Assembly Removal, Repair and Replacement	10-7	10-41
Preliminary Procedures.	10-7a	10-41
Removal	10-7b	10-43
Disassembly	10-7c	10-44
Cleaning	10-7d	10-62
Inspection and Repair	10-7e	10-63
Assembly and Adjustment	10-7f	10-69
Replacement	10-7g	10-97
Maintenance of Bearings	10-8	10-99
Removal of Bearing from Shaft by Pressing	10-8a	10-99
Removal of Bearing from Shaft by Pulling	10-8b	10-100
Removal of Bearing from Housing by Pressing	10-8c	10-101
Removal of Bearing from Housing by Pulling	10-8d	10-102
Cleaning of Bearings	10-8e	10-103
Inspection of Bearings	10-8f	10-104
Replacement of Bearing onto Shaft	10-8g	10-105
Replacement of Bearing into Housing	10-8h	10-106
Section IV. Steering Mechanism		10-107
Front Axle Steering Arm Repair	10-9	10-107
Preliminary Procedure	10-9a	10-107
Removal	10-9b	10-107
Disassembly	10-9c	10-109
Cleaning	10-9d	10-110
Inspection and Repair	10-9e	10-110
Assembly.	10-9f	10-111
Replacement	10-9g	10-112
Wheel Hub Spindle Repair	10-10	10-114
Preliminary Procedure	10-10a	10-114
Removal	10-10b	10-115
Cleaning	10-10c	10-116
Inspection and Repair	10-10d	10-116
Replacement	10-10e	10-117

TABLE OF CONTENTS-CONT

	Paragraph	Page
CHAPTER 11. REAR AXLE GROUP MAINTENANCE		
Section I. Scope		11-1
Equipment Items Covered	11-1	11-1
Equipment Items Not Covered	11-2	11-1
Section II. Rear Axle Assembly		11-1
Forward-Rear Axle Assembly Removal and Replacement	11-3	11-1
Preliminary Procedures	11-3a	11-1
Removal	11-3b	11-2
Replacement	11-3c	11-5
Rear-Rear Axle Assembly Removal and Replacement	11-4	11-8
Preliminary Procedures	11-4a	11-8
Removal	11-4b	11-8
Replacement	11-4c	11-11
Forward-Rear and Rear-Rear Axle Housing Repair	11-5	11-14
Preliminary Procedures	11-5a	11-14
Disassembly	11-5b	11-14
Cleaning	11-5c	11-15
Inspection and Repair	11-5d	11-15
Assembly	11-5e	11-16
Rear Axle Hub Repair	11-6	11-17
Preliminary Procedures	11-6a	11-17
Disassembly	11-6b	11-17
Cleaning	11-6c	11-19
Inspection	11-6d	11-20
Repair	11-6e	11-21
Assembly	11-6f	11-21
Rear Suspension System Removal, Repair, and Replacement	11-7	11-23
Preliminary Procedures	11-7a	11-23
Removal	11-7b	11-24
Inspection and Cleaning Before Disassembly	11-7c	11-26
Disassembly	11-7d	11-26
Cleaning	11-7e	11-32
Inspection and Repair	11-7f	11-32
Assembly	11-7g	11-33
Replacement	11-7h	11-39
Crossrod and Spring Brackets Removal, Repair, and Replacement	11-8	11-41
Preliminary Procedures	11-8a	11-41
Removal	11-8b	11-42
Cleaning	11-8c	11-43
Inspection and Repair	11-8d	11-43
Replacement	11-8e	11-44

TABLE OF CONTENTS-CONT

	Paragraph	Page
CHAPTER 12. BRAKE SYSTEM GROUP MAINTENANCE		
Section I. Scope		12-1
Equipment Items Covered	12-1	12-1
Equipment Items Not Covered	12-2	12-1
Section II. Handbrake and Service Brake Assemblies.		12-1
Handbrake and Service Brakeshoe		
Repair	12-3	12-1
Preliminary Procedure	12-3a	12-1
Disassembly	12-3b	12-2
Cleaning	12-3c	12-3
Inspection and Repair	12-3d	12-3
Assembly	12-3e	12-4
Front and Rear Service Brake Drum		
Repair	12-4	12-5
Preliminary Procedure	12-4a	12-5
Cleaning	12-4b	12-5
Inspection and Repair	12-4c	12-6
Section III. Hydraulic Brake System		12-7
Air Hydraulic Cylinder Assembly		
Repair	12-5	12-7
Preliminary Procedures	12-5a	12-7
Disassembly Into Subassemblies	12-5b	12-8
Air Cylinder Piston Assembly		
Repair	12-5c	12-16
Air Cylinder and Air Tube Cleaning, Inspection, and Repair	12-5d	12-23
Slave Cylinder Body Repair.	12-5e	12-24
Pushrod Bushing Assembly Repair	12-5f	12-27
Slave Cylinder Compensator Assembly		
Repair	12-5g	12-28
Slave Cylinder Compensator piston Assembly Repair	12-5h	12-33
Slave Cylinder Control Valve Piston Assembly Repair	12-5i	12-35
Assembly of Air Hydraulic Cylinder Assembly	12-5j	12-37
Front Brake Hose Removal and Replacement	12-6	12-47
Preliminary Procedures	12-6a	12-47
Removal	12-6b	12-48
Replacement	12-6c	12-52
Section IV. Trailer Brake Connections and Controls		12-59
Air Brake Hand Control Valve		
Repair	12-7	12-59
Preliminary Procedure	12-7a	12-59
Disassembly	12-7b	12-60
Cleaning	12-7c	12-63
Inspection and Repair	12-7d	12-63
Assembly	12-7e	12-63

TABLE OF CONTENTS-CONT

	Paragraph	Page
CHAPTER 13. WHEEL SYSTEM GROUP MAINTENANCE		
Section I. Scope		13-1
Equipment Items Covered	13-1	13-1
Equipment Items Not Covered	13-2	13-1
Section II. Wheel Assembly		13-1
Wheel Repair	13-3	13-1
Preliminary Procedures	13-3a	13-1
Cleaning	13-3b	13-2
Inspection and Repair	13-3c	13-2
Tire Repair	13-4	13-3
CHAPTER 14. STEERING SYSTEM GROUP MAINTENANCE		
Section I. Scope		14-1
Equipment Items Covered	14-1	14-1
Equipment Items Not Covered	14-2	14-1
Section II. Mechanical Steering Gear Assembly		14-1
Mechanical Steering Gear Removal, Repair, and Replacement	14-3	14-1
Preliminary Procedures	14-3a	14-1
Removal	14-3b	14-2
Disassembly	14-3c	14-11
Cleaning	14-3d	14-20
Inspection and Repair	14-3e	14-20
Assembly	14-3f	14-26
Replacement	14-3g	14-37
Steering Gear Check Level Plug Installation	14-4	14-46
Preliminary Procedure	14-4a	14-46
Removal	14-4b	14-46
Replacement	14-4c	14-48
CHAPTER 15. FRAME AND TOWING ATTACHMENTS GROUP MAINTENANCE		
Section I. Scope		15-1
Equipment Items Covered	15-1	15-1
Equipment Items Not Covered	15-2	15-1
Section II. Frame Assembly		15-1
Frame Alinement Check	15-3	15-1
Preliminary Procedures	15-3a	15-1
Alinement Check	15-3b	15-2
Frame Components Removal, Repair, and Replacement	15-4	15-7
Side Member Support (Trucks M275A1 and M275A2)	15-4a	15-7
Fuel Tank Support (Trucks M275A1 and M275A2)	15-4b	15-9

TABLE OF CONTENTS-CONT

	Paragraph	Page
Taillight and Stoplight Assembly Bracket (Trucks M275A1 and M275A2)	15-4c	15-11
Skid Plate Bracket (Trucks M275A1 and M275A2)	15-4d	15-13
Rear Member Bracket (Trucks M275A1 and M275A2)	15-4e	15-15
Trailer Air Brake Coupling Bracket (Trucks M275A1 and M275A2)	15-4f	15-17
Rear Member (Trucks M275A1 and M275A2)	15-4g	15-19
Air Tank Support Brackets (Trucks M35A1, M35A2, M35A2C, M36A2, M49A1C, M49A2C, M50A1, M50A2, M50A3, M109A2, and M109A3)	15-4h	15-23
Running Board and Fuel Tank Supports (Trucks M35A1, M35A2, M35A2C, M36A2, M49A1C, M49A2C, M50A1, M50A2, M50A3, M109A2, and M109A3)	15-4i	15-25
Front Fender Supports (Trucks M35A1, M35A2, M35A2C, M36A2, M49A1C, M49A2C, M50A1, M50A2, M50A3, M109A2, and M109A3)	15-4j	15-27
Spare Tire Carrier (Trucks M35A1, M35A2, M35A2C, M36A2, M49A1C, M49A2C, M50A1, M50A2, M50A3, M109A2, and M109A3)	15-4k	15-29
Running Board Support (Trucks M35A1, M35A2, M35A2C, M36A2, M49A1C, M49A2C, M50A1, M50A2, M50A3, M109A2, and M109A3)	15-4l	15-31
Rear Frame Bracket (Trucks M35A1, M35A2, M35A2C, M36A2, M49A1C, M49A2C, M50A1, M50A2, M50A3, M109A2, and M109A3)	15-4m	15-33
Bumperettes (Trucks M35A1, M35A2, M35A2C, M36A2, M49A1C, M49A2C, M50A1, M50A2, M50A3, M109A2, and M109A3)	15-4n	15-35
Tool Box Supports (Truck M342A2)	15-4o	15-37
Right Running Board Supports (Truck M342A2)	15-4p	15-39
Left Running Board Supports (Truck M342A2)	15-4q	15-41

TABLE OF CONTENTS-CONT

		Paragraph	Page
	Running Board Support (Truck M342A2)	15- 4r	15-43
	Front Fender Supports (Truck M342A2)	15-4s	15-45
	Fuel Filter Bracket (Truck M342A2)	15-4t	15-47
	Front Crossmember Replacement Kit Installation Removal and Replacement	15-5	15-49
	Preliminary Procedures	15-5a	15-49
	Removal	15-5b	15-49
	Replacement	15-5c	15-53
Section III.	Fifth Wheel Assembly		15-57
	Fifth Wheel Assembly, Disassembly and Repair	15-6	15-57
	Preliminary Procedure	15-6a	15-57
	Disassembly	15-6b	15-57
	Cleaning	15-6c	15-65
	Inspection	15-6d	15-65
	Repair	15-6e	15-66
	Assembly	15-6f	15-66
CHAPTER 16.	SPRINGS GROUP MAINTENANCE		
Section I.	Scope		16-1
	Equipment Items Covered	16-1	16-1
	Equipment Items Not Covered	16-2	16-1
Section II.	Springs		16-1
	Drilling and Tapping Rear Spring Seat for Lubrication	16-3	16-1
	Installation of Lubrication Plug	16-3a	16-2
	Lubrication of Rear Spring Seat	16-3b	16-4
PART 2 OF 3			
CHAPTER 17.	BODY, CAB, HOOD, AND HULL GROUP MAINTENANCE		
Section I.	Scope		17-1
Section II.	Hood and Cab Components		17-1
Section III.	Fenders, Running Boards, and Windshield Assembly		17-79
Section IV.	Seats		17-122
Section V.	Cargo Body Components		17-147
Section VI.	Tank Body Components		17-165
Section VII.	Special Purpose Body Components		17-376

TABLE OF CONTENTS-CONT

PART 3 OF 3

	Paragraph	Page
CHAPTER 18. WINCH, HOIST, AND POWER TAKEOFF ASSEMBLIES GROUP MAINTENANCE		
Section I. Scope		18-1
Section II. Winch and Hoist Assemblies		18-1
Section III. Power Takeoff Assembly		18-274
CHAPTER 19. BUMPER AND GUARDS GROUP MAINTENANCE		
Section I. Scope		19-1
Section II. Bumper, Brackets, Guards, and Protective Devices		19-1
CHAPTER 20. BODY ACCESSORY ITEMS GROUP MAINTENANCE		
Section I. Scope		20-1
Section II. Canvas and Rubber Items		20-1
CHAPTER 21. MAINTENANCE OF MATERIAL USED IN CONJUNCTION WITH MAJOR ITEMS		
Section I. Scope		21-1
Section II. Winterization Kits		21-1
Section III. Deep Water Fording Kit		21-140
Section IV. Special Purpose Kits		21-199
APPENDIX A. REFERENCES		A-1
INDEX		Index 1

LIST OF TABLES

Number	Title	Page
1-1	Standard Torque Specifications	1-4
1-2	Special Tools and Equipment	1-5
10-1	Front Axle Assembly (Steering Knuckle) Wear Limits	10-17
10-2	Front Axle Assembly (Seal Retainer Seat) Wear Limits	10-32
10-3	Front Axle Shaft and Ball-Type Universal Joint Wear Limits	10-30
10-4	Front Axle Shaft and Universal Joint Wear Limits	10-34
10-5	Differential Case and Bearing Wear Limits	10-64
10-6	Spider and Spider Gear Wear Limits	10-65
10-7	Bearing Wear Limits	10-66
10-8	Pinion Gear and Shaft Wear Limits	10-68
11-1	Rear Axle Hub Assembly Wear Limits	11-20
14-1	Mechanical Steering Gear Wear Limits	14-24

LIST OF TABLES-CONT

Number	Title	Page
17-1	Rotor Shaft and Vane Wear Limits	17-238
17-2	Vane and Liner Wear Limits and Fit	17-239
17-3	Boring Case Gear Assembly Wear Limits	17-503
17-4	Adjusting Bearing, Worm, Gear Shaft, and Thrust Washer Wear Limits	17-596
17-5	Leveling Worm Gear Assemblies Wear Limits	17-617
17-6	Power Leveler Assembly Wear Limits	17-618
17-7	Feed and Drive Clutch Assembly Wear Limits	17-658
17-8	Power Leveler Wear Limits	17-680
18-1	Front Winch (Drum Shaft and Bearing) Wear Limits	18-15
18-2	Front Winch (Drum Sliding Clutch) Wear Limits	18-16
18-3	Front Winch (Gearcase and Gearcase Cover Bearings) Wear Limits	18-18
18-4	Front Winch (Drum Lock Poppet Spring and Clutch Control Lever Ball Spring) Wear Limits	18-19
18-5	Front Winch (Drag Brake Spring and End Frame Sleeve) Wear Limits	18-20
18-6	Rear Winch (Drum Shaft and Bearings) Wear Limits	18-49
18-7	Rear Winch (First Reduction Drive Assembly) Wear Limits	18-101
18-8	Rear Winch (Second Reduction Drive Assembly) Wear Limits	18-102
18-9	Rear Winch (Cable Level Winder Assembly) Wear Limits	18-105
18-10	Rear Winch (Drum and Shaft) Wear Limits	18-109
18-11	Rear Winch (Automatic Brake Assembly) Wear Limits	18-112

CHAPTER 1

GENERAL MAINTENANCE INFORMATION

1-1. SCOPE. This manual contains the direct support and general support maintenance instructions for the trucks listed below. This manual includes procedures for disassembly, cleaning, inspection, repair, test, adjustment and overhaul as authorized by the maintenance allocation chart.

Truck, Cargo:	2 1/2 ton, 6x6, M35A1, M35A2, M35A2C, and M36A2
Truck, Dump:	2 1/2 ton, 6x6, M342A2
Truck, Tractor:	2 1/2 ton, 6x6, M275A1 and M275A2
Truck, Tank, Fuel:	2 1/2 ton, 6x6, M49A1C and M49A2C
Truck, Tank, Water:	2 1/2 ton, 6x6, M50A1, M50A2, and M50A3
Truck, Repair Shop:	2 1/2 ton, 6x6, M185A2 and M185A3
Truck, Van, Shop:	2 1/2 ton, 6x6, M109A2 and M109A3
Truck, Maintenance, Earth Boring and Polesetting:	2 1/2 ton, 6x6, M764
Truck, Maintenance, Pipeline Construction:	2 1/2 ton, 6x6, M756A2

Information is provided on maintenance of trucks which is beyond the scope of tools, equipment, personnel or supplies normally available to operator or using organization.

1-2. GENERAL MAINTENANCE. The general maintenance and repair covered by other manuals and called out in this manual are as follows:

TM 9-214	Inspection, Care and Maintenance of Antifriction Bearings
TM 9-237	Operator's Manual: Welding Theory and Application (TO 34W4-1-5)
FM 43-3	General Repair for Canvas and Webbing
TM 9-247	Materials Used for Cleaning, Preserving, Abrading and Cementing Ordnance Materiel and Related Materials Including Chemicals
FM 43-2	Metal Body Repair and Related Operations.
TB 750-254	Cooling Systems: Tactical Vehicles
TB 43-0212	Purging, Cleaning and Coating Interior Ferrous and Terne Sheet Vehicle Fuel Tanks
TM 43-0139	Painting Instructions for Field Use.
TB 43-0209	Color, Marking and Camouflage Painting of Military Vehicles, Construction Equipment, and Materials Handling Equipment
TB 43-0213	(Rustproofing)
TM 9-2300-422-20	Security of Tactical Wheeled Vehicles

WARNING

Dry cleaning solvent is flammable. Do not use near an open flame. Keep a fire extinguisher nearby when solvent is used. Use only in well-ventilated places. Failure to do this may result in injury to personnel and damage to equipment.

1-3. CLEANING. All parts must be cleaned before inspection and assembly and after repair. Clean inner and outer surfaces of metallic parts and all areas subject to oil or grease with dry cleaning solvent, type II (SD-2), Fed. Spec P-D-680. Clean out sludge and gum with a stiff brush. Use steam cleaning to take off accumulated grease and dirt after dry cleaning solvent has been applied. Dry with clean rags. To clean

bearings, refer to TM 9-214. The general cleaning covered by other manuals and references called out in this manual are as follows:

- TM 9-247 Materials Used for Cleaning, Preserving, Abrading and Cementing Ordnance Materiel and Related Materials Including Chemicals.
- TM 9-214 Inspection, Care and Maintenance of Antifriction Bearings.

1-4. PAINTING. Instructions for the preparation of the material for painting, how to paint, and material to be used are in TM 43-0139. Instructions for camouflage painting are contained in FM 5-20B. Stenciling and marking must be done periodically due to weathering or repainting. Instructions for marking military trucks is called out in TB 746-93-1.

1-5. TORQUE VALUES. Critical torque values for a particular component are given in the maintenance procedures in chapter 2. When torque values are not given, bolts, screws, and nuts are to be tightened as given in table 1-1.

1-6. SPECIAL TOOLS AND EQUIPMENT. Special tools and equipment are provided to make it easier to do particular maintenance tasks and to keep the truck in good repair. Table 1-2 lists special tools and equipment and gives a reference to the maintenance paragraph where they are used and what they are used for.

1-7. SAFETY INSPECTION AND TESTING OF LIFTING DEVICES. Refer to TB 43-0142 for safety inspection and testing of lifting devices used in this manual.

1-8. FORMS AND RECORDS. Maintenance forms, records, and reports which are to be used by maintenance personnel at all levels are listed in and prescribed by TM 38-750.

1-9. EQUIPMENT IMPROVEMENT REPORT AND MAINTENANCE DIGEST (EIR MD) AND EQUIPMENT IMPROVEMENT REPORT AND MAINTENANCE SUMMARY (EIR MS). The quarterly Equipment Improvement Report and Maintenance Digest, TB 43-0001-39 series, contains valuable field information on the equipment covered in this manual. The information in the TB 43-0001-39 series is compiled from some of the Equipment Improvement Reports that you prepared on the vehicles covered in this manual. Many of these articles result from comments, suggestions, and improvement recommendations that you submitted to the EIR program. The TB 43-0001-39 series contains information on equipment improvements, minor alterations, proposed Modification Work Orders (MWO's), warranties (if applicable), actions taken on some of your DA Form 2028's (Recommended Changes to Publications), and advance information on proposed changes that may affect this manual. In addition, the more maintenance significant articles, including minor alterations, field-fixes, etc, that have a more permanent and continuing need in the field are republished in the Equipment Improvement Report and Maintenance Summary (EIR MS) for TARCOM Equipment (TM 43-0143). Refer to both of these publications (TB 43-0001-39 series and TM 43-0143) periodically, especially the TB 43-0001-39 series, for the most current and authoritative information on your equipment. The information will help you in doing your job better and will help in keeping you advised of the latest changes to this manual. Also refer to DA Pam 310-4, Index of Technical Publications, and Appendix A, References, of this manual.

1-10. REPORTING IMPROVEMENT RECOMMENDATIONS. If your truck needs improvement, let us know. Send us an EIR. You, the user, are the only one who can tell us what you don't like about your equipment. Let us know why you don't like the design. Tell us why a procedure is hard to perform. Put it on an SF 368 (Quality Deficiency Report). Mail it to us at: Commander, U.S. Army Tank Automotive Material Readiness Command, AT TN: DRSTA-MB, Warren, Michigan 48090. We'll send you a reply.

- 1-11. METRIC SYSTEM. The equipment/system described herein is nonmetric and does not require metric common or special tools. Therefore, metric units are not supplied. Tactical instructions, for sake of clarity, will also remain nonmetric.
- 1-12. DESTRUCTION TO PREVENT ENEMY USE. Follow procedures given in TM 750-244-6 for destruction of Army material to prevent enemy use.
- 1-13. ADMINISTRATIVE STORAGE. Refer to TM 740-90-1 for truck storage procedures.
- 1-14. TABULATED DATA. Refer to TM 9-2320-209-20 for tabulated data for the trucks covered by this manual. Additional data can be found in paragraphs dealing with individual trucks or components.
- 1-15. VEHICLE DESCRIPTION. For vehicle description refer to TM 9-2320-209-10 and TM 9-2320-209-20.
- 1-16. GENERAL SHIPPING INSTRUCTIONS. When shipping 2 1/2 ton, 6x6 trucks, the officer in charge of preparing shipments will be responsible for the materiel being shipped in a serviceable condition. Also, the trucks must be properly processed for shipment, including the preparation of shipping documents.
- 1-17. TRANSPORTABILITY GUIDANCE, Transportability guidance for logistic handling and movement of 2 1/2 ton, 6x6 trucks is in TM 55-2320-209-15-1.
- 1-18. MAINTENANCE REPAIR PARTS . Repair parts for direct and general support maintenance are listed and illustrated in TM 9-2320-209-34P.

Table 1-1. Standard Torque Specifications

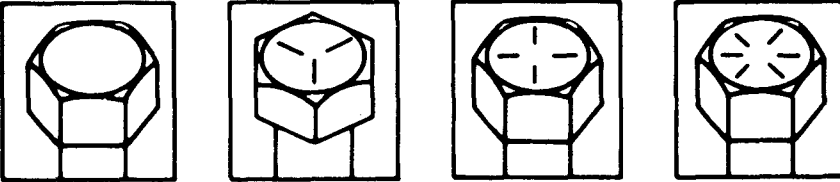
USAGE	MUCH USED	MUCH USED	USED AT TIMES	USED AT TIMES
CAPSCREW DIAMETER AND MINIMUM TENSILE STRENGTH PSI [KG/SQ CM]	To 1/2-69,000 [4850.7000]	To 3/4-120,000 [8436.0000]	To 5/8-140,000 [9842.0000]	150,000 [10545.0000]
	To 3/4-64,000 [4499.2000]	To 1 -115,000 [8084.5000]	To 3/4-133,000 [9349.9000]	
	To 1 -55,000 [3866.5000]			
QUALITY OF MATERIAL	INDETERMINATE	MINIMUM COMMERCIAL	MEDIUM COMMERCIAL	BEST COMMERCIAL
SAE GRADE NUMBER	1 or 2	5	6 or 7	8
CAPSCREW HEAD MARKINGS				
Manufacturer's marks may vary These are all SAE Grade 5 (3-line).				
 				
CAPSCREW BODY SIZE (INCHES)-(THREAD)	TORQUE FT-LB [KG M]	TORQUE FT-LB [KG M]	TORQUE FT-LB [KG M]	TORQUE FT-LB [KG M]
1/4-20	5 [0.6915]	8 [1.1064]	10 [1.3830]	12 [1.6596]
-28	6 [0.8298]	10 [1.3830]		14 [1.9362]
5/16-18	11 [1.5213]	17 [2.3511]	19 [2.6277]	24 [3.3192]
-24	13 [1.7979]	19 [2.6277]		27 [3.7341]
3/8-16	18 [2.4894]	31 [4.2873]	34 [4.7022]	44 [6.0852]
-24	20 [2.7660]	35 [4.8405]		49 [6.7767]
7/16-14	28 [3.8132]	49 [6.7767]	55 [7.6065]	70 [9.6810]
-20	30 [4.1490]	55 [7.6065]		78 [10.7874]
1/2-13	39 [5.3937]	75 [10.3725]	85 [11.7555]	105 [14.5215]
-20	41 [5.6703]	85 [11.7555]		120 [16.5960]
9/16-12	51 [7.0533]	110 [15.2130]	120 [16.5960]	155 [21.4365]
-18	55 [7.6065]	120 [16.5960]		170 [23.5110]
5/8-11	83 [11.4789]	150 [20.7450]	167 [23.0961]	210 [29.0430]
-18	95 [13.1385]	170 [23.5110]		240 [33.1920]
3/4-10	105 [14.5215]	270 [37.3410]	280 [38.7240]	375 [51.8625]
-16	115 [15.9045]	295 [40.7985]		420 [58.0860]
7/8-9	160 [22.1280]	395 [54.6285]	440 [60.8520]	605 [83.6715]
-14	175 [24.2025]	435 [60.1605]		675 [93.3525]
1-8	235 [32.5005]	590 [81.5970]	660 [91.2780]	910 [125.8530]
-14	250 [34.5750]	660 [91.2780]		990 [136.9170]

1. Always use the torque values listed above when specific specifications are not available

Note: Do not use above values in place of those specified in the engine groups of this manual, special attention should be observed in case of SAE Grade 6, 7 and 8 capscrews.

2. The above is based on use of clean and dry threads.

3. Reduce torque by 10% when engine oil is used as a lubricant.

4. Reduce torque by 20% if new plated capscrews are used.

Caution: Capscrews threaded into aluminum may require reductions in torque of 30% or more, unless inserts are used.

TA 113439

Table 1-2. Special Tools and Equipment

Item	Part No.	National Stock No.	Reference Paragraph	Use
BARRING TOOL, ENGINE	ST 747	4910-00-150-5798	2-11	Used to turn engine crankshaft pulley.
BURNISHER, SLEEVE BEARING, HAND: (Pitman Arm Shaft Bearings)	7083238	5120-00-708-3238	14-3	Used to burnish pitman arm shaft bearings.
FIXTURE: (Transfer Case)	8708279	4910-00-694-4777	9-5	Used to transport transfer.
FIXTURE: (Transfer Case)	8708898	5120-00-341-4974	9-3	Used to transport transfer.
GAGE, PRESSURE	7541305	6685-00-387-9654	21-31	Used to check pressure of engine shipping container.
HANDLE, REMOVER AND REPLACER	7083241	5120-00-708-3241	10-7	Used with removers 5120-00-708-3251, 5120-00-708-3249, and 5120-00-708-3250, remover and replacer 5120-00-708-3246, and replacers 5120-00-708-3252 and 5120-00-708-3256.
PULLER KIT	8708724	5120-00-338-6721	2-15	Used to take off camshaft gear.
			10-7	Used to takeoff differential carrier flange.
PULLER, MECHANICAL: (Differential Helical Pinion Bearing Gage)	8366689	5120-00-836-6689	10-7	Used to takeoff differential helical pinion bearing gage.

Table 1-2. Special Tools and Equipment - Cont

Item	Part No.	National Stock No.	Reference Paragraph	Use
PULLER, OIL SEAL	8708740	5120-00-310-4669	10-5	Used to remove oil seals and retainers.
REMOVER, BEARING: (Differential Helical Drive Pinion Bearing)	7083251	5120-00-708-3251	10-7	Used with handle 5120-00-708-3241 to takeout differential helical drive pinion bearing.
REMOVER, OIL SEAL: (Differential Carrier Shaft Front Oil Seal)	7083249	5120-00-708-3241	10-7	Used with handle 5120-00-708-3241 to take off differential carrier through shaft front oil seal.
REMOVER, OIL SEAL: (Differential Carrier Through Shaft Rear Oil Seal)	7083250	5120-00-708-3250	10-7	Used with handle 5120-00-708-3241 to take off differential carrier through shaft rear oil seal.
REMOVER AND REPLACER , (Differential Carrier Bevel Gear Bearing Sleeve)	7083246	5120-00-708-3246	10-7	Used with screw 5120-00-708-3216 to take off and put back differential carrier bevel gear bearing sleeve.
REMOVER AND REPLACER , BUSHING: (Pitman Arm Shaft Bushing)	7083248	5120-00-795-0137	14-3	Used to take off and put back pitman arm shaft bushing.
REPLACER , BEARING CUP: (Differential Helical Drive Pinion Bearing cup)	7083252	5120-00-708-3252	10-7	Used with handle 5120-00-708-3241 to put back differential helical drive pinion bearing cup.

Table 1-2. Special Tools and Equipment - Cont

Item	Part No.	National Stock No.	Reference Paragraph	Use
REPLACER, GEAR: (Differential Carrier Bevel Gear)	7083257	5120-00-708-3257	10-7	Used to put back differential carrier bevel gear.
REPLACER, OIL SEAL: (Differential Carrier Through Shaft Oil Seals)	7083256	5120-00-708-3256	10-7	Used with handle 5120-00-708-3241 to put back differential carrier through shaft oil seals.
REPLACER, OIL SEAL: (Front Axle Uni- versal Joint Oil Seal)	7083258	5120-00-708-3258	10-5	Used with 5120-708-3241 handle to replace oil seals.
SCREW	7083216	5120-00-708-3216	10-7	Used with remover and replacer 5120-00-708-3246 to take off and put back differential carrier bevel gear bearing sleeve.
WRENCH, AIR COMPRESSOR	8390170	5120-00-390-7779	9-5	Used to loosen and tighten transfer mounting nuts.
WRENCH, BOX	10951485	5120-00-930-6346	2-6	Used to tighten cylinder head nuts.
WRENCH, HOOK SPANNER	11623221	5120-00-118-4387	17-52	Used to take off and adjust rack feed idler gear bearing and adjusting nuts.
WRENCH, HOOK SPANNER	11623223	5120-00-118-4467	17-52	Used to adjust clutch feed shaft bearing adjusting nut and drive sleeve bearing.

Table 1-2. Special Tools and Equipment - Cont

Item	Part No.	National Stock No.	Reference Paragraph	Use
WRENCH, HOOK (Dif-ferential Side Bearing Ad-justing Ring)	7083260	5120-00-708-3260	10-7	Used to adjust differential side bearing adjusting ring.
WRENCH, HOOK (Worm Adjusting Bearing)	11623222	5120-00-118-4402	17-49	Used to take off and adjust horizon-tal and vertical worm gear adjust-ing bearing.
WRENCH, PULLEY ADJUSTING: (Air Compressor Pulley)	10935288	5120-00-070-7809	2-8	Used to adjust air compressor pulley.
WRENCH, SPANNER	CT 685	5120-00-293-0316	17-47	Used to take off intermediate case feed pinion shaft adjusting nut.

CHAPTER 2

ENGINE SYSTEM GROUP MAINTENANCE

Section I. SCOPE

2-1. EQUIPMENT ITEMS COVERED. This chapter gives equipment maintenance procedures for the engine assembly, crankcase, block and cylinder head, crankshaft, flywheel, pistons and connecting rods, valves, camshaft and timing system, engine lubricating system, and manifolds for which there are authorized corrective maintenance tasks at the direct and general support maintenance levels.

2-2. EQUIPMENT ITEMS NOT COVERED, All equipment items for which corrective maintenance is authorized at the direct and general support maintenance levels are covered in this chapter.

Section II. ENGINE ASSEMBLY

2-3. ENGINE REMOVAL AND REPLACEMENT.

TOOLS: No special tools required

SUPPLIES: Tags

PERSONNEL: Two

EQUIPMENT CONDITION: Truck parked, engine off, handbrake set.

NOTE

This task is the same for all engines except as noted.
This task is shown for the LD 465-1.

a. Preliminary Procedures.

(1) Disconnect battery ground cable. Refer to TM 9-2320-209-20.

(2) Open hood and side panels. Refer to TM 9-2320-209-10.

(3) Remove air cleaner. Refer to TM 9-2320-209-20.

(4) Drain cooling system. Refer to TM 9-2320-209-20.

(5) Remove transmission-to-transfer propeller shaft. Refer to Propeller Shaft and Universal Joint Removal and Replacement, TM 9-2320-209-20.

(6) If truck has front winch, remove front winch propeller shaft. Refer to Propeller Shaft and Universal Joint Removal and Replacement, TM 9-2320-209-20.

(7) For truck M342A2, remove hoist pump propeller shaft. Refer to Propeller Shaft and Universal Joint Removal and Replacement, TM 9-2320-209-20.

(8) Remove front and intermediate cab tunnels. Refer to TM 9-2320-209-20.

(9) Remove radiator brush guard. Refer to Part 3, para 19-5.

(10) Remove radiator. Refer to TM 9-2320-209-20.

(11) Remove clutch linkage. Refer to TM 9-2320-209-20.

(12) Remove transfer reverse shift linkage. Refer to Transmission Transfer Controls and Linkage (Without Power Takeoff) Removal, Repair, and Replacement, TM 9-2320-209-20.

(13) Remove fuel line from primary filter to injector pump. Refer to Fuel Lines and Fittings and Fittings Removal and Replacement, TM 9-2320-209-20.

(14) Remove both front service headlight assemblies. Refer to TM 9-2320-209-20.

b. Removal.

FRAME 1

1. Take connector (1) off oil pressure transmitter (2).

GO TO FRAME 2

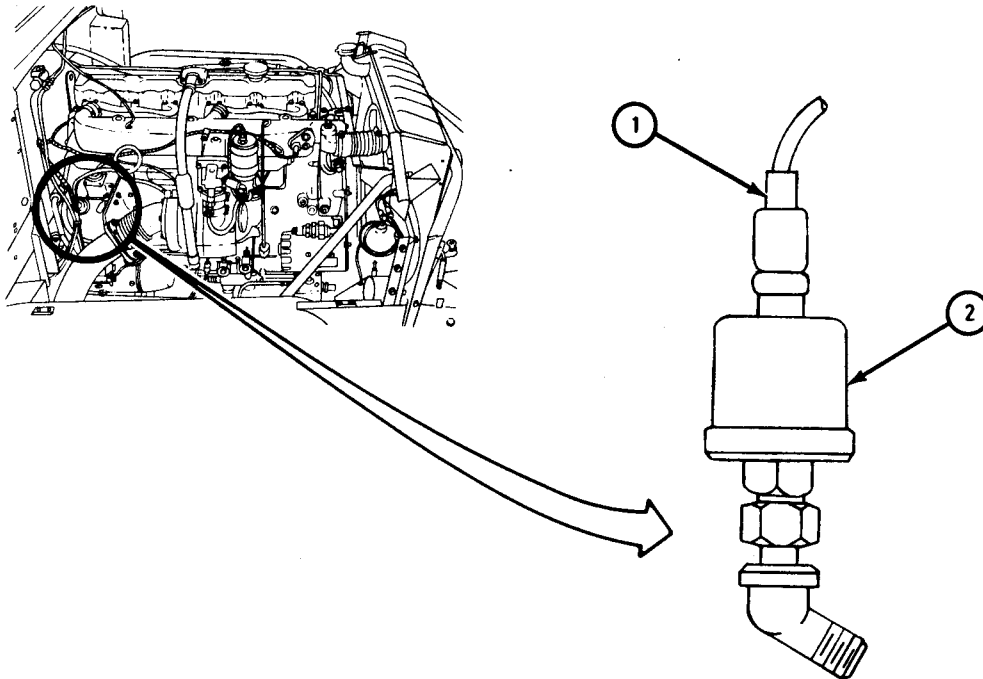

TA 088461

FRAME 2

1. Takeout three screws (1) and take off nuts (2). Takeout gasket (3).
 2. Takeoff nut (4). Tag wires (5 and 6), take them off, and move them out of the way.
 3. Unscrew nut (7) and take off cable (8).
- GO TO FRAME 3

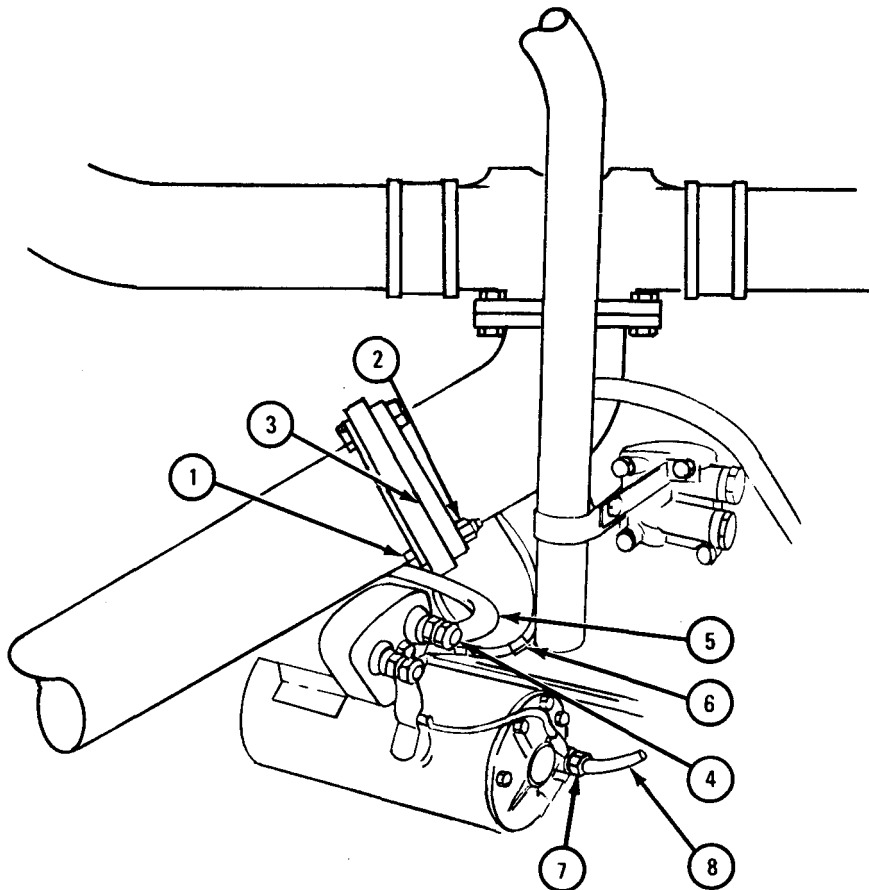

TA 088462

FRAME 3

1. Take out screw and washer (1). Take off ground strap (2).
2. Take off regulator-to-generator cable (3).

GO TO FRAME 4

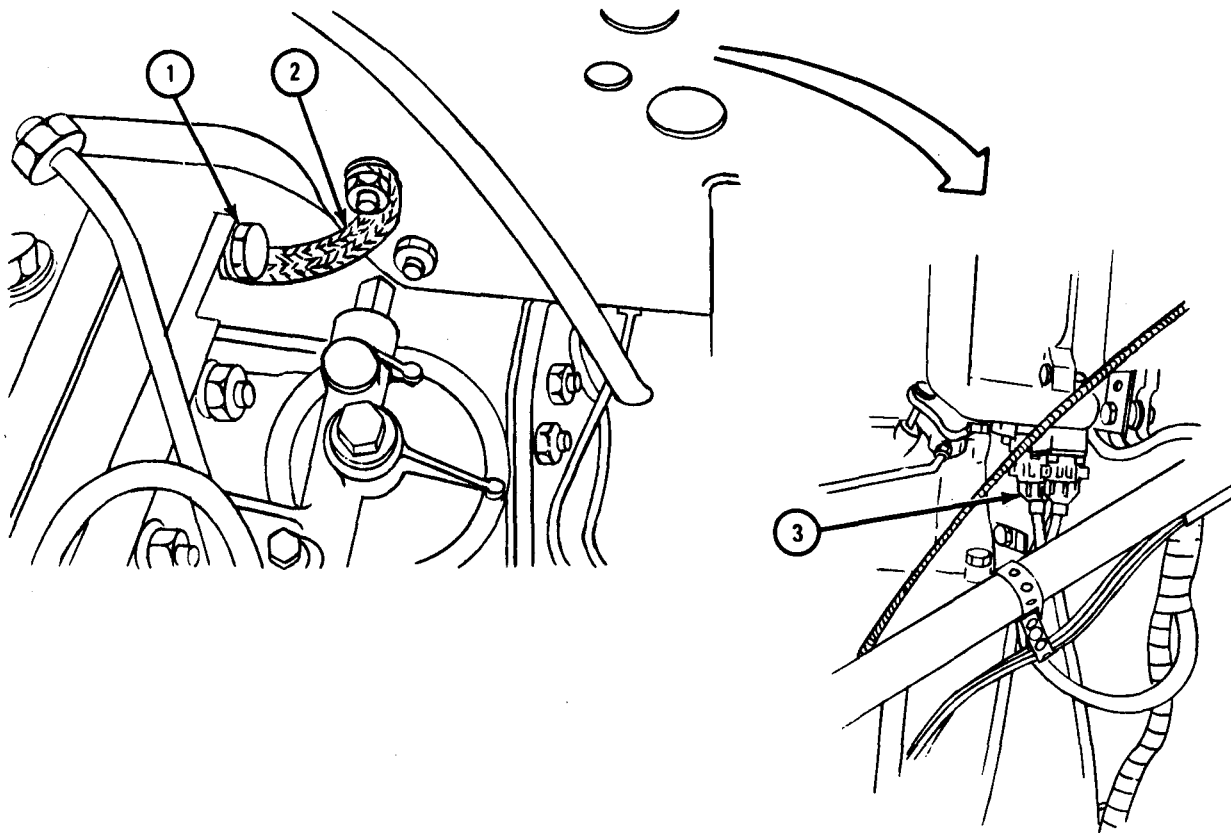

TA 088463

FRAME 4

1. Loosen screws (1 and 2). Take out fuel shutoff cable (3) and move it out of the way.
2. Take out spring (4).
3. Take out cotter pin (5) and pin (6).

GO TO FRAME 5

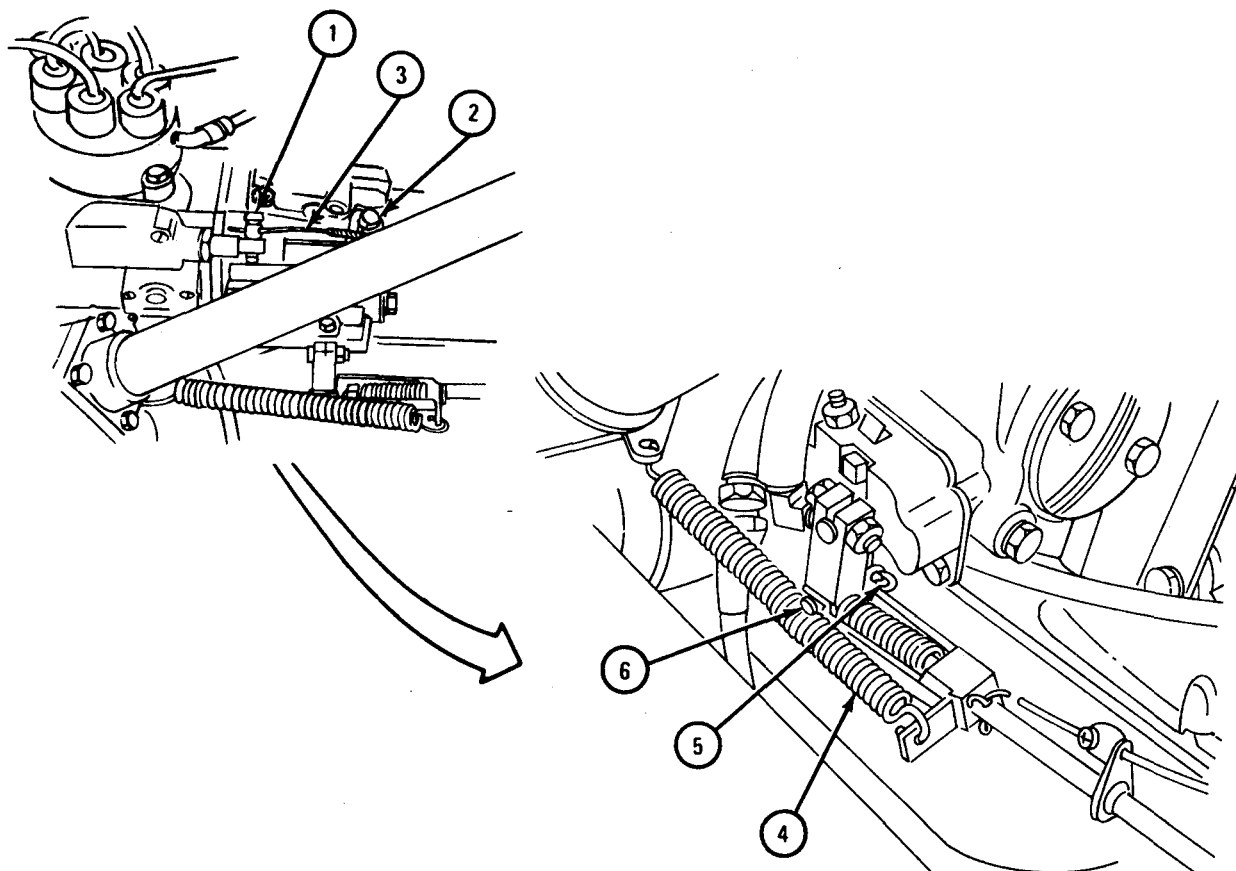

TA 088464

FRAME 5

1. Take off three locknuts (1) and takeout bolts (2).
2. Take three clamps (3) off brackets (4). Spread clamps and take them off flexible shaft assembly (5).

GO TO FRAME 6

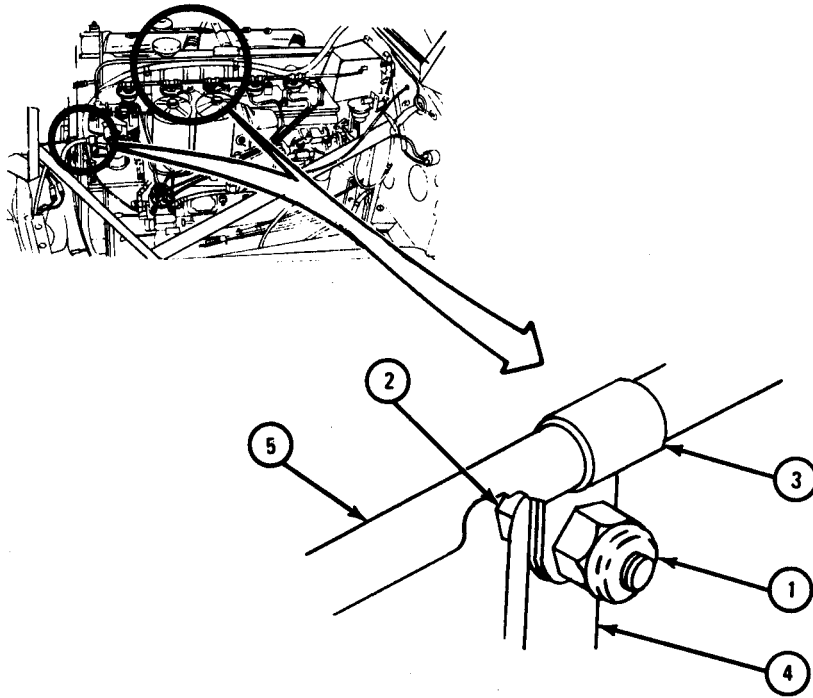

TA 088465

FRAME 6

1. Unscrew nut (1). Pull flexible shaft assembly (2) away from right angle adapter (3).
2. Take off and throw away gasket (4).
3. Take out flexible shaft assembly (2) and move it out of the way.

GO TO FRAME 7

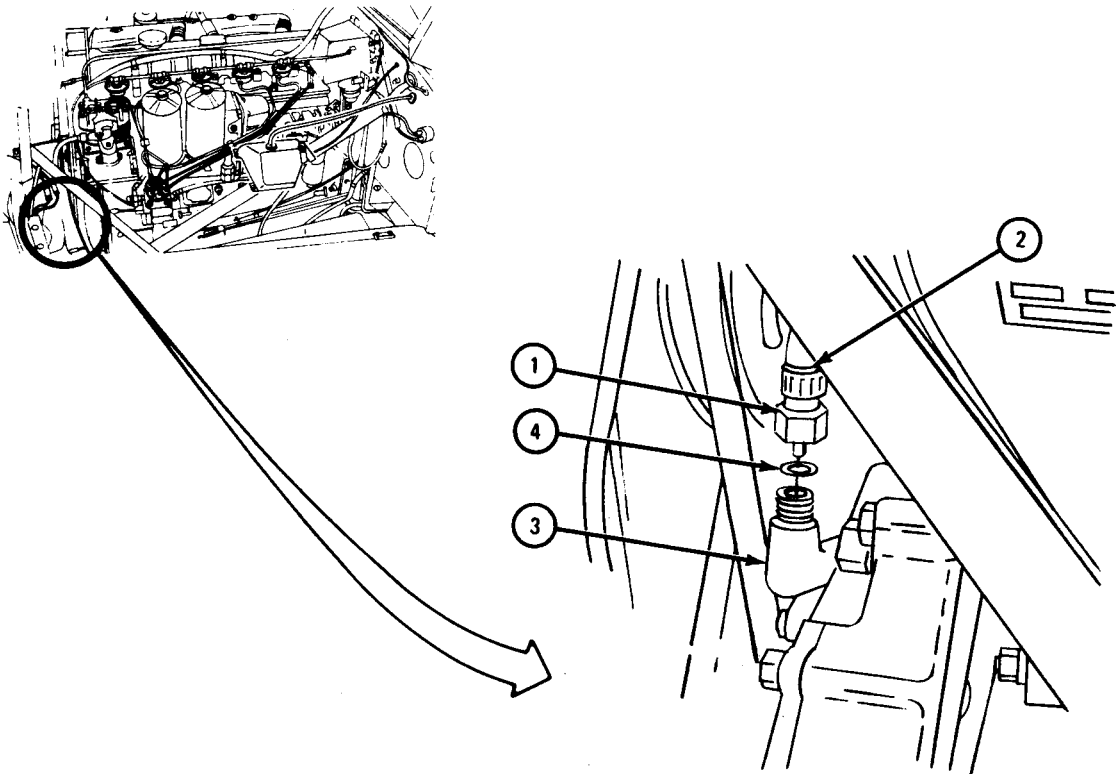

TA 088466

FRAME 7

1. Take off line and fitting (1) and move it out of the way.
- GO TO FRAME 8

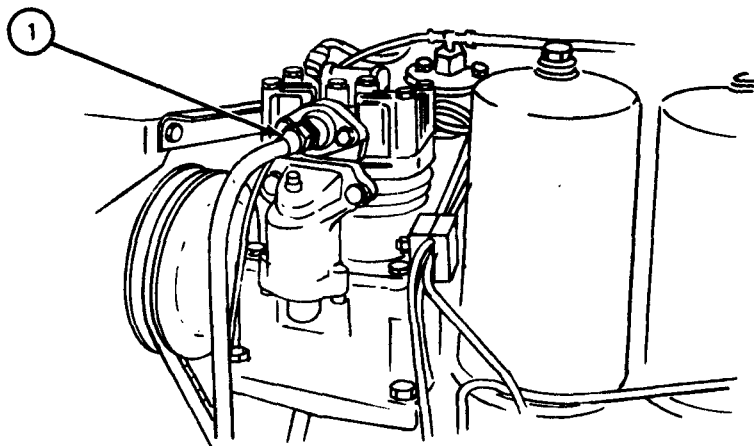

TA 088467

FRAME 8

1. Take off fuel return line and fitting (1) and move it out of the way.

IF WORKING ON ENGINE LDT 465-1C, GO TO FRAME 9.

IF WORKING ON ENGINE LDS 427-2, GO TO FRAME 10.

IF WORKING ON ENGINE LD 465-1C, GO TO FRAME 11.

IF WORKING ON ENGINE LD 465-1, GO TO FRAME 12

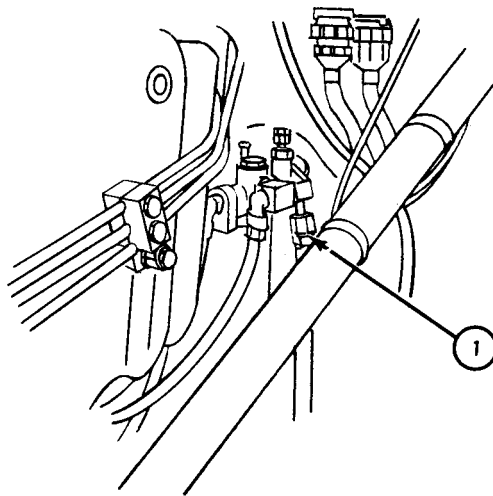

TA 088468

FRAME 9

1. Loosen clamp (1) and take exhaust hose (2) off turbocharger (3).
2. Working under front of truck, unscrew and pull apart two fuel lines (4). Plug open ends of fuel lines.

GO TO FRAME 12

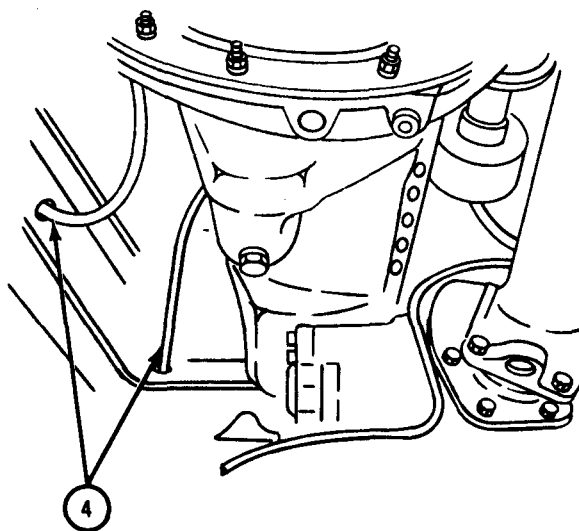
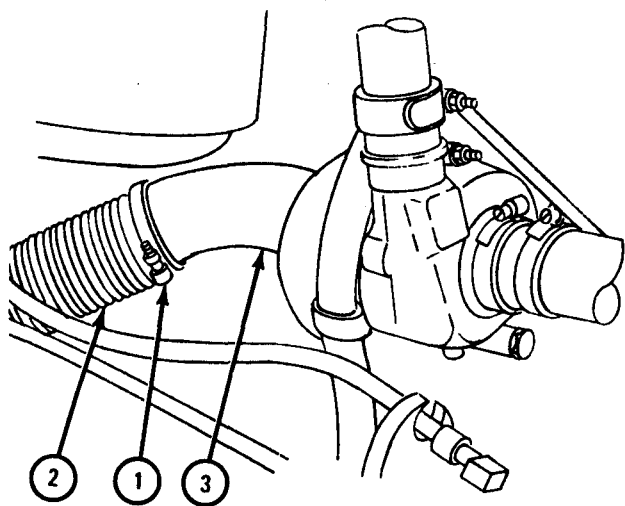

TA 088469

FRAME 10

1. Take three nuts (1) off studs (2) and pull off exhaust pipe (3).
2. Unscrew and pull apart engine preheat fuel pump main fuel line (4). Plug and tag main fuel line.
3. Do step 2 again for engine preheat fuel pump return line (5).

GO TO FRAME 12

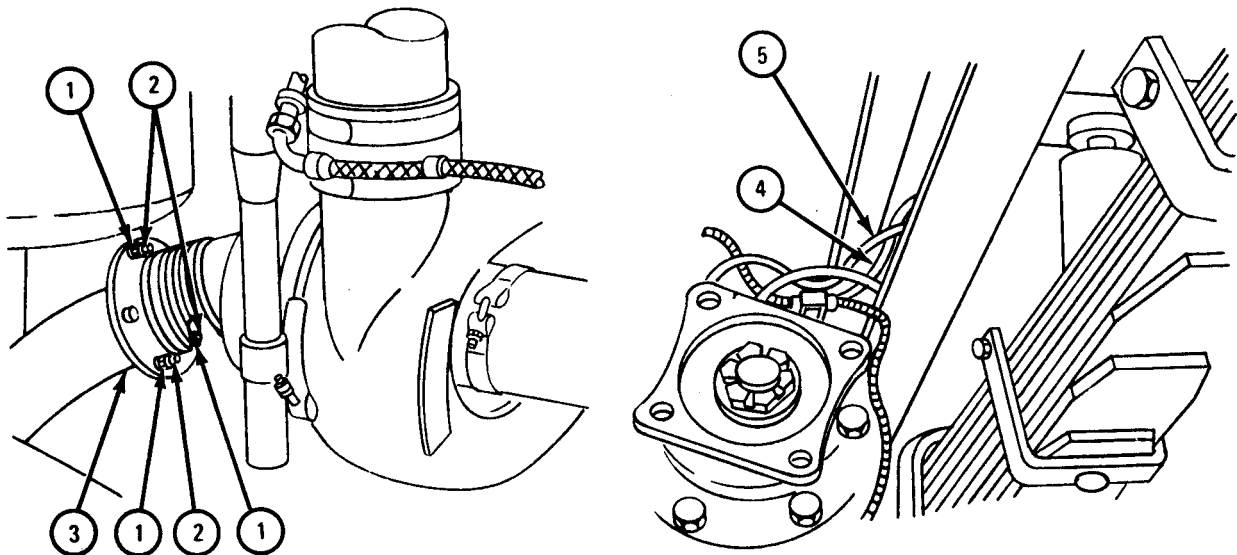

TA 088470

FRAME 11

1. Working under front of truck, take off two nuts (1) and take out two bolts (2).
 2. Take off nut (3) and take out screw (4) from throttle cable mounting bracket (5).
- GO TO FRAME 13

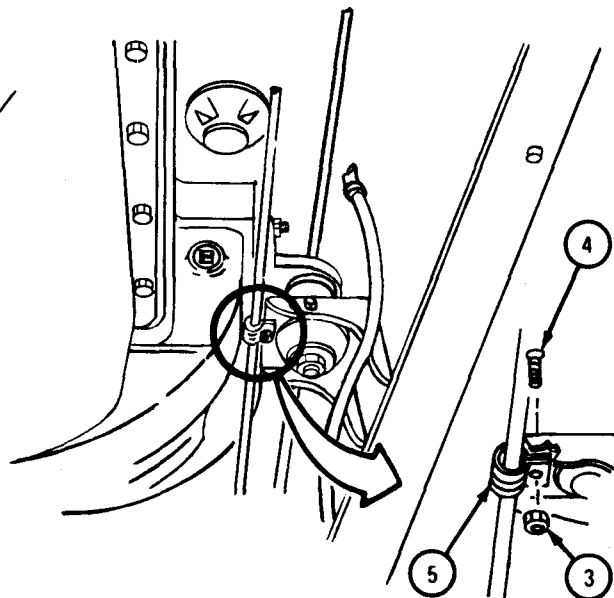
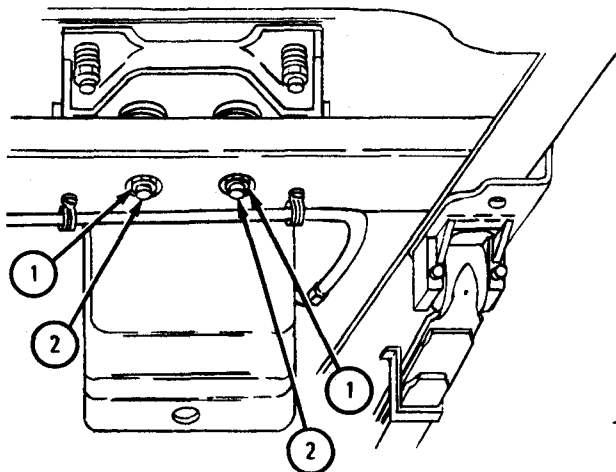

TA 088471

FRAME 12

1. Take off two nuts (1), washers (2), and bushings (3) from left front mount (4) and right front mount (5).

GO TO FRAME 13

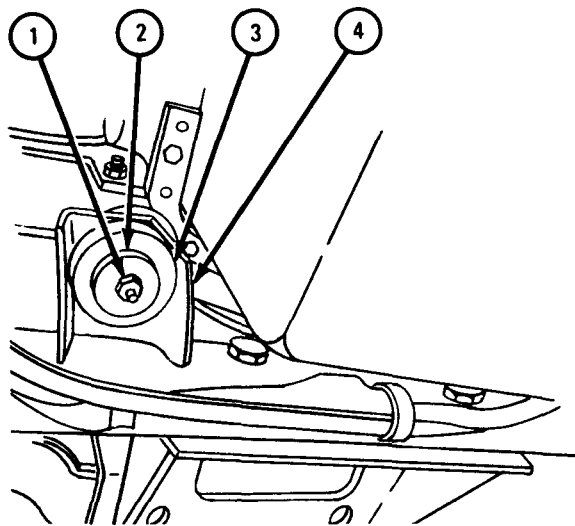

LEFT SIDE

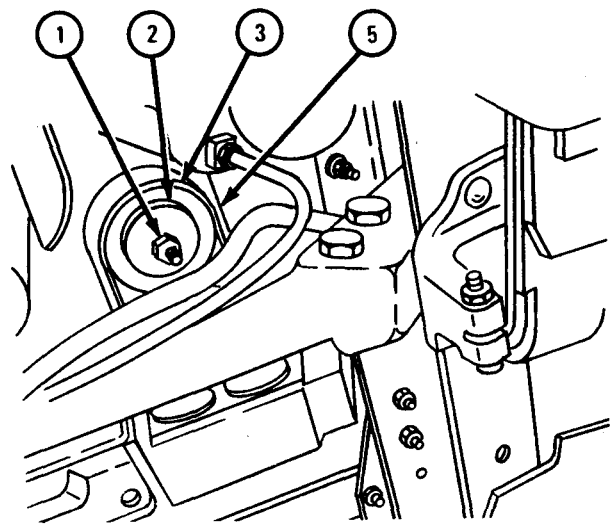

RIGHT SIDE

TA 088473

FRAME 13

1. Take off nut (1), washer (2), and bushing (3) from left rear motor mount (4).
GO TO FRAME 14

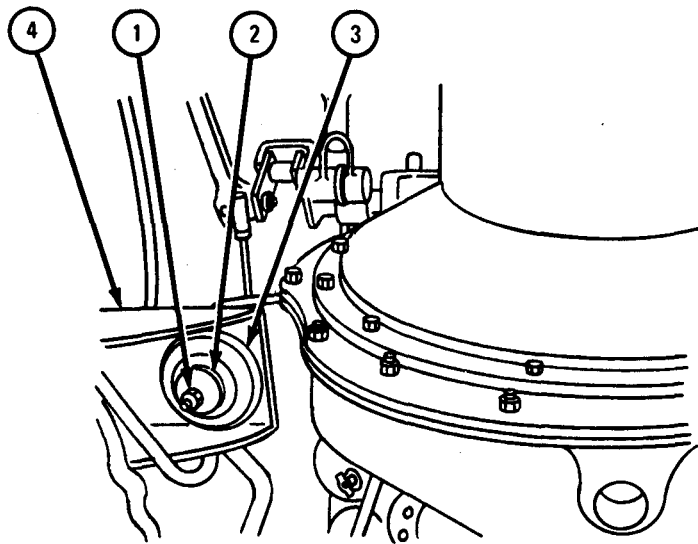

TA 088474

FRAME 14

1. Take off nut (1), washer (2), and bushing (3) from right rear engine mount (4).

2. Take out screw and washer (5) and take off ground strap (6).

GO TO FRAME 15

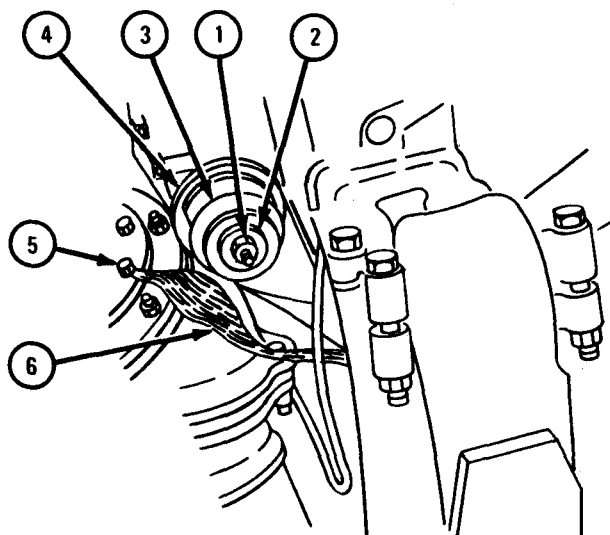

TA 088475

FRAME 15

1. Take off air governor line (1).
2. Take off nut (2) and wire (3).
3. Take off coupling nut (4) and move tube (5) out of the way.
4. Take off nut (6) and clamp (7).
5. Disconnect electrical leads (8) and (9).

GO TO FRAME 16

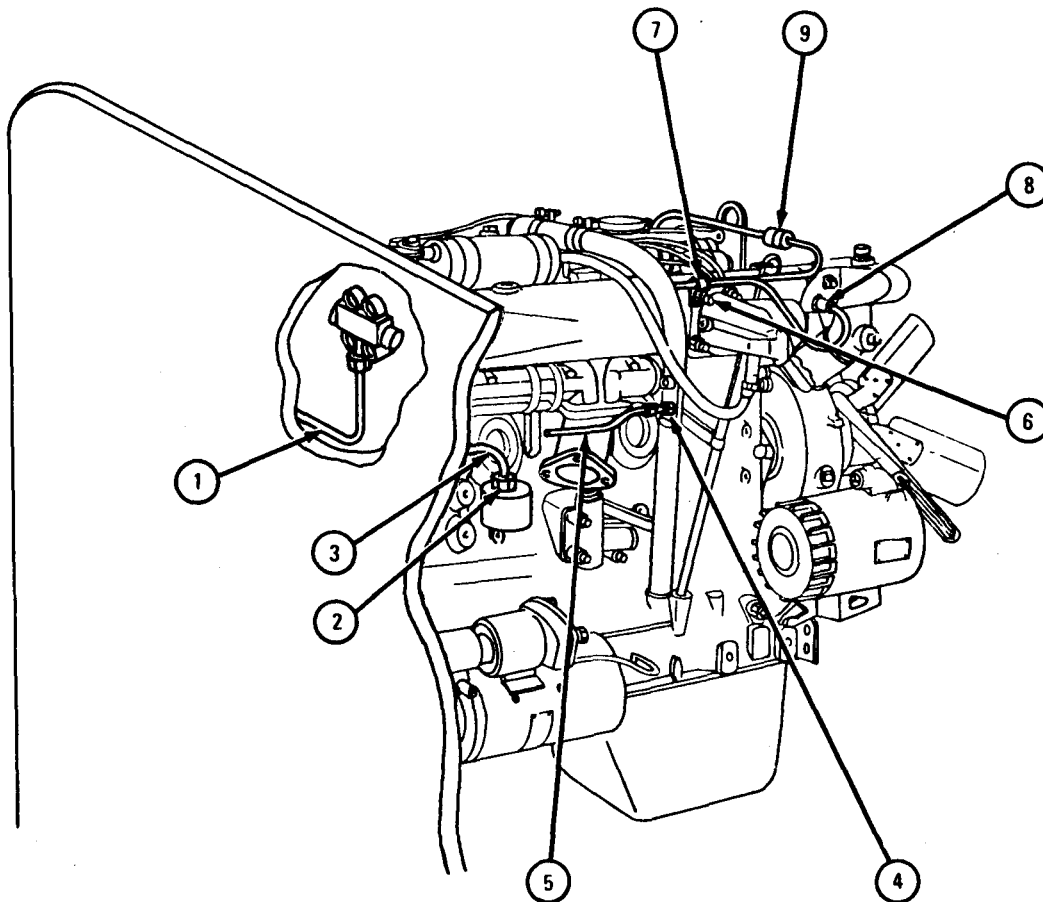

TA 105678

FRAME 16

1. Put lifting bar (1) in eyes (2). Put in two pins (3).
2. Join hoist to lifting bar (1).

GO TO FRAME 17

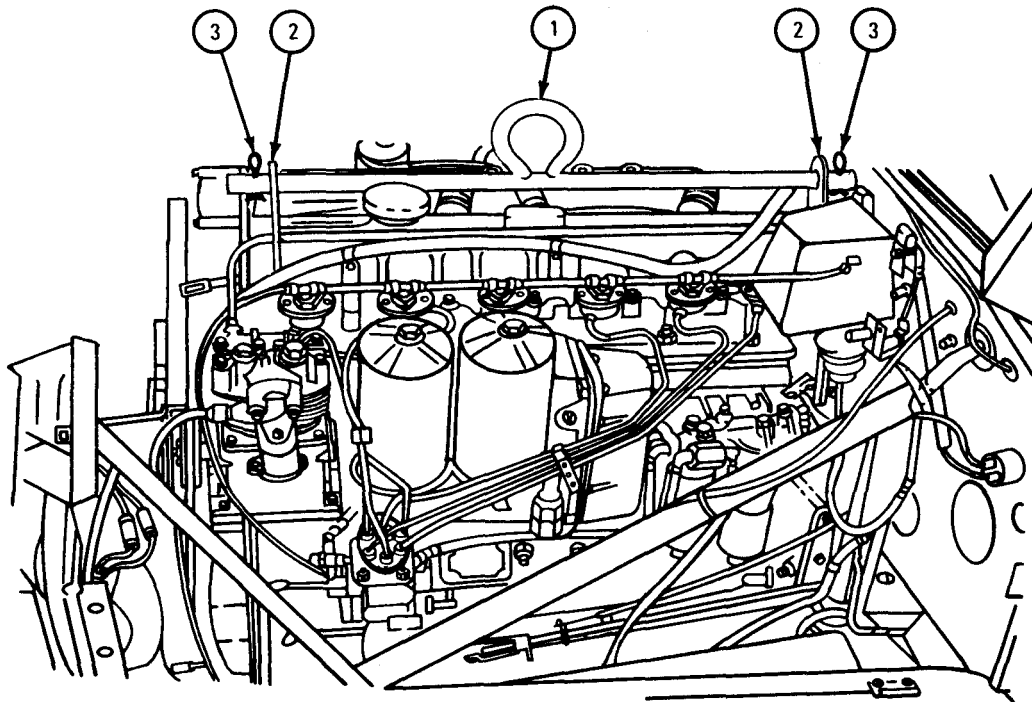

TA 088477

FRAME 17

- Soldier A 1. Using hoist, raise engine (1) slowly until soldier B tells you to stop.
- Soldier B 2. Tell soldier A to stop raising engine when there is enough room to take out upper bushing (2) and screw (3) from each of four engine mounts (4).
3. Take out four screws (3) and upper bushings (2).

GO TO FRAME 18

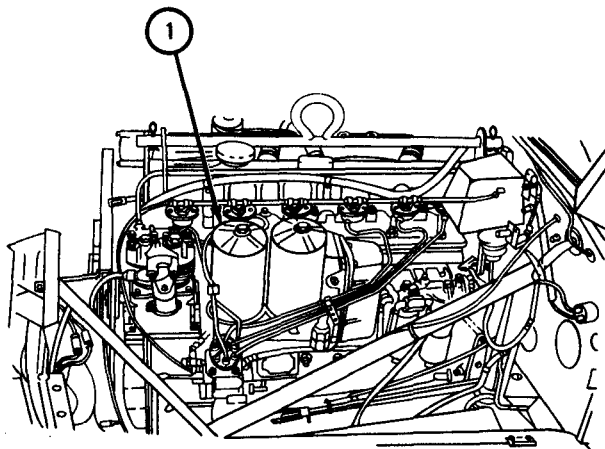

SOLDIER A

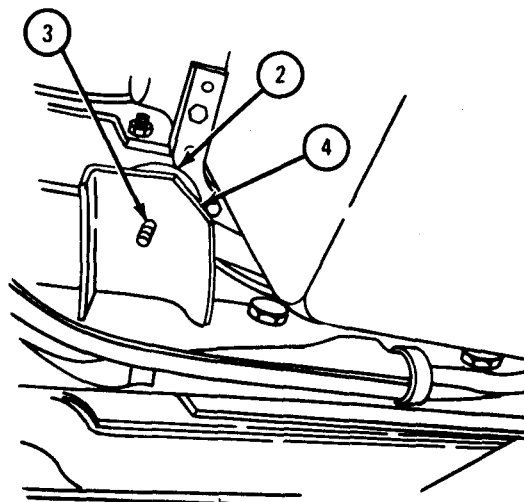

SOLDIER B

TA 085315

FRAME 18

1. Working under front of truck, take out four nuts (1) and bolts (2) and take off bracket (3).
2. Take off nut (4) and ground strap (5).

GO TO FRAME 19

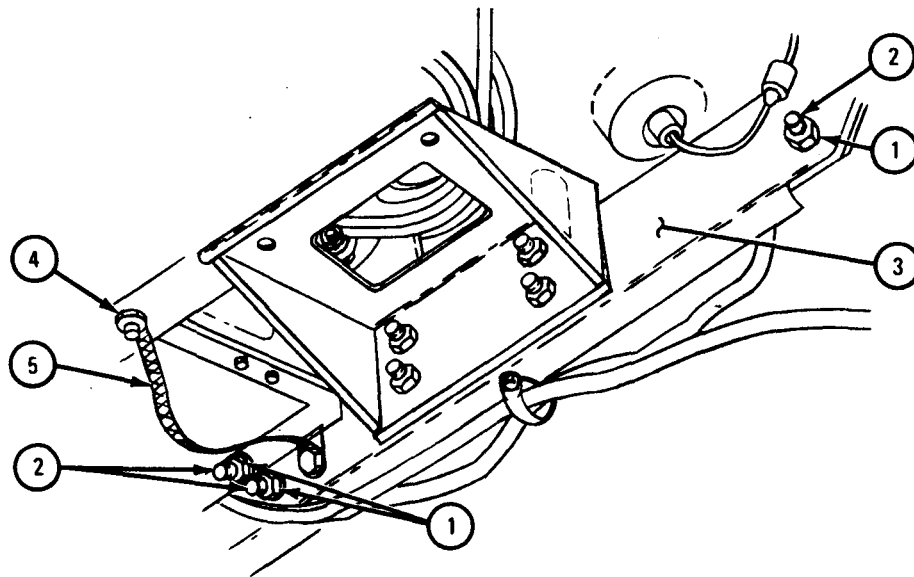

TA 088472

FRAME 19

WARNING

The engine is heavy and bulky. Make sure there is enough clearance around and over truck before lifting unit. This will stop damage to equipment and injury to personnel.

Soldier A 1. Hoist engine (1) up and out of truck and set it down on wood blocks as soldier B guides it.

Soldier B 2. Guide engine (1) up and out of truck and onto wood blocks as soldier A lifts it.

GO TO FRAME 20

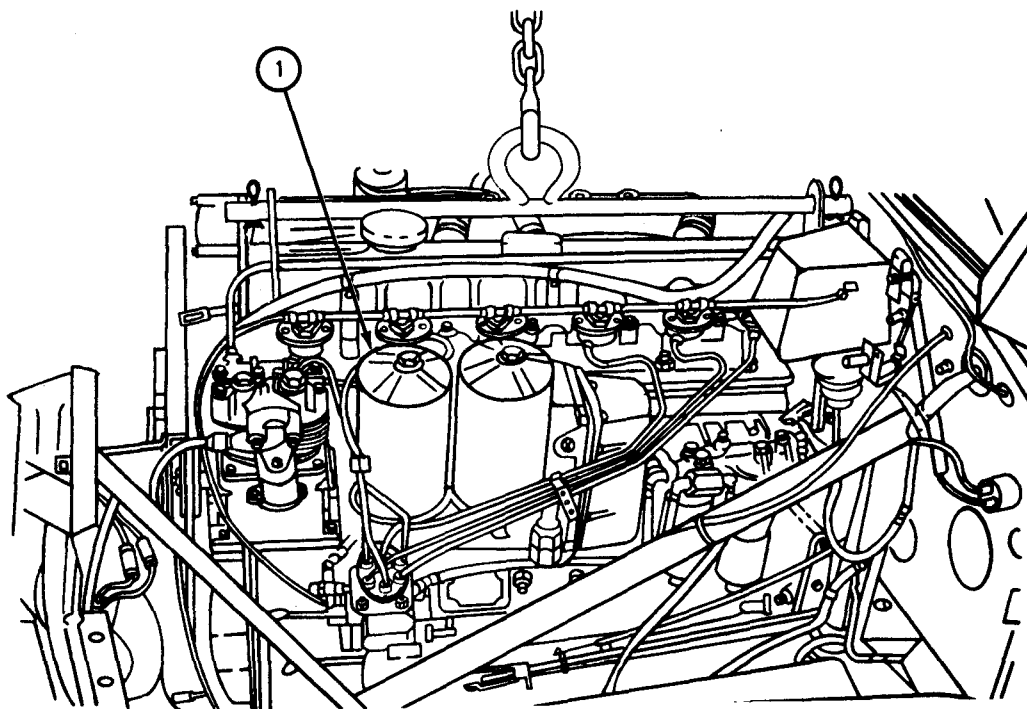

TA 085316

FRAME 20

1. Put jack under transmission (1).
2. Take out 12 screws and lockwashers (2).
3. Slide transmission (1) away from engine (3).

END OF TASK

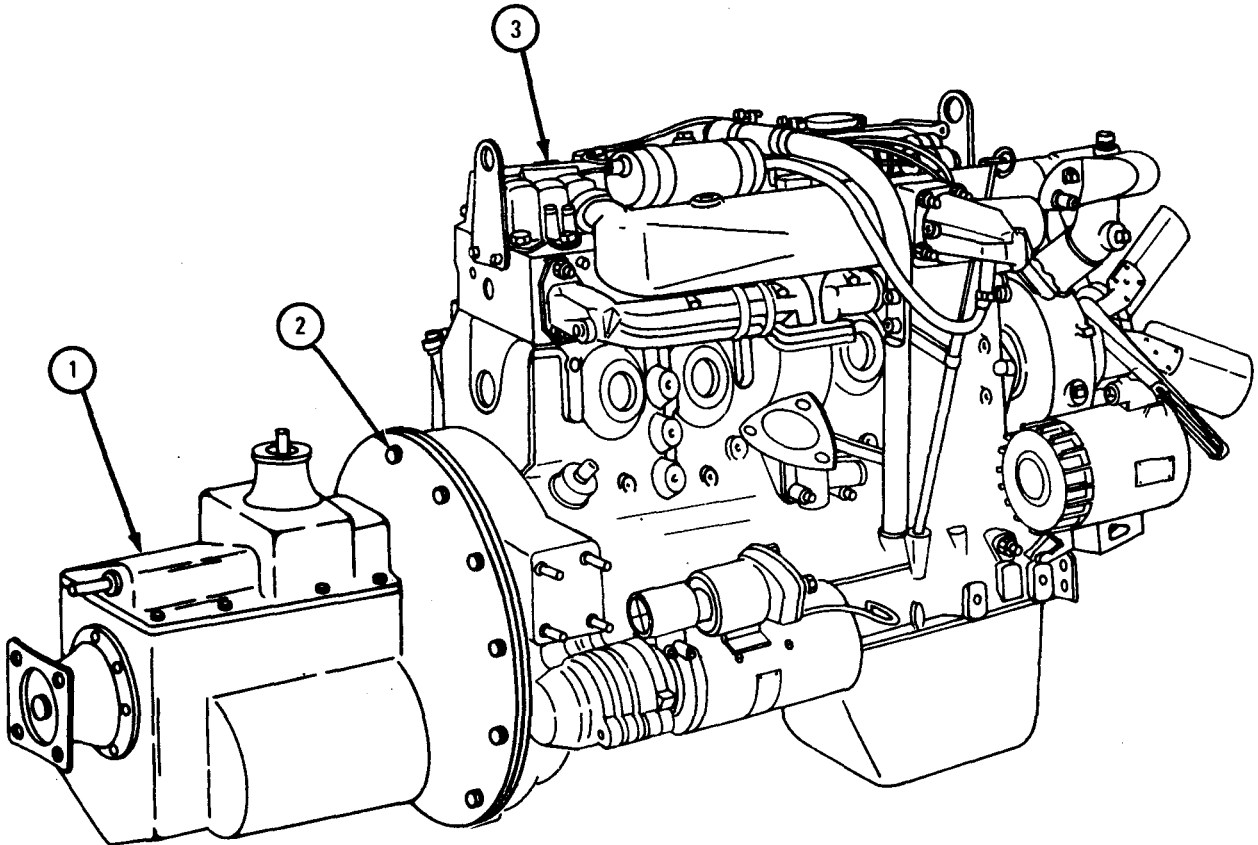

TA 085339

c. Replacement.

FRAME 1

1. Put jack under transmission (1) and slide transmission into engine (2).
2. Put in 12 screws with lockwashers (3).

GO TO FRAME 2

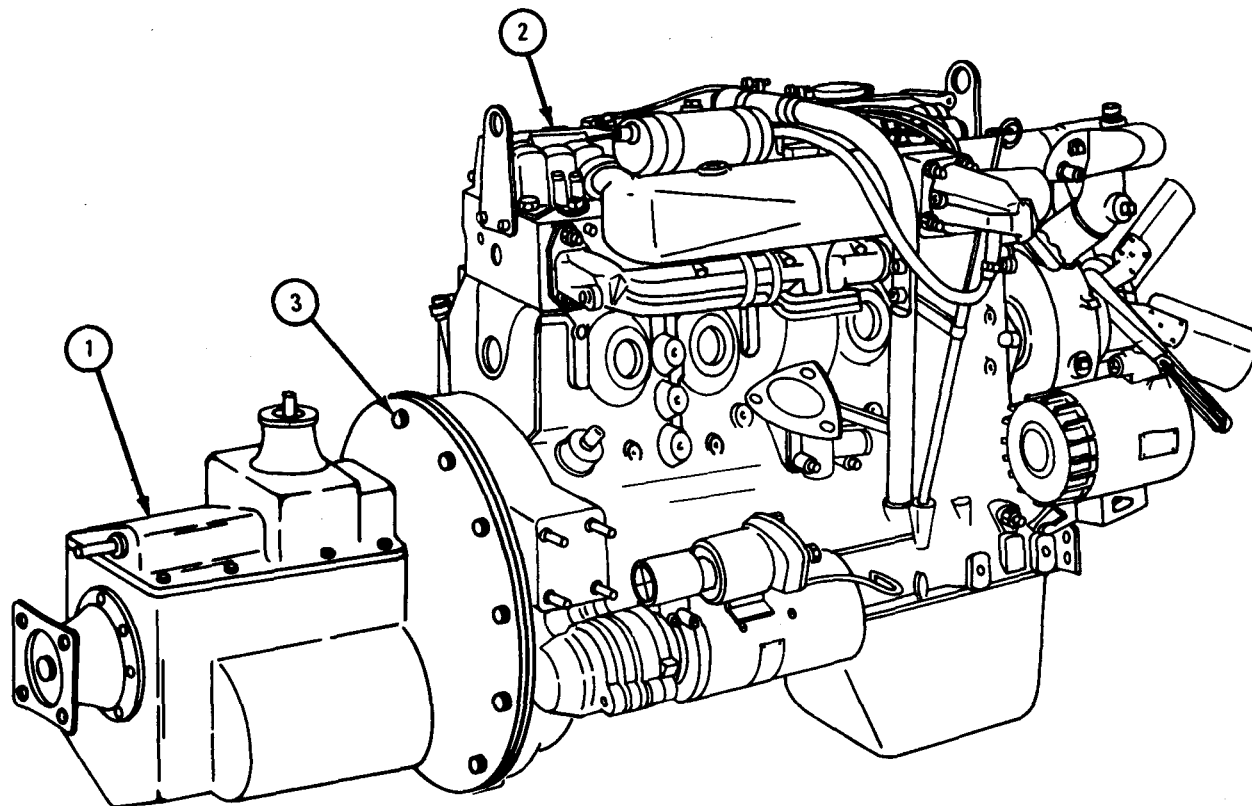

TA 088478

FRAME 2

WARNING

The engine is heavy and bulky. Make sure there is enough clearance around and over truck before lifting unit. This will stop damage to equipment and injury to personnel.

Soldier A 1. Hoist engine (1) off wood blocks and lower it into truck as soldier B guides it.

Soldier B 2. Guide engine (1) into place in engine compartment as soldier A lowers it.

GO TO FRAME 3

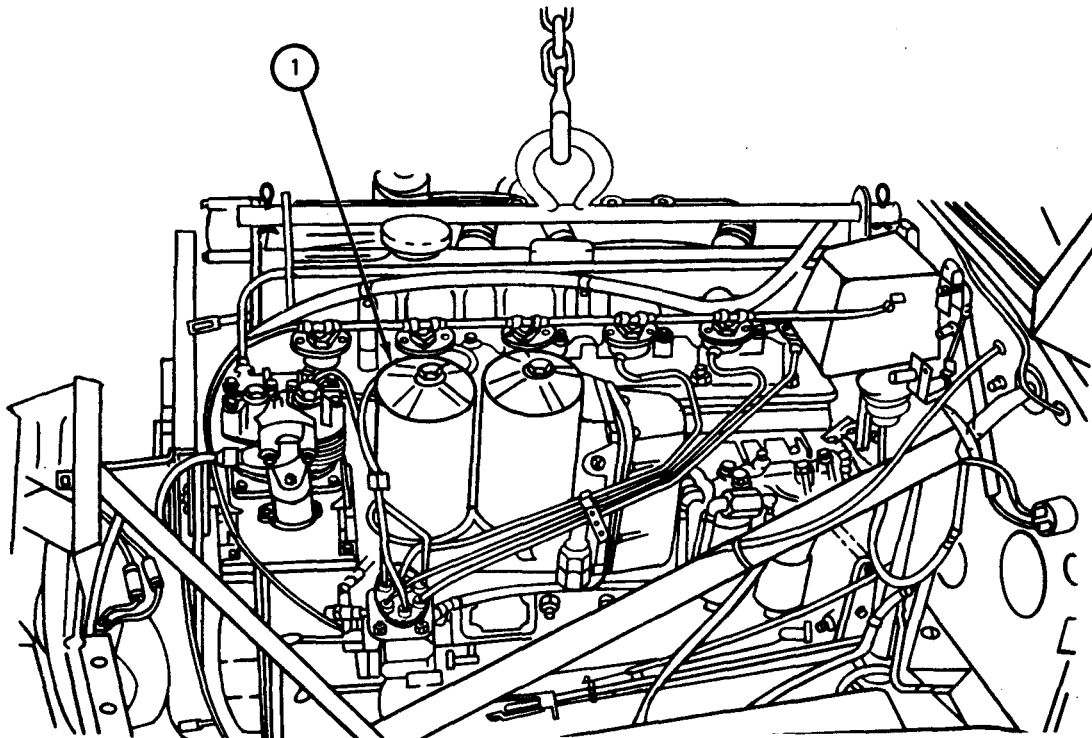

TA 085316

FRAME 3

1. Put bracket (1) in place and put in four bolts (2).
2. Put on four nuts (3).
3. Put on ground strap (4) and put on nut (5).

GO TO FRAME 4

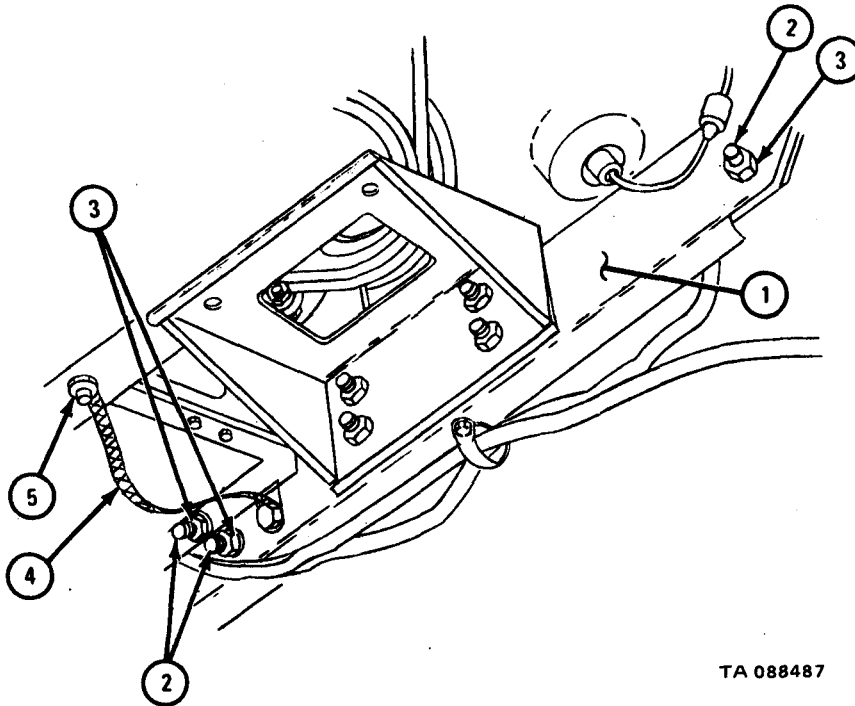

TA 088487

FRAME 4

- Soldier A 1. Raise or lower engine (1) as directed by soldier B.
- Soldier B 2. Guide engine to about three inches above engine mounts (2) as soldier A moves it.
3. Put in four upper bushings (3) and screws (4). Aline screws with holes in four engine mounts (2). Tell soldier A to lower engine (1) into place.
- Soldier A 4. Lower engine (1) into place.
- Soldier B 5. Take off lifting bar.
- GO TO FRAME 5

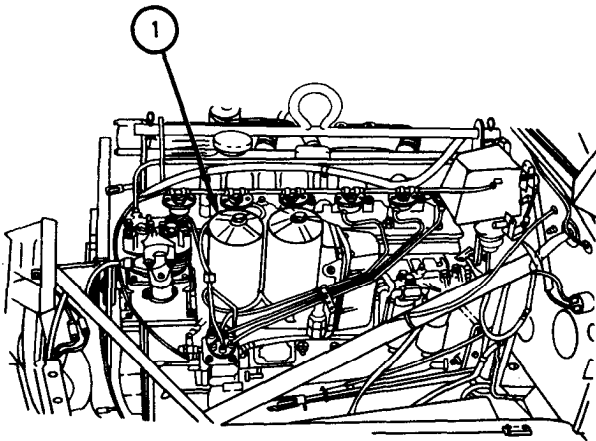

SOLDIER A

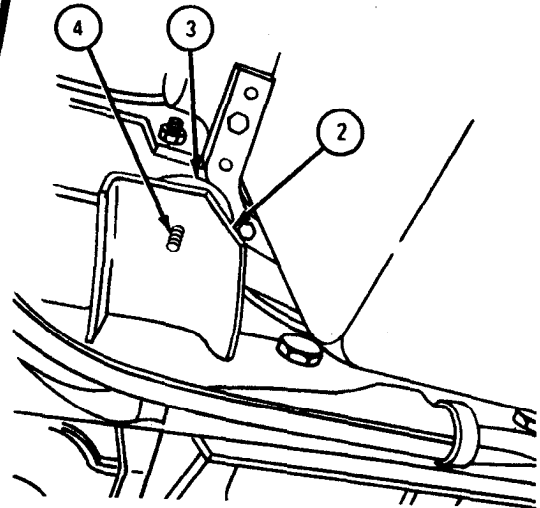

SOLDIER B

TA 088479

FRAME 5

1. Put ground strap (1) in place. Put in screw and washer (2).
 2. Put bushing (3), washer (4), and nut (5) on right rear engine mount (6).
- GO TO FRAME 6

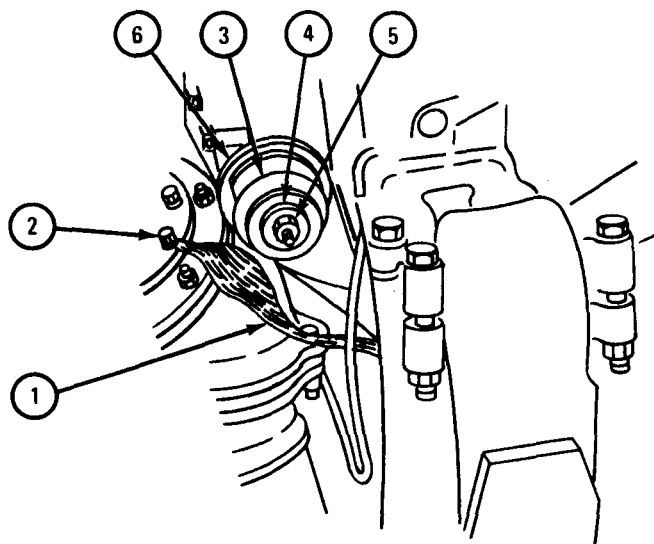

TA 088481

FRAME 6

1. Put bushing (1), washer (2), and nut (3) on left rear engine mount (4).
GO TO FRAME 7

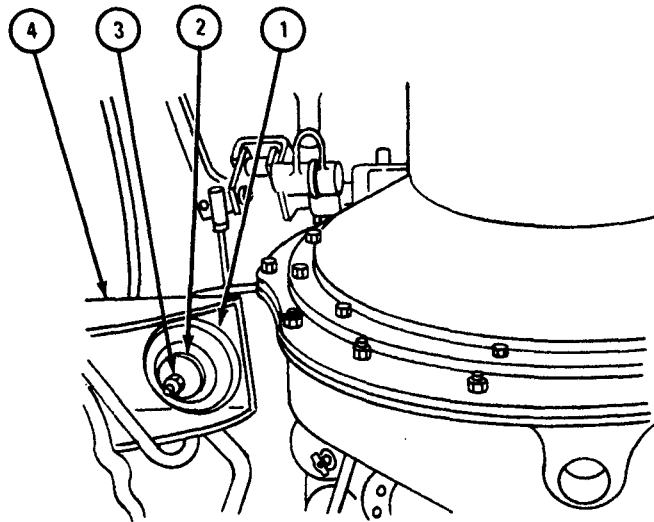

TA 088482

FRAME 7

1. Put bushings (1), washers (2), and nuts (3) on two front engine mounts (4).
IF WORKING ON ENGINE LDT 465-1C, GO TO FRAME 8.
IF WORKING ON ENGINE LDS 427-2, GO TO FRAME 9.
IF WORKING ON ENGINE LD 465-1C, GO TO FRAME 10.
IF WORKING ON ENGINE LD 465-1, GO TO FRAME 11

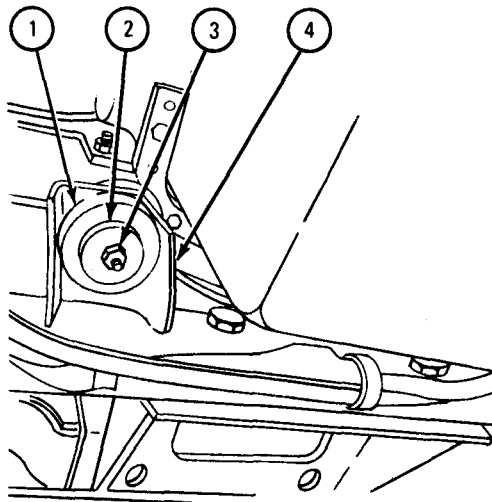

LEFT SIDE

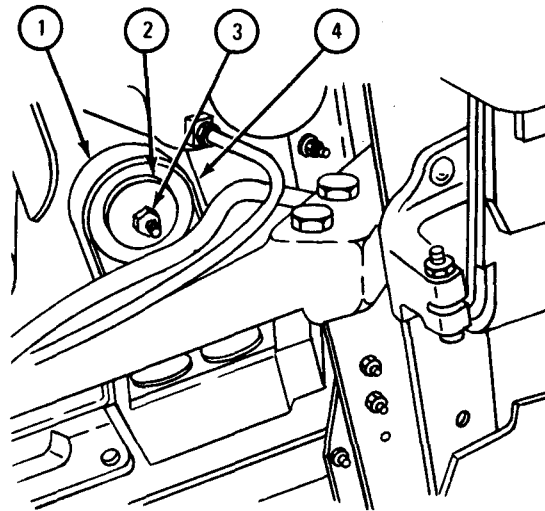

RIGHT SIDE

TA 088483

FRAME 8

1. Unplug fuel lines (1) and put them together.
 2. Put exhaust hose (2) on turbocharger (3) and tighten clamp (4).
- GO TO FRAME 11**

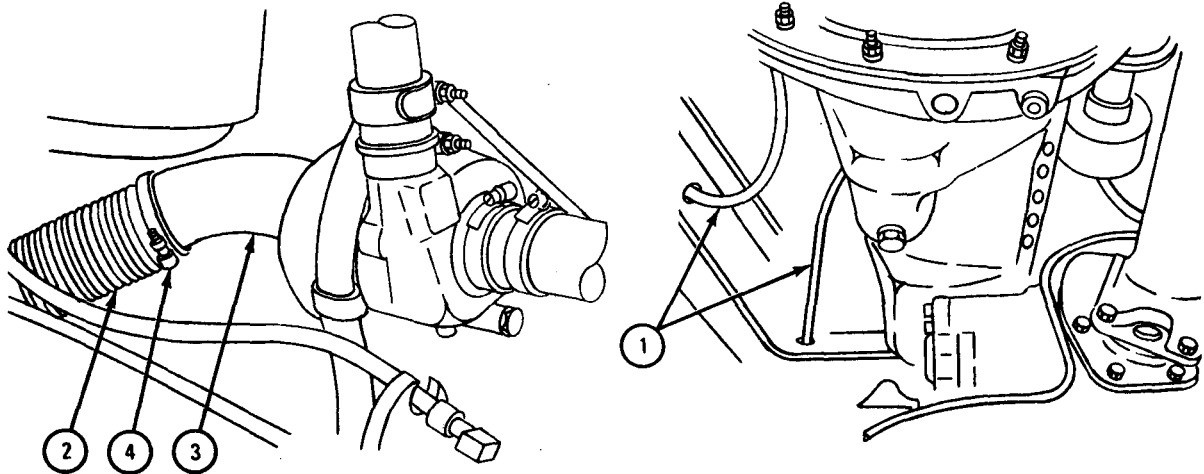

TA 088484

FRAME 9

1. Aline exhaust pipe (1) with exhaust tube (2) and put on three nuts (3).
2. Join two parts of engine preheat fuel pump main fuel line (4) as tagged. Take off tags.
3. Do step 2 again for engine preheat fuel pump return line (5).

GO TO FRAME 11

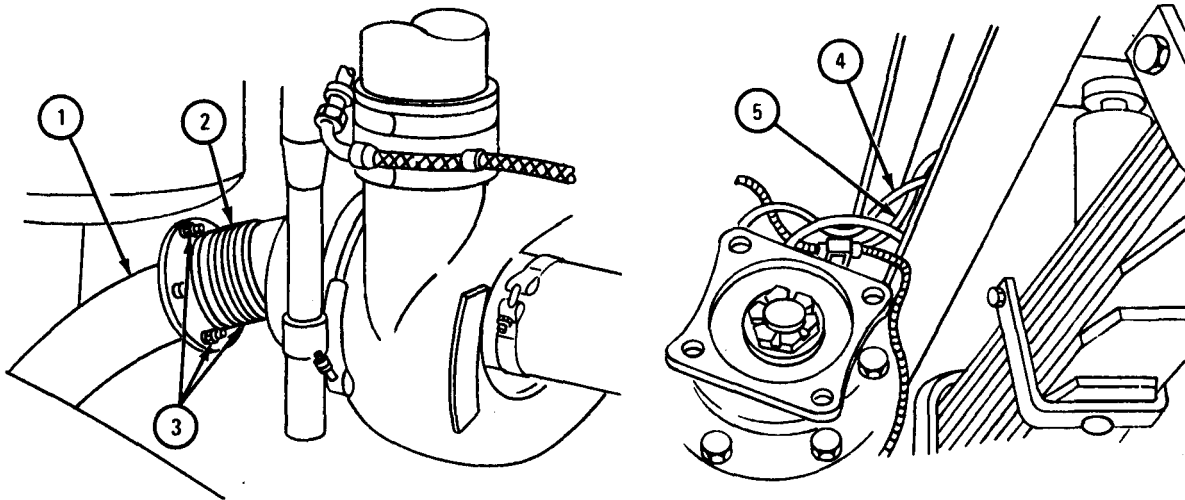

TA 088485

FRAME 10

1. Working under front of truck, put in two bolts (1) and put on nuts (2).
2. Aline throttle cable mounting bracket (3) with rear motor mount (4) and put screw (5) through throttle cable mounting bracket and rear motor mount.
3. Put on nut (6).

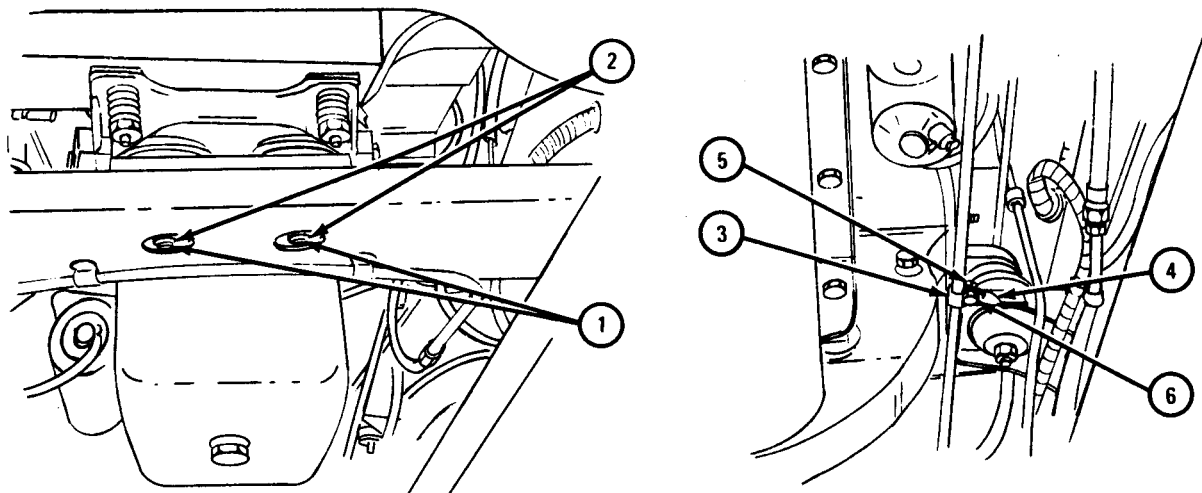
GO TO FRAME 11

TA 088486

FRAME 11

1. Put on fuel return line and fitting (1).
GO TO FRAME 12

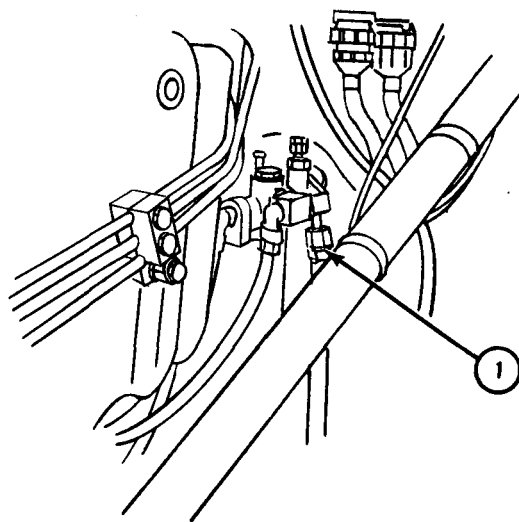

TA 088468

FRAME 12

1. Put on line and fitting (1).
- GO TO FRAME 13

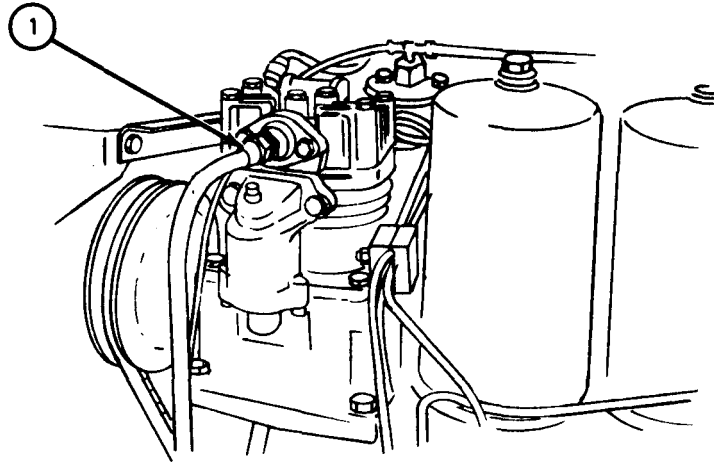

TA 088467

FRAME 13

1. Put flexible shaft assembly (1) in place in clamps (2).
2. Put in three bolts (3) and put on nuts (4).

GO TO FRAME 14

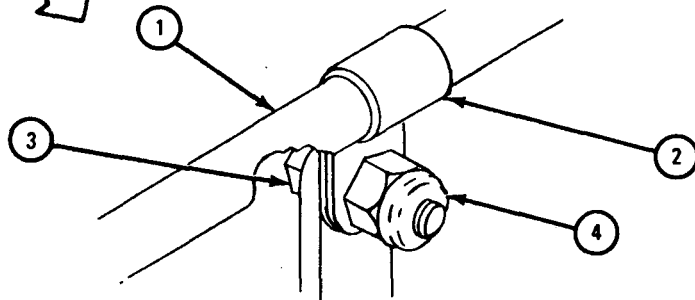
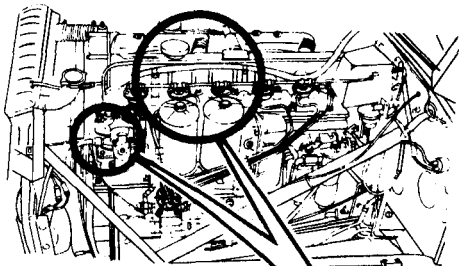

TA 088488

FRAME 14

1. Put gasket (1) in place.
 2. Screw nut (2) on flexible shaft assembly (3) onto right angle adapter (4).
- GO TO FRAME 15

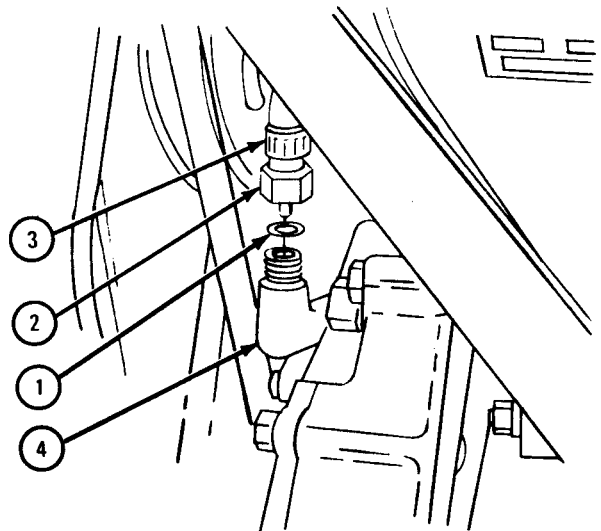
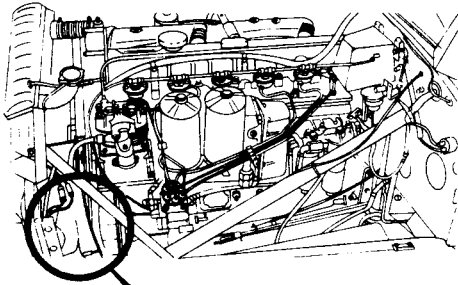

TA 088489

FRAME 15

1. Put fuel shutoff cable (1) in place. Tighten screws (2 and 3).
2. Put accelerator linkage (4) in place. Put in pin (5) and cotter pin (6).
3. Put in spring (7).

GO TO FRAME 16

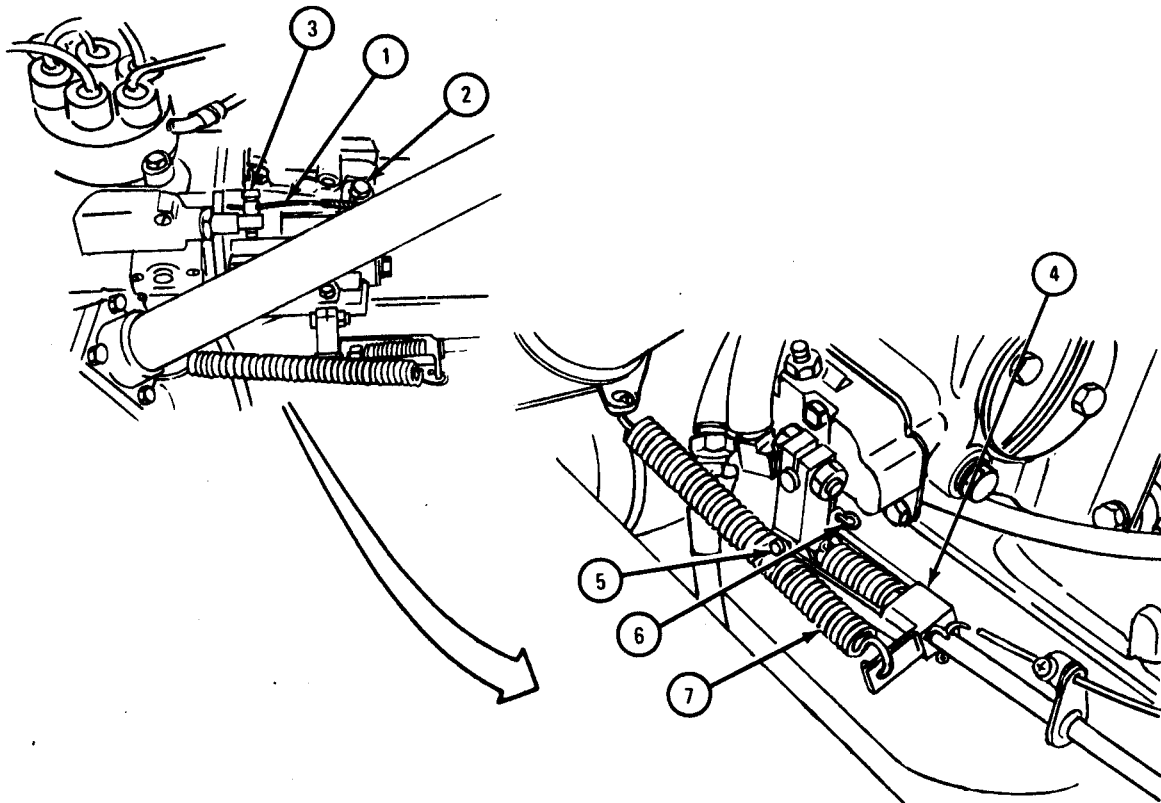

TA 088490

FRAME 16

1. Put ground strap (1) in place. Put in screw and washer (2).
2. Put on regulator-to-generator cable (3).

GO TO FRAME 17

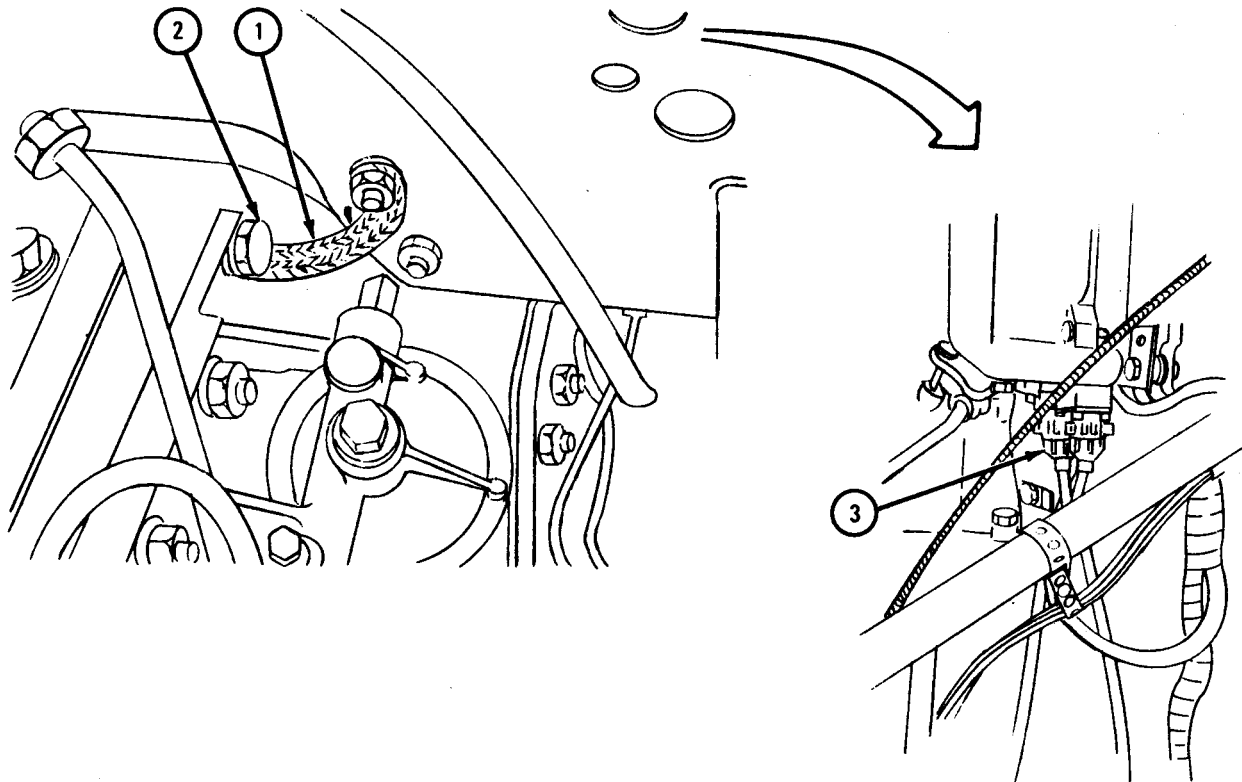

TA 088491

FRAME 17

1. Put wire leads (1 and 2) in place. Put on nut (3).
2. Put gasket (4) in place. Put in three screws (5) and put on nuts (6).
3. Put on cable (7). Put on nut (8).

GO TO FRAME 18

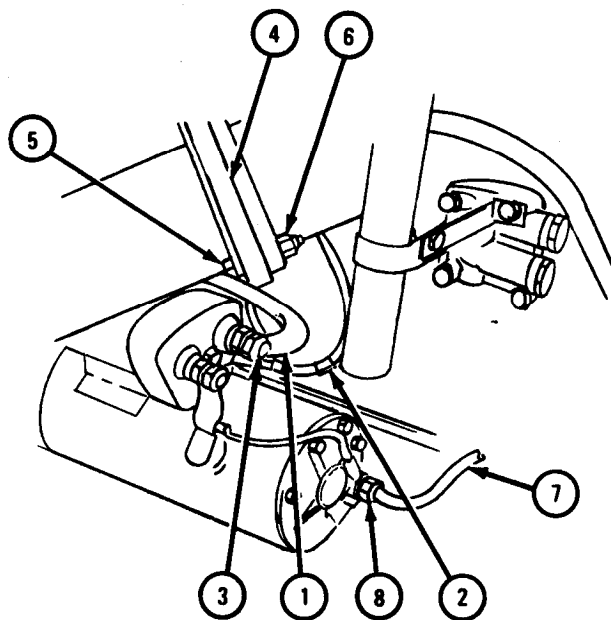

TA 088492

FRAME 18

1. Plug connector (1) into oil pressure transmitter (2).
- GO TO FRAME 19**

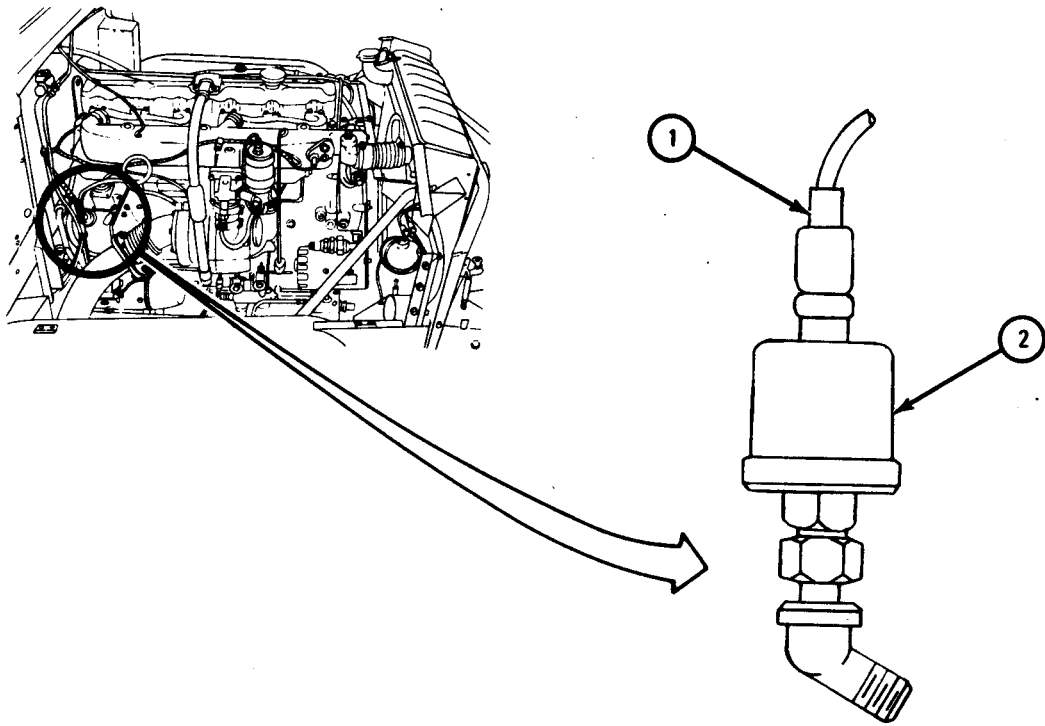

TA 088461

FRAME 19

1. Put on air governor line (1).
2. Put on nut (2) and wire (3).
3. Put on coupling nut (4) and move tube (5) into place.
4. Hold clamp (6) in place and put on nut (7).
5. Plug in electrical leads (8 and 9).

GO TO FRAME 20

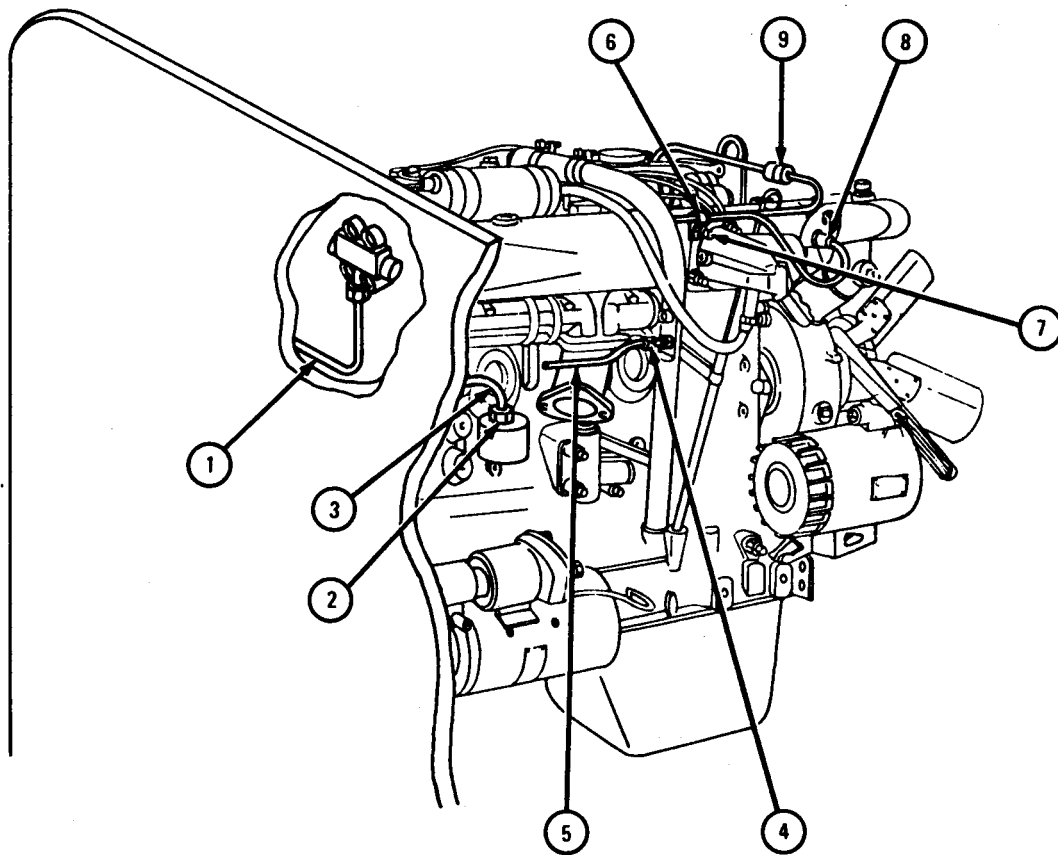

TA 105679

FRAME 20

NOTE

Follow-on Maintenance Action Required:

1. Reconnect battery ground cable. Refer to TM 9-2320-209-20.
2. Replace radiator. Refer to TM 9-2320-209-20.
3. Replace radiator brush guard. Refer to Part 3, para 19-5.
4. Replace front and intermediate cab tunnels. Refer to TM 9-2320-209-20.
5. If working on truck M342A2, replace hoist pump propeller shaft. Refer to Propeller Shaft and Universal Joint Removal and Replacement, TM 9-2320-209-20.
6. If working on truck with front winch, replace front winch propeller shaft. Refer to Propeller Shaft and Universal Joint Removal and Replacement, TM 9-2320-209-20.
7. Replace transmission-to-transfer propeller shaft. Refer to Propeller Shaft and Universal Joint Removal and Replacement, TM 9-2320-209-20.
8. Fill cooling system. Refer to TM 9-2320-209-20.
9. Replace air cleaner. Refer to TM 9-2320-209-20.
10. Close hood and side panels. Refer to TM 9-2320-209-10.

END OF TASK

2-4. ENGINE (LD 465-1, LD 465-1C, AND LDT 465-1C) REPAIR. Refer to TM 9-2815-210-34 for procedures to repair engines LD 465-1, LD 465-1C, and LDT 465-1C.

2-5. ENGINE (LDS 427-2) REPAIR. Refer to TM 9-2815-204-35 for procedures to repair engine.

Section III. CRANKCASE , BLOCK, AND CYLINDER HEAD

2-6. CYLINDER HEAD REMOVAL, REPAIR, AND REPLACEMENT (TRUCKS WITH ENGINES LD 465-1, LD 465-1C , AND LDT 465-1C) .

TOOLS : Box wrench, pn 10951485

SUPPLIES :

- Thermostat housing gasket
- Front cylinder head cover gasket
- Rear cylinder head cover gasket
- Intake manifold elbow gasket
- Front intake manifold gasket
- Rear intake manifold gasket
- Water outlet manifold gasket (6)
- Front cylinder head gasket
- Rear cylinder head gasket
- Front cylinder head fire rings (3)
- Rear cylinder head fire rings (3)
- Gasket sealant MIL-S-7916B
- Lubricating oil, ICE, OE /HDO 30, MIL-L-2104
- Tags
- Breather tube adapter flat copper washer (4)
- Turbocharger-to-exhaust manifold gasket
- Plugs

PERSONNEL : Two

EQUIPMENT CONDITION : Truck parked, engine off, handbrake set.

a. Preliminary Procedures.

- (1) Open hood and side panels. Refer to TM 9-2320-209-10.
- (2) Drain cooling system. Refer to TM 9-2320-209-20.
- (3) Remove air cleaner assembly. Refer to TM 9-2320-209-20.
- (4) Disconnect battery ground cable. Refer to TM 9-2320-209-20.

b. Removal.**FRAME 1**

1. Take off two locknuts (1) and bolts (2).
 2. Take two clamps (3) off brackets (4).
 3. Move tachometer flexible shaft assembly (5) out of the way.
- GO TO FRAME 2

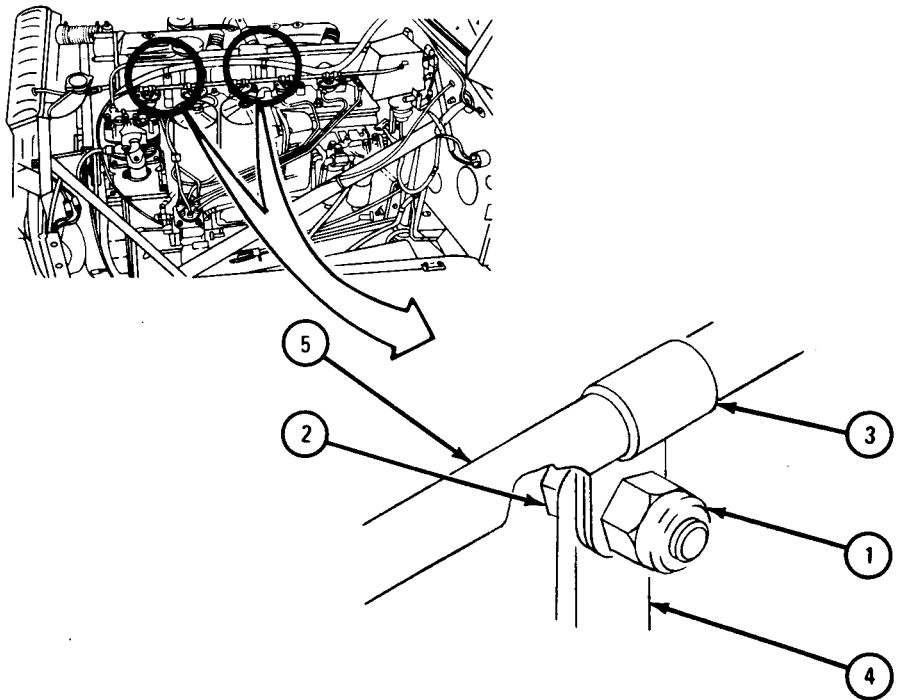

TA 101895

FRAME 2

1. Take out four screws and locknuts (1). Take off four tube clamps (2).
2. Take out two screws, four flat washers, and two locknuts (3). Take off outer half of tube clamp (4).
3. Take off nut, lockwasher, and flat washer (5). Take off inner half of tube clamp (4).
4. Take out two screws, flat washers, and locknuts (6). Take off tube clamp (7).
5. Take out two screws and locknuts (8).

GO TO FRAME 3

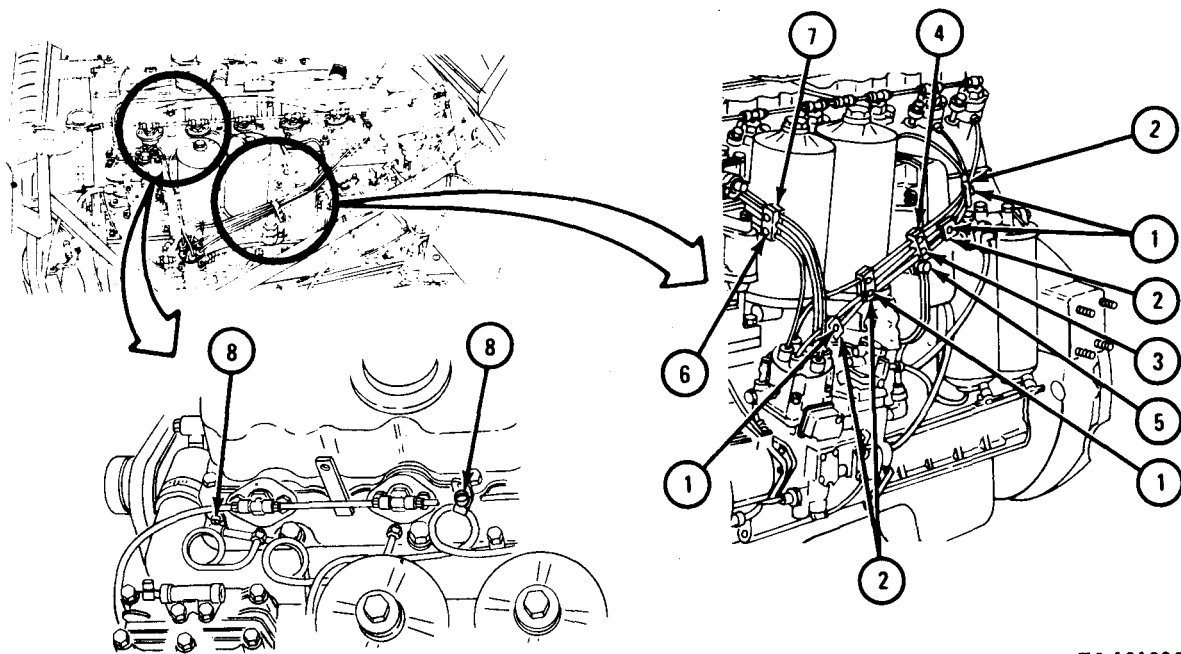

TA 101896

FRAME 3

NOTE

Tag six fuel injector tubes (1) so they can be put back in the same place.

1. Slide six dust caps (2) up fuel injector tubes (1).
2. Unscrew six tube nuts (3) and six tube nuts (4). Carefully take out six fuel injector tubes (1), one at a time from front to rear.
3. Plug six holes in fuel injection pump head (5) and holes in six fuel injector nozzles (6).

GO TO FRAME 4

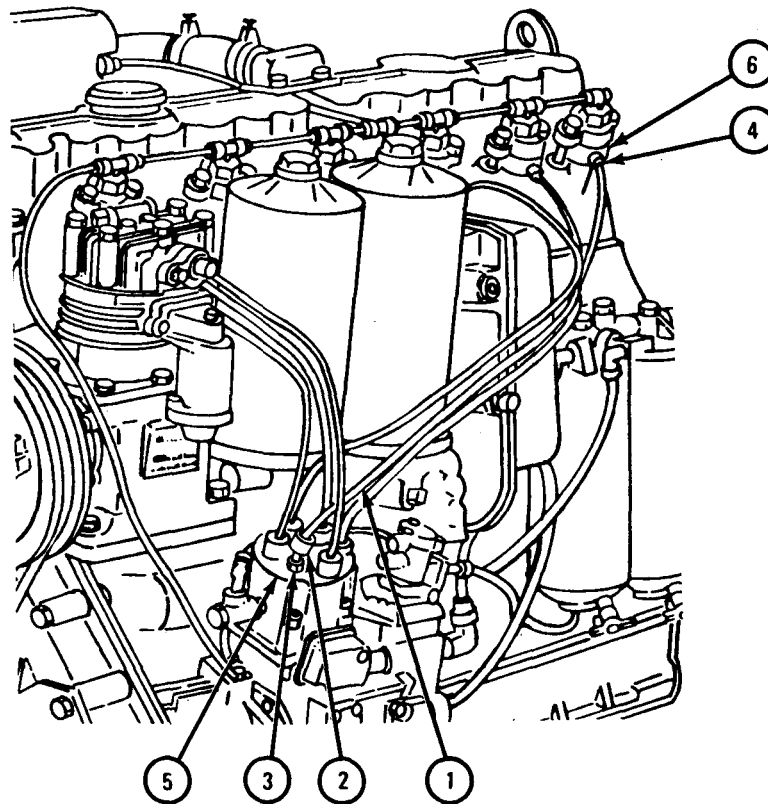

TA 101897

FRAME 4

1. Loosen two screws (1) on two clamps (2).
 2. Unscrew nut (3) from screw (4) and take nut off. Pull screw out of rod end clevis (5).
 3. Pull radiator (6) forward at top just enough to take off preformed hose (7).
- GO TO FRAME 5**

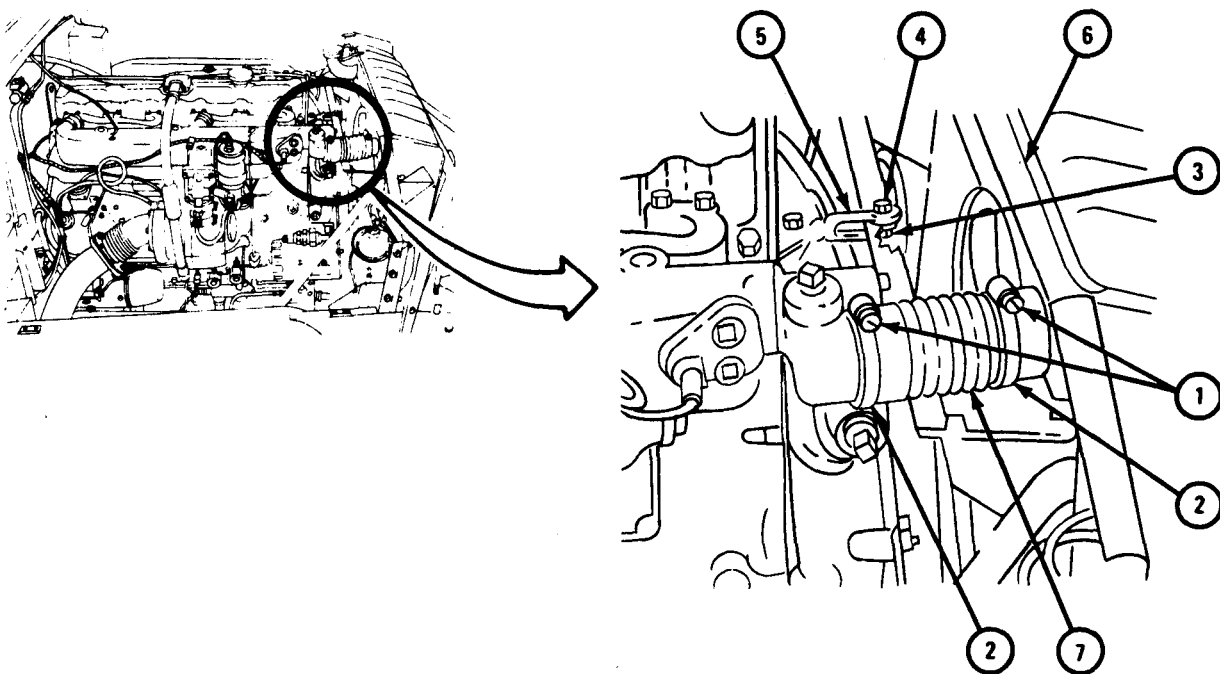

TA 101898

FRAME 5

1. Take two screws (1) with two flat washers (2) out of thermostat housing (3).
2. Loosen screw (4) on clamp (5).
3. Pull thermostat housing (3) away from intake manifold (6) and from hose (7). Pull gasket (8) away from intake manifold (6) and throw gasket away.
4. Take out thermostat housing (3).

GO TO FRAME 6

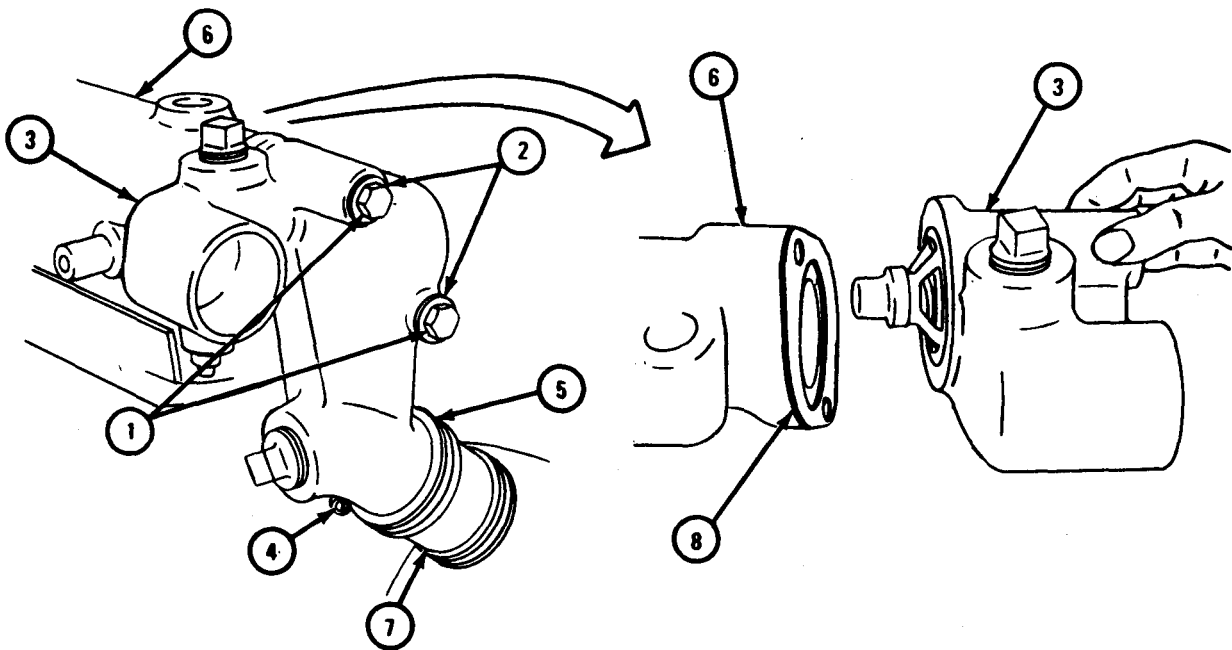

TA 101899

FRAME 6

1. Hold adapter fitting (1) and loosen tube nut (2). Unscrew adapter fitting (1) and move line out of way.

NOTE

If working on system without turbocharger, do steps 2, 4, and 5. If working on system with turbocharger, do steps 3, 4, and 5.

2. Take out capscrew (3) and nut (4). Spread open and take off clamp (5).
3. Take out capscrew and lockwasher (6).
4. Take off four self-locking nuts (7) and flat copper washers (8). Throw away washers.
5. Take off breather tube adapter (9) with breather tube (10).

IF WORKING ON ENGINE LDT 465-1C, GO TO FRAME 7.

IF WORKING ON ENGINES LD 465-1 OR LD 465-1C, GO TO FRAME 11

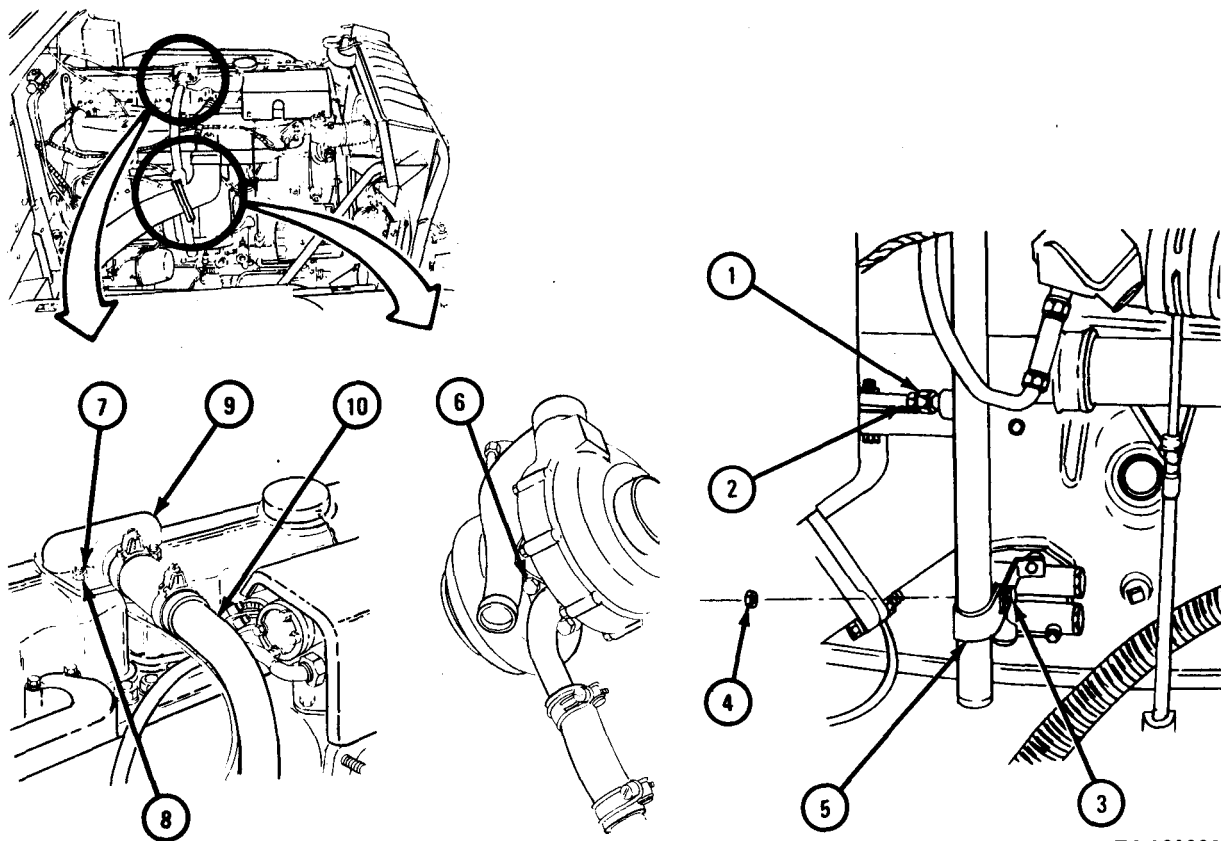

TA 101902

FRAME 7

1. Take off two coupling nuts (1 and 2).
2. Take off ignition unit lead (3).
3. Loosen two nuts (4) and slide hose (5) up on manifold elbow (6).
4. Take off four nuts (7) and lockwashers (8).
5. Take off manifold elbow (6) and gasket (9). Throw away gasket.

GO TO FRAME 8

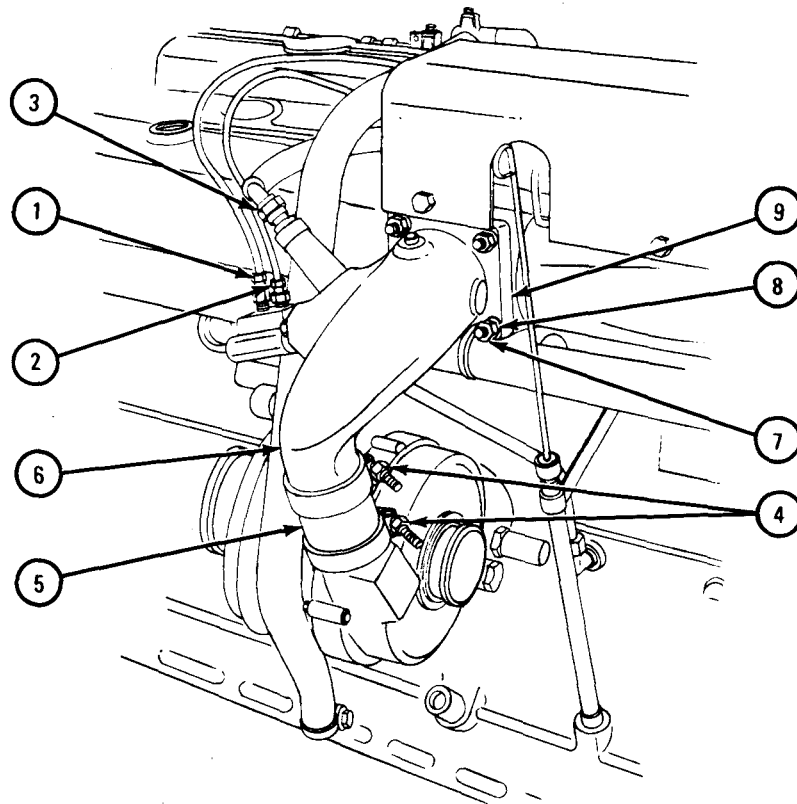

TA 101900

FRAME 8

1. Take out two capscrews and lockwashers (1).
 2. Loosen screw (2).
 3. Take out oil drain tube (3) and gasket (4). Throw away gasket.
- GO TO FRAME 9

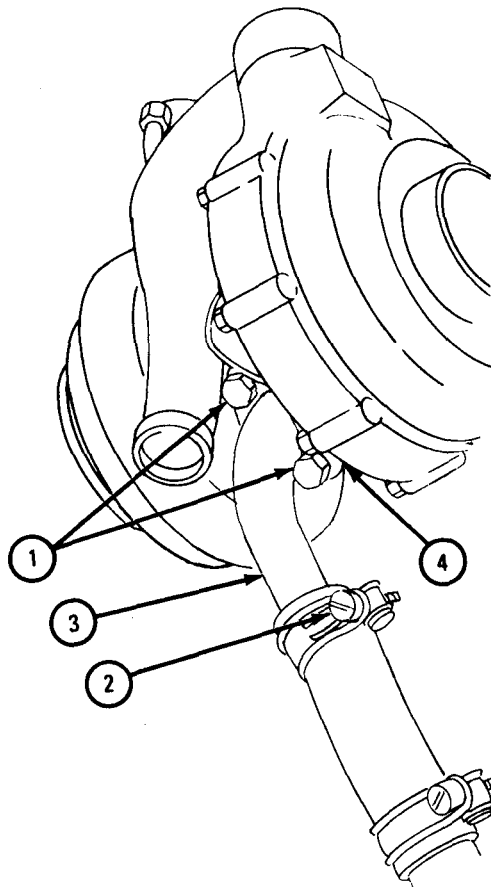

TA 101901

FRAME 9

1. Take off two coupling nuts (1). Take off oil inlet tube (2).
2. Take out two capscrews (3) and four self-locking nuts (4).
3. Take off turbocharger (5) and gasket (6). Throw away gasket.

GO TO FRAME 10

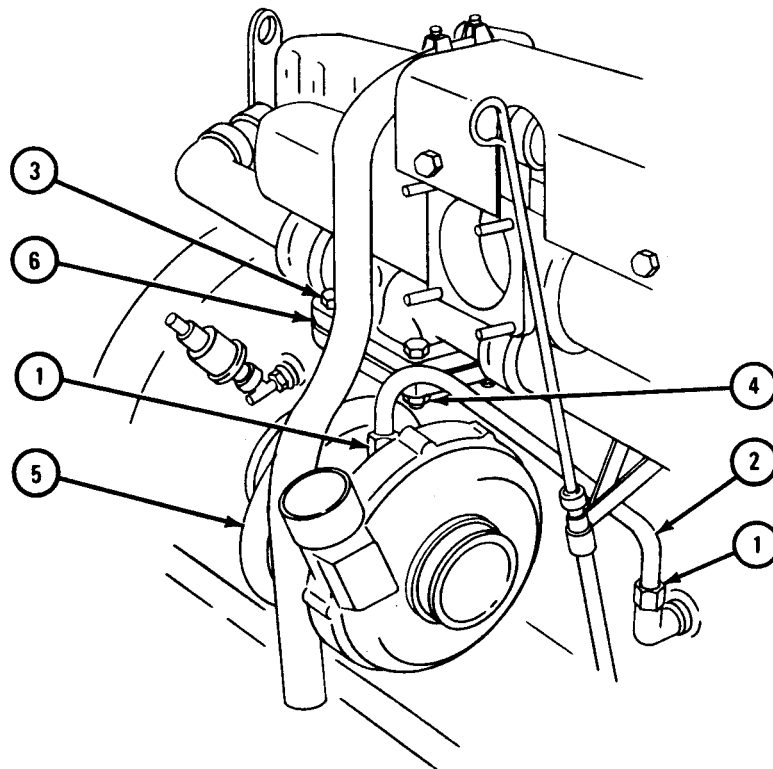

TA 101903

FRAME 10

1. Loosen two hose clamps (1).
2. Take off air induction hose assembly (2).

GO TO FRAME 11

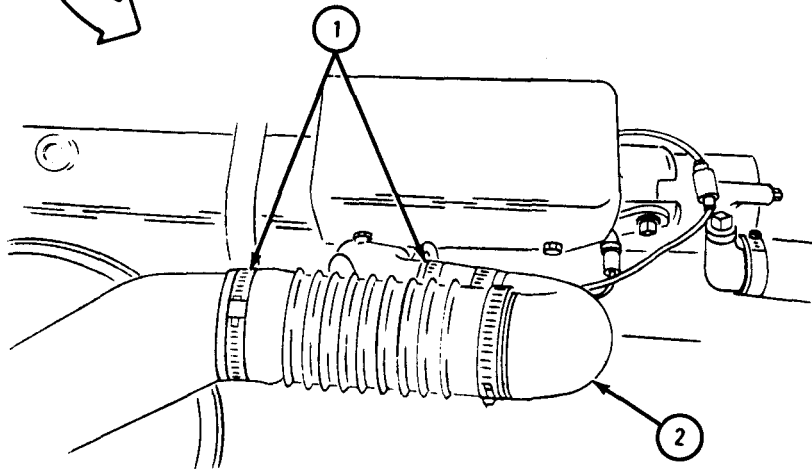
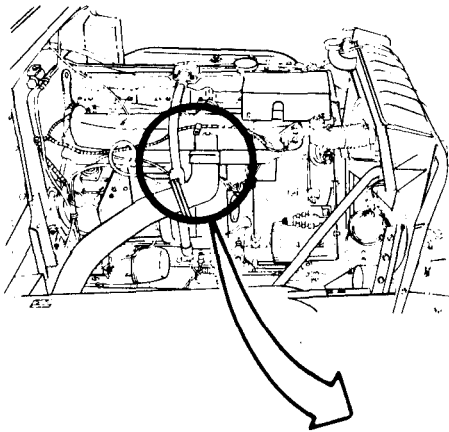

TA 101905

FRAME 11

1. Unscrew nut (1) and take off ignition cable and conduit assembly (2).
2. Hold adapter (3) and take off inverted nut and tube (4).
3. Hold adapter (5) and take off inverted nut and tube (6).

IF WORKING ON ENGINE WITH TOP-MOUNTED, COVERED MANIFOLD HEATER
IGNITION UNIT, GO TO FRAME 12.

IF WORKING ON ENGINE WITH TOP-MOUNTED, UNCOVERED MANIFOLD HEATER
IGNITION UNIT, GO TO FRAME 15

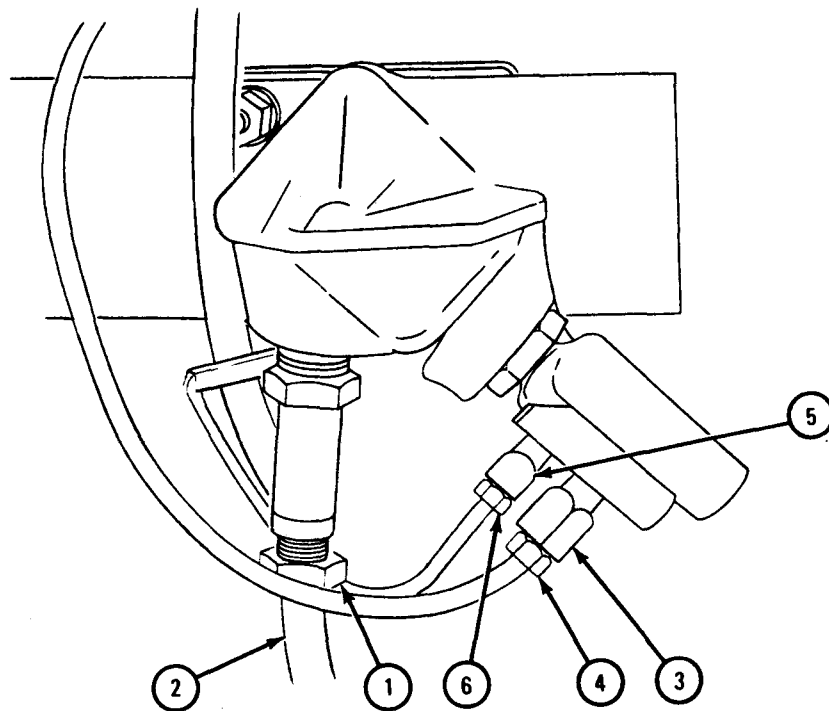

TA 101906

FRAME 12

1. Take out four capscrews (1).

2. Take off cover (2).

GO TO FRAME 13

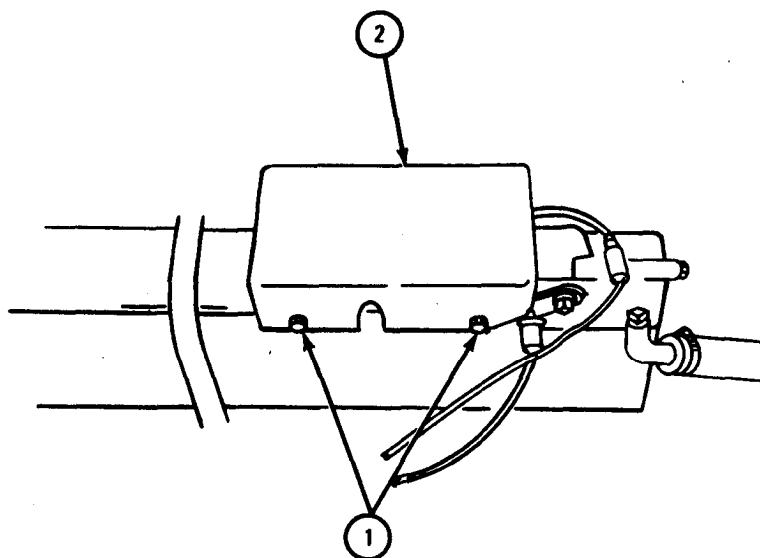

TA 101908

FRAME 13

1. Take off electrical cable connector (1).
2. Take off electrical cable connector (2).
3. Take off electrical cable connector (3) from fuel pump (4).
4. Take off tube fitting (5).
5. Take off tube fitting (6).
6. Take off four clamps (7).
7. Take off ignition unit (8) and fuel pump (4).

GO TO FRAME 14

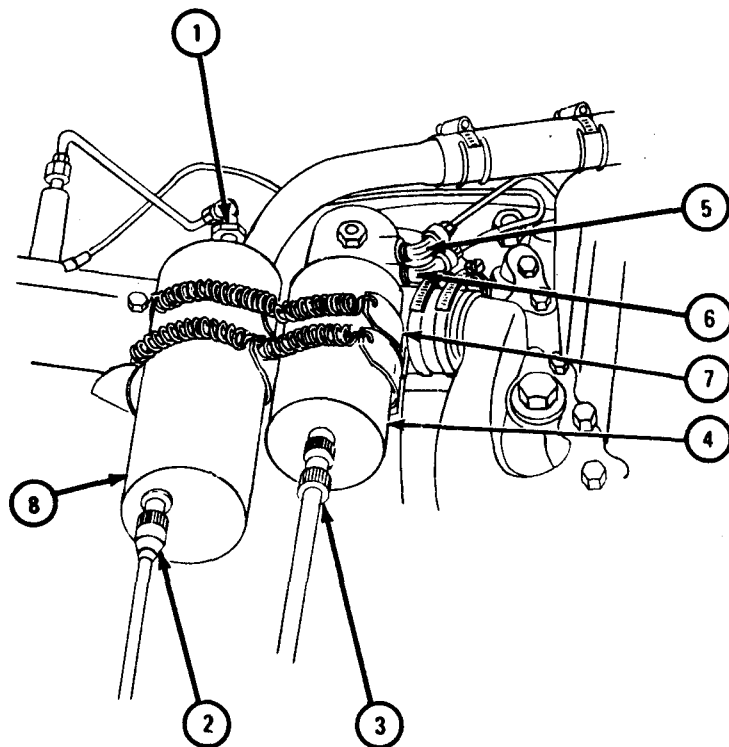

TA 101909

FRAME 14

1. Take out three machine screws (1) and lockwashers (2).
2. Take off ignition unit support (3).

GO TO FRAME 15

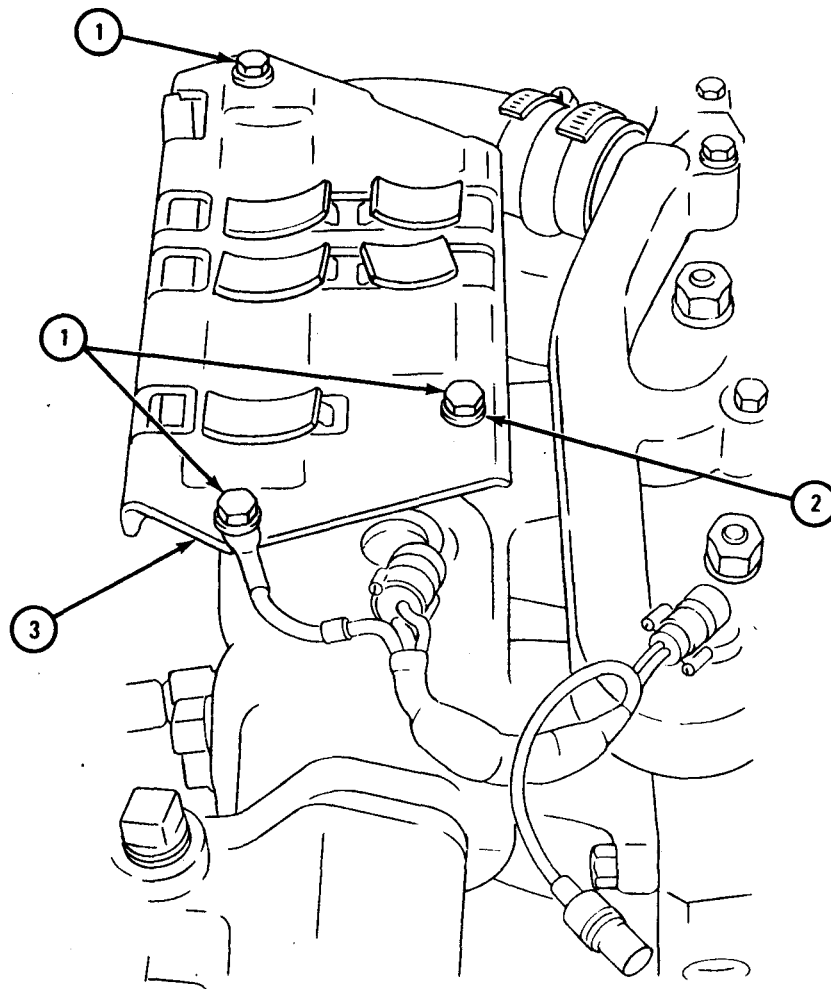

TA 101910

FRAME 15

1. Take off four nuts and lockwashers (1).
2. Pull intake manifold heater elbow (2) off intake manifold (3).
3. Take off intake manifold heater elbow gasket (4). Throw away gasket.

IF WORKING ON ENGINE WITH TOP-MOUNTED, UNCOVERED MANIFOLD HEATER IGNITION UNIT, GO TO FRAME 16.

IF WORKING ON ENGINE WITH TOP-MOUNTED, COVERED MANIFOLD HEATER IGNITION UNIT, GO TO FRAME 18

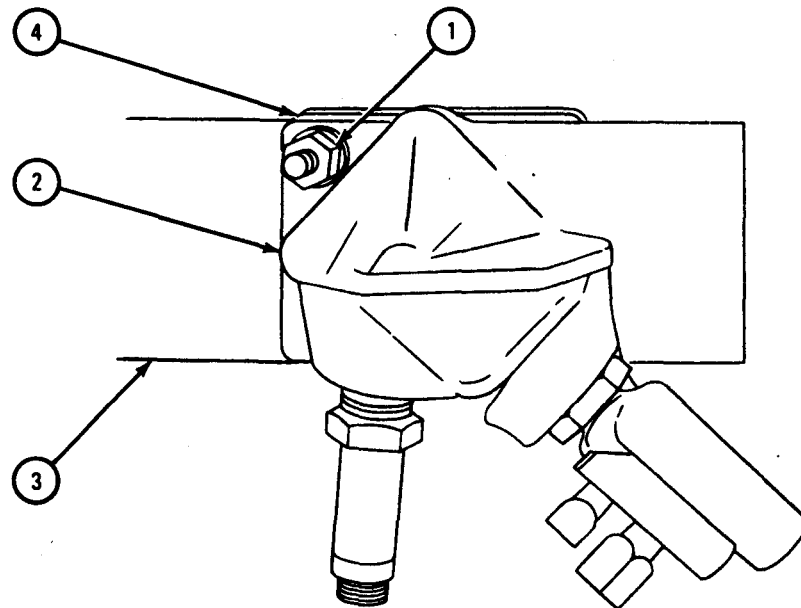

TA 101907

FRAME 16

1. Take off electrical cable connector (1) from ignition unit (2).
2. Take off electrical cable connector (3) from ignition unit (2).
3. Take out two screws with washers (4).
4. Slide off two clamps (5) from ignition unit (2).
5. Take out ignition unit (2).

GO TO FRAME 17

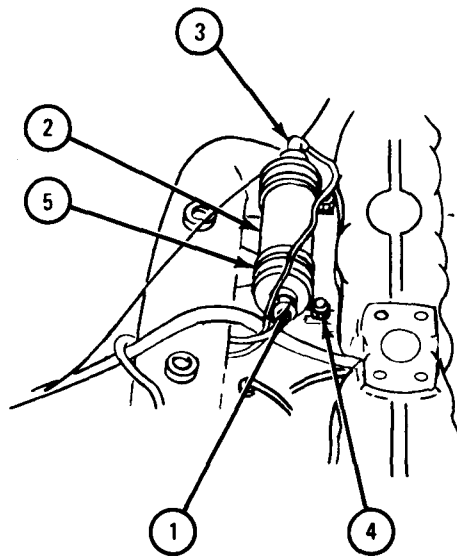

TA 101911

FRAME 17

1. Take off electrical connector (1).
2. Take off tube adapter (2) with tube (3).
3. Take off tube adapter (4) with tube (5).
4. Take out two screws with washers (6).
5. Take out fuel pump (7) and filter (8).

GO TO FRAME 18

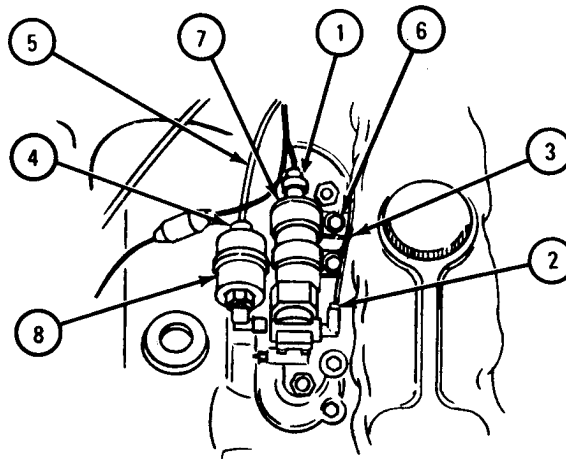

TA 101912

FRAME 18

1. Take out lockbolt (1) and take off tachometer cable bracket (2).
2. Take out two lockbolts (3) and take off two tube clamps (4).
3. Take out two capscrews (5) and lockwashers (6). Take off front engine lifting bracket (7) and radiator support rod (8).

GO TO FRAME 19

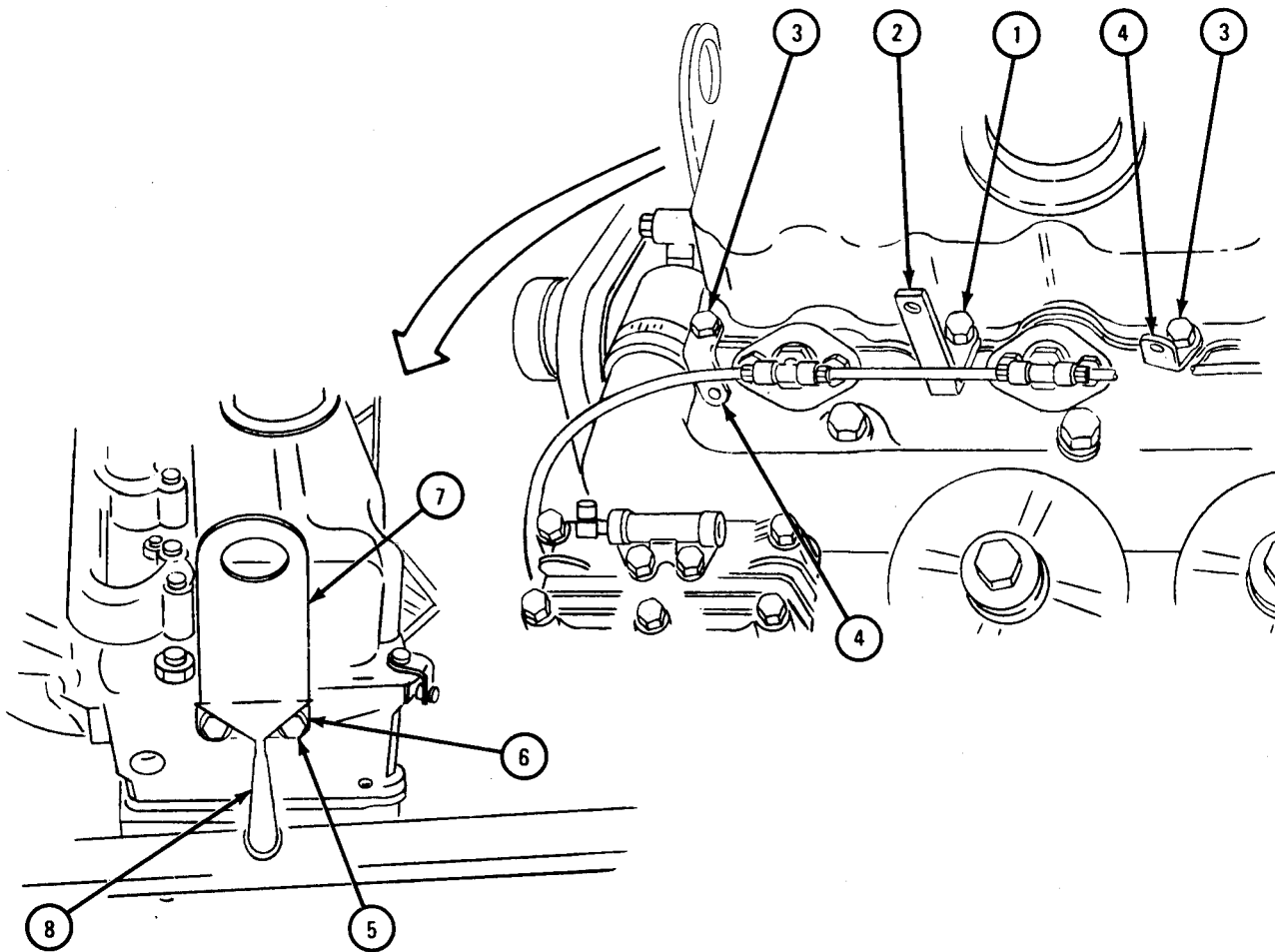

TA 101913

FRAME 19

1. Take off oil filler cap chain (1) at washer (2). Take out oil filler cap (3).
 2. Take off locknut and flat washer (4).
 3. Take out four lockbolts and washers (5).
 4. Take off front cylinder head cover (6) and gasket (7). Throw away gasket.
- GO TO FRAME 20

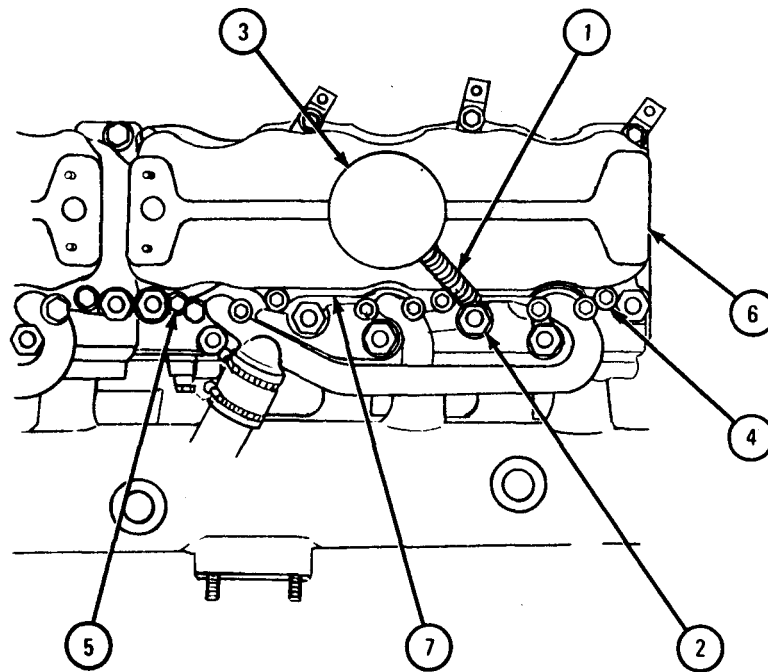

TA 101914

FRAME 20

1. Take off locknut and washer (1).
2. Take out lockbolt and washer (2). Take off tachometer cable mounting bracket (3).
3. Take out six lockbolts and washers (4). Take off rear cylinder head cover (5).
4. Take off and throw away cylinder head cover gasket (6).
5. Take out two capscrews (7) and lockwashers (8). Take off rear engine lifting bracket (9).

GO TO FRAME 21

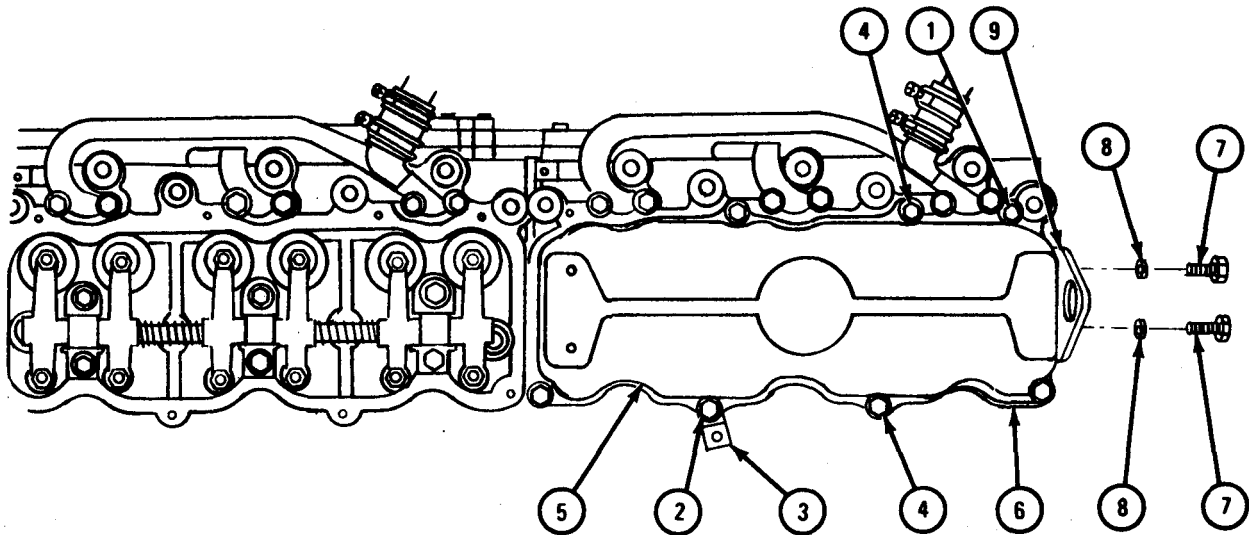

TA 101915

FRAME 21

1. Take off four nuts (1).
2. Take out two screws (2).
3. Pull exhaust elbow assembly (3) down and take out gasket (4) and throw gasket away.

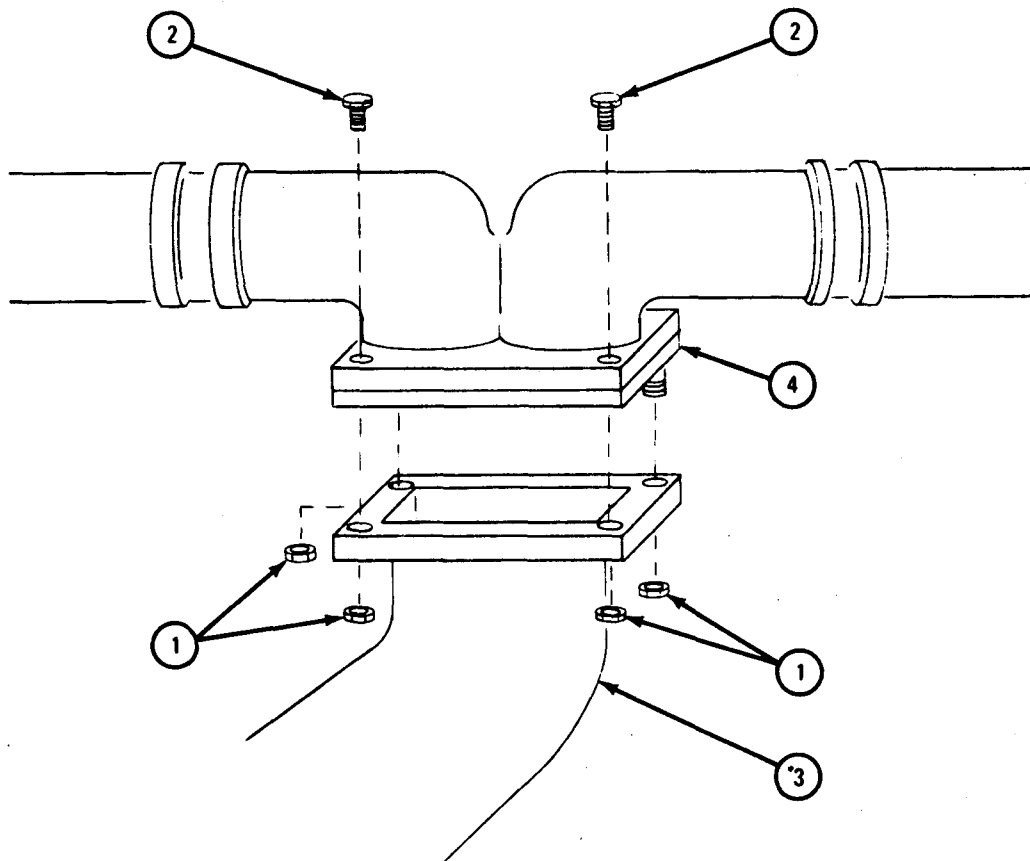
GO TO FRAME 22

TA 118450

FRAME 22

1. Take out oil gage rod (1).
 2. Take off six nuts (2) and flat washers (3).
 3. Take off oil gage rod support bracket (4).
 4. Take off six self-locking nuts (5) and flat washers (6).
- GO TO FRAME 23

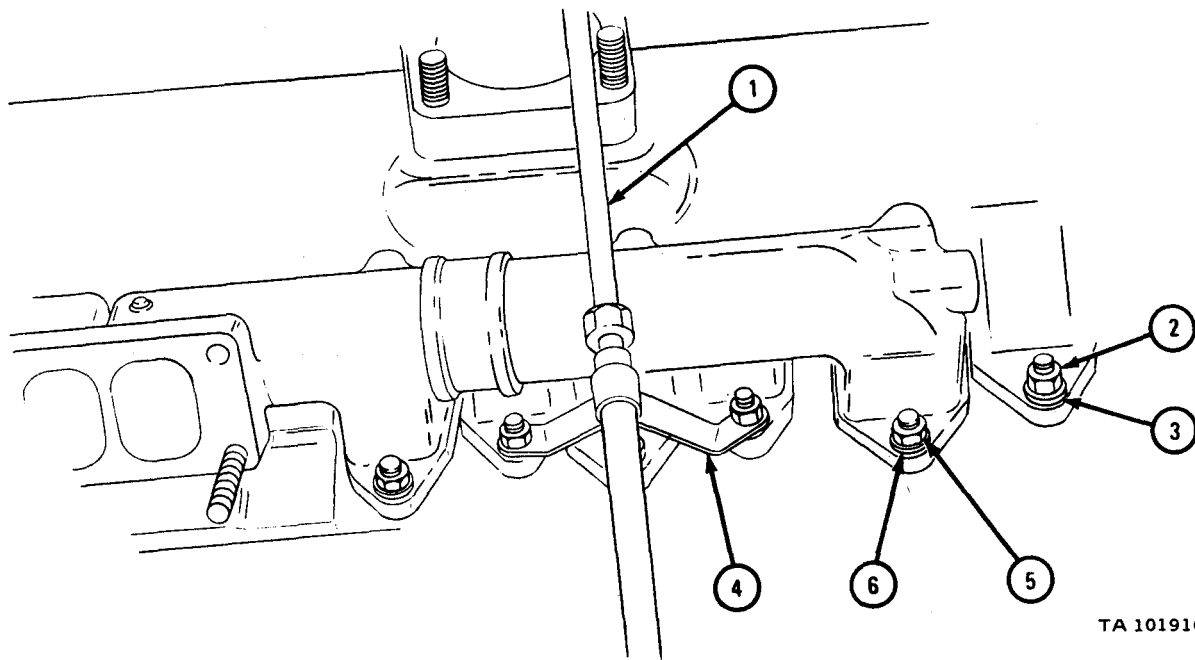

TA 101916

FRAME 23

NOTE

If engine has top-mounted, uncovered manifold heater ignition unit, four of 12 machine bolts (1) were taken out with ignition unit.

1. Take out 12 machine bolts (1).
2. Loosen two screws (2) on hose clamps (3).
3. Take off water outlet manifolds (4) and six gaskets (5). Throw gaskets away.
4. Take off six self-locking nuts and flat washers (6).
5. Take off 12 nuts and flat washers (7).
6. Take off intake and exhaust manifolds (8) together. Take off manifold gasket (9) and throw it away.

GO TO FRAME 24

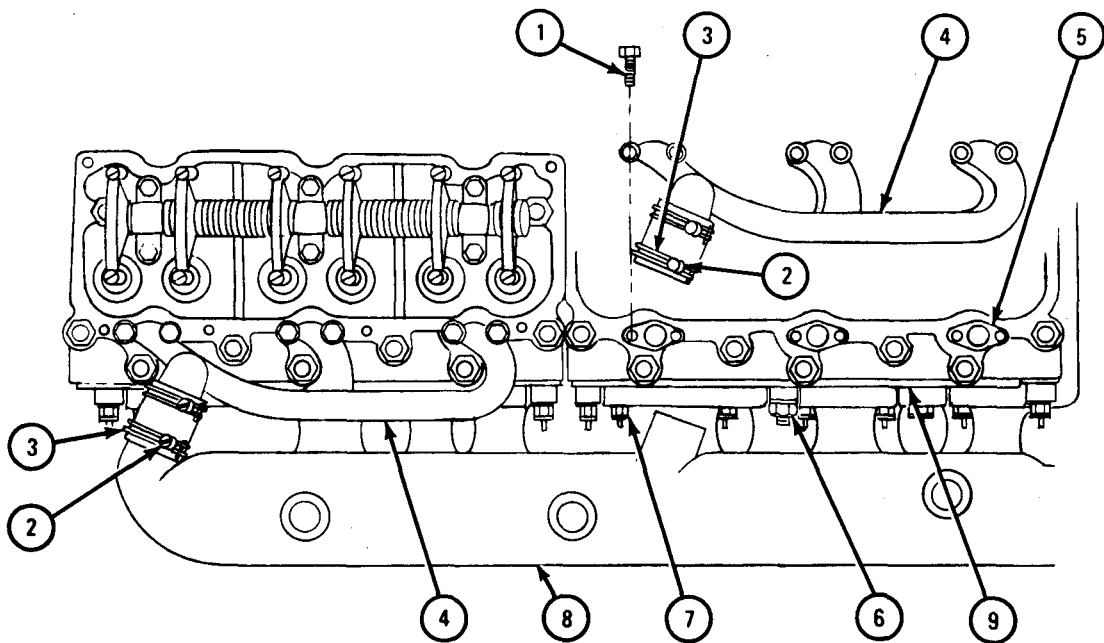

TA 101917

FRAME 24

1. Remove three fuel injectors (1). Refer to TM 9-2815-210-34.
2. Loosen six adjusting screw locknuts (2) and six adjusting screws (3).
3. Take out six capscrews (4) and lockwashers (5).
4. Take off front rocker arm assembly (6).
5. Do steps 1 through 4 again for rear rocker arm assembly (7).

GO TO FRAME 25

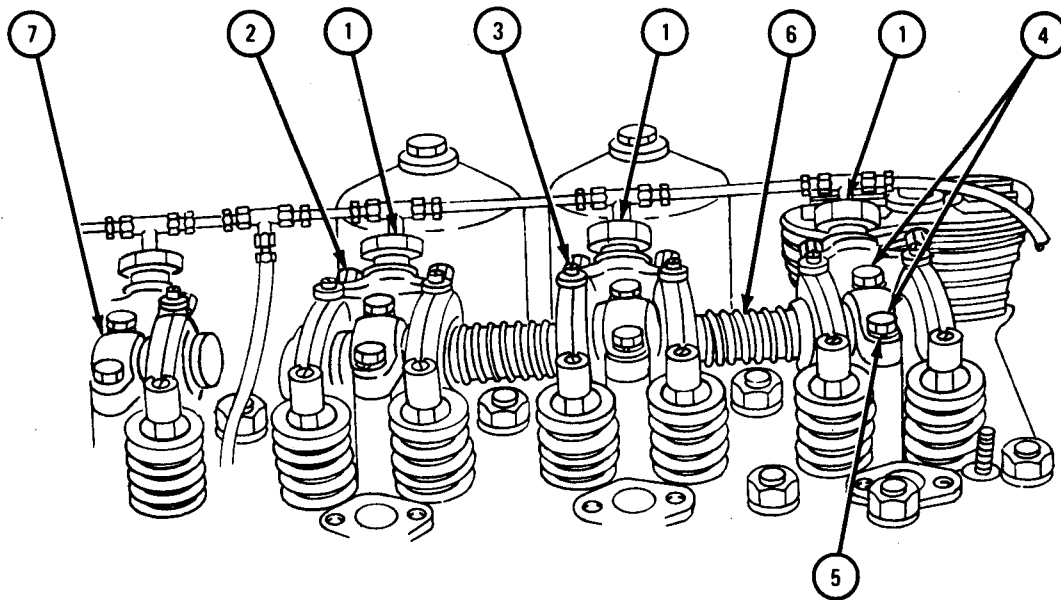

TA 101918

FRAME 25

1. Tag and take out six rocker arm pushrods (1).
2. Take out 11 nuts (2) and flat washers (3).

NOTE

Early model engines have sleeve spacer instead of flat washers (5).

3. Take off three nuts (4) and flat washers (5).
 4. Lift front cylinder head assembly (6) straight up and out.
- Soldiers
A and B
5. Do steps 1 through 4 again to take out rear cylinder head assembly (7).

GO TO FRAME 26

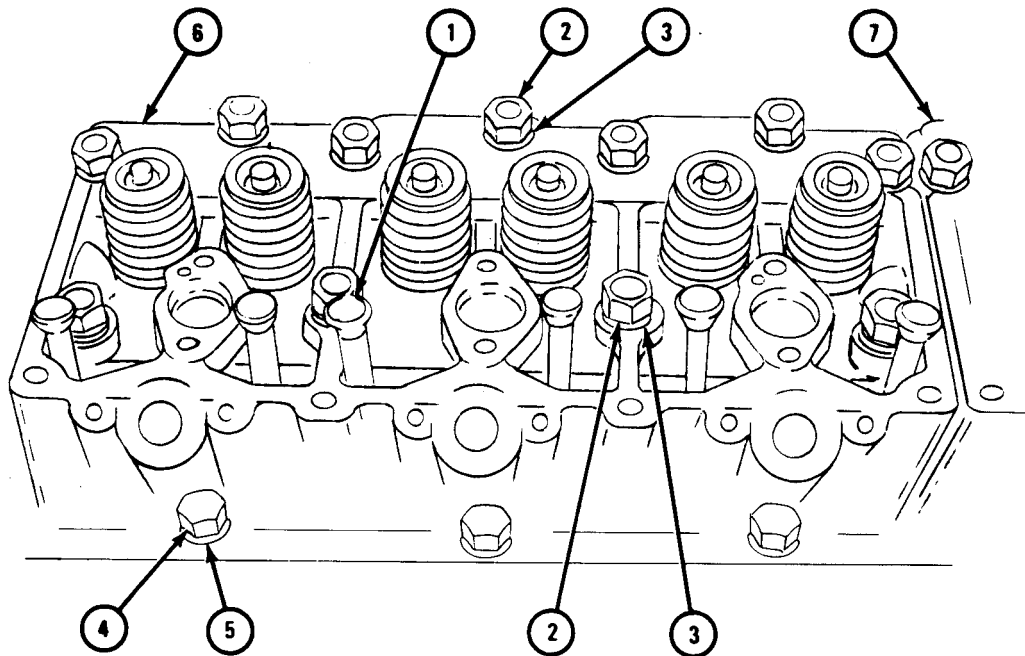

TA 101919

FRAME 26

1. Take off and throw away front cylinder head gasket (1).
2. Take out and throw away three fire rings (2).
3. Do steps 1 and 2 again for rear cylinder head (3).

END OF TASK

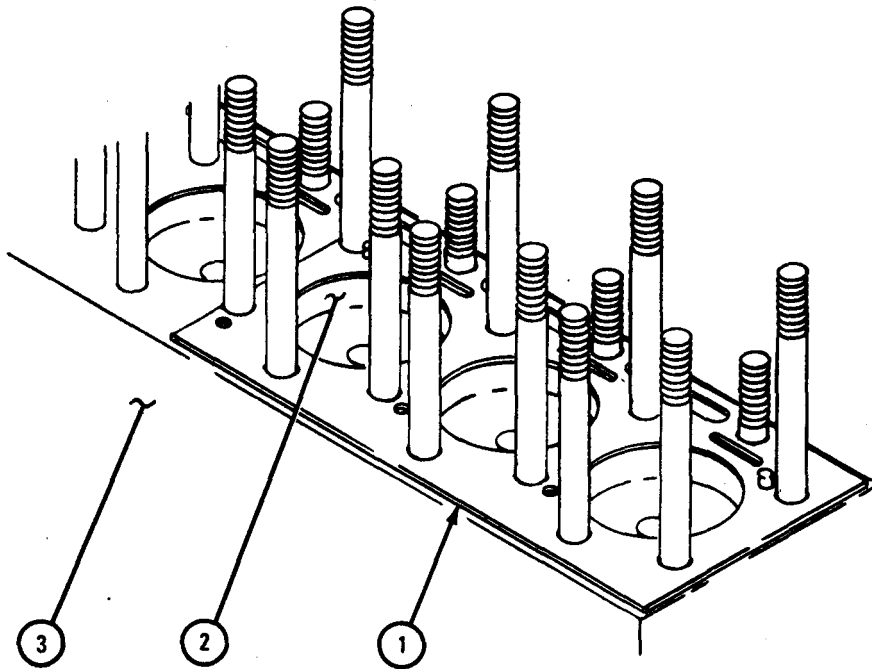

TA 101920

c. Cleaning, Inspection, and Repair. For cleaning, inspection, and repair of cylinder heads on engines LD-465-1, LD-465-1C, and LDT-465-1C, refer to TM 9-2815-210-34.

d. Replacement.

FRAME 1

1. Put on front cylinder head gasket (1).
2. Put in three fire rings (2).
3. Do steps 1 through 3 again for rear cylinder head (3).

GO TO FRAME 2

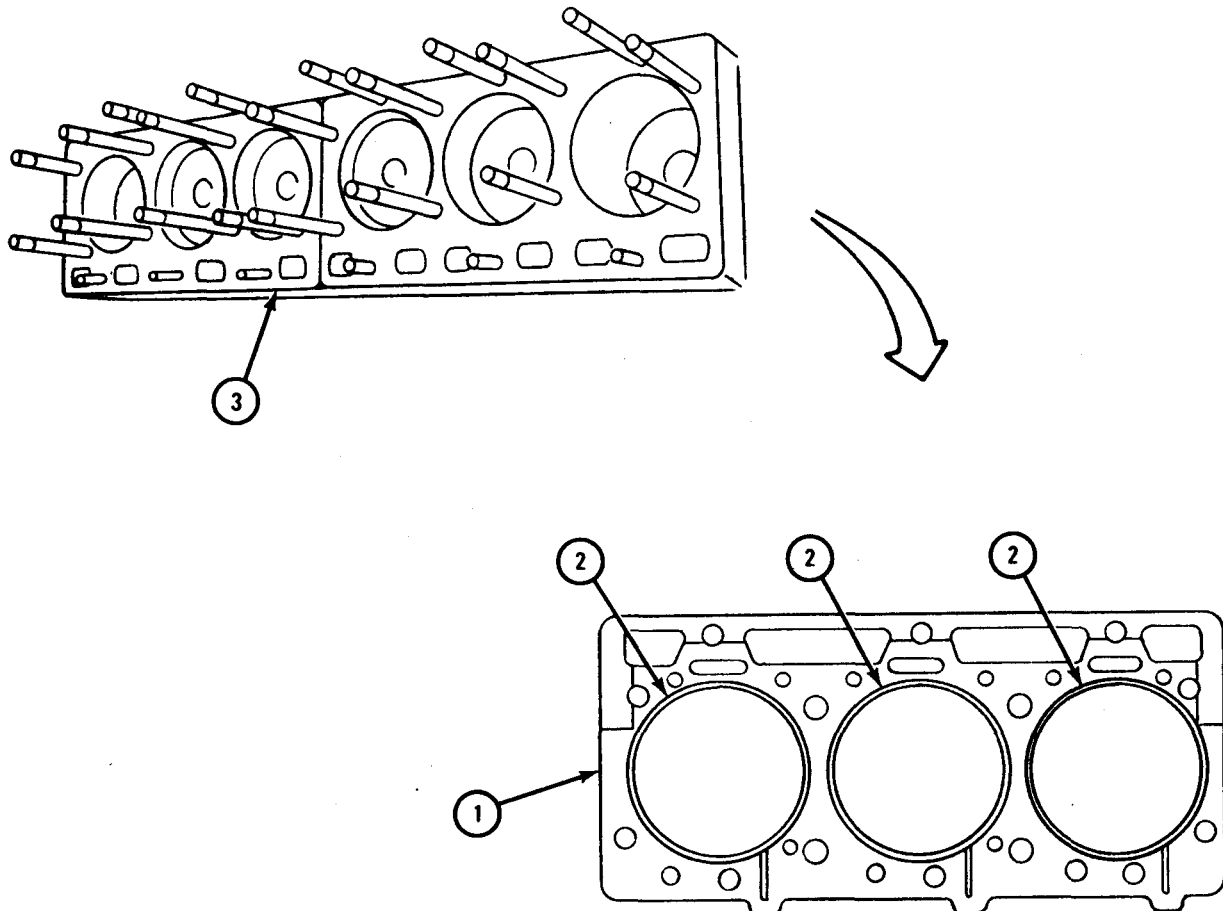

TA 101921

FRAME 2

1. Coat all front cylinder head stud threads, nut threads, and flat washers with engine oil.
2. Put front cylinder head (1) into place.

NOTE

Early model engines have sleeve spacers instead of flat washers (2). If sleeve spacers were taken off, put on sleeve spacers instead of flat washers (3).

3. Put on three nuts (2) and flat washers (3).
4. Put on 11 nuts (4) and flat washers (5).
5. Do steps 1 through 4 again for rear cylinder head (6).

GO TO FRAME 3

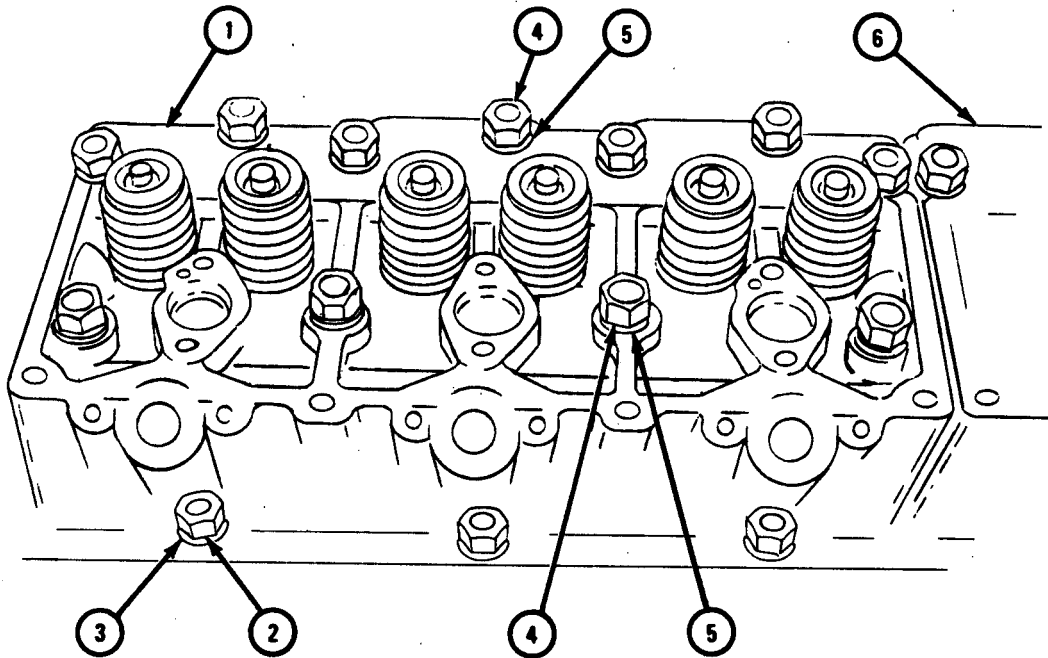

TA 101922

FRAME 3

1. Find the engine data plate (1) on right front of engine block (2).
2. Look to right of engine data plate (1) and note if letters TD are cast on engine block (2).

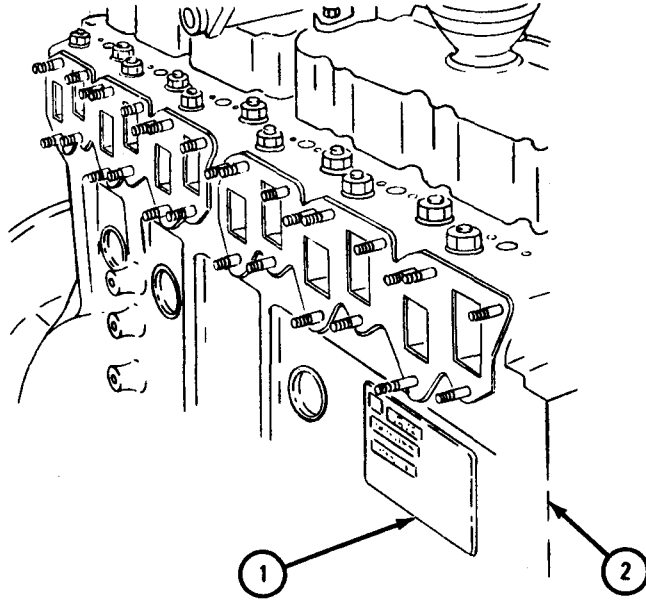
GO TO FRAME 4

TA 101923

FRAME 4

1. Tighten nuts 1 through 14 to 40 pound-feet in order shown.
2. Tighten nuts 1 through 14 to 80 pound-feet in order shown.
3. Tighten nuts 1 through 14 to 110 pound-feet in order shown.
4. Tighten nuts 1 through 14 to 130 pound-feet in order shown.
5. If letters TD are cast on engine block as noted in frame 3, tighten nuts 1 through 14 to 157 pound-feet in order shown.

GO TO FRAME 5

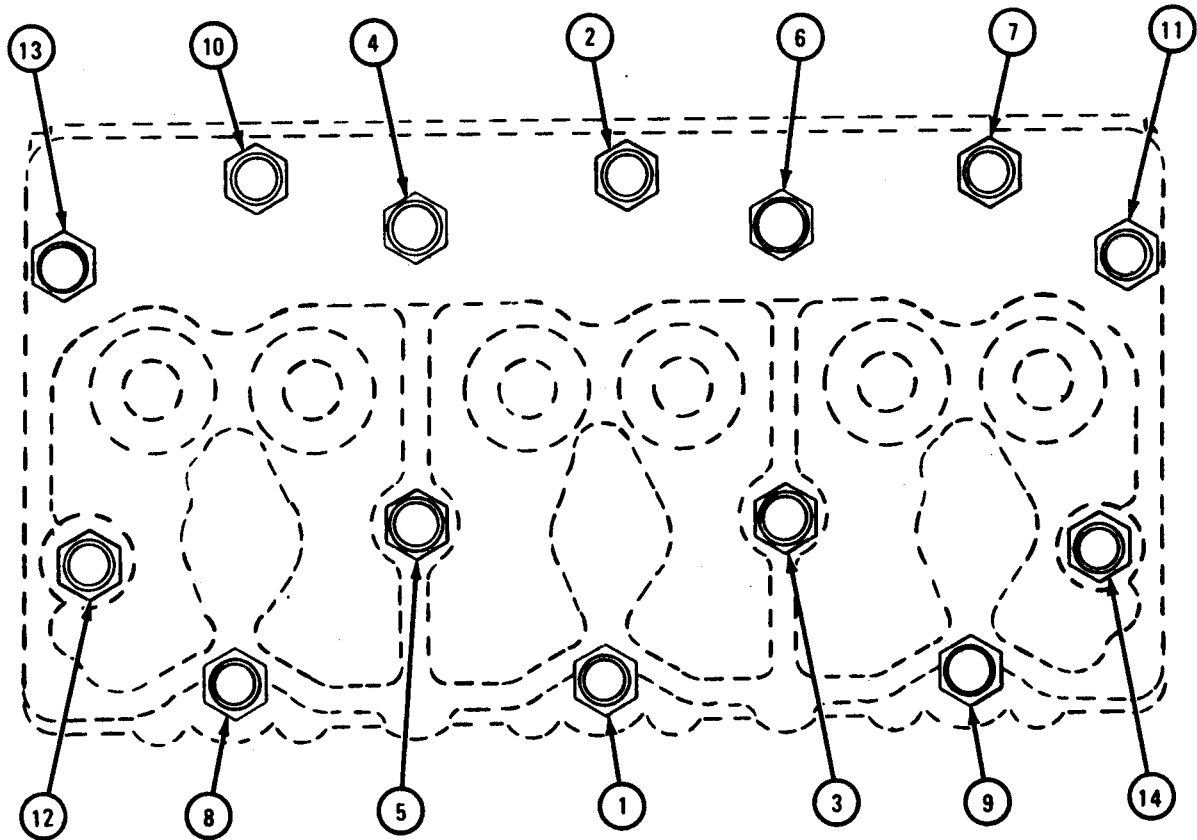

TA 101924

FRAME 5

1. Put in six front rocker arm assembly push rods (1).
2. Put front rocker arm assembly (2) into place and align screw holes.
3. Put in and hand tighten six capscrews (3) and lockwashers (4).
4. Tighten six capscrews (3) to 28 pound-feet.
5. Do steps 1 through 4 again for rear rocker arm assembly (5).

GO TO FRAME 6

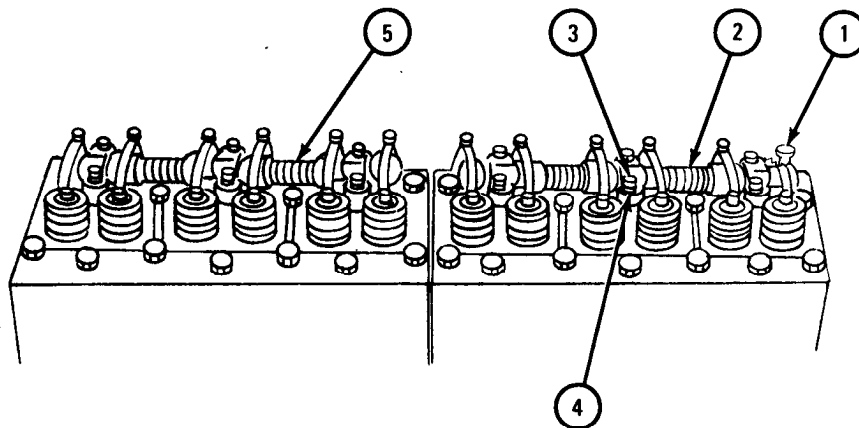

TA 101925

FRAME 6

1. Put transfer shift lever (1) in neutral position. Refer to Driver's Compartment Controls and Indicators, TM 9-2320-209-10.
2. Put transmission gear shift lever (2) in 4th gear.
3. Pull out ENG STOP control (3) and turn to lock position. Refer to Driver's Compartment Controls and Indicators, TM 9-2320-209-10.

CAUTION

Turn transmission output propeller shaft (5) to the right to prevent damage to equipment.

- Soldier A**
1. Working under truck, using bar (4), turn transmission output propeller shaft (5) to the right until soldier B tells you to stop.

NOTE

Cylinders are numbered from front of truck to rear.
Intake valves are toward front of truck.

- Soldier B**
2. Watch cylinder No. 1 intake valve rocker arm pushrod (6). When pushrod is in its highest position, tell soldier A to stop.

GO TO FRAME 7

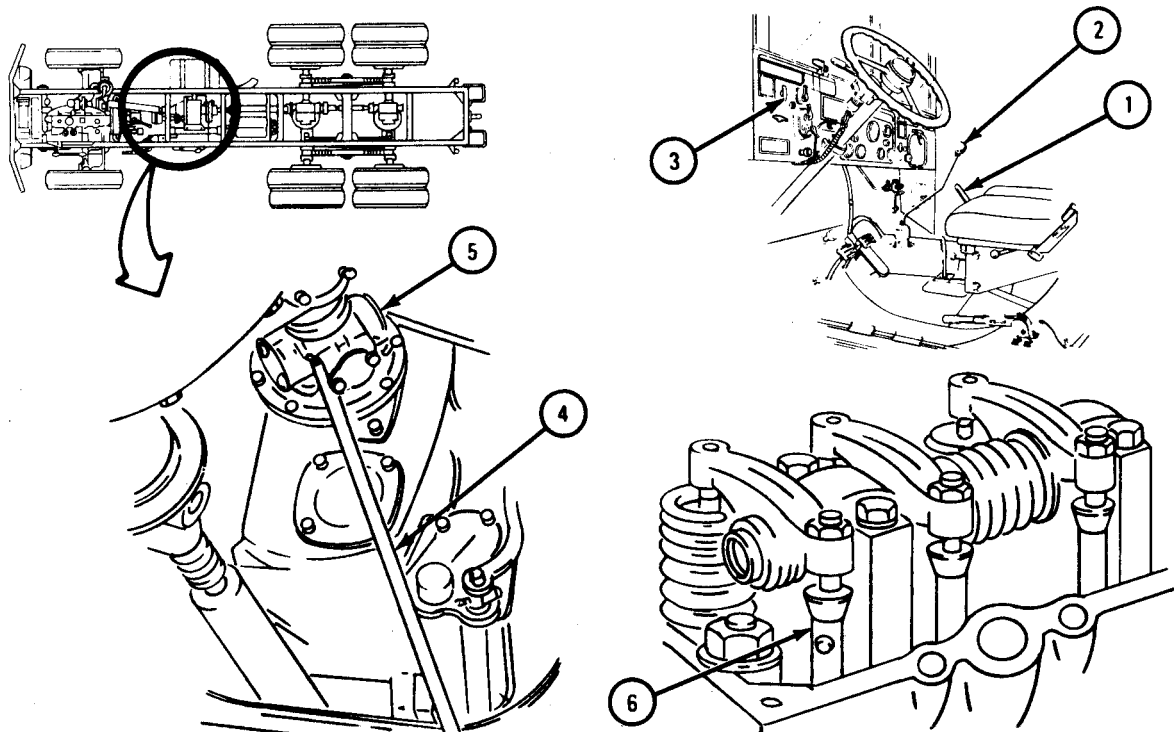

TA 101926

FRAME 7

NOTE

Cylinder No. 1 intake valve is now fully open. Intake valves for cylinders No. 2, 3, and 6 and exhaust valves for cylinders No. 1, 2, 4 must be set in this position. Use 0.010-inch feeler gage for intake valves and 0.025-inch feeler gage for exhaust valves.

1. Push feeler gage between rocker arm pad (1) and cylinder No. 2 intake valve stem (2).
2. Do step 1 again for intake valves (2, 3, and 4) and exhaust valves (5, 6, and 7).

IF FEELER GAGE FIT IS NOT SNUG FOR ANY VALVE, GO TO FRAME 8.
IF FEELER GAGE FIT IS SNUG FOR ALL VALVES, GO TO FRAME 9

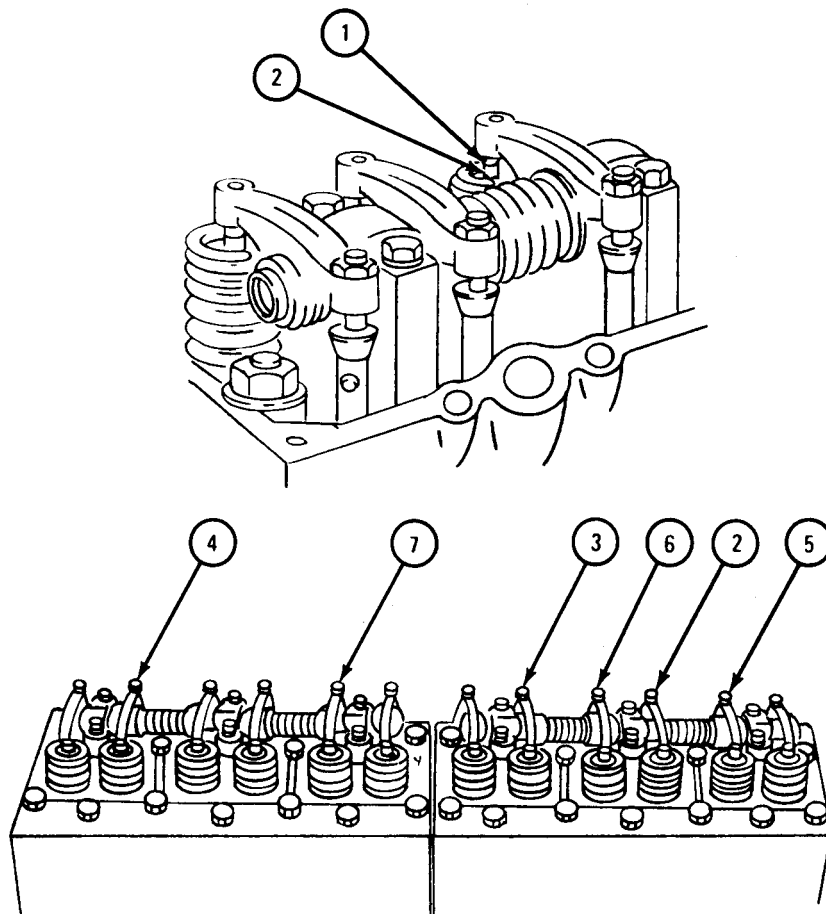

TA 101928

FRAME 8

NOTE

These steps must be done for any valve where feeler gage fit is not snug.

1. Keep adjusting screw (1) from moving and loosen locknut (2).
2. Turn adjusting screw (1) until feeler gage fit is snug between rocker arm pad (3) and valve stem (4).
3. Keep adjusting screw (1) from moving and tighten locknut (2).

GO TO FRAME 9

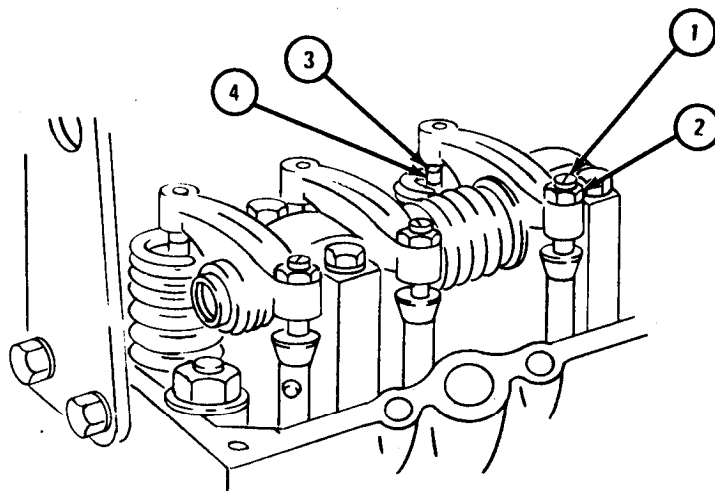

TA 101929

FRAME 9

- Soldier A
1. Put transfer shift lever (1) in neutral position. Refer to Driver's Compartment Controls and Indicators, TM 9-2320-209-10.
 2. Put transmission gear shift lever (2) in 4th gear.
 3. Pull out ENG STOP control (3) and turn to lock position. Refer to Driver's Compartment Controls and Indicators, TM 9-2320-209-10.

CAUTION

Turn transmission output propeller shaft (5) to the right to prevent damage to equipment.

4. Working under truck using bar (4), turn transmission output propeller shaft (5) to the right until soldier B tells you to stop.

NOTE

Cylinders are numbered from front of truck to rear.
Intake valves are toward front of truck.

- Soldier B
5. Watch cylinder No. 6 intake valve rocker arm pushrod (6). When pushrod is in its highest position, tell soldier A to stop.

GO TO FRAME 10

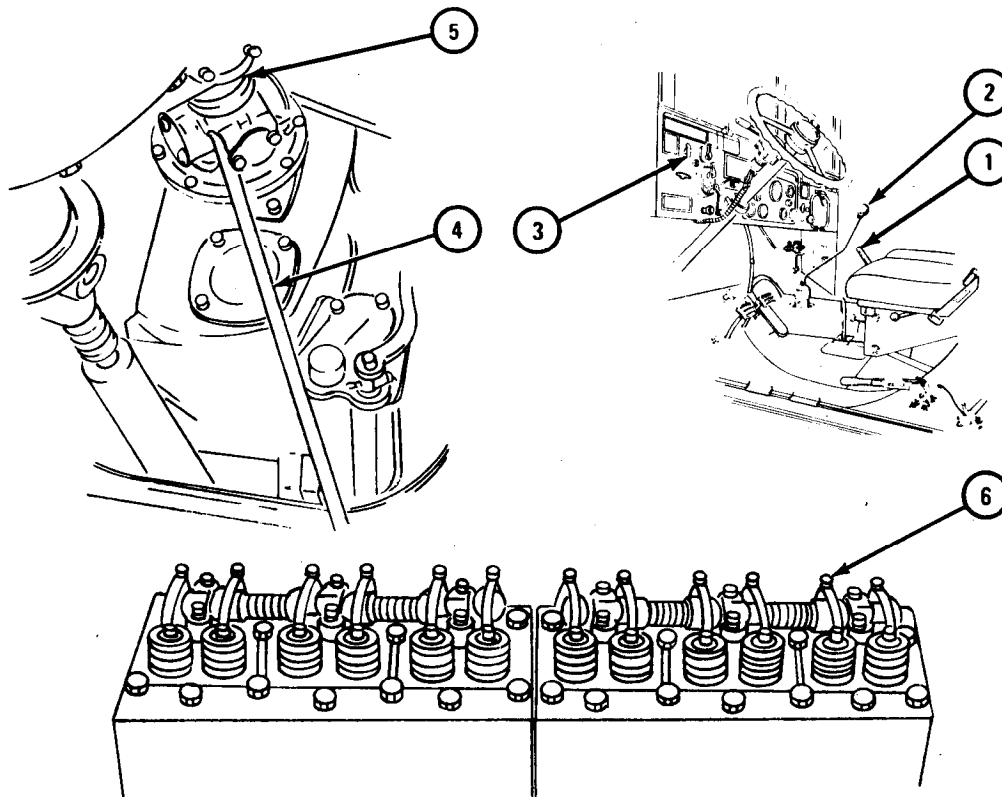

TA 101930

FRAME 10

NOTE

Cylinder No. 6 intake valve is now fully open. Intake valves for cylinders No. 1, 4, and 5 and exhaust valves for cylinders No. 3, 5, and 6 must be set in this position. Use 0.010-inch feeler gage for intake valves and 0.025-inch feeler gage for exhaust valves.

1. Push feeler gage between rocker arm pad (1) and cylinder No. 1 intake valve stem (2).
2. Do step 1 for intake valves Nos. 1 (3), 4 (4), and 5 (5) and exhaust valves Nos. 3 (6), 5 (7), and 6 (8).

IF FEELER GAGE FIT IS NOT SNUG FOR ANY VALVE, GO TO FRAME 11.
IF FEELER GAGE FIT IS SNUG FOR ALL VALVES, GO TO FRAME 12

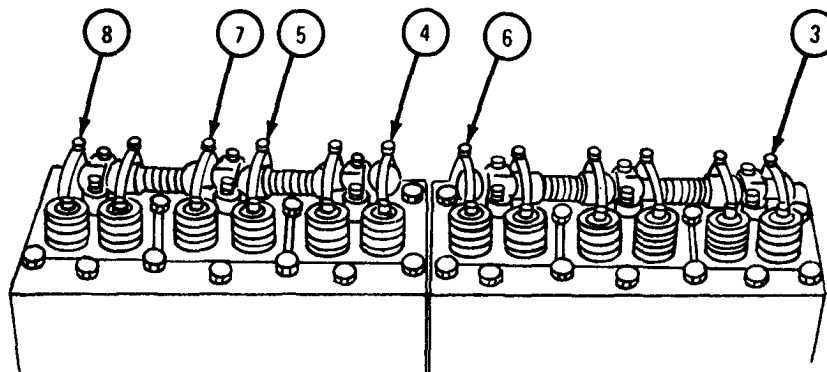
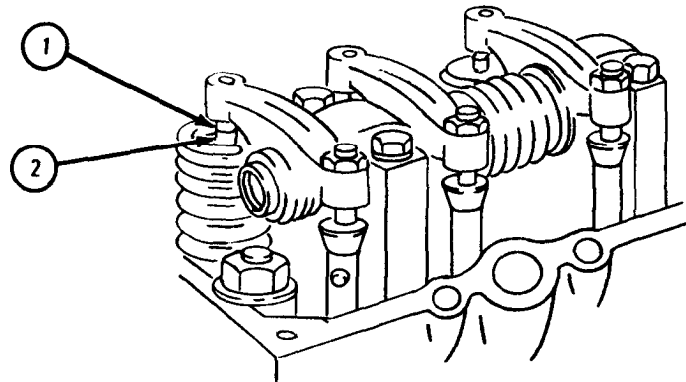

TA 101931

FRAME 11

NOTE

These steps must be done for any valve where feeler gage fit is not snug.

1. Keep adjusting screw (1) from moving and loosen locknut (2).
2. Turn adjusting screw (1) until feeler gage fit is snug between rocker arm pad (3) and valve stem (4).
3. Keep adjusting screw (1) from moving and tighten locknut (2).

GO TO FRAME 12

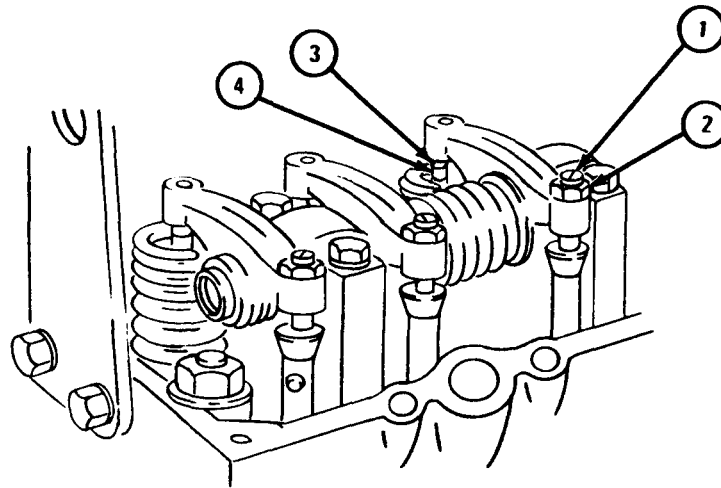

TA 101929

FRAME 12

1. Put transmission gear shift lever (1) in neutral position.
 2. Put transfer shift lever (2) in HIGH position.
 3. Unlock and push in ENG STOP control (3).
- GO TO FRAME 13

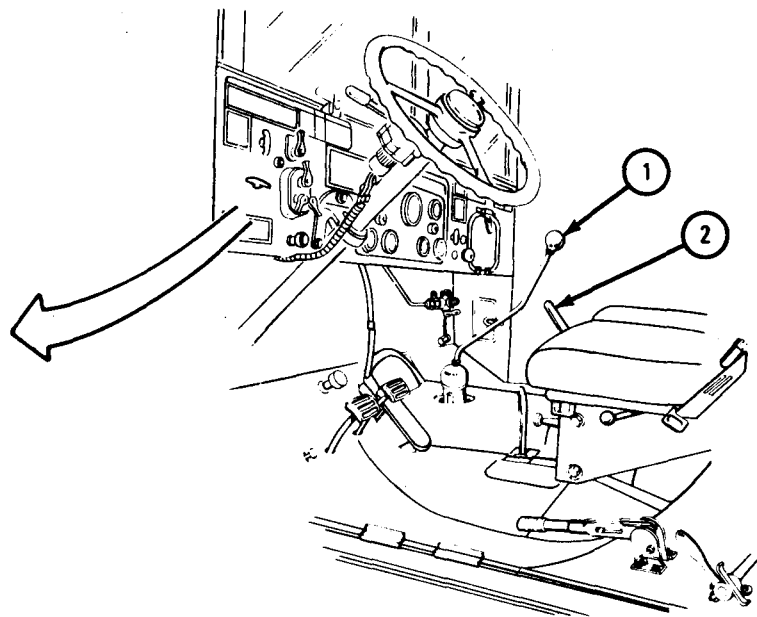
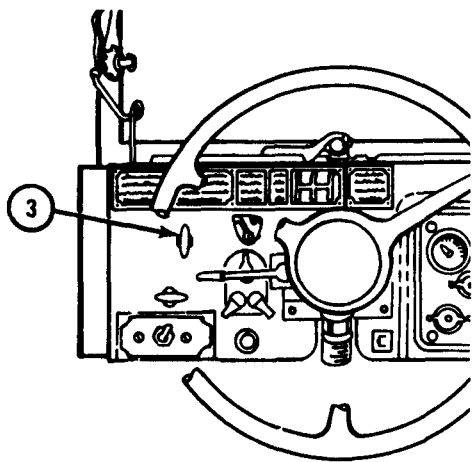

TA 101932

FRAME 13

1. Put on intake exhaust manifold gasket (1).
2. Put on intake and exhaust manifolds (2).
3. Put on six self-locking nuts and flat washers (3).
4. Put on 12 nuts and flat washers (4).
5. Put on six water outlet manifold gaskets (5).
6. Put hose (6) on water inlet (7).
7. Put water outlet manifold (8) in place and put in six machine bolts (9).
8. Tighten hose clamp screw (10).
9. Do steps 6, 7, and 8 again for other water outlet manifold (8).

GO TO FRAME 14

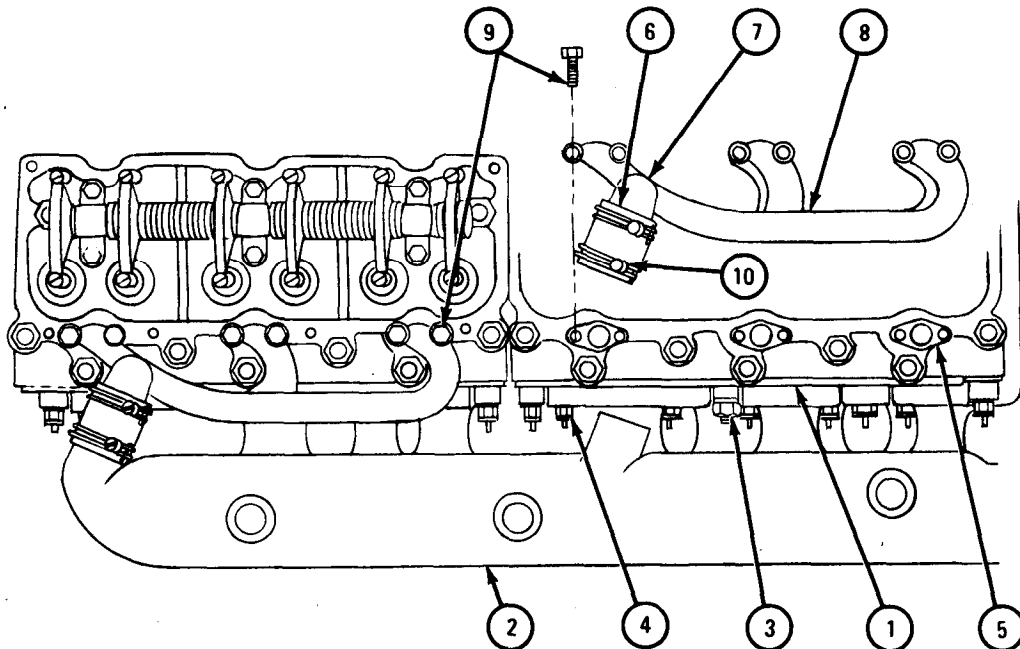

TA 101933

FRAME 14

1. Put on six nuts (1) and flat washers (2).
2. Put oil gage rod support bracket (3) on studs (4).
3. Put on six self-locking nuts (5) and flat washers (6).
4. Put in oil gage rod (7).

GO TO FRAME 15

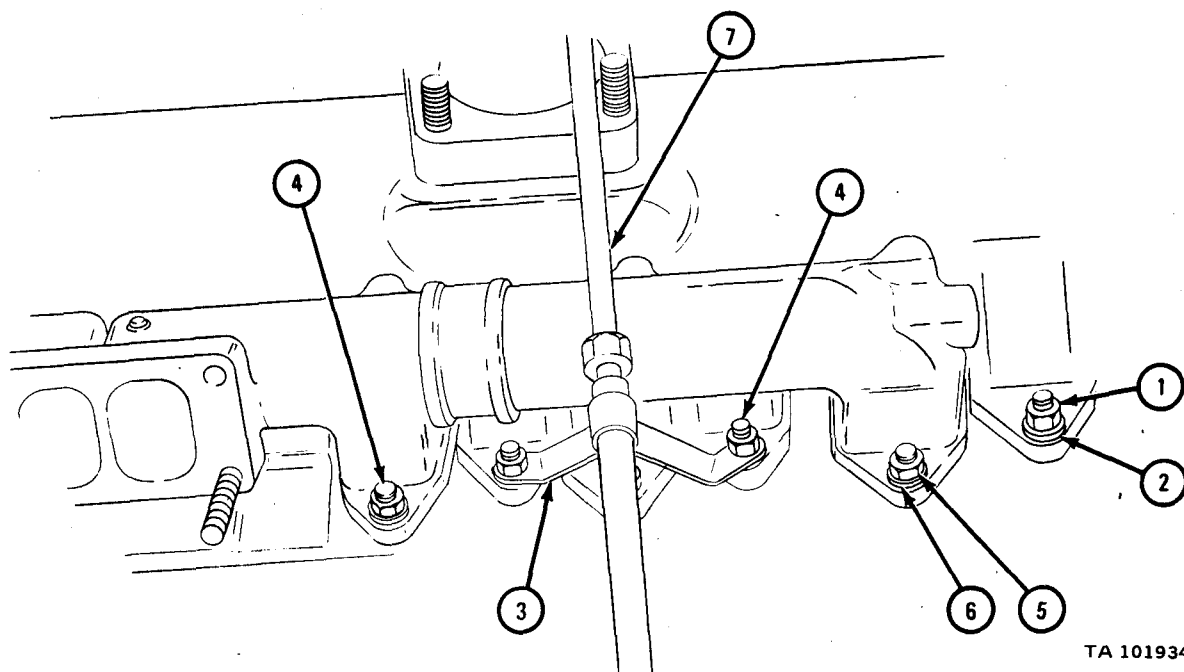

TA 101934

FRAME 15

1. Put exhaust gasket (1) on studs (2).
2. Put elbow pipe (3) on studs (2).
3. Put in screws (4) and screw on nuts (5).

GO TO FRAME 16

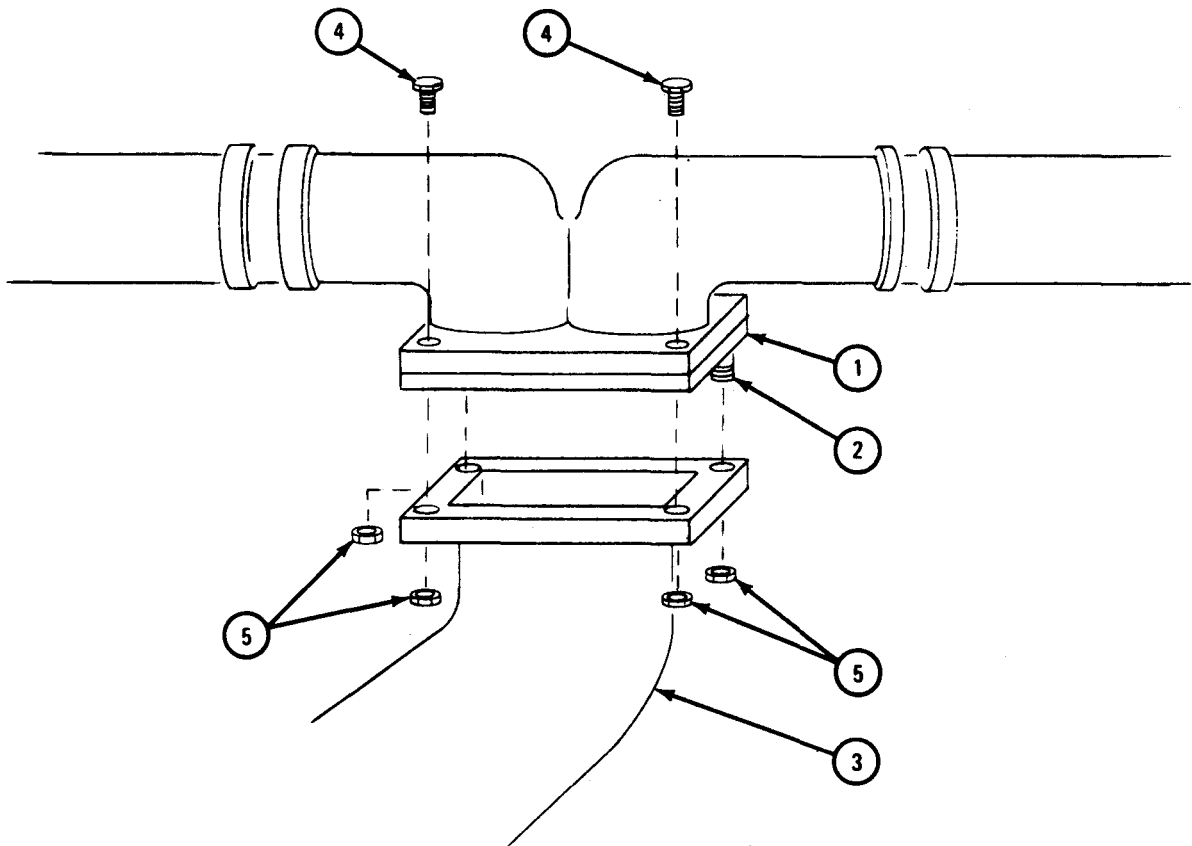

TA 118451

FRAME 16

1. Put in three fuel injectors. Refer to TM 9-2815-210-34.
2. Put on rear cylinder head gasket (1) and rear cylinder head cover (2).
3. Put tachometer cable mounting bracket (3) in place and put on lockbolt and washer (4).
4. Put in six lockbolts and washers (5).
5. Put on locknut and washer (6).
6. Tighten locknut (6) and lockbolts (4 and 5) to 55 to 60 pound-inches.
7. Put rear engine lifting bracket (7) in place and put in two capscrews (8) and lockwashers (9).

GO TO FRAME 17

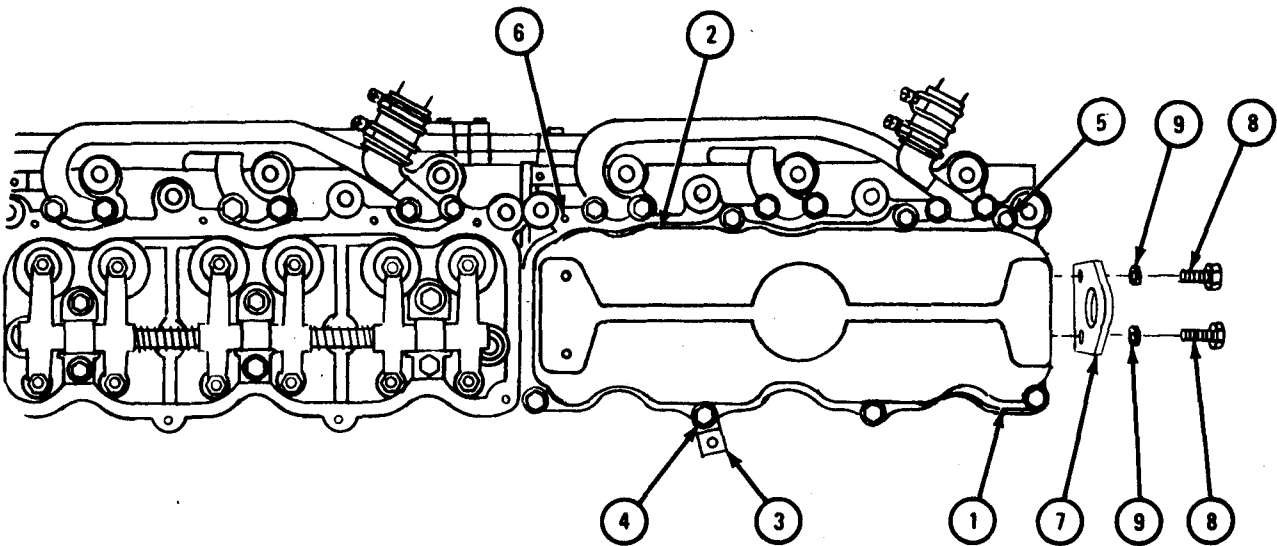

TA 101935

FRAME 17

1. Put in three fuel injectors (1). Refer to TM 9-2815-210-34.
2. Put on front cylinder head gasket (2) and front cylinder head cover (3).
3. Put in two tube clamps (4) and two lockbolts (5).
4. Put tachometer cable bracket (6) in place and put in lockbolt (7).
5. Put in four lockbolts (8).
6. Put on locknut and flat washer (9).
7. Tighten seven lockbolts (6, 7, and 8) and locknut (9) to 55 to 60 pound-inches.

GO TO FRAME 18

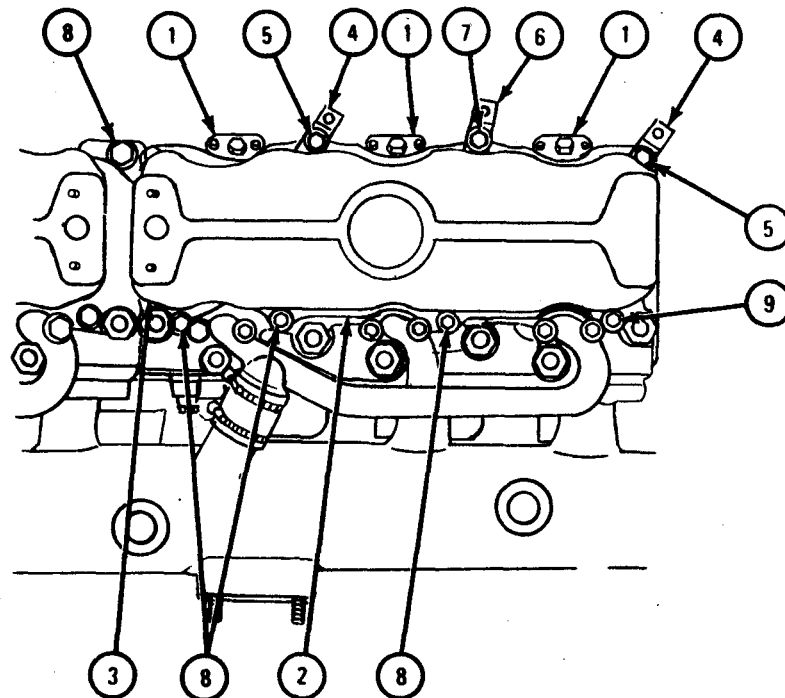

TA 101937

FRAME 18

1. Put front engine lifting bracket (1) in place. Put in two capscrews (2) and lockwashers (3).
2. Put on oil filler cap (4) with chain (5).
3. Hook chain (5) to washer (6).

GO TO FRAME 19

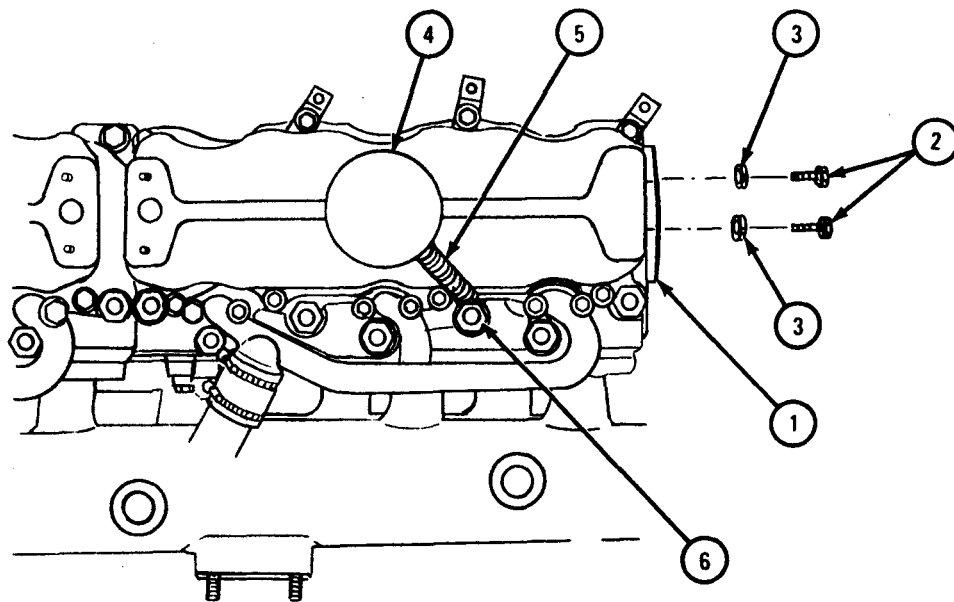

TA 101938

FRAME 19

1. Place intake manifold heater elbow gasket (1) on intake manifold heater elbow studs (2).
2. Put intake manifold heater elbow (3) on intake manifold studs (2).
3. Put on four nuts and lockwashers (4).

IF WORKING ON ENGINE WITH TOP-MOUNTED, COVERED MANIFOLD HEATER IGNITION UNIT, GO TO FRAME 20.

IF WORKING ON ENGINE WITH TOP-MOUNTED, UNCOVERED MANIFOLD HEATER IGNITION UNIT, GO TO FRAME 23

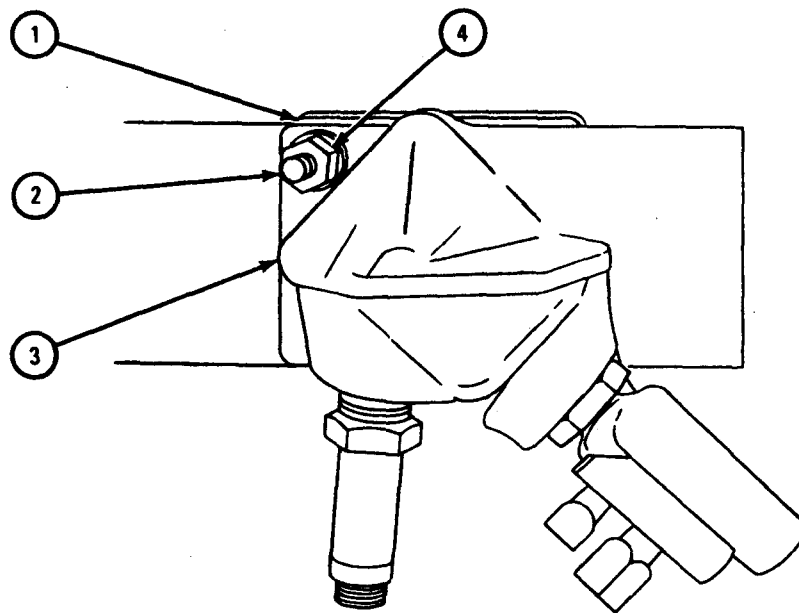

TA 101944

FRAME 20

1. Put ignition unit support (1) into place and align screw holes.
2. Put in two screws (2) and lockwashers (3).
3. Put harness (4) into place and align screw holes. Put in screw (5) and lockwasher (6).

GO TO FRAME 21

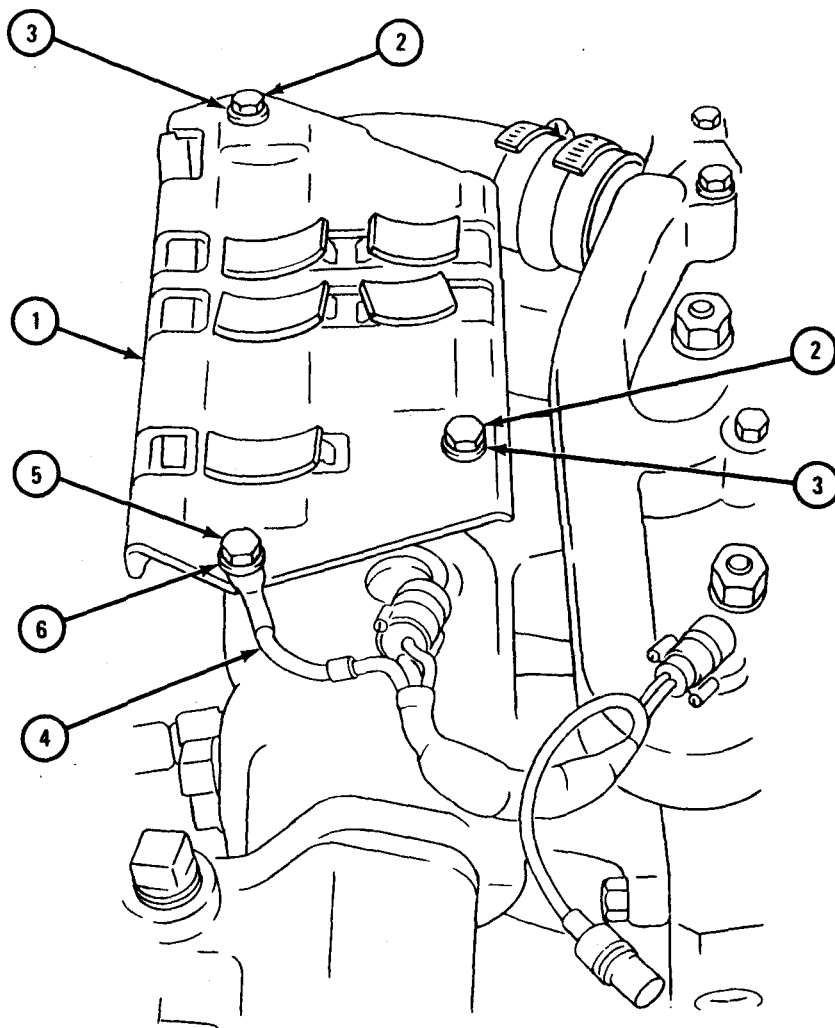

TA 101939

FRAME 21

1. Put ignition coil (1) and fuel pump (2) in place. Put on four clamps (3).
 2. Put on two tube fittings (4 and 5).
 3. Put electrical cable connector (6) on fuel pump (2).
 4. Put on two electrical cable connectors (7 and 8) on ignition coil (1).
- GO TO FRAME 22

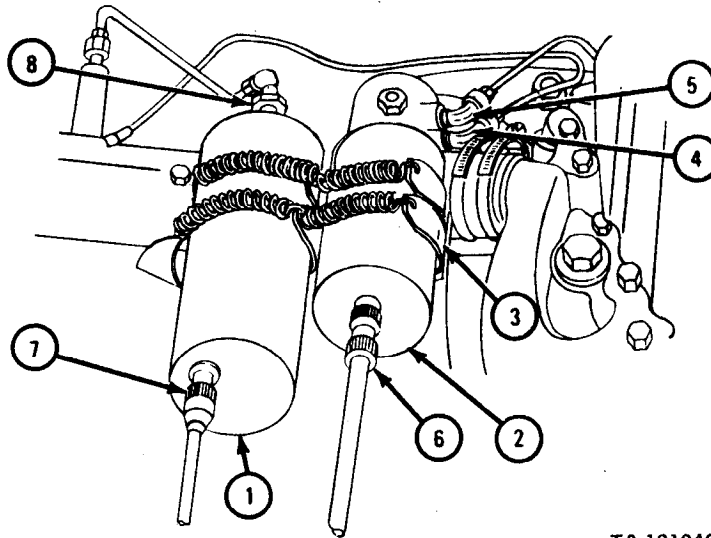

TA 101940

FRAME 22

1. Put cover (1) in place and aline screw holes.
2. Screw on and tighten four capscrews (2).

GO TO FRAME 23

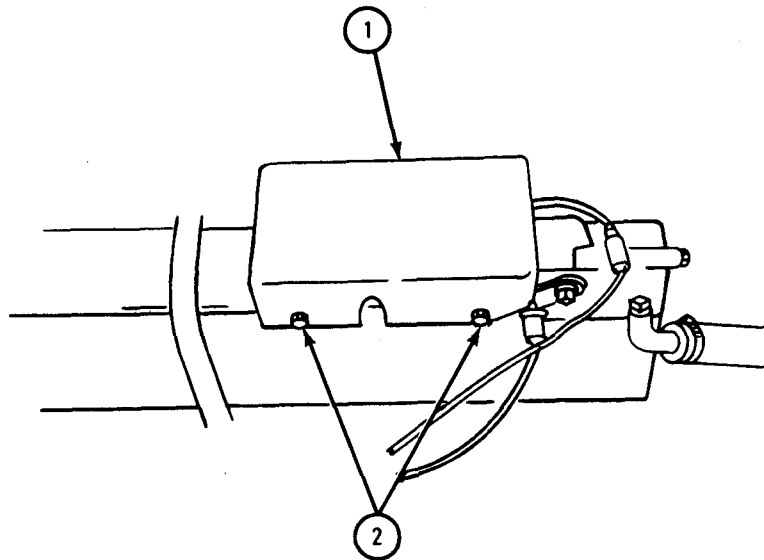

TA 101941

FRAME 23

1. Hold adapter (1) and put on inverted nut and tube (2).
2. Hold adapter (3) and put on inverted nut and tube (4).
3. Put on nut and ignition cable and conduit assembly (5).

IF WORKING ON ENGINE WITH TOP-MOUNTED, UNCOVERED HEATER IGNITION UNIT, GO TO FRAME 24.

IF WORKING ON ENGINE WITH TOP-MOUNTED, COVERED HEATER IGNITION UNIT, GO TO FRAME 26

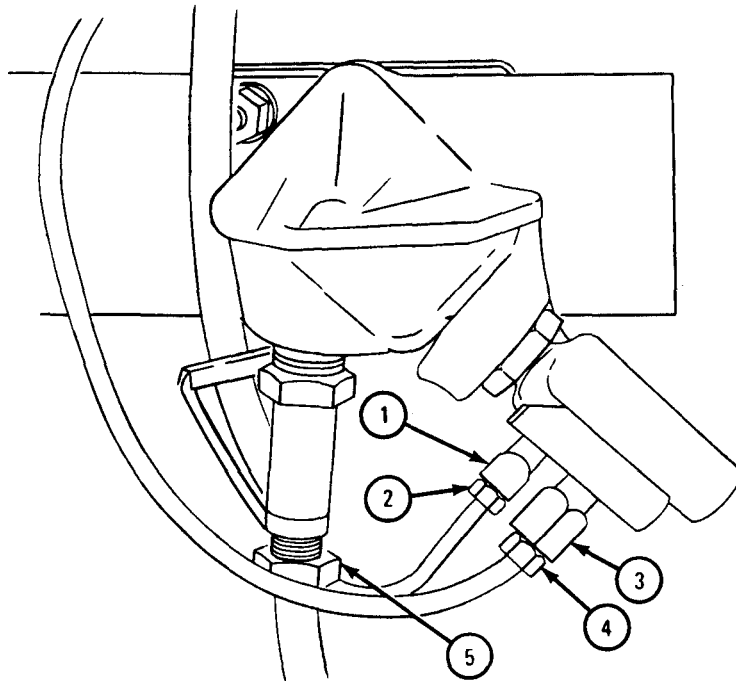

TA 101945

FRAME 24

1. Slide two clamps (1) on ignition unit (2).
2. Put ignition unit (2) with two clamps (1) in place and aline screw holes.
3. Put in two machine screws with washers (3).
4. Put electrical cable connector (4) on ignition unit (2).
5. Put electrical cable connector (5) on ignition unit (2).

GO TO FRAME 25

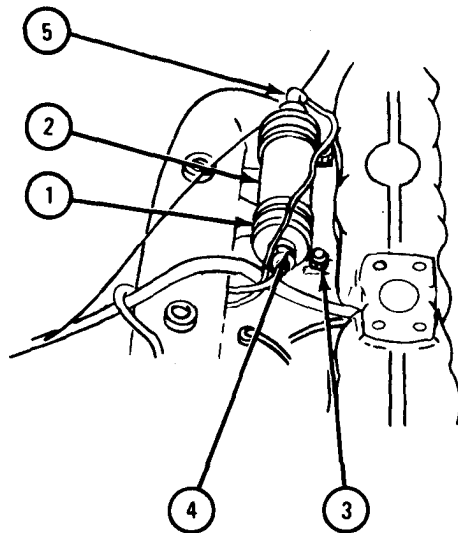

TA 101942

FRAME 25

1. Put fuel filter (1) and fuel pump (2) in place. Aline holes of two brackets (3).
2. Put in two machine screws with washers (4).
3. Put tube adapter (5) on filter (1).
4. Put tube adapter (6) on pump (2).
5. Put electrical connector (7) on fuel pump (2).

IF WORKING ON TRUCK WITH ENGINE LDT 465-1C, GO TO FRAME 26.

IF WORKING ON TRUCK WITH ENGINE LD 465-1 OR LD 465-1C, GO TO FRAME 31

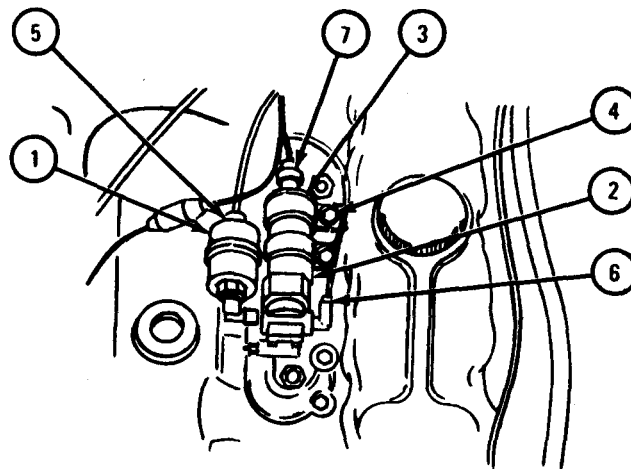

TA 101943

FRAME 26

1. Put air induction hose assembly (1) on intake manifold heater elbow (2) and air cleaner outlet (3).
2. Tighten two hose clamps (4).

GO TO FRAME 27

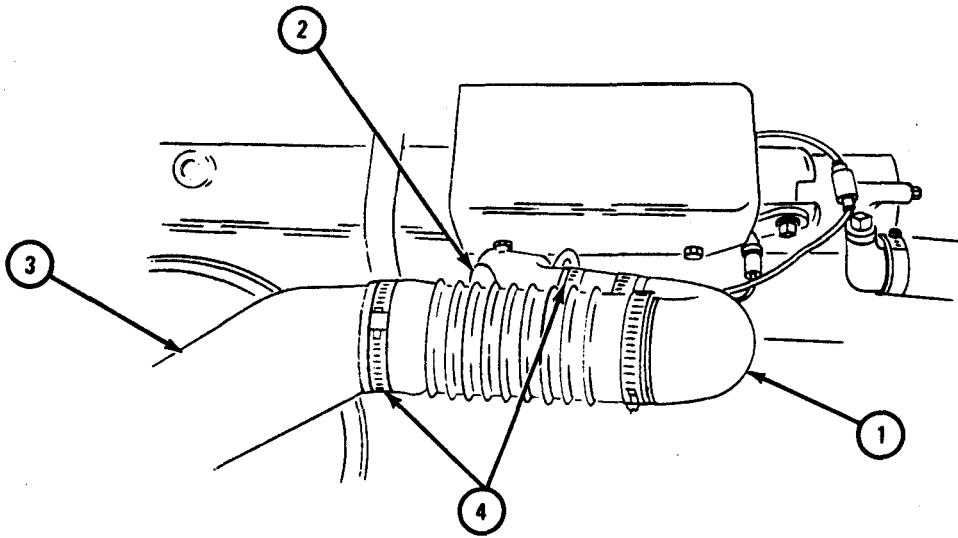

TA 101946

FRAME 27

Soldier A 1. Put on gasket (1) and turbocharger (2) and hold in place.

Soldier B 2. Put in two capscrews (3) and four self-locking nuts (4).

3. Put oil inlet tube (5) in place. Screw on two coupling nuts (6).

GO TO FRAME 28

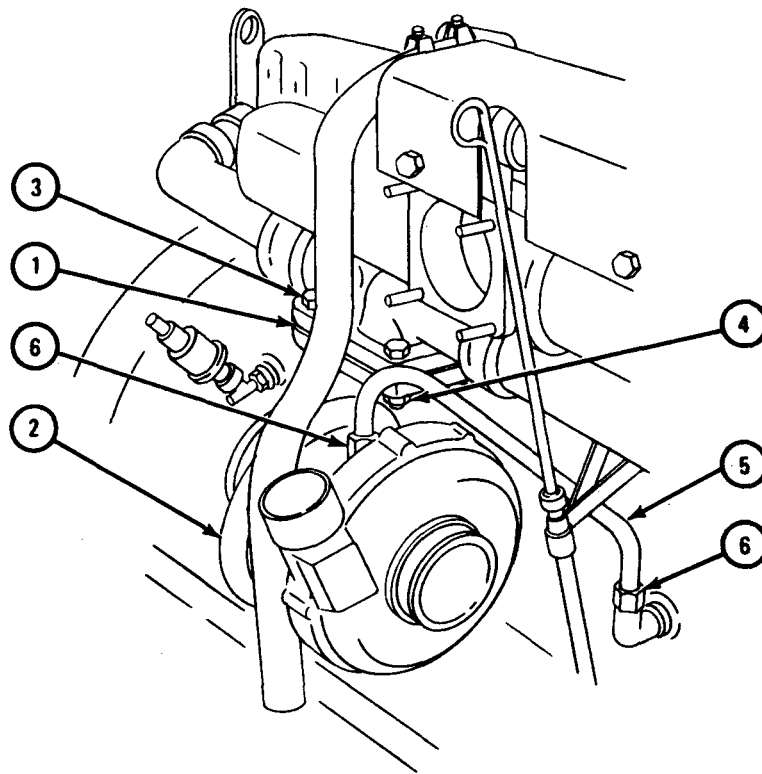

TA 101949

FRAME 28

1. Put gasket (1) and oil drain tube (2) in place and align screw holes. Put in capscrews and lockwashers (3).
2. Put hose (4) on oil drain tube (2). Tighten screw (5).

GO TO FRAME 29

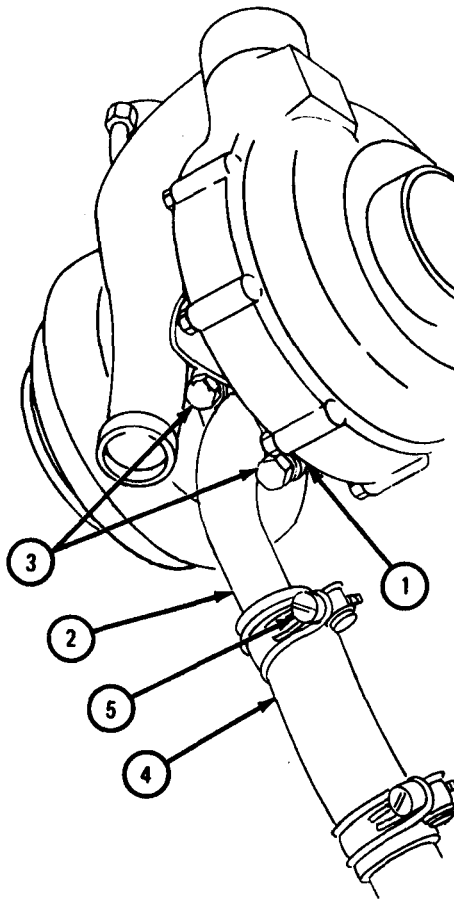

TA 101951

FRAME 29

1. Put gasket (1) and manifold elbow (2) in place. Put on four nuts (3) and lockwashers (4).
2. Slide hose (5) in place. Tighten two nuts (6).
3. Put on ignition unit lead (7).
4. Screw on two coupling nuts (8 and 9).

GO TO FRAME 30

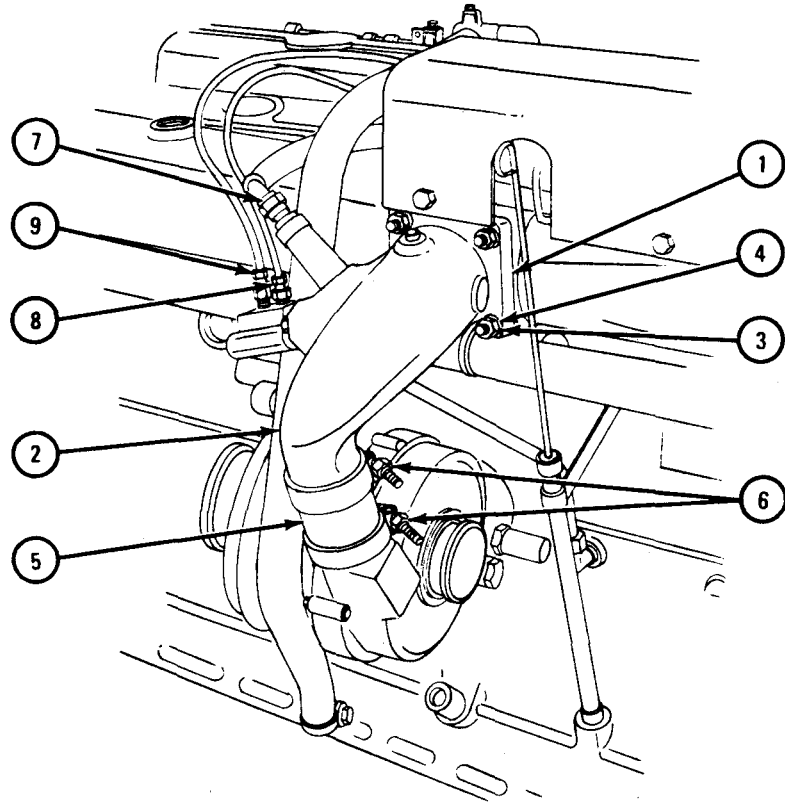

TA 101952

FRAME 30

1. Put on breather tube (1) with adapter (2).
2. Put on four flat copper washers and self-locking nuts (3).

NOTE

If working on system with turbocharger, do steps 3 and 5. If no turbocharger is used, do steps 4 and 5.

3. Put in capscrew and lockwasher (4).
4. Put clamp (5) on breather tube (1). Put screw (6) through clamp (5) and bracket (7). Put on nut (8).
5. Hold adapter fitting (9) and screw in and tighten tube nut (10).

GO TO FRAME 31

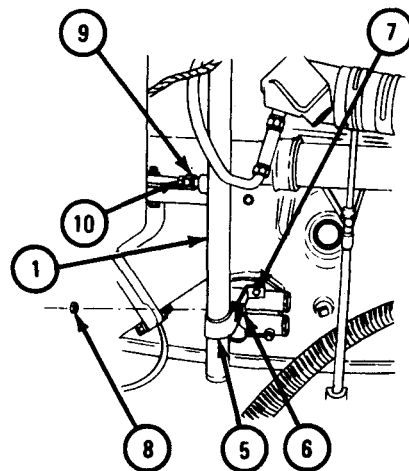
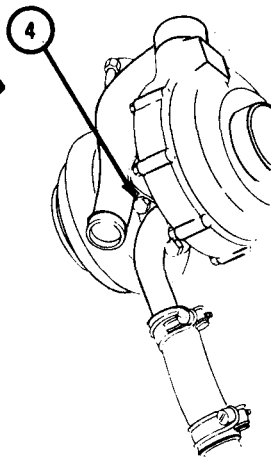
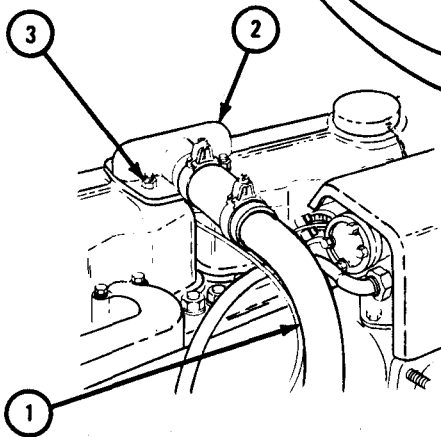
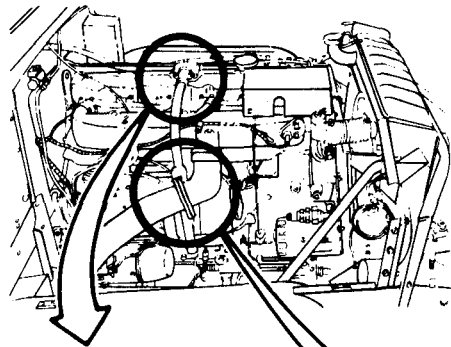

TA 101948

FRAME 31

1. Make sure surface of intake manifold flange (1) is clean. Put gasket (2) on flange.
2. Hold thermostat housing (3) in engine compartment.
3. Join hose (4) to thermostat housing (3) but do not tighten clamp (5).
4. Put thermostat housing (3) against intake manifold flange (1). Make sure lip (6) of thermostat housing seats in recess (7) of intake manifold flange.

GO TO FRAME 32

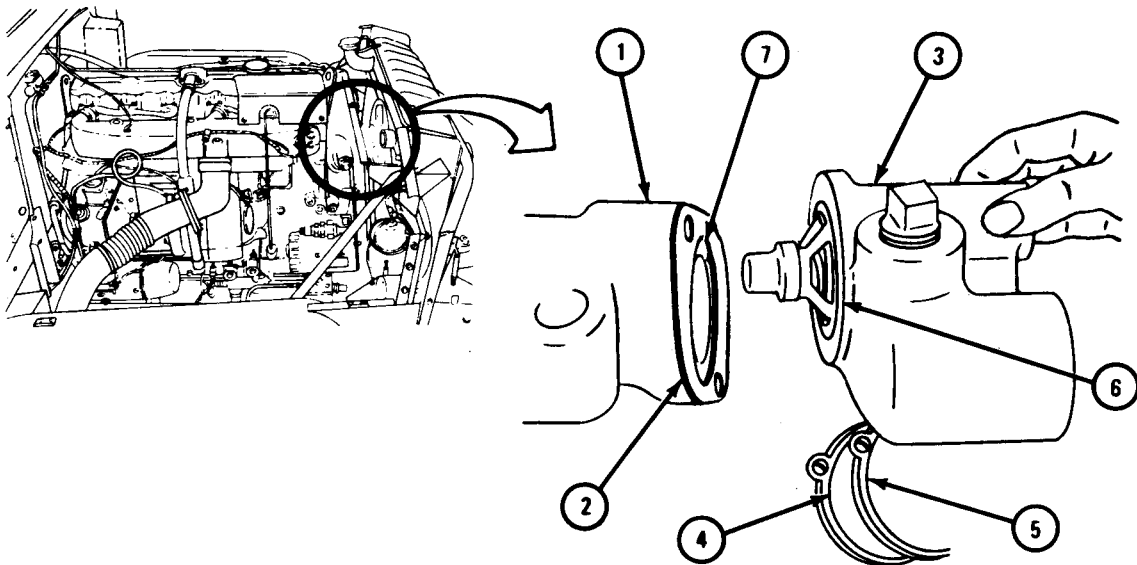

TA 101953

FRAME 32

1. Hold thermostat housing (1) firmly against intake manifold (2).
2. Put two screws (3) with flat washers (4) through thermostat housing (1) and screw into intake manifold (2). Tighten screws evenly.
3. Put clamp (5) squarely over hose (6) as shown.
4. Tighten screw (7) on clamp (5).

GO TO FRAME 33

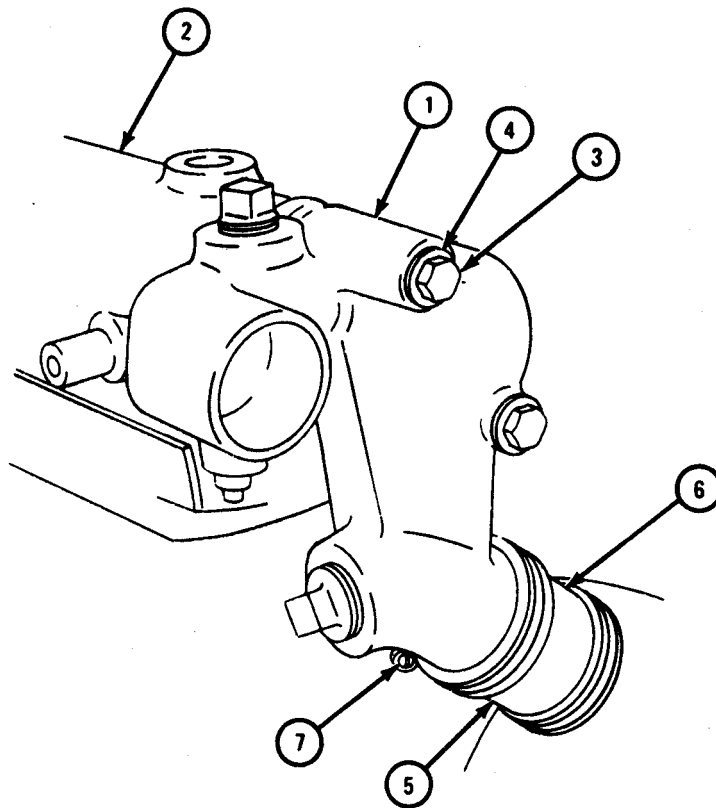

TA 101954

FRAME 33

1. Pull radiator (1) forward just enough to slip preformed hose (2) onto radiator inlet fitting (3).
2. Slip other end of preformed hose (2) on thermostat housing outlet fitting (4).
3. Put two clamps (5) on preformed hose (2) where shown. Do not tighten clamp screws (6) at this time.

GO TO FRAME 34

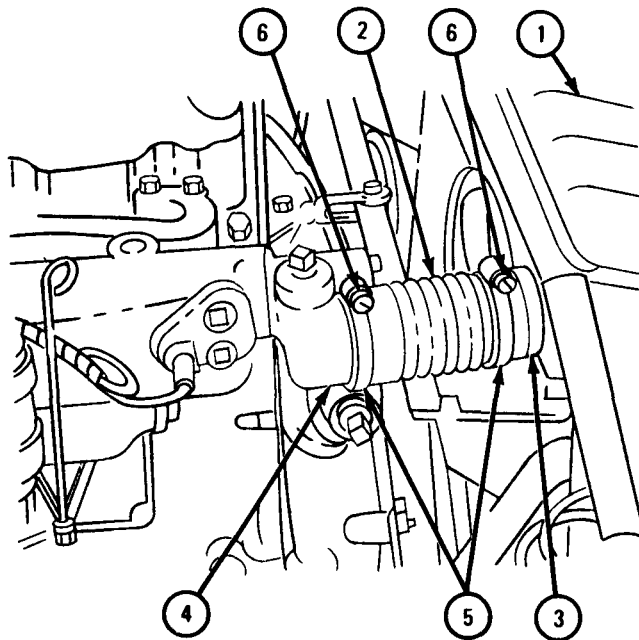

TA 101955

FRAME 34

1. Aline hole in rod end clevis (1) with hole in bracket (2) by moving radiator (3).
2. Put bolt (4) through clevis (1) and bracket (2). Put locknut (5) on bolt.
3. Make sure clamps (6) are positioned squarely on hose (7). Tighten two clamp screws (8).

GO TO FRAME 35

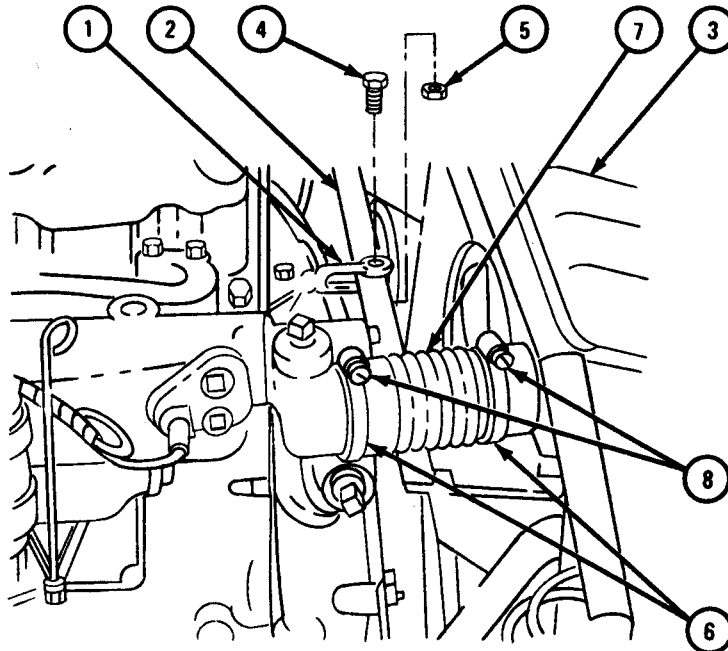

TA 101956

FRAME 35

1. Unplug six holes in fuel injector pump (1) and holes in six fuel injector nozzles (2).
2. Put six fuel injector tubes (3) in place as tagged. Screw on six tube nuts (4) and six tube nuts (5). Take off tags.
3. Slide six dust caps (6) in place.

GO TO FRAME 36

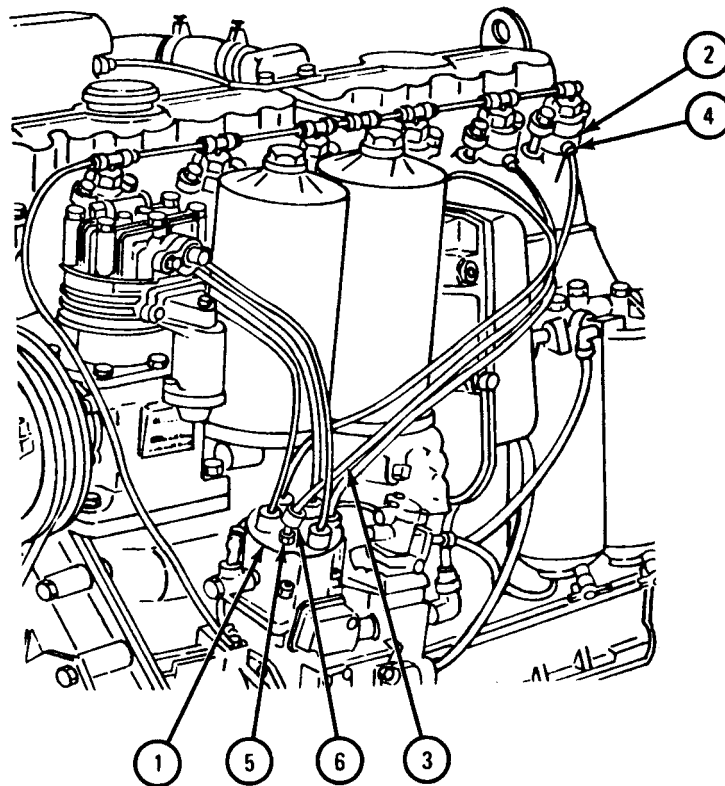

TA 101957

FRAME 36

1. Put two clamps (1) in place and align screw holes. Put in two screws and locknuts (2).
2. Put tube clamp (3) in place and align screw holes. Put in two screws, flat washers, and locknuts (4).
3. Put inner half of tube clamp (5) in place and align screw holes. Put on nut, lockwasher, and flat washer (6).
4. Put outer half of tube clamp (5) in place and align screw holes. Put in two screws, four flat washers, and two locknuts (7).
5. Put four tube clamps (8) in place and align screw holes. Put in four screws and locknuts (9).

GO TO FRAME 37

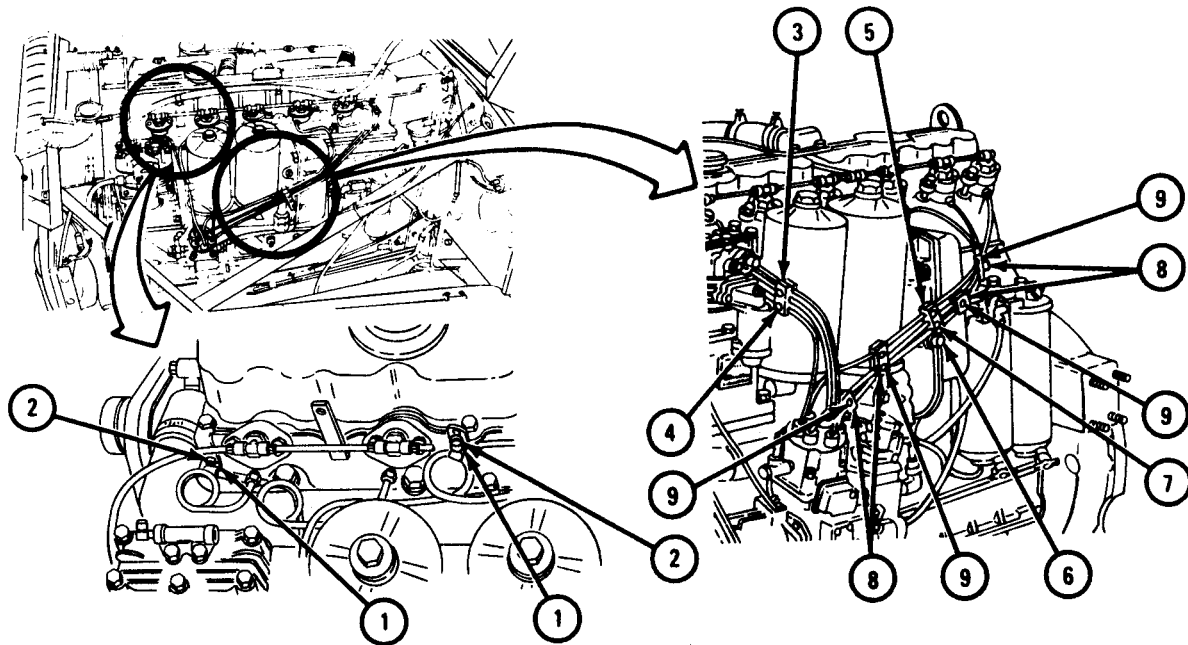

TA 101958

FRAME 37

1. Put tachometer flexible shaft assembly (1) in place.
2. Put two clamps (2) in place and align screw holes. Put in two screws (3) and locknuts (4).

NOTE

Follow-On Maintenance Action Required:

1. Fill cooling system. Refer to TM 9-2320-209-20.
2. Change oil. Refer to LO 9-2320-209-12/1.
3. Close hood and side panels. Refer to TM 9-2320-209-10.
4. Replace air cleaner. Refer to TM 9-2320-209-20.
5. Reconnect battery ground cable. Refer to TM 9-2320-209-20.

END OF TASK

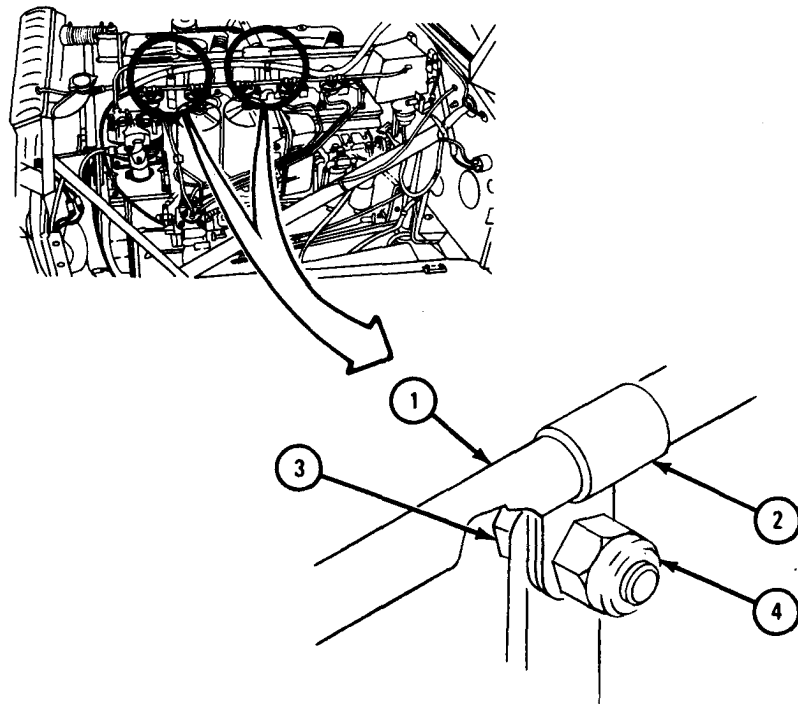

TA 101959

2-7. CYLINDER SLEEVE REMOVAL AND REPLACEMENT. Refer to TM 9-2815-210-34 for procedures to remove and replace cylinder sleeve.

Section IV. CRANKSHAFT

2-8. VIBRATION DAMPER REMOVAL AND REPLACEMENT.

TOOLS: Air compressor pulley adjusting wrench, pn 10935288

SUPPLIES: Lubricating oil, ICE, OE/HDO 10, MIL-L-2104

PERSONNEL: One

EQUIPMENT CONDITION: Truck parked, engine off, handbrake set.

a. Preliminary Procedures.

(1) Open hood and side panels. Refer to TM 9-2320-209-10.

(2) Remove radiator. Refer to TM 9-2320-209-20.

b. Removal.

FRAME 1

NOTE

Hold fan (1) while taking out bolts (2).

1. Take out four bolts and lockwashers (2).
2. Lift off fan (1).

GO TO FRAME 2

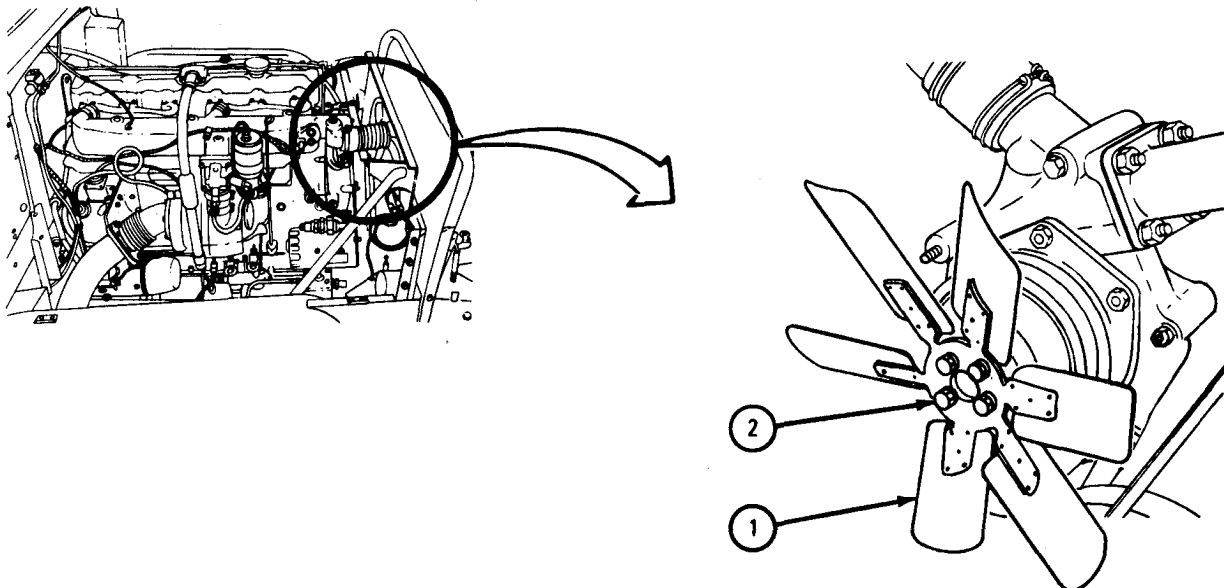

TA 101963

FRAME 2

1. Loosen capscrew (1) and washer (2) that hold adjusting arm (3) to generator (4).

GO TO FRAME 3

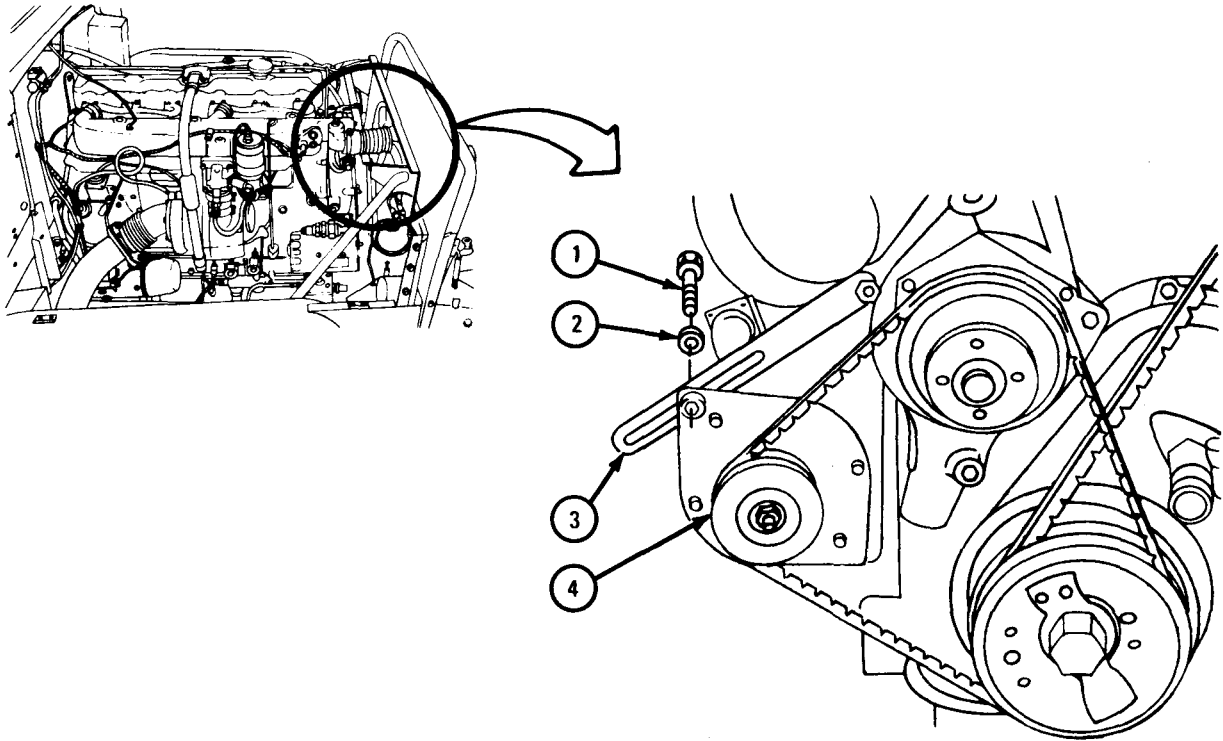

TA 101964

FRAME 3

1. Push generator (1) toward engine. Take off two fan drive belts (2) from generator pulley (3), coolant pump pulley (4), and crankshaft pulley (5).
GO TO FRAME 4

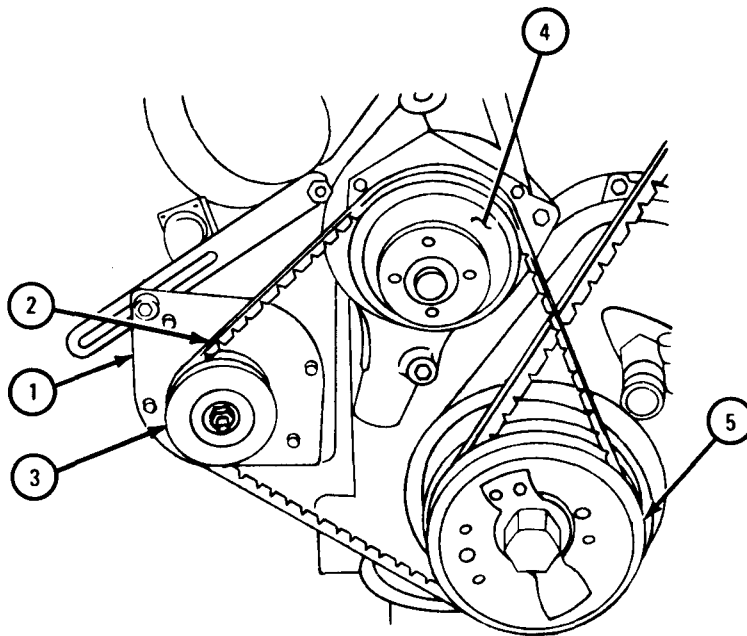

TA 101965

FRAME 4

1. Using air compressor pulley wrench, hold pulley flange (1). Unscrew nut (2).
2. Loosen screws (3 and 4) until lockwashers (5 and 6) do not hold.
3. Using air compressor pulley wrench, unscrew pulley flange (1) until drive belt (7) is loose enough to take off. Take drive belt off pulley (8).

GO TO FRAME 5

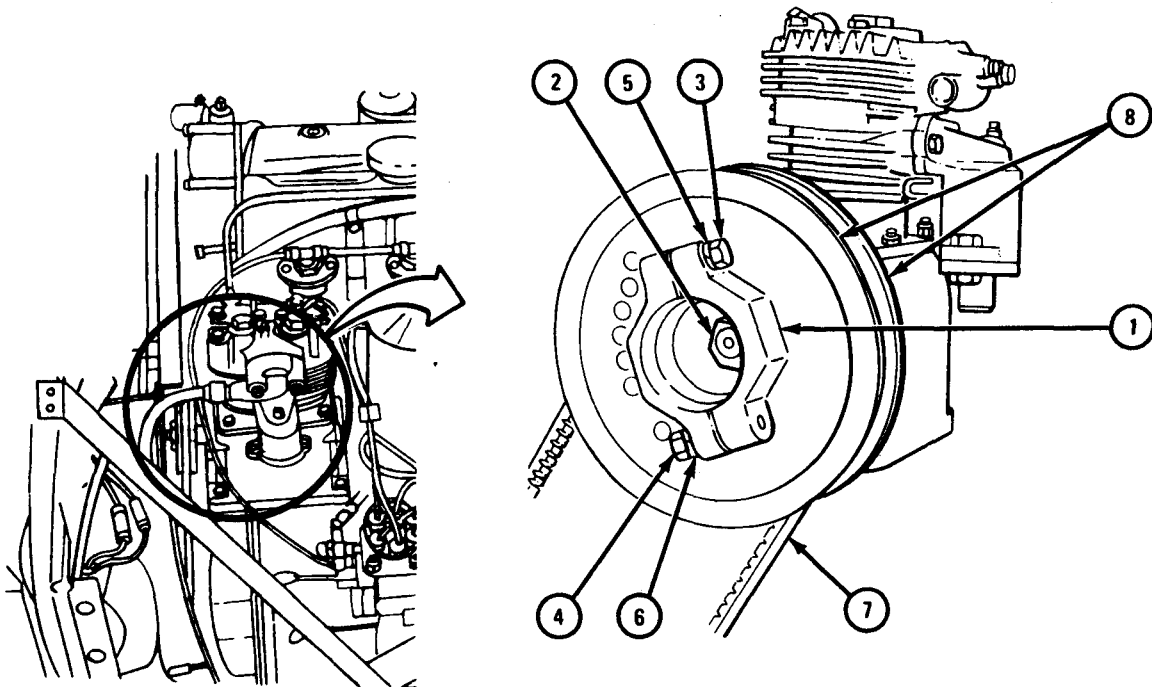

TA 101966

FRAME 5

1. Take out two capscrews and lockwashers (1).
2. Take out retaining bolt (2), lockplate (3), and retaining washer (4).
3. Put in retaining bolt (2) and tighten it to 225 to 250 pound-feet.

GO TO FRAME 6

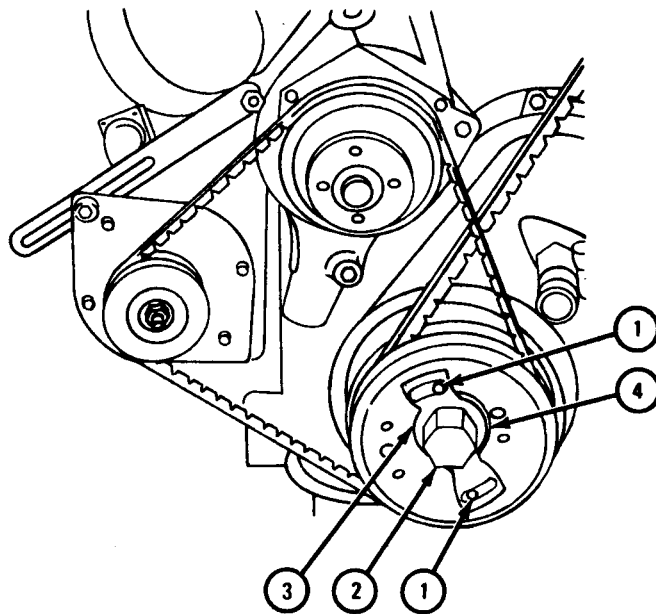

TA 101967

FRAME 6

1. Put mechanical puller on damper (1) as shown.
2. Pull off damper (1).
3. Take out retaining bolt (2).

GO TO FRAME 7

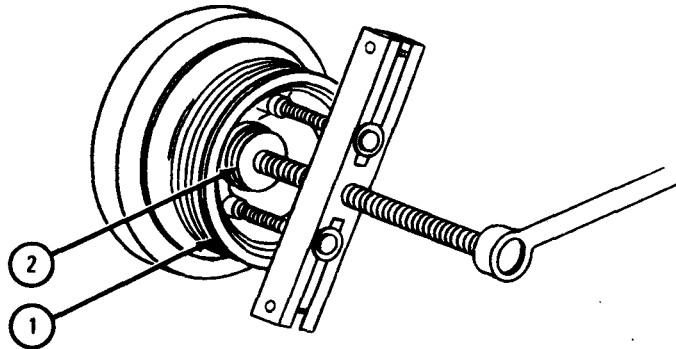

TA 101968

FRAME 7

1. Take out keyway seal (1).

END OF TASK

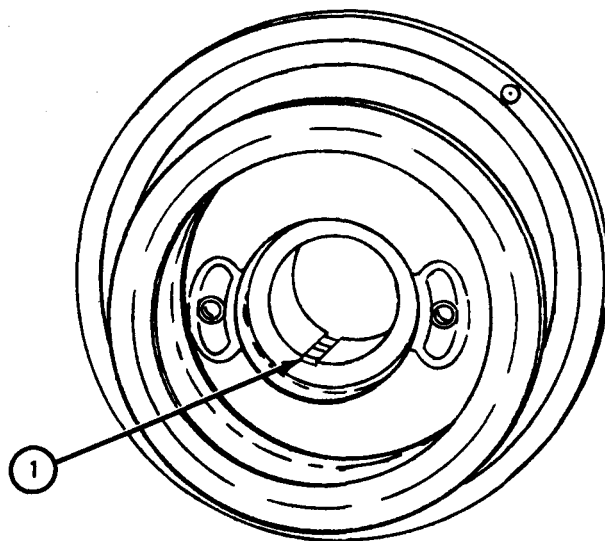

TA 101969

c. Replacement.**FRAME 1**

1. Coat crankshaft oil seal (1), back side and bore of damper (2), crankshaft (3), and key (4) with lubricating oil.
2. Heat damper (2).

WARNING

Damper (2) is hot. Wear welder's gloves when handling damper to avoid injury to personnel.

NOTE

Put on damper (2) before it has a chance to cool.

3. Aline keyway in damper (2) with key (4). Put on damper.

GO TO FRAME 2

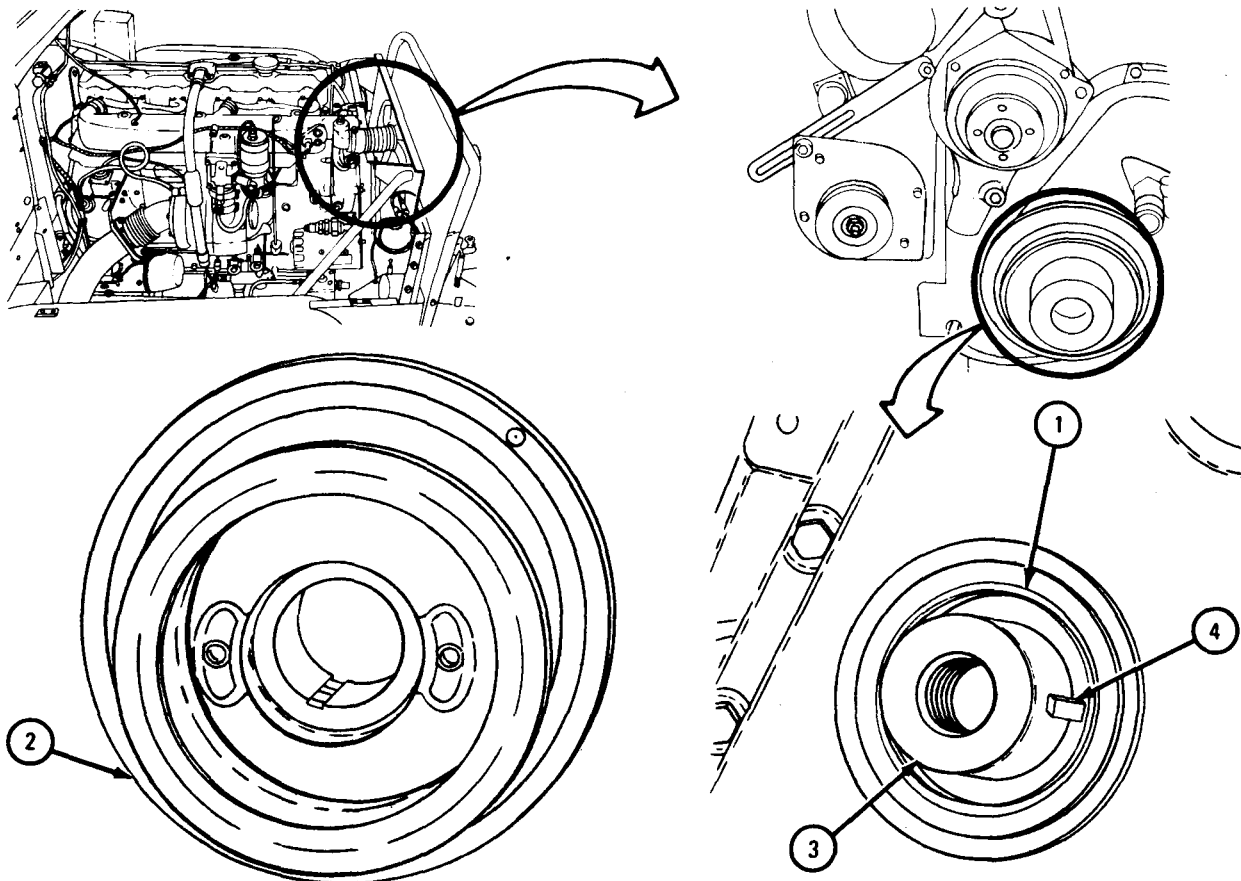

TA 101970

FRAME 2

1. Put in keyway seal (1).
 2. Put on retaining washer (2), lockplate (3), and retaining bolt (4). Tighten retaining bolt to 225 to 250 pound-feet.
 3. Put in two capscrews (5) and lockwashers (6).
- GO TO FRAME 3

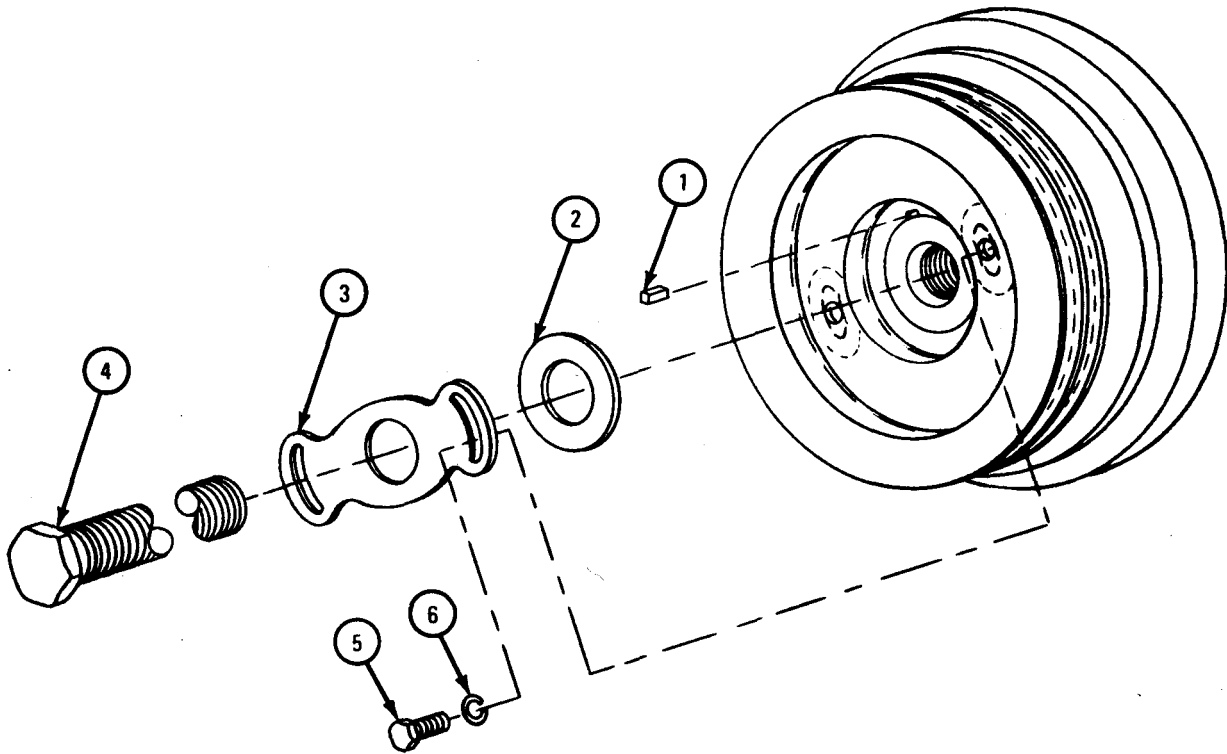

TA 101971

FRAME 3

1. Put on air compressor drive belt (1).
2. Hold straight edge (2) against drive belt (1). Using finger pressure and 6-inch ruler (3), push against center of drive belt.
3. Using air compressor pulley wrench, screw on pulley flange (4) until 6-inch ruler (3) measures $3/4$ inch to straight edge (2).
4. Tighten screws (5 and 6).

GO TO FRAME 4

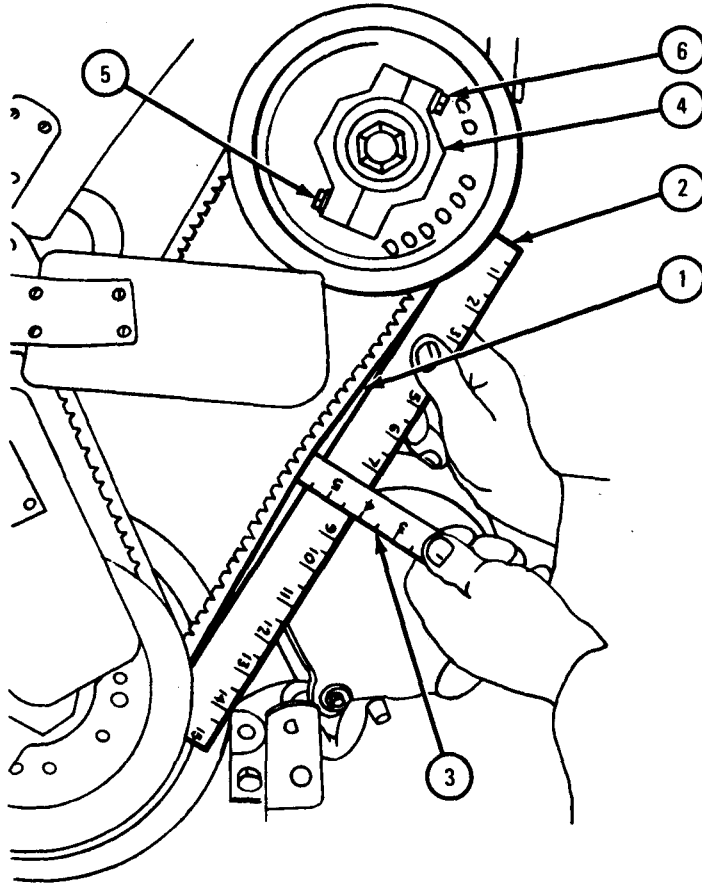

TA 101972

FRAME 4

1. Place two fan drive belts (1) over coolant pump pulley (2), crank shaft pulley (3), and generator pulley (4).
2. Hand tighten capscrew (5).

GO TO FRAME 5

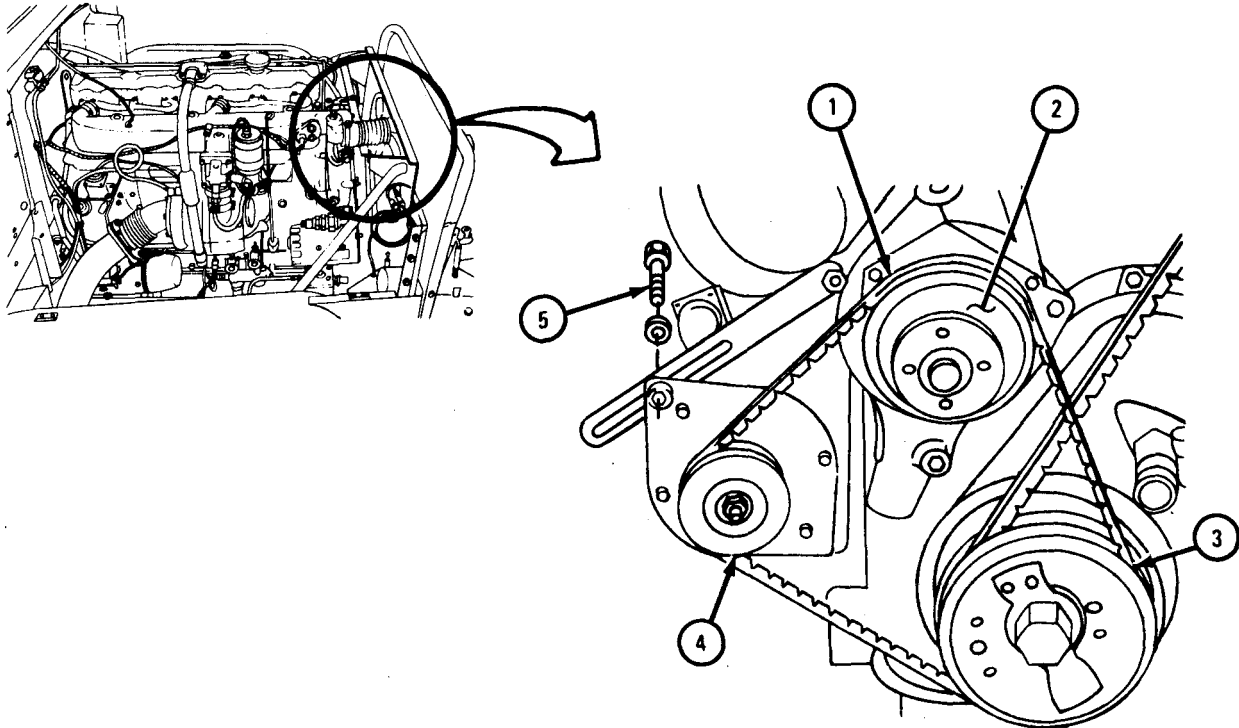

TA 101973

FRAME 5

1. Place end of 30-inch bar (1) between crankcase (2) and generator (3).
GO TO FRAME 6

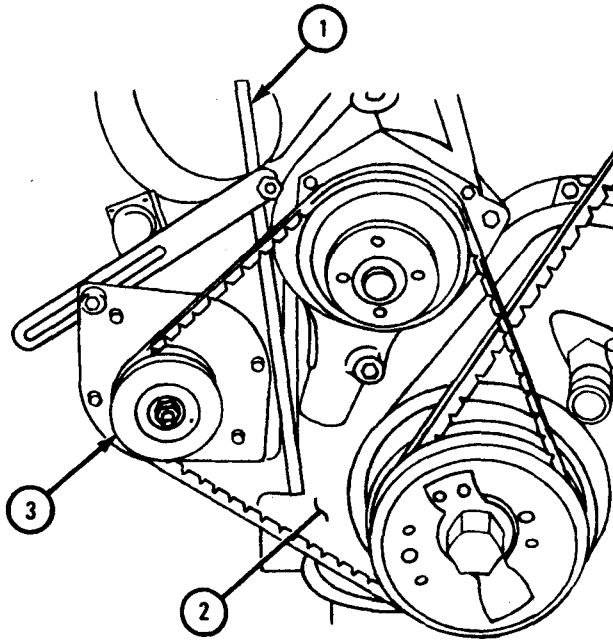

TA 101974

FRAME 6

1. Using spring scale (1), pull upper end of bar (2) with force of 50 pounds and using 9/16-inch wrench, tighten capscrew (3). Take out bar.
2. Push on belts (4) at point midway between coolant pump pulley (5) and generator pulley (6). Belts should give about 3/4 inch at this point.

GO TO FRAME 7

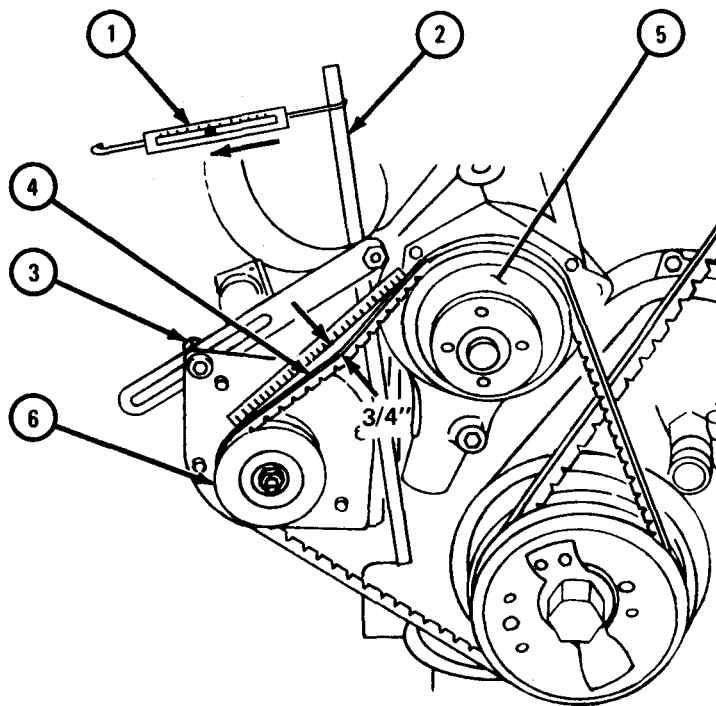

TA 101975

FRAME 7

1. Place fan (1) on hub of drive assembly (2) and align four holes.

NOTE

Hold fan (1) while tightening bolts (3).

2. Screw four bolts (3) with lockwashers (4) through mounting holes in fan (1) and into drive assembly (2).
3. Tighten four bolts (3).

NOTE

Follow-on Maintenance Action Required:

1. Replace radiator. Refer to TM 9-2320-209-20.
2. Close hood and side panels. Refer to TM 9-2320-209-10.

END OF TASK

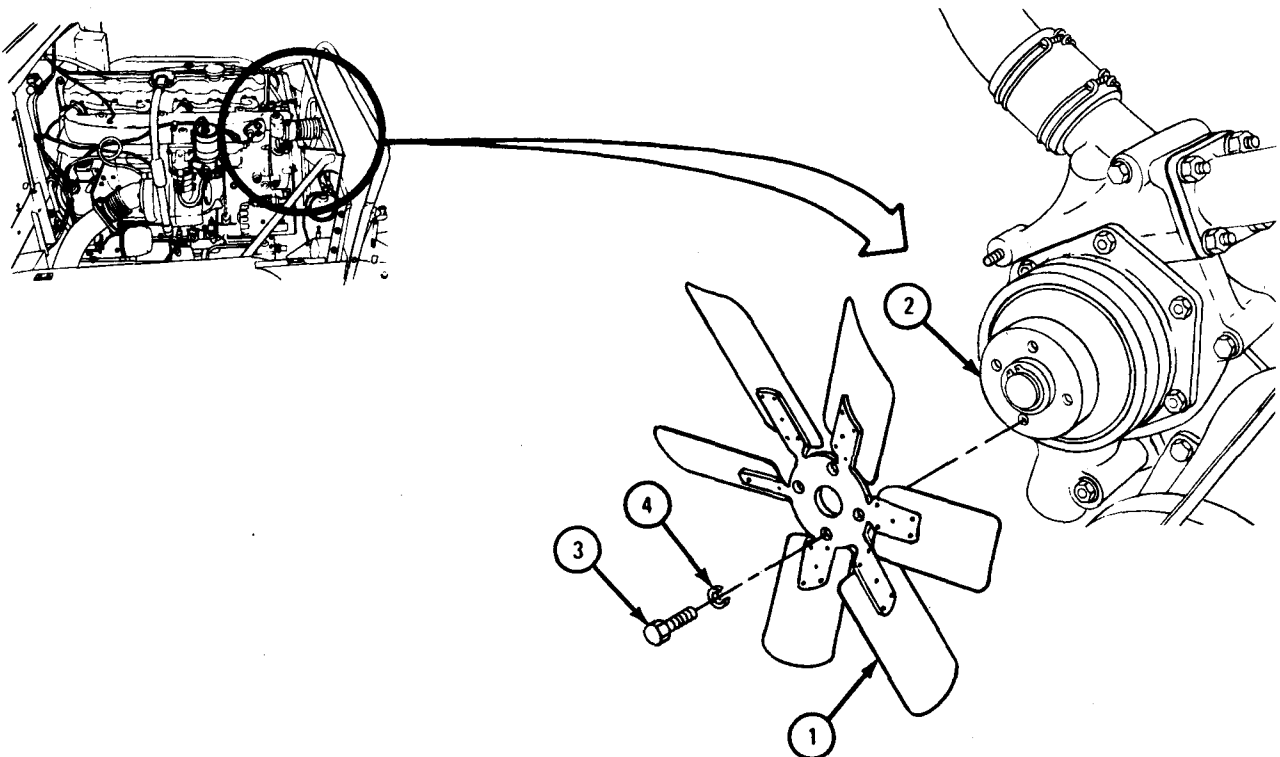

TA 101976

2-9. MAIN BEARINGS REMOVAL AND REPLACEMENT. Refer to TM 9-2815-210-34 for procedures to remove and replace main bearings.

2-10. CRANKSHAFT FRONT OIL SEAL REMOVAL AND REPLACEMENT.

TOOLS: No special tools required

SUPPLIES: Crankshaft front oil seal (outer)
Crankshaft front oil seal (inner)
Lubricating oil, ICE, OE/HDO 10, MIL-L-2104

PERSONNEL: One

EQUIPMENT CONDITION: Truck parked, engine off, handbrake set.

a. Preliminary Procedures.

(1) Remove radiator. Refer to TM 9-2320-209-20.

(2) Remove fan. Refer to Engine Cooling Fan Removal and Replacement, TM 9-2320-209-20.

(3) Remove fan drive belts. Refer to Fan Drive Belts Removal and Replacement, and Adjustment, TM 9-2320-209-20.

(4) Remove tachometer drive adapter and cable. Refer to Tachometer Assembly Removal, Repair, and Replacement, TM 9-2320-209-20.

(5) Remove air compressor drive belt. Refer to TM 9-2320-209-20.

(6) Remove vibration damper and pulley assembly. Refer to para 2-8.

b. Removal.

FRAME 1

1. Using puller, pull out inner oil seal (1) and outer oil seal (2).

END OF TASK

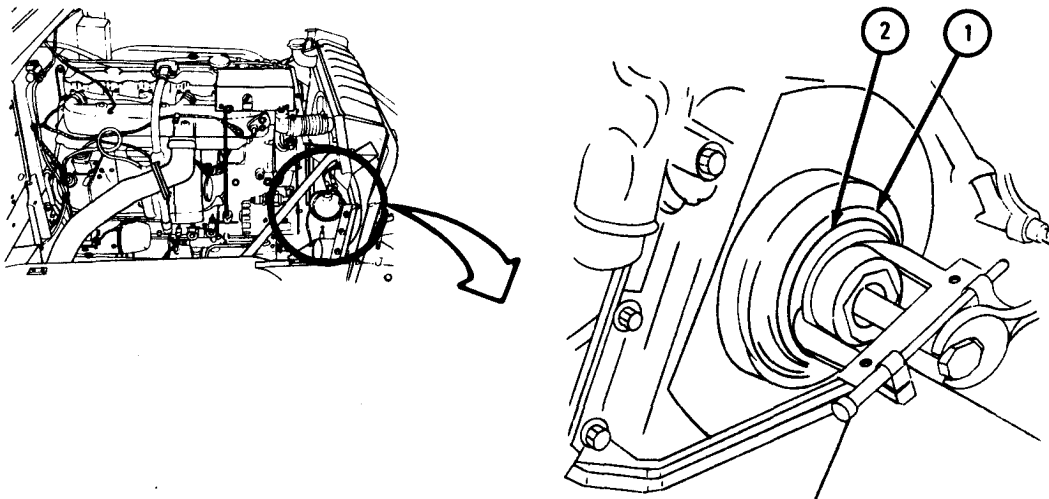

TA 103348

c. Replacement.

FRAME 1

NOTE

Apply a light coat of engine oil on seal (1) and seal (2) before putting them back in.

1. Put seals (1 and 2) on oil seal replacer (3).
2. Put replacer (3) and seals (1 and 2) on crankshaft (4).
3. Put on crankshaft retaining screw (5).
4. Turn retaining screw (5) until seals (1 and 2) are seated inside timing gear cover (6).
5. Take off replacer (3) and take out retaining screw (5).

GO TO FRAME 2

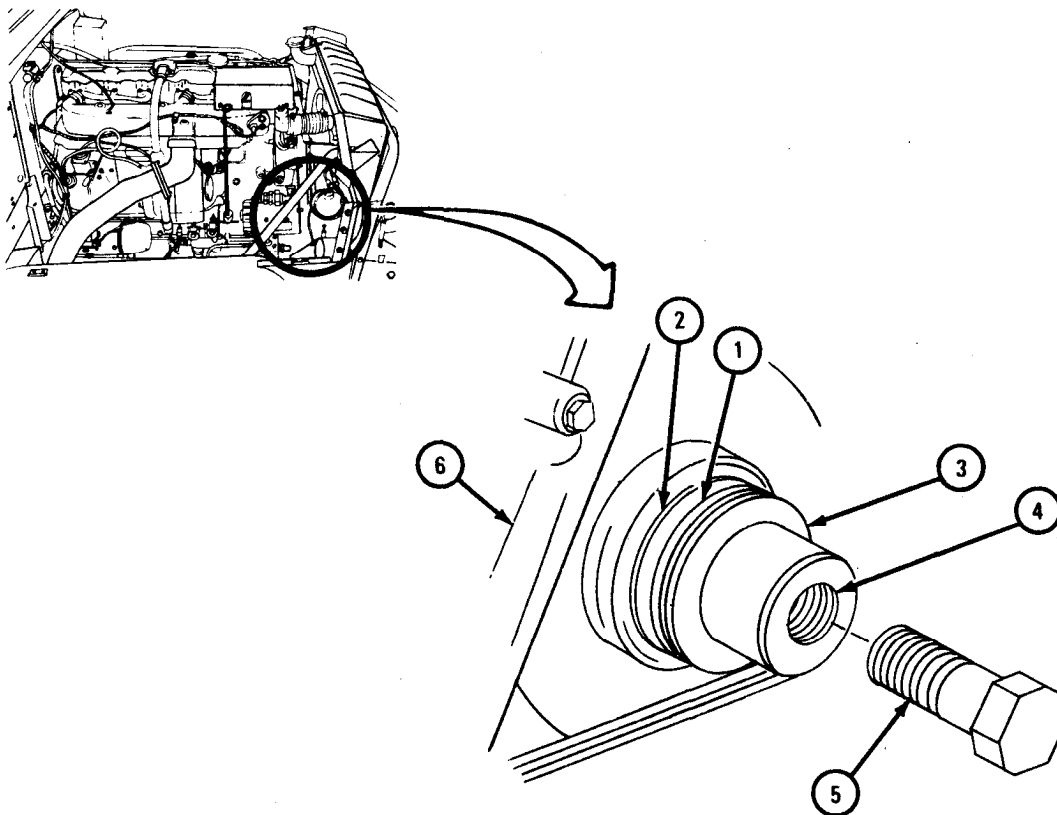

TA 103349

FRAME 2

NOTE

Follow-on Maintenance Action Required:

1. Replace vibration damper and pulley assembly.
Refer to para 2-8.
2. Replace air compressor drive belt. Refer to
TM 9-2320-209-20.
3. Replace tachometer drive adapter and cable.
Refer to Tachometer Assembly Removal, Repair,
and Replacement, TM 9-2320-209-20.
4. Replace fan drive belts. Refer to Fan Drive Belts
Removal, Replacement, and Adjustment,
TM 9-2320-209-20.
5. Replace fan. Refer to Engine Cooling Fan Removal
and Replacement, TM 9-2320-209-20.
6. Replace radiator. Refer to TM 9-2320-209-20.

END OF TASK

Section V. FLYWHEEL

2-11. FLYWHEEL REMOVAL, REPAIR, AND REPLACEMENT (ENGINES LD 465-1, LD 465-1C and LDT 465-1C).

TOOLS: Engine barring tool, ST 747

SUPPLIES: Gasket, transmission adapter

PERSONNEL: Two

EQUIPMENT CONDITION: Truck parked, engine off, handbrake set.

a. Preliminary Procedures.

- (1) Remove transmission. Refer to para 8-4.
- (2) Remove clutch assembly. Refer to para 3-3.
- (3) Remove radiator. Refer to TM 9-2320-209-20.
- (4) Remove engine cooling fan assembly. Refer to TM 9-2320-209-20.
- (5) Remove all drive belts. Refer to TM 9-2320-209-20.

b. Removal.**FRAME 1**

1. Take out 12 capscrews with lockwashers (1).
 2. Take off transmission adapter with gasket (2). Throw gasket away.
- GO TO FRAME 2**

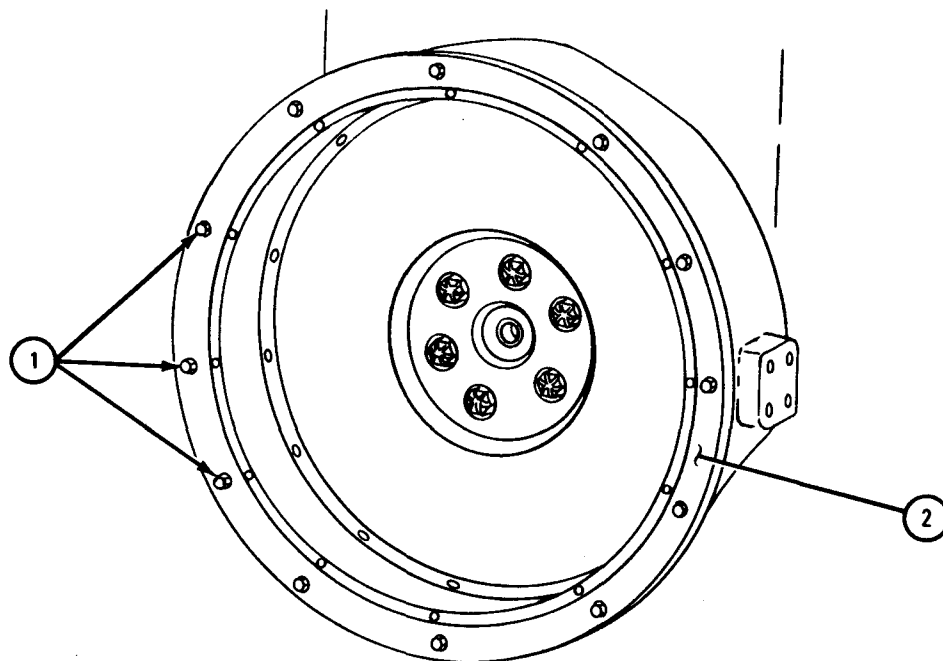

TA 103492

FRAME 2

NOTE

One threaded hole in the crankshaft flange (1) is offset about 1/16 inch. Because of this, flywheel (2) can be replaced on crankshaft flange (1) in only one position.

1. Draw a line on crankshaft flange (1) and edge of flywheel (2) so flywheel can be put back in same position on crankshaft flange.
2. Take off whichever lockbolt (3) is near the top of flywheel (2).

GO TO FRAME 3

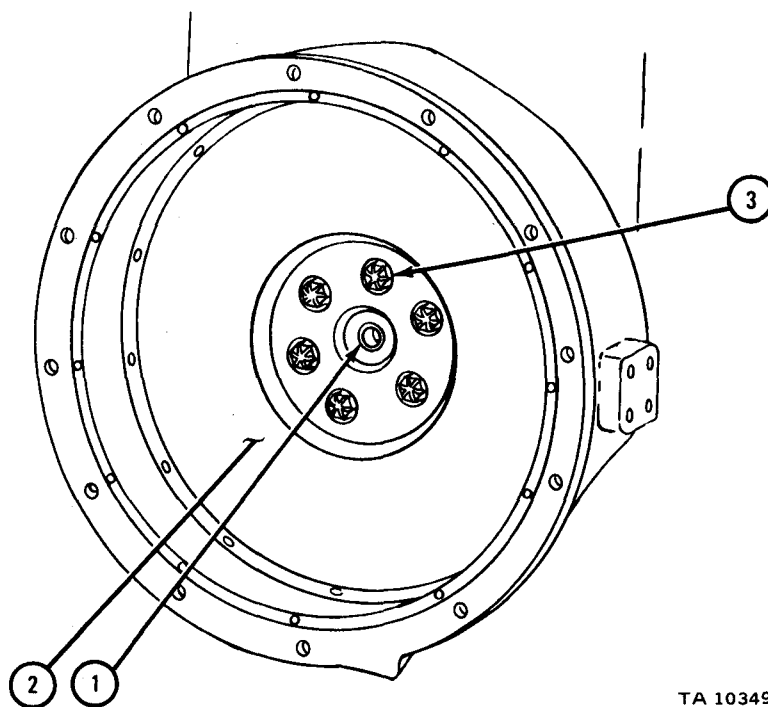

TA 103493

FRAME 3

1. Make a pilot bolt (1) by cutting the head off a 1/2 - 20 x 3 1/2-inch hexhead bolt and grinding sharp edges off cut end.
2. Put pilot bolt (1) in bolt hole in flywheel (2).

WARNING

Flywheel (2) is heavy. Hold it up and against crankshaft firmly when taking out five lock bolts (3). It can fall and cause injury to personnel and damage to equipment.

Soldier A 3. Hold flywheel (2) against crankshaft so it will not fall when five lockbolts (3) are taken out.

Soldier B 4. Take out five lockbolts (3).

Soldiers A and B 5. Hold up flywheel (2) and lift it clear of pilot bolt (1).

END OF TASK

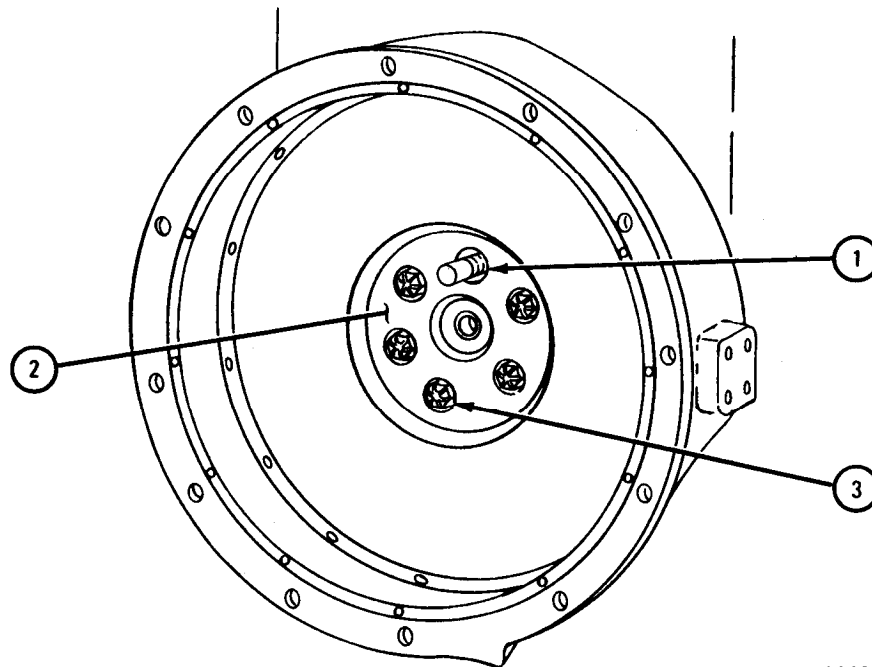

TA 103494

c. Cleaning. There are no special cleaning procedures. For cleaning procedures, refer to TM 9-247.

d. Inspection and Repair. For inspection and repair procedures, refer to TM 9-2815-210-34.

e. Replacement.

FRAME 1

NOTE

One threaded hole in crankshaft flange is offset about 1/16 inch so the flywheel can be put on only in one position. Crankshaft flange and flywheel were marked during removal so flywheel could be easily lined up with crankshaft flange.

Make sure crankshaft flange and flywheel are clean before flywheel is mounted.

WARNING

Flywheel is very heavy and should be lifted and put into place by two people. After flywheel is in position on crankshaft flange with pilot bolt, it must be held firmly. Failure to do this may cause flywheel to fall, causing injury to personnel and damage to equipment.

- Soldiers 1. Lift flywheel (1) into position. Aline scribe marks (2) and slide A and B
A and B flywheel onto pilot bolt (3).
- Soldier A 2. Hold flywheel firmly against crankshaft flange (4).
- Soldier B 3. Coat six lockbolts (5) lightly with engine oil. Put in five lockbolts (5) hand tight.

GO TO FRAME 2

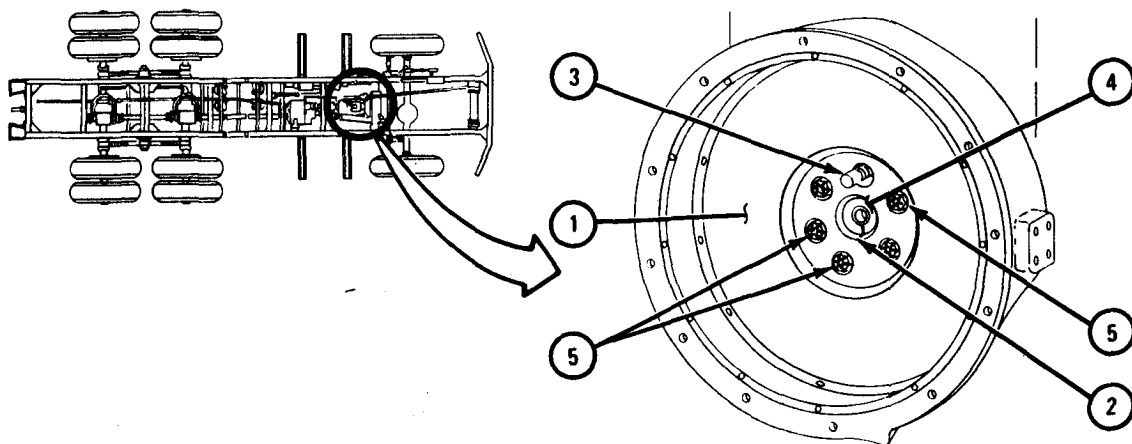

TA 103495

FRAME 2

1. Take out pilot bolt (1). Put in self-locking bolt (2).
 2. Using torque wrench, tighten six self-locking bolts (3) to 80 to 90 lb-ft.
 3. Using torque wrench, tighten six self-locking bolts (3) to 115 to 120 lb-ft.
- END OF TASK

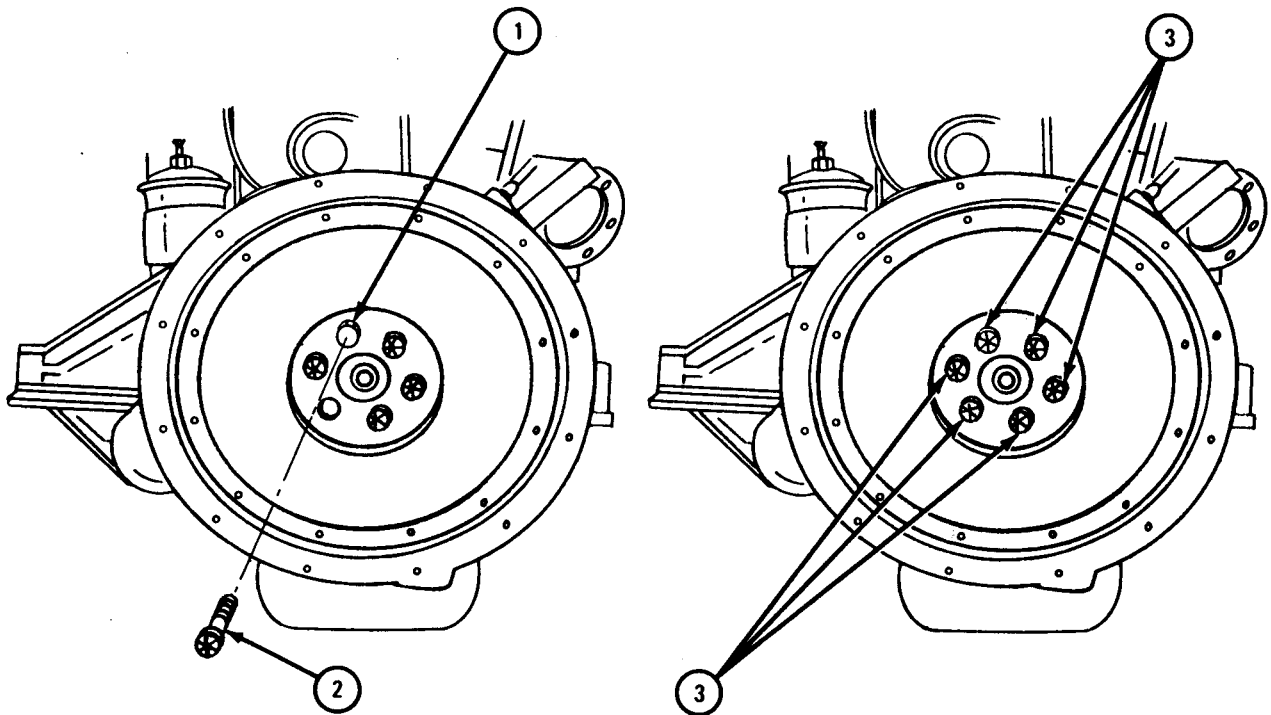

TA 103496

f. Test.

FRAME 1

NOTE

Flywheel (1) must be pushed firmly in against engine when dial indicator is set to zero, while pulley (2) is turned, and while dial indicator is read. If this is not done, readings may be wrong.

- Soldier A 1. Mount dial indicator on flywheel housing (3) as shown.
2. Make chalk mark (4) on flywheel (1) as shown.
3. Set dial indicator to 0. Tell soldier B when ready.
- Soldier B 4. When soldier A is ready, using engine barring wrench, turn pulley (2) slowly to the right until soldier A says to stop.
- Soldier A 5. Note dial indicator readings. When chalk mark (4) reaches dial indicator again, tell soldier B to stop.
- Soldiers A and B 6. Check your reading by doing steps 3 through 5 again.
7. If reading noted in Step 5 is more than 0.008 inch, do the following:
(a) Remove flywheel. Refer to para 2-11b.
(b) Clean, inspect, and repair flywheel. Refer to TM 9-2815-210-34.
(c) Replace flywheel. Refer to para 2-11e.
(d) Do steps 1 through 6 again.
8. Take off dial indicator.

GO TO FRAME 2

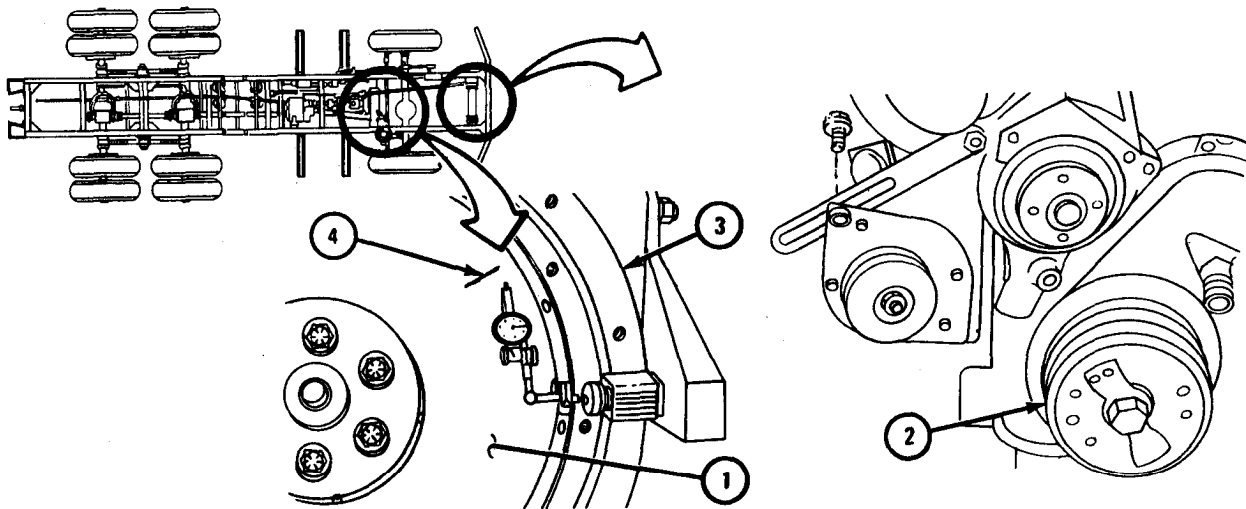

TA 103982

FRAME 2

NOTE

Be sure flywheel housing, transmission adapter gasket, and transmission adapter are clean before putting adapter and gasket on flywheel housing.

1. Put transmission adapter with gasket (1) on flywheel housing (2). Aline holes and notch.
2. Put in twelve capscrews with lockwashers (3).
3. Using torque wrench, tighten twelve capscrews to 23 to 27 pound-feet.

GO TO FRAME 3

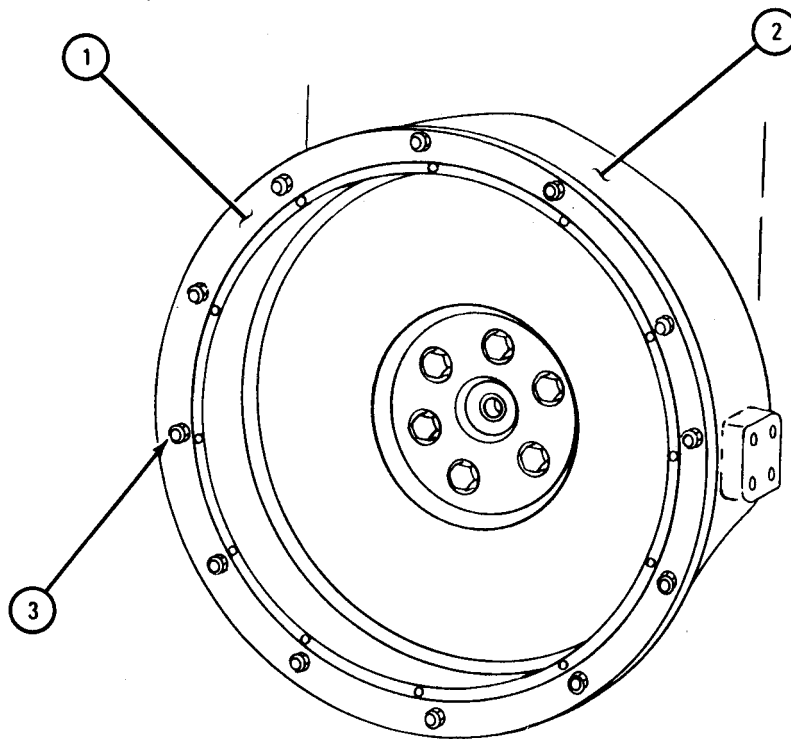

TA 103983

FRAME 3

NOTE

While checking transmission adapter face, runout pressure must be exerted against flywheel (1) to eliminate possibility of crankshaft end play causing a bad reading.

- Soldier A 1. Mount dial indicator on face of flywheel (1) and place dial indicator arm against face of transmission adapter (2). Tell soldier B when ready.
- Soldier B 2. Using engine barring tool on crankshaft pulley, turn pulley one complete turn to the right.

NOTE

If runout exceeds 0.008 inch, remove transmission adapter and check for foreign material between adapter and flywheel housing face. Replace adapter and do steps 1, 2, and 3 again. If runout still exceeds 0.008 inch, get a new adapter.

- Soldier A 3. Read dial indicator. Runout must not exceed 0.008 inch.
4. Take off dial indicator.

GO TO FRAME 4

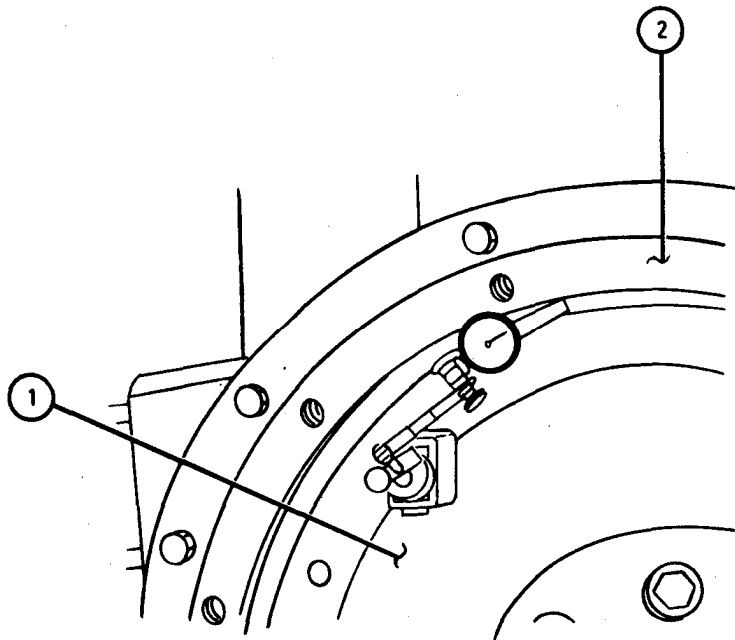

TA 103984

FRAME 4

Soldier A 1. Mount dial indicator on face of flywheel (1) and place dial indicator arm against inside edge of transmission adapter (2). Tell soldier B when ready.

Soldier B 2. Using engine barring tool, on crankshaft pulley, turn pulley one complete turn to the right.

NOTE

If runout exceeds 0.008 inch, get a new transmission adapter.

Soldier A 3. Read dial indicator. Runout must not exceed 0.008 inch.
4. Take off dial indicator.

NOTE

Follow-on Maintenance Action Required:

1. Replace clutch assembly. Refer to para 3-3.
2. Replace transmission. Refer to para 8-4.
3. Replace all drive belts. Refer to TM 9-2320-209-20.
4. Replace engine fan assembly. Refer to TM 9-2320-209-20.
5. Replace radiator. Refer to TM 9-2320-209-20.

END OF TASK

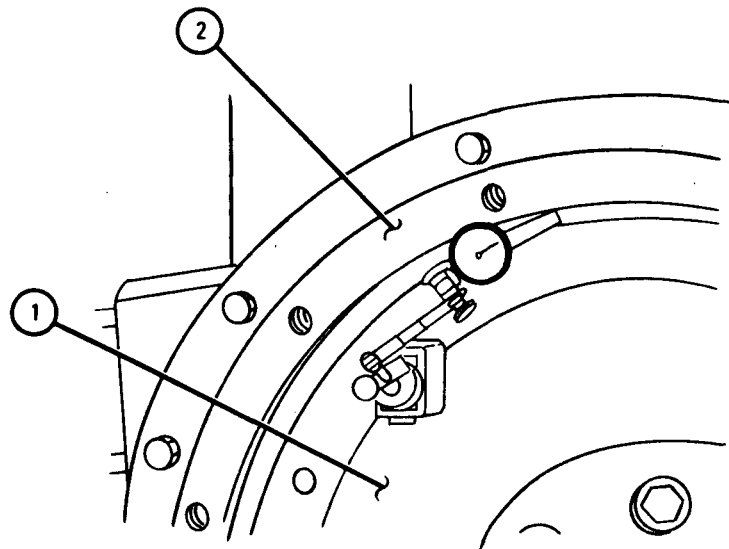

TA 103985

Section VI. PISTONS AND CONNECTING RODS

2-12. CONNECTING ROD BEARINGS REMOVAL AND REPLACEMENT. Refer to TM 9-2815-210-34 for procedures to remove and replace connecting rod bearings.

2-13. PISTON AND CONNECTING ROD ASSEMBLY REMOVAL, REPAIR, AND REPLACEMENT. Refer to TM 9-2815-210-34 for procedures to remove, repair, and replace piston and connecting rod assembly.

Section VII. VALVES, CAMSHAFT, AND TIMING SYSTEM

2-14. POPPET VALVE PUSHROD REMOVAL AND REPLACEMENT.

TOOLS: No special tools required

SUPPLIES: Gasket, front cylinder head cover
Gasket, rear cylinder head cover
Washer, breather tube adapter flat copper (4)

PERSONNEL: Two

EQUIPMENT CONDITION: Truck parked, engine off, handbrake set.

a. Preliminary Procedure. Open hood and side panel. Refer to TM 9-2320-209-10.

b. Removal.**FRAME 1**

1. Take off oil filler cap (1).
2. Take off four self-locking nuts (2), clamp (3), and four flat copper washers (4).
3. Loosen two clamps (5). Slide hose (6) down breather tube (7).
4. Take off breather tube adapter (8) and two gaskets (9).

GO TO FRAME 2

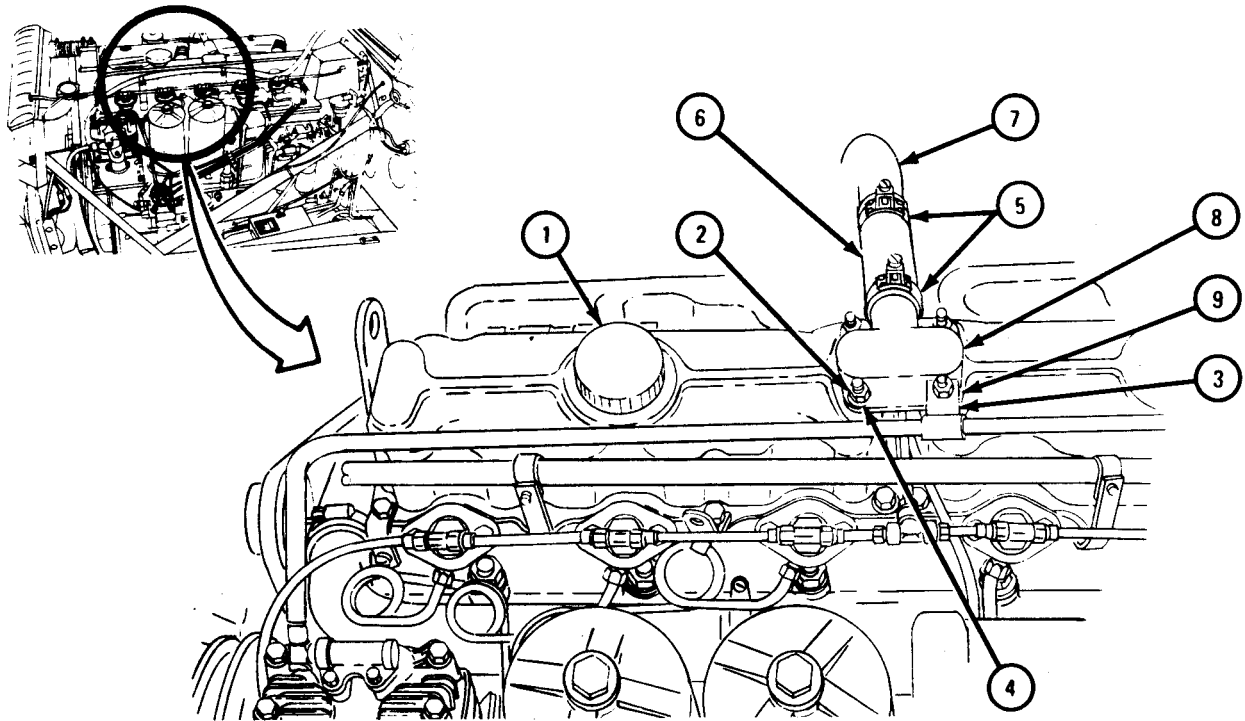

TA 103317

FRAME 2

1. Take off two coupling nuts (1). Take off air line (2).
GO TO FRAME 3

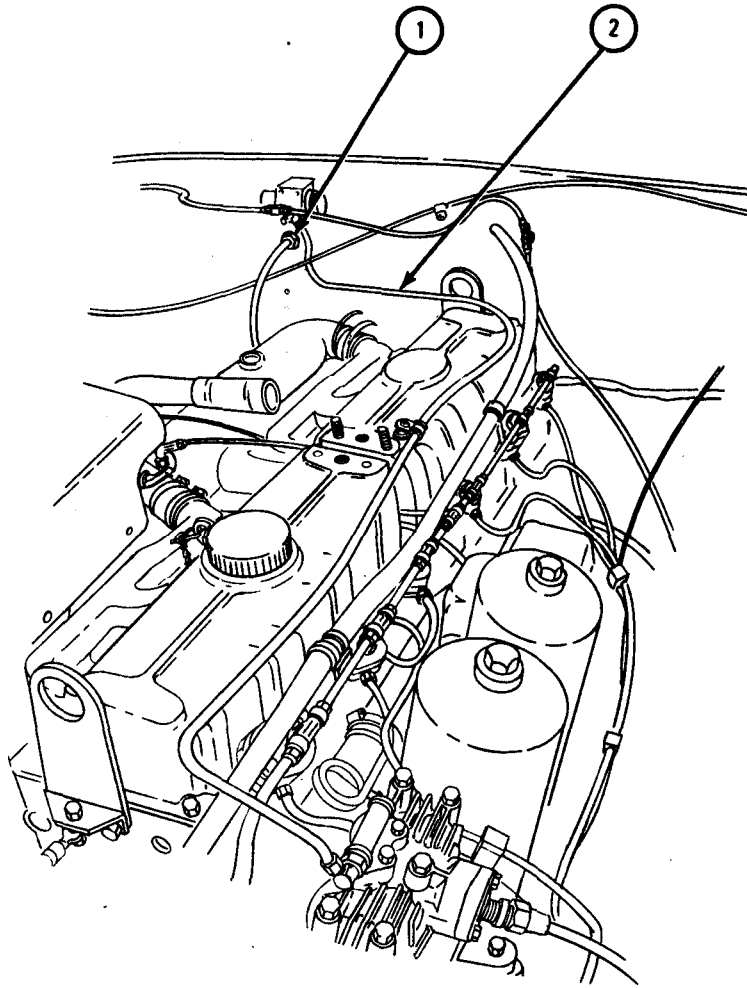

TA 103435

FRAME 3

1. Take out seven lockbolts (1) and flat washers (2).
2. Take off tachometer cable bracket (3).
3. Take off self-locking nut (4) and flat washer (5).
4. Take off front cylinder head cover (6) and gasket (7). Throw away gasket.
5. Do steps 1 through 4 again for rear cylinder head cover (8).

GO TO FRAME 4

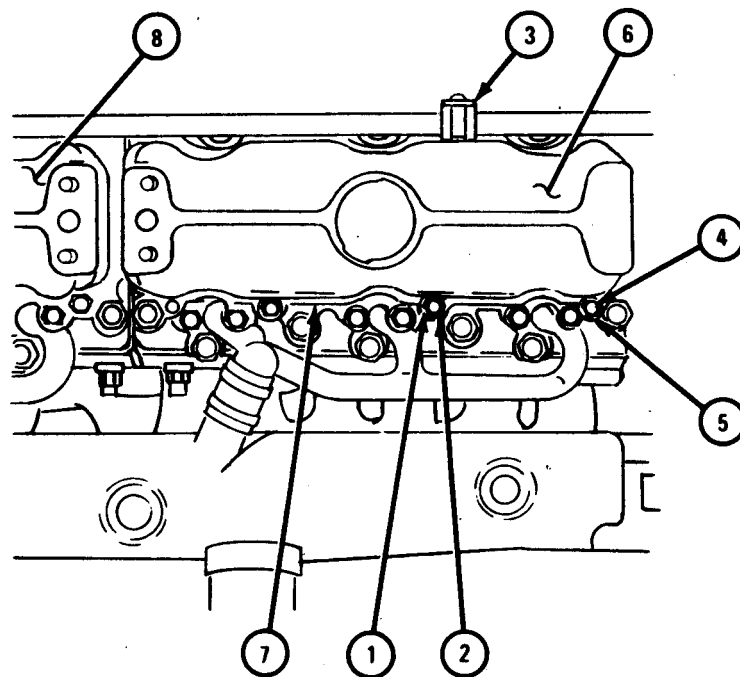

TA 103318

FRAME 4

1. Loosen six adjusting screw locknuts (1) and adjusting screws (2).
 2. Take out six capscrews (3) and lockwasher (4).
 3. Take off front rocker arm assembly (5).
 4. Take out six front cylinder poppet valve pushrods (6).
 5. Do steps 1 through 4 again for six rear cylinder poppet valve pushrods (7).
- END OF TASK

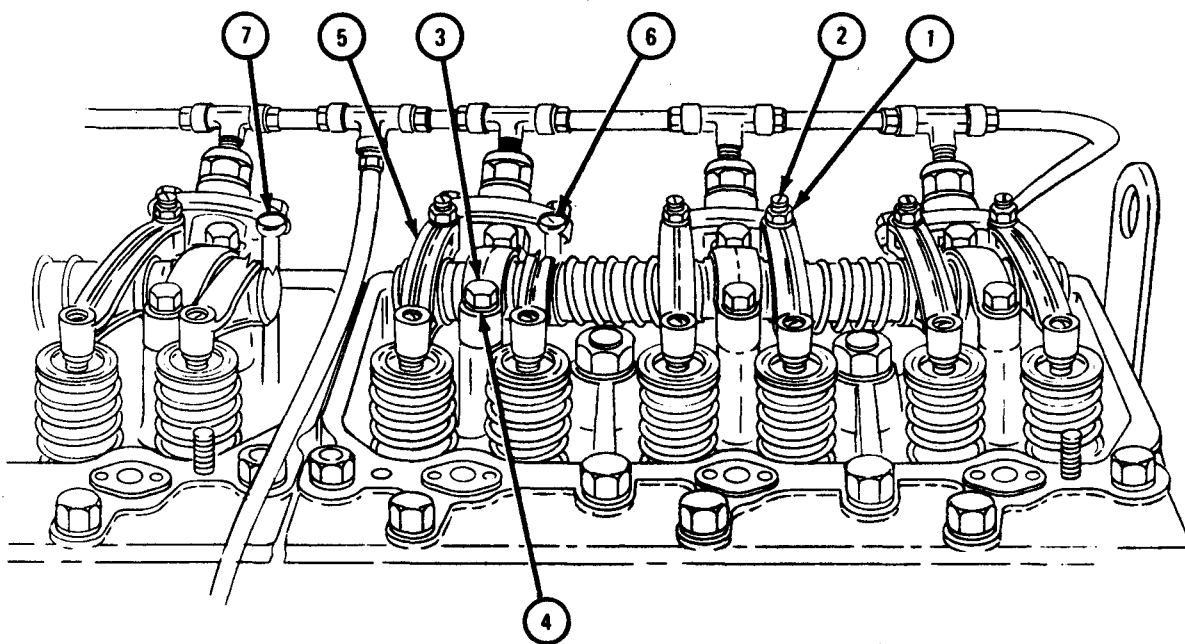

TA 103319

c. Replacement.

FRAME 1

1. Put in six front cylinder poppet valve pushrods (1).
2. Put front rocker arm assembly (2) into place, alining screwholes.
3. Put in and hand tighten six capscrews (3) and lockwashers (4).
4. Do steps 1 through 3 again for rear rocker arm assembly (5).
5. Torque 12 capscrews (3) to 28 pound-feet.

GO TO FRAME 2

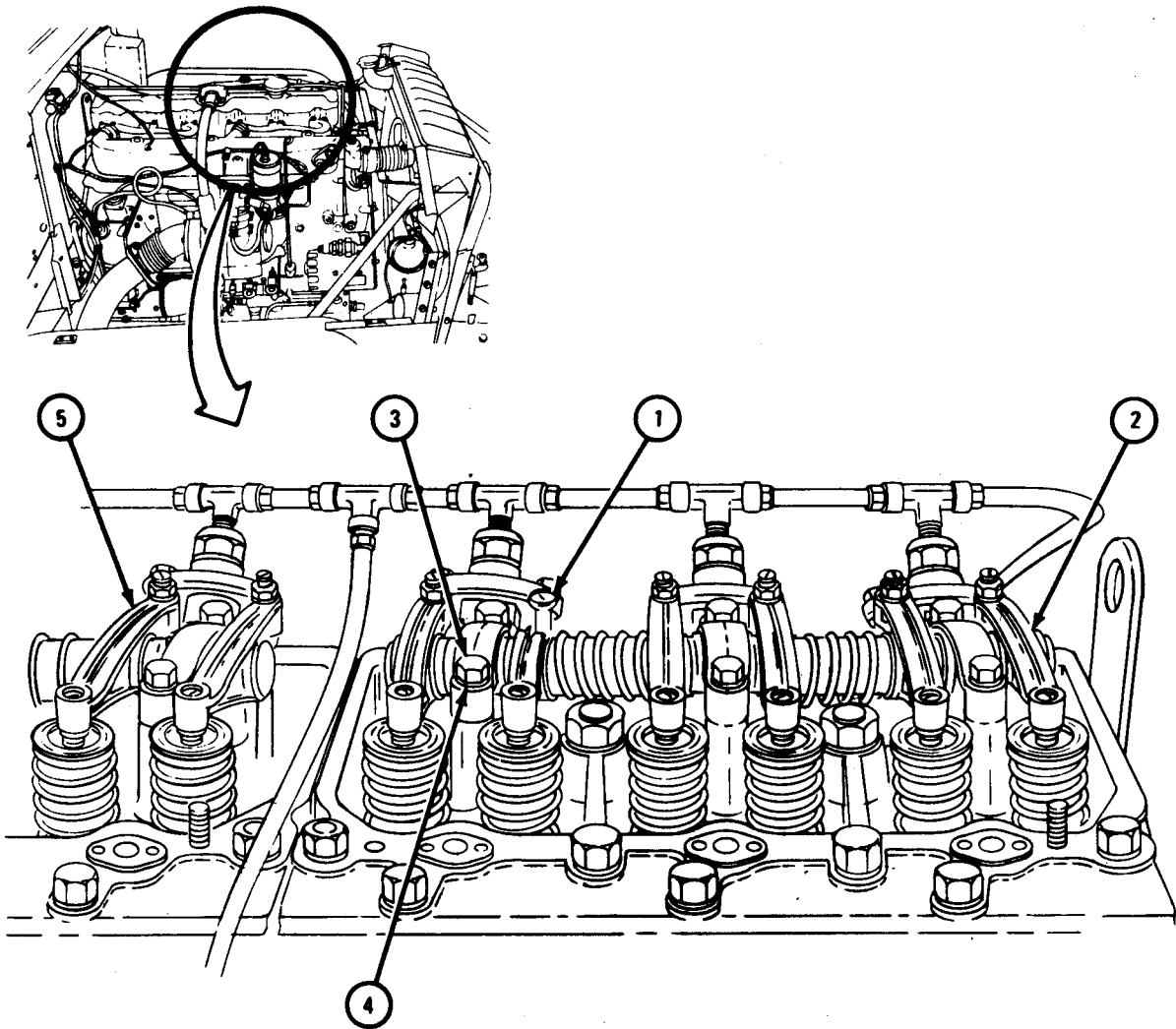

TA 103320

FRAME 2

- Soldier A
1. Put transfer shift lever (1) in neutral position. Refer to Driver's Compartment Controls and Indicators, TM 9-2320-209-10.
 2. Put transmission gearshift lever (2) in 4th gear.
 3. Pull out ENG STOP control (3) and turn to lock position. Refer to Driver's Compartment Controls and Indicators, TM 9-2320-209-10.
 4. Push START button (4) and let go quickly.
 5. Do step 4 until soldier B tells you to stop.

NOTE

Cylinders are numbered from front of truck to rear. Intake valves are toward front of truck.

- Soldier B
6. Watch cylinder No. 1 intake rocker arm pushrod (5). When pushrod is almost in its highest position, tell soldier A to stop.

GO TO FRAME 3

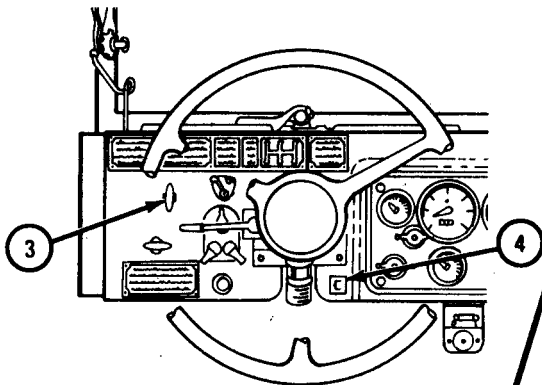
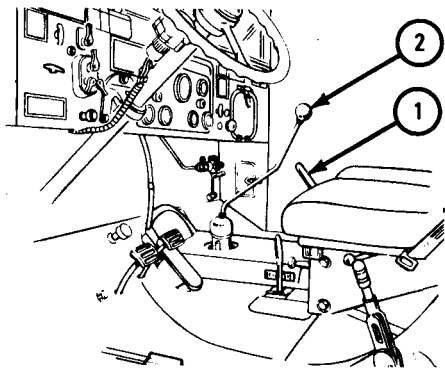

SOLDIER A

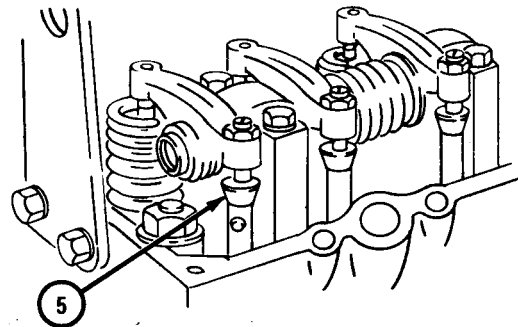
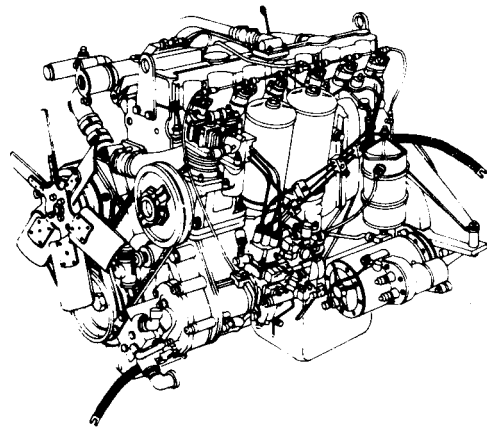

SOLDIER B

TA 118452

FRAME 3

CAUTION

Turn transmission-to-transfer propeller shaft (1) only to the right to stop damage to equipment.

Soldier A 1. Working under truck, and using bar (2), turn transmission-to-transfer propeller shaft (1) to the right until soldier B tells you to stop.

Soldier B 2. Watch cylinder No. 1 intake valve rocker arm pushrod (3). When pushrod is in its highest position, tell soldier A to stop.

GO TO FRAME 4

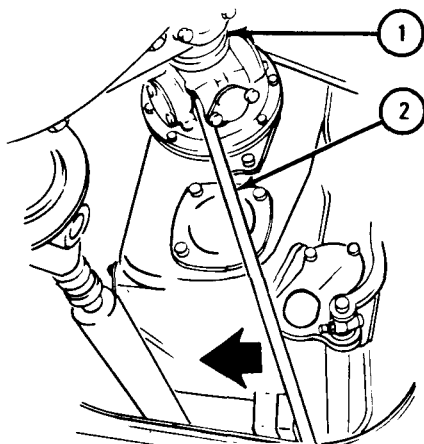
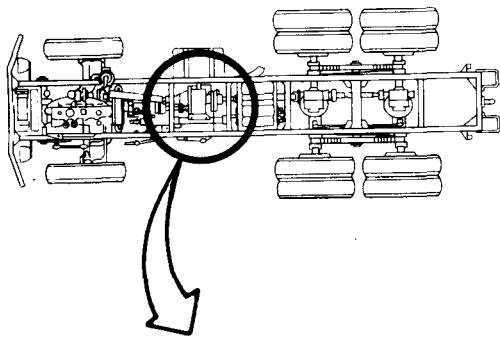

SOLDIER A

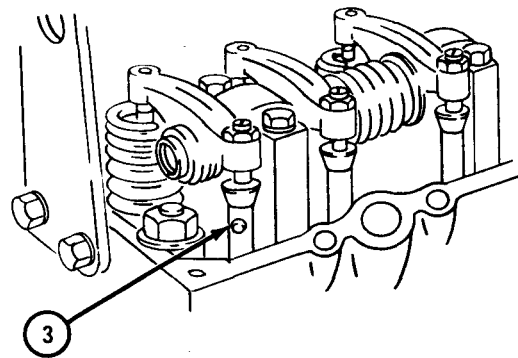

SOLDIER B

TA 118453

FRAME 4

NOTE

Cylinder No. 1 intake valve is now fully open. Intake valves for cylinders Nos. 2, 3, and 6 and exhaust valves for cylinders Nos. 1, 2, and 4 must be set in this position. Use 0.010-inch feeler gage for intake valves and 0.025-inch feeler gage for exhaust valves. Do step 1 for intake valves Nos. 2, 3, and 6 and exhaust Nos. 1, 2, and 4.

1. Push feeler gage between rocker arm pad (1) and cylinder No. 2 intake valve stem (2).

IF FEELER GAGE DOES NOT FIT WELL FOR ANY VALVE, GO TO FRAME 5.
IF FEELER GAGE FITS WELL FOR ALL VALVES, GO TO FRAME 6

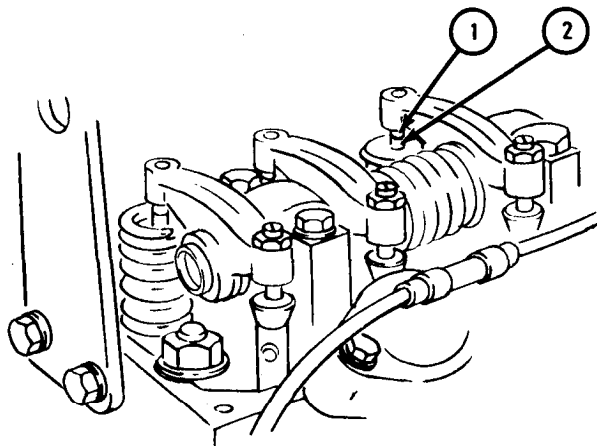

TA 118455

FRAME 5

NOTE

These steps must be done for any valve where the feeler gage does not fit well.

1. Keep adjusting screw (1) from moving and loosen locknut (2).
2. Turn adjusting screw (1) until feeler gage fits well between rocker arm pad (3) and valve stem (4).
3. Keep adjusting screw (1) from moving and tighten locknut (2).

GO TO FRAME 6

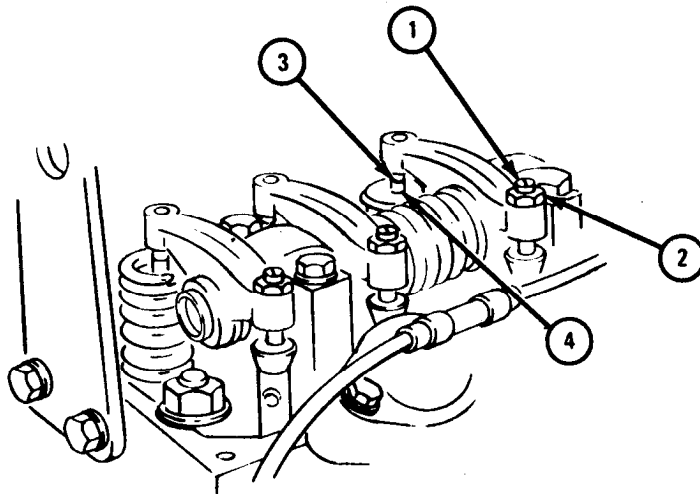

TA 103323

FRAME 6

- Soldier A**
1. Put transmission gearshift lever (1) in neutral position.
 2. Push START button (2) and let go quickly.
 3. Do step 2 until soldier B tells you to stop.
- Soldier B**
4. Watch cylinder No. 6 intake valve rocker arm push rod (3). When pushrod is almost in its highest position, tell soldier A to stop.
- Soldier A**
5. Put transmission gearshift lever (1) in 4th gear.
- GO TO FRAME 7**

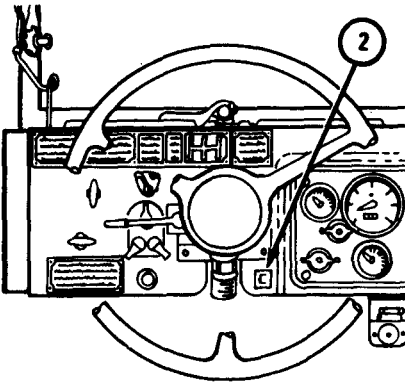
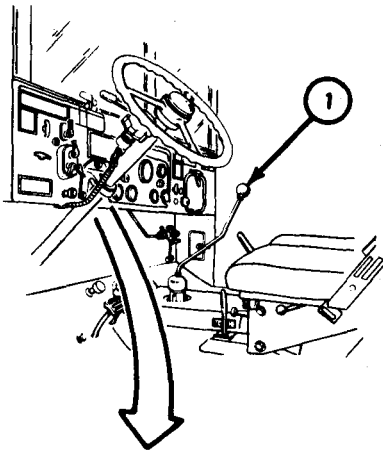

SOLDIER A

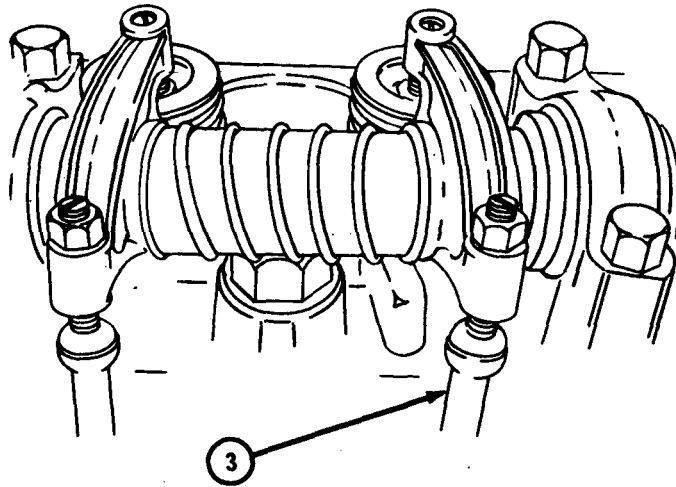

SOLDIER B

TA 103486

FRAME 7

CAUTION

Turn transmission-to-transfer propeller shaft (1) only to the right to stop damage to equipment.

Soldier A 1. Working under truck and using bar (2), turn transmission-to-transfer propeller shaft (1) to the right until soldier B tells you to stop.

Soldier B 2. Watch cylinder No. 6 intake valve rocker arm pushrod (3). When pushrod is in its highest position, tell soldier A to stop.

3. Set intake valves Nos. 1, 4, and 5 and exhaust valves Nos. 3, 5 and 6. Refer to para 2-6, d, frames 10, 11, and 12.

GO TO FRAME 8

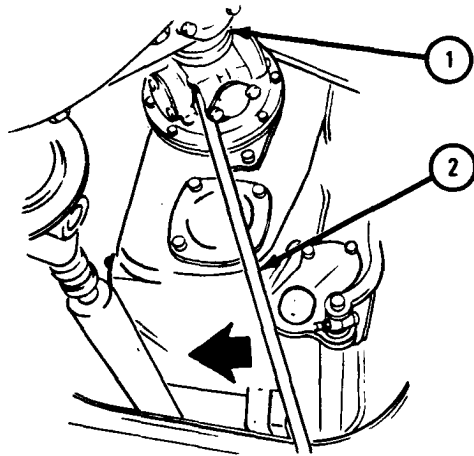
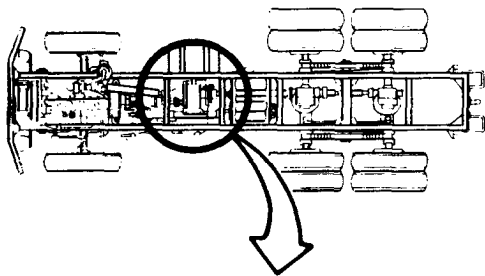

SOLDIER A

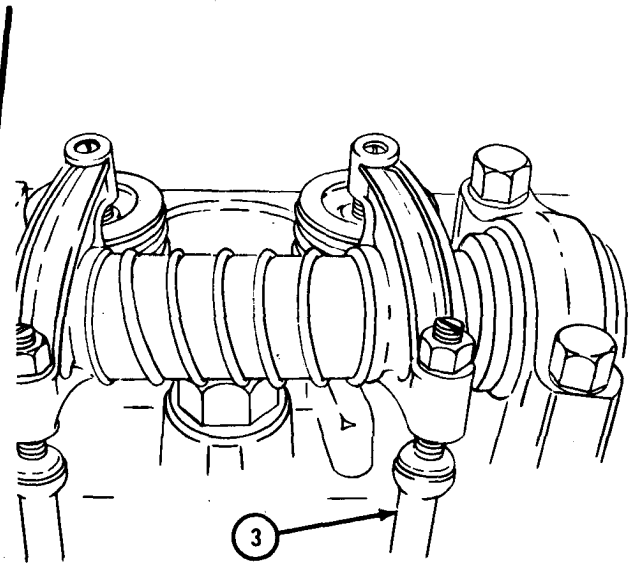

SOLDIER B

TA 103487

FRAME 8

1. Put transmission gearshift lever (1) in neutral position.
2. Put transfer shift lever (2) in HIGH position.
3. Unlock and push in ENG STOP control (3).

GO TO FRAME 9

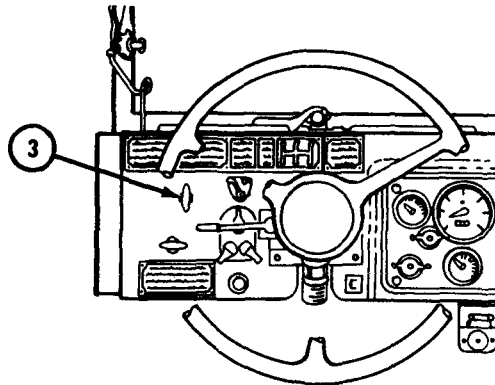
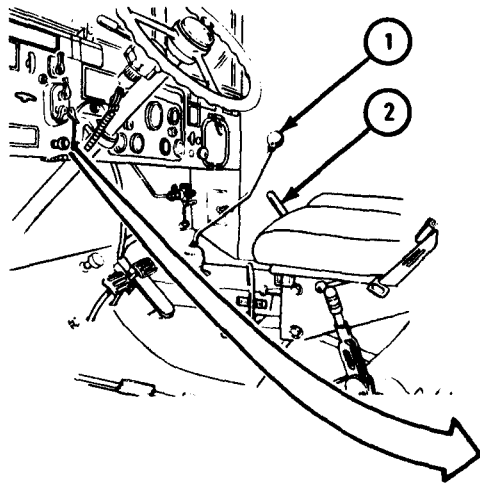

TA 118454

FRAME 9

1. Put on front cylinder head cover gasket (1) and front cylinder head cover (2), alining screw holes.
2. Put tachometer cable mounting bracket (3) in place, alining screw holes. Put in lockbolt and flat washer (4).
3. Put in six lockbolts and flat washers (5).
4. Put on flat washer (6) and self-locking nut (7).
5. Tighten lockbolt (4), six lockbolts (5), and self-locking nut (7) to 55 to 60 pound-inches.
6. Do step 5 again.
7. Do step 1 through 6 again for rear cylinder head cover (8).

GO TO FRAME 10

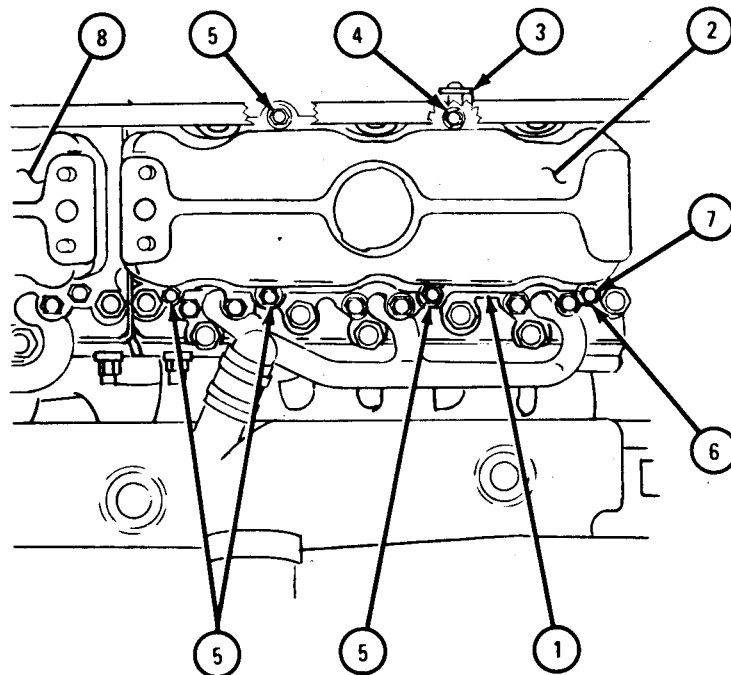

TA 103321

FRAME 10

1. Put two gaskets (1) and breather tube adapter (2) in place.
2. Put on four flat copper washers (3).
3. Put air line (4) in place. Put air line clamp (5) on stud (6).
4. Put on four self-locking nuts (7).
5. Slide hose (8) in place and tighten two clamps (9).

GO TO FRAME 11

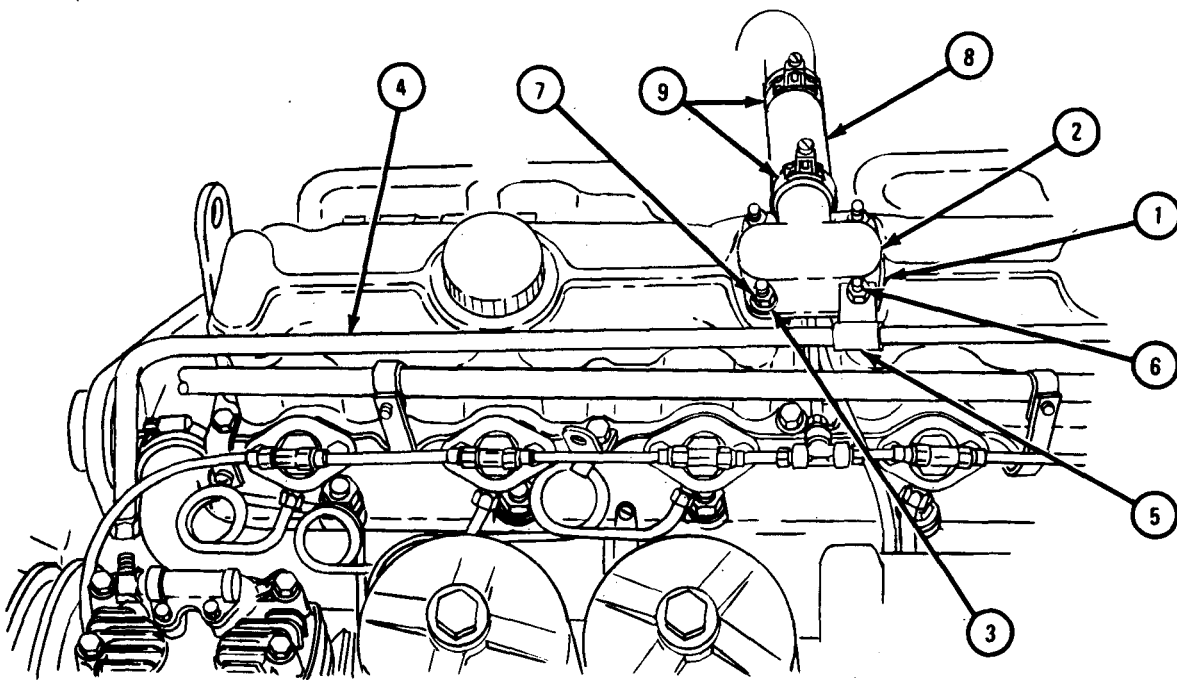

TA 103322

FRAME 11

1. Put on two coupling nuts (1) and filler caps (2).

NOTE

Follow-on Maintenance Action Required:

Close hood and side panels. Refer to TM 9-2320-209-10.

END OF TASK

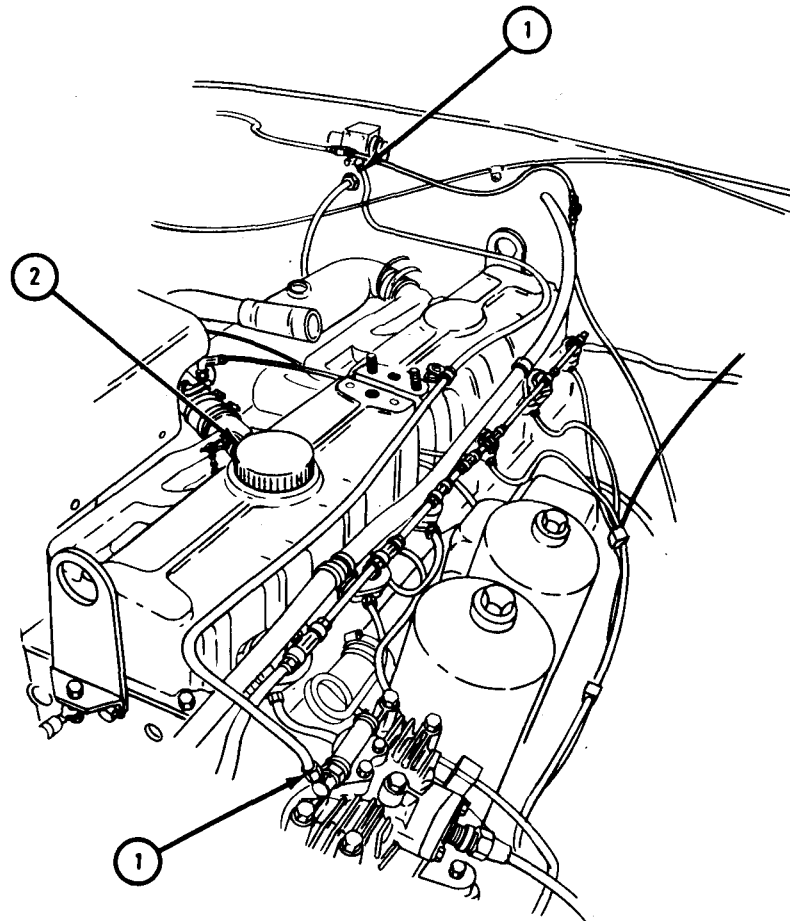

TA 103488

2-15. CAMSHAFT ASSEMBLY REMOVAL AND REPLACEMENT.

TOOLS: Mechanical puller kit, pn 8708724

SUPPLIES: Gear cover-to-engine front plate gasket

PERSONNEL: One

EQUIPMENT CONDITION: Truck parked, engine off, handbrake set.

a. Preliminary Procedures.

- (1) Open hood. Refer to TM 9-2320-209-10.
- (2) Drain cooling system. Refer to TM 9-2320-209-20.
- (3) Remove radiator. Refer to TM 9-2320-209-20.
- (4) Remove fuel filter. Refer to TM 9-2320-209-20.
- (5) Remove oil filter. Refer to TM 9-2320-209-20.
- (6) Remove injector lines. Refer to TM 9-2815-210-34.
- (7) Remove oil cooler. Refer to para 2-18.
- (8) Remove engine cooling fan. Refer to TM 9-2320-209-20.
- (9) Remove all drive belts. Refer to TM 9-2320-209-20.
- (10) Remove air compressor and air compressor bracket. Refer to TM 9-2320-209-20.
- (11) Remove water pump. Refer to TM 9-2320-209-20.
- (12) Remove tappet chamber cover. Refer to TM 9-2815-210-34.
- (13) Remove crankcase breather adapter. Refer to TM 9-2815-210-34.
- (14) Remove rocker arm cover. Refer to TM 9-2815-210-34.
- (15) Remove rocker arm assembly. Refer to TM 9-2815-210-34.
- (16) Remove push rods. Refer to para 2-14.
- (17) Remove valve tappets. Refer to TM 9-2815-210-34.
- (18) Remove vibration damper and pulley assembly. Refer to para 2-8.
- (19) Remove tachometer right angle adapter and flexible shaft. Refer to Tachometer Assembly, TM 9-2320-209-20
- (20) Remove injector pump drive gear access cover. Refer to para 2-16.
- (21) Remove oil pan. Refer to TM 9-2815-210-34.

b. Removal.

FRAME 1

1. Take out six capscrews and lockwashers (1).
2. Take off nut with lockwasher (2).
3. Take out two capscrews (3), lockwashers (4), and nuts (5).
4. Take off timing cover (6) and gasket (7). Throw away gasket.

GO TO FRAME 2

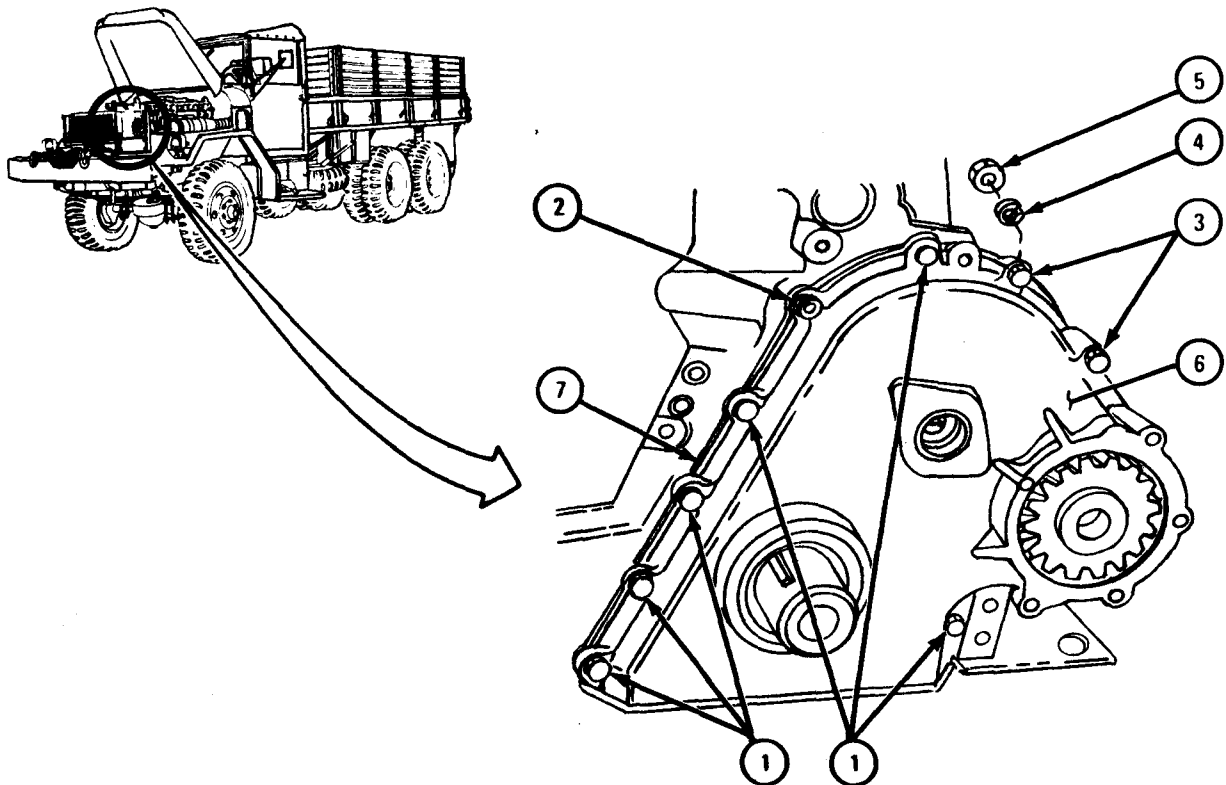

TA 105259

FRAME 2

1. Pull off camshaft dirt and liquid deflector (1).
2. Put brass rod (2) between camshaft gear (3) and crankshaft gear (4).
3. Take off nut (5).

GO TO FRAME 3

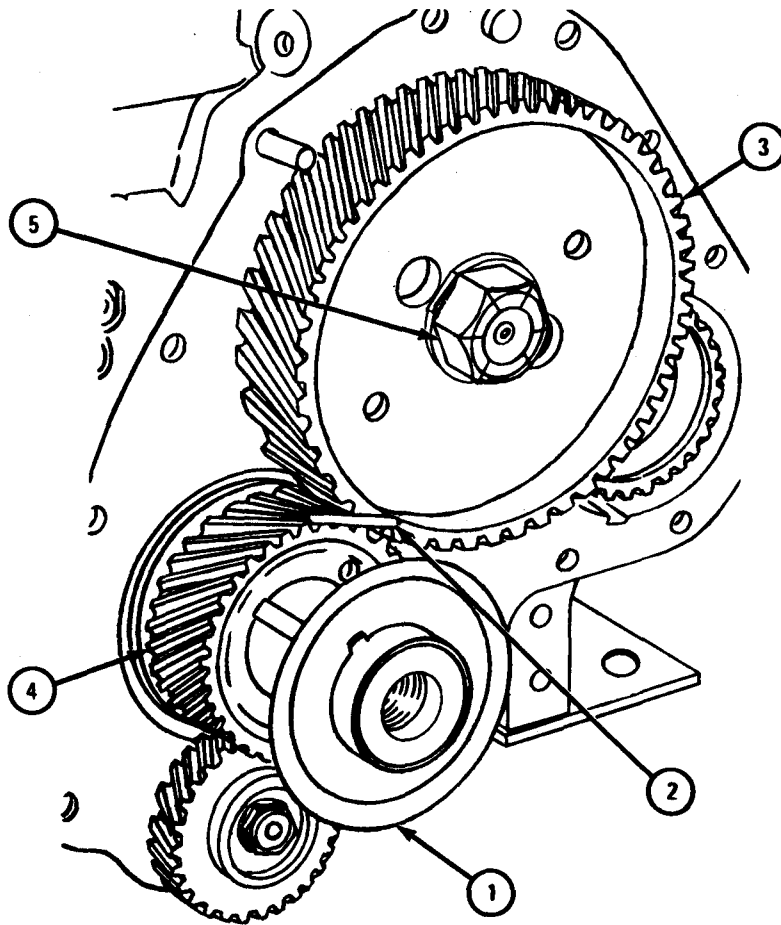

TA 105260

FRAME 3

1. Using mechanical puller, take off camshaft gear (1).
- GO TO FRAME 4

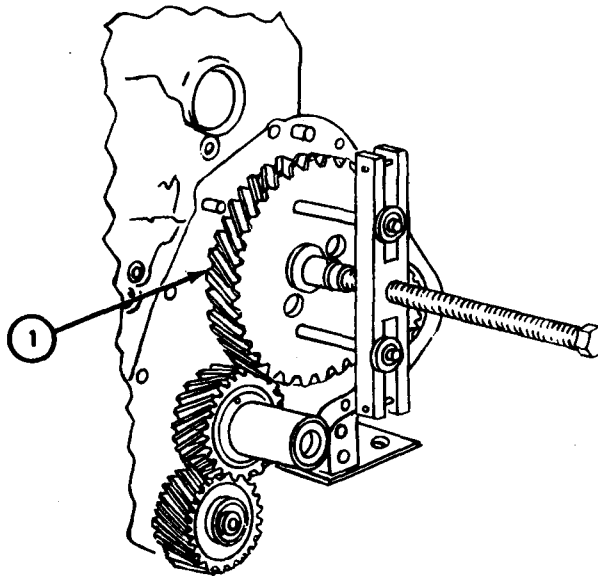

TA 105261

FRAME 4

1. Take out two capscrews (1) and lockwashers (2).
2. Take off thrust plate (3).
3. Take out camshaft assembly (4).

END OF TASK

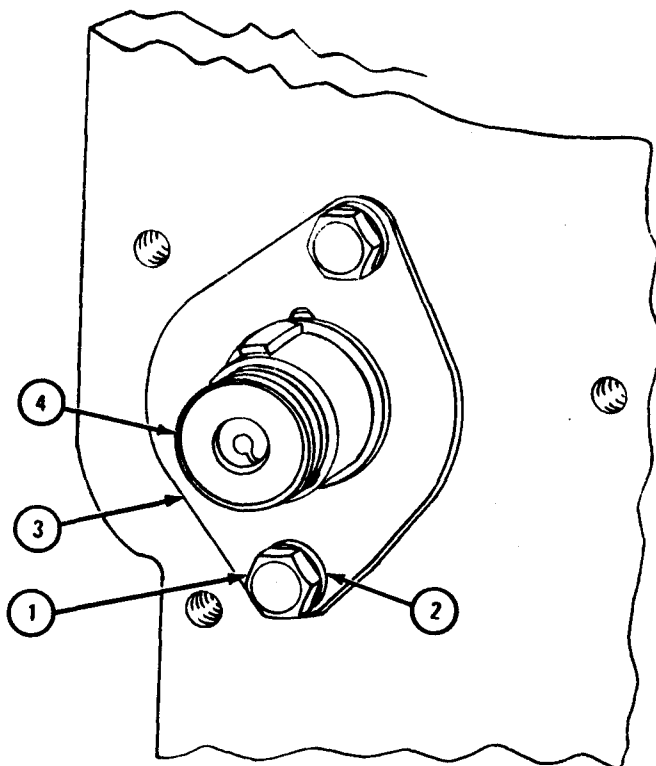

TA 105262

c. Replacement.

FRAME 1

1. Put camshaft assembly (1) into engine block (2).
2. Put thrust plate (3) in place and align screw holes.
3. Put in two capscrews (4) and lockwashers (5).

GO TO FRAME 2

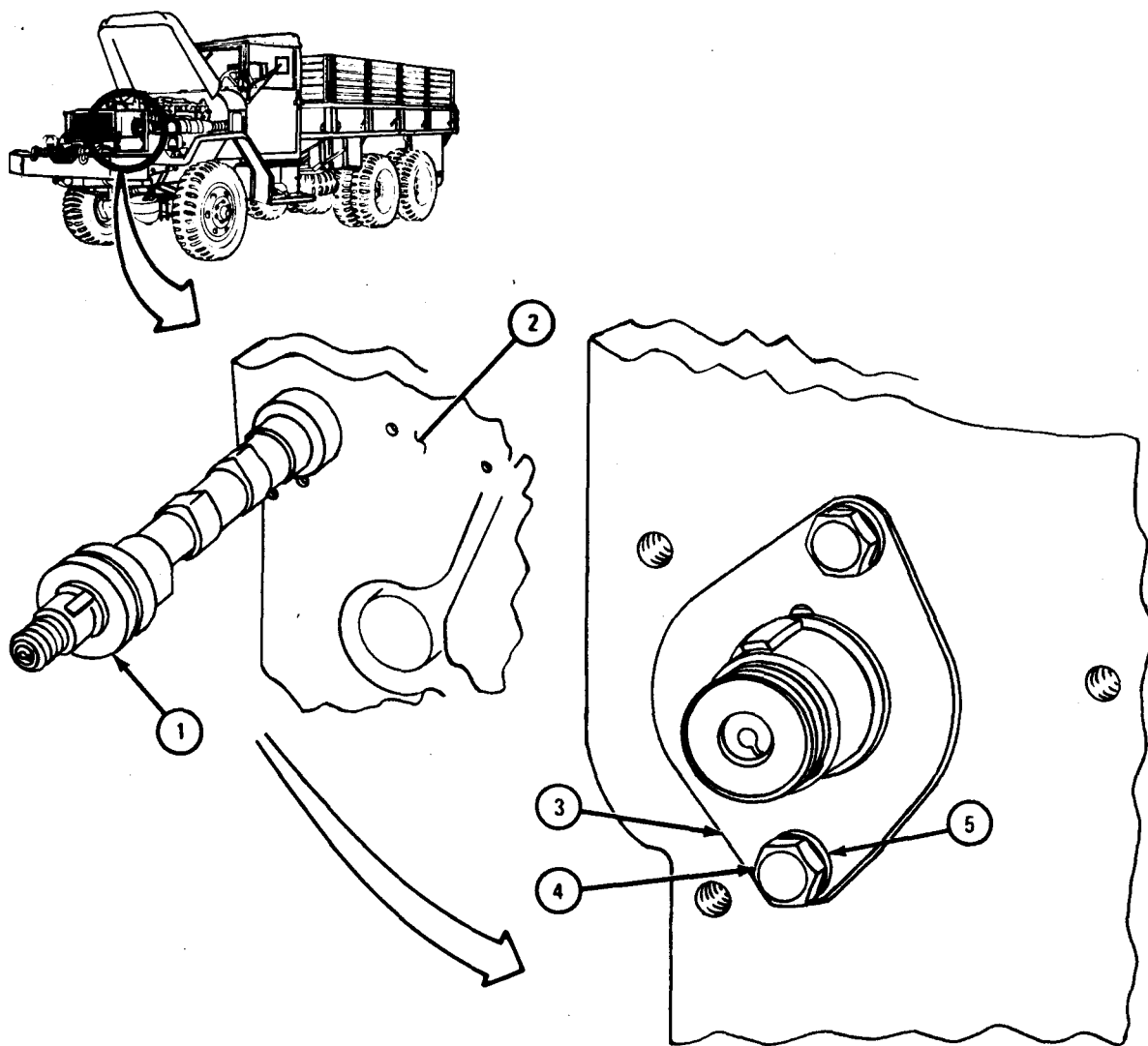

TA 105263

FRAME 2

1. Put on camshaft gear (1).
2. Put brass rod (2) between camshaft gear (1) and crankshaft gear (3).
3. Put on nut (4).
4. Take out brass rod (2).
5. Put on camshaft dirt and liquid deflector (5).

GO TO FRAME 3

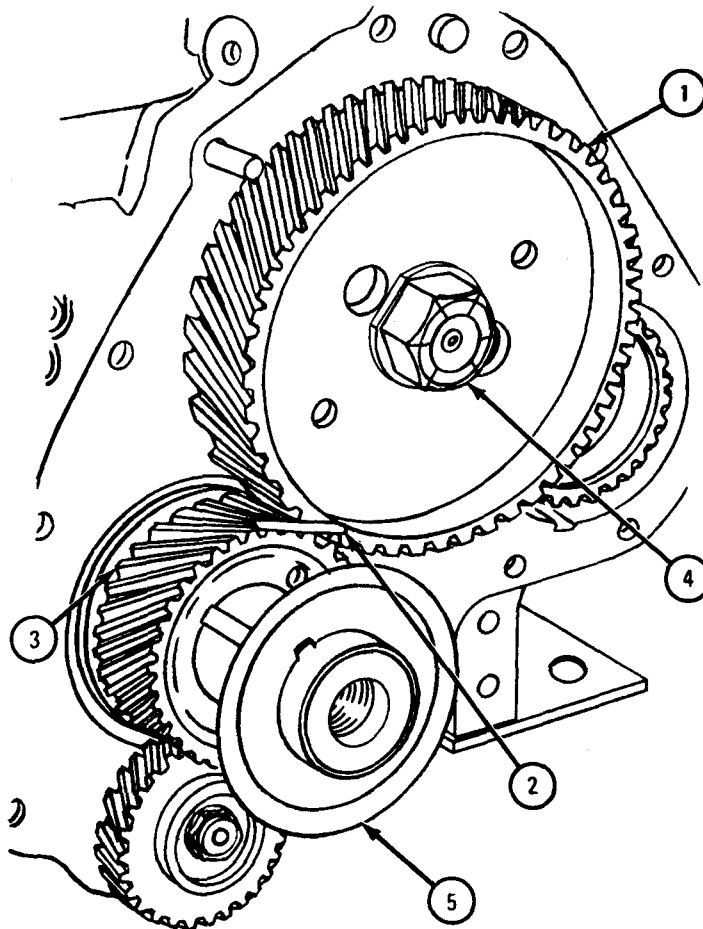

TA 105265

FRAME 3

1. Put gasket (1) and timing cover (2) in place and aline screw holes.
2. Put in six capscrews and lockwashers (3).
3. Put in two capscrews (4), lockwashers (5), and nuts (6).
4. Put on nut with lockwasher (7).

GO TO FRAME 4

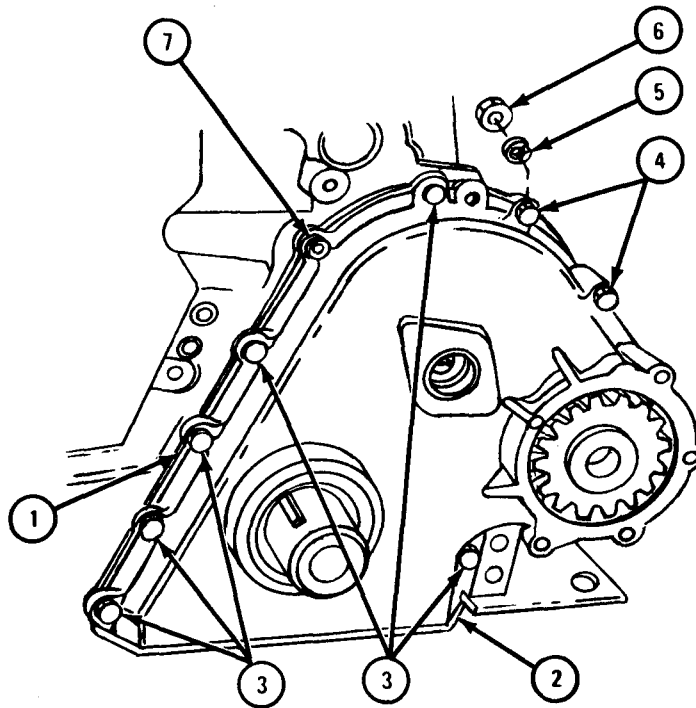

TA 105266

FRAME 4

NOTE

Follow-on Maintenance Action Required:

1. Put on injector pump drive gear access cover.
Refer to para 2-16.
2. Put on tachometer right angle adapter and flexible shaft.
Refer to Tachometer Assembly, TM 9-2320-209-20.
3. Put on vibration damper and pulley assembly.
Refer to para 2-8.
4. Put in valve tappets. Refer to TM 9-2815-210-34.
5. Put in push rods. Refer to para 2-14.
6. Put on rocker arm assembly. Refer to TM 9-2815-210-34.
7. Put on rocker arm cover. Refer to TM 9-2815-210-34.
8. Put on crankcase breather adapter. Refer to
TM 9-2815-210-34.
9. Put on tappet chamber cover. Refer to
TM 9-2815-210-34.
10. Put on water pump. Refer to TM 9-2320-209-20.
11. Put on air compressor bracket and air compressor.
Refer to TM 9-2320-209-20.
12. Put on all drive belts. Refer to TM 9-2320-209-20.
13. Put on engine cooling fan. Refer to TM 9-2320-209-20.
14. Put on oil cooler. Refer to para 2-18.
15. Put on injector lines. Refer to TM 9-2815-210-34.
16. Put on oil filter. Refer to TM 9-2320-209-20.
17. Put on fuel filter. Refer to TM 9-2320-209-20.
18. Put in radiator. Refer to TM 9-2320-209-20.
19. Put on oil pan. Refer to TM 9-2815-210-34.
20. Fill cooling system. Refer to TM 9-2320-209-20.
21. Close hood. Refer to TM 9-2320-209-10.

END OF TASK

2-16. CAMSHAFT AND CRANKSHAFT GEARS REMOVAL AND REPLACEMENT.

TOOLS: No special tools required

SUPPLIES: Timing gear cover gasket
Fuel pump drive gear access cover gasket
Oil pan gasket
Timing cover gasket

PERSONNEL: One

EQUIPMENT CONDITION: Truck parked, engine off, handbrake set.

a. Preliminary Procedures.

- (1) Remove radiator. Refer to TM 9-2320-209-20.
- (2) Remove engine cooling fan. Refer to TM 9-2320-209-20.
- (3) Remove tachometer drive adapter and cable. Refer to TM 9-2320-209-20.
- (4) Remove air compressor drive belt. Refer to TM 9-2320-209-20.
- (5) Remove fan drive belts. Refer to TM 9-2320-209-20.
- (6) Remove vibration damper and pulley assembly. Refer to para 2-8.
- (7) Drain oil from engine. Refer to LO 9-2320-209-12/1.
- (8) Remove water pump. Refer to TM 9-2320-209-20.

b. Removal.

FRAME 1

1. Takeout dipstick (1).
 2. Takeout 30 screws (2) and lockwashers (3).
 3. Take off oil pan (4) and gasket (5). Throw away gasket.
- GO TO FRAME 2

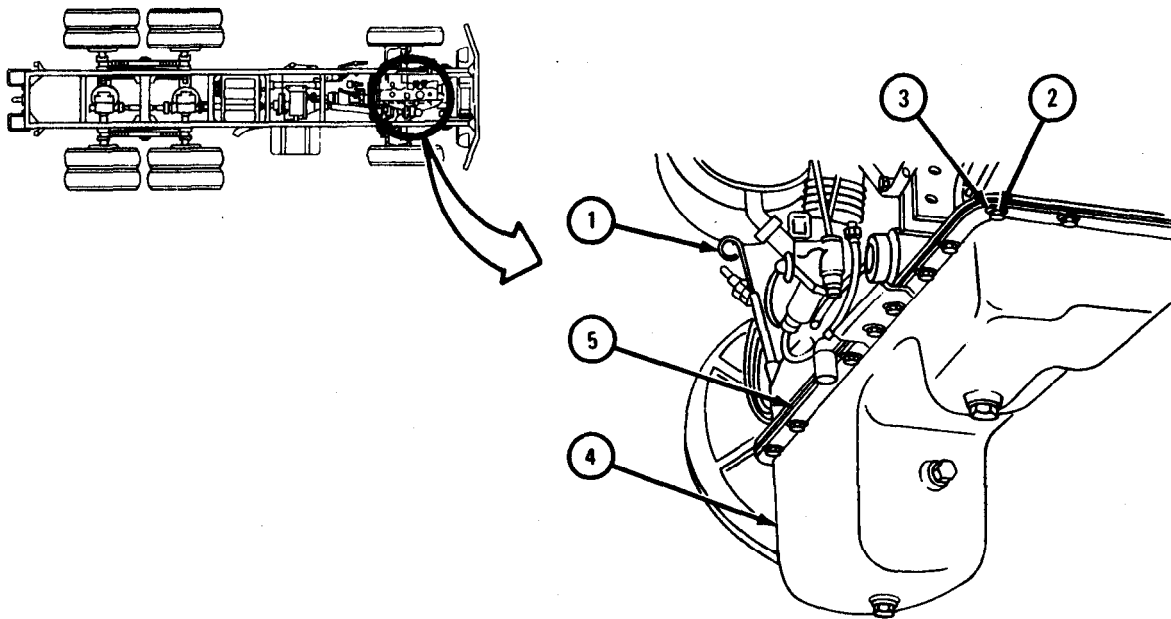

TA 103337

FRAME 2

1. Take off five nuts (1) and lockwashers (2).
2. Take out two screws (3) and lockwashers (4).
3. Take off fuel injection pump drive gear access cover (5) and gasket (6).
Throw away gasket.

GO TO FRAME 3

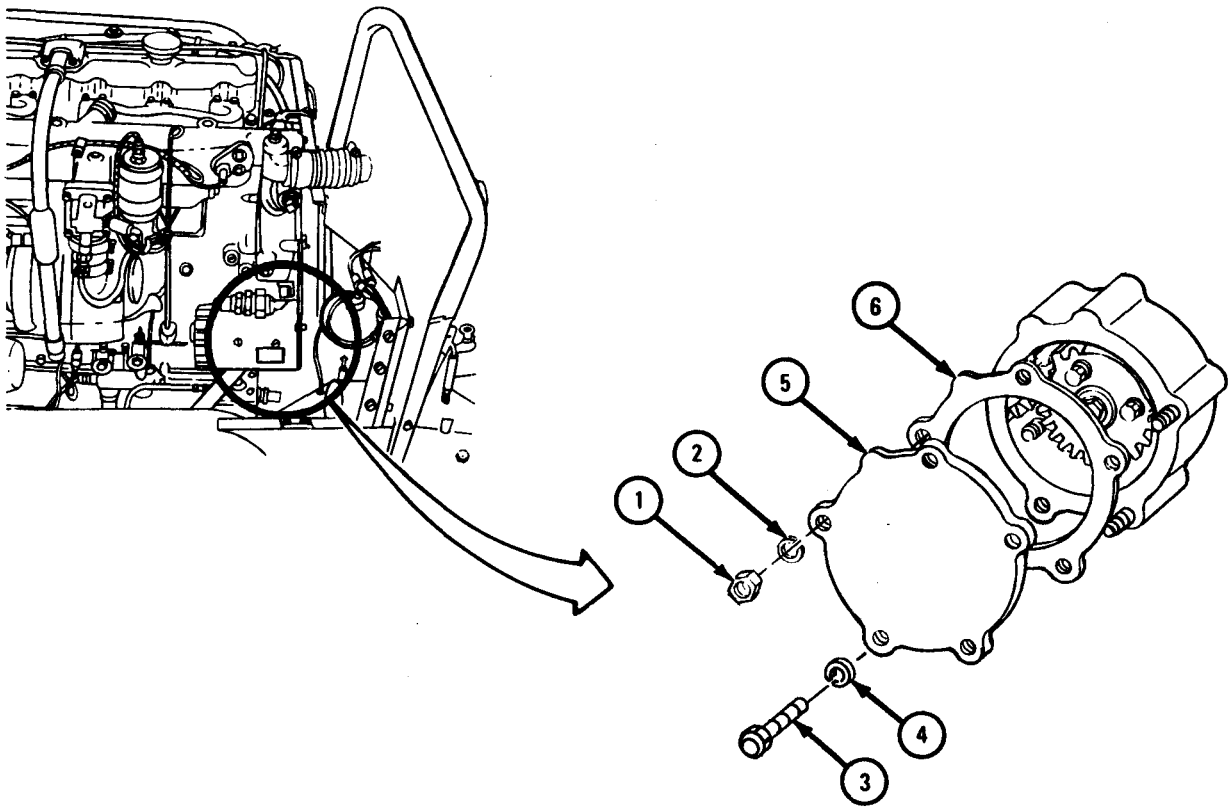

TA 103338

FRAME 3

1. Take off two nuts (1), lockwashers (2), and screws (3).
2. Take off nut (4) and lockwasher (5).
3. Take out six screws and lockwashers (6).
4. Take off timing gear cover (7). Take off and throw away timing gear cover gasket (8).

GO TO FRAME 4

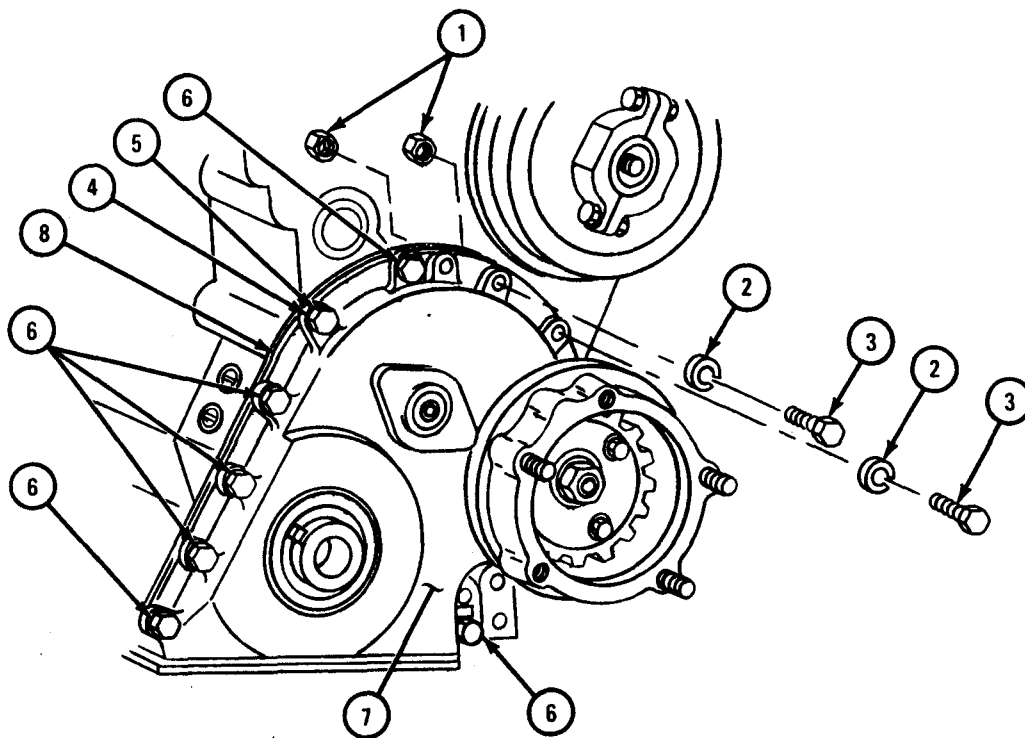

TA 103339

FRAME 4

1. Take off oil deflector (1).
2. Wedge a piece of wood or brass rod between fuel injection pump drive gear (2) and camshaft gear (3). Do this so gears will not turn while camshaft gear retaining nut (4) is being loosened.
3. Loosen camshaft gear retaining nut (4) and take out wood wedge.
4. Aline timing marks (5) on camshaft gear (3) with timing mark (6) on crankshaft gear (7).
5. Using puller, pull off crankshaft gear (7).
6. Take out three screws and washers (8).
7. Take off drive gear retaining plate (9).
8. Take out drive gear (2).

GO TO FRAME 5

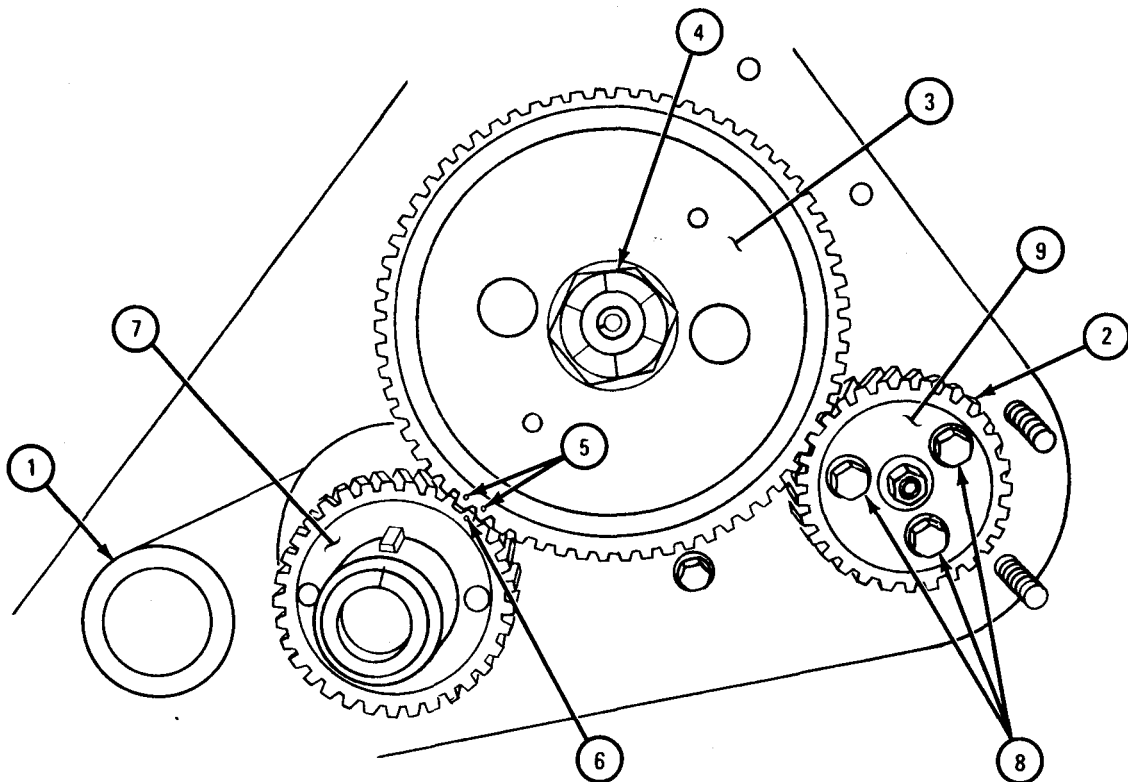

TA 103340

FRAME 5

1. Take off camshaft gear retaining nut (1).
 2. Using puller and drift bar, pull off camshaft gear (2).
- END OF TASK

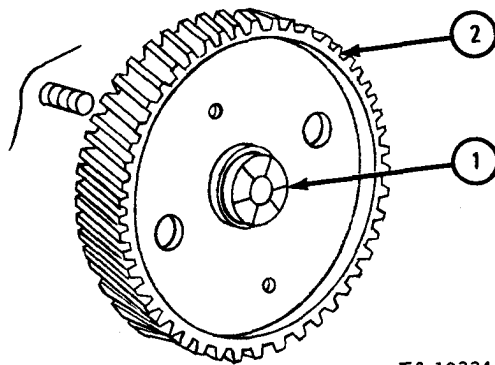

TA 103341

c. Replacement.**FRAME 1****NOTE**

Crankshaft and camshaft gears must be put on, and camshaft gear retaining nut put on and tightened as soon as possible after the gears are heated.

1. Heat crankshaft gear (1) and camshaft gear (2) to 250° F.
2. Aline keyway in crankshaft gear (1) with key on crankshaft (3) and push crankshaft gear in place on crankshaft, making sure crankshaft gear teeth mesh with teeth on oil pump idler gear (4).

CAUTION

Do not turn crankshaft gear (1) while camshaft gear (2) is off or valves will be damaged.

3. As camshaft gear (2) is being put on to camshaft (5), aline keyway in camshaft gear with key on camshaft.
4. Aline timing marks (6) on camshaft gear (2) with timing mark (7) on crankshaft gear (1).

GO TO FRAME 2

FRAME 2

1. Put retaining nut (1) on camshaft (2).
2. Put wooden wedge between camshaft gear (3) and crankshaft gear (4) so that gears will not move while retaining nut (1) is tightened.
3. Tighten retaining nut (1) to 325 to 350 pound-feet.
4. Put on crankshaft oil deflector (5).
5. Put on fuel injection pump drive gear (6).
6. Aline holes in gear (6) and put on retaining plate (7).
7. Aline holes in plate (7) with holes in gear (6).
8. Put in three screws (8) and lockwashers (9). Do not tighten screws (8) until fuel pump timing has been set.

GO TO FRAME 3

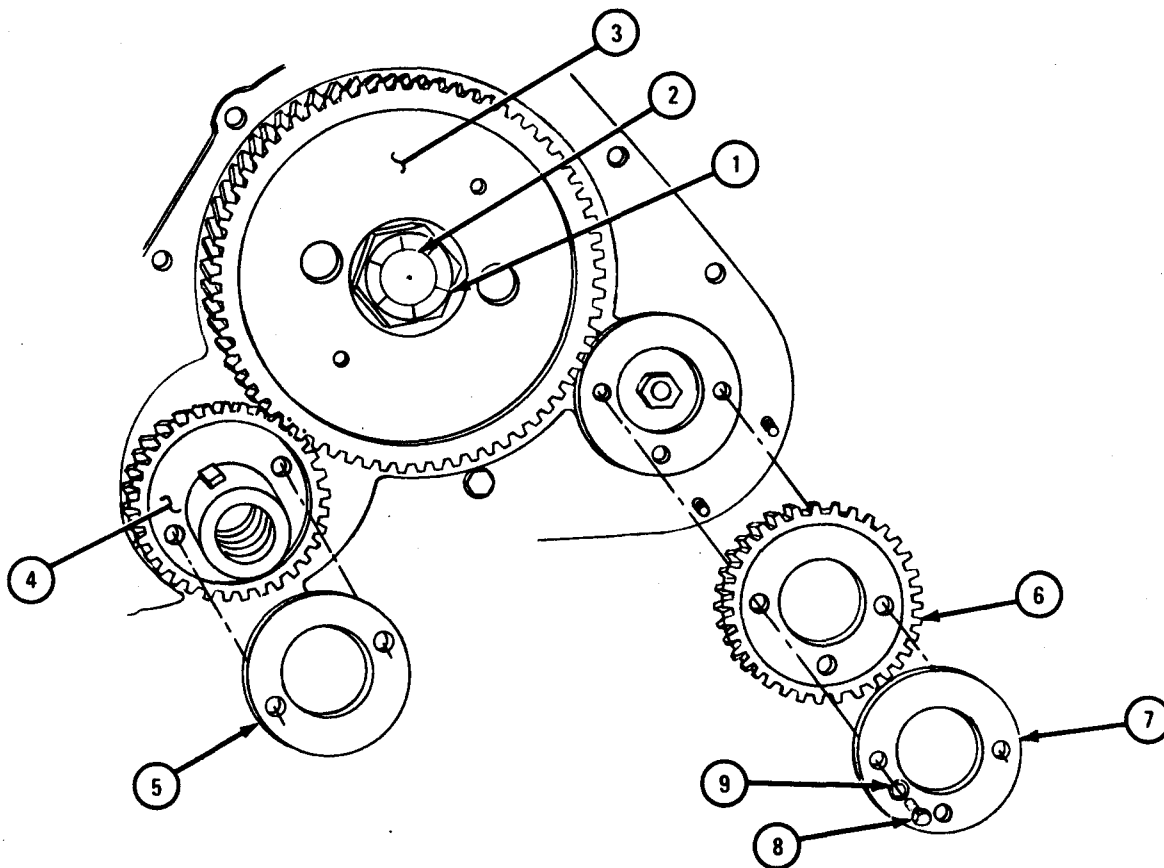

TA 103343

FRAME 3

1. Put on timing gear gasket (1) and timing gear cover (2).
2. Put in six screws and lockwashers (3).
3. Put on nut and lockwasher (4).
4. Put in two nuts (5), lockwashers (6), and screws (7).

GO TO FRAME 4

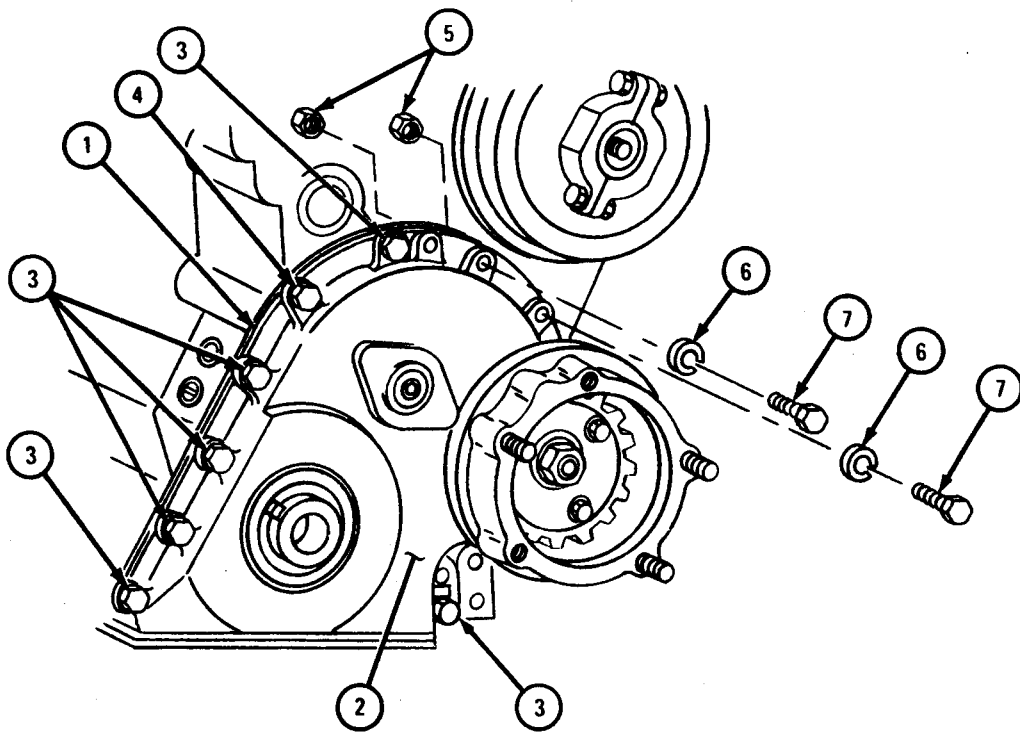

TA 103344

FRAME 4

1. Takeout four screws (1) and washers (2).
2. Takeoff timing cover (3) and gasket (4).
3. Hold nut (5) in place.
4. Look in timing window (6). Check that timing mark (7) is alined with pointer (8).
5. If mark (7) is not alined with pointer (8), turn nut (5) until mark and pointer aline.
6. Tighten three screws (9) to 23 to 27 pound-feet. Make sure that drive gear (10) does not turn while screws are being tightened.

GO TO FRAME 5

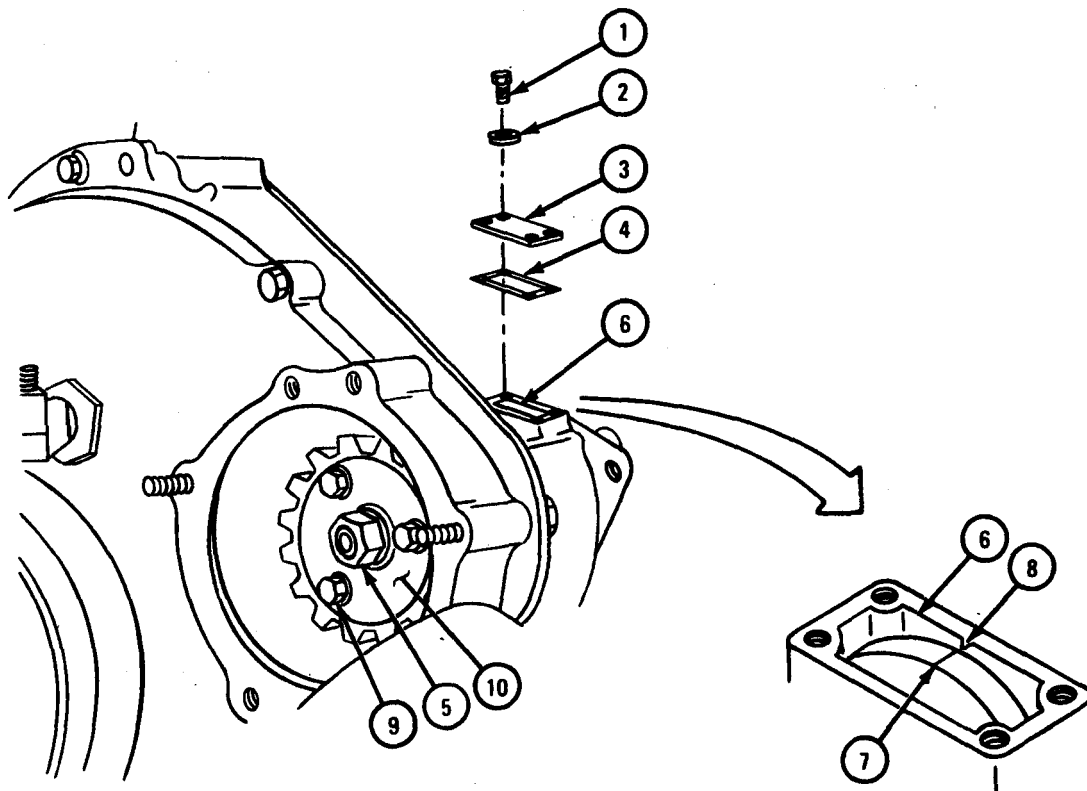

TA 103345

FRAME 5

1. Put on timing gear cover gasket (1) and timing gear cover (2).
2. Put in four screws (3) and lockwashers (4).
3. Put on fuel pump drive gear access cover gasket (5) and access cover (6).
4. Put on three nuts (7) and lockwashers (8).
5. Put in two capscrews (9) and lockwashers (10).

GO TO FRAME 6

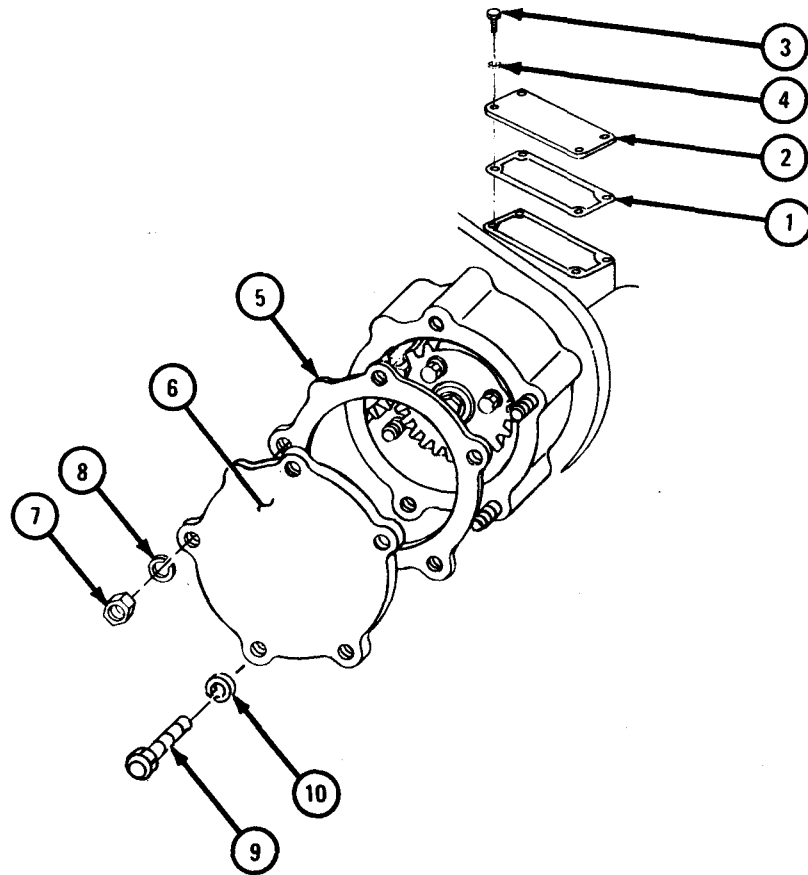

TA 103346

FRAME 6

1. Put on oil pan gasket (1) and oil pan (2).
2. Put in 30 capscrews (3) and lockwashers (4).
3. Put in dipstick (5).

NOTE

Follow-on Maintenance Action Required:

1. Fill engine with oil. Refer to LO 9-2320-209-12/1.
2. Replace vibration damper and pulley assembly. Refer to para 2-8.
3. Replace fan drive belts. Refer to TM 9-2320-209-20.
4. Replace air compressor drive belt. Refer to TM 9-2320-209-20.
5. Replace tachometer drive adapter and cable. Refer to TM 9-2320-209-20.
6. Replace fan. Refer to TM 9-2320-209-20.
7. Replace radiator. Refer to TM 9-2320-209-20.
8. Replace water pump. Refer to TM 9-2320-209-20.

END OF TASK

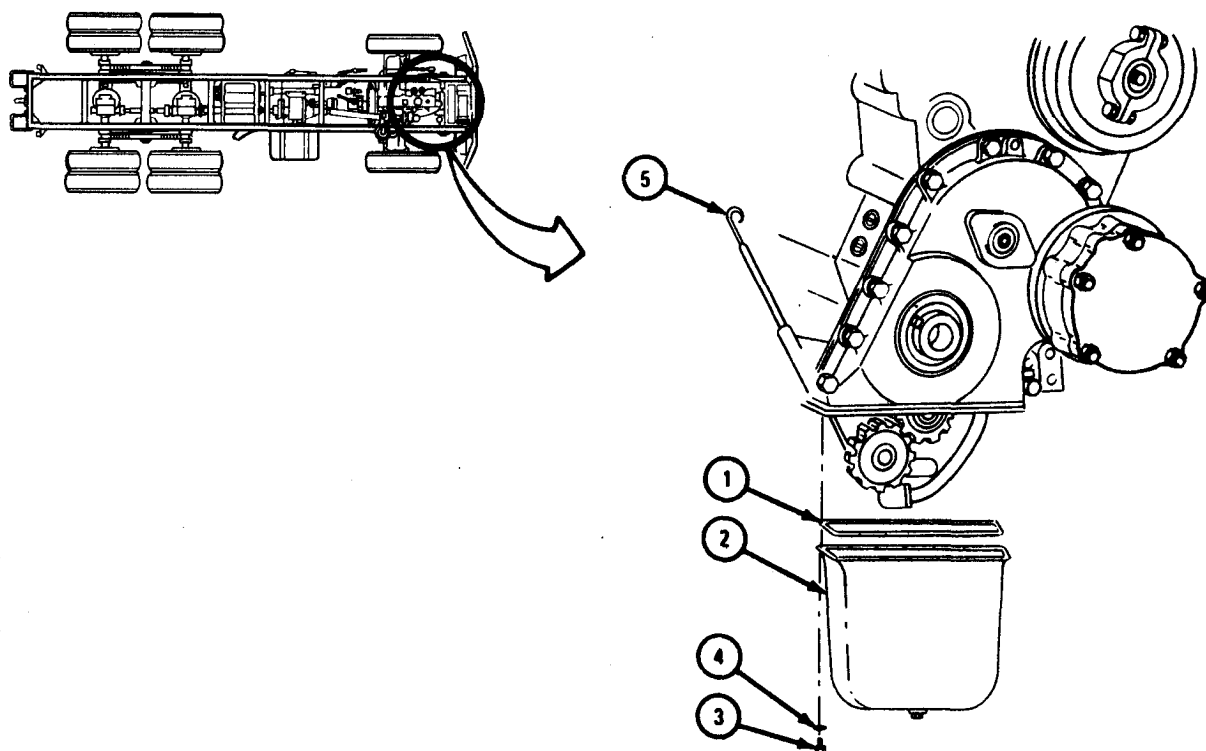

TA 103347

Section VIII. ENGINE LUBRICATING SYSTEM AND MANIFOLDS

2-17. LUBRICATING OIL PUMP ASSEMBLY REMOVAL, REPAIR, AND REPLACEMENT.

TOOLS: No special tools required

SUPPLIES: Solvent, dry cleaning, type II (SD-2), Fed. Spec P-D-680
Oil pan gasket
Pickup tube gasket
Inlet tube gasket
Outlet tube gasket
Preformed packing
Spacer
Cotter pin
Safety wire

PERSONNEL: One

EQUIPMENT CONDITION: Truck parked, engine off, handbrake set.

a. Preliminary Procedure. Drain crankcase oil. Refer to LO 9-2320-209-12-1.

b. Removal.

FRAME 1

1. Take out 30 capscrews with lockwashers (1). Take off oil pan with gasket (2). Throw gasket away.
2. Take out cap screw with nut end lockwasher (3), two capscrews with lockwashers (4), take off oil pump pickup tube with gasket (5), and clamp (6). Throw gasket away.

GO TO FRAME 2

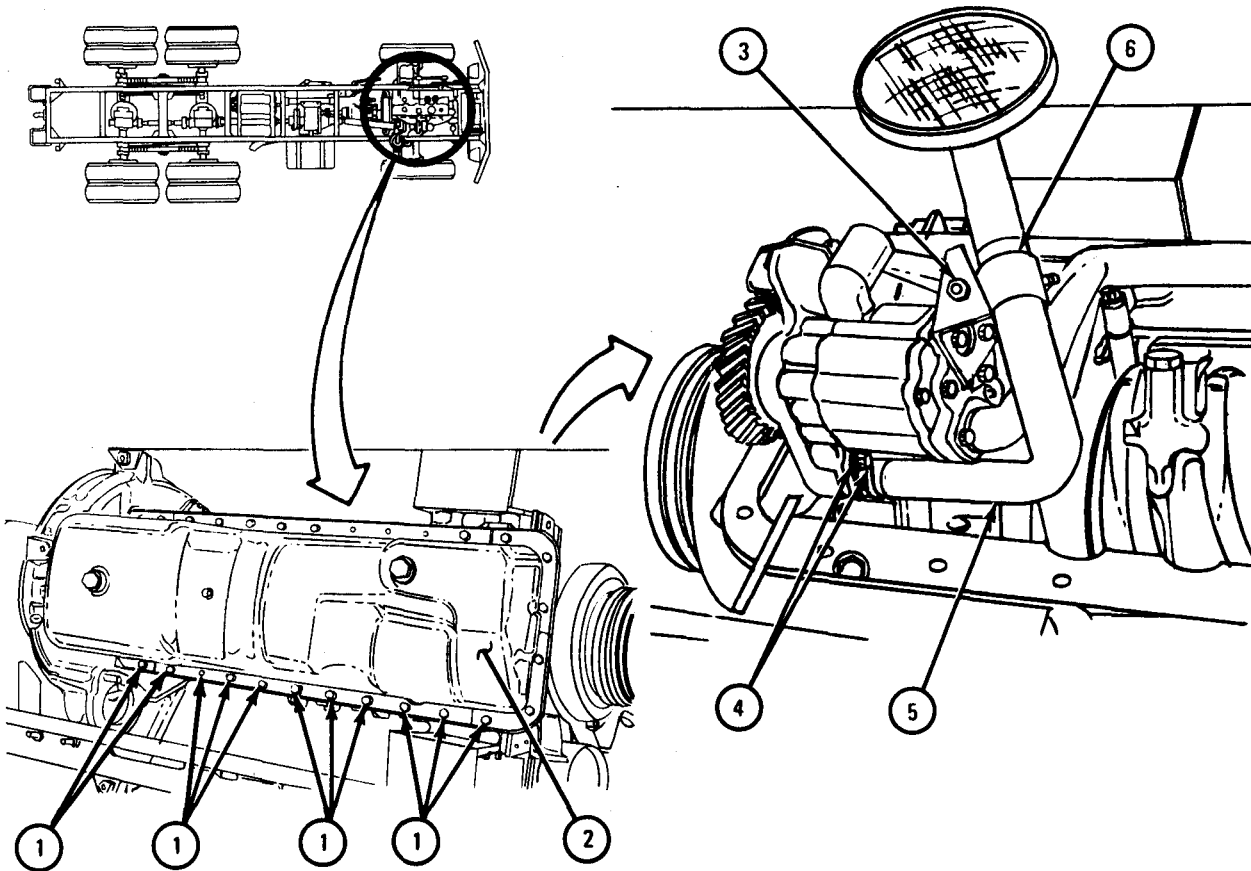

TA 103462

FRAME 2

1. Cut and take out safety wire (1). Take out two drilled-head bolts (2).
2. Take out two screws (3) and lockwashers (4).
3. Take out pressure oil pump outlet tube (5) and outlet tube flange (6).
4. Take off and throw away outlet tube flange preformed packing (7).
5. Take off and throw away outlet tube gasket (8).

GO TO FRAME 3

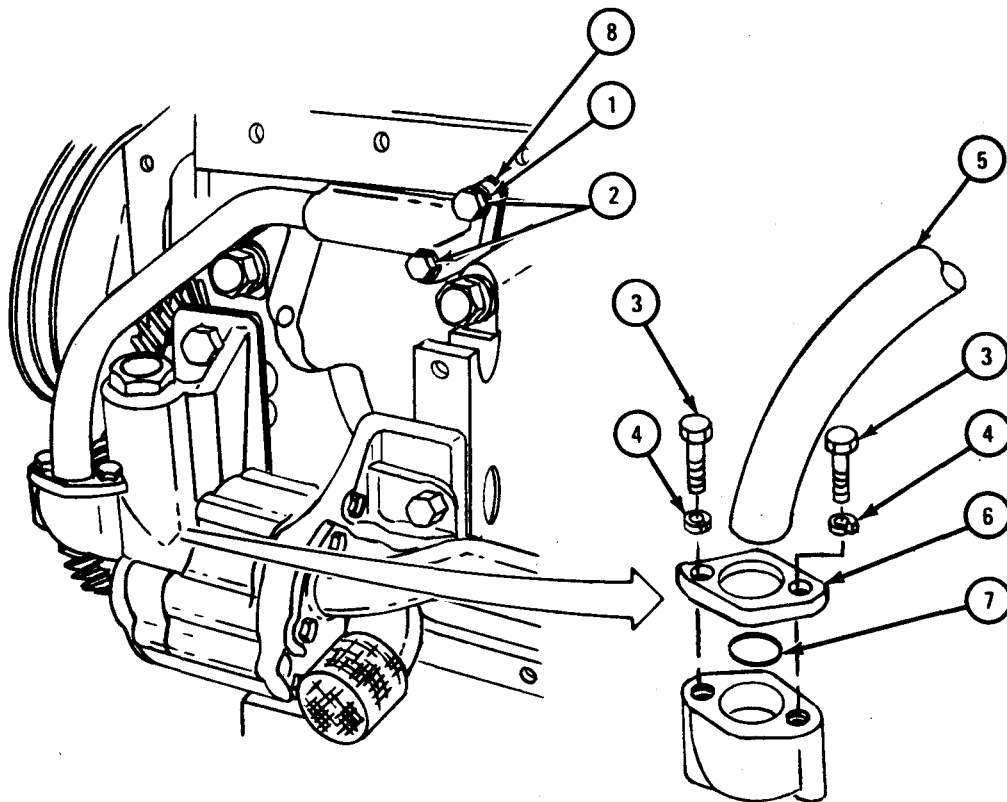

TA 103463

FRAME 3

1. Take out two screws and lockwashers (1).
2. Take out two screws and lockwashers (2).
3. Take out oil pump inlet tube (3) and two tube clamps (4).
4. Take off inlet tube gasket (5). Throw gasket away.

GO TO FRAME 4

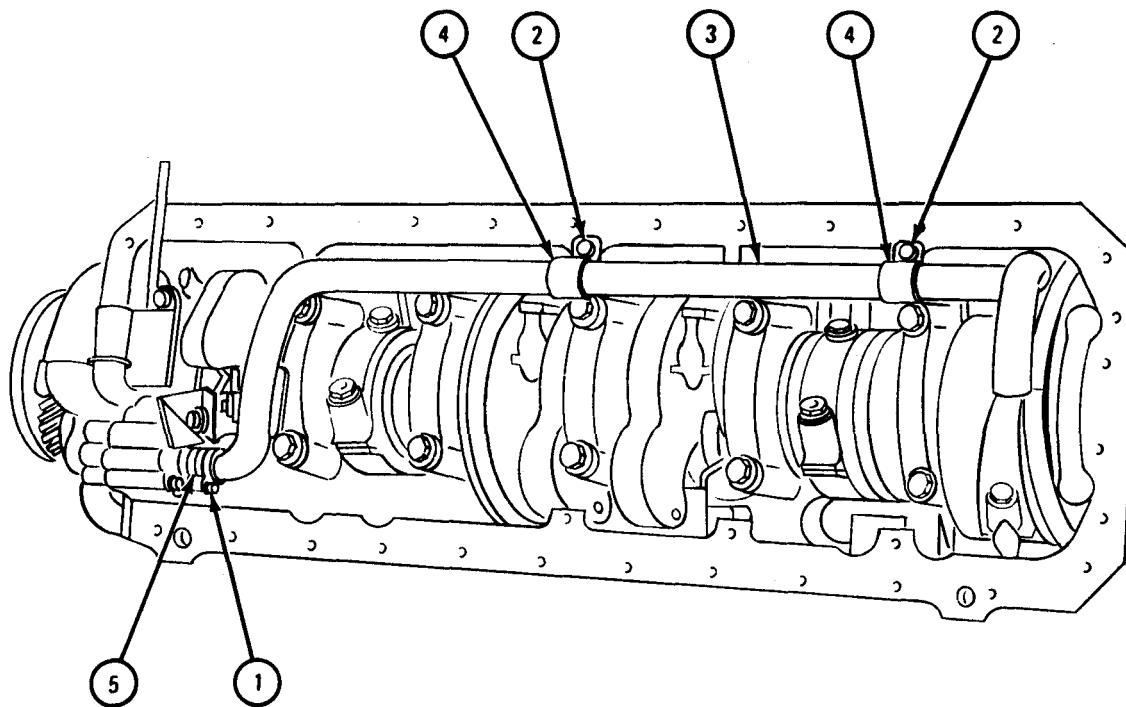

TA 103464

FRAME 4

1. Using feeler gage as shown, check backlash between the oil pump drive gear (1) and the oil pump idler gear (2). Backlash should be between 0.006 and 0.014 inches.
2. If backlash is not within limits given, mark oil pump driver gear (1) and oil pump idler gear (2) for replacement.

GO TO FRAME 5

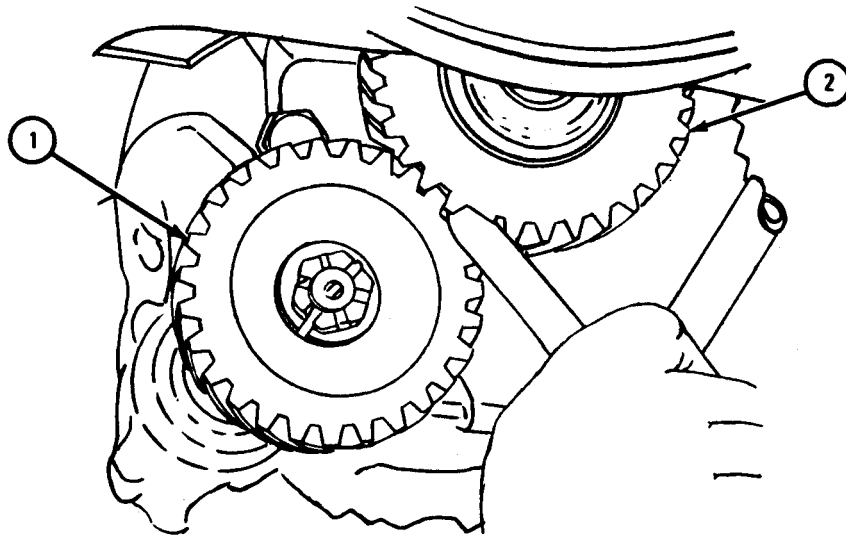

TA 103465

FRAME 5

1. Take out three lockbolts (1) and take out oil pump assembly (2).

END OF TASK

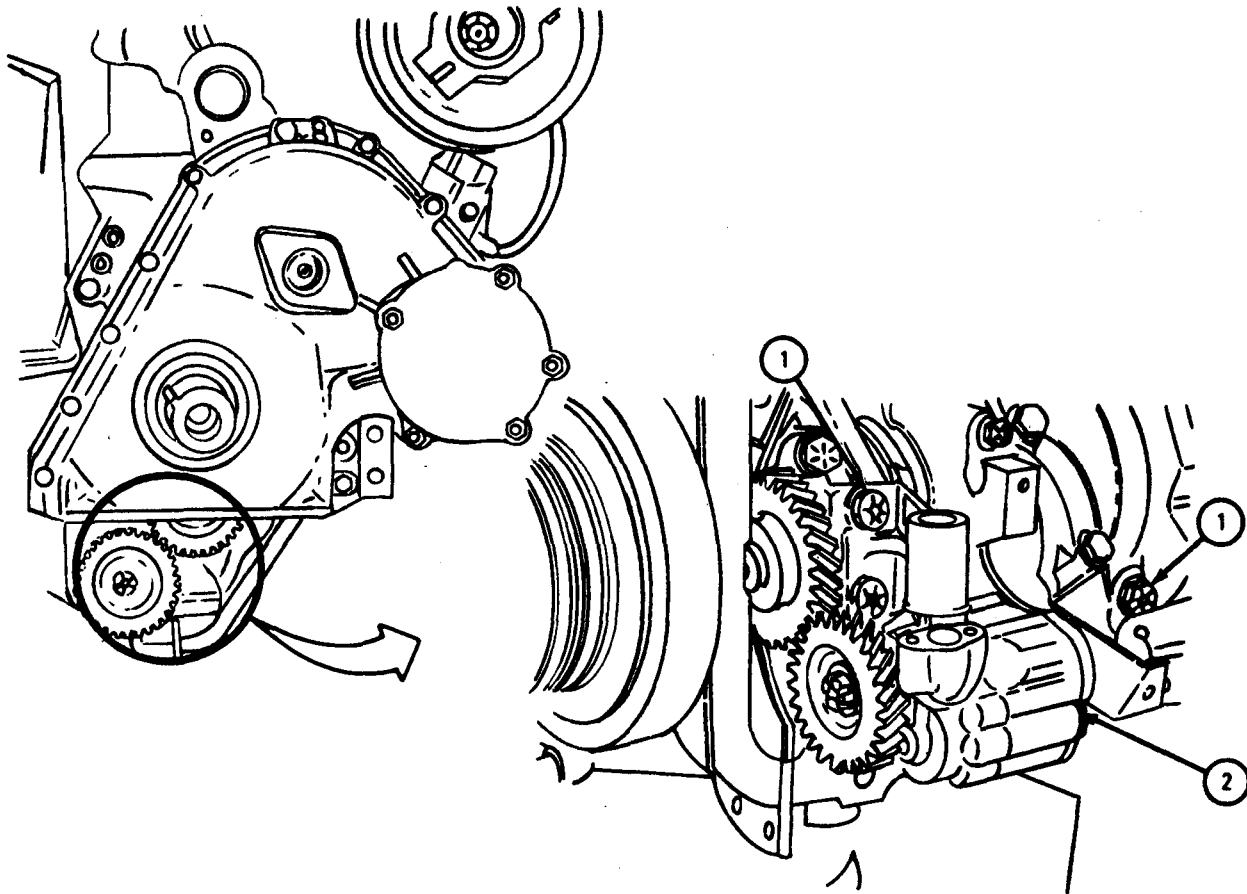

TA 103466

c. Disassembly.**FRAME 1**

1. Take out and throw away cotter pin (1) and take off slotted nut (2).
2. Using universal puller, pull off pump drive gear (3).

GO TO FRAME 2

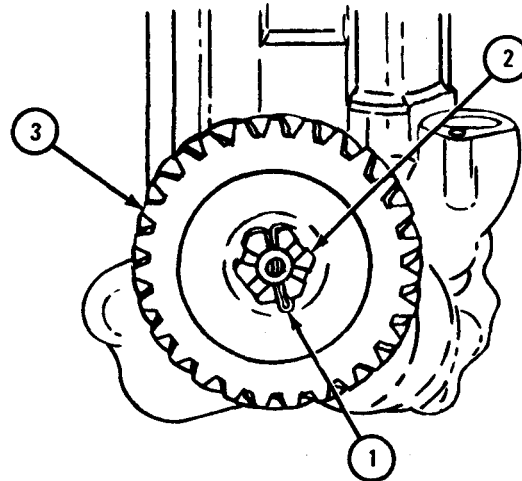

TA 103467

FRAME 2

CAUTION

The pressure relief valve is spring-loaded. Be careful when disassembling or parts may be lost.

NOTE

Shims (5) are used to adjust the pressure relief valve. The number of shims inside the relief valve may be different on different pumps.

Some pump pressure relief valve springs are retained by a threaded cap; others are retained by a pin and retainer. If working on a pump with a pin and retainer go to step 2.

1. Take out threaded cap (1). Go to step 3.

NOTE

If a copper spacer is used in place of the spring retainer, take out spacer and throw away.

2. Take out retaining spring pin (2). Take out spring retainer (3).
3. Take out spring (4), shims (5), and pressure relief valve (6).

GO TO FRAME 3

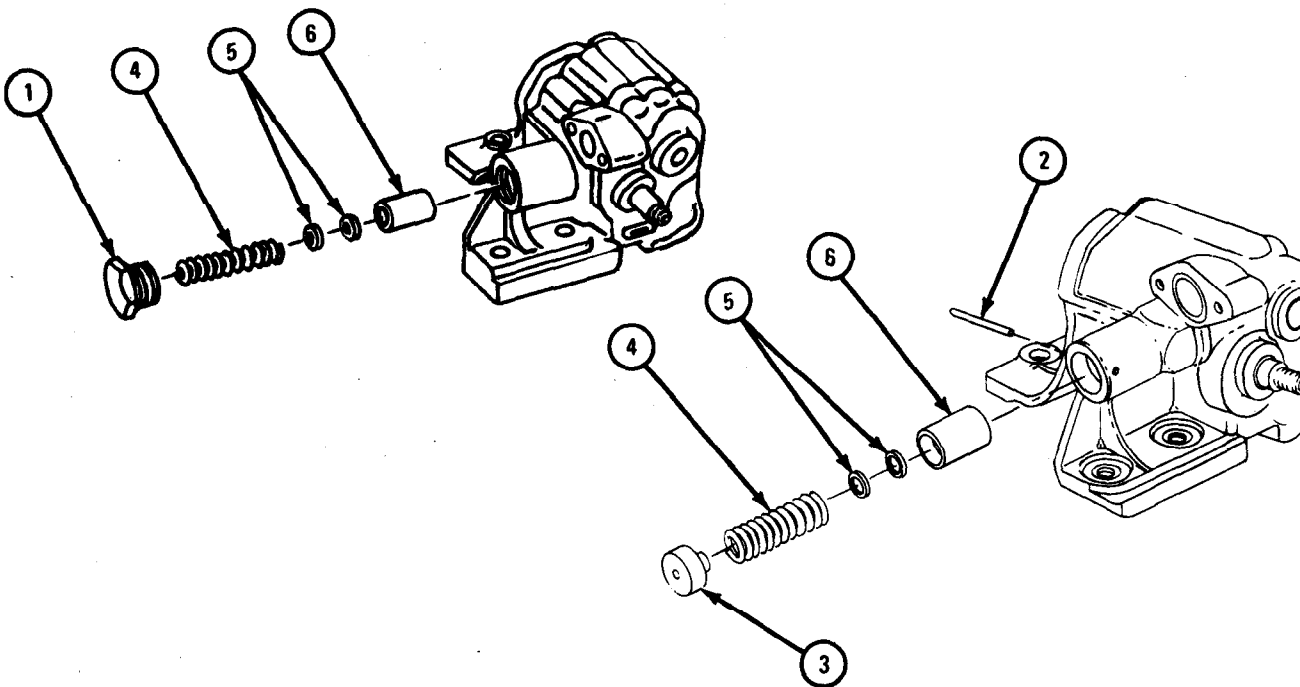

TA 10346f

FRAME 3

1. Take out four screws with lockwashers (1). Take off bracket (2) and scavenger oil pump cover (3).
 2. Take out scavenger oil pump drive impeller (4) and driven impeller (5).
 3. Take scavenger oil pump housing (6) apart from pressure oil pump housing (7).
- GO TO FRAME 4

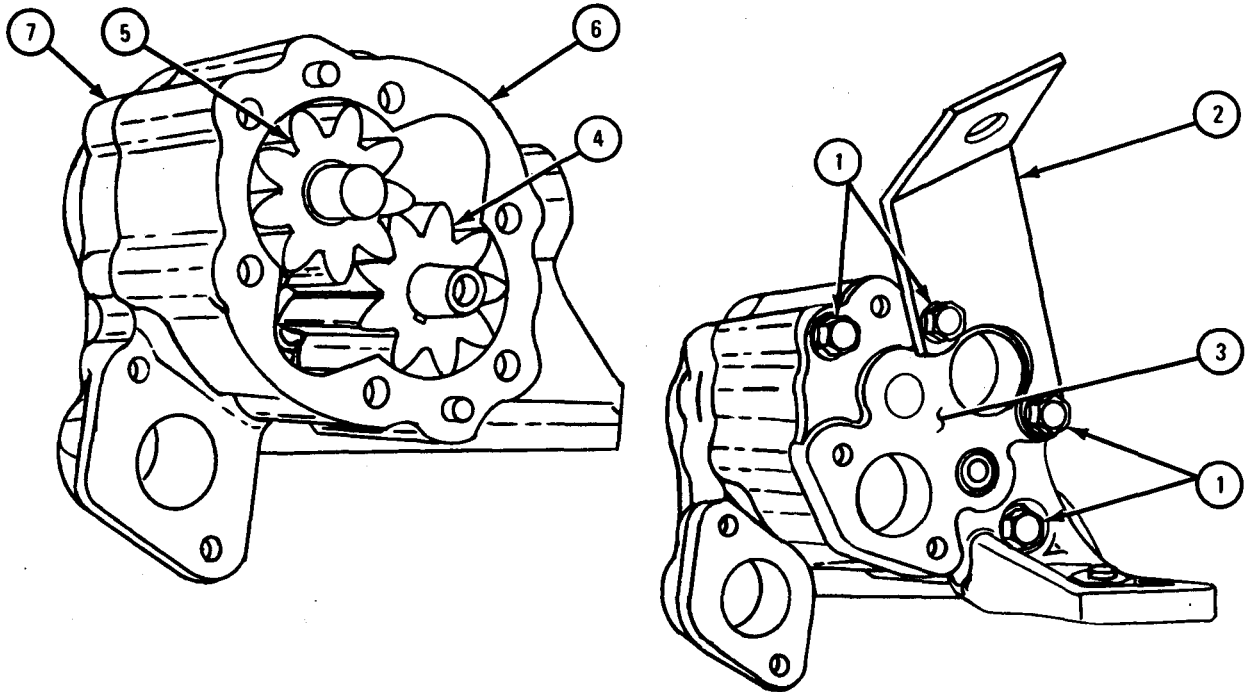

TA 103469

FRAME 4

1. Take out pressure oil pump drive shaft impeller (1).
2. Take pressure oil pump driven impeller (2) off driven impeller shaft (3).
3. Take square key (4) out of shaft of pressure oil pump drive shaft impeller (1).

END OF TASK

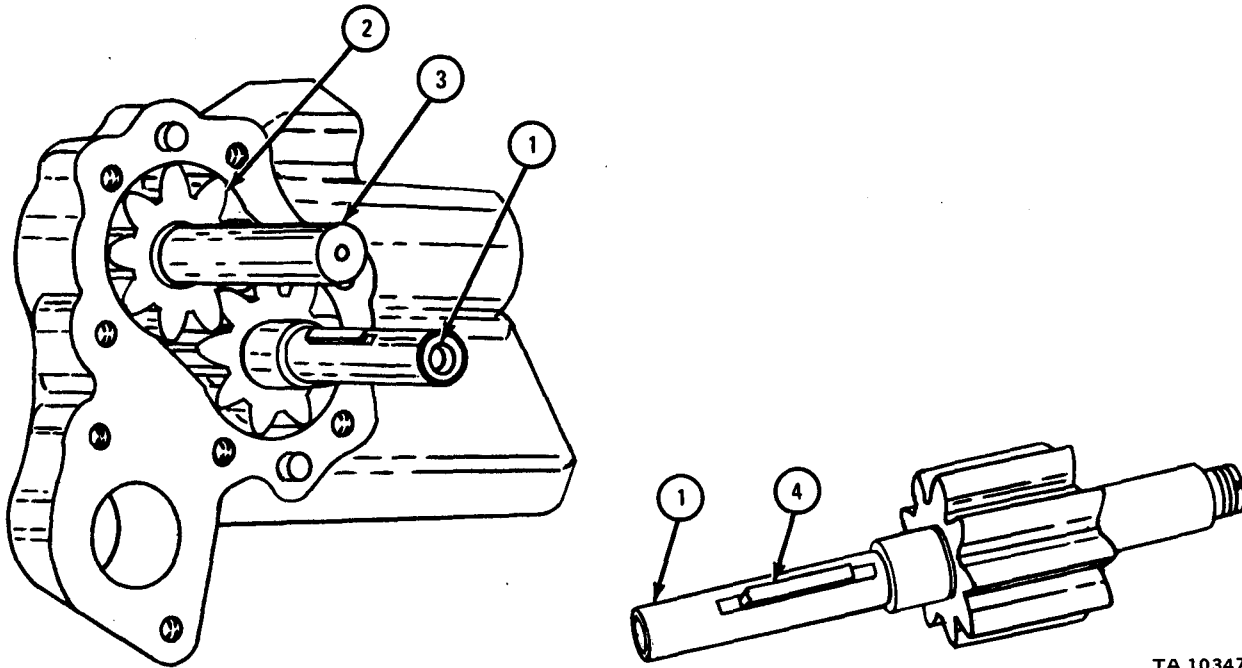

TA 103470

d. **Cleaning.** There are no special cleaning procedures required. Refer to cleaning procedures given in para 1-3.

e. Inspection and Repair.

FRAME 1

1. Check that scavenger oil pump cover (1), scavenger oil pump housing (2), and pressure oil pump housing (3) are not bent, dented or cracked. To straighten, refer to FM 43-2. To repair cracks by welding, refer to TM 9-237.
2. Check the surfaces of the scavenger oil pump cover (1), scavenger oil pump housing (2), and the pressure oil pump housing (3) for nicks, burrs or raised metal. Fix nicks, burrs and raised metal with a fine mill file or crocus cloth.
3. Check that four impellers (4, 5, 6, and 7) are not badly worn, scored, or damaged. If impellers are worn, scored or damaged, get a new oil pump.
4. Check that four impellers (4, 5, 6, and 7) do not have nicks, burrs, or raised metal. Fix nicks, burrs or raised metal with a fine mill file or crocus cloth.

GO TO FRAME 2

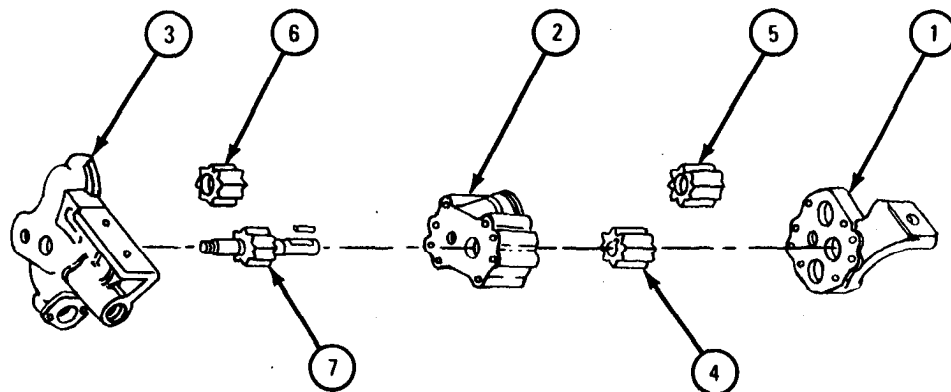

NOTE: CHECK ONLY THOSE PARTS WHICH ARE CALLED OUT. PARTS WITHOUT CALLOUTS ARE SHOWN ONLY FOR REFERENCE PURPOSES.

TA 103471

FRAME 2

1. Check that threaded cap (1) is not cracked or has any damaged threads. Fix minor thread damage with a threader. Throw away cracked cap and get a new one.

NOTE

Shims (2) are used to adjust pressure relief valve. The number of shims may differ from pump to pump. Some pumps may have no shims. The pressure relief valve spring (3) comes in a kit which contains new shims (2). Save the shims even if the pump you are working on had no shims. They will be used later for pump test and adjustment.

2. Check that pressure relief valve (4) is not cracked or damaged. If damage is found, get a new part.

WARNING

Dry cleaning solvent is flammable. Do not use near an open flame. Keep a fire extinguisher nearby when solvent is used. Use only in well-ventilated places. Failure to do this may result in injury to personnel and damage to equipment.

3. Check that pressure relief valve (4) does not have cracks or burrs, Fix small burrs with a fine mill or crocus cloth dipped in dry cleaning solvent. If pressure relief valve is cracked, throw it away and get a new one.

END OF TASK

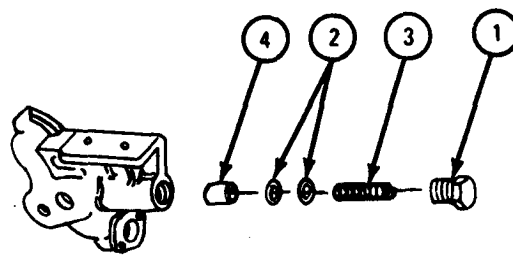

NOTE: CHECK ONLY THOSE PARTS WHICH ARE CALLED OUT. PARTS WITHOUT CALLOUTS ARE SHOWN ONLY FOR REFERENCE PURPOSES.

TA 103472

f. Assembly.**FRAME 1**

1. Put square key (1) on shaft of oil pump drive shaft impeller (2).
2. Put pressure oil pump driven impeller (3) on driven impeller shaft (4).
3. Put in oil pump drive shaft impeller (2).

GO TO FRAME 2

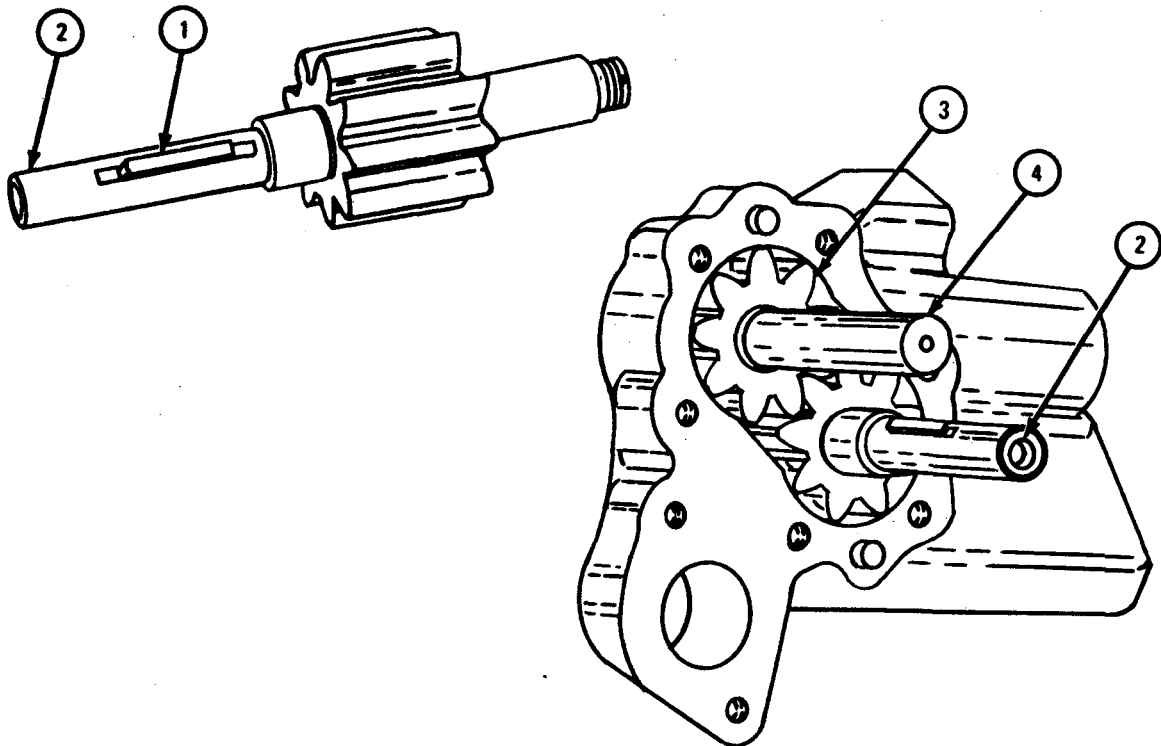

TA 103473

FRAME 2

1. Put pressure oil pump housing (1) on scavenger oil pump housing (2).
2. Put in driven impeller (3) and scavenger oil pump drive impeller (4).
3. Put on scavenger oil pump cover (5). Put on bracket (6) and put in four screws and lockwashers (7).

GO TO FRAME 3

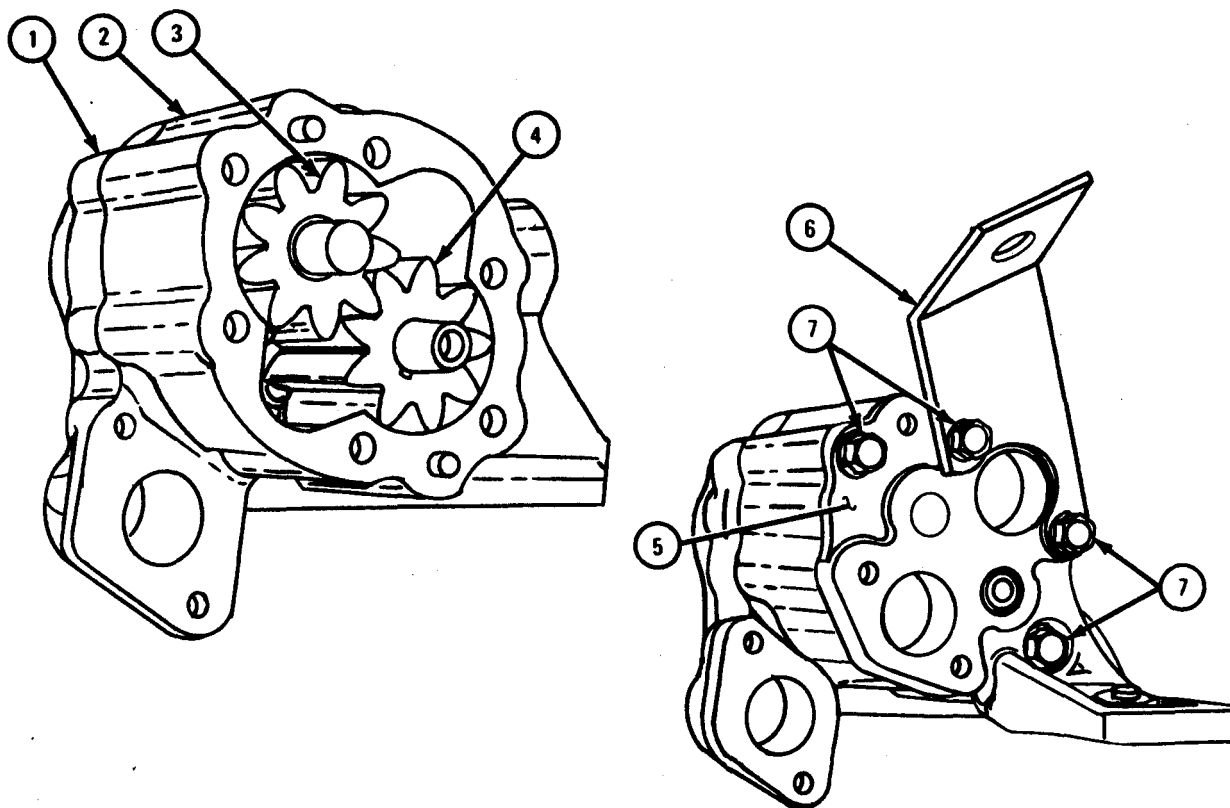

TA 103474

FRAME 3

1. Put pressure relief valve (1), shims (2), and spring (3) into oil pump pressure housing (4).

NOTE

Some oil pumps use a threaded cap to retain the parts of the pressure relief valve. Some oil pumps use a retaining spring pin and spring retainer or spacer. If a spring retainer copper spacer is used, throw the old spacer away and get a new one. If a threaded cap is used, do step 2. If a retaining spring pin is used, get a new pin and do step 3.

2. Put in threaded cap (5). Skip step 3.
3. Put in spring retainer (6) or retaining copper spacer (7), and put in retaining spring pin (8).

GO TO FRAME 4

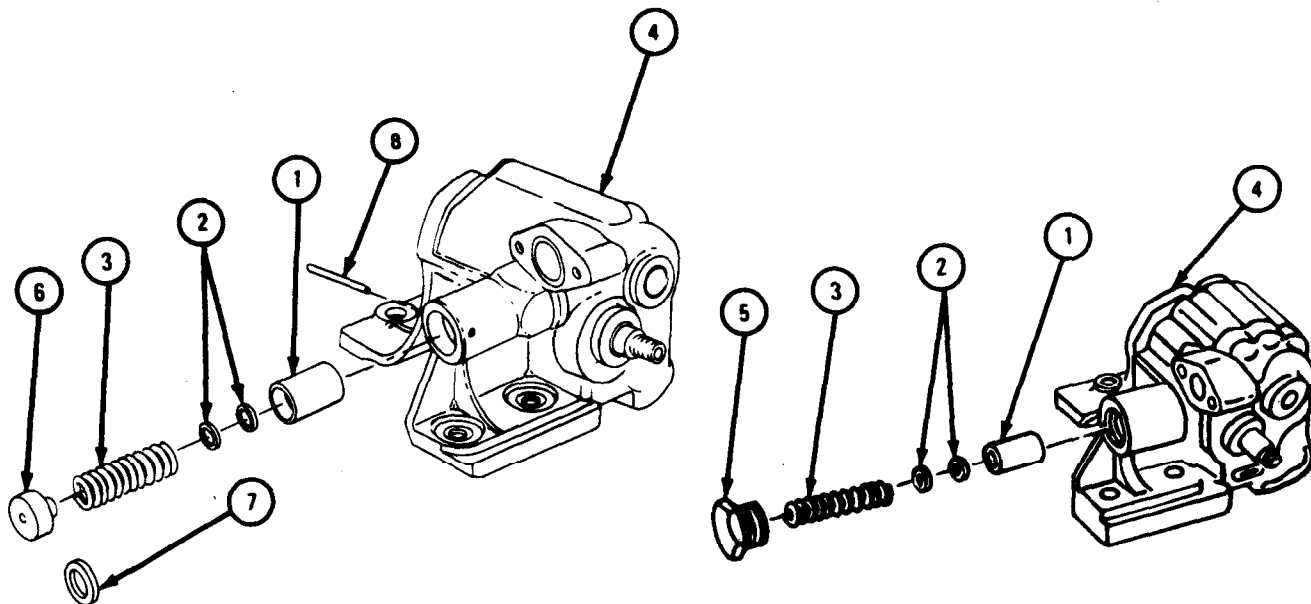

TA 103475

FRAME 4

1. Put on pump drive gear (1).
2. Put on slotted nut (2).
3. Put in cotter pin (3).

END OF TASK

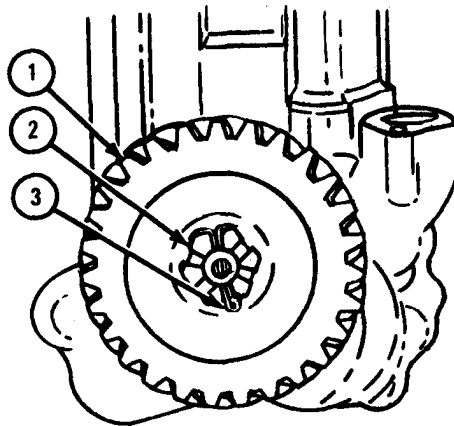

TA 103476

g. Replacement.

FRAME 1

1. Put oil pump assembly (1) in place.
 2. Put in three lockbolts (2).
- GO TO FRAME 2

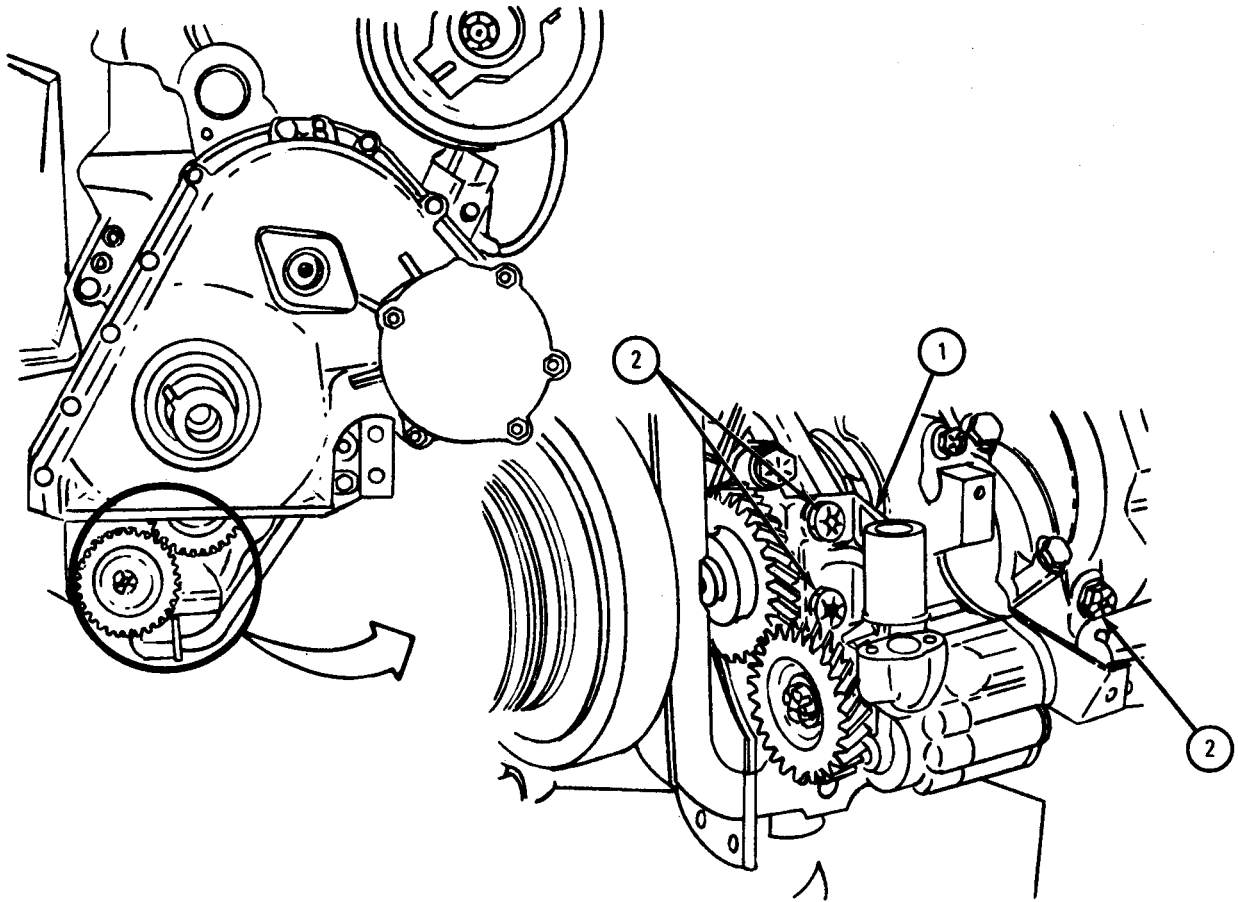

TA 103477

FRAME 2

1. Put on inlet tube gasket (1) and inlet tube (2).
2. Put on two clamps (3).
3. Put in two screws and lockwashers (4).
4. Put in two screws and lockwashers (5).

GO TO FRAME 3

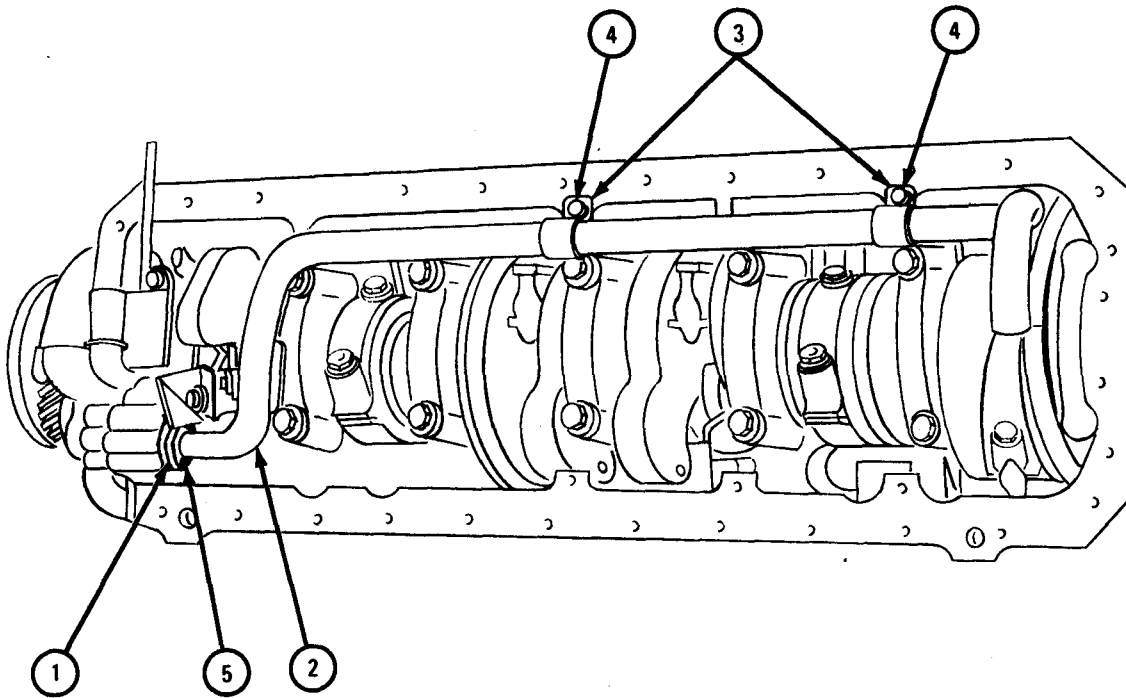

TA 103478

FRAME 3

1. Put on outlet tube gasket (1).
2. Put on outlet tube flange preformed packing O-ring (2).
3. Put on outlet tube flange (3) and outlet tube (4).
4. Put in two screws (5) and lockwashers (6).
5. Put in two drilled head bolts (7) and lockwire (8).

GO TO FRAME 4

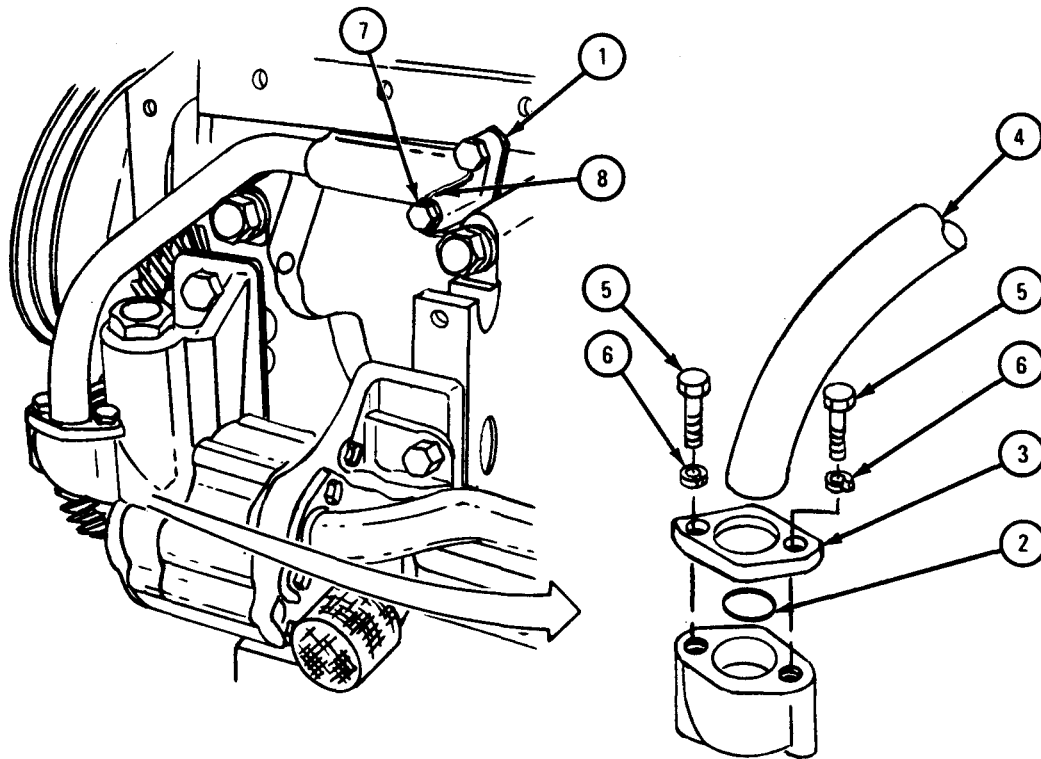

TA 103479

FRAME 4

1. Put on pickup tube gasket (1) and pickup tube (2).
2. Put on clamp (3) and put in screw, lockwasher, and nut (4).
3. Put in two screws and lockwashers (5).
4. Put on gasket (6) and oil pan (7). Put in thirty screws (8) and lockwashers (9).

NOTE

Follow-on Maintenance Action Required:

Fill crankcase with oil. Refer to LO 9-2320-209-12/1.

END OF TASK

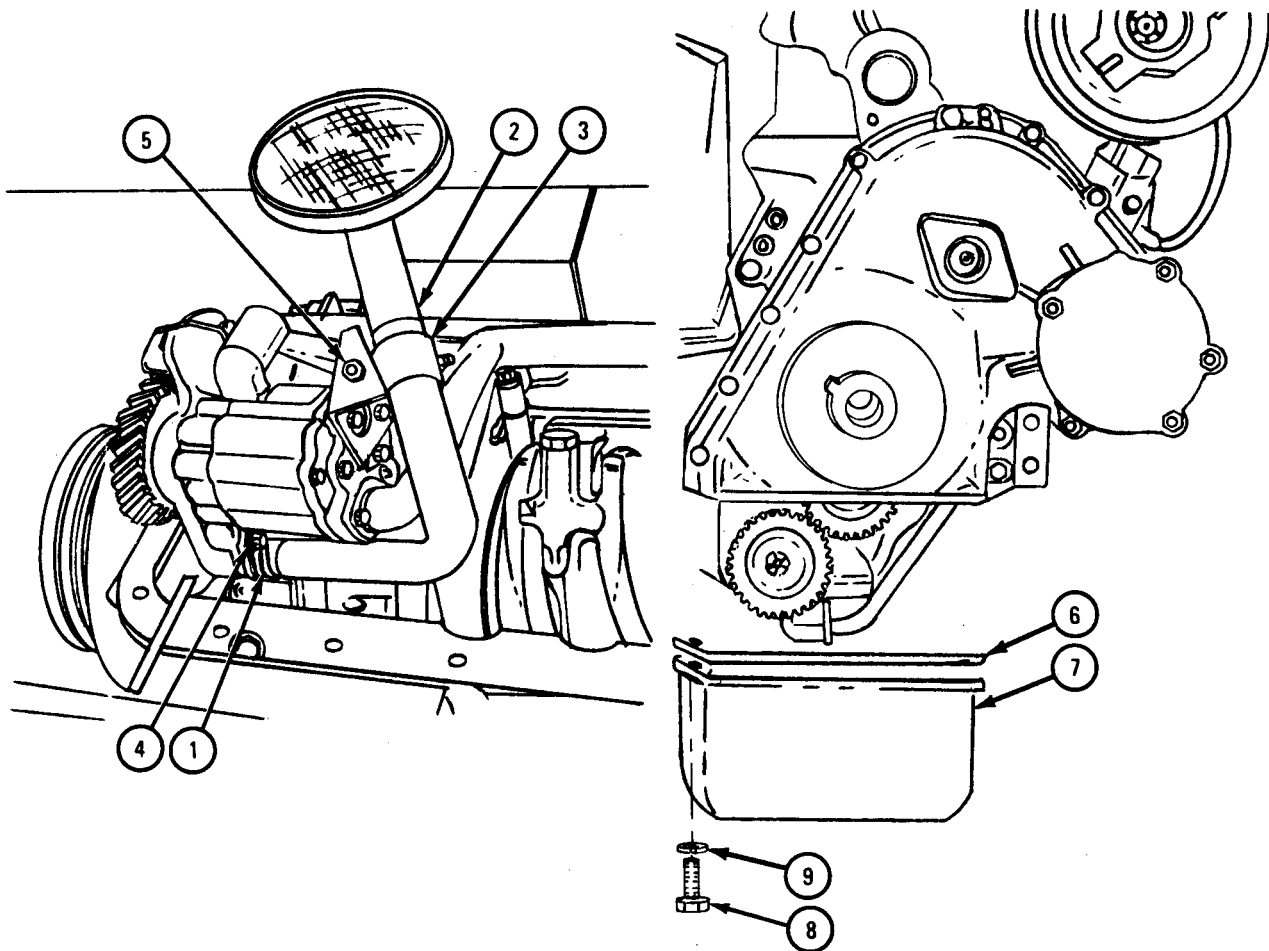

TA 103480

2-18. OIL COOLER RADIATOR REMOVAL AND REPLACEMENT.

TOOLS: No special tools required

SUPPLIES: Oil cooler gasket and preformed packing set
 Artillery and automotive grease, type GAA, MIL-G-10924
 Tags
 Oil cooler cover gasket

PERSONNEL: One

EQUIPMENT CONDITION: Truck parked, engine off, handbrake set.

a. Preliminary Procedures.

(1) Open hood and side panels. Refer to TM 9-2320-209-10.

(2) Drain cooling system. Refer to TM 9-2320-209-20.

b. Removal.**FRAME 1**

1. Take out two capscrews, flat washers, and self-locking nuts (1). Take off outer clamp (2).
2. Take out four capscrews and nuts (3). Take off four clamps (4).
3. Slide three dust covers (5) up three fuel injector tubes (6).

NOTE

Tag three fuel injector tubes (6) so they will be put back the same way.

4. Take off six tube nuts (7 and 8). Take off three fuel injector tubes (6).
5. Plug holes in three fuel injectors (9) and three holes in injector pump head (10).

GO TO FRAME 2

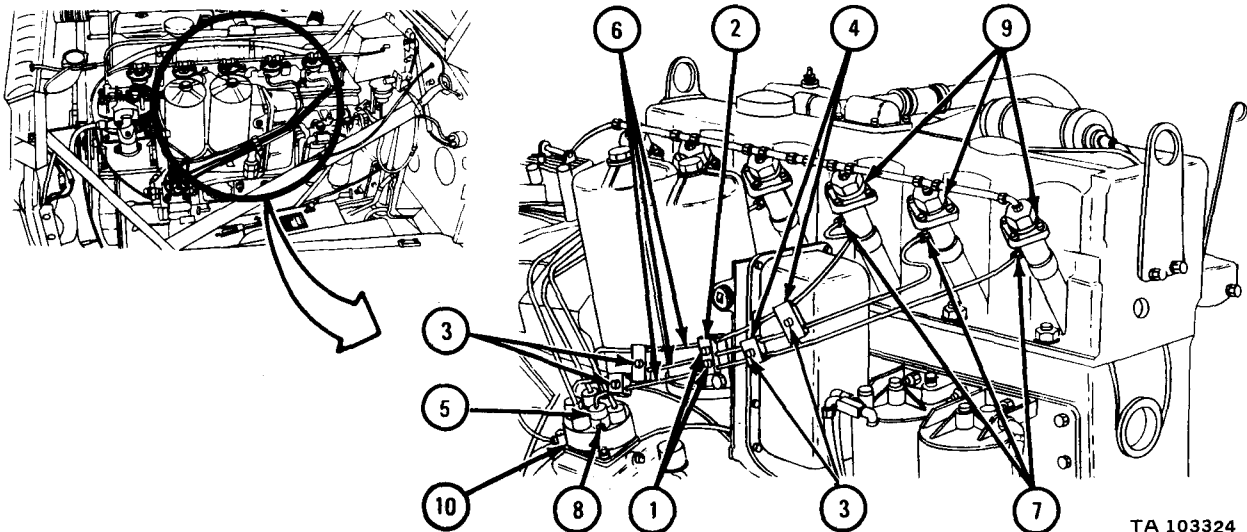

FRAME 2

1. Take off three nuts and lockwashers (1).
2. Move fuel filter assembly (2) out of the way and support it.

GO TO FRAME 3

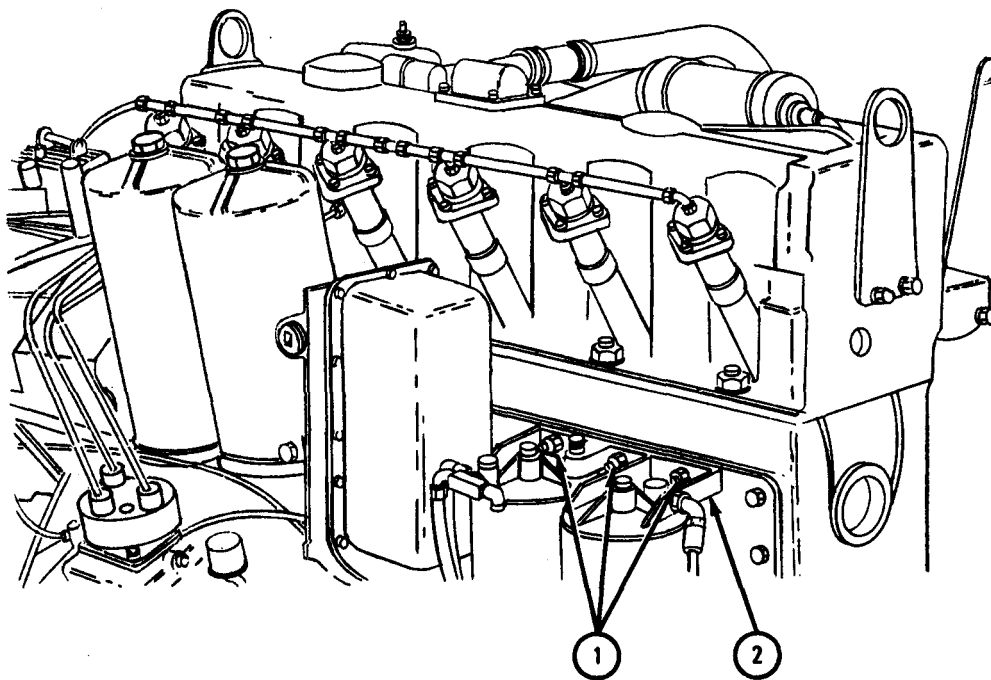

TA 103325

FRAME 3

1. Take off 12 nuts and lockwashers (1). Take off oil cooler cover (2).
GO TO FRAME 4

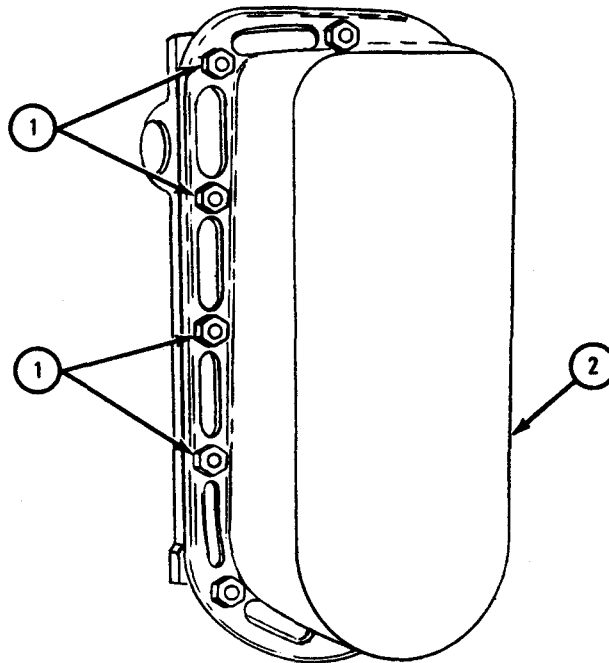

TA 103326

FRAME 4

1. Take off oil cooler cover gasket (1), oil cooler radiator (2), oil cooler gasket (3), and two preformed packings (4). Throw away two gaskets and preformed packings.
2. Plug two holes in oil cooler housing (5).

END OF TASK

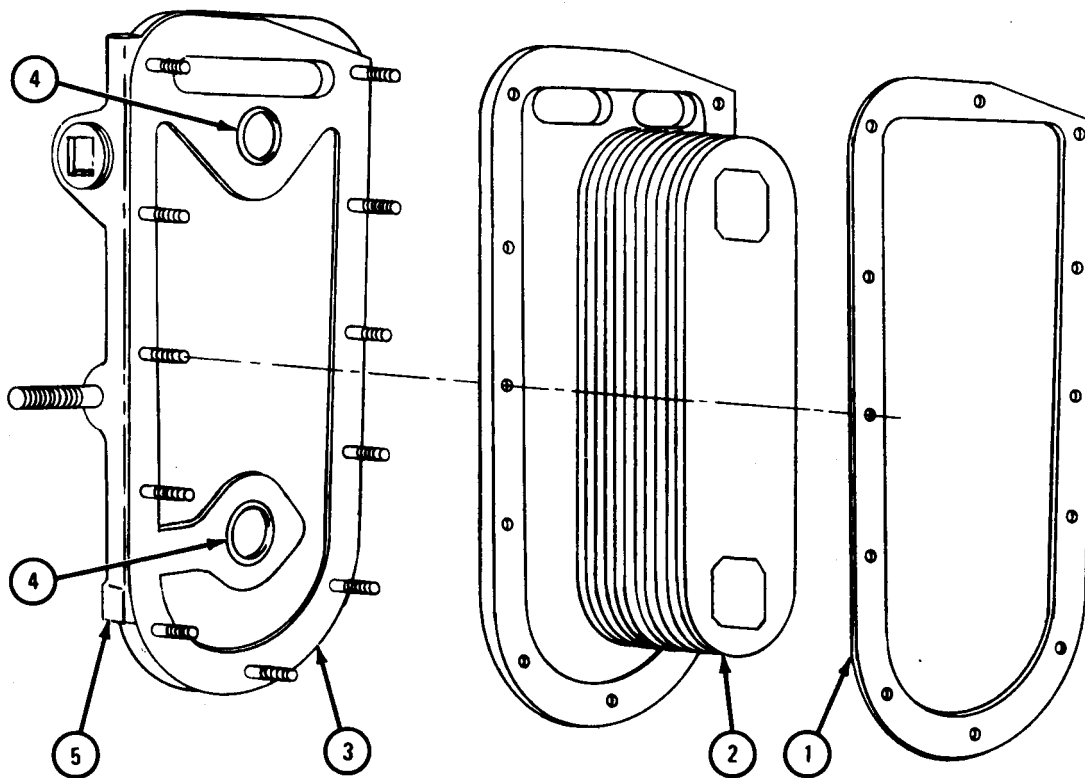

TA 103327

c. Replacement.**FRAME 1**

1. Unplug two holes in oil cooler housing (1).
2. Put a coat of grease on back side of two preformed packings (2) and put on preformed packings.
3. Put on oil cooler gasket (3), oil cooler radiator (4), and oil cooler cover gasket (5).

GO TO FRAME 2

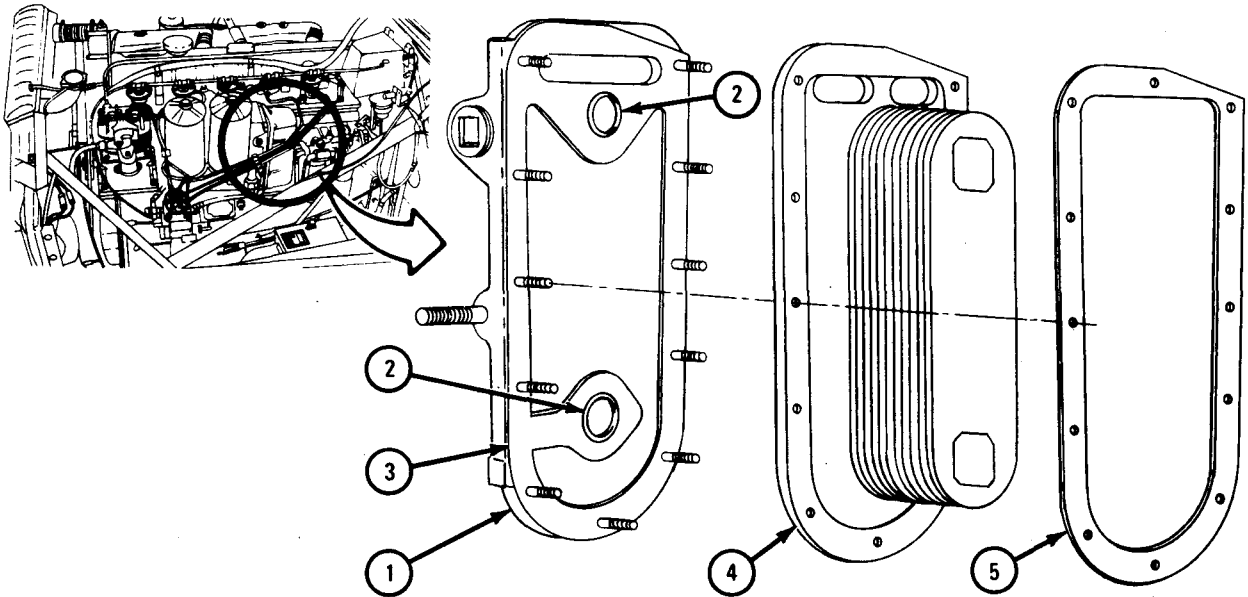

TA 103328

FRAME 2

1. Put on oil cooler cover (1).
 2. Put on 12 nuts and lockwashers (2).
- GO TO FRAME 3

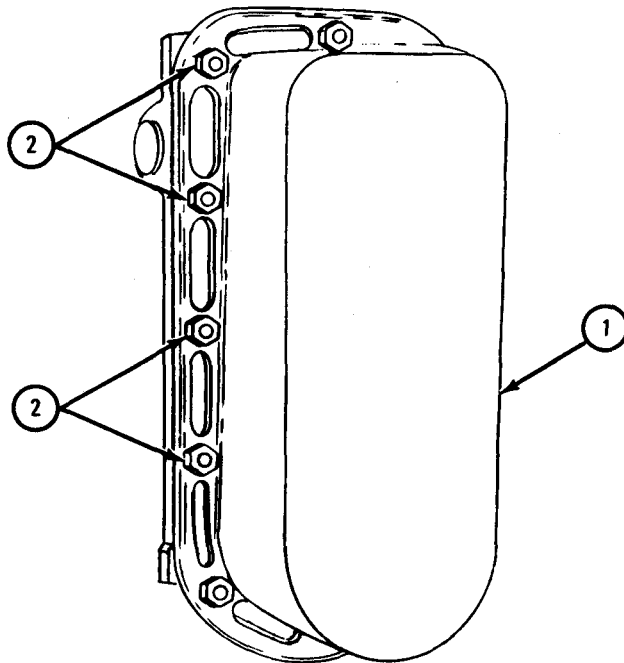

TA 103329

FRAME 3

1. Put fuel filter assembly (1) in place. Put on three nuts and lockwashers (2).
GO TO FRAME 4

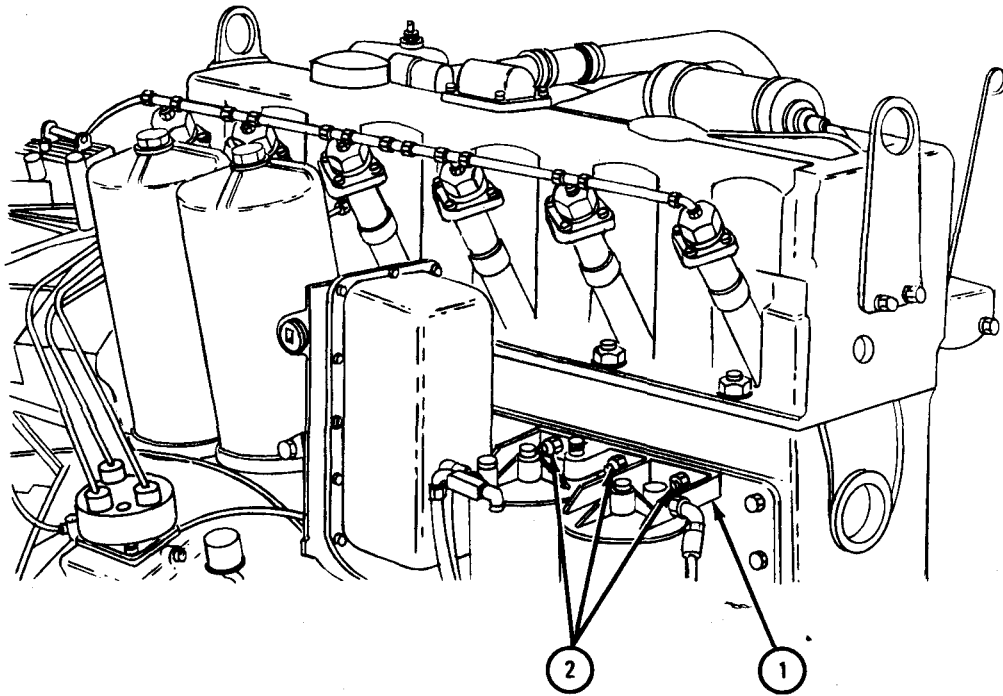

TA 103330

FRAME 4

1. Unplug holes in three fuel injectors (1) and three holes in injector pump head (2).
2. Put three fuel injector tubes (3) in place. Put on three tube nuts (4) and three tube nuts (5).
3. Tighten three tube nuts (5) to 23 to 25 pound-feet.
4. Slide three dust covers (6) into place.
5. Put four clamps (7) in place. Put in four capscrews and nuts (8).
6. Put outer clamp (9) in place. Put in two capscrews, flat washers, and self-locking nuts (10).

NOTE

Follow-on Maintenance Action Required:

1. Fill cooling system. Refer to TM 9-2320-209-20.
2. Close hood and side panels. Refer to TM 9-2320-209-10.

END OF TASK

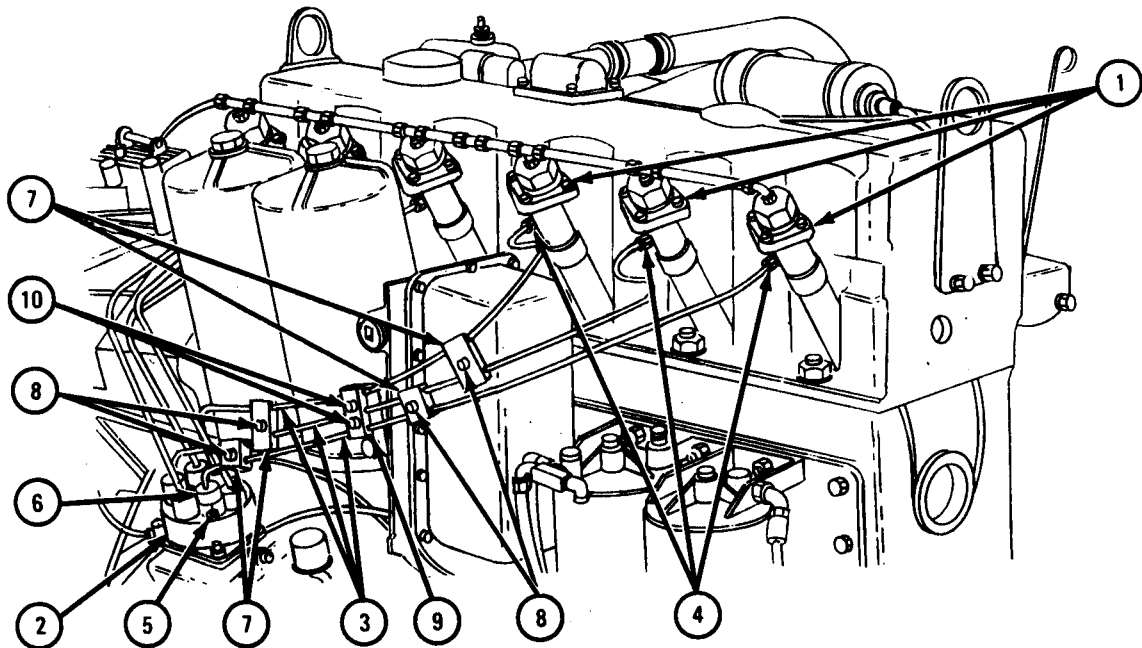

TA 103331

2-19. OIL PRESSURE REGULATOR REMOVAL, REPAIR, AND REPLACEMENT.

TOOLS: No special tools required

SUPPLIES: Gasket, oil pressure regulator housing to crankcase,
NSN 2815-00-930-9229
Oil pressure regulator housing assembly, NSN 2815-00-194-2454

PERSONNEL REQUIREMENTS: One

EQUIPMENT CONDITION: Truck parked, engine off and cool, handbrake set.

a. Preliminary Procedures.

(1) Open hood and right side panel. Refer to TM 9-2320-209-10.

(2) If working on engine LDT 465-1C (with turbocharger), remove turbocharger air intake hose. Refer to para 2-21.

b. Removal.

FRAME 1

NOTE

If working on engine LD 465-1 or LD 465-1C (without turbocharger), see view A and do step 1.

If working on engine LDT 465-1C (with turbocharger), see view B and do steps 2 and 3.

1. Take out four cap screws with lockwashers (1). Move breather tube support bracket (2) off oil pressure regulator (3). Take off oil pressure regulator.
2. Working under turbocharger (4), take out three capscrews with lockwashers (5, 6, and 7). Unscrew capscrew with lockwasher (8). Move cable clip (9) off oil pressure regulator (10).
3. Take off oil pressure regulator (10) with capscrew and lockwasher (8).
4. Take out capscrew with lockwasher (8) from oil pressure regulator (10).

GO TO FRAME 2

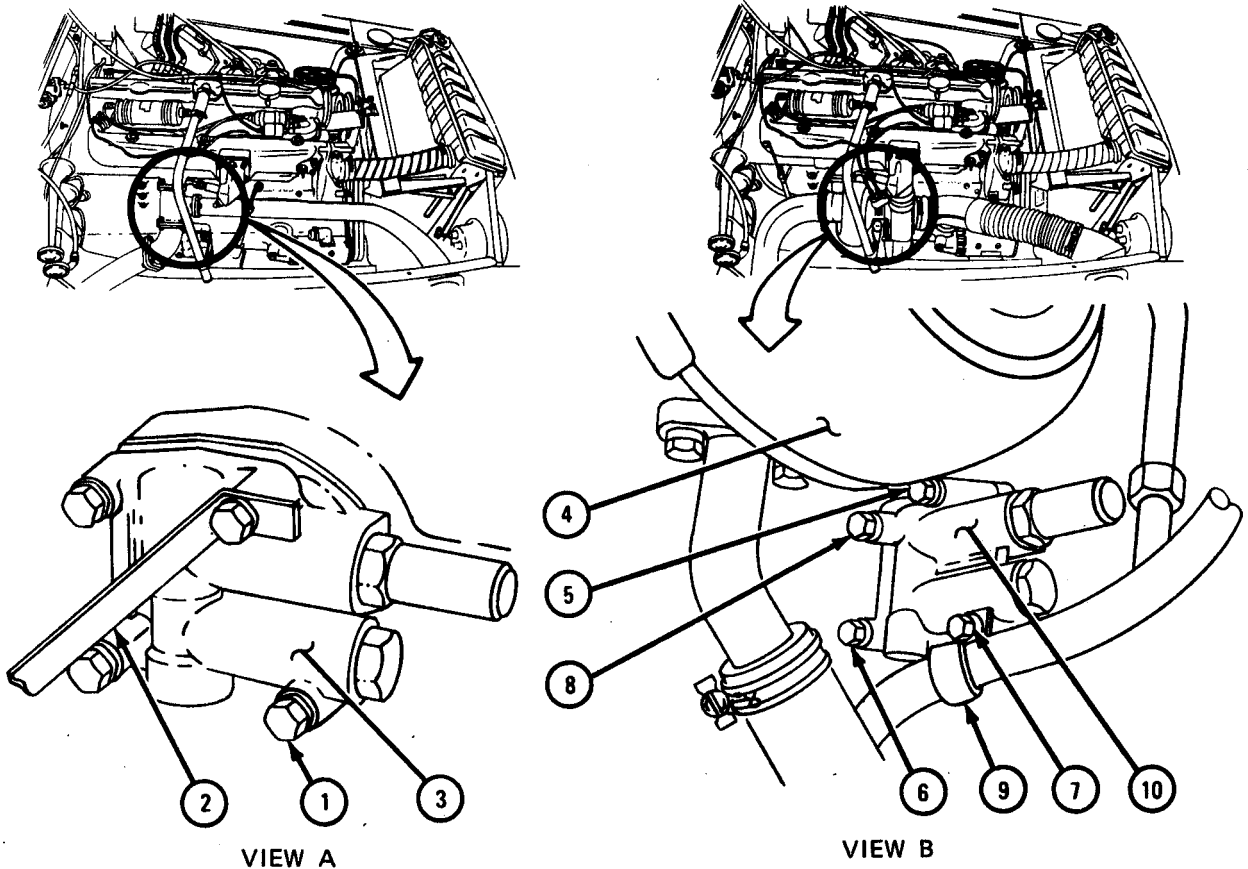

TA 105652

FRAME 2

1. Take off gasket (1) from engine crankcase (2). Throw away gasket.

CAUTION

To stop clogging of oil system and damage to engine, dust and other matter must not get into oil system openings.

2. Cover oil pressure regulator gasket (1) area of engine crankcase (2).

END OF TASK

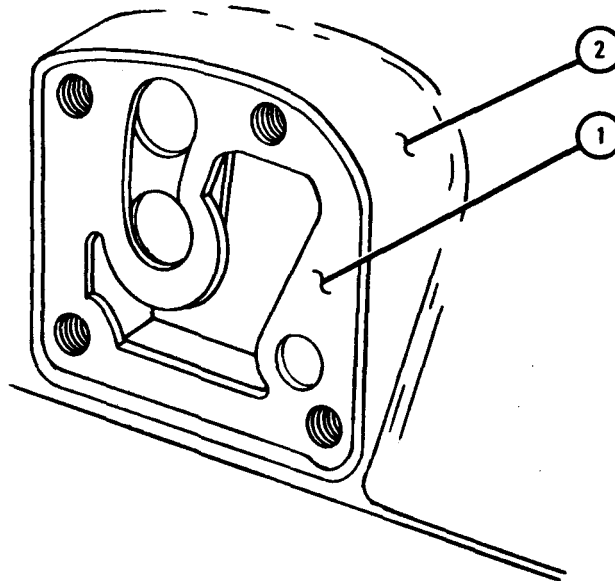

TA 105653

c. Cleaning, Inspection, and Repair. Refer to TM 9-2815-210-34 for procedure to clean, inspect and repair oil pressure regulating valve.

d. Replacement.

FRAME 1

1. Put new gasket (1) on engine crankcase (2).

IF WORKING ON ENGINE LD 465-1 OR LD 465-1C (WITHOUT TURBOCHARGER), GO TO FRAME 2.

IF WORKING ON ENGINE LDT 465-1C (WITH TURBOCHARGER), GO TO FRAME 3

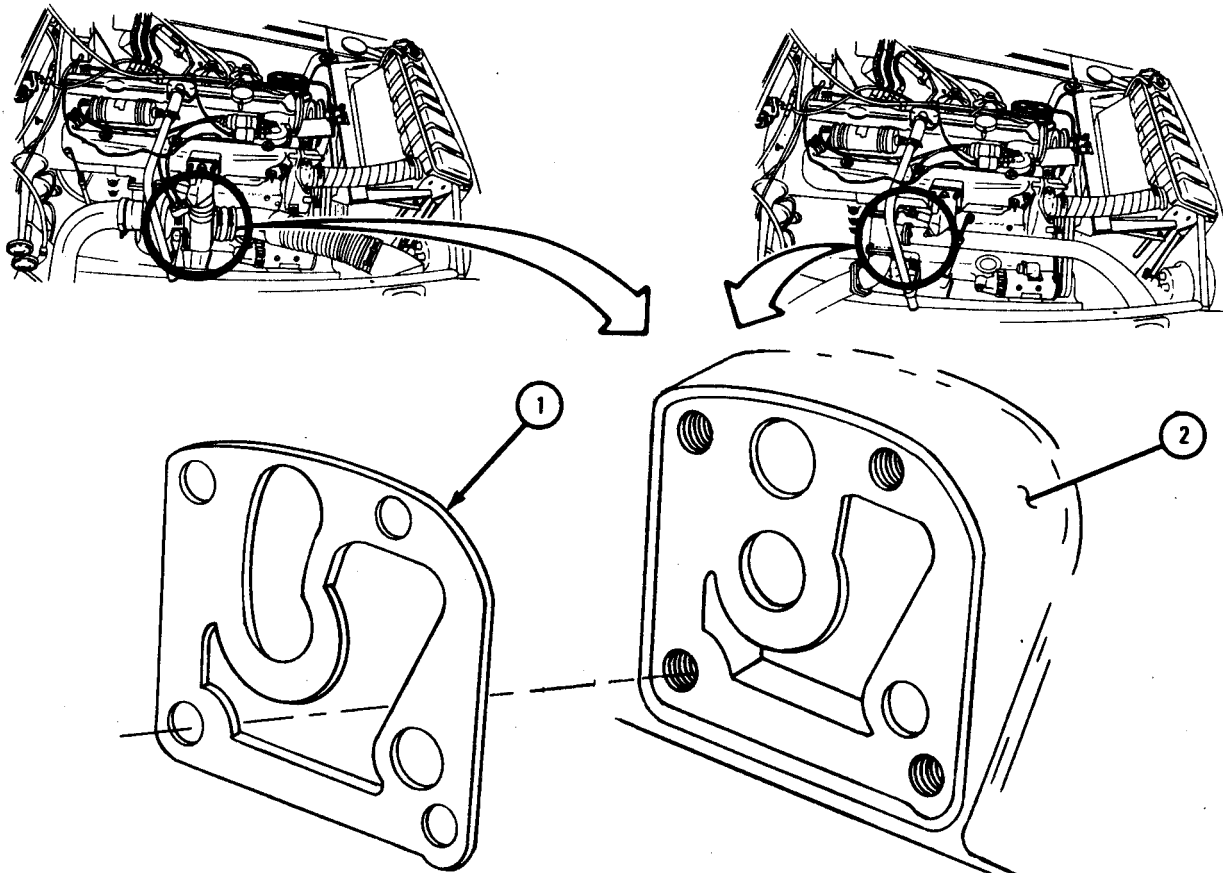

TA 121222

FRAME 2

1. Put new oil pressure regulator (1) on gasket (2). Move breather tube support bracket (3) over screwhole (4).
2. Put in and tighten four capscrews (5) with lockwashers (6).

NOTE

Follow-on Maintenance Action Required:

Close right side panel and hood. Refer to
TM 9-2320-209-10.

END OF TASK

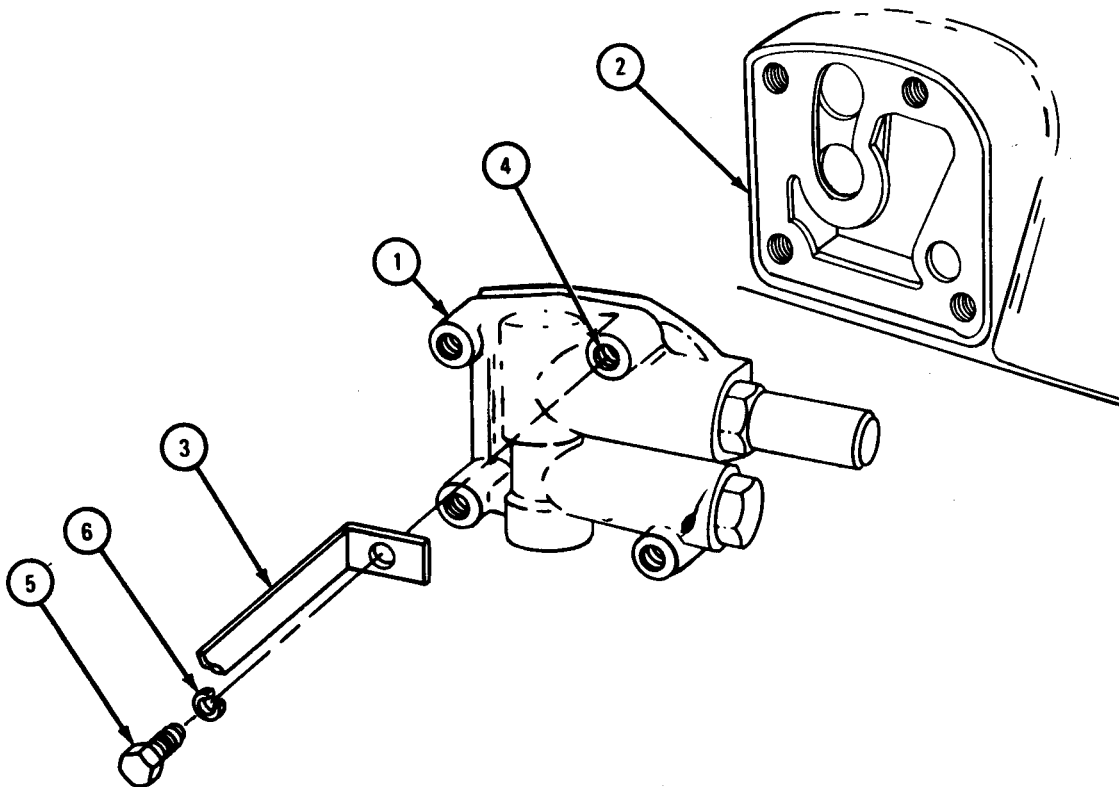

TA 105661

FRAME 3

1. Put capscrew (1) with lockwasher (2) in screwhole (3) of oil pressure regulator (4).
2. Put new oil pressure regulator (4) on gasket (5).
3. Put hole in cable clamp (6) over screwhole (7) of oil pressure regulator (4).
4. Put capscrews (1) with lockwashers (2) in three screwholes (7, 8, and 9) of oil pressure regulator (4).
5. Tighten capscrew (10) and three capscrews in screwholes (7, 8, and 9).

NOTE

Follow-on Maintenance Action Required:

1. Put on turbocharger air intake hose. Refer to para 2-21.
2. Check for oil leak. Refer to TM 9-2320-209-10.
3. Close right side panel and hood. Refer to TM 9-2320-209-10.

END OF TASK

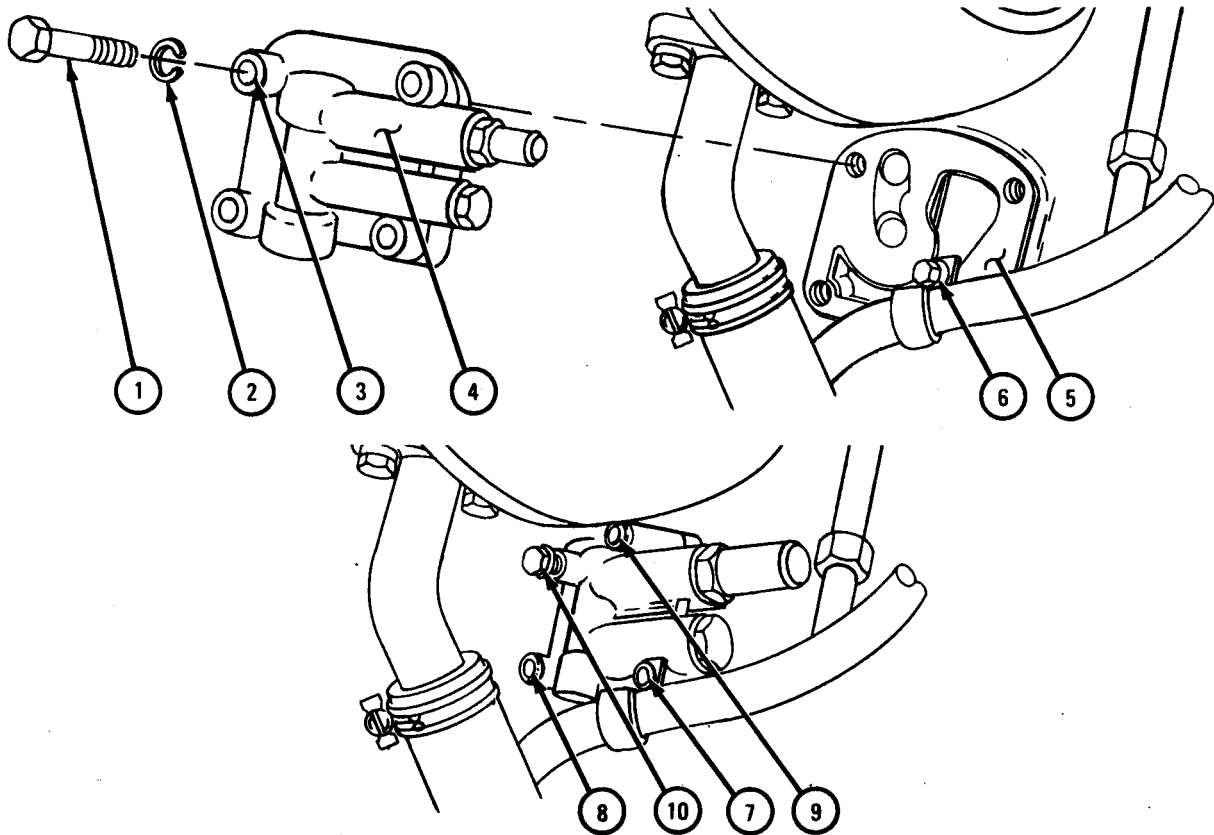

TA 105662

2-20. OIL COOLER BYPASS VALVE REMOVAL, REPAIR AND REPLACEMENT.

TOOLS: No special tools required

SUPPLIES: Gasket
Oil cooler bypass

PERSONNEL: One

EQUIPMENT CONDITION: Truck parked, engine off, handbrake set.

a. Preliminary Procedure. Open hood and left side panel. Refer to TM 9-2320-209-10.

b. Removal.

FRAME 1

1. Take out plug (1), gasket (2), spring (3), and plunger (4). Throw away gasket.

END OF TASK

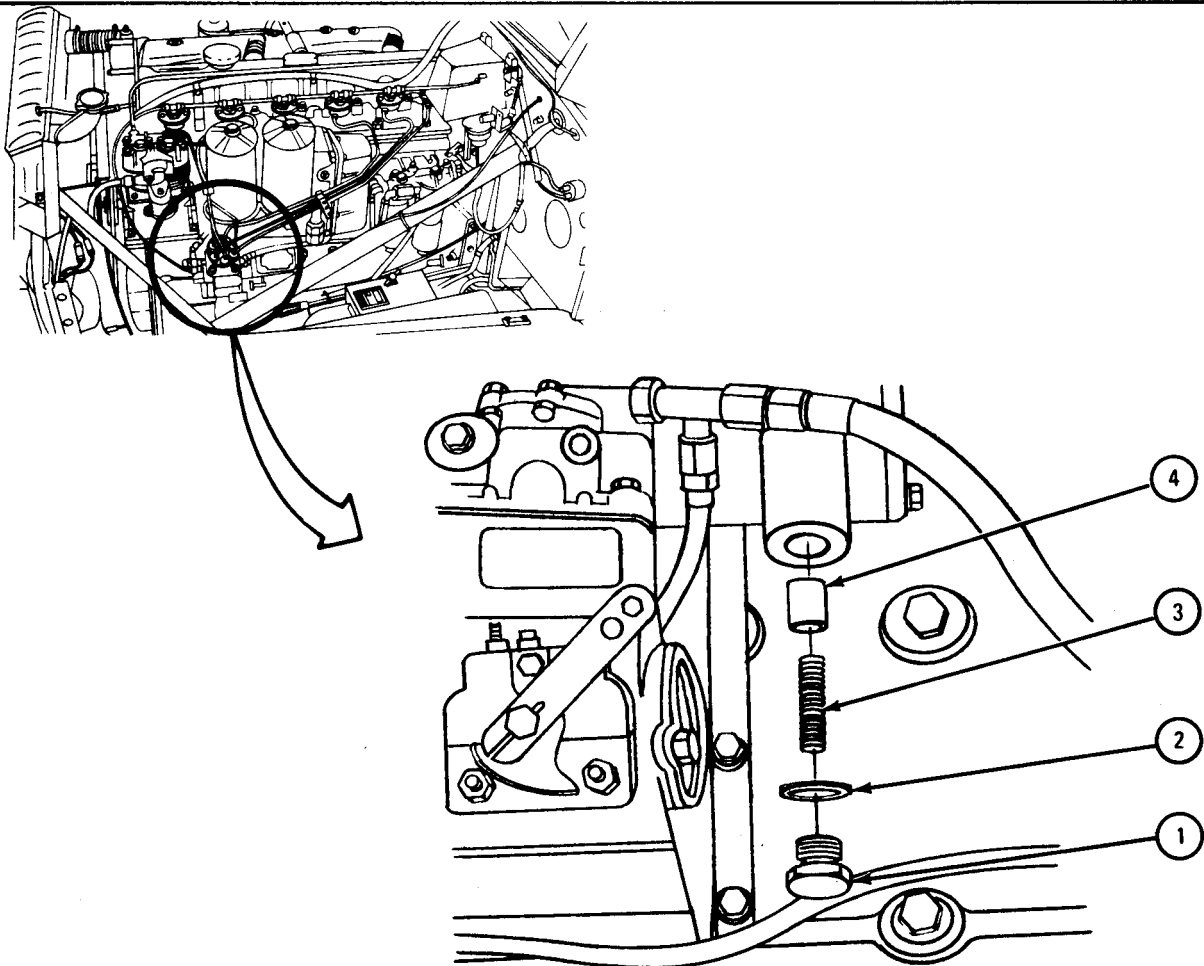

TA 105655

c. Inspection and Repair. Refer to TM 9-2815-210-34 for procedure to inspect and repair oil cooler bypass valve.

d. Replacement.

FRAME 1

1. Put in plunger (1), spring (2), gasket (3), and plug (4).

NOTE

Follow-on Maintenance Action Required:

Close hood and left side panel. Refer to TM 9-2320-209-10.

END OF TASK

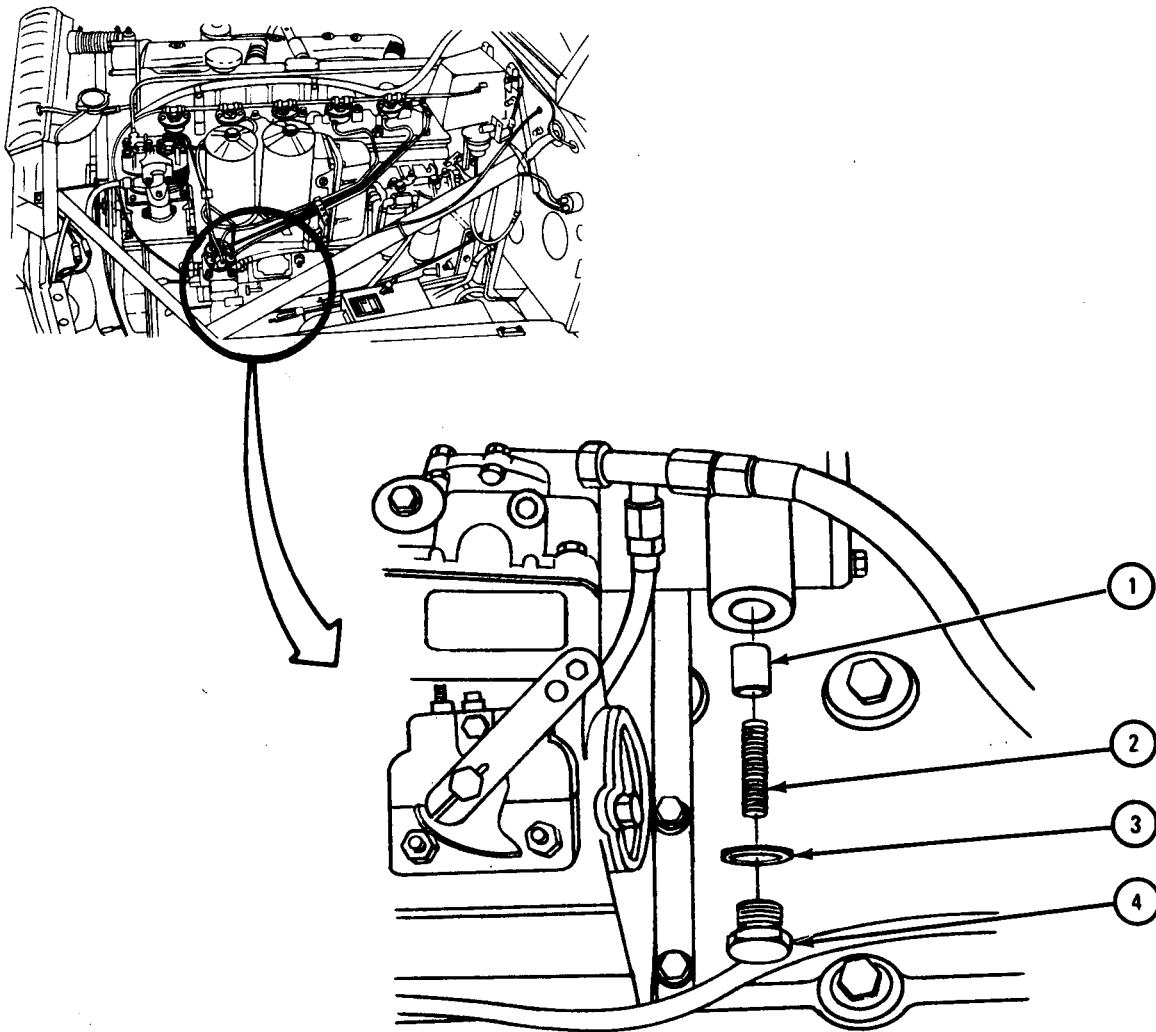

TA 105656

2-21. AIR INTAKE AND EXHAUST MANIFOLDS REMOVAL, REPAIR, AND REPLACEMENT.

TOOLS: No special tools required

SUPPLIES: Sealing compound, MIL-S-15204
Thermostat housing gasket
Intake manifold elbow-to-intake manifold gasket
Turbocharger oil drain tube gasket
Intake and exhaust manifold-to-cylinder head (2)
Water manifold-to-cylinder head gasket (6)

PERSONNEL: Two

EQUIPMENT CONDITION: Truck parked, engine off, handbrake set.

a. Preliminary Procedures.

- (1) Open hood and side panels. Refer to TM 9-2320-209-10.
- (2) Drain cooling system. Refer to TM 9-2320-209-20.
- (3) Remove turbocharger exhaust outlet hose. Refer to Turbocharger System Hoses and Clamps Removal and Replacement, TM 9-2320-209-20.

b. Removal.

FRAME 1

1. Open battery compartment door (1).
 2. Loosen two thumbscrews (2) and push clamps (3) down to clear battery box (4).
 3. Pull battery box (4) out onto running board (5).
- GO TO FRAME 2

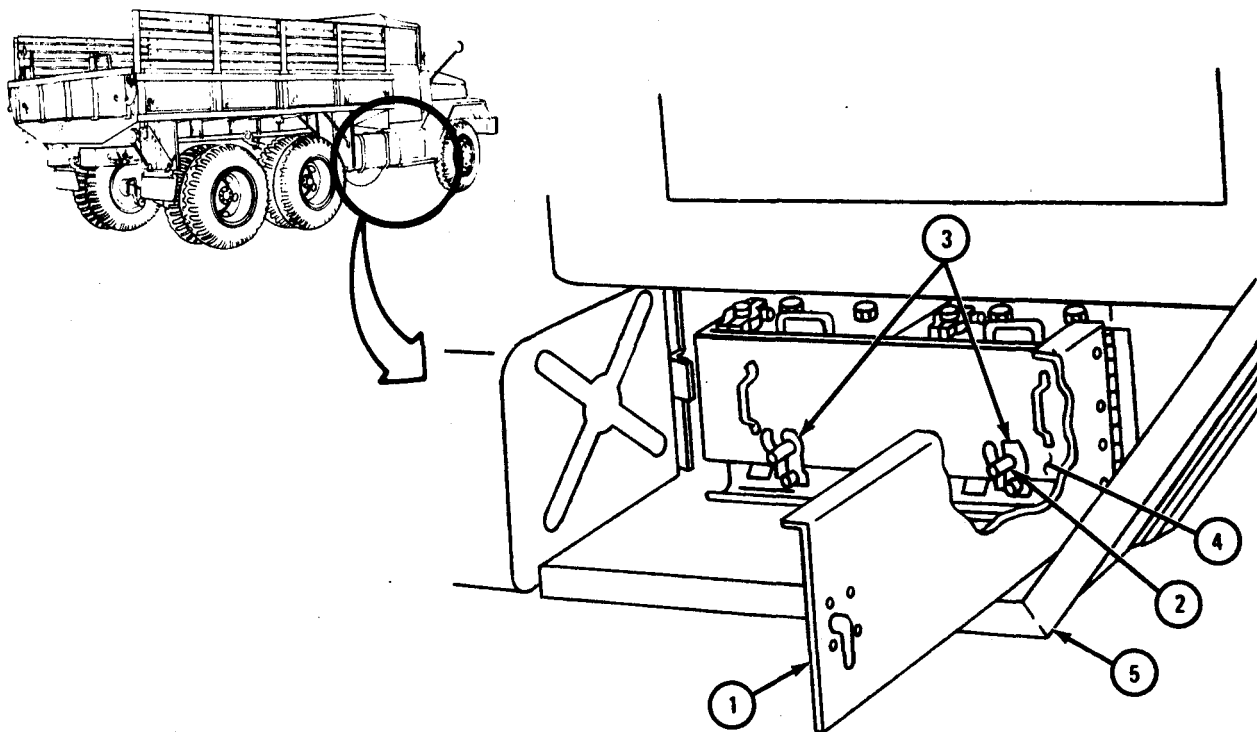

TA 118456

FRAME 2WARNING

Do not let tool touch positive terminal on battery and truck or there will be a direct short, arcing, and tool will heat. This could cause equipment damage and injury to personnel.

1. Loosen nut (1) and take off battery ground terminal (2).
2. Move battery ground cable (3) out of the way so ground terminal (2) will not touch either of two batteries (4).

GO TO FRAME 3

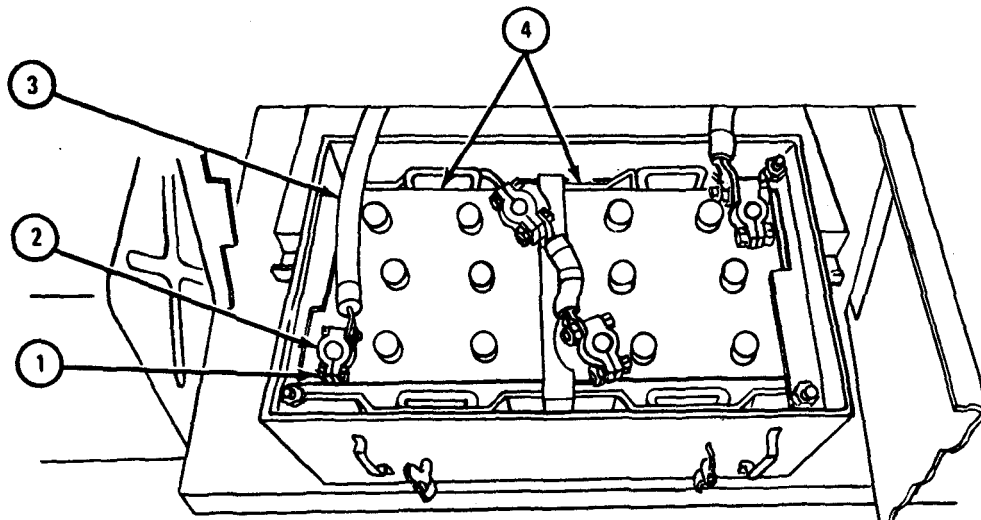

TA 118457

FRAME 3

1. Unsnap three clips (1) on air cleaner head (2) and take off cannister (3), filter (4) and gasket (5).
 2. Take out coupling nut (6) from connector filter (7).
 3. Pull tube assembly (8) out of connector filter (7).
 4. Take connector filter (7) out of air cleaner head (2).
- GO TO FRAME 4

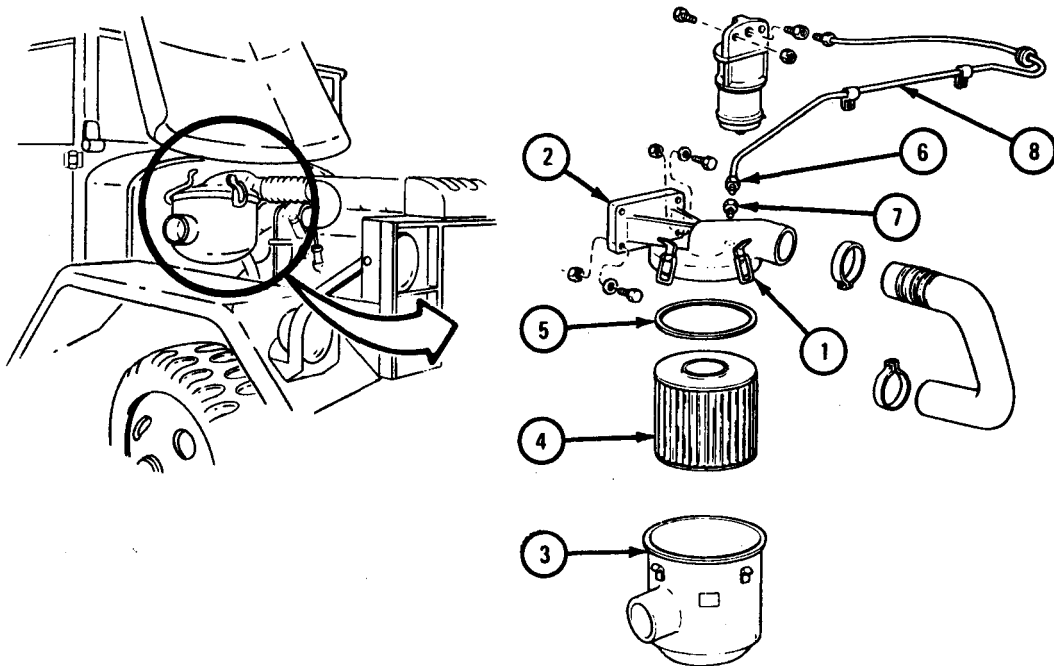

TA 103350

FRAME 4

1. Loosen clamp screw (1) and take tube assembly (2) off air cleaner head (3).
2. Hold air cleaner head (3) and take out four screws (4) and washers (5).
3. Lift out air cleaner head (3).

GO TO FRAME 5

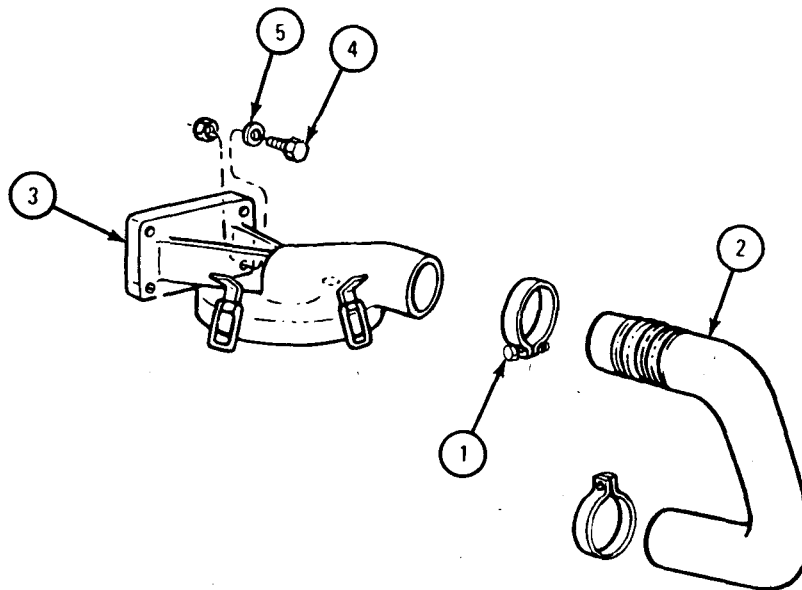

TA 118470

FRAME 5

1. Take connector (1) off water temperature transmitter (2).
2. Take off water temperature transmitter (2).

GO TO FRAME 6

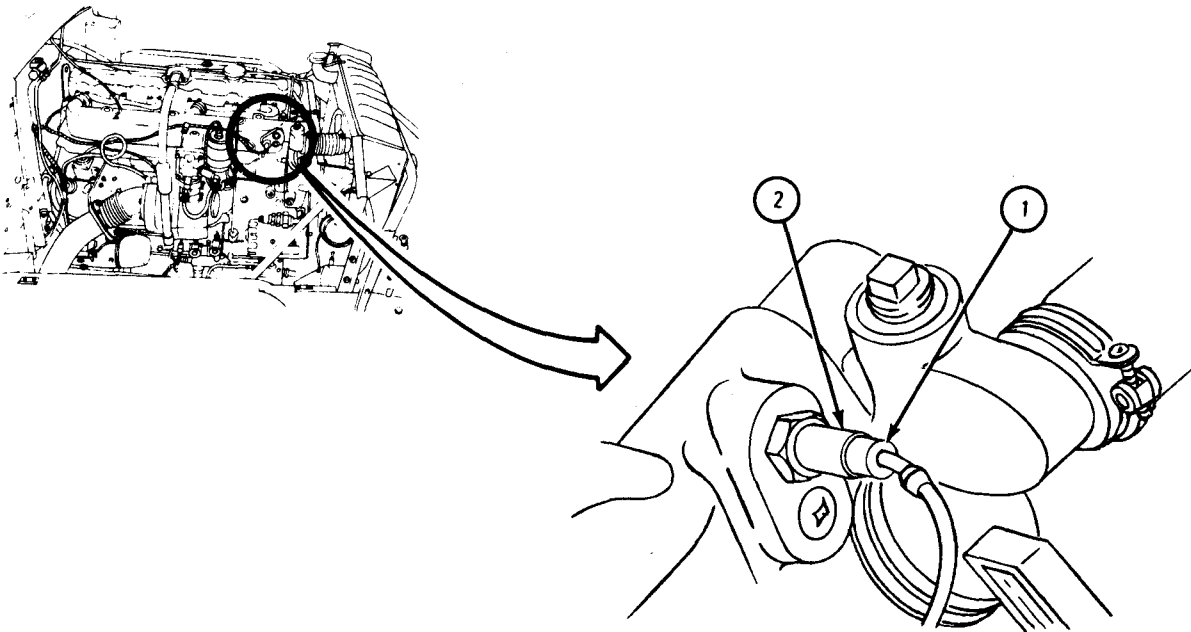

TA 103352

FRAME 6

1. Loosen two screws (1) on two clamps (2). Spread both clamps and take off hose (3).
2. Unscrew and take off nut (4) from bolt (5). Pull bolt out of rod end clevis (6).
3. Pull radiator (7) forward at top, just enough to take off preformed hose (3).

GO TO FRAME 7

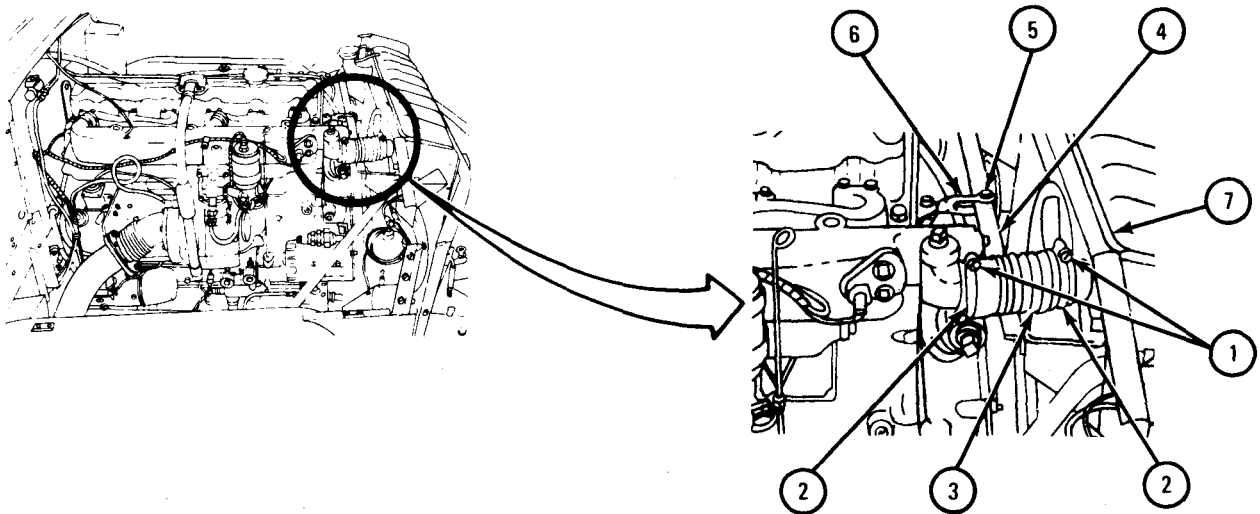

TA 103353

FRAME 7

1. Unscrew two bolts (1). Take bolts with two flat washers (2) out of thermostat housing (3).
2. Loosen screw (4) on clamp (5).
3. Pull thermostat housing (3) away from intake manifold (6) and from hose (7). Pull gasket (8) away from intake manifold and throw gasket away.

IF WORKING ON TRUCK WITH ENGINE LD 465-1 OR LD 465-1C, GO TO FRAME 8.
IF WORKING ON TRUCK WITH ENGINE LDT 465-1C, GO TO FRAME 10

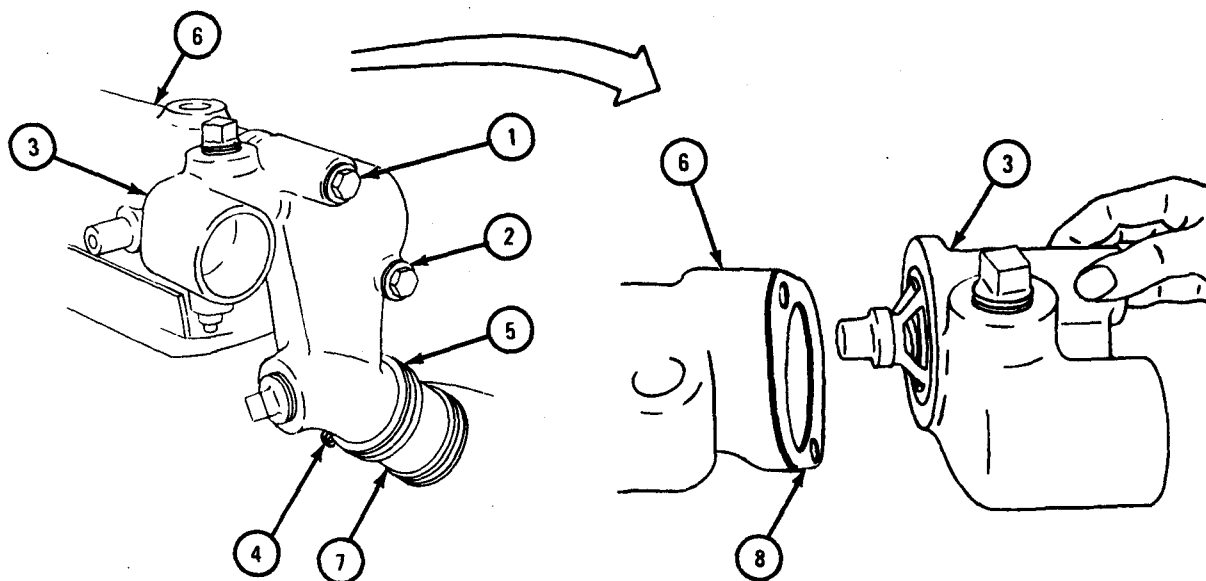

TA 118458

FRAME 8

1. Hold adapter fitting (1) and take off tube nut (2). Take off adapter fitting.
2. Take off capscrew (3) and nut (4). Spread open and take off clamp (5).
3. Loosen two hose clamps (6). Pull off hose (7) with crankcase breather tube (8) from breather tube adapter (9).
4. Take off two hose clamps (6) and hose (7) from crankcase breather tube (8).

GO TO FRAME 9

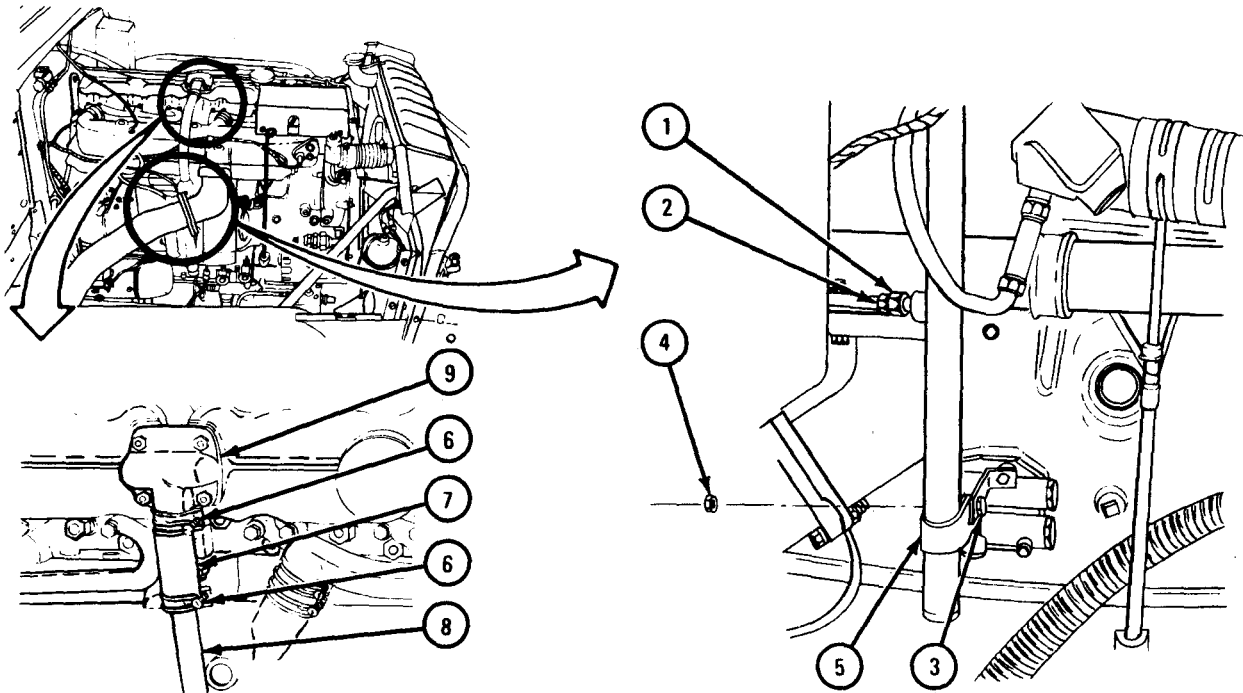

TA 118459

FRAME 9

1. Take two nuts (1) and lockwashers (2) off two capscrews (3). Take out two capscrews (3).
2. Take off two nuts (4) and washers (5). Move exhaust pipe (6) out of the way.

GO TO FRAME 15

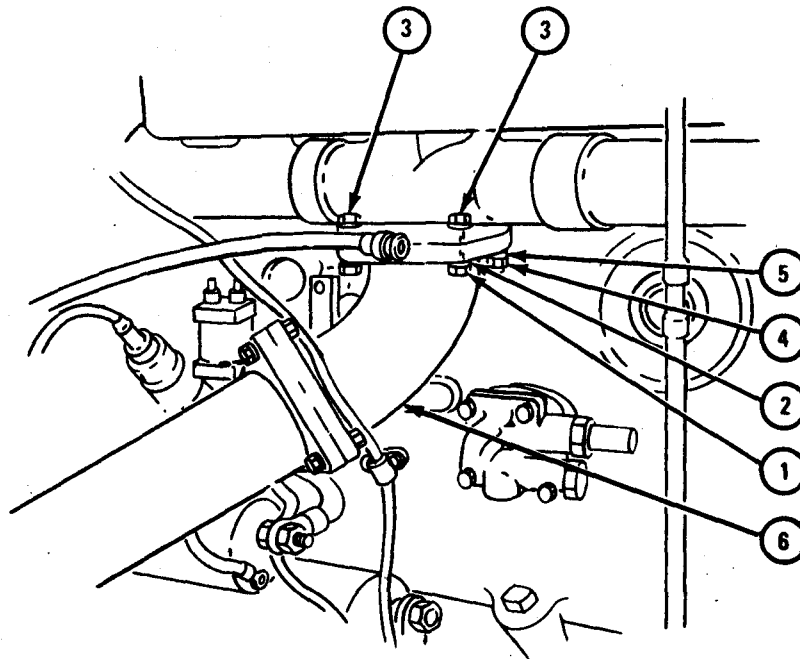

TA 104004

FRAME 10

1. Takeout four capscrews and lockwashers (1). Take off cover (2).
- GO TO FRAME 11

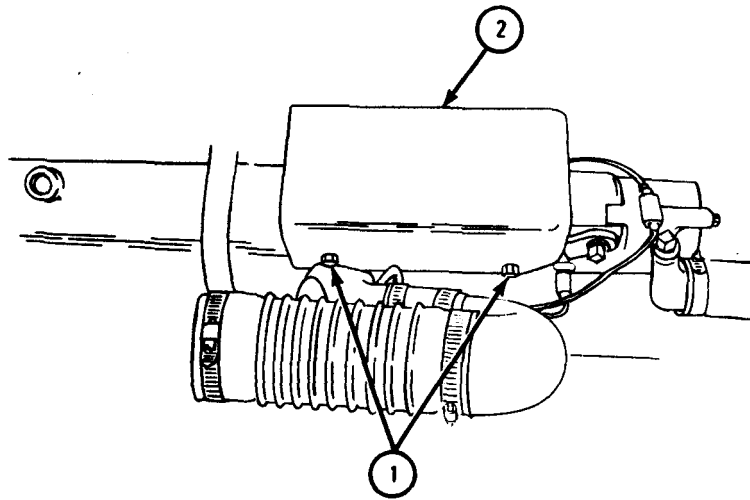

TA 103356

FRAME 11

1. Take off two coupling nuts (1 and 2).
 2. Take off ignition unit lead (3).
 3. Loosen two nuts (4) and slide hose (5) upon manifold elbow (6).
 4. Take off four nuts (7) and lockwashers (8).
 5. Take off intake manifold elbow (6) and gasket (9). Throw away gasket.
- GO TO FRAME 12

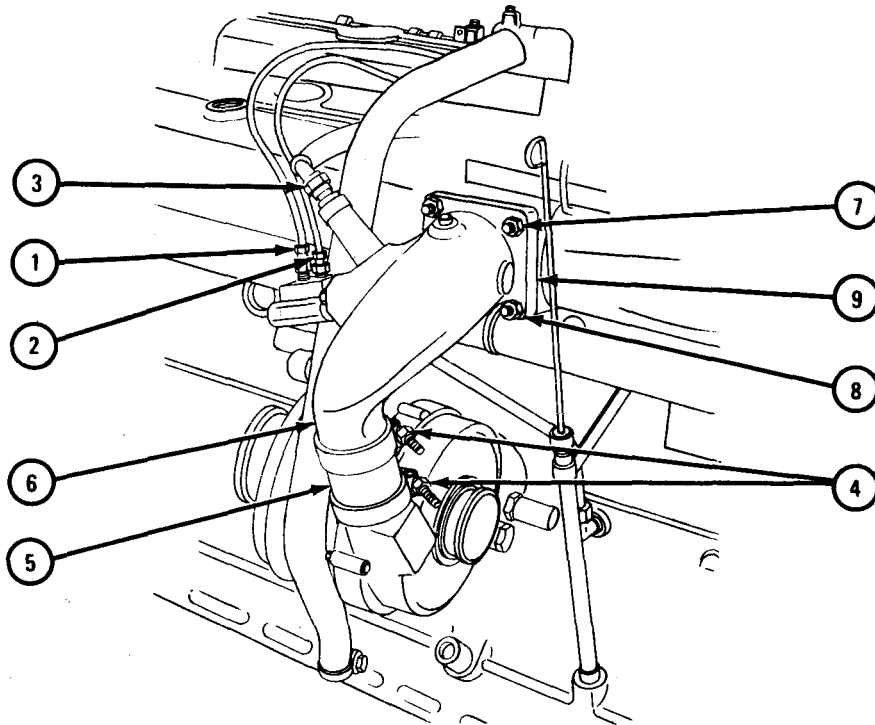

TA 118460

FRAME 12

1. Take out two capscrews and lockwashers (1).
2. Loosen capscrew (2).
3. Take out oil drain tube (3) and gasket (4). Throw away gasket.

GO TO FRAME 13

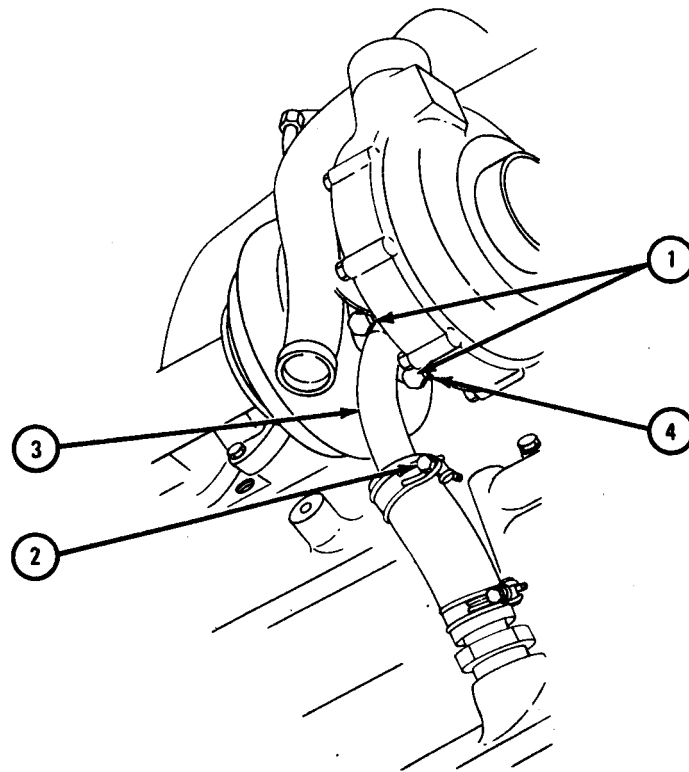

TA 118461

FRAME 13

1. Loosen hose clamp (1). Pull off hose (2) with crankcase breather tube (3).
GO TO FRAME 14

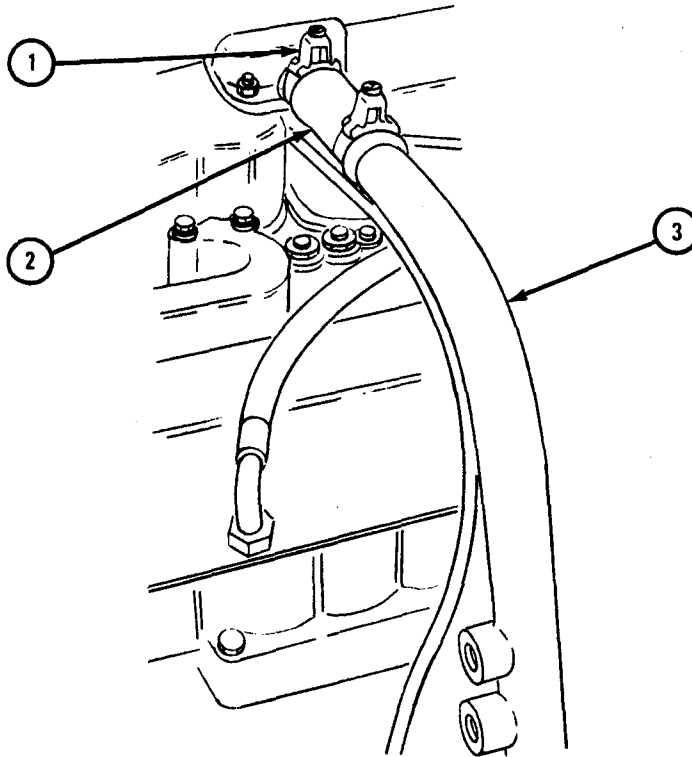

TA 118462

FRAME 14

1. Take off two coupling nuts (1). Take off oil inlet tube (2).
 2. Take out two cap screws (3) and four self-locking nuts (4).
 3. Take off turbocharger (5) and gasket (6). Throw away gasket.
- GO TO FRAME 17

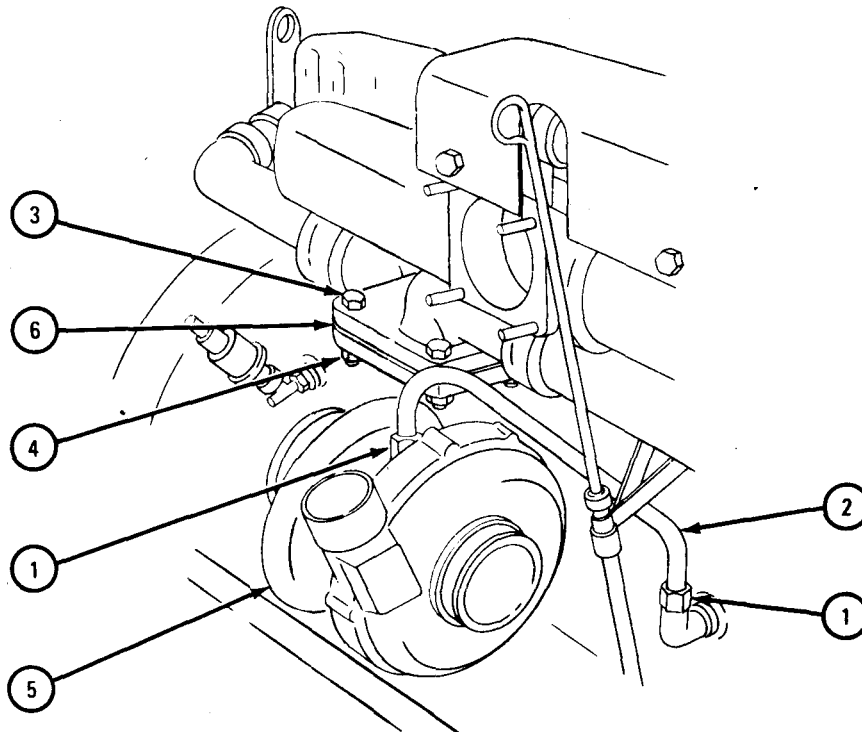

TA 118463

FRAME 15

1. Take electrical cable connector (1) off ignition unit (2).
2. Take electrical cable connector (3) off ignition unit (2).
3. Take out two screws with washers (4).
4. Slide off two clamps (5) from ignition unit (2).
5. Take out ignition unit (2).

GO TO FRAME 16

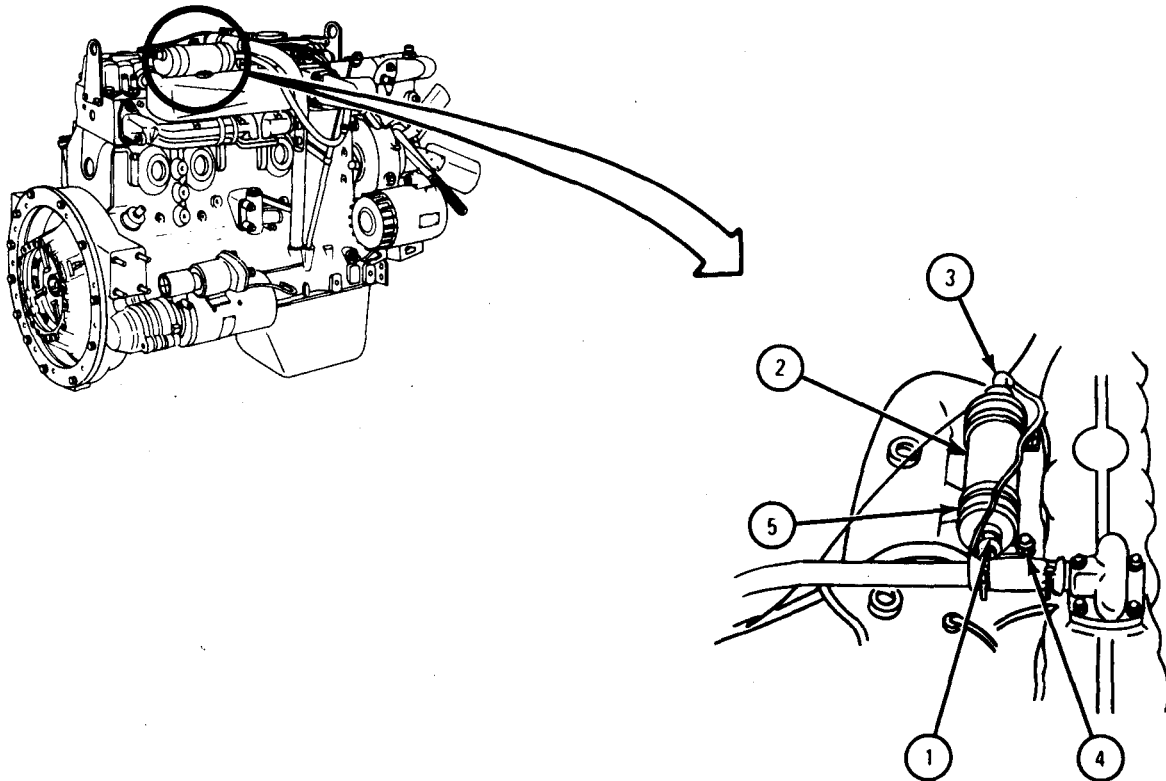

TA 103355

FRAME 16

1. Take off electrical connector (1).
2. Take off tube adapter (2) with tube (3).
3. Take off tube adapter (4) with tube (5).
4. Take out two screws with washers (6).
5. Take out fuel pump (7) and filter (8).

GO TO FRAME 19

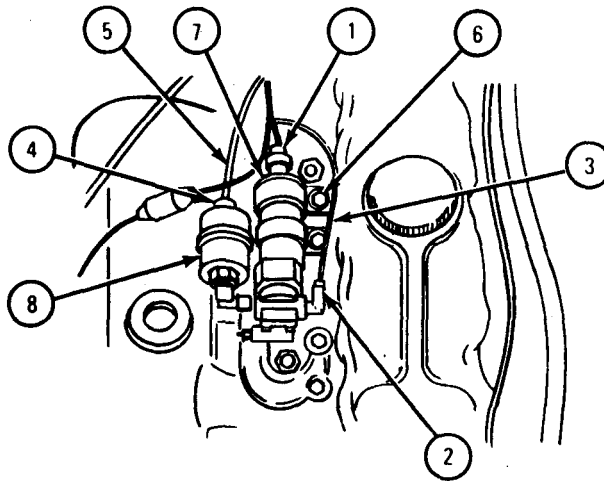

TA 118464

FRAME 17

1. Unscrew and take off inverted nut and tube (1).
2. Unscrew and take off inverted nut and tube (2).
3. Unscrew wiring harness connector (3) off fuel pump (4).
4. **Push down on fuel pump clamp assembly (5) and unhook it from exciter and support bracket assembly (6).**
5. **Lift off flame heater fuel pump (4).**

GO TO FRAME 18

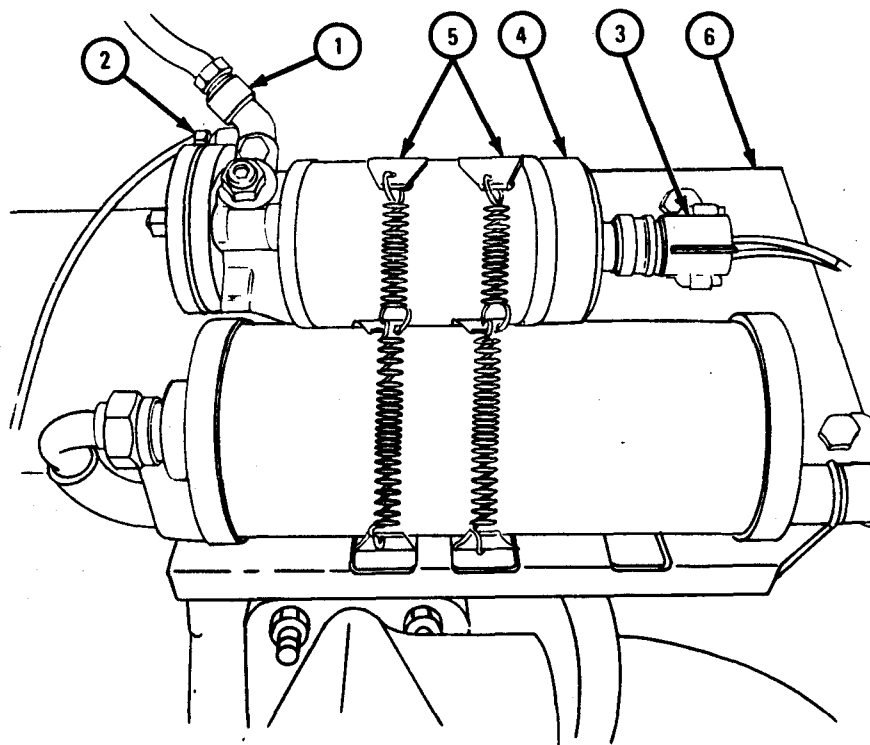

TA 103357

FRAME 18**WARNING**

Do not touch any uninsulated or live connections during this task. Voltage output of ignition unit can cause dangerous electrical shock. Read warning notice on ignition unit.

1. Unscrew nut (1) from ignition unit (2) and take out ignition cable and conduit assembly plug (3).
2. Unscrew wiring harness connector (4) off ignition unit (2).
3. Push down ignition unit clamp assembly (5) and unhook it from support bracket assembly (6). Take off ignition unit (2).
4. Pull apart plug (7).
5. Take out three capscrews and lockwashers (8), and lift support bracket assembly (6) and wiring harness (4) off intake manifold (9).

GO TO FRAME 22

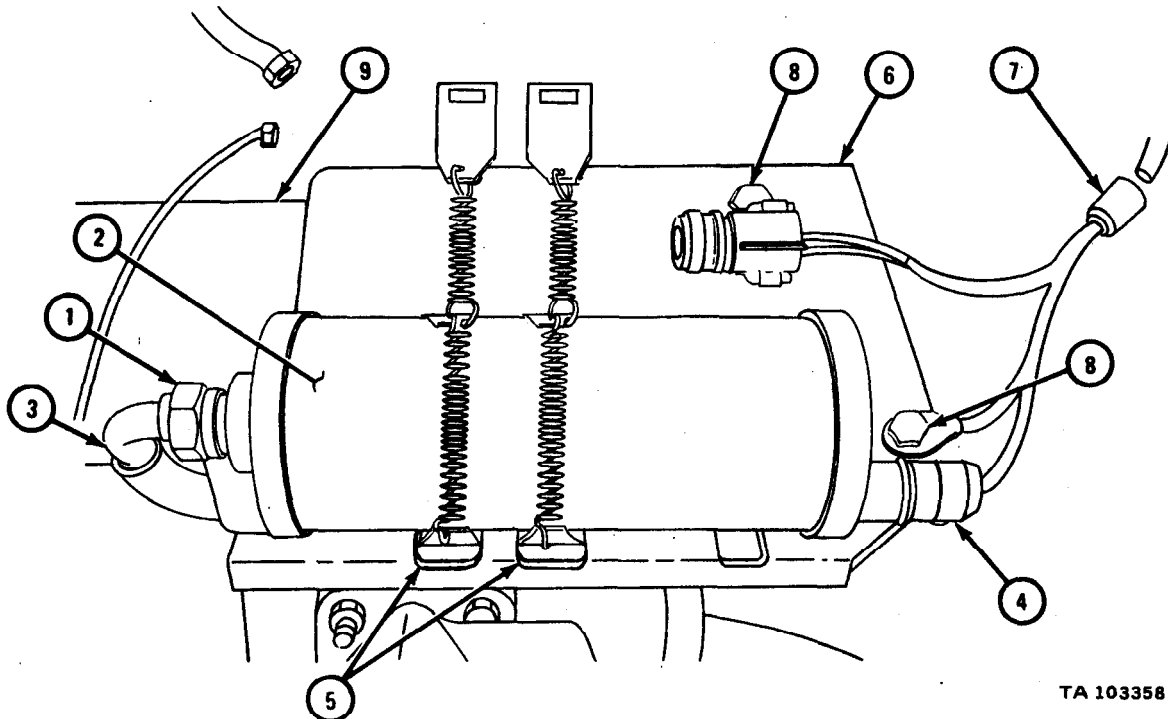

TA 103358

FRAME 19

1. Loosen two hose clamps (1).
2. Take off air induction hose assembly (2).

GO TO FRAME 20

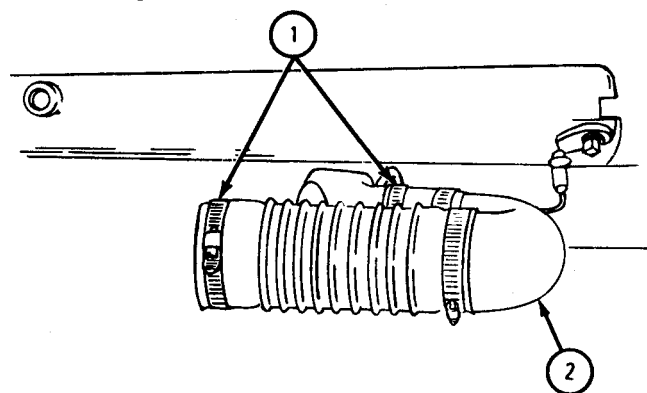
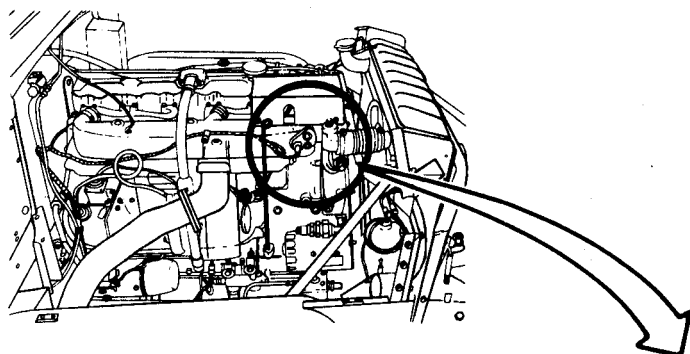

TA 103359

FRAME 20

1. Unscrew nut (1) and take off ignition cable and conduit assembly (2).
2. Hold adapter (3) and take off inverted nut and tube (4).
3. Hold adapter (5) and take off inverted nut and tube (6).

GO TO FRAME 21

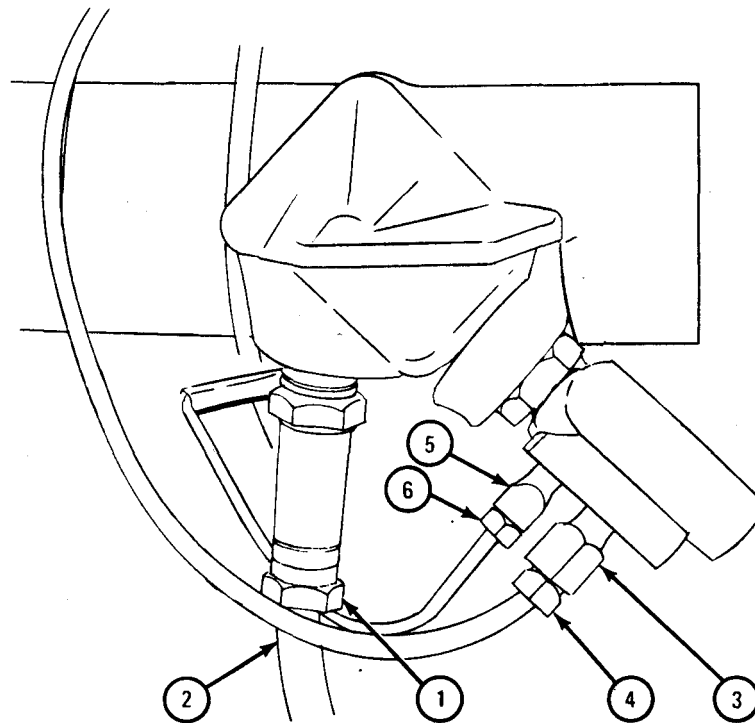

TA 118465

FRAME 21

1. Take off four nuts and lockwashers (1).
 2. Pull intake manifold heater elbow (2) off intake manifold (3).
 3. Take off intake manifold heater elbow gasket (4). Throw away gasket.
- GO TO FRAME 22

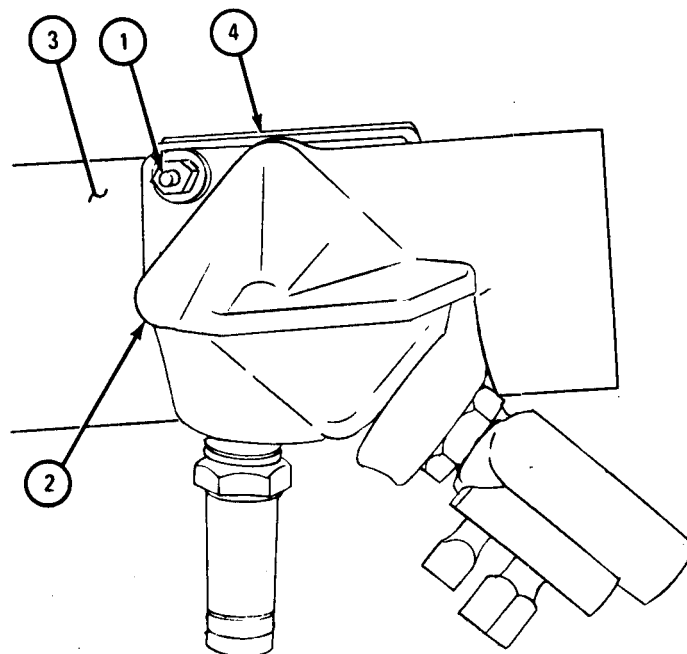

TA 118466

FRAME 22

1. Takeout oil gage rod (1).
2. Take off six self-locking nuts (2) and flat washers (3).
3. Take off oil gage rod support bracket (4).
4. Take off six nuts (5) and flat washers (6).

GO TO FRAME 23

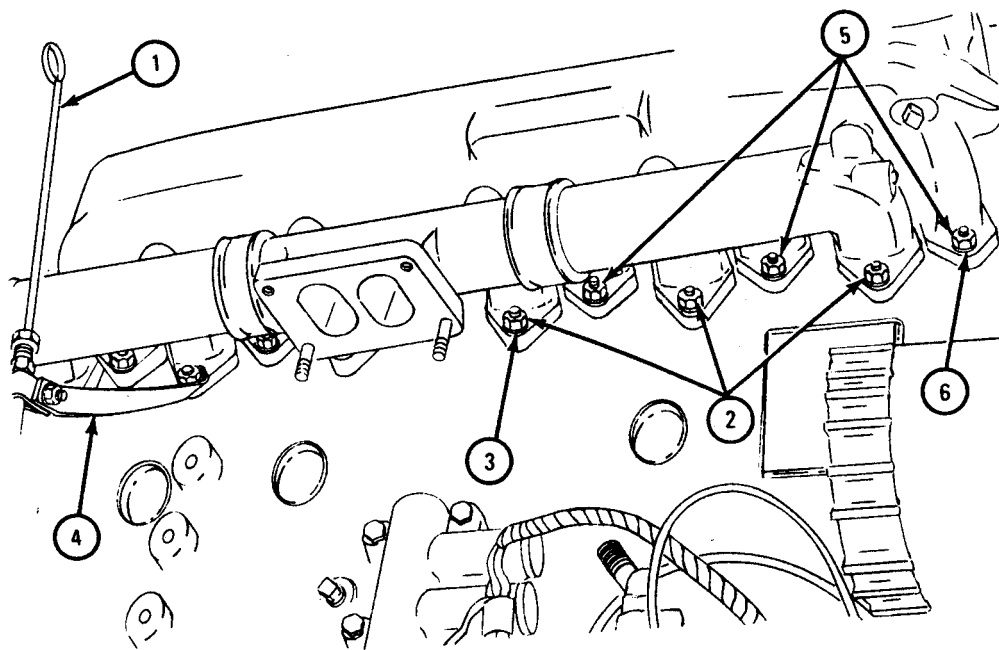

TA 118467

FRAME 23

NOTE

If engine has top-mounted, uncovered manifold heater ignition unit, four of 12 machine bolts (1), were taken out with ignition unit.

1. Take out 12 screws (1).
2. Loosen screws (2) on hose clamps (3).
3. Take off front and rear cylinder head water outlet manifolds (4).
4. Take off 12 nuts and washers (5).
5. Take off six water outlet manifold gaskets (6) and throw away.

GO TO FRAME 24

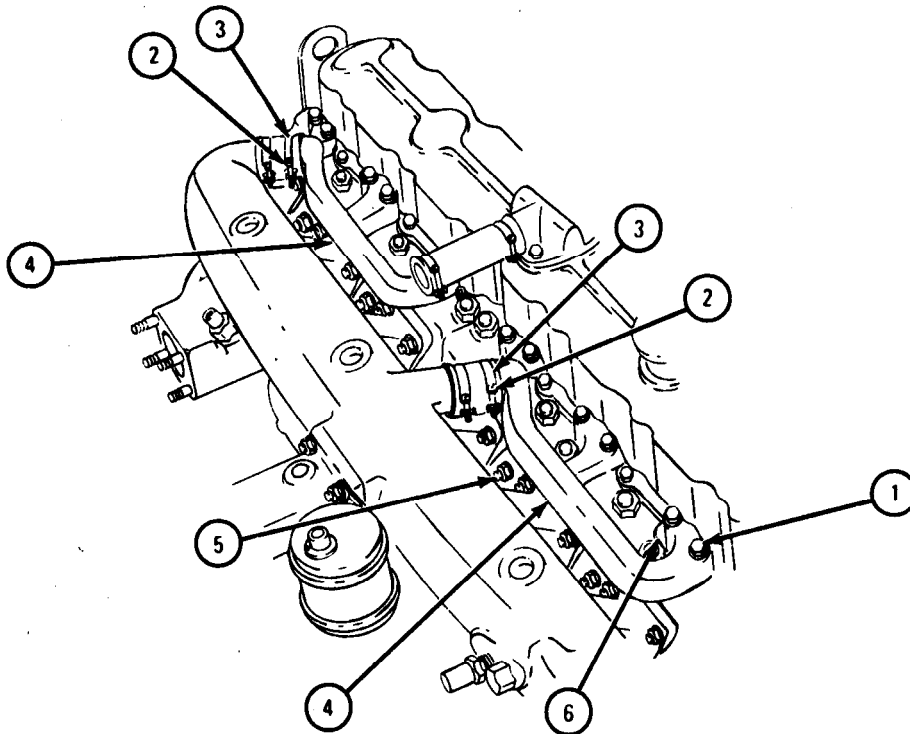

TA 103360

FRAME 24

1. Take off six self-locking nuts (1).
2. Pull off intake and exhaust manifolds (2) as one unit.
3. Take off two gaskets (3) and throw away.

GO TO FRAME 25

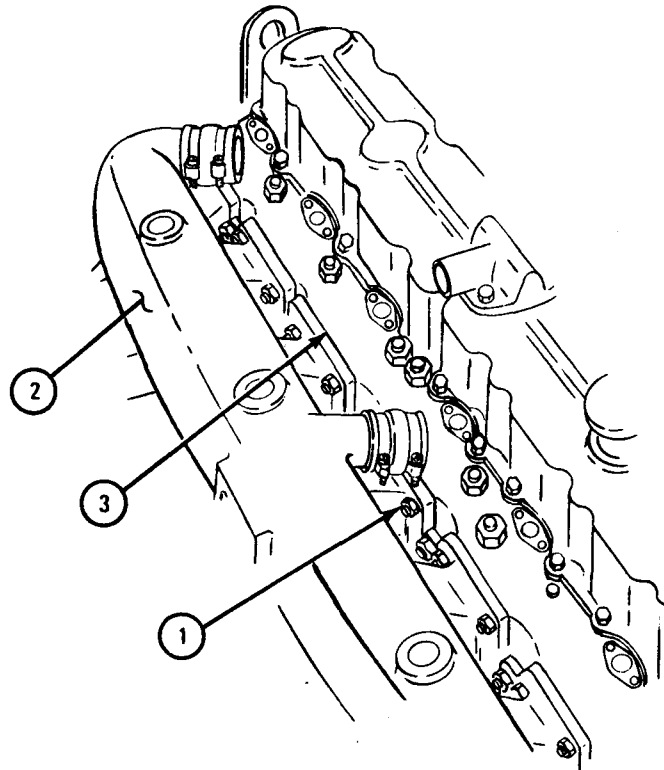

TA 104215

FRAME 25

1. Heat center exhaust manifold section joint (1).
2. Pull apart front manifold section (2) from center manifold section (3).
3. Take off and throw away three sealing rings (4).
4. Do steps 1, 2, and 3 again for rear exhaust manifold section (5).

END OF TASK

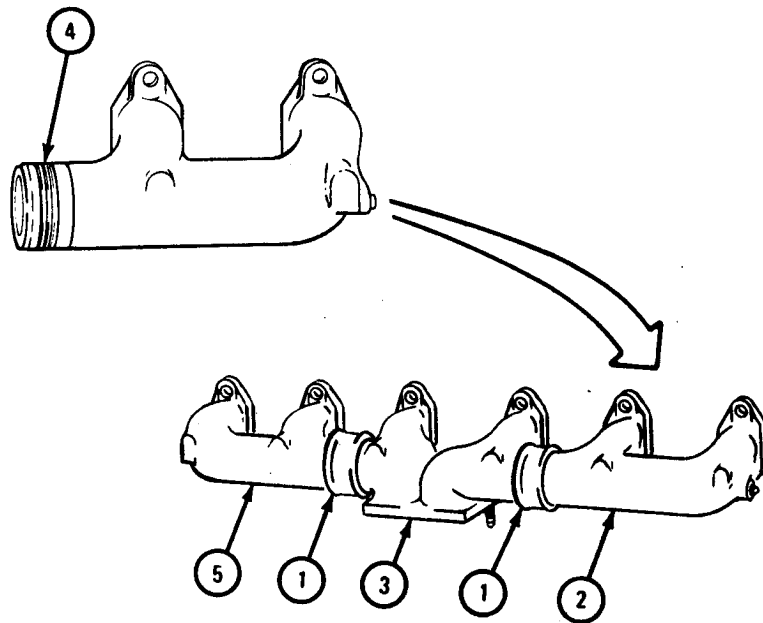

TA 104216

c. Repair. For procedures to repair air intake and exhaust manifolds, refer to TM 9-2815-210-34.

d. Replacement.

FRAME 1

1. Put three ring seals (1) on front exhaust manifold section (2). Stagger gaps one-third of a turn apart.
2. Heat center manifold section joint (3) and push front manifold section (2) into center manifold section (4).
3. Aline gasket sealing surfaces (5).
4. Do steps 1, 2, and 3 again on rear exhaust manifold section (6).

GO TO FRAME 2

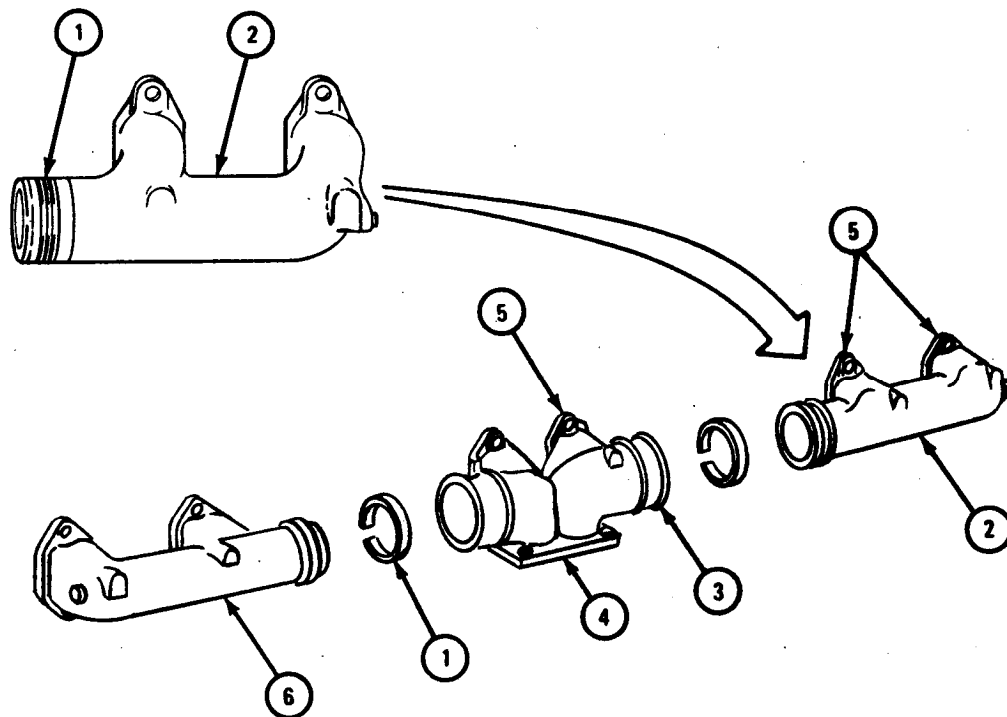

TA 104217

FRAME 2

1. Put front and rear manifold gaskets (1) on engine (2).
2. Put exhaust and intake manifolds (3) on engine (2), as a unit.
3. Put oil gage rod support bracket (4) on stud (5).
4. Put on 12 self-locking nuts (6).
5. Put on 18 nuts and washers (7).

GO TO FRAME 3

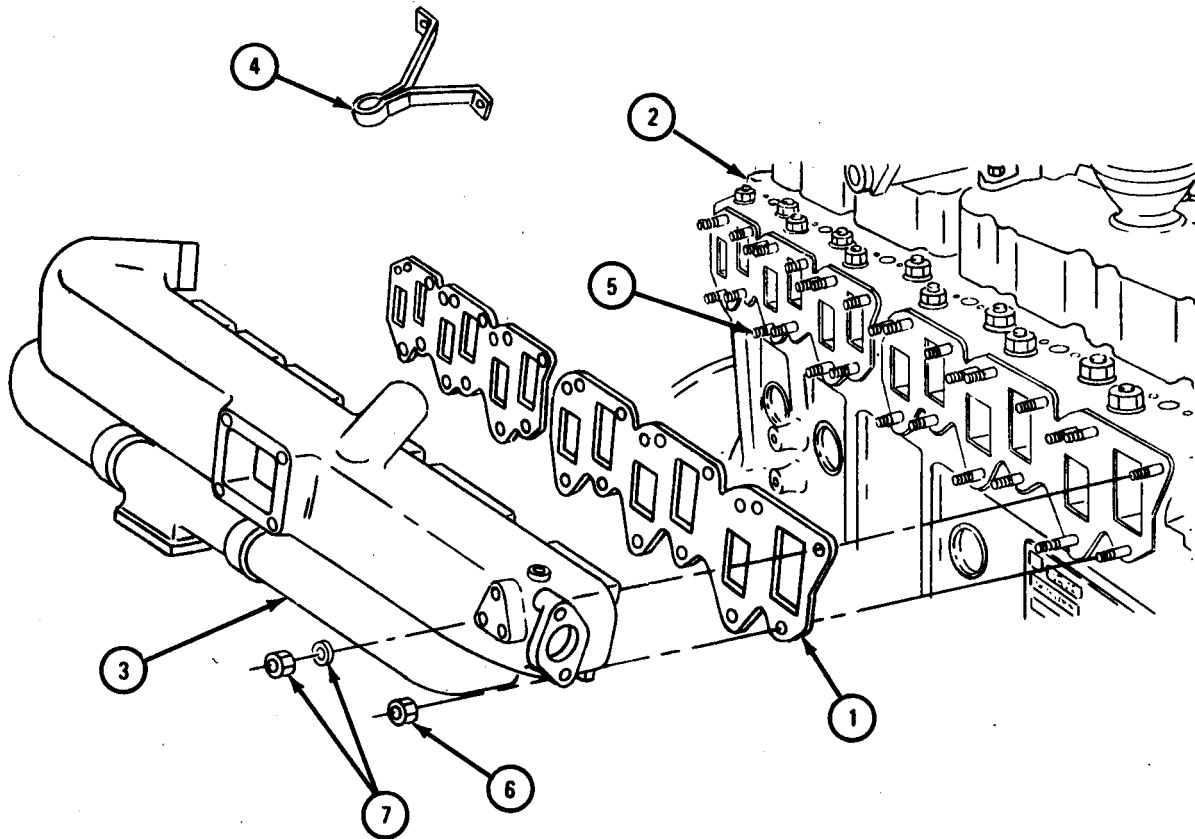

TA 104218

FRAME 3

1. Put on six gaskets (1) and align screw holes.
2. Put on front and rear cylinder head water outlet manifolds (2). Be sure hoses (3) are over manifold outlet pipes.
3. Put in eight screws and washers (4).
4. If working on engine with top-mounted, covered manifold heater, put in four screws (5).
5. Tighten hose clamps (6).

IF WORKING ON ENGINE LD-465-1 OR LD-465-1C, GO TO FRAME 4.

IF WORKING ON ENGINE LDT-465-1C, GO TO FRAME 8

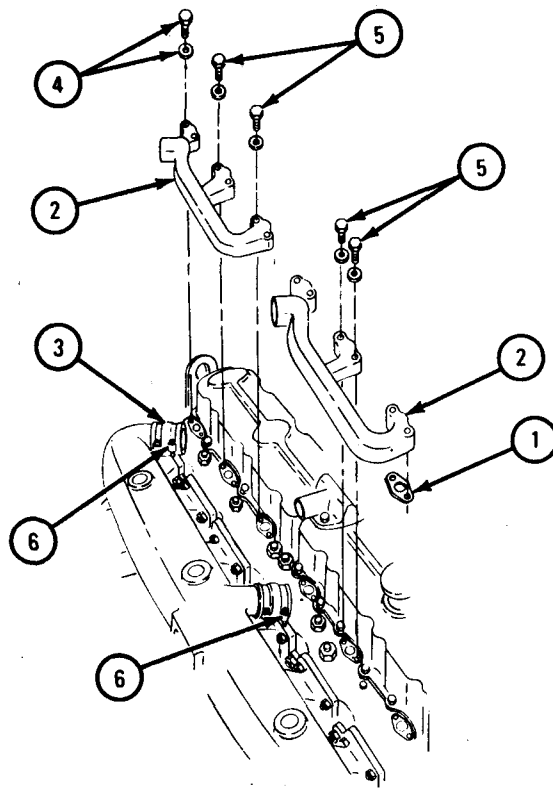

TA 104219

FRAME 4

1. Put on gasket (1) and intake manifold heater elbow (2). Put on four nuts and lockwashers (3).
2. Hold adapter (4) and put on inverted nut and tube (5).
3. Hold adapter (6) and put on inverted nut and tube (7).
4. Put on ignition cable and conduit assembly nut (8).

GO TO FRAME 9

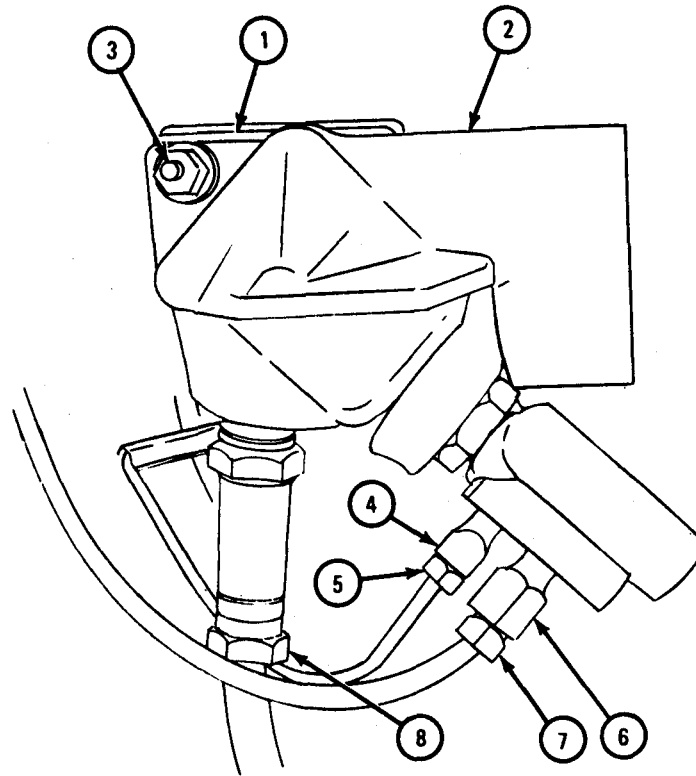

TA 103363

FRAME 5

1. Put air induction hose assembly (1) on intake manifold heater elbow (2).
2. Tighten hose clamp (3).

GO TO FRAME 6

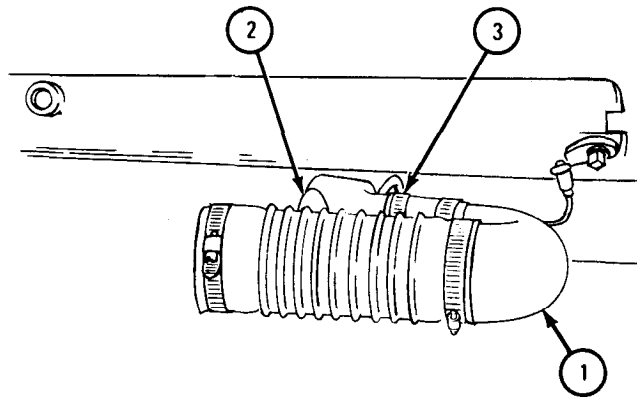

TA 103364

FRAME 6

1. Put exhaust pipe elbow (1) and gasket (2) on exhaust manifold (3).
 2. Put on two lockwashers and nuts (4) on studs (5).
 3. Put in two capscrews (6) and put on two nuts and washers (7).
- GO TO FRAME 7

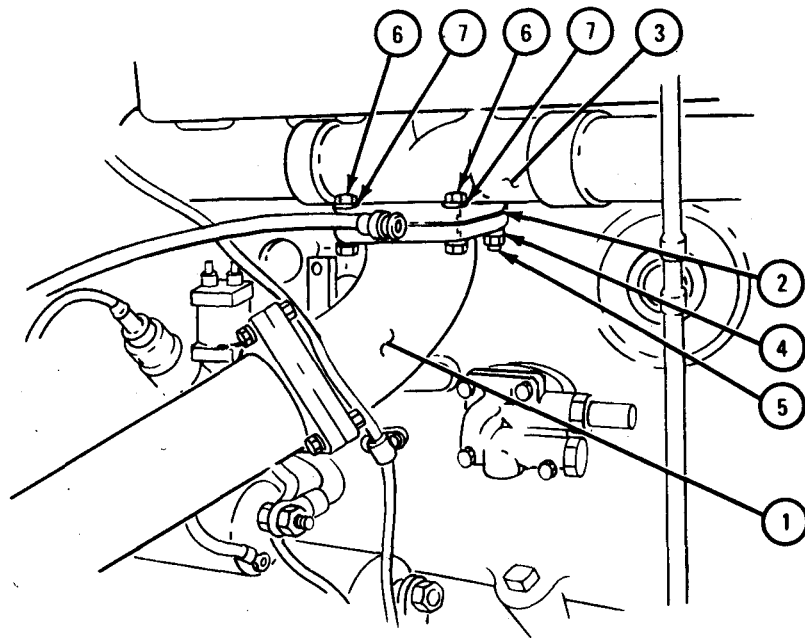

TA 104220

FRAME 7

1. Put hose (1) on breather tube adapter (2). Slide two hose clamps (3) on hose.
2. Put crankcase breather tube (4) in hose (1). Tighten two hose clamps (3) in place as shown.
3. Put clamp (5) over crankcase breather tube (4) and align screw hole in clamp with screw hole in bracket (6).
4. Put in capscrew (7) and nut (8).
5. Put in adapter fitting (9).
6. Put on tube nut (10).

GO TO FRAME 8

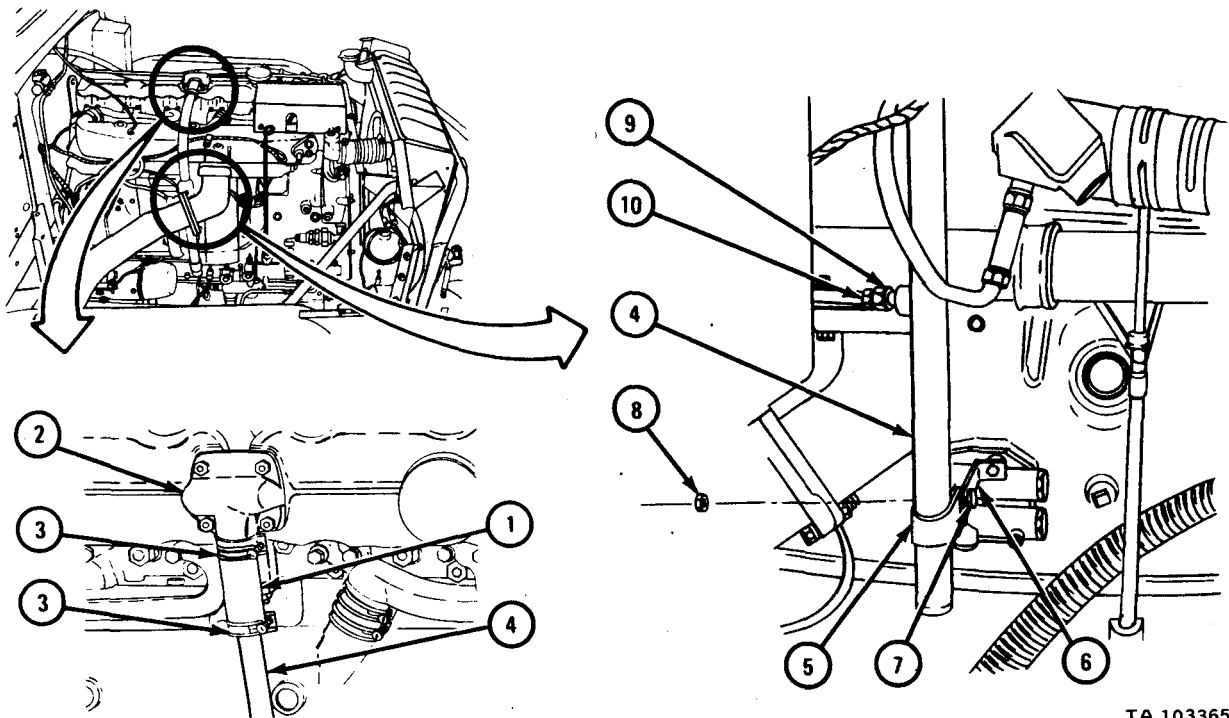

TA 103365

FRAME 8

- Soldier A 1. Put on gasket (1) and turbocharger (2) and hold in place.
Soldier B 2. Put in two capscrews (3) and four self-locking nuts (4).
3. Put oil inlet tube (5) in place. Put on two coupling nuts (6).
GO TO FRAME 9

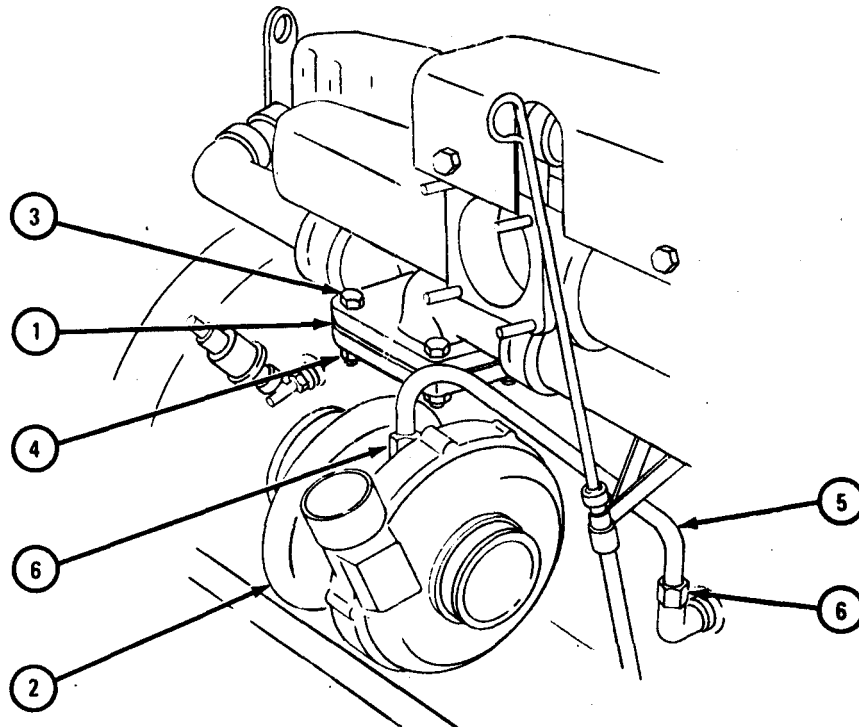

TA 103366

FRAME 9

1. Put hose (1) with breather tube (2) on breather tube adapter (3).
2. Tighten hose clamp (4).

GO TO FRAME 10

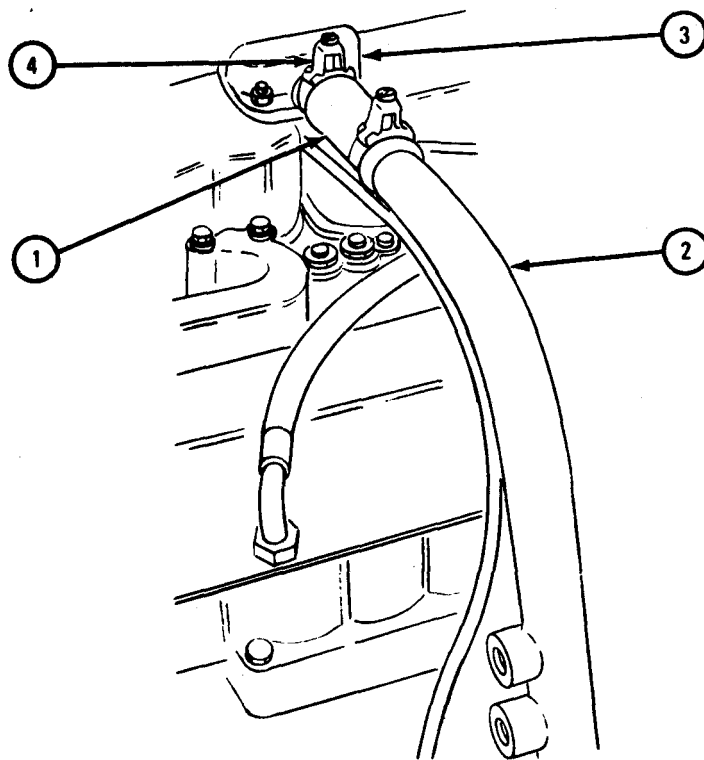

TA 103367

FRAME 10

1. Put gasket (1) and oil drain tube (2) in place and align screw holes. Put in two capscrews and lockwashers (3).

2. Put hose (4) on oil drain tube (2). Tighten capscrew (5).

GO TO FRAME 11

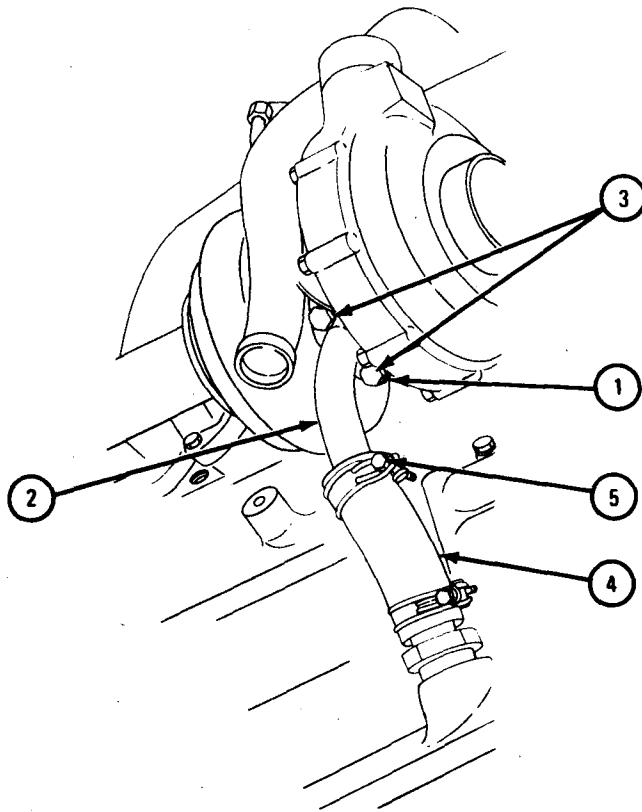

TA 118472

FRAME 11

1. Put gasket (1) and intake manifold elbow (2) in place. Put on four nuts (3) and lockwashers (4).
2. Slide hose (5) in place. Tighten two nuts (6).
3. Put on ignition unit lead (7).
4. Put on two coupling nuts (8 and 9).

IF WORKING ON ENGINE WITH TOP-MOUNTED, UNCOVERED MANIFOLD HEATER IGNITION UNIT, GO TO FRAME 12.

IF WORKING ON ENGINE WITH TOP-MOUNTED, COVERED MANIFOLD HEATER IGNITION UNIT, GO TO FRAME 14

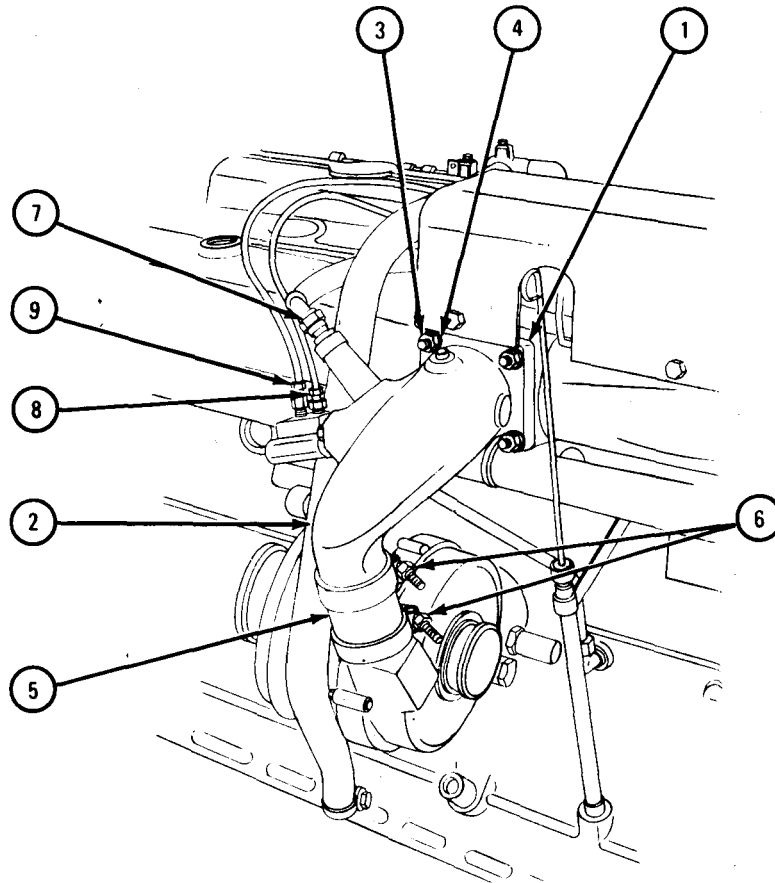

TA 103368

FRAME 12

1. Put fuel filter (1) and fuel pump (2) in place. Aline holes of two brackets (3).
2. Put on two screws with washers (4).
3. Put on tube adapter (5).
4. Put on tube adapter (6).
5. Put on electrical connector (7).

GO TO FRAME 13

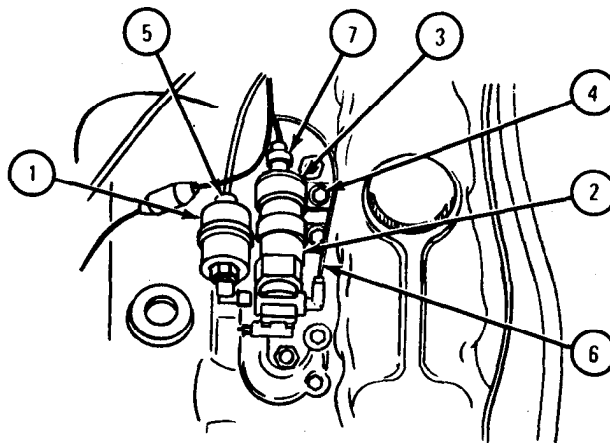

TA 103369

FRAME 13

1. Slide two clamps (1) on ignition unit (2).
2. Put ignition unit (2) with two clamps (1) in place and align screw holes.
3. Put on two screws with washers (3).
4. Put on electrical cable connector (4).
5. Put on electrical cable connector (5).

GO TO FRAME 17

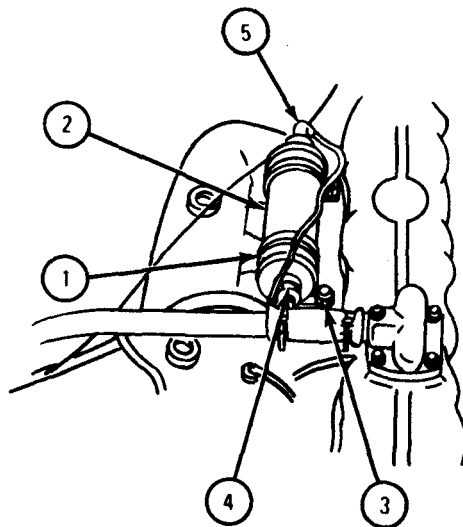

TA 103370

FRAME 14

1. Put support bracket assembly (1) on intake manifold (2).
2. Put wiring harness ground terminal (3) under capscrew and lockwasher (4) at front of support bracket assembly (1).
3. Put in three capscrews and lockwashers (4).
4. Place ignition unit (5) on support bracket assembly (1) and hook up ignition unit clamp assembly (6).
5. Put ignition cable and conduit plug (7) in ignition unit (5). Put on nut (8).
6. Put wiring harness connector (9) on terminal of ignition unit (5).

GO TO FRAME 15

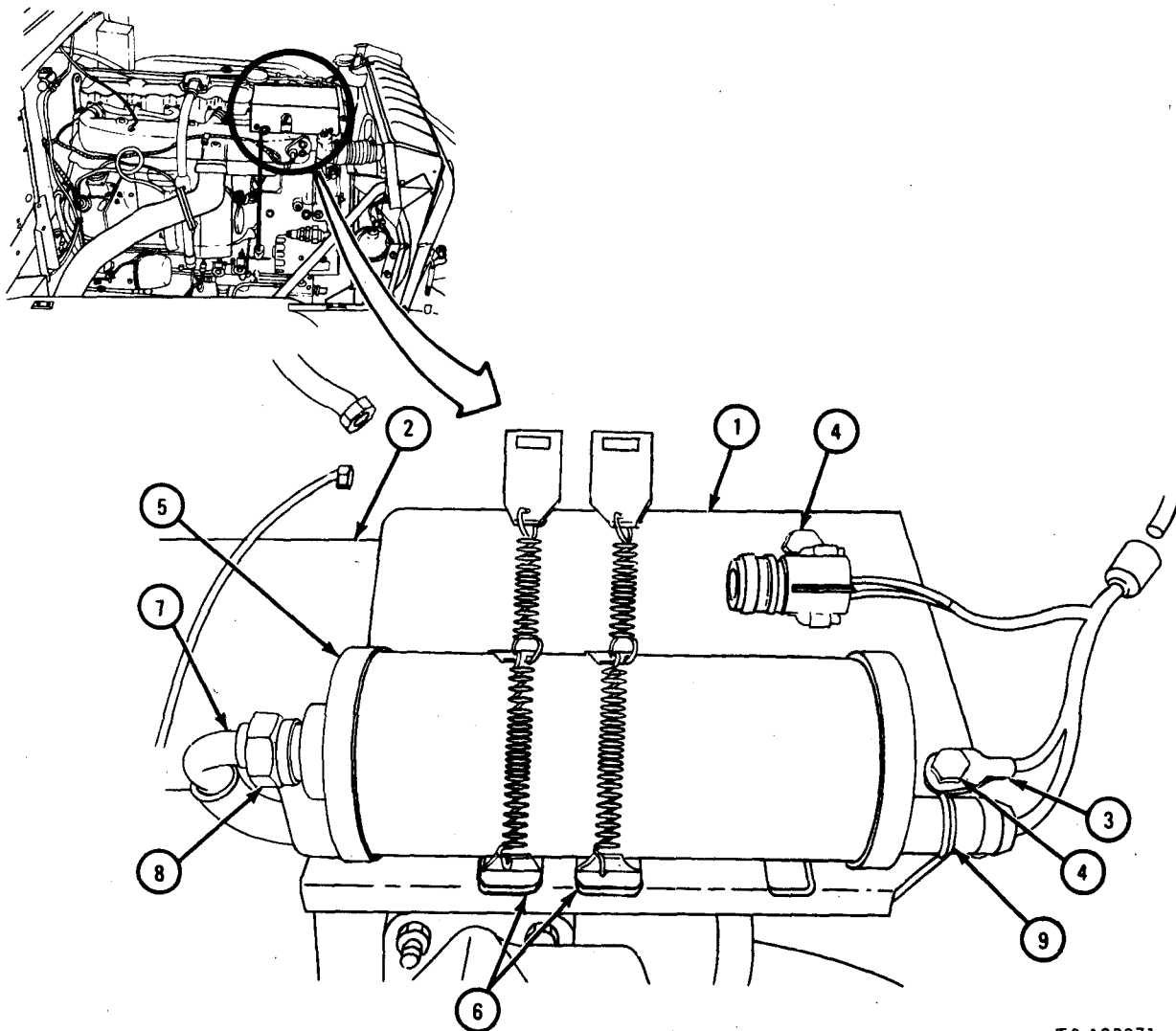

TA 103371

FRAME 15CAUTION

Engine manifold flame heater fuel pump is negative grounded. "A" pin is positive and "B" pin is negative. Do not switch positions of pins or there could be permanent damage to pump.

1. Place fuel pump (1) on support bracket assembly (2). Hook fuel pump clamp assembly (3) to support bracket assembly (2).
2. Put wiring harness connector (4) on fuel pump terminal (5).
3. Put on inverted nut and tube (6).
4. Put on inverted nut and tube (7).
5. Put together harness plugs (8).

GO TO FRAME 16

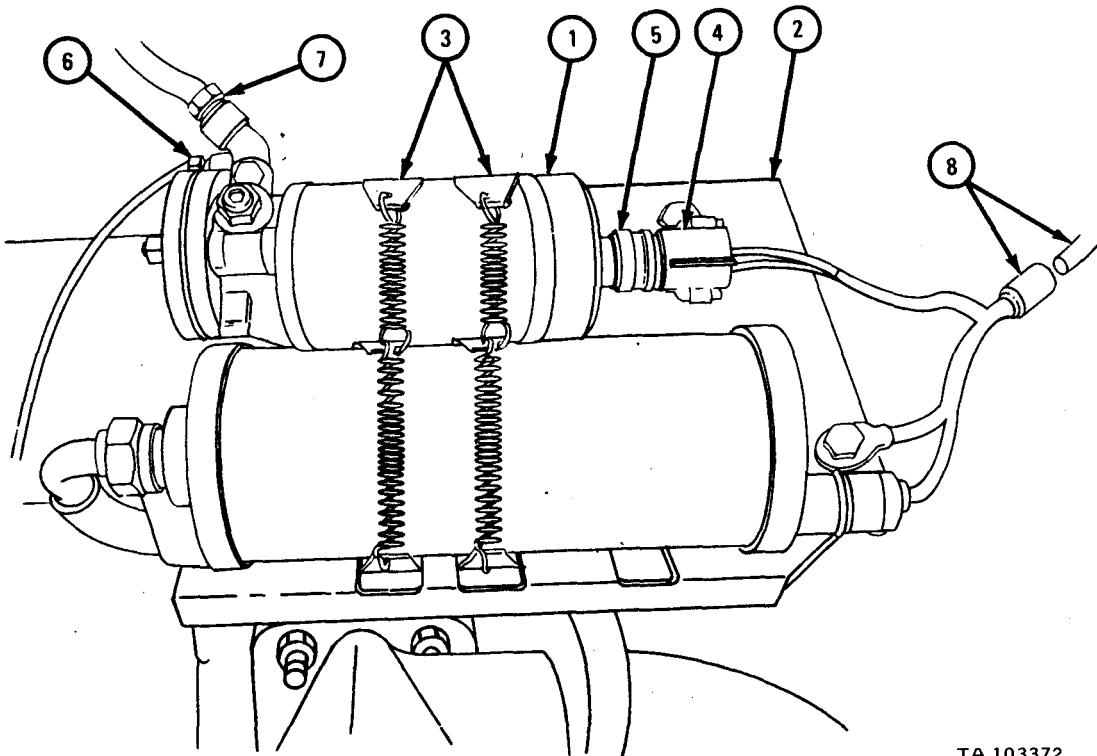

TA 103372

FRAME 16

1. Put cover (1) in place. Put in four capscrews and lockwashers (2).
- GO TO FRAME 17

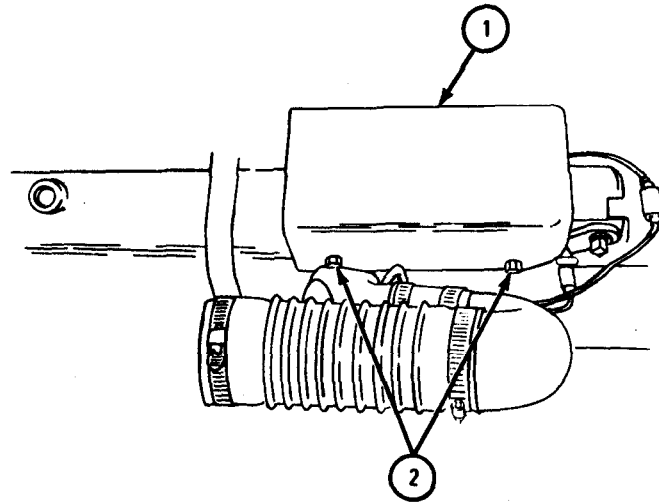

TA 103373

FRAME 17

1. Make sure surface of intake manifold flange (1) is clean. Put gasket (2) on flange.
2. Hold thermostat housing (3) in engine compartment as shown.
3. Join hose (4) to thermostat housing (3) but do not tighten clamp (5).
4. Put thermostat housing (3) against intake manifold flange (1). Make sure lip (6) of thermostat housing seats in recess (7) of intake manifold flange.

GO TO FRAME 18

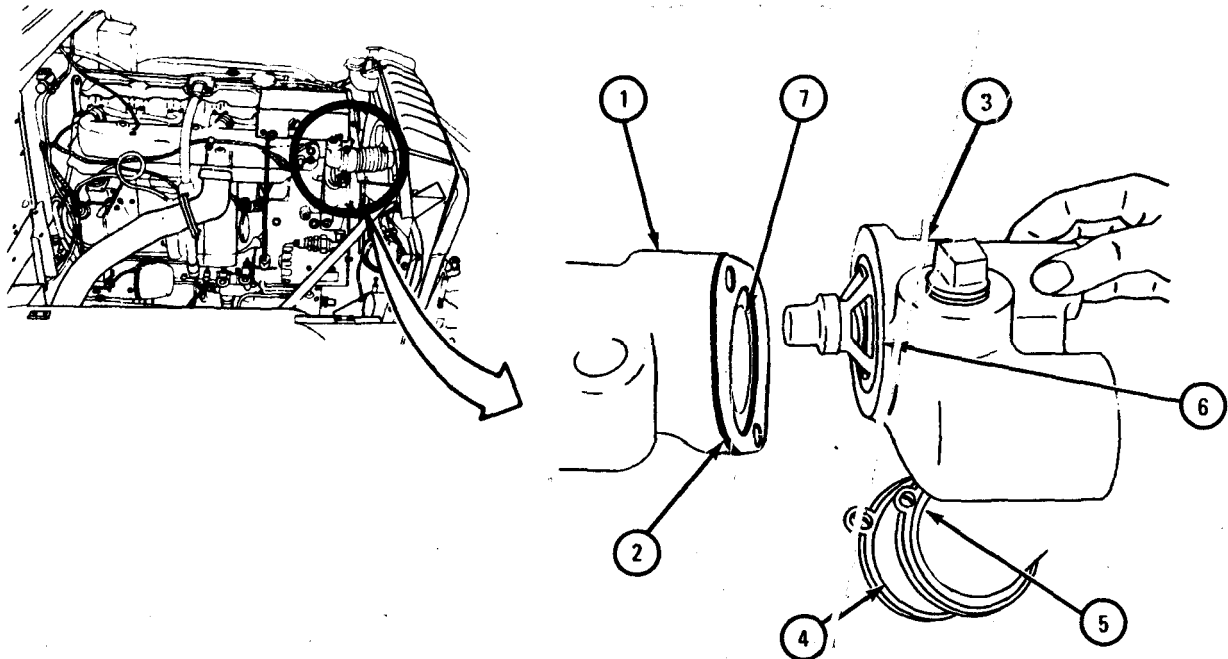

TA 118468

FRAME 18

1. **Hold thermostat housing (1) firmly against intake manifold (2).**
2. Put two bolts (3) with flat washers (4) through thermostat housing (1) and screw into intake manifold (2). Tighten bolts evenly.
3. Put clamp (5) squarely over hose (6) as shown.
4. Tighten screw (7) on clamp (5).

GO TO FRAME 19

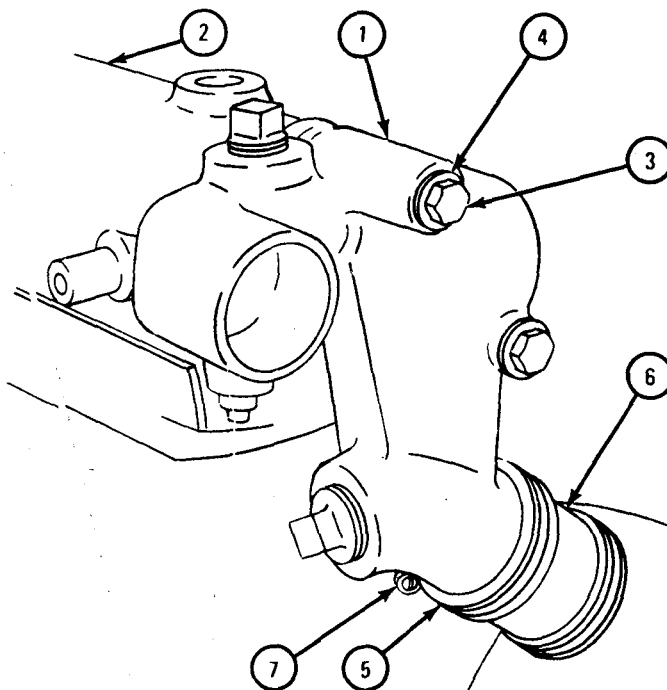

TA 118469

FRAME 19

1. Aline hole in rod end clevis (1) with hole in bracket (2) by moving radiator (3).
2. Put bolt (4) through clevis (1) and bracket (2). Put locknut (5) on bolt.
3. Make sure clamps (6) are positioned squarely on hose (7). Tighten two clamp screws (8).

GO TO FRAME 20

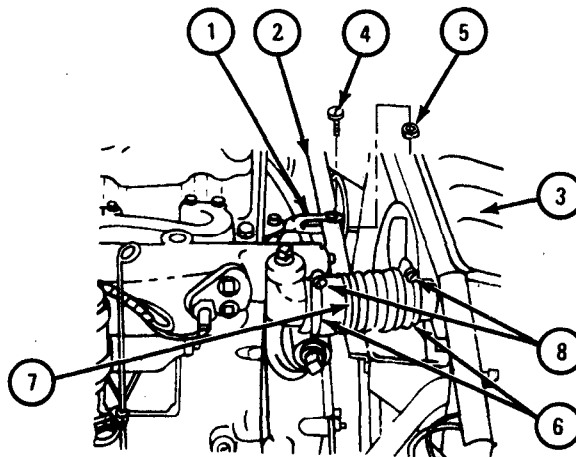

TA 103374

FRAME 20

1. Put a thin coating of heat resistant sealer on threads (1) of temperature transmitter (2).
2. Put temperature transmitter (2) into hole in intake manifold (3).
3. Plug connector (4) into temperature transmitter (2).

GO TO FRAME 21

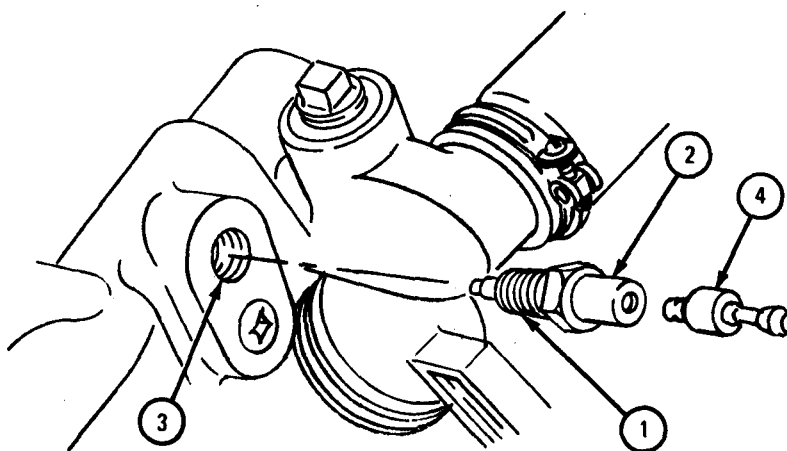
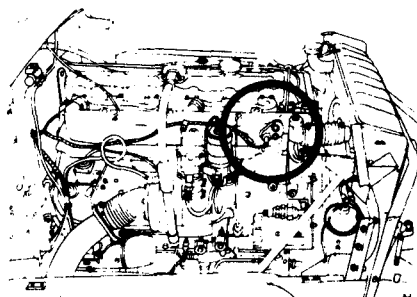

TA 103375

FRAME 21

1. Put air cleaner head (1) on truck and put in four screws and washers (2).
2. Put tube assembly (3) on air cleaner head (1). Tighten clamp screw (4).
3. Put on gasket (5), filter (6), and cannister (7).
4. Snap on three clips (8).

GO TO FRAME 22

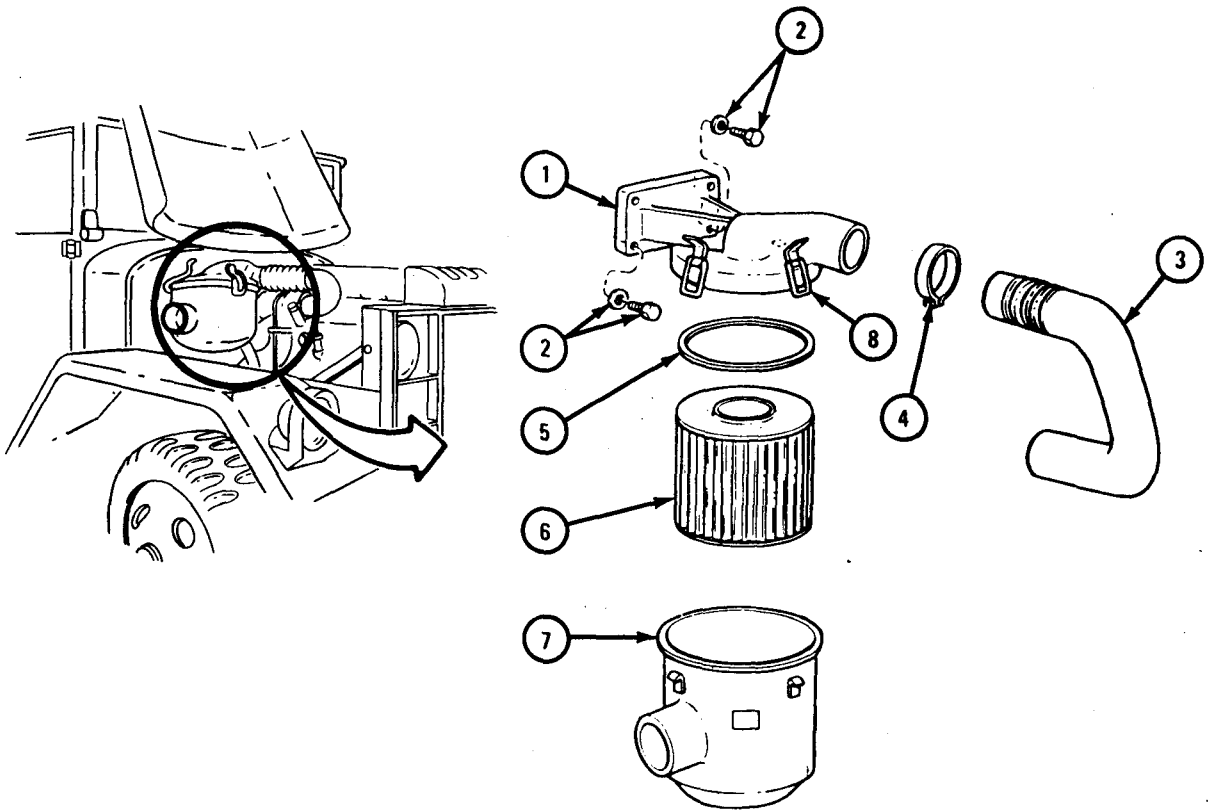

TA 103376

FRAME 22

1. Put connector filter (1) in air cleaner head (2).
2. Put tube assembly (3) in connector filter (2) and tighten coupling nut (4).

GO TO FRAME 23

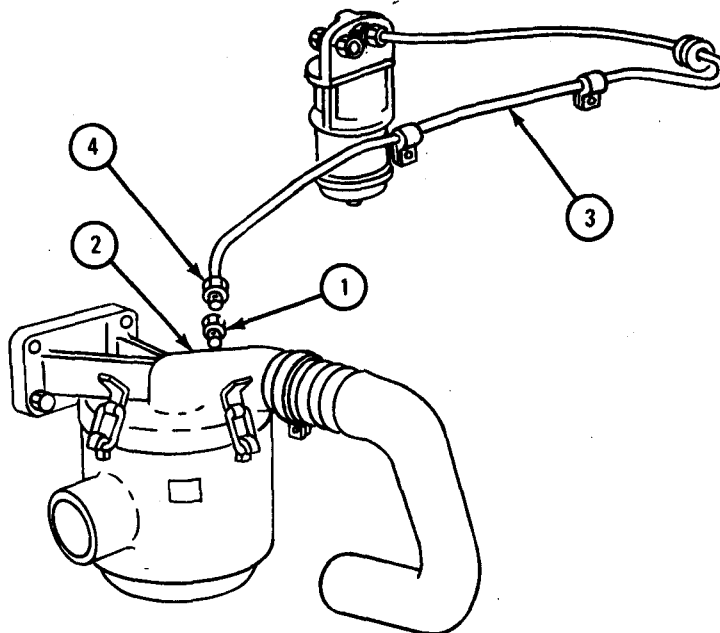

TA 104221

FRAME 23

WARNING

Do not let tool touch positive terminal on battery on truck or there will be a direct short, arcing, and tool will heat. This could cause equipment damage and injury to personnel.

1. Put ground cable terminal (1) on negative post (2) of rear battery (3).
2. Tighten nut (4).

GO TO FRAME 24

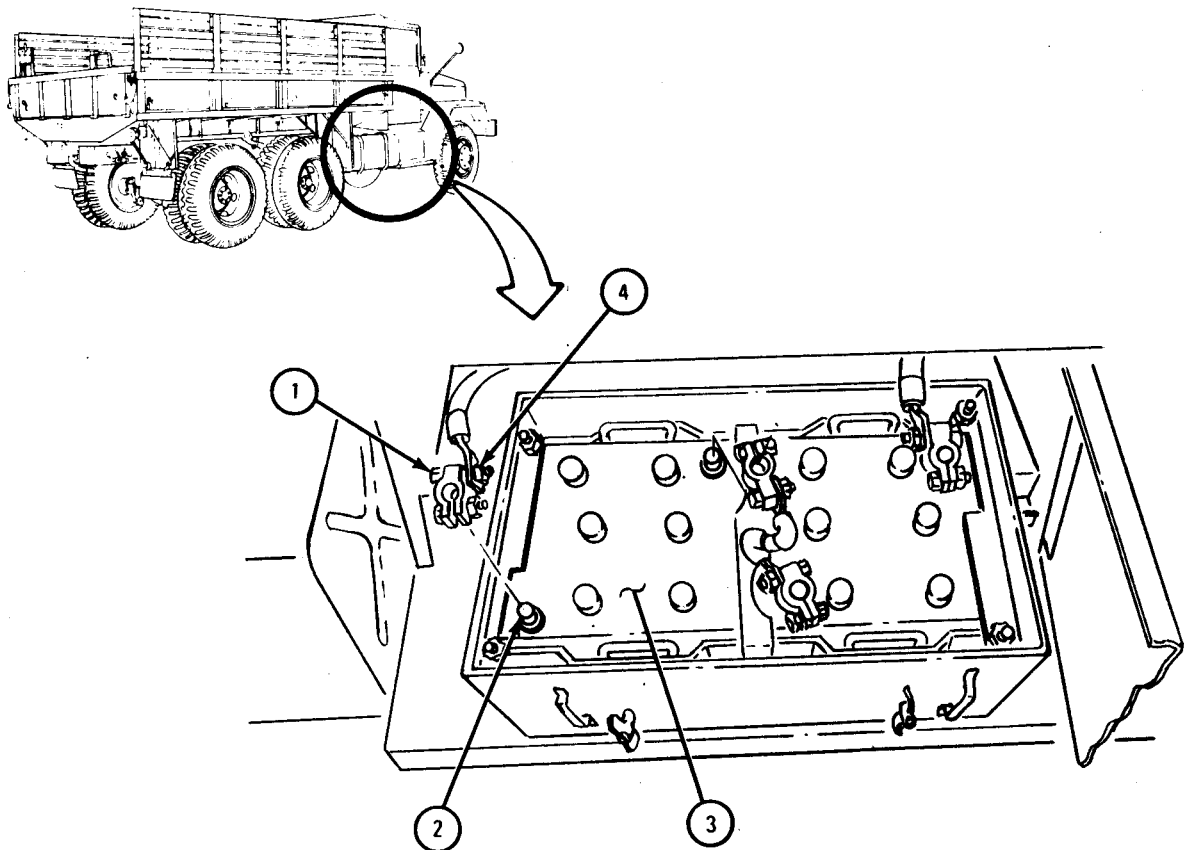

TA 118471

FRAME 24

1. Push battery box (1) off running board (2) onto battery compartment.
2. Latch two clamps (3) on thumbscrews (4) and tighten thumbscrews.
3. Close battery compartment door (5).

NOTE

Follow-on Maintenance Action Required:

1. Replace turbocharger exhaust outlet hose. Refer to Turbocharger System Hoses and Clamps Removal and Replacement, TM 9-2320-209-20.
2. Fill cooling system. Refer to TM 9-2320-209-20.
3. Close hood and side panels. Refer to TM 9-2320-209-10.

END OF TASK

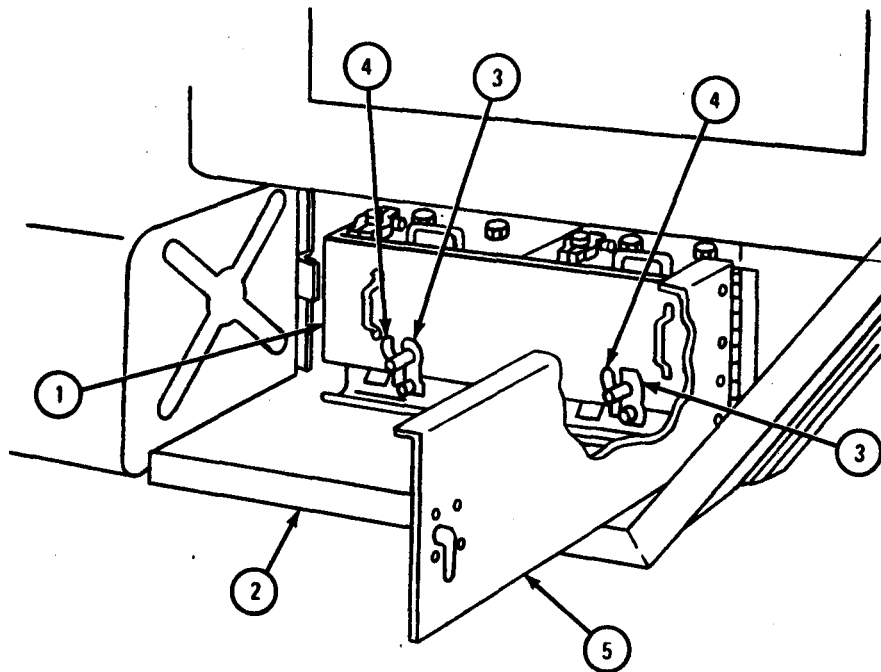

TA 105677

CHAPTER 3

CLUTCH SYSTEM GROUP MAINTENANCE

Section I. SCOPE

3-1. EQUIPMENT ITEMS COVERED. This chapter gives equipment maintenance procedures for the clutch assembly and the clutch release mechanism for which there are authorized corrective maintenance tasks at the direct and general support maintenance levels.

3-2. EQUIPMENT ITEMS NOT COVERED. All equipment items for which corrective maintenance is authorized at the direct and general support maintenance levels are covered in this chapter.

Section II. CLUTCH ASSEMBLY

3-3. CLUTCH ASSEMBLY REMOVAL AND REPLACEMENT.

TOOLS : No special tools required

SUPPLIES : Spacer block (4)

PERSONNEL: One

EQUIPMENT CONDITION : Truck parked, engine off, handbrake set.

- a. Preliminary Procedure. Remove transmission from truck. Refer to para 8-4.

b. Removal.

FRAME 1

1. Push in four clutch release levers (1), one at a time, and put four clutch release lever spacer blocks (2) between lever and pressure plate (3).

CAUTION

Unscrew eight capscrews (4) and lockwashers (5) one or two turns at a time to avoid damage to pressure plate assembly (6).

2. Take out eight capscrews (4) and lockwashers (5).
3. Take out pressure plate assembly (6) and clutch disk (7).

END OF TASK

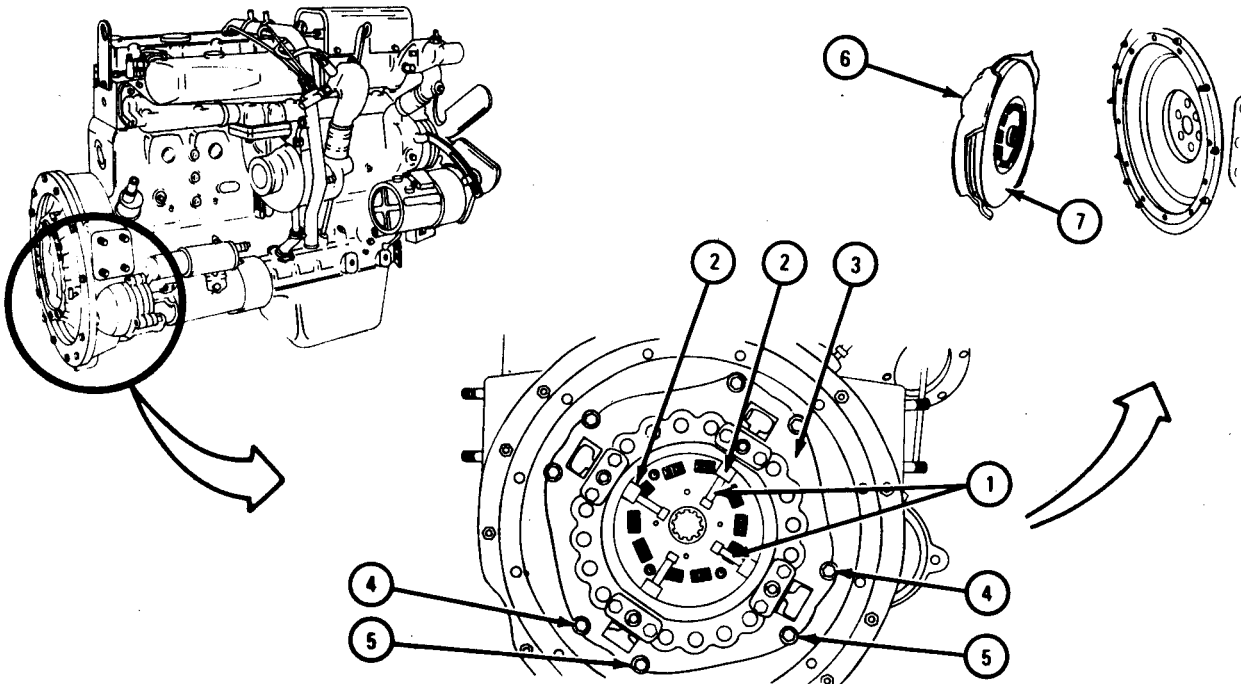

TA 085203

c. Replacement.

FRAME 1

1. Put clutch disk (1) to flywheel (2) with long end of drive hub (3) away from flywheel (2).
 2. Put universal clutch alinement tool (4) in clutch drive hub (3).
- GO TO FRAME 2

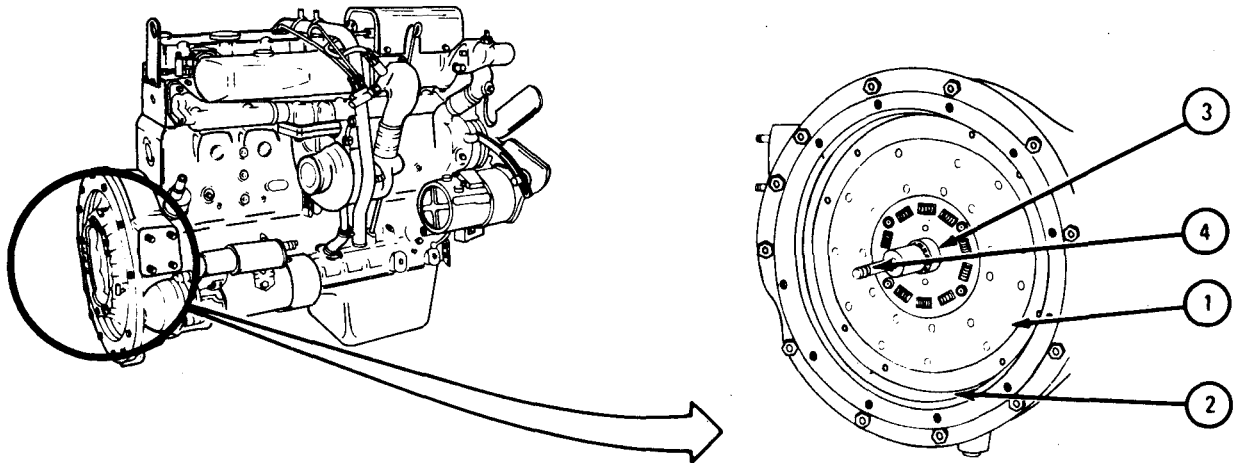

TA 085211

FRAME 2

1. Put pressure plate (1) on flywheel assembly (2) and put in eight capscrews with washers (3).
2. Tighten capscrews with washers (3) to 23 to 27 pound-feet.
3. Push in four clutch release levers (4), one at a time, and take out clutch release lever spacer blocks (5).
4. Take out clutch alignment tool (6).

NOTE

Follow-on Maintenance Action Required:
Replace transmission. Refer to para 8-4.

END OF TASK

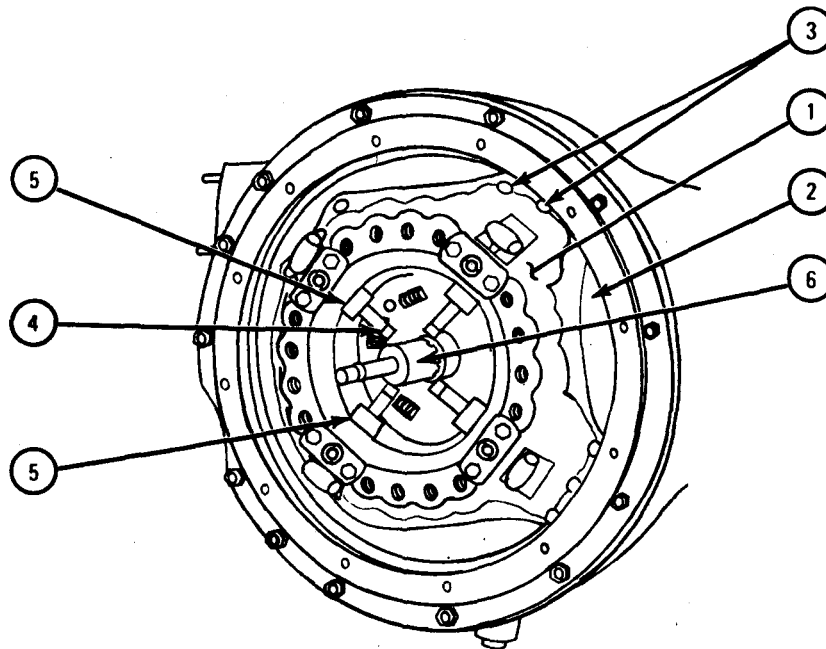

TA 085212

3-4. CLUTCH ASSEMBLY REPAIR. Refer to TM 9-2815-210-34 for repair procedures on the clutch assembly used on the LD-465-1 engines. Refer to TM 9-2815-204-35 for repair procedures on the clutch assembly used on the LDS-427-2 engines.

Section III. CLUTCH RELEASE MECHANISM

3-5. CLUTCH RELEASE BEARING AND THROWOUT SHAFT YOKE REMOVAL AND REPLACEMENT .

TOOLS : No special tools required

SUPPLIES : None

PERSONNEL : One

EQUIPMENT CONDITION : Truck parked, engine off, handbrake set.

- a. Preliminary Procedure. Remove transmission. Refer to para 8-4.
- b. Removal.

FRAME 1

1. Take out two clutch release bearing support springs (1).

2. Slide off release bearing support assembly (2).

GO TO FRAME 2

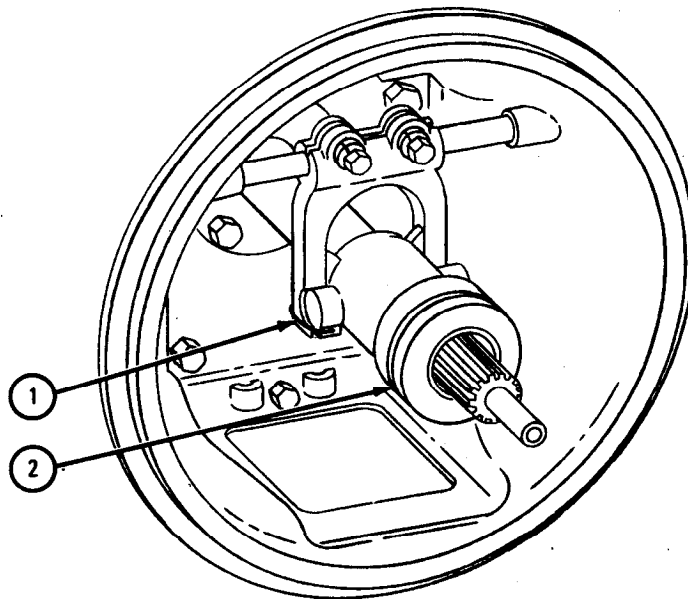

TA 085268

FRAME 2

1. Take out two screws (1) and lockwashers (2).
2. Slide clutch release shaft (3) partway through bell housing (4) as shown, and take out two yoke keys (5).
3. Take out clutch release shaft (3) and clutch release yoke (6).

END OF TASK

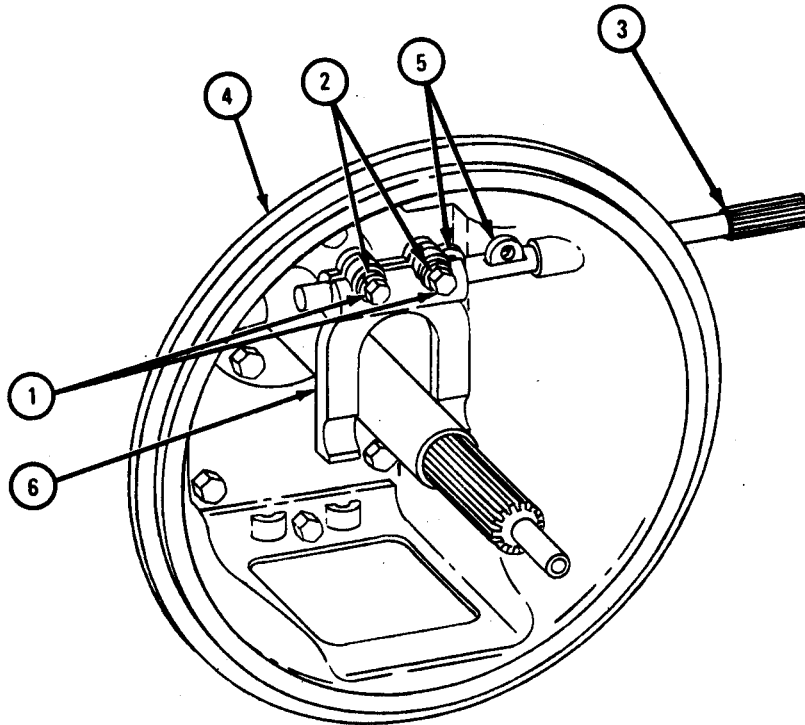

TA 085269

c. Replacement.**FRAME 1**

1. Slide clutch release shaft (1) in partway with square end facing right as shown.
 2. Put in two yoke keys (2).
 3. Put clutch release yoke (3) in place and slide clutch release shaft (1) through.
- GO TO FRAME 2

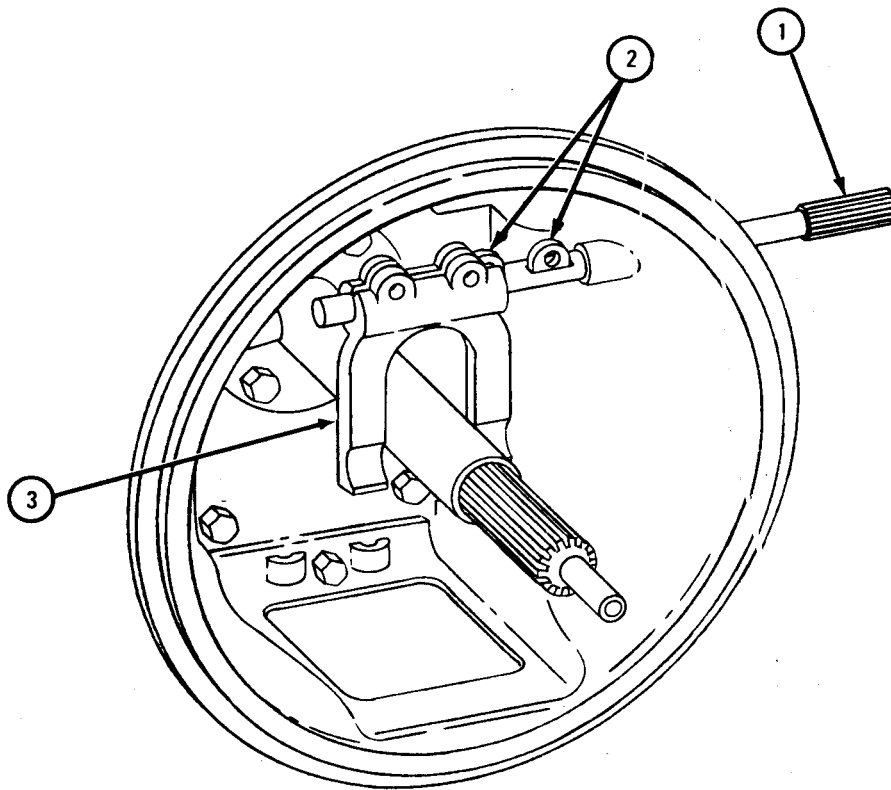

1'A 085270

FRAME 2

1. Put in two screws (1) and lockwashers (2).
2. Slide on release bearing support assembly (3).
3. Put in two support springs (4).

NOTE

Follow-on Maintenance Action Required:
Replace transmission. Refer to para 8-4.

END OF TASK

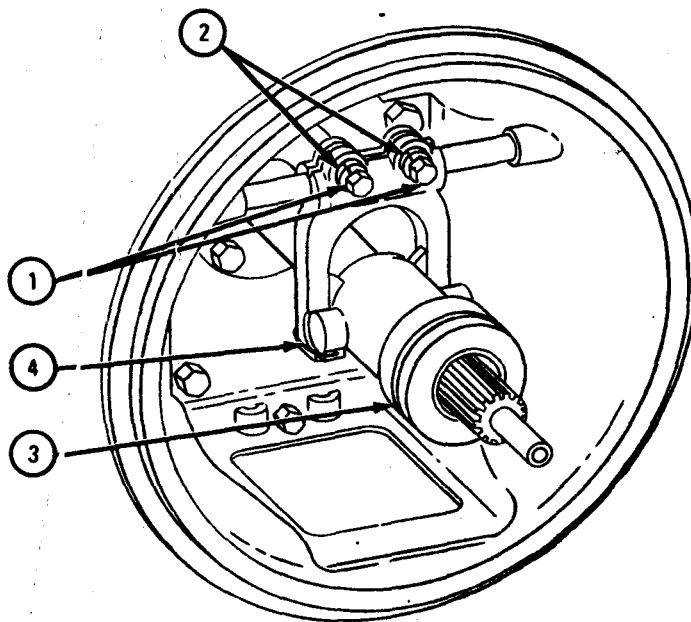

TA 085271

CHAPTER 4

FUEL SYSTEM GROUP MAINTENANCE

Section I. SCOPE

4-1. EQUIPMENT ITEMS COVERED. This chapter gives equipment maintenance procedures for the fuel injector, turbocharger, and fuel tanks for which there are authorized corrective maintenance tasks at the direct and general support maintenance levels.

4-2. EQUIPMENT ITEMS NOT COVERED. All equipment items for which corrective maintenance is authorized at the direct and general support maintenance levels are covered in this chapter.

Section II. FUEL INJECTOR

4-3. FUEL INJECTOR NOZZLE AND HOLDER ASSEMBLY REMOVAL AND REPLACEMENT .

TOOLS : No special tools required

SUPPLIES : Fuel injector and nozzle holder assembly gasket (16)
High temperature silicone compound, MIL-S-8660
Artillery and automotive grease, type GAA, MIL-G-10924

PERSONNEL : One

EQUIPMENT CONDITION : Truck parked, engine off, handbrake set.

a. Preliminary Procedure. Open hood and side panel. Refer to
TM 9-2320-209-10.

b. Removal.

FRAME 1

1. Take off two tube nuts (1).
2. Take off 11 tube nuts (2) and take out five tubes (3).
3. Take off five tube tees (4) and elbow (5).
4. Take out 12 machine bolts and lockwashers (6).

GO TO FRAME 2

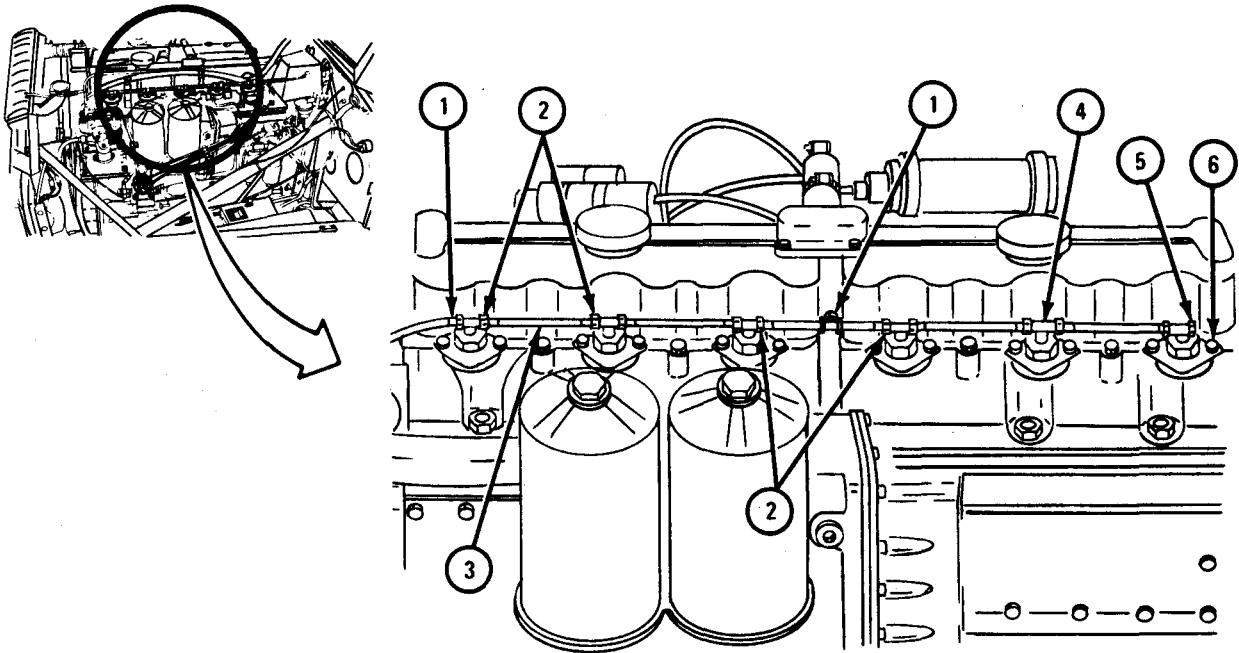

TA 103333

FRAME 2

1. Take out six fuel injector nozzle and holder assemblies (1).
2. Plug six fuel injector nozzle and holder assembly openings (2).
3. Take off and throw away six gaskets (3).

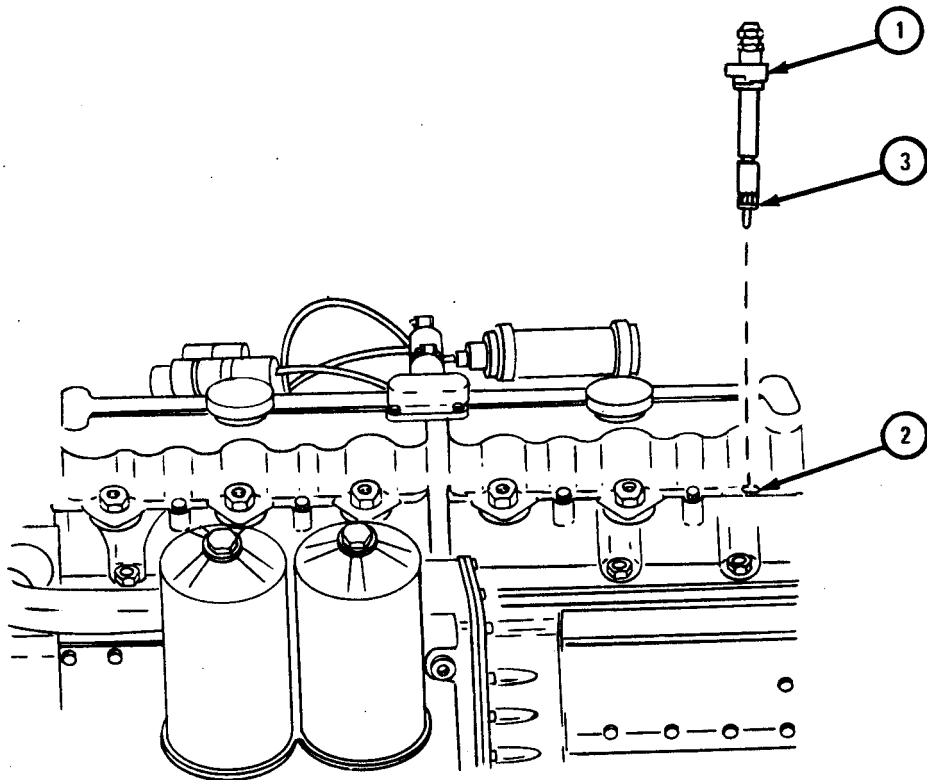
END OF TASK

TA 103334

c. Replacement.

FRAME 1

1. Put a coat of silicone compound on fuel injector nozzle body (1).
2. Put a light coat of grease on gasket (2) and put on gasket.
3. Unplug fuel injector nozzle and holder assembly opening (3).
4. Put in fuel injector nozzle and holder assembly (4).
5. Do steps 1 through 4 again for five fuel injector and holder assemblies (5).

GO TO FRAME 2

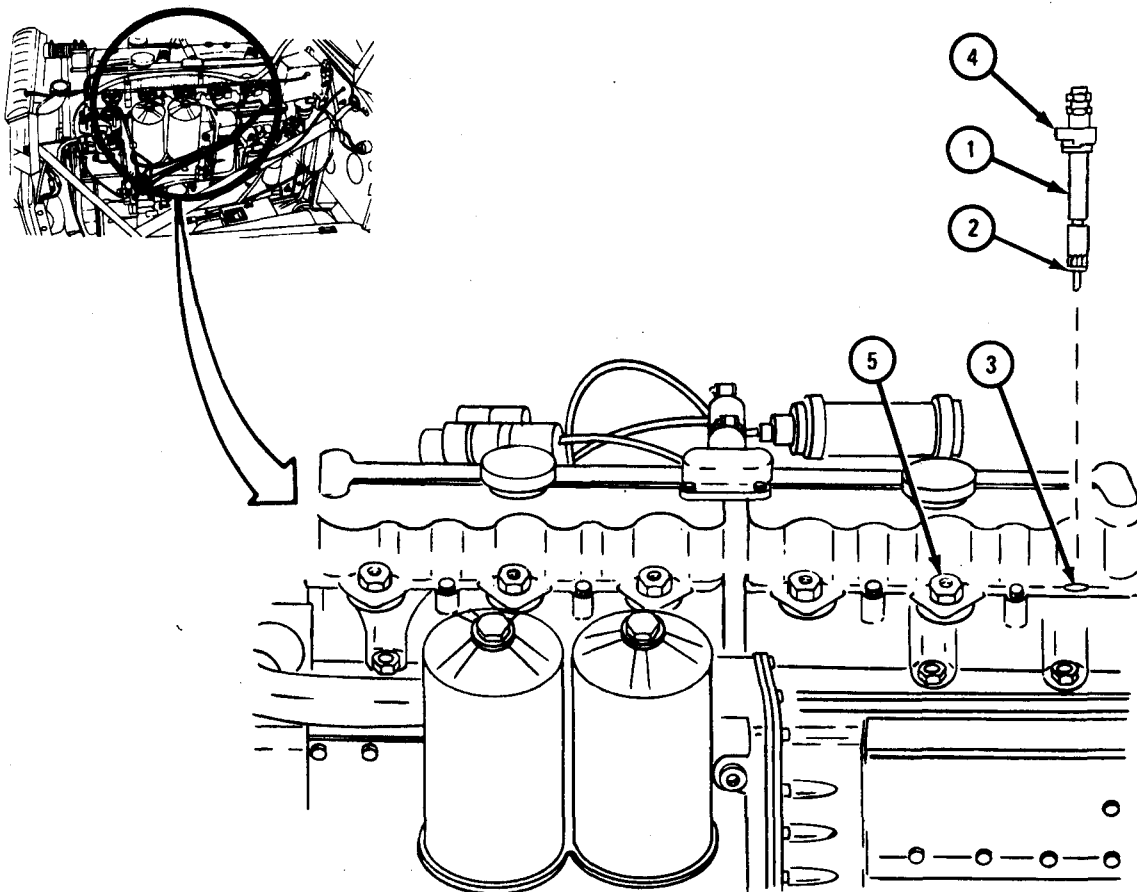

TA 103335

FRAME 2

1. Put in 12 machine bolts and lockwashers (1).
2. Put on five tube tees (2) and elbows (3).
3. Put five tubes (4) in place. Put on 11 tube nuts (5).
4. Evenly tighten 12 machine bolts (1) to 150 to 175 pound-inches.
5. Put on two tube nuts (6).

NOTE

Follow-on Maintenance Action Required:

Close hood and side panels. Refer to TM 9-2320-209-10.

END OF TASK

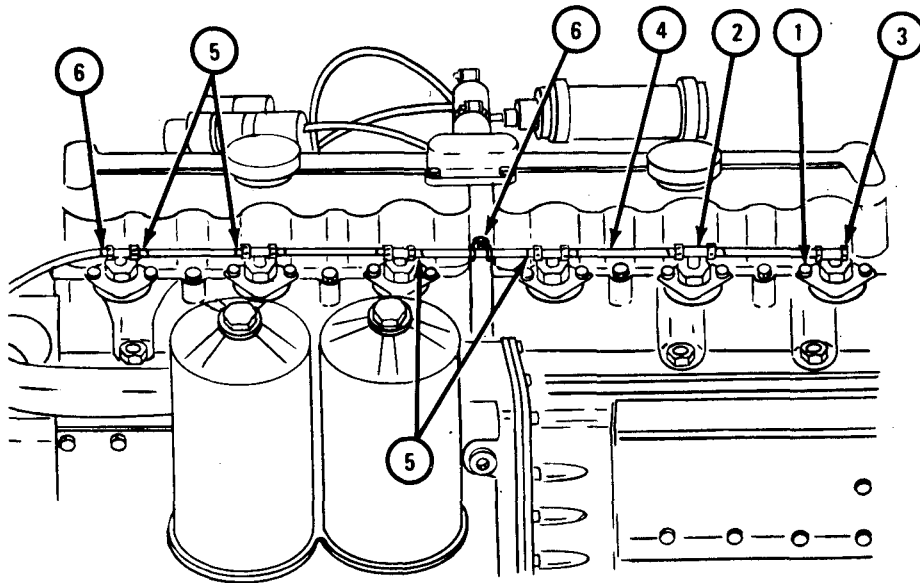

TA 103336

4-4. FUEL INJECTOR NOZZLE AND HOLDER ASSEMBLY REPAIR. Refer to TM 9-2815-210-34 for procedure to repair fuel injector nozzle and holder assembly.

4-5. FUEL INJECTOR PUMP REPAIR. Refer to TM 9-2815-210-34 for procedure to repair fuel injector pump.

Section III. TURBOCHARGER

4-6. TURBOCHARGER REPAIR. Refer to TM 9-2990-201-40&P for procedure to repair turbocharger.

Section IV. FUEL TANKS

4-7. FUEL TANK REPAIR (ALL TRUCKS EXCEPT TRUCKS M275A1, M275A2, AND M342A2).

TOOLS : No special tools required

SUPPLIES : Sending unit gasket
Vent cover gasket
Solvent, dry cleaning, type II (SD-2) , Fed. Spec P-D-680

PERSONNEL : One

EQUIPMENT CONDITION : Truck parked, engine off, handbrake set.

a. Preliminary Procedures.

(1) Remove in-tank fuel pump. Refer to TM 9-2320-209-20.

(2) Remove fuel tank. Refer to TM 9-2320-209-20.

b. Disassembly.

FRAME 1

1. Place container under drain plug (1) to catch any fuel in tank (2).
2. Take out drain plug (1).
3. Take off filler cap (3).
4. Take out filler cap gasket (4).
5. Take off filler sleeve (5).
6. Take out five screws (6).
7. Take out sending unit (7) and gasket (8). Throw away gasket.
8. Take off elbow (9).

END OF TASK

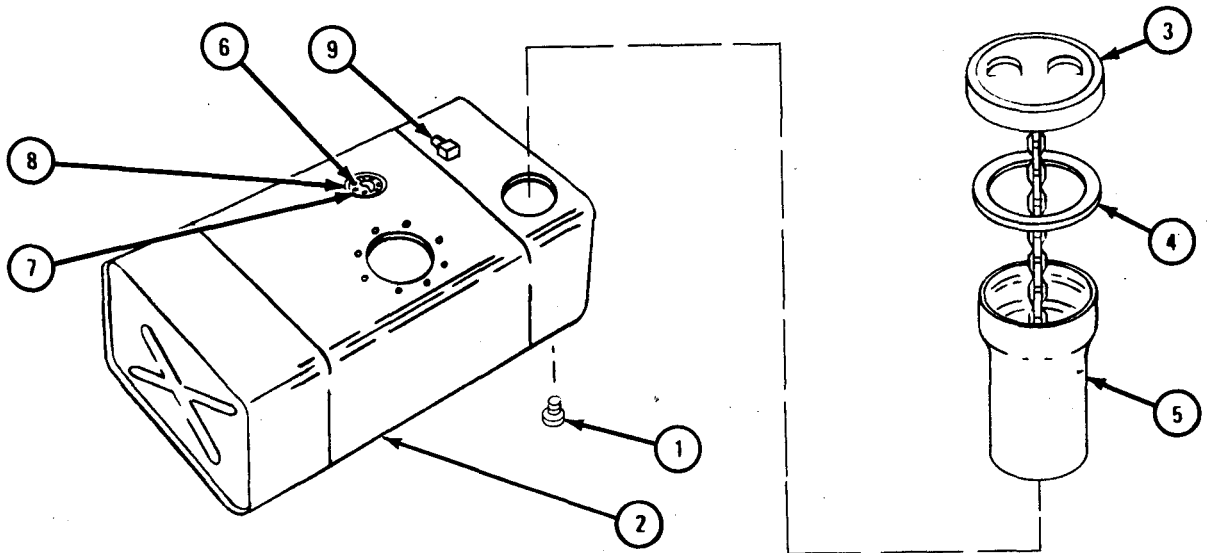

TA 105658

c. Cleaning.

WARNING

Dry cleaning solvent is flammable. Do not use near an open flame. Keep a fire extinguisher nearby when solvent is used. Use only in well-ventilated places. Failure to do this may result in injury to personnel and damage to equipment.

- (1) Clean outside of tank with solvent.
- (2) Using solvent, take out sediment on inside of tank.
- (3) Steam clean inside of tank to remove all fumes. Refer to TB 43-0212.
- (4) Clean all other parts with dry cleaning solvent.

d. Inspection and Repair.**FRAME 1**

1. Plug all openings in tank (1) except one. Put in air hose and put 6 psi of air pressure into tank. Listen for air leaks.

WARNING

Do not repair unless tank has been cleaned and properly treated to get rid of all inflammable or explosive fumes. Merely draining tank does not make it safe for welding. An "empty" tank can be more dangerous than a full one. Before repairing, thoroughly steam clean tank or use other approved methods to completely take out all fumes.

2. Weld small leaks. Refer to TM 9-237. If tank (1) has a large leak, get a new tank.
3. Check that filler cap (2) and filler sleeve (3) are not cracked or dented. If cap or sleeve is damaged, get a new one.
4. Check that filler cap gasket (4) is not worn or dried out. If gasket is worn or dried out, get a new one.
5. Check that drain plug (5) has no damaged threads. If plug has damaged threads, get a new one.
6. Check that sending unit (6) is not damaged in any way. If unit is damaged, get a new one.

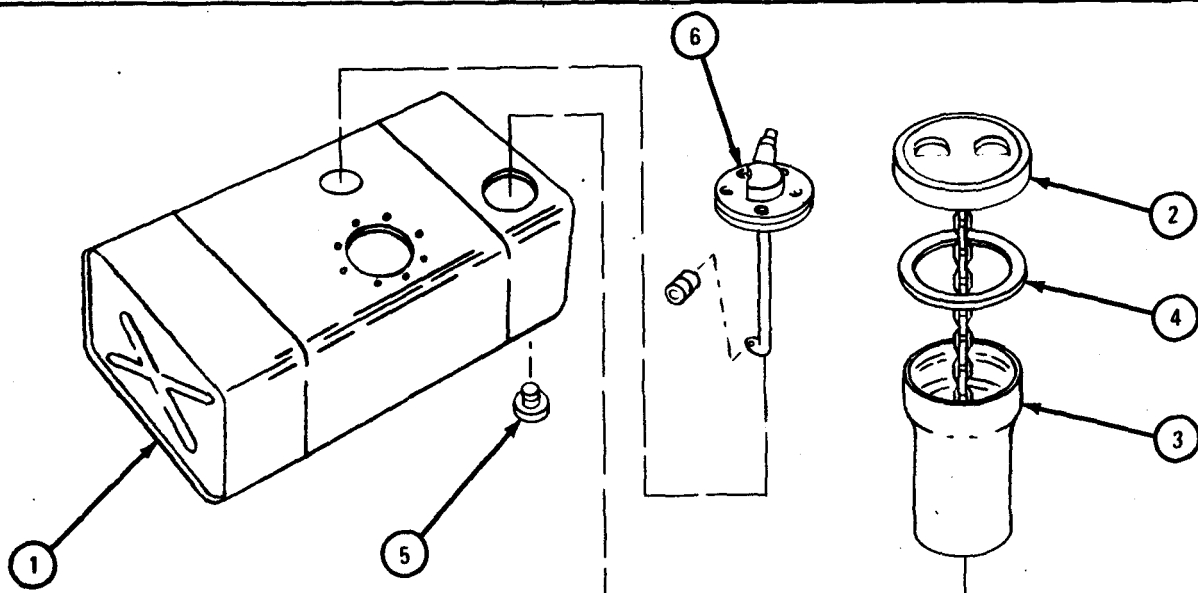
END OF TASK

TA 105659

e. Assembly.

FRAME 1

1. Put on elbow (1).
2. Put gasket (2) and sending unit (3) in place and align screwholes. Put in five screws (4).
3. Put gasket (5) in filler cap (6).
4. Put on chain (7).
5. Put in filler sleeve (8) and filler cap (6).
6. Put in drain plug (9).

NOTE

Follow-on Maintenance Action Required:

1. Replace fuel tank. Refer to TM 9-2320-209-20.
2. Replace in-tank fuel pump. Refer to TM 9-2320-209-20.

END OF TASK

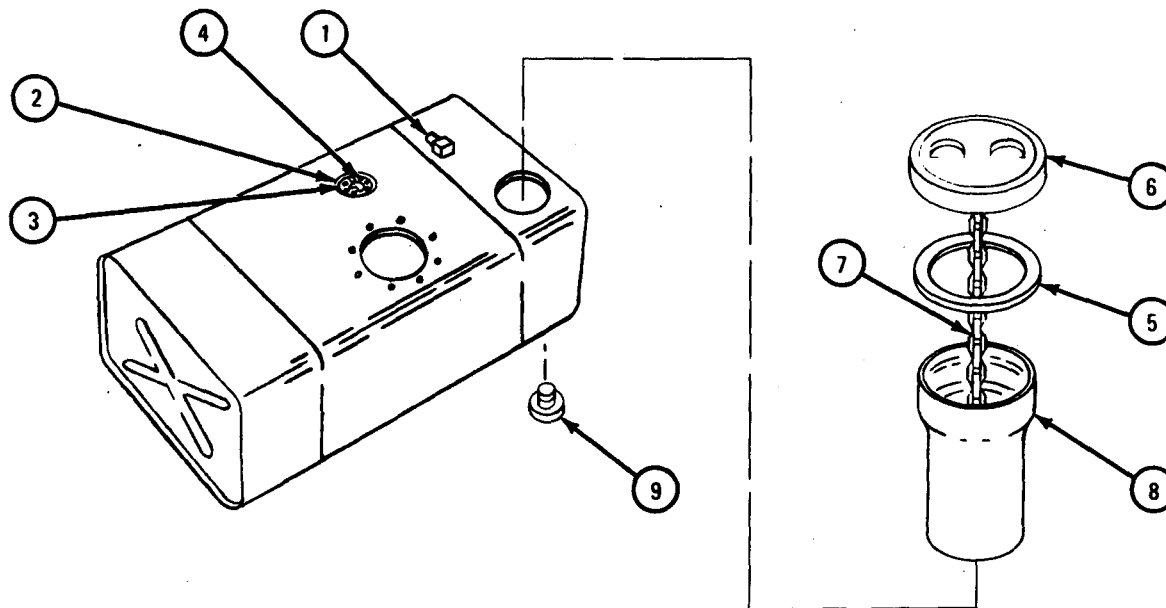

TA 105660

4-8. FUEL TANK REPAIR (TRUCKS M275A1, M275A2, AND M342A2) .

TOOLS : No special tools required

SUPPLIES : Solvent, dry cleaning, type II (SD-2), Fed. Spec P-D-680
Filler pipe cap gasket

PERSONNEL : One

EQUIPMENT CONDITION : Truck parked, engine off, handbrake set.

a. Preliminary Procedures.

(1) Remove tank. Refer to TM 9-2320-209-20.

(2) Remove fuel pump. Refer to TM 9-2320-209-20.

(3) Remove fuel gage sending unit. Refer to TM 9-2320-209-20.

b. Disassembly.

FRAME 1

1. Take off filler pipe cap (1) with gasket (2). Take out gasket (2) and throw it away.
2. Take off filler pipe sleeve (3) from tank (4).

END OF TASK

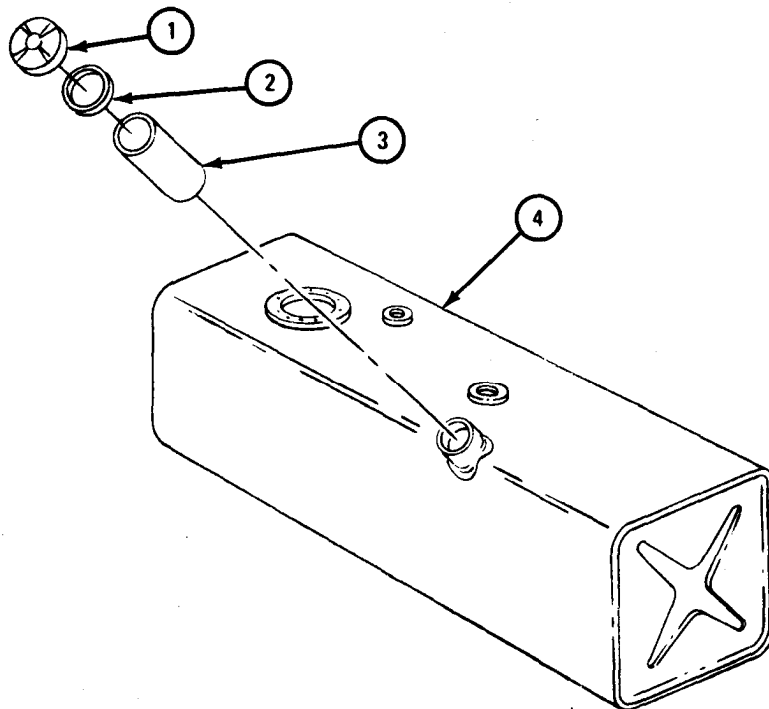

TA 085248

c. Cleaning, Inspection, and Repair.

WARNING

Dry cleaning solvent is flammable. Do not use near an open flame. Keep a fire extinguisher nearby when solvent is used. Use only in well-ventilated places. Failure to do this may result in injury to personnel and damage to equipment.

- (1) Cleaning. Cover all openings in tank. Clean outside of tank with solvent.
- (2) Inspection and Repair.

FRAME 1

1. Check that tank (1) is not dented or distorted. Fix by straightening.
2. Check that filler cap (2) and filler pipe sleeve (3) are not damaged. If they are damaged, get new ones in their place.
3. Check that tank (1) has no cracks or broken welds. If tank is damaged, send tank to depot maintenance for steam cleaning, in accordance with TB 43-0212, and welding repair, in accordance with TM 9-237.

END OF TASK

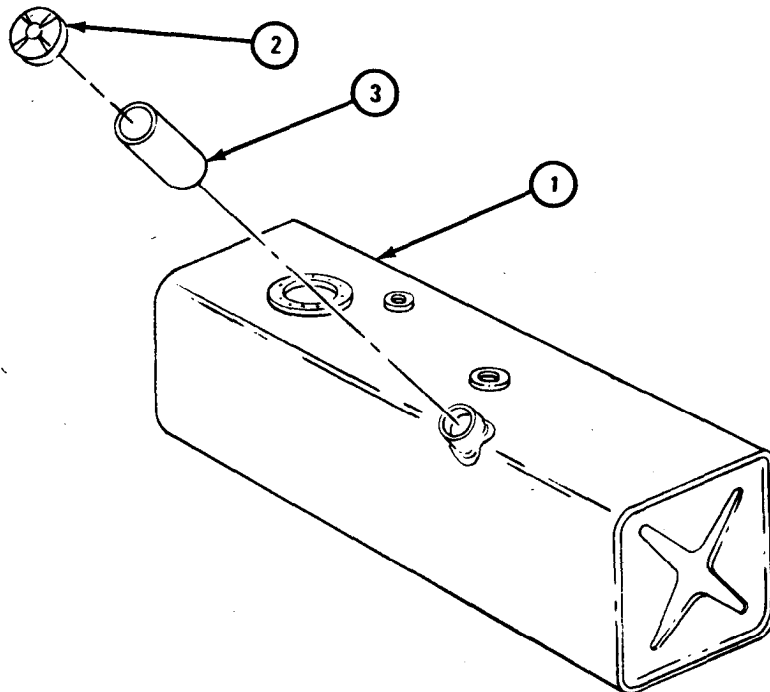

TA 085249

d. Assembly.

FRAME 1

1. Put on filler pipe sleeve (1).
2. Put on gasket (2) and filler pipe cap (3).

NOTE

Follow-on Maintenance Action Required:

1. Replace fuel gage sending unit. Refer to TM 9-2320-209-20.
2. Replace fuel pump. Refer to TM 9-2320-209-20.
3. Replace tank. Refer to TM 9-2320-209-20.

END OF TASK

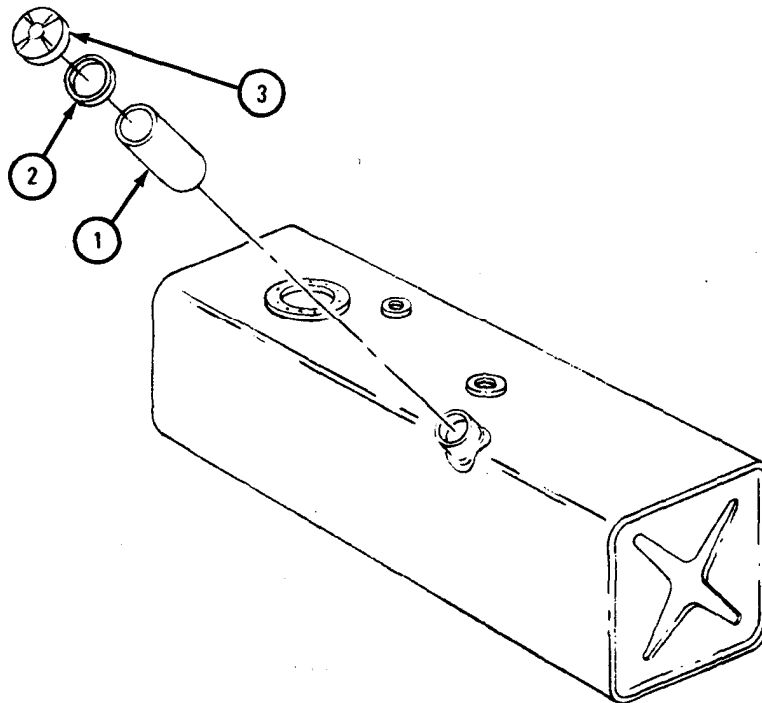

TA 085250

CHAPTER 5

EXHAUST SYSTEM GROUP MAINTENANCE

Section I. SCOPE

5-1. EQUIPMENT ITEMS COVERED . This chapter gives equipment maintenance procedures for exhaust pipes and mufflers for which there are authorized corrective maintenance tasks at the direct and general support maintenance levels.

5-2. EQUIPMENT ITEMS NOT COVERED. All equipment items for which corrective maintenance is authorized at the direct and general support maintenance levels are covered in this chapter. For models other than M50A1 and M50A2, refer to TM 9-2320-209-20.

Section II. EXHAUST PIPES AND MUFFLERS

5-3. EXHAUST BYPASS FORDING VALVE REMOVAL, REPAIR, AND REPLACEMENT (TRUCKS M50A1 AND M50A2) .

TOOLS : No special tools required

SUPPLIES : Solvent, dry cleaning, type II (SD-2) , Fed. Spec P-D-680
Clean rags
Bypass fording valve flange gasket (2)
Bypass fording valve packing

PERSONNEL : Two

EQUIPMENT CONDITION : Truck parked, engine off, handbrake set.

a. Preliminary Procedure. Remove spare wheel. Refer to TM 9-2320-209-10.

b. Remove.

FRAME 1

Soldier A 1. Hold eight nuts (1) in place.

Soldier B 2. Take out eight capscrews (2).

3. Take out exhaust bypass fording valve (3) and two gaskets (4). Throw away gaskets.

END OF TASK

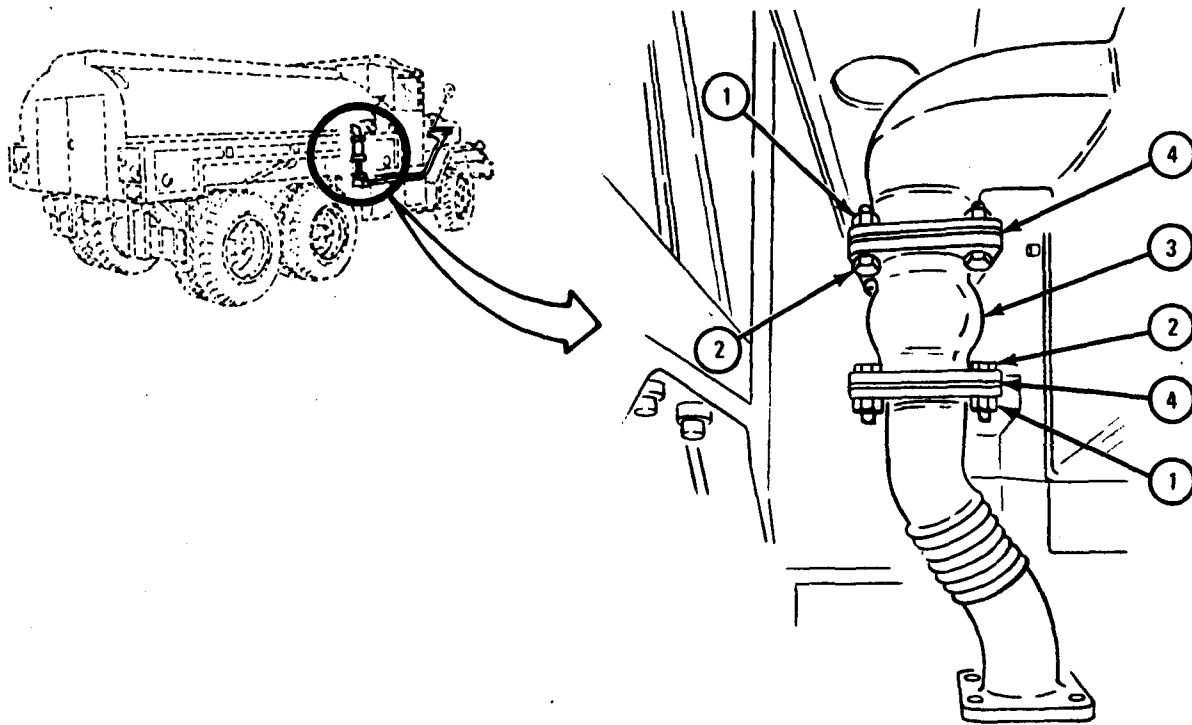

TA 089016

c. Disassemble.

FRAME 1

- 1. Take off nut (1).
 - 2. Lift handwheel (2) off stem (3).
 - 3. Take off nut (4).
 - 4. Take gland (5) and packing (6) out of bonnet (7). Throw away packing.
- GO TO FRAME 2

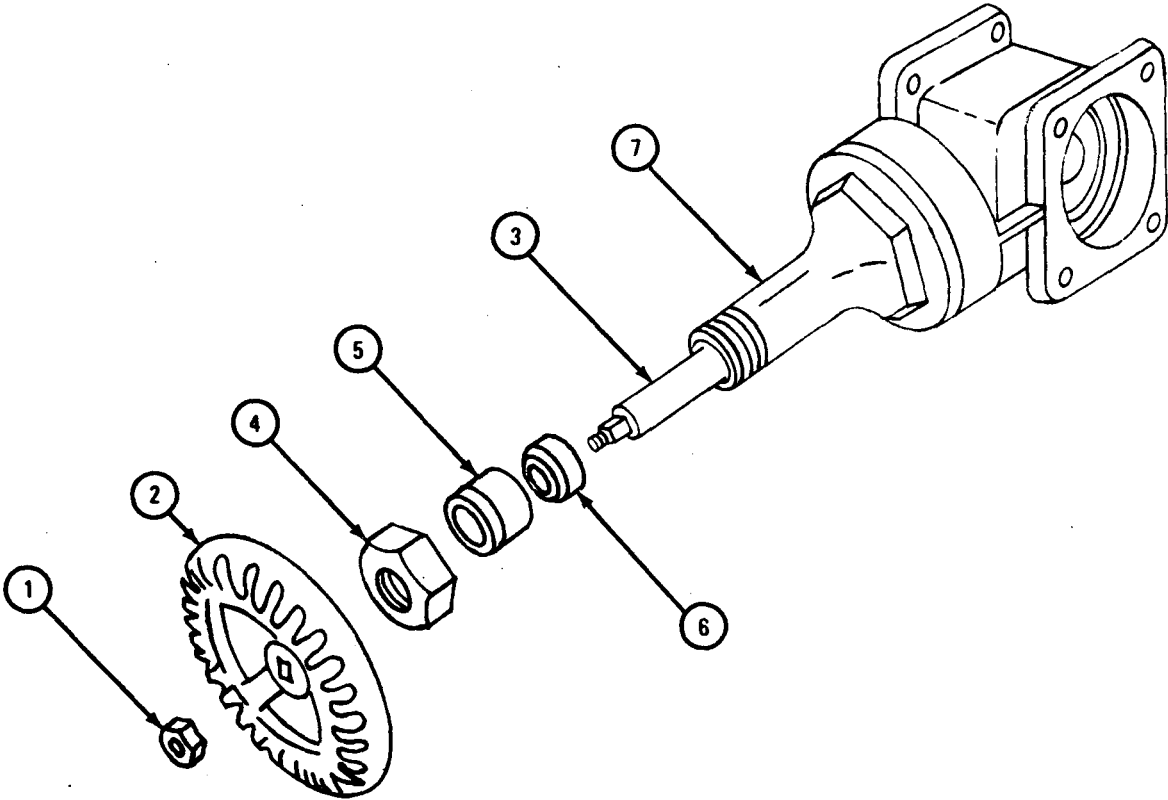

TA 089017

FRAME 2

1. Take bonnet (1) off valve body (2).
2. Take out stem (3) with disks (4 and 5).
3. Take disks (4 and 5) off stem (3).

END OF TASK

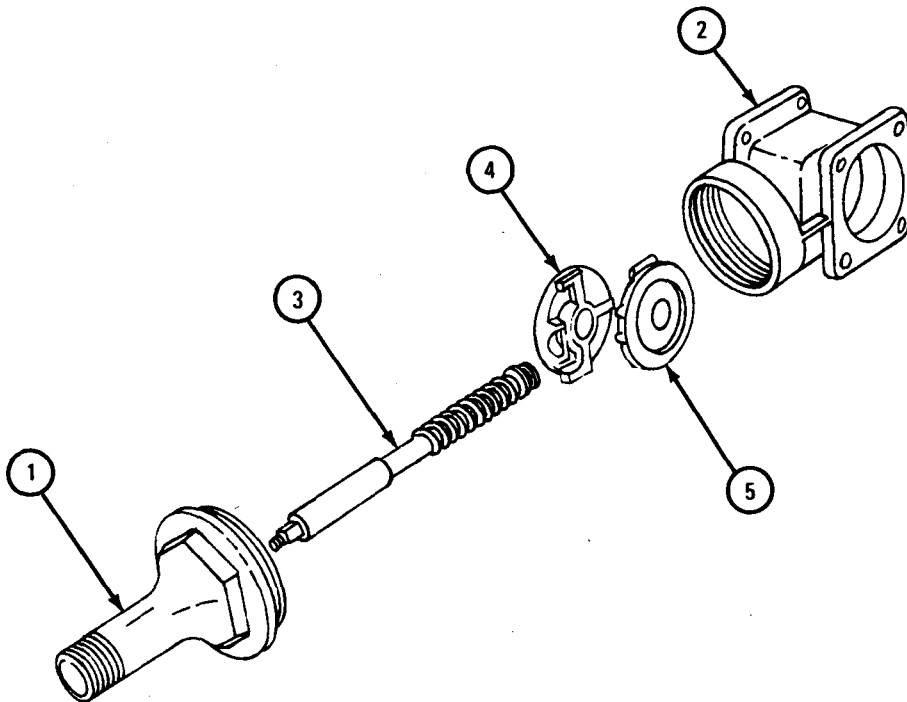

TA 089018

d. Cleaning. There are no special cleaning procedures needed. Refer to cleaning procedures given in para 1-3.

e. Inspection and Repair.

FRAME 1

1. Check that handwheel (1), gland (2), bonnet (3), stem (4), disks (5 and 6), and valve body (7) are not bent, dented or cracked. Weld cracks. Refer to TM 9-237. If more repair is needed, get new parts.

END OF TASK

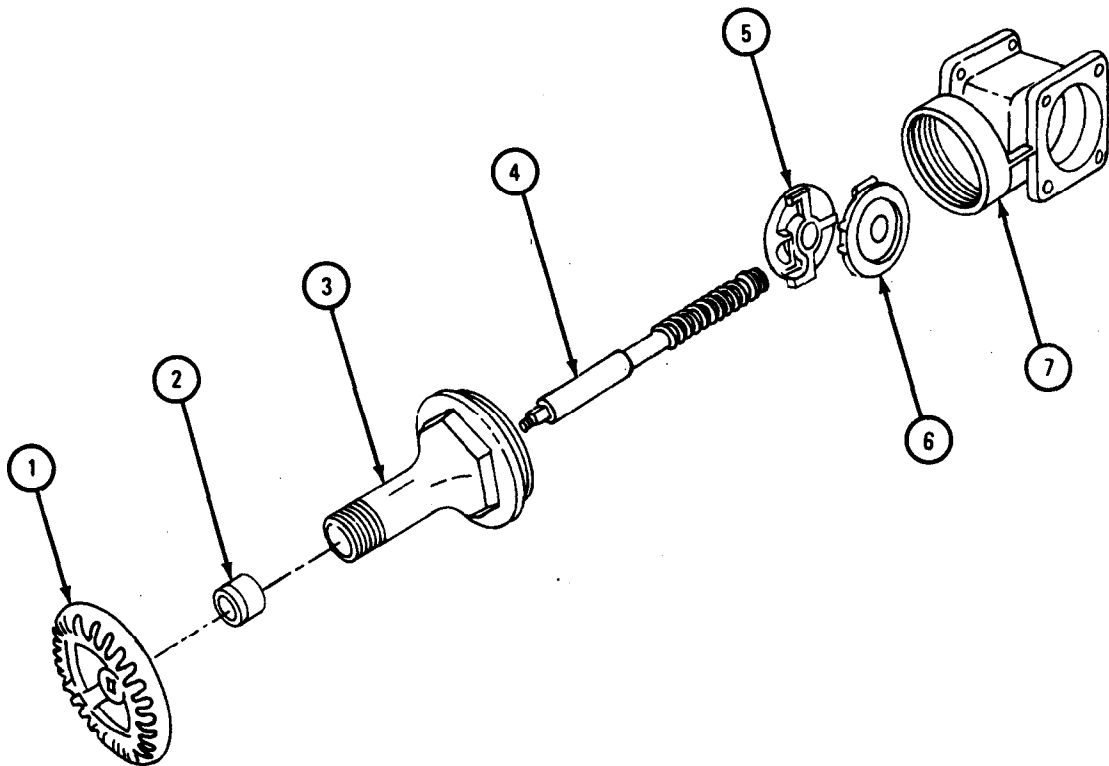

TA 089019

f. Assembly.

FRAME 1

1. Put disks (1 and 2) on stem (3).
2. Put in stem (3) with disks (1 and 2).
3. Put bonnet (4) on valve body (5).

GO TO FRAME 2

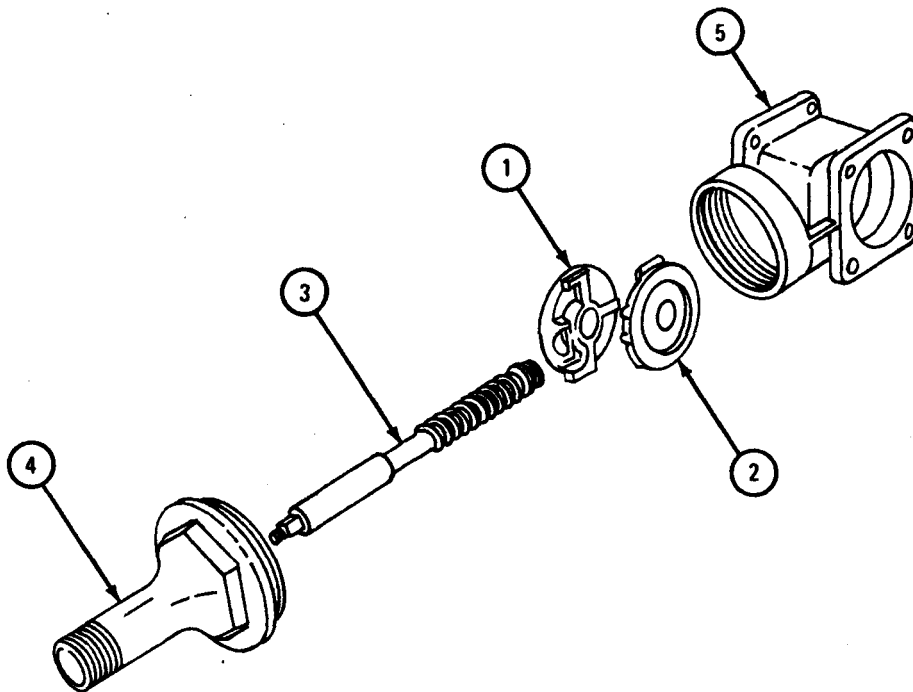

TA 089020

FRAME 2

1. Put packing (1) on stem (2).
2. Put gland (3) on stem (2). Using gland, push packing (1) into bonnet (4). Push gland into bonnet.
3. Put on nut (5).
4. Put handwheel (6) on stem (2).
5. Put on nut (7).

END OF TASK

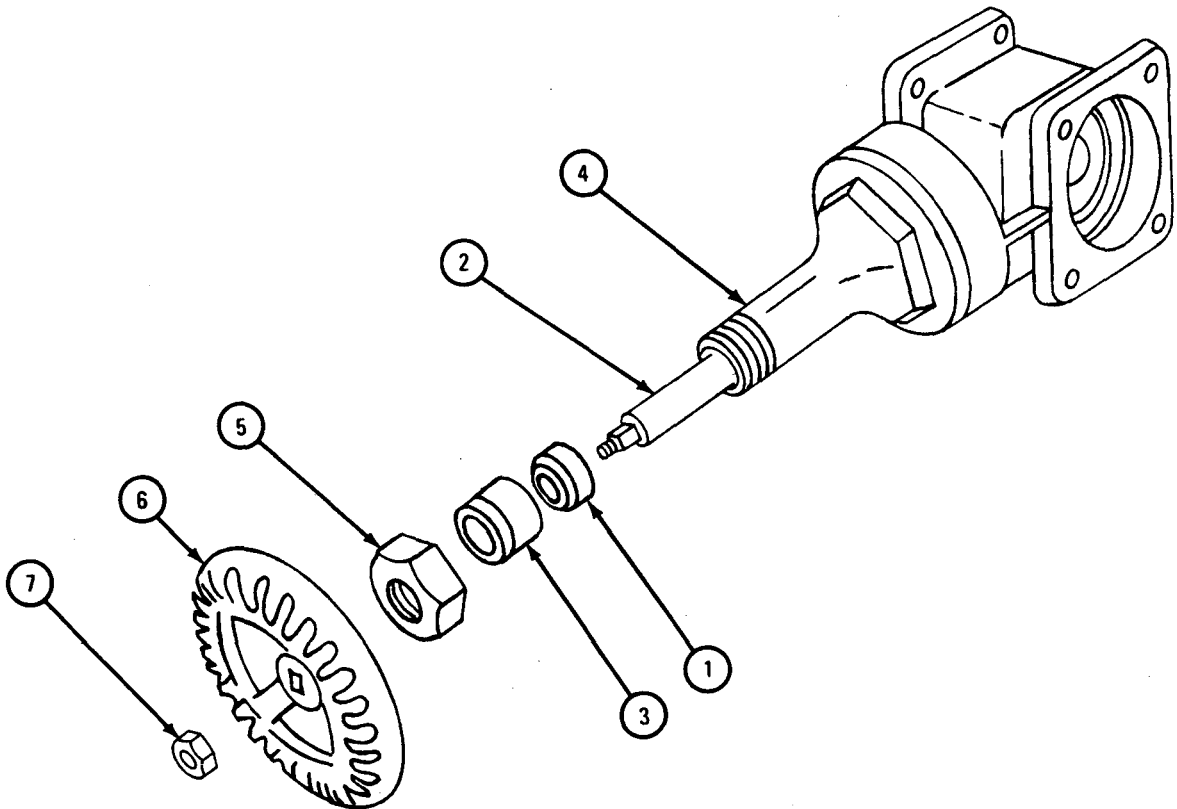

TA 089021

g. Replacement.

FRAME 1

- Soldier A 1. Put exhaust bypass fording valve (1) in place as shown.
2. Put one gasket (2) on each end of exhaust bypass fording valve (1) and align all screw holes.
- Soldier B 3. Put in and hold eight capscrews (3).
- Soldier A 4. Put on eight nuts (4).

NOTE

Follow-on Maintenance Action Required:

Replace spare wheel. Refer to TM 9-2320-209-10.

END OF TASK

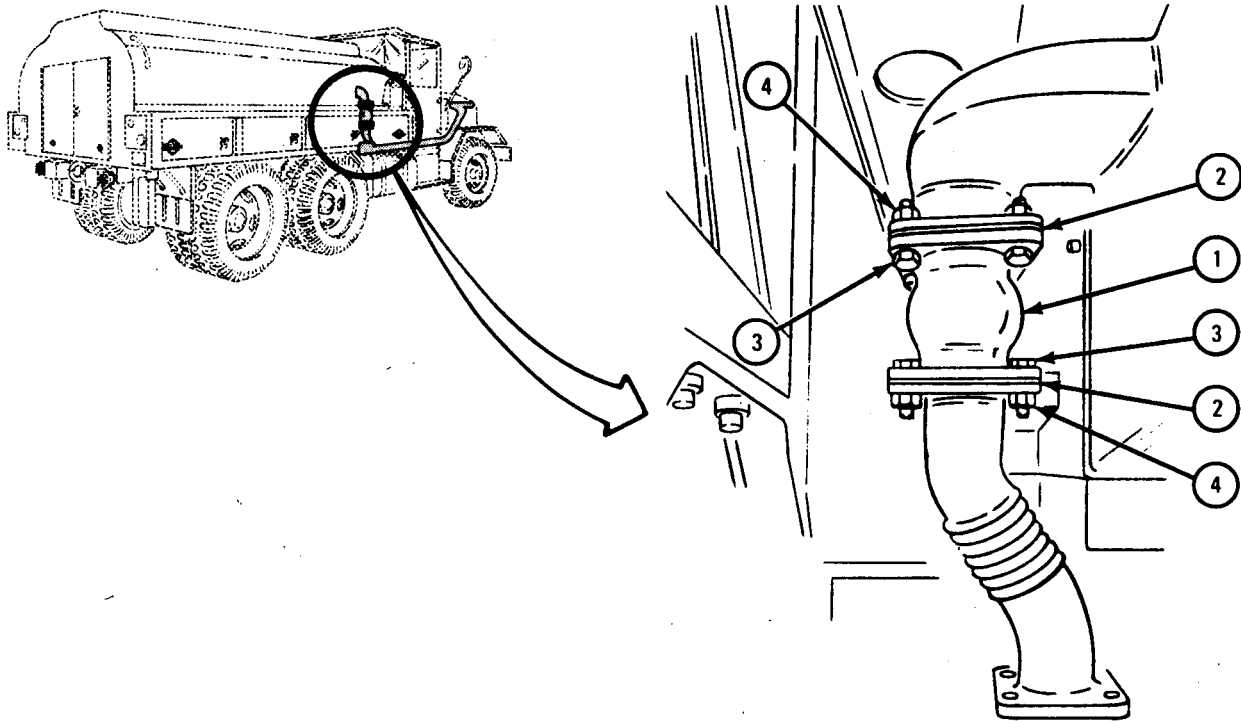

TA 089022

CHAPTER 6

COOLING SYSTEM GROUP MAINTENANCE

Section I. SCOPE

6-1. EQUIPMENT ITEMS COVERED. This chapter gives equipment maintenance procedures for the radiator and shrouds for which there are authorized corrective maintenance tasks at the direct and general support maintenance levels.

6-2. EQUIPMENT ITEMS NOT COVERED. All equipment items for which corrective maintenance is authorized at the direct and general support maintenance levels are covered in this chapter.

Section II. RADIATOR AND SHROUDS

6-3. RADIATOR REPAIR AND TEST. Refer to FM 43-2 for procedure to repair and test radiator.

6-4. RADIATOR SHROUD REPAIR. Refer to FM 43-2 for procedure to repair radiator shroud.

CHAPTER 7

ELECTRICAL SYSTEM GROUP MAINTENANCE

Section I. SCOPE

7-1. EQUIPMENT ITEMS COVERED. This chapter gives equipment maintenance procedures for the charging system, battery system, and chassis wiring harnesses for which there are authorized corrective maintenance tasks at the direct and general support maintenance levels.

7-2. EQUIPMENT ITEMS NOT COVERED. All equipment items for which corrective maintenance is authorized at the direct and general support maintenance levels are covered in this chapter.

Section II. CHARGING SYSTEM

7-3. ALTERNATOR AND REGULATOR REPAIR. Refer to TM 9-2920-225-34 for repair of alternator and regulator.

Section III. BATTERY SYSTEM

7-4. BATTERY INSPECTION, REMOVAL, SERVICE, AND REPLACEMENT.

- a. Battery Inspection. Refer to TM 9-2320-209-10 for battery inspection.
- b. Storage Battery Removal and Replacement. Refer to TM 9-2320-,209-20 for storage battery removal and replacement.
- c. Servicing the Batteries. Refer to TM 9-2320-209-20 for servicing the batteries.

Section IV. CHASSIS WIRING HARNESSSES

7-5. WIRING HARNESS CLAMPS REMOVAL AND REPLACEMENT.

TOOLS : No special tools required

SUPPLIES: Chalk, SS-C-266
Disposable plastic clamp

PERSONNEL : One

EQUIPMENT CONDITION : Truck parked, engine off, handbrake set.

a. Removal.

FRAME 1

1. Follow wire to clamp. If clamp is screw type (1), using 7/16-inch wrench, take off nut (2) from screw (3). Take off clamp (1). Circle hole in chassis with chalk.
2. If clamp is disposable plastic type (4), cut off clamp (4) and mark straight line with chalk on chassis.
3. If clamp is wrap-around type (5), unwrap and take out wire.

END OF TASK

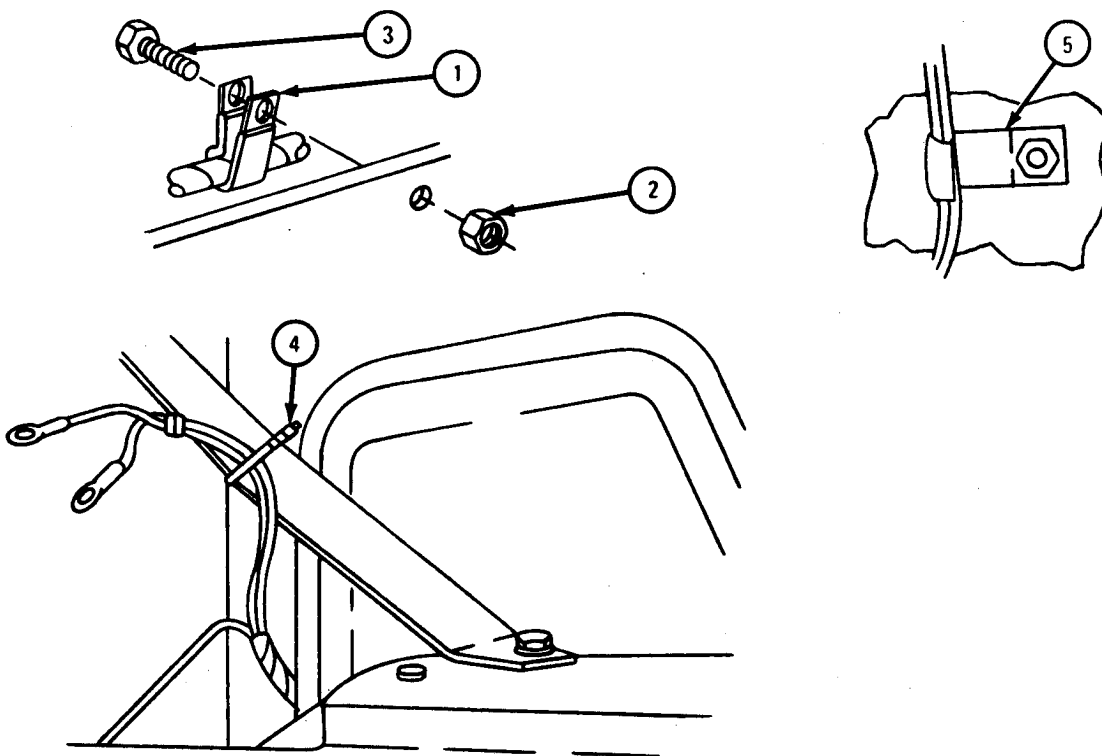

TA 105764

b. Replacement.

FRAME 1

1. If hole on chassis is circled with chalk, put on screw type clamp (1). Put in screw (2). Put on nut (3) using 7/16-inch wrench.
2. If chassis has straight chalk line, put on disposable plastic clamp (4). Put clamp around wire. Put end of clamp (5) through loop (6) and pull end of clamp until clamp is tight.
3. If clamp is wrap-around type (7), place wire in clamp and wrap metal strip around wire.

END OF TASK

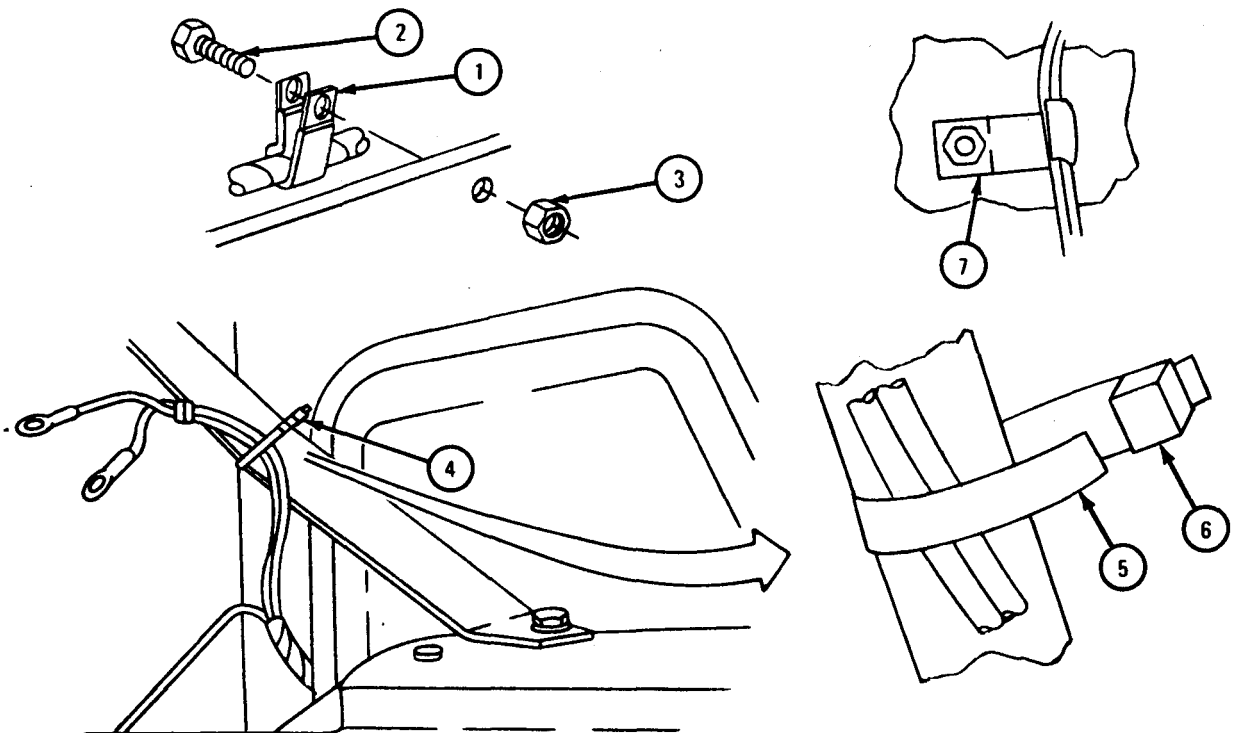

TA 105765

7-6. FRONT WIRING HARNESS REMOVAL AND REPLACEMENT (ALL TRUCKS EXCEPT TRUCKS M275A1, AND M275A2).

NOTE

Refer to removal and replacement procedures given in TM 9-2320-209-20 to take off and put back connectors and electrical leads covered in the following steps.

TOOLS : No special tools required

SUPPLIES : Tags

PERSONNEL : Two

EQUIPMENT CONDITION : Truck parked, engine off, handbrake set.

a. Preliminary Procedures.

(1) Disconnect battery ground. Refer to TM 9-2320-209-20.

(2) Open hood and side panels. Refer to TM 9-2320-209-10.

b. Removal.**FRAME 1****NOTE**

All leads must be tagged so they will be put back in the right places.

1. If truck has right composite light, unplug three leads (1). If truck has right blackout marker light, unplug two leads.
2. Unplug two leads (2) from right headlight.
3. If truck has electric horn, unplug two leads (3) from horn.
4. Unplug lead (4) from blackout driving light.
5. Unplug two leads (5) from left headlight.
6. If truck has left composite light, unplug three leads (6). If truck has left blackout marker light, unplug two leads.

GO TO FRAME 2

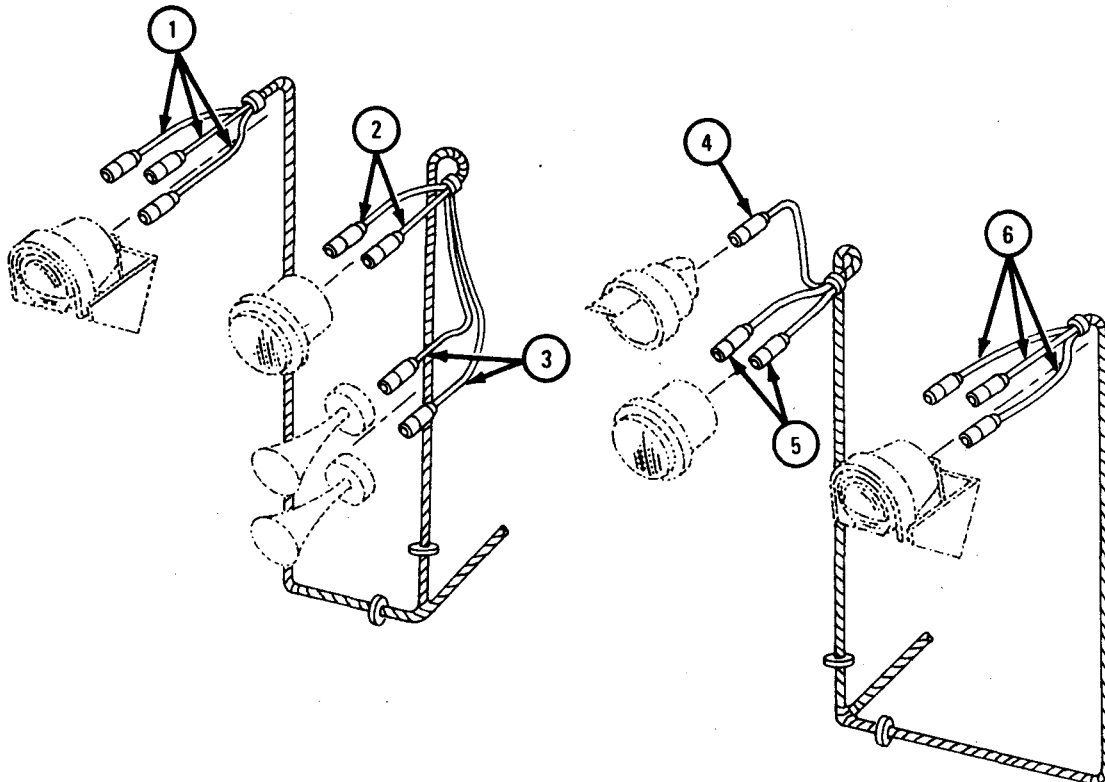

TA 103377

FRAME 2

1. Take off two leads (1) from starter magnetic switch.
2. Unplug lead (2) from engine temperature sending unit.
3. Unplug lead (3) from manifold heater.
4. Unplug lead (4) from oil pressure sending unit.
5. If truck has regulator, take lead (5) off regulator.
6. Unplug two leads (6) from circuit breaker.
7. Unplug three leads (7) from beam select switch.
8. Take off lead (8) from starter solenoid.
9. Take lead (9) and ground wire (10) from signal flasher unit.

GO TO FRAME 3

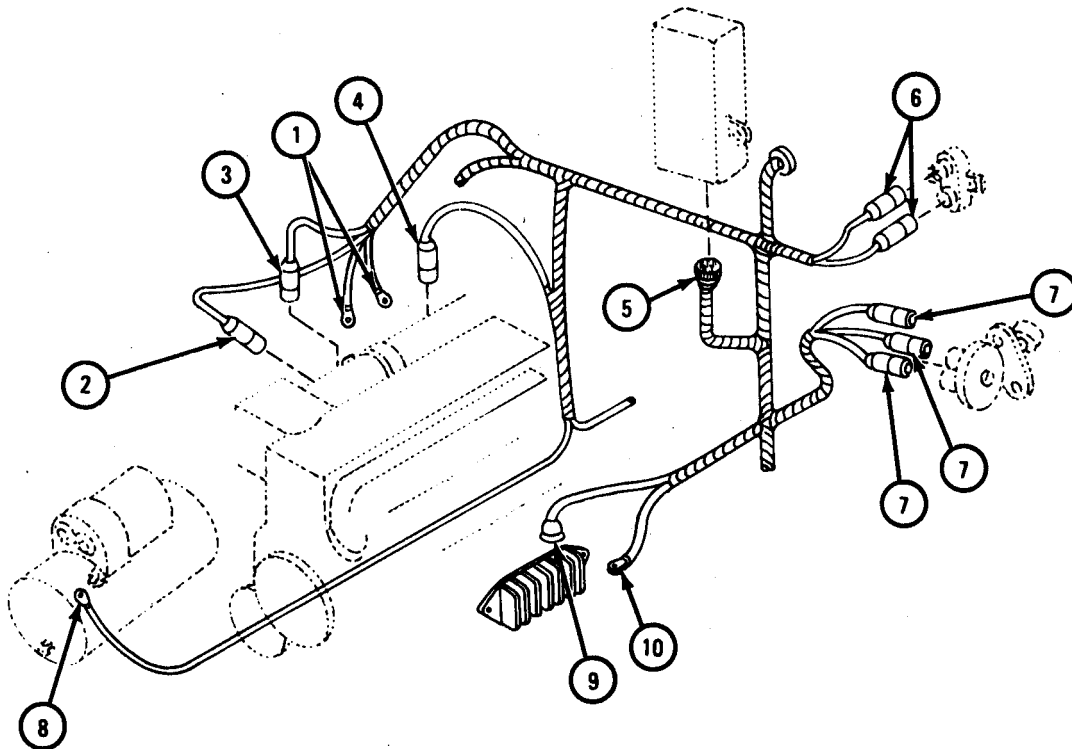

TA 103378

FRAME 3

1. Take lead (1) off light switch.
2. Unplug two leads (2) from manifold heater switch.
3. Unplug four leads (3) from accessory switch.
4. Unplug lead (4) from lead to electrical buzzer.
5. Unplug seven leads (5) from instrument panel.
6. Unplug lead (6) from starter button.
7. Unplug lead (7) from low air pressure switch.
8. Unplug two leads (8) from front wheel drive selector.
9. Unplug connector (9) from signal control lever assembly.
10. Unplug lead (10) from lead to air horn.

GO TO FRAME 4

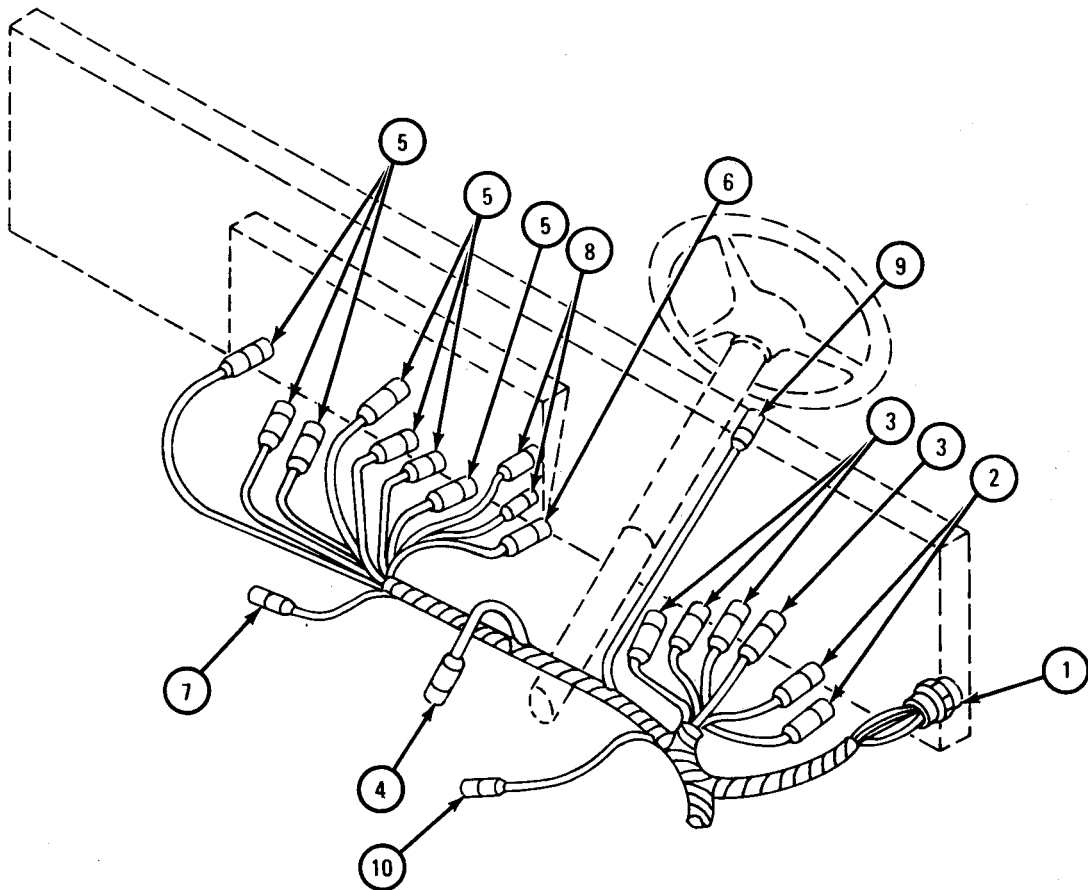

TA 103379

FRAME 4

1. Unplug lead (1) from hydraulic stoplight switch.
2. Unplug rear harness connector (2) from harness plug.
3. Take off all clamps. Refer to para 7-5.

Soldier A 4. Working inside cab, hold two screws (3).

Soldier B 5. Working in engine compartment, take off two nuts (4) and retainer (5).

6. Pull harness through firewall and take harness out of truck.

END OF TASK

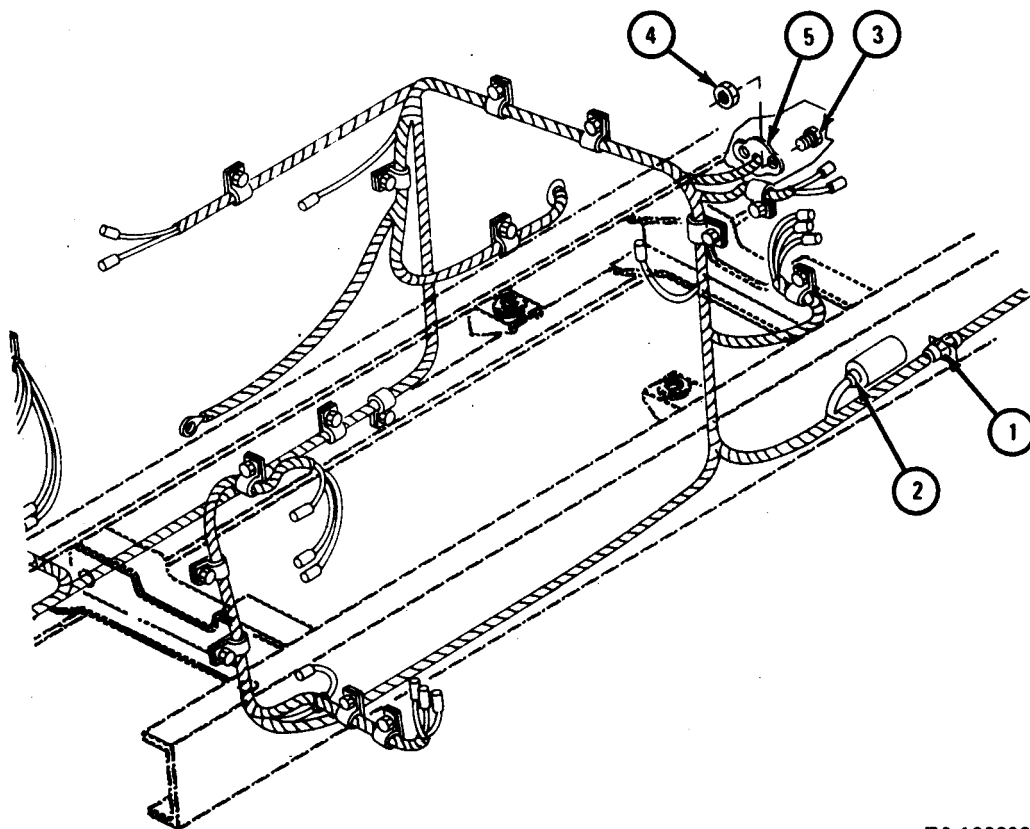

TA 103380

c. Replacement.**FRAME 1****NOTE**

If new harness is being put on, put old harness next to new harness and put tags in the same places as on old harness.

1. Route harness in engine compartment and through firewall as noted.
2. Put retainer (1) in place and align screw holes.
- Soldier A 3. Working inside cab, put in and hold two screws (2).
- Soldier B 4. Put on two nuts (3).
5. Put back all clamps. Refer to para 7-5.
6. Put rear harness connector (4) on rear harness plug.
7. Plug lead (5) into hydraulic stoplight switch.

GO TO FRAME 2

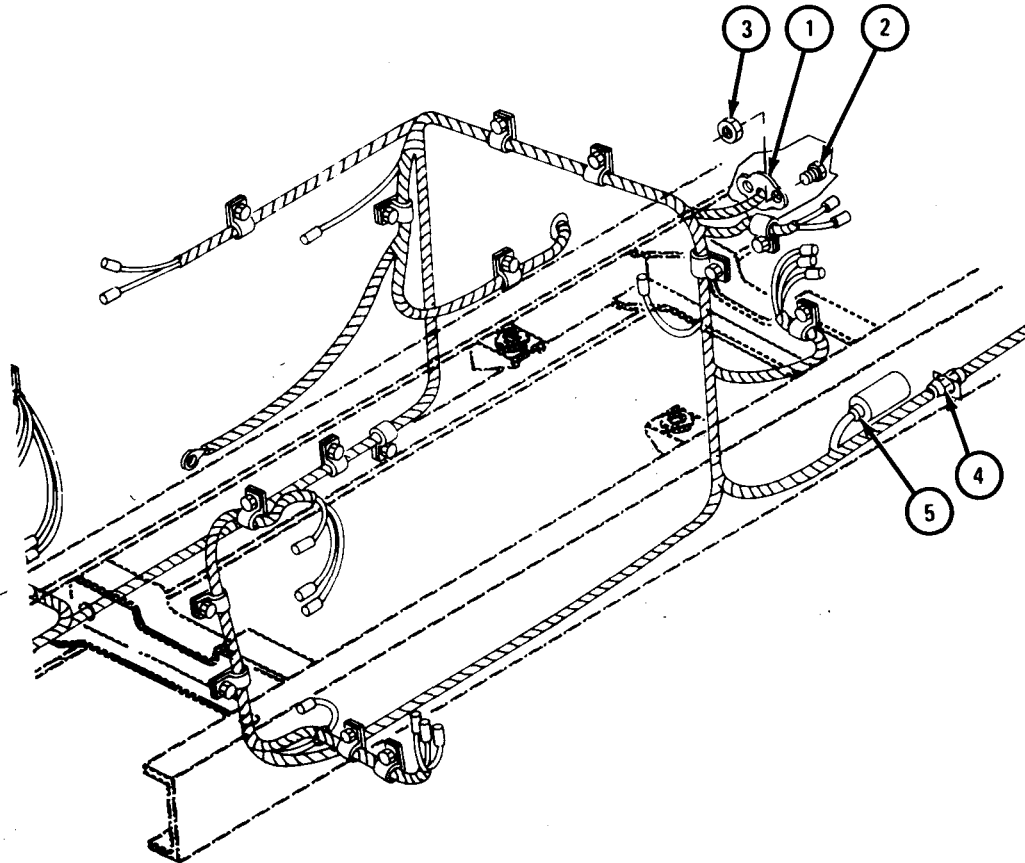

TA 103412

FRAME 2

1. Plug seven leads (1) into instrument panel.
2. Plug lead (2) into lead to electrical buzzer.
3. Plug four leads (3) into accessory switch.
4. Plug two leads (4) into manifold heater switch.
5. Put on lead (5) to light switch.
6. Plug lead (6) into starter switch.
7. Plug lead (7) into low air pressure switch.
8. Plug two leads (8) into front wheel drive selector.
9. Plug connector (9) into signal control lever assembly.
10. Plug lead (10) into lead to air horn.

GO TO FRAME 3

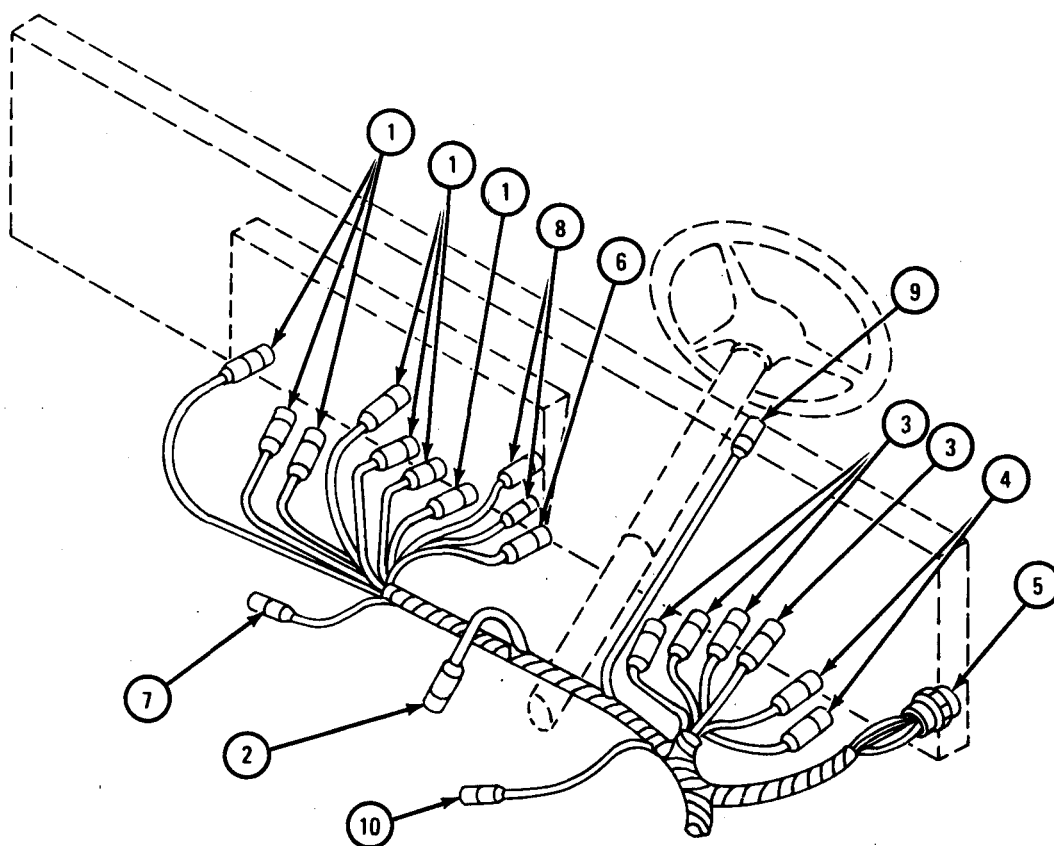

TA 103413

FRAME 3

1. Plug three leads (1) into beam selector switch.
2. Plug two leads (2) into circuit breaker.
3. If truck has regulator, put in lead (3) to regulator.
4. Plug lead (4) into oil pressure sending unit.
5. Plug lead (5) into manifold heater.
6. Plug lead (6) into engine temperature sending unit.
7. Put lead (7) on starter solenoid.
8. Put two leads (8) on starter magnetic switch.
9. Put lead (9) and ground wire (10) on signal flasher unit.

GO TO FRAME 4

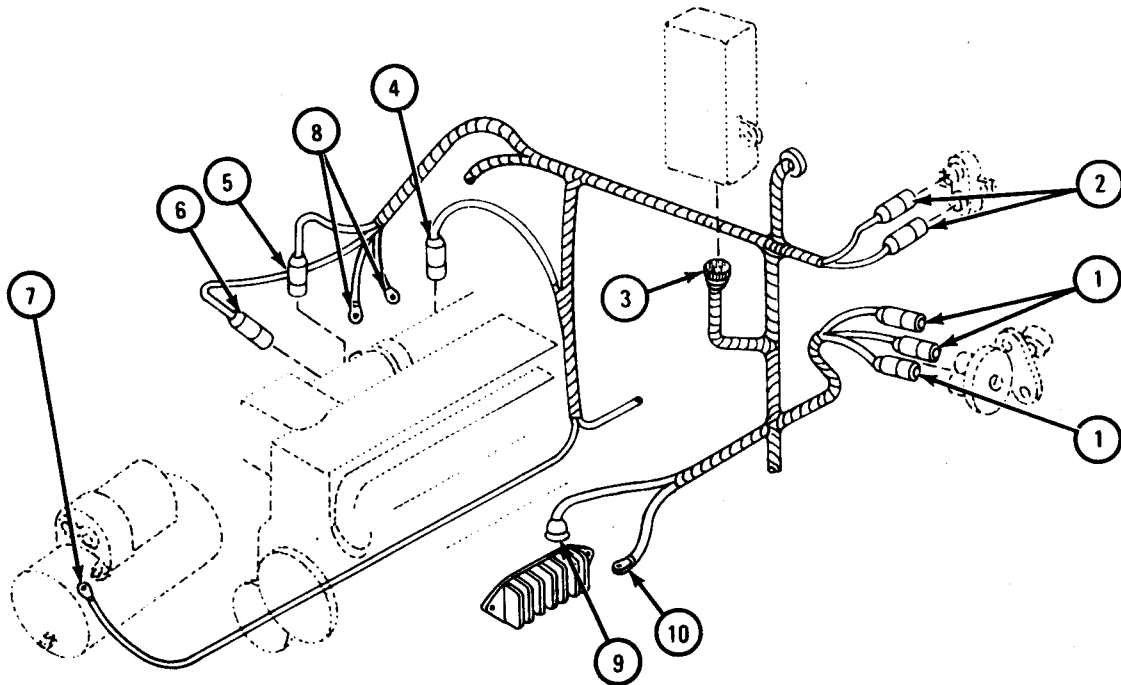

TA 103414

FRAME 4

1. If truck has left composite light, plug in three leads (1). If truck has left blackout marker light, plug in two leads.
2. If truck has electric horn, plug two leads (2) into horn.
3. Plug two leads (3) into left headlight.
4. Plug lead (4) into blackout driving light.
5. Plug two leads (5) into right headlight.
6. If truck has right composite light, plug in three leads (6). If truck has right blackout marker light, plug in two leads.

NOTE

Follow-on Maintenance Action Required:

1. Reconnect battery ground. Refer to TM 9-2320-209-20.
2. Close hood and side panels. Refer to TM 9-2320-209-10.

END OF TASK

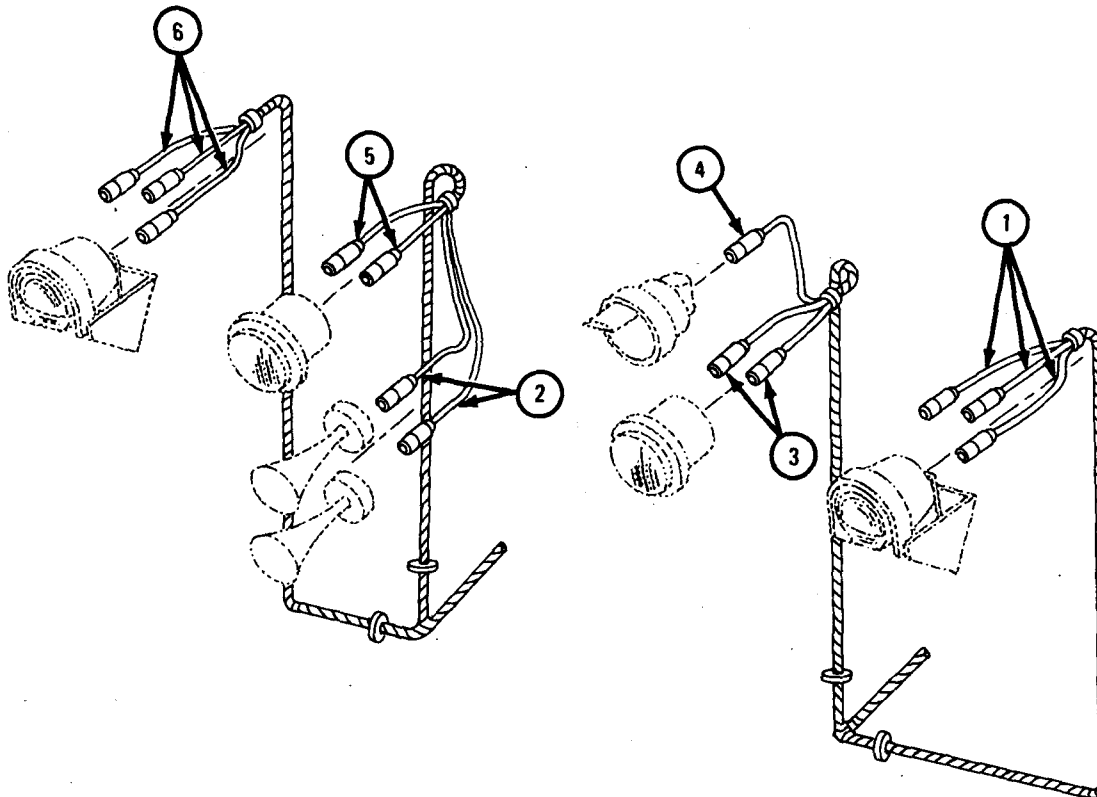

TA 103415

7-7. REAR WIRING HARNESS REMOVAL AND REPLACEMENT (ALL TRUCKS EXCEPT M275A1 AND M275A2).

TOOLS: No special tools required

SUPPLIES: None

PERSONNEL: One

EQUIPMENT CONDITION: Truck parked, engine off, handbrake set.

a. Preliminary Procedure. Disconnect battery ground cable. Refer to TM 9-2320-209-20.

NOTE

Refer to removal and replacement procedures given in TM 9-2320-209-20 if needed to take off connectors and electrical leads covered in the following steps. Tag all leads so that they are put back in the right place.

b. Removal.

FRAME 1

1. Unplug rear harness plug (1) from rear harness connector.

NOTE

Trucks with LDS-427 engine have only one lead (2) to fuel tank.

2. Unplug two leads (2) from fuel tank and take plugs off leads.

3. Unplug four leads (3) from left taillight.

4. Take off trailer coupling receptacle (4).

5. Unplug four leads (5) from right taillight.

GO TO FRAME 2

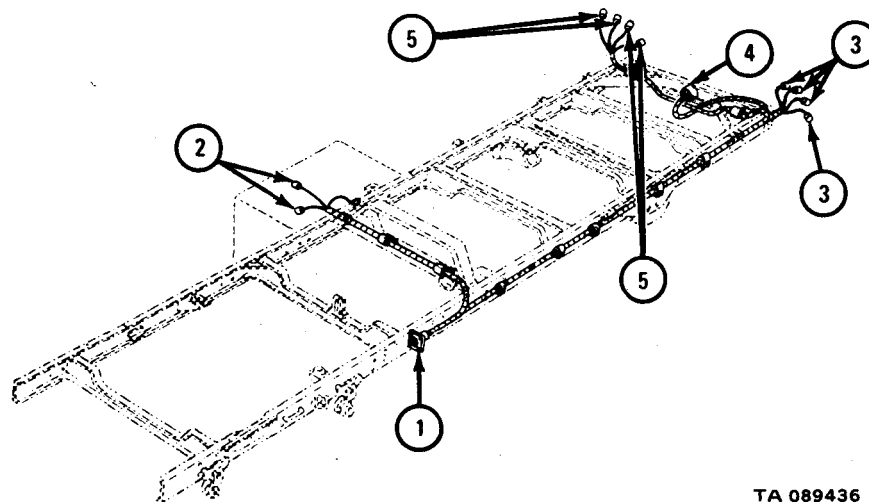

TA 089436

FRAME 2

NOTE

Note the way harness is routed so that it will be put back the same way. Trucks with LDS-427 engine do not have capscrew (1) or ground wire (2).

1. Unscrew and take off capscrew (1) and take off ground wire (2).
2. Unscrew and take off two capscrews (3) and nuts (4) holding two clamps (5). Spread open and take off clamps.
3. Unscrew and take off five capscrews (6) and nuts (7) holding five clamps (8). Spread open and take off clamps.
4. Unscrew and take off two capscrews (9) and nuts (10) holding five clamps (11). Spread open and take off clamps.
5. Take harness out of truck.

END OF TASK

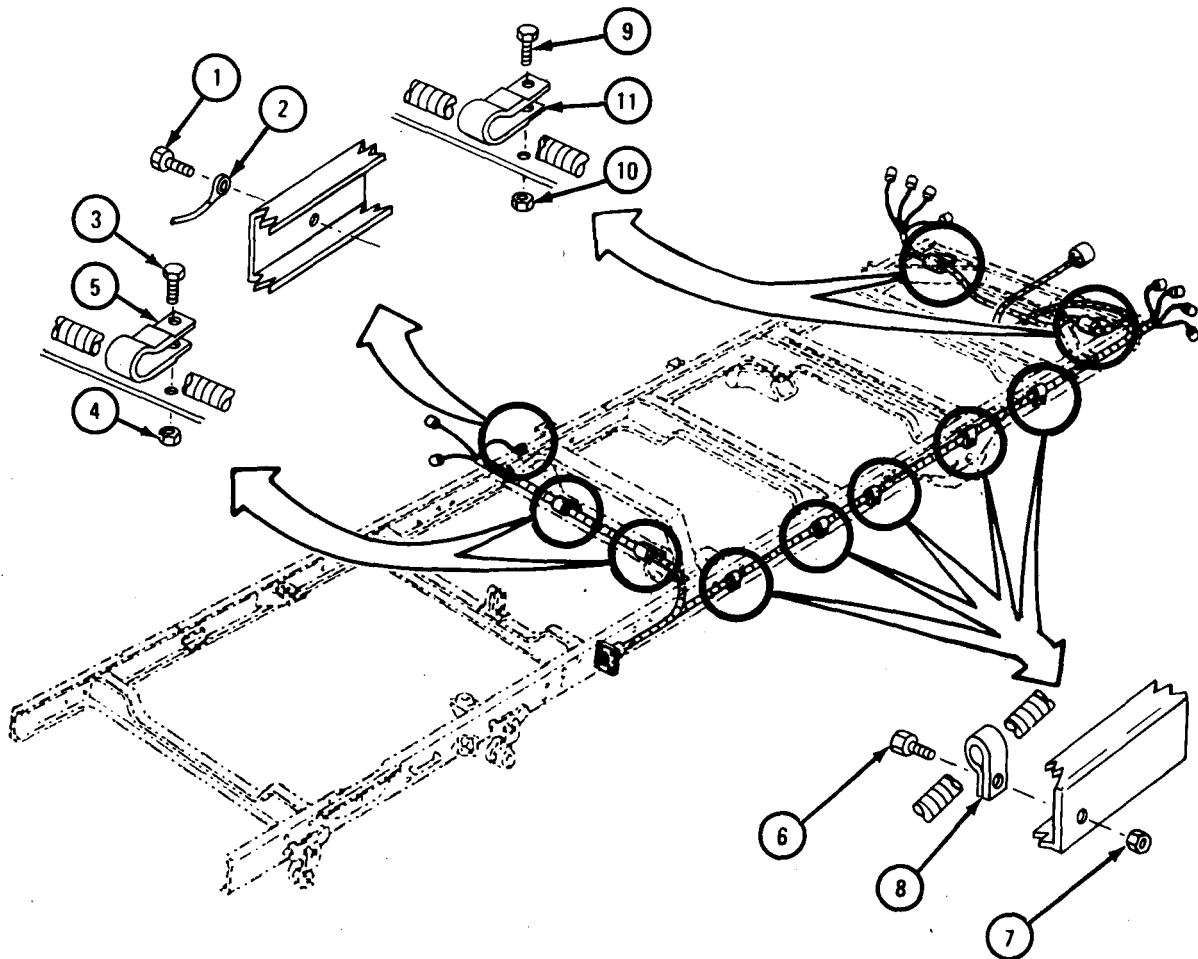

TA 089437

c. Replacement.

FRAME 1

1. Put harness back in truck as noted.
2. Put two clamps (1) on harness and put two capscrews (2) through clamps and frame. Put on two nuts (3).
3. Put five clamps (4) on harness and put five capscrews (5) through clamps and frame. Put on five nuts (6).
4. Put two clamps (7) on harness and put two capscrews (8) through clamps and frame. Put on two nuts (9).

NOTE

Trucks with LDS-427 engine do not have ground wire (10) or capscrew (11).

5. Put ground wire (10) on frame and put capscrew (11) through ground wire into frame.

GO TO FRAME 2

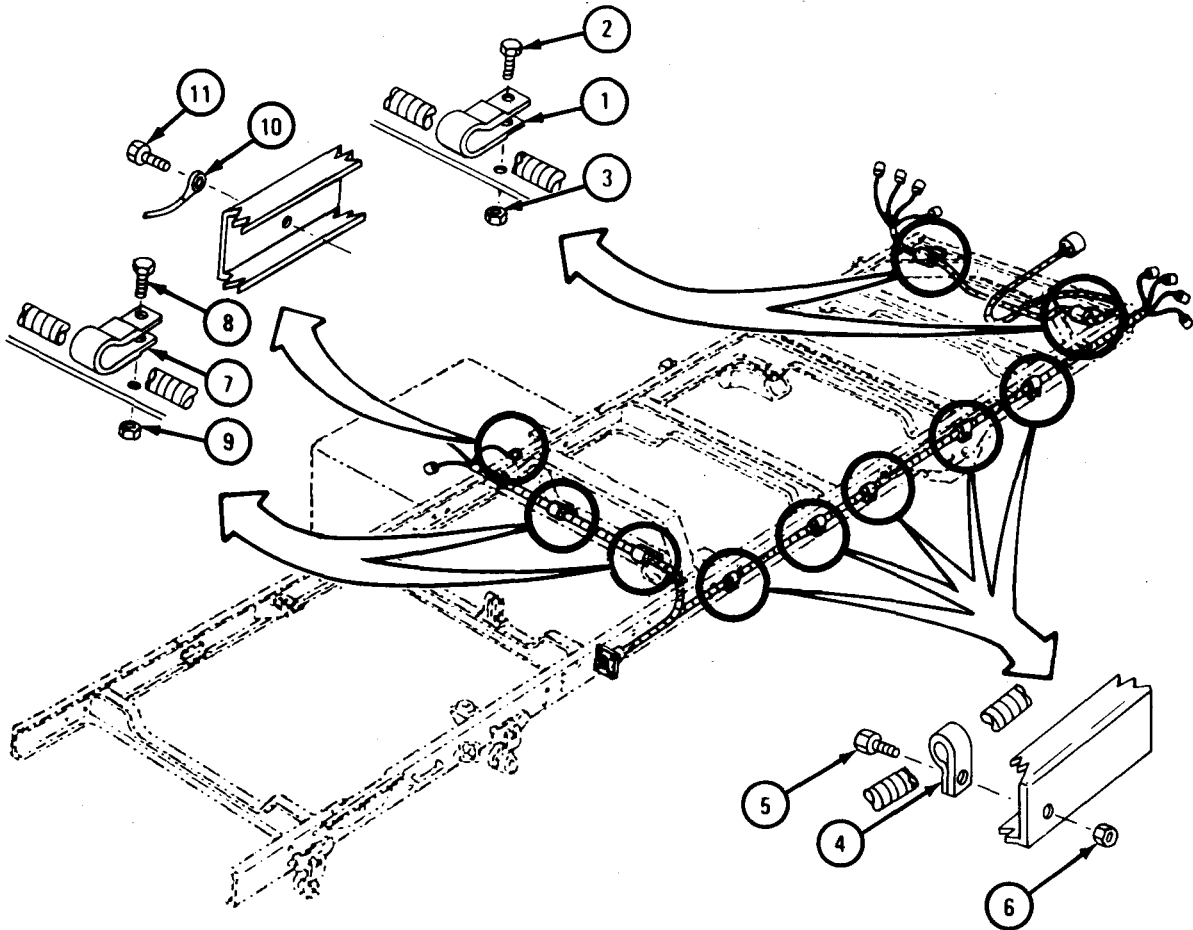

TA 089438

FRAME 2

1. Plug four leads (1) into right taillight.
2. Put on trailer coupling receptacle (2).
3. Plug four leads (3) into left taillight.

NOTE

Trucks with LDS-427 engine have only one lead (4) to fuel tank.

4. Put two plugs on two leads (4) and plug them into fuel tank.
5. Plug rear harness plug (5) into rear harness connector.

NOTE

Follow-on Maintenance Action Required:

Reconnect battery ground cable. Refer to TM 9-2320-209-20.

END OF TASK

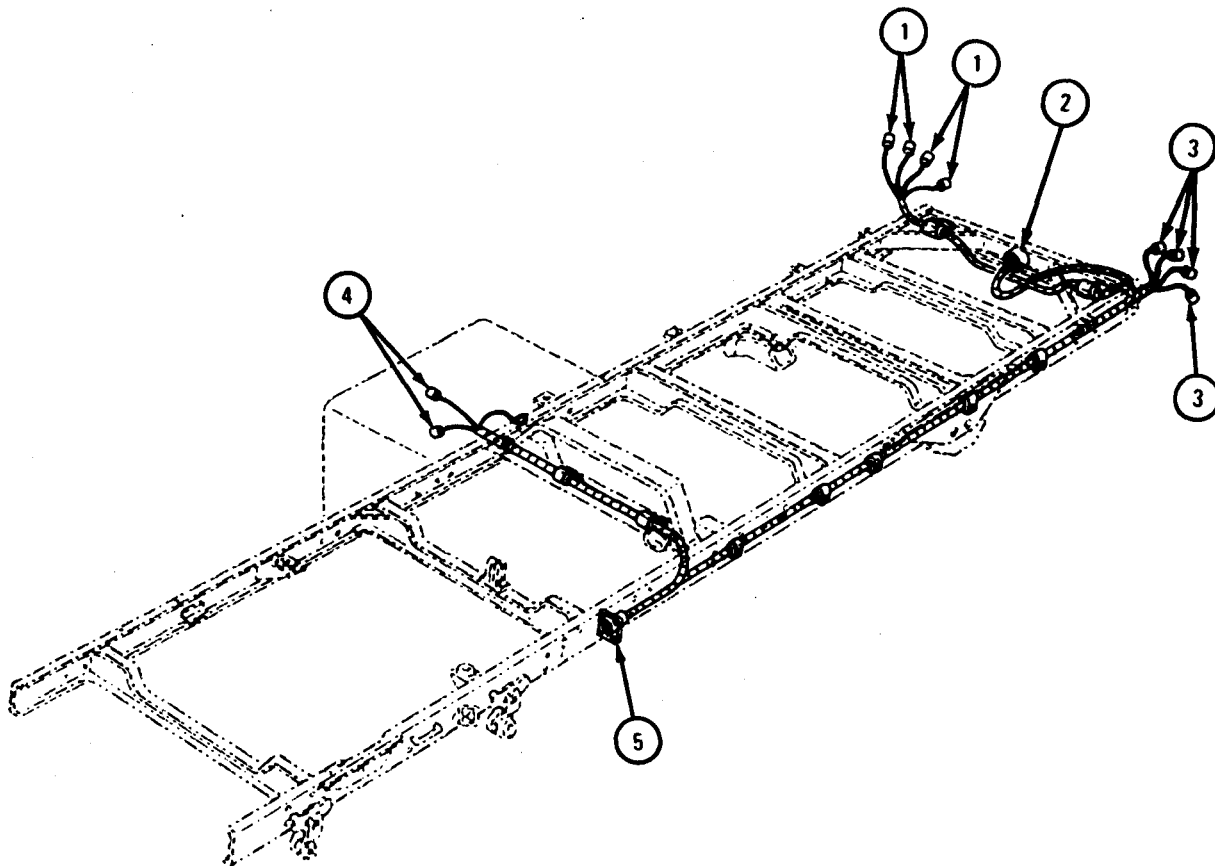

TA 089439

7-8. CHASSIS WIRING HARNESS REMOVAL AND REPLACEMENT (TRUCKS M275A1 AND M275A2).

TOOLS: No special tools required

SUPPLIES: Tags

PERSONNEL: One

EQUIPMENT CONDITION: Truck parked, engine off, handbrake set.

a. Preliminary Procedures.

- (1) Open hood and side panels. Refer to TM 9-2320-209-10.
- (2) Disconnect battery ground. Refer to TM 9-2320-209-20.
- (3) Disconnect speedometer cable. Refer to TM 9-2320-209-20.
- (4) Disconnect tachometer cable. Refer to TM 9-2320-209-20.

b. Removal.

NOTE

Refer to removal procedures given for each part in TM 9-2320-209-20, if needed, to work on connectors and electrical leads covered in this task.

Tag all wires so they are put back in the right places.

FRAME 1

1. Unplug three leads (1) from right composite light.
2. Unplug two leads (2) from right headlight.
3. Unplug two leads (3) from horns.
4. Unplug lead (4) from blackout driving light.
5. Unplug two leads (5) from left headlight.
6. Unplug lead (6) from horn.
7. Unplug three leads (7) from left composite light.

GO TO FRAME 2

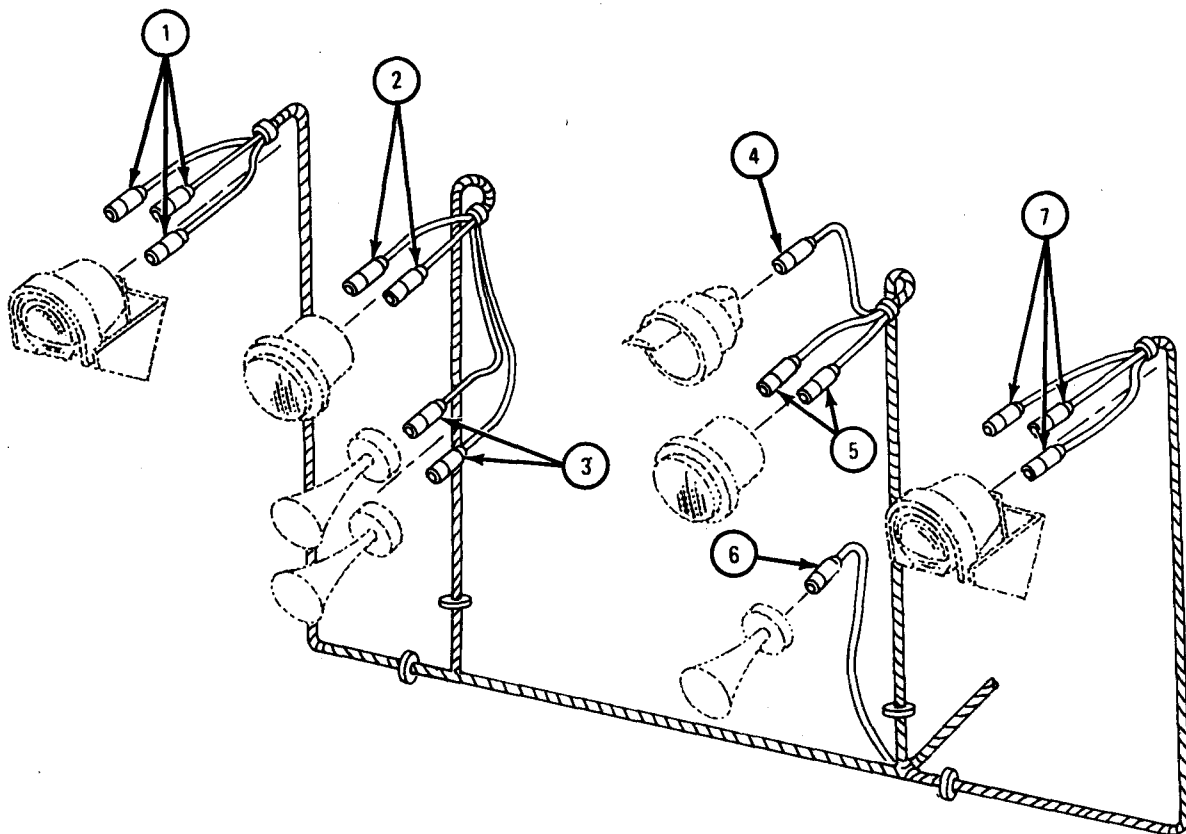

TA 103417

FRAME 2

1. Unplug lead (1) from engine temperature sending unit.
2. If working on multifuel engine, unplug lead (2) from manifold heater.
3. Unplug lead (3) from magnetic starter switch.
4. Unplug lead (4) from oil pressure sending unit.
5. Unscrew and take off lead (5) from regulator.
6. Unplug two leads (6) each from right and left circuit breakers.
7. Unplug three leads (7) from beam selector switch.
8. Unscrew and take off battery positive lead (8).

GO TO FRAME 3

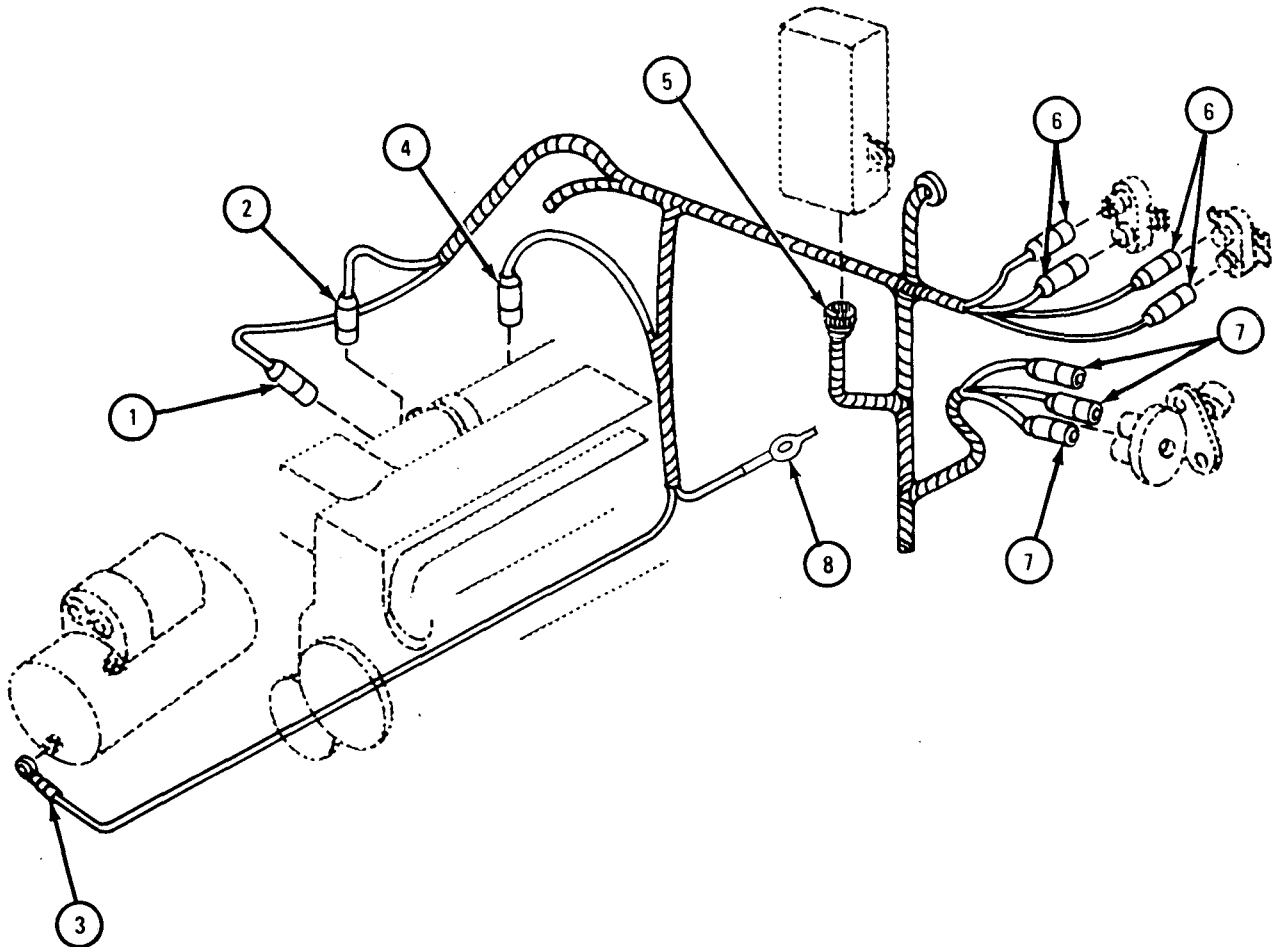

TA 103418

FRAME 3

1. Unscrew and take off lead (1) from light switch.
2. Unplug two leads (2) from manifold heater switch.
3. Unplug four leads (3) from accessory switch.
4. Unplug lead (4) from lead to electrical buzzer.
5. Unplug seven leads (5) from instrument panel.

GO TO FRAME 4

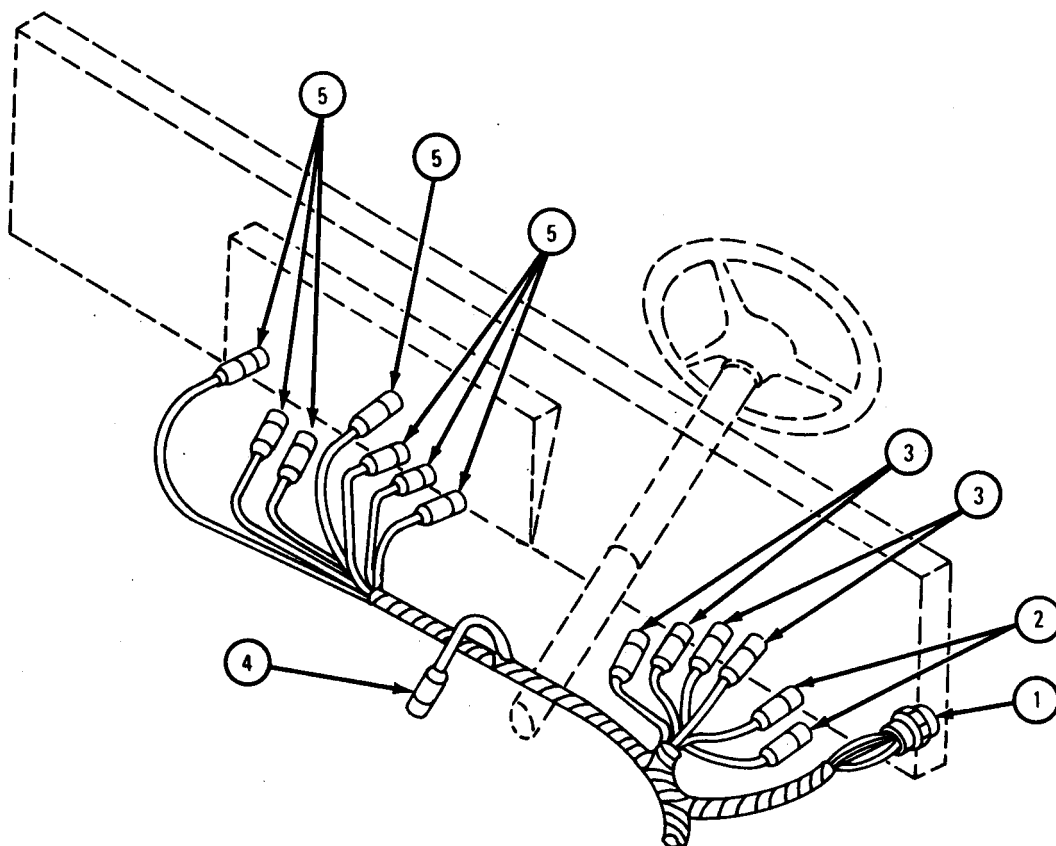

TA 103419

FRAME 4

1. Unplug two leads (1) from fuel pump.
 2. Unplug lead (2) from fuel gage sending unit.
 3. Take out trailer electric coupling receptacle (3) and ground wire (4).
 4. Unplug three leads (5) from left taillight.
 5. Take out trailer electric coupling receptacle (6) and ground wire (7).
 6. Unplug three leads (8) from right taillight.
 7. Take off lead (9) from blackout light.
 8. Unplug two leads (10) from air stoplight switch.
- GO TO FRAME 5

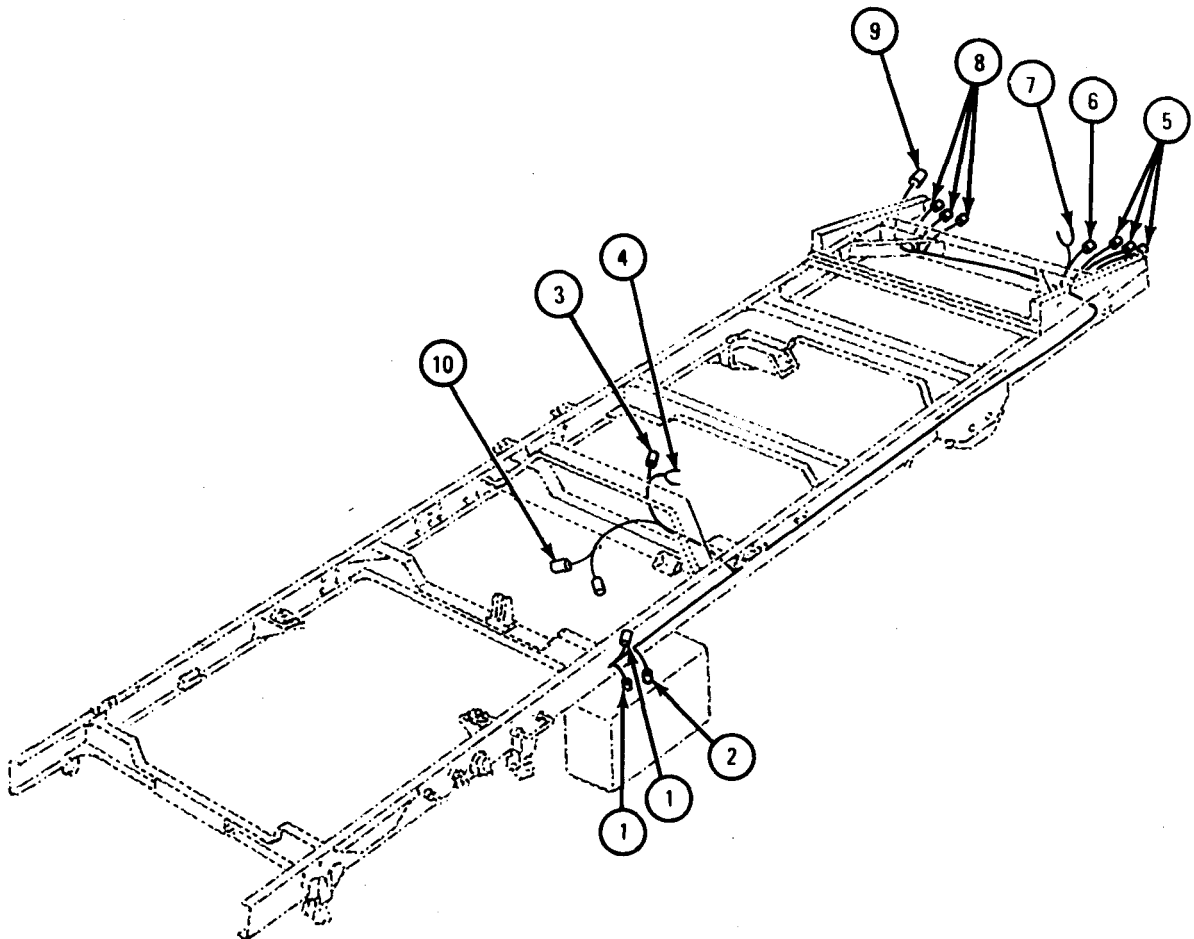

TA 103420

FRAME 5

1. Take off all clamps. Refer to para 7-5.
2. Take out two capscrews (1) and nuts (2). Take off two washers (3) and two grommets (4).
3. Take harness out of truck.

END OF TASK

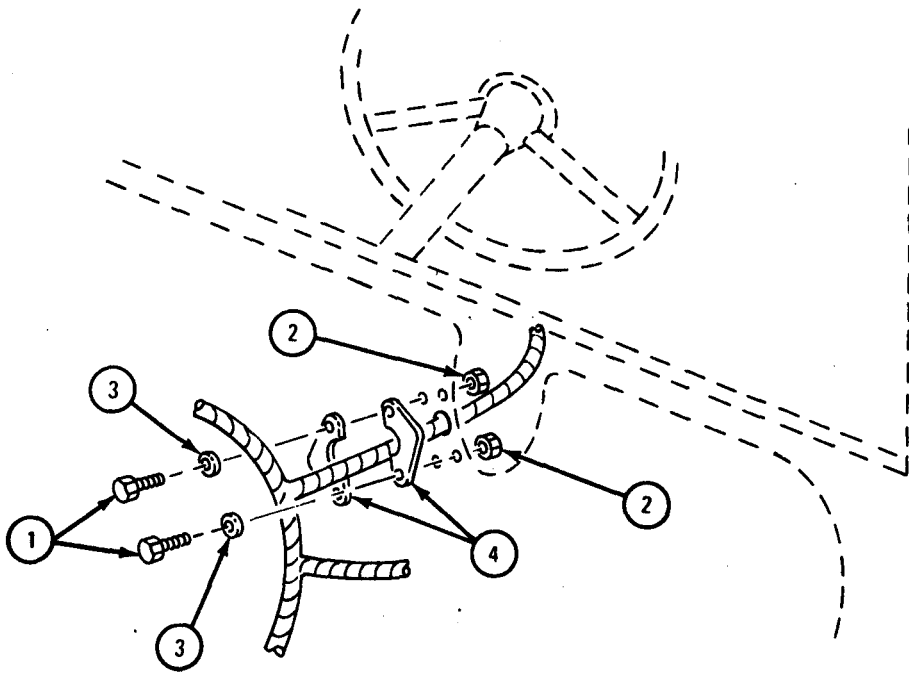

TA 103421

c. Replacement.

NOTE

If new harness is being put on, put old harness next to new harness and put tags in the same places as on old harness.

Refer to replacement procedures given for each part in TM 9-2320-209-20, if needed, to work on connectors and electrical leads covered in this task.

FRAME 1

1. Put harness back on truck.
 2. Put two grommets (1) on firewall and align screw holes. Put in two capscrews (2), washers (3), and nuts (4).
 3. Replace all clamps. Refer to para 7-5.
- GO TO FRAME 2

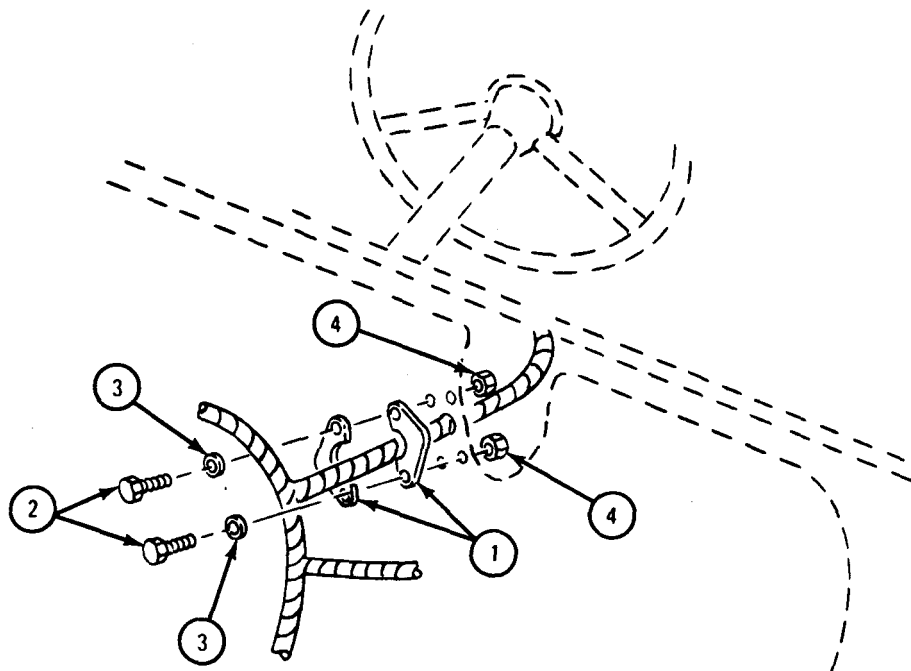

TA 103438

FRAME 2

1. Plug three leads (1) into right taillight.
 2. Put lead (2) into blackout light.
 3. Put in trailer electric coupling receptacle (3) and ground wire (4).
 4. Plug three leads (5) into left taillight.
 5. Put in trailer electric coupling receptacle (6) and ground wire (7).
 6. Plug lead (8) into fuel gage sending unit.
 7. Plug two leads (9) into fuel pump.
 8. Plug two leads (10) into air stoplight switch.
 9. Take off tags.
- GO TO FRAME 3 .

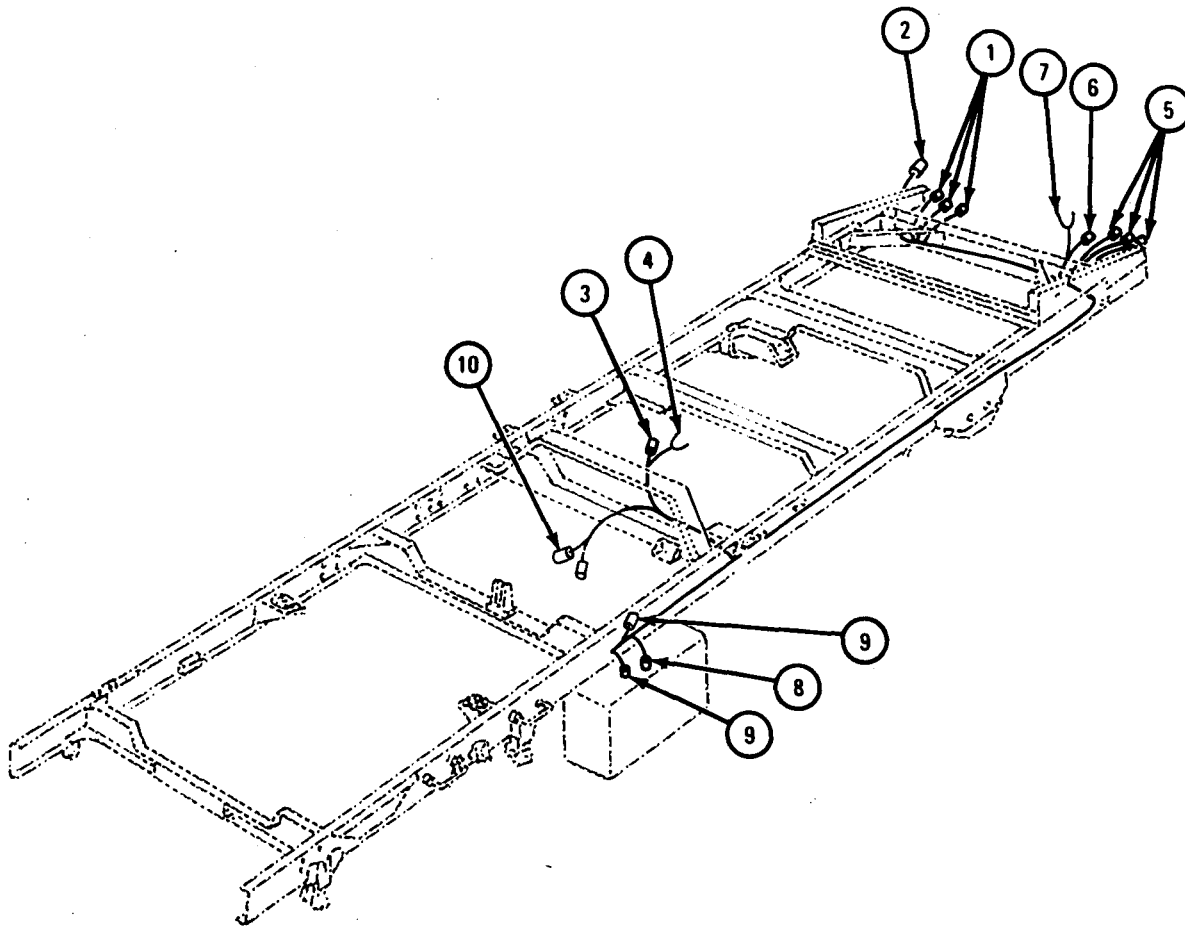

TA 103439

FRAME 3

1. Plug seven leads (1) into instrument panel,
2. Plug lead (2) into lead to electrical buzzer.
3. Plug four leads (3) into accessory switch.
4. Plug two leads (4) into manifold heater switch.
5. Screw on and tighten lead (5) to light switch.
6. Take off tags.

GO TO FRAME 4

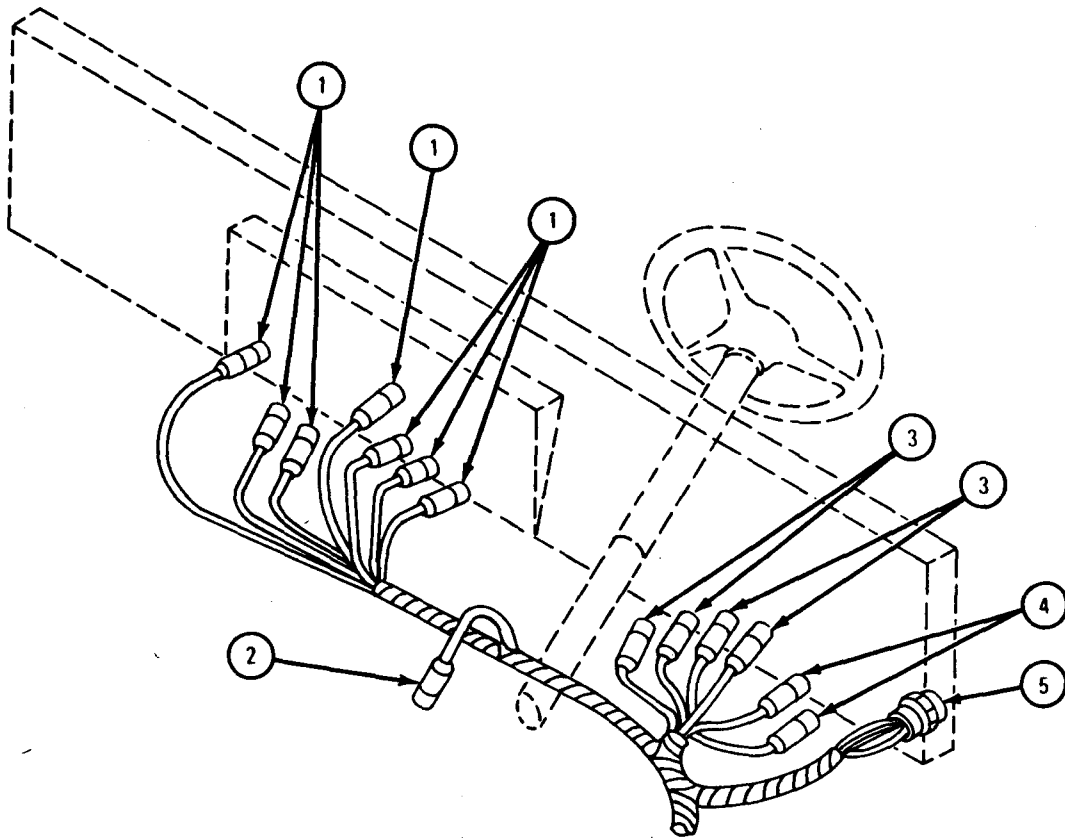

TA 103440

FRAME 4

1. Plug three leads (1) into beam selector switch.
2. Plug two leads (2) each into right and left circuit breakers.
3. Screw in and tighten lead (3) into regulator.
4. Plug lead (4) into oil pressure sending unit.
5. Plug lead (5) into magnetic starter switch.
6. If working on multifuel engine, plug lead (6) into manifold heater.
7. Plug lead (7) into engine temperature sending unit.
8. Screw on battery positive lead (8).
9. Take off tags.

GO TO FRAME 5

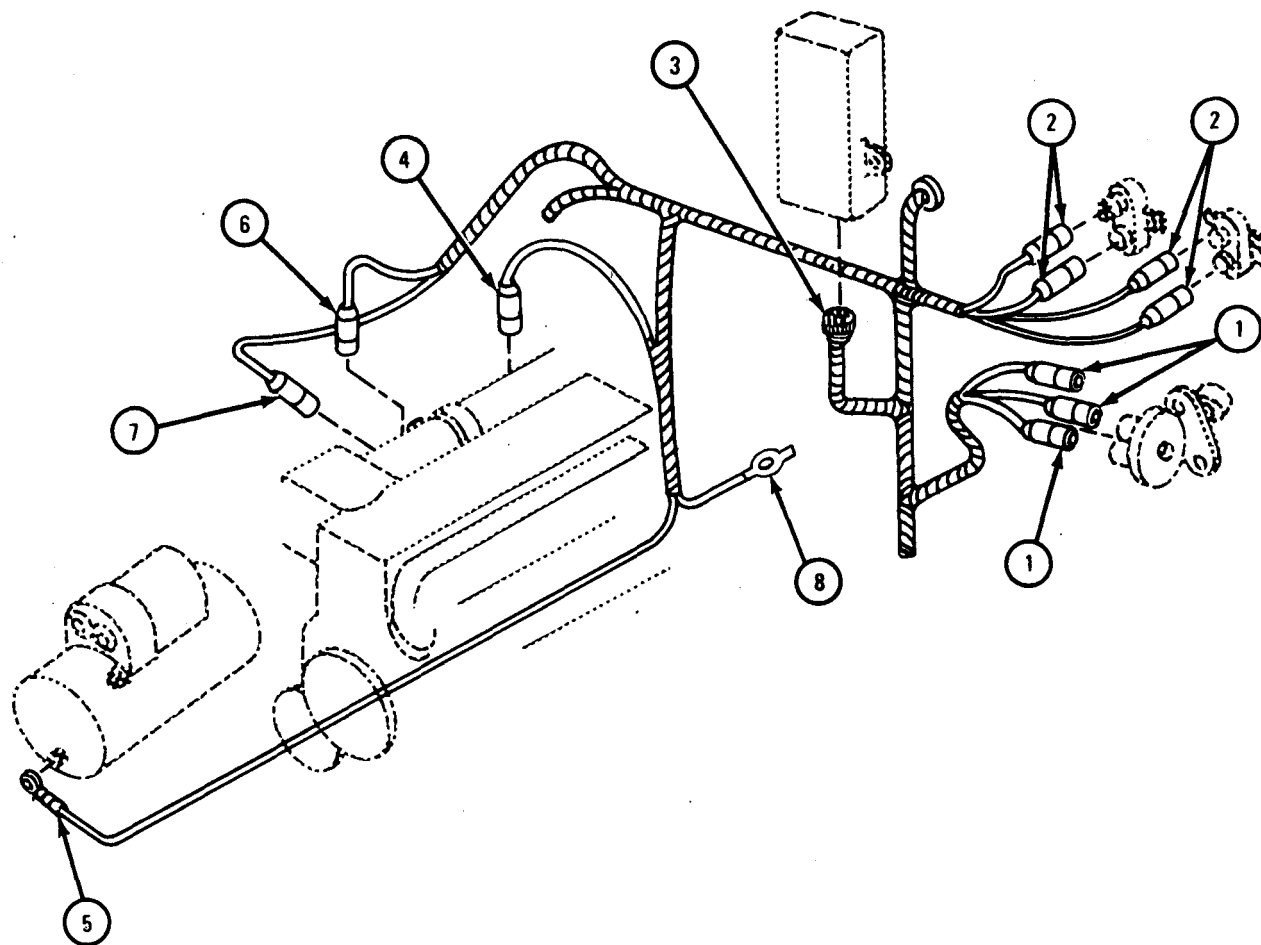

TA 103441

FRAME 5

1. Plug three leads (1) into left composite light.
2. Plug lead (2) into horn.
3. Plug two leads (3) into left headlight.
4. Plug lead (4) into blackout driving light.
5. Plug two leads (5) into horns.
6. Plug two leads (6) into right headlight.
7. Plug three leads (7) into right composite light.
8. Take off tags.

NOTE**Follow-on Maintenance Action Required:**

1. Reconnect battery ground. Refer to TM 9-2320-209-20.
2. Reconnect tachometer cable. Refer to TM 9-2320-209-20.
3. Reconnect speedometer cable. Refer to TM 9-2320-209-20.
4. Close hood and side panels. Refer to TM 9-2320-209-10.

END OF TASK

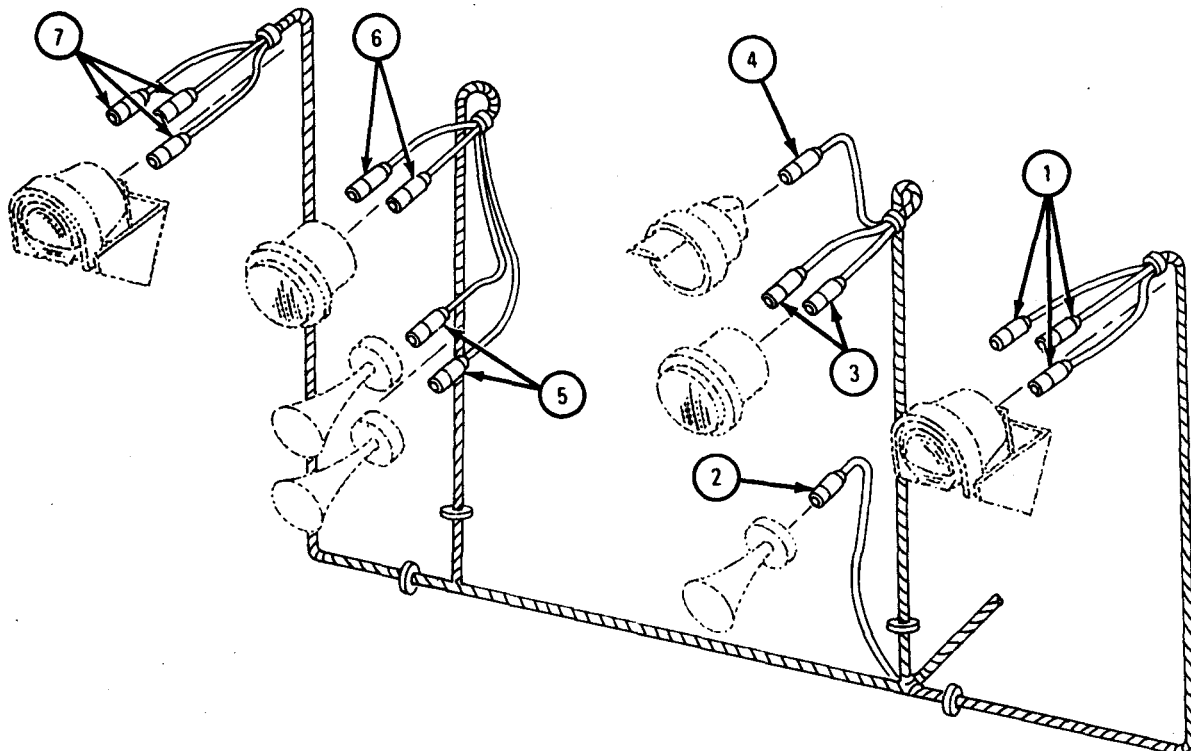

TA 103442

7-9. CLEARANCE LIGHT WIRING HARNESSES REMOVAL AND REPLACEMENT
(TRUCK M756A2) .

TOOLS : No special tools required

SUPPLIES : None

PERSONNEL: One

EQUIPMENT CONDITION: Truck parked, engine off, handbrake set.

Preliminary Procedure. Disconnect battery ground cable. Refer to
TM 9-2320-209-20.

NOTE

Refer to removal and replacement procedures given in TM 9-2320-209-20 if needed to take off connectors and electric leads covered in the following steps.

Tag all connectors and electrical leads so they can be put back in the same place.

Note the way wiring harness is routed so it can be put back the same way.

b. Removal.

(1) Side clearance light harness.

FRAME 1

1. Unplug two harness connectors (1) from clearance light connectors. Push two harness connectors through grommet (2).
2. Do step 1 again on other side of truck.
3. Unplug two harness connectors (3) from rear wiring harness.
4. Remove all clamps. Refer to para 7-5.
5. Take harness out of truck.

END OF TASK

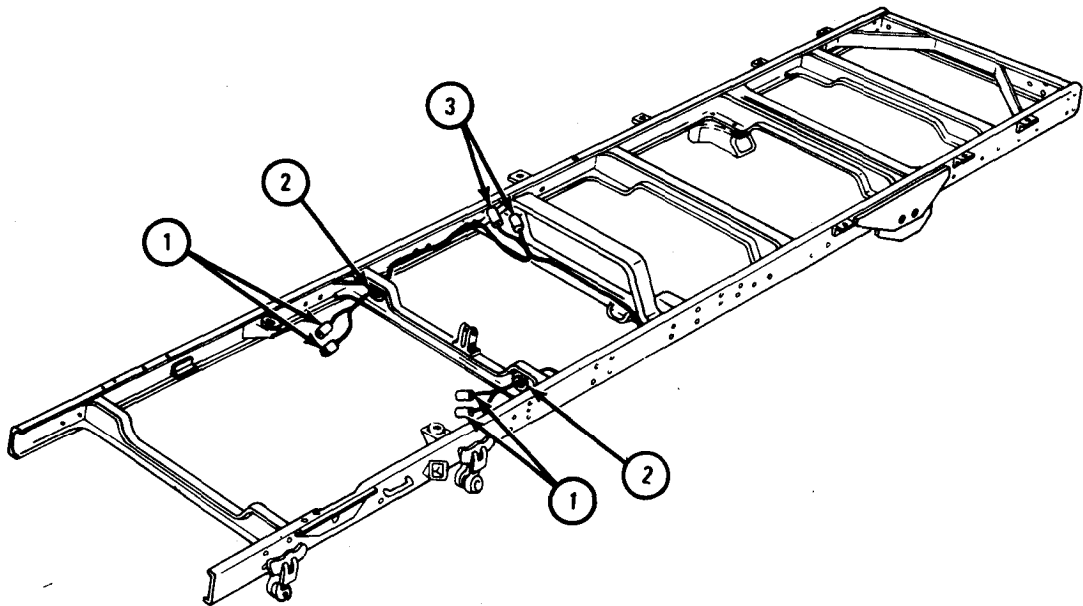

TA 121110

(2) Rear clearance light harness.

FRAME 1

1. Unplug three harness connectors (1) from rear wiring harness.
2. Unplug 11 connectors (2) from clearance lights.
3. Take harness out of truck.

END OF TASK

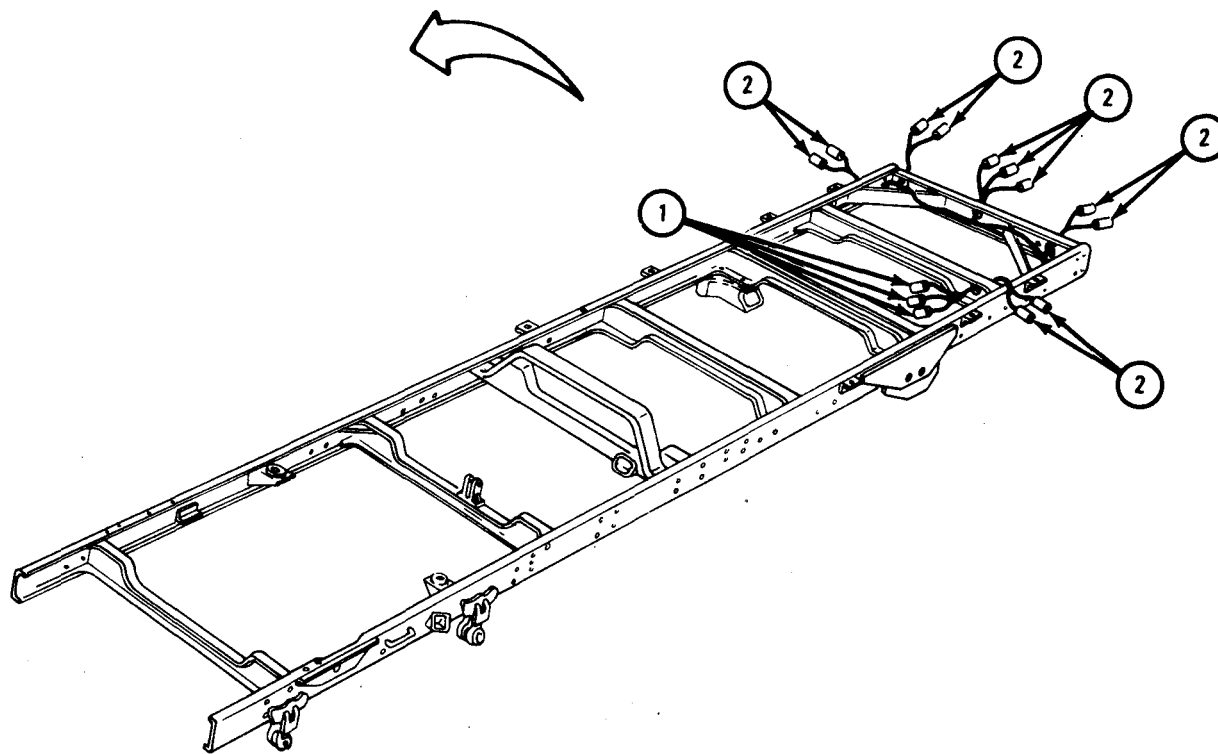

TA 121111

c. Replacement.

(1) Side clearance light harness.

FRAME 1

1. Put harness back in truck as noted.
2. Put two connectors (1) through grommet (2).
3. Plug two harness connectors (1) into clearance light connectors.
4. Do steps 2 and 3 again on other side of truck.
5. Plug two harness connectors (3) into rear wiring harness.
6. Replace all clamps. Refer to para 7-5.

NOTE

Follow-on Maintenance Action Required:

Reconnect battery ground cable. Refer to TM 9-2320-209-20.

END OF TASK

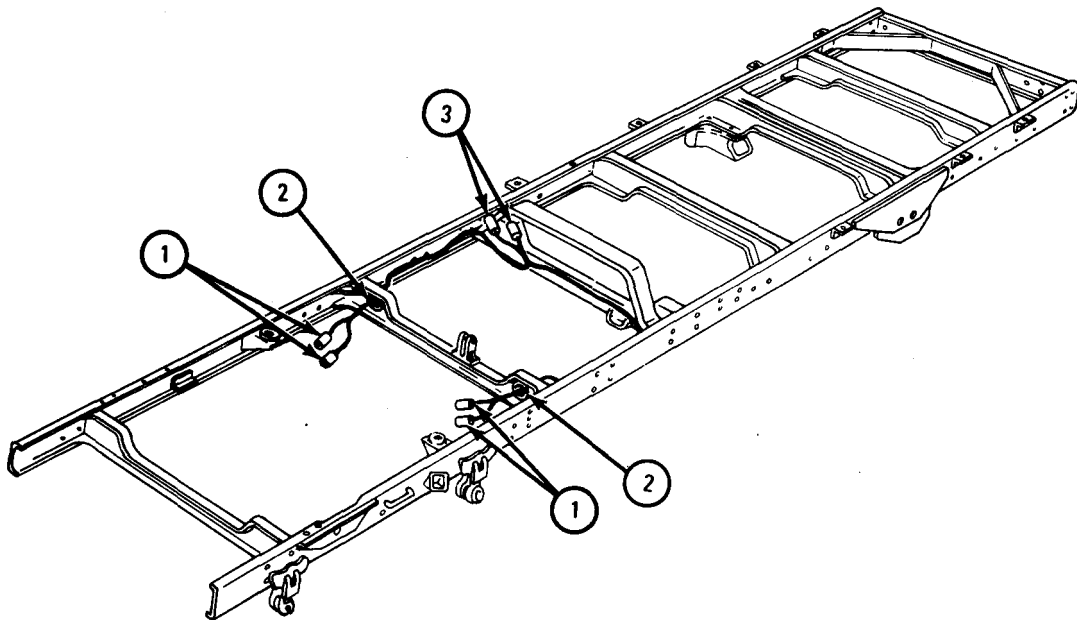

TA 121110

(2) Rear clearance light harness.

FRAME 1

1. Put harness back in truck as noted.
2. Plug three harness connectors (1) into rear wiring harness.
3. Plug 11 connectors (2) into clearance lights.

NOTE

Follow-on Maintenance Action Required:

Reconnect battery ground cable. Refer to TM 9-2320-209-20.

END OF TASK

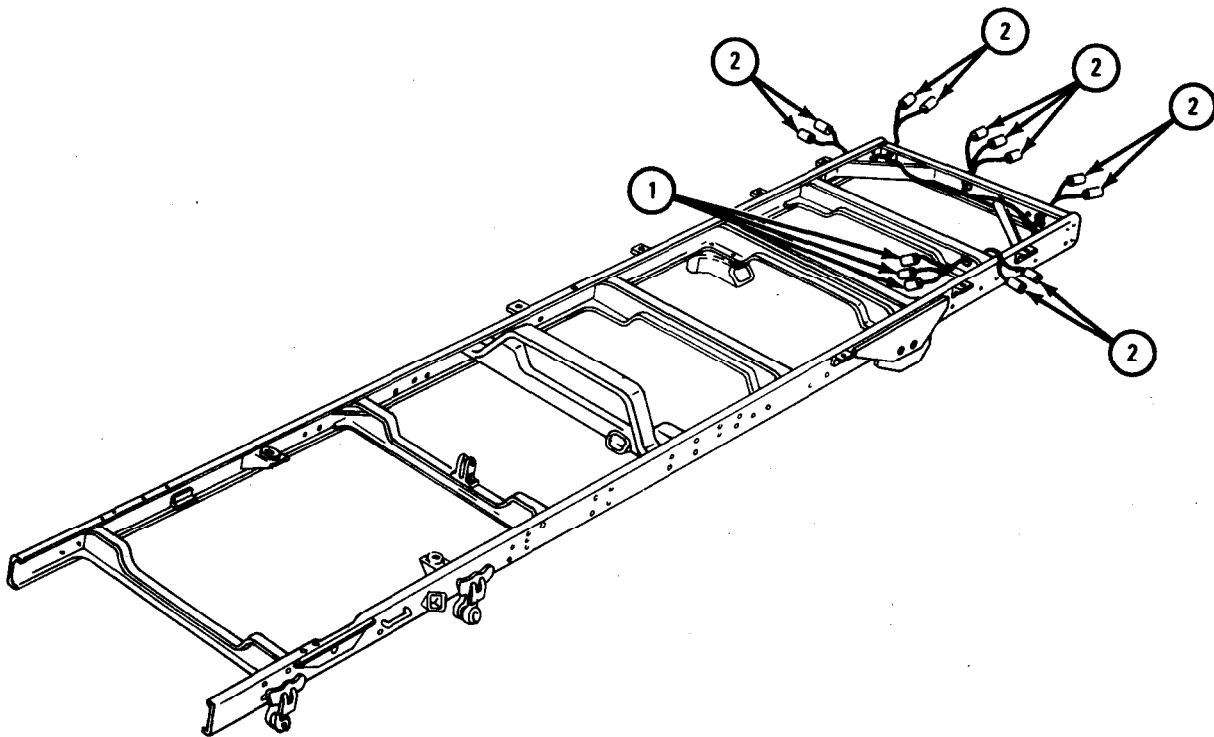

TA 121111

7-10. FLOODLIGHT HARNESS REMOVAL AND REPLACEMENT (TRUCK M756A2).

NOTE

Refer to removal and replacement procedures given in TM 9-2320-209-20, if needed, to work on connectors and electrical leads covered in this task.

TOOLS : No special tools required

SUPPLIES: 8 gauge wire, 6 feet

PERSONNEL: One

EQUIPMENT CONDITION : Truck parked, engine off, handbrake set.

- a. Preliminary Procedure. Remove cab protector. Refer to TM 9-2320-209-20.
- b. Removal.

NOTE

Tag all leads so that they are put back in the right place.

FRAME 1

1. Unplug four connectors (1) from left and right floodlights.
2. Unplug three connectors (2) from clearance lights.
3. Take off four grommets (3).
4. Put four connectors (1) through two holes and into cab protector.
5. Put three connectors (2) through hole and into cab protector.
6. Put three connectors (4) through hole and into cab protector.
7. Hook floodlight harness and pull it out through top right end of cab protector.

END OF TASK

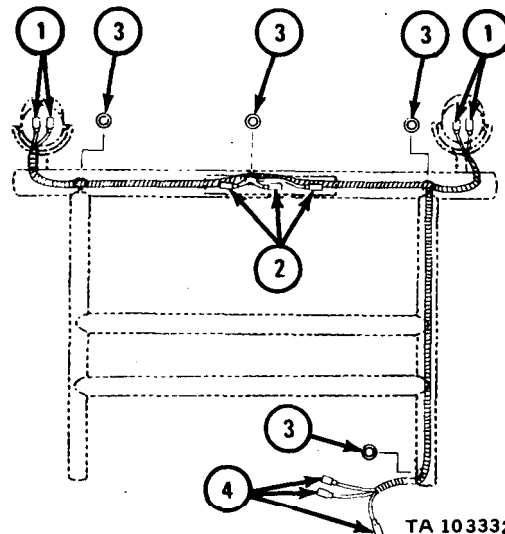

c. Replacement.

FRAME 1

1. Put wire (1) in right end of top rail (2) and feed it through rail to other end. Hook wire on end of floodlight harness with two connectors (3).
2. Pull wire (1) through top rail (2) until two connectors (3) are at hole (4). Working through hole, take wire off end of floodlight harness.
3. Pull two connectors (3) through hole (4).
4. Pull three connectors (5) through hole (6).
5. Pull two connectors (7) through hole (8).

GO TO FRAME 2

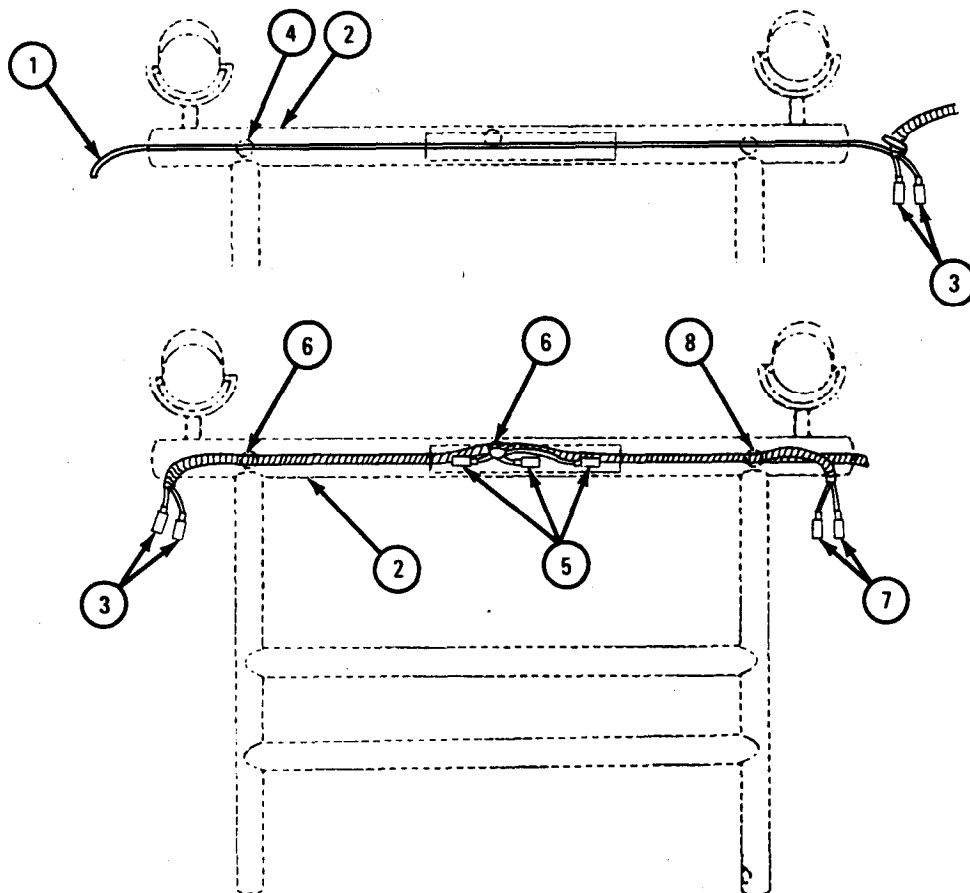

TA 101732

FRAME 2

1. Put wire into hole (1). Feed it through to other end and out left end of top rail (2). Hook wire onto end of floodlight harness with three connectors (3).
2. Pull wire through side rail (4) until three connectors (3) are at hole (1). Working through hole, take wire off end of floodlight harness.
3. Pull three connectors (3) through hole (1).
4. Put on four grommets (5).
5. Plug four connectors (6) into left and right floodlights.
6. Plug three connectors (7) into clearance lights.

NOTE

Follow-on Maintenance Action Required:
 Replace cab protector: Refer to TM 9-2320-209-20.

END OF TASK

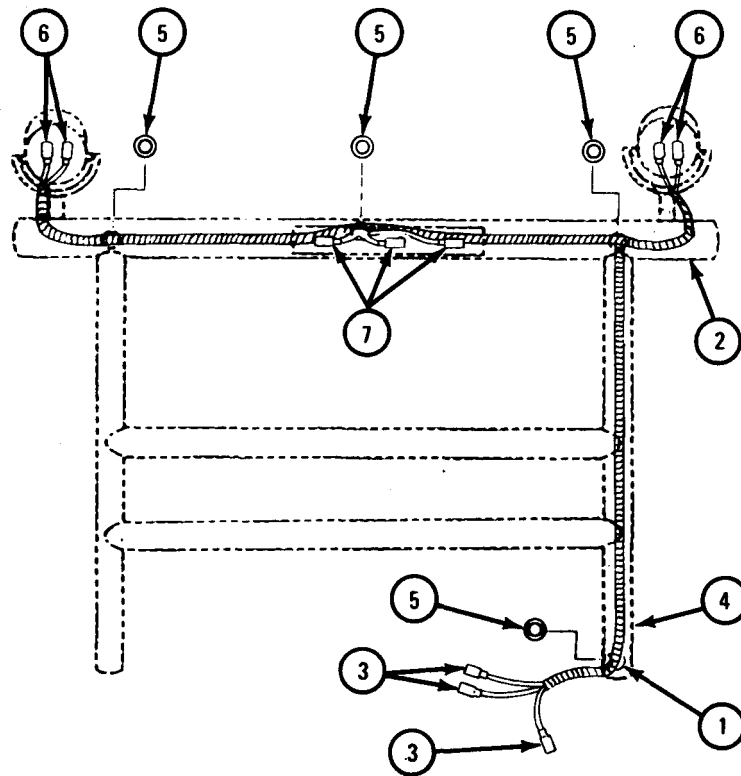

TA 101733

7-11. VAN MAIN WIRING HARNESS REMOVAL AND REPLACEMENT.

TOOLS : No special tools required

SUPPLIES : Tags

PERSONNEL: One

EQUIPMENT CONDITION : Truck parked, engine off, handbrake set.

a. Preliminary Procedures.

(1) Disconnect battery ground cable. Refer to TM 9-2320-209-20.

(2) Disconnect all van body external power sources. Refer to TM 9-2320-209-10.

(3) Remove all 115-volt dome light fixtures. Refer to TM 9-2320-209-20.

(4) Remove ceiling panels and insulation. Refer to Part 2, para 17-41.

(5) Remove front access panel. Refer to Part 2, para 17-41.

b. Removal.

FRAME 1

1. Takeout four screws (1). Take off circuit breaker box cover (2).

2. Take out two screws (3). Takeoff switch cover (4).

GO TO FRAME 2

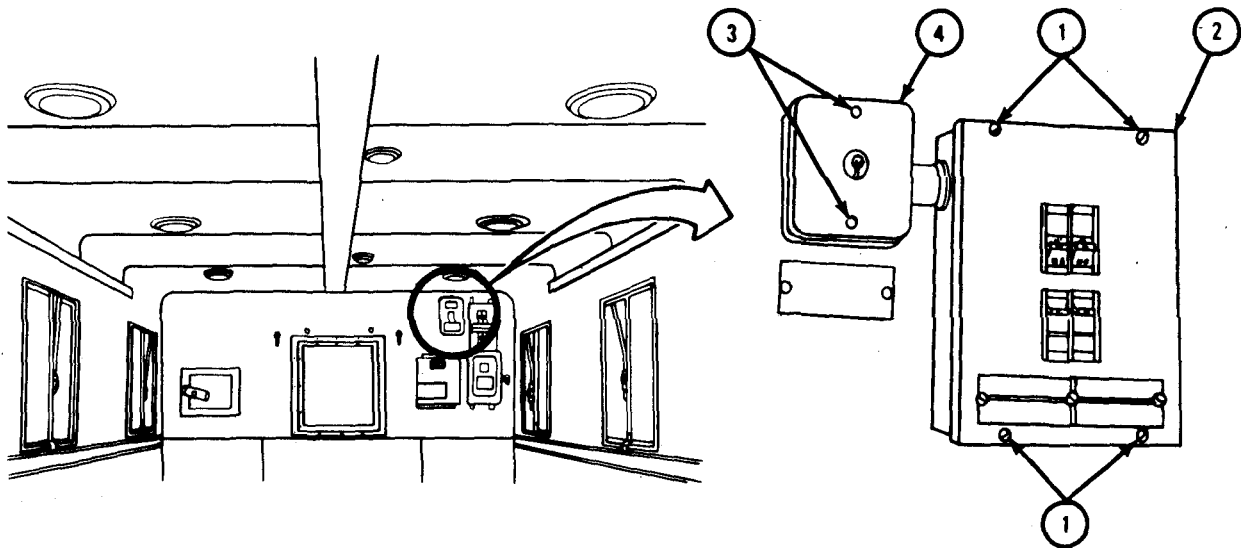

FRAME 2

NOTE

Tag all leads before taking them off so they can be put back in the same place.

1. Loosen screw (1) and take off lead (2).
2. Reach behind circuit breaker box (3) and pull out lead (2).
3. Take out screw (4) and take out lead (5).
4. Take out screw (6) and take off lead (7).
5. Reach behind switch box (8) and pull out two leads (5 and 7).

NOTE

Note the way harness is routed so it can be put back the same way.

6. Take out wiring harness.

END OF TASK

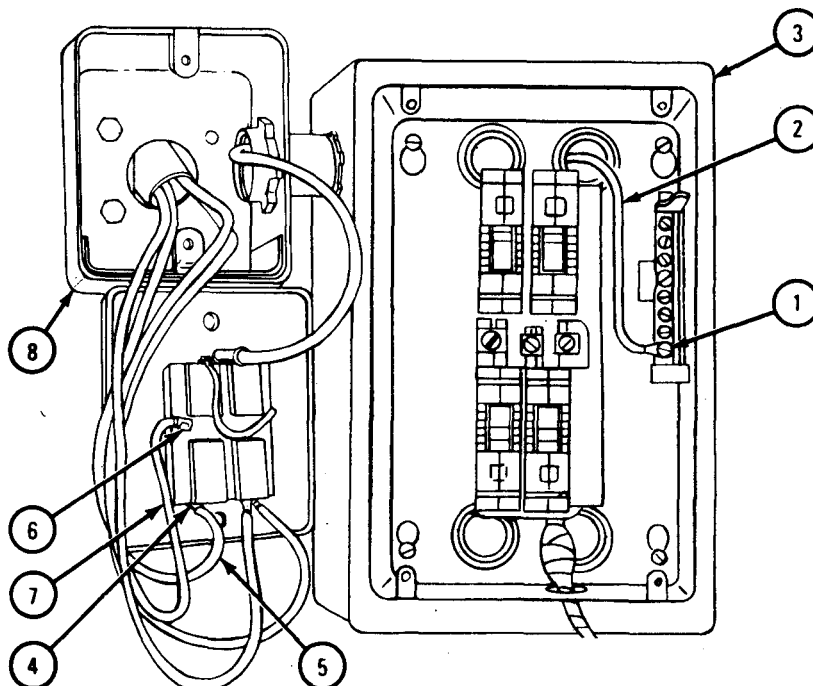

TA 121118

c. Replacement.

FRAME 1

1. Put harness back in truck as noted.
 2. Put two leads (1 and 2) through hole in switch box (3).
 3. Put lead (1) in place as tagged and align screw hole. Put in screw (4).
 4. Put lead (2) in place as tagged and align screw hole. Put in screw (5).
 5. Put lead (6) through hole in circuit breaker box (7).
 6. Put lead (6) in place as tagged and tighten screw (8).
 7. Take off tags.
- GO TO FRAME 2

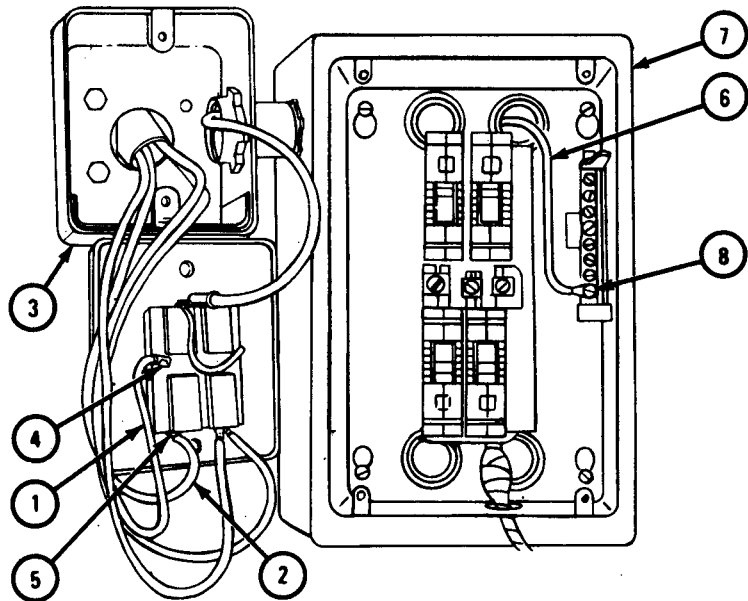
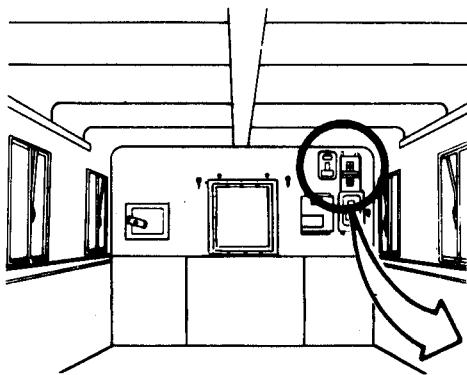

TA 121119

FRAME 2

1. Put switch cover (1) in place and align screw holes. Put in two screws (2).
2. Put circuit breaker box cover (3) in place and align screw holes. Put in four screws (4).

NOTE

Follow-on Maintenance Action Required:

1. Replace front access panel. Refer to Part 2, para 17-41.
2. Replace ceiling panels and insulation. Refer to Part 2, para 17-41.
3. Replace all 115-volt dome light fixtures. Refer to TM 9-2320-209-20.
4. Connect all van body external power sources. Refer to TM 9-2320-209-10.
5. Reconnect battery ground cable. Refer to TM 9-2320-209-20.

END OF TASK

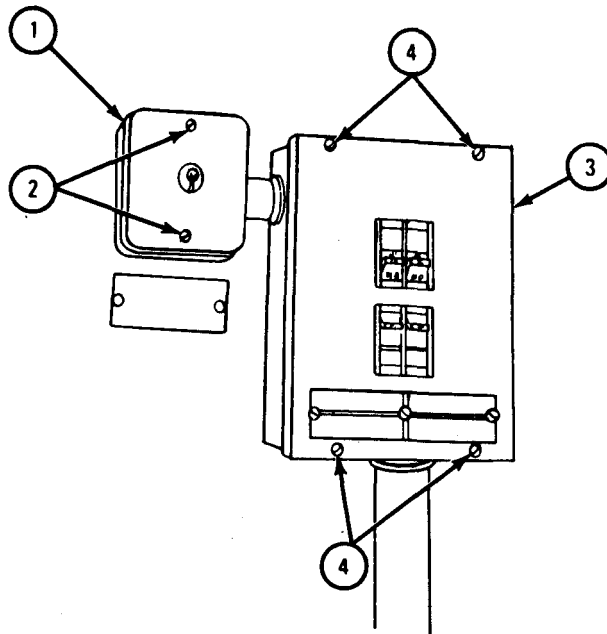

TA 121120

7-12. VAN 24-VOLT WIRING HARNESS REMOVAL AND REPLACEMENT.

TOOLS : No special tools required

SUPPLIES: None

PERSONNEL: One

EQUIPMENT CONDITION : Truck parked, engine off, handbrake set.

a. Preliminary Procedure. Disconnect battery negative (-) lead. Refer to TM 9-2320-209-20.

b. Removal.

NOTE

Tag both sides of connector before taking apart so it can be put back the same way. Give every connection a different name.

FRAME 1

1. Unscrew and unplug harness connector (1) from van body receptacle (2).
2. Unplug harness lead (3) from circuit breaker (4).
3. Unplug harness lead (5) from fuel pump (6).
4. Take out all clamps holding wiring harness to van body. Refer to para 7-5.
5. Take harness out of truck.

END OF TASK

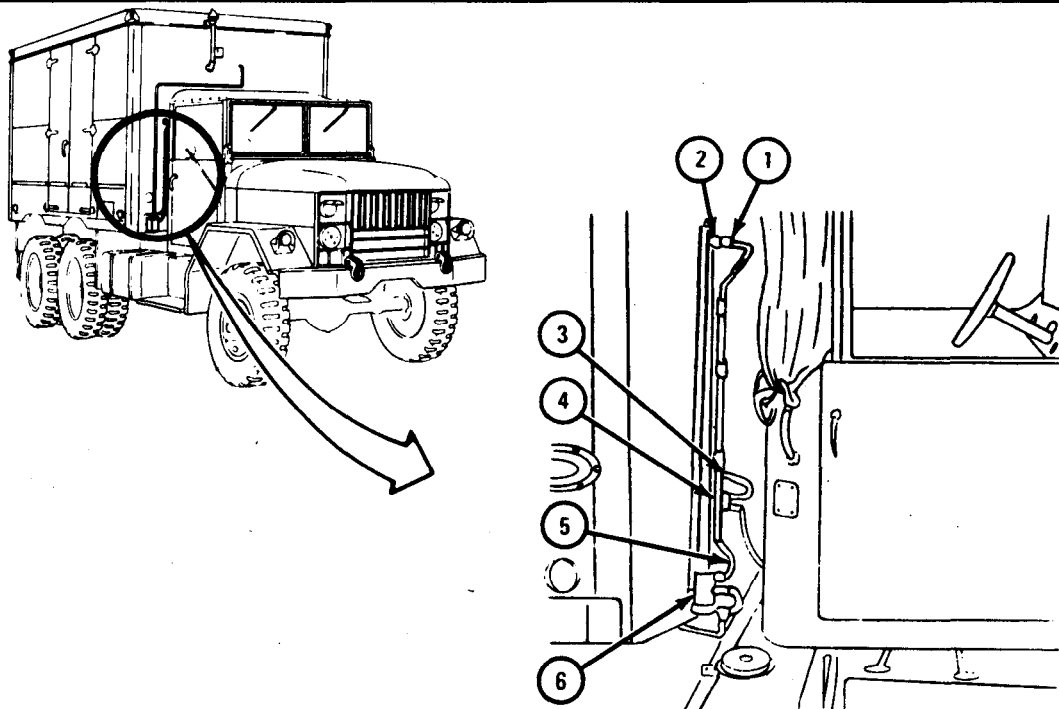

TA 118438

c. Replacement.

FRAME 1

1. Screw harness connector (1) into van body receptacle (2).
2. Plug harness lead (3) into circuit breaker (4).
3. Plug harness lead (5) into fuel pump (6).
4. Put in all clamps as noted in removal. Refer to para 7-5.

NOTE

Follow-on Maintenance Action Required:

Connect battery negative (-) lead. Refer to TM 9-2320-209-20.

END OF TASK

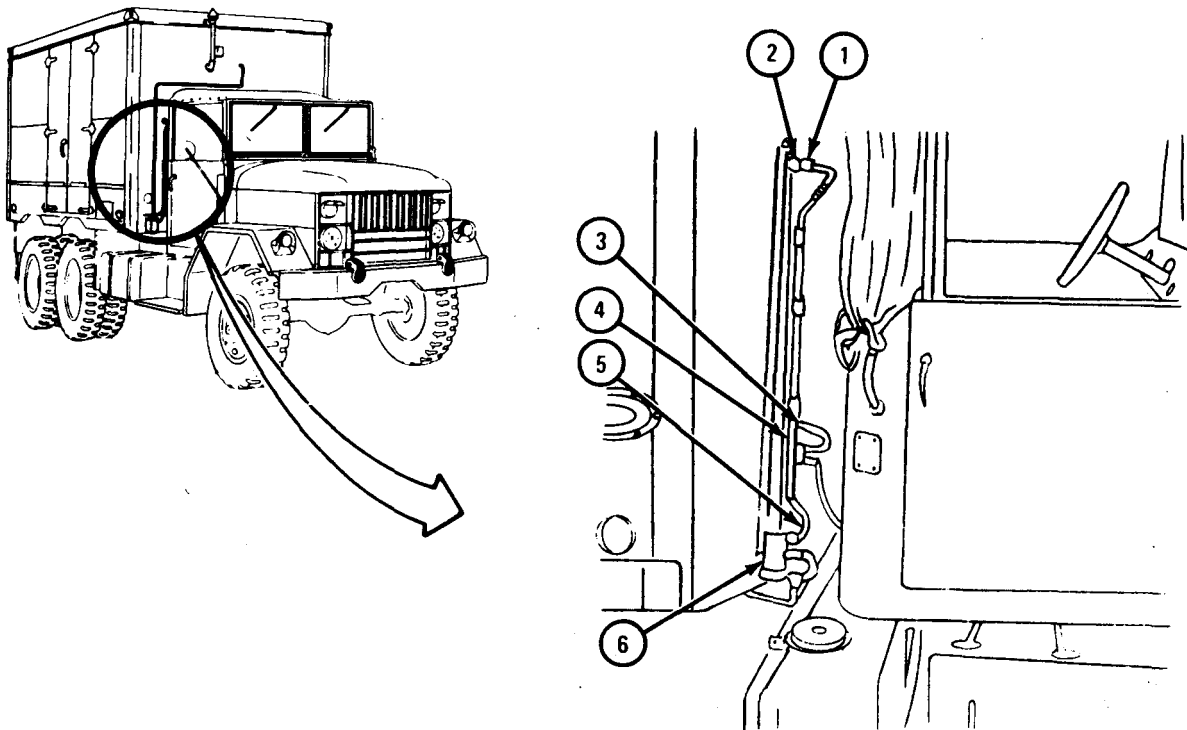

TA 118439

CHAPTER 8

TRANSMISSION SYSTEM GROUP MAINTENANCE

Section I. SCOPE

8-1. EQUIPMENT ITEMS COVERED . This chapter gives equipment maintenance procedures for the transmission assembly for which there are authorized corrective maintenance tasks at the direct and general support maintenance levels.

8-2. EQUIPMENT ITEMS NOT COVERED . All equipment items for which corrective maintenance is authorized at the direct and general support maintenance levels are covered in this chapter.

Section II. TRANSMISSION ASSEMBLY

8-3. TRANSMISSION COVER REMOVAL AND REPLACEMENT .

TOOLS : No special tools required

SUPPLIES: None

PERSONNEL : One

EQUIPMENT CONDITION : Truck parked, engine off, handbrake set.

a. Preliminary Procedure. Put transmission gear shift lever in neutral position.
Refer to TM 9-2320-209-10.

b. Removal.

FRAME 1

1. Slide rubber boot (1) up gear shift lever (2) as shown.
 2. Loosen nut (3). Lift off gear shift lever (2).
- GO TO FRAME 2

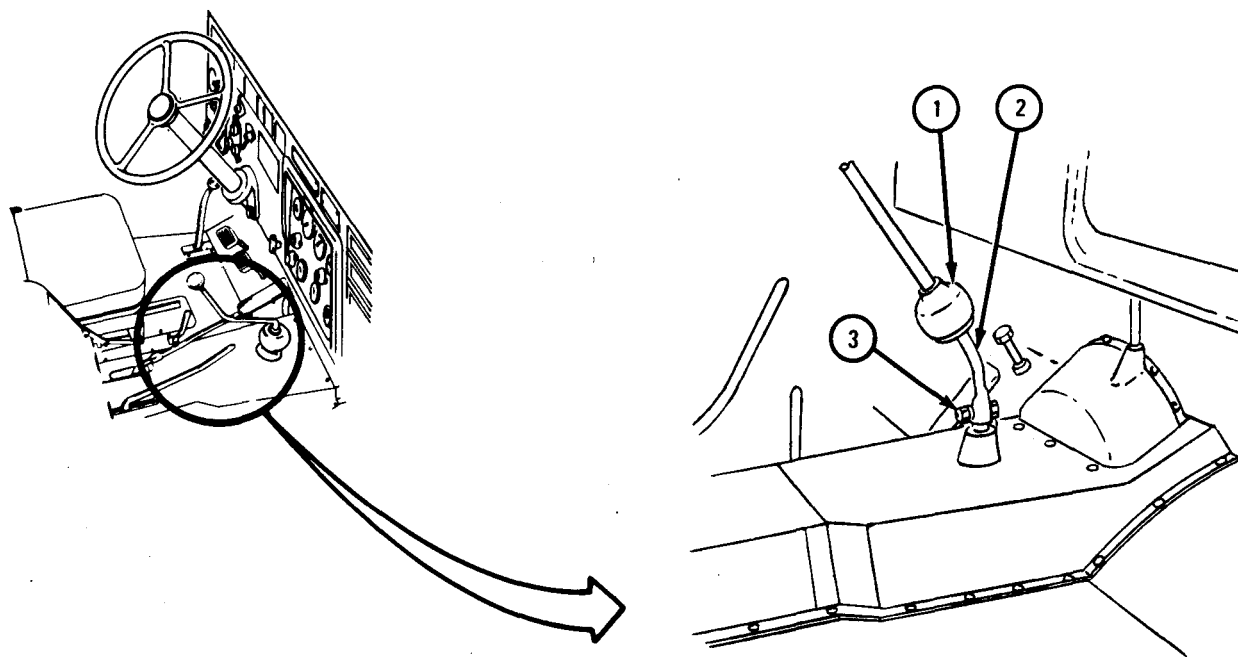

TA 102401

FRAME 2

1. Take out 13 screws (1) holding intermediate tunnel (2) to front tunnel (3), cab floor (4), and rear tunnel (5).
2. Lift off intermediate tunnel (2) and take it out of cab.

GO TO FRAME 3

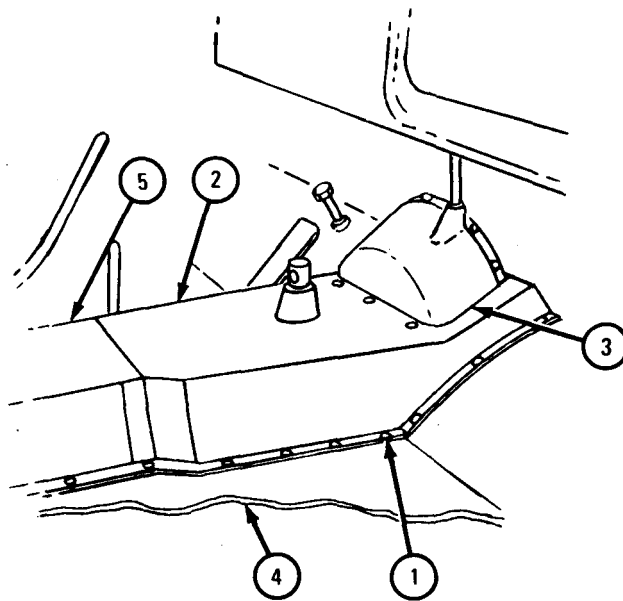

TA 102402

FRAME 3

1. Take off locknut (1). Take out bolt (2) and take yoke (3) away from reverse shifter

GO TO FRAME 4

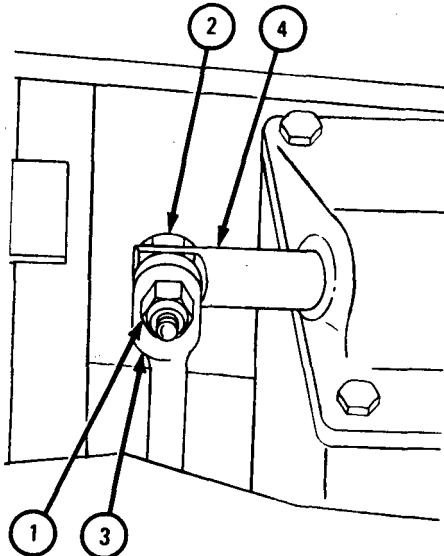

TA 102403

FRAME 4

1. Take out eight capscrews (1) and lockwashers (2).
2. Pull transmission cover (3) straight up and off.
3. Take off and throw away cover gasket (4).
4. Take out transmission cover (3).

END OF TASK

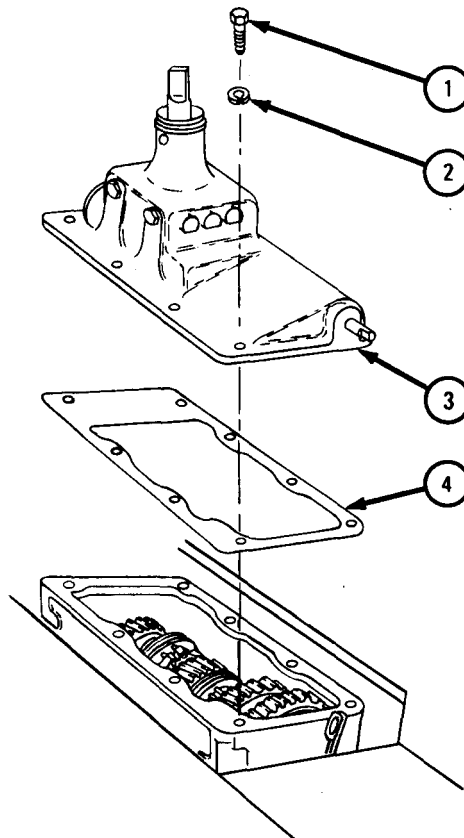

TA 102404

c. Disassembly.

FRAME 1

1. Working on inside of cover, cut and take out four safety wires (1). Throw away safety wires.
2. Take out four setscrews (2).

GO TO FRAME 2

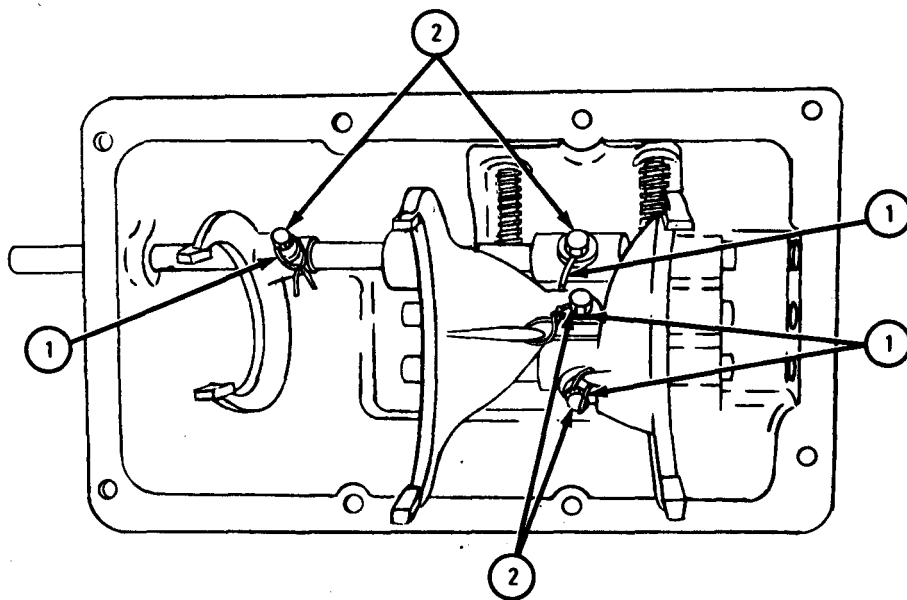

TA 102405

FRAME 2

1. Tap reverse shifter shaft (1) until expansion plug (2) comes out. Set plug aside.
2. Tap reverse shifter shaft (1) until ball (3) pops up. Take out ball and spring.
3. Tap shaft (1) all the way out and tag it.
4. Take out fork (4) and bracket (5). Tag fork.

GO TO FRAME 3

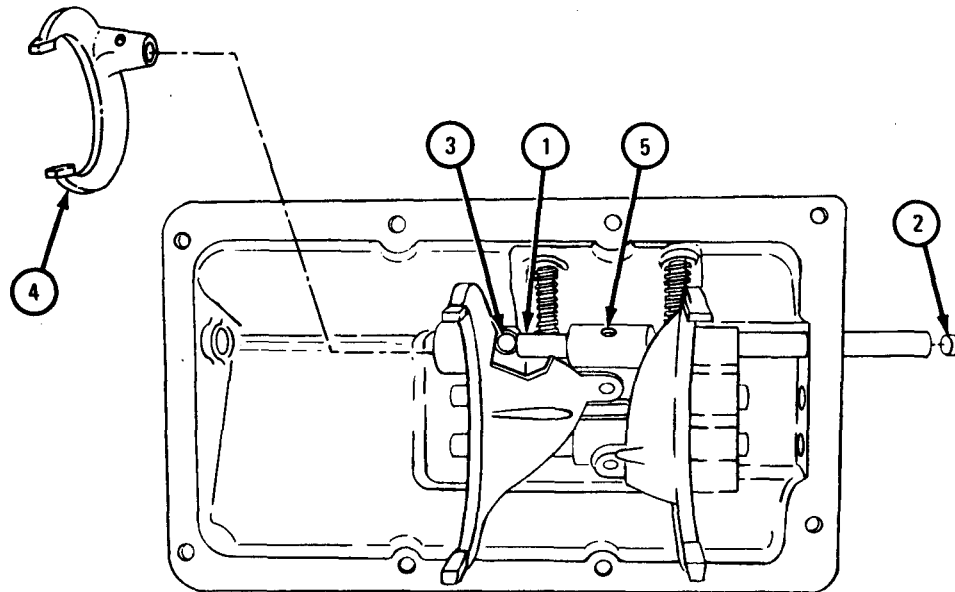

TA 102406

FRAME 3

1. Tap out second and third speed shifter shaft (1) until ball (2) pops up. Take out ball and spring.
2. Tap out shaft (1) until expansion plug (3) comes out. Set plug aside.
3. Tap shaft (1) all the way out and tag it.
4. Tag and take out fork (4).
5. Do steps 1 through 4 again for fourth and fifth speed shifter shaft (5).
6. Turn over cover assembly (6).

GO TO FRAME 4

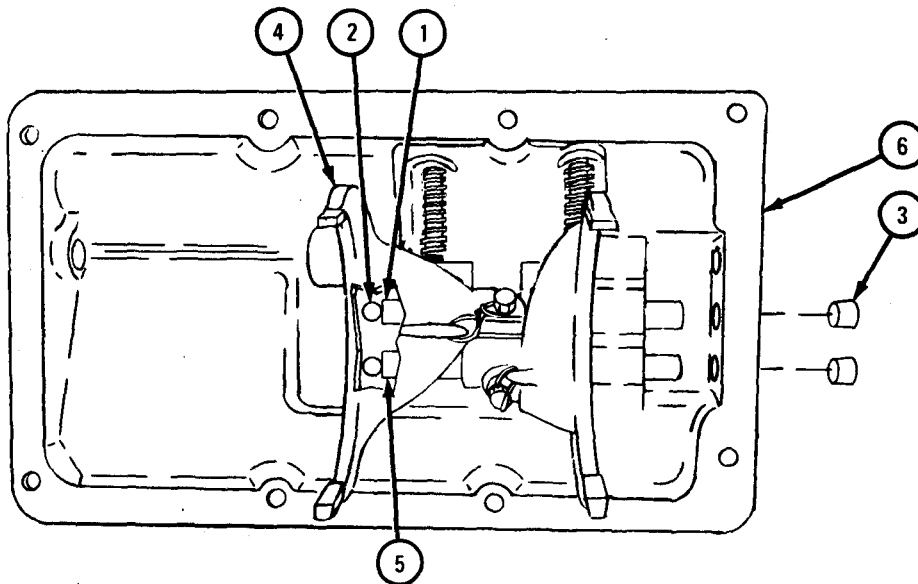

TA 102407

FRAME 4

1. Take off two interlock safety nuts (1) and washers (2).
 2. Turn over cover assembly (3).
- GO TO FRAME 5

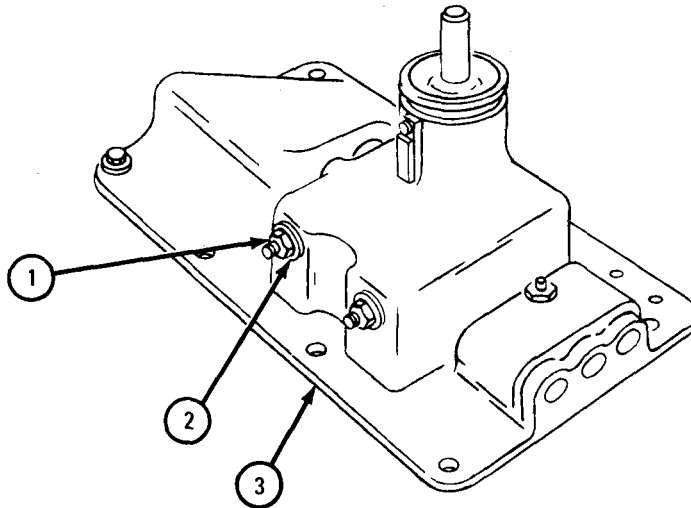

TA 102408

FRAME 5

1. Tap out two screws (1).
2. Take out six washers (2) and two springs (3).
3. Take out plate (4).
4. Tap out first and reverse shifter shaft oil seal (5).

GO TO FRAME 6

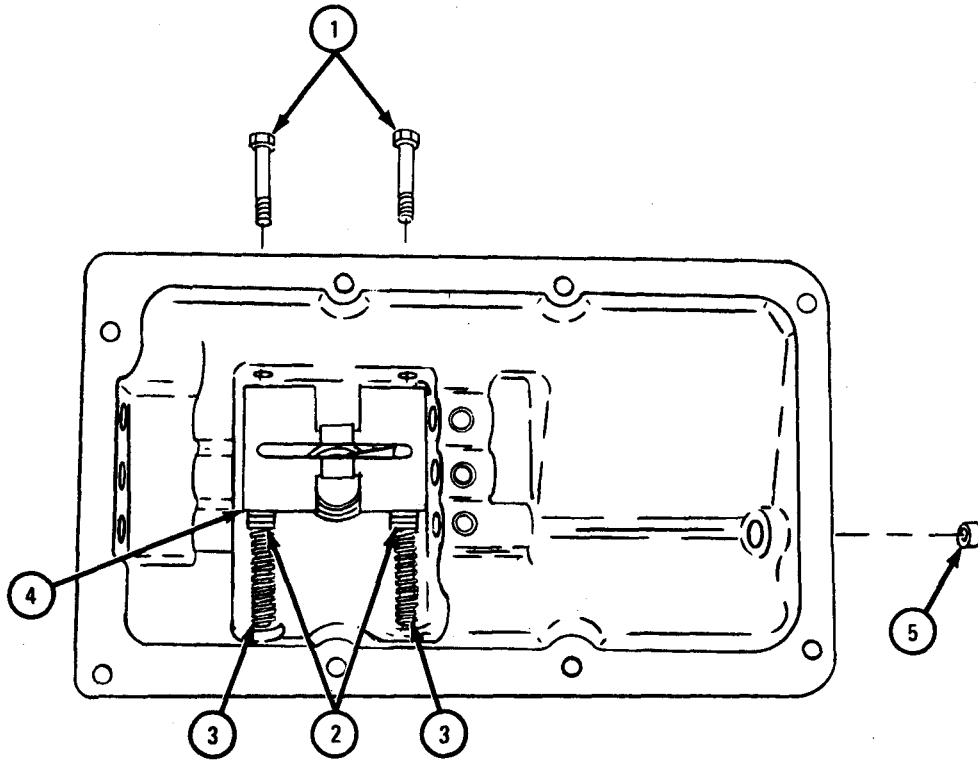

TA 102409

FRAME 6

CAUTION

When taking off lockring (1), spring (2) is under pressure.

1. Take out lockring (1), spring (2), and spring cup (3).
2. Slide out shifter shaft lever (4) through inside of transmission cover (5) as shown.

END OF TASK

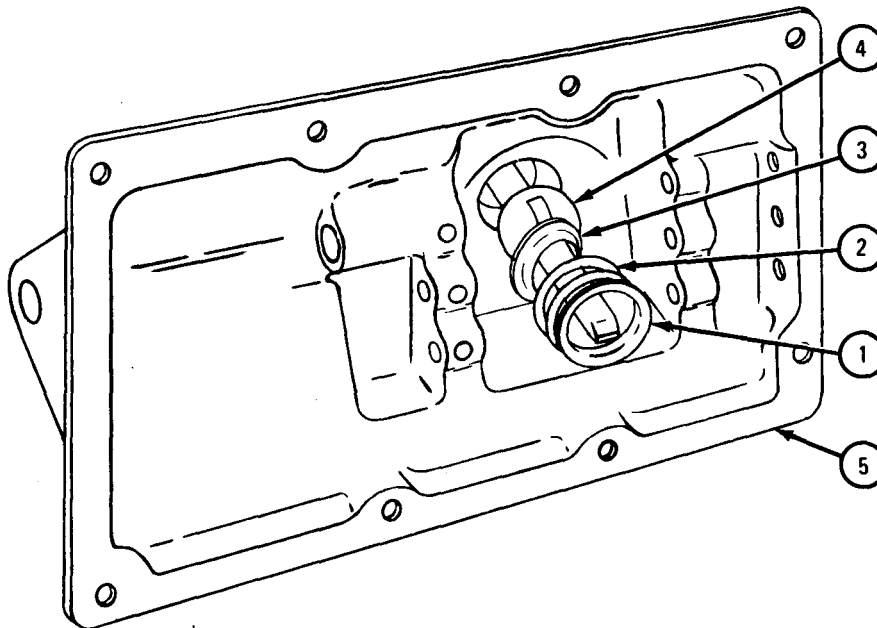

TA 102410

d. Cleaning. There are no special cleaning procedures needed. Refer to cleaning procedures given in para 1-3.

e. Inspection and Repair.

FRAME 1

1. Check that three shifter forks (1) and three shifter shafts (2) have no cracks, bends or other damage. Take out any chips, burrs or scratches with honing stone. If any fork or shaft is cracked or bent, get a new one.
2. Check that springs (3, 4, and 5) are not damaged in any way. If any spring is damaged, get a new one.

GO TO FRAME 2

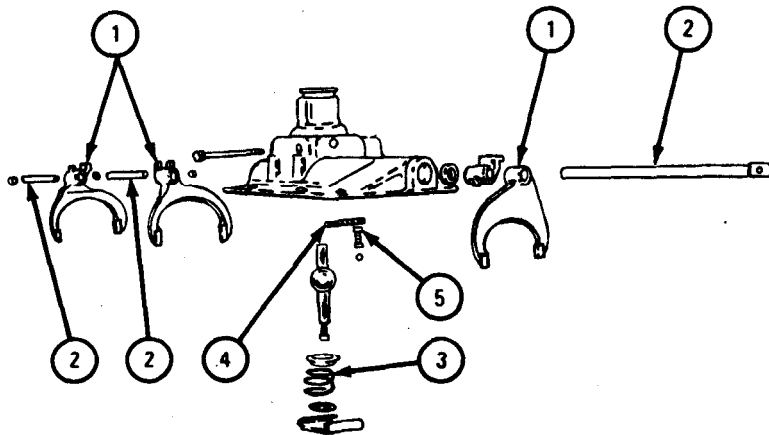

NOTE: PARTS WITHOUT CALLOUTS
ARE SHOWN ONLY FOR
REFERENCE PURPOSES.

TA 101876

FRAME 2

1. Check that three balls (1) have no flat spots, cracks or breaks. If any ball is damaged, get a new one.
2. Check that plate (2) is not warped or damaged. If plate is warped or damaged, get a new one.
3. Check that cover (3) is not cracked, chipped or warped and that it has no holes or other damage. If cover has cracks or holes, weld them. Refer to TM 9-237. If cover is chipped or warped, get a new one.

END OF TASK

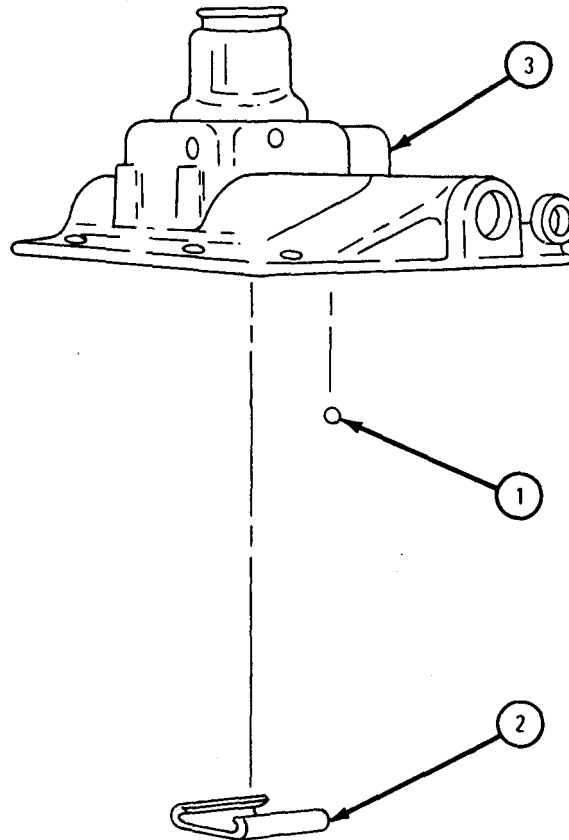

TA 101877

f. Assembly

FRAME 1

1. Put shifter shaft lever (1) in place as shown.
 2. Put on spring cup (2), spring (3), and lockring (4).
- GO TO FRAME 2

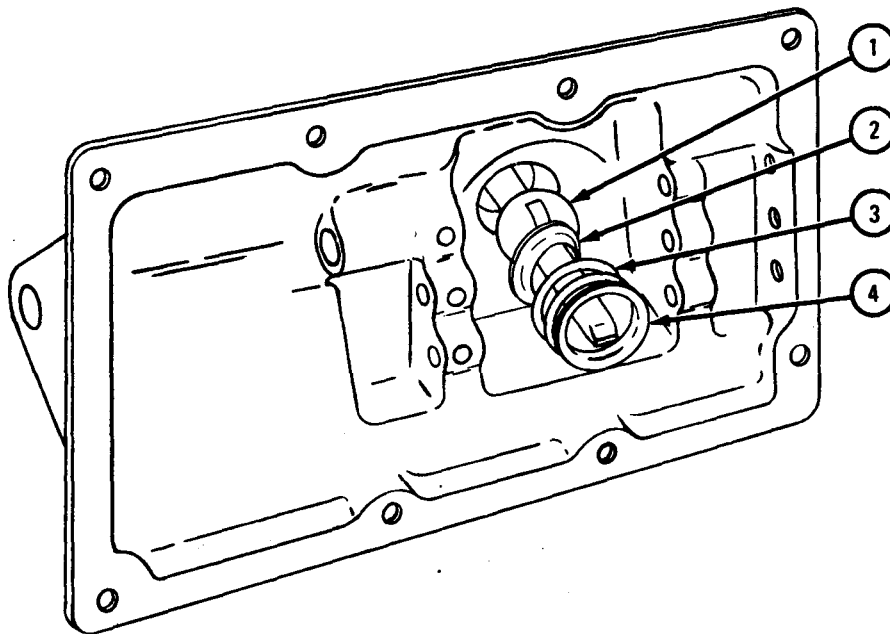

TA 102411

FRAME 2

1. Tap in first and reverse shifter shaft oil seal (1).
2. Put plate (2) in place, making sure that shift lever tab (3) goes through center slot of plate.
3. Put six washers (4) and two springs (5) in place as shown.
4. Put in two screws (6) through cover assembly (7) and put on six washers (4) and two springs (5).
5. Turn over cover assembly (7).

GO TO FRAME 3

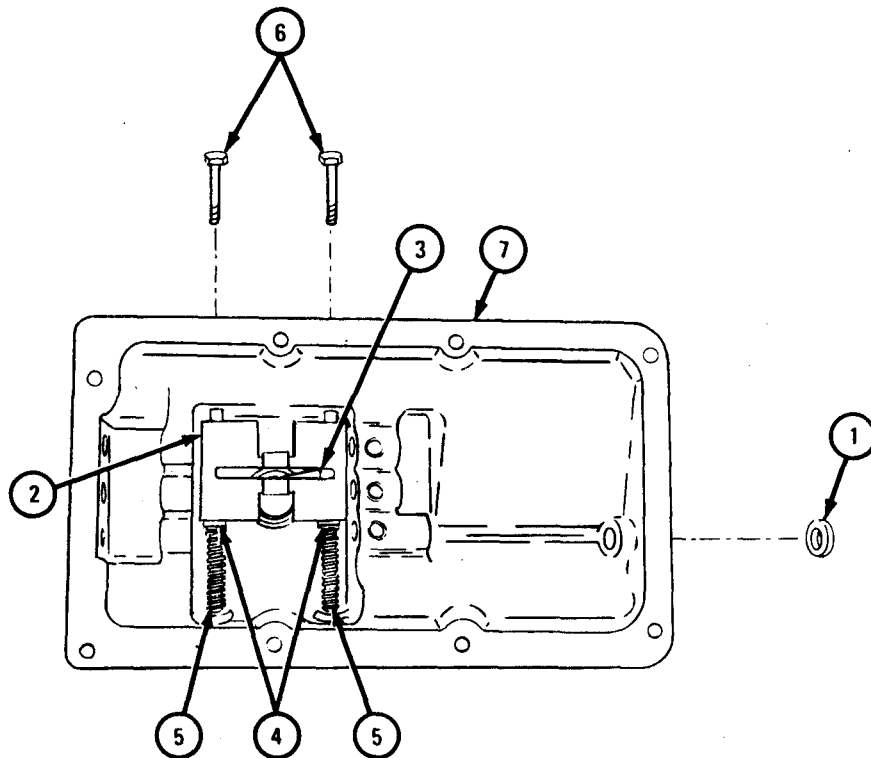

TA 102412

FRAME 3

1. Put on two washers (1) and interlock safety nuts (2). Tighten nuts 40 to 50 pound-feet.
 2. Turnover cover assembly (3).
- GO TO FRAME 4

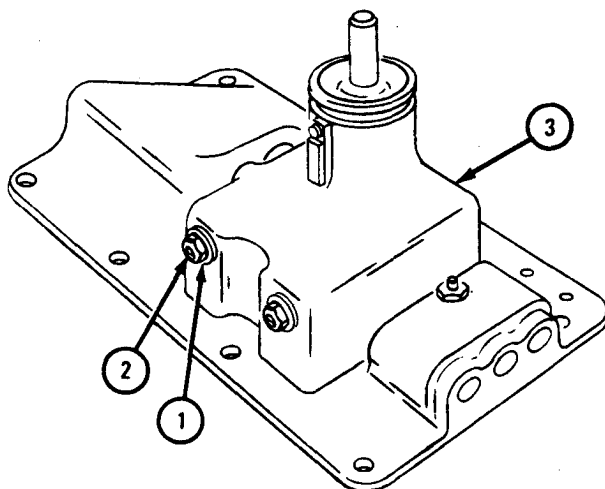

TA 102413

FRAME 4

1. Slide fourth and fifth speed shifter shaft (1) through hole in cover (2) as tagged. Leave hole (3) uncovered. Take off tag.
2. Slide fork (4) as tagged onto shaft (1) as shown. Take off tag.
3. Put spring (5) and ball (6) into hole (3). Hold ball down and slide shaft (1) over ball and into place.
4. Aline setscrew hole in fork (4) with setscrew hole in shaft (1). Make sure tab on fork sits in slot in plate (7). Put in setscrew (8).
5. Tap in expansion plug (9).
6. Do steps 1 through 5 again for second and third speed shifter shaft (10).

GO TO FRAME 5

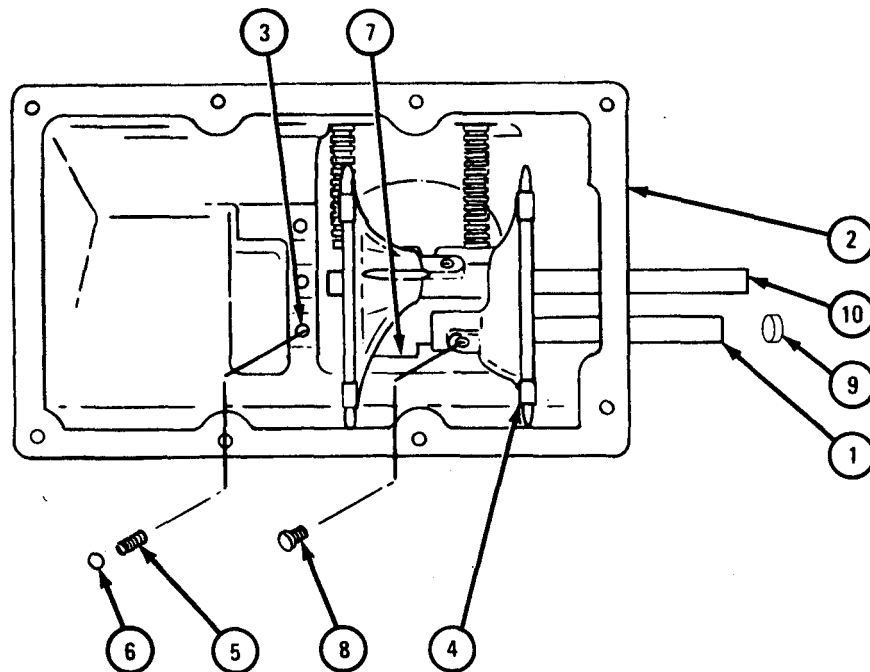

TA 102414

FRAME 5

1. Put bracket (1) into place in cover (2).
2. Slide first and reverse speed shifter shaft (3) through hole in cover (2) and bracket (1) as tagged. Leave hole (4) uncovered. Make sure that tab or bracket sits in slot in plate (5).
3. Put spring (6) and ball (7) into hole (4). Hold ball down and slide shaft (3) over ball. Take off tag.
4. Loosely put in setscrew (8).

GO TO FRAME 6

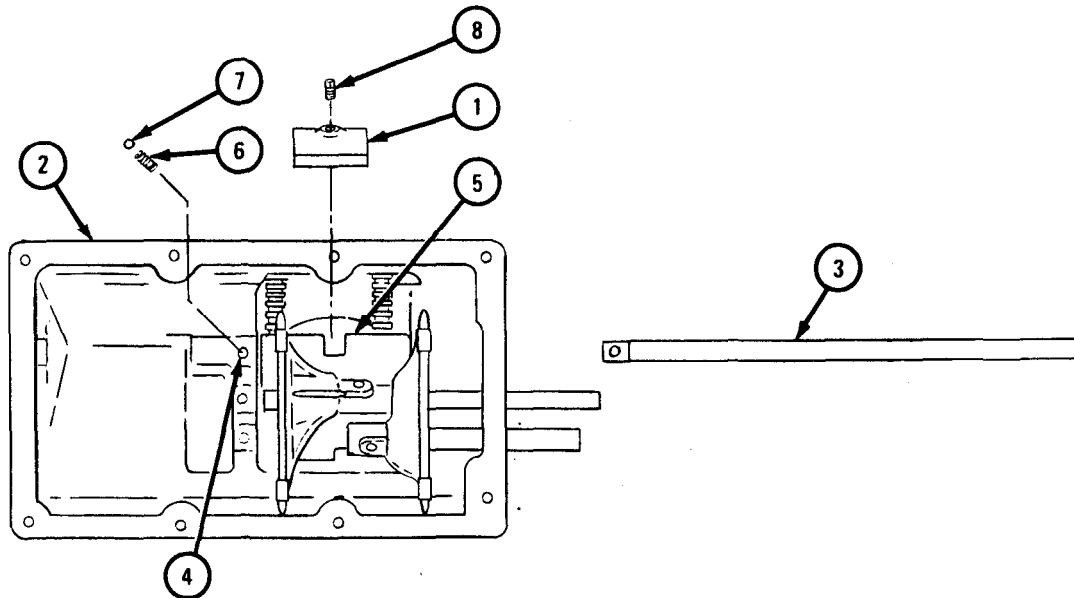

TA 102415

FRAME 6

1. Put in fork (1) as tagged and hold it in place. Take off tag.
2. Tap first and reverse speed shifter shaft (2) through fork (1) and into place as tagged. Take off tag.
3. Aline setscrew hole in fork (1) with setscrew hole in shaft (2). Put in setscrew (3). Tighten setscrew (4).
4. Put on four safety wires (5).
5. Tap in expansion plug (6).

END OF TASK

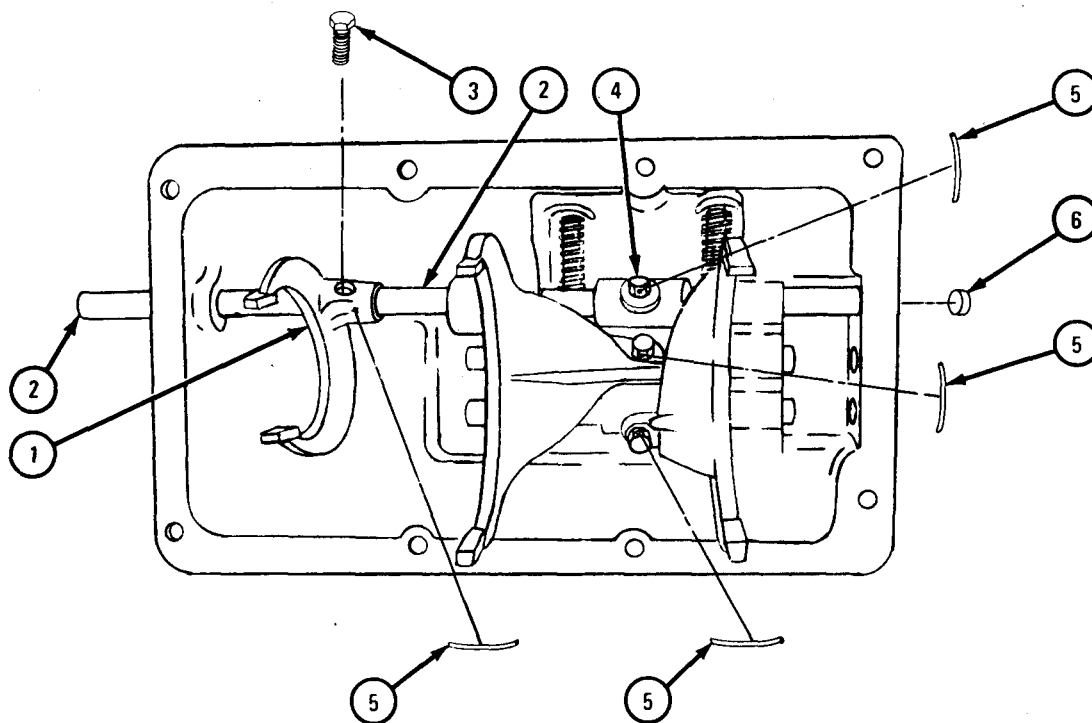

TA 102416

g. Replacement.

FRAME 1

1. Put on gasket (1), alining all screw holes.
2. Put shifter shaft (2) in neutral position. Refer to TM 9-2320-209-10.
3. Put on transmission cover (3), making sure three forks (4) go into synchronizer grooves (5) and groove in first and reverse gear (6).
4. Put in eight capscrews (7) and lockwashers (8). Tighten capscrews to 25 to 32 pound-feet.

GO TO FRAME 2

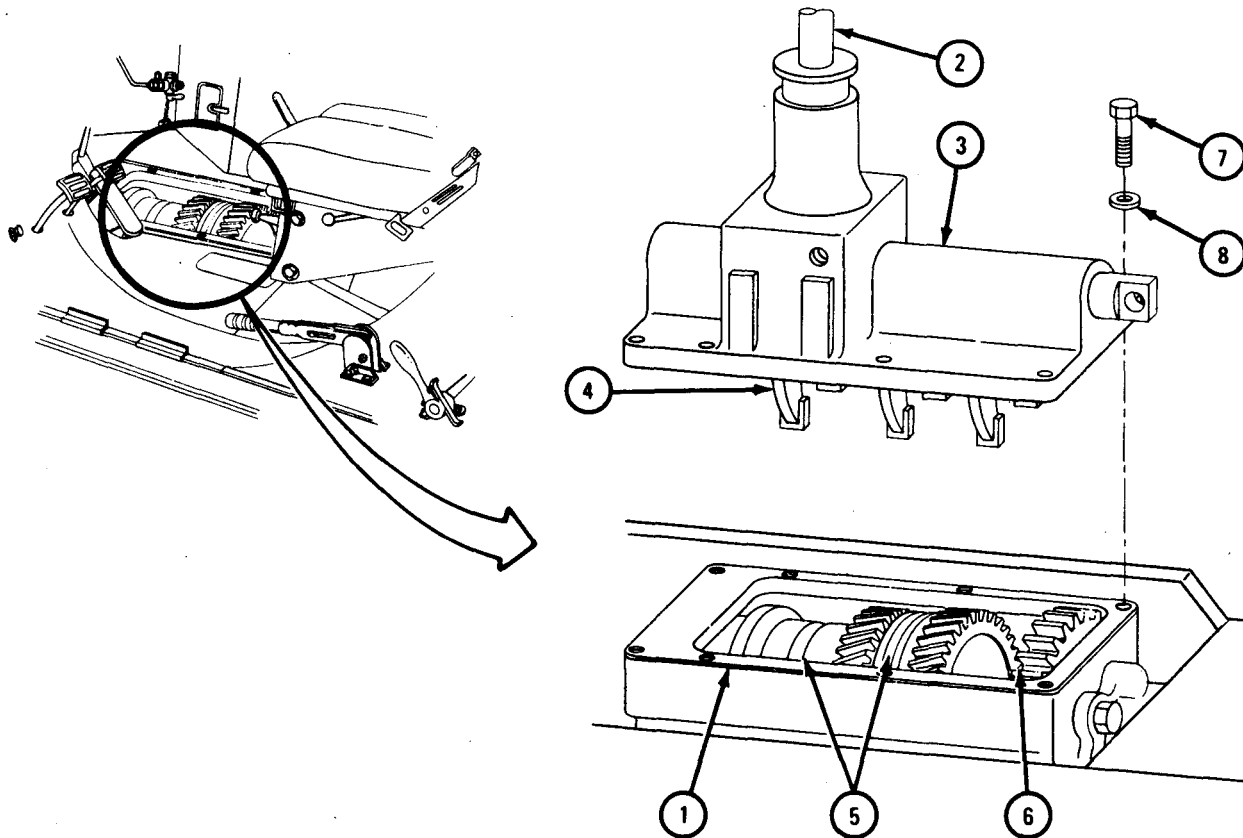

TA 102417

FRAME 2

1. Aline holes in yoke (1) with hole in shifter shaft (2). Put in bolt (3).
2. Put on locknut (4).

GO TO FRAME 3

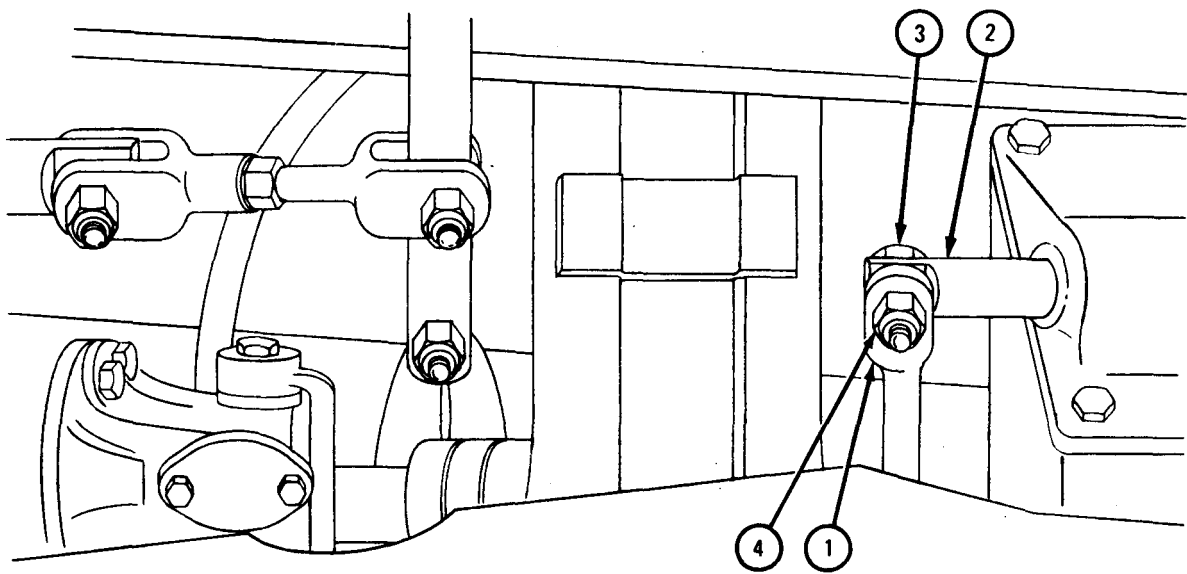

TA 102418

FRAME 3

1. Place intermediate tunnel (1) over front tunnel (2) and rear tunnel (3) as shown. Aline mounting holes and put in 14 screws (4).

GO TO FRAME 4

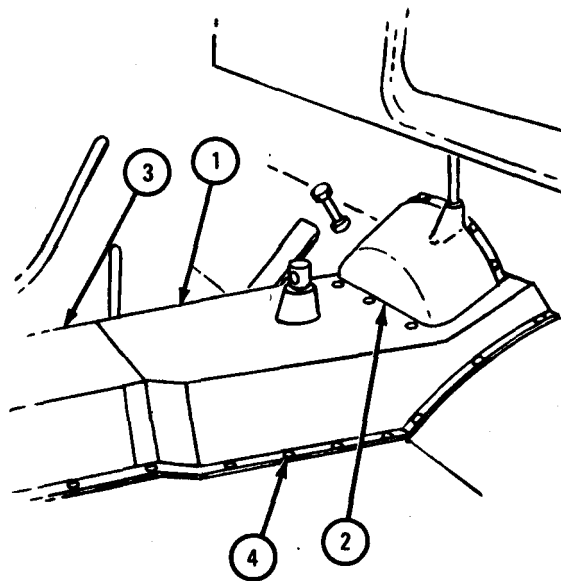

TA 102419

FRAME 4

1. Put gear shift lever (1) over stub shaft (2).
2. Tighten locknut (3).
3. Slide rubber boot (4) down over end of gear shift lever (1).

END OF TASK

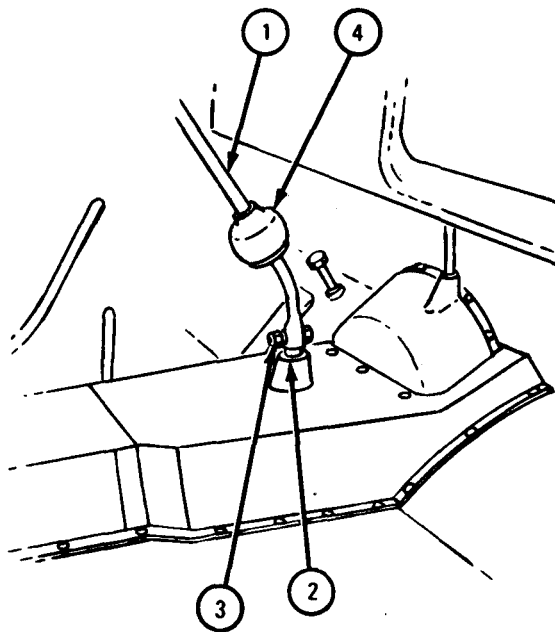

TA 102420

8-4. TRANSMISSION REMOVAL, REPAIR AND REPLACEMENT.

TOOLS : No special tools required

SUPPLIES : None

PERSONNEL: Two

EQUIPMENT CONDITION: Truck parked, engine off, handbrake set.

a. Preliminary Procedures.

(1) Drain transmission. Refer to LO 9-2320-209-12/1.

(2) Remove front and intermediate cab tunnels. Refer to TM 9-2320-209-20.

(3) Remove clutch control rod. Refer to Clutch Linkage Assembly,
TM 9-2320-209-20.

(4) Remove transfer reverse shift lever rod. Refer to TM 9-2320-209-20.

(5) Remove transmission-to-transfer propeller shaft. Refer to
TM 9-2320-209-20.

(6) Remove front winch drive shaft (trucks with front winch). Refer to
TM 9-2320-209-20.

(7) Remove transmission power takeoff rod (truck with front winch). Refer
to TM 9-2320-209-20.

(8) Remove hydraulic hoist pump driveshaft (truck M342A2). Refer to
TM 9-2320-209-20.

(9) Remove transmission power takeoff rod (truck M342A2). Refer to
TM 9-2320-209-20.

b. Removal.

FRAME 1

1. Loosen two screws (1). Take out 10 screws and lockwashers (2).
GO TO FRAME 2

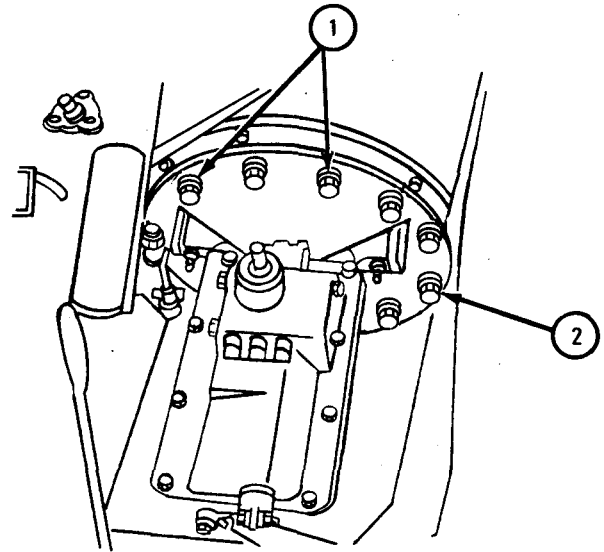
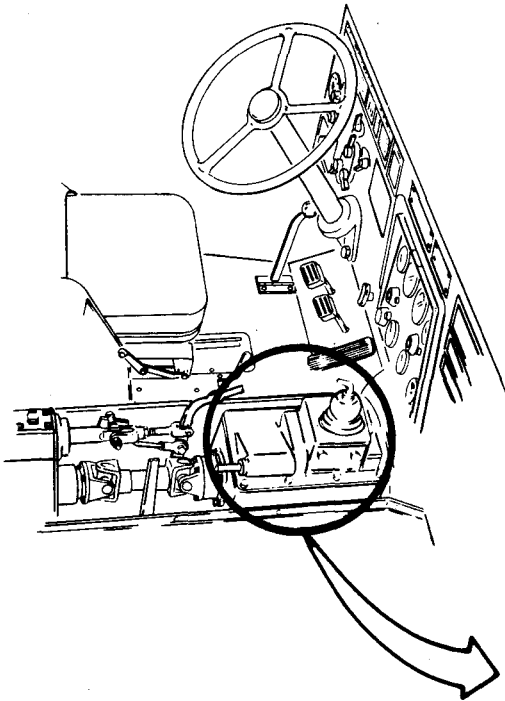

TA 085335

FRAME 2

- Soldiers A and B
1. Put jack under transmission (1). Raise jack and support transmission. Take out two screws and lockwashers (2).
 2. Slide transmission (1) toward rear of truck while lowering jack.

END OF TASK

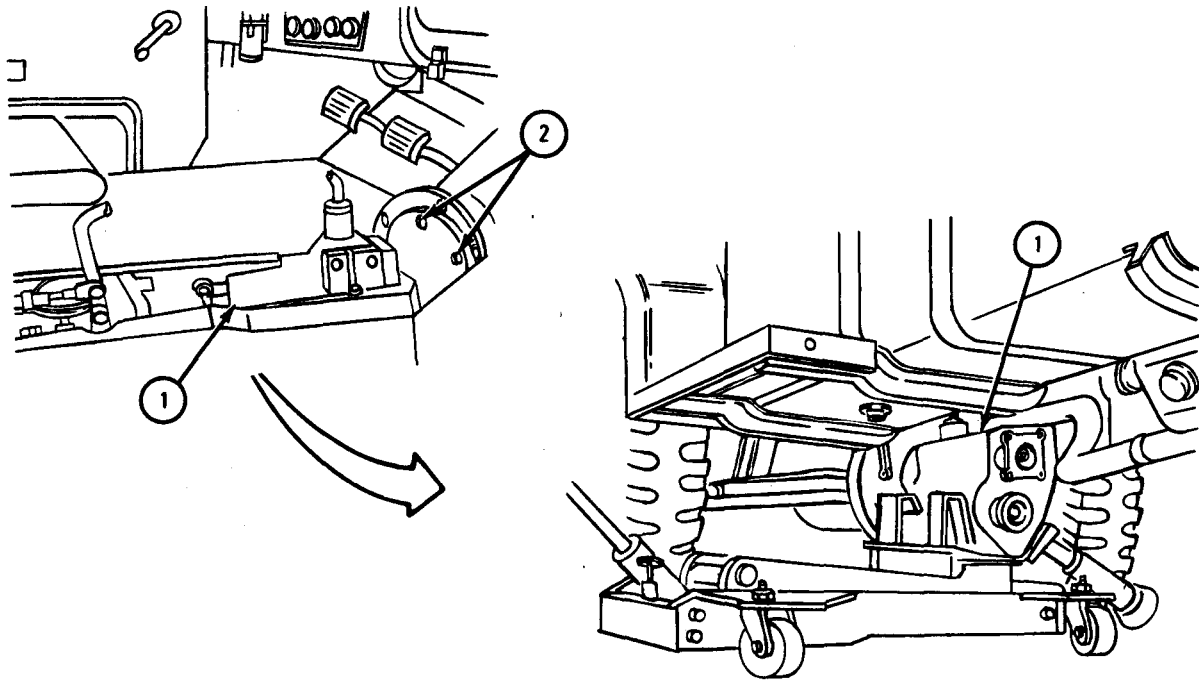

TA 085336

c. Repair. For procedures to repair transmission assembly, refer to TM 9-2520-246-34.

d. Replacement.

FRAME 1

Soldiers 1. Slide transmission (1) on jack under truck and into place on
A and B housing (2).

GO TO FRAME 2

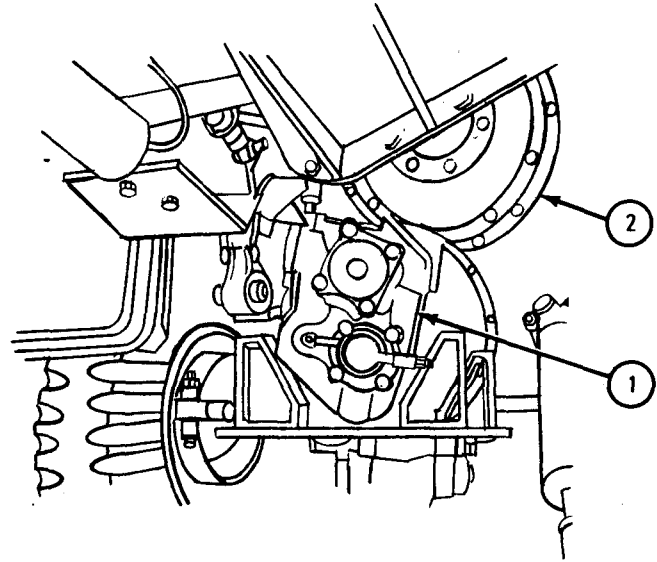
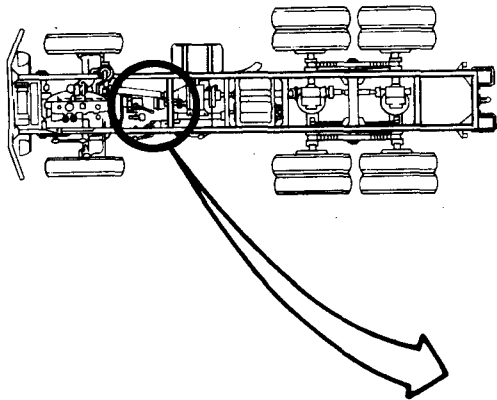

TA 085337

FRAME 2

1. Put in 12 screws and lockwashers (1).
2. Evenly tighten 12 screws and lockwashers (1) to 23 to 26 pound-feet.
3. Take jack out from under truck.

NOTE

Follow-on Maintenance Action Required:

1. Replace transmission power takeoff rod (truck M342A2). Refer to TM 9-2320-209-20.
2. Replace hydraulic hoist pump drive shaft (truck M342A2). Refer to TM 9-2320-209-20.
3. Replace transmission power takeoff rod (trucks with front winch). Refer to TM 9-2320-209-20.
4. Replace front winch drive shaft (trucks with front winch). Refer to TM 9-2320-209-20.
5. Replace transmission-to-transfer propeller shaft. Refer to TM 9-2320-209-20.
6. Replace transfer reverse shift lever rod. Refer to TM 9-2320-209-20.
7. Replace clutch control rod. Refer to Clutch Linkage Assembly, TM 9-2320-209-20.
8. Put in new front and intermediate cab tunnels. Refer to TM 9-2320-209-20.
9. Put in new transmission gearshift lever. Refer to TM 9-2320-209-20.
10. Fill transmission. Refer to LO 9-2320-209-12/1.

END OF TASK

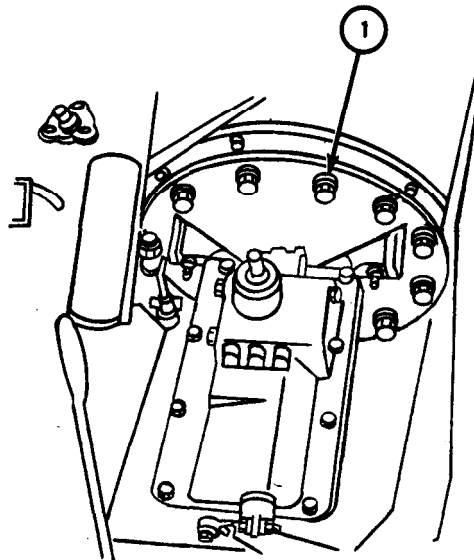

TA 085338

CHAPTER 9

TRANSMISSION TRANSFER SYSTEM GROUP MAINTENANCE

Section I. SCOPE

9-1. EQUIPMENT ITEMS COVERED. This chapter gives equipment maintenance procedures for the transmission transfer assembly for which there are authorized corrective maintenance tasks at the direct and general support maintenance levels.

9-2. EQUIPMENT ITEMS NOT COVERED. All equipment items for which corrective maintenance is authorized at the direct and general support maintenance levels are covered in this chapter.

Section II. TRANSMISSION TRANSFER ASSEMBLY

9-3. AIR ACTUATED TRANSMISSION TRANSFER ASSEMBLY REMOVAL AND REPLACEMENT .

TOOLS : Transfer case fixture, pn 8708898

SUPPLIES : None

PERSONNEL: One

EQUIPMENT CONDITION : Truck parked, engine off, wheels chocked.

a. Preliminary Procedures.

(1) Remove floorboard tunnels. Refer to TM 9-2320-209-20.

(2) Remove front axle propeller shaft, transmission-to-transfer propeller shaft, and forward-rear axle propeller shaft from transfer case. Refer to Propeller Shaft and Universal Joint Removal and Replacement, TM 9-2320-209-20.

(3) Remove transfer power takeoff shift control lever link. Refer to Transfer Controls and Linkage with Power Takeoff Removal and Replacement, TM 9-2320-209-20.

(4) For trucks M49A1C, M49A2C, M50A1, M50A2 or M50A3, remove delivery pump propeller shaft and auxiliary governor flexible shaft with adapter. Refer to Propeller Shaft and Universal Joint Removal and Replacement, TM 9-2320-209-20.

(5) Remove spare tire. Refer to TM 9-2320-209-10.

(6) Remove speedometer flexible shaft and adapter. Refer to Speedometer Assembly Removal, Rep sir, and Replacement, TM 9-2320-209-20.

(7) Remove handbrake cable from transfer. Refer to Handbrake Cable Assembly Removal and Replacement, TM 9-2320-209-20.

(8) Drain transfer case. Refer to LO 9-2320-209-12/1.

(9) For truck M764, remove power divider propeller shaft and yoke. Refer to Propeller Shaft and Universal Joint Removal and Replacement, TM 9-2320-209-20.

b. Removal.

FRAME 1

1. Working under truck at front of transfer case (1), takeoff airline (2).
GO TO FRAME 2

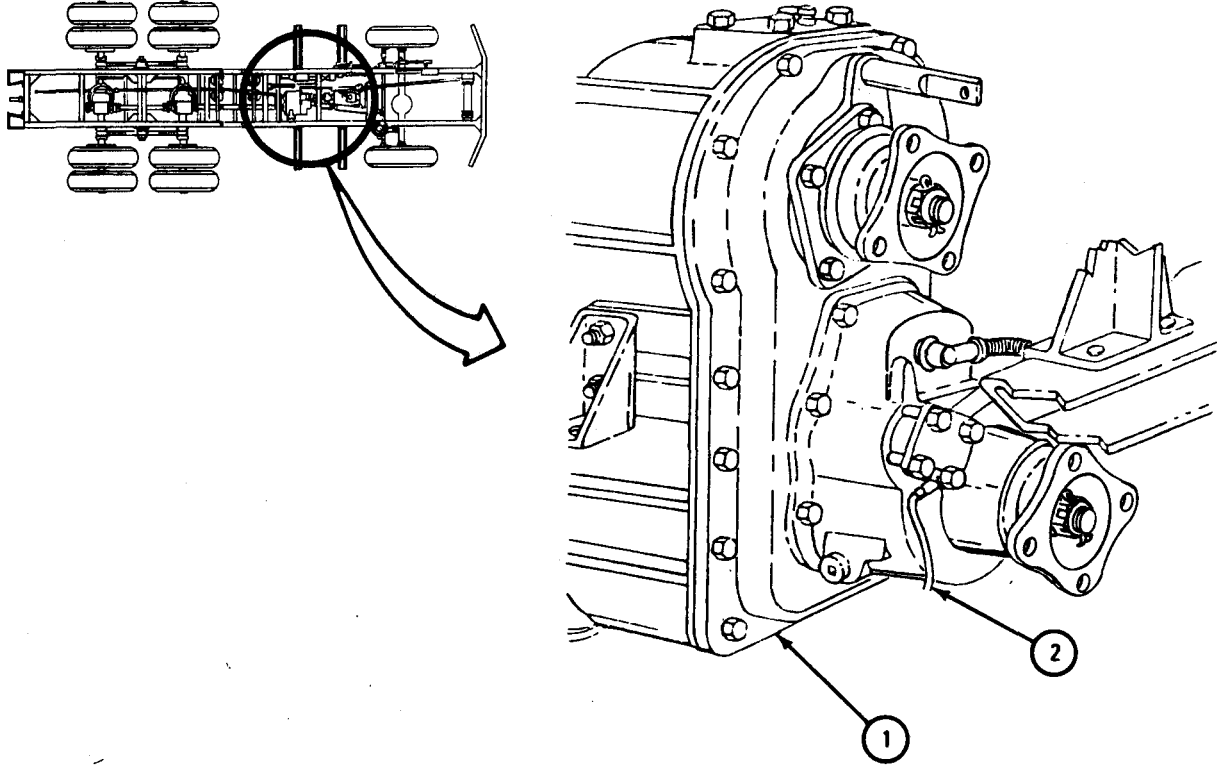

TA 085204

FRAME 2

1. Slide lift under transfer (1) and raise into place.
 2. Take off four nuts (2) and bolts (3).
 3. Take off two nuts (4), two washers (5), two bushings (6), and mounting plate (7).
- GO TO FRAME 3

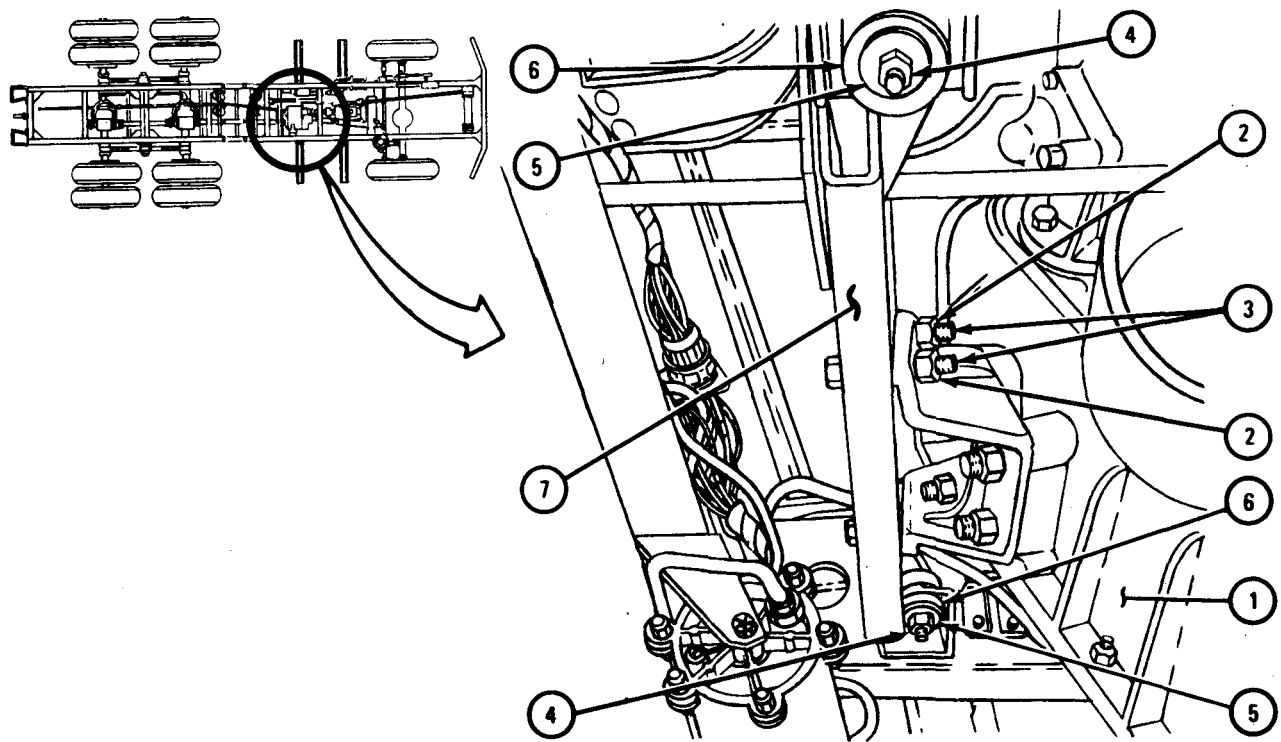

LEFT SIDE

TA 085323

FRAME 3

1. Take off right mount nut (1), washer (2), and bushing (3) from right side of transfer case.
2. Move transfer (4) down and away from truck.

END OF TASK

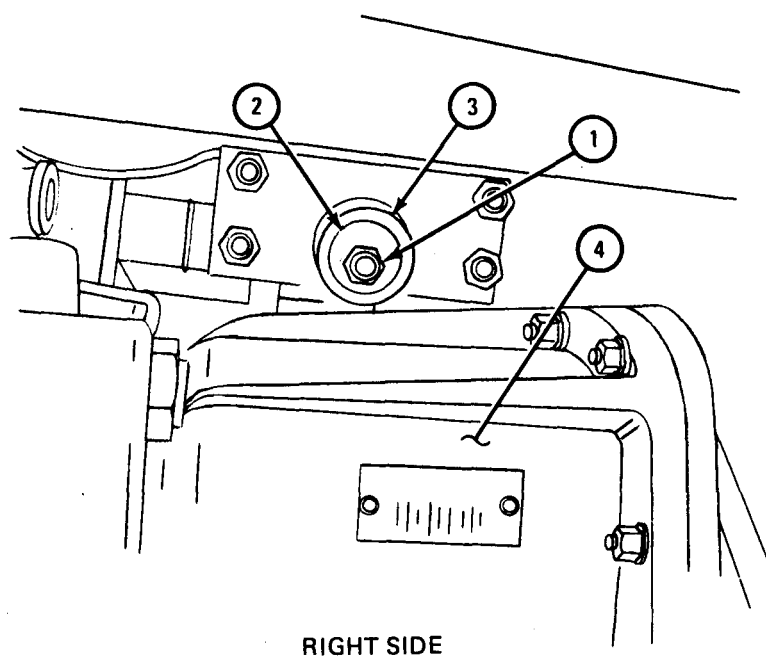

TA 085324

c. Replacement.

FRAME 1

1. Raise transfer (1) into place.
 2. Put on mounting plate (2), two mounts (3), and two washers (4), and hand tighten two nuts (5).
 3. Put in four bolts (6) and hand tighten four nuts (7).
- GO TO FRAME 2

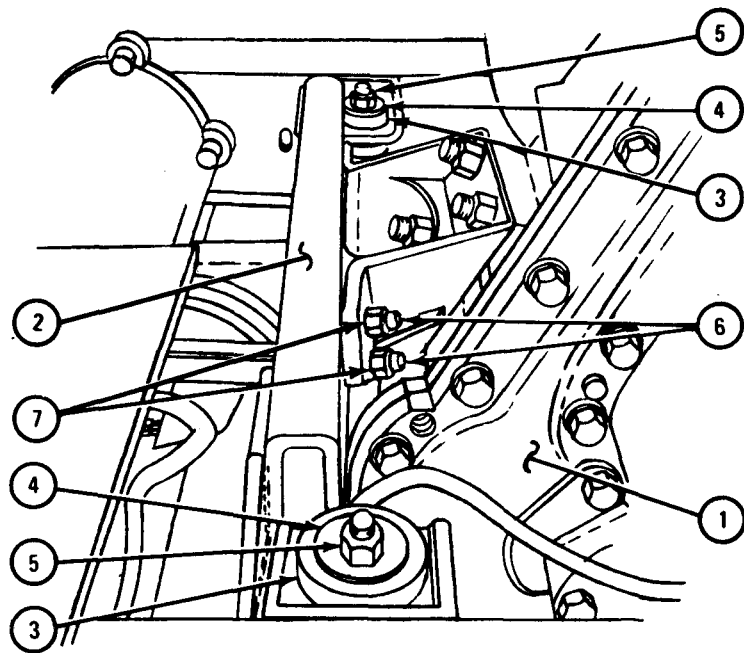
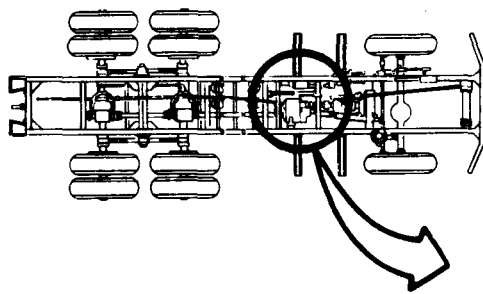

LEFT SIDE

TA 085325

FRAME 2

1. Put on mount (1), washer (2), and nut (3).
2. Tighten all mounting nuts.

GO TO FRAME 3

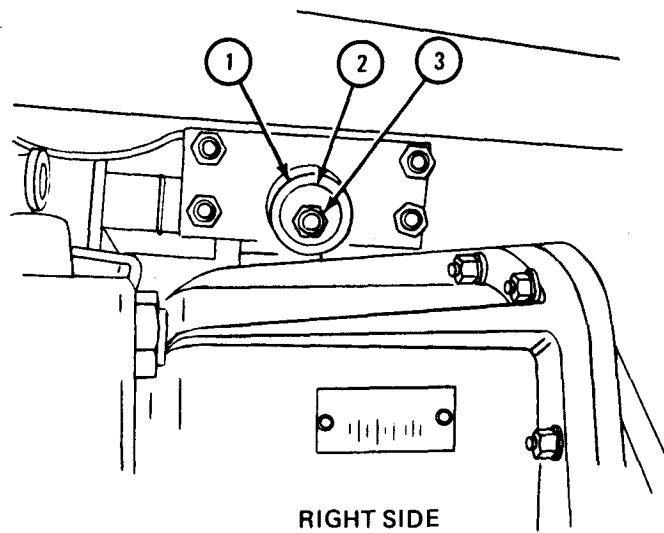

TA 085326

FRAME 3

1. Working under truck at front of transfer case (1), put on airline (2).

NOTE

Follow-on Maintenance Action Required:

1. Replace handbrake cable on transfer. Refer to Handbrake Cable Assembly Removal and Replacement, TM 9-2320-209-20.
2. Replace speedometer flexible shaft and adapter. Refer to Speedometer Assembly Removal, Repair, or Replacement, TM 9-2320-209-20.
3. For trucks M49A1C, M49A2C, M50A1, M50A2 or M50A3, replace delivery pump propeller shaft and auxiliary governor flexible shaft with adapter. Refer to Propeller Shaft and Universal Joint Removal and Replacement, TM 9-2320-209-20.
4. Replace transfer power takeoff shift control lever link. Refer to Transfer Controls and Linkage with Power Takeoff Removal and Replacement, TM 9-2320-209-20.
5. Replace front axle propeller shaft, transmission-to-transfer propeller shaft, and forward-rear axle propeller shaft on transfer case. Refer to Propeller Shaft and Universal Joint Removal and Replacement, TM 9-2320-209-20.
6. Fill transfer case. Refer to LO 9-2320-209-12/1 .
7. For truck M764, replace power divider propeller shaft and yoke. Refer to Propeller Shaft and Universal Joint Removal and Replacement, TM 9-2320-209-20.
8. Replace spare tire. Refer to TM 9-2320-209-10.
9. Replace floorboard tunnels. Refer to TM 9-2320-209-20.

END OF TASK

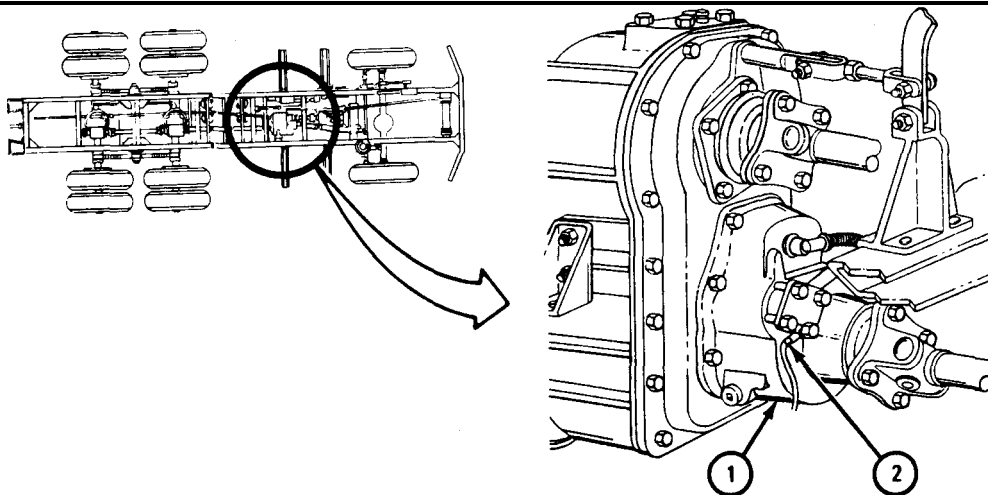

TA085205

9-4. AIR ACTUATED TRANSMISSION TRANSFER ASSEMBLY REPAIR. Refer to TM 9-2520-246-34-1 for procedures to repair the air actuated transmission transfer assembly.

9-5. DOUBLE SPRAG TRANSMISSION TRANSFER REMOVAL, REPAIR AND REPLACEMENT.

TOOLS : Transfer case fixture, pn 8708279
Air compressor wrench, pn 8390170

SUPPLIES : Lubricating oil, GO 80/90, MIL-L-2105
Kit, pn 5704132 (if available)

PERSONNEL: One

EQUIPMENT CONDITION: Truck parked, engine off, wheels chocked.

a. Preliminary Procedures.

(1) Raise one front wheel off ground. Refer to TM 9-2320-209-20.

(2) Remove floorboard tunnels. Refer to TM 9-2320-209-20.

(3) Remove front axle propeller shaft, transmission-to-transfer propeller shaft, and forward-rear axle propeller shaft from transfer. Refer to Propeller Shaft and Universal Joint Removal and Replacement, TM 9-2320-209-20.

(4) On trucks with transfer power takeoff, remove transfer power takeoff shift control lever linkage. Refer to Transfer Controls and Linkage with Power Takeoff Removal and Replacement, TM 9-2320-209-20.

(5) If working on trucks M49A1C, M49A2C, M50A2 or M50A3, remove delivery pump propeller shaft and auxiliary governor flexible shaft with adapter. Refer to Propeller Shaft and Universal Joint Removal and Replacement, TM 9-2320-209-20.

(6) Remove speedometer flexible shaft and adapter. Refer to Speedometer Assembly Removal, Repair, and Replacement, TM 9-2320-209-20.

(7) Remove handbrake cable from transfer. Refer to Handbrake Cable Assembly Removal and Replacement, TM 9-2320-209-20.

(8) Remove transmission transfer reverse shift linkage. Refer to TM 9-2320-209-20.

(9) Drain transfer case. Refer to LO 9-2320-209-12/1.

b. Removal.

FRAME 1

1. Slide lift under transfer (1) and raise it into place.
2. Take out four nuts (2).
3. Take out four nuts (3).
4. Using lift, move transfer (1) down and away from truck.

GO TO FRAME 2

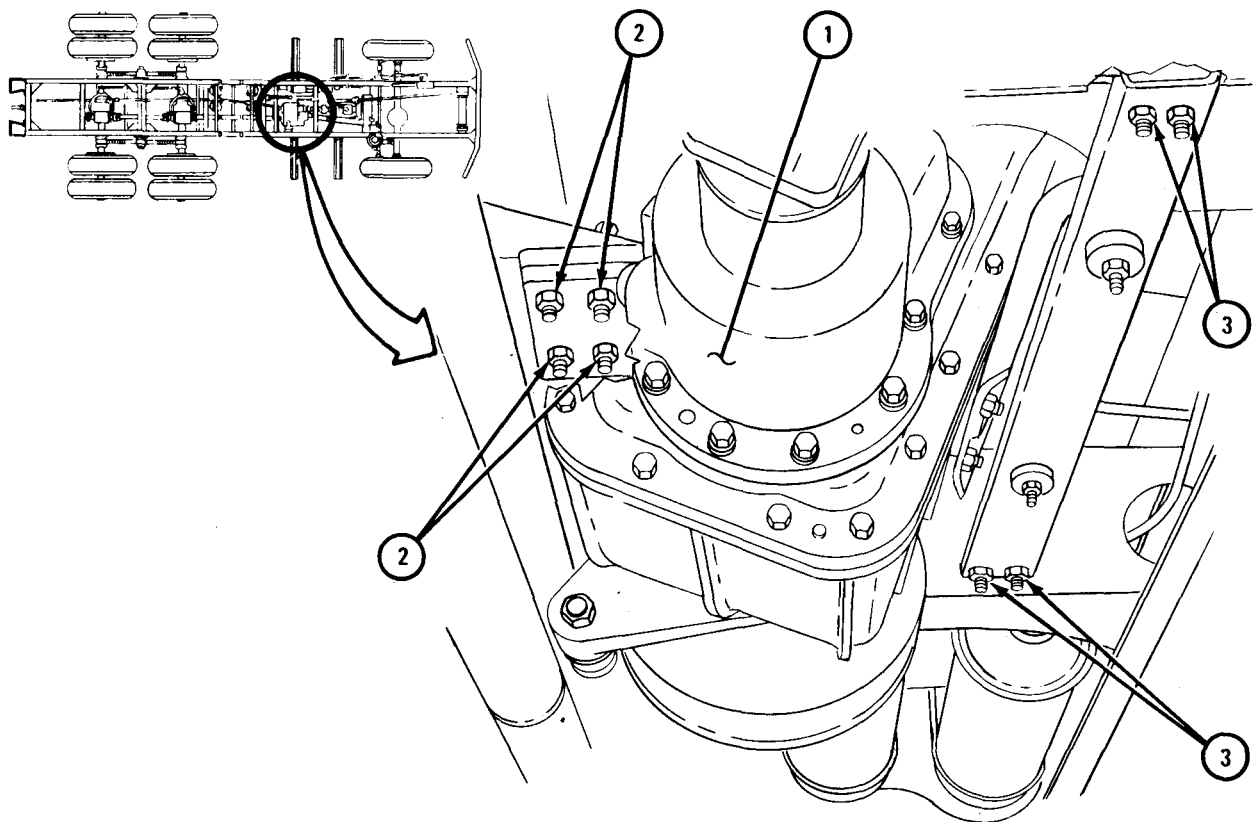

TA 085222

FRAME 2

1. Take off two nuts (1).
2. Take off right support (2) and right support bracket plate (3).
3. Take off two mount bolts (4) and left support (5).
4. Take out two screws (6).
5. Take off two nuts (7) and left support plate (8).

END OF TASK

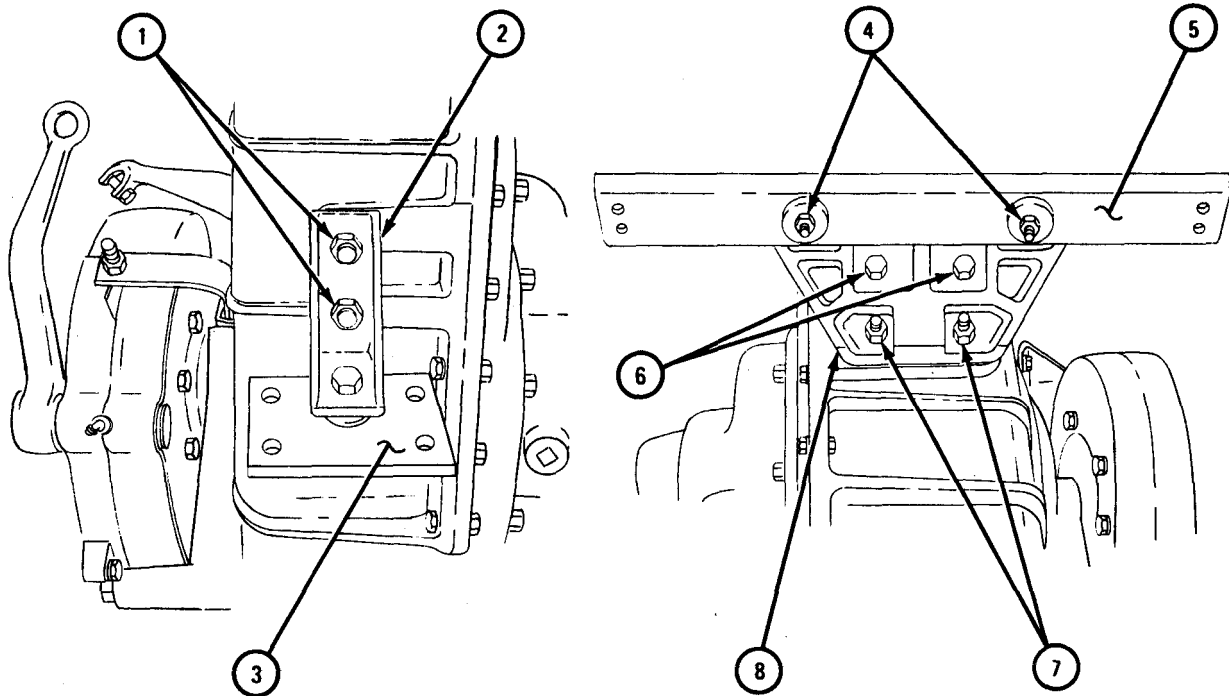

TA 085223

c. Repair. For procedure to repair double sprag transmission transfer, refer to TM 9-2520-246-34-1.

d. Replacement.

NOTE

If kit is available, put it in to change double sprag transfer to air actuated transfer. Refer to para 9-3. To replace air actuated transfer, refer to para 9-3. If kit is not available, do frames 1 through 3 to put back double sprag transfer.

FRAME 1

1. Put on left support plate (1), two nuts (2), and two screws (3).
2. Put on left support (4) and put in two mount screws (5).
3. Put on right support (6), right support plate (7), and nut (8).
4. Put on two nuts (9).

GO TO FRAME 2

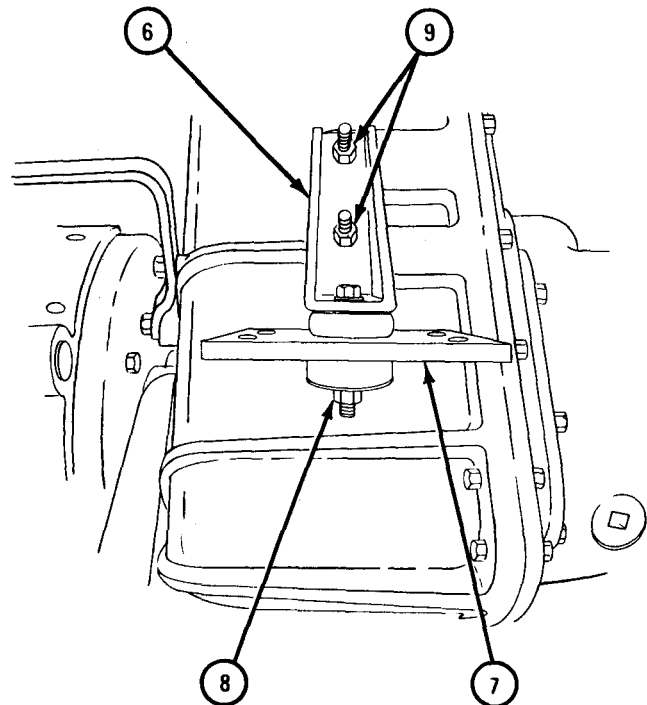
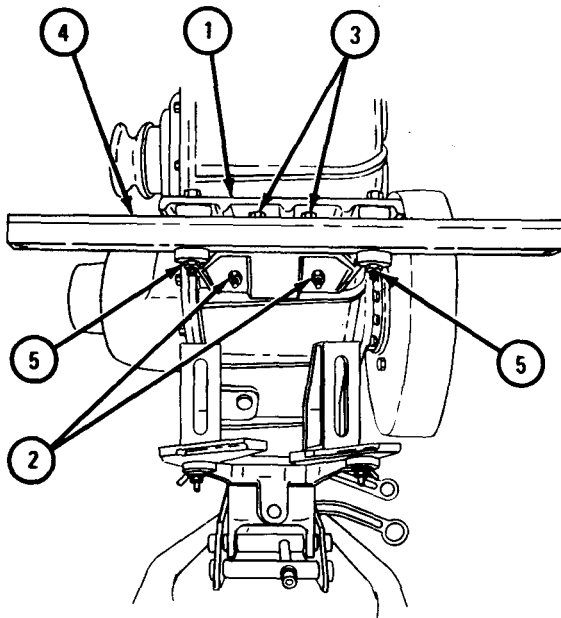

TA 085224

FRAME 2

1. Raise transfer (1) into position.
2. Hand tighten four nuts (2) on left support plate (3).
3. Hand tighten four nuts (4) on right support plate (5).
4. Tighten eight nuts (2 and 4).

GO TO FRAME 3

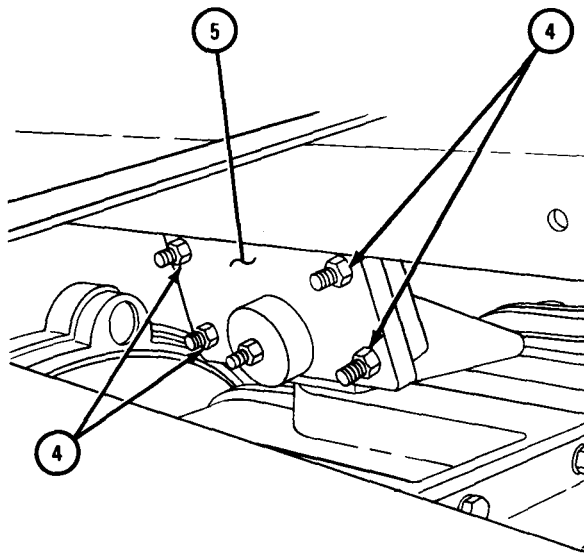
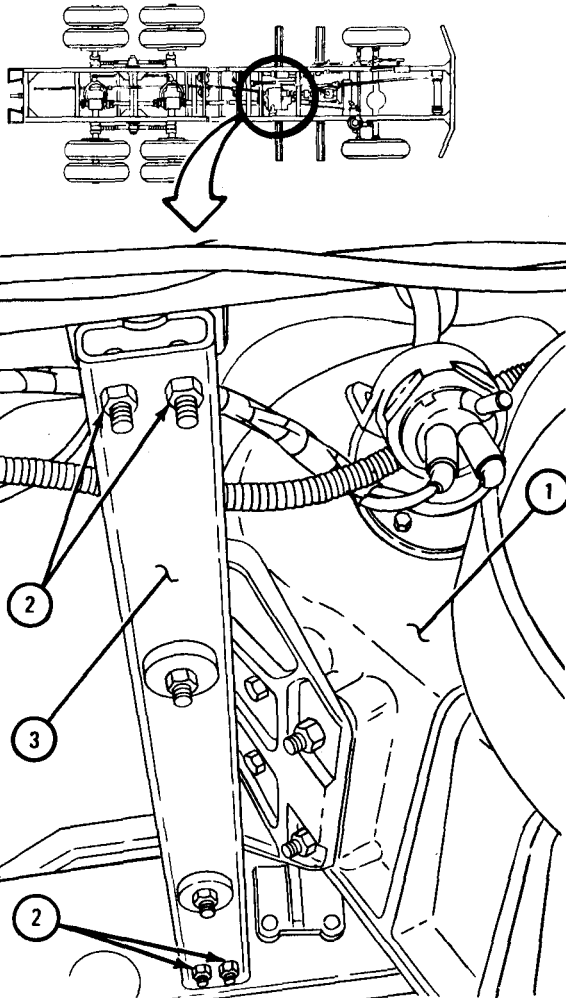

TA 085322

FRAME 3

NOTE

Follow-on Maintenance Action Required:

1. Replace transmission transfer reverse shift linkage. Refer to TM 9-2320-209-20.
2. Replace handbrake cable on transfer. Refer to Handbrake Cable Assembly Removal and Replacement, TM 9-2320-209-20.
3. Replace speedometer flexible shaft and adapter. Refer to Speedometer Assembly Removal, Repair, and Replacement, TM 9-2320-209-20.
4. On trucks M49A1C, M49A2C, M50A2 or M50A3, replace delivery pump propeller shaft and auxiliary governor flexible shaft with adapter. Refer to Propeller Shaft and Universal Joint Removal and Replacement, TM 9-2320-209-20.
5. On trucks with transfer power takeoff, replace transfer power takeoff shift control lever linkage. Refer to Transfer Controls and Linkage with Power Takeoff Removal and Replacement, TM 9-2320-209-20.
6. Replace front axle propeller shaft, transmission-to-transfer propeller shaft and forward-rear axle propeller shaft to transfer. Refer to Propeller Shaft and Universal Joint Removal and Replacement, TM 9-2320-209-20.
7. Replace floorboard tunnels. Refer to TM 9-2320-209-20.
8. Lower front wheel to ground. Refer to TM 9-2320-209-20.
9. Fill transfer case. Refer to LO 9-2320-209-12/1.

END OF TASK

CHAPTER 10

FRONT AXLE GROUP MAINTENANCE

Section I. SCOPE

10-1. EQUIPMENT ITEMS COVERED. This chapter gives equipment maintenance procedures for the front axle assembly, differential carrier assembly and the steering mechanism for which there are authorized corrective maintenance tasks at the direct and general support maintenance levels. Since bearings in the differential must be maintained, the procedure for the maintenance of bearings is also included in this chapter.

10-2. EQUIPMENT ITEMS NOT COVERED . All equipment items for which corrective maintenance is authorized at the direct and general support maintenance levels are covered in this chapter.

Section II. FRONT AXLE ASSEMBLY

10-3. FRONT AXLE ASSEMBLY REMOVAL AND REPLACEMENT.

TOOLS: No special tools required

SUPPLIES: None

PERSONNEL: Two

EQUIPMENT CONDITION: Truck parked, engine off, handbrake set.

a. Preliminary Procedures.

(1) Jack up and support front end of chassis. Refer to TM 9-2320-209-20.

(2) Remove front wheels. Refer to TM 9-2320-209-10.

(3) Remove front propeller shaft. Refer to Propeller Shaft and Universal Joint Removal and Replacement, TM 9-2320-209-20.

(4) Remove drag link. Refer to TM 9-2320-209-20.

(5) Remove brake line at tee fitting on front axle. Refer to Hydraulic Lines, Hoses, and Fittings Removal and Replacement, TM 9-2320-209-20.

b. Removal.

FRAME 1

1. Take off locknut (1) and nut (2).
2. Take off retainer (3) and rubber bushing (4).
3. Push up shock absorber (5).
4. Take off rubber bushing (6) and retainer (7).
5. Do steps 1 through 4 for other shock absorber (5).
6. Raise jack (8) until it is firmly against front axle (9).

GO TO FRAME 2

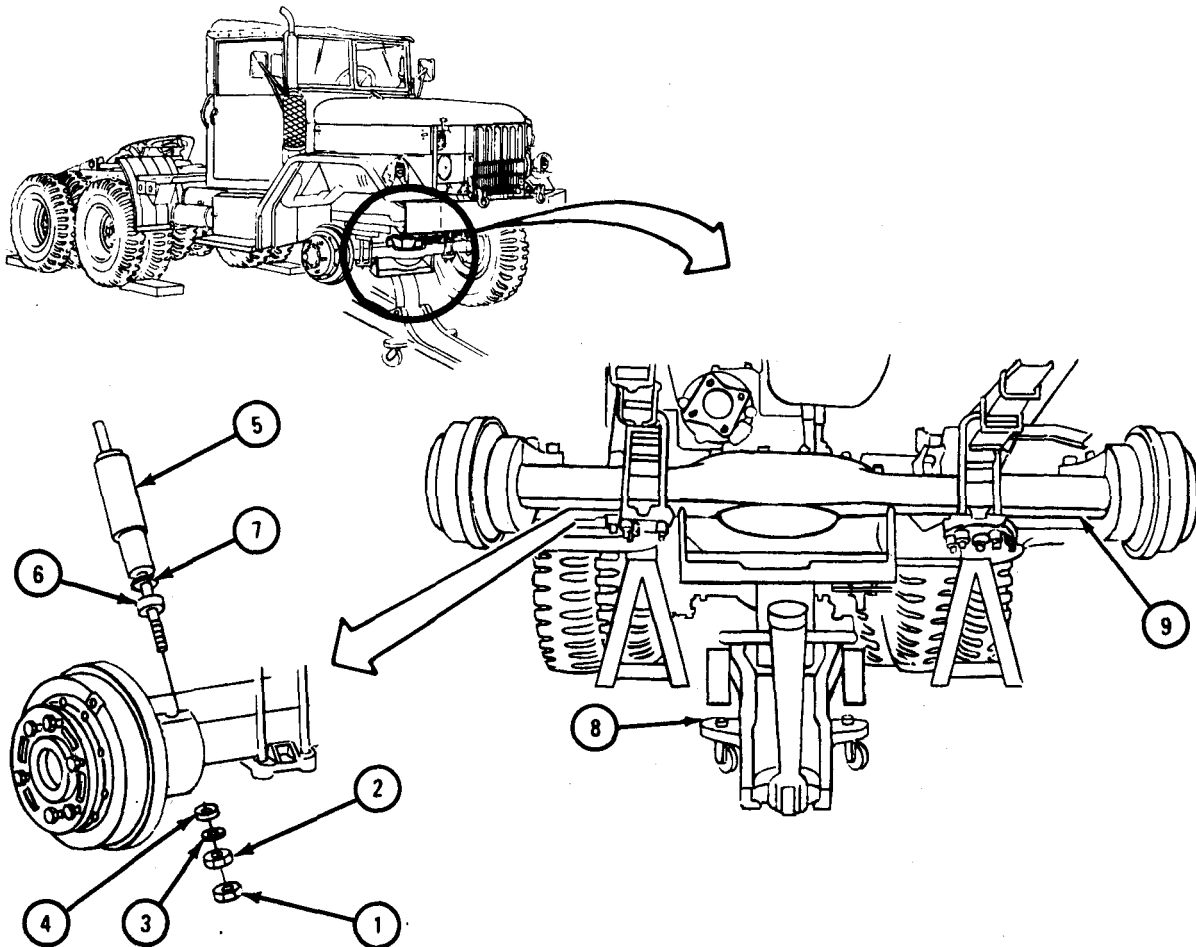

TA 047178

FRAME 2

- Soldier A 1. Take off eight nuts and lockwashers (1).
 2. Take off two clamp plates (2).
 3. Lift off two U-bolts (3) with saddle and rubber bumper (4) at each side of axle (5).
- Soldier B 4. Lower jack (6) until axle (5) clears truck.
- Soldiers A and B 5. Pull axle (5) out from under truck.
 6. Take out two spring seats (7).

END OF TASK

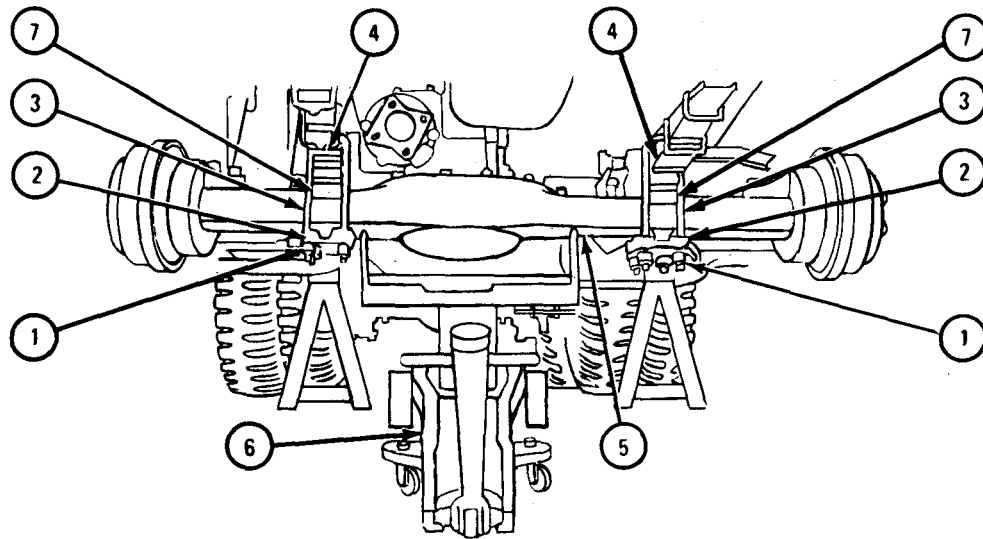

TA 047179

c. Replacement.

FRAME 1

- Soldiers A and B 1. Place front axle assembly (1) under front of truck.
- Soldier A 2. Put spring seat (2) on top of axle assembly (1).
3. Put rubber bumper (3) over spring centering bolt (4).
4. Put saddle plate (5) over rubber bumper (3). Put two U-bolts (6) on saddle plate.
5. Put retainer and bushing (7) on shock absorber (8).
- Soldier B 6. Do steps 2 through 5 again on left side of front axle assembly (1).
- Soldier A 7. Using dolly jack, raise axle assembly (1).
- Soldier B 8. Aline holes in spring seats (2) with spring centering bolts (4).
- GO TO FRAME 2

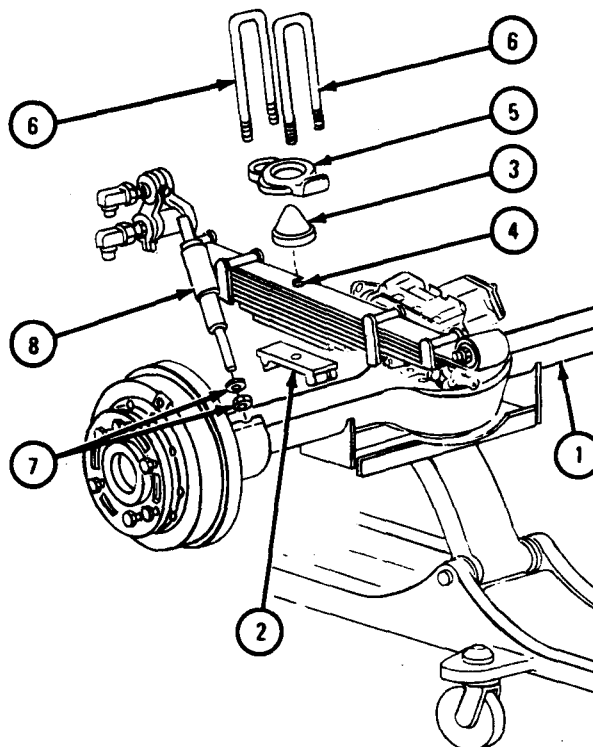
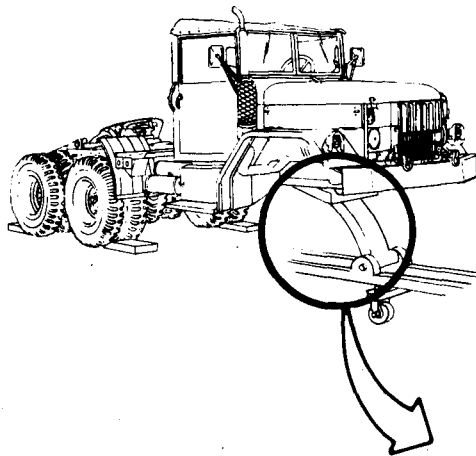

TA 047184

FRAME 2**NOTE**

Shock absorber mounting hole in clamp plates (1 and 2) must be on outside and toward rear of truck.

1. Put right clamp plate (1) on two U-bolts (3).
2. Put left clamp plate (2) on two U-bolts (4).
3. Put on eight nuts and lockwashers (5). Tighten nuts evenly to 170 to 180 pound-feet.

GO TO FRAME 3

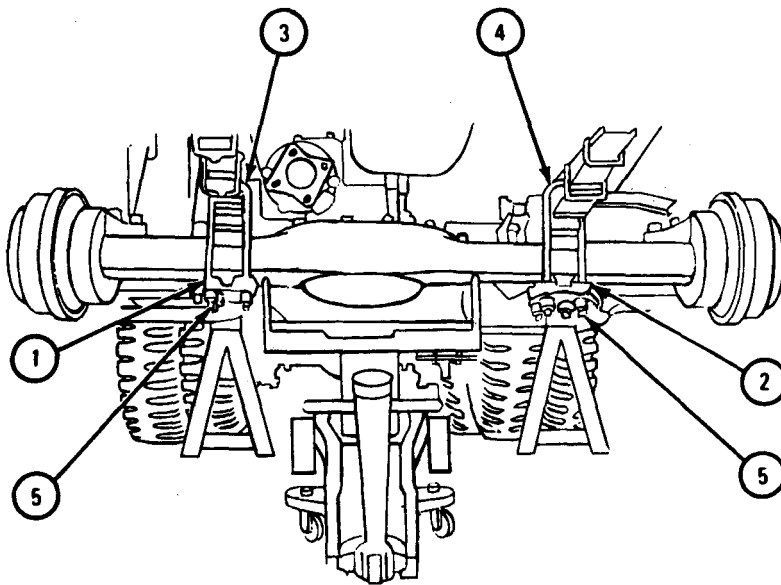

TA 047185

FRAME 3

- Soldier A
1. Check that retainer and bushing (1) are on shock absorber (2).
 2. Push up on rod (3) and put rod through rear hole in clamp plate (4) as shown.
 3. Put rubber bushing (5) and retainer (6) on end of rod (3). Put on nut (7) enough to squeeze rubber bushings (1 and 5).
 4. Put on nut (8) and tighten it against nut (7).

Soldier B 5. Do steps 1 through 4 again on other shock absorber (2).

GO TO FRAME 4

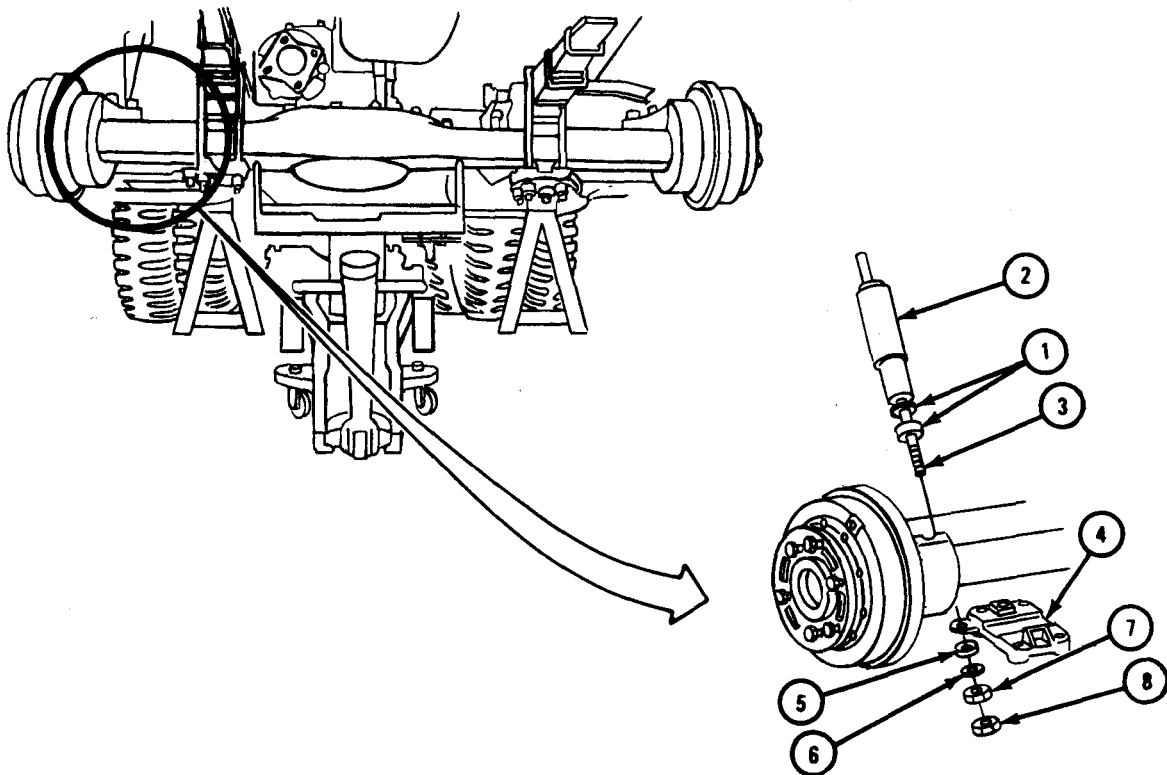

TA 047186

FRAME 4**NOTE**

Follow-on Maintenance Action Required:

1. Replace brake line at tee fitting on front axle. Refer to Hydraulic Lines, Hoses, and Fittings Removal and Replacement, TM 9-2320-209-20.
2. Replace drag link. Refer to TM 9-2320-209-20.
3. Replace front propeller shaft. Refer to Propeller Shaft and Universal Joint Removal and Replacement, TM 9-2320-209-20.
4. Replace front wheels. Refer to TM 9-2320-209-10.
5. Take out supports and jack down front of chassis. Refer to TM 9-2320-209-20.
6. If new axle assembly was put in, check toe-in and do adjustment if needed. Refer to Front Wheel Alinement, TM 9-2320-209-20.

END OF TASK

10-4. FRONT AXLE ASSEMBLY REPAIR.

TOOLS: No special tools required

SUPPLIES: Solvent, dry cleaning, type II (SD-2), Fed. Spec P-D-680
Clean rags

PERSONNEL: One

EQUIPMENT CONDITION: Truck parked, engine off, handbrake set.

a. Preliminary Procedures.

NOTE

Preliminary procedures (4), (5), (11), and (12)
are not required for repair of the steering knuckle.

- (1) Drain front axle housing. Refer to LO 9-2320-209-12/1.
- (2) Jack up and support truck. Refer to TM 9-2320-209-20.
- (3) Remove front wheels. Refer to TM 9-2320-209-10.
- (4) Remove front propeller shaft. Refer to Propeller Shaft and Universal Joint Removal and Replacement, TM 9-2320-209-20.
- (5) Remove brake lines at tee fittings on front axle. Refer to Hydraulic Lines, Hoses and Fitting Removal and Replacement, TM 9-2320-209-20.
- (6) Remove drag link. Refer to TM 9-2320-209-20.
- (7) Remove hub and drum assemblies. Refer to TM 9-2320-209-20.
- (8) Remove front axle shaft. Refer to TM 9-2320-209-20.
- (9) Remove steering knuckle boot guard and steering knuckle boot. Refer to TM 9-2320-209-20.
- (10) Remove tie rod. Refer to TM 9-2320-209-20.
- (11) Remove front axle assembly. Refer to para 10-3.
- (12) Remove differential. Refer to para 10-7.

b. Disassembly.**FRAME 1**

1. Working on left side of axle, take off two nuts (1) and lockwashers (2).
2. Tap steering arm (3) at point (4) to loosen four split dowels (5). Take out split dowels. Take off steering arm.
3. Take out lubrication fitting (6).

NOTE

Do not take out ball stud (7) unless it is damaged. Refer to para 10-4d for inspection procedures.

4. Take out cotter pin (8). Take off nut (9). Take out ball stud (7).

GO TO FRAME 2

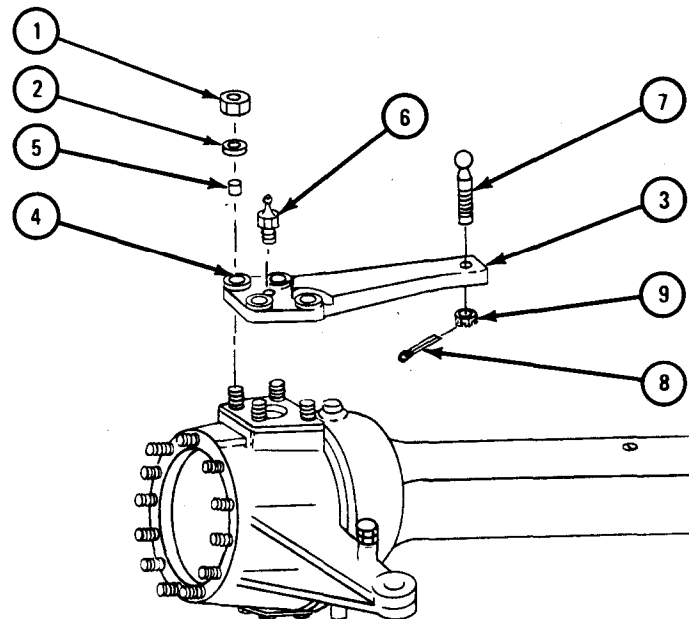

TA 085103

FRAME 2

1. Take out spacer (1).
2. Take out sleeve (2).
3. Take out two screws (3) and lockwashers (4). Take off plate (5).
4. Take out lubricating fitting (6).
5. Take off sleeve (7).

NOTE

Do not take out bushings (8 and 9) unless they are damaged. Refer to para 10-4d for inspection procedures.

6. Take out bushings (8 and 9).

GO TO FRAME 3

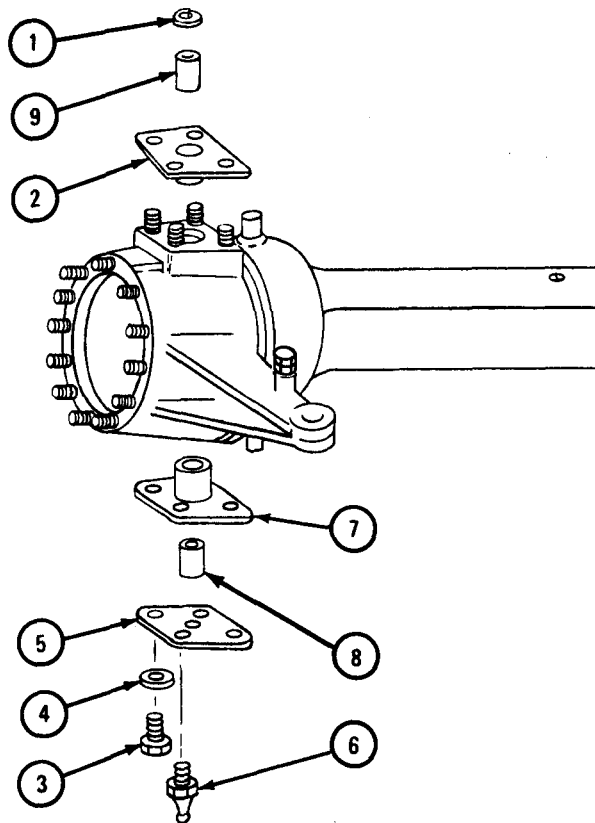

TA 085104

FRAME 3

1. Take off steering knuckle (1).
2. Take out four studs (2) and 12 studs (3).

NOTE

Do not take out turn angle screw (4) or locknut (5) unless they are damaged. Refer to para 10-4d for inspection procedure.

3. Break spot weld on turn angle screw (4) and locknut (5).
4. Loosen locknut (4). Take out turn angle screw (5) and take off locknut.

GO TO FRAME 4

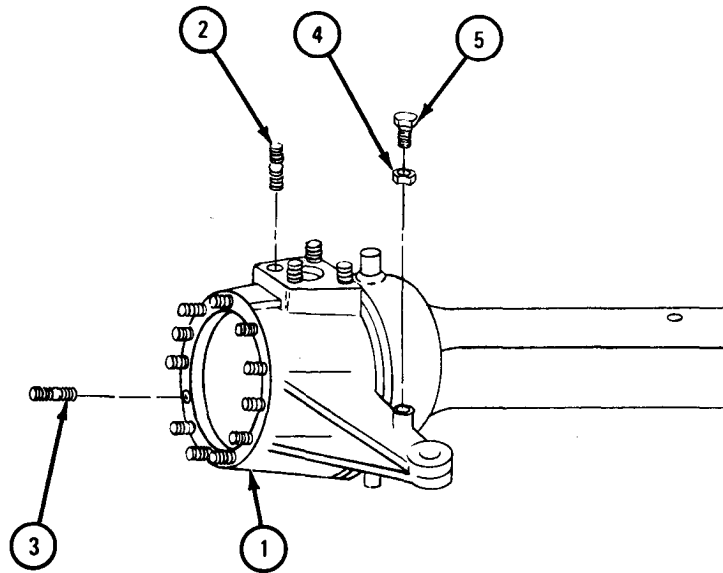

TA 085105

FRAME 4

1. Working on right side of axle, take off two screws (1) and lockwashers (2).
 2. Take off cover plate (3).
 3. Take out lube fitting (4).
- GO TO FRAME 5

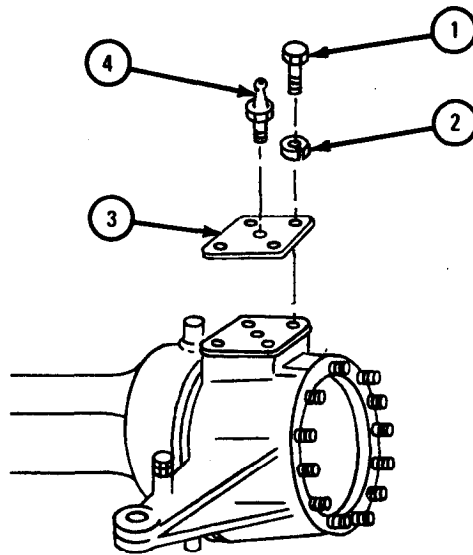

TA 101835

FRAME 5

1. Take out spacer (1).
2. Take out sleeve (2).
3. Take out two screws (3) and lockwashers (4).
4. Take off plate (5).
5. Take out lubrication fitting (6).
6. Take off sleeve (7).

NOTE

Do not take out bushings (8 and 9) unless they are damaged. Refer to para 10-4d for inspection procedures.

7. Take out bushings (8 and 9).

GO TO FRAME 6

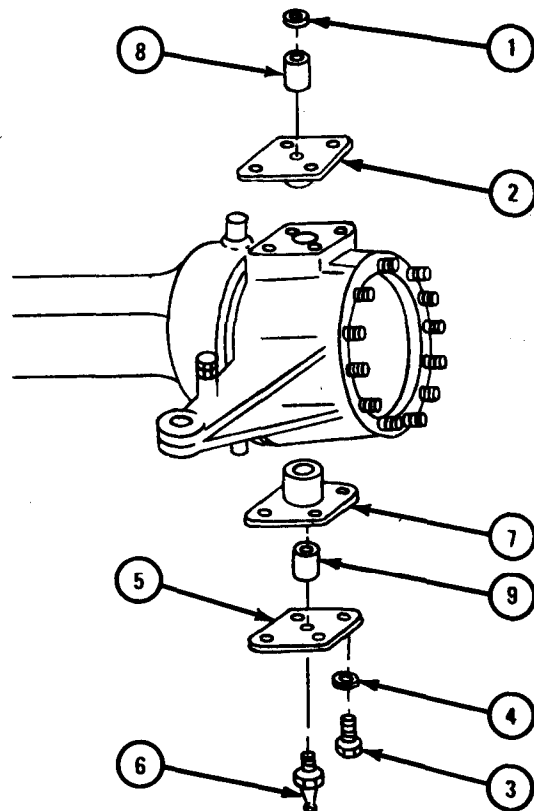

TA 101836

FRAME 6

1. Take off steering knuckle (1).
2. Take out 12 studs (2).

NOTE

Do not take out turn angle screw (3) or locknut (4) unless they are damaged. Refer to para 10-4d for inspection procedures.

3. Break spot weld on turn angle screw (3) and locknut (4).
4. Loosen locknut (4). Takeout turn angle screw (3) and locknut.

GO TO FRAME 7

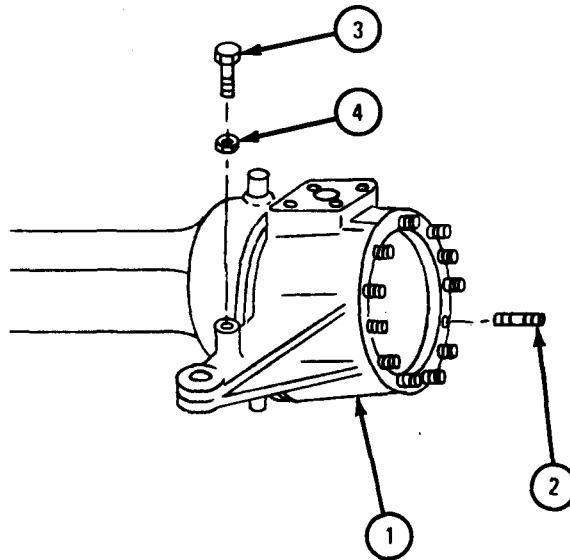

TA 101837

FRAME 7

NOTE

There is a relief valve (1) on each side of axle. There is only one relief valve (2), drain plug (3), fill plug (4), and gasket (5).

1. Take out two relief valves (1) and relief valve (2).
2. Take out drain plug (3).
3. Take out fill plug (4) and gasket (5). Throw away gasket.
4. Take out 12 studs (6).

END OF TASK

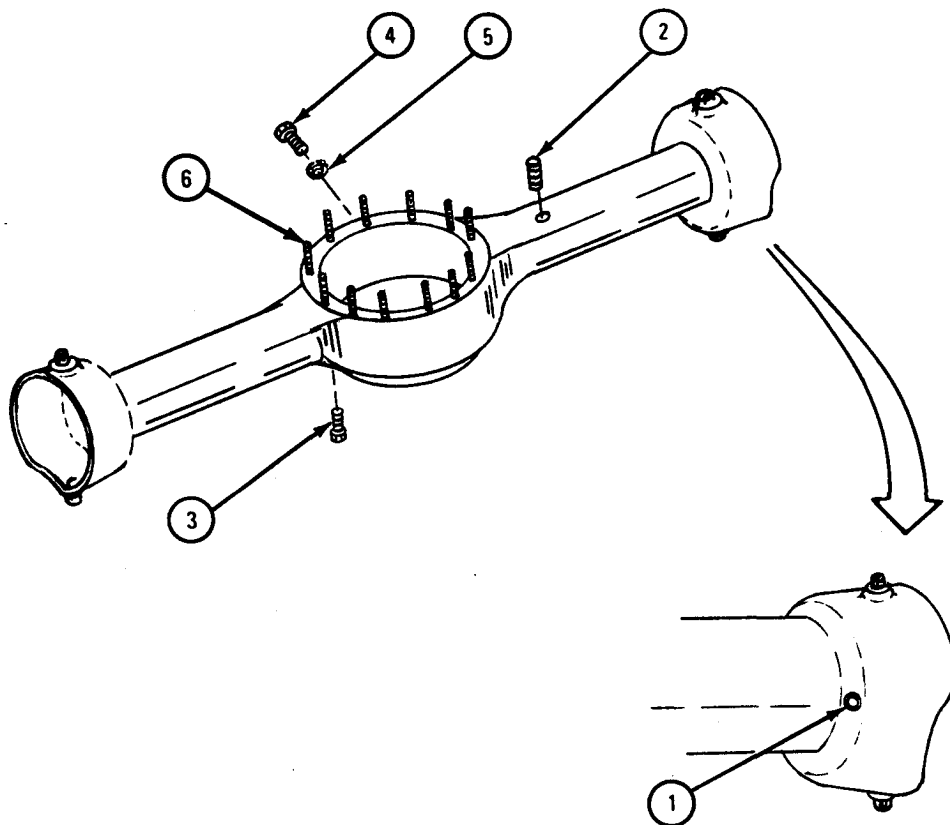

TA 085106

WARNING

Dry cleaning solvent is flammable. Do not use near an open flame. Keep a fire extinguisher nearby when solvent is used. Use only in well-ventilated places. Failure to do this may result in injury to personnel and damage to equipment.

- c. Cleaning. Clean all parts in solvent. Dry with clean rags.

d. Inspection and Repair.

FRAME 1

NOTE

Readings must be within limits given in table 10-1. If readings are not within given limits, throw away parts and get new ones.

1. Using micrometer, measure outside diameter of steering knuckle pins
2. Using micrometer, measure outside diameter of ball stud (2).
3. Using micrometer, measure inside diameter of steering knuckle sleeve (3).
4. Using micrometer, measure inside diameter of bushing (4 and 5).

GO TO FRAME 2

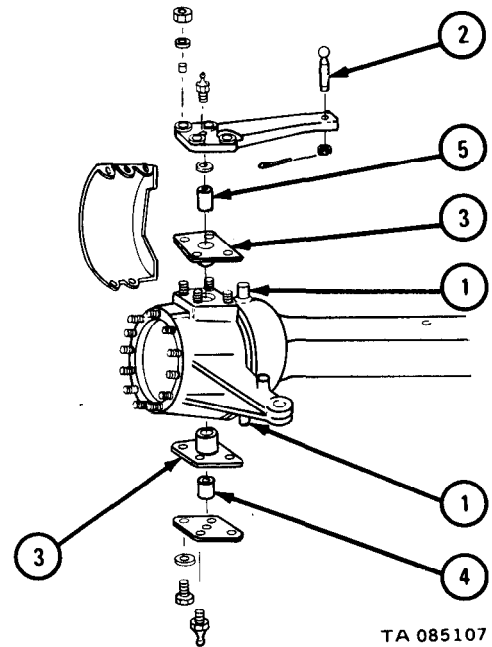

NOTE: CHECK ONLY THOSE PARTS WHICH ARE CALLED OUT IN THIS FRAME. PARTS WITHOUT CALLOUTS ARE SHOWN ONLY FOR REFERENCE PURPOSES OR ARE CHECKED IN ANOTHER FRAME.

Table 10-1. Front Axle Assembly (Steering Knuckle) Wear Limits

Index Number	Item/Point of Measurement	Size and Fit of New Parts (inches)	Wear Limit (inches)
1	Steering knuckle pin (outside diameter)	1.1240 to 1.1235	1.1230 to 1.1240
2	Ball stud (outside diameter)	1.245 to 1.235	1.225 to 1.245
3	Steering knuckle sleeves (inside diameter)	1.248 to 1.250	1.248 to 1.250
4 and 5	Bushing (inside diameter)	1.1250 to 1.1260	1.1250 to 1.1260

FRAME 2

NOTE

Readings must be within limits given in table 10-2.
 If readings are not within limits, throw away parts
 and get new ones.

1. Measure inside diameter of seal retainer seat (1).
2. Check that axle housing (2) has no nicks, burrs or scratches and is not bent or damaged in any other way. Rub out nicks, burrs or scratches with a fine mill file. If more repair is needed, get a new axle housing.
3. Check that relief valves (3) are not clogged. If valves are damaged, get new ones.
4. Check that filler plug (4), drain plug (5) and studs (6) have no stripped threads. If parts are damaged, get new ones.
5. Check that all threaded parts are not stripped or crossthreaded.

END OF TASK

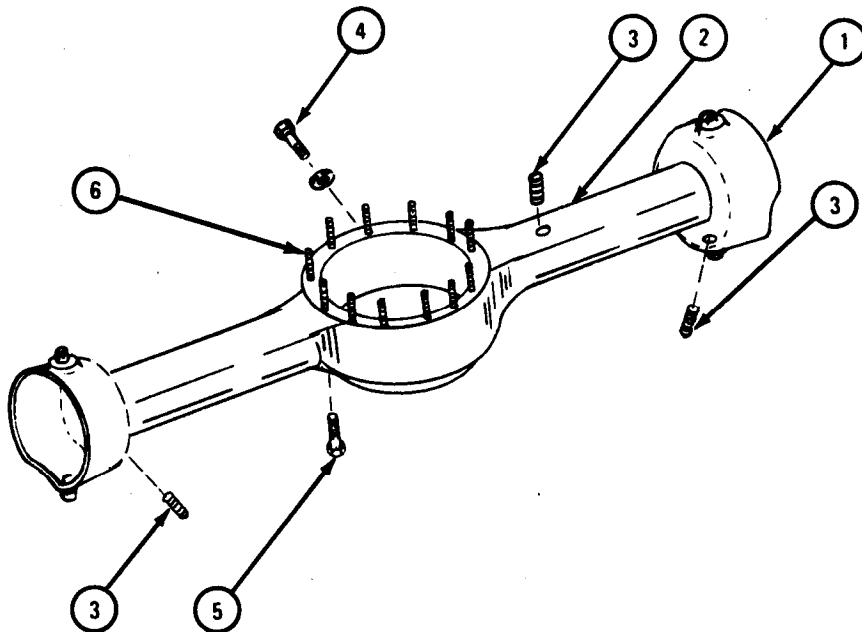

TA 085108

Table 10-2. Front Axle Assembly (Seal Retainer Seat) Wear Limits

Index Number	Item/Point of Measurement	Size and Fit of New Parts (inches)	Wear Limit (inches)
1	Seal retainer seat (inside diameter)	4.245 to 4.247	4.224

e. Assembly.

FRAME 1

NOTE

There is only one fill plug (1), gasket (2), drain plug (3), and relief valve (4). There are two relief valves (5).

1. Put in fill plug (1) and gasket (2).
2. Put in drain plug (3).
3. Put in relief valve (4) and two relief valves (5).
4. Put in 12 studs (6).

GO TO FRAME 2

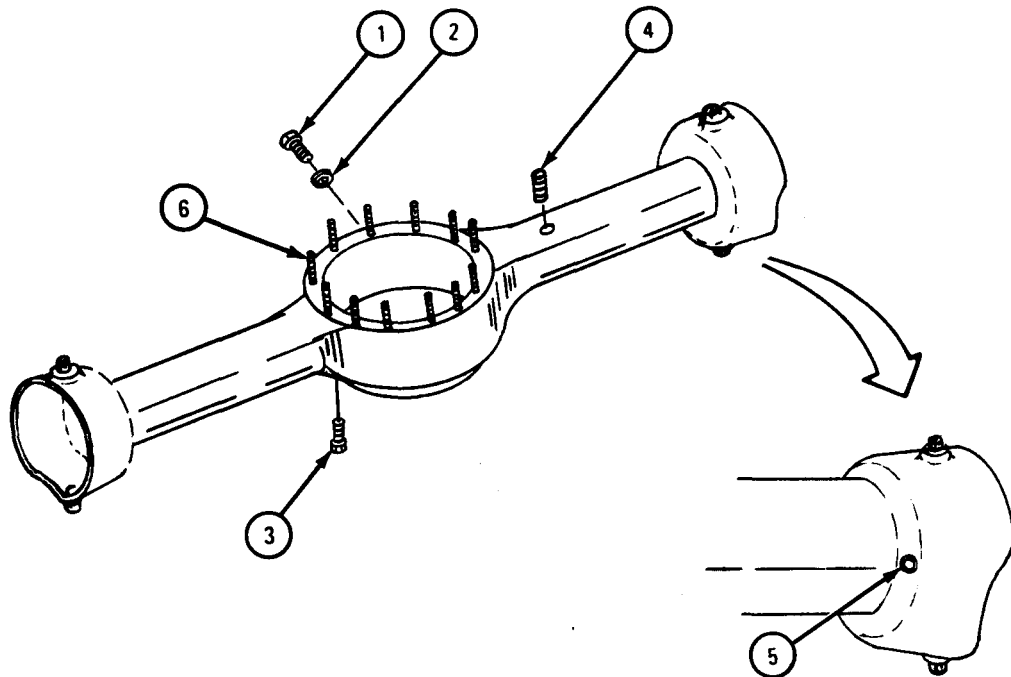

TA 085109

FRAME 2

1. If locknut (1) and turn angle screw (2) were taken out on left side of axle, put locknut on turn angle screw. Put in and hand tighten turn angle screw.
2. Put in 12 studs (3) and four studs (4).
3. Put on steering knuckle (5).

GO TO FRAME 3

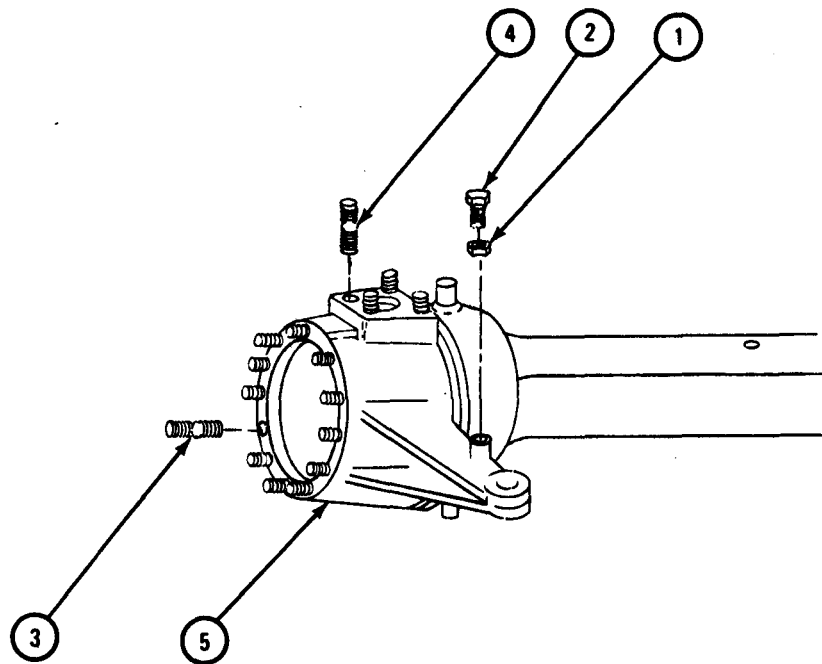

TA 085110

FRAME 3

1. If bushing (1) was taken out, press in new bushing.
2. Put in sleeve (2).
3. Put in lubrication fitting (3).
4. Put on plate (4). Put in two screws (5) and lockwashers (6).
5. If bushing (7) was taken out, press in new bushing.
6. Put on sleeve (8).
7. Put in spacer (9).

GO TO FRAME 4

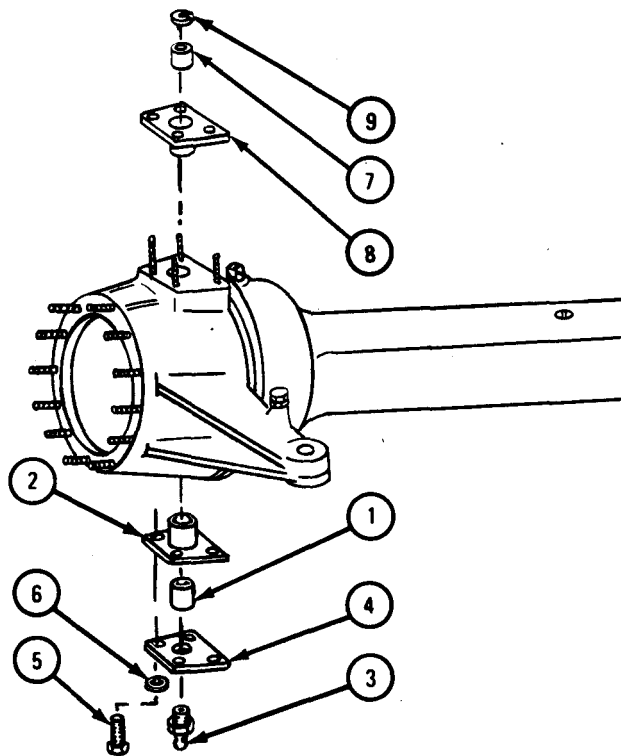

TA 085190

FRAME 4

1. If ball stud (1) was taken out, put in ball stud. Put on nut (2) and put in cotter pin (3).
2. Put in lubrication fitting (4).
3. Put on steering arm (5). Put in four split dowels (6).
4. Put on two nuts (7) and lockwashers (8).

GO TO FRAME 5

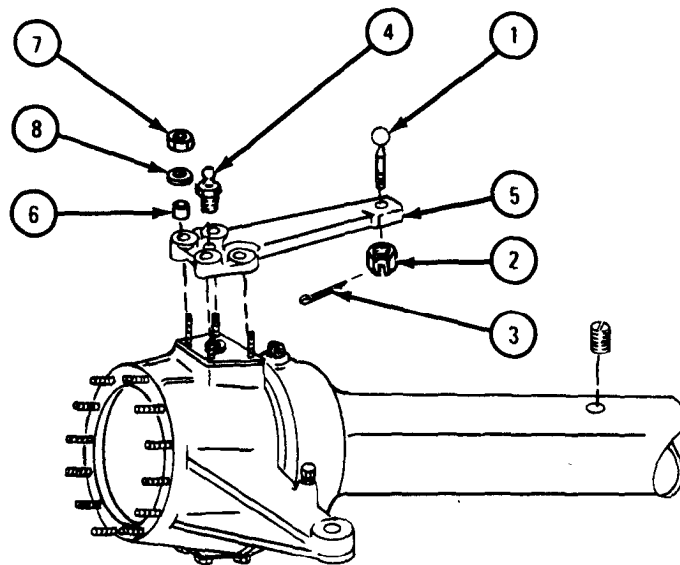

TA 085225

FRAME 5

1. Working on right side of axle, put in 12 studs (1).
2. Put on steering knuckle (2).
3. If locknut (3) and turn angle screw (4) were taken out, put locknut on turn angle screw. Put in and hand tighten turn angle screw.

GO TO FRAME 6

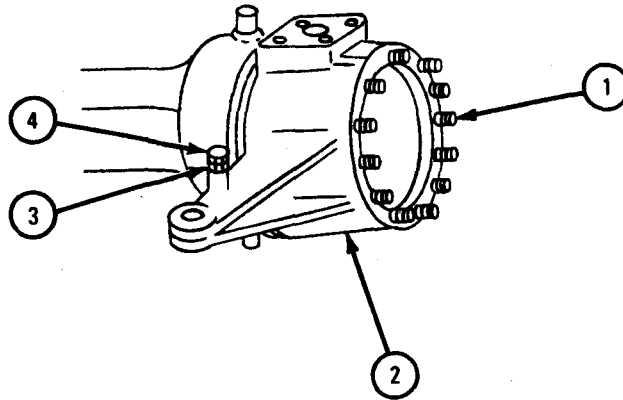

TA 101838

FRAME 6

1. If bushing (1) was taken out, press in new bushing.
2. Put in sleeve (2).
3. Put in lubrication fitting (3).
4. Put on plate (4) and two screws (5) with lockwashers (6).
5. If bushing (7) was taken out, press in new bushing.
6. Put on sleeve (8).
7. Put in spacer (9).

GO TO FRAME 7

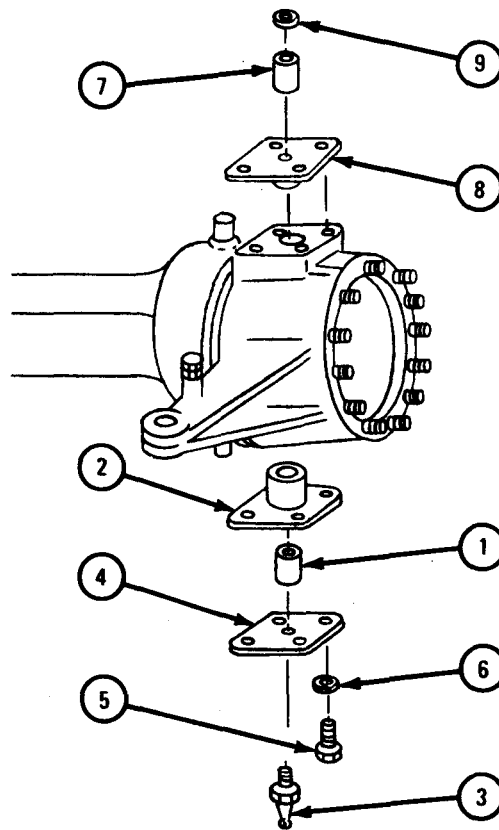

TA 101839

FRAME 7

1. Put in lubrication fitting (1).
 2. Put on cover plate (2).
 3. Put in two screws (3) with lockwashers (4).
- GO TO FRAME 8

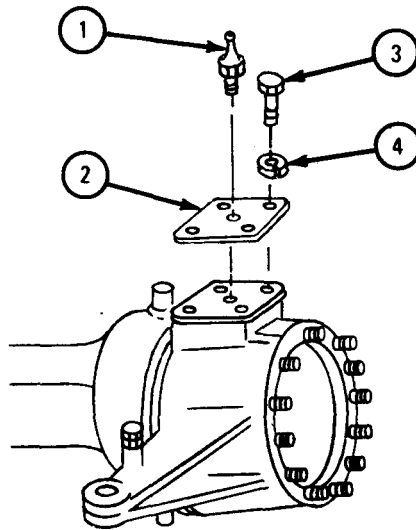

TA 101840

FRAME 8

NOTE

Follow-on Maintenance Action Required:

1. Replace differential. Refer to para 10-7.
2. Replace tie rod. Refer to TM 9-2320-209-20.
3. Replace steering knuckle boot and guard. Refer to TM 9-2320-209-20.
4. Replace front axle shafts. Refer to TM 9-2320-209-20.
5. Replace front hub and drum assemblies. Refer to TM 9-2320-209-20.
6. Replace front axle assembly. Refer to para 10-3.
7. Replace front propeller shaft. Refer to Propeller Shaft and Universal Joint Removal and Replacement, TM 9-2320-209-20.
8. Replace front wheels. Refer to TM 9-2320-209-10.
9. Lower truck. Refer to TM 9-2320-209-20.
10. Replace drag link. Refer to TM 9-2320-209-20.
11. Replace front axle hydraulic brake lines. Refer to Hydraulic Lines, Hoses, and Fittings Removal and Replacement, TM 9-2320-209-20.
12. Lubricate front axle. Refer to LO 9-2320-209-12/1.

END OF TASK

10-5. FRONT AXLE SHAFT AND UNIVERSAL JOINT REPAIR.

TOOLS: Oil Seal and retainer puller, pn 8708740
Oil seal replacer, pn 7083258

SUPPLIES: Solvent, dry cleaning, type II (SD-2), Fed. Spec P-D-680
Clean rags
Artillery and automotive grease, type GAA, MIL-G-10924

PERSONNEL: One

EQUIPMENT CONDITION: Truck parked, engine off, handbrake set.

a. Preliminary Procedure. Remove front axle shaft assembly. Refer to TM 9-2320-209-20.

b. Disassemble.

FRAME 1

NOTE

If working on ball-type universal joint, do step 1. If working on center cross-type universal joint, go to frame 4.

1. Drive universal joint grease pin (1) out of yoke (2) on outer shaft (3).
GO TO FRAME 2

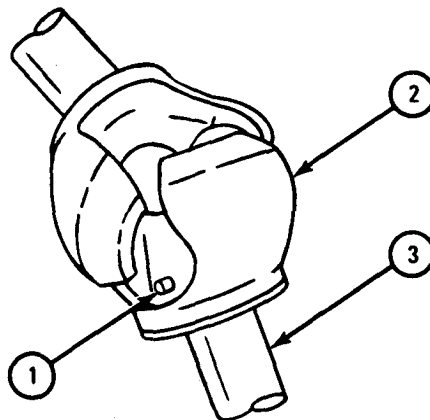

TA 101815

FRAME 2

CAUTION

Be careful not to damage splines (1) on outer shaft (2).

1. Holding axle shaft assembly as shown, tap it on wooden block until intermediate pin (3) falls out of ball (4).

NOTE

Pin (3) will drop farther into hole in universal joint outer shaft (2).

GO TO FRAME 3

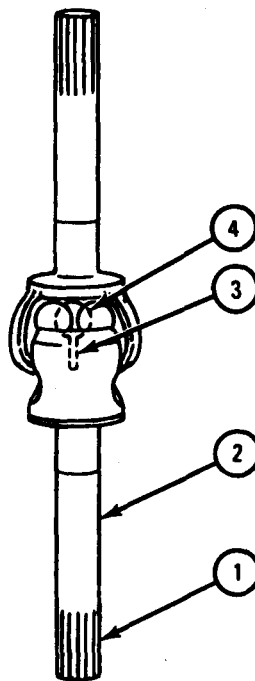

TA 101816

FRAME 3

1. With axle inner shaft (1) in vise, lower outer shaft (2) while pulling outward. Drive ball (3) will drop out of universal joint yoke (4).
2. Turn outer shaft (2) until hole for intermediate pin (5) is facing down and let intermediate pin drop out.

END OF TASK

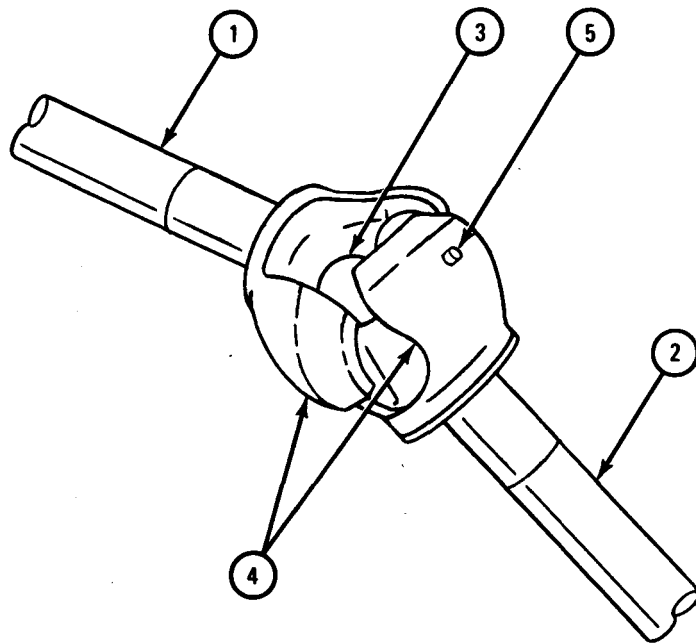

TA 101817

FRAME 4

1. Take off four lockrings (1).
2. Tap one end of yoke (2) until bearing (3) comes out of yoke.
3. Tap other end of yoke (2) until bearing (4) comes out of yoke.
4. Tilt yoke (2) and take yoke off of universal joint (5).
5. Tap universal joint (5) and take out two bearings (6).
6. Take off two thrust rings (7 and 8).

END OF TASK

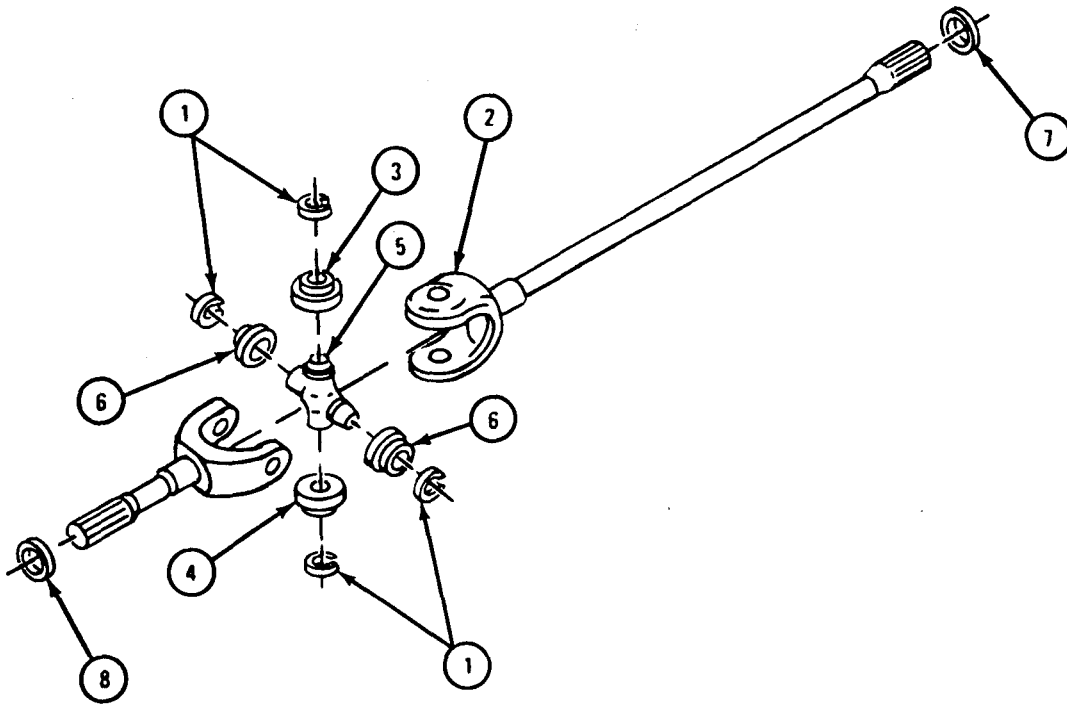

TA 101818

c. Cleaning. There are no special cleaning procedures needed. Refer to cleaning procedures given in para 1-3.

d. Inspection and Repair.

FRAME 1**NOTE**

If working on ball-type universal joint, do steps 1 and 2. If working on center cross-type universal joint, go to frame 3.

1. Check that five drive balls (1) have no cracks, chips or rough spots. If drive balls are damaged, get a new set of drive balls.
2. Check that inner shaft (2) and outer shaft (3) have no damaged splines (4), twisted or bent shafts or worn or damaged yokes (5). If inner shaft (2) or outer shaft (3) is damaged, get a new axle shaft assembly.

GO TO FRAME 2

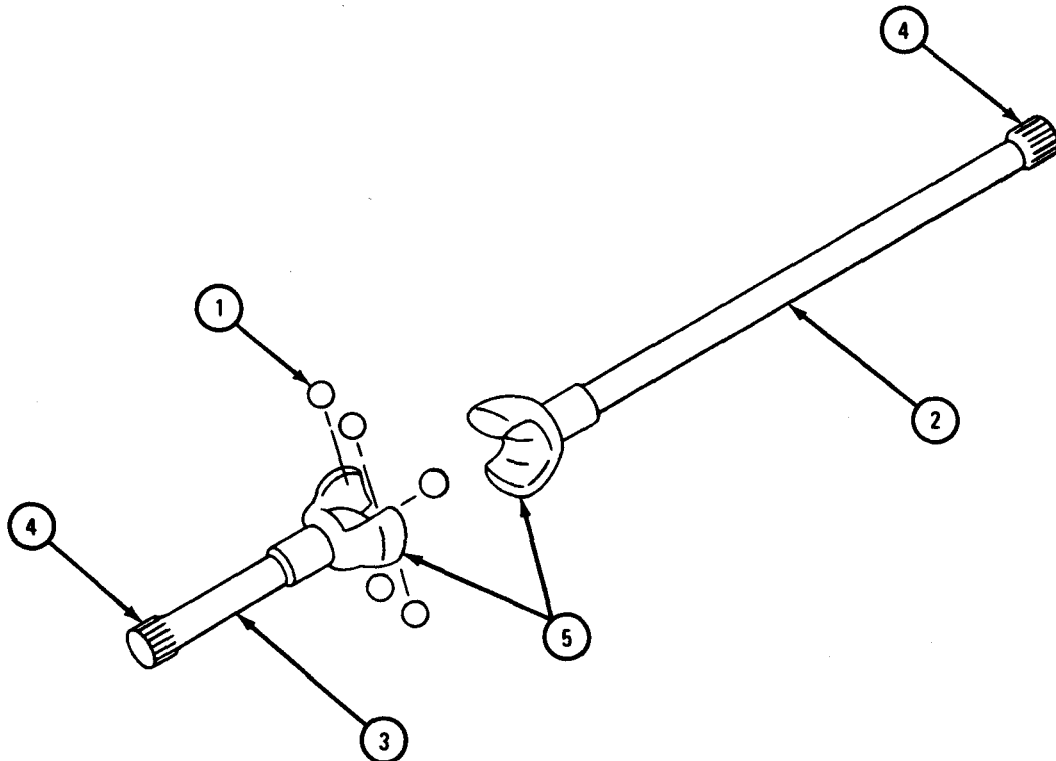

TA 101819

FRAME 2

NOTE

Readings must be within limits given in table 10-3. The letter L shows a loose fit. If readings are not within given limits, throw part away and get a new one.

1. Measure fit of shaft splines (1) in drive flange (2).
2. Measure diameter of outer shaft journal (3).
3. Measure diameter of inner shaft journal (4).
4. Measure diameter of drive balls (5).

NOTE

Drive balls (5) are 0.001, 0.002, and 0.003 inch under-size and 0.001, 0.002, and 0.003 inch oversize.

END OF TASK

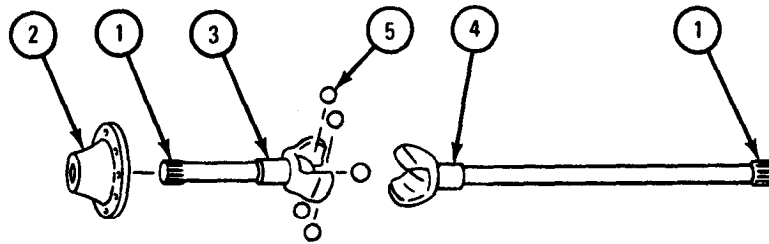

TA 101820

Table 10-3. Front Axle Shaft and Ball-type Universal Joint Wear Limits

Index Number	Item/Point of Measurement	Size and Fit of New Parts (inches)	Wear Limits (inches)
1 and 2	Spline shaft fit in drive flange	0.004 L	0.010 L
3	Outer shaft journal diameter	1.667 to 1.670	0.005
4	Inner shaft journal diameter	1.665 to 1.667	0.003

FRAME 3

1. Check that universal joint (1) is not worn or damaged. If universal joint is worn or damaged, get a new one.
2. Check that inner shaft (2) and outer shaft (3) have no damaged splines (4), twisted or bent shafts or worn or damaged yokes (5). If inner shaft (2) or outer shaft (3) is damaged, get a new axle shaft assembly.
3. Check that four bearings (6) are not worn or damaged. If needles drop out of bearing or if journal bearing surfaces (7) show marks of needles, get all new bearings and journal.

GO TO FRAME 4

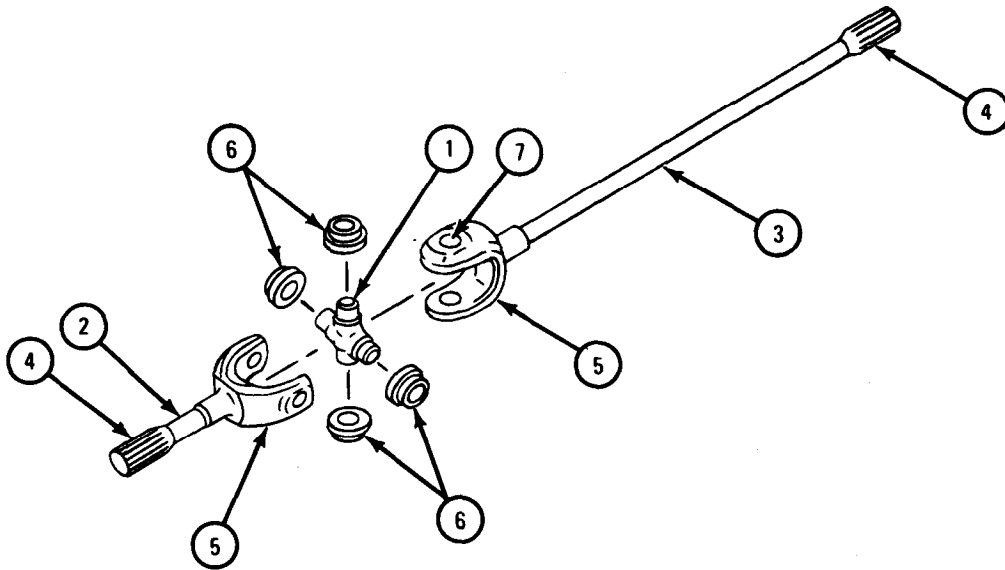

TA 101821

FRAME 4

NOTE

Readings must be within limits given in table 10-4. If readings are not within given limits, throw away part and get a new one.

1. Measure tooth width of shaft splines (1).
2. Measure diameter of outer shaft journal (2).
3. Measure diameter of inner shaft journal (3).
4. Measure outside diameter for bearing surface on universal joint (4).

END OF TASK

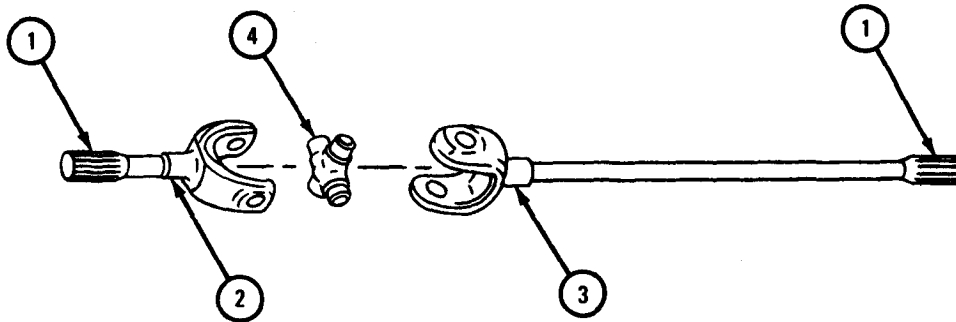

TA 101822

Table 10-4. Front Axle Shaft and Universal Joint Wear Limits

Index Number	Item/Point of Measurement	Size and Fit of New Parts (inches)	Wear Limits (inches)
1	Shaft spline tooth width	0.1704 to 0.1750	0.1699
2	Outer shaft journal diameter	1.668 to 1.670	1.666
3	Inner shaft journal diameter	1.668 to 1.670	1.666
4	Universal joint bearing surface	1.1614 to 1.1618	None

e. Assembly.**FRAME 1****NOTE**

If working on ball-type universal joint, do steps 1, 2, and 3.
If working on center cross-type universal joint, go to frame 3.

1. Put pin (1) into hole in outer shaft (2).
2. Holding outer shaft (2) up and down, place one of five drive balls (3) in socket of outer shaft.
3. Place inner shaft (4) against outer shaft (2) and put in two more drive balls (3).

GO TO FRAME 2

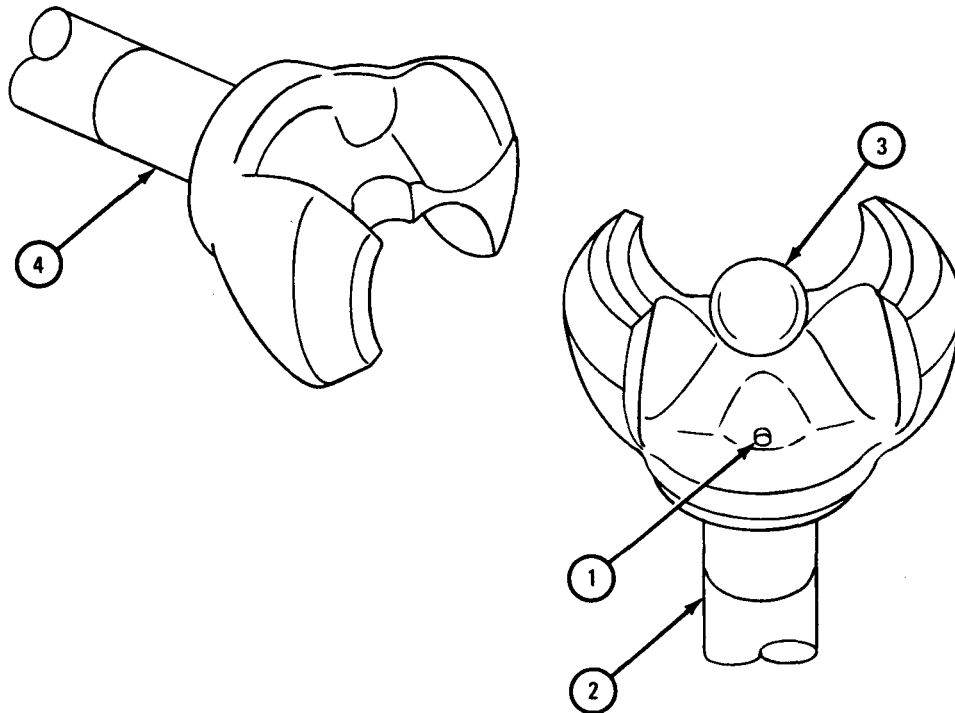

TA 101823

FRAME 2

1. Turn inner axle shaft (1) and outer axle shaft (2), making sure that three drive balls (3) do not fall out.
2. Put in two other drive balls (3).
3. With inner axle shaft (1) and outer axle shaft (2) up and down, and with inner shaft on the bottom, aline hole for intermediate ball (3) with pin (4) and put pin (5) in outer shaft.
4. Lightly grease drive balls (3) and splines (6).

GO TO FRAME 3

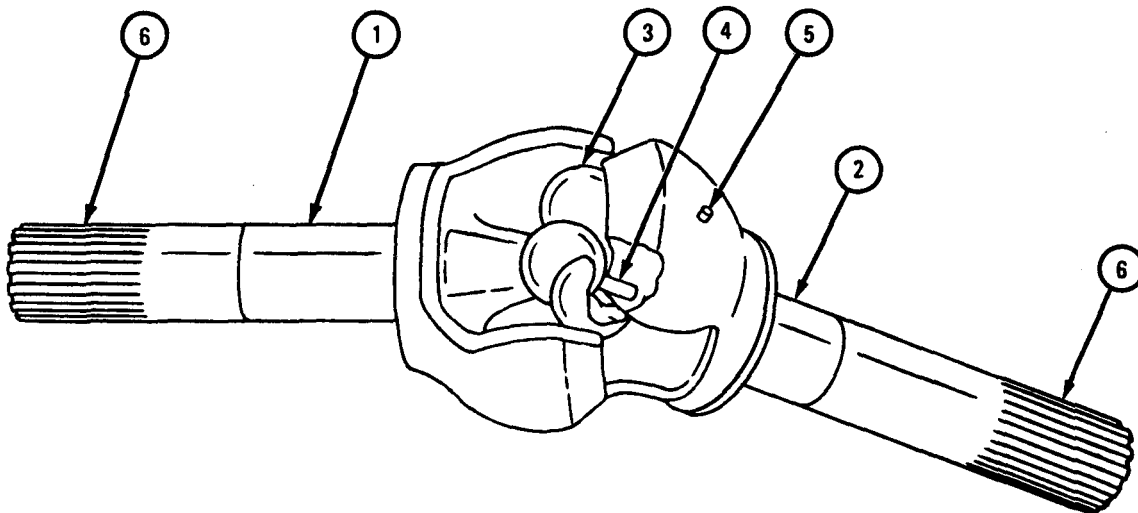

TA 101824

FRAME 3

1. Tap one bearing (1) into yoke (2). Put universal joint (3) into place and tap in other bearing (1).
2. Tap one bearing (4) into yoke (5).
3. Put universal joint (3) into place and tap in other bearing (4).
4. Put four lockrings (6) on four bearings (1 and 4).
5. Put thin thrust ring (7) on shaft (8).
6. Put thick thrust ring (9) on shaft (10).

NOTE

Follow-on Maintenance Action Required:

Replace front axle shaft assembly. Refer to TM 9-2320-209-20.

END OF TASK

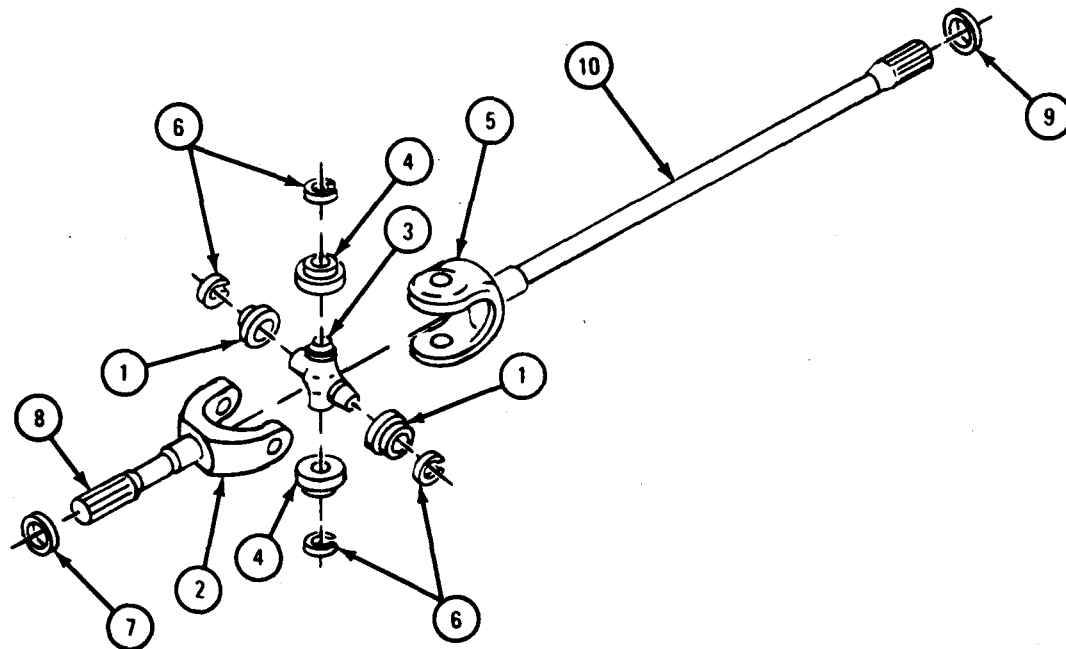

TA 101825

10-6. FRONT AXLE DRIVE FLANGE REPAIR.

NOTE

This task is the same for the left and right front axle drive flanges.

TOOLS: No special tools required

SUPPLIES: Artillery and automotive grease, type GAA, MIL-G-10924

PERSONNEL: One

EQUIPMENT CONDITION: Truck parked on level surface, engine off, handbrake set, rear wheels chocked.

a. Preliminary Procedure. Remove axle shaft drive flange. Refer to Front Hub and Brake Drum Assembly Removal and Replacement, TM 9-2320-209-20.

There are no special cleaning procedures needed. Refer to cleaning procedures given in para 1-3.

c. Disassembly.

FRAME 1

NOTE

Do not take out expansion plug (1) unless it is damaged. Refer to para 10-6d for inspection procedures.

1. Press out expansion plug (1).

END OF TASK

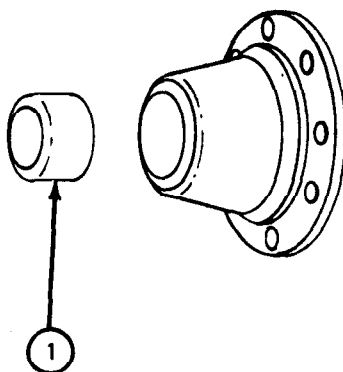

TA 089023

d. Inspection and Repair.**FRAME 1**

1. Check that drive flange (1) is not bent, dented or cracked.
2. Check that splines (2) are not chipped or worn.
3. Check that screw holes (3) are not out-of-round. If drive flange is damaged, get a new one.
4. Check that expansion plug (4) is not bent, dented or cracked. If expansion plug is damaged, get a new one.

END OF TASK

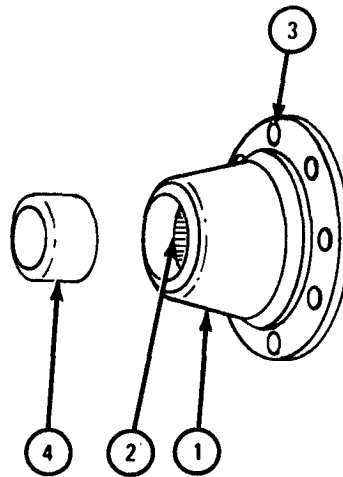

TA 089024

e. Assembly.

FRAME 1

1. If expansion plug (1) was taken out, press in expansion plug.
2. Put a light coat of grease inside drive flange (2).

NOTE

Follow-on Maintenance Action Required:

Replace axle shaft drive flange. Refer to Front Hub and Brake Drum Assembly Removal and Replacement, TM 9-2320-209-20.

END OF TASK

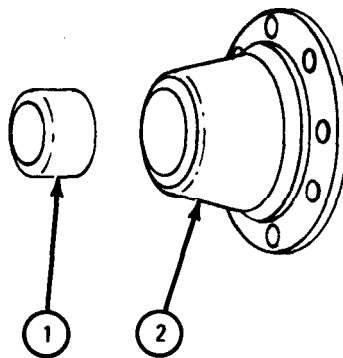

TA 089025

Section III. DIFFERENTIAL CARRIER ASSEMBLY

10-7. DIFFERENTIAL CARRIER ASSEMBLY REMOVAL, REPAIR, AND REPLACEMENT.

TOOLS: Mechanical puller kit, pn 4231596
 Mechanical puller kit, pn 8708724
 Handle, pn 7083241
 Puller, pn 8366689 (2)
 Bearing cup replacer, pn 7083252
 Oil seal replacer, pn 7083256
 Gear replacer, pn 7083257
 Oil seal remover, pn 7083250
 Bearing remover, pn 7083251
 Bearing sleeve remover/replacer, pn 7083246
 Hook spanner wrench, pn 7083260
 Oil seal remover, pn 7083249
 Screw, pn 7083216

SUPPLIES: Differential parts kit
 Gasket and shim set
 Bevel gear set
 Cleaning compound, MIL-C-1109
 Oil, MIL-L-17672
 Red lead pigment, TT-P-86
 Prussian blue, MIL-P-30501
 Solvent, dry cleaning, type II (SD-2), Fed. Spec P-D-680
 Fine lapping stone
 Safety wire, MS-20995
 Gear lubricating oil, GO 80/90, MIL-L-2105

PERSONNEL: Two

EQUIPMENT CONDITION: Truck parked, engine off, handbrake set.

a. Preliminary Procedures.

(1) Front axle differential.

(a) Jack up and support truck chassis. Put safety trestles under frame rails behind front axle housing. Refer to Jacking and Supporting Truck Chassis, TM 9-2320-209-20.

(b) Drain differential. Refer to LO 9-2320-209-12/1.

(c) Remove propeller shaft. Refer to Propeller Shaft and Universal Joint Removal and Replacement, TM 9-2320-209-20.

(d) Remove front wheels. Refer to TM 9-2320-209-10.

(e) Remove drag link. Refer to TM 9-2320-209-20.

(f) Remove brake hydraulic lines. Refer to TM 9-2320-209-20.

(g) Remove front axle assembly. Refer to para 10-3.

(h) Place axle on axle stand.

(i) Remove axle shafts. Refer to TM 9-2320-209-20.

(2) Forward-rear axle or rear-rear axle differential.

(a) Jack up and support truck chassis. Put safety trestles under both rear spring seats. Refer to Jacking and Supporting Truck Chassis, TM 9-2320-209-20.

(b) Drain differential. Refer to LO 9-2320-209-12/1.

(c) Remove propeller shafts. Refer to Propeller Shaft and Universal Joint Removal and Replacement, TM 9-2320-209-20.

(d) Remove rear center and inner wheels. Refer to TM 9-2320-209-10.

(e) Remove torque rods. Refer to TM 9-2320-209-20.

(f) Remove brake hydraulic lines. Refer to Hydraulic Lines, Hoses, and Fittings Removal and Replacement, TM 9-2320-209-20.

(g) Remove rear axle assembly. Refer to para 11-4.

(h) Place axle on axle stand.

(i) Remove axle shafts. Refer to TM 9-2320-20.

b. Removal.**FRAME 1**

1. Loosen 12 nuts (1) and lockwashers (2).
2. Take out eight nuts (1) and lockwashers (2).
3. Using chain sling (3) and hoist (4) as shown, lift differential carrier assembly (5) 1/2 inch out of axle housing (6).
4. Take out other four nuts (1) and lockwashers (2).
5. Take off and throw away gasket (7).

END OF TASK

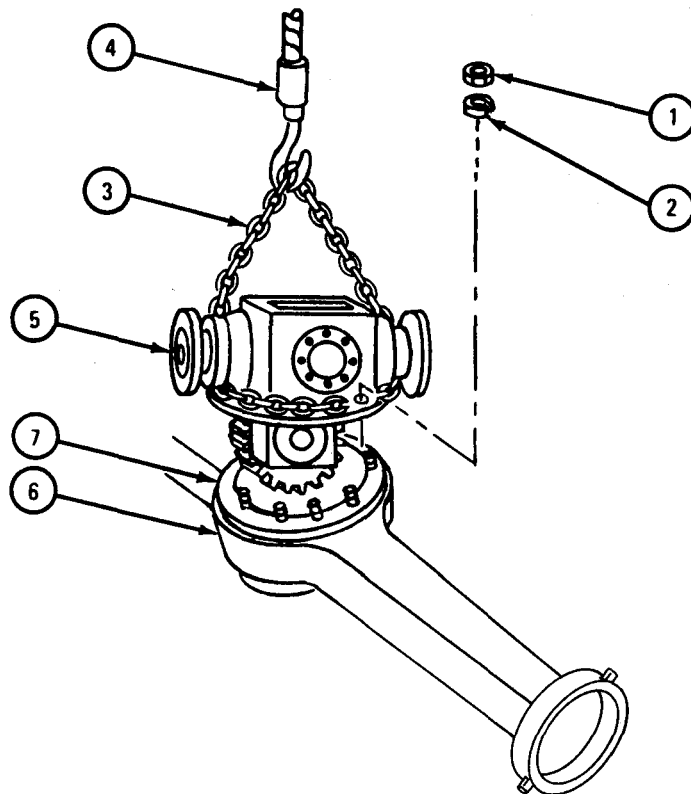

TA 085069

c. Disassembly.

FRAME 1

1. Mount differential carrier assembly (1) in holding device.
2. Center punch alinement marks (2) on each of two bearing caps (3) and bearing saddles (4).
3. Take out and throw away two safety wires (5).
4. Take out two bolts (6) and lockplates (7).
5. Unscrew and take out four bolts and lockwashers (8).
6. Tap two bearing caps (9) to loosen them and take them off.

GO TO FRAME 2

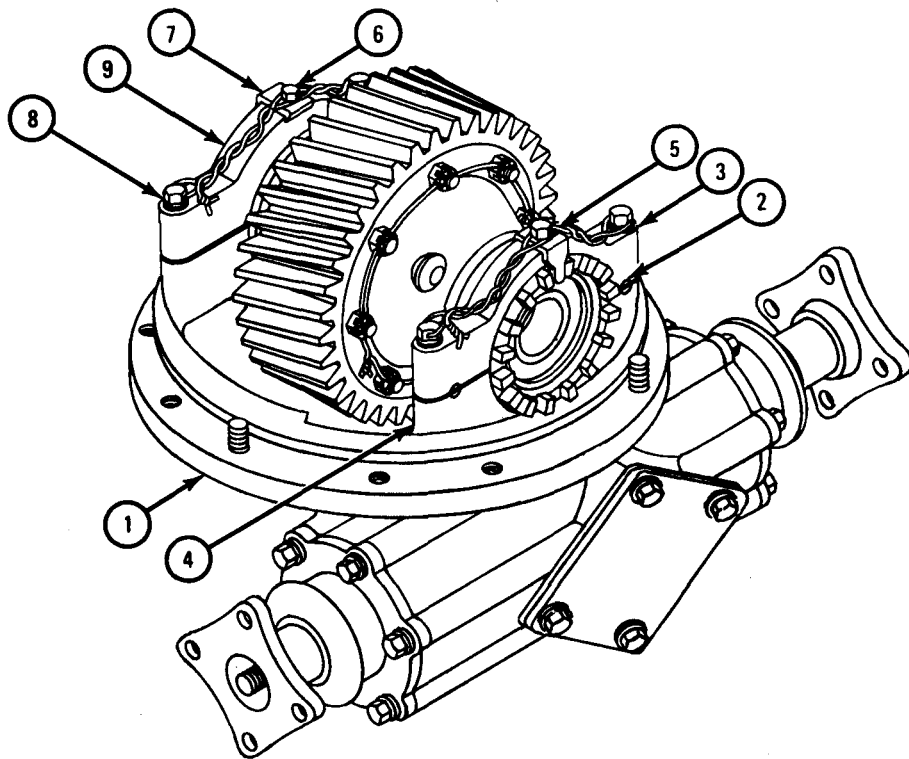

TA 085013

FRAME 2

1. Lift off two adjusting nuts (1).
 2. Lift differential drive gear (2) high enough to take off two bearing cups (3).
 3. Lift out differential drive gear assembly (2).
- GO TO FRAME 3

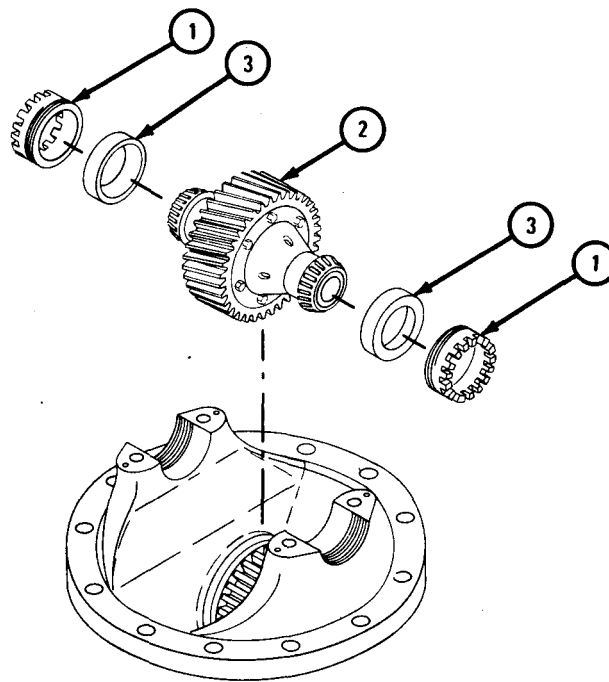

TA 085014

FRAME 3

1. Center punch alinement marks (1) on two case assemblies (2) and helical drive gear (3).
2. Take out and throw away safety wire (4).
3. Take out eight nuts (5) and bolts (6).

GO TO FRAME 4

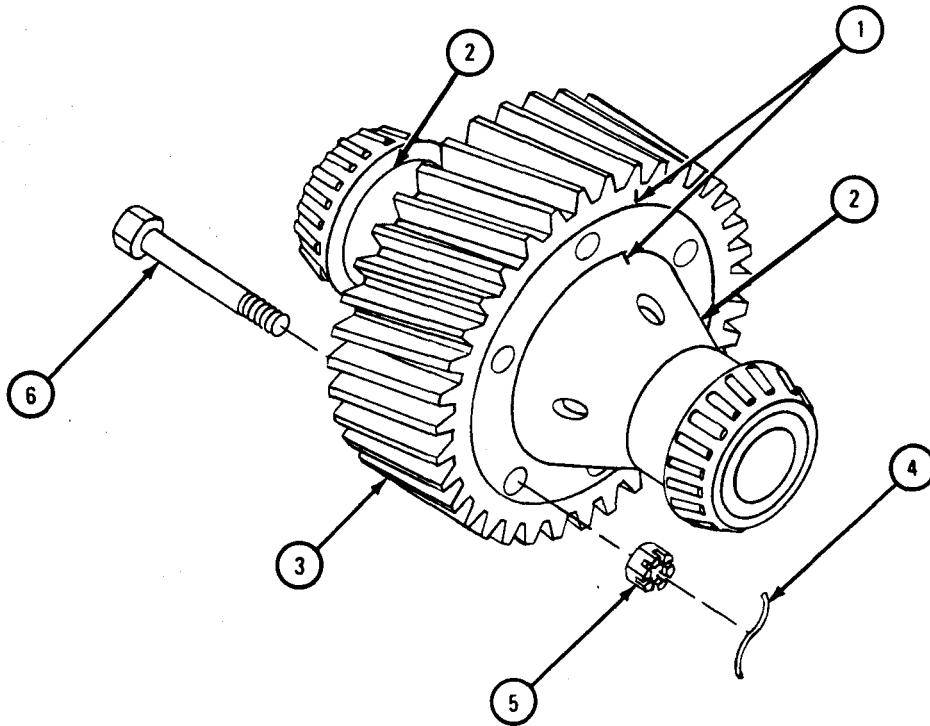

TA 085015

FRAME 4

1. Pull two differential case halves (1) off helical drive gear (2).
 2. Take off two thrust washers (3) and two side gears (4).
 3. Take off four thrust washers (5) and four pinion gears (6) from spider (7).
- GO TO FRAME 5

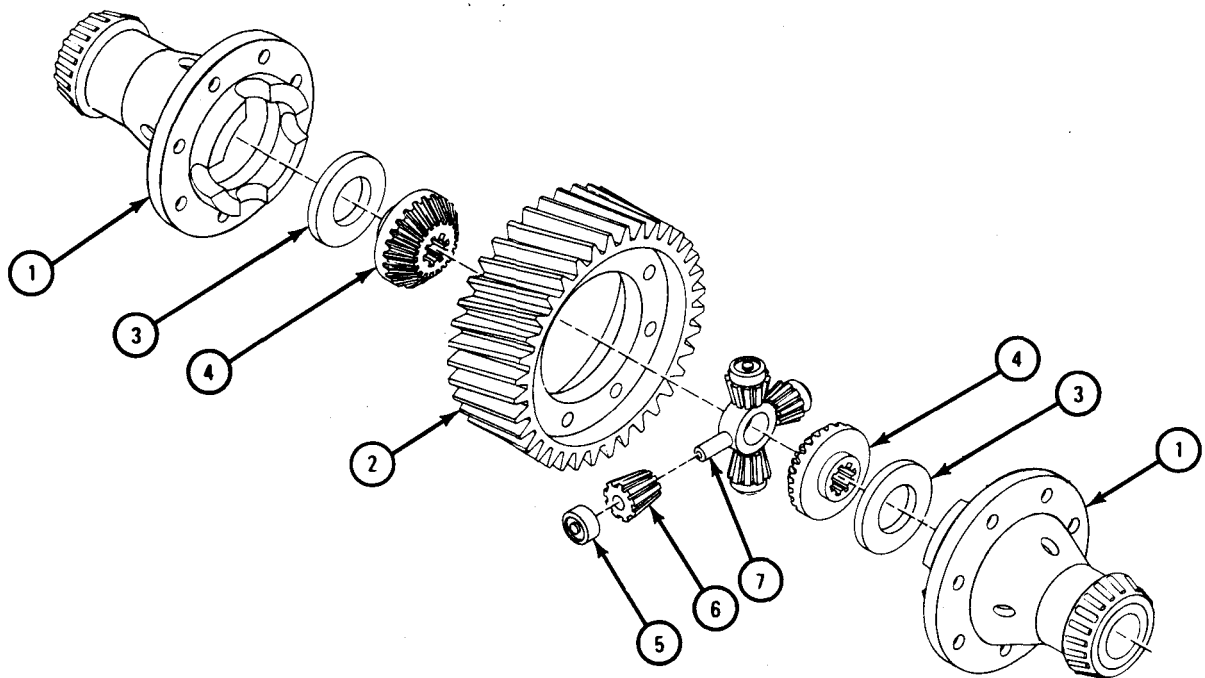

TA 085016

FRAME 5

1. Put adapter (1) from kit, pn 4231596, on case assembly (2).
2. Place two pieces of channel(3) across bed of press (4).
3. Place two steel spacers (5) across two channels (3).
4. Place case assembly (2) in press (4) with bearing cone adapter, pn 4231596, (1) resting on spacers (5).
5. Press bearing cone (6) from case assembly (2).

GO TO FRAME 6

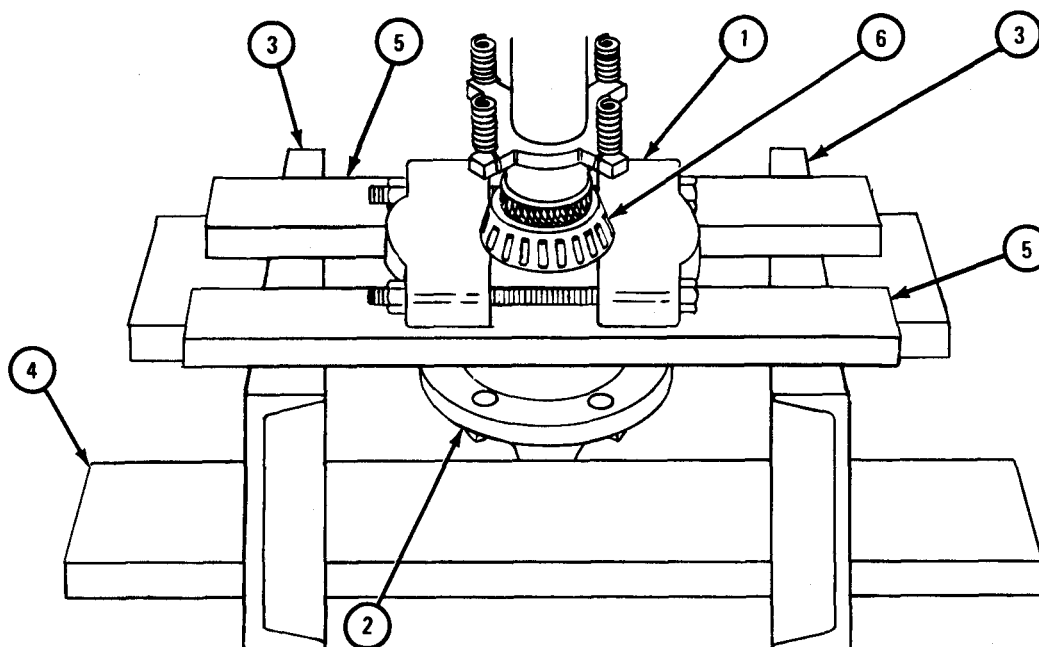

TA 085017

FRAME 6

1. Take out eight screws (1) and lockwashers (2) from top cover (3). Throw away gasket (4).
2. Take out four screws (5) and flat washers (6) from inspection cover (7). Throw away gasket (8).

GO TO FRAME 7

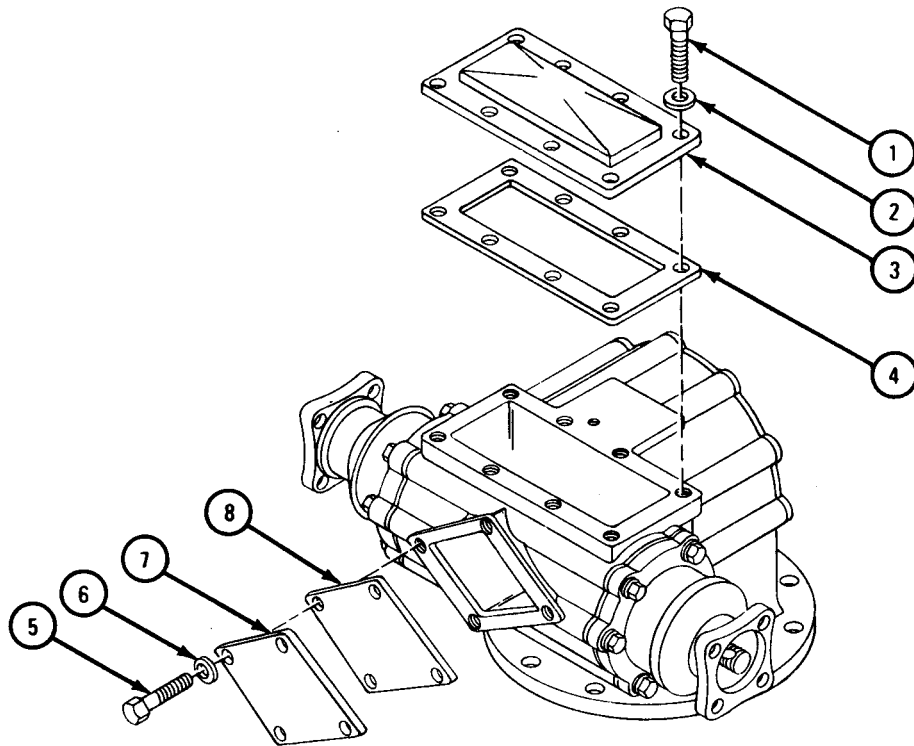

TA 085018

FRAME 7

1. Take out two cotter pins (1).
- Soldiers A and B
2. Take off two nuts (2) and spacer (3).
3. Using puller, pn 8708724 (4), take flange (5) off shaft (6).
4. Take off two dirt deflectors (7).

GO TO FRAME 8

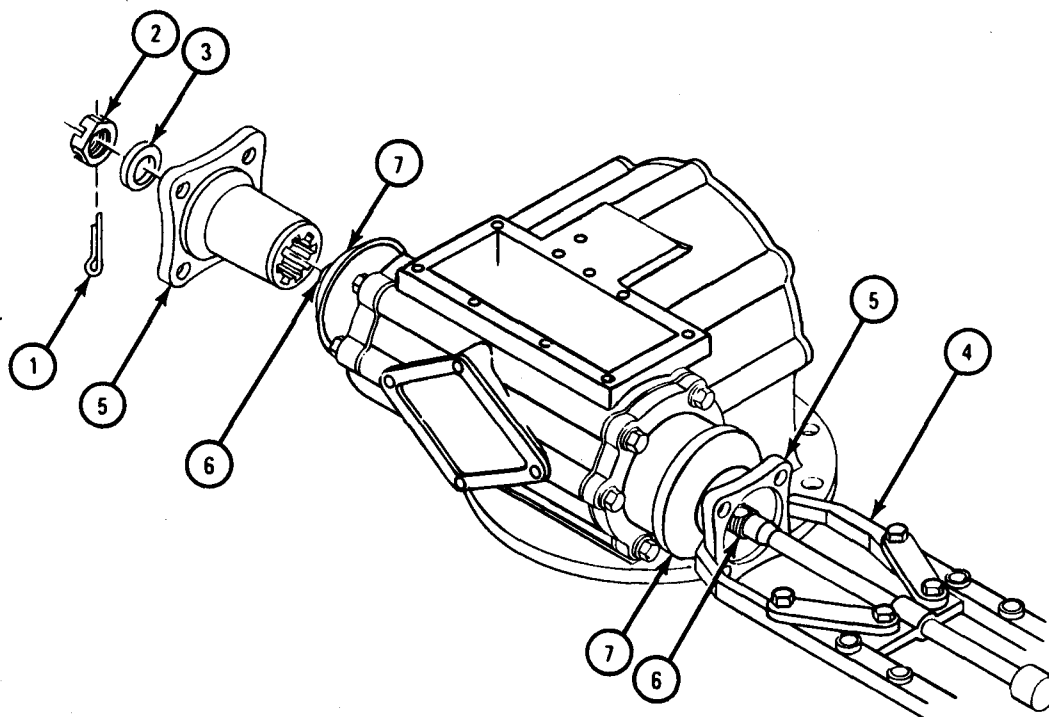

TA 085019

FRAME 8

1. Take out 12 screws (1) and flat washers (2).
2. Take off two retainers (3).
3. Take off shims (4). Tie shims (4) to retainers (3).
4. Take out spacer ring (5).

GO TO FRAME 9

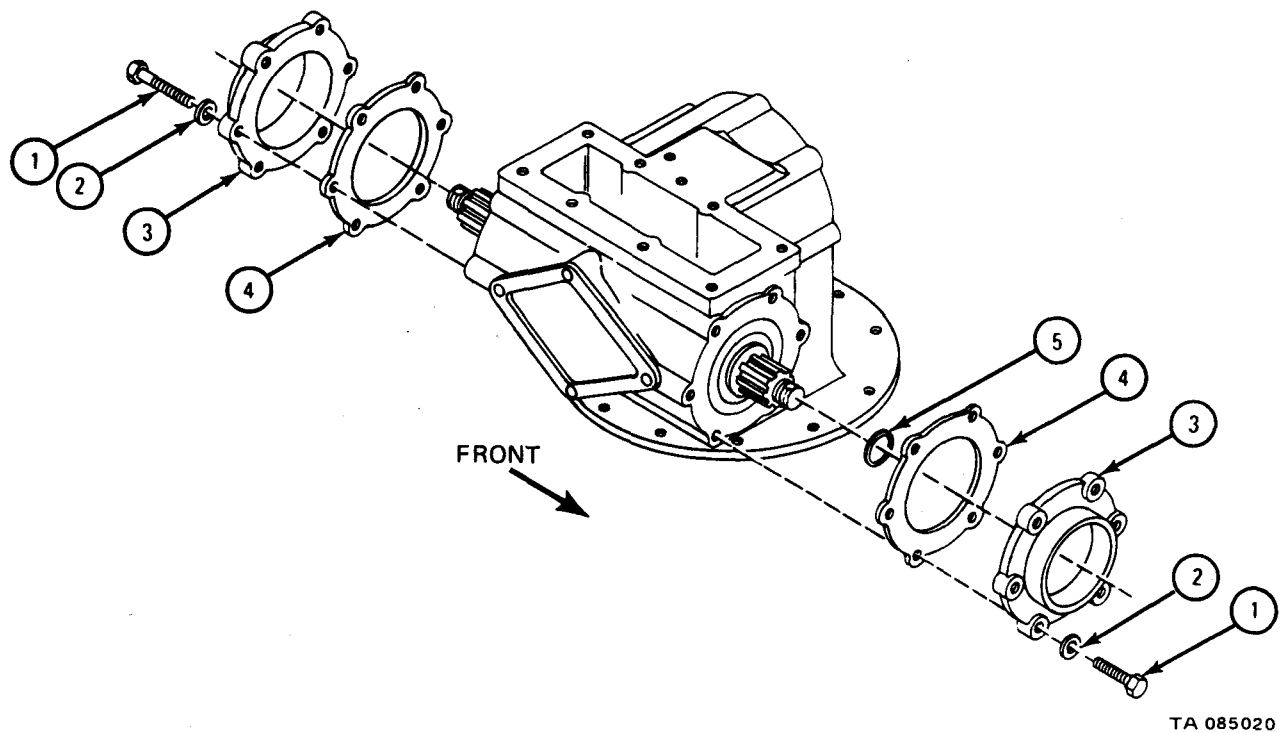

FRAME 9

1. Using remover, pn 7083249, (1) and handle (2), take out seal (3) from front retainer (4).
2. Using remover, pn 7083250, (5) and handle, pn 7083241, (2), take out seal (6) from rear retainer (7).

GO TO FRAME 10

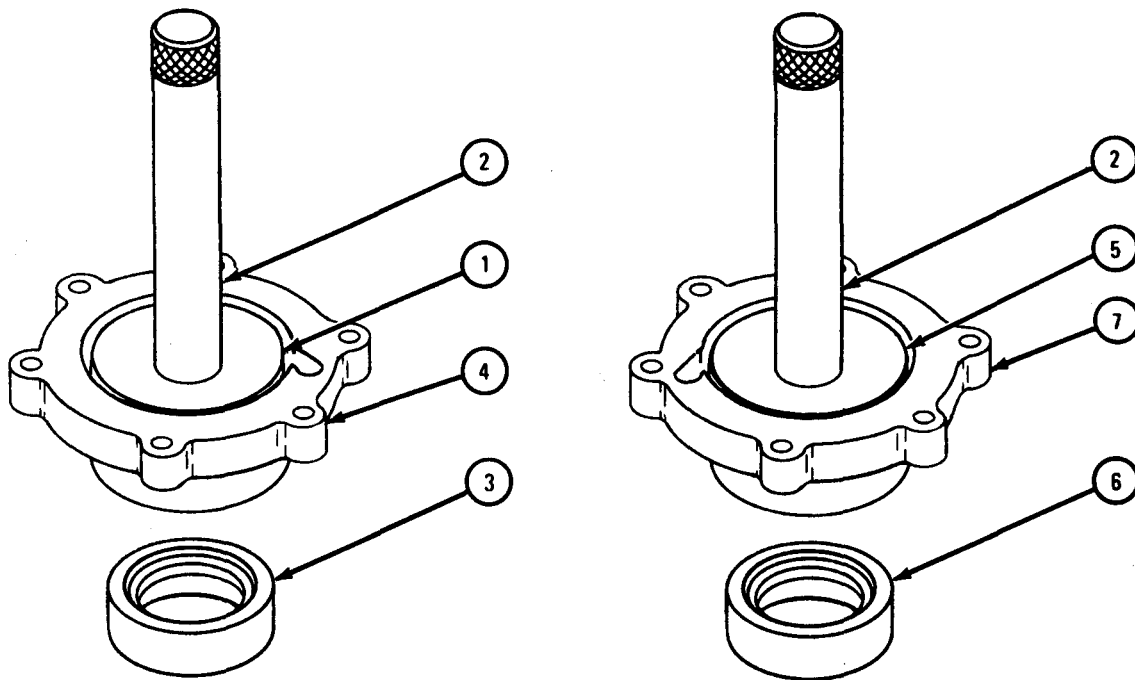

TA 085021

FRAME 10

1. Using hammer and brass drift pin, drive out through shaft (1) to rear of carrier case (2).
2. Take off rear bearing outer race (3).
3. Place two channels (6) across bed of press (7).
4. Place two steel spacers (8) across channels (6).
5. Put adapter (9) from kit, pn 4231596, in place as shown.
6. Press bearing (4) and spacer (5) off through shaft (1).

GO TO FRAME 11

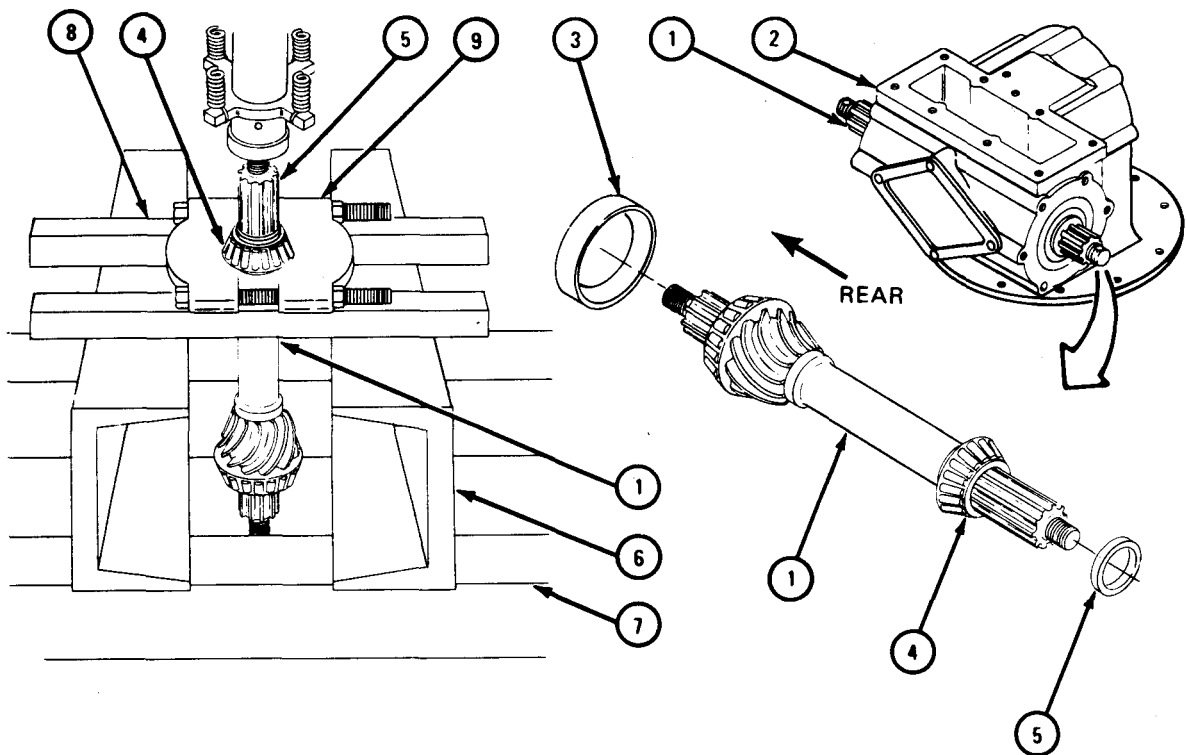

TA 085022

FRAME 11

1. Place two channels (1) across bed of press (2).
 2. Place two steel spacers (3) across channels (1).
 3. Put adapter (4) from kit, pn 4231596, in place as shown.
 4. Press gear (5) and bearing (6) off through shaft (7) as an assembly.
- GO TO FRAME 12

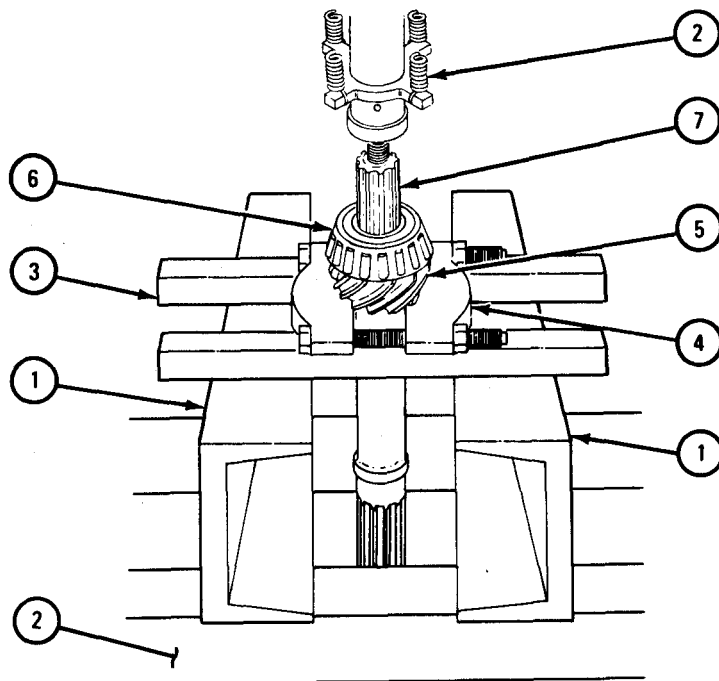

TA 085023

FRAME 12

1. Place two channels (1) across press (2).
2. Place two steel spacers (3) across channels (1).
3. Put adapter (4) from kit, pn 4231596, in place as shown.
4. Press out bearing (5) from pinion gear (6).

GO TO FRAME 13

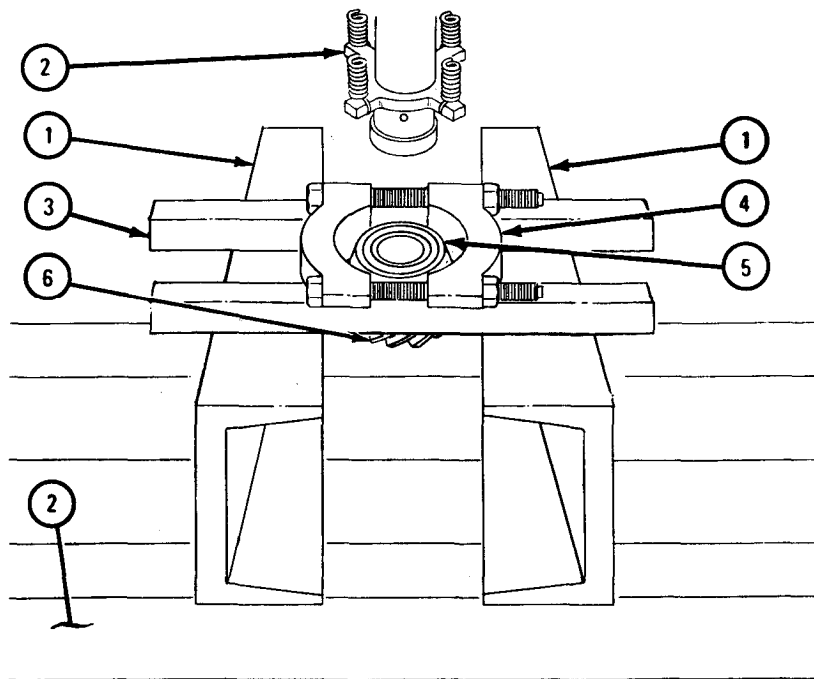

TA 085024

FRAME 13

1. Take off six screws (1) and lockwashers (2).
 2. Take off bearing cover (3) and shims (4). Tie shims to bearing cover (3).
- GO TO FRAME 14

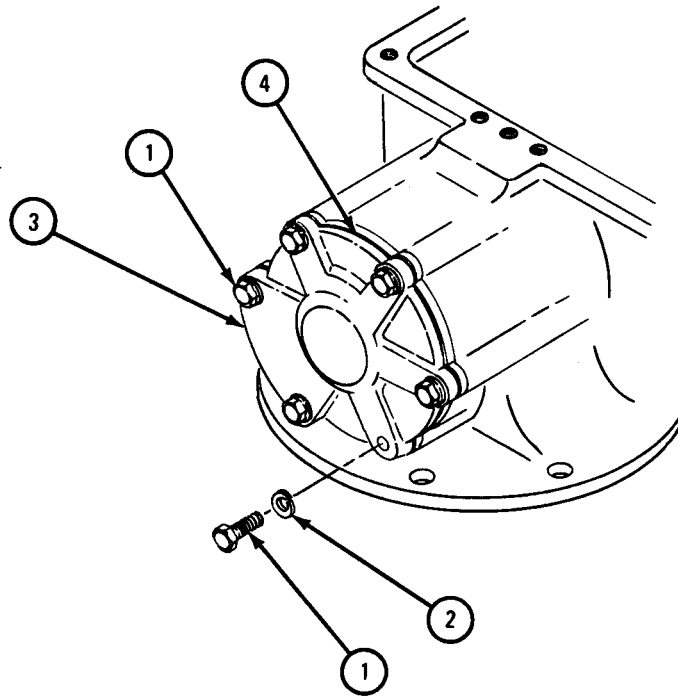

TA 085025

FRAME 14

1. Take off and throw away safety wire (1).
2. Take out two screws (2).
3. Take off plate (3).
4. Put two puller screws, pn 8366689, (4) in two holes (5).
5. Turn screws (4) evenly until bearing cage (6) is free of carrier (7). Take off bearing cage.
6. Take off shim (8). Tie shim to bearing cage (6).

GO TO FRAME 15

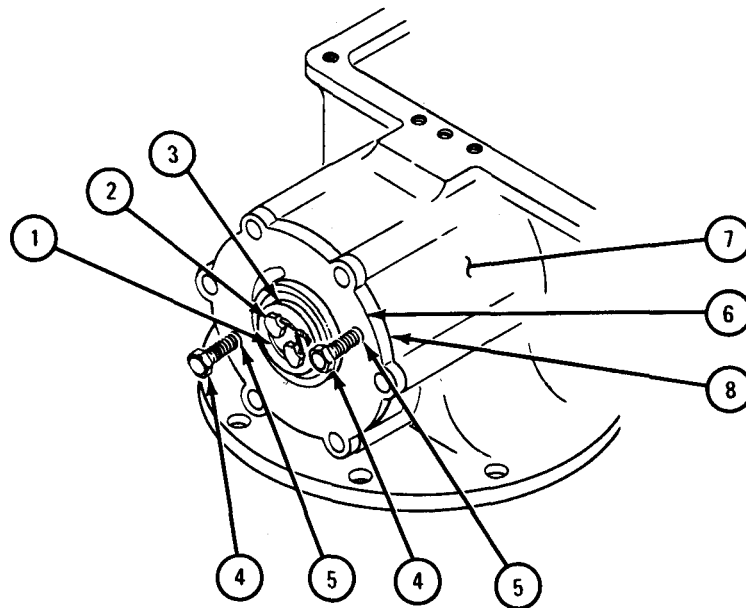

TA 085026

FRAME 15

1. Using remover, pn 7083251, (1) and handle (2), take out outer bearing cup (3) and cone (4) from bearing cage (5).
2. Using remover (1) and handle (2), take out inner bearing cone (6) and cup (7) from bearing cage (5).

GO TO FRAME 16

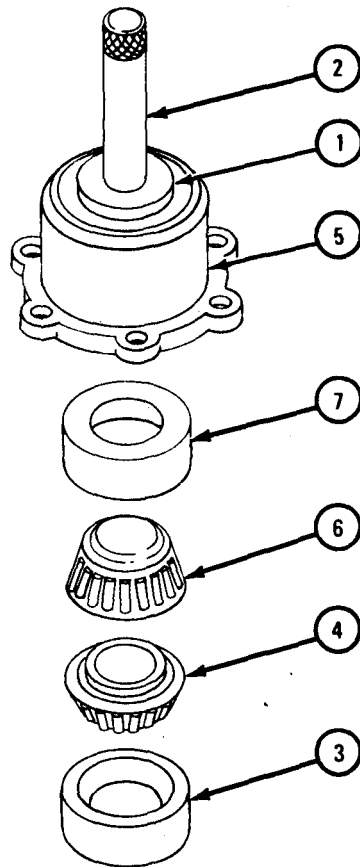

TA 085027

FRAME 16

1. Put two channels (1) across bed of press.
2. Put carrier case (2) on channels (1) as shown.
3. Put two parallels (3) under bevel drive gear (4) as shown.
4. Press helical drive pinion shaft (5) out of carrier case (2).
5. Take out key (6) from shaft (5).

GO TO FRAME 17

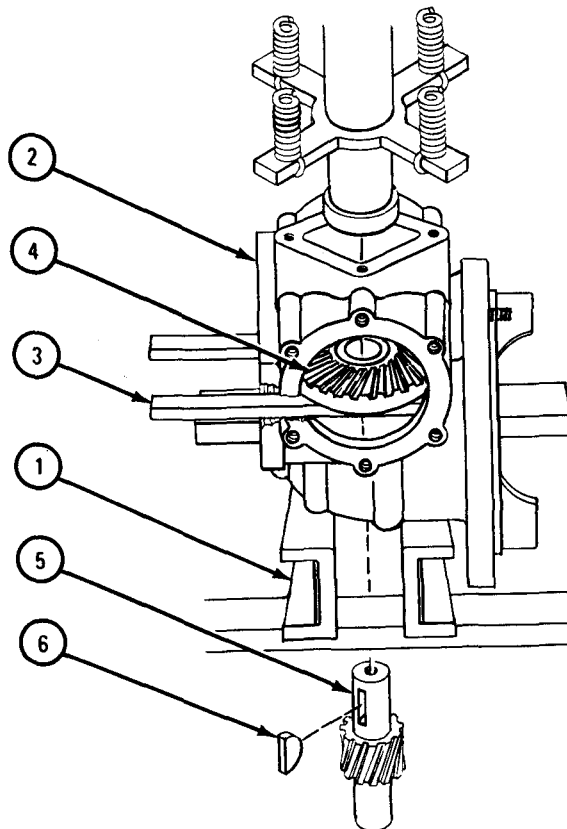

TA 085028

FRAME 17

1. Take off bearing spacer (1). Take out bevel drive gear (2) with bearing (3).
GO TO FRAME 18

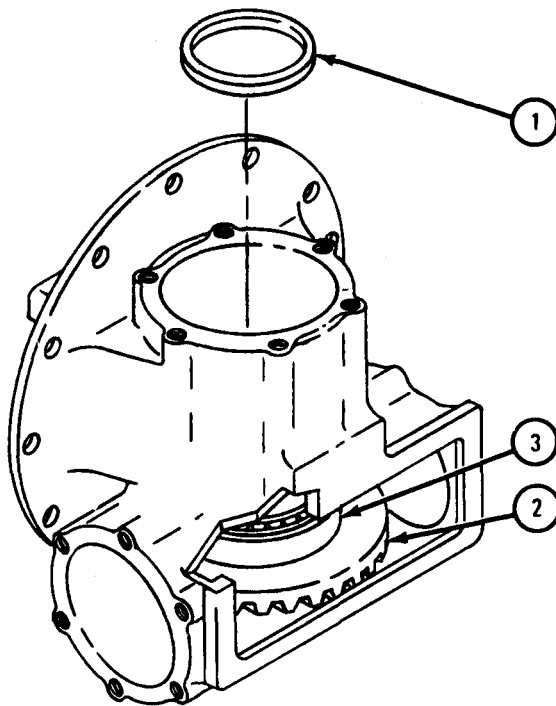

TA 085029

FRAME 18

1. Take out setscrew (1).
2. Using remover, pn 7083246, (2) and screw (3), take out sleeve (4) from carrier case (5).
3. Put puller, pn 7083215, (6) on inner bearing (7).
4. Take off bearing (7) from bevel gear (8).

END OF TASK

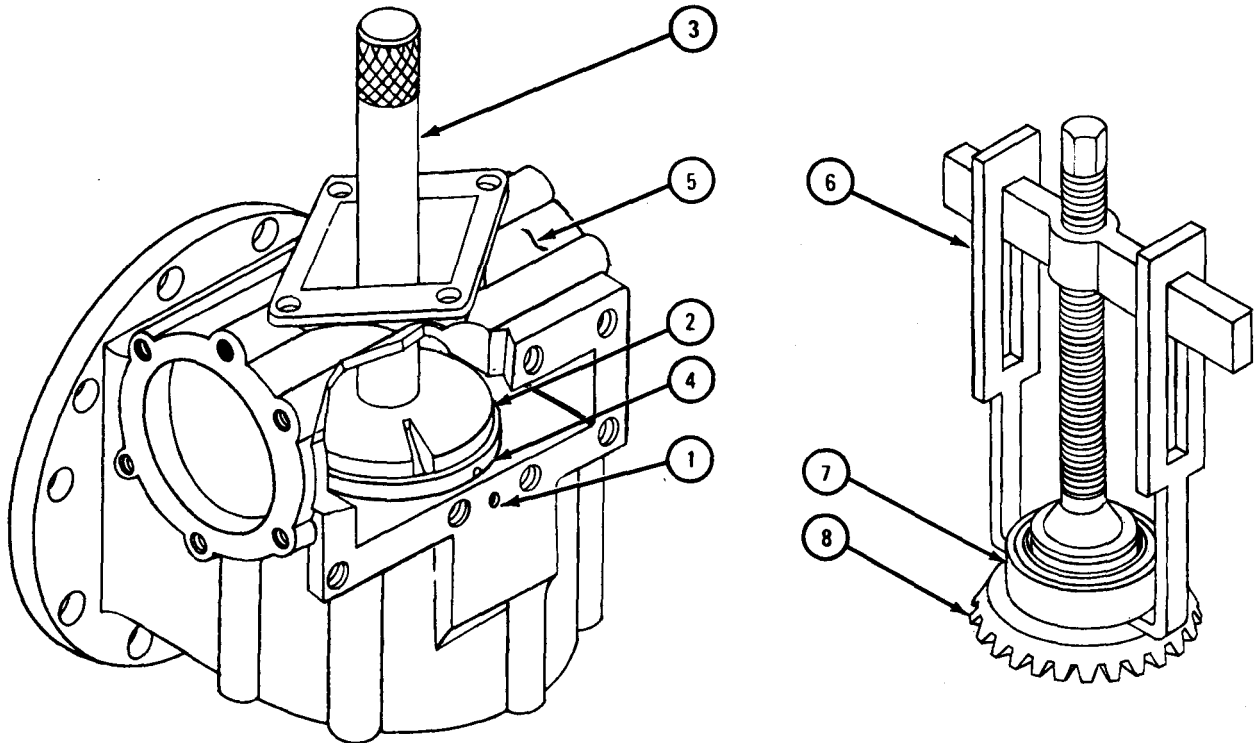

TA 085030

d. Cleaning.

- (1) Scrape off gasket cement and pieces of gaskets from parts.

WARNING

Dry cleaning solvent is flammable. Do not use near an open flame. Keep a fire extinguisher nearby when solvent is used. Use only in well-ventilated places. Failure to do this may result in injury to personnel and damage to equipment. Also, solvent dries quickly and can cause dry skin on hands. Use gloves to avoid cracks in skin and mild irritation or inflammation.

- (2) Using dry cleaning solvent, take off grease and oil from all parts.
- (3) Using solution of one part grease cleaning compound to four parts dry cleaning solvent, take off grease and oil from axle housing.
- (4) Rinse all parts thoroughly in cold water. Let parts dry.
- (5) Put a coat of light grade oil on all polished metal surfaces to stop rusting.

e. Inspection and Repair.**FRAME 1**

1. Check that differential carrier housing (1) and two cap assemblies (2) are not cracked or distorted. If either housing or cap assemblies are damaged, get a new housing and new cap assemblies.
2. Check that adjusting nut threads on differential carrier housing (1), cap assemblies (2), and two adjusting nuts (3) are not stripped or crossthreaded. If adjusting nuts or threads are damaged, get new adjusting nuts.
3. Check that tapped holes in differential carrier housing (1) are not stripped or crossthreaded. If threads are damaged, repair with correct size tap.

GO TO FRAME 2

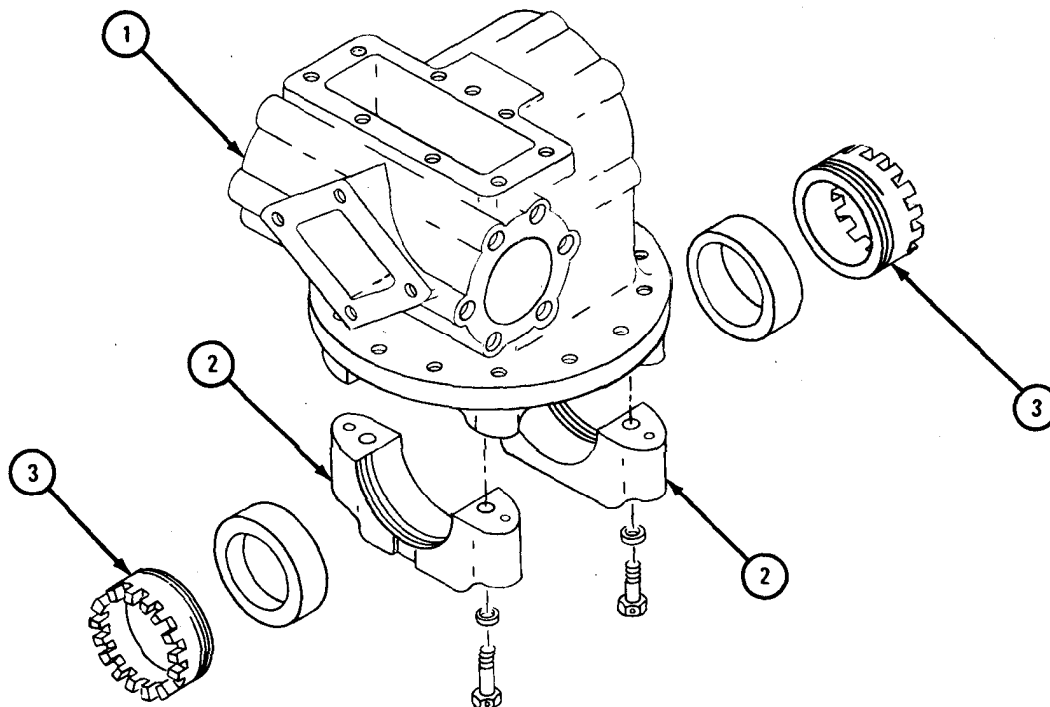

NOTE: CHECK ONLY THOSE PARTS WHICH ARE CALLED OUT IN THIS FRAME. PARTS WITHOUT CALLOUTS ARE SHOWN ONLY FOR REFERENCE PURPOSES OR ARE CHECKED IN ANOTHER FRAME.

TA 085031

FRAME 2

1. Check that two bearing cups (1) and two bearing cones (2) are not damaged. Refer to para 10-8.
2. Using inside micrometer, measure inside diameter of bearing cones (2). Note measurements.
3. Using out side micrometer, measure out side diameters of two differential case halves (3). Note measurements.
4. Subtract measurement made in step 3 from measurement made in step 2. Check that fit of bearing cones (2) on differential case halves (3) is within limits given in table 10-5. If fit of bearing cones is not within limits given, get new parts in place of worn ones.
5. Mount each differential case half (3) in a lathe. Place dial indicator against flange that mounts to helical drive gear (4). Check that runout flange of differential case half is not more than 0.002 inch.

WARNING

Dry cleaning solvent is flammable. Do not use near an open flame. Keep a fire extinguisher nearby when solvent is used. Use only in well-ventilated places. Failure to do this may result in injury to personnel and damage to equipment.

6. If differential case half (3) runout is more than 0.002 inch, use lathe to cut away only enough metal to bring runout within limit. Take off burrs with a honing stone. Clean differential case half with dry cleaning solvent.

GO TO FRAME 3

NOTE: CHECK ONLY THOSE PARTS WHICH ARE CALLED OUT IN THIS FRAME. PARTS WITHOUT CALLOUTS ARE SHOWN ONLY FOR REFERENCE PURPOSES OR ARE CHECKED IN ANOTHER FRAME.

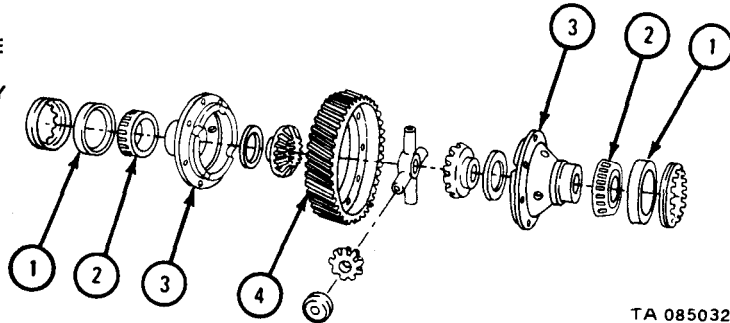

TA 085032

Table 10-5. Differential Case and Bearing Wear Limits
(The letter T shows a tight fit.)

Index Number	Item/Point of Measurement	Size and Fit of New Parts (inches)	Wear Limit (inches)
2 and 3	Fit of bearing on case	0.0025T to 0.0050T	0.0020T

FRAME 3

1. Check that teeth of helical drive gear (1), four spider gears (2), and two side gears (3) are not chipped, burred, cracked, scored or broken. Get a new helical drive gear if it is damaged. If any one of spider gears or side gears is damaged, get six new gears.
2. Check that bushings inside spider gears (2) are not pitted or damaged in any other way. Get new spider gears and side gears (3) if any bushing is damaged.
3. Using inside micrometer, check that inside of diameters of bushings in spider pinion gears (2) are within limits given in table 10-6. Get new spider gears and side gears (3) if any bushing is worn beyond limits given.
4. Using outside micrometer, check that each arm of spider (4) is within limits given in table 10-6. If arms are worn beyond limits given, get a new spider.
5. Subtract measurement in step 4 from measurement in step 3. Check that fit of pinion on spider is within limits given in table 10-6.
6. Check that four thrust washers (5) and two thrust washers (6) are not scored or worn unevenly. If washers are damaged, get new ones.

GO TO FRAME 4

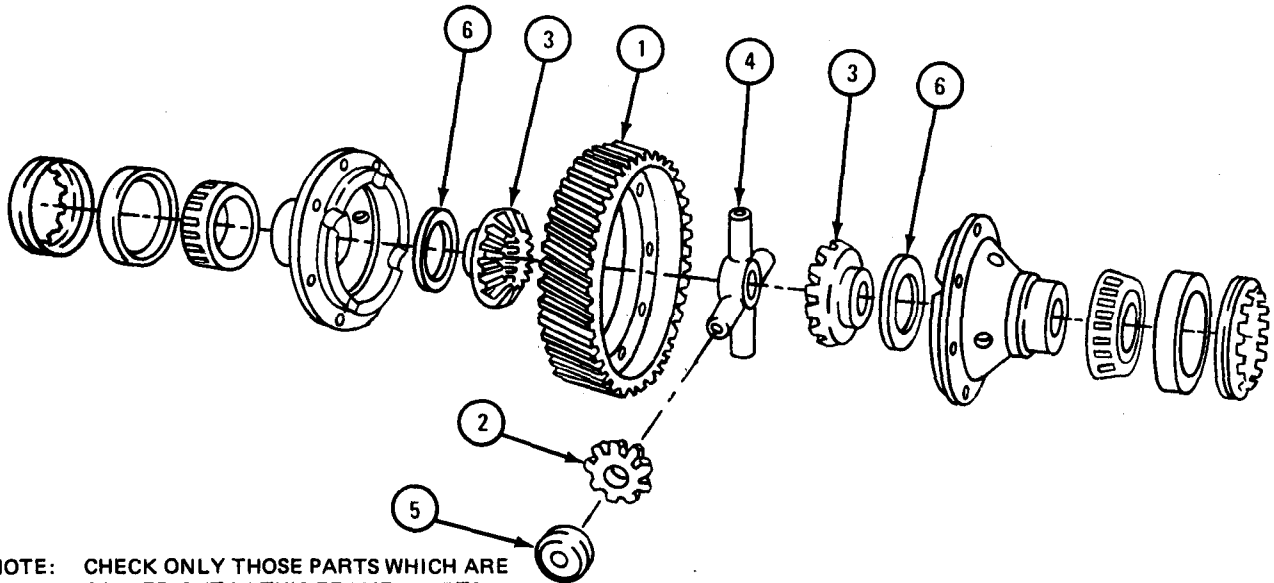

NOTE: CHECK ONLY THOSE PARTS WHICH ARE CALLED OUT IN THIS FRAME. PARTS WITHOUT CALLOUTS ARE SHOWN ONLY FOR REFERENCE PURPOSES OR ARE CHECKED IN ANOTHER FRAME.

TA 085033

Table 10-6. Spider and Spider Gear Wear Limits (The letter L shows a loose fit.)

Index Number	Item/Point of Measurement	Size and Fit of New Parts (inches)	Wear Limit (inches)
2 to 4	Fit of pinion on spider	0.004L to 0.008L	.0091

FRAME 4

1. Check that bearing assemblies (1 and 2) and bearing (3) are not damaged. Refer to para 10-8.
2. Using inside micrometer, measure inner diameter of cones of bearing assemblies (1 and 2). Note measurements.
3. Using outside micrometer, measure outer diameter of outer shaft end of spur gear pinion (4). Note measurement.
4. Subtract measurement made in step 3 from measurement made in step 2. Check that fits of bearing assembly cones (1 and 2) to spur gear pinion (4) are within limits given in table 10-7. If fits of cones of bearing assembly are not within limits given, get new parts for worn one.
5. Do steps 2 through 4 again and check that fits of bearing (3) to hypoid drive gear (5) and sleeve (6) are within limits given in table 10-7. Get new parts for parts worn beyond limits.

GO TO FRAME 5

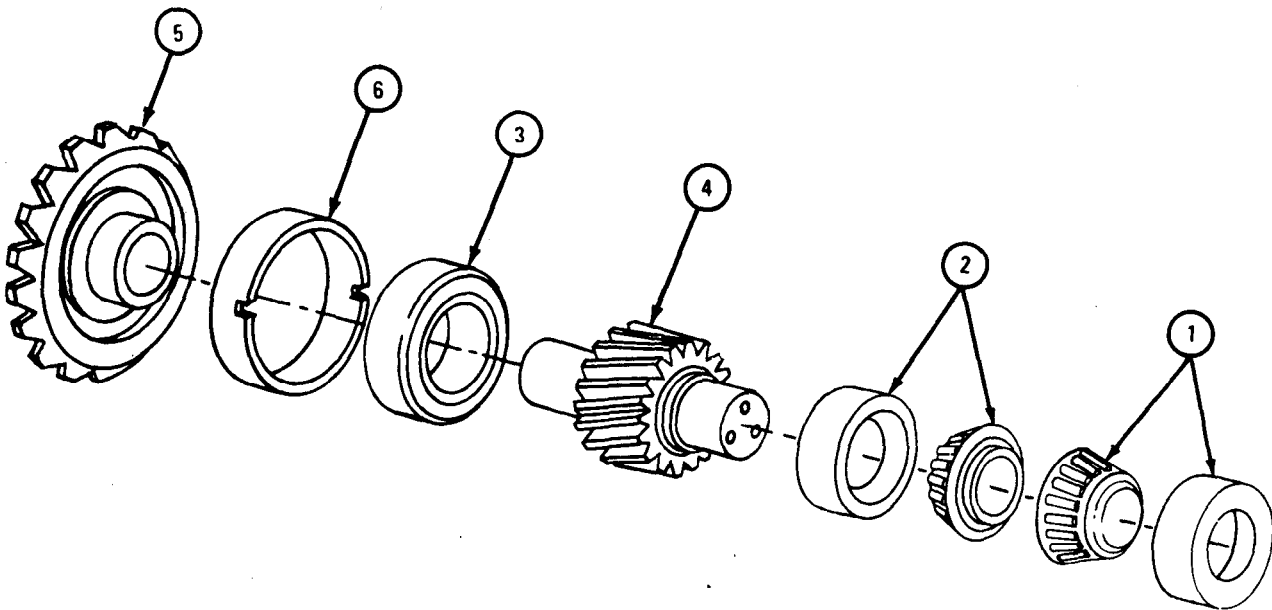

TA 085034

Table 10-7. Bearing Wear Limits (The letter T shows a tight fit and the letter L shows a loose fit.)

Number	Item/Point of Measurement	Size and Fit of New Parts (inches)	Wear Limit (inches)
1 and 2 to 4	Fit of bearing on shaft	0.0000T to 0.0015T	None
3 to 5	Fit of bearing in sleeve	0.0032L to 0.0056L	None

FRAME 5

1. Check that teeth of spur gear pinion (1) and hypoid drive gear (2) are not chipped, cracked, scored or broken. Get a new gear if damage cannot be fixed with a honing stone.
2. Check that sleeve (3) is not scored, cracked or damaged in any other way. If sleeve is damaged, get a new one.

GO TO FRAME 6

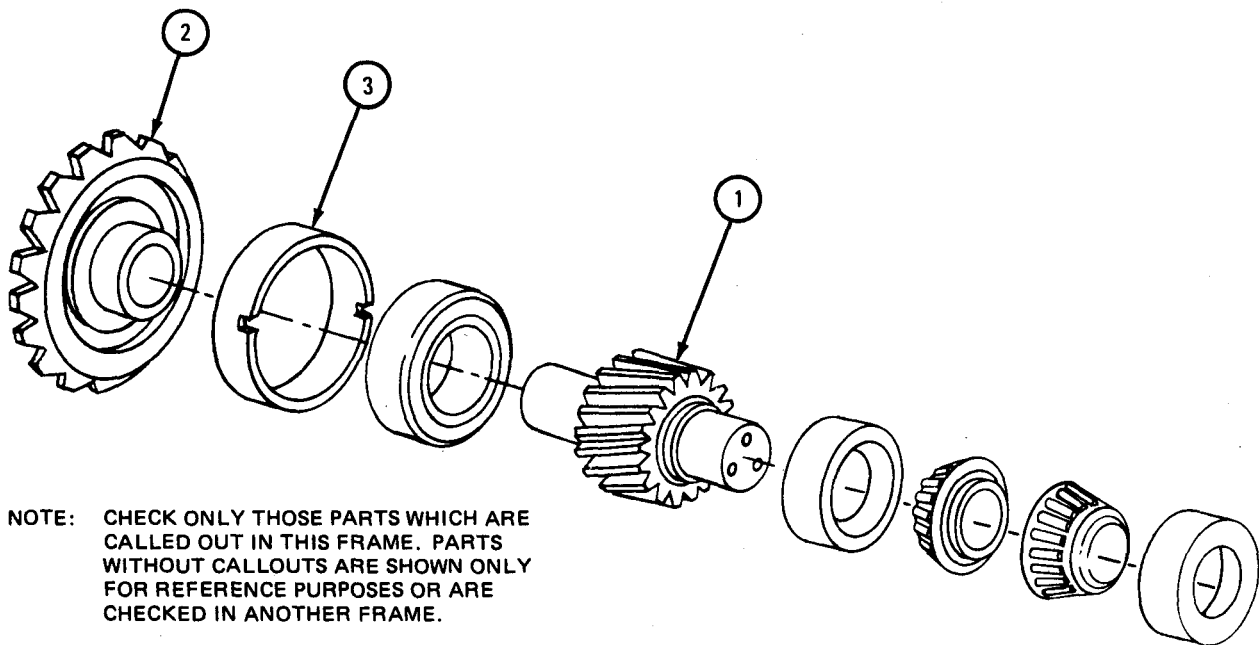

NOTE: CHECK ONLY THOSE PARTS WHICH ARE CALLED OUT IN THIS FRAME. PARTS WITHOUT CALLOUTS ARE SHOWN ONLY FOR REFERENCE PURPOSES OR ARE CHECKED IN ANOTHER FRAME.

TA 085035

FRAME 6

1. Check that front bearing (1) and rear bearing (2) are not damaged.
2. Using inside micrometer, measure inner diameter of front bearing (1) and rear bearing (2). Note measurements.
3. Using outside micrometer, measure outside diameter of pinion gear (3). Note measurement.
4. Using outside micrometer, measure outside diameter at front end of shaft (4). Note measurement.
5. Subtract measurement made in step 3 from measurement made in step 2. Check that fits of rear bearing (2) to pinion gear (3) are within limits given in table 10-8. If fits are not within limits given, get new parts for worn ones.
6. Subtract measurement made in step 4 from measurement made in step 2. Check that fits of front bearing (1) through shaft (4) are within limits given in table 10-8. If fits are not within limits given, get new parts for worn ones.
7. Using outside micrometer measure outer diameter of front bearing cup (5) and rear bearing cup (6). Note measurements.
8. Using inside micrometer, measure openings in differential carrier (7). Note measurements.
9. Subtract measurements made in step 7 from measurements in step 8. Check that fits of bearing cups (5 and 6) are within limits given in table 10-8. If fits are not within limits given, get new parts for worn ones.
10. Check that bevel pinion gear (3) is not chipped, burred, cracked, scored or broken. Get new gear if damage cannot be fixed with a honing stone.

END OF TASK

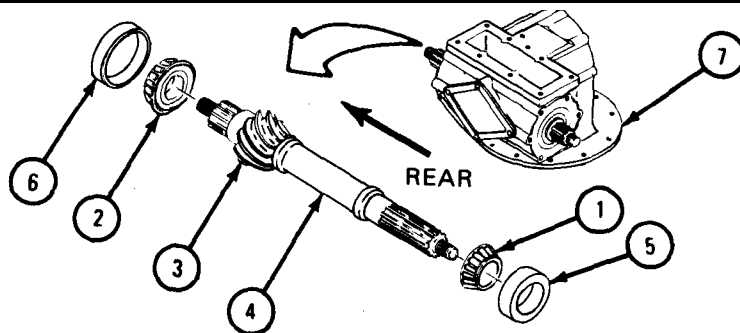

TA 085036

Table 10-8. Pinion Gear and Shaft Wear Limits (The letter T shows a tight fit and the letter L shows a loose fit.)

Number	Item/Point of Measurement	Size and Fit of New Parts (inches)	Wear Limit (inches)
1 to 4	Fit of bearing on shaft	0.0010L to 0.0015T	None
2 to 3	Fit of bearing on pinion	0.0000L to 0.0015T	None
5 to 7	Fit of bearing to case bore	0.0025T to 0.0050T	0.0020T
6 to 7	Fit of bearing to case bore	0.0025T to 0.0050T	0.0020T

f. Assembly and Adjustment.

NOTE

Coat bearings, gears, and seals with gear oil during assembly.

FRAME 1

1. Place channel (1) on press (2).
2. Place pinion gear (3) on channel (1).
3. Place bearing (4) on pinion gear (3).
4. Press bearing (4) onto pinion gear (3). Refer to para 10-8.
5. Place two iron spacers (5) across channels (1).
6. Place bearing (4) and pinion gear (3) on spacers (5).
7. Press through shaft (6) into pinion gear (3).

GO TO FRAME 2

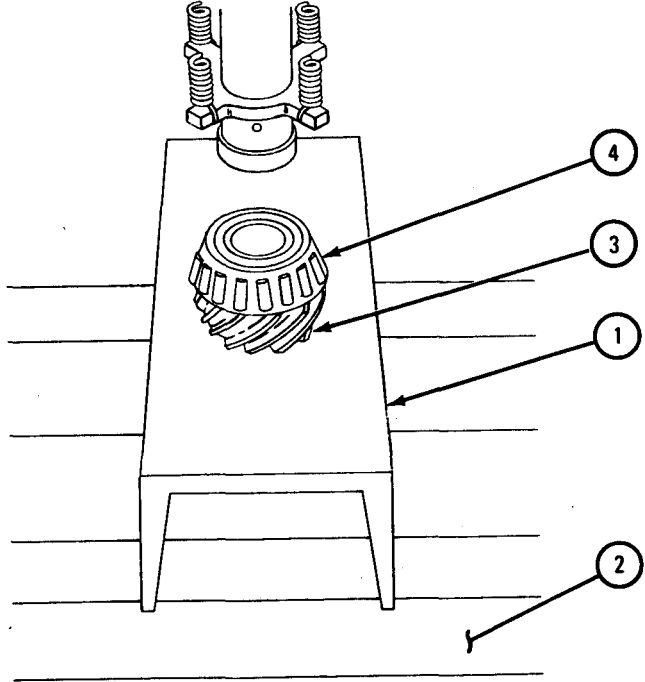
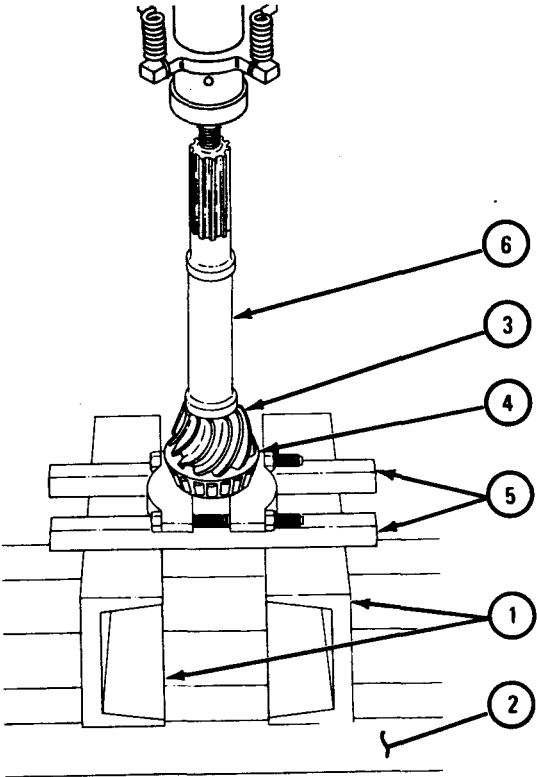

TA 085037

FRAME 2

1. Place channels (1) across bed of press (2).
2. Place two steel spacers (3) across channel (1).
3. Place front bearing cone (4) and spacer (5) on steel spacers (3).
4. Press through shaft (6) into bearing (4) and spacer (5).

GO TO FRAME 3

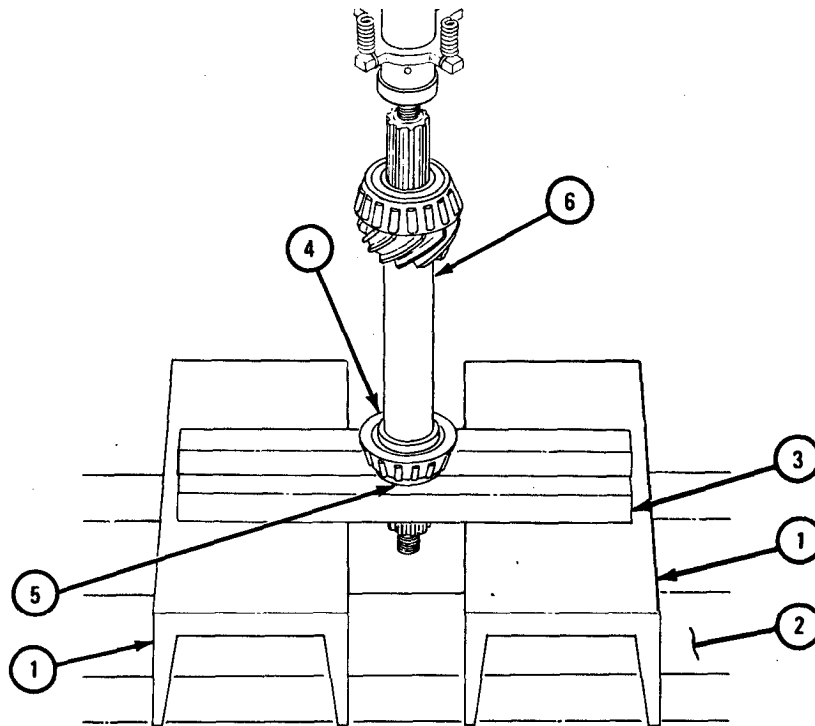

TA 085038

FRAME 3

1. Place through shaft assembly (1) into rear opening of carrier case (2).
2. Drive rear bearing outer race (3) into rear bore of carrier case (2).
3. Drive front bearing outer race (4) into front bore of carrier case (2).

GO TO FRAME 4

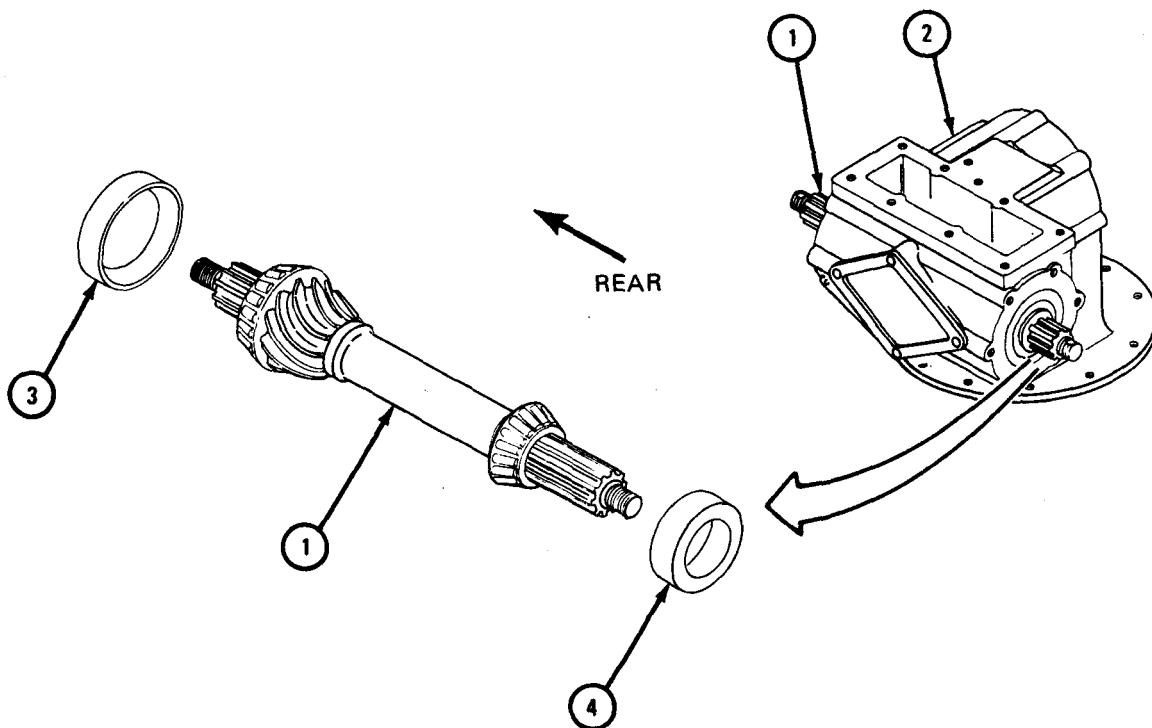

TA 085039

FRAME 4

1. Using replacer, pn 7083256, (1) and handle (2), put seal (3) into front and rear retainer (4).
 2. Put shims (5) and retainers (6) onto carrier case (7).
 3. Put in six screws (8) and lockwashers (9).
- GO TO FRAME 5

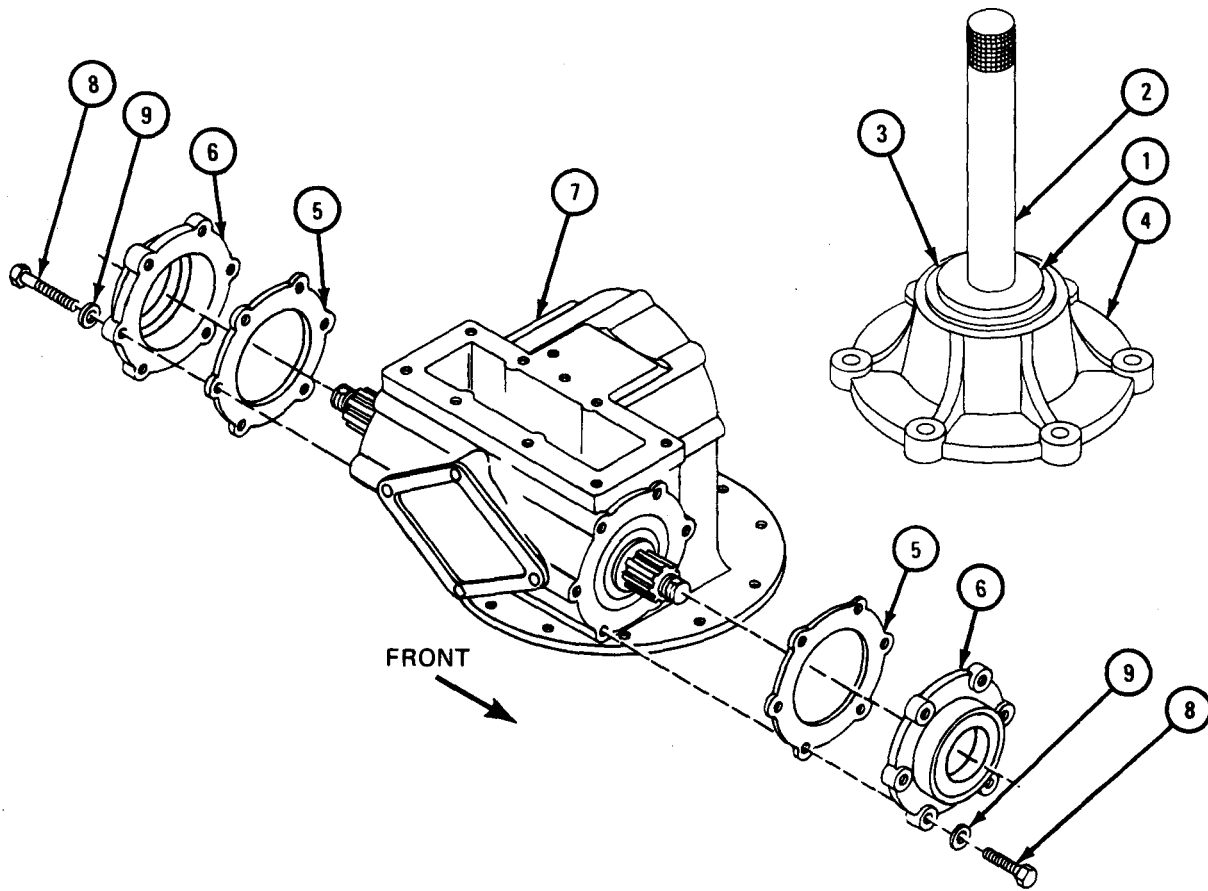

TA 085040

FRAME 5

1. Using bearing preload tester, pn 7950157, (1), wrap cable (2) around through shaft (3).
2. Pull on tester (1) until shaft turns. If original bearings are used, reading should be 4 to 8 pound-inches. If new bearings are used, reading should be 12 to 18 pound-inches.
3. Take off tester (1).

IF READING IS NOT WITHIN LIMITS GIVEN, GO TO FRAME 6.

IF READING IS WITHIN LIMITS GIVEN, TAKE OUT THROUGH SHAFT (3) (REFER TO PARA 10-7c, FRAME 10), THEN GO TO FRAME 7

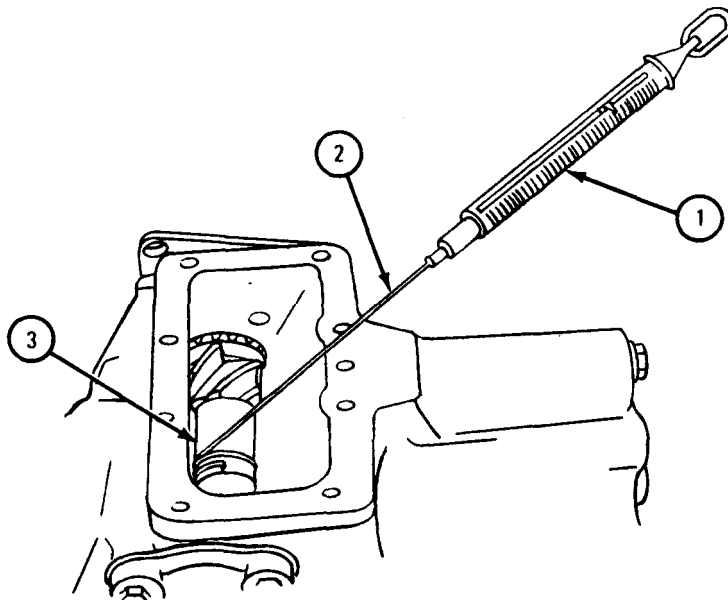

TA 085041

FRAME 6

1. Take out 12 screws (1) and lockwashers (2).
2. Take off two retainers (3).

NOTE

Keep shims (4) with retainer (3) from same side of carrier case so that bearing preload will not be changed.

3. Take off shims (4).
4. Using micrometer, measure thickness of each pack of shims (4).
5. If reading in frame 5 was more than limits given, use a thicker shim (4) or add a shim.
6. If reading in frame 5 was less than limits given, use a thinner shim (4) or take out a shim.
7. Take out through shaft assembly (5). Refer to para 10-7c, frame 10.

GO TO FRAME 7

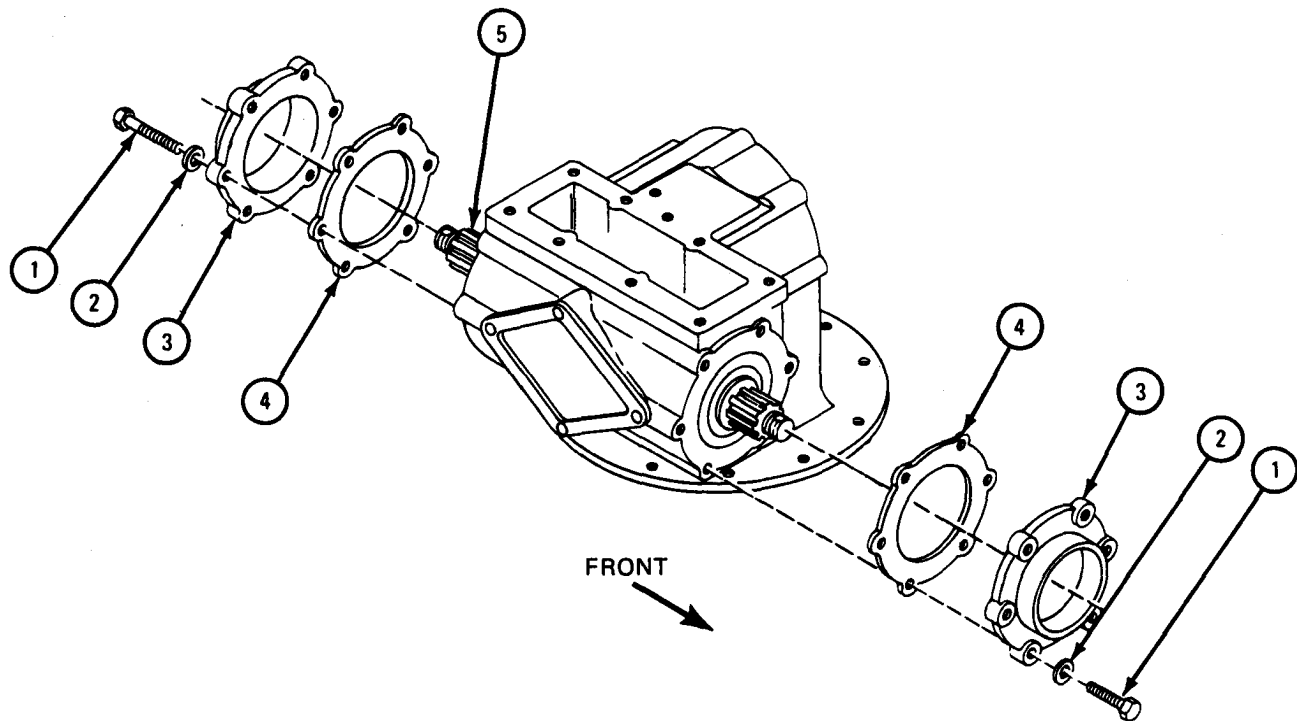

TA 085042

FRAME 7

1. Place two channels (1) across press (2).
2. Place bevel gear (3) on channels (1).
3. Press bearing (4) on bevel gear (3).

GO TO FRAME 8

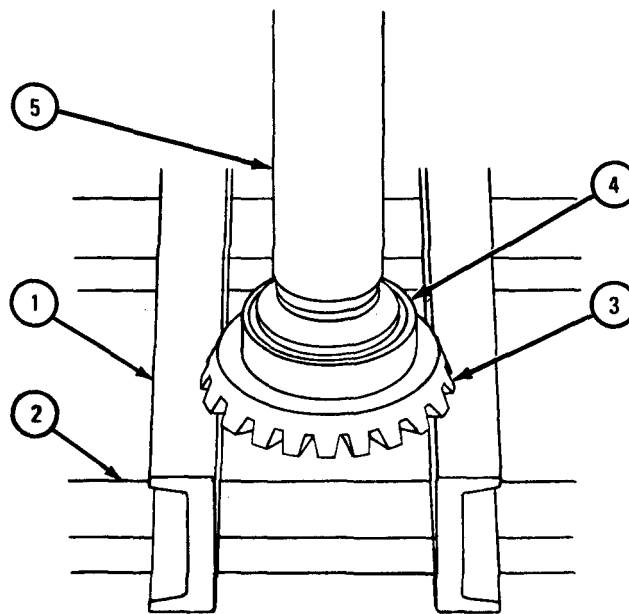

TA 085043

FRAME 8

1. Put sleeve (1) into carrier case (2). Make sure hole (3) in sleeve (1) is alined with hole (4) in carrier case (2).
2. Using replacer, pn 7083246, (5) and screw (6) , drive sleeve (1) into carrier case (2).
3. Put in setscrew (7).

GO TO FRAME 9

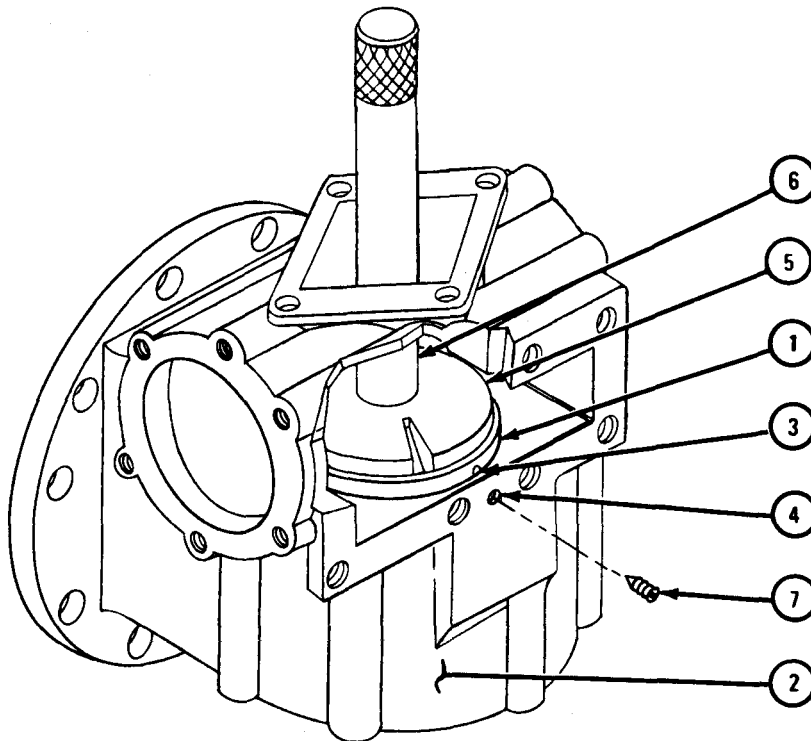

TA 085044

FRAME 9

1. Put two channels (1) across bed of press (2).
2. Place carrier (3) on channels (1) as shown.
3. Put in bevel gear spacer (4).
4. Press gear with bearing (5) into carrier (3).

GO TO FRAME 10

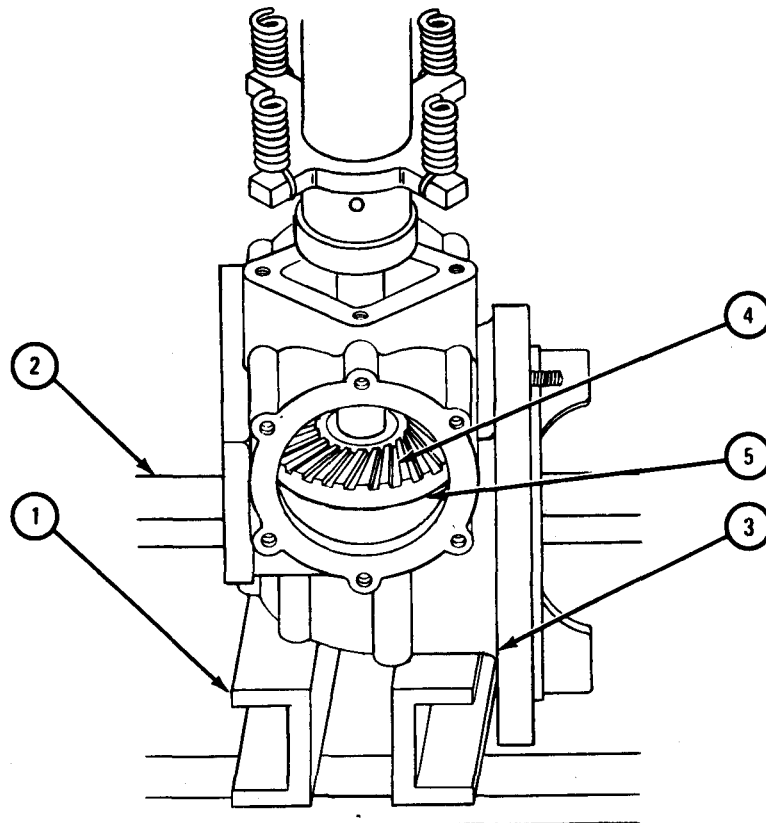

TA 085045

FRAME 10

1. Untie shims (1) from bearing cage (2).
2. Place bearing cage (2) and shims (1) on carrier case (3) and pinion shaft (4).

NOTE

Make sure that screws (5) and lockwashers (6) are tightened a little at a time so bearing cage (2) is pulled on evenly.

3. Put in six screws (5) and lockwashers (6) and pull cage (2) onto carrier (3) evenly.

GO TO FRAME 11

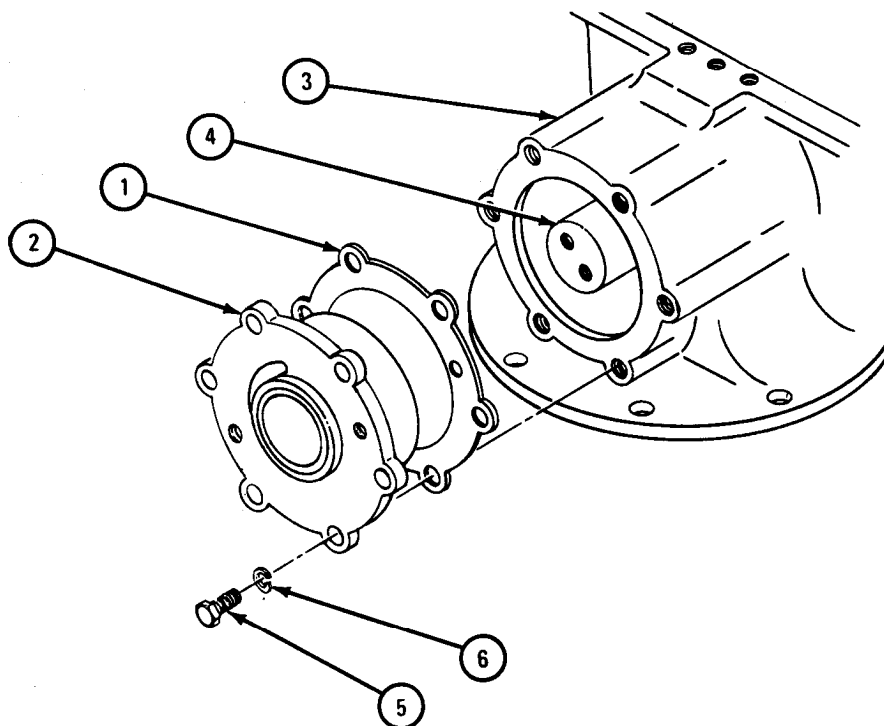

TA085048

FRAME 11

1. Using replacer, pn 7083252, (1) and handle (2), put inner bearing cup and cone (3) into bearing cage (4).
2. Using replacer, pn 7083252, (1) and handle (2), put outer bearing cup and cone (5) into bearing cage (4).

GO TO FRAME 12

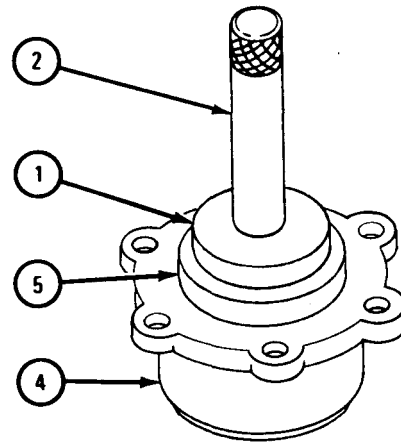
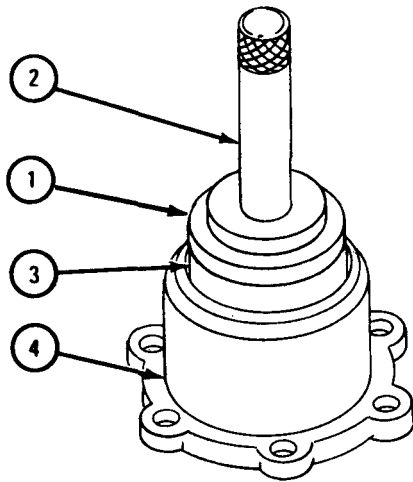

TA 085046

FRAME 12

1. Place carrier (1) in press (2) as shown.
2. Place key (3) into keyway in helical drive pinion shaft (4).
3. Aline key (3) with keyway in bevel gear (5).
4. Press helical drive pinion shaft (4) into bevel gear (5).

GO TO FRAME 13

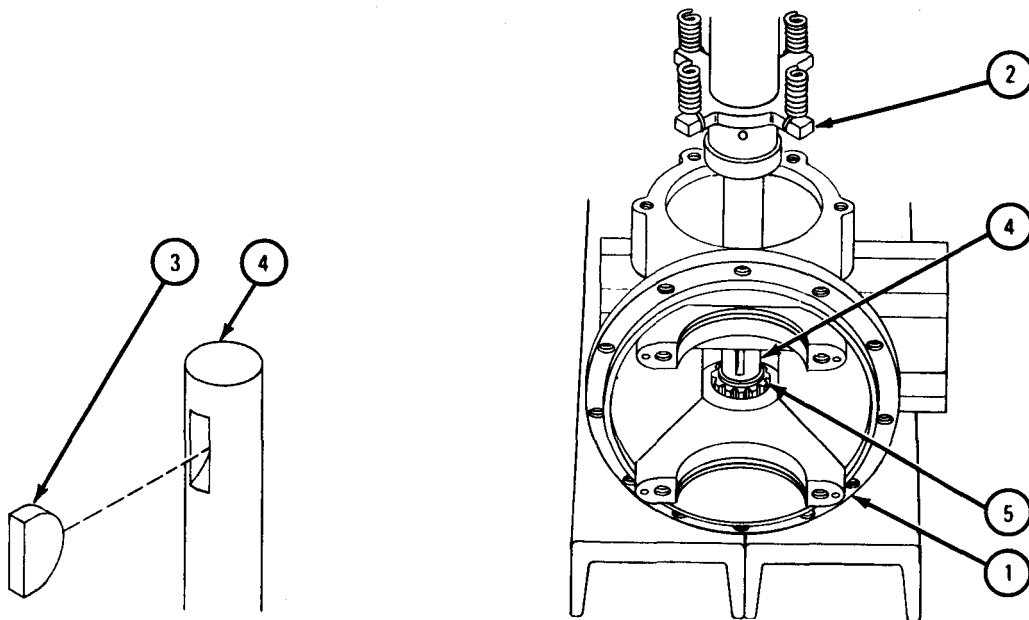

TA 085047

FRAME 13

1. Using bearing preload tester, pn 3475922, (1), wrap cable (2) around helical drive pinion (3).
2. Pull tester (1) and note reading on scale. Reading for old bearings should be 4 to 8 pound-inches. Reading for new bearings should be 12 to 18 pound-inches.

IF READING IS NOT WITHIN LIMITS GIVEN, GO TO FRAME 14.

IF READING IS WITHIN LIMITS GIVEN, GO TO FRAME 15

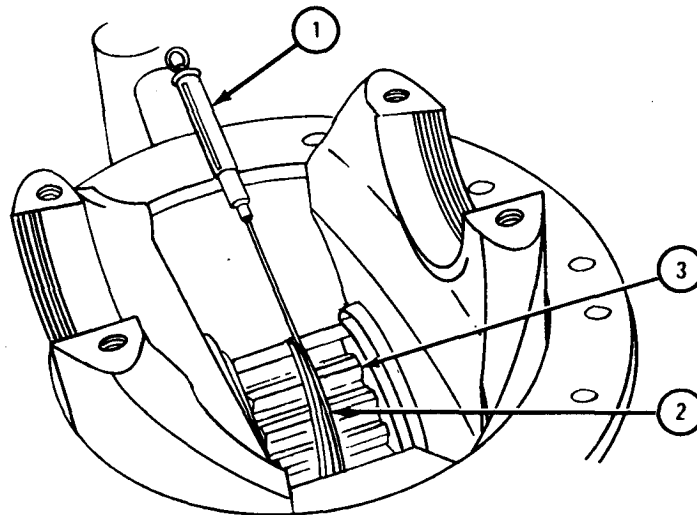

TA 085049

FRAME 14

1. Take out six screws (1) and lockwashers (2).
2. Put two puller screws, pn 8366689, (3) in two holes (4).
3. Turn screws (4) evenly until bearing cage (5) is free of carrier case (6).
4. Take off shims (7).
5. Using micrometer, measure thickness of shims (7).
6. If reading in frame 13 was more than limits given, use a thicker shim (7) or add a shim.
7. If preload reading was less than limits given, use a thinner shim (7) or take away a shim.

GO TO FRAME 15

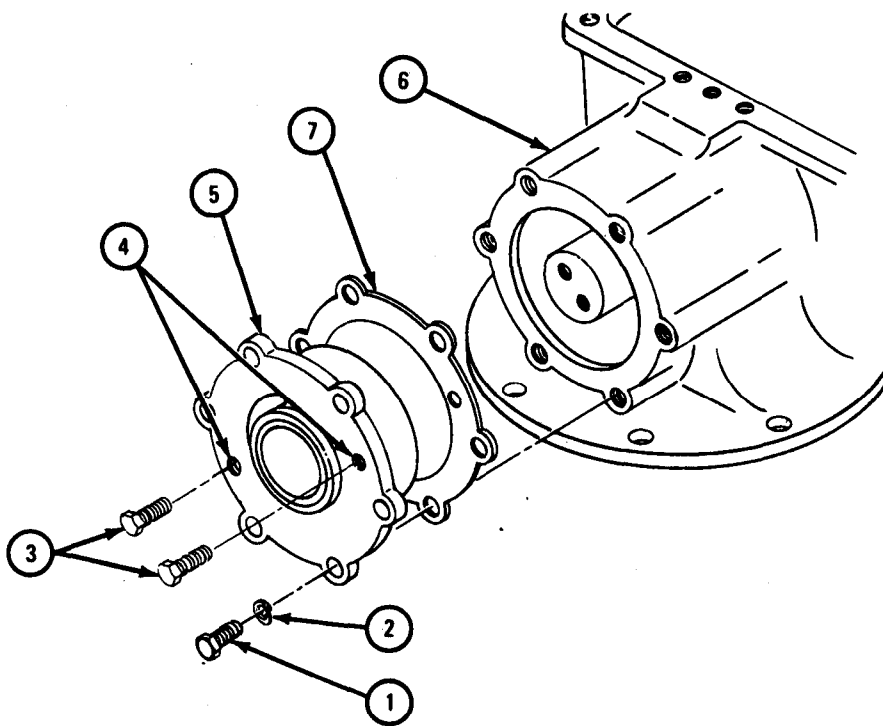

TA 085050

FRAME 15

1. Unscrew and take out six screws (1) and lockwashers (2).
2. Put on plate (3) and two screws (4).
3. Put in safety wire (5) as shown.
4. Put on shims (6) and bearing cage (7).
5. Put in six screws (8) and lockwashers (9).

GO TO FRAME 16

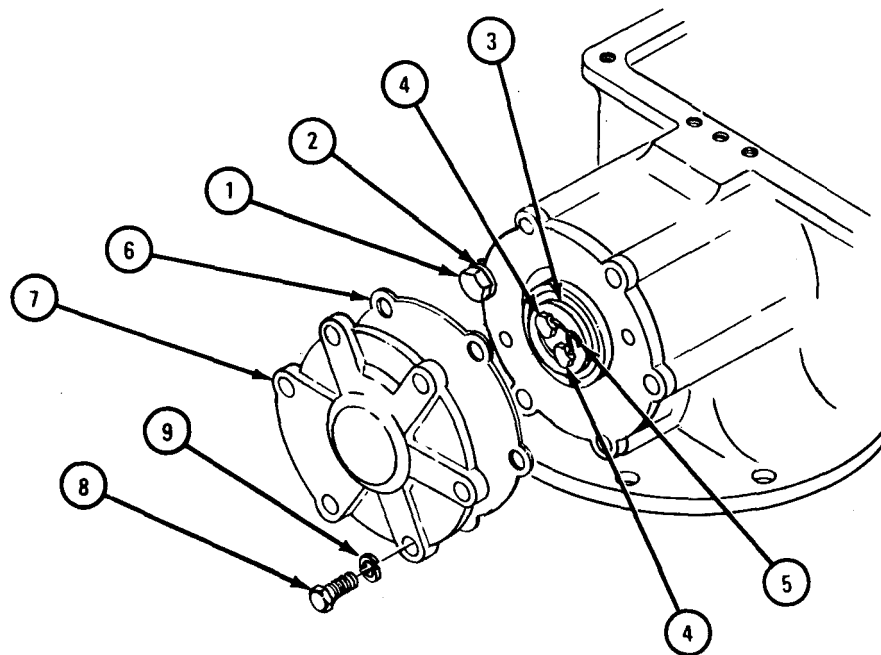

TA 085068

FRAME 16

1. Place through shaft assembly (1) into carrier case (2) through rear opening.
2. Drive rear bearing outer race (3) into rear bore of carrier case (2).

NOTE

Make sure that shims (4) and retainer (5) from same side of carrier case (2) stay together to keep preload setting the same.

3. Place needed number of shims (4) and two retainers (5) onto carrier case (2).
4. Put in six screws (6) and lockwashers (7).

GO TO FRAME 17

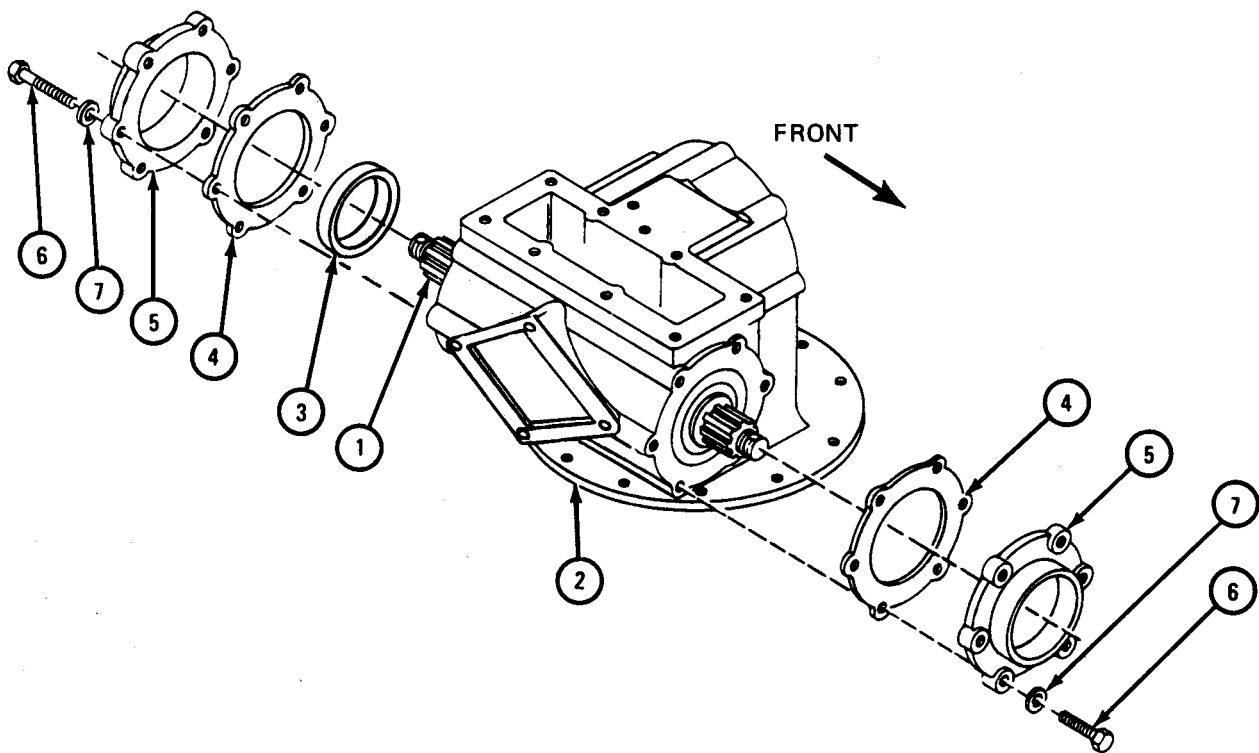

TA 085051

FRAME 17

NOTE

Gears that are not put back in matched sets generally are noisy at first. After new gear and mating old gear have been run in, noise usually disappears.

1. Paint teeth of bevel pinion gear (1) with red lead or Prussian blue.
2. Turn gears (1 and 2) and note contact marks. Pattern A shows correct tooth contact.

IF GEAR TOOTH SHOWS PATTERN B, C, D or E, GO TO FRAME 18.

IF GEAR TOOTH SHOWS PATTERN A, GO TO FRAME 19

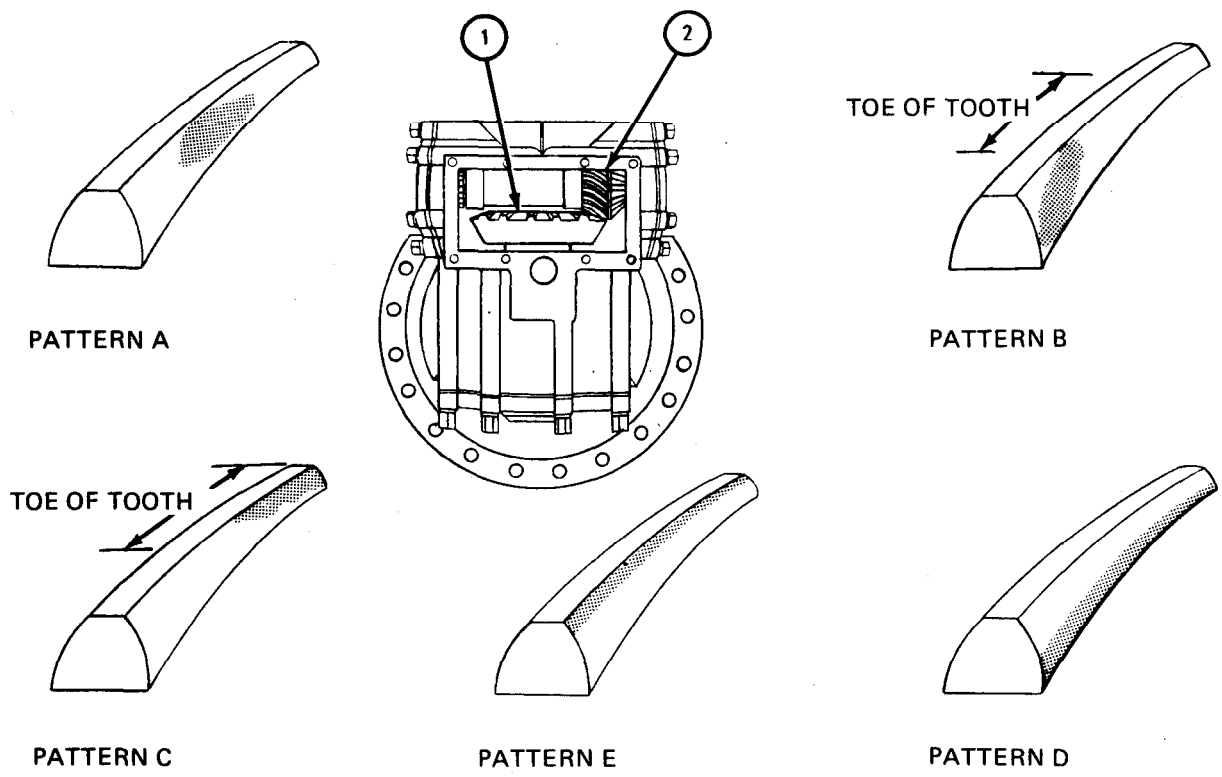

TA 085052

FRAME 18

1. For a short heel contact, pattern A, take out shim at point (1) and add shim at point (2).
2. Take out shims at point (3) to keep 0.007 to 0.014-inch backlash.
3. For a short toe contact, pattern B, take out shim at point (2) and add shim at point (1).
4. Add shim at point (3) to keep 0.007 to 0.014-inch backlash.
5. For a low narrow contact, pattern C, add shim at point (3). Take shim away from point (2) and add shim at point (3). Take shim away from point (2) and add shim at point (1) to keep 0.007 to 0.014-inch backlash.
6. For a high narrow contact, pattern D, take away shim at point (1) and add shim at point (2) to keep 0.007 to 0.014-inch backlash.

GO BACK TO FRAME 17

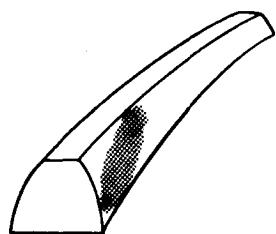

PATTERN A

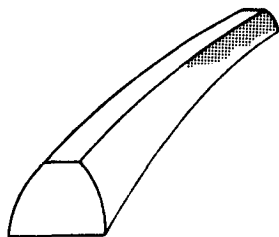

PATTERN B

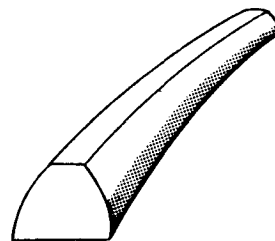
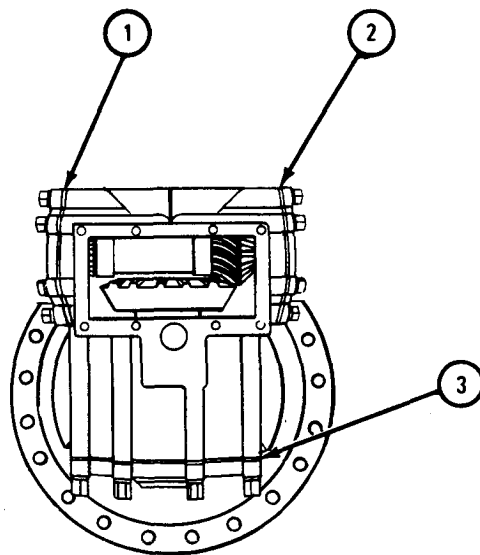

PATTERN C

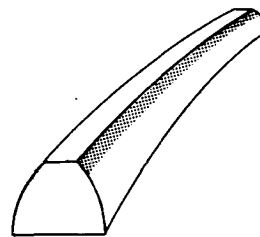

PATTERN D

TA 085053

FRAME 19

1. Take out six screws (1) and lockwashers (2).
2. Put plate (3) in place.
3. Put in two bolts (4).
4. Put in safety wire (5).
5. Put on shims (6) and cover (7).
6. Put in six screws (1) and lockwashers (2).

GO TO FRAME 20

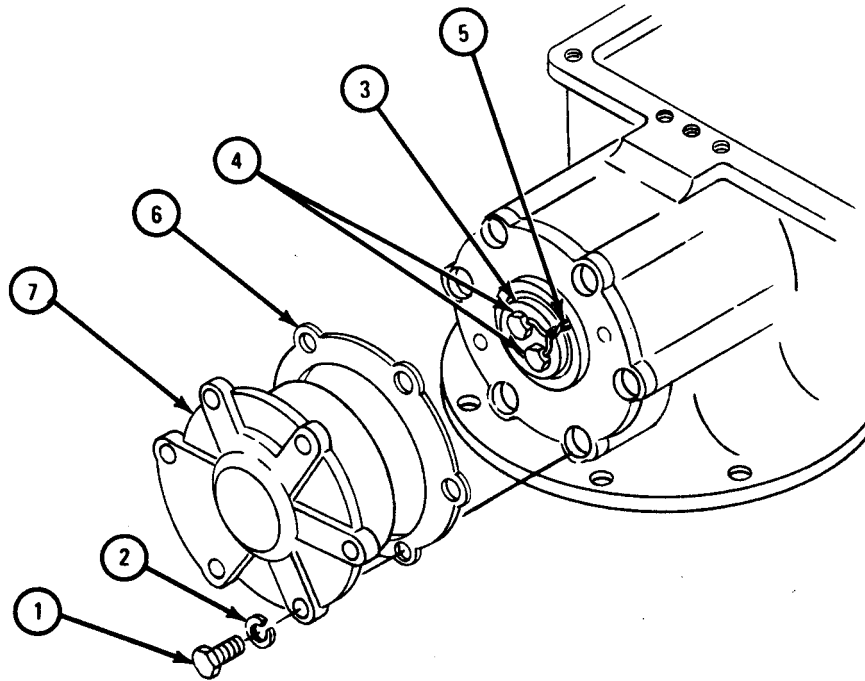

TA 085057

FRAME 20

1. Put on two dirt deflectors (1) and two flanges (2).
2. Put on two spacers (3) and two nuts (4).

Soldiers A and B 3. Tighten two nuts (4) to 300 to 400 pound-feet.

4. Put in cotter pin (5).

GO TO FRAME 21

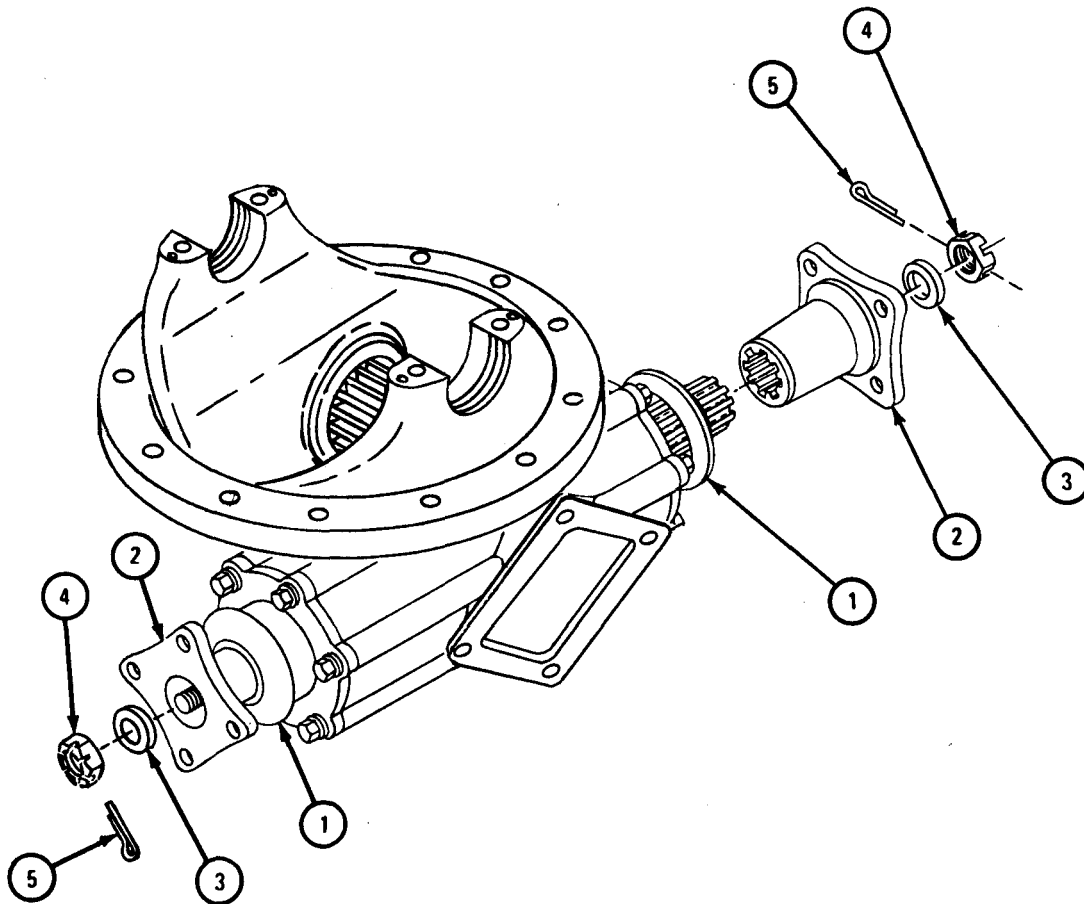

TA 085058

FRAME 21

1. Place channel (1) across bed of press (2).
 2. Place carrier case assembly half (3) on channel (1).
 3. Place bearing cone (4) on carrier case assembly half (3).
 4. press bearing cone (4) into place.
 5. Do steps 1 through 4 again for other carrier case assembly half.
- GO TO FRAME 22

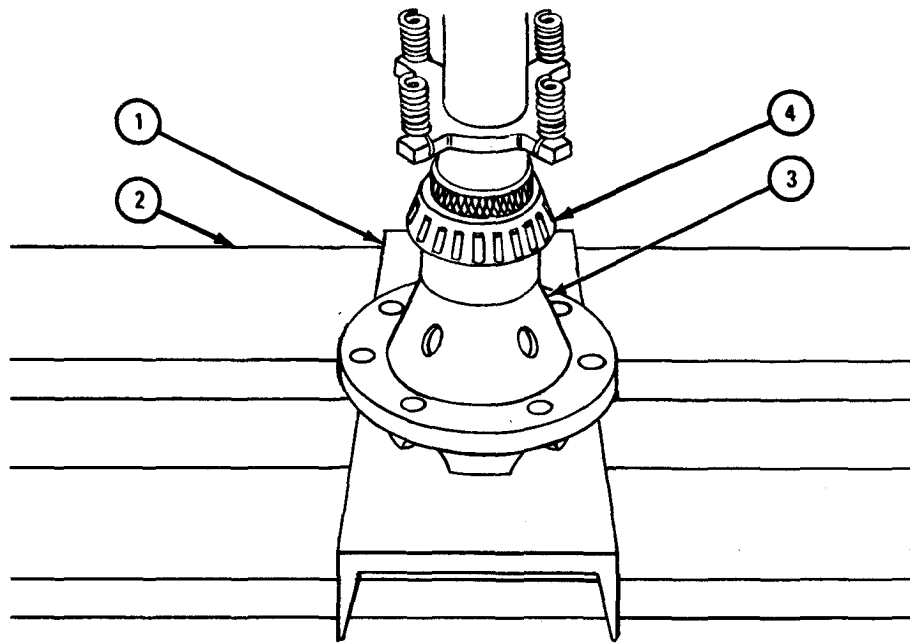

TA 085059

FRAME 22

1. Put helical gear (1) into vise.
2. Put four pinion gears (2) and four thrust washers (3) on spider (4).
- Soldier A 3. Hold spider assembly (4) together inside helical gear (1).
- Soldier B 4. Place two side gears (5) and thrust washers (6) into carrier case assembly (7).
5. Line up center punch marks on carrier case assembly (7) and helical gear (1) and put them together.
6. Put in eight bolts (8).
7. Put on eight nuts (9). Aline holes in nuts withholds in bolts (8).
8. Put safety wire (10) through eight nuts (9) and bolts (8).

GO TO FRAME 23

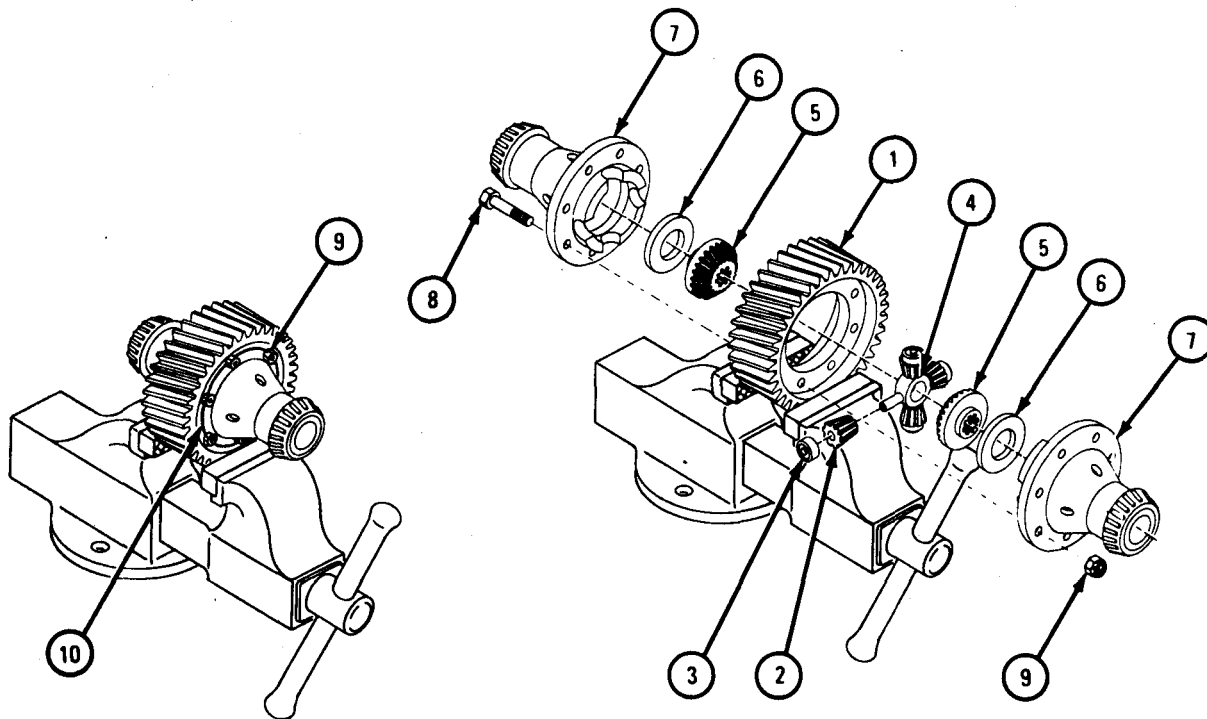

TA 085060

FRAME 23

1. Place differential drive gear assembly (1) into differential carrier assembly (2).
2. Lift differential drive gear assembly (1) one side at a time and put two bearing cups (5) over two bearing cones (6).
3. Seat bearing cups (5) in differential carrier assembly (2).

GO TO FRAME 24

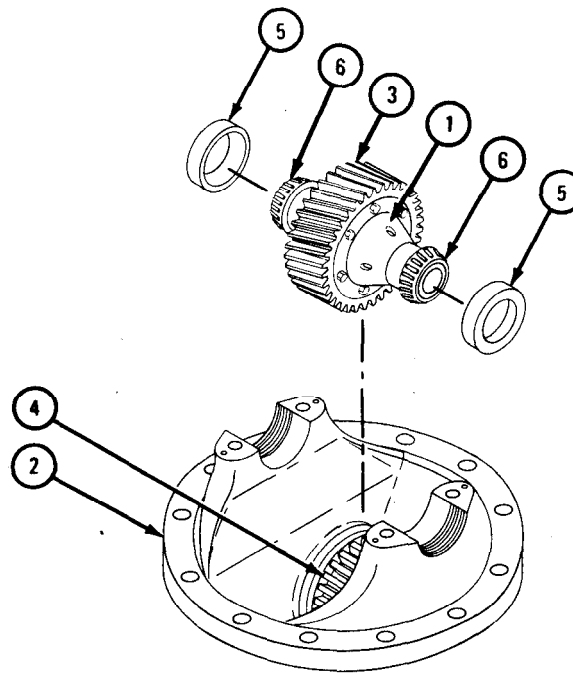

TA 085061

FRAME 24

1. Put two bearing caps (1) in place, alining alinement marks.
2. Finger tighten four screws (2) and washers (3).
3. Screw in two adjusting nuts (4) until they bind.
4. Tighten screws (2) just enough to firmly hold two bearing caps (5).
5. Using spanner wrench, tighten two adjusting nuts (4) a little at a time until nuts are tight and screwed in the same distance.

GO TO FRAME 25

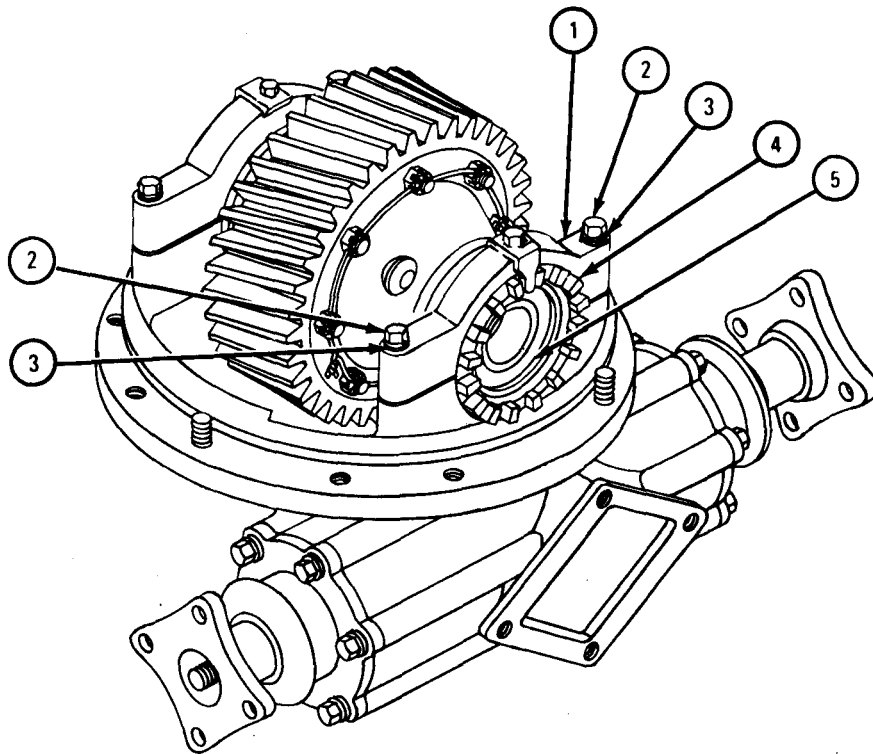

TA 085062

FRAME 25

1. Turn helical drive gear (1) several times to seat bearings.
2. Place dial indicator (2) on carrier flange (3) so plunger is against side face of helical gear (1).
3. Push and pull on helical drive gear (1) and check reading on dial indicator (2).
4. Using spanner wrench, tighten two adjusting nuts (4) a little at a time. Do step 3 again until dial indicator (2) reading is 0.000 inch.
5. Turn helical drive gear (1) one full turn. Check that runout on dial indicator (2) shows 0.008 inch or less.

GO TO FRAME 26

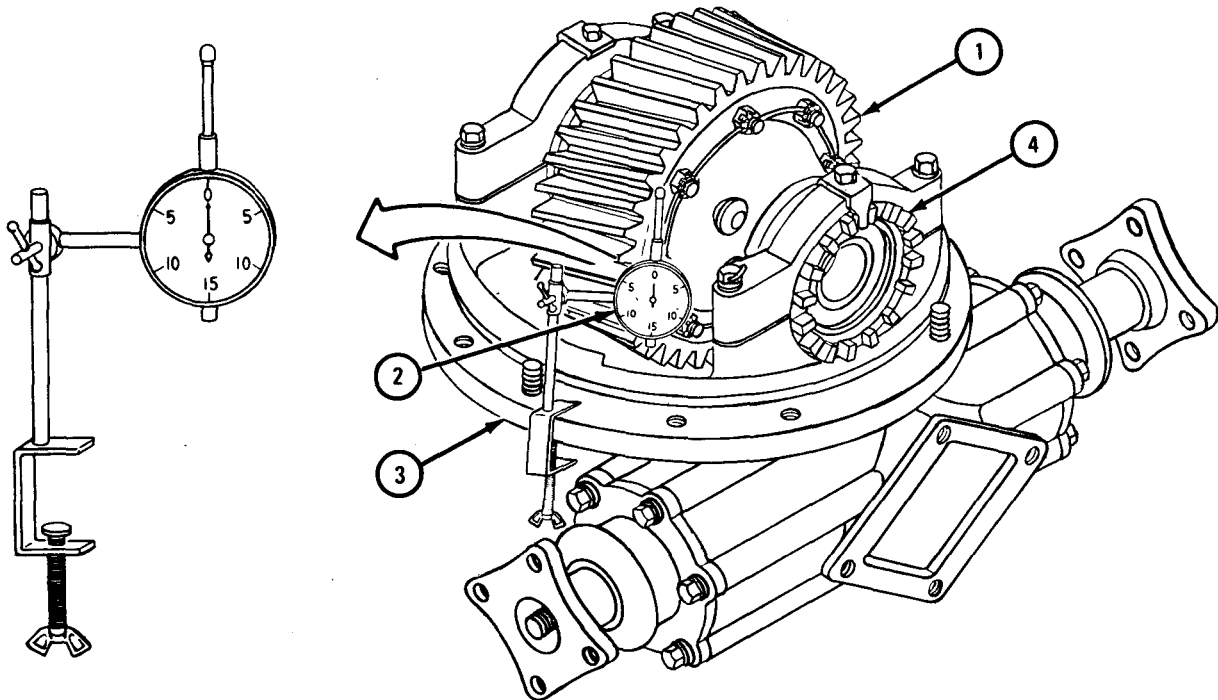

TA 085063

FRAME 26

1. Move dial indicator (1) so ball end is against a tooth of helical drive gear (2).
2. Hold spur gear pinion (3) to keep it from turning.
3. Rock helical drive gear (2) back and forth. Reading on dial indicator (1) should be between 0.007 and 0.014 inch.
4. Take off dial indicator (1).

GO TO FRAME 27

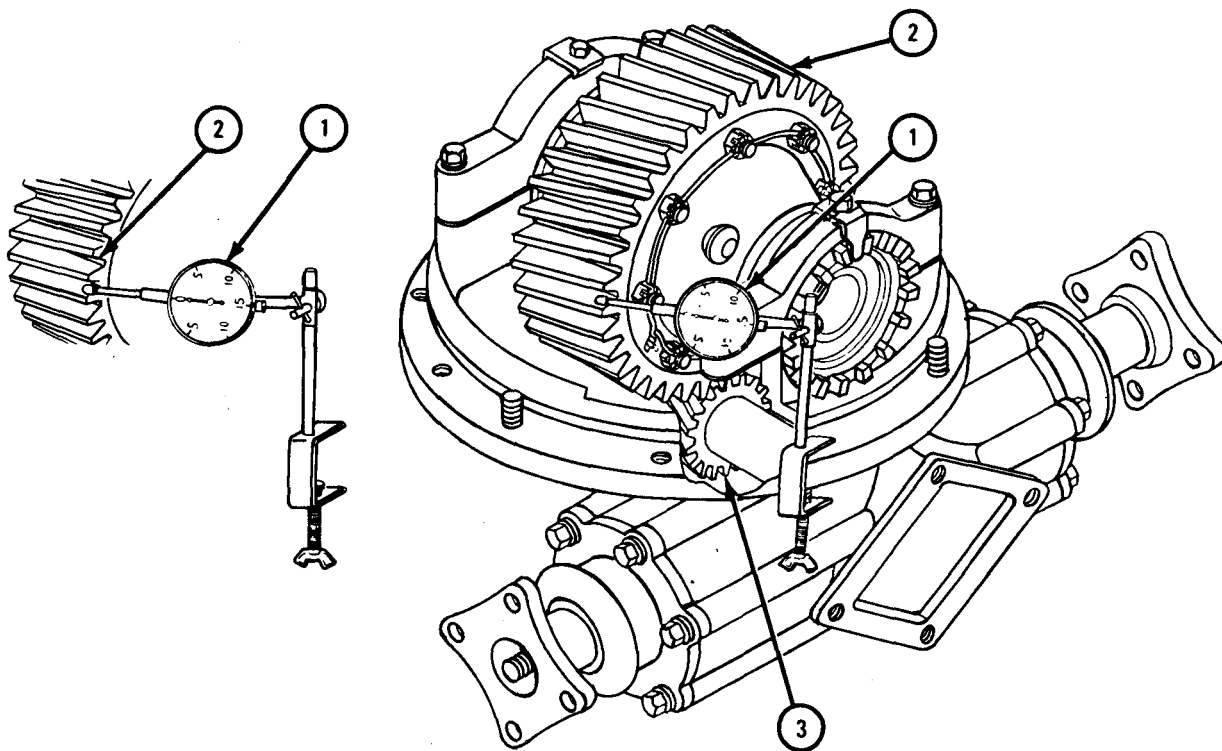

TA 085064

FRAME 27

1. Tighten each adjusting nut (1) one notch.
2. Put in two adjusting nut locks (2). If adjusting nuts (1) do not line up with nut locks (2), loosen nuts (1) enough to aline them.
3. Take out adjusting nut locks (2),
4. Tighten four screws (3) to 300 pound-feet.
5. Put two adjusting nut locks (2) in place.
6. Put in two screws (4).
7. Put safety wire (5) through four screws (3) and two screws (4) as shown.

GO TO FRAME 28

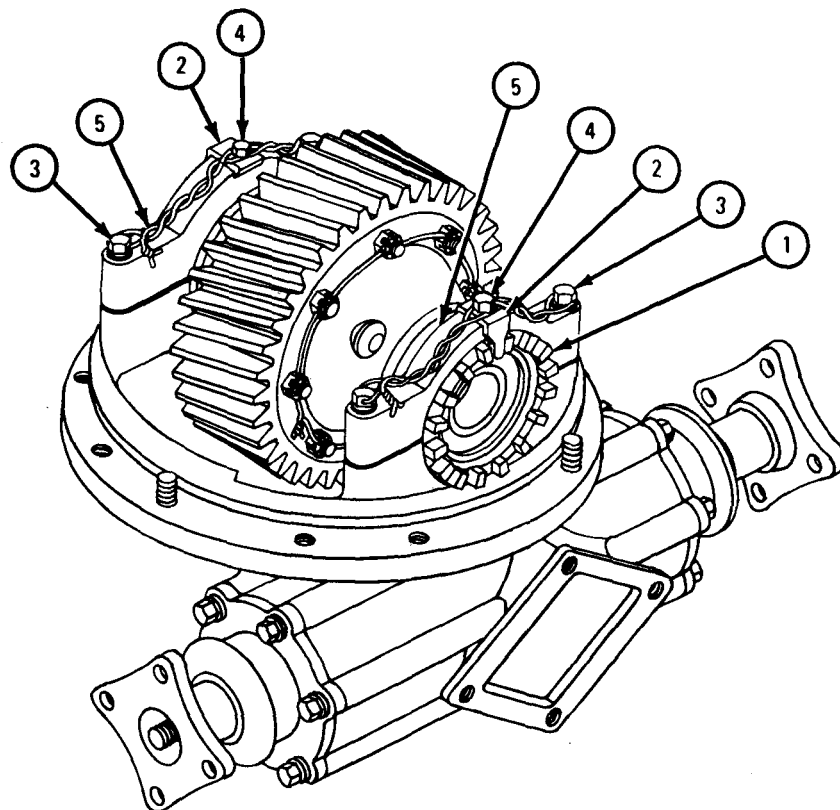

TA 085065

FRAME 28

1. Place gasket (1) and cover (2) onto differential carrier case assembly (3).
2. Put in eight screws (4) and lockwashers (5).
3. Tighten screws (4) to 27 to 35 pound-feet.
4. Place gasket (6) and cover (7) onto differential carrier case assembly (3).
5. Put in four screws (8) and lockwashers (9).
6. Tighten screws (8) to 27 to 35 pound-feet.

END OF TASK

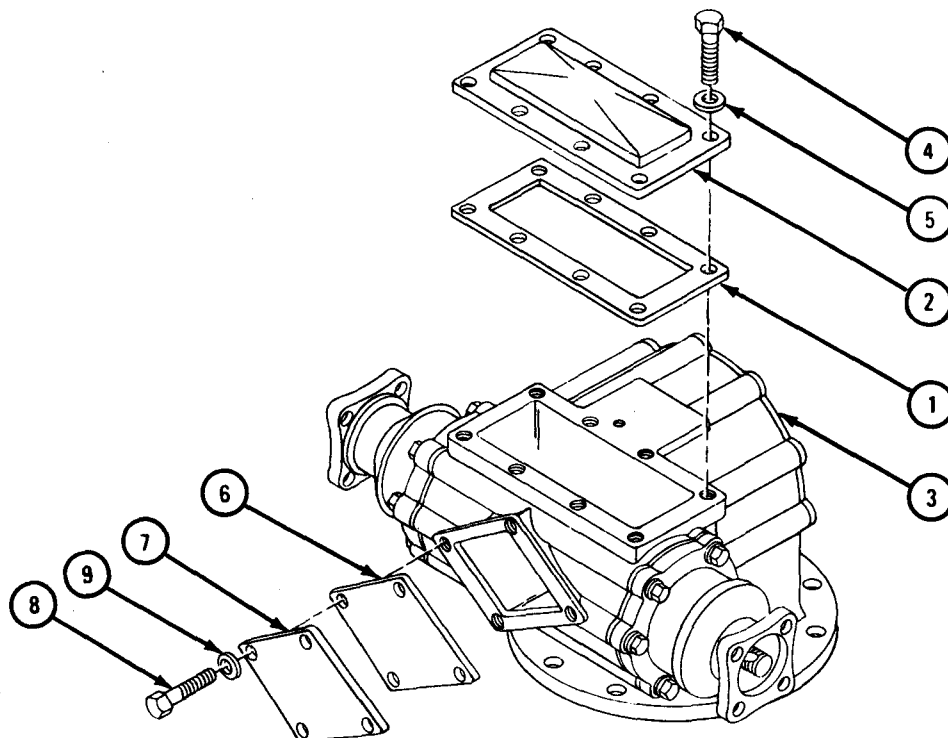

TA 085066

g. Replacement.**FRAME 1**

1. Put differential carrier gasket (1) in place on axle housing (2).
2. Using chain sling (3) and chain hoist (4), lift differential carrier assembly (5) into axle housing (2).
3. Lower differential carrier assembly (5) and put in four lockwashers (6) and four nuts (7).
4. Lower differential carrier assembly (5) until it is seated on axle housing (2). Unhook hoist (4) and take off chain sling (3).
5. Put on other eight lockwashers (6) and nuts (7).
6. Tighten 12 nuts (7) to 53 to 67 pound-feet.

GO TO FRAME 2

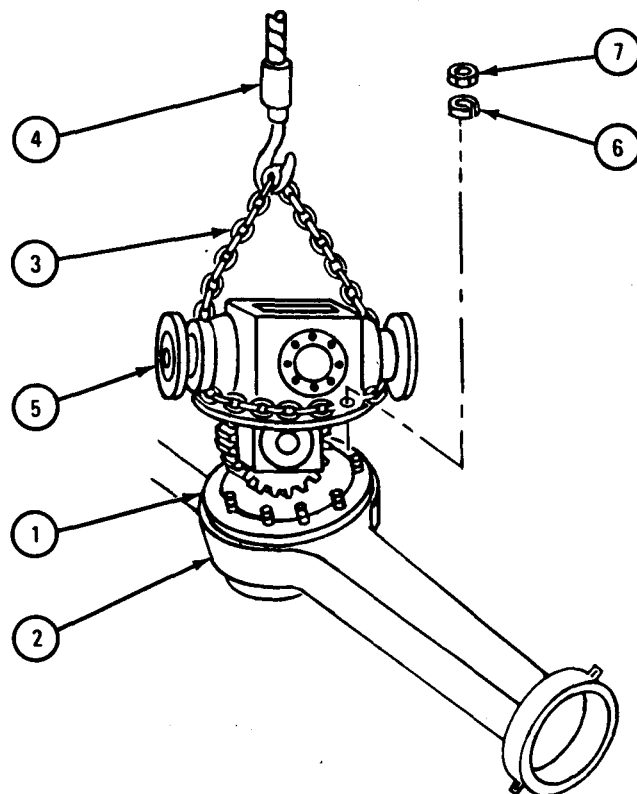

TA 085067

FRAME 2

NOTE

Follow-on Maintenance Action Required:

1. Front axle differential:
 - a. Replace axle shaft. Refer to para TM 9-2320-209-20.
 - b. Replace front axle assembly. Refer to para 10-3.
 - c. Replace and bleed brake hydraulic lines. Refer to Hydraulic Lines, Hoses, and Fittings Removal and Replacement, TM 9-2320-209-20.
 - d. Replace drag link. Refer to TM 9-2320-209-20.
 - e. Replace front wheels. Refer to TM 9-2320-209-10.
 - f. Replace propeller shaft. Refer to Propeller Shaft and Universal Joint Removal and Replacement, TM 9-2320-209-20.
 - g. Take out supports and jack down truck chassis. Refer to TM 9-2320-209-20.
 - h. Fill differential. Refer to LO 9-2320-209-12/1.
2. Forward-rear axle and rear-rear axle differential:
 - a. Replace axle shafts. Refer to TM 9-2320-209-20.
 - b. Replace axle housing. Refer to TM 9-2320-209-20.
 - c. Replace torque rods. Refer to TM 9-2320-209-20.
 - d. Replace and bleed brake hydraulic lines. Refer to TM 9-2320-209-20.
 - e. Replace rear inner and outer wheels. Refer to TM 9-2320-209-10.
 - f. Replace propeller shafts. Refer to TM 9-2320-209-20.
 - g. Take out supports and jack down truck chassis. Refer to TM 9-2320-209-20.
 - h. Fill differential. Refer to LO 9-2320-209-12/1.

END OF TASK

10-8. MAINTENANCE OF BEARINGS.

NOTE

Tasks are for general maintenance of bearings.
Refer to TM 9-214 for more detailed information.

a. Removal of Bearing from Shaft by Pressing.

TOOLS : No special tools required

SUPPLIES : None

PERSONNEL : One

FRAME 1

1. Hold shaft (1) with bearing (2) in arbor press (3).

CAUTION

Do not place steel bars (4) against shaft (1). Steel bars can scratch and score shaft.

2. Place two flat steel bars (4) between bearing (2) and base plate (5). Inner race (6) of bearing must rest firmly on steel bars.
3. Hold shaft (1) so it does not fall. Press bearing (2) from shaft.

END OF TASK

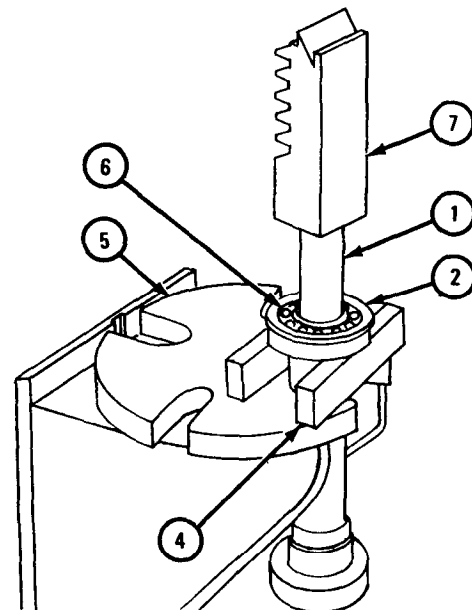
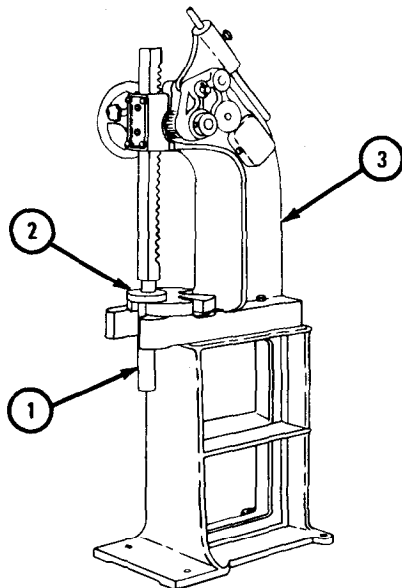

TA 053409

b. Removal of Bearing from Shaft by Pulling.

TOOLS : No special tools required

SUPPLIES: None

PERSONNEL: One

FRAME 1

1. Put puller plate (1) on shaft (2) with bearing (3) as shown. Close puller plate until inner race (4) of bearing (3) rests on puller plate but plate does not touch shaft (2).
2. Tighten two nuts (5) to keep puller plate (1) from opening.
3. Put puller wrench (6) on push-puller (7) as shown. Screw in and tighten two legs (8) into puller plate (1).
4. Pull bearing (3) off shaft (2).

END OF TASK

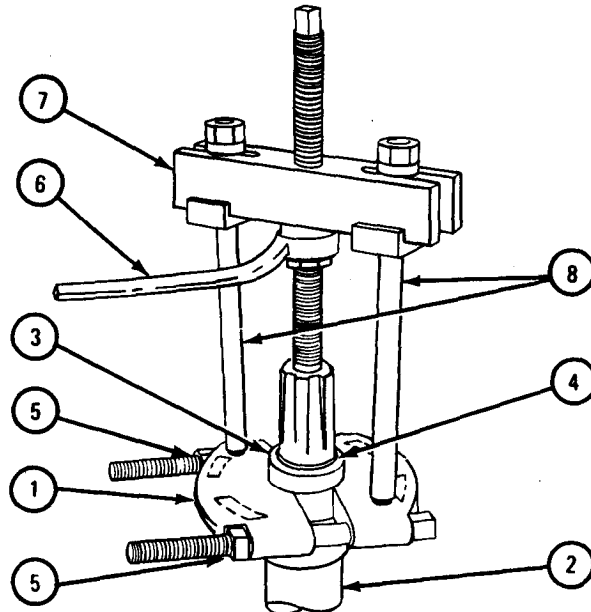

TA 105657

c. Removal of Bearing from Housing by Pressing.

TOOLS : No special tools required

SUPPLIES : None

PERSONNEL: One

FRAME 1

1. Hold housing (1) with bearing (2) in arbor press (3).
2. Place two steel bars (4) on rim of housing (1) but not touching outer race (5) of bearing (2).
3. Place steel bar (6) in notches in housing (1).
4. Press bearing (2) out of housing (1).

END OF TASK

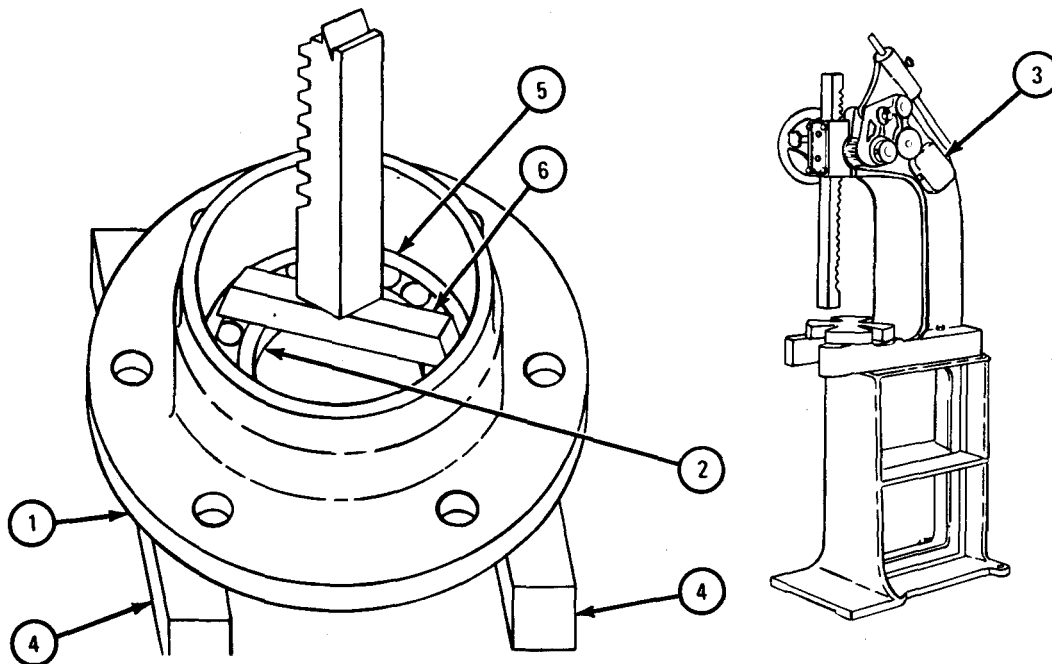

TA 084281

d. Removal of Bearing from Housing by Pulling.

TOOLS : No special tools required

SUPPLIES: None

PERSONNEL: One

FRAME 1

1. Hold pulling attachment (1) in bearing (2). Tighten nut (3) to spread two legs (4) .
2. Join pulling attachment (1), reducing adapter (5), and puller (6) as shown.
3. Pull bearing (2) from housing (7).

END OF TASK

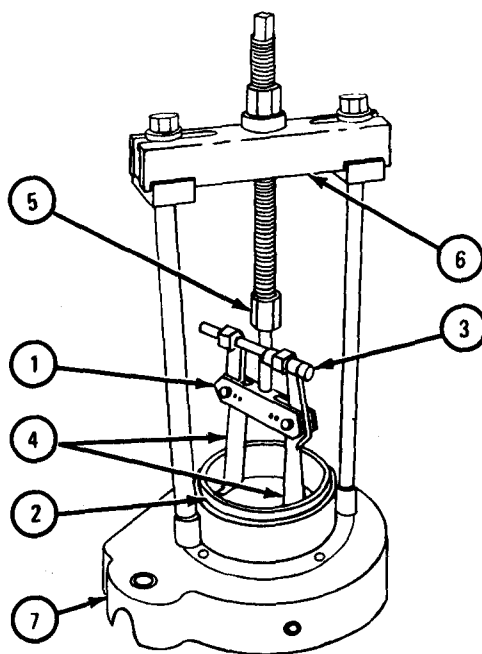

TA 102151

e. Cleaning of Bearings.

TOOLS : No special tools required

SUPPLIES : Solvent, dry cleaning, type II (SD-2), Fed. Spec P-D-680

PERSONNEL: One

FRAME 1

WARNING

Dry cleaning solvent is flammable. Do not use near an open flame. Keep a fire extinguisher nearby when solvent is used. Use only in well-ventilated places. Failure to do this may result in injury to personnel and damage to equipment.

NOTE

All old lubricant must be taken off bearing cones (1) during cleaning. Soak bearing cones as long as needed to take off all old lubricant.

1. Soak bearing (1) in solvent.
2. Rinse bearing cone (1) in clean solvent.

WARNING

Do not dry bearing with compressed air. Spinning bearings may explode and cause serious injury to personnel.

3. Let bearing (1) dry.
4. Using clean rags, wipe all old grease from inside hub (2).

END OF TASK

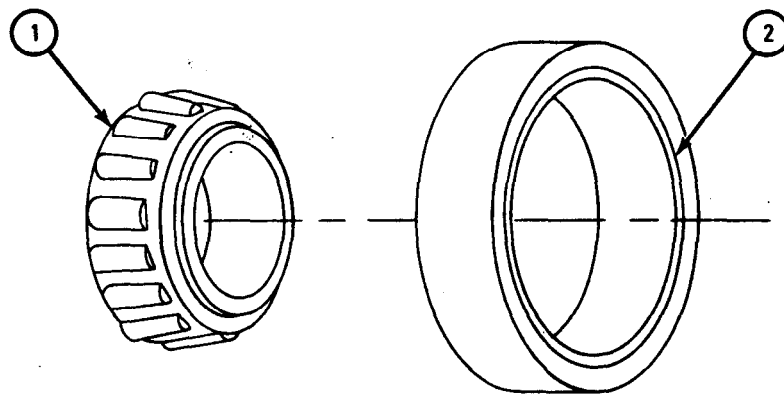

TA 101887

f. Inspection of Bearings.

FRAME 1

1. Place a light behind bearing assembly.
2. Hold wheel bearing cone (1) and turn inner race (2) slowly.
3. Check that rollers (3) and wheel bearing cone (1) have no cracks, flaking, pitting, or long or deep scratches.
4. Check that wheel bearing cone (1) has not overheated. Wheel bearing cone will turn blue where it has overheated.
5. Check that bearing cup (4) has no scoring, pitting or long or deep scratches.

NOTE

If bearing rollers (3) are damaged, throw bearing cone (1) away and get a new one.

6. Throw away damaged parts and get new ones.

END OF TASK

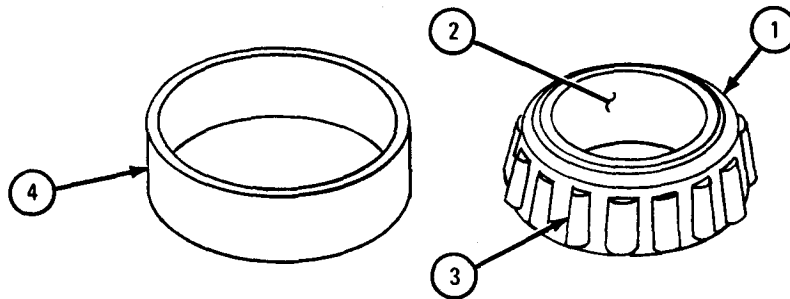

TA 101879

g. Replacement of Bearing onto Shaft.

TOOLS : No special tools required

SUPPLIES : Solvent, dry cleaning, Type II (SD- 2), Fed. Spec P-D-680
Anti-seize compound, white lead, Fed. Spec TT-A-680-B-2

PERSONNEL: One

FRAME 1

WARNING

Dry cleaning solvent is flammable. Do not use near an open flame. Keep a fire extinguisher nearby when solvent is used. Use only in well-ventilated places. Failure to do this may result in injury to personnel and damage to equipment.

1. Coat bearing seat on shaft (1) with anti-seize compound.
2. Hold shaft (1) in place in arbor press (2).
3. Place bearing (3) squarely on top of shaft (1).
4. Place sleeve (4) on inner race (5). Put steel drive plate (6) on sleeve (4) .
5. Press bearing (3) into place on shaft (1).

END OF TASK

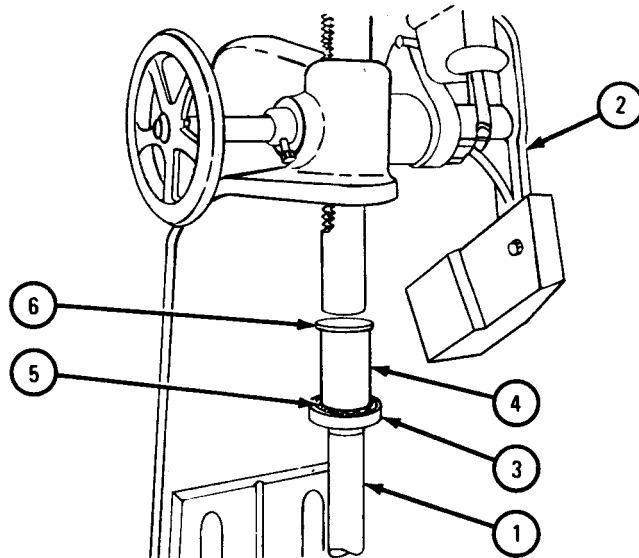

TA 101880

h. Replacement of Bearing into Housing.

TOOLS: No special tools required

SUPPLIES: Solvent, dry cleaning, type II (SD-2), Fed. Spec P-D-680
Anti-seize compound, white lead, Fed. Spec TT-A-680-B-2

PERSONEL: One

FRAME 1

WARNING

Dry cleaning solvent is flammable. Do not use near an open flame. Keep a fire extinguisher nearby when solvent is used. Use only in well-ventilated places. Failure to do this may result in injury to personnel and damage to equipment.

1. Using solvent, clean bore of housing (1).
2. Coat bore of housing (1) with anti-seize compound.
3. Put housing (1) in place in arbor press (2).
4. Place bearing (3) squarely on bore of housing (1).
5. Put sleeve (4) on outer race (5) of bearing (3).
6. Put steel drive plate (6) on top of sleeve (4).
7. Push bearing (3) into housing (1).

END OF TASK

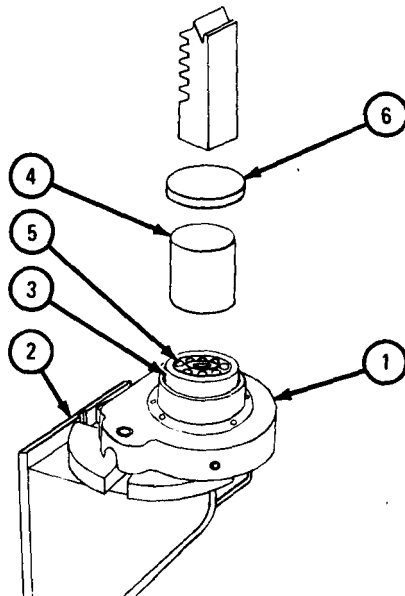

TA 103484

Section IV. STEERING MECHANISM

10-9. FRONT AXLE STEERING ARM REPAIR.

NOTE

This task is the same for the left and right steering arms. This task is shown for the left steering arm.

TOOLS : No special tools required

SUPPLIES : Cotter pin (2)

PERSONNEL : One

EQUIPMENT CONDITION : Truck parked, engine off, handbrake set.

a. Preliminary Procedures.

- (1) Jack up and support front axle housing. Refer to TM 9-2320-209-20.
- (2) Remove front wheel. Refer to TM 9-2320-209-10.

b. Removal.

FRAME 1

1. Take out and throw away cotter pin (1).
2. Unscrew plug (2) until it is halfway out of drag link (3).
3. Turn steering wheel (4) from side to side to loosen drag link (3).
4. Lift off drag link (3).

GO TO FRAME 2

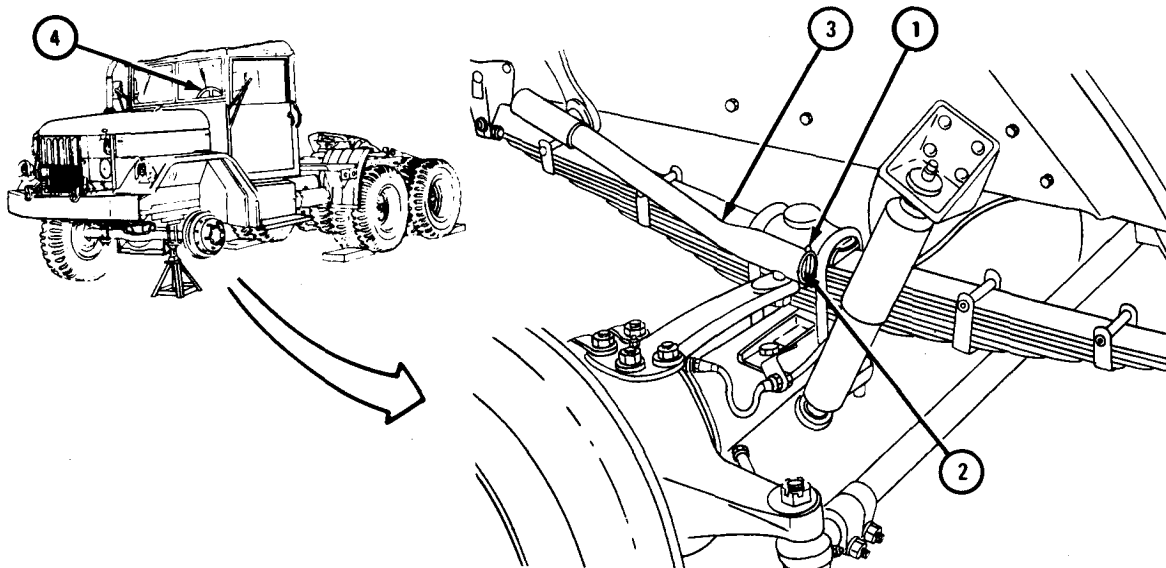

TA 089026

FRAME 2

1. Take off four nuts (1) and lockwashers (2).
2. Lift bootguard (3) off two studs (4).
3. Take off steering arm (5).

END OF TASK

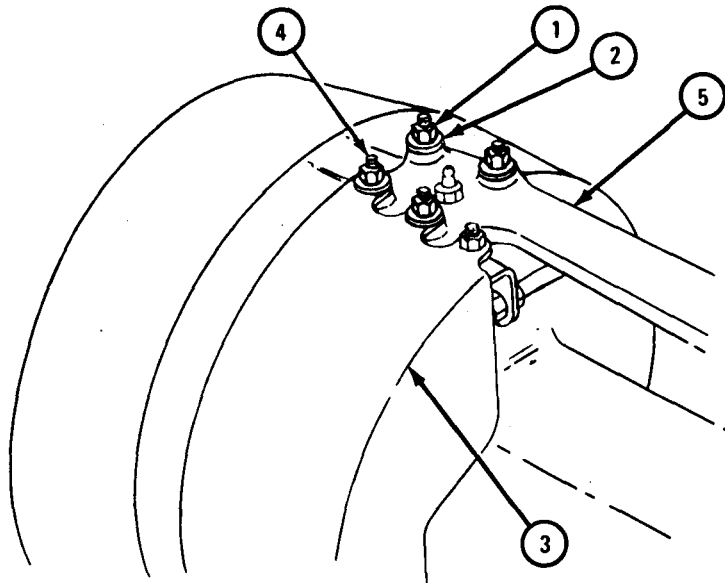

TA 085226

c. Disassembly.

NOTE

If no parts are worn or damaged, go to para 10-9g.

FRAME 1

1. Take out grease fitting (1).
2. Press out four bushings (2).
3. Take out and throw away cotter pin (3).
4. Take off nut (4).
5. Press out ball stud (5).

END OF TASK

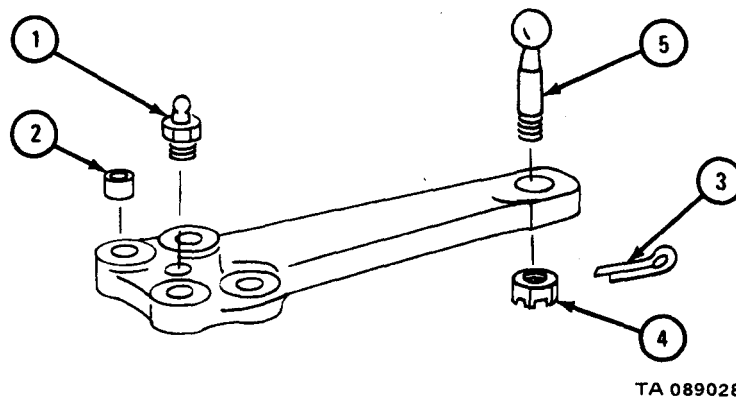

d. Cleaning. There are no special cleaning procedures needed. Refer to cleaning procedures given in para 1-3.

e. Inspection and Repair.

FRAME 1

1. Check that steering arm (1) is not bent, cracked or damaged.
2. Check that bushings (2) are not worn or damaged.
3. Check that five nuts (3), four lockwasher (4), grease fitting (5) , and ball stud (6) are not worn or damaged.
4. If any part is worn or damaged, get a new one.

END OF TASK

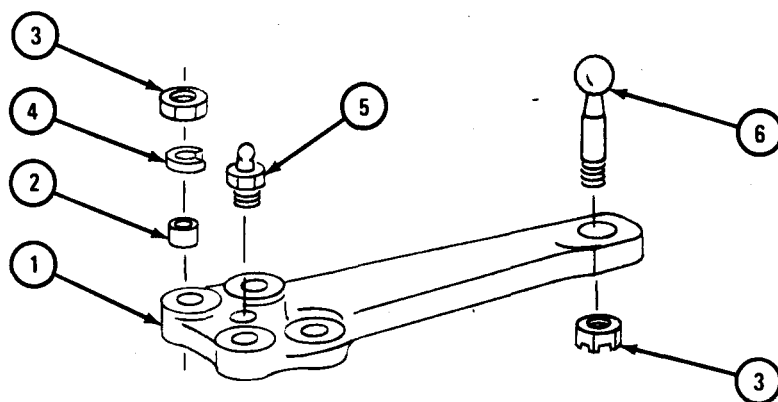

TA 089027

f. Assembly.**FRAME 1**

1. Press in four bushings (1).
2. Press in ball stud (2).
3. Put on nut (3).
4. Put in cotter pin (4).
5. Put in grease fitting (5).

END OF TASK

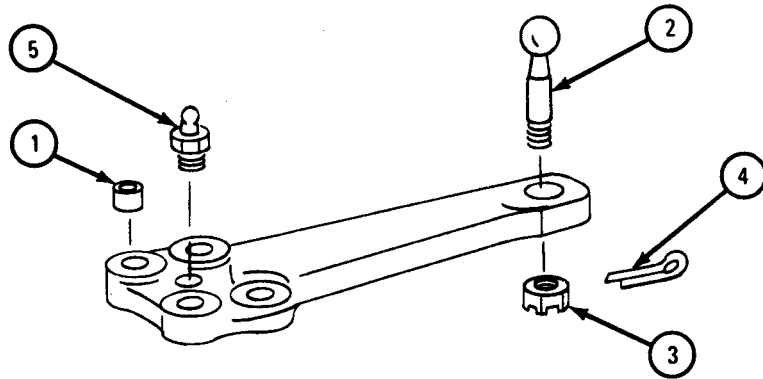

TA 089029

g. Replacement.

FRAME 1

1. Put on steering arm (1).
2. Put bootguard (2) on two studs (3).
3. Put on four lockwashers (4) and nuts (5).

GO TO FRAME 2

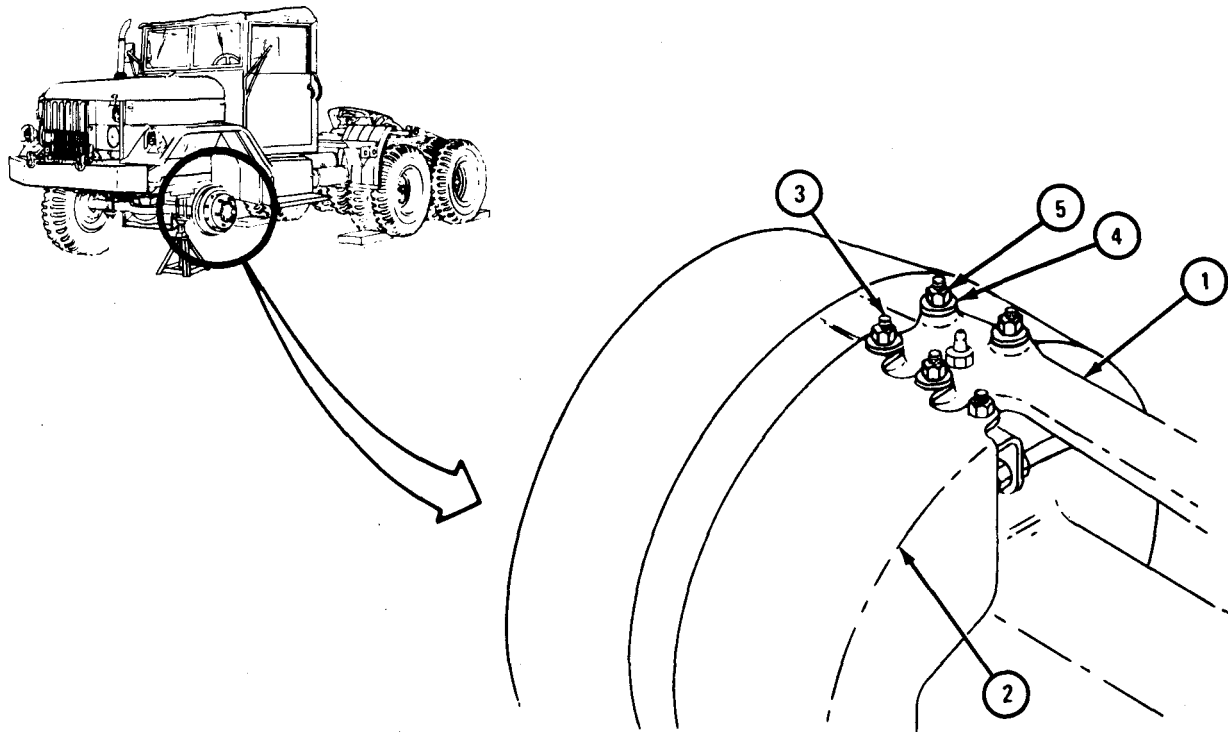

TA 085307

FRAME 2

1. Put drag link (1) on ball stud (2).
2. Tighten plug (3). Back out plug until holes for cotter pin (4) in drag link (1) align with slot in plug.
3. Put in cotter pin (4).

NOTE

Follow-on Maintenance Action Required:

1. Replace front wheel. Refer to TM 9-2320-209-10.
2. Remove support and lower axle housing. Refer to TM 9-2320-209-20.

END OF TASK

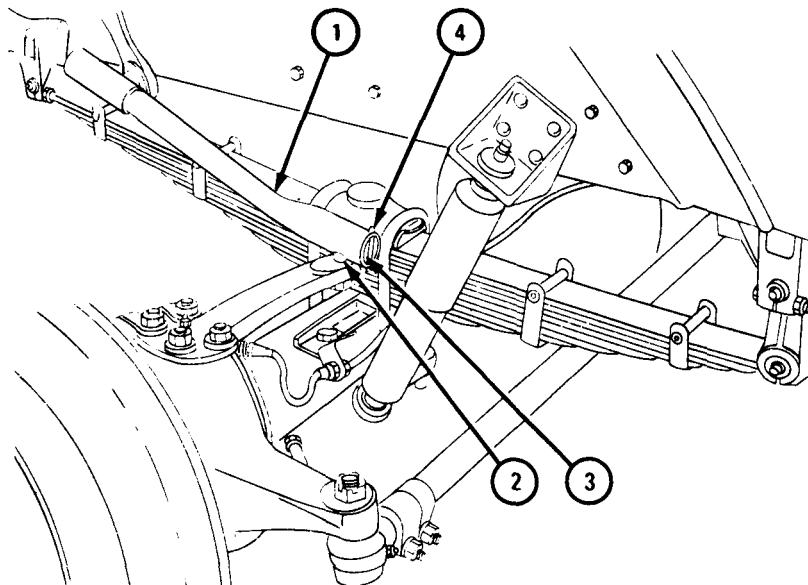

TA 089030

10-10. WHEEL HUB SPINDLE REPAIR.

NOTE

This task is the same for the left and right front wheel hub spindles. This task is shown for the right front wheel hub spindle.

TOOLS : No special tools required

SUPPLIES : Artillery and automotive grease, type GAA, MIL-G-10924

PERSONNEL: One

EQUIPMENT CONDITION : Truck parked on level surface, engine off, handbrake set, rear wheels chocked.

Preliminary Procedure. Remove hub and brake drum assembly. Refer to TM 9-2320-209-20.

b. Removal.

FRAME 1

1. Take out 12 nuts and washers (1).
2. Take off backing plate with brakeshoe assembly (2). Tie brake assembly to truck so it does not hang from brake hose.
3. Slide out wheel hub spindle assembly (3).

END OF TASK

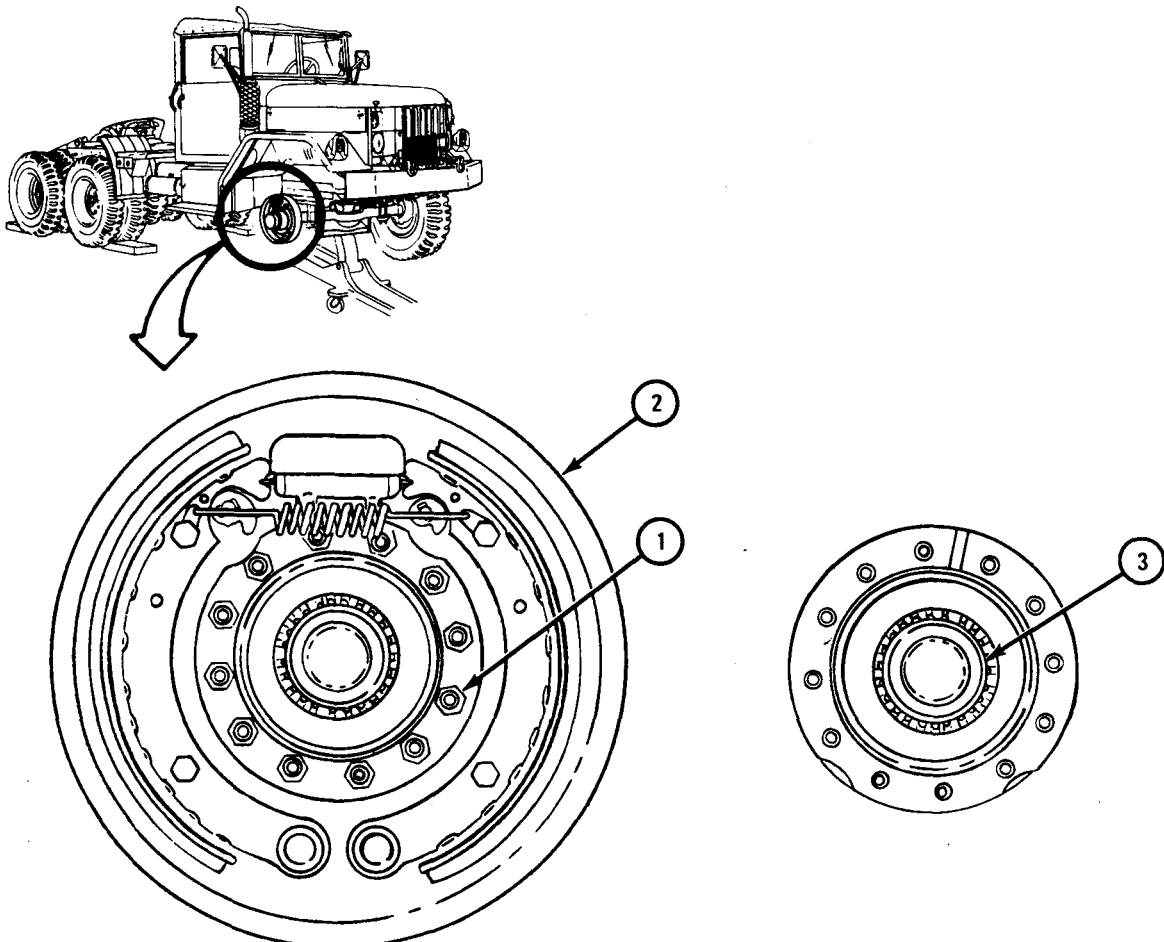

TA 089031

c. Cleaning. There are no special cleaning procedures needed. Refer to cleaning procedures given in para 1-3.

d. Inspection and Repair.

FRAME 1

1. Check that front wheel hub spindle (1) is not bent or cracked and that threads are not damaged. If spindle is damaged, throw it away and get a new one.
2. Check that bearing (2) is not worn or damaged. If bearing is damaged, press out old bearing and press in a new one. Refer to para 10-8.

END OF TASK

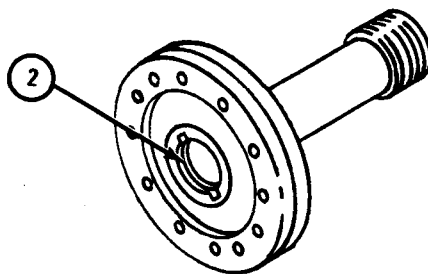
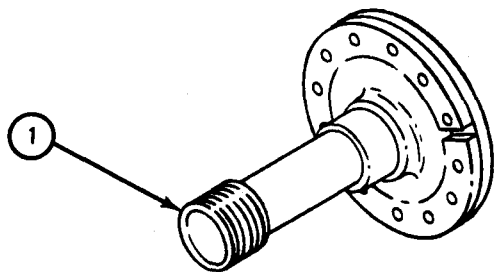

TA 089032

e. Replacement.

FRAME 1

1. Put wheel hub spindle assembly (1) in place as shown.
2. Untie backing plate with brakeshoe assembly (2) and put it on 12 studs (3).
3. Put on 12 nuts and washers (4).

NOTE

Follow-on Maintenance Action Required:
Replace front hub and drum assembly. Refer to
TM 9-2320-209-20.

END OF TASK

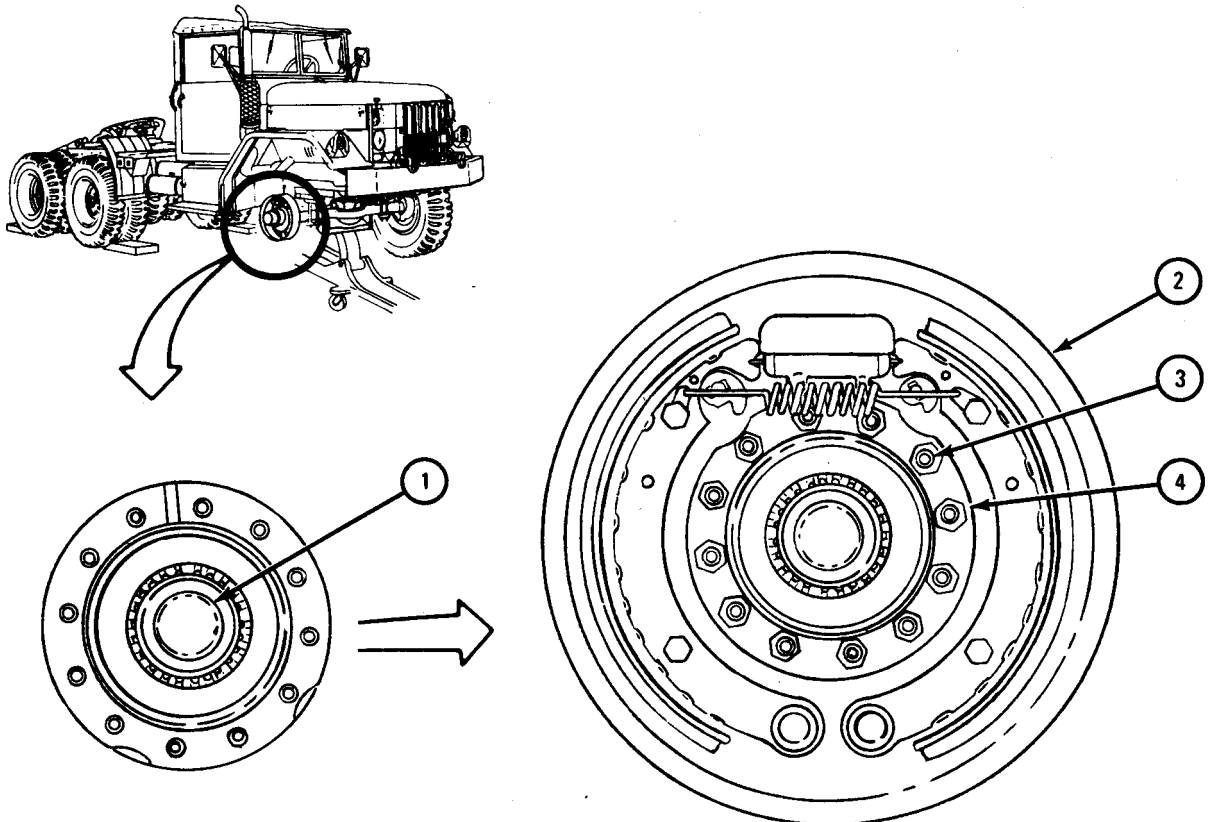

TA 089033

CHAPTER 11

REAR AXLE GROUP MAINTENANCE

Section I. SCOPE

11-1. EQUIPMENT ITEMS COVERED. This chapter gives equipment maintenance procedures for the rear axle assembly for which there are authorized corrective maintenance tasks at the direct and general support maintenance levels.

11-2. EQUIPMENT ITEMS NOT COVERED. All equipment items for which corrective maintenance is authorized at the direct and general support maintenance levels are covered in this chapter.

Section II. REAR AXLE ASSEMBLY

11-3. FORWARD-REAR AXLE ASSEMBLY REMOVAL AND REPLACEMENT.

TOOLS : No special tools required

SUPPLIES : None

PERSONNEL: Two

EQUIPMENT CONDITION : Truck parked, engine off, handbrake set.

a. Preliminary Procedures.

(1) Jack up and support rear of chassis. Refer to TM 9-2320-209-20.

(2) Remove transfer to forward-rear axle propeller shaft. Refer to Propeller Shaft and Universal Joint Removal and Replacement, TM 9-2320-209-20.

(3) Remove forward-rear to rear-rear propeller shaft. Refer to Propeller Shaft and Universal Joint Removal and Replacement, TM 9-2320-209-20.

(4) Take off forward-rear outer and inner wheels. Refer to TM 9-2320-209-10.

b. Removal.

FRAME 1

1. Place container under tee fitting (1) to catch brake fluid.
 2. Take off brake line (2).
- GO TO FRAME 2

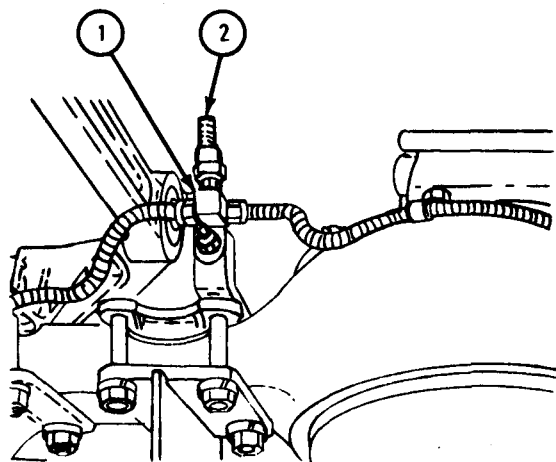
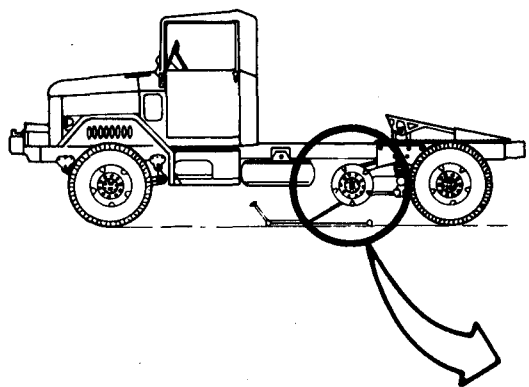

TA 046342

FRAME 2

- Soldiers A and B 1. Put jack under axle assembly (1) and take off three nuts (2) and lockwashers (3).
- Soldier A 2. Put prybar between two torque rods (4) and mounting brackets (5) and put pressure on torque rod.
- Soldier B 3. Hit two mounting brackets (5) at point (6) and take out torque rod.
- Soldier A 4. Put prybar between torque rod (7) and mounting bracket (8) and put pressure on torque rod.
- Soldier B 5. Hit mounting bracket (8) at point (9) and take out torque rod.
- Soldier A 6. Tie torque rod (7) out of the way.
- GO TO FRAME 3

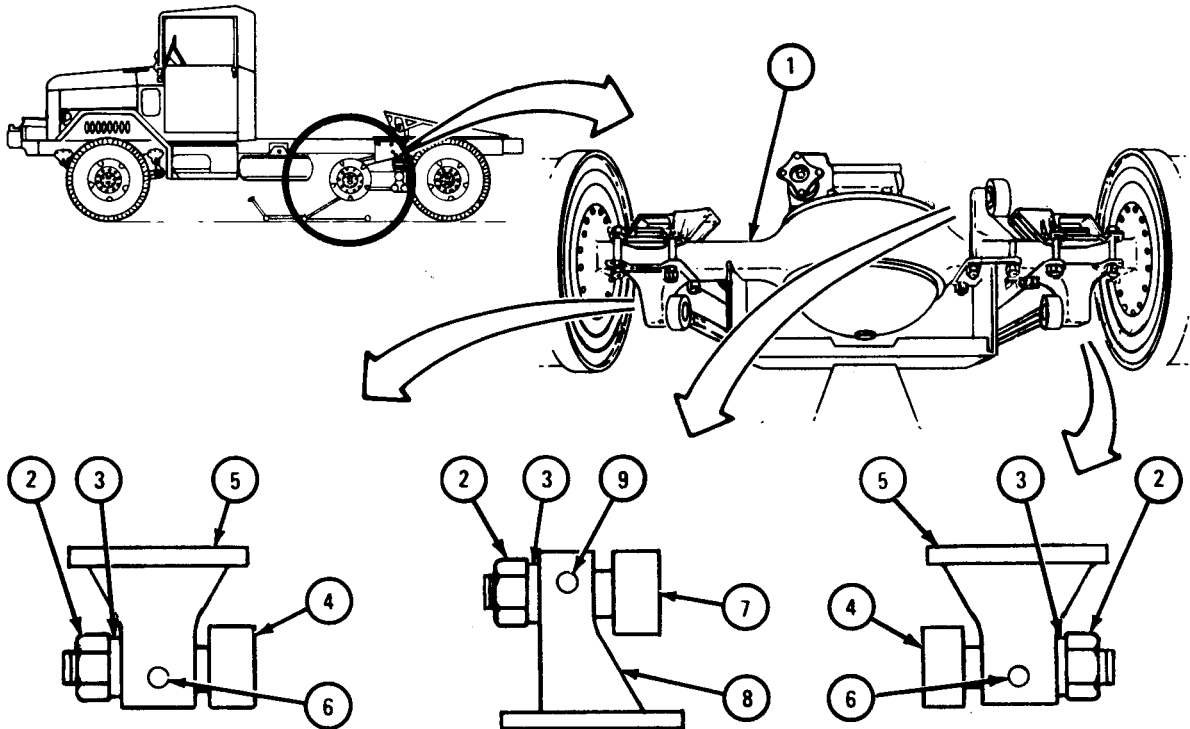

TA 046343

FRAME 3

1. Pull jack (1) to front of truck until springs (2) are out of brackets (3).
2. Lower jack (1) and pull axle (4) out from under truck.

END OF TASK

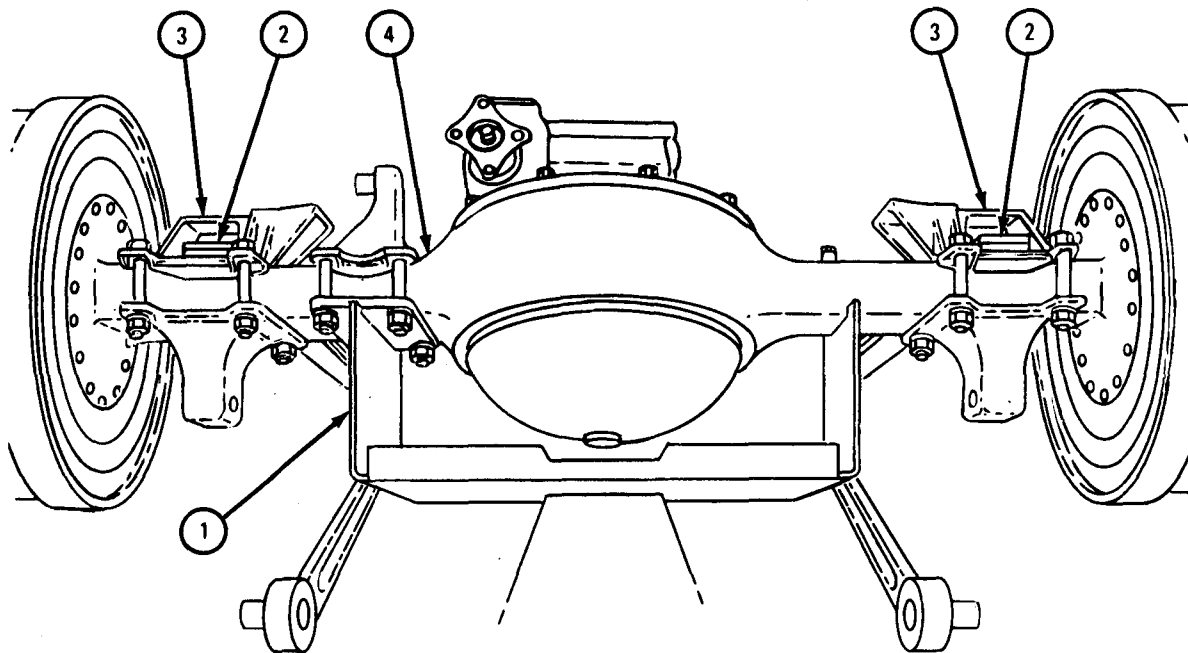

TA 046344

c. Replacement.

FRAME 1

1. Push jack and forward-rear axle assembly (1) under truck. Raise axle assembly and align brackets (2) with springs (3).
 2. Guide springs (3) into brackets (2).
- GO TO FRAME 2

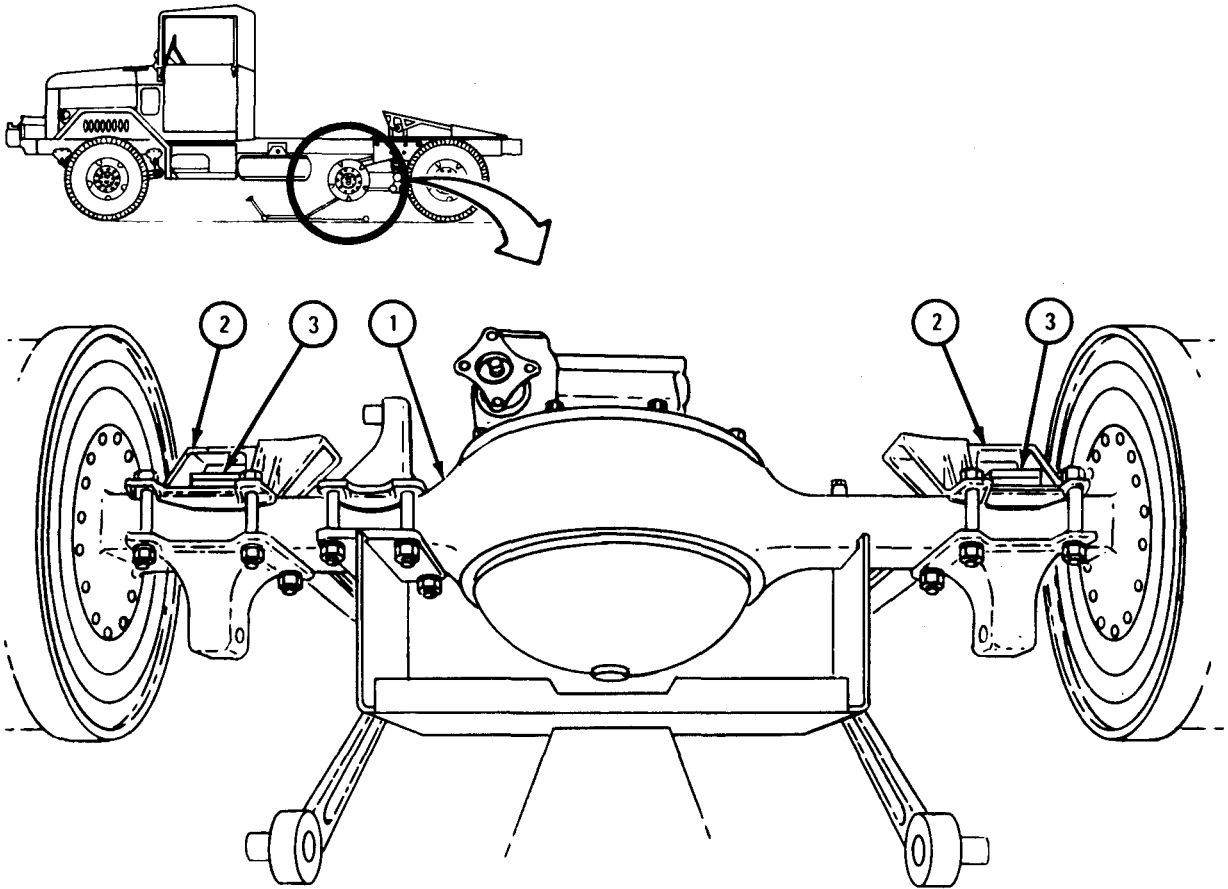

TA 046345

FRAME 2

1. Put two torque rods (1) into brackets (2). Put on two lockwashers (3) and two nuts (4).
2. Put torque rod (5) in bracket (6). Put on lockwasher (7) and nut (8).
3. Tighten three nuts (4 and 8) to 175 to 200 pound-feet.

GO TO FRAME 3

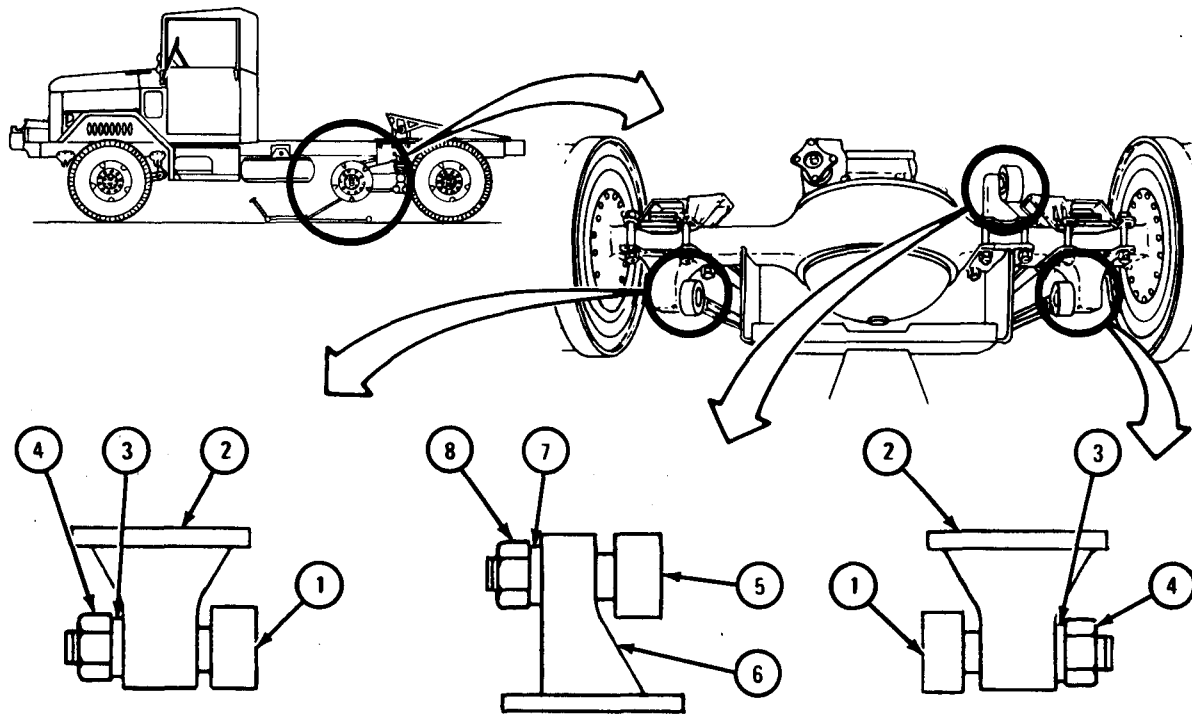

TA 046346

FRAME 3

1. Put brake line (1) on tee fitting (2). Put on nut (3).

NOTE

Follow-on Maintenance Action Required:

1. Replace forward-rear inner and outer wheels. Refer to TM 9-2320-209-10.
2. Replace forward-rear to rear-rear propeller shaft. Refer to Propeller Shaft and Universal Joint Removal and Replacement, TM 9-2320-209-20.
3. Replace transfer to forward-rear propeller shaft. Refer to Propeller Shaft and Universal Joint Removal and Replacement, TM 9-2320-209-20.
4. Remove supports and jack down rear of chassis. Refer to TM 9-2320-209-20.
5. Bleed brake system. Refer to TM 9-2320-209-20.

END OF TASK

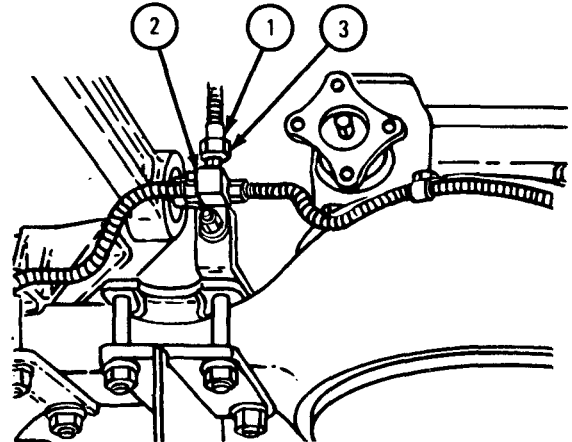
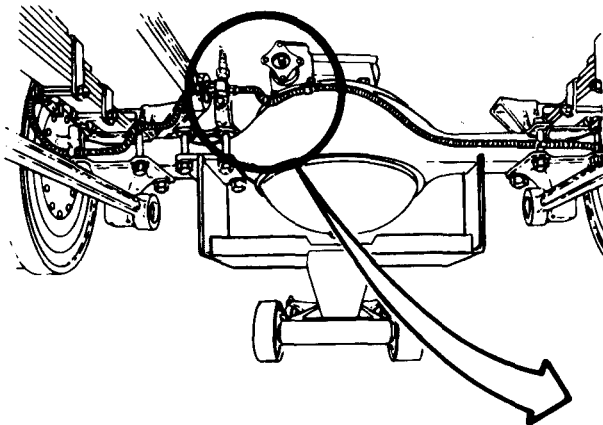

TA 046348

11-4. REAR-REAR AXLE ASSEMBLY REMOVAL AND REPLACEMENT.

TOOLS: No special tools required

SUPPLIES: None

PERSONNEL: One

EQUIPMENT CONDITION: Truck parked, engine off, handbrake set, front wheels chocked.

a. Preliminary Procedures.

(1) Raise and support rear of chassis on both sides. Refer to TM 9-2320-209-20.

(2) Remove forward-rear to rear-rear propeller shaft. Refer to Propeller Shaft and Universal Joint Removal and Replacement, TM 9-2320-209-20.

(3) Remove rear-rear outer and inner wheels. Refer to TM 9-2320-209-10.

b. Removal.

FRAME 1

1. Hold tee fitting (1) and take off line nut (2). Take off brake line (3).

2. Put cap on end of brake line (3) to keep dirt out of system.

GO TO FRAME 2

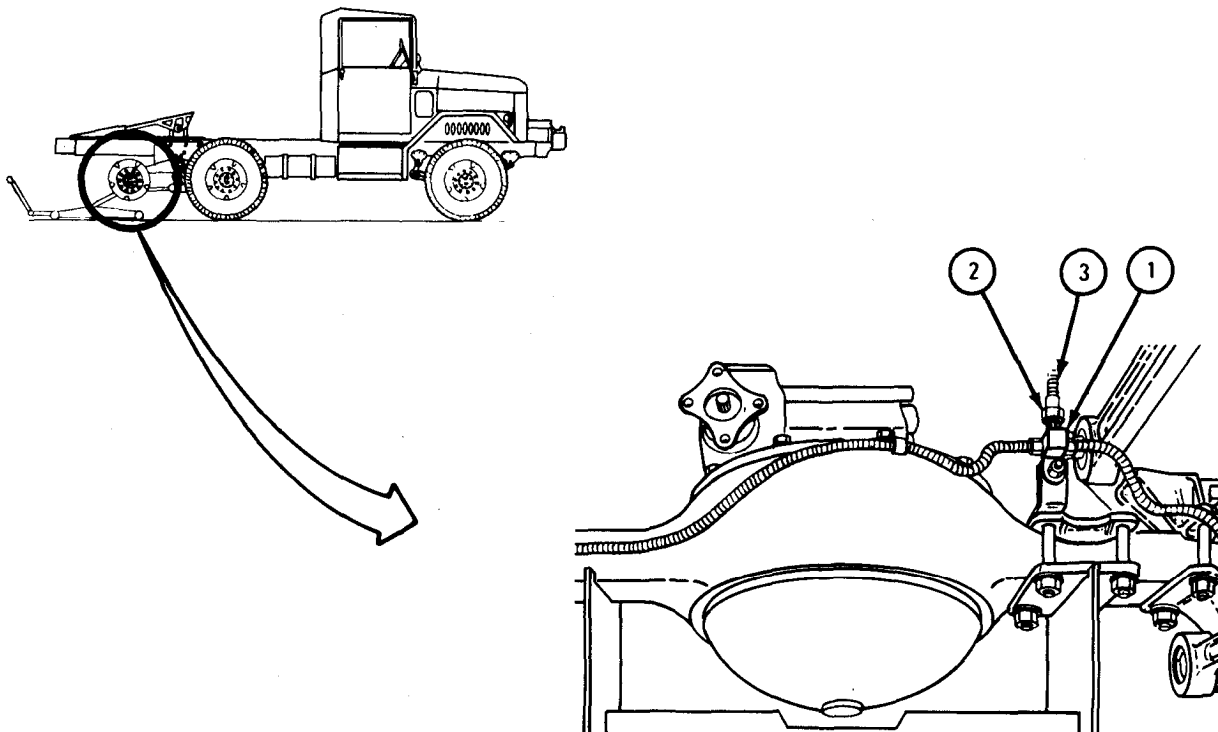

TA 046334

FRAME 2

1. Take off two nuts (1) and two lockwashers (2).
2. Hit front of two torque rods (3) and brackets (4) at points (5).
3. Take off nut (6) and lockwasher (7).
4. Hit front of torque rod (8) and bracket (9) at point (10).
5. Using safety wire, tie torque rod (8) out of the way.

GO TO FRAME 3

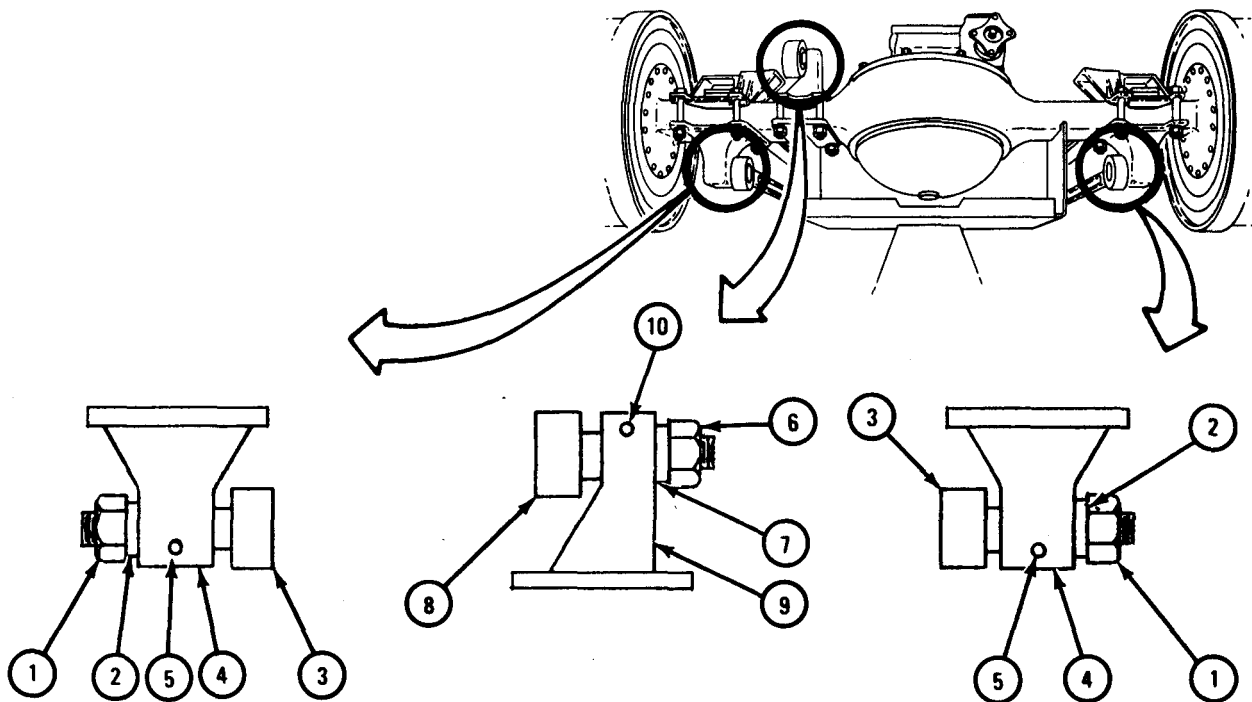

TA 046335

FRAME 3

1. Pull lift (1) to rear of truck until springs (2) are out of spring guide brackets (3).
2. Lower lift (1) and pull axle (4) out from under truck.
3. Take out air breather valve (5).

END OF TASK

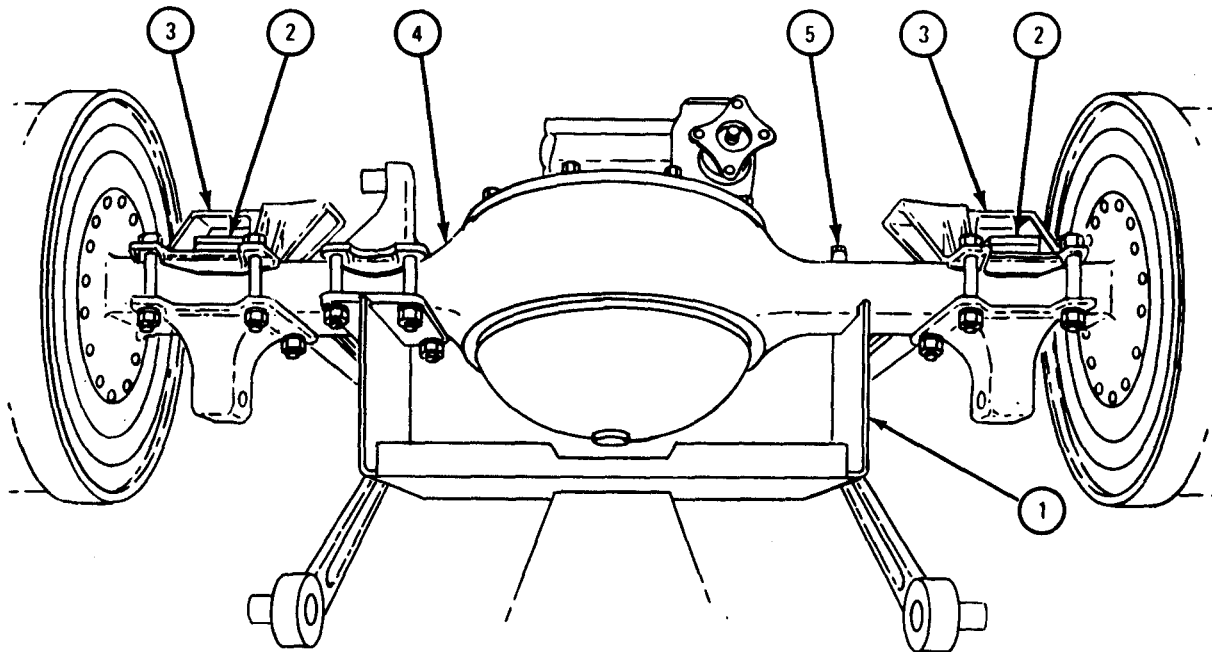

TA 046336

c. Replacement.

FRAME 1

1. Put lift (1) and axle (2) under truck so spring guide brackets (3) align with springs (4). Put springs in spring guide brackets.

GO TO FRAME 2

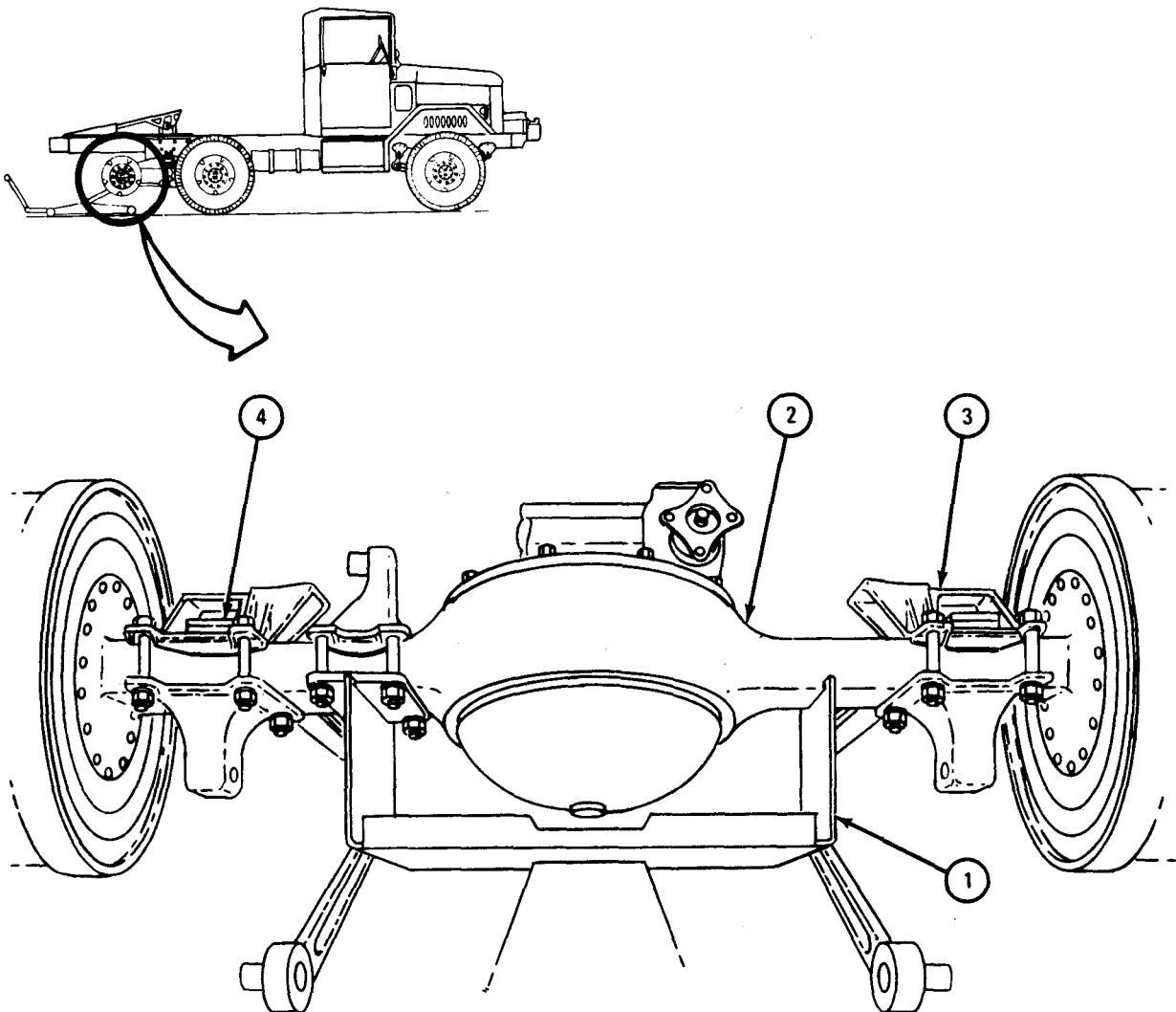

TA 046337

FRAME 2

1. Put two lower torque arms (1) into two torque arm brackets (2).
2. Hand tighten lockwashers (3) and nuts (4).
3. Take off safety wire. Put upper torque arm (5) into torque arm bracket (6).
4. Hand tighten lockwashers (7) and nuts (8).
5. Tighten nuts (4 and 8) to 175 to 200 pound-feet.

GO TO FRAME 3

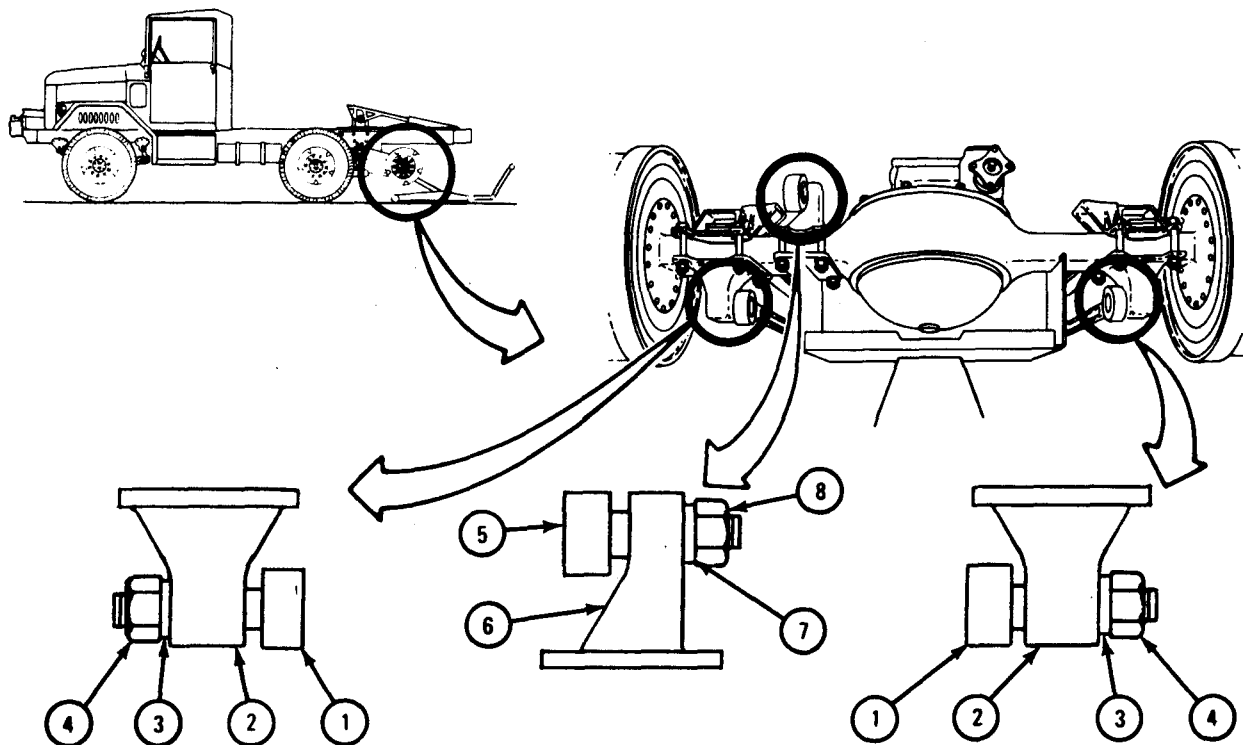

TA 046338

FRAME 3

1. Put on brake line (1). Hold tee fitting (2) and tighten nut (3).
2. Put in air breather valve (4).

NOTE

Follow-on Maintenance Action Required:

1. Replace propeller shaft. Refer to Propeller Shaft and Universal Joint Removal and Replacement, TM 9-2320-209-20.
2. Bleed brakes. Refer to TM 9-2320-209-20.
3. Replace rear-rear wheels. Refer to TM 9-2320-209-10.
4. Lubricate rear-rear axle and propeller shaft. Refer to LO 9-2320-209-12/1.
5. Remove supports and jack down truck chassis. Refer to TM 9-2320-209-20.

END OF TASK

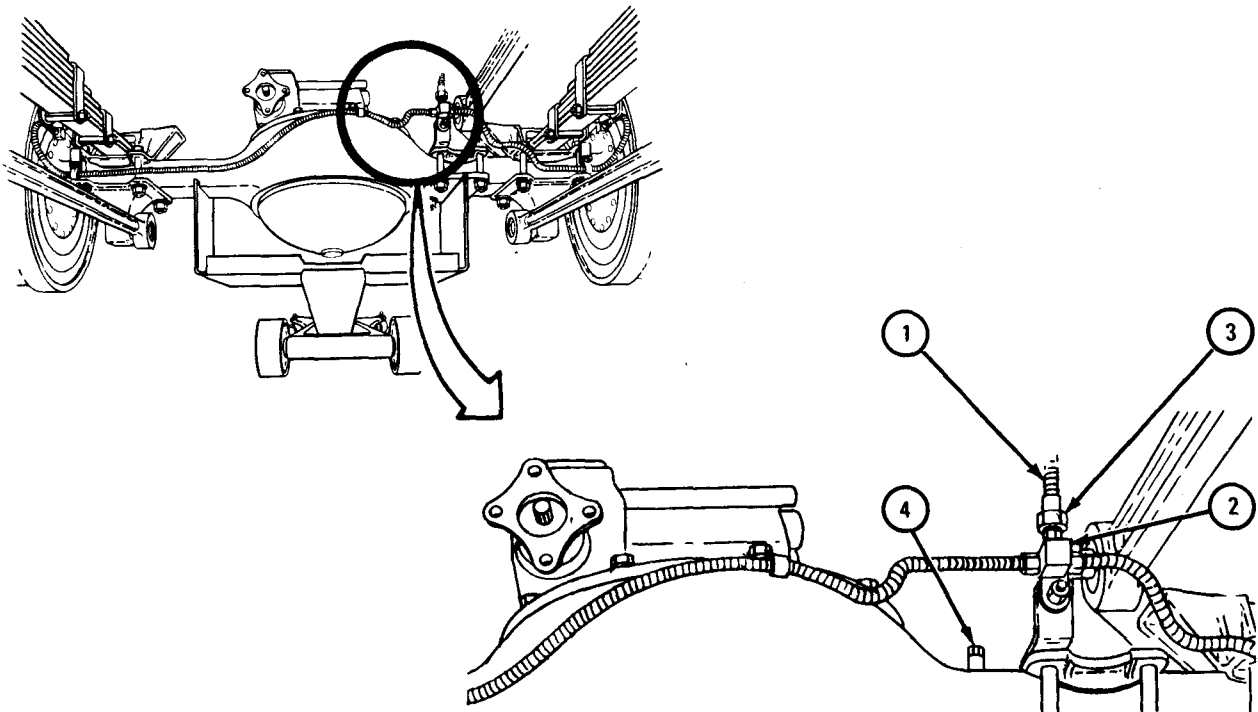

TA 046340

11-5. FORWARD-REAR AND REAR-REAR AXLE HOUSING REPAIR.

TOOLS : No special tools required

SUPPLIES : Solvent, dry cleaning, type II (SD-2), Fed. Spec P-D-680

PERSONNEL : One

EQUIPMENT CONDITION: Truck parked, engine off, handbrake set.

a. Preliminary Procedures.

(1) If forward-rear axle is to be repaired, remove it. Refer to para 11-3. If rear-rear axle is to be repaired, remove it. Refer to para 11-4.

(2) Remove differential. Refer to para 10-7.

(3) Remove hub and drum assemblies. Refer to TM 9-2320-209-20.

(4) Remove brake assemblies. Refer to TM 9-2320-209-20.

(5) Remove wheel cylinders. Refer to TM 9-2320-209-20.

b. Disassemble.

FRAME 1

1. Take relief valve (1) out of axle housing (2).

NOTE

Do not take out studs (3) unless they are damaged.

2. Take out studs (3).

3. Take out fill plug (4), gasket (5), and drain plug (6). Throw away gasket.

END OF TASK

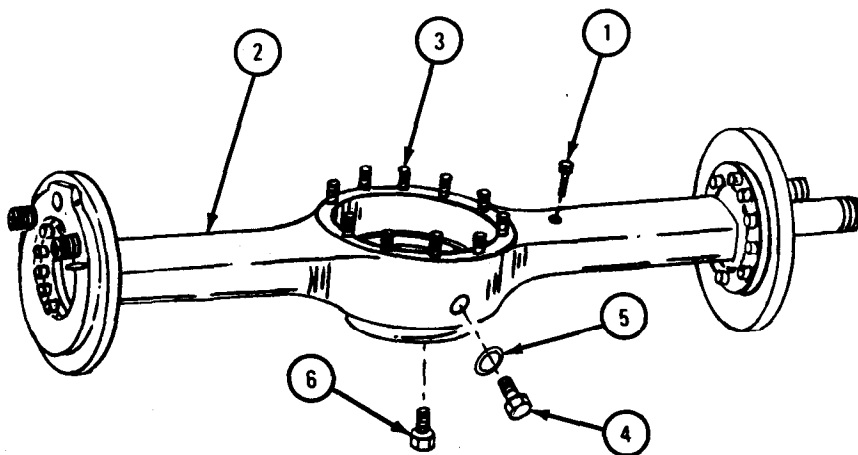

TA 085460

WARNING

Dry cleaning solvent inflammable. Do not use near an open flame. Keep a fire extinguisher nearby when solvent is used. Use only in well-ventilated places. Failure to do this may result in injury to personnel and damage to equipment.

c. Cleaning.

- (1) Clean all parts with solvent and wire brush.
- (2) Dry parts with clean rags.

d. Inspection and Repair.

FRAME 1

1. Check that relief valve (1) is not clogged or damaged in any other way. If valve is damaged, get a new one.
2. Check that axle housing (2) has no cracks, bends or any other damage. If housing is damaged, get a new one.
3. Check that mechanical surfaces of axle housing (2) have no nicks or burrs. Using fine mill file, take out nicks and burrs.
4. Check that drain plug (3) and fill plug (4) are not damaged. If parts are damaged, get new ones.

END OF TASK

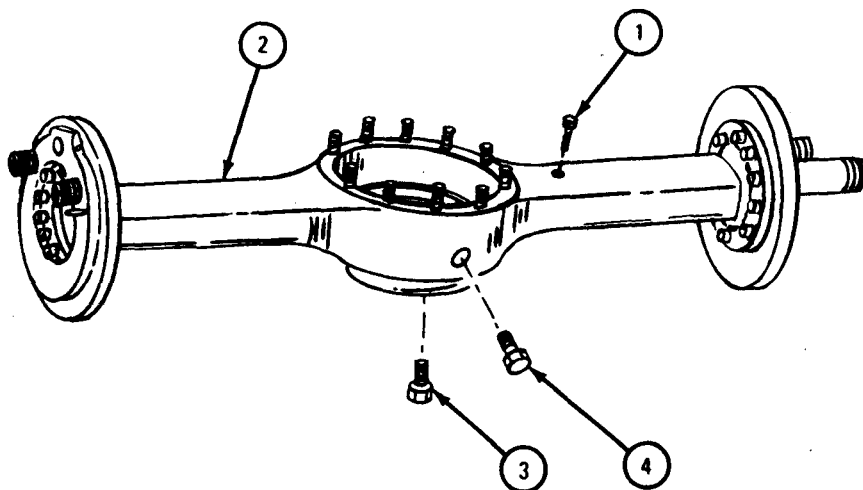

TA 085461

e. Assembly.

FRAME 1

1. Put in gasket (1), fill plug (2), and drain plug (3).
2. If studs (4) were taken out, put in new ones.
3. Put in relief valve (5).

NOTE

Follow-on Maintenance Action Required:

1. Replace wheel cylinders. Refer to TM 9-2320-209-20.
2. Replace brake assemblies. Refer to TM 9-2320-209-20.
3. Replace hub and drum assemblies. Refer to TM 9-2320-209-20.
4. Replace differential. Refer to para 10-7.
5. If forward-rear axle was repaired, replace it. Refer to para 11-3. If rear-rear axle was removed, replace it. Refer to para 11-4.

END OF TASK

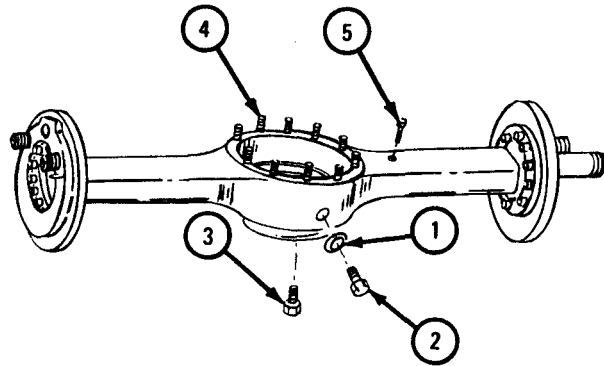

TA 085462

11-6. REAR AXLE HUB REPAIR.

TOOLS : No special tools required

SUPPLIES : Solvent, dry cleaning, type II (SD-2), Fed. Spec P-D-680

PERSONNEL: One

EQUIPMENT CONDITION: Truck parked, engine off, handbrake set.

a. Preliminary Procedures.

(1) Remove wheel and tire assembly. Refer to TM 9-2320-209-10.

(2) Remove rear hub and brake drum assembly. Refer to TM 9-2320-209-20.

b. Disassembly.**FRAME 1**

1. Put brake drum (1) on top of two wood blocks (2).
2. Take off 10 nuts (3), washers (4), and inspection cover (5).
3. Tap hub assembly (6) out of drum (1).

GO TO FRAME 2

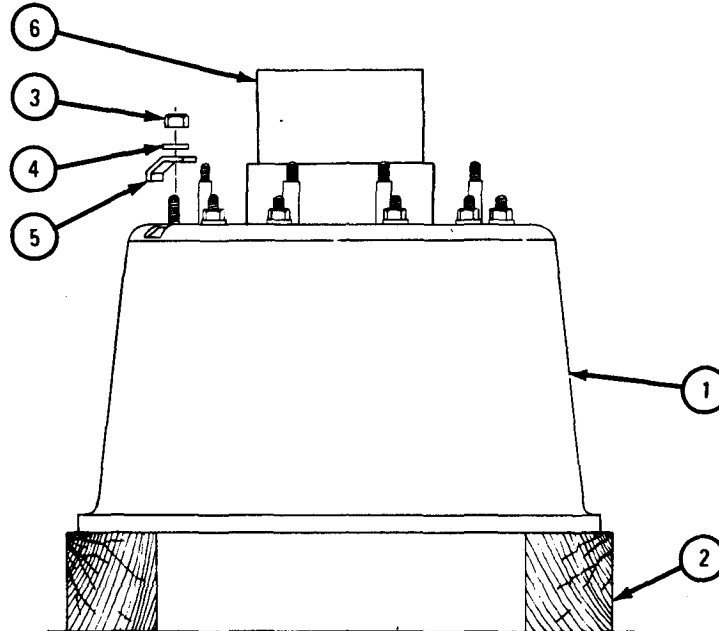

TA 105210

FRAME 2

1. Take out and throw away 10 studs (1). Take off deflector (2).
2. Cut and take off safety wire (3).
3. Take out eight capscrews (4) and washers (5). Take off adapter (6).
4. Take out and throw away six wheel studs (7).

END OF TASK

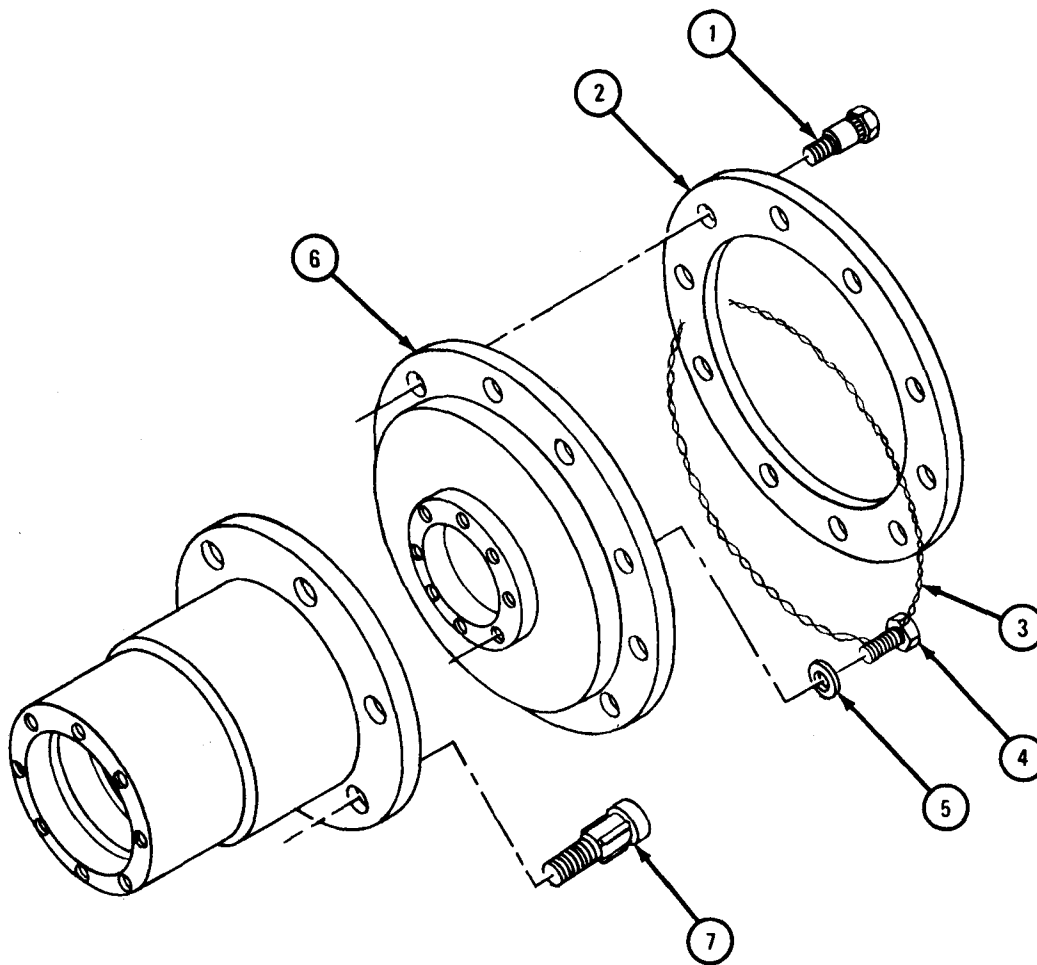

TA 105211

c. Cleaning.

WARNING

Do not use a wire brush or compressed air to clean brake drums. There may be asbestos dust on brake drums which can be dangerous to your health if you breathe it in.

Dry cleaning solvent is flammable. Do not use near an open flame. Keep a fire extinguisher nearby when solvent is used. Use only in well-ventilated places. Failure to do this may result in injury to personnel and damage to equipment.

- (1) Clean dirt and grease from all parts with dry cleaning solvent.
- (2) Clean all parts with water to take off dirt and mud.

d. Inspection.

FRAME 1	<p style="text-align: center;">NOTE</p> <p style="text-align: center;">Readings must be within limits given in table 11-1. The Letter T shows a tight fit. If readings are not within given limits, throw away part and get a new one.</p> <ol style="list-style-type: none"> 1. Measure inside diameter of hub (1). 2. Measure fit of bearing cup (2) in hub (1). <p>END OF TASK</p> <div style="text-align: center; margin-top: 20px;"> <p style="text-align: right; margin-top: 10px;">NOTE: CHECK ONLY THOSE PARTS WHICH ARE CALLED OUT. PARTS WITHOUT CALLOUTS ARE SHOWN ONLY FOR REFERENCE PURPOSES.</p> <p style="text-align: right; font-size: small;">TA 105212</p> </div>
----------------	--

Table 11-1. Rear Axle Hub Assembly Wear Limits

Index Number	Item/Point of Measurement	Size and Fit of New Parts (inches)	Wear Limits (inches)
1	Inside diameter of hub	4.4345 to 4.4365	4.4370
2	Fit of bearing cup in hub	0.001T to 0.0035T	0.005T

- e. Repair. Repair is limited to getting new parts for damaged ones.
- f. Assembly.

FRAME 1

1. Put in six wheel studs (1).
2. Aline inside row of holes in adapter (2) with threaded screw holes in hub (3).
3. Put in and tighten 8 capscrews (4) with washers (5).
4. Put on safety wire (6).
5. Aline 10 holes in deflector (7) with holes in adapter (2).
6. Put in 10 studs (8).

GO TO FRAME 2

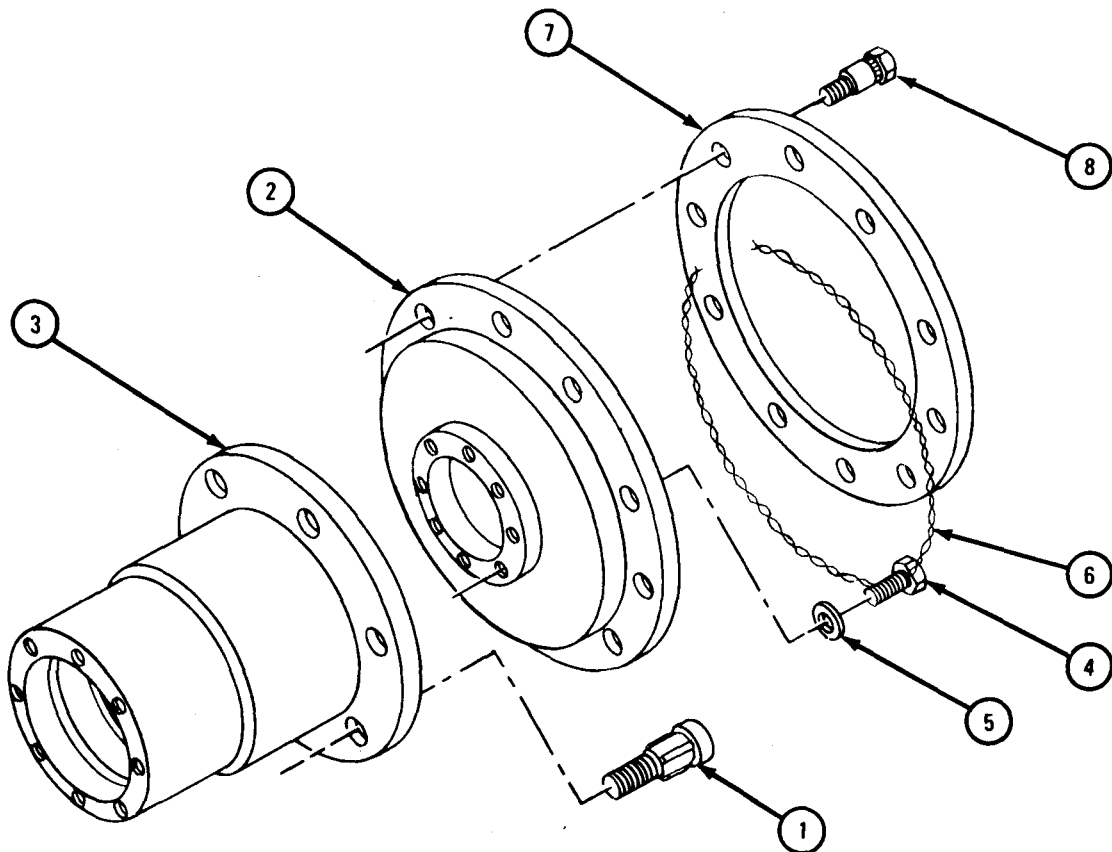

TA 105213

FRAME 2

1. Aline 10 shorter studs on hub (1) with holes in drum (2). Put hub into drum.
2. Put inspection cover (3) on stud next to inspection hole in drum (2) so hole is covered.
3. Put on 10 washers (4) and nuts (5).

NOTE

Follow-on Maintenance Action Required:

1. Replace rear hub and brake drum assembly. Refer to TM 9-2320-209-20.
2. Replace wheel and tire assembly. Refer to TM 9-2320-209-10.

END OF TASK

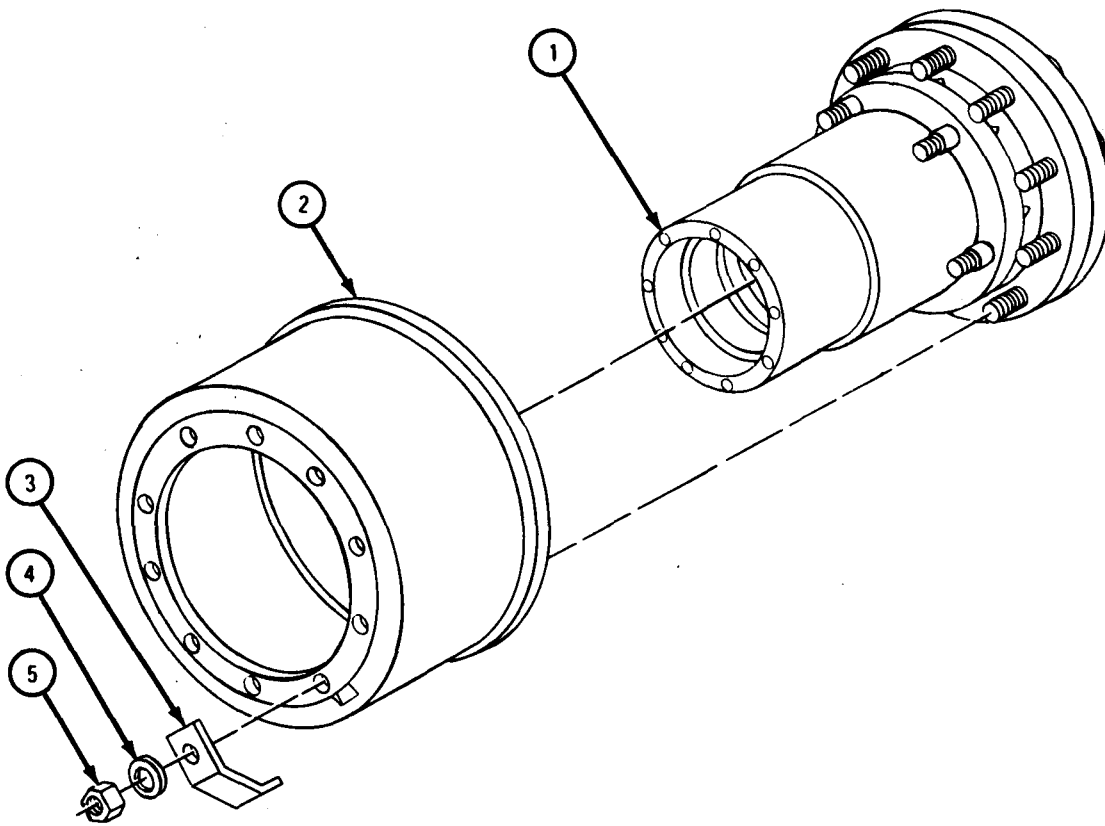

TA 105214

11-7. REAR SUSPENSION SYSTEM REMOVAL, REPAIR, AND REPLACEMENT.

TOOLS : No special tools required

SUPPLIES : Clean rags

PERSONNEL: Four

EQUIPMENT CONDITION : Truck parked, engine off, handbrake set, front wheels chocked.

a. Preliminary Procedures.

(1) Remove rear axle hydraulic brake lines. Refer to Hydraulic Lines, Hoses, and Fittings Removal and Replacement, TM 9-2320-209-20.

(2) Remove upper torque rods. Refer to TM 9-2320-209-20.

(3) Remove transfer-to-forward rear axle propeller shaft. Refer to Propeller Shaft and Universal Shaft Removal and Replacement, TM 9-2320-209-20.

(4) Remove forward rear-to-rear rear propeller shaft. Refer to TM 9-2320-209-20.

WARNING

This procedure should only be done with the hydraulic jack and jack stands listed. Failure to do so can cause injury to personnel or damage to equipment.

CAUTION

It is easy to damage the equipment or injure personnel if you do not know what you are doing. Do not try to do this task unless you are experienced at it or you have an experienced person with you.

b. Removal.

FRAME 1

WARNING

Crossrod (1) is heavy and may drop a few inches when 12 screws (2) and nuts (3) are taken out. Keep all parts of body out from under crossrod when taking out screws and nuts.

1. Take out six screws (2) and nuts (3).
2. Do step 1 again on other side of truck.

GO TO FRAME 2

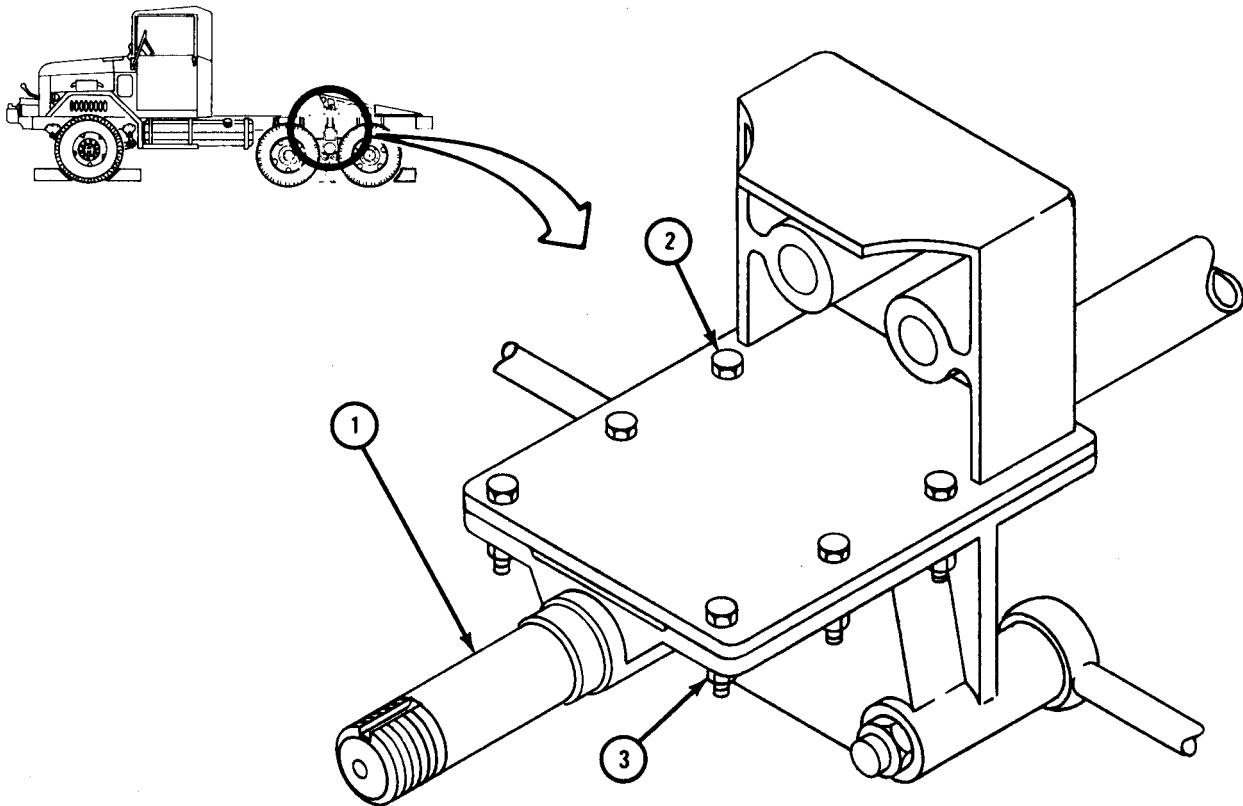

TA 084336

FRAME 2

- Soldier A 1. Using hoist, lift rear of truck up off rear suspension system (1).
- Soldiers B, C and D 2. Roll out rear suspension system (1) from under truck (3).
- Soldiers B and C 3. Put safety jacks (2) under frame or truck (3) and tell soldier A when ready.
- Soldier A 4. Lower frame onto safety jacks (2).
- END OF TASK

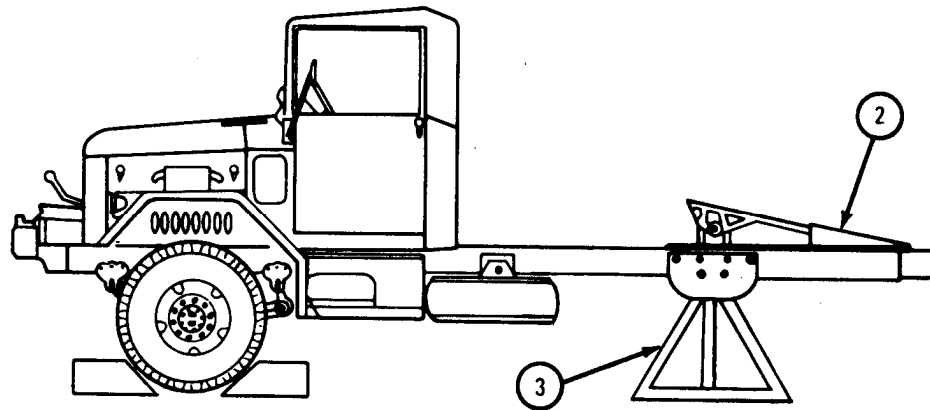
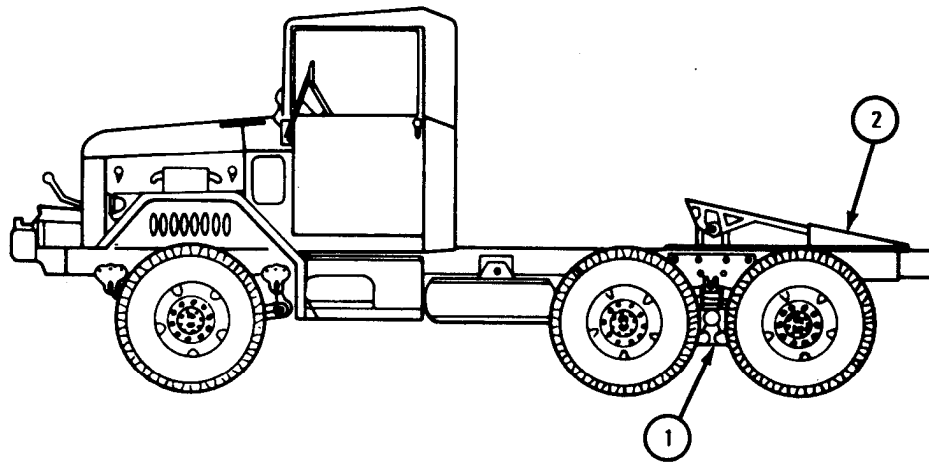

TA 084338

c. Inspection and Cleaning Before Disassembly. Check that suspension assembly has no lubrication leaks. Scribe marks on suspension assembly where leaks are found. Steam clean suspension assembly and dry with clean rag.

d. Disassembly.

FRAME 1

1. Take out four screws (1) and nuts and lockwashers (2). Take off torque rod upper bracket (3) and lower bracket (4).

2. Do step 1 again for other upper torque rod bracket assembly (5).

GO TO FRAME 2

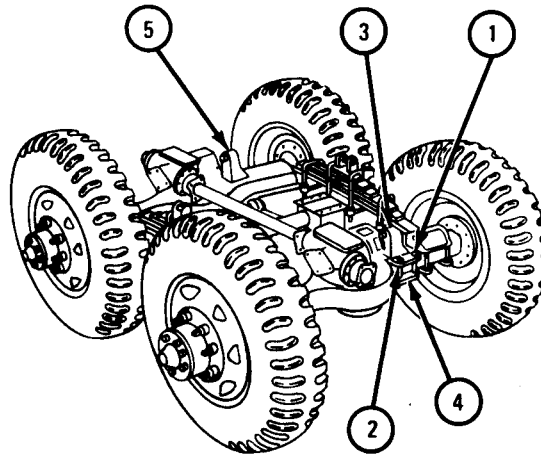

TA 084339

FRAME 2

WARNING

Rear axle system is extremely heavy. Be careful when raising axles and putting in jack stands to avoid injury to personnel.

- Soldier A 1. Jack up forward-rear axle (1).
- Soldiers B and C 2. Put jack stands (2) in place.
- Soldier A 3. Lower forward-rear axle (1) onto stands (2).
- Soldiers A, B and C 4. Do steps 1 through 3 again for rear-rear axle (3).

GO TO FRAME 3

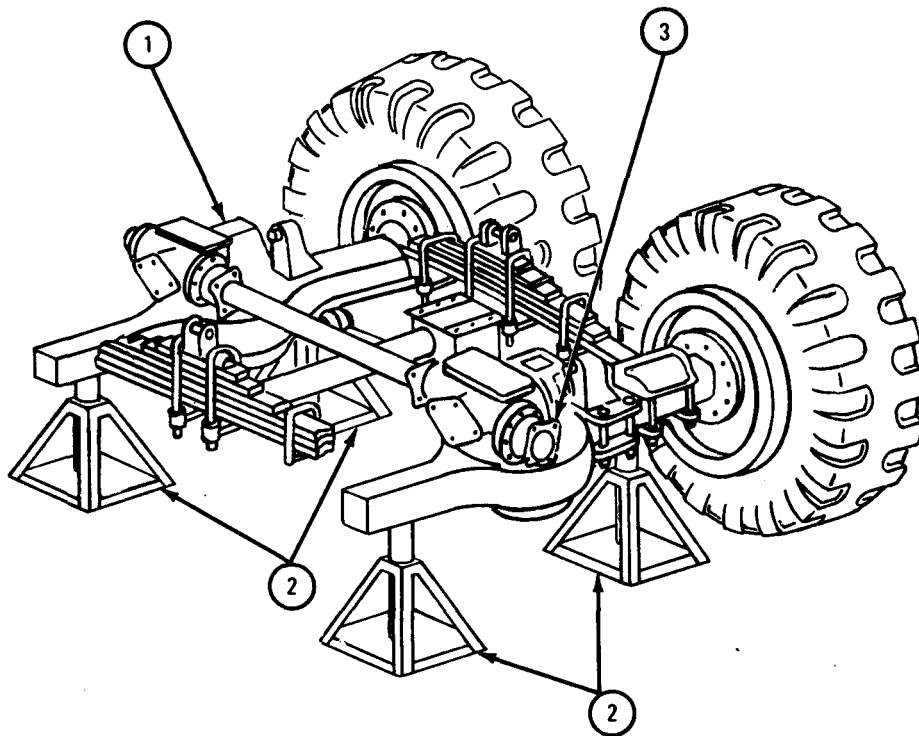

TA 084340

FRAME 3

1. Take off nut and lockwasher (1).
2. Using sledge hammer, hit bracket at point (2) until torque rod end (3) is loose.
3. Loosen nut and lockwasher (4) until nut is even with torque rod end (5).
4. Using sledge hammer, hit torque rod end (5) until it is loose.
5. Take off nut and lockwasher (4). Take out torque rod (6).
6. Do steps 1 through 5 for other three lower torque rods.

GO TO FRAME 4

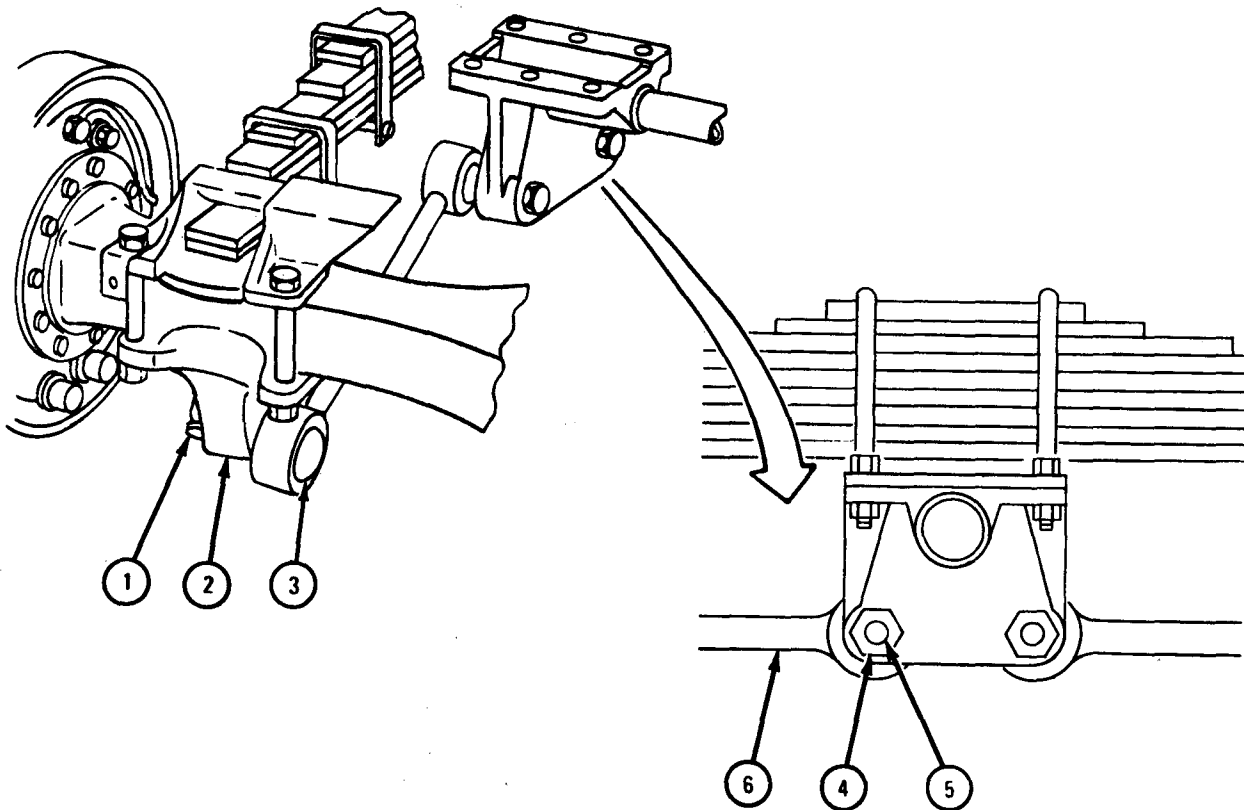

TA 084341

FRAME 4

1. Take out four screws (1), nuts and lockwashers (2) and bracket (3). Take off lower part of torque rod bracket (4).
2. Do step 1 for other three lower torque rod brackets.

GO TO FRAME 5

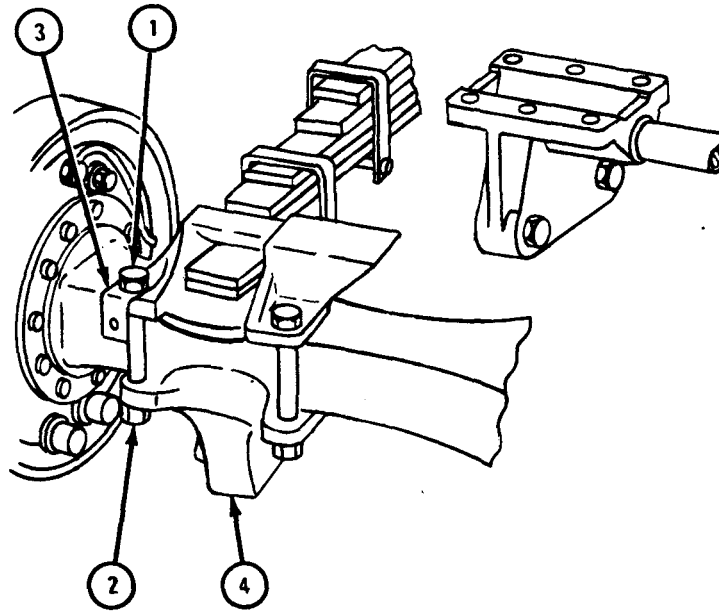

TA 085093

FRAME 5

1. Hook up lifting sling to U-bolt seats (1 and 2) as shown.
2. Lift crossrod and springs assembly (3) off rear axles (4 and 5) and set it down on wood blocks.
3. Take off four spring guides (6).

GO TO FRAME 6

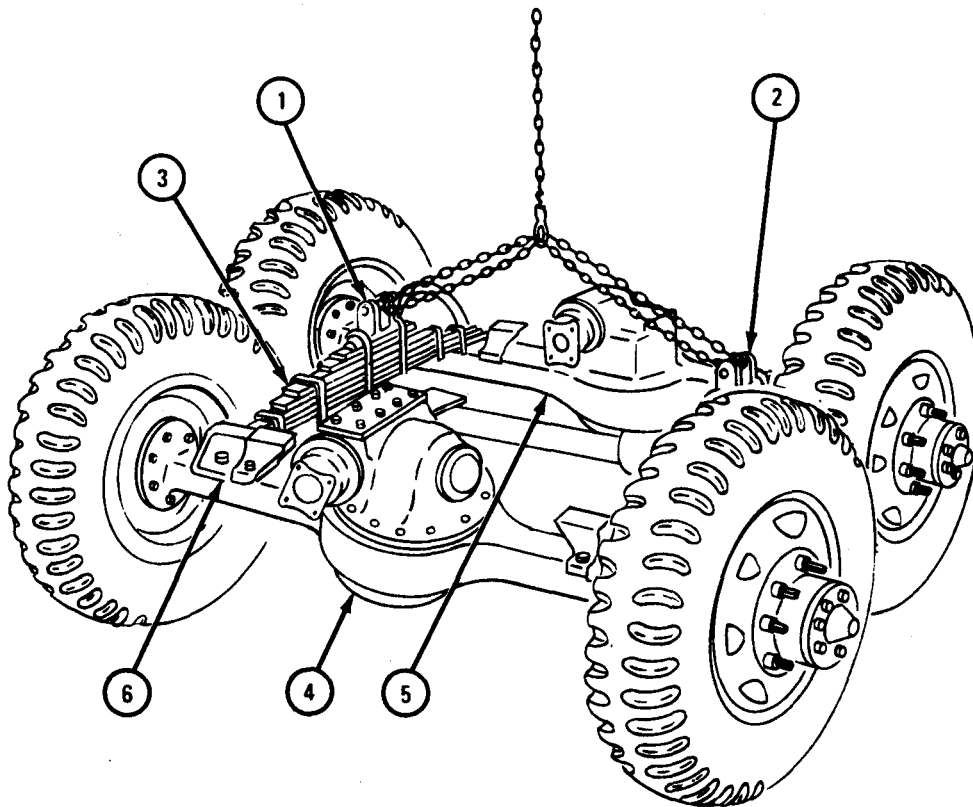

TA 085094

FRAME 6

1. Put safety jacks under crossrod (1) and two spring seats (2) so they do not fall.
2. Take off four nuts and lockwashers (3). Take out two U-bolts (4).
3. Take off U-bolt seat (5).
4. Take out two screws and lockwashers (6). Take off spring (7).
5. Do steps 2 through 4 again on other side of crossrod (1).

END OF TASK

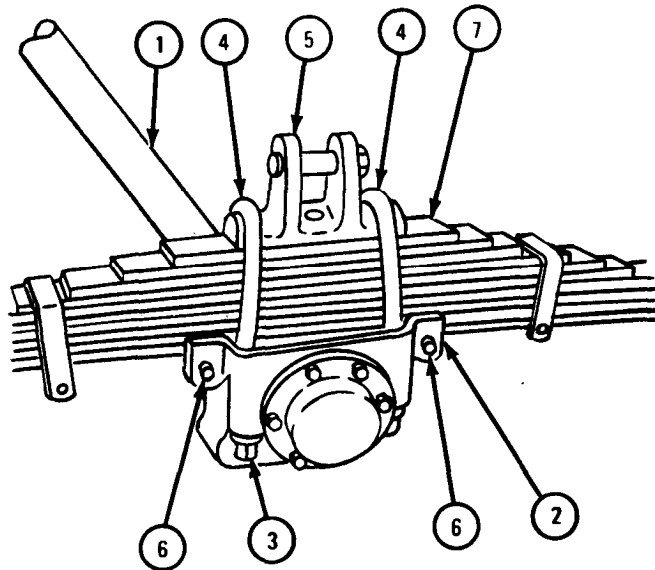

TA 085095

e. Cleaning. There are no special cleaning procedures needed. Refer to cleaning procedures given in para 1-3.

f. Inspection and Repair.

FRAME 1

1. For repair of springs, refer to TM 9-2320-209-20.
2. For repair of spring seats, refer to TM 9-2320-209-20.
3. For repair of crossrod, refer to para 11-8.
4. Check that U-bolts (1) are not bent or damaged and that threads are not damaged. If U-bolts are damaged, get new ones.
5. Check that U-bolt seats (2) are not bent, cracked or damaged. Weld any small cracks. Refer to TM 9-237. If more repair is needed, get new parts.
6. Check that torque rod (3) is not bent or damaged. Check that torque rod ends (4) are not loose or damaged and threads are not damaged. If torque rod or torque ends are damaged, get a new torque rod.
7. Check that spring guides (5), lower torque rod brackets (6), and upper torque rod bracket assemblies (7) are not cracked or damaged. Weld any small cracks. Refer to TM 9-237. If more repair is needed, get new parts.

END OF TASK

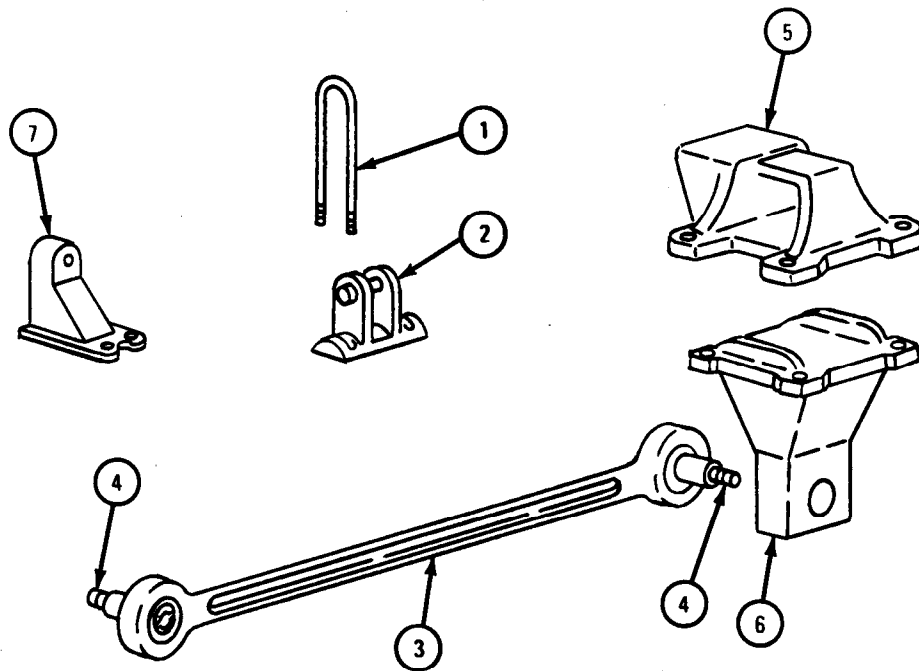

TA 085096

g. Assembly.

FRAME 1

1. Put spring (1) on seat (2). Put in two screws and lockwashers (3).
2. Put on U-bolt seat (4).
3. Put in two U-bolts (5). Put on four nuts and lockwashers (6).
4. Do steps 1 through 3 again on other end of crossrod (7).

GO TO FRAME 2

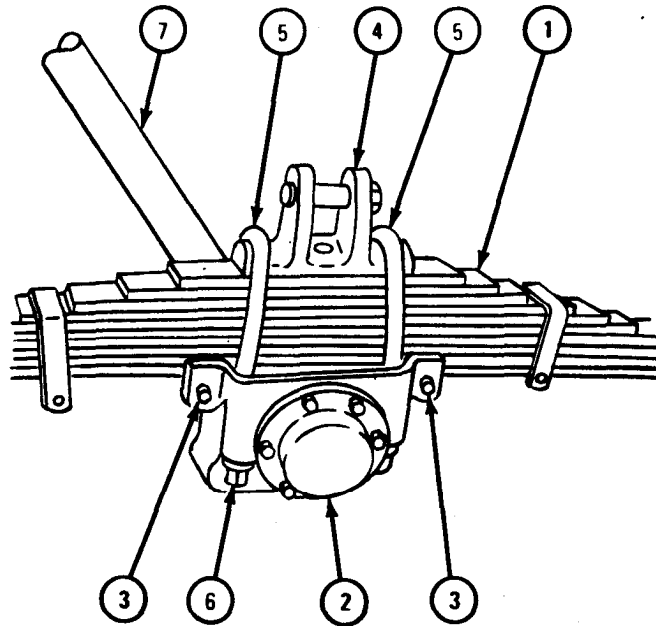

TA 085097

FRAME 2

1. Put on four spring guides (1).
 2. Lift crossrod and spring assemblies (2) onto rear axles (3 and 4).
- GO TO FRAME 3

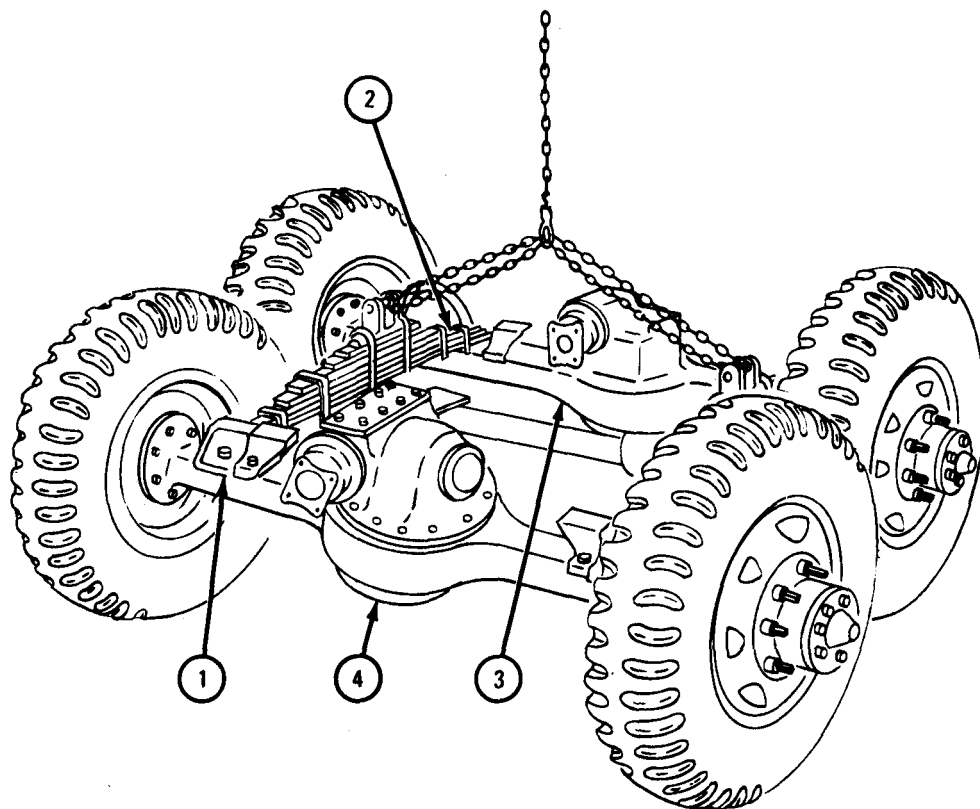

TA 085098

FRAME 3

1. Put on lower torque rod bracket (1).
 2. Put on bracket (2) and four screws (3) and nuts and lockwashers (4).
 3. Do steps 1 and 2 again for other three lower torque rod brackets.
- GO TO FRAME 4

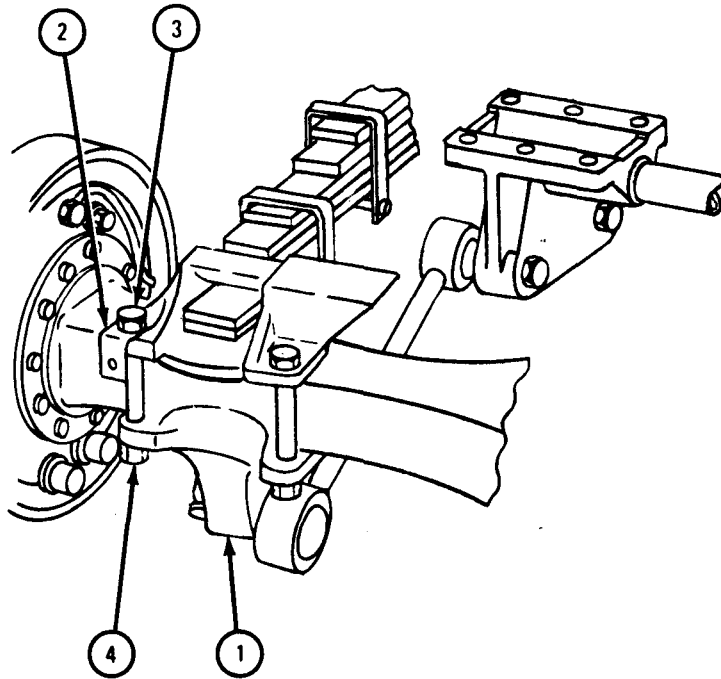

TA 085099

FRAME 4

1. Put in torque rod (1). Put on and hand tighten nut and lockwasher (2).
 2. Put on and hand tighten nut and lockwasher (3).
 3. Do steps 1 and 2 again for other three lower torque rods.
- GO TO FRAME 5

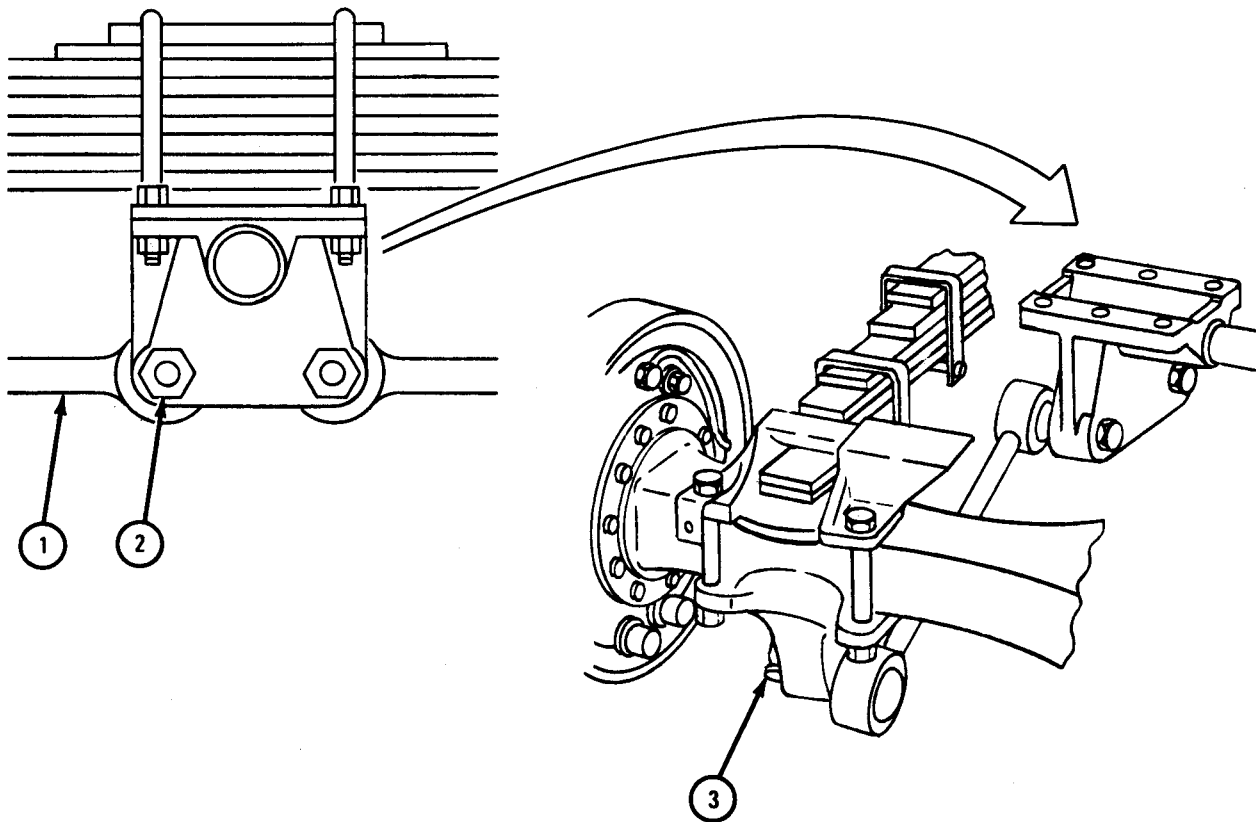

TA 085100

FRAME 5

CAUTION

Rear axle system is extremely heavy. Care must be taken when raising axles and removing jack stands.

- Soldier A 1. Jack up forward-rear axle (1).
- Soldiers B and C 2. Take out jack stands (2).
- Soldier A 3. Lower forward-rear axle (1).
4. Do steps 1 through 3 again for rear-rear axle (3).

GO TO FRAME 6

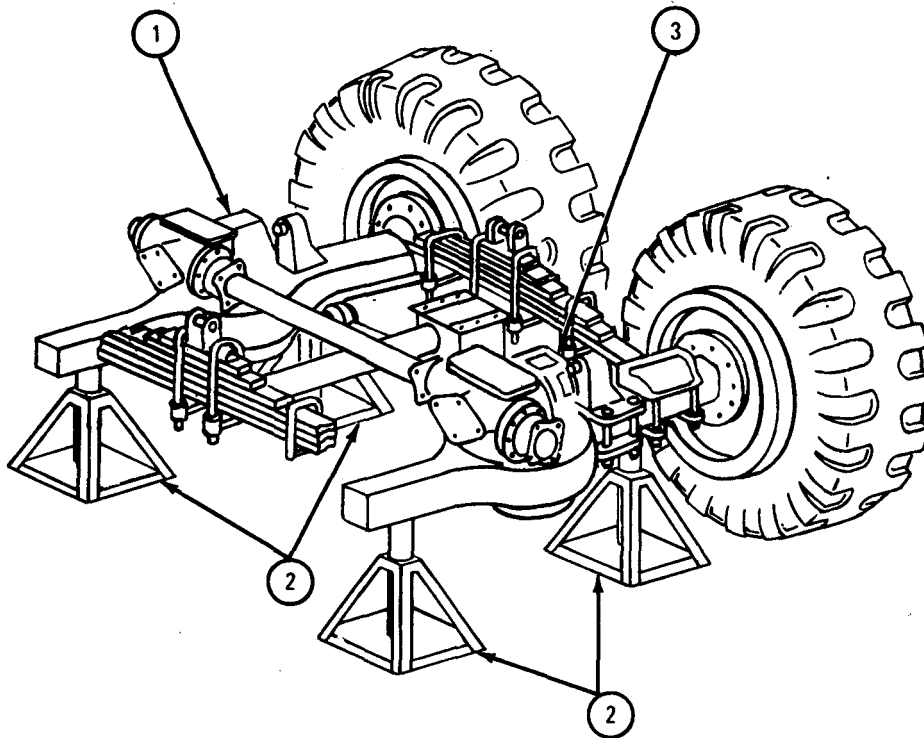

TA 084340

FRAME 6

1. Put on torque rod upper bracket (1) and lower bracket (2). Put in four screws (3) and nuts and lockwashers (4).

2. Do step 1 again for other upper torque rod bracket assembly (5).

END OF TASK

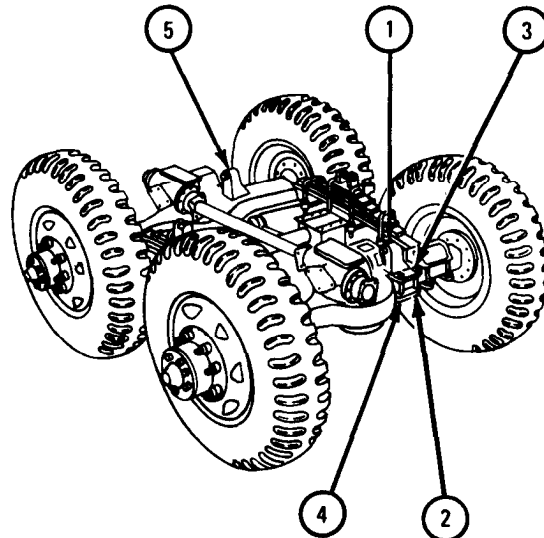

TA 085101

h. Replacement.

FRAME 1

- Soldier A** 1. Using hoist, lift rear of truck (1) up off safety jacks (2) and take out jacks.
- Soldiers B, C and D** 2. Roll rear suspension system (3) under truck (1) and tell soldier A when ready.
- Soldier A** 3. Lower rear of truck (1) slowly so mounting holes can be alined.
- GO TO FRAME 2**

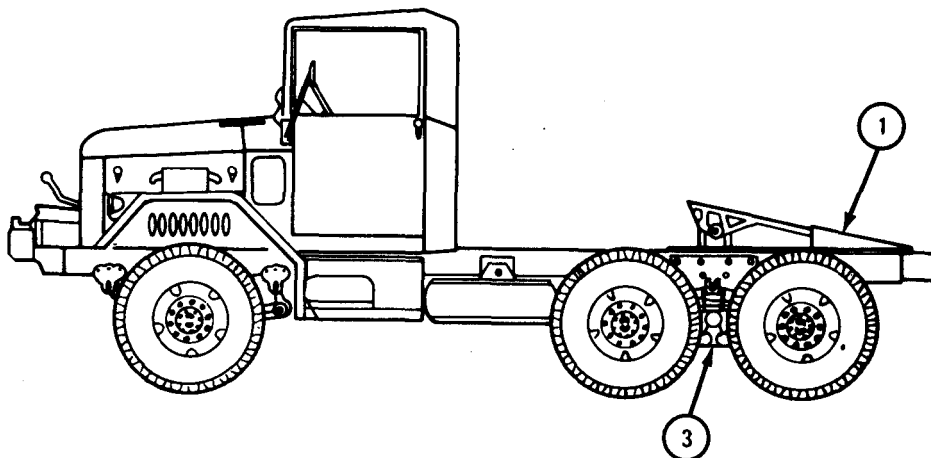
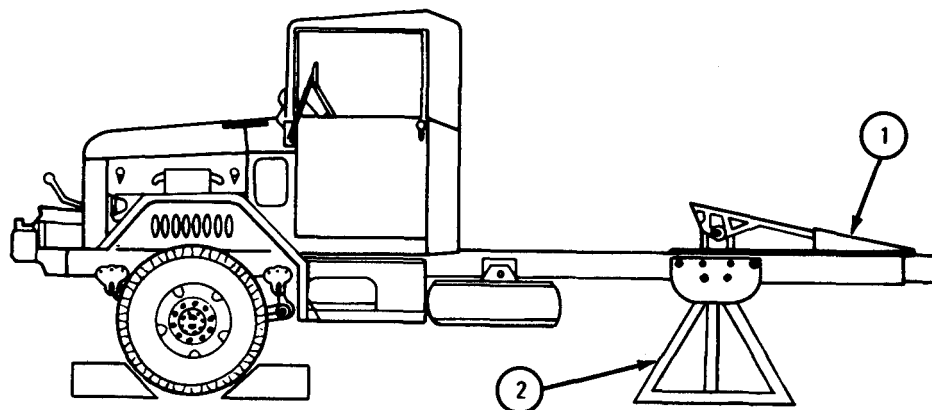

TA 084337

FRAME 2

1. Put in six screws (1) and nuts (2).
2. Do step 1 again on other side of truck.
3. Tighten lower torque rod mounting bolts (3).

NOTE

Follow-on Maintenance Action Required:

1. Replace forward rear-to-rear rear propeller shaft. Refer to Propeller Shaft and Universal Joint Removal and Replacement, TM 9-2320-209-20.
2. Replace transfer-to-forward rear propeller shaft. Refer to Propeller Shaft and Universal Joint Removal and Replacement, TM 9-2320-209-20.
3. Replace upper torque rods. Refer to TM 9-2320-209-20.
4. Replace rear axle hydraulic brake lines. Refer to Hydraulic Lines, Hoses, and Fittings Removal and Replacement, TM 9-2320-209-20.

END OF TASK

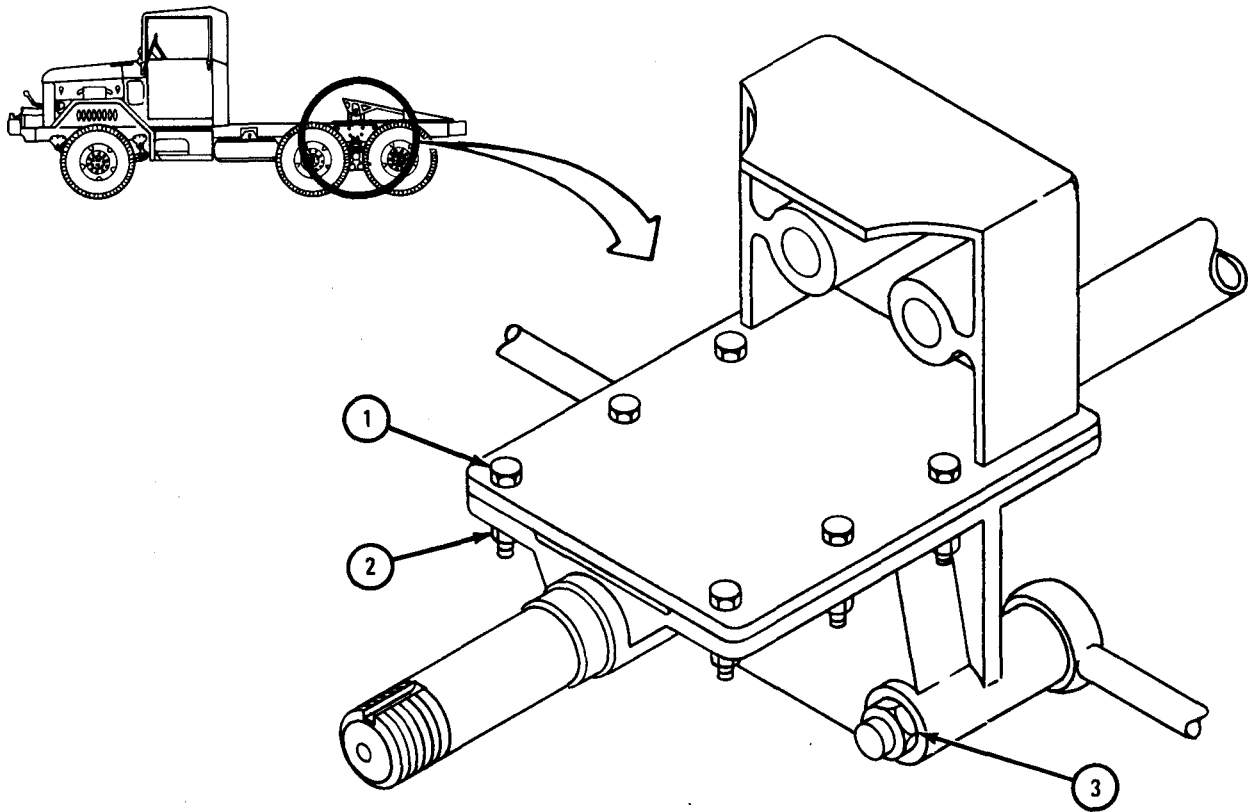

TA 085281

11-8. CROSSROD AND SPRING BRACKETS REMOVAL, REPAIR, AND REPLACEMENT.

TOOLS : No special tools required

SUPPLIES : Solvent, dry cleaning, type II (SD-2), Fed. Spec P-D-680
Clean rags

PERSONNEL : Two

EQUIPMENT CONDITION : Truck parked, engine off, handbrake set.

a. Preliminary Procedures.

(1) Remove rear and intermediate outer and inner wheels. Refer to
TM 9-2320-209-10.

(2) Remove lower torque rods. Refer to TM 9-2320-209-20.

(3) Remove springs. Refer to TM 9-2320-209-20.

(4) Remove rear spring seats. Refer to TM 9-2320-209-20.

b. Removal.

FRAME 1

WARNING

Crossrod is heavy. If crossrod falls, it can cause serious injury to personnel and damage to equipment.

- Soldier A 1. Put jack (1) under spring bracket (2).
- Soldier B 2. Take out six screws (3) and nuts (4).
- Soldiers A and B 3. Do steps 1 and 2 again on other side of crossrod (5).
4. Lower jacks (1) and take out crossrod (5) with two spring brackets (2).

END OF TASK

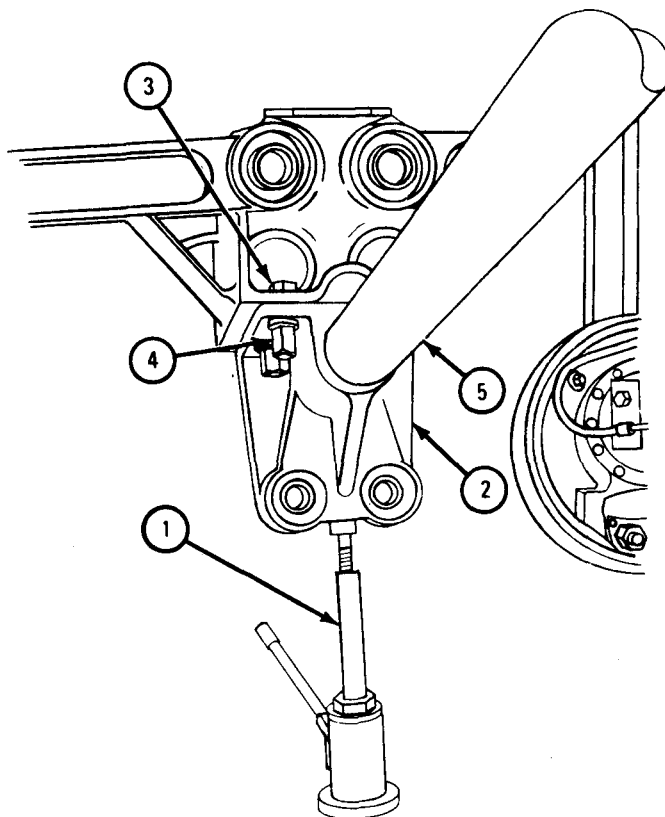
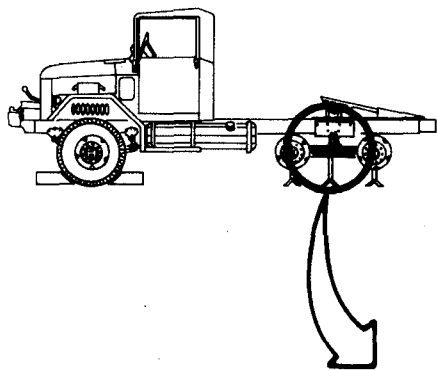

TA 085412

WARNING

Dry cleaning solvent is flammable. Do not use near an open flame. Keep a fire extinguisher nearby when solvent is used. Use only in well-ventilated places. Failure to do so may result in injury to personnel and damage to equipment.

c. Cleaning. Clean crossrod and spring brackets with solvent and wire brush. Dry with clean rags.

d. Inspection and Repair.

FRAME 1

1. Check that crossrod (1) is not bent or damaged in any other way. Fix small bends by straightening. If more fixing is needed, get a new crossrod.
2. Check that spring brackets (2) have no bends, cracks or broken welds. Repair damage by straightening or welding. Refer to TM 9-237. If more fixing is needed, get new spring brackets.

END OF TASK

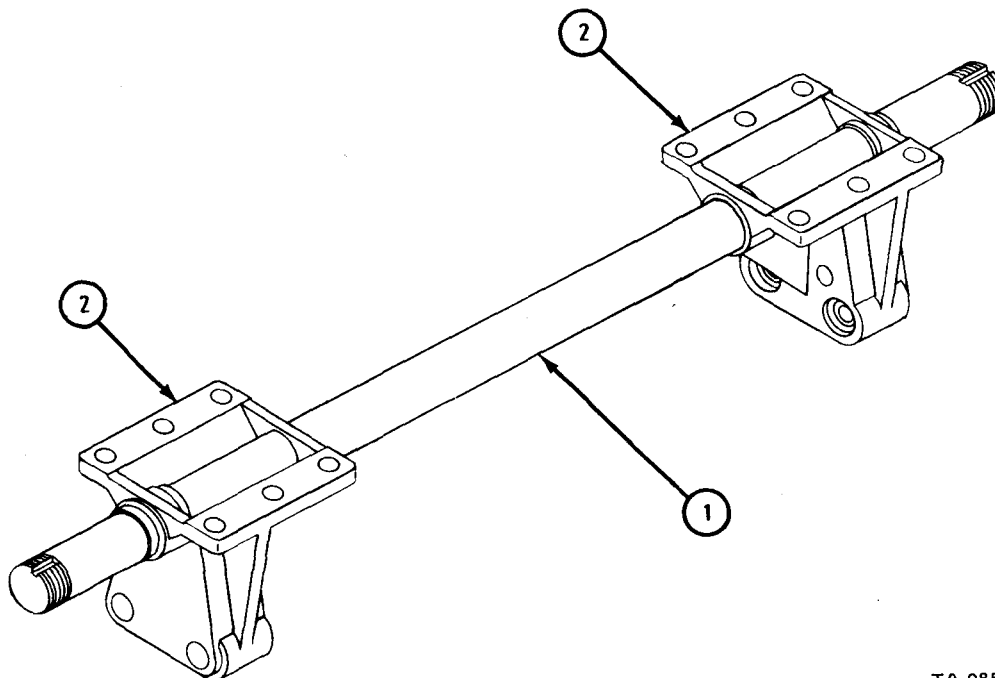

TA 085413

e. Replacement.

FRAME 1

WARNING

Crossrod is heavy. If crossrod falls, it can cause serious injury to personnel and damage to equipment.

- Soldiers 1. Put crossrod (1) under truck and set it on jacks (2). Raise jacks A and B until crossrod is in place. Aline holes.
- Soldier A 2. Put in six screws (3) and nuts (4) on each side of crossrod (1).
- Soldier B 3. Takeout jacks (2).

NOTE

Follow-on Maintenance Action Required:

1. Replace spring seats. Refer to TM 9-2320-209-20.
2. Replace springs. Refer to TM 9-2320-209-20.
3. Replace torque rods. Refer to TM 9-2320-209-20.
4. Replace rear, intermediate, and outer wheels. Refer to TM 9-2320-209-10.

END OF TASK

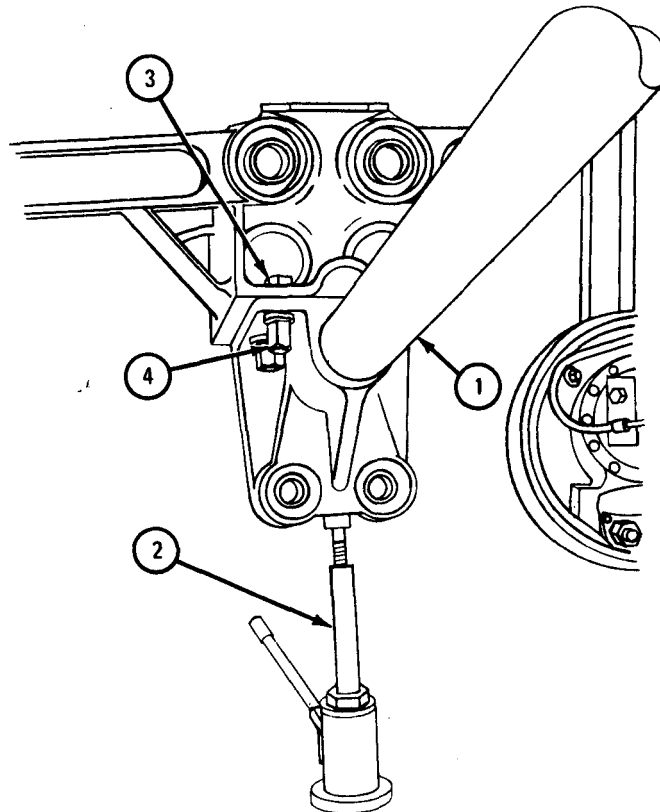
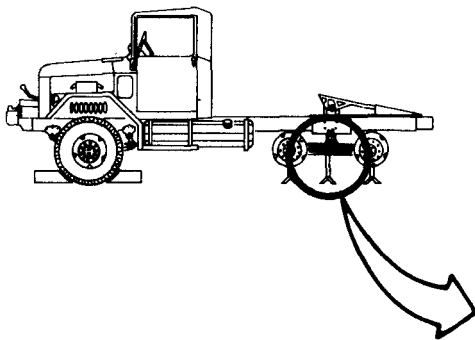

TA 085414

CHAPTER 12

BRAKE SYSTEM GROUP MAINTENANCE

Section I. SCOPE

12-1. EQUIPMENT ITEMS COVERED . This chapter gives equipment maintenance procedures for the handbrake and service brake assemblies, hydraulic brake system, and trailer brake connections and controls for which there are authorized corrective maintenance tasks at the direct and general support maintenance levels.

12-2. EQUIPMENT ITEMS NOT COVERED . All equipment items for which corrective maintenance is authorized at the direct and general support maintenance levels are covered in this chapter.

Section II. HANDBRAKE AND SERVICE BRAKE ASSEMBLIES

12-3. HANDBRAKE AND SERVICE BRAKESHOE REPAIR.

TOOLS : No special tools required

SUPPLIES : Rivet (28)

PERSONNEL: One

EQUIPMENT CONDITION : Truck parked, engine off, handbrake set, wheels chocked.

a. Preliminary Procedure. Remove brake shoe assembly. Refer to TM 9-2320-209-20.

b. Disassembly.

FRAME 1

1. Punch 14 rivets (1) out of brakeshoe (2).
 2. Pry off lining (3).
 3. Do steps land 2 again for other brakeshoe (4).
- END OF TASK

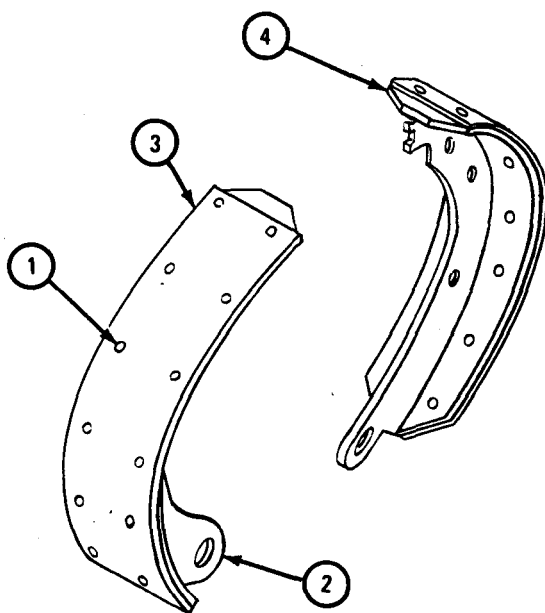

TA 085207

c. Cleaning.WARNING

Do not use a wire brush or compressed air **to clean brakeshoes. There may be asbestos** dust on brakeshoes which can be dangerous to your health if you breathe it in.

- (1) Clean dirt or mud from brakeshoes using a brush and water.

WARNING

Dry cleaning solvent is flammable. Do not use near an open flame. Keep a fire extinguisher nearby when solvent is used. Use only in well-ventilated places. Failure to do this may result in injury to personnel and damage to equipment.

- (2) To take off any oil or grease from brakeshoes, use dry cleaning solvent.

d. Inspection and Repair.

FRAME 1

1. Check that brakeshoes have no cracks in faces (1) or webs (2).
2. Check that brakeshoes have no warping or flat spots on faces (1) and that rivet holes (3) are not ragged or out-of-round.
3. Check that face (1) does not have oil or grease on it.
4. If brakeshoe is damaged, get a new one.

END OF TASK

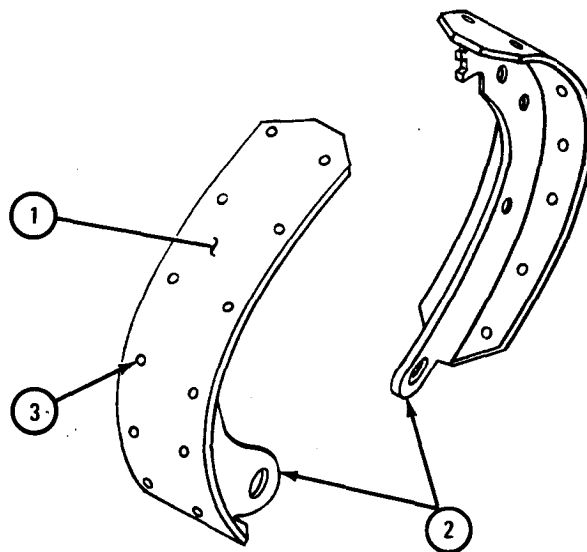

TA 085206

e. Assembly.

FRAME 1

1. Aline holes in lining (1) with holes in brakeshoes (2) and put in 14 rivets (3).
2. Do step 1 again for other brakeshoe (4).

NOTE

Follow-on Maintenance Action Required:

Replace brakeshoe assembly. Refer to TM 9-2320-209-20.

END OF TASK

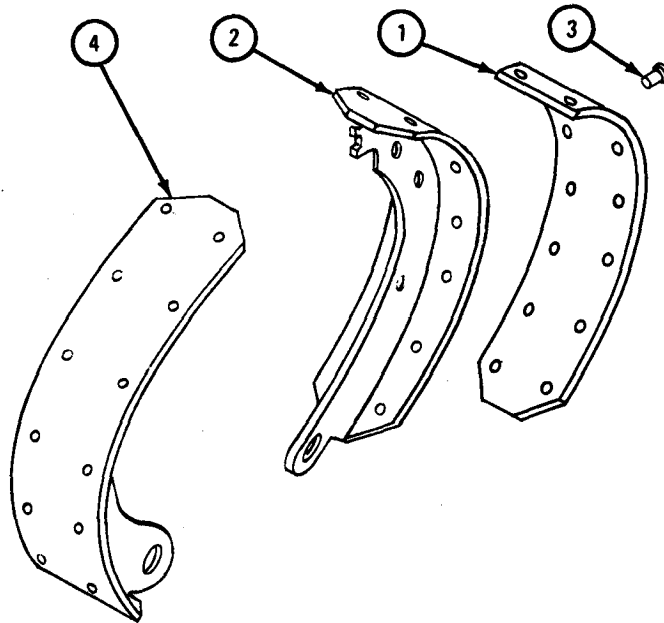

TA 085208

12-4. FRONT AND REAR SERVICE BRAKE DRUM REPAIR.

TOOLS : Drum turn arbor fixture, pn 11660096

SUPPLIES : None

PERSONNEL: One

EQUIPMENT CONDITION: Truck parked, engine off, handbrake set.

a. Preliminary Procedure. Remove brake drum assembly. Refer to TM 9-2320-209-20.

b. Cleaning.

FRAME 1

WARNING

Do not use a wire brush or compressed air to clean brake drum (1). There may be asbestos dust on the drum which can be dangerous to your health if you breathe it in.

1. Clean dirt or mud from brake drum (1) using a brush and water.

WARNING

Dry cleaning solvent is flammable. Do not use near an open flame. Keep a fire extinguisher nearby when solvent is used. Use only in well-ventilated places. Failure to do this may result in injury to personnel and damage to equipment.

2. To take off any oil or grease from brake drum (1), use dry cleaning solvent.

END OF TASK

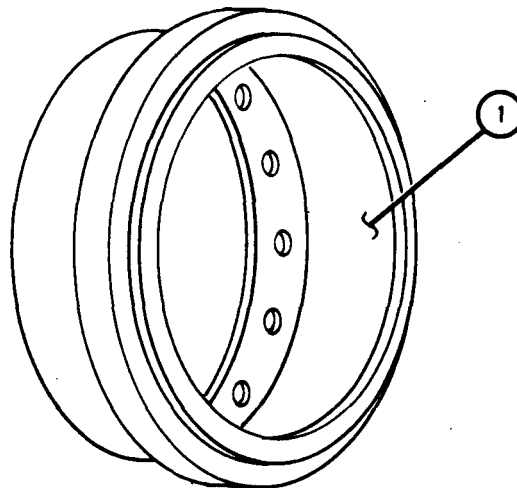

TA 101962

c. Inspection and Repair.

FRAME 1

1. Check that brake drum (1) is not warped or cracked. If brake drum is warped or cracked, throw away drum and get a new one.
2. Check that brake drum (1) is not scored or pitted. If brake drum is scored or pitted, measure inside diameter (2). If inside diameter is more than 15.130 inches, throw away drum and get a new one.
3. If inside diameter (2) is not more than 15.130 inches and brake drum (1) is scored or pitted, cut drum. Cut drum only as needed to take off scores and pitting. Refer to TM 9-4910-482-10.
4. If brake drum (1) was cut, measure inside diameter (2). If reading is more than 15.130 inches, throw away drum and get a new one.

NOTE

Follow-on Maintenance Action Required:

Replace brake drum. Refer to TM 9-2320-209-20.

END OF TASK

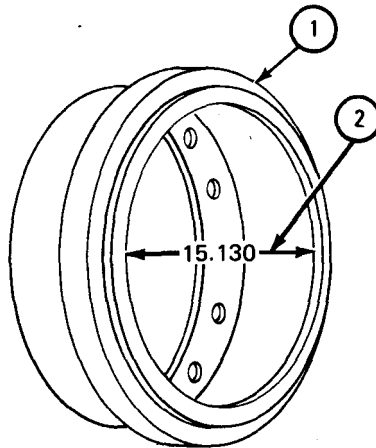

TA 085209

Section III. HYDRAULIC BRAKE SYSTEM

12-5. AIR HYDRAULIC CYLINDER ASSEMBLY REPAIR.

TOOLS : Guide rod of same diameter as air cylinder piston pushrod, 12 to 15 inches long, tapered at one end

SUPPLIES : Hydraulic slave cylinder repair kit
Solvent, dry cleaning, type II (SD-2), Fed. Spec P-D-680
Preservative oil, PL-MED
Hydraulic Brake Fluid, silicone, type MIL-B-46176
Crocus cloth

PERSONNEL: One

EQUIPMENT CONDITION : Truck parked, engine off, handbrake set.

a. Preliminary Procedures.

- (1) Remove air hydraulic cylinder. Refer to TM 9-2320-209-20.
- (2) Remove hydraulic stoplight switch. Refer to TM 9-2320-209-20.

b. Disassembly Into Subassemblies.

(1) Removal of air cylinder piston assembly.

FRAME 1

CAUTION

Use only bench vise with soft copper or lead jaws. Parts can be damaged.

1. Put air cylinder (1) into vise.
2. Take out plug (2) and gasket (3). Throw away gasket.
3. Take out outer spring (4) and inner spring (5).
4. Take off bleeder screw (6).

GO TO FRAME 2

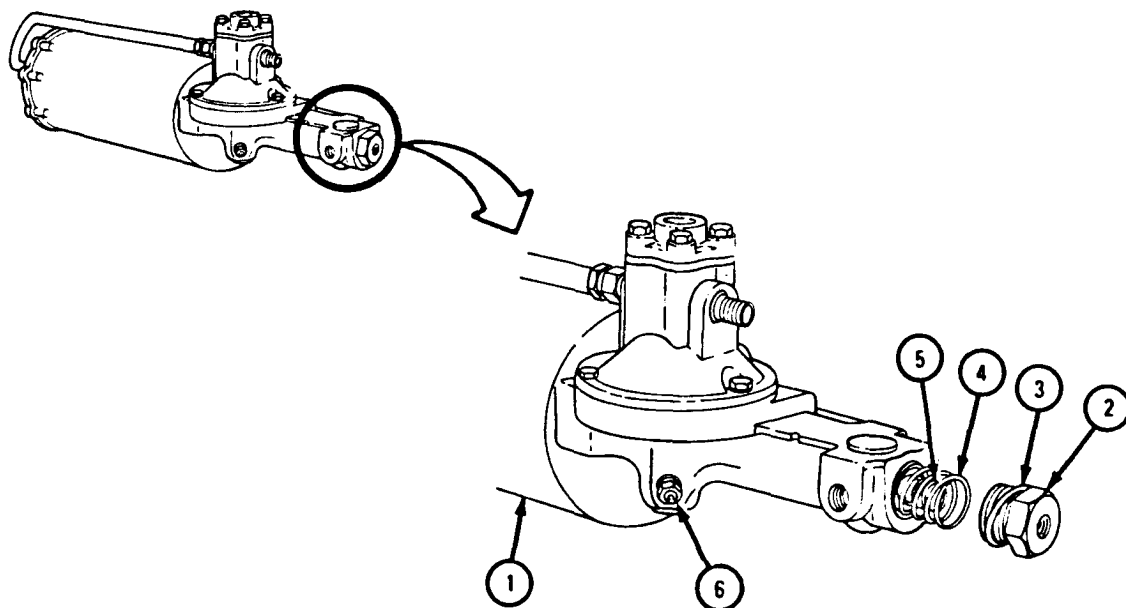

TA 084253

FRAME 2

1. Hold fitting (1) and take off tube nut (2).
2. Hold fitting (3) and take off tube nut (4). Take off air tube (5).

GO TO FRAME 3

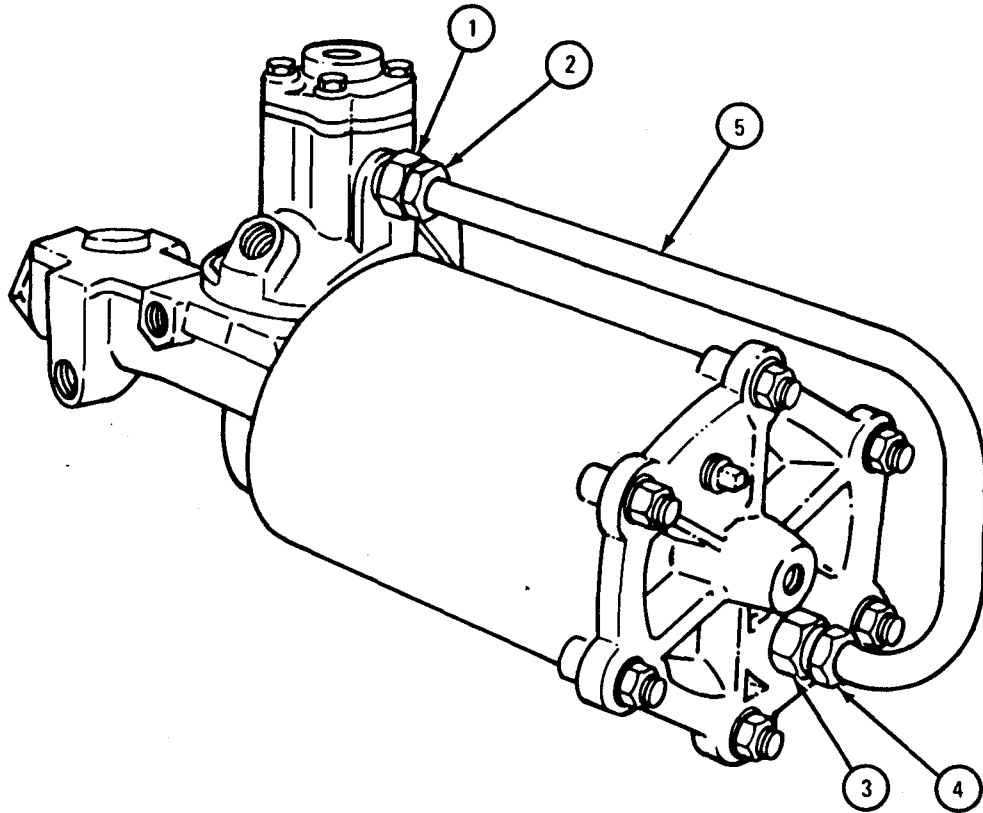

TA 084254

FRAME 3

CAUTION

Piston is spring loaded and may fly out when taking off cover or piston.

NOTE

Mark end cover (1) and air cylinder (2) so that end cover will be put back in the same position.

1. Take off six nuts (3) and lockwashers (4).
2. Take off end cover (1) and nonmetallic washer (5). Throw away washer.
3. Take out piston (6) and spring (7).

END OF TASK

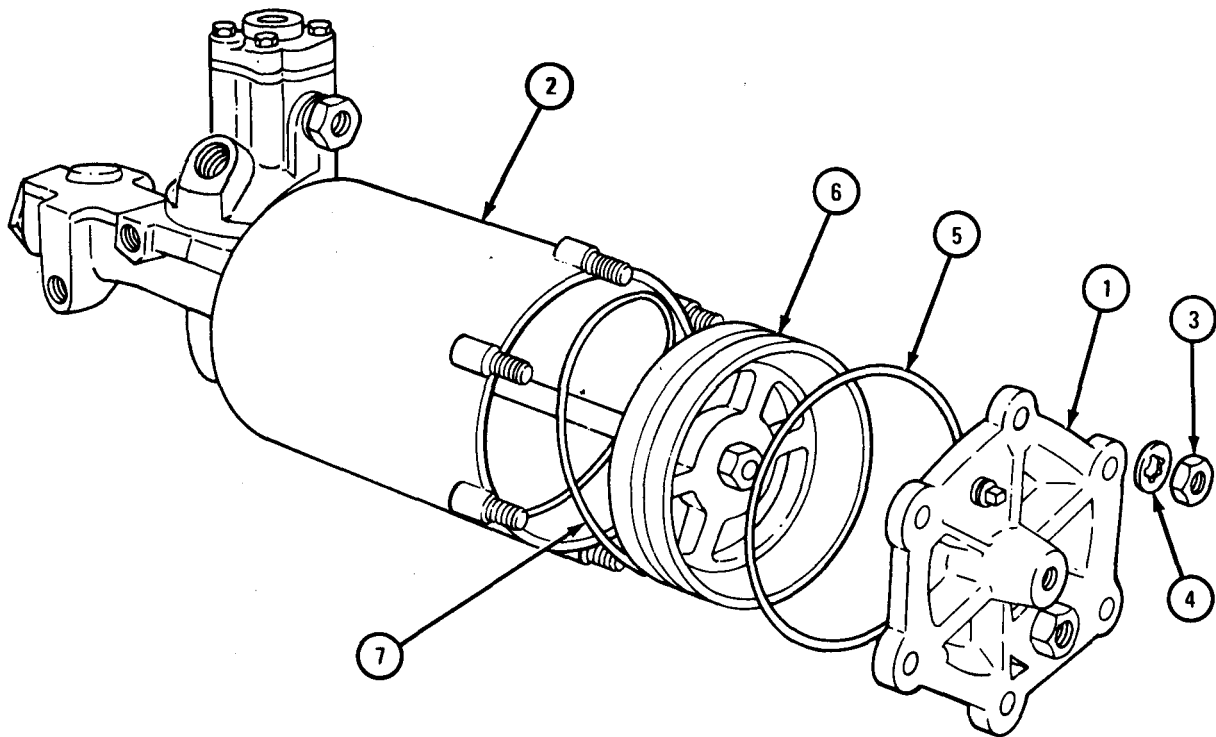

TA 084255

(2) Removal of air cylinder shell.

FRAME 1

CAUTION

Use only bench vise with soft copper or lead jaws. Parts can be damaged.

1. Take out spring retainer (1).
2. Put slave cylinder body (2) in vise.
3. Take out four capscrews (3) lockwashers (4).

GO TO FRAME 2

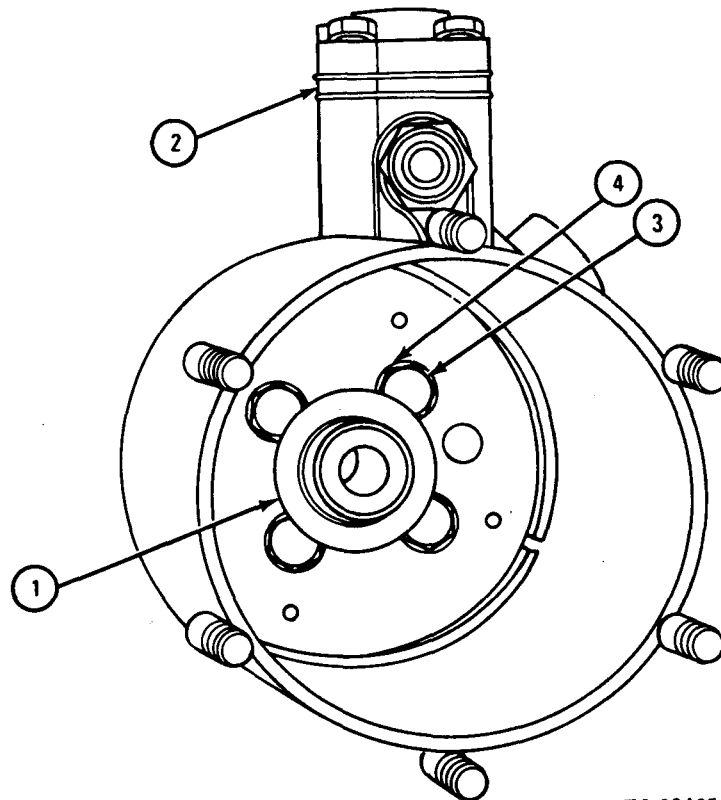

TA 084256

FRAME 2

NOTE

Mark air cylinder shell (1) and slave cylinder body (2) so that air cylinder shell will be put back in the same position.

1. Take air cylinder shell (1) off slave cylinder body (2).
2. Take off and throw away gasket (3) and O-ring (4).
3. Take out pushrod bushing (5).

END OF TASK

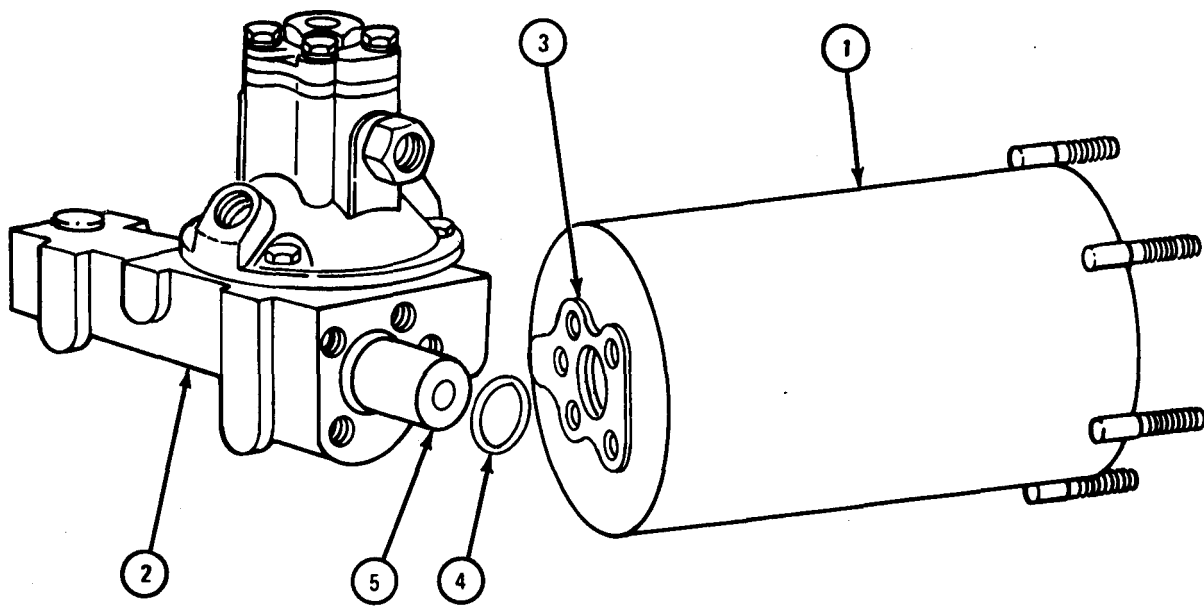

TA 084257

(3) Removal of slave cylinder piston assembly.

FRAME 1

1. Push brass drift into hole (1) in slave cylinder body (2).
2. Push out spring seat (3), piston cup (4), piston (5), and pushrod seal (6).
3. Throw out piston cup (4), piston (5), and pushrod seal (6).

END OF TASK

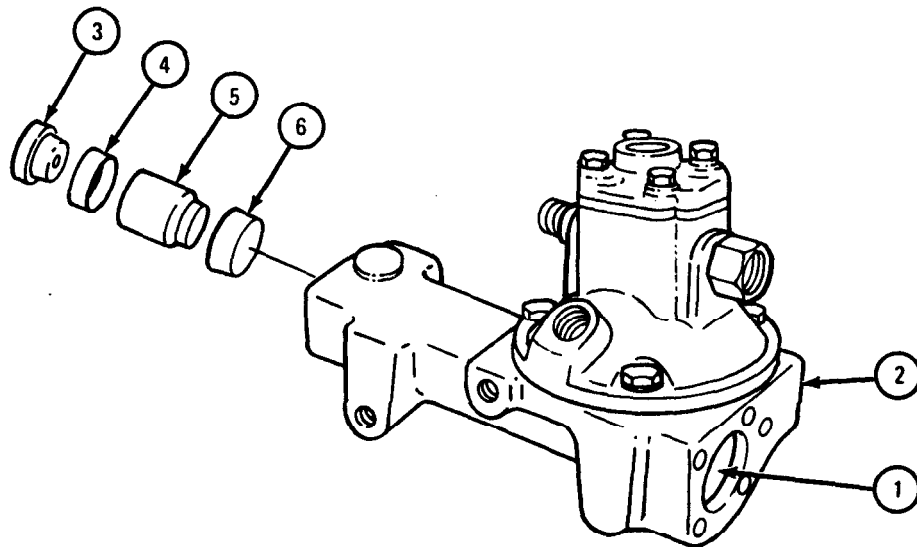

TA 084258

(4) Removal of slave cylinder compensator body assembly.

FRAME 1

NOTE

Mark compensator body (1) and slave cylinder body (2) so that compensator body will be put back in the same position.

1. Take off nut (3) and lockwasher (4).
2. Take out bolt (5).
3. Take out two screws (6) and lockwashers (7).

GO TO FRAME 2

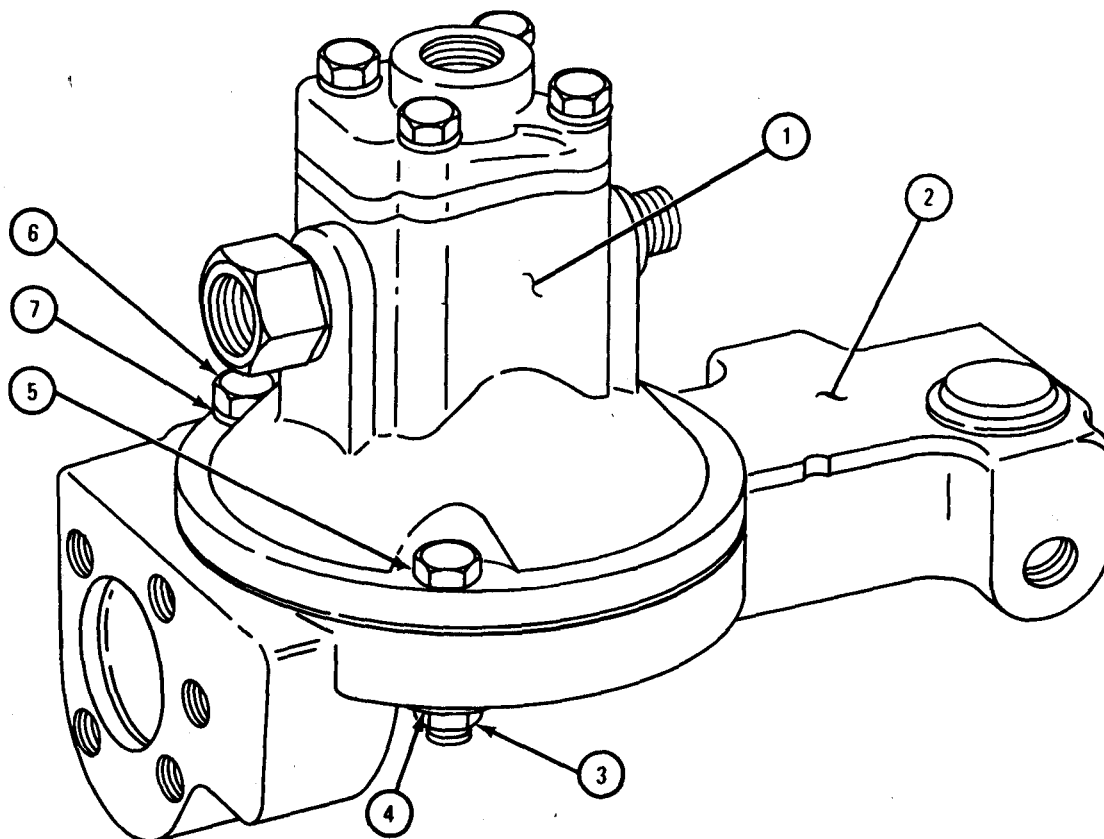

TA 084259

FRAME 2

1. Lift up compensator body (1) clear of spring (2). Take off compensator body.
2. Take off and throw away gasket (3).
3. Take out spring (2) and compensator piston (4).

NOTE

If spring (2) and compensator piston (4) stick inside compensator body (1), hit compensator body against palm of hand to make spring and piston drop out.

4. Take out control valve piston (5).

END OF TASK

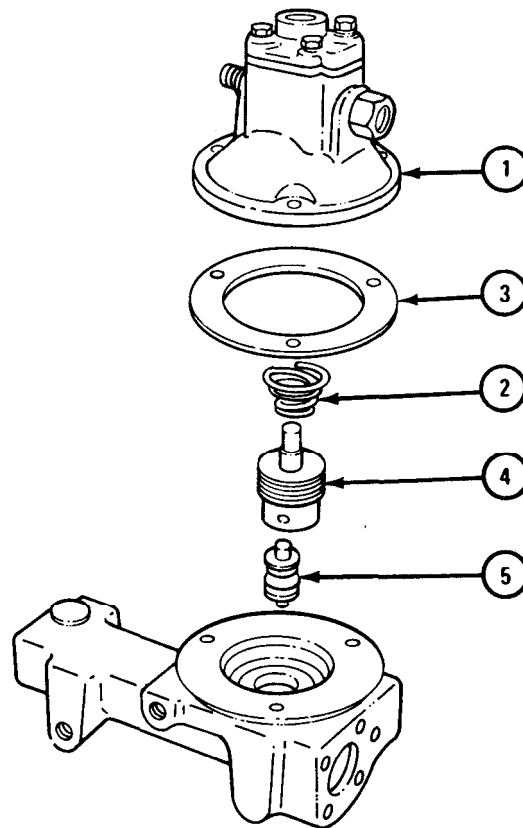

TA 084260

c. Air Cylinder Piston Assembly Repair.

(1) Disassembly.

FRAME 1

CAUTION

Use only bench vise with soft copper or lead jaws. Parts can be damaged.

1. Put pushrod (1) into vise close to piston (2).
2. Take off nut (3) and follower (4).

GO TO FRAME 2

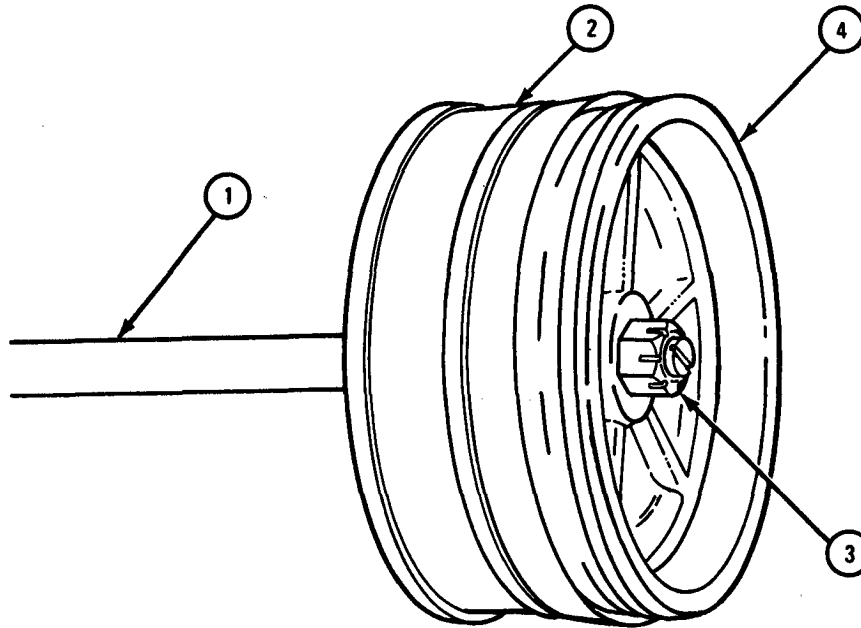

TA 084273

FRAME 2

1. Takeout and throw away felt ring (1).
 2. Take off cup expander (2).
- GO TO FRAME 3

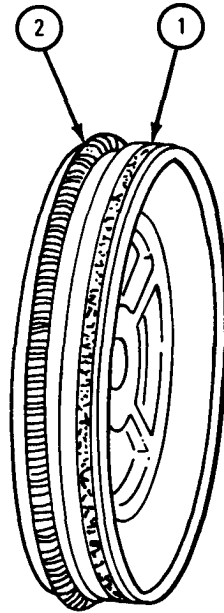

TA 084274

FRAME 3

1. Take off preformed packing (1) and cup (2). Throw away preformed packing and cup.

2. Take off pressure plate (3).

GO TO FRAME 4

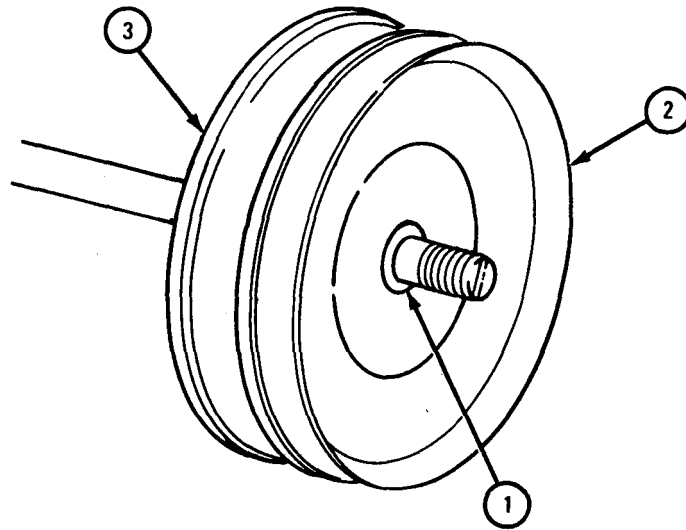

TA 084275

FRAME 4

1. Take off snap ring collar (1).

NOTE

Do not take snapping (2) off pushrod (3) unless snapping is damaged. If snapping is damaged, throw it away and put on a new one.

2. Take pushrod (3) out of vise.

END OF TASK

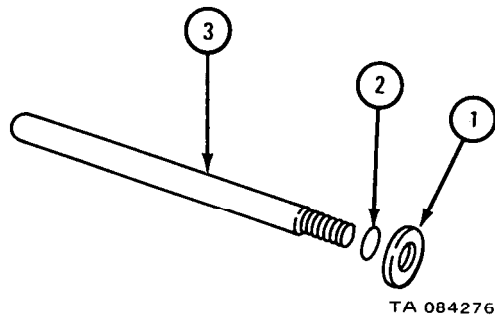

(2) Cleaning, inspection, and repair.

FRAME 1

WARNING

Dry cleaning solvent is flammable. Do not use near an open flame. Keep a fire extinguisher nearby when solvent is used. Use only in well-ventilated places. Failure to do this may result in injury to personnel and damage to equipment.

1. Clean pushrod (1), snapping (2), snapping collar (3), pressure plate (4), cup expander (5), and follower (6) with dry cleaning solvent.
2. Check that pushrod (1) has no nicks or scratches. Rub out small scratches with crocus cloth. If more repair is needed, throw away pushrod and get a new one.
3. Check that pressure plate (4) and follower (6) have no nicks or scratches. Rub out small scratches with crocus cloth. If more repair is needed, throw away air hydraulic cylinder and get a new one.
4. If cup expander (5) is broken or damaged, throw it away and get a new one.

END OF TASK

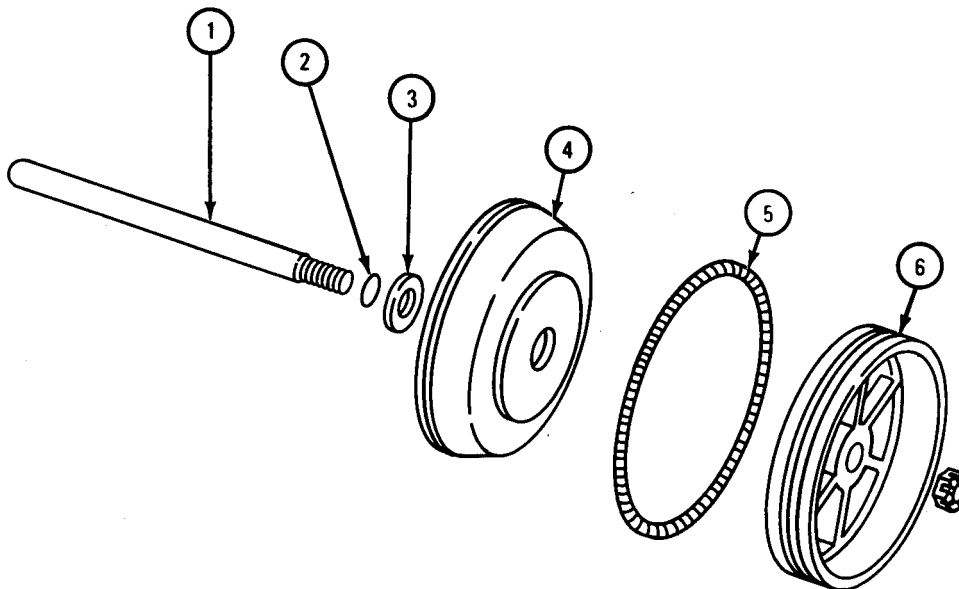

TA 084277

(3) Assembly.

FRAME 1CAUTION

Use only in bench vise with soft copper or lead jaws.
Parts can be damaged.

1. Put a coat of preservative oil on all metal parts.
2. Put pushrod (1) into vise so that threaded end sticks out about five inches.
3. Put on snapping collar (2). Recessed side of snapping collar must face snapping (3).
4. Put on pressure plate (4) with cupped side facing snapping collar (2).
5. Put preformed packing (5) into recess in face of pressure plate (4).
6. Put cup (6) on pushrod (1) against pressure plate (4).

GO TO FRAME 2

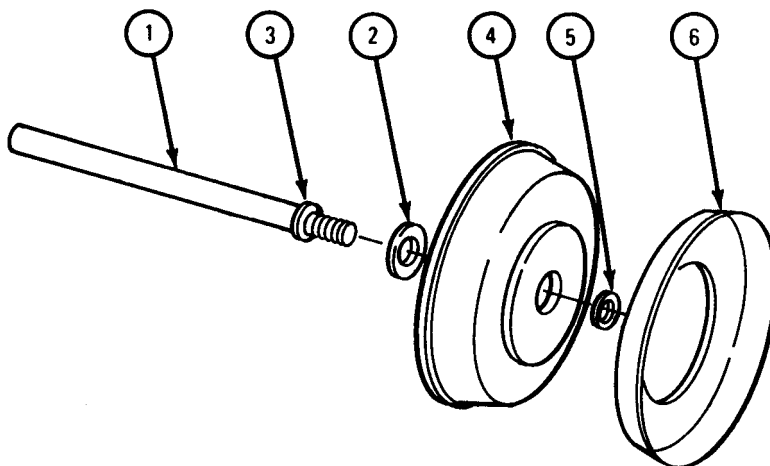

TA 084278

FRAME 2

1. Put on felt ring (1).
2. Put on cup expander (2).
3. Put follower (3) on pushrod (4) against pressure plate (5).
4. Put on nut (6).
5. Take pushrod (4) out of vise.

END OF TASK

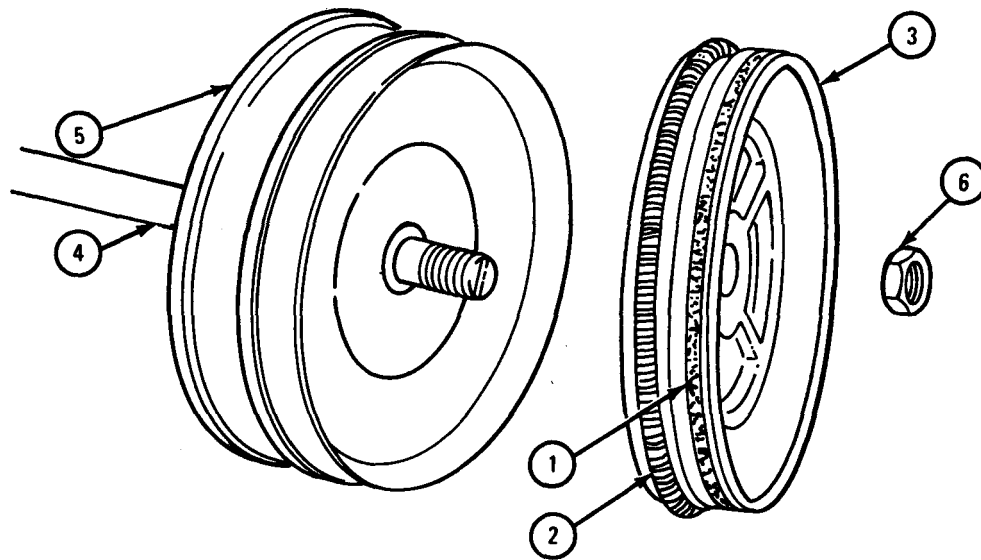

TA 084279

d. Air Cylinder and Air Tube Cleaning, Inspection, and Repair.**FRAME 1****WARNING**

Dry cleaning solvent is flammable. Do not use near an open flame. Keep a fire extinguisher nearby when solvent is used. Use only in well-ventilated places. Failure to do this may result in injury to personnel and damage to equipment.

1. Clean air cylinder (1) and end cover (2) with dry cleaning solvent.
2. Check that inside of air cylinder (1) and end cover (2) has no scratches or nicks. Small scratches can be rubbed out with crocus cloth. If any scratches cannot be rubbed out, throw away air hydraulic cylinder and get a new one.
3. Put a coat of preservative oil on air cylinder (1) and end cover (2).
4. Check that air tube (3) has no cracks, flattened areas or other damage. If air tube is damaged, throw it away and get a new one.

END OF TASK

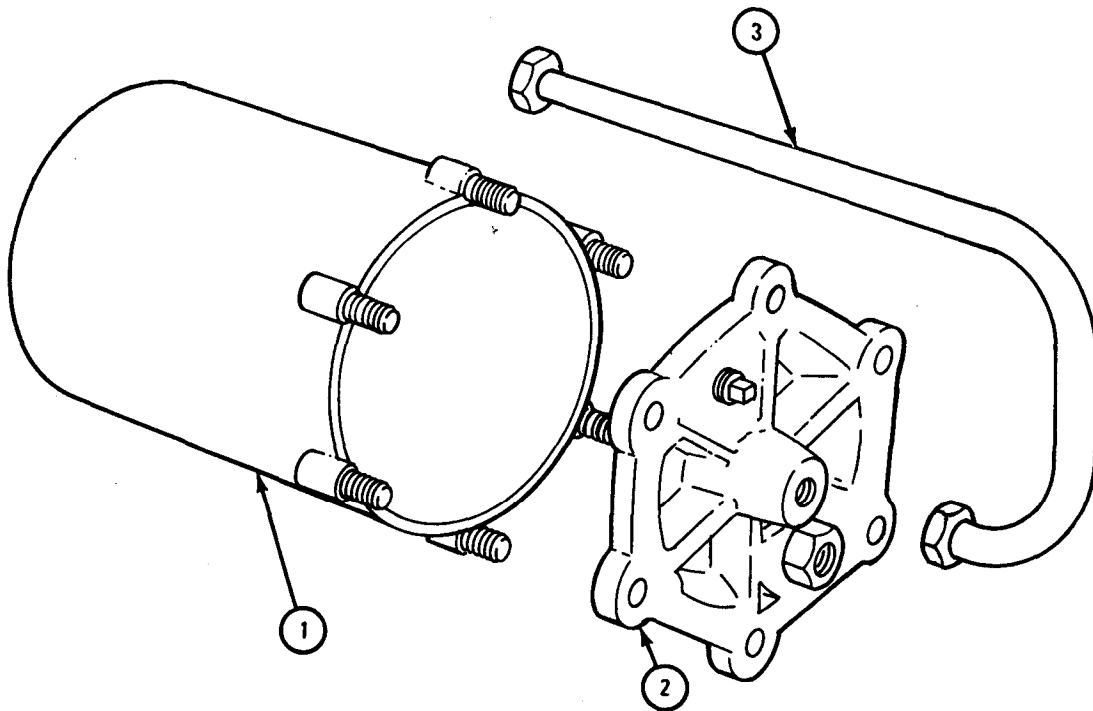

TA 084282

- e. Slave Cylinder Body Repair.
 - (1) Disassembly.

FRAME 1

- 1. Take out plug (1). Take out and throw away gasket (2).
- END OF TASK

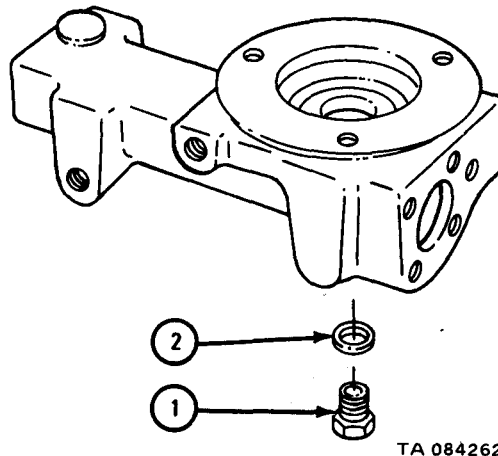

(2) Cleaning, inspection, and repair.

FRAME 1**WARNING**

Dry cleaning solvent is flammable. Do not use near an open flame. Keep a fire extinguisher nearby when solvent is used. Use only in well-ventilated places. Failure to do this may result in injury to personnel and damage to equipment.

1. Clean slave cylinder body (1) with dry cleaning solvent.
2. Check that all openings in slave cylinder body (1) have no dirt, dust or grime.
3. Check that piston bore (2) is not scored or scratched. If piston bore is scored or scratched, polish it with crocus cloth. If scratches cannot be taken out, get a new air hydraulic cylinder.
4. Check that finished surfaces on slave cylinder body (1) have no scratches. If surfaces are scratched, rub out any scratches with honing stone. If scratches cannot be rubbed out easily, get a new air hydraulic cylinder.
5. Check that threads in all threaded openings of slave cylinder body (1) are not stripped or crossthreaded. Fix damaged threads with thread chaser. If threads cannot be fixed, get a new air hydraulic cylinder.

END OF TASK

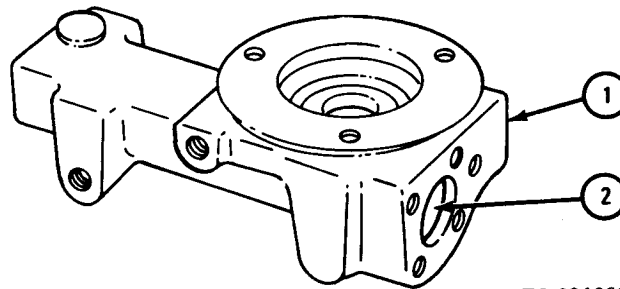

TA 084263

(3) Assembly.

FRAME 1

1. Put gasket (1) on plug (2).

2. Put in plug (2).

END OF TASK

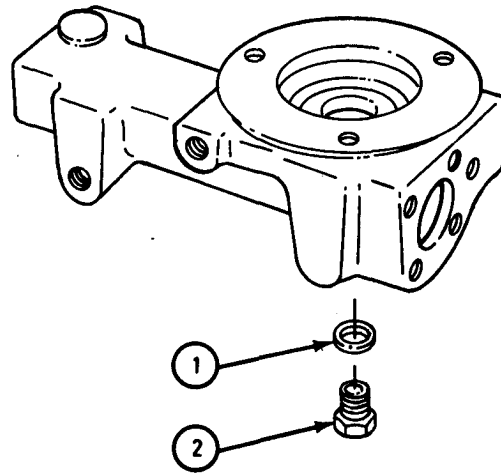

TA 084264

f. Pushrod Bushing Assembly Repair.

FRAME 1

WARNING

Care must be taken not to damage seal area or pushrod bushing. Failure to do this may result in brake failure which may cause injury to personnel and damage to equipment.

NOTE

Use a blunt instrument to aid in the removal and installation of the seal.

1. Pry out seal (1) through center hole of washer at the end of pushrod bushing
- (2) Throw away seal.
2. Check that bore of pushrod bushing (2) and seal area is not scored, scratched, or damaged in any way. If bushing is damaged, get a new pushrod bushing assembly.
3. Lubricate pushrod bushing (2) with silicone brake fluid.

WARNING

Ensure seal is correctly installed in accordance with Position shown in illustration. Failure to install correctly could cause loss of life, personal injury and/or destruction of property.

4. Lubricate seal (1) with silicone brake fluid, then install by compressing and inserting through the washer center into pushrod bushing (2). Carefully work seal into place.

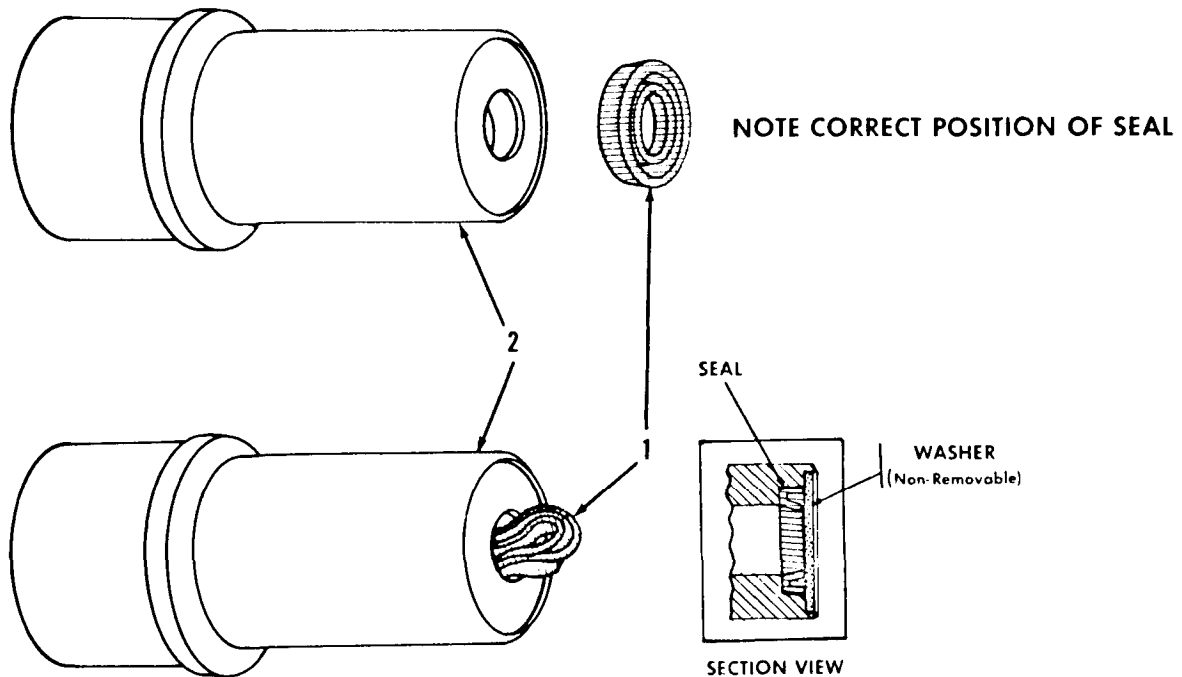

TA 483077

- g. Slave Cylinder Compensator Assembly Repair.
(1) Disassembly.

FRAME 1

1. Put compensator body (1) in vise.
 2. Take out four screws (2) and lockwashers (3).
 3. Take off cover (4). Take off and throw away gasket (5).
 4. Take off cage (6). Take off and throw away gasket (7).
- END OF TASK

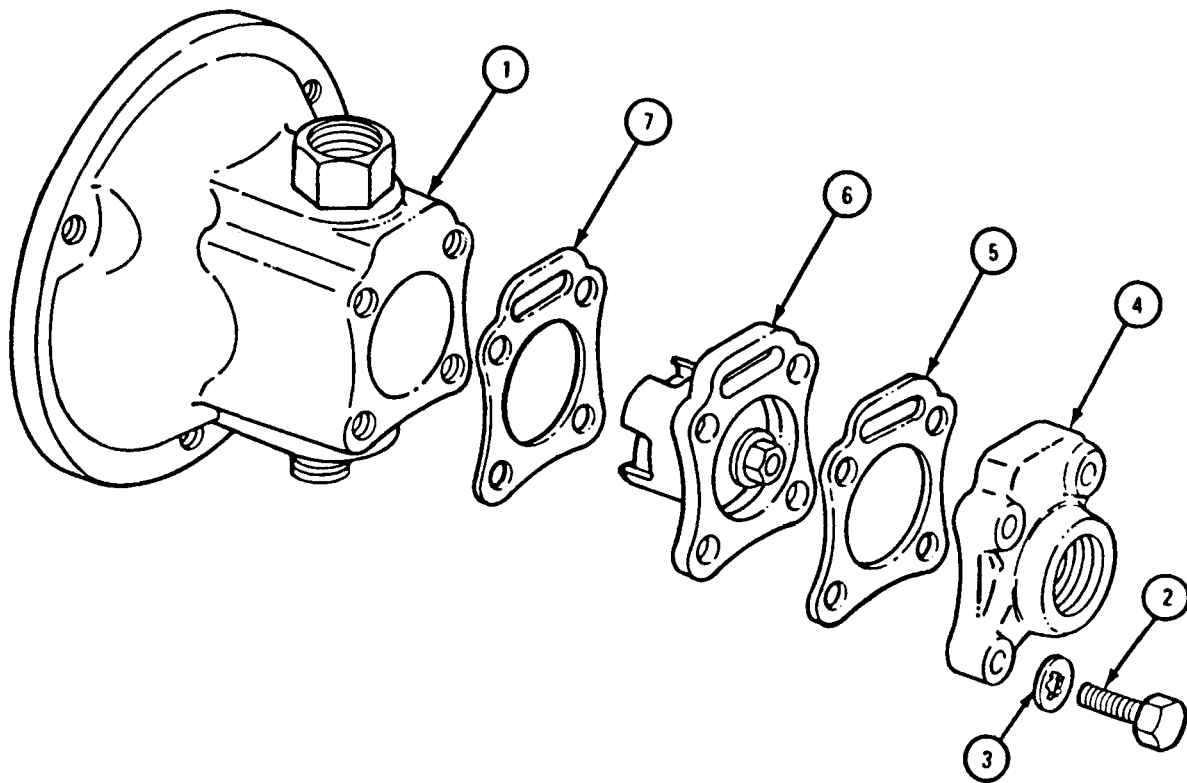

TA 084261

(2) Cleaning, inspection, and repair.

FRAME 1**WARNING**

Dry cleaning solvent is flammable. Do not use near an open flame. Keep a fire extinguisher nearby when solvent is used. Use only in well-ventilated places. Failure to do this may result in injury to personnel and damage to equipment.

1. Clean compensator body (1) and cage cover (2) with dry cleaning solvent.
2. Check that all finished surfaces on compensator body (1) and cage cover (2) have no scratches. If finished surfaces are scratched, rub out any scratches with honing stone. If scratches will not rub out easily, get a new compensator body (1) and cage cover (2).

NOTE

Do not take out tube fitting (3) or pipe plug (4).

4. Check that tube fitting (3) and pipe plug (4) are not damaged. If air tube fitting or pipe plug is damaged, get a new compensator body (1) and cage cover (2).

GO TO FRAME 2

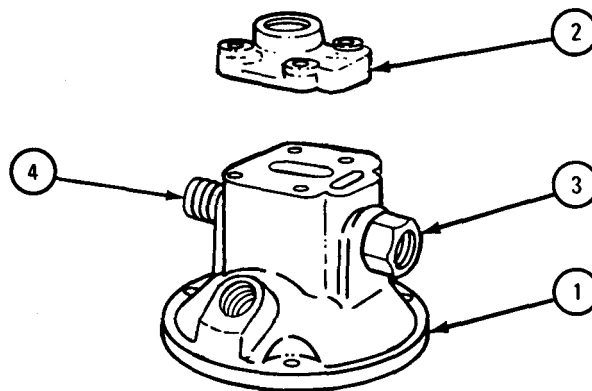

TA 084265

FRAME 2

1. Take off nut (1).
2. Take out and throw away exhaust valve (2).
3. Take out and throw away spring (3).
4. Take out and throw away inlet valve (4).

WARNING

Dry cleaning solvent is flammable. Do not use near an open flame. Keep a fire extinguisher nearby when solvent is used. Use only in well-ventilated places. Failure to do this may result in injury to personnel and damage to equipment.

5. Clean cage (5) in dry cleaning solvent.
6. Check that cage (5) is not damaged. If cage is damaged, throw it away and get a new one.

GO TO FRAME 3

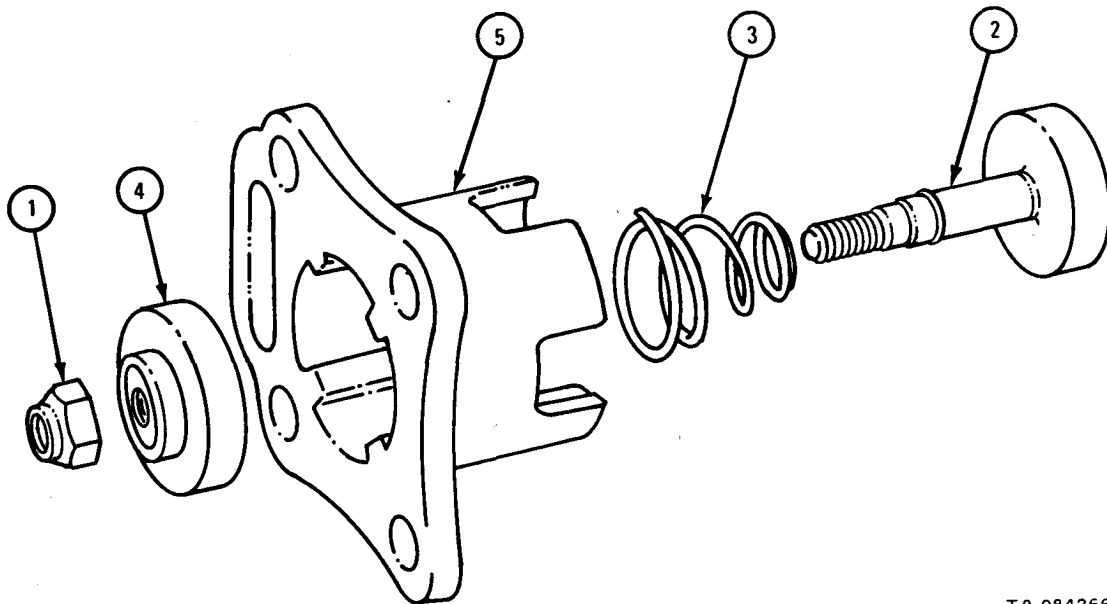

TA 084266

FRAME 3

1. Put new spring (1) on stem of new exhaust valve (2) as shown.
2. Put exhaust valve (2) and spring (1) into cage (3).
3. Put new inlet valve (4) on stem of exhaust valve (2) so that rubber side of inlet valve faces cage (3) as shown.
4. Put nut (5) on stem of exhaust valve (2) so that one full thread of exhaust valve sticks out.
5. Put a coat of preservative oil on all parts.

END OF TASK

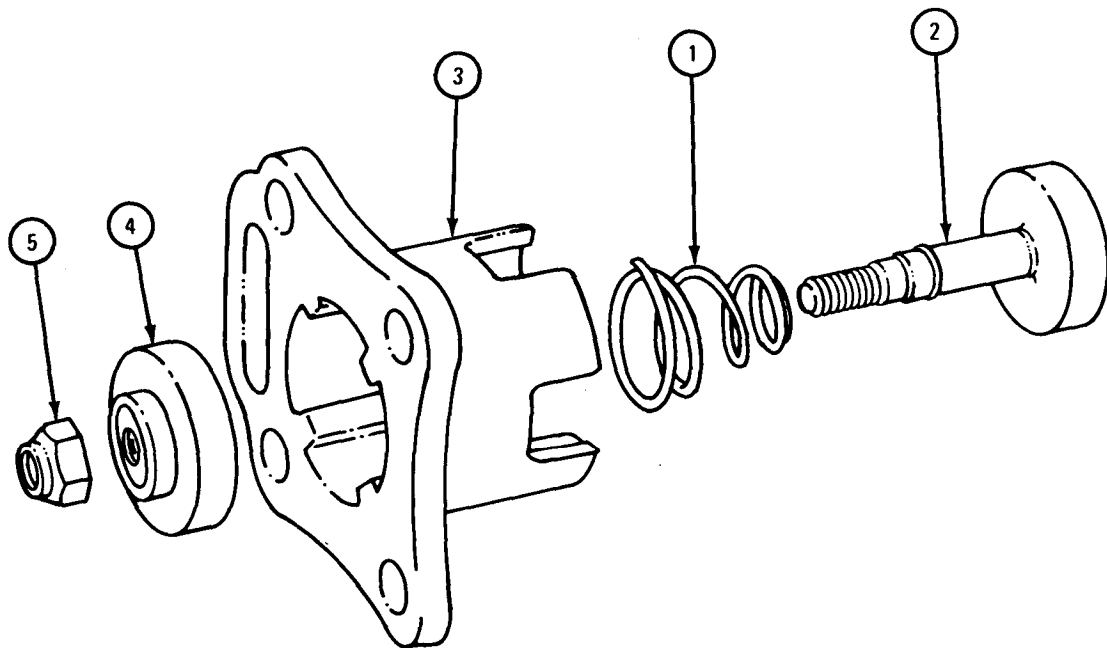

TA 084267

(3) Assembly.

FRAME 1

1. Put gasket (1) on compensator body (2).
2. Put encage (3).
3. Put on gasket (4).
4. Put on cover (5).
5. Put in four screws (6) and lockwashers (7).

END OF TASK

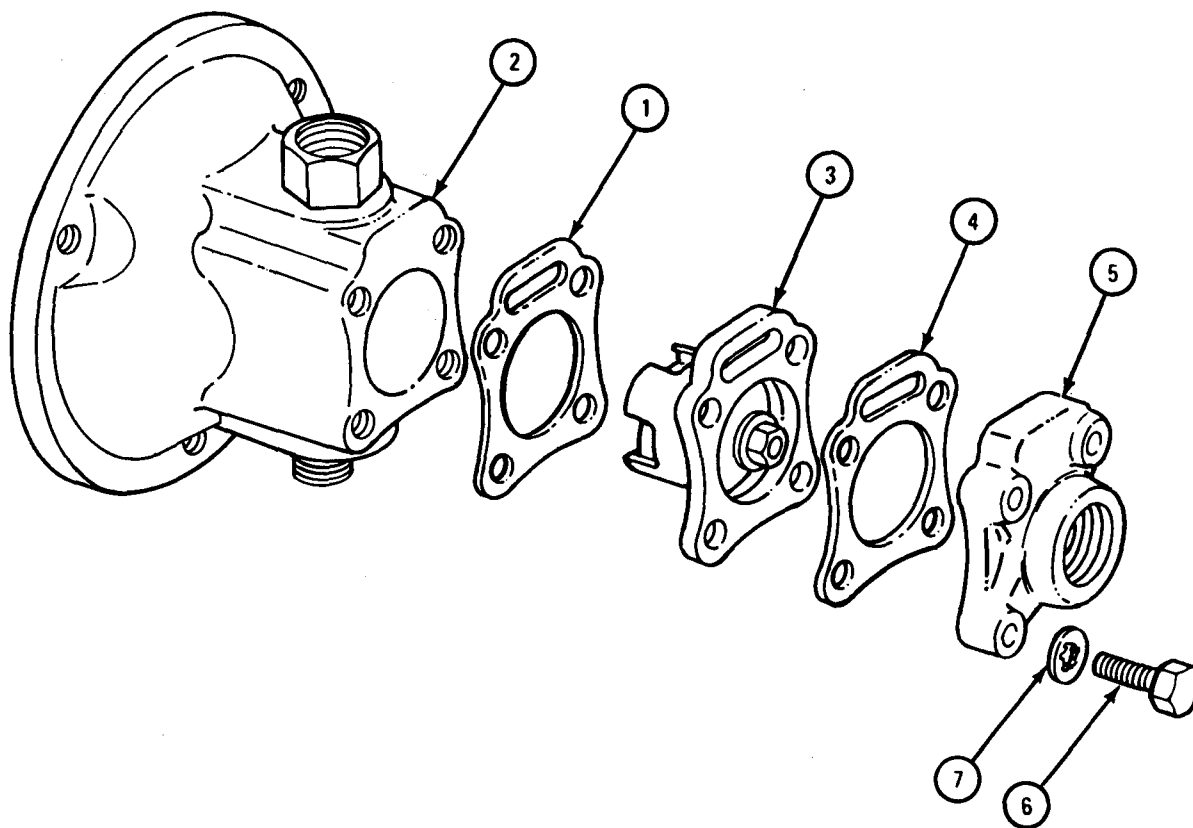

TA 084268

h. Slave Cylinder Compensator Piston Assembly Repair.

FRAME 1

1. Take out and throw away felt ring (1) and cup (2).

WARNING

Dry cleaning solvent is flammable. Do not use near an open flame. Keep a fire extinguisher nearby when solvent is used. Use only in well-ventilated places. Failure to do this may result in injury to personnel and damage to equipment.

2. Clean compensator piston (3) with dry cleaning solvent.
3. Be sure that center hole and cross holes of compensator piston (3) are clean and open.
4. If grooves of piston (3) are chipped or broken, throw out air hydraulic cylinder and get a new one.

GO TO FRAME 2

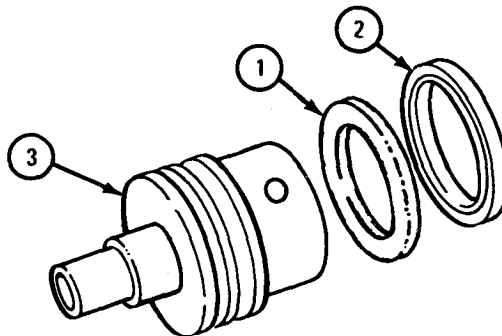

TA 084271

FRAME 2

1. Put a coat of clean hydraulic brake fluid on new felt ring (1), new piston cup (2), and compensator piston (3).
2. Put cup (2) into second groove on compensator piston (3). Lip of cup must face away from hole in side of piston.
3. Put felt ring (1) into first groove on compensator piston (3).

END OF TASK

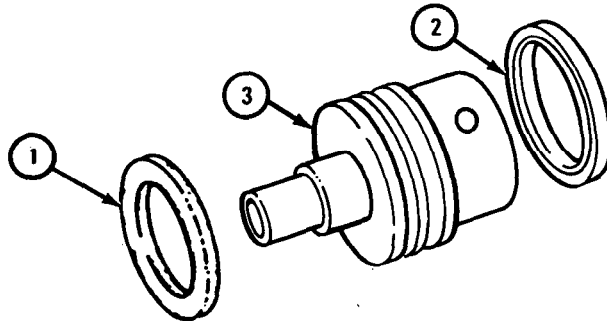

TA 084272

i. Slave Cylinder Control Valve Piston Assembly Repair.

FRAME 1

1. Take off and throw away outer cup (1).
2. Take off and throw away inner cup (2).

WARNING

Dry cleaning solvent is flammable. Do not use near an open flame. Keep a fire extinguisher nearby when solvent is used. Use only in well-ventilated places. Failure to do this may result in injury to personnel and damage to equipment.

3. Clean control valve piston (3) with dry cleaning solvent.
4. Check that control valve piston (3) is not scratched, scored or damaged in any other way. If it is damaged, throw away air hydraulic cylinder and get a new one.

GO TO FRAME 2

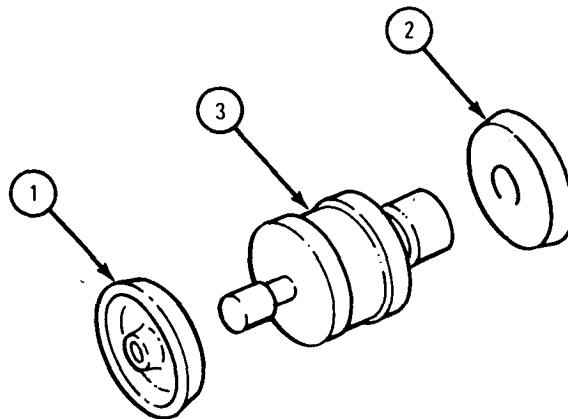

TA 084269

FRAME 2

1. Put a coat of clean hydraulic brake fluid on control valve piston (1), new outer cup (2), and new inner cup (3).

NOTE

Outer cup (2) has smaller hole in center than inner cup (3).

2. Push outer cup (2) over smaller stem of control valve piston (1). Flat face of outer cup must seat against end of control valve piston.
3. Push inner cup (3) over larger stem of control valve piston (1). Flat face of inner cup must seat against end of control valve piston.

END OF TASK

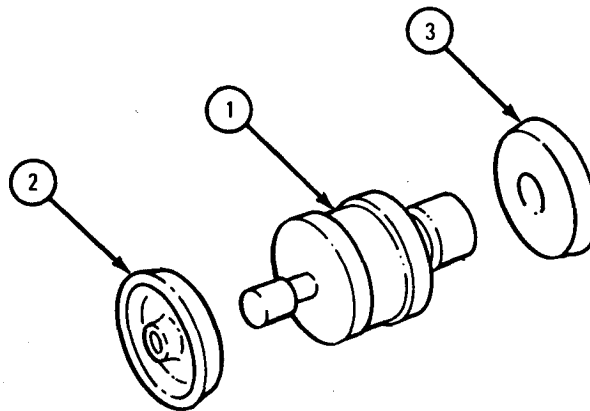

TA 084270

j. Assembly of Air Hydraulic Cylinder Assembly.

(1) Slave cylinder compensator body assembly replacement.

FRAME 1CAUTION

Use only bench vise with soft copper or lead jaws.

1. Put slave cylinder body (1) in vise.
2. Put control valve piston (2) into bore in slave body (1). Small end of control valve piston should point down. Be sure that lip of cup (3) does not fold back.

GO TO FRAME 2

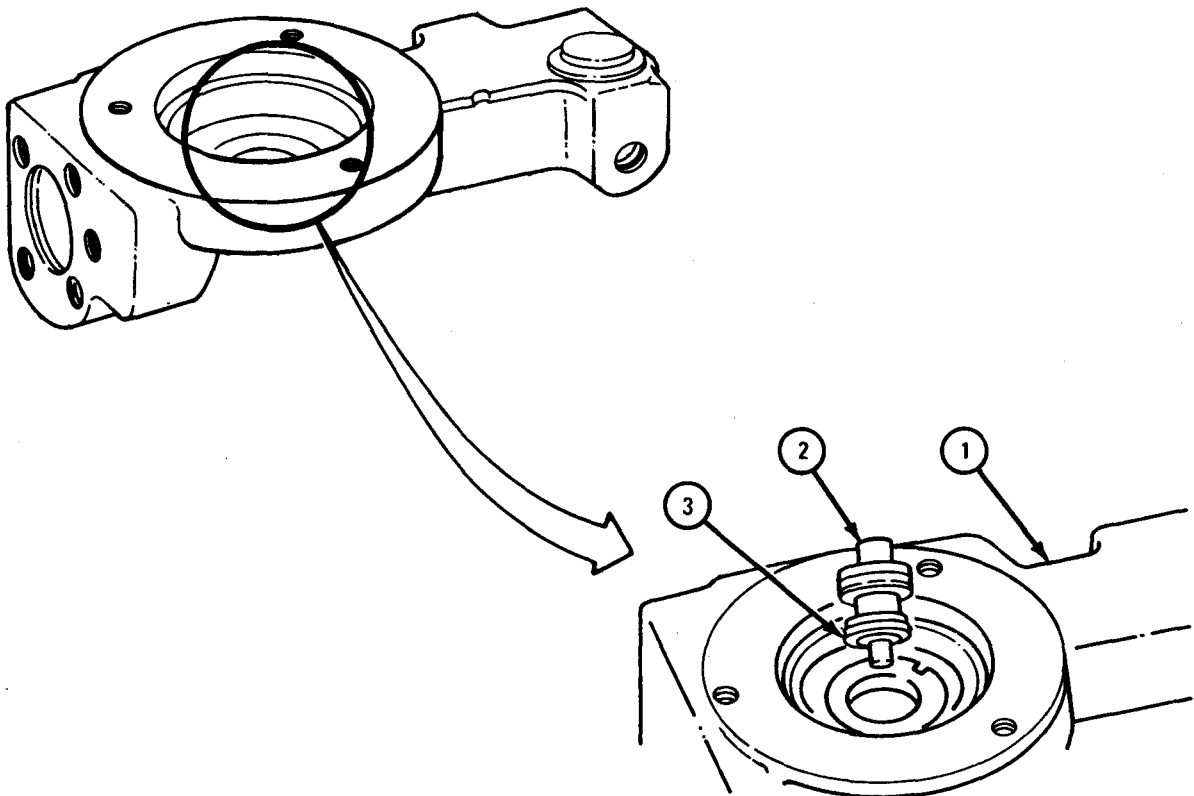

TA 084283

FRAME 2

1. Put in spring (1) so that large end of spring seats against closed end of cylinder in compensator body (2).
2. Put compensator piston (3) on spring (1) so that stem is in center of spring.
3. Push compensator piston (3) down into compensator body (2) as far as possible. Be careful not to fold over lip of cup (4).

GO TO FRAME 3

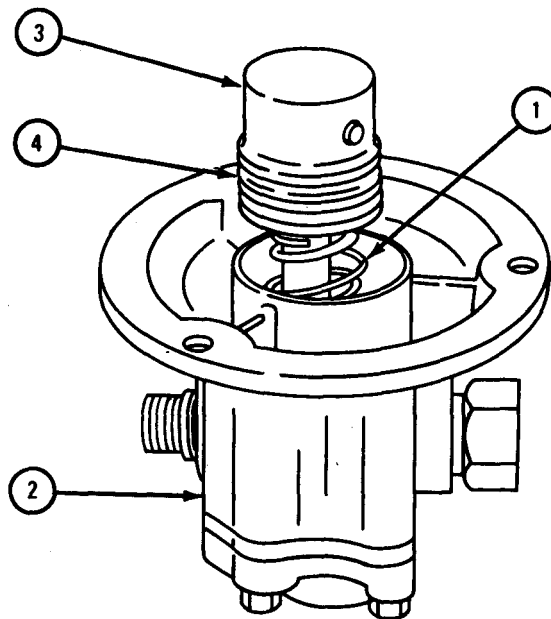

FRAME 3

1. Put on new gasket (1).
2. Put compensator body (2) on slave cylinder body (3) so that compensator piston (4) sits on control valve piston (5).
3. Aline marks made on slave cylinder body (3) with compensator body (2).
4. Put in two capscrews (6) and lockwashers (7).
5. Put in bolt (8). Put on lockwasher (9) and nut (10).

END OF TASK

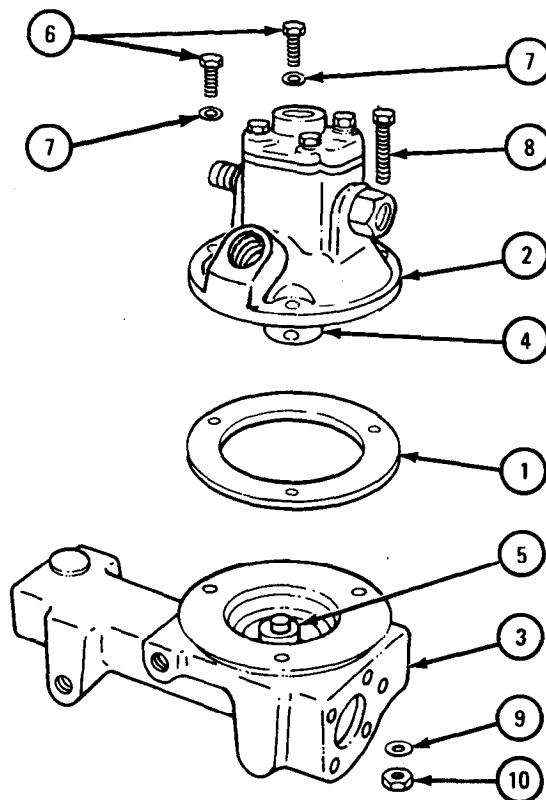

TA 084285

(2) Air cylinder shell replacement.

FRAME 1

1. Put in pushrod bushing (1) wider end first.
2. Put new gasket (2) and O-ring (3) on air cylinder (4) as shown.
3. Put air cylinder (4) on slave cylinder body (5).
4. Aline marks made on slave cylinder body (5) and air cylinder (4).

GO TO FRAME 2

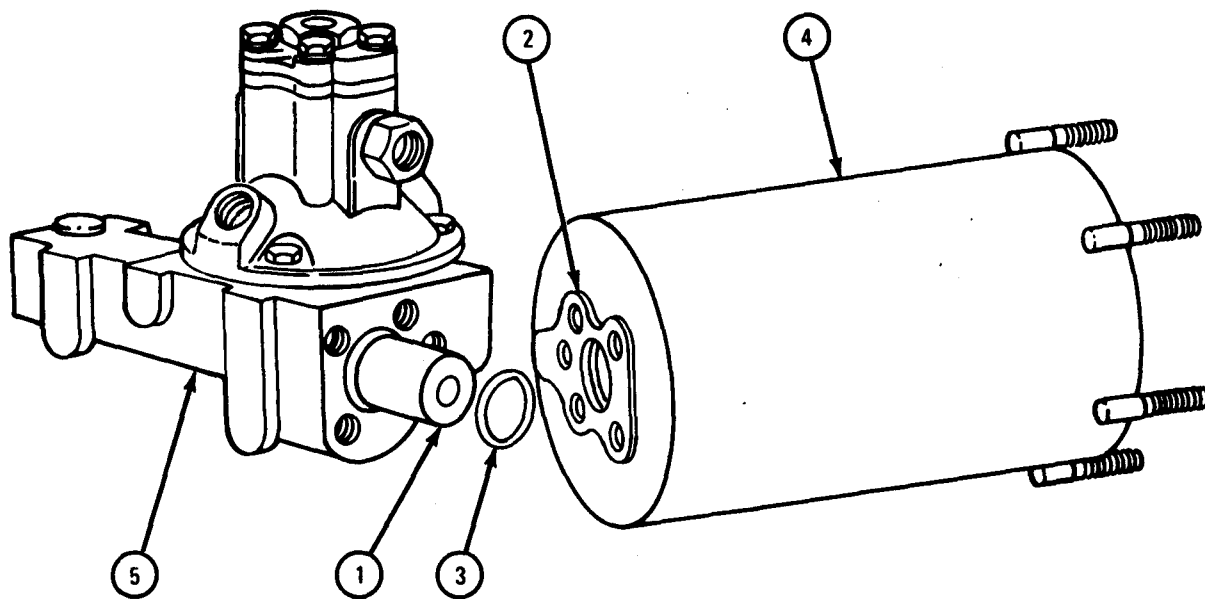

TA 084286

FRAME 2

1. Put in four screws (1) and lockwashers (2).
2. Slide spring retainer (3) over pushrod bushing (4). Flat side of spring retainer must seat against heads of screws (1).

END OF TASK

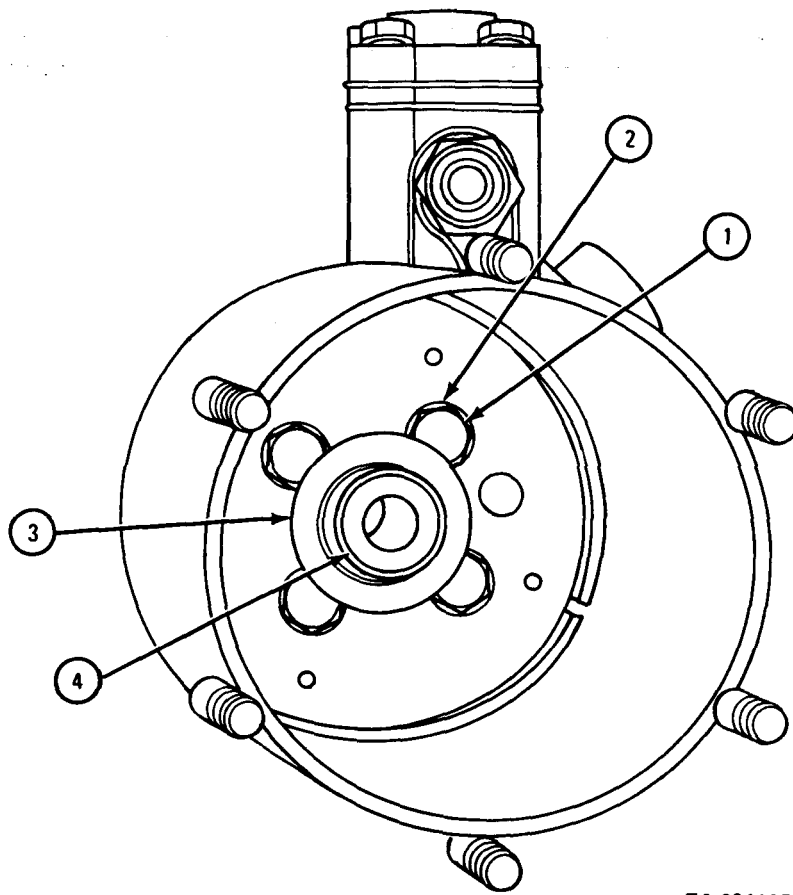

TA 084287

(3) Air cylinder piston assembly replacement.

FRAME 1

1. Put spring (1) into air cylinder (2) so that small end of spring is around spring retainer (3).
2. Put a coat of hydraulic brake fluid on pushrod (4).
3. Put pushrod (4) through air cylinder (2) and into bushing (5).
4. Push piston (6) into air cylinder (2).

GO TO FRAME 2

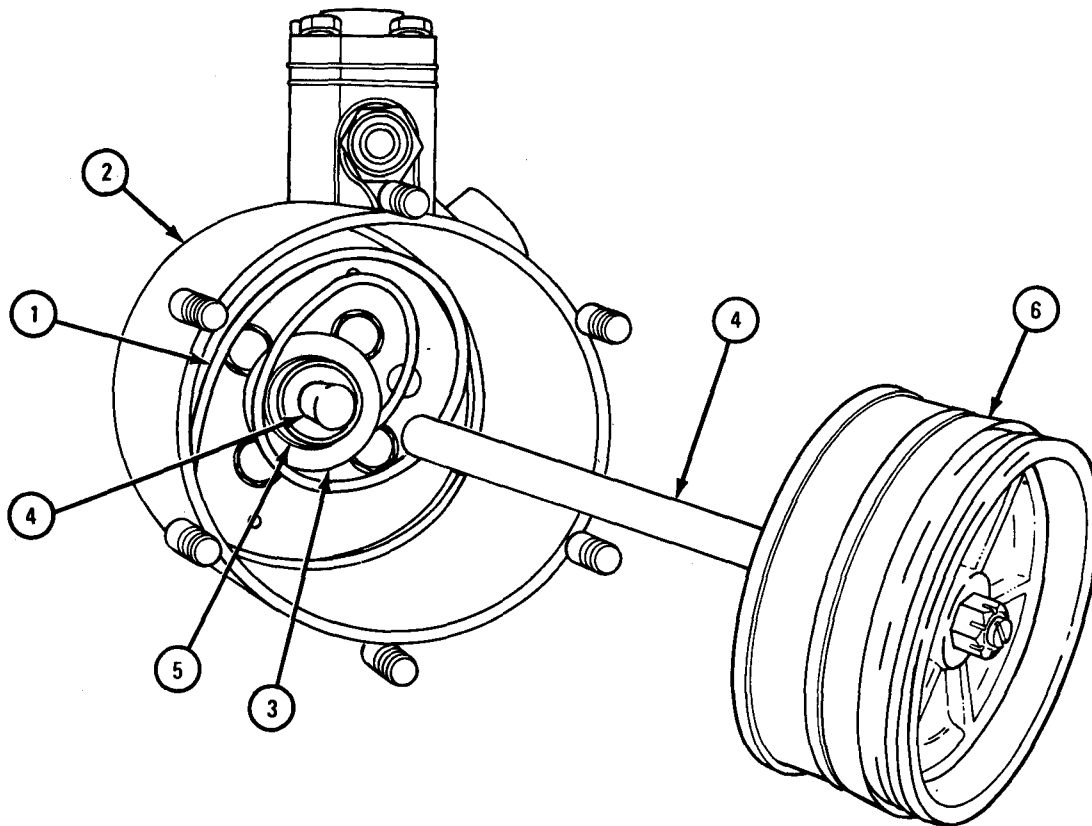

TA 084288

FRAME 2

1. Put on nonmetallic washer (1).
2. Aline mark on air cylinder (2) with mark on end cover (3). Put on end cover.
3. Put on six nuts (4) and lockwashers (5).

GO TO FRAME 3

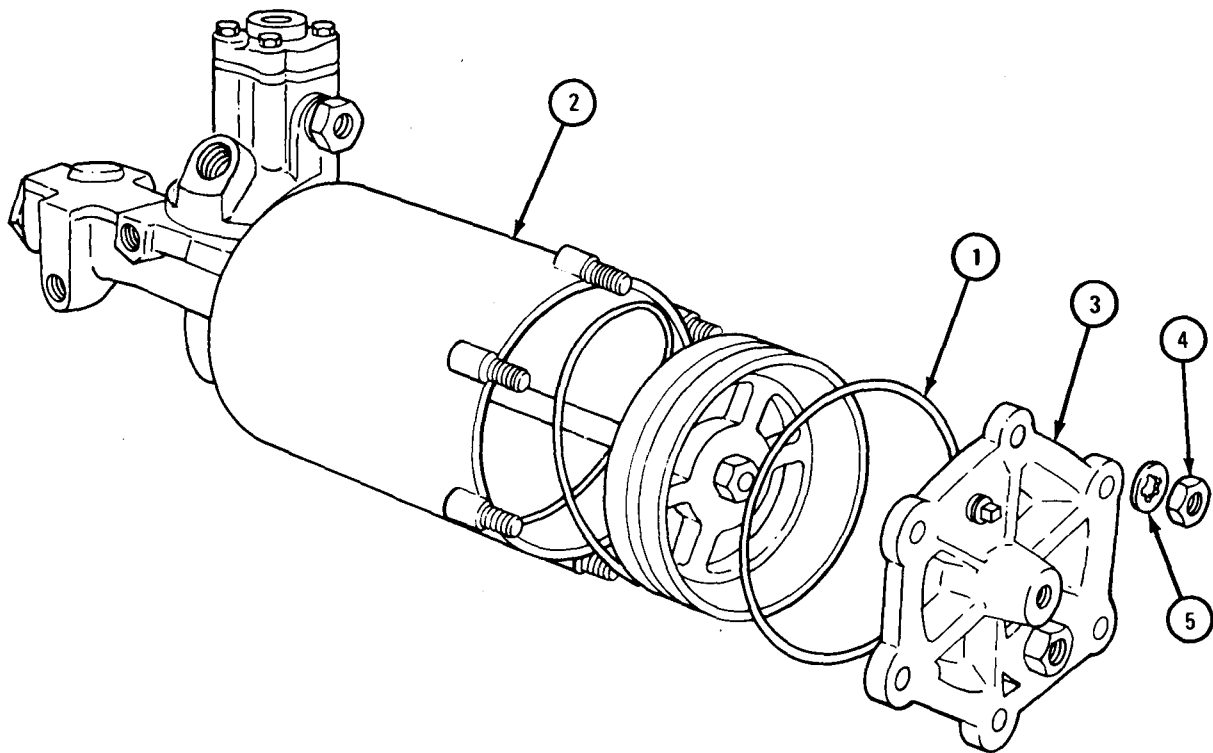

TA 084289

FRAME 3

1. Put air tube (1) in place as shown. Tighten tube nuts (2 and 3).

END OF TASK

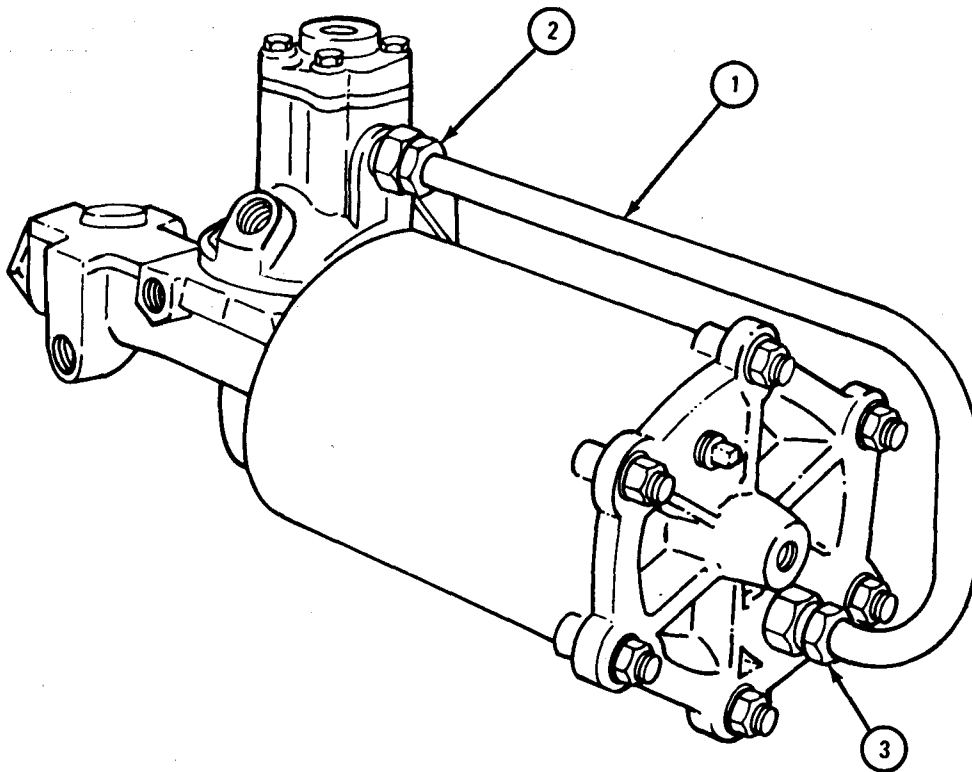

TA 084290

(4) Slave cylinder piston assembly replacement.

FRAME 1

NOTE

Pushrod seal (1) and piston cup (2) look the same. Piston cup has larger opening. Do not mix them up.

1. Put pushrod seal (1) into hole in end of slave cylinder body (3) with lip facing out.
2. Put piston (4) into hole in slave cylinder body (3).
3. Put piston cup (2) into hole in slave cylinder body (3) with lip facing out.
4. Put spring retainer (5) into slave cylinder body (3). Small end of spring retainer must go in first.

GO TO FRAME 2

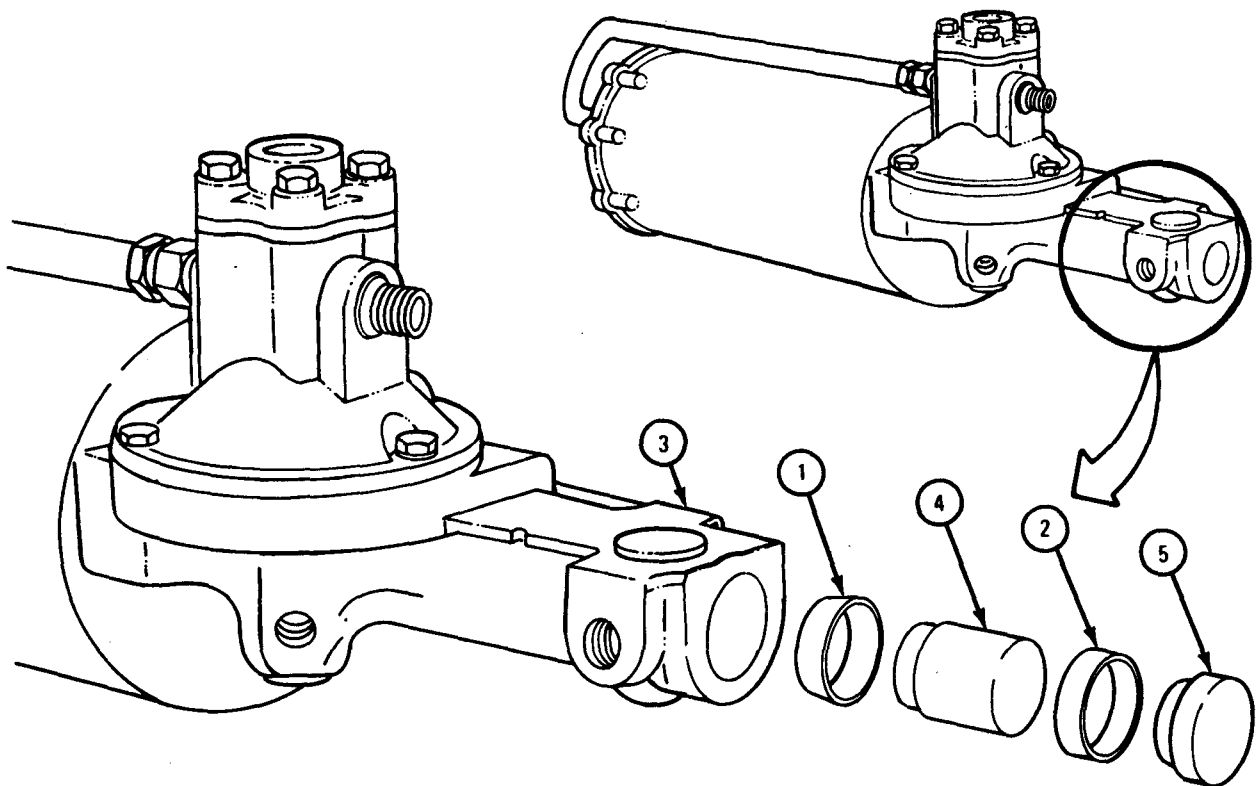

TA 084291

FRAME 2

1. Put inner spring (1) inside outer spring (2) and put springs inside slave cylinder body (3) as shown.
2. Put gasket (4) on plug (5).
3. Put in plug (5).
4. Finger tighten bleeder screw (6) into slave cylinder body (3). Using wrench, turn 1/8 turn more.

NOTE

Follow-on Maintenance Action Required:

1. Replace hydraulic stoplight switch. Refer to TM 9-2320-209-20.
2. Replace air hydraulic cylinder. Refer to TM 9-2320-209-20.

END OF TASK

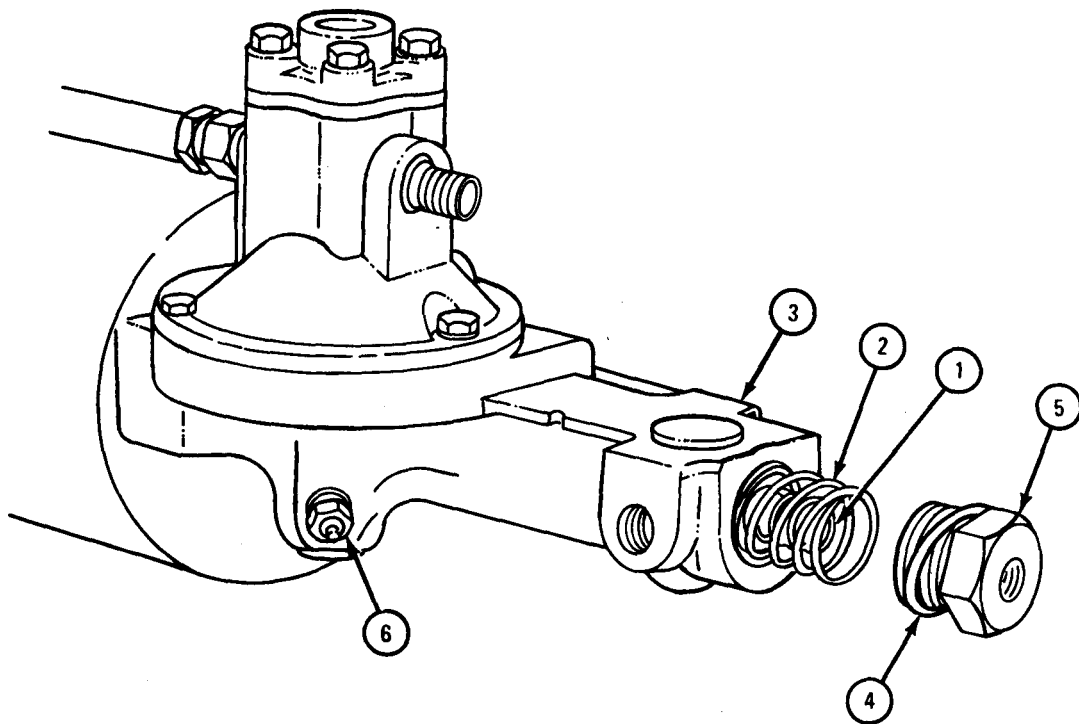

TA 084292

12-6. FRONT BRAKE HOSE REMOVAL AND REPLACEMENT.

NOTE

Original brake hoses will be replaced with modified brake hoses.

This task is the same for the left and right front brake hoses. Original and modified brake hoses are shown.

TOOLS : No special tools required

SUPPLIES : Modified hose kit

PERSONNEL : One

EQUIPMENT CONDITION : Truck parked, engine off, handbrake set.

a. Preliminary Procedures.

(1) Drain brake lines. Refer to TM 9-2320-209-20.

(2) If working on truck with original brake hoses, remove steering knuckle boot. Refer to TM 9-2320-209-20.

b. Removal.

NOTE

If taking off original brake hose, do frames 1 and 2. If taking off modified brake hose, go to frame 3.

FRAME 1

1. Take off line nut (1).
2. Take off locknut (2) and washer (3).
3. Do steps 1 and 2 again for other end of brake hose (4).
4. Take off brake hose (4) and bracket (5). Throw away bracket.
5. Take out screw (6) and washer (7).
6. Take off bracket (8).

GO TO FRAME 2

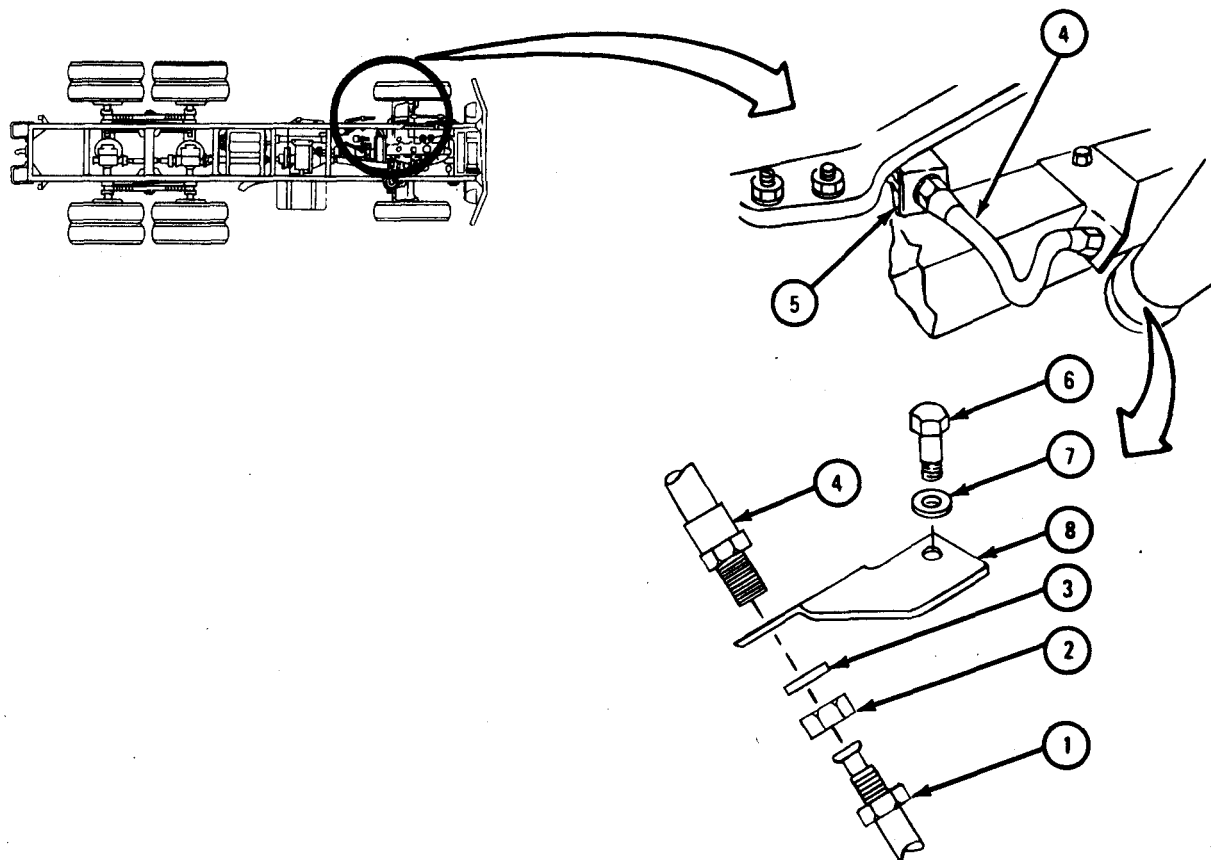

TA 085299

FRAME 2

1. Unscrew tubing nut (1) and take off brake line (2).

END OF TASK

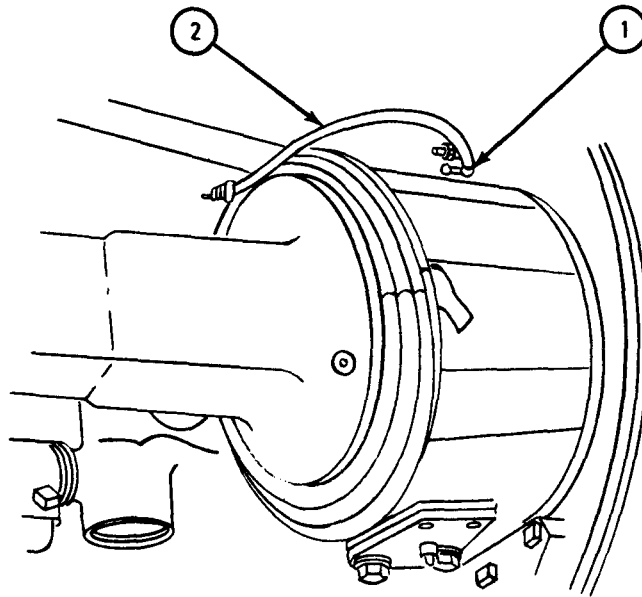

TA 118442

FRAME 3

1. Take spring (1) off spring plate (2).
2. Take off nut (3). Take out screw (4) and spring (1).
3. Take off hose clamp (5).
4. Unscrew line nut (6).
5. Take off locknut (7) and washer (8).

NOTE

Screw (9) is a nut on left side of truck.

GO TO FRAME 4

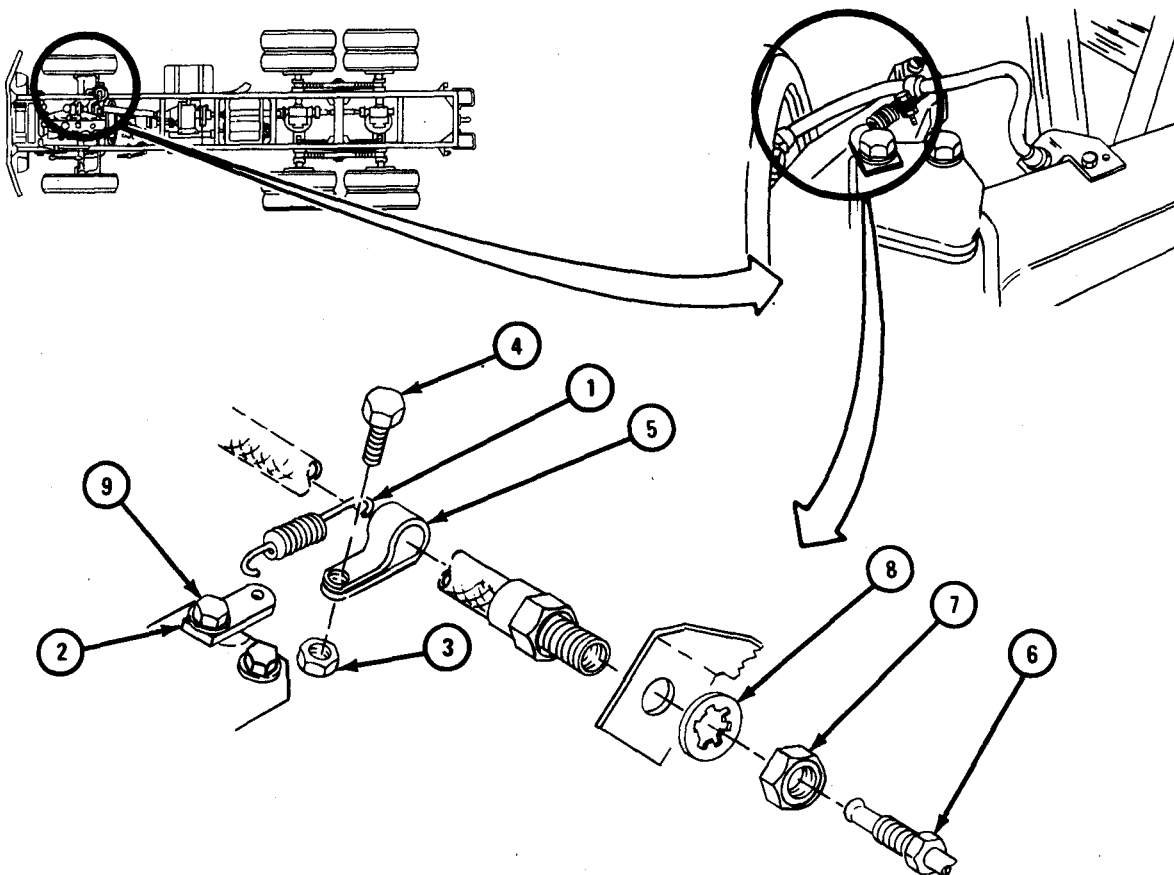

TA 085301

FRAME 4

1. Unscrew brake hose (1) from inlet connector (2) and take off hose.
END OF TASK

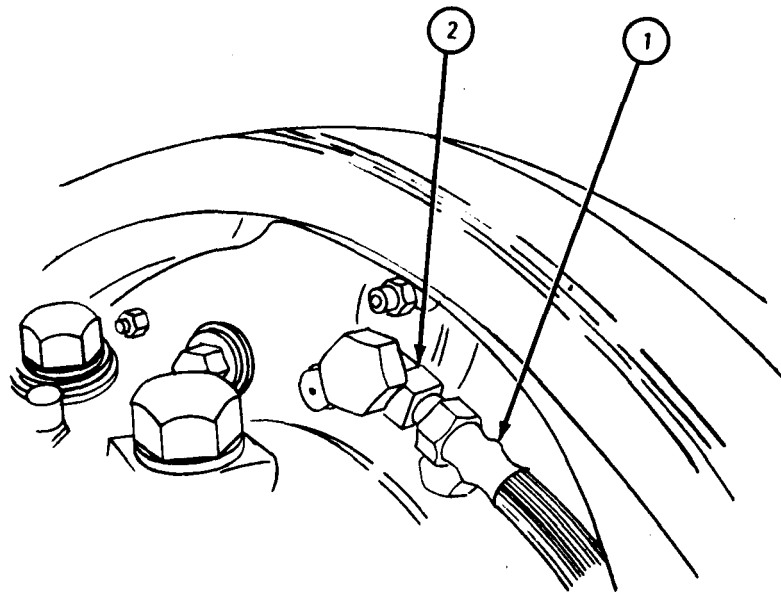

TA 103998

c. Replacement.

NOTE

If modifying original brake hose, do frames 1 through 5. If putting in modified brake hose, do frames 6 and 7.

FRAME 1

1. Bend tab on hose angle bracket (1) to 45° angle as shown.
2. Drill 0.406-inch hole in hose angle bracket (1) as shown.
3. Check that bend in hose angle bracket (1) has no cracks. If bracket is cracked, get a new one.

GO TO FRAME 2

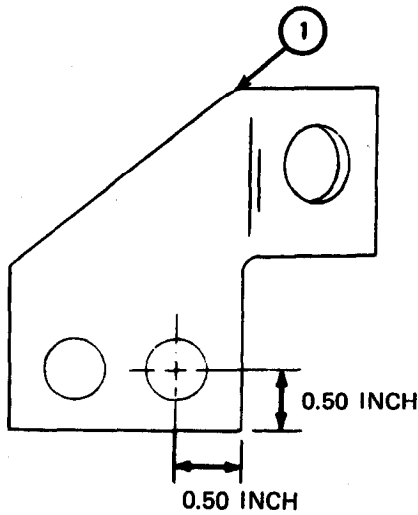

TOP VIEW

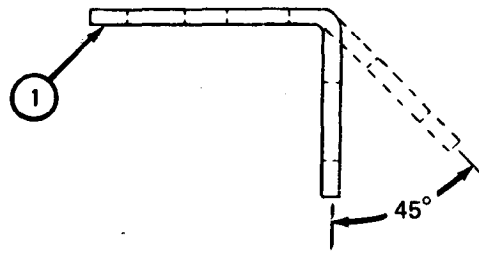

SIDE VIEW

TA 085300

FRAME 2

1. Loosen brake cylinder inlet connector bolt (1).
2. Turn inlet connector (2) one-half turn so inlet hole faces toward rear of truck.
3. Tighten brake cylinder inlet connector bolt (1).

GO TO FRAME 3

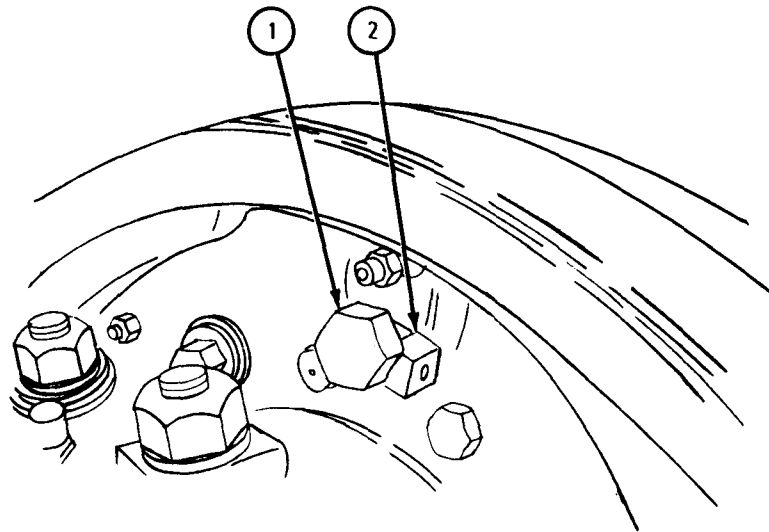

TA 118443

FRAME 3

1. Screw hose (1) into inlet connector (2) and tighten.
2. Unscrew and take off nut and lockwasher (3). Put on spring anchor plate (4) and screw on and tighten nut and lockwasher (3).

GO TO FRAME 4

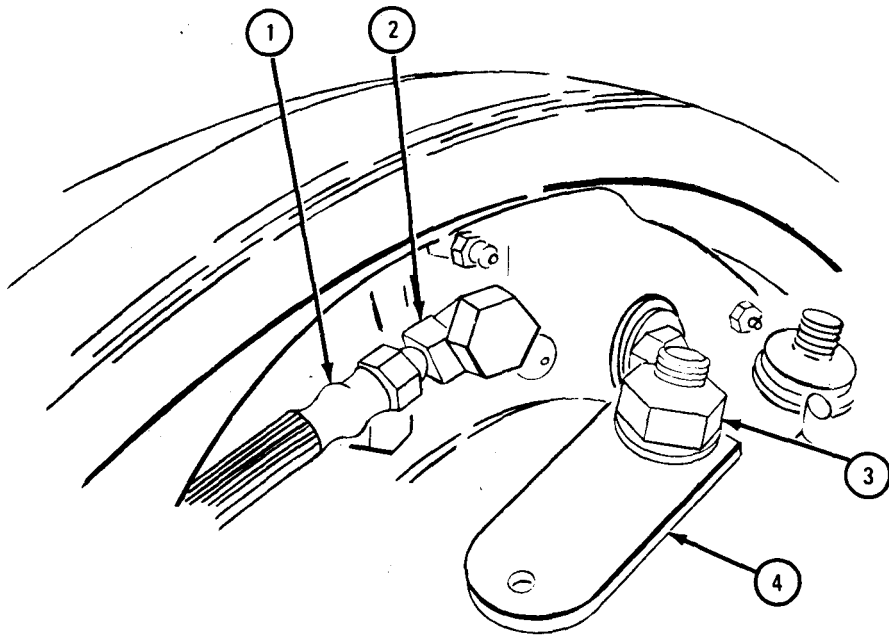

TA 118444

FRAME 4

1. Put bracket (1) in place. Screw in and tighten screw (2) and lockwasher (3).
2. Put hose (4) through hole in bracket (1) and screw on and tighten nut (5) and lockwasher (6).
3. Put hydraulic line (7) into hose (4). Screw in and tighten tube nut (8).

GO TO FRAME 5

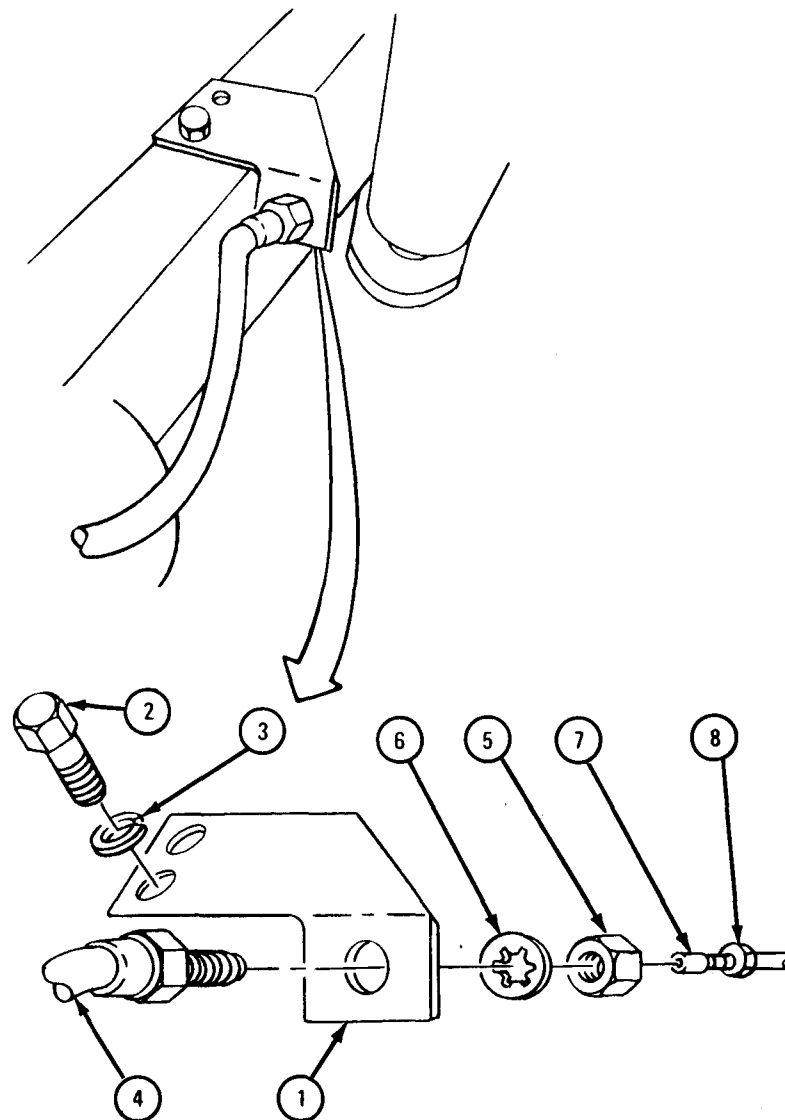

TA 118446

FRAME 5

1. Put hose clamp (1) on hose (2).
2. Put screw (3) through hose clamp (1).
3. Put spring (4) around screw (3) and screw on and tighten nut (5).
4. Hook spring (4) into spring anchor plate (6).

NOTE

Follow-on Maintenance Action Required:

1. Replace steering knuckle boot. Refer to TM 9-2320-209-20.
2. Fill brake system. Refer to TM 9-2320-209-20.
3. Bleed brake system. Refer to TM 9-2320-209-20.

END OF TASK

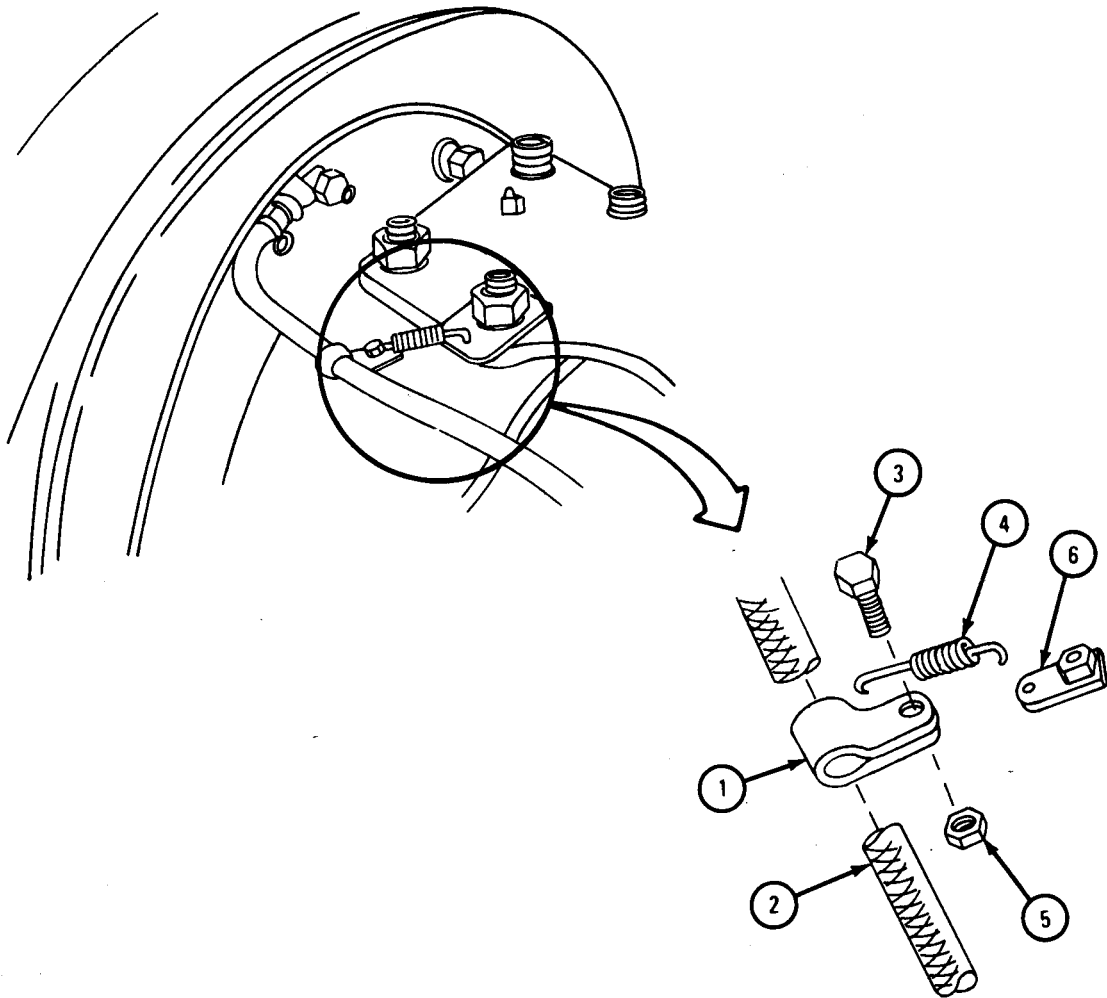

TA 118447

FRAME 6

1. Screw in and tighten brake hose (1) into inlet connector (2).
- GO TO FRAME 7

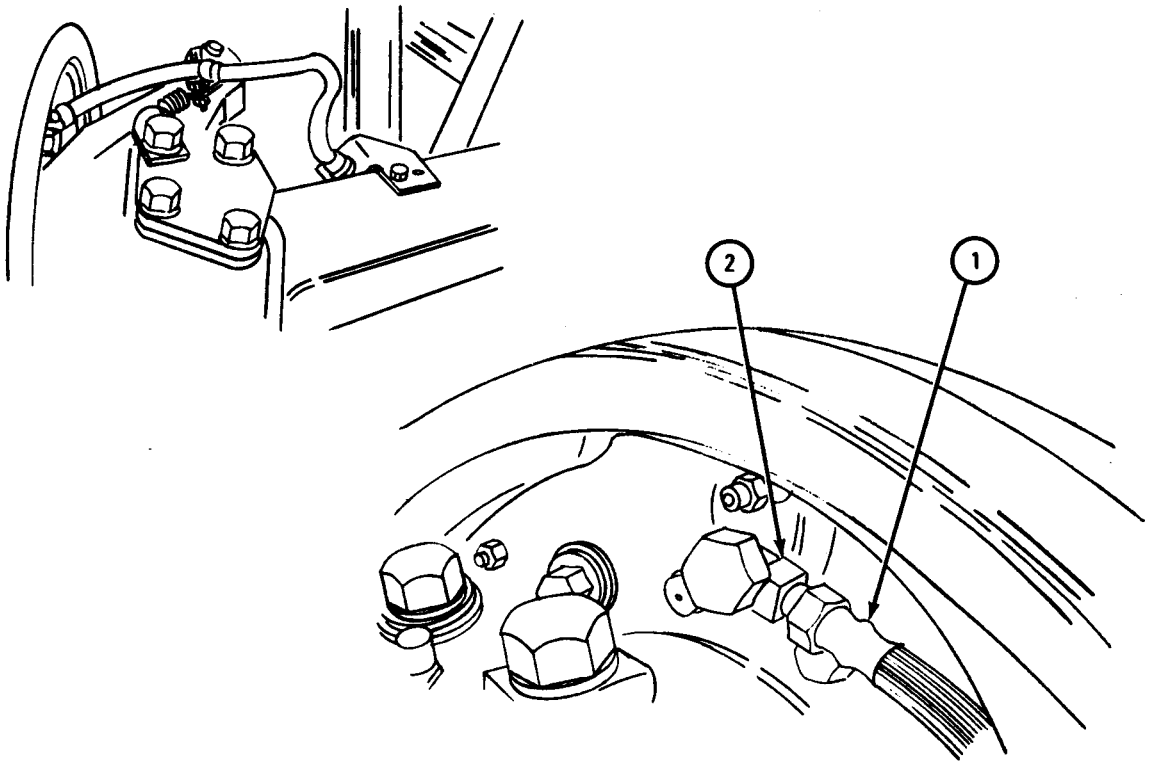

TA 118448

FRAME 7

1. Put brake hose fitting (1) through bracket (2).
2. Put on lockwasher (3) and screw on and tighten nut (4).
3. Put line and tube nut (5) in brake hose fitting (1), and screw in and tighten tube nut (5).
4. Put hose clamp (6) on brake hose fitting (1).
5. Put screw (7) through hose clamp (6).
6. Put spring (8) around screw (7) and screw on and tighten nut (9).
7. Hook spring (8) into spring anchor plate (10).

NOTE

Follow-on Maintenance Action Required:

1. Fill brake system. Refer to TM 9-2320-209-20.
2. Bleed brake system. Refer to TM 9-2320-209-20.

END OF TASK

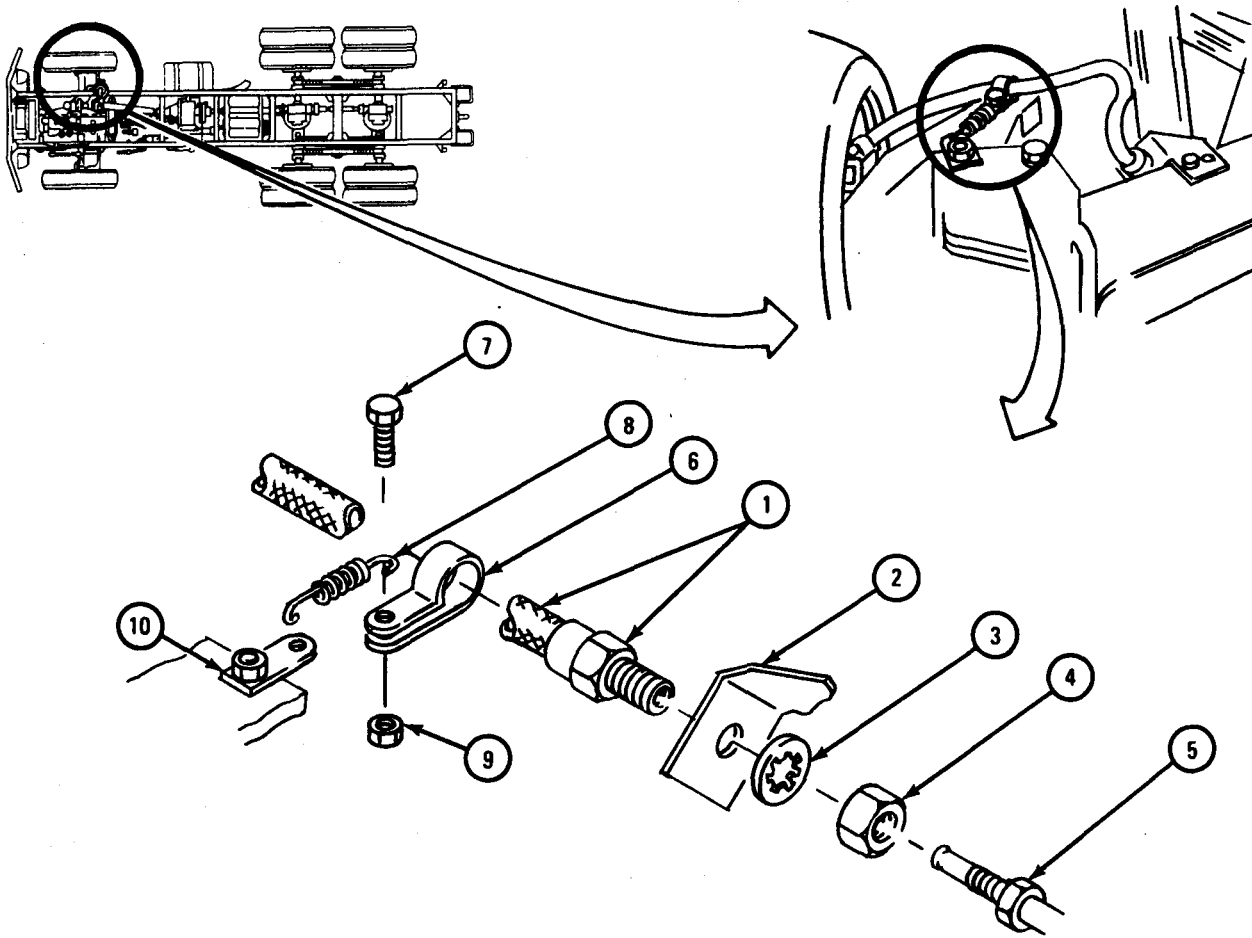

TA 118449

Section IV. TRAILER BRAKE CONNECTIONS AND CONTROLS

12-7. AIR BRAKE HAND CONTROL VALVE REPAIR.

TOOLS : No special tools required

SUPPLIES : Solvent, dry cleaning, type II (SD-2), Fed. Spec P-D 680
Grease, artillery and automotive, type GAA, MIL-G-10924
Kit, hand control valve, pn 8720224

PERSONNEL: One

EQUIPMENT CONDITION : Truck parked, engine off, handbrake set.

a. Preliminary Procedure. Remove air brake hand control valve. Refer to
TM 9-2320-209-20.

b. Disassembly.

FRAME 1

NOTE

Mark cover (1) and body (2) to make sure they are put together the same way.

1. Take out setscrew (3). Take off handle (4).
2. Take out grommet (5) and washer key (6).

NOTE

Mark position of valve adjusting ring (7) on cover (1).

3. Take out valve adjusting ring (7).
4. Take out four screws (8).

CAUTION

Control valve body (2) is under spring tension. Do not allow internal parts to jump out or they will be lost.

5. Tap body (2) lightly with soft nose mallet. Carefully take cover (1) off of body (2).

GO TO FRAME 2

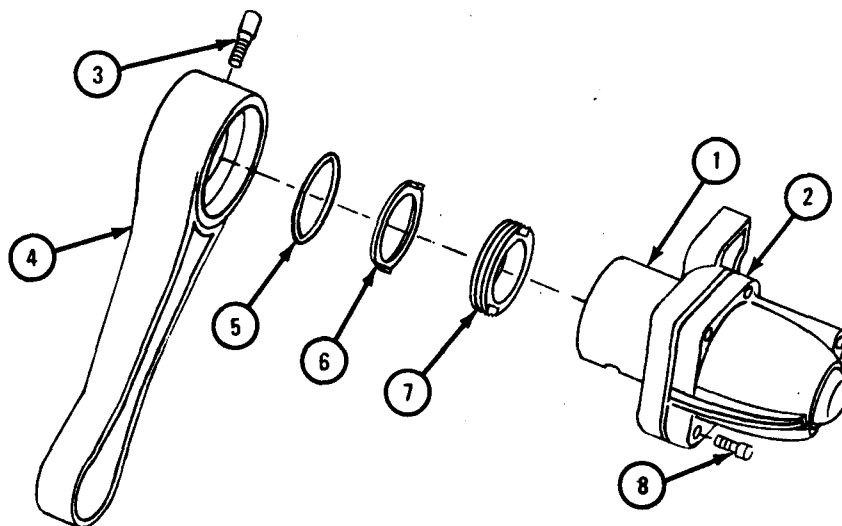

TA 085251

FRAME 2

1. Take out valve cams (1 and 2), compression spring (3), piston (4) grommet (5), and spring (6) from cover (7). Throw away grommet.
2. Take gasket (8) from body (9). Throw away gasket.

GO TO FRAME 3

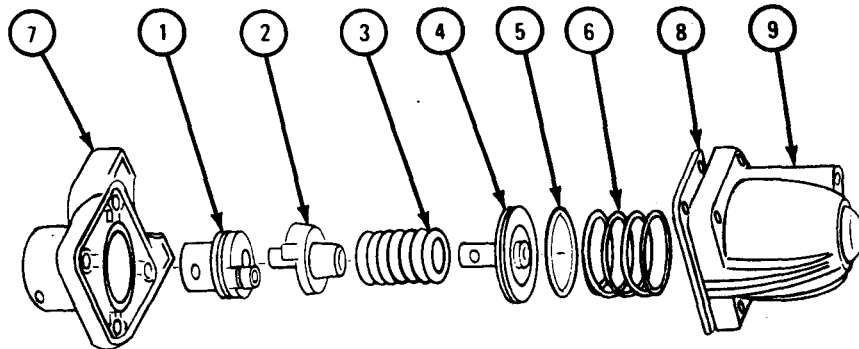

TA 085252

FRAME 3

1. Place body (1) in a vise with soft jaw caps. Take out adapter plug (2).
2. Take out spring (3), valve (4), and grommet (5) from body (1).
Throw out grommet.

END OF TASK

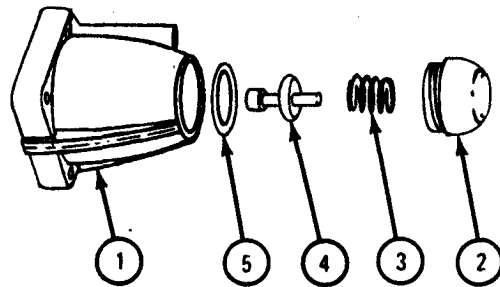

TA 085253

c. Cleaning.WARNING

Dry cleaning solvent is flammable. Do not use near an open flame. Keep a fire extinguisher nearby when solvent is used. Use only in well-ventilated places. Failure to do this may result in injury to personnel and damage to equipment.

(1) Clean all parts in dry cleaning solvent.

(2) Dry with clean rags.

d. Inspection and Repair. Check that all parts have no cracks or damage. If any part is damaged, get a new one.

e. Assembly.

FRAME 1**NOTE**

During assembly, lightly coat bores and cams with grease.

1. Place cover (1) in vise with soft jaw caps. Put grommet (2), on piston (3). Place valve cam (4), cam (5), compression spring (6), grommet and piston as a unit in cover.
2. Place return spring (7) in body (8).
3. Place gasket (9) on body (8).
4. Aline marks on cover (1) and body (8). Press down assembly and tighten four screws (10) to 18 to 20 pound-feet.

GO TO FRAME 2

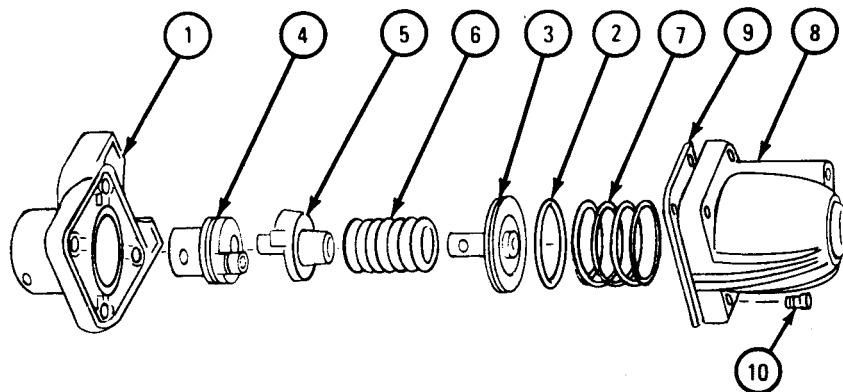

TA 085254

FRAME 2

NOTE

Face machine stub end of valve (1) toward valve piston in body assembly (2).

1. Put grommet (3), valve (1), and spring (4) in body assembly (2).
2. Tighten adapter plug (5) to 25 to 30 pound-feet.

GO TO FRAME 3

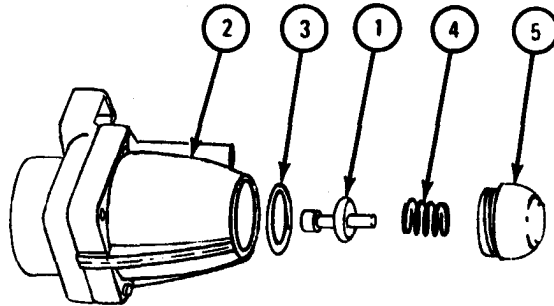

TA 085255

FRAME 3

1. Put in valve adjusting ring (1), alining marks on cover (2) and ring.
2. Put on washer key (3) and grommet (4).
3. Place handle (5) on valve cam (6). Put in setscrew (7).

NOTE

Follow-on Maintenance Action Required:

Replace air brake hand control valve. Refer to TM 9-2320-209-20.

END OF TASK

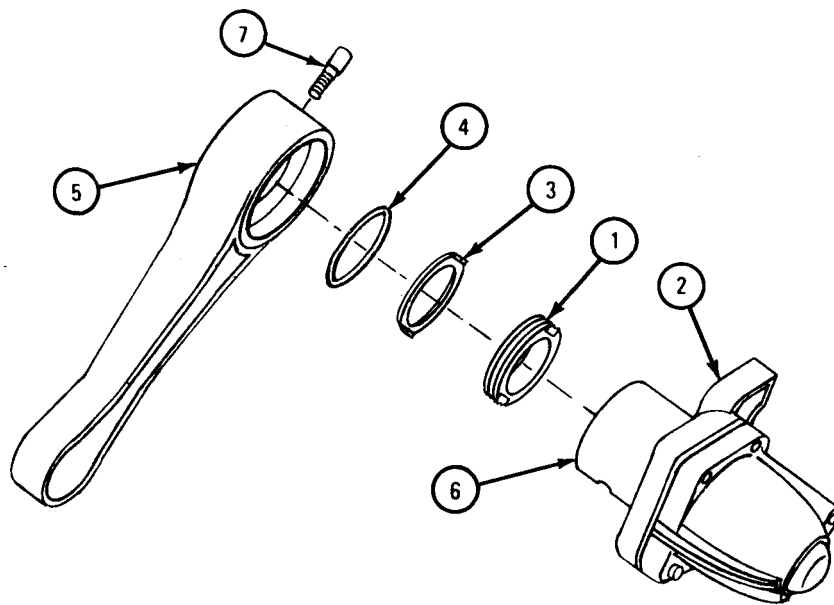

TA 085256

CHAPTER 13**WHEEL SYSTEM GROUP MAINTENANCE**

Section I. SCOPE

13-1. **EQUIPMENT ITEMS COVERED.** This chapter gives equipment maintenance procedures for the wheel assembly for which there are authorized corrective maintenance tasks at the direct and general support maintenance levels.

13-2. **EQUIPMENT ITEMS NOT COVERED.** All equipment items for which corrective maintenance is authorized at the direct and general support maintenance levels are covered in this chapter.

Section II. WHEEL ASSEMBLY

13-3. WHEEL REPAIR.

TOOLS : No special tools required

SUPPLIES : None

PERSONNEL : One

EQUIPMENT, CONDITION : Truck parked, engine off, handbrake set

a. Preliminary Procedures .

(1) Remove wheel. Refer to TM 9-2320-209-10.

(2) Remove tire from rim. Refer to TM 9-2320-209-20.

b. Cleaning. There are no special cleaning procedures needed. Refer to cleaning procedures given in para 1-3.

c. Inspection and Repair.

FRAME 1

1. Check that wheel (1) and retaining ring (2) are not bent, dented, cracked or damaged in any other way. If parts are damaged, get new ones.
2. Check that six wheel stud holes (3) are not worn or damaged in any other way. If holes are worn or wheel is damaged, get a new wheel.
3. Check that paint on wheel (1) is not chipped or cracked, and that there is no bare metal. Repaint wheel as needed. Refer to TM-213.

NOTE

Follow-on Maintenance Action Required:

1. Replace tire on rim. Refer to TM 9-2320-209-20.
2. Replace wheel. Refer to TM 9-2320-209-10.

END OF TASK

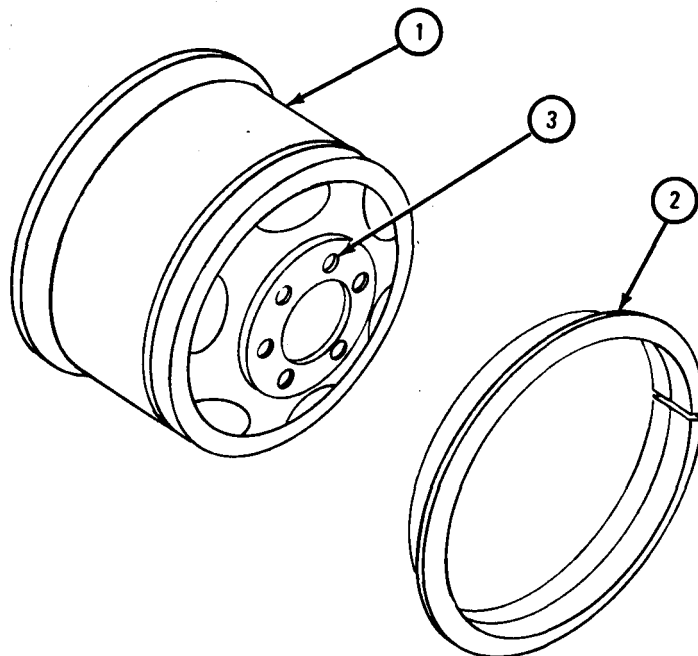

TA 085332

13-4. TIRE REPAIR. Refer to TM 9-2610-200-20 for repair of tire.

CHAPTER 14

STEERING SYSTEM GROUP MAINTENANCE

Section I. SCOPE

14-1. EQUIPMENT ITEMS COVERED. This chapter gives equipment maintenance procedures for the mechanical steering gear assembly for which there are authorized corrective maintenance tasks at the direct and general support maintenance levels.

14-2. EQUIPMENT ITEMS NOT COVERED. All equipment items for which corrective maintenance is authorized at the direct and general support maintenance levels are covered in this chapter.

Section II. MECHANICAL STEERING GEAR ASSEMBLY

14-3. MECHANICAL STEERING GEAR REMOVAL , REPAIR, AND REPLACEMENT.

TOOLS : Bushing remover/replacer, pn 7083248
Sleeve bearing hand burnisher, pn 7083238

SUPPLIES: Solvent, dry cleaning, type II (SD-2), Fed. Spec P-D-680
Tags
Plastic tiedown strap
Tape
Artillery and automotive grease, type GAA, MIL-G-10924
Lubricating oil, ICE, OE /HDO 10, MIL-L-2104
Housing side cover gasket
Cup, ball, and ring kit
Jacket-to-housing shim kit

PERSONNEL : One

EQUIPMENT CONDITION : Truck parked, engine off, handbrake set.

a. Preliminary Procedures.

- (1) Remove pitman arm. Refer to TM 9-2320-209-20.
- (2) Remove steering wheel. Refer to TM 9-2320-209-20.
- (3) Remove air cleaner indicator. Refer to TM 9-2320-209-20.
- (4) Open hood. Refer to TM 9-2320-209-10.
- (5) Disconnect battery ground. Refer to TM 9-2320-209-20.
- (6) Remove radiator and fan. Refer to TM 9-2320-209-20.
- (7) Remove turn signal control. Refer to TM 9-2320-209-20.
- (8) Remove engine rear lifting bracket. Refer to TM 9-2815-210-34.
- (9) Remove throttle control and linkage. Refer to TM 9-2320-209-20.

b. Removal.

FRAME 1

NOTE

If band (1) is plastic, do step 1. If band is brass, do step 2.

1. Cut band (1) and throw it away.
2. Bend tab and take off band (1).

GO TO FRAME 2

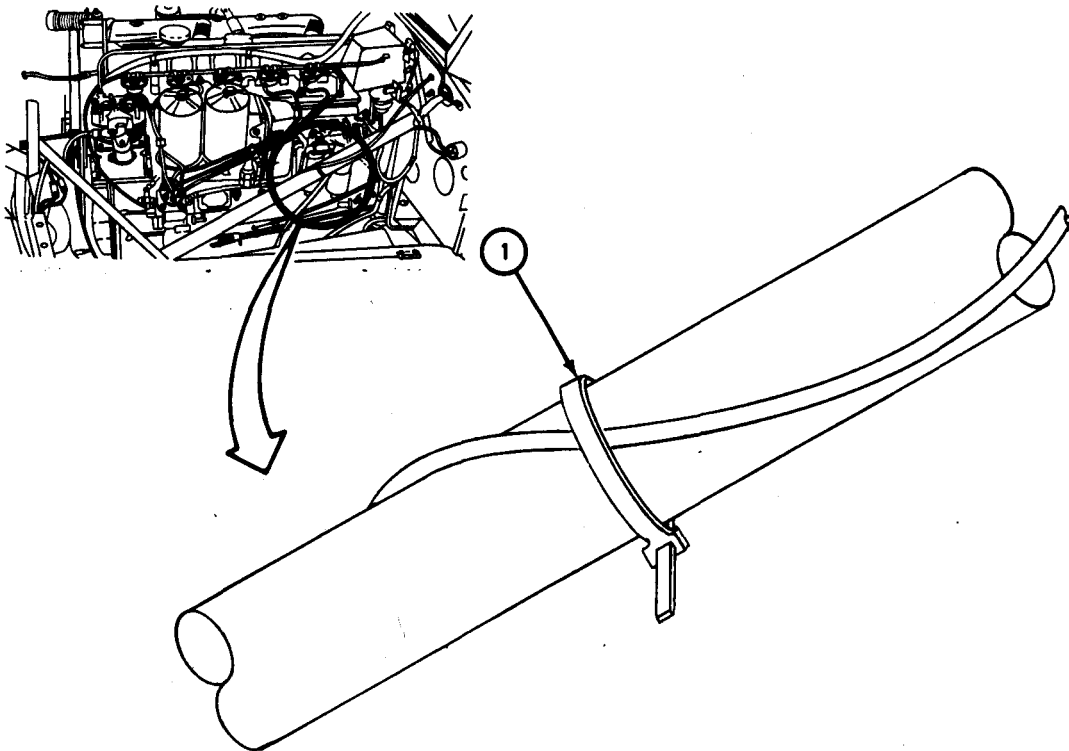

TA 085140

FRAME 2

1. Pull electric horn plug (1) out of connector (2).
- GO TO FRAME 3

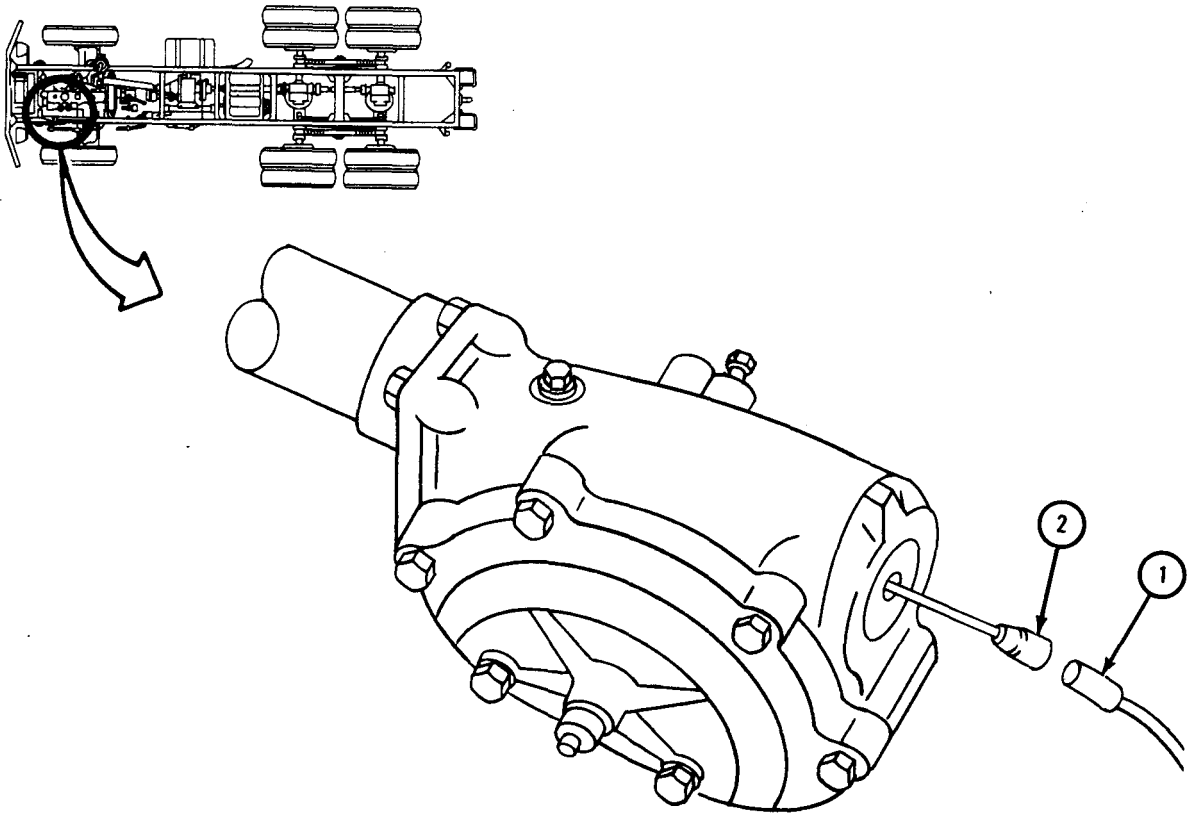

TA 085141

FRAME 3

1. Put hoist on front engine lifting eye (1) and take up any slack.
- GO TO FRAME 4**

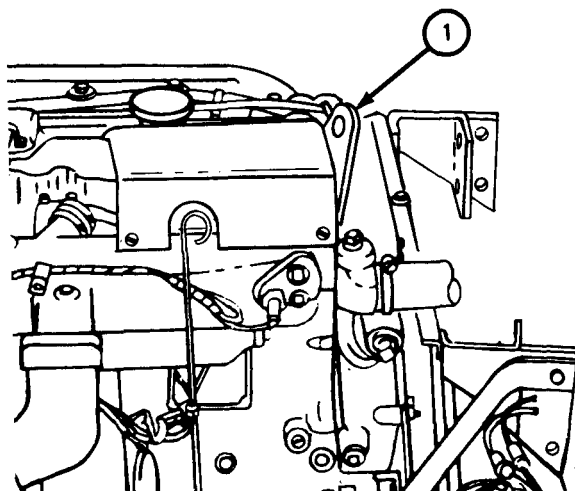

TA 085142

FRAME 4

1. Take off two nuts with flat washers (1).
2. Take out two capscrews with flat washers (2).

GO TO FRAME 5

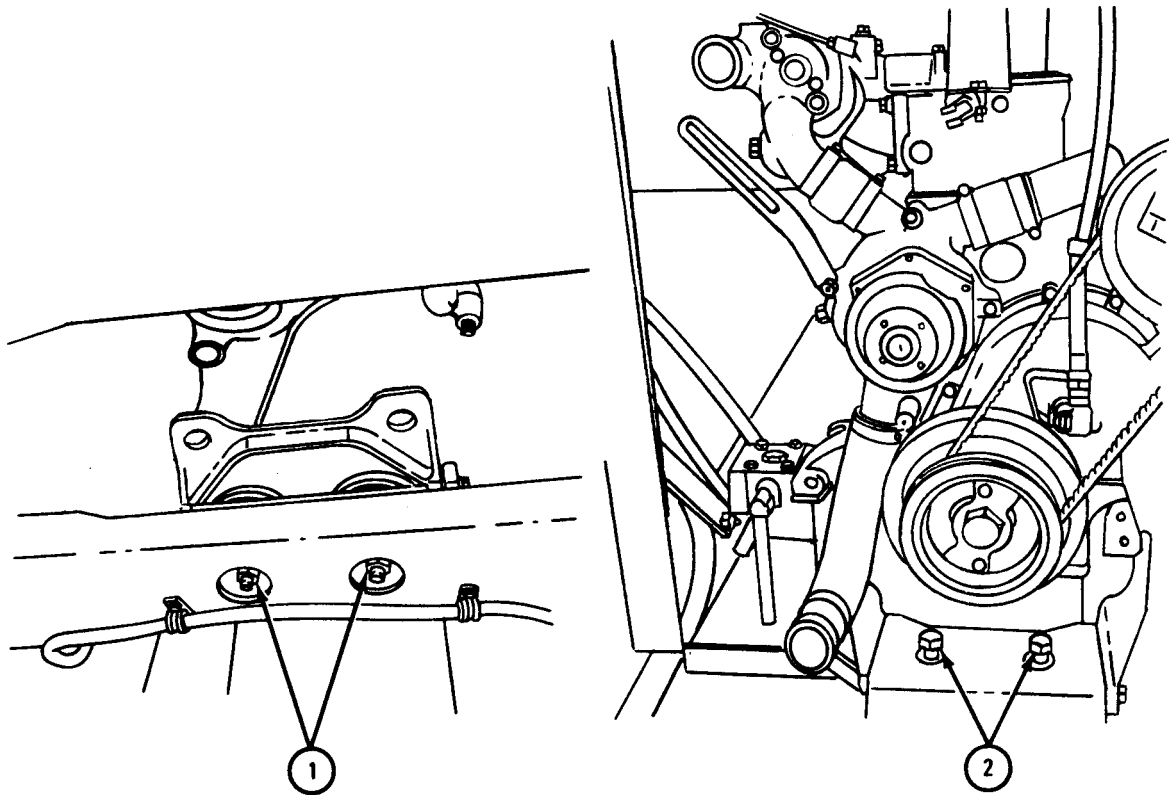

TA 085143

FRAME 5

1. Take off primary fuel filter inlet line (1) and outlet line (2).
2. Take off two nuts and lockwashers (3), and capscrews (4).
3. Take out primary fuel filter (5).

GO TO FRAME 6

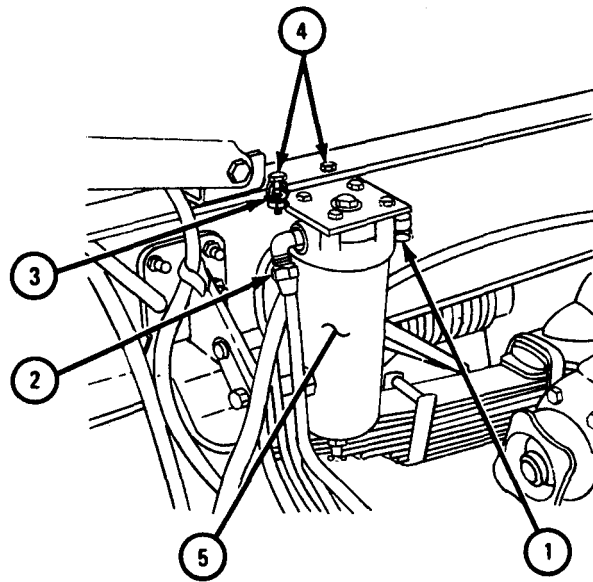
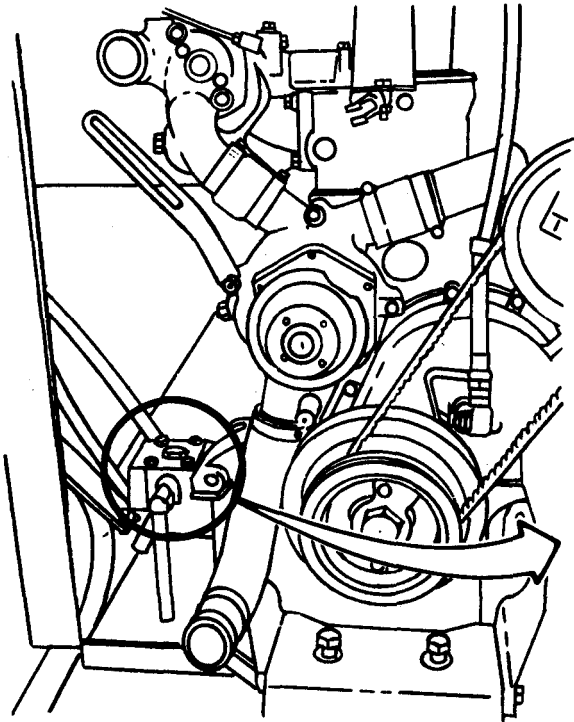

TA 085102

FRAME 6

1. Take out screw (1), two insulators (2), and nut (3).
2. Loosen screw (1) on other side of engine.

GO TO FRAME 7

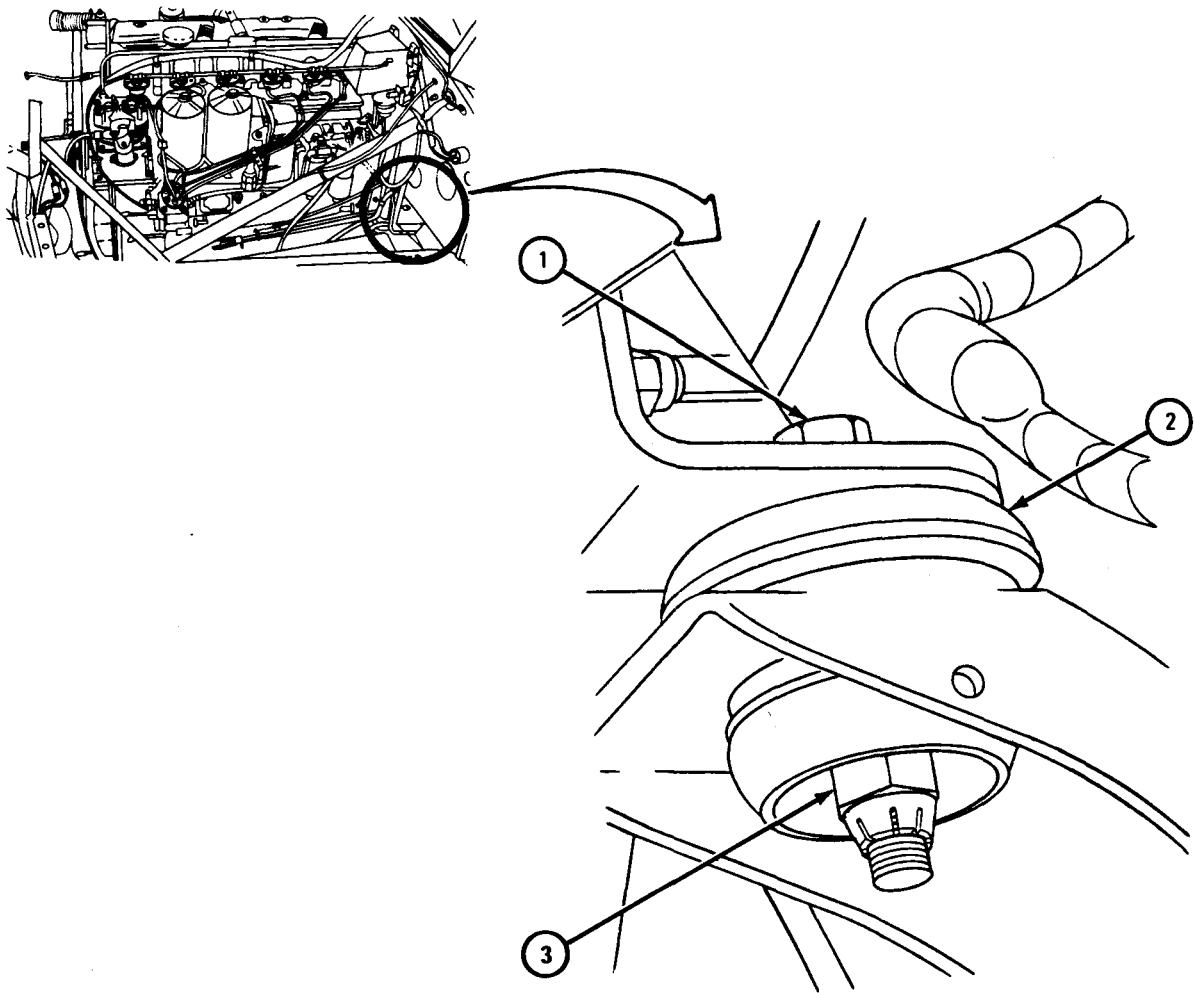

TA 085144

FRAME 7

1. Take out screw (1) and bushing (2).
2. Take out four screws (3) and washers (4).
3. Take off pad (5).

GO TO FRAME 8

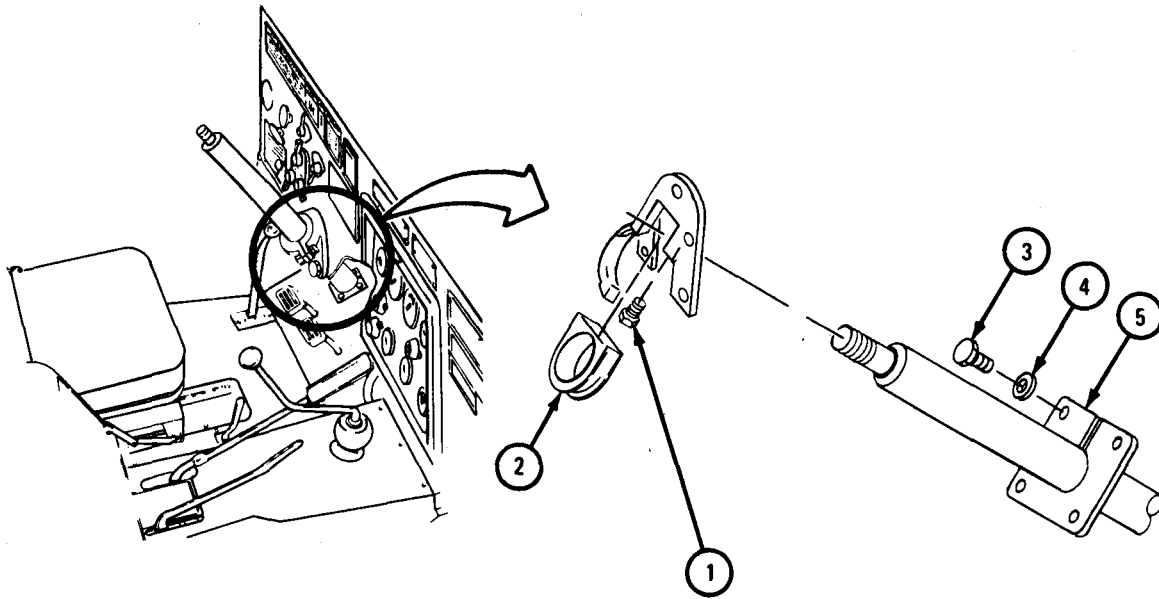

TA 085145

FRAME 8

1. Take off exhaust pipe (1) at engine (2) and take off intake hose (3) at air cleaner (4).

2. Move engine (2) to the right.

GO TO FRAME 9

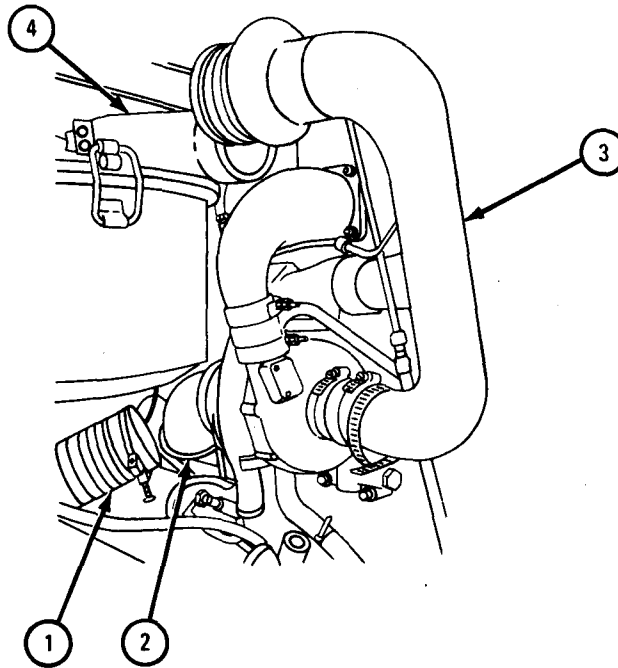

TA 085146

FRAME 9

1. Take out four screws (1) and take off two straps (2).
2. Take out steering column (3) and gearbox (4).

END OF TASK

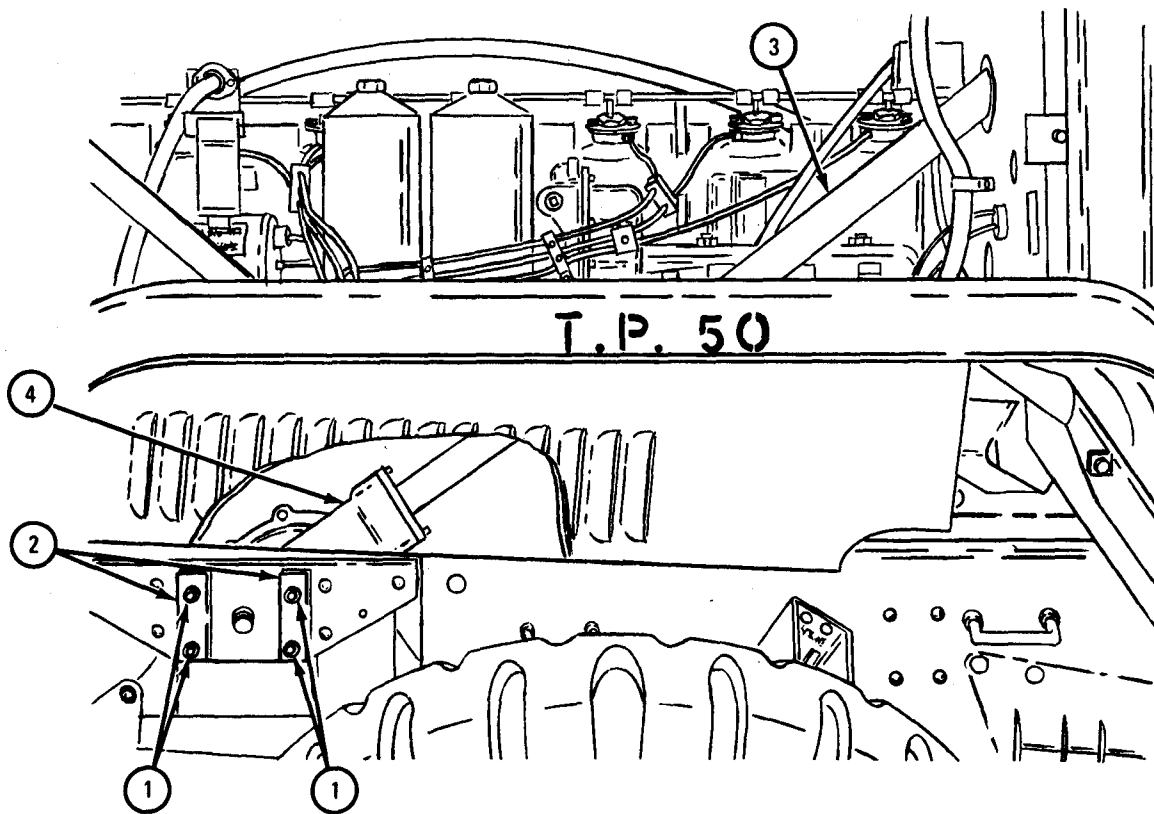

TA 085147

c. Disassembly.

FRAME 1

1. Take out plug (1).
2. Loosen six screws with washers (2) three turns and drain oil into container.
3. Loosen locknut (3) and adjusting screw (4) three turns each.
4. Take out six screws with washers (2).
5. Take off cover (5) and gasket (6). Throw away gasket.
6. Take off locknut (3) and adjusting screw (4).

GO TO FRAME 2

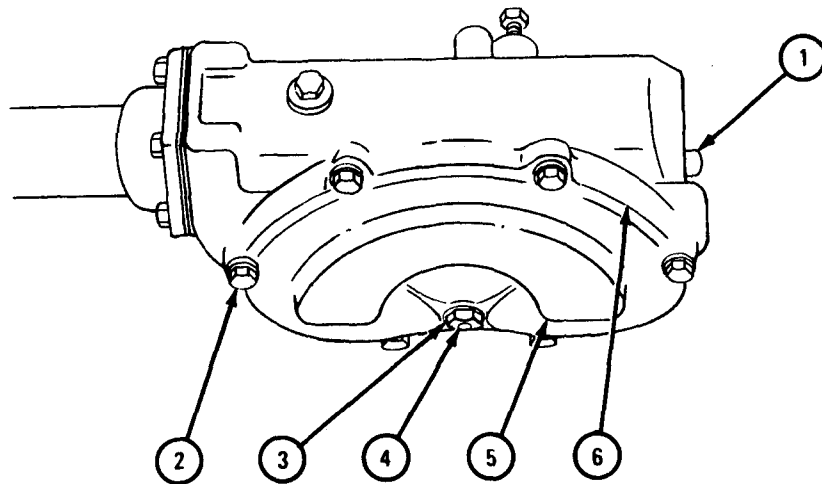

TA 085148

FRAME 2

1. Take off paint, rust, and burrs from external end of pitman arm shaft (1).
 2. Pull pitman arm shaft (1) out of housing (2).
- GO TO FRAME 3

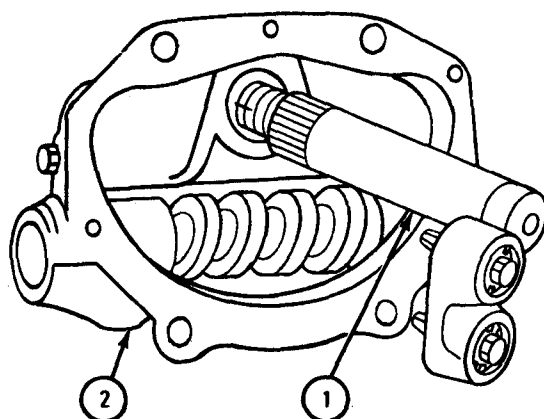

TA 085149

FRAME 3

1. Using torque wrench, check that preload of two stud locknuts (1) is 3.0 to 3.5 pound-inches.

NOTE

If preload cannot be set within limits, given do steps 2, 3, and 4. If preload is within limits given, go to frame 4.

2. Bend down locking tangs (2) and take off two locknuts (1) and locking tangs.
3. Take four bearings (3) and two studs (4) out of pitman arm shaft lever (5). Throw away bearings and studs and get new ones in their place.
4. If cups (6) are worn or scratched, using hammer and brass rod, drive out cups. Get new ones in their place.

GO TO FRAME 4

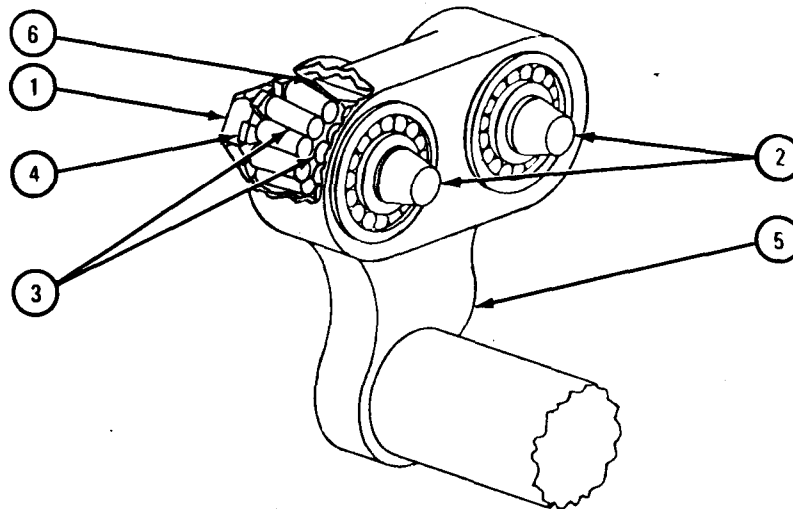

TA 085150

FRAME 4

1. Take out four screws (1), jacket (2), and upper cover (3).
 2. Take out and tag shims (4) so that they are put back in the same place.
- GO TO FRAME 5

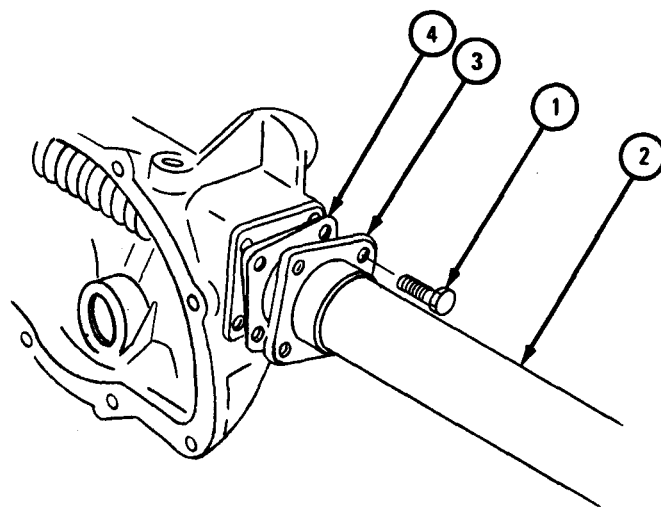

TA 085152

FRAME 5

1. Check that jacket bearing (1) is not damaged. If jacket bearing (1) is damaged, put long bar in lower end of jacket (2) and drive out bearing (1).

GO TO FRAME 6

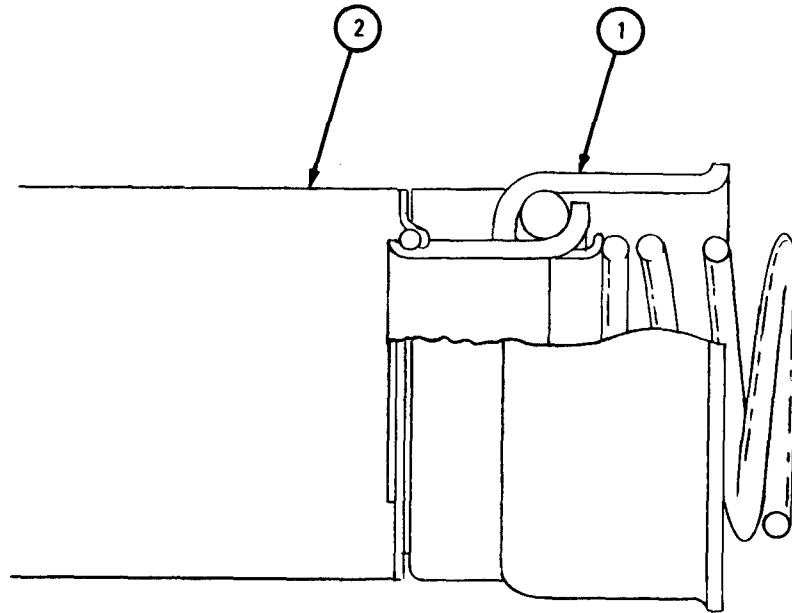

TA 085153

FRAME 6

CAUTION

Do not jam cam (1) against housing (2) or housing may be damaged.

1. Clamp housing (2) in vise with shaft (3) sticking up.
2. Pull shaft (3) from housing (2).

GO TO FRAME 7

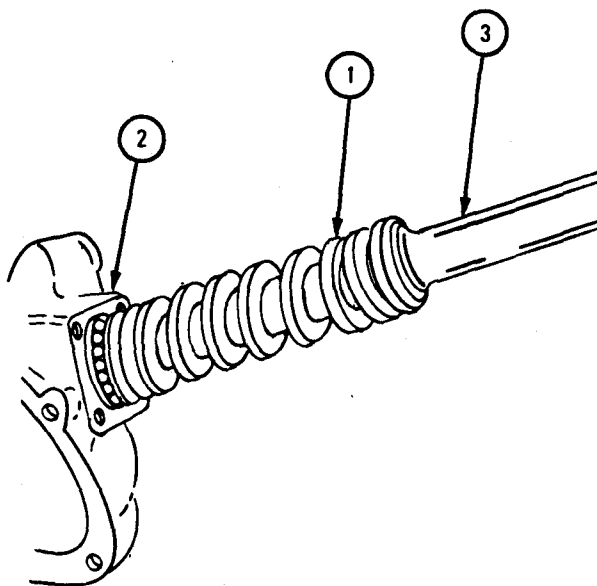

TA 085154

FRAME 7

1. Take bearing cup (1) off each end of cam (2).
2. Take bearing (3) off each end of cam (2).

GO TO FRAME 8

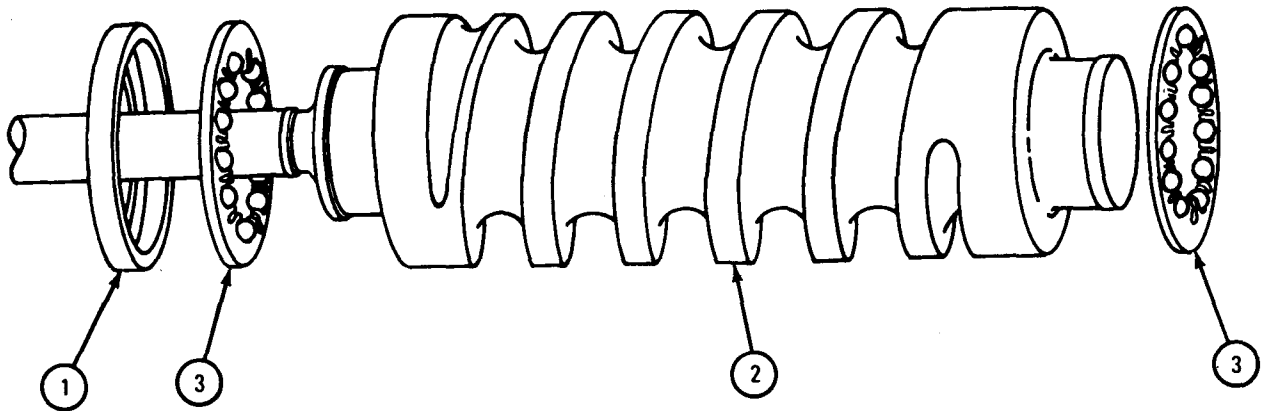

TA 085155

FRAME 8

1. Pry out oil seal (1).

NOTE

Do not take out two bushings (2) unless they are worn or damaged. Refer to para 14-3e for inspection procedures.

2. Using bushing remover/replacer, press out bushings (2) from housing (3).

GO TO FRAME 9

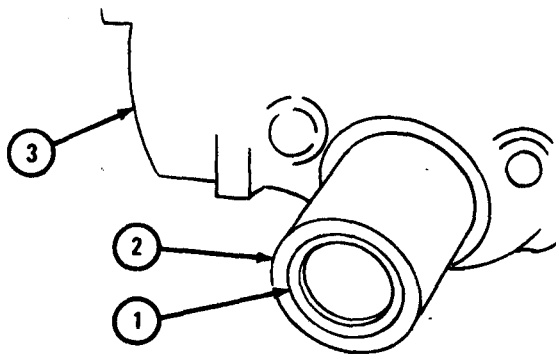

TA 085156

FRAME 9

1. Check that end cover (1) has no oil leaks. If it has no oil leaks, END OF TASK. If it is leaking oil, do step 2.
2. Drive end cover (1) out of housing (2).

END OF TASK

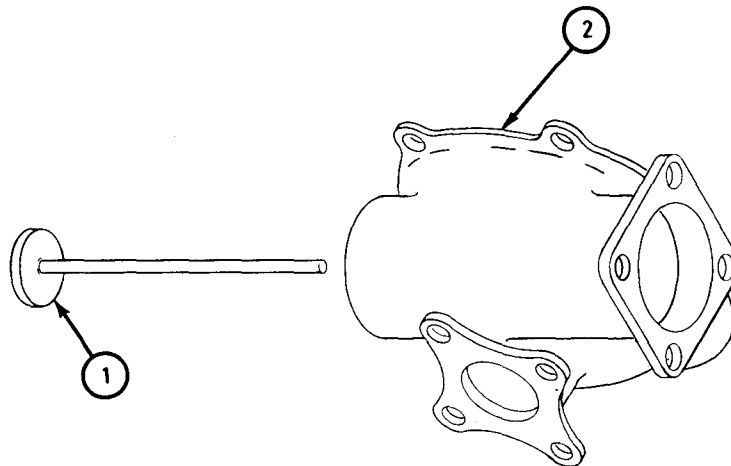

TA 085157

d. Cleaning. There are no special cleaning procedures needed. Refer to cleaning procedures given in para 1-3.

e. Inspection and Repair.

FRAME 1

NOTE

Wearing away of copper plating by studs in cam groove (1) is normal.

1. Check that cam groove (1) has no scratches, cracks or other damaged. If cam groove is damaged, throw out shaft (2) with cam (1) and get new ones in their place.
2. Check that cam thrust bearing race (3) has no scratches or other damage. If bearing race is damaged, throw out shaft (2) with cam (1) and get new ones in their place.

GO TO FRAME 2

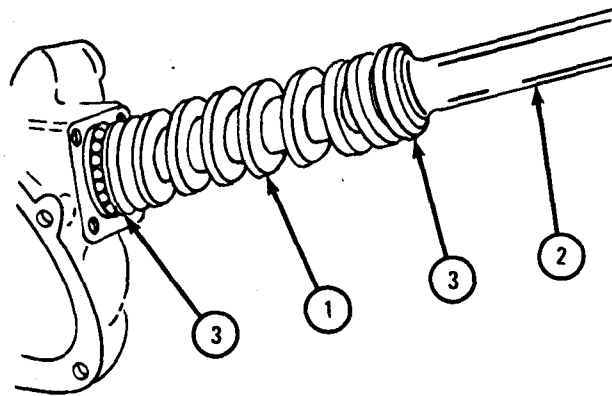

TA 085158

FRAME 2

1. Check that screws and nuts have no damaged threads. If threads are damaged, get new ones in their place.
2. Using magnifying glass, check that shaft (1) has no cracks, breaks or other damage. If shaft is damaged, get a new one.

GO TO FRAME 3

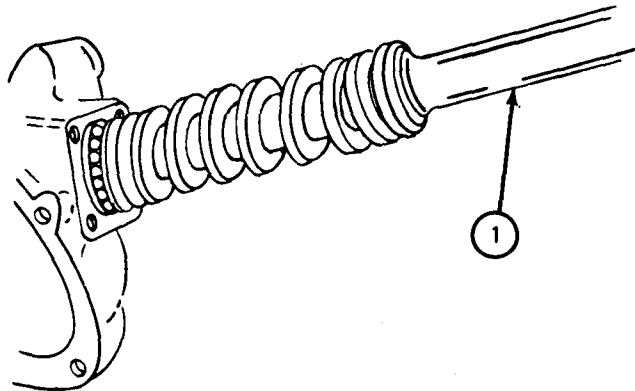

TA 085159

FRAME 3

1. Check that two ball bearings (1) have no flat spots or other damage. If ball bearings are damaged, get new ones.
2. Check that bearing cups (2) have no cracks, dents or other damage. If bearing cups are damaged, get new ones.

GO TO FRAME 4

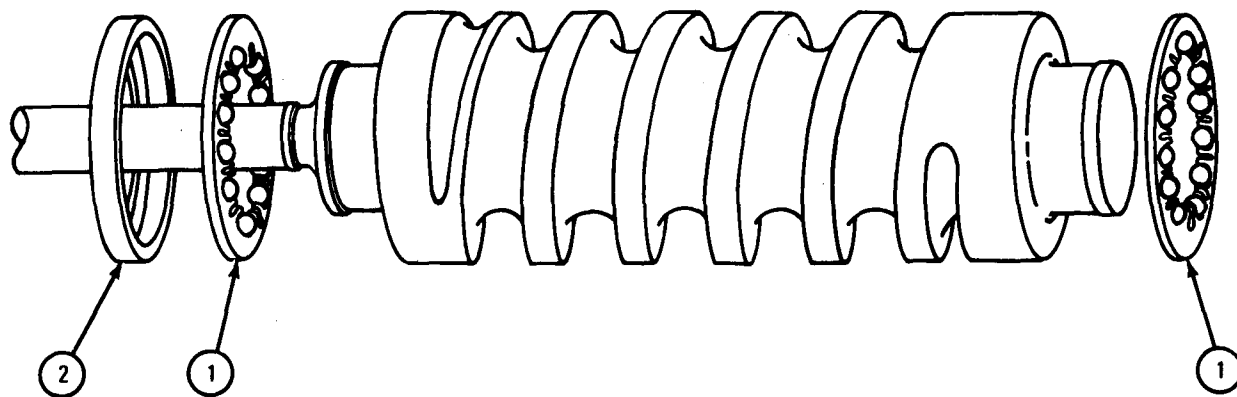

TA085160

FRAME 4

1. Check that studs (1) have no nicks, cracks or flat spots. If studs are damaged, get new ones.
2. Check that bearing cups (2) have no scratches, cracks or other damage. If bearing cups are damaged, get new ones.
3. Check that pitman arm shaft (3) has no twists, cracks or other damage. If shaft is damaged, get a new one.

GO TO FRAME 5

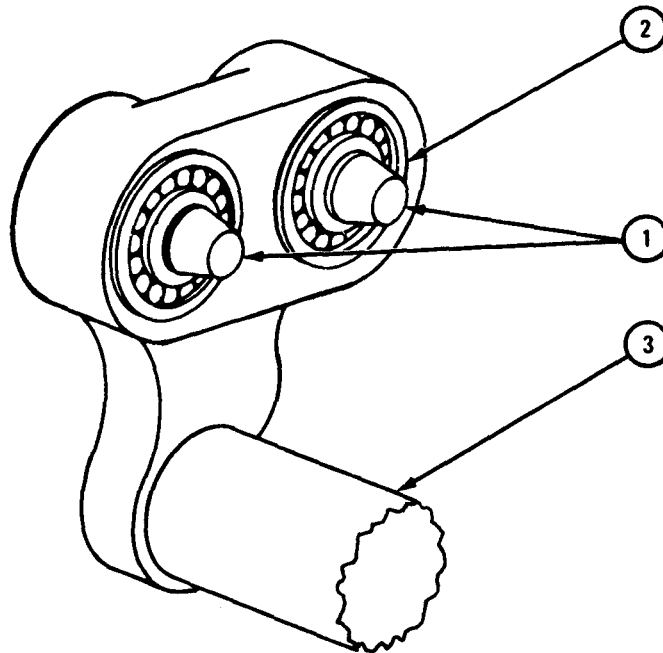

TA 085161

FRAME 5

NOTE

Readings must be within limits given in table 14-1. The letter L indicates a loose fit and the letter T indicates a tight fit. If readings are not within given limits, throw away part and get a new one.

1. Measure outside diameter of pitman arm shaft (1).
2. Measure length and outside and inside diameters of inner bearing (2).
3. Measure length and outside and inside diameters of outer bearing (3).

NOTE

If bearings (2 and 3) are within given limits but fit in housing (4) is not, get a new housing.

4. Measure fit of inner bearing (2) and outer bearing (3) in bore of housing (4).
5. Measure fit of pitman arm shaft (1) in bearings (2 and 3).

GO TO FRAME 6

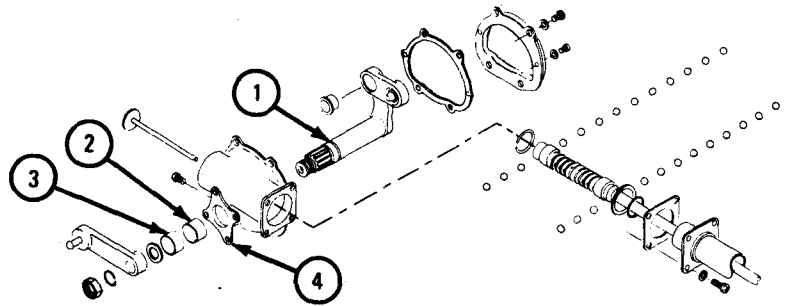

NOTE

CHECK ONLY THOSE PARTS WHICH ARE CALLED OUT. PARTS WITHOUT CALLOUTS ARE SHOWN FOR REFERENCE PURPOSES ONLY.

TA 085162

Table 14-1. Mechanical Steering Gear Wear Limits

Index Number	Item/Point of Measurement	Size and Fit of New Parts (inches)	Wear Limit (inches)
1	Pitman arm shaft diameter	1.373	None
2	Inner bearing length	1.500	None
2	Inner bearing outside diameter	1.503 to 1.501	1.500
2	Inner bearing inside diameter	1.3735 to 1.3750	1.376
3	Outer bearing length	1.500	None
3	Outer bearing outside diameter	1.503 to 1.501	1.500
3	Outer bearing inside diameter	1.3735 to 1.3750	1.376
2 and 4	Fit of bearing in housing bore	0.001L to 0.004T	None
3 and 4	Fit of bearing in housing bore	0.001L to 0.004T	None
1 and 2	Fit of shaft in bearings	0.005L to 0.002L	0.003
1 and 3	Fit of shaft in bearings	0.005L to 0.002L	0.003

FRAME 6

1. Check that housing (1) has no signs of strain or stress at mounting flange (2). Weld small cracks. Refer to TM 9-237. If more repair is needed, get a new housing.
2. Check that all machined surfaces have no burrs, nicks, cuts or holes. Take off small burrs, nicks or cuts with crocus cloth. If more repair is needed, get new parts.
3. Check that bearing cup bore (3) is not worn. If bore is damaged, get a new housing.

END OF TASK

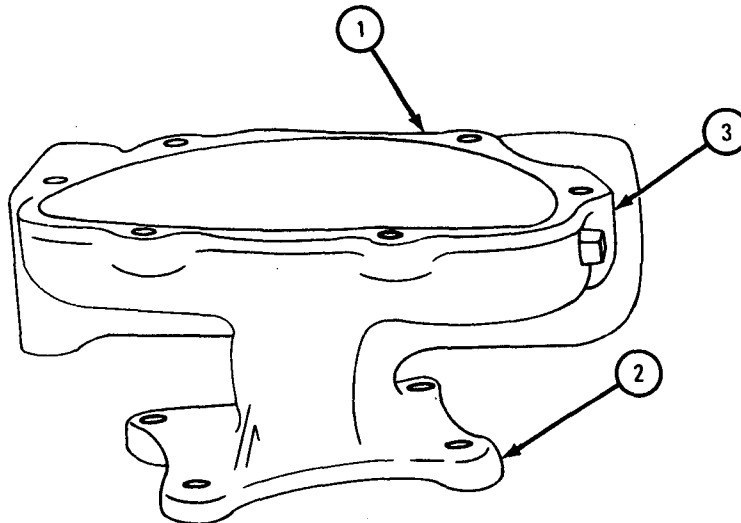

TA 085163

f. Assembly.

FRAME 1

1. Press inner bushing (1) into housing (2) until it is flush.
 2. Press outer bearing (3) into housing (2) from other side until it is flush.
- GO TO FRAME 2

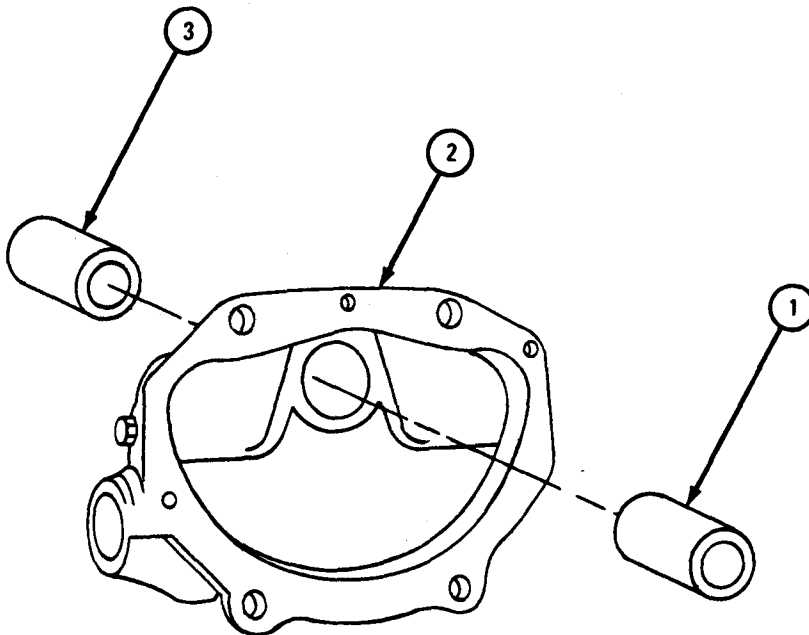

TA 085164

FRAME 2

1. Ream and burnish bushings (1) to 1.3735 to 1.375 inches.

GO TO FRAME 3

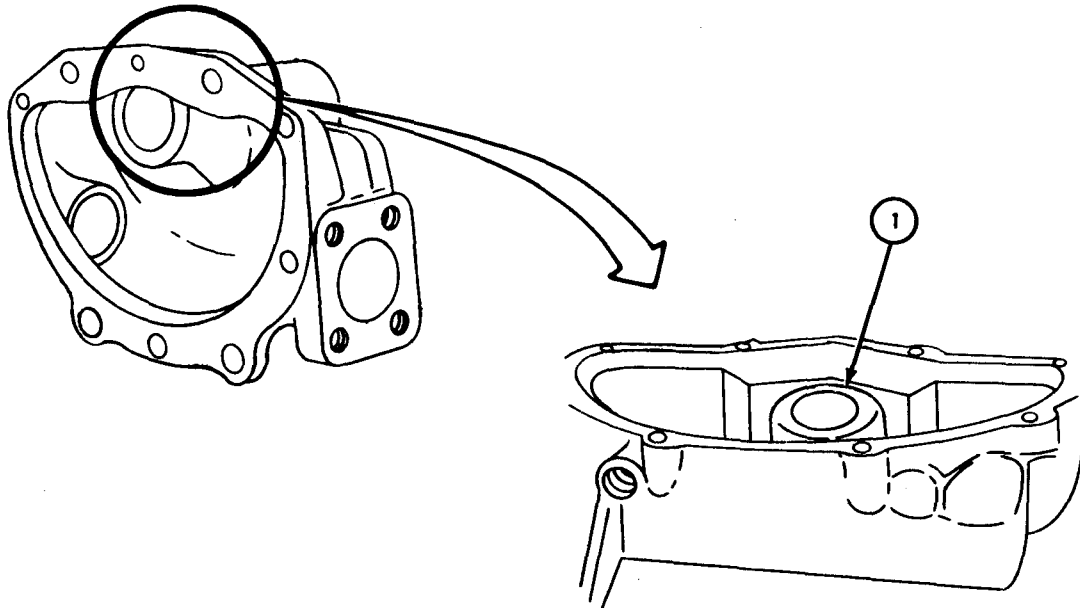

TA 085165

FRAME 3

1. Put bearing (1) on shaft gear (2).
 2. Put bearing (3) and bearing cup (4) on other end of shaft gear (2).
- GO TO FRAME 4

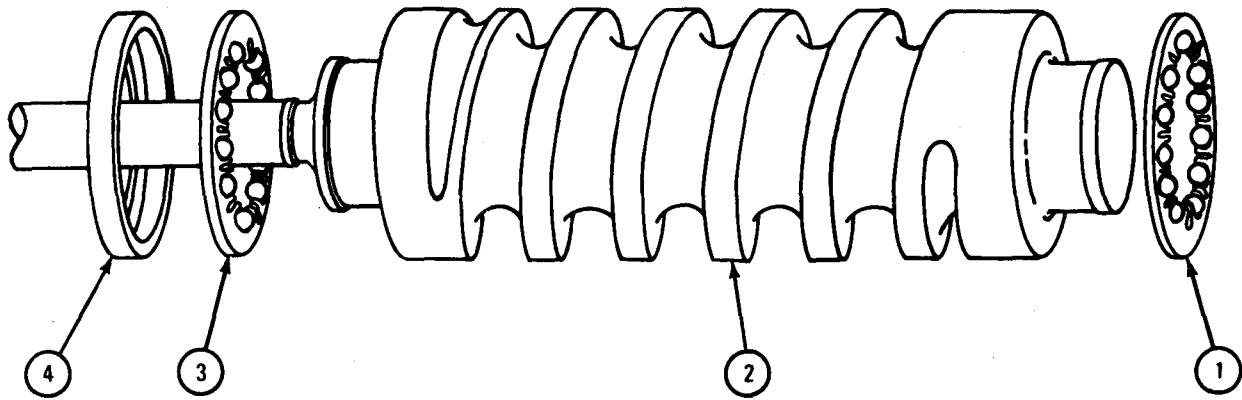

TA085166

FRAME 4

CAUTION

Do not hit cam (1) against housing (2) or it may damage housing.

1. Put housing (2) in vise and put cam (1) into housing.
2. Check that bearing cups (3) are seated in housing (1).

GO TO FRAME 5

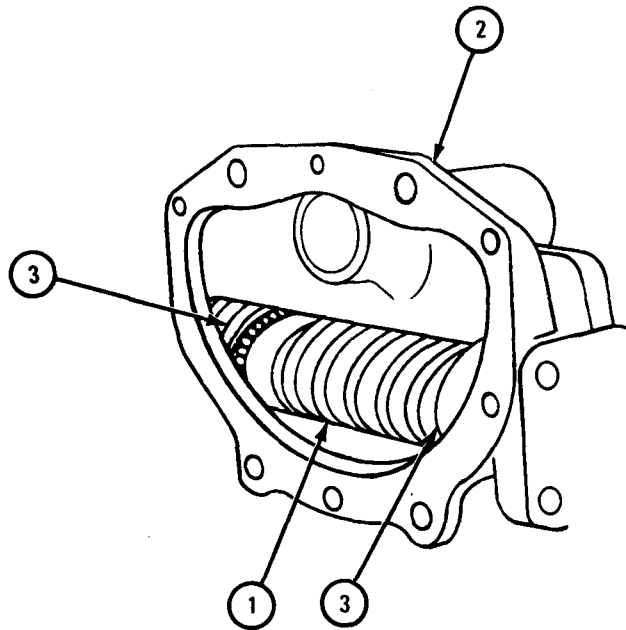

TA 085167

FRAME 5

CAUTION

Shims (1) must be at least 0.015 inch thick or cam thrust bearings will be damaged.

1. With housing (2) in vise, put on shims (1) as noted, cover (3), and jacket (4).
2. Put in four screws (5).

GO TO FRAME 6

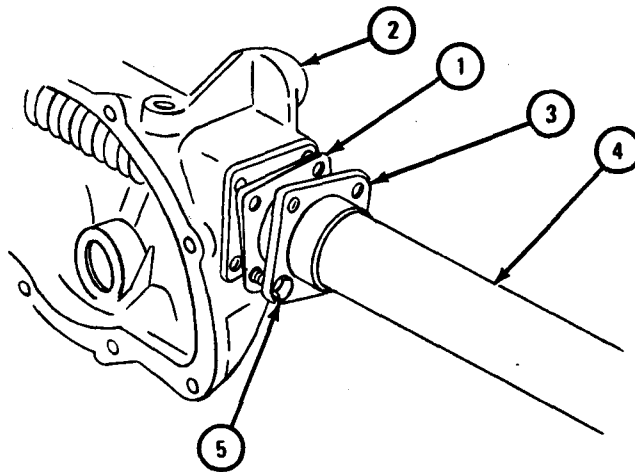

TA 085168

FRAME 6

1. Using torque wrench, check that cam thrust bearing preload is 3.0 to 3.5 pounds-inches by turning shaft (1).
2. If preload is not within given limits, add or take out a shim (2).
3. Do steps 1 and 2 until preload is within given limits.

GO TO FRAME 7

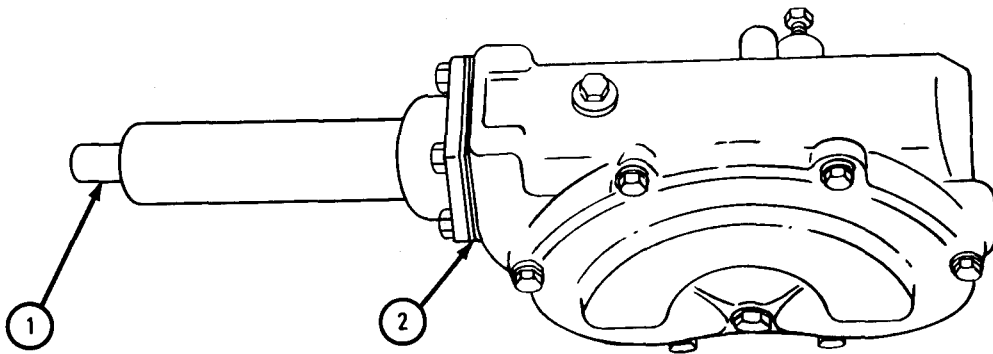

TA 085169

FRAME 7

1. Put in seal (1).
2. If jacket bearing (2) was taken out, press in a new one.
3. Put in spring seat (3) and spring (4).

GO TO FRAME 8

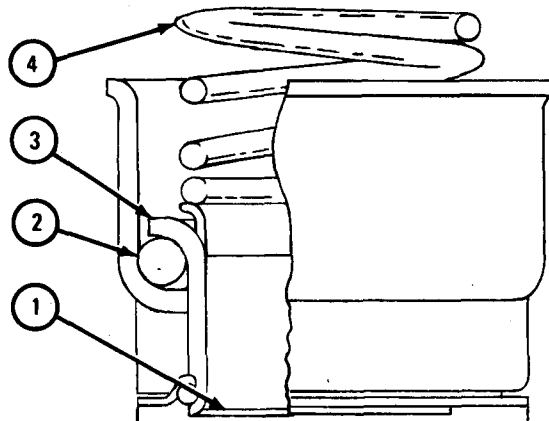

TA 085170

FRAME 8

1. Put a light coat of lubricating oil on outside of two bearing cups (1) and press them into place.
2. Put a coat of grease on two studs (2).
3. Put rollers (3) on two studs (2).
4. Put two studs (2) with rollers (3) in two bearing cups (1).
5. Put on two tang washers (4) and locknuts (5).
6. Tighten nuts (5) to 3.0 to 3.5 pound-inches.

GO TO FRAME 9

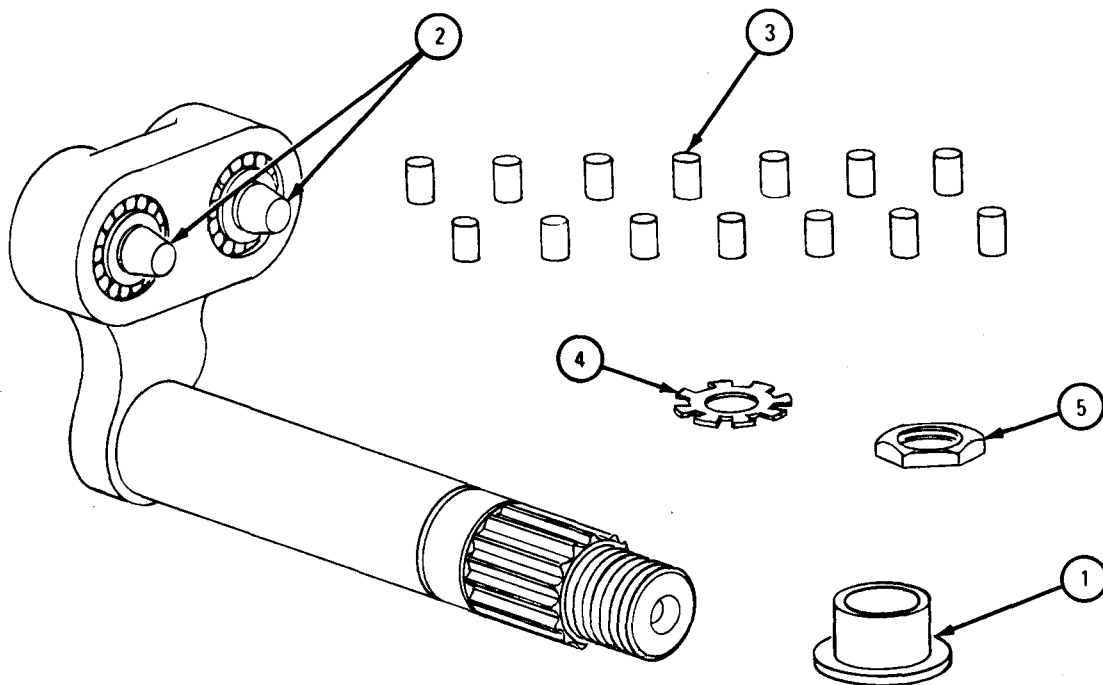

TA 085171

FRAME 9

1. Put oil seal (1) into housing (2).
2. Put pitman arm shaft (3) into housing (2), seating tapered studs (4) in cam grooves (5).

GO TO FRAME 10

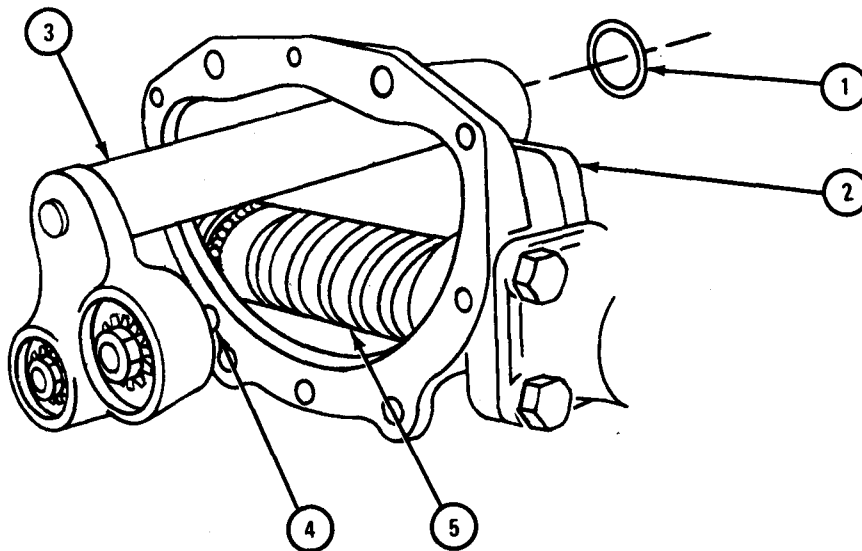

TA 085172

FRAME 10

1. Put on gasket (1) and side cover (2).
2. Put in six screws (3).
3. Put adjusting screw (4) and locknut (5) in side cover (2).
4. Loosen locknut (5) and tighten adjusting screw (4) to 7 to 12 pound-inches.
5. Hold adjusting screw (4) and tighten locknut (5).

GO TO FRAME 11

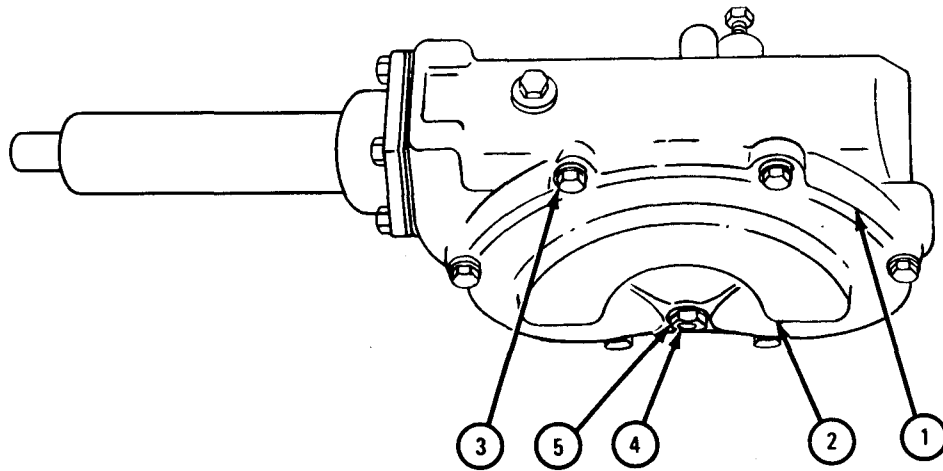

TA 085173

FRAME 11

1. Put housing (1) in vise.
2. If end cover (2) was taken out, put it back in housing (1).
3. Put plug (3) in housing (1).

END OF TASK

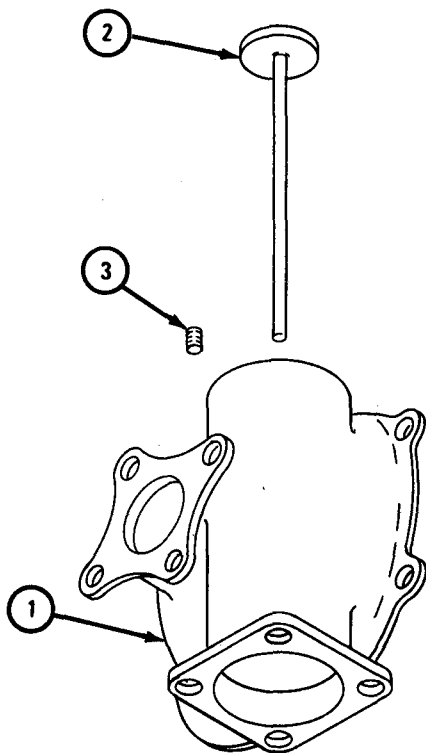

TA 085174

g. Replacement.

FRAME 1

1. Put steering column (1) through hole in panel (2) and put gearbox (3) into frame (4).
2. Aline holes in two straps (5) with holes in frame (4) and put in four screws (6).

GO TO FRAME 2

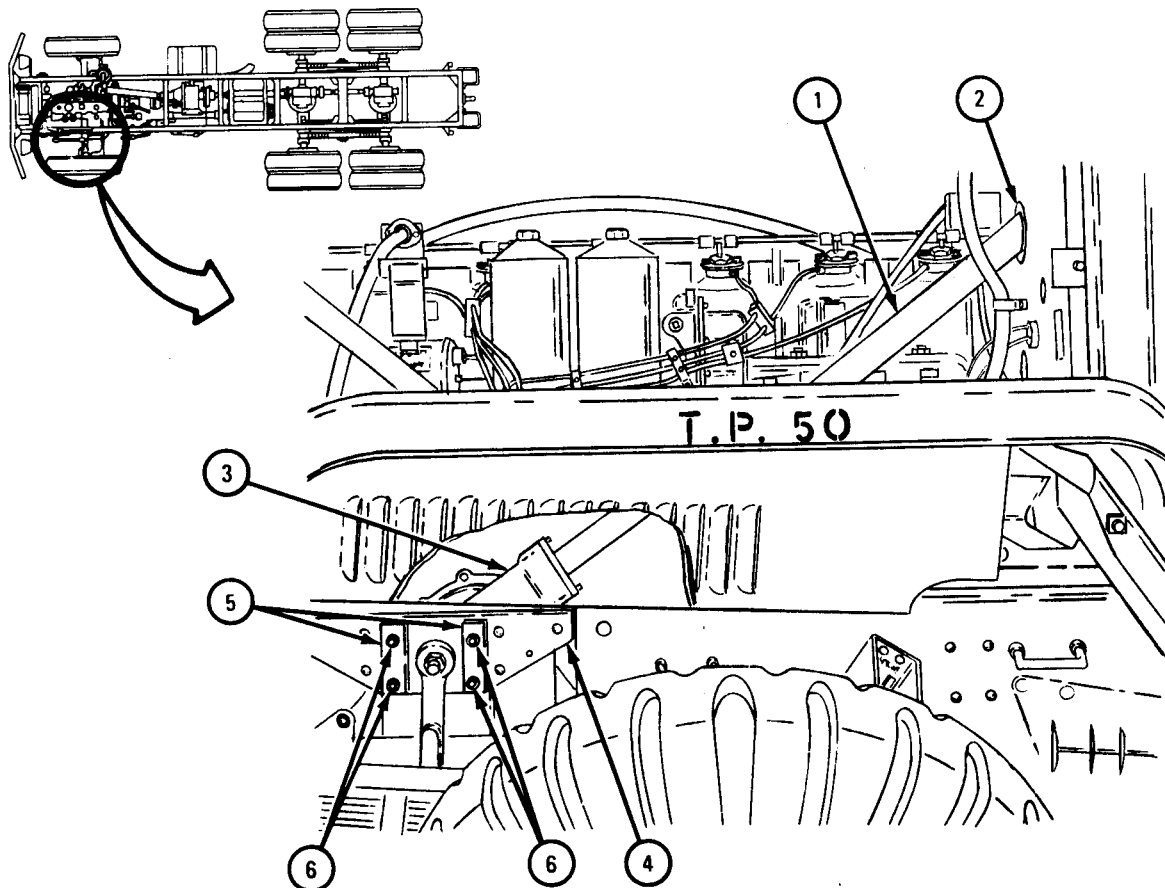

TA 085175

FRAME 2

1. Put pad (1) around steering column (2) and put in four screws (3) and washers (4).
2. Put on grommet (5).
3. Close bracket (6) and put in screw (7).

GO TO FRAME 3

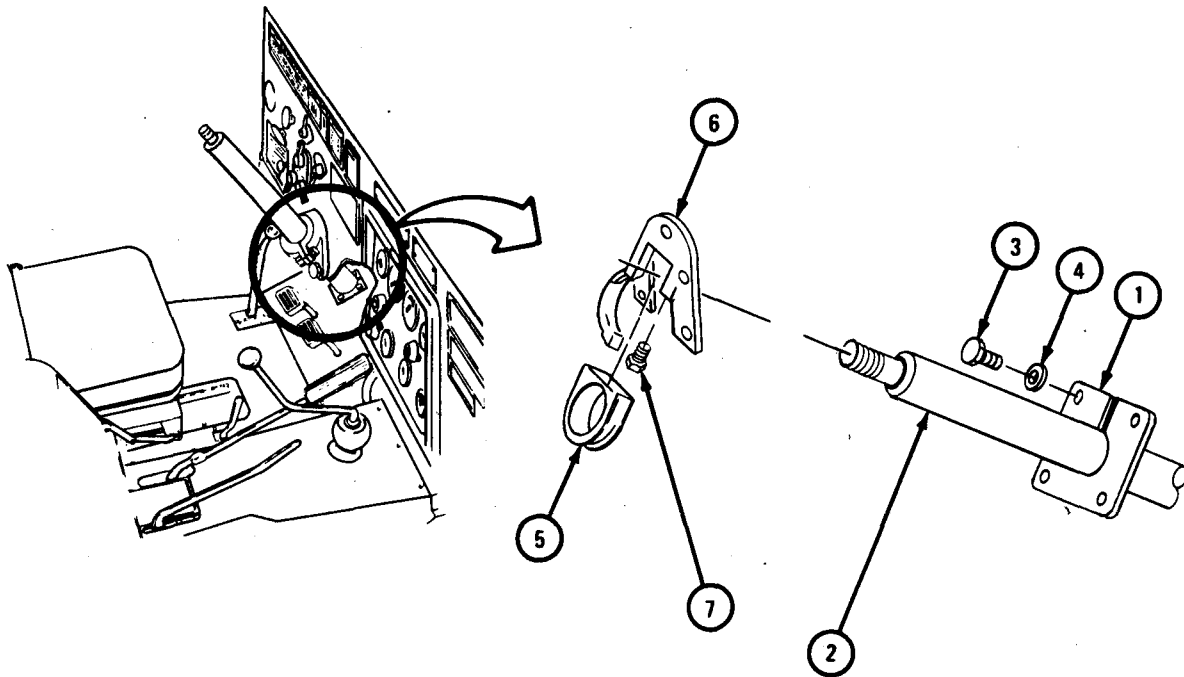

TA 085176

FRAME 3

1. Put primary fuel filter (1) on frame rail (2) and put in two capscrews (3).
2. Put on two lockwashers with nuts (4).
3. Put on primary fuel filter inlet line (5) and outlet line (6).

GO TO FRAME 4

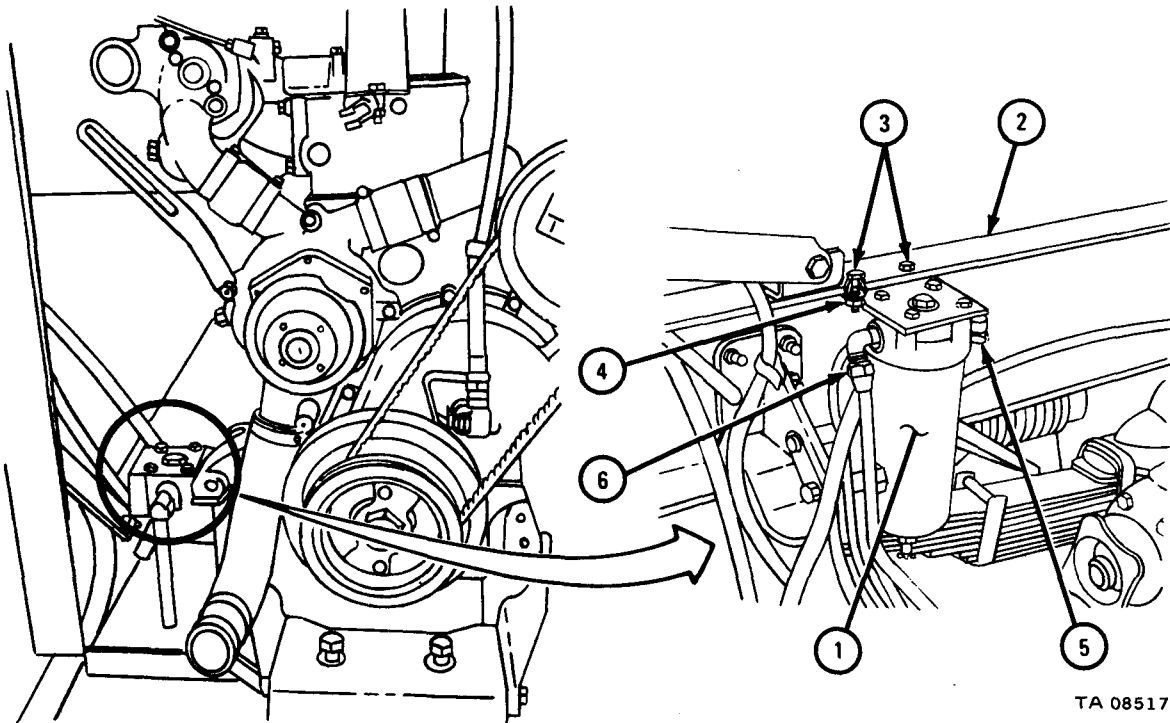

TA 085177

FRAME 4

1. Put on exhaust pipe (1) at engine (2) and put on intake hose (3) at air cleaner (4).

GO TO FRAME 5

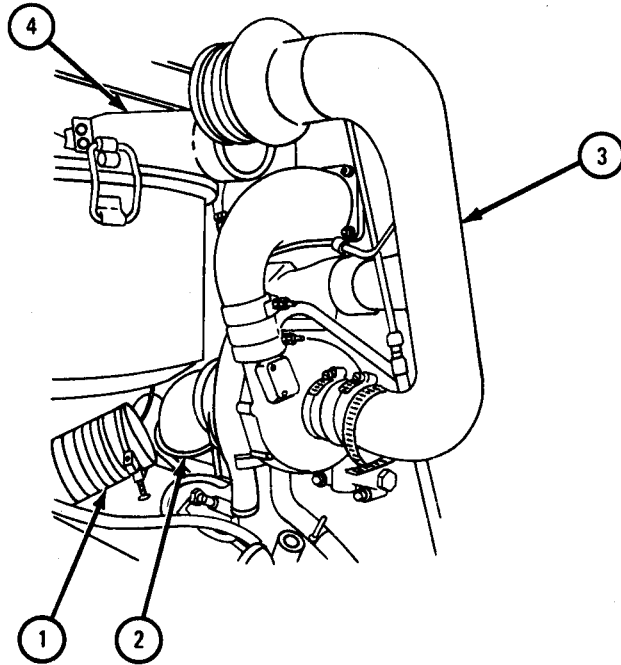

TA 085146

FRAME 5

1. Move engine (1) into place above engine mounts (2).
2. Lower engine (1) until it is about two inches above engine mounts (2).
3. Aline insulator (3) between rear engine mount (4) and engine mount (2) and put in bolt (5).
4. Put insulator (6) on bolt (5) and hand tighten nut (7).
5. Do steps 3 and 4 again for other engine mounting bolt (5).
6. Tighten two nuts (7).

GO TO FRAME 6

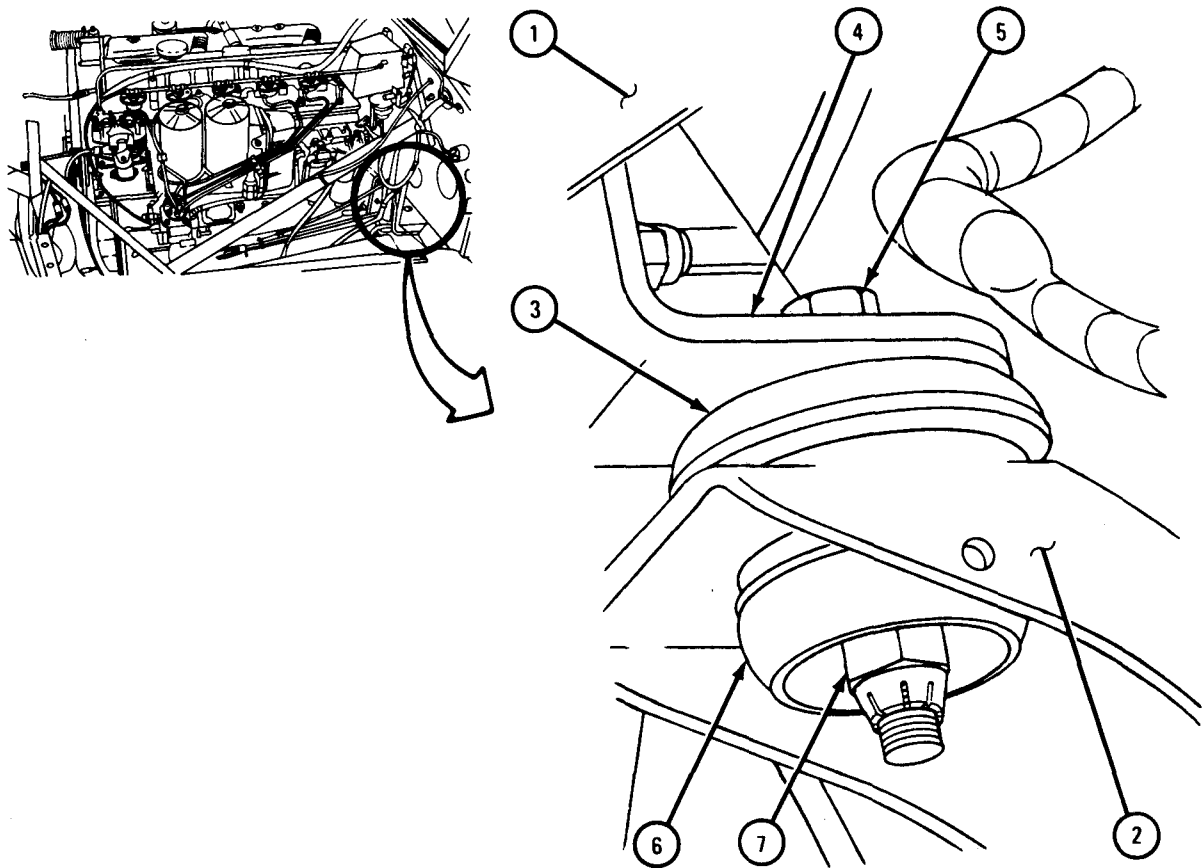

TA 085178

FRAME 6

1. Lower engine (1).
2. Put in two capscrews with flat washers (2).
3. Put on two nuts with flat washers (3).

GO TO FRAME 7

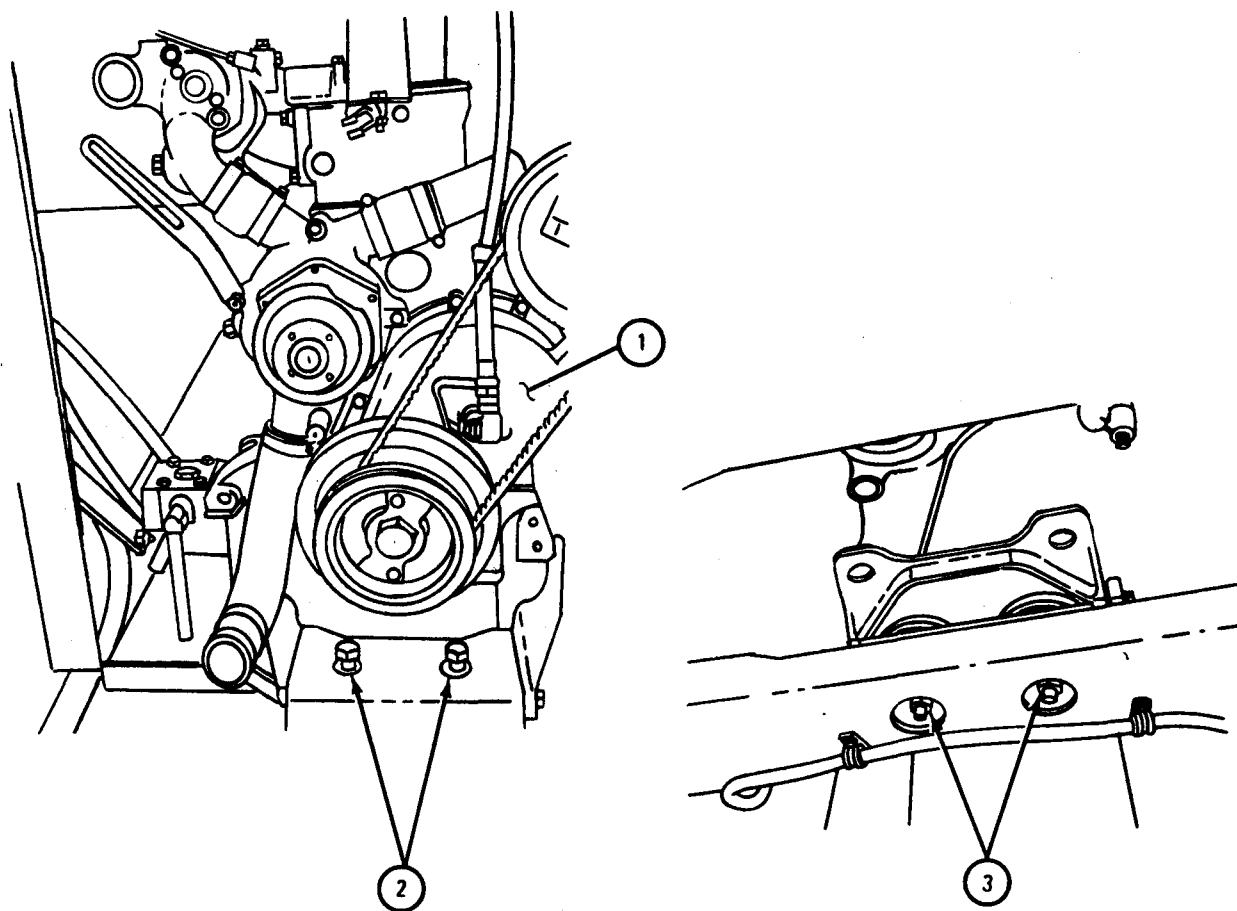

TA 085179

FRAME 7

1. Take hoist off front engine lifting eye (1).

GO TO FRAME 8

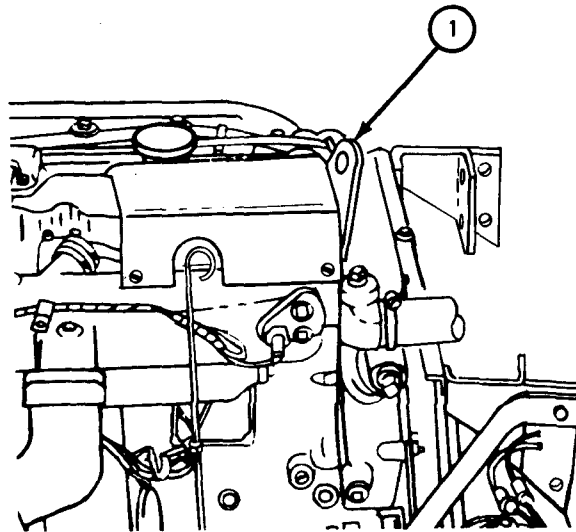

TA 085180

FRAME 8

1. Plug electric horn plug (1) to connector (2).
- GO TO FRAME 9

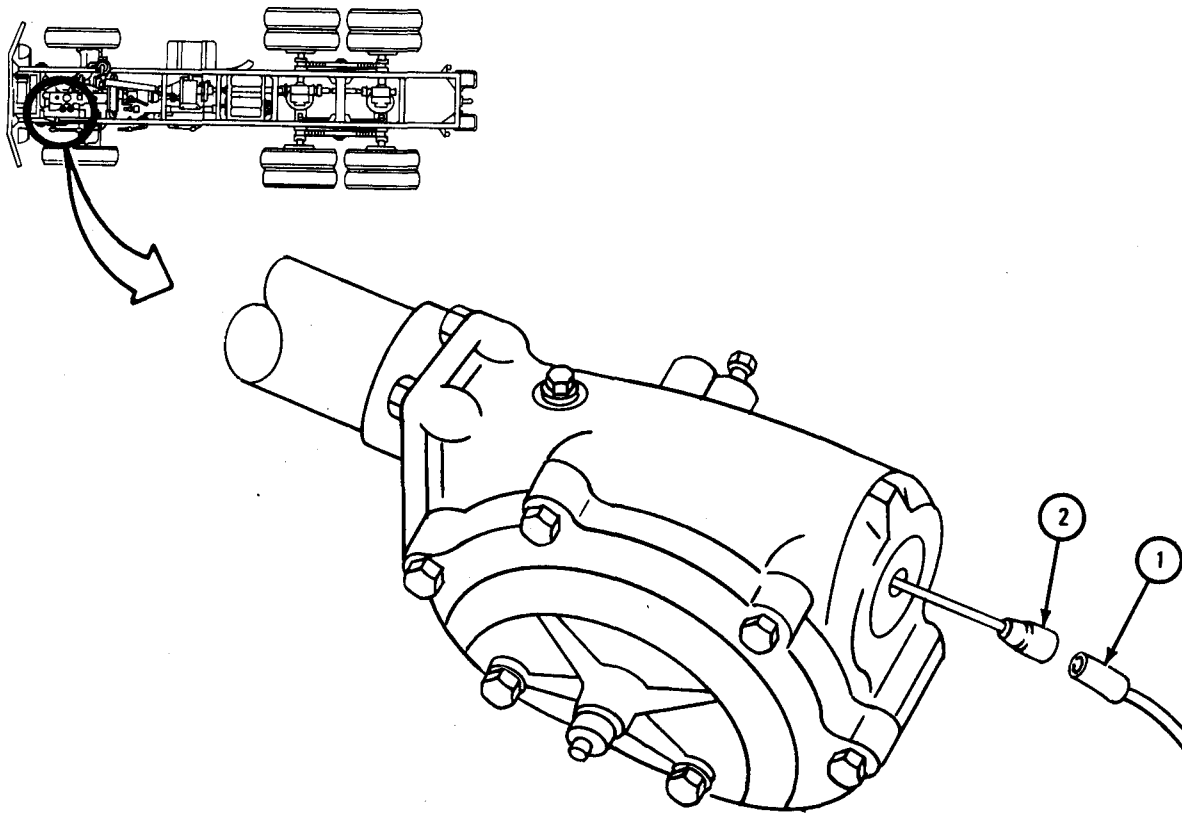

TA 085181

FRAME 9

1. Put on band (1).

NOTE

Follow-on Maintenance Action Required:

1. Replace throttle control and linkage. Refer to TM 9-2320-209-20.
2. Tighten all engine mounting bolts. Refer to TM 9-2320-209-20.
3. Replace rear engine lifting bracket. Refer to TM 9-2815-210-34.
4. Replace turn signal controls. Refer to TM 9-2320-209-20.
5. Replace pitman arm. Refer to TM 9-2320-209-20.
6. Replace steering wheel. Refer to TM 9-2320-209-20.
7. Replace radiator and fan. Refer to TM 9-2320-209-20.
8. Replace air cleaner indicator. Refer to TM 9-2320-209-20.
9. Reconnect battery ground. Refer to TM 9-2320-209-20.
10. Close hood. Refer to TM 9-2320-209-10.
11. Lubricate steering gear. Refer to LO 9-2320-209-12/1.

END OF TASK

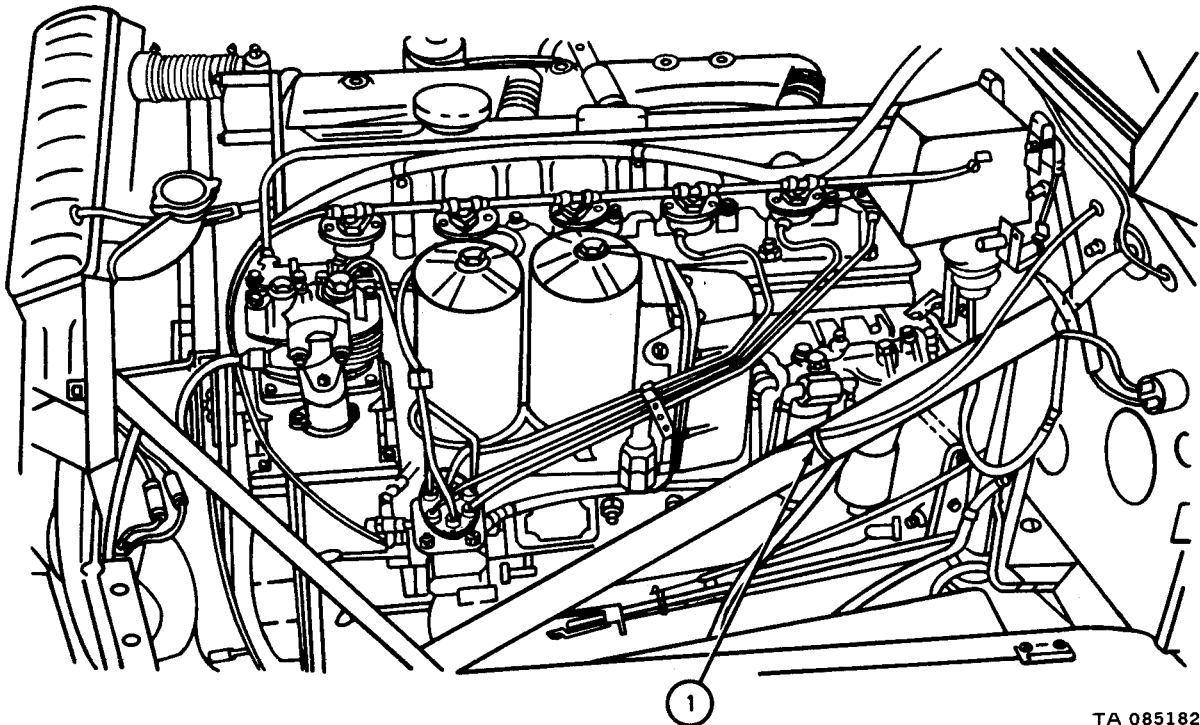

TA 085182

14-4. STEERING GEAR CHECK LEVEL PLUG INSTALLATION.

TOOLS: No special tools required

SUPPLIES: Steering gear housing gasket
Steering gear check level plug

PERSONNEL: One

EQUIPMENT CONDITION: Truck parked, engine off, handbrake set.

a. Preliminary Procedure. Drain steering gear housing. Refer to LO 9-2320-209-12/1.

b. Removal.

FRAME 1

1. Take out six screws (1) and flat washers (2).
2. Take off housing cover (3) and gasket (4). Throw away gasket.
3. Take housing cover (3) to machine shop to have check level plug hole drilled and tapped. Figure 14-1 gives dimensions for drilling.

END OF TASK

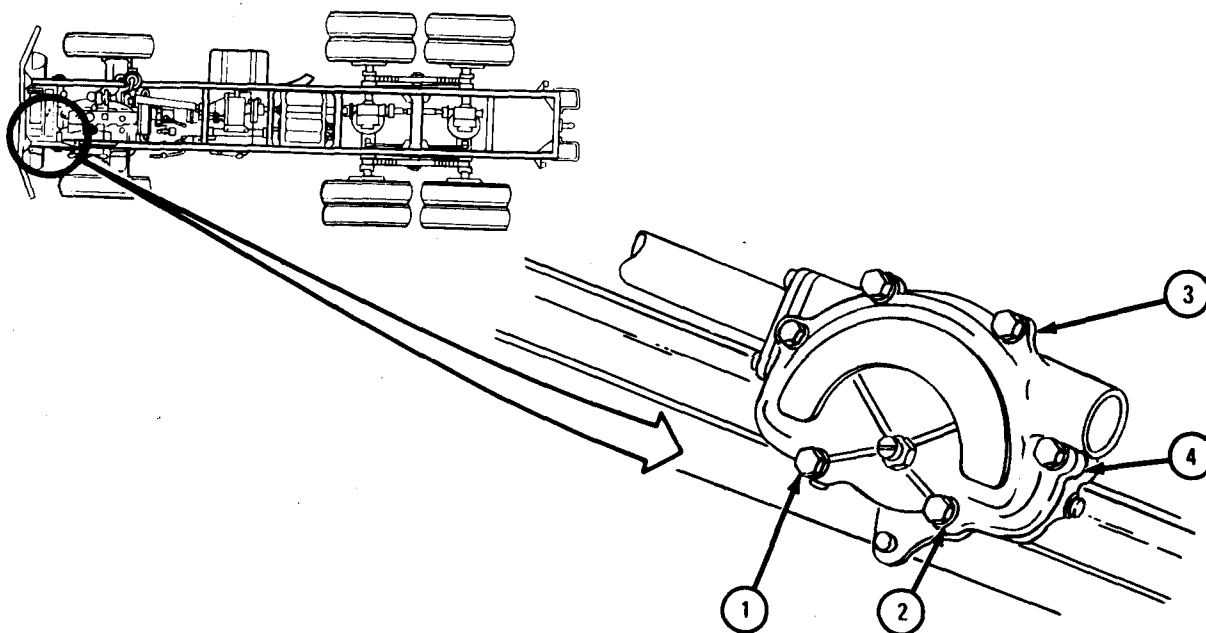

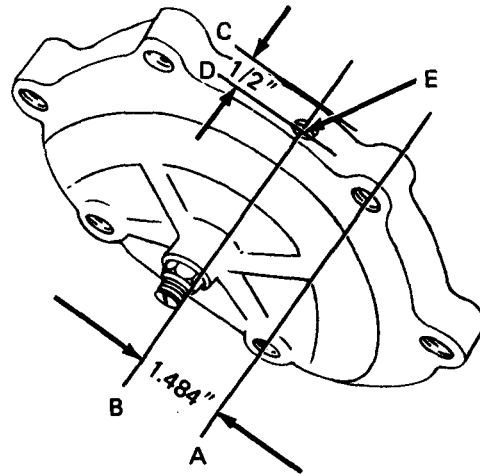

TA 102430

INDEX	Item/Point of Measurement	Measurement (inches)
A-B	Center of upper capscrew opening	1.484
C-D	Mounting edge of housing cover	0.500
E	1/8-27 NPT	None

Figure 14-1. Dimensions for Steering Gear Check Level Plug

c. Replacement.

FRAME 1

1. Put gasket (1) and housing (2) in place and align screw holes.
2. Put in six screws (3) and flat washers (4).
3. Put in check level plug (5).

NOTE

Follow-on Maintenance Action Required:

1. Fill steering gear housing. Refer to LO 9-2320-209-12/1.
2. Adjust steering gear. Refer to TM 9-2320-209-20.

END OF TASK

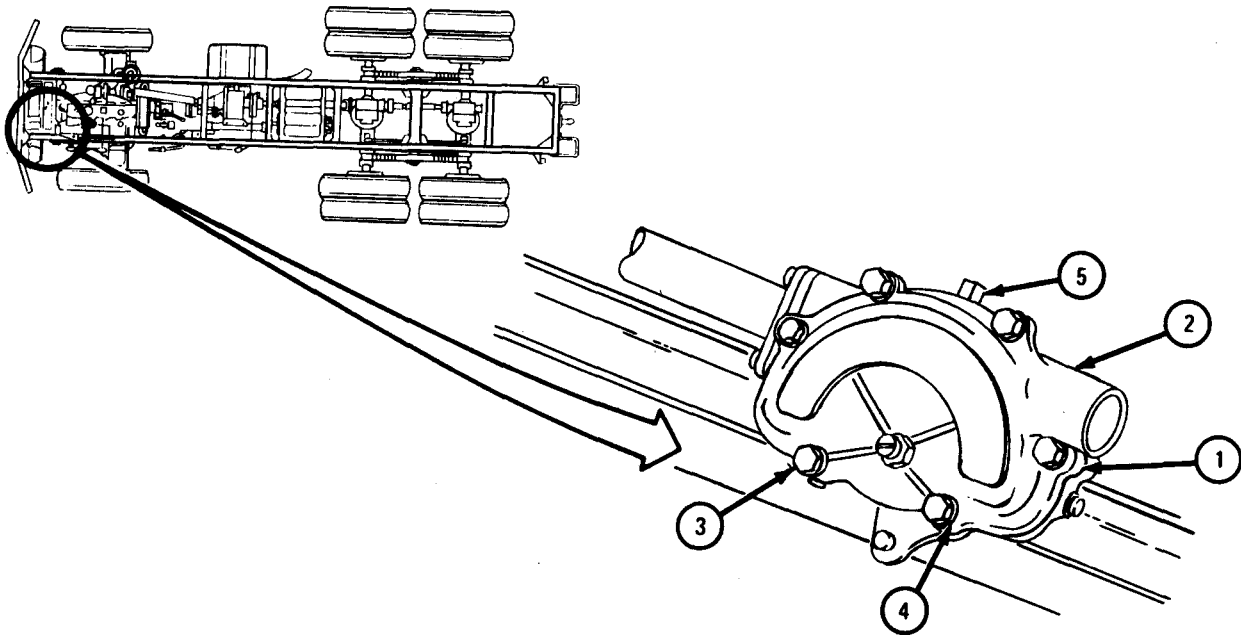

TA 102431

CHAPTER 15

FRAME AND TOWING ATTACHMENTS GROUP MAINTENANCE

Section I. SCOPE

15-1. **EQUIPMENT ITEMS COVERED.** This chapter gives equipment maintenance procedures for the frame assembly and fifth wheel assembly for which there are authorized corrective maintenance tasks at the direct and general maintenance levels.

15-2. **EQUIPMENT ITEMS NOT COVERED.** All equipment items for which corrective maintenance is authorized at the direct and general support maintenance levels are covered in this chapter.

Section II. FRAME ASSEMBLY

15-3. FRAME ALINEMENT CHECK.

TOOLS: No special tools required

SUPPLIES: Paper, 5 inches by 8 inches
Masking tape
Measuring tape

PERSONNEL: Two

EQUIPMENT CONDITION: Truck parked on level floor, engine off, handbrake set.

a. Preliminary Procedures.

(1) Make sure truck is parked in a straight line so rear axles are not on a twist or binding from turning action.

(2) Make sure rear spring seat bearings are properly adjusted. Refer to TM 9-2320-209-20.

b. Alinement Check.

FRAME 1

1. Tape paper to floor below both sides of front fender support (1), two frame crossmembers (2), and two rear suspension support brackets (3).
2. With plumb bob, carefully mark point on paper below both sides of front fender support (1), two frame crossmembers (2), and two rear suspension support brackets (3) at points shown.
3. Start engine and drive truck off marked paper. Stop engine. Refer to TM 9-2320-209-10.

GO TO FRAME 2

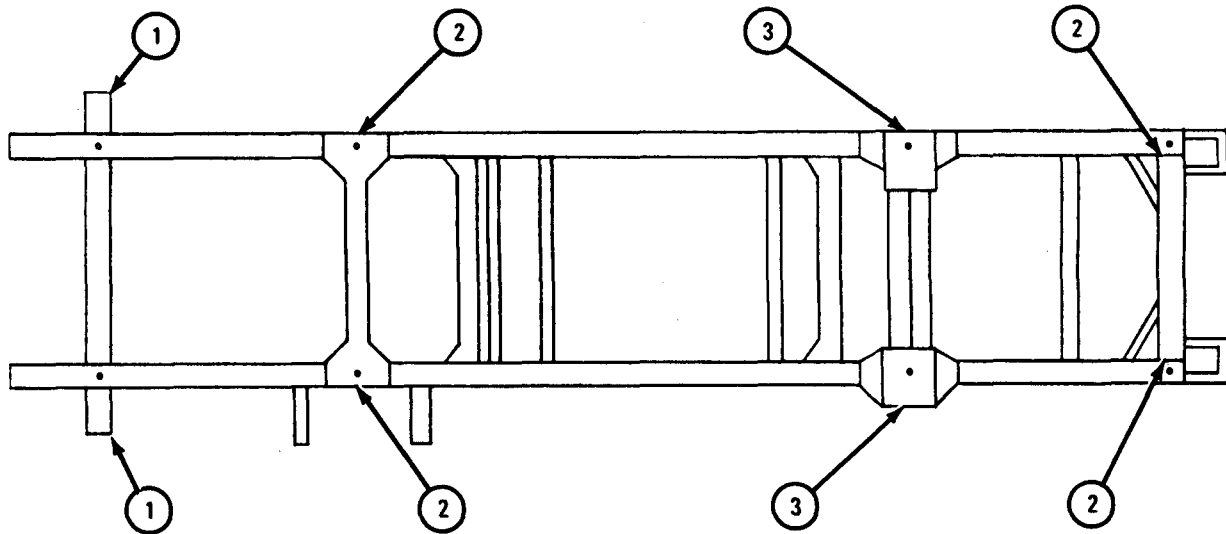

TA 104934

FRAME 2

Soldiers
A and B

1. Mark a chalk line between points 1 and 2 and between points 3 and 4.
2. Mark a chalk line between points 3 and 6 and between points 2 and 5.
3. Mark a chalk line between points 5 and 8 and between points 6 and 7.

GO TO FRAME 3

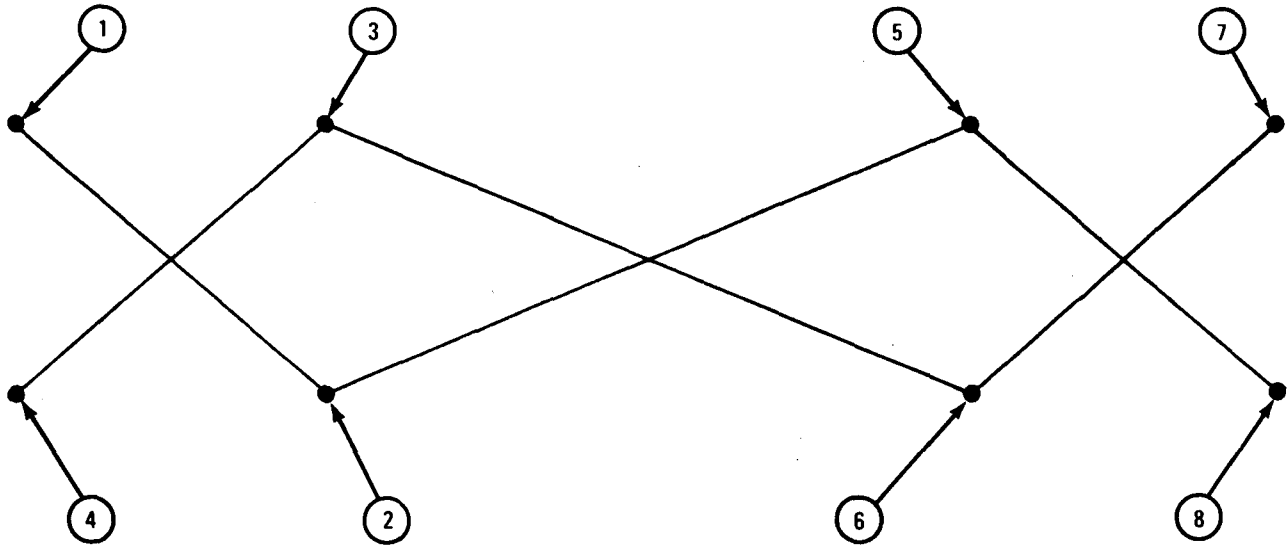

TA 104935

FRAME 3

1. Measure length of two lines (A and B).
2. If line A is longer or shorter than line B by more than 1/8 inch, repair damaged section. Refer to para 15-4.

GO TO FRAME 4

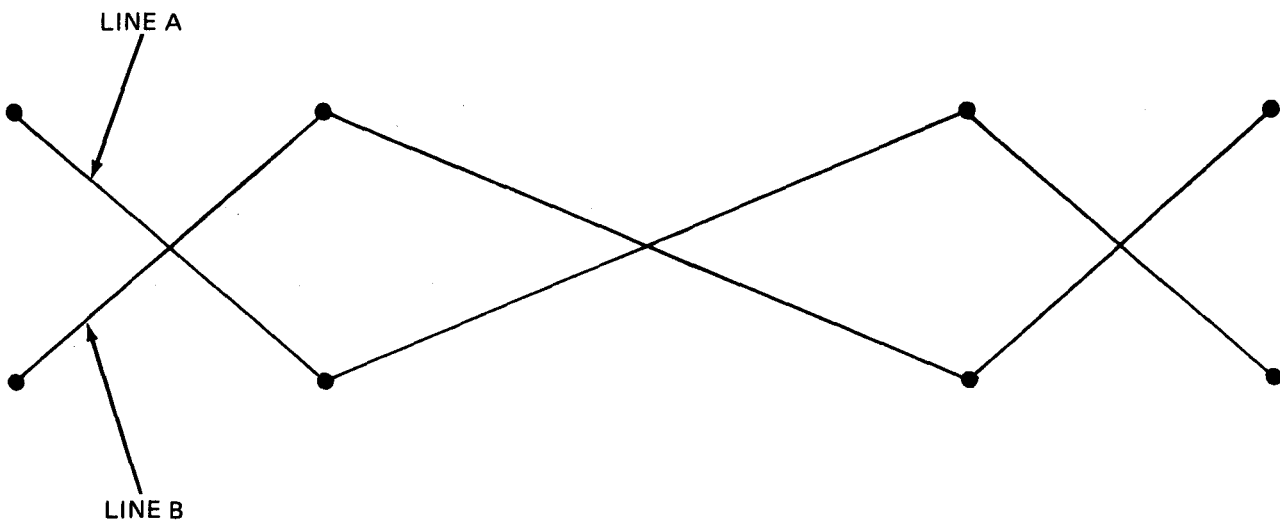

TA 104936

FRAME 4

1. Measure length of two lines (A and B).
2. If line A is longer or shorter than line B by more than 1/8 inch, repair damaged section. Refer to para 15-4.

GO TO FRAME 5

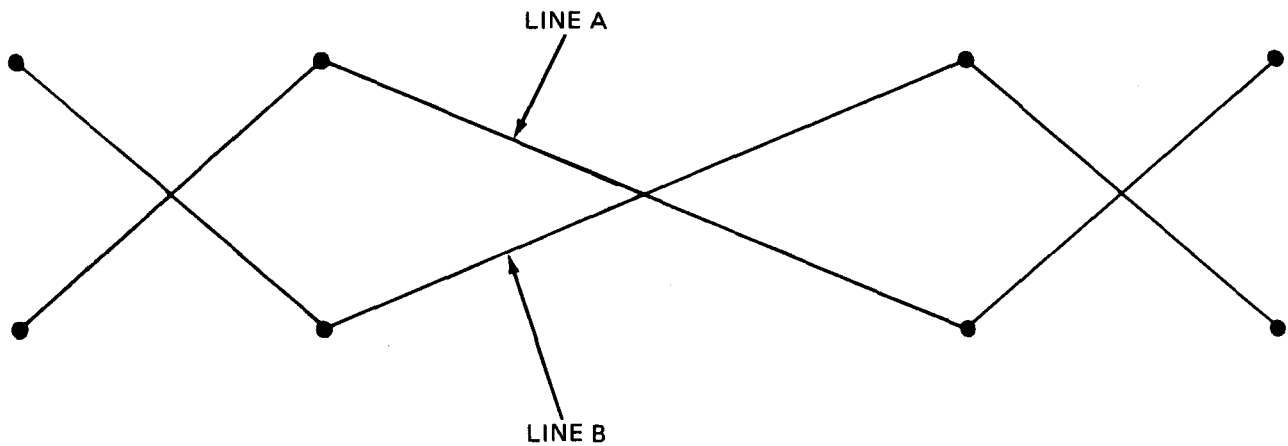

TA 104937

FRAME 5

1. Measure length of two lines (A and B).
2. If line A is longer or shorter than line B by more than 1/8 inch, repair damaged section. Refer to para 15-4.

END OF TASK

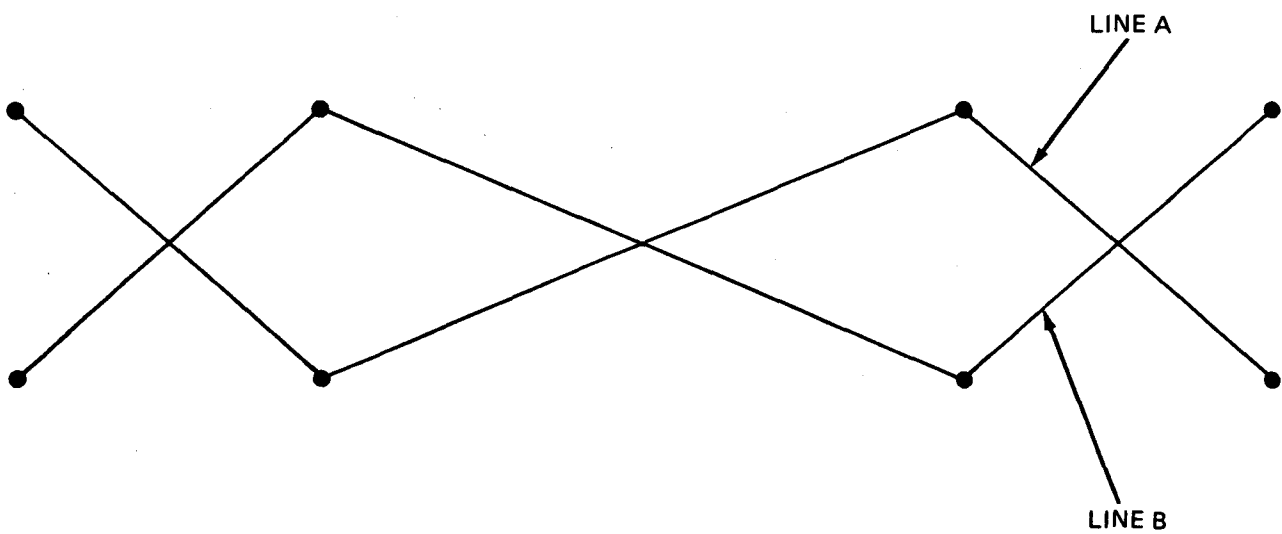

TA 104938

15-4. FRAME COMPONENTS REMOVAL, REPAIR, AND REPLACEMENT.

NOTE

The repair of frame components is limited to standard cleaning, inspection, and repair procedures. There are no special cleaning, inspection, or repair procedures needed. Refer to general maintenance procedures given in Chapter 1.

TOOLS: No special tools required

SUPPLIES: Rivets

PERSONNEL: Two

EQUIPMENT CONDITION: Truck parked, engine off, handbrake set.

a. Side Member Support (Trucks M275A1 and M275A2).

(1) Preliminary procedure. Remove air reservoirs. Refer to TM 9-2320-209-20.

(2) Removal.

FRAME 1

1. Take out four screws (1), spacer (2), support (3), and four nuts (4). Take off support (5).

END OF TASK

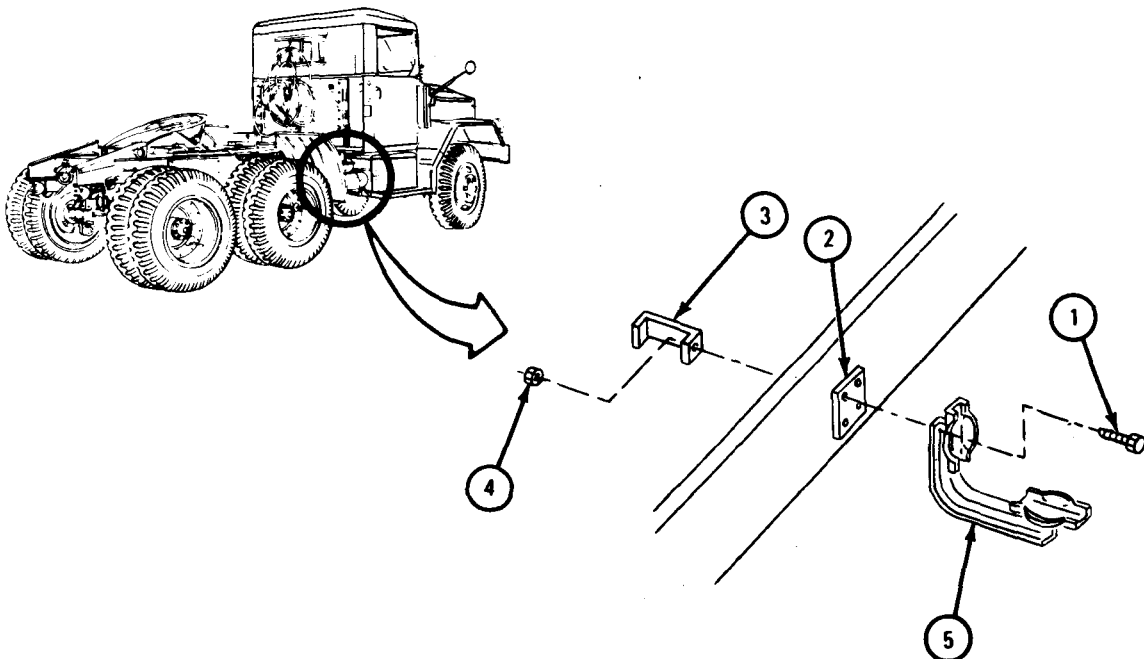

TA 105218

(3) Replacement.

FRAME 1

1. Put support (1), spacer (2), and support (3) in place and aline screw holes. Put in four screws (4) and nuts (5).

NOTE

Follow-on Maintenance Action Required:
Replace air reservoirs. Refer to TM 9-2320-209-20.

END OF TASK

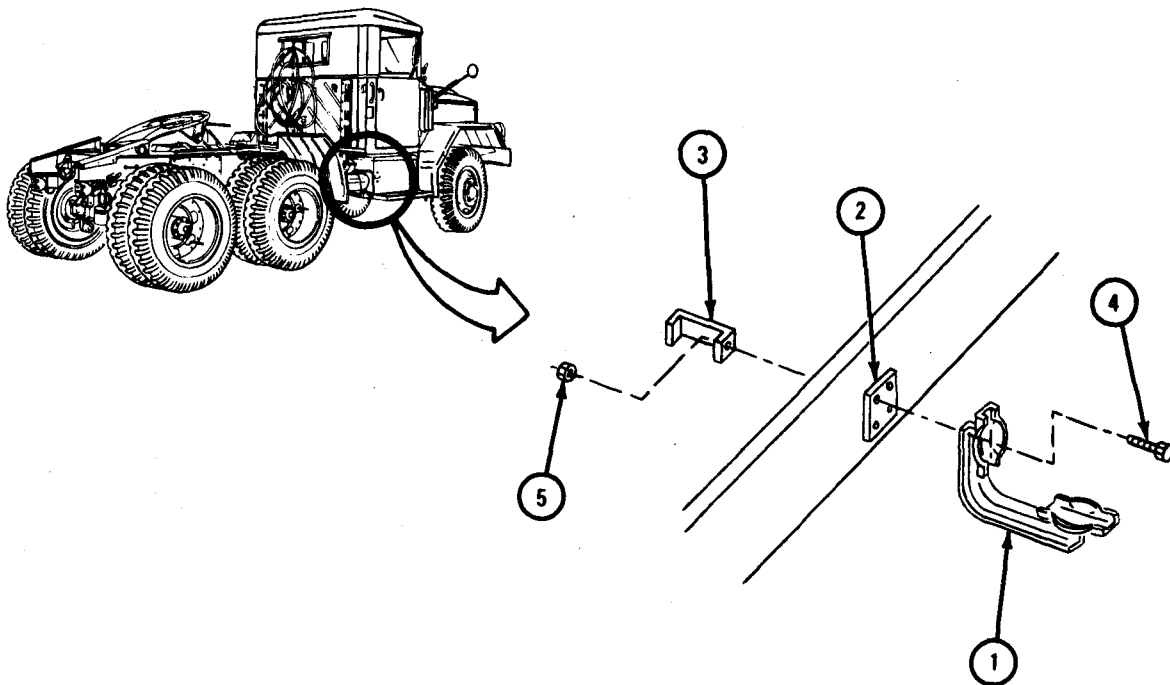

TA 105238

b. Fuel Tank Support (Trucks M275A1 and M275A2).

(1) Preliminary procedures.

(a) Remove left running board. Refer to Part 2, para 17-10.

(b) Remove fuel tank. Refer to TM 9-2320-209-20.

(2) Removal.

FRAME 1

1. Take out nine screws (1), support (2), and nine nuts (3). Take off three supports (4).

END OF TASK

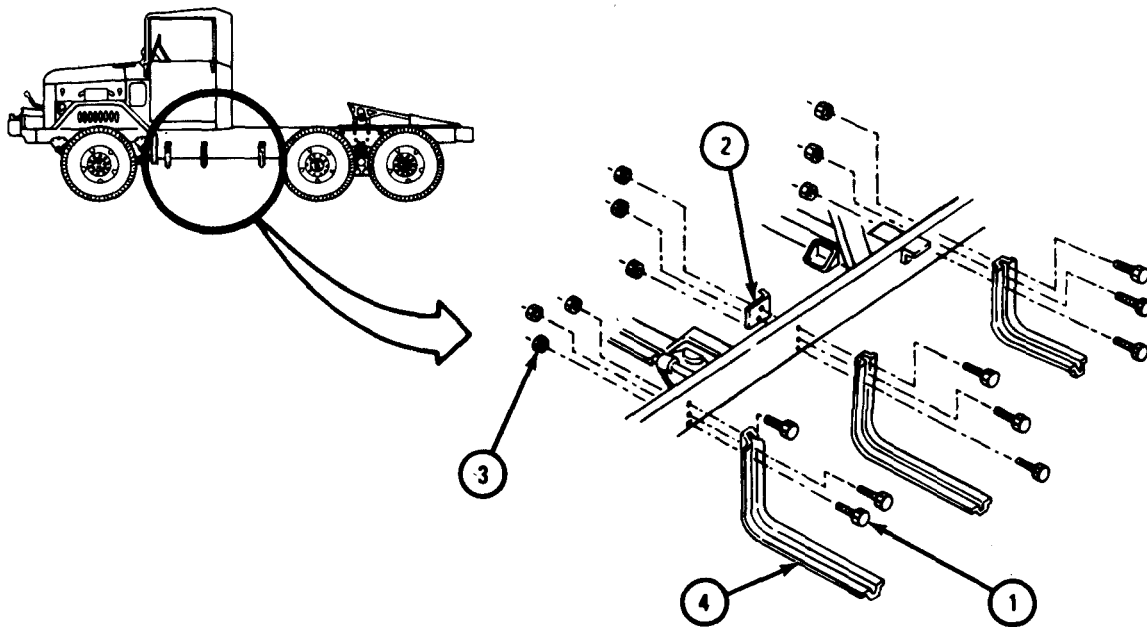

TA 105219

(3) Replacement.

FRAME 1

1. Put three supports (1) and support (2) in place and aline screw holes. Put in nine screws (3) and nuts (4).

NOTE

Follow-on Maintenance Action Required:

1. Replace fuel tank. Refer to TM 9-2320-209-20.
2. Replace left running board. Refer to Part 2, para 17-10.

END OF TASK

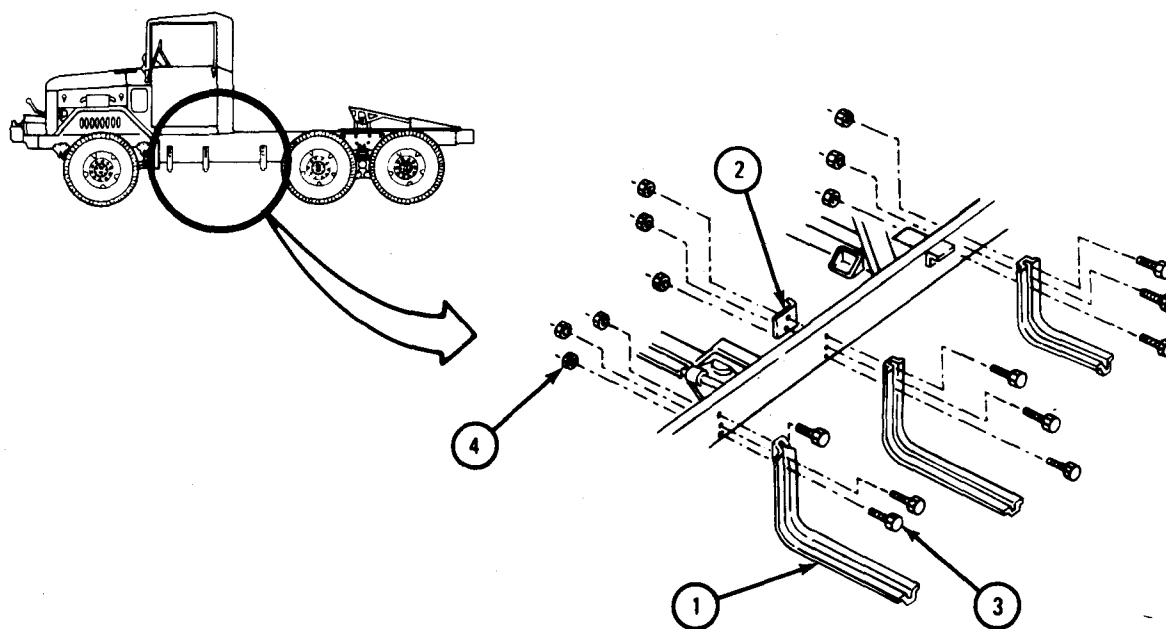

TA 105239

c. Taillight and Stoplight Assembly Bracket (Trucks M275A1 and M275A2).

NOTE

This task is shown for the left taillight and stoplight assembly bracket. This task is the same for the right taillight and stoplight assembly bracket.

(1) Preliminary procedure. Remove left taillight and stoplight assembly. Refer to TM 9-2320-209-20.

(2) Removal.

FRAME 1

1. Take out two screws (1), lockwashers (2), and nuts (3). Take off bracket (4).

END OF TASK

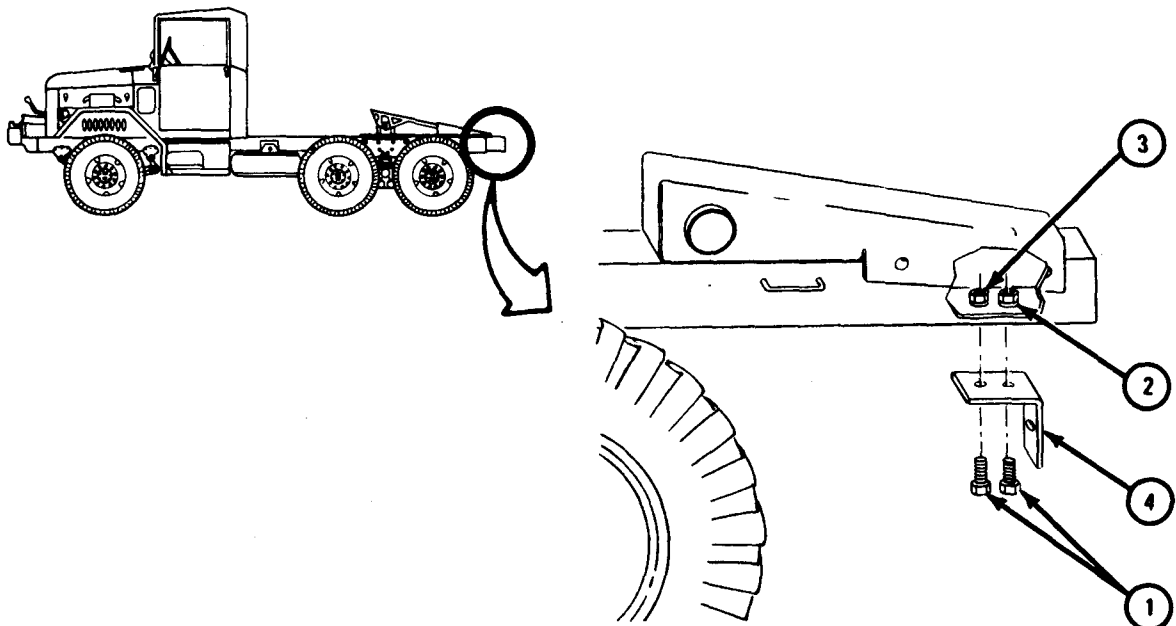

TA 105220

(3) Replacement.

NOTE

This task is shown for the left taillight and stoplight assembly bracket. The task is the same for the right taillight and stoplight assembly bracket.

FRAME 1

1. Put bracket (1) in place and align screw holes. Put in two screws (2), lockwashers (3), and nuts (4).

NOTE

Follow-on Maintenance Action Required:

Replace left taillight and stoplight assembly. Refer to TM 9-2320-209-20.

END OF TASK

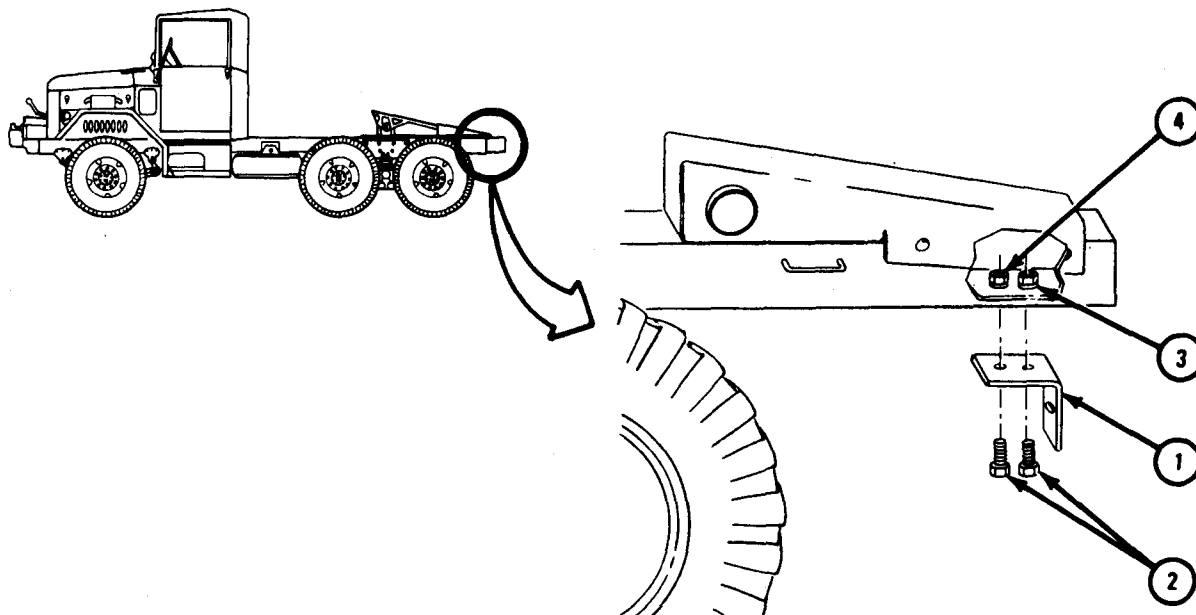

TA 105240

d. Skid Plate Bracket (Trucks M275A1 and M275A2).

NOTE

This task is shown for the left skid plate brackets.
The task is the same for the right skid plate
brackets.

(1) Removal.

FRAME 1

- Soldier A 1. Take out two screws (1) and nuts (2).
2. Hold two nuts (3).
- Soldier B 3. Take out two screws (4). Take off bracket (5).
- Soldiers A and B 4. Do steps 1, 2, and 3 again.
- END OF TASK

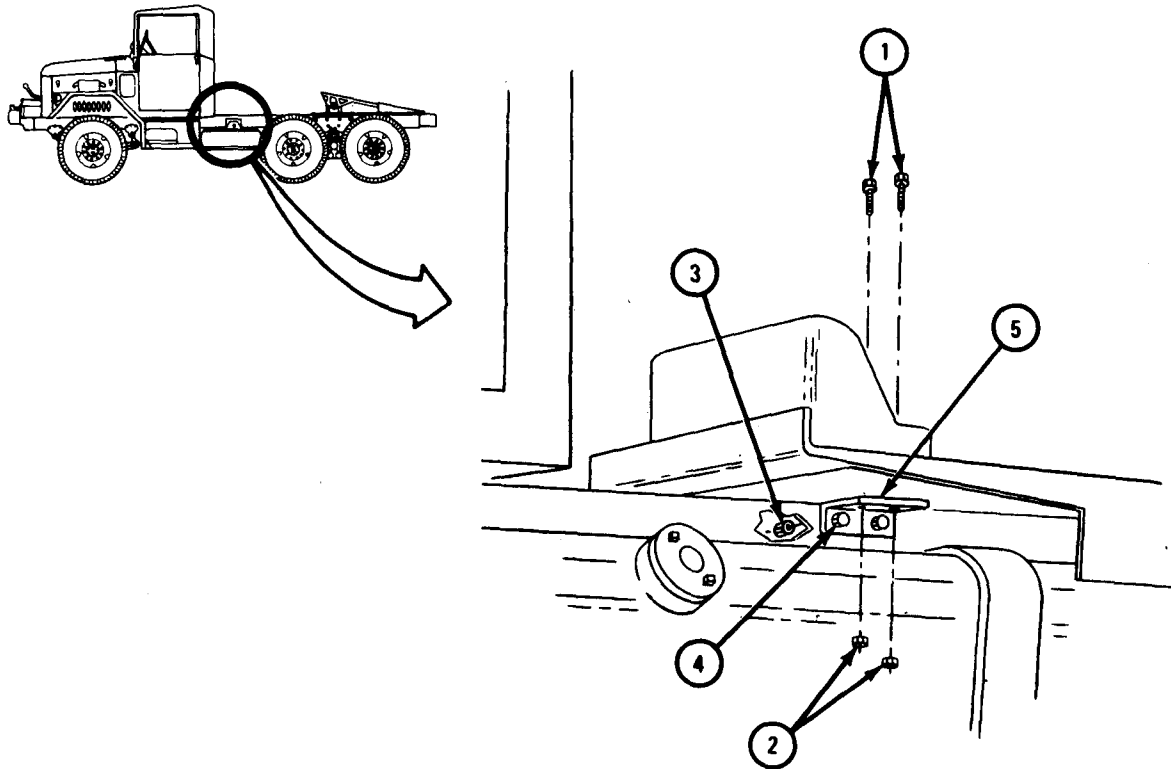

TA 105221

(2) Replacement.

FRAME 1

Soldier A 1. Put bracket (1) in place and align screw holes. Put in and hold two screws (2).

Soldier B 2. Put on two nuts (3).

3. Put in two screws (4) and nuts (5).

Soldiers A and B 4. Do steps 1, 2, and 3 for other bracket.

END OF TASK

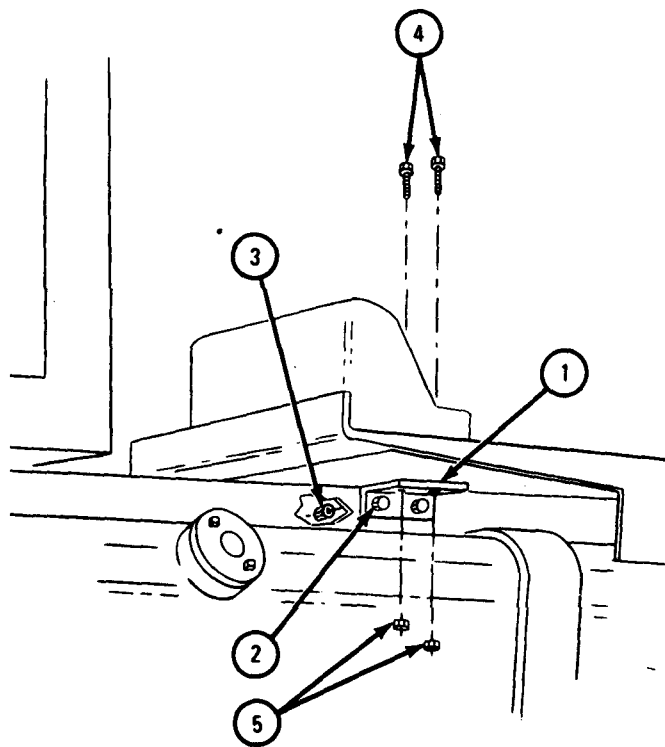
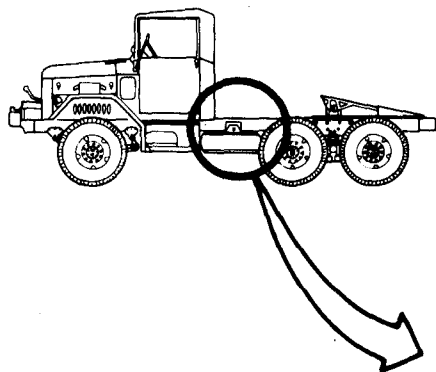

TA 105241

e. Rear Member Bracket (Truck M275A1 and M275A2).

NOTE

This task is shown for the right rear member bracket. The task is the same for the left rear member bracket.

(1) Removal.

FRAME 1

1. Take out three screws (1) and nuts (2). Take off bracket (3).

END OF TASK

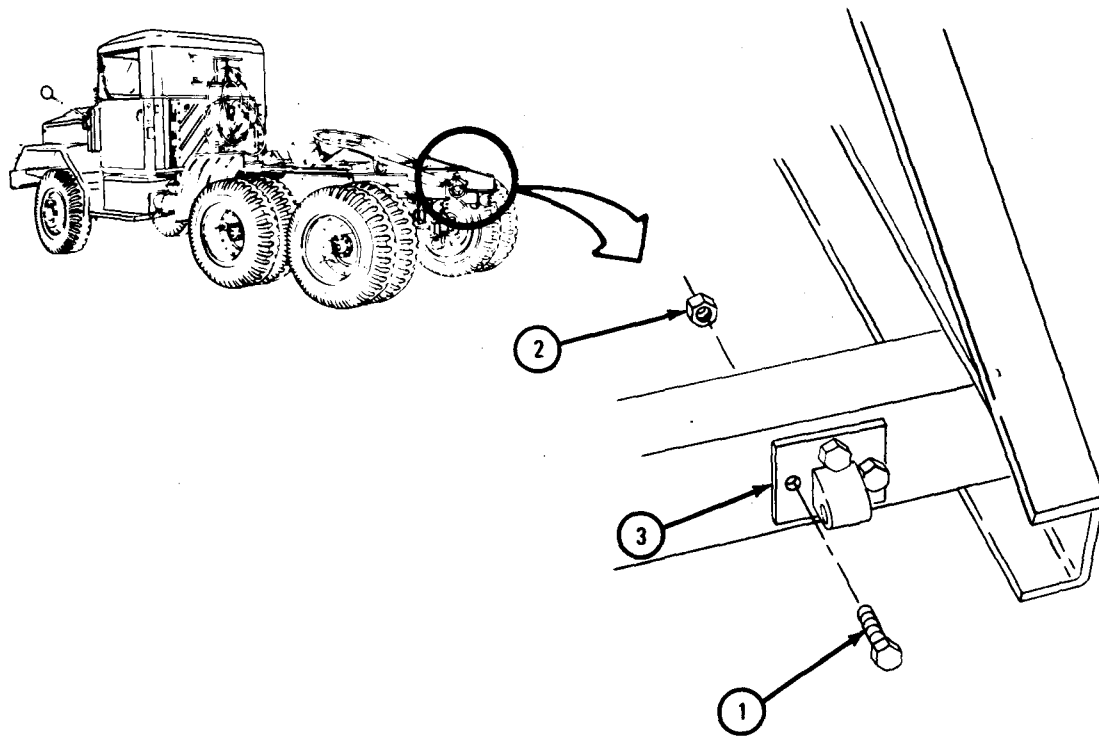

TA 105222

(2) Replacement.

FRAME 1

1. Put bracket (1) in place and align screw holes. Put in three screws (2) and nuts (3).

END OF TASK

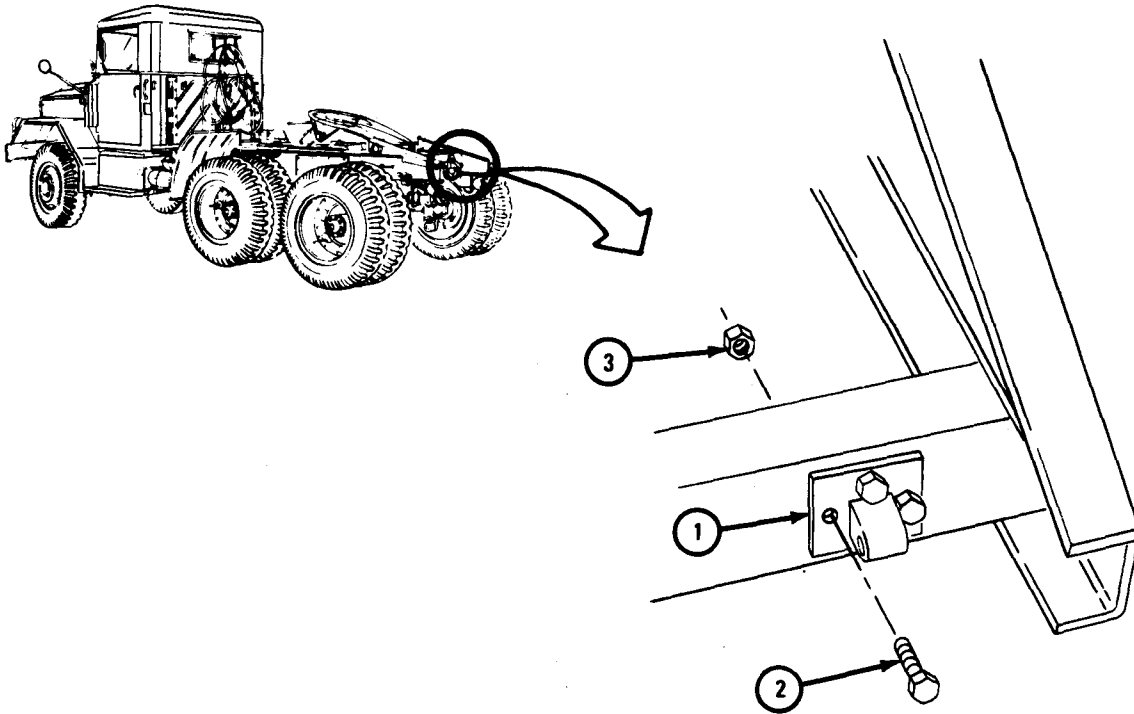

TA 105242

f. Trailer Air Brake Coupling Bracket (Trucks M275A1 and M275A2).

NOTE

This task is shown for the left air brake coupling bracket. The task is the same for the right rear air brake coupling bracket.

- (1) Preliminary procedures.
 - (a) Vent air system pressure. Refer to TM 9-2320-209-20.
 - (b) Remove trailer hose coupling. Refer to TM 9-2320-209-20.
- (2) Removal.

FRAME 1

1. Take out two screws (1) and nuts (2). Take off bracket (3).

END OF TASK

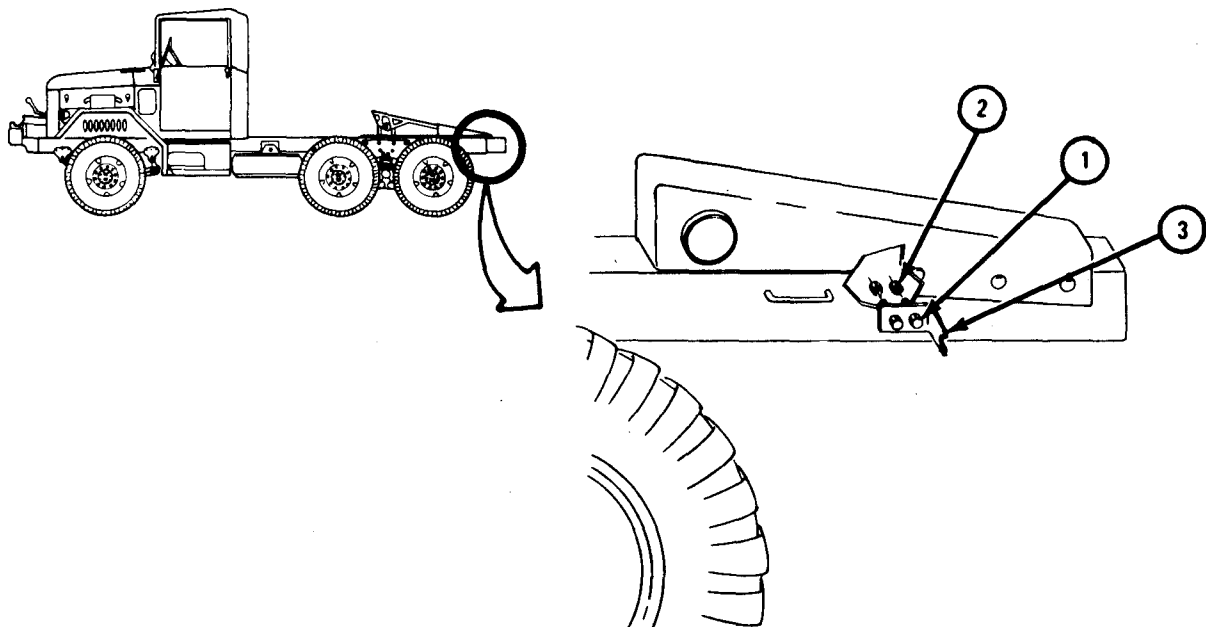

TA 105223

(3) Replacement.

FRAME 1

1. Put bracket (1) in place and aline screw holes. Put in two screws (2) and nuts (3).

NOTE

Follow-on Maintenance Action Required:

Replace trailer hose coupling. Refer to TM 9-2320-209-20.

END OF TASK

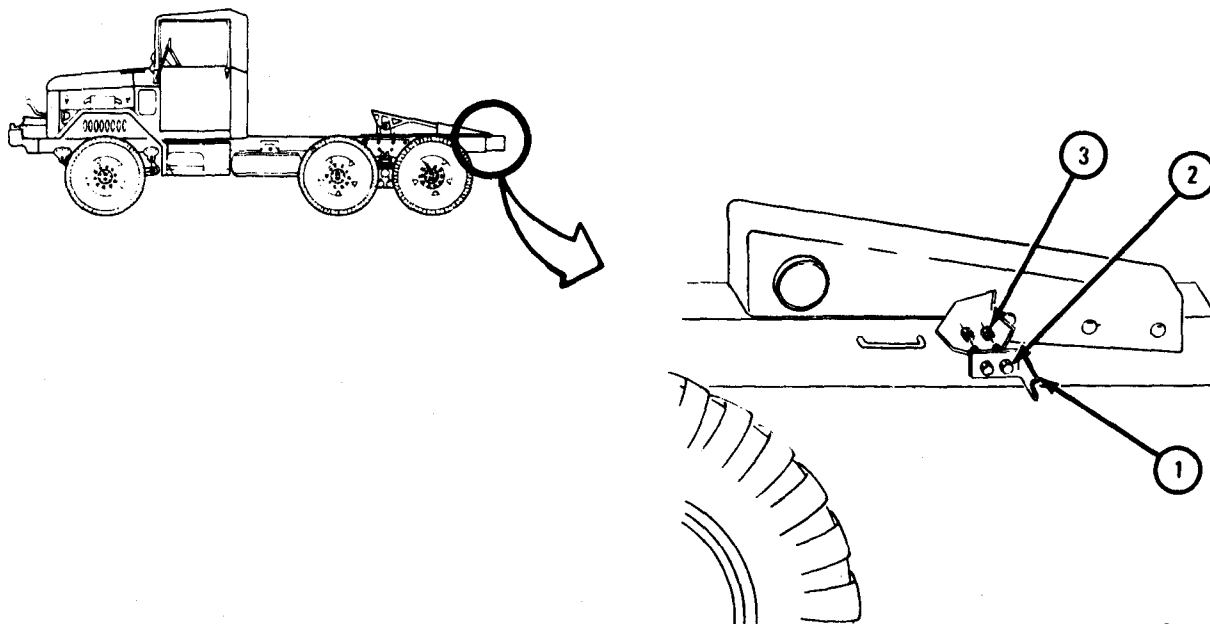

TA 105243

g. Rear Member (Trucks M275A1 and M275A2).

(1) Preliminary procedures.

(a) Remove fifth wheel assembly. Refer to TM 9-2320-209-20.

(b) Remove rear member brackets. Refer to para 15-4.

(2) Removal.

FRAME 1

- Soldier A 1. Take out six screws (1) and nuts (2).
2. Do step 1 again on other side of bracket (3).
- Soldiers 3. Take off bracket (3).
- A and B

GO TO FRAME 2

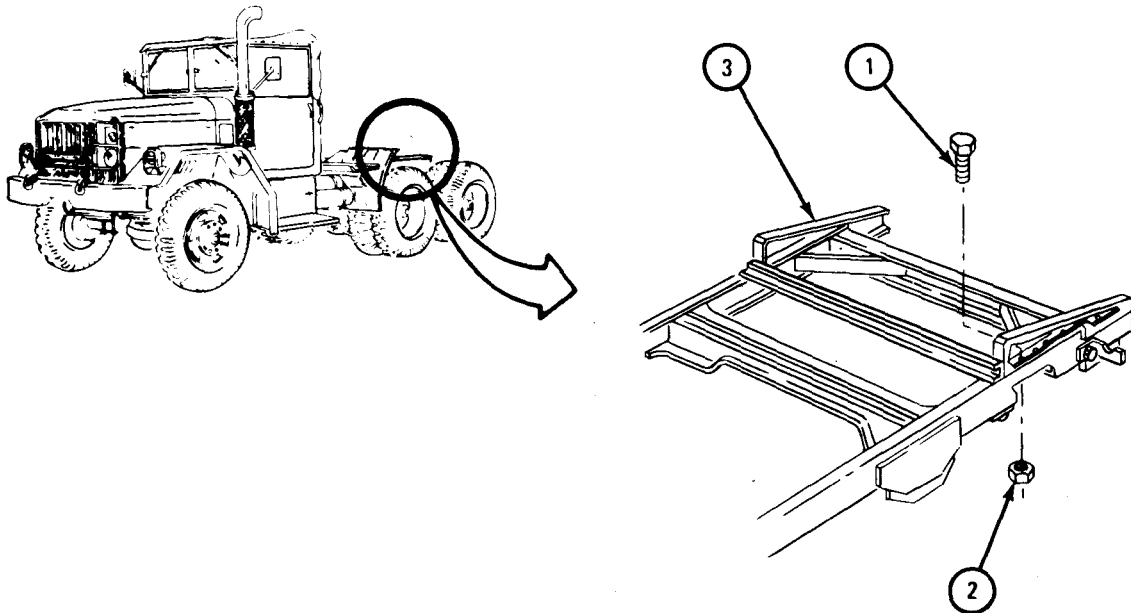

TA 105224

FRAME 2

- Soldier A
1. Take out six rivets (1).
 2. Do step 1 again on other side of rear member (2).

- Soldiers
A and B
3. Take off rear member (2).

END OF TASK

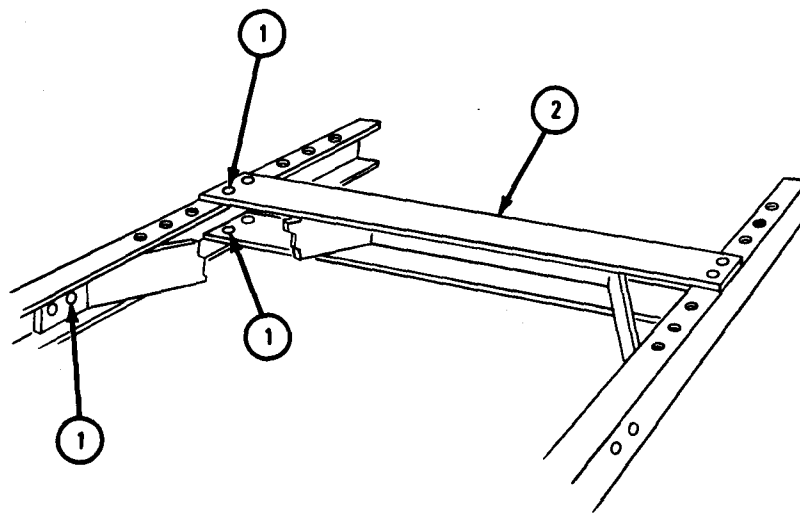

TA 105225

(3) Replacement.

FRAME 1

Soldiers A and B 1. Put rear member (1) in place and aline bolt holes (2).

Soldier A 2. Put in six bolts (3) and nuts (4) where rivets were taken out. Refer to TB 9-2300-247-40.

3. Do step 2 again on other side of rear member (1).

GO TO FRAME 2

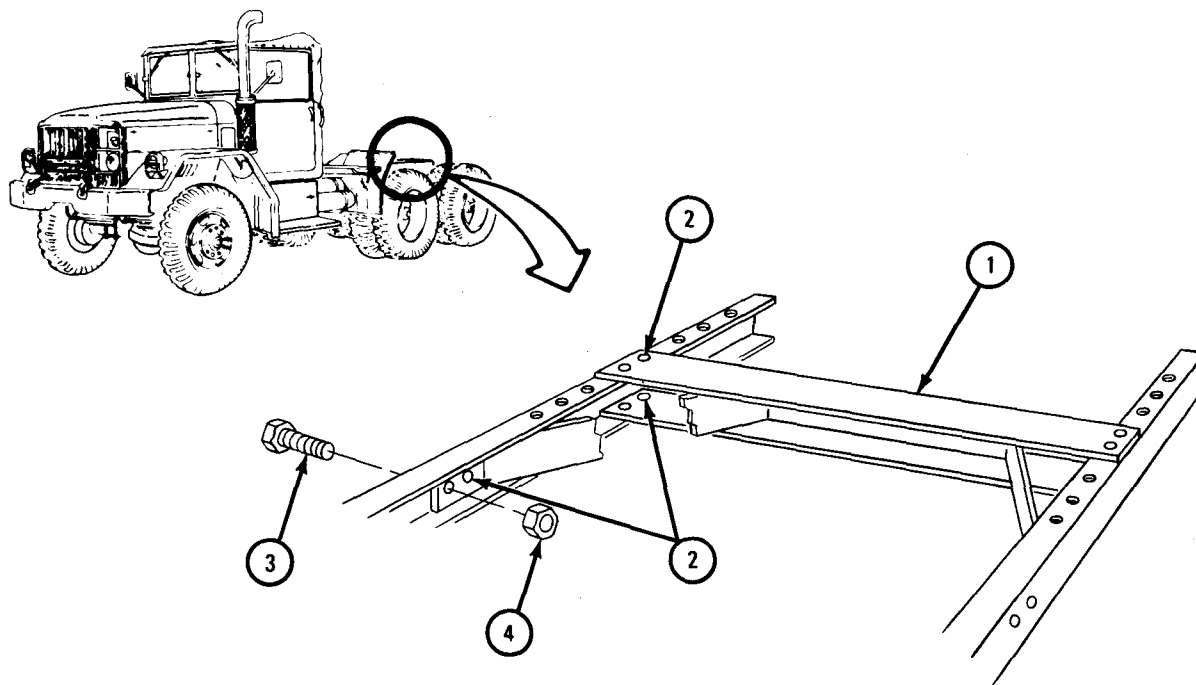

TA 105244

FRAME 2

- Soldiers A and B 1. Put bracket (1) in place and aline screw holes.
- Soldier A 2. Put in six screws (2) and nuts (3).
3. Do step 2 again on other side of bracket (1).

NOTE

Follow-on Maintenance Action Required:

1. Replace rear member brackets. Refer to para 15-4.
2. Replace fifth wheel assembly. Refer to TM 9-2320-209-20.

END OF TASK

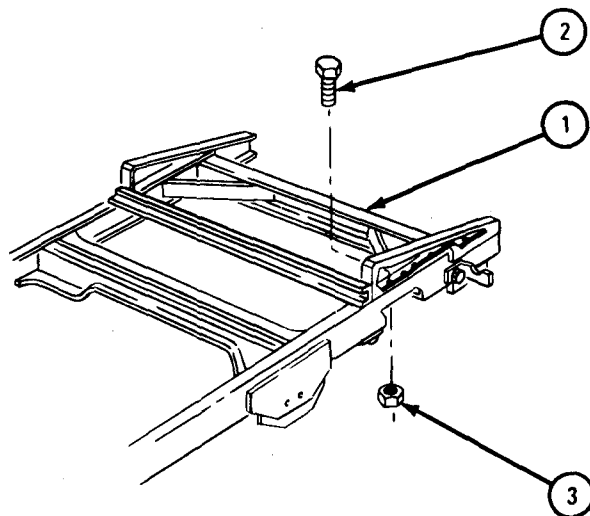

TA 105245

h. Air Tank Support Brackets (Trucks M35A1, M35A2, M35A2C, M36A2, M49A1C, M49A2C, M50A1, M50A2, M50A3, M109A2, and M109A3).

(1) Preliminary procedure. Remove air reservoirs. Refer to TM 9-2320-209-20.

(2) Removal.

FRAME 1

1. Take out four screws (1), four nuts (2), eight flat washers (3), and four lockwashers (4).
2. Take off two supports (5).

END OF TASK

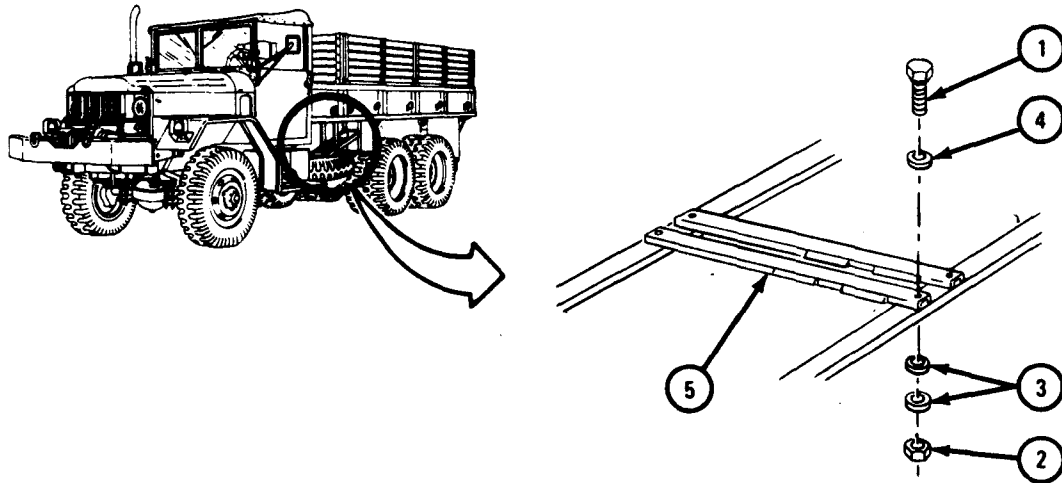

TA 105226

(3) Replacement.

FRAME 1

1. Put supports (1) onto frame side members (2), alining holes.
2. Put on four screws (3) with eight flat washers (4), four lockwashers (5), and four nuts (6).

NOTE

Follow-on Maintenance Action Required:

Replace air reservoirs. Refer to TM 9-2320-209-20.

END OF TASK

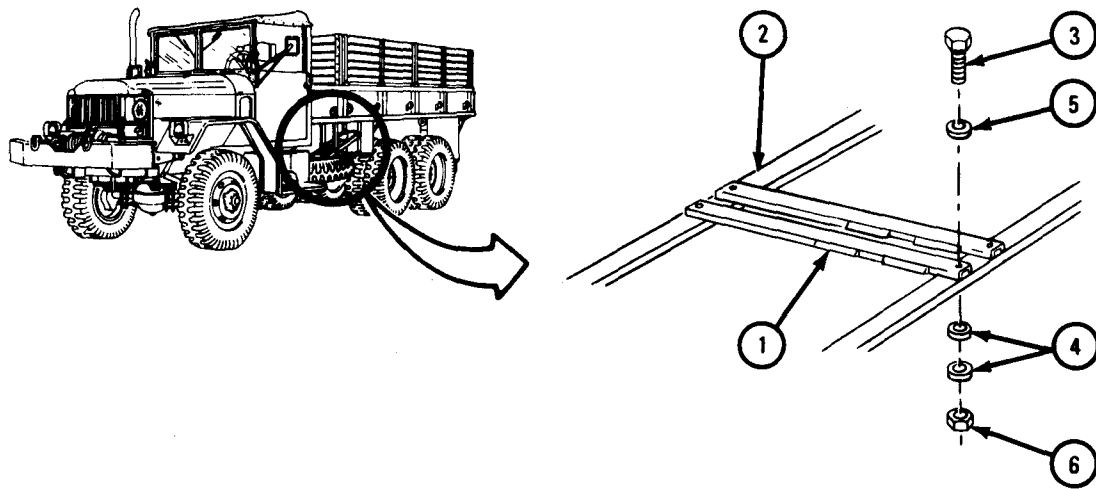

TA 105246

i. Running Board and Fuel Tank Supports (Trucks M35A1, M35A2, M35A2C, M36A2, M49A1C, M49A2C, M50A1, M50A2, M50A3, M109A2, and M109A3).

- (1) Preliminary procedures.
 - (a) Remove fuel tank. Refer to TM 9-2320-209-20.
 - (b) Remove right running board. Refer to Part 2, para 17-9.
 - (c) Remove batteries. Refer to TM 9-2320-209-20.
- (2) Removal.

FRAME 1

1. Take out 16 screws (1) and 16 nuts (2).
2. Take out supports (3) and brackets (4 and 5).

END OF TASK

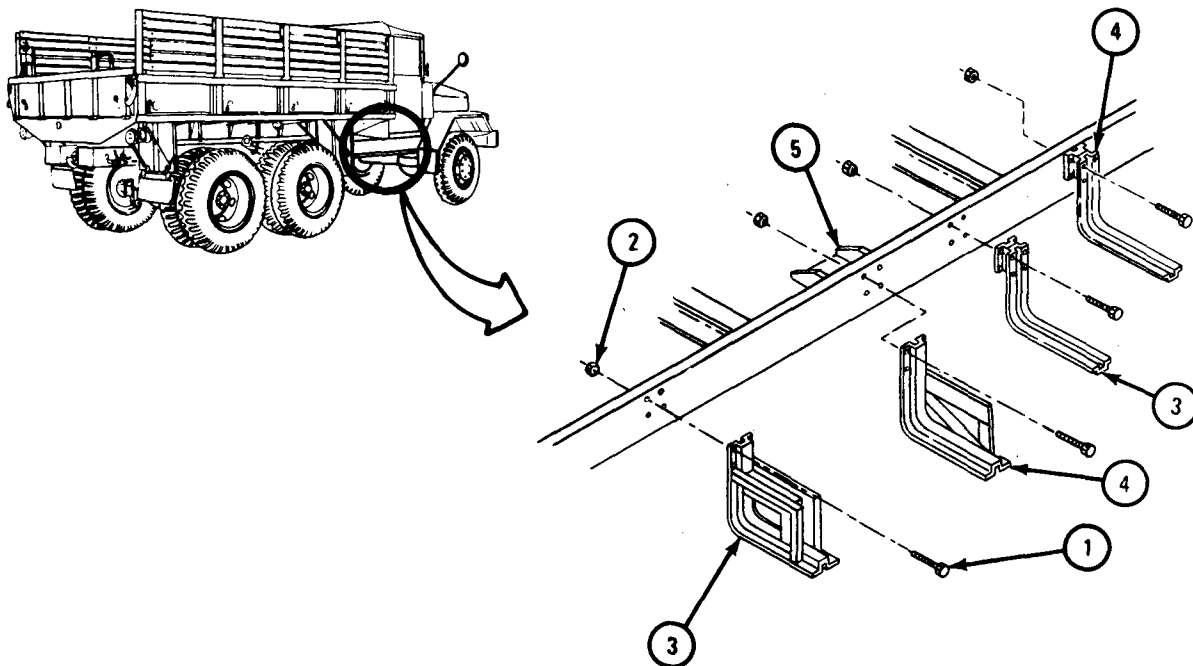

TA 105227

(3) Replacement.

FRAME 1

1. Put brackets (1 and 2) in place on frame (3). Put in four screws (4) and four nuts (5).
2. Put bracket (6) and two supports (7) in place on frame (3). Put in 12 screws (8) and 12 nuts (9).

NOTE

Follow-on Maintenance Action Required:

1. Replace fuel tank. Refer to TM 9-2320-209-20.
2. Replace right running board. Refer to Part 2, para 17-9.
3. Replace batteries. Refer to TM 9-2320-209-20.

END OF TASK

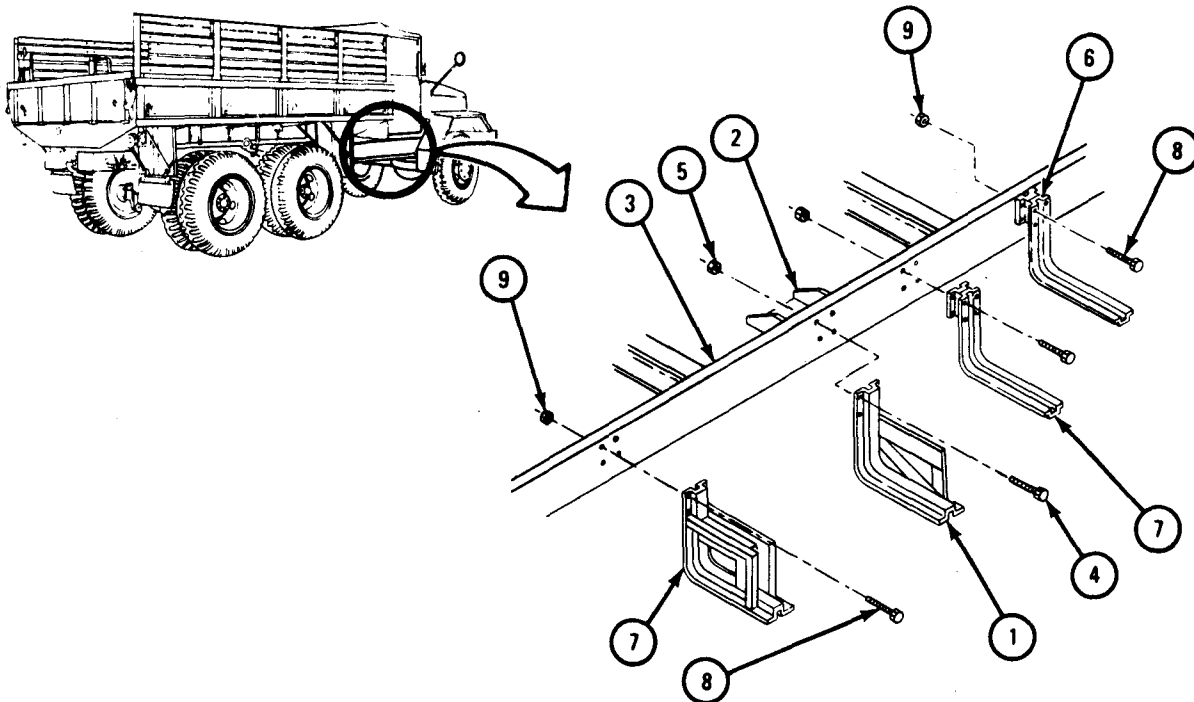

TA 105247

j. Front Fender Supports (Trucks M35A1, M35A2, M35A2C, M36A2, M49A1C, M49A2C, M50A1, M50A2, M50A3, M109A2, and M109A3).

NOTE

This task is shown for the right front fender support. This task is the same for the left front fender support.

- (1) Preliminary procedures.
 - (a) Remove front fender. Refer to Part 2, para 17-7.
 - (b) Disconnect marker light and remove tow clamps from fender support. Refer to Part 2, para 17-7.
- (2) Removal.

FRAME 1

1. Take off four screws and washers (1), four nuts (2), and four lockwashers (3).
 2. Take off front fender support (4) from frame (5).
- END OF TASK

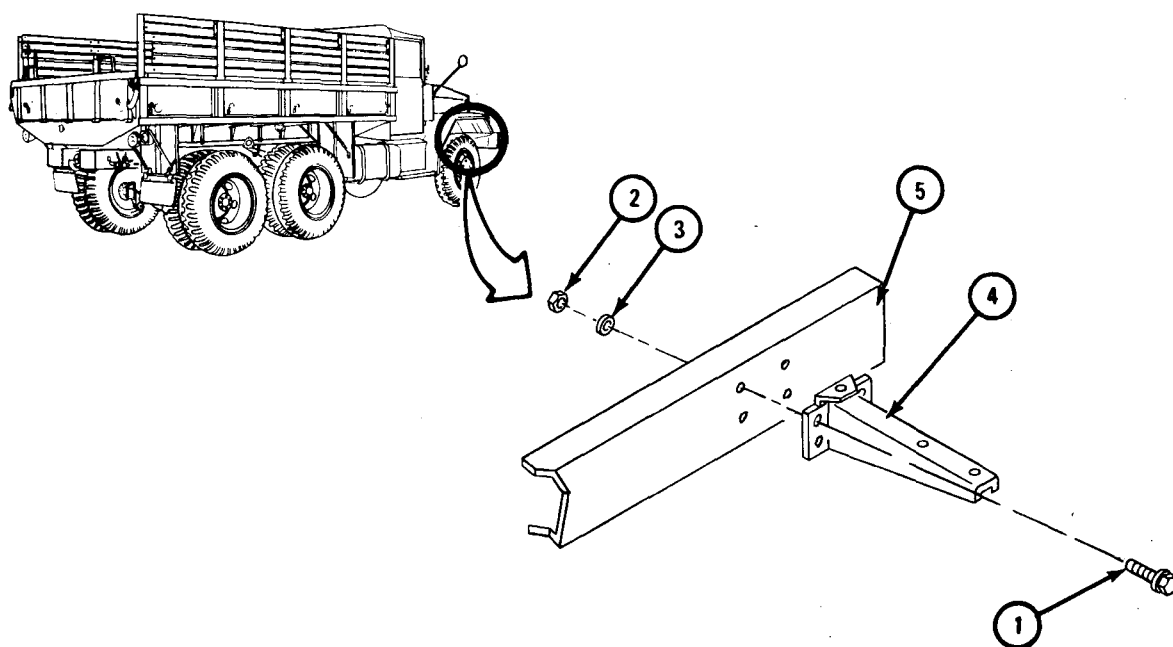

TA 105228

(3) Replacement.

FRAME 1

1. Put support (1) onto frame (2) and align holes.
2. Put in four screws and washers (3), four lockwashers (4), and four nuts (5) and tighten.

NOTE

Follow-on Maintenance Action Required:

1. Connect marker light assembly and replace two clamps on fender support. Refer to Part 2, para 17-7.
2. Replace front fender. Refer to Part 2, para 17-7.

END OF TASK

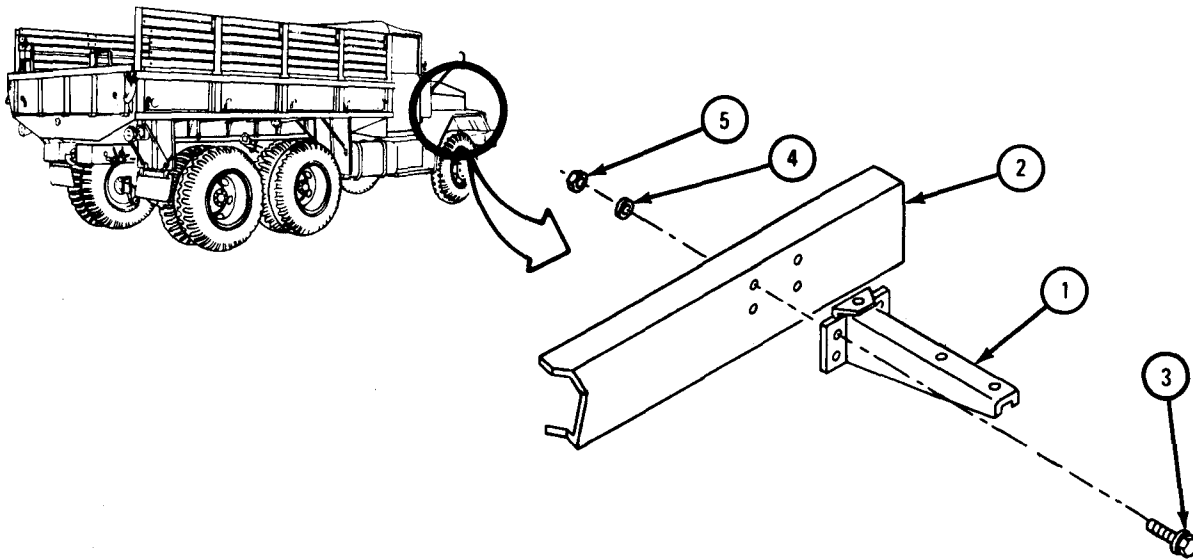

TA 105248

k. Spare Tire Carrier (Trucks M35A1, M35A2, M35A2C, M36A2, M49A1C, M49A2C, M50A1, M50A2, M50A3, M109A2, and M109A3).

(1) Preliminary procedure. Remove spare wheel. Refer to TM 9-2320-209-10.

(2) Removal.

FRAME 1

1. Take out four screws (1) with four nuts (2).
2. Take off spare tire carrier (3).

END OF TASK

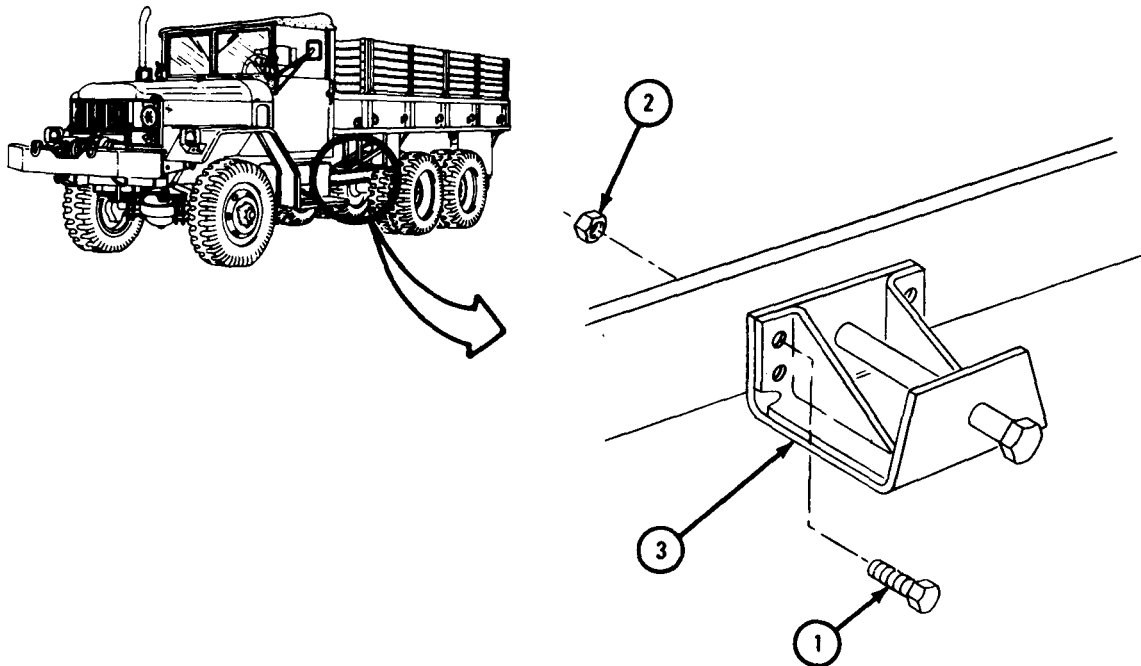

TA 105229

(3) Replacement.

FRAME 1

1. Put spare tire carrier (1) onto frame (2) alining holes.
2. Put four screws (3) into holes of frame (2) and screw on and tighten four nuts (4).

NOTE

Follow-on Maintenance Action Required:

Replace spare wheel. Refer to TM 9-2320-209-10.

END OF TASK

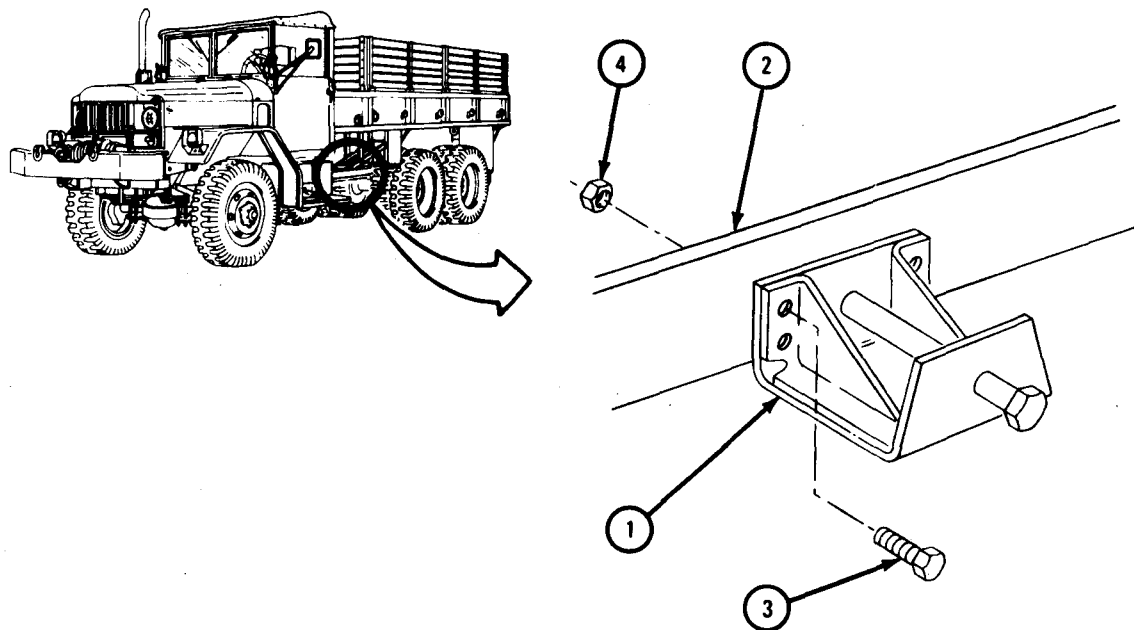

TA 105249

1. Running Board Support (Trucks M35A1, M35A2, M35A2C, M36A2, M49A1C, M49A2C, M50A1, M50A2, M50A3, M109A2, and M109A3).

- (1) Preliminary procedures.
 - (a) Remove left running board. Refer to Part 2, para 17-10.
 - (b) Remove tool box carrier. Refer to Part 2, para 17-10.
- (2) Removal.

FRAME 1

- 1. Take out eight screws (1), bracket (2), and eight nuts (3). Take off two supports (4).

END OF TASK

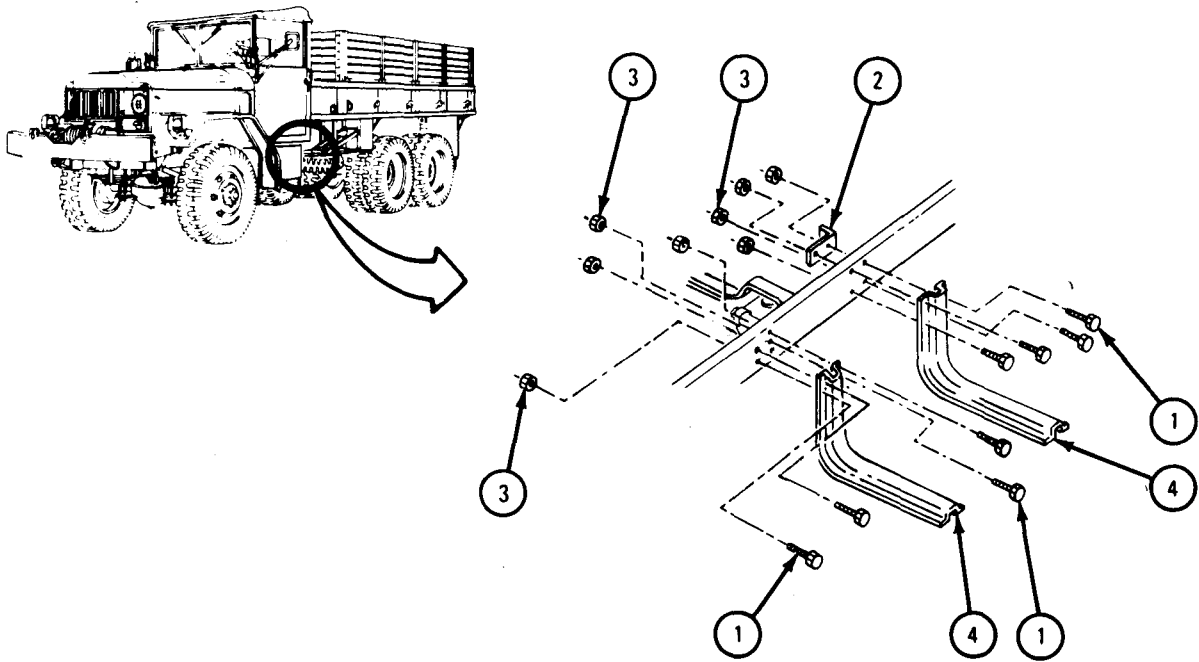

TA 105230

(3) Replacement.

FRAME 1

1. Put two supports (1) and brackets (2) in place and aline screw holes. Put in eight screws (3) and nuts (4).

NOTE

Follow-on Maintenance Action Required:

1. Replace left running board. Refer to Part 2, para 17-10.
2. Replace tool box carrier. Refer to Part 2, para 17-10.

END OF TASK

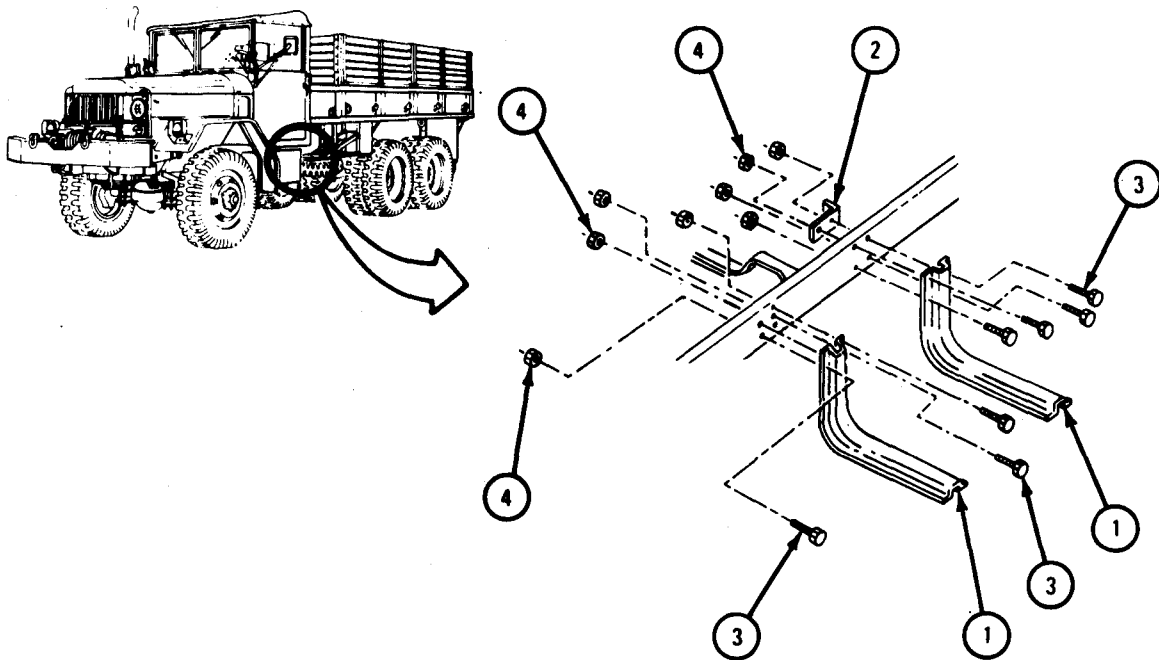

TA 105250

m. Rear Frame Bracket (Trucks M35A1, M35A2, M35A2C, M36A2, M49A1C, M49A2C, M50A1, M50A2, M50A3, M109A2, and M109A3).

(1) Preliminary procedure. Remove the holddown bolt. Refer to Part 2, para 17-16.

(2) Removal.

FRAME 1

1. Take out three rivets (1).
2. Take off bracket (2).

END OF TASK

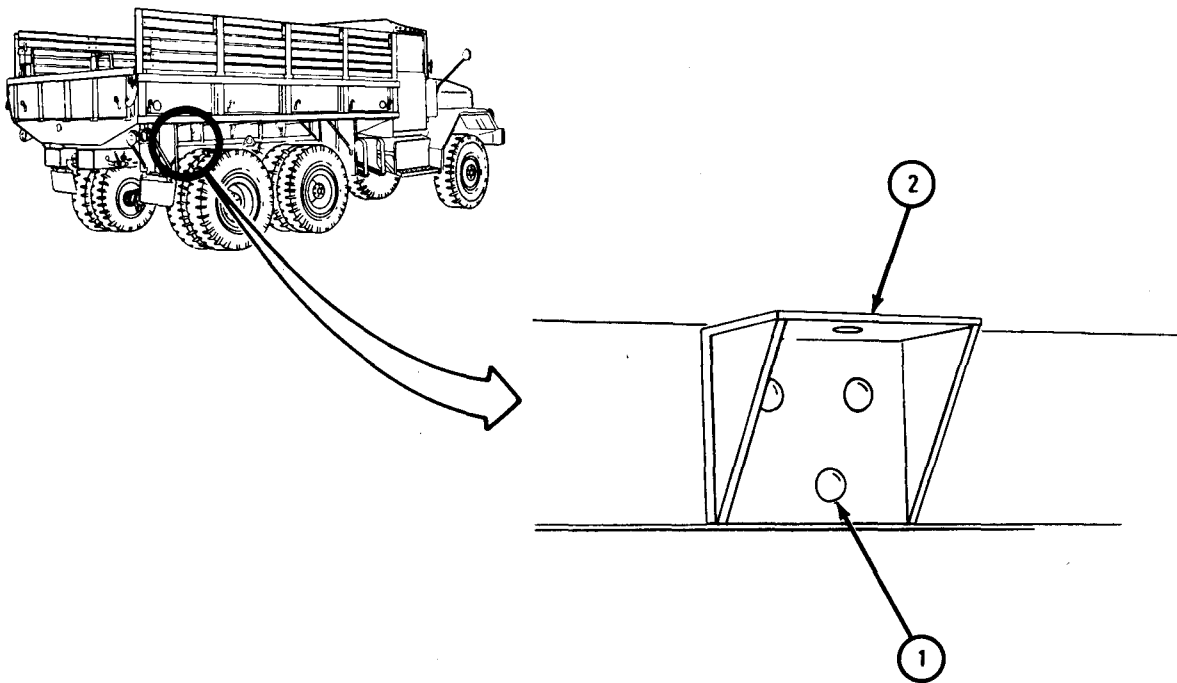

TA 105231

(3) Replacement.

FRAME 1

1. Put bracket (1) in place on frame (2), alining holes.
2. Put on three screws (3) and nuts (4). Refer to TB 9-2300-247-40.

NOTE

Follow-on Maintenance Action Required:

Replace the holddown bolt. Refer to Part 2, para 17-16.

END OF TASK

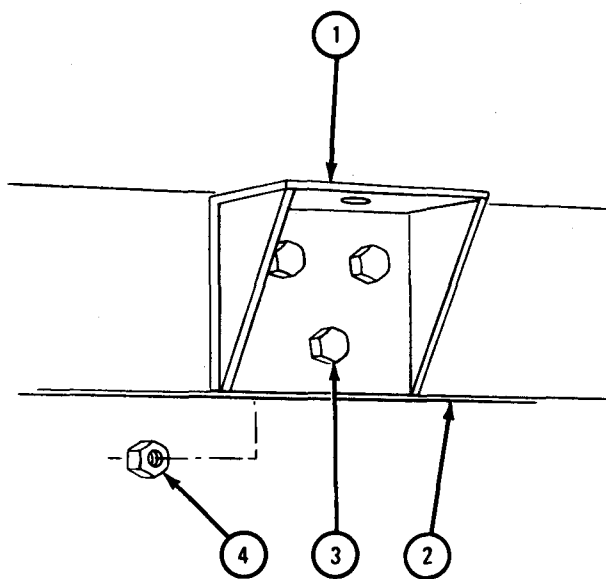
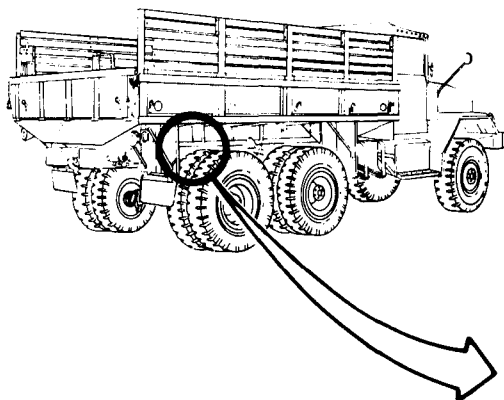

TA 105251

n. Bumperettes (Trucks M35A1, M35A2, M35A2C, M36A2, M49A1C, M49A2C, M50A1, M50A2, M50A3, M109A2, and M109A3).

NOTE

This task is shown for the left rear bumperette.
This task is the same for the right rear bumperette.

(1) Removal.

FRAME 1

1. Take off four bolts (1) and nuts (2). Take off bracket (3).
 2. Take off two bolts (4) and with nuts (5). Take off bumperette (6).
- END OF TASK

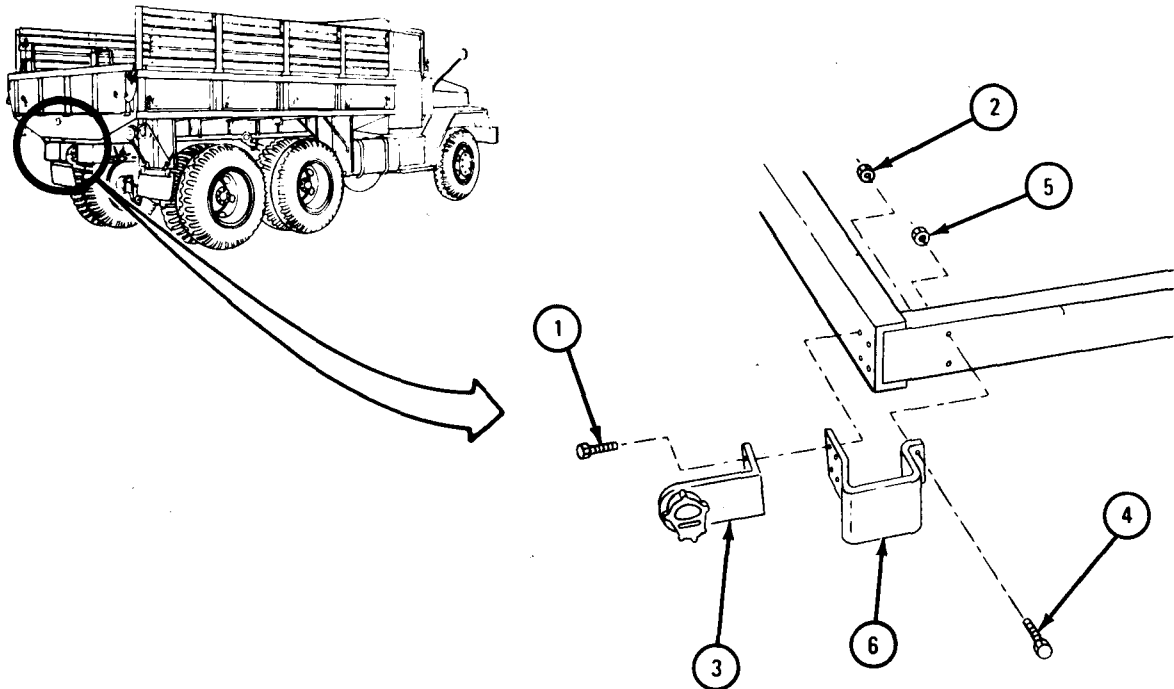

TA 105232

(2) Replacement.

FRAME 1

1. Put bumperette (1) on frame (2), alining holes.
 2. Put in two bolts (3) and nuts (4).
 3. Put bracket (5) in place and put in four bolts (6) and nuts (7).
- END OF TASK

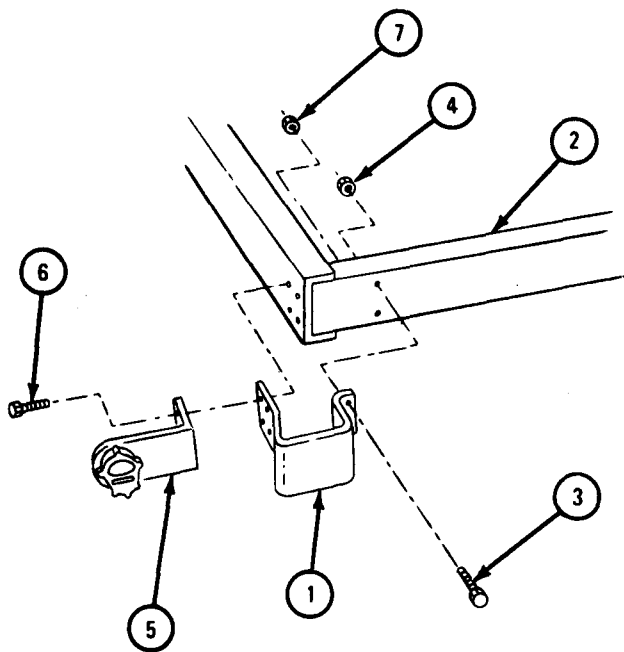
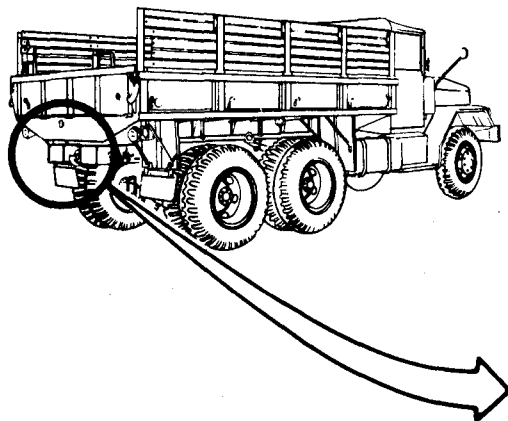

TA 105252

o. Tool Box Supports (Truck M342A2).

(1) Preliminary procedures.

(a) Remove tool box. Refer to Part 2, para 17-10.

(b) Remove spare wheel. Refer to TM 9-2320-209-10.

(2) Removal.

FRAME 1

1. Take off four screws (1) and four nuts (2).

2. Take off two screws (3), two nuts (4), four washers (5), two springs (6) and two insulators (7). Take off supports (8).

END OF TASK

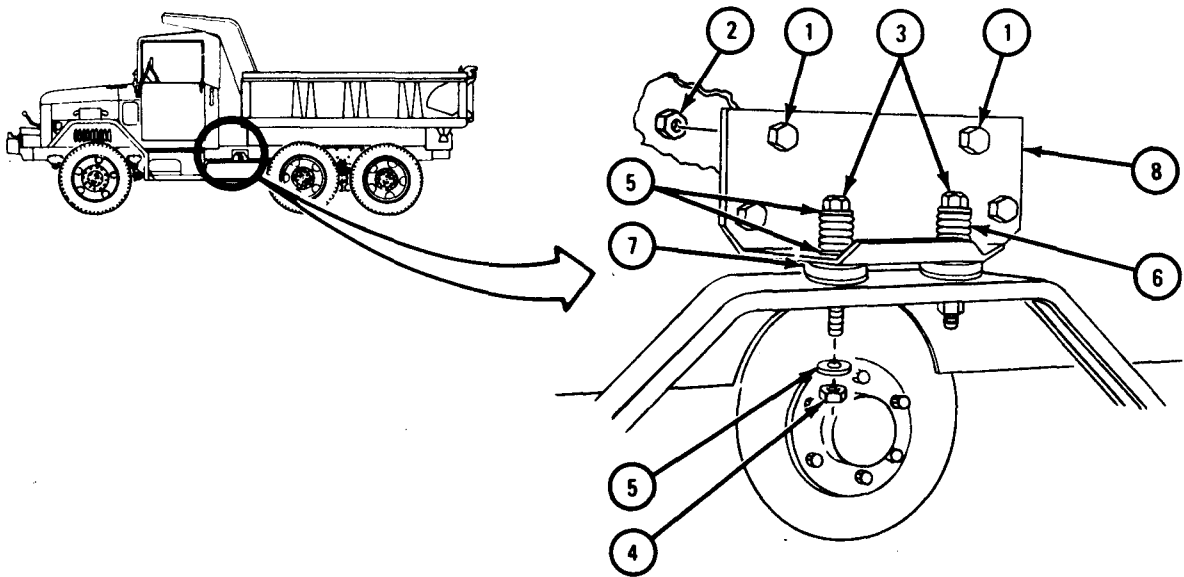

TA 105233

(3) Replacement.

FRAME 1

1. Put support (1) in place and aline screwholes.
2. Put in four screws (2) and nuts (3).
3. Put in two screws (4), six washers (5), two springs (6), two insulators (7), and two nuts (8).

NOTE

Follow-on Maintenance Action Required:

1. Replace tool box. Refer to Part 2, para 17-10.
2. Replace spare wheel. Refer to TM 9-2320-209-10.

END OF TASK

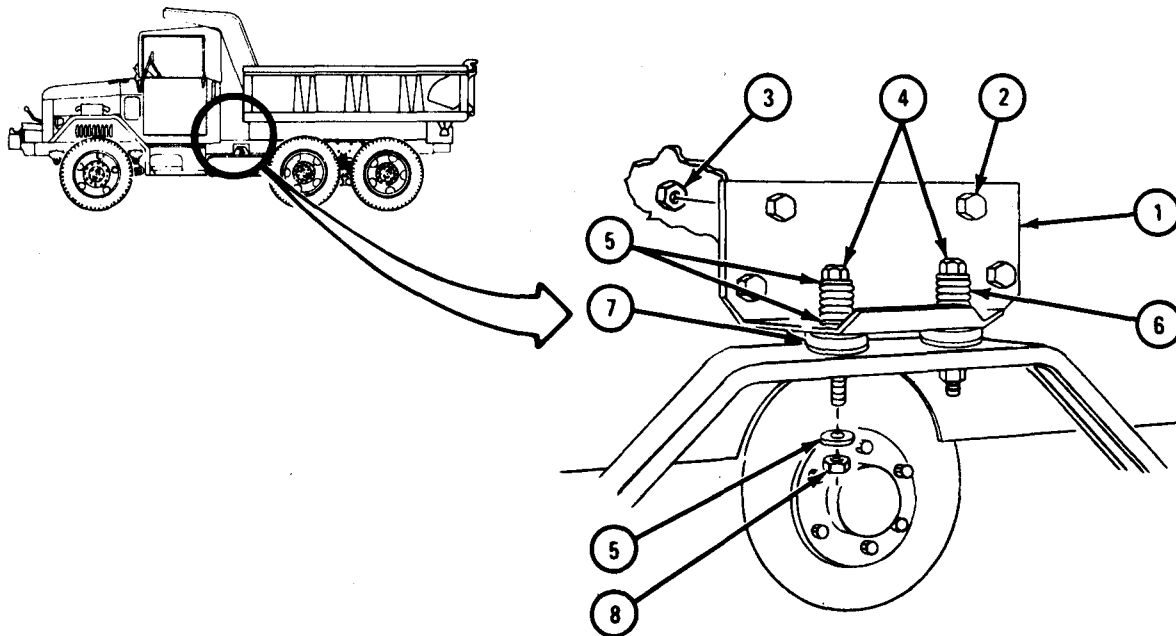

TA 105254

p. Right Running Board Supports (Truck M342A2).

- (1) Preliminary procedures.
 - (a) Remove right running board. Refer to Part 2, para 17-9.
 - (b) Remove fuel tank. Refer to TM 9-2320-209-20.
 - (c) Remove battery box. Refer to TM 9-2320-209-20.
- (2) Removal.

FRAME 1

1. Take out 16 screws (1) and 16 nuts (2).
 2. Take off running board supports (3) and fuel tank supports (4).
- END OF TASK

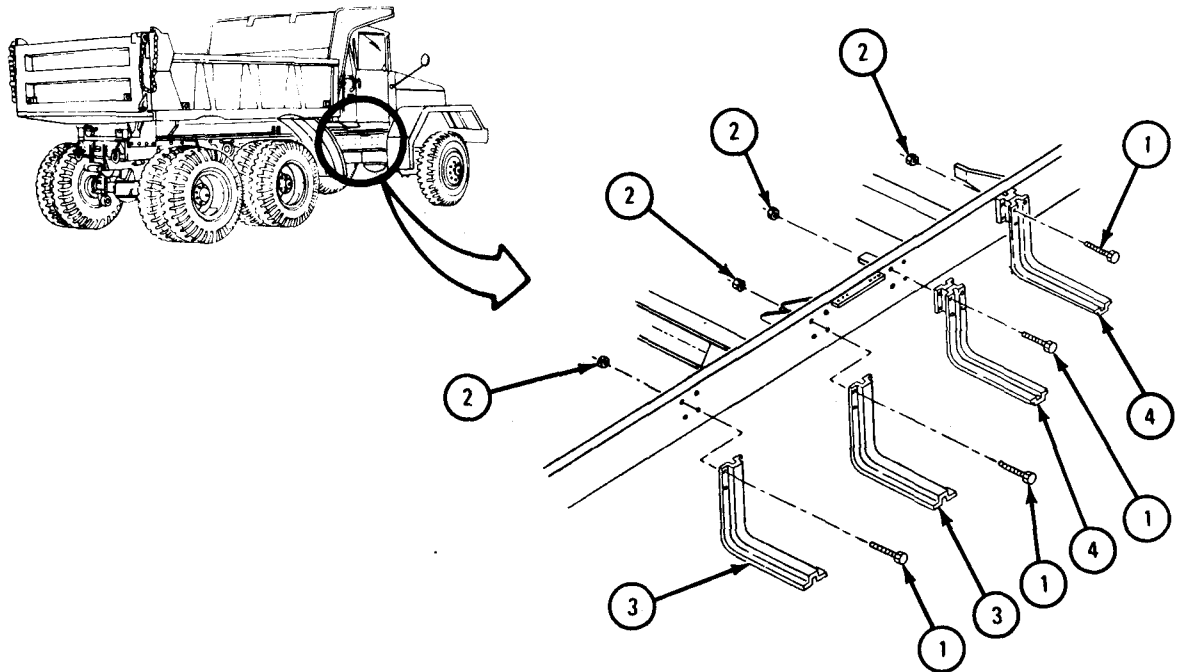

TA 105699

(3) Replacement.

FRAME 1

1. Put supports (1) and fuel tank supports (2) in place on frame (3), alining holes.
2. Put on 16 screws (4) and 16 nuts (5).

NOTE

Follow-on Maintenance Action Required:

1. Replace right running board. Refer to Part 2, para 17-9.
2. Replace fuel tank. Refer to TM 9-2320-209-20.

END OF TASK

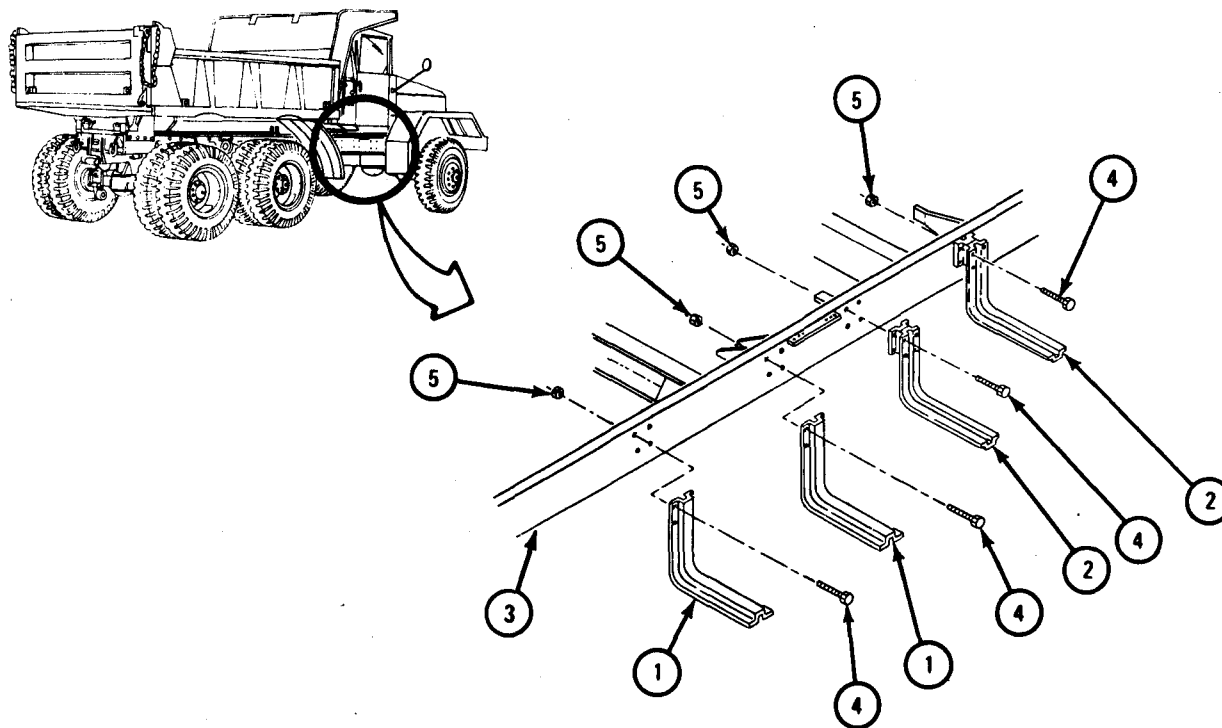

TA 105253

q. Left Running Board Supports (Truck M342A2).

(1) Preliminary procedure. Remove air reservoirs. Refer to TM 9-2320-209-20.

(2) Removal.

FRAME 1

1. Take out eight screws (1) and eight nuts (2).

2. Take off two supports (3).

END OF TASK

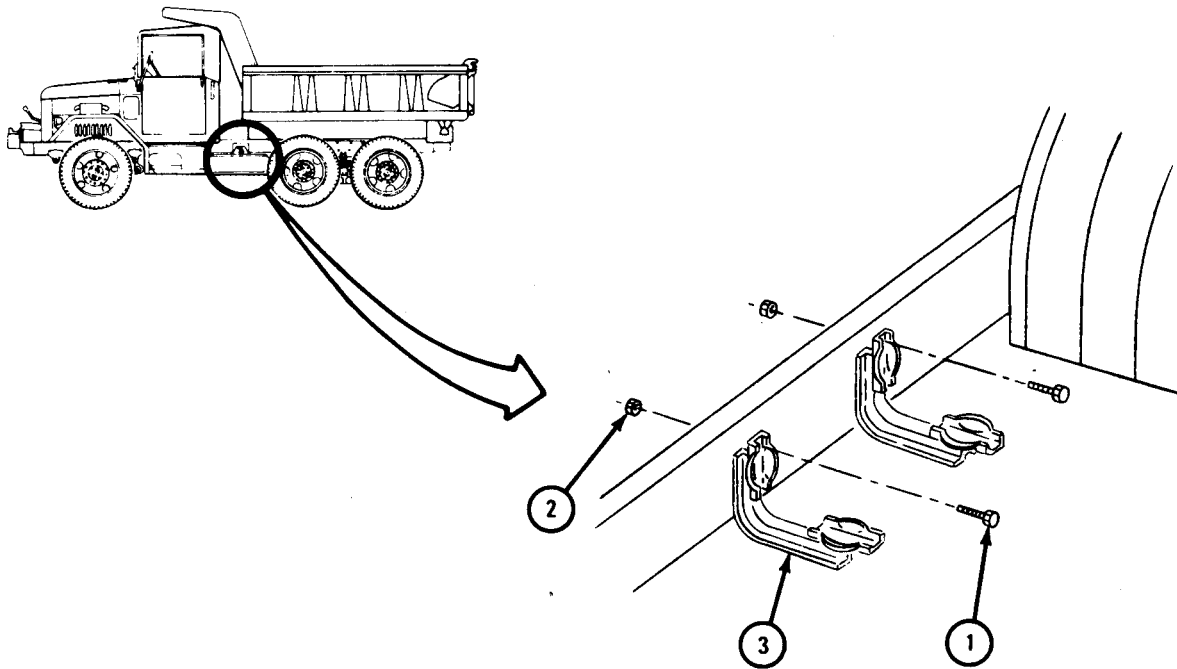

TA 105234

(3) Replacement.

FRAME 1

1. Put two supports (1) in place on frame (2).
2. Put on eight screws (3) and eight nuts (4).

NOTE

Follow-on Maintenance Action Required:

Replace air reservoirs. Refer to TM 9-2320-209-20.

END OF TASK

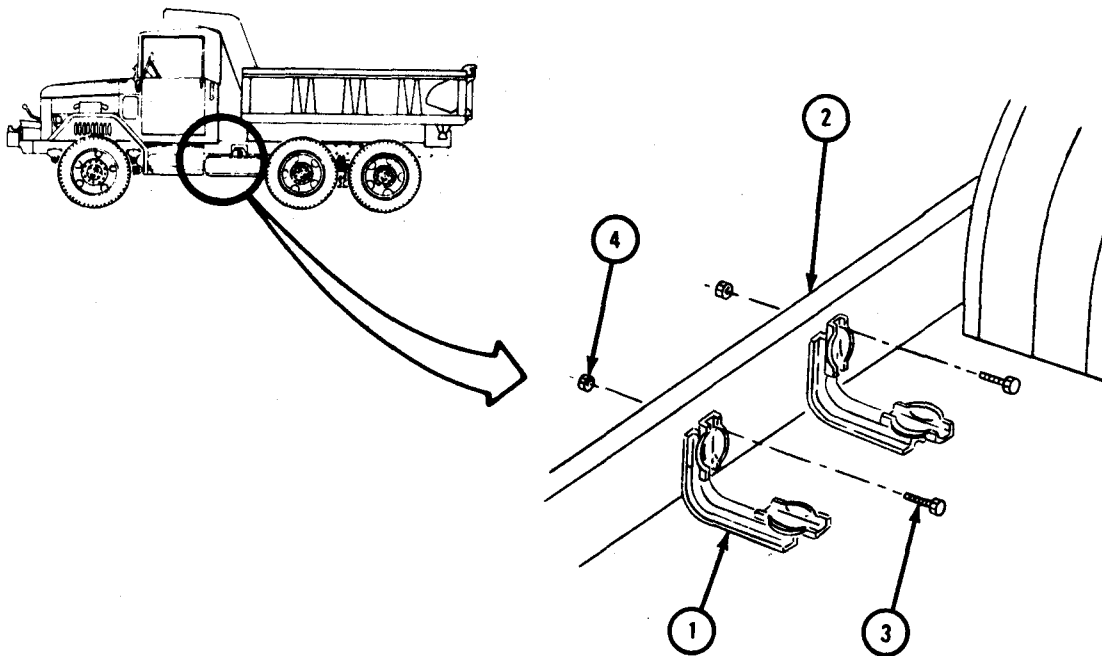

TA 105255

r. Running Board Support (Truck M342A2).

(1) Preliminary procedures.

(a) Remove left running board. Refer to Part 2, para 17-10.

(b) Remove tool box. Refer to Part 2, para 17-10.

(2) Removal.

FRAME 1

1. Take out eight screws (1) and eight nuts (2). Take off two supports (3) and support (4).

END OF TASK

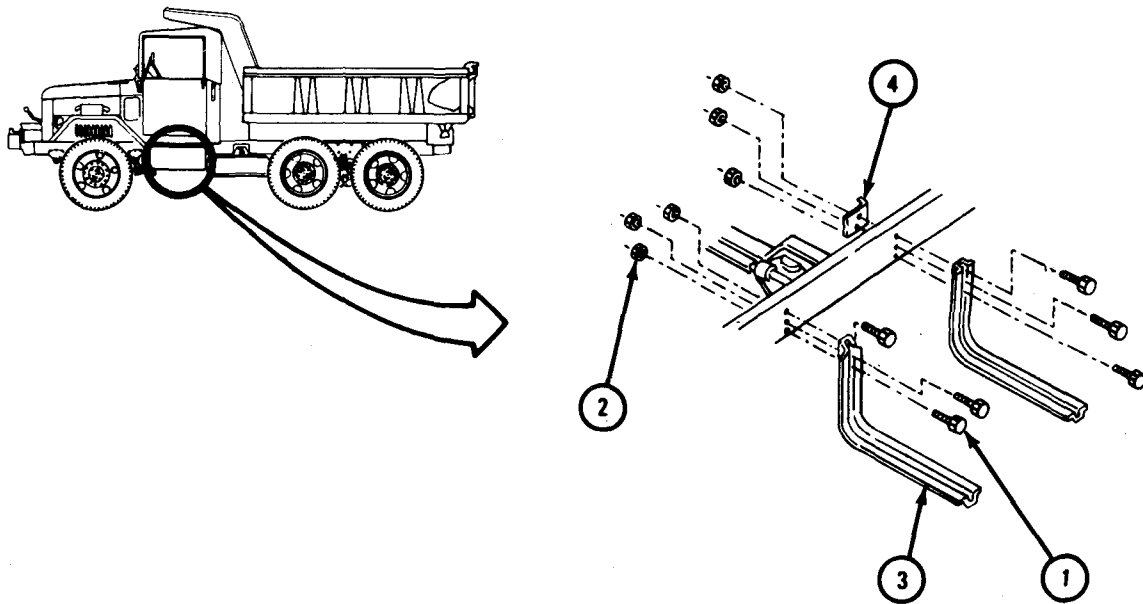

TA 105235

(3) Replacement.

FRAME 1

1. Put two supports (1) and support (2) in place and align screw holes. Put in eight screws (3) and nuts (4).

NOTE

Follow-on Maintenance Action Required:

1. Replace left running board. Refer to Part 2, para 17-10.
2. Replace tool box. Refer to Part 2, para 17-10.

END OF TASK

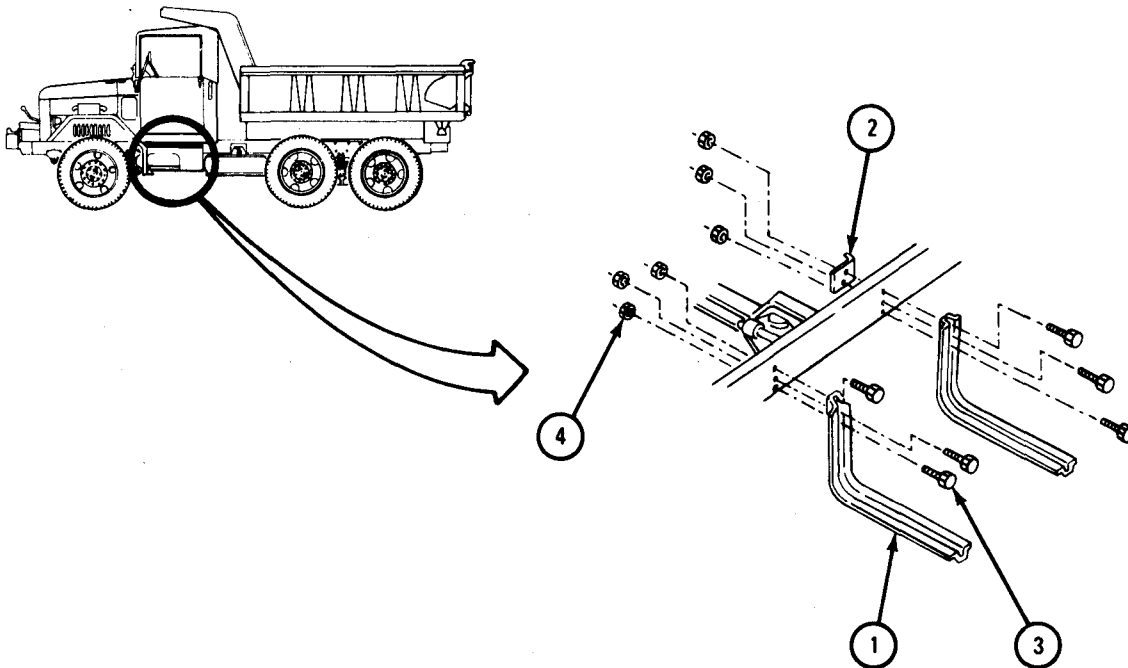

TA 105256

s. Front Fender Supports (Truck M342A2).

NOTE

This task is for the right front fender support.
This task is the same for the left front fender support.

- (1) Preliminary procedure. Remove front fender. Refer to Part 2, para 17-7.
- (2) Removal.

FRAME 1

1. Take out four screws (1), nuts (2), and lockwashers (3). Take off front fender support (4).

END OF TASK

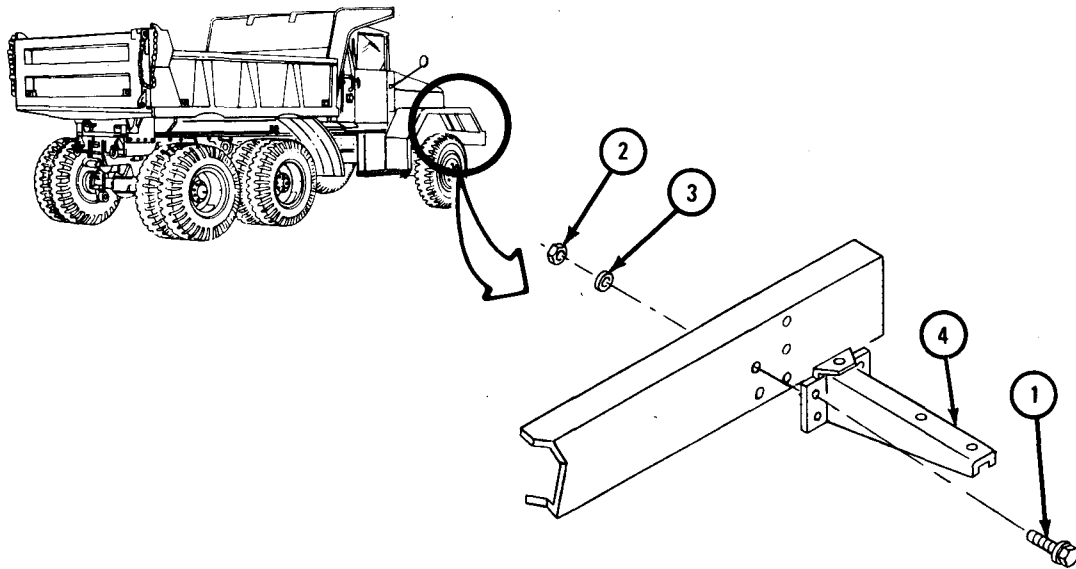

TA 105236

(3) Replacement.

FRAME 1

1. Put support (1) onto frame (2) and aline holes.
2. Put four screws (3) through support (1) and put on four nuts (4) and lockwashers (5).

NOTE

Follow-on Maintenance Action Required:
Replace front fender. Refer to Part 2, para 17-7.

END OF TASK

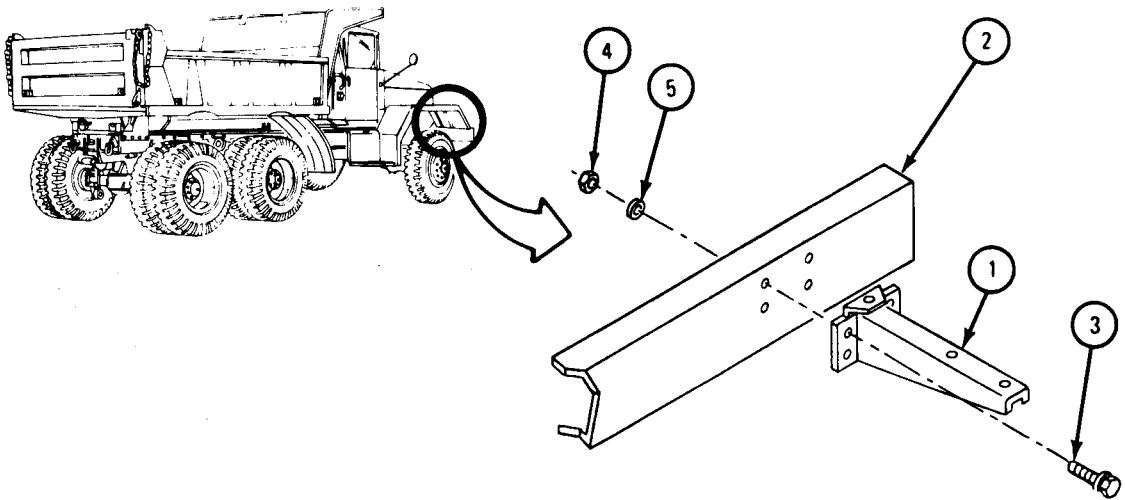

t. Fuel Filter Bracket (Truck M342A2).

(1) Preliminary procedure. Remove fuel filter. Refer to TM 9-2320-209-20.

(2) Removal.

FRAME 1

1. Take out two screws (1) and two nuts (2).

2. Take off bracket (3).

END OF TASK

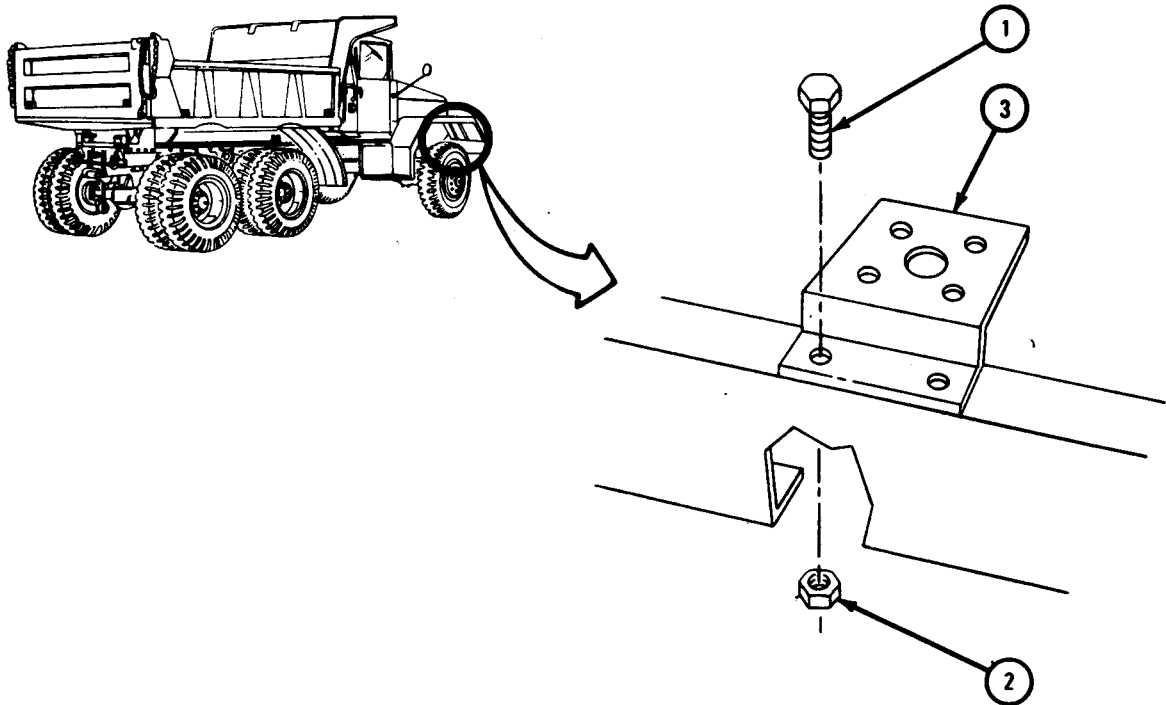

TA 105237

(3) Replacement.

FRAME 1

1. Put bracket (1) in place on frame (2). Aline holes.
2. Put in two screws (3) and two nuts (4).

NOTE

Follow-on Maintenance Action Required:
Replace fuel filter. Refer to TM 9-2320-209-20.

END OF TASK

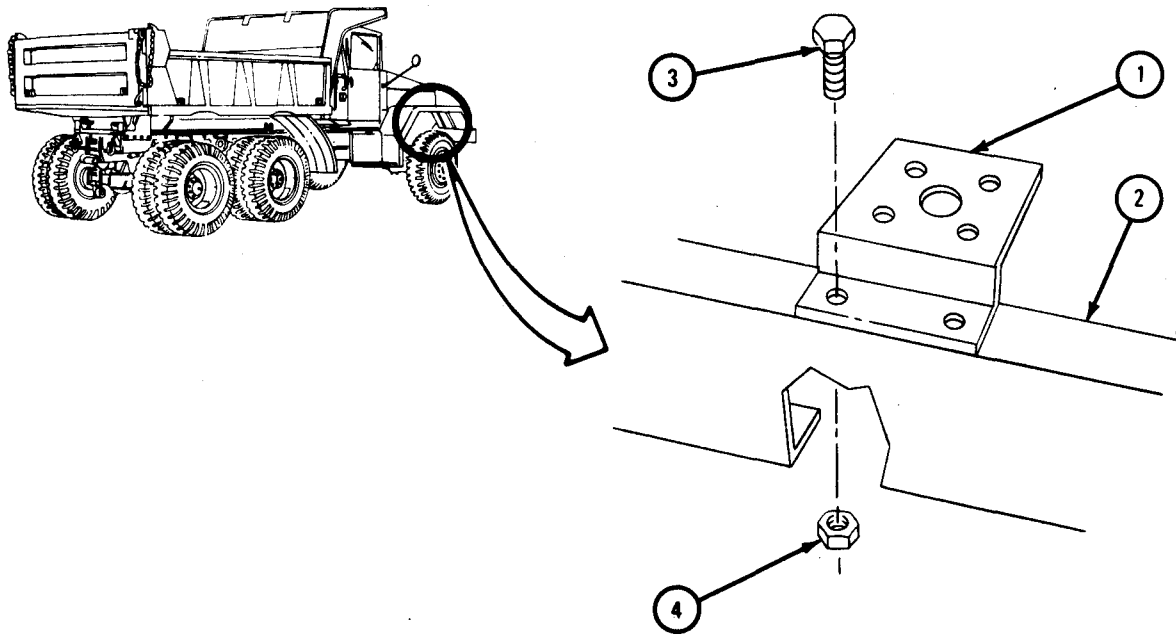

TA 105258

15-5. FRONT CROSSMEMBER REPLACEMENT KIT INSTALLATION REMOVAL AND REPLACEMENT.

TOOLS: No special tools required

SUPPLIES: Clean rags

Solvent, dry cleaning, type II (SD-2), Fed. Spec P-D-680

Front crossmember replacement kit

PERSONNEL: Two

EQUIPMENT CONDITION: Truck parked, engine off, handbrake set.

a. Preliminary Procedures.

(1) Remove radiator with ground strap. Refer to TM 9-2320-209-20.

(2) Jack up truck and support frame with jack stands. Refer to TM 9-2320-209-10.

b. Removal.

FRAME 1

1. Take out screws (1).

2. Put jack under front differential for support.

GO TO FRAME 2

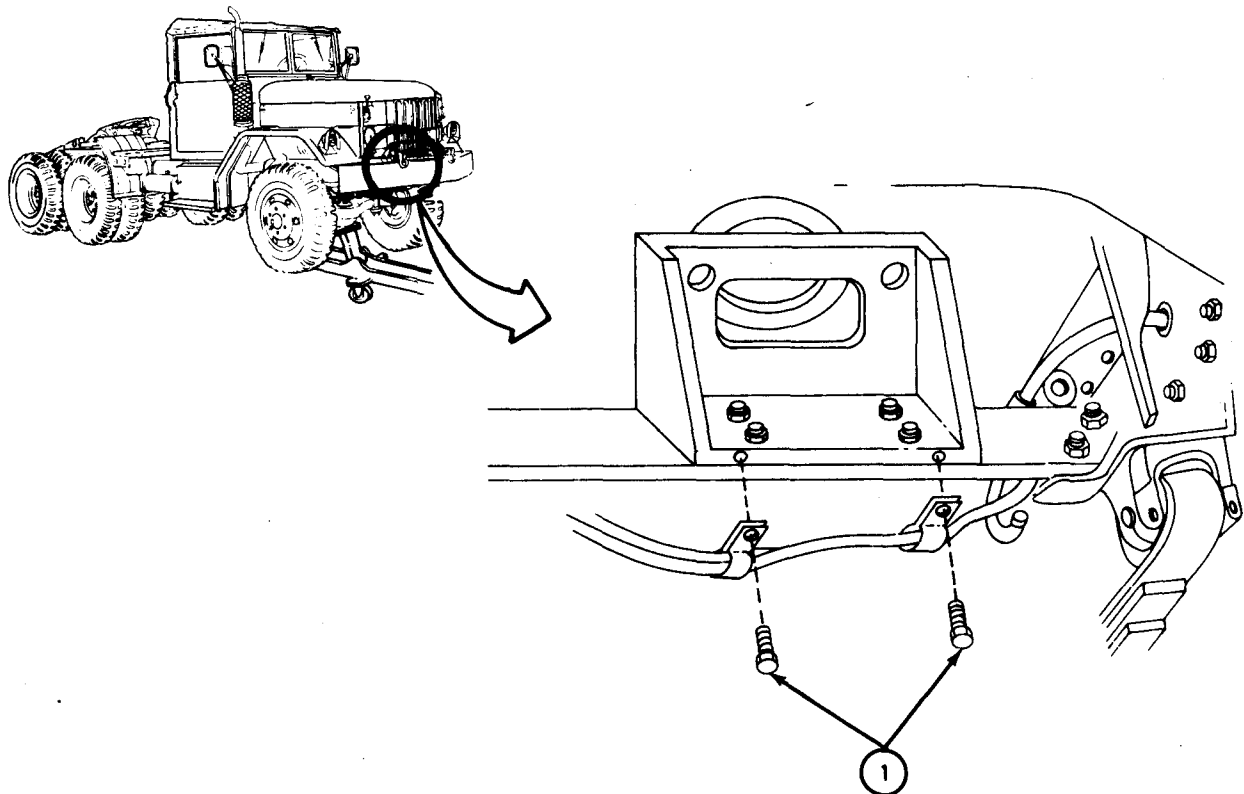

TA 118725

FRAME 2

1. Take off two nuts (1), two lockwashers (2), two bolts (3), and four resilient mounts (4).

Soldier A 2. Put hoisting chain on front lifting eye (5). Tell soldier B when ready.

Soldier B 3. Lift engine (6) approximately two inches in the front.

GO TO FRAME 3

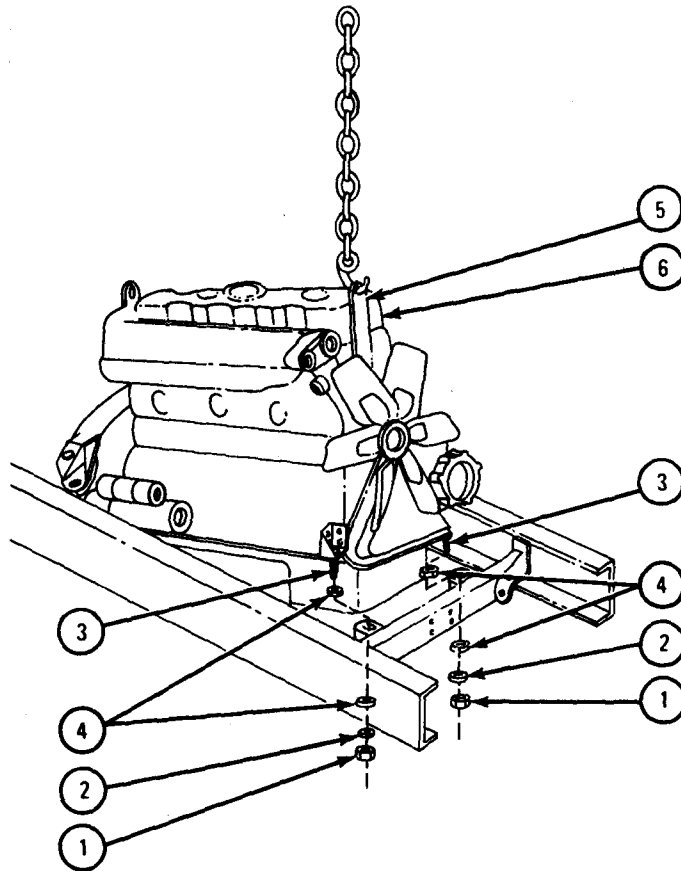

TA 118726

FRAME 3

WARNING

While working on spring, keep body clear of underside of spring. When parts are taken off, spring may come out and cause injury to personnel.

1. Take off two nuts (1), two bolts (2), and pin (3).
2. Do step 1 again for other spring hanger (4) and lower jack to drop springs (5) out of the way.

GO TO FRAME 4

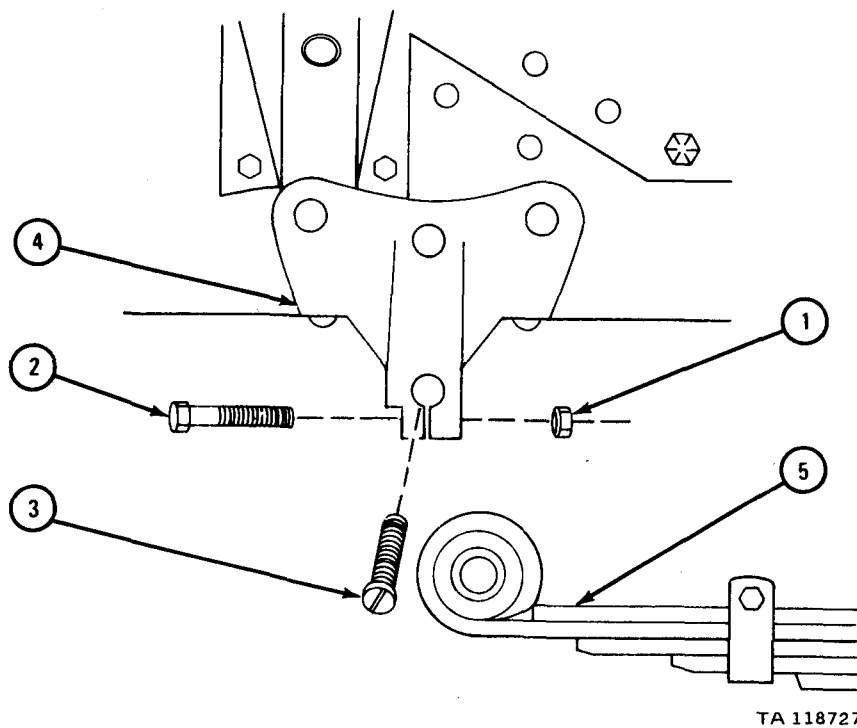

FRAME 4

1. Take off two nuts (1) and lockwashers (2).
2. Take out two screws (3).
3. Do step 1 and 2 for other side.
4. Take out eight rivets (4).
5. Take out bracket (5 and 6).
6. Do steps 4 and 5 for other side.

END OF TASK

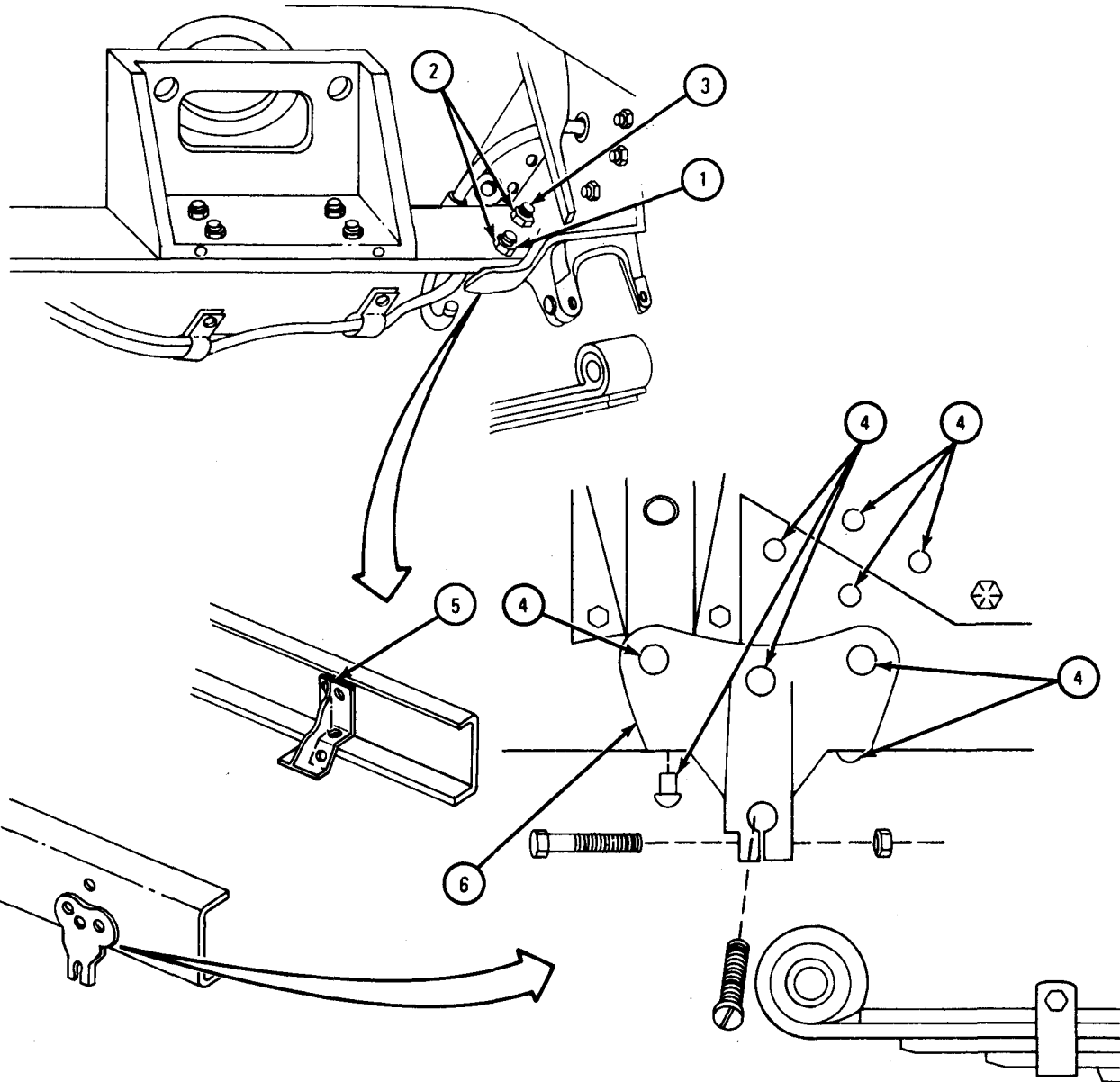

TA 118728

c. Replacement.

NOTE

For installation of engine mounts and other parts not shown here, see kit instruction sheet supplied with kit.

FRAME 1

Soldiers
A and B

1. Ream old mounting holes (1) to .4380 to .4365-inch diameter.
2. Put new front crossmember (2) in place.
3. Put in two screws and washers (3).
4. Put on two nuts and washers (4) and tighten nuts to 35 to 40 pound-feet.
5. Put bracket (5) in place.
6. Put in three screws and washers (6).
7. Put on three washers and nuts (7) and tighten nuts to 35 to 40 pound-feet.
8. Do steps 1 through 6 for other side.

GO TO FRAME 2

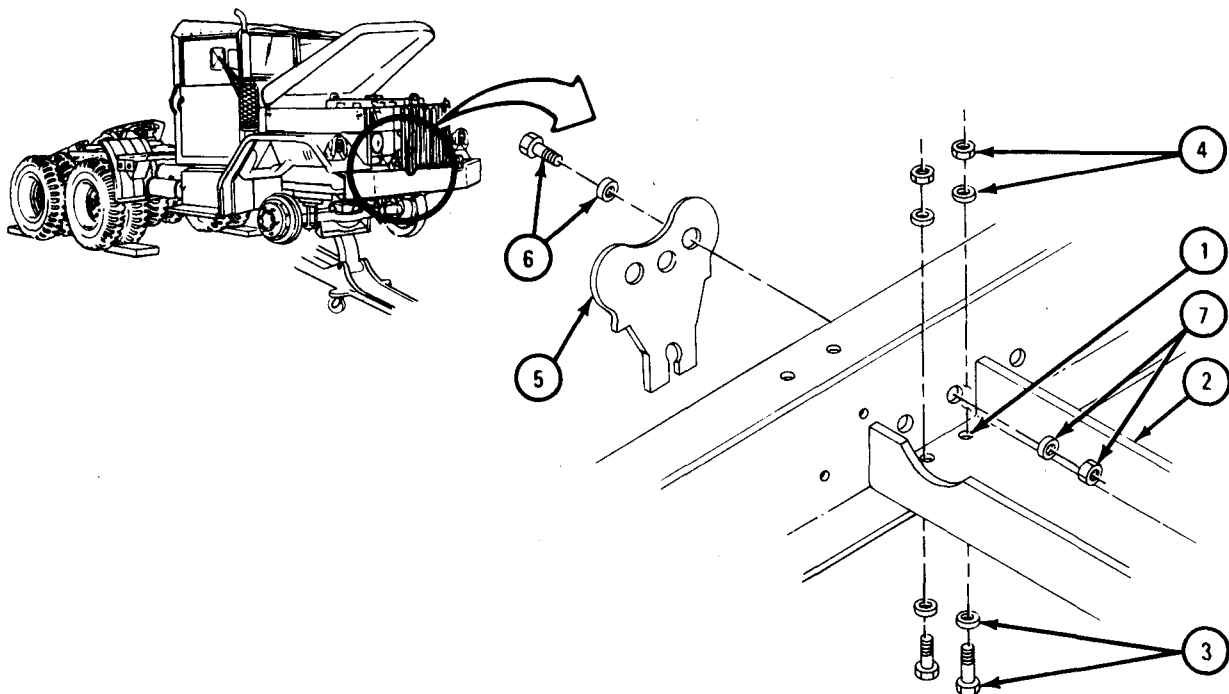

TA 101860

FRAME 2

Soldier A 1. Using hoisting chain, lower engine (1). Tell soldier B when ready.

Soldier B 2. Put back two bolts (2), four resilient mounts (3), two lockwashers (4), and two nuts (5).

Soldier A 3. Take hoisting chain off lifting eye (6).

GO TO FRAME 3

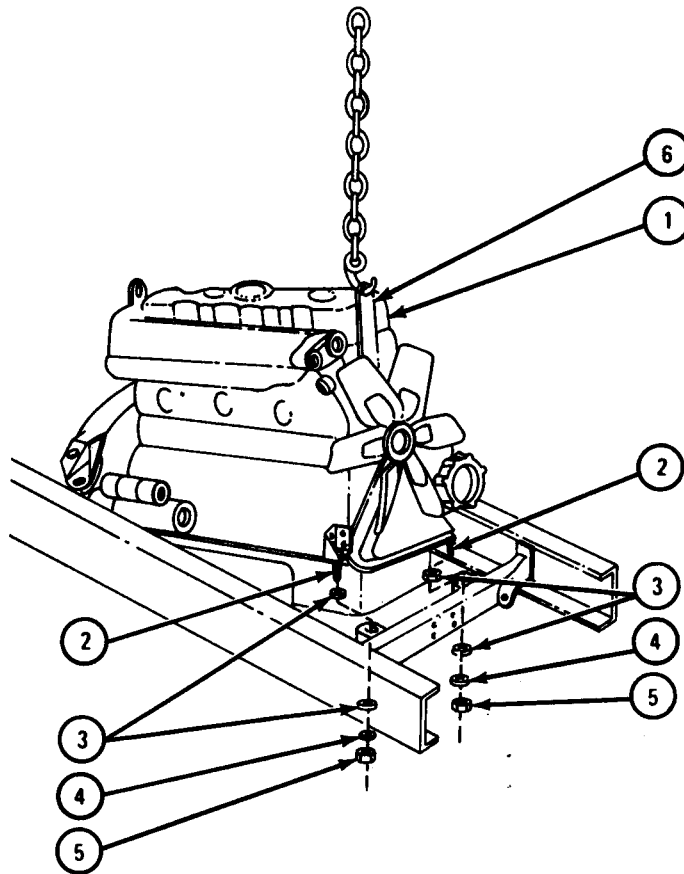

TA 121042

FRAME 3

Soldier A 1. Raise front axle assembly to aline hole in spring (1) to hole in spring hanger (2).

Soldier B 2. Aline slot in pin (3) with screw hole in spring hanger (2).

3. Put in two screws (4) and two nuts (5).

4. Do step 2 again for other spring hanger (2).

GO TO FRAME 4

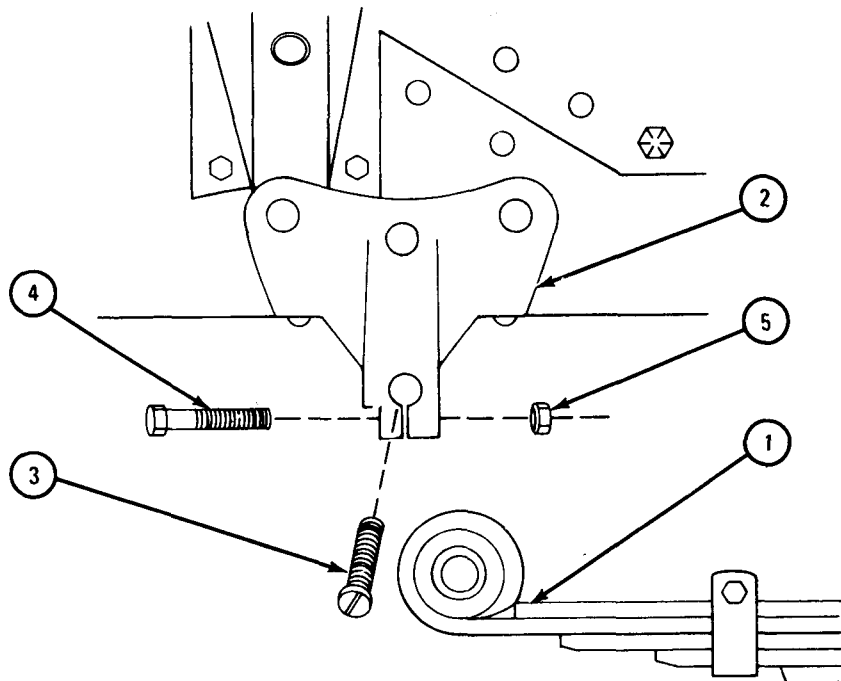

TA 121041

FRAME 4

1. Put two clamps (1) in place and aline screwholes. Put in two screws (2).

NOTE

Follow-on Maintenance Action Required:

1. Jack up truck and remove jack stands. Refer to TM 9-2320-209-10.
2. Replace radiator with ground strap. Refer to TM 9-2320-209-20.

END OF TASK

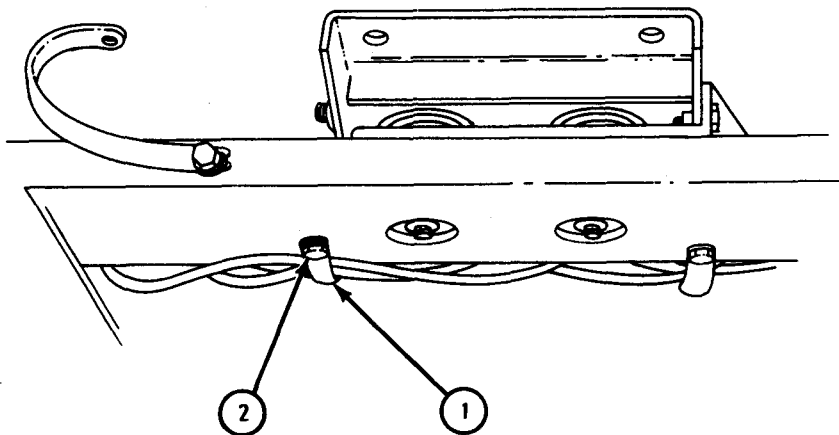

TA 101864

Section III. FIFTH WHEEL ASSEMBLY

15-6. FIFTH WHEEL ASSEMBLY, DISASSEMBLY AND REPAIR.

TOOLS: No special tools required

SUPPLIES: Safety wire
Solvent, dry cleaning, type II (SD-2), Fed. Spec P-D-680
Rags
Cotter pins

PERSONNEL: Two

EQUIPMENT CONDITION: Truck parked, engine off, handbrake set.

a. Preliminary Procedure. Remove fifth wheel assembly. Refer to TM 9-2320-209-20.

b. Disassembly.

FRAME 1

WARNING

The fifth wheel is heavy and bulky. Make sure there is enough clearance around working area before lifting unit to avoid injury to personnel and damage to equipment.

1. Take off nut (1) and lockwasher (2). Take out screw (3) from lateral pivot shaft (4).
2. Take out lube fittings (5) from top of walking beam (6).

GO TO FRAME 2

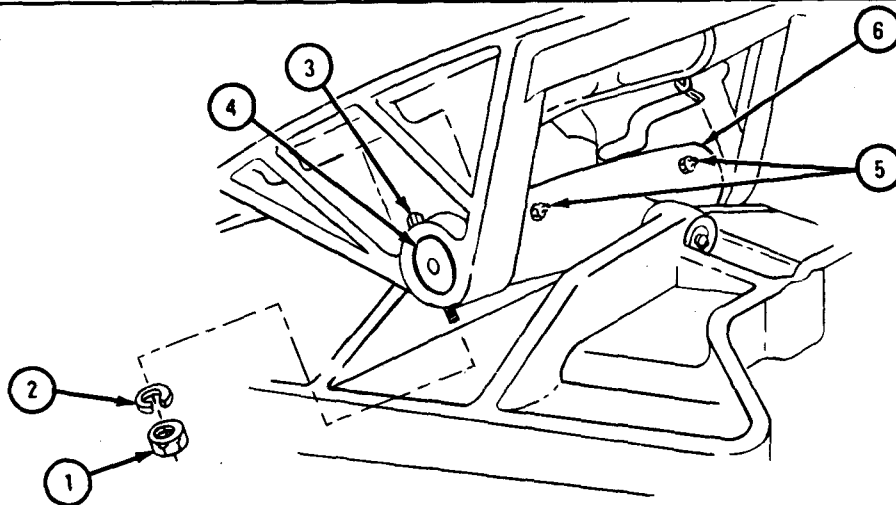

TA 084293

FRAME 2

- Soldier A 1. Using chain hoist, lift base (1) off walking beam (2).
- Soldier B 2. Drive lateral pivot shaft (3) out of walking beam (2).
- Soldier A 3. Using chain hoist, lift base (1) and set it upside down.
- GO TO FRAME 3

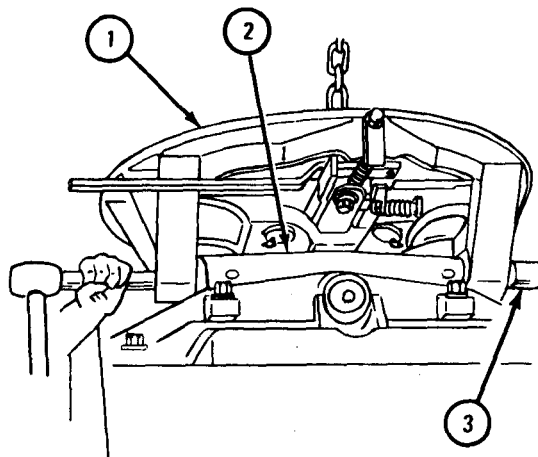

TA 084294

FRAME 3

1. Take out two lube fittings (1).
2. Drive base pivot shaft (2) out of walking beam (3).
3. Lift walking beam off subbase (4) and set it aside.

GO TO FRAME 4

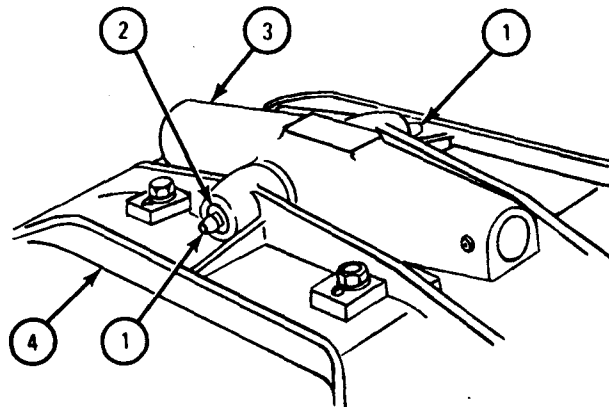

TA 084295

FRAME 4

1. Take off two leveling springs (1).
2. Take out two capscrews (2), two washers and lockwashers (3), and two nuts (4).
3. Take out two adjusting wedges (5).

GO TO FRAME 5

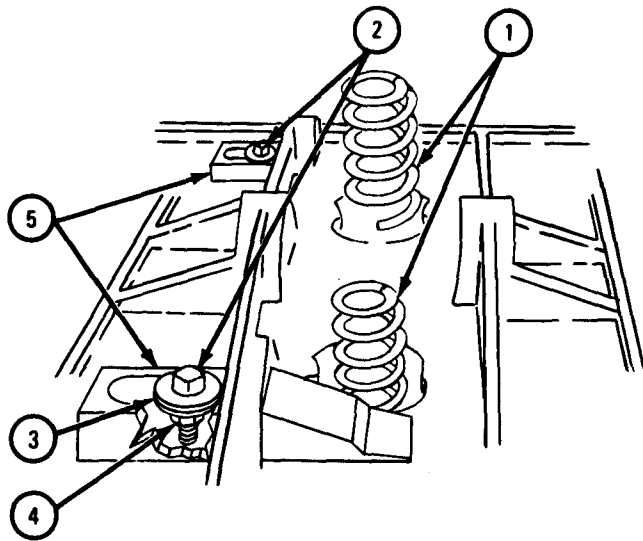

TA 084296

FRAME 5

1. Take out and throw away cotter pin (1).
2. Take out nut and washer (2).
3. Take out two cotter pins (3) and throw them away.
4. Take out two nuts and washers (4).
5. Unhook locking plunger latch spring (5).
6. Take out locking plunger latch (6).

GO TO FRAME 6

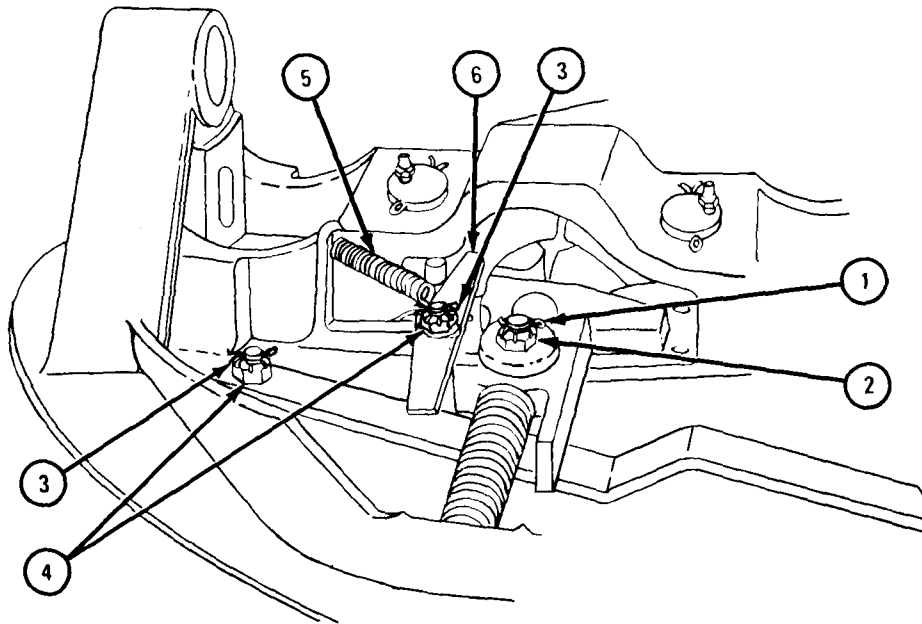

TA 084297

FRAME 6

WARNING

Plunger spring (1) is under tension. Be careful while removing or injury to personnel may result.

NOTE

On some trucks the locking assembly sleeve (2) is welded into place.

1. Lift and take out locking plunger lever (3), locking plunger (4), locking plunger spring (1), and locking assembly sleeve (2).
2. Take out safety latch screw (5) and take out safety latch (6).

GO TO FRAME 7

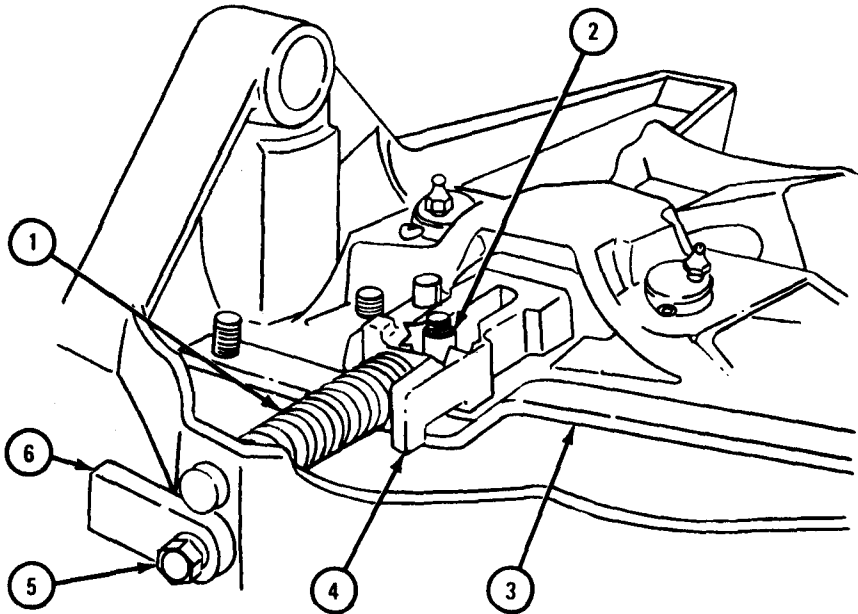

TA 084298

FRAME 7

1. Take out and throw away two cotter pins (1).
2. Take out four lube fittings (2).

GO TO FRAME 8

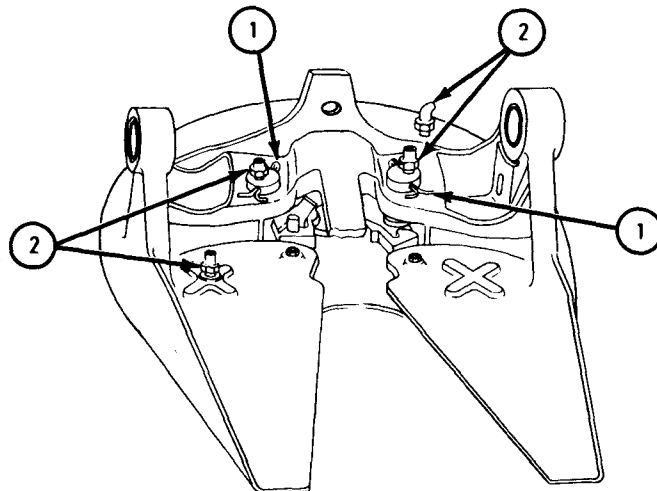

TA 084299

FRAME 8

Soldier A 1. Using chain hoist, turn base (1) on its side and push out two jaw coupler pins (2).

Soldier B 2. Take out two coupler jaws (3).

Soldier A 3. Using chain hoist, set base (1) upside down again.

END OF TASK

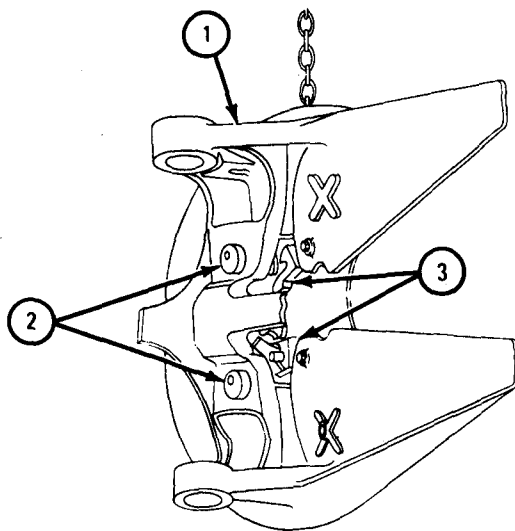

TA 084300

c. Cleaning.WARNING

Dry cleaning solvent is flammable. Do not use near an open flame. Keep a fire extinguisher nearby when solvent is used. Use only in well-ventilated places. Failure to do this may result in injury to personnel and damage to equipment.

- (1) Clean large parts with steam and wire brush.
- (2) Clean small parts with solvent.
- (3) Make sure all grease passages are clean.

d. Inspection.

FRAME 1

1. Check that base (1) and subbase (2) are not cracked.
2. Check that all other parts are not cracked, pitted, bent or worn.

END OF TASK

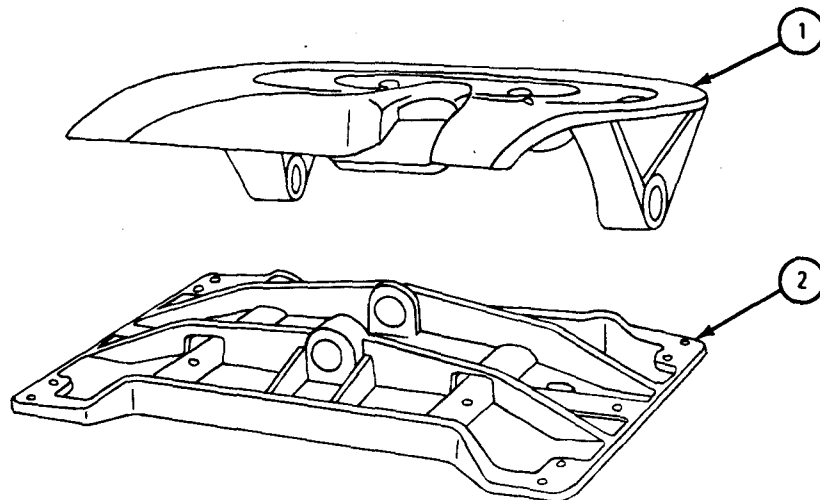

TA 084301

e. Repair.

(1) If subbase is cracked, weld it. Refer to TM 9-237. Weld only cracks found in center of base or subbase. If more fixing is needed, throw part away and get a new one.

(2) If other parts are damaged, throw them away and get new ones.

f. Assembly.

FRAME 1

- Soldier A 1. Using chain hoist, turn base (1) on its side.
- Soldier B 2. Push two jaw coupler pins (2) partway through base (1).
- Soldier A 3. Put coupler jaws (3) on coupler pins (2) and seat coupler pins.
4. Using chain hoist, set base (1) upside down again.

GO TO FRAME 2

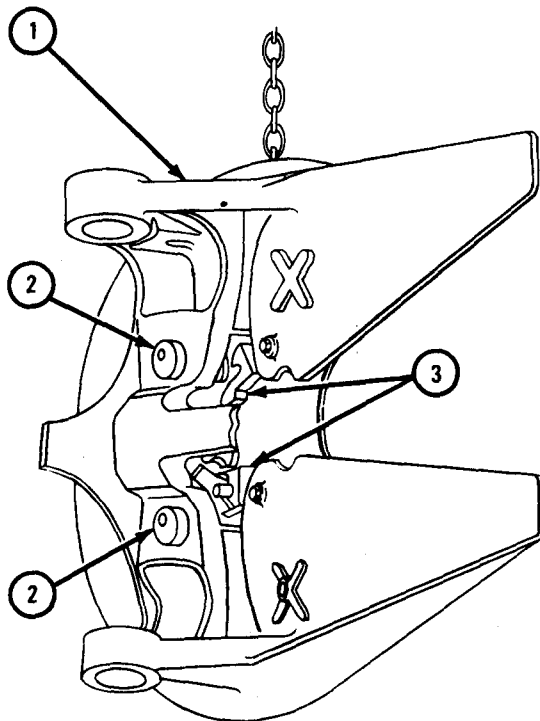

TA 084302

FRAME 2

1. Put two cotter pins (1) in pivot pins (2).
2. Put four lube fittings (3) in place.

GO TO FRAME 3

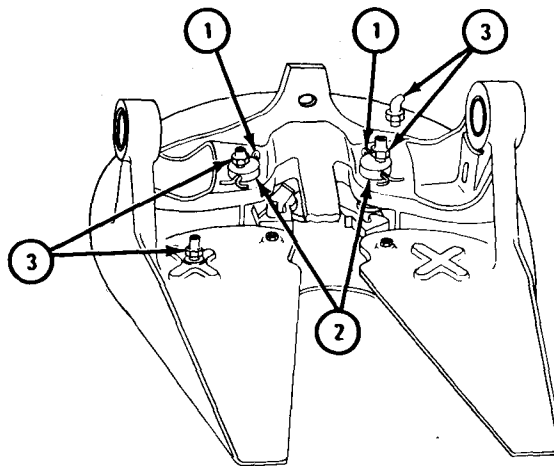

TA 084303

FRAME 3

1. Put safety latch screw (1) through safety latch (2) into base (3).
2. Put locking plunger lever (4) in place on stud (5).
3. Put on nut and washer (6). Put in cotter pin (7).

NOTE

On some trucks, locking assembly sleeve (8) is welded into place and was not removed.

4. Put locking assembly sleeve (8) on stud (9).

GO TO FRAME 4

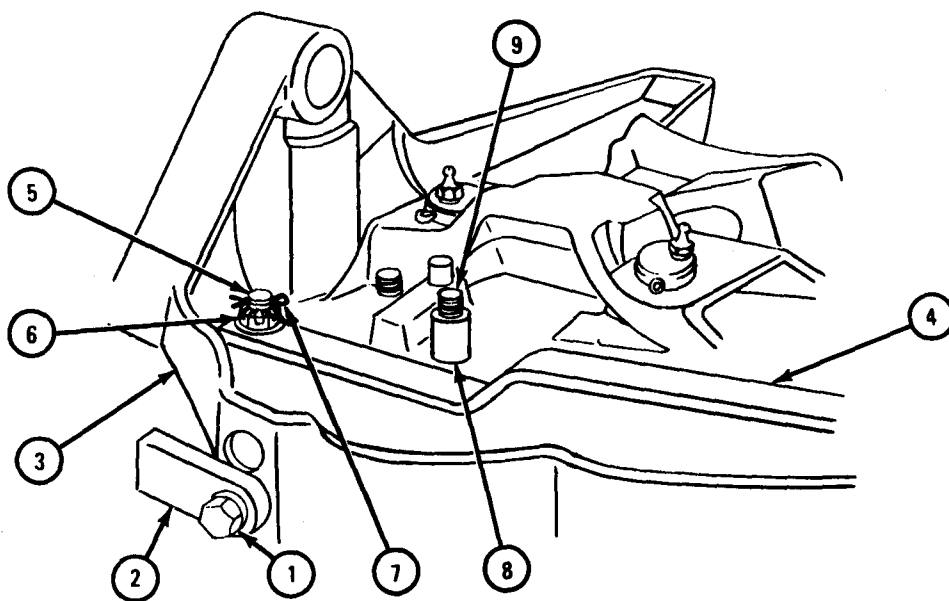

TA 084304

FRAME 4

WARNING

Plunger spring (1) is under tension. Be careful when putting it back or injury to personnel may result.

1. Put spring (1) in place on locking plunger (2).
2. Push locking plunger (2) through hole in base (3) and over stud (4).
3. Put on nut and washer (5).
4. Put in cotter pin (6).

GO TO FRAME 5

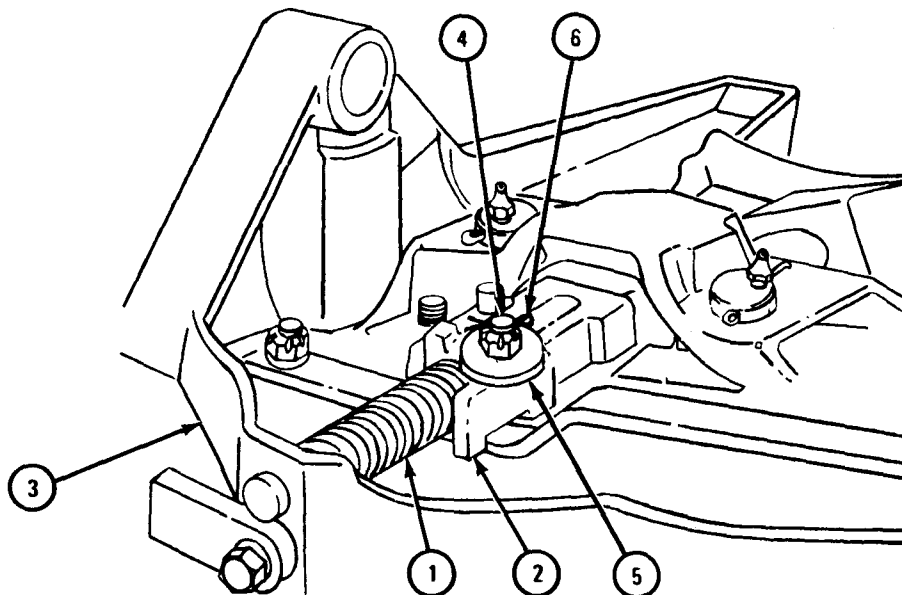

TA 084305

FRAME 5

1. Put locking plunger latch (1) on stud (2).
2. Put on nut and washer (3).
3. Put in cotter pin (4).
4. Hook locking plunger latch spring (5) in holes of base (6) and locking plunger latch (1).
5. Pull locking plunger lever (7) forward and check that locking plunger latch (1) locks plunger (8) in forward position.

GO TO FRAME 6

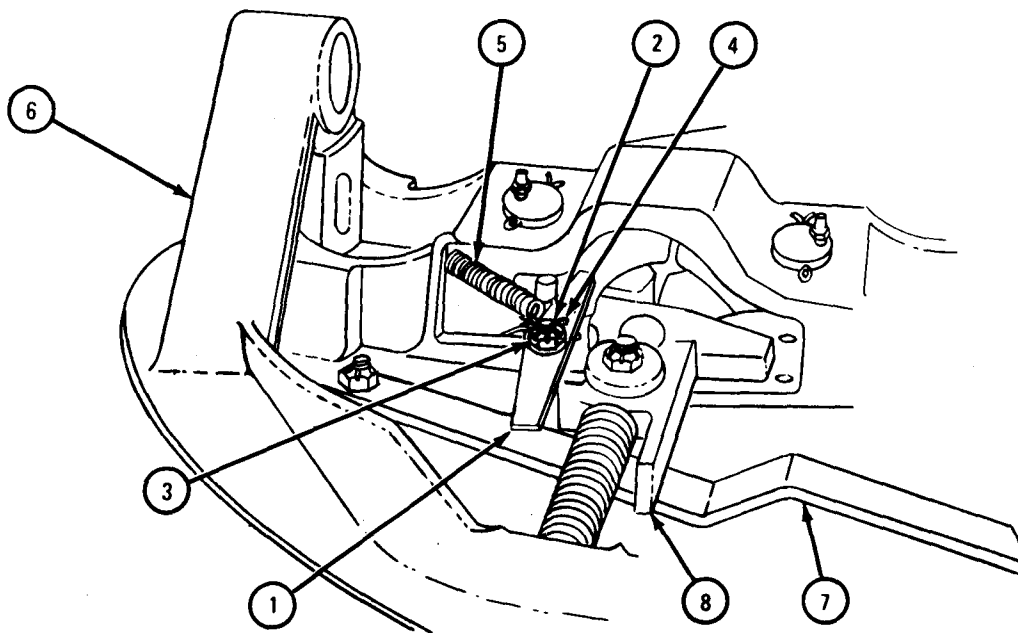

TA 084306

FRAME 6

1. Put in two leveling springs (1).

GO TO FRAME 7

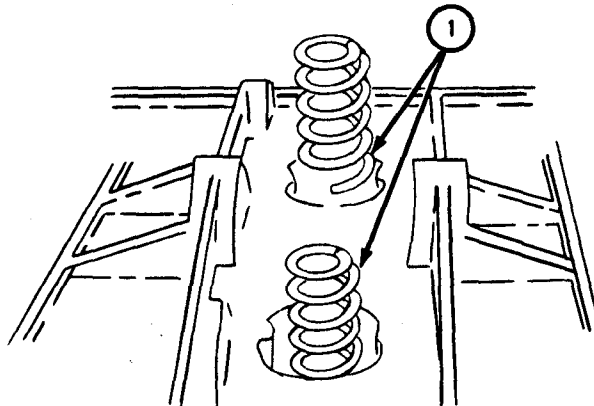

TA 084308

FRAME 7

- Soldier A 1. Using pry bar chain and block of wood, push walking beam (1) down on subbase (2) and aline holes in walking beam with holes in subbase.
- Soldier B 2. Make sure groove (3) in base pivot shaft (4) is facing up. Drive pivot shaft into subbase and walking beam (1).
- GO TO FRAME 8

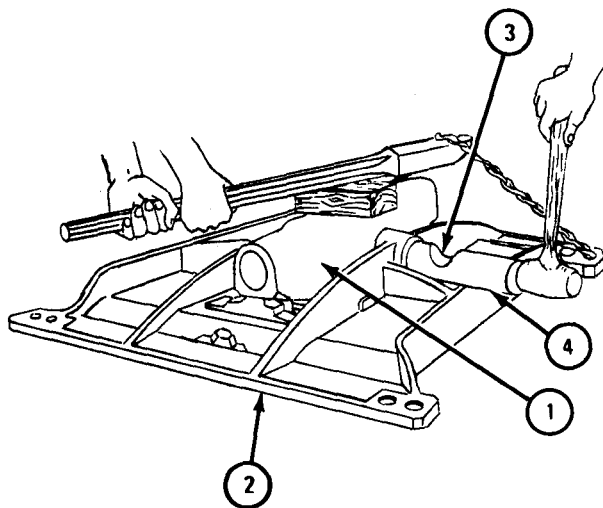

TA 084309

FRAME 8

1. Put two lube fittings (1) into ends of base pivot shaft (2).

GO TO FRAME 9

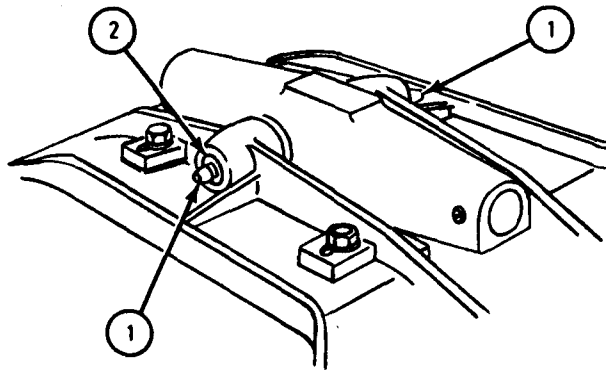

TA 084310

FRAME 9

- Soldier A 1. Using chain hoist, place base (1) in mounting position on walking beam (2). Aline holes in base with holes in walking beam.
- Soldier B 2. Start lateral pivot shaft (3) in hole in base (1). Make sure screw in lateral pivot shaft lines up with screw hole in walking beam (2).
3. Drive base lateral pivot shaft (3) into centered position in base (1) and walking beam (2).

GO TO FRAME 10

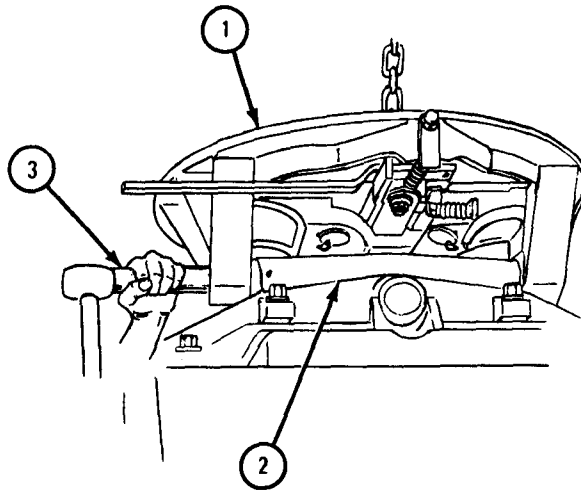

TA 084311

FRAME 10

1. Push screw (1) through holes in walking beam (2) and base shaft (3). Put lockwasher (4) and nut (5) on screw.
2. Put in two lubrication fittings (6).

GO TO FRAME 11

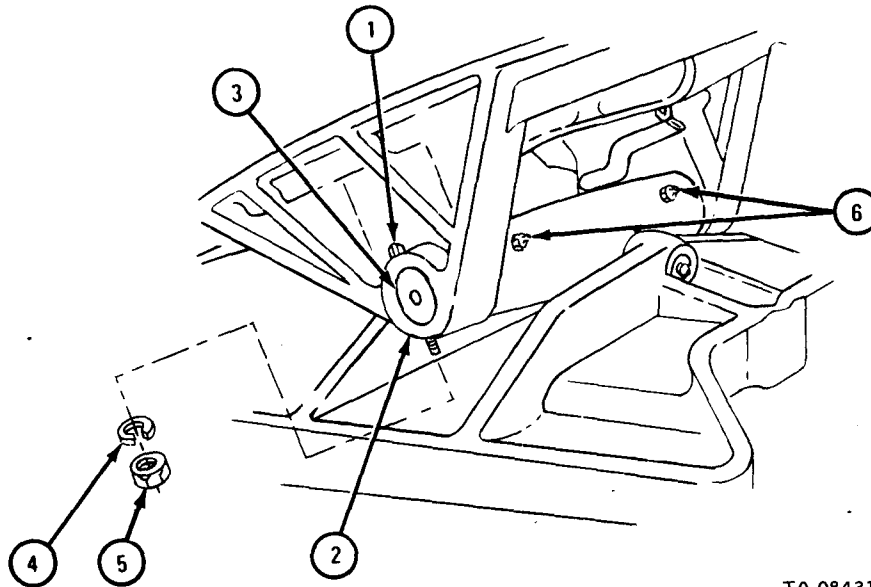

TA 084312

FRAME 11

1. Put two wedges (1) into position on subbase (2).
2. Put two lockwashers (3) and flatwashers (4) on screws (5) and put in screws.

NOTE

Follow-on Maintenance Action Required:

1. Replace fifth wheel assembly. Refer to TM 9-2320-209-20.
2. Lubricate fifth wheel assembly. Refer to LO 9-2320-209-12/1.

END OF TASK

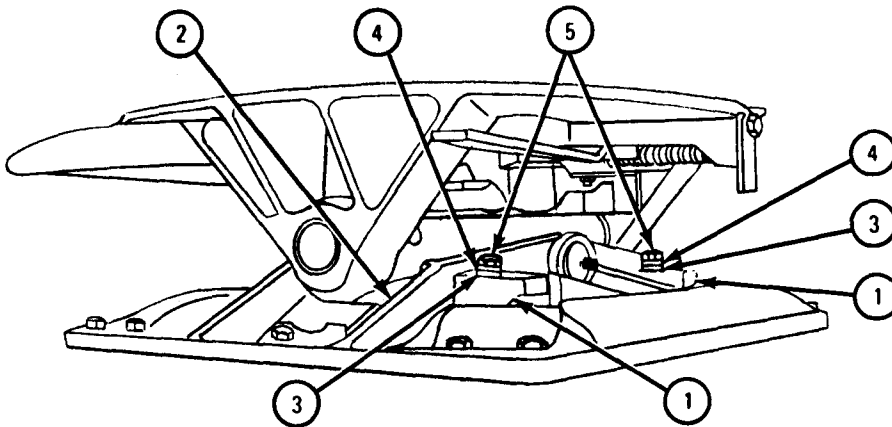

TA 084313

CHAPTER 16

SPRINGS GROUP MAINTENANCE

Section I. SCOPE

16-1. **EQUIPMENT ITEMS COVERED.** This chapter gives equipment maintenance procedures for the springs for which there are authorized corrective maintenance tasks at the direct and general support maintenance levels.

16-2. **EQUIPMENT ITEMS NOT COVERED.** All equipment items for which corrective maintenance is authorized at the direct and general support maintenance levels are covered in this chapter.

Section II. SPRINGS

16-3. **DRILLING AND TAPPING REAR SPRING SEAT FOR LUBRICATION.**

NOTE

Drill and tap rear spring seats at yearly or 6,000 mile maintenance or when spring or spring seat is being worked on. Do not take trucks away from normal duties to have holes drilled. Lubrication should be done about every 1,500 miles.

TOOLS: No special tools required

SUPPLIES: Plug, pn 96906-20913-15
Lubrication fitting

PERSONNEL: One

EQUIPMENT CONDITION: Truck parked, engine off, handbrake set.

a. Installation of Lubrication Plug.

FRAME 1

1. Drill a 0.339-inch hole (1) in bottom center of spring seat (2).
2. Tap hole (1) using 1/8-27 NPSF thread tap.
3. Put in plug (3).

GO TO FRAME 2

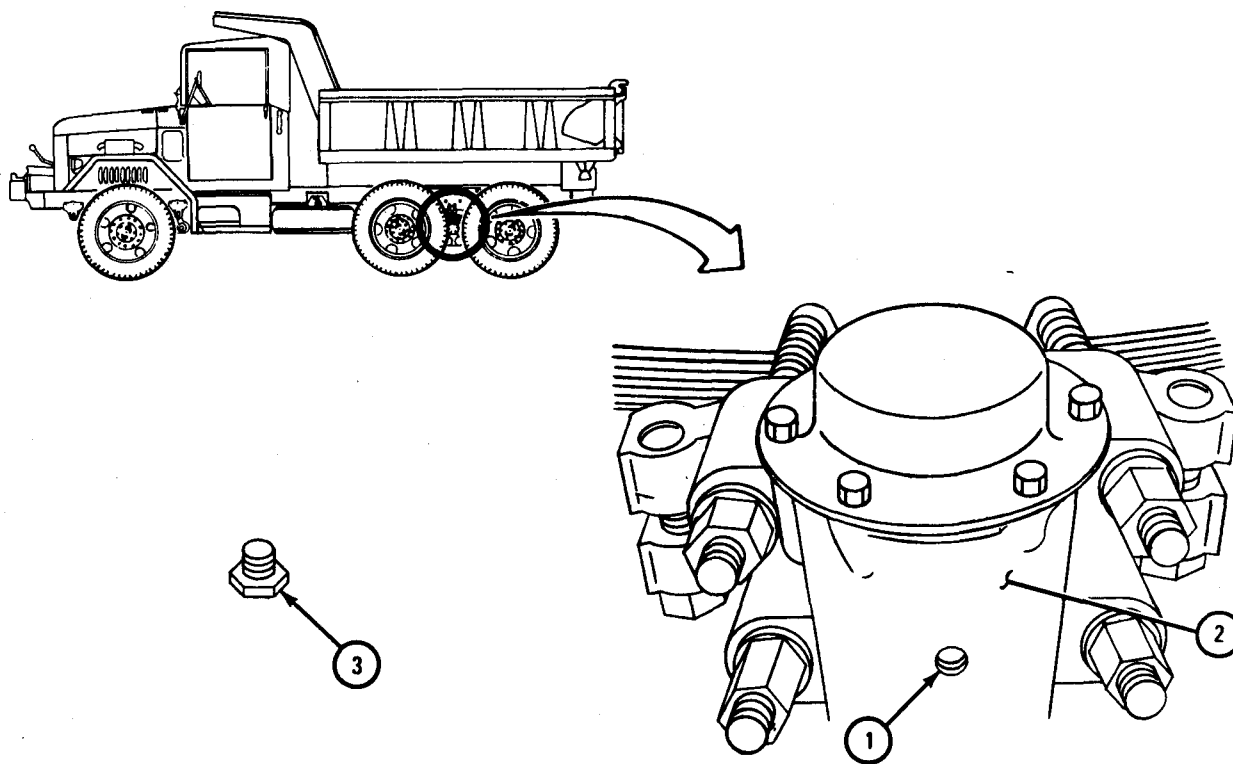

TA085111

FRAME 2

1. Drill hole (1) through spring seat (2).

NOTE

All dimensions shown are in inches.

END OF TASK

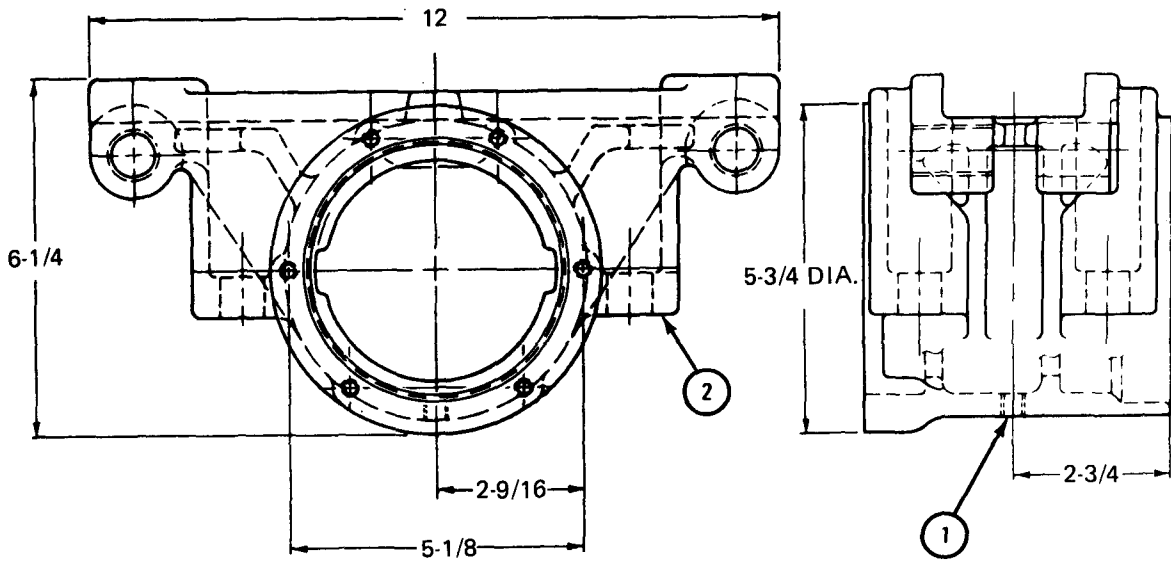

TA 084128

b. Lubrication of Rear Spring Seat.

FRAME 1

1. Take plug (1) out of hole (2).
2. Put lubrication fitting (3) in hole (2).
3. Grease spring seat (4). Refer to LO 9-2320-209-12/1.
4. Take out lubrication fitting (3).
5. Put in plug (1).

END OF TASK

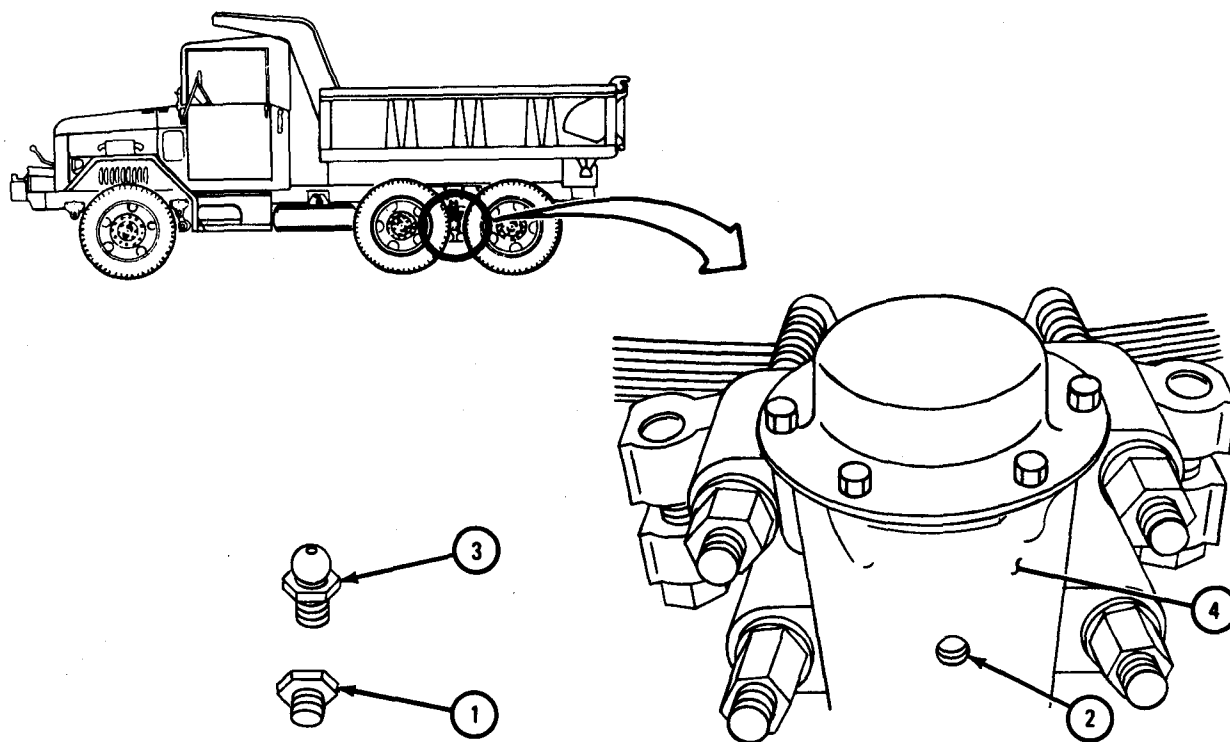

TA085112

By Order of the Secretaries of the Army and the Air Force:

E. C. MEYER
General, United States Army
Chief of Staff

Official:

J. C. PENNINGTON
Major General, United States Army
The Adjutant General

LEW ALLEN, JR., General, USAF
Chief of Staff

Official:

VAN L. CRAWFORD, JR., Colonel, USAF
Director of Administration

Distribution:

To be distributed in accordance with DA Form 12-38, Direct and General Support Maintenance requirements for 2-1/2 Ton Truck Cargo, and 2-1/2 Ton Truck Van, etc.



RECOMMENDED CHANGES TO EQUIPMENT TECHNICAL PUBLICATIONS



THEN... JOT DOWN THE DOPE ABOUT IT ON THIS FORM, CAREFULLY TEAR IT OUT, FOLD IT AND DROP IT IN THE MAIL!

SOMETHING WRONG WITH THIS PUBLICATION?

FROM: (PRINT YOUR UNIT'S COMPLETE ADDRESS)

CDR, 1st Bn, 65th ADA
Attn: SP4 Jane Idone
Key West, FL 33040

DATE SENT

Date sent in

PUBLICATION NUMBER

TM 9-2320-209-34-2-1

PUBLICATION DATE

20 May 1981

PUBLICATION TITLE

DIR. & GEN. SUPPORT
MAINT. MANUAL

BE EXACT... PIN-POINT WHERE IT IS

PAGE NO	PARA-GRAPH	FIGURE NO	TABLE NO
2-21	2-3 b		
4-7	4-7 b		
5-5	5-3		

IN THIS SPACE TELL WHAT IS WRONG AND WHAT SHOULD BE DONE ABOUT IT:

FRAME 20, change illustration callouts.
Reason: callouts for transmission (1) and engine (3) are reversed.

FRAME 1, step 6 reads "Take out seven screws (6)." Should read "Take out five screws (6)."

Subparagraph d, second sentence refers to para 4-3. Should refer to para 1-3.

SAMPLE

PRINTED NAME GRADE OR TITLE AND TELEPHONE NUMBER

SP4 Jane Idone Avonon 222-2224

SIGN HERE

Jane Idone

DA FORM 2028-2
1 JUL 79

PREVIOUS EDITIONS ARE OBSOLETE.

PS --IF YOUR OUTFIT WANTS TO KNOW ABOUT YOUR RECOMMENDATION MAKE A CARBON COPY OF THIS AND GIVE IT TO YOUR HEADQUARTERS

FILL IN YOUR
UNIT'S ADDRESS

FOLD

DEPARTMENT OF THE ARMY

POSTAGE AND FEES PAID
DEPARTMENT OF THE ARMY
DOD 314



OFFICIAL BUSINESS
PENALTY FOR PRIVATE USE \$.

SAMPLE

TEAR ALONG PERFORATED LINE

Commander
U.S. Army Tank-Automotive Command
ATTN: DRSTA-MB
Warren, MI 48090

FILL IN YOUR
UNIT'S ADDRESS

FOLD BACK

DEPARTMENT OF THE ARMY

POSTAGE AND FEES PAID
DEPARTMENT OF THE ARMY
DOD 314



OFFICIAL BUSINESS
PENALTY FOR PRIVATE USE \$300

TEAR ALONG PERFORATED LINE

Commander
U.S. Army Tank-Automotive Command
ATTN: DRSTA-MB
Warren, MI 48090

FILL IN YOUR
UNIT'S ADDRESS

FOLD BACK

DEPARTMENT OF THE ARMY

POSTAGE AND FEES PAID
DEPARTMENT OF THE ARMY
DOD 314



OFFICIAL BUSINESS
PENALTY FOR PRIVATE USE \$300

TEAR ALONG PERFORATED LINE

Commander
U.S. Army Tank-Automotive Command
ATTN: DRSTA-MB
Warren, MI 48090

RECOMMENDED CHANGES TO EQUIPMENT TECHNICAL PUBLICATIONS



THEN... JOT DOWN THE DOPE ABOUT IT ON THIS FORM, CAREFULLY TEAR IT OUT, FOLD IT AND DROP IT IN THE MAIL!

SOMETHING WRONG WITH THIS PUBLICATION?

FROM: (PRINT YOUR UNIT'S COMPLETE ADDRESS)

DATE SENT

PUBLICATION NUMBER

TM 9-2320-209-34-2-1

PUBLICATION DATE

20 May 1981

PUBLICATION TITLE

DIR. & GEN. SUPPORT
MAINT. MANUAL

BE EXACT... PIN-POINT WHERE IT IS

PAGE
NO

PARA-
GRAPH

FIGURE
NO

TABLE
NO

IN THIS SPACE TELL WHAT IS WRONG
AND WHAT SHOULD BE DONE ABOUT IT:

PRINTED NAME GRADE OR TITLE AND TELEPHONE NUMBER

SIGN HERE

FILL IN YOUR
UNIT'S ADDRESS

FOLD BACK

DEPARTMENT OF THE ARMY

POSTAGE AND FEES PAID
DEPARTMENT OF THE ARMY
DOD 314



TEAR ALONG PERFORATED LINE

OFFICIAL BUSINESS
PENALTY FOR PRIVATE USE \$300

COMMANDER
U.S. ARMY TANK - AUTOMOTIVE
MATERIEL READINESS COMMAND
ATTN: DRSTA MB
WARREN, MI 48090

THE METRIC SYSTEM AND EQUIVALENTS

LINEAR MEASURE

1 Centimeter = 10 Millimeters = 0.01 Meters = 0.3937 Inches
 1 Meter = 100 Centimeters = 1000 Millimeters = 39.37 Inches
 1 Kilometer = 1000 Meters = 0.621 Miles

WEIGHTS

1 Gram = 0.001 Kilograms = 1000 Milligrams = 0.035 Ounces
 1 Kilogram = 1000 Grams = 2.2 Lb
 1 Metric Ton = 1000 Kilograms = 1 Megagram = 1.1 Short Tons

LIQUID MEASURE

1 Milliliter = 0.001 Liters = 0.0338 Fluid Ounces
 1 Liter = 1000 Milliliters = 33.82 Fluid Ounces

SQUARE MEASURE

1 Sq Centimeter = 100 Sq Millimeters = 0.155 Sq Inches
 1 Sq Meter = 10,000 Sq Centimeters = 10.76 Sq Feet
 1 Sq Kilometer = 1,000,000 Sq Meters = 0.386 Sq Miles

CUBIC MEASURE

1 Cu Centimeter = 1000 Cu Millimeters = 0.06 Cu Inches
 1 Cu Meter = 1,000,000 Cu Centimeters = 35.31 Cu Feet

TEMPERATURE

$5/9 (^{\circ}\text{F} - 32) = ^{\circ}\text{C}$
 212^o Fahrenheit is equivalent to 100^o Celsius
 90^o Fahrenheit is equivalent to 32.2^o Celsius
 32^o Fahrenheit is equivalent to 0^o Celsius
 $9/5 \text{ C}^{\circ} + 32 = \text{F}^{\circ}$

APPROXIMATE CONVERSION FACTORS

TO CHANGE	TO	MULTIPLY BY
Inches	Centimeters	2.540
Feet	Meters	0.305
Yards	Meters	0.914
Miles	Kilometers	1.609
Square Inches	Square Centimeters	6.451
Square Feet	Square Meters	0.093
Square Yards	Square Meters	0.836
Square Miles	Square Kilometers	2.590
Acres	Square Hectometers	0.405
Cubic Feet	Cubic Meters	0.028
Cubic Yards	Cubic Meters	0.765
Fluid Ounces	Milliliters	29.573
Pints	Liters	0.473
Quarts	Liters	0.946
Gallons	Liters	3.785
Ounces	Grams	28.349
Pounds	Kilograms	0.454
Short Tons	Metric Tons	0.907
Pound-Feet	Newton-Meters	1.356
Pounds per Square Inch	Kilopascals	6.895
Miles per Gallon	Kilometers per Liter	0.425
Miles per Hour	Kilometers per Hour	1.609

TO CHANGE	TO	MULTIPLY BY
Centimeters	Inches	0.394
Meters	Feet	3.280
Meters	Yards	1.094
Kilometers	Miles	0.621
Square Centimeters	Square Inches	0.155
Square Meters	Square Feet	10.764
Square Meters	Square Yards	1.196
Square Kilometers	Square Miles	0.386
Square Hectometers	Acres	2.471
Cubic Meters	Cubic Feet	35.315
Cubic Meters	Cubic Yards	1.308
Milliliters	Fluid Ounces	0.034
Liters	Pints	2.113
Liters	Quarts	1.057
Liters	Gallons	0.264
Grams	Ounces	0.035
Kilograms	Pounds	2.205
Metric Tons	Short Tons	1.102
Newton-Meters	Pound-Feet	0.738
Kilopascals	Pounds per Square Inch	0.145
Kilometers per Liter	Miles per Gallon	2.354
Kilometers per Hour	Miles per Hour	0.621

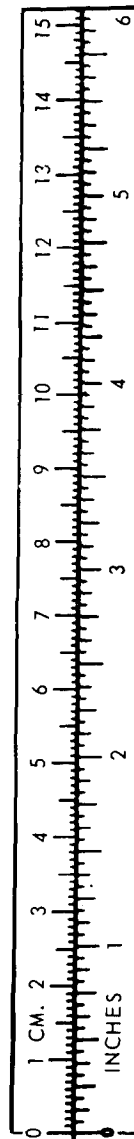

TAO89991