

**ARMY TM 9-2320-386-24-1-1
AIR FORCE TO 36A12-1B-1122-1**

**TECHNICAL MANUAL
EXTENDED SERVICE PROGRAM
(ESP)**

**UNIT, DIRECT SUPPORT,
AND GENERAL SUPPORT
MAINTENANCE MANUAL**

FOR

**2-1/2-TON, 6X6, M44A3
SERIES TRUCKS (DIESEL)**

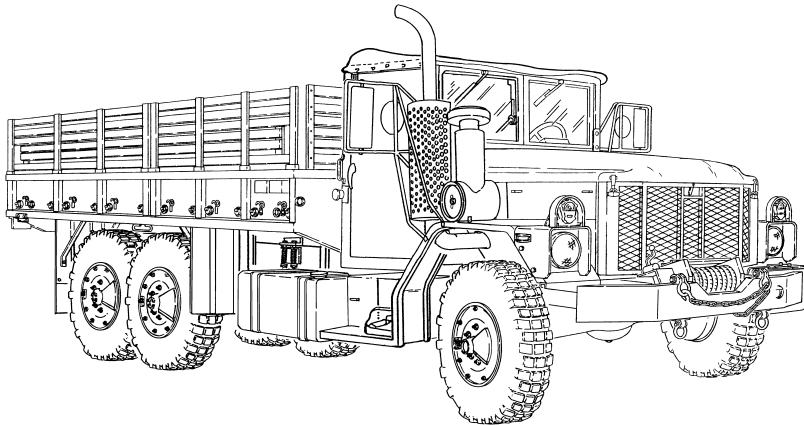

**TRUCK, CARGO: 2-1/2-TON, 6X6
M35A3 (2320-01-383-2047) (EIC: BHK);
(2320-01-383-3850) (EIC: BHL)**

**M35A3C (2320-01-383-2050) (EIC: BHP);
(2320-01-383-2049) (EIC: BHQ)**

**M36A3 (2320-01-383-2048) (EIC: BHM);
(2320-01-383-2046) (EIC: BHN).**

HOW TO USE THIS MANUAL

GENERAL INFORMATION

CHAPTER 1
DESCRIPTION AND THEORY
OF OPERATION

CHAPTER 2
UNIT TROUBLESHOOTING PROCEDURES

CHAPTER 3
UNIT MAINTENANCE INSTRUCTIONS

CHAPTER 4
DIRECT SUPPORT TROUBLESHOOTING

CHAPTER 5
DIRECT SUPPORT MAINTENANCE

CHAPTER 6
GENERAL SUPPORT MAINTENANCE

CHAPTER 7
GENERAL MAINTENANCE

CHAPTER 8
SHIPMENT AND LIMITED STORAGE

CHAPTER 9
SUPPORTING INFORMATION

DISTRIBUTION STATEMENT A. Approved for public release; distribution is unlimited.

HEADQUARTERS, DEPARTMENTS OF THE ARMY AND AIR FORCE

1 MAY 2001

WARNING

EXHAUST GASES CAN KILL

1. DO NOT operate vehicle engine in enclosed area.
2. DO NOT idle vehicle engine with vehicle windows closed.
3. DO NOT drive vehicle with inspection plates or cover plates removed.
4. BE ALERT at all times for exhaust odors.
5. BE ALERT for exhaust poisoning symptoms. They are:
 - Headache
 - Dizziness
 - Sleepiness
 - Loss of muscular control
6. If YOU SEE another person with exhaust poisoning symptoms:
 - Remove person from area
 - Expose to open air
 - Keep person warm
 - Do not permit person to move
 - Administer artificial respiration * or CPR if necessary

* For artificial respiration, refer to FM 21-11.
7. BE AWARE, the field protective mask for Nuclear-Biological-Chemical (NBC) protection will not protect you from carbon monoxide poisoning. **THE BEST DEFENSE AGAINST EXHAUST POISONING IS ADEQUATE VENTILATION.**

WARNING SUMMARY

Hearing protection is required for the driver and co-driver. Hearing protection is also required for all personnel working in and around this vehicle while the engine is running (reference AR 40-5 and TB MED 501).

If required to remain inside the vehicle during extreme heat, occupants should follow the water intake, work/rest cycle, and other heat stress preventive medicines measures contained in FM 21-10, Field Hygiene and Sanitation.

All personnel must stand clear during lifting operations. A snapped chain, or shifting or swinging load may cause injury to personnel.

Use prybar to free engine or transmission during lifting operations. Failure to do so may cause injury to personnel.

Lifting device must have weight capacity greater than weight of engine and transmission to prevent injury to personnel and damage to equipment.

Weight of vehicle must be supported on jack stands at all times. Failure to do so may result in injury to personnel.

WARNING SUMMARY (Contd)

Alternator is heavy. Assistant will help with alternator replacement. Failure to do so may cause injury to personnel.

Air system components are subject to high pressure. Always relieve pressure before loosening or removing air system components. Failure to do so may result in injury to personnel.

Ensure tire is completely deflated before loosening nuts on clamp ring. Clamp ring can fly off and cause injury to personnel.

When inflating tires, use tire cage to prevent injury to personnel should tire break from wheel assembly.

Compressed air source will not exceed 30 psi (207 kPa). When cleaning with compressed air, eyeshields must be worn. Failure to do so may result in injury to personnel.

Improper cleaning methods and use of unauthorized cleaning solvents may result in injury to personnel.

Skysol-100 mixture is combustible. Use mechanical ventilation whenever product is used in a confined space, is heated above ambient temperatures, or is agitated.

Eyeshields must be worn when cleaning with a wire brush. Flying rust and metal particles may cause injury to personnel.

Contact with Skysol-100 may cause skin irritation. Use chemical resistant gloves. In case of skin contact, remove any contaminated clothing and wash skin thoroughly with soap and water.

Keep rear of transmission tilted slightly downward to prevent converter from separating from transmission. Failure to do so may result in injury to personnel or damage to equipment.

Completely deflate tires before removing wheels from axles if there is obvious damage to wheel components. Injury to personnel may result from exploding wheel components.

Operation of a deadlined vehicle, without preliminary inspection, may cause injury to personnel and/or damage to equipment.

Diesel fuel is flammable. Do not perform procedures near open flame, sparks, or electricity. Injury to personnel may result.

Do not remove slave receptacle before disconnecting battery ground cable. If energized battery cable contacts vehicle, a direct short will result and may cause injury to personnel.

If NBC exposure is suspected, all air filter media should be handled by personnel wearing protective equipment. Consult your unit NBC officer or NBC NCO for appropriate handling or disposal instructions.

When lowering spare wheel, hold wrench handle bar securely. Do not release bar until wheel touches ground. If bar must be released before wheel touches ground, lock shaft in place with pawl. Failure to do this may cause wheel to drop and bar to spin, resulting in injury to personnel.

Direct all personnel to stand clear of winch cable during winch operation. A snapped winch cable may result in injury to personnel.

Remove all jewelry such as rings, dog tags, bracelets, etc. If jewelry contacts battery terminal, a direct short may result in instant heating of tools, damage to equipment, and injury to personnel.

Wear hand protection when handling winch cable. Broken wires may cause injury to personnel.

Super-single wheels and tires together weigh 382 lbs (173 kgs). Do not attempt to remove and install a wheel and tire without assistant. Doing so may result in injury to personnel.

Ether is extremely flammable. Perform procedure in a well-ventilated area away from flames and sparks. Failure to do so may result in injury to personnel.

Eye protection is required when performing fuel system checks. Failure to wear eye protection may result in injury to personnel.

WARNING SUMMARY (Contd)

Hot coolant is under pressure. Care should be used when removing surge tank filler cap or inspecting hot engine coolant leaks. Steam or hot coolant under pressure may cause injury to personnel.

When removing battery cables, disconnect ground cable first. Do not allow tools to come in contact with vehicle when disconnecting cable clamps. A direct short can result, causing instant heating of tools, tool damage, battery damage, or battery explosion, and severe injury to personnel.

Battery acid (electrolyte) is extremely harmful. Always wear safety goggles and rubber gloves when performing battery maintenance. Severe injury may result if acid contacts eyes or skin.

Clean master cylinder reservoir cap and surrounding area before removing cap. System contamination can result in injury to personnel or equipment damage.

Accidental or intentional introduction of liquid contaminants into the environment is in violation of state, federal, and military regulation. Refer to Army POL (WP 0001 00) for information concerning storage, use, and disposal of these liquids. Failure to do so may result in injury or death.

Volatile mineral spirits burn easily and fumes can explode. Do not smoke or allow flames nearby when using volatile mineral spirits. Failure to do so may cause serious injury or death to personnel.

Engine oil may be hot when it is drained from crankcase. Use caution when removing drainplug from oil pan. Failure to do so may cause injury to personnel.

Piston is under spring compression. Do not remove snapping until pressure is applied to spring retainer. Failure to do so may result in injury to personnel.

Main-pressure regulator and valve lockup springs are under spring compression. Do not remove retainer ring or lower pin until remover/installer is in place, as springs will fly out causing injury.

Torque converter leak test fixture is under pressure. Ensure all air pressure is exhausted from torque converter prior to removing test fixture to prevent injury to personnel.

Axle is heavy. Axle assembly with differential installed is not balanced and may flip forward or backward if not properly secured with chains. Ensure personnel are clear before lowering axle. Failure to do so may result in injury to personnel.

Do not remove lifting device until transmission is stable on holding fixture. Failure to do so may result in injury to personnel or damage to equipment.

Torque converter must be supported by retaining straps at all times to prevent torque converter from falling out, causing injury to personnel.

Valve springs are under tension. Decompress spring slowly to avoid injury to personnel and damage to equipment.

Never add solvents to any kind of epoxy. Injury to personnel may result.

Keep the epoxy mixture container lids closed tight when not in use. Use only in well-ventilated places.

Always wear gloves while working with epoxy as it irritates the skin.

Keep epoxy away from extreme heat and open flame. Most resins are flammable before hardened.

Transmission container is pressurized. Ensure pressure is released before opening container. Failure to do so may result in injury to personnel.

Ensure transmission is properly supported before removal. Failure to do so may cause injury to personnel and damage to equipment.

Install transmission jack under transmission to support transmission and prevent injury to personnel.

No personnel is to be under transmission after transmission jack has been removed. Failure to do so may cause injury to personnel.

WARNING SUMMARY (Contd)

Do not place fingers or hands between transmission and flywheel housing or between rear braces at rear of transmission when moving transmission forward or lowering transmission. Doing so may cause injury to personnel.

Do not detach chain from engine until engine is supported. An improperly supported engine may result in injury to personnel or damage to equipment.

Keep fingers clear of hood and cowling when replacing hinge. Failure to do so may result in injury to personnel.

Do not smoke or allow open flames or sparks near batteries when performing this procedure. Batteries can explode if exposed to heat, flames, or sparks. Failure to comply may result in injury to personnel and damage to equipment.

Do not touch hot exhaust system components with bare hands. Severe injury to personnel may result.

Do not perform testing near fuel tank with fill cap or sending unit removed. Fuel may ignite causing injury to personnel.

LIST OF EFFECTIVE PAGES/WORK PACKAGES

Date of issue for original pages/
work packages for volume 1 are:

Original 0 1 May 01

Date of issue for original pages/
work packages for volume 2 are:

Original 0 1 May 01

TOTAL NUMBER OF VOLUME 1 FRONT AND REAR MATTER PAGES IS 60 AND TOTAL NUMBER OF WORK PACKAGES IS 289.

TOTAL NUMBER OF VOLUME 2 FRONT AND REAR MATTER PAGES IS 35 AND TOTAL NUMBER OF WORK PACKAGES IS 107.

THE PAGES/WORK PACKAGES CONSIST OF THE FOLLOWING:

Page/Work Package No.	*Change No.	Page/Work Package No	*Change No.
VOLUME 1		VOLUME 2	
Warning a - Warning d0	Warning a - Warning d0
A0	A0
B blank0	B blank0
i0	i0
ii blank0	ii blank0
iii - vii0	iii0
viii blank0	iv blank0
WP 0001 - 02880	WP 0289 - 03950
Index-1 - Index-460	Glossary-10
		Glossary-2 blank0
		Index-1 - Index-130
		Index-14 blank0
		FP-10
		FP-2 blank0
		FP-30
		FP-4 blank0
		FP-50
		FP-6 blank0
		FP-70
		FP-8 blank0
		FP-90
		FP-10 blank0

*Zero in this column indicates an original page or work package.

A/B blank

**TECHNICAL MANUAL
NO. 9-2320-386-24-1-1**

**TECHNICAL ORDER
NO. 36A12-1B-1122-1**

**HEADQUARTERS,
DEPARTMENT OF THE ARMY
AND AIR FORCE
WASHINGTON, D.C., 1 May 2001**

**EXTENDED SERVICE PROGRAM (ESP)
TECHNICAL MANUAL
UNIT, DIRECT SUPPORT, AND
GENERAL SUPPORT MAINTENANCE
FOR
2-1/2-TON, 6X6, M44A3 SERIES TRUCKS**

TRUCK	MODEL	EIC	NSN W/O WINCH	NSN W/WINCH
Cargo, Fixed Side	M35A3	BHK	2320-01-383-2047	
Cargo, Fixed Side	M35A3	BHL		2320-01-383-3850
Cargo, Drop Side	M35A3C	BHP	2320-01-383-2050	
Cargo, Drop Side	M35A3C	BHQ		2320-01-383-2049
Cargo, Long Wheelbase	M36A3	BHM	2320-01-383-2048	
Cargo, Long Wheelbase	M36A3	BHN		2320-01-383-2046

This manual will provide maintenance instructions for ESP vehicles.

REPORTING ERRORS AND RECOMMENDING IMPROVEMENTS

You can help improve this publication. If you find any mistakes or if you know of a way to improve the procedures, please let us know. Submit your DA Form 2028 (Recommended Changes to Equipment Technical Publications), through the Internet, on the Army Electronic Product Support (AEPS) website. The Internet address is <http://aeps.ria.army.mil>. If you need a password, scroll down and click on "ACCESS REQUEST FORM". The DA Form 2028 is located in the ONLINE FORMS PROCESSING section of the AEPS. Fill out the form and click on SUBMIT. Using this form on the AEPS will enable us to respond quicker to your comments and better manage the DA Form 2028 program. You may also mail, fax or E-mail your letter or DA Form 2028 direct to: AMSTA-LC-CI/TECH PUBS, TACOM-RI, 1 Rock Island Arsenal, Rock Island, IL 61299-7630. The email address is TACOM-TECH-PUBS@ria.army.mil. The fax number is DSN 793-0726 or Commercial (309) 782-0726.

This manual is published in two parts. TM 9-2320-386-24-1-1 contains front matter and chapters 1, 2, and 3, (consisting of work packages 0001 00 through 0288 00). TM 9-2320-386-24-1-2 contains chapters 4 through 9 (consisting of work packages 0289 00 through 0395 00) and rear matter.

This manual contains a table of contents and alphabetical index for both volumes.

This publication supersedes TM 9-2320-386-24 dated 26 January 1996.

DISTRIBUTION STATEMENT A — Approved for public release; distribution is unlimited.

VOLUME 1 OF 2
TABLE OF CONTENTS

	<u>WP Sequence No.</u>
WARNING SUMMARY	
HOW TO USE THIS MANUAL	
GENERAL INFORMATION	0001 00
CHAPTER 1 DESCRIPTION AND THEORY OF OPERATION	
Section I. Equipment Description and Data	0002 00
II. Theory of Operation	0004 00
CHAPTER 2 UNIT TROUBLESHOOTING	
Section I. Introduction to Troubleshooting	0006 00
II. Unit Troubleshooting Procedures	0008 00
CHAPTER 3 UNIT MAINTENANCE INSTRUCTIONS	
Section I. Service Upon Receipt	0020 00
II. Preventive Maintenance Checks and Services	0022 00
III. Engine System Maintenance	0026 00
IV. Air Intake System Maintenance	0036 00
V. Fuel System Maintenance	0044 00
VI. Exhaust System Maintenance	0065 00
VII. Engine Cooling System Maintenance	0067 00
VIII. Electrical System Maintenance	0088 00
IX. Transmission Maintenance	0131 00
X. Transfer Case Maintenance	0144 00
XI. Propeller Shafts, Axles, and Suspension System Maintenance	0146 00
XII. Axle Maintenance	0150 00
XIII. Compressed Air and Brake System Maintenance	0153 00
XIV. Wheel Maintenance	0171 00
XV. Steering System Maintenance	0178 00
XVI. Frame Maintenance	0187 00
XVII. Spring Maintenance	0192 00
XVIII. Body and Cab Maintenance	0194 00
XIX. Front Winch Maintenance	0212 00
XX. Bumper and Guards Maintenance	0226 00
XXI. Accessories Maintenance	0231 00
XXII. Personnel Hot Water Heater Maintenance	0237 00
XXIII. Arctic Winterization Kits Maintenance	0245 00
XXIV. Swingfire Heater Kit Maintenance	0256 00
XXV. Deepwater Fording Kit Maintenance	0264 00
XXVI. Chemical Agent Automatic Alarm Mounting Kit Replacement	0270 00
XXVII. Air Brake Trailer Kit Maintenance	0272 00
XXVIII. 100-AMP Alternator Kit Maintenance	0276 00
XXIX. CTIS Maintenance	0280 00
XXX. Non-Electrical Gauges Maintenance	0285 00

VOLUME 2 OF 2
TABLE OF CONTENTS (Contd)

		<i>WP Sequence No.</i>
CHAPTER 4	DIRECT SUPPORT TROUBLESHOOTING	
Section I.	Introduction to Troubleshooting	0289 00
II.	Direct Support Troubleshooting Procedures	0291 00
CHAPTER 5	DIRECT SUPPORT MAINTENANCE	
Section I.	Power Plant Maintenance	0294 00
II.	Engine Maintenance	0299 00
III.	Fuel System Maintenance	0318 00
IV.	Engine Cooling System Maintenance	0327 00
V.	Electrical System Maintenance	0329 00
VI.	Transmission Maintenance	0333 00
VII.	Transfer Case Maintenance	0339 00
VIII.	Front and Rear Axle Maintenance	0342 00
IX.	Wheel Maintenance	0346 00
X.	Steering System Maintenance	0348 00
XI.	Body and Cab Maintenance	0350 00
CHAPTER 6	GENERAL SUPPORT MAINTENANCE INSTRUCTIONS	
Section I.	Engine Maintenance	0354 00
II.	Transmission Maintenance	0365 00
CHAPTER 7	GENERAL MAINTENANCE	
	General Maintenance Procedures	0383 00
	Illustrated List of Manufactured Items	0384 00
	Torque Limits	0385 00
	Wiring Diagram Introduction	0386 00
CHAPTER 8	SHIPMENT AND LIMITED STORAGE	
	General Preparation of Vehicle for Shipment	0387 00
	Loading and Movement of Vehicle	0388 00
	Limited Storage	0389 00
CHAPTER 9	SUPPORTING INFORMATION	
	References	0390 00
	Maintenance Allocation Chart (MAC) Introduction	0391 00
	Maintenance Allocation Chart	0392 00
	Expendable and Durable Items List	0393 00
	Tool Identification List	0394 00
	Mandatory Replacement Parts	0395 00

HOW TO USE THIS MANUAL

ABOUT YOUR MANUAL

Spend some time looking through this manual. You will find that it has a new, different look, designed in a work package format.

Features added to improve the convenience of this manual and increase your efficiency are:

- a. **Accessing Information** – These include physical entry features such as the bleed-to-edge indicators on the cover and edge of the manual. Extensive troubleshooting guides for specific systems lead directly to step-by-step directions for problem solving and maintenance tasks in each work package (WP). Lubrication instructions have been added to the TM, as part of Preventive Maintenance Checks and Services. Unit maintenance instructions are followed by direct support maintenance and general support maintenance instructions. A list of repair parts and special tools to perform tasks is contained in TM 9-2320-386-24P.
- b. **Work Package Format** – This manual is organized in Work Packages, each of which is a stand alone portion of the TM. A WP logically divides all data required for a certain function, and may include descriptive information, operating tasks, maintenance tasks, troubleshooting, preventive maintenance checks and services, repair parts, or supporting information. Work packages appear in numerical sequence and are continuous throughout the two volumes of the manual. An example of work package numbering is: 0030 00-1. The 0030 is the work package number; the 00 is to be used in the event a work package(s) is added between work packages at a future date; the -1 is the page number.

To find the WP you require, first go to the table of contents (or to the bleed-to-edge indicator on the cover). This will lead you to the specific chapter, then section titles, to enable you to locate specific maintenance tasks and information in this manual. A title page for each chapter precedes the first section of the chapter and lists section numbers and/or titles which guide you to a section table of contents work package.

- c. **Illustrations** – A variety of methods are used to make locating and fixing components much easier. Locator illustrations with keyed text, exploded views, and cut-away diagrams make the information in this manual easier to understand and follow.
- d. **Keying Text With Illustrations** – Instructions are located with figure(s) that illustrate the specific task you are working on. The task steps and figure(s) are located side-by-side.

HOW TO USE YOUR MANUAL

You must familiarize yourself with the entire maintenance procedure before beginning the maintenance task.

Here's an example of how to use your manual:

PROBLEM: The unit maintenance mechanic gets a report that the engine cranks but will not start.

SOLUTION: Follow the troubleshooting steps:

1. Look at the cover of this manual. You will see subjects listed from top to bottom on the right-hand side.
2. Look at the right edge of the manual. On some of the pages you will see black bars (edge indicators) that are aligned with the subject bars on the cover. These are the locations of the subjects in the text.
3. Look at section II on the chapter 2 title page. This section guides you to WP 0008 00, Unit Troubleshooting Procedures Table of Contents, which in turn leads you to WP 0009 00, Mechanical Troubleshooting Symptom Index.

HOW TO USE THIS MANUAL (Contd)

4. Look down the list until you find ENGINE. Beneath that heading you will find the symptom noted by the maintenance mechanic: Engine cranks but will not start.
5. Turn to the work package and page indicated, WP 0010 00-2.
6. In WP 0010 00-2, there are steps and text related to resolving the problem of engine cranks but will not start.
 - Step 1. You follow the steps listed under engine cranks but will not start and determine that the fuel filter needs replacing. WP 0054 00, Fuel Filter Maintenance, is referenced.
 - Step 2. The rest of the inspection shows no other cause for the problem.
7. Detailed procedures include everything you must do to accomplish a basic maintenance task.
 - a. Before beginning the maintenance task, look through the procedure. You must familiarize yourself with the entire maintenance procedure before beginning the maintenance task. The entire procedure for WP 0054 00, Fuel Filter Maintenance, includes draining, removal, cleaning, inspection, and installation instructions.
 - b. The seven basic headings under INITIAL SETUP outline the information required by the user before starting the detailed procedure. They are:
 - Test Equipment: Test equipment required to perform the procedure.
 - Tools and Special Tools: Those tools needed to perform the maintenance task.
 - Materials/Parts: All mandatory replacement parts and materials needed to perform the task.
 - Personnel Required: The number of personnel required for a task if task requires more than one.
 - References: Those manuals needed to complete the task.
 - Equipment Condition: Notes the conditions that must exist before starting the task.
 - Special Environmental Conditions: Any special environmental conditions that are required.
8. Refer to WP 0054 00, Fuel Filter Maintenance, as you review the following points:
 - a. **Modular Text**: Both text and illustrations are used together. This manual was designed so that the two would be visible at once, making part identification and procedure sequence easy to follow.
 - b. **Initial Setup**: Outlines task conditions.
 - c. **Illustrations**: An exploded diagram of the component, removed from the vehicle, shows part locations, attachments, and spatial relationships.
9. Your manual is easier to use once you understand its design. We hope it will encourage you to use it more often.

EXTENDED SERVICE PROGRAM VEHICLE ENHANCEMENTS

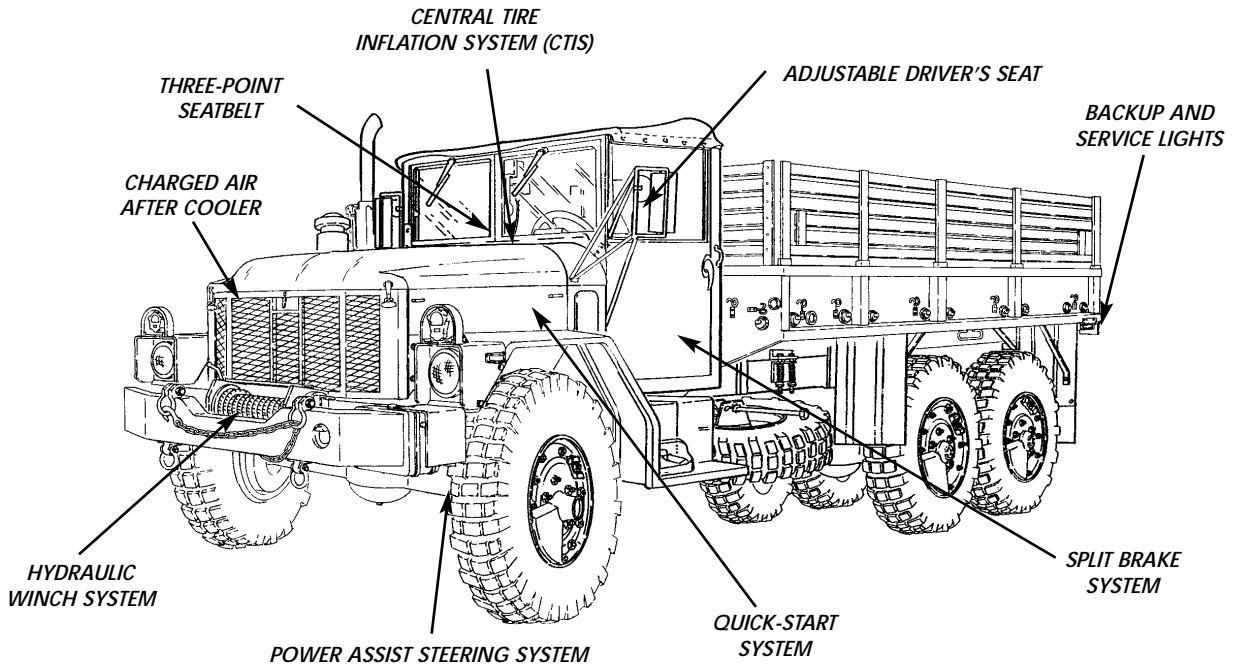

M35A3

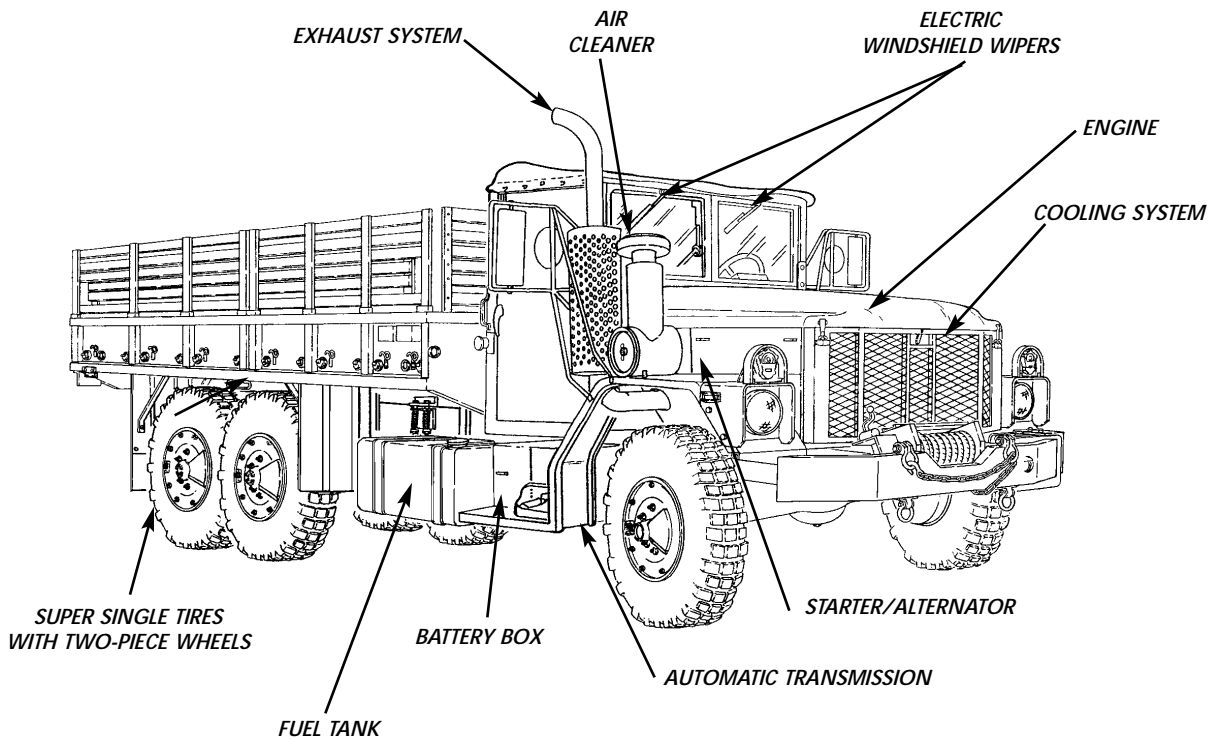

M36A3

**GENERAL INFORMATION
FOR
TRUCK, CARGO, 2-1/2-TON, 6X6, M44A3 SERIES TRUCKS (DIESEL)**

General Information WP 0001 00



GENERAL INFORMATION

SCOPE

a. This manual contains instructions for servicing and maintenance of 2-1/2-ton, 6x6, M44A2 series vehicles which have been rebuilt through the Extended Service Program (ESP). These vehicles are:

- (1) M35A3, Cargo Truck, WO/W and W/W (Fixed Side)
- (2) M35A3C, Cargo Truck, WO/W and W/W (Dropside)
- (3) M36A3, Cargo Truck, WO/W and W/W (Long Wheelbase)

b. The material presented here provides unit, direct support, and general support maintenance personnel with information and procedures needed to provide the safest and most efficient operation and servicing of these vehicles. This information includes:

- (1) Vehicle limitations.
- (2) The function of unique controls.
- (3) Cautions and warnings to operators regarding safety to personnel and equipment.
- (4) Troubleshooting procedures to be followed by unit, direct support, and general support maintenance personnel if the vehicle malfunctions.
- (5) Unit maintenance checks and services.
- (6) Repair procedures to be followed by unit, direct support, and general support maintenance personnel.

c. This manual contains unit, direct support, and general support procedures unique to M44A3, ESP series vehicles. Refer to TM 9-2320-361-20 for unit maintenance procedures or TM 9-2320-361-34 for direct support and general support procedures common to M44A2 series vehicles.

MAINTENANCE FORMS, RECORDS, AND REPORTS

Department of the Army forms and procedures used for equipment maintenance will be those prescribed by DA Pam 738-750, The Army Maintenance Management System (TAMMS).

REPORTING EQUIPMENT IMPROVEMENT RECOMMENDATIONS (EIR'S)

If the design of your vehicle needs improvement, let us know. If your vehicle is in proper operating condition and there are problems with vehicle or equipment performance, send us an EIR. You, the user, are the only one who can tell us what you don't like about your equipment. It is not necessary to show a new design or a better way to perform a procedure. Just let us know why you don't like the design or performance. Put in on an SF 368 (Quality Deficiency Report). Mail it to us at: Commander, U.S. Army Tank-automotive and Armaments Command, ATTN: AMSTA-IM-MMAA, Warren, Michigan 48397-5000. We'll send you a reply. You may also mail, fax or email your letter, DA Form 2028, or DA Form 2028-2 direct to: AMSTA-LC-CI/TECH PUBS, TACOM-RI, 1 Rock Island Arsenal, Rock Island, IL 61299-7630. The email address is TACOM-TECH-PUBS@ria.army.mil. The fax number is DSN 793-0726 or Commercial (309) 782-0726.

HAND RECEIPT

This manual has a companion document with a TM number followed by -HR (which stands for Hand Receipt). TM 9-2320-386-10-HR consists of preprinted hand receipts that list end item related equipment (i.e., COEI, BII, and AAL) that must be accounted for. As an aid to property accountability, additional HR manuals may be requisitioned through normal publication channels.

CORROSION PREVENTION AND CONTROL (CPC)

Corrosion Prevention and Control (CPC) of Army materiel is a continuing concern. It is important that any corrosion problem(s) be reported so corrections and/or improvements can be made to prevent the problem(s) in future items.

While corrosion is typically associated with rusting of metals, it can also include deterioration of other materials, such as rubber and plastic. Unusual cracking, softening, swelling, or breaking of these materials may be a corrosion problem.

If a corrosion problem is identified, it can be reported using Standard Form 368, Product Quality Deficiency Report. Use of key words such as corrosion, rust, deterioration, or cracking will ensure that the information is identified as a CPC problem.

The form should be submitted to the address specified in DA Pam 738-750.

DESTRUCTION OF ARMY MATERIEL TO PREVENT ENEMY USE

Procedures for destruction of Army materiel to prevent enemy use can be found in TM 750-244-6.

PREPARATION FOR STORAGE OR SHIPMENT

Storage and limited storage instructions are in Chapter 8 of this manual. Additional information can be found in TM 746-10, Marking, Packing, and Shipment of Supplies and Equipment: General Packaging Instructions for Field Use.

WARRANTY INFORMATION

Extended Service Program (ESP) vehicles have an engine (Caterpillar) warranty of 150,000 miles or three years. They also have a transmission (Allison) warranty of two years with unlimited mileage. The warranty starts on the date found in block 23, DA Form 2408-9, in the log book.

USE OF THE METRIC SYSTEM

The equipment/system described herein contains metric components and requires metric common and special tools; therefore, metric units in addition to U.S. standard units will be used throughout this publication.

LIST OF ABBREVIATIONS

The following is a list of special abbreviations that appear in this manual. For a list of standard abbreviations that appear in this manual, refer to MIL-STD-12.

A – Annually	kg – kilogram
AAL – Additional Authorization List	kPa – Kilopascal
AC – Alternating Current	L – Liter
AMP HR – Ampere hour	LCD – Liquid Crystal Display
AOAP – Army Oil Analysis Program	m – Meter
AR – Army Regulation	m³/min – Cubic meters per minute
ATAAC – Air-To-Air Aftercooler	MIL-STD – Military Standard
B – Biennially	mL – Milliliter
BFS – Brake Fluid, Silicone	mm – Millimeter
BII – Basic Issue Item	MT – Metric ton
C – Country	N – Neutral
cm – Centimeter	N – Newton
cmm – Cubic meters per minute	NATO – North Atlantic Treaty Organization
C/MR – Change when Maintenance Requires	NBC – Nuclear, Biological, Chemical
CAGEC – Commercial and Government	NSN – National Stock Number
Entity Code	N•m – Newton meter
cfm – Cubic feet per minute	OC – On-condition
COEI – Components of End Item	OEA – Oil, Engine (arctic)
Contd – Continued	OE/HDO – Lubricating Oil, Internal
CPC – Corrosion Prevention and Control	Combustion Engine, Tactical
CTIS – Central Tire Inflation System	PMCS – Preventive Maintenance Checks
CW – Chain (and) Wire Rope (lubricating oil)	and Services
°C – Celsius	PPS – Priority Pressure Switch
DA – Department of the Army	psi – Pounds per square inch
DF – Diesel Fuel	R – Reverse
E – Emergency	RPM – Revolutions per minute
ECU – Electronic Control Unit	S – Semiannually
EIR – Equipment Improvement Recommendations	S – Snow
EIR MD – Equipment Improvement Report and	SF – Standard Form
Maintenance Digest	STE/ICE-R – Simplified Test Equipment for
ESP – Extended Service Program	Internal Combustion Engines-Reprogrammable
°F – Fahrenheit	TAMMS – The Army Maintenance
GAA – Grease, Automotive, and Artillery	Management System
GO – Lubricating Oil	TB – Technical Bulletin
g – Gram	TM – Technical Manual
H – Highway	TP – Technical Publication
HP – Horsepower	v – Volts
km – Kilometer	WP – Work Package

ARMY PETROLEUM, OIL, AND LUBRICANTS (POL)

Proper disposal of hazardous waste material is vital to protecting the environment and providing a safe work environment. Materials such as batteries, oils, and antifreeze must be disposed of in a safe and efficient manner.

The following references are provided as a means to ensure that proper disposal methods are followed:

Technical Guide No. 126 (from the U.S. Army Environmental Hygiene Agency (USAEHA))

National Environmental Policy Act of 1969 (NEPA)

Clean Air Act (CAA)

Resource Conservation and Recovery Act (RCRA)

Comprehensive Environmental Response, Compensation, and Liability Act (CERCLA)

Emergency Planning and Community Right to Know Act (EPCRA)

Toxic Substances Control Act (TSCA)

Occupational Health and Safety Act (OHSA)

The disposal of Army Petroleum, Oils and Lubricants (POL) products are affected by some of these regulations. State regulations may also be applicable to POL.

If you are unsure of which legislation affects you, contact state or local agencies for regulations regarding proper disposal of Army POL.

COMMON TOOLS AND EQUIPMENT

For authorized common tools and equipment, refer to the Modified Table of Organization and Equipment (MTOE) applicable to your unit.

SPECIAL TOOLS, TMDE, AND SUPPORT EQUIPMENT

Special tools, test, measurement, and diagnostic equipment (TMDE); and support equipment used to maintain the components covered in this manual can be found in WP 0392 00, Maintenance Allocation Chart (MAC), and TM 9-2320-386-24P.

REPAIR PARTS

Repair parts are listed and illustrated in TM 9-2320-386-24P.

END OF WORK PACKAGE

CHAPTER 1

**DESCRIPTION AND THEORY OF OPERATION
FOR
TRUCK, CARGO, 2-1/2-TON, 6X6, M44A3 SERIES TRUCKS (DIESEL)**

Section I.	Equipment Description and Data	WP 0002 00
Section II.	Theory of Operation	WP 0004 00



DESCRIPTION AND THEORY OF OPERATION

EXTENDED SERVICE PROGRAM (ESP)

TRUCK, CARGO, 2-1/2-TON, 6X6, M44A3 SERIES TRUCKS (DIESEL)

M35A3, W/O WINCH (NSN 2320-01-383-2047); W/WINCH (NSN 2320-01-383-3850);

M35A3C, W/O WINCH (NSN 2320-01-383-2050); W/WINCH (NSN 2320-01-383-2049);

M36A3, W/O WINCH (NSN 2320-01-383-2048); W/WINCH (NSN 2320-01-383-2046).

Section I. EQUIPMENT DESCRIPTION AND DATA

TABLE OF CONTENTS

<i>WP Title</i>	<i>WP Sequence No.-Page No.</i>
Equipment Characteristics, Capabilities, and Features	0003 00-1
Location and Description of Major Components	0003 00-4
Differences Between Models	0003 00-6
Equipment Data	0003 00-7
Location and Description of Data Plates	0003 00-9

END OF WORK PACKAGE

DESCRIPTION AND THEORY OF OPERATION

EXTENDED SERVICE PROGRAM (ESP)

TRUCK, CARGO, 2-1/2-TON, 6X6, M44A3 SERIES TRUCKS (DIESEL)

M35A3, W/O WINCH (NSN 2320-01-383-2047); W/WINCH (NSN 2320-01-383-3850);
 M35A3C, W/O WINCH (NSN 2320-01-383-2050); W/WINCH (NSN 2320-01-383-2049);
 M36A3, W/O WINCH (NSN 2320-01-383-2048); W/WINCH (NSN 2320-01-383-2046).

Section I. EQUIPMENT DESCRIPTION AND DATA

EQUIPMENT CHARACTERISTICS, CAPABILITIES, AND FEATURES

The M35A3, M35A3C, and M36A3 cargo trucks are used for transporting troops or heavy loads. The trucks have a new engine, automatic transmission, and drivetrain, and rebuilt transfer case and axles. Other new subsystems include new cooling, exhaust, air intake, split-brakes, fuel, electrical, power-assist steering, driver's seatbelts, super-single tires with two-piece wheels, Chemical Agent Resistant Coating (CARC) paint, Simplified Test Equipment/Internal Combustion Engines-Reprogrammable (STE/ICE-R), and Central Tire Inflation System (CTIS).

All ESP trucks have improved mobility and can traverse all types of roads and cross-country terrain in extreme high or low temperatures and humidity. The trucks are capable of fording hard-bottom water crossings up to 30 inches (76 centimeters) without a deepwater fording kit, and 72 inches (183 centimeters) with the fording kit. Front lifting shackles and vehicle tiedown brackets provide a means of lifting and securing the truck during transport.

Cargo Truck With Fixed Sides, WO/W and W/W, M35A3. The M35A3 cargo truck is used to transport equipment, materials, and/or personnel. Since it has permanent steel-welded sides, it is the preferred vehicle for use in transporting bulky payloads that may shift during transit. The truck body provides 270 cubic feet (7.6 cubic meters) of cargo space. Side racks have built-in troop seats for troop transport operations.

NOTE

The M35A3 cargo truck is not suited operations that require easy access to cargo. An example of this is a ground-to-truck forklift operation. The M35A3C cargo truck with dropsides is preferred for such operations.

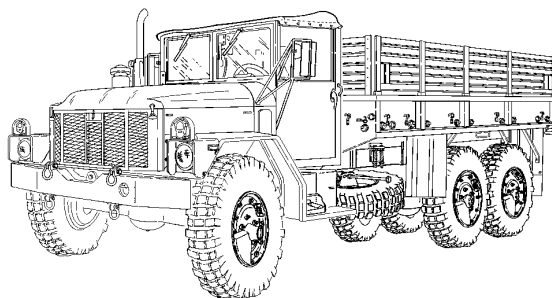

M35A3 WO/W

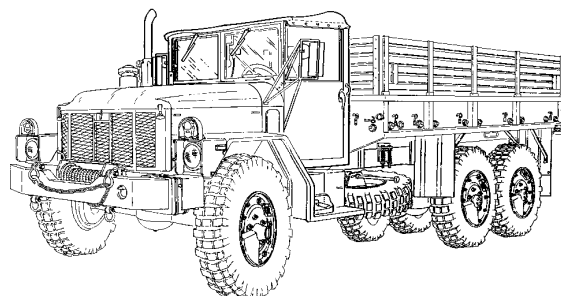

M35A3 W/W

EQUIPMENT CHARACTERISTICS, CAPABILITIES, AND FEATURES (Contd)

Cargo Truck With Dropsides, WO/W and W/W, M35A3C. The M35A3C cargo truck with dropsides is used to transport equipment, materials, and/or personnel. The hinged steel sides can be folded down or removed for easy side loading and unloading operations. The truck body provides 270 cubic feet (7.6 cubic meters) of cargo space. Side racks have built-in troop seats for troop transport operations.

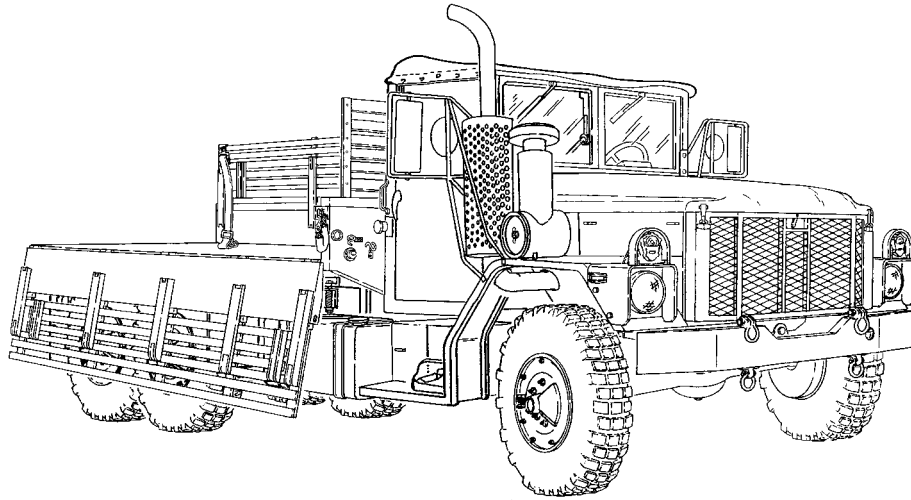

M35A3C WO/W

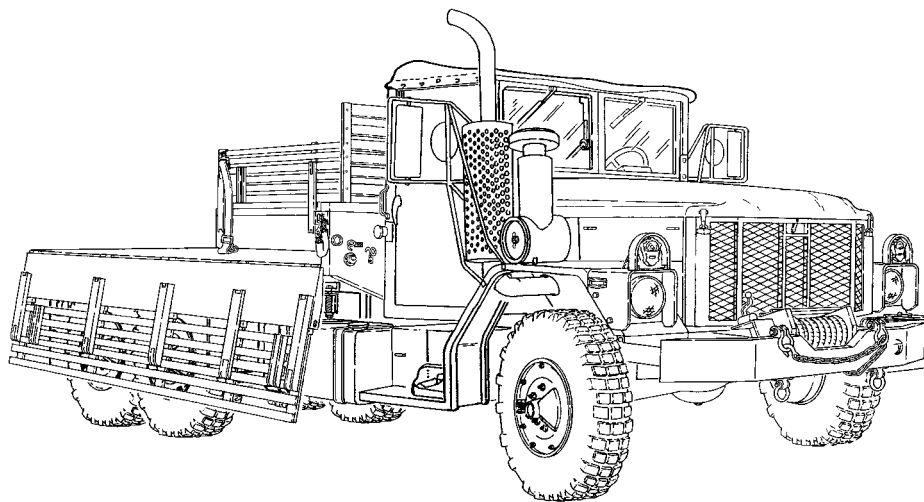

M35A3C W/W

EQUIPMENT CHARACTERISTICS, CAPABILITIES, AND FEATURES (Contd)

Cargo Truck With Extra Long Wheelbases, WO/W and W/W, M36A3. The M36A3 cargo truck with extra long wheelbase has the same basic purpose as the M35A3 cargo truck, except that the longer wheelbase on the M36A3 body provides 410 cubic feet (11.5 cubic meters) of cargo space. The hinged right side can be folded down or removed for easy side loading and unloading operations.

NOTE

The M36A3 cargo truck with extra long wheelbase is not suited for operations that require maneuverability in limited spaces.

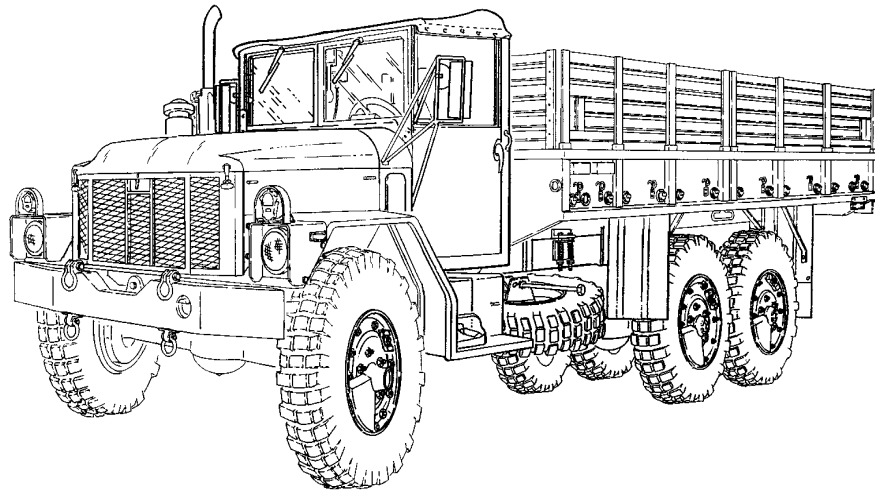

M36A3 WO/W

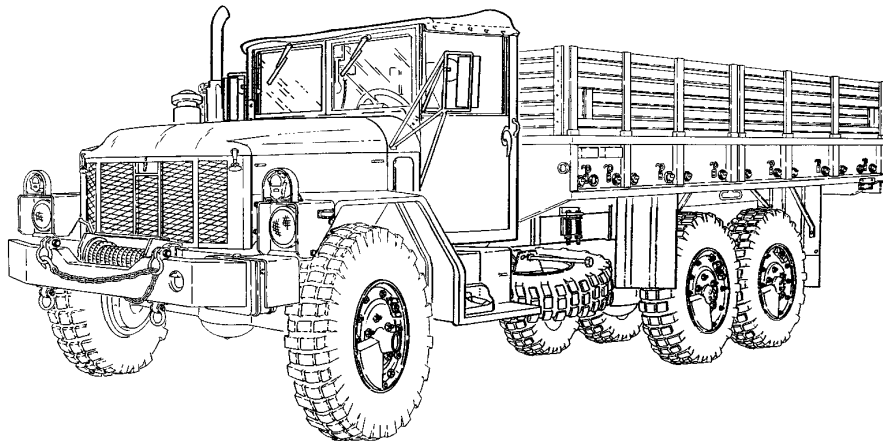

M36A3 W/W

LOCATION AND DESCRIPTION OF MAJOR COMPONENTS**EQUIPMENT FEATURES:**

- (A) DRAG LINK** – Manufactured by Sycon, 1-83504-1.
- (B) ENGINE** – Caterpillar 3116 Air-To-Air After Cooler (ATAAC), diesel, 170 HP, 420 lb-ft (570 N•m), designed to meet or exceed performance requirements of the 2-1/2-ton ESP vehicles.
- (C) CHARGED AIR COOLER** – Manufactured by G & O.
- (D) RADIATOR** – Manufactured by G & O, cross flow.
- (E) SURGE TANK** – Holds excessive coolant and helps in venting air from cooling system.
- (F) FRONT AXLES** – Rockwell C-240.
- (G) AIR CLEANER** – Capacity of 26.9 hours at 580 CFM; manufactured by Nelson.
- (H) BATTERIES** – Two-piece 6TL, 12 volts, 74 lb, 120 AMP HR rating.
- (I) TRANSFER CASE** – Rockwell T-136, 2-speed which, in conjunction with the transmission, provides up to 8 forward and 2 rearward speed ranges to front and rear differentials.
- (J) REAR AXLES** – Rockwell C-240.
- (K) WHEELS/TIRES** – Two-piece Motorwheel 20x11.00 wheels; tires are Michelin 14.5 R20XL tubeless radials with a minimum life of 10,000 miles (16,090 km). Central Tire Inflation System (CTIS), designed by AM General, allows the truck operator to monitor and regulate tire pressure from driver's compartment before and during vehicle operation.
- (L) AIR DRYER** – Dries air and purges moisture from system to protect CTIS components, brake system, and air system.
- (M) AUTOMATIC TRANSMISSION** – Allison AT-1545P, 4-speed, which shifts automatically in all forward ranges and requires no operator action uncommon to standard automatic transmission.
- (N) POWER ASSIST STEERING CYLINDER** – Manufactured by Sycon, 1-85610.

LOCATION AND DESCRIPTION OF MAJOR COMPONENTS (Contd)

This illustration shows the location of major equipment and components of ESP trucks. Each component in a category is illustrated and keyed with an encircled capital letter. Look on the opposite page and find the key to that component description.

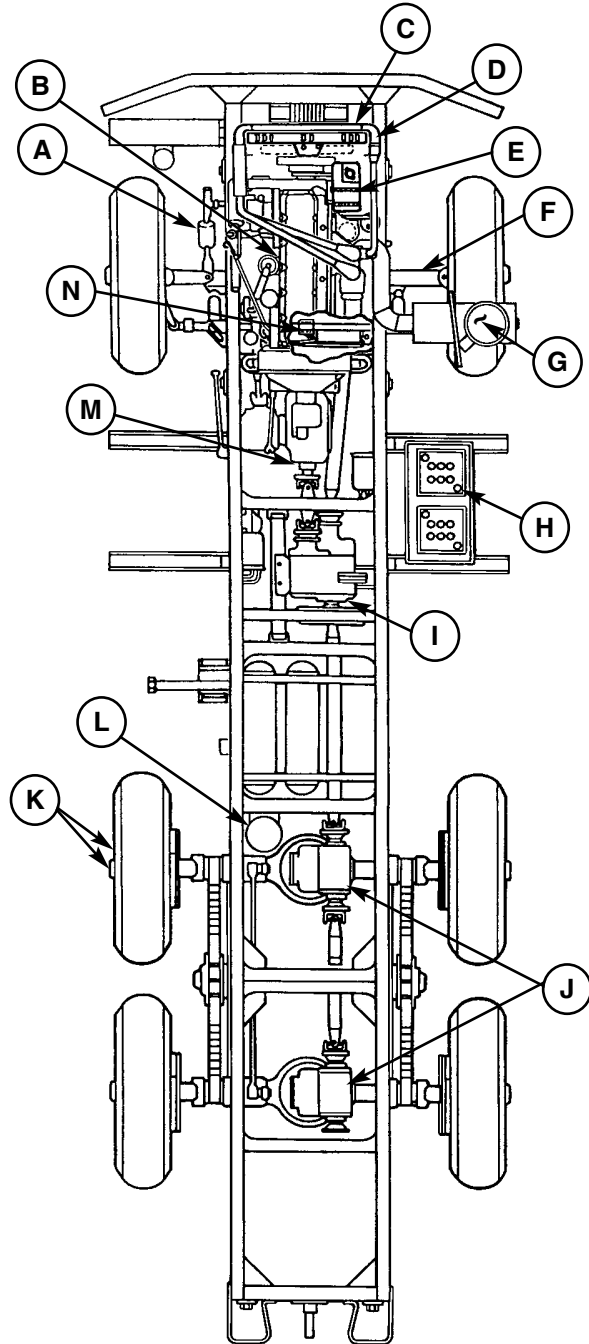

DIFFERENCES BETWEEN MODELS

This chart shows major equipment and component differences between models of ESP trucks arranged in a tabular format for easy referencing by operators.

<i>EQUIPMENT/FUNCTION</i>	<i>M35A3</i>	<i>M35A3C</i>	<i>M36A3</i>
Personnel/Cargo Operations	X	X	X
Front Winch	X	X	X
Wheelbases:			
154 in. (391 cm)	X	X	
190 in. (483 cm)			X
Body:			
Cargo Dropside		X	
Cargo (Permanent Sides)	X		X
Fuel Tank:			
Single Tank, 50 gal. (189 L)	X	X	X
Tires:			
14.5R20 XL	X	X	X
Length Overall:			
With Winch			
278.3 in. (707 cm)	X	X	
343 in. (871 cm)			X
Without Winch			
329 in. (836 cm)			X
264.3 in. (671 cm)	X	X	
Width Overall:			
96 in. (244 cm)	X		X
97.8 in. (248 cm)		X	
Ground Clearance:			
12.8 in. (32.5 cm)	X	X	X
Transmission:			
Automatic	X	X	X
Central Tire Inflation System	X	X	X

EQUIPMENT DATA

The following equipment data has been prepared in table form to assist referencing:

	<i>STANDARD</i>	<i>METRIC</i>
1. CAPACITIES		
Cooling System		
Dry	29 qt	27.4 L
Drain and Refill	27 qt	26 L
Engine Crankcase:		
Dry	21 qt	19.9 L
W/Filter	19 qt	18 L
WO/Filter	18 qt	17 L
Fuel Tank	50 gal.	189.3 L
Transmission:		
Dry	20 qt	18.9 L
Drain and Refill	16 qt	15.1 L
After Rebuild	22 qt	20.8 L
Front Winch:		
Winch Gearcase	2.75 pt	1.30 L
Winch End Frame Housing	1.25 pt	0.6 L
Winch Hydraulic Reservoir:		
Dry	42 qt	39.7 L
Drain and Refill	39 qt	36.9 L
Master Cylinder Reservoir	2 qt	1.9 L
Transfer Case	7 qt	6.6 L
2. ENGINE		
Manufacturer	Caterpillar	
Model	3116 ATAAC	
Type	Diesel, four-cycle in-line, 6-cylinder, turbocharged	
Weight	1198 lb	544 kg
Displacement	403 cu. in.	6.6 L
Operating Speed (Full Load)	2700 RPM	
Brake Horsepower	170 HP	
Maximum Torque (@1,550 RPM)	420 lb-ft	570 N•m
Oil Pressure	35-70 psi	241-483 kPa
Compression Ratio	18:1	
Fuel Consumption (Approx.)	7-8 mpg	
Firing Order	1, 5, 3, 6, 2, 4	
Engine Idle	750-850 RPM	
3. FUEL SYSTEM		
Fuel Pump Location	On front of engine	
Fuel Filter/Water Separator Manufacturer	DAVCO	
4. COOLING SYSTEM		
Radiator Filler Cap Pressure	10 psi	69 kPa
Thermostat:		
Starts To Open	178°F	81°C
Fully Open	198°F	92°C
Radiator:		
Manufacturer	G & O	
Type	Cross flow	

EQUIPMENT DATA (Contd)

	<i>STANDARD</i>	<i>METRIC</i>
4. COOLING SYSTEM (Contd)		
Charged Air Cooler:		
Manufacturer	G & O	
Transmission Oil Cooler:		
Manufacturer	G & O	
Transmission Oil Cooler (Oil-to-Air):		
Manufacturer	Hayden	
5. ELECTRICAL SYSTEM		
Batteries:		
Model	6TL	
Voltage	12 volts	
Weight (Filled)	74 lb	33.6 kg
Number of Batteries	2	
Rating	120 AMP HR	
Alternator:		
Manufacturer	Prestolite	
Model	AMA-5102UT	
Voltage Output	28 volts	
Armature Speed (Peak)	8000 RPM	
Manufacturer	Leece-Neville	
Model	3002AC	
Voltage Output	28 volts	
Armature Speed (Peak)	8000 RPM	
Starter:		
Manufacturer	Prestolite	
Model	EO-33405	
Voltage	28 volt	
Specification	MIL-G-46795-F (AT)	
Capacity (Peak)	8.5 HP	
6. TRANSMISSION (AUTOMATIC)		
Manufacturer	Allison	
Model	AT-1545P	
Type	Constant mesh	
Weight:		
Dry	280 lb	127 kg
Wet	320 lb	145 kg
Speeds	Four forward, one reverse	
Gear Ratios:		
First Speed	3.45 to 1	
Second Speed	2.25 to 1	
Third Speed	1.41 to 1	
Fourth Speed	1.10 to 1	
Reverse	5.02 to 1	
7. WHEELS		
Manufacturer	Motorwheel	
Size	20x11.00	
8. TIRES		
Manufacturer	Michelin	
Size	14.5 R20XL	

EQUIPMENT DATA (Contd)

	<i>STANDARD</i>	<i>METRIC</i>
9. CENTRAL TIRE INFLATION SYSTEM (CTIS)		
Manufacturer:	CM Automotive	
Type:	Electronic system	
10. POWER STEERING SYSTEM		
Drag link:		
Manufacturer	Sycon	
Model	1-83504-1	
Power Assist Cylinder:		
Manufacturer	Sycon	
Model	1-85610	

LOCATION AND DESCRIPTION OF DATA PLATES

The location and contents of warning, caution, and data plates are provided in this paragraph. A complete list and location of warning, caution, and data plates is in TM 9-2320-386-24P and TM 9-2320-361-20P. If any plate is worn, broken, painted over, missing, or unreadable, it must be replaced.

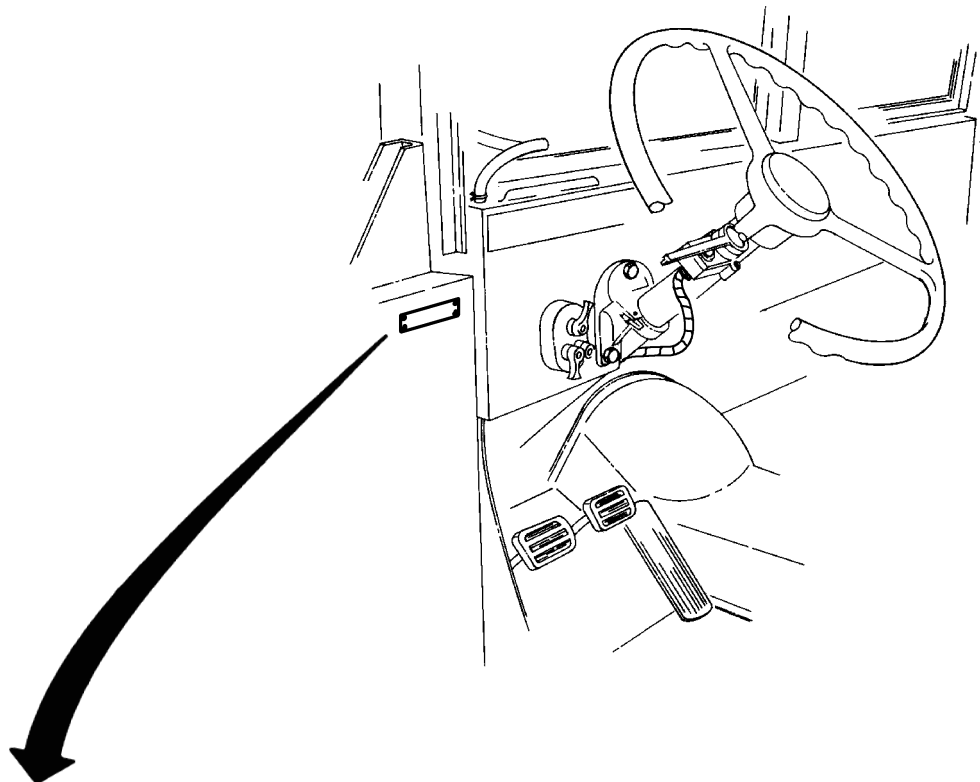

CAUTION

TURN ALL ELECTRICAL SWITCHES
OFF BEFORE TURNING ENGINE OFF

LOCATION AND DESCRIPTION OF DATA PLATES (Contd)

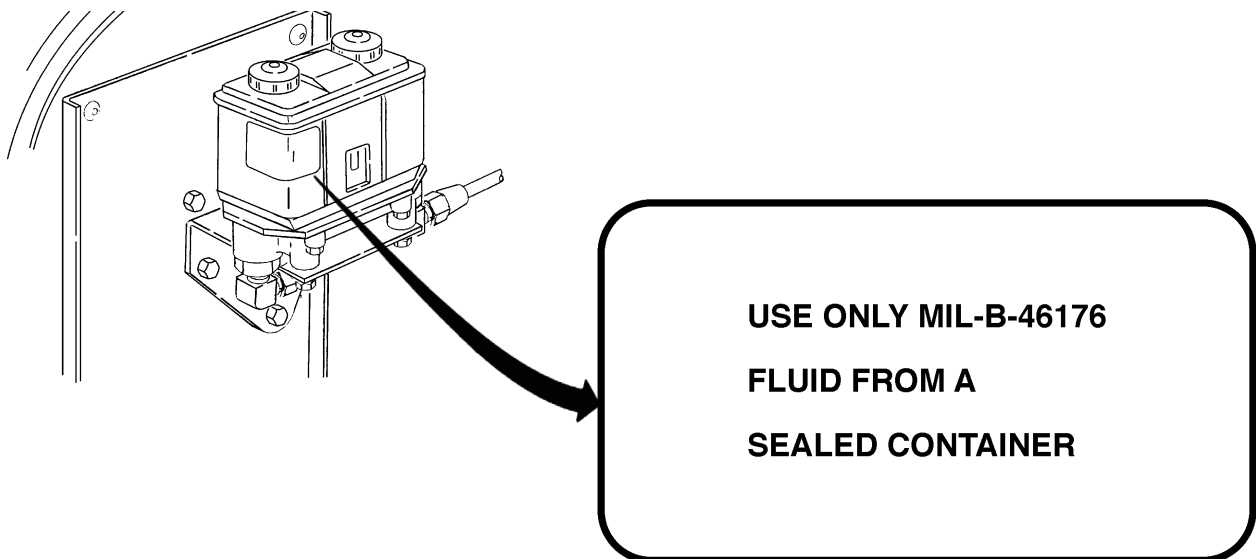
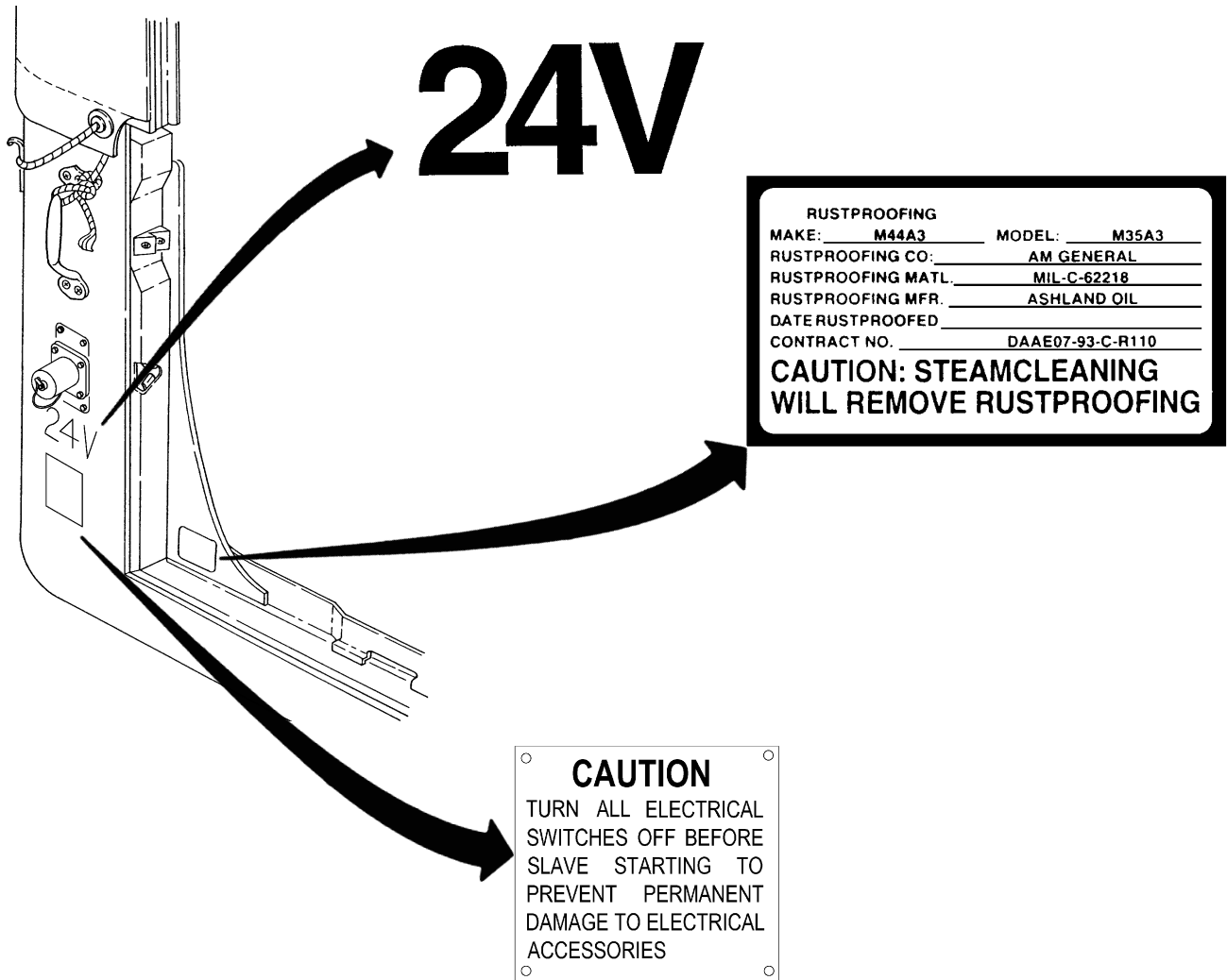

LOCATION AND DESCRIPTION OF DATA PLATES (Contd)

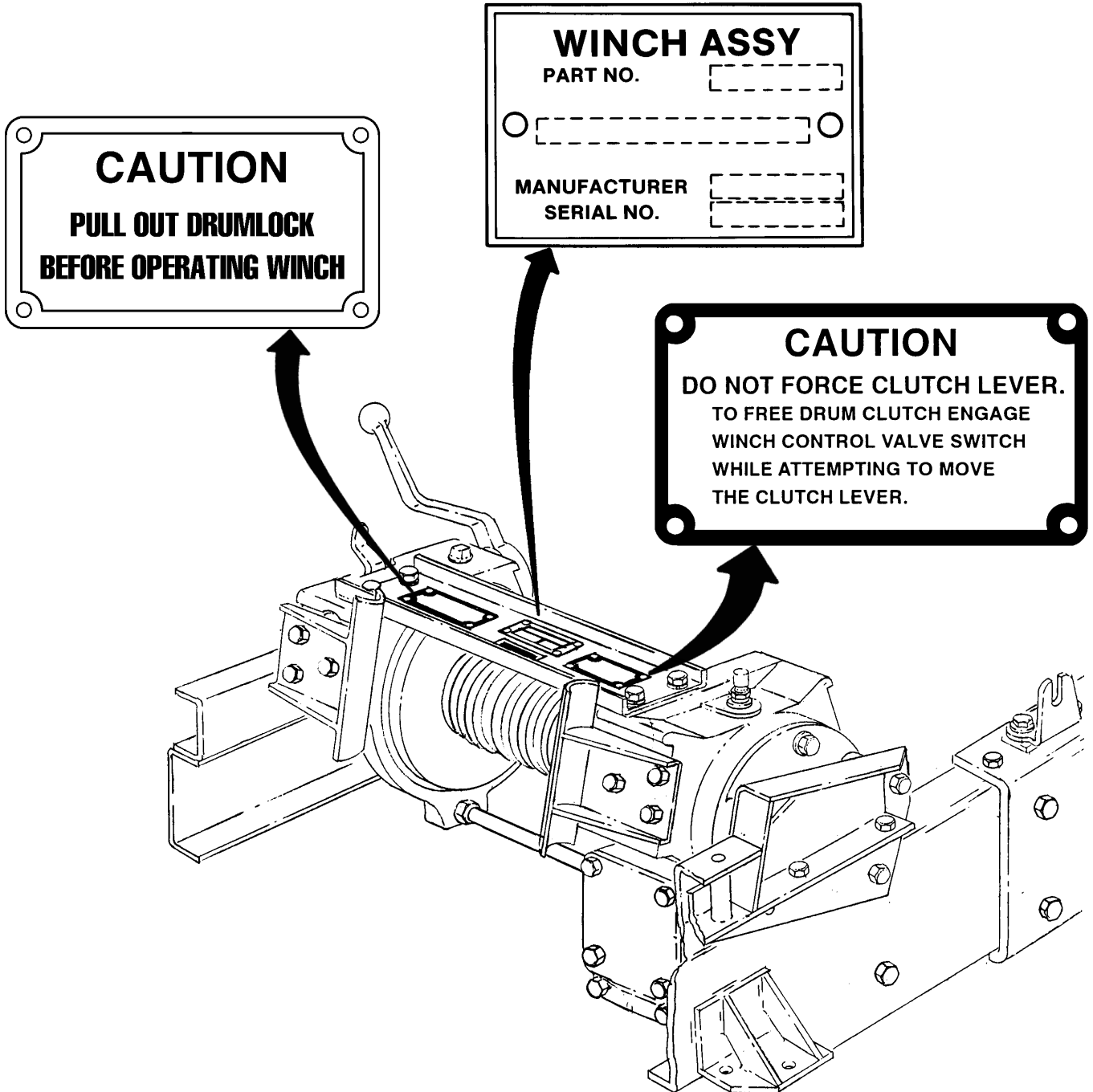

LOCATION AND DESCRIPTION OF DATA PLATES (Contd)

WARNING
DO NOT USE WINCH TO
PAY OUT LINE LOADS
GREATER THAN 3000
LBS FOR ANY DISTANCE
GREATER THAN 10 FT.

WINCH RATING
FIRST LAYER: 10,000 LB Single Line Pull
Rated Per ATPD-2174A, para. 3.9.9.1

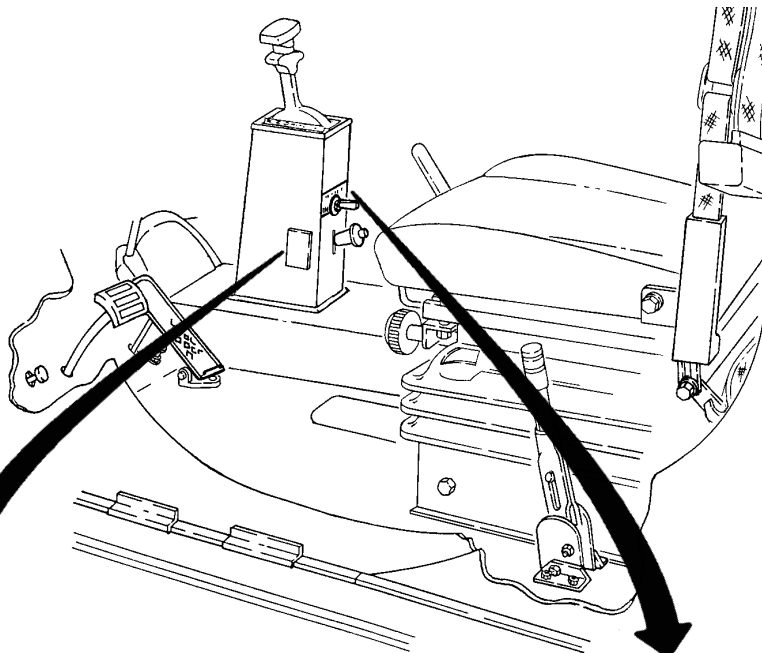
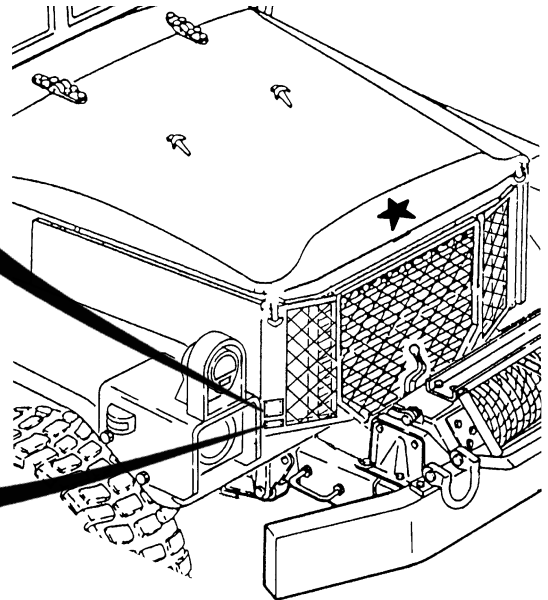

WINCH CONTROL VALVE
ENGAGE

DISENGAGE

WINCH SPOOL DIRECTION
IN

OUT

LOCATION AND DESCRIPTION OF DATA PLATES (Contd)

WARNING !	FRONT TRANSMISSION	TRANSFER CASE	WARNING !
BUZZER SOUNDING INDICATES UNSAFE AIR PRESSURE LEVEL. DETERMINE CAUSE IMMEDIATELY	R N D 3 2 1	HIGH (UP) ↑ LOW (DOWN)	DO NOT SHIFT TRANSFER CASE TO LOW WHEN VEHICLE SPEED IS OVER DRIVE ----- 25 MPH THIRD ----- 17 MPH SECOND ----- 11 MPH FIRST ----- 7 MPH REVERSE ----- 5 MPH

AUTHORIZED FUELS

DF-1, DF-2, DF-A
VV-F-800
MIL-T-83133 (JP8)
ALTERNATE FUELS
MIL-F-16884
MIL-T-5624 (JP5)
EMERGENCY FUEL
MIL-T-5624 (JP4)

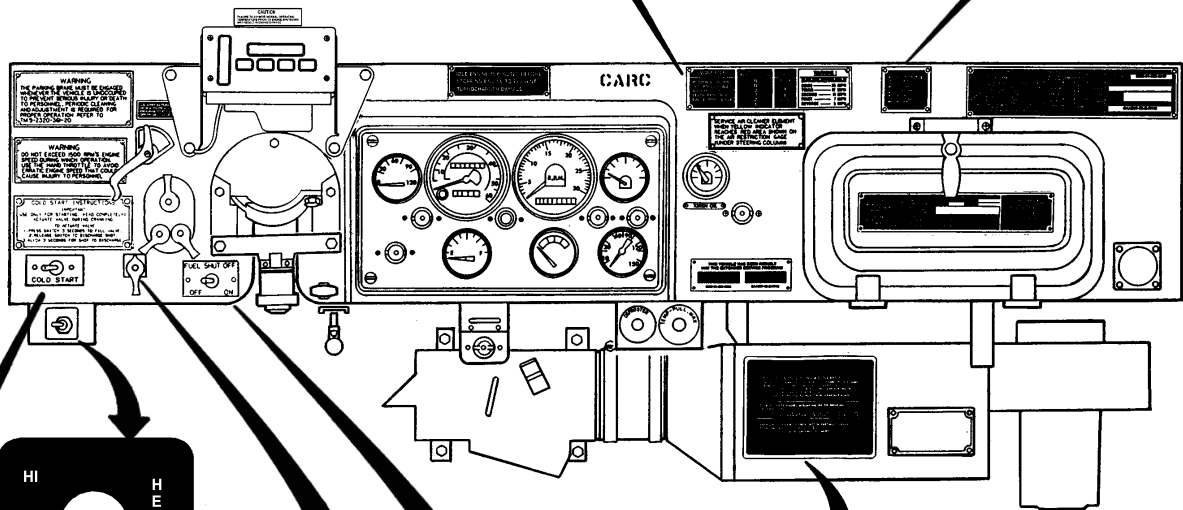

HI
OFF
LOW

HEATER

START

OFF ON

FUEL SHUT OFF

COLD START

SERVICING INSTRUCTIONS: AIR CLEANER

CONSULT VEHICLE MANUAL FOR DETAILED CLEANING INSTRUCTIONS
USE 75-100 PSI DRY COMPRESSED AIR TO CLEAN ELEMENT.

1. BLOW THROUGH ELEMENT FROM CLEAN SIDE (INSIDE)
2. BLOW DOWN OUTSIDE OF PLEATS
3. BLOW THROUGH ELEMENT FROM CLEAN SIDE AGAIN

ELEMENT CAN BE WASHED IN SOAP AND WATER, RINSE AND DRY THOROUGHLY

NEVER USE GASOLINE OR OTHER SOLVENTS

EMERGENCY CLEANING: ELEMENT MAY BE PARTIALLY CLEANED BY PATTING LIGHTLY. **DO NOT STRIKE ENDS**
USE REPLACEMENT ELEMENT

LOCATION AND DESCRIPTION OF DATA PLATES (Contd)

WARNING
THE PARKING BRAKE MUST BE ENGAGED WHENEVER THE VEHICLE IS UNOCCUPIED TO PREVENT SERIOUS INJURY OR DEATH TO PERSONNEL. PERIODIC CLEANING AND ADJUSTMENT IS REQUIRED FOR PROPER OPERATION REFER TO TM-9-2320-361-20

U.S. ARMY NATIONAL GUARD
DEDICATED PROCUREMENT
PROGRAM, FY 93 FUNDS
DPP PROJECT CODE RA3

IDLE ENGINE 5 MINUTES BEFORE
STOPPING ENGINE TO PREVENT
TURBOCHARGER DAMAGE

CTIS CONTROL

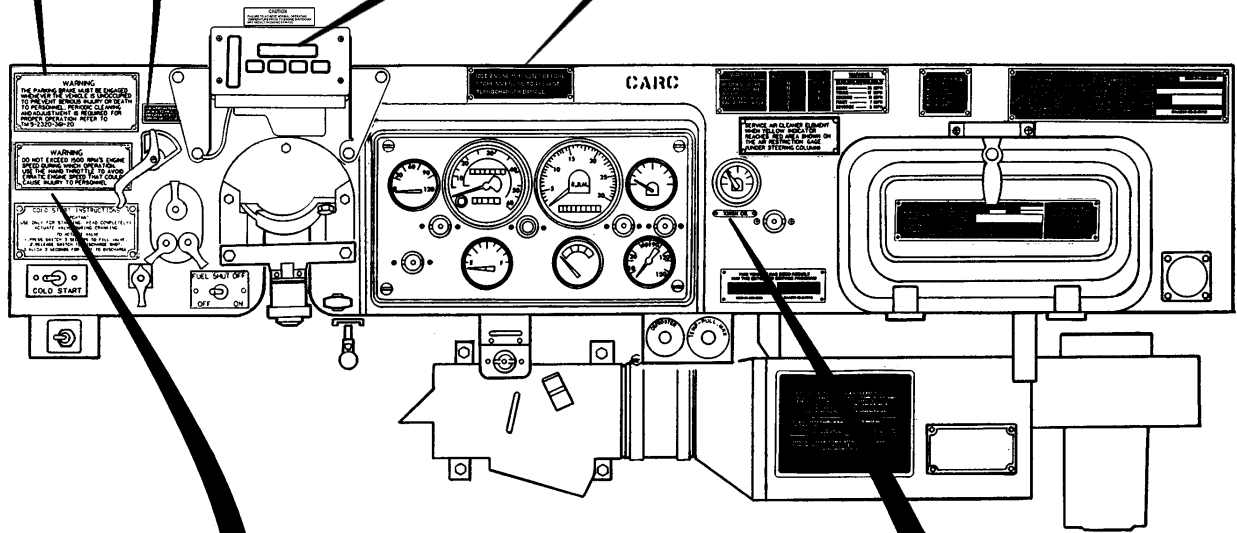

WARNING
DO NOT EXCEED 1500 RPM'S ENGINE SPEED DURING WINCH OPERATION. USE THE HAND THROTTLE TO AVOID ERRATIC ENGINE SPEED THAT COULD CAUSE INJURY TO PERSONNEL

XMSN OIL

LOCATION AND DESCRIPTION OF DATA PLATES (Contd)

TRUCK, CARGO: 2 1/2 TON, 6X6, M35A3, WO/W

CG LOCATION BASED ON 5,000 LBS PAYLOAD W/O CREW	WEIGHTS W/O CREW		FOR AIR TRANSPORT ONLY	
	EMPTY	LOADED	EMPTY	LOADED
	PAYLOAD	5,000	7,640 MAX	
	FRONT AXLE	6,550	6,733	7,850 MAX
	INTER AXLE	3,650	6,162	7,850 MAX
	REAR AXLE	3,350	5,655	
TOTAL LBS	13,550	18,550	21,300 MAX	
MAX TOWED LOAD LBS	6,000			
SHIPPING CUBAGE:	1,207 CU FT			

IDENTIFICATION DATA
 NSN **2320-01-383-2047**
 IDENTIFICATION NO. _____
 MFD BY: **AM GENERAL CORP.**
SOUTH BEND, INDIANA
 CONTRACT NO. **DAAE07-93-C-R110**
 U.S. PROPERTY



CAUTION
 FAILURE TO ACHIEVE NORMAL OPERATING TEMPERATURE PRIOR TO ENGINE SHUTDOWN MAY RESULT IN ENGINE DAMAGE

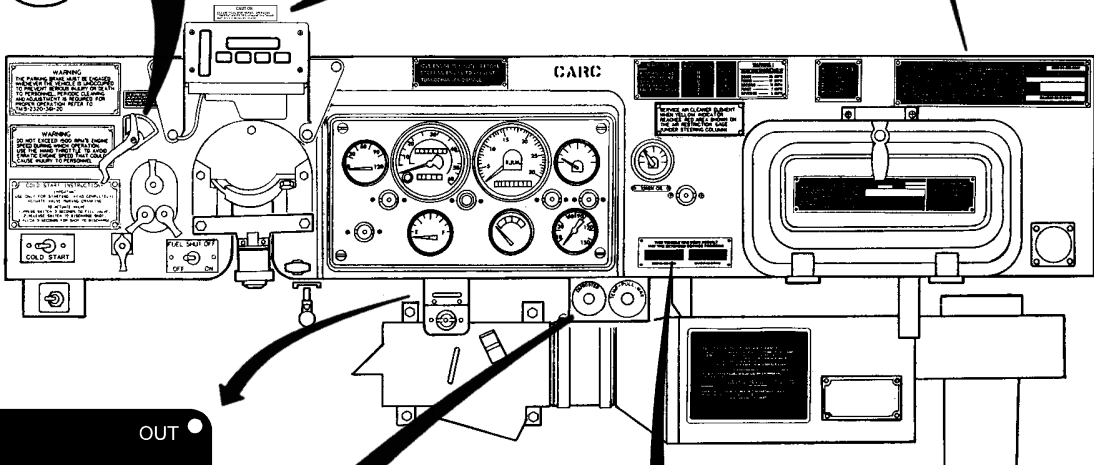

THIS VEHICLE HAS BEEN REBUILT IAW THE EXTENDED SERVICE PROGRAM

2320-01-383-2050 DAAE07-93-C-R110

LOCATION AND DESCRIPTION OF DATA PLATES (Contd)

SERVICING DATA		TRUCK, 2 1/2 TON 6 X 6		PUBLICATIONS APPLYING TO THIS VEHICLE	
ELECTRICAL SYSTEM 24V		MIN INFLATION PRESSURES		- TIRES -	
CRANKCASE CAPACITY 19-QTS.		HIGHWAY 43-47 PSI		SIZE: 14.5R20	
COOLING SYSTEM CAPACITY 29-QTS.		CROSS COUNTRY 31-35 PSI		ALL SPEEDS 0-36 MPH	
FUEL TANK CAPACITY 50-GAL.		MUD, SAND, SNOW EMERGENCY 18-22 PSI		0-16 MPH	
TRANSMISSION CAPACITY 10-QTS.				0-5 MPH	
TEMPERATURE ABOVE -4° F		ENGINE / TRANS OIL OE/HDO-15W/40		GEAR OIL GO 80/90	
BELOW -4° F		OEA		SEE LO9-2320-386-12	
				GO 75	
				OPERATOR'S MANUAL—	
				TM9-2320-386-10	
				MAINTENANCE MANUAL—	
				TM9-2320-361-20	
				TM9-2320-361-34	
				TM9-2320-386-24	
				PARTS LIST—	
				TM9-2320-361-20P	
				TM9-2320-361-34P	
				TM9-2320-386-24P	

SERVICE AIR CLEANER ELEMENT WHEN YELLOW INDICATOR REACHES RED AREA SHOWN ON THE AIR RESTRICTION GAGE (UNDER STEERING COLUMN)

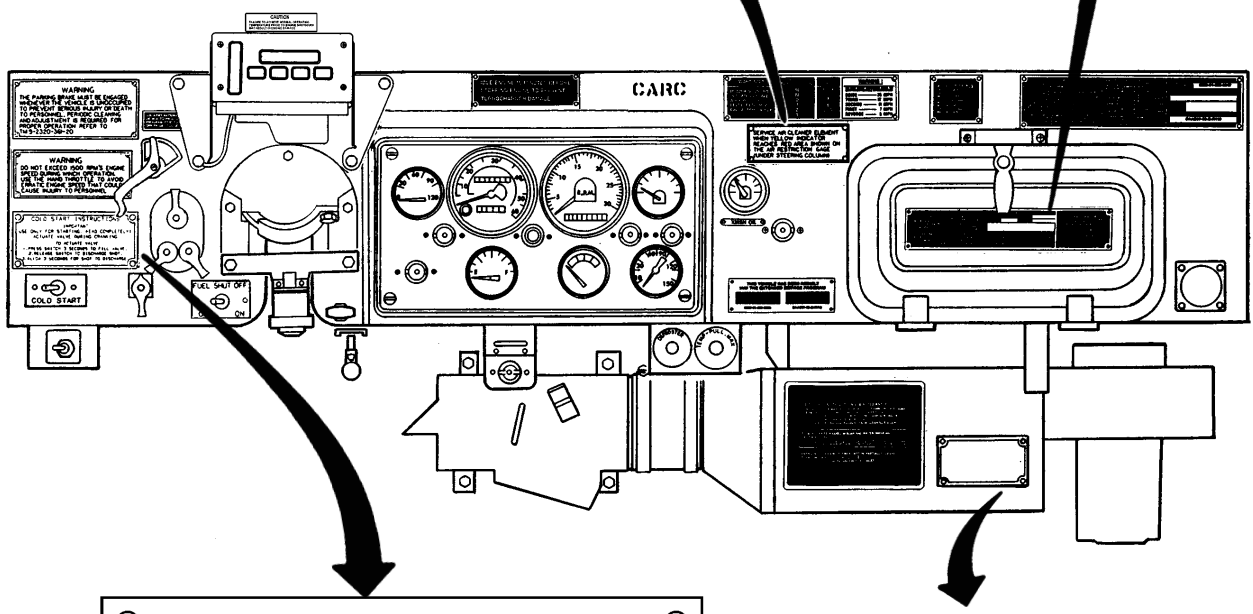

COLD START INSTRUCTIONS
IMPORTANT
 USE ONLY FOR STARTING. READ COMPLETELY!
 ACTUATE VALVE DURING CRANKING

TO ACTUATE VALVE

1. PRESS SWITCH 3 SECONDS TO FILL VALVE.
2. RELEASE SWITCH TO DISCHARGE SHOT.
3. ALLOW 3 SECONDS FOR SHOT TO DISCHARGE.

STOCK NO.

MODEL NO.

RATING

SERIAL NO.

VOLTS AMPS

HUNTER MFG. CO.
 SOLON, OHIO U.S.A.

LOCATION AND DESCRIPTION OF DATA PLATES (Contd)

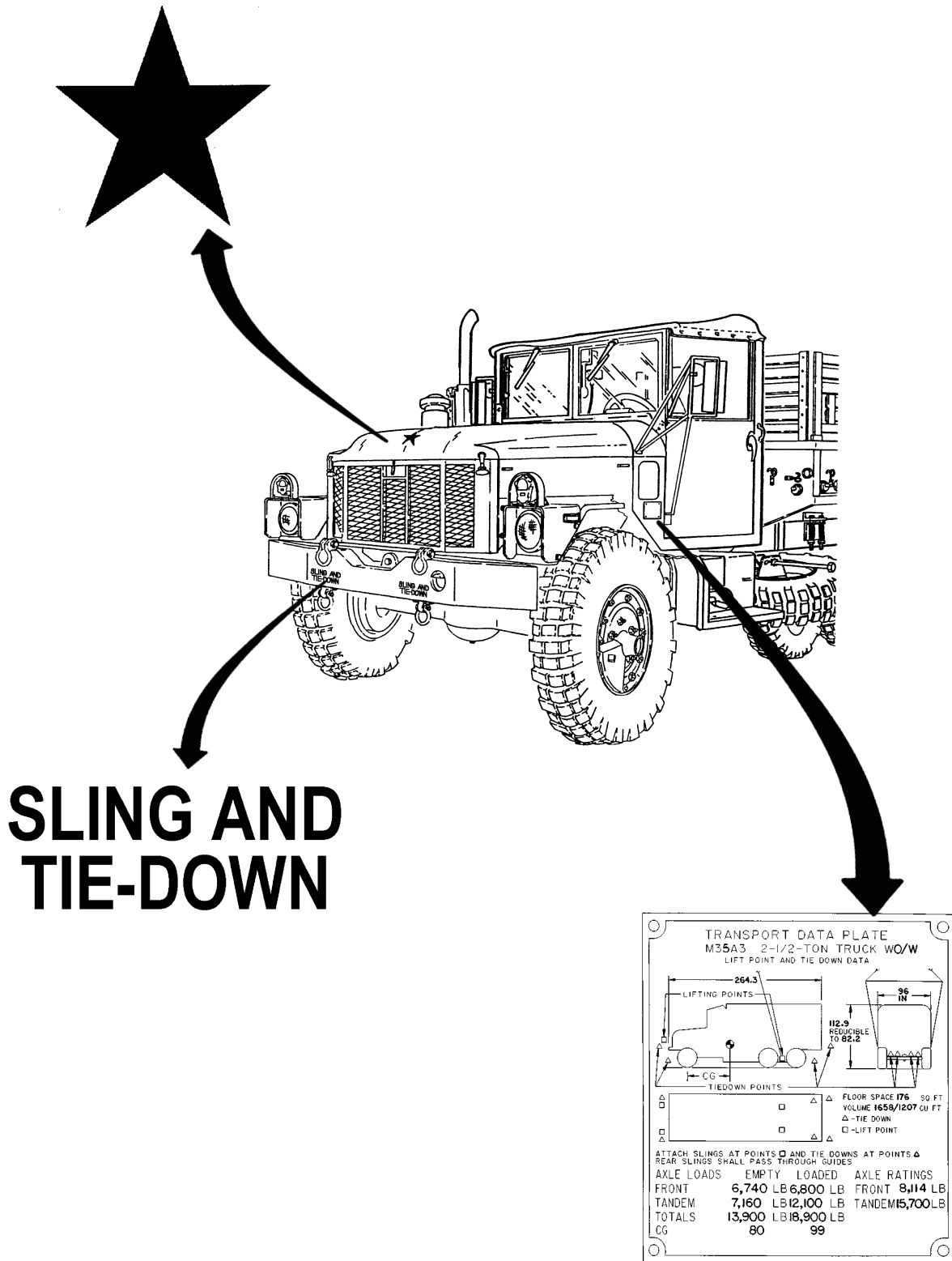

LOCATION AND DESCRIPTION OF DATA PLATES (Contd)

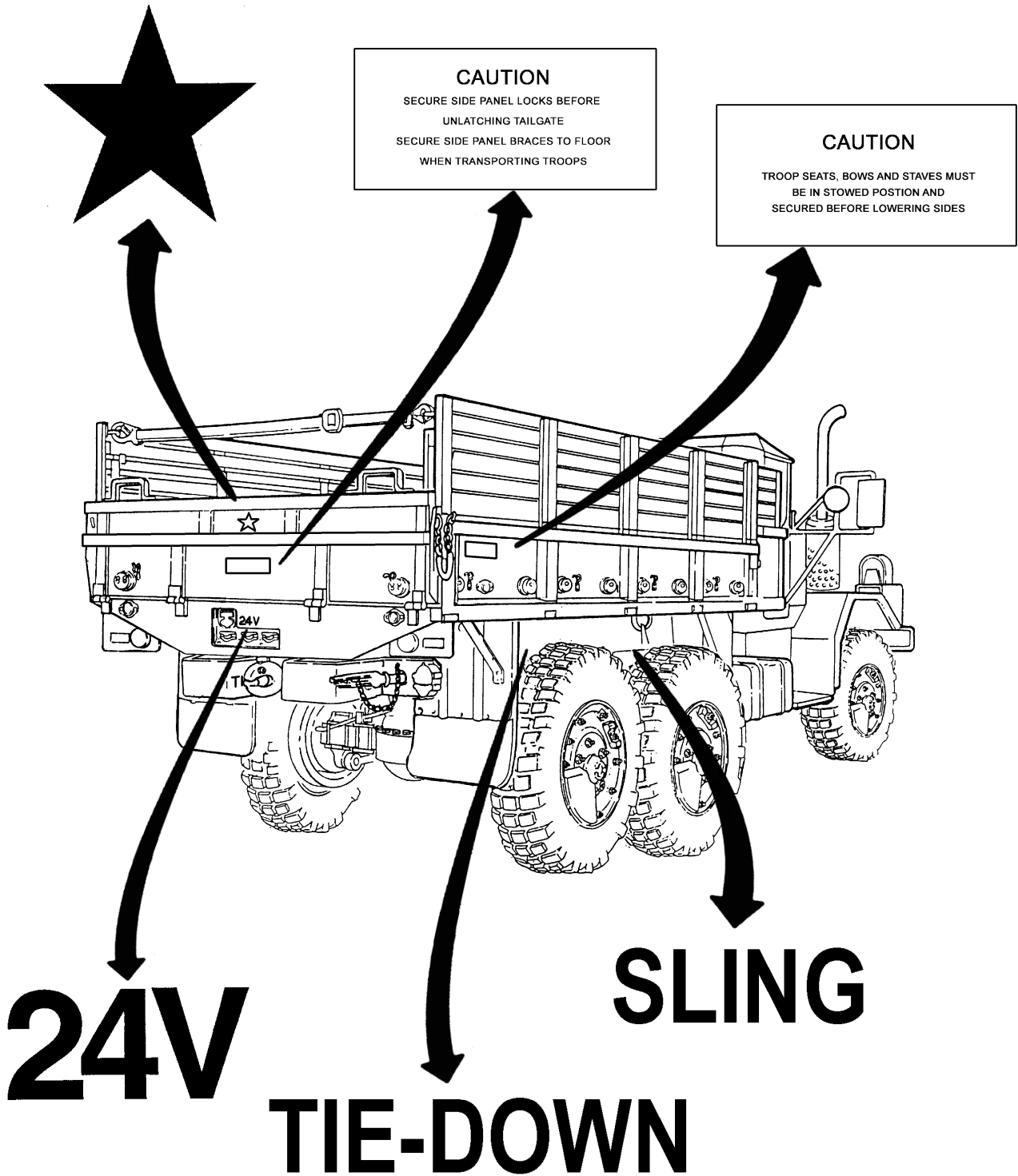

LOCATION AND DESCRIPTION OF DATA PLATES (Contd)

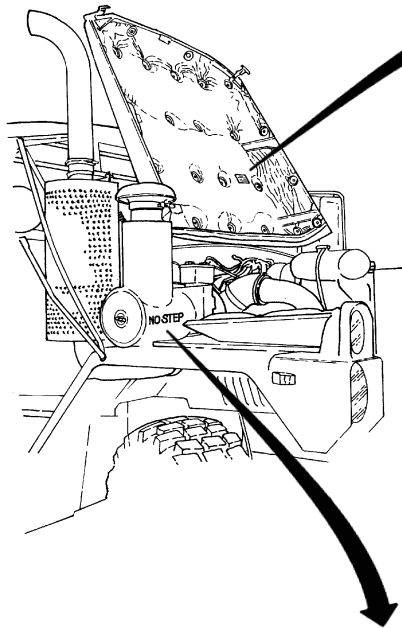

WARNING
SECURE HOOD IN RAISED
POSITION WITH SAFETY
HOOK BEFORE SERVICING
ENGINE

NO STEP

CAUTION
*HIGH INTENSITY NOISE
HEARING PROTECTION
REQUIRED*

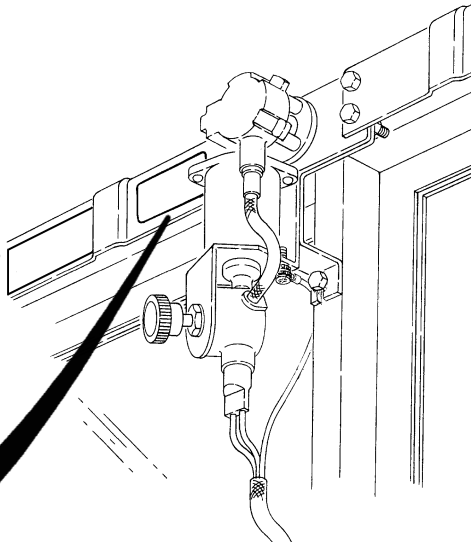

WARNING
DO NOT USE HAND THROTTLE AS AN
AUTOMATIC VEHICLE SPEED OR CRUISE CONTROL.
THE HAND THROTTLE WILL NOT DISENGAGE
AUTOMATICALLY WHEN BRAKE IS APPLIED.

LOCATION AND DESCRIPTION OF DATA PLATES (Contd)

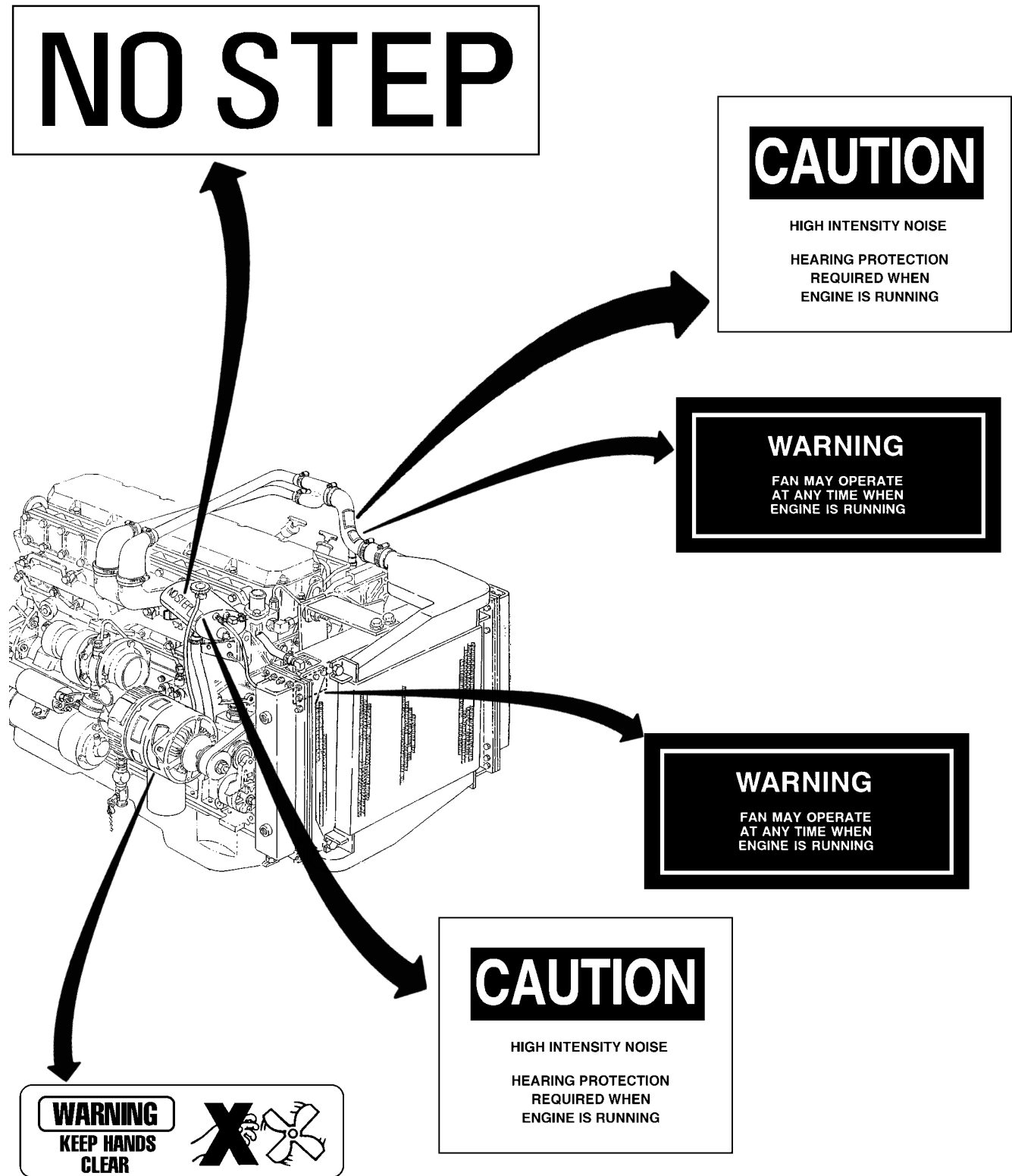

END OF WORK PACKAGE

DESCRIPTION AND THEORY OF OPERATION

EXTENDED SERVICE PROGRAM (ESP)

TRUCK, CARGO, 2-1/2-TON, 6X6, M44A3 SERIES TRUCKS (DIESEL)

*M35A3, W/O WINCH (NSN 2320-01-383-2047); W/WINCH (NSN 2320-01-383-3850);
M35A3C, W/O WINCH (NSN 2320-01-383-2050); W/WINCH (NSN 2320-01-383-2049);
M36A3, W/O WINCH (NSN 2320-01-383-2048); W/WINCH (NSN 2320-01-383-2046).*

**Section II. THEORY OF OPERATION
TABLE OF CONTENTS**

<i>WP Title</i>	<i>WP Sequence No.-Page No.</i>
General	0005 00-1
Engine System Operation	0005 00-1
Fuel System Operation	0005 00-1
Compressed Air System Operation	0005 00-1
Central Tire Inflation (CTIS) Operation	0005 00-1
Cooling System Operation	0005 00-2
Electrical System Operation	0005 00-3
Simplified Test Equipment/Internal Combustion Engines - Reprogrammable (STE/ICE-R)	0005 00-2
Front Winch Operation	0005 00-3
Power Steering Assist System Operation	0005 00-3
Split Air-Hydraulic Brake System Operation	0005 00-3

END OF WORK PACKAGE

DESCRIPTION AND THEORY OF OPERATION

EXTENDED SERVICE PROGRAM (ESP)

TRUCK, CARGO, 2-1/2-TON, 6X6, M44A3 SERIES TRUCKS (DIESEL)

M35A3, W/O WINCH (NSN 2320-01-383-2047); W/WINCH (NSN 2320-01-383-3850);

M35A3C, W/O WINCH (NSN 2320-01-383-2050); W/WINCH (NSN 2320-01-383-2049);

M36A3, W/O WINCH (NSN 2320-01-383-2048); W/WINCH (NSN 2320-01-383-2046).

Section II. THEORY OF OPERATION

GENERAL

This section explains how components of the ESP vehicles work. A functional description of these components and their related parts will be covered in the following paragraphs.

ENGINE SYSTEM OPERATION

The Caterpillar 3116 engine has a 403 cu in.(6.6 L) displacement, with 4.13 in. (105 mm) bore and 5.0 in. (127 mm) stroke. The engine is a four-stroke cycle, in-line 6-cylinder with direct fuel injection. The engine is turbocharged with an Air-to-Air Aftercooler (ATAAC) system, and is rated 170 hp at 2700 RPM.

The engine lubricating oil, which is both cooled and filtered, is supplied by a gear-type pump. Bypass valves provide unrestricted flow of lubrication oil to the engine parts when oil viscosity is high, or if either the oil cooler or the oil filter elements should become clogged.

FUEL SYSTEM OPERATION

A mechanical governor, transfer pump, and high pressure unit injection fuel system provides engine response and fuel economy for ESP vehicles.

The transfer pump creates a vacuum that draws fuel from the fuel tank. It then pumps fuel under low pressure to the fuel/water separator where water and contaminants are removed. Filtered fuel is then carried to the injectors. The injectors use a plunger-and-barrel system to create the high pressures needed for injection. Inside the injector, a spring-loaded needle valve lifts from its seat to allow high pressure fuel to be injected into each cylinder. Excess fuel is routed from the engine cylinder head back to the governor and then to the fuel tank. A fuel shutoff solenoid mounted on the fuel pump cuts the flow of fuel to the injectors when the operator turns the accessory switch off.

COMPRESSED AIR SYSTEM OPERATION

The ESP vehicles are equipped with a compressed air system that supplies clean dry filtered air to operate air-actuated or assisted accessories throughout the vehicle.

The air is supplied from engine air compressor through an air dryer and stored in two air reservoirs.

The air from reservoirs is piped along frame rails back to two rear couplings. The left side air coupling is the service coupling and is used to supply air to operate trailer brakes. The right side air coupling is the emergency coupling and is used to release spring brakes if trailer is so equipped and to connect an air hose to manually inflate vehicle tires.

The air reservoirs also supply air forward to air pressure gauge, two air hydraulic brake boosters, steering assist cylinder, drag link assist, air horns, transfer case air cylinder, front axle engagement switch, and cooling fan actuator and clutch.

CENTRAL TIRE INFLATION SYSTEM (CTIS) OPERATION

The CTIS allows the operator to manually select a tire pressure suitable to the terrain being traversed. The system incorporates an Electronic Control Unit (ECU) and air regulating system which provides and maintains the correct air pressure to all tires at the same time. The ECU controls the manifold which automatically directs compressed air to inflate the tires or signals the deflation port to deflate the tires according to the operator-selected terrain setting. The ECU monitors and regulates air system pressure in 30-minute intervals and compensates for thermal tire pressure changes as recommended by the tire manufacturer.

The CTIS is activated and deactivated with an ON/OFF button on the ECU. In the event the unit is not deactivated prior to engine shutdown, it will automatically activate when the engine is started again.

Terrain switches on the ECU are pressed by the operator for the terrain conditions which are identified as emergency, sand/mud/snow, cross-country, and highway. Once the terrain switch has been pressed for desired pressure setting, the air system inflates and maintains all tires to the appropriate tire pressure corresponding to a recommended vehicle speed. Provided operator does not experience overspeed conditions, no additional operator inputs are required once presets have been selected.

The air regulating system consists of a controller overspeed signal generator, power manifold, and wheel valves. If the operator exceeds the recommended vehicle speed in either emergency, sand/mud/snow, or cross country modes, an overspeed warning will activate, (flashing max speed display) alerting the operator of the overspeed condition and to decrease vehicle speed or select a higher tire pressure on the ECU. In the event the operator fails to slow down or select a higher tire pressure in approximately one minute, the system will automatically increase air pressure to the tires to the next higher tire pressure setting.

In the event of one or more small air leaks anywhere in the system, such as from a tire puncture or leak at a connecting line, pressure can be maintained by pressing a terrain switch on the control panel. When doing so the initial test pressure sequence begins. If the air feeder lines cannot hold at least 6 psi (41 kPa) the controller display will read FLAT in the upper right corner, indicating to the vehicle operator that a large air leak, such as a damaged/disconnected air line or a flat tire, exists. When FLAT is indicated, the vehicle operator may elect to call for assistance, or try to drive to a repair center using the vehicle's run flat mode.

Should a particular tire or connecting line experience catastrophic failure or a leak which exceeds the capacity of the compressor, the CTIS may be turned off allowing the wheel valves to keep each tire individually isolated. Additionally, the damaged portion will remain isolated, as a safety measure, until it is repaired. A priority pressure switch in the manifold monitors the pressure in the air reservoirs and isolates the CTIS if this pressure drops below 75 psi (517 kPa). Minimum requirement for the operation of priority systems (brakes, power steering assist, horn) is less than 75 psi (517 kPa), so safe operation is assured. If the CTIS suffers complete failure, the operator accesses a manual wheel valve at each wheel and inflates each tire from an external air source. If tire pressure falls below 10 psi, CTIS will not inflate tire. The CTIS should be deactivated during operation in extreme cold, 0° to -65° F (-18° to -54° C). Extremely cold temperatures can cause air seals located at each wheel to fail.

COOLING SYSTEM OPERATION

The engine has a pressurized cooling system with a shunt line. The system can safely operate at a temperature higher than the normal boiling point of water, which prevents cavitation in the water pump.

ESP vehicles have a 10-plate transmission oil cooler located in the radiator outlet tank and an auxiliary oil cooler in front of the radiator. The oil coolers are designed to keep the automatic transmission running at a safe operating temperature.

Major components of the cooling system are the radiator, charged air cooler, water pump, surge tank, water thermostat regulator, fan, and fan actuator.

ELECTRICAL SYSTEM OPERATION

The ESP series electrical system operates similarly to the M44A2 series vehicle electrical system. Electrical component installation procedures and connections unique to ESP vehicles are found in this manual.

SIMPLIFIED TEST EQUIPMENT/INTERNAL COMBUSTION ENGINES - REPROGRAMMABLE (STE/ICE-R)

The STE/ICE-R system is a reprogrammable version of the STE/ICE system commonly used to test the serviceability of standard M44A2, 2-1/2-ton vehicles. When in operation, test data are transmitted from transducers to a permanently mounted Diagnostic Connector Assembly (DCA) located under the instrument panel on the passenger side of the vehicle. The data are then transferred through a DCA cable to the Vehicle Test Meter (VTM). The VTM uses the data received, and stored vehicle information, to give a result.

The STE/ICE-R can measure standard voltage, current, resistance, pressure, temperature, and speed. Special tests, such as the compressor unbalance test and starter system evaluations, are also performed by STE/ICE-R.

FRONT WINCH OPERATION

The ESP vehicle uses the same front winch commonly found on the M44A2 series vehicle. The front winch is powered by a hydraulic system that transmits pressurized fluid from an engine-driven pump to drive hydraulic winch motor attached to the rear of the winch at the input shaft. The pump is driven by the engine and creates a vacuum that draws oil from the reservoir to a bypass valve. When the winch is not engaged, the bypass valve routes the oil, via the filter, back to the reservoir. To engage the winch, the lower air valve lever on the shift tower is pulled out and up, compressed air closes the bypass valve reservoir return port and opens the control valve supply port. The control valve determines the direction of drum rotation by routing the oil in either a clockwise or counterclockwise direction through the hydraulic motor by engaging the upper air valve lever on the control tower. The upper air valve uses compressed air to open and close the ports on the control valve.

POWER STEERING ASSIST SYSTEM OPERATION

The ESP series power steering assist operation is designed to ease manual steering operations when a compressed air supply, 9 CFM minimum (0.252 cm) is available.

Major components of the system are the sealed torque valve, power assist steering cylinder, air safety valve, and manual shutoff valve.

The torque valve senses the steering forces and automatically meters the appropriate amount of air to the power assist steering cylinder. The power assist steering cylinder operates from the normal vehicle air pressure, 120 psi (827 kPa).

The air safety valve conserves air if the air pressure in the reservoir falls below 65 psi (448 kPa). When this occurs, steering automatically reverts to manual. When the air pressure builds to approximately 12 psi (83 kPa) above cut-off setting, the valve will re-open and power steering assist is restored.

Closing the manual shutoff valve must be done prior to inspecting and servicing the components of the power steering assist system. In the event of a failure to the system, the manual shutoff valve can be closed and operation of the vehicle continued using manual steering.

SPLIT AIR-HYDRAULIC BRAKE SYSTEM OPERATION

The ESP vehicle uses the split air-hydraulic brake system. It provides two independent air and hydraulic systems for actuation of the vehicle service brakes. One system actuates the front steering axle brakes, while the second system actuates the forward-rear and rear-rear axle brakes.

With the split system, under normal conditions, the two systems work together, actuating all six service brake positions concurrently as the brake pedal is depressed. The operator will notice no difference in brake actuation, feel, or stopping distance compared to a single brake system.

Under unusual conditions, if one brake system fails and air or hydraulic pressure is lost, the second brake system will still function. This will allow the vehicle to be brought to a controlled stop.

CHAPTER 2

UNIT TROUBLESHOOTING PROCEDURES FOR TRUCK, CARGO, 2-1/2-TON, 6X6, M44A3 SERIES TRUCKS (DIESEL)

Section I.	Introduction to Troubleshooting	WP 0006 00
Section II.	Unit Troubleshooting Procedures	WP 0008 00



UNIT TROUBLESHOOTING PROCEDURES

EXTENDED SERVICE PROGRAM (ESP)

TRUCK, CARGO, 2-1/2-TON, 6X6, M44A3 SERIES TRUCKS (DIESEL)

M35A3, W/O WINCH (NSN 2320-01-383-2047); W/WINCH (NSN 2320-01-383-3850);

M35A3C, W/O WINCH (NSN 2320-01-383-2050); W/WINCH (NSN 2320-01-383-2049);

M36A3, W/O WINCH (NSN 2320-01-383-2048); W/WINCH (NSN 2320-01-383-2046).

SECTION I. INTRODUCTION TO TROUBLESHOOTING

TABLE OF CONTENTS

WP Title

WP Sequence No.-Page No.

Introduction to Troubleshooting 0007 00-1

END OF WORK PACKAGE

UNIT TROUBLESHOOTING PROCEDURES

EXTENDED SERVICE PROGRAM (ESP)

TRUCK, CARGO, 2-1/2-TON, 6X6, M44A3 SERIES TRUCKS (DIESEL)

M35A3, W/O WINCH (NSN 2320-01-383-2047); W/WINCH (NSN 2320-01-383-3850);
M35A3C, W/O WINCH (NSN 2320-01-383-2050); W/WINCH (NSN 2320-01-383-2049);
M36A3, W/O WINCH (NSN 2320-01-383-2048); W/WINCH (NSN 2320-01-383-2046).

INTRODUCTION TO TROUBLESHOOTING

GENERAL

WARNING

Operation of a deadlined vehicle without preliminary inspection may cause injury to personnel and/or damage to equipment.

NOTE

If malfunction corrective action does not correct malfunction, notify direct support maintenance.

- a. This chapter provides the information needed to diagnose and correct malfunctions of the mechanical, electrical, CTIS, and compressed air and brake systems at the unit maintenance level.
- b. The troubleshooting procedures in this chapter cannot give all of the answers or correct all vehicle malfunctions encountered. However, these procedures are a step-by-step approach to a problem that directs tests and inspections toward the source of a problem and a successful solution.
- c. Each malfunction symptom given for an individual component or system is followed by step(s) to determine the cause and corrective action you must take to remedy the problem.
- d. Before taking any corrective action for a possible malfunction, the following rules should be followed:
 - (1) Question operator to obtain any additional information that might help you to determine the cause of the problem.
 - (2) Never overlook the chance the problem could be of simple origin. The problem could require only a minor adjustment.
 - (3) Use all senses to observe and locate troubles.
 - (4) Use test instruments or gauges to help you to determine and isolate problems.
 - (5) Always isolate the system where the malfunction occurs and then locate the defective component.
 - (6) Use standard automotive theories and principles when troubleshooting the vehicles covered in this manual.
- e. This chapter cannot list all malfunctions that may occur. If a malfunction occurs that is not listed, notify direct support maintenance.

END OF WORK PACKAGE

UNIT TROUBLESHOOTING PROCEDURES

EXTENDED SERVICE PROGRAM (ESP)

TRUCK, CARGO, 2-1/2-TON, 6X6, M44A3 SERIES TRUCKS (DIESEL)

M35A3, W/O WINCH (NSN 2320-01-383-2047); W/WINCH (NSN 2320-01-383-3850);

M35A3C, W/O WINCH (NSN 2320-01-383-2050); W/WINCH (NSN 2320-01-383-2049);

M36A3, W/O WINCH (NSN 2320-01-383-2048); W/WINCH (NSN 2320-01-383-2046).

SECTION II. UNIT TROUBLESHOOTING PROCEDURES

TABLE OF CONTENTS

<i>WP Title</i>	<i>WP Sequence No.-Page No.</i>
Mechanical Troubleshooting Symptom Index	0009 00-1
Mechanical Troubleshooting	0010 00-1
Electrical Troubleshooting Symptom Index	0011 00-1
Electrical Troubleshooting	0012 00-1
Compressed Air and Brake System Troubleshooting Symptom Index	0013 00-1
Compressed Air and Brake System Troubleshooting	0014 00-1
STE/ICE-R Troubleshooting Introduction	0015 00-1
STE/ICE-R Troubleshooting (GO Chain Tests)	0016 00-1
STE/ICE-R Troubleshooting (NO-GO Chain Tests)	0017 00-1
CTIS Troubleshooting Symptom Index	0018 00-1
CTIS Troubleshooting	0019 00-1

END OF WORK PACKAGE

UNIT TROUBLESHOOTING PROCEDURES

EXTENDED SERVICE PROGRAM (ESP)

TRUCK, CARGO, 2-1/2-TON, 6X6, M44A3 SERIES TRUCKS (DIESEL)

M35A3, W/O WINCH (NSN 2320-01-383-2047); W/WINCH (NSN 2320-01-383-3850);

M35A3C, W/O WINCH (NSN 2320-01-383-2050); W/WINCH (NSN 2320-01-383-2049);

M36A3, W/O WINCH (NSN 2320-01-383-2048); W/WINCH (NSN 2320-01-383-2046).

UNIT MECHANICAL TROUBLESHOOTING SYMPTOM INDEX

MALFUNCTION NO.	MALFUNCTION	TROUBLESHOOTING WP-PAGE
ENGINE		
1.	Engine will not crank	0010 00-1
2.	Engine cranks but will not start	0010 00-2
3.	Starter cranks engine slowly.	0010 00-3
4.	Engine stops during normal operation.	0010 00-3
5.	Engine stops when accelerator is returned to idle position	0010 00-3
6.	Engine fails to stop	0010 00-3
7.	Engine misfires during operation	0010 00-4
8.	Poor acceleration and/or lack of power.	0010 00-4
9.	Engine surges	0010 00-4
10.	Excessive engine oil loss or consumption during normal operation	0010 00-5
11.	Engine oil pressure too low or too high at normal operating temperature.	0010 00-5
12.	Excessive vibration or clunking.	0010 00-5
13.	Excessive fuel consumption	0010 00-6
EXHAUST SYSTEM		
14.	Exhaust color blue during normal operation	0010 00-6
15.	Exhaust color white during normal operation and idle	0010 00-6
16.	Excessive exhaust noise	0010 00-6
17.	Exhaust fumes in cab.	0010 00-7
ETHER START SYSTEM		
18.	Engine cranks but will not start in cold weather (fuel system operating properly)	0010 00-7
COOLING SYSTEM		
19.	Engine temperature gauge above 230°F (110°C).	0010 00-7
20.	Engine does not reach normal operating temperature.	0010 00-8
21.	Coolant loss during normal operation	0010 00-8
TRANSMISSION		
22.	Transmission shifts occur at too high a speed	0010 00-8
23.	Excessive noise during shifting.	0010 00-9
24.	Transmission shifting irregularly	0010 00-9
25.	Transmission oil leakage	0010 00-9
26.	No response to shift lever movement.	0010 00-9
27.	Rough shifting.	0010 00-10
28.	Transmission overheats (according to transmission temperature gauge)	0010 00-10

UNIT MECHANICAL TROUBLESHOOTING SYMPTOM INDEX (Contd)

<i>MALFUNCTION NO.</i>	<i>MALFUNCTION</i>	<i>TROUBLESHOOTING WP-PAGE</i>
29.	Dirt or metal particles in oil	0010 00-10
30.	Oil thrown from filler tube	0010 00-10
31.	Transmission oil dirty, foamy, and/or milky	0010 00-10
<i>DIFFERENTIAL</i>		
32.	Differential noisy	0010 00-11
33.	Differential clunks during turns or initial takeoff	0010 00-11
34.	Differential vibrates	0010 00-12
35.	Differential leaks oil at brakedrum	0010 00-12
36.	Differential leaks oil at companion flange	0010 00-12
<i>WHEELS AND TIRES</i>		
37.	Uneven tire wear	0010 00-12
38.	Wheel shimmy or wobble	0010 00-12
<i>STEERING</i>		
39.	Hard steering	0010 00-13
40.	Vehicle wanders or pulls to one side	0010 00-14
41.	Excessive play in steering wheel	0010 00-15
42.	Shimmy	0010 00-15
<i>FRONT WINCH</i>		
43.	Winch does not operate	0010 00-16
44.	Winch operates in one direction only	0010 00-16
45.	Drag brake does not operate	0010 00-16
46.	Winch will not hold load	0010 00-17
47.	Automatic brake overheats	0010 00-17
<i>AIR COMPRESSOR</i>		
48.	Low air pressure(no air leaks, governor properly adjusted and operative)	0010 00-17
49.	Air compressor passes excessive oil (excessive oil bled from air reservoirs)	0010 00-17
50.	Air compressor does not unload (air governor adjusted and operative) . .	0010 00-17
51.	Water leaking from compressor head	0010 00-17
<i>PERSONNEL HEATER</i>		
52.	Heater will not operate in HIGH or LOW position	0010 00-17
53.	Heater will not operate	0010 00-17
<i>PERSONNEL FUEL BURNING HEATER/POWER PLANT HEATER KIT</i>		
54.	Heater will not operate in HIGH or LOW position	0010 00-18
55.	Heater will not operate	0010 00-18

END OF WORK PACKAGE

UNIT TROUBLESHOOTING PROCEDURES

EXTENDED SERVICE PROGRAM (ESP)

TRUCK, CARGO, 2-1/2-TON, 6X6, M44A3 SERIES TRUCKS (DIESEL)

M35A3, W/O WINCH (NSN 2320-01-383-2047); W/WINCH (NSN 2320-01-383-3850);
 M35A3C, W/O WINCH (NSN 2320-01-383-2050); W/WINCH (NSN 2320-01-383-2049);
 M36A3, W/O WINCH (NSN 2320-01-383-2048); W/WINCH (NSN 2320-01-383-2046).

MECHANICAL TROUBLESHOOTING

GENERAL

NOTE

If malfunction corrective action does not correct malfunction, notify direct support maintenance.

- a. This work package provides information to diagnose and correct malfunctions of the mechanical system at the unit maintenance level.
- b. This work package cannot list all mechanical malfunctions that may occur. If a malfunction occurs that is not listed, notify direct support maintenance.

Unit Mechanical Troubleshooting

<p>MALFUNCTION TEST OR INSPECTION CORRECTIVE ACTION</p>

ENGINE

NOTE

Engine should be test run after each completed action.

1. ENGINE WILL NOT CRANK

Step 1. Check that transmission is in neutral position.

Place in NEUTRAL position if transmission is engaged.

Step 2. Check starting system (Electrical Troubleshooting, WP 0011 00).

Step 3. Check belt-driven engine accessories for seizure.

- a. Remove fan and water pump drivebelts (WPs 0081 00 and 0084 00).
- b. Manually turn drive pulley of each accessory.
- c. Replace component if any accessory drive pulley will not turn.

Step 4. Check air compressor for seizure.

- a. Remove air compressor (WP 0169 00), and manually turn drive gear.

Replace air compressor if drive gear does not turn (WP 0169 00).

- b. If engine will not crank, notify direct support maintenance.

Step 5. Check engine for fluid-locked pistons.

Remove exhaust and intake tubes from turbocharger. If water is present, notify direct support maintenance.

*Unit Mechanical Troubleshooting (Contd)***MALFUNCTION****TEST OR INSPECTION****CORRECTIVE ACTION**

- Step 6. Remove starter (WP 0091 00) and visually check starter drive and flexplate ring gear for broken and missing teeth.
- Replace starter if starter teeth are missing (WP 0091 00).
 - If flexplate ring gear is damaged, notify direct support maintenance.
 - Install starter (WP 0091 00) if vehicle evacuation is required.

END OF TESTING!

2. ENGINE CRANKS BUT WILL NOT START

Step 1. Check fuel level in fuel tanks.

Fill to proper level if necessary.

Step 2. Check starting system (Electrical Troubleshooting, WP 0011 00).

Step 3. Check air cleaner indicator.

- If yellow appears at indicator window, inspect air intake tube for restrictions. If restrictions are not present, replace air cleaner element (WP 0040 00).
- Reset air cleaner indicator (WP 0041 00).

Step 4. Check for white exhaust smoke during cranking.

If white smoke can be seen:

- Air may be in fuel system. Prime fuel system (TM 9-2320-386-10).
- Coolant may be inside combustion chambers. Remove engine oil dipstick. If coolant is present on dipstick, notify direct support maintenance.

WARNING

Diesel fuel is flammable. Do not perform fuel system procedures near open flame. Injury or death to personnel may result.

Compressed air source will not exceed 30 psi (207 kPa). When cleaning with compressed air, eyeshields must be worn. Failure to wear eyeshields may result in injury to personnel.

Step 5. Drain 1/2-pint (0.25-liter) of fuel from fuel/water separator. Check for contaminated fuel.

If water or contamination is present:

- Drain and remove fuel tank (WP 0045 00).
- Clean and flush entire fuel system. Dry with compressed air.
- Replace fuel filter (WP 0054 00).

Step 6. Check for restricted fuel filter.

- Disconnect fuel line from fuel filter to rear of cylinder head.
- Crank engine. If no fuel is present, remove fuel filter (WP 0054 00) and check for dirt and clogs. Replace fuel filter if dirty or clogged (WP 0054 00).
- Crank engine. If no fuel is present, replace fuel/water separator (WP 0053 00).

Step 7. Check fuel supply line for restrictions or clogged or defective check valve on pick-up tube.

- Disconnect fuel supply line from transfer pump and fuel tank.
- Apply air pressure to the fuel supply line.
- Remove pick-up tube and clean or replace check valve
- Connect fuel supply line to transfer pump and fuel tank.
- Prime fuel system (TM 9-2320-386-10).
- Crank engine. If engine does not start, perform step 8.

*Unit Mechanical Troubleshooting (Contd)***MALFUNCTION****TEST OR INSPECTION****CORRECTIVE ACTION**

Step 8. Check fuel transfer pump operation. (Notify direct support maintenance.)

END OF TESTING!

3. STARTER CRANKS ENGINE SLOWLY

Step 1. Check starting system (Electrical Troubleshooting, WP 0011 00).

Step 2. In cold weather, ensure proper engine oil is being used and/or replace oil (WP 0023 00).

Step 3. Check belt-driven engine accessories (malfunction 1, step 3).

Step 4. Engine cranks, but fails to start at outside temperatures below -0°F (18°C). Use cold-start procedures (TM 9-2320-386-10).

END OF TESTING!

4. ENGINE STOPS DURING NORMAL OPERATION

Step 1. Check air cleaner indicator for restrictions (malfunction 2, step 3).

Step 2. Check fuel system for contamination and restrictions (malfunction 2, steps 5 through 7).

Step 3. Check for restrictions in exhaust system. Ensure exhaust system is not bent, restricted, or damaged.

If exhaust system is bent, restricted, or damaged, replace damaged parts (WP 0065 00).

Step 4. Check fuel level in fuel tank.

If empty, add fuel (TM 9-2320-386-10).

Step 5. Check air cleaner system for major restrictions.

If air cleaner system is restricted, clean or replace defective components (WP 0036 00).

Step 6. Check for restrictions in air tubes of charged air cooler.

If air is restricted, clean or replace defective components (WP 0073 00).

Step 7. Check engine idle speed.

If engine idle speed is below specifications, adjust (WP 0052 00).

END OF TESTING!

5. ENGINE STOPS WHEN ACCELERATOR IS RETURNED TO IDLE POSITION

Perform malfunction 4, steps 5, 6, and 7.

END OF TESTING!

6. ENGINE FAILS TO STOP**NOTE**

Engine failing to stop when fuel shutoff switch is pressed may indicate a defective fuel shutoff solenoid, or leaking or excessive fuel at injectors.

Step 1. Stop engine (TM 9-2320-386-10).

NOTE

Assistant will help with step 2.

Step 2. Direct assistant to turn accessory/battery switch on and listen for fuel solenoid to click.

If fuel solenoid plunger is not heard cycling, perform malfunction 4, Electrical Troubleshooting (WP 0011 00).

Step 3. Perform malfunction 13, step 3.

END OF TESTING!

Unit Mechanical Troubleshooting (Contd)

<p>MALFUNCTION TEST OR INSPECTION CORRECTIVE ACTION</p>

7. ENGINE MISFIRES DURING OPERATION

Step 1. Check air cleaner indicator for restrictions (malfunction 2, step 3).

Step 2. Check for air or water in fuel system (malfunction 2, steps 4 and 5).

END OF TESTING!

8. POOR ACCELERATION AND/OR LACK OF POWER

Step 1. Check air cleaner indicator for restrictions (malfunction 2, step 3).

Step 2. Check air cleaner system for restrictions.

If air induction system is restricted, clean or replace defective components (WP 0036 00).

Step 3. Check for restrictions of air to the aftercooler.

If air is restricted, clean or replace defective components (WP 0072 00).

Step 4. Check fuel system for contamination and restrictions (malfunction 2, steps 5 through 7).

Step 5. Check exhaust system for restrictions.

Replace restricted or damaged parts (WP 0066 00).

Step 6. Inspect accelerator pedal for full travel.

Adjust accelerator pedal travel (WP 0063 00).

Step 7. Check vehicle for dragging brakes, low tire inflation, or cargo overload limit.

a. If defects are evident during check, adjust or replace components.

b. Correct overload condition.

Step 8. Check throttle and accelerator cables for binding and sticking.

If cable(s) are binding or sticking, replace throttle or accelerator cable (WP 0062 00 or WP 0064 00).

Step 9. Check engine idle speed is set within specifications.

If engine idle speed setting is incorrect, adjust (WP 0052 00).

Step 10. Check turbocharger hoses and intake tubes for leaks.

a. Tighten intake tube clamps. Replace any missing clamps.

b. If turbocharger mounting nuts are loose, notify direct support maintenance.

c. If no improvement during test run, turbocharger malfunction is indicated. Notify direct support maintenance.

NOTE

Lack of power will occur in altitudes above 10,000 ft.

Step 11. Check for too much oil in transmission (TM 9-2320-386-10).

Drain transmission to proper level if necessary (WP 0023 00).

END OF TESTING!

9. ENGINE SURGES

Step 1. Check fuel system for contamination and restrictions (malfunction 2, steps 5 through 7).

Step 2. Inspect accelerator cable for proper operation and adjustment.

If accelerator cable does not operate properly, adjust or replace as necessary (WP 0064 00). Notify direct support maintenance if condition continues.

END OF TESTING!

*Unit Mechanical Troubleshooting (Contd)***MALFUNCTION****TEST OR INSPECTION****CORRECTIVE ACTION****10. EXCESSIVE ENGINE OIL LOSS OR CONSUMPTION DURING NORMAL OPERATION**

Step 1. Check oil for overfilling. Check oil level (TM 9-2320-386-10).

If oil level is too high, drain crankcase to safe operating level (WP 0023 00). Recheck oil level (TM 9-2320-386-10).

Step 2. Check for external oil leaks at oil pan, drainplug, oil filter, oil filter housing, oil cooler, oil dipstick tube, rocker arm cover, and oil feed lines.

Tighten any loose connections or loose screws. If leaking continues, replace defective component or notify direct support maintenance.

END OF TESTING!

11. ENGINE OIL PRESSURE TOO LOW OR TOO HIGH AT NORMAL OPERATING TEMPERATURE**CAUTION**

Do not operate engine except during testing. If no oil pressure is evident, continued operations may damage engine internally.

Step 1. Check engine oil level (TM 9-2320-386-10).

a. If level is low, check for external oil leaks at oil pan, drainplug, oil filter, oil filter housing, oil cooler, oil dipstick tube, and rocker arm cover.

b. Tighten any loose connections or loose screws that may cause leaks.

Step 2. Check engine for excessive engine operating temperature (malfunction 19).

Step 3. Check oil pressure gauge for proper operation.

a. Check operation of oil pressure gauge (Electrical Troubleshooting, WP 0011 00).

b. Check oil pressure. Oil pressure should be 35-70 psi (241-483 kPa).

c. If oil pressure is still too high or too low, notify direct support maintenance.

Step 4. Check that engine oil grade is correct for vehicle use and climate conditions (WP 0023 00).

Replace engine oil if grade is incorrect (WP 0023 00).

Step 5. Check all external oil lines for restrictions or leakage.

Clear restrictions or repair leaks.

Step 6. Check for fuel in oil.

If fuel is present, notify direct support maintenance.

Step 7. Check for clogged or dirty oil filter.

Replace oil filter if clogged or dirty (WP 0033 00).

END OF TESTING!

12. EXCESSIVE VIBRATION OR CLUNKING

Step 1. Check engine mounting brackets and pads for looseness or damage.

a. Tighten if loose.

b. Replace front engine mounting pad(s) if damaged (WP 0027 00) and notify direct support maintenance to replace rear mounting pads.

Step 2. Check vibration damper for looseness.

Notify direct support maintenance if vibration damper is loose.

END OF TESTING!

Unit Mechanical Troubleshooting (Contd)

<i>MALFUNCTION</i>
<i>TEST OR INSPECTION</i>
<i>CORRECTIVE ACTION</i>

13. EXCESSIVE FUEL CONSUMPTION

Step 1. Check for air cleaner indicator restrictions (malfunction 2, step 3).

Step 2. Inspect fuel lines, hoses, and connections for leaks and damage.

- a. Tighten any loose connections.
- b. If fuel lines, hoses, or connections are leaking or damaged, notify direct support maintenance.

Step 3. Check maximum engine idle speed is set within specifications. If maximum engine idle speed is incorrect, adjust (WP 0052 00).

END OF TESTING!

EXHAUST SYSTEM**14. EXHAUST COLOR BLUE DURING NORMAL OPERATION****NOTE**

Blue exhaust indicates presence of excess engine oil in cylinder combustion space.

Step 1. Check that engine oil grade is correct for vehicle use and climatic conditions (WP 0023 00).

If oil grade is incorrect, replace oil and oil filters (WP 0033 00).

Step 2. Check that engine fuel grade is correct for vehicle use and climatic conditions (TM 9-2320-386-10).

- a. If fuel grade is incorrect, drain complete fuel system and replace with correct grade of fuel (TM 9-2320-386-10).
- b. If problem persists, notify direct support maintenance.

END OF TESTING!

15. EXHAUST COLOR WHITE DURING NORMAL OPERATION AND IDLE**CAUTION**

Thick white smoke indicates coolant is present in engine combustion chambers during operation. When this condition is evident, shut engine down immediately and determine cause. Continued engine operations may result in permanent engine damage.

Step 1. Check engine temperature. Ensure engine temperature is at specified level.

If engine temperature is above operating level, perform malfunction 19.

Step 2. Check for presence of water in fuel. If water is present, drain fuel system and refill fuel tanks. Replace fuel filter (WP 0054 00).

Step 3. If problem persists, notify direct support maintenance.

END OF TESTING!

16. EXCESSIVE EXHAUST NOISE

Step 1. Inspect turbocharger for secure mounting and exhaust leaks.

If turbocharger mountings are loose, notify direct support maintenance.

Step 2. Inspect exhaust pipes, stack, and muffler for secure connections, cracks, breaks, and excessive rust. Replace exhaust pipes if cracked, broken, or rusted (WP 0066 00). Tighten if loose.

Step 3. Inspect exhaust manifold for leaks. If leaking, notify direct support maintenance.

END OF TESTING!

*Unit Mechanical Troubleshooting (Contd)***MALFUNCTION****TEST OR INSPECTION****CORRECTIVE ACTION****17. EXHAUST FUMES IN CAB**

Step 1. Inspect exhaust pipes and connections for leaks.

- a. Tighten connections if loose.
- b. Replace damaged parts (WP 0066 00).

Step 2. Inspect exhaust manifold and turbocharger for leaks.

If leaking, notify direct support maintenance.

END OF TESTING!

ETHER START SYSTEM**WARNING**

Ether is extremely flammable. Do not perform ether start system testing procedures near fire. Injury to personnel may result.

18. ENGINE CRANKS BUT WILL NOT START IN COLD WEATHER (FUEL SYSTEM OPERATING PROPERLY)

Step 1. Check quick-start cylinder.

- a. Remove quick-start cylinder (WP 0055 00 or WP 0059 00) from valve, shake quick-start cylinder, and listen for liquid splashing inside cylinder.
- b. Replace quick-start if cylinder is empty (WP 0055 00 or WP 0059 00).

Step 2. Check quick-start valve for proper operation.

- a. Disconnect tubing at quick-start valve.
- b. Press quick-start switch, hold for 2 to 3 seconds, then release. A small amount of ether should be released by quick-start valve.
- c. If ether is not evident, check electrical system (Electrical Troubleshooting, WP 0011 00).
- d. If electrical system works properly, replace quick-start valve (WP 0055 00 or WP 0059 00).

Step 3. Check atomizer and atomizer tubing for restrictions.

- a. Disconnect tubing at quick-start valve and apply compressed air to determine if system is clear.
- b. If restricted, disconnect tubing from atomizer and check for restrictions in tubing.
- c. If tubing is clear, replace atomizer (WP 0057 00).
- d. If tubing is restricted, replace tubing (WP 0056, or WP 0060 00 if vehicle built after serial number 504923.)

END OF TESTING!

COOLING SYSTEM**19. ENGINE TEMPERATURE GAUGE ABOVE 230°F (110°C)****WARNING**

Use caution when removing surge tank filler cap. Steam or hot coolant under pressure may cause injury to personnel.

Step 1. If fuel grade is incorrect, completely drain fuel system (TM 9-2320-386-10), replace fuel filter (WP 0054 00), and replace fuel with correct grade (TM 9-2320-386-10).

Ensure engine fuel supply grade is correct for vehicle use and climatic conditions (TM 9-2320-386-10).

*Unit Mechanical Troubleshooting (Contd)***MALFUNCTION****TEST OR INSPECTION****CORRECTIVE ACTION**

Step 2. Check engine temperature gauge and engine temperature sending unit (Electrical Troubleshooting, WP 0011 00).

- a. Replace engine temperature gauge if defective (WP 0094 00).
- b. Replace engine temperature sending unit if defective (WP 0114 00).

Step 3. Inspect drivebelts, belt tensioners, and pulleys of belt-driven accessories.
Replace any damaged parts (WP 0087 00, WP 0081 00, or WP 0084 00).

Step 4. Inspect fan for broken or missing blades.
Replace fan if blades are broken or missing (WP 0082 00).

Step 5. Inspect fan actuator and clutch for proper operation.
If fan turns freely, replace fan actuator and clutch (WP 0082 00 and WP 0085 00).

Step 6. Replace thermostat (WP 0077 00).

Start engine (TM 9-2320-386-10) and observe temperature gauge. If gauge reading exceeds 230°F (110°C), perform step 7.

Step 7. Remove surge tank filler cap and visually check coolant for proper circulation. Stop engine if coolant is not circulating properly; replace water pump (WP 0080 00).

Step 8. Check coolant protection level with antifreeze tester.
If coolant is not within safe range, service cooling system (WP 0068 00).

Step 9. Check for clogged or broken radiator and charged air cooler.
a. For cleaning and flushing instructions, refer to TB 750-651.
b. Replace radiator or charged air cooler if damaged (WP 0069 00 or WP 0072 00).

END OF TESTING!

20. ENGINE DOES NOT REACH NORMAL OPERATING TEMPERATURE

Step 1. Start engine (TM 9-2320-386-10). Remove surge tank filler cap and visually check coolant for proper circulation.

Stop engine. If coolant is circulating below 100°F (38°C), replace thermostat (WP 0077 00).

Step 2. Test coolant temperature gauge, sending unit, and electrical circuits (Electrical Troubleshooting, WP 0011 00).

END OF TESTING!

21. COOLANT LOSS DURING NORMAL OPERATION

Step 1. Pressurize cooling system and check for leaks.

- a. Tighten loose clamps, fasteners, or fittings.
- b. Replace damaged parts (WP 0067 00).

Step 2. Check surge tank filler cap for proper relief pressure (TM 750-254). Relief pressure should be 10 psi (69 kPa). Replace surge tank filler cap if defective.

Step 3. Check for coolant in oil.
If coolant is found in oil, notify direct support maintenance.

END OF TESTING!

TRANSMISSION**22. TRANSMISSION SHIFTS OCCUR AT TOO HIGH A SPEED**

Check transmission oil level (TM 9-2320-386-10).

Drain or fill as necessary (WP 0023 00).

END OF TESTING!

*Unit Mechanical Troubleshooting (Contd)***MALFUNCTION****TEST OR INSPECTION****CORRECTIVE ACTION****23. EXCESSIVE NOISE DURING SHIFTING**

- Step 1. Check transmission fluid level (TM 9-2320-386-10).
Drain or fill fluid as necessary (WP 0023 00).
- Step 2. Check propeller shaft flanges for loose mounting bolts.
Tighten mounting bolts if loose.
- Step 3. Inspect propeller shaft universal joints for looseness, wear, and damage.
- Tighten universal joint yoke if loose.
 - Replace worn or damaged universal joints (WP 0149 00).

END OF TESTING!

24. TRANSMISSION SHIFTING IRREGULARLY

- Step 1. Check transmission fluid level (TM 9-2320-386-10).
Drain or fill fluid as necessary (WP 0023 00).
- Step 2. Check for clogged or dirty transmission oil filter.
Replace transmission oil filter if clogged or dirty (WP 0143 00 and WP 0142 00).
- Step 3. Check for restricted or leaking transmission oil cooler hoses.
Tighten or replace transmission oil cooler hoses (WP 0139 00).
- Step 4. Check for clogged or restricted transmission auxiliary oil cooler.
Replace transmission auxiliary oil cooler if clogged or restricted (WP 0140 00).
- Step 5. Check engine idle speed.
If engine idle speed is set below specifications, adjust (WP 0052 00).

END OF TESTING!

25. TRANSMISSION OIL LEAKAGE

- Step 1. Inspect for oil leak at output shaft.
If output oil seal is leaking, notify direct support maintenance.
- Step 2. Inspect drainplug for leaks.
- Tighten drainplug if loose.
 - If leak continues, notify direct support maintenance.
- Step 3. Inspect transmission at oil pan gasket for leaks.
- Tighten mounting screws if loose.
 - If problem continues, replace oil pan gasket (WP 0143 00).
- Step 4. Inspect transmission housing for leaks.
If leaking, notify direct support maintenance.
- Step 5. Remove flywheel housing inspection plate and inspect for oil pump seal leak.
If leak is present, notify direct support maintenance.

END OF TESTING!

26. NO RESPONSE TO SHIFT LEVER MOVEMENT

- Step 1. Check transmission oil level (TM 9-2320-386-10).
Drain or fill oil as necessary (WP 0023 00).
- Step 2. Check for broken or disconnected shift cable.
- If disconnected, connect shift cable (WP 0132 00).
 - If broken, replace shift cable (WP 0132 00).

END OF TESTING!

*Unit Mechanical Troubleshooting (Contd)***MALFUNCTION****TEST OR INSPECTION****CORRECTIVE ACTION****27. ROUGH SHIFTING**

Step 1. Check transmission oil level (TM 9-2320-386-10).

Drain or fill transmission to proper oil level as necessary (WP 0023 00).

Step 2. Check transmission select lever and shift cable for proper operation.

a. Replace select lever if damaged (WP 0132 00).

b. Replace shift cable if bent, kinked, broken, or frayed (WP 0132 00).

c. Adjust shift cable (WP 0132 00).

END OF TESTING!

28. TRANSMISSION OVERHEATS (ACCORDING TO TRANSMISSION TEMPERATURE GAUGE)

Step 1. Check transmission oil level (TM 9-2320-386-10).

Drain or fill oil as necessary (WP 0023 00).

Step 2. Check for clogged or restricted transmission oil cooler and auxiliary oil cooler.

Replace transmission auxiliary oil cooler if clogged or restricted (WP 0140 00).

Step 3. Check transmission temperature sending unit (Electrical Troubleshooting, WP 0012 00), malfunction 16, test 3).

Step 4. Check for restricted or clogged transmission oil cooler hoses.

Tighten or replace transmission oil cooler hoses (WP 0139 00).

Step 5. Test transmission temperature gauge for proper operation using a gauge known to be good.

Replace transmission temperature gauge if test gauge does not indicate overheating (WP 0096 00).

END OF TESTING!

29. DIRT OR METAL PARTICLES IN OIL

Take transmission oil sample. Submit special sample in accordance with TB 43-0210.

END OF TESTING!

30. OIL THROWN FROM FILLER TUBE

Step 1. Check transmission fluid level for overfilling (TM 9-2320-386-10).

Drain oil to proper level (WP 0023 00). Recheck transmission for proper fluid level (TM 9-2320-386-10).

Step 2. Check for clogged or restricted vent line.

Disconnect and clean or replace vent line.

Step 3. Check for loose dipstick tube.

Tighten if loose.

END OF TESTING!

31. TRANSMISSION OIL DIRTY, FOAMY, AND/OR MILKY**NOTE**

Dirt/grit in transmission oil indicates oil needs to be changed (step 1). Foaminess indicates contamination by air (step 2) or water (step 3). Milkiness indicates contamination by water (step 3).

Check oil filler tube seal.

*Unit Mechanical Troubleshooting (Contd)***MALFUNCTION****TEST OR INSPECTION****CORRECTIVE ACTION**

Step 1. Check for dirt/grit.

- a. Replace transmission internal oil filter (WP 0143 00).
- b. Replace transmission external oil filter (WP 0142 00).
- c. Replace transmission. Notify direct support maintenance.

Step 2. Check for excessive foaming.

Ensure transmission fluid is at proper level (TM 9-2320-386-10). Drain or fill fluid as necessary (WP 0023 00).

Step 3. Check radiator for contamination.

Replace radiator if contaminated (WP 0069 00).

END OF TESTING!

DIFFERENTIAL**32. DIFFERENTIAL NOISY**

Step 1. Check to see if front wheel drive is engaged.

Disengage front wheel drive when traveling on hard, flat surfaces.

Step 2. Check lubrication level in axle housing differential (WP 0023 00). If low, fill to proper oil level (WP 0023 00).

Step 3. Check for loose inner wheel adapter nuts or loose lugnuts.

- a. If inner wheel adapter nuts are loose, tighten 425-475 lb-ft (576-644 N•m).
- b. If wheel stud nuts are loose, tighten hollow wheel stud nut 275-300 lb-ft (373-407 N•m) and other nine wheel stud nuts 390-420 lb-ft (529-569 N•m).

Step 4. Check for loose or damaged wheel bearings. Raise wheel off ground, using prybar, check for excessive play.

- a. Adjust wheel bearings (TM 9-2320-361-20).
- b. If damaged, replace wheel bearings (TM 9-2320-361-20).

Step 5. Check differential operation. Remove differential propeller shaft(s) (WP 0146 00). Raise wheels (TM 9-2320-386-10) and manually turn wheels and observe differential operation.

- a. If tires will not rotate, check brakeshoe condition and operation (TM 9-2320-361-20).
- b. Remove brakedrums (TM 9-2320-361-20). If brake system components are defective, repair or replace (TM 9-2320-361-20, or notify direct support maintenance).
- c. If tires still will not rotate, notify direct support maintenance.
- d. If tire rotation drags at some points during full rotation, remove and inspect axle shafts (TM 9-2320-361-20).
- e. If axle shafts are defective, replace (TM 9-2320-361-20).

END OF TESTING!

33. DIFFERENTIAL CLUNKS DURING TURNS OR INITIAL TAKEOFF

Step 1. Check condition of differential propeller shaft(s) and universal joint(s) (WP 0148 00 and WP 0149 00).

Repair or replace defective components (WP 0148 00 and WP 0149 00).

Step 2. Check front axle shafts and universal joints for defects (TM 9-2320-361-20).

Repair or replace defective components (TM 9-2320-361-20).

Step 3. If internal problems in differential exist, notify direct support maintenance.

END OF TESTING!

Unit Mechanical Troubleshooting (Contd)

<i>MALFUNCTION</i>
<i>TEST OR INSPECTION</i>
<i>CORRECTIVE ACTION</i>

34. DIFFERENTIAL VIBRATES

Step 1. Check conditions of tires and rims. Repair or replace defective components (WP 0174 00).

Step 2. Complete troubleshooting malfunction 32, steps 1 and 2.

Step 3. If internal problems in differential exist, notify direct support maintenance.

END OF TESTING!

35. DIFFERENTIAL LEAKS OIL AT BRAKEDRUM

Check condition of axle seals. Inspect drum for presence of gear oil.

If gear oil is present in or around drums, replace axle seals (WP 0152 00).

END OF TESTING!

36. DIFFERENTIAL LEAKS OIL AT COMPANION FLANGE

Step 1. Check through-shaft for free play.

Place end of prybar between differential housing and companion flange. Apply pressure to prybar.

Step 2. If companion flange moves, notify direct support maintenance.

END OF TESTING!

WHEELS AND TIRES**NOTE**

A broken radial belt will cause symptoms as outlined in malfunctions 37, 38, 40, and 42.

37. UNEVEN TIRE WEAR

Step 1. Check for loose or missing wheel stud nuts and wheel studs.

a. Tighten wheel stud nut on hollow stud 275-300 lb-ft (373-407 N•m) and wheel stud nuts 390-420 lb-ft (529-569 N•m).

b. Replace missing wheel stud nuts and/or wheel studs (WP 0173 00 or WP 0172 00).

Step 2. Check for improper toe-in adjustment if wear is on front tires.

Adjust toe-in (WP 0179 00).

Step 3. Check wheel bearings for proper adjustment and damage. Raises wheel off ground.

Use prybar to lift up on bottom of tire. Excessive play indicates improperly adjusted or damaged bearings.

a. Adjust wheel bearings (TM 9-2320-361-20).

b. Replace damaged bearings (TM 9-2320-361-20).

c. Check tires are inflated properly (TM 9-2320-386-10).

END OF TESTING!

38. WHEEL SHIMMY OR WOBBLE

Step 1. Inspect wheels for bends and damage.

Replace bent or damaged wheels (WP 0174 00).

*Unit Mechanical Troubleshooting (Contd)***MALFUNCTION****TEST OR INSPECTION****CORRECTIVE ACTION**

Step 2. Inspect wheel bearings for proper adjustment and damage. Raise wheels off ground. Use prybar to lift up on bottom of tire. Excessive play indicates improperly adjusted or damaged bearings.

- a. Adjust wheel bearings (TM 9-2320-361-20).
- b. Replace damaged bearings (TM 9-2320-361-20).
- c. Check tie rod ends for wear. Replace if worn (TM 9-2320-361-20).

END OF TESTING!

STEERING**39. HARD STEERING**

Step 1. Inspect all air lines and hoses for leaks.

Tighten loose fittings and replace leaking lines (WP 0186 00).

Step 2. Ensure arrow on regulator points toward front of vehicle.

- a. Remove from vehicle, if not on correct (WP 0184 00).
- b. Install regulator on vehicle (WP 0184 00).

Step 3. Check air pressure from regulator. Pressure should be between 35-45 psi (241-310 kPa). Adjust regulator to correct pressure setting.

Step 4. Check steering assist cylinder and drag link for leaks and damage.

Replace drag link or steering assist cylinder if leaking or damaged (WP 0181 00).

Step 5. Inspect steering linkage for binding, damage, and improper lubrication.

- a. Repair or replace binding or damaged linkage (TM 9-2320-361-20).
- b. Lubricate linkage (WP 0023 00).

Step 6. Inspect steering knuckles for binding. Raise front wheels off ground. Disconnect drag link at steering arm. Turn wheels from side to side to determine binding.

If wheels bind, notify direct support maintenance.

Step 7. Check spring U-bolts for tightness.

Tighten U-bolts 350-400 lb-ft (475-542 N·m).

Step 8. Check front wheel alignment.

- a. Check front tires for underinflation and uneven tire pressure. Inflate tires to proper pressure.
- b. Adjust toe-in to specifications (WP 0179 00).

Step 9. Check drag link for internal leakage.

- a. Ensure wheels are straight ahead.
- b. Build up air pressure to 120 psi (827 kPa). Shut down engine.
- c. Slowly disconnect exhaust hose from drag link. If air leaks from exhaust port with wheels straight ahead, replace drag link.
- d. Disconnect two air lines from drag link leading to steering assist cylinder. Install two pipe plugs in drag link.
- e. Turn steering wheel and extend torque valve. Minimal or no air should escape torque valve exhaust ports. If air constantly leaks, replace drag link (WP 0181 00).

Unit Mechanical Troubleshooting (Contd)

<p>MALFUNCTION TEST OR INSPECTION CORRECTIVE ACTION</p>

Step 10. Check steering assist cylinder for internal leakage.

- a. Ensure wheels are straight ahead.
- b. Build up air pressure to 120 psi (827 kPa). Shut down engine.
- c. Slowly disconnect air hose from drag link.
- d. Turn steering wheel and extend drag link a full turn. If a substantial amount of air leaks from the disconnected hose, replace steering assist cylinder (WP 0183 00).

END OF TESTING!

40. VEHICLE WANDERS OR PULLS TO ONE SIDE

Step 1. Check front tires for underinflation and uneven tire pressure.

Inflate tires to proper pressure (TM 9-2320-386-10).

Step 2. Check front tires for uneven wear (indicates alignment problem).

Adjust toe-in to specifications (WP 0179 00).

Step 3. Check for dragging service brakes.

Raise wheel(s) off ground and spin wheels by hand. Wheels should turn with slight drag. If wheels bind, adjust service brake (TM 9-2320-361-20).

Step 4. Check for contaminated service brakeshoes.

- a. Remove hub and drum (WP 0173 or WP 0172 00).
- b. Check wheel cylinder for leaks and damage. Replace wheel cylinder if leaking or damaged (TM 9-2320-361-20).
- c. Check service brakeshoes for contamination. Replace service brake shoes if contaminated (TM 9-2320-361-20).

Step 5. Check for defective master cylinder.

- a. Direct assistant to pump brakes.
- b. Check master cylinder for leaks.
- c. Replace master cylinder if brake fluid leaks from dust boot area (WP 0155 00).

Step 6. Check for defective air-hydraulic booster.

- a. Repeat steps 3 through 5.
- b. Replace air-hydraulic booster (WP 0157 00).

Step 7. Check wheel bearings for proper adjustment and damage. Raise wheels off ground. Use prybar to lift up on bottom of tire. Excessive play indicates improperly adjusted or damaged bearings.

- a. Adjust wheel bearings (TM 9-2320-361-20).
- b. Replace damaged bearings (TM 9-2320-361-20).

Step 8. Inspect power steering assist cylinder for damage.

Replace power steering assist cylinder if damaged (WP 0183 00).

Step 9. Inspect tie rod for looseness and damage.

Tighten or replace tie rod assembly (TM 9-2320-361-20).

Step 10. Check for loose steering gear mounting bolts.

Tighten if loose.

*Unit Mechanical Troubleshooting (Contd)***MALFUNCTION****TEST OR INSPECTION****CORRECTIVE ACTION**

- Step 11. Check for worn pitman arm.
Replace worn pitman arm (WP 0180 00).
- Step 12. Check front spring shackle pins for damage and breaks.
Replace worn or broken shackle pins (TM 9-2320-361-20).
- Step 13. Check toe-in for improper adjustment.
Adjust toe-in (WP 0179 00).

END OF TESTING!

41. EXCESSIVE PLAY IN STEERING WHEEL

- Step 1. Check steering wheel free play.
- With engine running, place a stiff wire, which is long enough to touch steering wheel rim, against dash.
 - Turn steering wheel left, then right, until there is resistance.
 - Mark the points on the steering wheel where the travel ends.
 - Measure the distance between these points. If there is more than 2-1/2 in. (6.4 cm) of play, proceed to step 2.
- Step 2. Check drag link for looseness and damage.
Tighten or replace drag link (WP 0181 00).
- Step 3. Inspect tie rods for damage and loose ends. No free play is allowed.
Tighten or replace tie rods (TM 9-2320-361-20).
- Step 4. Inspect pitman arm for damage.
Replace pitman arm if damaged (WP 0180 00).
- Step 5. Inspect power steering assist cylinder for damage.
Replace power steering assist cylinder if damaged (WP 0183 00).
- Step 6. If 2-1/2 in. (6.4 cm) of play still exists, the steering gear needs adjustment (TM 9-2320-361-20).

END OF TESTING!

42. SHIMMY

- Step 1. Check for loose or missing wheel stud nuts.
- Tighten wheel stud nut on hollow stud 275-300 lb-ft (373-407 N•m) and other wheel stud nuts 390-420 lb-ft (529-569 N•m).
 - Replace any missing wheel stud nuts.
- Step 2. Inspect wheels for bends and damage.
Replace bent or damaged wheels (WP 0172 00).
- Step 3. Check for improper wheel bearing adjustment.
- Raise wheels off ground.
 - Use prybar to lift up on bottom of tire. Excessive play indicates improper adjustment or damaged bearings.
 - Adjust or replace wheel bearings (TM 9-2320-361-20).
- Step 4. Check toe-in alignment.
Adjust toe-in alignment to specifications (WP 0179 00).
- Step 5. Check for loose front axle steering knuckle(s). Raise wheels off ground. Turn wheels from side to side to observe loose steering knuckle(s). If loose, notify direct support maintenance.

*Unit Mechanical Troubleshooting (Contd)***MALFUNCTION****TEST OR INSPECTION****CORRECTIVE ACTION**

Step 6. Check tie rod ends for wear.
Replace tie rod if worn (TM 9-2320-361-20).

Step 7. Check tires for broken belts.
Replace tire(s) if belts are broken (WP 0174 00).

END OF TESTING!

FRONT WINCH**43. WINCH DOES NOT OPERATE**

Step 1. Check hydraulic oil reservoir for proper fluid level (WP 0023 00).

Step 2. Check for proper operation of winch control switch and winch control valve lever.
Replace winch control if not operating properly (WP 0223 00).

Step 3. Check all oil lines for damage and leaks.
a. Tighten loose fittings.
b. Replace leaking or damaged hoses (WP 0221 00).

Step 4. Check winch oil filter for leaks and clogs.
a. Tighten winch oil filter.
b. If leaking is not corrected, notify direct support maintenance.
c. Replace oil filter if clogged (WP 0214 00).

Step 5. Check winch pump for leaks and overheating.
a. Tighten loose fittings.
b. Replace winch pump if leaking (WP 0222 00).

Step 6. Check winch motor for leaks.
a. Tighten loose fittings.
b. Replace winch motor if leaking (WP 0220 00).

Step 7. Check control valve shaft movement in and out.
Replace control valve if shaft will not move (WP 0218 00).

END OF TESTING!

44. WINCH OPERATES IN ONE DIRECTION ONLY

Step 1. Inspect control valve for damage and leaks.
a. Tighten loose fittings.
b. Replace control valve if leaking (WP 0218 00).

Step 2. Check control valve shaft movement in and out.
Replace control valve if shaft will not move (WP 0218 00).

Step 3. Check winch for damage.
Replace front winch if damaged (WP 0225 00).

END OF TESTING!

45. DRAG BRAKE DOES NOT OPERATE

Check drag brake adjustment.
Adjust drag brake (WP 0225 00).

END OF TESTING!

*Unit Mechanical Troubleshooting (Contd)***MALFUNCTION****TEST OR INSPECTION****CORRECTIVE ACTION****46. WINCH WILL NOT HOLD LOAD**

Check automatic brake adjustment.

Adjust automatic brake (WP 0225 00).

END OF TESTING!

47. AUTOMATIC BRAKE OVERHEATS

Step 1. Check weight limits of winch.

Adjust size of load.

Step 2. Adjust setscrew 1/4-turn counterclockwise. Recheck brake for overheating.

If condition continues, notify direct support maintenance.

END OF TESTING!

AIR COMPRESSOR**48. LOW AIR PRESSURE (NO AIR LEAKS, GOVERNOR PROPERLY ADJUSTED AND OPERATIVE)**

Replace air compressor (WP 0169 001).

END OF TESTING!

49. AIR COMPRESSOR PASSES EXCESSIVE OIL (EXCESSIVE OIL BLED FROM AIR RESERVOIRS)

Slowly bleed and check reservoirs for excessive amounts of oil (TM 9-2320-386-10).

If reservoirs bleed oil, replace air compressor (WP 0169 00).

END OF TESTING!

50. AIR COMPRESSOR DOES NOT UNLOAD (AIR GOVERNOR ADJUSTED AND OPERATIVE)

Replace air compressor (WP 0169 00).

END OF TESTING!

51. WATER LEAKING FROM COMPRESSOR HEAD

Step 1. Ensure compressor coolant lines and fittings are tight and sealed properly.

Tighten or reseal lines and fittings.

Step 2. Check compressor head for cracks and loose mounting screws.

a. Tighten loose mounting screws.

b. Replace air compressor if leaking continues (WP 0169 00).

END OF TESTING!

PERSONNEL HEATER**52. HEATER WILL NOT OPERATE IN HIGH OR LOW POSITION**

Refer to Electrical Troubleshooting, WP 0011 00.

END OF TESTING!

53. HEATER WILL NOT OPERATE**NOTE**

Sticking thermostat will cause heater to blow cold air.

Step 1. Check personnel heater controls for proper operation (TM 9-2320-386-10).

Step 2. Refer to Electrical Troubleshooting, WP 0011 00.

END OF TESTING!

Unit Mechanical Troubleshooting (Contd)

MALFUNCTION TEST OR INSPECTION CORRECTIVE ACTION

PERSONNEL FUEL BURNING HEATER/POWER PLANT HEATER KIT**54. HEATER WILL NOT OPERATE IN HIGH OR LOW POSITION**

Refer to Electrical Troubleshooting, WP 0011 00.

55. HEATER WILL NOT OPERATE**WARNING**

Diesel fuel is flammable. Do not perform fuel system procedures near open flame. Injury or death to personnel may result.

Compressed air source will not exceed 30 psi (207 kPa). When cleaning with compressed air, eyeshields must be worn. Failure to wear eyeshields may result in injury to personnel.

Step 1. Refer to Electrical Troubleshooting, WP 0011 00.

Step 2. Check fuel shutoff valve and ensure it is in full ON position.

If fuel shutoff valve is damaged (or stuck in OFF or partial ON position), replace fuel shutoff valve (TM 9-2320-361-20).

Step 3. Check heater fuel filter for contamination.

If water or contamination is present, clean and flush entire fuel system. Dry with compressed air (TM 9-2320-386-10).

Step 4. Check fuel lines for breaks, bends, kinks, or leaking joints.

If broken, kinked, or if leaky joints are found, refer to TM 9-243.

Step 5. Check fuel pump discharge.

a. Remove fuel line from fuel pump output.

b. Use clean container for fuel discharge recovery.

c. Position heater control box to RUN position.

d. If fuel pump fails to pump adequate amount of fuel, 1/2 pint (0.24 L) in 30 seconds, replace fuel pump (WP 0249 00).

Step 6. Inspect exhaust system for restrictions.

If exhaust pipe is restricted or damaged, repair or replace exhaust pipe (WP 0251 00).

Step 7. If fuel burning heater still fails to operate, replace fuel burning heater (WP 0247 00).

Step 8. Check for proper operation of defroster and heat diverter control cables (TM 9-2320-386-10).

If control cables or vent are broken, replace (WP 0242 00).

END OF TESTING!

END OF WORK PACKAGE

UNIT TROUBLESHOOTING PROCEDURES

EXTENDED SERVICE PROGRAM (ESP)

TRUCK, CARGO, 2-1/2-TON, 6X6, M44A3 SERIES TRUCKS (DIESEL)

M35A3, W/O WINCH (NSN 2320-01-383-2047); W/WINCH (NSN 2320-01-383-3850);

M35A3C, W/O WINCH (NSN 2320-01-383-2050); W/WINCH (NSN 2320-01-383-2049);

M36A3, W/O WINCH (NSN 2320-01-383-2048); W/WINCH (NSN 2320-01-383-2046).

ELECTRICAL TROUBLESHOOTING SYMPTOM INDEX

MALFUNCTION NO.	MALFUNCTION	TROUBLESHOOTING WP-PAGE
BATTERY SYSTEM		
1.	All vehicle electrical systems inoperative	0012 00-1
STARTING SYSTEM		
2.	Starter will not crank	0012 00-3
3.	Starter motor operates, but engine cranks slowly	0012 00-6
4.	Engine cranks but will not start	0012 00-7
CHARGING SYSTEM (60 AMP)		
5.	No alternator output (battery gauge in left-hand red)	0012 00-8
6.	Batteries not charging properly (battery gauge in yellow or right-hand red)	0012 00-10
7.	Batteries hot or boiling, corrected specific gravity of all cells is 1.280	0012 00-11
8.	Batteries use excessive water	0012 00-11
9.	Batteries run down in operation	0012 00-11
CHARGING SYSTEM (100 AMP)		
10.	No alternator output (battery gauge in left-hand red)	0012 00-11
11.	Batteries not charging properly (battery gauge in yellow or right-hand red)	0012 00-12
12.	Batteries hot or boiling, correct specific gravity of all cells is 1.280	0012 00-13
13.	Batteries use excessive water	0012 00-13
14.	Batteries run down in operation	0012 00-13
INDICATORS, GAUGES, AND WARNING SYSTEM		
15.	All gauges inoperative	0012 00-13
16.	Engine temperature gauge inoperative	0012 00-14
17.	Fuel gauge inoperative	0012 00-15
18.	Oil pressure gauge inoperative	0012 00-16
19.	Battery gauge inoperative	0012 00-17
20.	Tachometer inoperative	0012 00-18
21.	Transmission temperature gauge inoperative	0012 00-19
22.	Horn does not operate	0012 00-19
ELECTRICAL ACCESSORIES		
23.	Windshield wipers fail to work on HIGH or LOW setting	0012 00-20
24.	Engine cranks but will not start (fuel available)	0012 00-21
25.	Air dryer heater fails to work 40 degrees or below	0012 00-21

ELECTRICAL TROUBLESHOOTING SYMPTOM INDEX (Contd)

<i>MALFUNCTION NO.</i>	<i>MALFUNCTION</i>	<i>TROUBLESHOOTING WP-PAGE</i>
----------------------------	--------------------	------------------------------------

PERSONNEL HEATERS

26.	Personnel hot water heater does not operate or does not operate in HIGH or LOW position	0012 00-22
27.	Personnel fuel burning/power plant heater inoperative	0012 00-23
28.	Heater control box light inoperative, but heater operative	0012 00-24

END OF WORK PACKAGE

UNIT TROUBLESHOOTING PROCEDURES

EXTENDED SERVICE PROGRAM (ESP)

TRUCK, CARGO, 2-1/2-TON, 6X6, M44A3 SERIES TRUCKS (DIESEL)

M35A3, W/O WINCH (NSN 2320-01-383-2047); W/WINCH (NSN 2320-01-383-3850);
 M35A3C, W/O WINCH (NSN 2320-01-383-2050); W/WINCH (NSN 2320-01-383-2049);
 M36A3, W/O WINCH (NSN 2320-01-383-2048); W/WINCH (NSN 2320-01-383-2046).

ELECTRICAL TROUBLESHOOTING

GENERAL

a. This work package provides the information needed to diagnose and correct malfunctions of the electrical system.

b. Listed are electrical malfunctions that may occur in individual systems of the vehicle. The wiring schematic found in WP 0386 00 is to be used as a reference when performing electrical troubleshooting procedures. The following is also provided for finding specific problems and solutions in Electrical Troubleshooting.

c. In troubleshooting the electrical system, multimeters will be used to make resistance or continuity tests and voltage or low ampere current tests. Multimeters may be found in common no. 1 and no. 2 unit maintenance automotive shop sets.

Electrical Troubleshooting

MALFUNCTION
TEST OR INSPECTION
CORRECTIVE ACTION

BATTERY SYSTEM

1. ALL VEHICLE ELECTRICAL SYSTEMS INOPERATIVE

WARNING

Battery acid (electrolyte) is extremely harmful. Always wear safety goggles and rubber gloves when performing battery maintenance. Severe injury will result if acid contacts eyes or skin.

Do not smoke, have open flame, or make sparks when performing battery maintenance. Batteries may explode, causing severe injury to personnel.

Remove all jewelry such as rings, dog tags, bracelets, etc. If jewelry or disconnected battery ground cable contacts battery positive post, a direct short can result, causing damage to equipment or severe injury to personnel.

When removing battery cables, disconnect ground cable first. Do not allow tools to come in contact with vehicle when disconnecting cable clamps. A direct short can result, causing instant heating of tools, tool damage, battery damage, or battery explosion, and severe injury to personnel.

*Electrical Troubleshooting (Contd)***MALFUNCTION****TEST OR INSPECTION****CORRECTIVE ACTION****CAUTION**

During installation of battery terminals, ensure positive clamps are installed on positive (+) posts and negative clamps are installed on negative (-) posts. Failure to connect clamps to correct posts will reverse polarity of circuitry and may cause damage to rectifier diodes in alternator, vehicle wiring, and radios (if equipped).

Do not use a hammer during installation of battery terminals or damage may result. Spread battery terminal open.

- Step 1. Open door of battery compartment, remove battery box, and place on running board (TM 9-2320-386-10). Visually check connection of battery cables.
Ensure battery cables are correctly connected to batteries (WP 0121 00).
- Step 2. Visually check batteries for cracks and leaks. Check terminal posts for corrosion and breaks (TM 9-6140-200-14).
- Replace any battery that is cracked, leaking, or has broken terminal posts (WP 0122 00).
 - If terminal posts or cable clamps are corroded, use soda and water solution to neutralize battery acid. Remove battery ground cable no. 7 from negative post first. Remove cable clamps from battery posts (WP 0121 00). Clean posts and clamp mating surfaces to bright metal. Install cable clamps.
 - If battery terminals are clean and malfunction still exists, go to test 1.
- Test 1. Check specific gravity of each cell before adding distilled water.
- Step 1. Using optical battery tester, which requires no temperature compensation, check specific gravity of electrolyte in each cell (TM 9-6140-200-14).
If specific gravity of any cell is below 1.255, battery must be replaced or recharged. Add distilled water as necessary after checking battery. Charge battery as necessary (TM 9-6140-200-14).
- Step 2. Check specific gravity of cells after battery has been charged (TM 9-6140-200-14).
Each cell in a battery must test within 0.025 points of each other. If specific gravity of any cell is lower than 1.255 [correct to 80°F (27°C), if necessary] after 25 hours of charging, replace battery (WP 0122 00).
- Test 2. Disconnect battery ground cable (WP 0121 00) and test battery cables as follows:
- Step 1. Set multimeter to measure continuity.
- Step 2. Check for continuity of battery cables 6 and 68 and for worn or frayed insulation.
- If continuity is greater than 1 ohm, replace or repair battery cables (WP 0121 00).
 - If insulation is worn or frayed, replace or repair battery cables (WP 0121 00).
- Step 3. Check continuity of battery ground cable 7 to STE/ICE-R.
- If resistance measures greater than 1 ohm, clean cable 7 connection at STE/ICE-R.
 - If continuity is still greater than 1 ohm, replace or repair battery cable (WP 0121 00).
- Step 4. Connect battery ground cable (WP 0121 00).

Electrical Troubleshooting (Contd)

<p>MALFUNCTION TEST OR INSPECTION CORRECTIVE ACTION</p>

Test 3. Check for battery voltage at starter solenoid.

Step 1. Set multimeter to a voltage range that will measure 24 Vdc.

Step 2. Check cable 6 at starter solenoid for battery voltage.

If battery voltage is not present, clean connections of cable 6 at starter solenoid.

END OF TESTING!

STARTING SYSTEM**2. STARTER WILL NOT CRANK****NOTE**

Ensure transmission gear shift lever is in NEUTRAL position.

Test 1. Check batteries and cables (malfunction 1).

Test 2. Test for battery voltage at starter solenoid with accessory/battery switch turned to ON position.

Step 1. Engage accessory/battery switch and listen for starter solenoid to “thump” sound when energized.

a. If “thump” sound is heard, go to step 2.

b. If “thump” sound is not heard, go to step 3.

Step 2. Check lead 6 at starter solenoid for battery voltage.

a. Check for seized engine (WP 0009 00, Mechanical Troubleshooting, malfunction 1).

b. If voltage is present but less than 19 Vdc, check for corrosion and/or loose connections.

c. If engine is not seized, replace starter motor (WP 0091 00).

d. If no voltage is present and engine still fails to start, go to step 3.

Step 3. Check lead 214 for battery voltage at starter solenoid.

a. If voltage is not present, go to test 3.

b. If voltage is present and solenoid does not engage starter motor, proceed to step 4.

Step 4. Set multimeter to measure continuity. Check continuity between starter solenoid ground and frame ground.

a. If continuity is greater than 1 ohm, remove starter (WP 0091 00) and starter motor ground cables. Replace or repair cables (WP 0125 00) that have resistance greater than 1 ohm. Clean cable ends. Clean connections on starter motor and frame ground. Connect ground cables and ensure all connections are tight. Repeat test 1, step 1.

b. If continuity is greater than 1 ohm, starter solenoid is defective. Replace starter motor (WP 0091 00).

Step 5. Check battery cables for voltage drop (malfunction 3, tests 4 through 7).

Test 3. Test for battery voltage at lead 74B of magnetic starter relay.

Step 1. With accessory/battery switch ON, engage starter switch and, at same time, check for battery voltage at lead 74B on magnetic starter relay.

a. If 19 Vdc is not present, go to test 4.

b. If voltage is present, go to step 2.

Step 2. Set multimeter to measure continuity. Check continuity of ground lead between magnetic starter relay and ground on frame.

*Electrical Troubleshooting (Contd)***MALFUNCTION****TEST OR INSPECTION****CORRECTIVE ACTION**

- a. If continuity is 1 ohm or less, go to step 3.
- b. If continuity is greater than 1 ohm, disconnect ground lead from magnetic starter relay. Repair or replace ground lead (WP 0125 00), go to test 1, step 1, and retest.
- Step 3. Check for battery voltage at lead 214 of magnetic starter relay with starter switch engaged.
 - a. If voltage is present, go to step 5.
 - b. If voltage is not present, go to step 4.
- Step 4. Check for battery voltage at leads 10 and 14 on magnetic starter relay. Voltage should be present.

If voltage is not present, replace or repair lead 14 (WP 0125 00), go to test 1, step 1, and retest.
- Step 5. Check continuity of lead 214 between magnetic starter relay and starter solenoid.

If continuity is not present, replace or repair lead 214 (WP 0125 00). Clean connections before reinstalling lead. Ensure all connections are tight, go to test 1, step 1, and retest.
- Test 4. Test continuity of neutral safety switch.
 - Step 1. Set parking brake (TM 9-2320-386-10).
 - Step 2. Ensure transmission is in neutral.
 - Step 3. Disconnect lead 74A from neutral safety switch and starter switch.
 - Step 4. Set multimeter to measure continuity. Check continuity of lead 74A.
 - a. If continuity is not present, repair or replace lead 74A (WP 0125 00).
 - b. If continuity is present, go to step 5.
 - Step 5. Disconnect lead 74B from neutral safety switch.
 - Step 6. Check continuity of neutral safety switch.
 - a. If continuity is present, connect leads 74A and 74B to leads of neutral safety switch and go to test 5.
 - b. If continuity is not present, replace neutral safety switch (WP 0098 00).
- Test 5. Test for battery voltage into accessory/battery switch pins A and C.
 - Step 1. Remove two leads 11 from accessory/battery switch pins A and C. Using multimeter, check for battery voltage on contact ends of leads 11.
 - a. If voltage is not present, go to test 6.
 - b. If voltage is present, install both leads 11 into pins A and C, and go to step 2.
 - Step 2. Observe battery gauge in dash for proper operation.
 - a. If battery gauge works, go to step 5.
 - b. If battery gauge does not work, go to step 3.
 - Step 3. Remove lead 27/400 from pin B of accessory/battery switch. With accessory/battery switch turned ON, check for battery voltage at pin B.
 - a. If voltage is present, go to test 6.
 - b. If voltage is not present, go to step 4.
 - Step 4. Remove two leads 11 from pins A and C and lead 27 from pin D. With accessory/battery switch in ON position, check continuity between pins A and B, followed by pins C and D.

Electrical Troubleshooting (Contd)

<p>MALFUNCTION TEST OR INSPECTION CORRECTIVE ACTION</p>

- a. If continuity is not found, replace accessory/battery switch (TM 9-2320-361-20). Check continuity of new accessory/battery switch before installation. Install leads 11 in pins A and C. Install lead 27/400 in pin B and lead 27 in pin D. Attempt to start engine (TM 9-2320-386-10).
- b. If starter does not crank engine, go to step 5.
- Step 5. Remove lead 74A from pin B of starter switch. With accessory/battery switch in ON position, engage starter switch, and check for battery voltage at pin B.
 - a. If voltage is not present, go to step 6.
 - b. If voltage is present, perform continuity check on lead 74A. If continuity is not found, replace or repair lead (WP 0125 00).
- Step 6. Remove lead 74 from pin D on starter switch, turn accessory/battery switch to ON position, and check for battery voltage on contact end of lead 74.
 - a. If voltage is not present, disconnect lead 27/400 from pin B at accessory/battery switch and check continuity between lead 27/400 and its connection to lead 74.
 - b. If continuity is not found, replace or repair lead (WP 0125 00). Install lead 74 into pin D.
- Step 7. Attempt to start engine (TM 9-2320-386-10).
If starter does not engage engine, go to step 8.
- Step 8. Remove lead 74 from pin D and lead 74A from pin B of starter switch. Engage starter switch and perform continuity check between pins D and B.
 - a. If continuity is not found, replace starter switch (WP 0093 00).
 - b. Check continuity of new starter switch before installation.
 - c. Install lead 74A in pin B and lead 74 in pin D.
 - d. Engage starter switch. Starter should turn engine. If not, continue with testing.
- Test 6. Check for battery voltage at circuit breakers.
 - Step 1. Remove leads 10 from circuit breakers. Using voltmeter, check for battery voltage on contact end of leads 10.
 - a. If voltage is present, go to step 2.
 - b. If voltage is not present, perform test 3.
 - Step 2. Remove leads 11 from circuit breakers. Using multimeter, check for battery voltage at circuit breaker.
 - a. If voltage is present at either circuit breaker, replace or repair lead 11 (WP 0125 00).
 - b. If voltage is not present, replace circuit breaker (TM 9-2320-361-20).

END TESTING!

Electrical Troubleshooting (Contd)

<p>MALFUNCTION TEST OR INSPECTION CORRECTIVE ACTION</p>

3. STARTER MOTOR OPERATES, BUT ENGINE CRANKS SLOWLY**NOTE**

If STE/ICE-R is available, perform NG80 – Starter Circuit Tests (WP 0017 00).

Test 1. Check batteries for overheating by cranking engine for 15 seconds and touching battery terminal connections.

If battery terminal is hot, a loose or corroded connection is indicated.

- a. Clean corroded connection to bright metal.
- b. Tighten all loose connections at batteries, ground, and starter.

Test 2. Test specific gravity for each battery.

Perform a specific gravity test (TM 9-6140-200-14). If specific gravity of any cell is below 1.255, battery must be replaced or recharged. Add distilled water as necessary after checking battery. Charge battery as necessary (TM 9-6140-200-14).

- a. Charge all batteries not meeting requirements (TM 9-6140-200-14) and check specific gravity again.
- b. If 0.025-point variation still exists between cells within any battery, it is defective and must be replaced (WP 0122 00).

Test 3. Test starter motor voltage.

- Step 1. Set multimeter to a voltage range that will measure 24 Vdc.
- Step 2. Connect multimeter positive lead to positive terminal lug of starter motor and negative lead to terminal lug on end plate of starter motor.
- Step 3. Crank engine and observe cranking voltage on multimeter. Voltage should exceed 19 Vdc. If not, charge batteries (TM 9-6140-200-14).

Test 4. Test starter motor-to-solenoid strap voltage drop.

- Step 1. Set multimeter to a voltage range that will measure tenths of a volt.
- Step 2. Connect multimeter negative lead to positive terminal lug of starter motor and multimeter positive lead to starter motor solenoid ground terminal lug.
- Step 3. Crank engine and observe multimeter. A voltage reading exceeding 0.2 volts indicates a bad connection at starter motor solenoid ground terminal lug and terminal lug of starter motor.
 - a. Clean and tighten connections.
 - b. If malfunction still exists, go to test 5.

Test 5. Test starter motor solenoid contact voltage drop.

- Step 1. Set multimeter to a voltage range that will measure tenths of a volt.
- Step 2. Connect multimeter between starter motor solenoid ground terminal lug 3 and lug 2 at leads 6, 2, and 14.
- Step 3. Crank engine and observe multimeter. A voltage reading exceeding 0.4 volts indicates a defective starter motor solenoid.
 - a. Replace starter motor (WP 0091 00).
 - b. If malfunction still exists, go to test 6.

Electrical Troubleshooting (Contd)

<p>MALFUNCTION TEST OR INSPECTION CORRECTIVE ACTION</p>

Test 6. Test negative cable 7 voltage drop from batteries to starter motor.

Step 1. Set multimeter to a voltage range that will measure tenths of a volt.

Step 2. Connect multimeter positive lead to terminal stud on end plate of starter motor and negative lead to frame ground.

Step 3. Crank engine and observe multimeter. A voltage reading exceeding 0.4 volts indicates a defective starter motor solenoid.

a. Replace starter motor (WP 0091 00).

b. If malfunction still exists, go to tests 7 and 8.

Test 7. Test positive cable 6 voltage drop from batteries to starter motor solenoid.

Step 1. Set multimeter to a voltage range that will measure tenths of a volt.

Step 2. Connect multimeter positive lead to positive terminal post on batteries and negative lead to starter motor solenoid.

Step 3. Crank engine and observe multimeter. A voltage reading exceeding 0.4 volts indicates a loose or corroded connection.

Clean and tighten cable connections at batteries, starter, and chassis.

Test 8. Test battery voltage while cranking engine.

Step 1. Set multimeter to a voltage range that will measure 24 Vdc.

Step 2. Connect multimeter directly across battery terminal posts, positive lead to positive post, and negative lead to negative post.

Step 3. With fuel shutoff switch engaged, crank engine for 15 seconds. Voltage reading should be 19 Vdc or more during cranking.

a. If battery voltage is not satisfactory, go to malfunction 1 and check battery.

b. If battery voltage is satisfactory, replace starter motor and solenoid assembly (WP 0091 00).

Step 4. Release fuel shutoff switch.

If engine still cranks slowly, notify direct support maintenance.

END OF TESTING!

4. ENGINE CRANKS BUT WILL NOT START

Step 1. Check for defective fuel shutoff solenoid.

a. Turn accessory/battery ON and listen for a “click” indicating fuel solenoid plunger has opened.

b. If “click” is heard, refer to WP 0009 00, Mechanical Troubleshooting, malfunction 2.

c. If “click” is not heard, go to step 2.

Step 2. Check if plunger is stuck inside fuel solenoid.

a. Tap fuel solenoid lightly.

b. Turn accessory/battery switch OFF, then ON.

c. If “click” is not heard, go to test 1.

d. If “click” is heard, replace fuel shutoff solenoid (WP 0050 00).

Test 1. Check for voltage at fuel shutoff solenoid.

Electrical Troubleshooting (Contd)

<p>MALFUNCTION TEST OR INSPECTION CORRECTIVE ACTION</p>

Remove lead 54A from fuel shutoff solenoid.

- a. Using multimeter, check for voltage at lead 54A and fuel shutoff solenoid terminal.
- b. If voltage is present, replace fuel shutoff solenoid (WP 0050 00).
- c. If voltage is not present, go to test 2.

Test 2. Check for voltage at fuel shutoff switch.

Step 1. Remove lead 54 from fuel shutoff switch.

- a. Using multimeter, check for voltage at lead 54 and fuel shutoff switch.
- b. If voltage is present, go to step 2.
- c. If voltage is not present, go to malfunction 2, test 4.

Step 2. Check for continuity of fuel shutoff switch.

- a. Remove lead 54A from fuel shutoff solenoid.
- b. Set multimeter to measure continuity.
- c. If continuity is found, replace lead 54A.
- d. If continuity is not found, replace fuel shutoff switch (WP 0103 00).

END OF TESTING!

CHARGING SYSTEM (60 AMP)

5. NO ALTERNATOR OUTPUT (BATTERY GAUGE IN LEFT-HAND RED)

NOTE

Voltage regulator is built into alternator.

If STE/ICE-R is available, perform NG50 – Charging Circuit Tests (WP 0017 00).

Test 1. Check for loose or missing fan drivebelt.

Adjust and replace fan drivebelt (WP 0084 00).

Test 2. Test charging system output voltage.

Step 1. Open door of battery compartment, remove battery box, and place on running board (TM 9-2320-386-10).

Step 2. Use multimeter to check battery voltage.

NOTE

If vehicle is equipped with a slave receptacle, check voltage at receptacle.

Step 3. Start engine (TM 9-2320-386-10).

Step 4. Set engine speed at 1200 rpm.

Step 5. Turn vehicle headlights and accessories to ON position.

Step 6. Use multimeter to check battery voltage. Charging voltage on batteries should be 28.0 ± 0.2 Vdc.

- a. If battery voltage measures 24 Vdc, alternator has no output. Go to test 3 and check input voltage.
- b. If battery voltage is between 24 and 26 Vdc, alternator output is weak. Go to test 3 and check input voltage.

Electrical Troubleshooting (Contd)

<p>MALFUNCTION TEST OR INSPECTION CORRECTIVE ACTION</p>

- c. If battery voltage measures 28 ± 0.2 Vdc and voltmeter on instrument panel shows no voltage, an electrical problem exists between voltmeter and accessory/battery switch. Go to malfunction 2, test 5, step 3.
- d. If battery voltage measures between 26 and 30 Vdc, adjust voltage regulator in alternator (Prestolite) (WP 0089 00) or (Leece-Neville) (WP 0090 00) until voltage across batteries is 28 ± 0.2 Vdc. Go to step 7 and check regulator stability.
- e. If regulator voltage across batteries cannot be adjusted to 28 ± 0.2 Vdc, replace alternator (Prestolite) (WP 0089 00) or (Leece-Neville) (WP 0090 00).
- f. If battery voltage is greater than 30 Vdc, first try to adjust voltage regulator (TM 9-2320-361-20) in alternator down to 28 Vdc. If voltage regulator cannot be adjusted to 28 Vdc, replace alternator (Prestolite) (WP 0089 00) or (Leece-Neville) (WP 0090 00).

Step 7. Check voltage regulator stability as follows:

- a. Decrease engine speed to 1000 rpm with headlights in ON position. Regulated battery voltage should remain at 28.0 ± 0.2 Vdc.
- b. If battery voltage drops below 27.5 Vdc, replace alternator (Prestolite) (WP 0089 00) or (Leece-Neville) (WP 0090 00).
- c. Increase engine speed to 2000 rpm. Regulated battery voltage should remain at 28.0 ± 0.2 Vdc.
- d. If battery voltage increases above 28.5 Vdc, replace alternator (Prestolite) (WP 0089 00) or (Leece-Neville) (WP 0090 00).
- e. Return engine speed to 1200 rpm.
- f. Turn headlights OFF and ON and observe change of battery voltage.
- g. If battery voltage changes more than ± 0.5 Vdc and does not return quickly to 28.0 ± 0.2 Vdc, replace alternator (Prestolite) (WP 0089 00) or (Leece-Neville) (WP 0090 00).

Test 3. Test input voltage to alternator.

Step 1. Turn headlights to OFF position. Stop engine (TM 9-2320-386-10).

Step 2. Disconnect lead 1 from lead 568 at alternator.

Step 3. Turn accessory/battery switch to ON position.

Step 4. Check for battery voltage at contact end of lead 1. Voltage should be 24.0 Vdc.

- a. If voltage is not present, an open lead or bad connection exists in input circuit. Go to test 6.
- b. If voltage is 24.0 Vdc (normal), remove access cover from top of alternator to expose output terminals (Prestolite) (WP 0089 00) or (Leece-Neville) (WP 0090 00).
- c. Connect lead 1 to lead 568, and go to step 5.

Step 5. Measure voltage at terminal end of lead 568.

- a. If battery voltage is present (normal), the alternator is determined to be defective. Go to test 4 and check positive output of alternator.
- b. If voltage is not present, an open lead or bad contact exists in lead 568. Repair or replace lead (WP 0125 00), and go to test 2 and retest.

Test 4. Test positive output of alternator.

Electrical Troubleshooting (Contd)

<p>MALFUNCTION TEST OR INSPECTION CORRECTIVE ACTION</p>

NOTE

Access cover was removed in test 3.

A decrease in input voltage normally causes an increase in alternator output voltage.

- Step 1. Start engine (TM 9-2320-386-10).
- Step 2. Set engine speed at 1200 rpm.
- Step 3. Turn headlights and accessories to ON position.
- Step 4. Using multimeter, measure alternator output voltage at positive terminal (lead 2).
- If output voltage is between 24.0 and 26.0 Vdc, replace alternator (Prestolite) (WP 0089 00) or (Leece-Neville) (WP 0090 00).
 - If output voltage is more than 28.5 Vdc, go to test 5 and check voltage drop on lead 2.
- Test 5. Test voltage drop on lead 2.
- Step 1. Place multimeter positive lead on alternator positive output. Place multimeter negative lead on starter solenoid lug at leads 2, 6, and 14.
- Step 2. If voltage drop on lead 2 is greater than 0.4 volts, replace or repair lead (WP 0125 00) and go to test 2 and retest.
- Step 3. If voltage drop on lead 2 is less than 0.4 volts (normal), voltage regulator output is too high. Replace alternator (Prestolite) (WP 0089 00) or (Leece-Neville) (WP 0090 00).
- Test 6. Test battery voltage into accessory/battery switch (malfunction 2, test 5).
- Step 1. Disconnect lead 1 from accessory/battery switch.
- Step 2. Turn accessory/battery switch to ON position.
- Step 3. Check voltage at accessory/battery switch. Battery voltage should be present.
- If battery voltage is present, go to step 4 and check continuity of lead 1.
 - If voltage is not present, perform malfunction 2, test 5, step 4 to test continuity of accessory/battery switch.
 - If continuity is found in accessory/battery switch, go to step 4.
- Step 4. With both ends of lead 1 disconnected, check continuity.
- If continuity is found, reconnect lead 1 to accessory/battery switch. With accessory/battery switch in ON position, battery voltage should be present at lead 1.
 - If continuity is not present, replace or repair lead 1 (WP 0125 00).

END OF TESTING!

6. BATTERIES NOT CHARGING PROPERLY (BATTERY GAUGE IN YELLOW OR RIGHT-HAND RED)**NOTE**

If STE/ICE-R is available, perform NG50 – Charging Circuit Tests (WP 0017 00).

- Test 1. Check for loose or missing fan drivebelt.
 Adjust or replace fan drivebelt (WP 0084 00).
- Test 2. Test battery voltage (malfunction 5, test 2).

Electrical Troubleshooting (Contd)

MALFUNCTION TEST OR INSPECTION CORRECTIVE ACTION

NOTE

Battery voltmeter located on instrument panel is not always accurate and should not be used to adjust voltage. Indicator needle in voltmeter located on instrument panel should cover the white dot at edge of green area when battery voltage is 28.0 ± 0.2 Vdc.

If voltage across batteries cannot be adjusted to 28.0 ± 0.2 Vdc, go to malfunction 5, test 3 and check voltage.

END OF TESTING!

7. BATTERIES HOT OR BOILING, CORRECTED SPECIFIC GRAVITY OF ALL CELLS IS 1.280**NOTE**

If STE/ICE-R is available, perform NG50 – Charging Circuit Tests (WP 0017 00).

Test charging voltage (malfunction 5, test 2).

END OF TESTING!

8. BATTERIES USE EXCESSIVE WATER**NOTE**

If STE/ICE-R is available, perform NG81 – Battery Test or NG50 – Charging Circuit Tests (WP 0017 00).

NOTE

If STE/ICE-R is available, perform NG81 – Battery Test or NG50 – Charging Circuit Tests (WP 0017 00).

9. BATTERIES RUN DOWN IN OPERATION**NOTE**

If STE/ICE-R is available, perform NG50 – Charging Circuit Tests (WP 0017 00).

Test 1. Check for loose or missing fan drivebelt.

Adjust or replace fan drivebelt (WP 0084 00).

Test 2. Test charging voltage (malfunction 5, test 2).

NOTE

If proper voltage is indicated, problem is not in charging system. Refer to battery system troubleshooting (malfunction 1).

END OF TESTING!

CHARGING SYSTEM (100 AMP)**10. NO ALTERNATOR OUTPUT (BATTERY GAUGE IN LEFT-HAND RED)****NOTE**

If STE/ICE-R is available, perform NG50 – Charging Circuit Test (WP 0017 00).

Test 1. Check for loose alternator mounting or missing drivebelt.

a. Tighten loose mounting hardware.

b. Replace missing drivebelt (WP 0084 00).

Test 2. Test charging system output voltage.

Electrical Troubleshooting (Contd)

MALFUNCTION TEST OR INSPECTION CORRECTIVE ACTION

NOTE

Voltage regulators in both the 100-amp and 60-amp charging systems regulate battery voltage to 28.0 ± 0.2 Vdc.

The 100-amp voltage regulator is separate from the 100 amp alternator.

Battery voltage fluctuations are not to go above 28.5 Vdc or less than 27.5 Vdc as headlights are turned ON, OFF, and ON with engine running at 1200 rpm.

For test purposes only, charging voltage across batteries can be varied between 26.0 to 30.0 Vdc with engine running at 1200 rpm and headlights off.

- Step 1. Turn off engine.
- Step 2. Open door of battery compartment. Remove batteries onto running board (TM 9-2320-386-10).
- Step 3. Use multimeter to check battery for voltage.
- Step 4. Start engine (TM 9-2320-386-10).
- Step 5. Set engine speed at 1200 rpm.
- Step 6. Turn ON vehicle headlights and accessories.
- Step 7. Use multimeter to check battery voltage. Normal charging voltage on batteries is 28.0 ± 0.2 Vdc.

CAUTION

Do not puncture waterproof covering on cable between alternator and voltage regulator to make voltage checks. The cable will be unserviceable.

- a. If battery voltage measures between 24.0 and 26.0 Vdc and alternator has no or very weak output, replace alternator (Prestolite) (WP 0089 00) or (Leece-Neville) (WP 0090 00).
 - b. If battery voltage measures between 26.0 to 30.0 Vdc, adjust voltage regulator (if equipped with adjustment screw). If charging voltage across batteries cannot be adjusted to 28.0 ± 0.2 Vdc, replace voltage regulator (WP 0279 00). If charging voltage across batteries can be adjusted to 28.0 ± 0.2 Vdc, go to step 8.
- Step 8. Check voltage regulator stability.
Go to malfunction 5, test 2, step 7.

END OF TESTING!

11. BATTERIES NOT CHARGING PROPERLY (BATTERY GAUGE IN YELLOW OR RIGHT-HAND RED)**NOTE**

If STE/ICE is available, perform NG50 – Charging Circuit Tests (WP 0017 00).

- Test 1. Check for loose alternator mounting or missing drivebelt.
- a. Tighten loose mounting hardware.
 - b. Replace missing drivebelt (WP 0084 00).
- Test 2. Test battery voltage.
Go to malfunction 10, test 2.

Electrical Troubleshooting (Contd)

MALFUNCTION TEST OR INSPECTION CORRECTIVE ACTION

END OF TESTING!

12. BATTERIES HOT OR BOILING, CORRECTED SPECIFIC GRAVITY OF ALL CELLS IS 1.280

NOTE

If STE/ICE is available, perform NG50 – Charging Circuit Tests (WP 0017 00).

Test charging voltage (malfunction 10, test 2).

END OF TESTING!

13. BATTERIES USE EXCESSIVE WATER

NOTE

If STE/ICE is available, perform NG50 – Charging Circuit Tests (WP 0017 00).

Test charging voltage (malfunction 10, test 2).

END OF TESTING!

14. BATTERIES RUN DOWN IN OPERATION

NOTE

If STE/ICE is available, perform NG50 – Charging Circuit Tests (WP 0017 00).

Test 1. Check for loose alternator mounting or missing drivebelt.

- a. Tighten loose mounting hardware.
- b. Replace missing drivebelt (WP 0084 00).

Test 2. Test charging voltage (malfunction 10, test 2).

END OF TESTING!

INDICATORS, GAUGES, AND WARNING SYSTEM

15. ALL GAUGES INOPERATIVE

NOTE

If STE/ICE-R is available, perform NG31 – Gauge Test (WP 0017 00).

Test 1. Test starter for proper operation.

Step 1. Turn accessory/battery switch to ON position.

Step 2. Engage starter button.

- a. If starter cranks engine, go to test 2.
- b. If starter does not crank engine, go to malfunction 2 and troubleshoot starter circuit.

Test 2. If problem is still present, test instrument cluster voltage.

Step 1. Turn accessory/battery switch to OFF position.

Step 2. Remove instrument cluster panel (WP 0094 00).

Step 3. Connect battery ground cable (WP 0121 00).

Step 4. Connect jumper wire from instrument panel to a good frame ground.

*Electrical Troubleshooting (Contd)***MALFUNCTION****TEST OR INSPECTION****CORRECTIVE ACTION**

- Step 5. Disconnect lead 27 from temperature gauge.
- Step 6. Use multimeter or 24-volt test lamp to check voltage on contact end of lead 27 at temperature gauge.
- Place positive lead on contact end of lead 27.
 - Place negative lead on frame ground.
 - If battery voltage is present, go to malfunction 11. Set multimeter to measure continuity.
- Step 8. Check continuity of lead 27.
- Disconnect lead 27 from front wiring harness.
 - If continuity is not present, replace or repair lead 27 (WP 0125 00).

END OF TESTING!

16. ENGINE TEMPERATURE GAUGE INOPERATIVE**NOTE**

If STE/ICE-R is available, perform NG31 – Gauge Test (WP 0017 00).

Test 1. Test coolant temperature gauge operation.

- Disconnect lead 33 from coolant temperature sending unit.
- Turn accessory/battery switch to ON position.
- Coolant temperature gauge should read MINIMUM temperature.
- Touch contact end of lead 33 to frame ground. Coolant temperature gauge should read MAXIMUM temperature.
- If coolant temperature gauge operates properly, go to test 3 and check temperature sending unit.
- If coolant temperature gauge does not operate properly, go to test 2.

Test 2. Test for battery voltage into temperature gauge (malfunction 15, test 2).

Test 3. Test temperature sending unit.

- Allow coolant to cool.
- Set multimeter to measure continuity.

WARNING

Hearing protection is required for the driver and co-driver. Hearing protection is also required for all personnel working in and around this vehicle while the engine is running (Reference AR 40-5 and TB MED. 501).

- Start engine (TM 9-2320-386-10).
- Connect multimeter negative lead to engine ground and positive lead to temperature sending unit. Multimeter reading should decrease as engine coolant temperature increases.
 - If resistance does not show any decrease as temperature increases, replace temperature transmitter (WP 0114 00).
 - If resistance does show a decrease as temperature increases, go to test 4.

Test 4. Check continuity of lead 33.

- Disconnect lead 33 from temperature gauge.

Electrical Troubleshooting (Contd)

MALFUNCTION TEST OR INSPECTION CORRECTIVE ACTION

Step 2. Touch negative lead of multimeter to contact end of lead 33 at temperature transmitter.

Step 3. Touch positive lead of multimeter to contact end of lead 33 at temperature transmitter.

a. If continuity is not found, replace or repair lead 33 (WP 0125 00).

b. If continuity is found, replace temperature gauge (WP 0094 00).

END OF TESTING!

17. FUEL GAUGE INOPERATIVE

WARNING

Do not perform testing near fuel tank with fill cap or sending unit removed. Fuel may ignite causing injury to personnel.

NOTE

Before performing test, ensure fuel tank is full.

If STE/ICE-R is available, perform NG31 – Gauge Test (WP 0017 00)

Test 1. Test for battery voltage to fuel level sending unit.

Step 1. Disconnect lead 28 from fuel level sending unit.

Step 2. Set multimeter to a voltage range that will measure 24 Vdc.

Step 3. Connect negative lead to frame ground and touch positive lead to contact end of lead 28.

a. If battery voltage is present, go to test 2.

b. If battery voltage is not present, go to test 3.

Test 2. Test fuel gauge operation.

Step 1. Turn accessory/battery switch to OFF position.

Step 2. With lead 28 already disconnected from fuel level sending unit, touch contact end to frame ground.

Step 3. Turn accessory/battery switch to ON position.

Step 4. Fuel gauge should read EMPTY.

a. If fuel gauge shows EMPTY, go to step 5.

b. If fuel gauge does not show EMPTY, replace fuel gauge (WP 0094 00).

Step 5. Lift lead 28 from frame ground. Fuel gauge should now read FULL.

a. If fuel gauge shows FULL, it is operational. Remove fuel level sending unit (WP 0115 00) and go to test 5.

b. If fuel gauge does not show FULL, replace fuel gauge (WP 0094 00).

Test 3. Test fuel gauge voltage.

Perform malfunction 15, test 2.

Test 4. Test continuity of lead 28.

Step 1. Turn accessory/battery switch to OFF position.

Step 2. Disconnect lead 28 from fuel gauge and from fuel level sending unit.

Step 3. Connect jumper wire from fuel level sending unit end of lead 28 to frame ground.

Step 4. Set multimeter to measure continuity.

Step 5. Connect negative lead of multimeter to frame ground and touch positive lead of multimeter to contact end of lead 28.

a. If continuity is found, reconnect lead 28 and recheck fuel gauge operation.

Electrical Troubleshooting (Contd)

<p>MALFUNCTION TEST OR INSPECTION CORRECTIVE ACTION</p>

b. If continuity is not found, replace or repair wiring (WP 0125 00).

Test 5. Test continuity of fuel level sending unit.

Step 1. Set multimeter to measure continuity.

Step 2. Connect multimeter leads to fuel level sending unit.

Step 3. Position float in empty position.

a. If resistance is between 0.00 and 0.50 ohms, go to step 4.

b. If resistance is not between 0.00 and 0.50 ohms, replace fuel level sending unit (WP 0115 00).

Step 4. Position float in full position.

a. If resistance is between 29.50 and 31.50 ohms, reinstall fuel level sending unit (WP 0115 00) and recheck gauge operation.

b. If resistance is not between 29.50 and 31.50 ohms, replace fuel level sending unit (WP 0115 00).

END OF TESTING!

18. OIL PRESSURE GAUGE INOPERATIVE

NOTE

If STE/ICE-R is available, perform NG31 – Gauge Test (WP 0017 00).

Test 1. Test oil pressure gauge operation.

Step 1. Disconnect lead 36 from oil pressure sending unit.

Step 2. Turn accessory/battery switch to ON position.

Step 3. Oil pressure gauge should show MINIMUM pressure.

Step 4. Touch contact end of lead 36 to frame ground. Oil pressure gauge should show MAXIMUM pressure.

a. If oil pressure gauge operates properly, go to test 3.

b. If oil pressure gauge does not operate properly, go to test 2.

Test 2. Test battery voltage to oil pressure gauge (malfunction 15, test 2).

Test 3. Test oil pressure sending unit.

Step 1. Set multimeter to measure continuity.

Step 2. Connect negative lead to frame ground on engine.

Step 3. Touch positive lead to contact of oil pressure sending unit. Resistance should measure less than 1 ohm with engine off (no oil pressure).

Step 4. If resistance is 1 ohm or more, replace oil pressure sending unit (WP 0100 00).

Step 5. If resistance is less than 1 ohm, go to step 6.

Step 6. Remove oil pressure sending unit (WP 0100 00).

Step 7. Install mechanical gauge.

Step 8. Start engine (TM 9-2320-386-10) and check oil pressure on gauge.

a. If oil pressure is 10 psi (69 kPa) or above at idle, replace oil pressure sending unit (WP 0100 00).

b. If oil pressure is less than 10 psi (69 kPa) at idle, notify direct support maintenance.

Test 4. Test continuity of lead 36.

*Electrical Troubleshooting (Contd)***MALFUNCTION****TEST OR INSPECTION****CORRECTIVE ACTION**

- Step 1. Disconnect lead 36 from oil pressure gauge (warm engine).
- Step 2. Set multimeter to measure continuity.
- Step 3. Touch positive lead of multimeter to one end of lead 36 and negative lead of multimeter to other end of lead 36.
 - a. If continuity is not found, replace or repair lead 36 (WP 0125 00).
 - b. If continuity is found, replace oil pressure gauge (WP 0094 00).

END OF TESTING!

19. BATTERY GAUGE INOPERATIVE**NOTE**

If STE/ICE-R is available, perform NG31 – Gauge Test (WP 0017 00).

Test 1. Test battery gauge.

- Step 1. Turn accessory/battery switch to ON position. Do not start engine.
- Step 2. Battery gauge indicator should rest between lower edge of GREEN area and upper edge of YELLOW area on gauge (24 volts).
- Step 3. Start engine (TM 9-2320-386-10) and observe battery gauge on instrument cluster.
- Step 4. Battery gauge should rise as engine speeds up and stop over white dot in green area (approximately 28.0 Vdc).

If battery gauge does not perform as specified in steps 2 and 3, stop engine and go to test 2.

Test 2. Test battery voltage to battery gauge (malfunction 15, test 2).

Check frame ground to multimeter.

- a. Set multimeter to RX1 scale.
- b. Connect negative lead to panel ground on instrument cluster.
- c. Touch positive lead to battery gauge bracket. Continuity should be found. Ensure instrument panel is grounded.
- d. If continuity is found, reinstall battery gauge on instrument cluster (WP 0094 00) and recheck battery gauge operation.
- e. If continuity is not found, remove alternator (Prestolite) (WP 0089 00) or (Leece-Neville) (WP 0090 00) and check for corrosion around alternator body.

END OF TESTING!

20. TACHOMETER INOPERATIVE

Electrical Troubleshooting (Contd)

MALFUNCTION
TEST OR INSPECTION
CORRECTIVE ACTION

- Step 1. Check harness connector for continuity and voltage.
- Separate instrument cluster from instrument panel (WP 0094 00).
 - Disconnect harness connector from tachometer.

NOTE

Place accessory/battery switch in ON position when checking pin A to pin D, and pin B to pin C. Switch is in OFF position when checking pin C to pin D, and pin D to ground.

- Using multimeter, test harness connector as shown in chart below. Replace tachometer if harness connector passes test (WP 0095 00).
- If reading from pin B to pin C is not within limits, perform step 2.

Tachometer Harness Connector Test

TEST POINT	READING
Pin A to pin D	28 Vdc
Pin B to pin C	0.5-5 Vdc; 0.2 Vdc max.
Pin C to pin D	0 ohms
Pin D to ground	0 ohms

- Step 2. Check if magnetic sensor is defective.
- Check that 2-pin connector is intact with front wiring harness.
 - Reset gap of magnetic sensor.
 - Loosen jamnut and turn magnetic sensor clockwise to bottom-out on flywheel.
 - Turn magnetic sensor 1 to 1-1/2 turns counterclockwise and tighten jamnut against flywheel housing.
 - Retest pin B to pin C. If reading is not within limits, replace magnetic speed sensor (WP 0097 00).

END OF TESTING!

WIRING DIAGRAM OF TACHOMETER CIRCUIT

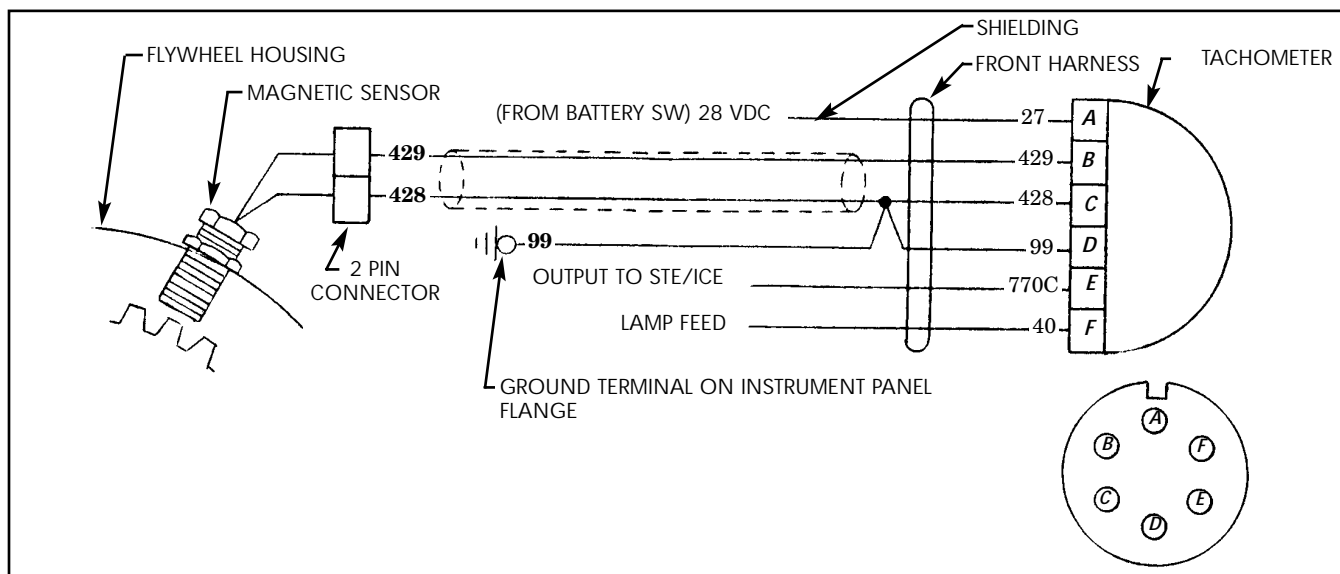

Electrical Troubleshooting (Contd)

MALFUNCTION TEST OR INSPECTION CORRECTIVE ACTION

21. TRANSMISSION TEMPERATURE GAUGE INOPERATIVE**NOTE**

If STE/ICE-R is available, perform NG31 – Gauge Test (WP 0017 00).

Test 1. Test transmission temperature gauge voltage.

Step 1. Remove transmission oil temperature gauge (WP 0096 00).

Step 2. Place accessory/battery switch to ON position.

Step 3. Set multimeter to a voltage range that will measure 24 Vdc.

Step 4. Touch negative lead of multimeter to ground and positive lead of multimeter to lead 27.

a. If voltage is present, go to test 2.

b. If voltage is not present, perform malfunction 2, test 5 for battery voltage at accessory/battery switch.

Test 2. Test continuity of transmission oil temperature gauge.

Step 1. Set multimeter to measure continuity.

Step 2. Touch leads of multimeter to pins A and B of transmission oil temperature gauge.

a. If continuity is present, go to test 3.

b. Replace transmission oil temperature gauge if continuity is not present (WP 0096 00).

Test 3. Test temperature sending unit.

Step 1. Remove cab tunnel to expose transmission oil temperature sending unit (WP 0117 00).

Step 2. Allow transmission fluid to cool.

Step 3. Start engine (TM 9-2320-386-10).

Step 4. Touch negative lead of multimeter to ground and positive lead to transmission temperature switch. Multimeter reading should increase as transmission fluid temperature increases.

a. If reading increases, perform test 4.

b. Replace transmission oil temperature sending unit if reading does not increase (WP 0117 00).

Test 4. Check continuity of lead 324.

Step 1. Set multimeter to measure continuity.

Step 2. Touch negative lead of multimeter to transmission temperature sending unit end of lead 324. Touch positive lead of multimeter to transmission temperature gauge end of lead 324.

a. If continuity is not present, replace or repair lead 324 (WP 0125 00).

b. If continuity is present, replace transmission temperature gauge (WP 0096 00).

END OF TESTING!

22. HORN DOES NOT OPERATE**NOTE**

Electrical troubleshooting of the electric horn or air horn is the same.

Test 1. Test air horn solenoid voltage.

Step 1. Remove lead 25 from pin B of air horn solenoid.

*Electrical Troubleshooting (Contd)***MALFUNCTION****TEST OR INSPECTION****CORRECTIVE ACTION**

- Step 2. Connect negative lead of multimeter to frame ground.
- Step 3. Touch positive lead to pin B of solenoid.
- If voltage is present, go to test 2.
 - If voltage is not present, go to step 4.
- Step 4. Remove lead 26 connected to pin A of air horn solenoid. Connect negative lead to frame ground. Touch positive lead to contact end of lead 26.
- If voltage is present, replace air horn solenoid (WP 0119 00).
 - If voltage is not present, replace or repair lead 26.
- Test 2. Test horn switch input voltage.
- Step 1. Remove horn button (TM 9-2320-361-20) until lead 25 can be seen.
- Step 2. Set multimeter to voltage range that will measure 24 Vdc.
- Step 3. Connect negative lead to frame ground.
- Step 4. Touch positive lead to lead 25 contact end.
- If voltage is not present, replace or repair lead 25 (WP 0125 00).
 - If voltage is present, go to test 3.
- Test 3. Test horn switch continuity.
- Step 1. Disconnect lead 25 from air horn solenoid to protect multimeter.
- Step 2. Install horn button cap, spring, and contact (TM 9-2320-361-20).
- Step 3. Set multimeter to RX1 scale.
- Step 4. Connect negative lead to a good frame ground.
- Step 5. Touch positive lead to lead 25 and press down until contact touches base plate.
- If continuity is present, reconnect lead 25 and recheck horn operation.
 - If continuity is not present, remove horn button and clean or replace horn button (TM 9-2320-361-20).

END OF TESTING!

ELECTRICAL ACCESSORIES**23. WINDSHIELD WIPERS FAIL TO WORK ON HIGH OR LOW SETTING**

Test 1. Check mechanical linkage for binding or interference. Replace damaged linkage (WP 0233 00).

Test 2. Test for voltage at wiper switch.

- Step 1. Disconnect harness from wiper switch.
- Step 2. Set multimeter to a voltage range that will measure 24 Vdc.
- Step 3. Place accessory/battery switch to ON position.
- Step 4. Touch negative lead of multimeter to ground and positive lead to lead 27 of harness receptacle.
- If voltage is present, go to test 3.
 - If voltage is not present, perform step 2, test 5 to check operation of accessory/battery switch.

Electrical Troubleshooting (Contd)

MALFUNCTION TEST OR INSPECTION CORRECTIVE ACTION

Test 3. Test for voltage at wiper motor.

Step 1. Disconnect harness from wiper motor.

Step 2. Set wiper switch to LOW position.

Step 3. Touch negative lead of multimeter to ground and positive lead to pin 2 of harness receptacle.

a. If voltage is present, go to step 4.

b. If voltage is not present, replace wiper switch (WP 0232 00).

Step 4. Set wiper switch to HIGH position.

Step 5. Touch negative lead of multimeter to ground and positive lead to pin 1 of harness receptacle.

a. If voltage is present, replace wiper motor (WP 0232 00).

b. If voltage is not present, replace wiper switch (WP 0232 00).

END OF TESTING!

24. ENGINE CRANKS BUT WILL NOT START (FUEL AVAILABLE)

Test 1. Check quick-start cylinder.

Step 1. Remove quick-start cylinder from valve, shake, and listen for liquid splashing inside cylinder.

a. If empty, replace with full cylinder and try starting engine.

b. If full, reinstall cylinder and go to test 2.

Test 2. Test for voltage at quick-start switch.

Step 1. Touch negative lead of multimeter to ground and positive lead to quick-start switch.

Step 2. Turn accessory/battery switch to ON position.

Step 3. Crank engine, engage quick-start switch, and observe multimeter.

a. If voltage is found, replace lead 569A (WP 0125 00).

b. If voltage is not found, go to step 4.

Step 4. Disconnect lead 569 from quick-start switch.

Step 5. Touch negative lead of multimeter to ground and positive lead to lead 569.

Step 6. Turn accessory/battery switch to ON position.

a. If voltage is found, replace quick-start switch (WP 0104 00).

b. If voltage is not found, test accessory/battery switch operation (TM 9-2320-361-20).

END OF TESTING!

25. AIR DRYER HEATER FAILS TO WORK 40 DEGREES OR BELOW

Test 1. Check for continuity of air dryer heater.

Step 1. Disconnect harness plug from air dryer connector.

Step 2. Set multimeter to measure continuity.

NOTE

Air dryer heater will not have continuity between pin 1 and pin 2 unless air dryer heater is cooled to below 54°F (13°C).

*Electrical Troubleshooting (Contd)***MALFUNCTION****TEST OR INSPECTION****CORRECTIVE ACTION**

- Step 3. Touch negative lead to pin 1 of air dryer heater connector and positive lead to pin 2 of air dryer heater connector.
- If continuity is found, go to test 2.
 - If continuity is not found, it may be necessary to remove air dryer heater and recheck after being cooled to 53°F (12°C) before replacing air dryer heater (WP 0281 00).
- Test 2. Check for continuity of ground lead.
- Step 1. Touch negative lead of multimeter to ground at crossmember and positive lead to pin 1 of harness plug.
- If continuity is found, go to test 3.
 - If continuity is not found, replace ground lead.
- Test 3. Check for voltage at air dryer heater connector.
- Step 1. Set multimeter to a voltage range that will measure 24 Vdc.
- Step 2. Turn accessory/battery switch to ON position.
- Step 3. Touch negative lead of multimeter to ground and positive lead to pin 2 of harness plug.
- If voltage is found, replace air dryer heater (WP 0281 00).
 - If voltage is not found, go to test 4.
- Test 4. Check for voltage at connector.
- Step 1. Disconnect lead 27 from connector.
- Step 2. Touch negative lead to ground and positive lead to connector.
- If voltage is found, replace lead 27 from connector to air dryer heater (WP 0281 00).
 - If voltage is not found, go to test 5.
- Test 5. Test for voltage at front-to-rear harness connector.
- Step 1. Disconnect rear harness from front harness.
- Step 2. Turn accessory/battery switch to ON position.
- Step 3. Touch negative lead of multimeter to ground and positive lead to pin F of front harness receptacle.
- If voltage is found, replace lead 27 to connector (WP 0125 00).
 - If voltage is not found, perform step 2, test 5 to check accessory/battery switch operation.

END OF TESTING!

PERSONNEL HEATERS**26. PERSONNEL HOT WATER HEATER DOES NOT OPERATE OR DOES NOT OPERATE IN HIGH OR LOW POSITION**

- Test 1. Check heater high/low switch for power input.
- Step 1. Set multimeter to a range that will measure 24 Vdc.
- Step 2. Disconnect lead 400 at rear of heater switch.
- Step 3. Touch multimeter positive lead to contact end of lead 400 at heater switch.
- Step 4. Touch multimeter negative lead to frame ground. Voltage should be present.
- If voltage is present, go to test 2.
 - If voltage is not present, replace or repair lead 400 (WP 0125 00).

Electrical Troubleshooting (Contd)

<p>MALFUNCTION TEST OR INSPECTION CORRECTIVE ACTION</p>

Test 2. Test for power output at heater high/low switch.

- Step 1. Set multimeter to range that will measure 24 Vdc.
- Step 2. Disconnect lead 400A at rear of heater switch.
- Step 3. Touch positive lead of multimeter to contact end of power output at the heater switch.
- Step 4. Touch negative lead of multimeter to frame ground. Voltage should be present.
 - a. If voltage is present, go to test 3.
 - b. If voltage is not present, replace heater switch (WP 0243 00).

Test 3. Test personnel heater for power input.

- Step 1. Ensure heater switch is in HIGH position.
- Step 2. Set multimeter to a range that will measure 24 Vdc.
- Step 3. Disconnect lead 400A from personnel heater.
- Step 4. Touch multimeter positive lead to contact end of lead 400A.
- Step 5. Touch multimeter negative lead to frame ground. Voltage should be present.
 - a. If voltage is not present, replace or repair lead 400A (WP 0125 00).
 - b. If voltage is present, and personnel heater fails to operate, replace personnel heater (WP 0239 00).

END OF TESTING!

27. PERSONNEL FUEL BURNING/POWER PLANT HEATER INOPERATIVE

Test 1. Test lead 10 for power input to heater control box.

- Step 1. Set multimeter to a range that will measure 24 Vdc.
- Step 2. Disconnect lead 10 from heater control box.
- Step 3. Touch multimeter positive lead to contact end of lead 10.
- Step 4. Touch negative lead of multimeter to frame ground. Voltage should be present.
 - a. If voltage is present, go to test 3.
 - b. If voltage is not present, replace or repair lead 10 (WP 0125 00).

Test 2. Check heater control box for power output.

- Step 1. Set multimeter to a range that will measure 24 Vdc.
- Step 2. Disconnect harness connector from rear of control box.
- Step 3. Set heater control switch to START and hold.
- Step 4. Set heater control heat switch to HIGH.
- Step 5. Touch positive lead of multimeter to pin A.
- Step 6. Touch negative lead of multimeter to frame ground.
- Step 7. Repeat steps 5 and 6 for pins B, C, and D. Voltage should be present.
 - a. If voltage is present at all pins tested, go to test 4.
 - b. If voltage is not present at one or more pins, replace heater control box (WP 0248 00).

Test 3. Check for input power at fuel pump.

- Step 1. Set multimeter to a range that will measure 24 Vdc.
- Step 2. Disconnect lead 25 from fuel pump.

Electrical Troubleshooting (Contd)

<p>MALFUNCTION TEST OR INSPECTION CORRECTIVE ACTION</p>

Step 3. Touch multimeter negative lead to contact end of lead 25.

Step 4. Touch multimeter negative lead to frame ground. Voltage should be present.

- a. If voltage is present, replace personnel fuel burning heater (WP 0247 00).
- b. If voltage is not present, replace or repair lead 25 (WP 0125 00).

Test 4. Check fuel pump for proper operation.

Refer to WP 0009 00, Mechanical Troubleshooting, malfunction 48.

Test 6. Check for power input at personnel heater.

Step 1. Set multimeter to a range that will measure 24 Vdc.

Step 2. Disconnect harness connector at personnel heater.

Step 3. Set heater control switch to RUN.

Step 4. Touch multimeter positive lead to pin A of harness connector.

Step 5. Touch multimeter negative lead to frame ground.

Step 6. Repeat steps 4 and 5 for pins B, C, and D. Voltage should be present at all pins tested.

- a. If voltage is present, replace personnel fuel burning heater (WP 0247 00).
- b. If voltage is not present at one or more pins, replace or repair harness (WP 0125 00).

END OF TESTING!

28. HEATER CONTROL BOX LIGHT INOPERATIVE, BUT HEATER OPERATIVE

Test 1. Check for voltage at heater control box indicator lamp.

Step 1. Set multimeter to a voltage range that will measure 24 Vdc.

Step 2. Position heater control switch to RUN.

Step 3. Position heater switch to HIGH.

Step 4. Remove heater control box indicator lamp.

Step 5. Touch positive lead of multimeter to indicator lamp socket.

Step 6. Touch negative lead of multimeter to frame ground.

- a. If voltage is present, replace indicator lamp.
- b. If voltage is not present, go to test 2.

Test 2. Check for voltage between personnel heater and heater control box.

Step 1. Disconnect wiring harness at personnel heater.

Step 2. Connect jumper wire from pin D to pin E at personnel heater.

- a. If heater control box indicator lamp is lit, replace personnel fuel burning heater (WP 0247 00).
- b. If indicator lamp fails to light, replace or repair wiring harness (WP 0125 00).

END OF TESTING!

END OF WORK PACKAGE

UNIT TROUBLESHOOTING PROCEDURES

EXTENDED SERVICE PROGRAM (ESP)

TRUCK, CARGO, 2-1/2-TON, 6X6, M44A3 SERIES TRUCKS (DIESEL)

M35A3, W/O WINCH (NSN 2320-01-383-2047); W/WINCH (NSN 2320-01-383-3850);
 M35A3C, W/O WINCH (NSN 2320-01-383-2050); W/WINCH (NSN 2320-01-383-2049);
 M36A3, W/O WINCH (NSN 2320-01-383-2048); W/WINCH (NSN 2320-01-383-2046).

COMPRESSED AIR AND BRAKE SYSTEM TROUBLESHOOTING SYMPTOM INDEX

MALFUNCTION NO.	MALFUNCTION	TROUBLESHOOTING WP-PAGE
1.	No air pressure, or compressed air reads below 60 psi (414 kPa) (low air pressure warning buzzer sounding, indicating air pressure not building up to normal operating range as indicated by gauge)	0014 00-1
2.	Air pressure does not build up to normal operating pressure (above 90 psi [621 kPa]) according to gauge.	0014 00-2
3.	Air pressure exceeds maximum (gauge reads over 120 psi [827 kPa]) and safety valve opens to release pressure.	0014 00-2
4.	Low or no reading on air pressure gauge, and warning buzzer shuts off .	0014 00-3
5.	Warning buzzer fails to sound on low pressure (below 60 psi [414 kPa]) .	0014 00-3
6.	Front wheel drive does not engage (front wheel drive lock-in switch engaged).	0014 00-3
7.	Air horn does not work.	0014 00-4
8.	Air leaking from air dryer purge valve, or continuous purge cycle.	0014 00-4
9.	Water present when draining air reservoirs	0014 00-4

END OF WORK PACKAGE

UNIT TROUBLESHOOTING PROCEDURES

EXTENDED SERVICE PROGRAM (ESP)

TRUCK, CARGO, 2-1/2-TON, 6X6, M44A3 SERIES TRUCKS (DIESEL)

*M35A3, W/O WINCH (NSN 2320-01-383-2047); W/WINCH (NSN 2320-01-383-3850);
M35A3C, W/O WINCH (NSN 2320-01-383-2050); W/WINCH (NSN 2320-01-383-2049);
M36A3, W/O WINCH (NSN 2320-01-383-2048); W/WINCH (NSN 2320-01-383-2046).*

COMPRESSED AIR AND BRAKE SYSTEM TROUBLESHOOTING

GENERAL

- a. This work package provides information to diagnose and correct malfunctions of the compressed air and brake system of ESP series vehicles.
- b. Refer to TM 9-2320-361-20 for parking brake and service brake system troubleshooting procedures. The troubleshooting steps outlined in TM 9-2320-361-20 are valid for ESP series vehicles. When performing the troubleshooting procedures, keep in mind that there may be some minor differences. For example, you will have to adjust for the differences in the master cylinder reservoir location when checking the brake fluid level and remember there are two air-hydraulic cylinder units and additional lines and fittings.
- c. The compressed air schematic (WP 0386 00) shows the interrelationship of the compressed air and brake systems, and should be used as a reference when performing troubleshooting procedures. Listed are malfunctions of the compressed air system that may occur.

WARNING

Eyeshields must be worn when releasing compressed air.
Failure to do this may result in injury to personnel.

Do not disconnect air lines before draining air reservoirs. Small parts under pressure may shoot out with high velocity, causing injury to personnel.

Hearing protection is required for the driver and co-driver.
Hearing protection is also required for all personnel working in and around this vehicle while the engine is running (Reference AR 40-5 and TB MED. 501).

Compressed Air and Brake System Troubleshooting.

<i>MALFUNCTION</i>
<i>TEST OR INSPECTION</i>
<i>CORRECTIVE ACTION</i>

1. NO AIR PRESSURE, OR COMPRESSED AIR READS BELOW 60 PSI (414 kPa) (LOW AIR PRESSURE WARNING BUZZER SOUNDING, INDICATING AIR PRESSURE NOT BUILDING UP TO NORMAL OPERATING RANGE AS INDICATED BY GAUGE)

Step 1. Start engine (TM 9-2320-386-10) and feel compressor outlet line.

- a. If compressor outlet line is hot, proceed to test 1.
- b. If compressor outlet line is cool or warm, proceed to test 2.

Step 2. Check for leaking compressed air lines and fittings.

If leakage is found, repair or replace compressed air lines or fittings (WP 0167 00 or TM 9-243).

Step 3. Check air dryer for long or continuous purge cycle or air leaking from purge valve.

If air dryer is purging continuously or leaking air, perform malfunction 8.

Test 1. Check air reservoirs for air pressure.

*Compressed Air and Brake System Troubleshooting (Contd)***MALFUNCTION****TEST OR INSPECTION****CORRECTIVE ACTION****WARNING**

Eyeshields must be worn when working with compressed air system.
Failure to wear eyeshields may result in injury to personnel.

Step 1. Allow air pressure to build to normal operating pressure.

Step 2. Loosen air reservoir drainvalves.

- a. If a low volume of air pressure is released, perform step 3.
- b. If a high volume of air pressure is released, proceed to test 2.
- c. If water is present, perform malfunction 9.

Step 3. Check air compressor outlet line for restrictions.

- a. If air compressor outlet line is restricted, repair or replace (WP 0167 00 or TM 9-243).
- b. If air compressor outlet line is not restricted, proceed to test 2.

Test 2. Check for air pressure at air horn supply line.

Step 1. Stop engine and open all air reservoir drainvalves and allow brake system air pressure to vent. Close air reservoir drainvalves.

Step 2. Disconnect air horn supply line from air horn elbow.

Step 3. Connect air horn supply line to test gauge.

Step 4. Direct assistant to start engine (TM 9-2320-386-10) and allow sufficient time for pressure to build.

Step 5. Compare test gauge reading with gauge reading on instrument panel.

- a. If low or no air pressure is indicated on test gauge, check air horn supply line for restrictions or leaks. Repair or replace damaged compressed air lines (WP 0167 00 or TM 9-243).
- b. If air compressor is continuously unloading, and not allowing air compressor to build air pressure, adjust air governor (WP 0170 00).
- c. If air governor adjustment will not increase pressure and/or compressor outlet line is warm or cool, replace air compressor (WP 0169 00).

END OF TESTING!

2. AIR PRESSURE DOES NOT BUILD UP TO NORMAL OPERATING PRESSURE (ABOVE 90 PSI (621 kPa) ACCORDING TO GAUGE

Step 1. Check for leaking compressed air lines and fittings.

If leakage is found, repair or replace compressed air lines or fittings (WP 0167 00 or TM 9-243).

Step 2. Adjust air governor (WP 0170 00).

Step 3. Perform malfunction 1, test 2.

END OF TESTING!

3. AIR PRESSURE EXCEEDS MAXIMUM (GAUGE READS OVER 120 PSI [827 kPa]) AND SAFETY VALVE OPENS TO RELEASE PRESSURE

Step 1. Check governor signal line for crimps, bends, or leaks.

- a. If governor signal line is crimped, bent, or leaking, repair or replace governor signal line (WP 0170 00).
- b. If no restrictions are apparent, proceed to test 1.

Test 1. Check governor signal line pressure.

Step 1. Stop engine and open all air reservoir drainvalves and allow brake system air pressure to vent. Close air reservoir drainvalves.

*Compressed Air and Brake System Troubleshooting (Contd)***MALFUNCTION****TEST OR INSPECTION****CORRECTIVE ACTION**

- Step 2. Disconnect governor signal line from adapter.
- Step 3. Remove adapter from air governor.
- Step 4. Install tee on air governor.
- Step 5. Connect test gauge to tee and governor signal line to tee.
- Step 6. Direct assistant to start engine (TM 9-2320-386-10) and allow air supply to build to normal operating pressure.
- Step 7. Compare air pressure reading indicated on test gauge to air pressure indicated on instrument panel gauge.
- If test gauge reading is below 85 psi (586 kPa), adjust governor (WP 0170 00).
 - If governor adjustment will not increase governor signal line pressure above 85 psi (586 kPa) on test gauge, replace air governor (WP 0170 00).

END OF TESTING!

4. LOW OR NO READING ON AIR PRESSURE GAUGE, AND WARNING BUZZER SHUTS OFF

Test 1. Check air supply pressure to air pressure gauge.

- Step 1. Stop engine and open all air reservoir drainvalves and allow brake system air pressure to vent. Close air reservoir drainvalves.
- Step 2. Disconnect air supply line from air pressure gauge adapter.
- Step 3. Connect air supply line to test gauge.
- Step 4. Start engine (TM 9-2320-386-10) and allow air pressure to build to normal operating pressure.
- Step 5. Check test gauge reading.
- If reading is low or zero, check air supply line for bends, kinks, or leaks. Repair or replace air supply line if bent, kinked, or leaking (WP 0167 00).
 - If reading is above 85 psi (586 kPa) on test gauge, replace air pressure gauge (WP 0094 00).

END OF TESTING!

5. WARNING BUZZER FAILS TO SOUND ON LOW PRESSURE (BELOW 60 PSI [414 kPa])

Refer to Electrical Troubleshooting, WP 0011 00.

6. FRONT WHEEL DRIVE DOES NOT ENGAGE (FRONT WHEEL DRIVE LOCK-IN SWITCH ENGAGED)

- Step 1. Start engine (TM 9-2320-386-10) and allow air pressure to build to normal operating pressure.
- Step 2. Inspect lines and hoses for air leaks.
- If air leaks are found, repair as required (WP 0167 00 or TM 9-247).
 - If no leaks are found, perform test 1.

Test 1. Check front axle engagement air cylinder supply line pressure.

- Step 1. Stop engine and open all air reservoir drainvalves and allow brake system air pressure to vent. Close air reservoir drainvalves.
- Step 2. Disconnect supply line from air cylinder elbow.
- Step 3. Remove elbow from air cylinder.
- Step 4. Install tee on air cylinder.
- Step 5. Connect test gauge to tee and connect supply line to tee.
- Step 6. Start engine (TM 9-2320-386-10) and allow air pressure to build to normal operating pressure.

*Compressed Air and Brake System Troubleshooting (Contd)***MALFUNCTION****TEST OR INSPECTION****CORRECTIVE ACTION**

Step 7. Place front wheel drive lock-in switch in ON position.

Step 8. Check reading on test gauge and compare reading to instrument panel air pressure gauge.

a. If reading is zero, replace front wheel drive lock-in switch (WP 0145 00).

b. If reading is lower than instrument panel gauge and air can be heard escaping from transfer case vent, notify direct support maintenance.

Step 9. If air system is operating properly, notify direct support maintenance.

END OF TESTING!

7. AIR HORN DOES NOT WORK

Step 1. Refer to Electrical Troubleshooting, WP 0011 00.

Step 2. If malfunction still exists, perform malfunction 1, test 2, steps 1 through 4.

If air pressure reading of test 2 is comparable to air pressure gauge on instrument panel, replace air horn (TM 9-2320-361-20).

END OF TESTING!

8. AIR LEAKING FROM AIR DRYER PURGE VALVE, OR CONTINUOUS PURGE CYCLE

Step 1. Check for plugged or frozen purge orifice.

a. If plugged, clean purge orifice.

b. If frozen, refer to Electrical Troubleshooting, WP 0011 00.

Step 2. Check for faulty air governor.

a. Disconnect air line from purge valve.

b. If purge air stops from purge valve but continues from air line, replace air governor (WP 0170 00).

c. If purge air continues, replace air dryer (WP 0281 00).

END OF TESTING!

9. WATER PRESENT WHEN DRAINING AIR RESERVOIRS

Step 1. Refer to Mechanical Troubleshooting, WP 0009 00.

Step 2. Check if an excessive amount of water is seen purging from air dryer.

If cloudy/milky discharge is seen, replace desiccant and coalescing filter (WP 0281 00).

END OF TESTING!

END OF WORK PACKAGE

UNIT TROUBLESHOOTING PROCEDURES

EXTENDED SERVICE PROGRAM (ESP)

TRUCK, CARGO, 2-1/2-TON, 6X6, M44A3 SERIES TRUCKS (DIESEL)

M35A3, W/O WINCH (NSN 2320-01-383-2047); W/WINCH (NSN 2320-01-383-3850);

M35A3C, W/O WINCH (NSN 2320-01-383-2050); W/WINCH (NSN 2320-01-383-2049);

M36A3, W/O WINCH (NSN 2320-01-383-2048); W/WINCH (NSN 2320-01-383-2046).

STE/ICE-R TROUBLESHOOTING INTRODUCTION

SIMPLIFIED TEST EQUIPMENT FOR INTERNAL COMBUSTION ENGINES – REPROGRAMMABLE (STE/ICE-R) TROUBLESHOOTING

a. General. This work package contains information and tests which may be used with STE/ICE-R to locate malfunctions that may develop in the vehicle. The tests can be used during troubleshooting, PMCS, or after replacing parts to isolate malfunctions, anticipate failures, and to ensure that proper repairs have been made.

STE/ICE-R is used primarily with the vehicle electrical system. These tests cannot cover all possible troubles which may occur. If a particular malfunction is not covered, refer to Electrical Troubleshooting, WP 0011 00, and locate the troubleshooting procedure for the malfunction observed. To obtain the maximum number of observed symptoms of the malfunction, question the operator.

b. STE/ICE-R Chain Index. Preventive Maintenance Checks and Services (WP 0022 00) contains a list of various troubles which may occur during operation or inspection of the vehicle. When one of the malfunctions listed occurs, the mechanic proceeds to the associated STE/ICE-R Chain Index.

c. Vehicle Test Meter (VTM) Troubleshooting. Vehicle Test Meter (VTM) troubleshooting procedures can be found in Table 2, STE/ICE-R GO-Chain Test (WP 0016 00). For additional VTM troubleshooting, refer to TM 9-4910-571-12&P, Simplified Test Equipment for Internal Combustion Engine.

d. STE/ICE-R Test and Setup Procedures. STE/ICE-R setup and internal checks must be performed prior to testing. Specific setup procedures are listed in WP 0016 00, Table 1, Engine GO Index, Combined Mode Chain, Test Number GO 1. Those test capabilities applicable to the ESP PMCS are listed in WP 0017 00, Table 1, Engine NO-GO Index, Combined Mode Chain, and are included in WP 0017 00, Table 2, STE/ICE-R NO-GO Chain Test. Test capabilities that may be applied to troubleshooting procedures are found in WP 0016 00, Table 1, Engine GO Index, Combined Mode Chain.

e. STE/ICE-R Operation. For a description of the operation of STE/ICE-R, refer to TM 9-4910-571-12&P.

f. Vehicle Test Card (VTC). The VTC provides a quick, but limited reference for the operator when performing STE/ICE-R tests. These cards list the test numbers and summarized instructions for diagnosing and testing malfunctions on ESP vehicles.

g. Engine Chain Indexes. An index for ESP vehicles GO (WP 0016 00, Table 1) and NO-GO (WP 0017 00, Table 1) chain tests precedes the tests listed.

NOTE

Use VID entry 02 on test select switches.

ESP VEHICLE TEST CARD - VID 02

PRE-TEST INSPECTION

- | | |
|--------------------------------|-----------------------|
| 1. <u>ACCESSORY DRIVEBELTS</u> | 5. <u>BATTERIES</u> |
| 2. <u>OIL LEVELS</u> | 6. <u>RADIATOR</u> |
| 3. <u>COOLANT LEVEL</u> | 7. <u>AIR CLEANER</u> |
| 4. <u>FLUID LEVEL</u> | |

PERFORMANCE CHECKS

TEST NO.	LIMITS
	OIL PRESSURE (Gage Reading) 35 - 70 psi (241 - 483 kPa)@ Idle 50 - 60 psi (345 - 414 kPa)@ High Idle
	OIL AND COOLANT LEVELS
	COOLANT TEMPERATURE (Gage Reading) 160° - 300°F (71° - 149°C)
10	IDLE SPEED, 750 - 850 RPM MAX GOVERNOR SPEED, 2900±40 RPM
13	POWER 75% NATURAL, 60% TURBO
14	COMPRESSION UNBALANCE 0 - 10%
67	BATTERY VOLTAGE, 22 VOLTS MIN. @ ENGINE OFF 26.5-29.5 VOLTS @ FAST IDLE
72	START CURRENT, FIRST PEAK, 700 - 1500 AMPS

OPERATOR MESSAGES

PASS	TEST SUCCESSFULLY COMPLETED
CAL	OFFSET TEST IN PROGRESS, RELEASE TEST BUTTON
CIP	INITIATE CI POWER SIMULATION
CYL	ENTER NUMBER OF CYLINDERS OR CYLINDER PAIRS
FAIL	TEST FAILED
GO	CRANK ENGINE
OFF	IF CRANKING STOP! IF CI POWER, DECELERATE!
UEH	ENTER VEHICLE IDENTIFICATION NUMBER
66	DIAL 99, PUSH TEST BUTTON
---	VTM ACCEPTING DATA OR INITIAL TURN-ON
8.8.8.8	CHECK DISPLAY

ERROR MESSAGES

E000	INFORMATION NOT AVAILABLE
E001	TEST NON-EXISTENT
E002	TRANSDUCER NOT CONNECTED
E003	TEST NOT VALID IN THIS DCA
E004	VID OR NUMBER OF CYL. NOT ENTERED
E006	CAL NOT PERFORMED
E007	NUMBER OF CYL. CONFLICTS WITH VID
E008	TEST MODE NOT CONNECTED
E009	ENGINE NOT RUNNING
E010	BAD VID
E011	ACCEL/DECEL TIME TOO LARGE
E012	TACH PICKUP MISSING
E013	BAD DATA
E014	BAD NUMBER OF CYLINDERS
E018	TEST DISCONNECTED, EXCESSIVE TIME .9.9.9.9. OVERLOAD, OR NUMBER EXCEEDS CAPABILITY

TEST LIST

TEST NO.	OFFSET LIMITS	TEST NO.	OFFSET LIMITS
10	ENGINE RPM (Average)	76	±225 STARTER CURRENT, FIRST PEAK (Test Probe Cable and Current Probe)
12	POWER TEST (RPM/Sec)	77	±225 INTERNAL BATTERY RESISTANCE (Test Probe Cable and Current Probe)
13	POWER TEST (% Power)	78	±225 STARTER CIRCUIT RESISTANCE (Test Probe Cable and Current Probe)
14	COMPRESSION UNBALANCED (Power Cable)	79	±225 BATTERY RESISTANCE CHANGE (Test Probe Cable and Current Probe)
24	±45 FUEL SUPPLY PRESSURE	82	ALTERNATOR OUTPUT VOLTAGE
47	±7.5 0 - 50 IN. HG PRESSURE (Red Transducer)	83	ALTERNATOR FIELD VOLTAGE
48	±23 0 - 150 IN. WATER PRESSURE DROP (Red Transducer)	89	±6.8 0 - 45 VOLTS DC
49	±4 0 - 25 PSIG PRESSURE (Red Transducer)	90	±225 0 - 1500 AMPS DC
50	±150 0 - 1000 PSIG PRESSURE (Blue Transducer)	91	±225 0 - 1500 OHMS
67	BATTERY VOLTAGE	92	±6 0 - 40 K OHMS
68	STARTER MOTOR VOLTAGE		
69	STARTER NEGATIVE CABLE VOLTAGE DROP		
70	STARTER SOLENOID VOLTAGE		
72	±225 STARTER CURRENT, FIRST PEAK (Current Probe)		
73	±225 INTERNAL BATTERY RESISTANCE (Current Probe)		
74	±225 STARTER CIRCUIT RESISTANCE (Current Probe)		
75	±225 BATTERY RESISTANCE (Current Probe)		

INITIAL ENTRY

- TEST 60 VID ENTRY
- TEST 61 VID DISPLAY
- TEST 62 DCA ID
- TEST 66 CONFIDENCE TEST
(SECOND ENTRY - 99)

CONTROL OF NEXT TEST

- 01 INTERLEAVE WITH SPEED
- 02 DISPLAY MINIMUM VALUE
- 03 DISPLAY MAXIMUM VALUE
- 04 DISPLAY PEAK-PEAK VALUE

UNIT TROUBLESHOOTING PROCEDURES

EXTENDED SERVICE PROGRAM (ESP)

TRUCK, CARGO, 2-1/2-TON, 6X6, M44A3 SERIES TRUCKS (DIESEL)

M35A3, W/O WINCH (NSN 2320-01-383-2047); W/WINCH (NSN 2320-01-383-3850);

M35A3C, W/O WINCH (NSN 2320-01-383-2050); W/WINCH (NSN 2320-01-383-2049);

M36A3, W/O WINCH (NSN 2320-01-383-2048); W/WINCH (NSN 2320-01-383-2046).

STE/ICE-R TROUBLESHOOTING (GO CHAIN TESTS)

Table 1. Engine Go Index, Combined Mode Chain

<i>GO TEST NUMBER</i>	<i>MODE</i>	<i>TEST TITLE</i>	<i>WP-PAGE NUMBER</i>
G01	DCA	VTM Connections and Checkout	0016 00-2
G02	DCA	First Peak Test – Starter Current	0016 00-7
G03	DCA	Engine Start – Lubrication Check	0016 00-9
G04	DCA	Charging Circuit and Battery Voltage Test	0016 00-12
G05	DCA	Engine Warmup/Coolant Check	0016 00-14
G06	DCA	Governor Check/Power Test	0016 00-15
G07	DCA	Idle Speed/Governor Check	0016 00-18
G08	DCA	Compression Unbalance Test	0016 00-19

Table 2. STE/ICE-R GO-Chain Tests

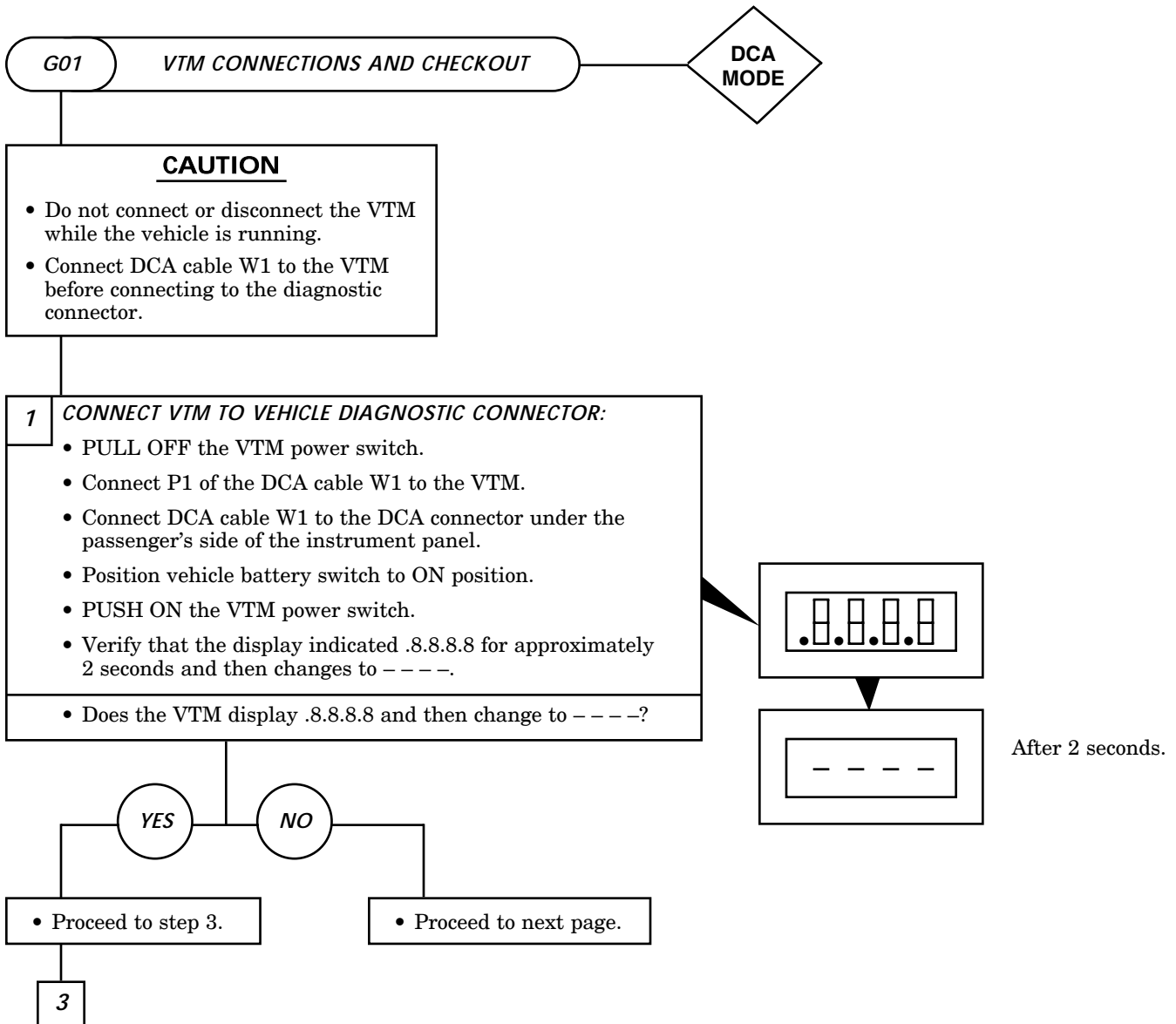
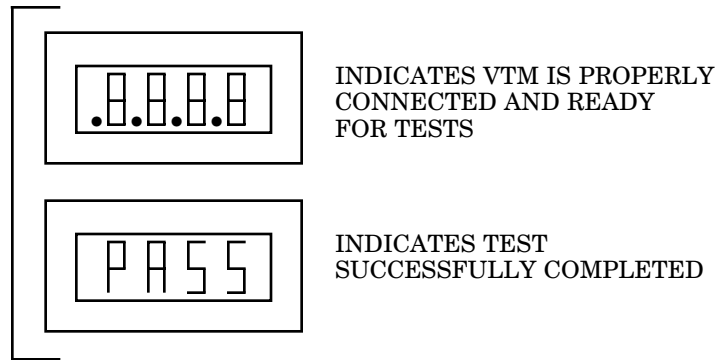

Table 2. STE/ICE-R GO-Chain Tests (Contd)

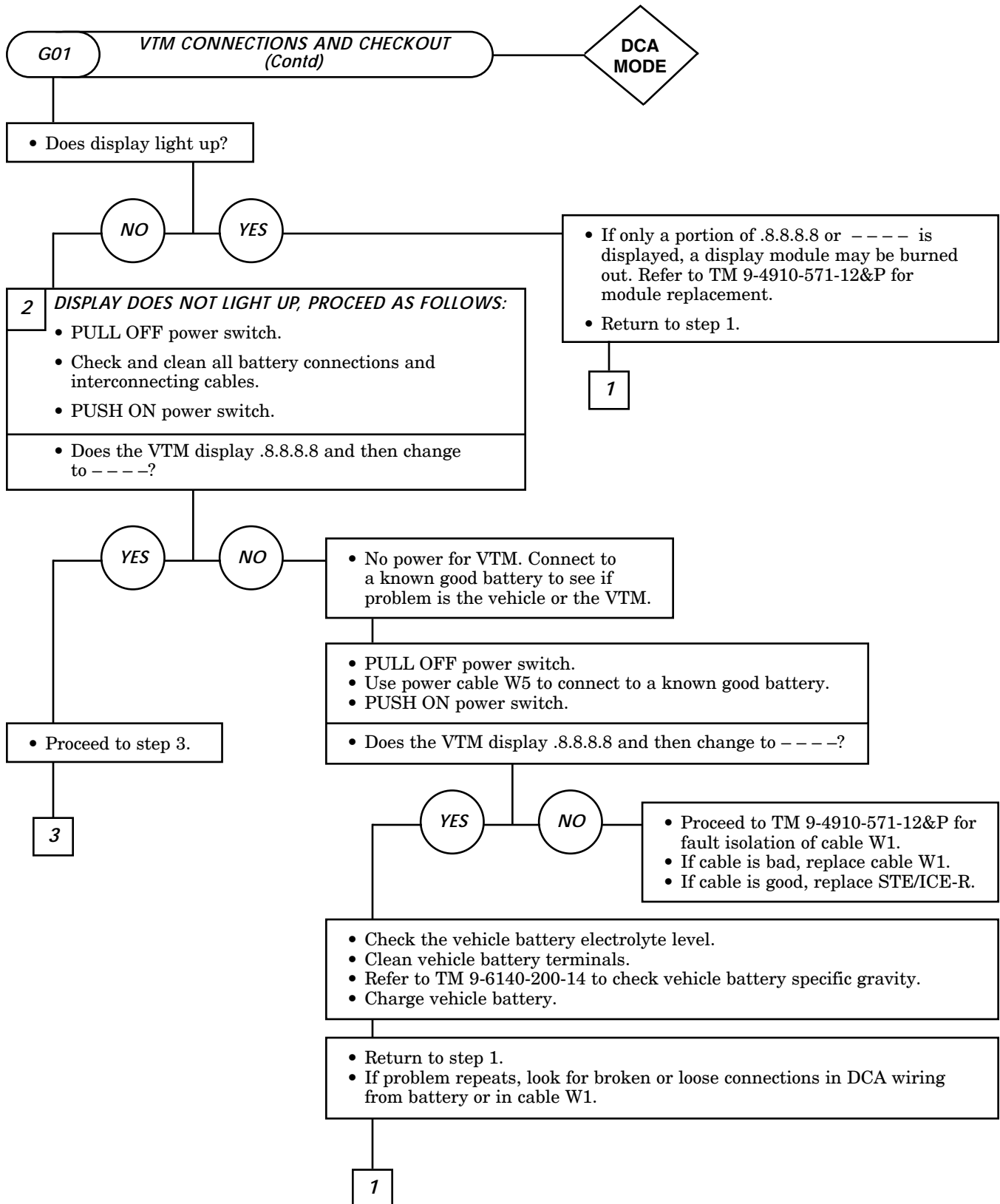

Table 2. STE/ICE-R GO-Chain Test (Contd)

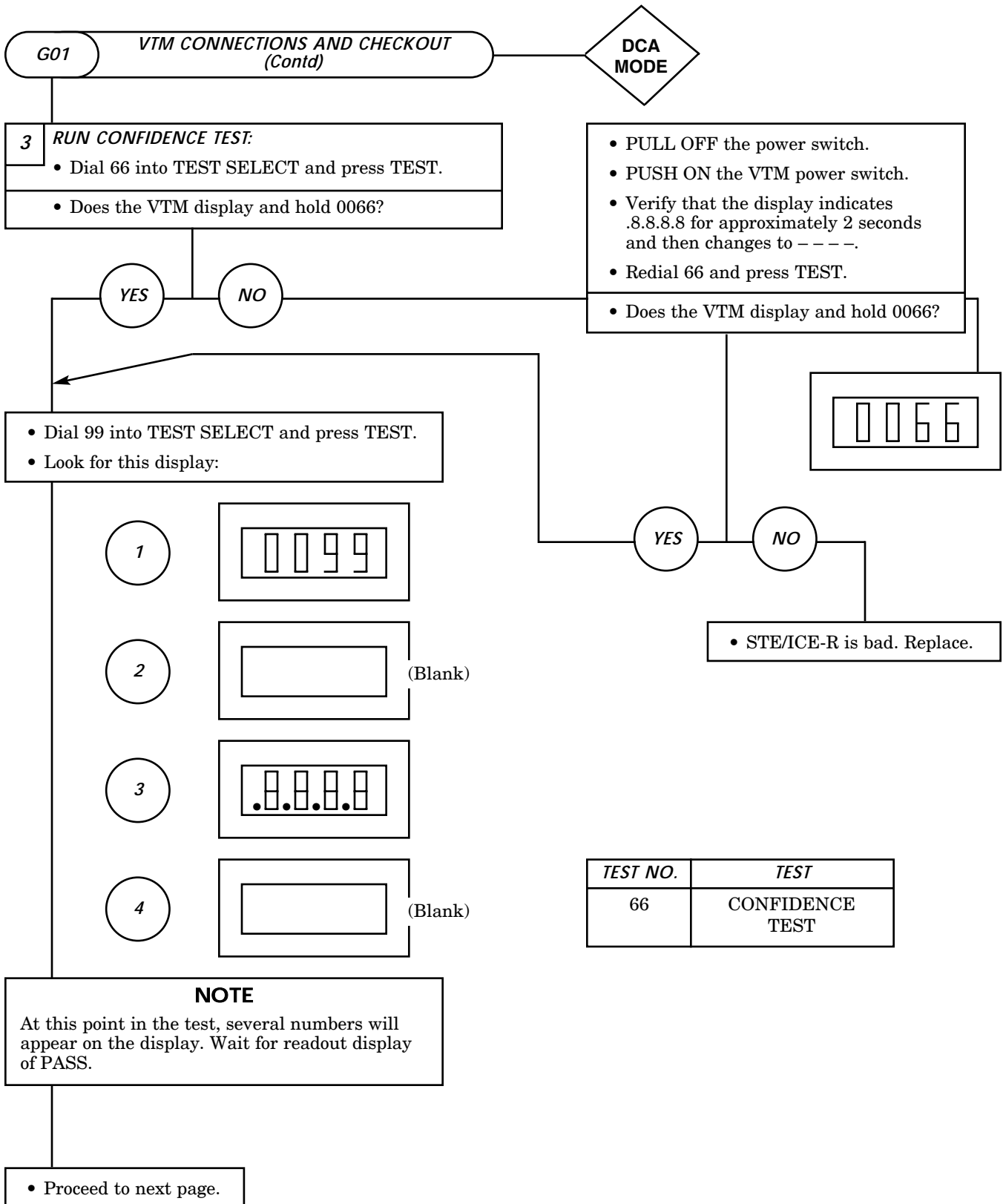

Table 2. STE/ICE-R GO-Chain Test (Contd)

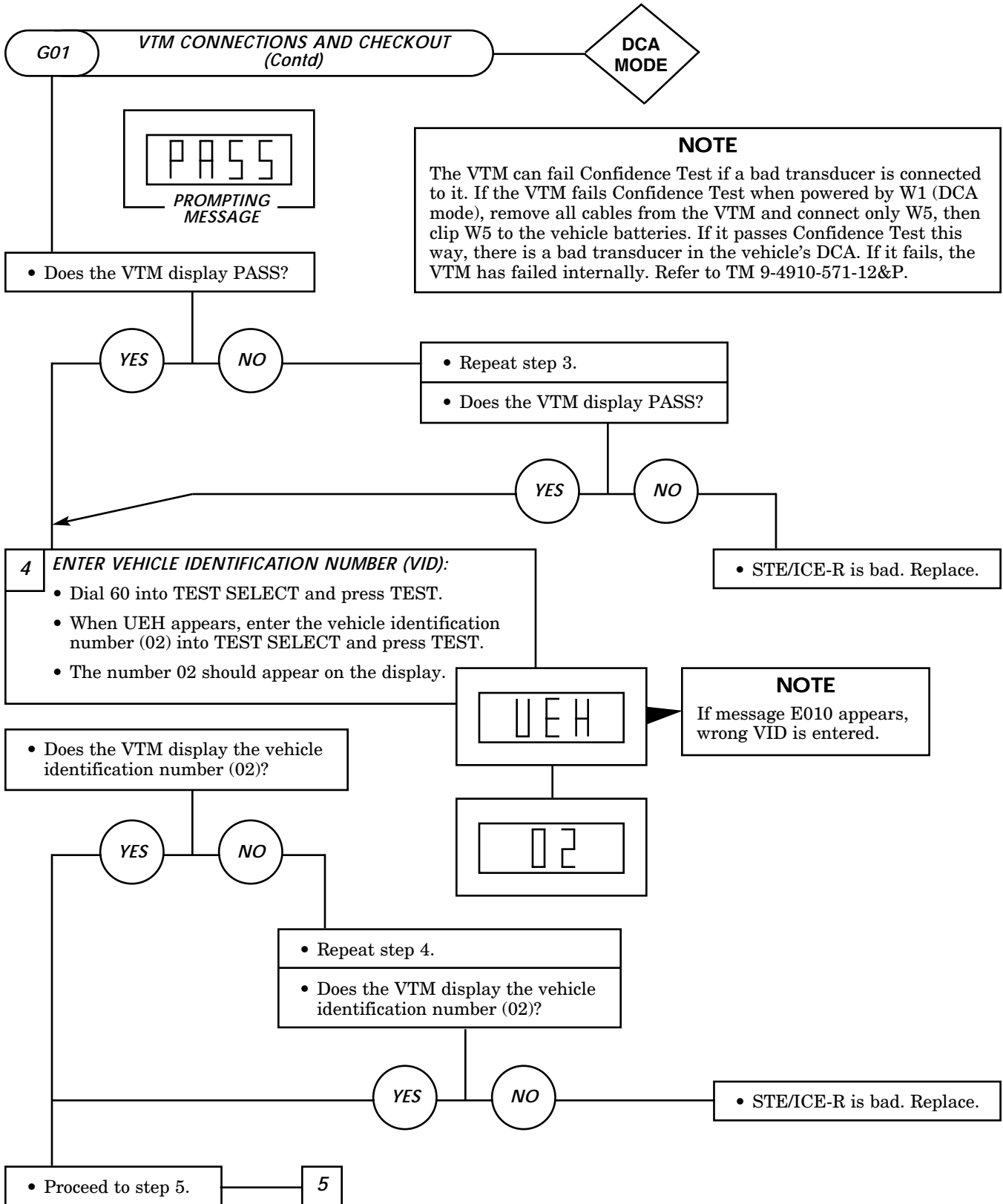

Table 2. STE/ICE-R GO-Chain Tests (Contd)

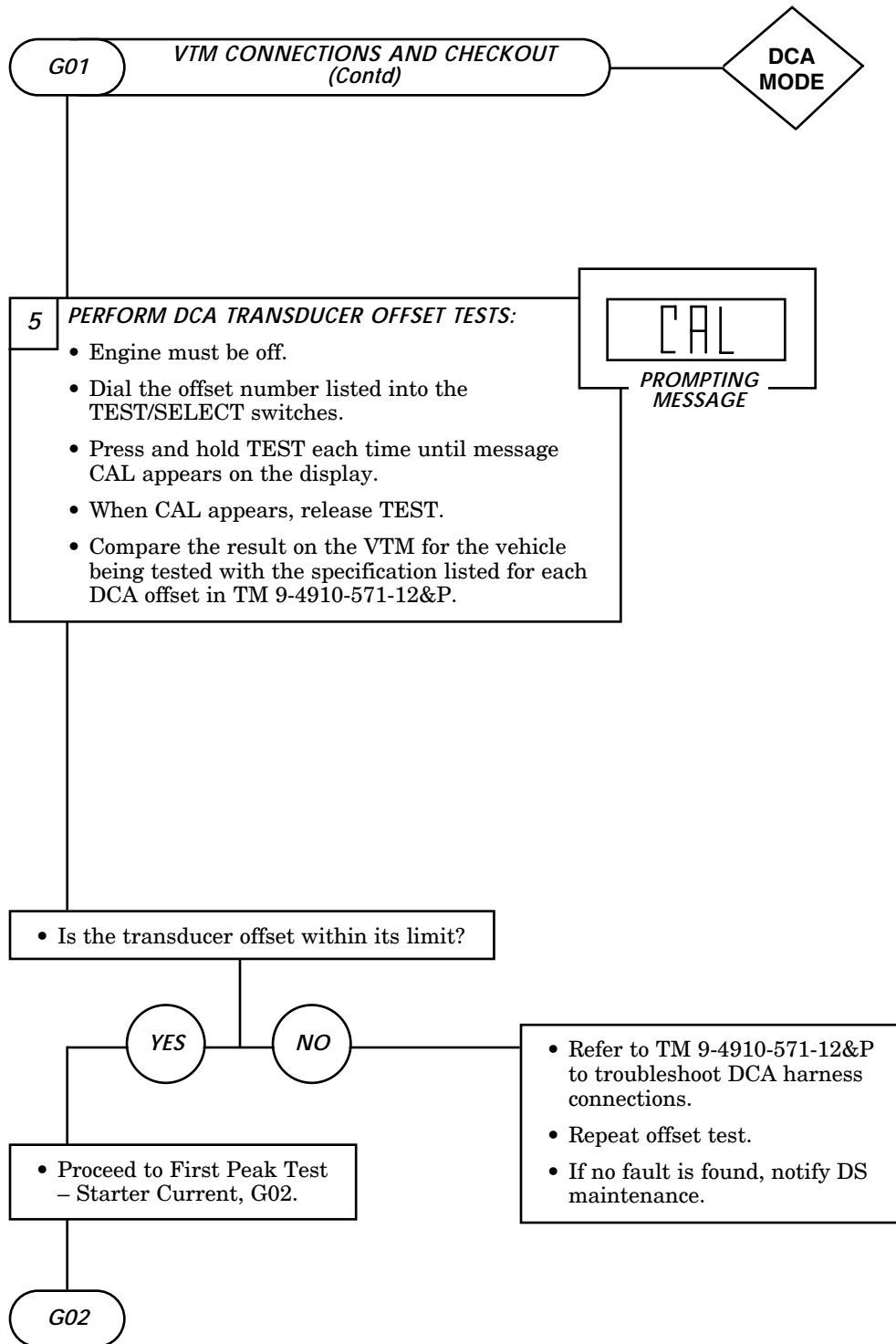

Table 2. STE/ICE-R GO-Chain Tests (Contd)

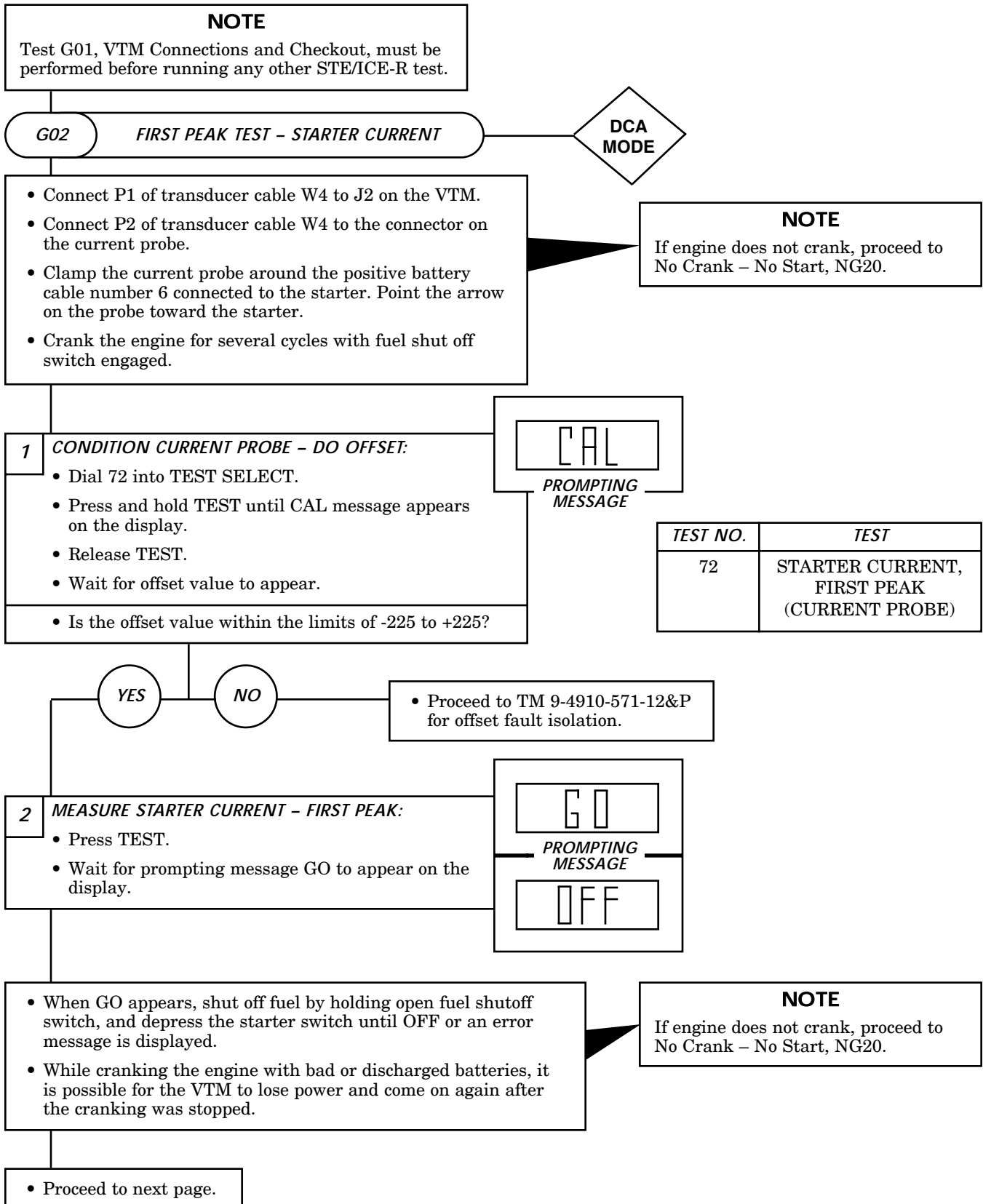

Table 2. STE/ICE-R GO-Chain Test (Contd)

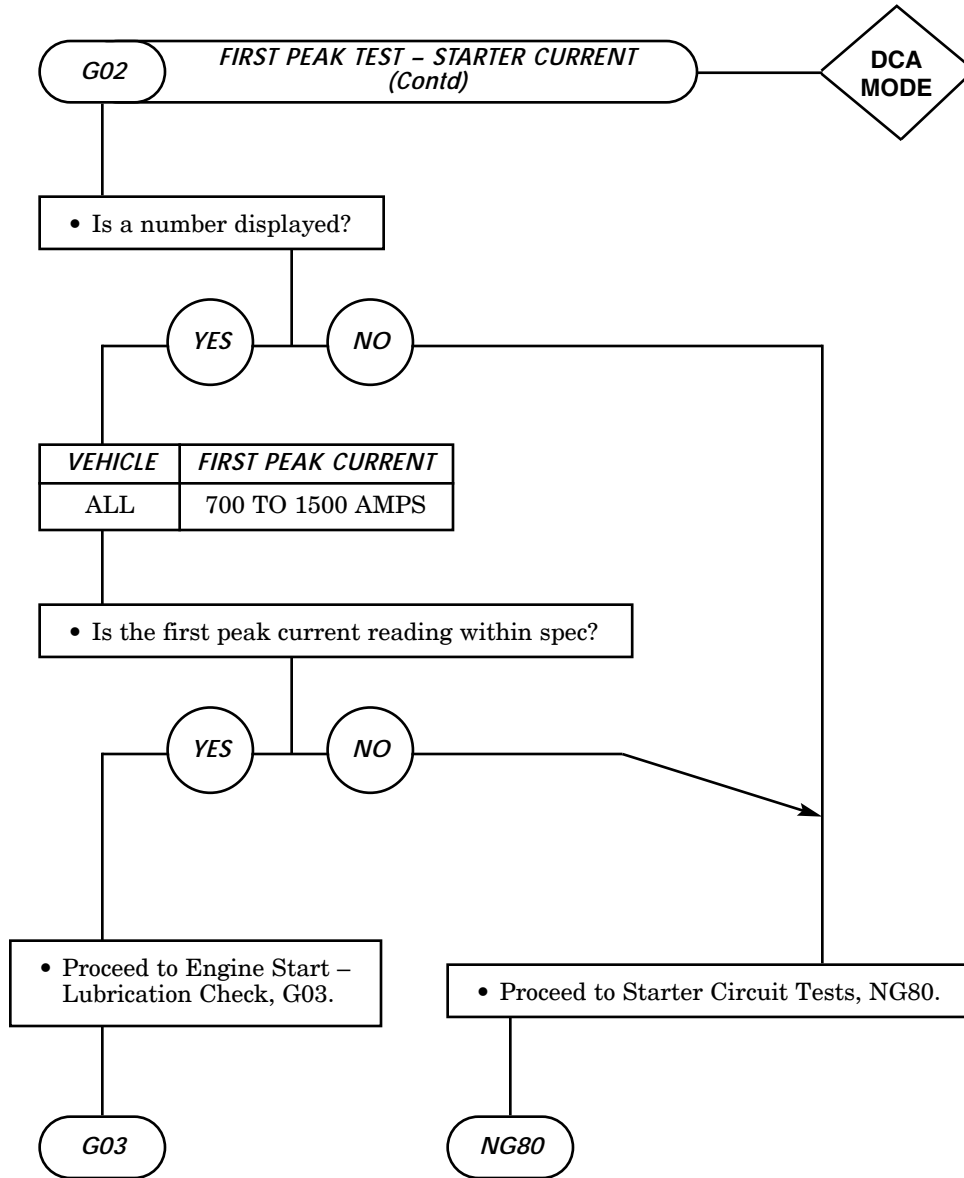

Table 2. STE/ICE-R GO-Chain Tests (Contd)

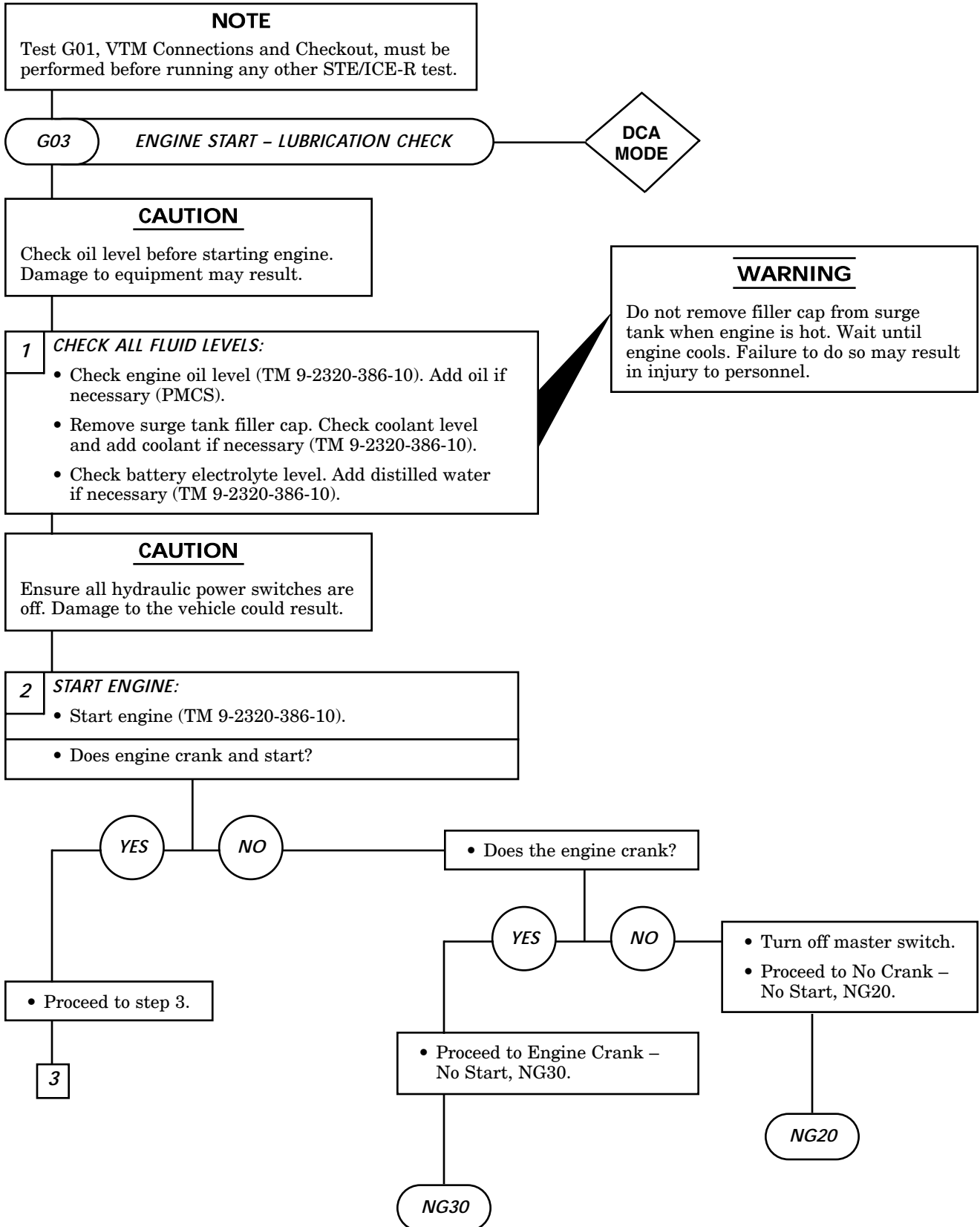

Table 2. STE/ICE-R GO-Chain Tests (Contd)

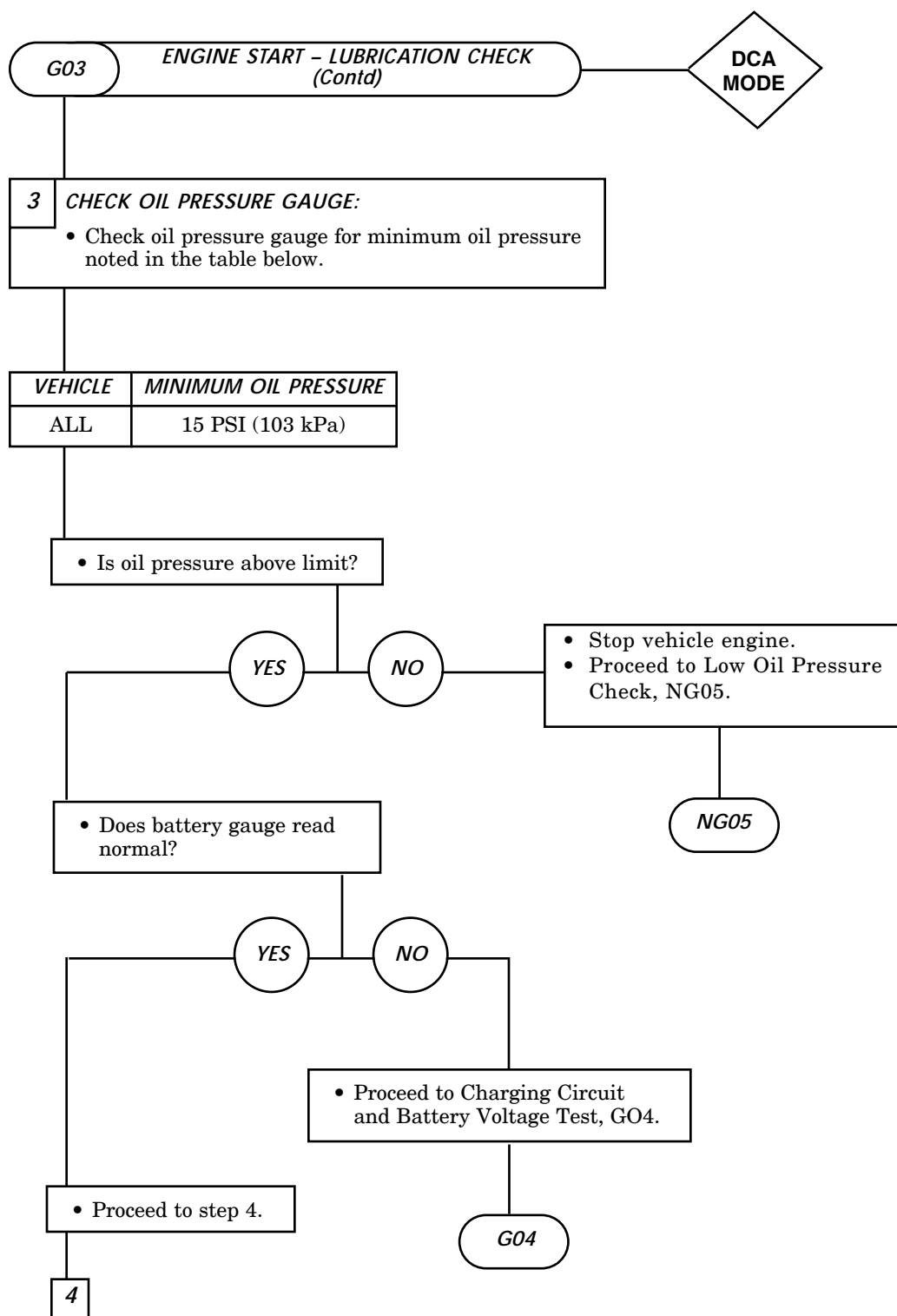

Table 2. STE/ICE-R GO-Chain Tests (Contd)

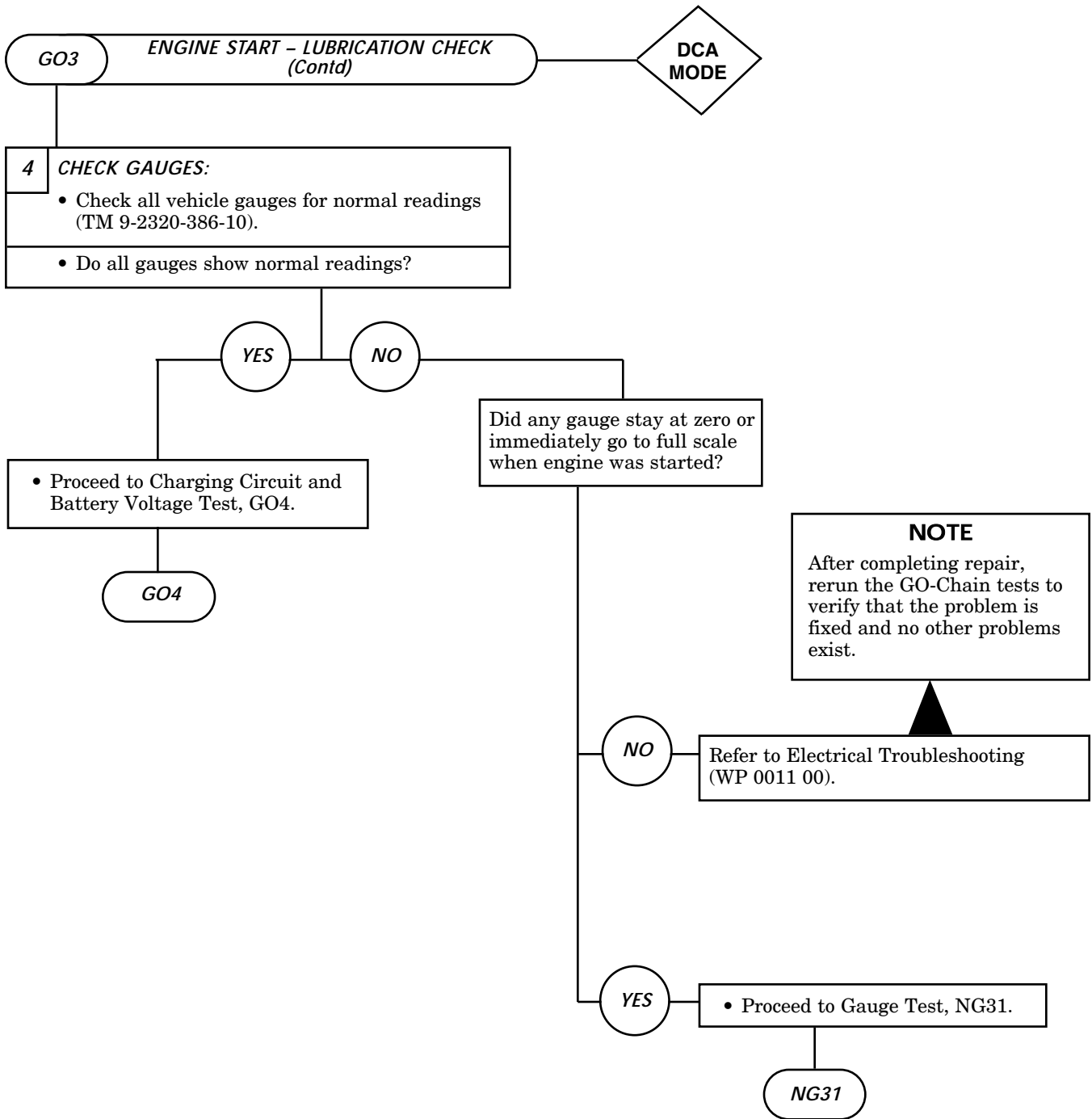

Table 2. STE/ICE-R GO-Chain Tests (Contd)

NOTE
Test G01, VTM Connections and Checkout, must be performed before running any other STE/ICE-R test.

G04 CHARGING CIRCUIT AND BATTERY VOLTAGE TEST



1 SET ENGINE RPM:

- Run vehicle at 1200-1400 RPM.
- Turn vehicle headlights and accessories ON to load charging system.

TEST NO.	TEST
67	BATTERY VOLTAGE

2 MEASURE BATTERY VOLTAGE:

- Dial 67 into TEST SELECT and press TEST.
- Watch display and verify that battery voltage is within 26.5-29.5 volts.

NOTE
After completing repair, rerun the GO-Chain tests to verify that the problem is fixed and that no other problems exist.

• Is battery voltage within limits?

YES

NO

• Is battery voltage low?

YES

NO

• Battery voltage is high.
• Refer to Electrical Troubleshooting (WP 0011 00) to troubleshoot regulator and wiring.

• Battery voltage is low.
• Allow vehicle to run for 5 minutes at 1200-1400 RPM and watch the display.
• Is the battery voltage within limits?

YES

NO

• Turn off headlights and accessories.
• Turn vehicle engine off.
• Proceed to Charging Circuit Tests, NG50.

• Proceed to next page.

NG50

Table 2. STE/ICE-R GO-Chain Tests (Contd)

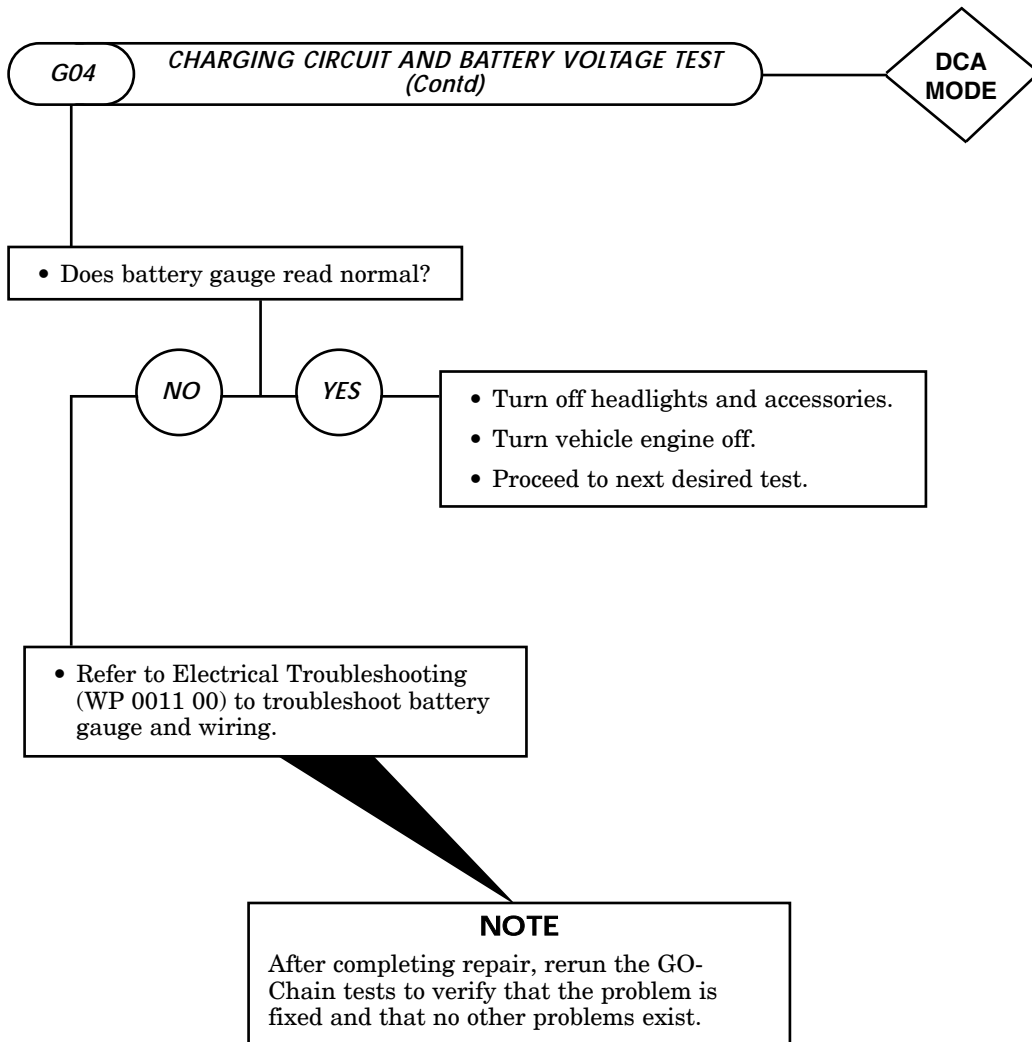

Table 2. STE/ICE-R GO-Chain Tests (Contd)

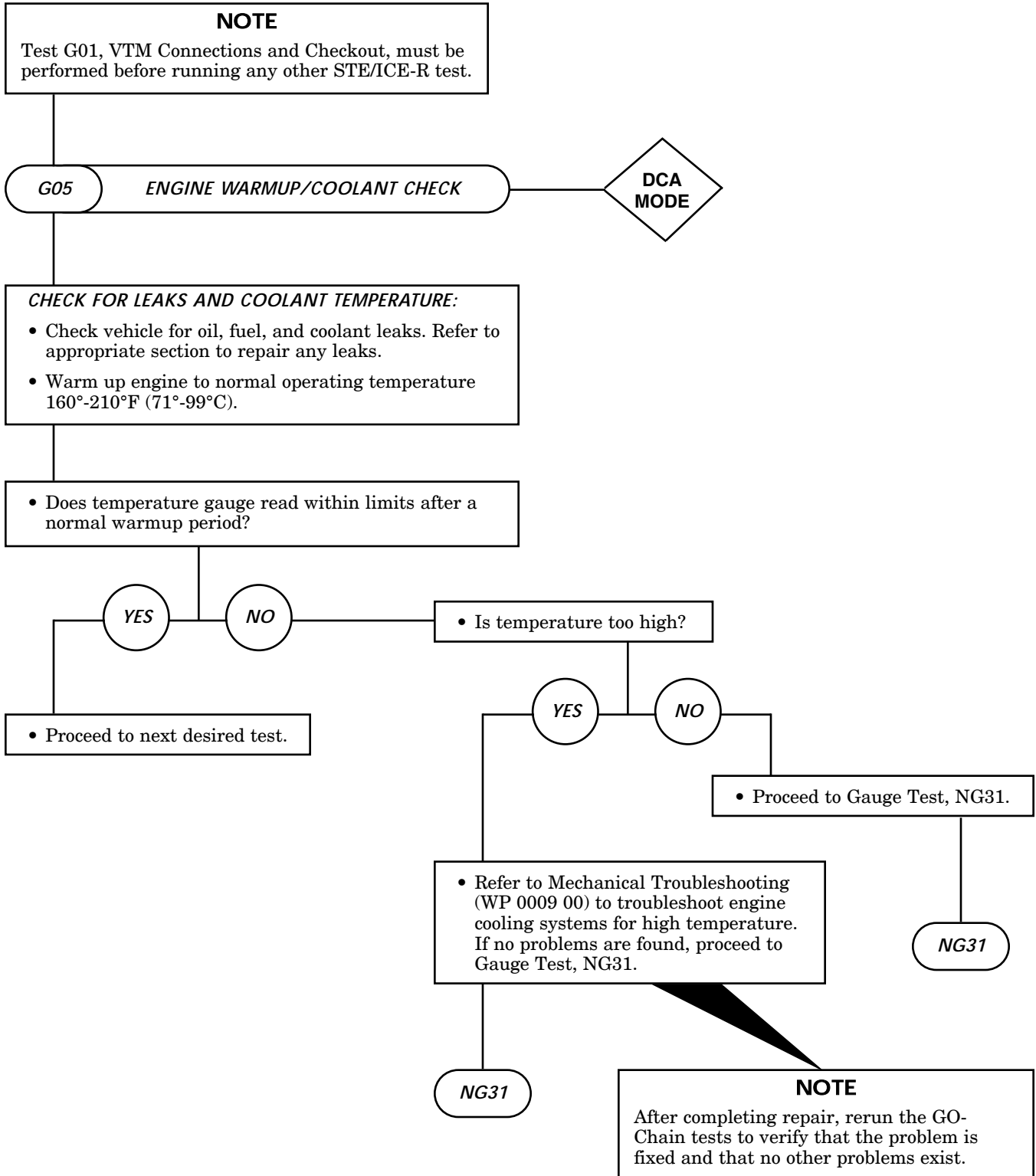

Table 2. STE/ICE-R GO-Chain Tests (Contd)

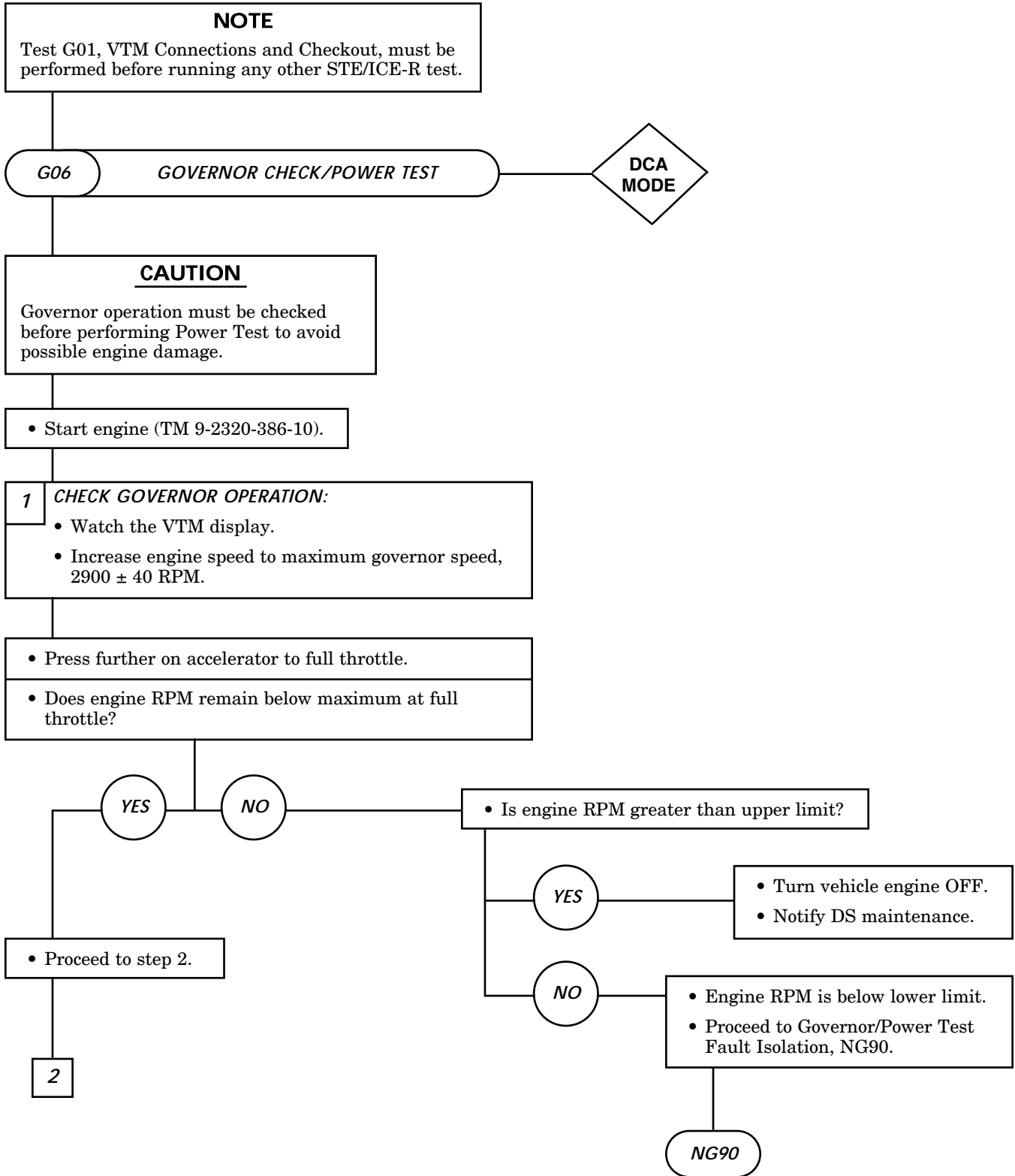

Table 2. STE/ICE-R GO-Chain Tests (Contd)

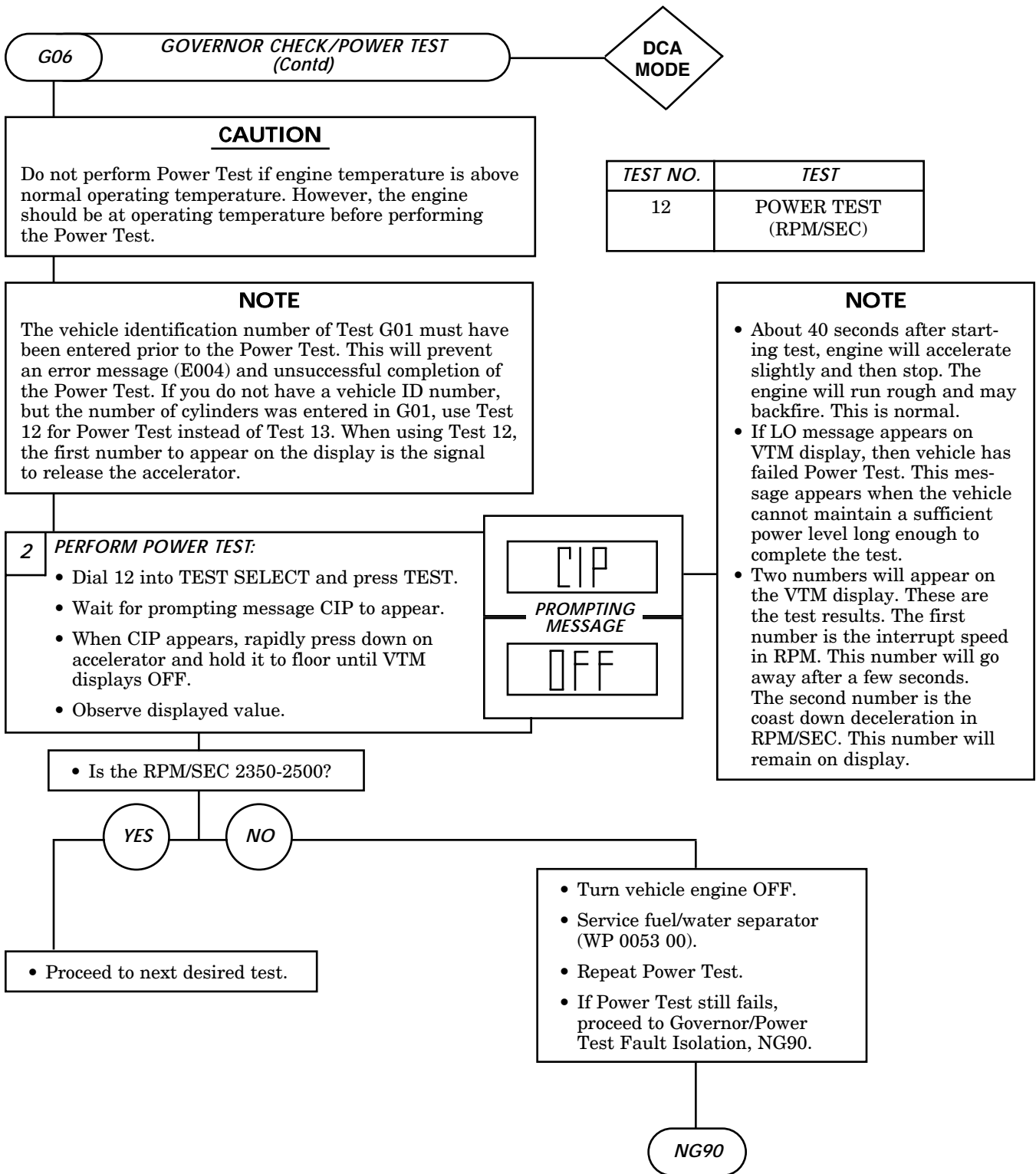

Table 2. STE/ICE-R GO-Chain Tests (Contd)

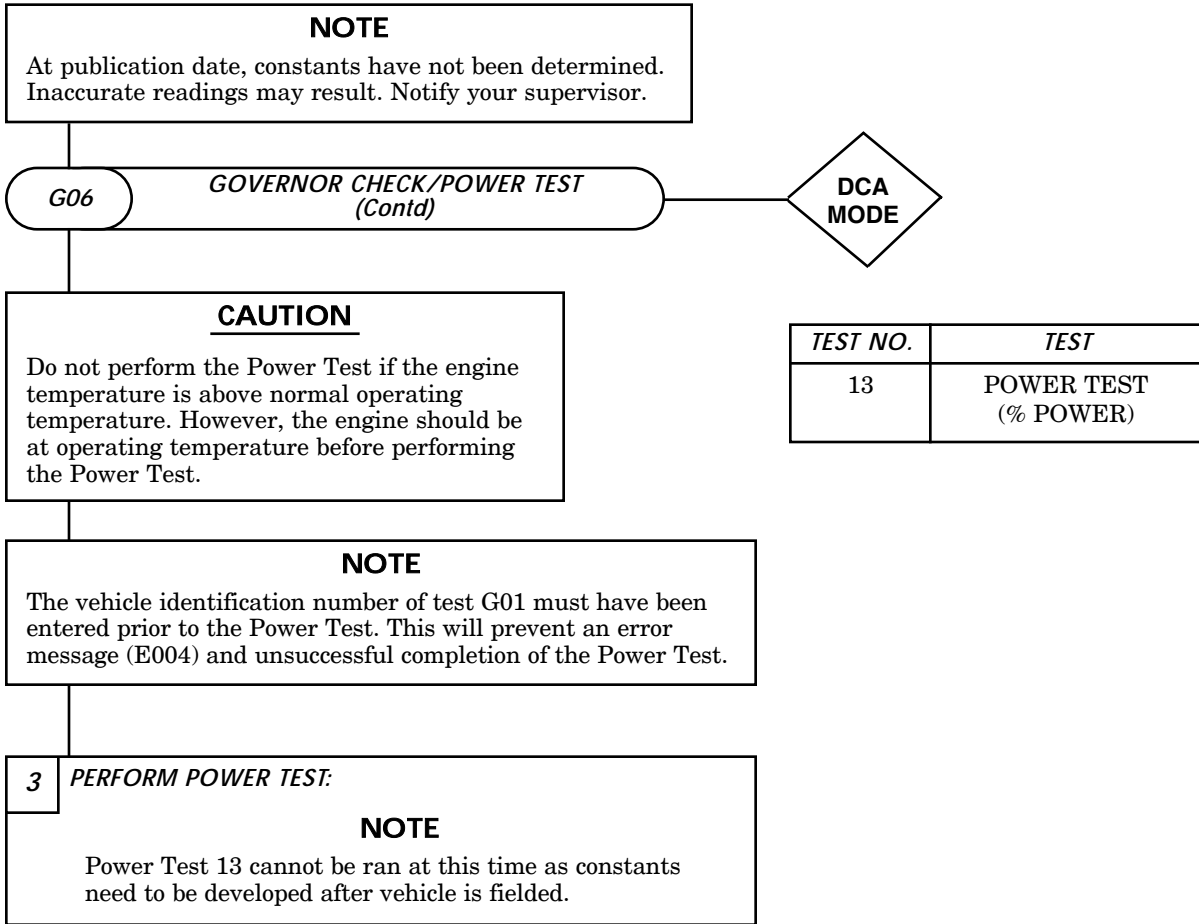

Table 2. STE/ICE-R GO-Chain Tests (Contd)

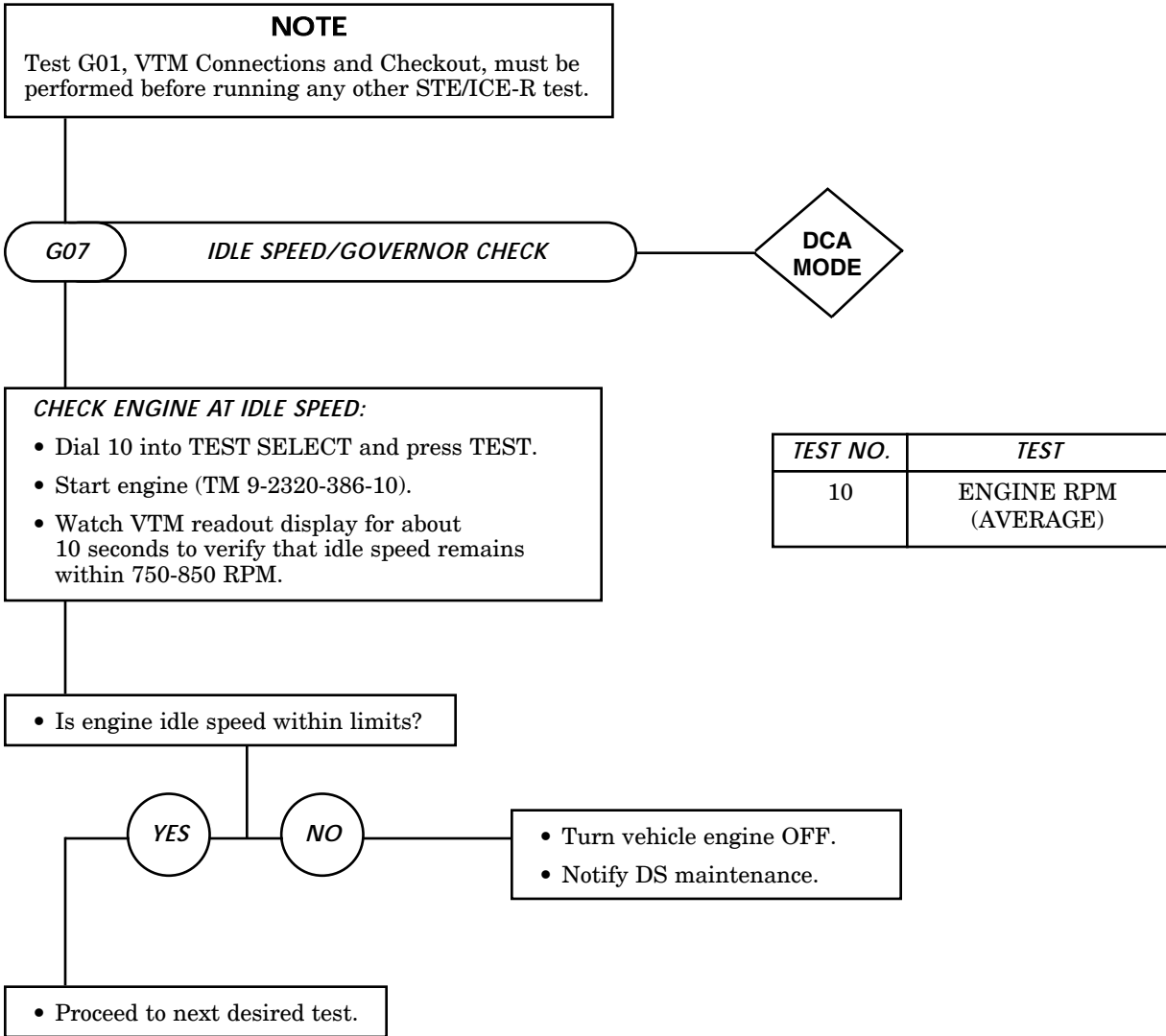
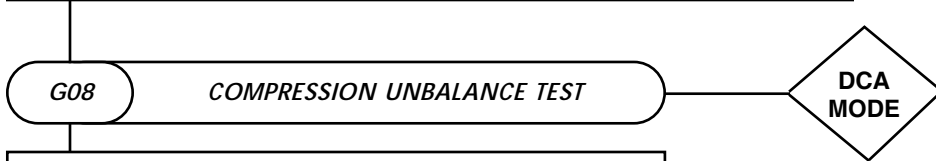

Table 2. STE/ICE-R GO-Chain Tests (Contd)

NOTE

- Test G01, VTM Connections and Checkout, must be performed before running any other STE/ICE-R test.
- At publication date, constants have not been determined. Inaccurate readings may result. Notify your supervisor.



CAUTION

Do not perform more than two Compression Unbalance Tests in a row, or vehicle batteries may be discharged. Engine must be at normal operating temperature before performing Compression Unbalance Test.

TEST NO.	TEST
14	COMPRESSION UNBALANCE (POWER CABLE)

NOTE

The Compression Unbalance Test takes approximately 15 seconds to run.

RUN COMPRESSION UNBALANCE TEST:

NOTE

Compression Balance Test 14 cannot be ran at this time as constants need to be developed after vehicle is fielded.

- The Compression Unbalance Test limit is 0-10%.

- Is the compression unbalance within limits?



- Rerun Compression Unbalance Test.
- If unbalance is still out of limits, notify DS maintenance.

- End of GO-Chain testing.

END OF WORK PACKAGE

UNIT TROUBLESHOOTING PROCEDURES

EXTENDED SERVICE PROGRAM (ESP)

TRUCK, CARGO, 2-1/2-TON, 6X6, M44A3 SERIES TRUCKS (DIESEL)

M35A3, W/O WINCH (NSN 2320-01-383-2047); W/WINCH (NSN 2320-01-383-3850);

M35A3C, W/O WINCH (NSN 2320-01-383-2050); W/WINCH (NSN 2320-01-383-2049);

M36A3, W/O WINCH (NSN 2320-01-383-2048); W/WINCH (NSN 2320-01-383-2046).

STE/ICE-R TROUBLESHOOTING NO-GO CHAIN TESTS

Table 1. Engine No-Go Index, Combined Mode Chain

NO-GO TEST NUMBER	MODE	TEST TITLE	WP NUMBER
NG05	TK	Low Oil Pressure Check	0017 00-2
NG20	DCA	No Crank - No Start	0017 00-3
NG30	DCA	Engine Crank - No Start	0017 00-4
NG31	DCA	Gauge Test	0017 00-8
NG50	DCA	Charging Circuit Tests	0017 00-10
NG80	DCA	Starter Circuit Tests	0017 00-12
NG81	DCA	Battery Tests	0017 00-16
NG90	DCA	Governor/Power Test Fault Isolation	0017 00-18

Table 2. STE/ICE-R NO-GO-Chain Tests

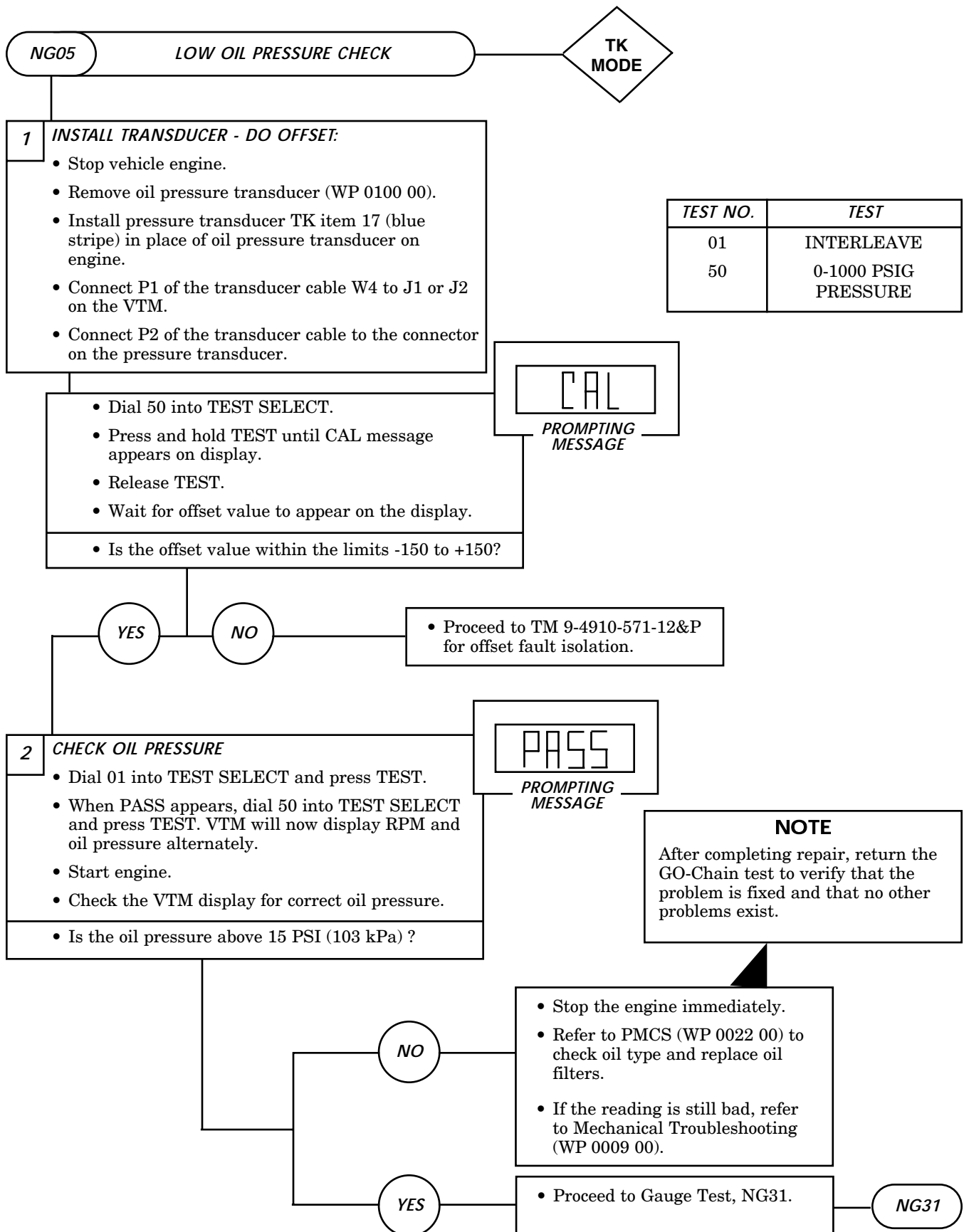

Table 2. STE/ICE-R NO-GO-Chain Test (Contd)

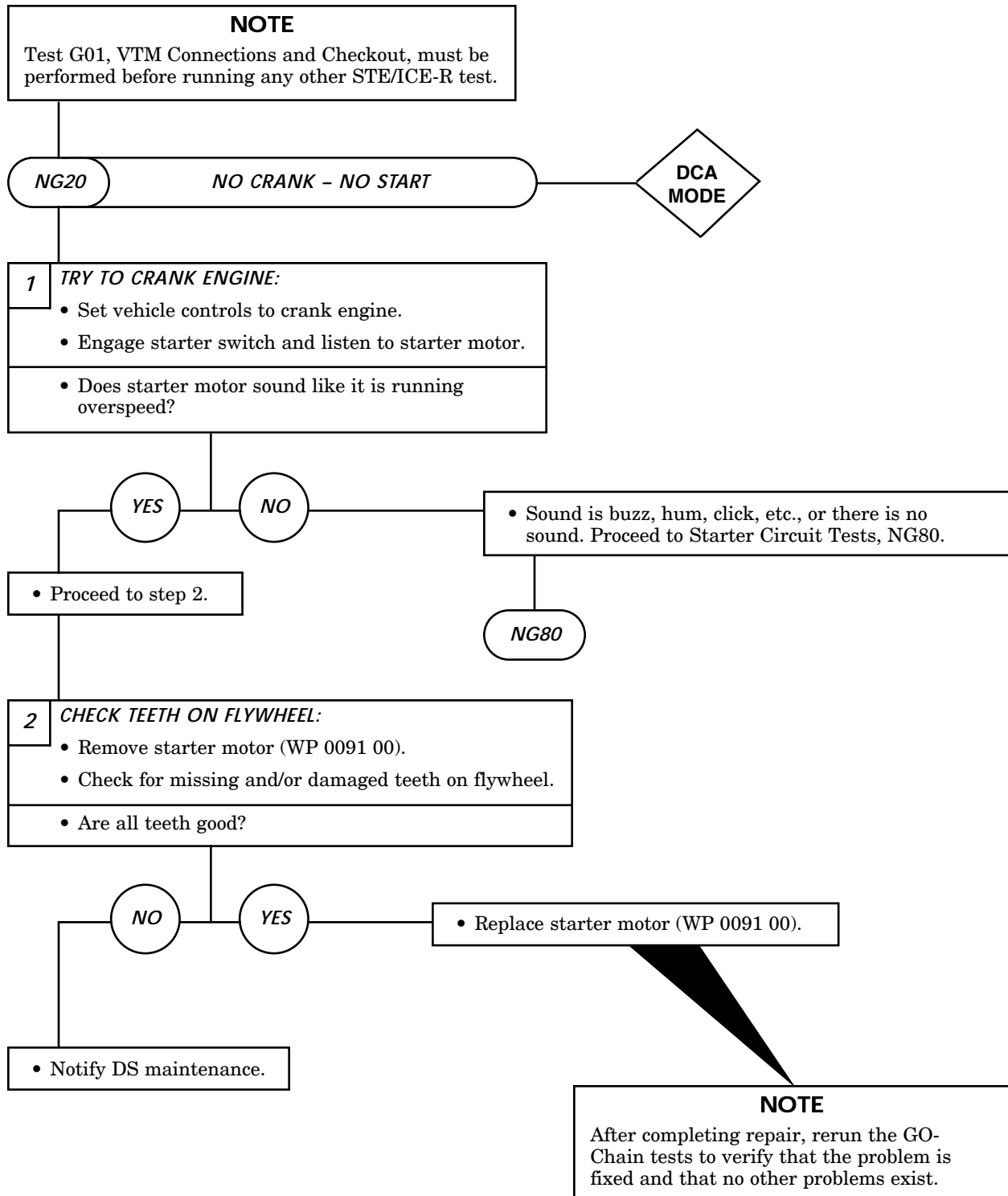

Table 2. STE/ICE-R NO-GO-Chain Tests (Contd)

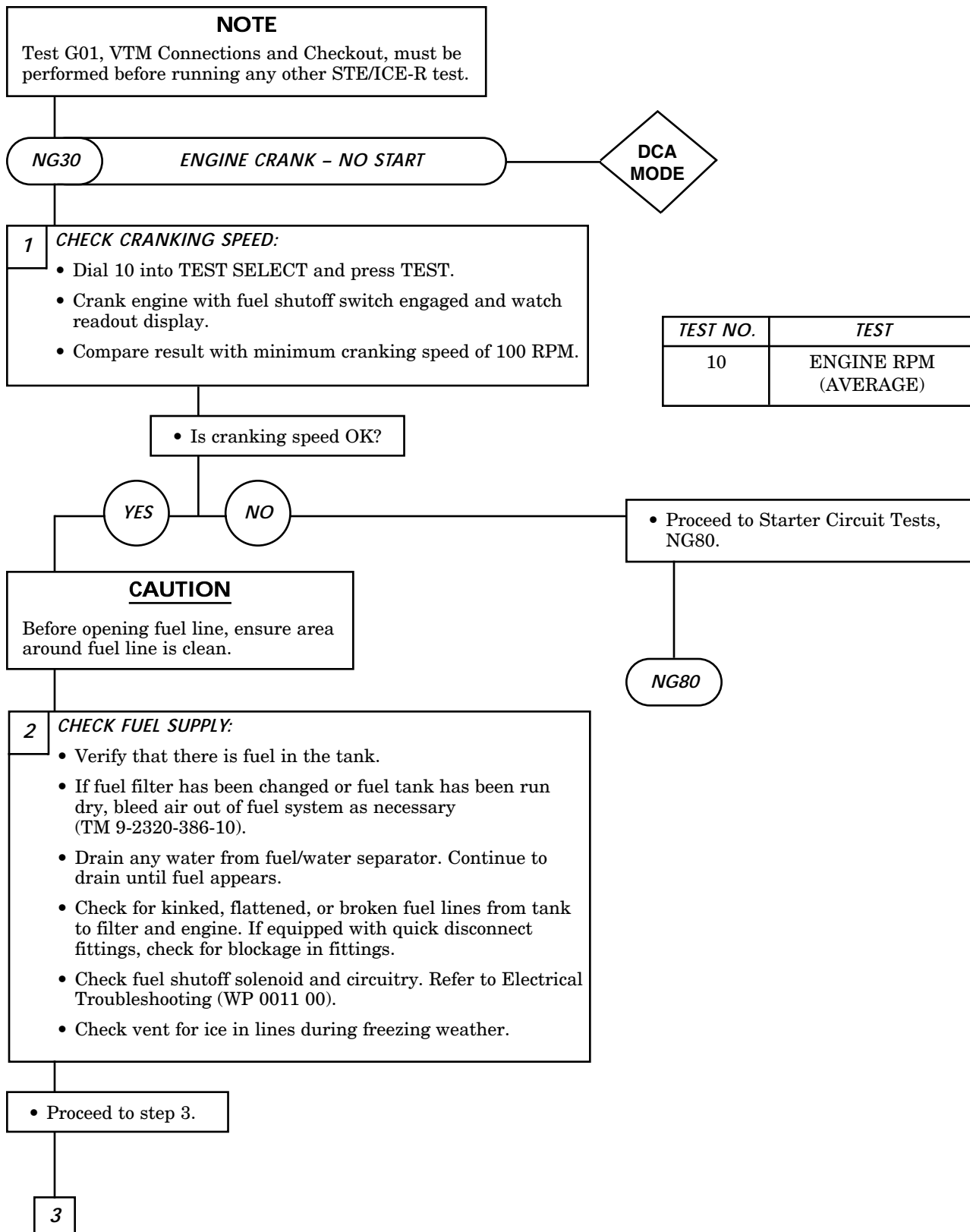

Table 2. STE/ICE-R NO-GO-Chain Tests (Contd)

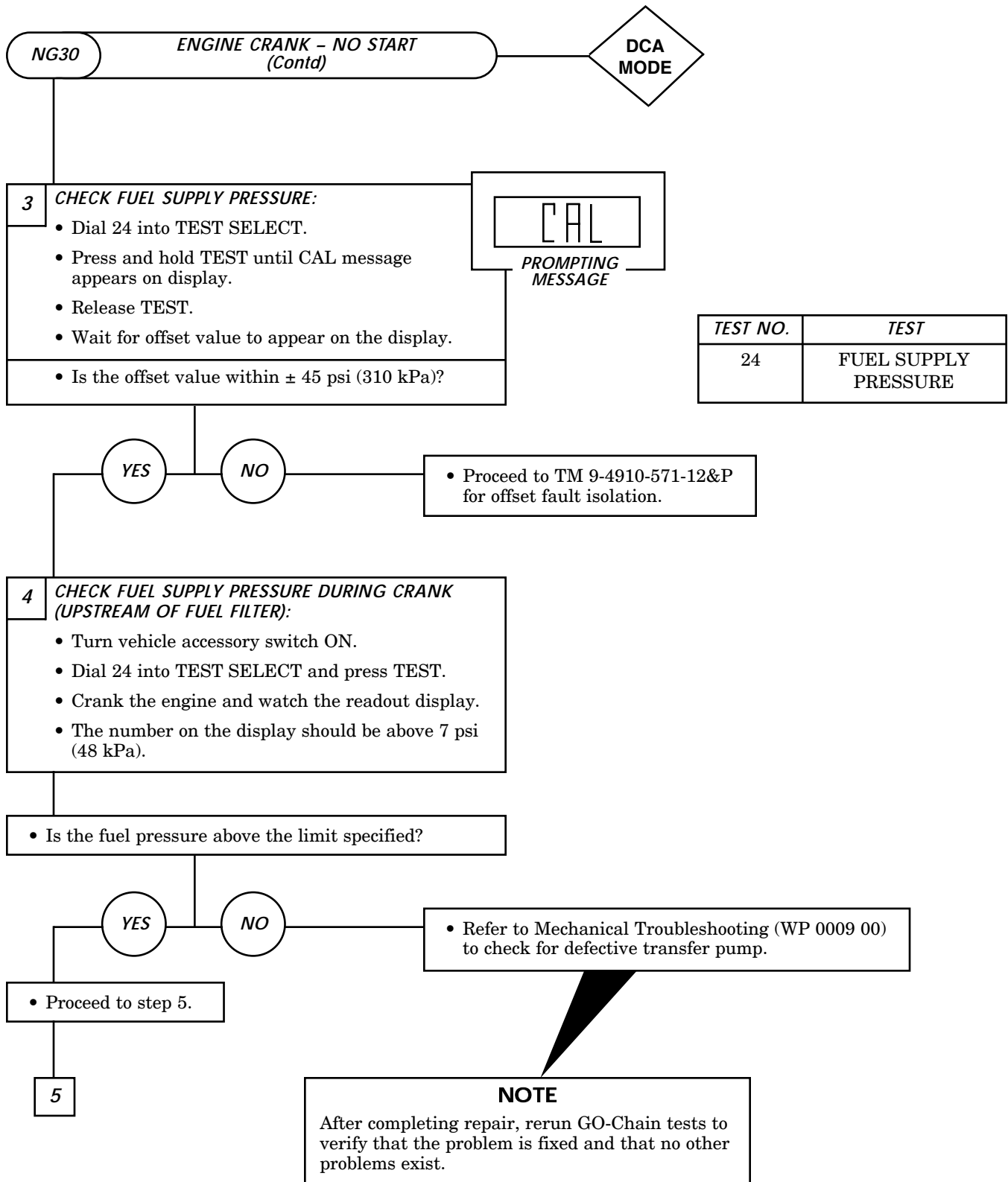

Table 2. STE/ICE-R NO-GO-Chain Tests (Contd)

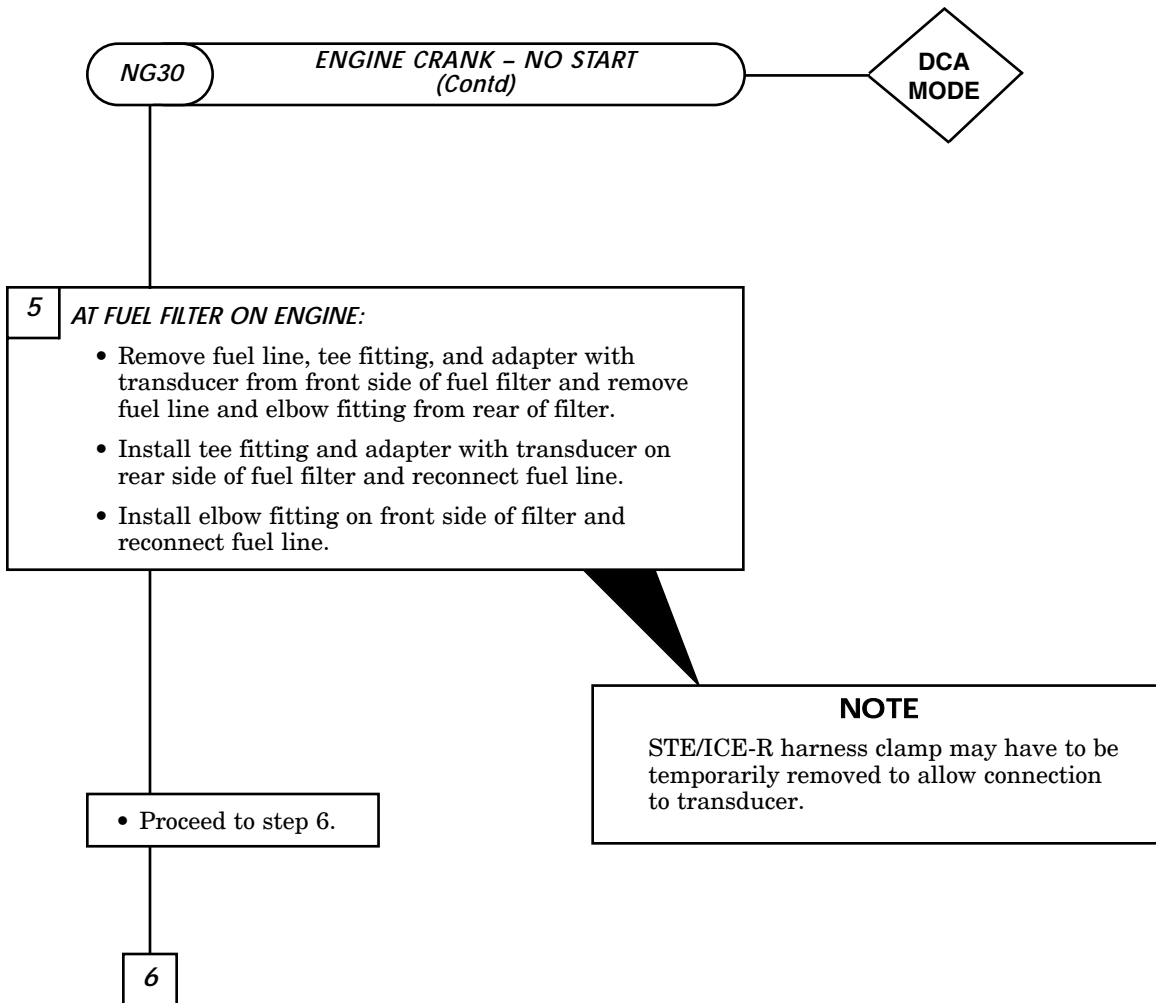

Table 2. STE/ICE-R NO-GO-Chain Tests (Contd)

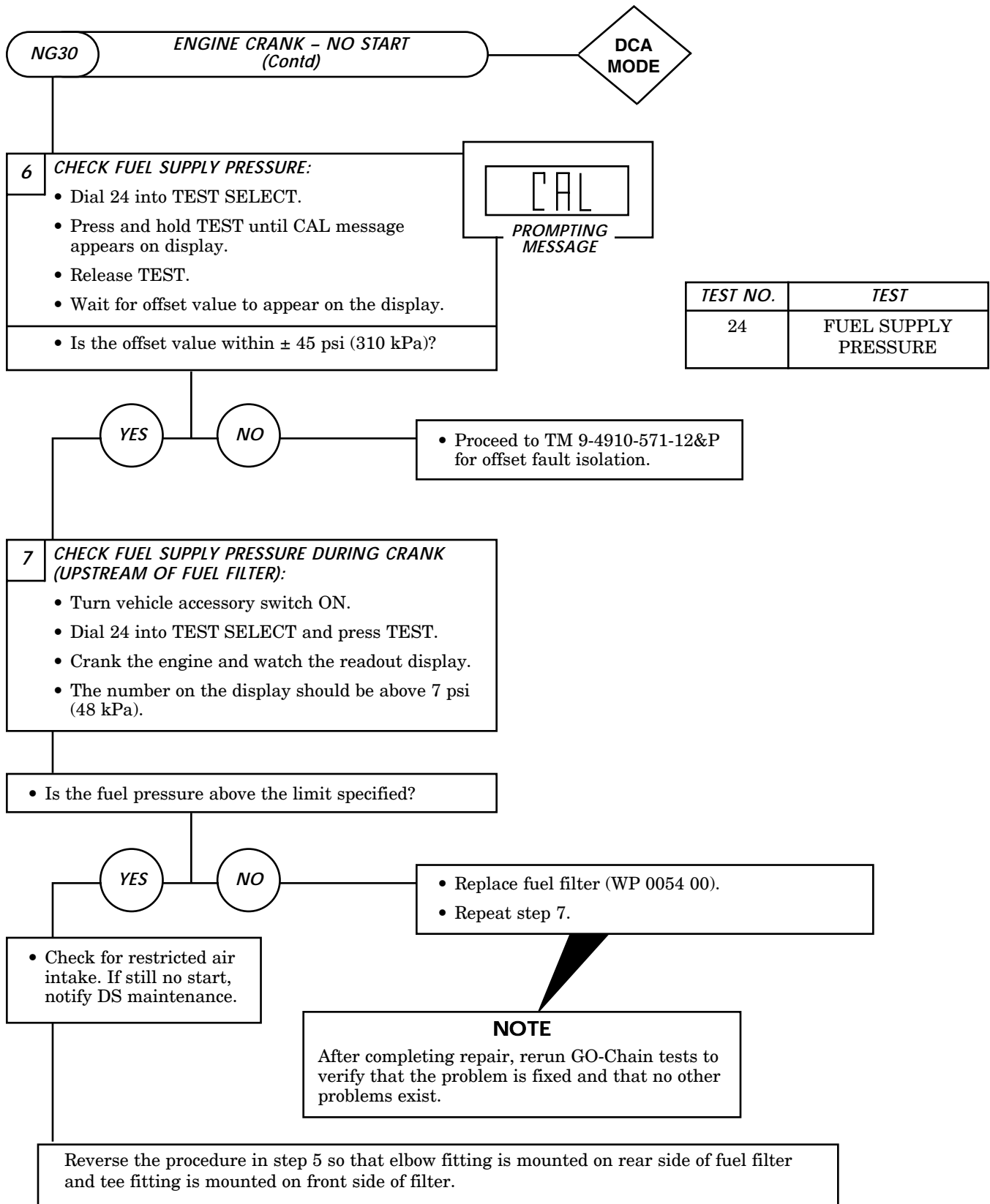

Table 2. STE/ICE-R NO-GO-Chain Tests (Contd)

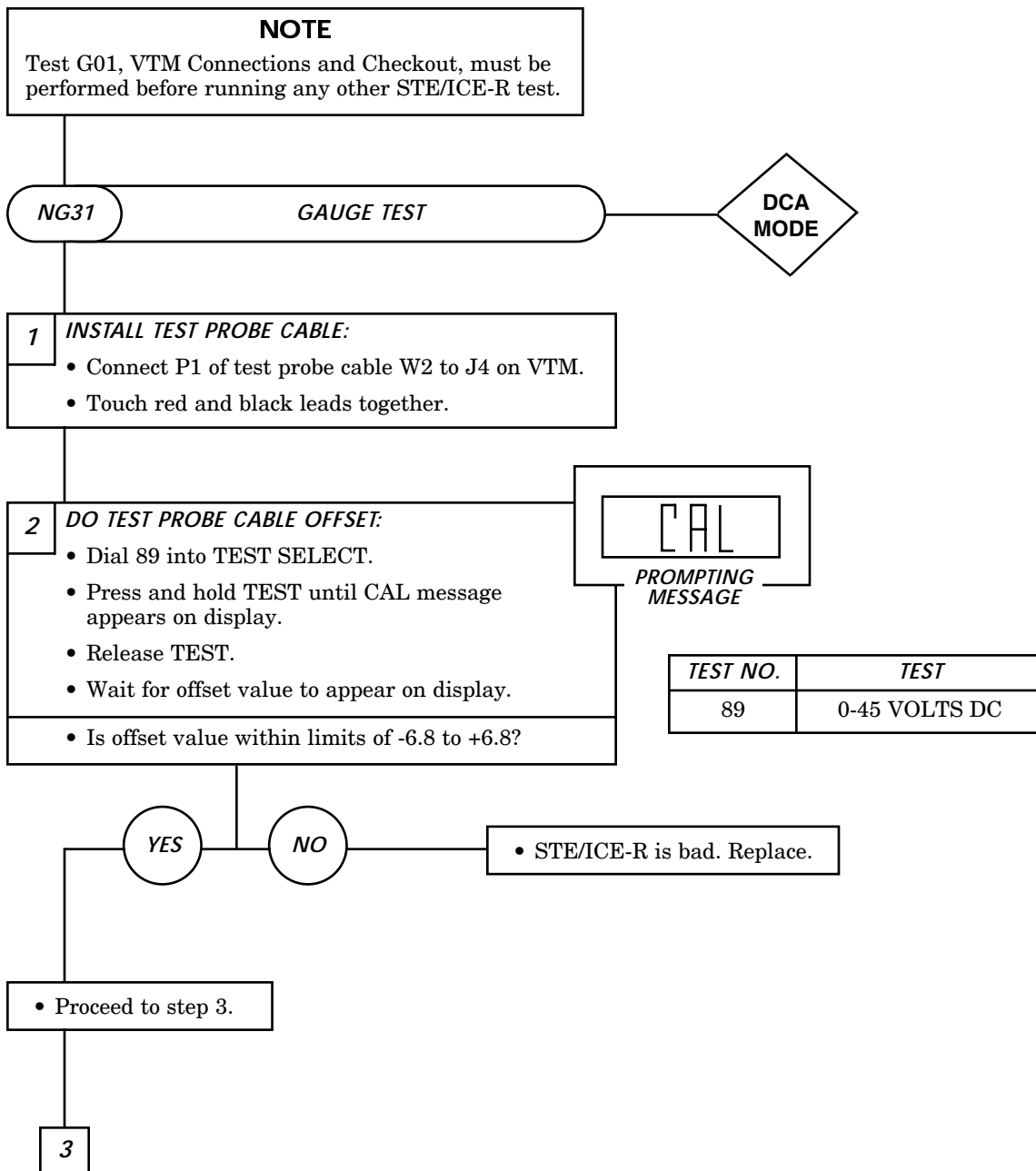

Table 2. STE/ICE-R NO-GO-Chain Tests (Contd)

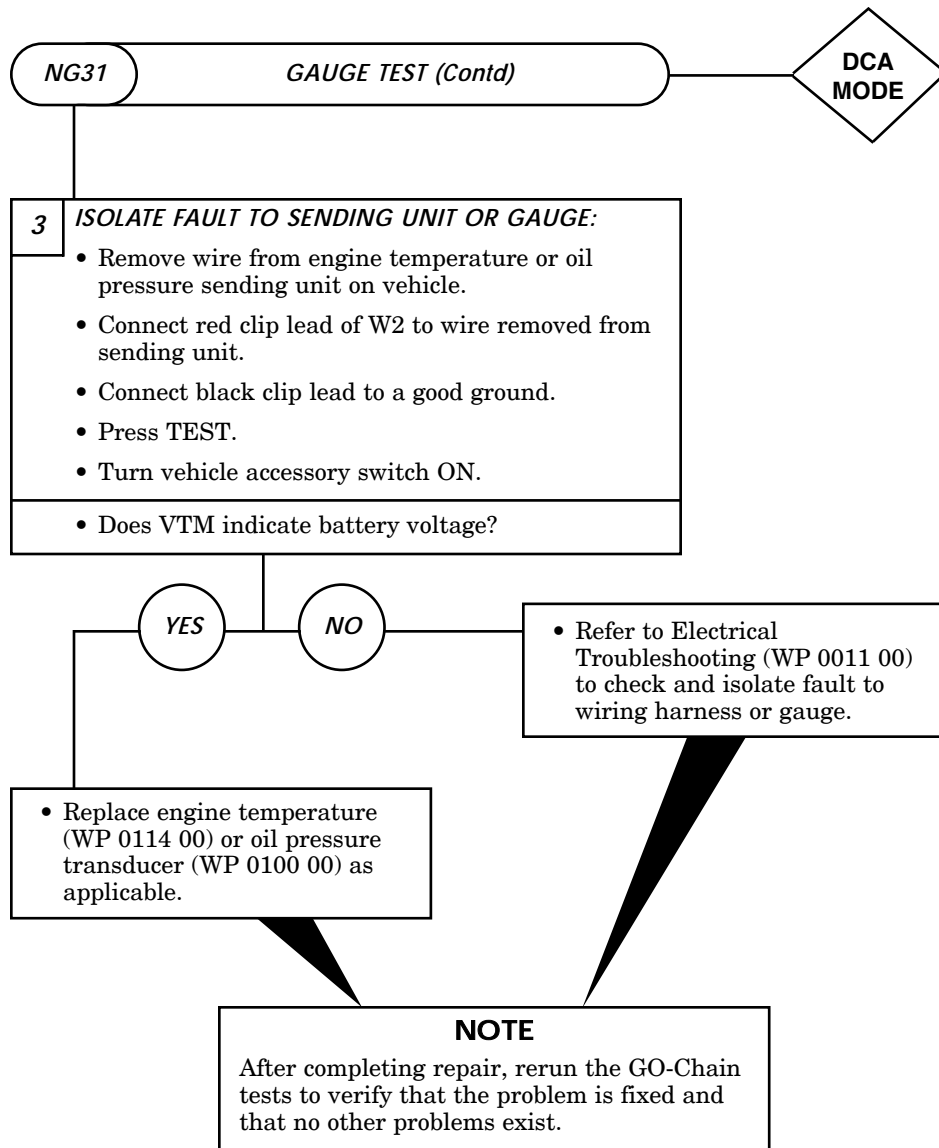

Table 2. STE/ICE-R NO-GO-Chain Tests (Contd)

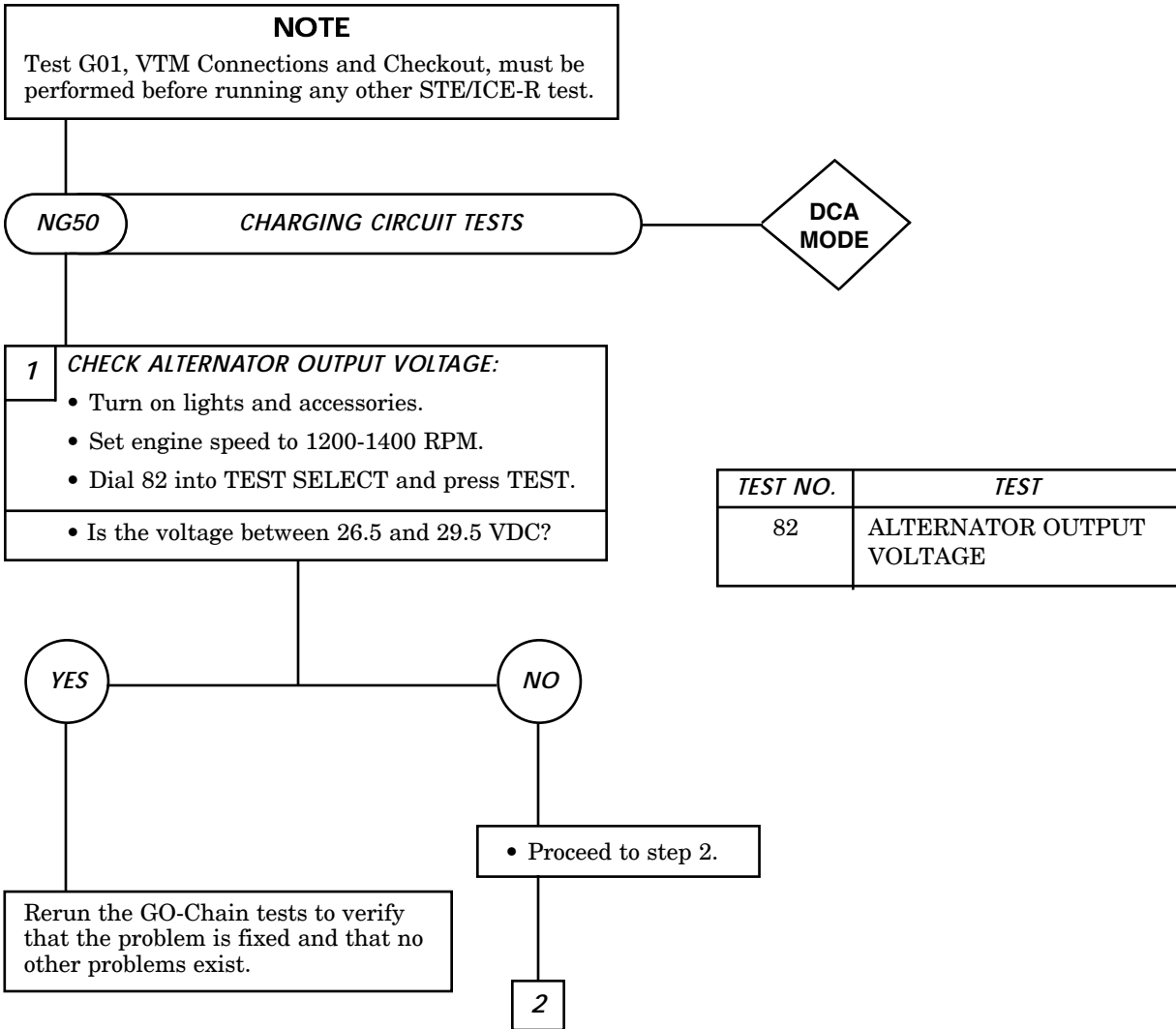

Table 2. STE/ICE-R NO-GO-Chain Tests (Contd)

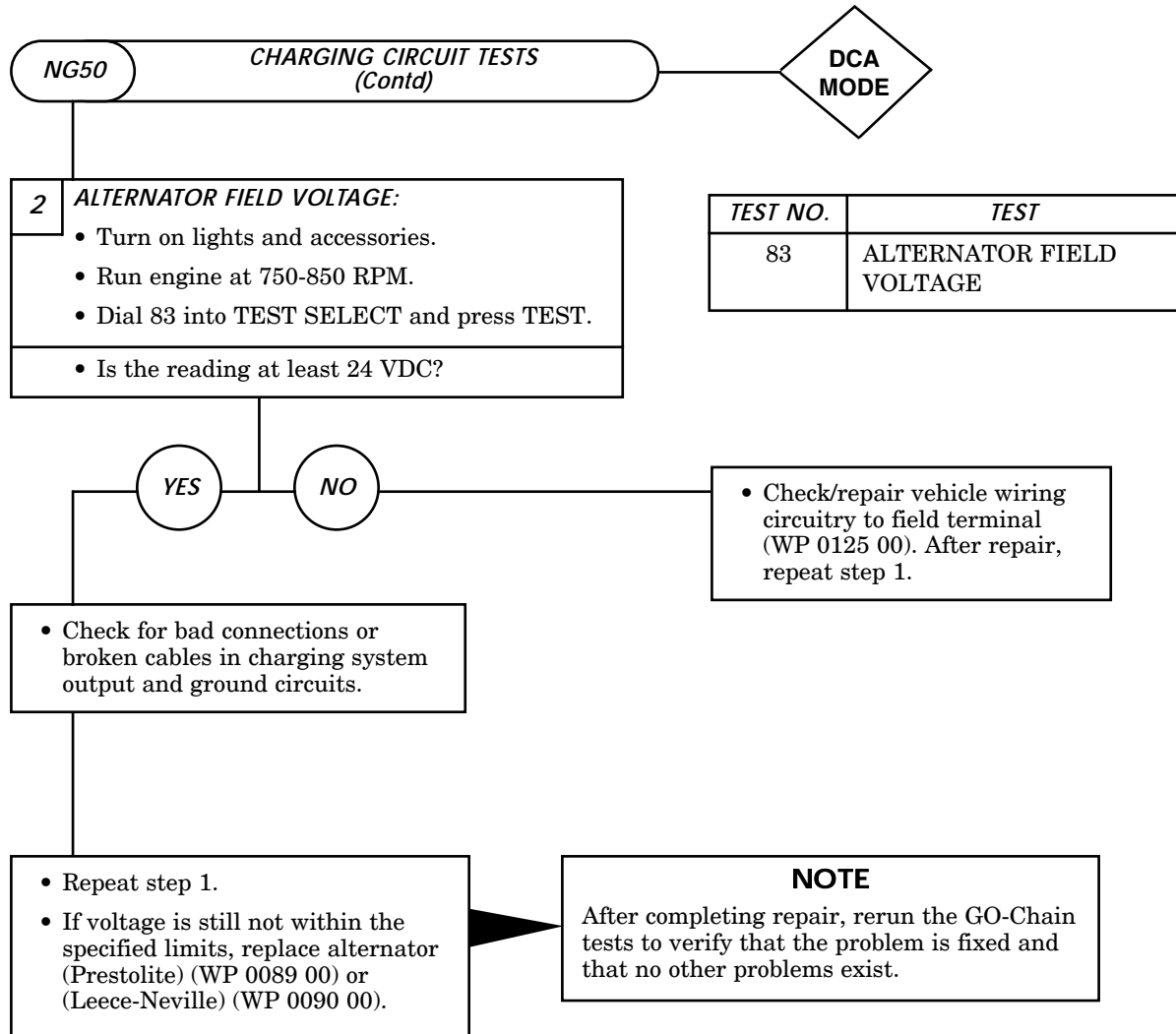
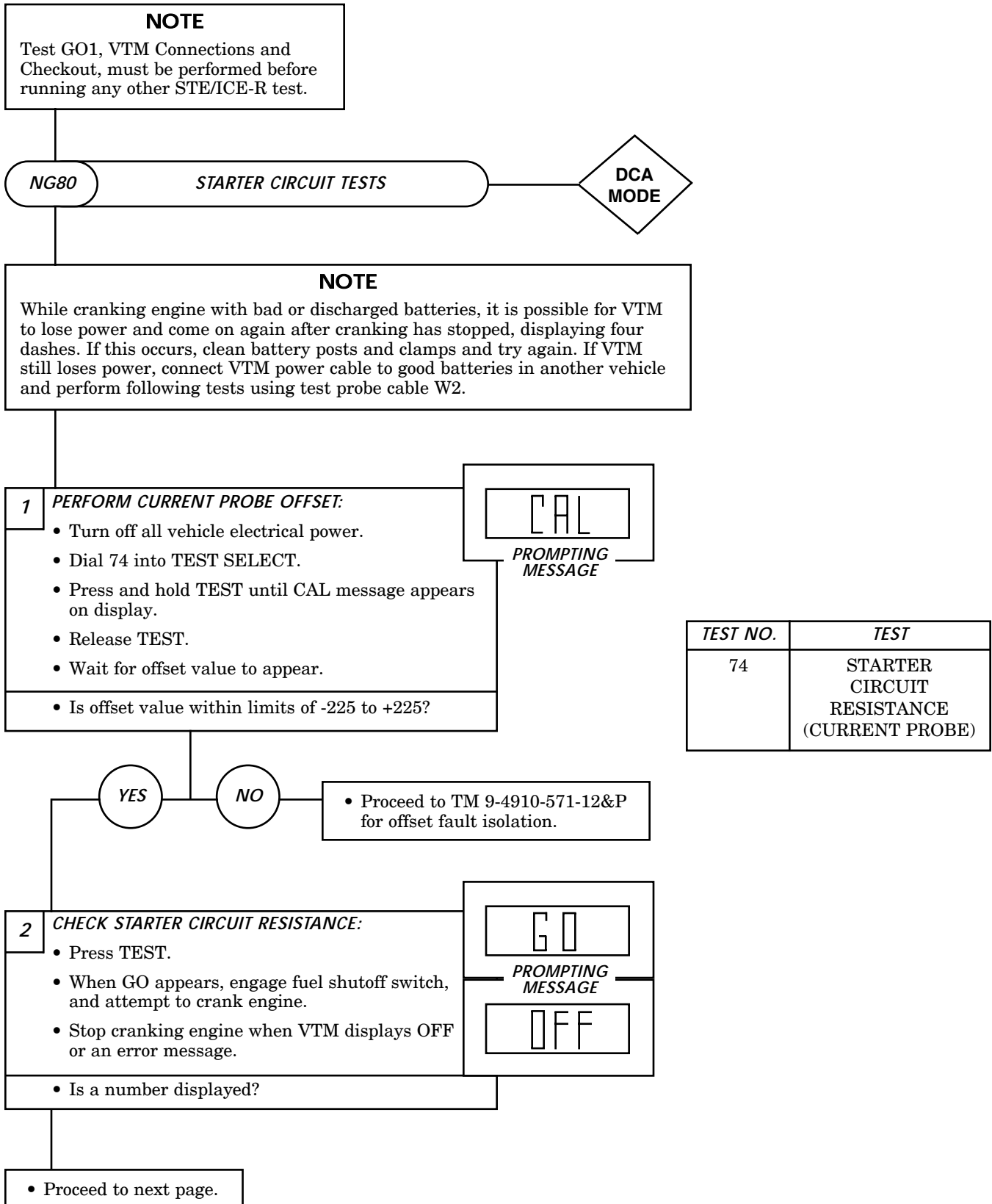

Table 2. STE/ICE-R NO-GO-Chain Tests (Contd)



TEST NO.	TEST
74	STARTER CIRCUIT RESISTANCE (CURRENT PROBE)

Table 2. STE/ICE-R NO-GO-Chain Tests (Contd)

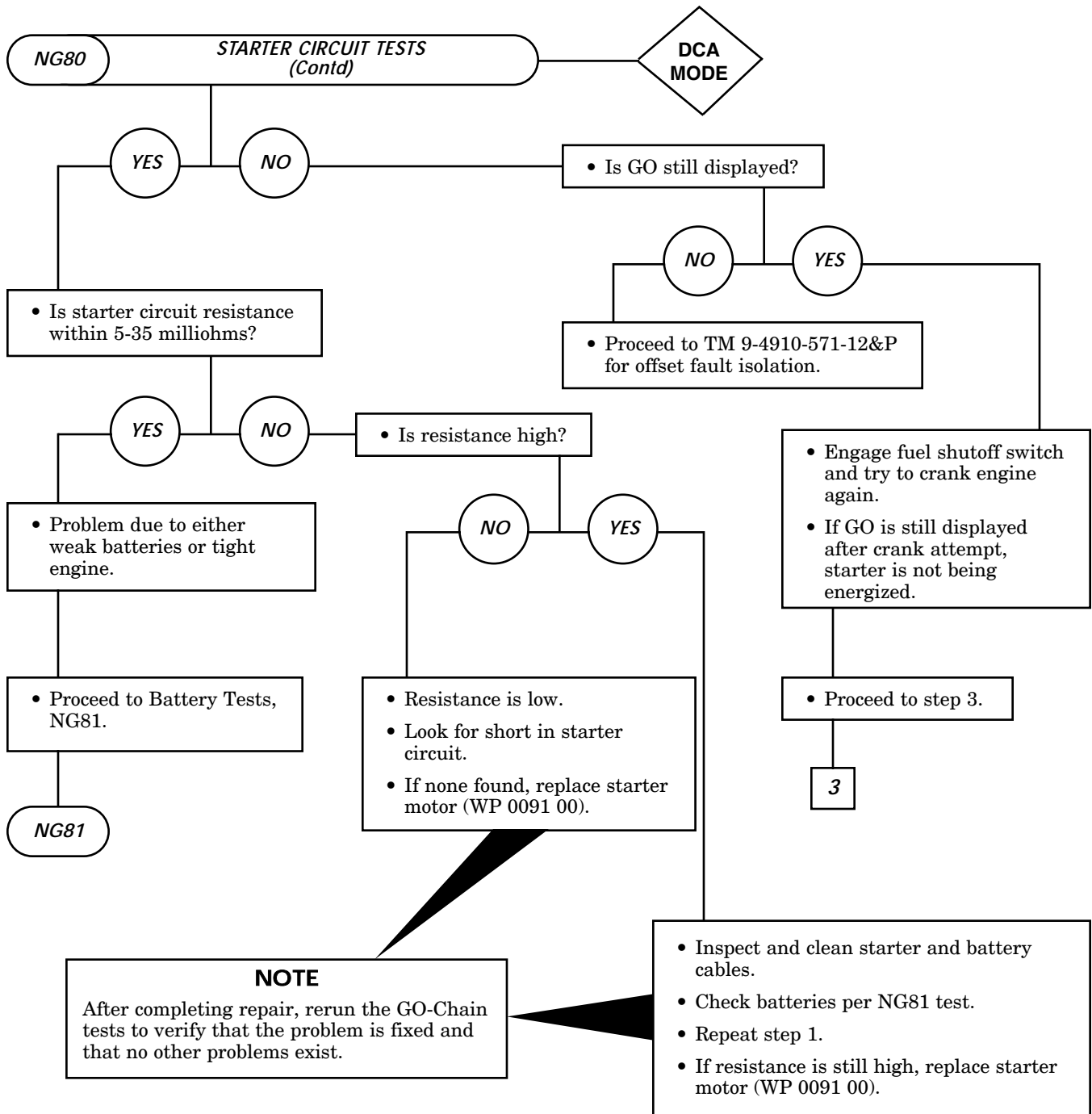

Table 2. STE/ICE-R NO-GO-Chain Tests (Contd)

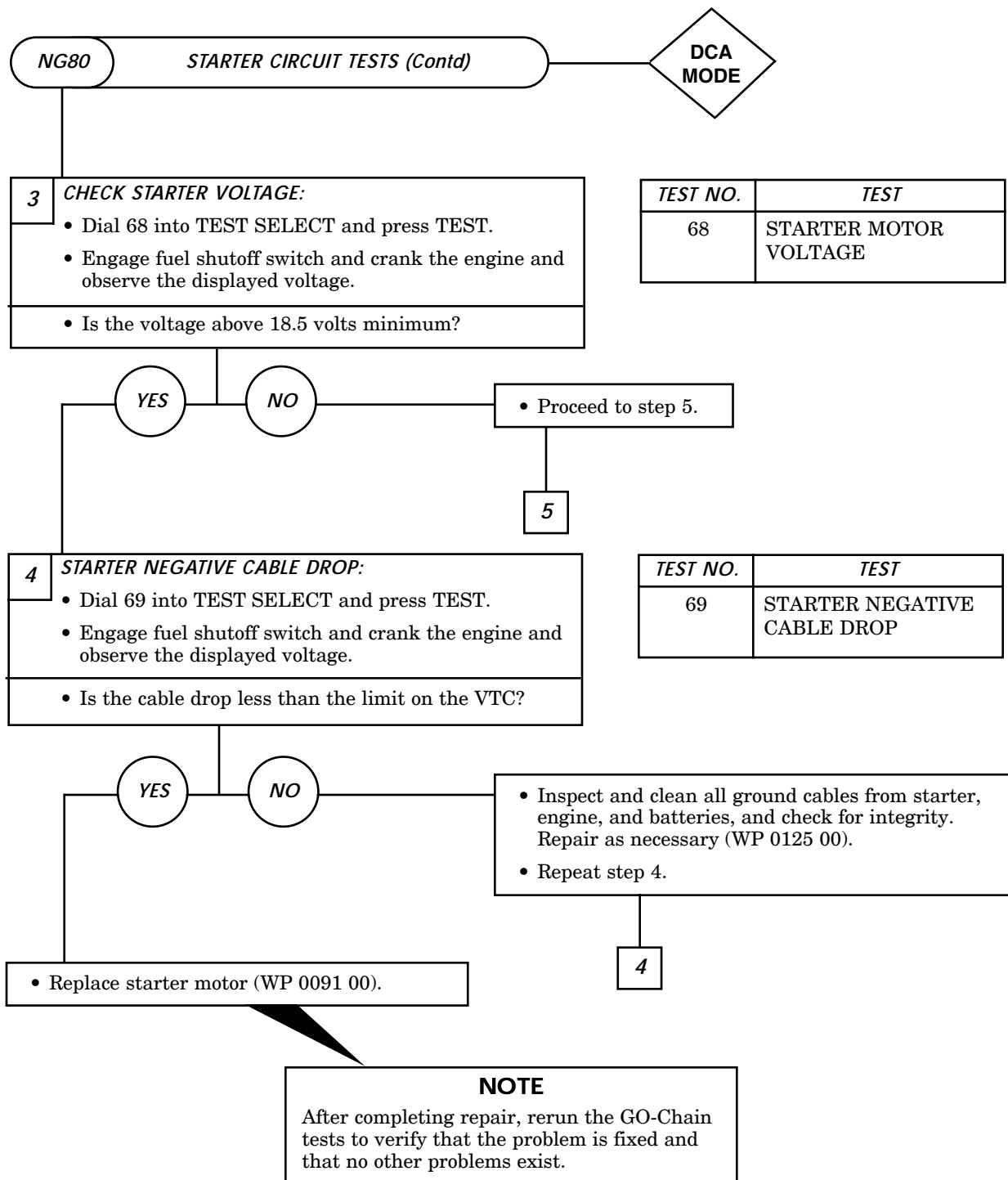

Table 2. STE/ICE-R NO-GO-Chain Tests (Contd)

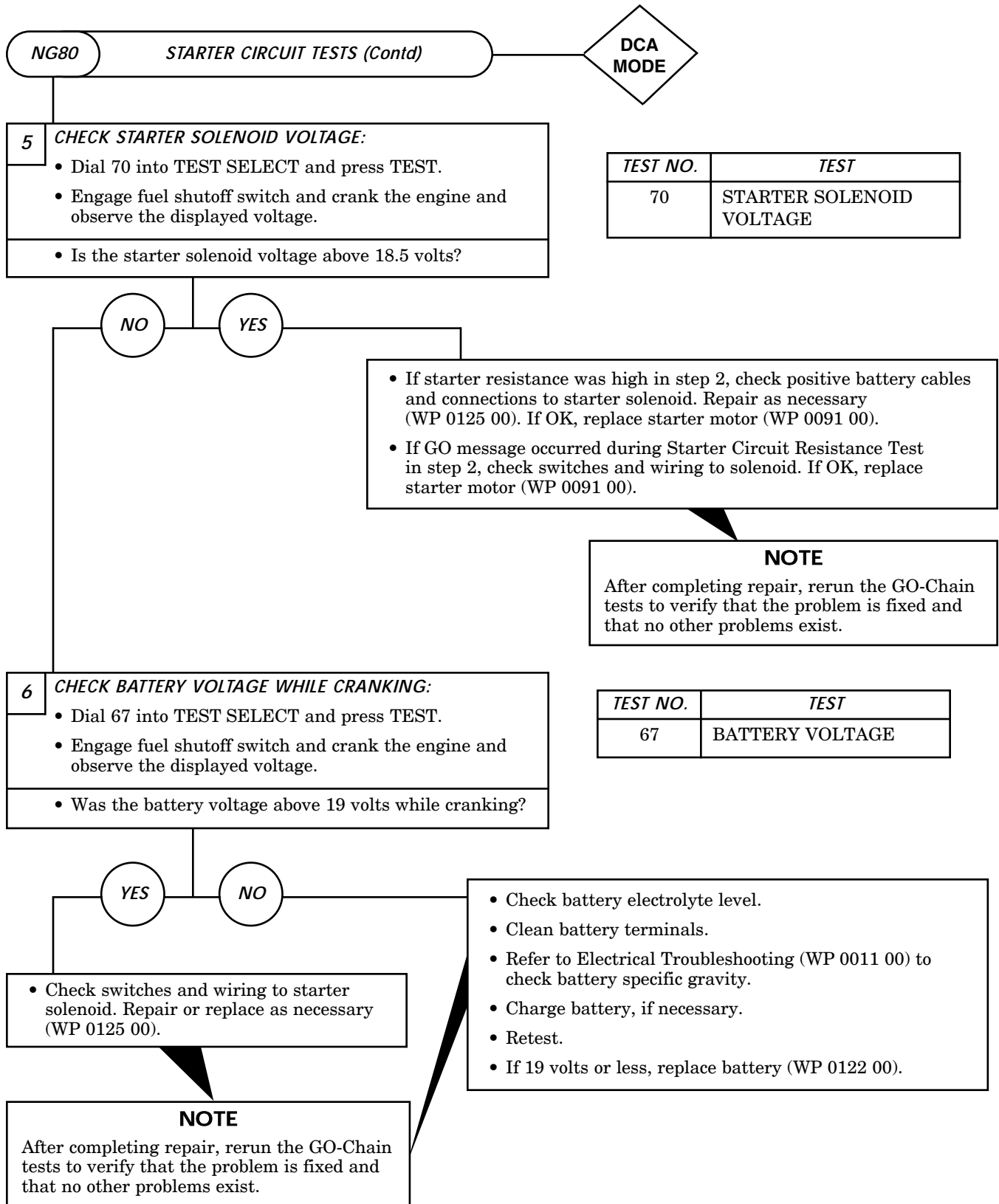

Table 2. STE/ICE-R NO-GO-Chain Tests (Contd)

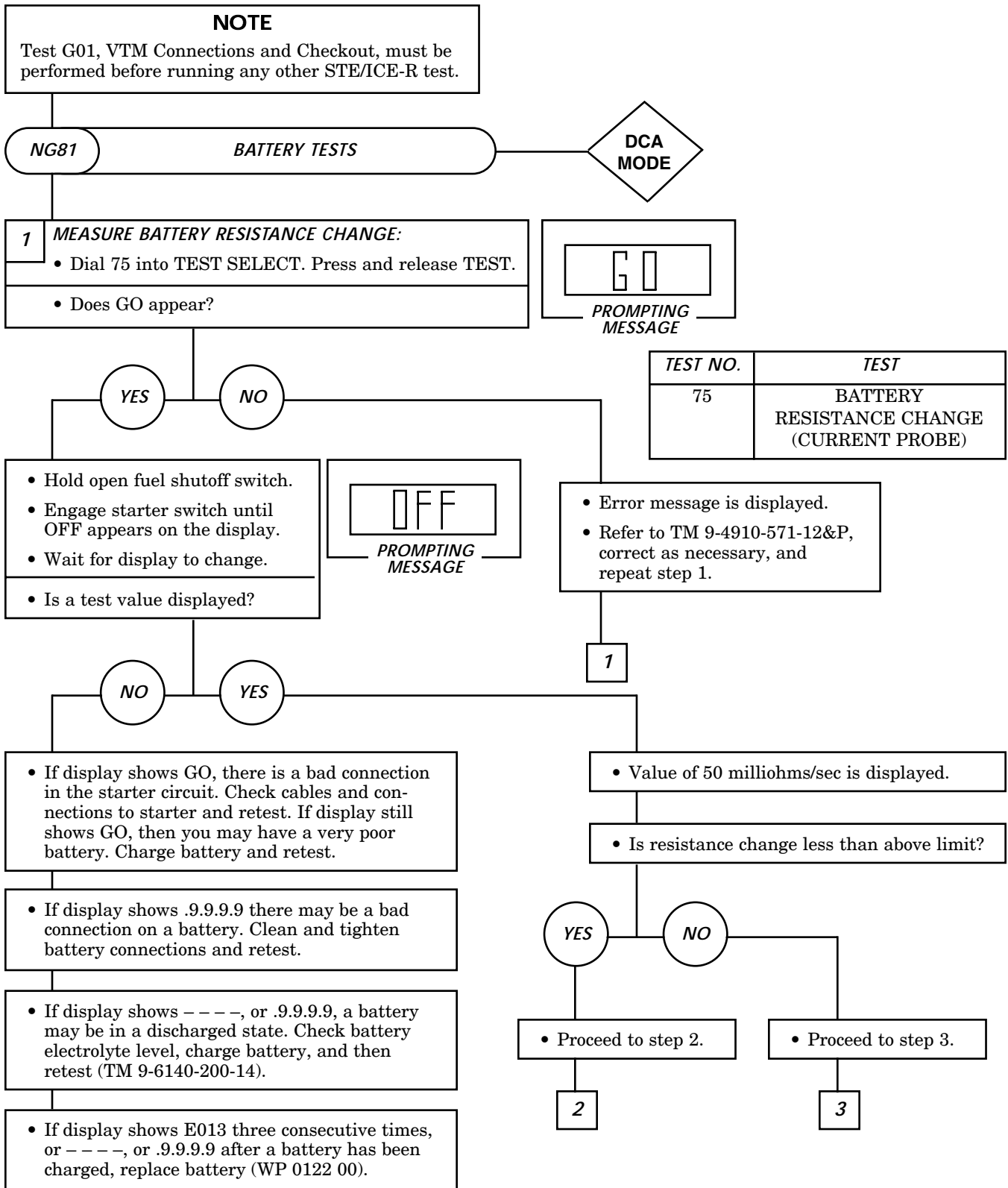

Table 2. STE/ICE-R NO-GO-Chain Tests (Contd)

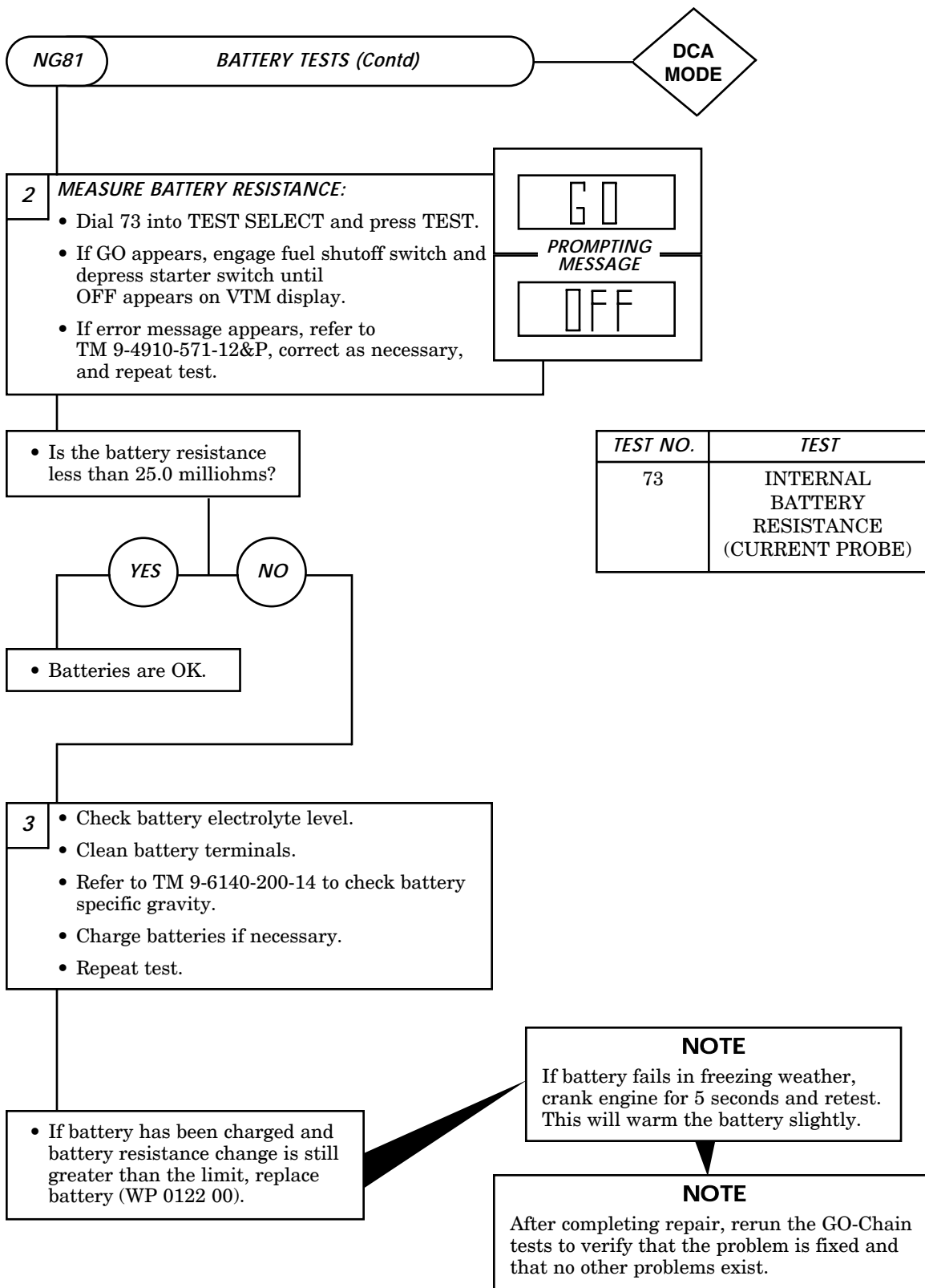

Table 2. STE/ICE-R NO-GO-Chain Tests (Contd)

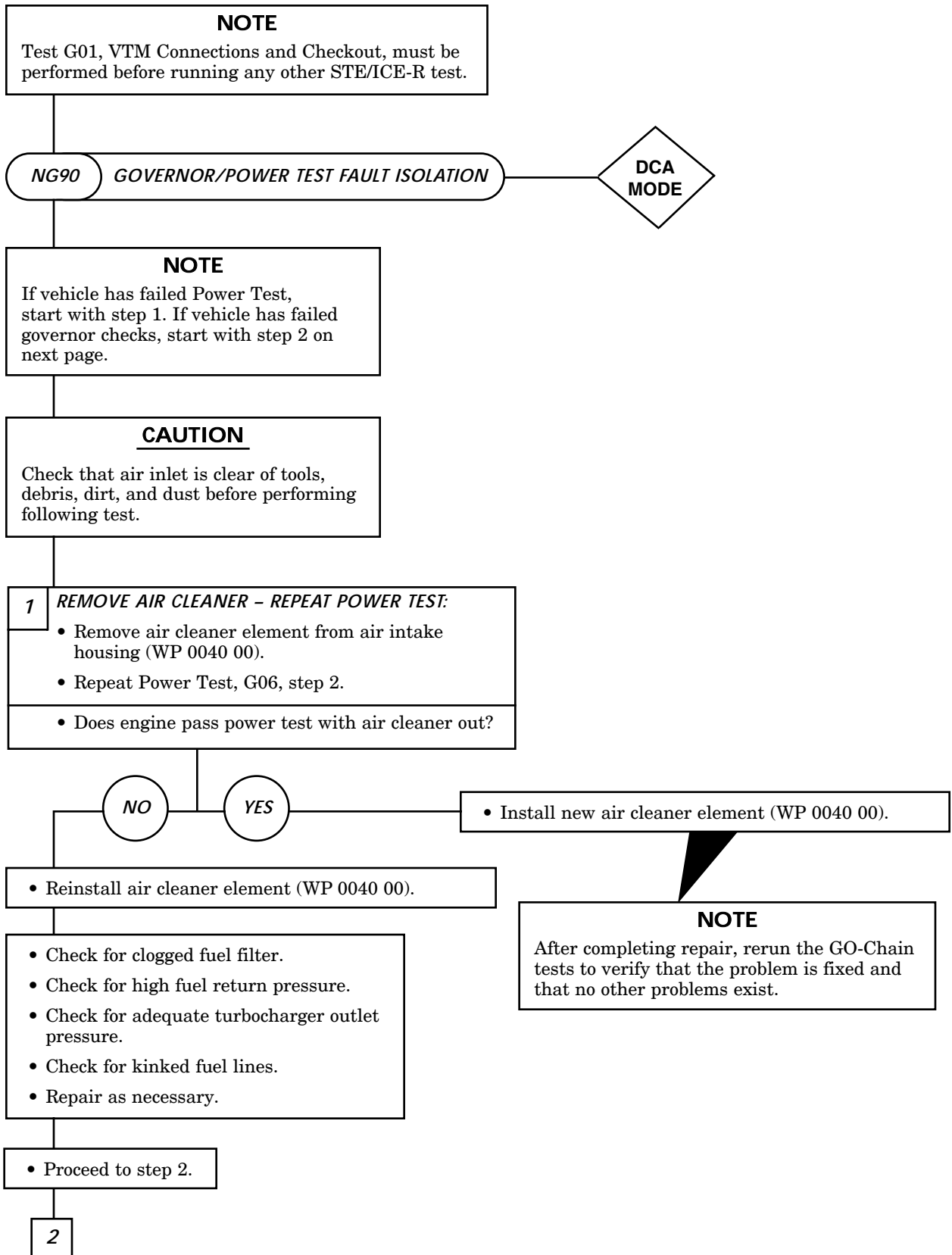
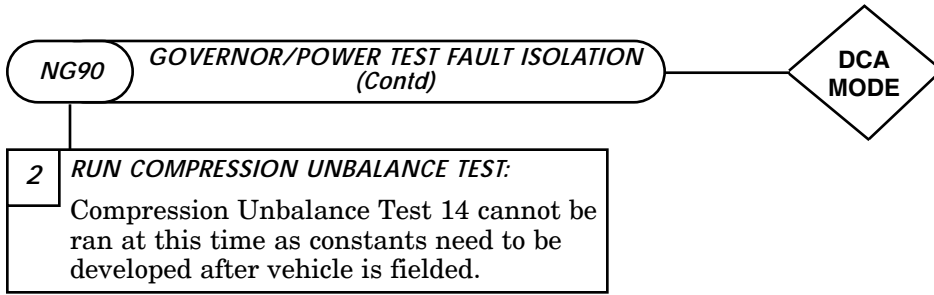

Table 2. STE/ICE-R NO-GO-Chain Tests (Contd)



END OF WORK PACKAGE

UNIT TROUBLESHOOTING PROCEDURES

EXTENDED SERVICE PROGRAM (ESP)

TRUCK, CARGO, 2-1/2-TON, 6X6, M44A3 SERIES TRUCKS (DIESEL)

M35A3, W/O WINCH (NSN 2320-01-383-2047); W/WINCH (NSN 2320-01-383-3850);

M35A3C, W/O WINCH (NSN 2320-01-383-2050); W/WINCH (NSN 2320-01-383-2049);

M36A3, W/O WINCH (NSN 2320-01-383-2048); W/WINCH (NSN 2320-01-383-2046).

CTIS TROUBLESHOOTING SYMPTOM INDEX

<i>MALFUNCTION NO.</i>	<i>MALFUNCTION</i>	<i>TROUBLESHOOTING WP-PAGE</i>
1.	CTIS will not inflate or deflate	0019 00-1
2.	Tire(s) will not maintain selected pressure	0019 00-2
3.	CTIS inflates tire(s) slowly	0019 00-3
4.	Tire(s) will not deflate	0019 00-4
5.	Overspeed signal generator/LCD backlight/LCD heater not working	0019 00-5
6.	ECU fails to operate	0019 00-5
7.	CTIS overinflates tire(s)	0019 00-5

END OF WORK PACKAGE

UNIT TROUBLESHOOTING PROCEDURES

EXTENDED SERVICE PROGRAM (ESP)

TRUCK, CARGO, 2-1/2-TON, 6X6, M44A3 SERIES TRUCKS (DIESEL)

M35A3, W/O WINCH (NSN 2320-01-383-2047); W/WINCH (NSN 2320-01-383-3850);

M35A3C, W/O WINCH (NSN 2320-01-383-2050); W/WINCH (NSN 2320-01-383-2049);

M36A3, W/O WINCH (NSN 2320-01-383-2048); W/WINCH (NSN 2320-01-383-2046).

CTIS TROUBLESHOOTING

a. This work package provides the information needed to diagnose and correct malfunctions of the CTIS. CTIS is used primarily with the vehicle compressed air system. If a particular malfunction is not covered, refer to Mechanical Troubleshooting (WP 0009 00), and locate the troubleshooting procedure for the malfunction observed. To obtain the maximum number of observed symptoms of the malfunction, question the operator.

b. Listed are CTIS malfunctions that may occur in the vehicle. The CTIS air system schematic found in WP 0386 00 is to be used as a reference when performing CTIS troubleshooting procedures. To find a specific malfunction, refer to the symptom index (WP 0018 00).

CTIS Troubleshooting

MALFUNCTION
TEST OR INSPECTION
CORRECTIVE ACTION

1. CTIS WILL NOT INFLATE OR DEFLATE

WARNING

Eyeshields must be worn when releasing compressed air. Failure to do this may result in injury to personnel.

Do not disconnect air lines before draining air reservoirs. Small parts under pressure may shoot out with high velocity, causing injury to personnel.

NOTE

If tire pressure falls below 10 psi (69 kPa), CTIS will not inflate tire.

- Step 1. If ECU is not operating, see malfunction 6.
- Step 2. Check compressed air system (WP 0013 00).

NOTE

If compressed air system falls below 75 psi (517 kPa), the priority pressure switch will shut off air supply to CTIS.

Test 1. Perform electrical inspection/continuity check.

- Step 1. Disconnect large pin 10 plug from ECU.
- Step 2. Turn ignition ON.
- Step 3. Using multimeter, measure the voltage from pin 9 to chassis ground. With ignition ON, the reading should be 10-15 volts. If voltage is not present, perform steps 6-12.
- Step 4. Turn ignition OFF. Pin 9 voltage should drop to zero volts.

CTIS Troubleshooting (Contd)

MALFUNCTION TEST OR INSPECTION CORRECTIVE ACTION

Step 5. Reconnect pin 10 control harness to the ECU.

Step 6. Disconnect manifold power harness from manifold.

Step 7. Turn ignition ON.

Step 8. Using multimeter, measure the voltage from manifold power harness lead 27 to ground. With the ignition ON, the voltage should be 24 volts. With the ignition OFF, the voltage should be 0 volts.

Step 9. If the voltage reads 0 volts with the ignition ON, disconnect manifold power harness from rear wiring harness and measure voltage across pins of rear wiring harness.

Step 10. If rear wiring harness has 24 volts present, turn ignition OFF. Notify DS maintenance.

Step 11. If 24 volts is not present on rear wiring harness, test rear wiring harness (WP 0011 00).

Step 12. Turn ignition OFF.

Step 13. Disconnect control harness (pin 10 harness) from ECU and manifold.

NOTE

It is left to the discretion of the technician as to whether the ground lead is to be removed.

The ground lead is part of the harness shield and plays no active part in the system operation.

Pin 5 of the control harness is plugged.

Step 14. Using the multimeter and extra long test leads, measure pin-for-pin continuity (i.e., pin 1 to pin 1, etc.), and measure pin-to-pin continuity (i.e. pin 1 to pin 2, etc.). If shorts or broken wires are detected, notify DS maintenance.

Step 15. If the control harness is good, reconnect control harness to ECU and replace manifold (WP 0282 00).

Step 16 If condition continues, perform malfunction 2, test 1 and malfunction 3, test 1.

END OF TESTING!

2. TIRE(S) WILL NOT MAINTAIN SELECTED PRESSURE

Step 1. Check for punctured or damaged tires. Repair tire(s) (WP 0175 00) or replace tire(s) (WP 0174 00), if damaged.

WARNING

Eyeshields must be worn when releasing compressed air. Failure to do this may result in injury to personnel.

Do not disconnect air lines before draining air reservoirs. Small parts under pressure may shoot out with high velocity, causing injury to personnel.

Step 2. Check wheel valve by disconnecting hub side air tube. Listen for air escaping from wheel valve. Repair wheel valve (WP 0177 00) or replace wheel valve (WP 0176 00) if air is escaping.

Test 1. If condition persists, perform visual leak inspection.

Step 1. Turn ignition OFF.

CTIS Troubleshooting (Contd)

<i>MALFUNCTION</i>
<i>TEST OR INSPECTION</i>
<i>CORRECTIVE ACTION</i>

- Step 2. Remove one air tube from tee at connection on rear axle to produce a large air leak.
- Step 3. Start engine and run at 1500-1700 RPM and select cross-country setting.
- Step 4. When FLAT appears on LCD display, hold cross-country button for three seconds to initiate RUN FLAT mode.
- Step 5. Install air tube on tee connection on rear axle.

NOTE

The display will indicate RUN FLAT ACTIVE and the vehicle air supply will run continuously. The system will attempt to pressurize to the set points, which will hold pressure in the air lines.

- Step 6. Lightly spray air lines and fittings with the liquid leak detector solution. Bubbling indicates leakage. Tighten loose fittings.
- Step 7. Return engine to idle speed and turn ignition OFF after inspection is completed.

END OF TESTING!

3. CTIS INFLATES TIRE(S) SLOWLY

- Step 1. Check for punctured or damaged tires. Repair tire(s) (WP 0175 00) or replace tire(s) (WP 0174 00), if damaged.

WARNING

Eyeshields must be worn when releasing compressed air. Failure to do this may result in injury to personnel.

Do not disconnect air lines before draining air reservoirs. Small parts under pressure may shoot out with high velocity, causing injury to personnel.

- Step 2. Check compressed air system (WP 0013 00).
- Step 3. Replace coalescing filter if oil is observed in wheel valve (WP 0281 00).
- Step 4. Check air flow at outlet end of wheel valve filter. Pressure should be between 13-45 psi (90-310 kPa). Replace wheel valve filter (WP 0176 00), if necessary.
- Step 5. Perform test 3.

CTIS Troubleshooting (Contd)

<p>MALFUNCTION TEST OR INSPECTION CORRECTIVE ACTION</p>

Test 1. Hub pressure test.

- Step 1. Remove two nuts (6), screws (8), lockwashers (7), and wheel cover (1) from wheel (5).
- Step 2. Remove tube and connector elbow (3) from hollow stud (4).
- Step 3. Remove elbow and valve assembly (2) from spare tire (9).
- Step 4. Install elbow and valve assembly (2) on hollow stud (4).
- Step 5. Disconnect air tube (11) from tee (10) at center of axle (12).

CAUTION

Do not damage O-ring inside of tee when plugging tee. Damaged O-ring may cause air leak when reassembling air line.

- Step 6. Plug tee (10).
- Step 7. Using BII air hose, pressurize hub to 50 psi (345 kPa) and observe the air pressure gauge.
- Step 8. If the air pressure drops rapidly, repair hub (WP 0173 00 or WP 0172 00).

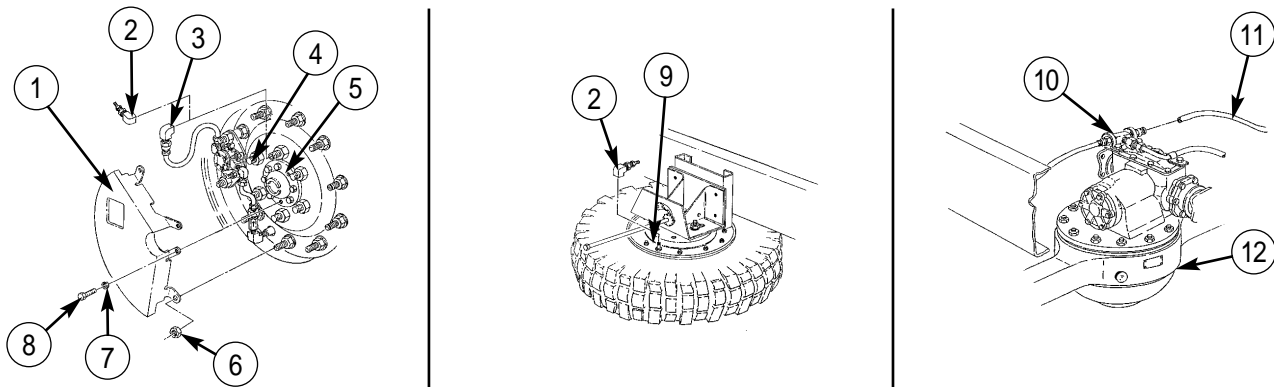

END OF TESTING!

4. TIRE(S) WILL NOT DEFLATE

WARNING

Eyeshields must be worn when releasing compressed air. Failure to do this may result in injury to personnel.

Do not disconnect air lines before draining air reservoirs. Small parts under pressure may shoot out with high velocity, causing injury to personnel.

- Step 1. If ECU is not operating, see malfunction 6.
- Step 2. If manifold is not operating, perform test 1.
- Step 3. Check air flow at turret valve. If no air is present, repair beadlock (WP 0175 00).

END OF TESTING!

*CTIS Troubleshooting (Contd)***MALFUNCTION****TEST OR INSPECTION****CORRECTIVE ACTION****5. OVERSPEED SIGNAL GENERATOR/LCD BACKLIGHT/LCD HEATER NOT WORKING**

- Step 1. Turn ignition OFF.
- Step 2. Disconnect small pin 4 connector from ECU (overspeed/backlight harness).
- Step 3. Turn ignition ON.
- Step 4. Measure the voltage on pin 3 with multimeter. Put positive (+) lead on pin 3 and negative (-) lead to chassis ground. Voltage should read 24 volts with three-position light switch on BRIGHT; 12 volts on DIM; and 0 volts on OFF position. If voltage is not present, notify DS maintenance.
- Step 5. Measure voltage from pin 4 to ground. This voltage should be 24 volts at all times. If voltage is not present, notify DS maintenance.
- Step 6. Turn ignition OFF.
- Step 7. Repeat step 5 to ensure that pin 4 remains at 24 volts (pin 4 supplies voltage to the LCD heater in the ECU).
- Step 8. Disconnect leads from front wiring harness, accessory/battery switch, and overspeed signal generator.
- Step 9. Using the multimeter and extra long test leads, measure pin-for-pin continuity (i.e., pin 1 to pin 1, etc.) and measure pin-to-pin continuity (i.e., pin 1 to pin 2, etc.). If shorts or broken wires are detected, notify DS maintenance.
- Step 10. If overspeed/backlight harness is good, reconnect overspeed/backlight to ECU, front wiring harness, accessory/battery switch, and overspeed signal generator.
- Step 11. Measure resistance between leads on signal generator. Resistance should be 193-227 ohms. If resistance is not within this range, replace overspeed signal generator (WP 0284 00).
- Step 12. Replace ECU with a known good ECU (WP 0283 00).

END OF TESTING!

6. ECU FAILS TO OPERATE

- Step 1. Perform test 1.
- Step 2. If harnesses are good, replace ECU with a known good ECU (WP 0283 00).

END OF TESTING!

7. CTIS OVERINFLATES TIRE(S)

Check ECU operation.

- a. Start engine (TM 9-2320-386-10).
- b. Turn ECU OFF, then ON, and cycle ECU from EMERGENCY to HIGHWAY modes.
- c. If overinflation continues, repeat step b.
- d. If CTIS does not return to normal operation after the third trial, replace ECU (WP 0283 00).

END OF TESTING!

END OF WORK PACKAGE

CHAPTER 3

UNIT MAINTENANCE INSTRUCTIONS FOR TRUCK, CARGO, 2-1/2-TON, 6X6, M44A3 SERIES TRUCKS (DIESEL)

Section I.	Service Upon Receipt	WP 0020 00-1
Section II.	Preventive Maintenance Checks and Services	WP 0022 00-1
Section III.	Engine System Maintenance	WP 0026 00-1
Section IV.	Air Intake System Maintenance	WP 0036 00-1
Section V.	Fuel System Maintenance	WP 0044 00-1
Section VI.	Exhaust System Maintenance	WP 0065 00-1
Section VII.	Engine Cooling System Maintenance	WP 0067 00-1
Section VIII.	Electrical System Maintenance	WP 0088 00-1
Section IX.	Transmission Maintenance	WP 0131 00-1
Section X.	Transfer Case Maintenance	WP 0144 00-1
Section XI.	Propeller Shafts, Axles, and Suspension System Maintenance	WP 0146 00-1
Section XII.	Axle Maintenance	WP 0150 00-1
Section XIII.	Compressed Air and Brake System Maintenance	WP 0153 00-1
Section XIV.	Wheel Maintenance	WP 0171 00-1
Section XV.	Steering System Maintenance	WP 0178 00-1
Section XVI.	Frame Maintenance	WP 0187 00-1
Section XVII.	Spring Maintenance	WP 0192 00-1
Section XVIII.	Body and Cab Maintenance	WP 0194 00-1
Section XIX.	Front Winch Maintenance	WP 0212 00-1
Section XX.	Bumper and Guards Maintenance	WP 0226 00-1
Section XXI.	Accessories Maintenance	WP 0231 00-1
Section XXII.	Personnel Hot Water Heater Maintenance	WP 0237 00-1
Section XXIII.	Arctic Winterization Kits Maintenance	WP 0245 00-1
Section XXIV.	Swingfire Heater Kit Maintenance	WP 0256 00-1
Section XXV.	Deepwater Fording Kit Maintenance	WP 0264 00-1
Section XXVI.	Chemical Agent Automatic Alarm Mounting Kit Replacement	WP 0270 00-1
Section XXVII.	Air Brake Trailer Kit Maintenance	WP 0272 00-1
Section XXVIII.	100-AMP Alternator Kit Maintenance	WP 0276 00-1
Section XXIX.	CTIS Maintenance	WP 0280 00-1
Section XXX.	Non-Electrical Gauges Maintenance	WP 0285 00-1

UNIT MAINTENANCE INSTRUCTIONS

EXTENDED SERVICE PROGRAM (ESP)

TRUCK, CARGO, 2-1/2-TON, 6X6, M44A3 SERIES TRUCKS (DIESEL)

M35A3, W/O WINCH (NSN 2320-01-383-2047); W/WINCH (NSN 2320-01-383-3850);

M35A3C, W/O WINCH (NSN 2320-01-383-2050); W/WINCH (NSN 2320-01-383-2049);

M36A3, W/O WINCH (NSN 2320-01-383-2048); W/WINCH (NSN 2320-01-383-2046).

Section I. SERVICE UPON RECEIPT

TABLE OF CONTENTS

<i>WP Title</i>	<i>WP Sequence No.-Page No.</i>
General	0021 00-1
General Inspection and Servicing Instructions	0021 00-1
Specific Inspection and Servicing Instructions	0021 00-2

END OF WORK PACKAGE

UNIT MAINTENANCE INSTRUCTIONS

EXTENDED SERVICE PROGRAM (ESP)

TRUCK, CARGO, 2-1/2-TON, 6X6, M44A3 SERIES TRUCKS (DIESEL)

M35A3, W/O WINCH (NSN 2320-01-383-2047); W/WINCH (NSN 2320-01-383-3850);
M35A3C, W/O WINCH (NSN 2320-01-383-2050); W/WINCH (NSN 2320-01-383-2049);
M36A3, W/O WINCH (NSN 2320-01-383-2048); W/WINCH (NSN 2320-01-383-2046).

SERVICE UPON RECEIPT

GENERAL

a. Upon receipt of a new, used, or reconditioned vehicle, you must determine if the vehicle has been properly prepared for service. The following steps should be performed:

- (1) Inspect all assemblies, subassemblies, and accessories to ensure they are in proper working order.
- (2) Secure, clean, lubricate, or adjust as needed.
- (3) Check all Basic Issue Items (BII) (TM 9-2320-386-10) to ensure every item is present, in good condition, and is properly mounted or stowed.
- (4) Follow general procedures for all services and inspections given in TM 9-2320-386-10.

b. The operator will assist when performing service upon receipt inspections.

c. Refer to TM 9-2320-386-10 when testing equipment for proper operation.

GENERAL INSPECTION AND SERVICING INSTRUCTIONS

The following steps should be taken while performing general inspections and services:

a. Refer to TM 9-2320-386-10, as well as other sections of this manual when servicing, inspecting, and lubricating equipment.

WARNING

Skysol-100 mixture is combustible. Use mechanical ventilation whenever product is used in a confined space, is heated above ambient temperatures, or is agitated. DO NOT use or store near heat, sparks, flame, or other ignition sources. Keep container sealed when not in use.

Contact with Skysol-100 may cause skin irritation. Use chemical resistant gloves. In case of skin contact, remove any contaminated clothing and wash skin thoroughly with soap and water. Wash contaminated clothing before reuse. Eye contact may cause irritation, tearing, or blurring of vision. Use face shield or goggles when eye contact may occur. In case of eye contact, flush eyes with large amounts of water for at least fifteen (15) minutes or until irritation subsides. Inhalation may cause irritation to upper respiratory passages. DO NOT have food or drink in the vicinity.

b. Clean all exterior surfaces coated with rust-preventive compounds with Skysol-100.

c. Read Processing and Deprocessing Record of Shipping, Storage, and Issue of Vehicles and Spare Engines, tag (DD Form 1397), and follow all precautions listed. This tag should be attached to steering wheel, shift column, or battery switch.

NOTE

If vehicle has been driven to using organization, all the above work should have been completed.

SPECIFIC INSPECTION AND SERVICING INSTRUCTIONS

The following steps should be taken while performing specific inspections and services:

- a. Perform the semiannual (S), six months, or 6,000 miles (9,654 kilometers) Preventive Maintenance Checks and Services (PMCS) listed in WP 0025 00 of this chapter.
- b. Lubricate the vehicle according to the instructions found in WP 0023 00. Do not lubricate gearcases or engine unless processing tag states that the oil is unsuitable for 500 miles (805 kilometers) of operation. If oil is suitable, just check level (TM 9-2320-386-10).
- c. Schedule semiannual service on DD Form 314 (Preventive Maintenance Schedule and Record Card).
- d. If vehicle is delivered with a dry-charged battery, activate it according to TM 9-6140-200-14.
- e. Check vehicle coolant level and determine if solution is proper for climate. (Refer to TB 750-651 for preparation of antifreeze solutions.)

END OF WORK PACKAGE

UNIT MAINTENANCE INSTRUCTIONS

EXTENDED SERVICE PROGRAM (ESP)

TRUCK, CARGO, 2-1/2-TON, 6X6, M44A3 SERIES TRUCKS (DIESEL)

M35A3, W/O WINCH (NSN 2320-01-383-2047); W/WINCH (NSN 2320-01-383-3850);

M35A3C, W/O WINCH (NSN 2320-01-383-2050); W/WINCH (NSN 2320-01-383-2049);

M36A3, W/O WINCH (NSN 2320-01-383-2048); W/WINCH (NSN 2320-01-383-2046).

Section II. PREVENTIVE MAINTENANCE CHECKS AND SERVICES

TABLE OF CONTENTS

<i>WP Title</i>	<i>WP Sequence No.-Page No.</i>
Lubrication Instructions	0023 00-1
Preventive Maintenance Checks and Services Introduction	0024 00-1
Preventive Maintenance Checks and Services	0025 00-1

END OF WORK PACKAGE

UNIT MAINTENANCE INSTRUCTIONS

EXTENDED SERVICE PROGRAM (ESP)

TRUCK, CARGO, 2-1/2-TON, 6X6, M44A3 SERIES TRUCKS (DIESEL)

M35A3, W/O WINCH (NSN 2320-01-383-2047); W/WINCH (NSN 2320-01-383-3850);

M35A3C, W/O WINCH (NSN 2320-01-383-2050); W/WINCH (NSN 2320-01-383-2049);

M36A3, W/O WINCH (NSN 2320-01-383-2048); W/WINCH (NSN 2320-01-383-2046).

LUBRICATION INSTRUCTIONS

GENERAL

This lubrication instruction is for unit maintenance and provides the lubrication requirements needed to support components of the Extended Service Program (ESP) vehicles. Included are table 1, Fluid Capacities and Lubricant Requirements, table 2, Lubrication Intervals, and Locations for lubricating the vehicles under normal and conditions.

SERVICE INTERVALS

(1) Service intervals are for normal operation of the vehicle in moderate temperatures, humidity, and atmospheric conditions. The intervals are hard-time intervals which are performed in accordance with the vehicle's age, calendar, or usage such as operating time or mileage. The hard-time intervals in table 2 are based on mileage and calendar times. An example of mileage and calendar intervals is: 3/5; 3 stands for 3,000 miles (4,827 km) and S stands for semiannually (every six months). The lubrication for the vehicle is to be performed at whichever interval occurs first.

(2) For equipment under manufacturer's warranty, hard-time oil service intervals shall be followed. Hard-time intervals may be shortened if lubricants are used under adverse conditions, including longer-than usual operating hours. Hard-time intervals may be extended during periods of low activity, although adequate preservation precautions must be taken. Hard-time intervals will be applied in the event Army Oil Analysis Program (AOAP) laboratory support is not available.

(3) Service intervals under unusual conditions will increase the frequency of lubricating service, such as high or low temperatures, prolonged high-speed driving, or extended cross-country operations. Such operations can diminish a lubricant's protective quality.

ARCTIC CONDITIONS

Refer to FM 9-207, Operation and Maintenance of Ordnance Materiel in Cold Weather 0° to -65°F (-18° to -54°C), or table 1, Fluid Capacities and Lubricant Requirements.

CORROSION PREVENTION AND CONTROL (CPC)

(1) Corrosion prevention and control (CPC) of Army materiel is a continuing concern. It is important that corrosion problems are reported so they can be corrected and improvements can be made to prevent future problems.

(2) While corrosion is typically associated with rusting of metals, it can also include deterioration of other materials, such as rubber and plastic. Unusual cracking, softening, swelling, or breaking of these materials may be a corrosion problem.

(3) If a corrosion problem is identified, it can be reported using Standard Form 368, Product Quality Deficiency Report. Use of key words such as corrosion, rust, deterioration, or cracking will ensure that the information is identified as a CPC problem.

(4) The form should be submitted to the address specified in DA Pam 738-750.

OIL FILTERS

Oil filters shall be changed as applicable, when:

- (1) They are known to be contaminated or clogged.
- (2) Service is recommended by AOAP laboratory analysis:
- (3) Prescribed hard-time intervals are reached.

AOAP REQUIREMENTS

(1) Engine oil, transmission oil, and hydraulic fluids must be sampled at 60 days or 1,000 miles (1,609 km). Reserve and National Guard units should perform oil sampling every 120 days or 1,000 miles (1,609 km) as prescribed by TB 43-0106 Aeronautical Equipment Army Oil Analysis Program (AOAP), or DA Pam 738-750, Functional User Guide for the Army Maintenance Management System (TAMMS).

(2) In the event AOAP laboratory support is not available, use on-condition (OC) hard-time intervals will be applied.

CLEANING

WARNING

Skysol-100 mixture is combustible. Use mechanical ventilation whenever product is used in a confined space, is heated above ambient temperatures, or is agitated. DO NOT use or store near heat, sparks, flame, or other ignition sources. Keep container sealed when not in use.

Contact with Skysol-100 may cause skin irritation. Use chemical resistant gloves. In case of skin contact, remove any contaminated clothing and wash skin thoroughly with soap and water. Wash contaminated clothing before reuse. Eye contact may cause irritation, tearing, or blurring of vision. Use face shield or goggles when eye contact may occur. In case of eye contact, flush eyes with large amounts of water for at least fifteen (15) minutes or until irritation subsides. Inhalation may cause irritation to upper respiratory passages. DO NOT have food or drink in the vicinity.

Keep all lubricants in closed container and store in clean, dry place, away from extreme heat. Failure to do so may result in injury to personnel.

CAUTION

Keep container covers clean and allow no dust, dirt, or other foreign material to mix with lubricants. Keep all lubrication equipment clean and ready to use.

- (1) Keep all external parts of equipment not requiring lubrication free of lubricants.
- (2) Before lubricating equipment, clean fittings. Use a biodegradable Skysol-100 to wipe all lubrication points free of dirt and grease and dry before lubricating. After servicing lubrication points, wipe off excess lubricants to prevent accumulation of foreign matter.

Table 1. Fluid Capacities and Lubricant Requirements

COMPONENT	CAPACITIES	EXPECTED TEMPERATURES		LUBRICANT MIL. SYMBOL (NATO CODE) SPECIFICATION
		°F	°C	
Engine	Crankcase Dry 21 qt (19.9 L)	-4 to +122	-20 to +50	SAE 15W40 (O-1236) MIL-PRF-2104
	W/filter 19 qt (18 L) W/o filter 18 qt (17 L)	-50 to -4	-46 to -20	OEA (O-183) MIL-PRF-46167
Transmission	Dry 20 qt (18.9 L)	-4 to +122	-20 to +50	SAE 15W40 (O-1236) MIL-PRF-2104
	Drain and refill 16 qt (15.1 L) After rebuild 22 qt (20.8 L)	-50 to -4	-46 to -20	OEA (O-183) MIL-PRF-46167
Winch Gear Case	2.75 pt (1.3 L)	-4 to +122	-20 to +50	GO 80/90 (O-226) MIL-L-2105
Winch End Frame Housing	1.25 pt (0.6 L)	-50 to -4	-46 to -20	GO 75 (O-186) MIL-L-2105
Winch Hydraulic System	Dry 42 qt (39.7 L)	-4 to +122	-20 to +50	SAE 15W40 (O-1236) MIL-PRF-2104
	Drain and refill 39 qt (36.9 L)	-50 to -4	-46 to -20	OEA (O-183) MIL-PRF-46167
Master Cylinder Reservoir	2 qt (1.9 L)	All Temperatures		BFS (H-547) MIL-B-46176
Front and Rear Axle Differentials	6 qt (5.7 L)	-4 to +122	-20 to +50	GO 80/90 (O-226) MIL-L-2105
		-50 to -4	-46 to -20	GO 75 (O-186) MIL-L-2105
Transfer Case	7 qt (6.6 L)	-4 to +122	-20 to +50	GO 80/90 (O-226) MIL-L-2105
		-50 to -4	-46 to -20	GO 75 (O-186) MIL-L-2105
Steering Gear	3.13 pt (1.48 L)	-4 to +122	-20 to +50	GO 80/90 (O-226) MIL-L-2105

- OE/HDO Lubricating oil, combustion engine, tactical (MIL-PRF-2104)
- GO Lubricating oil, gear, multipurpose (MIL-PRF-2105)
- BFS Brake fluid, silicone (MIL-B-46176)
- GAA Grease, automotive and artillery (MIL-PRF-10924)
- OEA Lubricating oil, internal combustion engine, arctic (MIL-PRF-46167)
- CW Lubricating oil, chain, exposed gear, and wire rope (VV-L-751)

Table 2. Lubrication Intervals

<i>COMPONENT</i>	<i>INTERVAL</i>
Engine Crankcase	Oil will be changed only when directed by AOAP laboratory. When AOAP laboratory support is not available, change oil and oil filter element every 6 months or 6,000 mi (9,654 km).
Engine Oil Filter	Replace at each engine oil change.
Fuel Filter/Water Separator	Replace fuel filter every 6 months or 6,000 mi (9,654 km).
Transmission, internal filter, and external oil filter	Oil will be changed only when directed by AOAP laboratory. When AOAP laboratory support is not available, change oil, internal filter, and external filter every 24 months or 24,000 mi (38,616 km).
Winch Hydraulic Oil Reservoir	Oil will be changed only when directed by AOAP laboratory every 12 months or 12,000 mi (19,308 km).
Winch Hydraulic Oil Filter	Replace at each winch hydraulic reservoir oil change - 12 months or 12,000 mi (19,308 km).
Winch	Change lubricant only when required by maintenance repair action, or if contaminated. Check oil level semiannually or 3,000 mi (4,827 km).
Master Cylinder Reservoir	Service every 6 months or 1,000 mi (1,609 km).
Front and Rear Axles	Check oil level semiannually or every 3,000 mi (4,827 km). Change oil only when required by maintenance repair action, or if contaminated.
Transfer Case	Check level semiannually or every 3,000 mi (4,827 km). Change oil only when required by maintenance repair action, or if contaminated.
Steering Gear	Check level every 1,000 mi (1,609 km). Change lubricant only when required by maintenance repair action, or if contaminated.
Accessory Drive Pulley	Lubricate fitting every 6,000 mi (9,654 km).

OC On-Condition, unless changed by the Army Oil Analysis Program (AOAP)
 C/MR Change gear lubricant only when required by maintenance repair action or if contaminated
 W Weekly
 M Monthly
 S Semiannually (6 months)
 A Annually (12 months)
 B Biennially (24 months)
 1 1,000 mi (1,609 km)
 3 3,000 mi (4,827 km)
 6 6,000 mi (9,654 km)
 12 12,000 mi (19,308 km)
 24 24,000 mi (38,616 km)

INTERVAL • LUBRICANT

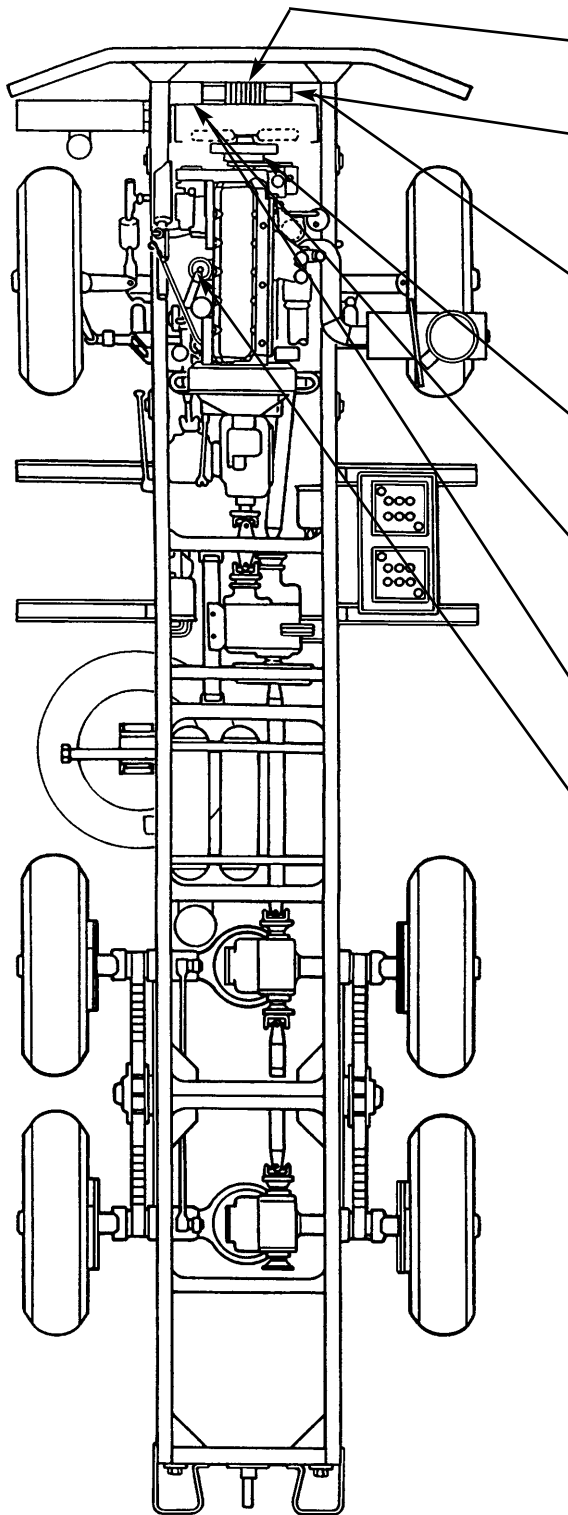

S	OE/HDO	Winch Cable (See note 2) (LV-A) (O)
C/MR	GO	Winch End Frame Housing (Drain and refill) (Cap. - 1.25 pt [0.6 L]) (See note 3) [LV-C, D] (O)
3/S	GO	Winch End Frame Housing Fill and Level (Check level) (See note 3) [LV-D] (O)
6	GAA	Accessory Drive Pulley (1 fitting) (Service) [LV-F] (O)
C/MR		Winch Worm Housing (Drain and refill) (Cap. 1.25 pt [0.6L]) (See note 3) [LV-B, E] (O)
3/S	GO	Winch Worm Housing Fill and Level (Check level) (See note 3) [LV-E] (O)
6		Engine Crankcase Breather (Service) (See note 4) [LV-G] (O)

NOTE

Letters in brackets refer to localized views (LV). (See pages 10 through 16.)

CHASSIS - M35A3, M35A3C, M36A3

INTERVAL • LUBRICANT

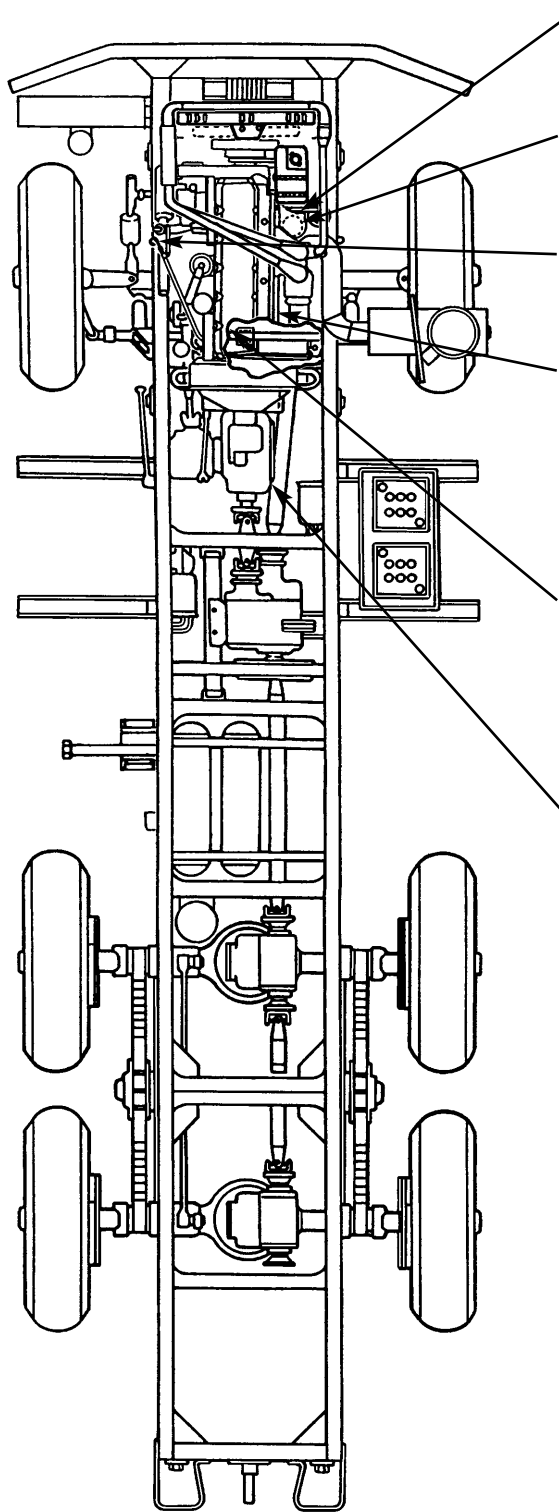

- 24/B Transmission External Oil Filter
(Replace) (See note 5) [LV-I] (O)
- OC Engine Oil Filter
(Replace) (See note 5) [LV-J] (O)
- OC 15W40 Engine Crankcase Fill Tube
(See note 6) [LV-H] (O)
- OC 15W40 Engine Crankcase Drain and Refill
(Cap. 19 qt [18 L])
(See note 6) [LV-H, K] (O)
- 6/S Engine Fuel Filter
(Replace) (See note 7) [LV-L] (O)
- OC 15W40 Transmission Oil Drain and Filter
(Drain and refill; replace filter as
required) (See notes 5 and 9)
(Cap. 16 qt [15.1 L]) [LV-N, M] (O)

NOTE

Letters in brackets refer to localized views (LV). (See pages 10 through 16.)

CHASSIS - M35A3, M35A3C, M36A3

INTERVAL • LUBRICANT

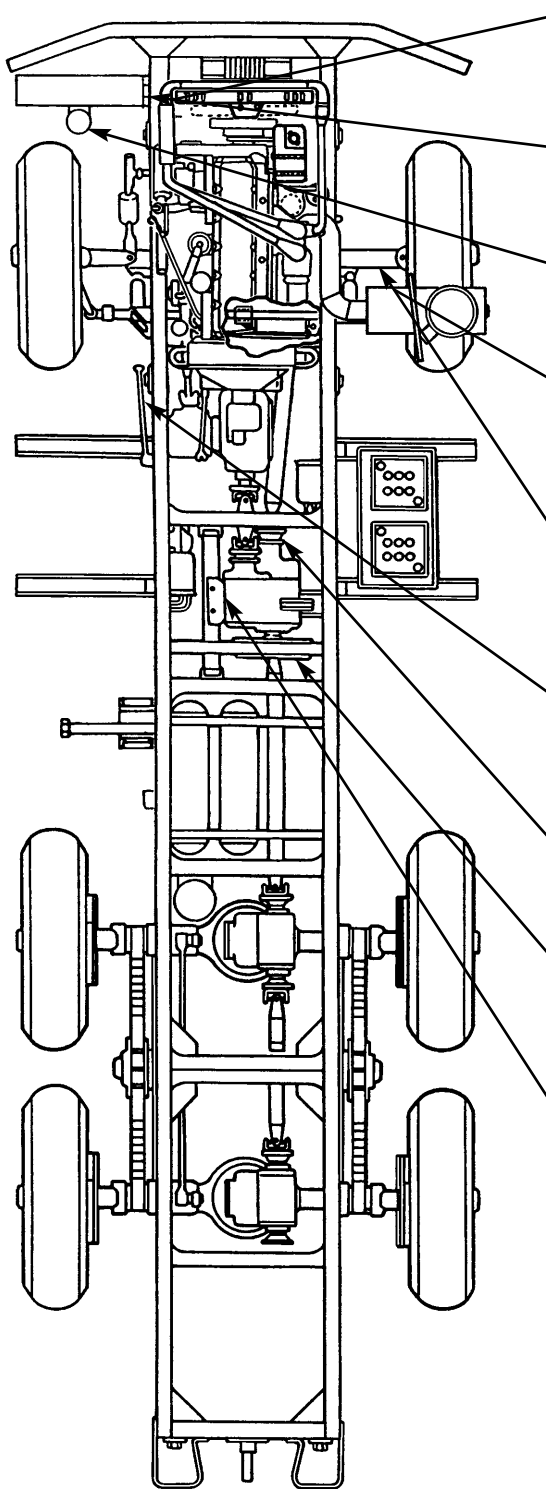

12/A	15W40	Winch Hydraulic Reservoir (Drain and refill) (Cap. 39 qt [36.9 L]) (See note 10) [LV-O, Q] (O)
OC	15W40	Winch Hydraulic Reservoir (See note 10) [LV-R, O] (O)
12/A		Winch Oil Filter (Replace) (See note 5) [LV-P] (O)
3/S	GO	Front Axle Differential Fill and Level (Check level) (See note 3) [LV-S] (O)
C/MR	GO	Front Axle Differential (Drain and refill) (Cap. 6 qt [5.7 L]) (See note 3) [LV-T, S] (O)
3/S	GAA	Brake Pedal and Pedal Shaft Bracket (3 fittings) (Service) [LV-U] (O)
3/S	GO	Transfer Case Fill and Level (Check level) (See note 3) [LV-V] (O)
3/S	GAA	Parking Brake Lever and Shoe Anchor Pins (4 fittings, sparingly) (Service) [LV-Z] (O)
C/MR	GO	Transfer Case (Drain and refill) (Cap. 7 qt [6.6 L]) (See note 3) [LV-V, W] (O)

NOTE

Letters in brackets refer to localized views (LV). (See pages 10 through 16.)

CHASSIS - M35A3, M35A3C, M36A3

INTERVAL • LUBRICANT

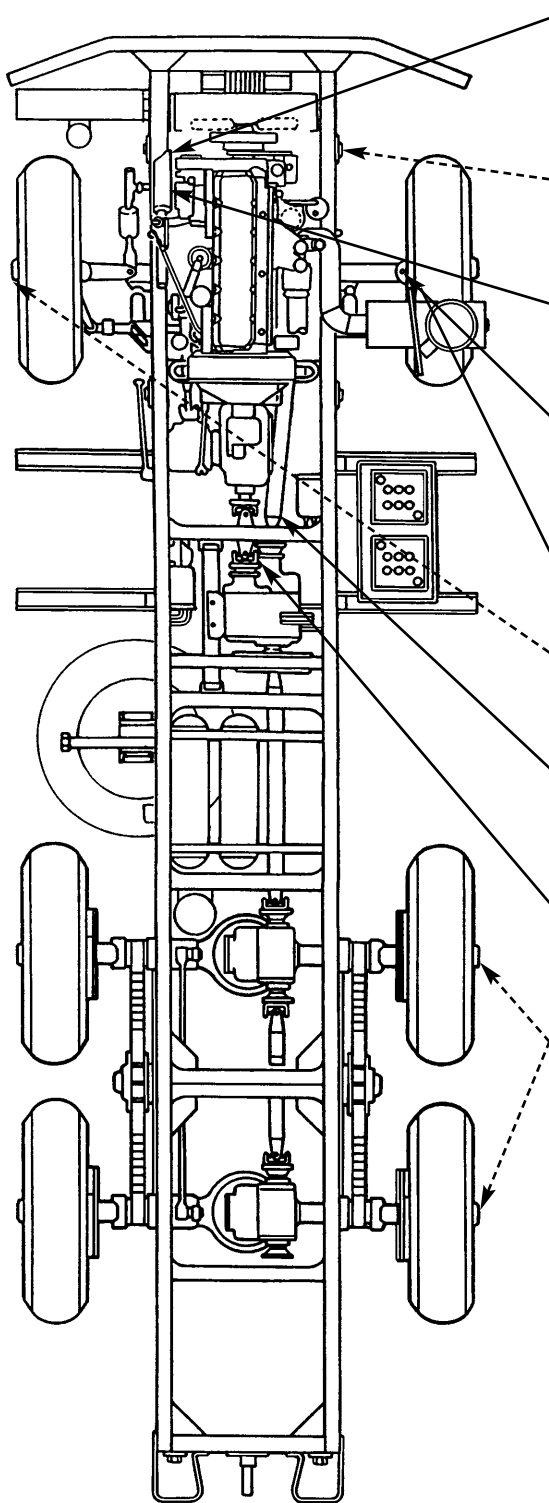

C/MR	GO	Steering Gear (Drain and refill) (Cap. 3.13 pt [1.48 L]) (See note 3) [LV-AA, AB] (O)
3/S	GAA	Spring Bolt (1 fitting) (Service) [LV-AC] (O)
1	GO	Steering Gear (Check level) [LV-AA] (O)
12/A	GAA	Steering Knuckle Bearings (Top and bottom, 2 fittings) (Service) (See note 11) [LV-AD] (O)
12/A	GAA	Front Wheel Universal Joint (2 fittings) (Service) (See note 11) [LV-AE] (O)
6/S	GAA	Front Wheel Bearings (See note 12) (O)
3/S	GAA	Front Axle Drive Shaft Universal and Slip Joints (2 fittings) (Service) [LV-AF] (O)
3/S	GAA	Transmission-to-Transfer Case Drive Shaft Universal and Slip Joint (3 fittings) (Service) [LV-X, Y] (O)
6/S	GAA	Rear Wheel Bearings (See note 12) (O)

NOTE

- Letters in brackets refer to localized views (LV). (See pages 10 through 16.)
- Broken arrow shafts indicate lubrication required on both sides of equipment.

CHASSIS - M35A3, M35A3C, M36A3

INTERVAL • LUBRICANT

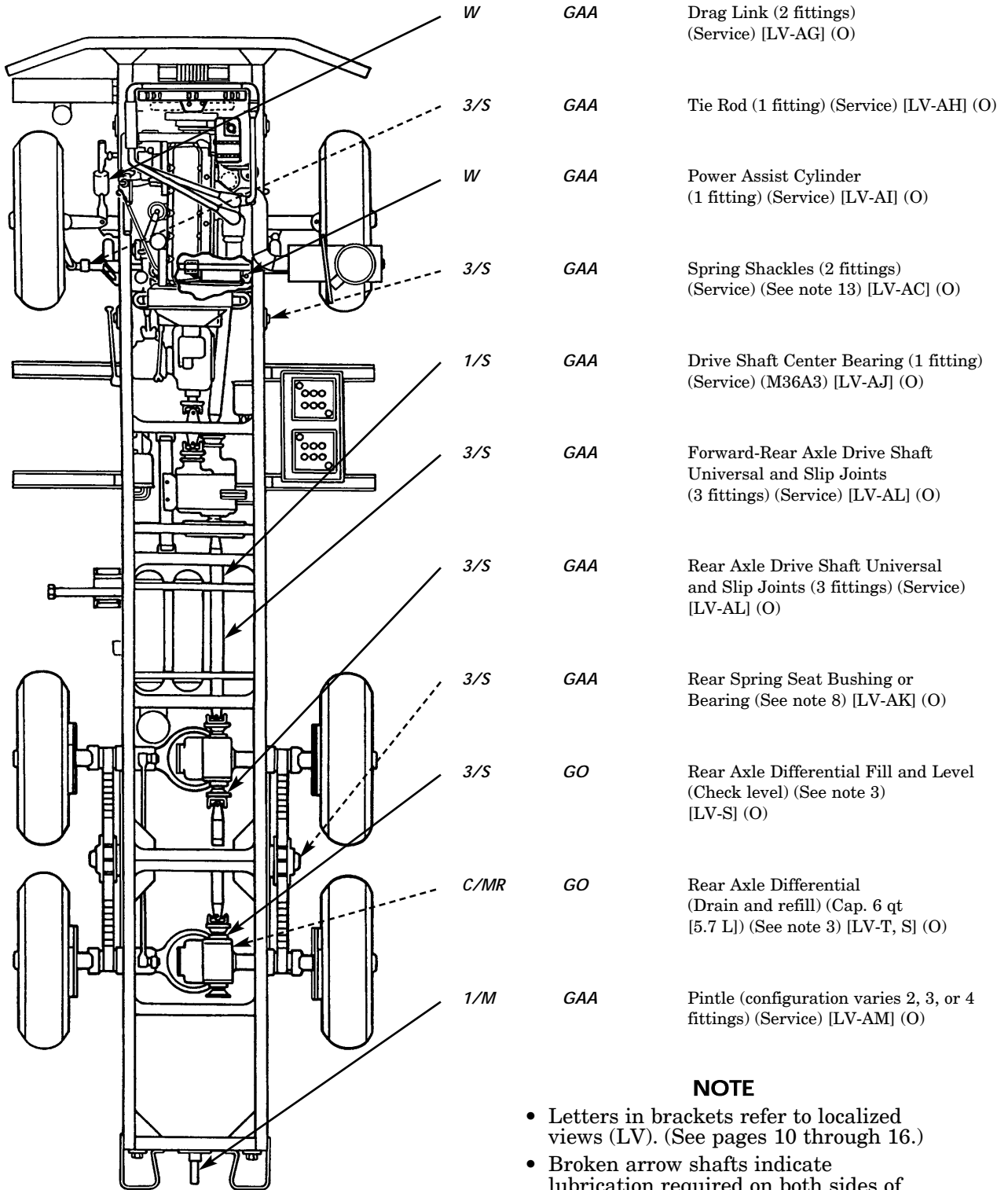

NOTE

- Letters in brackets refer to localized views (LV). (See pages 10 through 16.)
- Broken arrow shafts indicate lubrication required on both sides of equipment.

CHASSIS - M35A3, M35A3C, M36A3

LOCALIZED LUBRICATION POINTS (A THROUGH AM)

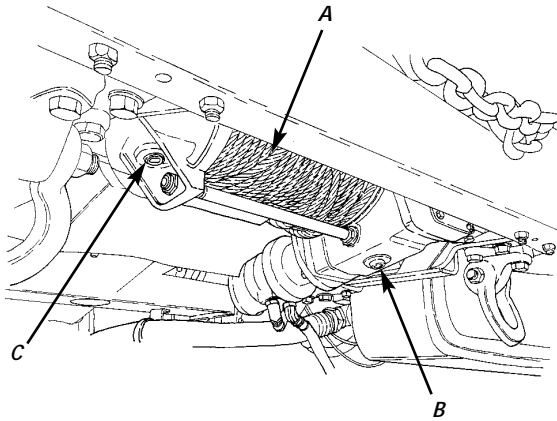

FRONT WINCH

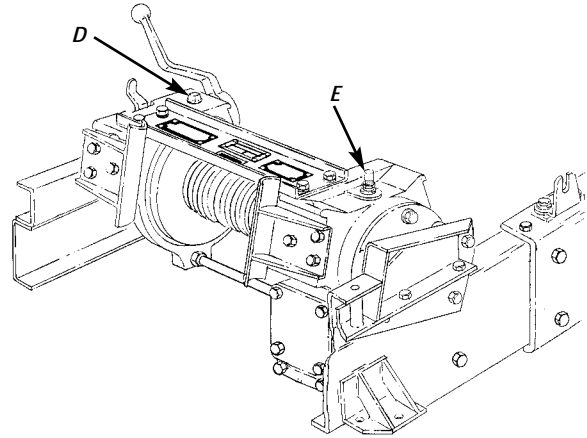

FRONT WINCH

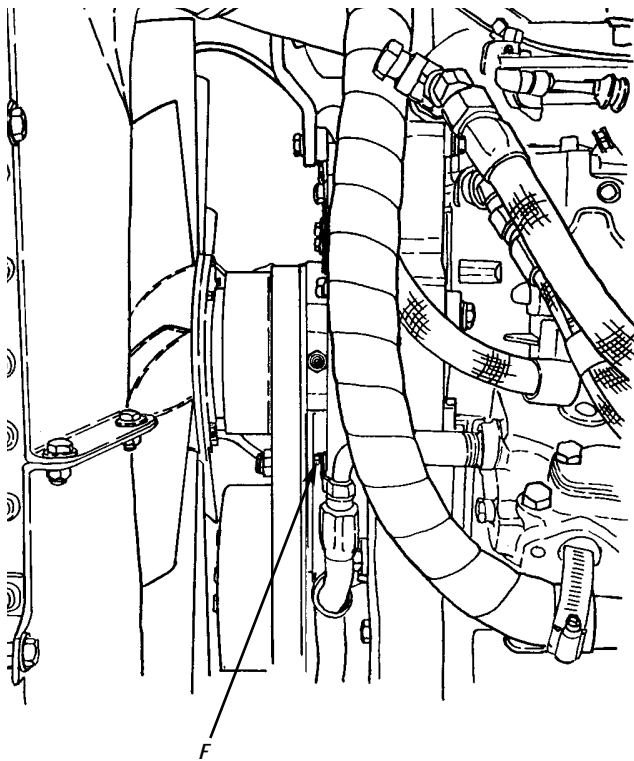

ACCESSORY DRIVE PULLEY

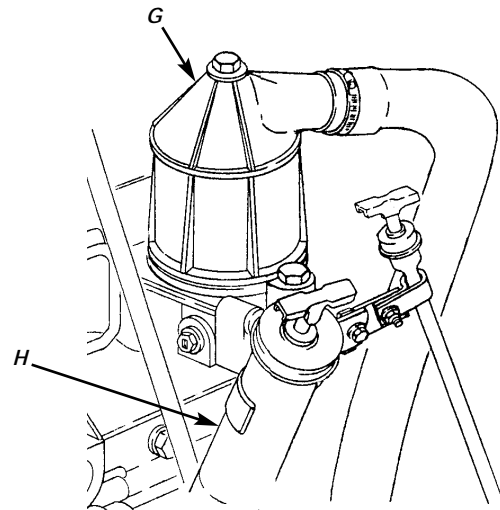

CRANKCASE FILL TUBE, BREATHER, AND DIPSTICK

LOCALIZED LUBRICATION POINTS (A THROUGH AM) (Contd)

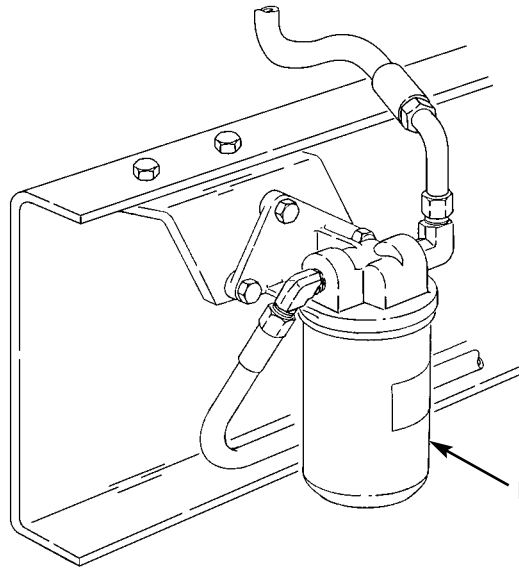

TRANSMISSION EXTERNAL OIL FILTER

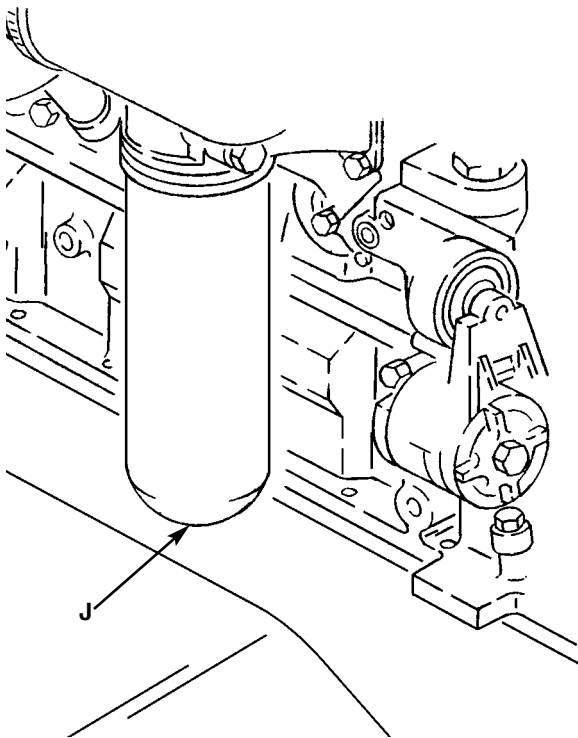

ENGINE OIL FILTER

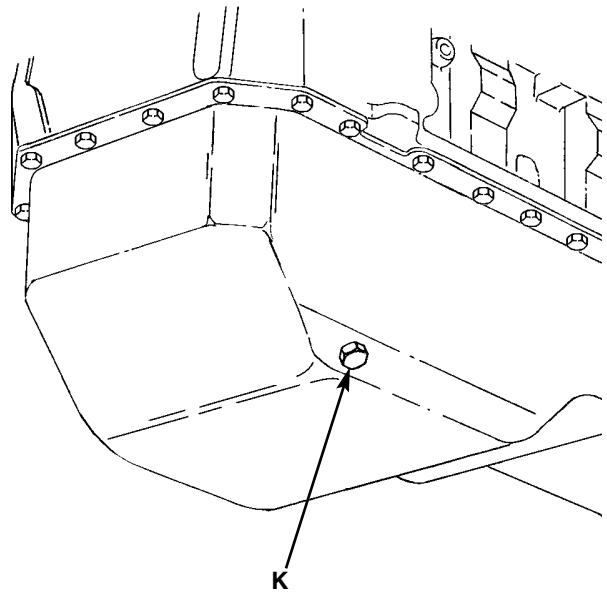

ENGINE CRANKCASE DRAINPLUG

LOCALIZED LUBRICATION POINTS (A THROUGH AM) (Contd)

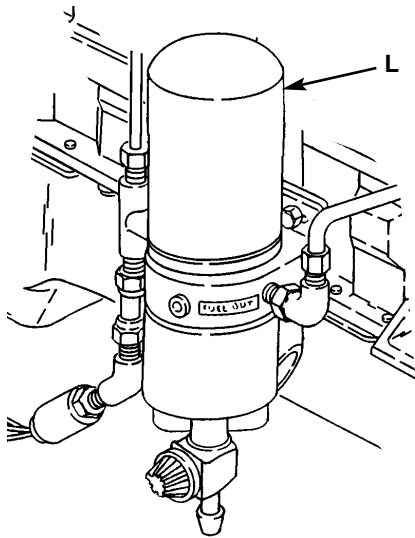

FUEL/WATER SEPARATOR

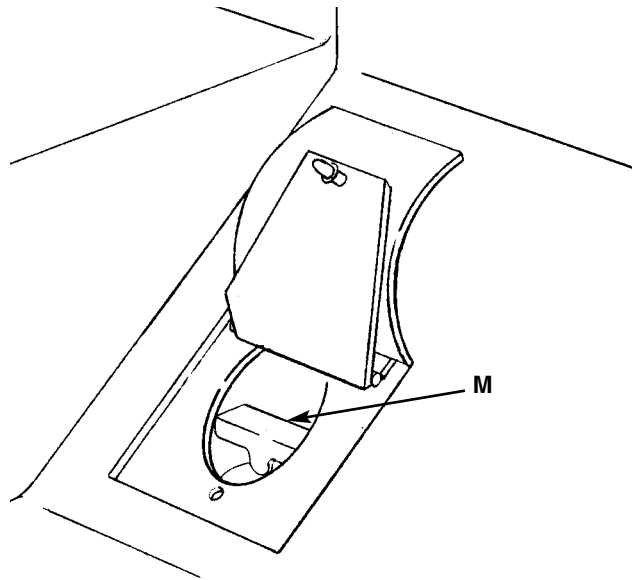

TRANSMISSION FILL TUBE AND DIPSTICK

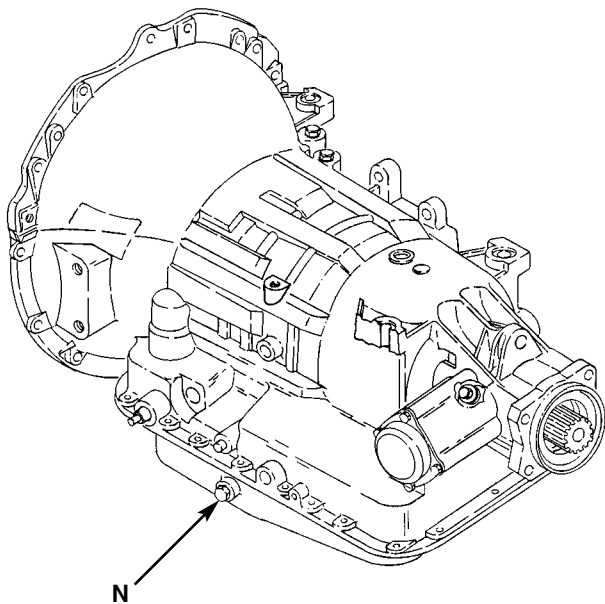

TRANSMISSION DRAINPLUG

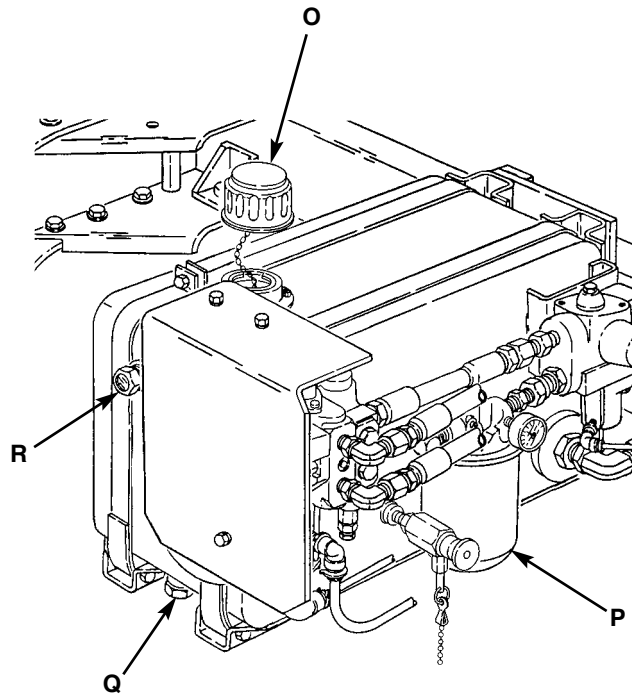

WINCH HYDRAULIC OIL RESERVOIR

LOCALIZED LUBRICATION POINTS (A THROUGH AM) (Contd)

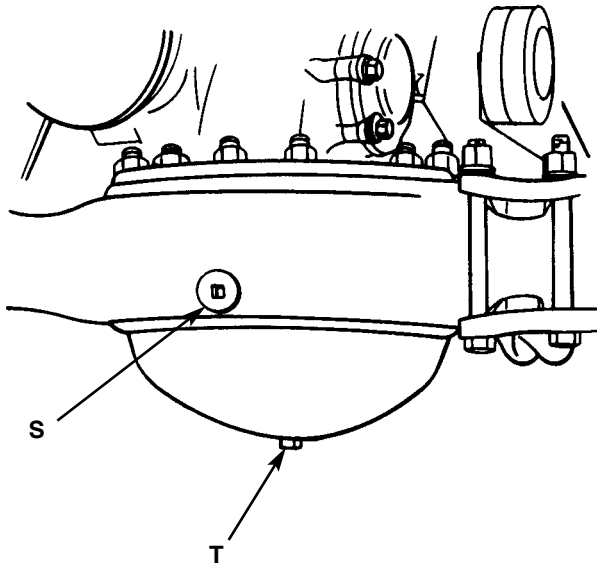

AXLE DIFFERENTIALS

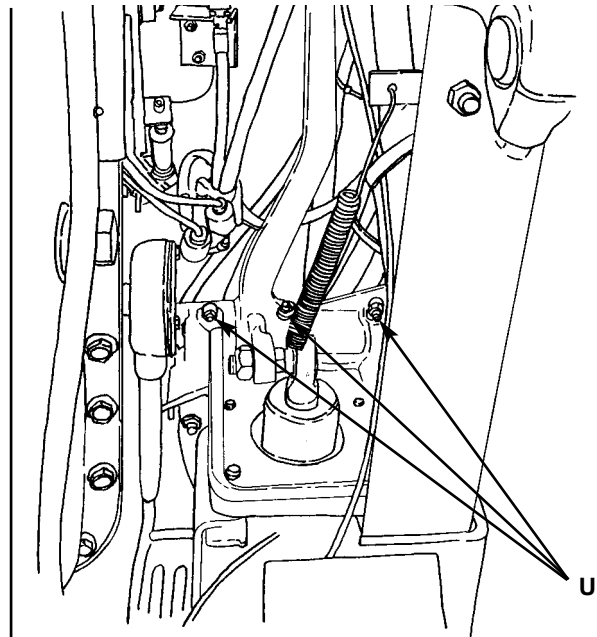

BRAKE PEDAL AND PEDAL SHAFT BRACKET

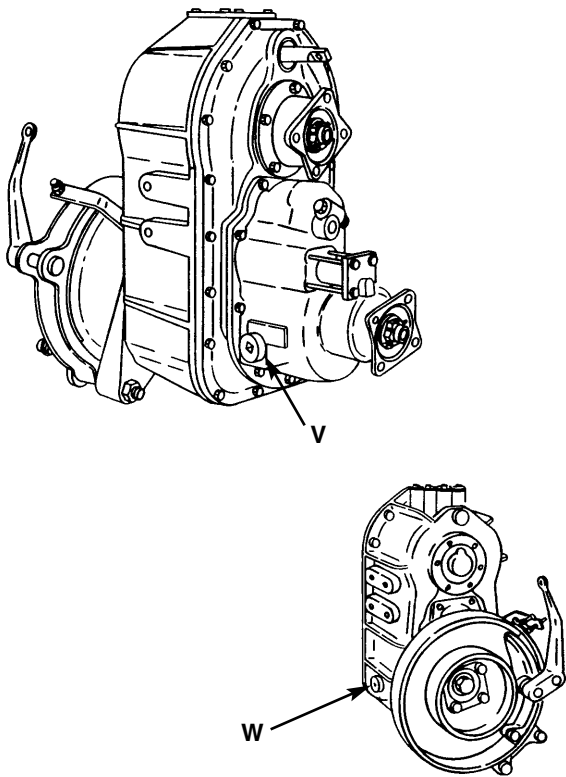

TRANSFER CASE

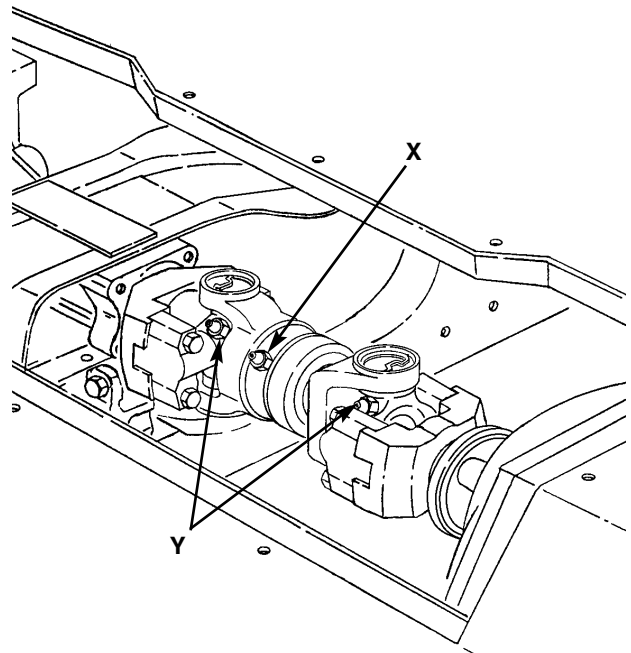

TRANSMISSION-TO-TRANSFER CASE DRIVE
SHAFT UNIVERSAL AND SLIP JOINT

LOCALIZED LUBRICATION POINTS (A THROUGH AM) (Contd)

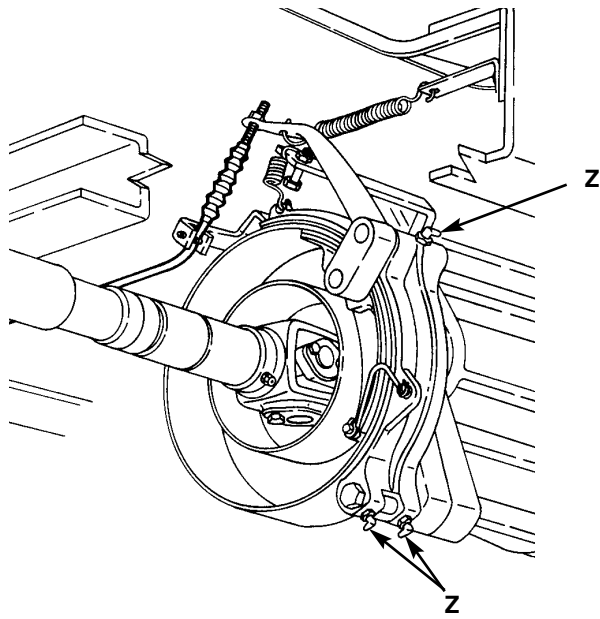

PARKING BRAKE LEVER

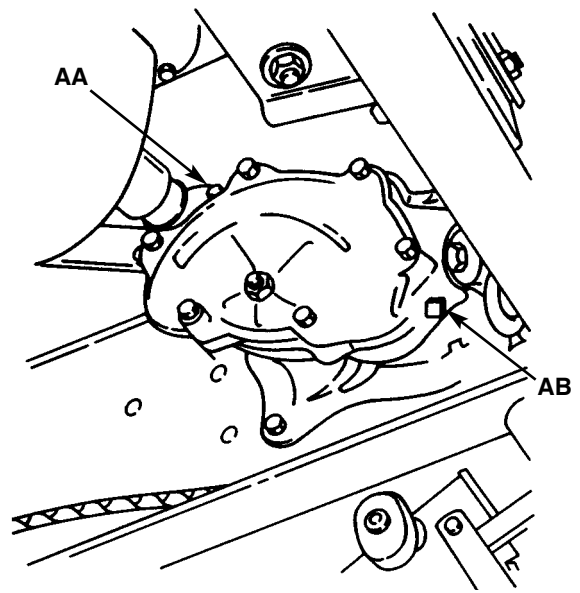

STEERING GEAR

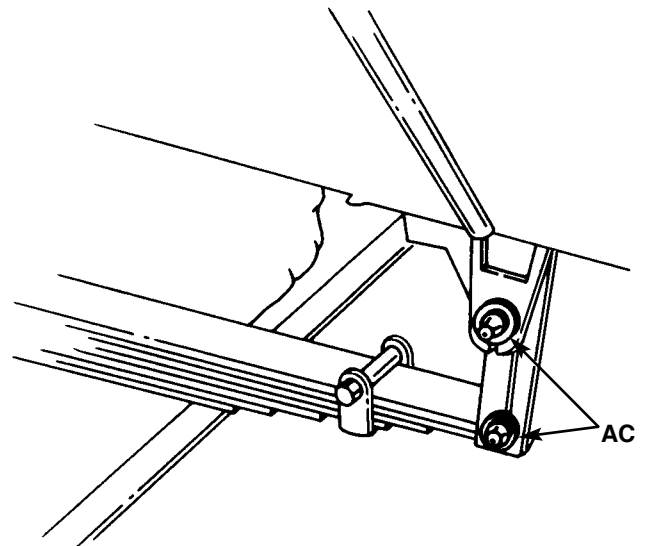
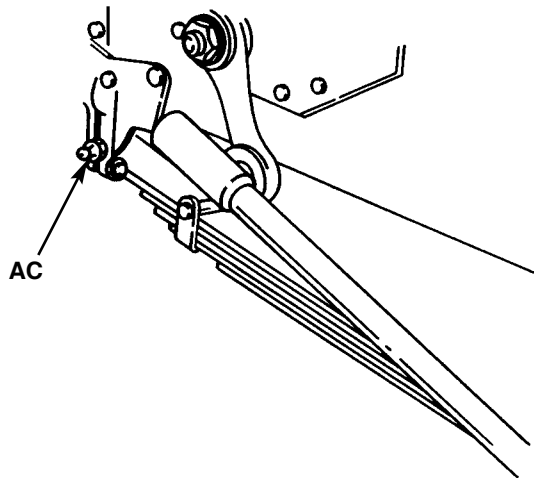

SPRING BOLT FITTINGS

LOCALIZED LUBRICATION POINTS (A THROUGH AM) (Contd)

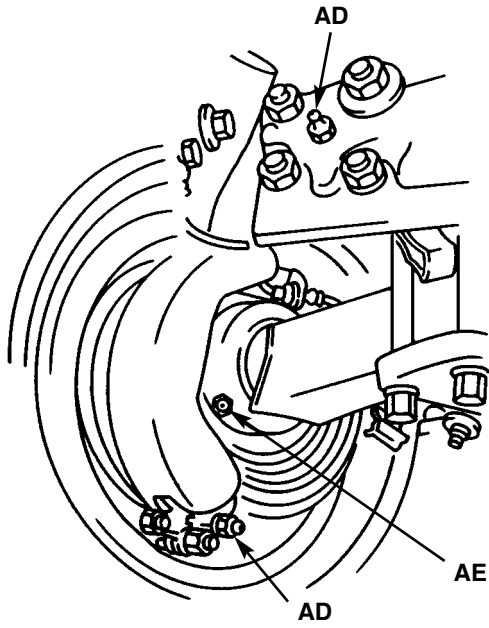

FRONT WHEEL

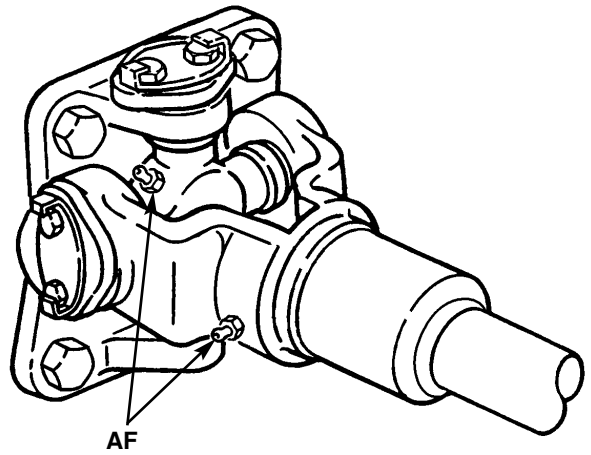

FRONT AXLE DRIVE SHAFT UNIVERSAL

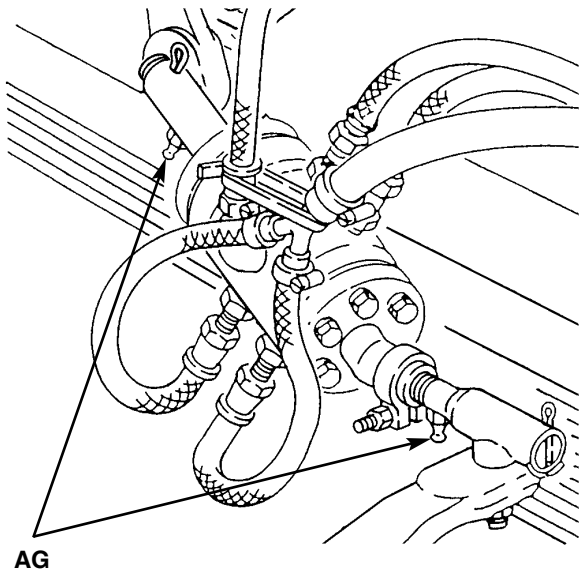

STEERING DRAG LINK

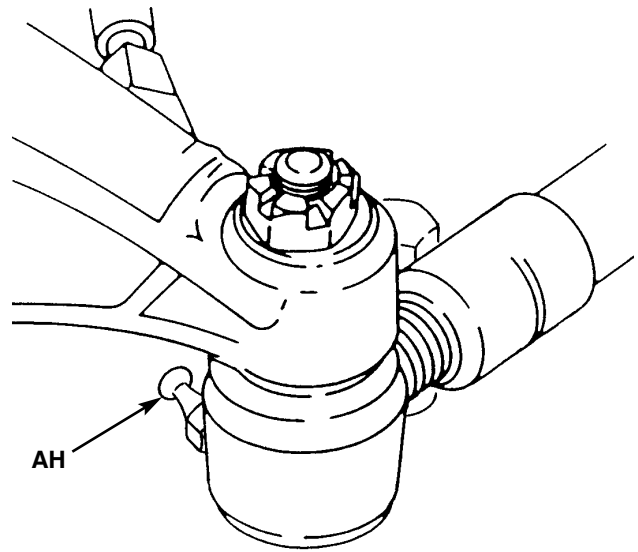

TIE ROD

LOCALIZED LUBRICATION POINTS (A THROUGH AM) (Contd)

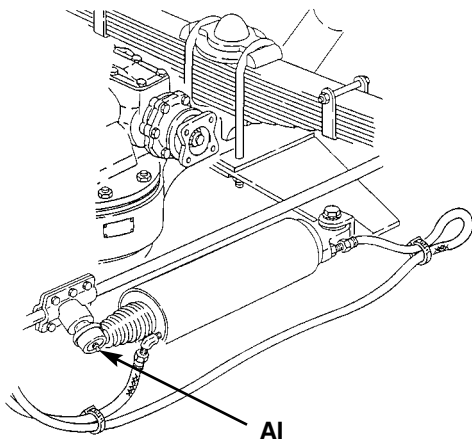

POWER ASSIST CYLINDER

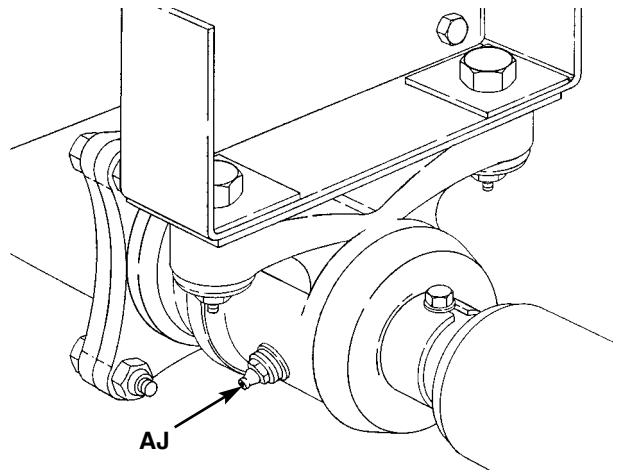

DRIVE SHAFT CENTER BEARING

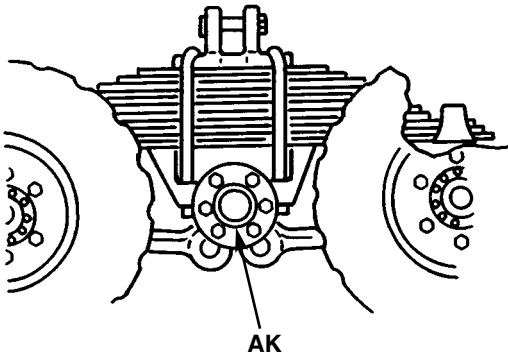

REAR SPRING SEAT BEARING

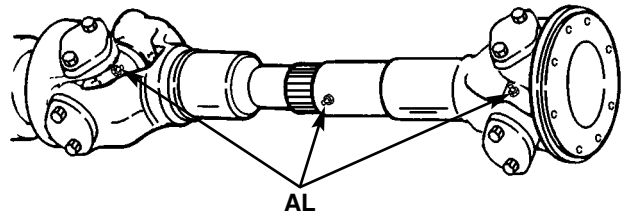

*FORWARD-REAR AND REAR-REAR AXLE
DRIVE SHAFT UNIVERSAL*

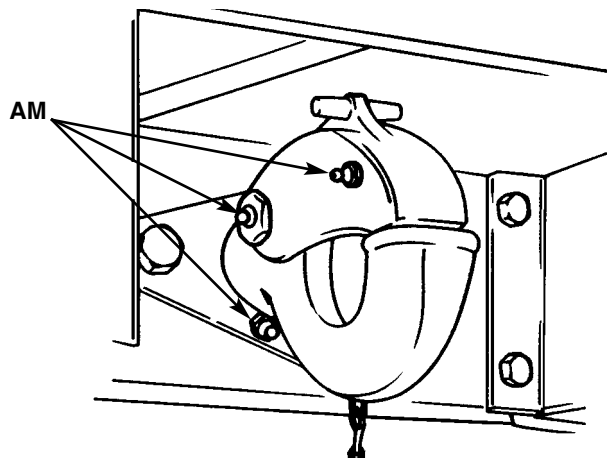

PINTLE

NOTES

1. INTERVALS

This lubrication instruction has been revised with the Department of Army program to extend intervals to conserve lubricants. This instruction applies only to vehicles in normal operation. Lubricate more frequently to compensate for abnormal or extreme conditions, such as high or low temperatures, emersion in water, or exposure to sand or dust. Lubricants which have become contaminated will be changed regardless of scheduled intervals. Points requiring lubrication at 3,000 miles (4,827 km) on vehicles not accumulating 3,000 miles (4,827 km) in a six-month period, will be lubricated at time of semiannual (S) preventive maintenance service. Points requiring lubrication at 6,000 miles (9,654 km) in a six-month period will be lubricated at least once a year. Points requiring lubrication at 12,000 miles (19,308 km) will be lubricated annually. When practicable, lubrication services will be made to coincide with semiannual preventive maintenance service. For this purpose, a 10-percent variation in specified lubrication point mileage is permissible.

2. WINCH CABLE

At semiannual service, if cable is not generally used, unwind entire cable. Use a brush to clean, and soak with new OE/HDO. Wipe off excess, and coat with CW before rewinding cable on drum.

3. GEARCASES

NOTE

When a safe level of lubricant within a gear housing is indicated at time of scheduled lubrication, the lubricant retaining seal is functional, even though the seal may indicate questionable leakage. Questionable leaks that may indicate a defective seal will be subject to frequent observation as a potential problem area. When seepage or leakage of lubricant adversely affects the proper function of parts within the area; e.g., brakes, the retaining seal is non-functional regardless of lubricant level.

Change gear lubricant only when required by maintenance repair action, or if contaminated by water or other foreign material. Semiannually, check lubricant for proper level and for contamination. Drain only when unit is hot after operation. At axle differentials, transfer case, and front winch, check level within 1/2 in. (12.70 mm) of level plug opening. Level in winch end housing is 6-7/8 in. (174.62 mm) below filler plug. Use the full level plug located on the right side on winch worm housing to check lubrication level.

4. CRANKCASE BREATHER

Check and clean crankcase breather and lines every 6,000 miles (9,654 km) under normal operating conditions.

5. OIL FILTERS

Oil filters shall be serviced/cleaned/changed as applicable when:

- They are known to be contaminated or clogged.
- Service is recommended by AOAP laboratory analysis.
- Prescribed hard-time intervals are reached.

6. CRANKCASE

NOTE

Submit oil samples as soon as they have been taken.

AOAP does not do away with seasonal oil changes. Make oil changes as seasonal temperatures require.

a. Sample oil every 60 days or 1,000 miles (1,609 km). Army Reserve Units will sample oil every 120 days or 1,000 miles (1,609 km). Oil will be changed only when directed by oil analysis laboratory.

To check engine oil level, wait at least one minute after shutting down engine to allow oil to drain into crankcase. Safe operating level is between ADD and FULL on dipstick. Do not overfill.

NOTES (Contd)

b. When vehicle or engine is placed in storage other than administrative storage, service the crankcase with OE/HDO 15W40 engine oil. Note that MIL-PRF-2104 engine oil is an operational lubricant and may be used until the initial scheduled oil change after reactivation of the vehicle or engine. For administrative storage, engine oil conforming to the specification and grade established in Table 1, Fluid Capacities and Lubricant Requirements, should be used.

7. FUEL/WATER SEPARATOR

Replace fuel filter every 6,000 miles (9,654 kilometers) or six months, whichever occurs first.

8. REAR SPRING SEAT BUSHINGS OR BEARINGS

a. Every 3,000 miles (4,827 km) or semiannually, whichever occurs first, remove bearing cap and tighten bearing adjusting nut in accordance with TM 9-2320-361-20. Install cap loosely, and lubricate bearings by removing pipe plug in bottom of spring seat and installing fitting. Lubricate with GAA grease through fitting until lubricant appears around cap. Remove fitting, and reinstall pipe plug.

b. Every 6,000 miles (9,654 km), or annually, whichever occurs first, remove, clean, and inspect bearings. Reinstall bearings, tighten adjusting nuts and locknuts, and lubricate bearings as described in step a. above.

9. TRANSMISSION

a. Check oil level of automatic transmission using the following procedure:

(1) Allow engine to idle. Shift transmission to neutral and apply parking brake.

(2) Withdraw dipstick slowly to prevent a false reading. If transmission oil temperature gauge reads 160°F (71°C) or below, level on dipstick should show between marks designated for normal run. If transmission oil temperature is above 160°F (71°C), allow transmission oil to cool.

CAUTION

Do not overfill transmission. Internal transmission component damage will result.

(3) If transmission oil level is low, add oil through filler tube. Return dipstick to filler tube, tighten dipstick handle, and wipe away any spilled oil.

b. When AOAP laboratory support is not available, change oil every 24,000 miles (38,616 km) or 24 months, whichever occurs first.

10. WINCH HYDRAULIC OIL RESERVOIR

Every 12,000 miles (19,308 km) or 12 months, whichever occurs first, remove drainplug from reservoir and drain oil. Always install drainplug after draining. Refill reservoir to middle of sight glass.

11. FRONT WHEEL UNIVERSAL JOINTS

Every 12,000 miles (19,308 km) or annually, whichever occurs first, remove plug from universal joint housing, fill to level of plug opening, and reinstall plug. Remove plugs on each side of steering knuckle, and fill to level of plug opening through upper and lower steering knuckle bearings. Do not disassemble.

12. WHEEL BEARINGS

Every 6,000 miles (9,654 km) or six months, whichever occurs first, remove, clean, dry, repack, and install wheel bearings.

NOTES (Contd)

13. FRONT SPRING SHACKLES

CAUTION

Wipe fittings clean before servicing to prevent damage to shackle pins and bushings.

Every 3,000 miles (4,827 km) or three months, whichever occurs first, lubricate with GAA until grease appears between shackle pin and bushing at both ends of spring shackle. If shackle pin does not accept GAA, remove pin. Clean and inspect shackle pin and bushing. Replace if necessary.

END OF WORK PACKAGE

UNIT MAINTENANCE INSTRUCTIONS

EXTENDED SERVICE PROGRAM (ESP)

TRUCK, CARGO, 2-1/2-TON, 6X6, M44A3 SERIES TRUCKS (DIESEL)

M35A3, W/O WINCH (NSN 2320-01-383-2047); W/WINCH (NSN 2320-01-383-3850);

M35A3C, W/O WINCH (NSN 2320-01-383-2050); W/WINCH (NSN 2320-01-383-2049);

M36A3, W/O WINCH (NSN 2320-01-383-2048); W/WINCH (NSN 2320-01-383-2046).

PREVENTIVE MAINTENANCE CHECKS AND SERVICES

INTRODUCTION

GENERAL (PMCS)

The best way to maintain vehicles covered by this manual is to inspect them on a regular basis so minor faults can be discovered and corrected before they result in serious damage or failure of vehicle and equipment or injury to personnel. WP 0025 00 contains systematic instructions for inspection, adjustment, and correction of vehicle components to avoid costly repairs or major breakdowns. This is referred to as Preventive Maintenance Checks and Services (PMCS).

REPORTING REPAIRS

All uncorrected defects will be recorded on Equipment Inspection and Maintenance Worksheet, DA Form 2404, in accordance with DA Pam 738-750.

GENERAL SERVICE AND INSPECTION PROCEDURES

a. While performing specific PMCS procedures, ensure items are correctly assembled, secure, serviceable, not worn, not leaking, and adequately lubricated as defined below:

(1) An item is **CORRECTLY ASSEMBLED** when all parts are present and in proper position.

(2) When wires, nuts, washers, hoses, or attaching hardware cannot be moved by hand, wrench, or prybar, they are **SECURE**.

(3) An item is **UNSERVICEABLE** if it is worn beyond established wear limits or is likely to fail before the next scheduled inspection.

(4) An item is **WORN** if there is play between joining parts, or warning and caution plates are not readable.

(5) **LEAKS**. TM 9-2320-386-10 contains definitions of class I, II, and III leaks and their effect on vehicle operation.

(6) If an item meets the requirements specified by the lubrication instructions, WP 0023 00, then it is **ADEQUATELY LUBRICATED**.

b. Where the instruction tighten appears in a procedure, you must tighten with a wrench to the given torque value even when the item appears to be secure.

WARNING

Skysol-100 mixture is combustible. Use mechanical ventilation whenever product is used in a confined space, is heated above ambient temperatures, or is agitated. DO NOT use or store near heat, sparks, flame, or other ignition sources. Keep container sealed when not in use.

Contact with Skysol-100 may cause skin irritation. Use chemical resistant gloves. In case of skin contact, remove any contaminated clothing and wash skin thoroughly with soap and water. Wash contaminated clothing before reuse. Eye contact may cause irritation, tearing, or blurring of vision. Use face shield or goggles when eye contact may occur. In case of eye contact, flush eyes with large amounts of water for at least fifteen (15) minutes or until irritation subsides. Inhalation may cause irritation to upper respiratory passages. DO NOT have food or drink in the vicinity.

c. Where the instruction clean appears in a procedure, you must use Skysol-100 to clean grease or oil from metal parts. After the item is cleaned, rinsed, and dried, apply a light grade of oil to unprotected surfaces to prevent rusting. To clean rubber and plastic materials, use soap and water.

END OF WORK PACKAGE

UNIT MAINTENANCE INSTRUCTIONS

EXTENDED SERVICE PROGRAM (ESP)

TRUCK, CARGO, 2-1/2-TON, 6X6, M44A3 SERIES TRUCKS (DIESEL)

M35A3, W/O WINCH (NSN 2320-01-383-2047); W/WINCH (NSN 2320-01-383-3850);

M35A3C, W/O WINCH (NSN 2320-01-383-2050); W/WINCH (NSN 2320-01-383-2049);

M36A3, W/O WINCH (NSN 2320-01-383-2048); W/WINCH (NSN 2320-01-383-2046).

PREVENTIVE MAINTENANCE CHECKS AND SERVICES

SPECIFIC PMCS PROCEDURES

NOTE

Designated intervals are performed under usual operating conditions. PMCS must be performed more frequently when operating under unusual conditions.

a. Perform all semiannual inspections in addition to annual inspections at the time of the annual inspection. Perform all annual and semiannual inspections in addition to biennial inspections at the time of the biennial inspection.

b. The preventive maintenance checks and services for which you are responsible are provided in table 1. The checks and services listed are arranged in logical order.

c. The following columns are left to right on the PMCS schedule:

(1) **Item Number.** Provides logical order for PMCS performance and is used as a source number for DA Form 2404, on which your PMCS results will be recorded.

(2) **Interval.** Indicates when check or service is to be performed. Intervals are:

(a) **Semiannually.** Every 6 months or 6,000 miles (9,654 kilometers), whichever comes first.

(b) **Annually.** Every 12 months or 12,000 miles (19,308 kilometers), whichever comes first.

(c) **Biennially.** Every 24 months or 24,000 miles (38,616 kilometers), whichever comes first.

(3) **Item To Check/Service.** Lists the system, common name, or location of the item to be inspected.

(a) Lists the system, common name, or location of the item to be inspected.

(b) The letters RPL in this column indicate replacement parts are required to complete the task or procedure. Check mandatory replacement parts list tables 2 and 3 at end of this procedure.

(4) **Procedure.** Provides instructions for servicing, inspection, replacement, or adjustment, and in some cases, having an item repaired at a higher level. If a defect is found, repair, fill, replace, or adjust as needed.

(5) **Equipment Not Ready/Available If.** Provides information for deadlining a vehicle when checks or services reveal a defect or deficiency with a component(s) of the vehicle.

Table 1. Unit Preventive Maintenance Checks and Services

ITEM NO.	INTERVAL	ITEM TO CHECK/SERVICE	PROCEDURE	EQUIPMENT NOT READY/AVAILABLE IF:
1	Semiannually	Starter	<p>PRIOR TO ROAD TEST</p> <p>Perform all Before Operation and Weekly checks listed TM 9-2320-386-10.</p> <p>Start engine (TM 9-2320-386-10). While cranking engine, listen for unusual noises and difficult cranking.</p>	
2	Semiannually	Engine and engine compartment	<p>a. Observe engine response to accelerator pedal (1). Listen for unusual noises. Observe for hesitation, varying idle speed, and sticking or binding of the accelerator pedal (1).</p>	<p>a. Accelerator pedal is sticking or binding.</p>
3	Semiannually	Throttle control	<p>b. Be alert for excessive vibration and the smell of fuel, oil, coolant, and exhaust.</p> <p>Check travel and free movement by pulling throttle control (2) all the way out. Ensure throttle control (2) does not bind or stick in any position.</p>	<p>Throttle is sticking or binding.</p>

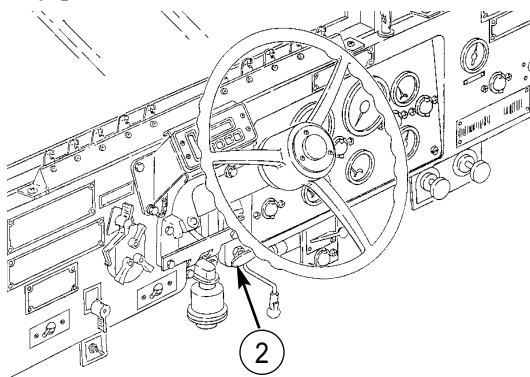
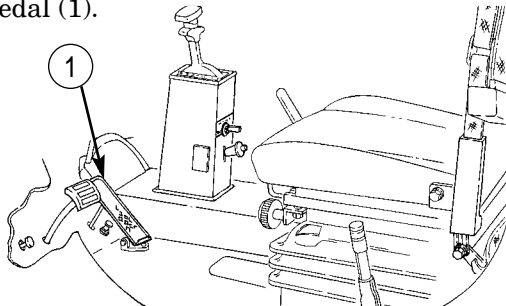

Table 1. Unit Preventive Maintenance Checks and Services (Contd).

ITEM NO.	INTERVAL	ITEM TO CHECK/SERVICE	PROCEDURE	EQUIPMENT NOT READY/AVAILABLE IF:
4	Semiannually	Brakes	<p style="text-align: center;">ROAD TEST</p> <p>Perform all During Operation checks listed in TM 9-2320-386-10. Drive the vehicle at least 5 mi (8 km) over varied terrain both on and off road. This will provide ample time to check reported malfunctions and locate unreported malfunctions.</p> <p>a. Reach a desired speed and lightly depress brake pedal (3) with a steady force. Vehicle should slow down immediately and stop smoothly, without noticeable side-pull or chatter.</p> <p>b. Check brake pedal (3) to ensure it stops no less than 2.0 in. (5.0 cm) above floor. If brake pedal (3) stops less than 2 in. (5.0 cm) above floor, check brakeshoe adjustment (WP 0163 00).</p> <p>c. Check brake pedal (3) for 0.2-0.5 in. (.06-1.25 cm) free travel. If brake pedal adjustment is required refer to WP 0163 00.</p>  <p>d. After stopping the vehicle and with transmission in drive, release brake pedal (3). The brakes should release immediately and without difficulty.</p>	<p>a. Service brakes do not operate properly, hydraulic or air leaks are evident.</p> <p>b. Pedal goes within 2.0 in. (5.0 cm) of floor.</p> <p>c. Brakes do not release.</p>

Table 2-1. Unit Preventive Maintenance Checks and Services (Contd).

ITEM NO.	INTERVAL	ITEM TO CHECK/SERVICE	PROCEDURE	EQUIPMENT NOT READY/AVAILABLE IF:
5	Semiannually	CTIS	<p>Observe response to pressure setting selected on ECU (1). CTIS should inflate and deflate tires without any hesitation, or over or under inflate.</p>	
6	Semiannually	Transmission	<p>a. Check for response to shifting and for smoothness of operation in all speed ranges</p> <p>b. Be alert for unusual noises and difficulty in shifting in any gear range.</p> <p>c. Check transmission oil temperature gauge (2) for proper reading.</p>	<p>b. Shifting is stiff, binding, or slipping.</p> <p>c. Oil temperature over 300°F (149°C).</p>
7	Semiannually	Steering System	<p>a. Check steering wheel (3) and ensure it does not exceed more than 2.5 in. (6.35 cm) free play</p> <p>b. Turn steering wheel (3) through full range to check for any hard steering, binding, or shimmying.</p> <p>c. With vehicle moving straight on level terrain, lightly hold steering wheel (3) to check for pull and wander.</p> 	<p>a. Steering wheel exceeds 2.5 in. (6.35 cm) free play.</p> <p>b. Steering wheel is binding or shimmying.</p>
8	Semiannually	Transfer case	<p>a. Check for response to shifting and smoothness of operation in all gear ranges.</p> <p>b. Be alert for unusual noises and difficulty in shifting in any gear range.</p>	<p>a. Transfer case is inoperative or jumps out of gear.</p> <p>b. Shifting is stiff or noisy.</p>
9	Semiannually	Suspension	<p>Observe vehicle response to road shocks. Side sway or continuous bouncing indicates a malfunction.</p>	

Table 1. Unit Preventive Maintenance Checks and Services (Contd).

ITEM NO.	INTERVAL	ITEM TO CHECK/SERVICE	PROCEDURE	EQUIPMENT NOT READY/AVAILABLE IF:
10	Semiannually	Fuel shut-off switch	<p align="center">NOTE</p> <p>Perform item 10 with engine running, transmission in N (neutral), and parking brake applied.</p> <p>Hold fuel shutoff switch (5) in ON position. Engine should stop immediately, without hesitation.</p> <p align="center">AFTER ROAD TEST</p> <p>Perform all After Operation, Weekly, and Monthly checks in TM 9-2320-386-10. Then make the following inspections in order given, including kit items on vehicle, if equipped.</p>	Fuel shutoff switch is inoperative.
11	Semiannually	Air cleaner	<p>Test air cleaner indicator (4) for proper operation:</p> <ol style="list-style-type: none"> a. Remove clamp and cap from air cleaner. b. Start engine (TM 9-2320-386-10) and run at 1200 rpm. c. Using a piece of cardboard, cover approximately 90 percent of air cleaner opening. d. Observe air cleaner indicator (4) to see if yellow band is visible. If yellow band is visible, air cleaner indicator (4) is working properly. If not, air cleaner indicator (4) is defective or indicator tube is obstructed. Stop engine (TM 9-2320-386-10). e. Remove cardboard and install cap on air cleaner with clamp. 	Air cleaner indicator inoperative or yellow band is not showing.

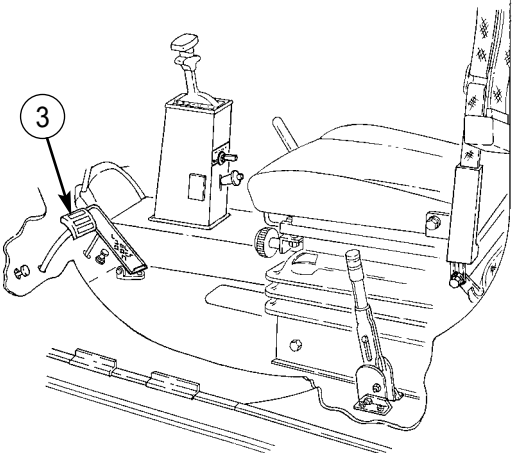
Table 1. Unit Preventive Maintenance Checks and Services (Contd).

ITEM NO.	INTERVAL	ITEM TO CHECK/SERVICE	PROCEDURE	EQUIPMENT NOT READY/AVAILABLE IF:
12	Semiannually	Batteries [RPL]	<p style="text-align: center;"><u>WARNING</u></p> <p>Battery acid (electrolyte) is extremely harmful. Always wear safety goggles and rubber gloves when performing battery maintenance. Severe injury will result if acid contacts eyes or skin.</p> <p>Do not smoke, allow open flames or sparks, or wear jewelry when performing battery maintenance. Batteries may explode, causing injury or death to personnel.</p> <p>Remove all jewelry such as rings, dog tags, bracelets, etc. If jewelry or disconnected battery ground cable contacts battery post, a direct short can result, causing damage to equipment or severe injury to personnel.</p> <p>a. Check specific gravity of each cell before adding distilled water. Using optical battery tester, which requires no temperature compensation, check specific gravity of electrolyte in each cell (TM 9-6140-200-14).</p> <p>b. Clean and inspect battery cables (WP 0121 00).</p> <p>c. If specific gravity of any cell is below 1.255, battery must be replaced or recharged. Add distilled water as necessary after checking battery. Charge batteries (1) as necessary (TM 9-6140-200-14).</p> 	
13	Semiannually	Vehicle exterior	<p>Inspect the following for completeness, security, and operation:</p> <ul style="list-style-type: none"> a. Glass b. Hinges c. Panels d. Data, caution, and warning plates. 	

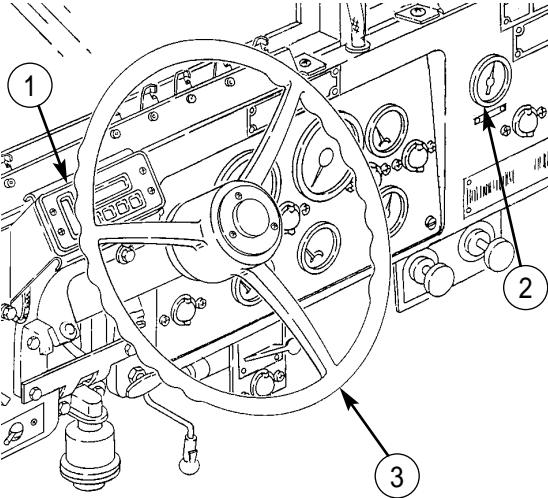
Table 1. Unit Preventive Maintenance Checks and Services (Contd).

ITEM NO.	INTERVAL	ITEM TO CHECK/SERVICE	PROCEDURE	EQUIPMENT NOT READY/AVAILABLE IF:
14	Semiannually	Body	<p>a. Remove heavy deposits of mud, rust, gravel, etc. from body sheet metal panels and frame rails. Use scraper and/or wire brush, if necessary.</p> <p>b. Thoroughly wash all underbody sheet metal panels and corners.</p> <p>c. Inspect for loose rivets, cracks, loose or missing mounting hardware, and general body damage.</p>	
15	Semiannually	Cooling system	<p style="text-align: center;">NOTE</p> <p>Open hood and secure with holddown catch (TM 9-2320-386-10).</p> <p>a. Inspect radiator (2) for clogged or bent fins (3) and protruding objects. Clean radiator (2) and straighten bent fins (3).</p> <p>b. Test coolant freeze point.</p> <p>c. Inspect radiator for corrosion. If excessive corrosion is found, flush radiator (2). Flush radiator (2) and cylinder block every four years (WP 0068 00).</p> <p>d. Inspect radiator mounts for cracks, breaks, or loose condition. If loose, tighten. If cracked or broken, replace (WP 0069 00).</p> <div data-bbox="646 1255 1117 1774" style="text-align: center;"> </div>	<p>a. Radiator is clogged, bent, or damaged.</p> <p>d. Radiator mount(s) is cracked, broken, or loose.</p>

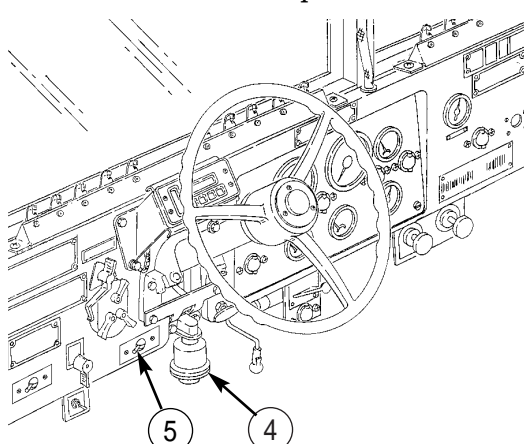
Table 1. Unit Preventive Maintenance Checks and Services (Contd).

ITEM NO.	INTERVAL	ITEM TO CHECK/SERVICE	PROCEDURE	EQUIPMENT NOT READY/AVAILABLE IF:
15 (Contd)	Semiannually	Cooling system	<p>e. Inspect fan (2) for cracks and missing or loose rivets and screws. Replace fan (2) if defective (WP 0082 00).</p> <p>f. Inspect water pump (1) for cracks, leaks, and loose condition. If loose, tighten. If broken, cracked, or leaking, replace (WP 0080 00).</p>	<p>e. Fan is cracked, broken, or loose.</p> <p>f. Water pump is broken, cracked, leaking, or loose.</p>
16	Semiannually	Engine drivebelts	<p>a. Inspect fan drivebelt (4) and water pump drivebelt (5) for wear and cracking. Replace belt(s) if necessary (WP 0081 00 or WP 0084 00).</p> <p>b. Check and adjust water pump drivebelt tension (WP 0081 00).</p> <p>c. Inspect engine drivebelt tensioner for unusual noise or wobbly pulley bearings. Replace engine drivebelt tensioner (3) if noisy or wobbly (WP 0087 00).</p> 	<p>a. Drivebelt(s) is worn or cracked. Serpentine belt is missing or broken. Belt fiber has more than one crack 1/8 in. (3.2 mm) in depth or 50% or frays more than 2 in. (5.1 cm) long</p> <p>c. Engine drivebelt tensioner is noisy or wobbly.</p>
17	Semiannually	Alternator and alternator wiring	<p>a. Inspect alternator (6) for secure mounting.</p> <p>b. Inspect alternator wiring for burned or frayed wires and loose or broken terminal connections. If loose, tighten. If burned, frayed, or broken, replace or repair wiring (WP 0125 00).</p>	<p>b. Wiring insulation is missing, frayed, or split; or poor connections are evident.</p>
18	Semiannually	Starter and starter wiring	<p>a. Inspect starter for security. If loose, tighten mounting screws to 55 lb-ft (75 N·m).</p> <p>b. Inspect starter wiring for missing, frayed, split, or poor connections. If corrosion is present, clean. If connections are loose, tighten. If damaged, repair (WP 0125 00).</p>	<p>b. Wiring insulation is missing, frayed, or split; or poor connections evident.</p>

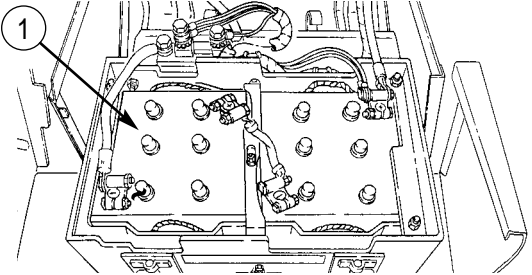
Table 1. Unit Preventive Maintenance Checks and Services (Contd).

ITEM NO.	INTERVAL	ITEM TO CHECK/SERVICE	PROCEDURE	EQUIPMENT NOT READY/AVAILABLE IF:
19	Semiannually	Air intake system	<p style="text-align: center;"><u>WARNING</u></p> <p>If NBC exposure is suspected, all air filter media should be handled by personnel wearing protective equipment. Consult your unit NBC officer or NBC NCO for appropriate handling or disposal instructions. NBC contaminated filters must be handled using adequate precautions (FM 21-40) and must be disposed of by trained personnel.</p> <p>a. Inspect air cleaner (7) and air intake tubes (9) for security and damage.</p> <p>b. Check air indicator tube (8) for kinks and bends. Replace air indicator tube if kinked or bent (WP 0041 00).</p> <p>c. Inspect air cleaner element for tears and presence of dirt and oil. Clean or replace as necessary (WP 0040 00).</p> 	<p>c. Air cleaner element is torn, dirty, or contaminated.</p>
20	Semiannually	Master cylinder	Inspect master cylinder for leaks, damage, and security. Tighten if loose, or replace if leaking or damaged (WP 0156 00).	Master cylinder is leaking or damaged.
21	Semiannually	Charged air cooler	Inspect charged air cooler for bent and broken fins, loose mounting, corrosion, and protruding objects. Clean charged air cooler, and straighten bent fins. Replace charged air cooler if damaged (WP 0072 00).	Charged air cooler is bent, broken, loose, or damaged.

Table 1. Unit Preventive Maintenance Checks and Services (Contd).

ITEM NO.	INTERVAL	ITEM TO CHECK/SERVICE	PROCEDURE	EQUIPMENT NOT READY/AVAILABLE IF:
22	Semiannually	Air compressor	<p>a. Inspect air compressor (3) for secure mounting. If loose, tighten mounting screws 35-50 lb-ft (48-68 N·m).</p> <p>b. Inspect all coolant lines (1) and oil line (2) for leaks due to cracking, softness next to clamp, and loose clamps. Replace lines that are cracked or soft; tighten loose clamps (WP 0168 00).</p> 	

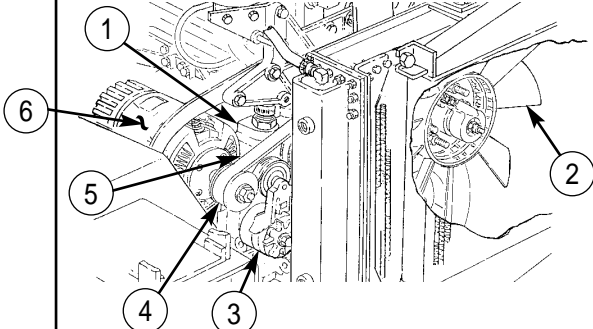
Table 1. Unit Preventive Maintenance Checks and Services (Contd).

ITEM NO.	INTERVAL	ITEM TO CHECK/SERVICE	PROCEDURE	EQUIPMENT NOT READY/AVAILABLE IF:
23	Semiannually	Engine [RPL]	Remove and clean engine crankcase breather (4) (WP 0029 00).	
24	Semiannually	Fuel system [RPL]	<p style="text-align: center;"><u>WARNING</u></p> <p>Diesel fuel is flammable. Do not perform fuel system maintenance near open flames. Injury or death to personnel may result.</p> <p>a. Replace fuel filter element (5) (WP 0054 00).</p> 	

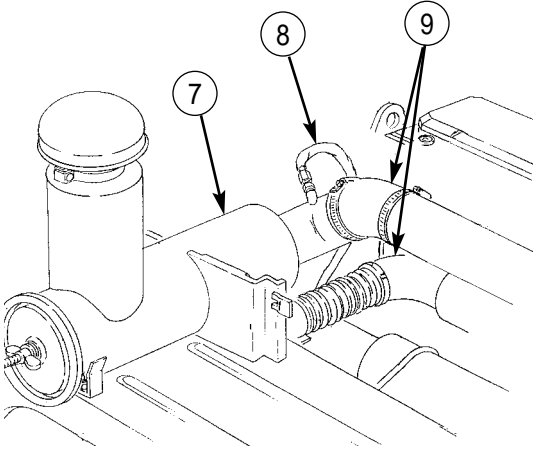
Table 1. Unit Preventive Maintenance Checks and Services (Contd).

ITEM NO.	INTERVAL	ITEM TO CHECK/SERVICE	PROCEDURE	EQUIPMENT NOT READY/AVAILABLE IF:
24 (Contd)	Semiannually	Fuel system	<p>b. Check fuel tank (1) for sludge. Open filler cap if excessive sludge is present. Drain water and sediment from fuel tank (1).</p> 	
25	Semiannually	Wheels	<p>Inspect wheels for cracks in welds, surface defects, and/or malformed parts. If damaged, replace (WP 0174 00).</p>	Wheels are cracked or damaged.
26	Semiannually	Tires	<p>a. Check each tire for wear using tire tread depth gauge. Tread depth should not be less than 4/32 in. (3 mm) as indicated on tire tread depth gage (TM 9-2610-200-14). Refer to TM 9-2610-200-14 for specific instructions for matching tires and tire rotation.</p> <p>b. Check for loose or missing wheel stud nuts and wheel studs. Tighten loose wheel stud nut on hollow stud 275-300 lb-ft (373-407 N•m) and other wheel stud nuts on solid studs 390-420 lb-ft (529-569 N•m) to within 4/32 in. Replace loose or missing wheel studs (WP 0173 00 or WP 0172 00).</p>	<p>a. Tire(s) have cuts, gouges, cracks, or leaks that would cause tire failure. Tires have cupping which cause erratic steering, or worn to within 4/32 in. (3 mm).</p>
27	Semiannually	Air dryer [RPL]	<p>a. Inspect air dryer for secure mounting or damage that could cause leaks.</p> <p>b. Replace desiccant filter and coalescing filter (WP 0281 00).</p>	

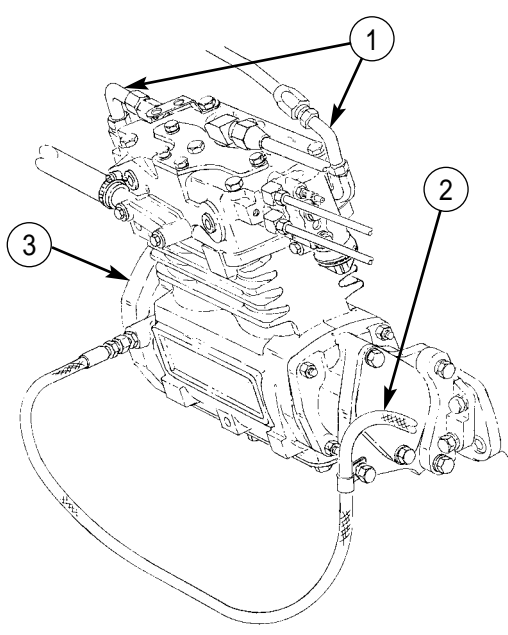
Table 1. Unit Preventive Maintenance Checks and Services (Contd).

ITEM NO.	INTERVAL	ITEM TO CHECK/SERVICE	PROCEDURE	EQUIPMENT NOT READY/AVAILABLE IF:
28	Semiannually	Brake system	<p>a. Inspect air hydraulic cylinders for leaks and damage. Replace if leaking or damaged (WP 0157 00).</p> <p>b. Inspect all flexible hydraulic brake hoses for bulges, pinches, cracks, crimping, chafing, abrasions, or leaks. If any of these conditions exist, replace or reposition to prevent failure. Check front brake hoses for loose or missing fittings, and make sure they are long enough to allow full steering travel. If brake hose is too short, replace with new longer hose (TM 9-2320-361-20).</p> <p>c. Inspect parking brakeshoes for wear. Replace both brakeshoes if lining thickness is 0.188 in. (4.76 mm) or less (TM 9-2320-361-20).</p> <p>d. Inspect parking brake cable, lever, and brakeshoe assembly for binding and loose or missing components. Tighten components if loose, or replace if missing or damaged.</p>	
29	Semiannually	Transmission	<p>a. Inspect transmission for loose screws and plugs that may cause leaks. If loose, tighten.</p> <p>b. Inspect transmission for missing or loose mounting screws. If loose, tighten 35-45 lb-ft (48-61 N·m). If missing, notify direct support maintenance.</p>	<p>b. Transmission mounting screws are loose or missing.</p>
30	Semiannually	Transmission oil cooler hoses	<p>Inspect hoses for loose connections, breaks, and leaks. Tighten loose connections. Replace hose(s) if broken or leaking (WP 0139 00).</p>	
31	Semiannually	Front winch	<p>a. Inspect front winch for secure mounting and broken or missing parts. If loose, tighten. Replace missing or broken parts (WP 0225 00).</p> <p>b. Test drag brake for proper operation (WP 0225 00).</p> <p>c. Test winch automatic brake for proper operation (WP 0225 00).</p>	<p>a. Front winch is loose.</p> <p>b. Drag brake inoperative.</p> <p>c. Automatic brake inoperative.</p>

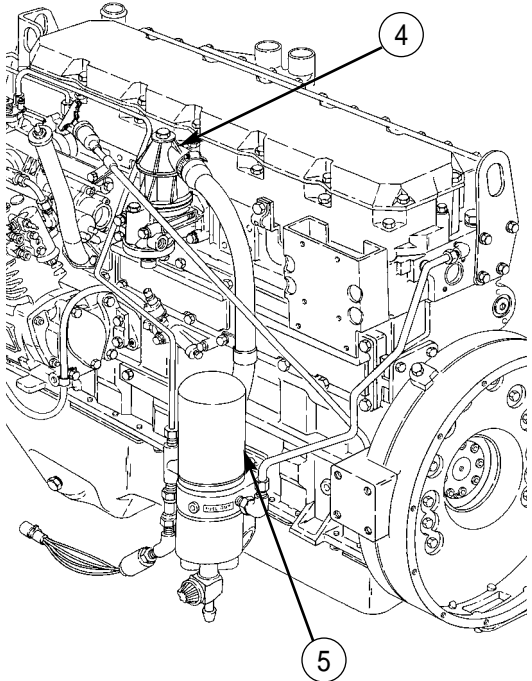
Table 1. Unit Preventive Maintenance Checks and Services (Contd).

ITEM NO.	INTERVAL	ITEM TO CHECK/SERVICE	PROCEDURE	EQUIPMENT NOT READY/AVAILABLE IF:
31 (Contd)	Semiannually	Front winch [RPL]	<p>d. Check front winch gearcase (2) and end frame housing (1) oil level (WP 0023 00).</p> <p>e. Change front winch filter oil only when required.</p>  <p style="text-align: center;">WARNING</p> <p>Wire rope can become frayed or contain broken wires. Wear heavy, leather-palmed work gloves when handling wire rope. Frayed or broken wires can injure hands.</p> <p>Never let moving wire rope slide through hands, even when wearing gloves. A broken wire could cut through glove and cut hand.</p> <p>f. Unwind entire cable, soak and clean with new oil, and inspect for kinks, frays, and wear. Refer to TM 9-2320-386-10 for operation.</p>	
32	Semiannually	Frame and cross-members	<p>a. Using a .001-in. (0.025-mm) thick feeler gauge, check for space between rivet head and riveted frame member. Penetration of the feeler gauge between the rivet and the riveted member is reason to suspect that the riveted connection and/or rivet should be replaced.</p> <p>b. Thoroughly clean rivet and riveted connection of all dirt, grease, and oil. Using an oil can, apply lubricating oil (WP 0023 00) around the suspect rivet and riveted connection. Allow approximately 10-20 seconds for the oil to penetrate. Wipe rivet and riveted connection free of oil. Tap rivet with an 8-pound hammer. Any indication of oil around the rivet indicates a loose rivet. Replace all loose rivets. Check all riveted connections for signs of movement, such as bare or shiny spots, or other indications of movement between rivet and framing member. If movement is indicated, rivet and connection are loose. Repair all loose connections (TM 9-2320-361-34).</p>	<p>b. Any loose or missing rivets.</p>

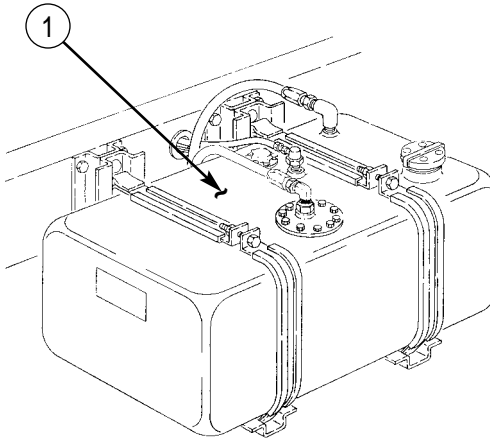
Table 1. Unit Preventive Maintenance Checks and Services (Contd).

ITEM NO.	INTERVAL	ITEM TO CHECK/SERVICE	PROCEDURE	EQUIPMENT NOT READY/AVAILABLE IF:
32 (Contd)	Semiannually	Frame and cross-members	<p>c. Check bolted frame connections for loose bolts and nuts, tightness, and proper mating with frame surfaces. Check the torque of all bolts not scheduled to be removed in accordance with Torque Limits WP 0385 00</p> <p>d. Check welded frame connections for integrity, deterioration, and flanking. Notify direct support maintenance to replace or repair welded frame connections.</p> <p style="text-align: center;">NOTE</p> <p>Perform all semiannual checks listed in this table.</p>	d. Any broken or cracked welds.
33	Annually	Engine	Inspect engine for accumulated grease and oil. Remove grease and oil by steam-cleaning engine.	
34	Annually	Engine mounts	Inspect engine mounts for damage and loose mounting hardware. If loose, tighten 240 lb-ft (325 N•m). Notify direct support maintenance if damaged.	Engine mounts are damaged or loose.
35	Annually	Turbo-charger	<p style="text-align: center;">CAUTION</p> <p>Turbocharger bearing failures can cause large quantities of oil to enter the air intake and exhaust systems. Loss of engine lubricant can result in serious engine damage.</p> <p>Do not continue engine operation until the turbocharger is repaired or replaced.</p> <p>a. Remove exhaust outlet piping and inlet piping from turbocharger (3) (WP 0066 00). Inspect turbine wheel and compressor wheel for contact with turbocharger housing.</p> <p>b. If there is contact, notify direct support maintenance.</p> <p>c. Visually check for oil leaks. Notify direct support maintenance if leaking</p> 	c. Any class III oil leakage.

Table 1. Unit Preventive Maintenance Checks and Services (Contd).

ITEM NO.	INTERVAL	ITEM TO CHECK/SERVICE	PROCEDURE	EQUIPMENT NOT READY/AVAILABLE IF:
36	Annually	Crankshaft vibration damper	<p>Inspect vibration damper (1) for looseness, cracks, or leaks. If loose, cracked, or leaking, notify direct support maintenance.</p> 	Vibration damper is loose, cracked, or kink is evident.
37	Annually	Front winch	<p>Inspect hydraulic lines (2), (3), (4), and (5) for loose fittings. If loose, tighten.</p> 	

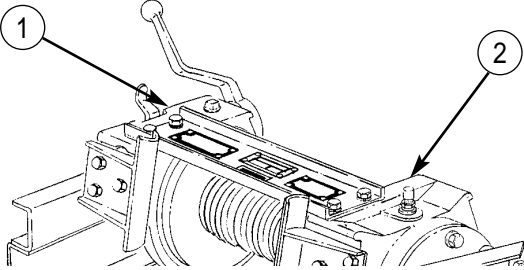
Table 1. Unit Preventive Maintenance Checks and Services (Contd).

ITEM NO.	INTERVAL	ITEM TO CHECK/SERVICE	PROCEDURE	EQUIPMENT NOT READY/AVAILABLE IF:
38	Biennially	Cooling system [RPL]	<p style="text-align: center;">NOTE</p> <p>Perform all semiannual and annual checks listed in this table.</p> <p>a. Replace thermostat (WP 0077 00). b. Clean and flush radiator (WP 0068 00).</p>	
39	Biennially	Air compressor	<p style="text-align: center;"><u>WARNING</u></p> <p>Air system components are subject to high pressure. Always relieve pressure before loosening or removing air system components. Failure to do so may result in serious injury to personnel.</p> <p>Always wear eye protection when draining air reservoirs. Failure to do so may result in injury to personnel.</p> <p>Remove discharge fittings and inspect compressor discharge port and discharge line for excessive carbon deposits. If there are excessive carbon deposits, clean or replace air compressor (WP 0169 00).</p>	

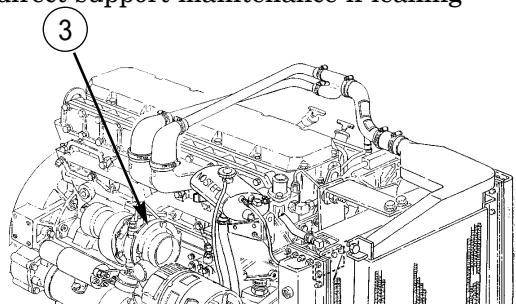
PMCS MANDATORY REPLACEMENT PARTS LIST

Table 2 is list of parts required when performing semiannual PMCS. The semiannual parts list contains the mandatory replacement parts for one semiannual PMCS. Table 3 is a list of annual or biennially part contains the mandatory replacement parts for one semiannual and the peculiar replacement parts for annual or biennial PMCS.

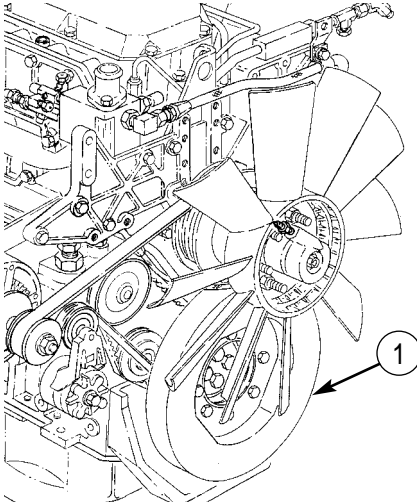
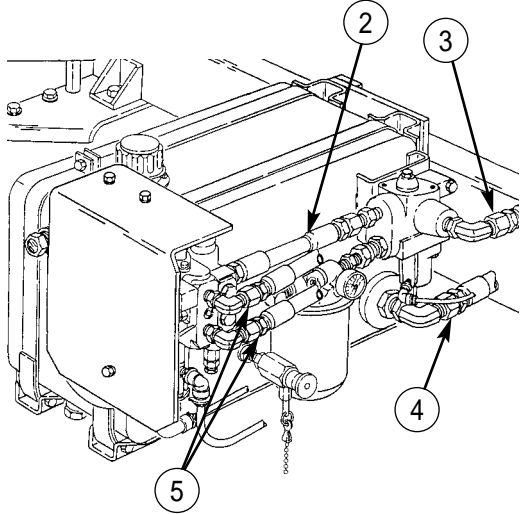
Table 2. Semiannual (6,000 Mile) Mandatory Replacement Parts List.

<i>ITEM NO.</i>	<i>PART NUMBER</i>	<i>NSN</i>	<i>NOMENCLATURE</i>	<i>QTY</i>	<i>PMCS STEPS NO.</i>
1.	MS 35338-46	5310-00-722-5658	Lockwasher	10	12
2.	3-904N552-90	5300-01-049-1292	O-ring	1	23
2.	4L9564	5330-00-828-8639	O-ring	1	23
2.	7C1159	5330-01-360-5941	Gasket	1	23
3.	7E9763	2910-01-363-3089	Fuel Filter	1	24a
4.	RN60Y	2530-01-442-4606	Kit, Air Dryer Filter	1	27b
5.	RE501	2940-01-442-4076	Winch Oil Filter	1	31e

Table 3. Annual (12,000 Mile) or Biennial (24,000 Mile) Mandatory Replacement Parts List.

<i>ITEM NO.</i>	<i>PART NUMBER</i>	<i>NSN</i>	<i>NOMENCLATURE</i>	<i>QTY</i>	<i>PMCS STEPS NO.</i>
	4P2684	5330-01-436-4400	Gasket	1	38a

END OF WORK PACKAGE

UNIT MAINTENANCE INSTRUCTIONS

EXTENDED SERVICE PROGRAM (ESP)

TRUCK, CARGO, 2-1/2-TON, 6X6, M44A3 SERIES TRUCKS (DIESEL)

*M35A3, W/O WINCH (NSN 2320-01-383-2047); W/WINCH (NSN 2320-01-383-3850);
M35A3C, W/O WINCH (NSN 2320-01-383-2050); W/WINCH (NSN 2320-01-383-2049);
M36A3, W/O WINCH (NSN 2320-01-383-2048); W/WINCH (NSN 2320-01-383-2046).*

**SECTION III. ENGINE SYSTEM MAINTENANCE
TABLE OF CONTENTS**

<i>WP Title</i>	<i>WP Sequence No.-Page No.</i>
Front Engine Mounting Pad Replacement	0027 00-1
Valve Cover Replacement	0028 00-1
Engine Crankcase Breather and Base Maintenance	0029 00-1
Engine Oil Dipstick and Tube Replacement	0030 00-1
Engine Oil Filler Tube Replacement	0031 00-1
Engine Oil Manifold Maintenance	0032 00-1
Engine Oil Filter Maintenance	0033 00-1
Engine Oil Sampling Valve Replacement	0034 00-1
Fan Drive Pulley Replacement	0035 00-1

END OF WORK PACKAGE

UNIT MAINTENANCE INSTRUCTIONS

EXTENDED SERVICE PROGRAM (ESP)

TRUCK, CARGO, 2-1/2-TON, 6X6, M44A3 SERIES TRUCKS (DIESEL)

M35A3, W/O WINCH (NSN 2320-01-383-2047); W/WINCH (NSN 2320-01-383-3850);

M35A3C, W/O WINCH (NSN 2320-01-383-2050); W/WINCH (NSN 2320-01-383-2049);

M36A3, W/O WINCH (NSN 2320-01-383-2048); W/WINCH (NSN 2320-01-383-2046).

FRONT ENGINE MOUNTING PAD REPLACEMENT

REMOVAL, INSTALLATION

INITIAL SETUP:

Tools and Special Tools

General mechanic's tool kit
(item 30, WP 0394 00)
Common No. 1 tool kit (item 15, WP 0394 00)
Lifting device
Supporting device

References

TM 9-2320-386-24P

Equipment Condition

Parking brake set (TM 9-2320-386-10).
Hood raised and secured (TM 9-2320-386-10).
Radiator and mounts removed (WP 0069 00).

Materials/Parts

Lockwasher (item 132, WP 0395 00)
Detergent (item 21, WP 0393 00)

FRONT ENGINE MOUNTING PAD REPLACEMENT (Contd)**REMOVAL**

1. Remove screw (6), lockwasher (5), and washer (4) from crossmember (7) and front engine mount (1). Discard lockwasher (5).

WARNING

Use suitable supporting device at front engine mount when removing mounting pad. Lifting device failure may cause injury to personnel.

2. Using a lifting device, raise engine (8) from crossmember (7).
3. Remove washer (2) and rubber mounting pad (3) from crossmember (7).
4. Lower engine (8) and remove lifting device.

INSTALLATION**WARNING**

Use suitable supporting device at front engine mount when installing mounting pad. Lifting device failure may cause injury to personnel.

1. Using a lifting device, raise engine (8) from crossmember (7).
2. Apply a detergent and water solution to rubber mounting pad (3).
3. Partially position rubber mounting pad (3) on crossmember (7) by pressing down on rubber mounting pad (3) and rotating.
4. Position washer (2) on rubber mounting pad (3) and lower engine (8) to seat rubber mounting pad (3) on crossmember (7).
5. Align hole of crossmember (7) with hole of engine mount (1) and install washer (4), new lockwasher (5), and screw (6). Tighten screw (6) 240 lb-ft (325 N•m).
6. Install radiator and mounts (WP 0069 00).

FRONT ENGINE MOUNTING PAD REPLACEMENT (Contd)

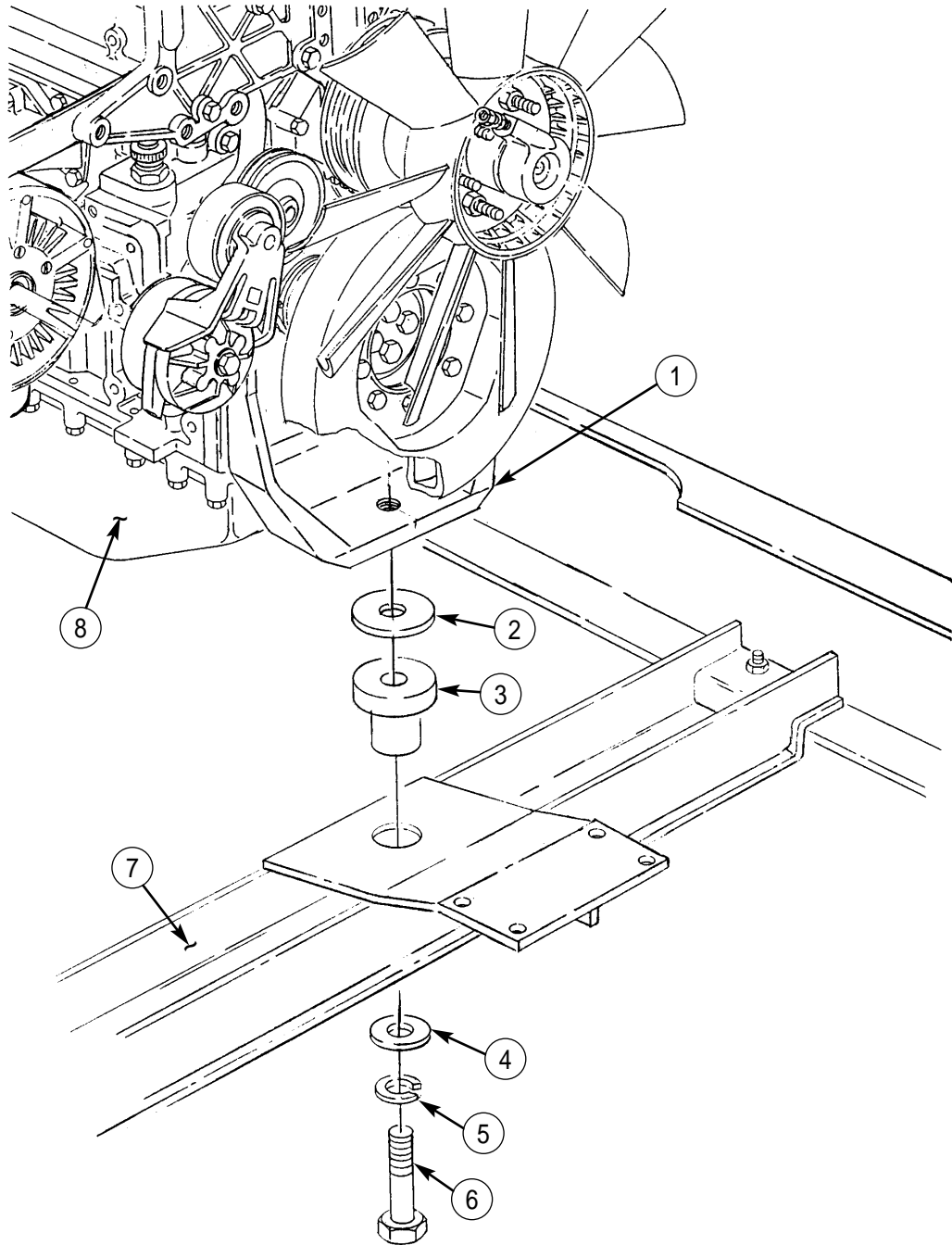

END OF WORK PACKAGE

UNIT MAINTENANCE INSTRUCTIONS

EXTENDED SERVICE PROGRAM (ESP)

TRUCK, CARGO, 2-1/2-TON, 6X6, M44A3 SERIES TRUCKS (DIESEL)

M35A3, W/O WINCH (NSN 2320-01-383-2047); W/WINCH (NSN 2320-01-383-3850);

M35A3C, W/O WINCH (NSN 2320-01-383-2050); W/WINCH (NSN 2320-01-383-2049);

M36A3, W/O WINCH (NSN 2320-01-383-2048); W/WINCH (NSN 2320-01-383-2046).

VALVE COVER REPLACEMENT

IN-VEHICLE PREP, REMOVAL, INSTALLATION, IN-VEHICLE FINISHING

INITIAL SETUP:

Tools and Special Tools

General mechanic's tool kit
(item 30, WP 0394 00)

Common No. 1 tool kit
(item 15, WP 0394 00)

Materials/Parts

Gasket (item 144, WP 0395 00)
Adhesive (item 5, WP 0393 00)

References

TM 9-2320-386-24P

Equipment Condition

Parking brake set (TM 9-2320-386-10).
Hood raised and secured (TM 9-2320-386-10).
Battery ground cable disconnected (WP 0121 00).
Quick-start atomizers removed (WP 0057 00).

VALVE COVER REPLACEMENT (Contd)

IN-VEHICLE PREP

1. Remove two clamps (6) and elbows (7) from air inlet elbows (5).
2. Remove clamp (3) and adapter (2) from tube (4).
3. Remove two tube assemblies (1) from vehicle.

REMOVAL

Remove fourteen screws (9), washers (10), valve cover (8), and gasket (11) from air intake manifold (12). Discard gasket (11).

INSTALLATION

1. Apply adhesive on new gasket (11) and position gasket (11) on valve cover (8).
2. Install valve cover (8) on air intake manifold (12) with fourteen washers (10) and screws (9). Tighten screws (9) 3-7 lb-ft (4-10 N•m) in sequence shown.

IN-VEHICLE FINISHING

1. Position two tube assemblies (1) in vehicle.
2. Install adapter (2) on tube (4) with clamp (3).
3. Install two elbows (7) on air inlet elbows (5) with clamps (6).
4. Install quick-start atomizers (WP 0057 00).
5. Connect battery ground cable (WP 0121 00).

VALVE COVER REPLACEMENT (Contd)

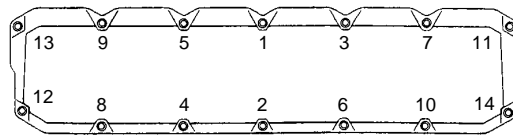
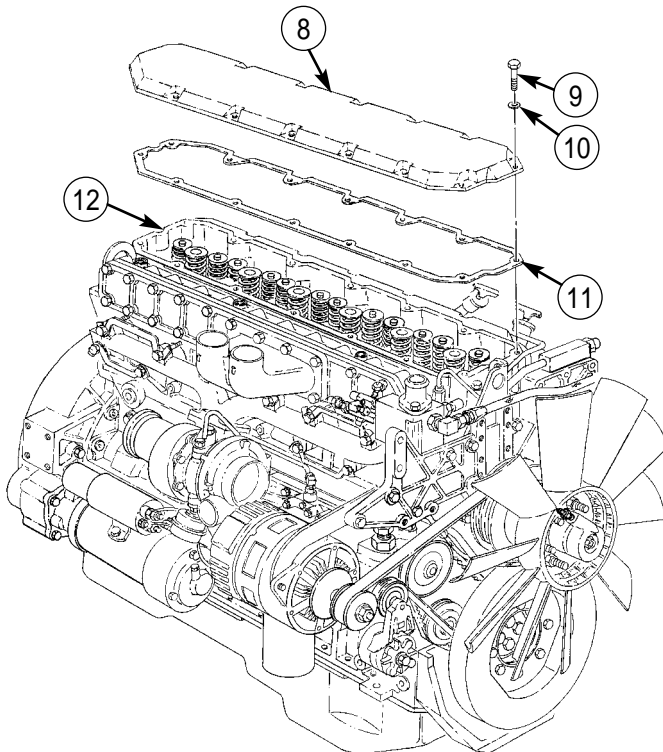
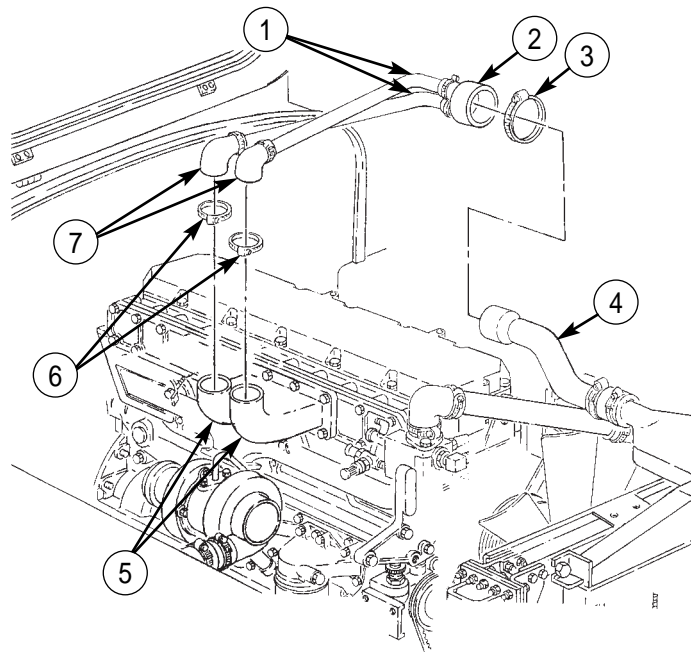

TORQUE SEQUENCE

END OF WORK PACKAGE

UNIT MAINTENANCE INSTRUCTIONS

EXTENDED SERVICE PROGRAM (ESP)

TRUCK, CARGO, 2-1/2-TON, 6X6, M44A3 SERIES TRUCKS (DIESEL)

**M35A3, W/O WINCH (NSN 2320-01-383-2047); W/WINCH (NSN 2320-01-383-3850);
M35A3C, W/O WINCH (NSN 2320-01-383-2050); W/WINCH (NSN 2320-01-383-2049);
M36A3, W/O WINCH (NSN 2320-01-383-2048); W/WINCH (NSN 2320-01-383-2046).**

ENGINE CRANKCASE BREATHER AND BASE MAINTENANCE

REMOVAL, CLEANING, INSTALLATION

INITIAL SETUP:

Tools and Special Tools

General mechanic's tool kit
(item 30, WP 0394 00)

References

TM 9-2320-386-24P

Materials/Parts

O-ring (item 214, WP 0395 00)
O-ring (item 228, WP 0395 00)
Gasket (item 281, WP 0395 00)
Skysol-100 (item 17, WP 0393 00)
Rags (item 35, WP 0393 00)
Lubricating oil (item 31, WP 0393 00)

Equipment Condition

Parking brake set (TM 9-2320-386-10).
Hood raised and secured (TM 9-2320-386-10).

ENGINE CRANKCASE BREATHER AND BASE MAINTENANCE (Contd)

REMOVAL

1. Remove screw (8), washer (7), clamp (6), breather tube (5), and spacer (16) from engine (12).
2. Remove clamp (4) and breather tube (5) from crankcase breather (3).
3. Remove screw (1), washer (2), crankcase breather (3), and O-ring (19) from base (14). Discard O-ring (19).
4. Remove plug (18) and O-ring (17) from base (14). Discard O-ring (17).
5. Remove two screws (9), washers (15), screws (10), washers (11), base (14), and gasket (13) from engine (12). Discard gasket (13).

CLEANING

WARNING

Skysol-100 mixture is combustible. Use mechanical ventilation whenever product is used in a confined space, is heated above ambient temperatures, or is agitated. DO NOT use or store near heat, sparks, flame, or other ignition sources. Keep container sealed when not in use.

Contact with Skysol-100 may cause skin irritation. Use chemical resistant gloves. In case of skin contact, remove any contaminated clothing and wash skin thoroughly with soap and water. Wash contaminated clothing before reuse. Eye contact may cause irritation, tearing, or blurring of vision. Use face shield or goggles when eye contact may occur. In case of eye contact, flush eyes with large amounts of water for at least fifteen (15) minutes or until irritation subsides. Inhalation may cause irritation to upper respiratory passages. DO NOT have food or drink in the vicinity.

Clean crankcase breather (3) with Skysol-100 and dry with clean rag.

INSTALLATION

1. Install new gasket (13) and base (14) on engine (12) with two washers (11), screws (10), washers (15), and screws (9).
2. Install new O-ring (17) and plug (18) on base (14).
3. Apply lubricating oil to new O-ring (19).
4. Install O-ring (19) and crankcase breather (3) on base (14) with washer (2) and screw (1).
5. Install breather tube (5) on crankcase breather (3) with clamp (4).
6. Install breather tube (5) and spacer (16) on engine (12) with clamp (6), washer (7), and screw (8).
7. Start engine (TM 9-2320-386-10) and check for leaks.

ENGINE CRANKCASE BREATHER AND BASE MAINTENANCE (Contd)

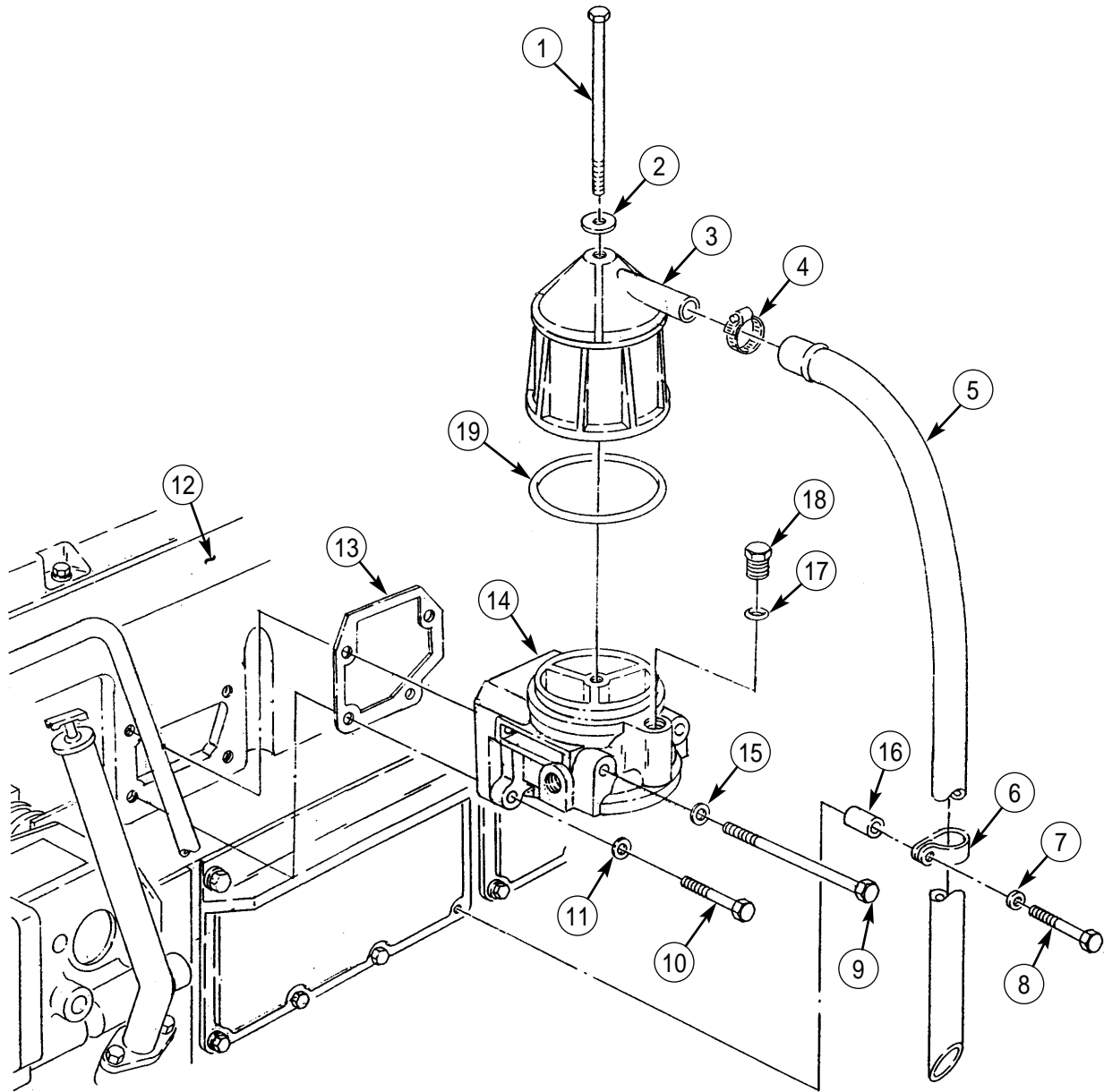

END OF WORK PACKAGE

UNIT MAINTENANCE INSTRUCTIONS

EXTENDED SERVICE PROGRAM (ESP)

TRUCK, CARGO, 2-1/2-TON, 6X6, M44A3 SERIES TRUCKS (DIESEL)

M35A3, W/O WINCH (NSN 2320-01-383-2047); W/WINCH (NSN 2320-01-383-3850);

M35A3C, W/O WINCH (NSN 2320-01-383-2050); W/WINCH (NSN 2320-01-383-2049);

M36A3, W/O WINCH (NSN 2320-01-383-2048); W/WINCH (NSN 2320-01-383-2046).

ENGINE OIL DIPSTICK AND TUBE REPLACEMENT

REMOVAL, INSTALLATION

INITIAL SETUP:

Tools and Special Tools

General mechanic's tool kit
(item 30, WP 0394 00)

Materials/Parts

Locknut (item 345, WP 0395 00)

References

TM 9-2320-386-24P

Equipment Condition

Parking brake set (TM 9-2320-386-10).
Hood raised and secured (TM 9-2320-386-10).

ENGINE OIL DIPSTICK AND TUBE REPLACEMENT (Contd)**REMOVAL****NOTE**

Have drainage container ready to catch any excess oil.

1. Remove dipstick (1) from dipstick tube (8).
2. Remove locknut (5), washer (4), screw (10), washer (9), clamp (2), and dipstick tube (8) from stabilizer bracket (3). Discard locknut (5).
3. Loosen jamnut (7) and remove dipstick tube (8) from hole on cylinder block (6).

INSTALLATION

1. Install dipstick tube (8) in hole on cylinder block (6) and tighten jamnut (7).
2. Install clamp (2) and dipstick tube (8) on stabilizer bracket (3) with washer (9), screw (10), washer (4), and new locknut (5).
3. Install dipstick (1) into dipstick tube (8).
4. Start engine (TM 9-2320-386-10) and check for leaks.

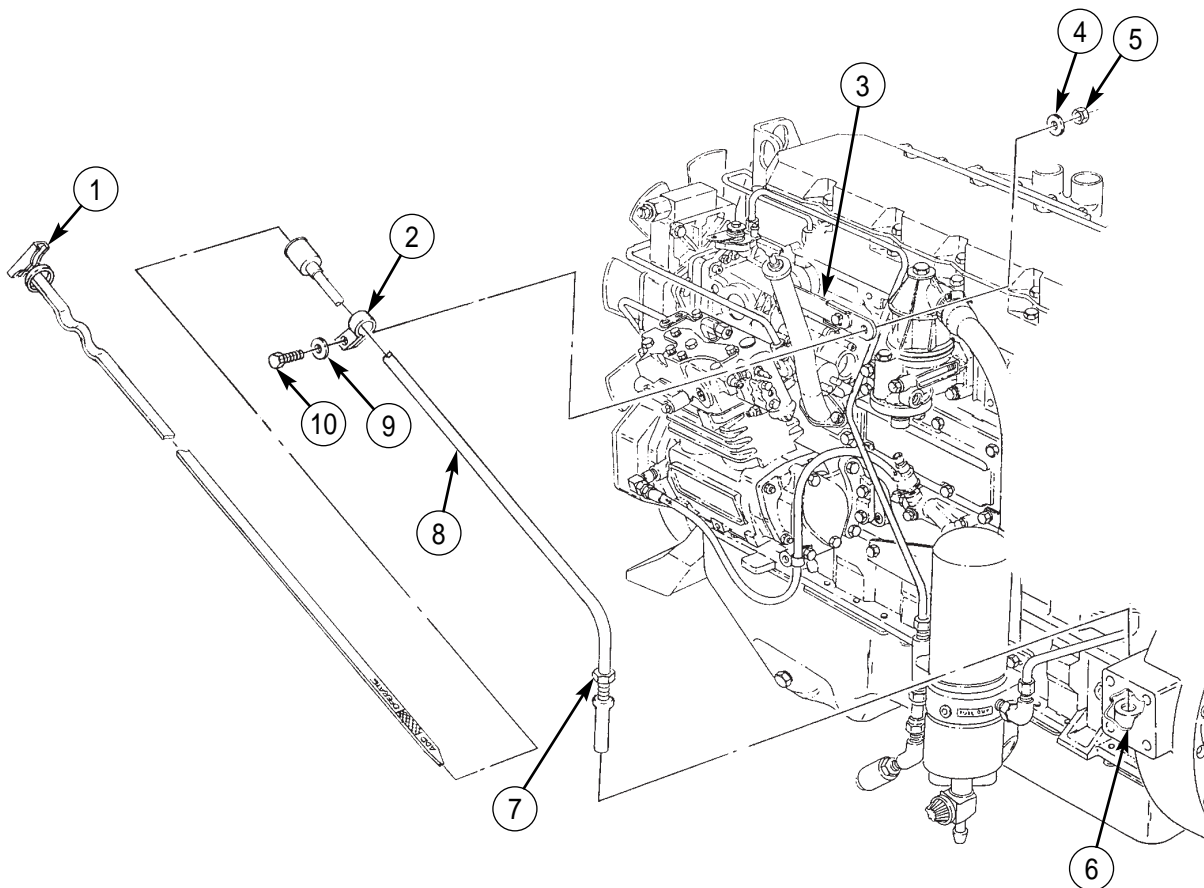

END OF WORK PACKAGE

UNIT MAINTENANCE INSTRUCTIONS

EXTENDED SERVICE PROGRAM (ESP)

TRUCK, CARGO, 2-1/2-TON, 6X6, M44A3 SERIES TRUCKS (DIESEL)

M35A3, W/O WINCH (NSN 2320-01-383-2047); W/WINCH (NSN 2320-01-383-3850);
M35A3C, W/O WINCH (NSN 2320-01-383-2050); W/WINCH (NSN 2320-01-383-2049);
M36A3, W/O WINCH (NSN 2320-01-383-2048); W/WINCH (NSN 2320-01-383-2046).

ENGINE OIL FILLER TUBE REPLACEMENT

REMOVAL, INSTALLATION

INITIAL SETUP:

Tools and Special Tools

General mechanic's tool kit
(item 30, WP 0394 00)
Common No. 1 tool kit (item 15, WP 0394 00)

Materials/Parts

Locknut (item 345, WP 0395 00)
Gasket (item 280, WP 0395 00)

References

TM 9-2320-386-24P

Equipment Condition

Parking brake set (TM 9-2320-386-10).
Hood raised and secured (TM 9-2320-386-10).

ENGINE OIL FILLER TUBE REPLACEMENT (Contd)**REMOVAL**

1. Remove cap (1) from filler tube (14).
2. Remove locknut (4), washer (3), screw (10), washer (3), two clamps (13), fuel hoses (11) and (12), and dipstick tube standoff bracket (2) from stabilizer bracket (5). Discard locknut (4).
3. Remove two screws (9), washers (8), filler tube (14), and gasket (7) from side cover (6). Discard gasket (7).

INSTALLATION

1. Install new gasket (7) and filler tube (14) on side cover (6) with two washers (8) and screws (9).
2. Install dipstick tube standoff bracket (2) and fuel hoses (11) and (12) with two clamps (13) on stabilizer bracket (5) with two washers (3), screw (10), and new locknut (4).
3. Install cap (1) on filler tube (14).
4. Start engine (TM 9-2320-386-10) and check for leaks.

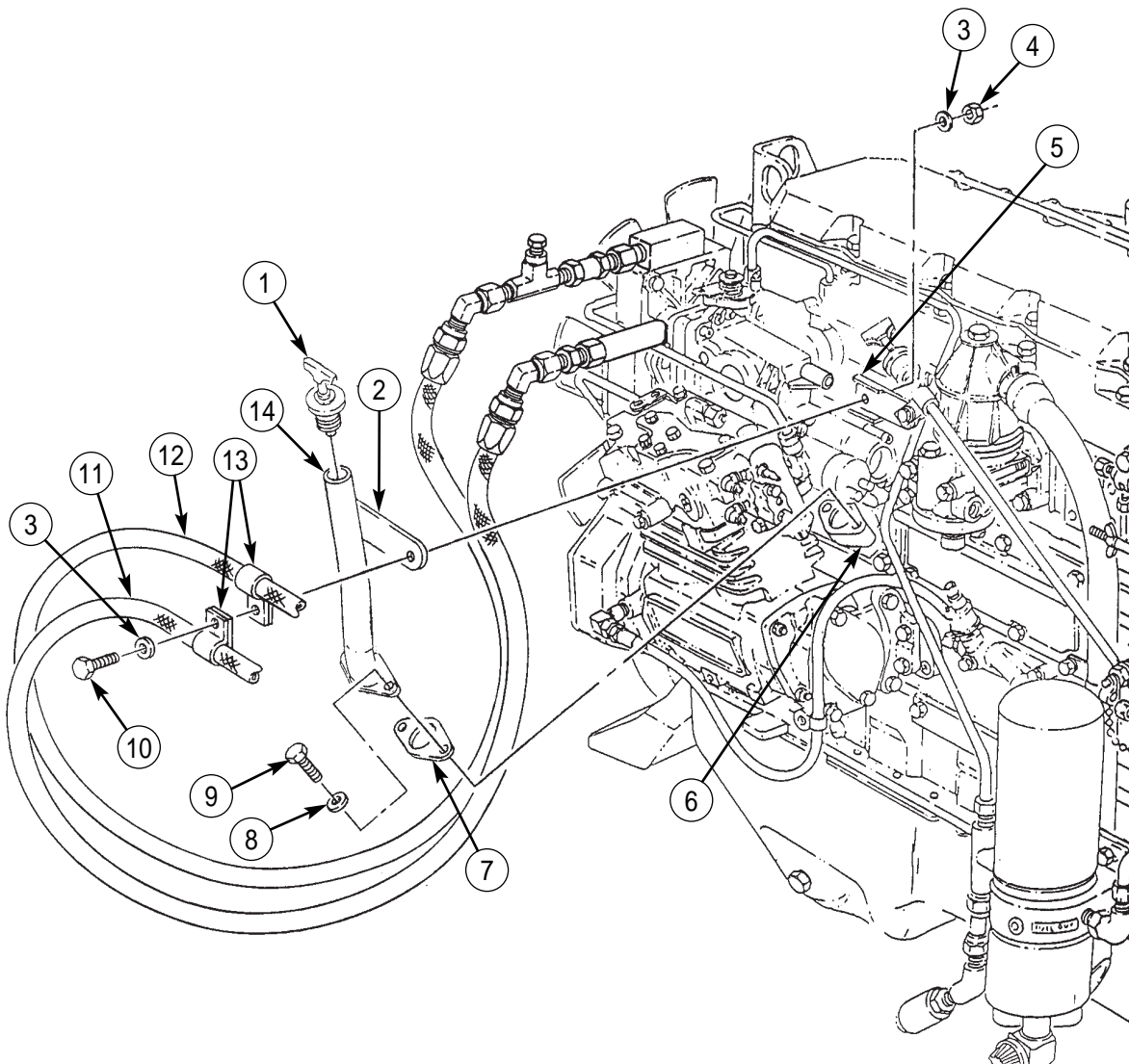
**END OF WORK PACKAGE**

UNIT MAINTENANCE INSTRUCTIONS

EXTENDED SERVICE PROGRAM (ESP)

TRUCK, CARGO, 2-1/2-TON, 6X6, M44A3 SERIES TRUCKS (DIESEL)

M35A3, W/O WINCH (NSN 2320-01-383-2047); W/WINCH (NSN 2320-01-383-3850);

M35A3C, W/O WINCH (NSN 2320-01-383-2050); W/WINCH (NSN 2320-01-383-2049);

M36A3, W/O WINCH (NSN 2320-01-383-2048); W/WINCH (NSN 2320-01-383-2046).

ENGINE OIL MANIFOLD MAINTENANCE

REMOVAL, DISASSEMBLY, ASSEMBLY, INSTALLATION

INITIAL SETUP:

Tools and Special Tools

General mechanic's tool kit
(item 30, WP 0394 00)

Common No. 1 tool kit (item 15, WP 0394 00)

Materials/Parts

O-ring (item 179, WP 0395 00)

O-ring (item 224, WP 0395 00)

References

TM 9-2320-386-24P

Equipment Condition

Parking brake set (TM 9-2320-386-10).

Hood raised and secured (TM 9-2320-386-10).

Front winch hydraulic pump removed (for
vehicles equipped with winch) (WP 0222 00).

ENGINE OIL MANIFOLD MAINTENANCE (Contd)**REMOVAL****NOTE**

Have drainage container ready to catch oil.

1. Disconnect hose (1) from elbow (9) on oil manifold (4).
2. Remove two screws (7), washers (6), oil manifold (4), and O-ring (3) from engine (2). Discard O-ring (3).

DISASSEMBLY

1. Remove pipe plug (5) from oil manifold (4).
2. Remove elbow (9) and O-ring (8) from oil manifold (4). Discard O-ring (8).

ASSEMBLY

1. Install new O-ring (8) and elbow (9) on oil manifold (4).
2. Install pipe plug (5) on oil manifold (4).

INSTALLATION

1. Install new O-ring (3) and oil manifold (4) on engine (2) with two washers (6) and screws (7).
2. Connect hose (1) to elbow (9) on oil manifold (4).
3. Install front winch hydraulic pump (for vehicles equipped with winch) (WP 0222 00).
4. Check oil level (TM 9-2320-386-10). Start engine and check for oil leaks.

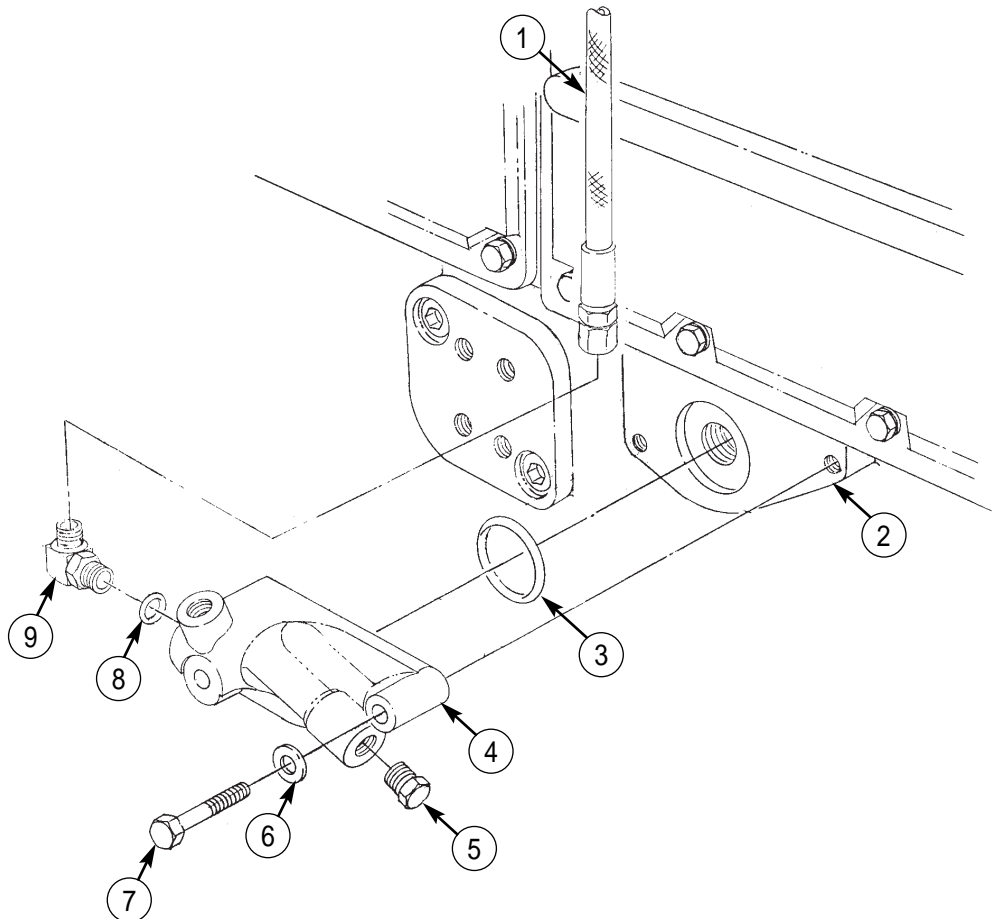

END OF WORK PACKAGE

UNIT MAINTENANCE INSTRUCTIONS

EXTENDED SERVICE PROGRAM (ESP)

TRUCK, CARGO, 2-1/2-TON, 6X6, M44A3 SERIES TRUCKS (DIESEL)

M35A3, W/O WINCH (NSN 2320-01-383-2047); W/WINCH (NSN 2320-01-383-3850);
M35A3C, W/O WINCH (NSN 2320-01-383-2050); W/WINCH (NSN 2320-01-383-2049);
M36A3, W/O WINCH (NSN 2320-01-383-2048); W/WINCH (NSN 2320-01-383-2046).

ENGINE OIL FILTER MAINTENANCE

DRAINING OIL, FILTER REMOVAL, CLEANING, FILTER INSTALLATION

INITIAL SETUP:

Tools and Special Tools

General mechanic's tool kit
(item 30, WP 0394 00)
Common No. 1 tool kit (item 15, WP 0394 00)

Materials/Parts

O-ring (item 318, WP 0395 00)
Oil filter (item 116, WP 0395 00)
Rags (item 35, WP 0393 00)
Lubricating oil (item 31, WP 0393 00)

References

TM 9-2320-386-24P

Equipment Condition

Parking brake set (TM 9-2320-386-10).
Hood raised and secured (TM 9-2320-386-10).

ENGINE OIL FILTER MAINTENANCE (Contd)

DRAINING OIL

WARNING

Accidental or intentional introduction of liquid contaminants into the environment is in violation of state, federal, and military regulations. Refer to Army POL (WP 0001 00) for information concerning storage, use, and disposal of these liquids. Failure to do so may result in injury or death.

CAUTION

Ensure crankcase is drained with oil warmed and engine stopped to prevent waste particles suspended in oil from recirculating through engine when oil is refilled.

NOTE

Vehicle must be parked on level ground when performing this procedure.

Have drainage container ready to catch oil.

1. Start engine (TM 9-2320-386-10) and allow engine to reach normal operating temperature. Stop engine.

WARNING

Engine oil may be hot when it is drained from crankcase. Use caution when removing drainplug from oil pan. Failure to do so may cause injury to personnel.

NOTE

On vehicles equipped with winch, it may be necessary to move hydraulic line to the side to drain engine oil.

2. Remove drainplug (2) and O-ring (3) from oil pan (1) and allow oil to drain. Discard O-ring (3).
3. Install new O-ring (3) and drainplug (2) on oil pan (1).

FILTER REMOVAL

Remove oil filter (6) from oil filter base (4). Discard oil filter (6).

CLEANING

Wipe sealing surface of oil filter base (4). Ensure sealing surface is clean and free from gasket remains.

FILTER INSTALLATION

1. Apply lubricating oil to surface of oil filter gasket (5). Install new oil filter (6) on oil filter base (4).
2. Tighten oil filter (6) until oil filter gasket (5) contacts sealing surface of oil filter base (4).
3. Tighten oil filter (6) an additional 3/4 turn.
4. Fill engine crankcase to proper fluid level (TM 9-2320-386-10).
5. Start engine (TM 9-2320-386-10) and check for leaks.

ENGINE OIL FILTER MAINTENANCE (Contd)

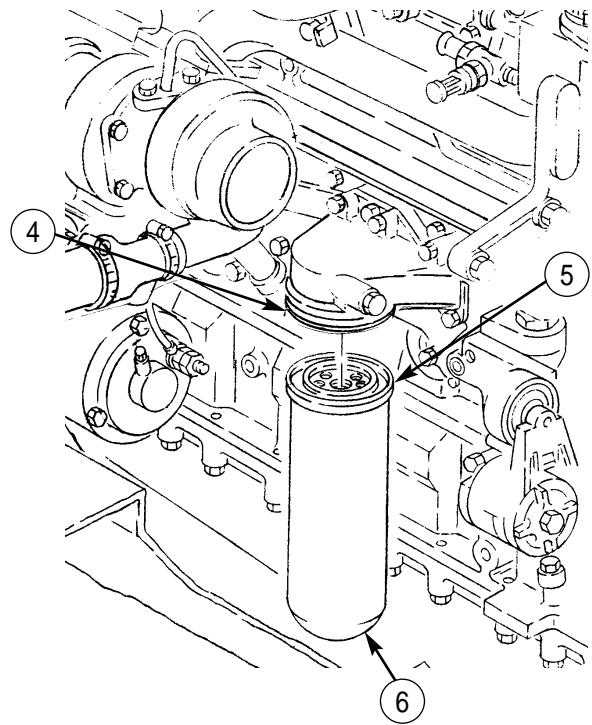
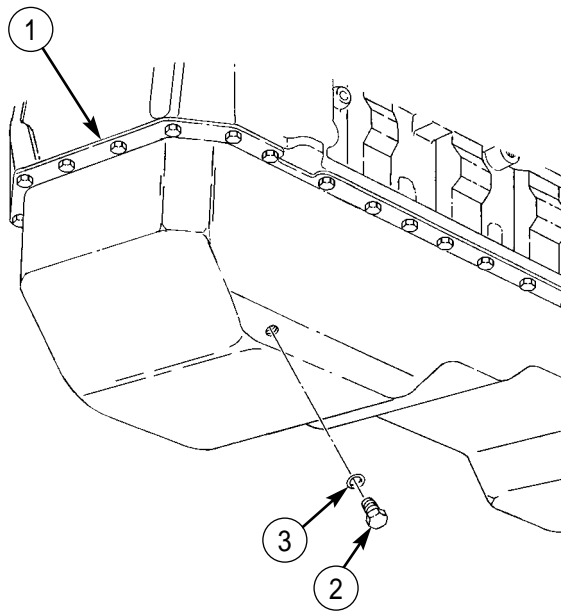

END OF WORK PACKAGE

UNIT MAINTENANCE INSTRUCTIONS

EXTENDED SERVICE PROGRAM (ESP)

TRUCK, CARGO, 2-1/2-TON, 6X6, M44A3 SERIES TRUCKS (DIESEL)

M35A3, W/O WINCH (NSN 2320-01-383-2047); W/WINCH (NSN 2320-01-383-3850);

M35A3C, W/O WINCH (NSN 2320-01-383-2050); W/WINCH (NSN 2320-01-383-2049);

M36A3, W/O WINCH (NSN 2320-01-383-2048); W/WINCH (NSN 2320-01-383-2046).

ENGINE OIL SAMPLING VALVE REPLACEMENT

REMOVAL, INSTALLATION

INITIAL SETUP:

Tools and Special Tools

General mechanic's tool kit
(item 30, WP 0394 00)

Materials/Parts

Teflon pipe sealant (item 41, WP 0393 00)

References

TM 9-2320-386-24P

Equipment Condition

Parking brake set (TM 9-2320-386-10).

Hood raised and secured (TM 9-2320-386-10).

ENGINE OIL SAMPLING VALVE REPLACEMENT (Contd)**REMOVAL****NOTE**

Note location and position of oil sampling valve for installation.
Have drainage container ready to catch oil.

Remove oil sampling valve (2) from coupling (1).

INSTALLATION

1. Apply sealant to male threads of oil sampling valve (2).
2. Install oil sampling valve (2) on coupling (1).
3. Start engine (TM 9-2320-386-10) and check for leaks.

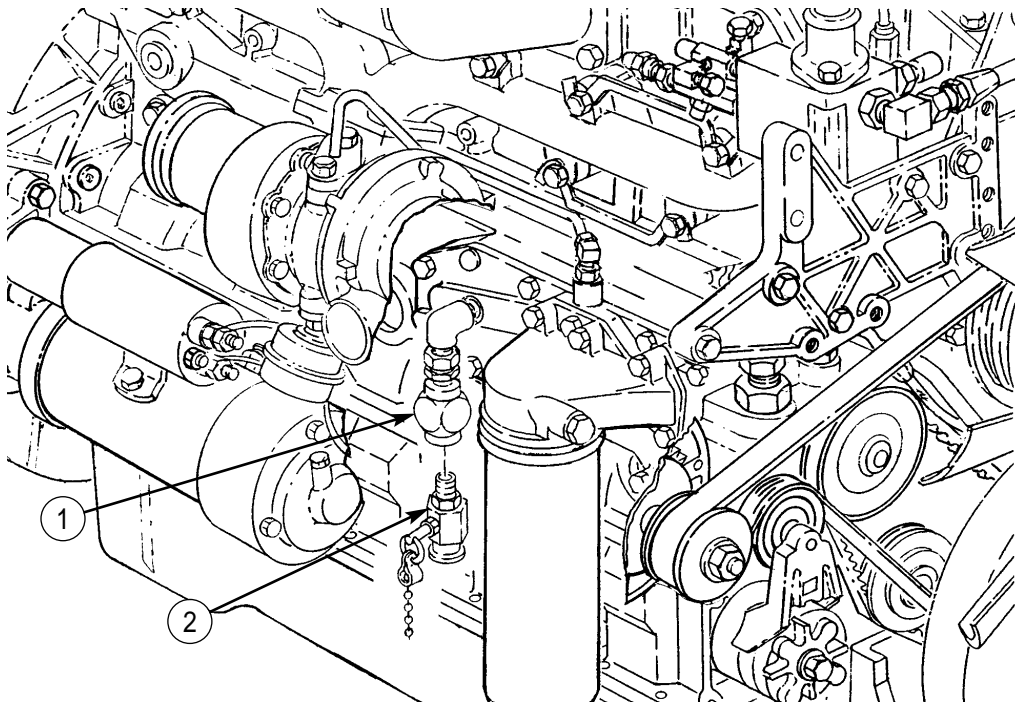

END OF WORK PACKAGE

UNIT MAINTENANCE INSTRUCTIONS

EXTENDED SERVICE PROGRAM (ESP)

TRUCK, CARGO, 2-1/2-TON, 6X6, M44A3 SERIES TRUCKS (DIESEL)

M35A3, W/O WINCH (NSN 2320-01-383-2047); W/WINCH (NSN 2320-01-383-3850);
M35A3C, W/O WINCH (NSN 2320-01-383-2050); W/WINCH (NSN 2320-01-383-2049);
M36A3, W/O WINCH (NSN 2320-01-383-2048); W/WINCH (NSN 2320-01-383-2046).

FAN DRIVE PULLEY REPLACEMENT

REMOVAL, INSTALLATION

INITIAL SETUP:

Tools and Special Tools

General mechanic's tool kit
(item 30, WP 0394 00)

Materials/Parts

O-ring (item 216, WP 0395 00)
Two locknuts (item 333, WP 0395 00)
Lockwasher (item 62, WP 0395 00)
Two locknuts (item 90, WP 0395 00)

References

TM 9-2320-386-24P

Equipment Condition

Parking brake set (TM 9-2320-386-10).
Hood raised and secured (TM 9-2320-386-10).
Upper radiator shroud removed (WP 0074 00).
Fan and fan clutch removed (WP 0082 00).

FAN DRIVE PULLEY REPLACEMENT (Contd)

REMOVAL

1. Remove screw (1), lockwasher (2), two locknuts (4), screws (6), and alternator bracket (3) from fan support bracket (5) and alternator (7). Discard lockwasher (2) and locknuts (4).
2. Rotate fan drive pulley (18) to access screws (19).
3. Remove four screws (19), washers (20), and fan drive pulley (18) from housing (15).
4. Remove two screws (28), spacer plate (29), shaft (33), and fan drive pulley (18) from retainer (32).
5. Remove two bearings (30) and O-ring (31) from retainer (32). Discard O-ring (31).
6. Remove four screws (17) and housing (15) from fan support bracket (5).
7. Remove grease fitting (16) from housing (15), if damaged.
8. Remove screw (21), washer (22), and clamp (23) from fan support bracket (5).
9. Remove screw (24) and washer (25) from fan support bracket (5) and mounting bracket (26).
10. Remove two locknuts (27), screws (12), and washers (11) from fan support bracket (5) and mounting bracket (8). Discard locknuts (27).
11. Remove five screws (14), washers (13), fan support bracket (5), and spacer (10) from engine (9).

INSTALLATION

1. Install spacer (10) and fan support bracket (5) on engine (9) with five washers (13) and screws (14).
2. Install two washers (11), screws (12), and new locknuts (27) on fan support bracket (5) and mounting bracket (8).
3. Install washer (25) and screw (24) on fan support bracket (5) and mounting bracket (26).
4. Install clamp (23), washer (22), and screw (21) on fan support bracket (5).
5. Install grease fitting (16) on housing (15), if removed.
6. Install housing (15) on support bracket (5) with four screws (17).
7. Install new O-ring (31) and two bearings (30) in retainer (32).
8. Install fan drive pulley (18), shaft (33), and spacer plate (29) on retainer (32) with two screws (28). Ensure shaft (33) and fan drive pulley (18) rotate freely.
9. Position fan drive pulley (18) on housing (15) and align holes in retainer (32) with holes in housing (15).
10. Install four washers (20) and screws (19) on fan drive pulley (18) and housing (15).
11. Install alternator bracket (3) on fan support bracket (5) and alternator (7) with two screws (6), new locknuts (4), new lockwasher (2), and screw (1).
12. Install fan and fan clutch (WP 0082 00).
13. Install upper radiator shroud (WP 0074 00).

FAN DRIVE PULLEY REPLACEMENT (Contd)

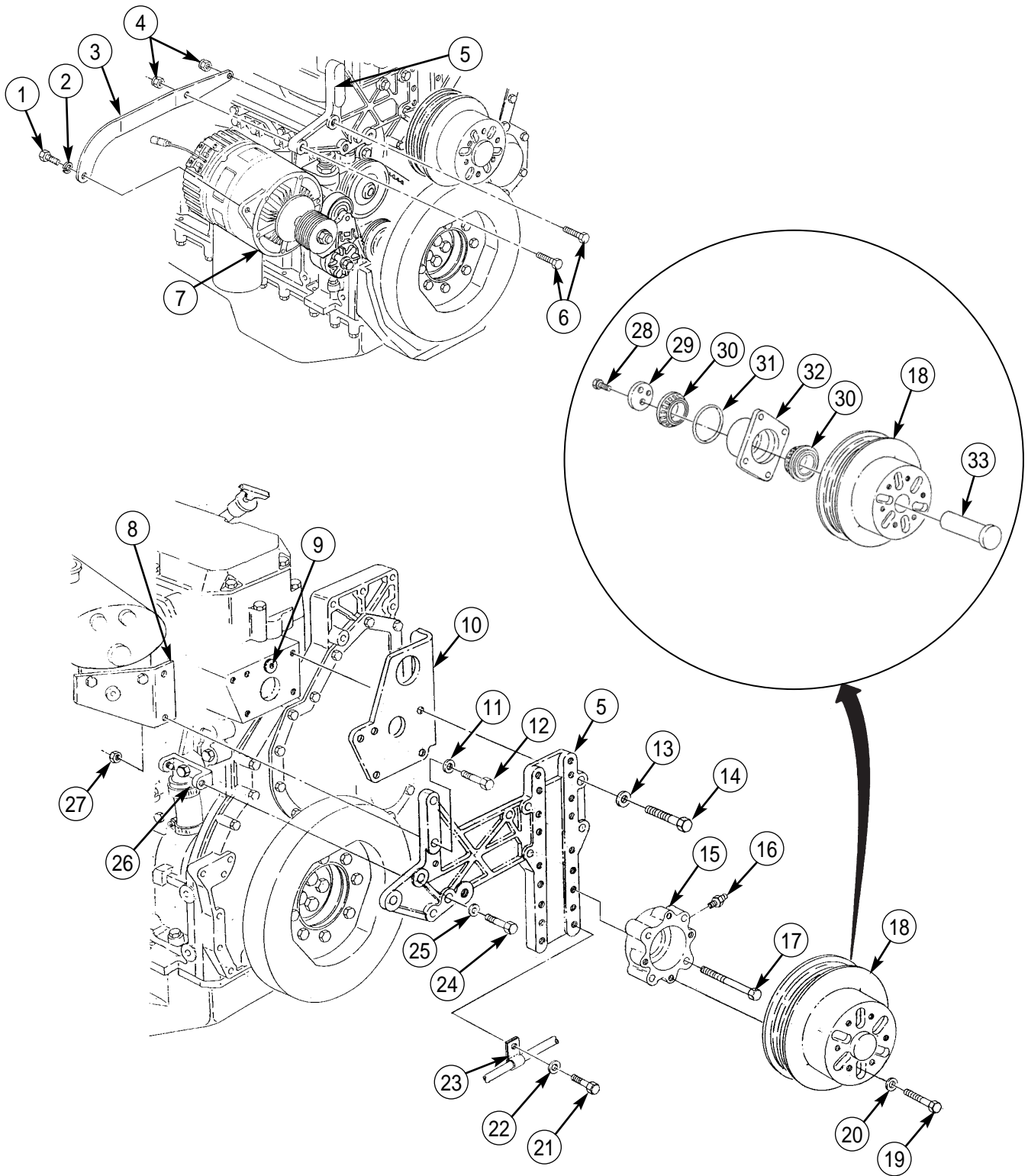

END OF WORK PACKAGE

UNIT MAINTENANCE INSTRUCTIONS

EXTENDED SERVICE PROGRAM (ESP)

TRUCK, CARGO, 2-1/2-TON, 6X6, M44A3 SERIES TRUCKS (DIESEL)

M35A3, W/O WINCH (NSN 2320-01-383-2047); W/WINCH (NSN 2320-01-383-3850);

M35A3C, W/O WINCH (NSN 2320-01-383-2050); W/WINCH (NSN 2320-01-383-2049);

M36A3, W/O WINCH (NSN 2320-01-383-2048); W/WINCH (NSN 2320-01-383-2046).

Section IV. AIR INTAKE SYSTEM MAINTENANCE

TABLE OF CONTENTS

<i>WP Title</i>	<i>WP Sequence No.-Page No.</i>
Air Cleaner Replacement	0037 00-1
Air Cleaner Hoses Replacement	0038 00-1
Dust Ejector Hose Replacement	0039 00-1
Air Cleaner Element Maintenance	0040 00-1
Air Cleaner Indicator and Tube Maintenance	0041 00-1
Turbocharger Oil Drain Tube Maintenance	0042 00-1
Turbocharger Oil Inlet Tube Replacement	0043 00-1

END OF WORK PACKAGE

UNIT MAINTENANCE INSTRUCTIONS

EXTENDED SERVICE PROGRAM (ESP)

TRUCK, CARGO, 2-1/2-TON, 6X6, M44A3 SERIES TRUCKS (DIESEL)

M35A3, W/O WINCH (NSN 2320-01-383-2047); W/WINCH (NSN 2320-01-383-3850);
M35A3C, W/O WINCH (NSN 2320-01-383-2050); W/WINCH (NSN 2320-01-383-2049);
M36A3, W/O WINCH (NSN 2320-01-383-2048); W/WINCH (NSN 2320-01-383-2046).

AIR CLEANER REPLACEMENT

REMOVAL, INSTALLATION

INITIAL SETUP:

Tools and Special Tools

General mechanic's tool kit
(item 30, WP 0394 00)

Materials/Parts

Four lockwashers (item 61, WP 0395 00)

References

TM 9-2320-386-24P

Equipment Condition

Parking brake set (TM 9-2320-386-10).
Hood raised and secured (TM 9-2320-386-10).
Air cleaner filter element removed (WP 0040 00).
Dust ejector hose removed (WP 0039 00).

AIR CLEANER REPLACEMENT (Contd)

REMOVAL

1. Remove clamp (2) and cap (1) from air cleaner (15).
2. Remove clamp (4) and hose (5) from air cleaner (15).
3. Disconnect tube (3) from air cleaner (15).
4. Remove three screws (12), lockwashers (10), and washers (13) from fender (14) and air cleaner (15). Discard lockwashers (10).
5. Remove screw (11), lockwasher (10), and washer (9) from fender (14), exhaust bracket (8), and air cleaner (15). Discard lockwasher (10).
6. Remove clamp (6) and air cleaner (15) from elbow (7) and fender (14).

INSTALLATION

1. Position air cleaner (15) on fender (14).
2. Install air cleaner (15) on elbow (7) with clamp (6).

NOTE

It may be necessary to loosen exhaust bracket to align air cleaner.

3. Install air cleaner (15) on fender (14) with three washers (13), new lockwashers (10), and screws (12).
4. Install washer (9), new lockwasher (10), and screw (11) on exhaust bracket (8), fender (14), and air cleaner (15).
5. Connect tube (3) to air cleaner (15).
6. Install hose (5) on air cleaner (15) with clamp (4).
7. Install cap (1) on air cleaner (15) with clamp (2).
8. Install dust ejector hose (WP 0039 00).
9. Install air cleaner filter element (WP 0040 00).

AIR CLEANER REPLACEMENT (Contd)

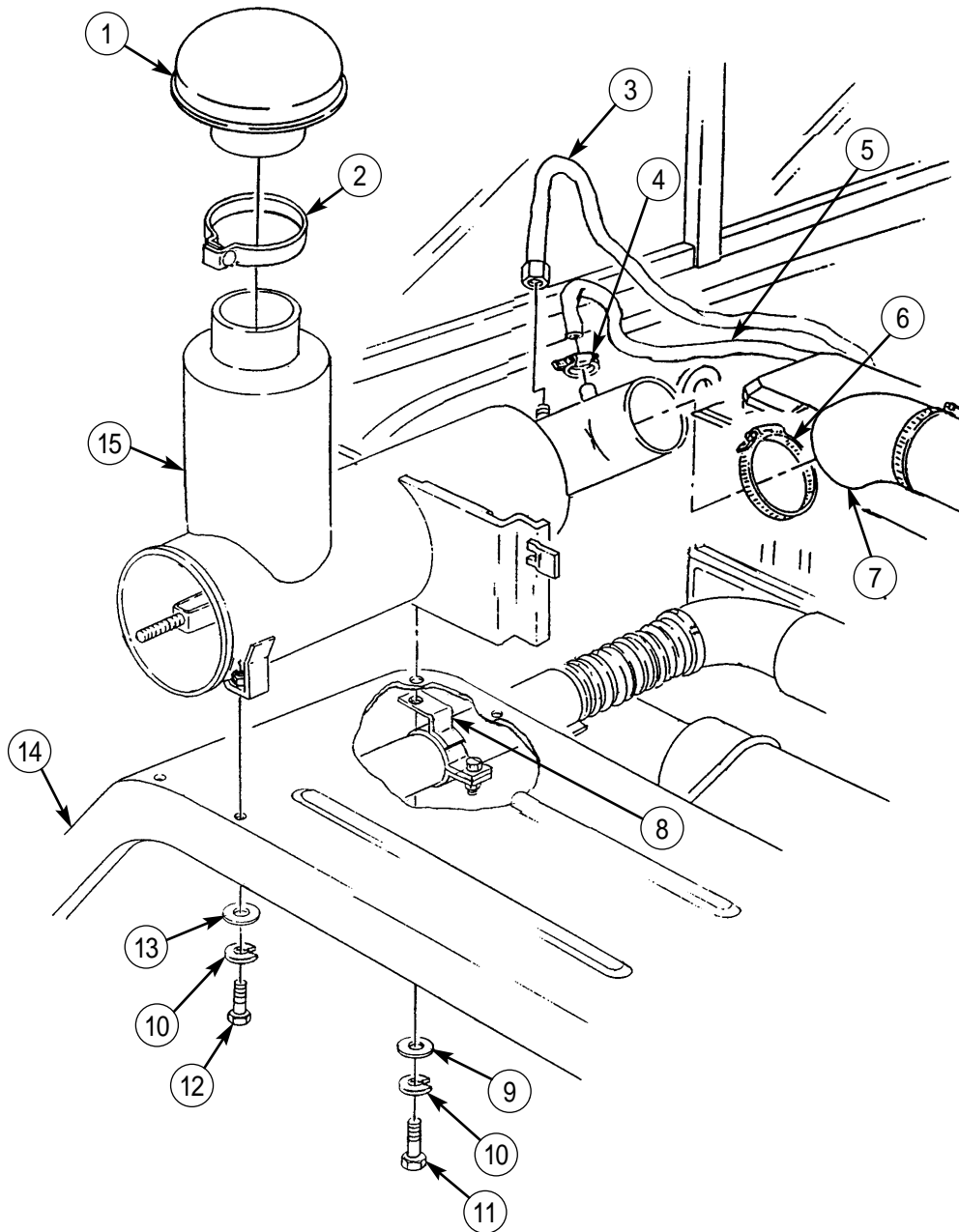

END OF WORK PACKAGE

UNIT MAINTENANCE INSTRUCTIONS

EXTENDED SERVICE PROGRAM (ESP)

TRUCK, CARGO, 2-1/2-TON, 6X6, M44A3 SERIES TRUCKS (DIESEL)

**M35A3, W/O WINCH (NSN 2320-01-383-2047); W/WINCH (NSN 2320-01-383-3850);
M35A3C, W/O WINCH (NSN 2320-01-383-2050); W/WINCH (NSN 2320-01-383-2049);
M36A3, W/O WINCH (NSN 2320-01-383-2048); W/WINCH (NSN 2320-01-383-2046).**

AIR CLEANER HOSES REPLACEMENT

REMOVAL, INSTALLATION

INITIAL SETUP:

Tools and Special Tools

General mechanic's tool kit
(item 30, WP 0394 00)

Equipment Condition

Parking brake set (TM 9-2320-386-10).
Hood raised and secured (TM 9-2320-386-10).

References

TM 9-2320-386-24P

AIR CLEANER HOSES REPLACEMENT (Contd)**REMOVAL****WARNING**

Do not perform this task when engine is hot. Doing so may result in injury to personnel.

1. Remove two clamps (2) and elbow (3) from air cleaner (1) and tube (4).
2. Remove two clamps (5), tube (4), and elbow (6) from turbocharger (7).

INSTALLATION

1. Install elbow (6) and tube (4) on turbocharger (7) with two clamps (5). Do not tighten clamps (5).
2. Install elbow (3) on tube (4) and air cleaner (1) with two clamps (2). Do not tighten clamps (2).
3. Tighten two clamps (2) and (5).

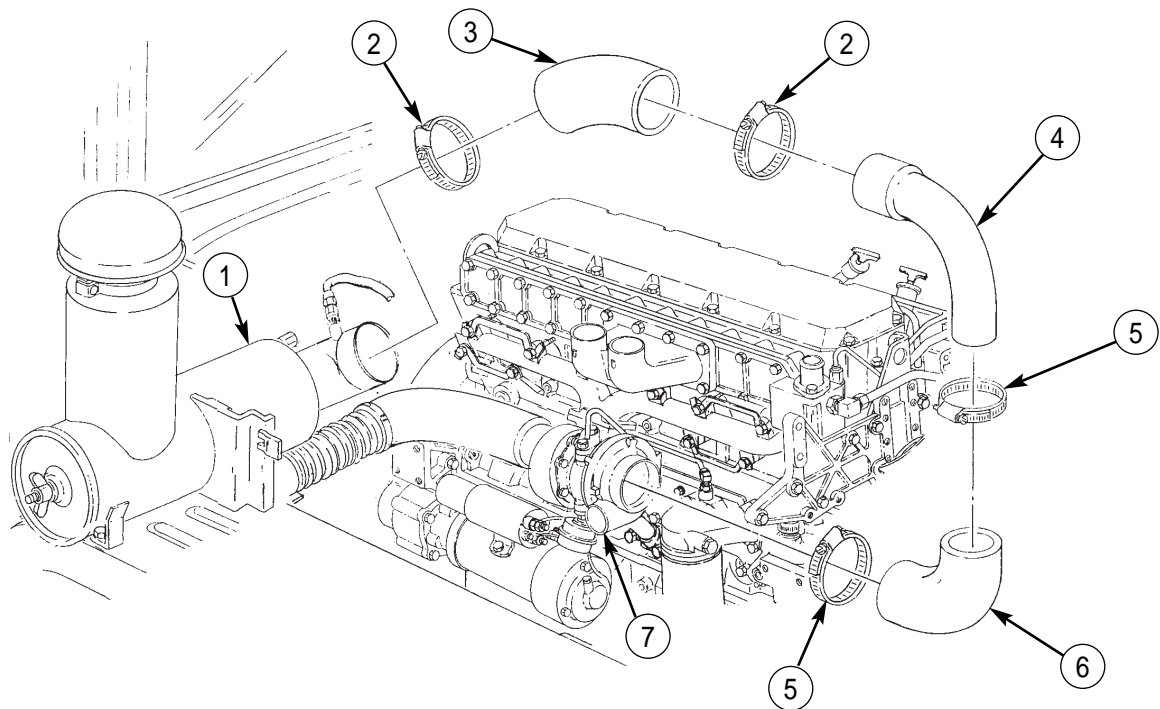
**END OF WORK PACKAGE**

UNIT MAINTENANCE INSTRUCTIONS

EXTENDED SERVICE PROGRAM (ESP)

TRUCK, CARGO, 2-1/2-TON, 6X6, M44A3 SERIES TRUCKS (DIESEL)

*M35A3, W/O WINCH (NSN 2320-01-383-2047); W/WINCH (NSN 2320-01-383-3850);
M35A3C, W/O WINCH (NSN 2320-01-383-2050); W/WINCH (NSN 2320-01-383-2049);
M36A3, W/O WINCH (NSN 2320-01-383-2048); W/WINCH (NSN 2320-01-383-2046).*

DUST EJECTOR HOSE REPLACEMENT

REMOVAL, INSTALLATION

INITIAL SETUP:

Tools and Special Tools

General mechanic's tool kit
(item 30, WP 0394 00)

Equipment Condition

Parking brake set (TM 9-2320-386-10).
Hood raised and secured (TM 9-2320-386-10).

References

TM 9-2320-386-24P

DUST EJECTOR HOSE REPLACEMENT (Contd)**REMOVAL****WARNING**

Do not touch hot exhaust system components with bare hands.
Severe injury to personnel may result.

Remove two clamps (3) and dust ejector hose (4) from air cleaner (1) and muffler (2).

INSTALLATION

Install dust ejector hose (4) on air cleaner (1) and muffler (2) with two clamps (3).

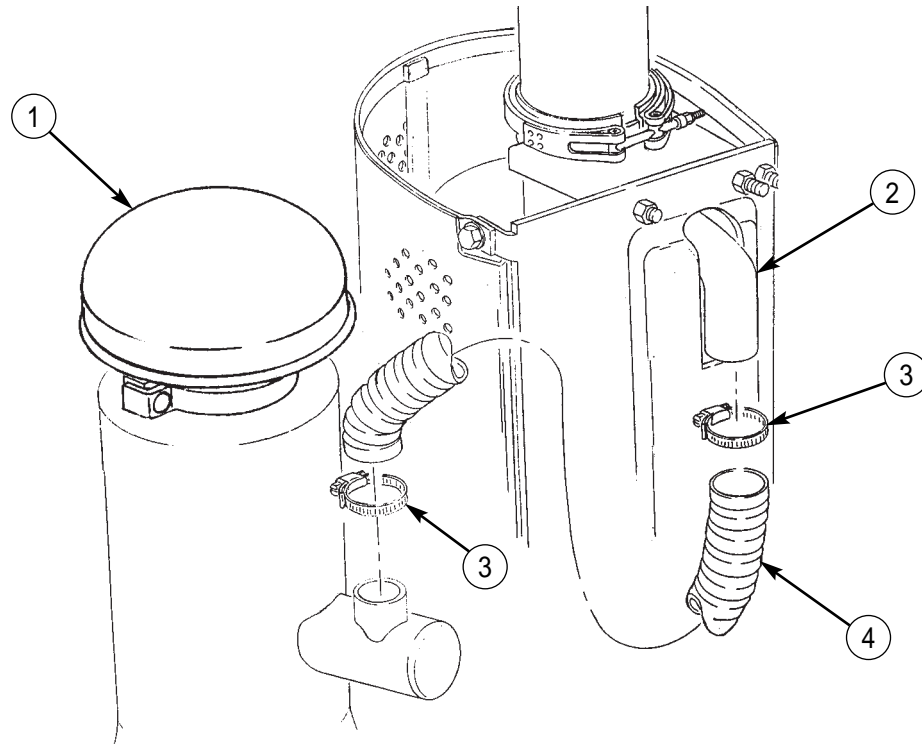

END OF WORK PACKAGE

UNIT MAINTENANCE INSTRUCTIONS

EXTENDED SERVICE PROGRAM (ESP)

TRUCK, CARGO, 2-1/2-TON, 6X6, M44A3 SERIES TRUCKS (DIESEL)

**M35A3, W/O WINCH (NSN 2320-01-383-2047); W/WINCH (NSN 2320-01-383-3850);
M35A3C, W/O WINCH (NSN 2320-01-383-2050); W/WINCH (NSN 2320-01-383-2049);
M36A3, W/O WINCH (NSN 2320-01-383-2048); W/WINCH (NSN 2320-01-383-2046).**

AIR CLEANER ELEMENT MAINTENANCE

REMOVAL, SERVICE, INSTALLATION

INITIAL SETUP:

Tools and Special Tools

General mechanic's tool kit
(item 30, WP 0394 00)

Materials/Parts

Air cleaner element (item 260, WP 0395 00)
Gasket (item 103, WP 0395 00)
Gasket (item 105, WP 0395 00)

References

TM 9-2320-386-24P

Equipment Condition

Parking brake set (TM 9-2320-386-10).
Hood raised and secured (TM 9-2320-386-10).

AIR CLEANER ELEMENT MAINTENANCE (Contd)**WARNING**

If NBC exposure is suspected, all air filtering media should be handled by personnel wearing protective equipment. Consult your unit NBC officer or NBC NCO for appropriate handling or disposal instructions.

NBC contaminated air cleaner elements must be handled using adequate precautions (FM 21-40) and must be disposed of by trained personnel.

REMOVAL

1. Loosen wingnut (8) and remove cover (1) and gasket (3) from air cleaner (5). Discard gasket (3).
2. Remove clip (2), wingnut (8), and gasket (7) from cover (1). Discard gasket (7).
3. Remove wingnut (4) and air cleaner element (6) from air cleaner (5). Clean or discard air cleaner element (6).

SERVICE**WARNING**

Compressed air used for cleaning purposes will not exceed 30 psi (207 kPa). Use only with effective chip guarding and personal protective equipment (goggles/shields, gloves, etc.).

Clean air cleaner element (6) by tapping lightly, or use compressed air to loosen and remove dirt. Replace air cleaner element (6) if necessary.

INSTALLATION

1. Install new air cleaner element (6) or cleaned air cleaner element (6) in air cleaner (5) with wingnut (4).
2. Install new gasket (7) and wingnut (8) on cover (1) with clip (2).
3. Install new gasket (3) and cover (1) on air cleaner (5) and tighten wingnut (8).

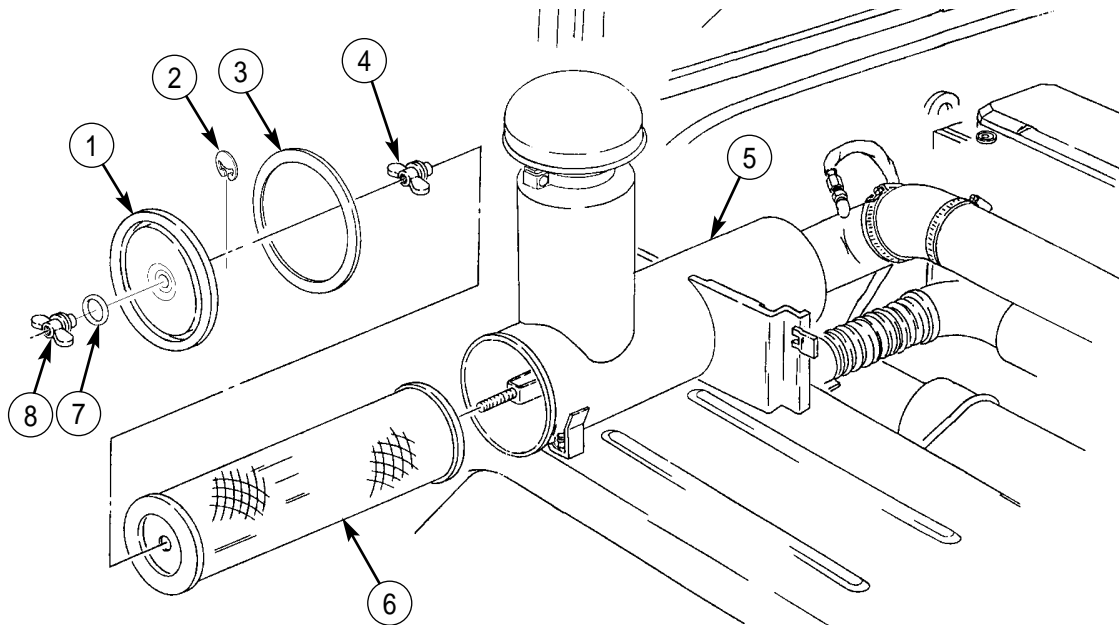

END OF WORK PACKAGE

UNIT MAINTENANCE INSTRUCTIONS

EXTENDED SERVICE PROGRAM (ESP)

TRUCK, CARGO, 2-1/2-TON, 6X6, M44A3 SERIES TRUCKS (DIESEL)

**M35A3, W/O WINCH (NSN 2320-01-383-2047); W/WINCH (NSN 2320-01-383-3850);
M35A3C, W/O WINCH (NSN 2320-01-383-2050); W/WINCH (NSN 2320-01-383-2049);
M36A3, W/O WINCH (NSN 2320-01-383-2048); W/WINCH (NSN 2320-01-383-2046).**

AIR CLEANER INDICATOR AND TUBE MAINTENANCE

TESTING, REMOVAL, CLEANING AND INSPECTION, INSTALLATION

INITIAL SETUP:

Tools and Special Tools

General mechanic's tool kit
(item 30, WP 0394 00)

References

TM 9-2320-386-24P

Materials/Parts

Teflon pipe sealant (item 41, WP 0393 00)

Equipment Condition

Parking brake set (TM 9-2320-386-10).
Hood raised and secured (TM 9-2320-386-10).

AIR CLEANER INDICATOR AND TUBE MAINTENANCE (Contd)**TESTING**

1. Remove clamp (2) and cap (1) from air cleaner (9).
2. Start engine (TM 9-2320-386-10) and set at 1200 rpm.

NOTE

Assistant will help with step 3.

3. Using a piece of cardboard (10), cover approximately 90 percent of air cleaner (9) opening.
4. Observe air cleaner indicator (15) to see if yellow band (14) is visible. If yellow band (14) is visible, air cleaner indicator (15) works properly. If not, air cleaner indicator (15) is defective or tube (3) is obstructed. Stop engine.
5. Remove cardboard (10) and install cap (1) on air cleaner (9) with clamp (2).

REMOVAL

1. Remove tube (3) from adapter (8).
2. Remove adapter (8) from air cleaner (9).
3. Loosen clamps (4) and (5) and pull tube (3) through clamps (4) and (5) on cab (6).
4. Remove tube (3) and grommet (7) from cab (6).
5. Disconnect tube (3) from adapter (16) on air cleaner indicator (15).
6. Remove tube (3) from vehicle.
7. Remove adapter (16) from air cleaner indicator (15).
8. Remove two nuts (11), screws (13), and air cleaner indicator (15) from bracket (12).

AIR CLEANER INDICATOR AND TUBE MAINTENANCE (Contd)

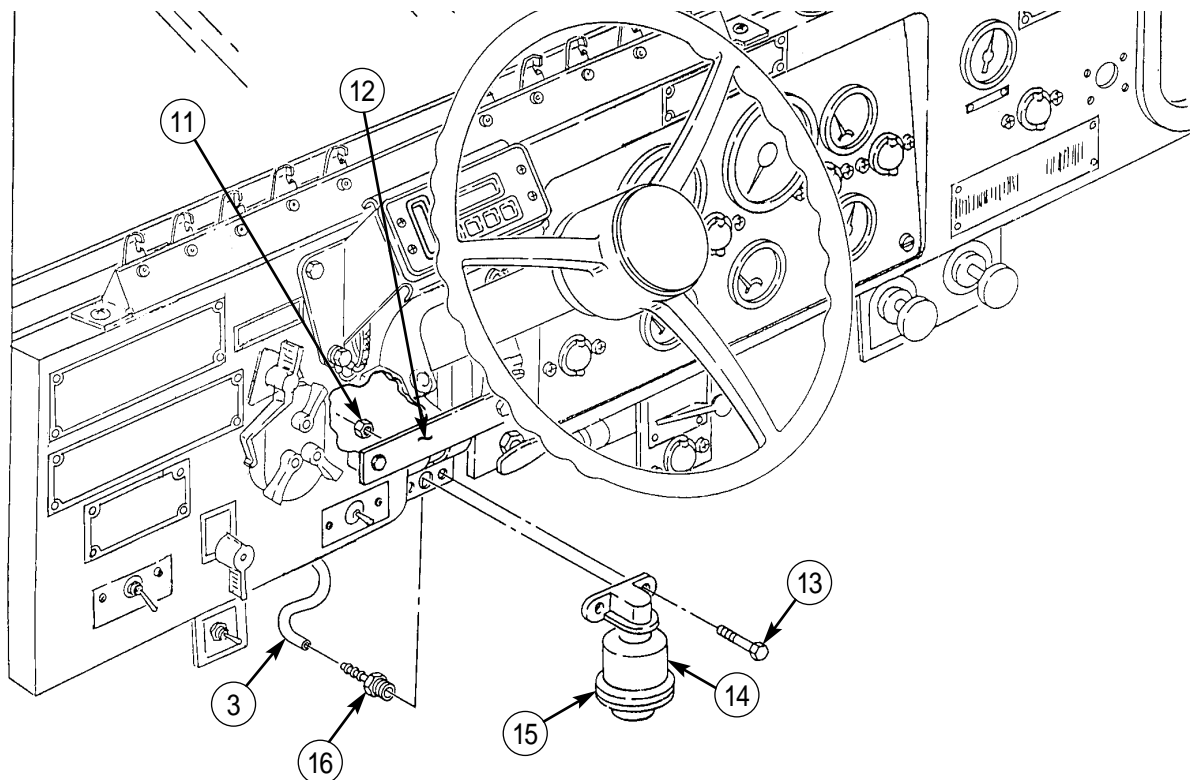
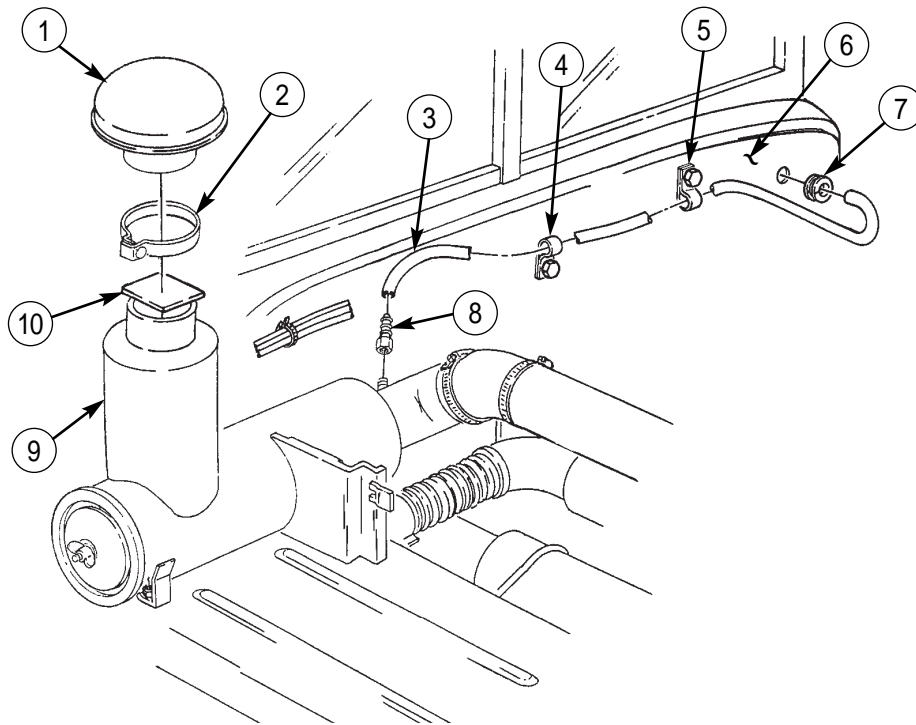

AIR CLEANER INDICATOR AND TUBE MAINTENANCE (Contd)

CLEANING AND INSPECTION

1. Inspect tube (5) for kinks and obstruction. Replace tube (5) if kinked or obstructed.

WARNING

Compressed air used for cleaning purposes will not exceed 30 psi (207 kPa). Use only with effective chip guarding and personal protective equipment (goggles/shields, gloves, etc.).

2. Clean tube (5) by blowing compressed air through tube (5).

INSTALLATION

1. Apply sealant to male threads of adapter (3) and stud (2) of air cleaner (1).
2. Install adapter (3) on stud (2) of air cleaner (1).
3. Connect tube (5) to adapter (3).
4. Route tube (5) from air cleaner (1) through clamps (4) and (6), insert through cab (7), and install grommet (8). Tighten clamps (4) and (6).
5. Install adapter (13) on air cleaner indicator (12).
6. Install air cleaner indicator (12) on bracket (10) with two screws (11) and nuts (9).
7. Connect tube (5) to adapter (13).

AIR CLEANER INDICATOR AND TUBE MAINTENANCE (Contd)

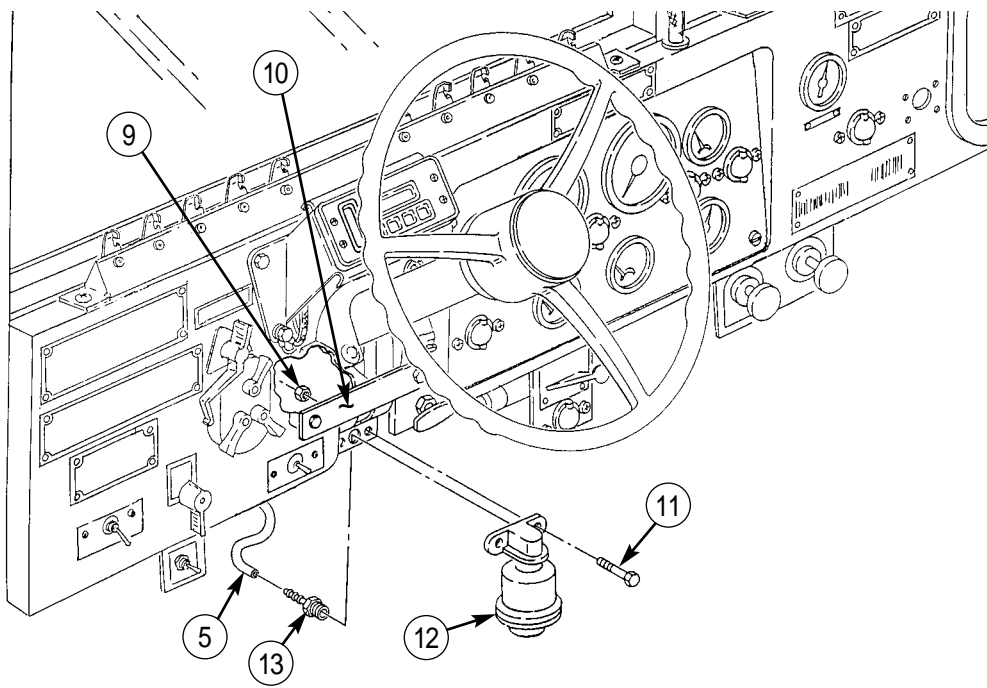
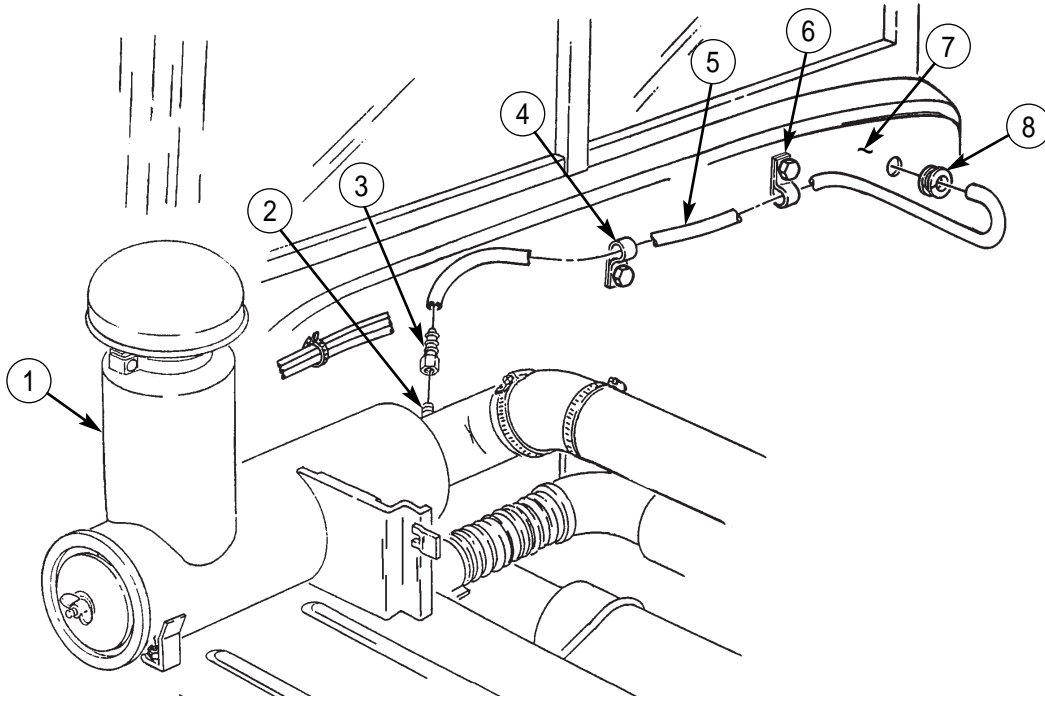

END OF WORK PACKAGE

UNIT MAINTENANCE INSTRUCTIONS

EXTENDED SERVICE PROGRAM (ESP)

TRUCK, CARGO, 2-1/2-TON, 6X6, M44A3 SERIES TRUCKS (DIESEL)

M35A3, W/O WINCH (NSN 2320-01-383-2047); W/WINCH (NSN 2320-01-383-3850);

M35A3C, W/O WINCH (NSN 2320-01-383-2050); W/WINCH (NSN 2320-01-383-2049);

M36A3, W/O WINCH (NSN 2320-01-383-2048); W/WINCH (NSN 2320-01-383-2046).

TURBOCHARGER OIL DRAIN TUBE MAINTENANCE

REMOVAL, DISASSEMBLY, ASSEMBLY, INSTALLATION

INITIAL SETUP:

Tools and Special Tools

General mechanic's tool kit
(item 30, WP 0394 00)

Materials/Parts

O-ring (item 223, WP 0395 00)
O-ring (item 326, WP 0395 00)
Gasket (item 300, WP 0395 00)
Lubricating oil (item 32, WP 0393 00)
Cap and plug set (item 14, WP 0393 00)

References

TM 9-2320-386-24P

Equipment Condition

Parking brake set (TM 9-2320-386-10).
Hood raised and secured (TM 9-2320-386-10).
Turbocharger oil inlet tube removed (WP 0043 00).

TURBOCHARGER OIL DRAIN TUBE MAINTENANCE (Contd)**REMOVAL****CAUTION**

Cap or plug all openings to prevent contaminants from entering engine or turbocharger. Failure to do so may result in turbocharger and/or engine damage.

1. Remove two clamps (3) and vacuum hose (4) from elbow (2) and canister (5).

NOTE

Note location and position of oil sampling valve for installation.
Have drainage container ready to catch oil.

2. Remove oil sampling valve (7) from coupling (6).
3. Remove two screws (10) from bottom of oil drain tube assembly (11) and engine (9).
4. Remove two screws (12), washers (13), oil drain tube assembly (11), and gasket (14) from turbocharger (1). Discard gasket (14).

DISASSEMBLY

1. Remove O-ring (18) from adapter (17). Discard O-ring (18).
2. Remove oil drain tube (15) and O-ring (16) from adapter (17). Discard O-ring (16).

ASSEMBLY

1. Install new O-ring (16) and oil drain tube (15) on adapter (17).
2. Install new O-ring (18) in groove of adapter (17).

INSTALLATION

1. Install new gasket (14) and oil drain tube assembly (11) with adapter (17) on turbocharger (1) with two washers (13) and screws (12).
2. Install bottom of oil drain tube assembly (11) on engine (9) with two screws (10).
3. Install oil sampling valve (7) on coupling (6).
4. Install vacuum hose (4) on elbow (2) and canister (5) with two clamps (3).

CAUTION

Ensure oil is added before operating vehicle. Failure to do so may result in damage to turbocharger bearings.

5. Pour 2 oz (59 mL) of lubricating oil into turbocharger (1) through oil inlet tube port (8).
6. Install turbocharger oil inlet tube (WP 0043 00).
7. Start engine (TM 9-2320-386-10) and check for leaks.

TURBOCHARGER OIL DRAIN TUBE MAINTENANCE (Contd)

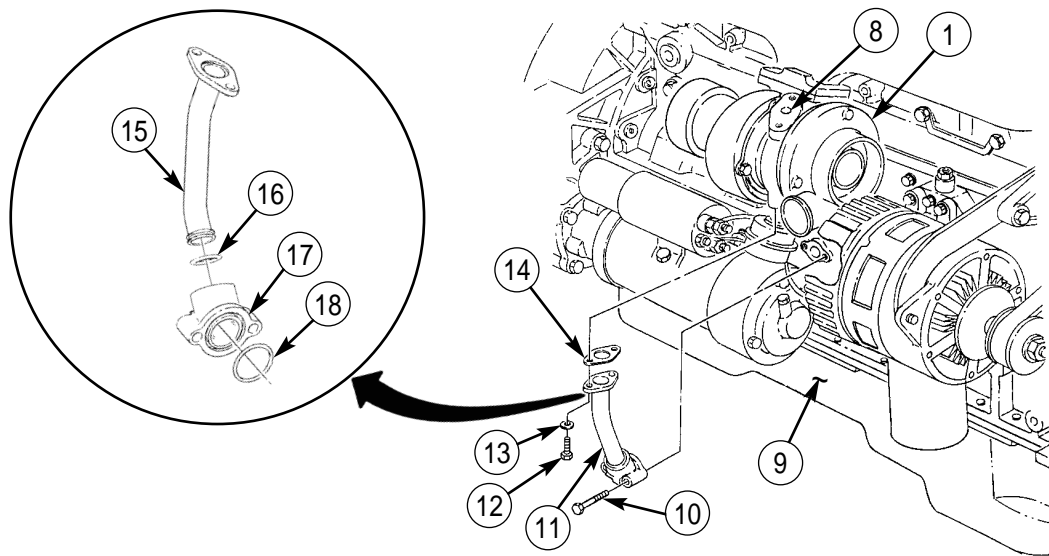
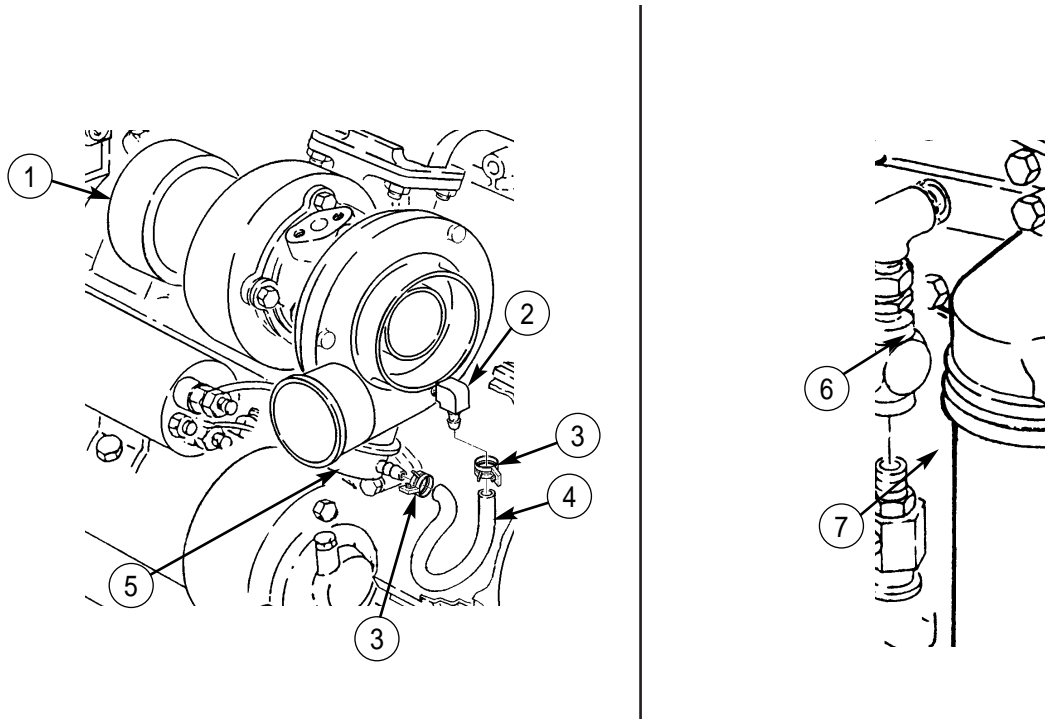

END OF WORK PACKAGE

UNIT MAINTENANCE INSTRUCTIONS

EXTENDED SERVICE PROGRAM (ESP)

TRUCK, CARGO, 2-1/2-TON, 6X6, M44A3 SERIES TRUCKS (DIESEL)

M35A3, W/O WINCH (NSN 2320-01-383-2047); W/WINCH (NSN 2320-01-383-3850);

M35A3C, W/O WINCH (NSN 2320-01-383-2050); W/WINCH (NSN 2320-01-383-2049);

M36A3, W/O WINCH (NSN 2320-01-383-2048); W/WINCH (NSN 2320-01-383-2046).

TURBOCHARGER OIL INLET TUBE REPLACEMENT

REMOVAL, INSTALLATION

INITIAL SETUP:

Tools and Special Tools

General mechanic's tool kit
(item 30, WP 0394 00)

Materials/Parts

O-ring (item 3, WP 0395 00)
O-ring (item 214, WP 0395 00)
Gasket (item 117, WP 0395 00)
Cap and plug set (item 14, WP 0393 00)

References

TM 9-2320-386-24P

Equipment Condition

Parking brake set (TM 9-2320-386-10).
Hood raised and secured (TM 9-2320-386-10).
Air cleaner hoses removed (WP 0038 00).

TURBOCHARGER OIL INLET TUBE REPLACEMENT (Contd)**REMOVAL****CAUTION**

Cap or plug all openings to prevent contaminants from entering engine or turbocharger. Failure to do so may result in turbocharger and/or engine damage.

1. Disconnect oil inlet tube (2) from elbow (4).
2. Remove two screws (1), washers (9), oil inlet tube (2), gasket (8), and O-ring (3) from turbocharger (7) and elbow (4). Discard gasket (8) and O-ring (3).
3. Remove elbow (4) and O-ring (5) from engine (6). Discard O-ring (5).

INSTALLATION

1. Install new O-ring (5) and elbow (4) on engine (6).
2. Position new O-ring (3) on oil inlet tube (2).
3. Install new gasket (8) and oil inlet tube (2) on turbocharger (7) with two washers (9) and screws (1).
4. Connect oil inlet tube (2) to elbow (4).
5. Install air cleaner hoses (WP 0038 00).
6. Start engine (TM 9-2320-386-10) and check for leaks.

TURBOCHARGER OIL INLET TUBE REPLACEMENT (Contd)

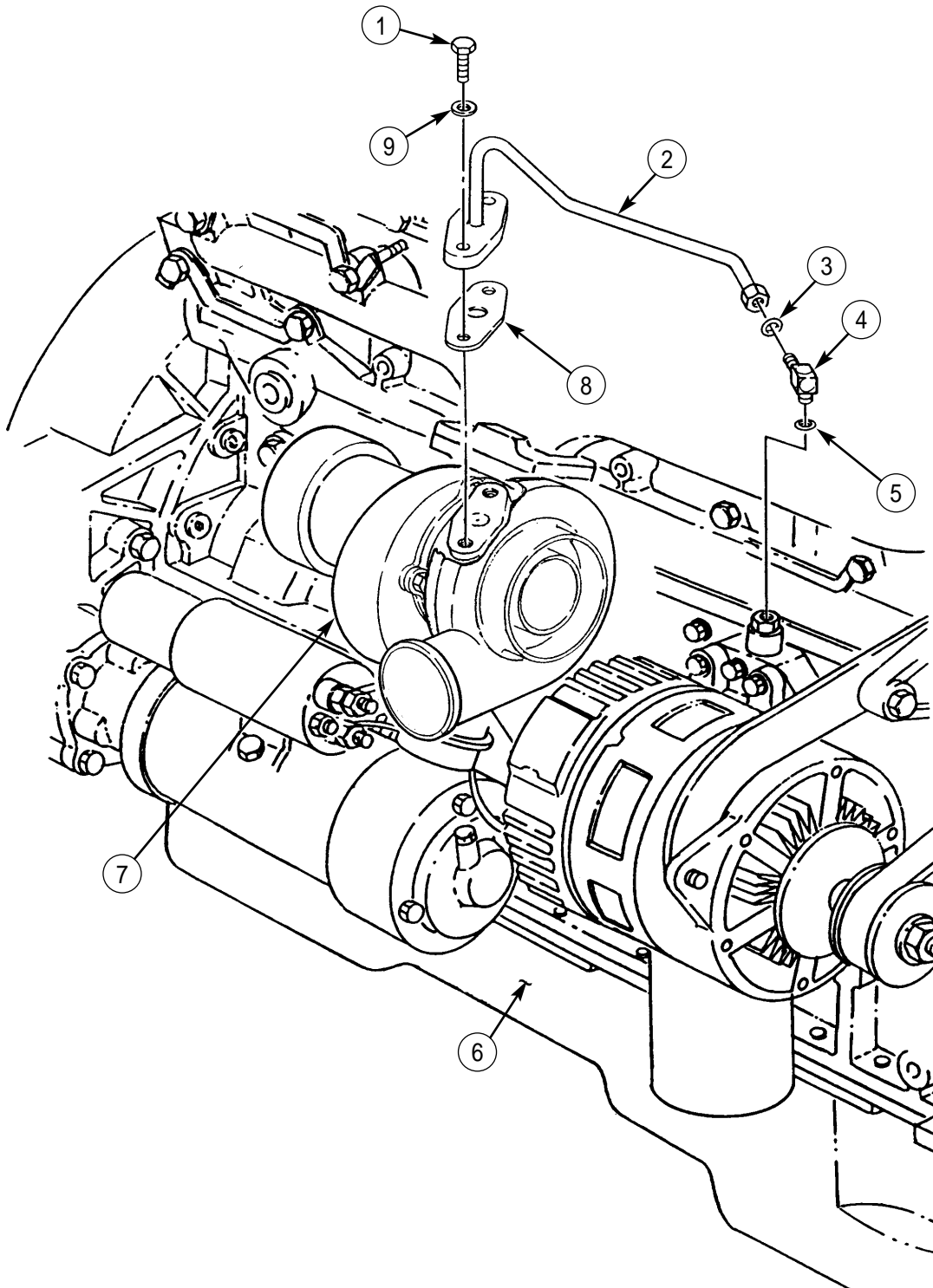

END OF WORK PACKAGE

UNIT MAINTENANCE INSTRUCTIONS

EXTENDED SERVICE PROGRAM (ESP)

TRUCK, CARGO, 2-1/2-TON, 6X6, M44A3 SERIES TRUCKS (DIESEL)

M35A3, W/O WINCH (NSN 2320-01-383-2047); W/WINCH (NSN 2320-01-383-3850);

M35A3C, W/O WINCH (NSN 2320-01-383-2050); W/WINCH (NSN 2320-01-383-2049);

M36A3, W/O WINCH (NSN 2320-01-383-2048); W/WINCH (NSN 2320-01-383-2046).

Section V. FUEL SYSTEM MAINTENANCE

TABLE OF CONTENTS

<i>WP Title</i>	<i>WP Sequence No.-Page No.</i>
Fuel Tank and Retaining Straps Replacement	0045 00-1
Fuel Check Valve Replacement	0046 00-1
Fuel Tank Filler Cap and Sleeve Replacement	0047 00-1
Fuel Tank Lines Replacement	0048 00-1
Fuel Vent Line Replacement	0049 00-1
Fuel Shutoff Solenoid Replacement	0050 00-1
Governor Fuel and Oil Lines Replacement	0051 00-1
Governor Low Idle Speed Adjustment	0052 00-1
Fuel/Water Separator and Bracket Replacement	0053 00-1
Fuel Filter Maintenance	0054 00-1
Quick-Start Cylinder and Valve Replacement (Built before serial number 504924) . . .	0055 00-1
Quick-Start Tubes Replacement (Built before serial number 504924)	0056 00-1
Quick-Start Atomizers Replacement	0057 00-1
Quick-Start Mounting Bracket Replacement (Built before serial number 504924)	0058 00-1
Quick-Start Cylinder, Valve, and Jumper Harness Replacement (Built after serial number 504923)	0059 00-1
Quick-Start Tubes Replacement (Built after serial number 504923)	0060 00-1
Quick-Start Mounting Bracket Replacement (Built after serial number 504923)	0061 00-1
Throttle Control Cable Replacement	0062 00-1
Accelerator Pedal and Brackets Replacement	0063 00-1
Accelerator Cable Maintenance	0064 00-1

END OF WORK PACKAGE

UNIT MAINTENANCE INSTRUCTIONS

EXTENDED SERVICE PROGRAM (ESP)

TRUCK, CARGO, 2-1/2-TON, 6X6, M44A3 SERIES TRUCKS (DIESEL)

M35A3, W/O WINCH (NSN 2320-01-383-2047); W/WINCH (NSN 2320-01-383-3850);

M35A3C, W/O WINCH (NSN 2320-01-383-2050); W/WINCH (NSN 2320-01-383-2049);

M36A3, W/O WINCH (NSN 2320-01-383-2048); W/WINCH (NSN 2320-01-383-2046).

FUEL TANK AND RETAINING STRAPS REPLACEMENT

REMOVAL, INSTALLATION

INITIAL SETUP:

Tools and Special Tools

General mechanic's tool kit
(item 30, WP 0394 00)

Materials/Parts

Four locknuts (item 19, WP 0395 00)
Two locknuts (item 339, WP 0395 00)
Antisqueak webbing pads
(item 163 and 164, WP 0395 00)
Teflon pipe sealant (item 41, WP 0393 00)
Cap and plug set (item 14, WP 0393 00)

References

TM 9-2320-386-24P

Equipment Condition

Parking brake set (TM 9-2320-386-10).
Fuel check valve removed (WP 0046 00).
Fuel level sending unit removed (WP 0115 00).

FUEL TANK AND RETAINING STRAPS REPLACEMENT (Contd)**WARNING**

Diesel fuel is flammable. Do not perform fuel system procedures near open flame, sparks, or electricity. Injury to personnel may result.

REMOVAL**CAUTION**

Cap or plug all hoses, connections, and openings immediately after disconnection or component removal to prevent contamination. Failure to do so may result in damage to equipment.

NOTE

Have drainage container ready to catch fuel.

1. Remove drainplug (7) and drain fuel from fuel tank (4).
2. Install drainplug (7) in fuel tank (4).

NOTE

Tag lines and fittings for installation.

3. Loosen nut (2) and disconnect fuel return line (1) from elbow (3).
4. Loosen nut (20) and disconnect vent line (21) with sleeve (19) and insert (17) from vent valve (16).
5. Remove elbow (3) and vent valve (16) from fuel tank (4).
6. Remove two locknuts (18) and screws (5) from retaining straps (6) and (13). Discard locknuts (18).

NOTE

Assistant will help with step 7. Perform step 8 only if inspection requires replacement.

7. Pull two retaining straps (6) down and remove fuel tank (4) from two tank hangers (11).
8. Remove two antisqueak webbing pads (8) and (15), locknuts (14) and (9), and screws (10) and (12) from retaining straps (6) and (13). Discard antisqueak webbing pads (8) and (15) and locknuts (9) and (14).

INSTALLATION

1. Apply sealant to male threads of elbow (3) prior to installation.

NOTE

Perform step 2 if antisqueak webbing pads were previously removed.

2. Install two new antisqueak webbing pads (8) and (15) on retaining straps (6) and (13).
3. Install two retaining straps (6) and (13) on tank hangers (11) with two screws (10) and (12) and new locknuts (9) and (14).

NOTE

Assistant will help with step 4.

4. Install fuel tank (4) on two tank hangers (11) with retaining straps (6) and (13), screws (5), and new locknuts (18).
5. Install elbow (3) and vent valve (16) on fuel tank (4).
6. Connect fuel return line (1) to elbow (3) and tighten nut (2).
7. Connect vent line (21) with sleeve (19) and insert (17) to vent valve (16) and tighten nut (20).
8. Install fuel check valve (WP 0046 00).
9. Install fuel level sending unit (WP 0115 00).
10. Fill fuel tank (TM 9-2320-386-10).
11. Start engine (TM 9-2320-386-10) and inspect fuel system for leaks.

FUEL TANK AND RETAINING STRAPS REPLACEMENT (Contd)

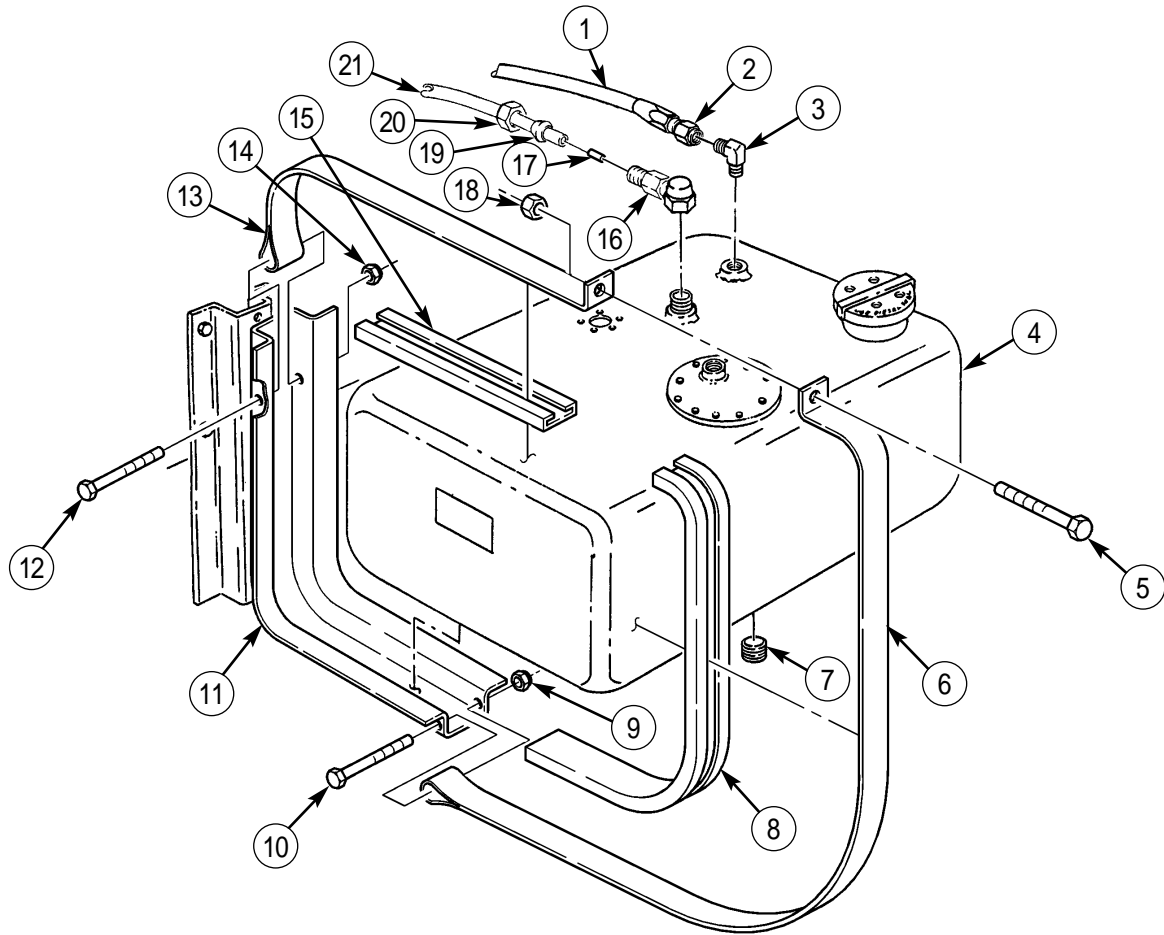

END OF WORK PACKAGE

UNIT MAINTENANCE INSTRUCTIONS

EXTENDED SERVICE PROGRAM (ESP)

TRUCK, CARGO, 2-1/2-TON, 6X6, M44A3 SERIES TRUCKS (DIESEL)

M35A3, W/O WINCH (NSN 2320-01-383-2047); W/WINCH (NSN 2320-01-383-3850);

M35A3C, W/O WINCH (NSN 2320-01-383-2050); W/WINCH (NSN 2320-01-383-2049);

M36A3, W/O WINCH (NSN 2320-01-383-2048); W/WINCH (NSN 2320-01-383-2046).

FUEL CHECK VALVE REPLACEMENT

REMOVAL, INSTALLATION

INITIAL SETUP:

Tools and Special Tools

General mechanic's tool kit
(item 30, WP 0394 00)

Materials/Parts

Teflon pipe sealant (item 41, WP 0393 00)

References

TM 9-2320-386-24P

Equipment Condition

Parking brake set (TM 9-2320-386-10).

Battery ground cable disconnected (WP 0121 00).

FUEL CHECK VALVE REPLACEMENT (Contd)**WARNING**

Diesel fuel is flammable. Do not perform fuel system procedures near open flame, sparks, or electricity. Injury to personnel may result.

REMOVAL

1. Disconnect fuel inlet line (1) from elbow (2).
2. Remove elbow (2) from check valve (3).
3. Remove check valve (3) from fuel tank (4).

INSTALLATION

1. Apply sealant to male threads of check valve (3) and elbow (2) prior to installation.
2. Install check valve (3) in fuel tank (4).
3. Install elbow (2) on check valve (3).
4. Connect fuel inlet line (1) to elbow (2).
5. Connect battery ground cable (WP 0121 00).
6. Start engine (TM 9-2320-386-10) and inspect fuel system for leaks.

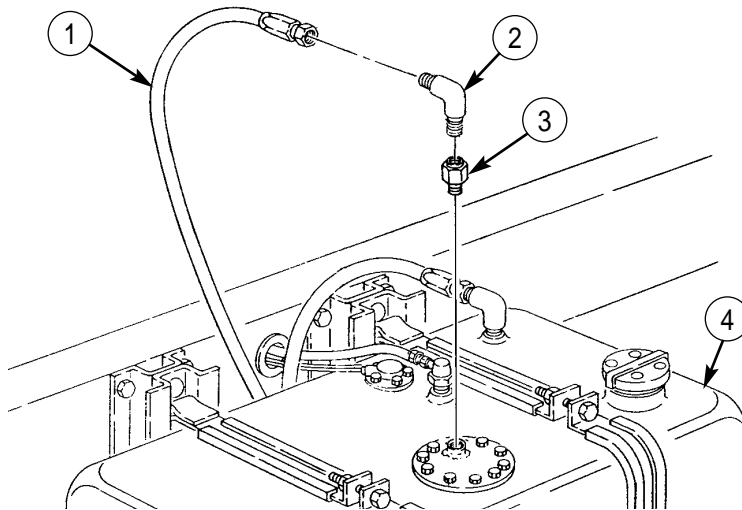

END OF WORK PACKAGE

UNIT MAINTENANCE INSTRUCTIONS

EXTENDED SERVICE PROGRAM (ESP)

TRUCK, CARGO, 2-1/2-TON, 6X6, M44A3 SERIES TRUCKS (DIESEL)

M35A3, W/O WINCH (NSN 2320-01-383-2047); W/WINCH (NSN 2320-01-383-3850);
M35A3C, W/O WINCH (NSN 2320-01-383-2050); W/WINCH (NSN 2320-01-383-2049);
M36A3, W/O WINCH (NSN 2320-01-383-2048); W/WINCH (NSN 2320-01-383-2046).

FUEL TANK FILLER CAP AND SLEEVE REPLACEMENT

REMOVAL, INSTALLATION

INITIAL SETUP:

Tools and Special Tools

General mechanic's tool kit
(item 30, WP 0394 00)

Materials/Parts

Gasket (item 278, WP 0395 00)
Locknut (item 247, WP 0395 00)

References

TM 9-2320-386-24P

Equipment Condition

Parking brake set (in-vehicle only)
(TM 9-2320-386-10).

FUEL TANK FILLER CAP AND SLEEVE REPLACEMENT (Contd)**WARNING**

Diesel fuel is flammable. Do not perform fuel system procedures near open flame, sparks, or electricity. Injury to personnel may result.

REMOVAL

1. Remove fuel tank filler cap (1) and sleeve (7) from fuel tank (4).
2. Remove chain with clip (3) from fuel tank (4).
3. Remove locknut (5), washer (6), screw (8), washer (6), fuel tank filler cap (1) with chain (2), and chain with clip (3) from sleeve (7). Discard locknut (5).
4. Remove gasket (9) from fuel tank filler cap (1). Discard gasket (9).

INSTALLATION

1. Install new gasket (9) on fuel tank filler cap (1).
2. Install chain with clip (3) and fuel tank filler cap (1) with chain (2) on sleeve (7) with washer (6), screw (8), washer (6), and new locknut (5).
3. Insert chain with clip (3) in fuel tank (4).
4. Install sleeve (7) and fuel tank filler cap (1) on fuel tank (4).

FUEL TANK FILLER CAP AND SLEEVE REPLACEMENT (Contd)

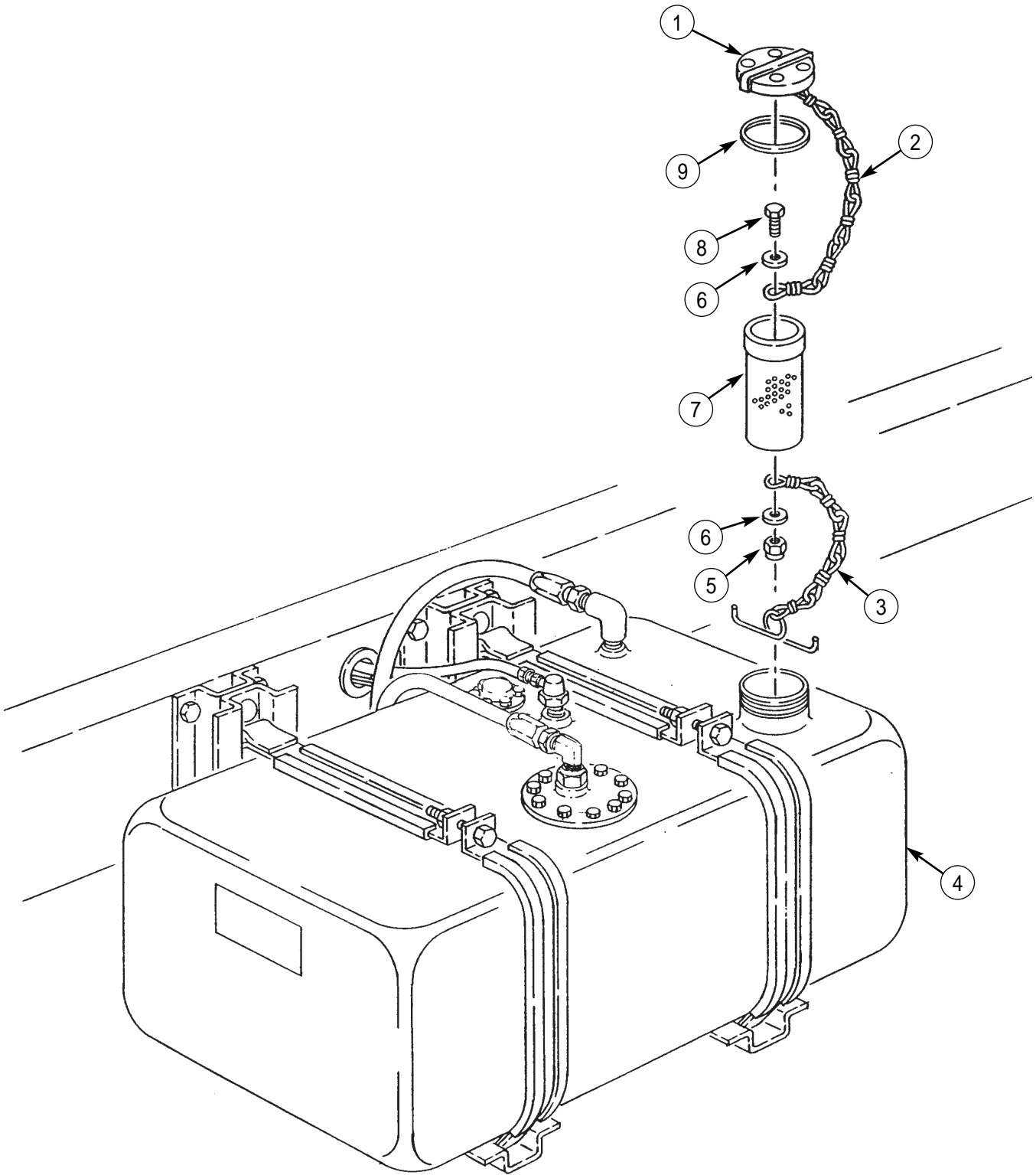

END OF WORK PACKAGE

UNIT MAINTENANCE INSTRUCTIONS

EXTENDED SERVICE PROGRAM (ESP)

TRUCK, CARGO, 2-1/2-TON, 6X6, M44A3 SERIES TRUCKS (DIESEL)

M35A3, W/O WINCH (NSN 2320-01-383-2047); W/WINCH (NSN 2320-01-383-3850);
M35A3C, W/O WINCH (NSN 2320-01-383-2050); W/WINCH (NSN 2320-01-383-2049);
M36A3, W/O WINCH (NSN 2320-01-383-2048); W/WINCH (NSN 2320-01-383-2046).

FUEL TANK LINES REPLACEMENT

REMOVAL, INSTALLATION

INITIAL SETUP:

Tools and Special Tools

General mechanic's tool kit
(item 30, WP 0394 00)

Materials/Parts

Tiedown straps (item 37, WP 0395 00)
Five locknuts (item 90, WP 0395 00)
Cap and plug set (item 14, WP 0393 00)

References

TM 9-2320-386-24P

Equipment Condition

Parking brake set (TM 9-2320-386-10).
Hood raised and secured (TM 9-2320-386-10).
Vent line removed (WP 0049 00).

FUEL TANK LINES REPLACEMENT (Contd)**WARNING**

Diesel fuel is flammable. Do not perform fuel system procedures near open flame, sparks, or electricity. Injury to personnel may result.

REMOVAL

1. Remove tiedown straps (5) from fuel lines (1) and (2) as necessary. Discard tiedown straps (5).

CAUTION

Cap or plug all hoses, connections, and openings immediately after disconnection or component removal to prevent contamination. Failure to do so may result in damage to equipment.

NOTE

The fuel return line is the smaller of the two fuel lines coming from elbows on top of fuel tank.

2. Disconnect fuel return line (1) from elbow (21) on fuel tank (18).
3. Disconnect fuel inlet line (2) from elbow (22) on fuel tank (18).
4. Remove locknut (19), screw (4), and clamp (3) from right frame rail (20). Discard locknut (19).
5. Remove two locknuts (6), washers (8), screws (16), washers (8), and clamps (17) from crossmember (7). Discard locknuts (6).
6. Disconnect spring (25) from bracket (24) on left frame rail (23).
7. Remove locknut (10), screw (9), bracket (24), and clamp (11) with fuel lines (1) and (2) from left frame rail (23). Discard locknut (10).
8. Remove fuel return line (1) and fuel inlet line (2) from clamp (11).
9. Disconnect fuel inlet line (2) from elbow (27).
10. Disconnect fuel return line (1) from elbow (26).
11. Remove locknut (15), washer (14), screw (13), two clamps (12), fuel return line (1), and fuel inlet line (2) from bracket (28). Discard locknut (15).
12. Remove fuel return line (1) and fuel inlet line (2) from vehicle.

FUEL TANK LINES REPLACEMENT (Contd)

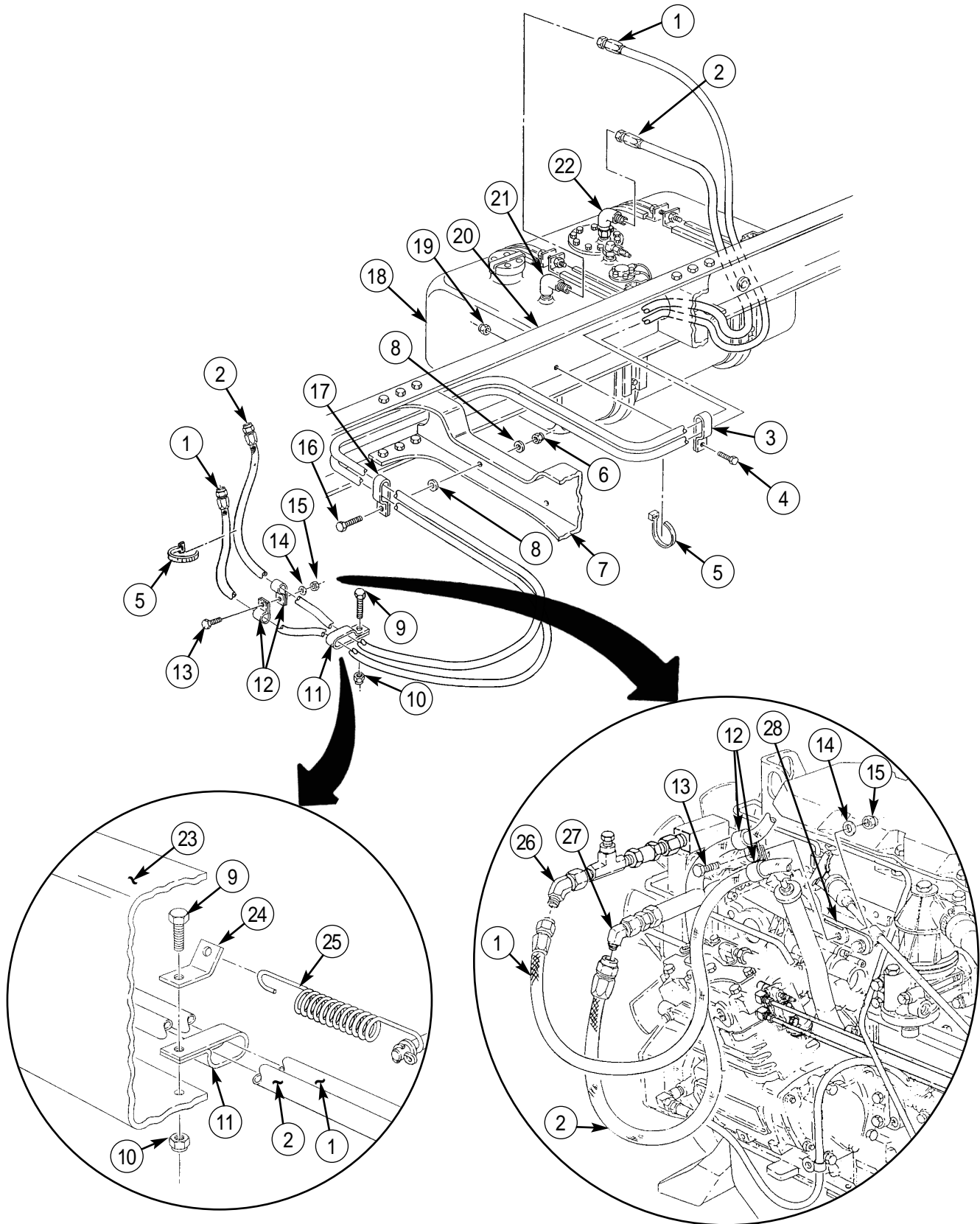

FUEL TANK LINES REPLACEMENT (Contd)**INSTALLATION****NOTE**

The fuel return line is the smaller of the two fuel lines.

1. Position fuel return line (1) and fuel inlet line (9) in vehicle.
2. Connect fuel return line (1) to elbow (2).
3. Connect fuel inlet line (9) to elbow (3).
4. Route fuel inlet line (9) and fuel return line (1) through openings in crossmember (20) and rear crossmember (15) at fuel tank (10).
5. Connect fuel return line (1) to elbow (13) on fuel tank (10).
6. Connect fuel inlet line (9) to elbow (14) on fuel tank (10).
7. Install clamp (24) on fuel return line (1) and fuel inlet line (9).
8. Install clamp (24) with fuel return line (1) and fuel inlet line (9) and bracket (28) on left frame rail (27) with screw (22) and new locknut (23).
9. Connect spring (29) to bracket (28) on left frame rail (27).
10. Install fuel inlet line (9) and fuel return line (1) on crossmember (20) with two clamps (26), screws (25), four washers (21), and two new locknuts (19).
11. Install fuel inlet line (9) and fuel return line (1) on right frame rail (12) with clamp (16), screw (17), and new locknut (11).
12. Install new tiedown straps (18) on fuel inlet line (9) and fuel return line (1) as necessary.
13. Install fuel inlet line (9) and fuel return line (1) on bracket (6) with two clamps (5), screw (4), washer (7), and new locknut (8).
14. Install vent line (WP 0049 00).
15. Start engine (TM 9-2320-386-10) and inspect fuel system for leaks.

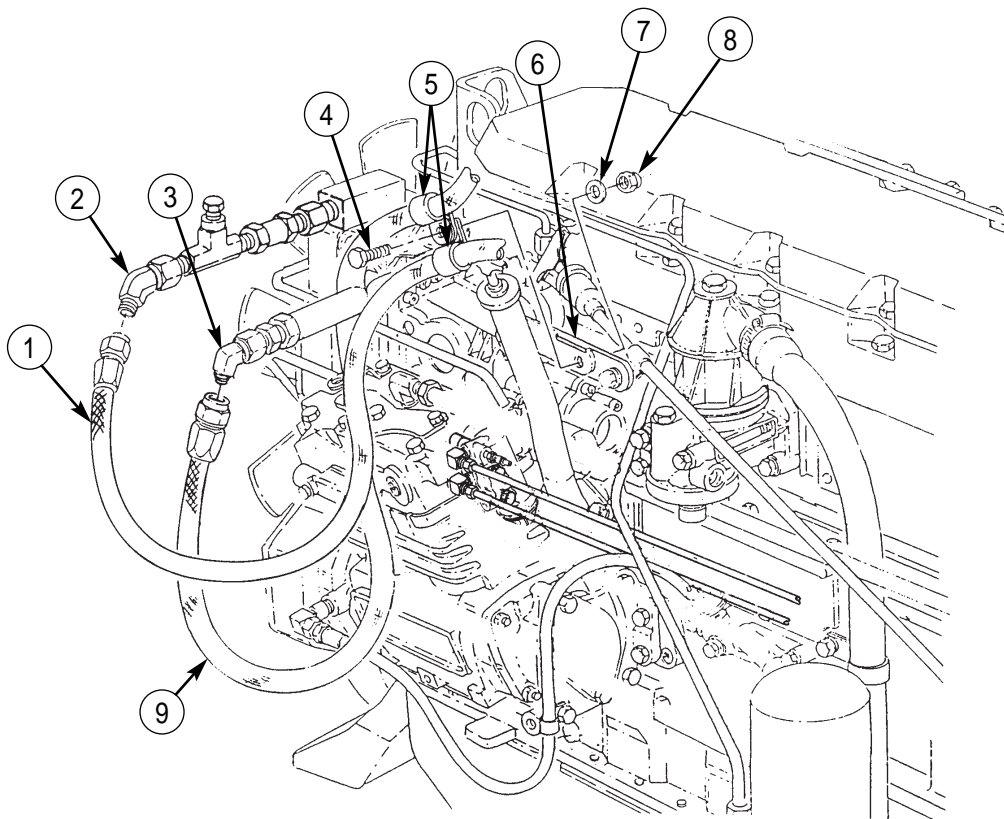

FUEL TANK LINES REPLACEMENT (Contd)

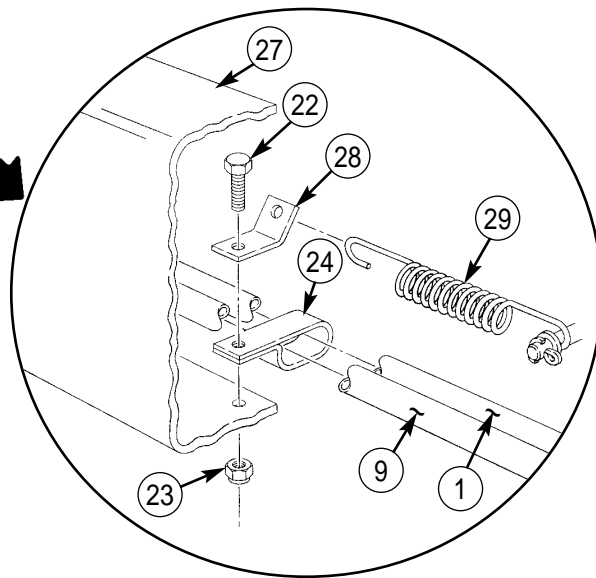
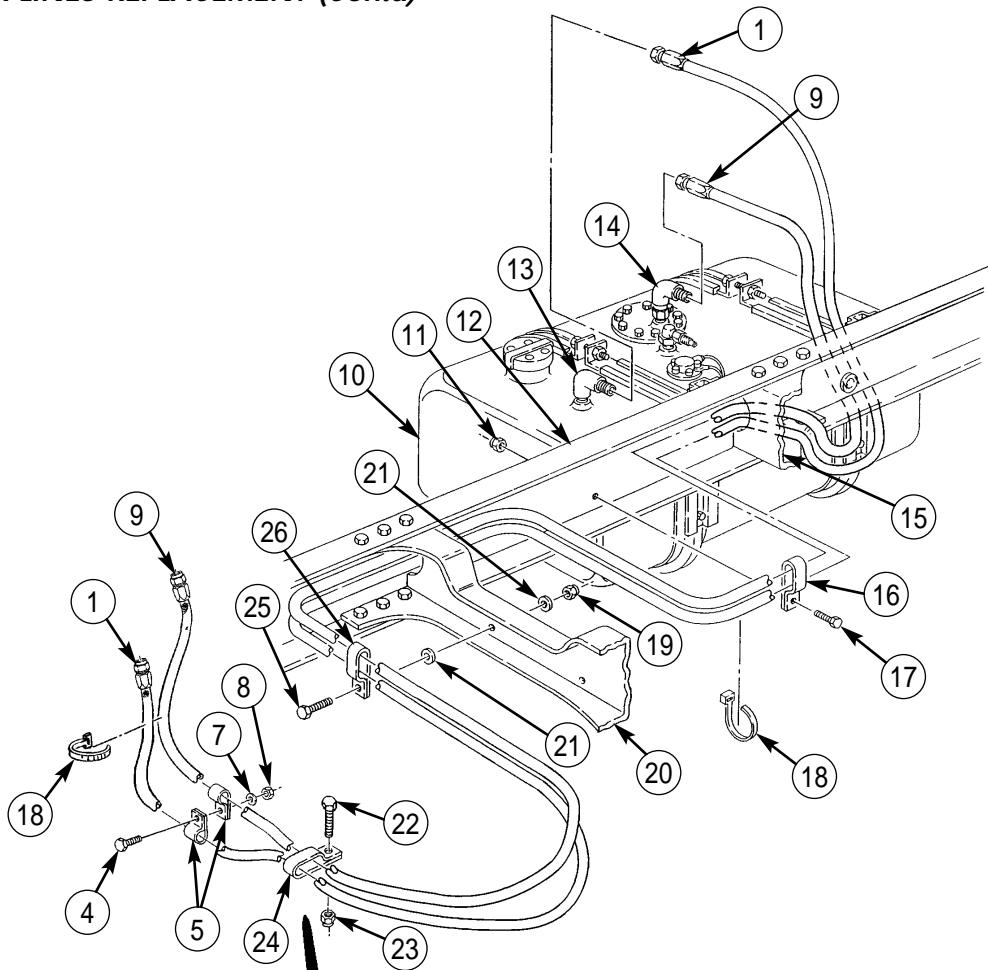

END OF WORK PACKAGE

UNIT MAINTENANCE INSTRUCTIONS

EXTENDED SERVICE PROGRAM (ESP)

TRUCK, CARGO, 2-1/2-TON, 6X6, M44A3 SERIES TRUCKS (DIESEL)

M35A3, W/O WINCH (NSN 2320-01-383-2047); W/WINCH (NSN 2320-01-383-3850);

M35A3C, W/O WINCH (NSN 2320-01-383-2050); W/WINCH (NSN 2320-01-383-2049);

M36A3, W/O WINCH (NSN 2320-01-383-2048); W/WINCH (NSN 2320-01-383-2046).

FUEL VENT LINE REPLACEMENT

REMOVAL, INSTALLATION

INITIAL SETUP:

Tools and Special Tools

General mechanic's tool kit
(item 30, WP 0394 00)

Materials/Parts

Cap and plug set (item 14, WP 0393 00)
Tiedown strap (item 38, WP 0395 00)

References

TM 9-2320-386-24P

Equipment Condition

Parking brake set (TM 9-2320-386-10).

FUEL VENT LINE REPLACEMENT (Contd)**REMOVAL****WARNING**

Diesel fuel is flammable. Do not perform fuel system procedures near open flame, sparks, or electricity. Injury to personnel may result.

CAUTION

When disconnecting air lines and hoses, plug all openings to prevent dirt from entering and causing damage to internal parts. Remove all plugs prior to installation.

1. Loosen nut (3) and remove fuel tank vent line (2) from vent valve (4) on fuel tank (5).
2. Remove tiedown strap (9), four screws (6), clamps (7), and fuel tank vent line (2) from cab (8). Discard tiedown strap (9).
3. Pull fuel tank vent line (2) through right frame rail (1) and remove from vehicle.

INSTALLATION

1. Route fuel tank vent line (2) through right frame rail (1) and connect fuel tank vent line (2) to vent valve (4) on fuel tank (5) and tighten nut (3).
2. Install four clamps (7) on fuel tank vent line (2) and other two vent lines and secure to cab (8) with four screws (6).
3. Secure three vent lines into a loop with new tiedown strap (9).

FUEL VENT LINE REPLACEMENT (Contd)

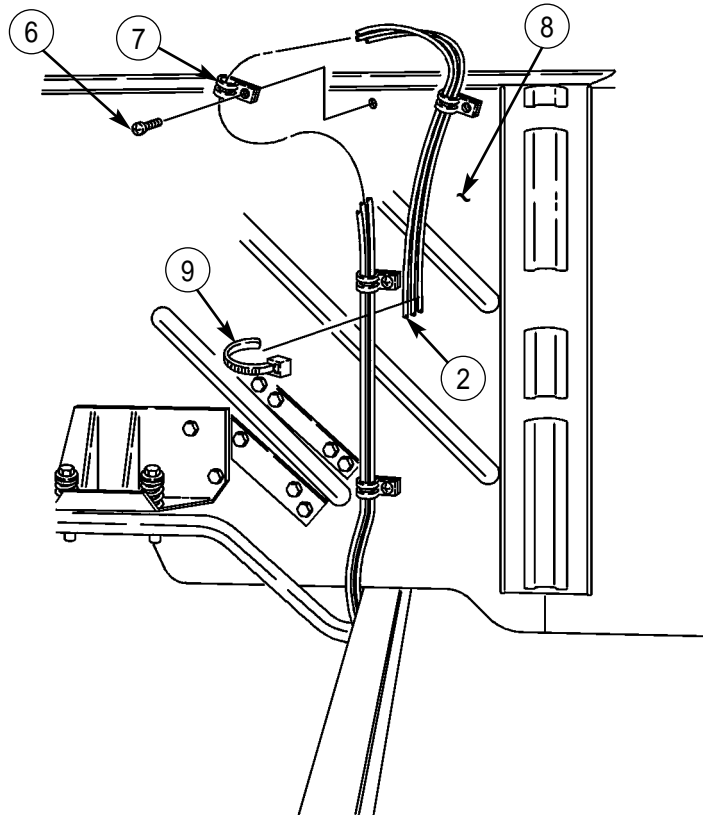
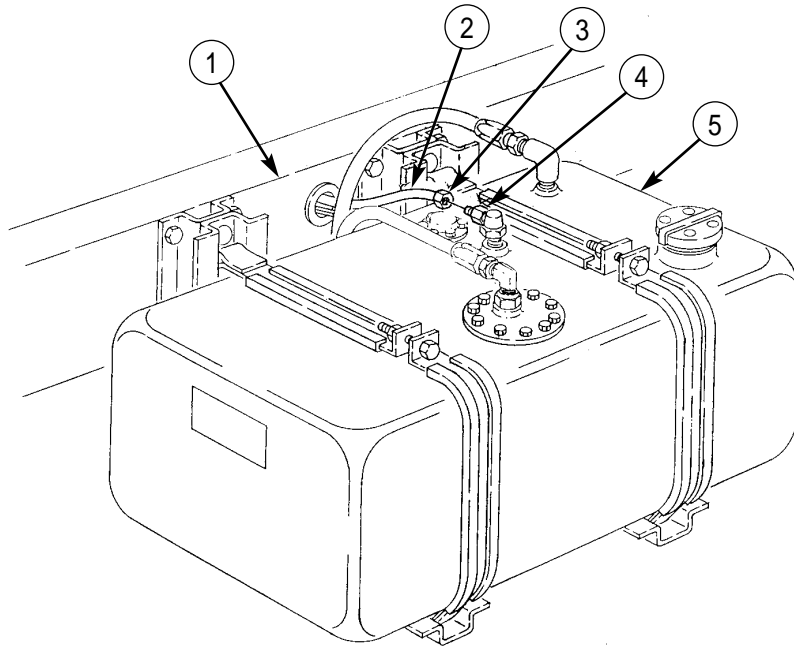

END OF WORK PACKAGE

UNIT MAINTENANCE INSTRUCTIONS

EXTENDED SERVICE PROGRAM (ESP)

TRUCK, CARGO, 2-1/2-TON, 6X6, M44A3 SERIES TRUCKS (DIESEL)

M35A3, W/O WINCH (NSN 2320-01-383-2047); W/WINCH (NSN 2320-01-383-3850);
M35A3C, W/O WINCH (NSN 2320-01-383-2050); W/WINCH (NSN 2320-01-383-2049);
M36A3, W/O WINCH (NSN 2320-01-383-2048); W/WINCH (NSN 2320-01-383-2046).

FUEL SHUTOFF SOLENOID REPLACEMENT

REMOVAL, INSTALLATION

INITIAL SETUP:

Tools and Special Tools

General mechanic's tool kit
(item 30, WP 0394 00)
Spanner wrench (item 97, WP 0394 00)

Materials/Parts

O-ring (item 226, WP 0395 00)
Two lockwashers (item 40, WP 0395 00)
Teflon pipe sealant (item 41, WP 0393 00)
Skysol-100 (item 17, WP 0393 00)
Cap and plug set (item 14, WP 0393 00)

References

TM 9-2320-386-24P

Equipment Condition

Parking brake set (TM 9-2320-386-10).
Hood raised and secured (TM 9-2320-386-10).
Air reservoirs drained. (TM 9-2320-386-10).
Oil filler tube removed (WP 0031 00).
Battery ground cable disconnected (WP 0121 00).

FUEL SHUTOFF SOLENOID REPLACEMENT (Contd)

WARNING

Diesel fuel is flammable. Do not perform fuel system procedures near open flame, sparks, or electricity. Injury to personnel may result.

Do not disconnect air lines or hoses before draining air reservoirs. Small parts under pressure may shoot out at high velocity causing injury to personnel.

Eyeshields must be worn when releasing compressed air. Failure to do so may cause injury to personnel.

REMOVAL

1. Loosen nut (15) and remove tube (16) from elbow (14).

NOTE

Note position of elbow for installation.

Note position of coolant hose for installation.

2. Remove elbow (14) from air compressor (1).
3. Loosen nut (4) one-half turn on elbow (5) and move coolant hose (2) out of the way to access fuel shutoff solenoid (11).

CAUTION

When disconnecting air lines and hoses, plug all openings to prevent dirt from entering and causing damage to internal parts. Remove all plugs prior to installation.

4. Remove two nuts (7), lockwashers (6), and ground (GND) lead (8) from one terminal and leads 54A (10) and 770-R (9) from other terminal on fuel shutoff solenoid (11). Discard lockwashers (6).
5. Using spanner wrench, remove fuel shutoff solenoid (11) and O-ring (13) from fuel pump (3). Discard O-ring (13).

INSTALLATION

WARNING

Skysol-100 mixture is combustible. Use mechanical ventilation whenever product is used in a confined space, is heated above ambient temperatures, or is agitated. DO NOT use or store near heat, sparks, flame, or other ignition sources. Keep container sealed when not in use.

Contact with Skysol-100 may cause skin irritation. Use chemical resistant gloves. In case of skin contact, remove any contaminated clothing and wash skin thoroughly with soap and water. Wash contaminated clothing before reuse. Eye contact may cause irritation, tearing, or blurring of vision. Use face shield or goggles when eye contact may occur. In case of eye contact, flush eyes with large amounts of water for at least fifteen (15) minutes or until irritation subsides. Inhalation may cause irritation to upper respiratory passages. DO NOT have food or drink in the vicinity.

1. Clean fuel shutoff solenoid sealing area (12) with Skysol-100.
2. Install new O-ring (13) on fuel shutoff solenoid (11).
3. Using spanner wrench, install fuel shutoff solenoid (11) on fuel pump (3).
4. Install ground (GND) lead (8) on one terminal and leads 54A (10) and 770-R (9) on other terminal of fuel shutoff solenoid (11) with two new lockwashers (6) and nuts (7).

FUEL SHUTOFF SOLENOID REPLACEMENT (Contd)

5. Move coolant hose (2) back to its original position and tighten nut (4) on elbow (5).
6. Apply sealant to threads of elbow (14) and install elbow (14) back in its original position on air compressor (1).
7. Install tube (16) on elbow (14) and tighten nut (15).
8. Install oil filler tube (WP 0031 00).
9. Connect battery ground cable (WP 0121 00).

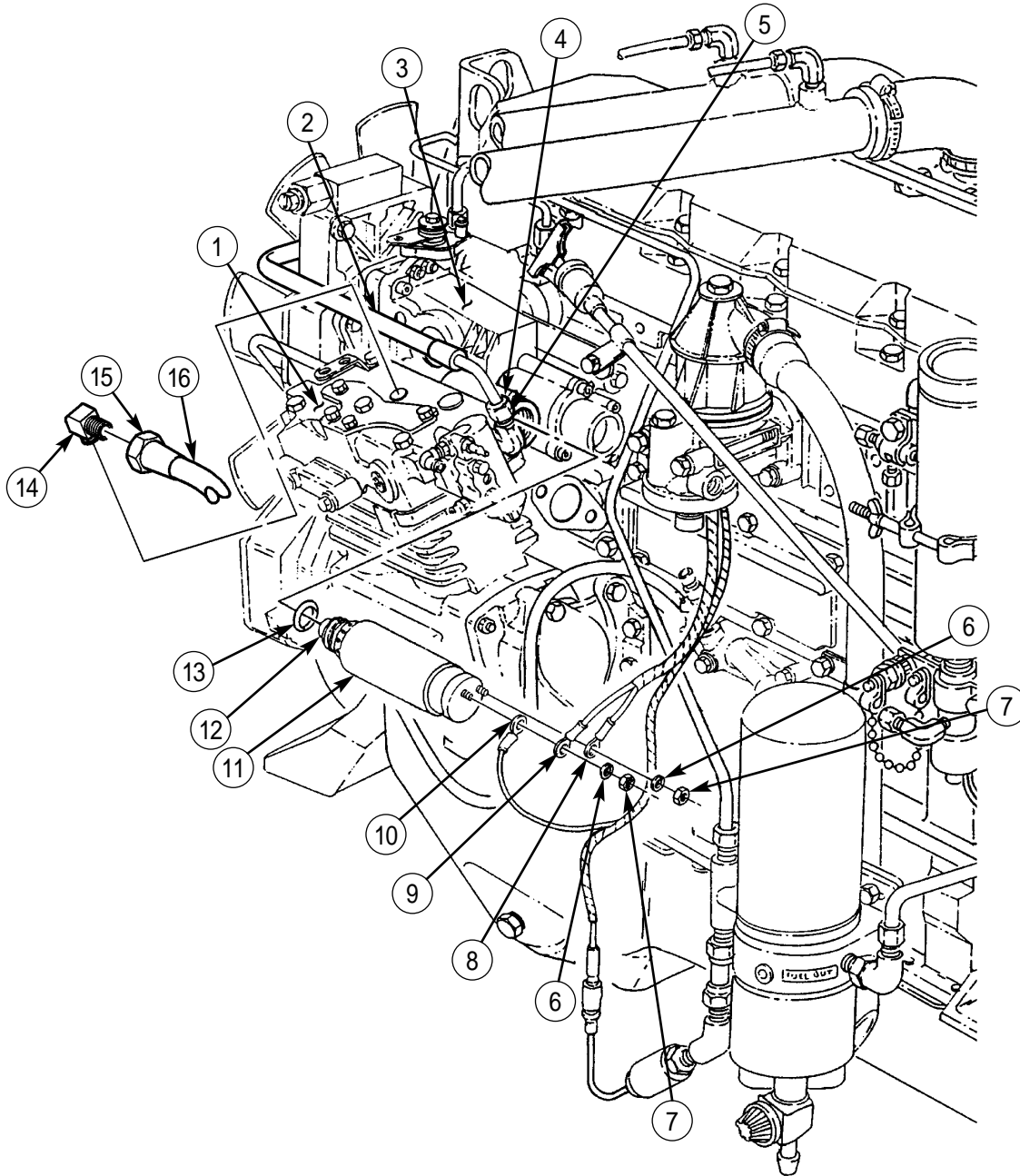

END OF WORK PACKAGE

UNIT MAINTENANCE INSTRUCTIONS

EXTENDED SERVICE PROGRAM (ESP)

TRUCK, CARGO, 2-1/2-TON, 6X6, M44A3 SERIES TRUCKS (DIESEL)

M35A3, W/O WINCH (NSN 2320-01-383-2047); W/WINCH (NSN 2320-01-383-3850);

M35A3C, W/O WINCH (NSN 2320-01-383-2050); W/WINCH (NSN 2320-01-383-2049);

M36A3, W/O WINCH (NSN 2320-01-383-2048); W/WINCH (NSN 2320-01-383-2046).

GOVERNOR FUEL AND OIL LINES REPLACEMENT

**RATIO CONTROL LINE REMOVAL, FUEL RETURN TUBE REMOVAL, GOVERNOR OIL LINE REMOVAL,
GOVERNOR OIL LINE INSTALLATION, FUEL RETURN TUBE INSTALLATION, RATIO CONTROL LINE INSTALLATION**

INITIAL SETUP:

Tools and Special Tools

General mechanic's tool kit
(item 30, WP 0394 00)

Materials/Parts

Four O-rings (item 225, WP 0395 00)
O-ring (item 252, WP 0395 00)
Cap and plug set (item 14, WP 0393 00)
O-ring (item 191, WP 0395 00)
O-ring (item 250, WP 0395 00)
Four O-rings (item 210, WP 0395 00)
O-ring (item 214, WP 0395 00)

References

TM 9-2320-386-24P

Equipment Condition

Parking brake set (TM 9-2320-386-10).
Hood raised and secured (TM 9-2320-386-10).

GOVERNOR FUEL AND OIL LINES REPLACEMENT (Contd)

WARNING

Diesel fuel is flammable. Do not perform fuel system procedures near open flame, sparks, or electricity. Injury to personnel may result.

CAUTION

Cap or plug all hoses, connections, and openings immediately after disconnecting fuel lines to prevent contamination. Failure to do so may result in damage to equipment.

RATIO CONTROL LINE REMOVAL

1. Remove screw (1), washer (2), and clamp (22) from ratio control line (21) and fuel return tube (18).
2. Remove ratio control line (21) from adapters (4) and (6).
3. Remove adapters (4) and (6) from engine (14) and ratio control (12).
4. Remove two O-rings (3) and (5) from adapters (4) and (6). Discard O-rings (3) and (5).

FUEL RETURN TUBE REMOVAL

1. Remove fuel return line (23) and elbow (24) from tee (25).
2. Remove tee (25) and fitting (26) from fuel return tube (18).
3. Remove O-ring (27) from fitting (26). Discard O-ring (27).
4. Remove two screws (15) and washers (16) from fuel return tube (18) and governor (13).
5. Remove screw (20), washer (19), fuel return tube (18), and O-ring (17) from engine (14). Discard O-ring (17).
6. Remove adapter (28), O-ring (29), spring (30), O-ring (31), and valve (32) from fuel return tube (18). Discard O-rings (31) and (29).

GOVERNOR OIL LINE REMOVAL

1. Remove oil line (9) from elbow (7) and adapter (11).
2. Remove adapter (11) and elbow (7) from governor (13) and engine (14).
3. Remove two O-rings (10) and (8) from adapter (11) and elbow (7). Discard O-rings (10) and (8).

GOVERNOR OIL LINE INSTALLATION

1. Install two new O-rings (10) and (8) on adapter (11) and elbow (7).
2. Install adapter (11) and elbow (7) on governor (13) and engine (14).
3. Install oil line (9) on elbow (7) and adapter (11).

FUEL RETURN TUBE INSTALLATION

1. Install new O-ring (17) and fuel return tube (18) on engine (14) with washer (19) and screw (20).
2. Install opposite end of fuel return tube (18) on governor (13) with two washers (16) and screws (15).
3. Install valve (32), new O-ring (31), spring (30), new O-ring (29), and adapter (28) in fuel return tube (18).
4. Install new O-ring (27), fitting (26), tee (25), elbow (24), and fuel return line (23) on fuel return tube (18).

RATIO CONTROL LINE INSTALLATION

1. Install two new O-rings (3) and (5) on adapters (4) and (6).
2. Install adapters (4) and (6) on engine (14) and ratio control (12).
3. Install ratio control line (21) on adapters (4) and (6).
4. Install ratio control line (21) on fuel return tube (18) with clamp (22), washer (2), and screw (1).

GOVERNOR FUEL AND OIL LINES REPLACEMENT (Contd)

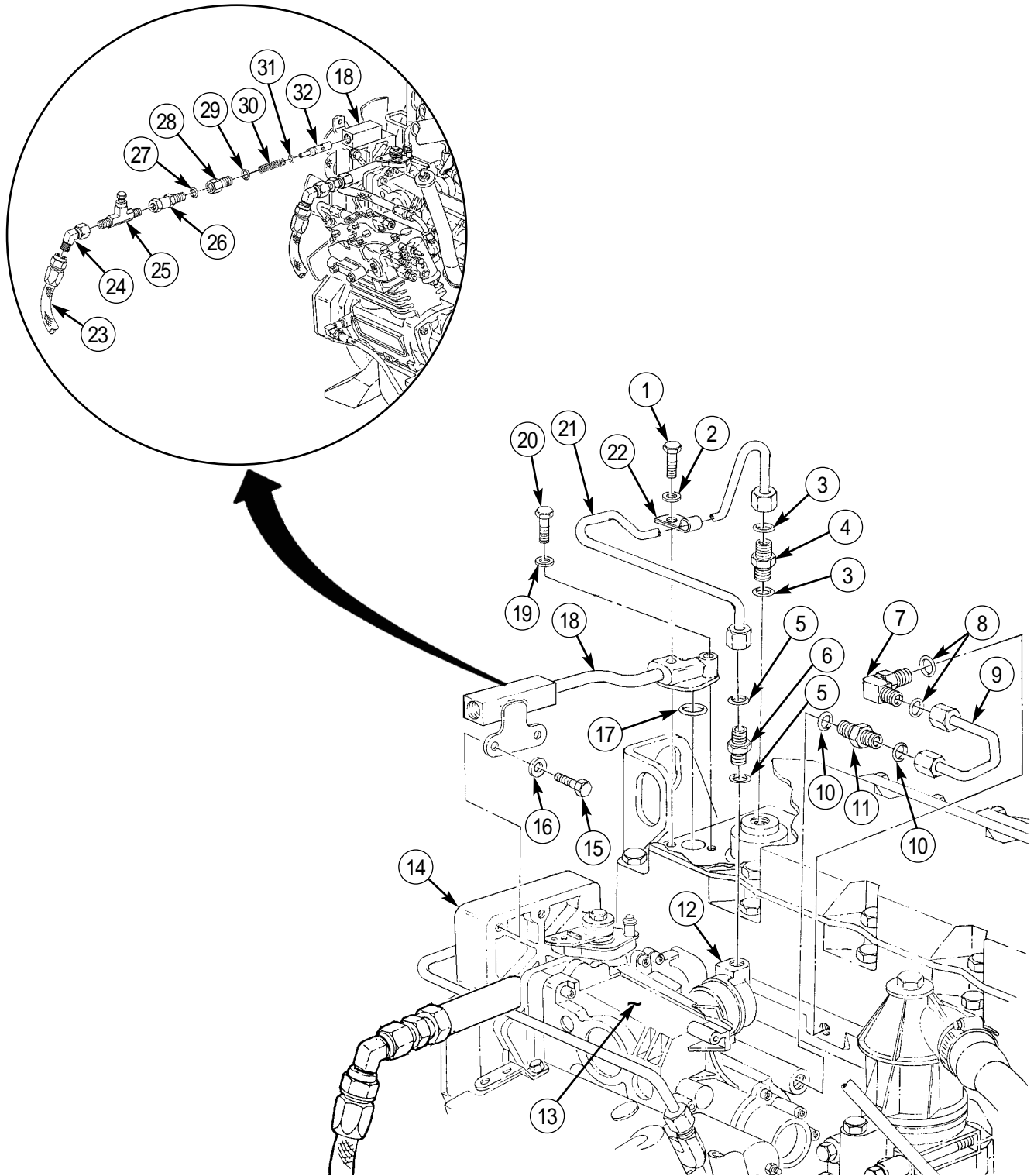

END OF WORK PACKAGE

UNIT MAINTENANCE INSTRUCTIONS

EXTENDED SERVICE PROGRAM (ESP)

TRUCK, CARGO, 2-1/2-TON, 6X6, M44A3 SERIES TRUCKS (DIESEL)

M35A3, W/O WINCH (NSN 2320-01-383-2047); W/WINCH (NSN 2320-01-383-3850);
M35A3C, W/O WINCH (NSN 2320-01-383-2050); W/WINCH (NSN 2320-01-383-2049);
M36A3, W/O WINCH (NSN 2320-01-383-2048); W/WINCH (NSN 2320-01-383-2046).

GOVERNOR LOW IDLE SPEED ADJUSTMENT

ADJUSTMENT

INITIAL SETUP:

Tools and Special Tools

General mechanic's tool kit
(item 30, WP 0394 00)

Equipment Condition

Parking brake set (TM 9-2320-386-10).
Hood raised and secured (TM 9-2320-386-10).

References

TM 9-2320-386-24P
TB MED 501
AR 40-5

GOVERNOR LOW IDLE SPEED ADJUSTMENT (Contd)**ADJUSTMENT****WARNING**

Hearing protection is required for the driver and co-driver. Hearing protection is also required for all personnel working in and around this vehicle while the engine is running (Reference AR 40-5 and TB MED. 501).

NOTE

Engine idle speed is 750-850 rpm.

1. Start engine (TM 9-2320-386-10) and check tachometer reading. If tachometer reading is not within range:
 - a. Loosen locknut (2) and turn adjusting screw (3) until engine idle is within the proper range.
 - b. Tighten locknut (2).
 - c. If proper engine idle speed cannot be achieved, notify direct support maintenance to replace governor (1).

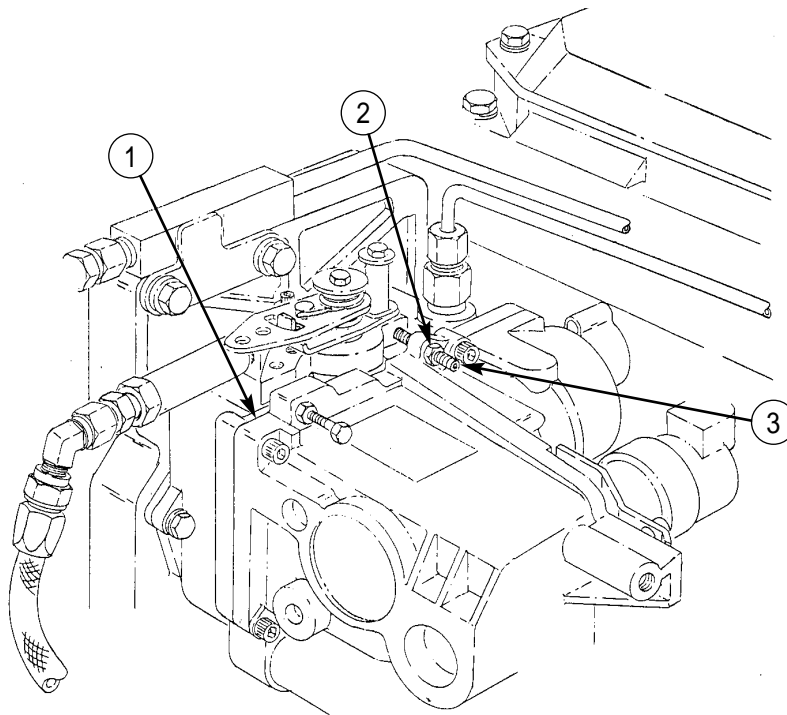

END OF WORK PACKAGE

UNIT MAINTENANCE INSTRUCTIONS

EXTENDED SERVICE PROGRAM (ESP)

TRUCK, CARGO, 2-1/2-TON, 6X6, M44A3 SERIES TRUCKS (DIESEL)

M35A3, W/O WINCH (NSN 2320-01-383-2047); W/WINCH (NSN 2320-01-383-3850);

M35A3C, W/O WINCH (NSN 2320-01-383-2050); W/WINCH (NSN 2320-01-383-2049);

M36A3, W/O WINCH (NSN 2320-01-383-2048); W/WINCH (NSN 2320-01-383-2046).

FUEL/WATER SEPARATOR AND BRACKET REPLACEMENT

REMOVAL, INSTALLATION

INITIAL SETUP:

Tools and Special Tools

General mechanic's tool kit
(item 30, WP 0394 00)

References

TM 9-2320-386-24P

Materials/Parts

Three O-rings (item 3, WP 0395 00)
Two O-rings (item 310, WP 0395 00)
Teflon pipe sealant (item 41, WP 0393 00)

Equipment Condition

Parking brake set (TM 9-2320-386-10)
Hood raised and secured (TM 9-2320-386-10).
Battery ground cable disconnected (WP 0121 00).
Fuel filter removed (WP 0054 00).

FUEL/WATER SEPARATOR AND BRACKET REPLACEMENT (Contd)**REMOVAL**

1. Loosen nuts (4) and (3) and remove fuel inlet line (1) and fuel outlet line (2) from tee (18) and elbow (7).
2. Disconnect pressure transducer plug (19) from STE/ICE-R wiring harness receptacle (20).
3. Remove two flange nuts (5), screws (10), washers (9), and fuel/water separator (8) from filter bracket (12).
4. Remove two screws (13) and filter bracket (12) from engine (11).
5. Remove elbow (7) from fuel/water separator (8).
6. Remove two O-rings (6) from elbow (7). Discard O-rings (6).
7. Remove pressure transducer (15) from elbow (16).
8. Remove elbow (16) and connector (17) from tee (18).
9. Remove tee (18) from fuel/water separator (8).
10. Remove three O-rings (14) from tee (18). Discard O-rings (14).

INSTALLATION

1. Install three new O-rings (14) on tee (18).
2. Install tee (18) on fuel/water separator (8).
3. Apply sealant to threads of elbow (16) and install elbow (16) and connector (17) on tee (18).
4. Install two new O-rings (6) on elbow (7).
5. Install elbow (7) on fuel/water separator (8).
6. Apply sealant to threads of pressure transducer (15) and connect pressure transducer (15) to elbow (16).
7. Install filter bracket (12) on engine (11) with two screws (13).
8. Install fuel/water separator (8) on filter bracket (12) with two washers (9), screws (10), and flange nuts (5).
9. Connect pressure transducer plug (19) to STE/ICE-R wiring harness receptacle (20).
10. Install fuel inlet line (1) to tee (18) and fuel outlet line (2) to elbow (7) and tighten nuts (4) and (3).
11. Install fuel filter (WP 0054 00).
12. Connect battery ground cable (WP 0121 00).

FUEL/WATER SEPARATOR AND BRACKET REPLACEMENT (Contd)

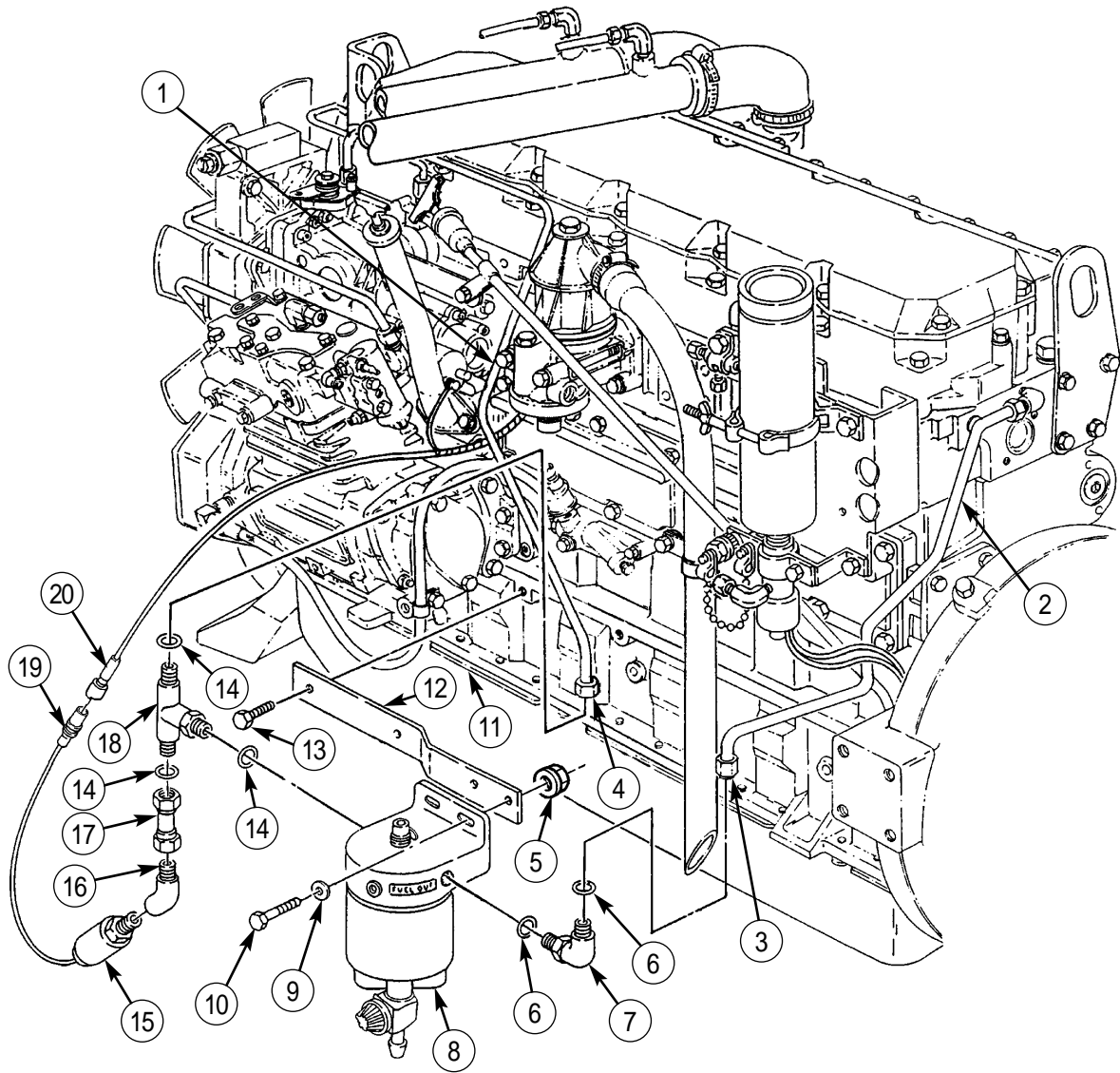

END OF WORK PACKAGE

UNIT MAINTENANCE INSTRUCTIONS

EXTENDED SERVICE PROGRAM (ESP)

TRUCK, CARGO, 2-1/2-TON, 6X6, M44A3 SERIES TRUCKS (DIESEL)

M35A3, W/O WINCH (NSN 2320-01-383-2047); W/WINCH (NSN 2320-01-383-3850);
M35A3C, W/O WINCH (NSN 2320-01-383-2050); W/WINCH (NSN 2320-01-383-2049);
M36A3, W/O WINCH (NSN 2320-01-383-2048); W/WINCH (NSN 2320-01-383-2046).

FUEL FILTER MAINTENANCE

DRAINING, REMOVAL, CLEANING AND INSPECTION, INSTALLATION

INITIAL SETUP:

Tools and Special Tools

General mechanic's tool kit
(item 30, WP 0394 00)

Materials/Parts

Fuel filter (item 298, WP 0395 00)
Lubricating oil (item 32, WP 0393 00)
Skysol-100 (item 17, WP 0393 00)

References

TM 9-2320-386-24P

Equipment Condition

Parking brake set (TM 9-2320-386-10).
Hood raised and secured (TM 9-2320-386-10).

FUEL FILTER MAINTENANCE (Contd)

WARNING

Diesel fuel is flammable. Do not perform fuel system procedures near open flame, sparks, or electricity. Injury to personnel may result.

DRAINING

NOTE

Have drainage container ready to catch fuel.

1. Open drainvalve (4) and drain fuel from fuel filter (1).
2. Close drainvalve (4).

REMOVAL

Remove fuel filter (1) from fuel/water separator (3). Discard fuel filter (1).

CLEANING AND INSPECTION

WARNING

Skysol-100 mixture is combustible. Use mechanical ventilation whenever product is used in a confined space, is heated above ambient temperatures, or is agitated. DO NOT use or store near heat, sparks, flame, or other ignition sources. Keep container sealed when not in use.

Contact with Skysol-100 may cause skin irritation. Use chemical resistant gloves. In case of skin contact, remove any contaminated clothing and wash skin thoroughly with soap and water. Wash contaminated clothing before reuse. Eye contact may cause irritation, tearing, or blurring of vision. Use face shield or goggles when eye contact may occur. In case of eye contact, flush eyes with large amounts of water for at least fifteen (15) minutes or until irritation subsides. Inhalation may cause irritation to upper respiratory passages. DO NOT have food or drink in the vicinity.

1. Clean sealing area (5) of fuel/water separator (3) with Skysol-100.
2. Apply clean lubricating oil to sealing area (5) of fuel/water separator (3).

INSTALLATION

1. Install new fuel filter (1) on fuel/water separator (3) until O-ring (2) touches fuel/water separator (3).
2. Hand-tighten fuel filter (1) an additional three-quarters of a turn.
3. Start engine (TM 9-2320-386-10) and inspect fuel system for leaks.

FUEL FILTER MAINTENANCE (Contd)

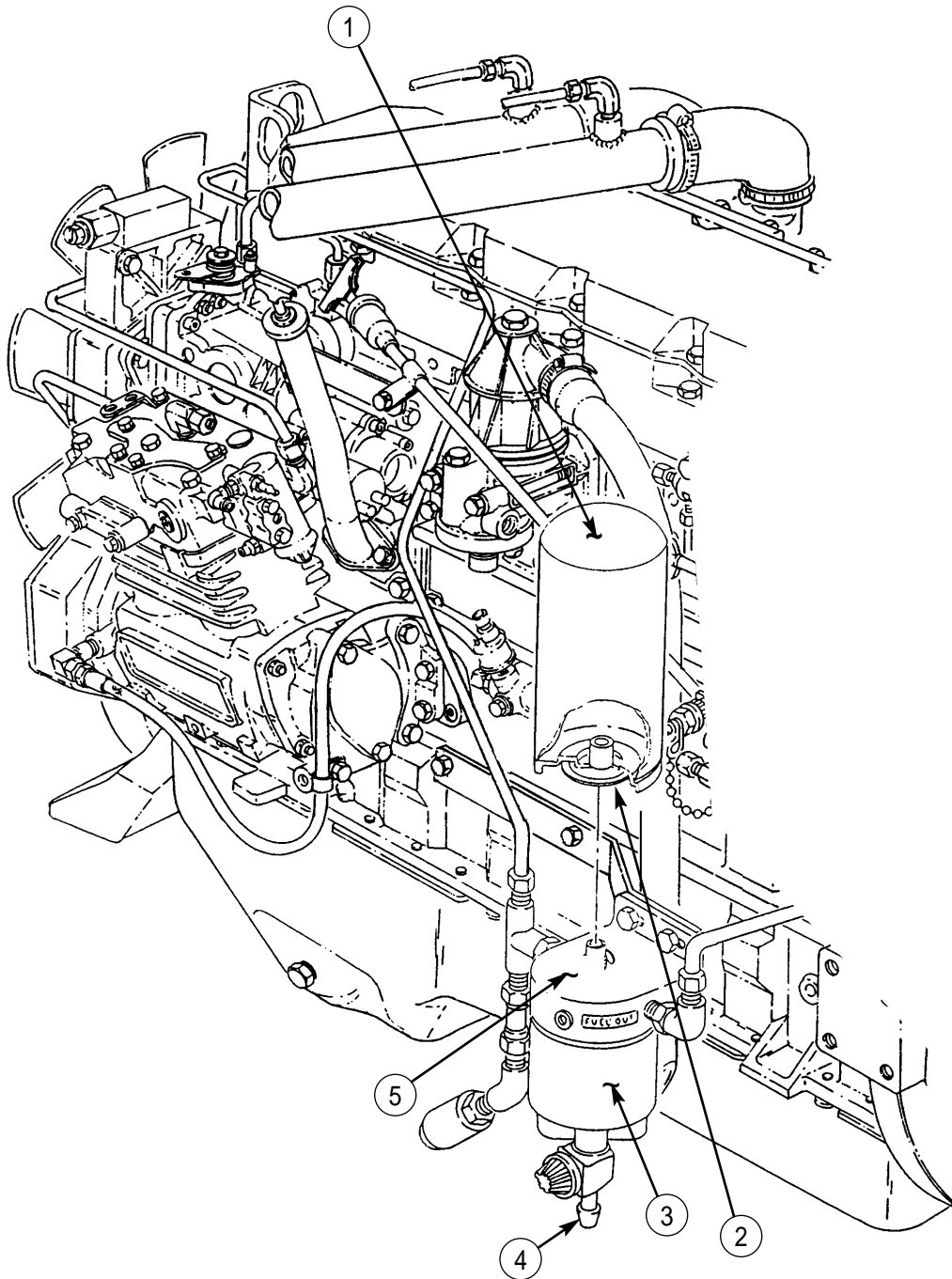

END OF WORK PACKAGE

UNIT MAINTENANCE INSTRUCTIONS

EXTENDED SERVICE PROGRAM (ESP)

TRUCK, CARGO, 2-1/2-TON, 6X6, M44A3 SERIES TRUCKS (DIESEL)

M35A3, W/O WINCH (NSN 2320-01-383-2047); W/WINCH (NSN 2320-01-383-3850);
M35A3C, W/O WINCH (NSN 2320-01-383-2050); W/WINCH (NSN 2320-01-383-2049);
M36A3, W/O WINCH (NSN 2320-01-383-2048); W/WINCH (NSN 2320-01-383-2046).

QUICK-START CYLINDER AND VALVE REPLACEMENT (BUILT BEFORE SERIAL NO. 504924)

REMOVAL, INSTALLATION

INITIAL SETUP:

Tools and Special Tools

General mechanic's tool kit
(item 30, WP 0394 00)

Materials/Parts

Teflon pipe sealant (item 41, WP 0393 00)
Gasket (item 104, WP 0395 00)

References

TM 9-2320-386-24P

Equipment Condition

Parking brake set (TM 9-2320-386-10).
Hood raised and secured (TM 9-2320-386-10).
Battery ground cable disconnected (WP 0121 00).

QUICK-START CYLINDER AND VALVE REPLACEMENT (BUILT BEFORE SERIAL NO. 504924) (Contd)**WARNING**

Ether is extremely flammable. Perform this procedure in a well-ventilated area away from flames and sparks. Failure to do so may result in injury to personnel.

REMOVAL

1. Loosen wingnut (1) and clamp (2) on cylinder (15).
2. Remove (turn counterclockwise) cylinder (15) from quick-start valve (9) and remove from clamp (2).
3. Remove gasket (11) from quick-start valve (9) if cracked or damaged.
4. Install plug with chain (13) on quick-start valve (9).
5. Disconnect harness plug with leads 569A and 569B (7) from quick-start valve lead connector (8).
6. Loosen nut (4) and remove tube (6) with sleeve (5) from elbow (10).
7. Remove two screws (12), plug with chain (13), clamp (14), and quick-start valve (9) from bracket (3).

NOTE

Note position of elbow for installation.

8. Remove elbow (10) from quick-start valve (9).

INSTALLATION

1. Apply sealant to threads of elbow (10) and install elbow (10) on quick-start valve (9).
2. Install quick-start valve (9), clamp (14), and plug with chain (13) on bracket (3) with two screws (12).
3. Install tube (6) with sleeve (5) on elbow (10) and tighten nut (4).
4. Remove plug with chain (13) from quick-start valve (9) and install plug with chain (13) on clamp (14).
5. If removed, install new gasket (11) on quick-start valve (9).
6. Insert cylinder (15) through clamp (2) and install (turn clockwise) on quick-start valve (9). Tighten wingnut (1) and clamp (2) on cylinder (15).
7. Connect harness plug with leads 569A and 569B (7) to quick-start valve lead connector (8).
8. Connect battery ground cable (WP 0121 00).

QUICK-START CYLINDER AND VALVE REPLACEMENT (BUILT BEFORE SERIAL NO. 504924) (Contd)

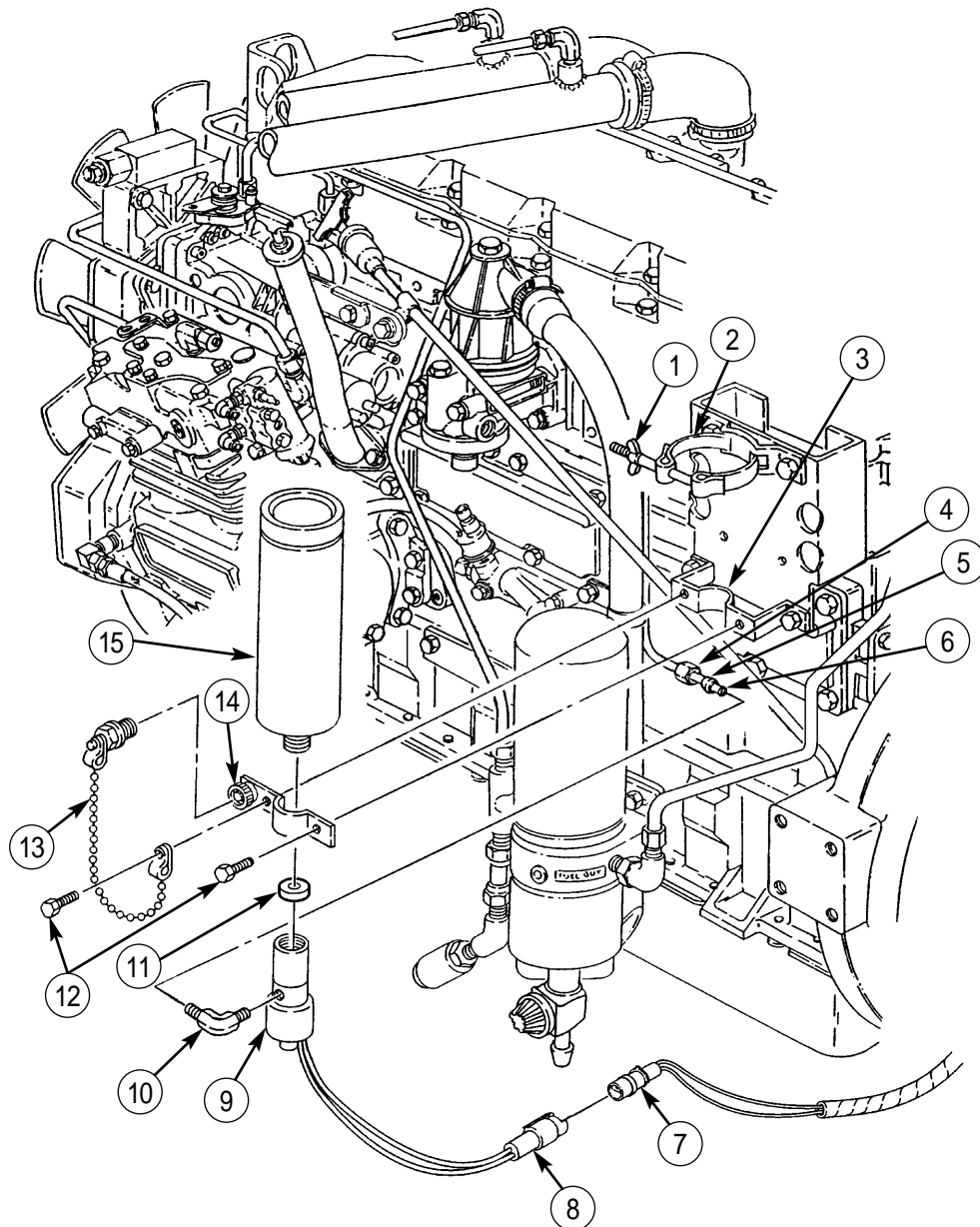

END OF WORK PACKAGE

UNIT MAINTENANCE INSTRUCTIONS

EXTENDED SERVICE PROGRAM (ESP)

TRUCK, CARGO, 2-1/2-TON, 6X6, M44A3 SERIES TRUCKS (DIESEL)

M35A3, W/O WINCH (NSN 2320-01-383-2047); W/WINCH (NSN 2320-01-383-3850);

M35A3C, W/O WINCH (NSN 2320-01-383-2050); W/WINCH (NSN 2320-01-383-2049);

M36A3, W/O WINCH (NSN 2320-01-383-2048); W/WINCH (NSN 2320-01-383-2046).

QUICK-START TUBES REPLACEMENT (BUILT BEFORE SERIAL NO. 504924)

REMOVAL, INSTALLATION

INITIAL SETUP:

Tools and Special Tools

General mechanic's tool kit
(item 30, WP 0394 00)

References

TM 9-2320-386-24P

Materials/Parts

Locknut (item 332, WP 0395 00)

Equipment Condition

Parking brake set (TM 9-2320-386-10).
Hood raised and secured (TM 9-2320-386-10).

QUICK-START TUBES REPLACEMENT (BUILT BEFORE SERIAL NO. 504924) (Contd)**WARNING**

Ether is extremely flammable. Perform this procedure in a well-ventilated area away from flames and sparks. Failure to do so may result in injury to personnel.

REMOVAL

1. Loosen two nuts (2) and remove tubes (1) with sleeves (3) from atomizers (4).
2. Loosen two nuts (11) and remove tubes (1) with sleeves (12) from atomizer tee (13).
3. Loosen two nuts (9) and remove tube (10) with sleeves (8) from atomizer tee (13) and elbow (7).
4. Remove locknut (6), screw (15), clamp (14), and atomizer tee (13) from mounting bracket (5). Discard locknut (6).

INSTALLATION

1. Install tube (10) with sleeves (8) on atomizer tee (13) and elbow (7) and tighten nuts (9).
2. Install two tubes (1) with sleeves (12) on atomizer tee (13) and tighten nuts (11).
3. Install two tubes (1) with sleeves (3) on atomizers (4) and tighten nuts (2).
4. Install atomizer tee (13) on mounting bracket (5) with clamp (14), screw (15), and new locknut (6).

QUICK-START TUBES REPLACEMENT (BUILT BEFORE SERIAL NO. 504924) (CONTD)

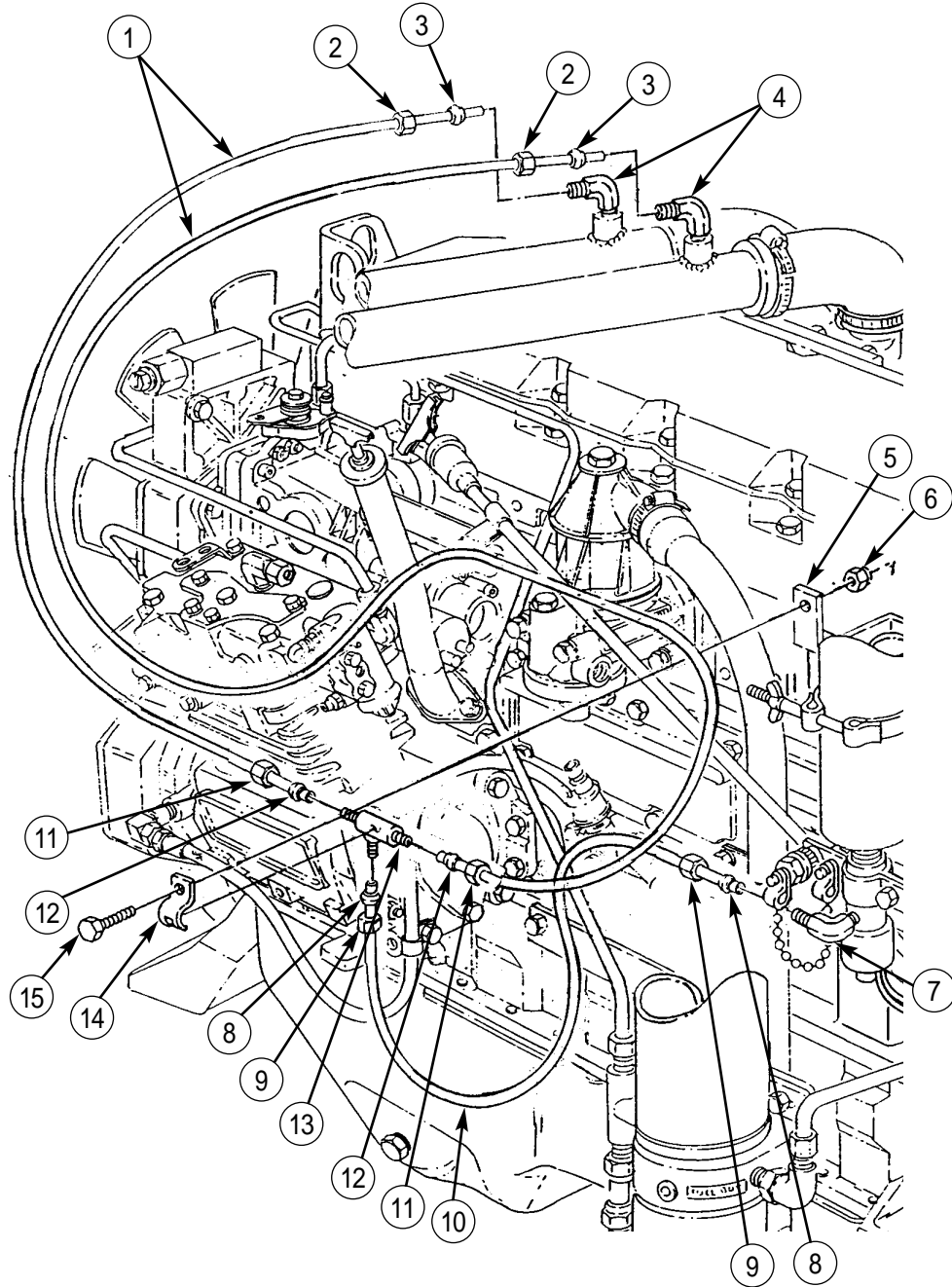

END OF WORK PACKAGE

UNIT MAINTENANCE INSTRUCTIONS

EXTENDED SERVICE PROGRAM (ESP)

TRUCK, CARGO, 2-1/2-TON, 6X6, M44A3 SERIES TRUCKS (DIESEL)

M35A3, W/O WINCH (NSN 2320-01-383-2047); W/WINCH (NSN 2320-01-383-3850);
M35A3C, W/O WINCH (NSN 2320-01-383-2050); W/WINCH (NSN 2320-01-383-2049);
M36A3, W/O WINCH (NSN 2320-01-383-2048); W/WINCH (NSN 2320-01-383-2046).

QUICK-START ATOMIZERS REPLACEMENT

REMOVAL, INSTALLATION

INITIAL SETUP:

Tools and Special Tools

General mechanic's tool kit
(item 30, WP 0394 00)

Materials/Parts

Teflon pipe sealant (item 41, WP 0393 00)

References

TM 9-2320-386-24P

Equipment Condition

Parking brake set (TM 9-2320-386-10).
Hood raised and secured (TM 9-2320-386-10).

QUICK-START ATOMIZERS REPLACEMENT (Contd)**WARNING**

Ether is extremely flammable. Perform this procedure in a well-ventilated area away from flames and sparks. Failure to do so may result in injury to personnel.

REMOVAL

1. Loosen two nuts (2) and remove tubes (1) with sleeves (3) from atomizers (4).

NOTE

Note position of atomizers for installation.

2. Remove two atomizers (4) from tubes (5).

INSTALLATION

1. Apply sealant to pipe threads of two atomizers (4) and install atomizers (4) on tubes (5).
2. Install two tubes (1) with sleeves (3) on atomizers (4) and tighten nuts (2).

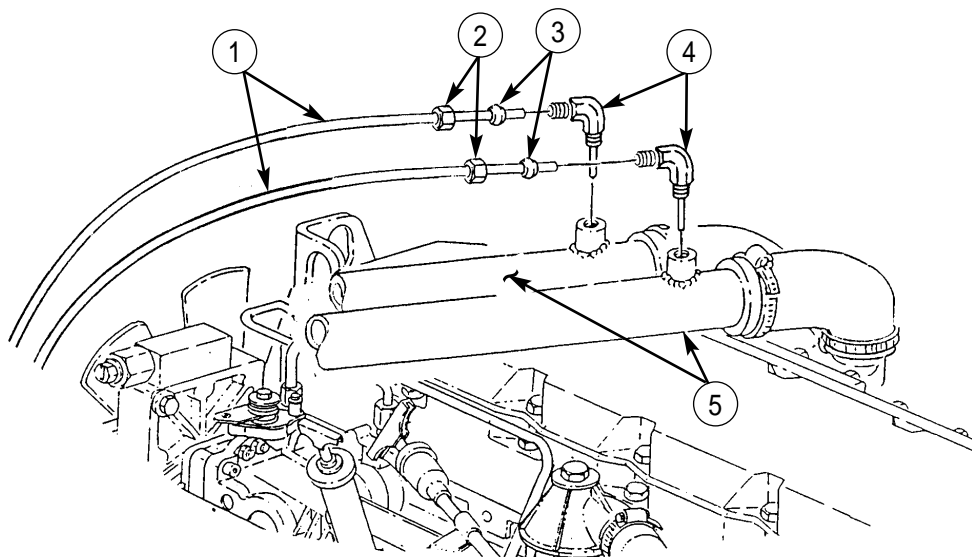

END OF WORK PACKAGE

UNIT MAINTENANCE INSTRUCTIONS

EXTENDED SERVICE PROGRAM (ESP)

TRUCK, CARGO, 2-1/2-TON, 6X6, M44A3 SERIES TRUCKS (DIESEL)

M35A3, W/O WINCH (NSN 2320-01-383-2047); W/WINCH (NSN 2320-01-383-3850);

M35A3C, W/O WINCH (NSN 2320-01-383-2050); W/WINCH (NSN 2320-01-383-2049);

M36A3, W/O WINCH (NSN 2320-01-383-2048); W/WINCH (NSN 2320-01-383-2046).

QUICK-START MOUNTING BRACKET REPLACEMENT (BUILT BEFORE SERIAL NO. 504924)

REMOVAL, INSTALLATION

INITIAL SETUP:

Tools and Special Tools

General mechanic's tool kit
(item 30, WP 0394 00)

Materials/Parts

Four locknuts (item 16, WP 0395 00)
Locknut (item 332, WP 0395 00)
Four lockwashers (item 130, WP 0395 00)
Lockwasher (item 54, WP 0395 00)

References

TM 9-2320-386-24P

Equipment Condition

Parking brake set (TM 9-2320-386-10).
Hood raised and secured (TM 9-2320-386-10).
Quick-start cylinder and valve removed
(WP 0055 00).

QUICK-START MOUNTING BRACKET REPLACEMENT (BUILT BEFORE SERIAL NO. 504924) (Contd)**REMOVAL**

1. Remove locknut (20), screw (15), clamp (16), atomizer tee (17), and tube (18) from mounting bracket (19). Discard locknut (20).
2. Remove four screws (10), lockwashers (11), ground strap (5), lockwasher (4), and mounting bracket (6) from engine (1). Discard lockwashers (11) and (4).
3. Remove two locknuts (2), screws (12), washers (13), and clamp (14) from mounting bracket (6). Discard locknuts (2).
4. Remove two locknuts (3), screws (8), washers (7), and bracket (9) from mounting bracket (6). Discard locknuts (3).

INSTALLATION

1. Install bracket (9) on mounting bracket (6) with two washers (7), screws (8), and new locknuts (3).
2. Install clamp (14) on mounting bracket (6) with two washers (13), screws (12), and new locknuts (2).
3. Install mounting bracket (6), new lockwasher (4), and ground strap (5) on engine (1) with four new lockwashers (11) and screws (10).
4. Install tube (18) and atomizer tee (17) on mounting bracket (19) with clamp (16), screw (15), and new locknut (20).
5. Install quick-start cylinder and valve (WP 0055 00).

QUICK-START MOUNTING BRACKET REPLACEMENT (BUILT BEFORE SERIAL NO. 504924) (Contd)

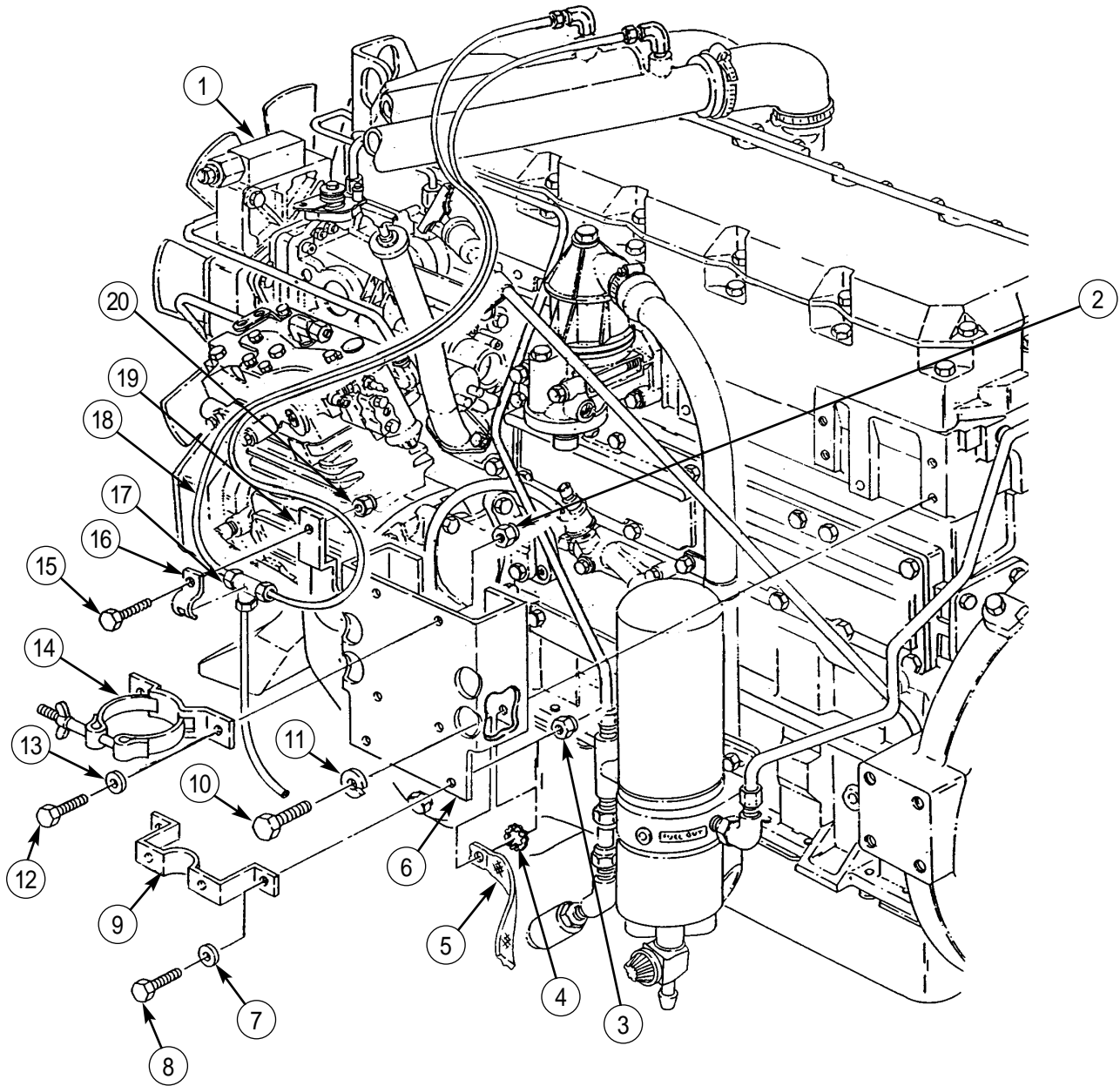

END OF WORK PACKAGE

UNIT MAINTENANCE INSTRUCTIONS

EXTENDED SERVICE PROGRAM (ESP)

TRUCK, CARGO, 2-1/2-TON, 6X6, M44A3 SERIES TRUCKS (DIESEL)

M35A3, W/O WINCH (NSN 2320-01-383-2047); W/WINCH (NSN 2320-01-383-3850);
M35A3C, W/O WINCH (NSN 2320-01-383-2050); W/WINCH (NSN 2320-01-383-2049);
M36A3, W/O WINCH (NSN 2320-01-383-2048); W/WINCH (NSN 2320-01-383-2046).

QUICK-START CYLINDER, VALVE, AND JUMPER HARNESS REPLACEMENT (BUILT AFTER SERIAL NO. 504923)

REMOVAL, INSTALLATION

INITIAL SETUP:

Tools and Special Tools

General mechanic's tool kit
(item 30, WP 0394 00)

Materials/Parts

Teflon pipe sealant (item 41, WP 0393 00)
Three tiedown straps (item 36, WP 0395 00)
Gasket (item 104, WP 0395 00)

References

TM 9-2320-386-24P

Equipment Condition

Parking brake set (TM 9-2320-386-10).
Hood raised and secured (TM 9-2320-386-10).
Battery ground cable disconnected (WP 0121 00).

QUICK-START CYLINDER, VALVE, AND JUMPER HARNESS REPLACEMENT (BUILT AFTER SERIAL NO. 504923) (Contd)**WARNING**

Ether is extremely flammable. Perform this procedure in a well-ventilated area away from flames and sparks. Failure to do so may result in injury to personnel.

REMOVAL

1. Disconnect jumper harness plug with leads 569A and 569B (8) from quick-start valve lead connector (9).
2. Loosen wingnut (21) and clamp (22) on cylinder (1).
3. Remove (turn counterclockwise) cylinder (1) from quick-start valve (15) and remove cylinder (1) from clamp (22).
4. Remove gasket (18) from quick-start valve (15) if cracked or damaged. Discard gasket (18).
5. Install plug with chain (16) on quick-start valve (15).
6. Loosen nut (10) and remove tube (12) with sleeve (11) and insert (13) from elbow (14).
7. Remove two screws (17), plug with chain (16), clamp (19), and quick-start valve (15) from bracket (20).

NOTE

Note position of elbow for installation.

8. Remove elbow (14) from quick-start valve (15).
9. Disconnect jumper harness plug with leads 569A and 569B (5) from harness connector (6).
10. Remove three tiedown straps (2) from chafeguard (3) and steering column (4).
11. Remove jumper harness (7) from chafeguard (3).

INSTALLATION

1. Install jumper harness (7) in chafeguard (3).
2. Install chafeguard (3) on steering column (4) with three new tiedown straps (2).
3. Connect jumper harness plug with leads 569A and 569B (5) to harness connector (6).
4. Apply sealant to pipe threads on elbow (14) and install elbow (14) on quick-start valve (15).
5. Install quick-start valve (15), clamp (19), and plug with chain (16) on bracket (20) with two screws (17).
6. Install tube (12) with sleeve (11) and insert (13) on elbow (14) and tighten nut (10).
7. Remove plug with chain (16) from quick-start valve (15) and install plug with chain (16) on clamp (19).
8. If removed, install new gasket (18) on quick-start valve (15).
9. Insert cylinder (1) through clamp (22) and install (turn clockwise) on quick-start valve (15).
10. Tighten wingnut (21) and clamp (22) on cylinder (1).
11. Connect jumper harness plug with leads 569A and 569B (8) to quick-start valve lead connector (9).
12. Connect battery ground cable (WP 0121 00).

QUICK-START CYLINDER, VALVE, AND JUMPER HARNESS REPLACEMENT (BUILT AFTER SERIAL NO. 504923) (Contd)

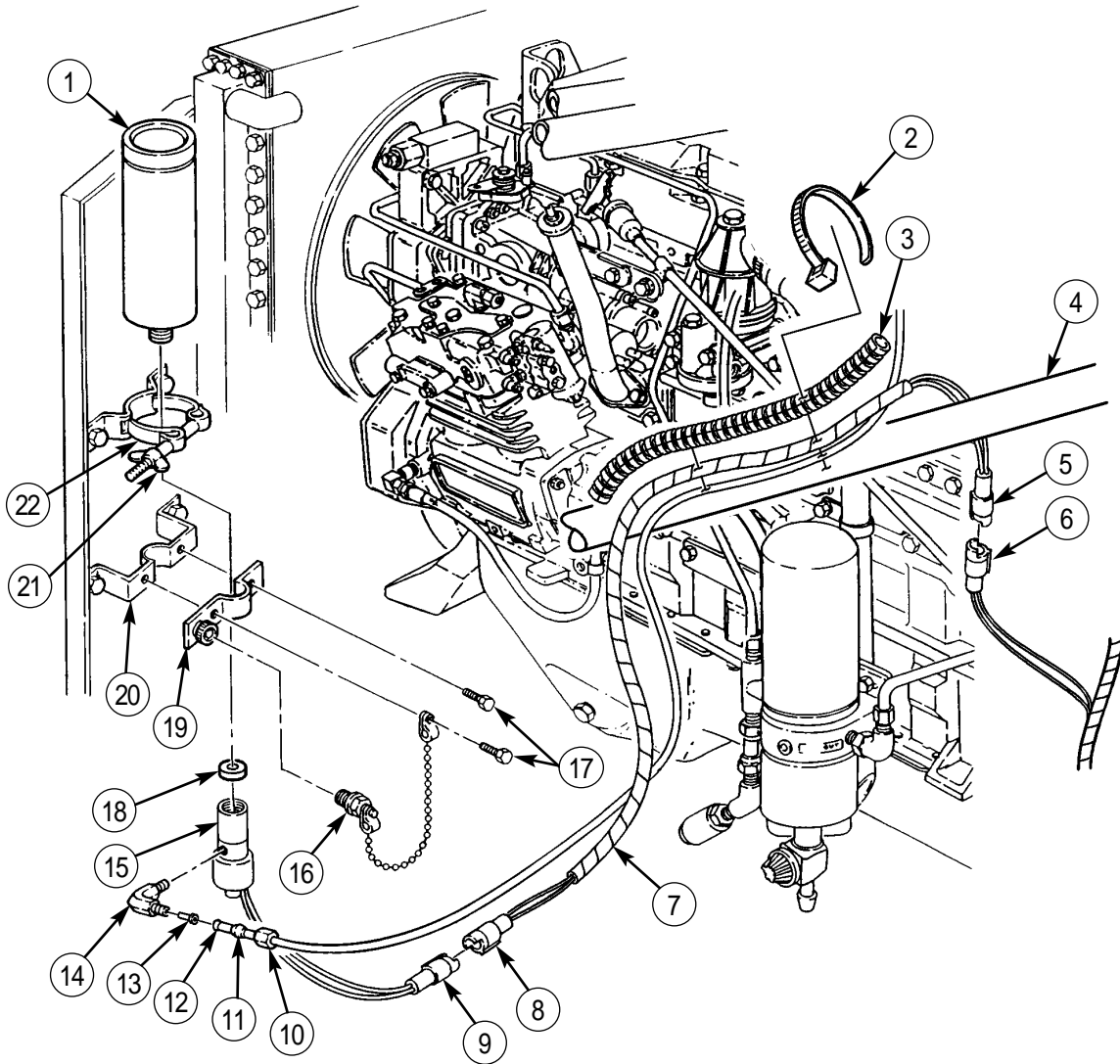

END OF WORK PACKAGE

UNIT MAINTENANCE INSTRUCTIONS

EXTENDED SERVICE PROGRAM (ESP)

TRUCK, CARGO, 2-1/2-TON, 6X6, M44A3 SERIES TRUCKS (DIESEL)

M35A3, W/O WINCH (NSN 2320-01-383-2047); W/WINCH (NSN 2320-01-383-3850);

M35A3C, W/O WINCH (NSN 2320-01-383-2050); W/WINCH (NSN 2320-01-383-2049);

M36A3, W/O WINCH (NSN 2320-01-383-2048); W/WINCH (NSN 2320-01-383-2046).

QUICK-START TUBES REPLACEMENT (BUILT AFTER SERIAL NO. 504923)

REMOVAL, INSTALLATION

INITIAL SETUP:

Tools and Special Tools

General mechanic's tool kit
(item 30, WP 0394 00)

References

TM 9-2320-386-24P

Materials/Parts

Three tiedown straps (item 38, WP 0395 00)

Equipment Condition

Parking brake set (TM 9-2320-386-10).
Hood raised and secured (TM 9-2320-386-10).

QUICK-START TUBES REPLACEMENT (BUILT AFTER SERIAL NO. 504923) (Contd)**WARNING**

Ether is extremely flammable. Perform this procedure in a well-ventilated area away from flames and sparks. Failure to do so may result in injury to personnel.

REMOVAL

1. Remove screw (6), washer (7), clamp (8), atomizer tee (13), and plate (12) from valve cover (17).
2. Loosen two nuts (2) and remove tubes (1) with sleeves (3) and inserts (4) from atomizers (5).
3. Loosen two nuts (9) and remove tubes (1) with sleeves (10) and inserts (11) from atomizer tee (13).
4. Remove three tiedown straps (20) securing tube (21) and jumper harness (22) to steering column (18). Discard tiedown straps (20).
5. Loosen two nuts (16) and remove tube (21) with two sleeves (15) and inserts (14) from atomizer tee (13), elbow (23), and chafeguard (19).

INSTALLATION

1. Install tube (21) and jumper harness (22) inside chafeguard (19).
2. Install tube (21) with two sleeves (15) and inserts (14) on atomizer tee (13) and elbow (23) and tighten two nuts (16).
3. Using three new tiedown straps (20), secure chafeguard (19) with tube (21) and jumper harness (22) to steering column (18).
4. Install tube (1) with two sleeves (10) and inserts (11) on atomizer tee (13) and tighten two nuts (9).
5. Install tube (1) with two sleeves (3) and inserts (4) on atomizers (5) and tighten two nuts (2).
6. Install plate (12), atomizer tee (13), and clamp (8) on valve cover (17) with washer (7) and screw (6).

QUICK-START TUBES REPLACEMENT (BUILT AFTER SERIAL NO. 504923) (Contd)

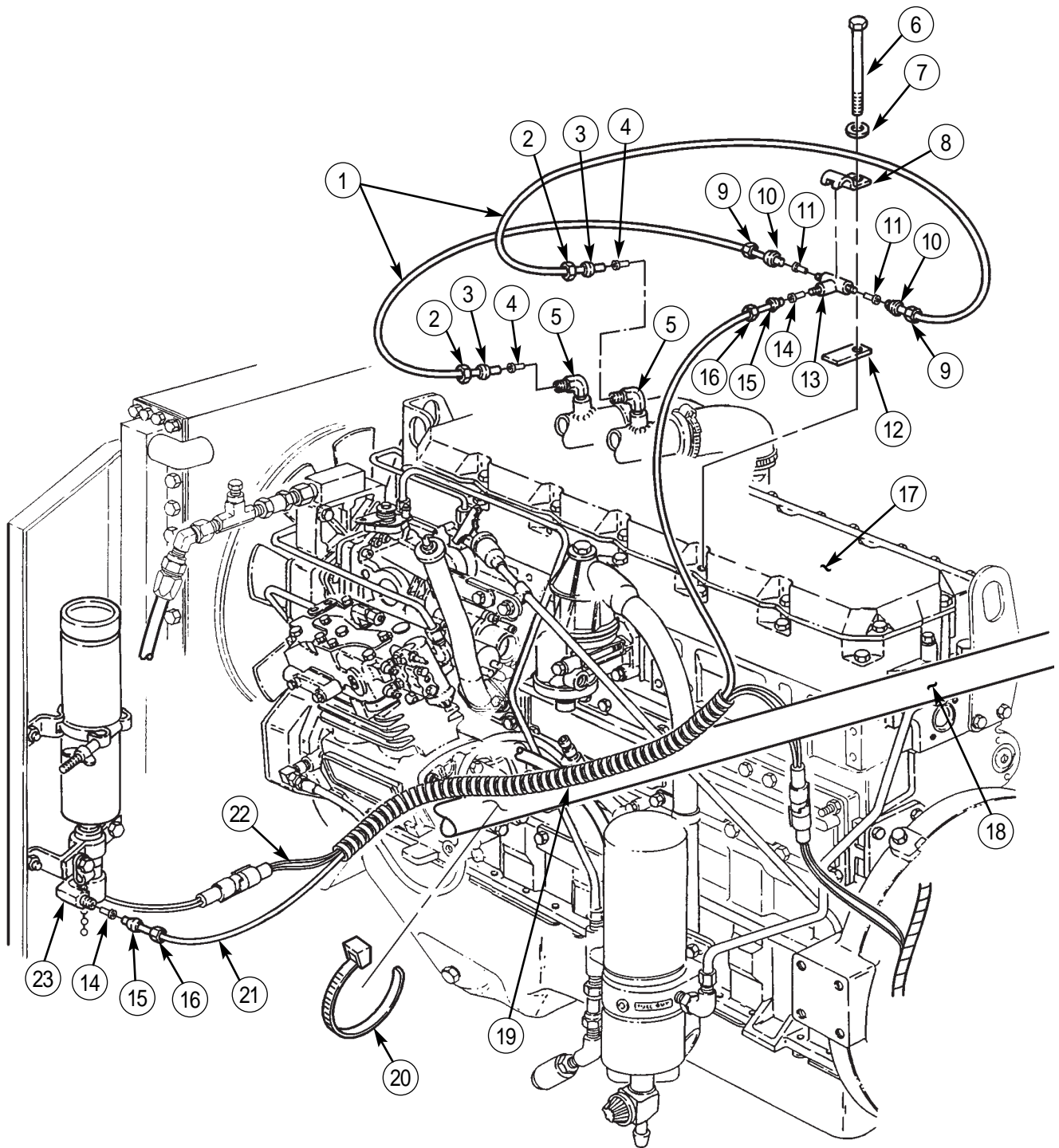

END OF WORK PACKAGE

UNIT MAINTENANCE INSTRUCTIONS

EXTENDED SERVICE PROGRAM (ESP)

TRUCK, CARGO, 2-1/2-TON, 6X6, M44A3 SERIES TRUCKS (DIESEL)

M35A3, W/O WINCH (NSN 2320-01-383-2047); W/WINCH (NSN 2320-01-383-3850);

M35A3C, W/O WINCH (NSN 2320-01-383-2050); W/WINCH (NSN 2320-01-383-2049);

M36A3, W/O WINCH (NSN 2320-01-383-2048); W/WINCH (NSN 2320-01-383-2046).

QUICK-START MOUNTING BRACKET REPLACEMENT (BUILT AFTER SERIAL NO. 504923)

REMOVAL, INSTALLATION

INITIAL SETUP:

Tools and Special Tools

General mechanic's tool kit
(item 30, WP 0394 00)

Materials/Parts

Four locknuts (item 16, WP 0395 00)

References

TM 9-2320-386-24P

Equipment Condition

Parking brake set (TM 9-2320-386-10).
Hood raised and secured (TM 9-2320-386-10).
Quick-start cylinder and valve removed
(WP 0059 00).

QUICK-START MOUNTING BRACKET REPLACEMENT (BUILT AFTER SERIAL NO. 504923) (Contd)**REMOVAL**

1. Remove two locknuts (3), clamp (2), two screws (9), and washers (8) from brushguard (1). Discard locknuts (3).
2. Remove two locknuts (5), bracket (4), two screws (7), and washers (6) from brushguard (1). Discard locknuts (5).

INSTALLATION

1. Install bracket (4) on brushguard (1) with two washers (6), screws (7), and new locknuts (5).

NOTE

Position clamp with wingnut facing away from radiator.

2. Install clamp (2) on brushguard (1) with two washers (8), screws (9), and new locknuts (3).
3. Install quick-start cylinder and valve (WP 0059 00).

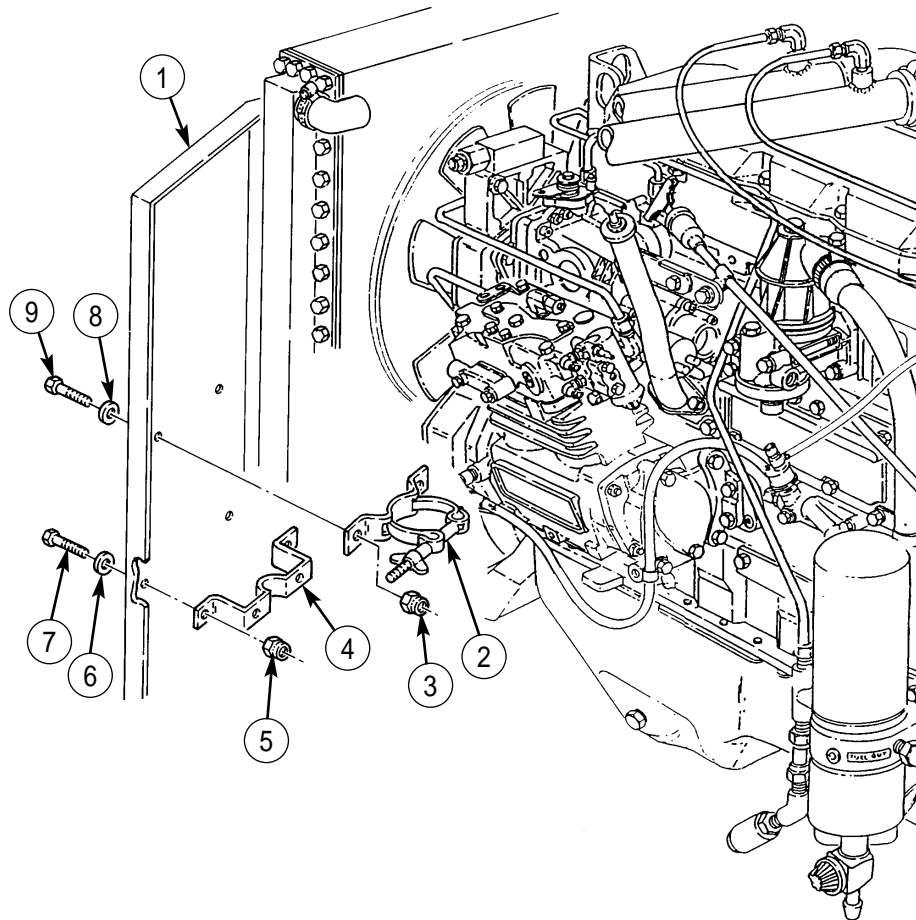

END OF WORK PACKAGE

UNIT MAINTENANCE INSTRUCTIONS

EXTENDED SERVICE PROGRAM (ESP)

TRUCK, CARGO, 2-1/2-TON, 6X6, M44A3 SERIES TRUCKS (DIESEL)

**M35A3, W/O WINCH (NSN 2320-01-383-2047); W/WINCH (NSN 2320-01-383-3850);
M35A3C, W/O WINCH (NSN 2320-01-383-2050); W/WINCH (NSN 2320-01-383-2049);
M36A3, W/O WINCH (NSN 2320-01-383-2048); W/WINCH (NSN 2320-01-383-2046).**

THROTTLE CONTROL CABLE REPLACEMENT

REMOVAL, INSTALLATION

INITIAL SETUP:

Tools and Special Tools

General mechanic's tool kit
(item 30, WP 0394 00)

Materials/Parts

Cotter pin (item 272, WP 0395 00)
Two locknuts (item 332, WP 0395 00)

References

TM 9-2320-386-24P

Equipment Condition

Parking brake set (TM 9-2320-386-10).
Hood raised and secured (TM 9-2320-386-10).

THROTTLE CONTROL CABLE REPLACEMENT (Contd)

REMOVAL

1. Remove spring (17) from brackets (10) and (16).
2. Remove screw (14), washer (13), clamp (15) with air compressor coolant line (12), and bracket (16) from engine (9).
3. Remove screw (2) and stop collar (1) from throttle cable (4).
4. Remove two locknuts (7) and screws (5) from lock support (6). Discard locknuts (7).
5. Slide lock support (6) to the right and lift throttle cable (4) from cable support (8).
6. Slide throttle cable (4) through pivot (3).
7. Remove cotter pin (11) and pivot (3) from bracket (10). Discard cotter pin (11).
8. Loosen nut (23) on throttle control (24).
9. Remove setscrew (21) and handle (22) from throttle control (24).
10. Remove nut (23), O-ring (20), and lockwasher (19) from throttle control (24).
11. Push throttle control (24) through hole in instrument panel (18).
12. Grasp throttle control (24), and remove cable (4) from below instrument panel (18) and through hole in firewall.

INSTALLATION

NOTE

Perform steps 1 and 2 if installing new throttle cable.

1. Remove setscrew (21) and handle (22) from new cable (4).
2. Remove nut (23), O-ring (20), and lockwasher (19) from throttle control (24).
3. Insert engine end of control cable (4) through hole in firewall and align on cable support (8).
4. Insert throttle control (24) from behind instrument panel (18) through hole in instrument panel (18).
5. Install lockwasher (19), O-ring (20), and nut (23) on throttle control (24).
6. Thread cable (4) through pivot (3) and stop collar (1).
7. Install handle (22) on throttle control (24) with setscrew (21).
8. Install bracket (16) and clamp (15) with air compressor coolant line (12) on engine (9) with washer (13) and screw (14).
9. Install pivot (3) on bracket (10) with new cotter pin (11).

NOTE

Assistant will help with step 10.

10. Adjust length of throttle cable (4) and install screw (2) in stop collar (1) to secure cable (4).
11. Install throttle cable (4) on cable support (8), align lock support (6) on with cable support (8), and install two screws (5) and new locknuts (7).
12. Install spring (17) on brackets (10) and (16).

THROTTLE CONTROL CABLE REPLACEMENT (Contd)

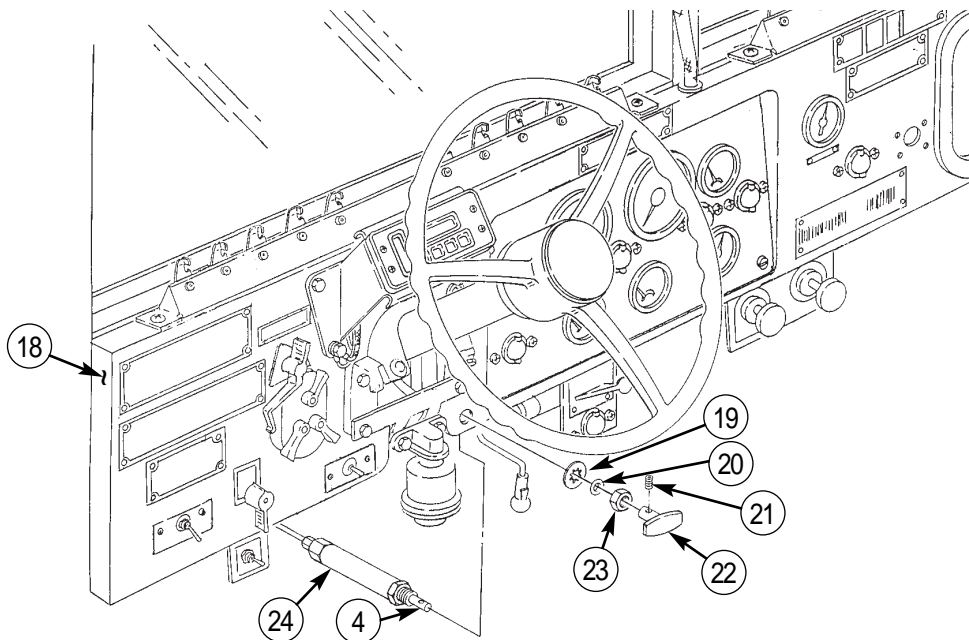
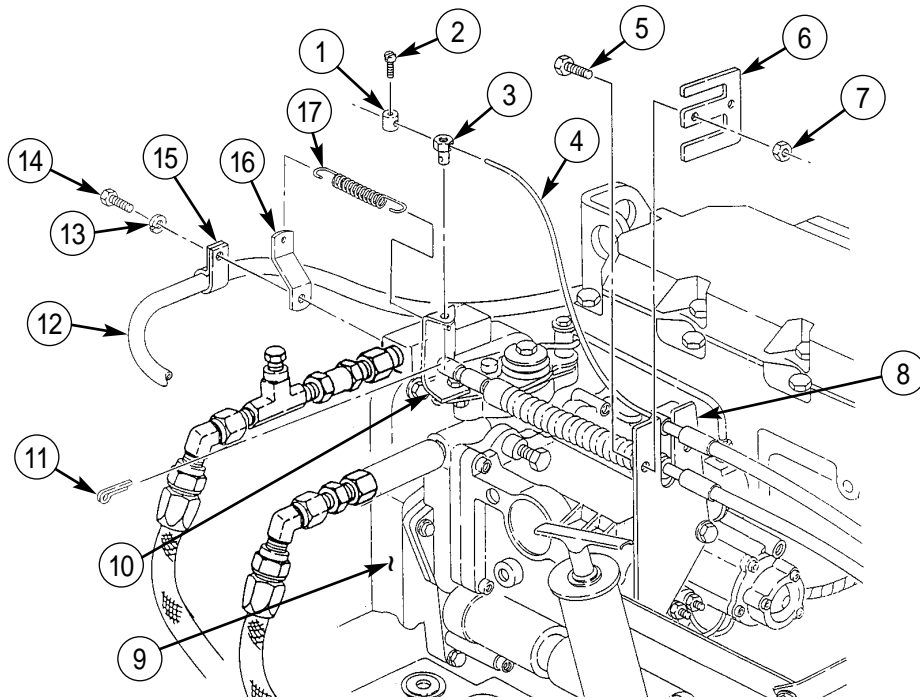

END OF WORK PACKAGE

UNIT MAINTENANCE INSTRUCTIONS

EXTENDED SERVICE PROGRAM (ESP)

TRUCK, CARGO, 2-1/2-TON, 6X6, M44A3 SERIES TRUCKS (DIESEL)

M35A3, W/O WINCH (NSN 2320-01-383-2047); W/WINCH (NSN 2320-01-383-3850);
M35A3C, W/O WINCH (NSN 2320-01-383-2050); W/WINCH (NSN 2320-01-383-2049);
M36A3, W/O WINCH (NSN 2320-01-383-2048); W/WINCH (NSN 2320-01-383-2046).

ACCELERATOR PEDAL AND BRACKETS REPLACEMENT

REMOVAL, INSTALLATION

INITIAL SETUP:

Tools and Special Tools

General mechanic's tool kit
(item 30, WP 0394 00)

Materials/Parts

Two cotter pins (item 145, WP 0395 00)
Cotter pin (item 120, WP 0395 00)
Cotter pin (item 27, WP 0395 00)
Cotter pin (item 148, WP 0395 00)
Two locknuts (item 332, WP 0395 00)
Two locknuts (item 335, WP 0395 00)
Two locknuts (item 184, WP 0395 00)
Two lockwashers (item 60, WP 0395 00)

Personnel Required

Assistant (1)

References

TM 9-2320-386-24P

Equipment Condition

Parking brake set (TM 9-2320-386-10).
Hood raised and secured (TM 9-2320-386-10).

ACCELERATOR PEDAL AND BRACKETS REPLACEMENT (Contd)

REMOVAL

1. Remove cotter pin (9), pin (7), and accelerator cable clevis (8) from bellcrank (5). Discard cotter pin (9).
2. Remove accelerator cable (10) from accelerator support bracket (12) and remove locknut (11), screw (2), and accelerator support bracket (12) from anchor (1). Discard locknut (11).
3. Remove locknut (6), screw (4), and anchor (1) from cab floor (3). Discard locknut (6).
4. Remove locknut (22) and slide modulator cable (16) from swivel (21). Discard locknut (22).
5. Remove two cotter pins (24), washers (23), swivel (21), and rod (13) from lever (20). Discard cotter pins (24).
6. Remove cotter pin (17), pin (19), and lever (20) from bracket (18). Discard cotter pin (17).
7. Remove two screws (15), lockwashers (14), and bracket (18) from cab floor (3). Discard lockwashers (14).
8. Remove cotter pin (25), washer (26), and rod (13) from accelerator pedal (27). Discard cotter pin (25).
9. Remove pin (29) and accelerator pedal (27) from accelerator pedal bracket (28).
10. Remove two locknuts (32), screws (30), anchor (31), and accelerator pedal bracket (28) from cab floor (3). Discard locknuts (32).
11. Remove locknut (33), screw (34), and modulator cable (16) from anchor (31). Discard locknut (33).

INSTALLATION

1. Install modulator cable (16) on anchor (31) with screw (34) and new locknut (33).
2. Install anchor (31) and accelerator pedal bracket (28) on cab floor (3) with two screws (30) and new locknuts (32).
3. Install accelerator pedal (27) on accelerator pedal bracket (28) with pin (29).
4. Install rod (13) on accelerator pedal (27) with washer (26) and new cotter pin (25).
5. Install bracket (18) on cab floor (3) with two new lockwashers (14) and screws (15).
6. Install lever (20) on bracket (18) with pin (19) and new cotter pin (17).
7. Install swivel (21) and rod (13) on lever (20) with two washers (23) and new cotter pins (24).
8. Insert modulator cable (16) through swivel (21) and install new locknut (22) on modulator cable (16).
9. Install anchor (1) on cab floor (3) with screw (4) and new locknut (6).
10. Install accelerator support bracket (12) on anchor (1) with screw (2) and new locknut (11). Install accelerator cable (10) on accelerator support bracket (12).
11. Install accelerator cable clevis (8) on bellcrank (5) with pin (7) and new cotter pin (9).
12. Position accelerator pedal (27) to full travel and pull modulator cable (16) to full stop position and tighten locknut (22) up to swivel (21).

ACCELERATOR PEDAL AND BRACKETS REPLACEMENT (Contd)

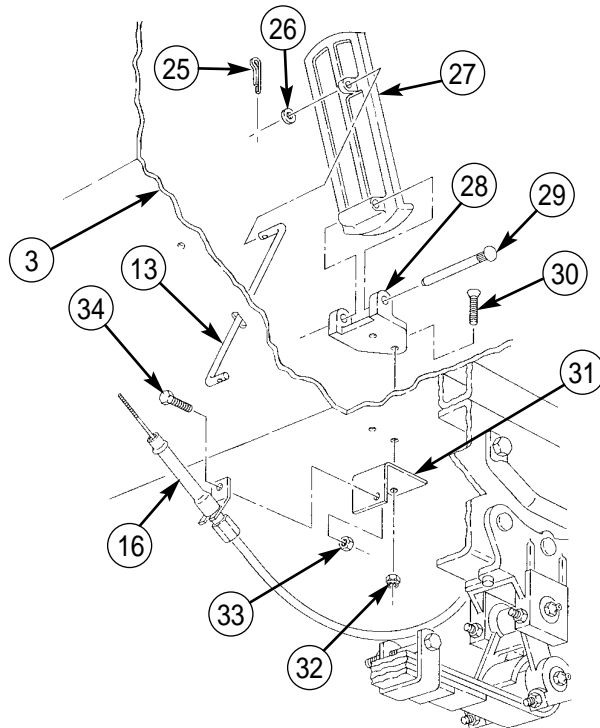
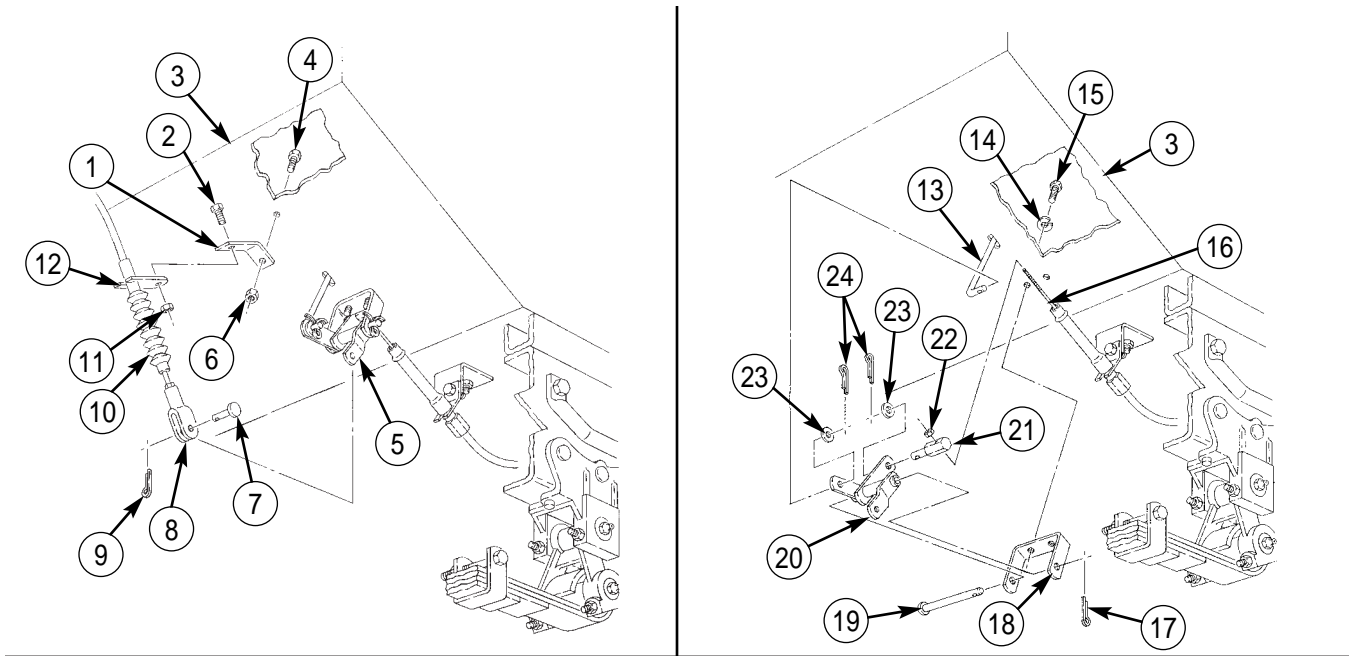

END OF WORK PACKAGE

UNIT MAINTENANCE INSTRUCTIONS

EXTENDED SERVICE PROGRAM (ESP)

TRUCK, CARGO, 2-1/2-TON, 6X6, M44A3 SERIES TRUCKS (DIESEL)

M35A3, W/O WINCH (NSN 2320-01-383-2047); W/WINCH (NSN 2320-01-383-3850);
M35A3C, W/O WINCH (NSN 2320-01-383-2050); W/WINCH (NSN 2320-01-383-2049);
M36A3, W/O WINCH (NSN 2320-01-383-2048); W/WINCH (NSN 2320-01-383-2046).

ACCELERATOR CABLE MAINTENANCE

REMOVAL, INSTALLATION, ADJUSTMENT

INITIAL SETUP:

Tools and Special Tools

General mechanic's tool kit
(item 30, WP 0394 00)

Materials/Parts

Cotter pin (item 272, WP 0395 00)
Cotter pin (item 120, WP 0395 00)
Two locknuts (item 332, WP 0395 00)
Two locknuts (item 335, WP 0395 00)
Lockwasher (item 59, WP 0395 00)

References

TM 9-2320-386-24P

Equipment Condition

Parking brake set (TM 9-2320-386-10).
Hood raised and secured (TM 9-2320-386-10).

ACCELERATOR CABLE MAINTENANCE (Contd)

REMOVAL

1. Remove spring (1) from throttle bracket (17) and anchor (18).
2. Remove screw (3) and stop collar (2) from throttle cable (5).
3. Remove cotter pin (19) from pivot (4) and pivot (4) from throttle bracket (17) and throttle cable (5). Discard cotter pin (19).
4. Pull sleeve (15) back on accelerator cable (10) and remove accelerator cable (10) from ball joint (16).
5. Remove nut (12), lockwasher (13), ball joint (16), and throttle bracket (17) from throttle lever (14). Discard lockwasher (13).
6. Remove two locknuts (8), screws (6), and lock support (7) from cable support (9). Discard locknuts (8).
7. Remove throttle cable (5) and accelerator cable (10) from cable support (9).
8. Loosen jamnut (11) and remove sleeve (15) from accelerator cable (10).
9. Remove cotter pin (28), pin (26), and accelerator cable clevis (27) from bellcrank (25). Discard cotter pin (28).
10. Loosen jamnut (29) and remove accelerator cable clevis (27) from accelerator cable (10).
11. Remove locknut (30), accelerator cable (10), and screw (20) from accelerator support bracket (21). Discard locknut (30).
12. Remove locknut (24), accelerator support bracket (21), and screw (22) from firewall (23). Discard locknut (24).
13. Remove accelerator cable (10) from vehicle.

ACCELERATOR CABLE MAINTENANCE (Contd)

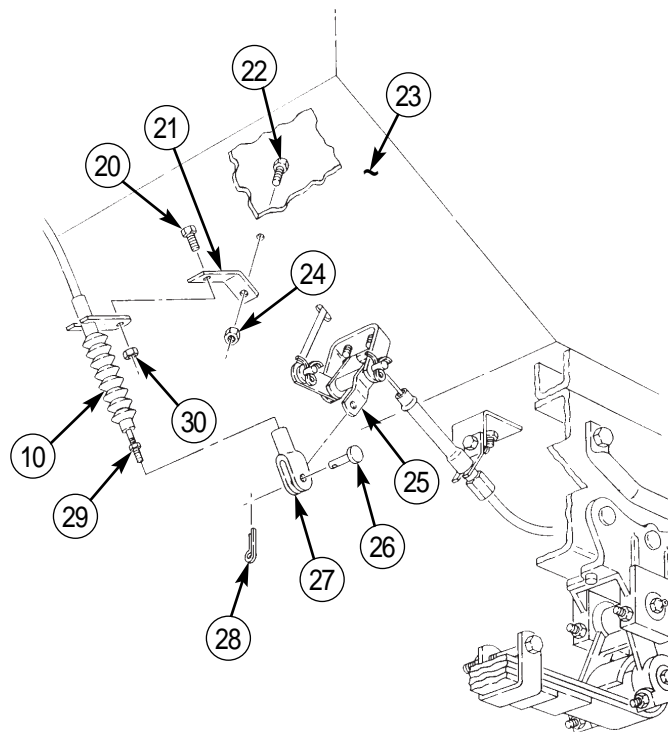
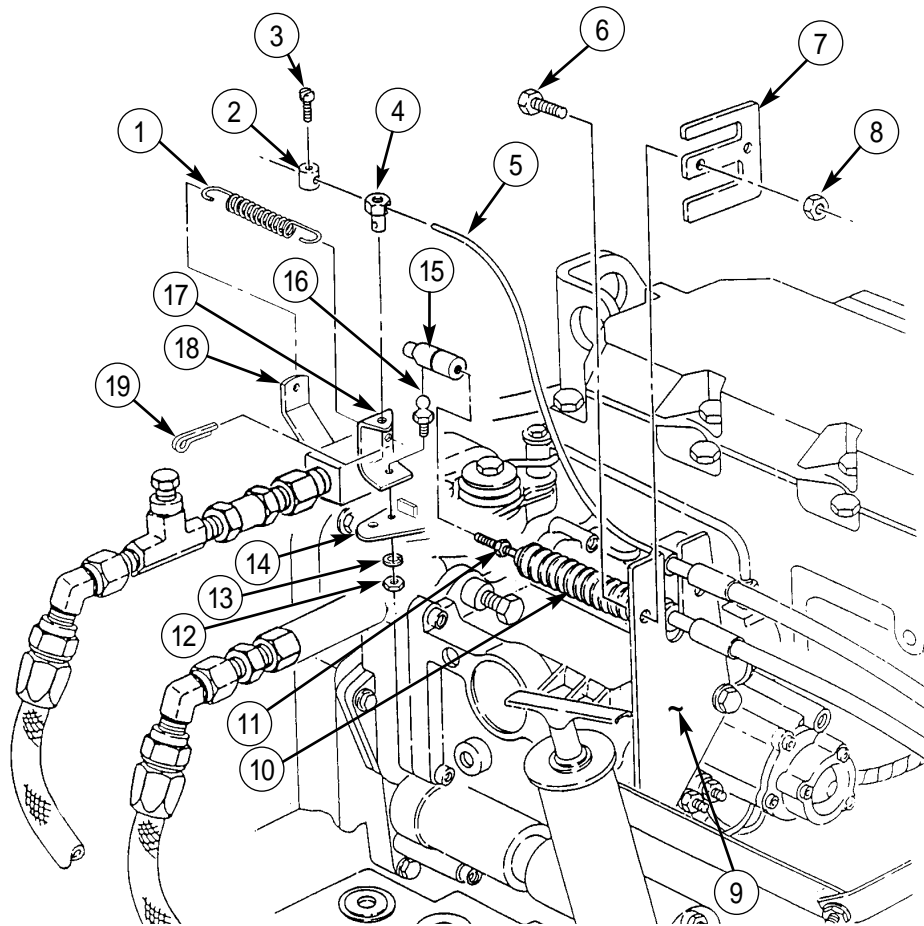

ACCELERATOR CABLE MAINTENANCE (Contd)

INSTALLATION

1. Route accelerator cable (10) through vehicle and position for installation.
2. Install accelerator support bracket (21) on firewall (23) with screw (22) and new locknut (24).
3. Install accelerator cable (10) on accelerator support bracket (21) with screw (20) and new locknut (30).

NOTE

Ensure jamnut is centered on threads of accelerator cable prior to installing accelerator cable clevis and sleeve.

4. Install accelerator cable clevis (27) on accelerator cable (10) until accelerator cable clevis (27) touches jamnut (29).
5. Install sleeve (15) on accelerator cable (10) until sleeve (15) touches jamnut (11).
6. Install accelerator cable clevis (27) on bellcrank (25) with pin (26) and new cotter pin (28).

NOTE

Ensure lock support is positioned to avoid interference with accelerator cable movement.

7. Install accelerator cable (10) and throttle cable (5) on lock support (7).
8. Install lock support (7) on cable support (9) with two screws (6) and new locknuts (8).
9. Install throttle bracket (17) and ball joint (16) on throttle lever (14) with new lockwasher (13) and nut (12).
10. Pull sleeve (15) back on accelerator cable (10) and install accelerator cable (10) on ball joint (16).
11. Position throttle cable (5) through pivot (4) and install pivot (4) on throttle bracket (17) with new cotter pin (19).
12. Install stop collar (2) on throttle cable (5) with screw (3).
13. Install spring (1) on anchor (18) and throttle bracket (17).

ADJUSTMENT

1. Loosen screw (3) securing stop collar (2) to throttle cable (5).
2. Remove nut (12), lockwasher (13), throttle bracket (17), spring (1), and accelerator cable (10) from throttle lever (14). Discard lockwasher (13).
3. Remove cotter pin (28), pin (26), and accelerator cable (10) from bellcrank (25). Discard cotter pin (28).
4. Loosen jamnuts (11) and (29) on accelerator cable (10).

NOTE

Ensure accelerator cable is fully extended towards throttle lever prior to adjusting.

5. Shorten or lengthen clevis (27) until holes in clevis (27) and bellcrank (25) align.
6. Shorten or lengthen sleeve (15) until balljoint (16) aligns with hole in throttle lever (14).
7. Tighten jamnuts (11) and (29) on accelerator cable (10).
8. Install accelerator cable (10) on bellcrank (25) with pin (26) and new cotter pin (28).
9. Install accelerator cable (10), throttle bracket (17), and spring (1) on throttle lever (14) with new lockwasher (13) and nut (12).
10. With accelerator in idle position, remove excess play in throttle cable (5) by sliding stop collar (2) to pivot (4) and tighten screw (3).

ACCELERATOR CABLE MAINTENANCE (Contd)

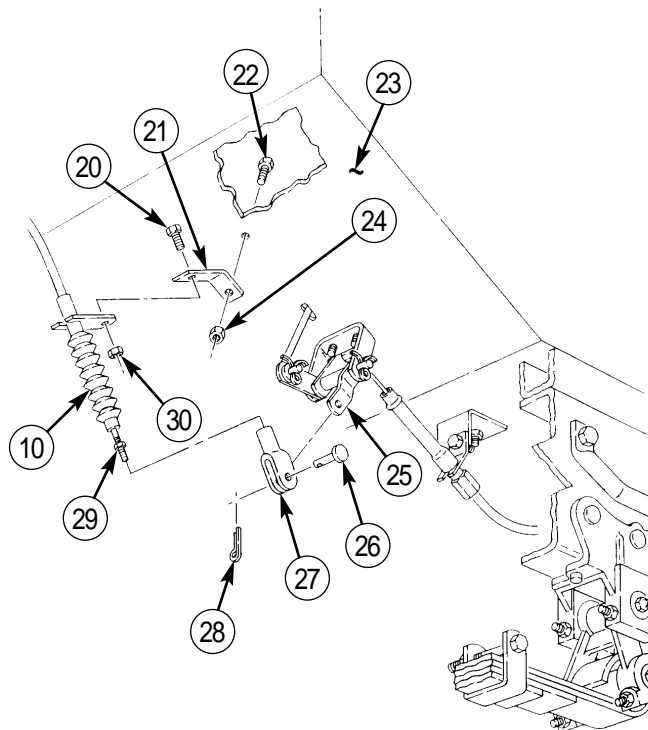
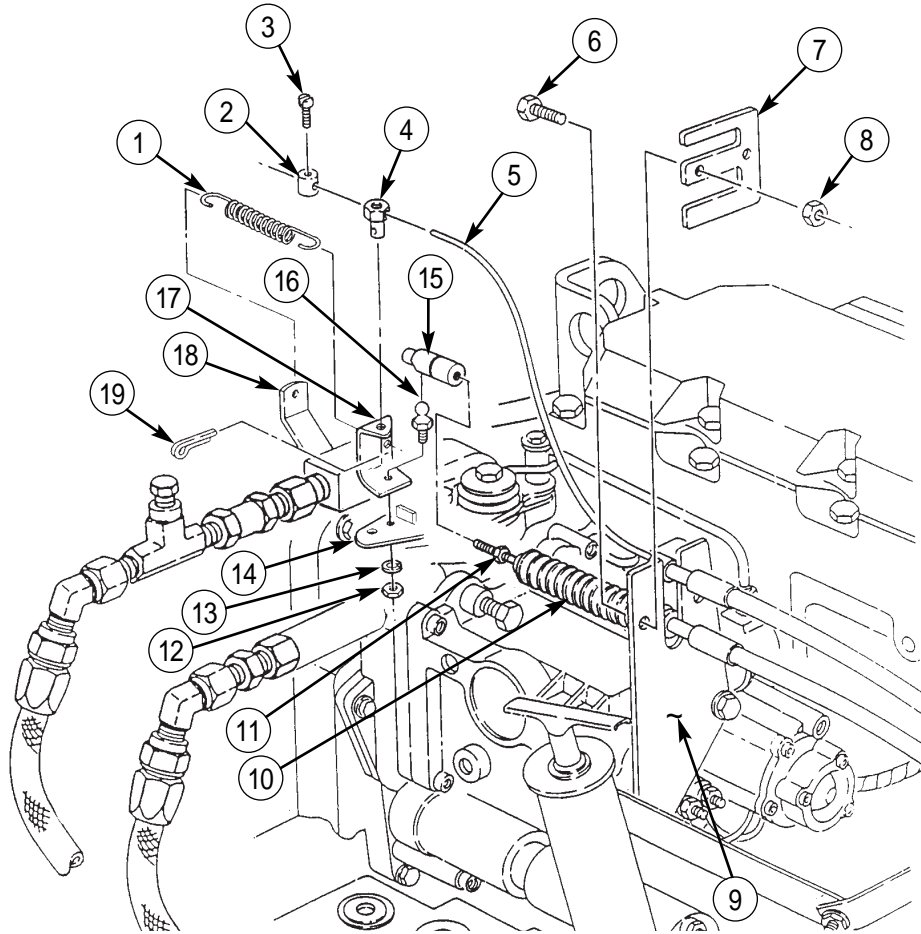

END OF WORK PACKAGE

UNIT MAINTENANCE INSTRUCTIONS

EXTENDED SERVICE PROGRAM (ESP)

TRUCK, CARGO, 2-1/2-TON, 6X6, M44A3 SERIES TRUCKS (DIESEL)

M35A3, W/O WINCH (NSN 2320-01-383-2047); W/WINCH (NSN 2320-01-383-3850);

M35A3C, W/O WINCH (NSN 2320-01-383-2050); W/WINCH (NSN 2320-01-383-2049);

M36A3, W/O WINCH (NSN 2320-01-383-2048); W/WINCH (NSN 2320-01-383-2046).

Section VI. EXHAUST SYSTEM MAINTENANCE

TABLE OF CONTENTS

WP Title

WP Sequence No.-Page No.

Exhaust System Replacement 0066 00-1

END OF WORK PACKAGE

UNIT MAINTENANCE INSTRUCTIONS

EXTENDED SERVICE PROGRAM (ESP)

TRUCK, CARGO, 2-1/2-TON, 6X6, M44A3 SERIES TRUCKS (DIESEL)

M35A3, W/O WINCH (NSN 2320-01-383-2047); W/WINCH (NSN 2320-01-383-3850);
M35A3C, W/O WINCH (NSN 2320-01-383-2050); W/WINCH (NSN 2320-01-383-2049);
M36A3, W/O WINCH (NSN 2320-01-383-2048); W/WINCH (NSN 2320-01-383-2046).

EXHAUST SYSTEM REPLACEMENT

REMOVAL, INSTALLATION

INITIAL SETUP:

Tools and Special Tools

General mechanic's tool kit
(item 30, WP 0394 00)

Materials/Parts

Three gaskets (item 150, WP 0395 00)
Gasket (item 151, WP 0395 00)
Four lockwashers (item 61, WP 0395 00)
Lockwasher (item 147, WP 0395 00)
Two lockwashers (item 334, WP 0395 00)
Six locknuts (item 137, WP 0395 00)
Two locknuts (item 19, WP 0395 00)
Three locknuts (item 138, WP 0395 00)

References

TM 9-2320-386-24P

Equipment Condition

Parking brake set (TM 9-2320-386-10).
Hood raised and secured (TM 9-2320-386-10).
Dust ejector hose removed (WP 0039 00).

EXHAUST SYSTEM REPLACEMENT (Contd)

WARNING

Do not touch hot exhaust system components with bare hands.
Severe injury to personnel may result.

REMOVAL

1. Remove two locknuts (9), screws (41) and (39), lockwashers (38), and heat shield (40) from bracket (6). Discard locknuts (9) and lockwashers (38).
2. Remove six locknuts (32), washers (33), screws (37), washers (36), and two spacers (35) from fender (34). Discard locknuts (32).
3. Remove locknut (15), nut (19), screw (20), clamps (14) and (18), gaskets (17) and (21), and flexpipe (16) from turbocharger (11) and elbow pipe (24). Discard gaskets (17) and (21), and locknut (15).
4. Remove two nuts (13), screws (22), clamp (23), and elbow pipe (24) from bracket (12).
5. Remove locknut (28), screw (26), clamp (25), elbow pipe (24), and gasket (27) from muffler (43). Discard gasket (27) and locknut (28).
6. Remove locknut (4), screw (44), clamp (3), stack pipe (1), and gasket (2) from muffler (43). Discard gasket (2) and locknut (4).
7. Remove four nuts (8), lockwashers (7), two U-bolts (42), clamps (5), and muffler (43) from bracket (6). Discard lockwashers (7).
8. Remove screw (29), lockwasher (30), washer (31), and bracket (12) from fender (34) and air cleaner (10). Discard lockwasher (30).

INSTALLATION

1. Install bracket (12) on fender (34) and air cleaner (10) with washer (31), new lockwasher (30), and screw (29).
2. Install muffler (43) on bracket (6) with two clamps (5), U-bolts (42), four new lockwashers (7), and nuts (8).
3. Install new gasket (2) and stack pipe (1) on muffler (43) with clamp (3), screw (44), and new locknut (4).
4. Install new gasket (27) and elbow pipe (24) on muffler (43) with clamp (25), screw (26), and new locknut (28).
5. Install two spacers (35) on fender (34) with six washers (36), screws (37), washers (33), and new locknuts (32).
6. Install new gaskets (21) and (17) and flexpipe (16) on elbow pipe (24) and turbocharger (11) with clamps (14) and (18), screw (20), new locknut (15), and nut (19).
7. Install elbow pipe (24) on bracket (12) with clamp (23), two screws (22), and nuts (13).
8. Install heat shield (40) on bracket (6) with two screws (41) and (39), new locknuts (9), and new lockwashers (38).
9. Install dust ejector hose (WP 0039 00).
10. Start engine (TM 9-2320-386-10) and check for exhaust leaks.

EXHAUST SYSTEM REPLACEMENT (Contd)

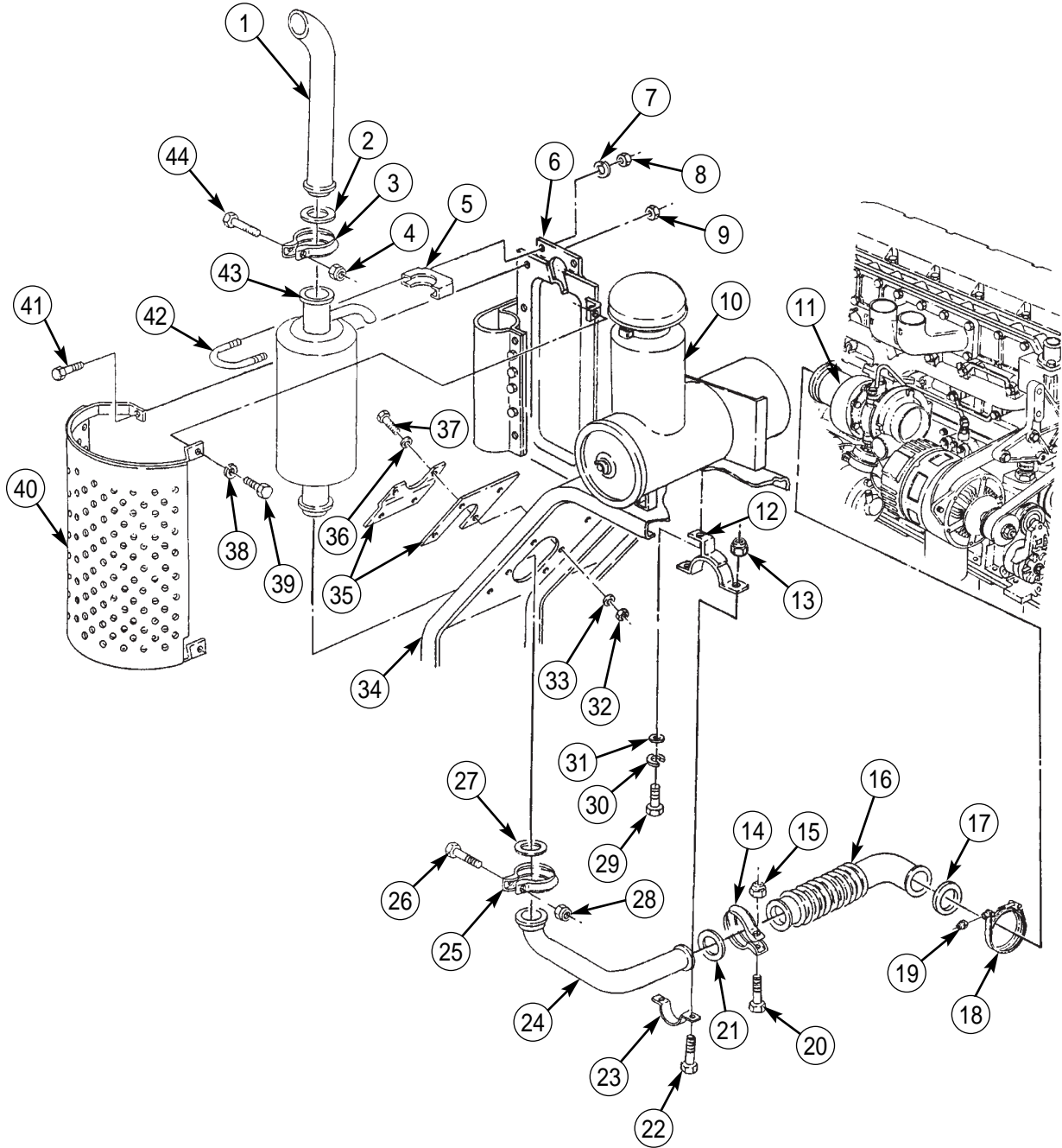

END OF WORK PACKAGE

UNIT MAINTENANCE INSTRUCTIONS

EXTENDED SERVICE PROGRAM (ESP)

TRUCK, CARGO, 2-1/2-TON, 6X6, M44A3 SERIES TRUCKS (DIESEL)

M35A3, W/O WINCH (NSN 2320-01-383-2047); W/WINCH (NSN 2320-01-383-3850);

M35A3C, W/O WINCH (NSN 2320-01-383-2050); W/WINCH (NSN 2320-01-383-2049);

M36A3, W/O WINCH (NSN 2320-01-383-2048); W/WINCH (NSN 2320-01-383-2046).

Section VII. ENGINE COOLING SYSTEM MAINTENANCE

TABLE OF CONTENTS

<i>WP Title</i>	<i>WP Sequence No.-Page No.</i>
Engine Cooling System Servicing	0068 00-1
Radiator and Mounting Brackets Replacement	0069 00-1
Radiator Hoses Replacement	0070 00-1
Surge Tank and Mounting Brackets Replacement	0071 00-1
Charged Air Cooler Replacement	0072 00-1
Charged Air Cooler Tubes Replacement	0073 00-1
Upper Radiator Shroud Replacement	0074 00-1
Lower Radiator Shroud and Pivot Mount Replacement	0075 00-1
Radiator Baffles Replacement	0076 00-1
Thermostat Replacement	0077 00-1
Coolant Temperature Quick-Start Switch Replacement	0078 00-1
Water Regulator Housing Replacement	0079 00-1
Water Pump Replacement	0080 00-1
Water Pump Drivebelt Maintenance	0081 00-1
Fan and Fan Clutch Replacement	0082 00-1
Shutterstat Air Valve Replacement	0083 00-1
Fan Drivebelt Maintenance	0084 00-1
Fan Actuator Replacement	0085 00-1
Fan Actuator Tube Maintenance	0086 00-1
Engine Drivebelt Tensioner Replacement	0087 00-1

END OF WORK PACKAGE

UNIT MAINTENANCE INSTRUCTIONS

EXTENDED SERVICE PROGRAM (ESP)

TRUCK, CARGO, 2-1/2-TON, 6X6, M44A3 SERIES TRUCKS (DIESEL)

M35A3, W/O WINCH (NSN 2320-01-383-2047); W/WINCH (NSN 2320-01-383-3850);
M35A3C, W/O WINCH (NSN 2320-01-383-2050); W/WINCH (NSN 2320-01-383-2049);
M36A3, W/O WINCH (NSN 2320-01-383-2048); W/WINCH (NSN 2320-01-383-2046).

ENGINE COOLING SYSTEM SERVICING

DRAIN SYSTEM, CLEANING AND FLUSHING SYSTEM, FILL SYSTEM

INITIAL SETUP:

Tools and Special Tools

General mechanic's tool kit
(item 30, WP 0394 00)
Common No. 1 tool kit
(item 15, WP 0394 00)

Materials/Parts

Antifreeze (item 10, WP 0393 00)
Cleaning compound (item 16, WP 0393 00)

References

TM 9-2320-386-24P

Equipment Condition

Parking brake set (TM 9-2320-386-10).
Hood raised and secured (TM 9-2320-386-10).

ENGINE COOLING SYSTEM SERVICING (Contd)

WARNING

Accidental or intentional introduction of liquid contaminants into the environment is in violation of state, federal, and military regulation. Refer to Army POL (WP 0001 00) for information concerning storage, use, and disposal of these liquids. Failure to do so may result in injury or death.

DRAIN SYSTEM

WARNING

Do not remove cap if engine is hot. Steam or hot coolant under pressure may cause injury to personnel.

1. Turn cap (1) to first stop. Allow any pressure to escape.
2. Remove cap (1) from surge tank (2).

NOTE

Have drainage container ready to catch coolant.

3. Open drainvalve (4) and drain coolant from radiator (3).

NOTE

Allow coolant to drain completely before performing step 4.

4. Close drainvalve (4).

CLEANING AND FLUSHING SYSTEM

Following cleaning and flushing instructions included in cleaning compound kit, clean and flush radiator (3) and cooling system.

FILL SYSTEM

1. Mix coolant solution.

CAUTION

Do not add antifreeze directly to cooling system. Premix the coolant solution required for vehicle operations. Failure to do so may result in damage to equipment.

NOTE

Capacity of system is 27 quarts (26 liters) of coolant.

A 50/50 solution of antifreeze-to-water will allow the engine to function in temperatures down to -25°F (-32°C).

2. Test freeze point of coolant solution.
3. Add coolant solution to surge tank (2), until coolant level is centered in sight glass (5).
4. Install cap (1) on surge tank (2).
5. Start engine (TM 9-2320-386-10) and allow engine to reach normal operating temperature.
6. Stop engine (TM 9-2320-386-10).

WARNING

Do not remove cap if engine is hot. Steam or hot coolant under pressure may cause injury to personnel.

7. Turn cap (1) to first stop. Allow any pressure to escape.
8. Remove cap (1) from surge tank (2), add coolant if necessary, and install cap (1) on surge tank (2).

ENGINE COOLING SYSTEM SERVICING (Contd)

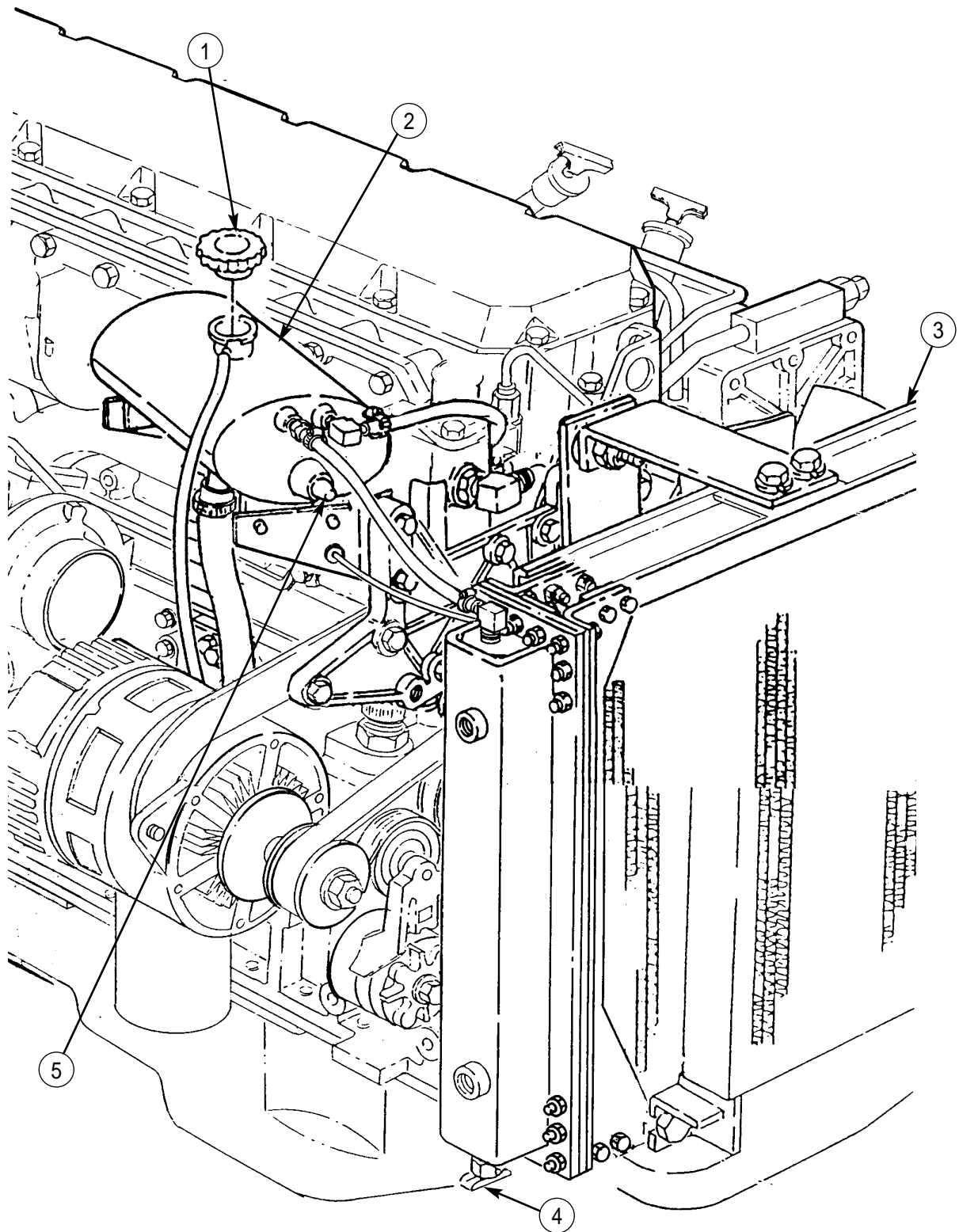

END OF WORK PACKAGE

UNIT MAINTENANCE INSTRUCTIONS

EXTENDED SERVICE PROGRAM (ESP)

TRUCK, CARGO, 2-1/2-TON, 6X6, M44A3 SERIES TRUCKS (DIESEL)

M35A3, W/O WINCH (NSN 2320-01-383-2047); W/WINCH (NSN 2320-01-383-3850);

M35A3C, W/O WINCH (NSN 2320-01-383-2050); W/WINCH (NSN 2320-01-383-2049);

M36A3, W/O WINCH (NSN 2320-01-383-2048); W/WINCH (NSN 2320-01-383-2046).

RADIATOR AND MOUNTING BRACKETS REPLACEMENT

REMOVAL, INSTALLATION

INITIAL SETUP:

Tools and Special Tools

General mechanic's tool kit
(item 30, WP 0394 00)

Lifting device
Chains

Materials/Parts

Bushing set (item 143, WP 0395 00)
Locknut (item 333, WP 0395 00)
Six locknuts (item 106, WP 0395 00)
Two lockwashers (item 147, WP 0395 00)
Two lockwashers (item 135, WP 0395 00)
Four lockwasher (item 68, WP 0395 00)
Teflon pipe sealant (item 41, WP 0393 00)

References

TM 9-2320-386-24P

Equipment Condition

Parking brake set (TM 9-2320-386-10).
Hood raised and secured (TM 9-2320-386-10).
Radiator hoses removed (WP 0070 00).
Upper radiator shroud removed (WP 0074 00).
Brushguard removed (WP 0230 00).

RADIATOR AND MOUNTING BRACKETS REPLACEMENT (Contd)**REMOVAL**

1. Remove two nuts (15), screws (18), and washers (17) from radiator (23), and install ends of chain on radiator (23) with two washers (17), screws (18), and nuts (15).
2. Install lifting device at center point of chain and take up slack.
3. Remove two screws (7) and lockwashers (6) from bracket (5) and engine (4). Discard lockwashers (6).
4. Remove locknut (11), washer (10), bushing (9), screw (8), bracket (5), washer (3), and bushing (2) from bracket (1). Discard locknut (11), bushing (2), and bushing (9).
5. Loosen hose clamp (31), remove vent line (32) from fitting (12), and fitting (12) from radiator (23).
6. Remove oil line (29) from fitting (30) on radiator (23), fittings (26) and (30) from side of radiator (23), and drainvalve fitting (44) from bottom of radiator (23).
7. Remove four locknuts (25), screws (20), and washers (21) from pivot mount (22) and crossmember (24). Discard locknuts (25).
8. Loosen charged air cooler hose clamps (14) and (27), and remove charged air cooler hose (13) from outlet (16) and charged air cooler hose (28) from inlet (40) and charged air cooler (19).

WARNING

All personnel must stand clear during lifting operations. A snapped chain, or shifting or swinging load may cause injury to personnel.

CAUTION

When removing radiator, avoid contact with fan actuator hub. Contact between radiator and fan actuator hub can damage radiator.

9. Lift radiator (23) and charged air cooler (19) from vehicle and lower onto pivot mount (22).
10. Remove two screws (38), lockwashers (39), and bracket (1) from radiator (23). Discard lockwashers (39).
11. Remove two screws (35), lockwashers (34), washers (33), locknuts (43), lockwashers (42), washers (41), screws (36), washers (37), and charged air cooler (19) from radiator (23). Discard lockwashers (34) and (42) and locknuts (43).
12. Tilt and lower radiator (23) onto its front side.
13. Remove two nuts (15), screws (18), washers (17), and lifting chain from radiator (23).

NOTE

Perform step 14 if new radiator is being installed.

14. Remove lower radiator shroud and pivot mount from radiator (23). (WP 0075 00.)

RADIATOR AND MOUNTING BRACKETS REPLACEMENT (Contd)

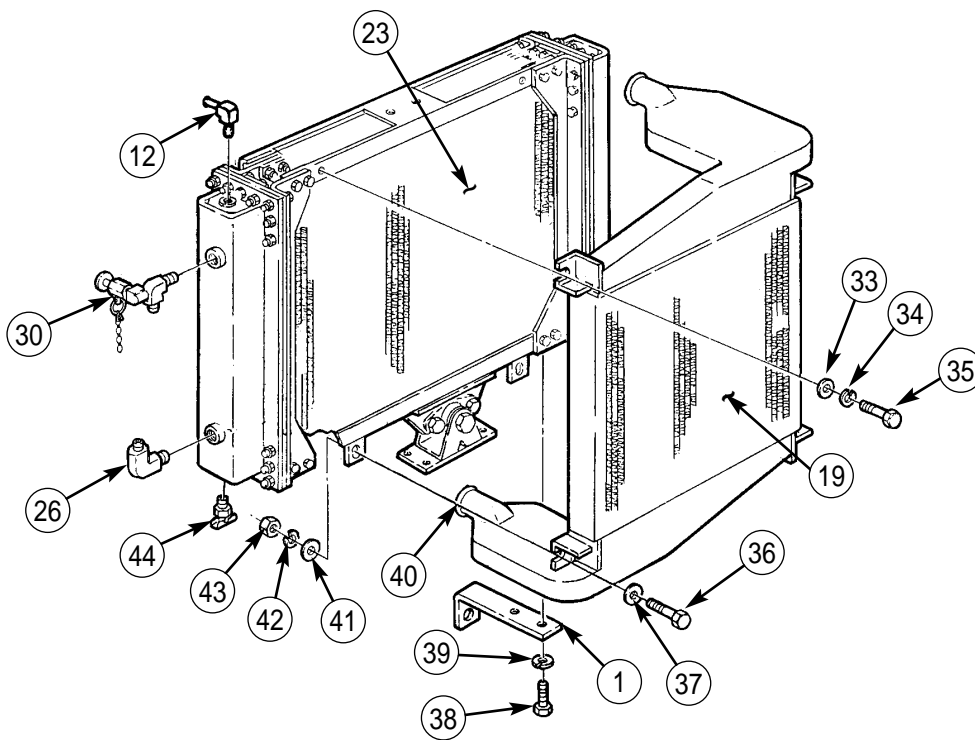
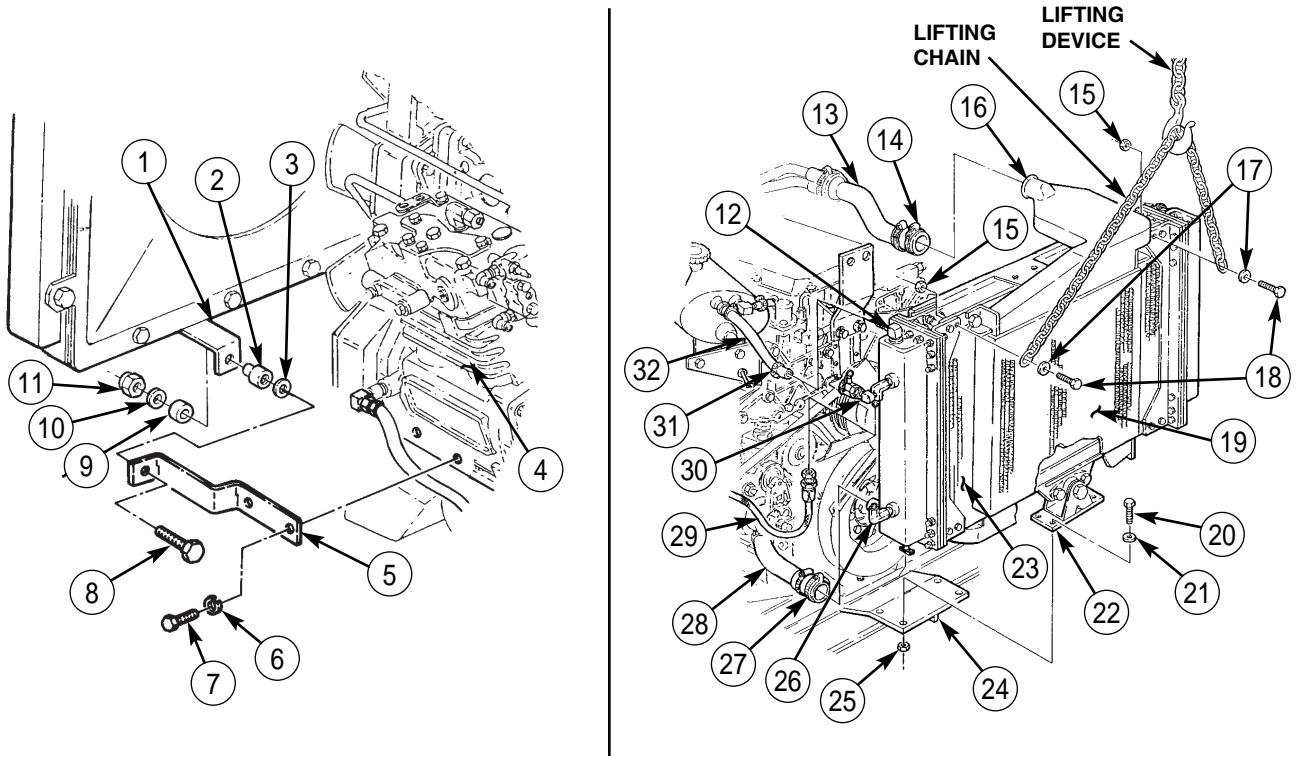

RADIATOR AND MOUNTING BRACKETS REPLACEMENT (Contd)**INSTALLATION****NOTE**

Perform step 1 if new radiator is being installed

1. Install lower radiator shroud and pivot mount on radiator (1). (Refer to WP 0075 00.)
2. Install ends of chain on radiator (1) with two washers (23), screws (24), and nuts (21).
3. Install lifting device at center point of chain, and take up slack.

WARNING

All personnel must stand clear during lifting operations. A snapped chain, or shifting or swinging load may cause injury to personnel.

4. Lift and stand radiator (1) on pivot mount (27).
5. Install charged air cooler (5) on radiator (1) with two washers (2), new lockwashers (3), screws (4), washers (7), screws (6), washers (12), new lockwashers (13), and new locknuts (14).
6. Install bracket (8) on radiator (1) with two new lockwashers (10) and screws (9).

CAUTION

When installing radiator, avoid contact with fan actuator hub. Contact between radiator and fan actuator hub can damage radiator.

7. Lift radiator (1) and charged air cooler (5) with lifting device and position in vehicle.
8. Install charged air cooler hoses (19) and (31) on charged air cooler inlet (22) and outlet (11) and tighten hose clamps (20) and (30).
9. Install pivot mount (27) on crossmember (28) with four washers (26), screws (25), and new locknuts (29).
10. Apply sealant to threads of fittings (16), (17), and (18) and drainvalve fitting (15).
11. Install drainvalve fitting (15) on bottom of radiator (1), oil line fittings (16) and (17) on side of radiator (1), and vent line fitting (18) on top of radiator (1).
12. Install oil line (32) on oil line fitting (17), and vent line (34) on vent line fitting (18), and tighten hose clamp (33).
13. Install bracket (38) on engine (37) with two new lockwashers (39) and screws (40).
14. Install bracket (38) on bracket (8) with new bushing (35), washer (36), screw (41), new bushing (42), washer (43), and new locknut (44).
15. Remove lifting device from chain. Remove two nuts (21), screws (24), and washers (23) from radiator (1) and ends of lifting chain. Install two washers (23), screws (24), and nuts (21) on radiator (1).
16. Install radiator brushguard (WP 0230 00).
17. Install radiator hoses (WP 0070 00).
18. Install upper radiator shroud (WP 0074 00).

RADIATOR AND MOUNTING BRACKETS REPLACEMENT (Contd)

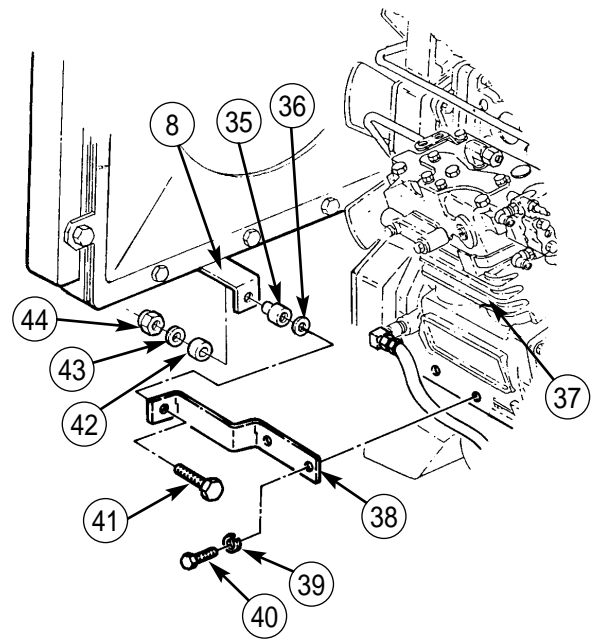
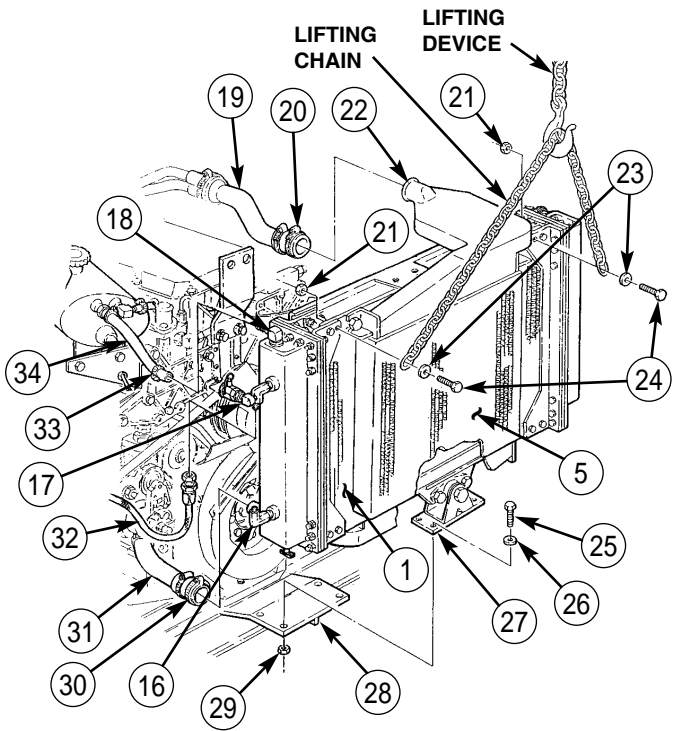
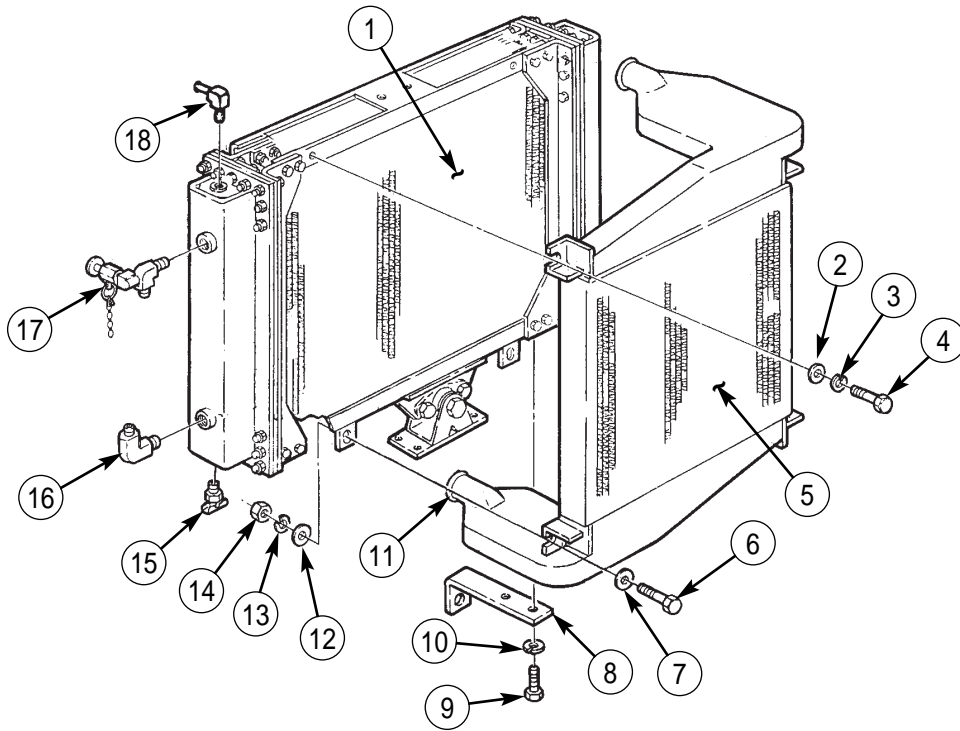

END OF WORK PACKAGE

UNIT MAINTENANCE INSTRUCTIONS

EXTENDED SERVICE PROGRAM (ESP)

TRUCK, CARGO, 2-1/2-TON, 6X6, M44A3 SERIES TRUCKS (DIESEL)

M35A3, W/O WINCH (NSN 2320-01-383-2047); W/WINCH (NSN 2320-01-383-3850);
M35A3C, W/O WINCH (NSN 2320-01-383-2050); W/WINCH (NSN 2320-01-383-2049);
M36A3, W/O WINCH (NSN 2320-01-383-2048); W/WINCH (NSN 2320-01-383-2046).

RADIATOR HOSES REPLACEMENT

REMOVAL, INSTALLATION

INITIAL SETUP:

Tools and Special Tools

General mechanic's tool kit
(item 30, WP 0394 00)

Equipment Condition

Parking brake set (TM 9-2320-386-10).
Hood raised and secured (TM 9-2320-386-10).
Cooling system drained (WP 0068 00).

References

TM 9-2320-386-24P

RADIATOR HOSES REPLACEMENT (Contd)

REMOVAL

1. Loosen and remove two clamps (7) and hose (8) from radiator (6) and water pump (9).
2. Loosen two clamps (5) and remove elbows (1) and (4), clamps (5), and tube (3) from water regulator (10) and radiator (6).
3. Loosen two clamps (2) and remove elbows (1) and (4) and clamps (2) from tube (3).

INSTALLATION

1. Install elbows (1) and (4) on tube (3) with two clamps (2).
2. Install elbow (1) on water regulator (10) with clamp (5).
3. Install elbow (4) on radiator (6) with clamp (5).
4. Install hose (8) on radiator (6) and water pump (9) with two clamps (7).
5. Fill cooling system (WP 0068 00).

RADIATOR HOSES REPLACEMENT (Contd)

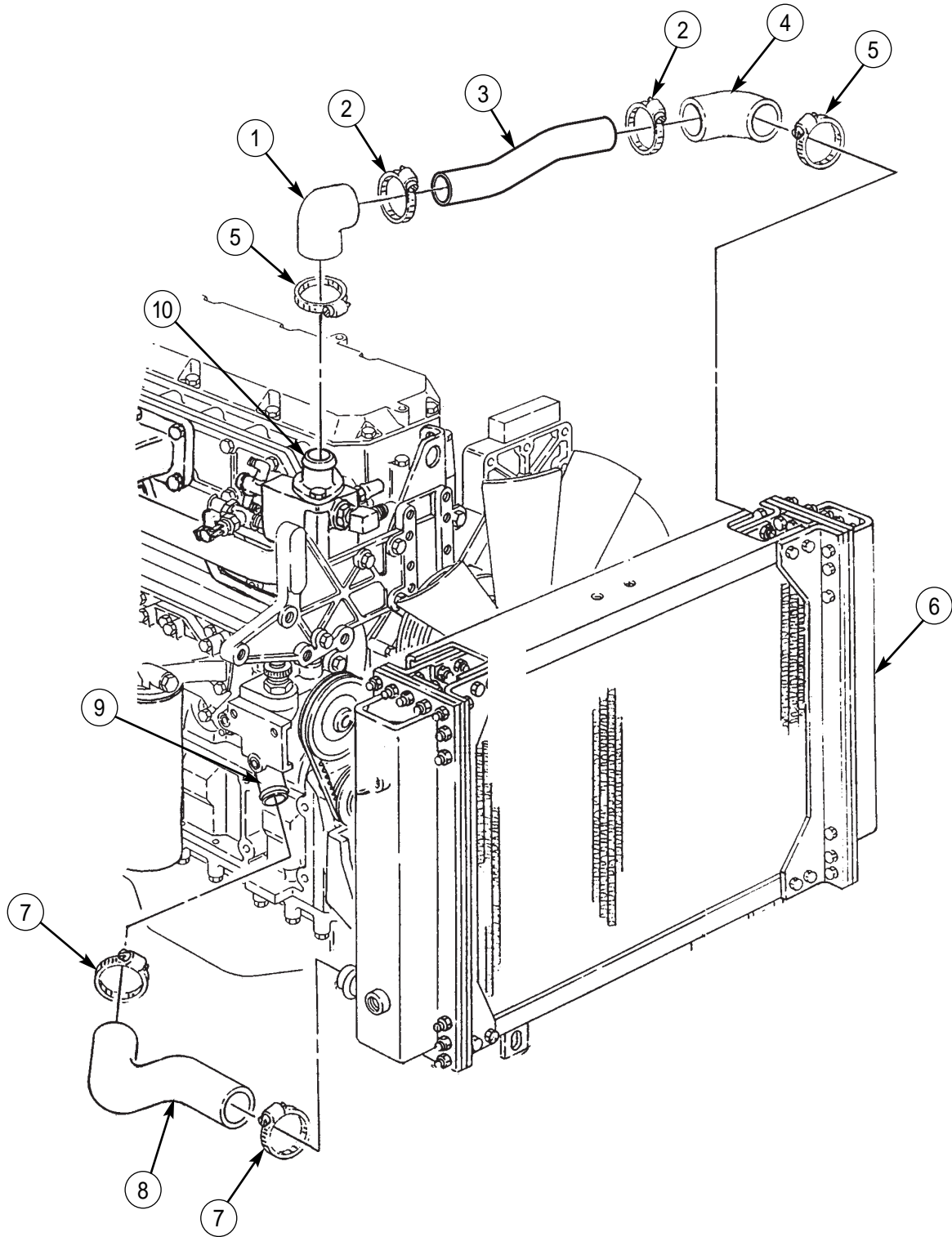

END OF WORK PACKAGE

UNIT MAINTENANCE INSTRUCTIONS

EXTENDED SERVICE PROGRAM (ESP)

TRUCK, CARGO, 2-1/2-TON, 6X6, M44A3 SERIES TRUCKS (DIESEL)

M35A3, W/O WINCH (NSN 2320-01-383-2047); W/WINCH (NSN 2320-01-383-3850);
M35A3C, W/O WINCH (NSN 2320-01-383-2050); W/WINCH (NSN 2320-01-383-2049);
M36A3, W/O WINCH (NSN 2320-01-383-2048); W/WINCH (NSN 2320-01-383-2046).

SURGE TANK AND MOUNTING BRACKETS REPLACEMENT

REMOVAL, INSTALLATION

INITIAL SETUP:

Tools and Special Tools

General mechanic's tool kit
(item 30, WP 0394 00)

Materials/Parts

Six locknuts (item 333, WP 0395 00)
O-ring (item 213, WP 0395 00)
Tiedown strap (item 37, WP 0395 00)
Teflon pipe sealant (item 41, WP 0393 00)
O-ring (item 102, WP 0395 00)

References

TM 9-2320-386-24P

Equipment Condition

Parking brake set (TM 9-2320-386-10).
Hood raised and secured (TM 9-2320-386-10).
Cooling system drained (WP 0068 00).
Fan actuator tube removed (WP 0086 00).

SURGE TANK AND MOUNTING BRACKETS REPLACEMENT (Contd)

REMOVAL

1. Remove cap (4) from surge tank (3). If not removed.
2. Loosen clamp (23) and remove hose (13) and clamp (23) from fitting (22).
3. Remove tiedown strap (14) from hoses (2) and (13). Discard tiedown strap (14).
4. Loosen clamp (12) and remove hose (13) and clamp (12) from surge tank (3).
5. Remove two clamps (10) and hose (9) from elbow (11) and fitting (15).
6. Remove two clamps (6) and hose (7) from elbow (8) and fitting (5).
7. Remove hose (2) from surge tank (3).
8. Remove four locknuts (1), screws (32), washers (31), and surge tank (3) from brackets (27) and (30). Discard locknuts (1).
9. Remove fitting (5) and elbow (11) from surge tank (3).
10. Remove two screws (29), washers (28), and bracket (30) from mounting plate (33).
11. Remove two locknuts (26), screws (24), washers (25), and bracket (27) from mounting bracket (19). Discard locknuts (26).
12. Remove fitting (15) from water regulator housing (16).
13. Remove elbow (8) from radiator (17).
14. Remove fitting (22), adapter (21), and O-ring (20) from water pump (18). Discard O-ring (20).
15. Remove sight glass (34) and O-ring (35) from surge tank (3). Discard O-ring (35).

INSTALLATION

1. Apply sealant to male threads of fittings (5), (15), and (22) and elbows (8) and (11).
2. Install new O-ring (20), adapter (21), and fitting (22) on water pump (18).
3. Install elbow (8) on radiator (17).
4. Install fitting (15) on water regulator housing (16).
5. Install bracket (27) on mounting bracket (19) with two washers (25), screws (24), and new locknuts (26).
6. Install bracket (30) on mounting plate (33) with two washers (28) and screws (29).
7. Install fitting (5) and elbow (11) on surge tank (3).
8. Install surge tank (3) on brackets (27) and (30) with four washers (31), screws (32), and new locknuts (1).
9. Install hose (2) on surge tank (3).
10. Install hose (7) on elbow (8) and fitting (5) with two clamps (6).
11. Install hose (9) on elbow (11) and fitting (15) with two clamps (10).
12. Install hose (13) on surge tank (3) with clamp (12).
13. Install hose (13) on fitting (22) with clamp (23).
14. Install new tiedown strap (14) on hoses (2) and (13).
15. Install cap (4) on surge tank (3).
16. Install new O-ring (35) and sight glass (34) on surge tank (3).
17. Install fan actuator tube (WP 0086 00).
18. Fill cooling system to proper level (WP 0068 00).

SURGE TANK AND MOUNTING BRACKETS REPLACEMENT (Contd)

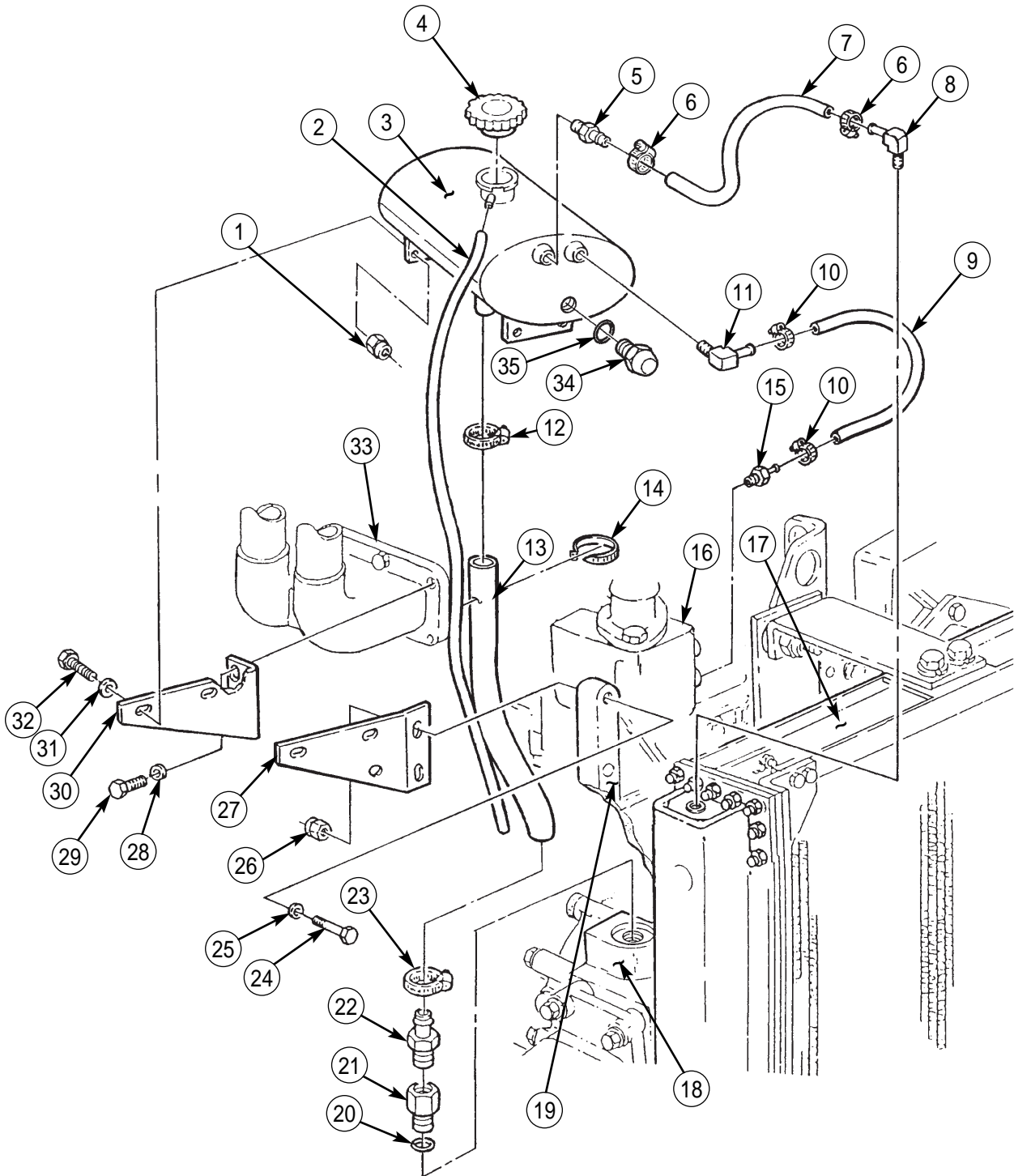

END OF WORK PACKAGE

UNIT MAINTENANCE INSTRUCTIONS

EXTENDED SERVICE PROGRAM (ESP)

TRUCK, CARGO, 2-1/2-TON, 6X6, M44A3 SERIES TRUCKS (DIESEL)

M35A3, W/O WINCH (NSN 2320-01-383-2047); W/WINCH (NSN 2320-01-383-3850);

M35A3C, W/O WINCH (NSN 2320-01-383-2050); W/WINCH (NSN 2320-01-383-2049);

M36A3, W/O WINCH (NSN 2320-01-383-2048); W/WINCH (NSN 2320-01-383-2046).

CHARGED AIR COOLER REPLACEMENT

REMOVAL, INSTALLATION

INITIAL SETUP:

Tools and Special Tools

General mechanic's tool kit
(item 30, WP 0394 00)

Materials/Parts

Four locknuts (item 185, WP 0395 00)
Locknut (item 349, WP 0395 00)
Two locknuts (item 106, WP 0395 00)
Four lockwashers (item 68, WP 0395 00)
Four lockwashers (item 186, WP 0395 00)

References

TM 9-2320-386-24P

Equipment Condition

Parking brake set (TM 9-2320-386-10).
Hood raised and secured (TM 9-2320-386-10).
Brushguard removed (WP 0230 00).

CHARGED AIR COOLER REPLACEMENT (Contd)

NOTE

Charged air cooler must be removed with radiator as an assembly for vehicles equipped with front winch. Refer to WP 0069 00.

REMOVAL

1. Remove clamp (16), reducer (18), and tube (17) from turbocharger (15).
2. Remove clamp (10), hose (14), and tube (17) from charged air cooler (7).
3. Remove clamp (3) and hose (1) from charged air cooler (7).
4. Remove two locknuts (13), lockwashers (12), washers (11), screws (8), and washers (9) from charged air cooler (7) and radiator (2). Discard locknuts (13) and lockwashers (12).
5. Remove two screws (6), lockwashers (5), and washers (4) from charged air cooler (7) and radiator (2). Discard lockwashers (5).
6. Remove four locknuts (20), screws (21), two brackets (22), and lower baffle (23) from frame rails (19). Discard locknuts (20).
7. Remove locknut (24) and screw (29) from pivot mount (25). Discard locknut (24).
8. Remove four screws (28), lockwashers (27), and pivot bracket (26) from radiator (2). Discard lockwashers (27).
9. Remove charged air cooler (7) from radiator (2).

INSTALLATION

1. Position charged air cooler (7) on radiator (2).
2. Position pivot bracket (26) in pivot mount (25).
3. Install pivot bracket (26) on radiator (2) with four new lockwashers (27) and screws (28). Finger-tighten screws (28).
4. Align pivot bracket (26) with pivot mount (25) and install screw (29) and new locknut (24).
5. Tighten screws (28).
6. Install lower baffle (23) and two brackets (22) between frame rails (19) with four screws (21) and new locknuts (20).
7. Install two washers (4), new lockwashers (5), and screws (6) on charged air cooler (7) and radiator (2). Finger-tighten screws (6).
8. Install two washers (9), screws (8), washers (11), new lockwashers (12), and new locknuts (13) on charged air cooler (7) and radiator (2). Finger-tighten locknuts (13).
9. Slide charged air cooler (7) to right of radiator (2) and tighten screws (6) and locknuts (13).
10. Install hose (1) on charged air cooler (7) with clamp (3).
11. Install hose (14) and tube (17) on charged air cooler (7) with clamp (10).
12. Install reducer (18) and tube (17) on turbocharger (15) with clamp (16).
13. Install brushguard (WP 0230 00).

CHARGED AIR COOLER REPLACEMENT (Contd)

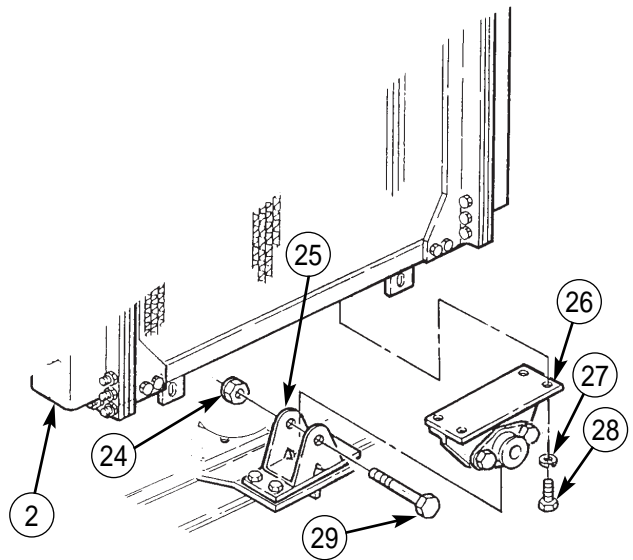
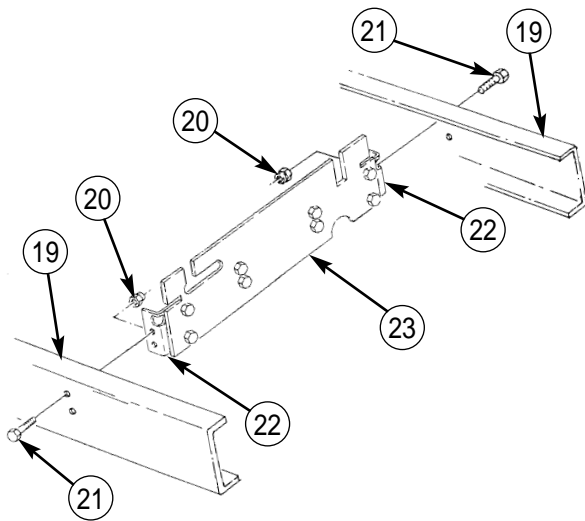
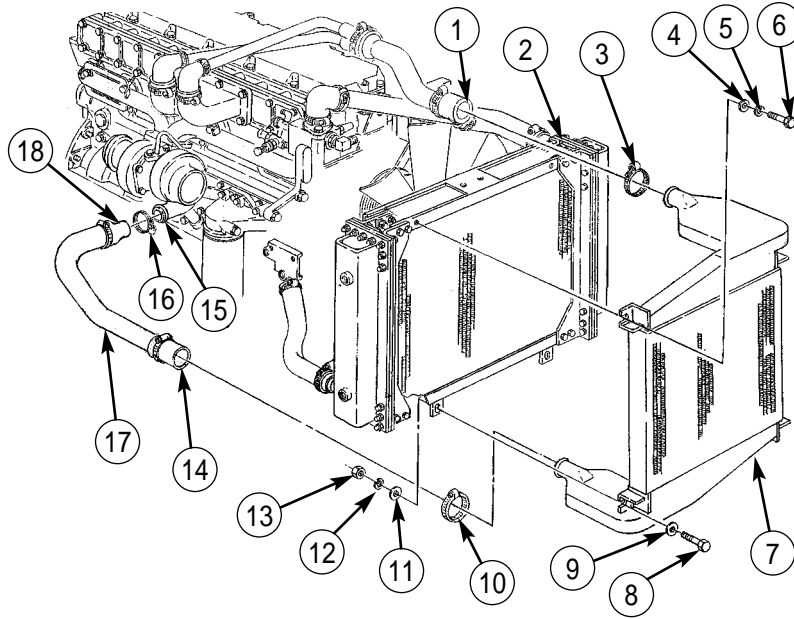

END OF WORK PACKAGE

UNIT MAINTENANCE INSTRUCTIONS

EXTENDED SERVICE PROGRAM (ESP)

TRUCK, CARGO, 2-1/2-TON, 6X6, M44A3 SERIES TRUCKS (DIESEL)

M35A3, W/O WINCH (NSN 2320-01-383-2047); W/WINCH (NSN 2320-01-383-3850);

M35A3C, W/O WINCH (NSN 2320-01-383-2050); W/WINCH (NSN 2320-01-383-2049);

M36A3, W/O WINCH (NSN 2320-01-383-2048); W/WINCH (NSN 2320-01-383-2046).

CHARGED AIR COOLER TUBES REPLACEMENT

REMOVAL, INSTALLATION

INITIAL SETUP:

Tools and Special Tools

General mechanic's tool kit
(item 30, WP 0394 00)

Equipment Condition

Parking brake set (TM 9-2320-386-10).
Hood raised and secured (TM 9-2320-386-10).

References

TM 9-2320-386-24P

CHARGED AIR COOLER TUBES REPLACEMENT (Contd)**NOTE**

Remove quick-start atomizers (WP 0057 00) if installing new charged air cooler tubes.

REMOVAL

1. Remove clamp (16) and hose (19) from charged air cooler (17).
2. Remove clamp (22) and hose (19) from tube (15).
3. Remove clamp (14) and tube (15) from hose reducer (13).
4. Remove clamp (12) and hose reducer (13) from turbocharger (18).
5. Remove clamp (29) and elbow (28) from intake manifold (20).
6. Remove clamp (27) and elbow (28) from tube (2).
7. Remove clamp (3) and tube (2) from hose (4).
8. Remove clamp (23) and elbow (24) from intake manifold (21).
9. Remove clamp (25) and elbow (24) from tube (1).
10. Remove clamp (26) and tube (1) from hose (4).
11. Remove clamp (5) and hose (4) from tube (6).
12. Remove two clamps (10) and hose (11) from air compressor (30) and tube (6).
13. Remove clamp (7) and tube (6) from hose (8).
14. Remove clamp (9) and hose (8) from charged air cooler (17).

INSTALLATION**NOTE**

Install quick-start atomizers (WP 0057 00) if installing new charged air cooler tubes.

1. Install hose (8) on charged air cooler (17) with clamp (9).
2. Install tube (6) on hose (8) with clamp (7).

NOTE

Use constant tension clamp to install hose to air compressor.

3. Install hose (11) on tube (6) and air compressor (30) with two clamps (10).
4. Install hose (4) on tube (6) with clamp (5).
5. Install tube (1) on hose (4) with clamp (26).
6. Install elbow (24) on tube (1) with clamp (25).
7. Install elbow (24) on intake manifold (21) with clamp (23).
8. Install tube (2) on hose (4) with clamp (3).
9. Install elbow (28) on tube (2) with clamp (27).
10. Install elbow (28) on intake manifold (20) with clamp (29).
11. Install hose reducer (13) on turbocharger (18) with clamp (12).
12. Install tube (15) on hose reducer (13) with clamp (14).
13. Install hose (19) on tube (15) with clamp (22).
14. Install hose (19) on charged air cooler (17) with clamp (16).

CHARGED AIR COOLER TUBES REPLACEMENT (Contd)

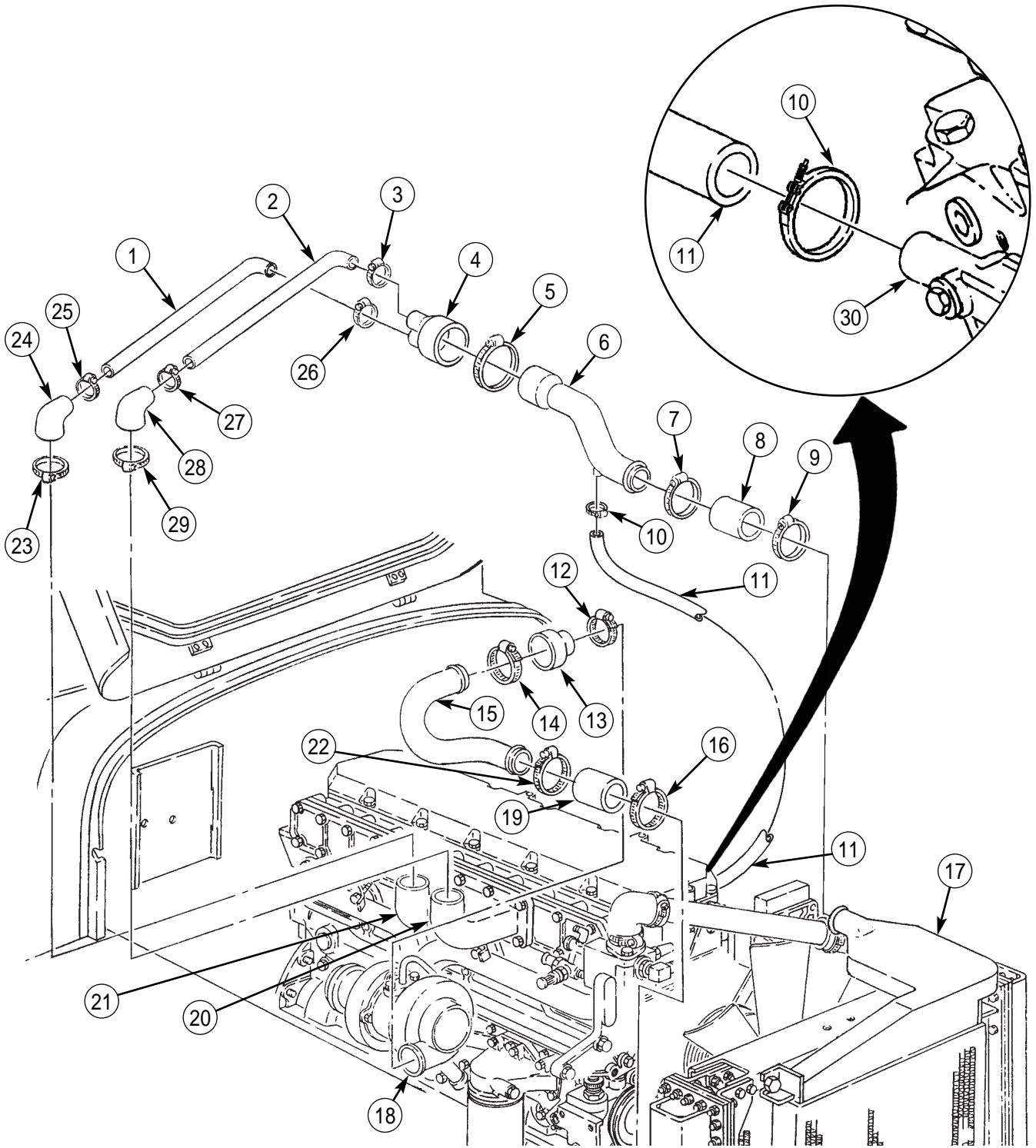

END OF WORK PACKAGE

UNIT MAINTENANCE INSTRUCTIONS

EXTENDED SERVICE PROGRAM (ESP)

TRUCK, CARGO, 2-1/2-TON, 6X6, M44A3 SERIES TRUCKS (DIESEL)

M35A3, W/O WINCH (NSN 2320-01-383-2047); W/WINCH (NSN 2320-01-383-3850);
M35A3C, W/O WINCH (NSN 2320-01-383-2050); W/WINCH (NSN 2320-01-383-2049);
M36A3, W/O WINCH (NSN 2320-01-383-2048); W/WINCH (NSN 2320-01-383-2046).

UPPER RADIATOR SHROUD REPLACEMENT

REMOVAL, INSTALLATION

INITIAL SETUP:

Tools and Special Tools

General mechanic's tool kit
(item 30, WP 0394 00)
Common No. 1 tool kit
(item 15, WP 0394 00)

Materials/Parts

Six locknuts (item 339, WP 0395 00)
Two locknuts (item 333, WP 0395 00)
Locknut (item 88, WP 0395 00)
Two lockwashers (item 147, WP 0395 00)
Two bushing sets (item 143, WP 0395 00)

References

TM 9-2320-386-24P

Equipment Condition

Parking brake set (TM 9-2320-386-10).
Hood raised and secured (TM 9-2320-386-10).
Fan actuator tube removed (WP 0086 00).

UPPER RADIATOR SHROUD REPLACEMENT (Contd)

REMOVAL

1. Remove two locknuts (15), washers (14), and screws (21) from radiator (13) and upper shroud (3). Discard locknuts (15).
2. Remove four locknuts (18), washers (17), and screws (20) from lower shroud (16) and upper shroud (3). Discard locknuts (18).
3. Remove two locknuts (11), washers (10), bushings (9), screws (19), washers (4), and bushings (5) from mounting bracket (12) and brace (8). Discard locknuts (11) and bushings (5) and (9).
4. Remove two screws (6), lockwashers (7), and brace (8) from radiator (13). Discard lockwashers (7).
5. Remove locknut (22) and bracket (23) from screw (1). Discard locknut (22).
6. Remove four screws (1), washers (2), and upper shroud (3) from radiator (13).

INSTALLATION

1. Install upper shroud (3) on radiator (13) with four washers (2) and screws (1).
2. Install brace (8) on radiator (13) with two new lockwashers (7) and screws (6).
3. Install brace (8) on mounting bracket (12) with two new bushings (5), washers (4), screws (19), bushings (9), washers (10), and new locknuts (11). Tighten locknuts (11) 30 lb-ft (41 N•m).
4. Install upper shroud (3) on lower shroud (16) with four screws (20), washers (17), and new locknuts (18).
5. Install upper shroud (3) on radiator (13) with two screws (21), washers (14), and new locknuts (15).
6. Install bracket (23) on screw (1) with new locknut (22).
7. Install fan actuator tube (WP 0086 00).

UPPER RADIATOR SHROUD REPLACEMENT (Contd)

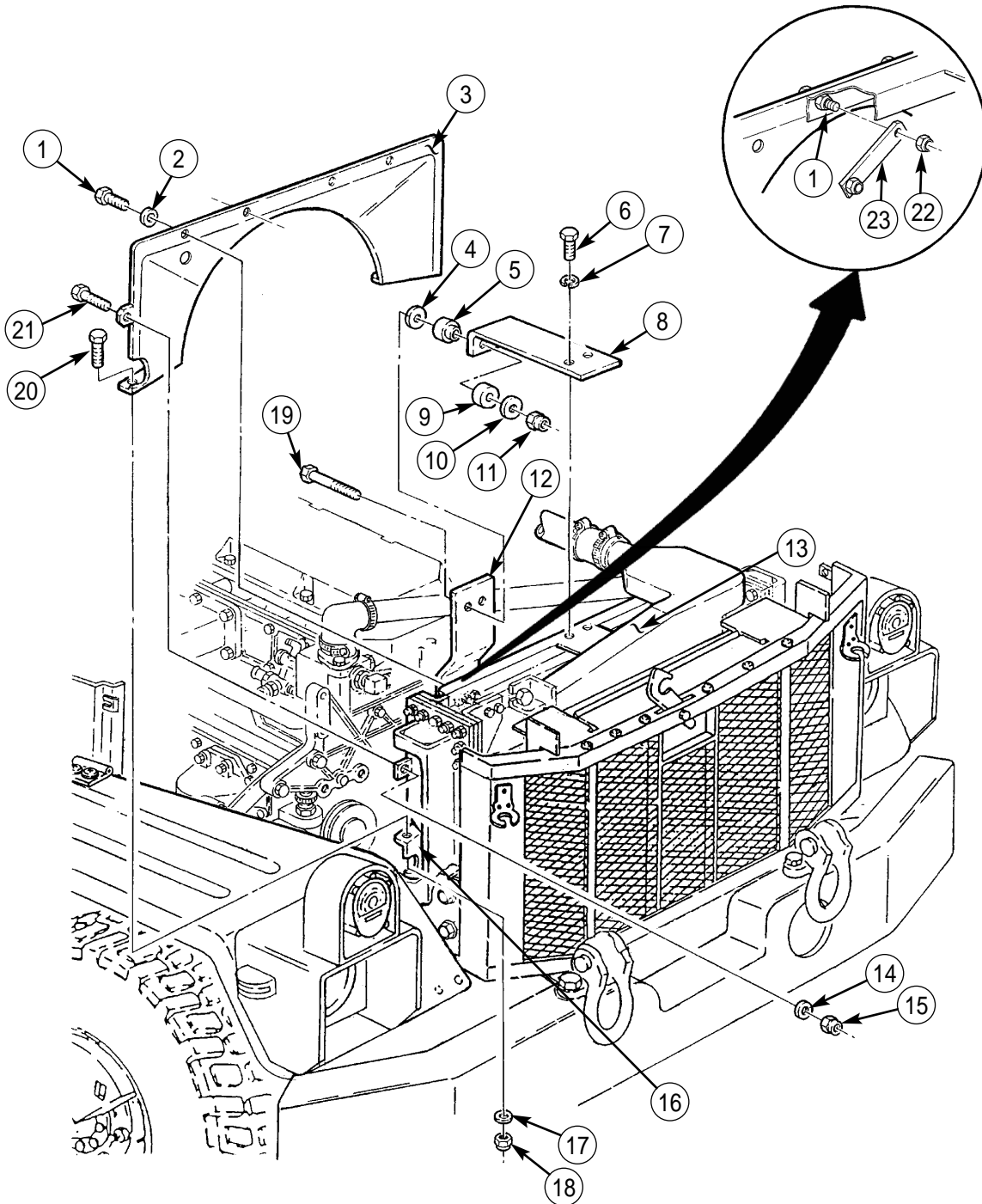

END OF WORK PACKAGE

UNIT MAINTENANCE INSTRUCTIONS

EXTENDED SERVICE PROGRAM (ESP)

TRUCK, CARGO, 2-1/2-TON, 6X6, M44A3 SERIES TRUCKS (DIESEL)

M35A3, W/O WINCH (NSN 2320-01-383-2047); W/WINCH (NSN 2320-01-383-3850);
M35A3C, W/O WINCH (NSN 2320-01-383-2050); W/WINCH (NSN 2320-01-383-2049);
M36A3, W/O WINCH (NSN 2320-01-383-2048); W/WINCH (NSN 2320-01-383-2046).

LOWER RADIATOR SHROUD AND PIVOT MOUNT REPLACEMENT

REMOVAL, INSTALLATION

INITIAL SETUP:

Tools and Special Tools

General mechanic's tool kit
(item 30, WP 0394 00)

Materials/Parts

Two locknuts (item 339, WP 0395 00)
Two locknuts (item 340, WP 0395 00)
Locknut (item 349, WP 0395 00)
Four lockwashers (item 186, WP 0395 00)

References

TM 9-2320-386-24P

Equipment Condition

Parking brake set (TM 9-2320-386-10).
Radiator removed (WP 0069 00).

LOWER RADIATOR SHROUD AND PIVOT MOUNT REPLACEMENT (Contd)**REMOVAL**

1. Remove two locknuts (11), washers (12), screws (14), four screws (16), washers (15), and lower shroud (13) from radiator (1). Discard locknuts (11).
2. Remove locknut (8), screw (6), and lower pivot mount (7) from pivot (4). Discard locknut (8).
3. Remove two locknuts (10), screws (5), and pivot (4) from upper pivot mount (9). Discard locknuts (10).
4. Remove four screws (3), lockwashers (2), and upper pivot mount (9) from radiator (1). Discard lockwashers (2).

INSTALLATION

1. Install lower shroud (13) on radiator (1) with four screws (16), washers (15), two screws (14), washers (12), and new locknuts (11).
2. Install upper pivot mount (9) on radiator (1) with four screws (3) and new lockwashers (2).
3. Install pivot (4) on upper pivot mount (9) with two screws (5) and new locknuts (10).
4. Install lower pivot mount (7) on pivot (4) with screw (6) and new locknut (8).
5. Install radiator (WP 0069 00).

LOWER RADIATOR SHROUD AND PIVOT MOUNT REPLACEMENT (Contd)

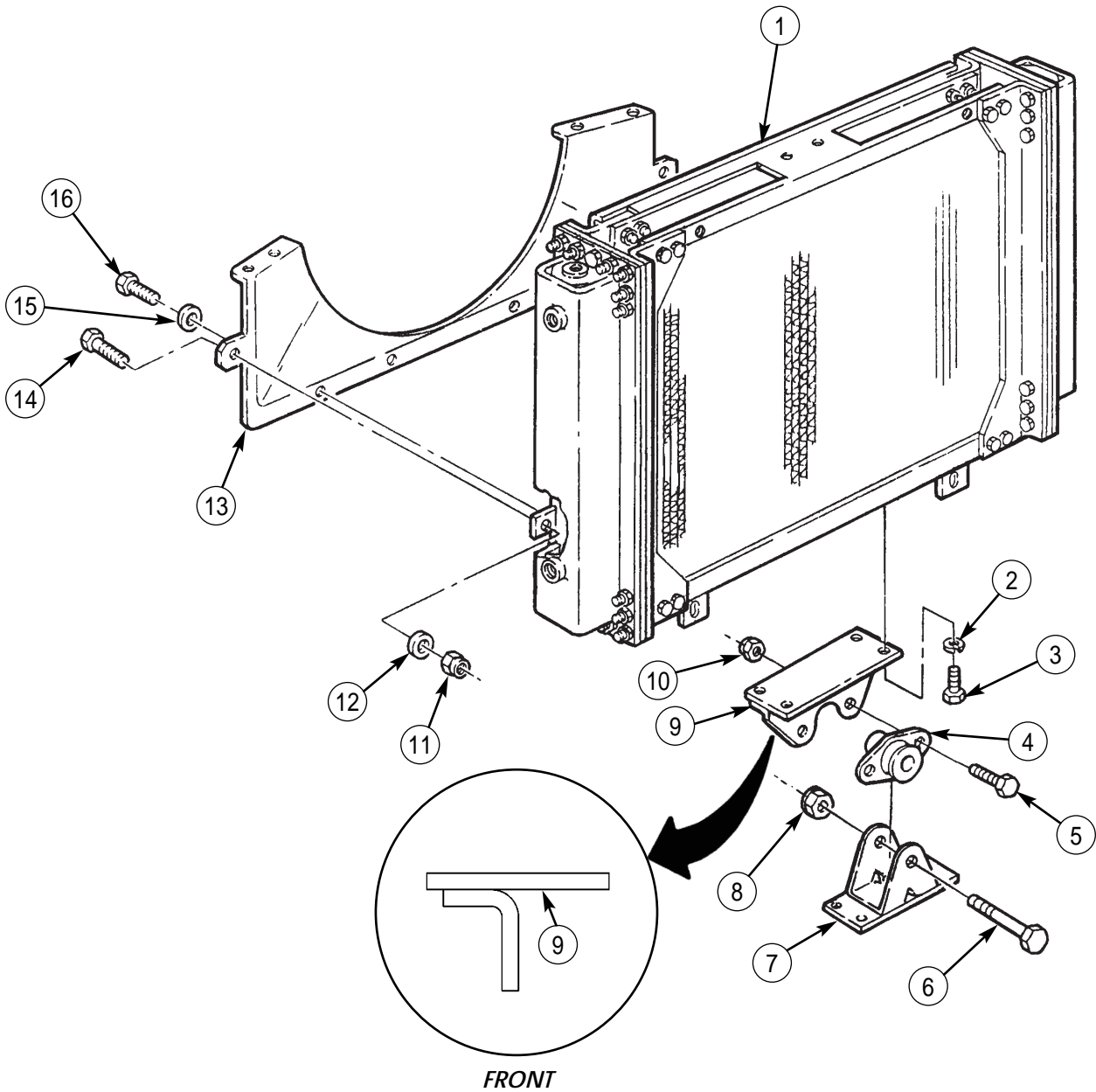

END OF WORK PACKAGE

UNIT MAINTENANCE INSTRUCTIONS

EXTENDED SERVICE PROGRAM (ESP)

TRUCK, CARGO, 2-1/2-TON, 6X6, M44A3 SERIES TRUCKS (DIESEL)

M35A3, W/O WINCH (NSN 2320-01-383-2047); W/WINCH (NSN 2320-01-383-3850);
M35A3C, W/O WINCH (NSN 2320-01-383-2050); W/WINCH (NSN 2320-01-383-2049);
M36A3, W/O WINCH (NSN 2320-01-383-2048); W/WINCH (NSN 2320-01-383-2046).

RADIATOR BAFFLES REPLACEMENT

REMOVAL, INSTALLATION

INITIAL SETUP:

Tools and Special Tools

General mechanic's tool kit
(item 30, WP 0394 00)

Materials/Parts

Eight locknuts (item 85, WP 0395 00)
Fifteen locknuts (item 175, WP 0395 00)
Four locknuts (item 185, WP 0395 00)

References

TM 9-2320-386-24P

Equipment Condition

Parking brake set (TM 9-2320-386-10).
Hood raised and secured (TM 9-2320-386-10).
Brushguard removed (WP 0230 00).

RADIATOR BAFFLES REPLACEMENT (Contd)

REMOVAL

1. Remove six screws (12), upper seal (2), and upper baffle (1) from brushguard (3).
2. Remove ten locknuts (9), washers (8), screws (11), and two side baffles (10) from brushguard (3). Discard locknuts (9).
3. Remove five locknuts (7), screws (4), shield (5), and lower baffle (6) from brushguard (3). Discard locknuts (7).
4. Remove four locknuts (16), screws (13), two brackets (15), and lower baffle (19) from between two frame rails (14). Discard locknuts (16).
5. Remove eight locknuts (17), washers (18), screws (20), washers (21), and lower baffle (19) from two brackets (15). Discard locknuts (17).

INSTALLATION

1. Install two brackets (15) on lower baffle (19) with eight washers (21), screws (20), washers (18), and new locknuts (17).
2. Install lower baffle (19) and two brackets (15) between frame rails (14) with four screws (13) and new locknuts (16).
3. Install lower baffle (6) and shield (5) on brushguard (3) with five screws (4) and new locknuts (7).
4. Install two side baffles (10) on brushguard (3) with ten screws (11), washers (8), and new locknuts (9).
5. Install upper baffle (1) and upper seal (2) on brushguard (3) with six screws (12).
6. Install brushguard (WP 0230 00).

RADIATOR Baffles REPLACEMENT (Contd)

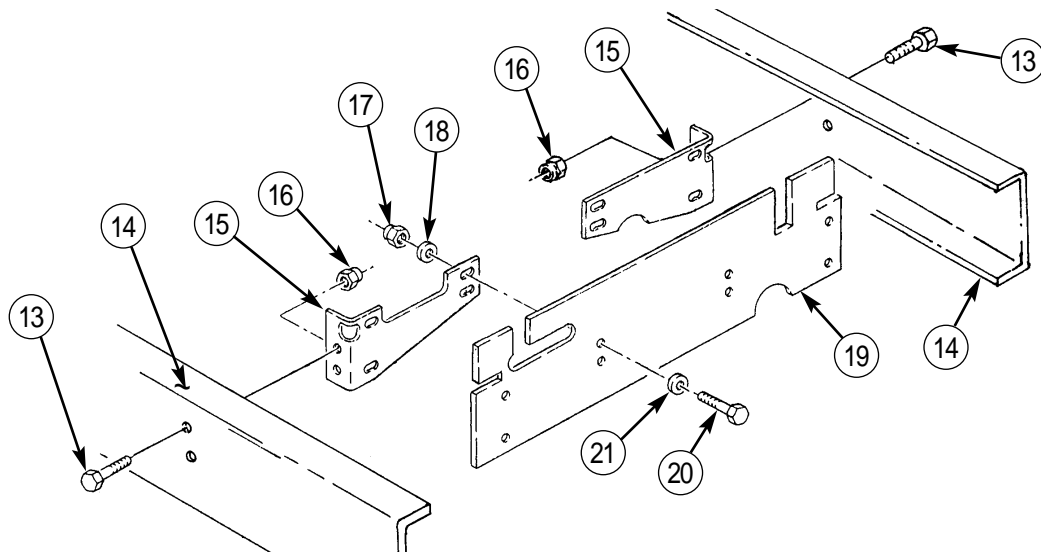
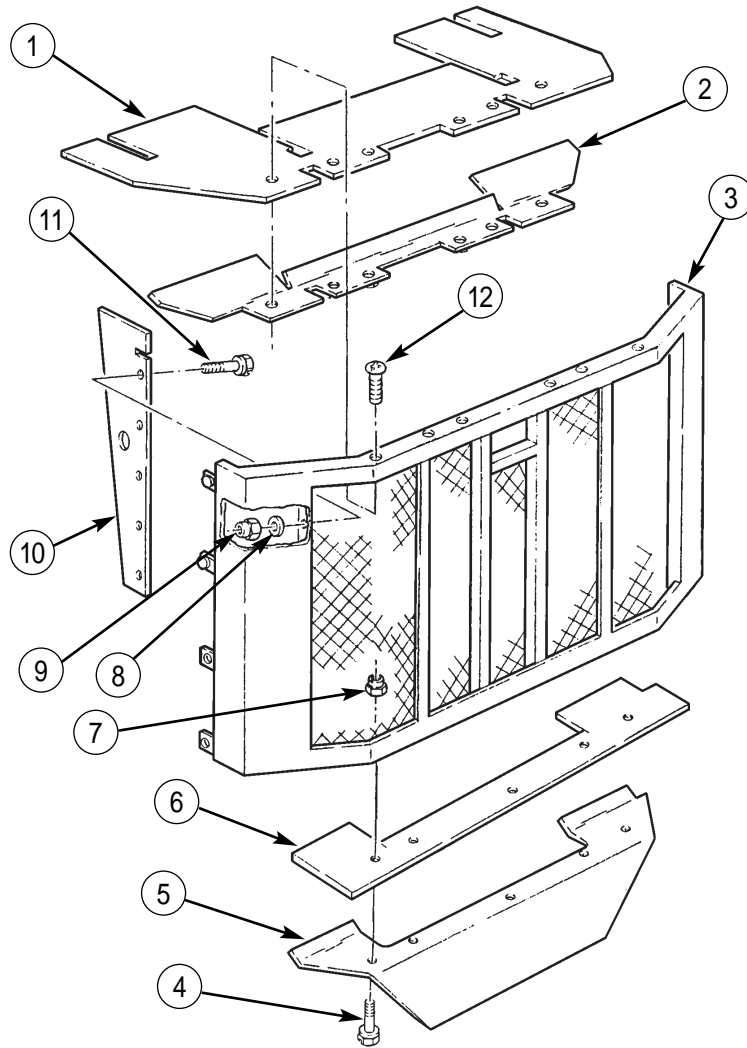

END OF WORK PACKAGE

UNIT MAINTENANCE INSTRUCTIONS

EXTENDED SERVICE PROGRAM (ESP)

TRUCK, CARGO, 2-1/2-TON, 6X6, M44A3 SERIES TRUCKS (DIESEL)

M35A3, W/O WINCH (NSN 2320-01-383-2047); W/WINCH (NSN 2320-01-383-3850);

M35A3C, W/O WINCH (NSN 2320-01-383-2050); W/WINCH (NSN 2320-01-383-2049);

M36A3, W/O WINCH (NSN 2320-01-383-2048); W/WINCH (NSN 2320-01-383-2046).

THERMOSTAT REPLACEMENT

REMOVAL, INSTALLATION

INITIAL SETUP:

Tools and Special Tools

General mechanic's tool kit
(item 30, WP 0394s 00)

Materials/Parts

Gasket (item 237, WP 0395 00)

References

TM 9-2320-386-24P

Equipment Condition

Parking brake set (TM 9-2320-386-10).
Hood raised and secured (TM 9-2320-386-10).
Cooling system drained (WP 0068 00).

THERMOSTAT REPLACEMENT (Contd)

REMOVAL

1. Remove clamp (2) and elbow (1) from pipe (8).
2. Remove two screws (3), washers (4), and pipe (8) from water regulator housing (6).
3. Remove thermostat (5) and gasket (7) from water regulator housing (6). Discard gasket (7).

INSTALLATION

1. Position new gasket (7) and thermostat (5) on water regulator housing (6).
2. Install pipe (8) on water regulator housing (6) with two washers (4) and screws (3).
3. Install elbow (1) on pipe (8) with clamp (2).
4. Fill cooling system to proper level (WP 0068 00).

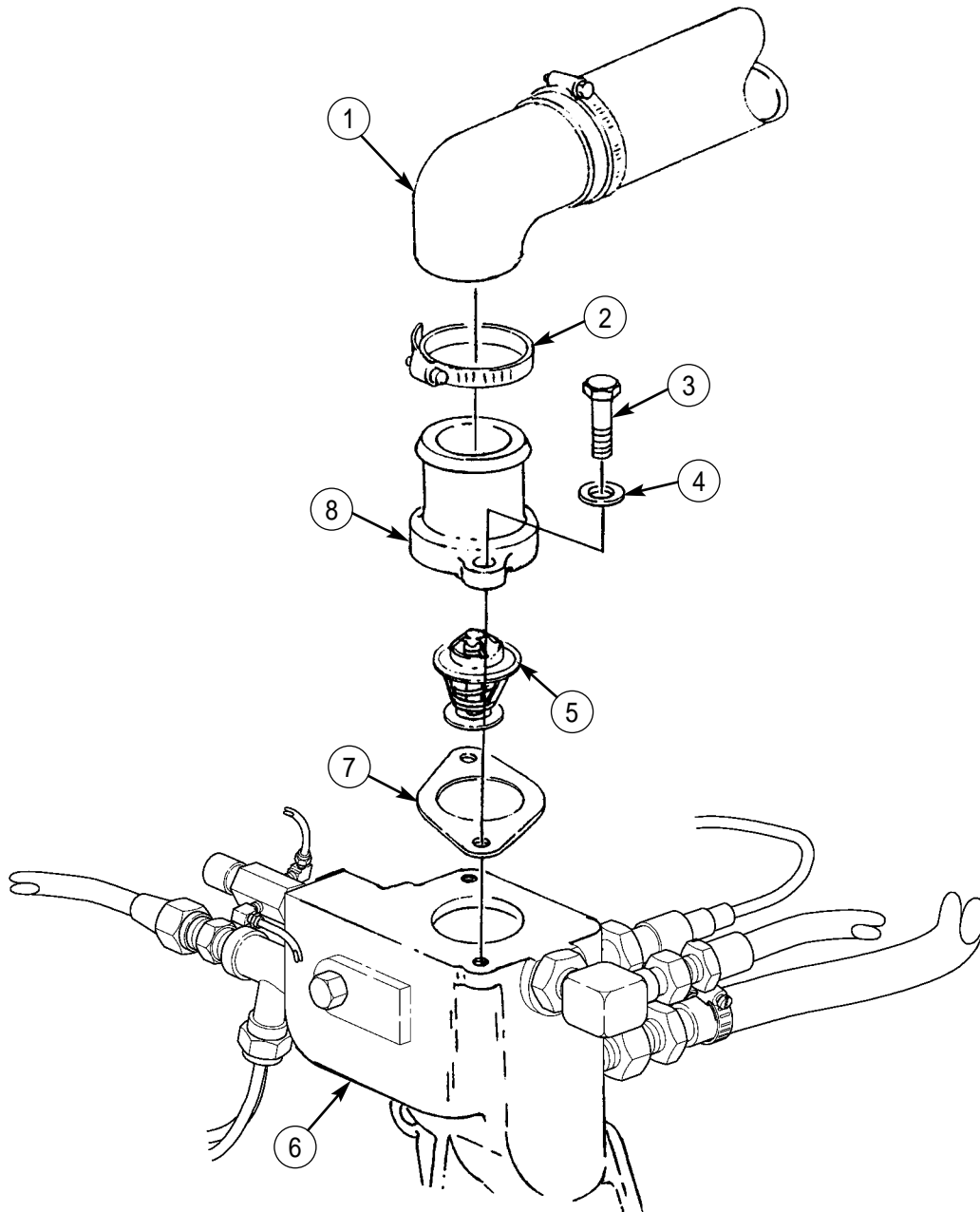

END OF WORK PACKAGE

UNIT MAINTENANCE INSTRUCTIONS

EXTENDED SERVICE PROGRAM (ESP)

TRUCK, CARGO, 2-1/2-TON, 6X6, M44A3 SERIES TRUCKS (DIESEL)

M35A3, W/O WINCH (NSN 2320-01-383-2047); W/WINCH (NSN 2320-01-383-3850);
M35A3C, W/O WINCH (NSN 2320-01-383-2050); W/WINCH (NSN 2320-01-383-2049);
M36A3, W/O WINCH (NSN 2320-01-383-2048); W/WINCH (NSN 2320-01-383-2046).

COOLANT TEMPERATURE QUICK-START SWITCH REPLACEMENT

REMOVAL, INSTALLATION

INITIAL SETUP:

Tools and Special Tools

General mechanic's tool kit
(item 30, WP 0394 00)

Materials/Parts

Teflon pipe sealant (item 41, WP 0393 00)

References

TM 9-2320-386-24P

Equipment Condition

Parking brake set (TM 9-2320-386-10).
Hood raised and secured (TM 9-2320-386-10).
Battery ground cable disconnected (WP 0121 00).
Coolant drained (WP 0068 00).

COOLANT TEMPERATURE QUICK-START SWITCH REPLACEMENT (Contd)**REMOVAL****NOTE**

Have drainage container ready to catch fluid.

1. Disconnect plug with leads 569B and ground (GND) (4) from coolant temperature quick-start switch connector (3).
2. Remove coolant temperature quick-start switch (5) from tee (2) on water regulator housing (1).

INSTALLATION

1. Apply sealant to male threads of coolant temperature quick-start switch (5) prior to installation.
2. Install coolant temperature quick-start switch (5) on tee (2) at water regulator housing (1).
3. Connect plug with leads 569B and ground (GND) (4) to coolant temperature quick-start switch connector (3).
4. Fill coolant system (WP 0068 00).
5. Connect battery ground cable (WP 0121 00).
6. Start engine (TM 9-2320-386-10) and inspect for leaks.

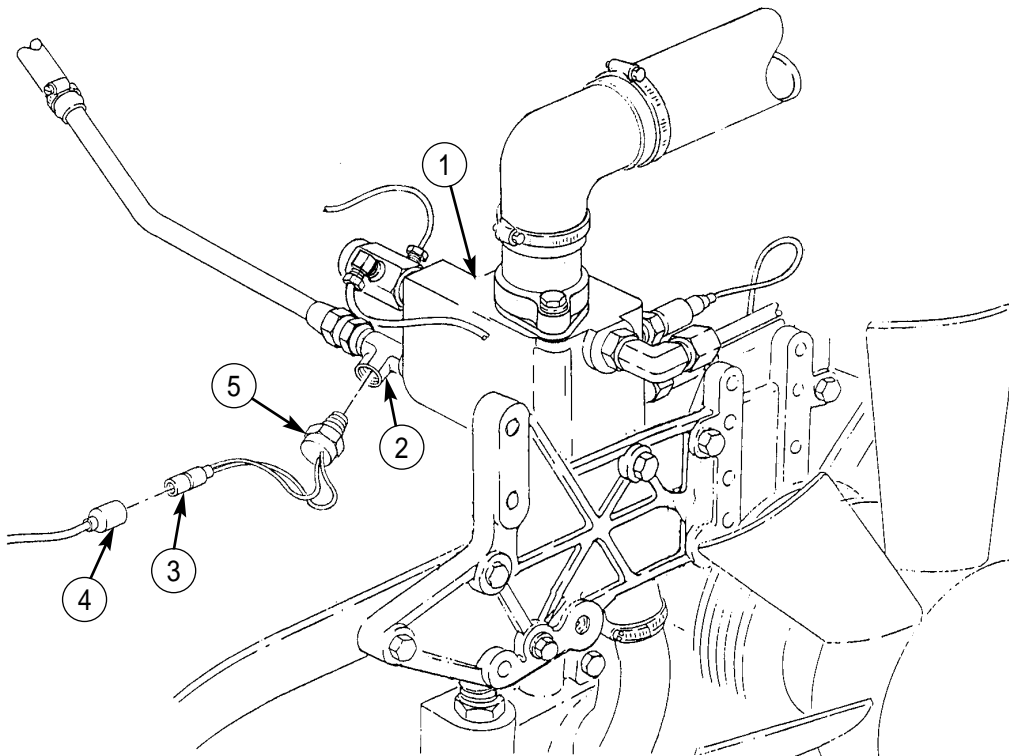
**END OF WORK PACKAGE**

UNIT MAINTENANCE INSTRUCTIONS

EXTENDED SERVICE PROGRAM (ESP)

TRUCK, CARGO, 2-1/2-TON, 6X6, M44A3 SERIES TRUCKS (DIESEL)

M35A3, W/O WINCH (NSN 2320-01-383-2047); W/WINCH (NSN 2320-01-383-3850);
M35A3C, W/O WINCH (NSN 2320-01-383-2050); W/WINCH (NSN 2320-01-383-2049);
M36A3, W/O WINCH (NSN 2320-01-383-2048); W/WINCH (NSN 2320-01-383-2046).

WATER REGULATOR HOUSING REPLACEMENT

REMOVAL, INSTALLATION

INITIAL SETUP:

Tools and Special Tools

General mechanic's tool kit
(item 30, WP 0394 00)

Materials/Parts

Gasket (item 182, WP 0395 00)
Lockwasher (item 80, WP 0395 00)
O-ring (item 215, WP 0395 00)
Teflon pipe sealant (item 41, WP 0393 00)

References

TM 9-2320-386-24P

Equipment Condition

Parking brake set (TM 9-2320-386-10).
Hood raised and secured (TM 9-2320-386-10).
Air reservoirs drained (TM 9-2320-386-10).
Battery ground cable disconnected (WP 0121 00).
Surge tank removed (WP 0071 00).
Thermostat removed (WP 0077 00).
Coolant temperature quick-start switch removed
(WP 0078 00).
Engine temperature transmitter removed
(WP 0114 00).
Shutterstat air valve removed (WP 0083 00).

WATER REGULATOR HOUSING REPLACEMENT (Contd)

REMOVAL

1. Remove screw (1), washer (2), and clamp (4) from personnel heater tube (3).
2. Loosen nut (5) and remove personnel heater tube (3) from adapter (6).
3. Remove nut (11) and remove air compressor coolant line (12) from elbow (10).
4. Remove screw (23), lockwasher (22), and ground lead (21) from bracket (24). Discard lockwasher (22).
5. Remove two screws (16), washers (17), and bracket (24) from support bracket (18) and water regulator housing (8).
6. Remove two clamps (20) from hose (14).
7. Remove two screws (25), water regulator housing (8), and gasket (13) from engine (19). Discard gasket (13).
8. Remove water regulator housing (8) and hose (14) from water pump (15).
9. Remove elbow (10), adapter (6), and tee (7) from water regulator housing (8).
10. Remove O-ring (9) from elbow (10). Discard O-ring (9).

INSTALLATION

1. Apply sealant to male threads of elbow (10), adapter (6), and tee (7).
2. Install new O-ring (9) on elbow (10).
3. Install elbow (10), tee (7), and adapter (6) on water regulator housing (8).
4. Install hose (14) on water pump (15) with two clamps (20). Do not tighten clamps (20).
5. Position water regulator housing (8) on hose (14).
6. Install new gasket (13) and water regulator housing (8) on engine (19) with two screws (25).
7. Tighten two clamps (20).
8. Install bracket (24) on water regulator housing (8) and support bracket (18) with two washers (17) and screws (16).
9. Install ground lead (21) on bracket (24) with new lockwasher (22) and screw (23).
10. Install air compressor coolant line (12) on elbow (10) and tighten nut (11).
11. Install personnel heater tube (3) on adapter (6) and tighten nut (5).
12. Install clamp (4) on personnel heater tube (3) with washer (2) and screw (1).
13. Install shutterstat air valve (WP 0083 00).
14. Install engine temperature transmitter (WP 0114 00).
15. Install coolant temperature quick-start switch (WP 0078 00).
16. Install thermostat (WP 0077 00).
17. Install surge tank (WP 0071 00).
18. Connect battery ground cable (WP 0121 00).

WATER REGULATOR HOUSING REPLACEMENT (Contd)

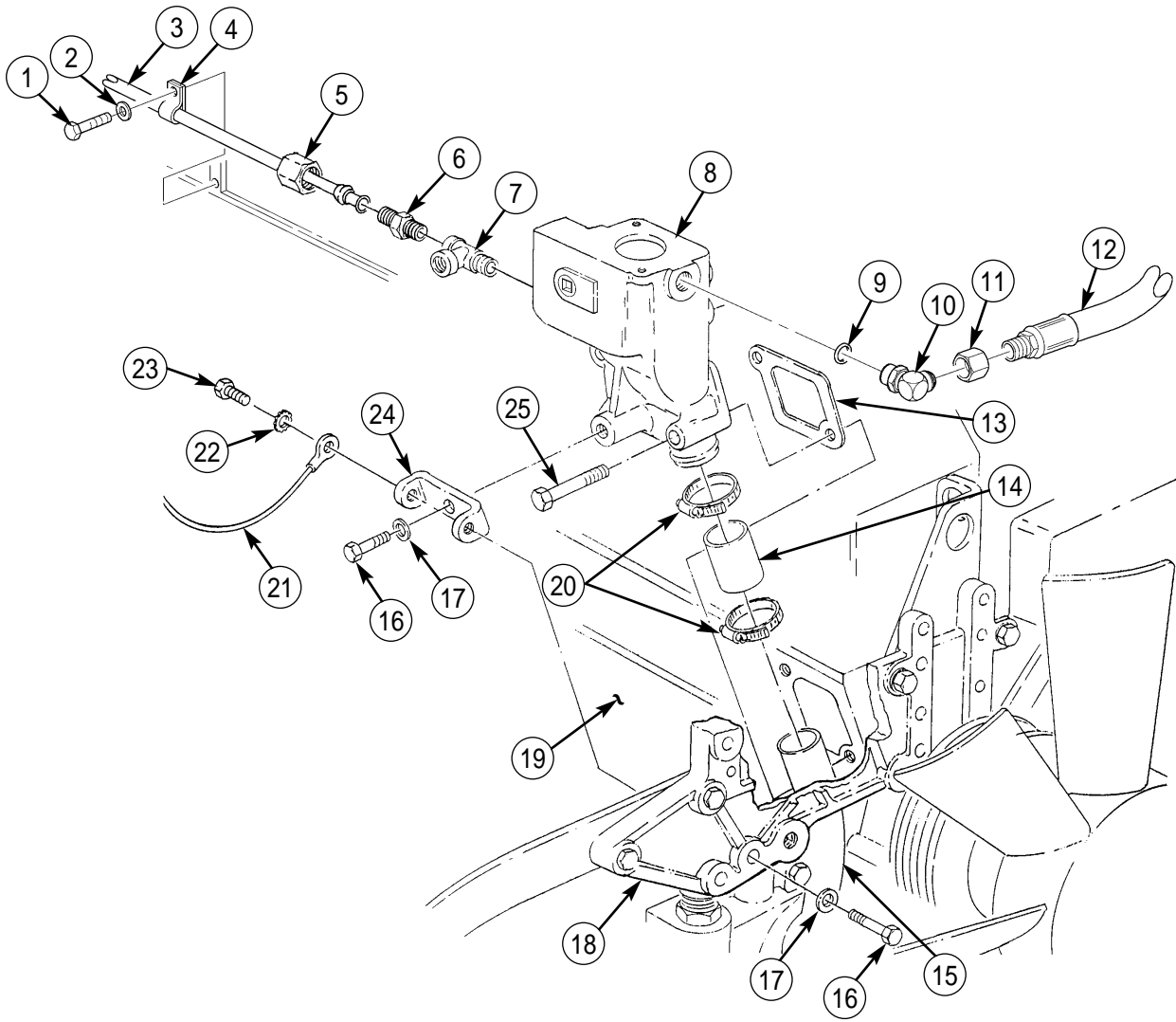

END OF WORK PACKAGE

UNIT MAINTENANCE INSTRUCTIONS

EXTENDED SERVICE PROGRAM (ESP)

TRUCK, CARGO, 2-1/2-TON, 6X6, M44A3 SERIES TRUCKS (DIESEL)

M35A3, W/O WINCH (NSN 2320-01-383-2047); W/WINCH (NSN 2320-01-383-3850);
M35A3C, W/O WINCH (NSN 2320-01-383-2050); W/WINCH (NSN 2320-01-383-2049);
M36A3, W/O WINCH (NSN 2320-01-383-2048); W/WINCH (NSN 2320-01-383-2046).

WATER PUMP REPLACEMENT

REMOVAL, INSTALLATION

INITIAL SETUP:

Tools and Special Tools

General mechanic's tool kit
(item 30, WP 0394 00)
Common No. 1 tool kit
(item 15, WP 0394 00)

Materials/Parts

O-ring (item 177, WP 0395 00)
O-ring (item 94, WP 0395 00)
Two O-rings (item 215, WP 0395 00)
Two O-rings (item 213, WP 0395 00)
Four lockwashers (item 61, WP 0395 00)
Lockwasher (item 60, WP 0395 00)
Two assembled-washer screws
(item 274, WP 0395 00)

Materials/Parts (Contd)

Two lockwashers (item 68, WP 0395 00)
Two lockwashers (item 349, WP 0395 00)
Antiseize compound (item 11, WP 0393 00)

References

TM 9-2320-386-24P

Equipment Condition

Parking brake set (TM 9-2320-386-10).
Hood raised and secured (TM 9-2320-386-10).
Battery ground cable disconnected (WP 0121 00).
Radiator drained (WP 0068 00).

WATER PUMP REPLACEMENT (Contd)

REMOVAL

1. Using a breaker bar, rotate belt tensioner (4) counterclockwise to relieve belt tension.

NOTE

Crankshaft pulley is located behind vibration damper.

2. Remove fan drivebelt (2) from alternator pulley (5), crankshaft pulley (3), and fan pulley (1).
3. Release belt tensioner (4).

NOTE

Vehicles may come equipped with a Leece-Neville or Prestolite alternator. STE/ICE-R wiring harness leads are connected to negative and positive posts on either alternator.

4. Remove screw (9), lockwasher (8), ground (GND) terminal lead (7), and STE/ICE-R terminal lead 770-P (18) from alternator (17). Discard lockwasher (8).

NOTE

Perform steps 5 and 6 for Prestolite alternators only.

Perform step 7 for Leece-Neville alternators only.

5. Remove two screws (6), lockwashers (22), and plate (21) from alternator (17). Discard lockwashers (22).
6. Remove two assembled-washer screws (11) and cover plate (10) from alternator (17). Discard assembled-washer screws (11).
7. Remove two screws (23), lockwashers (24), and cover plate (10) from alternator (17). Discard lockwashers (24).
8. Remove nut (12), lockwasher (13), positive lead 2 (14), and STE/ICE-R terminal lead 770-N (15) from stud (16). Discard lockwasher (13).
9. Disconnect lead 568 (21) from Y-connector (20).

WATER PUMP REPLACEMENT (Contd)

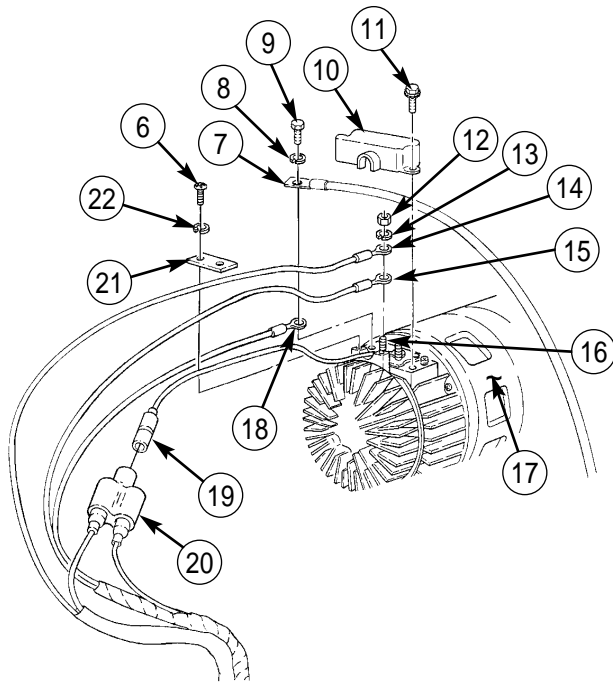
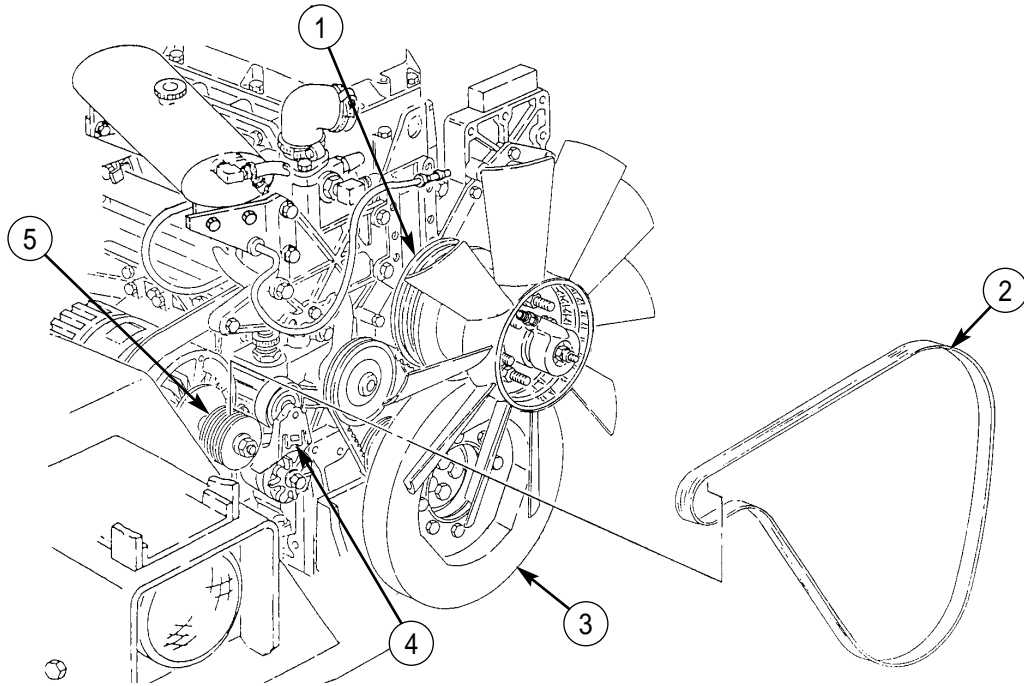

PRESTOLITE

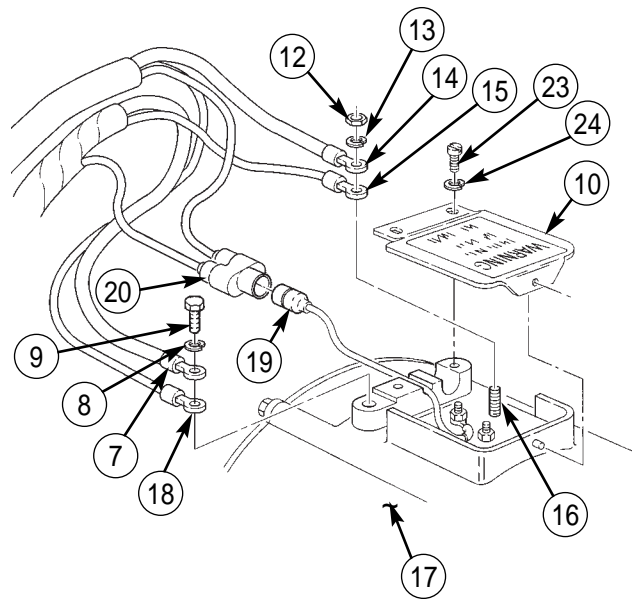

LEECE-NEVILLE

WATER PUMP REPLACEMENT (Contd)

10. Remove screw (9) and lockwasher (8) from bracket (10) and alternator (7). Discard lockwasher (8).
11. Remove two screws (3), lockwashers (2), and alternator (7) from bracket (4). Discard lockwashers (2).
12. Remove two screws (6), lockwashers (5), and bracket (4) from alternator mounting plate (1). Discard lockwashers (5).
13. Loosen clamp (12) and remove lower radiator hose (11) from water pump (13).
14. Loosen screws (18) and (21) and insert breaker bar in square slot (15) of tensioner plate (24) and rotate tensioner plate (24) counterclockwise to relieve tension from drivebelt (19).
15. Remove drivebelt (19) from tensioner pulley (20), water pump pulley (14), and crankshaft pulley (16).
16. Remove screws (18) and (21), washers (17) and (22), and tensioner plate (24) from engine (23).

WATER PUMP REPLACEMENT (Contd)

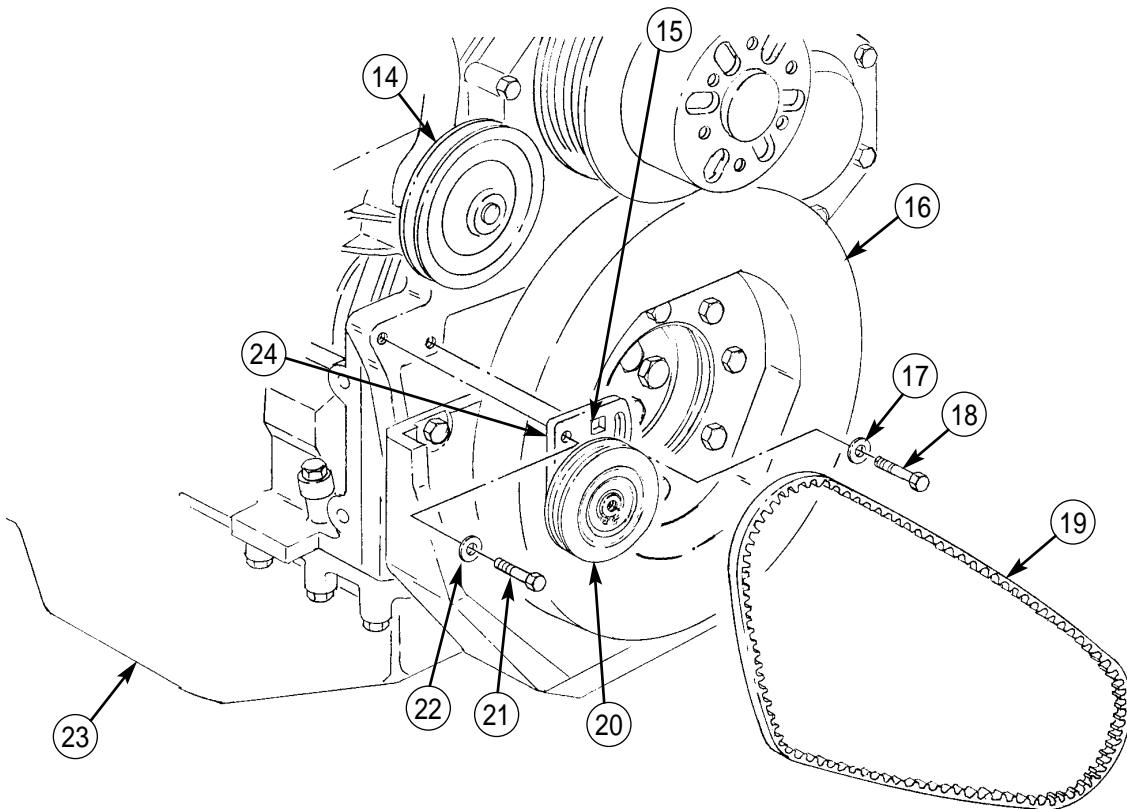
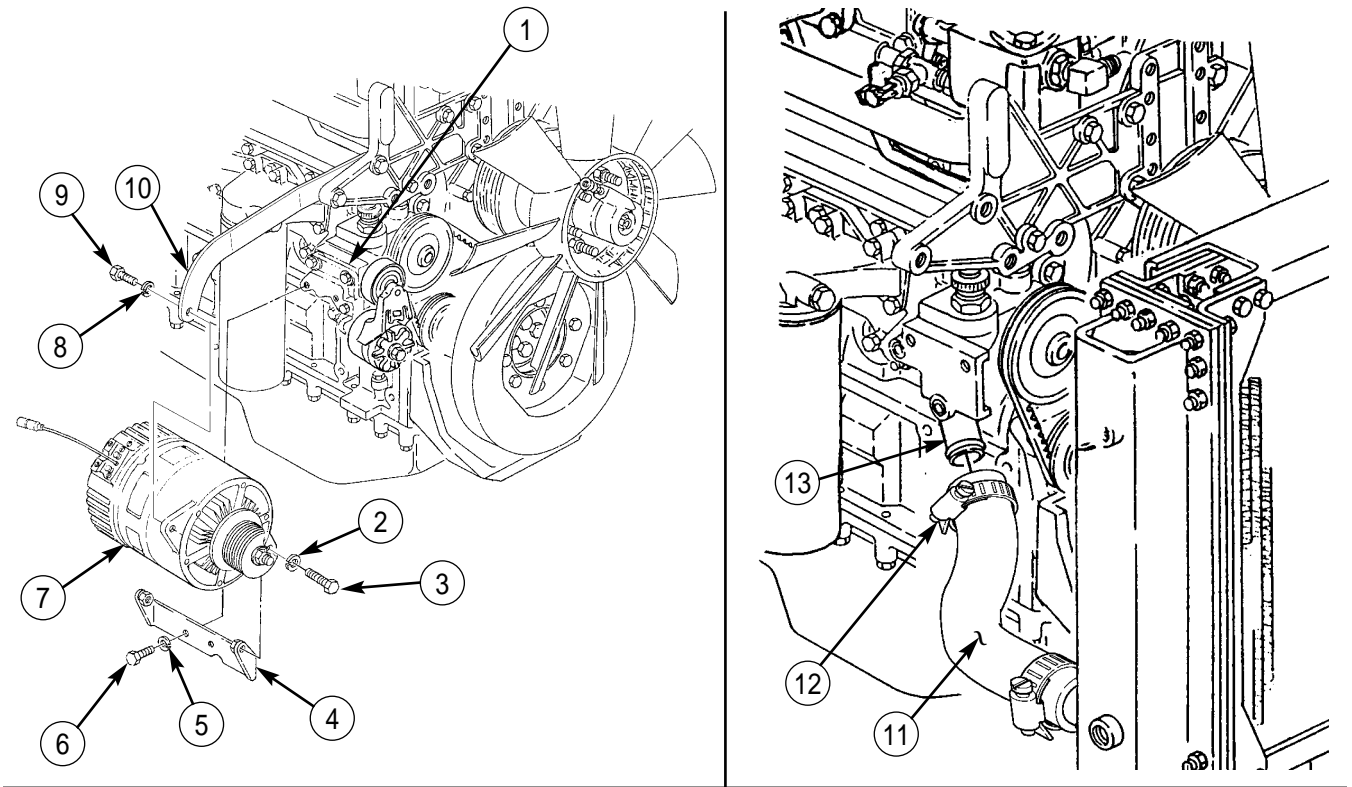

WATER PUMP REPLACEMENT (Contd)

17. Remove clamp (13) and heater hose (14) from fitting (8).
18. Loosen clamp (22) and remove hose (1) from fitting (18).
19. Remove three screws (15), washers (16), screw (12), washer (11), and alternator mounting plate (10) from water pump (7).
20. Remove tube (4) from elbow (5).
21. Remove four screws (6) and water pump (7) from engine (21).
22. Loosen clamp (3) and remove hose (2) from water pump (7).
23. Remove sleeve (17) and sleeve (9) from alternator mounting plate (10).
24. Remove O-ring (19) and O-ring (20) from water pump (7). Discard O-rings (19) and (20).
25. Remove fitting (8), adapter (28), and O-ring (27) from water pump (7). Discard O-ring (27).
26. Loosen nut (23) and remove elbow (5) and O-ring (24) from adapter (25). Discard O-ring (24).
27. Remove adapter (25) and O-ring (26) from water pump (7). Discard O-ring (26).
28. Remove fitting (18), adapter (30), and O-ring (29) from water pump (7). Discard O-ring (29).

INSTALLATION

1. Apply antiseize compound on male threads of fitting (18).
2. Install new O-ring (29), adapter (30), and fitting (18) on water pump (7).
3. Install new O-ring (27), adapter (28), and fitting (8) on water pump (7).
4. Install new O-ring (26), adapter (25), new O-ring (24), and elbow (5) on water pump (7) and tighten nut (23).
5. Install new O-rings (19) and (20) on water pump (7).
6. Install sleeves (9) and (17) in alternator mounting plate (10).
7. Install hose (2) on water pump (7) and tighten clamp (3).
8. Install water pump (7) on engine (21) with four screws (6).
9. Install tube (4) on elbow (5).
10. Install hose (1) on fitting (18) with clamp (22).
11. Install mounting plate (10) on water pump (7) with three washers (16), screws (15), washer (11), and screw (12).
12. Install heater hose (14) on fitting (8) with clamp (13).

WATER PUMP REPLACEMENT (Contd)

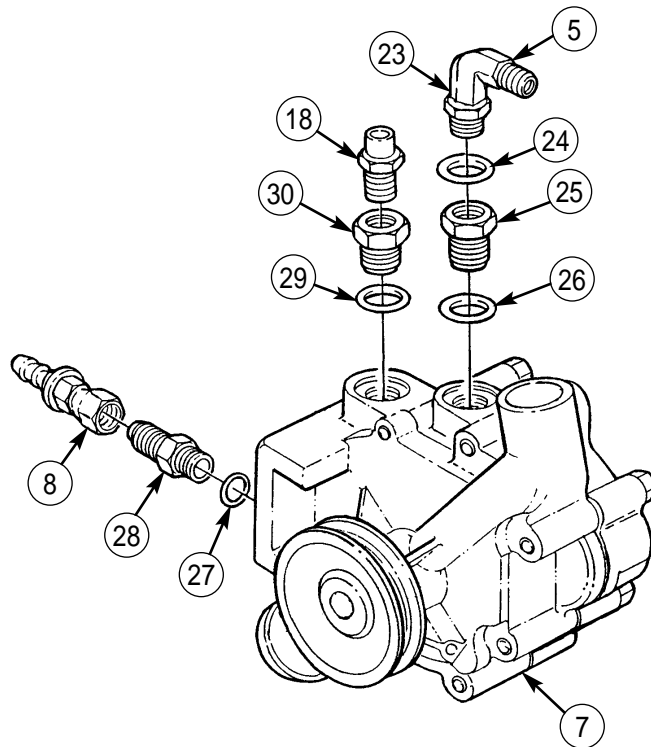
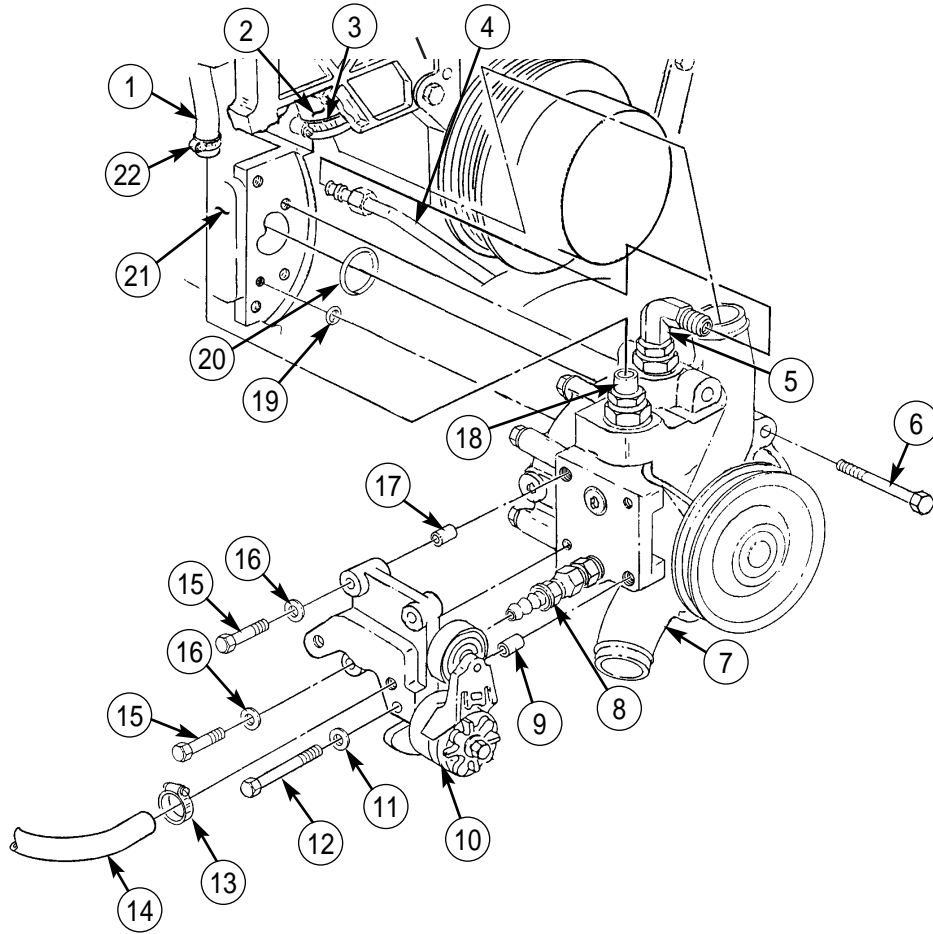

WATER PUMP REPLACEMENT (Contd)

13. Install tensioner plate (11), washer (4), washer (9), screw (5), and screw (8) on engine (10) and finger-tighten screws (5) and (8).

NOTE

Crankshaft pulley is located behind vibration dampener.

14. Install drivebelt (6) on tensioner pulley (7), water pump pulley (1), and crankshaft pulley (3).
15. Insert breaker bar in square slot (2) of tensioner plate (11) and rotate tensioner plate (11) clockwise to set drivebelt (6) to proper tension.
16. Adjust drivebelt (6) for proper tension and tighten screws (5) and (8).
17. Install lower radiator hose (14) on water pump (12) with clamp (13).
18. Install bracket (18) on alternator mounting plate (15) with two new lockwashers (19) and screws (20).
19. Install alternator (21) on bracket (18) with two new lockwashers (16) and screws (17).
20. Install new lockwasher (22) and screw (23) on bracket (24) and alternator (21).

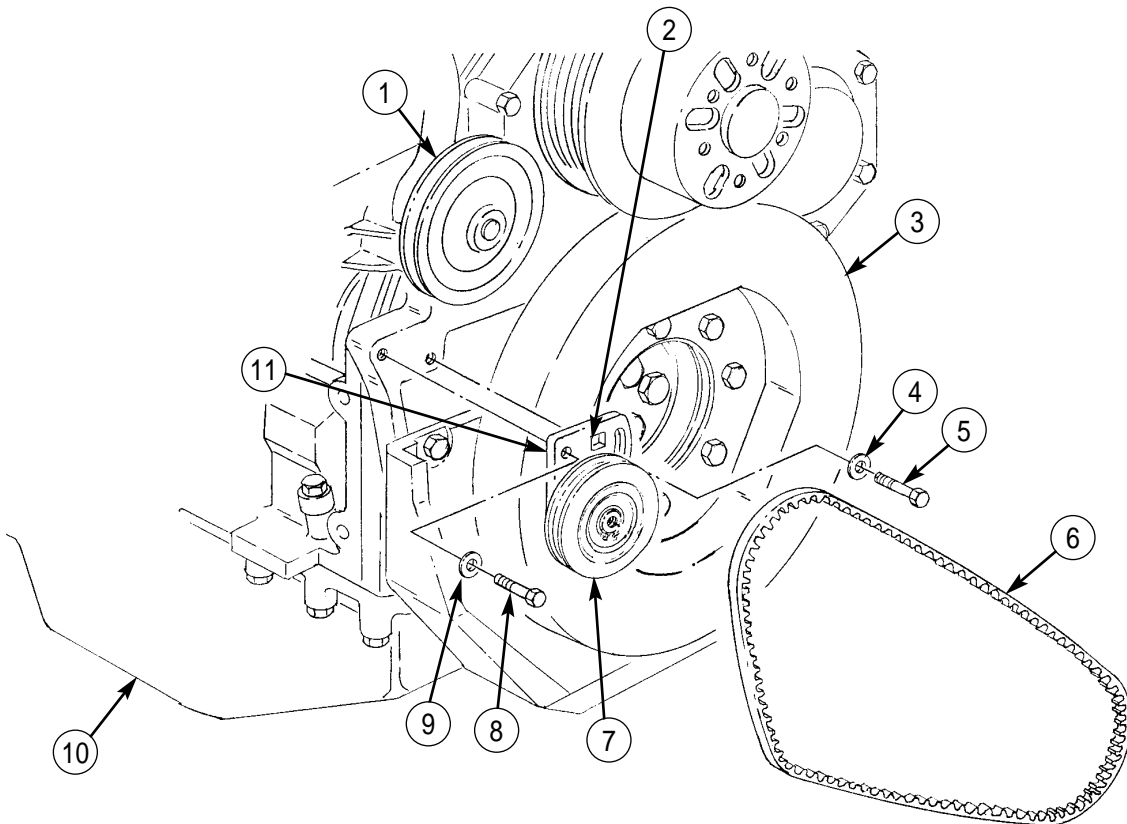

WATER PUMP REPLACEMENT (Contd)

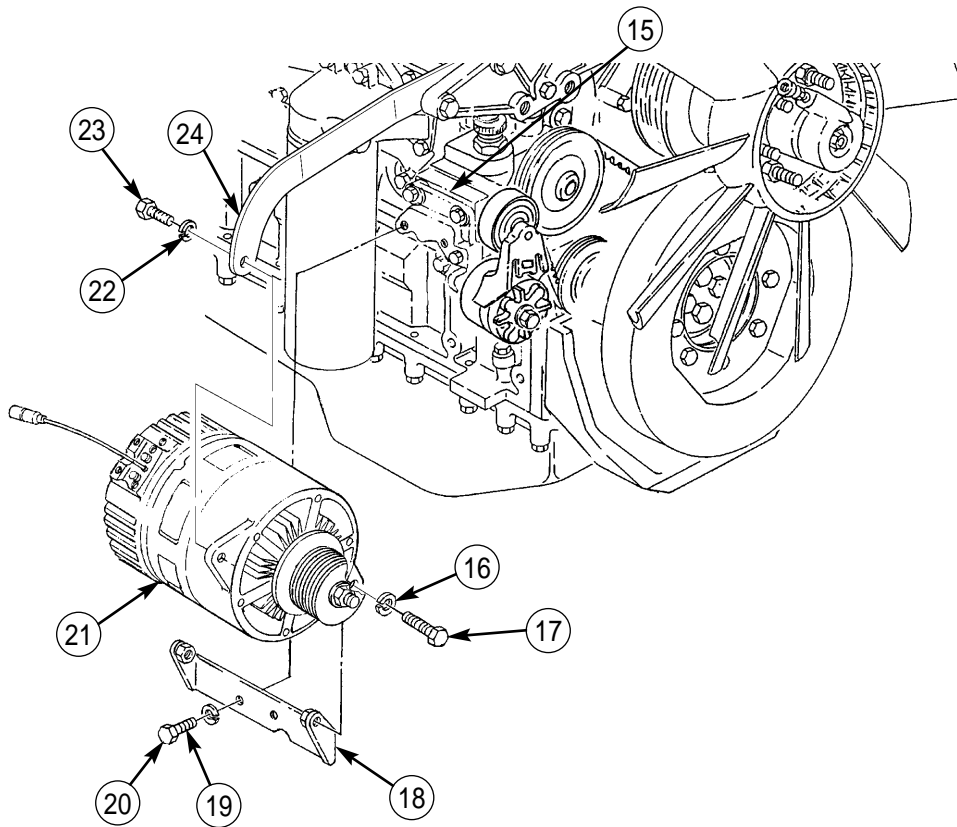
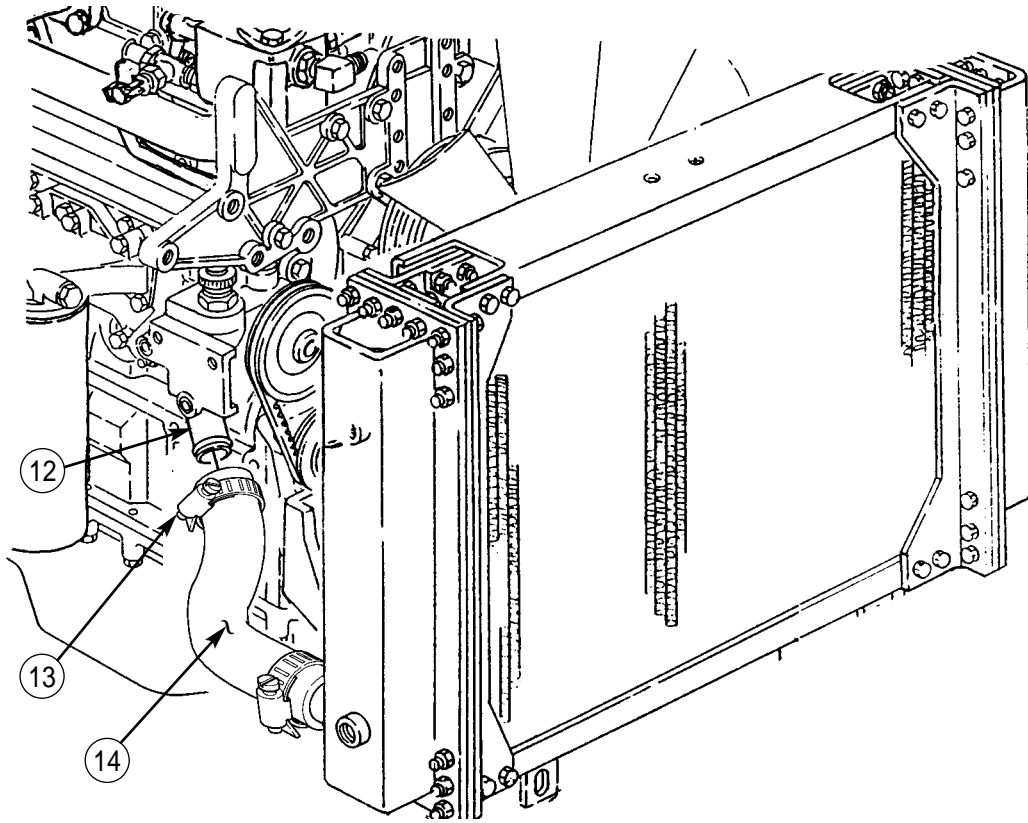

WATER PUMP REPLACEMENT (Contd)**NOTE**

Vehicles may come equipped with a Leece-Neville or Prestolite alternator. STE/ICE-R wiring harness leads are connected to negative and positive posts on either alternator.

21. Connect lead 568 (17) to Y-connector (16).
22. Install STE/ICE-R harness lead 770-N (12) and positive lead 2 (11) on stud (13) with new lockwasher (10) and nut (9). Tighten nut (9) 45-55 lb-in. (5.1-6.2 N•m).

NOTE

Perform steps 23 and 24 for Prestolite alternators only.

23. Install plate (3) on alternator (14) with two new lockwashers (2) and screws (1). Tighten screws (1) 30-35 lb-in. (3.4-3.9 N•m).
24. Install cover plate (7) on alternator (14) with two new assembled-washer screws (8).

NOTE

Perform step 25 for Leece-Neville alternators only.

25. Fill cover plate (7) or alternator wiring area with sealing compound and install cover plate (7) on alternator (14) with two new lockwashers (19) and screws (18). Tighten screws (18) 30-35 lb-in. (3.4-3.9 N•m).
26. Install ground (GND) lead (4) and STE/ICE-R harness lead 770-P (15) on alternator (14) with new lockwasher (5) and screw (6). Tighten screw (6) 83-102 lb-in. (9.4-11.5 N•m).
27. Using a breaker bar, rotate belt tensioner (24) counterclockwise.
28. Install fan drivebelt (22) on fan pulley (21), crankshaft pulley (23), and alternator pulley (20).
29. Release belt tensioner (24).
30. Connect battery ground cable (WP 0121 00).
31. Fill radiator to proper level (WP 0068 00).

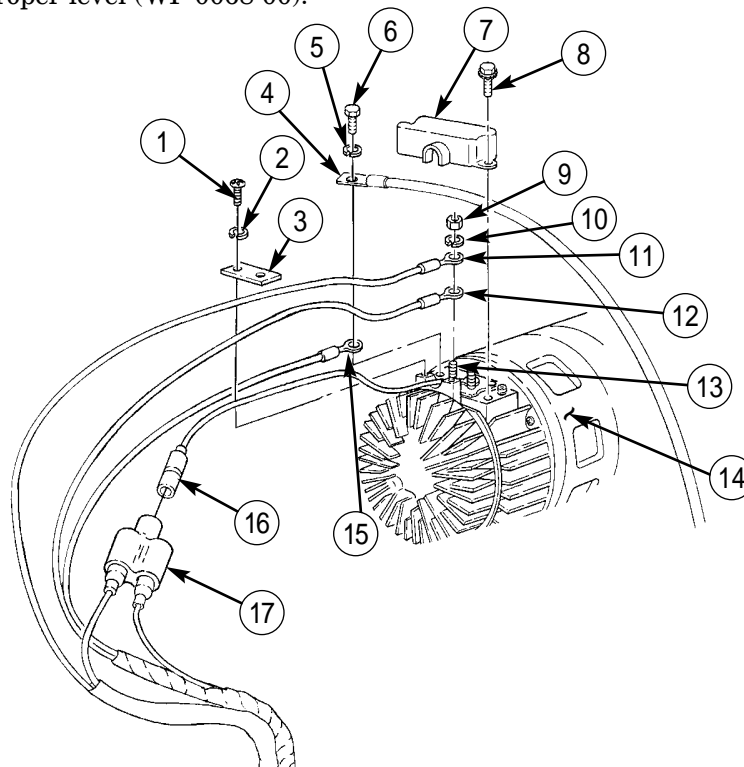
**PRESTOLITE**

WATER PUMP REPLACEMENT (Contd)

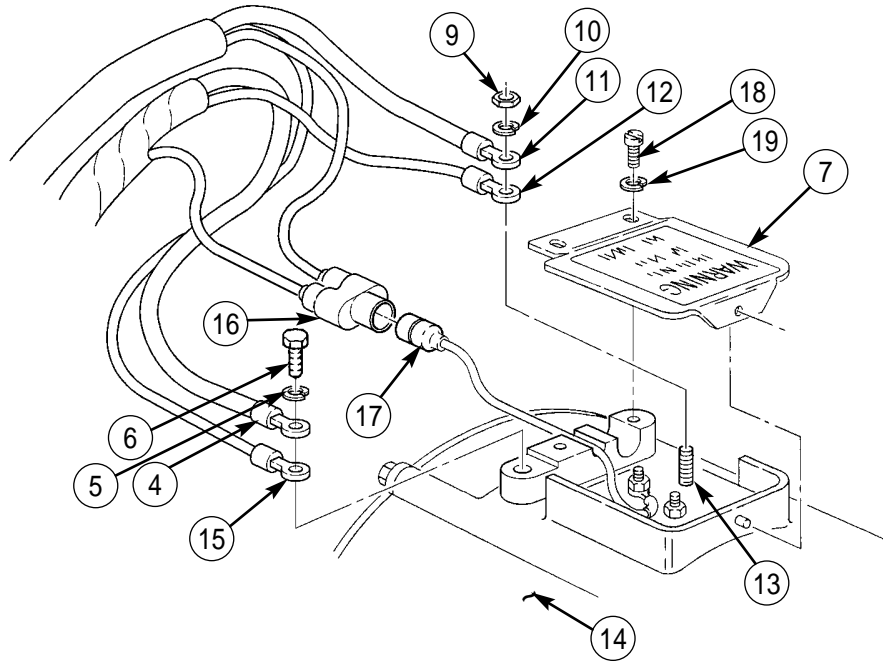

LEECE-NEVILLE

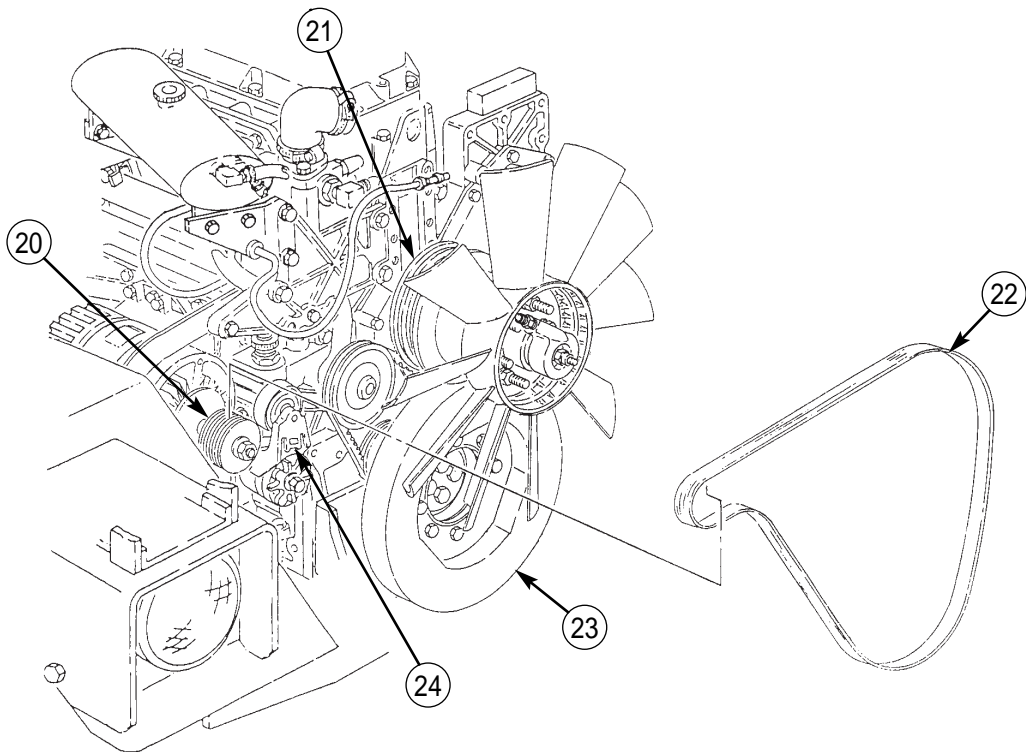

END OF WORK PACKAGE

UNIT MAINTENANCE INSTRUCTIONS

EXTENDED SERVICE PROGRAM (ESP)

TRUCK, CARGO, 2-1/2-TON, 6X6, M44A3 SERIES TRUCKS (DIESEL)

M35A3, W/O WINCH (NSN 2320-01-383-2047); W/WINCH (NSN 2320-01-383-3850);
M35A3C, W/O WINCH (NSN 2320-01-383-2050); W/WINCH (NSN 2320-01-383-2049);
M36A3, W/O WINCH (NSN 2320-01-383-2048); W/WINCH (NSN 2320-01-383-2046).

WATER PUMP DRIVEBELT MAINTENANCE

REMOVAL, INSPECTION, INSTALLATION, ADJUSTMENT

INITIAL SETUP:

Tools and Special Tools

General mechanic's tool kit
(item 30, WP 0394 00)
Common No. 1 tool kit
(item 15, WP 0394 00)

Equipment Condition

Parking brake set (TM 9-2320-386-10).
Hood raised and secured (TM 9-2320-386-10).
Fan drivebelt removed (WP 0084 00).

References

TM 9-2320-386-24P

WATER PUMP DRIVEBELT MAINTENANCE (Contd)

REMOVAL

1. Loosen screws (5) and (11) and rotate tensioner plate (14) counterclockwise to relieve tension from drivebelt (6).

NOTE

Crankshaft pulley is located behind vibration dampener.

2. Remove drivebelt (6) from tensioner pulley (8), water pump pulley (1), and crankshaft pulley (3).
3. Remove screws (5) and (11), washers (4) and (12), and tensioner plate (14) from engine (13).
4. Remove snapping (7), tensioner pulley (8), and bearing (9) from shaft (10).

INSPECTION

1. Inspect drivebelt (6) for frays, cracks, or excessive wear. Replace drivebelt (6) if damaged.
2. Inspect bearing (9) for wear or damage. Replace bearing (9) if worn or damaged.

INSTALLATION

1. Install bearing (9) and tensioner pulley (8) on shaft (10) with snapping (7).
2. Install tensioner plate (14) on engine (13) with washers (12) and (4) and screws (11) and (5). Fingertighten screws (5) and (11).
3. Install drivebelt (6) on tensioner pulley (8), water pump pulley (1), and crankshaft pulley (3).
4. Insert breaker bar in square slot (2) of tensioner plate (14), and rotate tensioner plate (14) clockwise to set drivebelt (6) to proper tension.
5. Tighten screws (5) and (11).

ADJUSTMENT

1. Place thumb and forefinger around drivebelt (6), and rotate drivebelt (6) 90 degrees.
2. If drivebelt (6) rotates 90 degrees, tension is correct.
3. If drivebelt (6) rotates less than 90 degrees, tension is too tight. Go to step 5.
4. If drivebelt (6) rotates more than 90 degrees, tension is too loose. Go to step 5.
5. Loosen screws (5) and (11).
6. Insert breaker bar in square slot (2) of tensioner plate (14), and rotate tensioner plate (14) clockwise to increase tension, or counterclockwise to decrease tension on drivebelt (6).
7. Tighten screws (5) and (11).
8. Install fan drivebelt (WP 0084 00).

WATER PUMP DRIVEBELT MAINTENANCE (Contd)

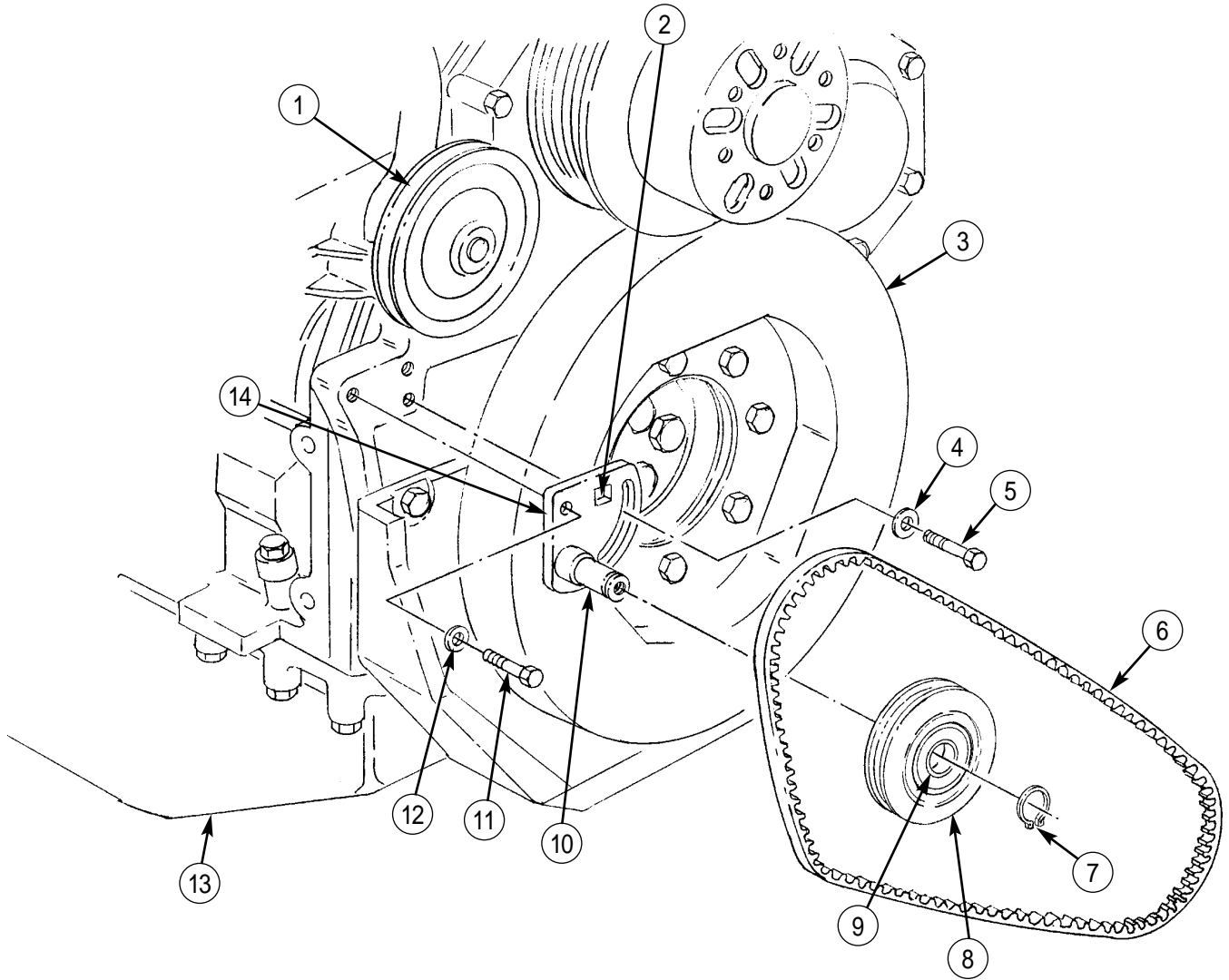

END OF WORK PACKAGE

UNIT MAINTENANCE INSTRUCTIONS

EXTENDED SERVICE PROGRAM (ESP)

TRUCK, CARGO, 2-1/2-TON, 6X6, M44A3 SERIES TRUCKS (DIESEL)

M35A3, W/O WINCH (NSN 2320-01-383-2047); W/WINCH (NSN 2320-01-383-3850);

M35A3C, W/O WINCH (NSN 2320-01-383-2050); W/WINCH (NSN 2320-01-383-2049);

M36A3, W/O WINCH (NSN 2320-01-383-2048); W/WINCH (NSN 2320-01-383-2046).

FAN AND FAN CLUTCH REPLACEMENT

REMOVAL, INSTALLATION

INITIAL SETUP:

Tools and Special Tools

General mechanic's tool kit
(item 30, WP 0394 00)

Materials/Parts

Six lockwashers (item 219, WP 0395 00)

Equipment Condition

Parking brake set (TM 9-2320-386-10).
Hood raised and secured (TM 9-2320-386-10).
Fan actuator removed (WP 0085 00).
Radiator removed (WP 0069 00).
Fan drivebelt removed (WP 0084 00).

References

TM 9-2320-386-24P

FAN AND FAN CLUTCH REPLACEMENT (Contd)

REMOVAL

NOTE

Mark front of fan for proper installation.

1. Remove six nuts (5), lockwashers (4), washers (3), and fan (2) from clutch (1). Discard lockwashers (4).
2. Install cylinder assembly (12) on actuator hub (6) with washer (13) and locknut (14).
3. Install fan actuator tube (7) with sleeve (9) and insert (10) on fitting (11) and tighten nut (8).
4. Disconnect air actuator tube (15) and reducer (16) from tee (17).

CAUTION

Compressed air source will not exceed 110 psi (758 kPa). When applying compressed air to fan actuator, eyeshields must be worn. Failure to do so may result in injury to personnel.

NOTE

Ensure engine temperature is below 180°F (82°C) prior to applying air pressure to release clutch.

To gain access to clutch screws, 96-110 psi (662-758 kPa) of compressed air must be applied to clutch to allow for free rotation during removal.

5. Apply air pressure to reducer (16) and turn clutch (1) until slots are aligned with screws (20).
6. Loosen nut (8) and remove fan actuator tube (7), sleeve (9), and insert (10) from fitting (11).
7. Remove locknut (14), washer (13), and cylinder assembly (12) from actuator hub (6). Discard locknut (14).
8. Remove six screws (20), clutch (1), and adapter plate (19) from fan mount (18).
9. Connect reducer (16) and air actuator tube (15) to tee (17).

INSTALLATION

1. Install adapter plate (19) and clutch (1) on fan mount (18) with six screws (20).
2. Install fan (2) on clutch (1) with six washers (3), new lockwashers (4), and nuts (5).
3. Install fan drivebelt (WP 0084 00).
4. Install radiator (WP 0069 00).
5. Install fan actuator (WP 0085 00).

FAN AND FAN CLUTCH REPLACEMENT (Contd)

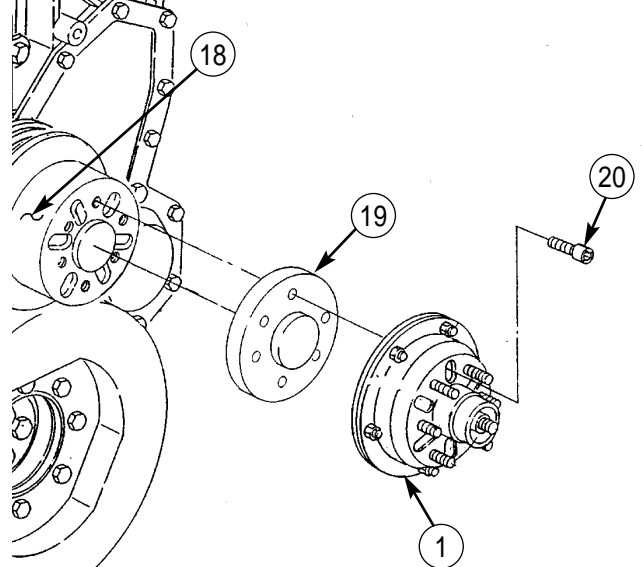
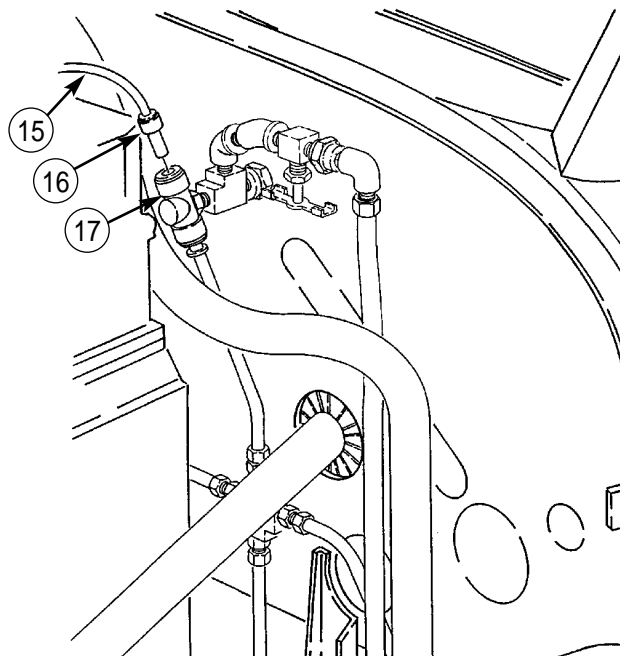
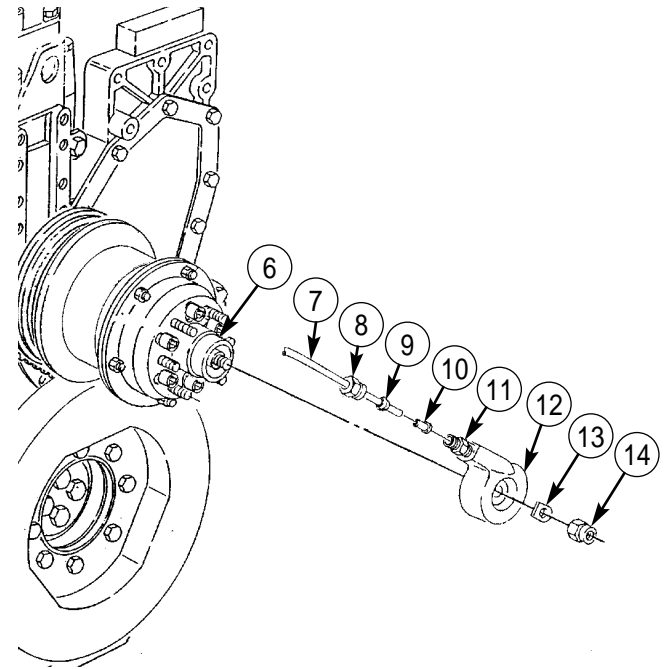
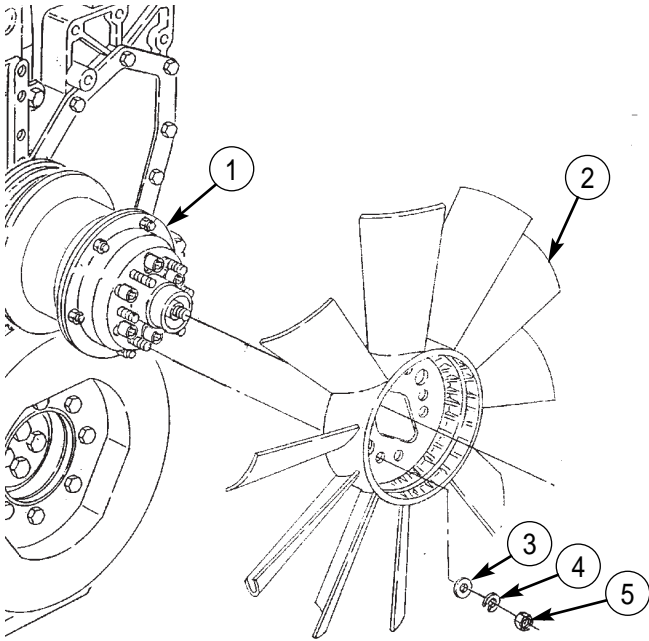

END OF WORK PACKAGE

UNIT MAINTENANCE INSTRUCTIONS

EXTENDED SERVICE PROGRAM (ESP)

TRUCK, CARGO, 2-1/2-TON, 6X6, M44A3 SERIES TRUCKS (DIESEL)

M35A3, W/O WINCH (NSN 2320-01-383-2047); W/WINCH (NSN 2320-01-383-3850);

M35A3C, W/O WINCH (NSN 2320-01-383-2050); W/WINCH (NSN 2320-01-383-2049);

M36A3, W/O WINCH (NSN 2320-01-383-2048); W/WINCH (NSN 2320-01-383-2046).

SHUTTERSTAT AIR VALVE REPLACEMENT

REMOVAL, INSTALLATION

INITIAL SETUP:

Tools and Special Tools

General mechanic's tool kit
(item 30, WP 0394 00)

Materials/Parts

Teflon pipe sealant (item 41, WP 0393 00)

References

TM 9-2320-386-24P

Equipment Condition

Parking brake set (TM 9-2320-386-10).
Hood raised and secured (TM 9-2320-386-10).
Air reservoirs drained (TM 9-2320-386-10).
Coolant system drained (WP 0068 00).

SHUTTERSTAT AIR VALVE REPLACEMENT (Contd)

REMOVAL

1. Loosen two nuts (2) and remove air actuator tubes (1) from elbows (3) on shutterstat air valve (4).
2. Remove two elbows (3) from shutterstat air valve (4).
3. Remove shutterstat air valve (4) from water regulator housing (5).

INSTALLATION

1. Apply sealant to male threads of two elbows (3) and shutterstat air valve (4).
2. Install shutterstat air valve (4) on water regulator housing (5).
3. Install two elbows (3) on shutterstat air valve (4).
4. Install two air actuator tubes (1) on elbows (3) on shutterstat air valve (4) and tighten nuts (2).
5. Fill engine coolant system to proper level (WP 0068 00).

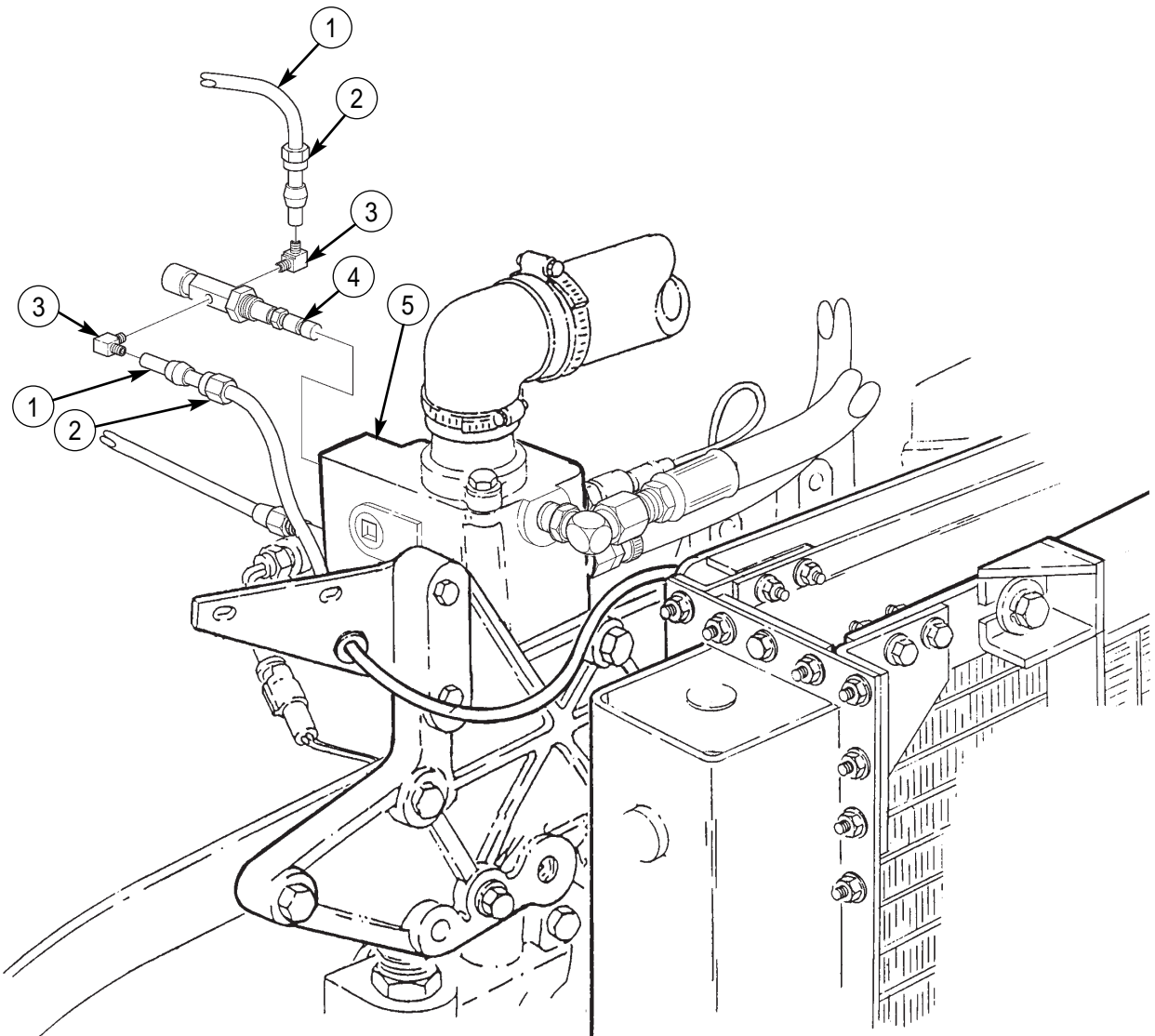

END OF WORK PACKAGE

UNIT MAINTENANCE INSTRUCTIONS

EXTENDED SERVICE PROGRAM (ESP)

TRUCK, CARGO, 2-1/2-TON, 6X6, M44A3 SERIES TRUCKS (DIESEL)

M35A3, W/O WINCH (NSN 2320-01-383-2047); W/WINCH (NSN 2320-01-383-3850);
M35A3C, W/O WINCH (NSN 2320-01-383-2050); W/WINCH (NSN 2320-01-383-2049);
M36A3, W/O WINCH (NSN 2320-01-383-2048); W/WINCH (NSN 2320-01-383-2046).

FAN DRIVEBELT MAINTENANCE

REMOVAL, INSPECTION, INSTALLATION

INITIAL SETUP:

Tools and Special Tools

General mechanic's tool kit
(item 30, WP 0394 00)

Equipment Condition

Parking brake set (TM 9-2320-386-10).
Hood raised and secured (TM 9-2320-386-10).
Air reservoirs drained (TM 9-2320-386-10).

References

TM 9-2320-386-24P

FAN DRIVEBELT MAINTENANCE (Contd)**REMOVAL**

1. Loosen nut (4) and remove fan actuator tube (1) with insert (3) from fan actuator (2).
2. Using a breaker bar, rotate belt tensioner (8) counterclockwise to relieve belt tension.

NOTE

Crankshaft pulley is located behind vibration damper.

3. Remove fan drivebelt (6) from alternator pulley (9), crankshaft pulley (7), and fan pulley (5).
4. Release belt tensioner (8).

INSPECTION

Inspect fan drivebelt (6) for cracks, frays, or excessive wear. Replace fan drivebelt (6) if damaged.

INSTALLATION

1. Using a breaker bar, rotate belt tensioner (8) counterclockwise.
2. Install fan drivebelt (6) on fan pulley (5), crankshaft pulley (7), and alternator pulley (9).
3. Release belt tensioner (8).
4. Install fan actuator tube (1) with insert (3) on fan actuator (2) and tighten nut (4).

FAN DRIVEBELT MAINTENANCE (Contd)

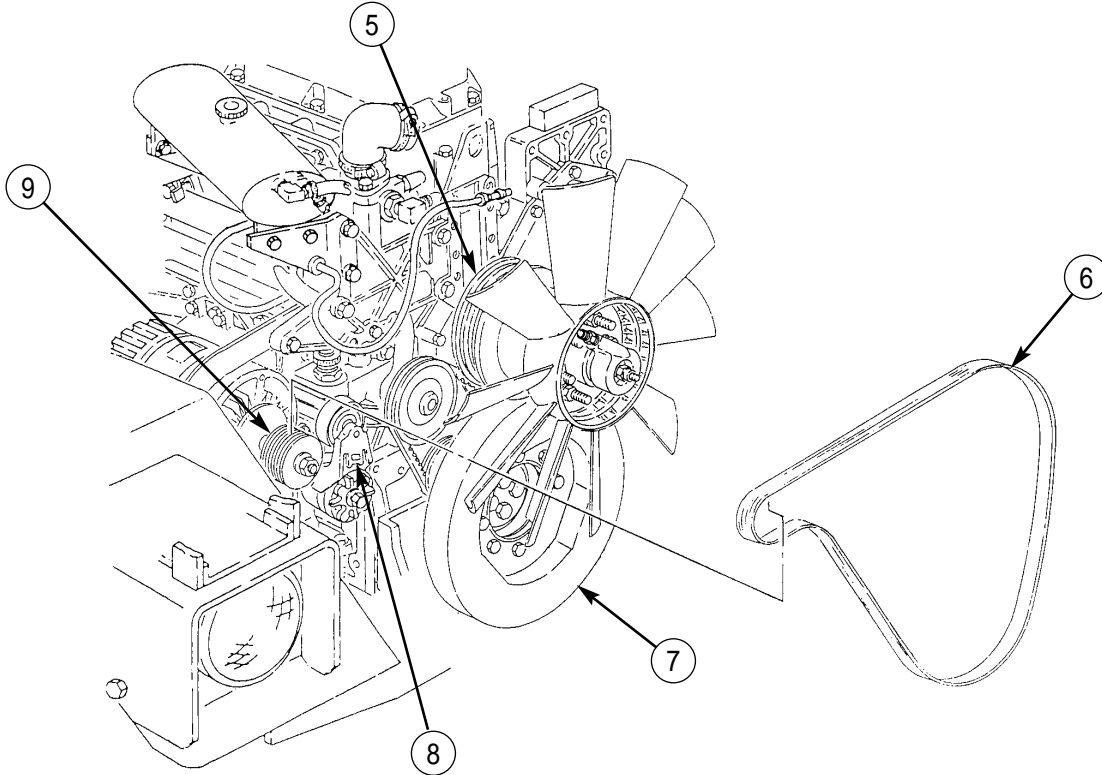
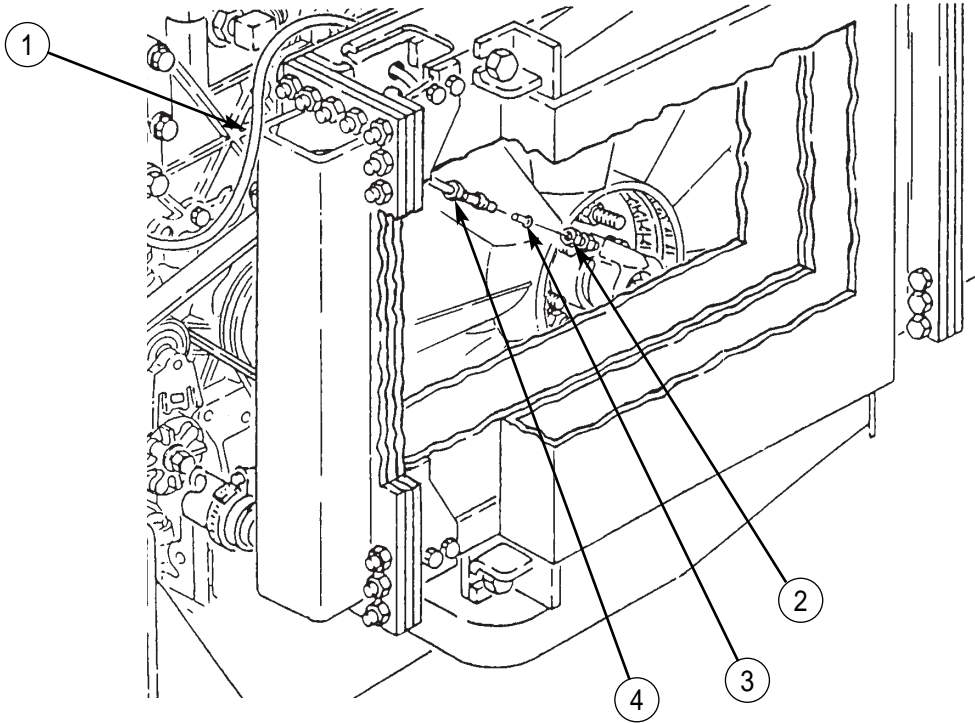

END OF WORK PACKAGE

UNIT MAINTENANCE INSTRUCTIONS

EXTENDED SERVICE PROGRAM (ESP)

TRUCK, CARGO, 2-1/2-TON, 6X6, M44A3 SERIES TRUCKS (DIESEL)

**M35A3, W/O WINCH (NSN 2320-01-383-2047); W/WINCH (NSN 2320-01-383-3850);
M35A3C, W/O WINCH (NSN 2320-01-383-2050); W/WINCH (NSN 2320-01-383-2049);
M36A3, W/O WINCH (NSN 2320-01-383-2048); W/WINCH (NSN 2320-01-383-2046).**

FAN ACTUATOR REPLACEMENT

REMOVAL, INSTALLATION

INITIAL SETUP:

Tools and Special Tools

General mechanic's tool kit
(item 30, WP 0394 00)
Common No. 1 tool kit
(item 15, WP 0394 00)

Materials/Parts

Locknut (item 218, WP 0395 00)

References

TM 9-2320-386-24P

Equipment Condition

Parking brake set (TM 9-2320-386-10).
Hood raised and secured (TM 9-2320-386-10).

FAN ACTUATOR REPLACEMENT (Contd)

REMOVAL

1. Loosen nut (3) and remove fan actuator tube (2) with insert (5) and sleeve (4) from fitting (6) on cylinder assembly (7).
2. Remove locknut (9), washer (8), and cylinder assembly (7) from actuator hub (1). Discard locknut (9).

INSTALLATION

1. Install cylinder assembly (7) on actuator hub (1) with washer (8) and new locknut (9). Tighten locknut (9) 84 lb-in (10 N•m).
2. Install fan actuator tube (2) with insert (5) and sleeve (4) on fitting (6) and tighten nut (3).
3. Start engine (TM 9-2320-386-10) and allow air pressure to build up to normal operating pressure. Check for air leaks and road test vehicle.

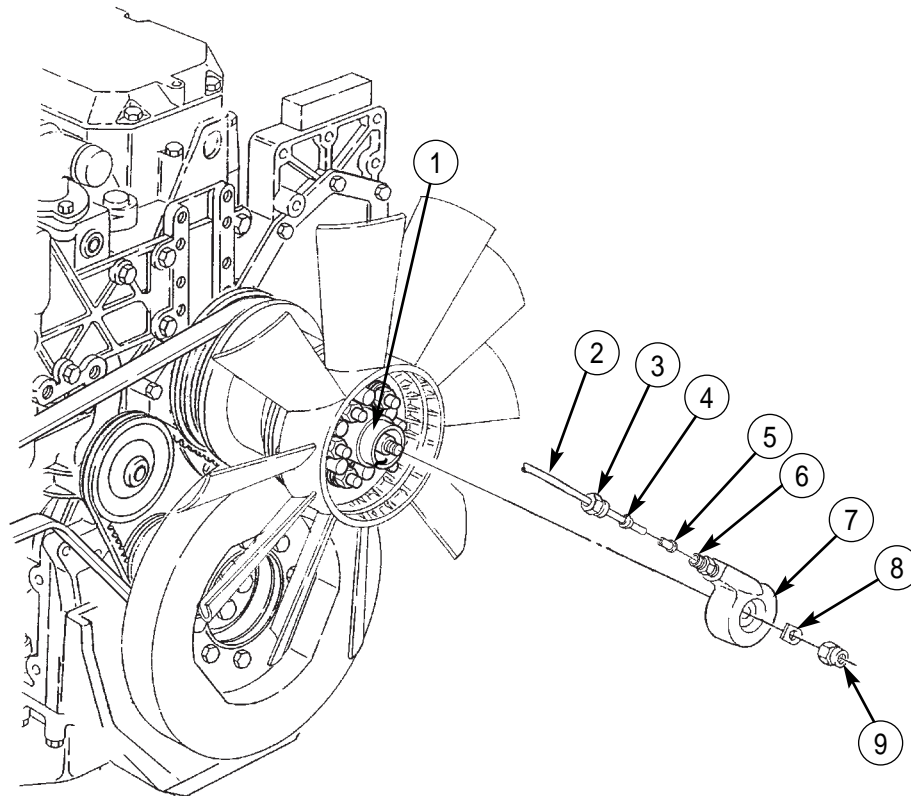

END OF WORK PACKAGE

UNIT MAINTENANCE INSTRUCTIONS

EXTENDED SERVICE PROGRAM (ESP)

TRUCK, CARGO, 2-1/2-TON, 6X6, M44A3 SERIES TRUCKS (DIESEL)

M35A3, W/O WINCH (NSN 2320-01-383-2047); W/WINCH (NSN 2320-01-383-3850);

M35A3C, W/O WINCH (NSN 2320-01-383-2050); W/WINCH (NSN 2320-01-383-2049);

M36A3, W/O WINCH (NSN 2320-01-383-2048); W/WINCH (NSN 2320-01-383-2046).

FAN ACTUATOR TUBE MAINTENANCE

REMOVAL, INSPECTION, INSTALLATION

INITIAL SETUP:

Tools and Special Tools

General mechanic's tool kit
(item 30, WP 0394 00)

Equipment Condition

Parking brake set (TM 9-2320-386-10).
Hood raised and secured (TM 9-2320-386-10).
Air reservoir drained (TM 9-2320-386-10).

References

TM 9-2320-386-24P

FAN ACTUATOR TUBE MAINTENANCE (Contd)

REMOVAL

1. Loosen nut (7) and remove fan actuator tube (2) with insert (8) from elbow (1).
2. Loosen nut (13) and remove fan actuator tube (2) with insert (11) from fan actuator fitting (10).
3. Remove screw (15) and clamp (14) from actuator tube (2) and bracket (9).
4. Remove fan actuator tube (2) and grommets (3) and (5) from upper radiator shroud (4) and surge tank support bracket (6).

INSPECTION

1. Inspect fan actuator fitting (10), elbow (1), compression sleeve (12), inserts (8) and (11), and fan actuator tube (2) for damage. Replace fan actuator fitting (10) or elbow (1) if tube inserts (8) and (11) or compression sleeve (12) are damaged.
2. Refer to WP 0167 00, Compressed Air Tubes Repair, if necessary.

INSTALLATION

1. Install fan actuator tube (2) and grommets (5) and (3) in surge tank bracket (6) and upper radiator shroud (4).
2. Install fan actuator tube (2) with insert (8) on elbow (1) and tighten nut (7).
3. Install fan actuator tube (2) with insert (11) on fan actuator fitting (10) and tighten nut (13).

CAUTION

Fan air actuator tube must hang loosely between surge tank bracket and upper radiator shroud to prevent breakage.

NOTE

Ensure fan actuator tube has a 1/2-in. (12.7 mm) deflection between clamp and fan actuator.

4. Pull fan actuator tube (2) until one-half inch deflection is felt in fan actuator tube (2) at fan actuator (10).
5. Install fan actuator tube (2) on bracket (9) with clamp (14) and screw (15).
6. Start engine (TM 9-2320-386-10). Allow air pressure to build up to normal operating air pressure. Check fan for proper operation.

FAN ACTUATOR TUBE MAINTENANCE (Contd)

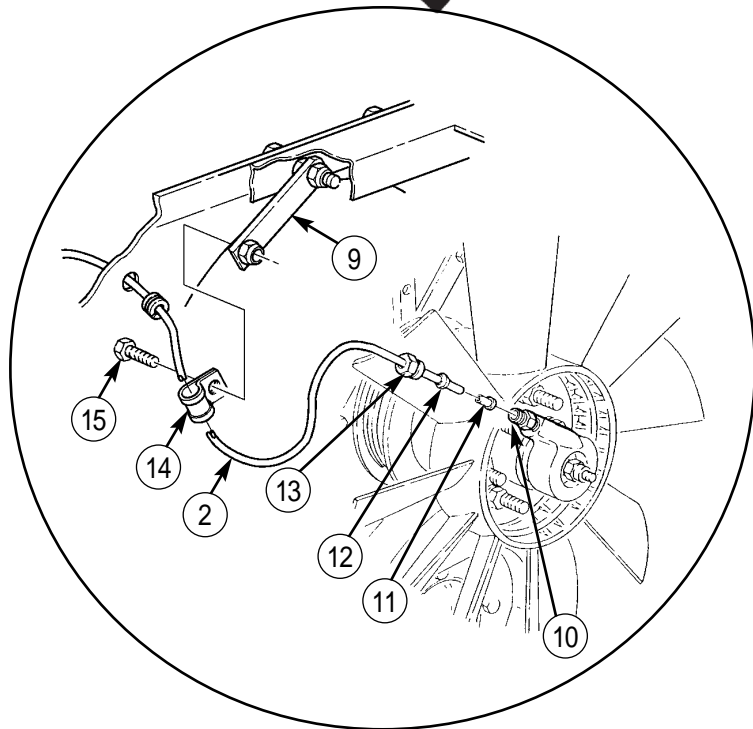
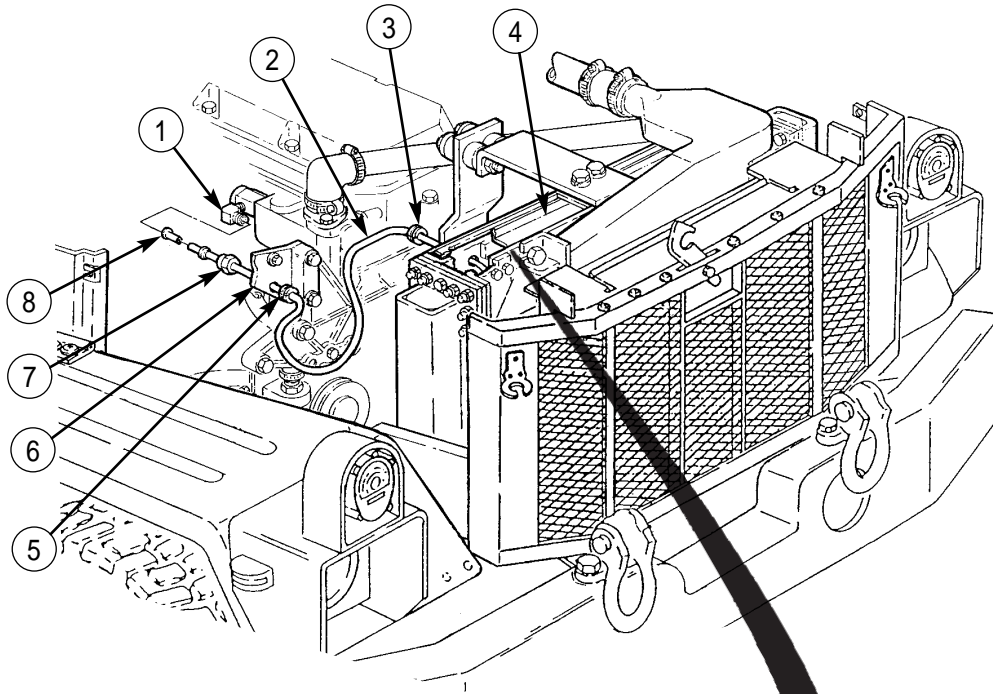

END OF WORK PACKAGE

UNIT MAINTENANCE INSTRUCTIONS

EXTENDED SERVICE PROGRAM (ESP)

TRUCK, CARGO, 2-1/2-TON, 6X6, M44A3 SERIES TRUCKS (DIESEL)

**M35A3, W/O WINCH (NSN 2320-01-383-2047); W/WINCH (NSN 2320-01-383-3850);
M35A3C, W/O WINCH (NSN 2320-01-383-2050); W/WINCH (NSN 2320-01-383-2049);
M36A3, W/O WINCH (NSN 2320-01-383-2048); W/WINCH (NSN 2320-01-383-2046).**

ENGINE DRIVEBELT TENSIONER REPLACEMENT

REMOVAL, INSTALLATION

INITIAL SETUP:

Tools and Special Tools

General mechanic's tool kit
(item 30, WP 0394 00)

Equipment Condition

Parking brake set (TM 9-2320-386-10).
Hood raised and secured (TM 9-2320-386-10).

References

TM 9-2320-386-24P

ENGINE DRIVEBELT TENSIONER REPLACEMENT (Contd)**REMOVAL**

1. Place breaker bar in square slot of drivebelt tensioner (6).
2. Rotate drivebelt tensioner (6) away from fan drivebelt (3) and remove fan drivebelt (3) from alternator (8).
3. Release drivebelt tensioner (6).
4. Remove screw (4), washer (5), and drivebelt tensioner (6) from engine (7).

INSTALLATION**CAUTION**

Ensure locator pin on drivebelt tensioner is installed in locator pin hole on drivebelt tensioner bracket.

1. Install drivebelt tensioner (6) on engine (7) with washer (5) and screw (4).

NOTE

Ensure fan drivebelt is aligned on all pulleys.

2. Install fan drivebelt (3) on alternator (8), fan pulley (1), and crankshaft pulley (2).
3. Place breaker bar in square slot of drivebelt tensioner (6).
4. Rotate drivebelt tensioner (6) away from fan drivebelt (3) and install fan drivebelt (3) over drivebelt tensioner (6).
5. Release drivebelt tensioner (6).
6. Start engine (TM 9-2320-386-10) and check fan drivebelt alignment.

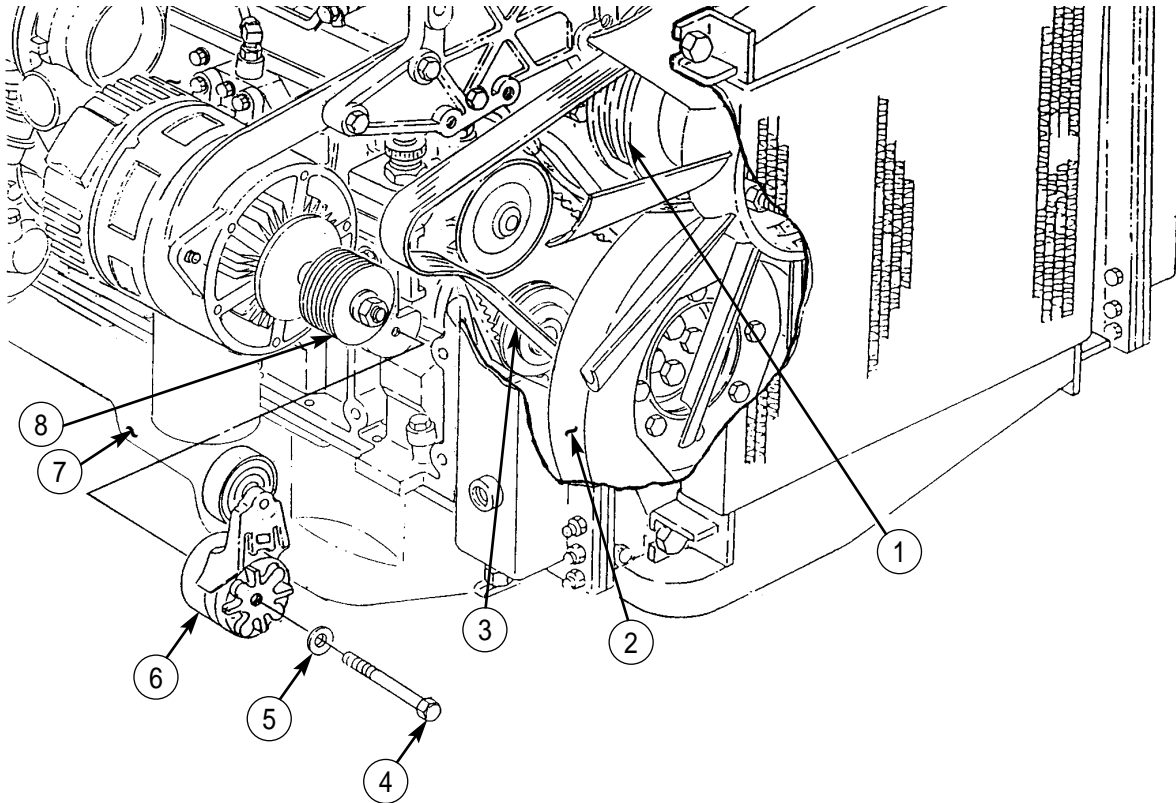

END OF WORK PACKAGE

UNIT MAINTENANCE INSTRUCTIONS

EXTENDED SERVICE PROGRAM (ESP)

TRUCK, CARGO, 2-1/2-TON, 6X6, M44A3 SERIES TRUCKS (DIESEL)

M35A3, W/O WINCH (NSN 2320-01-383-2047); W/WINCH (NSN 2320-01-383-3850);

M35A3C, W/O WINCH (NSN 2320-01-383-2050); W/WINCH (NSN 2320-01-383-2049);

M36A3, W/O WINCH (NSN 2320-01-383-2048); W/WINCH (NSN 2320-01-383-2046).

Section VIII. ELECTRICAL SYSTEM MAINTENANCE

TABLE OF CONTENTS

<i>WP Title</i>	<i>WP Sequence No.-Page No.</i>
Alternator (Prestolite) Maintenance	0089 00-1
Alternator (Leece-Neville) Maintenance	0090 00-1
Starter Motor Replacement	0091 00-1
Starter Relay Replacement	0092 00-1
Starter Switch Replacement	0093 00-1
Instrument Cluster Maintenance	0094 00-1
Tachometer Replacement	0095 00-1
Transmission Oil Temperature Gauge Replacement	0096 00-1
Magnetic Speed Sensor Replacement	0097 00-1
Transmission Neutral Safety Switch Replacement	0098 00-1
Transmission Backup Light Switch Replacement	0099 00-1
Engine Oil Pressure Transducer Replacement	0100 00-1
Engine and Transmission Ground Straps Replacement	0101 00-1
Parking Brake Light Switch Replacement	0102 00-1
Fuel Shutoff Switch Replacement	0103 00-1
Quick-Start Switch Replacement	0104 00-1
Blackout Drive Lamp and Housing Replacement	0105 00-1
Front and Rear Composite Lights and Lamps Replacement	0106 00-1
Headlights and Headlamps Maintenance	0107 00-1
Front Side Marker Lights and Lamps Replacement	0108 00-1
Headlight Mounting Bracket Replacement	0109 00-1
Backup Lights and Lamps Replacement	0110 00-1
Clearance and Rear Side Marker Lights and Lamps Replacement	0111 00-1
Rear Lights Bracket Replacement	0112 00-1
Rear Marker Light Bracket Replacement	0113 00-1

TABLE OF CONTENTS (Contd)

<i>WP Title</i>	<i>WP Sequence No.-Page No.</i>
Engine Temperature Transmitter Replacement	0114 00-1
Fuel Level Sending Unit Replacement	0115 00-1
Fuel Pressure Transducer Replacement	0116 00-1
Transmission Oil Temperature Sensor Replacement	0117 00-1
Low Air Pressure Switch Replacement	0118 00-1
Air Horn Replacement	0119 00-1
NATO Slave Receptacle Replacement	0120 00-1
Battery Cable and Clamps Replacement	0121 00-1
Battery Maintenance	0122 00-1
Battery Box Maintenance	0123 00-1
STE/ICE-R Shunt Replacement	0124 00-1
Electrical Wiring Harness Repair	0125 00-1
Rear Lighting Wiring Harness Replacement	0126 00-1
Wiper Motor Wiring Harness Replacement	0127 00-1
CTIS Controller-to-Signal Generator Wiring Harness Replacement	0128 00-1
CTIS Control Harness Replacement	0129 00-1
CTIS Manifold Power Harness Replacement	0130 00-1

END OF WORK PACKAGE

UNIT MAINTENANCE INSTRUCTIONS

EXTENDED SERVICE PROGRAM (ESP)

TRUCK, CARGO, 2-1/2-TON, 6X6, M44A3 SERIES TRUCKS (DIESEL)

M35A3, W/O WINCH (NSN 2320-01-383-2047); W/WINCH (NSN 2320-01-383-3850);

M35A3C, W/O WINCH (NSN 2320-01-383-2050); W/WINCH (NSN 2320-01-383-2049);

M36A3, W/O WINCH (NSN 2320-01-383-2048); W/WINCH (NSN 2320-01-383-2046).

ALTERNATOR (PRESTOLITE) MAINTENANCE

REMOVAL, INSTALLATION, TEST, ADJUSTMENT

INITIAL SETUP:

Tools and Special Tools

Multimeter (item 45, WP 0394 00)

General mechanic's tool kit
(item 30, WP 0394 00)

Common No. 1 tool kit
(item 15, WP 0394 00)

Materials/Parts

Lockwasher (item 61, WP 0395 00)

Three lockwashers (item 62, WP 0395 00)

Two lockwashers (item 69, WP 0395 00)

Two locknuts (item 90, WP 0395 00)

Locknut (item 24, WP 0395 00)

Adhesive sealant (item 2, WP 0393 00)

Sealing compound (item 44, WP 0393 00)

Two assembled-washer screws
(item 274, WP 0395 00)

Two lockwashers (item 130, WP 0395 00)

Lockwasher (item 60, WP 0395 00)

Woodruff key (item 71, WP 0395 00)

References

TM 9-2320-386-24P

Equipment Condition

Parking brake set (TM 9-2320-386-10).

Hood raised and secured (TM 9-2320-386-10).

Battery ground cable disconnected (WP 0121 00).

Fan drivebelt removed (WP 0084 00).

ALTERNATOR (PRESTOLITE) MAINTENANCE (Contd)**REMOVAL****CAUTION**

Never operate the alternator with output terminal (POS) disconnected. Damage to alternator will result.

NOTE

Tag all wires for installation.

All waterproofing sealant must be removed from wires.

Locking hardware in steps 1 through 4 is provisioned with alternator.

1. Remove two assembled-washer screws (6) and cover plate (5) from block (13). Discard assembled-washer screws (6).
2. Remove two screws (1), lockwashers (18), and plate (17) from block (13). Discard lockwashers (18).
3. Remove nut (7), lockwasher (8), and leads 2 (9) and 770-N (10) from stud (11). Discard lockwasher (8).
4. Remove screw (4), lockwasher (3), ground (GND) lead (2), and STE/ICE-R harness lead 770-P (16) from block (13). Discard lockwasher (3).
5. Disconnect lead 568 (15) from Y-connector (14).
6. Remove screw (33) and lockwasher (32) from bracket (19) and alternator (12). Discard lockwasher (32).
7. Remove two screws (24), lockwashers (25), and alternator (12) from bracket (29). Discard lockwashers (25).
8. Remove two locknuts (20), screws (22), and bracket (19) from engine (21). Discard locknuts (20).
9. Remove two screws (30), lockwashers (31), and bracket (29) from engine (21). Discard lockwashers (31).
10. Remove locknut (27) and washer (28) from alternator (12). Discard locknut (27).
11. Using puller, remove pulley (23) from alternator (12).
12. Remove woodruff key (26) from alternator (12). Discard woodruff key (26).

ALTERNATOR (PRESTOLITE) MAINTENANCE (Contd)

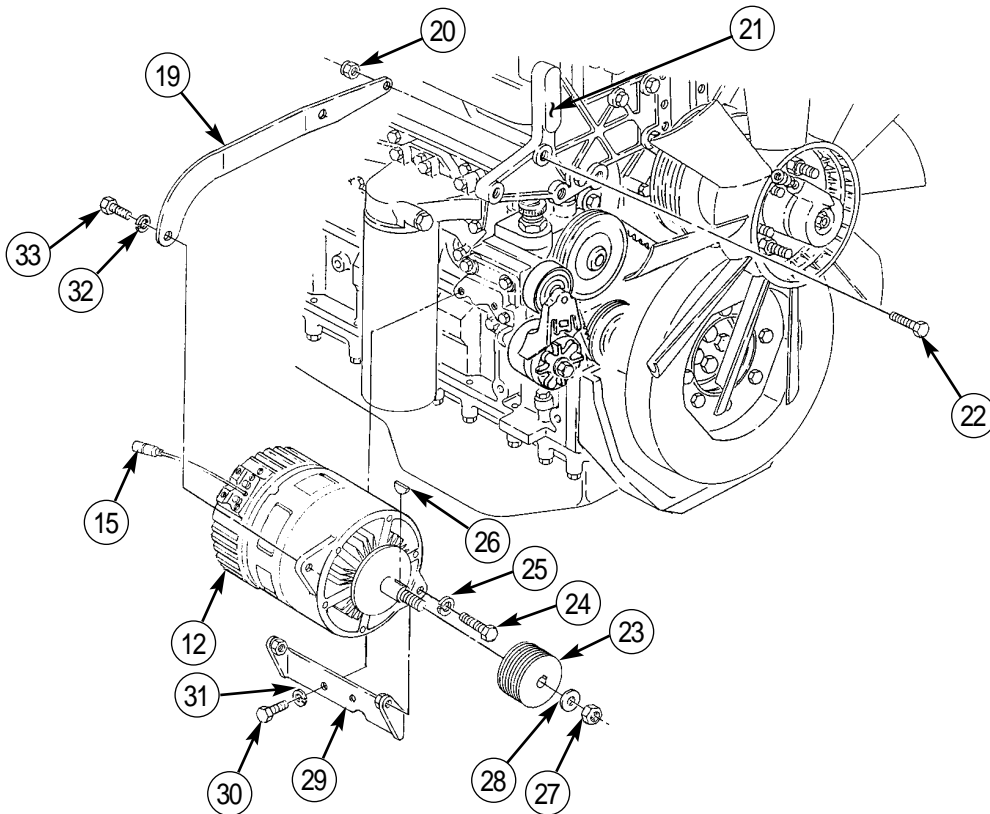
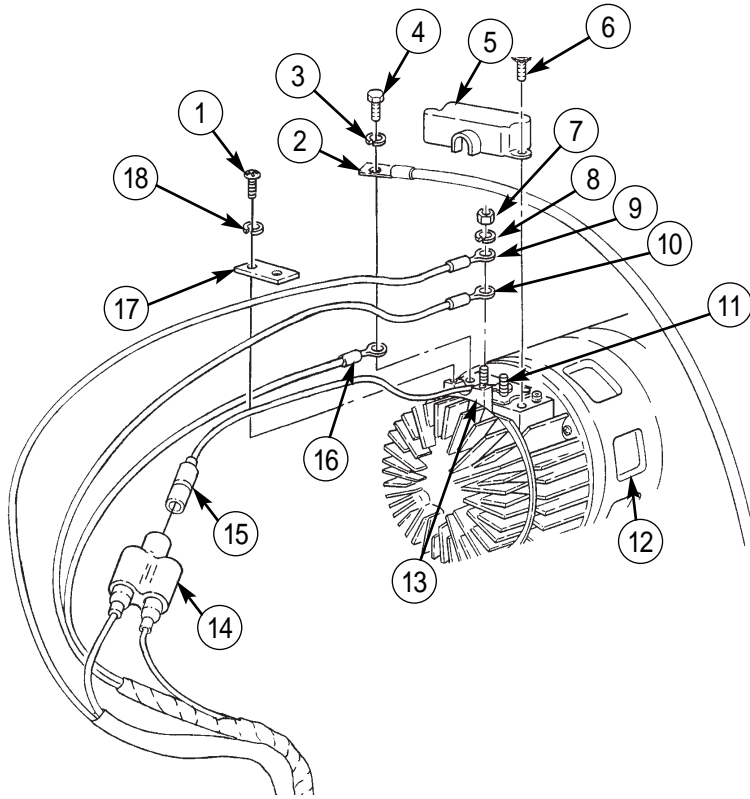

ALTERNATOR (PRESTOLITE) MAINTENANCE (Contd)**INSTALLATION****NOTE**

Ensure pulley is installed properly. Collar on pulley mounts toward rear of vehicle.

1. Install new woodruff key (10) and pulley (7) on alternator (14) with washer (6) and new locknut (5).
2. Install bracket (11) on engine (3) with two new lockwashers (13) and screws (12).
3. Install bracket (1) on engine (3) with two screws (4) and new locknuts (2).
4. Install alternator (14) on bracket (11) with two new lockwashers (9) and screws (8). Finger-tighten screws (8).
5. Secure bracket (1) to alternator (14) with new lockwasher (16) and screw (17).
6. Tighten two screws (8).

NOTE

Ensure wires and terminals are clean before connections are made.

7. Install leads 770-P (30) and ground (GND) (19) on block (29) with new lockwasher (20) and screw (21). Tighten screw (21) 82-102 lb-in. (9.4-11.5 N•m).
8. Install leads 770-N (27) and 2 (26) on stud (28) with new lockwasher (25) and nut (24). Tighten nut (24) 45-55 lb-in. (5.1-6.2 N•m).
9. Connect lead 568 (15) to Y-connector (31).
10. Install plate (32) on block (29) with two new lockwashers (33) and screws (18). Tighten screws (18) 30-35 lb-in. (3.4-3.9 N•m).
11. Connect battery ground cable (WP 0121 00).
12. Install fan drivebelt (WP 0084 00).

TEST

1. Start engine (TM 9-2320-386-10).
2. Set engine speed to 1200 rpm (TM 9-2320-386-10).
3. Turn on headlights (TM 9-2320-386-10) to place load on alternator.
4. Using multimeter, check alternator output voltage. Connect black lead to ground (GND) lead (19) and touch red lead to lead 2 (26). Output voltage should be 28.0 ± 0.2 VDC.
5. Turn off headlights (TM 9-2320-386-10).
6. Stop engine (TM 9-2320-386-10). If adjustment is required, continue to adjustment. If no adjustment is required, go to step 7.
7. Completely seal leads 568 (15), 770-P (30), ground (GND) (19), 2 (26), and 770-N (27), and two studs (28) with adhesive sealant.
8. Install cover plate (22) on block (29) with two new assembled-washer screws (23).

NOTE

If adjustment was performed, go to step 9.

9. Apply sealing compound to pipe plug (34) threads. Using hex-head driver, install pipe plug (34) and tighten 24-36 lb-in. (3-4 N•m).

ADJUSTMENT

1. Remove pipe plug (34) from alternator (14).
2. Turn adjusting screw counterclockwise to increase voltage or clockwise to decrease voltage.
3. Repeat test procedure to ensure voltage is at normal operating range.

ALTERNATOR (PRESTOLITE) MAINTENANCE (Contd)

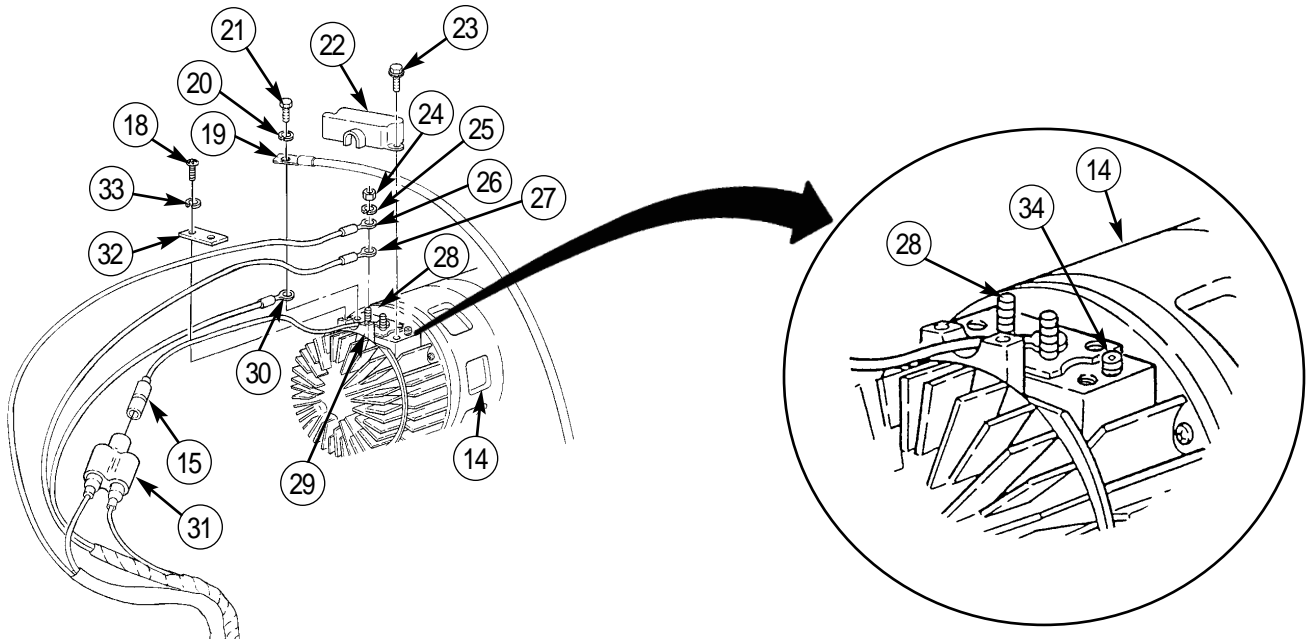
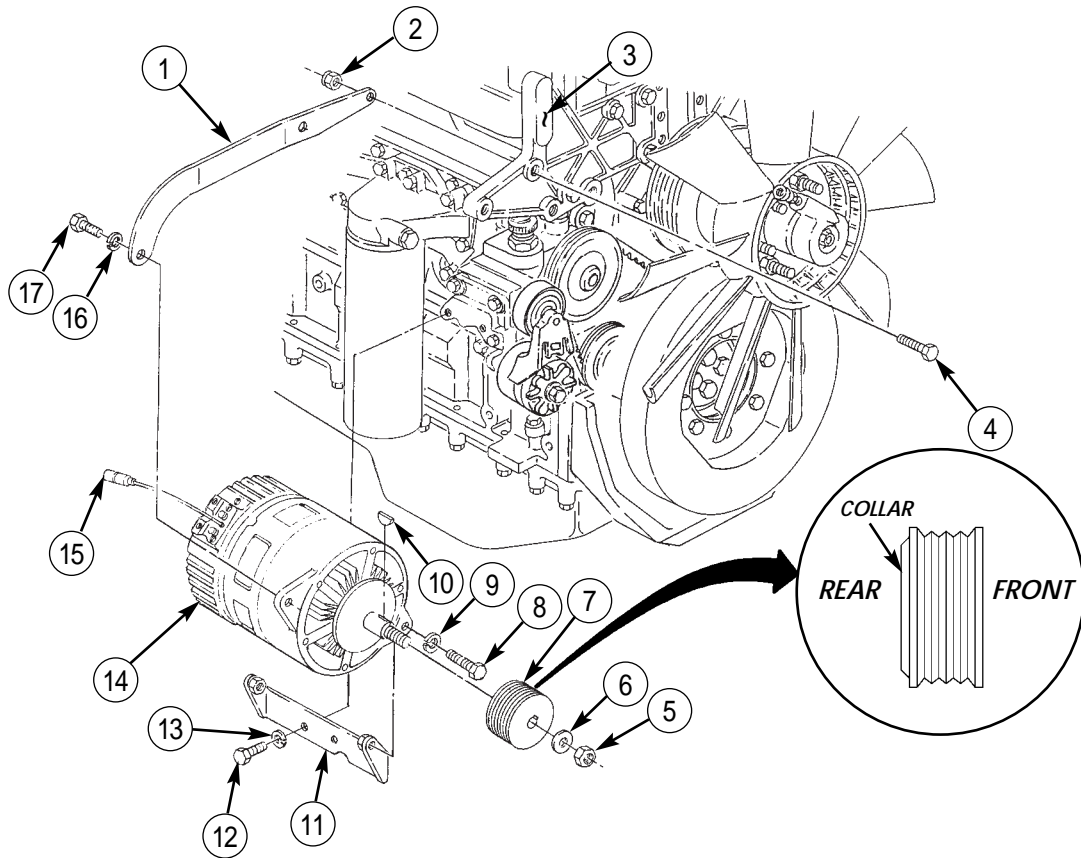

END OF WORK PACKAGE

UNIT MAINTENANCE INSTRUCTIONS

EXTENDED SERVICE PROGRAM (ESP)

TRUCK, CARGO, 2-1/2-TON, 6X6, M44A3 SERIES TRUCKS (DIESEL)

M35A3, W/O WINCH (NSN 2320-01-383-2047); W/WINCH (NSN 2320-01-383-3850);
M35A3C, W/O WINCH (NSN 2320-01-383-2050); W/WINCH (NSN 2320-01-383-2049);
M36A3, W/O WINCH (NSN 2320-01-383-2048); W/WINCH (NSN 2320-01-383-2046).

ALTERNATOR (LEECE-NEVILLE) MAINTENANCE

REMOVAL, INSTALLATION, TEST, ADJUSTMENT

INITIAL SETUP:

Tools and Special Tools

General mechanic's tool kit
(item 30, WP 0394 00)
Common No. 1 tool kit
(item 15, WP 0394 00)
Multimeter (item 45, WP 0394 00)

Materials/Parts

Three lockwashers (item 62, WP 0395 00)
Two locknuts (item 90, WP 0395 00)
Two lockwashers (item 130, WP 0395 00)
Locknut (item 24, WP 0395 00)
Adhesive sealant (item 2, WP 0393 00)
Sealing compound (item 44, WP 0393 00)
Two lockwashers (item 69, WP 0395 00)
Lockwasher (item 61, WP0395 00)
Lockwasher (item 60, WP 0395 00)
Woodruff key (item 71, WP 0395 00)

References

TM 9-2320-386-24P

Equipment Condition

Parking brake set (TM 9-2320-386-10).
Hood raised and secured (TM 9-2320-386-10).
Battery ground cable disconnected (WP 0121 00).
Fan drivebelt removed (WP 0084 00).

ALTERNATOR (LEECE-NEVILLE) MAINTENANCE (Contd)**REMOVAL****CAUTION**

Never operate the alternator with output terminal (POS) disconnected. Damage to alternator will result.

NOTE

Tag all wires for installation.

All waterproofing sealant must be removed from wires.

Locking hardware in steps 1 through 3 is provisioned with alternator.

1. Remove two screws (5), lockwashers (6), and cover plate (7) from block (9). Discard lockwashers (6).
2. Remove nut (1), lockwasher (2), and leads 2 (3) and 770-N (4) from stud (8). Discard lockwasher (2).
3. Remove screw (14), lockwasher (13), ground (GND) lead (12), and lead 770-P (11) from block (9). Discard lockwasher (13).
4. Disconnect lead 568 (16) from Y-connector (15).
5. Remove screw (31) and lockwasher (30) from bracket (32) and alternator (10). Discard lockwasher (30).
6. Remove two screws (24), lockwashers (25), and alternator (10) from bracket (27). Discard lockwashers (25).
7. Remove two locknuts (17), screws (19), and bracket (32) from engine (18). Discard locknuts (17).
8. Remove two screws (28), lockwashers (29), and bracket (27) from engine (18). Discard lockwashers (29).
9. Remove locknut (20) and washer (21) from alternator (10). Discard locknut (20).
10. Using puller, remove pulley (22) and external fan (23) from alternator (10).
11. Remove woodruff key (26) from alternator (10). Discard woodruff key (26).

ALTERNATOR (LEECE-NEVILLE) MAINTENANCE (Contd)

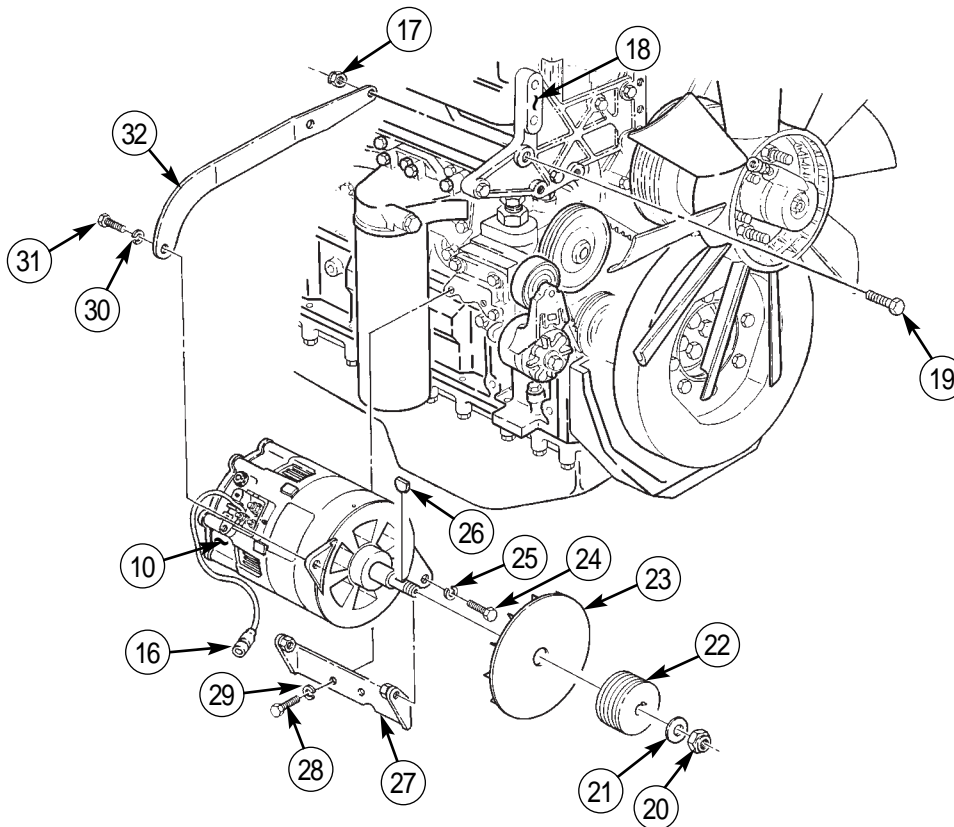
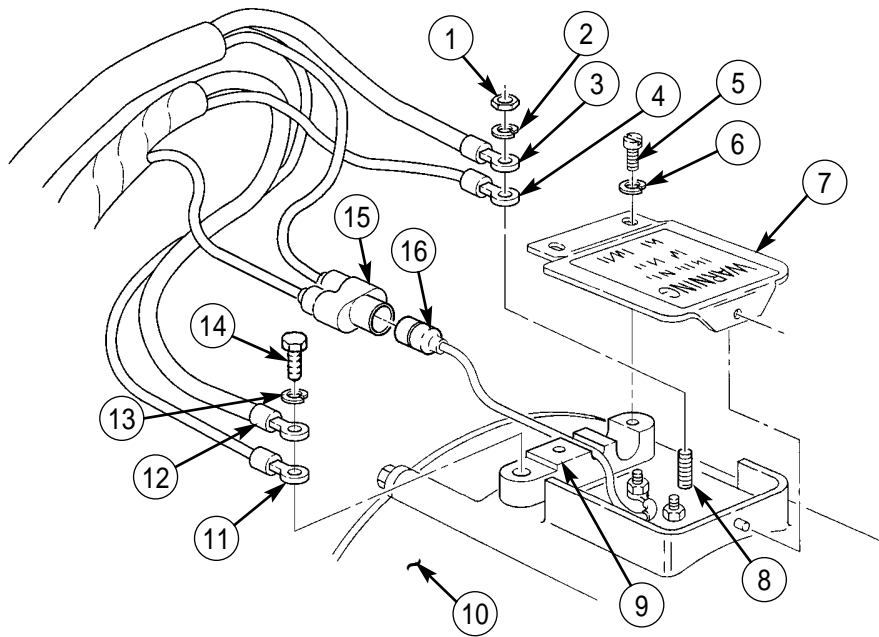

ALTERNATOR (LEECE-NEVILLE) MAINTENANCE (Contd)**INSTALLATION****NOTE**

Ensure pulley is properly installed. Collar on pulley mounts toward rear of vehicle.

1. Install new woodruff key (11), external fan (8), and pulley (7) on alternator (17) with washer (6) and new locknut (5).
2. Install bracket (12) on engine (3) with two new lockwashers (14) and screws (13).
3. Install bracket (1) on engine (3) with two screws (4) and new locknuts (2).
4. Install alternator (17) on bracket (12) with two new lockwashers (10) and screws (9). Finger-tighten screws (9).
5. Secure bracket (1) on alternator (17) with new lockwasher (18) and screw (19).
6. Tighten two screws (9).

NOTE

Ensure wires and terminals are clean before connections are made.

7. Install ground (GND) lead (30) and lead 770-P (29) on block (28) with new lockwasher (31) and screw (32). Tighten screw (32) 83-102 lb-in. (9.4-11.5 N·m).
8. Install leads 770-N (23) and 2 (22) on stud (27) with new lockwasher (21) and nut (20). Tighten nut (20) 45-55 lb-in. (5.1-6.2 N·m).
9. Connect lead 568 (15) to Y-connector (33).
10. Connect battery ground cable (WP 0121 00).
11. Install fan drivebelt (WP 0084 00).

TEST

1. Start engine (TM 9-2320-386-10).
2. Set engine speed to 1200 rpm (TM 9-2320-386-10).
3. Turn on headlights (TM 9-2320-386-10) to place load on alternator.
4. Using multimeter, check alternator output voltage. Connect black lead to ground (GND) lead (30) and touch red lead to lead 2 (22). Output voltage should be 28.0 ± 0.2 VDC.
5. Turn off headlights (TM 9-2320-386-10).
6. Stop engine (TM 9-2320-386-10). If adjustment is required, continue to adjustment. If no adjustment is required, go to step 7.
7. Completely seal leads 568 (15), 770-P (29), GND (30), 2 (22), and 770-N (23), and three studs (27) with adhesive sealant.
8. Install cover plate (26) on block (28) with two new lockwashers (25) and screws (24).

NOTE

If adjustment was performed, go to step 9.

9. Apply sealing compound to threads of pipe plug (16). Using hex-head driver, install pipe plug (16) on alternator (17) and tighten to 24-36 lb-in. (3-4 N·m).

ADJUSTMENT

1. Remove pipe plug (16) from alternator (17).
2. Turn adjusting screw counterclockwise to increase voltage or clockwise to decrease voltage.
3. Repeat test procedure to ensure voltage is at normal operating range.

ALTERNATOR (LEECE-NEVILLE) MAINTENANCE (Contd)

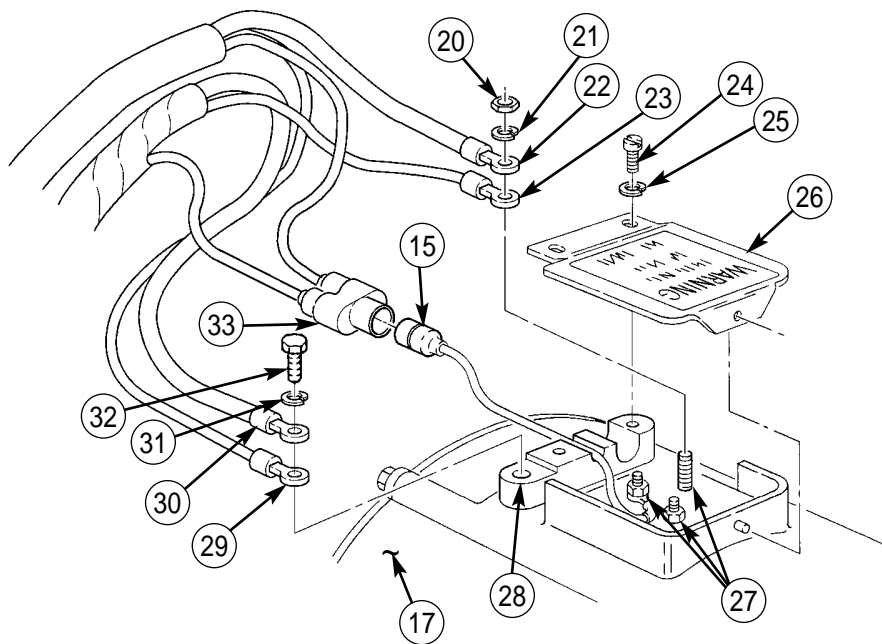
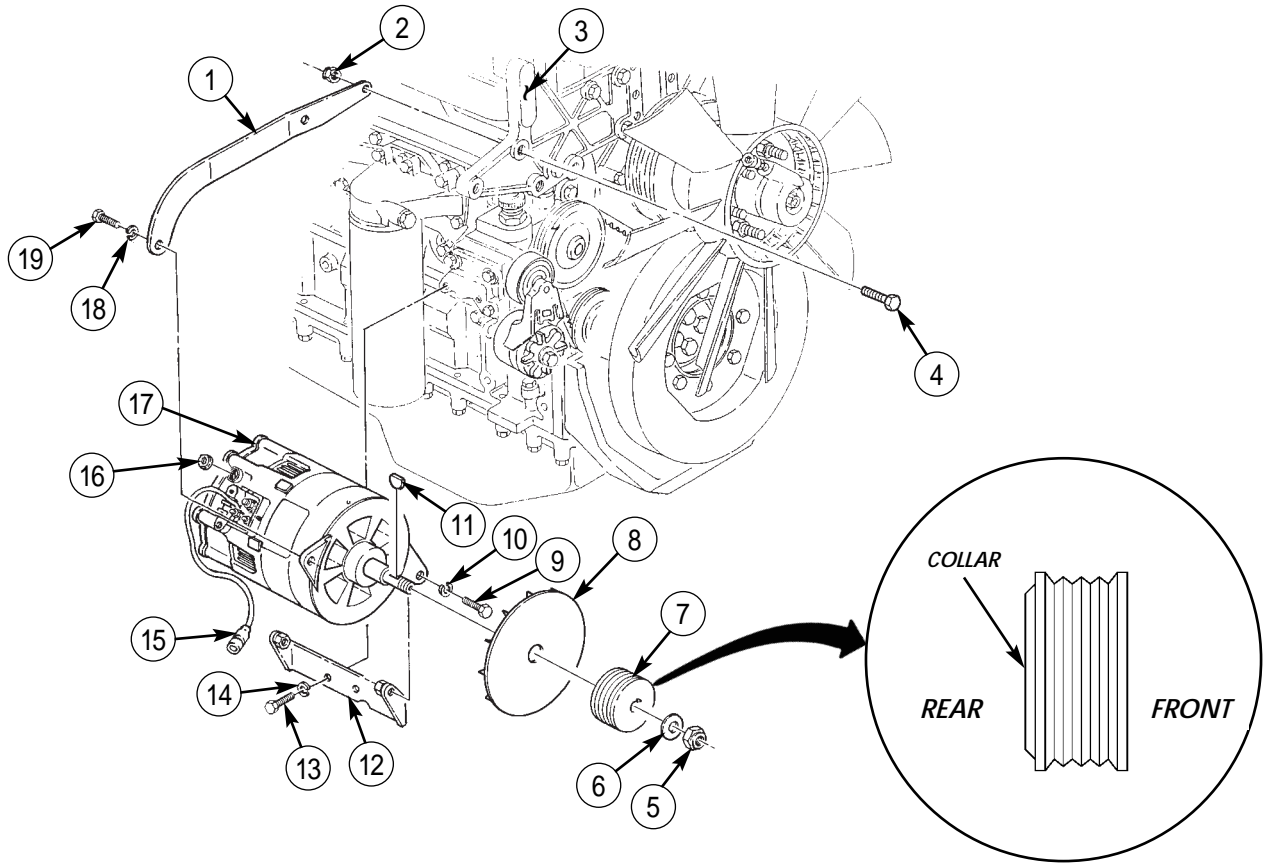

END OF WORK PACKAGE

UNIT MAINTENANCE INSTRUCTIONS

EXTENDED SERVICE PROGRAM (ESP)

TRUCK, CARGO, 2-1/2-TON, 6X6, M44A3 SERIES TRUCKS (DIESEL)

M35A3, W/O WINCH (NSN 2320-01-383-2047); W/WINCH (NSN 2320-01-383-3850);
M35A3C, W/O WINCH (NSN 2320-01-383-2050); W/WINCH (NSN 2320-01-383-2049);
M36A3, W/O WINCH (NSN 2320-01-383-2048); W/WINCH (NSN 2320-01-383-2046).

STARTER MOTOR REPLACEMENT

REMOVAL, INSTALLATION

INITIAL SETUP:

Tools and Special Tools

General mechanic's tool kit
(item 30, WP 0394 00)
Common No. 1 tool kit
(item 15, WP 0394 00)

Materials/Parts

Three lockwashers (item 134, WP 0395 00)
Gasket (item 108, WP 0395 00)
Three lockwashers (item 186, WP 0395 00)
Lockwasher (item 58, WP 0395 00)

References

TM 9-2320-386-24P

Equipment Condition

Parking brake set (TM 9-2320-386-10).
Hood raised and secured (TM 9-2320-386-10).
Battery ground cable disconnected (WP 0121 00).

STARTER MOTOR REPLACEMENT (Contd)**REMOVAL****NOTE**

Tag all wires for installation.

1. Remove nut (6), lockwasher (5), and leads 6 (4), 2 (3), and 14 (2) from solenoid (1). Discard lockwasher (5).
2. Remove nut (12), lockwasher (11), lead 770M (10), and ground (GND) 93 (13) from starter motor (14). Discard lockwasher (11).
3. Remove nut (7), lockwasher (8), and lead 770T (9) from starter motor (14). Discard lockwasher (8).
4. Remove nut (15), lockwasher (16), and leads 770S (17) and 214 (18) from solenoid (1). Discard lockwasher (16).
5. Remove three screws (19), lockwashers (20), starter motor (14), and gasket (21) from flywheel housing (22). Discard gasket (21) and lockwashers (20).

INSTALLATION

1. Install new gasket (21) and starter motor (14) on flywheel housing (22) with three new lockwashers (20) and screws (19). Tighten screws (19) 55 lb-ft (75 N•m).
2. Install leads 214 (18) and 770S (17) on solenoid (1) with new lockwasher (16) and nut (15).
3. Install lead 770T (9) on starter motor (14) with new lockwasher (8) and nut (7).
4. Install ground (GND) 93 (13) and lead 770M (10) on starter motor (14) with new lockwasher (11) and nut (12).

NOTE

One lead is equipped with rubber boot to protect against corrosion. Ensure the rubber boot is in place after installation.

5. Install leads 14 (2), 2 (3), and 6 (4) on solenoid (1) with new lockwasher (5) and nut (6).
6. Connect battery ground cable (WP 0121 00).

STARTER MOTOR REPLACEMENT (Contd)

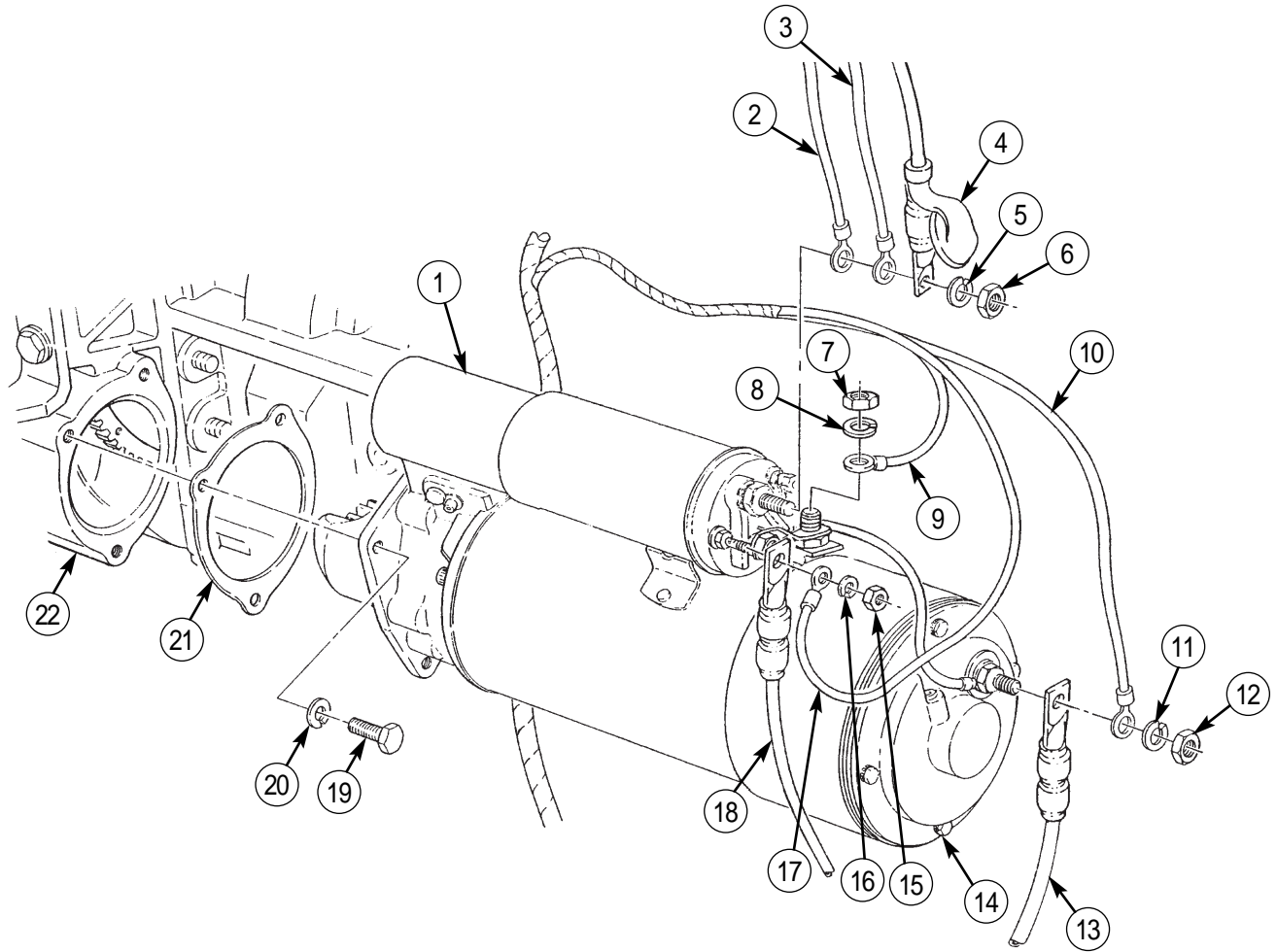

END OF WORK PACKAGE

UNIT MAINTENANCE INSTRUCTIONS

EXTENDED SERVICE PROGRAM (ESP)

TRUCK, CARGO, 2-1/2-TON, 6X6, M44A3 SERIES TRUCKS (DIESEL)

M35A3, W/O WINCH (NSN 2320-01-383-2047); W/WINCH (NSN 2320-01-383-3850);

M35A3C, W/O WINCH (NSN 2320-01-383-2050); W/WINCH (NSN 2320-01-383-2049);

M36A3, W/O WINCH (NSN 2320-01-383-2048); W/WINCH (NSN 2320-01-383-2046).

STARTER RELAY REPLACEMENT

REMOVAL, INSTALLATION

INITIAL SETUP:

Tools and Special Tools

General mechanic's tool kit
(item 30, WP 0394 00)

Materials/Parts

Two locknuts (item 248, WP 0395 00)
Two locknuts (item 333, WP 0395 00)
Two lockwashers (item 77, WP 0395 00)
Three lockwashers (item 61, WP 0395 00)
Lockwasher (item 147, WP 0395 00)

References

TM 9-2320-386-24P

Equipment Condition

Parking brake set (TM 9-2320-386-10).
Hood raised and secured (TM 9-2320-386-10).
Battery ground cable disconnected (WP 0121 00).

STARTER RELAY REPLACEMENT (Contd)**REMOVAL**

1. Remove clamp (3) and hose (4) from air cleaner (1).
2. Disconnect tube (2) from air cleaner (1).
3. Remove three screws (12), lockwashers (13), and washers (14) from air cleaner (1) and fender (8). Discard lockwashers (13).
4. Remove screw (11), lockwasher (10), and washer (9) from fender (8), exhaust bracket (7), and air cleaner (1). Discard lockwasher (10).
5. Remove clamp (5) and air cleaner (1) from elbow (6) and fender (8).

NOTE

Tag all leads for installation.

6. Remove nut (15), washer (16), and lead 74B (17) from relay (35).
7. Remove nut (29), washer (30), and leads 10 and 14 (28) from relay (35).
8. Remove nut (32), washer (33), and lead 214 (31) from relay (35).
9. Remove two locknuts (27), screws (18), lockwashers (19), lead 99A (20), clamp (26), and relay mounting flange (34) from bracket (25). Discard locknuts (18) and lockwashers (19).
10. Remove two locknuts (22), screws (24), washers (23), and bracket (25) from firewall (21). Discard locknuts (22).

INSTALLATION**NOTE**

Assistant will help with step 1.

1. Install bracket (25) on firewall (21) with two washers (23), screws (24), and new locknuts (22).
2. Install relay mounting flange (34), lead 99A (20), and clamp (26) on bracket (25) with two new lockwashers (19), screws (18), and new locknuts (27).
3. Install lead 214 (31) on relay (35) with washer (33) and nut (32).
4. Install leads 10 and 14 (28) on relay (35) with washer (30) and nut (29).
5. Install lead 74B (17) on relay (35) with washer (16) and nut (15).
6. Position air cleaner (1) on fender (8).
7. Install air cleaner (1) on elbow (6) with clamp (5).

NOTE

It may be necessary to loosen exhaust bracket to align air cleaner.

8. Install air cleaner (1) on fender (8) with three washers (14), new lockwashers (13), and screws (12).
9. Install washer (9), new lockwasher (10), and screw (11) on exhaust bracket (7) and air cleaner (1).
10. Connect tube (2) to air cleaner (1).
11. Install hose (4) on air cleaner (1) with clamp (3).
12. Connect battery ground cable (WP 0121 00).
13. Start engine (TM 9-2320-386-10).

STARTER RELAY REPLACEMENT (Contd)

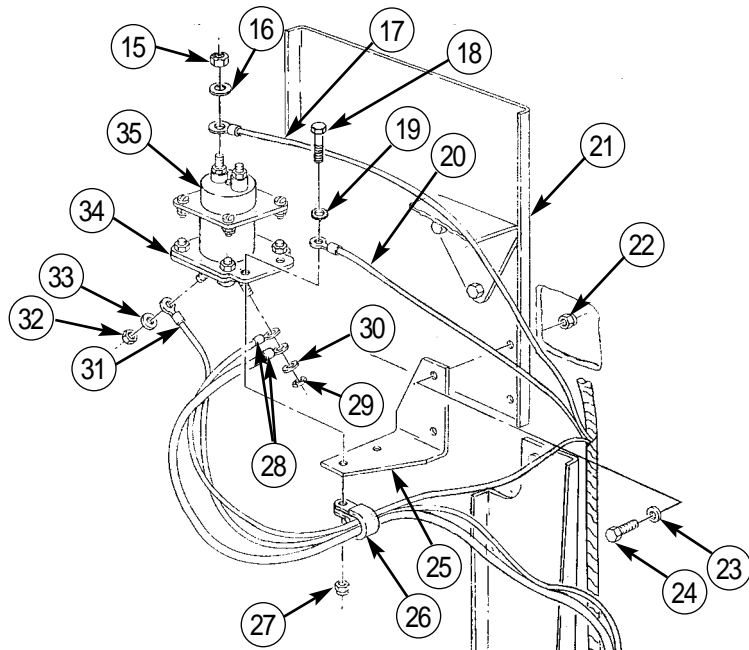
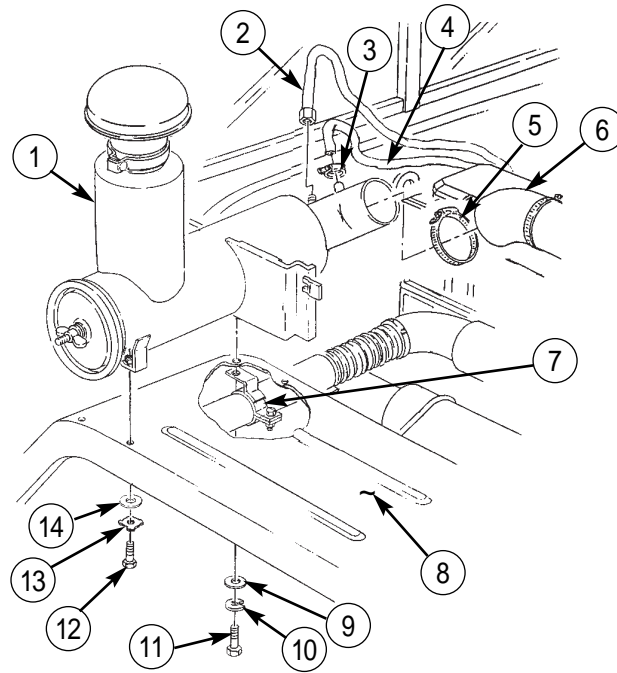

END OF WORK PACKAGE

UNIT MAINTENANCE INSTRUCTIONS

EXTENDED SERVICE PROGRAM (ESP)

TRUCK, CARGO, 2-1/2-TON, 6X6, M44A3 SERIES TRUCKS (DIESEL)

M35A3, W/O WINCH (NSN 2320-01-383-2047); W/WINCH (NSN 2320-01-383-3850);
M35A3C, W/O WINCH (NSN 2320-01-383-2050); W/WINCH (NSN 2320-01-383-2049);
M36A3, W/O WINCH (NSN 2320-01-383-2048); W/WINCH (NSN 2320-01-383-2046).

STARTER SWITCH REPLACEMENT

REMOVAL, INSTALLATION

INITIAL SETUP:

Tools and Special Tools

General mechanic's tool kit
(item 30, WP 0394 00)

Materials/Parts

Lockwasher (item 44, WP 0395 00)
Lockwasher (item 57, WP 0395 00)

References

TM 9-2320-386-24P

Equipment Condition

Parking brake set (TM 9-2320-386-10).
Battery ground cable disconnected (WP 0121 00).

STARTER SWITCH REPLACEMENT (Contd)**REMOVAL**

1. Remove screw (9), lockwasher (10), and handle (8) from starter switch (4). Discard lockwasher (10).
2. Remove nut (7), lockwasher (6), and switch plate (1) from starter switch (4). Discard lockwasher (6).
3. Remove starter switch (4) from instrument panel (5).

NOTE

Tag all wires for installation.

4. Disconnect wires 117 (11), 74A (12), 74 (13), and 118 (14) from starter switch (4).

INSTALLATION

1. Connect ground wire 117 (11) to port A, load wire 74A (12) to port B, battery wire 74 (13) to port D, and lamp wire 118 (14) to port C on starter switch (4).
2. Align pin (3) with hole (2) and install starter switch (4) and switch plate (1) on instrument panel (5) with new lockwasher (6) and nut (7).
3. Install handle (8) on starter switch (4) with new lockwasher (10) and screw (9).
4. Connect battery ground cable (WP 0121 00).
5. Start engine (TM 9-2320-386-10).

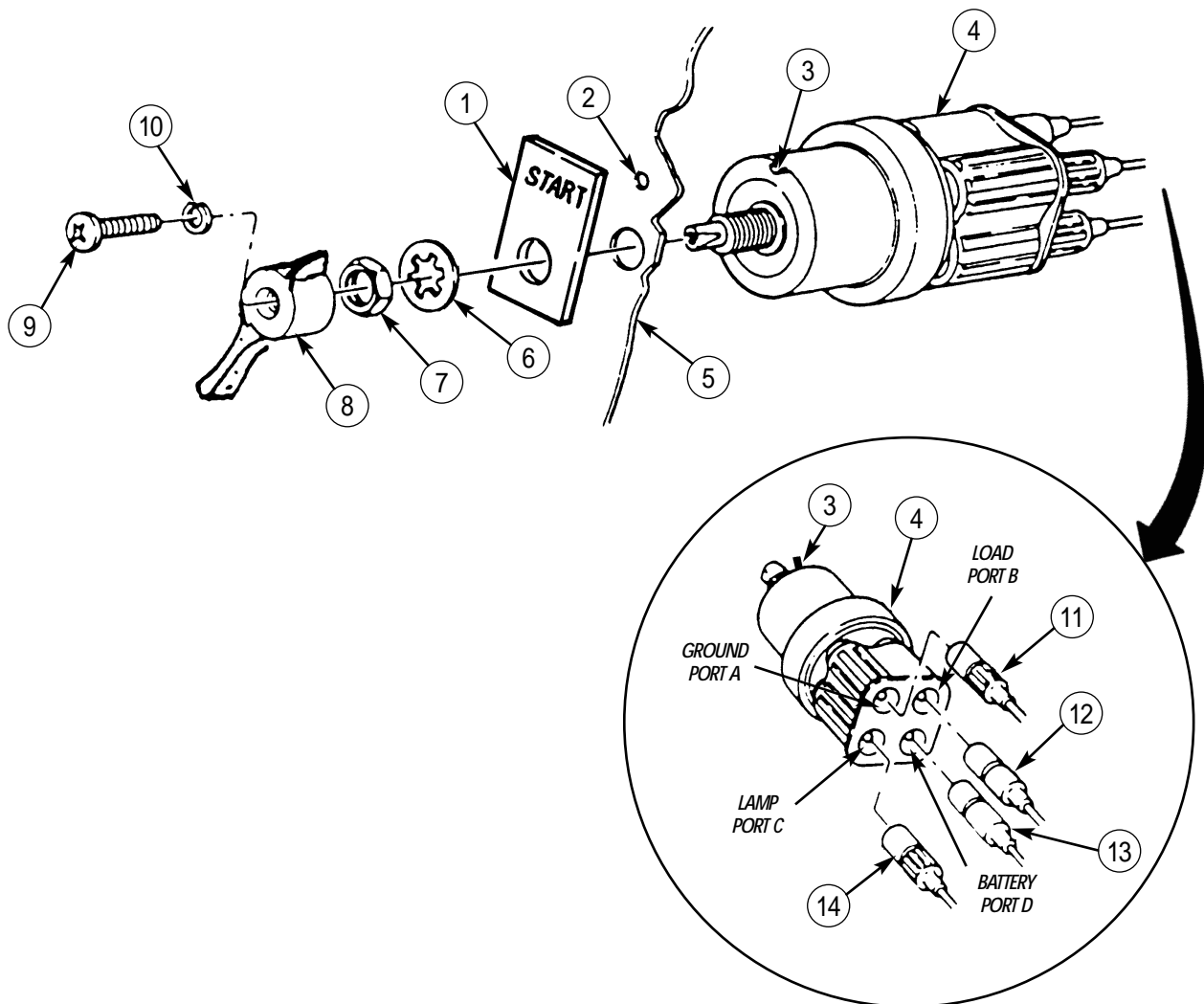

END OF WORK PACKAGE

UNIT MAINTENANCE INSTRUCTIONS

EXTENDED SERVICE PROGRAM (ESP)

TRUCK, CARGO, 2-1/2-TON, 6X6, M44A3 SERIES TRUCKS (DIESEL)

**M35A3, W/O WINCH (NSN 2320-01-383-2047); W/WINCH (NSN 2320-01-383-3850);
M35A3C, W/O WINCH (NSN 2320-01-383-2050); W/WINCH (NSN 2320-01-383-2049);
M36A3, W/O WINCH (NSN 2320-01-383-2048); W/WINCH (NSN 2320-01-383-2046).**

INSTRUMENT CLUSTER MAINTENANCE

REMOVAL, DISASSEMBLY, ASSEMBLY, INSTALLATION

INITIAL SETUP:

Tools and Special Tools

General mechanic's tool kit
(item 30, WP 0394 00)

Materials/Parts

Teflon pipe sealant (item 41, WP 0393 00)
Lockwasher (item 75, WP 0395 00)

References

TM 9-2320-386-24P

Equipment Condition

Parking brake set (TM 9-2320-386-10).
Air reservoirs drained (TM 9-2320-386-10).
Battery ground cable disconnected (WP 0121 00).

INSTRUMENT CLUSTER MAINTENANCE (Contd)**REMOVAL**

1. Turn four lockstuds (3) 1/4-turn to left and pull instrument mounting panel (2) away from vehicular panel (1).

NOTE

Tag each wire, air line, and driveshaft for installation.

2. Disconnect cannon plug (9) from tachometer (33).
3. Disconnect speedometer driveshaft (13) from speedometer (8).

WARNING

Do not disconnect air lines before draining air reservoir. Small parts under pressure may shoot out with high velocity, and result in injury to personnel.

Eyeshields must be worn when releasing compressed air. Failure to do this may result in injury to personnel.

4. Disconnect air line (28) from air pressure gauge (30).
5. Disconnect lead 27 (20) from lead 27 (7).
6. Disconnect lead 33 (6) and lead 27 (7) from engine temperature indicator (4).
7. Disconnect lead 36 (14) and lead 27 (7) from oil pressure gauge (17).
8. Disconnect lead 27 (7) and 28 (21) from fuel gauge (22).
9. Disconnect lead 17 (16) from high beam indicator (19).
10. Disconnect lead 40 (10) and lead 40 (15) from panel lights (31) and (18).
11. Disconnect lead 27 (7) from voltmeter (23).
12. Disconnect two leads 27 and 67 (12) from leads 27 and 67 (11).
13. Disconnect lead 85A (5) from indicator lamp (32).
14. Remove nut (24), ground (GND) terminals (25) and (26), lockwasher (27), and screw (29) from instrument mounting panel (2). Discard lockwasher (27).

INSTRUMENT CLUSTER MAINTENANCE (Contd)

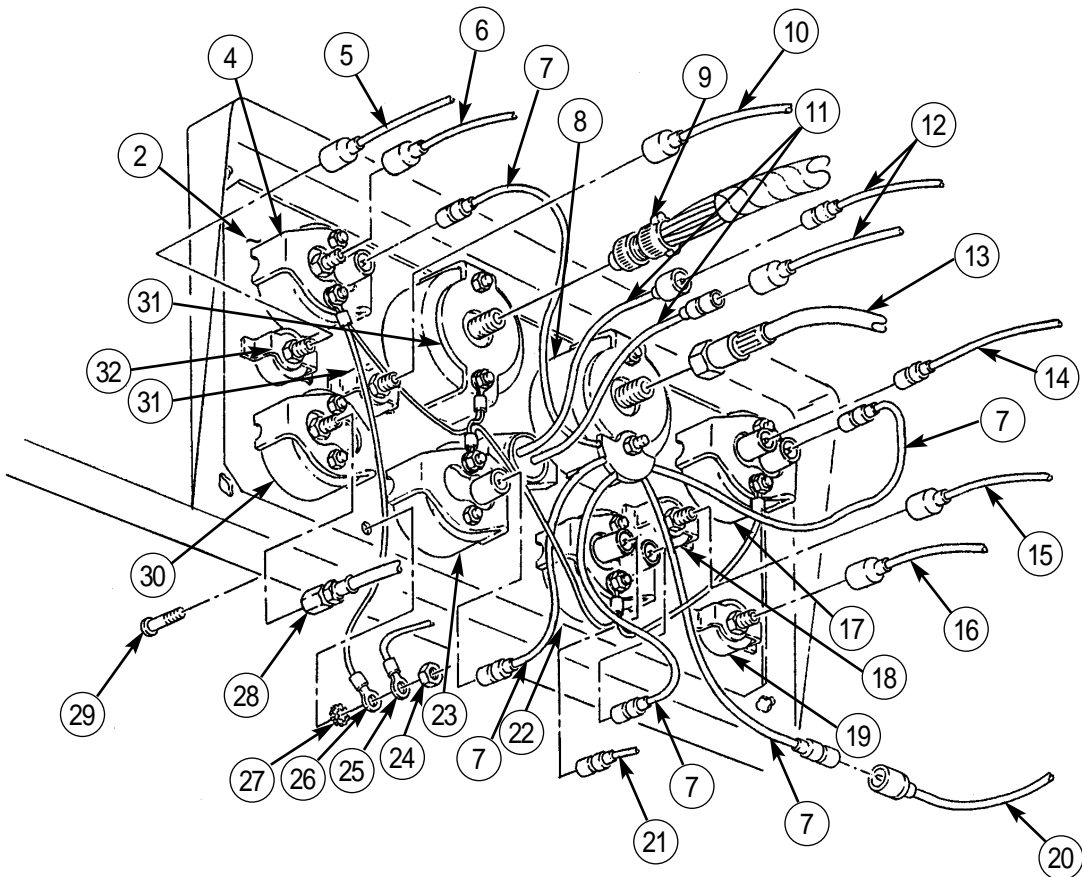
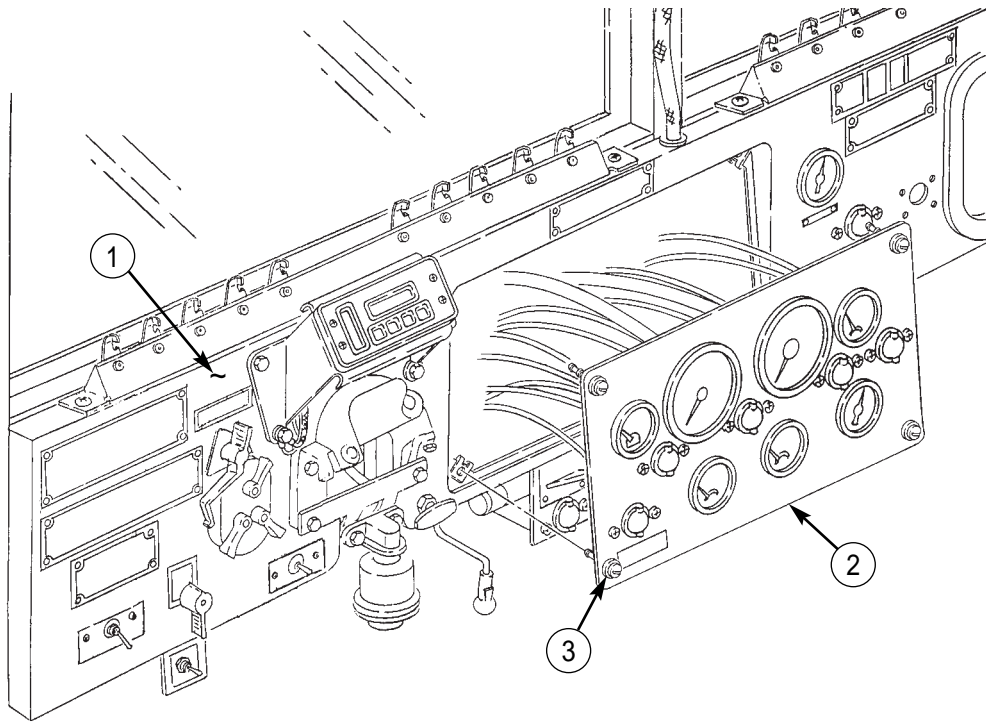

INSTRUMENT CLUSTER MAINTENANCE (Contd)**DISASSEMBLY**

1. Remove light lens (30) and light (25) from socket (24).
2. Remove light lens (36) and light (46) from socket (47).
3. Remove light lens (40) and light (44) from socket (45).
4. Remove two screws (35) and brake warning light (48) from instrument mounting panel (26).
5. Remove two nuts (15), lockwashers (18), ground (GND) lead (3), bracket (20), and speedometer (33) from instrument mounting panel (26).
6. Remove two nuts (21), lockwashers (22), bracket (23), and air pressure gauge (31) from instrument mounting panel (26).
7. Remove two nuts (16), lockwashers (17), ground (GND) lead (3), bracket (19), and engine temperature indicator (29) from instrument mounting panel (26).
8. Remove two nuts (11), lockwashers (12), ground (GND) lead (3), bracket (13), and voltmeter (34) from instrument mounting panel (26).
9. Remove two nuts (1), lockwashers (2), ground (GND) lead (3), bracket (4), and fuel indicator (37) from instrument mounting panel (26).
10. Remove two nuts (5), lockwashers (6), ground (GND) lead (3), bracket (7), and oil pressure gauge (43) from instrument mounting panel (26).
11. Remove two nuts (8), lockwashers (9), wiring harness (10), bracket (14), and tachometer (32) from instrument mounting panel (26).
12. Remove two screws (28), washers (27), and socket (24) from instrument mounting panel (26).
13. Remove two screws (38), washers (39), and socket (47) from instrument mounting panel (26).
14. Remove two screws (41), washers (42), and socket (45) from instrument mounting panel (26).

ASSEMBLY

1. Install brake warning light (48) on instrument mounting panel (26) with two screws (35).
2. Install socket (45) on instrument mounting panel (26) with two washers (42) and screws (41).
3. Install socket (47) on instrument mounting panel (26) with two washers (39) and screws (38).
4. Install socket (24) on instrument mounting panel (26) with two washers (27) and screws (28).
5. Install tachometer (32), bracket (14), and wiring harness (10) on instrument mounting panel (26) with two lockwashers (9) and nuts (8).
6. Install oil pressure gauge (43), bracket (7), and ground (GND) lead (3) on instrument mounting panel (26) with two lockwashers (6) and nuts (5).
7. Install fuel indicator (37), bracket (4), and ground (GND) lead (3) on instrument mounting panel (26) with two lockwashers (2) and nuts (1).
8. Install voltmeter (34), bracket (13), and ground (GND) lead (3) on instrument mounting panel (26) with two lockwashers (12) and nuts (11).
9. Install engine temperature indicator (29), bracket (19), and ground (GND) lead (3) on instrument mounting panel (26) with two lockwashers (17) and nuts (16).
10. Install air pressure gauge (31) and bracket (23) on instrument mounting panel (26) with two lockwashers (22) and nuts (21).
11. Install speedometer (33), bracket (20), and ground (GND) lead (3) on instrument mounting panel (26) with two lockwashers (18) and nuts (15).
12. Install light bulb (44) and light lens (40) on socket (45).
13. Install light bulb (46) and light lens (36) on socket (47).
14. Install light bulb (25) and light lens (30) on socket (24).

INSTRUMENT CLUSTER MAINTENANCE (Contd)

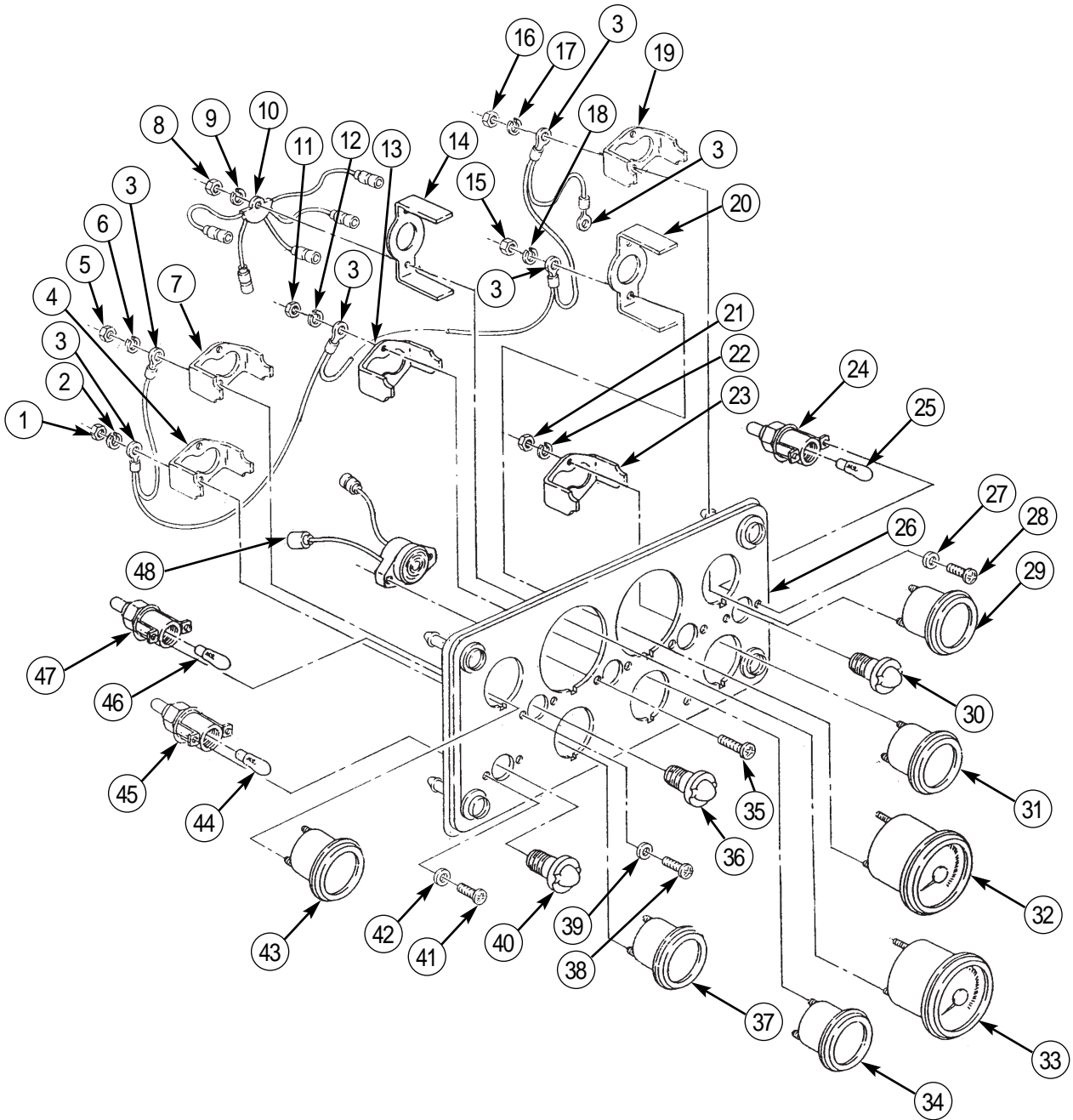

INSTRUMENT CLUSTER MAINTENANCE (Contd)

INSTALLATION

1. Connect lead 85A (3) to indicator lamp (30).
2. Connect two leads 27 and 67 (10) to leads 27 and 67 (9).
3. Connect lead 27 (5) to voltmeter (21).
4. Connect lead 40 (8) and lead 40 (13) to panel lights (29) and (16).
5. Connect lead 17 (14) to high beam indicator (17).
6. Connect lead 27 (5) and lead 28 (19) to fuel gauge (20).
7. Connect lead 36 (12) and lead 27 (5) to oil pressure gauge (15).
8. Connect lead 33 (4) and lead 27 (5) to engine temperature gauge (2).
9. Connect lead 27 (18) to lead 27 (5).
10. Install screw (27), new lockwasher (25), ground (GND) terminals (24) and (23), and nut (22) on instrument mounting panel (1).
11. Apply sealant on male threads of air pressure gauge (28).
12. Connect air line (26) to air pressure gauge (28).
13. Connect speedometer driveshaft (11) to speedometer (6).
14. Connect cannon plug (7) to tachometer (31).
15. Position instrument mounting panel (1) to vehicular panel (32) and install by turning four lockstuds (33) 1/4-turn to right.
16. Connect battery ground cable (WP 0121 00).
17. Start engine (TM 9-2320-386-10) and check gauges for proper operation.
18. Check for air leaks at air pressure gauge.

INSTRUMENT CLUSTER MAINTENANCE (Contd)

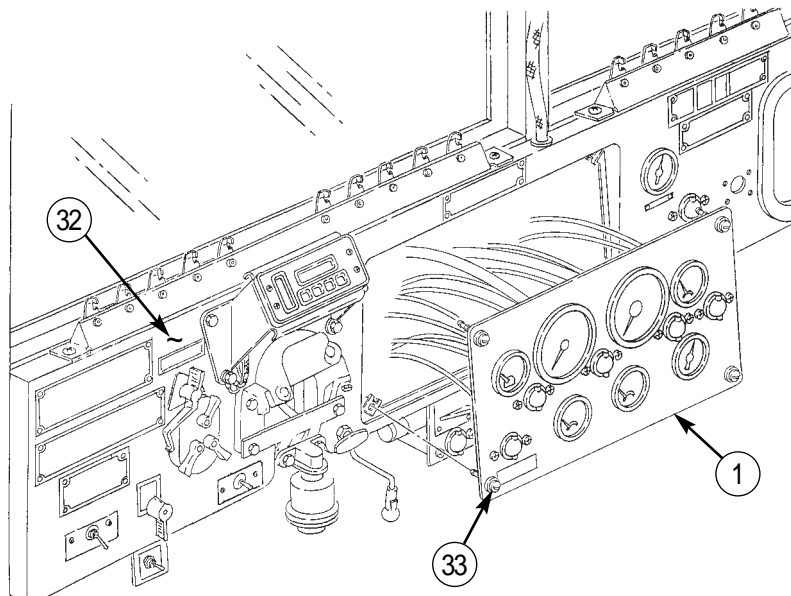
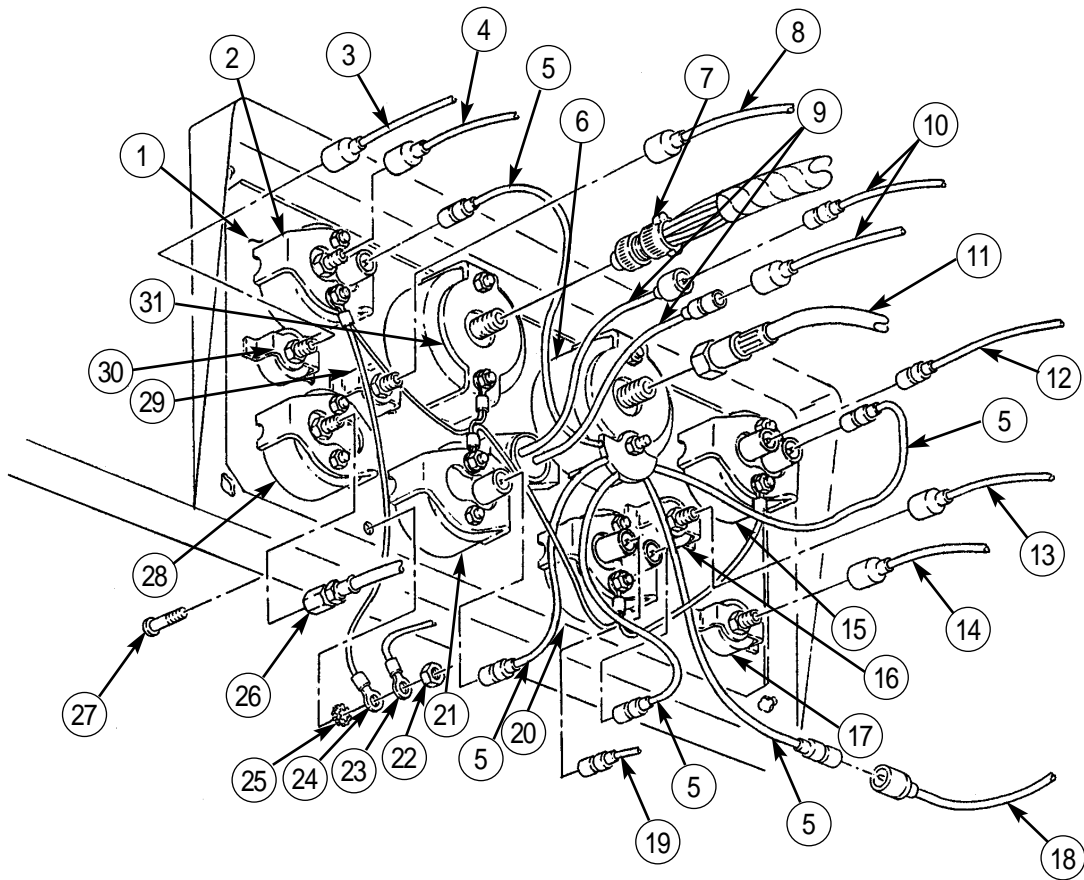

END OF WORK PACKAGE

UNIT MAINTENANCE INSTRUCTIONS

EXTENDED SERVICE PROGRAM (ESP)

TRUCK, CARGO, 2-1/2-TON, 6X6, M44A3 SERIES TRUCKS (DIESEL)

M35A3, W/O WINCH (NSN 2320-01-383-2047); W/WINCH (NSN 2320-01-383-3850);
M35A3C, W/O WINCH (NSN 2320-01-383-2050); W/WINCH (NSN 2320-01-383-2049);
M36A3, W/O WINCH (NSN 2320-01-383-2048); W/WINCH (NSN 2320-01-383-2046).

TACHOMETER REPLACEMENT

REMOVAL, INSTALLATION

INITIAL SETUP:

Tools and Special Tools

General mechanic's tool kit
(item 30, WP 0394 00)

Equipment Condition

Parking brake set (TM 9-2320-386-10).
Battery ground cable disconnected (WP 0121 00).

References

TM 9-2320-386-24P

TACHOMETER REPLACEMENT (Contd)**NOTE**

Appropriate locking hardware is provisioned with gauge.

REMOVAL

1. Turn four lockstuds (2) 1/4-turn to left and pull instrument mounting panel (3) away from instrument panel (1).
2. Disconnect cannon plug (5) from tachometer (4).
3. Remove two nuts (9), lockwashers (8), ground (GND) lead (6), bracket (7), and tachometer (4) from instrument mounting panel (3).

INSTALLATION

1. Install tachometer (4), bracket (7), and ground (GND) lead (6) on instrument mounting panel (3) with two lockwashers (8) and nuts (9).
2. Connect cannon plug (5) to tachometer (4).
3. Position instrument mounting panel (3) on instrument panel (1) and install by turning four lockstuds (2) 1/4-turn to right.
4. Connect battery ground cable (WP 0121 00).
5. Start engine (TM 9-2320-386-10) and check tachometer for proper operation.

TACHOMETER REPLACEMENT (Contd)

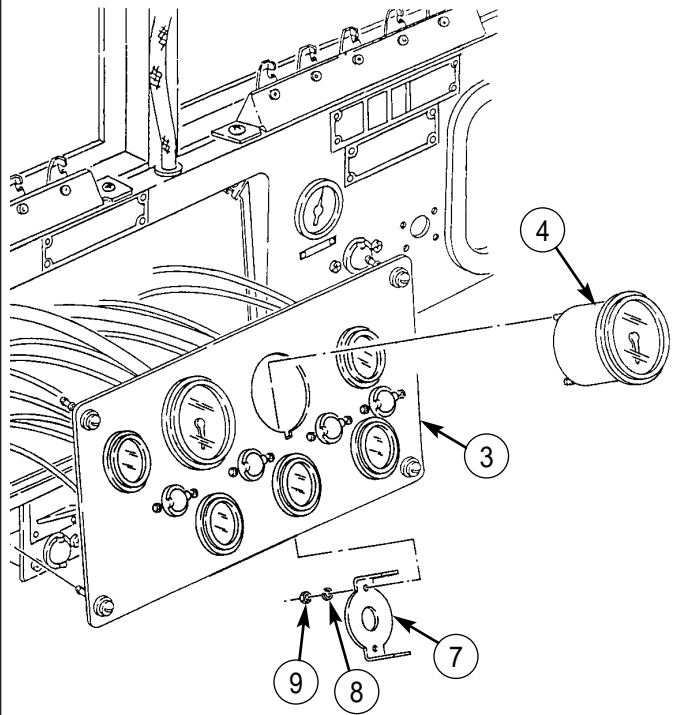
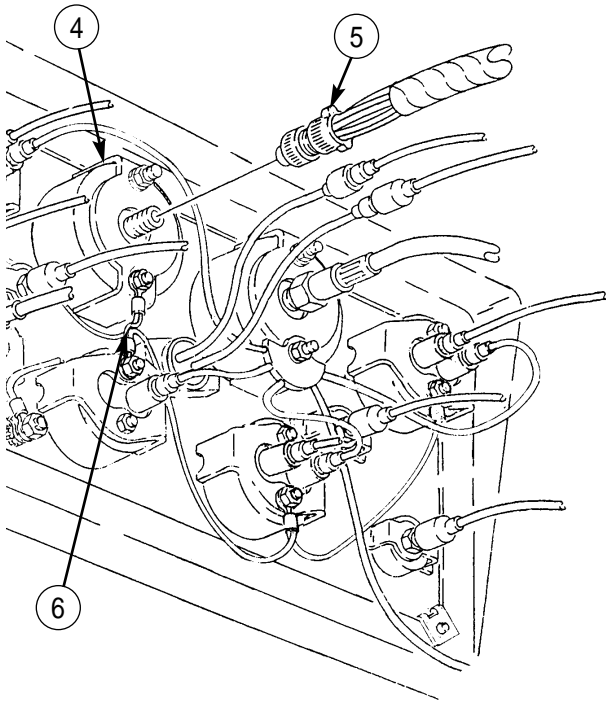
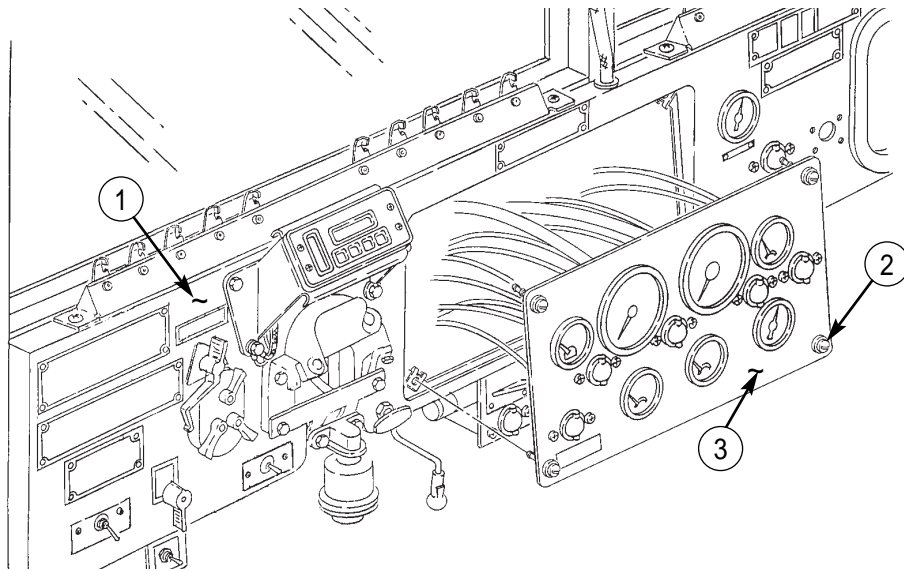

END OF WORK PACKAGE

UNIT MAINTENANCE INSTRUCTIONS

EXTENDED SERVICE PROGRAM (ESP)

TRUCK, CARGO, 2-1/2-TON, 6X6, M44A3 SERIES TRUCKS (DIESEL)

M35A3, W/O WINCH (NSN 2320-01-383-2047); W/WINCH (NSN 2320-01-383-3850);

M35A3C, W/O WINCH (NSN 2320-01-383-2050); W/WINCH (NSN 2320-01-383-2049);

M36A3, W/O WINCH (NSN 2320-01-383-2048); W/WINCH (NSN 2320-01-383-2046).

TRANSMISSION OIL TEMPERATURE GAUGE REPLACEMENT

REMOVAL, INSTALLATION

INITIAL SETUP:

Tools and Special Tools

General mechanic's tool kit
(item 30, WP 0394 00)

Equipment Condition

Parking brake set (TM 9-2320-386-10).
Battery ground cable disconnected (WP 0121 00).

References

TM 9-2320-386-24P

TRANSMISSION OIL TEMPERATURE GAUGE REPLACEMENT (Contd)**NOTE**

Appropriate locking hardware is provisioned with gauge.

REMOVAL

1. Disconnect leads 27 and 324 (2) from gauge (1).
2. Remove two nuts (7), lockwashers (6), ground (GND) terminal (5), mounting bracket (4), and gauge (1) from instrument panel (3).

INSTALLATION

1. Install gauge (1) on instrument panel (3) with mounting bracket (4), ground (GND) terminal (5), two lockwashers (6), and nuts (7).
2. Connect leads 27 and 324 (2) to gauge (1).
3. Connect battery ground cable (WP 0121 00).

TRANSMISSION OIL TEMPERATURE GAUGE REPLACEMENT (Contd)

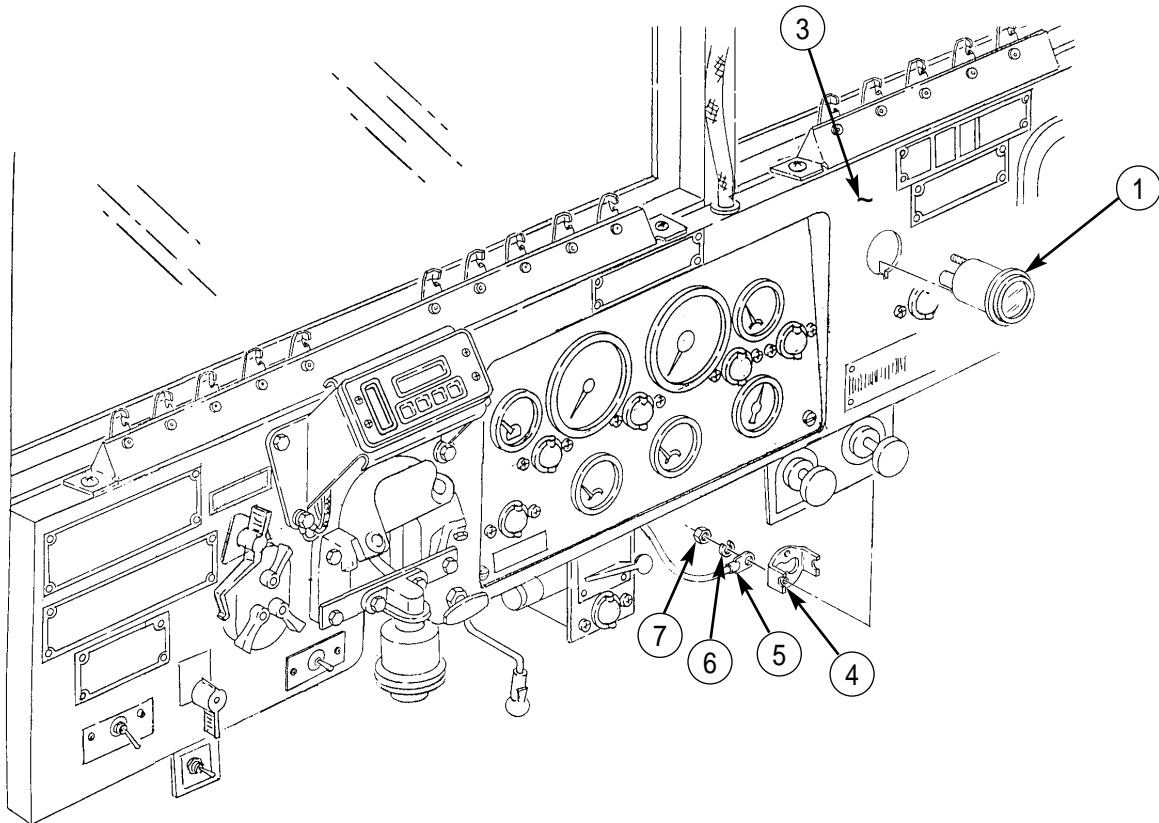
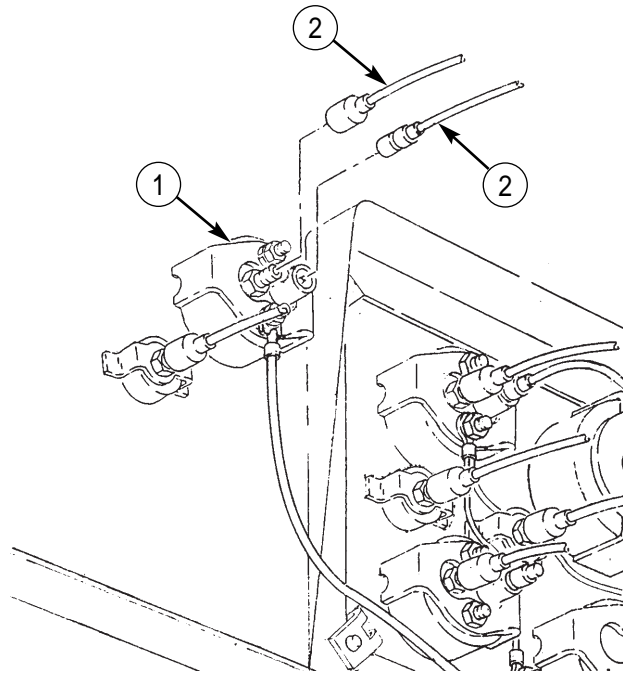

END OF WORK PACKAGE

UNIT MAINTENANCE INSTRUCTIONS

EXTENDED SERVICE PROGRAM (ESP)

TRUCK, CARGO, 2-1/2-TON, 6X6, M44A3 SERIES TRUCKS (DIESEL)

M35A3, W/O WINCH (NSN 2320-01-383-2047); W/WINCH (NSN 2320-01-383-3850);

M35A3C, W/O WINCH (NSN 2320-01-383-2050); W/WINCH (NSN 2320-01-383-2049);

M36A3, W/O WINCH (NSN 2320-01-383-2048); W/WINCH (NSN 2320-01-383-2046).

MAGNETIC SPEED SENSOR REPLACEMENT

REMOVAL, INSTALLATION

INITIAL SETUP:

Tools and Special Tools

General mechanic's tool kit
(item 30, WP 0394 00)

Equipment Condition

Parking brake set (TM 9-2320-386-10).
Battery ground cable disconnected (WP 0121 00).

References

TM 9-2320-386-24P

MAGNETIC SPEED SENSOR REPLACEMENT (Contd)**REMOVAL**

1. Remove nut (2) and two clamps (3) from engine (1).
2. Remove connector (7) from magnetic speed sensor plug (6)
3. Loosen jamnut (4) and remove sensor (5) from flywheel housing (8).

INSTALLATION**NOTE**

Before tightening jamnut on sensor, adjust sensor 1-1/4 turns out from flywheel. Nut functions as a jamnut to hold the sensor in position.

1. Install sensor (5) on flywheel housing (8) and tighten jamnut (4).
2. Install sensor wires into two clamps (3) and install clamps (3) on engine (1) with nut (2).
3. Install two leads 428 and 429 with connector (7) on magnetic speed sensor plug (6).
4. Connect battery ground cable (WP 0121 00).

MAGNETIC SPEED SENSOR REPLACEMENT (Contd)

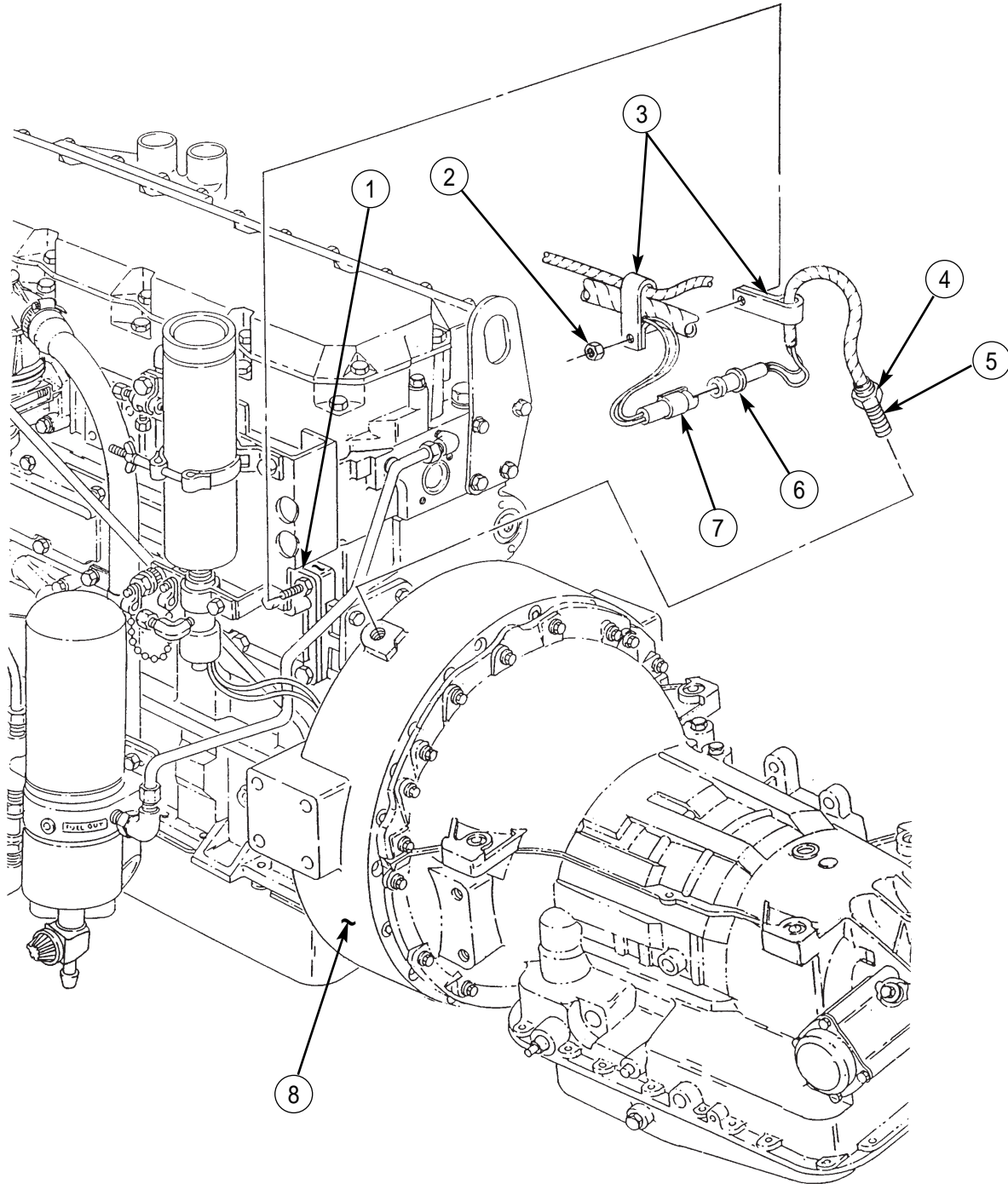

END OF WORK PACKAGE

UNIT MAINTENANCE INSTRUCTIONS

EXTENDED SERVICE PROGRAM (ESP)

TRUCK, CARGO, 2-1/2-TON, 6X6, M44A3 SERIES TRUCKS (DIESEL)

M35A3, W/O WINCH (NSN 2320-01-383-2047); W/WINCH (NSN 2320-01-383-3850);

M35A3C, W/O WINCH (NSN 2320-01-383-2050); W/WINCH (NSN 2320-01-383-2049);

M36A3, W/O WINCH (NSN 2320-01-383-2048); W/WINCH (NSN 2320-01-383-2046).

TRANSMISSION NEUTRAL SAFETY SWITCH REPLACEMENT

REMOVAL, INSTALLATION

INITIAL SETUP:

Tools and Special Tools

General mechanic's tool kit
(item 30, WP 0394 00)

Materials/Parts

Locknut (item 86, WP 0395 00)
Teflon pipe sealant (item 41, WP 0393 00)
Cap and plug set (item 14, WP 0393 00)
Wiping rag (item 35, WP 0393 00)

References

TM 9-2320-386-24P

Equipment Condition

Parking brake set (TM 9-2320-386-10).
Battery ground cable disconnected (WP 0121 00).

TRANSMISSION NEUTRAL SAFETY SWITCH REPLACEMENT (Contd)**REMOVAL**

1. Disconnect two leads 74B and 74A (8) from neutral safety switch plugs (7).
2. Remove locknut (3), screw (6), and clamps (2) and (9) from shift bracket (4). Discard locknut (3).
3. Remove two neutral safety switch plugs (7) from clamp (9).
4. Clean area around neutral safety switch (5) with rag.

CAUTION

Plug opening immediately after removing neutral safety switch to prevent dirt and dust from entering transmission. Failure to do so may cause damage to transmission. Remove plug prior to installation.

5. Remove neutral safety switch (5) from transmission (1).

INSTALLATION

1. Apply sealant to male threads of neutral safety switch (5).
2. Install neutral safety switch (5) on transmission (1).
3. Position clamp (9) on two neutral safety switch plugs (7).
4. Install clamps (9) and (2) on shift bracket (4) with screw (6) and new locknut (3).
5. Connect two leads 74B and 74A (8) to neutral safety switch plugs (7).
6. Connect battery ground cable (WP 0121 00).

TRANSMISSION NEUTRAL SAFETY SWITCH REPLACEMENT (Contd)

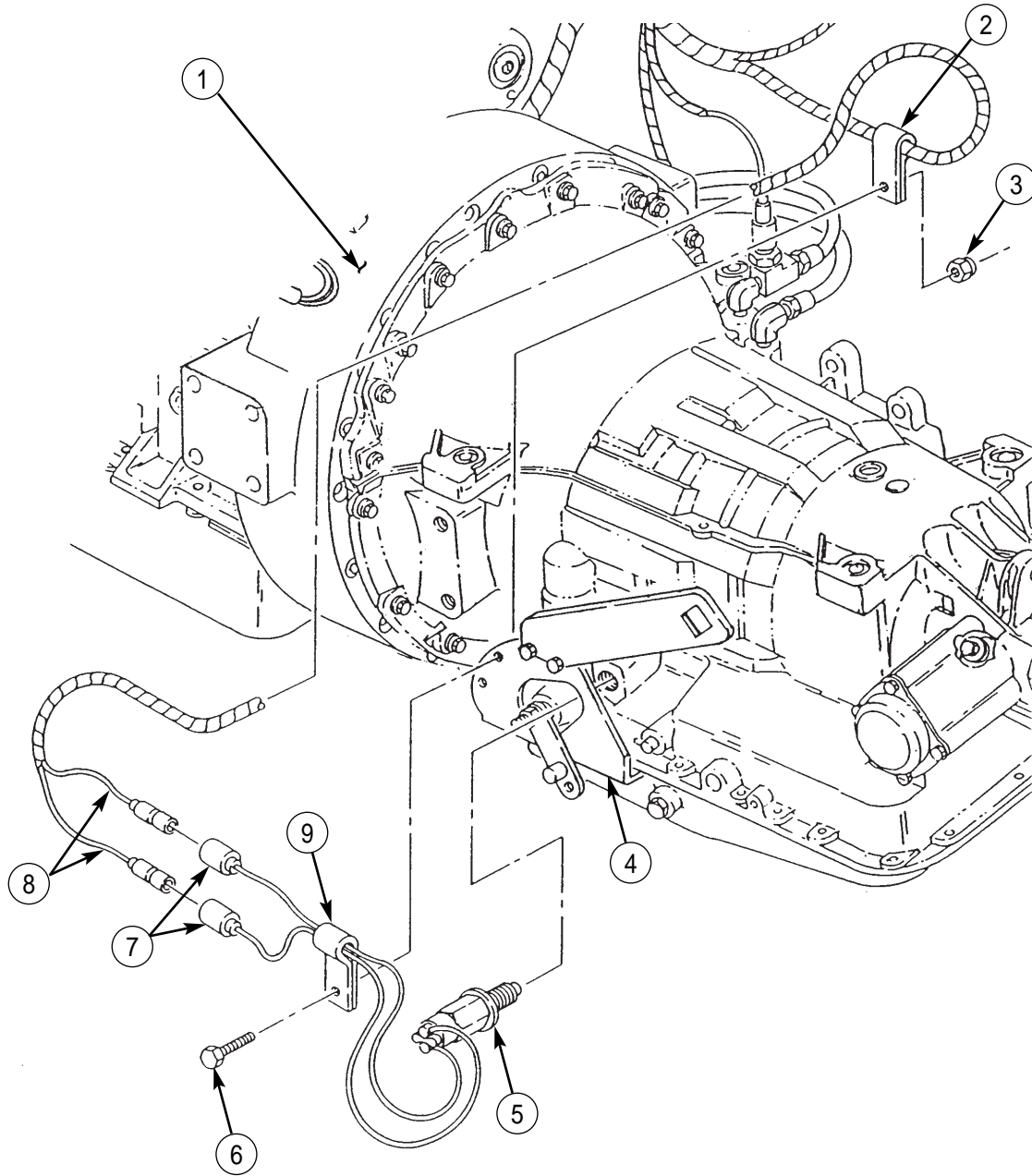

END OF WORK PACKAGE

UNIT MAINTENANCE INSTRUCTIONS

EXTENDED SERVICE PROGRAM (ESP)

TRUCK, CARGO, 2-1/2-TON, 6X6, M44A3 SERIES TRUCKS (DIESEL)

M35A3, W/O WINCH (NSN 2320-01-383-2047); W/WINCH (NSN 2320-01-383-3850);
M35A3C, W/O WINCH (NSN 2320-01-383-2050); W/WINCH (NSN 2320-01-383-2049);
M36A3, W/O WINCH (NSN 2320-01-383-2048); W/WINCH (NSN 2320-01-383-2046).

TRANSMISSION BACKUP LIGHT SWITCH REPLACEMENT

REMOVAL, INSTALLATION

INITIAL SETUP:

Tools and Special Tools

General mechanic's tool kit
(item 30, WP 0394 00)

Materials/Parts

Teflon pipe sealant (item 41, WP 0393 00)
Cap and plug set (item 14, WP 0393 00)
Wiping rag (item 35, WP 0393 00)

References

TM 9-2320-386-24P

Equipment Condition

Parking brake set (TM 9-2320-386-10).
Battery ground cable disconnected (WP 0121 00).

TRANSMISSION BACKUP LIGHT SWITCH REPLACEMENT (Contd)**REMOVAL****CAUTION**

Plug opening immediately after removing transmission backup light switch to prevent dirt and dust from entering transmission. Failure to do so may cause damage to transmission.

1. Disconnect plug with leads 380 and 380A (2) from backup light switch (3).
2. Clean area around backup light switch (3) with rag.
3. Remove backup light switch (3) from transmission (1).

INSTALLATION

1. Apply sealant to male threads of backup light switch (3).
2. Install backup switch (3) on transmission (1).
3. Connect plug with leads 380 and 380A (2) to backup light switch (3).
4. Connect battery ground cable (WP 0121 00).

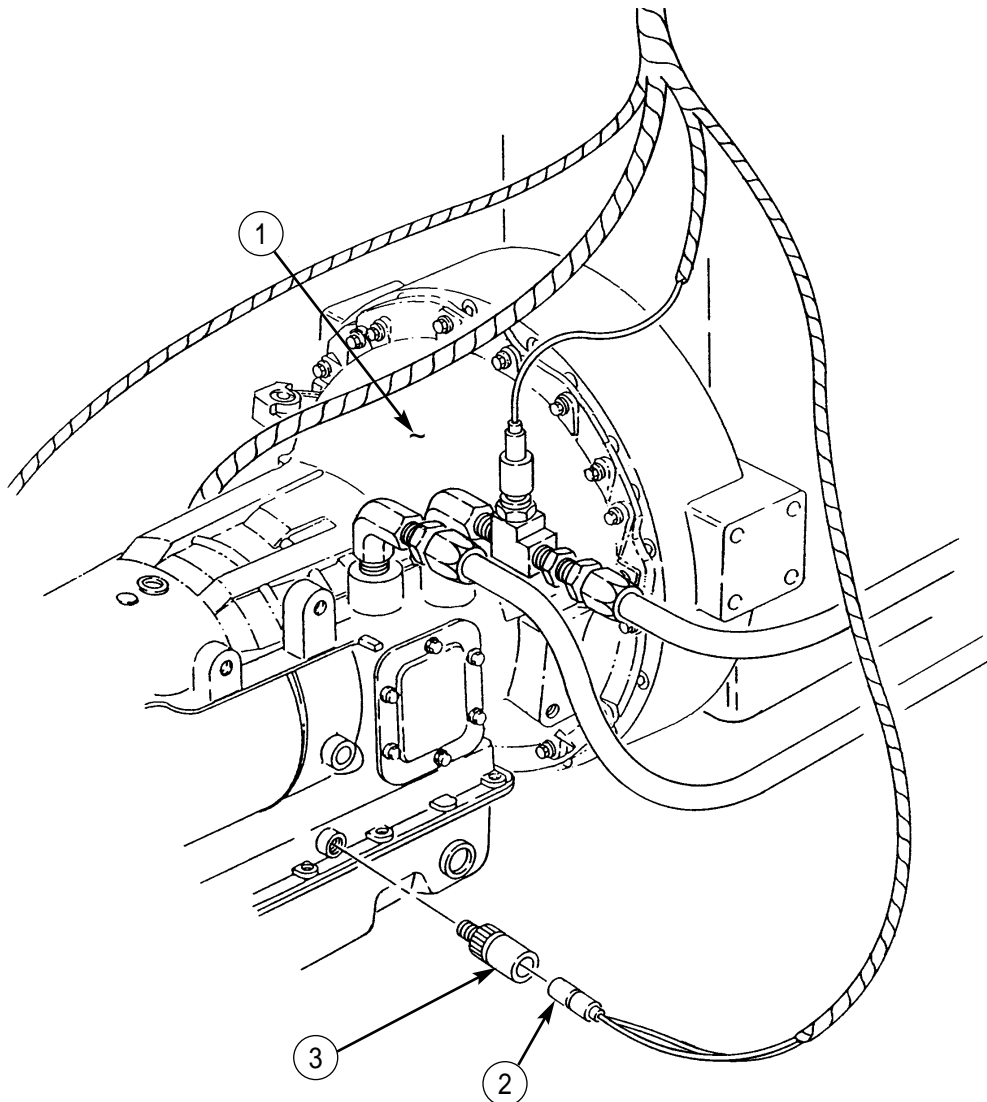
**END OF WORK PACKAGE**

UNIT MAINTENANCE INSTRUCTIONS

EXTENDED SERVICE PROGRAM (ESP)

TRUCK, CARGO, 2-1/2-TON, 6X6, M44A3 SERIES TRUCKS (DIESEL)

M35A3, W/O WINCH (NSN 2320-01-383-2047); W/WINCH (NSN 2320-01-383-3850);
M35A3C, W/O WINCH (NSN 2320-01-383-2050); W/WINCH (NSN 2320-01-383-2049);
M36A3, W/O WINCH (NSN 2320-01-383-2048); W/WINCH (NSN 2320-01-383-2046).

ENGINE OIL PRESSURE TRANSDUCER REPLACEMENT

REMOVAL, INSTALLATION

INITIAL SETUP:

Tools and Special Tools

Common No. 1 tool kit
(item 15, WP 0394 00)

Materials/Parts

Teflon pipe sealant (item 41, WP 0393 00)

References

TM 9-2320-386-24P

Equipment Condition

Parking brake set (TM 9-2320-386-10).
Hood raised and secured (TM 9-2320-386-10).
Battery ground cable disconnected (WP 0121 00).

ENGINE OIL PRESSURE TRANSDUCER REPLACEMENT (Contd)**REMOVAL**

1. Disconnect wire 36 (1) from transducer (3).
2. Remove transducer (3) from adapter (2).

INSTALLATION

1. Apply sealant to male threads of transducer (3).
2. Install transducer (3) on adapter (2).
3. Connect wire 36 (1) to transducer (3).
4. Connect battery ground cable (WP 0121 00).

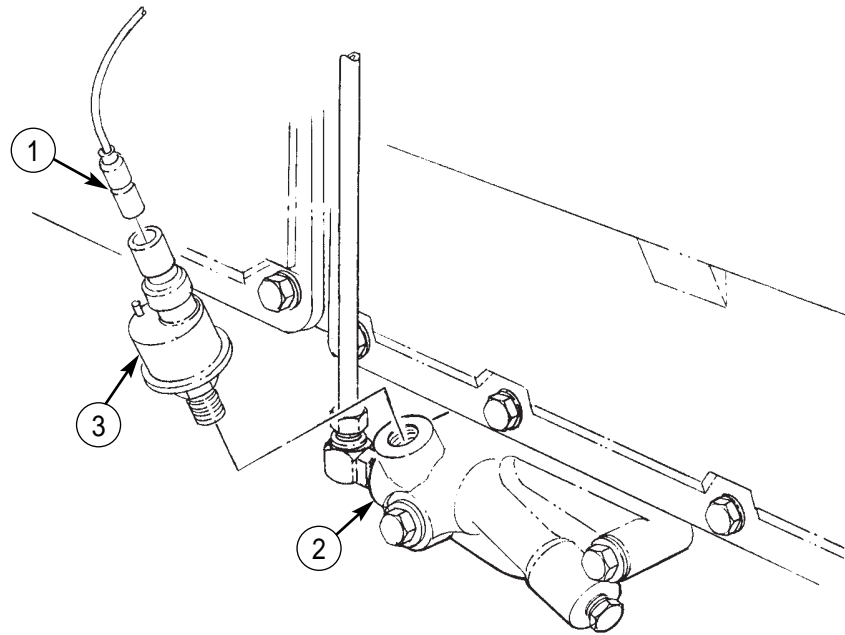

END OF WORK PACKAGE

UNIT MAINTENANCE INSTRUCTIONS

EXTENDED SERVICE PROGRAM (ESP)

TRUCK, CARGO, 2-1/2-TON, 6X6, M44A3 SERIES TRUCKS (DIESEL)

M35A3, W/O WINCH (NSN 2320-01-383-2047); W/WINCH (NSN 2320-01-383-3850);
M35A3C, W/O WINCH (NSN 2320-01-383-2050); W/WINCH (NSN 2320-01-383-2049);
M36A3, W/O WINCH (NSN 2320-01-383-2048); W/WINCH (NSN 2320-01-383-2046).

ENGINE AND TRANSMISSION GROUND STRAPS REPLACEMENT

ENGINE GROUND STRAP REMOVAL, ENGINE GROUND STRAP INSTALLATION,
TRANSMISSION GROUND STRAP REMOVAL, TRANSMISSION GROUND STRAP INSTALLATION

INITIAL SETUP:

Tools and Special Tools

General mechanic's tool kit
(item 30, WP 0394 00)

Materials/Parts

Five lockwashers (item 80, WP 0395 00)
Two locknuts (item 90, WP 0395 00)
Lockwasher (item 130, WP 0395 00)
Lockwasher (item 343, WP 0395 00)

References

TM 9-2320-386-24P

Equipment Condition

Parking brake set (TM 9-2320-386-10).
Hood raised and secured (TM 9-2320-386-10).

ENGINE AND TRANSMISSION GROUND STRAPS REPLACEMENT (Contd)**ENGINE GROUND STRAP REMOVAL**

1. Remove screw (3), lockwasher (2), ground strap (6), and lockwasher (7) from engine (8). Discard lockwashers (2) and (7).
2. Remove locknut (5), ground strap (6), and lockwasher (4) from firewall stud (1). Discard locknut (5) and lockwasher (4).

ENGINE GROUND STRAP INSTALLATION

1. Install ground strap (6) on firewall stud (1) with new lockwasher (4) and new locknut (5).
2. Install ground strap (6) on engine (8) with new lockwashers (7) and (2) and screw (3).

TRANSMISSION GROUND STRAP REMOVAL

1. Remove screw (9), lockwasher (10), ground strap (14), and lockwasher (11) from transmission (12). Discard lockwashers (10) and (11).
2. Remove locknut (16), lockwasher (17), screw (13), ground strap (14), and lockwasher (15) from frame rail (18). Discard locknut (16) and lockwashers (17) and (15).

TRANSMISSION GROUND STRAP INSTALLATION

1. Install ground strap (14) on frame rail (18) with new lockwashers (17) and (15), screw (13), and new locknut (16).
2. Install ground strap (14) on transmission (12) with new lockwashers (11) and (10) and screw (9).

ENGINE AND TRANSMISSION GROUND STRAPS REPLACEMENT (Contd)

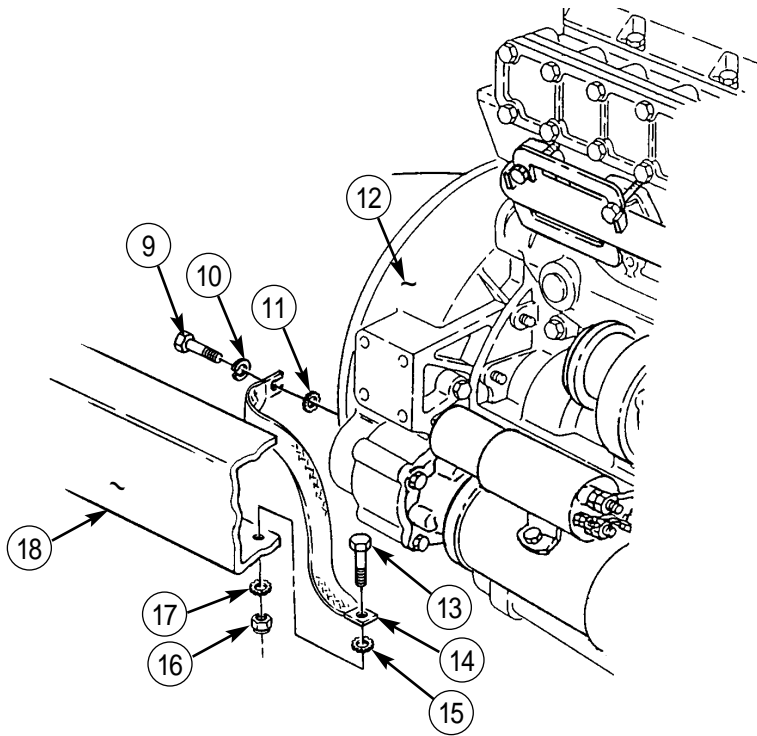
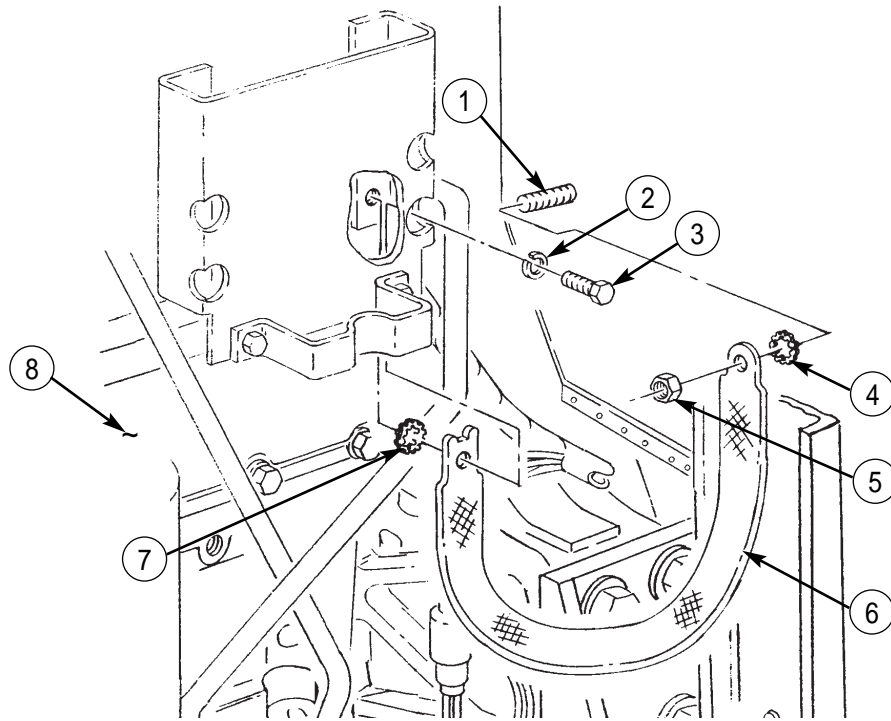

END OF WORK PACKAGE

UNIT MAINTENANCE INSTRUCTIONS

EXTENDED SERVICE PROGRAM (ESP)

TRUCK, CARGO, 2-1/2-TON, 6X6, M44A3 SERIES TRUCKS (DIESEL)

M35A3, W/O WINCH (NSN 2320-01-383-2047); W/WINCH (NSN 2320-01-383-3850);
M35A3C, W/O WINCH (NSN 2320-01-383-2050); W/WINCH (NSN 2320-01-383-2049);
M36A3, W/O WINCH (NSN 2320-01-383-2048); W/WINCH (NSN 2320-01-383-2046).

PARKING BRAKE LIGHT SWITCH REPLACEMENT

REMOVAL, INSTALLATION

INITIAL SETUP:

Tools and Special Tools

General mechanic's tool kit
(item 30, WP 0394 00)

Materials/Parts

Lockwasher (item 42, WP 0395 00)
Locknut (item 90, WP 0395 00)
Locknut (item 15, WP 0395 00)
Locknut (item 99, WP 0395 00)

References

TM 9-2320-386-24P

Equipment Condition

Parking brake set (TM 9-2320-386-10).
Battery ground cable disconnected (WP 0121 00).

PARKING BRAKE LIGHT SWITCH REPLACEMENT (Contd)**REMOVAL**

1. Pull back floor insulation to gain access to the parking brake (1).
2. Remove locknut (15), washer (16), screw (17), and parking brake switch (2) from parking brake (1). Discard locknut (15).
3. Remove locknut (3), lockwasher (4), and ground (GND) lead (5) from parking brake mounting screw (14). Discard locknut (3) and lockwasher (4).
4. Disconnect plug 67 (9) from connector 118 (10).
5. Remove locknut (12), clamp (11), and screw (8) from cab floor (13). Discard locknut (12).
6. Remove clamp (11) from lead (6) and pull lead (6) and grommet (7) from cab floor (13).
7. Remove grommet (7) from lead (6).

INSTALLATION

1. Install grommet (7) on lead (6).
2. Install clamp (11) on lead (6) and cab floor (13) with screw (8) and new locknut (12).
3. Connect plug 67 (9) to connector 118 (10).
4. Install ground (GND) lead (5) on parking brake mounting screw (14) with new lockwasher (4) and new locknut (3).
5. Install parking brake switch (2) on parking brake (1) with screw (17), washer (16), and new locknut (15).
6. Reposition floor insulation on cab floor (13).
7. Connect battery ground cable (WP 0121 00).

PARKING BRAKE LIGHT SWITCH REPLACEMENT (Contd)

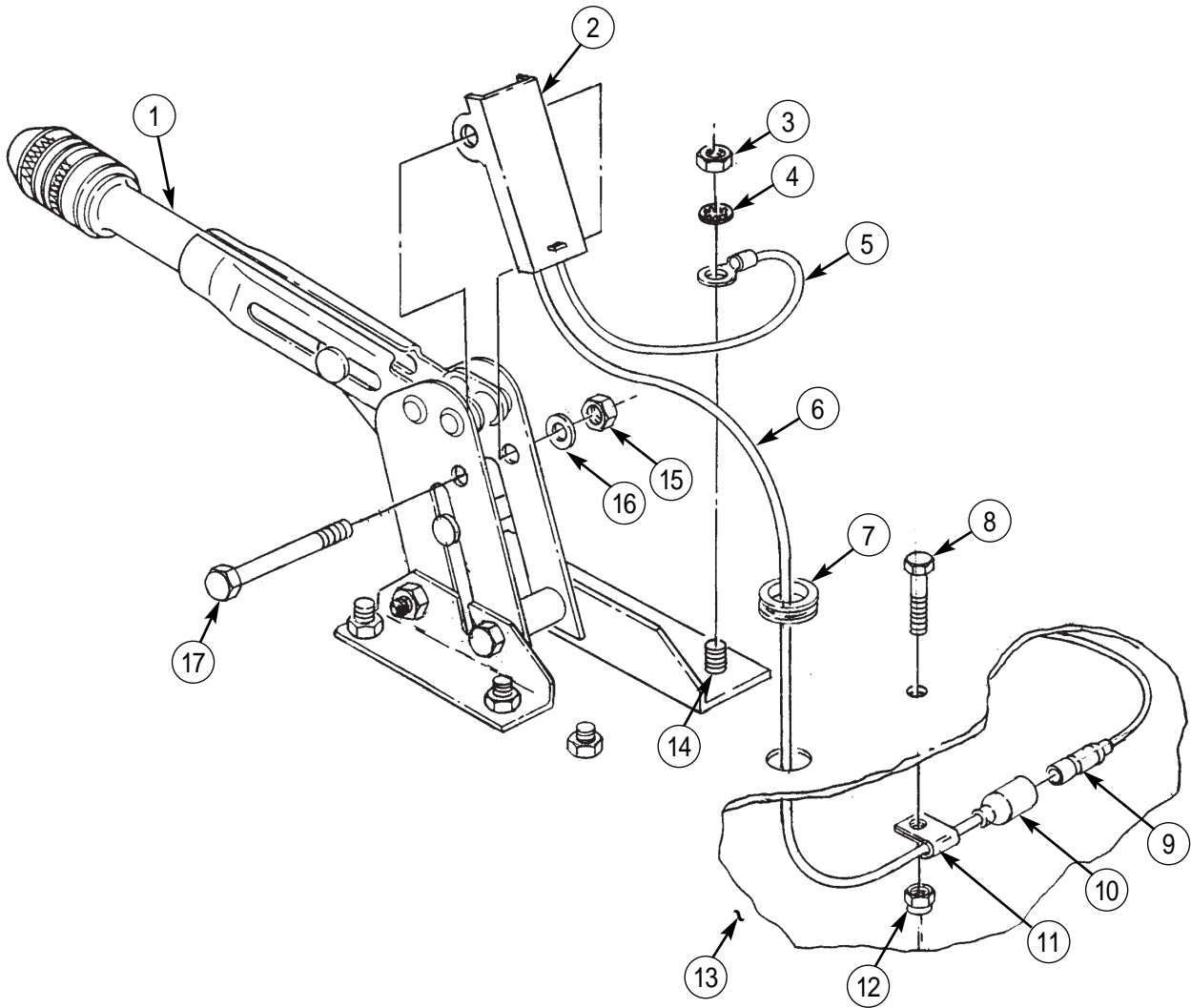

END OF WORK PACKAGE

UNIT MAINTENANCE INSTRUCTIONS

EXTENDED SERVICE PROGRAM (ESP)

TRUCK, CARGO, 2-1/2-TON, 6X6, M44A3 SERIES TRUCKS (DIESEL)

M35A3, W/O WINCH (NSN 2320-01-383-2047); W/WINCH (NSN 2320-01-383-3850);

M35A3C, W/O WINCH (NSN 2320-01-383-2050); W/WINCH (NSN 2320-01-383-2049);

M36A3, W/O WINCH (NSN 2320-01-383-2048); W/WINCH (NSN 2320-01-383-2046).

FUEL SHUTOFF SWITCH REPLACEMENT

REMOVAL, INSTALLATION

INITIAL SETUP:

Tools and Special Tools

General mechanic's tool kit
(item 30, WP 0394 00)

Equipment Condition

Parking brake set (TM 9-2320-386-10).
Battery ground cable disconnected (WP 0121 00).

References

TM 9-2320-386-24P

FUEL SHUTOFF SWITCH REPLACEMENT (Contd)

REMOVAL

1. Remove two screws (2), fuel shutoff data plate (3), and fuel shutoff switch (4) from instrument panel (1).
2. Disconnect two electrical leads 54A and 54 (5) from fuel shutoff switch (4).

INSTALLATION

1. Connect two electrical leads 54A and 54 (5) to fuel shutoff switch (4).
2. Install fuel shutoff switch (4) and fuel shutoff data plate (3) on instrument panel (1) with two screws (2).
3. Connect battery ground cable (WP 0121 00).

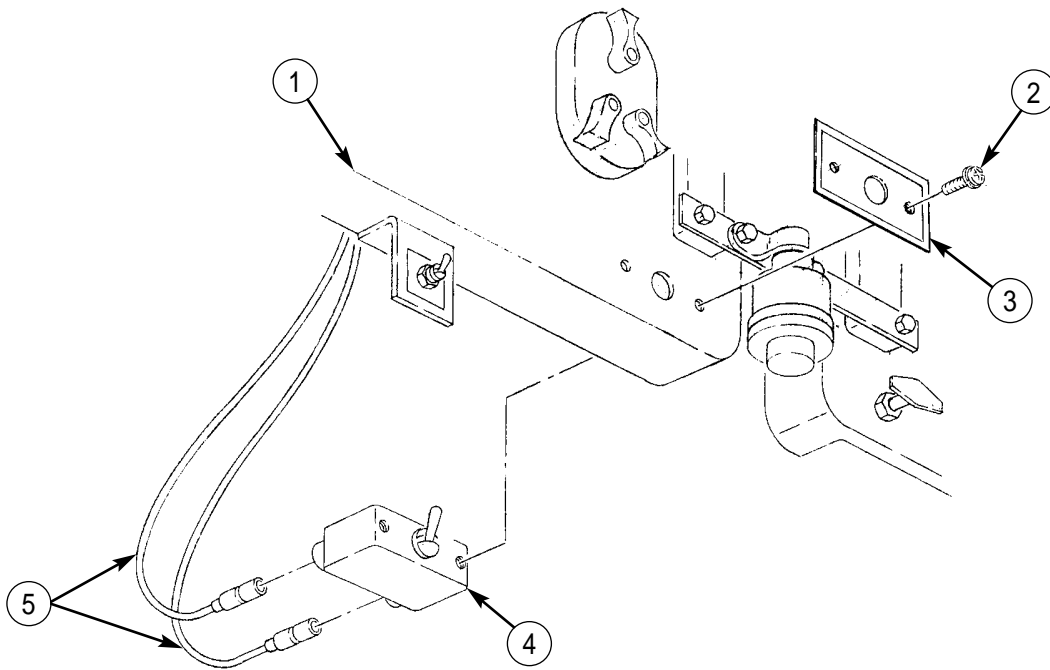

END OF WORK PACKAGE

UNIT MAINTENANCE INSTRUCTIONS

EXTENDED SERVICE PROGRAM (ESP)

TRUCK, CARGO, 2-1/2-TON, 6X6, M44A3 SERIES TRUCKS (DIESEL)

M35A3, W/O WINCH (NSN 2320-01-383-2047); W/WINCH (NSN 2320-01-383-3850);

M35A3C, W/O WINCH (NSN 2320-01-383-2050); W/WINCH (NSN 2320-01-383-2049);

M36A3, W/O WINCH (NSN 2320-01-383-2048); W/WINCH (NSN 2320-01-383-2046).

QUICK-START SWITCH REPLACEMENT

REMOVAL, INSTALLATION

INITIAL SETUP:

Tools and Special Tools

General mechanic's tool kit
(item 30, WP 0394 00)

Equipment Condition

Parking brake set (TM 9-2320-386-10).
Battery ground cable disconnected (WP 0121 00).

References

TM 9-2320-386-24P

QUICK-START SWITCH REPLACEMENT (Contd)

REMOVAL

1. Remove two screws (4), cold-start data plate (3), and quick-start switch (7) from instrument panel (5).

NOTE

Tag all wires for installation.

2. Disconnect leads 569A (1) and 569 (8) from quick-start switch (7) and remove quick-start switch (7).

INSTALLATION

1. Connect leads 569A (1) and 569 (8) to quick-start switch (7).
2. Push switch lever (6) through hole (2) in instrument panel (5).
3. Position cold-start data plate (3) on instrument panel (5).
4. Install quick-start switch (7) and cold-start data plate (3) on instrument panel (5) with two screws (4).
5. Connect battery ground cable (WP 0121 00).

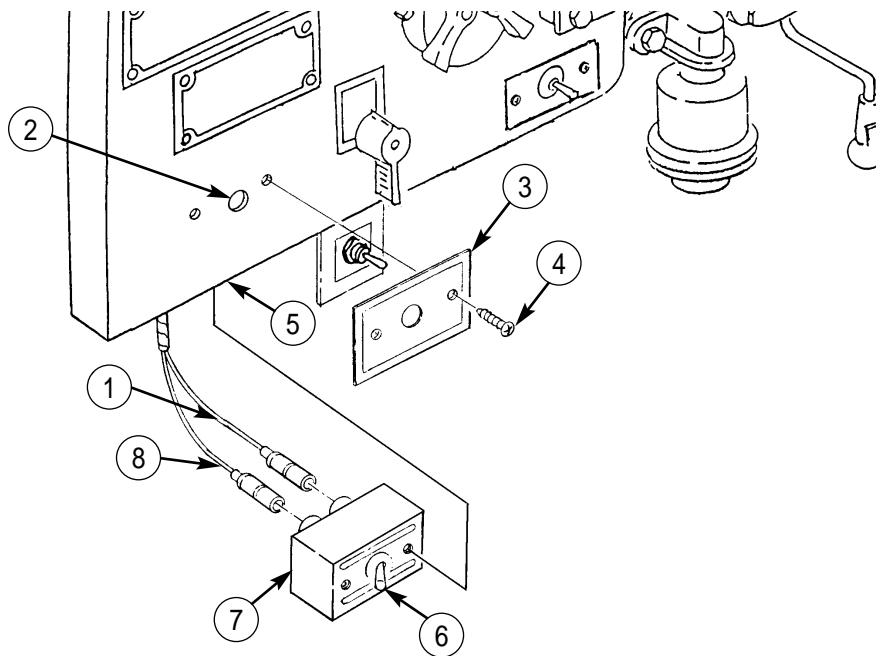

END OF WORK PACKAGE

UNIT MAINTENANCE INSTRUCTIONS

EXTENDED SERVICE PROGRAM (ESP)

TRUCK, CARGO, 2-1/2-TON, 6X6, M44A3 SERIES TRUCKS (DIESEL)

M35A3, W/O WINCH (NSN 2320-01-383-2047); W/WINCH (NSN 2320-01-383-3850);

M35A3C, W/O WINCH (NSN 2320-01-383-2050); W/WINCH (NSN 2320-01-383-2049);

M36A3, W/O WINCH (NSN 2320-01-383-2048); W/WINCH (NSN 2320-01-383-2046).

BLACKOUT DRIVE LAMP AND HOUSING REPLACEMENT

LAMP REMOVAL, LIGHT REMOVAL, LIGHT INSTALLATION, LAMP INSTALLATION

INITIAL SETUP:

Tools and Special Tools

General mechanic's tool kit
(item 30, WP 0394 00)

Materials/Parts

Two locknuts (item 7, WP 0395 00)
Two locknuts (item 107, WP 0395 00)
Lockwasher (item 142, WP 0395 00)
Lockwasher (item 61, WP 0395 00)
Lockwasher (item 56, WP 0395 00)
Gasket (item 96, WP 0395 00)

References

TM 9-2320-386-24P

Equipment Condition

Parking brake set (TM 9-2320-386-10).
Battery ground cable disconnected (WP 0121 00).

BLACKOUT DRIVE LAMP AND HOUSING REPLACEMENT (Contd)**LAMP REMOVAL****NOTE**

Screws are not removable from lens cover.

1. Loosen four screws (1) and remove lens cover (25) and gasket (24) from housing (2). Discard gasket (24).
2. Remove bulb (23) from housing (2).

LIGHT REMOVAL

1. Remove two locknuts (14), screws (18), and rain cover (17) from bracket (16). Discard locknuts (14).
2. Disconnect lead 24 (3) from housing (2).
3. Remove nut (20), lockwashers (21) and (22), ground (GND) lead (6), housing (2), lockwasher (4), finishing washer (5), and five washers (7) from mounting bracket (10). Discard lockwashers (21), (22), and (4).
4. Remove nut (8), screw (11), and clamp (9) from wiring harness (12) and mounting bracket (10).
5. Remove two locknuts (19), screws (13), and mounting bracket (10) from front bumper (15). Discard locknuts (19).

LIGHT INSTALLATION

1. Install mounting bracket (10) on front bumper (15) with two screws (13) and new locknuts (19).
2. Install wiring harness (12) on mounting bracket (10) with clamp (9), screw (11), and nut (8).
3. Install five washers (7), new lockwasher (4), finishing washer (5), housing (2), and ground (GND) lead (6) on mounting bracket (10) with new lockwashers (21) and (22) and nut (20).
4. Connect lead 24 (3) to housing (2).
5. Install rain cover (17) on bracket (16) with two screws (18) and new locknuts (14).

LAMP INSTALLATION

1. Install bulb (23) on housing (2).
2. Install new gasket (24) and lens cover (25) on housing (2) and tighten four screws (1).
3. Connect battery ground cable (WP 0121 00).
4. Check operation of blackout drivelight (TM 9-2320-386-10).

BLACKOUT DRIVE LAMP AND HOUSING REPLACEMENT (Contd)

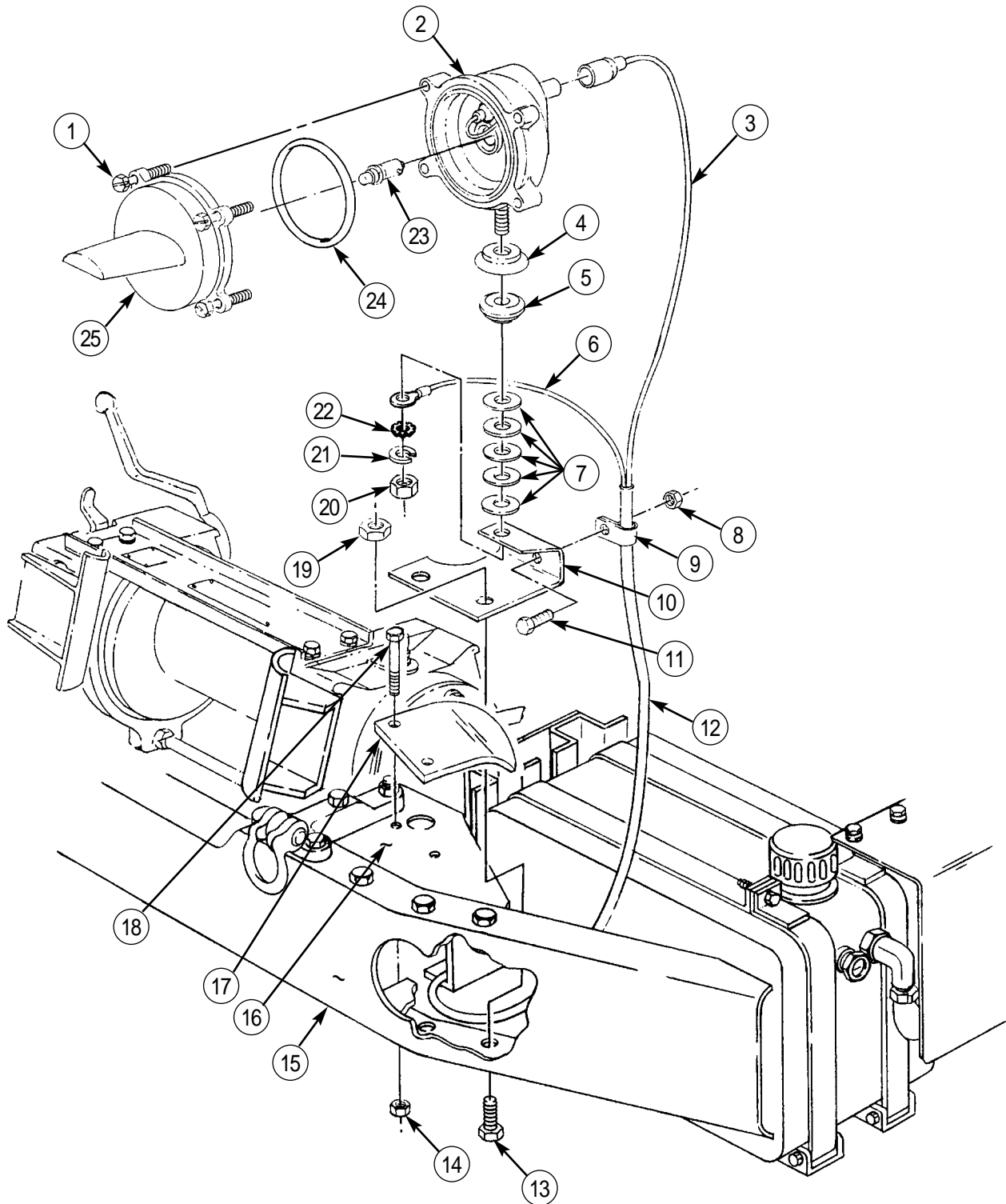

END OF WORK PACKAGE

UNIT MAINTENANCE INSTRUCTIONS

EXTENDED SERVICE PROGRAM (ESP)

TRUCK, CARGO, 2-1/2-TON, 6X6, M44A3 SERIES TRUCKS (DIESEL)

M35A3, W/O WINCH (NSN 2320-01-383-2047); W/WINCH (NSN 2320-01-383-3850);

M35A3C, W/O WINCH (NSN 2320-01-383-2050); W/WINCH (NSN 2320-01-383-2049);

M36A3, W/O WINCH (NSN 2320-01-383-2048); W/WINCH (NSN 2320-01-383-2046).

FRONT AND REAR COMPOSITE LIGHTS AND LAMPS REPLACEMENT

FRONT LAMP REMOVAL, REAR LAMP REMOVAL, FRONT COMPOSITE LIGHT REMOVAL, REAR COMPOSITE LIGHT REMOVAL, REAR COMPOSITE LIGHT ANGLE BRACKET REMOVAL, REAR COMPOSITE LIGHT ANGLE BRACKET INSTALLATION, FRONT COMPOSITE LIGHT INSTALLATION, REAR COMPOSITE LIGHT INSTALLATION, FRONT LAMP INSTALLATION, REAR LAMP INSTALLATION

INITIAL SETUP:

Tools and Special Tools

General mechanic's tool kit
(item 30, WP 0394 00)

Materials/Parts

Two lockwashers (item 61, WP 0395 00)
Two lockwashers (item 79, WP 0395 00)
Two lockwashers (item 78, WP 0395 00)
Four locknuts (item 339, WP 0395 00)
Two locknuts (item 333, WP 0395 00)
Locknut (item 86, WP 0395 00)
O-ring (item 139, WP 0395 00)
O-ring (item 140, WP 0395 00)

References

TM 9-2320-386-24P

Equipment Condition

Parking brake set (TM 9-2320-386-10).
Battery ground cable disconnected (WP 0121 00).
Quick-disconnect coupling halves removed
(TM 9-2320-361-20).

FRONT AND REAR COMPOSITE LIGHTS AND LAMPS REPLACEMENT (Contd)**NOTE**

Left and right front composite lamps, rear composite lamps, composite lights, rear composite lights, and composite light angle brackets are replaced the same. These procedures cover the left side.

Tag all wires for installation.

FRONT LAMP REMOVAL

1. Remove five screws (1), lens cover (12), and O-ring (11) from composite light housing (4). Discard O-ring (11).

NOTE

Perform step 2 for vehicles with lamp configuration. Perform steps 3 through 5 for vehicles with lamp and semiconductor device configuration.

2. Remove lamps (2), (3), and (10) from sockets (5), (6), and (7).
3. Remove lamps (2) and (3) from sockets (5) and (6).
4. Position semiconductor device (9) for access to socket (7).
5. Remove connector (8) from socket (7).

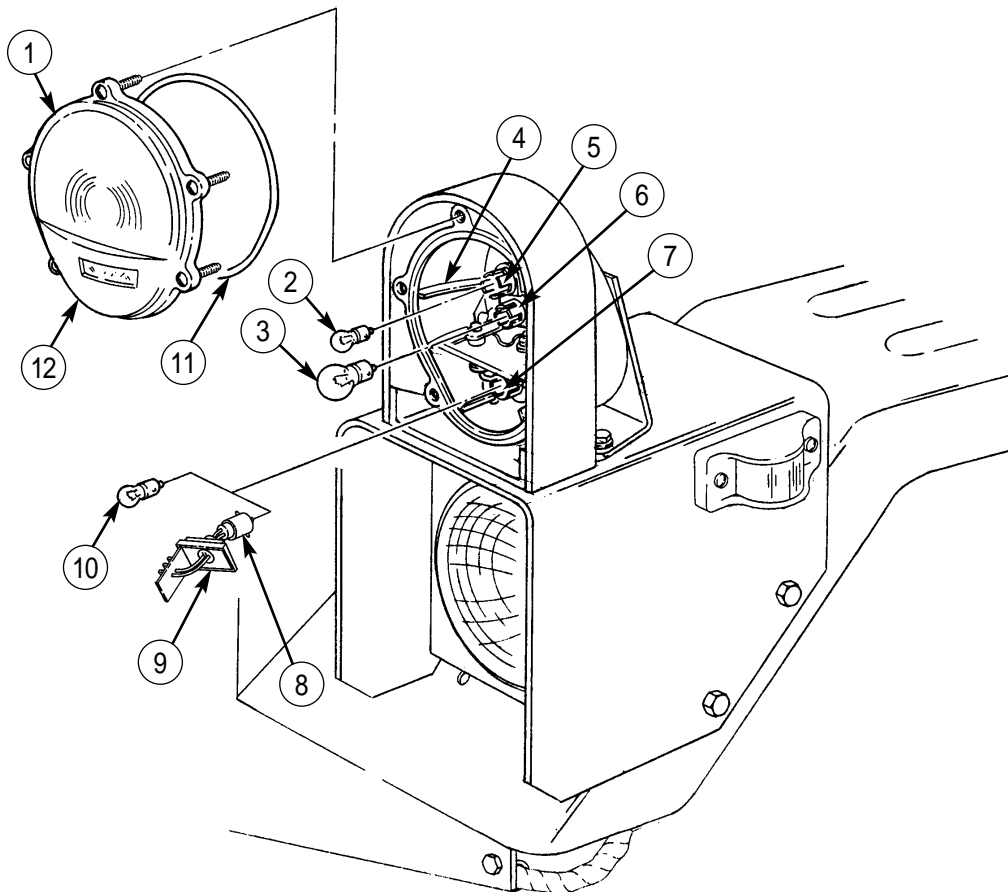

FRONT AND REAR COMPOSITE LIGHTS AND LAMPS REPLACEMENT (Contd)**REAR LAMP REMOVAL**

1. Remove six screws (23), light lens (22), and O-ring (24) from composite light housing (13). Discard O-ring (24).

NOTE

Perform step 2 for vehicles with lamp configuration. Perform steps 3 through 7 for vehicles with lamp, and clearance marker light and stoplight semiconductor device configuration.

2. Remove lamps (15), (16), and (19) from sockets (14), (27), (26), and (25).
3. Remove lamps (15) and (16) from sockets (14) and (27).
4. Position clearance marker light (18) for access to socket (26).
5. Remove connector (17) from socket (26).
6. Position stoplight (20) for access to socket (25).
7. Remove connector (21) from socket (25).

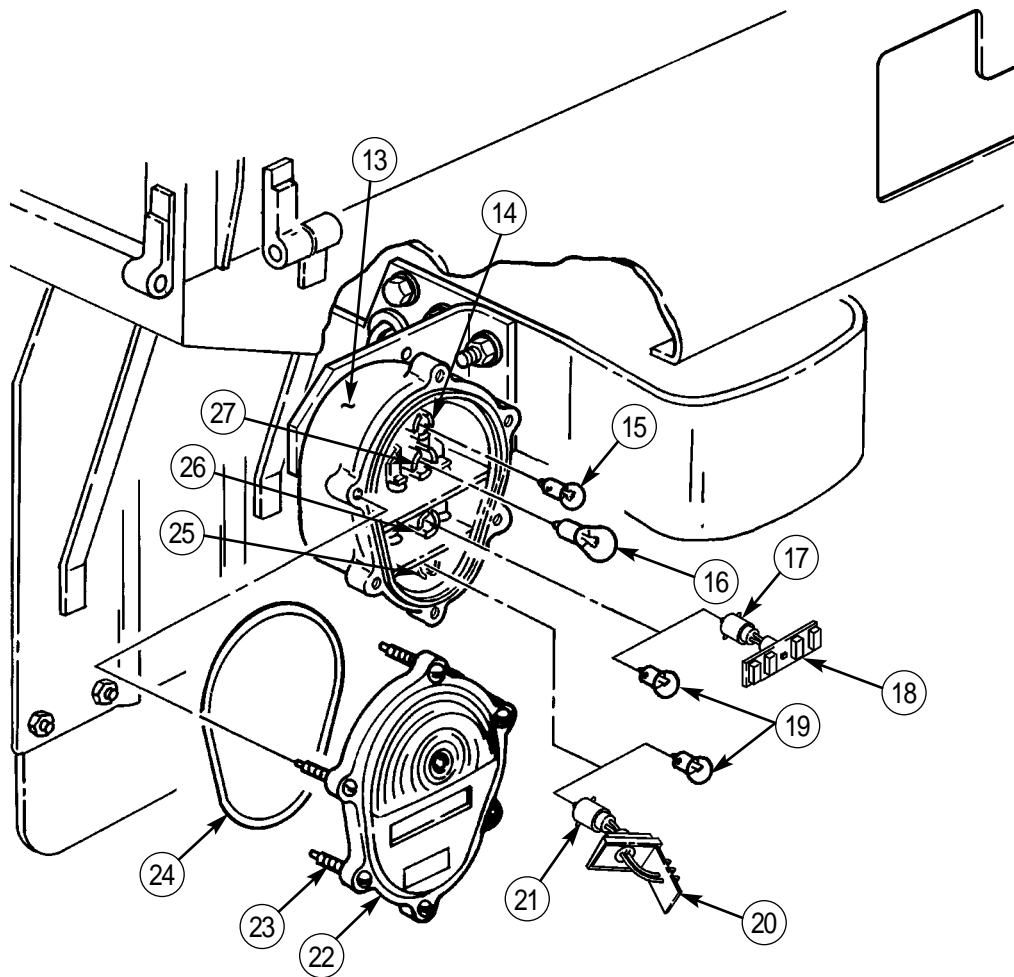

FRONT AND REAR COMPOSITE LIGHTS AND LAMPS REPLACEMENT (Contd)**FRONT COMPOSITE LIGHT REMOVAL**

1. Remove four locknuts (11), screws (14), and protector box (7) from fender (15). Discard locknuts (11).
2. Disconnect three composite light plugs 483, 20, and 484 (3) from leads 20 (9) on wiring harness (8).
3. Remove two locknuts (12), lockwashers (13), ground (GND) leads (17) and (18), two screws (2), and bracket (20) with composite light housing (1) from headlight mounting bracket (16). Discard lockwashers (13) and locknuts (12).
4. Remove grommet (6) from fender (15).
5. Remove grommet (10) from protector box (7).
6. Remove grommet (19) from headlight mounting bracket (16).
7. Remove two screws (4), lockwashers (5), and composite light housing (1) from bracket (20). Discard lockwashers (5).

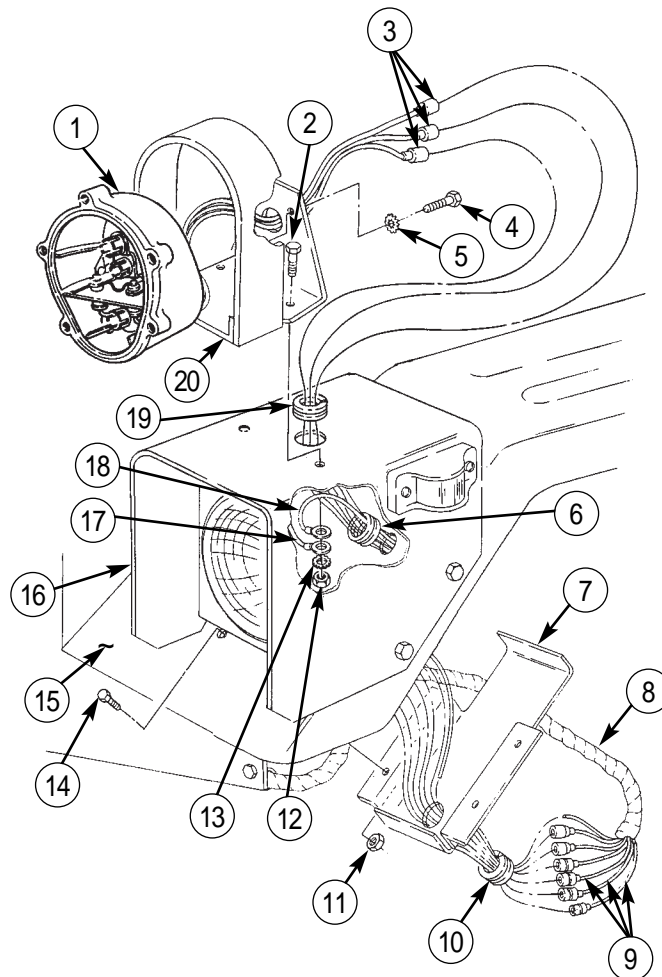

FRONT AND REAR COMPOSITE LIGHTS AND LAMPS REPLACEMENT (Contd)**REAR COMPOSITE LIGHT REMOVAL**

1. Remove locknut (24), screw (29), and clamp (28) from angle bracket (23). Discard locknut (24).
2. Remove four rear taillight leads 21, 22-461, 23, and 24 (25) on left side and 21, 22-460, 23 and 24 (25) on right side from harness leads 21, 22-461, 23, and 24 (26) on left side and 21, 22-460, 23, and 24 (26) on right side.
3. Remove two screws (21), lockwashers (22), and light housing (27) from angle bracket (23). Discard lockwashers (22).

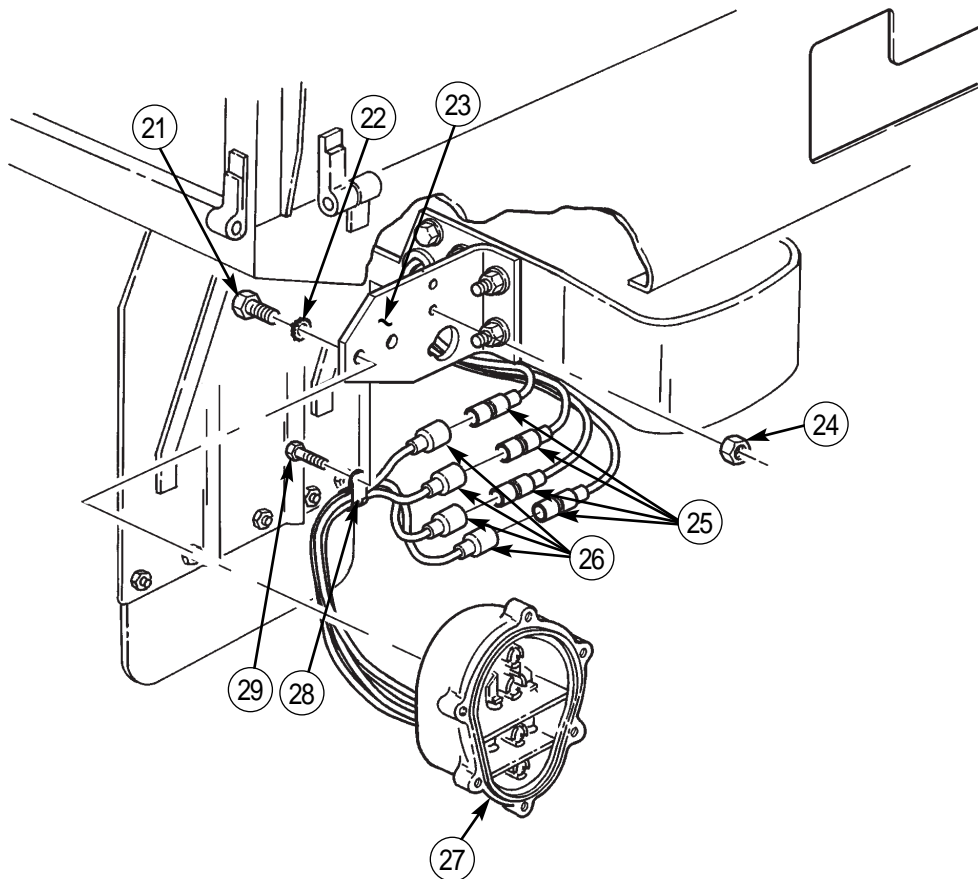

FRONT AND REAR COMPOSITE LIGHTS AND LAMPS REPLACEMENT (Contd)**REAR COMPOSITE LIGHT ANGLE BRACKET REMOVAL**

Remove two nuts (4), screws (1), and angle bracket (3) from bumper (2).

REAR COMPOSITE LIGHT ANGLE BRACKET INSTALLATION

Install angle bracket (3) on bumper (2) with two screws (1) and nuts (4).

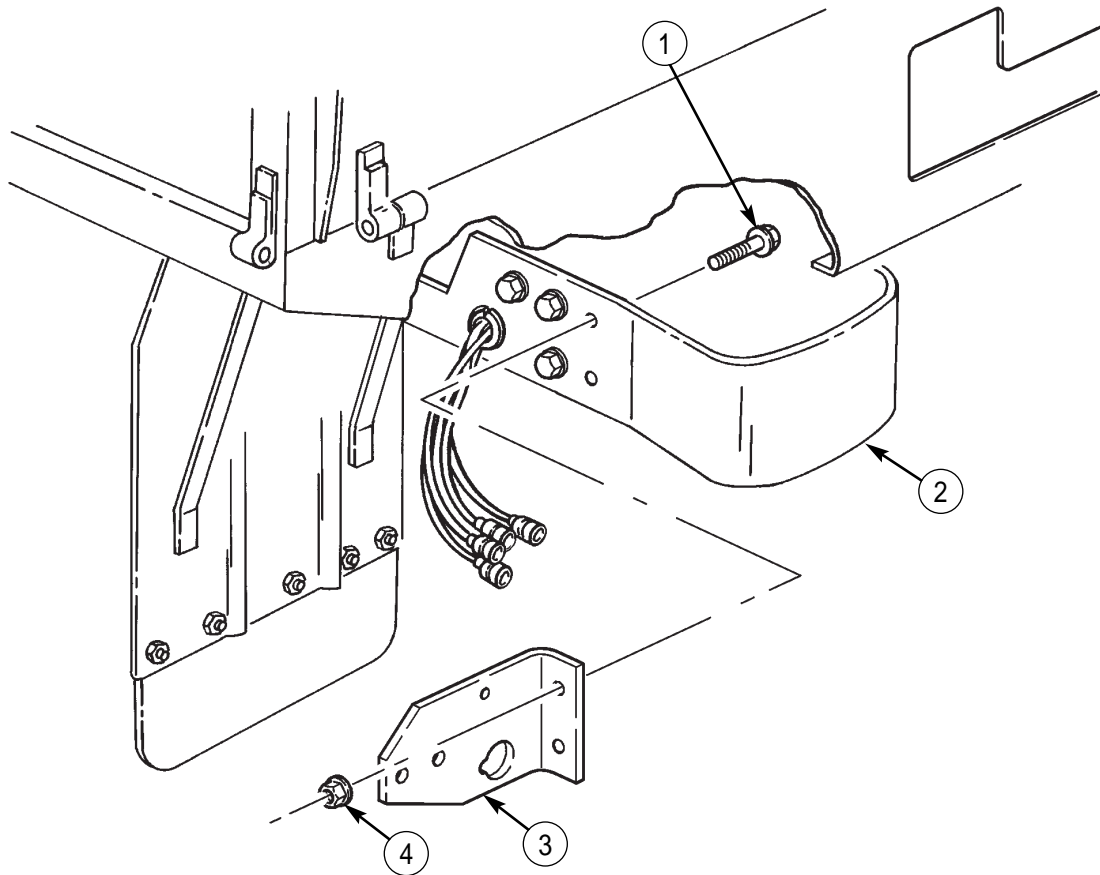

FRONT AND REAR COMPOSITE LIGHTS AND LAMPS REPLACEMENT (Contd)**FRONT COMPOSITE LIGHT INSTALLATION**

1. Route three composite light plugs 483, 20, and 484 (7) through hole in bracket (23).
2. Install composite light housing (5) on bracket (23) with two new lockwashers (24) and screws (8).
3. Route three composite light plugs 483, 20, and 484 (7) through hole in headlight mounting bracket (19) and fender (18).
4. Install grommet (9) on fender (18).
5. Install grommet (22) on headlight mounting bracket (19).
6. Route harness (11) through hole in protector box (10).
7. Install grommet (13) on protector box (10).
8. Install protector box (10) on fender (18) with four screws (17) and new locknuts (14).
9. Install bracket (23) and ground (GND) leads (20) and (21) on headlight mounting bracket (19) with two screws (6), new lockwashers (16), and new locknuts (15).
10. Connect three composite light plugs 483, 20, and 484 (7) on leads 20 (12).

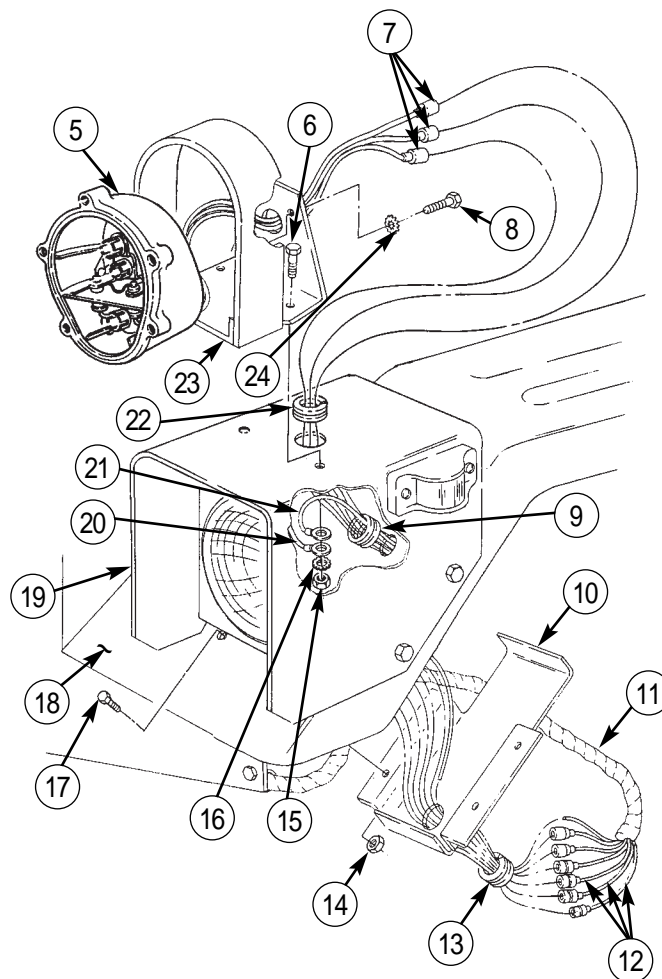

FRONT AND REAR COMPOSITE LIGHTS AND LAMPS REPLACEMENT (Contd)**REAR COMPOSITE LIGHT INSTALLATION**

1. Connect four harness leads 21, 22-461, 23, and 24 (6) on left side and 21, 22-460, 23, and 24 (6) on right side to taillight leads 21, 22-461, 23, and 24 (5) on left side and 21, 22-460, 23, and 24 (5) on right side.
2. Install loop clamp (8) on angle bracket (3) with screw (9) and new locknut (4).
3. Install light housing (7) on angle bracket (3) with two new lockwashers (2) and screws (1).

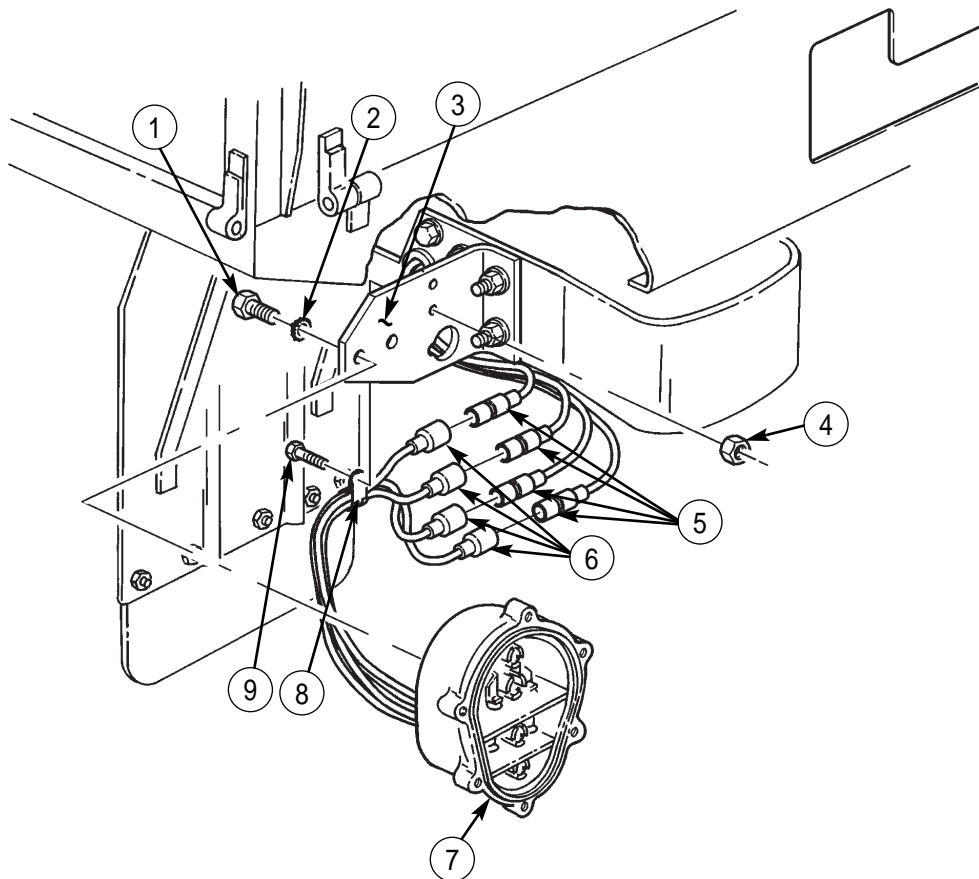

FRONT AND REAR COMPOSITE LIGHTS AND LAMPS REPLACEMENT (Contd)**FRONT LAMP INSTALLATION****NOTE**

Perform steps 1 and 5 for vehicles with lamp configuration.
Perform steps 2 through 5 for vehicles with lamp and semiconductor device configuration.

1. Install lamps (15), (16), and (19) in sockets (12), (13), and (14).
2. Install lamps (15) and (16) in sockets (12) and (13).
3. Install connector (17) in socket (14).
4. Position semiconductor device (18) on connector (17).
5. Install new O-ring (20) and lens cover (21) on composite light housing (11) with five screws (10).

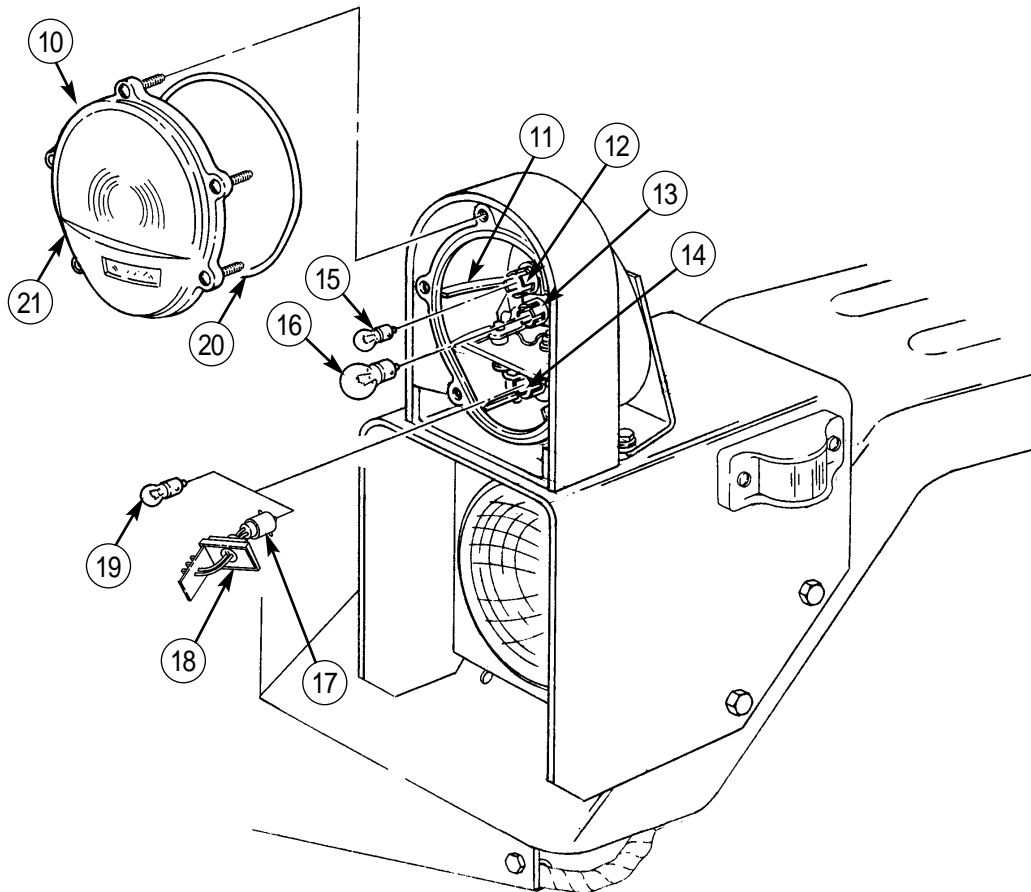

FRONT AND REAR COMPOSITE LIGHTS AND LAMPS REPLACEMENT (Contd)**REAR LAMP INSTALLATION****NOTE**

Steps 1, 5, and 6 are for vehicles with lamp configuration. Steps 2 through 6 are for vehicles with lamp and clearance marker light and stoplight semiconductor device configuration.

1. Install lamps (2), (3), and (6) in sockets (15), (14), (13), and (12).
2. Install lamps (2) and (3) in sockets (15) and (14).
3. Install connectors (4) and (8) in sockets (13) and (12).
4. Position clearance marker light (5) on connector (4) and stoplight (7) on connector (8).
5. Install new O-ring (11) and lens cover (9) on composite light housing (1) with six screws (10).
6. Connect battery ground cable (WP 0121 00).

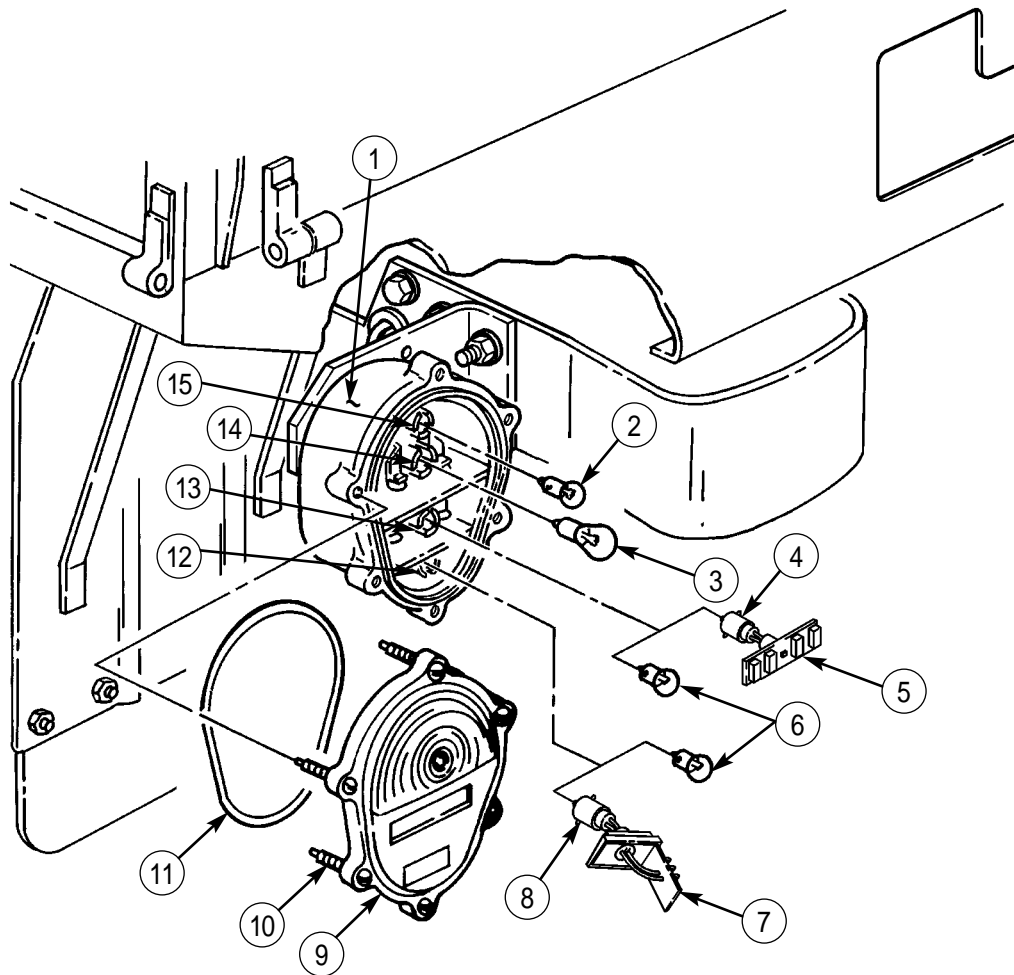

END OF WORK PACKAGE

UNIT MAINTENANCE INSTRUCTIONS

EXTENDED SERVICE PROGRAM (ESP)

TRUCK, CARGO, 2-1/2-TON, 6X6, M44A3 SERIES TRUCKS (DIESEL)

M35A3, W/O WINCH (NSN 2320-01-383-2047); W/WINCH (NSN 2320-01-383-3850);
M35A3C, W/O WINCH (NSN 2320-01-383-2050); W/WINCH (NSN 2320-01-383-2049);
M36A3, W/O WINCH (NSN 2320-01-383-2048); W/WINCH (NSN 2320-01-383-2046).

HEADLIGHTS AND HEADLAMPS MAINTENANCE

LAMP REMOVAL, HEADLIGHT REMOVAL, HEADLIGHT INSTALLATION, LAMP INSTALLATION, ALIGNMENT

INITIAL SETUP:

Tools and Special Tools

General mechanic's tool kit
(item 30, WP 0394 00)

Materials/Parts

Six lockwashers (item 59, WP 0395 00)
Chalk (item 15, WP 0393 00)

References

TM 9-2320-386-24P

Equipment Condition

Parking brake set (TM 9-2320-386-10).
Battery ground cable disconnected (WP 0121 00).

HEADLIGHTS AND HEADLAMPS MAINTENANCE (Contd)

LAMP REMOVAL

1. Remove three screws (6) and retaining ring (1) from headlight (3).

NOTE

Tag all wires for installation.

2. Remove three plugs (5) and headlamp (2) from adapter connectors (9).

HEADLIGHT REMOVAL

1. Remove three nuts (10), lockwashers (11), and headlight (3) from headlight mounting bracket (4). Discard lockwashers (11).
2. Remove three connectors 17, 18, 91 (12) from adapter connectors (9).
3. Remove two alignment screws (7), threaded bushings (18), and headlamp alignment housing (8) from retaining spring (14) and headlight (3).
4. Remove three nuts (17), lockwashers (16), spacers (15), and studs (13) from headlight (3). Discard lockwashers (16).

HEADLIGHT INSTALLATION

1. Position headlamp alignment housing (8) on headlight (3) with retaining spring (14).
2. Install headlamp alignment housing (8) on headlight (3) with two threaded bushings (18) and alignment screws (7).
3. Install headlight (3) on three studs (13) with spacers (15), new lockwashers (16), and nuts (17).
4. Connect three connectors 17, 18, 91 (12) to adapter connectors (9).
5. Install headlight (3) on headlight mounting bracket (4) with three new lockwashers (11) and nuts (10).

LAMP INSTALLATION

1. Connect three headlamp plugs (5) to adapter connectors (9).
2. Position headlamp (2) on headlight (3) and install retaining ring (1) on headlight (3) with three screws (6).

HEADLIGHTS AND HEADLAMPS MAINTENANCE (Contd)

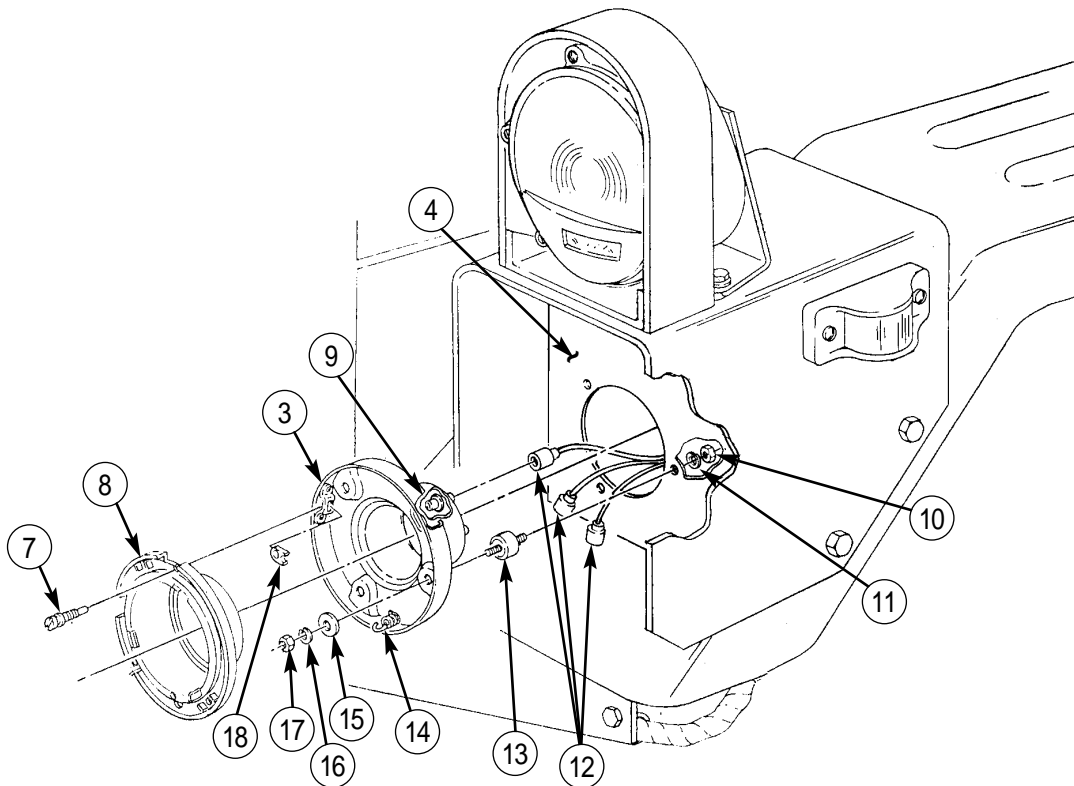
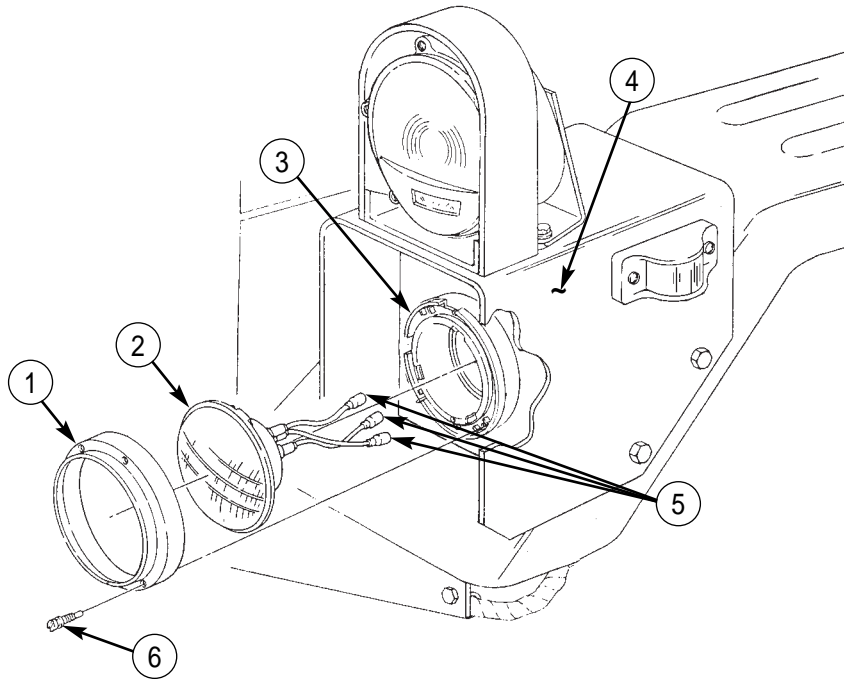

HEADLIGHTS AND HEADLAMPS MAINTENANCE (Contd)

ALIGNMENT

NOTE

Perform headlamp alignment for both headlamps.

Perform follow-on-task prior to headlight alignment.

1. Using chalk, draw a horizontal line (5) on a wall at the height of 3.25 ft (1 m).
2. Position truck facing wall so headlamps (2) are 25 ft (7.6 m) from wall.
3. Using chalk, draw a vertical line (7) through horizontal line (5) so it is in line with center of each headlamp (2).

NOTE

Turn headlamps on low beam (TM 9-2320-386-10) as necessary to check alignment.

Once retaining ring is removed, the headlamp must be supported on the headlight fixture. Electrical wires are not intended to support the weight of the headlamp.

4. Remove three screws (4) and retaining ring (1) from headlight (3).
5. Adjust headlamp (2) horizontal direction with adjusting screw (9) until left edge of light area (6) on wall is 2-6 in. (5-15 cm) right of vertical line (7).
6. Adjust headlamp (2) vertical direction with adjusting screw (8) until top edge of light area (6) on wall is touching lower side of horizontal line (5).
7. Install retaining ring (1) on headlight (3) with three screws (4).
8. Connect battery ground cable (WP 0121 00).

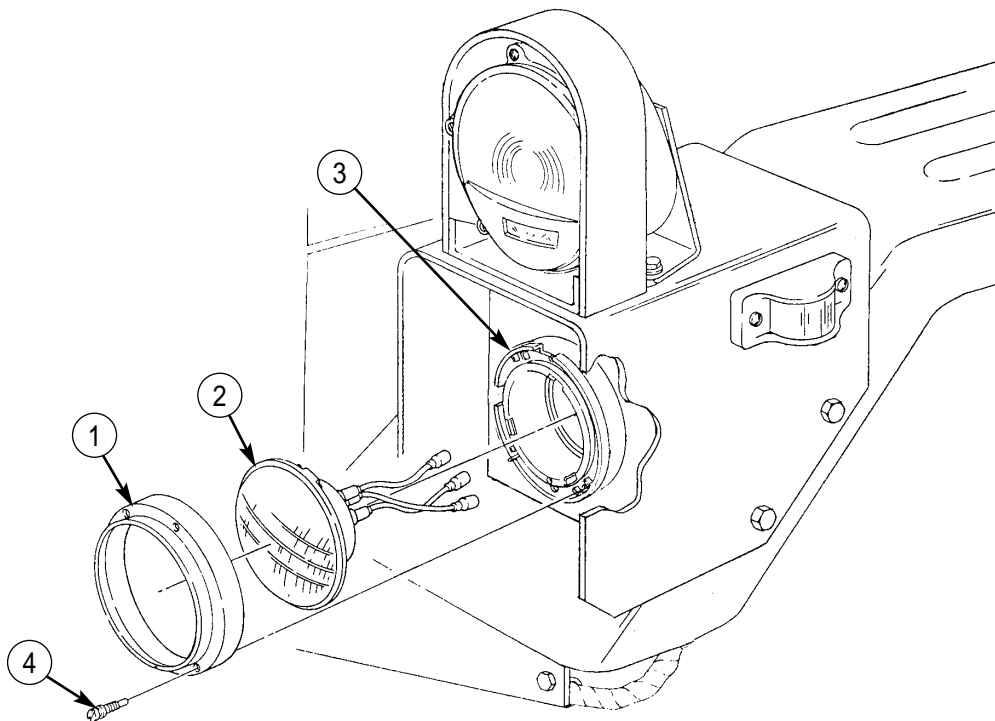

HEADLIGHTS AND HEADLAMPS MAINTENANCE (Contd)

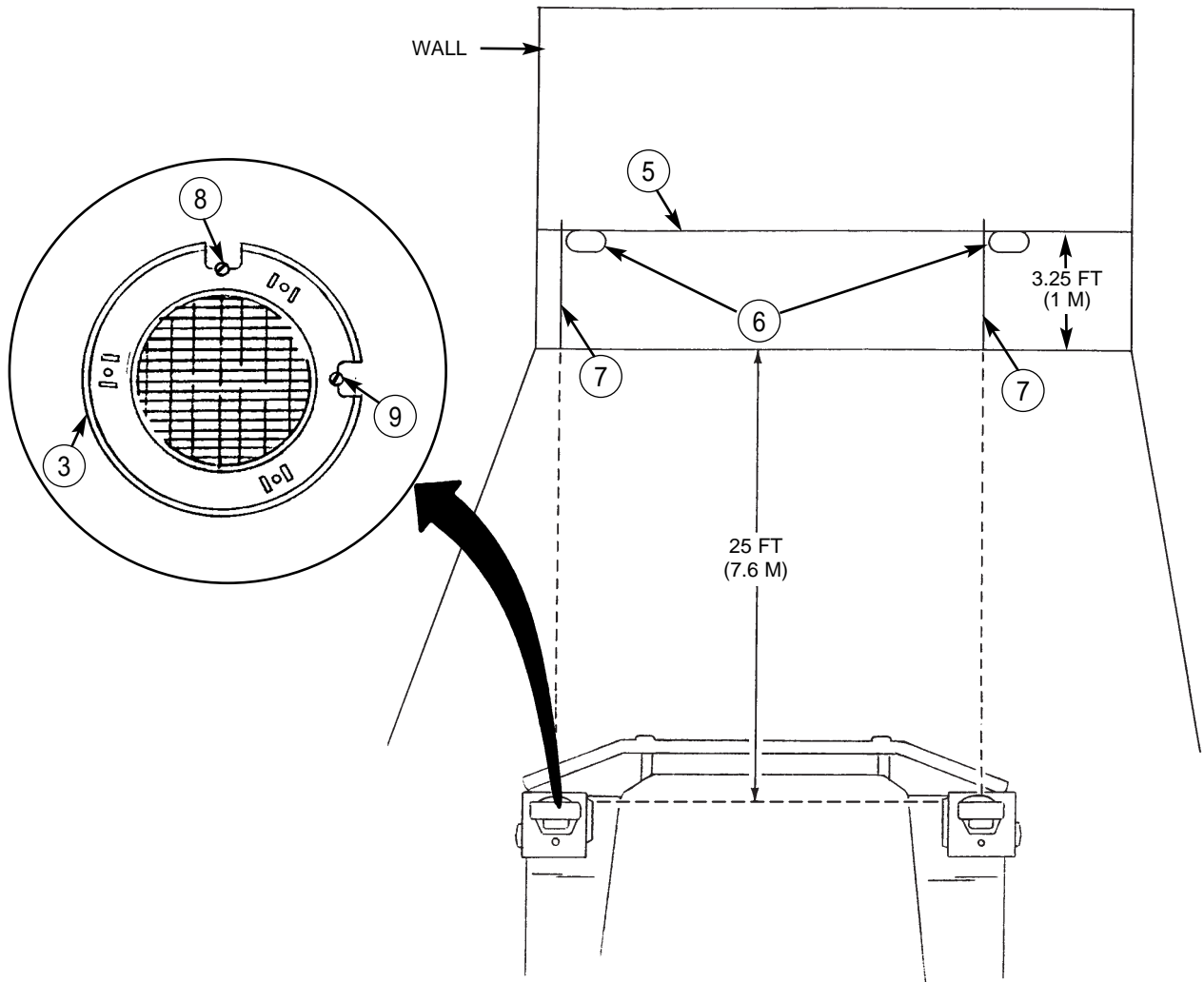

END OF WORK PACKAGE

UNIT MAINTENANCE INSTRUCTIONS

EXTENDED SERVICE PROGRAM (ESP)

TRUCK, CARGO, 2-1/2-TON, 6X6, M44A3 SERIES TRUCKS (DIESEL)

M35A3, W/O WINCH (NSN 2320-01-383-2047); W/WINCH (NSN 2320-01-383-3850);
M35A3C, W/O WINCH (NSN 2320-01-383-2050); W/WINCH (NSN 2320-01-383-2049);
M36A3, W/O WINCH (NSN 2320-01-383-2048); W/WINCH (NSN 2320-01-383-2046).

FRONT SIDE MARKER LIGHTS AND LAMPS REPLACEMENT

REMOVAL, INSTALLATION

INITIAL SETUP:

Tools and Special Tools

General mechanic's tool kit
(item 30, WP 0394 00)

Materials/Parts

Gasket (item 262, WP 0395 00)
Four lockwashers (item 76, WP 0395 00)
Four locknuts (item 333, WP 0395 00)

References

TM 9-2320-386-24P

Equipment Condition

Parking brake set (TM 9-2320-386-10).
Battery ground cable disconnected (WP 0121 00).

FRONT SIDE MARKER LIGHTS AND LAMPS REPLACEMENT (Contd)**NOTE**

Replacement of front left and right side marker lights are the same. This procedure covers the left side marker light.

REMOVAL

1. Remove two screws (12) and cover (11) with lens cover (10) from side marker light (6).
2. If lens cover (10) is damaged, remove two push clips (9) and lens cover (10) from cover (11).
3. Remove lamp (8) from side marker light (6).
4. Remove four locknuts (14) and screws (13), and lift rear of headlight mounting bracket (1) to access nuts (2), lockwashers (3), and electrical connectors. Discard locknuts (14).
5. Disconnect side marker light plug 489 (4) from wiring harness connector with lead 21 (15).
6. Remove four nuts (2), lockwashers (3), screws (7), side marker light (6), and gasket (5) from headlight mounting bracket (1). Discard lockwashers (3) and gasket (5).

INSTALLATION

1. Install new gasket (5) and side marker light (6) on headlight mounting bracket (1) with four screws (7), new lockwashers (3), and nuts (2).
2. Connect side marker light plug with lead 489 (4) to wiring harness connector with lead 21 (15).
3. Lower headlight mounting bracket (1) into position and secure with four screws (13) and new locknuts (14).
4. Install lamp (8) in side marker light (6).
5. If removed, install lens cover (10) on cover (11) with two push clips (9).
6. Install cover (11) with lens cover (10) on side marker light (6) with two screws (12).
7. Connect battery ground cable (WP 0121 00).

FRONT SIDE MARKER LIGHTS AND LAMPS REPLACEMENT (Contd)

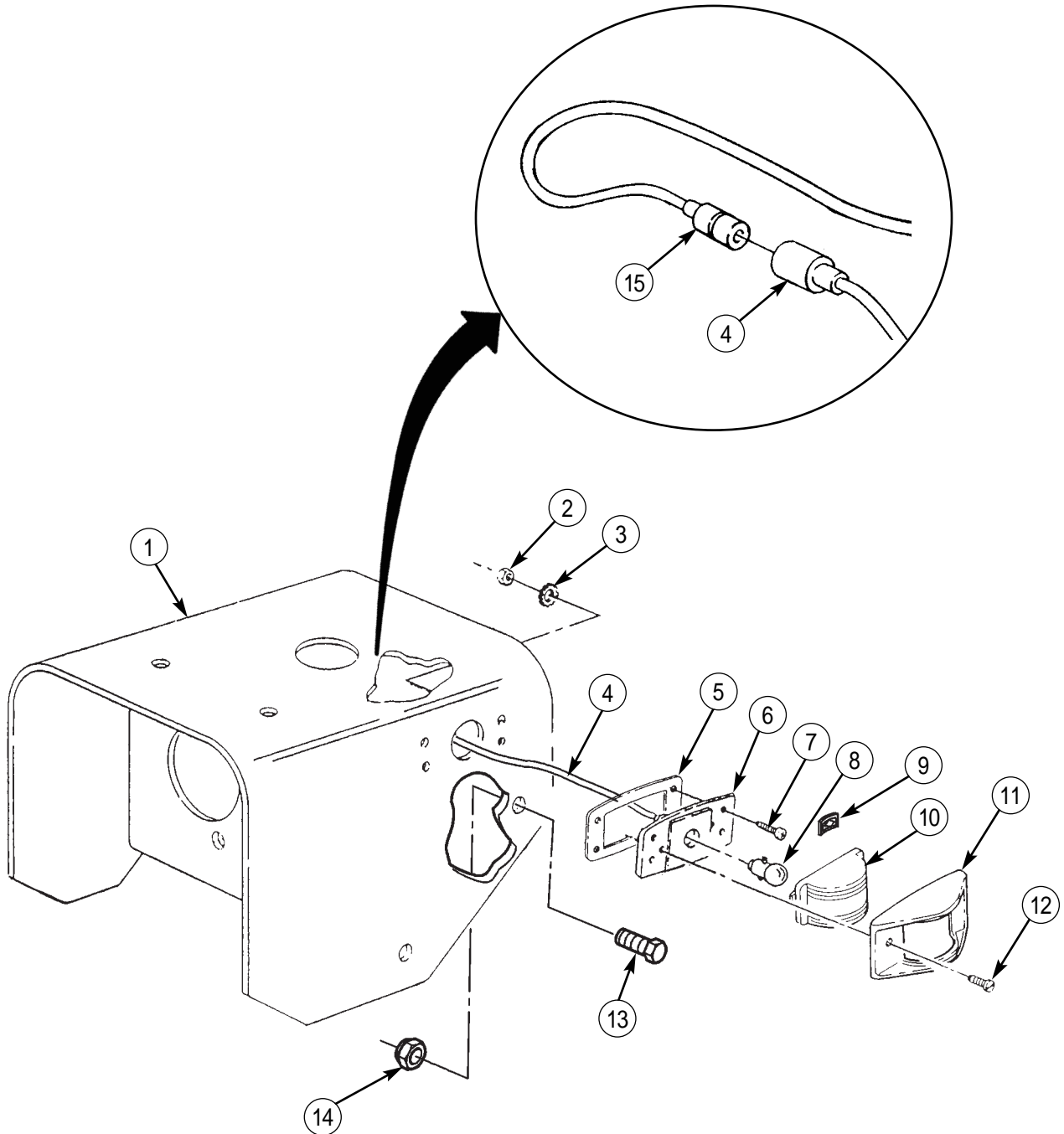

END OF WORK PACKAGE

UNIT MAINTENANCE INSTRUCTIONS

EXTENDED SERVICE PROGRAM (ESP)

TRUCK, CARGO, 2-1/2-TON, 6X6, M44A3 SERIES TRUCKS (DIESEL)

M35A3, W/O WINCH (NSN 2320-01-383-2047); W/WINCH (NSN 2320-01-383-3850);

M35A3C, W/O WINCH (NSN 2320-01-383-2050); W/WINCH (NSN 2320-01-383-2049);

M36A3, W/O WINCH (NSN 2320-01-383-2048); W/WINCH (NSN 2320-01-383-2046).

HEADLIGHT MOUNTING BRACKET REPLACEMENT

REMOVAL, INSTALLATION

INITIAL SETUP:

Tools and Special Tools

General mechanic's tool kit
(item 30, WP 0394 00)

Materials/Parts

Four locknuts (item 333, WP 0395 00)

References

TM 9-2320-386-24P

Equipment Condition

Parking brake set (TM 9-2320-386-10).

Headlight and headlamp removed (WP 0107 00).

Front composite light and lamp removed
(WP 0106 00).

HEADLIGHT MOUNTING BRACKET REPLACEMENT (Contd)

NOTE

Left and right side headlight mounting brackets are replaced basically the same. This procedure covers the left side headlight bracket.

REMOVAL

Remove four locknuts (3), screws (2), and headlight mounting bracket (1) from fender (4). Discard locknuts (3).

INSTALLATION

1. Install headlight mounting bracket (1) on fender (4) with four screws (2) and new locknuts (3).
2. Install front composite light and lamp (WP 0106 00).
3. Install headlight and headlamp (WP 0107 00).

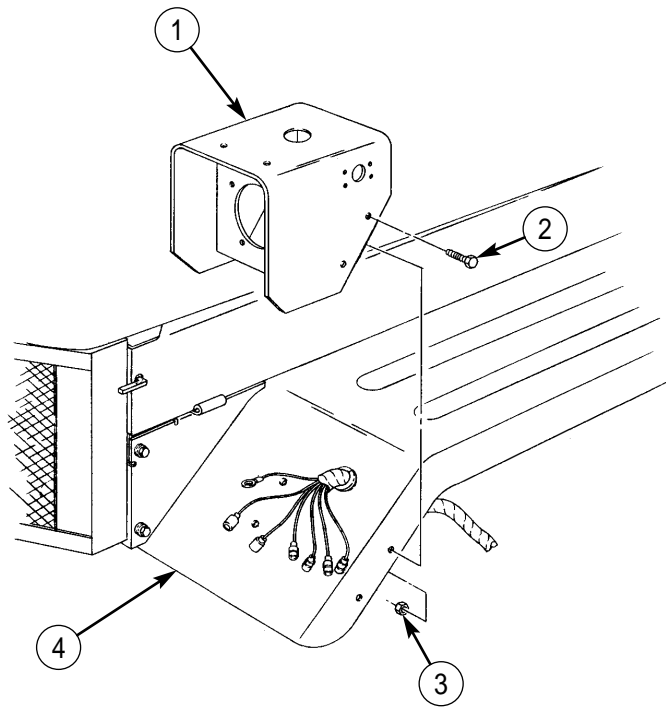

END OF WORK PACKAGE

UNIT MAINTENANCE INSTRUCTIONS

EXTENDED SERVICE PROGRAM (ESP)

TRUCK, CARGO, 2-1/2-TON, 6X6, M44A3 SERIES TRUCKS (DIESEL)

**M35A3, W/O WINCH (NSN 2320-01-383-2047); W/WINCH (NSN 2320-01-383-3850);
M35A3C, W/O WINCH (NSN 2320-01-383-2050); W/WINCH (NSN 2320-01-383-2049);
M36A3, W/O WINCH (NSN 2320-01-383-2048); W/WINCH (NSN 2320-01-383-2046).**

BACKUP LIGHTS AND LAMPS REPLACEMENT

LAMP REMOVAL, BACKUP LIGHT REMOVAL, BACKUP LIGHT INSTALLATION, LAMP INSTALLATION

INITIAL SETUP:

Tools and Special Tools

General mechanic's tool kit
(item 30, WP 0394 00)

Materials/Parts

Two lockwashers (item 49, WP 0395 00)
Gasket (item 271, WP 0395 00)

References

TM 9-2320-386-24P

Equipment Condition

Parking brake set (TM 9-2320-386-10).
Battery ground cable disconnected (WP 0121 00).

BACKUP LIGHTS AND LAMPS REPLACEMENT (Contd)**LAMP REMOVAL**

1. Remove two screws (5), bezel (4), lens cover (3), and gasket (2), from backup light (1). Discard gasket (2).
2. Remove lamp (6) from backup light (1).

BACKUP LIGHT REMOVAL

1. Disconnect backup light lead 467 (7) from wiring harness lead 380A (9).
2. Remove nut (12) and clamp (11) from bracket (13) and backup light lead (7).
3. Remove two nuts (10), lockwashers (8), and backup light (1) from bracket (13). Discard lockwashers (8).

BACKUP LIGHT INSTALLATION

1. Install backup light (1) on bracket (13) with two new lockwashers (8) and nuts (10).
2. Install clamp (11) and backup light lead 467 (7) on bracket (13) with nut (12).
3. Connect backup light lead 467 (7) to wiring harness lead 380A (9).

LAMP INSTALLATION

1. Install lamp (6) on backup light (1).
2. Install new gasket (2), lens cover (3), and bezel (4) on backup light (1) with two screws (5).
3. Connect battery ground cable (WP 0121 00).

BACKUP LIGHTS AND LAMPS REPLACEMENT (Contd)

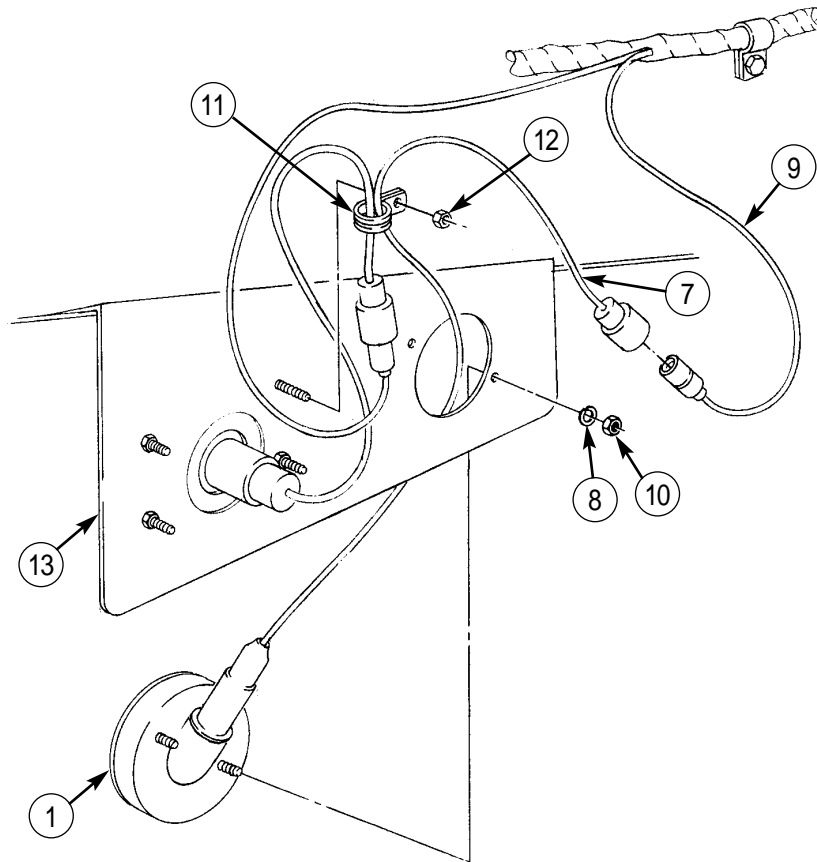
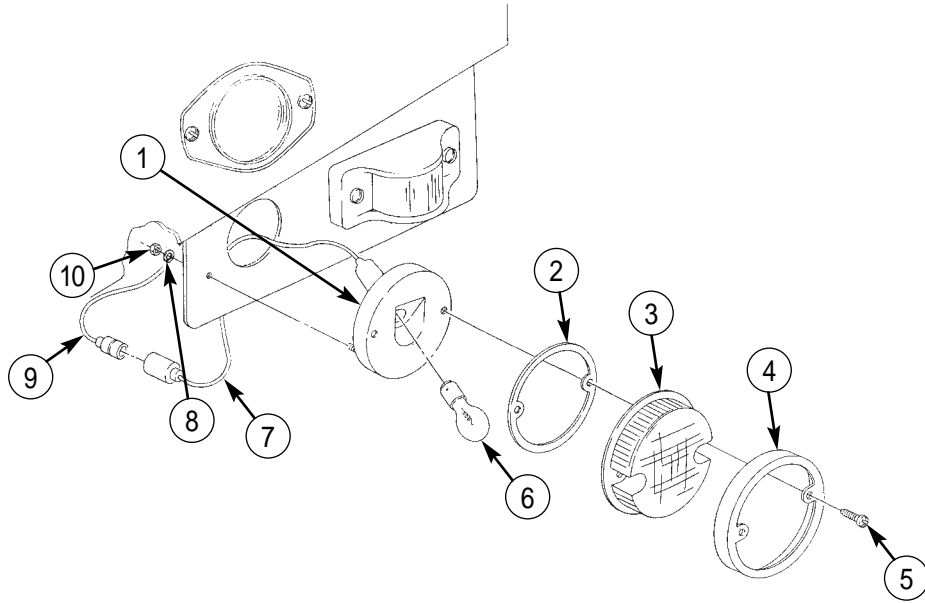

END OF WORK PACKAGE

UNIT MAINTENANCE INSTRUCTIONS

EXTENDED SERVICE PROGRAM (ESP)

TRUCK, CARGO, 2-1/2-TON, 6X6, M44A3 SERIES TRUCKS (DIESEL)

M35A3, W/O WINCH (NSN 2320-01-383-2047); W/WINCH (NSN 2320-01-383-3850);

M35A3C, W/O WINCH (NSN 2320-01-383-2050); W/WINCH (NSN 2320-01-383-2049);

M36A3, W/O WINCH (NSN 2320-01-383-2048); W/WINCH (NSN 2320-01-383-2046).

CLEARANCE AND REAR SIDE MARKER LIGHTS AND LAMPS REPLACEMENT

LAMP REMOVAL, LIGHT REMOVAL, LIGHT INSTALLATION, LAMP INSTALLATION

INITIAL SETUP:

Tools and Special Tools

General mechanic's tool kit
(item 30, WP 0394 00)

Materials/Parts

Gasket (item 262, WP 0395 00)
Four lockwashers (item 80, WP 0395 00)
Four lockwashers (item 49, WP 0395 00)

References

TM 9-2320-386-24P

Equipment Condition

Parking brake set (TM 9-2320-386-10).
Battery ground cable disconnected (WP 0121 00).

CLEARANCE AND REAR SIDE MARKER LIGHTS AND LAMPS REPLACEMENT (Contd)**NOTE**

Clearance lights have the same design as side marker lights. Only their location on the vehicle is different. This procedure covers the left rear side marker light.

LAMP REMOVAL

1. Remove two screws (5) and cover (4) with lens cover (3) from side marker light (6).
2. Remove lamp (1) from side marker light (6).
3. If lens cover (3) is damaged, remove two push clips (2) and lens cover (3) from cover (4).

LIGHT REMOVAL

1. Disconnect side marker light plug with lead 489 (17) from wiring harness connector with lead 380A (18).
2. Remove four nuts (16), lockwashers (15), screws (13), side marker light (6), and gasket (14) from bracket (11). Discard lockwashers (15) and gasket (14).
3. Remove two nuts (7), lockwashers (8), clamp (9), two screws (12), lockwashers (8), and bracket (11) from rail (10). Discard lockwashers (8).
4. Remove clamp (9) from wiring harness lead 380A (18).

LIGHT INSTALLATION

1. Position clamp (9) on wiring harness lead 380A (18).
2. Install bracket (11) and clamp (9) on rail (10) with two new lockwashers (8), screws (12), new lockwashers (8), and nuts (7).
3. Install new gasket (14) and side marker light (6) on bracket (11) with four screws (13), new lockwashers (15), and nuts (16).
4. Connect side marker light plug with lead 489 (17) to wiring harness connector with lead 380A (18).

LAMP INSTALLATION

1. Install lamp (1) in side marker light (6).
2. If removed, install lens cover (3) on cover (4) with two push clips (2).
3. Install cover (4) with lens cover (3) on side marker light (6) with two screws (5).
4. Connect battery ground cable (WP 0121 00).

CLEARANCE AND REAR SIDE MARKER LIGHTS AND LAMPS REPLACEMENT (Contd)

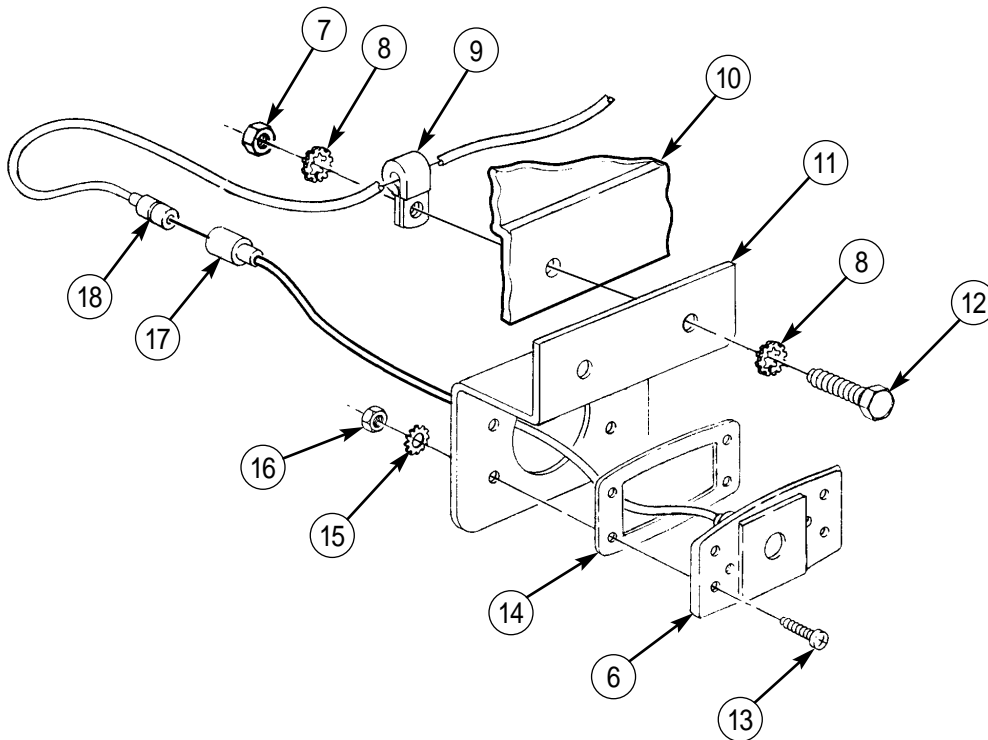
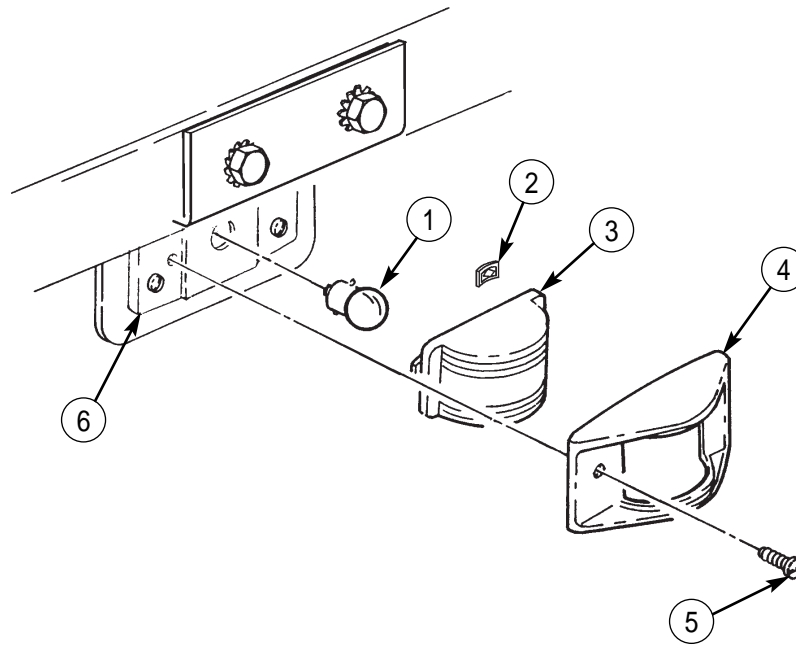

END OF WORK PACKAGE

UNIT MAINTENANCE INSTRUCTIONS

EXTENDED SERVICE PROGRAM (ESP)

TRUCK, CARGO, 2-1/2-TON, 6X6, M44A3 SERIES TRUCKS (DIESEL)

M35A3, W/O WINCH (NSN 2320-01-383-2047); W/WINCH (NSN 2320-01-383-3850);
M35A3C, W/O WINCH (NSN 2320-01-383-2050); W/WINCH (NSN 2320-01-383-2049);
M36A3, W/O WINCH (NSN 2320-01-383-2048); W/WINCH (NSN 2320-01-383-2046).

REAR LIGHTS BRACKET REPLACEMENT

REMOVAL, INSTALLATION

INITIAL SETUP:

Tools and Special Tools

General mechanic's tool kit
(item 30, WP 0394 00)

Materials/Parts

Four lockwashers (item 80, WP 0395 00)

References

TM 9-2320-386-24P

Equipment Condition

Parking brake set (TM 9-2320-386-10).
Backup light removed (WP 0110 00).
Clearance light removed (WP 0111 00).

REAR LIGHTS BRACKET REPLACEMENT (Contd)**NOTE**

Left and right side rear lights brackets are replaced basically the same. This procedure covers the right side rear lights bracket.

REMOVAL

Remove two nuts (1), lockwashers (2), screws (4), lockwashers (2), and bracket (3) from body (5). Discard lockwashers (2).

INSTALLATION

1. Install bracket (3) on body (5) with two new lockwashers (2), screws (4), new lockwashers (2), and nuts (1).
2. Install clearance light (WP 0111 00).
3. Install backup light (WP 0110 00).

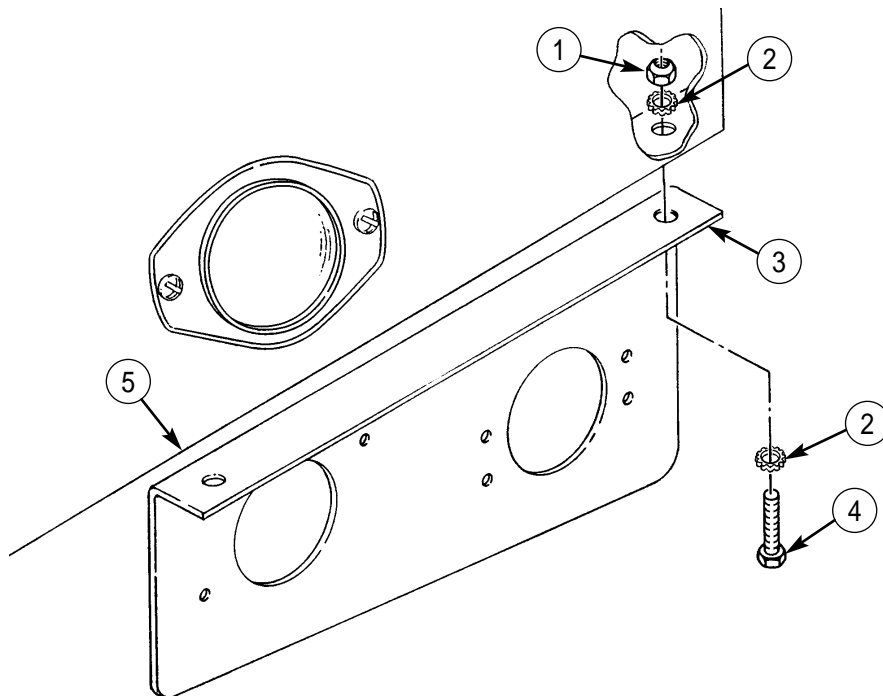

END OF WORK PACKAGE

UNIT MAINTENANCE INSTRUCTIONS

EXTENDED SERVICE PROGRAM (ESP)

TRUCK, CARGO, 2-1/2-TON, 6X6, M44A3 SERIES TRUCKS (DIESEL)

M35A3, W/O WINCH (NSN 2320-01-383-2047); W/WINCH (NSN 2320-01-383-3850);
M35A3C, W/O WINCH (NSN 2320-01-383-2050); W/WINCH (NSN 2320-01-383-2049);
M36A3, W/O WINCH (NSN 2320-01-383-2048); W/WINCH (NSN 2320-01-383-2046).

REAR MARKER LIGHT BRACKET REPLACEMENT

REMOVAL, INSTALLATION

INITIAL SETUP:

Tools and Special Tools

General mechanic's tool kit
(item 30, WP 0394 00)

Materials/Parts

Twelve lockwashers (item 80, WP 0395 00)
Seven locknuts (item 19, WP 0395 00)
Four locknuts (item 86, WP 0395 00)
Four lockwashers (item 77, WP 0395 00)

References

TM 9-2320-386-24P

Equipment Condition

Parking brake set (TM 9-2320-386-10).
Battery ground cable disconnected (WP 0121 00).
Clearance light removed (WP 0111 00).

REAR MARKER LIGHT BRACKET REPLACEMENT (Contd)**REMOVAL**

1. Remove four locknuts (10), screws (16), lockwashers (15), clamp (11), waterproof cover (17), and trailer receptacle (14) from marker light bracket (2). Discard locknuts (10) and lockwashers (15).
2. Route trailer receptacle (14) back through bracket (2).
3. Remove locknut (9), two ground (GND) leads (12), lockwasher (8), screw (20), and lockwasher (21) from upper left corner of cargo bed (13) and bracket (2). Discard locknut (9) and lockwashers (8) and (21).
4. Remove five locknuts (22), lockwashers (19), screws (18), lockwashers (19), and bracket (2) from cargo bed (13). Discard locknuts (22) and lockwashers (19).
5. Remove locknut (5), clamp (4) with harness (3), and screw (1) from bracket (2). Discard locknut (5).
6. Disconnect lead 21 (6) from connector with lead 489 (7).

INSTALLATION

1. Connect lead 21 (6) to connector with lead 489 (7).
2. Install clamp (4) with harness (3) on marker light bracket (2) with new locknut (5) and screw (1).
3. Install marker light bracket (2) on cargo bed (13) with five new lockwashers (19), screws (18), new lockwashers (19), and new locknuts (22).
4. Install two ground (GND) leads (12) on upper left corner of bracket (2) and cargo bed (13) with screw (20), new lockwasher (21), new lockwasher (8), and new locknut (9).
5. Route trailer receptacle (14) through bracket (2) and align mounting holes.
6. Install waterproof cover (17) and trailer receptacle (14) on bracket (2) with four new lockwashers (15), screws (16), clamp (11), and four new locknuts (10).
7. Install clearance light (WP 0111 00).
8. Install battery ground cable (WP 0121 00).

REAR MARKER LIGHT BRACKET REPLACEMENT (Contd)

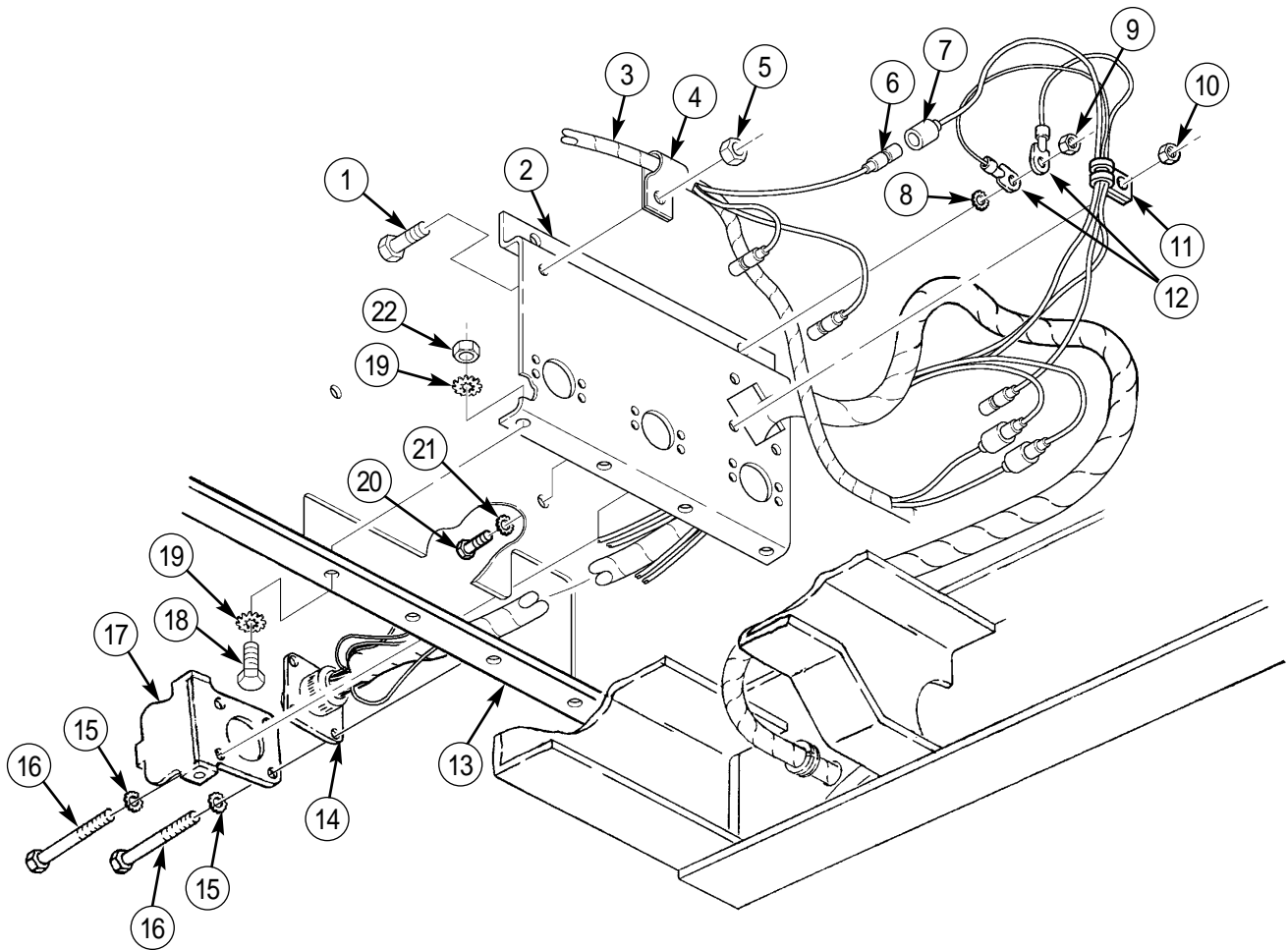

END OF WORK PACKAGE

UNIT MAINTENANCE INSTRUCTIONS

EXTENDED SERVICE PROGRAM (ESP)

TRUCK, CARGO, 2-1/2-TON, 6X6, M44A3 SERIES TRUCKS (DIESEL)

M35A3, W/O WINCH (NSN 2320-01-383-2047); W/WINCH (NSN 2320-01-383-3850);

M35A3C, W/O WINCH (NSN 2320-01-383-2050); W/WINCH (NSN 2320-01-383-2049);

M36A3, W/O WINCH (NSN 2320-01-383-2048); W/WINCH (NSN 2320-01-383-2046).

ENGINE TEMPERATURE TRANSMITTER REPLACEMENT

REMOVAL, INSTALLATION

INITIAL SETUP:

Tools and Special Tools

General mechanic's tool kit
(item 30, WP 0394 00)

Materials/Parts

Teflon pipe sealant (item 41, WP 0393 00)

References

TM 9-2320-386-24P

Equipment Condition

Parking brake set (TM 9-2320-386-10).
Hood raised and secured (TM 9-2320-386-10).
Battery ground cable disconnected (WP 0121 00).
Cooling system drained (WP 0068 00).

ENGINE TEMPERATURE TRANSMITTER REPLACEMENT (Contd)**REMOVAL**

1. Disconnect lead 33 (3) from transmitter (2).
2. Remove transmitter (2) from coolant pump housing (1).

INSTALLATION

1. Apply sealant to male threads of transmitter (2).
2. Install transmitter (2) on coolant pump housing (1).
3. Connect lead 33 (3) to transmitter (2).
4. Fill cooling system to proper level (WP 0068 00).
5. Connect battery ground cable (WP 0121 00).

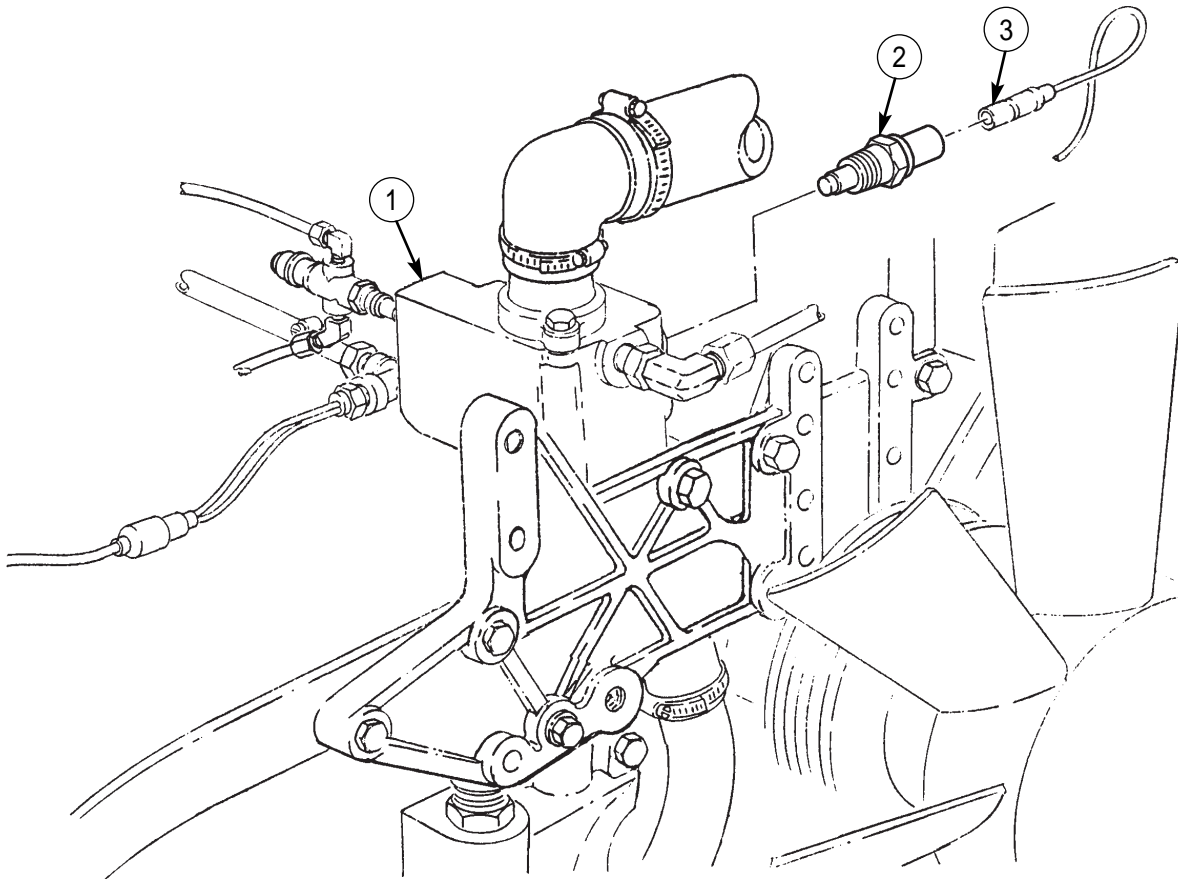
**END OF WORK PACKAGE**

UNIT MAINTENANCE INSTRUCTIONS

EXTENDED SERVICE PROGRAM (ESP)

TRUCK, CARGO, 2-1/2-TON, 6X6, M44A3 SERIES TRUCKS (DIESEL)

**M35A3, W/O WINCH (NSN 2320-01-383-2047); W/WINCH (NSN 2320-01-383-3850);
M35A3C, W/O WINCH (NSN 2320-01-383-2050); W/WINCH (NSN 2320-01-383-2049);
M36A3, W/O WINCH (NSN 2320-01-383-2048); W/WINCH (NSN 2320-01-383-2046).**

FUEL LEVEL SENDING UNIT REPLACEMENT

REMOVAL, INSTALLATION

INITIAL SETUP:

Tools and Special Tools

General mechanic's tool kit
(item 30, WP 0394 00)

Materials/Parts

Gasket (item 2, WP 0395 00)
Lockwasher (item 48, WP 0395 00)

References

TM 9-2320-386-24P

Equipment Condition

Parking brake set (TM 9-2320-386-10).
Battery ground cable disconnected (WP 0121 00).

FUEL LEVEL SENDING UNIT REPLACEMENT (Contd)**WARNING**

Diesel fuel is flammable. Do not perform fuel system procedures near open flame. Failure to comply may result in injury to personnel.

REMOVAL

1. Disconnect lead 28 (1) from sending unit (6).
2. Remove screw (3), washer (2), ground (GND) lead (4), and lockwasher (5) from sending unit (6). Discard lockwasher (5).
3. Remove four screws (11) and washers (10) from sending unit (6).
4. Remove sending unit (6) and gasket (7) from fuel tank (8). Discard gasket (7).

INSTALLATION

1. Guide floater arm (9) and install new gasket (7) and sending unit (6) on fuel tank (8) with four washers (10) and screws (11).
2. Install ground (GND) lead (4) on sending unit (6) with new lockwasher (5), washer (2), and screw (3).
3. Connect lead 28 (1) to sending unit (6).
4. Connect battery ground cable (WP 0121 00).
5. Start engine (TM 9-2320-386-10) and check fuel gauge for proper operation.

FUEL LEVEL SENDING UNIT REPLACEMENT (Contd)

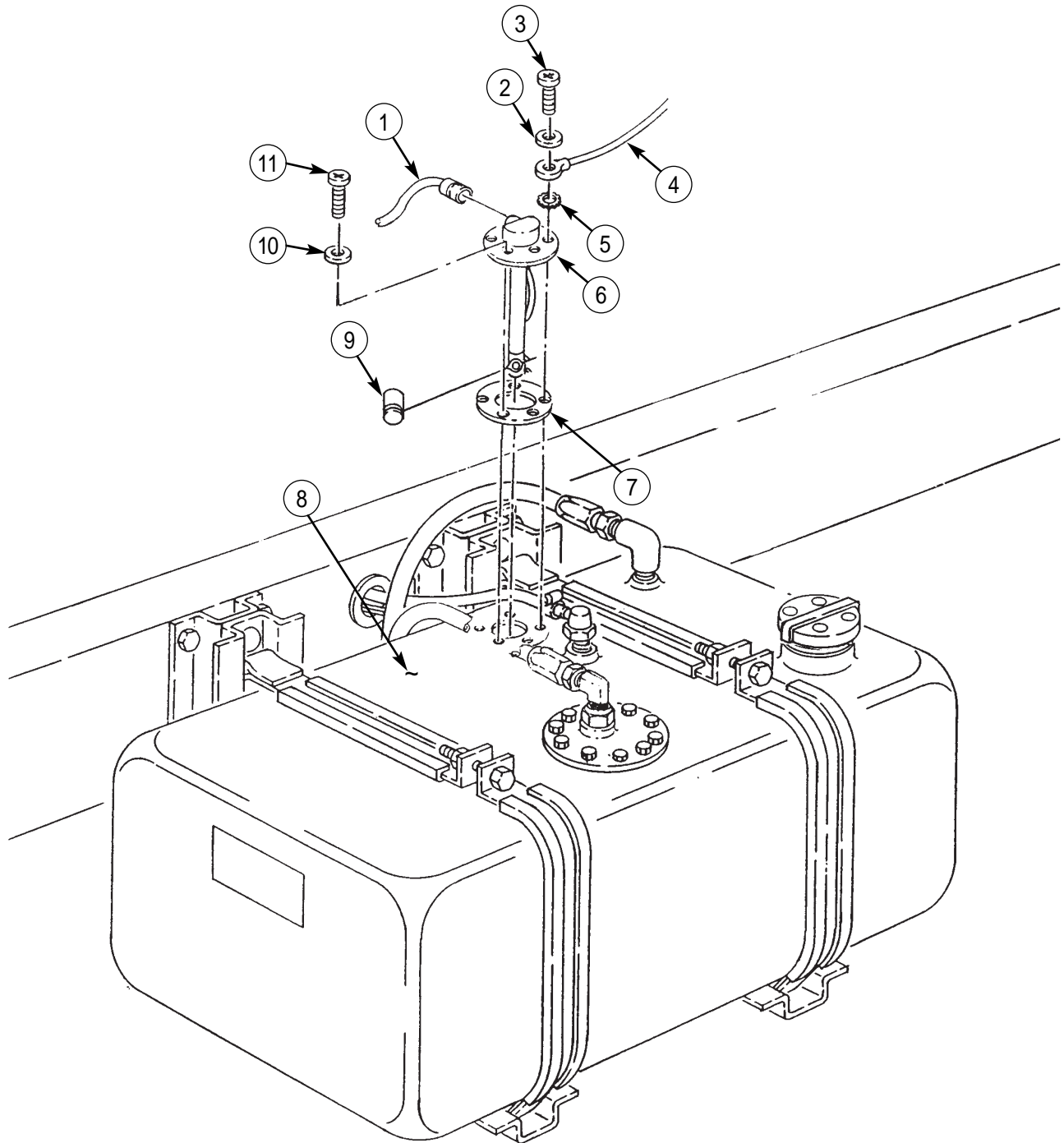

END OF WORK PACKAGE

UNIT MAINTENANCE INSTRUCTIONS

EXTENDED SERVICE PROGRAM (ESP)

TRUCK, CARGO, 2-1/2-TON, 6X6, M44A3 SERIES TRUCKS (DIESEL)

M35A3, W/O WINCH (NSN 2320-01-383-2047); W/WINCH (NSN 2320-01-383-3850);
M35A3C, W/O WINCH (NSN 2320-01-383-2050); W/WINCH (NSN 2320-01-383-2049);
M36A3, W/O WINCH (NSN 2320-01-383-2048); W/WINCH (NSN 2320-01-383-2046).

FUEL PRESSURE TRANSDUCER REPLACEMENT

REMOVAL, INSTALLATION

INITIAL SETUP:

Tools and Special Tools

General mechanic's tool kit
(item 30, WP 0394 00)

References

TM 9-2320-386-24P

Materials/Parts

Teflon pipe sealant (item 41, WP 0393 00)

Equipment Condition

Parking brake set (TM 9-2320-386-10).
Hood raised and secured (TM 9-2320-386-10).
Battery ground cable disconnected (WP 0121 00).

FUEL PRESSURE TRANSDUCER REPLACEMENT (Contd)**WARNING**

Diesel fuel is flammable. Do not perform fuel system procedures near open flame. Failure to comply may result in injury to personnel.

REMOVAL**NOTE**

Tag all wires for installation.

1. Disconnect lead (4) from socket (1).

NOTE

Have drainage container ready to catch fuel.

2. Remove fuel pressure transducer (3) from elbow (2).

INSTALLATION

1. Apply sealant to male threads of fuel pressure transducer (3).
2. Install fuel pressure transducer (3) on elbow (2).
3. Connect lead (4) to socket (1).
4. Connect battery ground cable (WP 0121 00).

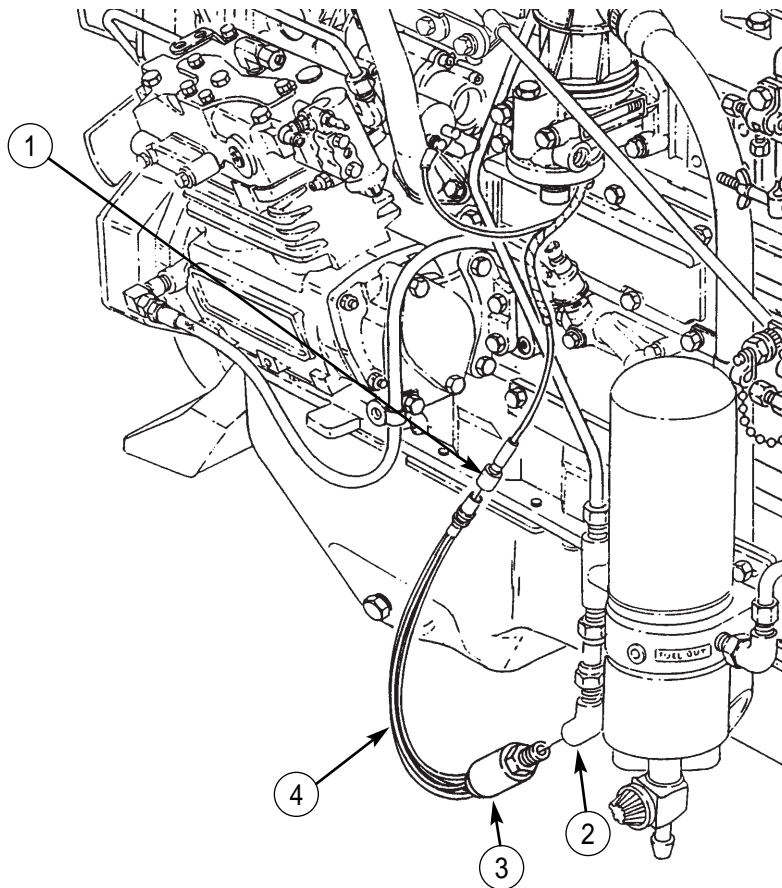

END OF WORK PACKAGE

UNIT MAINTENANCE INSTRUCTIONS

EXTENDED SERVICE PROGRAM (ESP)

TRUCK, CARGO, 2-1/2-TON, 6X6, M44A3 SERIES TRUCKS (DIESEL)

M35A3, W/O WINCH (NSN 2320-01-383-2047); W/WINCH (NSN 2320-01-383-3850);
M35A3C, W/O WINCH (NSN 2320-01-383-2050); W/WINCH (NSN 2320-01-383-2049);
M36A3, W/O WINCH (NSN 2320-01-383-2048); W/WINCH (NSN 2320-01-383-2046).

TRANSMISSION OIL TEMPERATURE SENSOR REPLACEMENT

REMOVAL, INSTALLATION

INITIAL SETUP:

Tools and Special Tools

General mechanic's tool kit
(item 30, WP 0394 00)

Materials/Parts

Teflon pipe sealant (item 41, WP 0393 00)
Cap and plug set (item 14, WP 0393 00)

References

TM 9-2320-386-24P

Equipment Condition

Parking brake set (TM 9-2320-386-10).
Battery ground cable disconnected (WP 0121 00).
Transmission select lever removed (WP 0134 00).
Cab tunnel removed (WP 0207 00).

TRANSMISSION OIL TEMPERATURE SENSOR REPLACEMENT (Contd)**REMOVAL**

1. Disconnect lead 324 (1) from sensor (2).

CAUTION

Plug opening immediately after removing temperature sensor to prevent dirt and dust from entering transmission. Failure to do so may cause damage to transmission. Remove plug before installation.

2. Remove sensor (2) from tee (3).

INSTALLATION

1. Apply sealant to male threads of sensor (2).
2. Install sensor (2) on tee (3).
3. Connect lead 324 (1) to sensor (2).
4. Install cab tunnel (WP 0207 00).
5. Install transmission select lever (WP 0134 00).
6. Connect battery ground cable (WP 0121 00).

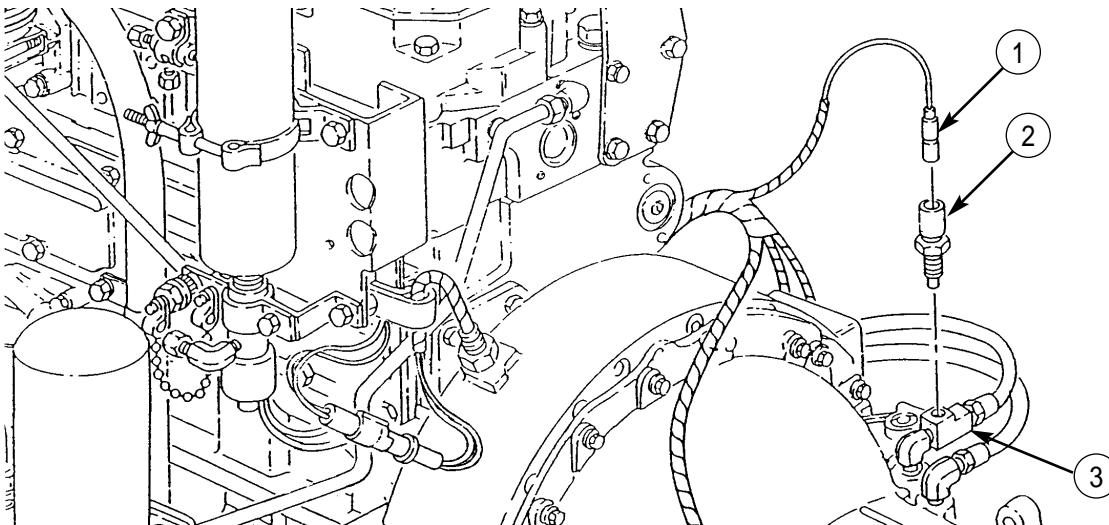

END OF WORK PACKAGE

UNIT MAINTENANCE INSTRUCTIONS

EXTENDED SERVICE PROGRAM (ESP)

TRUCK, CARGO, 2-1/2-TON, 6X6, M44A3 SERIES TRUCKS (DIESEL)

M35A3, W/O WINCH (NSN 2320-01-383-2047); W/WINCH (NSN 2320-01-383-3850);
M35A3C, W/O WINCH (NSN 2320-01-383-2050); W/WINCH (NSN 2320-01-383-2049);
M36A3, W/O WINCH (NSN 2320-01-383-2048); W/WINCH (NSN 2320-01-383-2046).

LOW AIR PRESSURE SWITCH REPLACEMENT

REMOVAL, INSTALLATION

INITIAL SETUP:

Tools and Special Tools

General mechanic's tool kit
(item 30, WP 0394 00)

Materials/Parts

Cap and plug set (item 14, WP 0393 00)
Teflon pipe sealant (item 41, WP 0393 00)

References

TM 9-2320-386-24P

Equipment Condition

Parking brake set (TM 9-2320-386-10).
Air reservoirs drained (TM 9-2320-386-10).
Battery ground cable disconnected (WP 0121 00).

LOW AIR PRESSURE SWITCH REPLACEMENT (Contd)**WARNING**

Eyeshields must be worn when releasing compressed air. Failure to do this may result in injury to personnel.

Do not disconnect air lines before draining air reservoirs. Small parts under pressure may shoot out with high velocity, causing injury to personnel.

CAUTION

When disconnecting air lines and hoses, plug all openings to prevent dirt from entering and causing damage to internal parts. Remove plugs prior to installation.

REMOVAL**NOTE**

Tag all wires for installation.

1. Turn four lockstuds (3) 1/4-turn to left and pull instrument mounting panel (2) away from instrument panel (1).
2. Disconnect two leads 85 and 85A (6) from low air pressure switch (4).
3. Remove low air pressure switch (4) from tube and hose manifold (5).

INSTALLATION

1. Apply sealant to male threads of low air pressure switch (4).
2. Install low air pressure switch (4) on tube and hose manifold (5).
3. Connect two leads 85 and 85A (6) to low air pressure switch (4).
4. Position instrument mounting panel (2) to instrument panel (1) and install by turning four lockstuds (3) 1/4-turn to right.
5. Connect battery ground cable (WP 0121 00).
6. Start engine (TM 9-2320-386-10) and check low air pressure switch operation.

LOW AIR PRESSURE SWITCH REPLACEMENT (Contd)

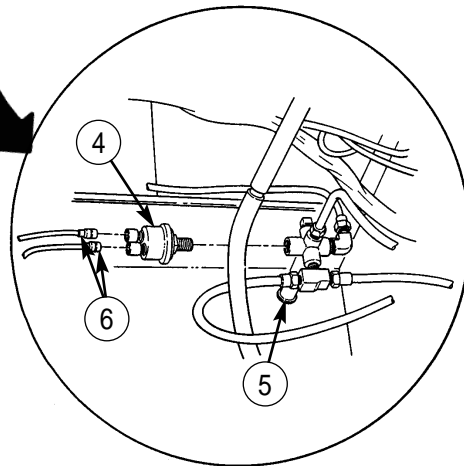
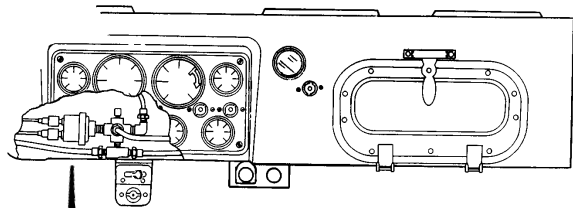
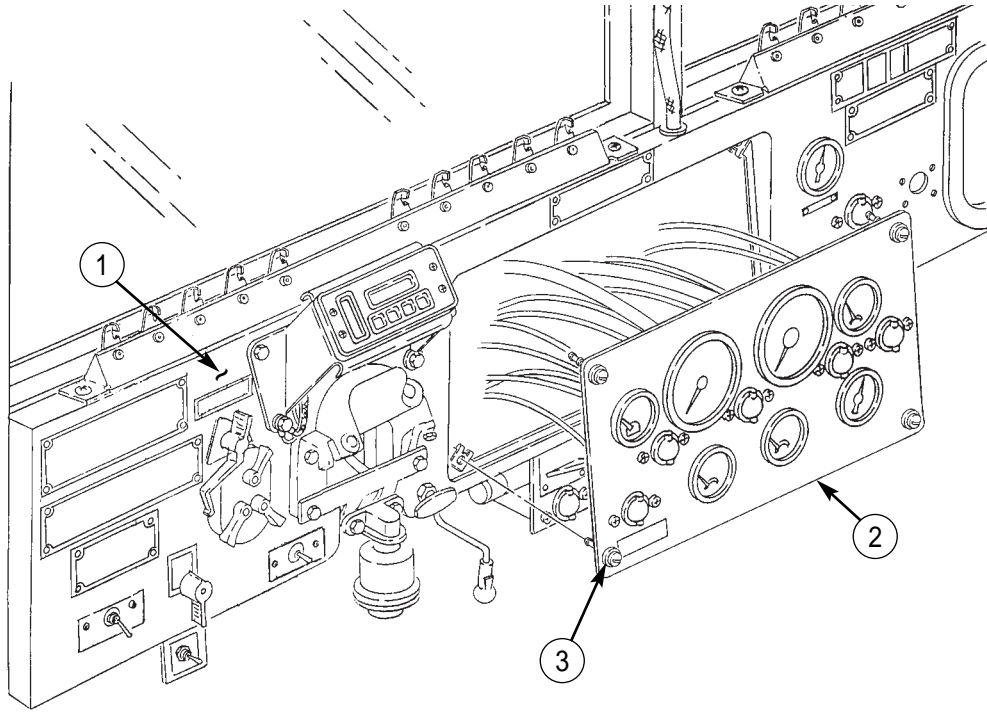

END OF WORK PACKAGE

UNIT MAINTENANCE INSTRUCTIONS

EXTENDED SERVICE PROGRAM (ESP)

TRUCK, CARGO, 2-1/2-TON, 6X6, M44A3 SERIES TRUCKS (DIESEL)

M35A3, W/O WINCH (NSN 2320-01-383-2047); W/WINCH (NSN 2320-01-383-3850);
M35A3C, W/O WINCH (NSN 2320-01-383-2050); W/WINCH (NSN 2320-01-383-2049);
M36A3, W/O WINCH (NSN 2320-01-383-2048); W/WINCH (NSN 2320-01-383-2046).

AIR HORN REPLACEMENT

REMOVAL, INSTALLATION

INITIAL SETUP:

Tools and Special Tools

General mechanic's tool kit
(item 30, WP 0394 00)

Materials/Parts

Tiedown strap (item 39, WP 0395 00)
Two locknuts (item 338, WP 0395 00)
Two lockwashers (item 54, WP 0395 00)
Teflon pipe sealant (item 41, WP 0393 00)

References

TM 9-2320-386-24P

Equipment Condition

Parking brake set (TM 9-2320-386-10).
Hood raised and secured (TM 9-2320-386-10).
Air reservoirs drained (TM 9-2320-386-10).
Battery ground cable disconnected (WP 0121 00).

AIR HORN REPLACEMENT (Contd)

REMOVAL

WARNING

Do not disconnect air lines before draining air reservoirs. Small parts under pressure may shoot out with high velocity, causing injury to personnel.

Eyeshields must be worn when releasing compressed air. Failure to do this may result in injury to personnel.

NOTE

Tag wires for installation.

1. Disconnect wire plugs 25 and 26 (5) from air solenoid (4).
2. Remove tiedown strap (13) from wiring harness (12) and horn (6). Discard tiedown strap (13).
3. Disconnect air line (14) from elbow (3) on solenoid (4).
4. Remove two locknuts (9), screws (2), bracket (8), and horn (6) from fender (1). Discard locknuts (9).
5. Remove two nuts (11), lockwashers (10), screws (7), and horn (6) from bracket (8). Discard lockwashers (10).
6. Remove elbow (3) from solenoid (4).
7. Remove solenoid (4) from horn (6).

INSTALLATION

1. Apply sealant to male threads of solenoid (4) and elbow (3).
2. Install solenoid (4) on horn (6).
3. Install elbow (3) on solenoid (4).
4. Install horn (6) on bracket (8) with two screws (7), new lockwashers (10), and nuts (11).
5. Install bracket (8) and horn (6) on fender (1) with two screws (2) and new locknuts (9).
6. Connect air line (14) on elbow (3) on solenoid (4).
7. Connect wire plugs 25 and 26 (5) on solenoid (4).
8. Install wiring harness (12) on horn (6) with new tiedown strap (13).
9. Connect battery ground cable (WP 0121 00).
10. Start engine (TM 9-2320-386-10) and allow air pressure to build up to normal operating range. Check for air leaks at horn and solenoid.

AIR HORN REPLACEMENT (Contd)

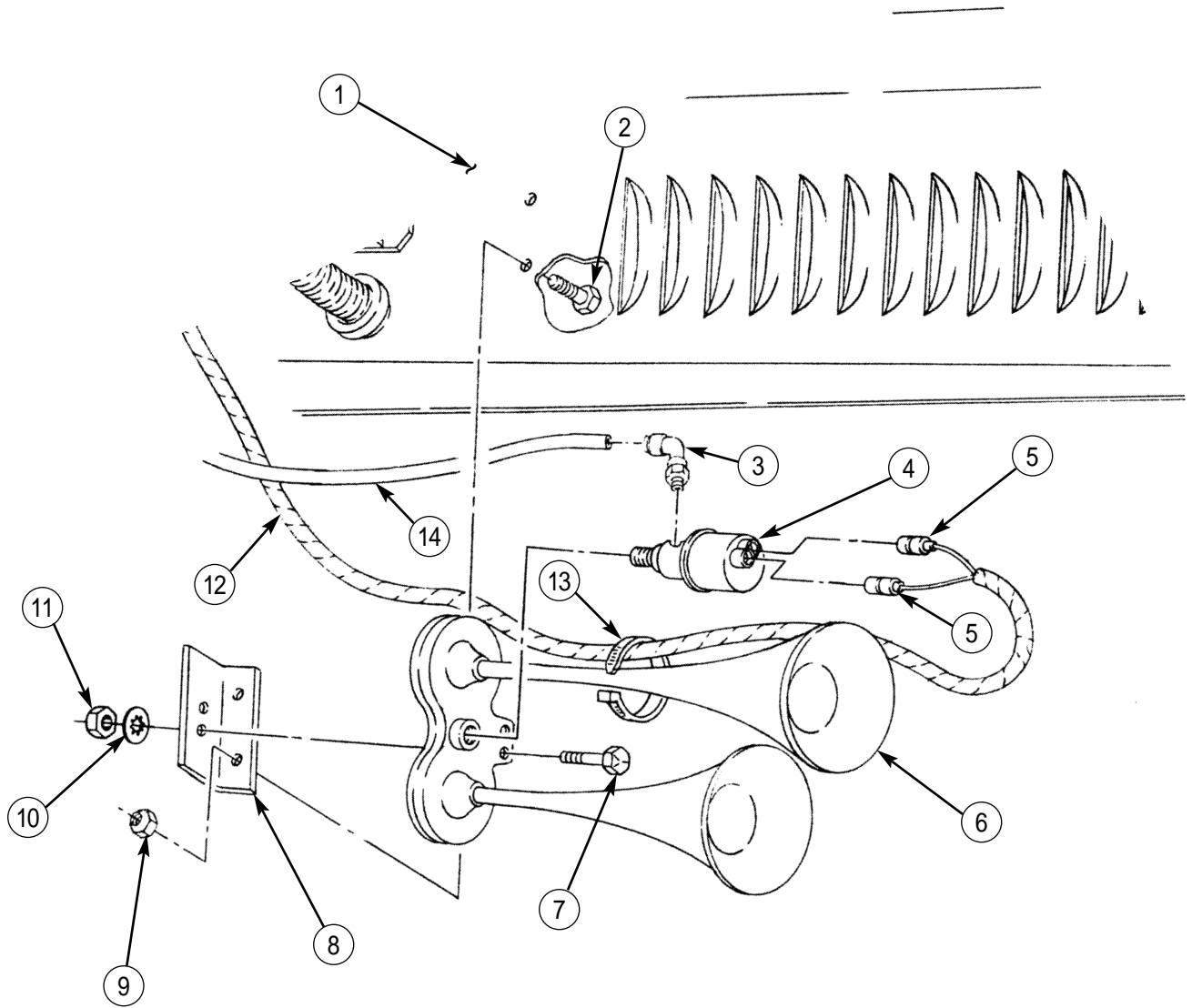

END OF WORK PACKAGE

UNIT MAINTENANCE INSTRUCTIONS

EXTENDED SERVICE PROGRAM (ESP)

TRUCK, CARGO, 2-1/2-TON, 6X6, M44A3 SERIES TRUCKS (DIESEL)

M35A3, W/O WINCH (NSN 2320-01-383-2047); W/WINCH (NSN 2320-01-383-3850);
M35A3C, W/O WINCH (NSN 2320-01-383-2050); W/WINCH (NSN 2320-01-383-2049);
M36A3, W/O WINCH (NSN 2320-01-383-2048); W/WINCH (NSN 2320-01-383-2046).

NATO SLAVE RECEPTACLE REPLACEMENT

REMOVAL, INSTALLATION

INITIAL SETUP:

Tools and Special Tools

General mechanic's tool kit
(item 30, WP 0394 00)

Materials/Parts

Five lockwashers (item 41, WP 0395 00)
Five locknuts (item 86, WP 0395 00)
Two lockwashers (item 80, WP 0395 00)
Plate insulator (item 168, WP 0395 00)

References

TM 9-2320-386-24P

Equipment Condition

Parking brake set (TM 9-2320-386-10).
Battery ground cable disconnected (WP 0121 00).

NATO SLAVE RECEPTACLE REPLACEMENT (Contd)

REMOVAL

WARNING

Do not remove slave receptacle before disconnecting battery ground cable. If energized battery cable contacts cab, a direct short will result and may result in injury to personnel.

1. Remove four nuts (7), screws (1), lockwashers (2), waterproof cap (30), mounting plate (3), and plate insulator (4) from cab (28) and slave receptacle (8). Discard lockwashers (2) and plate insulator (4).
2. Remove slave receptacle (8) and spacer (6) from spacer (5).
3. Remove four locknuts (32), screws (31), and spacer (5) from cab (28). Discard locknuts (32).
4. Remove nut (22), washer (21), and lead 49A (19) from terminal (20).
5. Remove nut (14), lockwasher (15), screw (23), leads 93 (18) and 50A (26), and lockwasher (17) from rail (16). Discard lockwashers (15) and (17).
6. Remove locknut (24), screw (13), and clamp (25) from cab (28). Discard locknut (24).
7. Remove screw (12), washer (11), lockwasher (10), clamp (9), and clamp (29) from cab (28). Discard lockwasher (10).
8. Remove leads 50A (26) and 49A (19) and two grommets (27) from cab (28).

INSTALLATION

1. Route leads 50A (26) and 49A (19) through two grommets (27) on cab (28).
2. Install clamps (9) and (29) and leads 50A (26) and 49A (19) on cab (28) with new lockwasher (10), washer (11), and screw (12).
3. Install clamp (25) and lead 49A (19) on cab (28) with screw (13) and new locknut (24).
4. Install leads 93 (18) and 50A (26) on rail (16) with new lockwashers (15) and (17), screw (23), and nut (14).
5. Install lead 49A (19) on terminal (20) with washer (21) and nut (22).
6. Install spacer (5) on cab (28) with four screws (31) and new locknuts (32).
7. Position spacer (6) and slave receptacle (8) on spacer (5).
8. Install new plate insulator (4), mounting plate (3), waterproof cap (30), and slave receptacle (8) on cab (28) with four new lockwashers (2), screws (1), and nuts (7).
9. Connect battery ground cable (WP 0121 00).

NATO SLAVE RECEPTACLE REPLACEMENT (Contd)

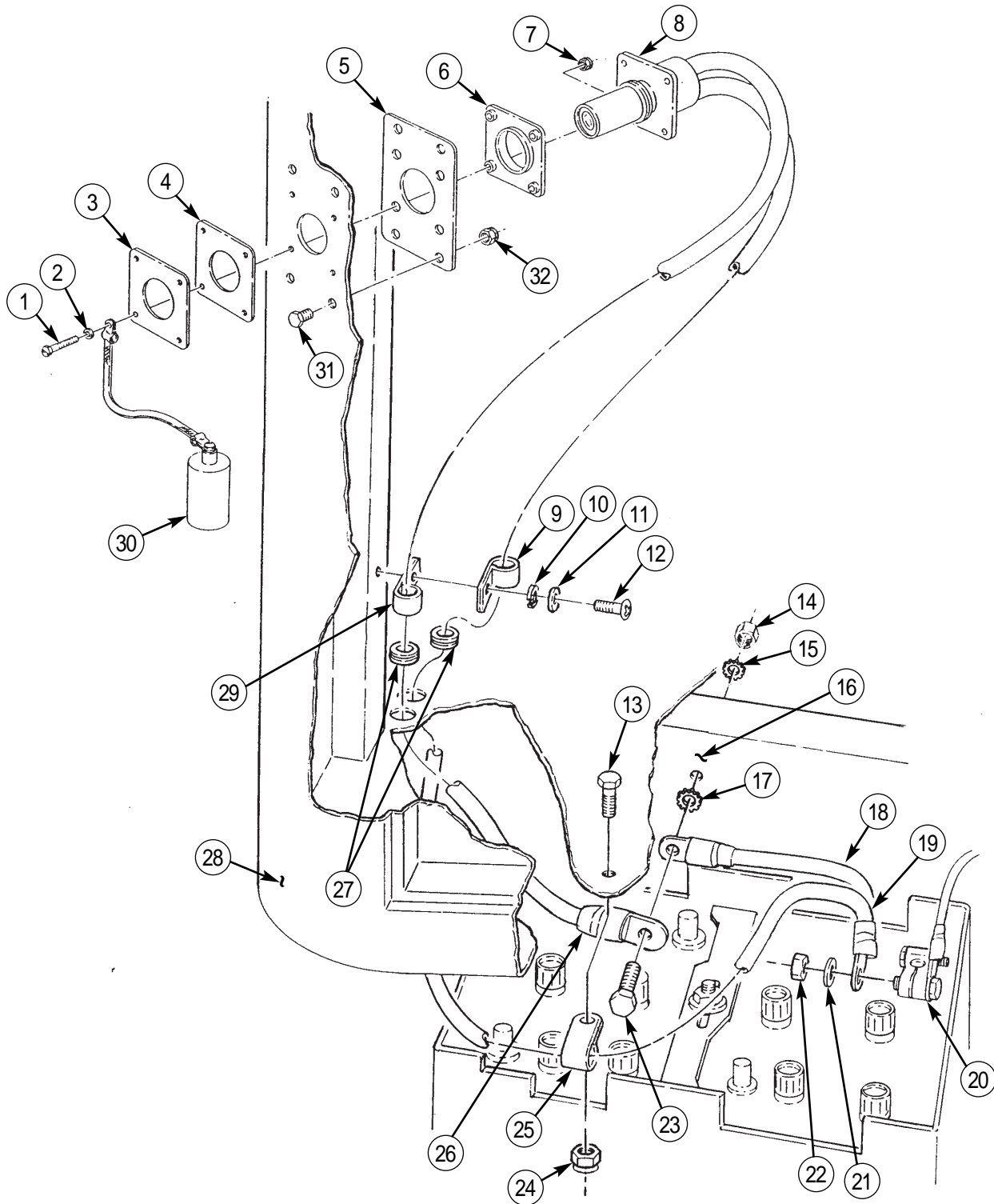

END OF WORK PACKAGE

UNIT MAINTENANCE INSTRUCTIONS

EXTENDED SERVICE PROGRAM (ESP)

TRUCK, CARGO, 2-1/2-TON, 6X6, M44A3 SERIES TRUCKS (DIESEL)

**M35A3, W/O WINCH (NSN 2320-01-383-2047); W/WINCH (NSN 2320-01-383-3850);
M35A3C, W/O WINCH (NSN 2320-01-383-2050); W/WINCH (NSN 2320-01-383-2049);
M36A3, W/O WINCH (NSN 2320-01-383-2048); W/WINCH (NSN 2320-01-383-2046).**

BATTERY CABLE AND CLAMPS REPLACEMENT

**DISCONNECT BATTERY GROUND CABLE, BATTERY CABLES SERVICING,
CONNECT BATTERY GROUND CABLE, REMOVAL, INSTALLATION**

INITIAL SETUP:

Tools and Special Tools

General mechanic's tool kit
(item 30, WP 0394 00)

References

TM 9-2320-386-24P
TM 9-6140-200-14

Equipment Condition

Parking brake set (TM 9-2320-386-10).
Open battery compartment door and pull battery box
onto running board (TM 9-2320-386-10).

BATTERY CABLE AND CLAMPS REPLACEMENT (Contd)

WARNING

Battery ground cable must be disconnected to break the path of electricity through vehicle electrical components. Failure to do so may result in a direct short and cause injury to personnel.

Remove all jewelry before performing this procedure. To avoid a direct short, do not allow tools or other objects to come in contact with vehicle locations.

A direct short can result in injury to personnel and instant heating of tools, jewelry or other objects.

Do not smoke or allow open flames or sparks near batteries when performing this procedure. Batteries can explode if exposed to heat, flames, or sparks. Failure to comply may result in injury to personnel and damage to equipment.

Always wear safety goggles and rubber gloves when performing battery maintenance. Battery acid (electrolyte) is extremely harmful. Failure to comply may result in injury to personnel.

DISCONNECT BATTERY GROUND CABLE

Loosen nut (3) and remove battery ground cable 7A (1) and terminal clamp (4) from battery negative (-) post (2).

BATTERY CABLES SERVICING

For battery cables servicing instructions, refer to TM 9-6140-200-14.

CONNECT BATTERY GROUND CABLE

1. Clean battery negative (-) post (2) and terminal clamp (4). For general cleaning instructions, refer to (WP 0383 00).
2. Install battery ground cable 7A (1) and terminal clamp (4) on battery negative (-) post (2) and tighten nut (3).

BATTERY CABLE AND CLAMPS REPLACEMENT (Contd)

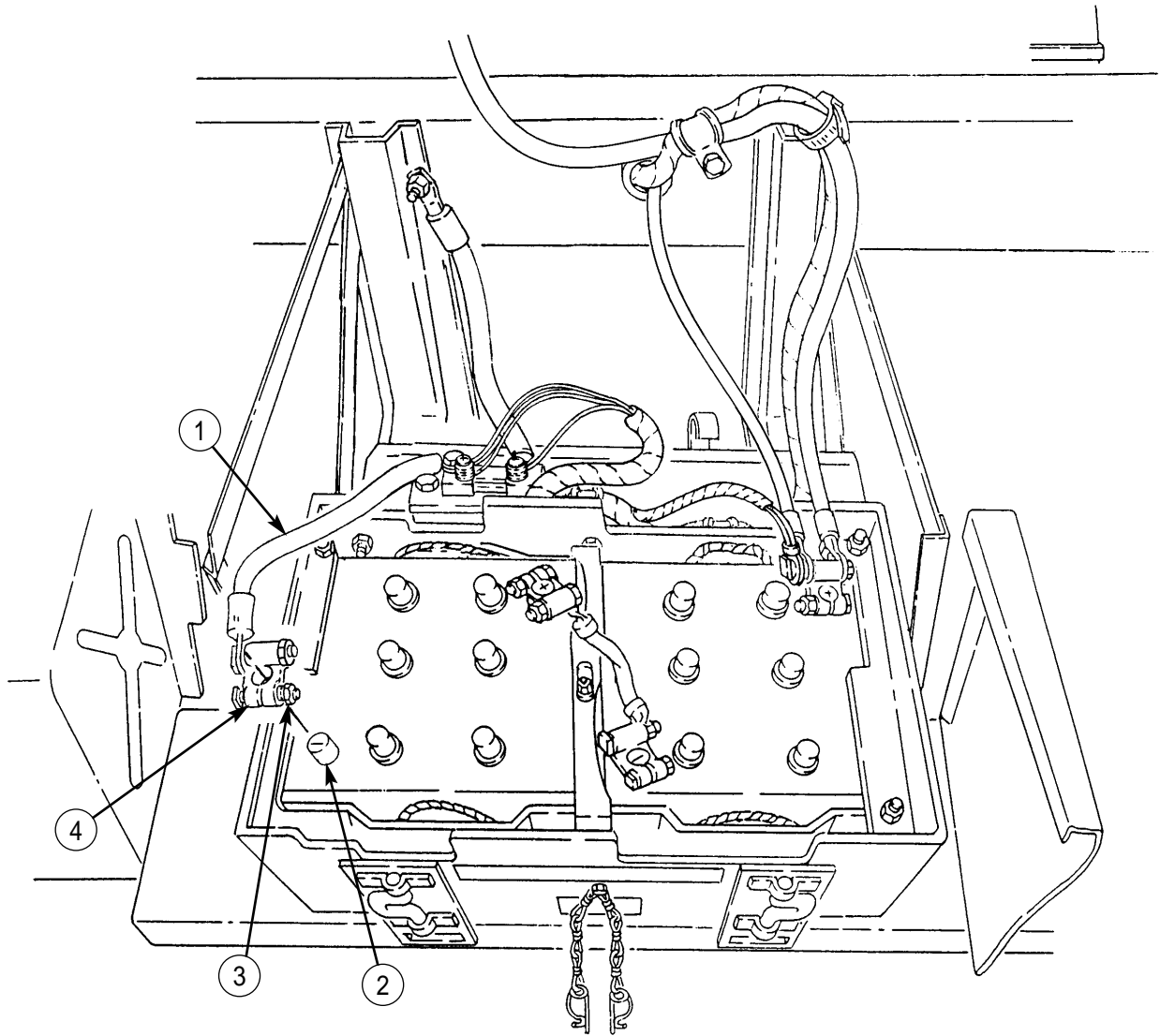

BATTERY CABLE AND CLAMPS REPLACEMENT (Contd)

REMOVAL

1. Remove nut (18), screw (21), and terminal clamp (19) from battery negative (-) post (20).
2. Remove nut (5), screw (2), and terminal clamp (4) from battery positive (+) post (23).
3. Remove nut (14), screws (12), and terminal clamp (13) with positive battery cable 49A (10), positive battery cable (9), and connector (7) with leads 770E and 770V from battery positive terminal (15).
4. Remove nuts (6) and (16), screws (3) and (22), and two terminal clamps (4) and (19) from jumper cable (17).
5. Remove nut (25), screw (26), and terminal clamp (28) from battery negative (-) post (24).
6. Remove nut (29), screw (27), and battery ground cable 7A (1) from terminal clamp (28).
7. Remove nut (8), screw (11), connector (7) with leads 770E and 770V, positive battery cable (9), and cable 49A (10).

INSTALLATION

1. Clean battery posts (15), (20), (23), and (24) and terminal clamps (4), (19), (13), and (28). For general cleaning instructions, refer to (WP 0383 00).
2. Install terminal clamps (4) and (19) on jumper cable (17) with screws (3) and (22) and nuts (6) and (16).
3. Install battery ground cable 7A (1) on terminal clamp (28) with screw (27) and nut (29).
4. Install positive battery cable 49A (10), positive battery cable (9), and connector (7) with leads 770E and 770V on terminal clamp (13) with screw (11) and nut (8).
5. Install jumper cable (17) and terminal clamps (4) and (19) on battery positive (+) post (23) and battery negative (-) post (20) with screws (2) and (21) and nut (5) and (18).
6. Install terminal clamp (13) with positive battery cable 49A (10), positive battery cable (9), and connector (7) with leads 770E and 770V on battery positive terminal (15) with screw (12) and nut (14).
7. Install terminal clamp (28) with battery ground cable 7A (1) on battery positive cable (+) post (24) with screw (26) and nut (25).
8. Slide battery box back into place and close battery compartment door (TM 9-2320-386-10).

BATTERY CABLE AND CLAMPS REPLACEMENT (Contd)

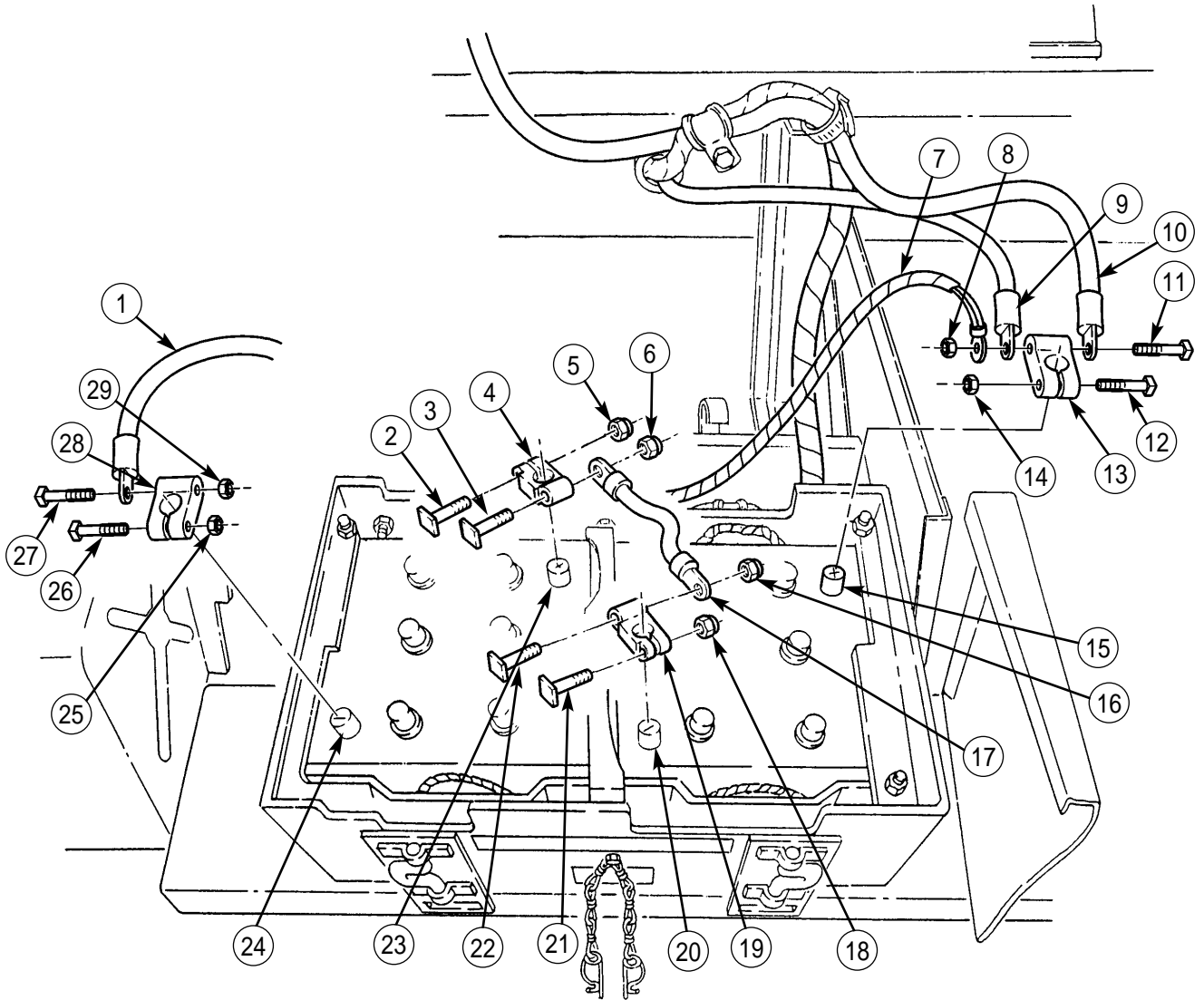

END OF WORK PACKAGE

UNIT MAINTENANCE INSTRUCTIONS

EXTENDED SERVICE PROGRAM (ESP)

TRUCK, CARGO, 2-1/2-TON, 6X6, M44A3 SERIES TRUCKS (DIESEL)

M35A3, W/O WINCH (NSN 2320-01-383-2047); W/WINCH (NSN 2320-01-383-3850);
M35A3C, W/O WINCH (NSN 2320-01-383-2050); W/WINCH (NSN 2320-01-383-2049);
M36A3, W/O WINCH (NSN 2320-01-383-2048); W/WINCH (NSN 2320-01-383-2046).

BATTERY MAINTENANCE

REMOVAL, INSPECTION, TESTING, INSTALLATION

INITIAL SETUP:

Tools and Special Tools

General mechanic's tool kit
(item 30, WP 0394 00)

References

TM 9-2320-386-24P
TM 9-6140-200-14

Materials/Parts

Four lockwashers (item 80, WP 0395 00)

Equipment Condition

Parking brake set (TM 9-2320-386-10).
Battery cables and clamps removed (WP 0121 00).

BATTERY MAINTENANCE (Contd)

WARNING

Battery acid (electrolyte) is extremely harmful. Always wear safety goggles and rubber gloves when performing battery maintenance. Severe injury will result if acid contacts eyes or skin.

Do not smoke, have open flame, or make sparks when performing battery maintenance. Batteries may explode causing severe injury to personnel.

Remove all jewelry such as rings, dog tags, bracelets, etc. If jewelry contacts battery terminal, a direct short may result in instant heating of tools, damage to equipment, and injury to personnel.

When removing battery cables, disconnect ground cable first. Do not allow tools to come in contact with vehicle when disconnecting cable clamps. A direct short can result, causing instant heating of tools, tool damage, battery damage, or battery explosion, and severe injury to personnel.

REMOVAL

1. Remove four nuts (2), lockwashers (3), J-bolts (4), and battery holddown (1) from battery box (6) and two batteries (5). Discard lockwashers (3).

NOTE

Assistant will help with step 2.

2. Remove two batteries (5) from battery box (6).

INSPECTION

Inspect battery posts, clamps, cables, and battery holddown for corrosion. If corrosion is evident, refer to TM 9-6140-200-14.

TESTING

For battery testing, refer to TM 9-6140-200-14.

INSTALLATION

1. Place two batteries (5) in battery box (6).
2. Install battery holddown (1) on battery box (6) and two batteries (5) with four J-bolts (4), new lockwashers (3), and nuts (2).
3. Install battery cables and clamps (WP 0121 00).

BATTERY MAINTENANCE (Contd)

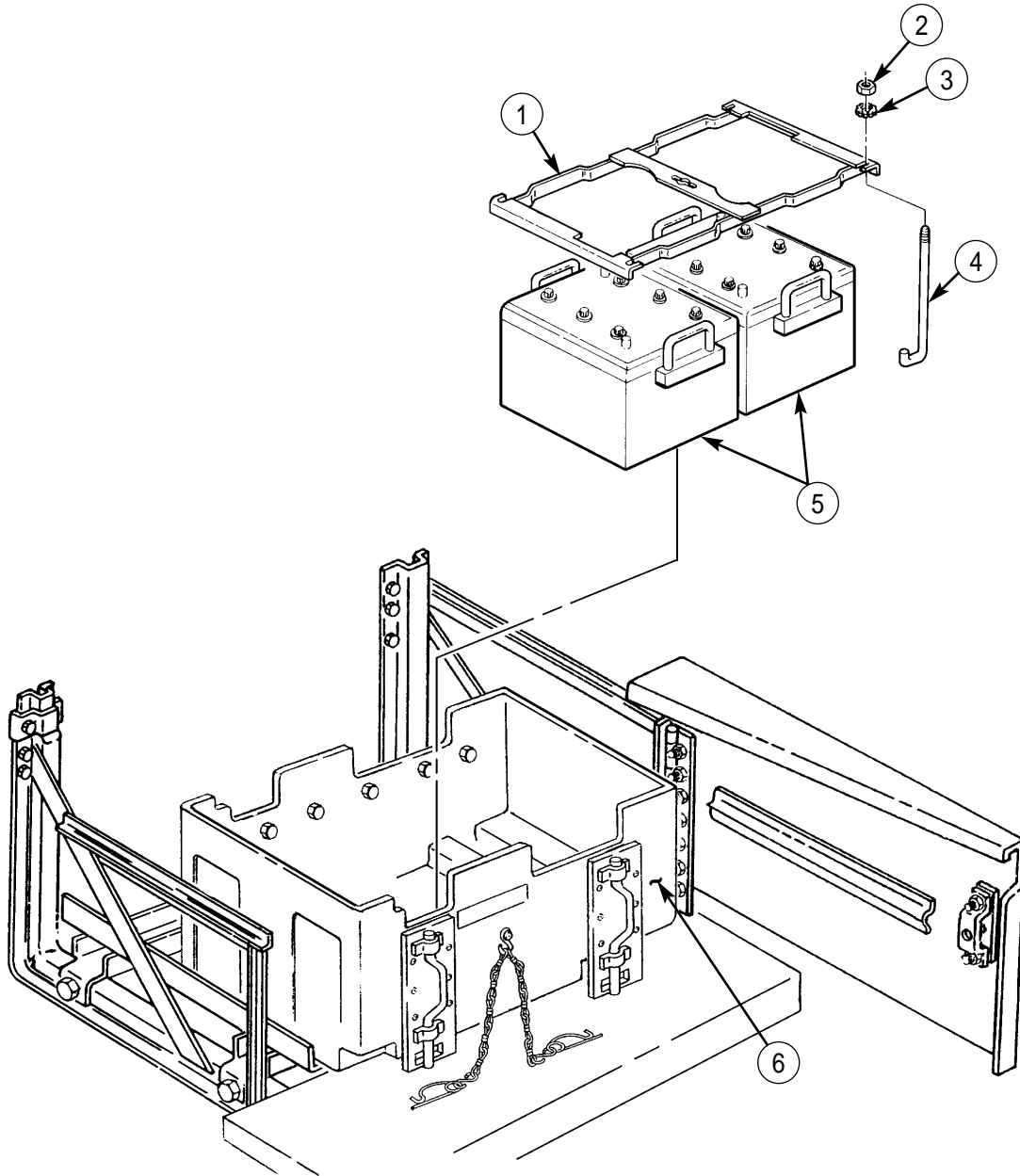

END OF WORK PACKAGE

UNIT MAINTENANCE INSTRUCTIONS

EXTENDED SERVICE PROGRAM (ESP)

TRUCK, CARGO, 2-1/2-TON, 6X6, M44A3 SERIES TRUCKS (DIESEL)

M35A3, W/O WINCH (NSN 2320-01-383-2047); W/WINCH (NSN 2320-01-383-3850);
M35A3C, W/O WINCH (NSN 2320-01-383-2050); W/WINCH (NSN 2320-01-383-2049);
M36A3, W/O WINCH (NSN 2320-01-383-2048); W/WINCH (NSN 2320-01-383-2046).

BATTERY BOX MAINTENANCE

REMOVAL, INSPECTION, REPAIR, INSTALLATION

INITIAL SETUP:

Tools and Special Tools

General mechanic's tool kit
(item 30, WP 0394 00)

Materials/Parts

Five locknuts (item 184, WP 0395 00)
Nine locknuts (item 14, WP 0395 00)

References

TM 9-237
TM 9-2320-386-24P
TM 9-6140-200-14

Equipment Condition

Parking brake set (TM 9-2320-386-10).
Batteries removed (WP 0122 00).
STE/ICE-R shunt removed (WP 0124 00).

BATTERY BOX MAINTENANCE (Contd)

REMOVAL

1. Remove battery box (11) from two supports (10).
2. Remove five locknuts (1), washers (2), screws (21), and STE/ICE-R shunt bracket (3) from battery box (11). Discard locknuts (1).
3. Remove locknut (12), washer (13), chain hook (15), and screw (4) from battery box (11). Discard locknut (12).
4. Remove two pins (14) from chain hooks (15) and three chain hooks (15) from two weldless chains (16).
5. Remove four locknuts (8), screws (5), washers (6), and two bow handles (7) from battery box (11). Discard locknuts (8).
6. Remove four locknuts (19), washers (20), screws (18), and two angle brackets (17) from battery box (11).

INSPECTION

1. Inspect battery box (11), STE/ICE-R shunt bracket (3), bow handles (7), angle brackets (17), and supports (10). Replace battery box (11), STE/ICE-R shunt bracket (3), and angle brackets (17) if cracked. Repair or replace cracked bow handles (7) and supports (10).
2. Inspect battery box (11), STE/ICE-R shunt bracket (3), bow handles (7), angle brackets (17), and supports (10) for corrosion. Clean battery box (11), STE/ICE-R shunt bracket (3), bow handles (7), angle brackets (17), and supports (10) if corroded. For cleaning instructions, refer to TM 9-6140-200-14.
3. Inspect decals (9) for legibility. If illegible, install new decals (9).

REPAIR

For repair welding of bow handles (7) or supports (10), refer to TM 9-237.

INSTALLATION

1. Install STE/ICE-R shunt bracket (3) on battery box (11) with five screws (21), washers (2), and new locknuts (1).
2. Position battery box (4) on two supports (10).
3. Install two angle brackets (17) on battery box (11) with four screws (18), washers (20), and new locknuts (19).
4. Install two bow handles (7) on battery box (11) with four washers (6), screws (5), and new locknuts (8).
5. Install two pins (14) on chain hooks (15) and chain hooks (15) on weldless chains (16).
6. Install two weldless chains (16) on chain hook (15) and install chain hook (15) on battery box (11) with screw (4), washer (13), and new locknut (12).
7. Install STE/ICE-R shunt (WP 0124 00).
8. Install batteries (WP 0122 00).

BATTERY BOX MAINTENANCE (Contd)

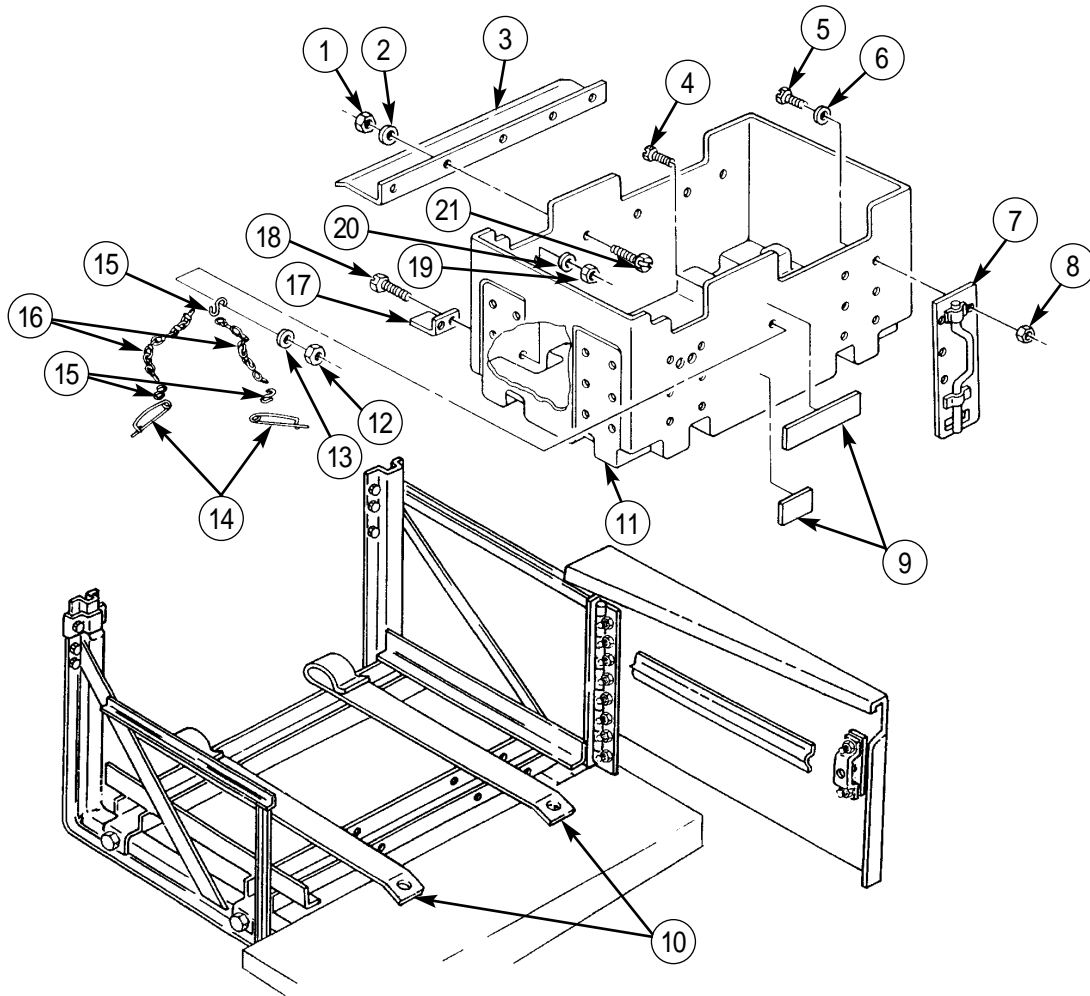

END OF WORK PACKAGE

UNIT MAINTENANCE INSTRUCTIONS

EXTENDED SERVICE PROGRAM (ESP)

TRUCK, CARGO, 2-1/2-TON, 6X6, M44A3 SERIES TRUCKS (DIESEL)

M35A3, W/O WINCH (NSN 2320-01-383-2047); W/WINCH (NSN 2320-01-383-3850);

M35A3C, W/O WINCH (NSN 2320-01-383-2050); W/WINCH (NSN 2320-01-383-2049);

M36A3, W/O WINCH (NSN 2320-01-383-2048); W/WINCH (NSN 2320-01-383-2046).

STE/ICE-R SHUNT REPLACEMENT

REMOVAL, INSTALLATION

INITIAL SETUP:

Tools and Special Tools

General mechanic's tool kit
(item 30, WP 0394 00)

Materials/Parts

Two locknuts (item 15, WP 0395 00)
Two lockwashers (item 56, WP 0395 00)
Two lockwashers (item 55, WP 0395 00)

References

TM 9-2320-386-24P

Equipment Condition

Parking brake set (TM 9-2320-386-10).
Battery ground cable disconnected (WP 0121 00).

STE/ICE-R SHUNT REPLACEMENT (Contd)

REMOVAL

1. Remove screw (2), lockwasher (3), terminal with leads 770Y and 770W (18) and terminal 770F (17), and washer (16) from STE/ICE-R shunt (14). Discard lockwasher (3).
2. Remove screw (4), lockwasher (8), terminal 770X (9), and washer (10) from STE/ICE-R shunt (14). Discard lockwasher (8).
3. Remove screw (1), lockwasher (20), and terminal 7A (19) from STE/ICE-R shunt (14). Discard lockwasher (20).
4. Remove screw (5), lockwasher (6), and terminal 7 (7) from STE/ICE-R shunt (14). Discard lockwasher (7).
5. Remove two locknuts (12), washers (11), screws (15), and STE/ICE-R shunt (14) from mounting bracket (13). Discard locknuts (12).

INSTALLATION

1. Install STE/ICE-R shunt (14) on mounting bracket (13) with two screws (15), washers (11), and new locknuts (12).
2. Install terminal 7 (7), new lockwasher (6), and screw (5) on STE/ICE-R shunt (14).
3. Install terminal 7A (19), new lockwasher (20), and screw (1) on STE/ICE-R shunt (14).
4. Install washer (10), terminal 770X (9), new lockwasher (8), and screw (4) on STE/ICE-R shunt (14).
5. Install washer (16), terminals with leads 770Y and 770W (18) and terminal 770F (17), new lockwasher (3), and screw (2) on STE/ICE-R shunt (14).
6. Connect battery ground cable (WP 0121 00).

STE/ICE-R SHUNT REPLACEMENT (Contd)

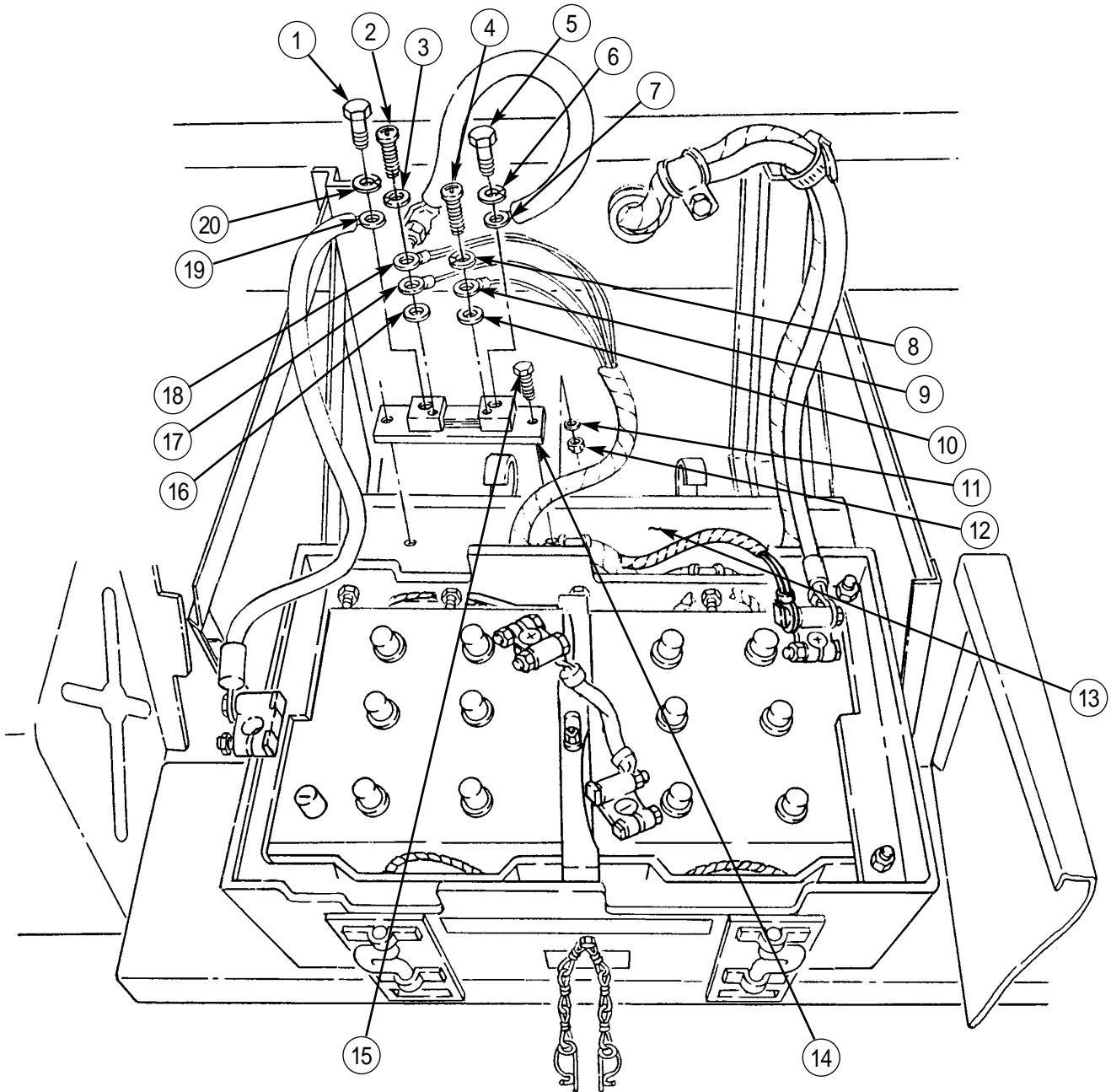

END OF WORK PACKAGE

UNIT MAINTENANCE INSTRUCTIONS

EXTENDED SERVICE PROGRAM (ESP)

TRUCK, CARGO, 2-1/2-TON, 6X6, M44A3 SERIES TRUCKS (DIESEL)

M35A3, W/O WINCH (NSN 2320-01-383-2047); W/WINCH (NSN 2320-01-383-3850);

M35A3C, W/O WINCH (NSN 2320-01-383-2050); W/WINCH (NSN 2320-01-383-2049);

M36A3, W/O WINCH (NSN 2320-01-383-2048); W/WINCH (NSN 2320-01-383-2046).

ELECTRICAL WIRING HARNESS REPAIR

TERMINAL CABLE REPAIR, LEAD REPAIR (MALE PLUG), LEAD REPAIR (FEMALE PLUG), CONNECTOR CABLE REPAIR

INITIAL SETUP:

Tools and Special Tools

General mechanic's tool kit
(item 30, WP 0394 00)
Electrical tool kit (item 26, WP 0394 00)
Heat gun (item 31, WP 0394 00)
Soldering torch kit (item 75, WP 0394 00)

Materials/Parts

Solder (item 47, WP 0393 00)
Heat shrinkable insulation tubing
(item 25, WP 0393 00)

References

TM 9-2320-386-24P
TM 9-237

Equipment Condition

Parking brake set (TM 9-2320-386-10).
Battery ground cable disconnected (WP 0121 00).

ELECTRICAL WIRING HARNESS REPAIR (Contd)**TERMINAL CABLE REPAIR****NOTE**

Heat shrink insulation tubing is used on specific terminals of all ESP vehicles. This tubing protects crimped connections at wiring harness locations that have been designated as “vulnerable to environmental conditions.”

1. Strip cable insulation tubing (1) from cable (2) to equal depth of terminal well (4).
2. Slide insulation tubing (3) over cable insulation tubing (1).
3. Insert cable (2) into terminal well (4) and crimp terminal well (4).
4. Slide insulation tubing (3) over crimped end of terminal (5).
5. Heat shrink insulation tubing (3) on insulation tubing (1) and terminal well (4).

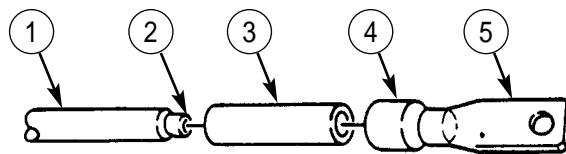
**LEAD REPAIR (MALE PLUG)**

1. Strip cable insulation tubing (1) from cable (2) to equal depth of terminal well (4).
2. Slide shell (6) over cable (2) and cable insulation tubing (1).
3. Insert cable (2) into terminal well (4) and crimp terminal well (4).
4. Place slotted washer (7) over crimped junction at terminal (8).
5. Slide shell (6) and terminal (8) over slotted washer (7).

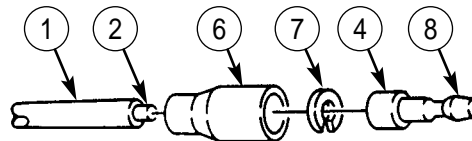
**LEAD REPAIR (FEMALE PLUG)**

1. Strip cable insulation (1) from cable (2) to equal depth of terminal well (4).
2. Slide shell (9) and sleeve (10) over cable (2) and cable insulator (1).
3. Position cable (2) into terminal well (4) and crimp terminal well (4).
4. Slide sleeve (10) and shell (9) over terminal (11).

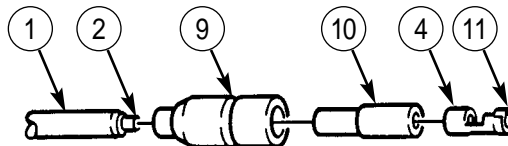

ELECTRICAL WIRING HARNESS REPAIR (Contd)**CONNECTOR CABLE REPAIR**

1. Strip cable insulation (12) to depth of solder wells (4) on inserts (15).
2. Slide cable ends (18) through retaining nut (13) and grommet (14).

NOTE

Refer to TM 9-237 for soldering instructions.

3. Position cable ends (18) into solder wells (4) and solder.

NOTE

Inserts may be either male or female. Coupling nuts will have a matching configuration.

4. Slide grommet (14) over inserts (15) and press grommet (14) into coupling nut (17) until seated.
5. Install grommet retaining nut (13) on threads (16) of coupling nut (17) and tighten until seated.
6. Connect battery ground cable (WP 0121 00).

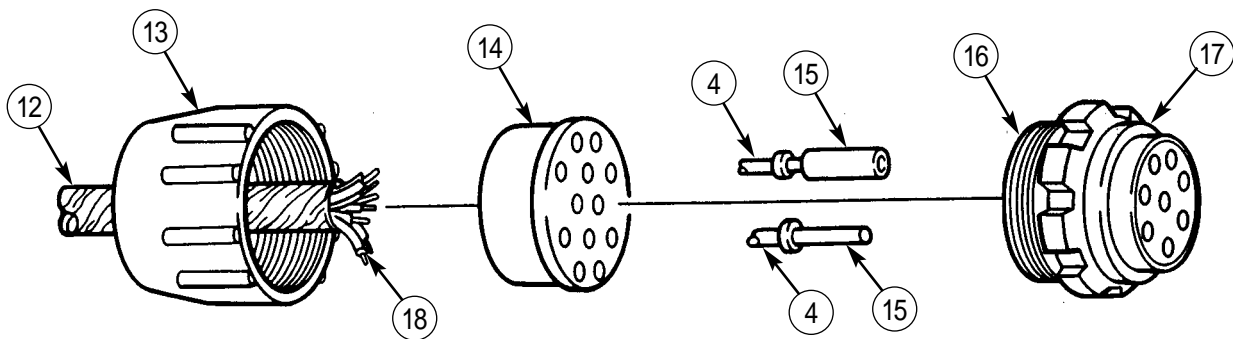

END OF WORK PACKAGE

UNIT MAINTENANCE INSTRUCTIONS

EXTENDED SERVICE PROGRAM (ESP)

TRUCK, CARGO, 2-1/2-TON, 6X6, M44A3 SERIES TRUCKS (DIESEL)

M35A3, W/O WINCH (NSN 2320-01-383-2047); W/WINCH (NSN 2320-01-383-3850);
M35A3C, W/O WINCH (NSN 2320-01-383-2050); W/WINCH (NSN 2320-01-383-2049);
M36A3, W/O WINCH (NSN 2320-01-383-2048); W/WINCH (NSN 2320-01-383-2046).

REAR LIGHTING WIRING HARNESS REPLACEMENT

REMOVAL, INSTALLATION

INITIAL SETUP:

Tools and Special Tools

General mechanic's tool kit
(item 30, WP 0394 00)

Materials/Parts

Two locknuts (item 90, WP 0395 00)
Locknut (item 19, WP 0395 00)
Four lockwashers (item 80 WP 0395 00)

References

TM 9-2320-386-24P

Equipment Condition

Parking brake set (TM 9-2320-386-10).
Battery ground cable disconnected (WP 0121 00).

REAR LIGHTING WIRING HARNESS REPLACEMENT (Contd)**REMOVAL****NOTE**

Tag all leads for installation.

For additional wiring harness replacement information, refer to WP 0386 00, Electrical System Wiring Diagram.

Left and right side wiring is replaced basically the same way. This procedure covers the left side.

1. Disconnect lead 21 (5) from rear side marker light plug 489 (6).
2. Remove locknut (4), two lockwashers (2), screw (1), clamp (3), and lead 21 (5) from side cargo bed rail (7). Discard locknut (4) and lockwashers (2).
3. Disconnect lead 21 (13) from clearance marker light plug 489 (15).
4. Disconnect lead 380A (12) from backup light plug 467 (16).
5. Remove locknut (9), screw (14), and clamp (10) from rear cargo body panel (8) and wiring harness (11). Discard locknut (9).
6. Disconnect three leads 21 (19) from clearance marker light leads 489 (20).
7. Disconnect lead 21 (21) and lead 380A (22) from plugs 21 (24) and 380A (23).
8. Remove locknut (18), screw (26), two lockwashers (25), and clamp (17) from panel (27) and wiring harness (11). Discard locknut (18) and lockwashers (25).

CAUTION

Prior to removal of wiring harness, ensure all clips are removed and disconnections have been performed. Failure to do so may result in damage to equipment.

Use care when removing rear lighting wiring harness. Pulling a snagged or attached harness from the vehicle may result in damage to equipment.

9. Remove rear lighting wiring harness (11) from vehicle.

REAR LIGHTING WIRING HARNESS REPLACEMENT (Contd)

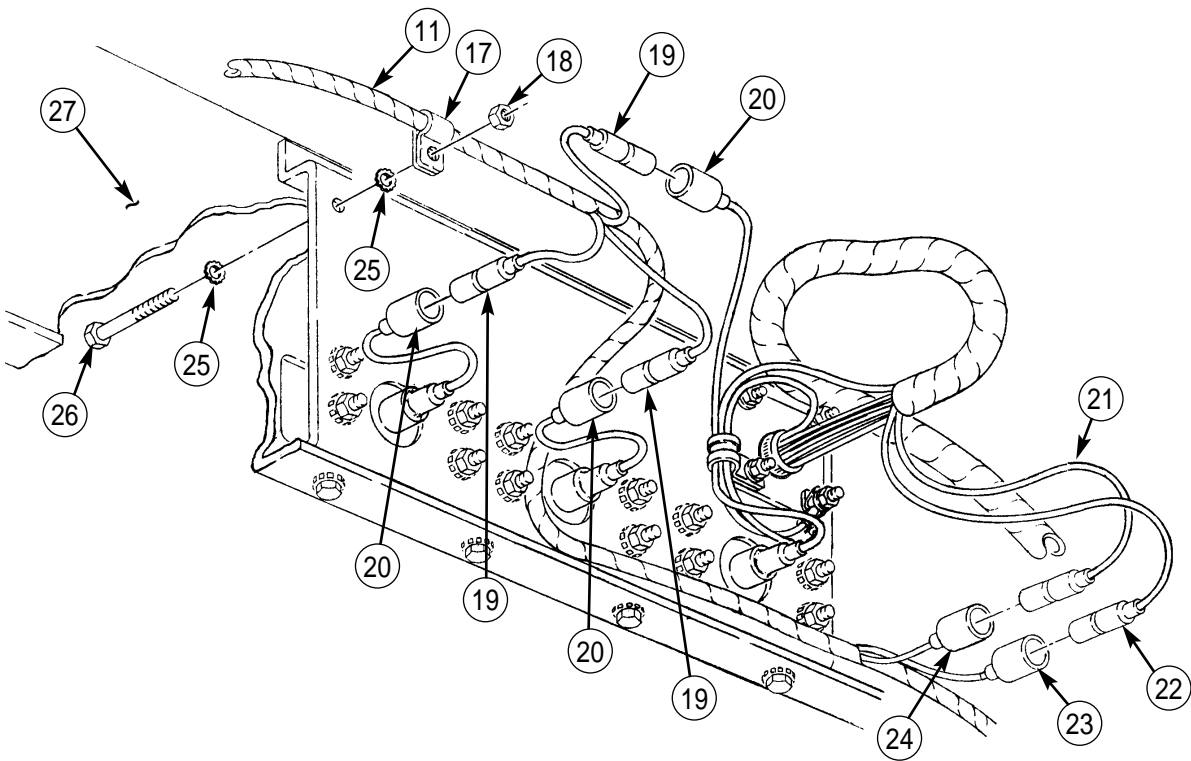
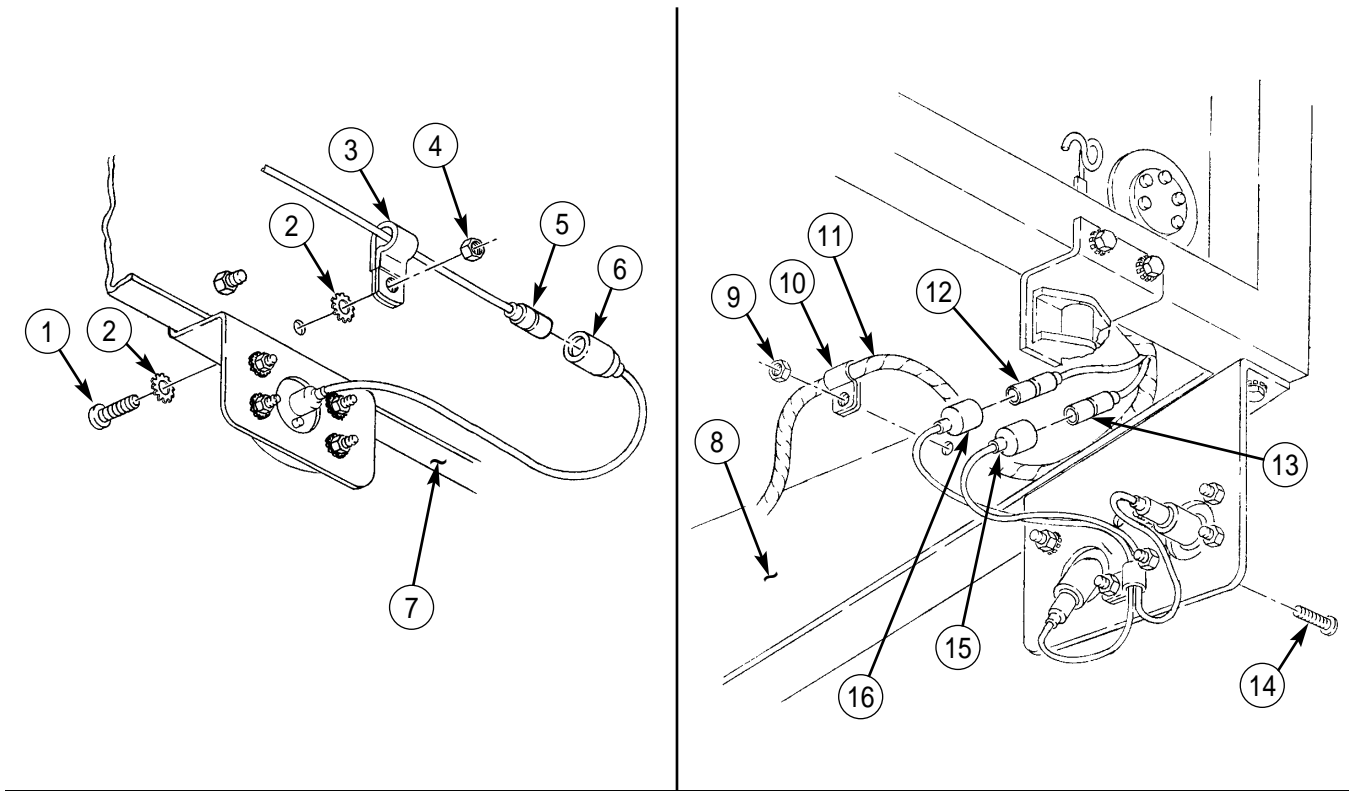

REAR LIGHTING WIRING HARNESS REPLACEMENT (Contd)**INSTALLATION****NOTE**

If new wiring harness is to be installed, transfer tags, applied during removal, from old harness to new harness.

If wiring harness requires repair, refer to WP 0125 00 for further instructions.

1. Position rear lighting wiring harness (1) in vehicle.

NOTE

As rear lighting wiring harness is installed, remove clamps from their tagged locations, then perform installation as specified for each location.

Wiring harness is engineered for each vehicle configuration.

Adjust wiring harness to remove slack or allow slack as required for proper installation.

2. Install wiring harness (1) on panel (12) with clamp (2), two new lockwashers (10), screw (11), and new locknut (3).
3. Connect three leads 21 (4) to clearance marker light leads 489 (5).
4. Connect leads 21 (6) and lead 380A (7) to plug 21 (9) and plug 380A (8).
5. Connect lead 380A (16) to backup light plug 467 (15).
6. Connect lead 21 (17) to clearance marker light plug 489 (18).
7. Install wiring harness (1) on body (20) with clamp (14), screw (19), and new locknut (13).
8. Connect lead 21 (25) to rear side marker light plug 489 (26).
9. Install clamp (23) on side cargo bed rail (27) with screw (21), two new lockwashers (22), and new locknut (24).
10. Connect battery ground cable (WP 0121 00).

REAR LIGHTING WIRING HARNESS REPLACEMENT (Contd)

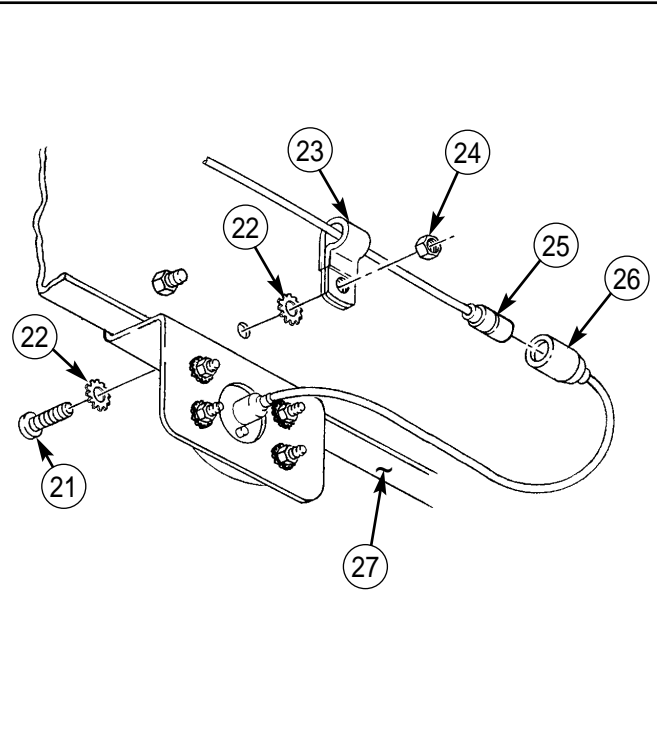
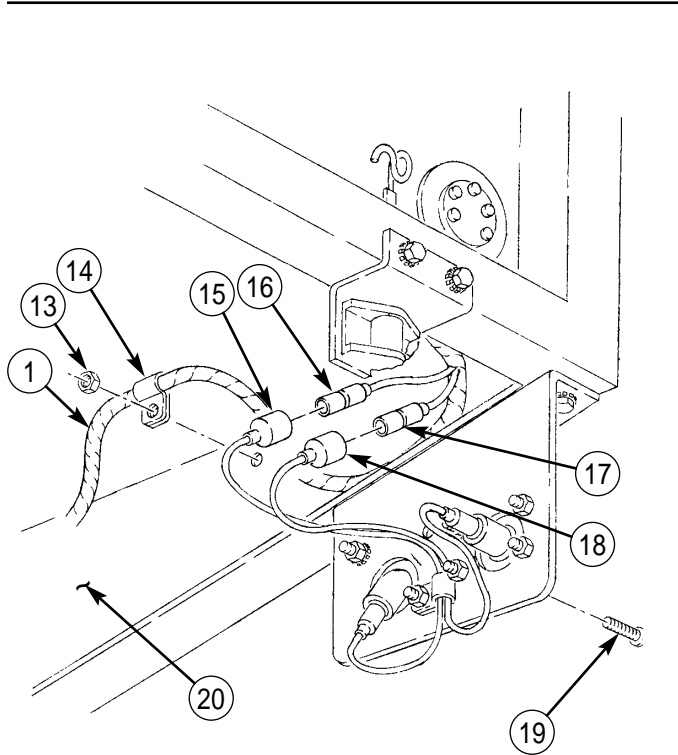
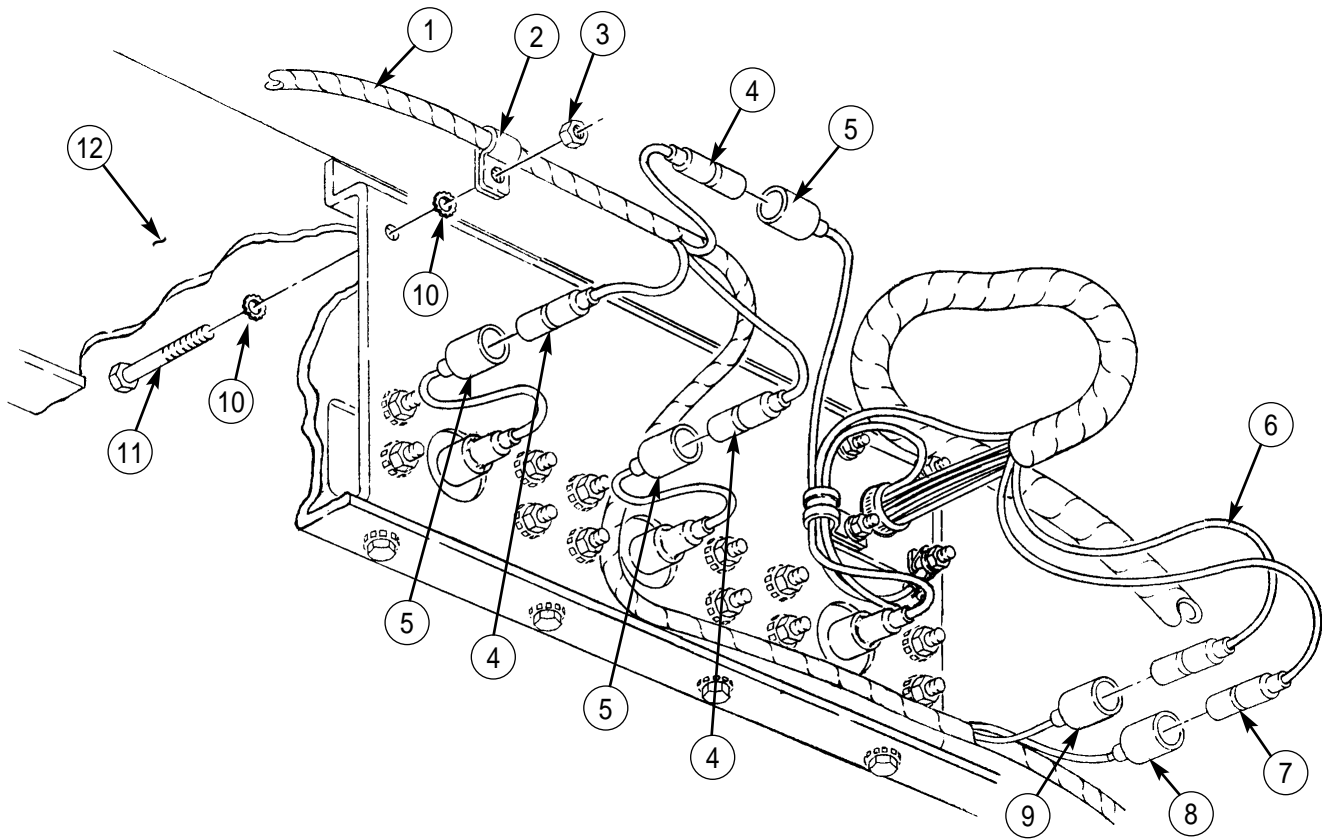

END OF WORK PACKAGE

UNIT MAINTENANCE INSTRUCTIONS

EXTENDED SERVICE PROGRAM (ESP)

TRUCK, CARGO, 2-1/2-TON, 6X6, M44A3 SERIES TRUCKS (DIESEL)

M35A3, W/O WINCH (NSN 2320-01-383-2047); W/WINCH (NSN 2320-01-383-3850);

M35A3C, W/O WINCH (NSN 2320-01-383-2050); W/WINCH (NSN 2320-01-383-2049);

M36A3, W/O WINCH (NSN 2320-01-383-2048); W/WINCH (NSN 2320-01-383-2046).

WIPER MOTOR WIRING HARNESS REPLACEMENT

REMOVAL, INSTALLATION

INITIAL SETUP:

Tools and Special Tools

General mechanic's tool kit
(item 30, WP 0394 00)

Materials/Parts

Three lockwashers (item 77, WP 0395 00)
Lockwasher (item 79, WP 0395 00)

References

TM 9-2320-386-24P

Equipment Condition

Parking brake set (TM 9-2320-386-10).
Battery ground cable disconnected (WP 0121 00).

WIPER MOTOR WIRING HARNESS REPLACEMENT (Contd)**NOTE**

For additional wiring harness replacement information, refer to WP 0386 00, Electrical System Wiring Diagram.

REMOVAL**NOTE**

Tag all leads for installation.

1. Disconnect wiper motor wiring harness lead 27 (9) from front wiring harness lead 400 (10).
2. Remove two nuts (6), screws (11), lockwashers (8), and four ground (GND) terminals (7) from instrument panel (12). Discard lockwashers (8).
3. Disconnect lead 27 (15) from wiper motor switch (16).
4. Remove screw (5), lockwasher (4), ground (GND) terminal (3), and lockwasher (2) from wiper motor mounting bracket (1). Discard lockwashers (2) and (4).
5. Remove grommet (13) from instrument panel (12) and wiper motor wiring harness (14).

CAUTION

Prior to removal of wiring harness, ensure all disconnections have been performed. Failure to do so may result in damage to equipment.

Use care when removing wiper motor wiring harness. Pulling a snagged or attached harness from the vehicle may result in damage to equipment.

6. Remove wiper motor wiring harness (14) from vehicle.

INSTALLATION**NOTE**

If new wiring harness is to be installed, transfer tags from old harness to new harness.

If wiring harness requires repair, refer to WP 0125 00 for further instructions.

1. Insert wiper motor wiring harness (14) through hole in instrument panel (12).

NOTE

Wiring harness is engineered for each vehicle configuration. Adjust wiring harness to remove slack or allow slack as required for proper installation.

2. Connect lead 27 (15) to wiper motor switch (16).
3. Install new lockwasher (2), ground (GND) terminal (3), new lockwasher (4), and screw (5) on wiper motor mounting bracket (1).
4. Install grommet (13) on wiring harness (14) and instrument panel (12).
5. Install four ground (GND) terminals (7) on instrument panel (12) with two screws (11), new lockwashers (8), and nuts (6).
6. Connect wiper motor wiring harness lead 27 (9) to front wiring harness lead 400 (10).
7. Connect battery ground cable (WP 0121 00).

WIPER MOTOR WIRING HARNESS REPLACEMENT (Contd)

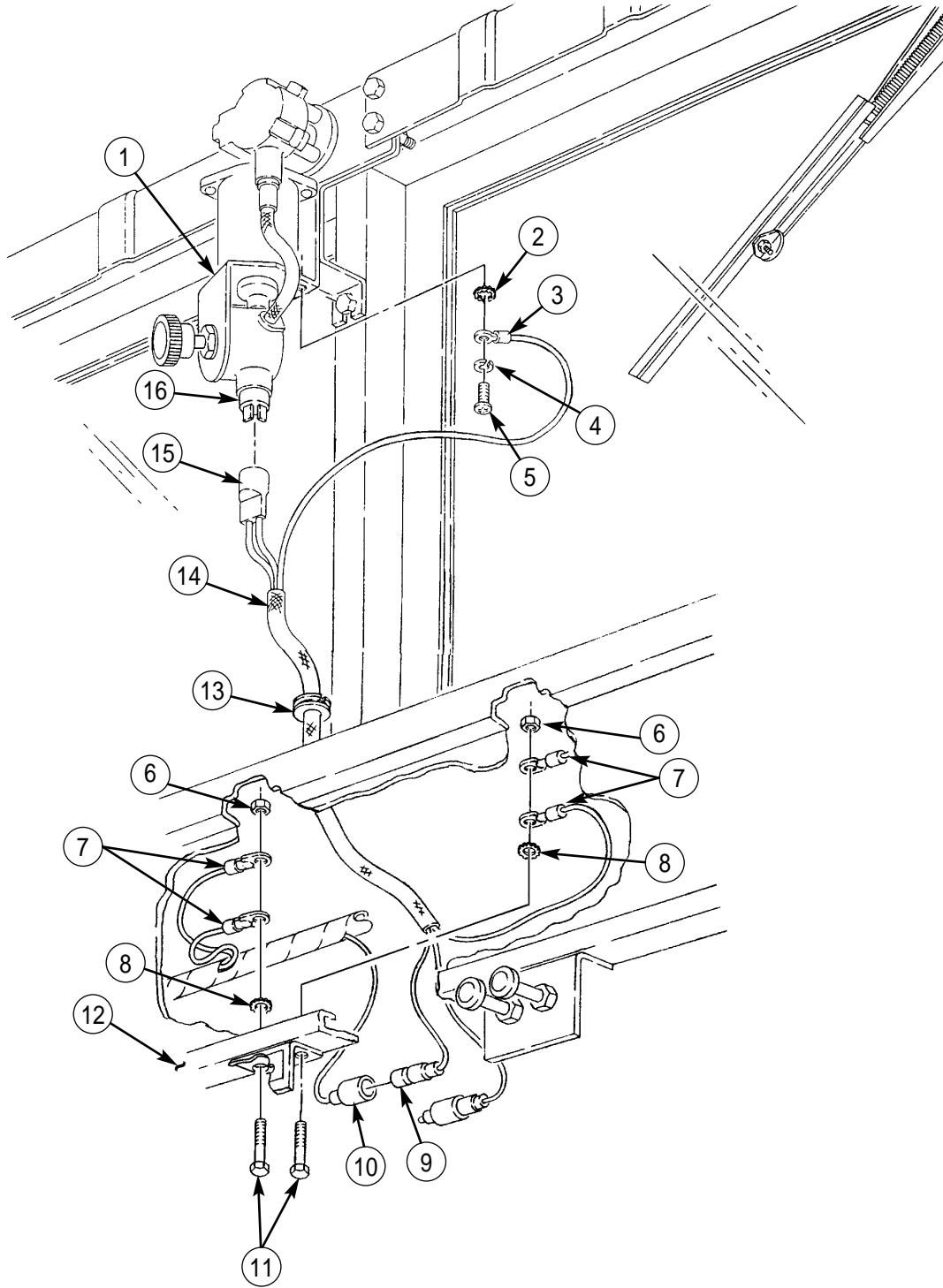

END OF WORK PACKAGE

UNIT MAINTENANCE INSTRUCTIONS

EXTENDED SERVICE PROGRAM (ESP)

TRUCK, CARGO, 2-1/2-TON, 6X6, M44A3 SERIES TRUCKS (DIESEL)

M35A3, W/O WINCH (NSN 2320-01-383-2047); W/WINCH (NSN 2320-01-383-3850);
M35A3C, W/O WINCH (NSN 2320-01-383-2050); W/WINCH (NSN 2320-01-383-2049);
M36A3, W/O WINCH (NSN 2320-01-383-2048); W/WINCH (NSN 2320-01-383-2046).

CTIS CONTROLLER-TO-SIGNAL GENERATOR WIRING HARNESS REPLACEMENT

REMOVAL, INSTALLATION

INITIAL SETUP:

Tools and Special Tools

General mechanic's tool kit
(item 30, WP 0394 00)

Materials/Parts

Tiedown straps (item 38, WP 0395 00)
Eight assembled-washer bolts
(item 174, WP 0395 00)
Four lockwashers (item 61, WP 0395 00)

References

TM 9-2320-386-24P

Equipment Condition

Parking brake set (TM 9-2320-386-10).
Battery ground cable disconnected (WP 0121 00).
ECU removed (WP 0283 00).
Toeboard and tunnel insulation removed
(WP 0201 00).

CTIS CONTROLLER-TO-SIGNAL GENERATOR WIRING HARNESS REPLACEMENT (CONTD)**REMOVAL****NOTE**

Route wiring harness back to nearest tiedown strap after each disconnection.

Tag all leads for installation.

1. Disconnect two leads 431 and 432 (1) from signal generator leads (2).
2. Remove tiedown straps (3) as necessary. Discard tiedown straps (3).
3. Disconnect lead 40 (5) from front wiring harness lead 40 (4).
4. Disconnect two leads 27 (6) from accessory/battery switch location D (8) and lead 27 (7).
5. Remove eight assembled-washer bolts (9) from toeboard (10). Discard assembled-washer bolts (9).
6. Remove four screws (12) and lockwashers (13) from intermediate cab tunnel (11) to allow for removal of controller-to-signal generator wiring harness (14). Discard lockwashers (13).
7. Remove toeboard (10) from vehicle.
8. Remove controller-to-signal generator wiring harness (14) from vehicle.

INSTALLATION**NOTE**

Transfer tags from old wiring harness to new wiring harness prior to installation.

1. Position controller-to-signal generator wiring harness (14) in vehicle.
2. Connect two leads 431 and 432 (1) to signal generator leads (2).
3. Connect two leads 27 (6) to accessory/battery switch location D (8) and lead 27 (7).
4. Connect lead 40 (5) to front wiring harness lead 40 (4).
5. Install new tiedown straps (3), as necessary, to hold controller-to-signal generator wiring harness (14) in position.
6. Position toeboard (10) in vehicle and install on intermediate cab tunnel (11) with four new lockwashers (13), screws (12), and eight new assembled-washer bolts (9).
7. Install toeboard and tunnel insulation (WP 0201 00)
8. Install ECU (WP 0283 00)
9. Connect battery ground cable (WP 0121 00).

CTIS CONTROLLER-TO-SIGNAL GENERATOR WIRING HARNESS REPLACEMENT (Contd)

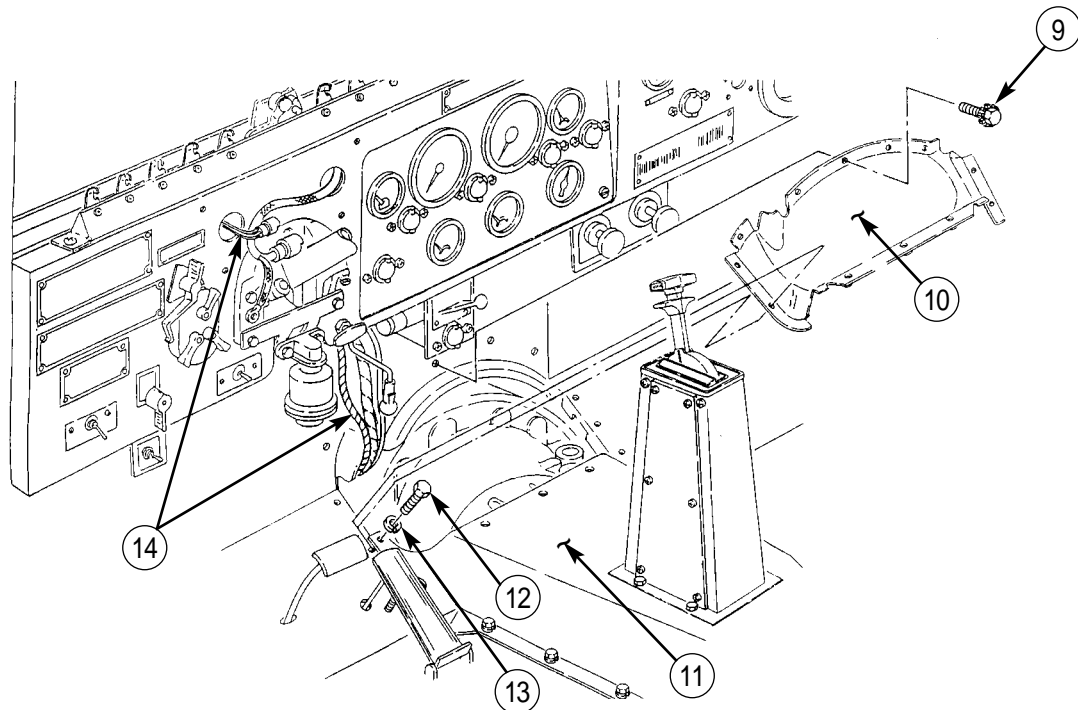
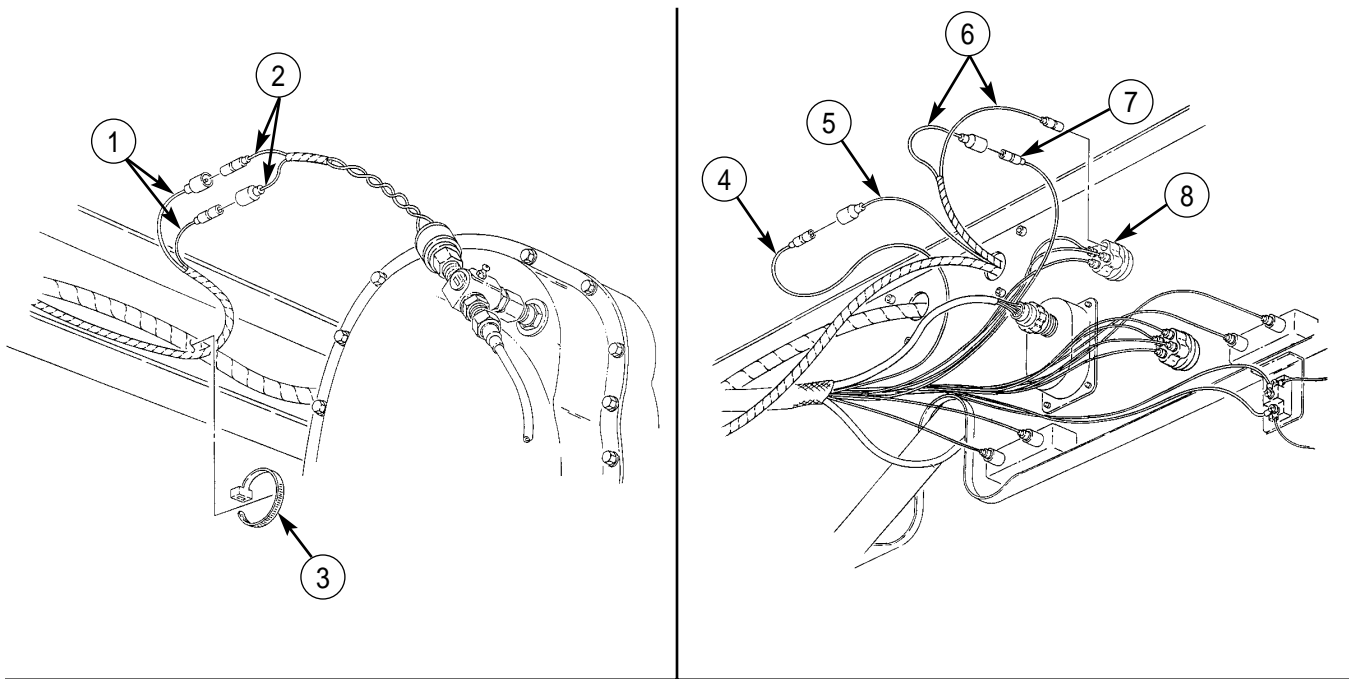

END OF WORK PACKAGE

UNIT MAINTENANCE INSTRUCTIONS

EXTENDED SERVICE PROGRAM (ESP)

TRUCK, CARGO, 2-1/2-TON, 6X6, M44A3 SERIES TRUCKS (DIESEL)

M35A3, W/O WINCH (NSN 2320-01-383-2047); W/WINCH (NSN 2320-01-383-3850);
M35A3C, W/O WINCH (NSN 2320-01-383-2050); W/WINCH (NSN 2320-01-383-2049);
M36A3, W/O WINCH (NSN 2320-01-383-2048); W/WINCH (NSN 2320-01-383-2046).

CTIS CONTROL HARNESS REPLACEMENT

REMOVAL, INSTALLATION

INITIAL SETUP:

Tools and Special Tools

General mechanic's tool kit
(item 30, WP 0394 00)

Materials/Parts

Lockwasher (item 47, WP 0395 00)
Eight assembled-washer bolts
(item 174, WP 0395 00)
Four lockwashers (item 61, WP 0395 00)
Five tiedown straps (item 36, WP 0395 00)

References

TM 9-2320-386-24P

Equipment Condition

Parking brake set (TM 9-2320-386-10).
Battery ground cable disconnected (WP 0121 00).
ECU removed (WP 0283 00).
Toeboard and tunnel insulation removed
(WP 0201 00).

CTIS CONTROL HARNESS REPLACEMENT (Contd)

REMOVAL

1. Remove tiedown straps (3) as necessary. Discard tiedown straps (3).
2. Disconnect CTIS control harness (2) from manifold (1).
3. Remove screw (4), lockwasher (5), and three ground (GND) leads (6) from manifold (1). Discard lockwasher (5).
4. Remove eight assembled-washer bolts (7) from toeboard (8) and four screws (10) and lockwashers (11) from intermediate cab tunnel (9) to allow for removal of CTIS control harness (2). Discard assembled-washer bolts (7) and lockwashers (11).
5. Remove toeboard (8) from vehicle.
6. Remove CTIS control harness (2) from vehicle.

INSTALLATION

1. Position CTIS control harness (2) in vehicle.
2. Install three ground (GND) leads (6) on manifold (1) with new lockwasher (5) and screw (4).
3. Connect CTIS control harness (2) to manifold (1).
4. Install tiedown straps (3) as necessary to secure CTIS control harness (2) and ground (GND) leads (6).
5. Position toeboard (8) in vehicle and install on intermediate cab tunnel (9) with four new lockwashers (11), screws (10), and eight new assembled-washer bolts (7).
6. Install toeboard and tunnel insulation (WP 0201 00).
7. Install ECU (WP 0283 00).
8. Connect battery ground cable (WP 0121 00).

CTIS CONTROL HARNESS REPLACEMENT (Contd)

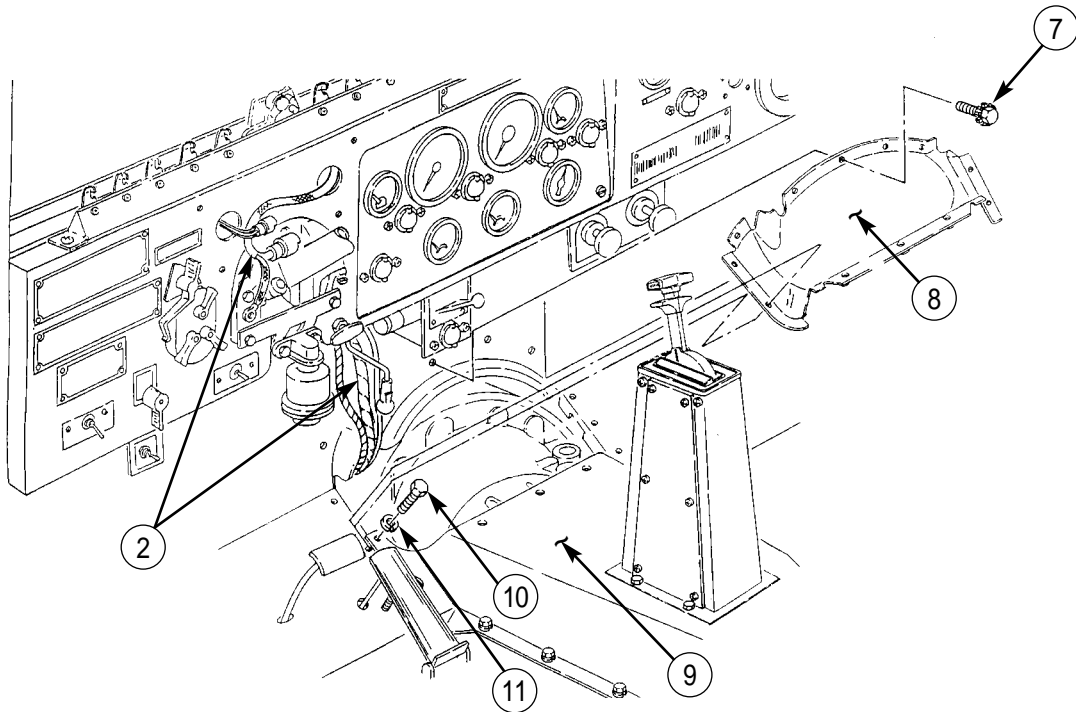
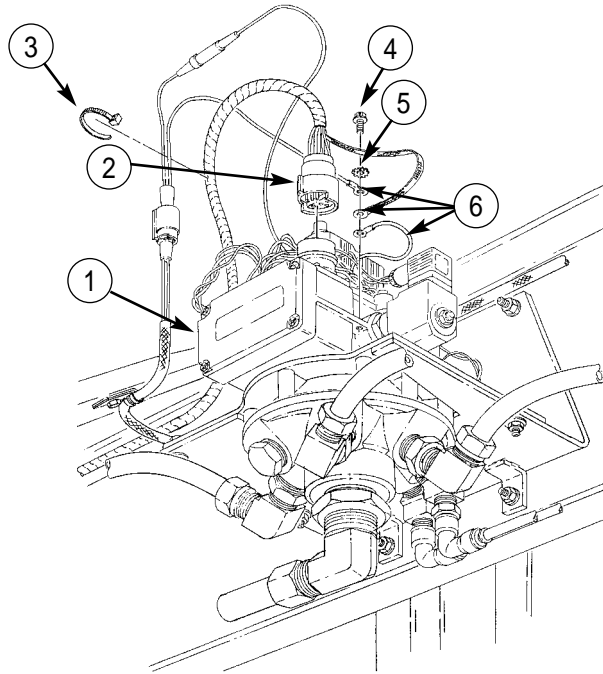

END OF WORK PACKAGE

UNIT MAINTENANCE INSTRUCTIONS

EXTENDED SERVICE PROGRAM (ESP)

TRUCK, CARGO, 2-1/2-TON, 6X6, M44A3 SERIES TRUCKS (DIESEL)

M35A3, W/O WINCH (NSN 2320-01-383-2047); W/WINCH (NSN 2320-01-383-3850);

M35A3C, W/O WINCH (NSN 2320-01-383-2050); W/WINCH (NSN 2320-01-383-2049);

M36A3, W/O WINCH (NSN 2320-01-383-2048); W/WINCH (NSN 2320-01-383-2046).

CTIS MANIFOLD POWER HARNESS REPLACEMENT

REMOVAL, INSTALLATION

INITIAL SETUP:

Tools and Special Tools

General mechanic's tool kit
(item 30, WP 0394 00)

Materials/Parts

Lockwasher (item 291, WP 0395 00)

References

TM 9-2320-386-24P

Equipment Condition

Parking brake set (TM 9-2320-386-10).

Battery ground cable disconnected (WP 0121 00).

CTIS MANIFOLD POWER HARNESS REPLACEMENT (Contd)**REMOVAL**

1. Remove screw (3), lockwasher (4), and three ground (GND) leads (5) from manifold (6). Discard lockwasher (4).
2. Disconnect manifold power connector lead 27 (1) from manifold lead 27 (2).
3. Disconnect manifold power connector with lead 27 and ground (GND) (8) from rear wiring harness connector with leads 27 and ground (GND) (7).

INSTALLATION

1. Connect manifold power connector lead 27 (1) to manifold lead 27 (2).
2. Connect manifold power connector with leads 27 and ground (GND) (8) to rear wiring harness connector (7) with leads 27 and ground (GND) .
3. Install three ground (GND) leads (5) on manifold (6) with new lockwasher (4) and screw (3).
4. Connect battery ground cable (WP 0121 00).

CTIS MANIFOLD POWER HARNESS REPLACEMENT (Contd)

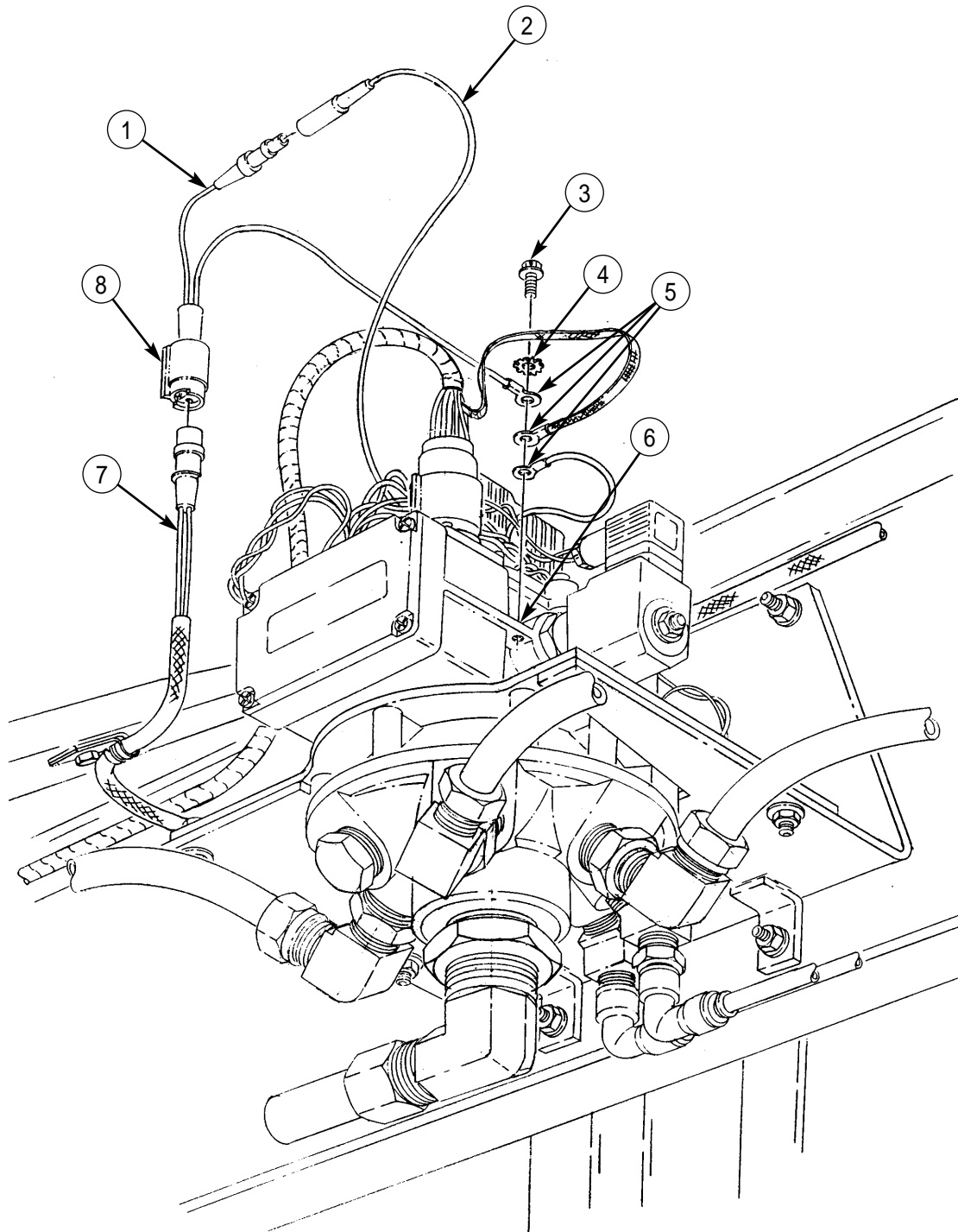

END OF WORK PACKAGE

UNIT MAINTENANCE INSTRUCTIONS

EXTENDED SERVICE PROGRAM (ESP)

TRUCK, CARGO, 2-1/2-TON, 6X6, M44A3 SERIES TRUCKS (DIESEL)

M35A3, W/O WINCH (NSN 2320-01-383-2047); W/WINCH (NSN 2320-01-383-3850);

M35A3C, W/O WINCH (NSN 2320-01-383-2050); W/WINCH (NSN 2320-01-383-2049);

M36A3, W/O WINCH (NSN 2320-01-383-2048); W/WINCH (NSN 2320-01-383-2046).

SECTION IX. TRANSMISSION MAINTENANCE

TABLE OF CONTENTS

<i>WP Title</i>	<i>WP Sequence No.-Page No.</i>
Transmission Shift Cable Maintenance	0132 00-1
Transmission Shift Tower Replacement	0133 00-1
Transmission Select Lever Maintenance	0134 00-1
Transmission Modulator Control Cable Maintenance	0135 00-1
Transmission Vent Line Replacement	0136 00-1
Transmission Oil Drainage	0137 00-1
Transmission Oil Dipstick Tube Replacement	0138 00-1
Transmission Oil Cooler Hoses Replacement	0139 00-1
Transmission Auxiliary Oil Cooler Replacement	0140 00-1
Transmission Oil Sampling Valve Replacement	0141 00-1
Transmission External Oil Filter and Base Replacement	0142 00-1
Transmission Internal Oil Filter Replacement	0143 00-1

END OF WORK PACKAGE

UNIT MAINTENANCE INSTRUCTIONS

EXTENDED SERVICE PROGRAM (ESP)

TRUCK, CARGO, 2-1/2-TON, 6X6, M44A3 SERIES TRUCKS (DIESEL)

M35A3, W/O WINCH (NSN 2320-01-383-2047); W/WINCH (NSN 2320-01-383-3850);

M35A3C, W/O WINCH (NSN 2320-01-383-2050); W/WINCH (NSN 2320-01-383-2049);

M36A3, W/O WINCH (NSN 2320-01-383-2048); W/WINCH (NSN 2320-01-383-2046).

TRANSMISSION SHIFT CABLE MAINTENANCE

REMOVAL, INSTALLATION, ADJUSTMENT

INITIAL SETUP:

Tools and Special Tools

General mechanic's tool kit
(item 30, WP 0394 00)

Materials/Parts

Cotter pin (item 140, WP 0395 00)
Two lockwashers (item 154, WP 0395 00)

References

TM 9-2320-386-24P

Equipment Condition

Parking brake set (TM 9-2320-386-10).
Transmission select lever removed (WP 0134 00).

TRANSMISSION SHIFT CABLE MAINTENANCE (Contd)**REMOVAL**

1. Remove cotter pin (7) and shift cable (3) from manual control lever (8). Discard cotter pin (7).
2. Remove two nuts (6), lockwashers (5), U-bolt (1), shift cable (3), and spacer (2) from bracket (4). Discard lockwashers (5).
3. Loosen jamnut (11) and remove connecting link (10) from shift cable (3).
4. Remove shift cable (3) from vehicle.

INSTALLATION

1. Route shift cable (3) to transmission (9) through hole in cab tunnel.
2. Install connecting link (10) to center of threads on end of shift cable (3) to allow for further adjustment. Do not tighten jamnut (11).
3. Install spacer (2) and shift cable (3) on bracket (4) with U-bolt (1), two new lockwashers (5), and nuts (6).

ADJUSTMENT

1. Move manual control lever (8) to full forward 1 (first) gear position and adjust connecting link (10) in or out on threads of shift cable (3) to align with hole in lever (8) and tighten jamnut (11).
2. Install connecting link (10) on lever (8) with new cotter pin (7).
3. Install transmission select lever (WP 0134 00).

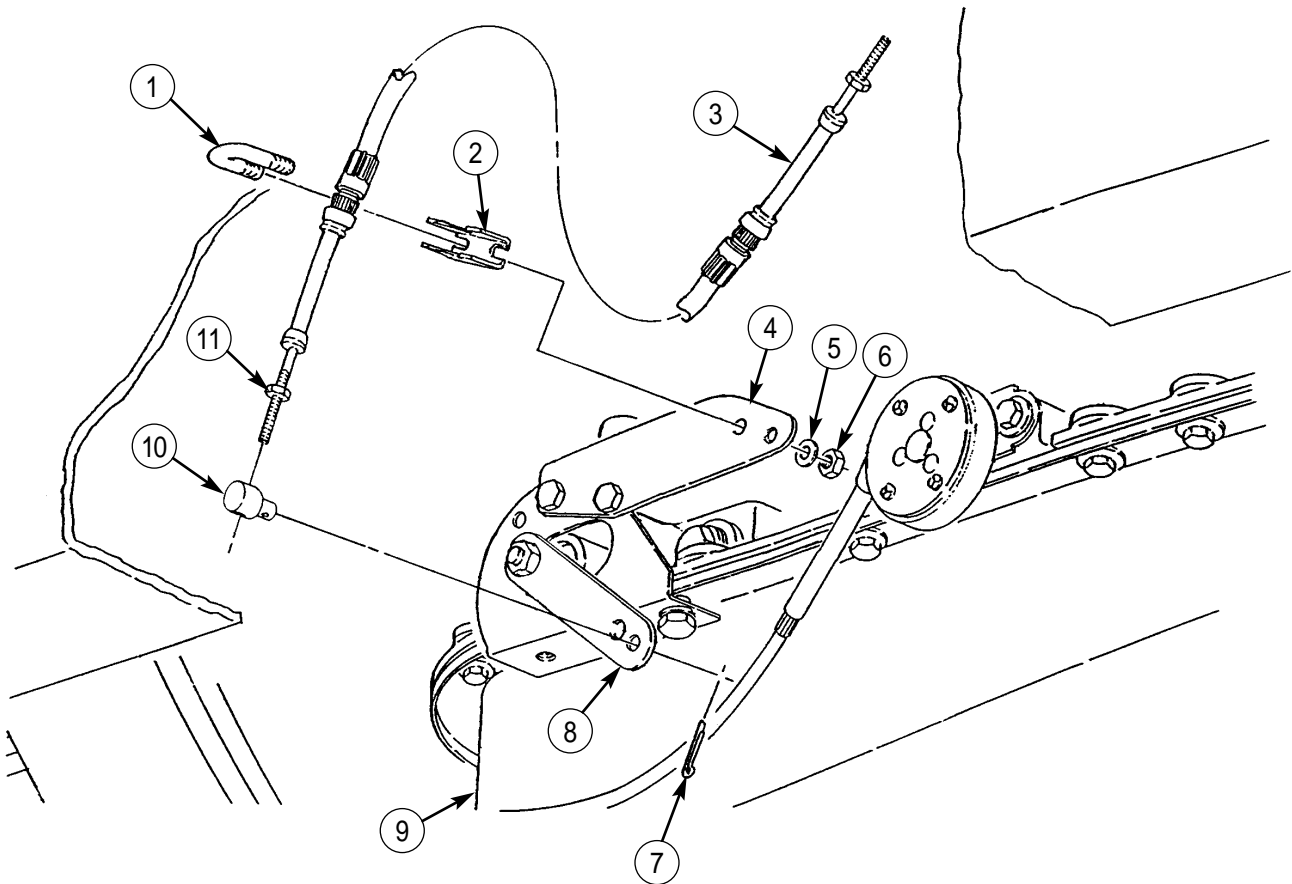
**END OF WORK PACKAGE**

UNIT MAINTENANCE INSTRUCTIONS

EXTENDED SERVICE PROGRAM (ESP)

TRUCK, CARGO, 2-1/2-TON, 6X6, M44A3 SERIES TRUCKS (DIESEL)

M35A3, W/O WINCH (NSN 2320-01-383-2047); W/WINCH (NSN 2320-01-383-3850);

M35A3C, W/O WINCH (NSN 2320-01-383-2050); W/WINCH (NSN 2320-01-383-2049);

M36A3, W/O WINCH (NSN 2320-01-383-2048); W/WINCH (NSN 2320-01-383-2046).

TRANSMISSION SHIFT TOWER REPLACEMENT

REMOVAL, INSTALLATION

INITIAL SETUP:

Tools and Special Tools

General mechanic's tool kit
(item 30, WP 0394 00)

Materials/Parts

Four locknuts (item 338, WP 0395 00)

Personnel required

Assistant (1)

References

TM 9-2320-386-24P

Equipment Condition

Parking brake set (TM 9-2320-386-10).
Transmission select lever removed (WP 0134 00).
Front winch controls removed, if equipped
(WP 0223 00).
Cab insulation removed (WP 0201 00).

TRANSMISSION SHIFT TOWER REPLACEMENT (Contd)**REMOVAL**

1. Remove four locknuts (6), screws (4), and shift tower (3) from cover (8) and cab tunnel (7). Discard locknuts (6).
2. Remove grommet (1) from cover (8) and pull harness (5) and shift cable (2) from cover (8).
3. Remove two screws (15) and supports (9) and (11) from base (10).

NOTE

Perform step 4 if support requires replacement. Step applies to vehicles without front winch only.

4. Remove plug (12), two screws (13), and cover (14) from support (11).

INSTALLATION**NOTE**

Perform step 1 if support was replaced. Step applies to vehicles without front winch only.

1. Install plug (12) on support (11).
2. Install cover (14) on support (11) with two screws (13).
3. Install supports (9) and (11) on base (10) with two screws (15).
4. Insert harness (5) and shift cable (2) through hole in cover (8).
5. Install grommet (1) in hole of cover (8).
6. Install shift tower (3) on cover (8) and cab tunnel (7) with four screws (4) and new locknuts (6).
7. Install cab insulation (WP 0201 00).
8. Install transmission select lever (WP 0134 00)
9. Install front winch controls, if equipped (WP 0223 00).

TRANSMISSION SHIFT TOWER REPLACEMENT (Contd)

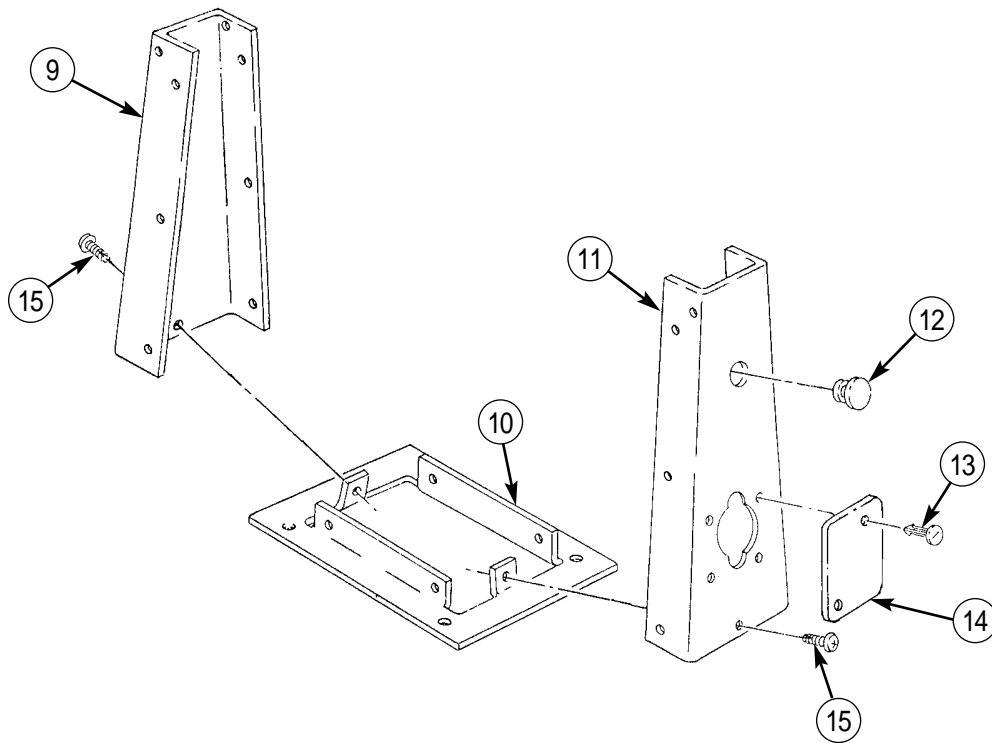
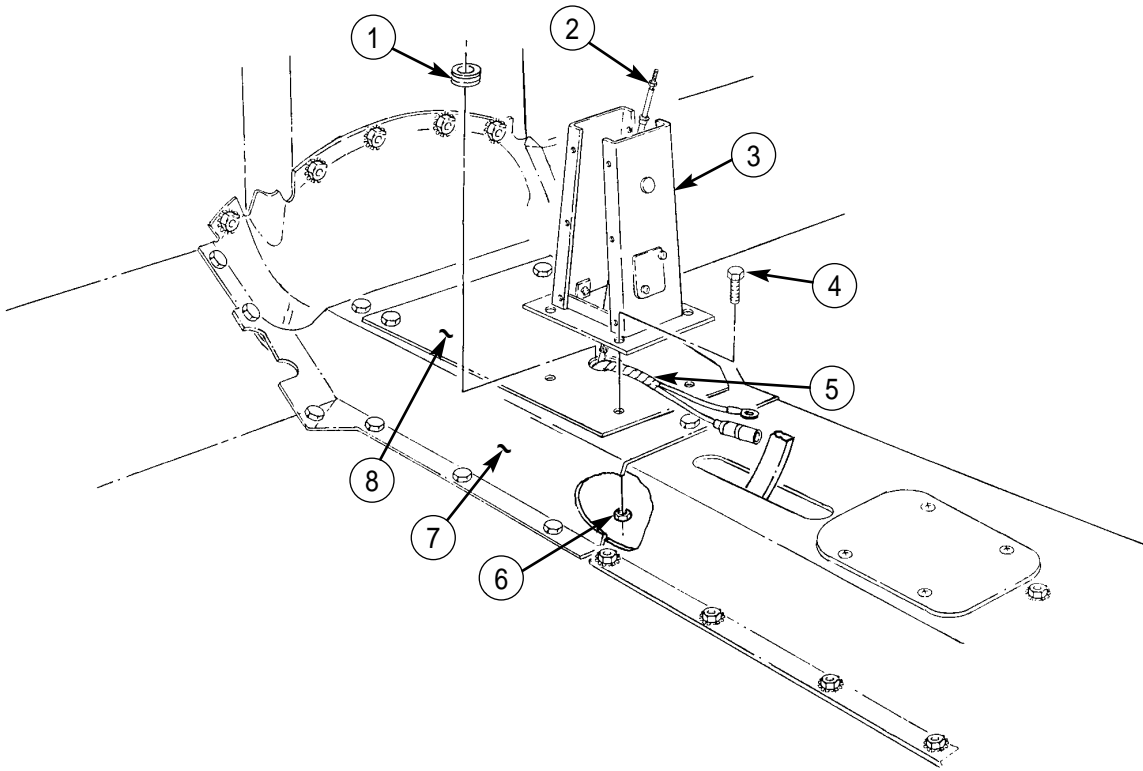

END OF WORK PACKAGE

UNIT MAINTENANCE INSTRUCTIONS

EXTENDED SERVICE PROGRAM (ESP)

TRUCK, CARGO, 2-1/2-TON, 6X6, M44A3 SERIES TRUCKS (DIESEL)

M35A3, W/O WINCH (NSN 2320-01-383-2047); W/WINCH (NSN 2320-01-383-3850);

M35A3C, W/O WINCH (NSN 2320-01-383-2050); W/WINCH (NSN 2320-01-383-2049);

M36A3, W/O WINCH (NSN 2320-01-383-2048); W/WINCH (NSN 2320-01-383-2046).

TRANSMISSION SELECT LEVER MAINTENANCE

REMOVAL, DISASSEMBLY, ASSEMBLY, INSTALLATION

INITIAL SETUP:

Tools and Special Tools

General mechanic's tool kit
(item 30, WP 0394 00)

Materials/Parts

Lockwasher (item 75, WP 0395 00)
Six lockwashers (item 123, WP 0395 00)
Lockpin (item 122, WP 0395 00)
Plain-assembled nut (item 348, WP 0395 00)

References

TM 9-2320-386-24P

Equipment Condition

Parking brake set (TM 9-2320-386-10).
Battery ground cable disconnected (WP 0121 00).

TRANSMISSION SELECT LEVER MAINTENANCE (Contd)**REMOVAL**

1. Remove twelve screws (16) and two side plates (15) from supports (21).
2. Disconnect wiring harness plug with lead 40 (14) from connector (13).
3. Remove four screws (19) and lockwashers (20) from two supports (21) and select lever (1). Discard lockwashers (20).
4. Raise select lever (1) from two supports (21) to access shift cable (5).
5. Remove lockpin (2) from connecting link (3). Discard lockpin (2).
6. Remove two nuts (17), lockwashers (18), clamp (12), shift cable (5), spacer (11), and two screws (6) from select lever (1). Discard lockwashers (18).
7. Remove plain-assembled nut (10), screw (8), ground (GND) wire 99A (9), and lockwasher (7) from select lever (1). Discard lockwasher (7) and plain-assembled nut (10).
8. Disconnect shift cable (5) with connecting link (3) from select lever (1).
9. Remove select lever (1) from two supports (21).
10. Loosen jamnut (4) and remove connecting link (3) from shift cable (5).

DISASSEMBLY

1. Remove four screws (22), cover plate (23), and cover seal (24) from select lever (1).
2. Remove lamp (25) from bracket (26).

TRANSMISSION SELECT LEVER MAINTENANCE (Contd)

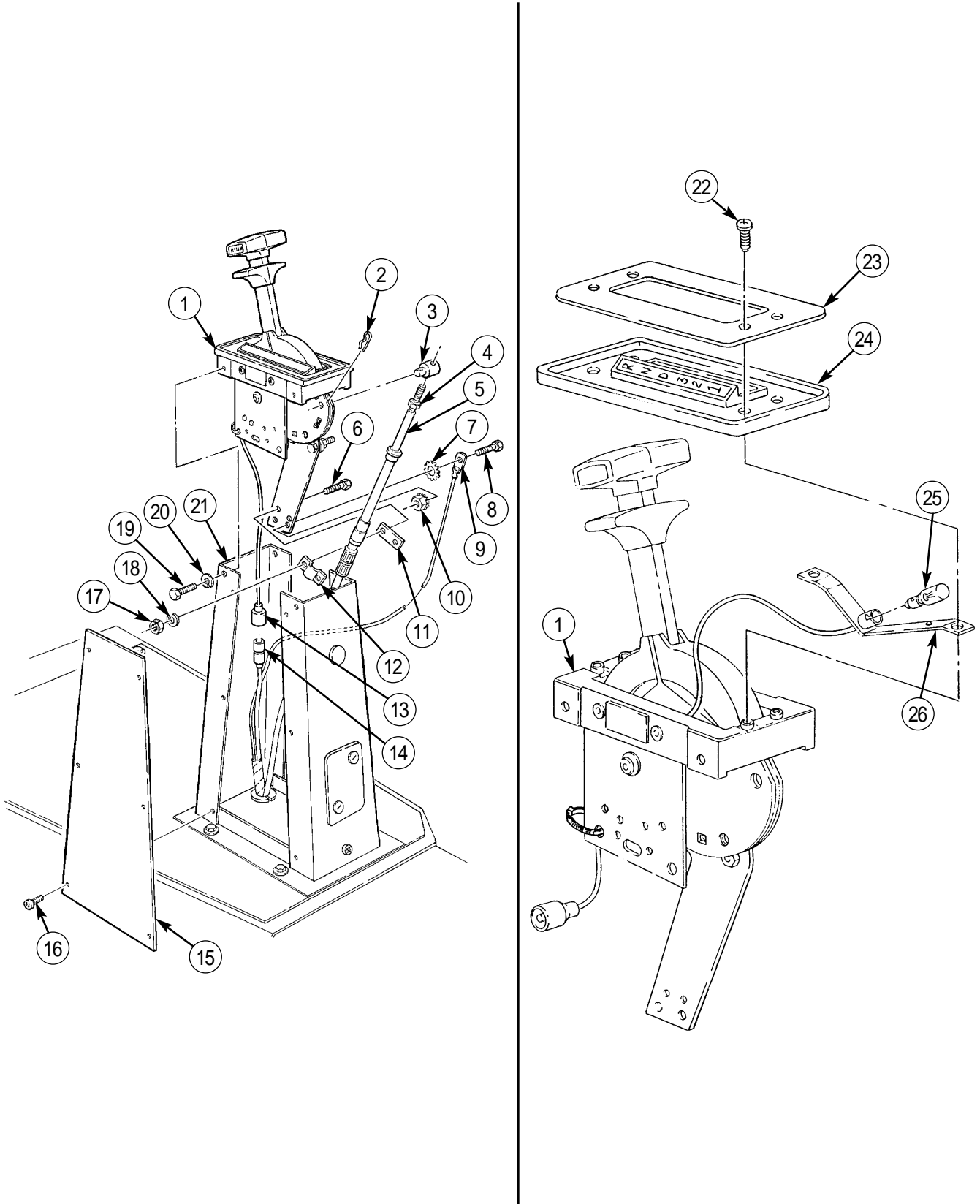

TRANSMISSION SELECT LEVER MAINTENANCE (Contd)**ASSEMBLY**

1. Install lamp (4) on bracket (5).
2. Position bracket (5) on select lever (6).
3. Install bracket (5), cover seal (3), and cover plate (2) on select lever (6) with four screws (1).

INSTALLATION

1. Install spacer (17), shift cable (11), and clamp (18) on select lever (6) with two screws (12), new lockwashers (19), and nuts (20).
2. Install new lockwasher (15), ground lead 99A (14), screw (13), and new plain-assembled nut (16) on select lever (6).
3. Install connecting link (8) on shift cable (11).

NOTE

Perform step 4 if additional clearance is required when adjusting shift cable.

4. Remove nut (10) and screw (28) from select lever (6).
5. Place select lever (6) and manual control lever on transmission in first gear position and check that connecting link (8) aligns with hole in select lever (6). Adjust connecting link (8) in or out on shift cable (11) if necessary.
6. Move select lever (6) and manual control lever to full rear position R (reverse) on transmission and check that connecting link (8) aligns with hole in select lever (6). Adjust connecting link (8) in or out on shift cable (11) if necessary and tighten jamnut (9).
7. Install shift cable (11) on select lever (6) with new lockpin (7).
8. If removed, install screw (28) and nut (10) on select lever (6).
9. Position select lever (6) on two supports (23) and install with four new lockwashers (27) and screws (26).
10. Connect wiring harness plug with lead 40 (22) to connector (21).
11. Install two side plates (24) on supports (23) with twelve screws (25).
12. Connect battery ground cable (WP 0121 00).

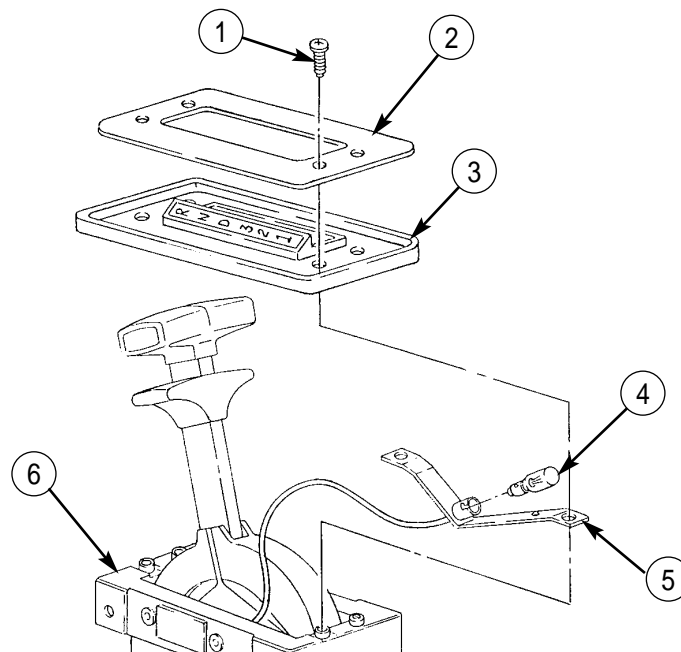

TRANSMISSION SELECT LEVER MAINTENANCE (Contd)

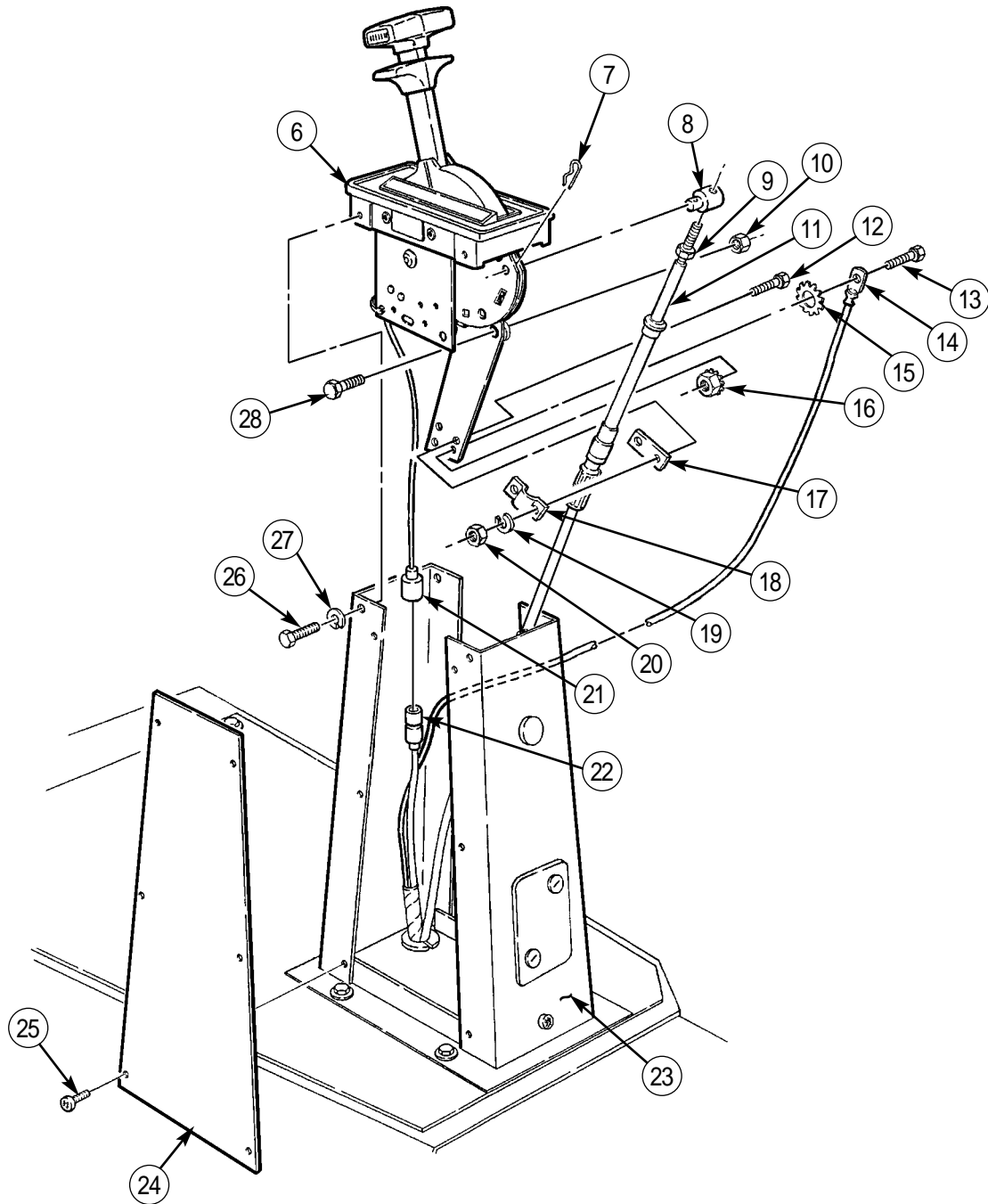

END OF WORK PACKAGE

UNIT MAINTENANCE INSTRUCTIONS

EXTENDED SERVICE PROGRAM (ESP)

TRUCK, CARGO, 2-1/2-TON, 6X6, M44A3 SERIES TRUCKS (DIESEL)

M35A3, W/O WINCH (NSN 2320-01-383-2047); W/WINCH (NSN 2320-01-383-3850);

M35A3C, W/O WINCH (NSN 2320-01-383-2050); W/WINCH (NSN 2320-01-383-2049);

M36A3, W/O WINCH (NSN 2320-01-383-2048); W/WINCH (NSN 2320-01-383-2046).

TRANSMISSION MODULATOR CONTROL CABLE MAINTENANCE

REMOVAL, INSTALLATION, ADJUSTMENT

INITIAL SETUP:

Tools and Special Tools

General mechanic's tool kit
(item 30, WP 0394 00)

Materials/Parts

Locknut (item 184, WP 0395 00)
Packing retainer (item 323, WP 0395 00)
Cotter pin (item 121, WP 0395 00)

References

TM 9-2320-386-24P

Equipment Condition

Parking brake set (TM 9-2320-386-10).

TRANSMISSION MODULATOR CONTROL CABLE MAINTENANCE (Contd)**REMOVAL**

1. Remove screw (2), clamp (3), modulator (1), and packing retainer (4) from transmission (5). Discard packing retainer (4).
2. Remove cotter pin (16), washer (15), and pivot (7) with modulator cable (10) from lever (6). Discard cotter pin (16).
3. Remove locknut (9), screw (11), and modulator cable (10) from bracket (8). Discard locknut (9).

NOTE

Perform step 4 if replacement of pivot is necessary.

4. Loosen jamnut (12) and remove pivot (7) from modulator cable (10).

INSTALLATION**NOTE**

Perform step 1 if pivot was removed.

1. Install pivot (7) on threaded end of modulator cable (10). Tighten jamnut (12).
2. Install new packing retainer (4) and modulator (1) on transmission (5) with clamp (3) and screw (2). Finger-tighten screw (2).
3. Route modulator cable (10) to front of cab (14) and install on bracket (8) with screw (11) and new locknut (9).
4. Install pivot (7) with modulator cable (10) in lever (6), and install washer (15) and new cotter pin (16).
5. Tighten screw (2).

ADJUSTMENT**NOTE**

Assistant will help with this procedure.

Check that accelerator cable is in full throttle position when accelerator is fully depressed.

Perform step 1 if pivot was not removed.

1. Remove cotter pin (16), washer (15), and pivot (7) with modulator cable (10) from lever (6). Discard cotter pin (16).
2. Direct assistant to depress accelerator to full throttle position.
3. Pull rod end (13) out of modulator cable (10) until full throttle position is achieved.
4. Install pivot (7) on lever (6).
 - a. If pivot (7) does not align with hole in lever (6), loosen jamnut (12) and adjust pivot (7) until pivot (7) aligns with hole in lever (6) and tighten jamnut (12).
 - b. If pivot (7) aligns with hole in lever (6), install washer (15) and new cotter pin (16).

TRANSMISSION MODULATOR CONTROL CABLE MAINTENANCE (Contd)

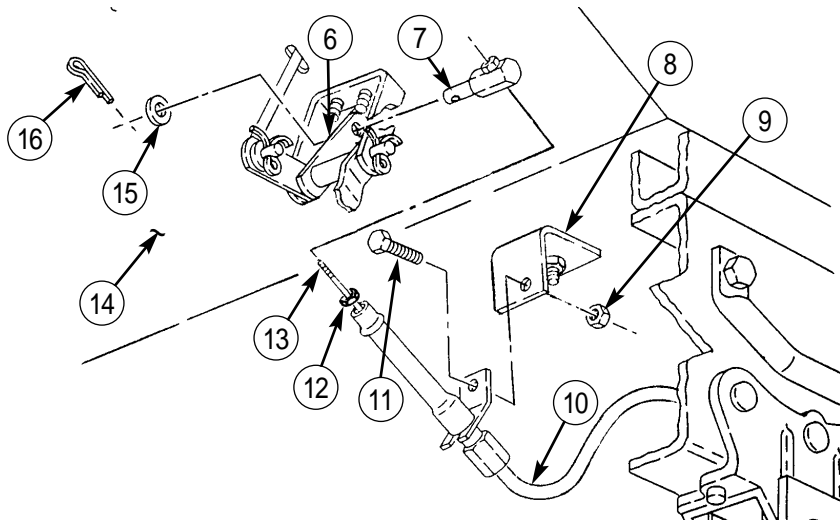
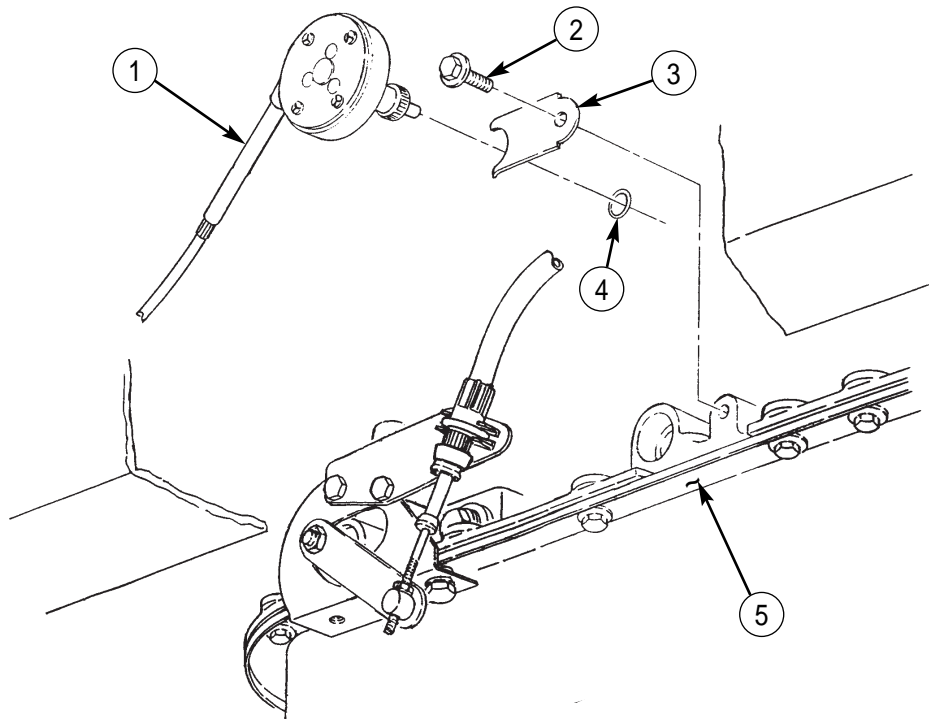

END OF WORK PACKAGE

UNIT MAINTENANCE INSTRUCTIONS

EXTENDED SERVICE PROGRAM (ESP)

TRUCK, CARGO, 2-1/2-TON, 6X6, M44A3 SERIES TRUCKS (DIESEL)

M35A3, W/O WINCH (NSN 2320-01-383-2047); W/WINCH (NSN 2320-01-383-3850);
M35A3C, W/O WINCH (NSN 2320-01-383-2050); W/WINCH (NSN 2320-01-383-2049);
M36A3, W/O WINCH (NSN 2320-01-383-2048); W/WINCH (NSN 2320-01-383-2046).

TRANSMISSION VENT LINE REPLACEMENT

TRANSMISSION VENT LINE REMOVAL, TRANSMISSION VENT LINE INSTALLATION

INITIAL SETUP:

Tools and Special Tools

General mechanic's tool kit
(item 30, WP 0394 00)

Materials/Parts

Cap and plug set (item 14, WP 0393 00)
Tiedown strap (item 38, WP 0395 00)

References

TM 9-2320-386-24P

Equipment Condition

Parking brake set (TM 9-2320-386-10).
Rear cab tunnel and toeboard removed (WP 0207 00).

TRANSMISSION VENT LINE REPLACEMENT (Contd)**TRANSMISSION VENT LINE REMOVAL****CAUTION**

When disconnecting air lines and hoses, plug all openings to prevent dirt from entering and causing damage to internal parts. Remove all plugs prior to installation.

1. Loosen nut (3) and remove transmission vent line (2) from elbow (4) on transmission (1).
2. Remove tiedown strap (8), four screws (5), clamps (6), and transmission vent line (2) from cab (7) and vehicle. Discard tiedown strap (8).

TRANSMISSION VENT LINE INSTALLATION

1. Install transmission vent line (2) to elbow (4) on transmission (1) and tighten nut (3).
2. Install four clamps (6) on transmission vent line (2) and other two vent lines and secure to cab (7) with four screws (5).
3. Secure three vent lines into a loop with new tiedown strap (8).
4. Install rear cab tunnel and toeboard (WP 0207 00).

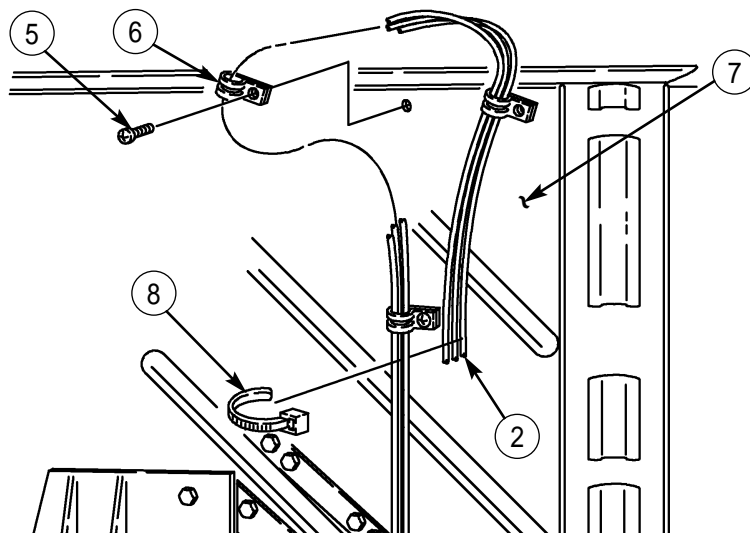
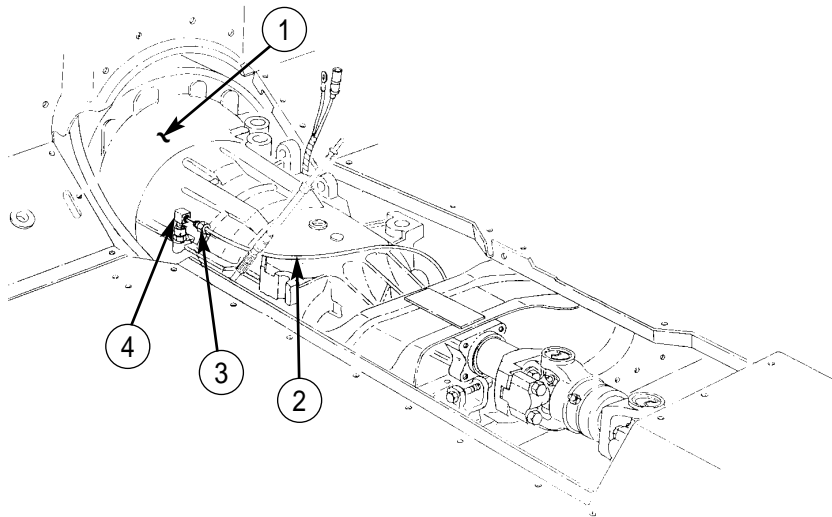

END OF WORK PACKAGE

UNIT MAINTENANCE INSTRUCTIONS

EXTENDED SERVICE PROGRAM (ESP)

TRUCK, CARGO, 2-1/2-TON, 6X6, M44A3 SERIES TRUCKS (DIESEL)

M35A3, W/O WINCH (NSN 2320-01-383-2047); W/WINCH (NSN 2320-01-383-3850);

M35A3C, W/O WINCH (NSN 2320-01-383-2050); W/WINCH (NSN 2320-01-383-2049);

M36A3, W/O WINCH (NSN 2320-01-383-2048); W/WINCH (NSN 2320-01-383-2046).

TRANSMISSION OIL DRAINAGE

DRAINAGE

INITIAL SETUP:

Tools and Special Tools

General mechanic's tool kit
(item 30, WP 0394 00)

Materials/Parts

Wiping rag (item 35, WP 0393 00)
Gasket (item 170, WP 0395 00)

References

TM 9-2320-386-24P

Equipment Condition

Parking brake set (TM 9-2320-386-10).

TRANSMISSION OIL DRAINAGE (Contd)**DRAINAGE****WARNING**

Accidental or intentional introduction of liquid contaminants into the environment is in violation of state, federal, and military regulation. Refer to Army POL (WP 0001 00) for information concerning storage, use, and disposal of these liquids. Failure to do so may result in injury or death.

Transmission oil may be hot when it is drained from the transmission oil pan. Use caution when removing drainplug from oil pan. Failure to do so may cause injury to personnel.

NOTE

Have container ready to catch oil.

1. Remove drainplug (1) and gasket (2) from transmission oil pan (4) and allow fluid to drain. Discard gasket (2).
2. After fluid has drained completely, wipe plug (1) and drain opening (3) with a clean, dry rag.
3. Install new gasket (2) and drainplug (1) on transmission oil pan (4).

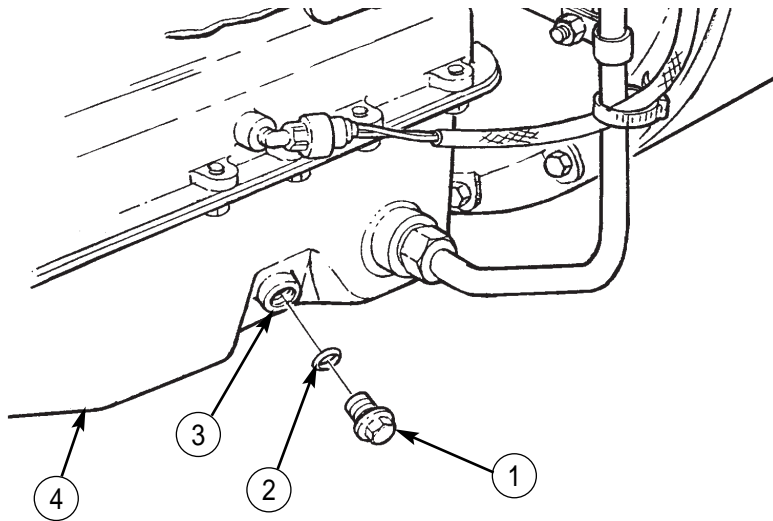

END OF WORK PACKAGE

UNIT MAINTENANCE INSTRUCTIONS

EXTENDED SERVICE PROGRAM (ESP)

TRUCK, CARGO, 2-1/2-TON, 6X6, M44A3 SERIES TRUCKS (DIESEL)

M35A3, W/O WINCH (NSN 2320-01-383-2047); W/WINCH (NSN 2320-01-383-3850);
M35A3C, W/O WINCH (NSN 2320-01-383-2050); W/WINCH (NSN 2320-01-383-2049);
M36A3, W/O WINCH (NSN 2320-01-383-2048); W/WINCH (NSN 2320-01-383-2046).

TRANSMISSION OIL DIPSTICK TUBE REPLACEMENT

REMOVAL, INSTALLATION

INITIAL SETUP:

Tools and Special Tools

General mechanic's tool kit
(item 30, WP 0394 00)

Materials/Parts

Tiedown strap (item 36, WP 0395 00)
Wiping rag (item 35, WP 0393 00)

References

TM 9-2320-386-24P

Equipment Condition

Parking brake set (TM 9-2320-386-10).
Transmission oil drained (WP 0137 00).

TRANSMISSION OIL DIPSTICK TUBE REPLACEMENT (Contd)**REMOVAL**

1. Lift soundproof material on passenger side floorboard to locate access door (1).
2. Open access door (1) and remove dipstick (2) from dipstick tube (6).

NOTE

Have container ready to catch oil.

3. Remove nut (5), screw (3), clamp (4), and dipstick tube (6) from bracket (7).
4. Remove tiedown strap (10) from dipstick tube (6) and lead 324 (11). Discard tiedown strap (10).

WARNING

Accidental or intentional introduction of liquid contaminants into the environment is in violation of state, federal, and military regulations. Refer to Army POL (WP 0001 00) for information concerning storage, use, and disposal of these liquids. Failure to do so may result in injury or death.

5. Remove dipstick tube (6) from transmission oil pan (9).
6. Wipe dipstick tube (6) and opening (8) with clean, dry rag.

INSTALLATION

1. Install dipstick tube (6) on transmission oil pan (9).
2. Install dipstick tube (6) and clamp (4) on bracket (7) with screw (3) and nut (5).
3. Install lead 324 (11) on dipstick tube (6) with new tiedown strap (10).
4. Install dipstick (2) in dipstick tube (6) and close access door (1).
5. Reposition soundproof material on passenger side floorboard.
6. Fill transmission to proper oil level (WP 0022 00).

TRANSMISSION OIL DIPSTICK TUBE REPLACEMENT (Contd)

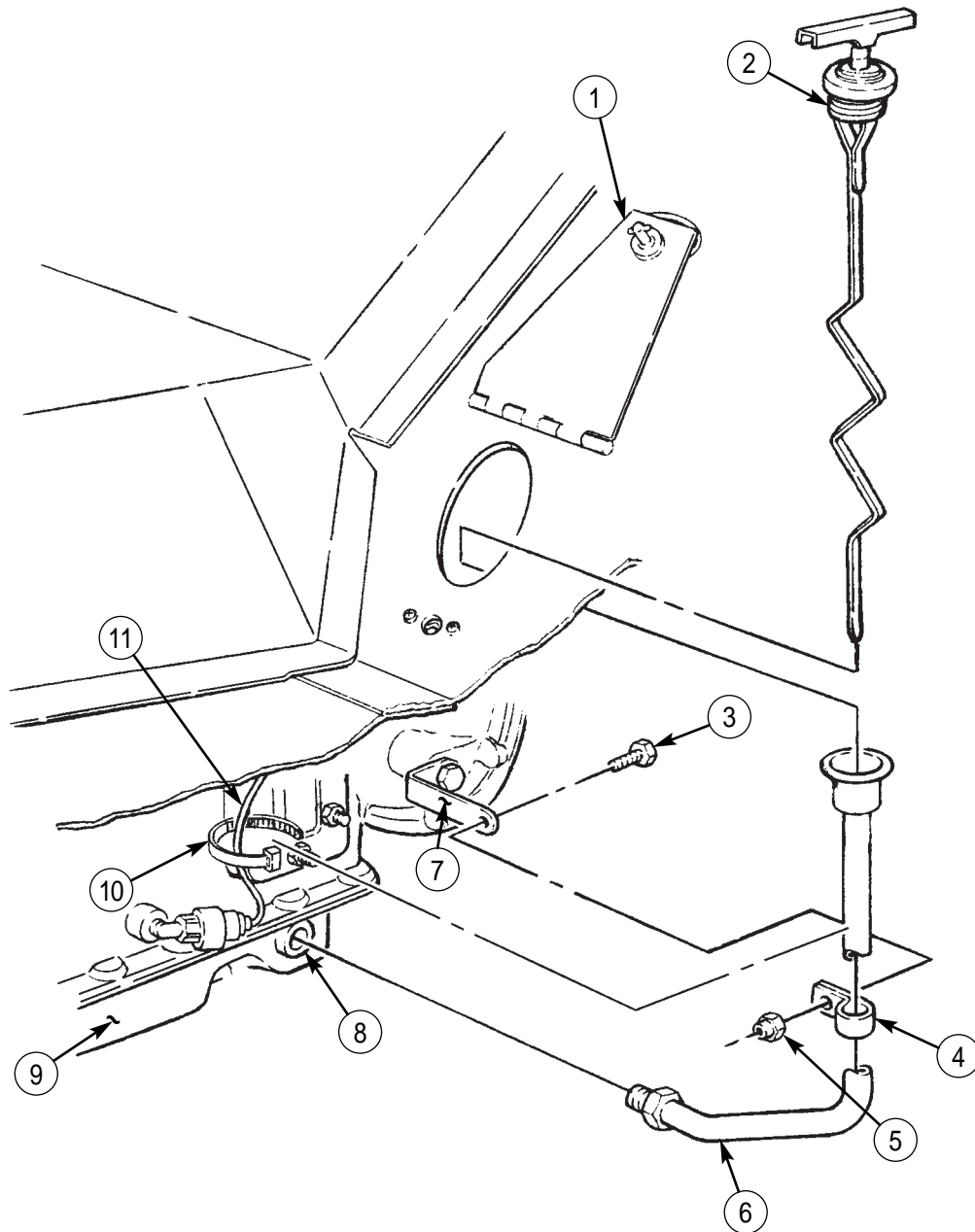

END OF WORK PACKAGE

UNIT MAINTENANCE INSTRUCTIONS

EXTENDED SERVICE PROGRAM (ESP)

TRUCK, CARGO, 2-1/2-TON, 6X6, M44A3 SERIES TRUCKS (DIESEL)

M35A3, W/O WINCH (NSN 2320-01-383-2047); W/WINCH (NSN 2320-01-383-3850);

M35A3C, W/O WINCH (NSN 2320-01-383-2050); W/WINCH (NSN 2320-01-383-2049);

M36A3, W/O WINCH (NSN 2320-01-383-2048); W/WINCH (NSN 2320-01-383-2046).

TRANSMISSION OIL COOLER HOSES REPLACEMENT

REMOVAL, INSTALLATION

INITIAL SETUP:

Tools and Special Tools

General mechanic's tool kit
(item 30, WP 0394 00)

Materials/Parts

Locknut (item 183, WP 0395 00)
Five locknuts (item 175, WP 0395 00)
Tiedown straps (item 39, WP 0395 00)
Lockwasher (item 343, WP 0395 00)
Two O-rings (item 211, WP 0395 00)
Teflon pipe sealant (item 41, WP 0393 00)

References

TM 9-2320-386-24P

Equipment Condition

Parking brake set (TM 9-2320-386-10).
Hood raised and secured (TM 9-2320-386-10).
Brushguard removed (WP 0230 00).
Intermediate cab tunnel and toeboard removed
(WP 0207 00).

TRANSMISSION OIL COOLER HOSES REPLACEMENT (Contd)**REMOVAL**

1. Remove tiedown straps (24), as required. Discard tiedown straps (24).
2. Remove locknuts (15), screws (12), and clamps (13) from hose (14) and frame (18) as required. Discard locknuts (15).
3. Remove three screws (6) and clamps (7) from supply hose (5) and fender (26).

WARNING

Accidental or intentional introduction of liquid contaminants into the environment is in violation of state, federal, and military regulations. Refer to Army POL (WP 0001 00) for information concerning storage, use and disposal of these liquids. Failure to do so may result in injury or death.

Transmission oil may be hot when it is drained from the transmission oil cooler. Use caution when disconnecting supply hoses. Failure to do so may cause injury to personnel.

NOTE

Have drainage container ready to catch oil.

4. Disconnect supply hose (5) and return hose (25) from adapter (4) and elbow (2) on transmission (30).

NOTE

Note position of elbows for installation.

If oil is leaking at elbows, perform steps 5 and 6.

5. Remove pipe tee (3) from elbow (2).
6. Remove two elbows (2) and O-rings (1) from transmission (30). Discard O-ring (1).
7. Disconnect supply hose (5) from elbow (10) on radiator (11).
8. Disconnect hose (14) and return hose (25) from elbows (16) and (19) on oil filter base (17).
9. Remove locknut (8), screw (21), and clamps (22) and (23) from return hose (25), brake line (20), and frame (18). Discard locknut (8).
10. Remove screw (29), lockwasher (28), and clamp (27) from return hose (25) and transmission (30). Discard lockwasher (28).
11. Disconnect hose (31) from elbow (32) on auxiliary oil cooler (33) and elbow (9) if not removed with brushguard.

INSTALLATION

1. Apply sealant to male threads of adapter (4) and elbows (10), (16), (19), and (32).
2. Connect return hose (25) and hose (14) to elbows (16) and (19) on oil filter base (17).
3. Connect supply hose (5) to elbow (10) on radiator (11).

NOTE

If removal steps 5 and 6 were performed, perform steps 4 through 6.

4. Apply sealant to male threads of pipe tee (3) and two elbows (2).
5. Install pipe tee (3) on elbow (2).
6. Install two new O-rings (1) and elbows (2) on transmission (30).
7. Route supply hose (5) and return hose (25) to transmission (30) and install on adapter (4) and elbow (2).
8. Install hose (14) on frame (18) with clamps (13), screws (12), and new locknuts (15) as required.
9. Install supply hose (5) on fender (26) with three clamps (7) and screws (6).

TRANSMISSION OIL COOLER HOSES REPLACEMENT (Contd)

10. Install return hose (25) and brake line (20) to frame (18) with clamps (23) and (22), screw (21), and new locknut (8).
11. Install return hose (25) on transmission (30) with clamp (27), new lockwasher (28), and screw (29).
12. Install new tiedown straps (24) as required.
13. Connect hose (31) to elbow (32) on auxiliary oil cooler (33) and elbow (9) on radiator (11).
14. Install brushguard (WP 0230 00).
15. Fill transmission to proper oil level (TM 9-2320-386-10).
16. Install intermediate cab tunnel and toeboard (WP 0207 00).

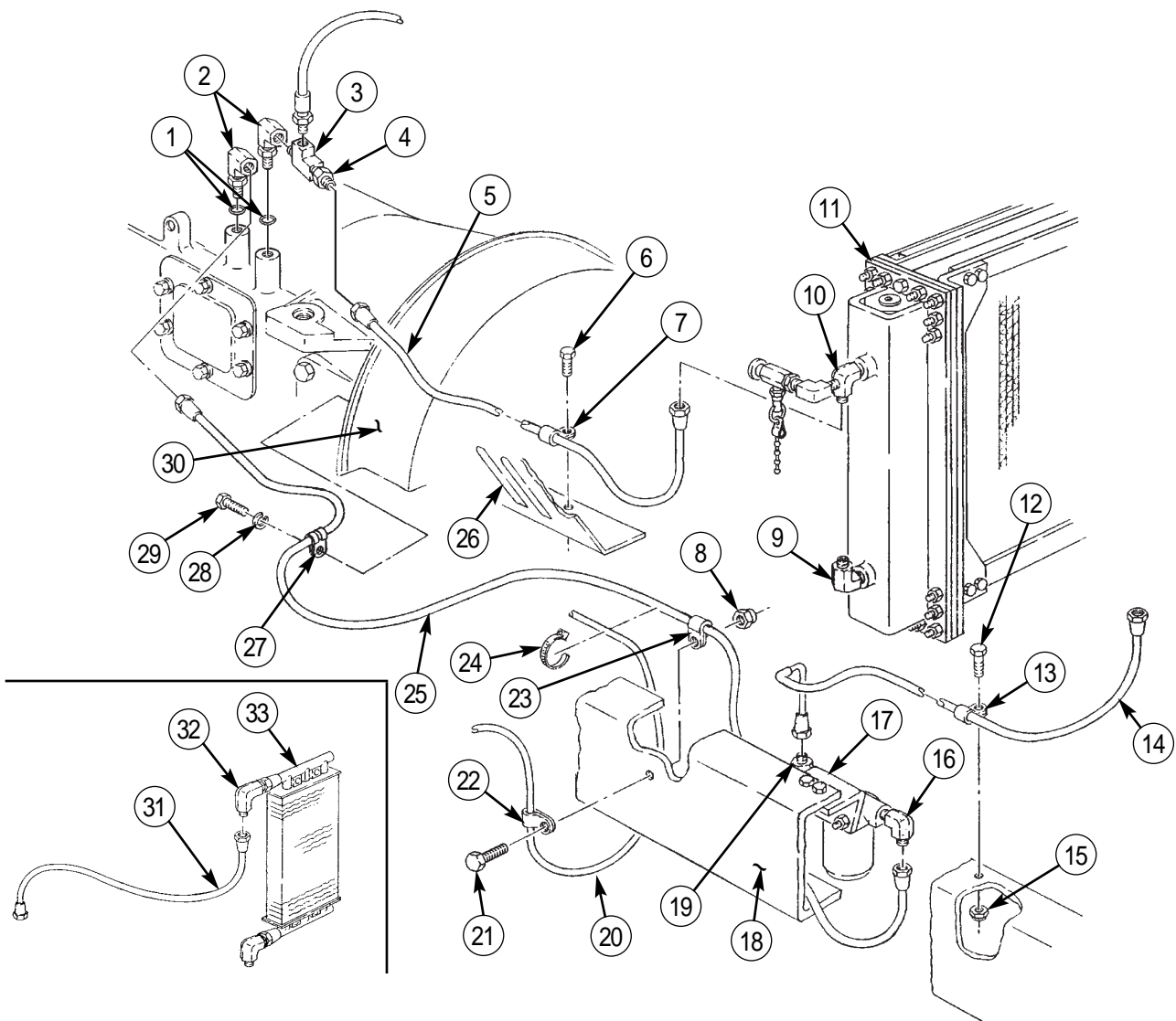

END OF WORK PACKAGE

UNIT MAINTENANCE INSTRUCTIONS

EXTENDED SERVICE PROGRAM (ESP)

TRUCK, CARGO, 2-1/2-TON, 6X6, M44A3 SERIES TRUCKS (DIESEL)

M35A3, W/O WINCH (NSN 2320-01-383-2047); W/WINCH (NSN 2320-01-383-3850);

M35A3C, W/O WINCH (NSN 2320-01-383-2050); W/WINCH (NSN 2320-01-383-2049);

M36A3, W/O WINCH (NSN 2320-01-383-2048); W/WINCH (NSN 2320-01-383-2046).

TRANSMISSION AUXILIARY OIL COOLER REPLACEMENT

REMOVAL, INSTALLATION

INITIAL SETUP:

Tools and Special Tools

General mechanic's tool kit
(item 30, WP 0394 00)

Materials/Parts

Teflon pipe sealant (item 41, WP 0393 00)

References

TM 9-2320-386-24P

Equipment Condition

Parking brake set (TM 9-2320-386-10).
Hood raised and secured (TM 9-2320-386-10).
Brushguard removed (WP 0230 00).

TRANSMISSION AUXILIARY OIL COOLER REPLACEMENT (Contd)**REMOVAL**

1. Remove four screws (4), washers (5), hose bushings (6), and oil cooler (3) from brushguard (7).
2. Remove hoses (1) and (9) and elbows (2) and (8) from oil cooler (3).

INSTALLATION

1. Apply sealant to male threads of elbows (8) and (2).
2. Install elbows (2) and (8) and hoses (1) and (9) on oil cooler (3).
3. Install oil cooler (3) on brushguard (7) with four hose bushings (6), washers (5), and screws (4).
4. Install brushguard (WP 0230 00).
5. Fill transmission to proper oil level (WP 0022 00).

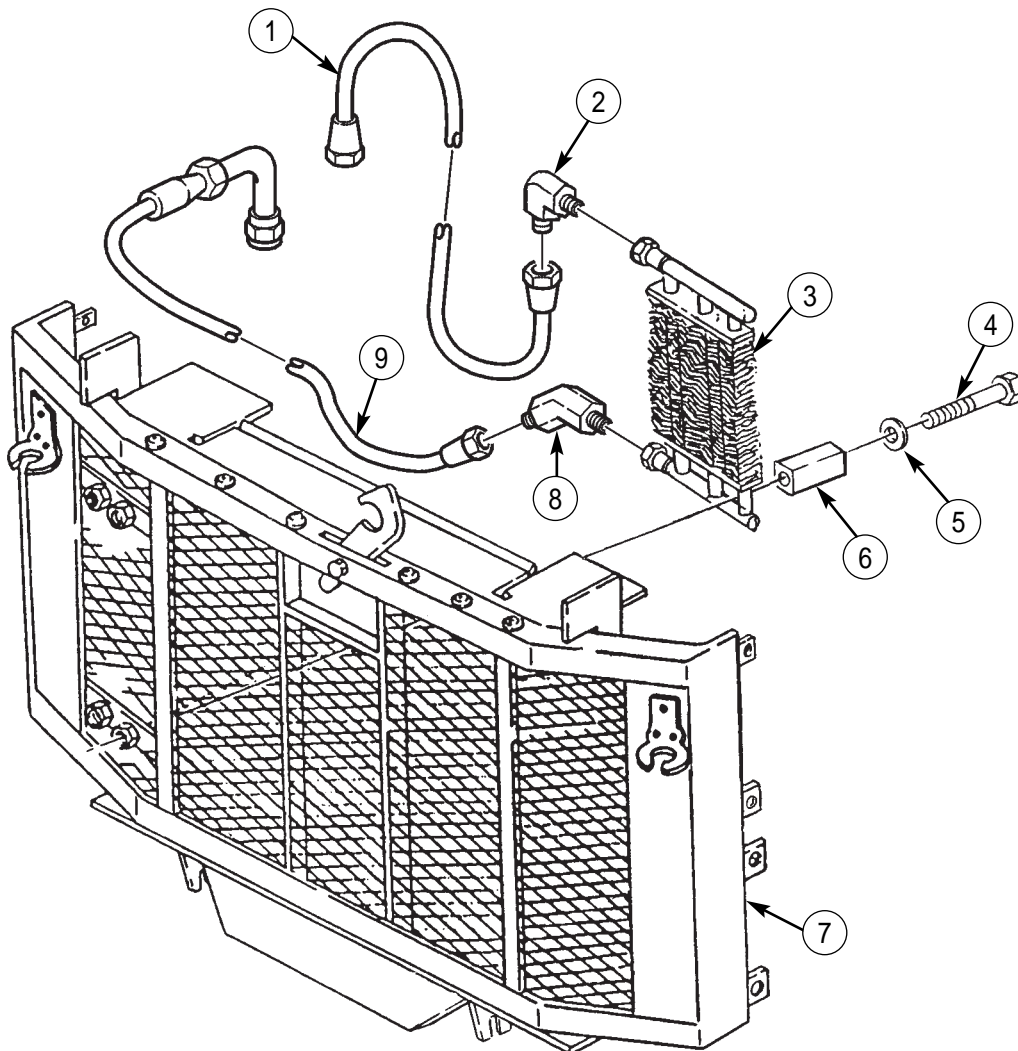

END OF WORK PACKAGE

UNIT MAINTENANCE INSTRUCTIONS

EXTENDED SERVICE PROGRAM (ESP)

TRUCK, CARGO, 2-1/2-TON, 6X6, M44A3 SERIES TRUCKS (DIESEL)

M35A3, W/O WINCH (NSN 2320-01-383-2047); W/WINCH (NSN 2320-01-383-3850);

M35A3C, W/O WINCH (NSN 2320-01-383-2050); W/WINCH (NSN 2320-01-383-2049);

M36A3, W/O WINCH (NSN 2320-01-383-2048); W/WINCH (NSN 2320-01-383-2046).

TRANSMISSION OIL SAMPLING VALVE REPLACEMENT

REMOVAL, INSTALLATION

INITIAL SETUP:

Tools and Special Tools

General mechanic's tool kit
(item 30, WP 0394 00)

Materials/Parts

Teflon pipe sealant (item 41, WP 0393 00)

References

TM 9-2320-386-24P

Equipment Condition

Parking brake set (TM 9-2320-386-10).

Hood raised and secured (TM 9-2320-386-10).

TRANSMISSION OIL SAMPLING VALVE REPLACEMENT (Contd)**REMOVAL**

1. Remove oil sampling valve (1) from elbow (3).
2. Remove elbow (3) from elbow (2).

INSTALLATION

1. Apply sealant to male threads of elbow (3) and oil sampling valve (1).
2. Install elbow (3) on elbow (2).
3. Install oil sampling valve (1) on elbow (3).

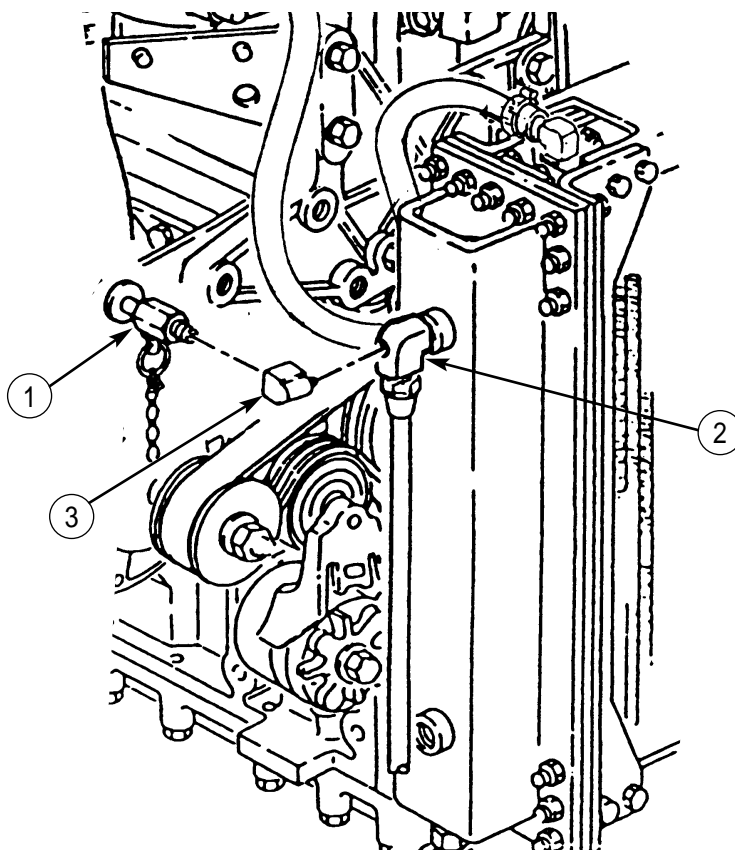
**END OF WORK PACKAGE**

UNIT MAINTENANCE INSTRUCTIONS

EXTENDED SERVICE PROGRAM (ESP)

TRUCK, CARGO, 2-1/2-TON, 6X6, M44A3 SERIES TRUCKS (DIESEL)

M35A3, W/O WINCH (NSN 2320-01-383-2047); W/WINCH (NSN 2320-01-383-3850);
M35A3C, W/O WINCH (NSN 2320-01-383-2050); W/WINCH (NSN 2320-01-383-2049);
M36A3, W/O WINCH (NSN 2320-01-383-2048); W/WINCH (NSN 2320-01-383-2046).

TRANSMISSION EXTERNAL OIL FILTER AND BASE REPLACEMENT

OIL FILTER REMOVAL, OIL FILTER BASE REMOVAL, OIL FILTER BASE INSTALLATION, OIL FILTER INSTALLATION

INITIAL SETUP:

Tools and Special Tools

General mechanic's tool kit
(item 30, WP 0394 00)

References

TM 9-2320-386-24P

Equipment Condition

Parking brake set (TM 9-2320-386-10).

Materials/Parts

Oil filter (item 156, WP 0395 00)
Two locknuts (item 345, WP 0395 00)
Three locknuts (item 333, WP 0395 00)
Teflon pipe sealant (item 41, WP 0393 00)
Lubricating oil (item 27, WP 0393 00)

TRANSMISSION EXTERNAL OIL FILTER AND BASE REPLACEMENT (Contd)

OIL FILTER REMOVAL

WARNING

Accidental or intentional introduction of liquid contaminants into the environment is in violation of state, federal, and military regulations. Refer to Army POL (WP 0001 00) for information concerning storage, use and disposal of these liquids. Failure to do so may result in injury or death.

NOTE

Have drainage container ready to catch oil.

Remove oil filter (8) from oil filter base (6). Discard oil filter (8).

OIL FILTER BASE REMOVAL

1. Remove oil filter (8) (see oil filter removal).
2. Disconnect oil inlet hose (4) and oil outlet hose (10) from elbows (5) and (9).
3. Remove two locknuts (12), screws (1), and mounting bracket (2) with base (6) from frame rail (13). Discard locknuts (12).
4. Remove three locknuts (11), screws (3), and base (6) from mounting bracket (2). Discard locknuts (11).
5. Remove elbows (5) and (9) from base (6).

OIL FILTER BASE INSTALLATION

1. Apply sealant to male threads of elbows (5) and (9).
2. Install elbows (5) and (9) on base (6).
3. Install base (6) on mounting bracket (2) with three screws (3) and new locknuts (11).
4. Install mounting bracket (2) with base (6) on frame rail (13) with two screws (1) and new locknuts (12).
5. Connect oil inlet hose (4) and oil outlet hose (10) to elbows (5) and (9).

OIL FILTER INSTALLATION

1. Coat new oil filter seal (7) with lubricating oil and install new oil filter (8) on oil filter base (6).
2. Tighten oil filter (8) finger-tight, and then turn oil filter clockwise another 1/4-turn.
3. Check transmission oil level and refill if necessary (WP 0022 00).

TRANSMISSION EXTERNAL OIL FILTER AND BASE REPLACEMENT (Contd)

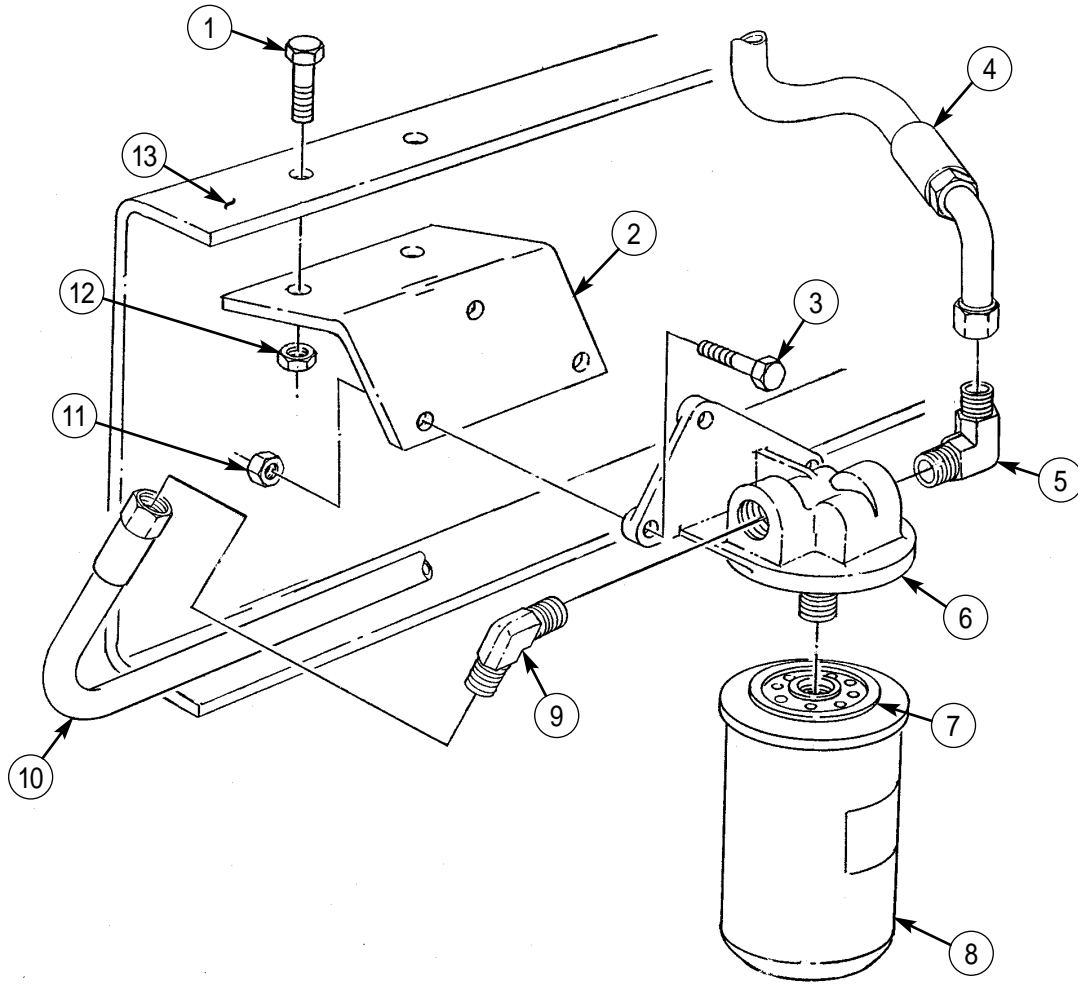

END OF WORK PACKAGE

UNIT MAINTENANCE INSTRUCTIONS

EXTENDED SERVICE PROGRAM (ESP)

TRUCK, CARGO, 2-1/2-TON, 6X6, M44A3 SERIES TRUCKS (DIESEL)

M35A3, W/O WINCH (NSN 2320-01-383-2047); W/WINCH (NSN 2320-01-383-3850);
M35A3C, W/O WINCH (NSN 2320-01-383-2050); W/WINCH (NSN 2320-01-383-2049);
M36A3, W/O WINCH (NSN 2320-01-383-2048); W/WINCH (NSN 2320-01-383-2046).

TRANSMISSION INTERNAL OIL FILTER MAINTENANCE

OIL FILTER REMOVAL, CLEANING AND INSPECTION, OIL FILTER INSPECTION

INITIAL SETUP:

Tools and Special Tools

General mechanic's tool kit
(item 30, WP 0394 00)
Common No. 1 tool kit
(item 15, WP 0394 00)

Materials/Parts

Lint-free cloth (item 18, WP 0393 00)
Mineral spirits (item 33, WP 0393 00)
Lubricating oil (item 32, WP 0393 00)
Oil filter kit (item 209, WP 0395 00)
Two lockwashers (item 343, WP 0395 00)

References

TM 9-2320-386-24P

Equipment Condition

Parking brake set (TM 9-2320-386-10).
Transmission oil dipstick tube removed
(WP 0138 00).

TRANSMISSION INTERNAL OIL FILTER MAINTENANCE (Contd)

OIL FILTER REMOVAL

1. Remove two screws (10) and lockwashers (11) from bracket (12), oil pan (8), and transmission (1). Discard lockwashers (11).
2. Remove nineteen screws (9), oil pan (8), and gasket (7) from transmission (1). Discard gasket (7).
3. Remove screw (6), oil filter (5), oil filter tube (4), and O-ring (3) from control valve body (2) in transmission (1). Discard O-ring (3).
4. Remove oil filter tube (4) from oil filter (5). Discard oil filter (5).
5. Disconnect transmission oil cooler hoses (13) and (15) from transmission external oil filter base (14).

WARNING

Eyeshields must be worn when releasing compressed air. Failure to do this may result in injury to personnel.

CAUTION

Compressed air source will not exceed 60 psi (414 kPa). Doing so may cause damage to internal components of the transmission.

6. Using compressed air, drain remaining oil from external transmission oil cooler hoses (13) and (15).

CLEANING AND INSPECTION

WARNING

Volatile mineral spirits burn easily and fumes can explode. Do not smoke or allow open flame nearby when using mineral spirits. Failure to do so may cause serious injury or death to personnel.

1. Clean oil pan (8) and oil pan magnet thoroughly with mineral spirits and dry with lint-free cloth.
2. Inspect oil pan (8) for cracks. Replace oil pan (8) if cracked.

OIL FILTER INSTALLATION

1. Connect transmission oil cooler hoses (13) and (15) to elbows (16) on transmission external oil filter base (14).
2. Replace transmission external oil filter (WP 0142 00).
3. Install new O-ring (3) and oil filter tube (4) on new oil filter (5).
4. Install oil filter tube (4) and new oil filter (5) on control valve body (2) in transmission (1) with screw (6).

NOTE

Soak new gasket in lubricating oil for five minutes prior to installation.

5. Install new gasket (7) and oil pan (8) on transmission (1) with nineteen screws (9). Tighten screws (9) 10-15 lb-ft (14-20 N•m).
6. Install oil pan (8) and bracket (12) on transmission (1) with two new lockwashers (11) and screws (10).
7. Install transmission oil dipstick tube (WP 0138 00).
8. Fill transmission oil to proper level (WP 0022 00).

TRANSMISSION INTERNAL OIL FILTER MAINTENANCE (Contd)

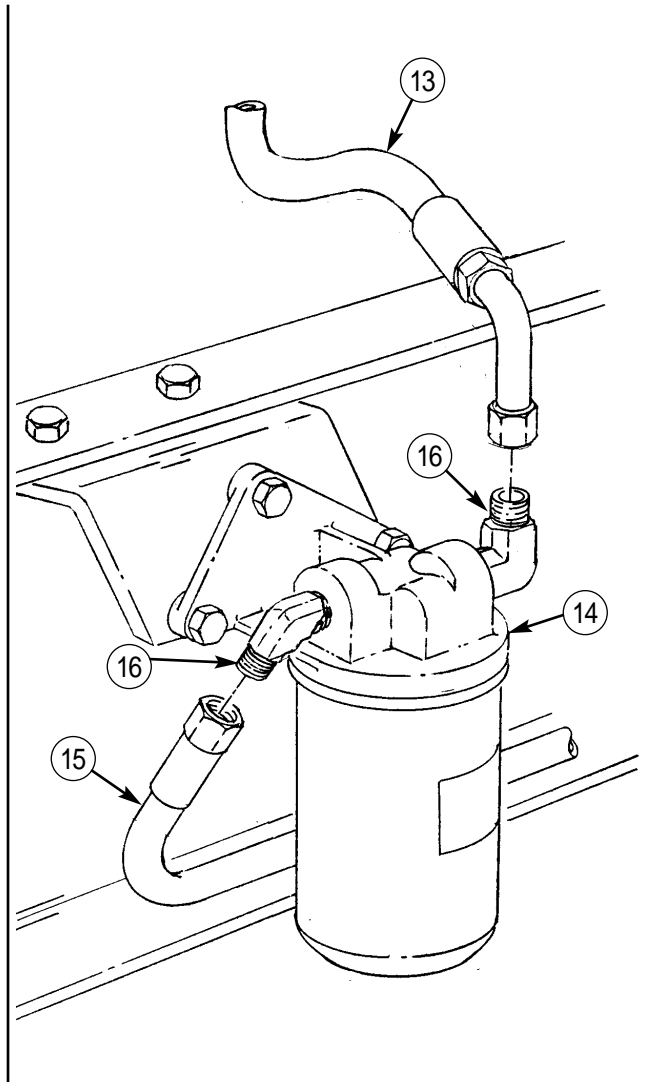
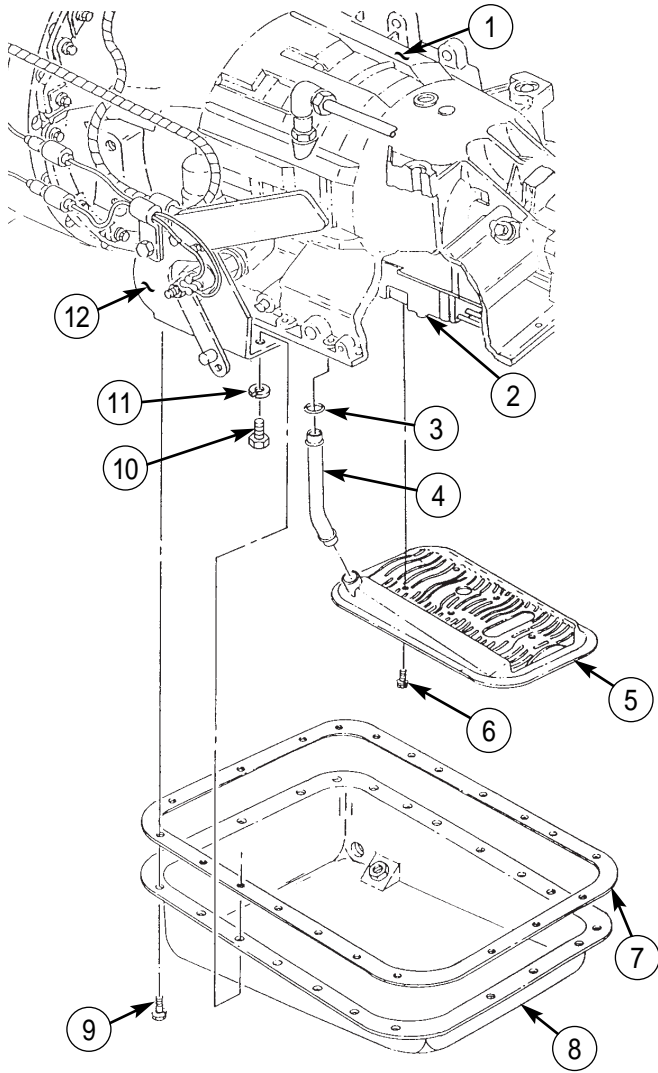

END OF WORK PACKAGE

UNIT MAINTENANCE INSTRUCTIONS

EXTENDED SERVICE PROGRAM (ESP)

TRUCK, CARGO, 2-1/2-TON, 6X6, M44A3 SERIES TRUCKS (DIESEL)

M35A3, W/O WINCH (NSN 2320-01-383-2047); W/WINCH (NSN 2320-01-383-3850);

M35A3C, W/O WINCH (NSN 2320-01-383-2050); W/WINCH (NSN 2320-01-383-2049);

M36A3, W/O WINCH (NSN 2320-01-383-2048); W/WINCH (NSN 2320-01-383-2046).

SECTION X. TRANSFER CASE MAINTENANCE

TABLE OF CONTENTS

WP Title

WP Sequence No.-Page No.

Transfer Case Controls and Linkage Maintenance 0144 01-1

Front Wheel Drive Lock-In Switch, Air Lines, and Indicator Replacement 0145 00-1

END OF WORK PACKAGE

UNIT MAINTENANCE INSTRUCTIONS

EXTENDED SERVICE PROGRAM (ESP)

TRUCK, CARGO, 2-1/2-TON, 6X6, M44A3 SERIES TRUCKS (DIESEL)

**M35A3, W/O WINCH (NSN 2320-01-383-2047); W/WINCH (NSN 2320-01-383-3850);
M35A3C, W/O WINCH (NSN 2320-01-383-2050); W/WINCH (NSN 2320-01-383-2049);
M36A3, W/O WINCH (NSN 2320-01-383-2048); W/WINCH (NSN 2320-01-383-2046).**

TRANSFER CASE CONTROLS AND LINKAGE MAINTENANCE

REMOVAL, CLEANING AND INSPECTION, INSTALLATION

INITIAL SETUP:

Tools and Special Tools

General mechanic's tool kit
(item 30, WP 0394 00)
Common No. 1 tool kit
(item 15, WP 0394 00)

References

TM 9-2320-386-24P

Equipment Condition

Parking brake set (TM 9-2320-386-10).

Materials/Parts

Three locknuts (item 340, WP 0395 00)
Rags (item 35, WP 0393 00)
Skysol-100 (item 17, WP 0393 00)

TRANSFER CASE CONTROLS AND LINKAGE MAINTENANCE (Contd)

REMOVAL

1. Loosen two jamnuts (10).
2. Remove two locknuts (2), screws (4), and link assembly (3) from transfer case shaft (5) and transfer case shift lever (1). Discard locknuts (2).
3. Remove two clevises (9) and jamnuts (10) from rod (11).
4. Remove locknut (6), screw (8), and transfer case shift lever (1) from transfer case shift bracket (7). Discard locknut (6).

CLEANING AND INSPECTION

WARNING

Skysol-100 mixture is combustible. Use mechanical ventilation whenever product is used in a confined space, is heated above ambient temperatures, or is agitated. DO NOT use or store near heat, sparks, flame, or other ignition sources. Keep container sealed when not in use.

Contact with Skysol-100 may cause skin irritation. Use chemical resistant gloves. In case of skin contact, remove any contaminated clothing and wash skin thoroughly with soap and water. Wash contaminated clothing before reuse. Eye contact may cause irritation, tearing, or blurring of vision. Use face shield or goggles when eye contact may occur. In case of eye contact, flush eyes with large amounts of water for at least fifteen (15) minutes or until irritation subsides. Inhalation may cause irritation to upper respiratory passages. DO NOT have food or drink in the vicinity.

1. Clean all parts with Skysol-100 and dry with clean rag.
2. Inspect all parts for breaks, cracks, and bends. Replace any parts if broken, cracked, or bent.

INSTALLATION

1. Install transfer case shift lever (1) on transfer case shift bracket (7) with screw (8) and new locknut (6). Do not overtighten locknut (6), shift lever (1) must move freely.
2. Install two jamnuts (10) and clevises (9) on rod (11), and adjust clevises (9) to 6.25 in. (15.9 cm) from center of clevis hole to clevis hole.
3. Install link assembly (3) on transfer case shift lever (1) and transfer case shaft (5) with two screws (4) and new locknuts (2). Do not tighten locknuts (2).
4. Ensure transfer case shift lever (1) moves through LOW, NEUTRAL, and HIGH positions.
 - a. If transfer case shift lever (1) moves through LOW, NEUTRAL, and HIGH positions, tighten two locknuts (2) and jamnuts (10).
 - b. If transfer case shift lever (1) does not move through LOW, NEUTRAL, and HIGH positions, go to step 5.
5. Remove locknut (2), screw (4), and one end of link assembly (3) from transfer case shift lever (1).
6. Rotate clevis (9) to lengthen or shorten distance between clevises (9) as necessary.
7. Install link assembly (3) on transfer case shift lever (1) with screw (4) and locknut (2). Do not tighten.
8. Repeat step 4.

TRANSFER CASE CONTROLS AND LINKAGE MAINTENANCE (Contd)

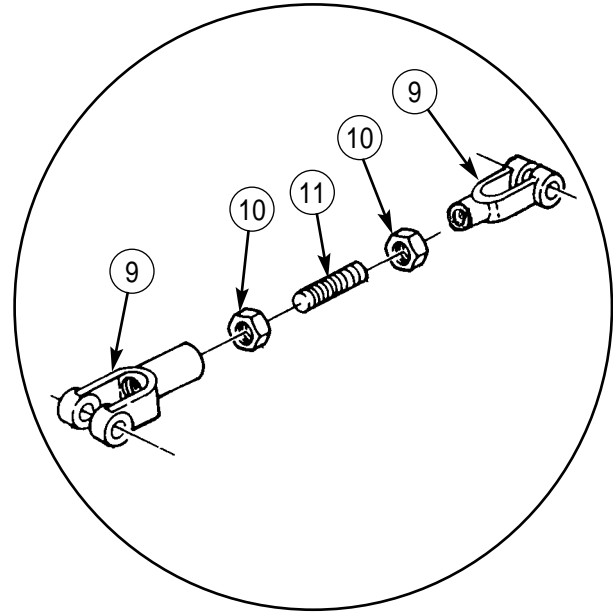
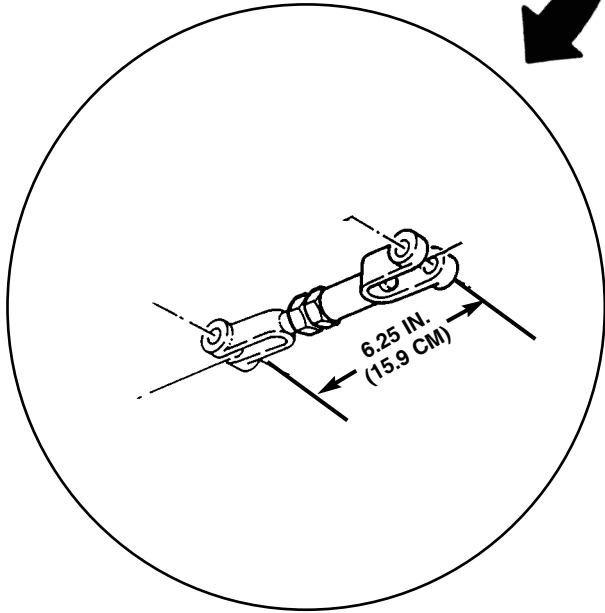
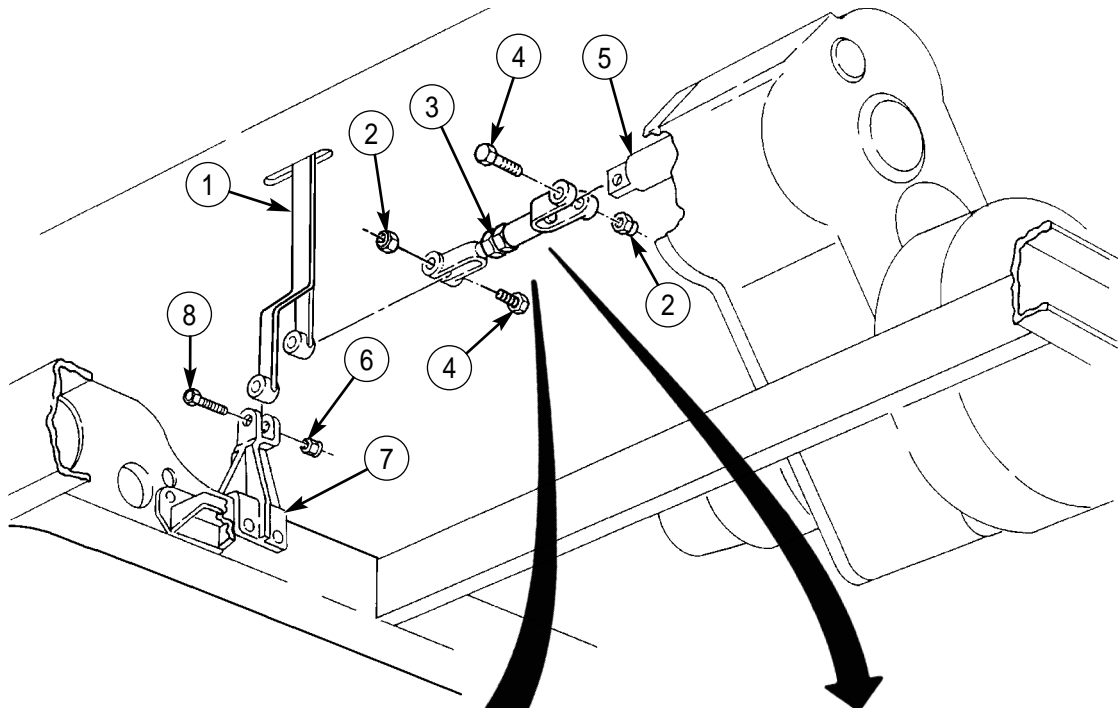

END OF WORK PACKAGE

UNIT MAINTENANCE INSTRUCTIONS

EXTENDED SERVICE PROGRAM (ESP)

TRUCK, CARGO, 2-1/2-TON, 6X6, M44A3 SERIES TRUCKS (DIESEL)

M35A3, W/O WINCH (NSN 2320-01-383-2047); W/WINCH (NSN 2320-01-383-3850);

M35A3C, W/O WINCH (NSN 2320-01-383-2050); W/WINCH (NSN 2320-01-383-2049);

M36A3, W/O WINCH (NSN 2320-01-383-2048); W/WINCH (NSN 2320-01-383-2046).

FRONT WHEEL DRIVE LOCK-IN SWITCH, AIR LINES, AND INDICATOR REPLACEMENT

REMOVAL, INSTALLATION

INITIAL SETUP:

Tools and Special Tools

General mechanic's tool kit
(item 30, WP 0394 00)

Materials/Parts

Two locknuts (item 88, WP 0395 00)
Two tiedown straps (item 39, WP 0395 00)
Two locknuts (item 99, WP 0395 00)
Two lockwashers (item 50, WP 0395 00)
Two lockwashers (item 77, WP 0395 00)
Cap and plug set (item 14, WP 0393 00)
Teflon pipe sealant (item 41, WP 0393 00)

References

TM 9-2320-386-24P

Equipment Condition

Parking brake set (TM 9-2320-386-10).
Air reservoirs drained (TM 9-2328-386-10).
Battery ground cable disconnected (WP 0121 00).

FRONT WHEEL DRIVE LOCK-IN SWITCH, AIR LINES, AND INDICATOR REPLACEMENT (Contd)**REMOVAL****WARNING**

Do not disconnect air lines before draining air reservoirs. Small parts under pressure may shoot out with high velocity, causing injury to personnel.

Eyeshields must be worn when releasing compressed air. Failure to do so may result in injury to personnel.

CAUTION

When disconnecting air lines and hoses, plug all openings to prevent dirt from entering and causing damage to internal parts. Remove all plugs prior to installation.

1. Disconnect plug with lead 27A (16) from indicator housing (15).
2. Disconnect plug with leads 27 and 27A (17) from pressure switch (19) on lock-in switch (18).
3. Disconnect air line (2) from bulkhead fitting (1) on firewall (23) and elbow (20) on lock-in switch (18).
4. Disconnect air supply line (22) from connector (21) on lock-in switch (18).
5. Remove two screws (9), plate (8), and lock-in switch (18) from mounting bracket (7).

NOTE

Note position of elbow for installation.

6. Remove elbow (20) and connector (21) from lock-in switch (18).
7. Remove pressure switch (19) from lock-in switch (18).
8. Remove lamp cover (11) and lamp (10) from indicator housing (15).
9. Remove two screws (12), lockwashers (13), and indicator housing (15) from mounting bracket (7). Discard lockwashers (13).
10. Remove two nuts (4), four ground (GND) leads 57, 99d, 770d, and 117 (5), two lockwashers (6), screws (14), and mounting bracket (7) from panel (3). Discard lockwashers (6).

FRONT WHEEL DRIVE LOCK-IN SWITCH, AIR LINES, AND INDICATOR REPLACEMENT (Contd)

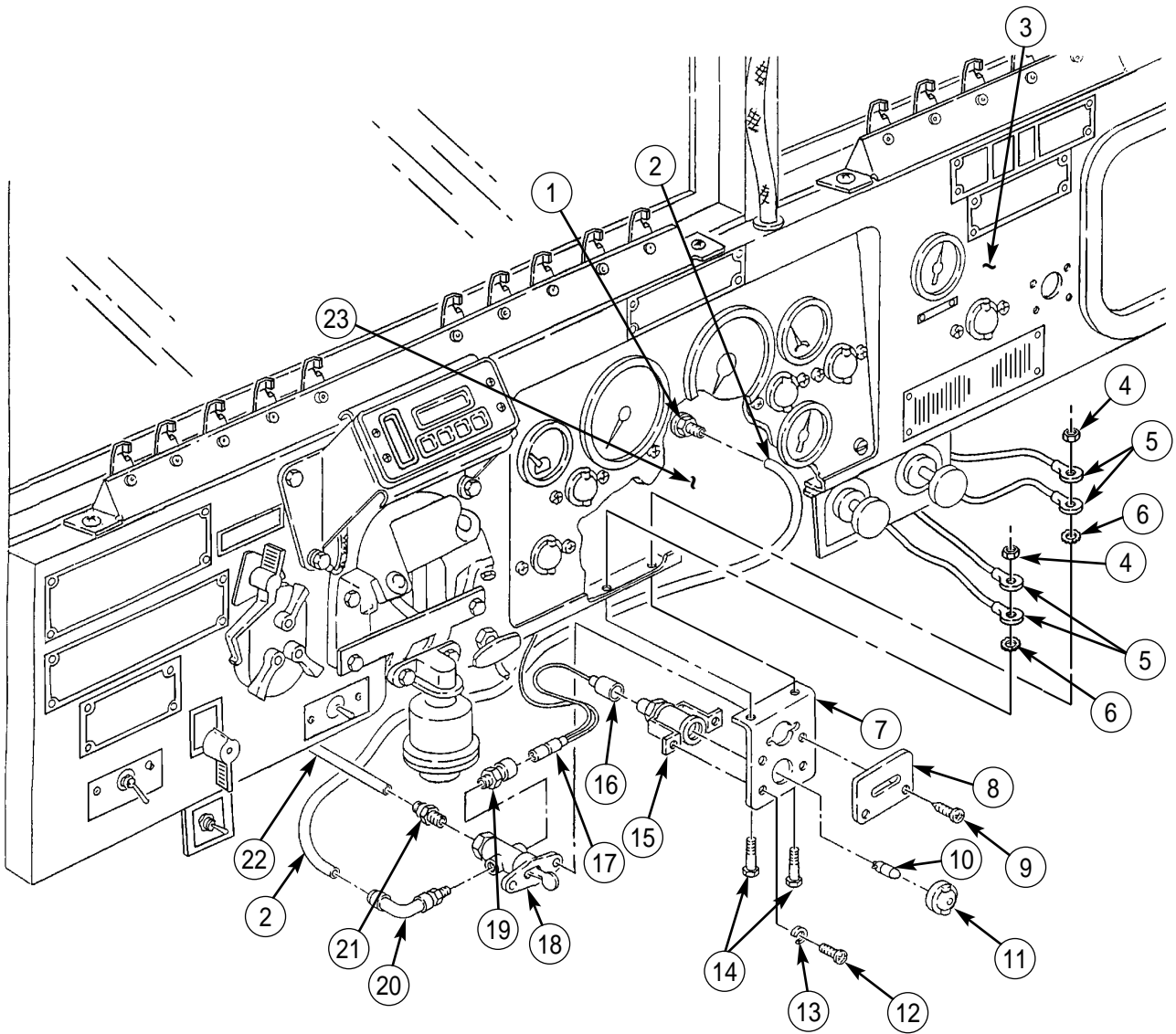

FRONT WHEEL DRIVE LOCK-IN SWITCH, AIR LINES, AND INDICATOR REPLACEMENT (Contd)

11. Remove air line (4) from elbow (3) on firewall (24).
12. Remove elbow (3) from bulkhead fitting (2).
13. Remove nut (1) and bulkhead fitting (2) from firewall (24).
14. Remove two tiedown straps (7) from air line (4). Discard tiedown straps (7).
15. Remove locknuts (5) and (8), screws (21) and (23), and clamps (6) and (9) from frame rail (20), support (22), and air line (4). Discard locknuts (5) and (8).
16. Remove air line (4) from connector (19) on pipe elbow (15) and vehicle.
17. Remove hose assembly (18) from adapter (17) on pipe elbow (15) and elbow (13) on front wheel drive vacuum booster (14).
18. Remove connector (19) and adapter (17) from pipe elbow (15) on crossmember (11).

NOTE

Note position of elbow for installation.

19. Remove elbow (13) from vacuum booster (14) on transfer case (12).
20. Remove two locknuts (10), screws (16), and pipe elbow (15) from crossmember (11). Discard locknuts (10).

INSTALLATION

1. Install pipe elbow (15) on crossmember (11) with two screws (16) and new locknuts (10).
2. Apply sealant to male threads of elbow (13), adapter (17), and connector (19) before installation.
3. Install elbow (13) on vacuum booster (14) on transfer case (12).
4. Install adapter (17) and connector (19) on pipe elbow (15).
5. Connect hose assembly (18) to adapter (17) on pipe elbow (15) and elbow (13) on vacuum booster (14).
6. Install air line (4) in vehicle and connect air line (4) to connector (19) on pipe elbow (15).
7. Install air line (4) on frame rail (20) and support (22) with clamps (9) and (6), screws (21) and (23), and new locknuts (8) and (5).
8. Install two new tiedown straps (7) as necessary to secure air line (4) in place.
9. Install bulkhead fitting (2) on firewall (24) with nut (1).
10. Install elbow (3) on bulkhead fitting (2) and connect air line (4) on elbow (3).

FRONT WHEEL DRIVE LOCK-IN SWITCH, AIR LINES, AND INDICATOR REPLACEMENT (Contd)

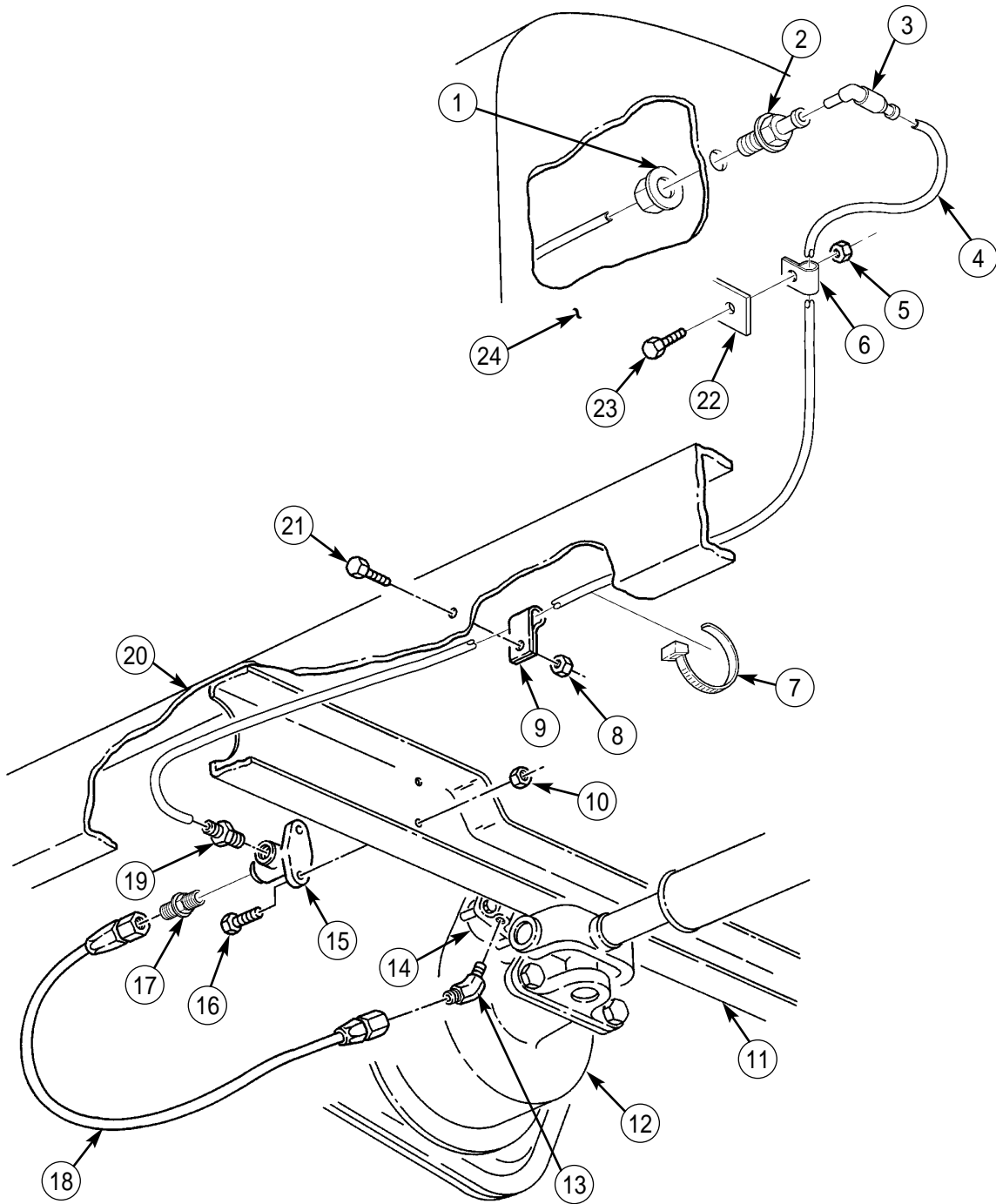

FRONT WHEEL DRIVE LOCK-IN SWITCH, AIR LINES, AND INDICATOR REPLACEMENT (Contd)

11. Install mounting bracket (7) on panel (3) with two new lockwashers (6), four ground (GND) leads 57, 99d, 770d, and 117 (5), two screws (14), and nuts (4).
12. Install indicator housing (15) on mounting bracket (7) with two new lockwashers (13) and screws (12).
13. Install lamp (10) and lamp cover (11) on indicator housing (15).
14. Apply sealant to male threads of pressure switch (19), elbow (20), and connector (21).
15. Install pressure switch (19) on lock-in switch (18).
16. Install elbow (20) and connector (21) on lock-in switch (18).
17. Install lock-in switch (18) and plate (8) on mounting bracket (7) with two screws (9).
18. Connect air supply line (22) to connector (21) on lock-in switch (18).
19. Connect air line (2) to bulkhead fitting (1) on firewall (23) and to elbow (20) on lock-in switch (18).
20. Connect plug with leads 27 and 27A (17) to pressure switch (19) on lock-in switch (18).
21. Connect plug with lead 27A (16) to indicator housing (15).
22. Connect battery ground cable (WP 0121 00).
23. Start engine (TM 9-2320-386-10) and allow air pressure to build up to normal operating pressure. Check for air leaks and road test vehicle.

FRONT WHEEL DRIVE LOCK-IN SWITCH, AIR LINES, AND INDICATOR REPLACEMENT (Contd)

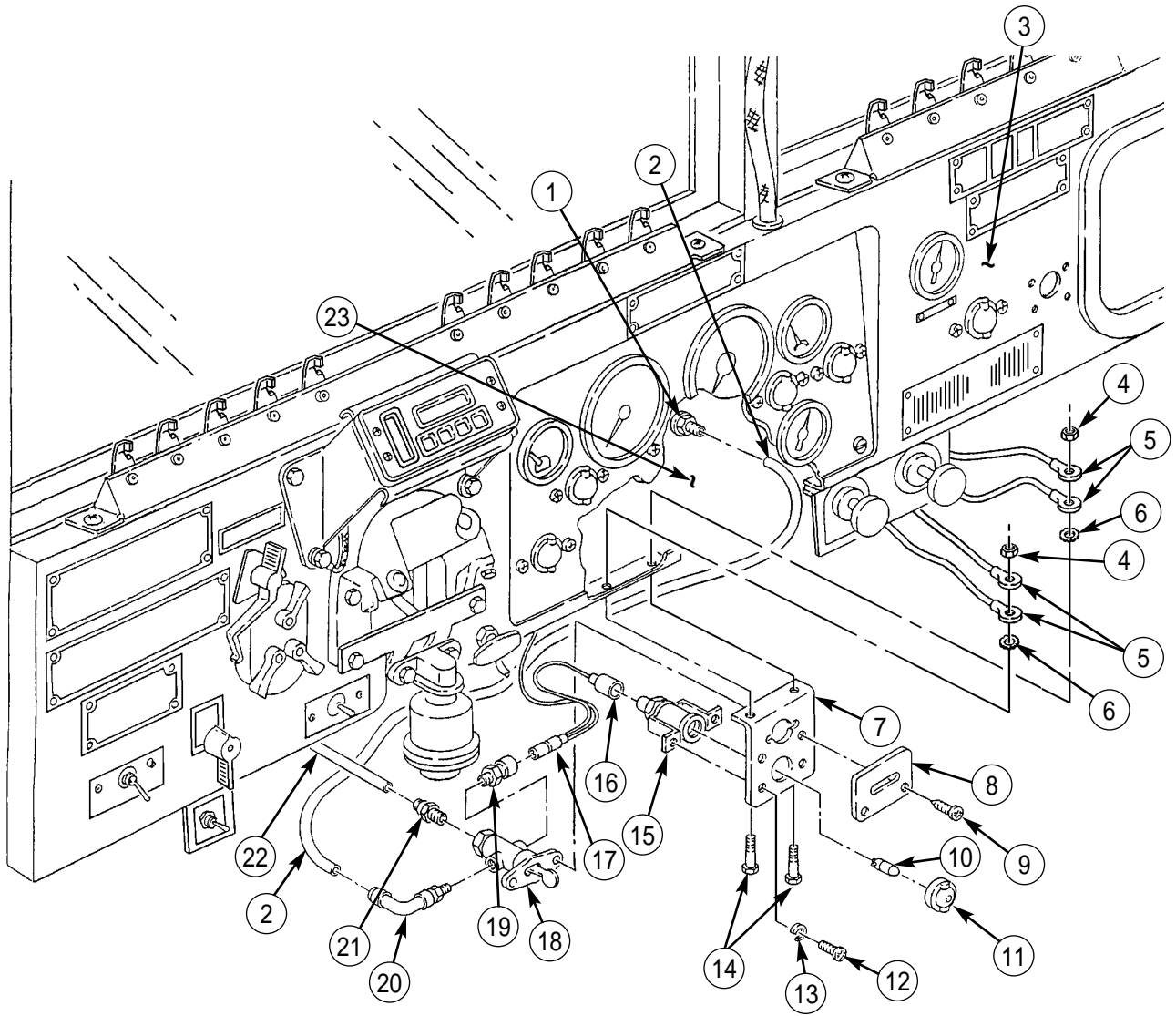

END OF WORK PACKAGE

UNIT MAINTENANCE INSTRUCTIONS

EXTENDED SERVICE PROGRAM (ESP)

TRUCK, CARGO, 2-1/2-TON, 6X6, M44A3 SERIES TRUCKS (DIESEL)

M35A3, W/O WINCH (NSN 2320-01-383-2047); W/WINCH (NSN 2320-01-383-3850);

M35A3C, W/O WINCH (NSN 2320-01-383-2050); W/WINCH (NSN 2320-01-383-2049);

M36A3, W/O WINCH (NSN 2320-01-383-2048); W/WINCH (NSN 2320-01-383-2046).

**SECTION XI. PROPELLER SHAFTS, AXLES, AND SUSPENSION SYSTEM MAINTENANCE
TABLE OF CONTENTS**

<i>WP Title</i>	<i>WP Sequence No.-Page No.</i>
Propeller Shaft Maintenance	0147 00-1
Intermediate Propeller Shaft Maintenance (M36A3)	0148 00-1
Universal Joint Maintenance	0149 00-1

END OF WORK PACKAGE

UNIT MAINTENANCE INSTRUCTIONS

EXTENDED SERVICE PROGRAM (ESP)

TRUCK, CARGO, 2-1/2-TON, 6X6, M44A3 SERIES TRUCKS (DIESEL)

M35A3, W/O WINCH (NSN 2320-01-383-2047); W/WINCH (NSN 2320-01-383-3850);
M35A3C, W/O WINCH (NSN 2320-01-383-2050); W/WINCH (NSN 2320-01-383-2049);
M36A3, W/O WINCH (NSN 2320-01-383-2048); W/WINCH (NSN 2320-01-383-2046).

PROPELLER SHAFT MAINTENANCE

REMOVAL, DISASSEMBLY, CLEANING AND INSPECTION, ASSEMBLY, INSTALLATION

INITIAL SETUP:

Tools and Special Tools

General mechanic's tool kit
(item 30, WP 0394 00)
Common No. 1 tool kit
(item 15, WP 0394 00)

References

TM 9-2320-386-24P

Equipment Condition

Parking brake set (TM 9-2320-386-10).

Materials/Parts

Seal (item 124, WP 0395 00)
GAA grease (item 23, WP 0393 00)
Skysol-100 (item 17, WP 0393 00)
Wiping rag (item 35, WP 0393 00)
Eight locknuts (item 20, WP 0395 00)

PROPELLER SHAFT MAINTENANCE (Contd)

REMOVAL

NOTE

All propeller shafts, except the M36A3 front intermediate propeller shaft, are replaced basically the same. This procedure covers the transfer case-to-forward rear axle propeller shaft.

1. Chock two wheels on one side of vehicle and raise two wheels on opposite side of vehicle (TM 9-2320-386-10).
2. Release parking brake (TM 9-2320-386-10).

NOTE

Mark propeller shaft flange positions for installation.

Rotate propeller shaft to gain access to propeller shaft mounting screws and locknuts.

3. Remove four locknuts (5) from studs (2) and separate flange (4) on propeller shaft (10) from flange (1) located in parking brakedrum (3). Discard locknuts (5).
4. Remove four locknuts (9) and screws (6) and separate flange (7) on propeller shaft (10)P from flange (8). Discard locknuts (9).

DISASSEMBLY

1. Loosen cap (15) and slide back on shaft (16).
2. Pull shaft (16) out of washer (14), seal (13), and tube of shaft (12).
3. Remove washer (14) and seal (13) from shaft (12). Discard seal (13).

NOTE

Perform step 4 or 5 if lubrication fitting is damaged.

4. Remove lubrication fitting (18) from shaft (12).
5. Remove lubrication fitting (11) from U-joint end of shaft (12).

CLEANING AND INSPECTION

1. Inspect U-joint for roughness, binding, looseness, and free play. Replace U-joint if there is any roughness, binding, looseness, or free play (WP 0149 00).

WARNING

Skysol-100 mixture is combustible. Use mechanical ventilation whenever product is used in a confined space, is heated above ambient temperatures, or is agitated. DO NOT use or store near heat, sparks, flame, or other ignition sources. Keep container sealed when not in use.

Contact with Skysol-100 may cause skin irritation. Use chemical resistant gloves. In case of skin contact, remove any contaminated clothing and wash skin thoroughly with soap and water. Wash contaminated clothing before reuse. Eye contact may cause irritation, tearing, or blurring of vision. Use face shield or goggles when eye contact may occur. In case of eye contact, flush eyes with large amounts of water for at least fifteen (15) minutes or until irritation subsides. Inhalation may cause irritation to upper respiratory passages. DO NOT have food or drink in the vicinity.

2. Clean splined end of shaft (16) with rag saturated with Skysol-100. Dry with clean rag.
3. Clean bore (17) of shaft (12) with Skysol-100. Clean outside of shaft (12) with rag saturated with Skysol-100.

PROPELLER SHAFT MAINTENANCE (Contd)

4. Clean lubrication fitting (11) and lubrication fitting (18) with Skysol-100.
5. Inspect shafts (12) and (16) for:
 - a. Breaks, cracks, or bends. Replace shafts (12) and (16) if damaged.
 - b. Crossed or stripped threads. Replace shafts (12) and (16) if threads are crossed or stripped.
6. Inspect flanges (4) and (7) for cracks and breaks. If flanges (4) and (7) are cracked or broken, replace flanges (4) and (7) and U-joints (WP 0149 00).

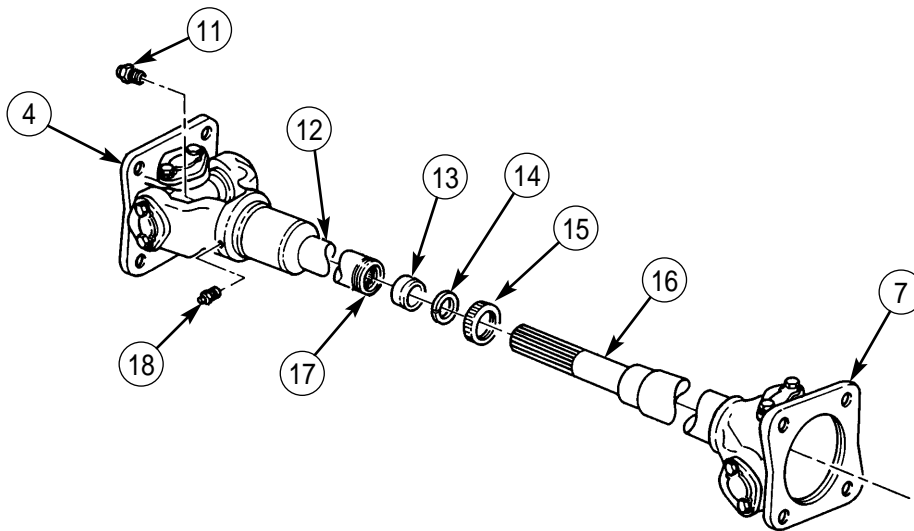
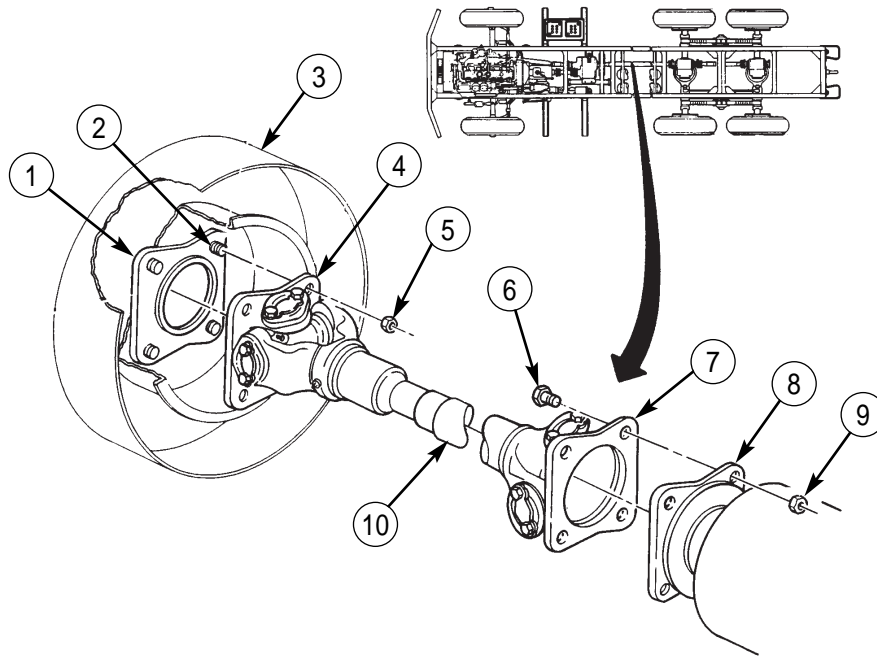

PROPELLER SHAFT MAINTENANCE (Contd)**ASSEMBLY****NOTE**

Perform step 1 or 2 if lubrication fitting was removed.

1. Install lubrication fitting (11) in U-joint end of shaft (12).
2. Install lubrication fitting (18) in shaft (12).
3. Install new seal (13) in bore (17) of shaft (12).
4. Install cap (15) on shaft (16), with open side toward splined end of shaft, and slide cap (15) up on shaft (16).
5. Install washer (14) on shaft (16).
6. Coat splines on shaft (16) with a thick film of GAA grease.
7. Slide splined end of shaft (16) through seal (13) and into internal splines of shaft (12).
8. Position washer (14) against seal (13) and install cap (15) on shaft (12).

INSTALLATION

1. Install flange (4) with propeller shaft (10) on studs (2) of flange (1) inside parking brakedrum (3) with four new locknuts (5). Tighten locknuts (5) 102-121 lb-ft (138-164 N•m).
2. Install flange (7) with propeller shaft (10) on flange (8) with four screws (6) and new locknuts (9). Tighten locknuts (9) 102-121 lb-ft (138-164 N•m).
3. Apply parking brake (TM 9-2320-386-10).
4. Lower wheels, and remove chocks (TM 9-2320-386-10).
5. Lubricate propeller shaft (WP 0023 00).

PROPELLER SHAFT MAINTENANCE (Contd)

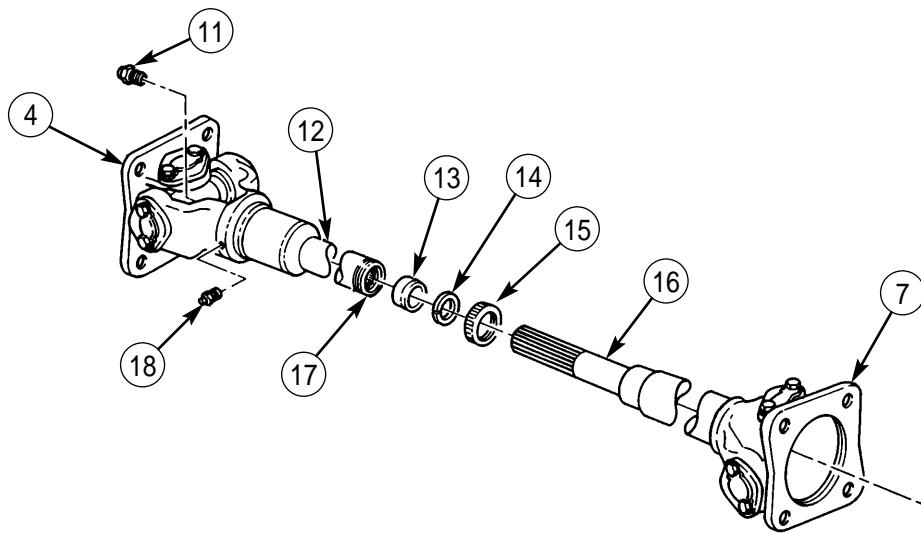
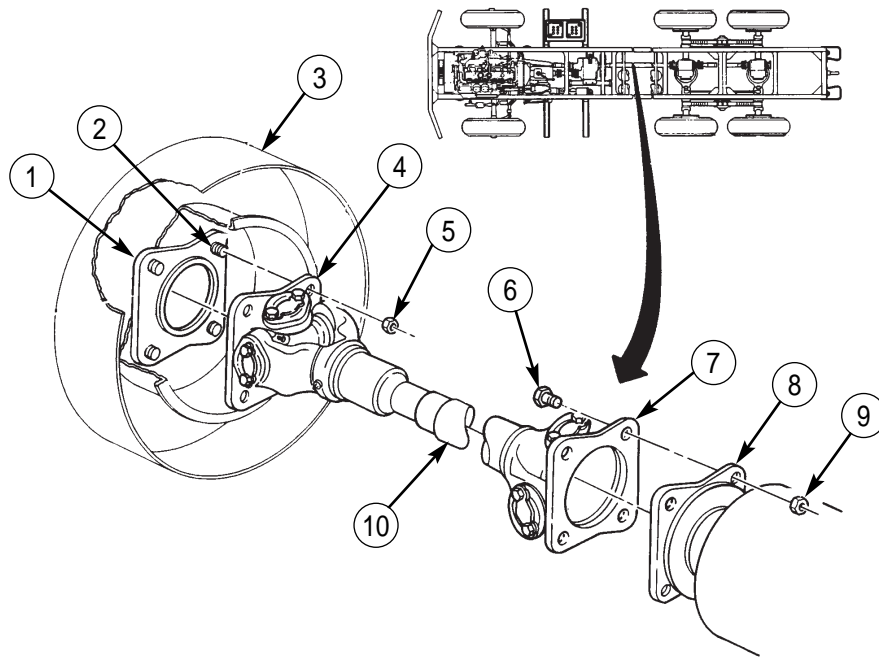

END OF WORK PACKAGE

UNIT MAINTENANCE INSTRUCTIONS

*EXTENDED SERVICE PROGRAM (ESP)
TRUCK, CARGO, 2-1/2-TON, 6X6, M44A3 SERIES TRUCKS (DIESEL)*

M36A3, W/O WINCH (NSN 2320-01-383-2048); W/WINCH (NSN 2320-01-383-2046).

INTERMEDIATE PROPELLER SHAFT MAINTENANCE (M36A3)

REMOVAL, DISASSEMBLY, CLEANING AND INSPECTION, ASSEMBLY, INSTALLATION

INITIAL SETUP:

Tools and Special Tools

General mechanic's tool kit
(item 30, WP 0394 00)
Common No. 1 tool kit
(item 15, WP 0394 00)

Materials/Parts

Eight locknuts (item 19, WP 0395 00)
Two locknuts (item 97, WP 0395 00)
Four locknuts (item 347, WP 0395 00)
Cotter pin (item 29, WP 0395 00)
Lockwasher (item 50, WP 0395 00)
Two seals (item 309, WP 0395 00)
GAA grease (item 23, WP 0393 00)
Skysol-100 (item 17, WP 0393 00)
Wiping rags (item 35, WP 0393 00)

Personnel Required

Assistant (1)

References

TM 9-214
TM 9-2320-386-24P

Equipment Condition

Parking brake set (TM 9-2320-386-10).

INTERMEDIATE PROPELLER SHAFT MAINTENANCE (M36A3) (Contd)**REMOVAL**

1. Chock two wheels on one side of vehicle and raise two rear wheels on opposite side of vehicle (TM 9-2320-386-10).
2. Release parking brake (TM 9-2320-386-10).

NOTE

- Mark propeller shaft flange positions for installation.
 - Rotate propeller shaft in step 3 to gain access to propeller shaft mounting screws and locknuts.
3. Remove four locknuts (27) and screws (29) and separate flange (28) on rear intermediate propeller shaft (30) from flange (11) on front intermediate propeller shaft (23). Discard locknuts (27).
 4. Lower rear intermediate propeller shaft (30) and position out of way.
 5. Remove cotter pin (8), nut (9), washer (10), flange (11), and deflector (12) from shaft (23). Discard cotter pin (8).

NOTE

Assistant will help with step 6.

6. Remove two locknuts (16), washers (15), screws (7), propeller shaft (23), and bearing housing (18) from frame support (4). Discard locknuts (16).
7. Remove four locknuts (25) from studs (1) and separate flange (24) from flange (26) in parking brakedrum (2). Discard locknuts (25).
8. Remove four locknuts (3), screws (5), and frame support (4) from crossmember (6). Discard locknuts (3).

DISASSEMBLY

1. Remove bearing housing (18) from propeller shaft (23).
2. Remove screw (22), lockwasher (21), and slide shield (20) from propeller shaft (23). Discard lockwasher (21).
3. Remove two seals (13) and bearing (19) from bearing housing (18). Discard seals (13).
4. Remove four rubber insulators (14) from bearing housing (18).

NOTE

Perform step 5 if lubrication fitting is damaged.

5. Remove lubrication fitting (17) from bearing housing (18).

INTERMEDIATE PROPELLER SHAFT MAINTENANCE (M36A3) (Contd)

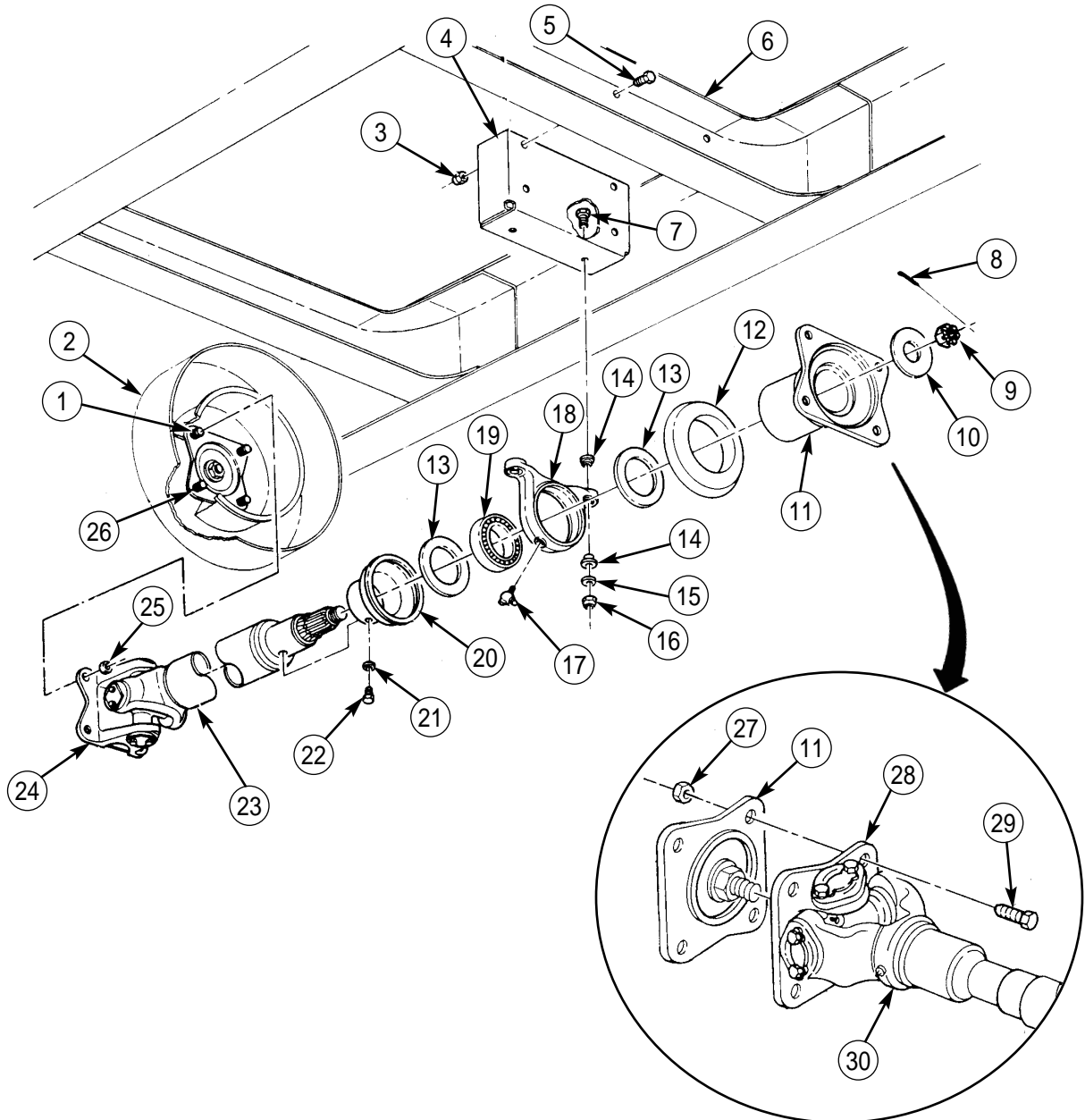

INTERMEDIATE PROPELLER SHAFT MAINTENANCE (M36A3) (Contd)

CLEANING AND INSPECTION

WARNING

Skysol-100 mixture is combustible. Use mechanical ventilation whenever product is used in a confined space, is heated above ambient temperatures, or is agitated. DO NOT use or store near heat, sparks, flame, or other ignition sources. Keep container sealed when not in use.

Contact with Skysol-100 may cause skin irritation. Use chemical resistant gloves. In case of skin contact, remove any contaminated clothing and wash skin thoroughly with soap and water. Wash contaminated clothing before reuse. Eye contact may cause irritation, tearing, or blurring of vision. Use face shield or goggles when eye contact may occur. In case of eye contact, flush eyes with large amounts of water for at least fifteen (15) minutes or until irritation subsides. Inhalation may cause irritation to upper respiratory passages. DO NOT have food or drink in the vicinity.

1. Clean and inspect bearing (20) in accordance with TM 9-214.
2. Inspect universal joint (25) for roughness, binding, looseness, and free play. Replace universal joint (25) if there is any roughness, binding, looseness, or free play (WP 0149 00).
3. Clean all parts with Skysol-100 and dry with clean rag.
4. Inspect propeller shaft (24) for:
 - a. Breaks, cracks, or bends. Replace shaft (24) if cracked, bent, or broken.
 - b. Crossed or stripped threads. Replace shaft (24) if threads are crossed or stripped.
 - c. Nicked or burred splines (28). Replace shaft (24) if splines (28) are cracked or chipped.
 - d. Nicked, burred, or scored bearing shoulder. Replace shaft (24) if bearing shoulder is nicked, burred, scored, or bearing (20) is frozen.
5. Inspect shield (21) for cracks, breaks, or bends. Replace shield (21) if cracked, broken, or bent.
6. Inspect flange (11) for cracks and breaks. Replace flange (11) if damaged.
7. Inspect deflector (12) for bends. Replace deflector (12) if bent.
8. Inspect rubber insulators (14) for tears or breaks. Replace rubber insulators (14) if torn or broken.
9. Inspect bearing housing (18) for cracks and breaks. Replace bearing housing (18) if cracked or broken.
10. Inspect frame support (4) for breaks and cracks. Replace frame support (4) if broken or cracked.

ASSEMBLY

1. Apply a light film of GAA grease to outer race of bearing (20) and inner bore (17) of bearing housing (18), and install bearing (20) in bore (17), ensuring bearing (20) is seated square in bore (17) of bearing housing (18).
2. Install two new seals (13) in shaft side of bearing housing (18).
3. Slide shield (21) on shaft (24) as far as it will go, and install with new lockwasher (22) and screw (23).
4. Install four rubber insulators (14) in bearing housing (18).

NOTE

Perform step 5 if lubrication fitting was removed.

5. Install lubrication fitting (19) in bearing housing (18).

INSTALLATION

1. Install frame support (4) to crossmember (6) with four screws (5) and new locknuts (3).
2. Install flange (26) on studs (1) of flange (29) in parking brakedrum (2) with four new locknuts (27), ensuring scribed marks align. Tighten locknuts (27) 102-121 lb-ft (138-164 N·m).
3. Install bearing housing (18) on frame support (4) with two screws (7), washers (15), and new locknuts (16).

INTERMEDIATE PROPELLER SHAFT MAINTENANCE (M36A3) (Contd)

4. Install deflector (12) and flange (11) on propeller shaft (24) with washer (10) and nut (9). Tighten nut (9) 260-290 lb-ft (353-393 N•m).
5. Install new cotter pin (8) through nut (9).
6. Ensure shaft (24) turns freely and with no side play at U-joint (25) and support bearing (20).
7. Install rear intermediate propeller shaft flange (31) on front intermediate propeller shaft flange (11) with four screws (32) and new locknuts (30). Tighten locknuts (30) 102-121 lb-ft (138-164 N•m).
8. Apply parking brake (TM 9-2320-386-10).
9. Lower wheels and remove chocks (TM 9-2320-386-10).
10. Lubricate bearing housing (WP 0023 00).

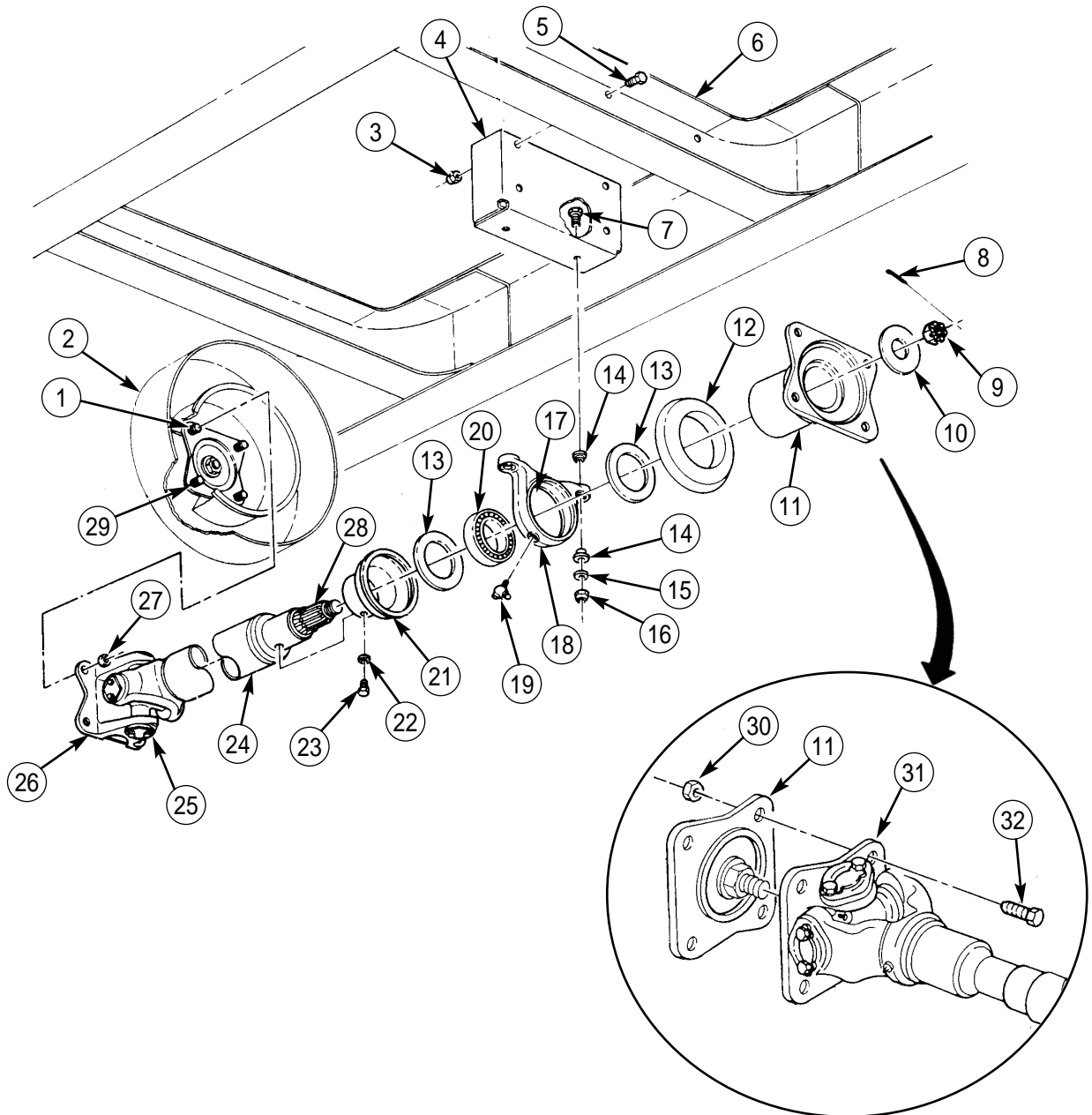
**END OF WORK PACKAGE**

UNIT MAINTENANCE INSTRUCTIONS

EXTENDED SERVICE PROGRAM (ESP)

TRUCK, CARGO, 2-1/2-TON, 6X6, M44A3 SERIES TRUCKS (DIESEL)

M35A3, W/O WINCH (NSN 2320-01-383-2047); W/WINCH (NSN 2320-01-383-3850);
M35A3C, W/O WINCH (NSN 2320-01-383-2050); W/WINCH (NSN 2320-01-383-2049);
M36A3, W/O WINCH (NSN 2320-01-383-2048); W/WINCH (NSN 2320-01-383-2046).

UNIVERSAL JOINT MAINTENANCE

DISASSEMBLY, CLEANING AND INSPECTION, ASSEMBLY

INITIAL SETUP:

Tools and Special Tools

General mechanic's tool kit
(item 30, WP 0394 00)

References

TM 9-214
TM 9-2320-386-24P

Materials/Parts

Four snaprings (item 259 WP 0395 00)
Universal joint parts kit (snapring)
(item 4 WP 0395 00)
Universal joint parts kit (cap)
(item 220, WP 0395 00)
GAA grease (item 22, WP 0393 00)
Skysol-100 (item 17, WP 0393 00)
Rags (item 35, WP 0393 00)

Equipment Condition

Propeller shaft removed (WP 0147 00).
Intermediate propeller shaft removed (M36A3)
(WP 0148 00).

UNIVERSAL JOINT MAINTENANCE (Contd)**NOTE**

Do not remove bearings from caps, except when replacing caps.

Mark mating yoke position for installation.

DISASSEMBLY

1. Snapping type:
 - a. Remove four snaprings (1) from yoke (5) and yoke flange (3) from spider cross (4). Discard snaprings (1).
 - b. Remove four bearing caps (2), yoke flange (3), and spider cross (4) from yoke (5). Discard bearing caps (2) and spider cross (4).
 - c. Remove four seals (6) and lubrication fitting (7) from spider cross (4). Discard seals (6).
2. Cap type:
 - a. Remove eight screws (8), four straps (9) and bearing caps (10) from yoke (12) and yoke flange (11).
 - b. Remove yoke flange (11) and spider cross (4) from yoke (12).
 - c. Remove four seals (6) and lubrication fitting (7) from spider cross (4). Discard seals (6).

UNIVERSAL JOINT MAINTENANCE (Contd)

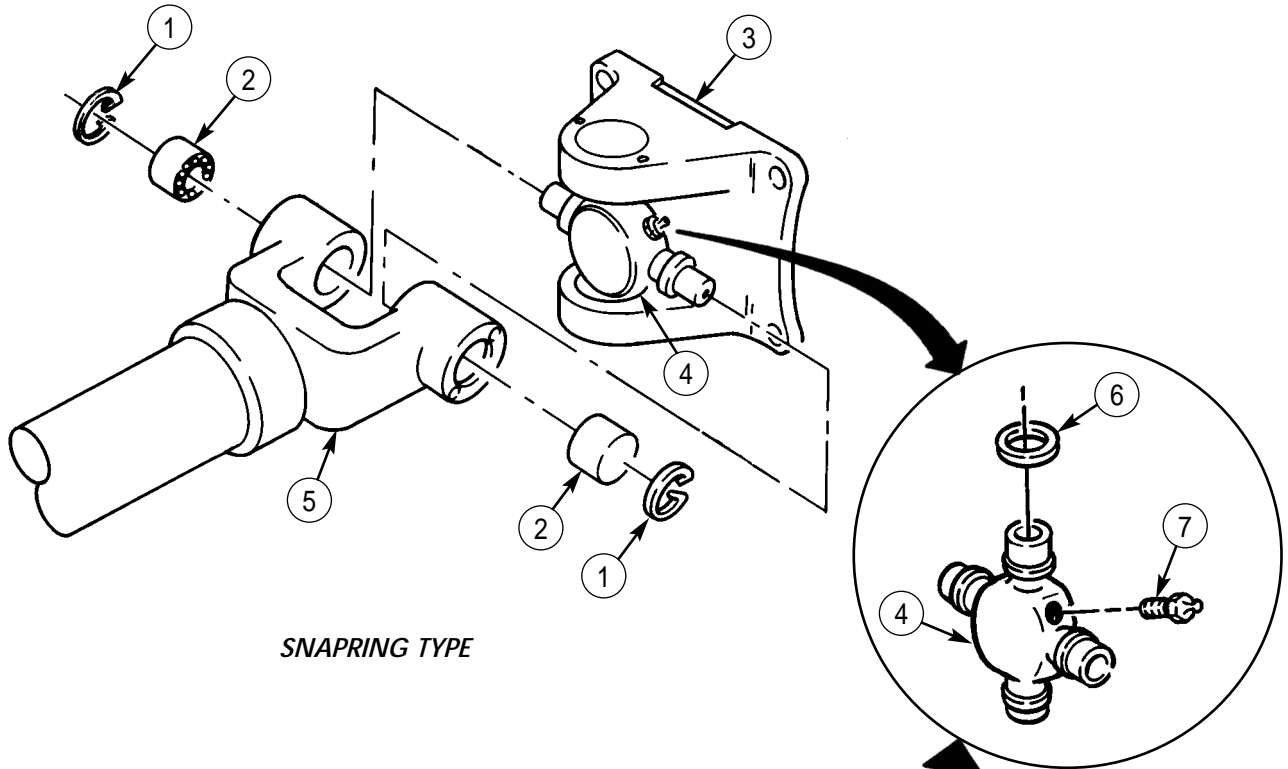

SNAPRING TYPE

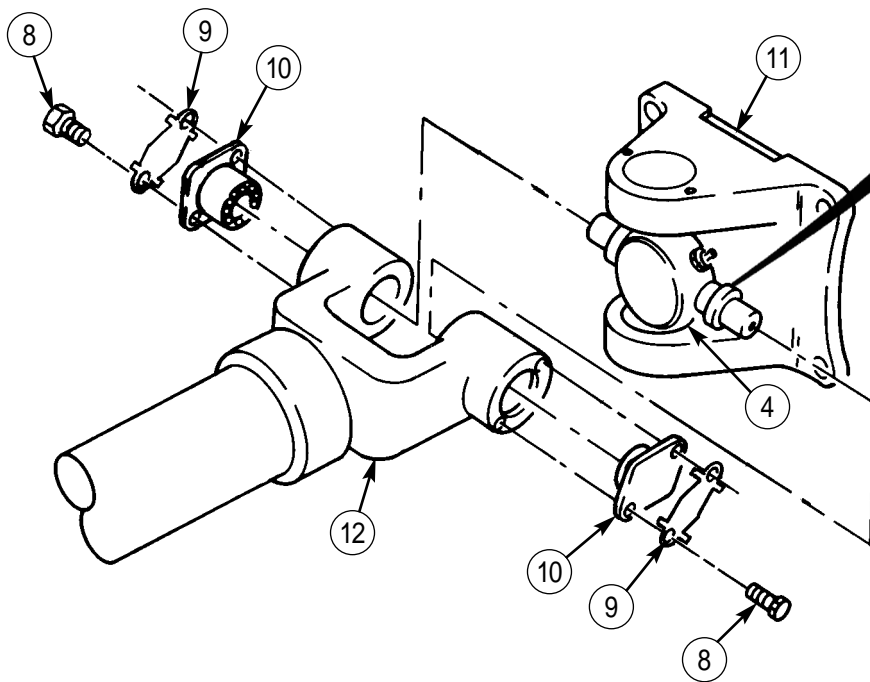

CAP TYPE

UNIVERSAL JOINT MAINTENANCE (Contd)

CLEANING AND INSPECTION

WARNING

Skysol-100 mixture is combustible. Use mechanical ventilation whenever product is used in a confined space, is heated above ambient temperatures, or is agitated. DO NOT use or store near heat, sparks, flame, or other ignition sources. Keep container sealed when not in use.

Contact with Skysol-100 may cause skin irritation. Use chemical resistant gloves. In case of skin contact, remove any contaminated clothing and wash skin thoroughly with soap and water. Wash contaminated clothing before reuse. Eye contact may cause irritation, tearing, or blurring of vision. Use face shield or goggles when eye contact may occur. In case of eye contact, flush eyes with large amounts of water for at least fifteen (15) minutes or until irritation subsides. Inhalation may cause irritation to upper respiratory passages. DO NOT have food or drink in the vicinity.

1. Clean all parts with Skysol-100 and dry with clean rag.
2. Inspect yokes (3) for breaks, cracks, and bends. Replace yokes (3) if damaged.
3. Inspect snapping grooves (1) for damage. Replace yoke flange (2) or yoke (3) if damaged.
4. Inspect shafts (4) for bends, cracks, damaged threads (6), and splines (5). Replace shaft (4) if damaged.
5. Inspect bearings (7) in bearing cap (8) (TM 9-214). Replace U-joint (spider cross (9), bearing (7), and bearing caps (8)) if damaged.

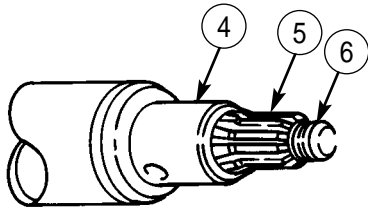
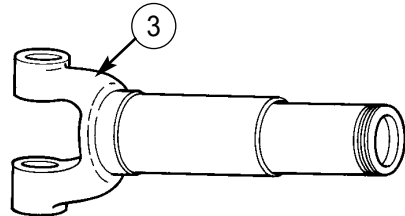
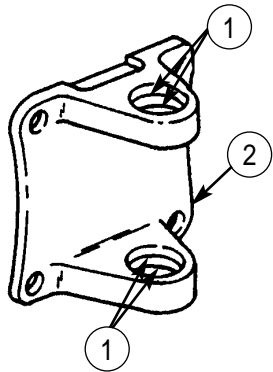

ASSEMBLY

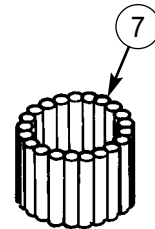

1. Snapping type:

- a. Apply thick film of GAA grease to bearing caps (8) to hold bearings (7) in place during assembly.
- b. Install four new rubber seals (12) on spider cross journals (13).
- c. Install spider cross journals (13) in yoke flange (2). Press two bearing caps (8) into yoke flange loops (11).

UNIVERSAL JOINT MAINTENANCE (Contd)

- d. Ensure snapping groove (1) in outside edge of both yoke loops (11) are visible. Install two new snaprings (9).

NOTE

Align marks on yokes before assembling bearing caps in shaft yoke.

- e. Position yoke (3) on spider cross journals (13), and install two bearing caps (8) and four new snaprings (9).
- f. Install lubrication fitting (14) on spider cross (10).
- g. Install propeller shaft (WP 0147 00).
- h. Install intermediate propeller shaft (M36A3) (WP 0148 00).

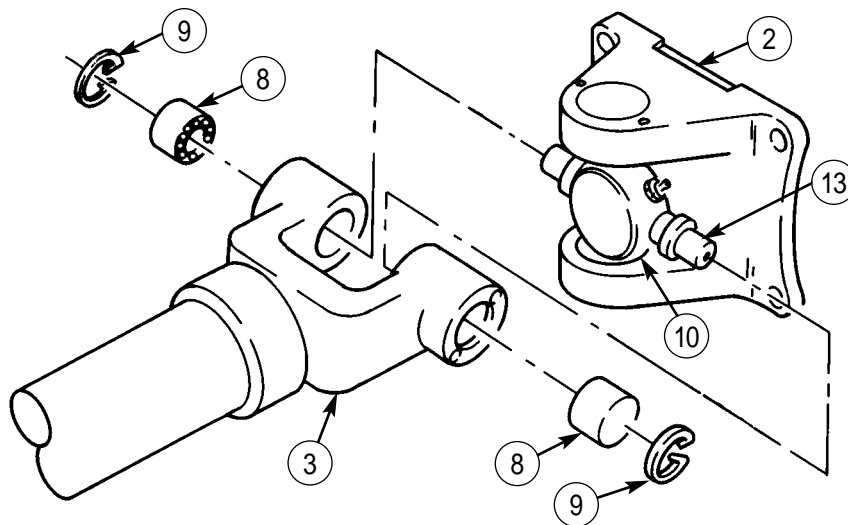
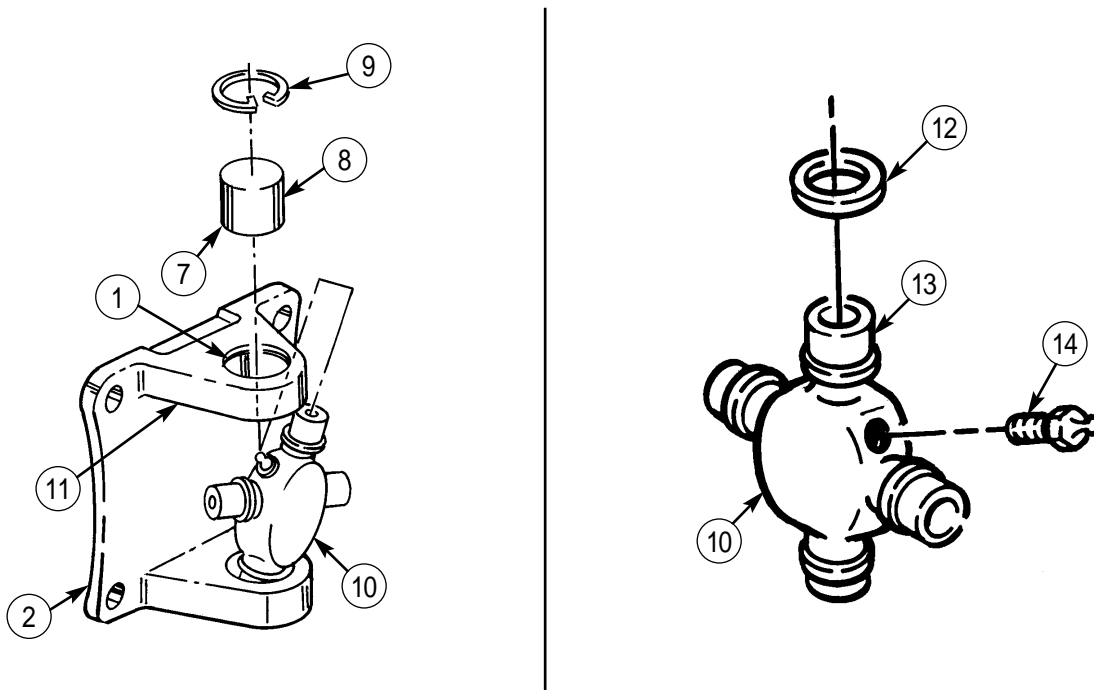

SNAPRING TYPE

UNIVERSAL JOINT MAINTENANCE (Contd)**NOTE**

Align marks on yokes before assembling bearing caps in shaft yoke.

2. Cap type:
 - a. Install four new seals (8) on spider cross journals (9).
 - b. Install lubrication fitting (10) on spider cross (7).
 - c. Install spider cross (7) in upper yoke flange loop (5) with lubrication fitting (10) angled away from yoke flange (6).
 - d. Apply GAA grease in bearing caps (3) to hold bearing (4) in place during assembly.
 - e. Install two bearing caps (3) on spider cross journal (9) and upper yoke flange loop (5).
 - f. Position two locking straps (2) on bearing caps (3) and install with four screws (1). Tighten screws (1) 18-25 lb-ft (24-34 N·m). Bend tabs of locking straps (2) up to hold screws (1) in place.

NOTE

Align marks on yokes before assembling bearing caps in shaft yoke.

- g. Position shaft yoke (11) on spider cross journals (9) and install two bearing caps (3) with new locking straps (2) and four screws (1). Tighten screws (1) 18-25 lb-ft (24-34 N·m).
- h. Bend tabs of locking straps (2) up to hold screws (1) in place.
- i. Shaft yokes (11) and yoke flange (6) should move smoothly and have no free play.
- j. Install propeller shaft (WP 0147 00).
- k. Install intermediate propeller shaft (M36A2) (WP 0148 00).

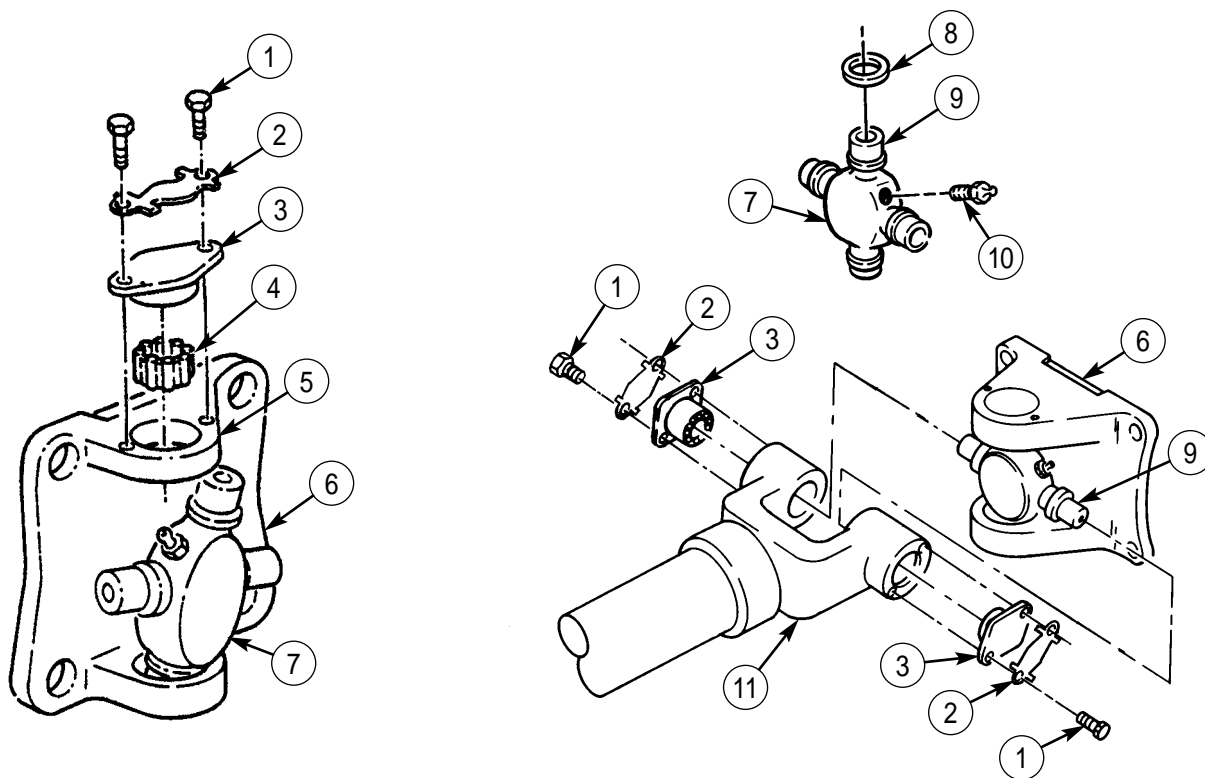

CAP TYPE

END OF WORK PACKAGE

UNIT MAINTENANCE INSTRUCTIONS

EXTENDED SERVICE PROGRAM (ESP)

TRUCK, CARGO, 2-1/2-TON, 6X6, M44A3 SERIES TRUCKS (DIESEL)

M35A3, W/O WINCH (NSN 2320-01-383-2047); W/WINCH (NSN 2320-01-383-3850);

M35A3C, W/O WINCH (NSN 2320-01-383-2050); W/WINCH (NSN 2320-01-383-2049);

M36A3, W/O WINCH (NSN 2320-01-383-2048); W/WINCH (NSN 2320-01-383-2046).

SECTION XII. AXLE MAINTENANCE

TABLE OF CONTENTS

WP Title

WP Sequence No.-Page No.

Axle Breather Maintenance 0151 00-1

Front Axle Oil Seal Replacement 0152 00-1

END OF WORK PACKAGE

UNIT MAINTENANCE INSTRUCTIONS

EXTENDED SERVICE PROGRAM (ESP)

TRUCK, CARGO, 2-1/2-TON, 6X6, M44A3 SERIES TRUCKS (DIESEL)

M35A3, W/O WINCH (NSN 2320-01-383-2047); W/WINCH (NSN 2320-01-383-3850);
M35A3C, W/O WINCH (NSN 2320-01-383-2050); W/WINCH (NSN 2320-01-383-2049);
M36A3, W/O WINCH (NSN 2320-01-383-2048); W/WINCH (NSN 2320-01-383-2046).

AXLE BREATHER MAINTENANCE

REMOVAL, CLEANING, INSTALLATION

INITIAL SETUP:

Tools and Special Tools

General mechanic's tool kit
(item 30, WP 0394 00)

References

TM 9-2320-386-24P

Materials/Parts

Skysol-100 (item 17, WP 0393 00)
Wiping rag (item 35, WP 0393 00)
Teflon pipe sealant (item 41, WP 0393 00)

Equipment Condition

Parking brake set (TM 9-2320-386-10).

AXLE BREATHER MAINTENANCE (Contd)

NOTE

Front and rear axle housing breathers are maintained the same. This procedure covers the front axle housing breather.

REMOVAL

Remove breather (1) from axle housing (2).

CLEANING

WARNING

Skysol-100 mixture is combustible. Use mechanical ventilation whenever product is used in a confined space, is heated above ambient temperatures, or is agitated. DO NOT use or store near heat, sparks, flame, or other ignition sources. Keep container sealed when not in use.

Contact with Skysol-100 may cause skin irritation. Use chemical resistant gloves. In case of skin contact, remove any contaminated clothing and wash skin thoroughly with soap and water. Wash contaminated clothing before reuse. Eye contact may cause irritation, tearing, or blurring of vision. Use face shield or goggles when eye contact may occur. In case of eye contact, flush eyes with large amounts of water for at least fifteen (15) minutes or until irritation subsides. Inhalation may cause irritation to upper respiratory passages. DO NOT have food or drink in the vicinity.

Clean breather (1) with Skysol-100 and dry with clean rag.

INSTALLATION

1. Apply sealant to male threads of breather (1).
2. Install breather (1) on axle housing (2).

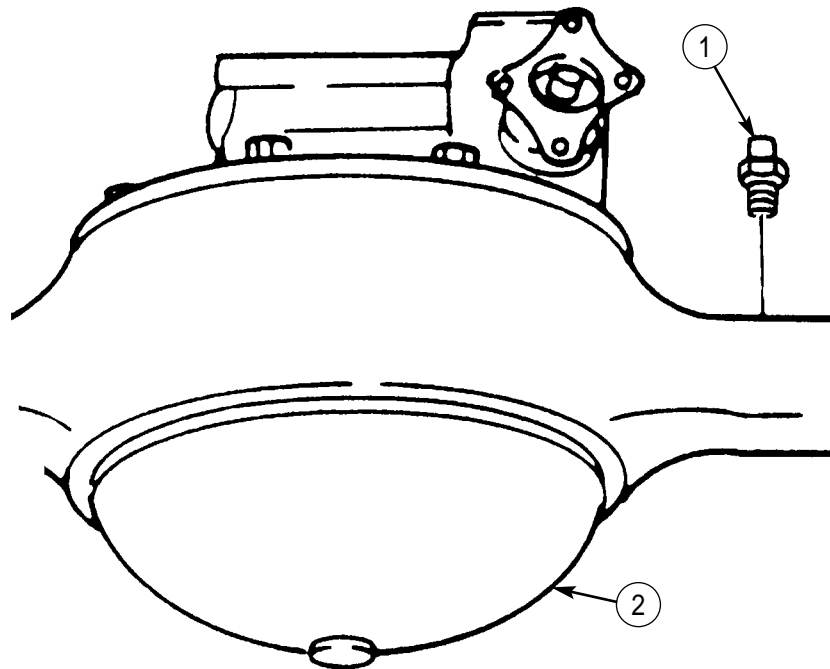

END OF WORK PACKAGE

UNIT MAINTENANCE INSTRUCTIONS

EXTENDED SERVICE PROGRAM (ESP)

TRUCK, CARGO, 2-1/2-TON, 6X6, M44A3 SERIES TRUCKS (DIESEL)

M35A3, W/O WINCH (NSN 2320-01-383-2047); W/WINCH (NSN 2320-01-383-3850);
M35A3C, W/O WINCH (NSN 2320-01-383-2050); W/WINCH (NSN 2320-01-383-2049);
M36A3, W/O WINCH (NSN 2320-01-383-2048); W/WINCH (NSN 2320-01-383-2046).

FRONT AXLE OIL SEAL REPLACEMENT

REMOVAL, INSTALLATION

INITIAL SETUP:

Tools and Special Tools

General Mechanic's tool kit
(item 30, WP 0394 00)
Mechanical puller (item 40, WP 0394 00)
Oil seal and retainer inserter
(item 47, WP 0394 00)

Materials/Parts

Oil seal (item 110, WP 0395 00)

References

TM 9-2320-386-24P

Equipment Condition

Parking brake set (TM 9-2320-386-10).
Front wheel hub and drum removed (WP 0172 00).
Front axle shaft removed (TM 9-2320-361-20).

FRONT AXLE OIL SEAL REPLACEMENT (Contd)

REMOVAL

1. Using mechanical puller, remove retainer (1) with oil seal (2) attached from axle housing (3).
2. Remove oil seal (2) from retainer (1). Discard oil seal (2).

INSTALLATION

1. Install new oil seal (2) on retainer (1).
2. Using oil seal and retainer inserter, install retainer (1) with oil seal (2) attached on axle housing (3).
3. Install front axle shaft (TM 9-2320-361-20).
4. Install front wheel hub and drum (WP 0172 00).

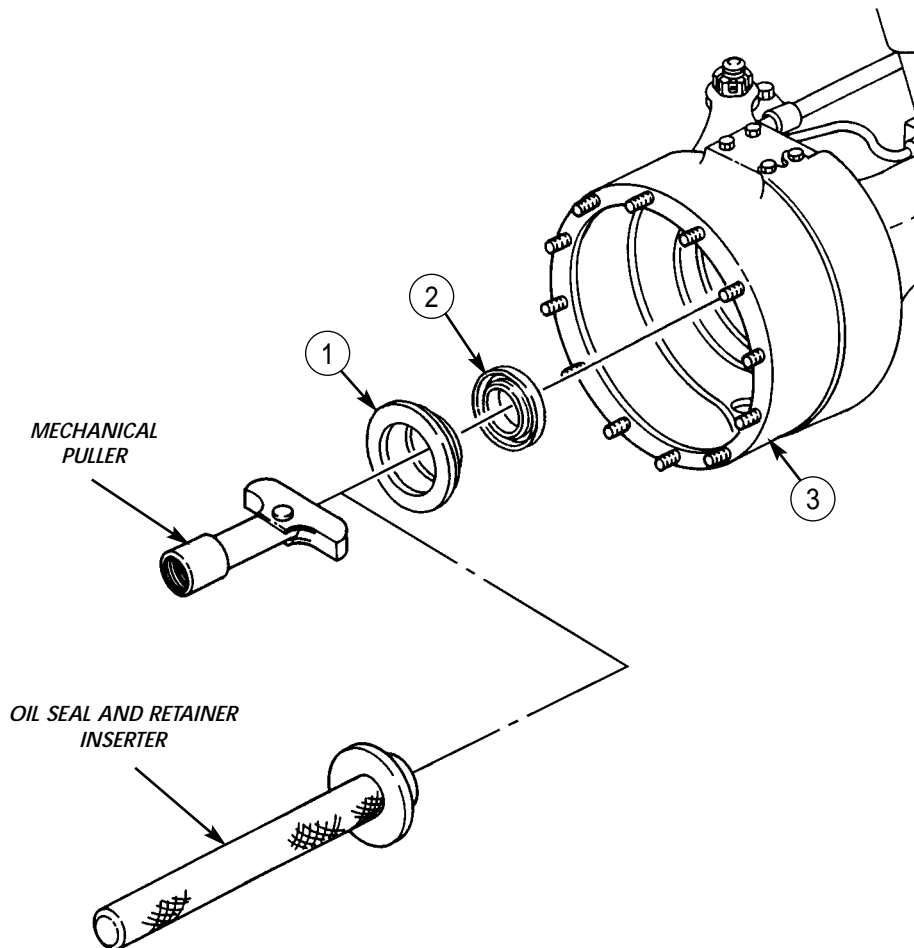

END OF WORK PACKAGE

UNIT MAINTENANCE INSTRUCTIONS

EXTENDED SERVICE PROGRAM (ESP)

TRUCK, CARGO, 2-1/2-TON, 6X6, M44A3 SERIES TRUCKS (DIESEL)

M35A3, W/O WINCH (NSN 2320-01-383-2047); W/WINCH (NSN 2320-01-383-3850);

M35A3C, W/O WINCH (NSN 2320-01-383-2050); W/WINCH (NSN 2320-01-383-2049);

M36A3, W/O WINCH (NSN 2320-01-383-2048); W/WINCH (NSN 2320-01-383-2046).

**SECTION XIII. COMPRESSED AIR AND BRAKE SYSTEM MAINTENANCE
TABLE OF CONTENTS**

<i>WP Title</i>	<i>WP Sequence No.-Page No.</i>
Service Brake System Bleeding	0154 00-1
Master Cylinder Replacement	0155 00-1
Master Cylinder Reservoir Replacement	0156 00-1
Air-Hydraulic Booster Replacement	0157 00-1
Air-Hydraulic Booster Brake Lines Replacement	0158 00-1
Air-Hydraulic Booster Vent Line Replacement	0159 00-1
Proportional Valve Replacement	0160 00-1
Front Axle Hydraulic Brake Line Replacement	0161 00-1
Forward-Rear and Rear-Rear Axle Hydraulic Brake Lines Replacement	0162 00-1
Brake Pedal Maintenance	0163 00-1
Trailer Air Coupling Replacement	0164 00-1
Air Reservoir Replacement	0165 00-1
Air Reservoir Drainvalves Replacement	0166 00-1
Compressed Air Lines Replacement and Repair	0167 00-1
Air Compressor Coolant Lines Replacement	0168 00-1
Air Compressor Replacement	0169 00-1
Air Compressor Governor Maintenance	0170 00-1

END OF WORK PACKAGE

UNIT SUPPORT MAINTENANCE INSTRUCTIONS

EXTENDED SERVICE PROGRAM (ESP)

TRUCK, CARGO, 2-1/2-TON, 6X6, M44A3 SERIES TRUCKS (DIESEL)

M35A3, W/O WINCH (NSN 2320-01-383-2047); W/WINCH (NSN 2320-01-383-3850);
M35A3C, W/O WINCH (NSN 2320-01-383-2050); W/WINCH (NSN 2320-01-383-2049);
M36A3, W/O WINCH (NSN 2320-01-383-2048); W/WINCH (NSN 2320-01-383-2046).

SERVICE BRAKE SYSTEM BLEEDING

FILLING MASTER CYLINDER, BLEEDING AIR-HYDRAULIC CYLINDERS, BLEEDING WHEEL CYLINDERS

INITIAL SETUP:

Tools and Special Tools

General mechanic's tool kit
(item 30, WP 0394 00)

Materials/Parts

Brake fluid (item 13, WP 0393 00)
Wiping rag (item 35, WP 0393 00)

References

TM 9-2320-386-24P

Equipment Condition

Parking brake set (TM 9-2320-386-10).
Hood raised and secured (TM 9-2320-386-10).

SERVICE BRAKE SYSTEM BLEEDING (Contd)**FILLING MASTER CYLINDER****WARNING**

Accidental or intentional introduction of liquid contaminants into the environment is in violation of state, federal, and military regulations. Refer to Army POL (WP 0001 00) for information concerning storage, use and disposal of these liquids. Failure to do so may result in injury or death.

Clean master cylinder reservoir filler cap and surrounding area before removing cap. System contamination can result in injury to personnel or equipment damage.

1. Remove two master cylinder reservoir filler caps (1) from master cylinder reservoir (2).

NOTE

Fluid added to master cylinder reservoir will also fill master cylinder.

2. Using a clean flexible neck oil filler can, fill master cylinder reservoir (2) with silicone brake fluid from a sealed container labeled MIL-B-46176.
3. Install two master cylinder reservoir caps (1) on master cylinder reservoir (2).

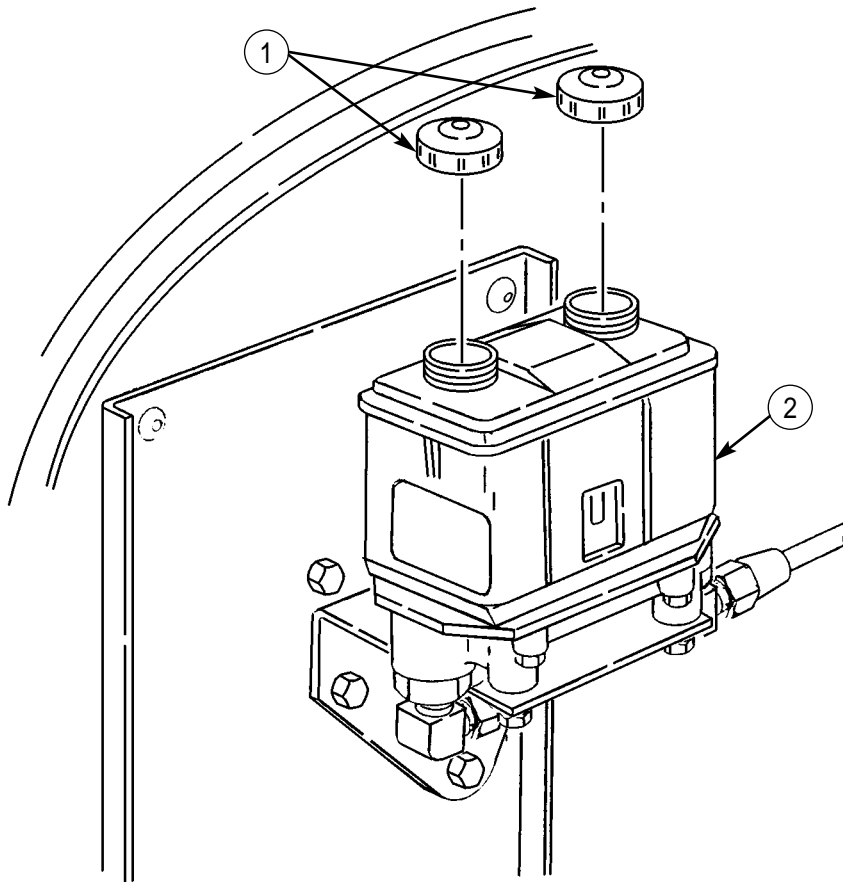

SERVICE BRAKE SYSTEM BLEEDING (Contd)**BLEEDING AIR-HYDRAULIC CYLINDERS****NOTE**

Start with the left-hand air-hydraulic cylinder. Repeat all steps for the right-hand air-hydraulic cylinder, after ensuring that the master cylinder reservoir has been refilled.

1. Using clean rag, clean bleeder screw (3) on air-hydraulic cylinder (6).
2. Install one end of bleeder hose (5) on bleeder screw (3).
3. Place other end of bleeder hose (5) into transparent container (4).
4. Fill transparent container (4) with silicone brake fluid until transparent container (4) is one-half full.
5. Ensure that end of bleeder hose (5) is below level of fluid in transparent container (4).

NOTE

Assistant will help with steps 6 through 9.

6. Slowly pump brake pedal three times and hold pedal down after last pump until told to release.
7. Loosen bleeder screw (3) three-fourths of a turn.
8. Look for air bubbles in silicone brake fluid in transparent container (4).
9. Tighten bleeder screw (3), have assistant release pedal, and fill master cylinder reservoir (2) with silicone brake fluid.
10. Repeat steps 6 through 9 until there are no air bubbles in transparent container (4).
11. Remove bleeder hose (5) from bleeder screw (3) and transparent container (4).
12. Ensure bleeder screw (3) is tightened and master cylinder reservoir (2) is full.
13. Dispose of silicone brake fluid in transparent container (4) in approved disposal area.
14. Repeat steps 1 through 13 for right-hand air-hydraulic cylinder.

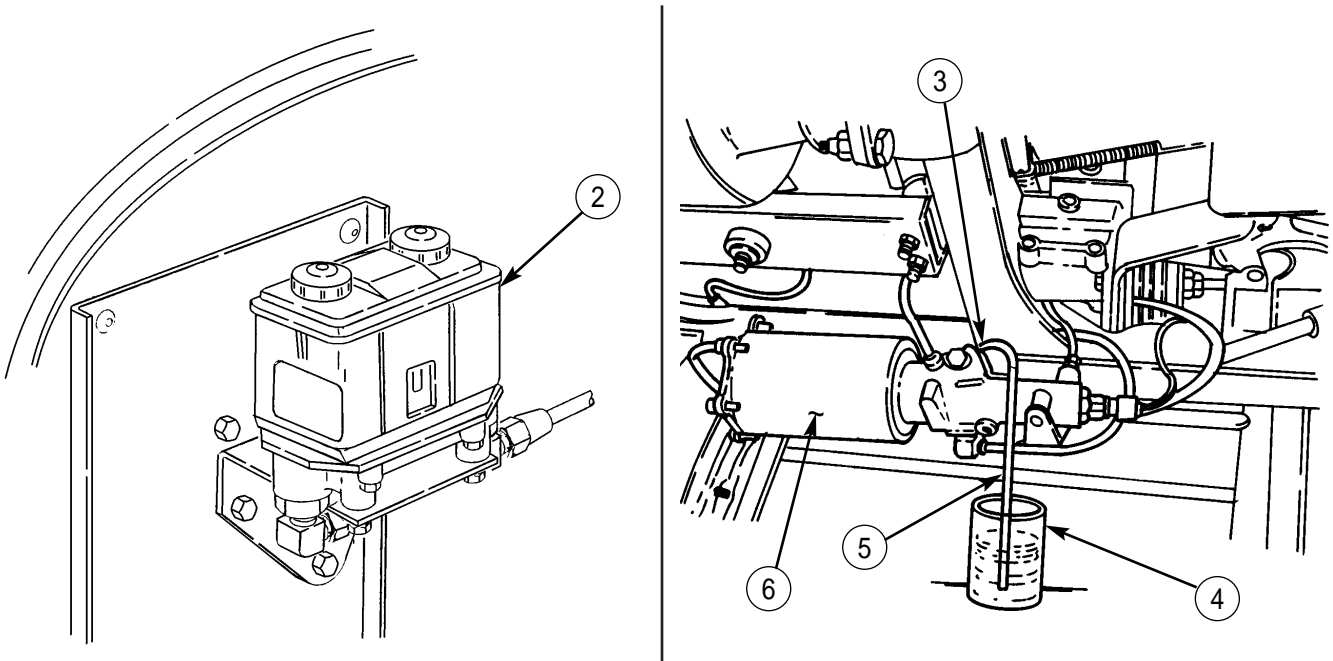

SERVICE BRAKE SYSTEM BLEEDING (Contd)**BLEEDING WHEEL CYLINDERS****CAUTION**

The air-hydraulic cylinders must be bled before bleeding wheel cylinders or brakes will not work properly.

NOTE

The left-hand air-hydraulic unit controls the rear axle brakes. The right-hand air-hydraulic unit controls brakes on the front axle.

When a brake line has been taken off at only one wheel, bleed the wheel cylinder at that wheel only.

When all wheel cylinders must be bled, start with the wheel cylinder farthest away from the master cylinder on that system.

When replacing both air-hydraulic units, bleed right-front and right-rear wheel cylinders to ensure no air is in line.

When replacing only one air-hydraulic unit, bleed the appropriate wheel cylinder to ensure no air is in line.

1. Ensure master cylinder reservoir (1) is full.
2. Using clean rag, clean bleeder screw (2) on wheel cylinder (5).
3. Install one end of bleeder hose (3) on bleeder screw (2).
4. Place other end of bleeder hose (3) into transparent container (4).
5. Fill transparent container (4) one-half full with silicone brake fluid.
6. Ensure that end of bleeder hose (3) is below level of silicone brake fluid.

NOTE

Assistant will help with steps 7 through 10.

7. Slowly pump brake pedal three times and hold brake pedal down after last pump.
8. Loosen bleeder screw (2) three-fourths of a turn.
9. Look for air bubbles in silicone brake fluid in transparent container (4).
10. Tighten bleeder screw (2), have assistant release brake pedal, and fill master cylinder reservoir (1) with silicone brake fluid.
11. Repeat steps 7 through 10 until there are no air bubbles in transparent container (4).
12. Remove bleeder hose (3) from bleeder screw (2) and transparent container (4). Ensure bleeder screw (2) is tight and master cylinder reservoir (1) is full.
13. Dispose of silicone brake fluid in transparent container (4) in approved disposal area.
14. Repeat steps 1 through 13, as required, for each wheel cylinder.

SERVICE BRAKE SYSTEM BLEEDING (Contd)

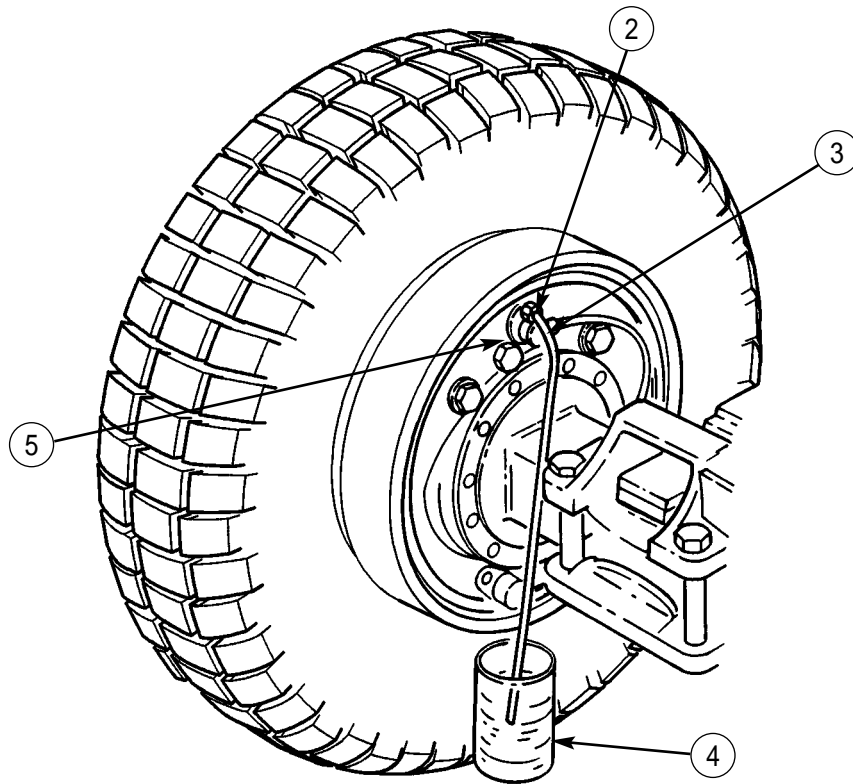
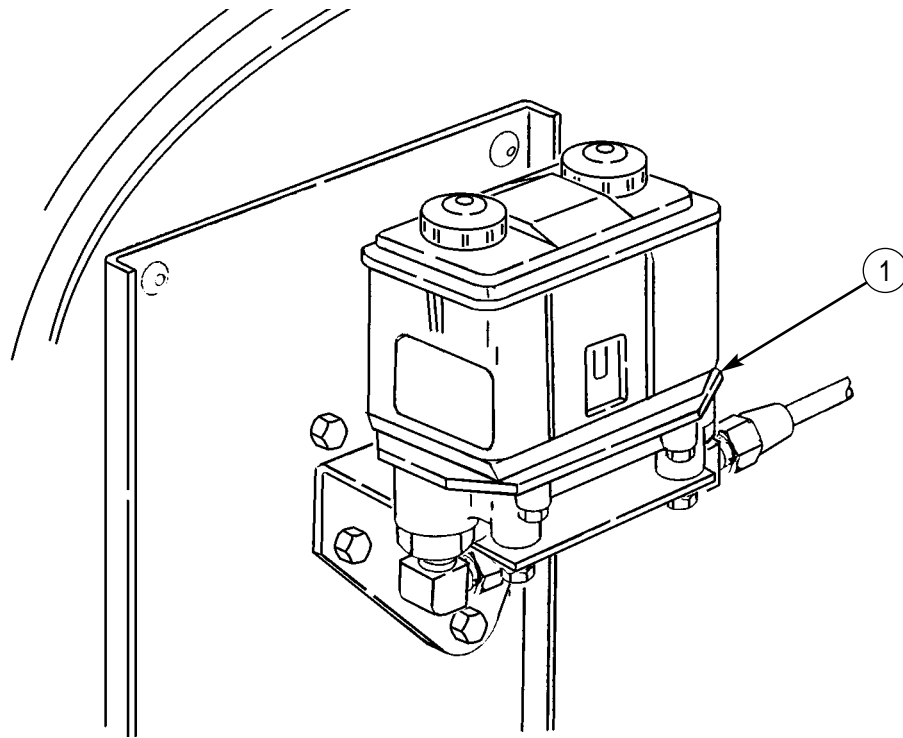

END OF WORK PACKAGE

UNIT MAINTENANCE INSTRUCTIONS

EXTENDED SERVICE PROGRAM (ESP)

TRUCK, CARGO, 2-1/2-TON, 6X6, M44A3 SERIES TRUCKS (DIESEL)

M35A3, W/O WINCH (NSN 2320-01-383-2047); W/WINCH (NSN 2320-01-383-3850);
M35A3C, W/O WINCH (NSN 2320-01-383-2050); W/WINCH (NSN 2320-01-383-2049);
M36A3, W/O WINCH (NSN 2320-01-383-2048); W/WINCH (NSN 2320-01-383-2046).

MASTER CYLINDER REPLACEMENT

REMOVAL, INSTALLATION

INITIAL SETUP:

Tools and Special Tools

General mechanic's tool kit
(item 30, WP 0394 00)

References

TM 9-2320-386-24P

Materials/Parts

Cotter pin (item 28, WP 0395 00)
Four lockwashers (item 61, WP 0395 00)
Cap and plug set (item 14, WP 0393 00)
Teflon pipe sealant (item 41, WP 0393 00)

Equipment Condition

Parking brake set (TM 9-2320-386-10).

MASTER CYLINDER REPLACEMENT (Contd)**REMOVAL****CAUTION**

When disconnecting hydraulic lines and hoses, cap and plug all openings to prevent dirt and dust from entering. Contamination of the brake system may result in damage to equipment. Remove caps and plugs prior to installation.

NOTE

Have drainage container ready to catch brake fluid.

Tag all brake lines for installation.

1. Loosen nut (3) and remove tube (4) and sleeve (2) from elbow (1).
2. Loosen nut (6) and remove tube (7) and sleeve (5) from elbow (8).
3. Loosen nut (10) and remove brake line (11) from master cylinder (9).
4. Loosen nut (23) and remove brake line (24) from master cylinder (9).
5. Loosen nuts (22) and (25) and remove brake lines (11) and (24) from differential valve (28).
6. Remove two screws (30), lockwashers (31), and differential valve bracket (29) from master cylinder (9) and bracket (12). Discard lockwashers (31).
7. Remove cotter pin (17) and washer (18) from retaining pin (21). Discard cotter pin (17).
8. Remove retaining pin (21), clevis (19), and spring (16) from lever (13).
9. Loosen nut (20) and remove clevis (19) from pushrod (15).
10. Remove pushrod (15) and boot (14) from master cylinder mounting bracket (12).
11. Remove two screws (27), lockwashers (26), and master cylinder (9) from mounting bracket (12). Discard lockwashers (26).
12. Remove elbows (1) and (8) from master cylinder (9).

MASTER CYLINDER REPLACEMENT (Contd)

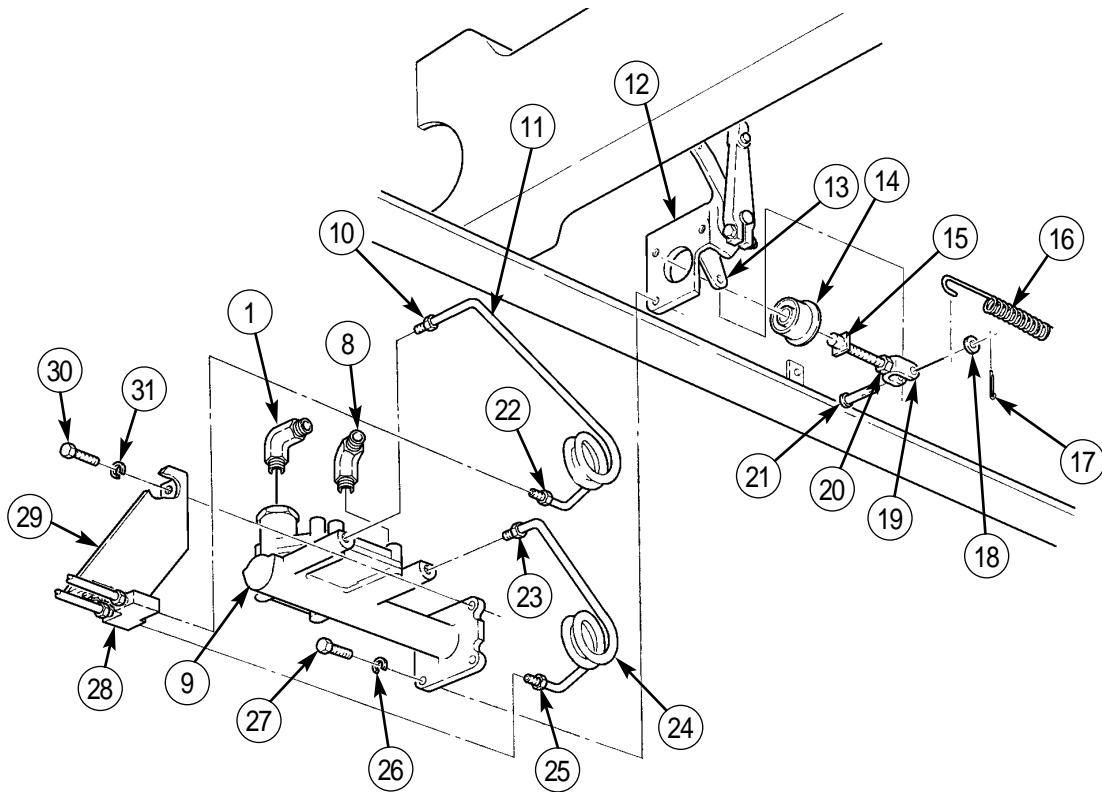
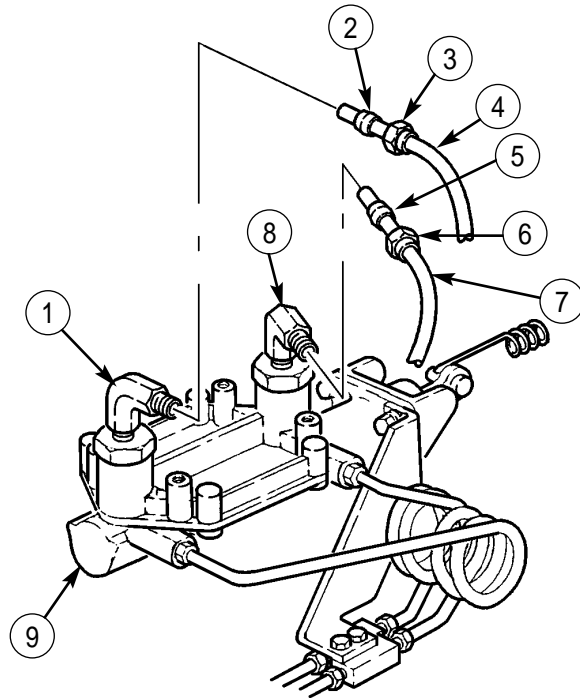

MASTER CYLINDER REPLACEMENT (Contd)

INSTALLATION

1. Apply sealant to male threads of brake lines (2) and (15) and elbows (24) and (25).
2. Install elbows (24) and (25) on master cylinder (19).
3. Install brake lines (2) and (15) on differential valve (20) and tighten nuts (13) and (16).
4. Install master cylinder (19) and differential valve bracket (21) on mounting bracket (3) with two new lockwashers (17) and (23) and screws (18) and (22).
5. Install brake line (2) on master cylinder (19) and tighten nut (1).
6. Install brake line (15) on master cylinder (19) and tighten nut (14).
7. Install boot (5) and pushrod (6) on mounting bracket (3).
8. Install clevis (10) on pushrod (6) and tighten nut (11).
9. Install clevis (10) on lever (4) with retaining pin (12), washer (9), spring (7), and new cotter pin (8).
10. Install tube (28) and sleeve (26) on elbow (24) and tighten nut (27).
11. Install tube (31) and sleeve (29) on elbow (25) and tighten nut (30).
12. Bleed service brakes (WP 0154 00) and road test vehicle.

MASTER CYLINDER REPLACEMENT (Contd)

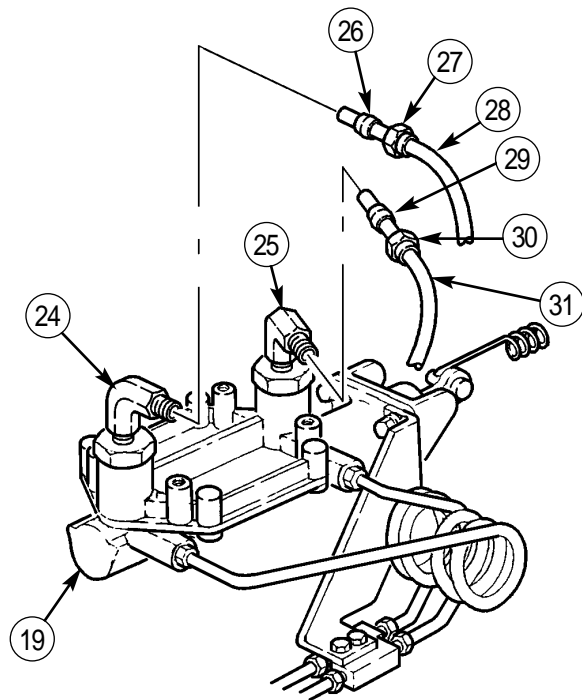
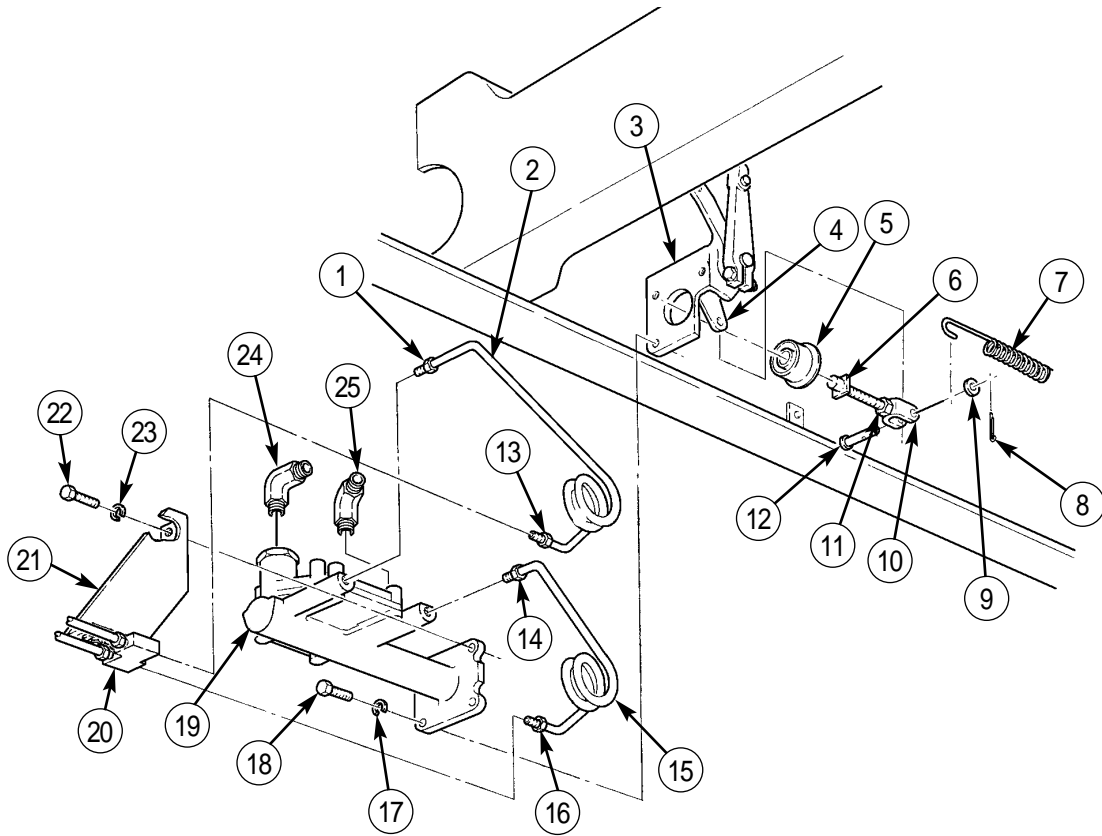

END OF WORK PACKAGE

UNIT MAINTENANCE INSTRUCTIONS

EXTENDED SERVICE PROGRAM (ESP)

TRUCK, CARGO, 2-1/2-TON, 6X6, M44A3 SERIES TRUCKS (DIESEL)

M35A3, W/O WINCH (NSN 2320-01-383-2047); W/WINCH (NSN 2320-01-383-3850);
M35A3C, W/O WINCH (NSN 2320-01-383-2050); W/WINCH (NSN 2320-01-383-2049);
M36A3, W/O WINCH (NSN 2320-01-383-2048); W/WINCH (NSN 2320-01-383-2046).

MASTER CYLINDER RESERVOIR REPLACEMENT

REMOVAL, INSTALLATION

INITIAL SETUP:

Tools and Special Tools

General mechanic's tool kit
(item 30, WP 0394 00)

References

TM 9-2320-386-24P

Materials/Parts

Four lockwashers (item 60, WP 0395 00)
Two locknuts (item 19, WP 0395 00)
Teflon pipe sealant (item 41, WP 0393 00)
Cap and plug set (item 14, WP 0393 00)

Equipment Condition

Parking brake set (TM 9-2320-386-10).
Hood raised and secured (TM 9-2320-386-10).

MASTER CYLINDER RESERVOIR REPLACEMENT (Contd)**REMOVAL****WARNING**

Accidental or intentional introduction of liquid contaminants into the environment is in violation of state, federal, and military regulations. Refer to Army POL (WP 0001 00) for information concerning storage, use and disposal of these liquids. Failure to do so may result in injury or death.

CAUTION

When disconnecting hydraulic lines and hoses, plug all openings to prevent dirt and dust from entering and causing internal parts damage. Remove caps and plugs prior to installation.

NOTE

Have drainage container ready to catch brake fluid.

1. Loosen nut (5) and remove tube (6) with sleeve (4) from connector (3).
2. Loosen nut (8) and remove tube (7) with sleeve (12) from elbow (13).
3. Remove four screws (9), lockwashers (10), and master cylinder reservoir (2) from mounting bracket (14). Discard lockwashers (10).

NOTE

Note position of elbow for installation.

4. Remove elbow (13) and connector (3) from master cylinder reservoir (2).

NOTE

Assistant will help with step 5.

5. Remove two locknuts (16), screws (11), and mounting bracket (14) from bracket (15) and firewall (1). Discard locknuts (16).

INSTALLATION

1. Apply sealant to male threads of elbow (13) and connector (3).

NOTE

Assistant will help with step 2.

2. Install mounting bracket (14) on bracket (15) and firewall (1) with two screws (11) and new locknuts (16).
3. Install elbow (13) and connector (3) on master cylinder reservoir (2).
4. Install master cylinder reservoir (2) on mounting bracket (14) with four new lockwashers (10) and screws (9).
5. Install tube (7) with sleeve (12) on elbow (13) and tighten nut (8).
6. Install tube (6) with sleeve (4) on connector (3) and tighten nut (5).
7. Bleed service brakes (WP 0154 00) and road test vehicle.

MASTER CYLINDER RESERVOIR REPLACEMENT (Contd)

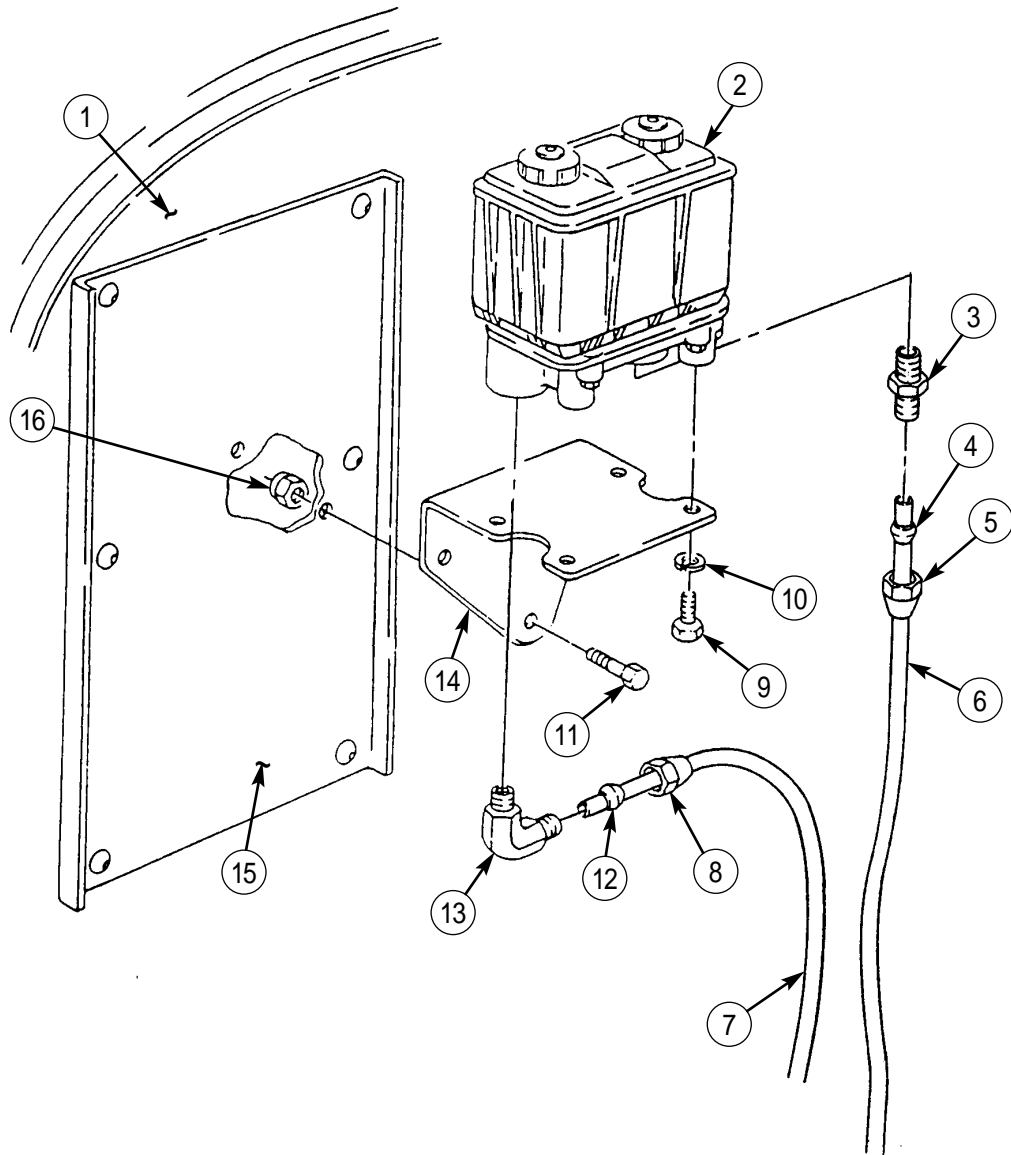

END OF WORK PACKAGE

UNIT MAINTENANCE INSTRUCTIONS

EXTENDED SERVICE PROGRAM (ESP)

TRUCK, CARGO, 2-1/2-TON, 6X6, M44A3 SERIES TRUCKS (DIESEL)

M35A3, W/O WINCH (NSN 2320-01-383-2047); W/WINCH (NSN 2320-01-383-3850);

M35A3C, W/O WINCH (NSN 2320-01-383-2050); W/WINCH (NSN 2320-01-383-2049);

M36A3, W/O WINCH (NSN 2320-01-383-2048); W/WINCH (NSN 2320-01-383-2046).

AIR-HYDRAULIC BOOSTER REPLACEMENT

REMOVAL, INSTALLATION

INITIAL SETUP:

Tools and Special Tools

General mechanic's tool kit
(item 30, WP 0394 00)

Materials/Parts

Two lockwashers (item 62, WP 0395 00)
Lockwasher (item 186, WP 0395 00)
Two gaskets (item 256, WP 0395 00)
Cap and plug set (item 14, WP 0393 00)
Teflon pipe sealant (item 41, WP 0393 00)

References

TM 9-2320-386-24P

Equipment Condition

Parking brake set (TM 9-2320-386-10).
Air reservoirs drained (TM 9-2320-386-10).

AIR-HYDRAULIC BOOSTER REPLACEMENT (Contd)**NOTE**

For schematic representation of air line locations and routing, refer to WP 0386 00.

REMOVAL**WARNING**

Do not disconnect air lines before draining air reservoirs. Small parts under pressure may shoot out with high velocity, causing injury to personnel.

Eyeshields must be worn when releasing compressed air. Failure to do so may result in injury to personnel.

CAUTION

When disconnecting air lines and hoses, plug all openings to prevent dirt from entering and causing damage to internal parts. Remove all plugs prior to installation.

NOTE

Tag air lines for installation.

Have drainage container ready to catch brake fluid.

Both left and right air-hydraulic boosters are replaced basically the same. This procedure covers the left air-hydraulic booster.

1. Remove two screws (7), lockwashers (6), and skid plate (1) from air-hydraulic booster (13) and mounting bracket (2). Discard lockwashers (6).
2. Reinstall one screw (7) to secure air-hydraulic booster (13) on mounting bracket (2).
3. Remove nut (18) and tube (17) from elbow (19).
4. Remove nut (15) and tube (16) from elbow (14).
5. Remove nut (31) and tube (32) from adapter (30).
6. Remove nut (9) and tube (8) from adapter (10).
7. Remove nut (26) and tube (25) from stop elbow (27).
8. Disconnect two leads 75 (24) from stoplight switch (23).
9. Remove screw (4), lockwasher (3), screw (7), and air-hydraulic booster (13) from mounting brackets (2) and (5). Discard lockwasher (3).

NOTE

Note position of elbows and tee for installation.

10. Remove elbow (27) from tee (22).
11. Remove elbow (14) from port (20).
12. Remove elbow (19) from port (21).
13. Remove adapter (10) and gasket (11) from port (12). Discard gasket (11).
14. Remove adapter (30) and gasket (29) from port (28). Discard gasket (29).
15. Remove stoplight switch (23) from tee (22).
16. Remove tee (22) from air-hydraulic booster (13).

AIR-HYDRAULIC BOOSTER REPLACEMENT (Contd)

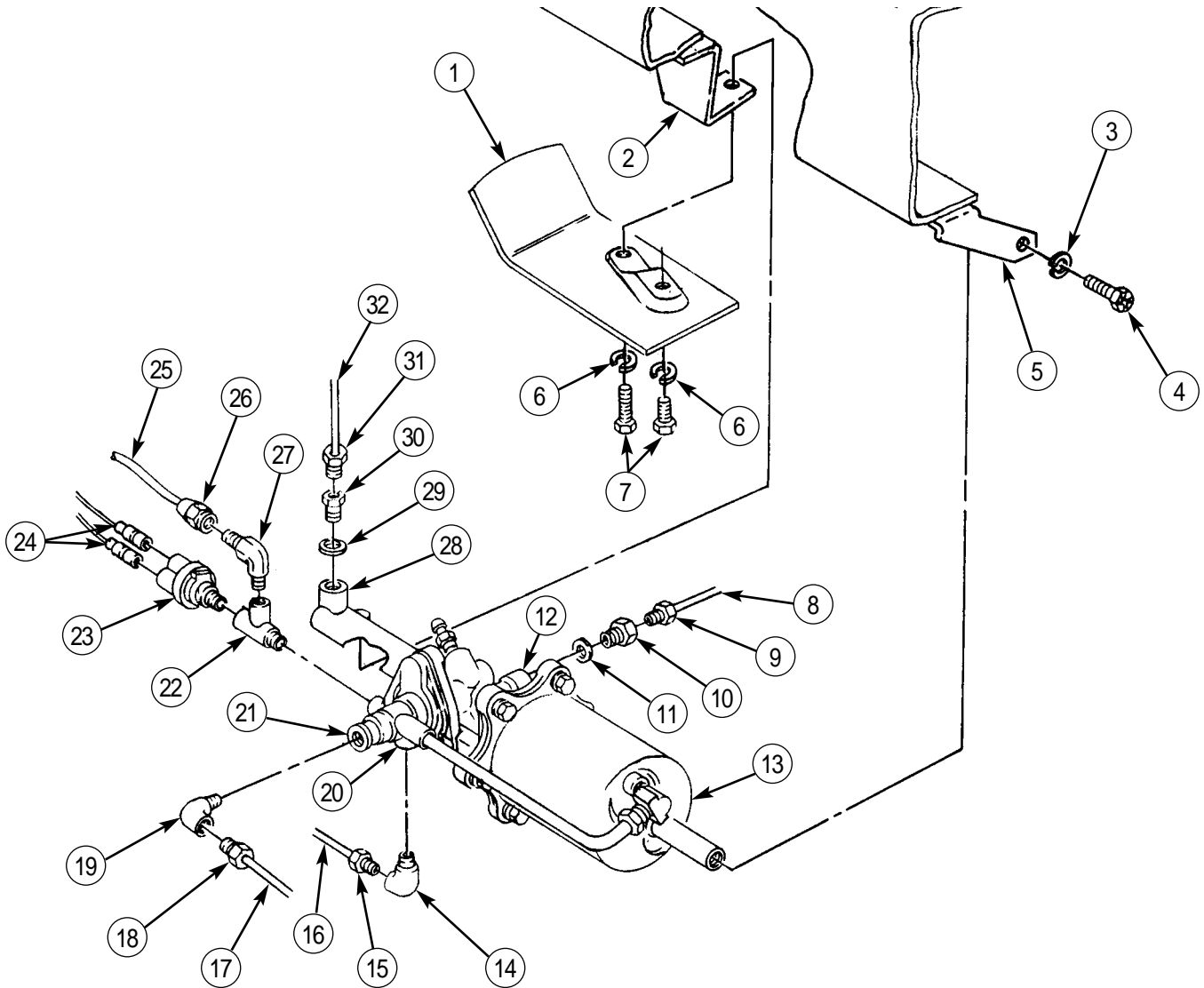

AIR-HYDRAULIC BOOSTER REPLACEMENT (Contd)**INSTALLATION**

1. Apply antiseize tape to male threads of stoplight switch (23), tee (22), elbows (14), (19), and (27), and adapters (10) and (30).
2. Install tee (22) on air-hydraulic booster (13).
3. Install stoplight switch (23) on tee (22).
4. Install elbow (19) on port (21).
5. Install elbow (14) on port (20).
6. Install elbow (27) on tee (22).
8. Install new gasket (11) and adapter (10) on port (12).
7. Install new gasket (29) and adapter (30) on port (28).
9. Install air-hydraulic booster (13) on mounting bracket (5) with new lockwasher (3) and screw (4).
10. Install one screw (7) to support air-hydraulic booster (13) on mounting bracket (2).
11. Install tube (32) on adapter (30) with nut (31).
12. Install tube (25) on elbow (27) with nut (26).
13. Install tube (8) on adapter (10) with nut (9).
14. Install tube (16) on elbow (14) with nut (15).
15. Install tube (17) on elbow (19) with nut (18).
16. Remove screw (7) and install air-hydraulic booster (13) and skid plate (1) on mounting bracket (2) with two screws (7) and new lockwashers (6).
17. Install two leads 75 (24) on stoplight switch (23).
18. Bleed service brakes (WP 0154 00).
19. Start engine (TM 9-2320-386-10) and allow air pressure to build and check system for leaks.

AIR-HYDRAULIC BOOSTER REPLACEMENT (CONTD)

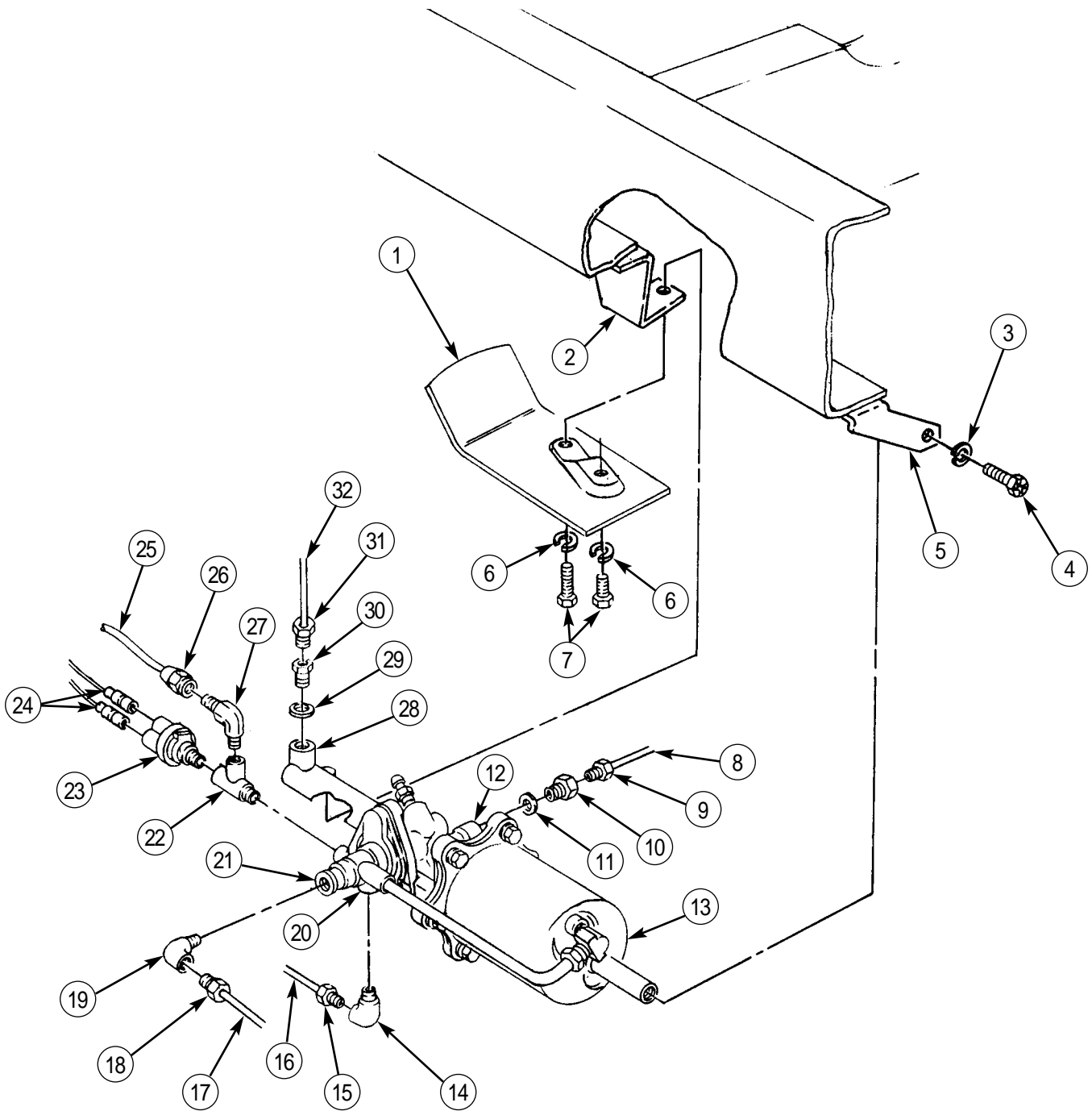

END OF WORK PACKAGE

UNIT MAINTENANCE INSTRUCTIONS

EXTENDED SERVICE PROGRAM (ESP)

TRUCK, CARGO, 2-1/2-TON, 6X6, M44A3 SERIES TRUCKS (DIESEL)

M35A3, W/O WINCH (NSN 2320-01-383-2047); W/WINCH (NSN 2320-01-383-3850);
M35A3C, W/O WINCH (NSN 2320-01-383-2050); W/WINCH (NSN 2320-01-383-2049);
M36A3, W/O WINCH (NSN 2320-01-383-2048); W/WINCH (NSN 2320-01-383-2046).

AIR-HYDRAULIC BRAKE BOOSTER LINES REPLACEMENT

LEFT BOOSTER BRAKE LINE REMOVAL, RIGHT BOOSTER BRAKE LINE REMOVAL,
LEFT BOOSTER BRAKE LINE INSTALLATION, RIGHT BOOSTER BRAKE LINE INSTALLATION

INITIAL SETUP:

Tools and Special Tools

General mechanic's tool kit
(item 30, WP 0394 00)

Materials/Parts

Two locknuts (item 249, WP 0395 00)
Two locknuts (item 91, WP 0395 00)
Two locknuts (item 99, WP 0395 00)
Four tiedown straps (item 39, WP 0395 00)
Lockwasher (item 9, WP 0395 00)
Cap and plug set (item 14, WP 0393 00)

References

TM 9-2320-386-24P

Equipment Condition

Parking brake set (TM 9-2320-386-10).

AIR-HYDRAULIC BRAKE BOOSTER LINES REPLACEMENT (Contd)**CAUTION**

When disconnecting hydraulic brake lines and hoses, cap and plug all openings to prevent dirt and dust from entering. Contamination of the brake system may result in damage to equipment. Remove caps and plugs prior to installation.

LEFT BOOSTER BRAKE LINE REMOVAL**NOTE**

Have drainage container ready to catch brake fluid.

Tag all brake lines for installation.

1. Remove hydraulic brake line (2) from differential valve (1) and hydraulic brake booster (3).
2. Remove hydraulic brake line (18) from hydraulic brake booster (3) and tee (5) on frame rail (14).
3. Remove hydraulic brake line (11) from tee (5).
4. Remove locknut (17), screw (4), and tee (5) from frame rail (14). Discard locknut (17).
5. Remove locknut (6), screw (16), and clamp (7) from frame rail (14). Discard locknut (6).
6. Remove locknut (9), screw (15), and clamp (8) from clamp (10) and frame rail (14). Discard locknut (9).
7. Disconnect hydraulic brake line (11) from tee (12) on crossmember (13) and remove from vehicle.

RIGHT BOOSTER BRAKE LINE INSTALLATION**NOTE**

Have drainage container ready to catch brake fluid.

Tag all brake lines for installation.

1. Remove hydraulic brake line (31) from differential valve (1).
2. Remove locknut (29), screw (32), and clamp (30) from hydraulic brake line (31) and crossmember (27). Discard locknut (29).
3. Remove locknut (28) and screw (33) from crossmember (27) and open clamp (34) to remove hydraulic brake line (31). Discard locknut (28).
4. Remove hydraulic brake line (31) from hydraulic brake booster (35) and vehicle.
5. Remove hydraulic brake line (26) from end of hydraulic brake booster (35) and flexible hydraulic brake line (19).
6. Remove four tiedown straps (24) from wiring harnesses (25) and remove hydraulic brake line (26) from vehicle. Discard tiedown straps (24).
7. Remove nut (36), lockwasher (37), and flexible hydraulic brake line (19) from bracket (21). Discard lockwasher (37).
8. Remove locknut (22), screw (20), and bracket (21) from frame rail (23). Discard locknut (22).

AIR-HYDRAULIC BRAKE BOOSTER LINES REPLACEMENT (Contd)

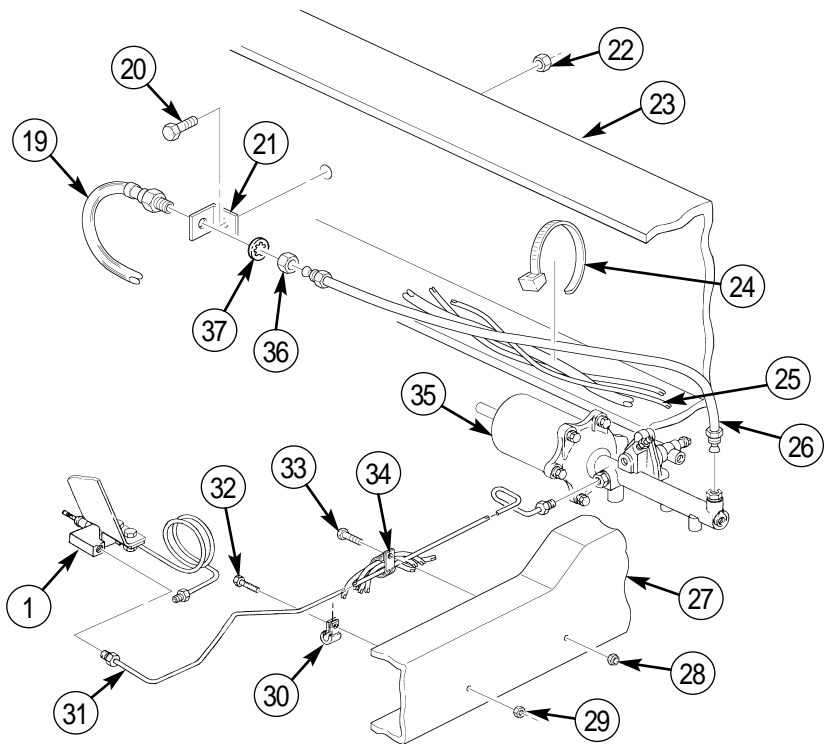
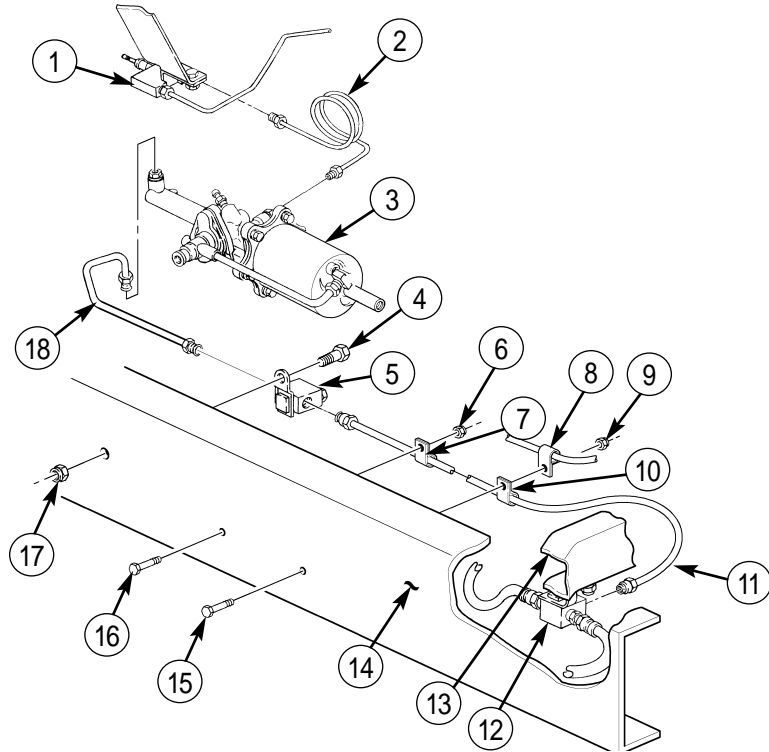

AIR-HYDRAULIC BRAKE BOOSTER LINES REPLACEMENT (Contd)**LEFT BOOSTER LINE INSTALLATION**

1. Position hydraulic brake line (11) in vehicle and connect to tee (12) on crossmember (13).
2. Install clamp (10) with hydraulic brake line (11) and clamp (8) on frame rail (14) with screw (15) and new locknut (9).
3. Install clamp (7) with hydraulic brake line (11) on frame rail (14) with screw (16) and new locknut (6).
4. Install tee (5) on frame rail (14) with screw (4) and new locknut (17).
5. Connect hydraulic brake line (11) to tee (5).
6. Connect hydraulic brake line (18) to tee (5) and hydraulic brake booster (3).
7. Install hydraulic brake line (2) to hydraulic brake booster (3) and differential valve (1).

RIGHT BOOSTER LINE INSTALLATION

1. Install bracket (21) on frame rail (23) with screw (20) and new locknut (22).
2. Install flexible hydraulic brake line (19) on bracket (21) with new lockwasher (37) and nut (36).
3. Connect hydraulic brake line (26) to flexible hydraulic brake line (19) and hydraulic brake booster (35).
4. Install four new tiedown straps (24) around hydraulic brake line (26) and wiring harnesses (25).
5. Install hydraulic brake line (31) in clamp (34) on crossmember (27).
6. Install hydraulic brake line (31) on hydraulic brake booster (35).
7. Install clamp (30) on hydraulic brake line (31) and crossmember (27) with screw (32) and new locknut (29).
8. Close clamp (34) around hydraulic brake line (31) and install clamp (34) on crossmember (27) with screw (33) and new locknut (28).
9. Install hydraulic brake line (31) on differential valve (1).
10. Bleed service brakes (WP 0154 00) and road test vehicle.

AIR-HYDRAULIC BRAKE BOOSTER LINES REPLACEMENT (Contd)

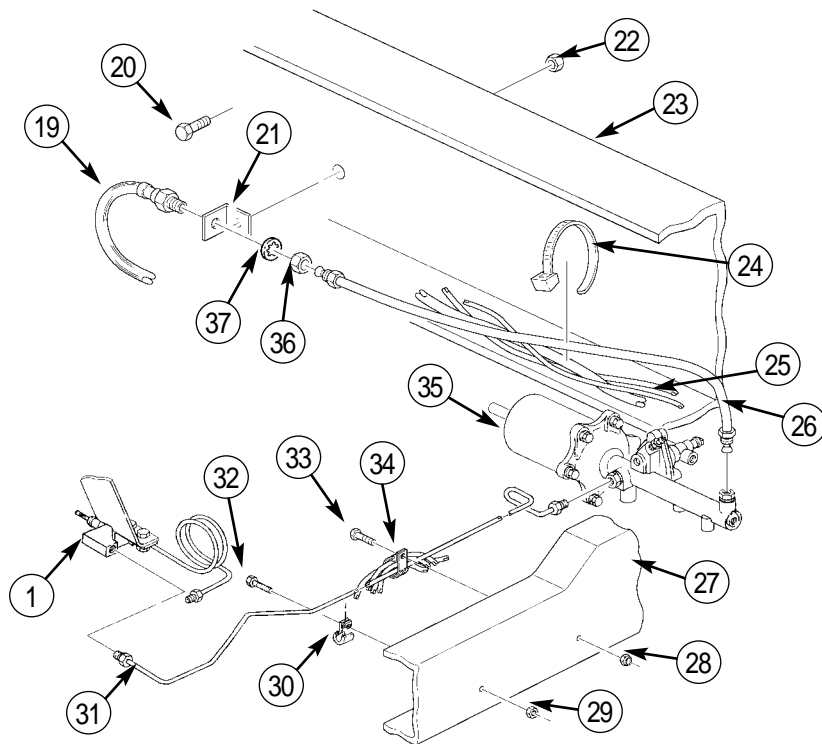
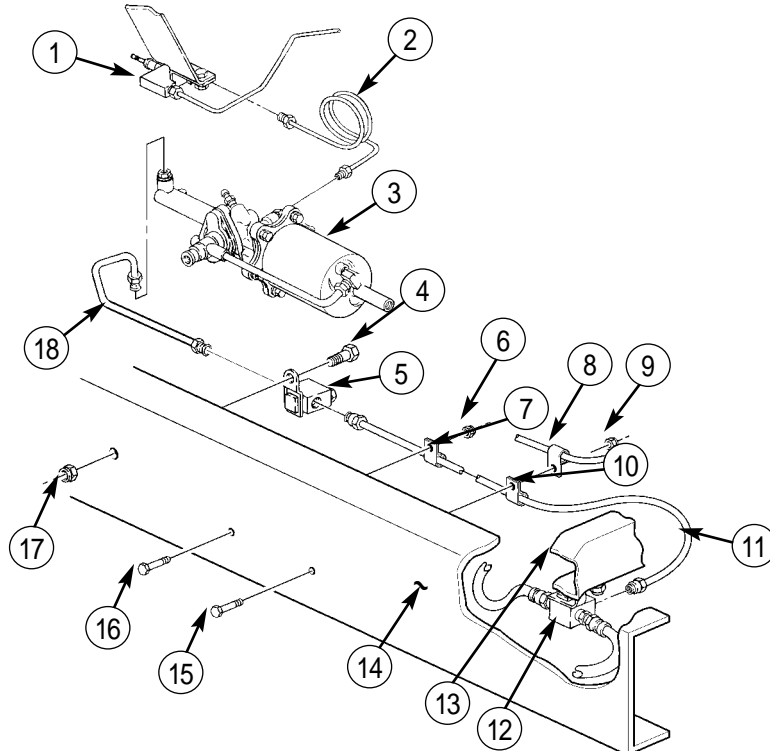

END OF WORK PACKAGE

UNIT MAINTENANCE INSTRUCTIONS

EXTENDED SERVICE PROGRAM (ESP)

TRUCK, CARGO, 2-1/2-TON, 6X6, M44A3 SERIES TRUCKS (DIESEL)

M35A3, W/O WINCH (NSN 2320-01-383-2047); W/WINCH (NSN 2320-01-383-3850);

M35A3C, W/O WINCH (NSN 2320-01-383-2050); W/WINCH (NSN 2320-01-383-2049);

M36A3, W/O WINCH (NSN 2320-01-383-2048); W/WINCH (NSN 2320-01-383-2046).

AIR-HYDRAULIC BOOSTER VENT LINE REPLACEMENT

REMOVAL, INSTALLATION

INITIAL SETUP:

Tools and Special Tools

General mechanic's tool kit
(item 30, WP 0394 00)

Materials/Parts

Cap and plug set (item 14, WP 0393 00)
Locknut (item 90, WP 0395 00)
Two tiedown straps (item 38, WP 0395 00)

References

TM 9-2320-386-24P

Equipment Condition

Parking brake set (TM 9-2320-386-10).
Air-hydraulic booster skid plates removed
(WP 0157 00)

AIR-HYDRAULIC BOOSTER VENT LINE REPLACEMENT (Contd)**REMOVAL****CAUTION**

When disconnecting air lines and hoses, plug all openings to prevent dirt from entering and causing damage to internal parts. Remove all plugs prior to installation.

1. Loosen two nuts (6) and remove air-hydraulic booster vent lines (5) and (12) from elbows (7) on air-hydraulic boosters (8).
2. Remove tiedown strap (1), locknut (11), screw (2), and clamp (3) from crossmember (4). Discard locknut (11) and tiedown strap (1).
3. Remove air-hydraulic booster vent lines (5), (9), and (12) from tee (10).
4. Remove tiedown strap (16), four screws (13), clamps (14), and air-hydraulic booster vent line (9) from cab (15) and vehicle. Discard tiedown strap (16).

INSTALLATION

1. Install air-hydraulic booster vent lines (5), (9), and (12) on tee (10).
2. Route air-hydraulic booster vent line (5) along crossmember (4) and secure with new tiedown strap (1), clamp (3), screw (2), and new locknut (11).
3. Install air-hydraulic booster vent lines (5) and (12) to elbows (7) on air-hydraulic boosters (8) and tighten two nuts (6).
4. Install four clamps (14) on air-hydraulic booster vent line (9) and other two vent lines and secure to cab (15) with four screws (13).
5. Secure three vent lines into a loop with new tiedown strap (16).
6. Install air hydraulic booster skid plates (WP 0157 00).

AIR-HYDRAULIC BOOSTER VENT LINE REPLACEMENT (Contd)

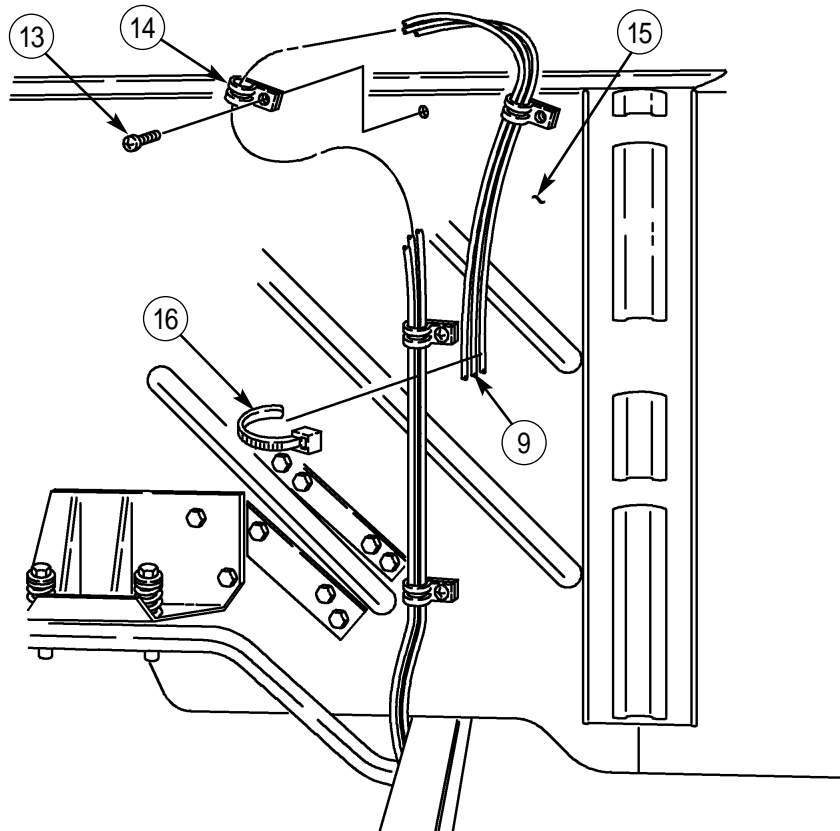
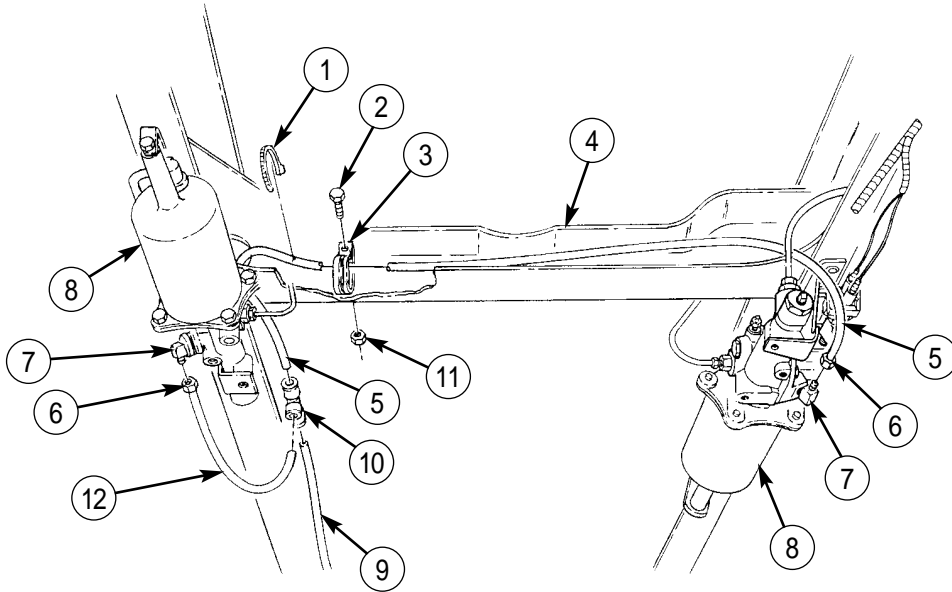

END OF WORK PACKAGE

UNIT MAINTENANCE INSTRUCTIONS

EXTENDED SERVICE PROGRAM (ESP)

TRUCK, CARGO, 2-1/2-TON, 6X6, M44A3 SERIES TRUCKS (DIESEL)

M35A3, W/O WINCH (NSN 2320-01-383-2047); W/WINCH (NSN 2320-01-383-3850);
M35A3C, W/O WINCH (NSN 2320-01-383-2050); W/WINCH (NSN 2320-01-383-2049);
M36A3, W/O WINCH (NSN 2320-01-383-2048); W/WINCH (NSN 2320-01-383-2046).

PROPORTIONAL VALVE REPLACEMENT

REMOVAL, INSTALLATION

INITIAL SETUP:

Tools and Special Tools

General mechanic's tool kit
(item 30, WP 0394 00)
Common No. 1 tool kit
(item 15, WP 0394 00)

References

TM 9-2320-386-24P

Equipment Condition

Battery ground cable disconnected (WP 0121 00).

Materials/Parts

Two locknuts (item 338, WP 0395 00)
Two lockwashers (item 62, WP 0395 00)
Cap and plug set (item 14, WP 0393 00)

PROPORTIONAL VALVE REPLACEMENT (Contd)

REMOVAL

1. Remove two screws (10), lockwashers (11), and skid plate (12) from air hydraulic booster (14). Discard lockwashers (11).
2. Disconnect wiring harness lead 116 (5) from proportional valve (7).

CAUTION

Cap or plug all tubes, connections, and openings immediately after disconnection to prevent contamination. Failure to do so may result in damage to equipment. Remove all plugs prior to installation.

NOTE

Have drainage container ready to catch brake fluid.

3. Disconnect tube (2) from proportional valve (7).
4. Disconnect tube (13) from proportional valve (7).
5. Disconnect tube (4) from proportional valve (7).
6. Disconnect tube (6) from proportional valve (7).
7. Remove two locknuts (9), washers (8), capscrews (1), and proportional valve (7) from bracket (3). Discard locknuts (9).

INSTALLATION

1. Install proportional valve (7) on bracket (3) with two capscrews (1), washers (8), and new locknuts (9). Tighten locknuts (9) to 11 lb-ft (15 N•m).
2. Connect tube (6) to proportional valve (7).
3. Connect tube (4) to proportional valve (7).
4. Connect tube (13) to proportional valve (7).
5. Connect tube (2) to proportional valve (7).
6. Connect wiring harness lead 116 (5) to proportional valve (7).
7. Install skid plate (12) on air hydraulic booster (14) with two new lockwashers (11) and screws (10).
8. Connect battery ground cable (WP 0121 00).
9. Bleed service brakes (WP 0154 00).

PROPORTIONAL VALVE REPLACEMENT (Contd)

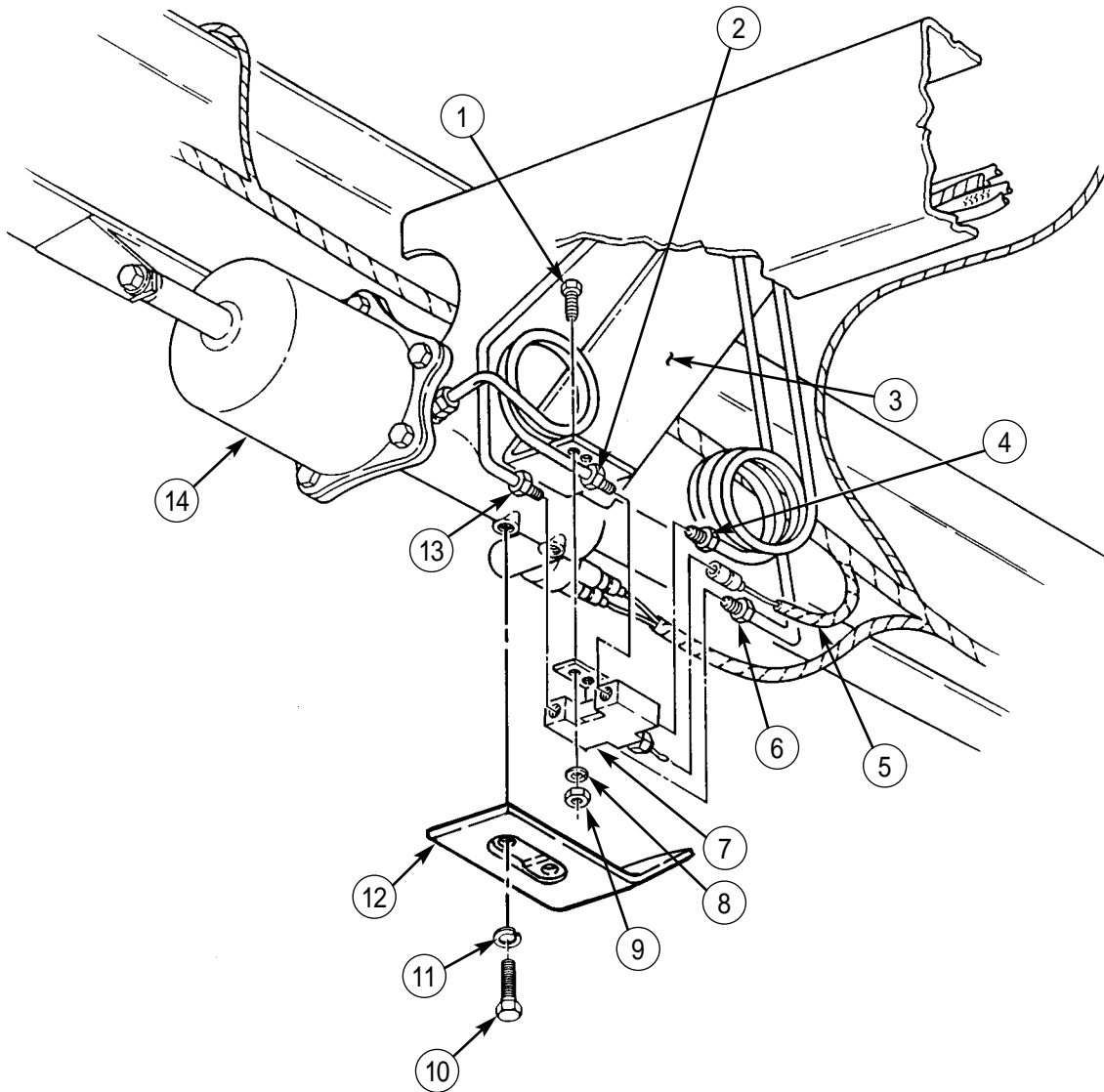

END OF WORK PACKAGE

UNIT MAINTENANCE INSTRUCTIONS

EXTENDED SERVICE PROGRAM (ESP)

TRUCK, CARGO, 2-1/2-TON, 6X6, M44A3 SERIES TRUCKS (DIESEL)

M35A3, W/O WINCH (NSN 2320-01-383-2047); W/WINCH (NSN 2320-01-383-3850);
M35A3C, W/O WINCH (NSN 2320-01-383-2050); W/WINCH (NSN 2320-01-383-2049);
M36A3, W/O WINCH (NSN 2320-01-383-2048); W/WINCH (NSN 2320-01-383-2046).

FRONT AXLE HYDRAULIC BRAKE LINE REPLACEMENT

REMOVAL, INSTALLATION

INITIAL SETUP:

Tools and Special Tools

General mechanic's tool kit
(item 30, WP 0394 00)
Common No. 1 tool kit
(item 15, WP 0394 00)

References

TM 9-2320-386-24P

Equipment Condition

Parking brake set (TM 9-2320-386-10).

Materials/Parts

Four assembled-washer bolts
(item 243, WP 0395 00)
Two locknuts (item 17, WP 0395 00)
Three lockwashers (item 45, WP 0395 00)
Brake fluid (item 13, WP 0393 00)
Cap and plug set (item 14, WP 0393 00)
Two washers (item 257, WP 0395 00)
Two washers (item 258, WP 0395 00)

FRONT AXLE HYDRAULIC BRAKE LINE REPLACEMENT (Contd)**REMOVAL****CAUTION**

When disconnecting hydraulic brake lines and hoses, cap and plug all openings to prevent dirt and dust from entering. Contamination of the brake system may result in damage to equipment. Remove caps and plugs prior to installation.

NOTE

Right and left side flexible hydraulic brake lines are removed the same. This procedure shows the left side flexible hydraulic brake line.

Have drainage container ready to catch brake fluid.

Tag all brake lines for installation.

1. Disconnect spring (7) from spring plate (5).
2. Remove locknut (15), screw (6), spring (7), and clamp (8) from flexible hydraulic brake line (16). Discard locknut (15).
3. Remove hydraulic brake line (13) from flexible hydraulic brake line (16).
4. Remove nut (12), lockwasher (14), and flexible hydraulic brake line (16) from bracket (10). Discard lockwasher (14).
5. Remove screw (4), washer (2), connector (3) with flexible hydraulic brake line (16), and washer (2) from hydraulic wheel cylinder (1). Discard washers (2).
6. Remove flexible hydraulic brake line (16) from connector (3).
7. Remove two assembled-washer bolts (9) and bracket (10) from axle housing (11). Discard assembled-washer bolts (9).

NOTE

Repeat steps 1 through 7 to remove right side flexible hydraulic brake line.

8. Remove nut (31), washer (30), clamp (29), and hydraulic brake line (13) from differential carrier (28).
9. Remove hydraulic brake line (13) from tee (26).
10. Remove hydraulic brake line (25) from tee (26).
11. Remove flexible hydraulic brake line (17) from tee (26).
12. Remove screw (23), washer (24), and tee (26) from differential housing cover (27).
13. Disconnect hydraulic brake line (22) from flexible hydraulic brake line (17).
14. Remove nut (21), lockwasher (20), and flexible hydraulic brake line (17) from bracket (19) on frame rail (18). Discard lockwasher (20).

FRONT AXLE HYDRAULIC BRAKE LINE REPLACEMENT (Contd)

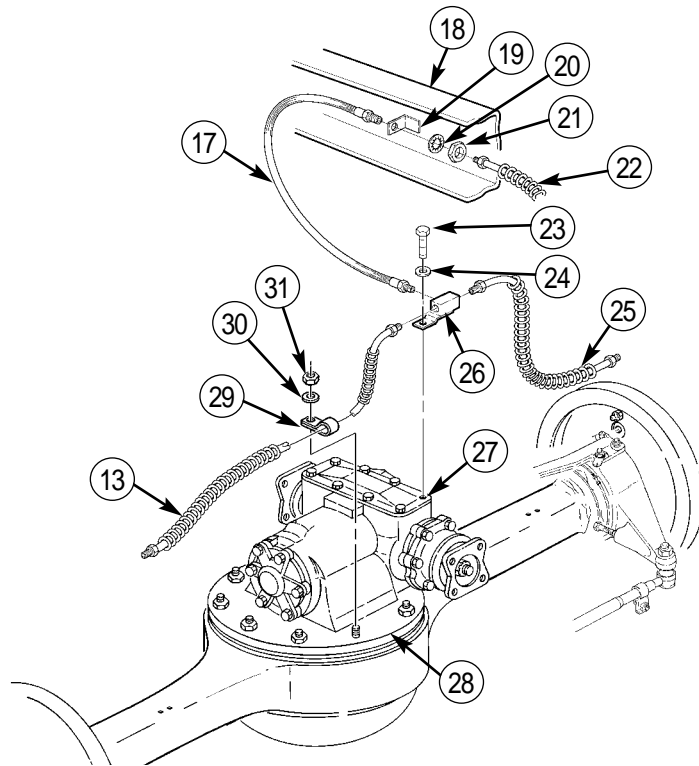
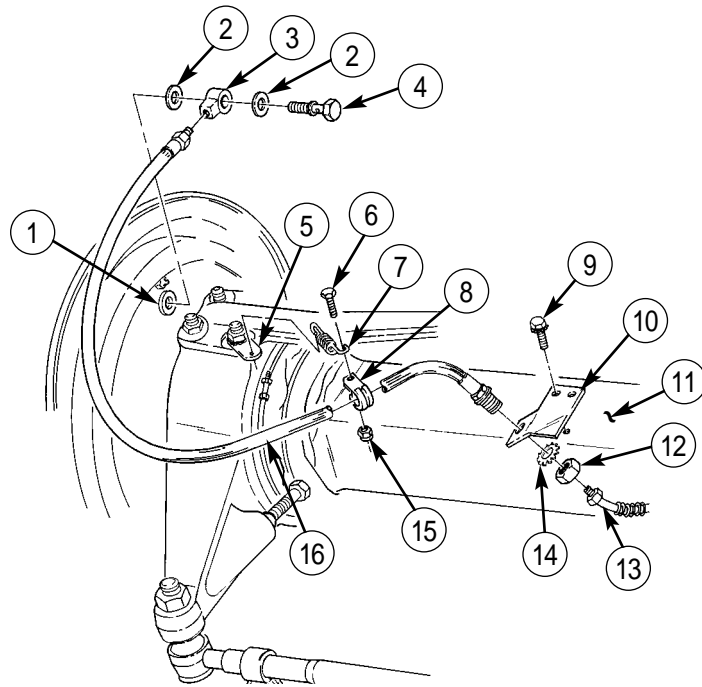

FRONT AXLE HYDRAULIC BRAKE LINE REPLACEMENT (Contd)**INSTALLATION**

1. Install flexible hydraulic brake line (1) to bracket (3) on frame rail (2) with new lockwasher (4) and nut (5).
2. Install hydraulic brake line (6) on flexible hydraulic brake line (1).
3. Install tee (10) on differential housing cover (11) with washer (8) and screw (7).
4. Install flexible hydraulic brake line (1) on tee (10).
5. Install hydraulic brake line (9) on tee (10).
6. Install hydraulic brake line (13) on tee (10).
7. Install hydraulic brake line (13) on differential carrier (12) with clamp (14), washer (15), and nut (16). Tighten nut (16) 53-76 lb-ft (72-103 N·m).
8. Install bracket (26) on axle housing (27) with two new assembled-washer bolts (25).
9. Install connector (19) on flexible hydraulic brake line (31).
10. Install connector (19) with flexible hydraulic brake line (31) on hydraulic wheel cylinder (17) with two new washers (18) and screw (20).
11. Install flexible hydraulic brake line (31) on bracket (26) with new lockwasher (29) and nut (28).
12. Install hydraulic brake line (13) on flexible hydraulic brake line (31).
13. Install spring (23) and clamp (24) on flexible hydraulic brake line (31) with screw (22) and new locknut (30).
14. Connect spring (23) to spring plate (21).

NOTE

Repeat steps 8 through 14 to install right side flexible hydraulic brake line.

15. Bleed service brakes (WP 0154 00) and road test vehicle.

FRONT AXLE HYDRAULIC BRAKE LINE REPLACEMENT (Contd)

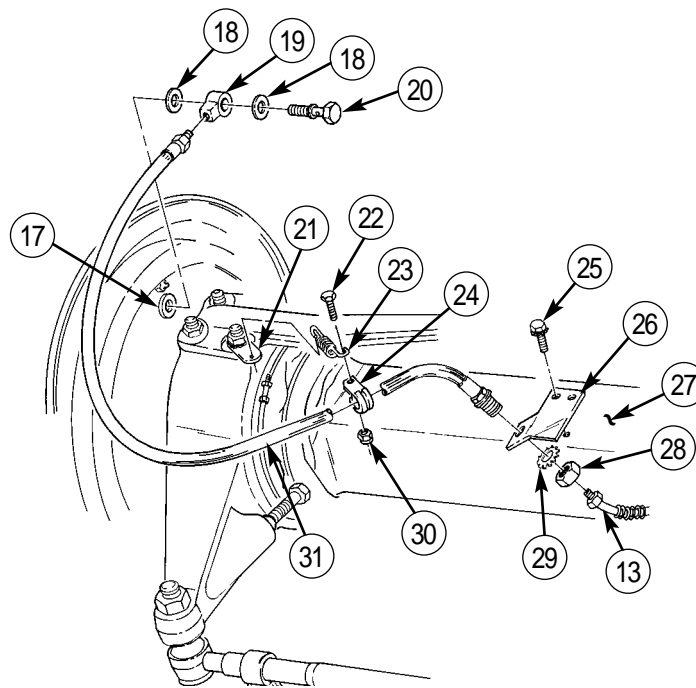
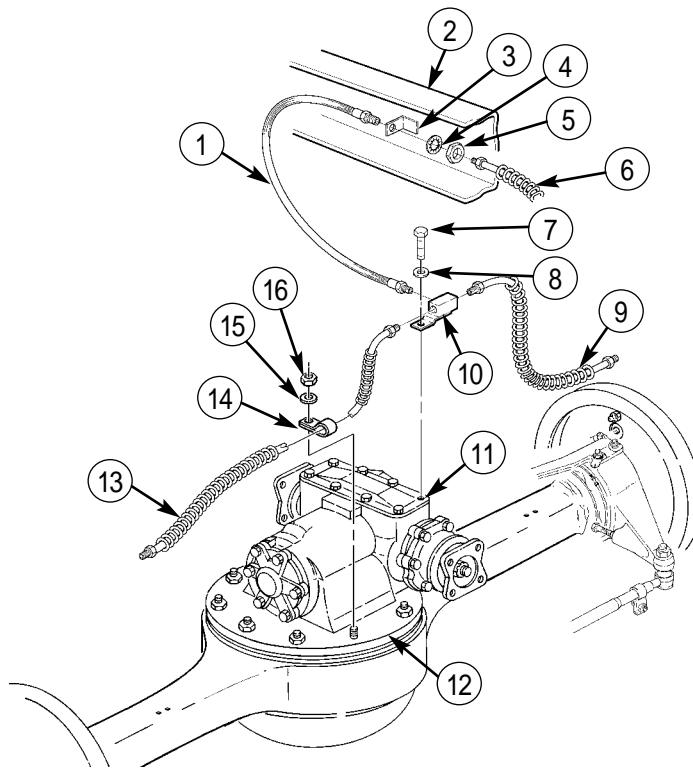

END OF WORK PACKAGE

UNIT MAINTENANCE INSTRUCTIONS

EXTENDED SERVICE PROGRAM (ESP)

TRUCK, CARGO, 2-1/2-TON, 6X6, M44A3 SERIES TRUCKS (DIESEL)

M35A3, W/O WINCH (NSN 2320-01-383-2047); W/WINCH (NSN 2320-01-383-3850);

M35A3C, W/O WINCH (NSN 2320-01-383-2050); W/WINCH (NSN 2320-01-383-2049);

M36A3, W/O WINCH (NSN 2320-01-383-2048); W/WINCH (NSN 2320-01-383-2046).

FORWARD-REAR AND REAR-REAR AXLE HYDRAULIC BRAKE LINES REPLACEMENT

REMOVAL, INSTALLATION

INITIAL SETUP:

Tools and Special Tools

General mechanic's tool kit
(item 30, WP 0394 00)

References

TM 9-2320-386-24P

Equipment Condition

Parking brake set (TM 9-2320-386-10).

Materials/Parts

Three locknuts (item 99, WP 0395 00)
Brake fluid (item 13, WP 0393 00)
Cap and plug set (item 14, WP 0393 00)
Two washers (item 257, WP 0395 00)
Two washers (item 258, WP 0395 00)

FORWARD-REAR AND REAR-REAR AXLE HYDRAULIC BRAKE LINES REPLACEMENT (Contd)**REMOVAL****CAUTION**

When disconnecting hydraulic brake lines and hoses, cap and plug all openings to prevent dirt and dust from entering. Contamination of the brake system may result in damage to equipment. Remove caps and plugs prior to installation.

NOTE

The rear-rear and forward-rear axle hydraulic brake lines are replaced basically the same. This procedure covers the rear-rear axle hydraulic brake line.

Have drainage container ready to catch brake fluid.

Tag all brake lines for installation.

1. Remove two screws (17), connectors (19), and four seal washers (18) from two hydraulic wheel cylinders (1). Discard washers (18).
2. Remove two locknuts (15), screws (16), clamps (5), and hydraulic brake lines (7) and (11) from two brackets (4). Discard locknuts (15).
3. Disconnect flexible hydraulic brake line (10) from tee (9).
4. Remove nut (14), washer (13), clamp (12), and hydraulic brake line (11) from differential carrier (2).
5. Remove locknut (3), screw (8), and tee (9) from bracket (6). Discard locknut (3).
6. Remove hydraulic brake lines (7) and (11) from tee (9).
7. Remove hydraulic brake lines (7) and (11) from connectors (19).

INSTALLATION

1. Install connectors (19) on hydraulic brake lines (7) and (11).
2. Install hydraulic brake lines (7) and (11) on tee (9).
3. Install tee (9) on bracket (6) with screw (8) and new locknut (3).
4. Install hydraulic brake line (11) on differential carrier (2) with clamp (12), washer (13), and nut (14). Tighten nut (14) 53-76 lb-ft (72-103 N•m).
5. Connect flexible hydraulic brake line (10) on tee (9).
6. Install hydraulic brake lines (7) and (11) on two brackets (4) with clamps (5), screws (16), and new locknuts (15).
7. Install two connectors (19) on hydraulic wheel cylinders (1) with four new washers (18) and screws (17).
8. Bleed service brakes (WP 0154 00) and road test vehicle.

FORWARD-REAR AND REAR-REAR AXLE HYDRAULIC BRAKE LINES REPLACEMENT (Contd)

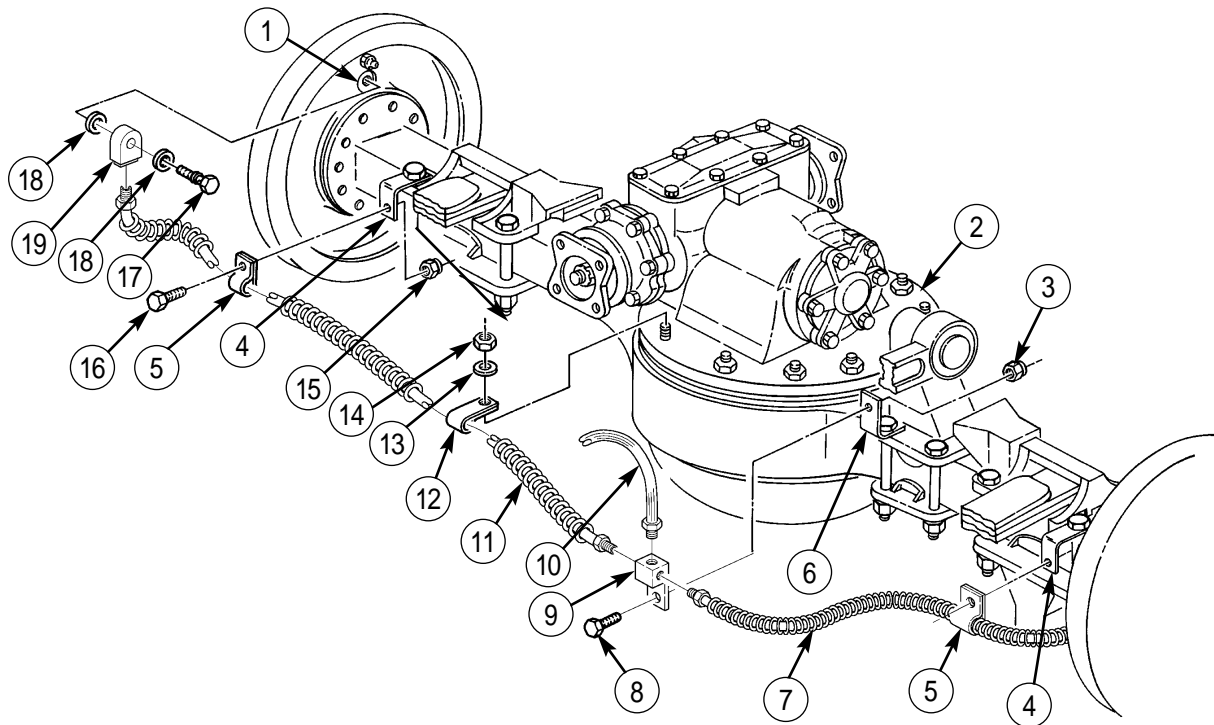

END OF WORK PACKAGE

UNIT MAINTENANCE INSTRUCTIONS

EXTENDED SERVICE PROGRAM (ESP)

TRUCK, CARGO, 2-1/2-TON, 6X6, M44A3 SERIES TRUCKS (DIESEL)

**M35A3, W/O WINCH (NSN 2320-01-383-2047); W/WINCH (NSN 2320-01-383-3850);
M35A3C, W/O WINCH (NSN 2320-01-383-2050); W/WINCH (NSN 2320-01-383-2049);
M36A3, W/O WINCH (NSN 2320-01-383-2048); W/WINCH (NSN 2320-01-383-2046).**

BRAKE PEDAL MAINTENANCE

REMOVAL, INSTALLATION, ADJUSTMENT

INITIAL SETUP:

Tools and Special Tools

General mechanic's tool kit
(item 30, WP 0394 00)
Common No. 1 tool kit
(item 15, WP 0394 00)

References

TM 9-2320-386-24P

Equipment Condition

Parking brake set (TM 9-2320-386-10).

Materials/Parts

Cotter pin (item 28, WP 0395 00)
Five locknuts (item 333, WP 0395 00)
Locknut (item 249, WP 0395 00)
Adhesive (item 7, WP 0393 00)
Chalk (item 15, WP 0393 00)

BRAKE PEDAL MAINTENANCE (Contd)**REMOVAL**

1. Remove spring (23) from retaining pin (19) and spring bracket (24).
2. Remove cotter pin (22), washer (21), retaining pin (19), and clevis (20) from lever (2). Discard cotter pin (22).
3. Remove screw (1) and pedal (4) with washer (3) from lever (2).
4. Loosen nut (10) and remove screw (9) from rotating eye bracket (13).
5. Support lever (2), and push shaft (12) with woodruff key (11) from lever (2) and bracket (13).
6. Remove lube fitting (6) from lever (2).
7. Remove pedal pad (5) from pedal (4).
8. Remove locknut (25), screw (26), and spring bracket (24) from vehicle body (15). Discard locknut (25).
9. Remove two locknuts (14) and screws (16) from rotating eye bracket (13) and vehicle body (15). Discard locknuts (14).
10. Remove three locknuts (7), two screws (17), screw (18), and rotating eye bracket (13) from vehicle body (15). Discard locknuts (7).

INSTALLATION

1. Install rotating eye bracket (13) on vehicle body (15) with two screws (16), screws (17), and new locknuts (14) and (7).
2. Secure rotating eye bracket (13) to vehicle body (15) with screw (18) and new locknut (7).
3. Install spring bracket (24) on vehicle body (15) with screw (26) and new locknut (25).
4. Install lube fitting (6) on lever (2).
5. Install lever (2) on bracket (13), and push shaft (12) through one side of bracket (13) into lever (2).
6. Align woodruff key (11) with slot (8) in bracket (13) and push shaft (12) in flush with end of bracket (13).
7. Install nut (10) up to head of screw (9) and apply adhesive to threads of screw (9).
8. Install screw (9) with nut (10) into bracket (13) over woodruff key (11). Tighten screw (9) 30-38 lb-ft (41-52 N·m), and tighten nut (10) down on bracket (13).
9. Apply adhesive to threads of screw (1).

WARNING

Install brake pedal in bottom groove (highest pedal position) for proper brake operation. Failure to do so may result in injury or death to personnel.

10. Install washer (3) and pedal (4) on lever (2) with screw (1).
11. Install clevis (20) on lever (2) with retaining pin (19), washer (21), and new cotter pin (22).
12. Install spring (23) on retaining pin (19) and spring bracket (24).

BRAKE PEDAL MAINTENANCE (Contd)

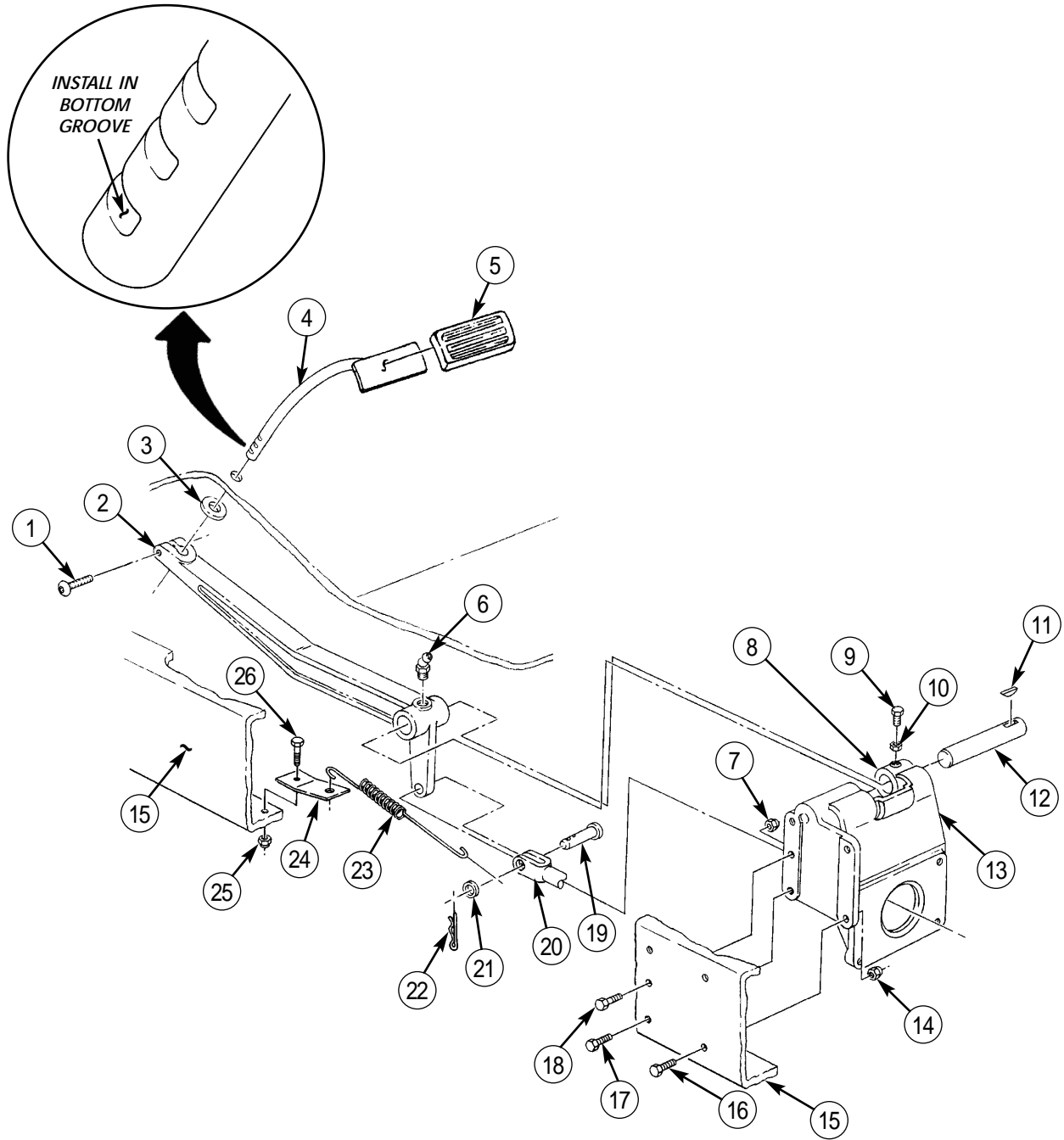

BRAKE PEDAL MAINTENANCE (Contd)***ADJUSTMENT***

1. Mark brake pedal rod (2) with chalk, marking it even with cab floor (3).
2. Push brake pedal (1) down until freeplay is gone.
3. Mark brake pedal rod (2) with chalk, marking it even with the cab floor (3), and then release brake pedal (1).
4. Measure distance between two marks (4). If distance is 0.25-0.5 in. (6.35-12.7 mm), adjustment is correct. Perform steps 5 through 7 only if out of adjustment.
5. Remove spring (12) from clevis pin (6) and spring bracket (13).
6. Remove cotter pin (11), washer (10), clevis pin (6), and yoke (9) from brake pedal lever (5). Discard cotter pin (11).
7. Loosen jamnut (7) and adjust pushrod (8) until proper adjustment is obtained.
8. Install yoke (9) on brake pedal lever (5) with clevis pin (6).
9. Install spring (12) to clevis pin (6) and spring bracket (13).
10. Repeat steps 1 through 9 until freeplay is corrected as indicated in step 4.
11. Install washer (10) and new cotter pin (11) through clevis pin (6).
12. Tighten jamnut (7) against yoke (9).

BRAKE PEDAL MAINTENANCE (Contd)

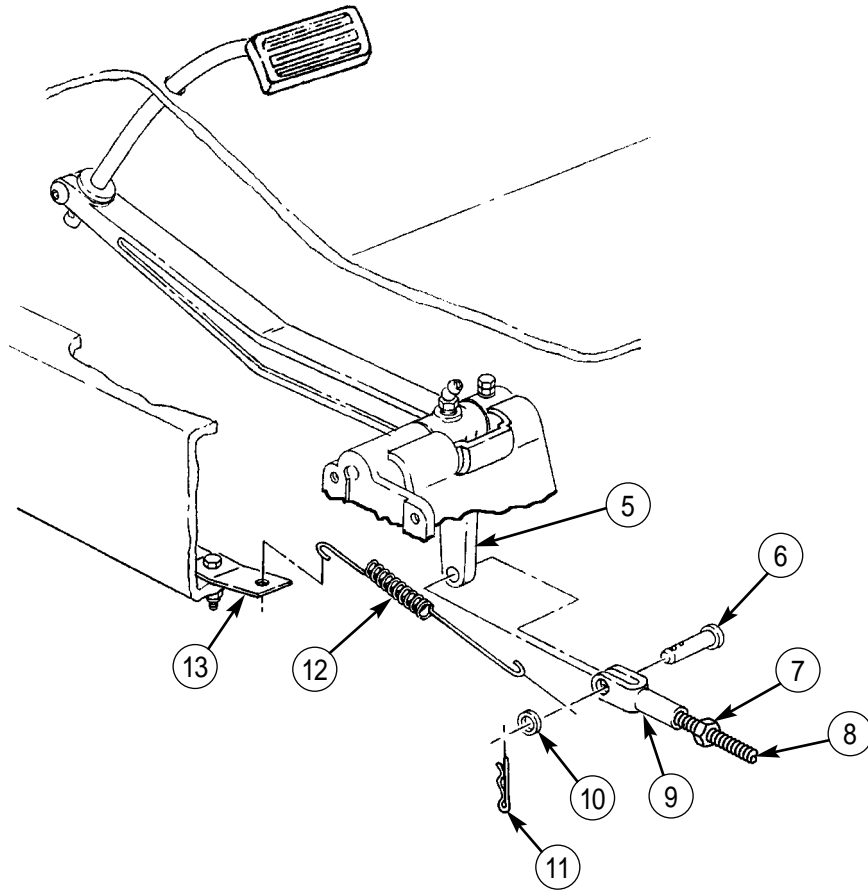
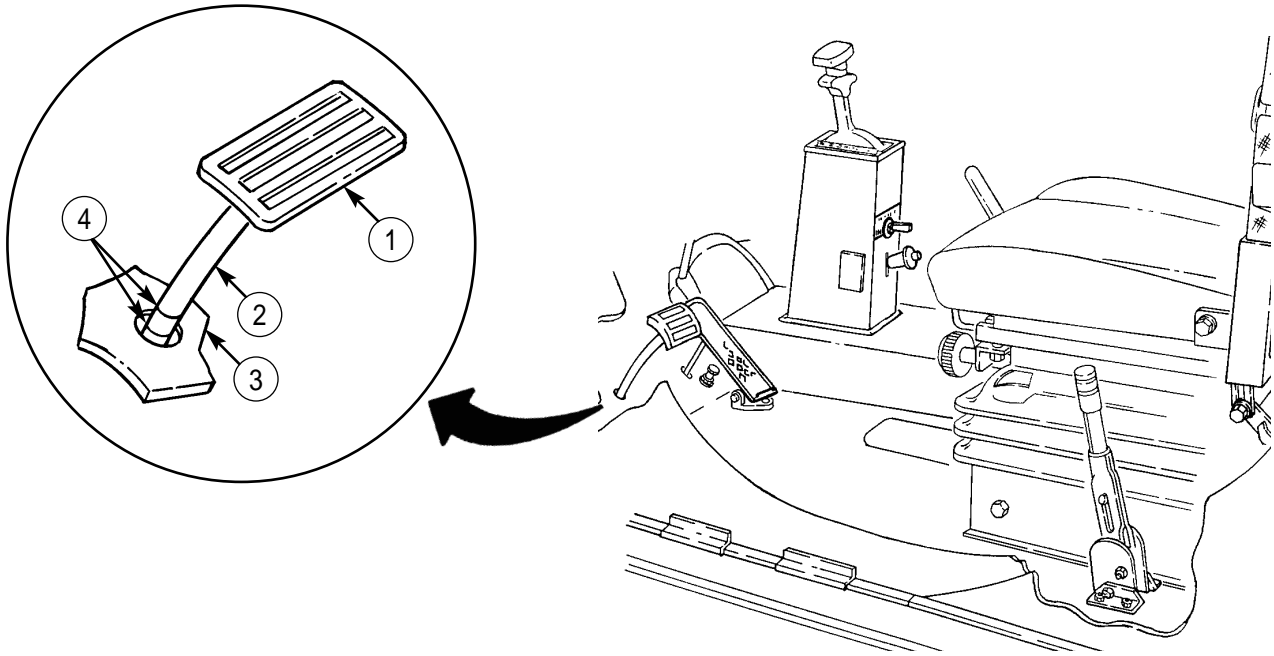

END OF WORK PACKAGE

UNIT MAINTENANCE INSTRUCTIONS

EXTENDED SERVICE PROGRAM (ESP)

TRUCK, CARGO, 2-1/2-TON, 6X6, M44A3 SERIES TRUCKS (DIESEL)

M35A3, W/O WINCH (NSN 2320-01-383-2047); W/WINCH (NSN 2320-01-383-3850);
M35A3C, W/O WINCH (NSN 2320-01-383-2050); W/WINCH (NSN 2320-01-383-2049);
M36A3, W/O WINCH (NSN 2320-01-383-2048); W/WINCH (NSN 2320-01-383-2046).

TRAILER AIR COUPLING REPLACEMENT

REMOVAL, INSTALLATION

INITIAL SETUP:

Tools and Special Tools

General mechanic's tool kit
(item 30, WP 0394 00)

Materials/Parts

Cap and plug set (item 14, WP 0393 00)
Teflon pipe sealant (item 41, WP 0393 00)

References

TM 9-2320-386-24P

Equipment Condition

Parking brake set (TM 9-2320-386-10).
Air reservoirs drained (TM 9-2320-386-10).

TRAILER AIR COUPLING REPLACEMENT (Contd)

NOTE

For schematic representation of air line locations and routing, see WP 0386 00 of this manual.

REMOVAL

WARNING

Do not disconnect air lines before draining air reservoirs. Small parts under pressure may shoot out with high velocity, causing injury to personnel.

Eyeshields must be worn when releasing compressed air. Failure to do so may result in injury to personnel.

CAUTION

When disconnecting air lines and hoses, plug all openings to prevent dirt from entering and causing damage to internal parts. Remove all plugs prior to installation.

NOTE

Tag air lines for installation.

Note position of elbows and air coupling for installation.

Both left and right air couplings are replaced basically the same. This procedure covers the left trailer air coupling.

1. Remove nut (16), tube (15), and sleeve (17) from elbow (14).
2. Remove elbow (14) from adapter (2).
3. Remove coupling handle (9) from coupling (10).
4. Remove chain (3) and coupling handle (9) from taillight bracket (4).
5. Remove coupling (10) from adapter (11).
6. Remove adapter (11) from elbow (6).
7. Remove elbow (6) from valve (5).
8. Remove nut (13), washer (12), and adapter (2) from frame rail (1).
9. Remove valve (5) from adapter (2).
10. Remove two screws (7) and coupling bracket (8) from coupling (10).

INSTALLATION

1. Apply sealant to male threads of elbows (6) and (14) and adapters (2) and (11).
2. Install coupling bracket (8) on coupling (10) with two screws (7).
3. Install valve (5) on adapter (2).
4. Install adapter (2) on frame rail (1) with washer (12) and nut (13).
5. Install elbow (6) on valve (5).
6. Install adapter (11) on elbow (6).
7. Install coupling (10) on adapter (11).
8. Install chain (3) on taillight bracket (4).
9. Install elbow (14) on adapter (2).
10. Install tube (15) and sleeve (17) on elbow (14) with nut (16).
11. Install coupling handle (9) on coupling (10).
12. Start engine (TM 9-2320-386-10) and check system for air leaks.

TRAILER AIR COUPLING REPLACEMENT (Contd)

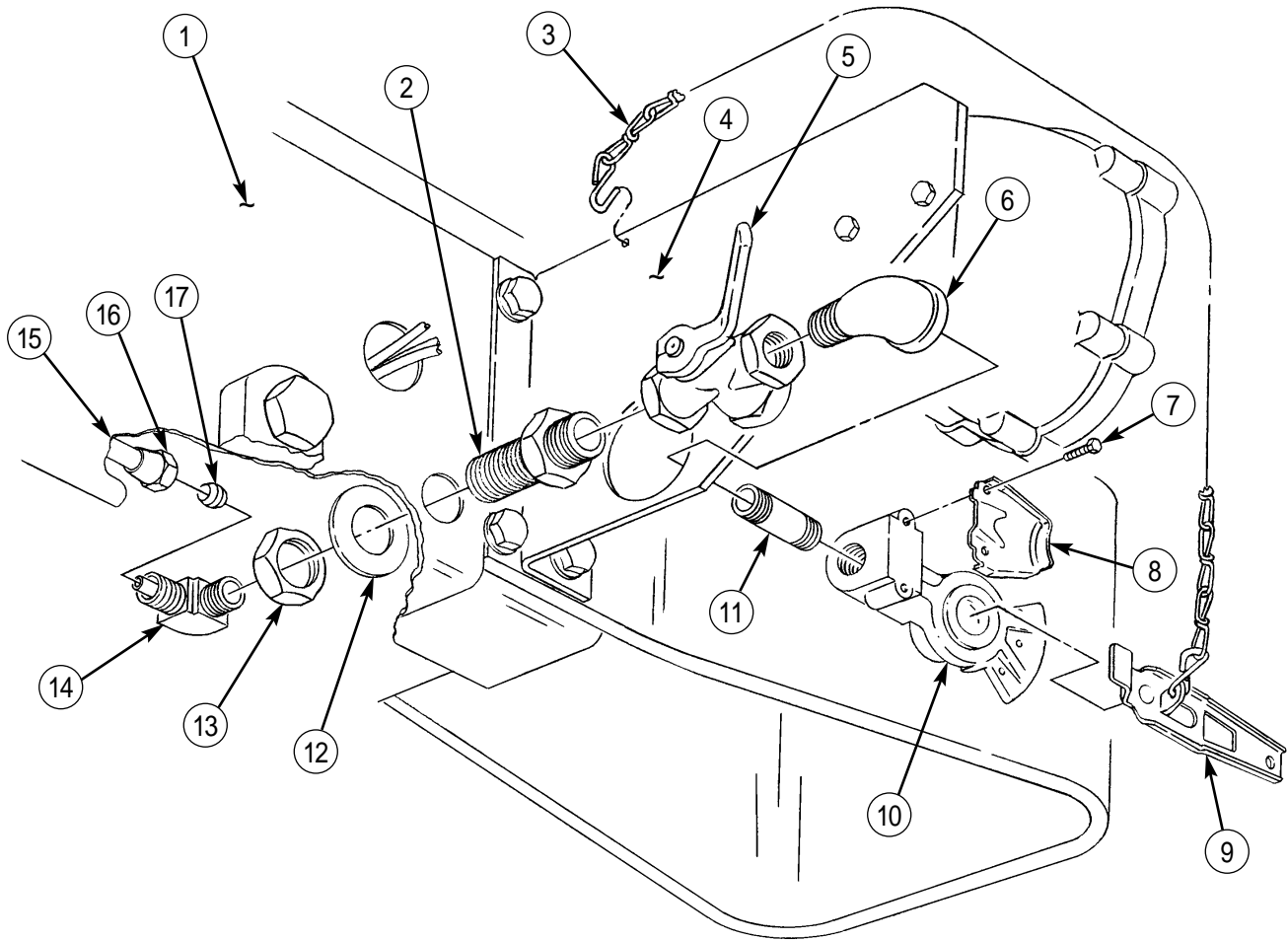

END OF WORK PACKAGE

UNIT MAINTENANCE INSTRUCTIONS

EXTENDED SERVICE PROGRAM (ESP)

TRUCK, CARGO, 2-1/2-TON, 6X6, M44A3 SERIES TRUCKS (DIESEL)

**M35A3, W/O WINCH (NSN 2320-01-383-2047); W/WINCH (NSN 2320-01-383-3850);
M35A3C, W/O WINCH (NSN 2320-01-383-2050); W/WINCH (NSN 2320-01-383-2049);
M36A3, W/O WINCH (NSN 2320-01-383-2048); W/WINCH (NSN 2320-01-383-2046).**

AIR RESERVOIR REPLACEMENT

REMOVAL, INSTALLATION

INITIAL SETUP:

Tools and Special Tools

General mechanic's tool kit
(item 30, WP 0394 00)

References

TM 9-2320-386-24P

Materials/Parts

Two locknuts (item 99, WP 0395 00)
Teflon pipe sealant (item 41, WP 0393 00)
Cap and plug set (item 14, WP 0393 00)

Equipment Condition

Parking brake set (TM 9-2320-386-10).
Spare tire removed (TM 9-2320-386-10).
Air reservoir drainvalves removed (WP 0166 00).

AIR RESERVOIR REPLACEMENT (Contd)**NOTE**

For schematic representation of air line locations and routing, refer to WP 0386 00.

REMOVAL**CAUTION**

When disconnecting air lines and hoses, plug all openings to prevent dirt from entering and causing damage to internal parts.

NOTE

Tag hoses and air reservoirs prior to removal for installation.

Note position of elbows for installation.

1. Remove two locknuts (2), hook bolts (4), and brackets (1) and (5) from air reservoirs (3) and (13). Discard locknuts (2).
2. Loosen nut (18) and remove hose (19) from elbow (17).
3. Loosen nut (15) and remove hose (14) from elbow (16).
4. Loosen nut (9) and remove hose (10) from connector (6).
5. Loosen nut (11) and remove hose (10) from tee (12).
6. Loosen nut (8) and remove hose (7) from tee (12).
7. Loosen nut (24) and remove hose (25) from elbow (23).
8. Loosen nut (28) and remove hose (29) from reducer (27).
9. Remove elbow (20) from connector (21).
10. Loosen nut (31) and remove hose (30) from connector (32).
11. Loosen nut (34) and remove hose (35) from connector (33).

CAUTION

When removing air reservoirs, ensure fittings and elbows do not become damaged.

12. Remove air reservoirs (3) and (13) from supports (22) and (26).

AIR RESERVOIR REPLACEMENT (Contd)

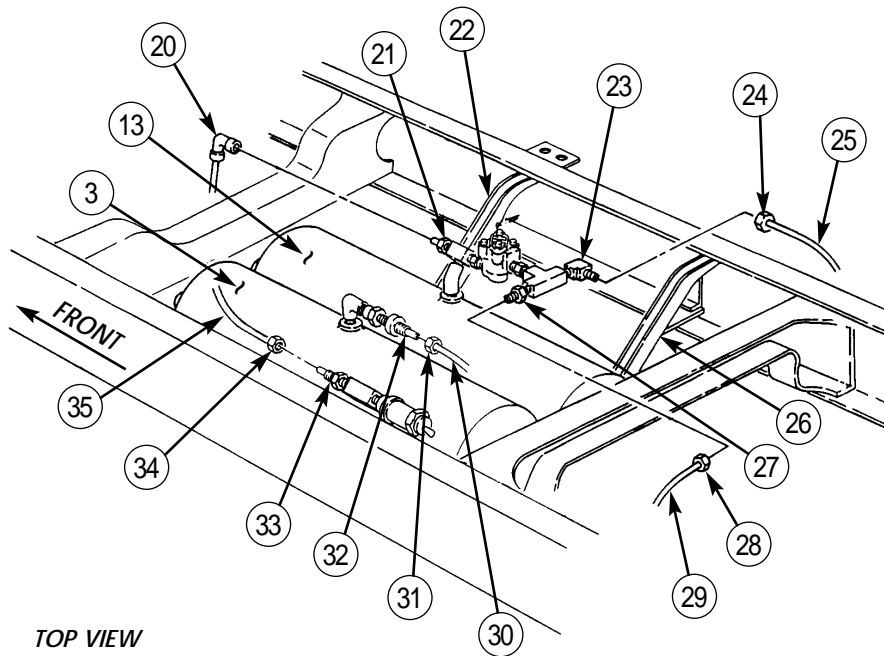
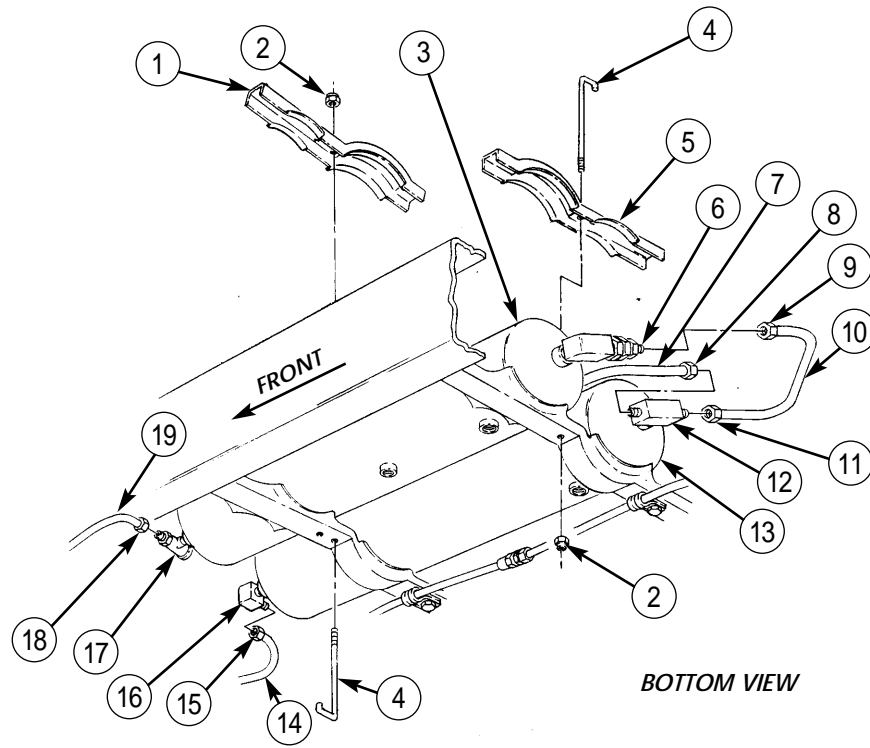

AIR RESERVOIR REPLACEMENT (Contd)

13. Remove elbow (22) from air reservoir (18).
14. Remove elbow (23) from air reservoir (12).
15. Remove connector (15), valve (16), and elbow (17) from air reservoir (18).
16. Remove tee (14) from air reservoir (12).
17. Remove elbow (9), tee (10), reducers (13) and (8), valve (7), reducer (6), tee (5), elbow (11), and connector (4) from air reservoir (12).
18. Remove connector (3), valve (2), and elbow (1) from air reservoir (18).
19. Remove connector (21), tee (20), and valve (19) from air reservoir (18).

INSTALLATION**NOTE**

Apply sealant to male threads of elbows prior to installation.

1. Install connector (21) and valve (19) on tee (20).
2. Install tee (20) on air reservoir (18).
3. Install valve (2) and connector (3) on elbow (1).
4. Install elbow (1) on air reservoir (18).
5. Install connector (4) and reducer (6) on tee (5).
6. Install valve (7) on reducer (6).
7. Install elbow (9) and reducers (8) and (13) on tee (10).
8. Install reducer (8) on valve (7).
9. Install tee (5) on elbow (11).
10. Install elbow (11) on air reservoir (12).
11. Install tee (14) on air reservoir (12).
12. Install elbow (17), valve (16), and connector (15) on air reservoir (18).
13. Install elbow (23) on air reservoir (12).
14. Install elbow (22) on air reservoir (18).

AIR RESERVOIR REPLACEMENT (Contd)

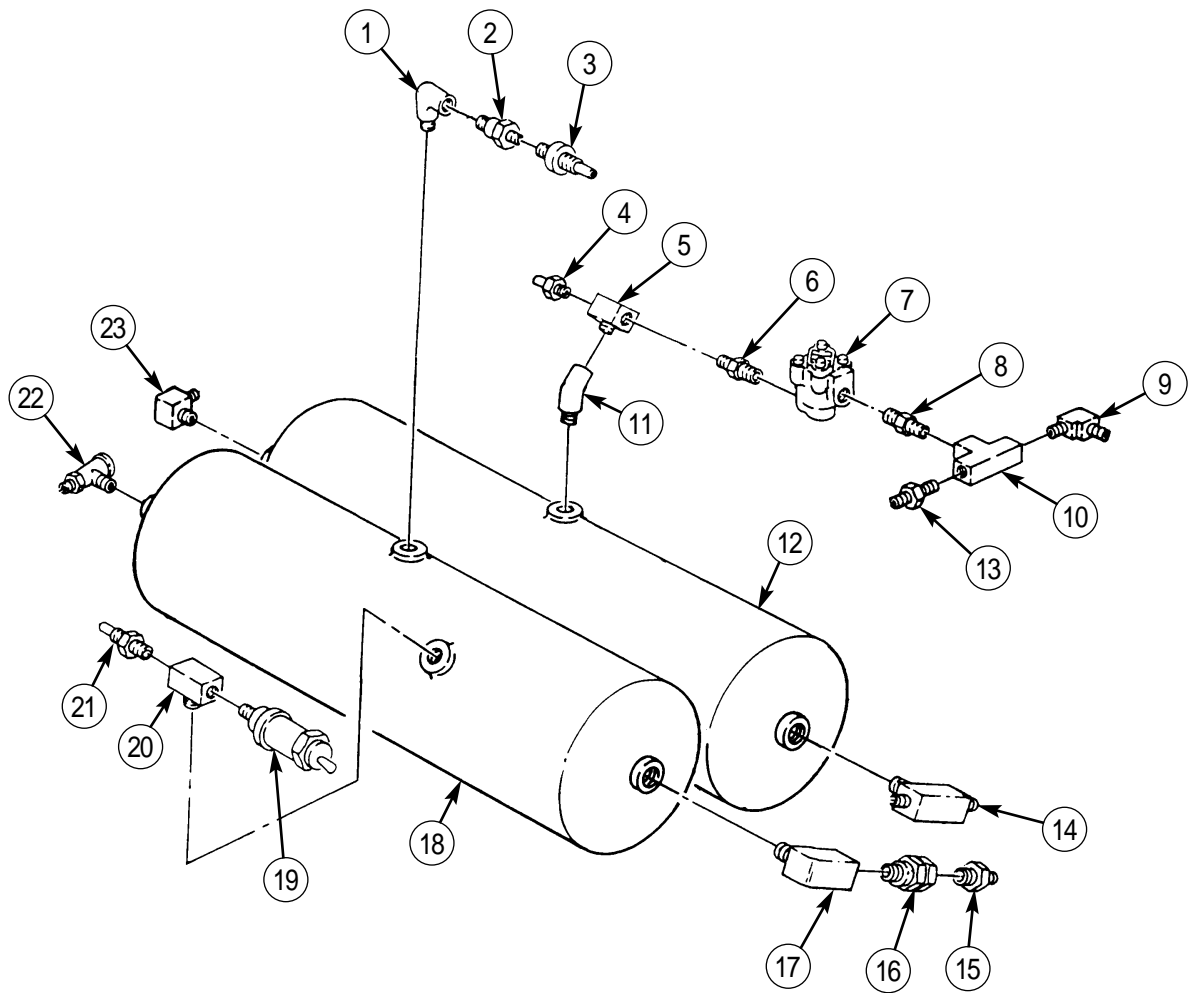

AIR RESERVOIR REPLACEMENT (Contd)**CAUTION**

When installing air reservoirs, ensure fittings and elbows do not become damaged.

NOTE

Air reservoirs must be installed with drainvalve ports facing straight down to allow for drainage.

15. Install air reservoirs (1) and (18) on supports (4) and (8).
16. Connect hose (17) to connector (15) and tighten nut (16).
17. Connect hose (12) to connector (14) and tighten nut (13).
18. Connect elbow (2) to connector (3).
19. Connect hose (11) to reducer (9) and tighten nut (10).
20. Connect hose (7) to elbow (5) and tighten nut (6).
21. Connect hose (24) to tee (29) and tighten nut (25).
22. Connect hose (27) to tee (29) and tighten nut (28).
23. Connect hose (27) to connector (23) and tighten nut (26).
24. Connect hose (31) to elbow (33) and tighten nut (32).
25. Connect hose (36) to elbow (34) and tighten nut (35).
26. Install brackets (19) and (22) on air reservoirs (18) and (30) with two hook bolts (21) and new locknuts (20).
27. Install air reservoir drainvalves (WP 0166 00).
28. Install spare tire (TM 9-2320-386-10).

AIR RESERVOIR REPLACEMENT (Contd)

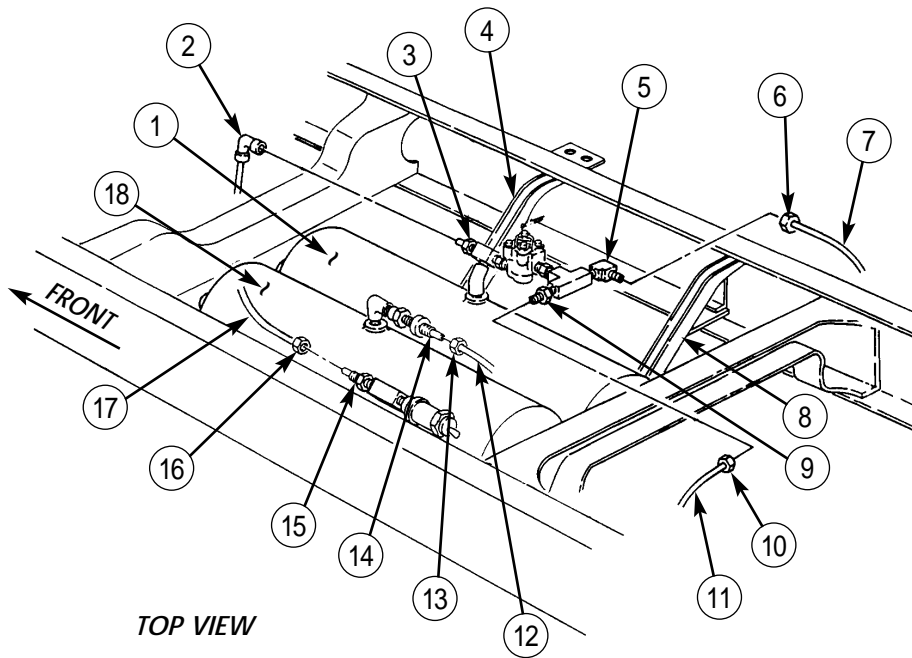

TOP VIEW

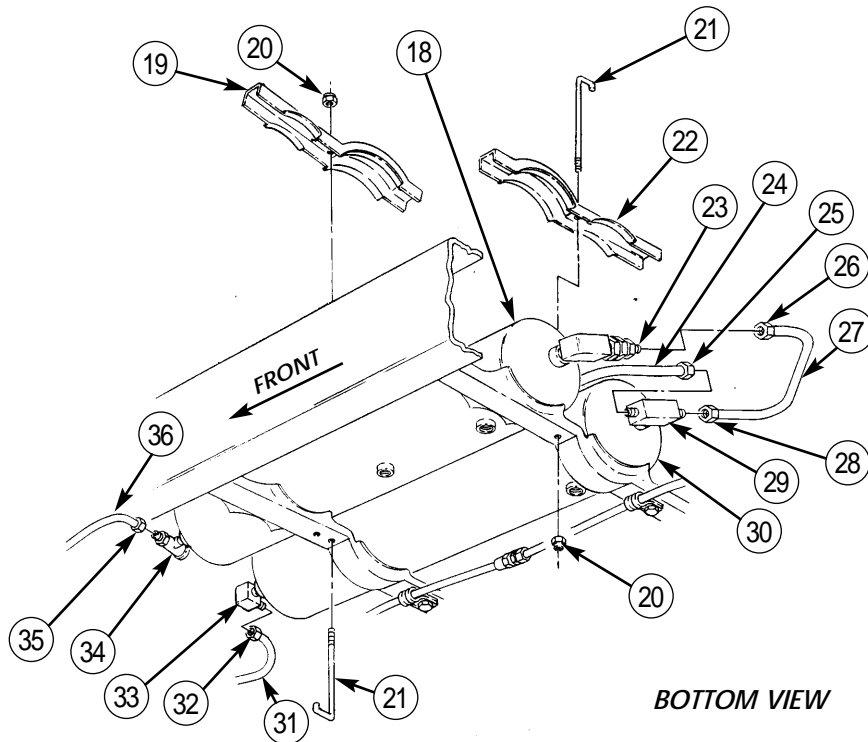

BOTTOM VIEW

END OF WORK PACKAGE

UNIT MAINTENANCE INSTRUCTIONS

EXTENDED SERVICE PROGRAM (ESP)

TRUCK, CARGO, 2-1/2-TON, 6X6, M44A3 SERIES TRUCKS (DIESEL)

M35A3, W/O WINCH (NSN 2320-01-383-2047); W/WINCH (NSN 2320-01-383-3850);
M35A3C, W/O WINCH (NSN 2320-01-383-2050); W/WINCH (NSN 2320-01-383-2049);
M36A3, W/O WINCH (NSN 2320-01-383-2048); W/WINCH (NSN 2320-01-383-2046).

AIR RESERVOIR DRAINVALVES REPLACEMENT

REMOVAL, INSTALLATION

INITIAL SETUP:

Tools and Special Tools

General mechanic's tool kit
(item 30, WP 0394 00)

References

TM 9-2320-386-24P

Materials/Parts

Cap and plug set (item 14, WP 0393 00)
Teflon pipe sealant (item 41, WP 0393 00)

Equipment Condition

Parking brake set (TM 9-2320-386-10).
Air reservoirs drained (TM 9-2320-386-10).

AIR RESERVOIR DRAINVALVES REPLACEMENT (Contd)

REMOVAL

WARNING

Do not disconnect air lines before draining air reservoirs. Small parts under pressure may shoot out with high velocity, causing injury to personnel.

Eyeshields must be worn when releasing compressed air. Failure to do so may result in injury to personnel.

CAUTION

When disconnecting air lines and hoses, plug all openings to prevent dirt from entering and causing damage to internal parts. Remove all plugs prior to installation.

1. Remove drainvalve (5) from air reservoir (4).
2. Remove drainvalve (6) from air reservoir (3).
3. Remove drainvalve (14) from fitting (13) on bracket (15).

NOTE

Note position of elbows for installation.

4. Remove nuts (10) and (18), air tube (16) with inserts (11) and (17), and sleeves (9) and (19) from elbows (7) and (20).
5. Remove elbow (20) from air reservoir (3).
6. Remove elbow (7) from fitting (13).
7. Remove nut (8), fitting (13), and lockwasher (12) from bracket (15).
8. Remove nut (2), screw (21), and bracket (15) from frame rail (1).

INSTALLATION

1. Apply sealant to male threads of drainvalves (5), (6), and (14), and elbows (7) and (20).
2. Install bracket (15) on frame rail (1) with screw (21) and nut (2).
3. Install lockwasher (12) and fitting (13) on bracket (15) with nut (8).
4. Install elbow (7) on fitting (13).
5. Install elbow (20) on air reservoir (3).
6. Install air tube (16) with inserts (11) and (17) and sleeves (9) and (19) on elbows (7) and (20) with nuts (10) and (18).
7. Install drainvalve (14) on fitting (13).
8. Install drainvalve (6) on air reservoir (3).
9. Install drainvalve (5) on air reservoir (4).
10. Start engine (TM 9-2320-386-10) and allow air pressure to build up to normal operating pressure. Check for air leaks and road test vehicle.

AIR RESERVOIR DRAINVALVES REPLACEMENT (Contd)

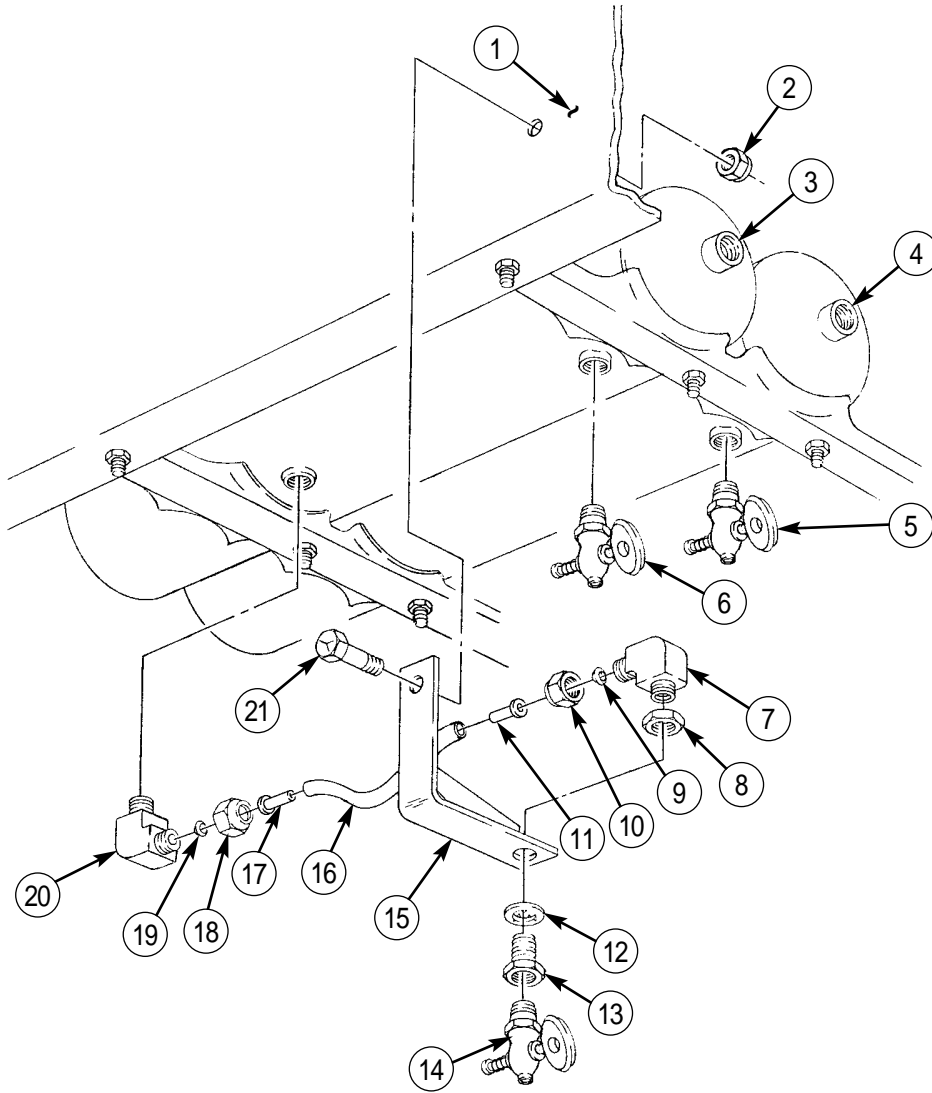

END OF WORK PACKAGE

UNIT MAINTENANCE INSTRUCTIONS

EXTENDED SERVICE PROGRAM (ESP)

TRUCK, CARGO, 2-1/2-TON, 6X6, M44A3 SERIES TRUCKS (DIESEL)

M35A3, W/O WINCH (NSN 2320-01-383-2047); W/WINCH (NSN 2320-01-383-3850);

M35A3C, W/O WINCH (NSN 2320-01-383-2050); W/WINCH (NSN 2320-01-383-2049);

M36A3, W/O WINCH (NSN 2320-01-383-2048); W/WINCH (NSN 2320-01-383-2046).

COMPRESSED AIR LINES REPLACEMENT AND REPAIR

DAMAGE AT ENDPOINT, DAMAGE AT POINT BETWEEN FITTINGS, DAMAGE TO SECTION BETWEEN FITTINGS

INITIAL SETUP:

Tools and Special Tools

General mechanic's tool kit
(item 30, WP 0394 00)

Equipment Condition

Parking brake set (TM 9-2320-386-10).
Air reservoirs drained (TM 9-2320-386-10).

References

TM 9-2320-386-24P

COMPRESSED AIR LINES REPLACEMENT AND REPAIR (Contd)**NOTE**

As a general rule, due to repairs, an air tube may have up to two connectors installed on its length between end-points. Air tubes that require additional repair should be replaced.

Refer to WP 0385 00 for tubing application and tightening instructions.

DAMAGE AT ENDPOINT**NOTE**

Damage to the air tube can hamper the locking capability of the fitting. After connecting and installing fittings and air tubes, test for possible damage at end point of the air tube, or damage to the fitting may result.

1. Test lock as follows:
 - a. Tighten fitting (1).
 - b. Placing hand close to fitting (1), attempt to pull tube (2) free from fitting (1). If tube (2) is removed from fitting (1), repair tube (2).
2. Repair tube (2) as follows:
 - a. Cut tube (2) so that locking surface (3) is free from damage. Discard damaged section (4).

NOTE

A click indicates tube passing the internal O-ring, locking the air tube into the fitting.

- b. Insert tube (2) into fitting (1).
3. Test lock by attempting to pull tube (2) free from fitting (1). If tube (2) is removed from fitting (1), replace fitting (1).

DAMAGE AT POINT BETWEEN FITTINGS

1. Cut tube (5) at locations (6). Discard damaged section (7).
2. Install connector (9) on tubes (5) and (8).

COMPRESSED AIR LINES REPLACEMENT AND REPAIR (Contd)

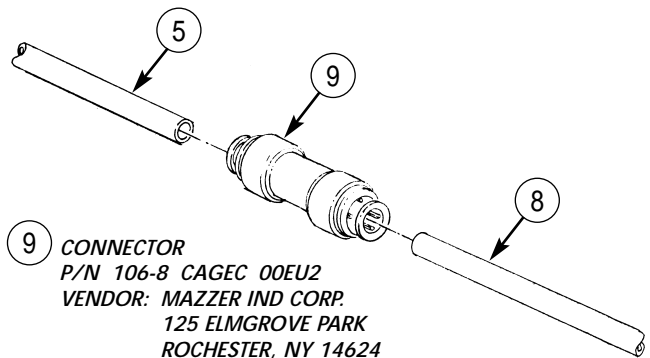
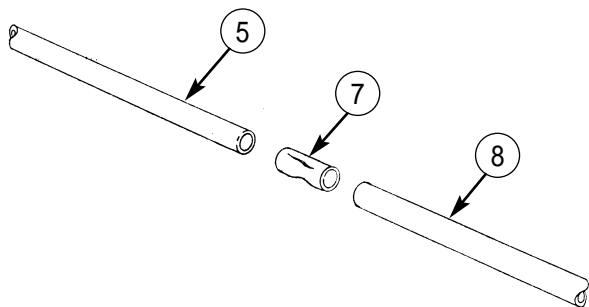
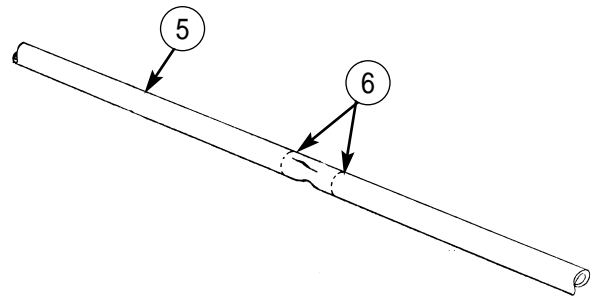
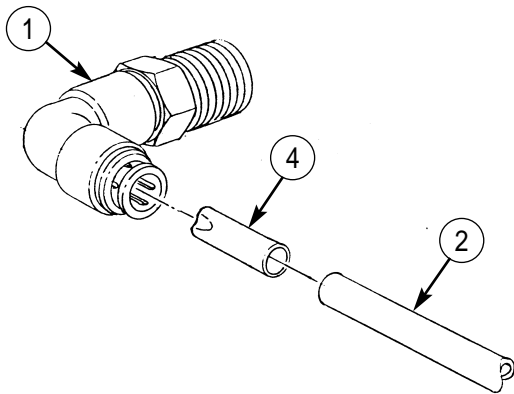
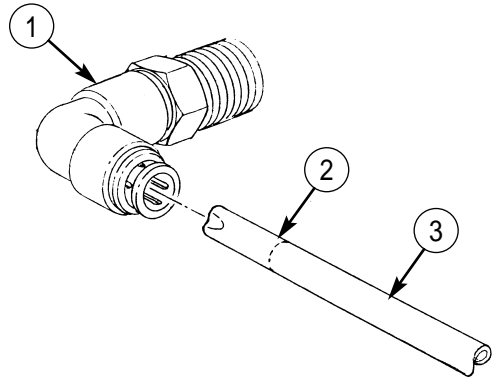
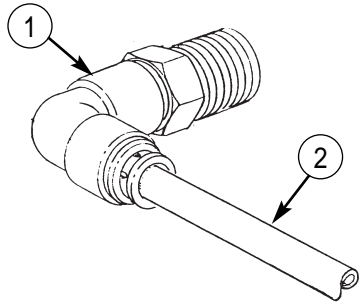

9 CONNECTOR
P/N 106-8 CAGEC 00EU2
VENDOR: MAZZER IND CORP.
125 ELMGROVE PARK
ROCHESTER, NY 14624
(716) 247-0311

COMPRESSED AIR LINES REPLACEMENT AND REPAIR (Contd)**DAMAGE TO SECTION BETWEEN FITTINGS**

1. Cut tube (1) at locations (2).
2. Replace damaged section (3) with tube (6).
3. Install connector (5) on tubes (1) and (6).
4. Install connector (7) on tubes (6) and (4).
5. Start engine (TM 9-2320-386-10) and allow air pressure to build up to normal operating pressure. Check for air leaks and road test vehicle.

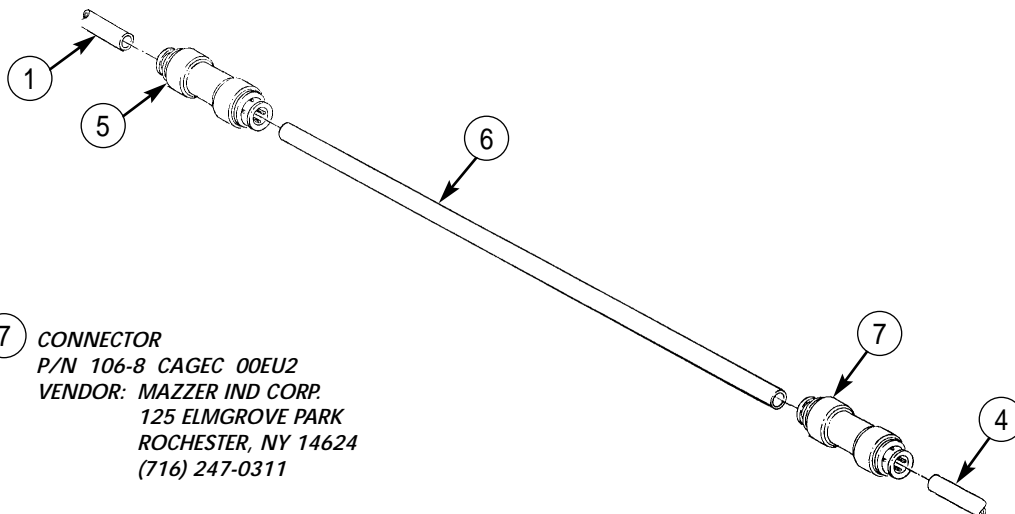
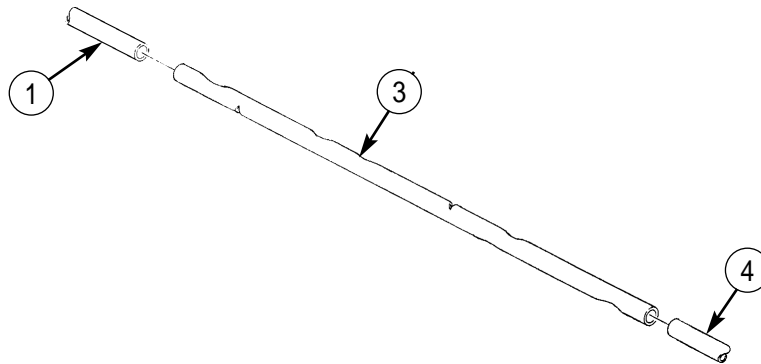
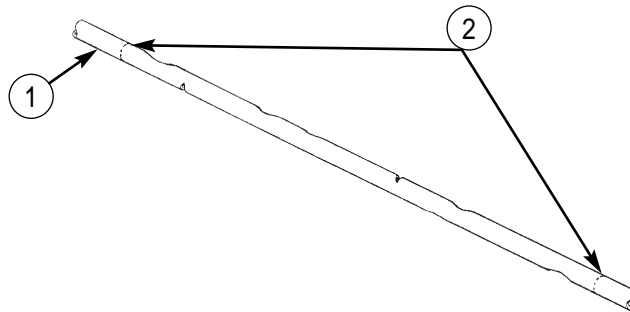

(5) AND (7) CONNECTOR
 P/N 106-8 CAGEC 00EU2
 VENDOR: MAZZER IND CORP.
 125 ELMGROVE PARK
 ROCHESTER, NY 14624
 (716) 247-0311

END OF WORK PACKAGE

UNIT MAINTENANCE INSTRUCTIONS

EXTENDED SERVICE PROGRAM (ESP)

TRUCK, CARGO, 2-1/2-TON, 6X6, M44A3 SERIES TRUCKS (DIESEL)

M35A3, W/O WINCH (NSN 2320-01-383-2047); W/WINCH (NSN 2320-01-383-3850);
M35A3C, W/O WINCH (NSN 2320-01-383-2050); W/WINCH (NSN 2320-01-383-2049);
M36A3, W/O WINCH (NSN 2320-01-383-2048); W/WINCH (NSN 2320-01-383-2046).

AIR COMPRESSOR COOLANT LINES REPLACEMENT

REMOVAL, INSTALLATION

INITIAL SETUP:

Tools and Special Tools

General mechanic's tool kit
(item 30, WP 0394 00)

References

TM 9-2320-386-24P

Equipment Condition

Parking brake set (TM 9-2320-386-10).
Air reservoirs drained (TM 9-2320-386-10).
Hood raised and secured (TM 9-2320-386-10).
Engine cooling system drained (WP 0068 00).
Engine oil filler tube removed (WP 0031 00).

AIR COMPRESSOR COOLANT LINES REPLACEMENT (Contd)**REMOVAL**

1. Remove throttle return spring (22) from brackets (5) and (21).
2. Remove connector (19) from water pump elbow (20).
3. Remove connector (12) from air compressor fitting (11).
4. Disconnect main air line (7) from air compressor outlet elbow (9).
5. Remove connector (6) from elbow (8).
6. Remove connector (2) from water temperature regulator elbow (1).
7. Remove screw (17), washer (16), and hose (18) with clamp (15) from engine (10).
8. Remove screw (3), washer (4), bracket (5), hose (14), and clamp (13) from engine (10).

INSTALLATION

1. Position clamp (13) on hose (14), and install bracket (5) and clamp (13) on engine (10) with screw (3), and washer (4).
2. Position clamp (15) on hose (18), and install clamp (15) on engine (10) with screw (17) and washer (16).
3. Install connector (2) on water temperature regulator elbow (1).
4. Install connector (6) on elbow (8).
5. Connect main air line (7) on air compressor outlet elbow (9).
6. Install connector (12) on air compressor fitting (11).
7. Install connector (19) on water pump elbow (20).
8. Install throttle return spring (22) on brackets (5) and (21).
9. Install engine oil filler tube (WP 0031 00).
10. Fill engine coolant to proper level (WP 0068 00).

AIR COMPRESSOR COOLANT LINES REPLACEMENT (Contd)

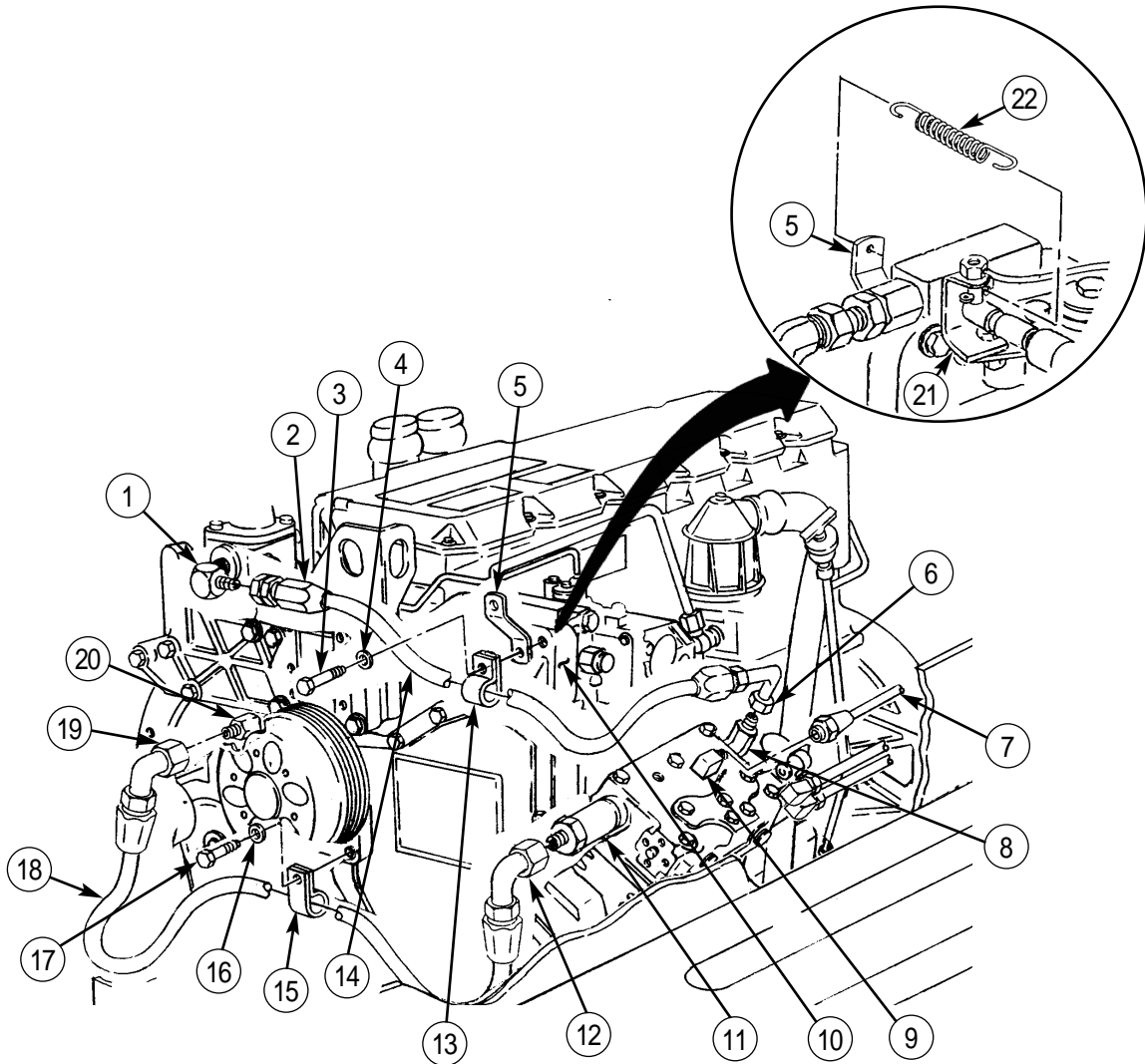

END OF WORK PACKAGE

UNIT MAINTENANCE INSTRUCTIONS

EXTENDED SERVICE PROGRAM (ESP)

TRUCK, CARGO, 2-1/2-TON, 6X6, M44A3 SERIES TRUCKS (DIESEL)

M35A3, W/O WINCH (NSN 2320-01-383-2047); W/WINCH (NSN 2320-01-383-3850);
M35A3C, W/O WINCH (NSN 2320-01-383-2050); W/WINCH (NSN 2320-01-383-2049);
M36A3, W/O WINCH (NSN 2320-01-383-2048); W/WINCH (NSN 2320-01-383-2046).

AIR COMPRESSOR REPLACEMENT

REMOVAL, INSTALLATION

INITIAL SETUP:

Tools and Special Tools

General mechanic's tool kit
(item 30, WP 0394 00)

Materials/Parts

Gasket (item 328, WP 0395 00)
Gasket (item 269, WP 0395 00)
Cap and plug set (item 14, WP 0393 00)
Teflon pipe sealant (item 41, WP 0393 00)

References

TM 9-2320-386-24P

Equipment Condition

Parking brake set (TM 9-2320-386-10).
Air reservoirs drained (TM 9-2320-386-10).
Wheels chocked (TM 9-2320-386-10).
Cooling system drained (WP 0068 00).
Front winch hydraulic pump removed, if equipped
(WP 0222 00).

AIR COMPRESSOR REPLACEMENT (Contd)**REMOVAL****WARNING**

Do not disconnect air lines before draining air reservoirs. Small parts under pressure may shoot out with high velocity, causing injury to personnel.

Eyeshields must be worn when releasing compressed air. Failure to do so may result in injury to personnel.

CAUTION

When disconnecting air lines and hoses, plug all openings to prevent dirt from entering and causing damage to internal parts. Remove all plugs prior to installation.

NOTE

Tag air lines and hoses for installation.

1. Remove nut (13) and tube (14) with sleeve (12) from elbow (8).
2. Remove nut (22) and tube (21) with sleeve (23) from elbow (24).
3. Remove screw (32), washer (31), screw (34), and washer (33) from mounting bracket (28) and engine (18).
4. Remove two screws (30), washers (29), and mounting bracket (28) from air compressor (39).
5. Remove clamp (49) and hose (48) from strainer (43).
6. Remove two screws (19), washers (20), governor (15), and gasket (25) from air compressor (39). Discard gasket (25).
7. Remove nut (6) and tube (7) from elbow (26).
8. Remove nut (2) and tube (1) from adapter (3).
9. Remove nut (45), tube (44), and sleeve (46) from elbow (47). Discard sleeve (46).
10. Remove connector (40) from elbow (41).
11. Remove screw (35), washer (36), clamp (38), and hose (37) from air compressor (39).
12. Remove two screws (9), washers (10), air compressor (39), and gasket (17) from housing (11). Discard gasket (17).
13. Remove elbow (26) from port (27).
14. Remove adapter (3) from port (4).
15. Remove elbow (47) from port (5).
16. Remove elbow (41) from port (42).
17. Remove elbows (8) and (24) from governor (15).
18. Remove valve (16) from governor (15).

AIR COMPRESSOR REPLACEMENT (Contd)

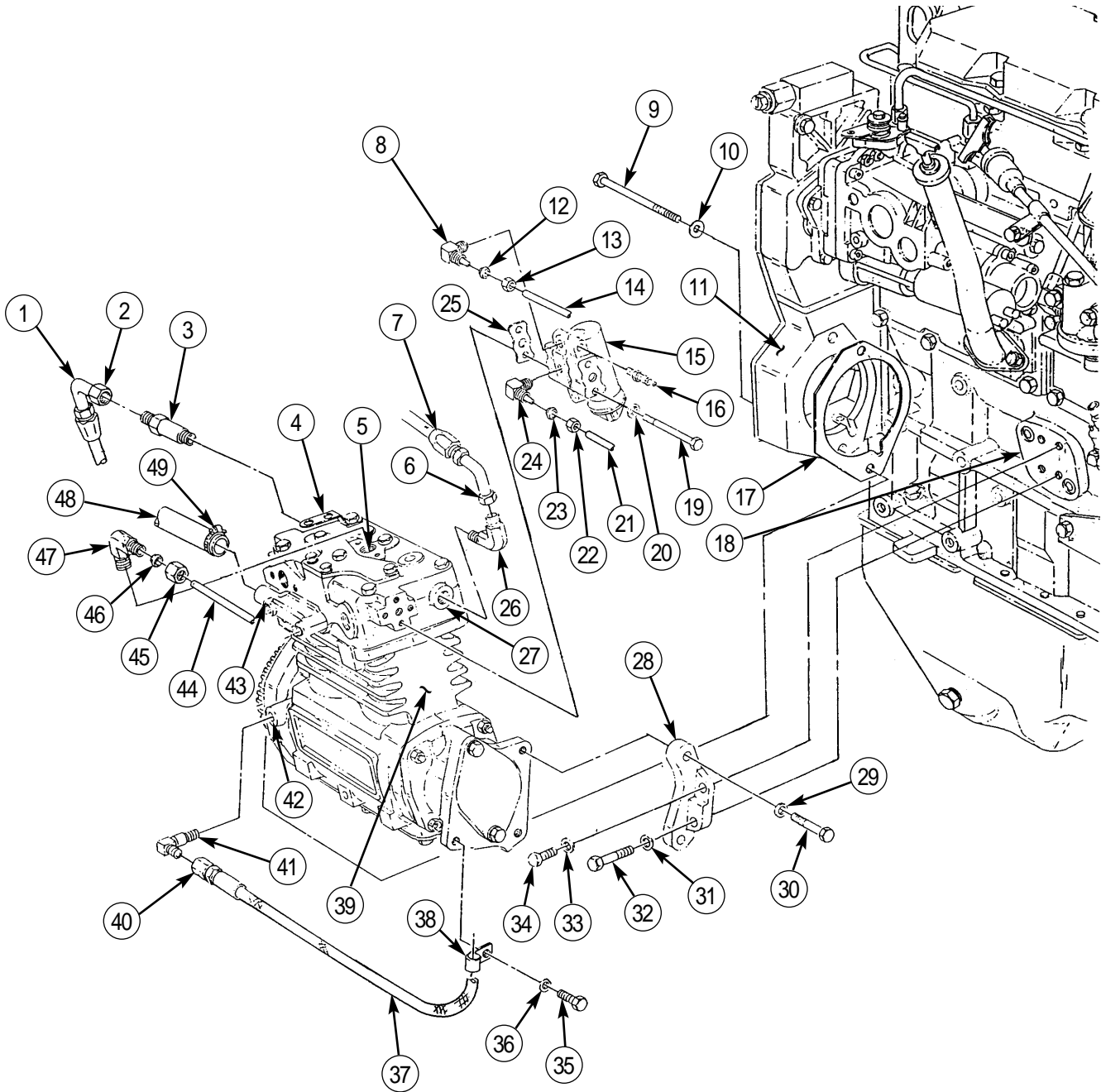

AIR COMPRESSOR REPLACEMENT (Contd)

INSTALLATION

1. Apply sealant to male threads on adapter (3), valve (16), and elbows (8), (24), (26), (41), and (47).
2. Install elbow (41) on port (42).
3. Install elbow (47) on port (5).
4. Install adapter (3) on port (4).
5. Install elbow (26) on port (27).
6. Install new gasket (17) and air compressor (39) on housing (11) with two washers (10) and screws (9).
7. Install mounting bracket (28) on air compressor (39) with two washers (29) and screws (30).
8. Install mounting bracket (28) on engine (18) with washer (33), screw (34), washer (31), and screw (32).
9. Install connector (40) on elbow (41).
10. Install tube (44) on elbow (47) with sleeve (46) and nut (45).
11. Install line (1) on engine adapter (3) with nut (2).
12. Install line (7) on elbow (26) with nut (6).
13. Install new gasket (25) and governor (15) on air compressor (39) with two washers (20) and screws (19).
14. Install elbows (8) and (24) on governor (15).
15. Install valve (16) on governor (15).
16. Install hose (48) on strainer (43) with clamp (49).
17. Install tube (14) and sleeve (12) on elbow (8) with nut (13).
18. Install tube (21) and sleeve (23) on elbow (24) with nut (22).
19. Install hose (37) on air compressor (39) with clamp (38), washer (36), and screw (35).
20. Install front winch hydraulic pump, if equipped (WP 0222 00).
21. Fill engine cooling system to proper level (WP 0068 00).
22. Start engine (TM 9-2320-386-10) and allow air pressure to build up to normal operating pressure. Check for air leaks and road test vehicle.

AIR COMPRESSOR REPLACEMENT (Contd)

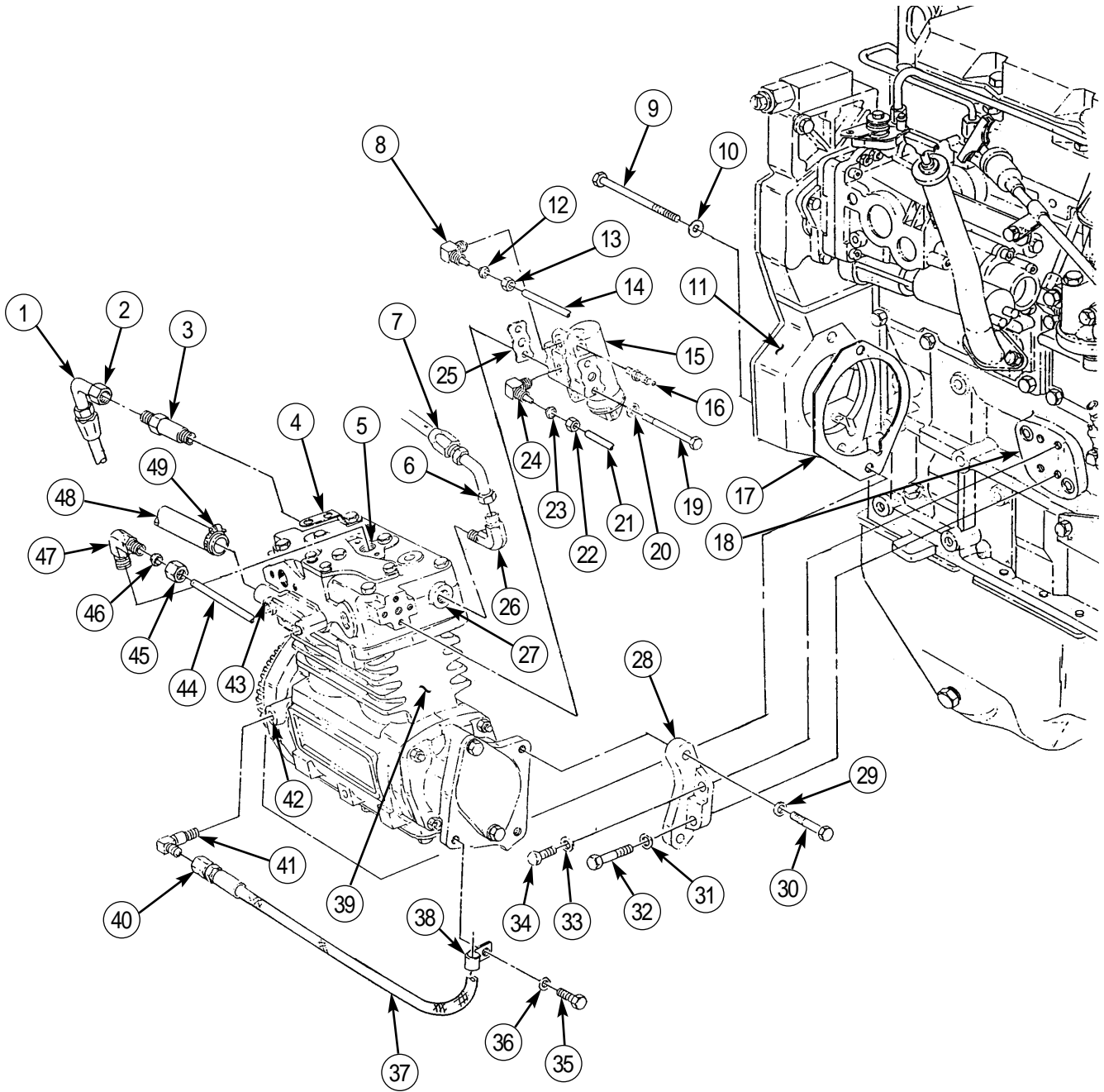

END OF WORK PACKAGE

UNIT MAINTENANCE INSTRUCTIONS

EXTENDED SERVICE PROGRAM (ESP)

TRUCK, CARGO, 2-1/2-TON, 6X6, M44A3 SERIES TRUCKS (DIESEL)

M35A3, W/O WINCH (NSN 2320-01-383-2047); W/WINCH (NSN 2320-01-383-3850);

M35A3C, W/O WINCH (NSN 2320-01-383-2050); W/WINCH (NSN 2320-01-383-2049);

M36A3, W/O WINCH (NSN 2320-01-383-2048); W/WINCH (NSN 2320-01-383-2046).

AIR COMPRESSOR GOVERNOR MAINTENANCE

REMOVAL, INSTALLATION, CHECK AND ADJUSTMENT

INITIAL SETUP:

Tools and Special Tools

General mechanic's tool kit
(item 30, WP 0394 00)

Materials/Parts

Gasket (item 269, WP 0395 00)
Two lockwashers (item 227, WP 0395 00)
Cap and plug set (item 14, WP 0393 00)
Teflon pipe sealant (item 41, WP 0393 00)

References

TM 9-2320-386-24P

Equipment Condition

Parking brake set (TM 9-2320-386-10).
Air reservoirs drained (TM 9-2320-386-10).

AIR COMPRESSOR GOVERNOR MAINTENANCE (Contd)

REMOVAL

WARNING

Do not disconnect air lines before draining air reservoirs. Small parts under pressure may shoot out with high velocity, causing injury to personnel.

Eyeshields must be worn when releasing compressed air. Failure to do so may result in injury to personnel.

CAUTION

When disconnecting air lines and hoses, plug all openings to prevent dirt from entering and causing damage to internal parts. Remove plugs prior to installation.

NOTE

Tag air lines for installation.

1. Remove nuts (5) and (15), air lines (6) and (14) with sleeves (4) and (16) from elbows (3) and (17) on governor (7).
2. Remove elbows (3) and (17) from governor (7).
3. Remove schader valve (8) from governor (7).
4. Remove two screws (10), lockwashers (9), governor (7), and gasket (2) from air compressor (1). Discard lockwashers (9) and gasket (2).

INSTALLATION

1. Apply sealant to male threads of elbows (3) and (17) and schader valve (8).
2. Install new gasket (2) and governor (7) on air compressor (1) with two new lockwashers (9) and screws (10).
3. Install elbows (3) and (17) on governor (7).
4. Install air lines (6) and (14) with sleeves (4) and (16) on elbows (3) and (17) with nuts (5) and (15).
5. Install schader valve (8) on governor (7).

CHECK AND ADJUSTMENT

1. Check air pressure. Gauge should read 120 psi (827 kPa).
2. If air pressure gauge reading is correct, task is complete.
3. If air pressure gauge reading is too low:
 - a. Remove cap (11), loosen jamnut (13), and turn screw (12) 1/4-turn counterclockwise.
 - b. Repeat step a. If air pressure is still low, check for air leaks and repeat step a until air pressure is correct.
 - c. If air pressure is correct, tighten jamnut (13) on screw (12), and install cap (11).
4. If air pressure gauge reading is too high:
 - a. Bleed air pressure until gauge reads below 120 psi (827 kPa).
 - b. Remove cap (11), loosen jamnut (13), and turn screw (12) 1/4-turn clockwise.
 - c. Repeat step b. If pressure is still high, repeat step b until air pressure is correct.
 - d. If air pressure is correct, tighten jamnut (13) on screw (12), and install cap (11).
5. Start engine (TM 9-2320-386-10) and allow air pressure to build up to normal operating pressure. Check for air leaks and road test vehicle.

AIR COMPRESSOR GOVERNOR MAINTENANCE (Contd)

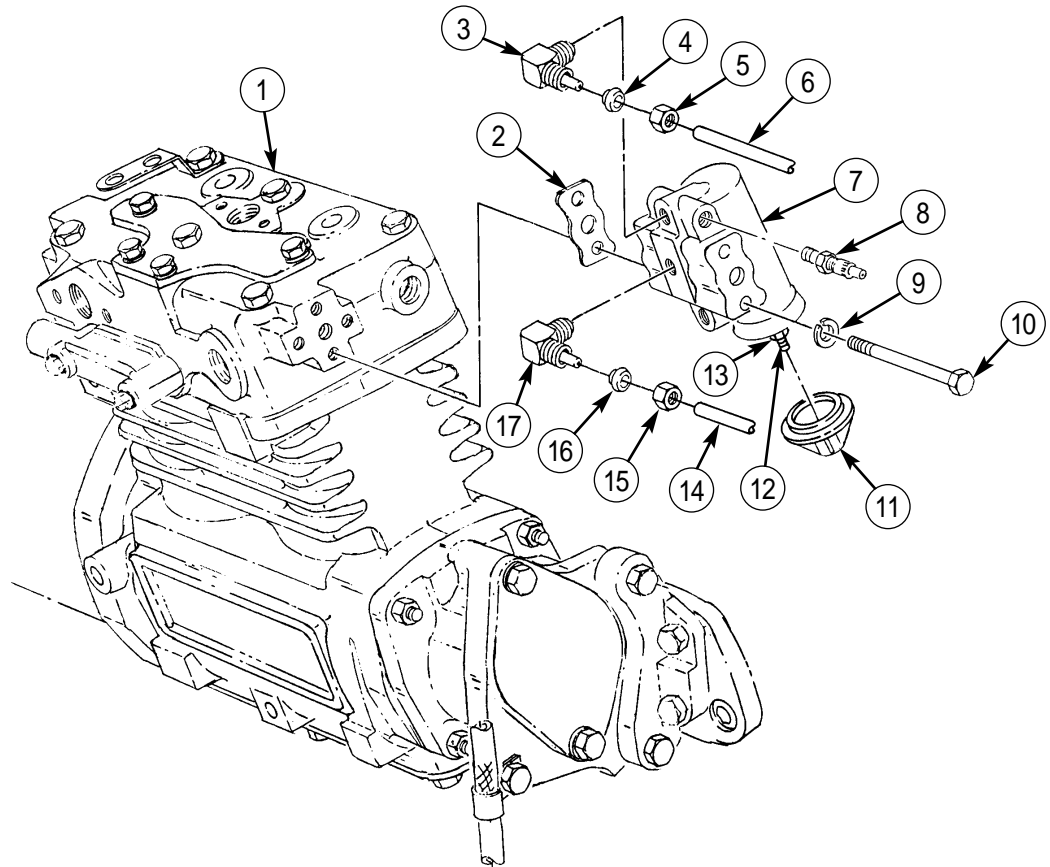

END OF WORK PACKAGE

UNIT MAINTENANCE INSTRUCTIONS

EXTENDED SERVICE PROGRAM (ESP)

TRUCK, CARGO, 2-1/2-TON, 6X6, M44A3 SERIES TRUCKS (DIESEL)

M35A3, W/O WINCH (NSN 2320-01-383-2047); W/WINCH (NSN 2320-01-383-3850);

M35A3C, W/O WINCH (NSN 2320-01-383-2050); W/WINCH (NSN 2320-01-383-2049);

M36A3, W/O WINCH (NSN 2320-01-383-2048); W/WINCH (NSN 2320-01-383-2046).

SECTION XIV. WHEEL MAINTENANCE

TABLE OF CONTENTS

<i>WP Title</i>	<i>WP Sequence No.-Page No.</i>
Front Wheel Hub Maintenance	0172 00-1
Rear Wheel Hub Maintenance	0173 00-1
Tire and Wheel Replacement	0174 00-1
Tire and Wheel Repair	0175 00-1
CTIS Wheel Valve and Filter Maintenance	0176 00-1
CTIS Wheel Valve Repair	0177 00-1

END OF WORK PACKAGE

UNIT MAINTENANCE INSTRUCTIONS

EXTENDED SERVICE PROGRAM (ESP)

TRUCK, CARGO, 2-1/2-TON, 6X6, M44A3 SERIES TRUCKS (DIESEL)

M35A3, W/O WINCH (NSN 2320-01-383-2047); W/WINCH (NSN 2320-01-383-3850);
M35A3C, W/O WINCH (NSN 2320-01-383-2050); W/WINCH (NSN 2320-01-383-2049);
M36A3, W/O WINCH (NSN 2320-01-383-2048); W/WINCH (NSN 2320-01-383-2046).

FRONT WHEEL HUB MAINTENANCE

REMOVAL, DISASSEMBLY, CLEANING AND INSPECTION, ASSEMBLY, INSTALLATION

INITIAL SETUP:

Tools and Special Tools

General mechanic's tool kit
(item 30, WP 0394 00)
Common No. 1 tool kit
(item 15, WP 0394 00)

Materials/Parts

O-ring (item 100, WP 0395 00)
O-ring (item 101, WP 0395 00)
Two quad seals (item 165, WP 0395 00)
Two quad seals w/seal retainers
(item 109, WP 0395 00)
Key washer (item 154, WP 0395 00)
Six lockwashers (item 186, WP 0395 00)
Ten lockwashers (item 61, WP 0395 00)
Twelve lockwashers (item 67, WP 0395 00)
Ten screws (item 125, WP 0395 00)
Gasket (item 315, WP 0395 00)
Hollow stud, LH (item 161, WP 0395 00)
Hollow stud, RH (item 162, WP 0395 00)
Cap and plug set (item 14, WP 0393 00)
Teflon pipe sealant (item 41, WP 0393 00)
Adhesive (item 8, WP 0393 00)
Grease (item 22, WP 0393 00)
Tape (item 48, WP 0393 00)
Skysol-100 (item 17, WP 0393 00)
Lint-free cloth (item 18, WP 0393 00)

References

TM 9-2320-386-24P

Equipment Condition

Parking brake set (TM 9-2320-386-10).
Front wheel(s) removed (WP 0174 00).

FRONT WHEEL HUB MAINTENANCE (Contd)**NOTE**

Left and right front wheel hubs are replaced the same.

REMOVAL**WARNING**

Do not disconnect air lines before draining air reservoirs. Small parts under pressure may shoot out with high velocity, causing injury to personnel.

Eyeshields must be worn when releasing compressed air. Failure to do so may result in injury to personnel.

CAUTION

When disconnecting air lines and hoses, plug all openings to prevent dirt from entering and causing damage to internal parts. Remove all plugs prior to installation

1. Remove six screws (1), lockwashers (2), companion flange (12) with expansion plug (13), and gasket (11) from hub and drum assembly (10). Discard lockwashers (2) and gasket (11).
2. Bend tabs of key washer (4) away from flats of outer nut (3) and inner nut (5).
3. Remove outer nut (3) and key washer (4) from spindle (9). Discard key washer (4).
4. Remove inner nut (5) from spindle (9).

CAUTION

Use extreme caution when removing hub and drum from spindle. Any jarring or sliding of hub and drum over threaded end of spindle may cause damage to O-rings, quad seals, or contact surfaces of spindle and hub.

NOTE

Tag bearing for installation.

5. Remove outer bearing (6) and O-ring (7) from spindle (9). Discard O-ring (7).

NOTE

Assistant will help with step 6.

6. Remove hub and drum assembly (10) from spindle (9).
7. Remove O-ring (8) from ring groove of inner bearing on hub and drum assembly (10). Discard O-ring (8).

FRONT WHEEL HUB MAINTENANCE (Contd)

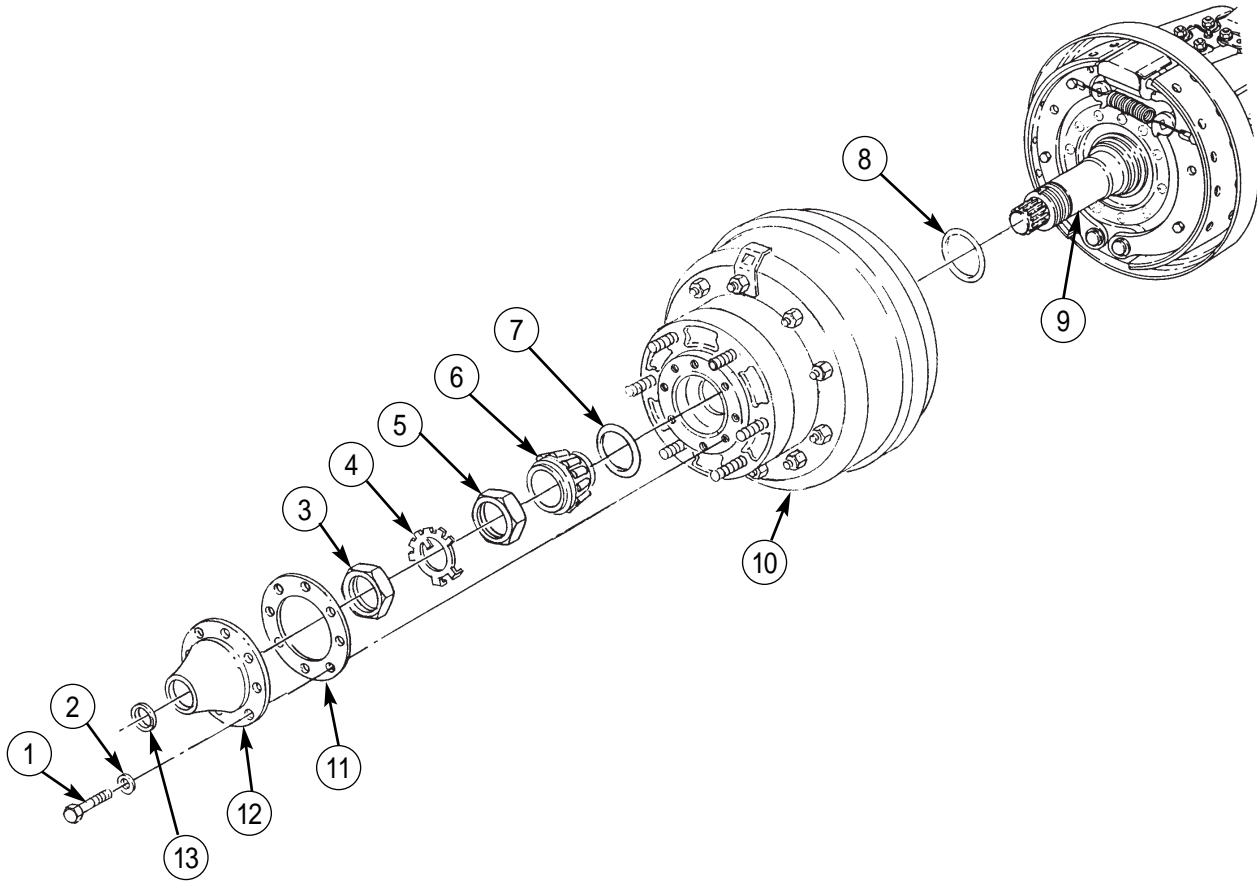

FRONT WHEEL HUB MAINTENANCE (Contd)**DISASSEMBLY**

1. Remove ten nuts (1), lockwashers (2), inspection plate (3), and ten screws (6) from drum (4) and adapter (5). Discard lockwashers (2) and screws (6).
2. Remove drum (4) from adapter (5) and hub (21).

NOTE

Mark tube positions for installation.

3. Remove nut (16) with sleeve (15) and tube (12) from elbow (14).
4. Remove nut (11) with sleeve (10) and tube (12) from elbow (9).

NOTE

Mark elbow and hollow stud positions for installation.

5. Remove elbow (9) from hollow stud (8).
6. Remove hollow stud (8) from adapter (5) and hub (21). Discard hollow stud (8).
7. Remove elbows (14) and (13) from hub (21).

NOTE

Perform step 8 if wheel studs are damaged.

8. Remove five wheel studs (7) from adapter (5) and hub (21). Discard wheel studs (7).
9. Place hub (21) on bench.

NOTE

Tag bearing and bearing cups for installation.

10. Using hammer and brass drift, tap inner bearing (17) from inner bearing cup (18) and hub (21).

CAUTION

Removal of bearing cups in steps 11 through 13 will destroy seal retainers. Perform steps 11 through 13 only if replacing bearing assemblies or seal retainers.

11. Using hammer and brass drift, remove inner bearing cup (18) with seal retainer (19) and quad seal (20) from hub (21).
12. Turn hub (21) on opposite end and remove outer bearing cup (24) with seal retainer (23) and quad seal (22) from hub (21).
13. Remove seal retainers (19) and (23) with quad seals (20) and (22) from inner bearing cup (18) and outer bearing cup (24). Discard seal retainers (19) and (23) and quad seals (20) and (22).

NOTE

Perform steps 15 through 17 if spindle or backing plate is damaged.

CAUTION

Support backing plate to prevent damaging brake line.

14. Disconnect air supply line (33) from connector (32).
15. Remove connector (32) from air line (31).
16. Remove twelve nuts (26), lockwashers (27), deflector (28), brake backing plate (29), and spindle (30) with air line (31) from twelve steering knuckle studs (34). Discard lockwashers (27).

FRONT WHEEL HUB MAINTENANCE (Contd)**CLEANING AND INSPECTION****WARNING**

Skysol-100 mixture is combustible. Use mechanical ventilation whenever product is used in a confined space, is heated above ambient temperatures, or is agitated. DO NOT use or store near heat, sparks, flame, or other ignition sources. Keep container sealed when not in use.

Contact with Skysol-100 may cause skin irritation. Use chemical resistant gloves. In case of skin contact, remove any contaminated clothing and wash skin thoroughly with soap and water. Wash contaminated clothing before reuse. Eye contact may cause irritation, tearing, or blurring of vision. Use face shield or goggles when eye contact may occur. In case of eye contact, flush eyes with large amounts of water for at least fifteen (15) minutes or until irritation subsides. Inhalation may cause irritation to upper respiratory passages. DO NOT have food or drink in the vicinity.

1. Clean hub (21), inner bearing (17), outer bearing (25), and adapter (5) thoroughly with Skysol-100 and dry with a lint-free cloth.
2. Inspect outer bearing (25), inner bearing (17), outer bearing cup (24), inner bearing cup (18), and seal retainers (23) and (19) for scoring, nicks, burrs, and wear. Replace part(s) if damaged.
3. Inspect hub (21), drum (4), and adapter (5) for cracks, wear, or breaks. Replace part(s) if damaged.

NOTE

Perform step 4 if spindle was removed.

4. Clean all adhesive from spindle (30), tube (12), air line (31), and steering knuckle studs (34).

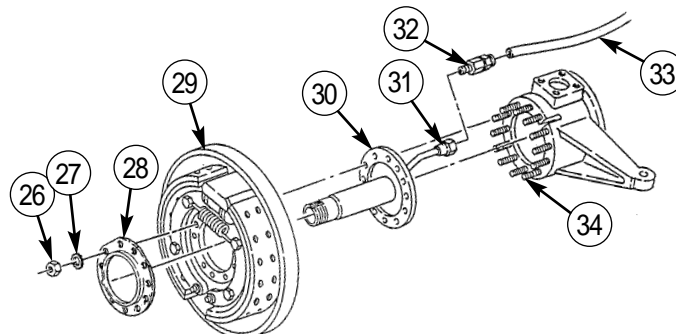
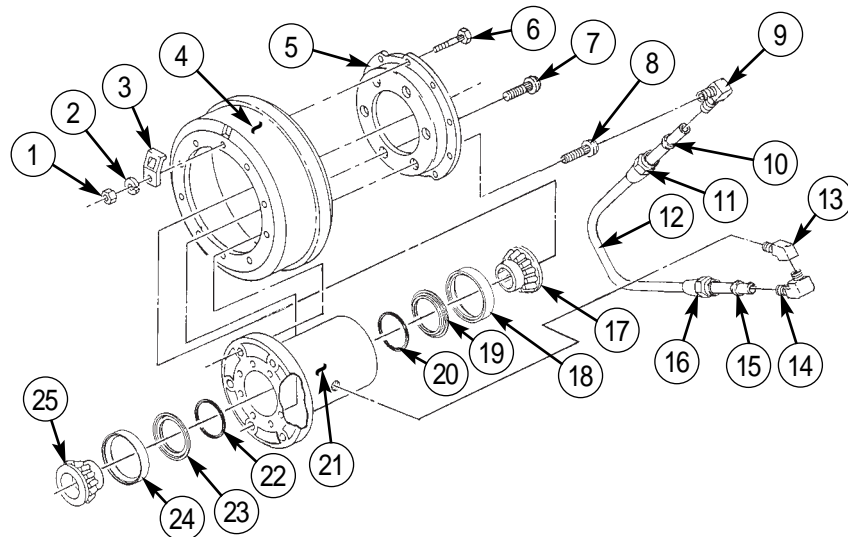

FRONT WHEEL HUB MAINTENANCE (Contd)**ASSEMBLY****CAUTION**

All mating surfaces must be clean and dry prior to wheel hub assembly. Failure to do so may weaken ability of adhesive to hold air.

NOTE

Perform steps 1 through 9 if inner and outer bearing cups were removed.

1. Apply a thin layer of adhesive to counterbore ledge of inner bearing cup (18) and outer bearing cup (24).
2. Drive new seal retainers (19) and (23) with quad seals (20) and (22) in inner bearing cup (18) and outer bearing cup (24) evenly. Wipe off any excess adhesive.
3. Apply adhesive on inner counterbore ledge of hub (21).
4. Apply adhesive to outer side of inner bearing cup (18) and mating surface of hub (21).
5. Drive inner bearing cup (18) with new seal retainer (19) and quad seal (20) in hub (21). Ensure seal retainer (19) is seated against counterbore ledge of hub (21).
6. Apply adhesive on outer counterbore ledge of hub (21).
7. Apply adhesive to outer side of outer bearing cup (24) and mating surface of hub (21).
8. Drive outer bearing cup (24) with new seal retainer (23) and quad seal (22) in hub (21). Ensure seal retainer (23) is seated against counterbore ledge of hub (21).
9. Lubricate quad seals (20) and (22) in new seal retainers (19) and (23) sparingly with GAA grease.
10. Install new quad seals (20) and (22) in seal retainers (19) and (23).

NOTE

Pack inner bearing with GAA grease prior to installation.

11. Install inner bearing (17) in inner bearing cup (18) and tap inner bearing (17) to seat into inner bearing cup (18).

NOTE

Perform step 12 if wheel studs were removed.

12. Install adapter (5) on hub (21) with five new wheel studs (7). Ensure wheel studs (7) are seated against adapter (5).
13. Apply sealant to male threads of elbows (9), (13), and (14) and new hollow stud (8).
14. Install elbows (13) and (14) on hub (21).
15. Install elbow (9) on new hollow stud (8).
16. Install short end of tube (12) on elbow (9) with sleeve (10) and nut (11).
17. Install tube (12), elbow (9), and new hollow stud (8) on adapter (5) and hub (21). Use lugnut to seat hollow stud (8) against adapter (5).
18. Install tube (12) on elbow (14) with sleeve (15) and nut (16).
19. Install drum (4) on adapter (5) with ten new screws (6), inspection plate (3), ten new lockwashers (2), and nuts (1). Tighten nuts (1) 31-39 lb-ft (42-53 N•m).

FRONT WHEEL HUB MAINTENANCE (Contd)

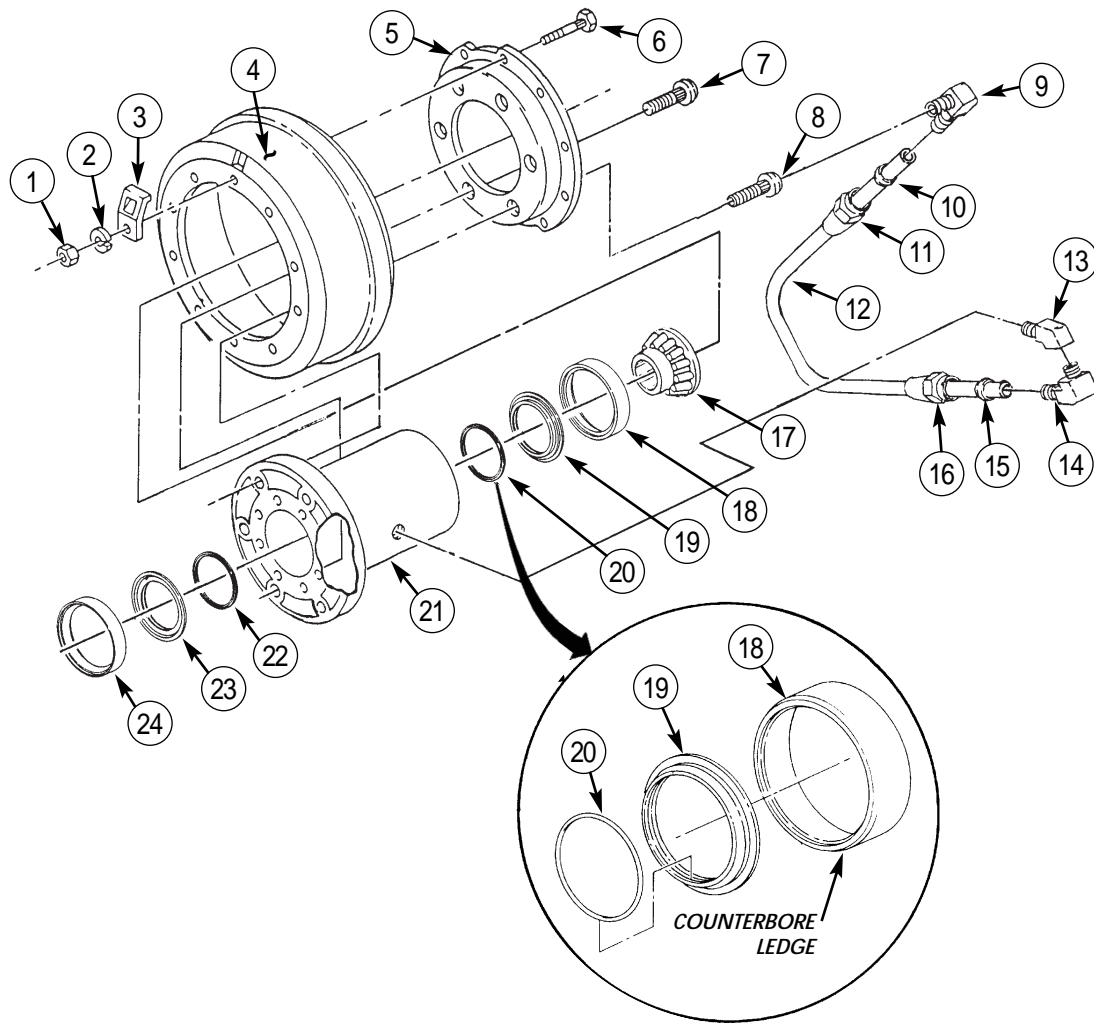

FRONT WHEEL HUB MAINTENANCE (Contd)**NOTE**

Perform steps 20 through 24 if spindle or backing plate were removed.

20. Apply adhesive to mating surface of spindle (5) and steering knuckle (9).
21. Install spindle (5) on steering knuckle (9). Ensure air line (6) seats properly in groove of steering knuckle (9).
22. Install brake backing plate (4) and deflector (3) on spindle (5) and steering knuckle (9) with twelve new lockwashers (2) and nuts (1). Tighten nuts (1) 24-35 lb-ft (33-48 N•m).
23. Install connector (7) on air line (6).
24. Fill groove between air line (6) and steering knuckle (9) with adhesive and connect air supply line (8) to connector (7).

INSTALLATION**NOTE**

Allow 12 hours for adhesives to cure before installing hub on vehicle.

1. Lubricate new O-ring (17) sparingly with GAA grease prior to installing.
2. Install new O-ring (17) in ring groove of inner bearing on hub and drum assembly (18).
3. Cover threaded end of spindle (5) with tape and apply grease to spindle (5).

CAUTION

Use extreme caution when installing hub and drum on spindle. Any jarring or sliding of hub and drum over threaded end of spindle may cause damage to O-rings, quad seals, or contact surfaces of spindle and hub.

NOTE

Assistant will help with step 4.

4. Install hub and drum assembly (18) on spindle (5), and remove tape from threaded end of spindle (5).
5. Lubricate new O-ring (16) sparingly with GAA grease prior to installing.
6. Install new O-ring (16) inside outer bearing (15).

CAUTION

Use extreme caution when installing outer bearing on spindle. Install outer bearing slowly over spindle to prevent damage to O-ring.

NOTE

Pack outer bearing with GAA grease prior to installation.

7. Install outer bearing (15) on spindle (5) with inner nut (14). While turning hub and drum assembly (18), tighten inner nut (14) 50 lb-ft (68 N•m), then back off 1/16- to 1/4-turn.
8. Install new key washer (13) and outer nut (12) on spindle (5). Tighten outer nut (12) 100-200 lb-ft (136-271 N•m).
9. Bend tabs on key washer (13) down over inner nut (14) and outer nut (12).
10. Install new gasket (19) and companion flange (20) with expansion plug (21) on hub and drum assembly (18) with six new lockwashers (11) and screws (10).
11. Adjust service brakes (TM 9-2320-361-20).
12. Install front wheel(s) (WP 0174 00).
13. Start engine (TM 9-2320-386-10) and check for air leaks.

FRONT WHEEL HUB MAINTENANCE (Contd)

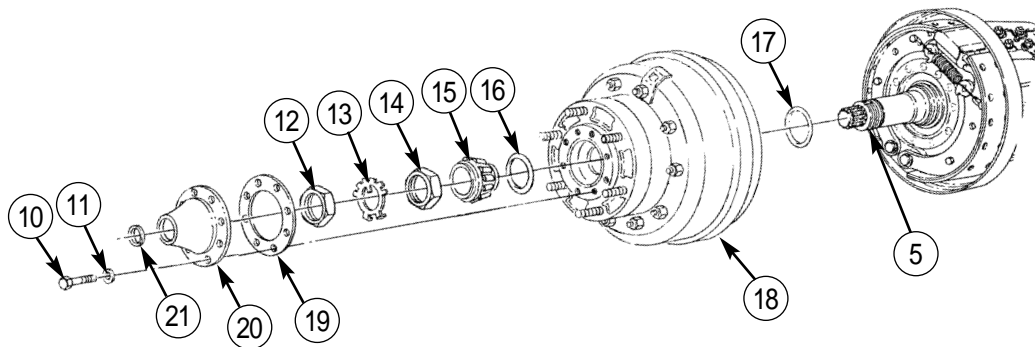
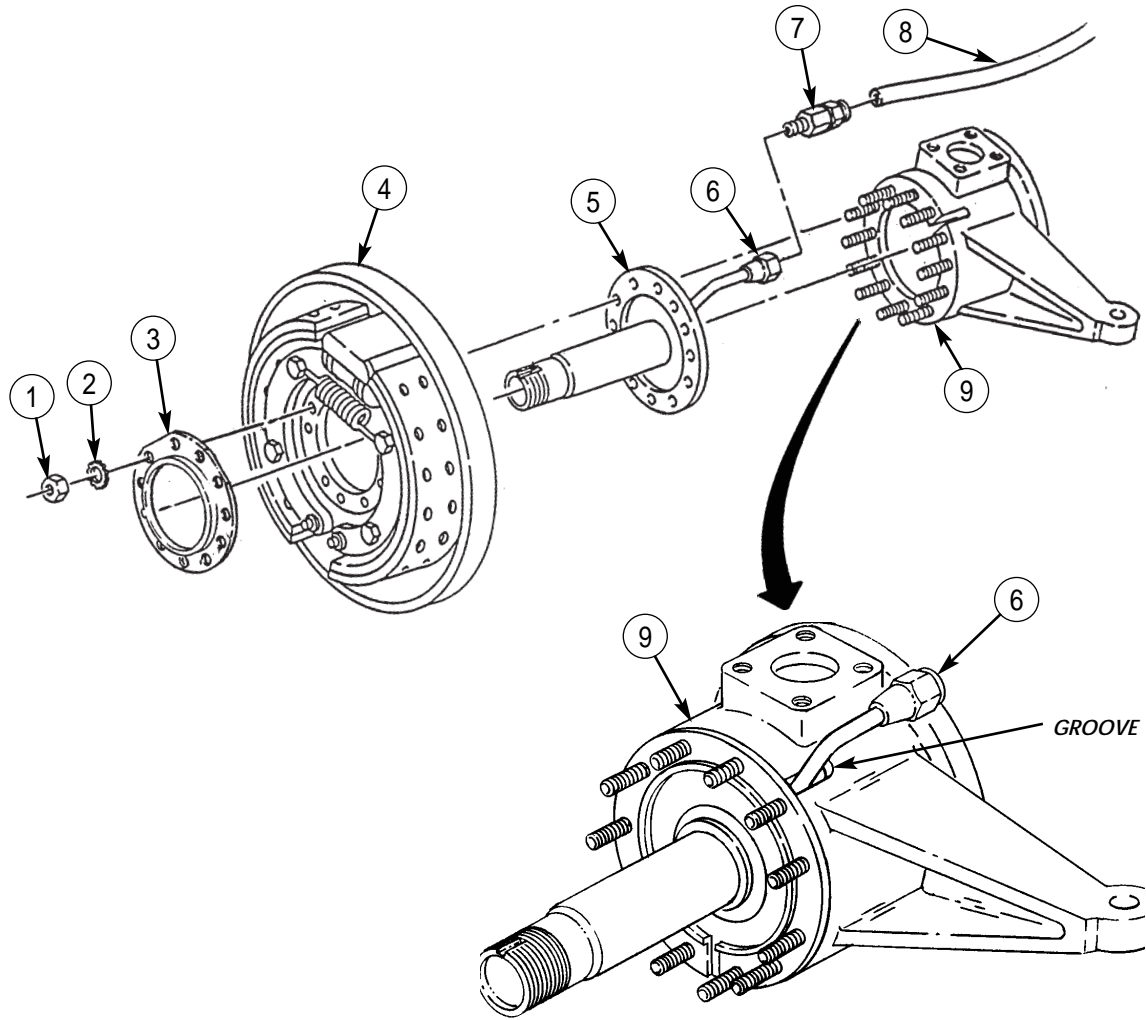

END OF WORK PACKAGE

UNIT MAINTENANCE INSTRUCTIONS

EXTENDED SERVICE PROGRAM (ESP)

TRUCK, CARGO, 2-1/2-TON, 6X6, M44A3 SERIES TRUCKS (DIESEL)

M35A3, W/O WINCH (NSN 2320-01-383-2047); W/WINCH (NSN 2320-01-383-3850);
M35A3C, W/O WINCH (NSN 2320-01-383-2050); W/WINCH (NSN 2320-01-383-2049);
M36A3, W/O WINCH (NSN 2320-01-383-2048); W/WINCH (NSN 2320-01-383-2046).

REAR WHEEL HUB MAINTENANCE

REMOVAL, DISASSEMBLY, CLEANING AND INSPECTION, ASSEMBLY, INSTALLATION

INITIAL SETUP:

Tools and Special Tools

General mechanic's tool kit
(item 30, WP 0394 00)
Common No. 1 tool kit
(item 15, WP 0394 00)

Materials/Parts

Two quad seals (item 165, WP 0395 00)
Two quad seals w/seal retainers
(item 109, WP 0395 00)
Key washer (item 154, WP 0395 00)
Hollow stud, LH (item 159, WP 0395 00)
Hollow stud, RH (item 160, WP 0395 00)
Eighteen lockwashers (item 186, WP 0395 00)
Ten screws (item 125, WP 0395 00)
O-ring (item 101, WP 0395 00)
O-ring (item 100, WP 0395 00)
Seal (item 1, WP 0395 00)
Gasket (item 254, WP 0395 00)
Safety wire (item 36, WP 0393 00)
Teflon pipe sealant (item 41, WP 0393 00)
Adhesive (item 8, WP 0393 00)
Cap and plug set (item 14, WP 0393 00)
Grease (item 22, WP 0393 00)
Tape (item 48, WP 0393 00)
Skysol-100 (item 17, WP 0393 00)
Lint-free cloth (item 18, WP 0393 00)

References

TM 9-2320-361-20
TM 9-2320-386-24P

Equipment Condition

Parking brake set (TM 9-2320-386-10).
Rear wheel(s) removed (WP 0174 00).
Rear axle shaft removed (TM 9-2320 361-20).

REAR WHEEL HUB MAINTENANCE (Contd)**NOTE**

Left and right rear wheel hubs are replaced the same.

REMOVAL**WARNING**

Do not disconnect air lines before draining air reservoirs. Small parts under pressure may shoot out with high velocity, causing injury to personnel.

Eyeshields must be worn when releasing compressed air. Failure to do so may result in injury to personnel.

CAUTION

When disconnecting air lines and hoses, plug all openings to prevent dirt from entering and causing damage to internal parts. Remove all plugs prior to installation.

1. Bend tabs of key washer (2) away from flats of outer nut (1) and inner nut (3).
2. Remove outer nut (1) and key washer (2) from spindle (22). Discard key washer (2).
3. Remove inner nut (3), seal (4), and cork gasket (5) from spindle (22). Discard seal (4) and cork gasket (5).

CAUTION

Use extreme caution when removing hub and drum from spindle. Any jarring or sliding of hub and drum over threaded end of spindle may cause damage to O-rings, quad seals, or contact surfaces of spindle and hub.

NOTE

Tag bearing for installation.

4. Remove outer bearing (6) and O-ring (7) from spindle (22). Discard O-ring (7).

NOTE

Assistant will help with step 5.

5. Remove hub (11) and drum (15) from spindle (22).
6. Remove O-ring (23) from ring groove of inner bearing (24). Discard O-ring (23).

DISASSEMBLY

1. Remove safety wire (19) from eight screws (20). Discard safety wire (19).
2. Remove eight screws (20), lockwashers (21), and hub (11) from adapter (16). Discard lockwashers (21).
3. Remove ten nuts (12), lockwashers (13), and inspection plate (14) from drum (15). Discard lockwashers (13).
4. Remove ten screws (18), slinger (17), and adapter (16) from drum (15). Discard screws (18).
5. Remove elbow (29) from hub (11).
6. Remove tube (30) from elbows (29) and (31).
7. Remove elbow (31) from hollow stud (32).
8. Remove hollow stud (32) from hub (11). Discard hollow stud (32).

NOTE

Perform step 9 if wheel studs are damaged.

9. Remove five wheel studs (28) from hub (11). Discard wheel studs (28).
10. Place hub (11) on bench.

NOTE

Tag bearing and bearing cups for installation.

11. Using hammer and brass drift, tap inner bearing (24) from inner bearing cup (25).

REAR WHEEL HUB MAINTENANCE (Contd)**CAUTION**

Removal of bearing cups in steps 12 through 14 will destroy seal retainers. Perform steps 12 through 14 only if replacing bearing assemblies or seal retainers.

12. Using hammer and brass drift, remove inner bearing cup (25) with seal retainer (26) and quad seal (27) from hub (11).
13. Turn hub (11) on opposite end and remove outer bearing cup (8) with seal retainer (9) and quad seal (10) from hub (11).
14. Remove seal retainers (9) and (26) with quad seals (10) and (27) from outer bearing cup (8) and inner bearing cup (25). Discard seal retainers (9) and (26) and quad seals (10) and (27).

CLEANING AND INSPECTION**WARNING**

Skysol-100 mixture is combustible. Use mechanical ventilation whenever product is used in a confined space, is heated above ambient temperatures, or is agitated. DO NOT use or store near heat, sparks, flame, or other ignition sources. Keep container sealed when not in use.

Contact with Skysol-100 may cause skin irritation. Use chemical resistant gloves. In case of skin contact, remove any contaminated clothing and wash skin thoroughly with soap and water. Wash contaminated clothing before reuse. Eye contact may cause irritation, tearing, or blurring of vision. Use face shield or goggles when eye contact may occur. In case of eye contact, flush eyes with large amounts of water for at least fifteen (15) minutes or until irritation subsides. Inhalation may cause irritation to upper respiratory passages. DO NOT have food or drink in the vicinity.

1. Clean hub (11), inner bearing (24), outer bearing (6), adapter (16), and slinger (17) thoroughly with Skysol-100 and dry with a lint-free cloth.
2. Inspect outer bearing (6), inner bearing (24), outer bearing cup (8), inner bearing cup (25), and seal retainers (9) and (26) for scoring, nicks, burrs, and wear. Replace part(s) if damaged.
3. Inspect hub (11), drum (15), adapter (16), and slinger (17) for cracks, wear, or breaks. Replace part(s) if damaged.

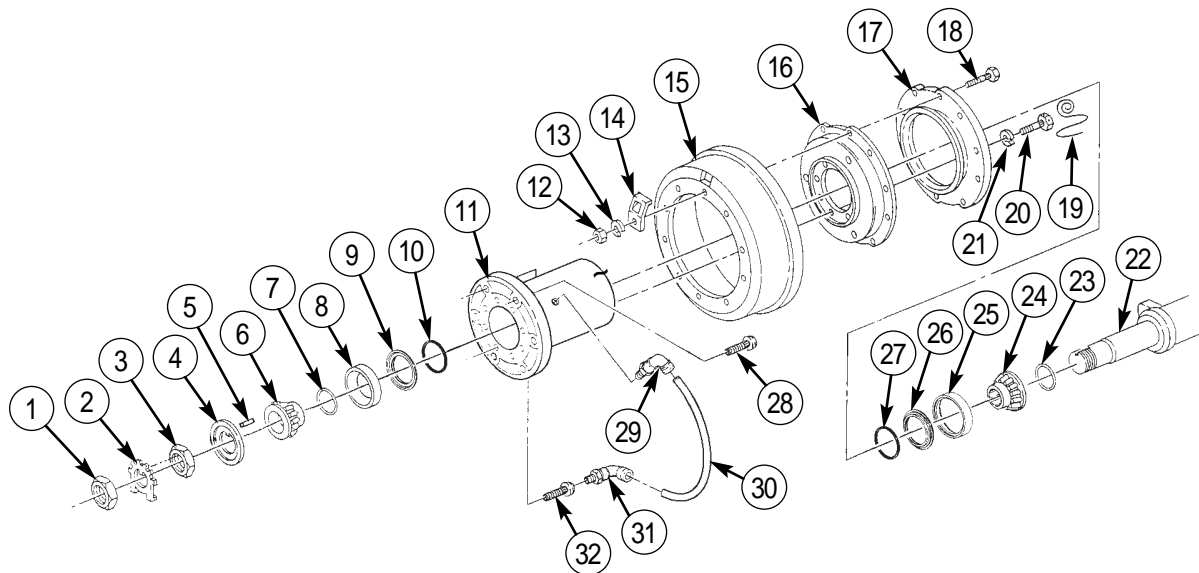

REAR WHEEL HUB MAINTENANCE (Contd)**ASSEMBLY****CAUTION**

All mating surfaces must be clean and dry prior to wheel hub assembly. Failure to do so may weaken ability of adhesive to hold air.

NOTE

Perform steps 1 through 9 if inner and outer bearing cups were removed.

1. Apply a thin layer of adhesive to counterbore ledge of inner bearing cup (16) and outer bearing cup (1).
2. Drive new seal retainers (17) and (2) with quad seals (18) and (3) in inner bearing cup (16) and outer bearing cup (1) evenly. Wipe off any excess adhesive.
3. Apply adhesive on inner counterbore ledge of hub (4).
4. Apply adhesive to outer side of inner bearing cup (16) and mating surface of hub (4).
5. Drive inner bearing cup (16) with new seal retainer (17) and quad seal (18) in hub (4). Ensure seal retainer (17) is seated against counterbore ledge of hub (4).
6. Apply adhesive on outer counterbore ledge of hub (4).
7. Apply adhesive to outer side of outer bearing cup (1) and mating surface of hub (4).
8. Drive outer bearing cup (1) with new seal retainer (2) and quad seal (3) in hub (4). Ensure seal retainer (2) is seated against counterbore ledge of hub (4).
9. Lubricate quad seals (3) and (18) in new seal retainers (2) and (17) sparingly with GAA grease.
10. Lubricate new quad seals (3) and (18) sparingly with GAA grease prior to installing.
11. Install new quad seals (3) and (18) in seal retainers (2) and (17).

NOTE

Pack inner bearing with GAA grease prior to installation.

12. Install inner bearing (15) in inner bearing cup (16) and tap inner bearing (15) to seat into inner bearing cup (16).

NOTE

Perform step 13 if wheel studs were removed.

13. Install five new wheel studs (19) on hub (4). Ensure wheel studs (19) are seated against hub (4).
14. Apply sealant to male threads of elbows (21) and (22) and new hollow stud (23).
15. Install new hollow stud (23) on hub (4).
16. Install elbow (22) on new hollow stud (23).
17. Install elbow (21) on hub (4).
18. Install tube (20) on elbows (21) and (22).
19. Install adapter (9) and slinger (10) on drum (8) with ten new screws (11), inspection plate (7), ten new lockwashers (6), and nuts (5). Tighten nuts (5) 31-39 lb-ft (42-53 N•m).
20. Install hub (4) on adapter (9) with eight new lockwashers (14) and screws (13). Tighten screws (13) 81-104 lb-ft (110-141 N•m).
21. Install new safety wire (12) on eight screws (13).

REAR WHEEL HUB MAINTENANCE (Contd)

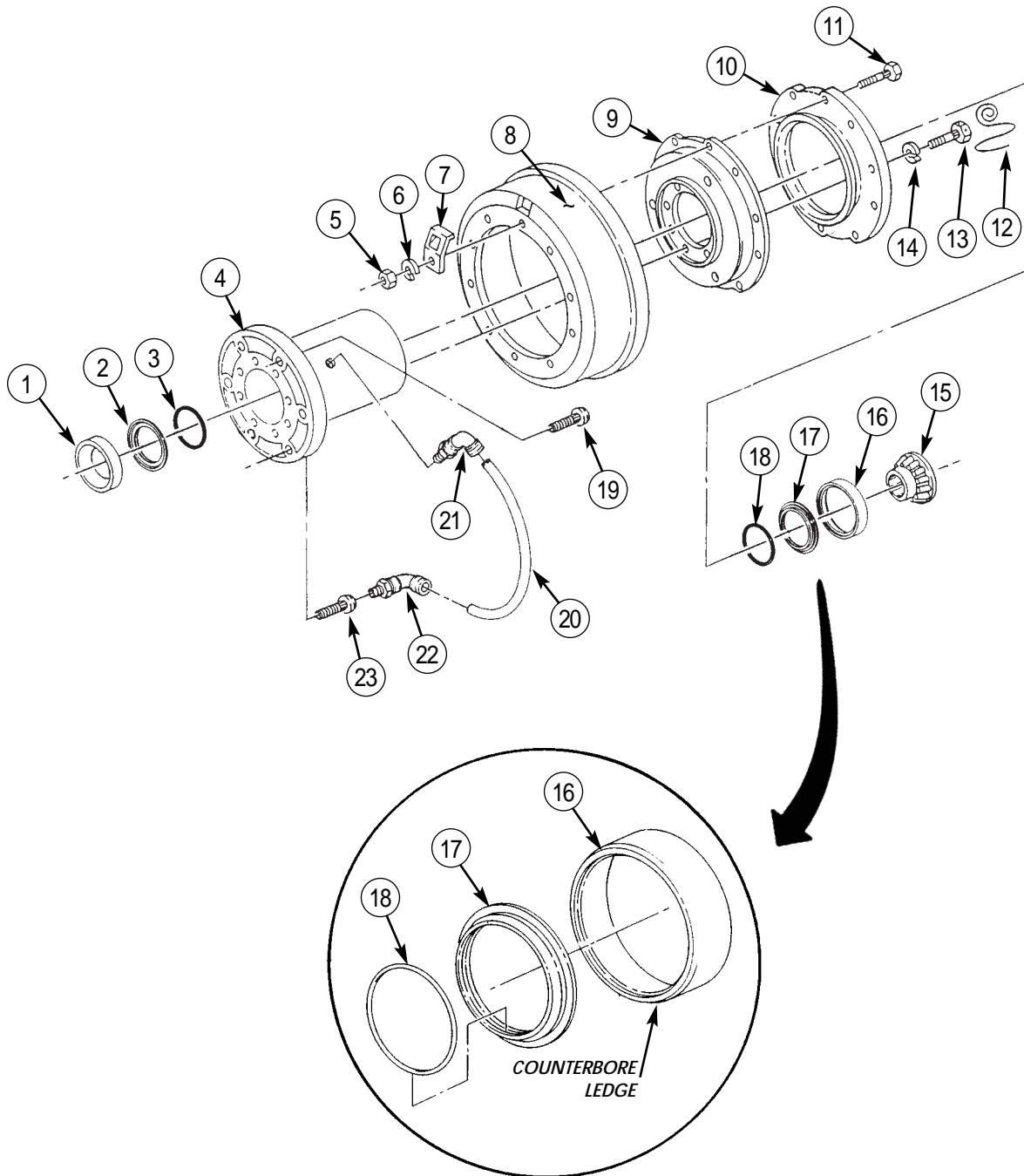

REAR WHEEL HUB MAINTENANCE (Contd)**INSTALLATION****NOTE**

Allow 12 hours for adhesives to cure before installing hub on vehicle.

1. Lubricate new O-ring (9) sparingly with GAA grease prior to installing.
2. Install new O-ring (9) in ring groove of inner bearing on hub and drum assembly (8).
3. Cover threaded end of spindle (10) with tape and apply grease to spindle (10).

CAUTION

Use extreme caution when installing hub and drum on spindle. Any jarring or sliding of hub and drum over threaded end of spindle may cause damage to O-rings, quad seals, or contact surfaces of spindle and hub.

NOTE

Assistant will help with step 4.

4. Install hub and drum assembly (8) on spindle (10), and remove tape from threaded end of spindle (10).
5. Lubricate new O-ring (7) sparingly with GAA grease prior to installing.
6. Install new O-ring (7) inside outer bearing (6).

NOTE

Pack outer bearing with GAA grease prior to installation.

Use extreme caution when installing outer bearing on spindle.

Install outer bearing slowly over spindle to prevent damage to O-ring.

7. Install outer bearing (6), new cork gasket (5), and new seal (4) on spindle (10) with inner nut (3). While turning hub and drum assembly (8), tighten inner nut (3) 50 lb-ft (68 N•m), then back-off 1/16 to 1/4 turn.
8. Install new key washer (2) and outer nut (1) on spindle (10). Tighten outer nut (1) 100-200 lb-ft (136-271 N•m).
9. Bend tabs on key washer (2) down over inner nut (3) and outer nut (1).
10. Adjust service brakes (TM 9-2320-361-20).
11. Install rear axle shaft (TM 9-2320-361-20).
12. Install rear wheel(s) (WP 0174 00).
13. Start engine (TM 9-2320-386-10) and check for air leaks.

REAR WHEEL HUB MAINTENANCE (Contd)

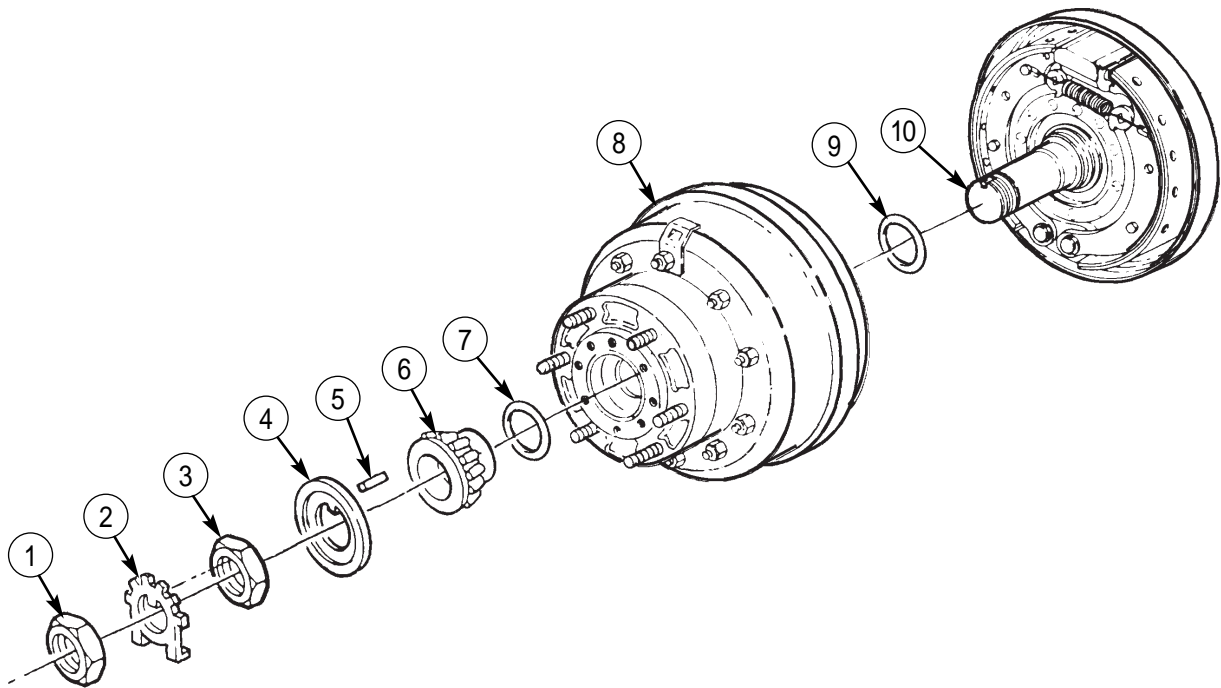

END OF WORK PACKAGE

UNIT MAINTENANCE INSTRUCTIONS

EXTENDED SERVICE PROGRAM (ESP)

TRUCK, CARGO, 2-1/2-TON, 6X6, M44A3 SERIES TRUCKS (DIESEL)

**M35A3, W/O WINCH (NSN 2320-01-383-2047); W/WINCH (NSN 2320-01-383-3850);
M35A3C, W/O WINCH (NSN 2320-01-383-2050); W/WINCH (NSN 2320-01-383-2049);
M36A3, W/O WINCH (NSN 2320-01-383-2048); W/WINCH (NSN 2320-01-383-2046).**

TIRE AND WHEEL REPLACEMENT

REMOVAL, INSTALLATION

INITIAL SETUP:

Tools and Special Tools

General mechanic's tool kit
(item 30, WP 0394 00)
Common No. 1 tool kit
(item 15, WP 0394 00)
Common No. 2 tool kit
(item 96, WP 0394 00)

References

TM 9-2320-386-24P

Equipment Condition

Parking brake set (TM 9-2320-386-10).
Wheel(s) chocked (TM 9-2320-386-10).
Air reservoirs drained (TM 9-2320-386-10).

Materials/Parts

Two lockwashers (item 186, WP 0395 00)
Teflon pipe sealant (item 41, WP 0393 00)
Cap and plug set (item 14, WP 0393 00)

TIRE AND WHEEL REPLACEMENT (Contd)**REMOVAL****WARNING**

Air system components are subject to high pressure. Always relieve pressure before loosening or removing air system components.

Eyeshields must be worn when releasing compressed air. Failure to do so may result in injury to personnel.

CAUTION

When disconnecting air lines and hoses, plug all openings to prevent dirt from entering and causing damage to internal parts. Remove all plugs prior to installation.

NOTE

Front and rear wheels are replaced the same. This procedure is for the front wheel.

1. Remove two screws (1) and lockwashers (13) from stone shield (3) and flange (5). Discard lockwashers (13).
2. Remove two nuts (2) and stone shield (3) from studs (4).
3. Remove air tube (12) from adapter (11).
4. Remove adapter (11) from elbow (10).

NOTE

Mark hollow stud-to-wheel position for installation.

5. Remove elbow (10) from hollow stud (7).
6. Loosen six nuts (9).
7. Raise vehicle (TM 9-2320-386-10).
8. Place jack stand under axle of vehicle and lower vehicle onto jack stand.

NOTE

Assistant will help with step 9.

9. Remove six nuts (9) and wheel (8) from hub (6).

TIRE AND WHEEL REPLACEMENT (Contd)**INSTALLATION**

1. Apply sealant to male threads of adapter (11) and hollow stud (7).

CAUTION

Do not slide wheel over threaded hollow stud or damage to equipment may result.

NOTE

Assistant will help with step 2.

When installing wheel, ensure it is positioned in previously marked position.

2. Install wheel (8) on hub (6) with six nuts (9). Alternately tighten nuts (9).
3. Raise vehicle from jack stand (TM 9-2320-386-10) and lower to ground.
4. Tighten nut (9) on hollow stud 275-300 lb-ft (373-407 N·m) and nuts (9) on solid studs 390-420 lb-ft (529-569 N·m).
5. Install elbow (10) on hollow stud (7).
6. Install adapter (11) on elbow (10).
7. Install air tube (12) on adapter (11).
8. Inflate tire to proper pressure (TM 9-2320-386-10).
9. Install stone shield (3) on two studs (4) with nuts (2). Tighten nuts (2) 60-80 lb-ft (81-108 N·m).
10. Install stone shield (3) on flange (5) with two new lockwashers (13) and screws (1). Tighten screws (1) 81-104 lb-ft (110-141 N·m).
11. Start engine (TM 9-2320-386-10) and allow air pressure to build. Check for air leaks.

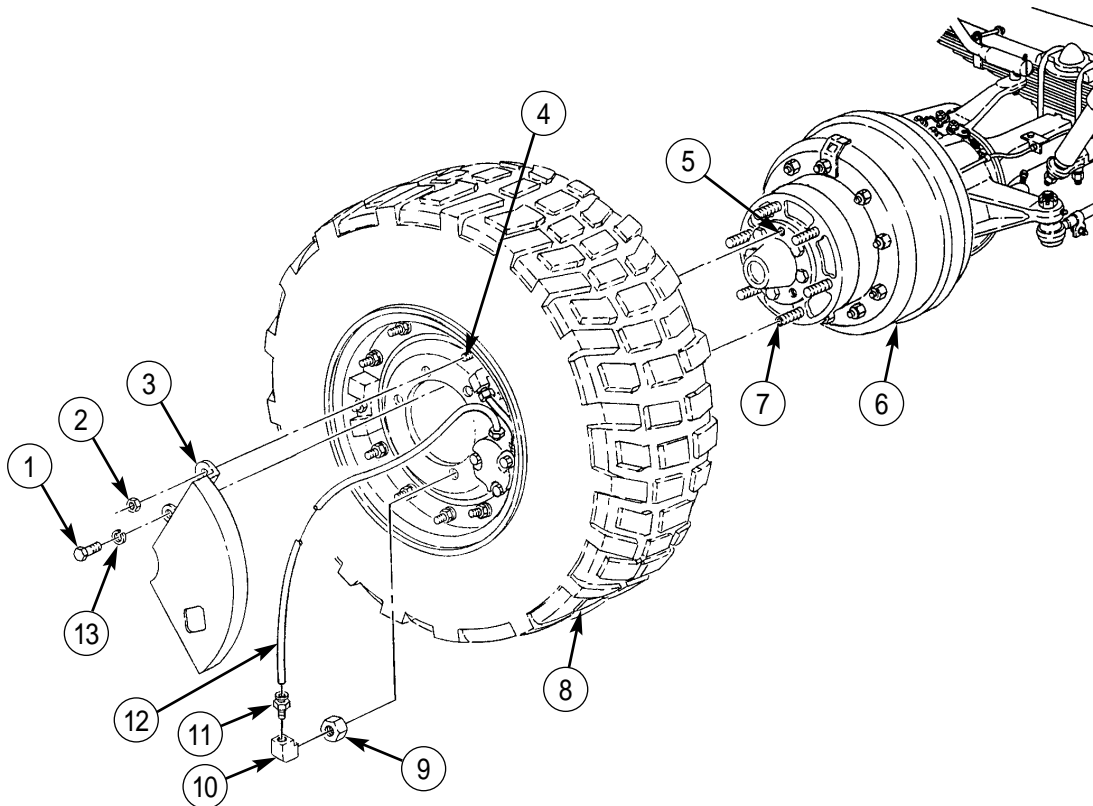

END OF WORK PACKAGE

UNIT MAINTENANCE INSTRUCTIONS

EXTENDED SERVICE PROGRAM (ESP)

TRUCK, CARGO, 2-1/2-TON, 6X6, M44A3 SERIES TRUCKS (DIESEL)

M35A3, W/O WINCH (NSN 2320-01-383-2047); W/WINCH (NSN 2320-01-383-3850);
M35A3C, W/O WINCH (NSN 2320-01-383-2050); W/WINCH (NSN 2320-01-383-2049);
M36A3, W/O WINCH (NSN 2320-01-383-2048); W/WINCH (NSN 2320-01-383-2046).

TIRE AND WHEEL REPAIR

DISASSEMBLY, CLEANING, INSPECTION, AND REPAIR, ASSEMBLY

INITIAL SETUP:

Tools and Special Tools

General mechanic's tool kit
(item 30, WP 0394 00)
Common No. 1 tool kit
(item 15, WP 0394 00)

Materials/Parts

Four locknuts (item 85, WP 0395 00)
Ten locknuts (item 152, WP 0395 00)
O-ring (item 157, WP 0395 00)
Lubricating oil (item 31, WP 0393 00)
Teflon pipe sealant (item 41, WP 0393 00)

References

TM 9-2610-200-14
TM 9-2320-386-24P

Equipment Condition

Parking brake set (TM 9-2320-386-10).
Tire and wheel removed (WP 0174 00).

TIRE AND WHEEL REPAIR (Contd)**DISASSEMBLY****WARNING**

Ensure tire is completely deflated before attempting to remove from rim. Failure to do so may cause injury to personnel.

Do not remove tire locknuts before deflating tire. Clamp ring can fly off, resulting in injury to personnel.

CAUTION

Loosen locknuts no more than 1/2-turn at a time. Uneven beadlock pressure on clamp ring may result in damage to wheel rim studs.

1. Remove nut (35) and counterweight (36) from stud (4).
2. Loosen nuts (16) and (18) and remove air tube (17) with sleeves (15) and (19) from connector (14) and elbow (20).
3. Remove connector (14) and adapter (13) from elbow (12).

CAUTION

Position and location of elbows must be noted prior to removal. Failure to do so may cause kinking of air lines when installed.

4. Remove elbow (12) from turret valve (5).
5. Remove elbow (20) from air valve (24).
6. Remove air hose (31) from adapter (32) and elbow (33).
7. Loosen nut (29) and remove air hose (31) with sleeve (30) from elbow (28).
8. Remove elbow (28) from air valve (24).
9. Remove adapter (32) from elbow (33).
10. Remove cap (27), valve core (26), and valve (25) from elbow (21).

NOTE

Mark position of air valve for installation.

Relationship of air valve to hollow stud is important for proper installation.

11. Remove elbow (21) from air valve (24).
12. Remove two nuts (22) and mounting bracket (10) from outer rim (9) and two studs (4).
13. Remove four locknuts (23), screws (11), and air valve (24) from mounting bracket (10). Discard locknuts (23).
14. Remove ten locknuts (34), outer rim (9), O-ring (8), and tire (2) from inner rim (3) and ten studs (4). Discard locknuts (34) and O-ring (8).
15. Remove nut (7), turret valve (5), and grommet (6) from inner rim (3).
16. Remove beadlock (1) from tire (2).

TIRE AND WHEEL REPAIR (Contd)

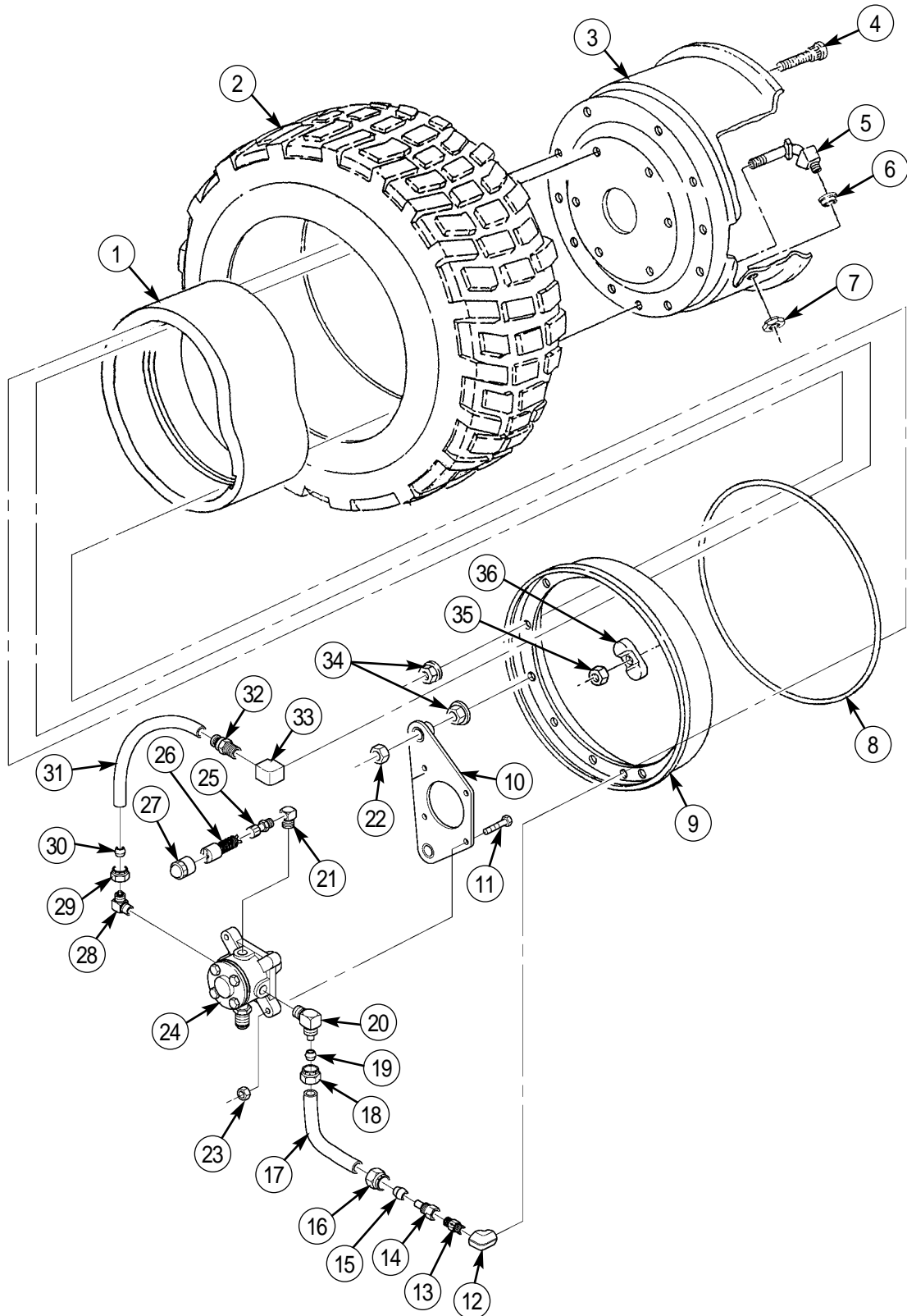

TIRE AND WHEEL REPAIR (Contd)**CLEANING, INSPECTION, AND REPAIR**

For cleaning, inspection, and repair of tires and rims, refer to TM 9-2610-200-14.

ASSEMBLY

1. Apply sealant to threads of elbows (12), (20), (21), (28), and (33), adapters (13) and (32), connector (14), and valve (25).

NOTE

Assistant will help with steps 2 and 3.

2. Center beadlock (1) in tire (2).
3. Install grommet (6) and turret valve (5) on inner rim (3) with nut (7). Tighten nut (7) 40-65 lb-ft (54-88 N•m).

NOTE

Assistant will help with step 4.

Do not stretch or twist seal.

Lubricate O-ring before installation.

4. Install beadlock (1) and tire (2) on inner rim (3).
5. Install new O-ring (8) on groove of inner rim (3).
6. Install outer rim (9) on ten inner rim studs (4) with new locknuts (34). Finger-tighten locknuts (34).
7. Alternately and evenly tighten ten locknuts (34) on inner rim studs (4). Tighten locknuts (34) 425-475 lb-ft (576-644 N•m).
8. Install air valve (24) on mounting bracket (10) with four screws (11) and new locknuts (23).
9. Install mounting bracket (10) on two studs (4) with nuts (22).

CAUTION

Elbows must be installed in their proper position and location as previously noted. Failure to do so may cause kinking to air lines when installed.

10. Install elbow (21) on air valve (24).
11. Install valve (25), valve core (26), and cap (27) on elbow (21).
12. Install elbows (20) and (28) on air valve (24).
13. Install elbow (12) on turret valve (5).
14. Install adapters (13) and (32) on elbows (12) and (33).
15. Install connector (14) on adapter (13).
16. Install air tube (17) on connector (14) with sleeve (15) and nut (16).
17. Install air tube (17) on elbow (20) with sleeve (19) and nut (18).
18. Install counterweight (36) on inner rim stud (4) with nut (35).
19. Install air tube (31) on adapter (32) and elbow (33).
20. Install air tube (31) on elbow (28) with sleeve (30) and nut (29).
21. Inflate tire to proper pressure (TM 9-2320-386-10).
22. Install tire and wheel (WP 0174 00).
23. Start engine (TM 9-2320-386-10) and allow air pressure to build. Check for air leaks.

TIRE AND WHEEL REPAIR (Contd)

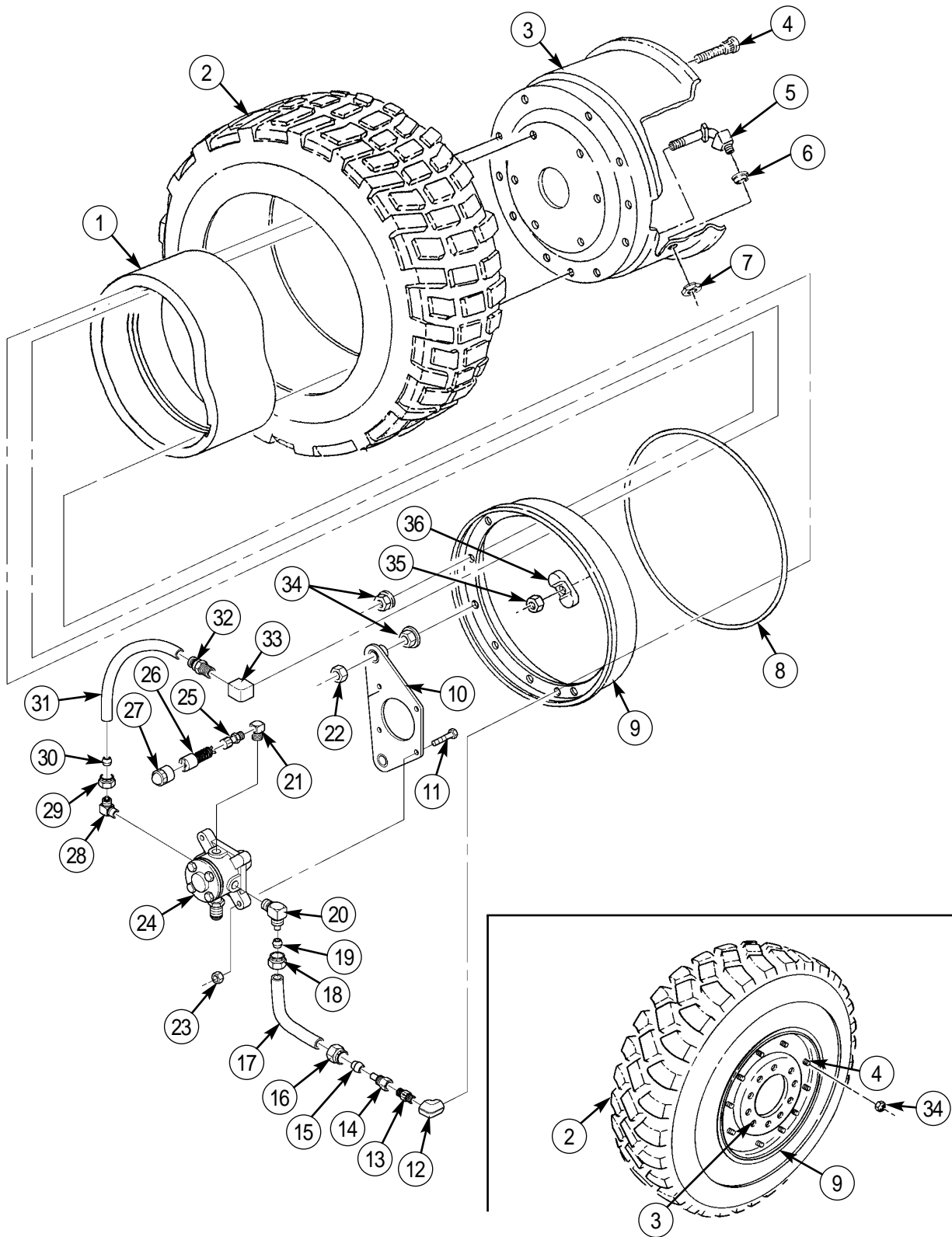

END OF WORK PACKAGE

UNIT MAINTENANCE INSTRUCTIONS

EXTENDED SERVICE PROGRAM (ESP)

TRUCK, CARGO, 2-1/2-TON, 6X6, M44A3 SERIES TRUCKS (DIESEL)

M35A3, W/O WINCH (NSN 2320-01-383-2047); W/WINCH (NSN 2320-01-383-3850);

M35A3C, W/O WINCH (NSN 2320-01-383-2050); W/WINCH (NSN 2320-01-383-2049);

M36A3, W/O WINCH (NSN 2320-01-383-2048); W/WINCH (NSN 2320-01-383-2046).

CTIS WHEEL VALVE AND FILTER MAINTENANCE

REMOVAL, IN-LINE FILTER INSPECTION AND CLEANING, INSTALLATION

INITIAL SETUP:

Tools and Special Tools

General mechanic's tool kit
(item 30, WP 0394 00)

References

TM 9-2320-386-24P

Materials/Parts

Four locknuts (item 85, WP 0395 00)
Two lockwashers (item 186, WP 0395 00)
Teflon pipe sealant (item 41, WP 0393 00)
Skysol-100 (item 17, WP 0393 00)

Equipment Condition

Parking brake set (TM 9-2320-386-10).
Air reservoirs drained (TM 9-2320-386-10).

CTIS WHEEL VALVE AND FILTER MAINTENANCE (Contd)**REMOVAL****WARNING**

Do not disconnect air lines and fittings before draining reservoirs. Small parts under pressure may shoot out with high velocity, causing injury to personnel.

Eyeshields must be worn when releasing compressed air. Failure to do so may result in injury to personnel.

NOTE

Front and rear wheel valve assemblies are replaced basically the same. This procedure covers the left front wheel valve.

Tag all hoses, lines, and tubes for installation.

1. Remove cap (2) from wheel valve stem (4) and drain air from tire. Install cap (2) on wheel valve (4).
2. Remove two nuts (21), screws (23), lockwashers (22), and stone shield (1) from wheel (13). Discard lockwashers (22).
3. Remove air line (5) from elbow (3) and connector (7).
4. Remove air line (18) from elbow (19) and connector (17).
5. Remove two nuts (8) and mounting plate (10) from wheel (13).
6. Remove four locknuts (6), screws (11), and wheel valve (20) from mounting plate (10). Discard locknuts (6).
7. Remove elbows (3) and (19) from wheel valve (20).
8. Remove in-line filter (16) and connector (17) from elbow (15).
9. Remove connector (7) from elbow (9).
10. Remove elbows (9) and (15) from hollow stud (12) and turret valve (14).

IN-LINE FILTER CLEANING AND INSPECTION**WARNING**

Skysol-100 mixture is combustible. Use mechanical ventilation whenever product is used in a confined space, is heated above ambient temperatures, or is agitated. DO NOT use or store near heat, sparks, flame, or other ignition sources. Keep container sealed when not in use.

Contact with Skysol-100 may cause skin irritation. Use chemical resistant gloves. In case of skin contact, remove any contaminated clothing and wash skin thoroughly with soap and water. Wash contaminated clothing before reuse. Eye contact may cause irritation, tearing, or blurring of vision. Use face shield or goggles when eye contact may occur. In case of eye contact, flush eyes with large amounts of water for at least fifteen (15) minutes or until irritation subsides. Inhalation may cause irritation to upper respiratory passages. DO NOT have food or drink in the vicinity.

1. Inspect in-line filter (16) for dirt, oil, debris, and other contaminants.
2. Clean in-line filter (16) in Skysol-100 and air dry.

CTIS WHEEL VALVE AND FILTER MAINTENANCE (Contd)

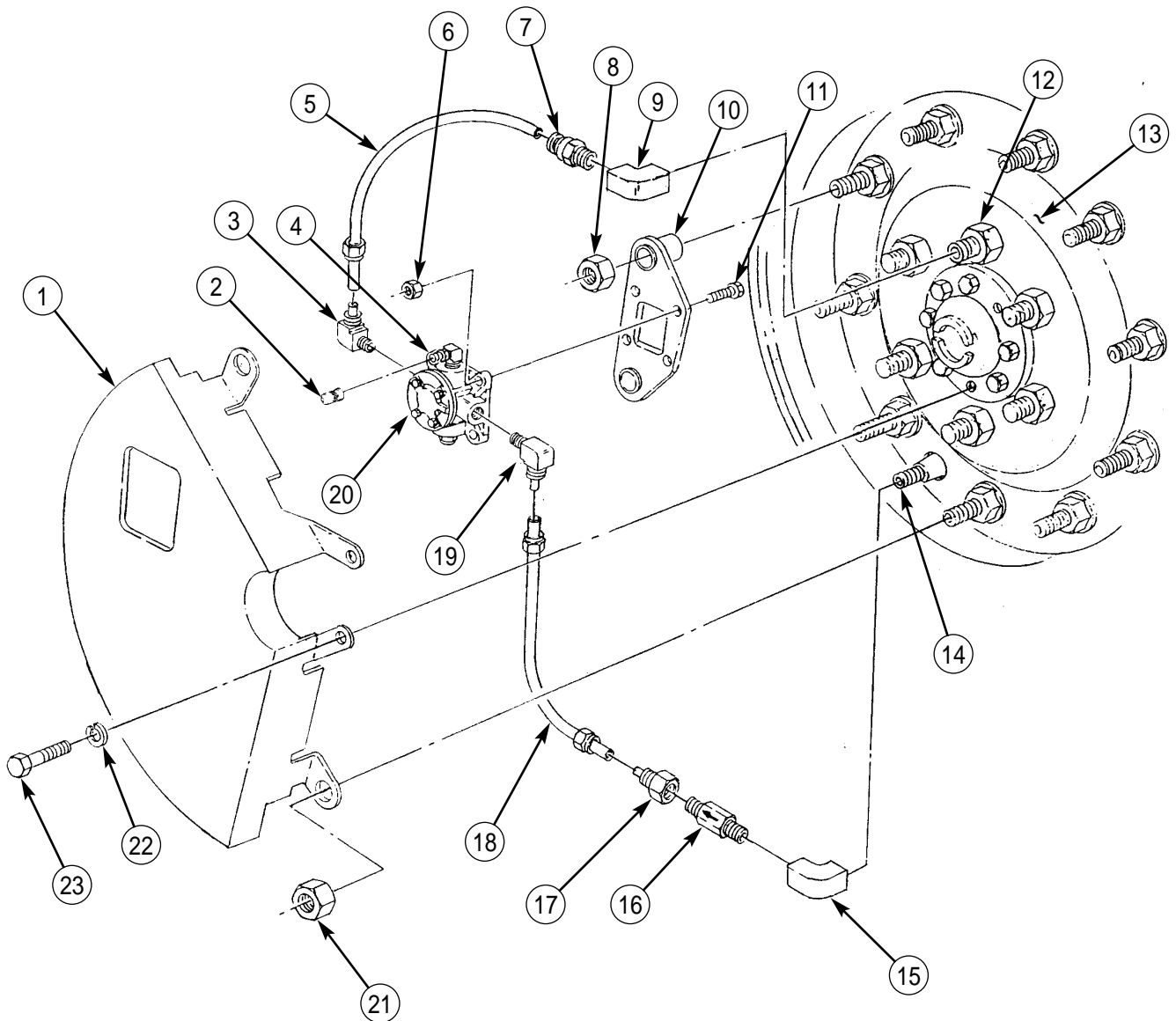

CTIS WHEEL VALVE AND FILTER MAINTENANCE (Contd)**INSTALLATION**

1. Apply sealant to male threads of in-line filter (15), connectors (6) and (16), elbows (3) and (18), hollow stud (11), and turret valve (13).
2. Install elbows (3) and (18) on wheel valve (2).
3. Install wheel valve (2) on mounting plate (9) with four screws (10) and new locknuts (5). Tighten locknuts (5) 18 lb-ft (24 N•m).
4. Install elbows (8) and (14) on hollow stud (11) and turret valve (13).
5. Install connector (6) on elbow (8).

NOTE

Arrow on in-line filter must point toward wheel valve.

6. Install connector (16) and in-line filter (15) on elbow (14).
7. Install air line (17) on elbow (18) and connector (16).
8. Install mounting plate (9) on wheel (12) with two nuts (7).
9. Install air line (4) on elbow (3) and connector (6).
10. Install stone shield (1) on wheel (12) with two nuts (19), new lockwashers (20), and screws (21). Tighten screws (21) 81-104 lb-ft (110-141 N•m) and nuts (19) 60-80 lb-ft (81-108 N•m).
11. Start engine (TM 9-2320-386-10) and allow air pressure to build up to normal operating pressure. Check for air leaks and road test vehicle.

CTIS WHEEL VALVE AND FILTER MAINTENANCE (Contd)

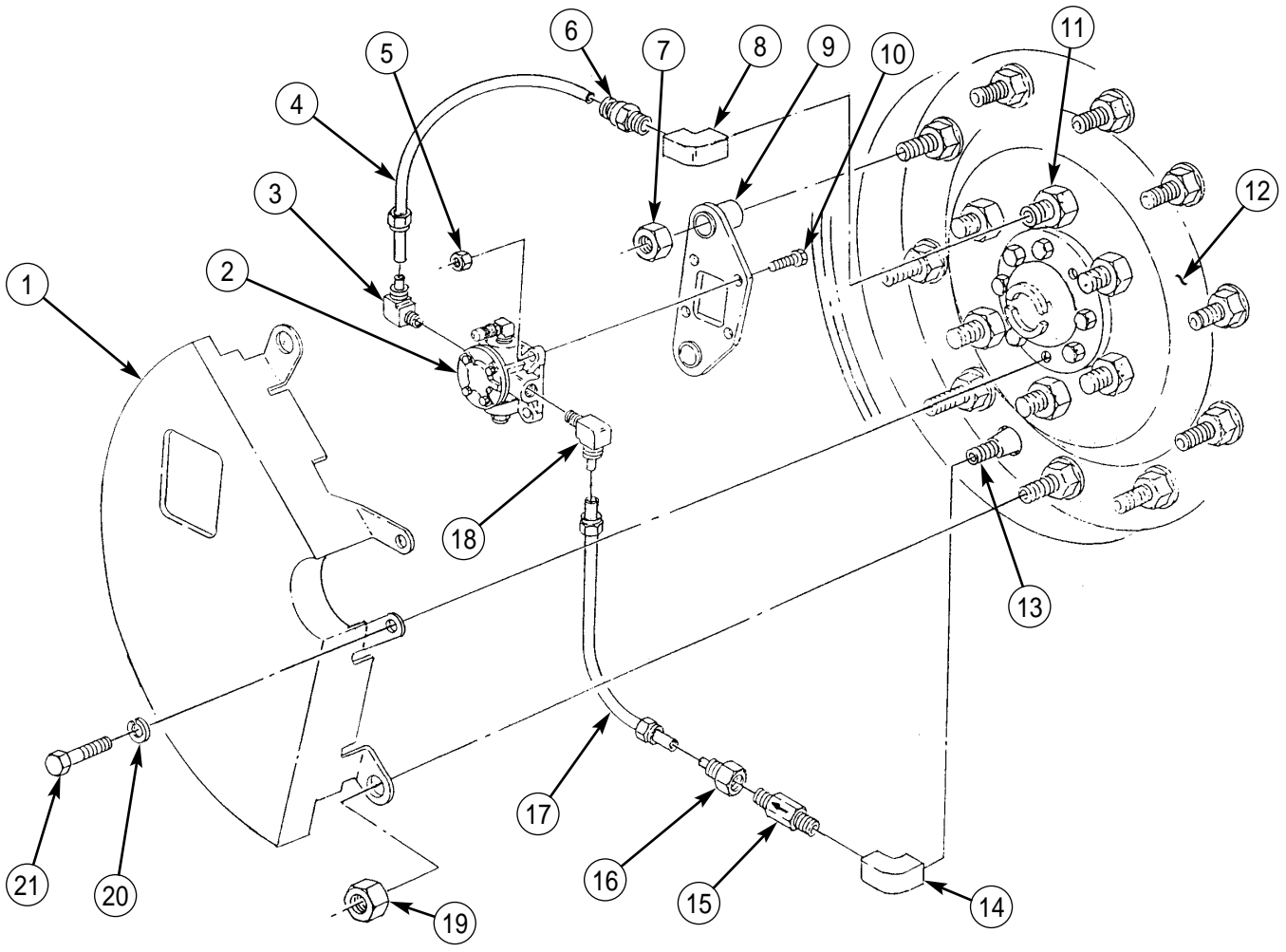

END OF WORK PACKAGE

UNIT MAINTENANCE INSTRUCTIONS

EXTENDED SERVICE PROGRAM (ESP)

TRUCK, CARGO, 2-1/2-TON, 6X6, M44A3 SERIES TRUCKS (DIESEL)

M35A3, W/O WINCH (NSN 2320-01-383-2047); W/WINCH (NSN 2320-01-383-3850);

M35A3C, W/O WINCH (NSN 2320-01-383-2050); W/WINCH (NSN 2320-01-383-2049);

M36A3, W/O WINCH (NSN 2320-01-383-2048); W/WINCH (NSN 2320-01-383-2046).

CTIS WHEEL VALVE REPAIR

REMOVAL, DISASSEMBLY, CLEANING AND INSPECTION, ASSEMBLY, INSTALLATION

INITIAL SETUP:

Tools and Special Tools

General mechanic's tool kit
(item 30, WP 0394 00)
Common No. 1 tool kit
(item 15, WP 0394 00)

References

TM 9-2320-386-24P

Equipment Condition

Parking brake set (TM 9-2320-386-10).
Air reservoirs drained (TM 9-2320-386-10).

Materials/Parts

Two lockwashers (item 186, WP 0395 00)
Four locknuts (item 85, WP 0395 00)
Teflon pipe sealant (item 41, WP 0393 00)
Skysol-100 (item 17, WP 0393 00)
Wheel valve repair kit
(item 255, WP 0395 00)

CTIS WHEEL VALVE REPAIR (Contd)**REMOVAL****WARNING**

Do not disconnect air lines and fittings before draining reservoirs. Small parts under pressure may shoot out with high velocity, causing injury to personnel.

Eyeshields must be worn when releasing compressed air. Failure to do so may result in injury to personnel.

NOTE

Front and rear wheel valve assemblies are repaired the same. This procedure covers the left front wheel valve.

Tag all hoses, lines, and tubes for installation.

1. Remove two screws (16) and lockwashers (15) from stone shield (17) and flange (6). Discard lockwashers (15).
2. Remove two nuts (14) and stone shield (17) from two studs (7).
3. Remove valve cap (18) and valve core (19) from air valve (12) and deflate tire. Install valve core (19) and valve cap (18) on air valve (12) after deflating tire.
4. Loosen nut (21) and remove air line (1) from elbow (20) on wheel valve (13).
5. Remove two nuts (2) from studs (5) and wheel valve mounting plate (3).
6. Loosen nut (9) and remove wheel valve mounting plate (3) and air line (10) from adapter (8) and studs (5) at the same time.
7. Remove four locknuts (11), screws (4), and wheel valve (13) from wheel valve mounting plate (3). Discard locknuts (11).

CTIS WHEEL VALVE REPAIR (Contd)

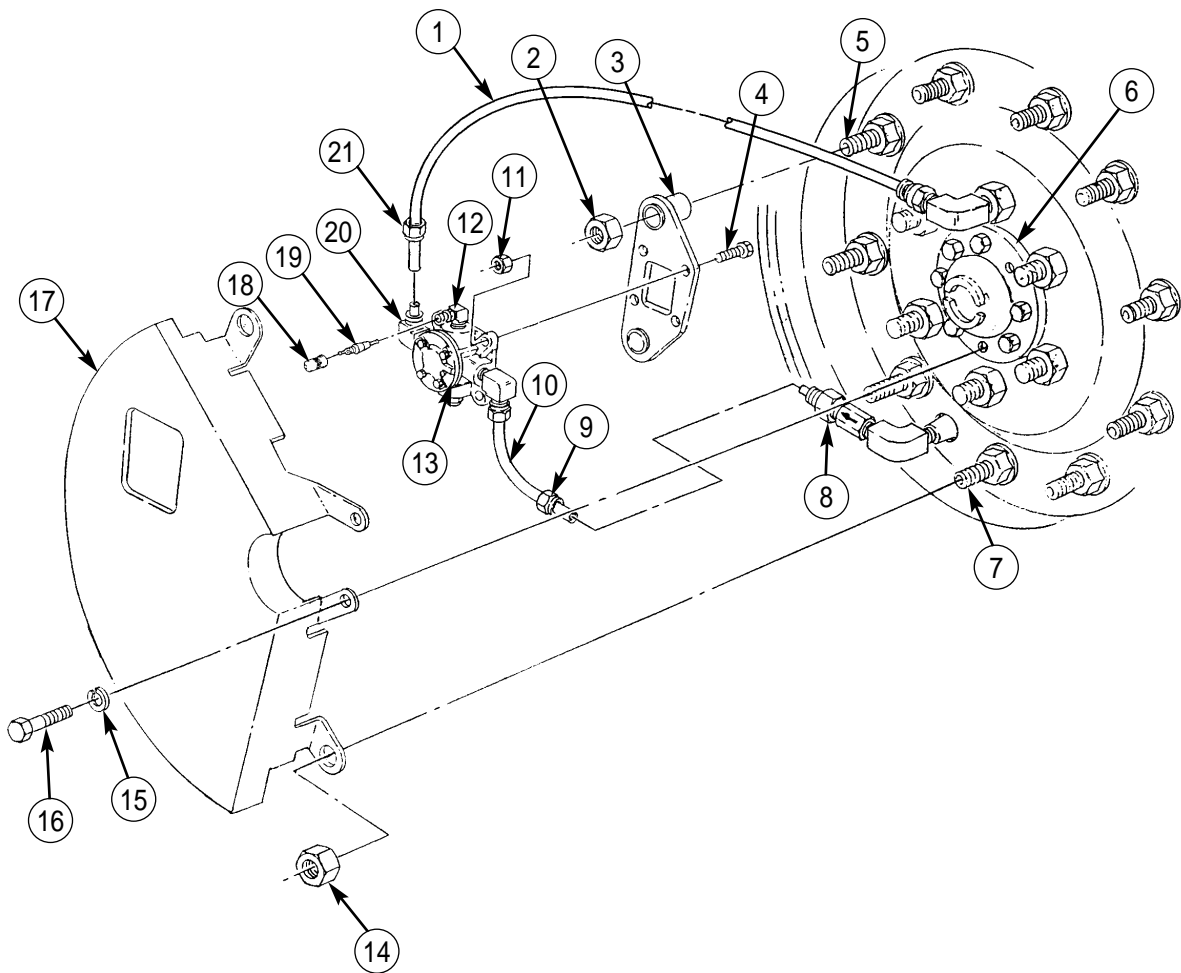

CTIS WHEEL VALVE REPAIR (Contd)

DISASSEMBLY

NOTE

CTIS wheel valves are disassembled the same.

Note position of elbows if removed, for installation.

1. If replacement is necessary, remove elbows (1), (10), and (11) from wheel valve (2).
2. Remove four screws (13), poppet valve end cover (12), spring (14), poppet valve (15), and O-ring (16) from wheel valve (2). Discard screws (13), spring (14), O-ring (16), and poppet valve (15).
3. Remove four screws (9), pilot valve end cover (8), and diaphragm (7) from wheel valve (2). Discard screws (9) and diaphragm (7).
4. Remove piston (6) from wheel valve (2) and remove O-ring (5) from piston (6). Discard O-ring (5).
5. Remove breather (3) from wheel valve (2).
6. Remove check valve (4) from breather (3). Discard check valve (4).

CLEANING AND INSPECTION

WARNING

Skysol-100 mixture is combustible. Use mechanical ventilation whenever product is used in a confined space, is heated above ambient temperatures, or is agitated. DO NOT use or store near heat, sparks, flame, or other ignition sources. Keep container sealed when not in use.

Contact with Skysol-100 may cause skin irritation. Use chemical resistant gloves. In case of skin contact, remove any contaminated clothing and wash skin thoroughly with soap and water. Wash contaminated clothing before reuse. Eye contact may cause irritation, tearing, or blurring of vision. Use face shield or goggles when eye contact may occur. In case of eye contact, flush eyes with large amounts of water for at least fifteen (15) minutes or until irritation subsides. Inhalation may cause irritation to upper respiratory passages. DO NOT have food or drink in the vicinity.

1. Clean all metal parts with Skysol-100 and dry with clean compressed air.
2. Inspect all metal parts and valve seats for cracks, wear, nicks, silt buildup, stripped threads and other signs of wear.
3. Replace all damaged parts as necessary.

ASSEMBLY

1. If elbows (1), (10), and (11) were removed, apply sealant to male threads and install on wheel valve (2).
2. Apply sealant to male threads of breather (3) and install breather (3) on wheel valve (2).
3. Install new check valve (4) on breather (3).
4. Install new O-ring (5) on piston (6) and slide piston (6) into wheel valve (2).

NOTE

Align slot in pilot valve end cover, hole in diaphragm, and hole in wheel valve at assembly.

5. Install new diaphragm (7) with flanged lip down on piston (6) and wheel valve (2).
6. Install pilot end cover (8) on diaphragm (7) and wheel valve (2) with four new screws (9).
7. Install new O-ring (16), new poppet valve (15), new spring (14), and poppet valve end cover (12) on wheel valve (2) with four new screws (13).

CTIS WHEEL VALVE REPAIR (Contd)

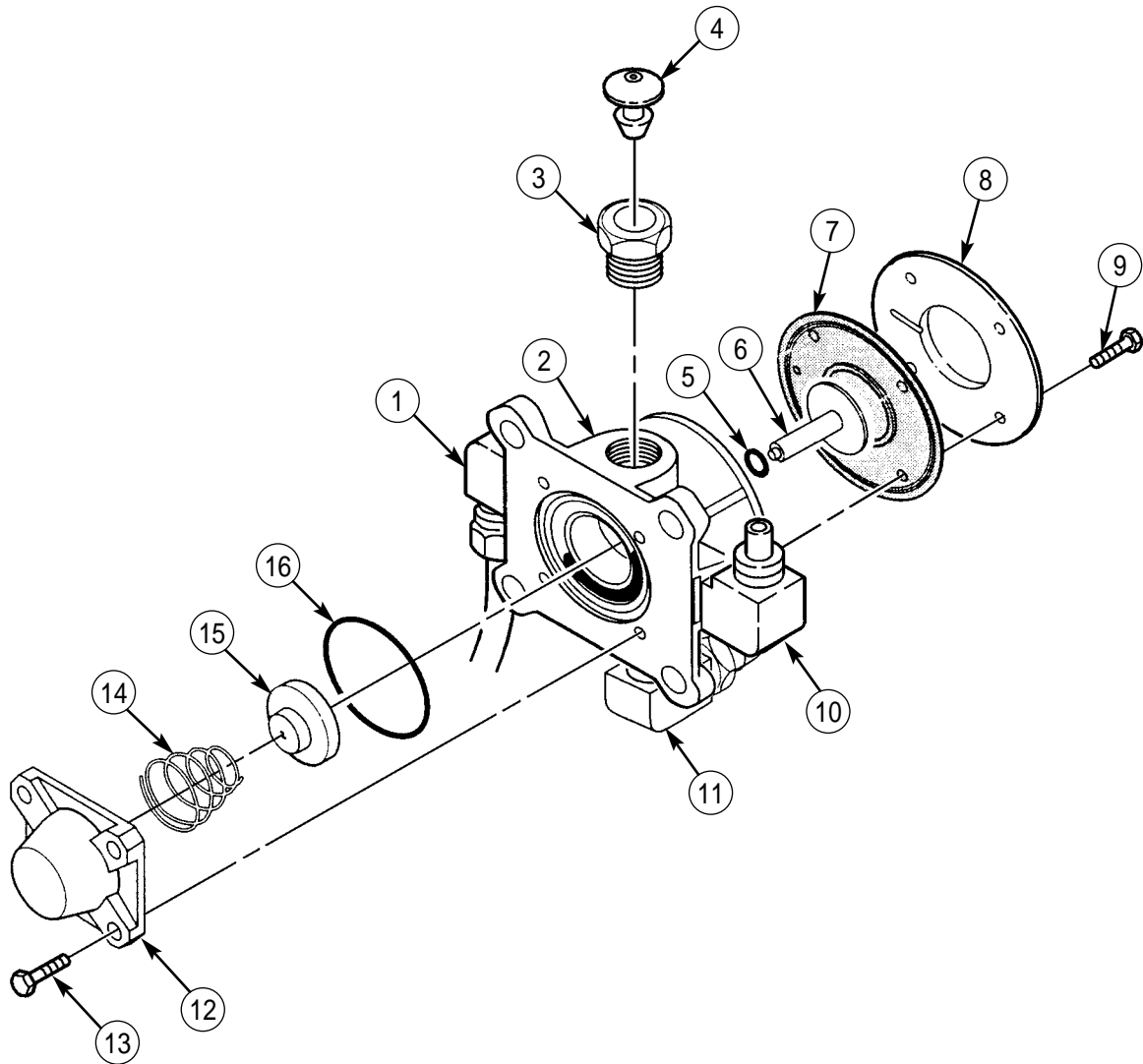

CTIS WHEEL VALVE REPAIR (Contd)**INSTALLATION**

1. Install wheel valve (13) on wheel valve mounting plate (3) with four screws (4) and new locknuts (11). Tighten locknuts (11) 18 lb-ft (24 N•m).
2. Connect air line (10) on adapter (8) and tighten nut (9) at the same time as wheel valve mounting plate (3) is installed on studs (5) with two nuts (2).
3. Install air line (1) to elbow (19) on wheel valve (13) and tighten nut (20).
4. Install stone shield (17) on two studs (7) with two nuts (14). Tighten nuts (14) 60-80 lb-ft (81-108 N•m).
5. Install stone shield (17) on flange (6) with two new lockwashers (15) and screws (16). Tighten screws (16) 81-104 lb-ft (110-141 N•m).
6. Remove valve cap (18) from air valve (12), inflate tire, and install valve cap (18).
7. Start engine (TM 9-2320-386-10) and allow air pressure to build up to normal operating pressure. Check for air leaks and road test vehicle.
8. Operate CTIS (TM 9-2320-386-10) and check for air leaks.

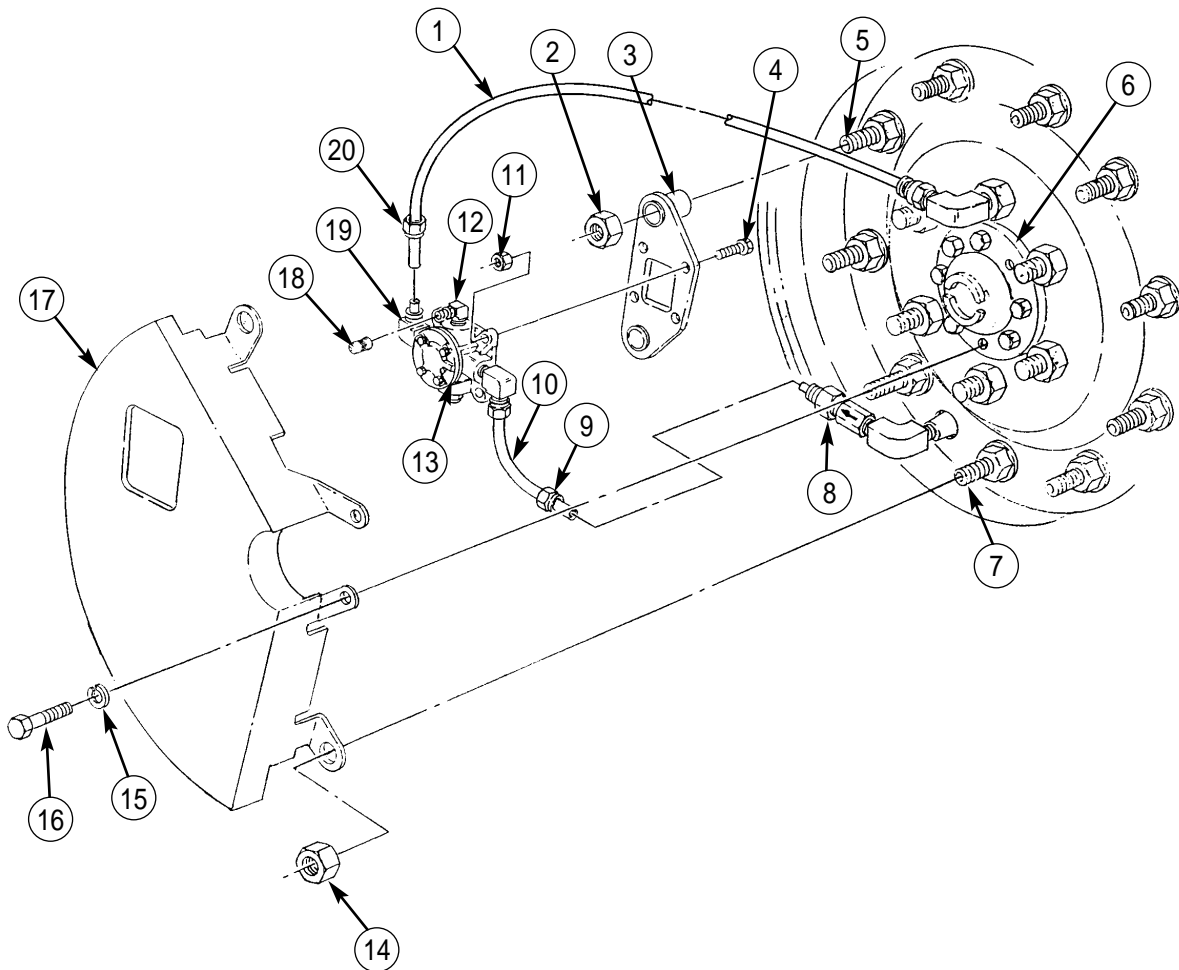
**END OF WORK PACKAGE**

UNIT MAINTENANCE INSTRUCTIONS

EXTENDED SERVICE PROGRAM (ESP)

TRUCK, CARGO, 2-1/2-TON, 6X6, M44A3 SERIES TRUCKS (DIESEL)

M35A3, W/O WINCH (NSN 2320-01-383-2047); W/WINCH (NSN 2320-01-383-3850);

M35A3C, W/O WINCH (NSN 2320-01-383-2050); W/WINCH (NSN 2320-01-383-2049);

M36A3, W/O WINCH (NSN 2320-01-383-2048); W/WINCH (NSN 2320-01-383-2046).

Section XV. STEERING SYSTEM MAINTENANCE

TABLE OF CONTENTS

<i>WP Title</i>	<i>WP Sequence No.-Page No.</i>
Toe-In Check and Adjustment	0179 00-1
Pitman Arm Maintenance	0180 00-1
Drag Link Maintenance	0181 00-1
Steering Gear Adjustment	0182 00-1
Steering Assist Cylinder Maintenance	0183 00-1
Steering Assist Regulator Replacement	0184 00-1
Manual Shutoff Valve Replacement	0185 00-1
Steering Assist Hose Replacement	0186 00-1

END OF WORK PACKAGE

UNIT MAINTENANCE INSTRUCTIONS

EXTENDED SERVICE PROGRAM (ESP)

TRUCK, CARGO, 2-1/2-TON, 6X6, M44A3 SERIES TRUCKS (DIESEL)

M35A3, W/O WINCH (NSN 2320-01-383-2047); W/WINCH (NSN 2320-01-383-3850);
M35A3C, W/O WINCH (NSN 2320-01-383-2050); W/WINCH (NSN 2320-01-383-2049);
M36A3, W/O WINCH (NSN 2320-01-383-2048); W/WINCH (NSN 2320-01-383-2046).

TOE-IN CHECK AND ADJUSTMENT

CHECK, ADJUSTMENT

INITIAL SETUP:

Tools and Special Tools

General mechanic's tool kit
(item 30, WP 0394 00)
Common No. 1 tool kit (item 15, WP 0394 00)

Materials/Parts

Six lockwashers (item 186, WP 0395 00)

Personnel Required

Assistant (1)

References

TM 9-2320-386-24P

Equipment Condition

Parking brake set (TM 9-2320-386-10).
Tires inflated to proper level (TM 9-2320-386-10).
Tires inspected for wear (TM 9-2320-386-10).
Wheel bearings adjusted (TM 9-2320-361-20).
Steering gear adjusted (WP 0182 00).

Special Environmental Conditions

Vehicle must be on flat, level surface.

TOE-IN CHECK AND ADJUSTMENT (Contd)

CHECK

1. Remove two screws (6) and lockwashers (5) from stone shield (2) and flange (3). Discard lockwashers (5).
2. Remove two nuts (1) and stone shield (2) from studs (4).
3. Repeat steps 1 and 2 to remove other two stone shields on same side of truck.
4. Using string, align front wheels with rear wheels so wheels are positioned straight ahead.

TOE-IN CHECK AND ADJUSTMENT (Contd)

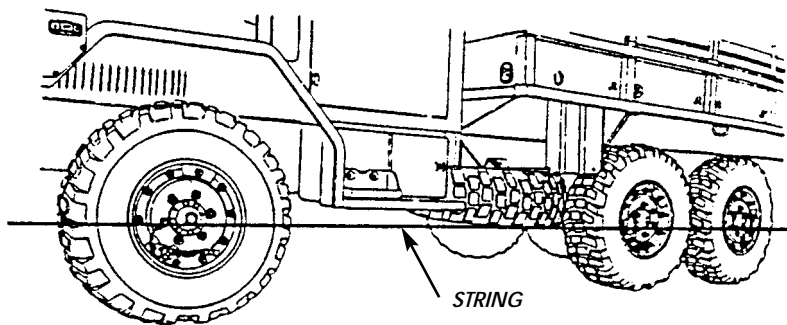
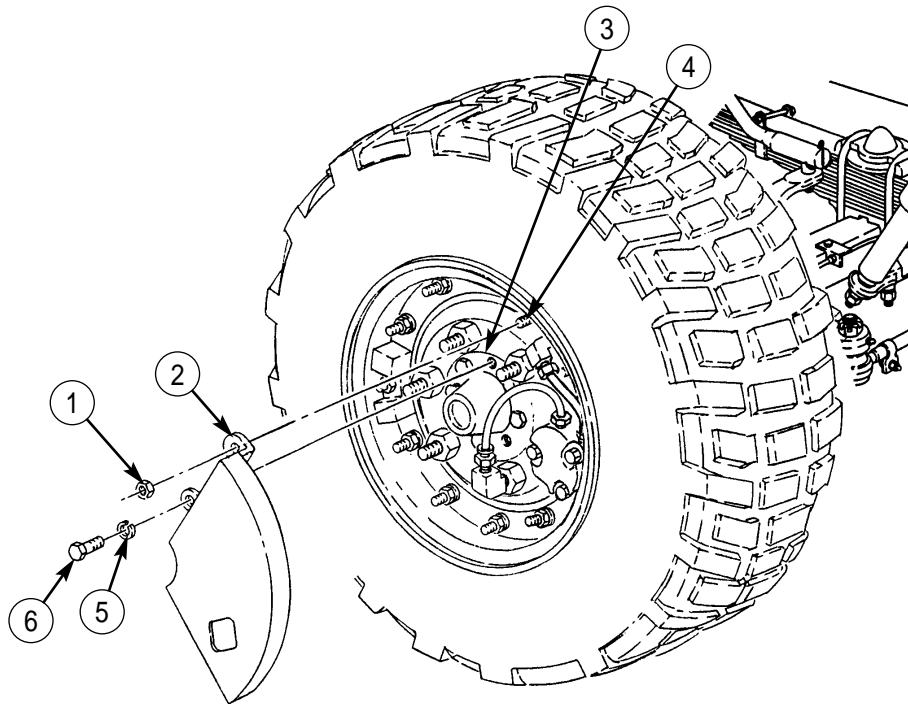

TOE-IN CHECK AND ADJUSTMENT (Contd)**NOTE**

Ensure all steering system components are tightened to proper installation specifications. Replace any damaged steering component.

Steps 5 through 7 will determine centerline of tire.

Points of measurement for checking toe-in will be where lines marked in steps 5 and 7 intersect.

Ensure tie rod ends are centered in opposite direction when tires are centered.

5. Mark line (1) on center tread (2) of tire (3) 18-5/16 in. (46.5 cm) from ground.
6. Measure total width of tire tread (4) and record.
7. Mark line (6) on center tread (2) at one-half total tread width (4).
8. Repeat steps 5 through 7 for opposite tire.
9. Measure center tread distance (5) on front side of tires (3) and record.
10. Rotate tires (3) by moving vehicle forward until points of measurement are 18-5/16 in. (46.5 cm) above the ground at rear side of tires (3).
11. Measure center tread distance (7) on rear side of tires (3) and record.

NOTE

If measurement is larger on front side of tires than measurement on rear side of tires, tires have a toe-out condition.

If toe-in alignment does not meet specifications, repeat checking procedures to eliminate any possible reading errors.

12. Subtract front tire measurement, obtained in step 9, from rear tire measurement obtained in step 11. The result of this subtraction represents toe-in. Proper toe-in is 1/16-3/16 in. (1.59-4.76 mm).

TOE-IN CHECK AND ADJUSTMENT (Contd)

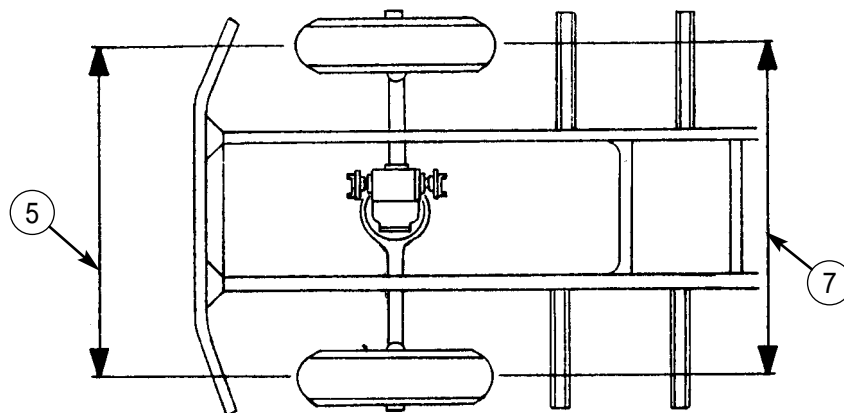
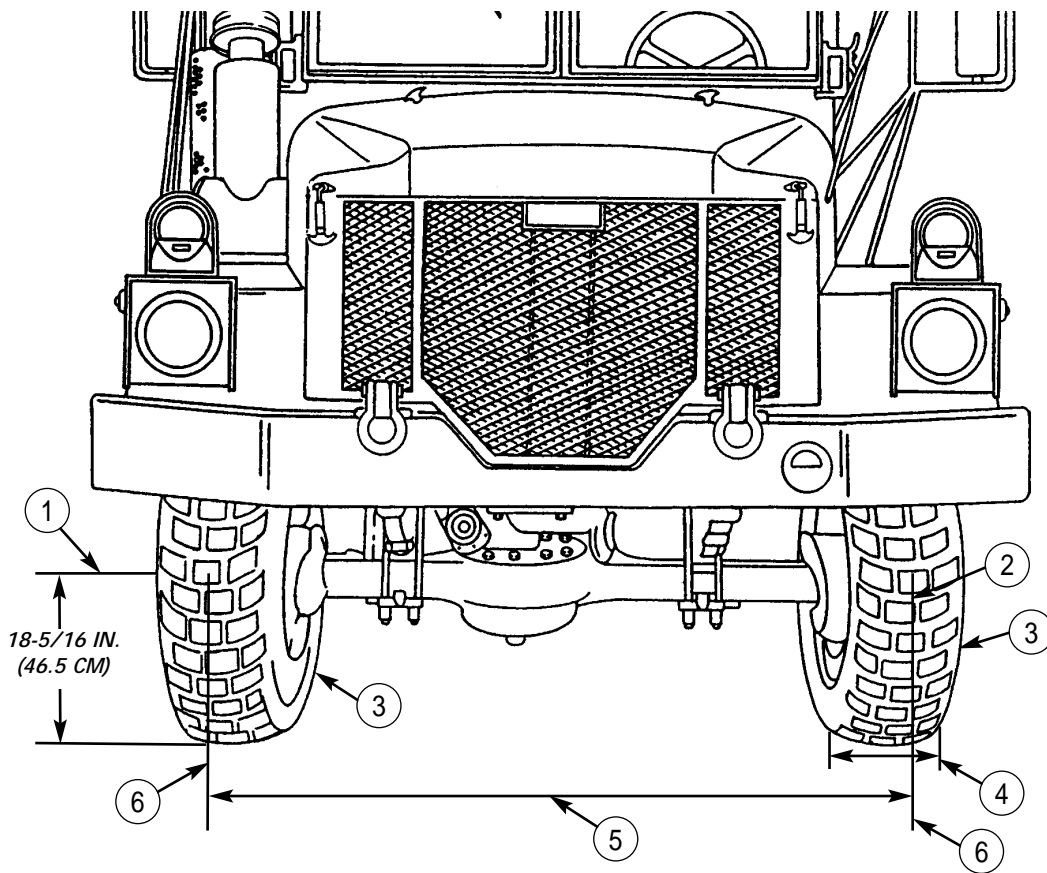

TOE-IN CHECK AND ADJUSTMENT (Contd)**ADJUSTMENT**

1. Loosen two nuts (2) at each end of tie rod (1).
2. Turn tie rod (1) in one-half turn increments, measure toe-in until toe-in of 1/16-3/16 in. (1.59-4.76 mm) is obtained, and tighten two nuts (2) 170 lb-ft (231 N•m).
3. Install stone shield (4) on two studs (6) with nuts (3). Tighten nuts (3) 60-80 lb-ft (81-108 N•m).
4. Install stone shield (4) on flange (5) with two new lockwashers (7) and screws (8). Tighten screws (8) 81-104 lb-ft (110-141 N•m).
5. Repeat steps 3 and 4 to install other two stone shields.

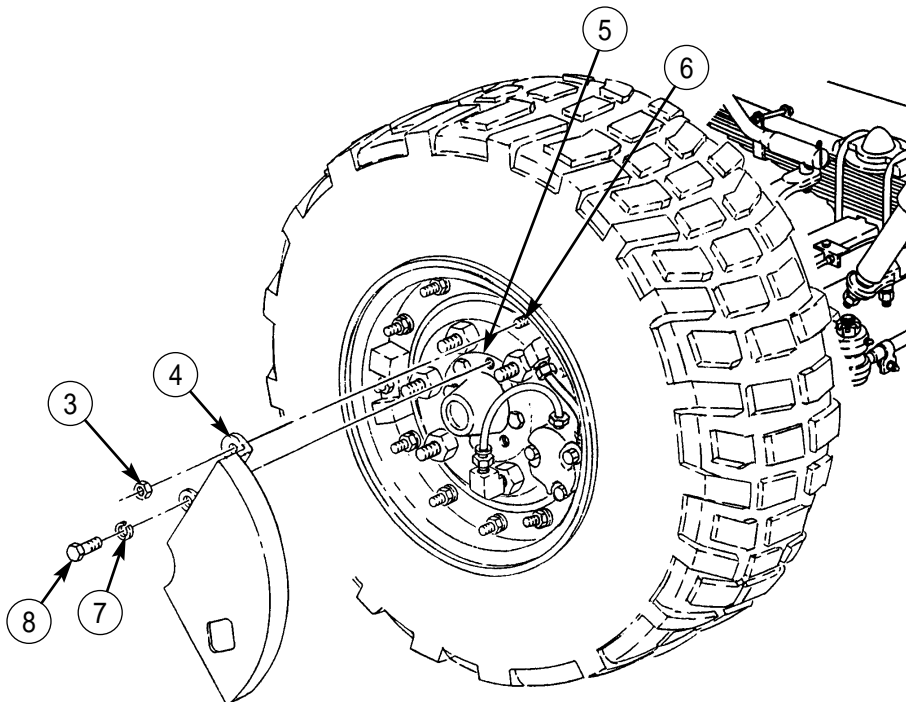
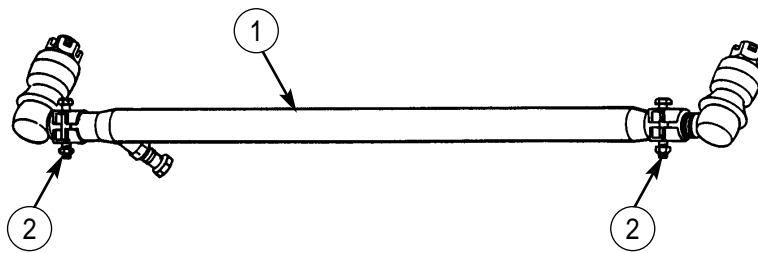
**END OF WORK PACKAGE**

UNIT MAINTENANCE INSTRUCTIONS

EXTENDED SERVICE PROGRAM (ESP)

TRUCK, CARGO, 2-1/2-TON, 6X6, M44A3 SERIES TRUCKS (DIESEL)

M35A3, W/O WINCH (NSN 2320-01-383-2047); W/WINCH (NSN 2320-01-383-3850);
M35A3C, W/O WINCH (NSN 2320-01-383-2050); W/WINCH (NSN 2320-01-383-2049);
M36A3, W/O WINCH (NSN 2320-01-383-2048); W/WINCH (NSN 2320-01-383-2046).

PITMAN ARM MAINTENANCE

REMOVAL, INSPECTION, INSTALLATION

INITIAL SETUP:

Tools and Special Tools

General mechanic's tool kit
(item 30, WP 0394 00)
Common No. 1 tool kit (item 15, WP 0394 00)

Materials/Parts

Cotter pin (item 31, WP 0395 00)
Lockwasher (item 66, WP 0395 00)
Six lockwashers (item 186, WP 0395 00)
Grease (item 22, WP 0393 00)

References

TM 9-2320-386-24P

Equipment Condition

Parking brake set (TM 9-2320-386-10).
Rear wheels chocked (TM 9-2320-386-10).

PITMAN ARM MAINTENANCE (Contd)**REMOVAL**

1. Remove two screws (6) and lockwashers (5) from stone shield (2) and flange (3). Discard lockwashers (5).
2. Remove two nuts (1) and stone shield (2) from studs (4).
3. Repeat steps 1 and 2 to remove other two stone shields on same side of truck.
4. Using string, align front wheels with rear wheels so wheels are positioned straight ahead.

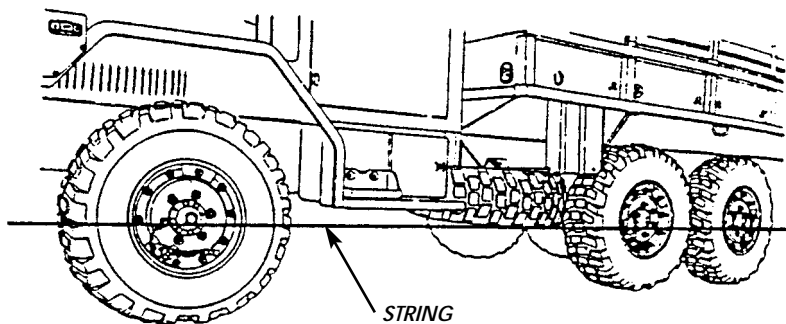
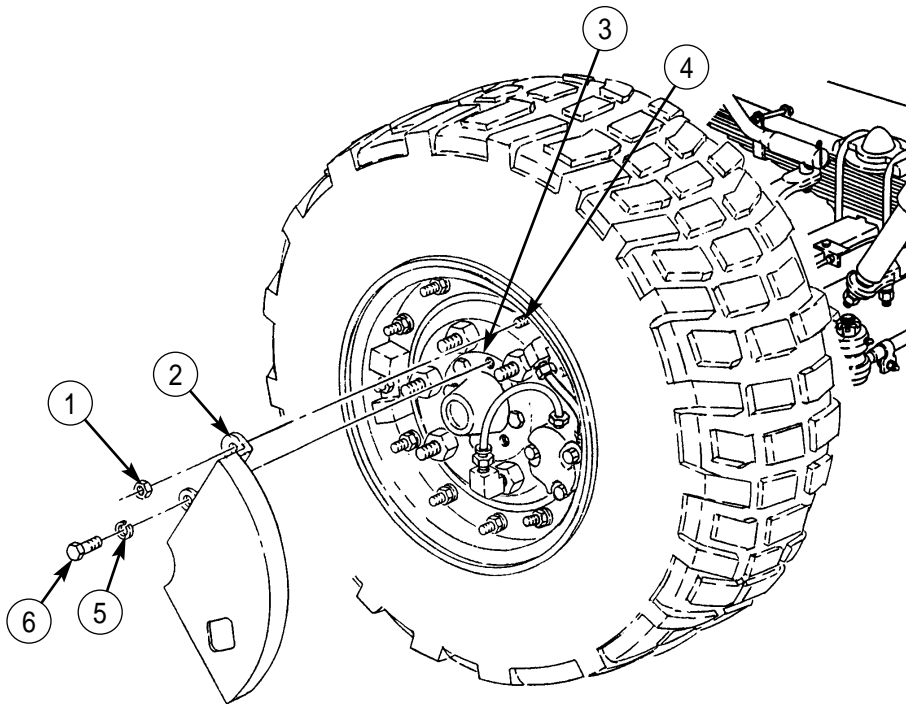

PITMAN ARM MAINTENANCE (Contd)

5. Remove cotter pin (5) from drag link (6). Discard cotter pin (5).
6. Loosen adjusting plug (7) until it is almost out of drag link (6).
7. Turn steering wheel one-half turn right and remove drag link (6) from pitman arm ball (8).
8. Remove nut (1) and lockwasher (2) from shaft (4). Discard lockwasher (2).

NOTE

Mark pitman arm and shaft for installation.

9. Remove pitman arm (3) from shaft (4).

INSPECTION

1. Inspect pitman arm (3) for crack, wear, or damage to spline. Replace pitman arm (3) if necessary.
2. Inspect pitman arm ball (8) for wear or damage to ball. Replace pitman arm (3) if necessary.

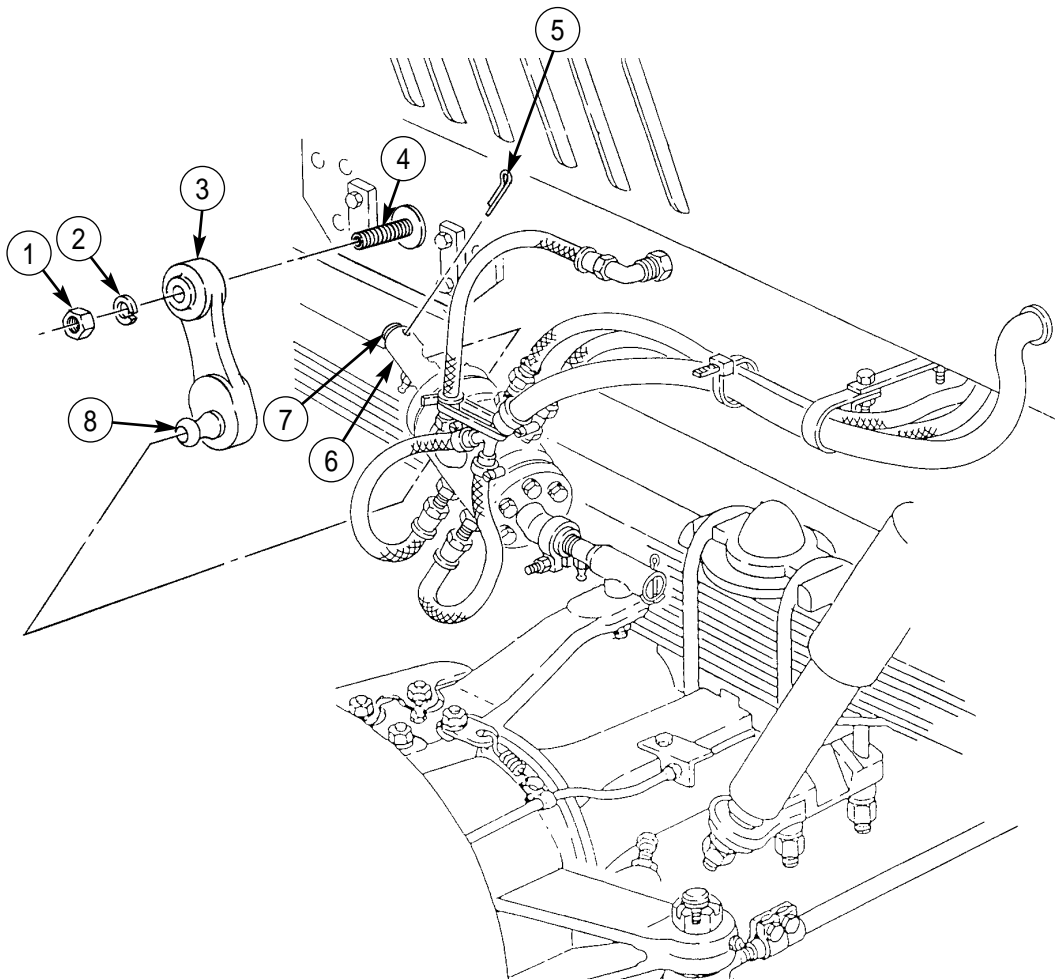

PITMAN ARM MAINTENANCE (Contd)**INSTALLATION**

1. Align marks on pitman arm (3) and shaft (4) and slide pitman arm (3) on shaft (4) until threaded end of shaft (4) is exposed.
2. Install new lockwasher (2) and nut (1) on shaft (4). Tighten nut (1) 180-200 lb-ft (244-271 N•m).
3. Install drag link (6) on pitman arm ball (8).
4. Lubricate drag link (6) with (GAA) grease.
5. Tighten adjusting plug (7) until seated (metal-to-metal), then back off adjusting plug (7) (minimum one-half turn), and install new cotter pin (5).
6. Install stone shield (10) on studs (12) with two nuts (9). Tighten nuts (9) 60-80 lb-ft (81-108 N•m).
7. Install stone shield (10) on flange (11) with two new lockwashers (13) and screws (14). Tighten screws (14) 81-104 lb-ft (110-141 N•m).
8. Repeat steps 6 and 7 to install two stone shields.

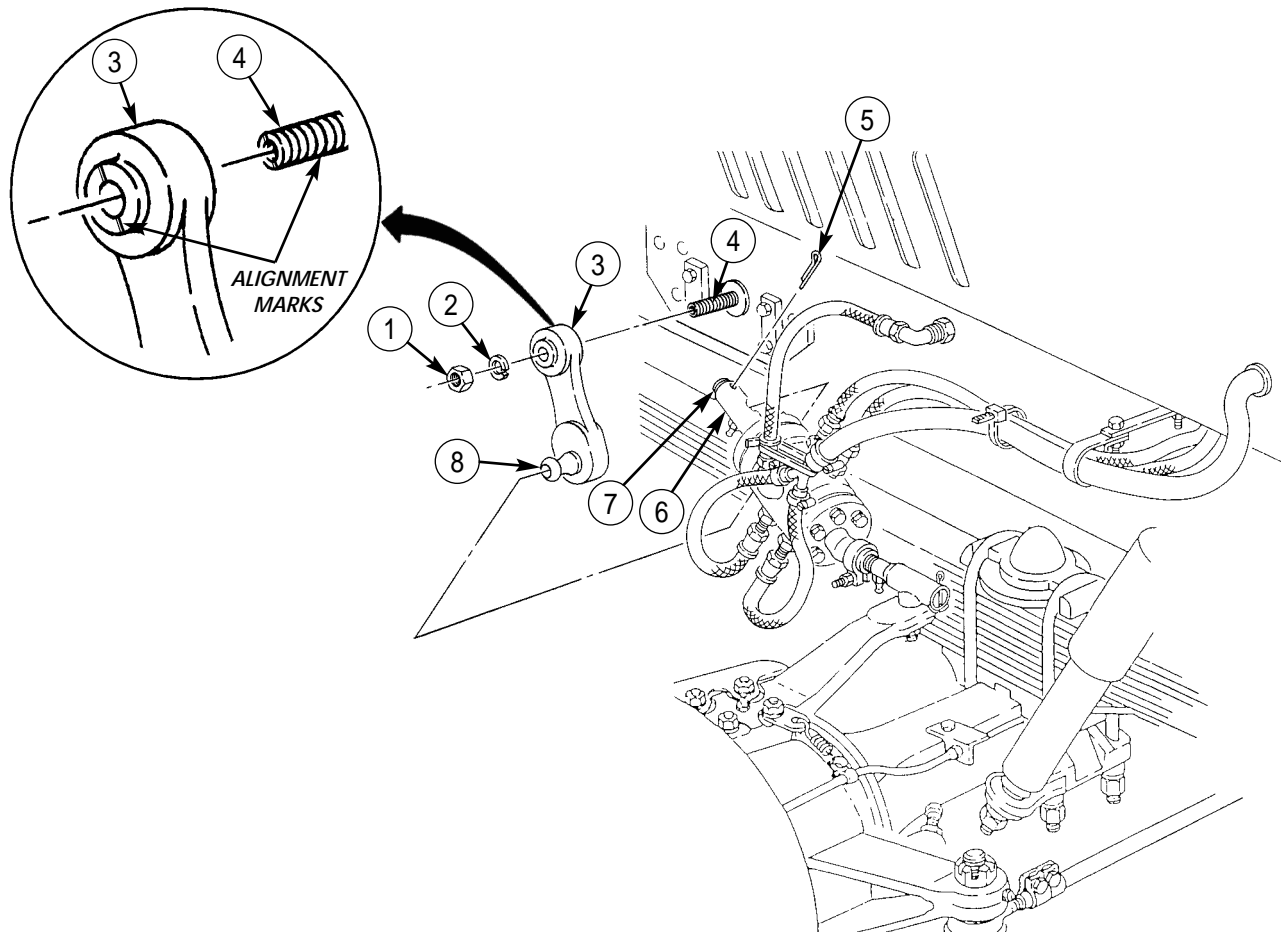

PITMAN ARM MAINTENANCE (Contd)

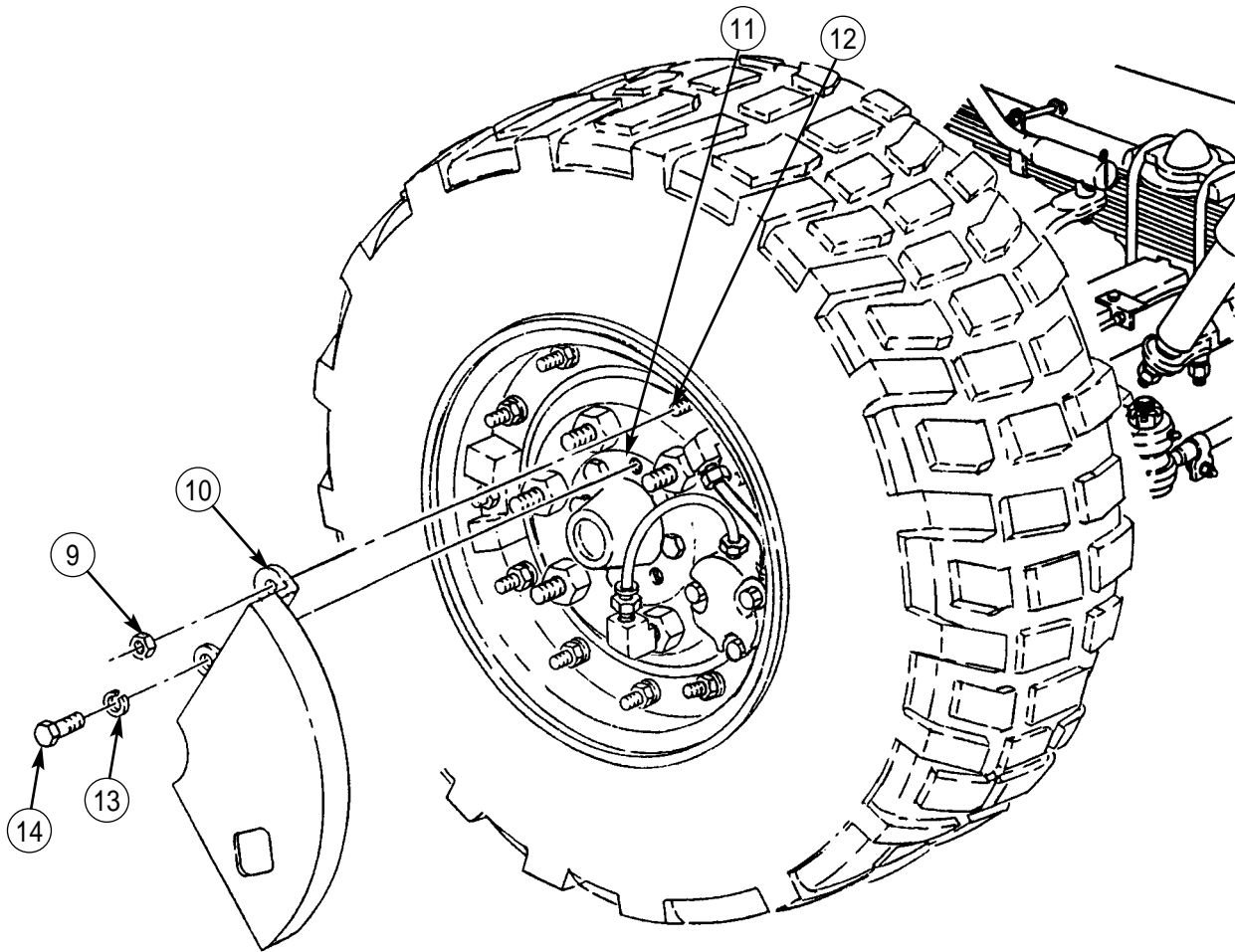

END OF WORK PACKAGE

UNIT MAINTENANCE INSTRUCTIONS

EXTENDED SERVICE PROGRAM (ESP)

TRUCK, CARGO, 2-1/2-TON, 6X6, M44A3 SERIES TRUCKS (DIESEL)

M35A3, W/O WINCH (NSN 2320-01-383-2047); W/WINCH (NSN 2320-01-383-3850);
M35A3C, W/O WINCH (NSN 2320-01-383-2050); W/WINCH (NSN 2320-01-383-2049);
M36A3, W/O WINCH (NSN 2320-01-383-2048); W/WINCH (NSN 2320-01-383-2046).

DRAG LINK MAINTENANCE

REMOVAL, INSTALLATION, ADJUSTMENT

INITIAL SETUP:

Tools and Special Tools

General mechanic's tool kit
(item 30, WP 0394 00)
Common No. 1 tool kit (item 15, WP 0394 00)

Materials/Parts

Six lockwashers (item 186, WP 0395 00)
Two cotter pins (item 31, WP 0395 00)
Tiedown strap (item 36, WP 0395 00)
Teflon pipe sealant (item 41, WP 0393 00)
Cap and plug set (item 14, WP 0393 00)
Grease (item 22, WP 0393 00)

References

TM 9-2320-386-24P

Equipment Condition

Parking brake set (TM 9-2320-386-10).
Rear wheels chocked (TM 9-2320-386-10).

DRAG LINK MAINTENANCE (Contd)**REMOVAL****WARNING**

Do not disconnect air lines before draining air reservoirs. Small parts under pressure may shoot out with high velocity, causing injury to personnel.

Eyeshields must be worn when releasing compressed air. Failure to do this may result in injury to personnel.

CAUTION

When disconnecting air lines and hoses, plug all openings to prevent dirt from entering and causing damage to internal parts.

NOTE

Tag all air lines and hoses for installation.

1. Remove two screws (6) and lockwashers (5) from stone shield (2) and flange (3). Discard lockwashers (5).
2. Remove two nuts (1) and stone shield (2) from studs (4).
3. Repeat steps 1 and 2 to remove other two stone shields.
4. Using string, align front wheels with rear wheels so wheels are positioned straight ahead.

DRAG LINK MAINTENANCE (Contd)

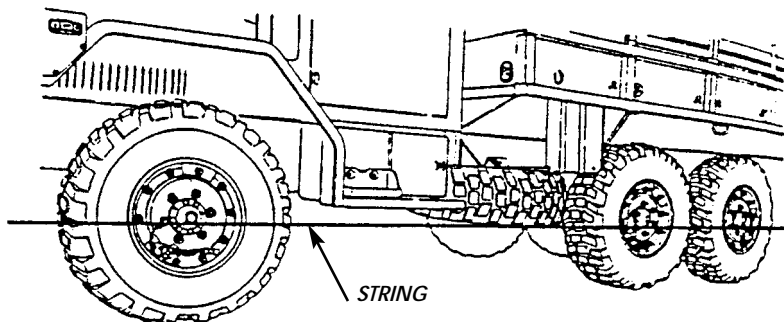
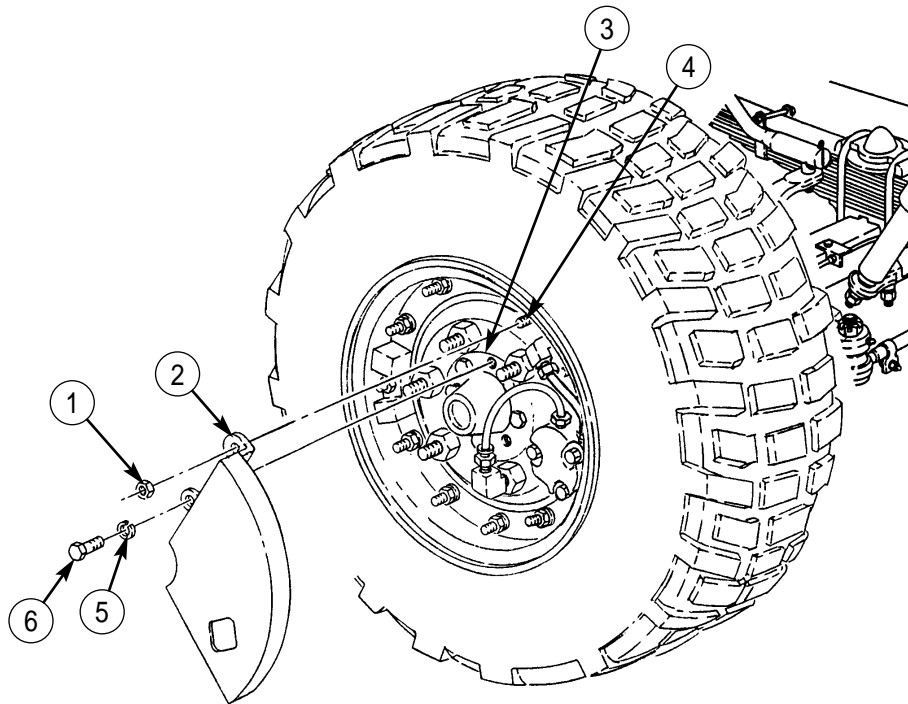

DRAG LINK MAINTENANCE (Contd)

5. Remove cotter pins (1) and (9) from drag link (17). Discard cotter pins (1) and (9).
6. Remove connector (4) from fitting (3).
7. Remove connector (7) from fitting (8).
8. Remove connector (18) from elbow (16).
9. Remove tiedown strap (2) from splitter (13). Discard tiedown strap (2).
10. Remove connector (12) from fitting (11).
11. Remove connector (14) from fitting (15).
12. Turn adjusting plugs (10) and (19) until almost out of drag link (17).
13. Turn steering wheel as needed to remove drag link (17) from steering arm (6) and pitman arm (5).
14. Remove elbow (16) and fittings (3), (8), (11) and (15) from drag link (17).

INSTALLATION**NOTE**

Remove all plugs prior to installation of air lines.

The steering arm end of the drag link is the side with the adjustable end.

When installed, the drag link must have exhaust ports in the down position.

1. Apply sealant to male threads of elbow (16) and fittings (3), (8), (11) and (15).
2. Install elbow (16) and fittings (3), (8), (11), and (15) on drag link (17).
3. Install drag link (17) on pitman arm (5) and steering arm (6).
4. Straighten steering wheel to center position.
5. Lubricate drag link (17) with GAA grease.
6. Tighten adjusting plugs (10) and (19) until seated (metal to metal), then back off one-half turn, and install new cotter pins (1) and (9).
7. Install connector (4) on fitting (3).
8. Install connector (7) on fitting (8).
9. Install connector (18) on elbow (16).
10. Install new tiedown strap (2) on splitter (13).
11. Install connector (12) on fitting (11).
12. Install connector (14) on fitting (15).

DRAG LINK MAINTENANCE (Contd)

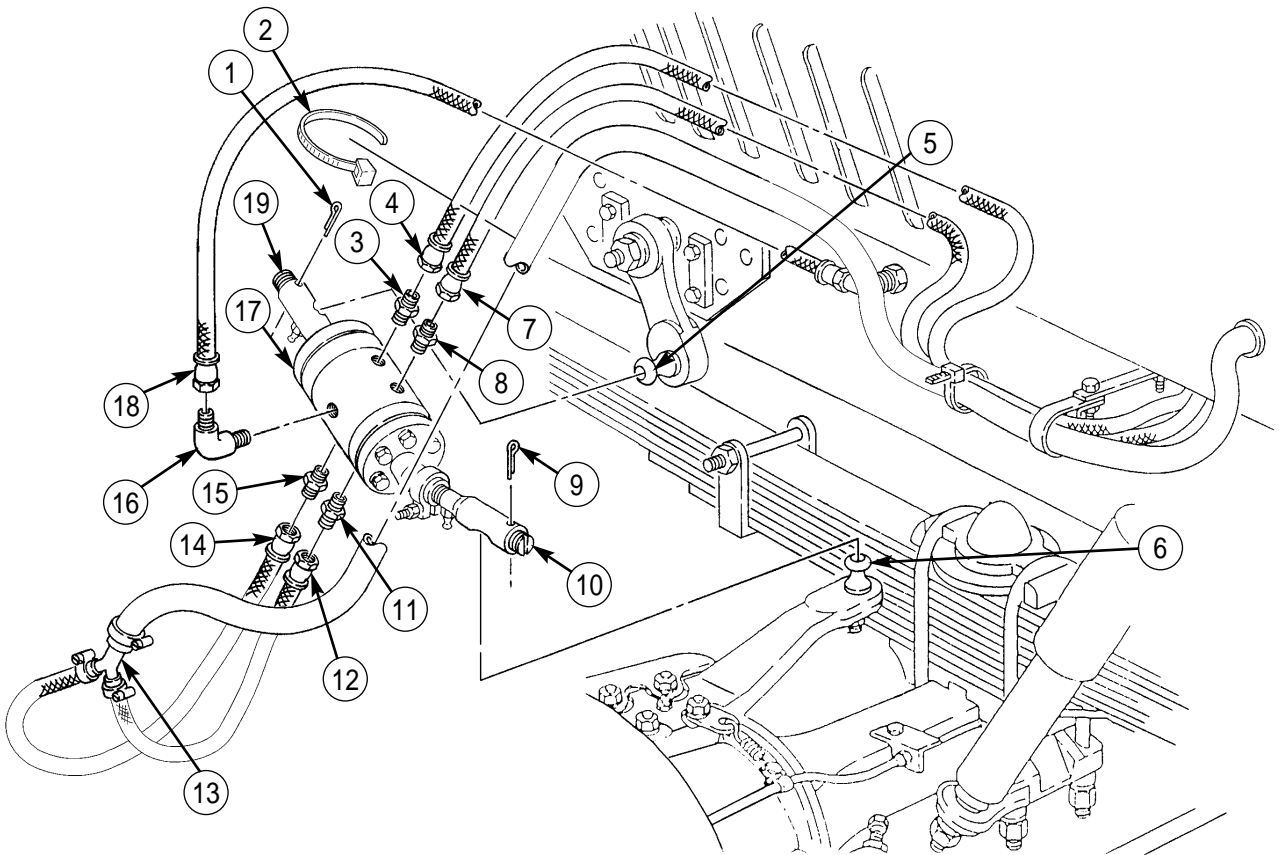

DRAG LINK MAINTENANCE (Contd)

ADJUSTMENT

1. Check and adjust toe-in and toe-out (WP 0179 00) before adjusting drag link (6).
2. Remove cotter pins (1) and (4) and backout plugs (7) and (5) to remove drag link (6) from pitman arm (2) and steering arm (3). Discard cotter pins (1) and (4).
3. Turn steering wheel all the way to the right, then all the way to the left, counting the number of turns.
4. Turn steering wheel to the right, one-half the number of turns counted, and mark position of pitman arm (2) on frame rail (10).
5. Install drag link (6) on pitman arm (2) and tighten adjusting plug (7) until seated (metal to metal), then back off one-half turn, and install a new cotter pin (1).

NOTE

A minimum thread engagement of one-half times thread diameter must be maintained.

6. Loosen nut (9) on clamp (8) and adjust length of drag link (6) as necessary to install drag link (6) on steering arm (3).
7. Ensure pitman arm (2) is in position marked in step 4.
8. Tighten adjusting plug (5) on drag link (6) until sealed (metal-to-metal), then back off one-half turn, and install a new cotter pin (4).
9. Tighten nut (9) on clamp (8) 110-125 lb-ft (140-170 N•m).
10. Turn steering wheel all the way to right and then to left and ensure steering stops contacts axle housing.
11. Using string, reverify straightness of wheels.

DRAG LINK MAINTENANCE (Contd)

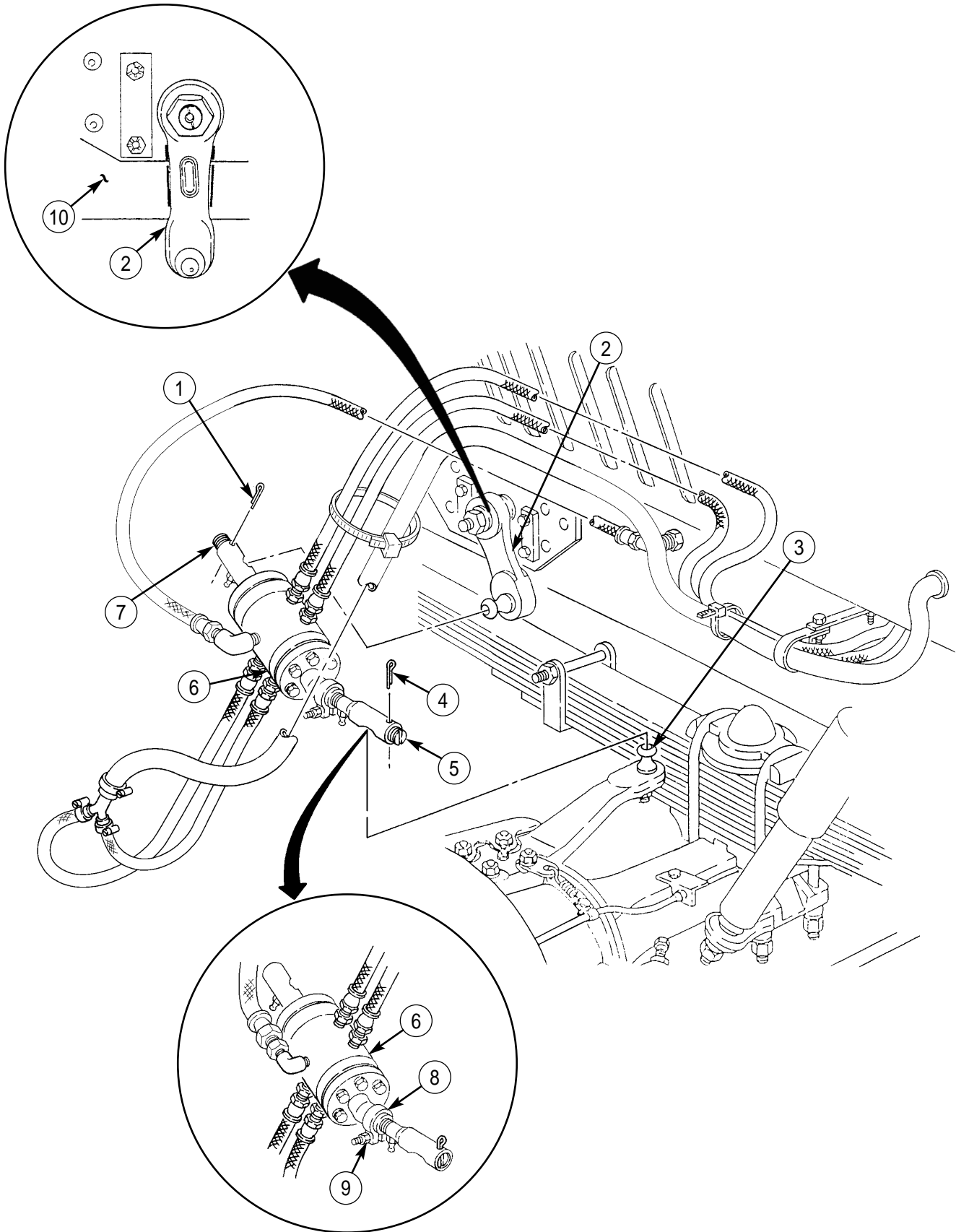

DRAG LINK MAINTENANCE (Contd)

12. Install stone shield (2) on studs (4) with two nuts (1). Tighten nuts (1) 60-80 lb-ft (81-108 N•m).
13. Install stone shield (2) on flange (3) with two new lockwashers (5) and screws (6). Tighten screws (6) 81-104 lb-ft (110-141 N•m).
14. Repeat steps 12 and 13 to install other two stone shields.
15. Start engine (TM 9-2320-386-10) and allow air pressure to build up to normal operating pressure. Check for air leaks and road test vehicle.

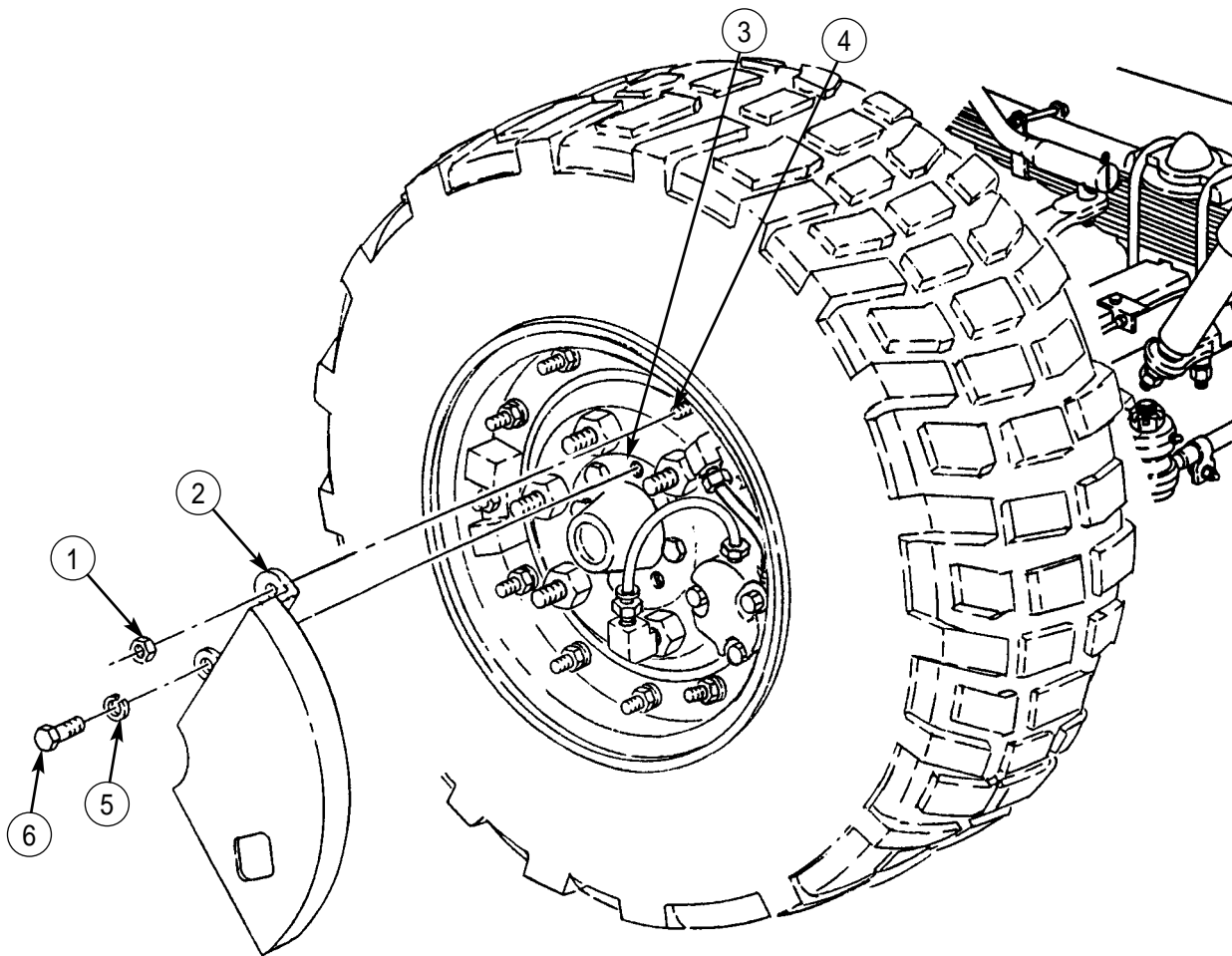
**END OF WORK PACKAGE**

UNIT MAINTENANCE INSTRUCTIONS

EXTENDED SERVICE PROGRAM (ESP)

TRUCK, CARGO, 2-1/2-TON, 6X6, M44A3 SERIES TRUCKS (DIESEL)

M35A3, W/O WINCH (NSN 2320-01-383-2047); W/WINCH (NSN 2320-01-383-3850);

M35A3C, W/O WINCH (NSN 2320-01-383-2050); W/WINCH (NSN 2320-01-383-2049);

M36A3, W/O WINCH (NSN 2320-01-383-2048); W/WINCH (NSN 2320-01-383-2046).

STEERING GEAR ADJUSTMENT

ADJUSTMENT

INITIAL SETUP:

Tools and Special Tools

General mechanic's tool kit
(item 30, WP 0394 00)
Common No. 1 tool kit (item 15,
WP 0394 00)

Materials/Parts

Cotter pin (item 31, WP 0395 00)
Seal (item 149, WP 0395 00)

References

TM 9-2320-386-24P

Equipment Condition

Parking brake set (TM 9-2320-386-10).
Battery ground cable disconnected (WP 0121 00).

STEERING GEAR ADJUSTMENT (Contd)**ADJUSTMENT****NOTE**

Ensure all steering system components are tight. If any steering component is damaged, replace. If loose tighten.

1. Remove cotter pin (1) from drag link (2). Discard cotter pin (1).

NOTE

Assistant will help with step 2.

2. Back out adjusting plug (3) until it is almost out of drag link (2) and turn steering wheel (5) 1/2-turn right.

NOTE

Be careful not to let inner parts fall out of drag link when drag link is removed.

3. Remove drag link (2) from pitman arm (4).
4. Remove three screws (8), and lift horn button (7) from top of steering wheel (5).
5. Disconnect horn button connector (9) from air horn button lead 25 (11).
6. Remove horn button (7), seal (6), and spring (10) from steering wheel (5). Discard seal (6).
7. Hold screw (16) tight, loosen nut (15), then loosen screw (16) on steering gear (14).
8. Turn steering wheel (5) all the way to the right, then all the way to the left, counting the number of turns.
9. Turn steering wheel (5) right, half the number of turns counted in step 8.
10. Tighten screw (16) until it is slightly snug, and tighten nut (15).
11. Turn steering wheel (5) one turn each way around mid-position.

NOTE

Assistant will help with step 12.

12. With steering wheel (5) at mid-position, hold screw (16) still, loosen nut (15), then tighten screw (16) until torque at nut (12) on steering column (13) reads 9-35 lb-in. (1-4 N·m).
13. Hold screw (16) tight and tighten nut (15) on steering gear (14).
14. Position spring (10) and new seal (6) on steering wheel (5).
15. Connect air horn lead 25 (11) to horn button connector (9).
16. Install horn button (7) on top of steering wheel (5) with three screws (8).
17. Install drag link (2) on pitman arm (4).
18. Tighten adjusting plug (3) until seated (metal-to-metal), then back off one-half turn, and install new cotter pin (1).
19. Connect battery ground cable (WP 0121 00).

STEERING GEAR ADJUSTMENT (Contd)

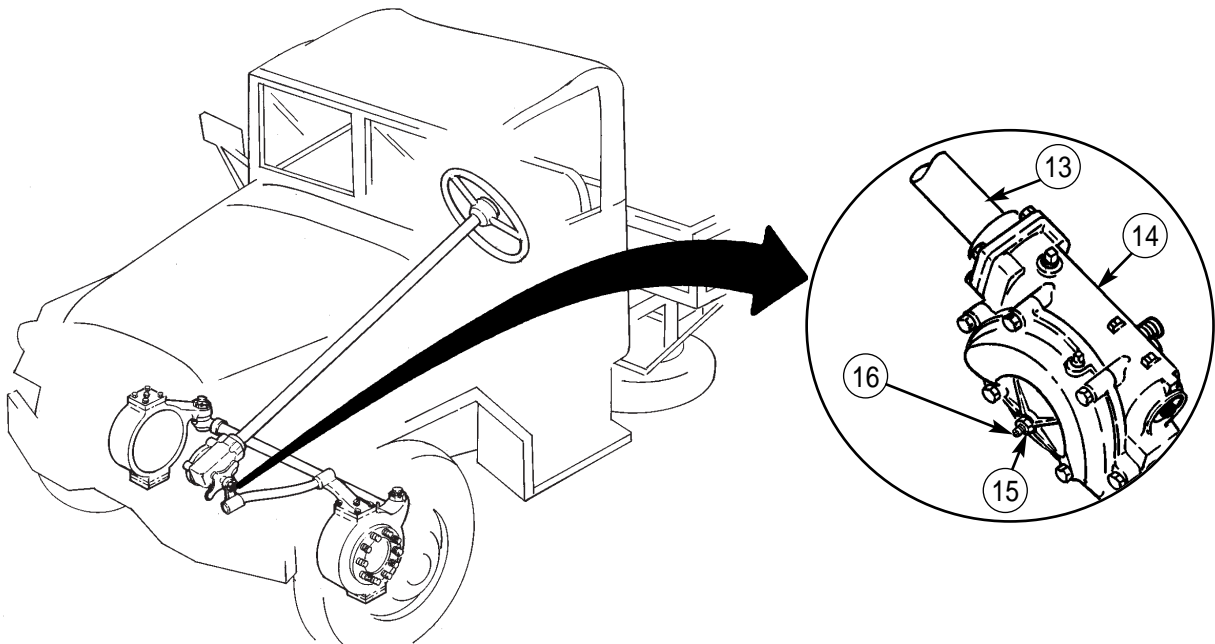
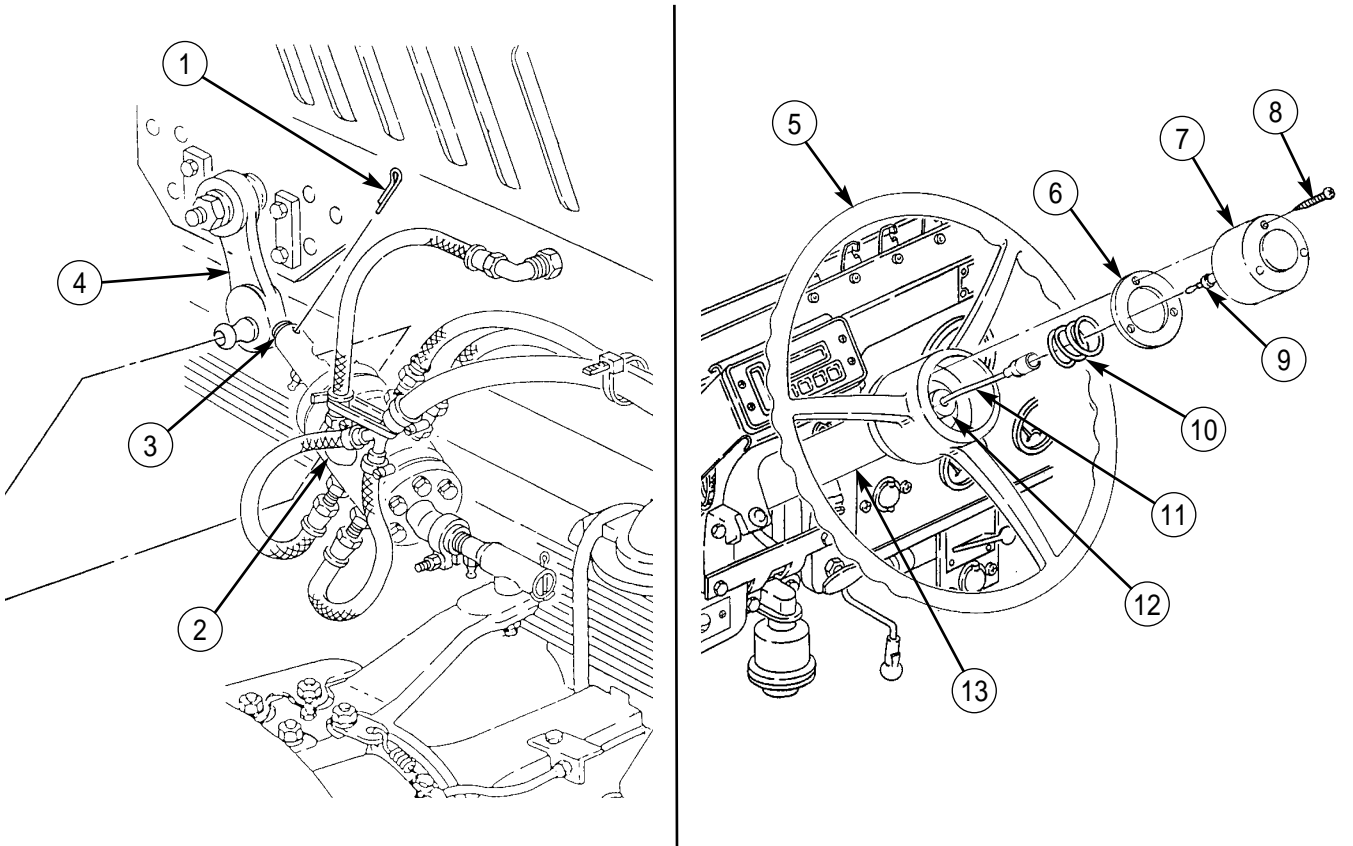

END OF WORK PACKAGE

UNIT MAINTENANCE INSTRUCTIONS

EXTENDED SERVICE PROGRAM (ESP)

TRUCK, CARGO, 2-1/2-TON, 6X6, M44A3 SERIES TRUCKS (DIESEL)

**M35A3, W/O WINCH (NSN 2320-01-383-2047); W/WINCH (NSN 2320-01-383-3850);
M35A3C, W/O WINCH (NSN 2320-01-383-2050); W/WINCH (NSN 2320-01-383-2049);
M36A3, W/O WINCH (NSN 2320-01-383-2048); W/WINCH (NSN 2320-01-383-2046).**

STEERING ASSIST CYLINDER MAINTENANCE

REMOVAL, INSTALLATION, ADJUSTMENT

INITIAL SETUP:

Tools and Special Tools

General mechanic's tool kit
(item 30, WP 0394 00)
Common No. 1 tool kit (item 15,
WP 0394 00)

Materials/Parts

Locknut (item 203, WP 0395 00)
Tiedown straps (item 38, 0395 00)
Cap and plug set (item 14, 0393 00)
Antiseize compound (item 11, 0393 00)
Teflon pipe sealant (item 41, 0393 00)

References

TM 9-2320-386-24P

Equipment Condition

Parking brake set (TM 9-2320-386-10).
Rear wheels chocked (TM 9-2320-386-10).
Front wheels centered.
Air reservoir drained (TM 9-2320-386-10).

STEERING ASSIST CYLINDER MAINTENANCE (Contd)**REMOVAL****WARNING**

Do not disconnect air lines before draining air reservoirs. Small parts under pressure may shoot out with high velocity, causing injury to personnel.

Eyeshields must be worn when releasing compressed air. Failure to do this may result in injury to personnel.

CAUTION

When disconnecting air lines and hoses, plug all openings to prevent dirt from entering and causing damage to internal parts.

NOTE

Tag all air lines and hoses for installation.

1. Raise vehicle (TM 9-2320-386-10), place jack stands under front axle, and lower vehicle onto jack stands.
2. Remove tiedown straps (1) as required. Discard tiedown straps (1).
3. Remove air hose (20) from elbow (19).
4. Remove air hose (2) from adapter (3).
5. Remove elbow (19) and adapter (3) from steering assist cylinder (12).
6. Remove six jamnuts (13) from screws (17).

NOTE

Support steering assist cylinder during removal.

7. Remove six nuts (14), tie rod top bracket (15), six screws (17), and tie rod bottom bracket (16) from tie rod (18).

NOTE

Assistant will help with step 8.

8. Remove locknut (10), washer (9), screw (4), washer (5), support bracket (6) with air hose (2), and steering assist cylinder (12) from axle bracket (8). Discard locknut (10).
9. Remove two spacers (7) and pull steering assist cylinder (12) with rubber bearing shields (11) from axle bracket (8).

STEERING ASSIST CYLINDER MAINTENANCE (Contd)

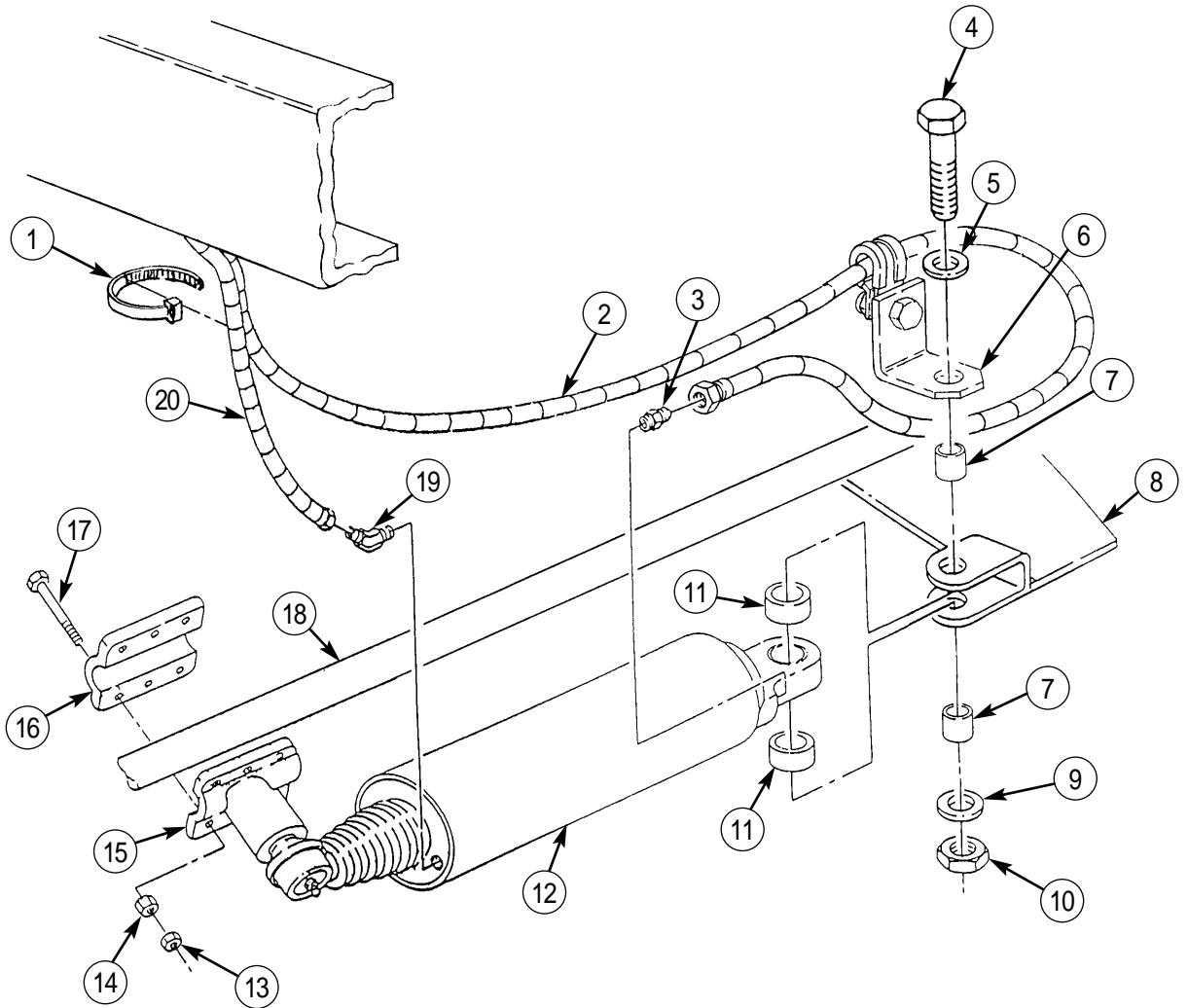

STEERING ASSIST CYLINDER MAINTENANCE (Contd)**INSTALLATION****NOTE**

Remove all plugs prior to installation of air lines and hoses.

1. Apply sealant to male threads of adapter (3) and elbow (22).
2. Apply antiseize compound to spherical bearing (20), screw (4), and spacers (7) and (9).

NOTE

Support steering assist cylinder for installation.

Assistant will help with steps 3 through 9.

3. Install steering assist cylinder (13) on tie rod (19) with tie rod bottom bracket (17), six screws (18), tie rod top bracket (16), and six nuts (15). Tighten nuts (15) to support one end of steering assist cylinder (13).
4. Position rubber bearing shield (21) on top of spherical bearing (20) and insert end of steering assist cylinder (13) into end of axle bracket (8).
5. Insert spacer (7) through top hole of axle bracket (8) and align spacer (7) in center of rubber bearing shield (21).
6. Position support bracket (6) and washer (5) on axle bracket (8) and insert screw (4) through washer (5), support bracket (6), axle bracket (8), spacer (7), rubber bearing shield (21), and into spherical bearing (20).
7. Place a floor jack under lip end of steering assist cylinder (13) and lift up on steering assist cylinder (13) until rubber bearing shield (12) can be installed between spherical bearing (20) and axle bracket (8).
8. Lower floor jack and insert spacer (9) through bottom hole of axle bracket (8) and align with rubber bearing shield (12).
9. Push screw (4) through spacer (9), rubber bearing shield (12), and out of axle bracket (8).
10. Install washer (10) and new locknut (11) on screw (4). Tighten locknut (11) until locknut (11) connects axle bracket (8).
11. Install six jamnuts (14) on screws (18). Do not tighten jamnuts (14) until adjustment task.
12. Install adapter (3) and elbow (22) on steering assist cylinder (13).
13. Perform adjustment task.
14. Install air hose (23) on elbow (22).
15. Install air hose (2) on adapter (3).
16. Install new tiedown straps (1), as required.
17. Raise vehicle (TM 9-2320-386-10), remove jack stands from front axle, and lower vehicle to ground.

STEERING ASSIST CYLINDER MAINTENANCE (Contd)

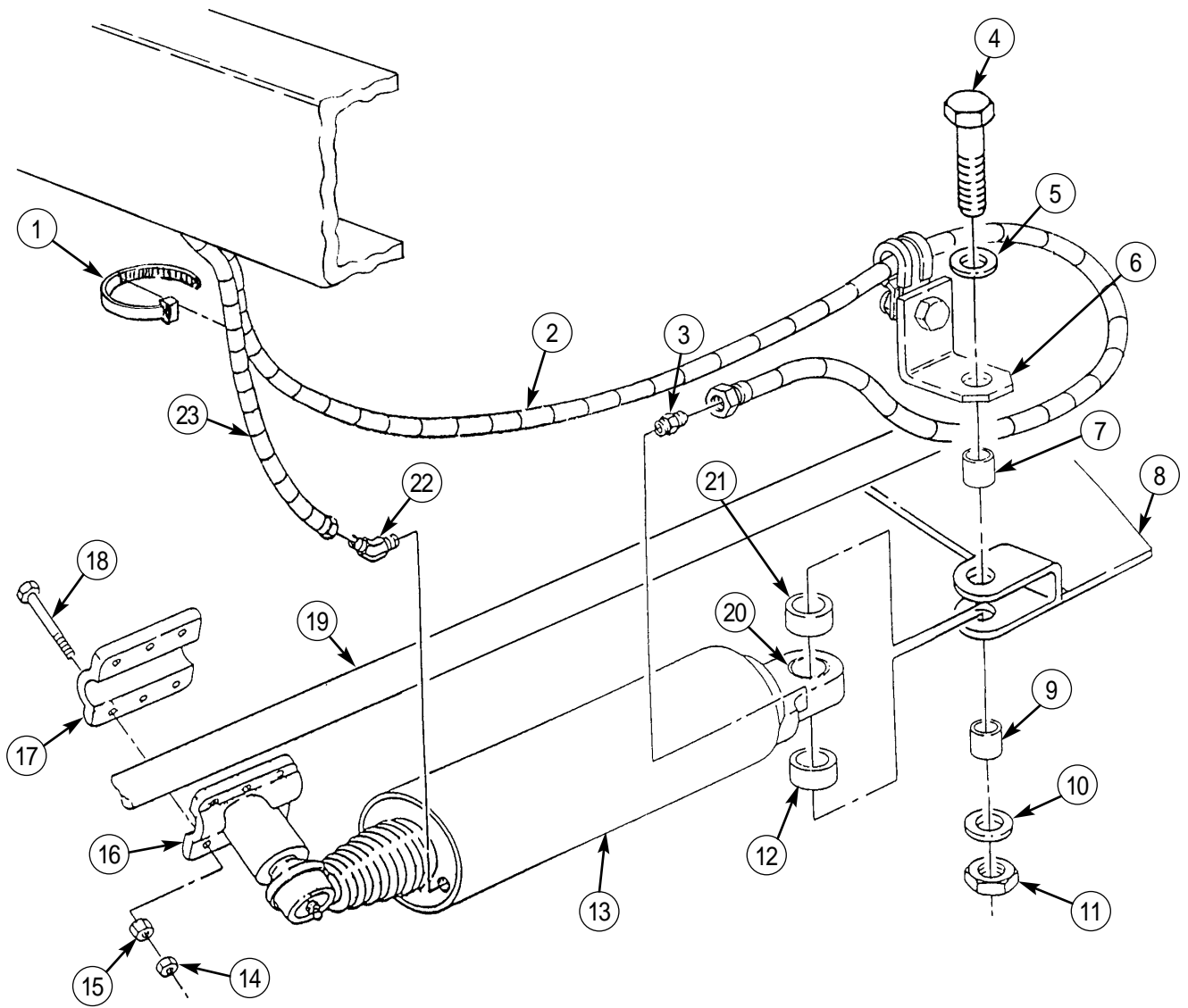

STEERING ASSIST CYLINDER MAINTENANCE (Contd)**ADJUSTMENT****NOTE**

Perform steps 1 and 2 if steering assist cylinder was not removed.

When power is applied to the steering assist cylinder on a tie rod installation, the tie rod may have a tendency to crank. To limit this condition, perform steps 1 through 10.

1. Remove six jamnuts (6) from screws (4).
2. Loosen six nuts (9) on screws (4).
3. Turn wheels in full right-hand turn.
4. Loosen one of the tie rod ends (1), and turn the socket shells (2) in opposite directions.
5. Tighten tie rod end (1) 170 lb-ft (231 N·m).
6. Turn wheels in a full left-hand turn to ensure tie rod (3) does not bind.
7. Position steering assist cylinder rod (8) approximately 1/2 in. (13 mm) from being fully retracted.
8. Position wheels in a full left-hand turn.
9. Tighten center screws (4) and nuts (9) at top and bottom center of the tie rod bracket assembly (5).

NOTE

Power assist cylinder must be parallel to the tie rod for proper operation.

10. Turn wheels in full-right and left-hand turns, checking the maximum and minimum strokes of the steering assist cylinder (7). Adjust, as required, the position of the tie rod bracket assembly (5) so the steering assist cylinder (7) operates as close to the minimum dimension as possible, and is parallel to the tie rod (3) when wheels are in the straight-ahead position.
11. Tighten six nuts (9) to 30-35 lb-ft (41-47 N·m) at tie rod bracket assembly (5).
12. Install six jamnuts (6) on screws (4) and tighten jamnuts (6) to 15-19 lb-ft (20-26 N·m) against nuts (9).
13. Start engine (TM 9-2320-386-10) and allow air pressure to build up to normal operating pressure. Check for leaks and road test vehicle.

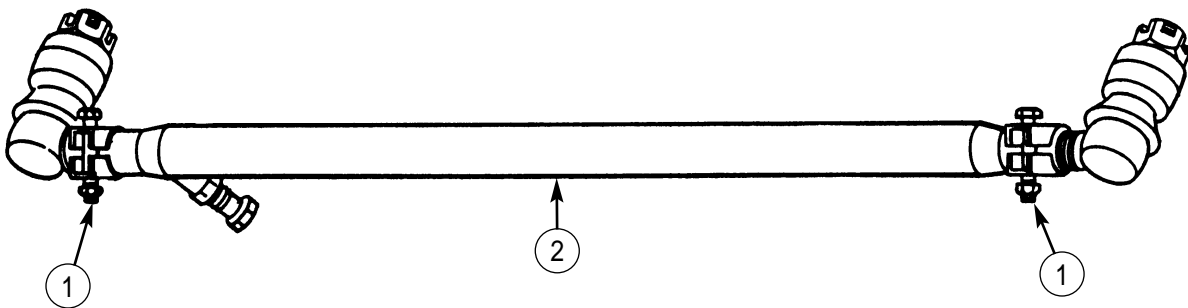

STEERING ASSIST CYLINDER MAINTENANCE (Contd)

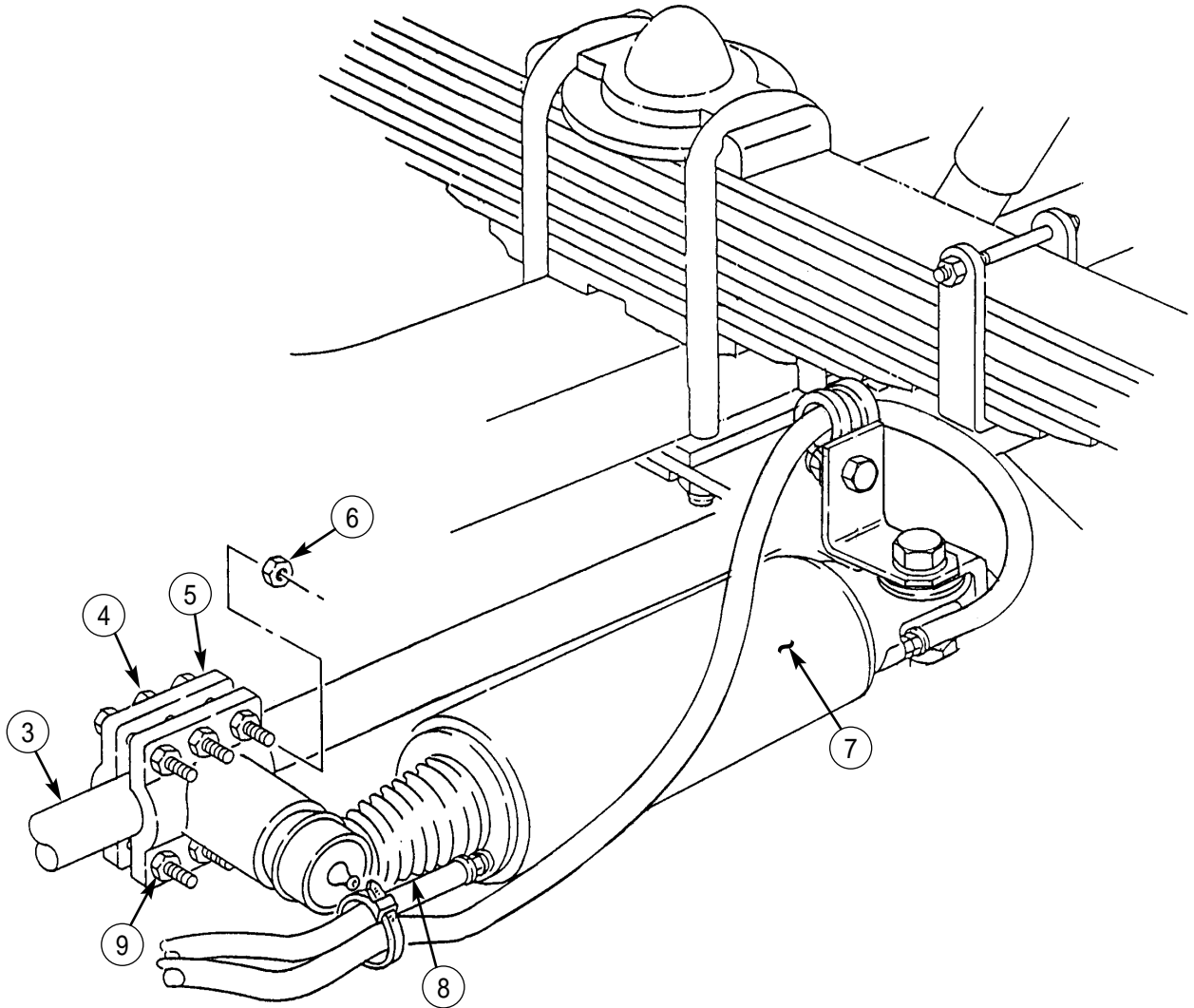

END OF WORK PACKAGE

UNIT MAINTENANCE INSTRUCTIONS

EXTENDED SERVICE PROGRAM (ESP)

TRUCK, CARGO, 2-1/2-TON, 6X6, M44A3 SERIES TRUCKS (DIESEL)

**M35A3, W/O WINCH (NSN 2320-01-383-2047); W/WINCH (NSN 2320-01-383-3850);
M35A3C, W/O WINCH (NSN 2320-01-383-2050); W/WINCH (NSN 2320-01-383-2049);
M36A3, W/O WINCH (NSN 2320-01-383-2048); W/WINCH (NSN 2320-01-383-2046).**

STEERING ASSIST REGULATOR REPLACEMENT

REMOVAL, INSTALLATION

INITIAL SETUP:

Tools and Special Tools

General mechanic's tool kit
(item 30, WP 0394 00)

Materials/Parts

Lockwasher (item 62, WP 0395 00)
Cap and plug set (item 14, WP 03933 00)
Teflon pipe sealant (item 41, WP 0393 00)

References

TM 9-2320-386-24P

Equipment Condition

Parking brake set (TM 9-2320-386-10).
Air reservoirs drained (TM 9-2320-386-10).

STEERING ASSIST REGULATOR REPLACEMENT (Contd)**REMOVAL****WARNING**

Do not disconnect air lines before draining air reservoirs. Small parts under pressure may shoot out with high velocity, causing injury to personnel.

Eyeshields must be worn when releasing compressed air. Failure to do this may result in injury to personnel.

CAUTION

When disconnecting air lines and hoses, plug all openings to prevent dirt from entering and causing damage to internal parts.

1. Remove tube (9) from fitting (10).
2. Remove fitting (10) from elbow (11).
3. Remove elbow (11) from hollow stud (7).
4. Remove tube (1) from adapter (2).
5. Remove nut (12) and lockwasher (13) from hollow stud (7) and regulator (3) from rail (8). Discard lockwasher (13).
6. Remove hollow stud (7) from fitting (6).
7. Remove fitting (6) from elbow (5).
8. Remove elbow (5) from fitting (4).
9. Remove fittings (2) and (4) from regulator (3).

INSTALLATION**NOTE**

Remove all plugs prior to installation of air lines.

1. Apply sealant to male threads of fittings (2), (4), (6), and (10), elbows (5) and (11), and hollow stud (7).
2. Install fittings (2) and (4) on regulator (3).
3. Install elbow (5) on fitting (4).
4. Install fitting (6) on elbow (5).
5. Install hollow stud (7) on fitting (6).
6. Position regulator (3) on rail (8) and install hollow stud (7) on rail (8) with new lockwasher (13) and nut (12).
7. Install tube (1) on adapter (2).
8. Install elbow (11) on hollow stud (7).
9. Install fitting (10) on elbow (11).
10. Install tube (9) on fitting (10).
11. Start engine (TM 9-2320-386-10) and allow air pressure to build up to normal operating pressure. Check for air leaks and road test vehicle.

STEERING ASSIST REGULATOR REPLACEMENT (Contd)

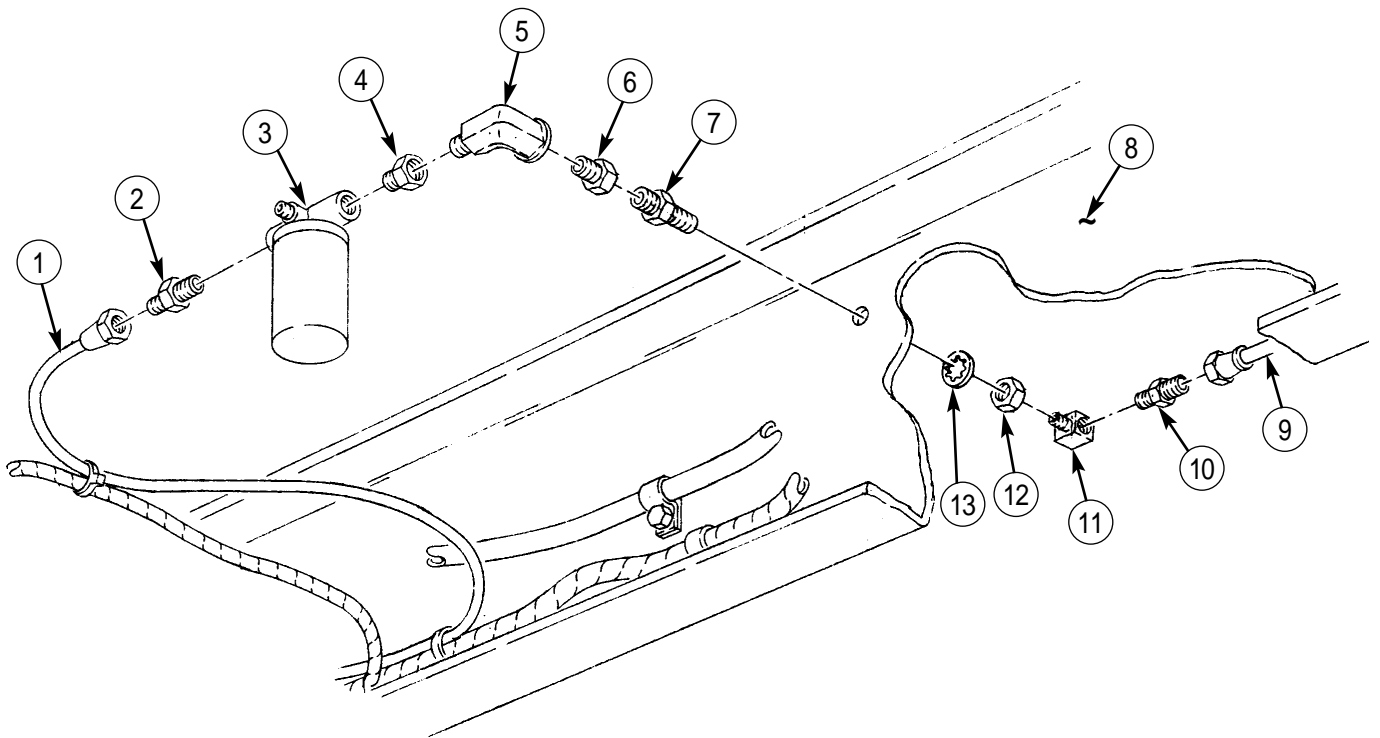

END OF WORK PACKAGE

UNIT MAINTENANCE INSTRUCTIONS

EXTENDED SERVICE PROGRAM (ESP)

TRUCK, CARGO, 2-1/2-TON, 6X6, M44A3 SERIES TRUCKS (DIESEL)

M35A3, W/O WINCH (NSN 2320-01-383-2047); W/WINCH (NSN 2320-01-383-3850);

M35A3C, W/O WINCH (NSN 2320-01-383-2050); W/WINCH (NSN 2320-01-383-2049);

M36A3, W/O WINCH (NSN 2320-01-383-2048); W/WINCH (NSN 2320-01-383-2046).

MANUAL SHUTOFF VALVE REPLACEMENT

REMOVAL, INSTALLATION

INITIAL SETUP:

Tools and Special Tools

General mechanic's tool kit
(item 30, WP 0394 00)

Materials/Parts

Cap and plug set (item 14, WP 0393 00)
Teflon pipe sealant (item 41, WP 0393 00)

References

TM 9-2320-386-24P

Equipment Condition

Parking brake set (TM 9-2320-386-10).
Rear wheels chocked (TM 9-2320-386-10).

MANUAL SHUTOFF VALVE REPLACEMENT (Contd)**REMOVAL****WARNING**

Do not disconnect air lines before draining air reservoirs. Small parts under pressure may shoot out with high velocity, causing injury to personnel.

Eyeshields must be worn when releasing compressed air. Failure to do this may result in injury to personnel.

CAUTION

When disconnecting air lines and hoses, plug all openings to prevent dirt from entering and causing damage to internal parts.

1. Disconnect hose (5) from elbow (4).
2. Remove elbow (4) from coupling (3).
3. Remove coupling (3) from manual shutoff valve (2).
4. Remove manual shutoff valve (2) from adapter (1).

INSTALLATION**NOTE**

Remove all plugs prior to installation of air lines.

1. Apply sealant to male threads of elbow (4) and manual shutoff valve (2).
2. Install manual shutoff valve (2) on adapter (1).
3. Install coupling (3) on manual shutoff valve (2).
4. Install elbow (4) on coupling (3).
5. Connect hose (5) to elbow (4).
6. Start engine (TM 9-2320-386-10) and allow air pressure to build up to normal operating pressure. Check for air leaks and road test vehicle.

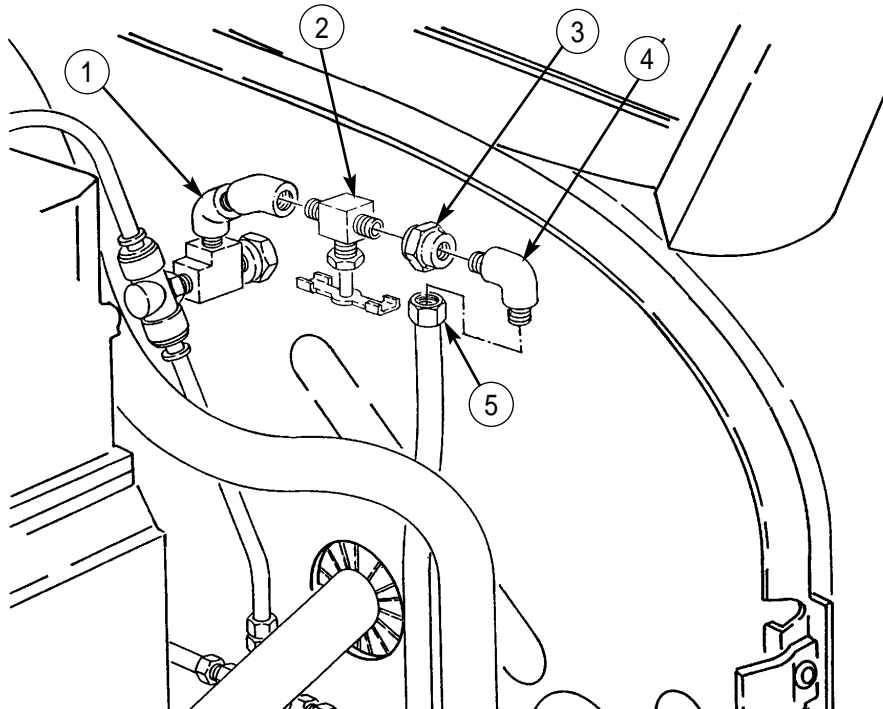

END OF WORK PACKAGE

UNIT MAINTENANCE INSTRUCTIONS

EXTENDED SERVICE PROGRAM (ESP)

TRUCK, CARGO, 2-1/2-TON, 6X6, M44A3 SERIES TRUCKS (DIESEL)

M35A3, W/O WINCH (NSN 2320-01-383-2047); W/WINCH (NSN 2320-01-383-3850);
M35A3C, W/O WINCH (NSN 2320-01-383-2050); W/WINCH (NSN 2320-01-383-2049);
M36A3, W/O WINCH (NSN 2320-01-383-2048); W/WINCH (NSN 2320-01-383-2046).

STEERING ASSIST HOSE REPLACEMENT

REMOVAL, INSTALLATION

INITIAL SETUP:

Tools and Special Tools

General mechanic's tool kit
(item 30, WP 0394 00)

Materials/Parts

Tiedown strap (item 38, WP 0395 00)
Locknut (item 14, WP 0395 00)
Locknut (item 90, WP 0395 00)
Cap and plug (item 14, WP 0393 00)
Teflon pipe sealant (item 41, WP 0393 00)

References

TM 9-2320-386-24P

Equipment Condition

Parking brake set (TM 9-2320-386-10).
Rear wheels chocked (TM 9-2320-386-10).
Air reservoirs drained (TM 9-2320-386-10).

STEERING ASSIST HOSE REPLACEMENT (Contd)**REMOVAL****WARNING**

Do not disconnect air lines before draining air reservoirs. Small parts under pressure may shoot out with high velocity, causing injury to personnel.

Eyeshields must be worn when releasing compressed air. Failure to do this may result in injury to personnel.

CAUTION

When disconnecting air lines and hoses, plug all openings to prevent dirt from entering and causing damage to internal parts.

1. Remove tiedown strap (16) from hoses (13) and (17). Discard tiedown strap (16).
2. Remove connector (20) from fitting (19).
3. Remove connector (22) from fitting (21).
4. Remove connector (15) from elbow (14).
5. Remove connector (11) from fitting (12).
6. Remove locknut (18), screw (1), and hoses (13) and (17) from clamp (3) and mounting bracket (2). Discard locknut (18).
7. Remove hoses (13) and (17) and grommets (4) and (5) from fender (6).
8. Remove locknut (7), screw (10), and hose (13) from clamp (8) and mounting bracket (9).

INSTALLATION**NOTE**

Remove all plugs prior to installation of air lines and hoses.

1. Apply sealant to male threads of elbow (14) and fittings (12), (19), and (21).
2. Install hoses (13) and (17) and grommets (4) and (5) in fender (6).
3. Install connector (11) on fitting (12).
4. Install connector (15) on elbow (14).
5. Install connector (20) on fitting (19).
6. Install connector (22) on fitting (21).
7. Install hoses (13) and (17) on mounting bracket (2) with clamp (3), screw (1), and new locknut (18).
8. Install hose (13) on mounting bracket (9) with clamp (8), screw (10), and new locknut (7).
9. Install new tiedown strap (16) on hoses (13) and (17).
10. Start engine (TM 9-2320-386-10) and allow air pressure to build up to normal operating level. Check for air leaks and road test vehicle.

STEERING ASSIST HOSE REPLACEMENT (Contd)

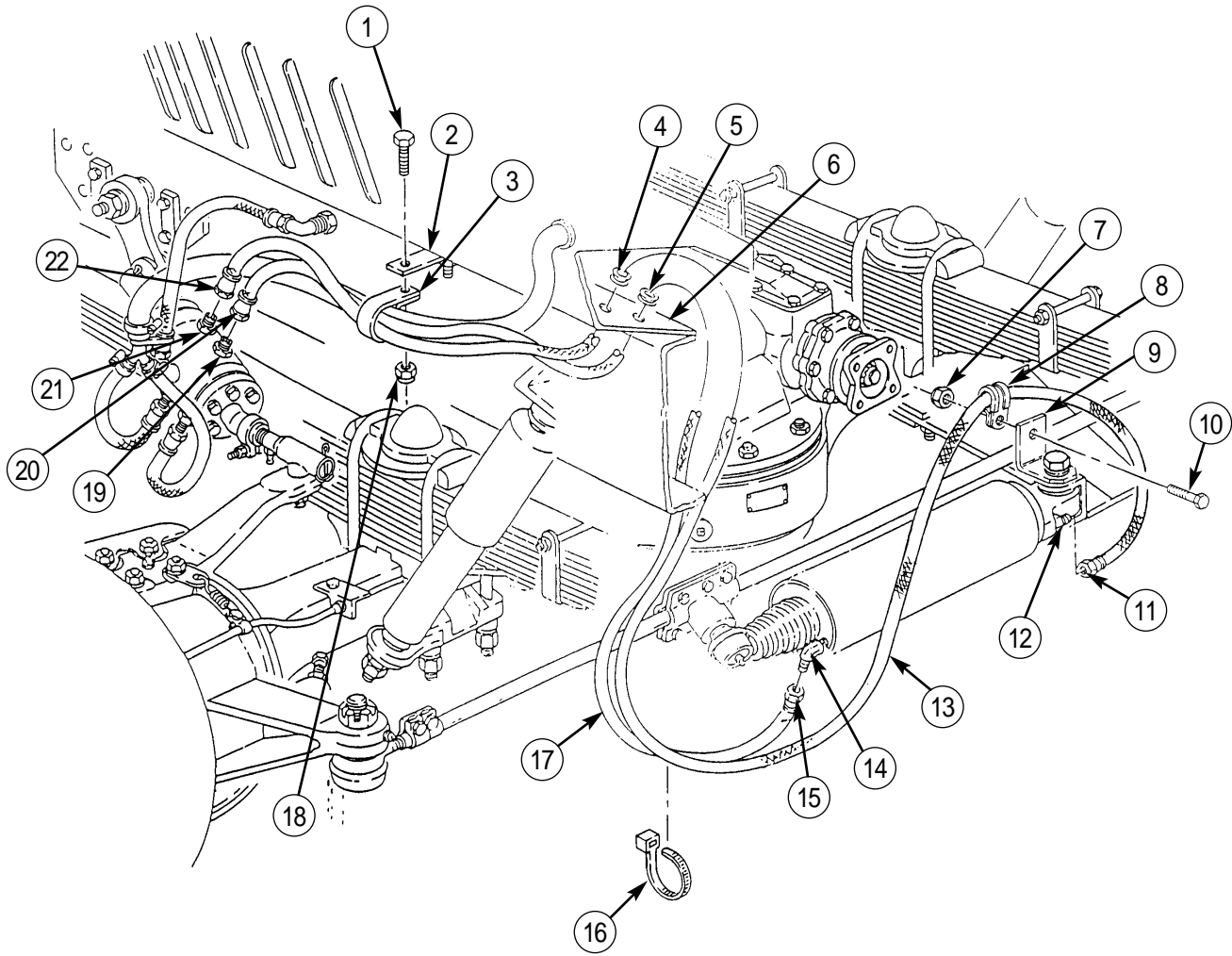

END OF WORK PACKAGE

UNIT MAINTENANCE INSTRUCTIONS

EXTENDED SERVICE PROGRAM (ESP)

TRUCK, CARGO, 2-1/2-TON, 6X6, M44A3 SERIES TRUCKS (DIESEL)

M35A3, W/O WINCH (NSN 2320-01-383-2047); W/WINCH (NSN 2320-01-383-3850);

M35A3C, W/O WINCH (NSN 2320-01-383-2050); W/WINCH (NSN 2320-01-383-2049);

M36A3, W/O WINCH (NSN 2320-01-383-2048); W/WINCH (NSN 2320-01-383-2046).

Section XVI. FRAME MAINTENANCE

TABLE OF CONTENTS

<i>WP Title</i>	<i>WP Sequence No.-Page No.</i>
Front Upper and Lower Shackles and Brackets (WO/Winch) Replacement	0188 00-1
Front Upper and Lower Shackles and Brackets (W/Winch) Replacement	0189 00-1
Rear Shackles and Brackets Replacement	0190 00-1
Spare Tire Carrier Maintenance	0191 00-1

END OF WORK PACKAGE

UNIT MAINTENANCE INSTRUCTIONS

EXTENDED SERVICE PROGRAM (ESP)

TRUCK, CARGO, 2-1/2-TON, 6X6, M44A3 SERIES TRUCKS (DIESEL)

M35A3, W/O WINCH (NSN 2320-01-383-2047);

M35A3C, W/O WINCH (NSN 2320-01-383-2050);

M36A3, W/O WINCH (NSN 2320-01-383-2048).

FRONT UPPER AND LOWER SHACKLES AND BRACKETS (WO/WINCH) REPLACEMENT

REMOVAL, INSTALLATION

INITIAL SETUP:

Tools and Special Tools

General mechanic's tool kit
(item 30, WP 394 00)

Materials/Parts

Four locknuts (item 340, WP 0395 00)
Two locknuts (item 342, WP 0395 00)
Two locknuts (item 341, WP 0395 00)
Two locknuts (item 158, WP 0395 00)

References

TM 9-2320-386-24P

Equipment Condition

Parking brake set (TM 9-2320-386-10).
Blackout drive lamp and housing removed
(WP 0105 00).
Brushguard removed (WP 0230 00).

FRONT UPPER AND LOWER SHACKLES AND BRACKETS (WO/WINCH) REPLACEMENT (Contd)**NOTE**

Left and right upper and lower shackles and brackets are replaced basically the same way. This task covers the right upper and lower shackles and brackets.

REMOVAL

1. Remove retaining pin (9) from pin (8).
2. Remove pin (8) and upper shackle (7) from upper bracket (11).
3. Remove locknut (19), screw (15), and lower shackle (18) from lower bracket (14). Discard locknut (19).
4. Remove two locknuts (10), screws (17), four washers (16), locknut (20), screw (6), lower bracket (14), spacer (21), and three spacers (1) from upper bracket (11) and bumper (3). Discard locknuts (10) and (20).
5. Remove locknut (2), screw (5), bracket (4), and upper bracket (11) from bumper (3). Discard locknut (2).

INSTALLATION

1. Install upper bracket (11) and bracket (4) on bumper (3) with screw (5) and new locknut (2).
2. Position spacer (21) and lower bracket (14) on lower bumper support bracket (13).
3. Install three spacers (1) and upper bracket (11) on upper bumper support bracket (12) and bumper (3) with screw (6), two screws (17), four washers (16), two new locknuts (10), and new locknut (20).
4. Install lower shackle (18) on lower bracket (14) with screw (15) and new locknut (19).
5. Install upper shackle (7) on upper bracket (11) with pin (8).
6. Install retaining pin (9) in pin (8). Latch retaining pin (9).
7. Install brushguard (WP 0230 00).
8. Install blackout drive lamp and housing (WP 0105 00).

FRONT UPPER AND LOWER SHACKLES AND BRACKETS (WO/WINCH) REPLACEMENT (Contd)

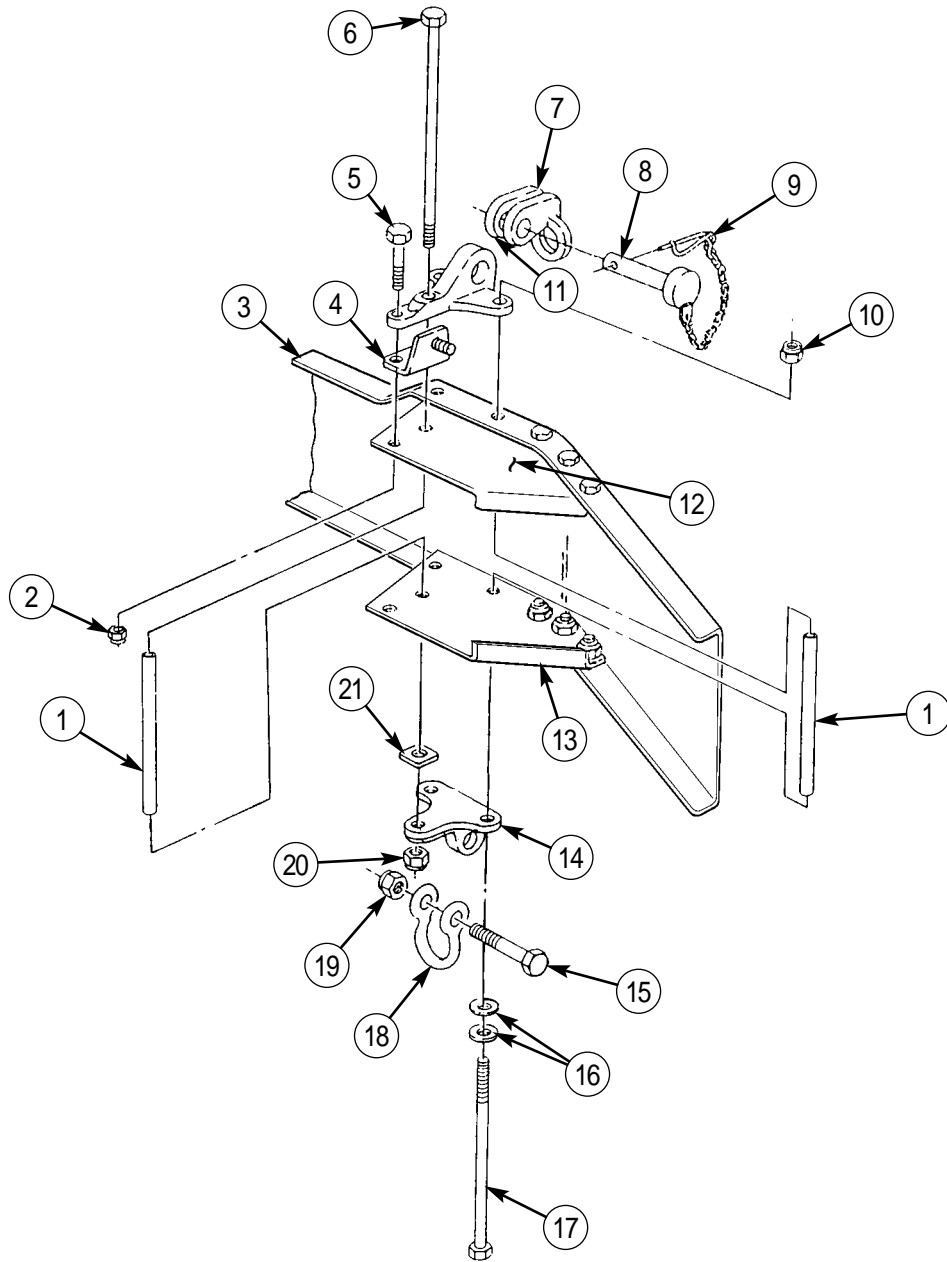

END OF WORK PACKAGE

UNIT MAINTENANCE INSTRUCTIONS

EXTENDED SERVICE PROGRAM (ESP)

TRUCK, CARGO, 2-1/2-TON, 6X6, M44A3 SERIES TRUCKS (DIESEL)

M35A3, W/WINCH (NSN 2320-01-383-3850);

M35A3C, W/WINCH (NSN 2320-01-383-2049);

M36A3, W/WINCH (NSN 2320-01-383-2046).

FRONT UPPER AND LOWER SHACKLES AND BRACKETS (W/WINCH) REPLACEMENT

**UPPER SHACKLES AND BRACKETS REMOVAL, LOWER SHACKLES AND BRACKETS REMOVAL,
LOWER SHACKLES AND BRACKETS INSTALLATION, UPPER SHACKLES AND BRACKETS INSTALLATION**

INITIAL SETUP:

Tools and Special Tools

General mechanic's tool kit
(item 30, WP 0394 00)

Materials/Parts

Four locknuts (item 340, WP 0395 00)
Two locknuts (item 341, WP 0395 00)
Six locknuts (item 342, WP 0395 00)
Two locknuts (item 93, WP 0395 00)
Two locknuts (item 7, WP 0395 00)
Two locknuts (item 107, WP 0395 00)

References

TM 9-2320-386-24P

Equipment Condition

Parking brake set (TM 9-2320-386-10).
Winch chain removed from bumper
(TM 9-2320-386-10).

FRONT UPPER AND LOWER SHACKLES AND BRACKETS (W/WINCH) REPLACEMENT (Contd)**UPPER SHACKLES AND BRACKETS REMOVAL**

1. Remove two locknuts (1), screws (5), and blackout drive lamp (2) with mounting bracket (3) from left lower bumper support bracket (6) and move blackout drive lamp (2) aside. Discard locknuts (1).
2. Remove two locknuts (7), screws (9), and rain cover (4) from left upper bumper support bracket (8). Discard locknuts (7).
3. Remove two retaining pins (11) from pins (12).
4. Remove two pins (12) and upper shackles (13) from upper brackets (16).
5. Remove four locknuts (23), screws (10), and three spacers (21) from between upper bumper support brackets (8) and (19), lower bumper support brackets (6) and (22), and two upper brackets (16) and bumper (20). Discard locknuts (23).
6. Remove two locknuts (18) and screws (14) from upper brackets (16), and left (8) and right (19) upper bumper support brackets. Discard locknuts (18).
7. Remove two locknuts (15), screws (24), upper brackets (16), and spacers (17) from bumper (20) and left (8) and right (19) upper bumper support brackets. Discard locknuts (15).

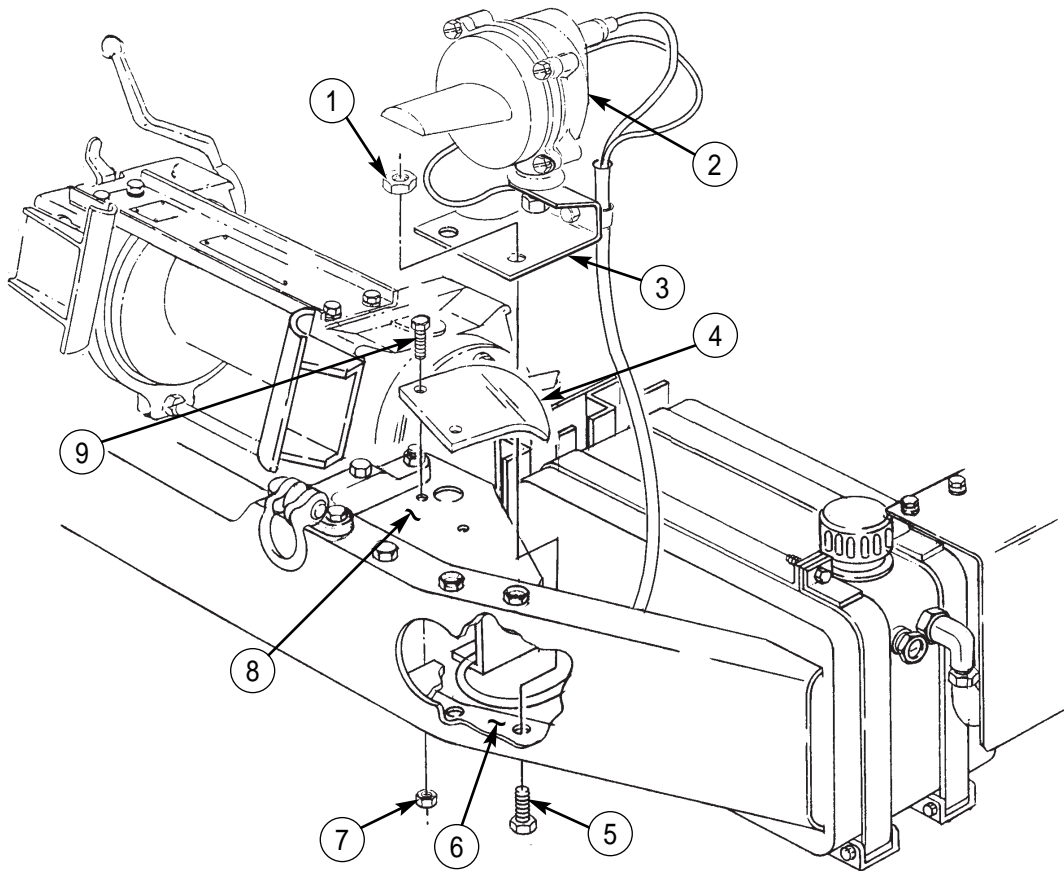

FRONT UPPER AND LOWER SHACKLES AND BRACKETS (W/WINCH) REPLACEMENT (Contd)

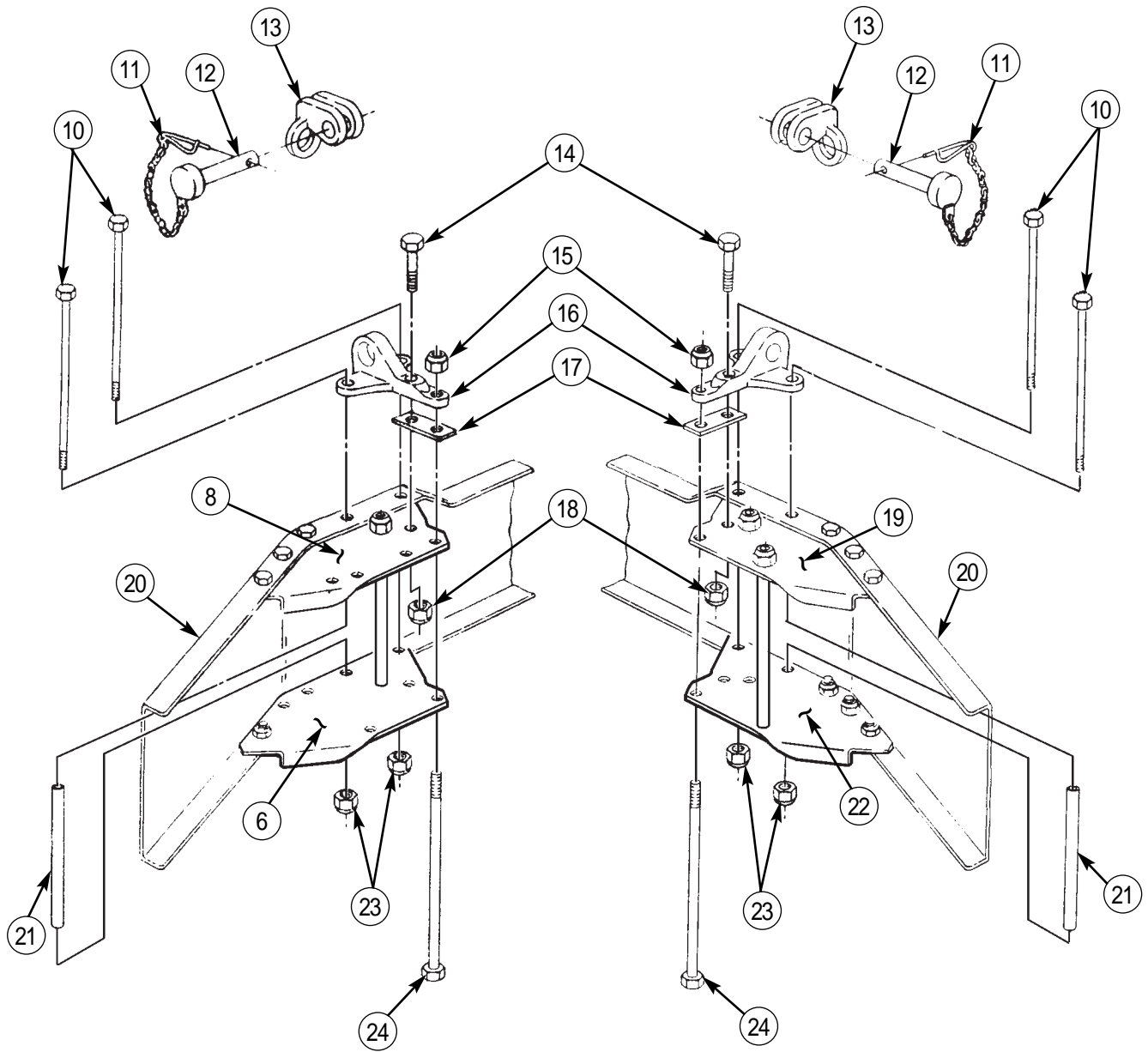

LEFT SIDE

RIGHT SIDE

FRONT UPPER AND LOWER SHACKLES AND BRACKETS (W/WINCH) REPLACEMENT (Contd)**LOWER SHACKLES AND BRACKETS REMOVAL**

1. Remove two locknuts (12), screws (10), and lower shackles (11) from lower brackets (8). Discard locknuts (12).
2. Remove two locknuts (4) and screws (13) from lower brackets (8) and left (2) and right (5) upper bumper support brackets and bumper (1). Discard locknuts (4).
3. Remove locknut (15) and screw (14) from lower bracket (8) and left lower bumper support bracket (16). Discard locknut (15).
4. Remove locknut (3), screw (9), spacer (6), and lower bracket (8) from left upper (2) and lower (16) bumper support brackets and bumper (1). Discard locknut (3).
5. Remove two locknuts (3), screws (9), spacers (6), and lower bracket (8) from right upper (5) and lower (7) bumper support brackets. Discard locknuts (3).

LOWER SHACKLES AND BRACKETS INSTALLATION

1. Install two lower brackets (8) on left (16) and right (7) lower bumper support brackets and bumper (1) with two screws (13) and new locknuts (4).
2. Secure lower bracket (8) to left lower bumper support bracket (16) with screw (14) and new locknut (15).
3. Install spacer (6) between left upper (2) and lower (16) bumper support brackets with screw (9) and new locknut (3).
4. Install two spacers (6) between right upper (5) and lower (7) bumper support brackets with two screws (9) and new locknuts (3).
5. Install two lower shackles (11) on lower brackets (8) with two screws (10) and new locknuts (12).

FRONT UPPER AND LOWER SHACKLES AND BRACKETS (W/WINCH) REPLACEMENT (Contd)

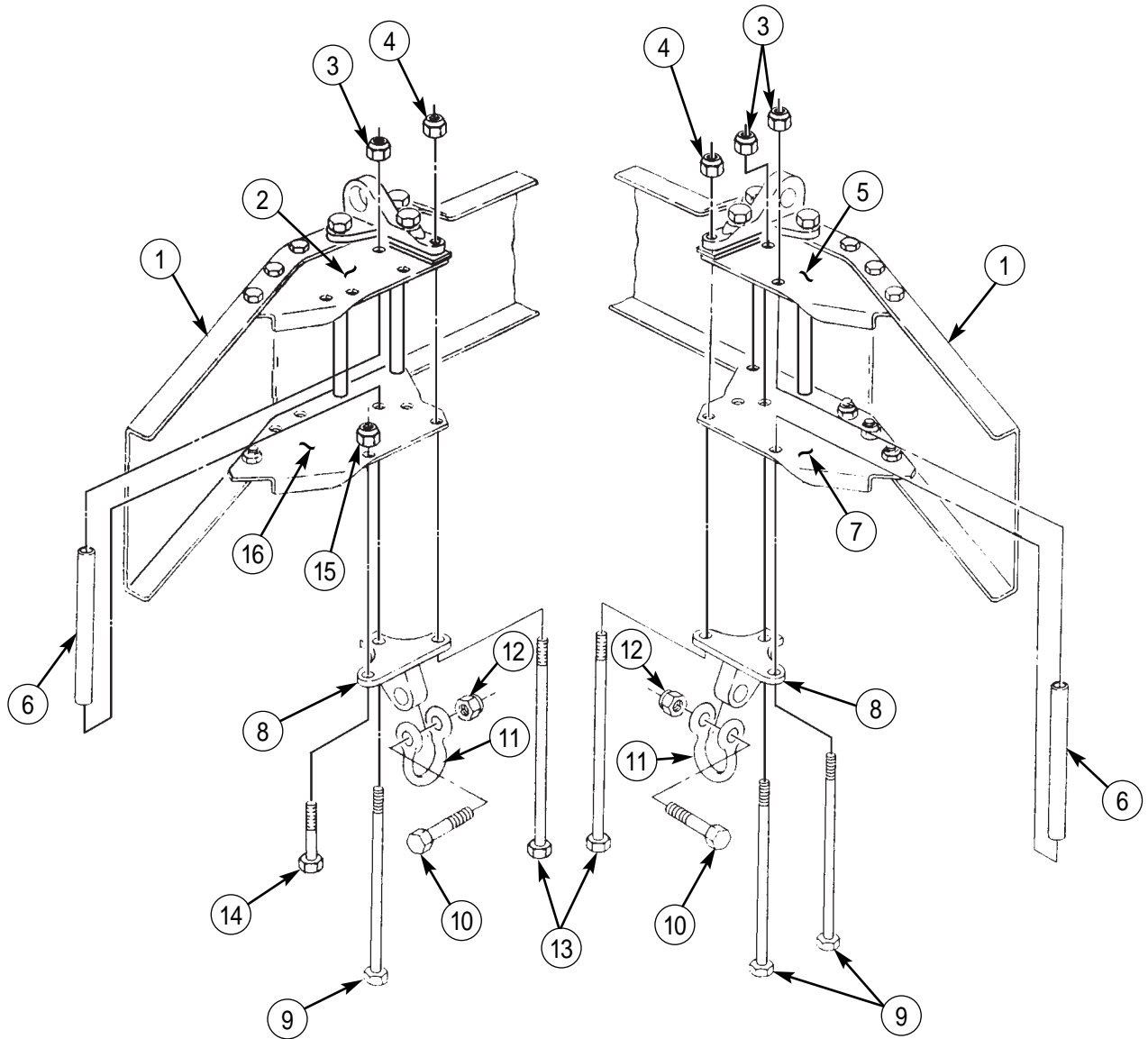

LEFT SIDE

RIGHT SIDE

FRONT UPPER AND LOWER SHACKLES AND BRACKETS (W/WINCH) REPLACEMENT (Contd)**UPPER SHACKLES AND BRACKETS INSTALLATION**

1. Install two spacers (8) and upper brackets (7) on bumper (11) and left (17) and right (10) upper bumper support brackets with two screws (5) and new locknuts (9).
2. Install three spacers (12) between upper (17) and (10) and lower (16) and (13) bumper support brackets with four screws (1) and new locknuts (14).
3. Slide two screws (15) through lower bumper support brackets (16) and (13) and upper brackets (7) and install new locknuts (6).
4. Install two upper shackles (4) on upper brackets (7) with pins (3).
5. Install two retaining pins (2) on pins (3). Latch retaining pins (2).
6. Install rain cover (21) on left upper bumper support bracket (17) with two screws (24) and new locknuts (23).
7. Install blackout drive lamp (19) with mounting bracket (20) on left lower bumper support bracket (16) with two screws (22) and new locknuts (18).
8. Install winch chain on bumper (TM 9-2320-386-10).

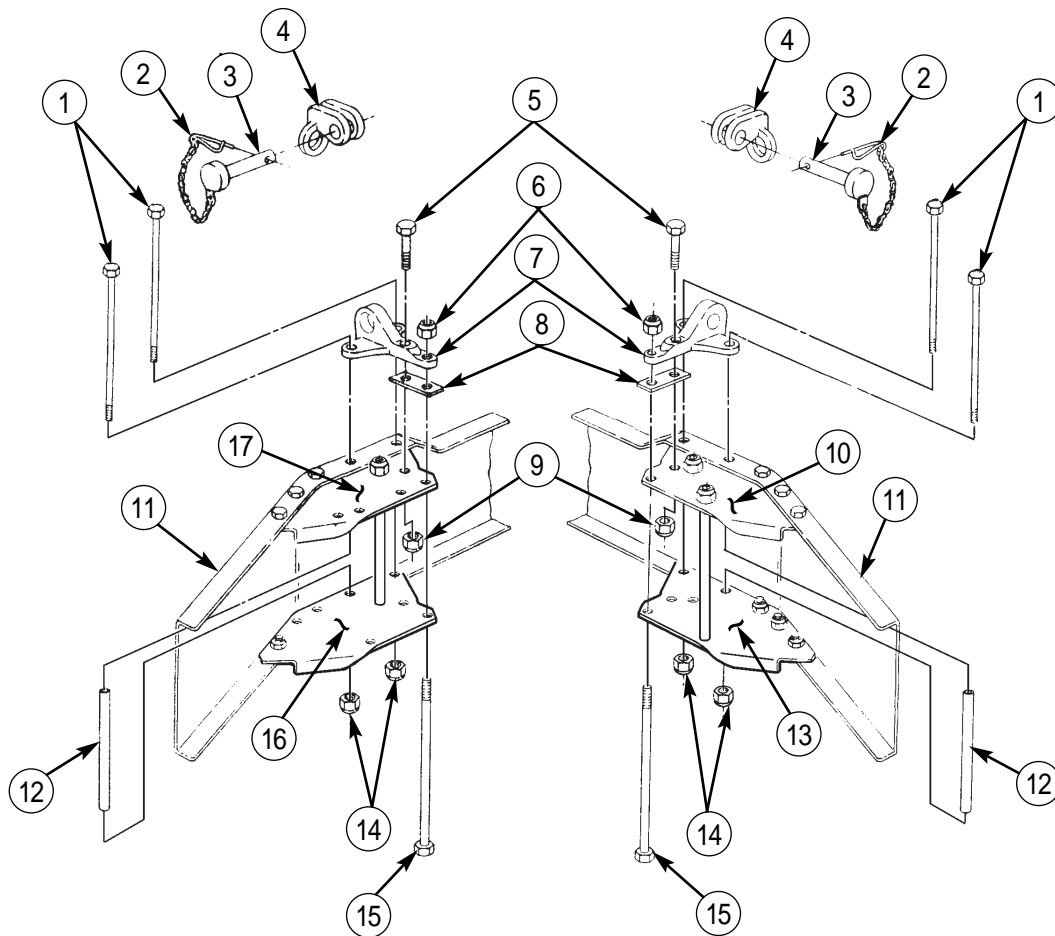

LEFT SIDE

RIGHT SIDE

FRONT UPPER AND LOWER SHACKLES AND BRACKETS (W/WINCH) REPLACEMENT (Contd)

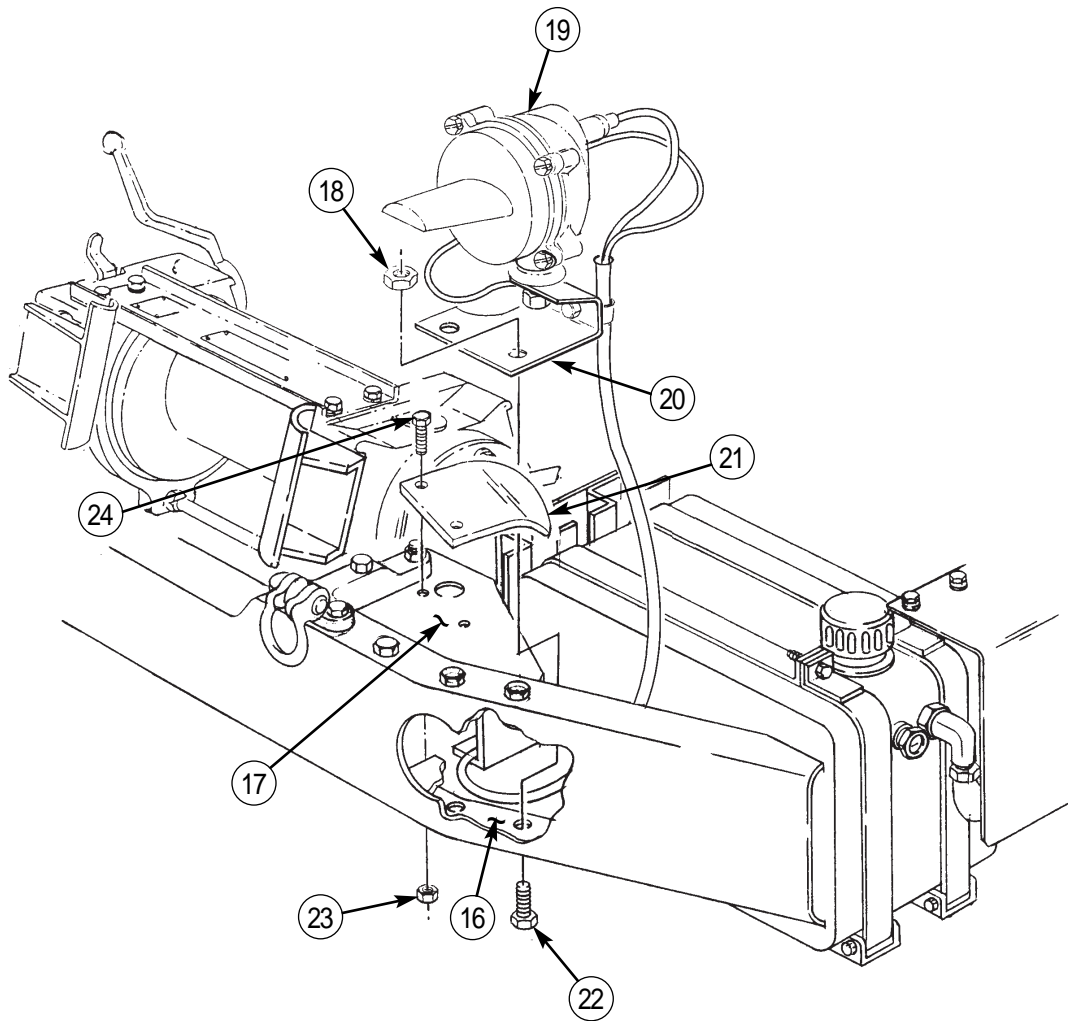

END OF WORK PACKAGE

UNIT MAINTENANCE INSTRUCTIONS

EXTENDED SERVICE PROGRAM (ESP)

TRUCK, CARGO, 2-1/2-TON, 6X6, M44A3 SERIES TRUCKS (DIESEL)

M35A3, W/O WINCH (NSN 2320-01-383-2047); W/WINCH (NSN 2320-01-383-3850);

M35A3C, W/O WINCH (NSN 2320-01-383-2050); W/WINCH (NSN 2320-01-383-2049);

M36A3, W/O WINCH (NSN 2320-01-383-2048); W/WINCH (NSN 2320-01-383-2046).

REAR SHACKLES AND BRACKETS REPLACEMENT

REMOVAL, INSTALLATION

INITIAL SETUP:

Tools and Special Tools

General mechanic's tool kit
(item 30, WP 0394 00)

References

TM 9-2320-386-24P

Materials/Parts

Six locknuts (item 107, WP 0395 00)

Equipment Condition

Parking brake set (TM 9-2320-386-10).

Rear bumperettes removed (WP 0228 00).

REAR SHACKLES AND BRACKETS REPLACEMENT (Contd)**NOTE**

Left and right rear shackles and brackets are replaced the same way. This task covers the left rear shackle and bracket only.

REMOVAL

1. Remove retaining pin (3) from pin (5).
2. Remove pin (5) and shackle (4) from bracket (2).
3. Remove three locknuts (7), screws (6), and bracket (2) from crossmember (1). Discard locknuts (7).

INSTALLATION

1. Install bracket (2) on crossmember (1) with three screws (6) and new locknuts (7).
2. Install shackle (4) on bracket (2) with pin (5) and retaining pin (3).
3. Install rear bumperettes (WP 0228 00).

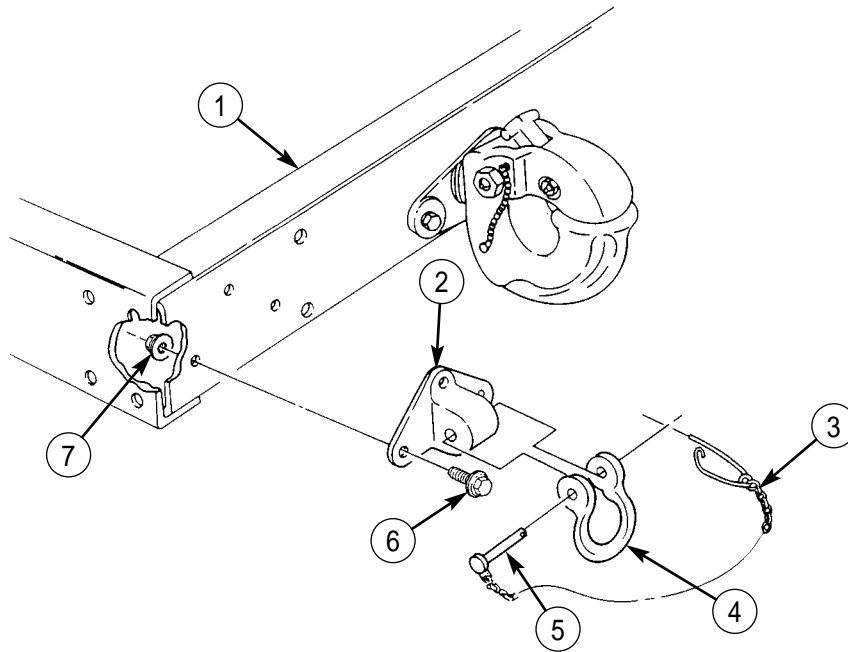

END OF WORK PACKAGE

UNIT MAINTENANCE INSTRUCTIONS

EXTENDED SERVICE PROGRAM (ESP)

TRUCK, CARGO, 2-1/2-TON, 6X6, M44A3 SERIES TRUCKS (DIESEL)

M35A3, W/O WINCH (NSN 2320-01-383-2047); W/WINCH (NSN 2320-01-383-3850);
M35A3C, W/O WINCH (NSN 2320-01-383-2050); W/WINCH (NSN 2320-01-383-2049);
M36A3, W/O WINCH (NSN 2320-01-383-2048); W/WINCH (NSN 2320-01-383-2046).

SPARE TIRE CARRIER MAINTENANCE

REMOVAL, DISASSEMBLY, INSPECTION, ASSEMBLY, INSTALLATION

INITIAL SETUP:

Tools and Special Tools

General mechanic's tool kit
(item 30, WP 0394 00)

Materials/Parts

Four locknuts (item 107, WP 0395 00)
Four lockwashers (item 59, WP 0395 00)
Cotter pin (item 34, WP 0395 00)

References

TM 9-2320-386-24P

Equipment Condition

Parking brake set (TM 9-2320-386-10).
Spare tire removed (TM 9-2320-386-10).
Air reservoirs removed (WP 0165 00).

SPARE TIRE CARRIER MAINTENANCE (Contd)

REMOVAL

Remove four locknuts (1), screws (3), and spare tire carrier (2) from frame (4). Discard locknuts (1).

DISASSEMBLY

1. Remove two nuts (6) and pickup member (7) from spare tire carrier (2).
2. Remove four nuts (12), lockwashers (10), two U-bolts (9), and ends of cable (8) from pickup member (7). Discard lockwashers (10).

WARNING

Wear leather gloves when handling cable. Do not let cable run through hands. Broken or rusty wires can cause injury to personnel.

3. Remove cable (8) from shaft (13).
4. Remove cotter pin (5) from shaft (13) and remove shaft (13) from spare tire carrier (2). Discard cotter pin (5).

INSPECTION

1. Inspect spare tire carrier (2) for cracks, breaks, and broken welds. Replace spare tire carrier (2) if cracked, bent, or welds are broken.
2. Inspect pickup member (7) for cracks, breaks, and loose studs (11). Replace pickup member (7) if cracked, broken, or studs (11) are loose.
3. Inspect shaft (13) and ratchet (14) for cracks, breaks, bends, and broken teeth on ratchet (14). Replace shaft (13) if cracked, broken, bent, or teeth are broken on ratchet (14).
4. Inspect cable (8) for breaks and frays. Replace cable (8) if broken or frayed.

ASSEMBLY

1. Install shaft (13) in spare tire carrier (2) with new cotter pin (5).
2. Install ends of cable (8) through holes in shaft (13) and feed ends of cable (8) through hole in bottom of spare tire carrier (2).

NOTE

Ensure cable ends are of equal length through shaft.

3. Install two U-bolts (9) on pickup member (7) with four new lockwashers (10) and nuts (12). Do not tighten nuts (12).

NOTE

Ensure cable ends extend through U-bolts before tightening nuts.

4. Install ends of cable (8) through holes in pickup member (7) and U-bolts (9). Tighten nuts (12).

INSTALLATION

1. Install spare tire carrier (2) on frame (4) with four screws (3) and new locknuts (1).
2. Install air reservoirs (WP 0165 00).
3. Install spare tire (TM9-2320-386-10).

SPARE TIRE CARRIER MAINTENANCE (Contd)

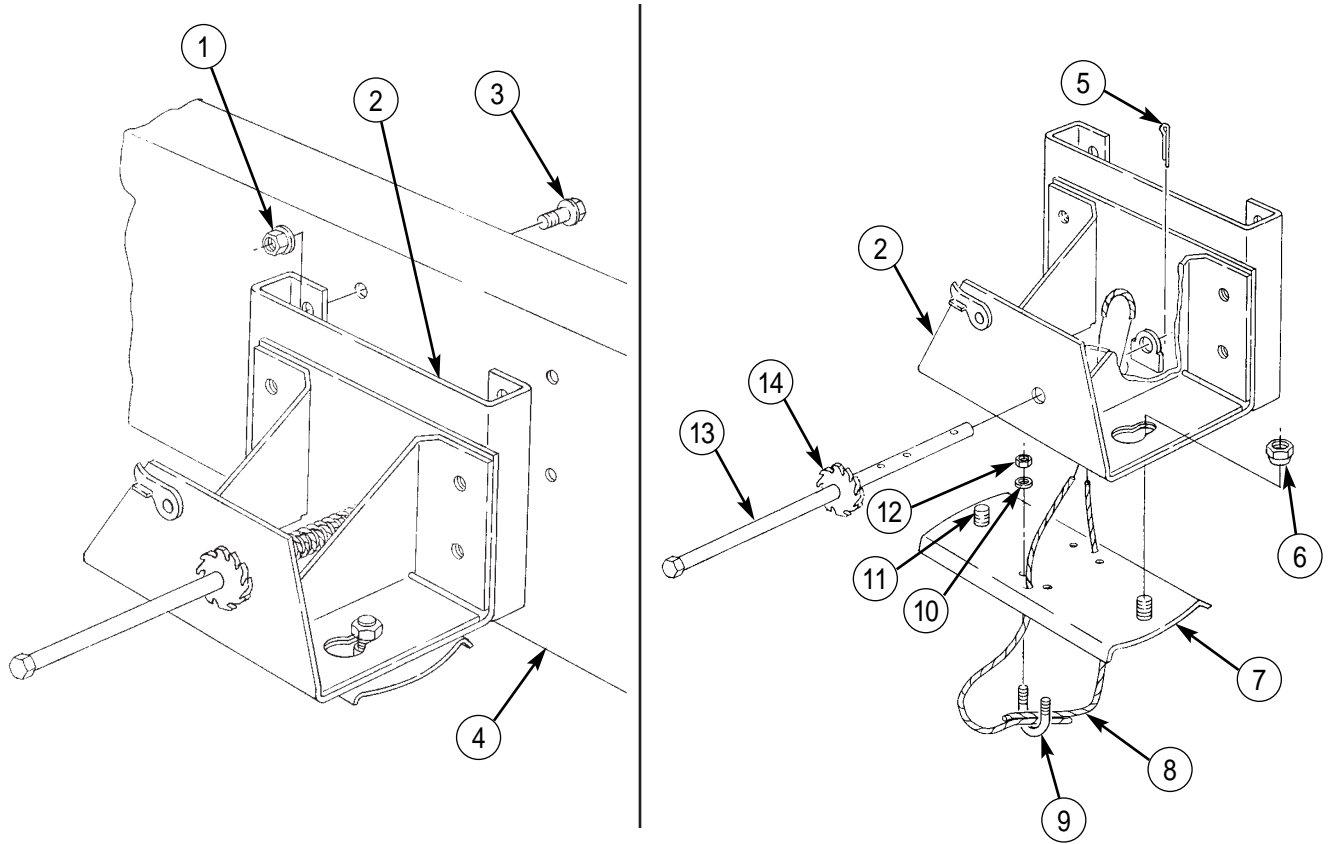

END OF WORK PACKAGE

UNIT MAINTENANCE INSTRUCTIONS

EXTENDED SERVICE PROGRAM (ESP)

TRUCK, CARGO, 2-1/2-TON, 6X6, M44A3 SERIES TRUCKS (DIESEL)

M35A3, W/O WINCH (NSN 2320-01-383-2047); W/WINCH (NSN 2320-01-383-3850);

M35A3C, W/O WINCH (NSN 2320-01-383-2050); W/WINCH (NSN 2320-01-383-2049);

M36A3, W/O WINCH (NSN 2320-01-383-2048); W/WINCH (NSN 2320-01-383-2046).

Section XVII. SPRING MAINTENANCE

TABLE OF CONTENTS

WP Title

WP Sequence No.-Page No.

Front Spring Replacement 0193 00-1

END OF WORK PACKAGE

UNIT MAINTENANCE INSTRUCTIONS

EXTENDED SERVICE PROGRAM (ESP)

TRUCK, CARGO, 2-1/2-TON, 6X6, M44A3 SERIES TRUCKS (DIESEL)

M35A3, W/O WINCH (NSN 2320-01-383-2047); W/WINCH (NSN 2320-01-383-3850);
M35A3C, W/O WINCH (NSN 2320-01-383-2050); W/WINCH (NSN 2320-01-383-2049);
M36A3, W/O WINCH (NSN 2320-01-383-2048); W/WINCH (NSN 2320-01-383-2046).

FRONT SPRING REPLACEMENT

REMOVAL, INSTALLATION

INITIAL SETUP:

Tools and Special Tools

General mechanic's tool kit
(item 30, WP 0394 00)

Materials/Parts

Four locknuts (item 99, WP 0395 00)
Four lockwashers (item 70, WP 0395 00)
Adhesive sealant (item 7, WP 0393 00)

References

TM 9-2320-386-24P

Equipment Condition

Parking brake set (TM 9-2320-386-10).
Wheel removed (WP 0174 00).
Steering assist cylinder removed (WP 0183 00).

FRONT SPRING REPLACEMENT (Contd)**NOTE**

Left and right front springs are replaced the same way. This procedure covers the right front spring.

REMOVAL

1. Raise front of vehicle and remove two jack stands from under front axle (5).
2. Support vehicle at frame (18) with two jack stands.
3. Place hydraulic jack under front axle (5).
4. Remove jamnut (10), nut (11), retainer (12), and rubber bushing (13) from shock absorber piston rod (17).
5. Push shock absorber piston rod (17) up and out of right axle bracket (7).
6. Remove rubber bushing (15) and retainer (16) from piston rod (17).
7. Remove four nuts (9), lockwashers (8), and right axle bracket (7) from two U-bolts (1). Discard lockwashers (8).
8. Remove two U-bolts (1), saddle (2), and rubber bumper (3) from spring (4).
9. Remove two locknuts (20) and screws (23) from shackle (19). Discard locknuts (20).
10. Remove two locknuts (20) and screws (23) from hanger (24). Discard locknuts (20).
11. Remove two lubrication fittings (21) from pins (22).

NOTE

Assistant will help with steps 12 through 17.

12. Remove pin (22) from shackle (19) and spring (4).
13. Remove pin (22) from hanger (24) and spring (4).
14. Push shackle (19) toward front of vehicle.
15. Push spring (4) clear of rear hanger (24).
16. Lift spring (4) clear of spring seat (6) and remove from vehicle.
17. Remove spring seat (6) from centering peg (14) and front axle (5).

FRONT SPRING REPLACEMENT (Contd)

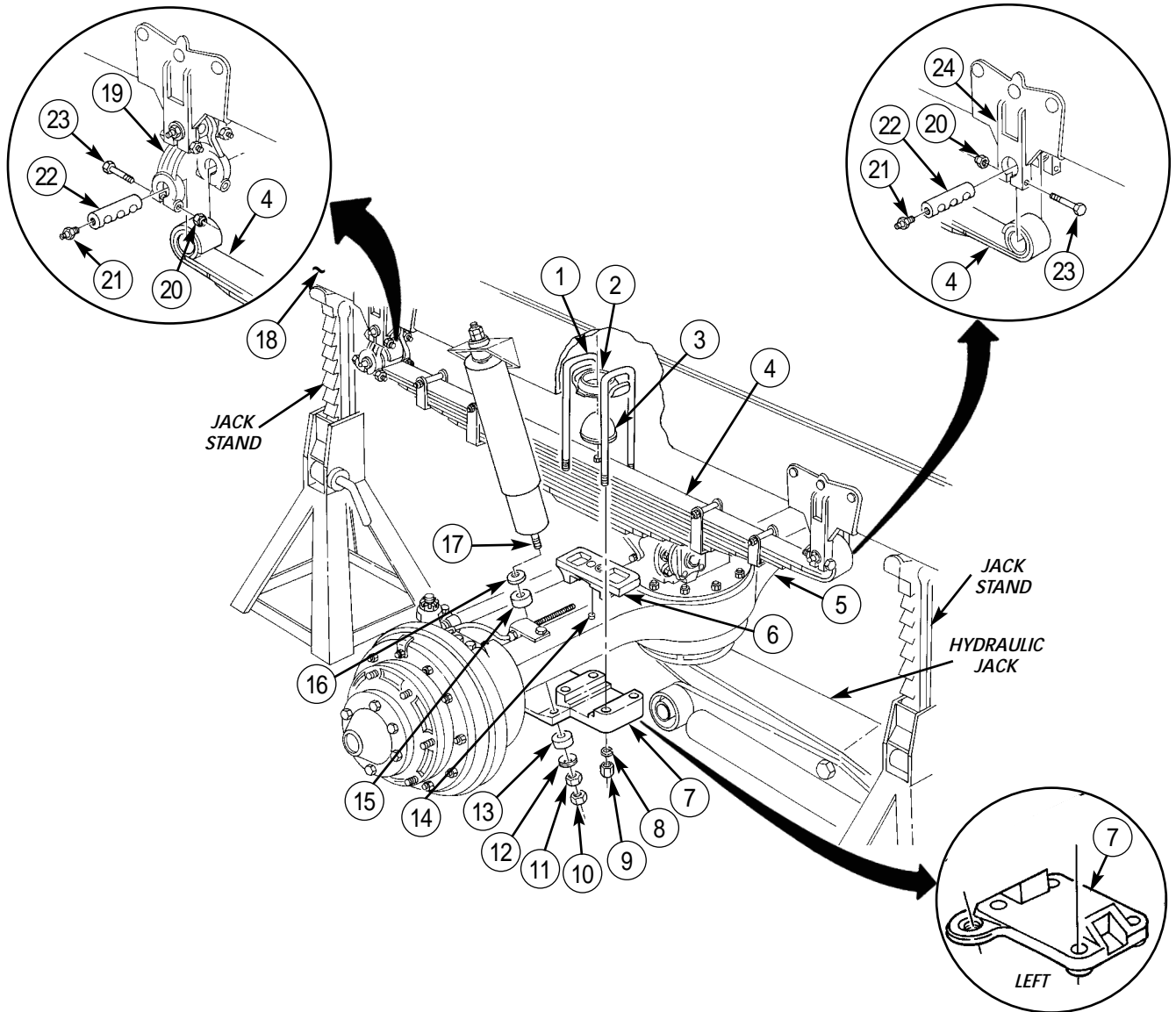

FRONT SPRING REPLACEMENT (Contd)**INSTALLATION****NOTE**

Assistant will help with steps 1 through 5.

1. Ensure spring seat (6) is properly positioned on centering peg (14) of front axle (5). Place spring (4) on spring seat (6) so nut on bottom of center bolt (18) is in spring seat (6).
2. Using hydraulic jack, raise or lower axle (5) to align holes in spring (4) with holes in shackle (20) and hanger (25).
3. Install spring (4) on shackle (20) and hanger (25) with two pins (23).
4. Turn pins (23) to align pin retaining screw slots with holes in shackle (20) and hanger (25).
5. Install two screws (24) and new locknuts (21) on shackle (20).
6. Install two screws (24) and new locknuts (21) on hanger (25).
7. Install two lubrication fittings (22) on pins (23).
8. Ensure center bolt (18) of spring (4) is still seated in spring seat (6). If not seated, realign spring (4) and spring seat (6).
9. Apply sealant around top mating surface of metal base of rubber bumper (3) and saddle (2) and seat bumper (3) base in saddle (2).
10. Install saddle (2) over spring (4) so center bolt (18) is in recess of rubber bumper (3) base.
11. Install two U-bolts (1) over saddle (2) and spring (4).
12. Position right axle bracket (7) on U-bolts (1) under axle housing (5), and install four new lockwashers (8) and nuts (9). Right axle bracket (7) must have shock absorber hole on wheel side of spring (4) toward rear of front axle housing (5) and angled down. Tighten nuts (9) 190-230 lb-ft (258-312 N·m).
13. Install retainer (16) and rubber bushing (15) on shock absorber piston rod (17) and extend through hole in plate (7). Ensure projecting lip of bushing (15) is seated in plate (7).
14. Install rubber bushing (13), retainer (12), and nut (11) on shock absorber piston rod (17). Tighten nut (11) until bushings (13) and (15) start to bulge.
15. Install jamnut (10) and tighten against nut (11).
16. Raise vehicle and remove two jack stands from frame (19) and place under front axle (5) to allow front wheel installation.
17. Install front right wheel (WP 0174 00).
18. Lubricate shackle and hanger fittings (WP 0023 00).
19. Install steering assist cylinder (WP 0183 00).

FRONT SPRING REPLACEMENT (Contd)

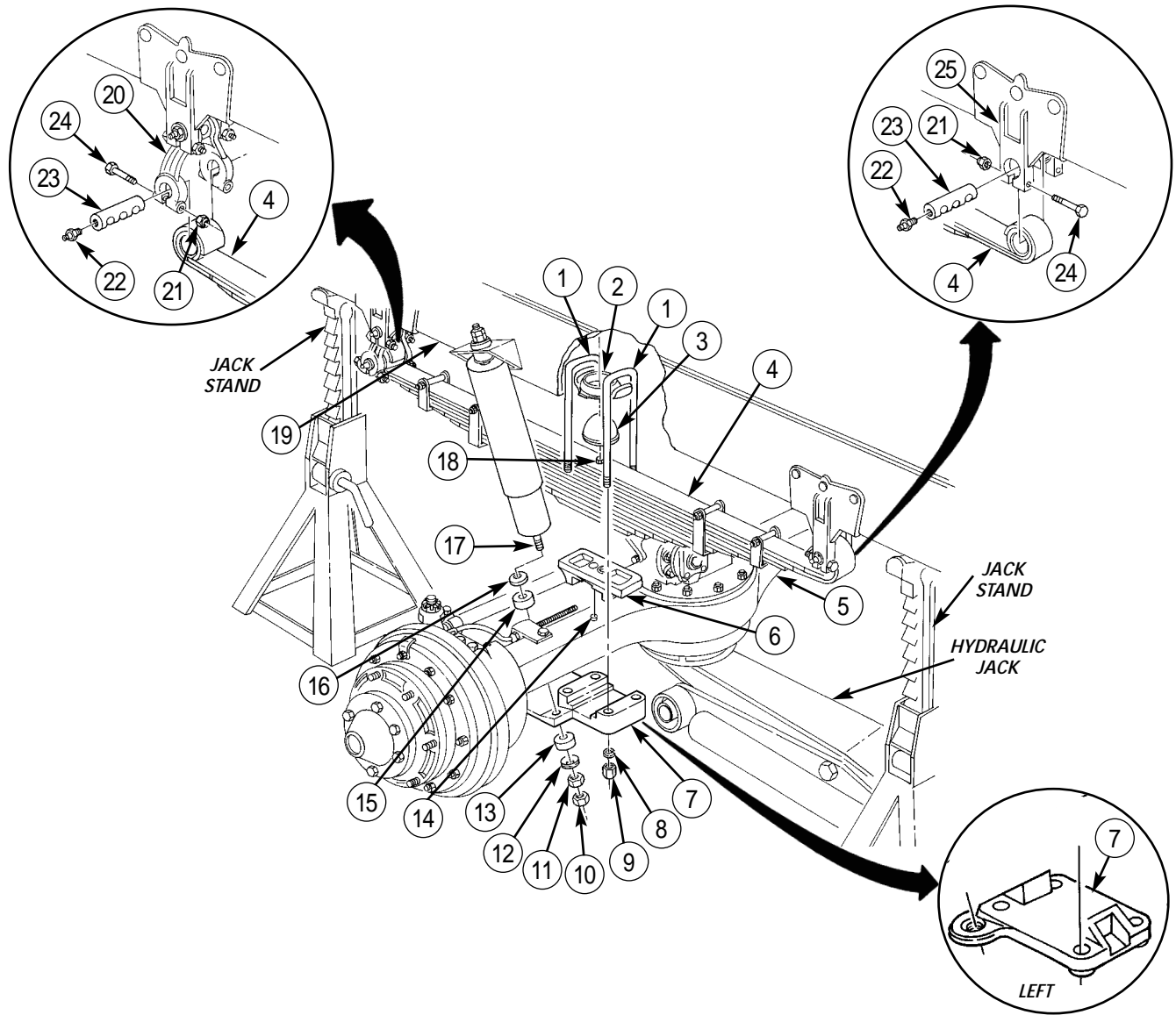

END OF WORK PACKAGE

UNIT MAINTENANCE INSTRUCTIONS

EXTENDED SERVICE PROGRAM (ESP)

TRUCK, CARGO, 2-1/2-TON, 6X6, M44A3 SERIES TRUCKS (DIESEL)

M35A3, W/O WINCH (NSN 2320-01-383-2047); W/WINCH (NSN 2320-01-383-3850);

M35A3C, W/O WINCH (NSN 2320-01-383-2050); W/WINCH (NSN 2320-01-383-2049);

M36A3, W/O WINCH (NSN 2320-01-383-2048); W/WINCH (NSN 2320-01-383-2046).

Section XVIII. BODY AND CAB MAINTENANCE

TABLE OF CONTENTS

<i>WP Title</i>	<i>WP Sequence No.-Page No.</i>
Hood Maintenance	0195 00-1
Hood Hinges Replacement	0196 00-1
Composite Hood Maintenance (Built After Serial No. 504923)	0197 00-1
Composite Hood Hinges Replacement (Built After Serial No. 504923)	0198 00-1
Composite Hood Insulation Replacement (Built After Serial No. 504923)	0199 00-1
Hood and Side Panel Insulation Replacement	0200 00-1
Cab Insulation Replacement	0201 00-1
Firewall Insulation Replacement	0202 00-1
Side Panel Replacement	0203 00-1
Front Fender Replacement	0204 00-1
Windshield Assembly Maintenance	0205 00-1
Windshield Arm, Window, and Handle Replacement	0206 00-1
Rear and Intermediate Cab Tunnel and Toeboard Replacement	0207 00-1
Driver's and Companion Seat Replacement	0208 00-1
Driver's Seat Repair	0209 00-1
Seatbelt Posts and Brackets Replacement	0210 00-1
Seatbelts Maintenance	0211 00-1

END OF WORK PACKAGE

UNIT MAINTENANCE INSTRUCTIONS

EXTENDED SERVICE PROGRAM (ESP)

TRUCK, CARGO, 2-1/2-TON, 6X6, M44A3 SERIES TRUCKS (DIESEL)

M35A3, W/O WINCH (NSN 2320-01-383-2047); W/WINCH (NSN 2320-01-383-3850);
M35A3C, W/O WINCH (NSN 2320-01-383-2050); W/WINCH (NSN 2320-01-383-2049);
M36A3, W/O WINCH (NSN 2320-01-383-2048); W/WINCH (NSN 2320-01-383-2046).

HOOD MAINTENANCE

REMOVAL, DISASSEMBLY, INSPECTION AND REPAIR, ASSEMBLY, INSTALLATION

INITIAL SETUP:

Tools and Special Tools

General mechanic's tool kit
(item 30, WP 0394 00)

Materials/Parts

Six locknuts (item 333, WP 0395 00)
Eight locknuts (item 15, WP 0395 00)
Eight locknuts (item 175, WP 0395 00)
Eight lockwashers (item 59, WP 0395 00)

References

TB 43-0209
TB 43-0213
TC 9-510
TM 9-237
TM 9-450
TM 9-2320-386-24P

Equipment Condition

Parking brake set (TM 9-2320-386-10).
Side panels removed (WP 0203 00).

HOOD MAINTENANCE (Contd)

REMOVAL

NOTE

Assistant will help with steps 1 through 4.

1. Remove eight screws (20), lockwashers (21), and two reinforcements (19) from hood (5) and two hinges (22). Discard lockwashers (21).
2. Remove two holddown latches (13) from brackets (15) on brushguard (8).
3. Push hood latch (7) to left and hold, lift hood (5), and release hood latch (7).
4. Remove hood (5) from vehicle.

DISASSEMBLY

1. Remove six locknuts (10), washers (9), and three handles (6) from hood (5). Discard locknuts (10).
2. Remove insulation from hood (5) (WP 0200 00).
3. Remove eight locknuts (17), four screws (2) and (4), two reinforcements (18), brackets (1), and latch assemblies (3) from hood (5). Discard locknuts (17).
4. Remove four locknuts (12), screws (11), and two holddown latches (13) from hood (5). Discard locknuts (12).
5. Remove four locknuts (14), screws (16), and two brackets (15) from brushguard (8). Discard locknuts (14).

INSPECTION AND REPAIR

1. Inspect hood (5) for loose or missing rivets.
2. Replace loose or missing rivets (refer to TM 9-450).
3. Refer to TM 9-237 for welding repair.
4. Refer to TC 9-510 for metal body repair.
5. Refer to TB 43-0209 for painting instructions.
6. Refer to TB 43-0213 for rustproofing instructions.

HOOD MAINTENANCE (Contd)

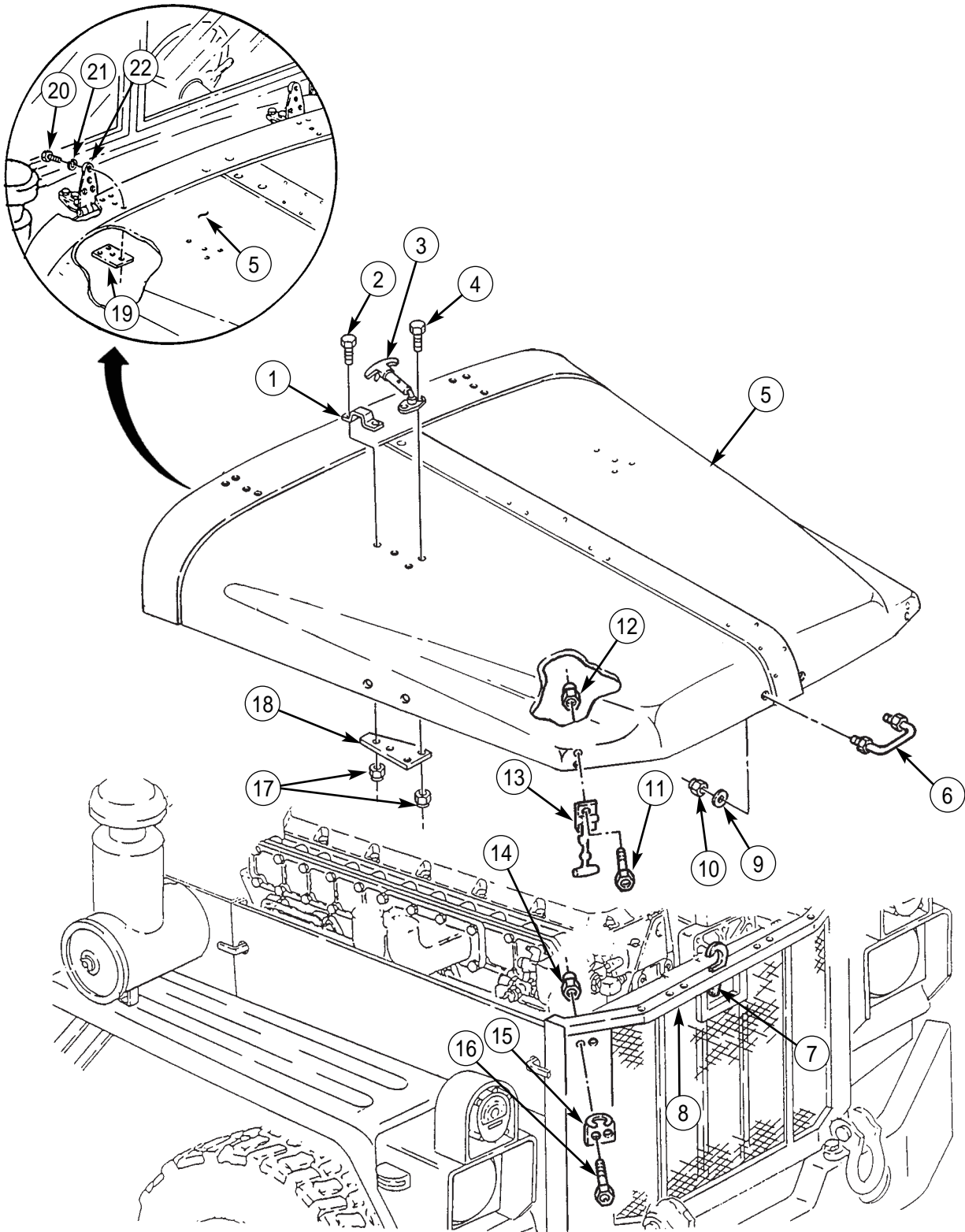

HOOD MAINTENANCE (Contd)

ASSEMBLY

1. Install two brackets (15) on brushguard (8) with four screws (16) and new locknuts (14).
2. Install two holddown latches (13) on hood (5) with four screws (11) and new locknuts (12).
3. Install two brackets (1), latch assemblies (3), and reinforcements (18) on hood (5) with four screws (2) and (4) and eight new locknuts (17).
4. Install insulation on hood (5) (WP 0200 00).
5. Install three handles (6) on hood (5) with six washers (9) and new locknuts (10).

INSTALLATION

NOTE

Assistant will help with steps 1 through 4.

1. Position hood (5) on vehicle.
2. Push hood latch (7) to left and hold, lower hood (5), and release hood latch (7).
3. Secure two holddown latches (13) to brackets (15) on brushguard (8).
4. Install two hinges (22) and reinforcements (19) on hood (5) with eight new lockwashers (21) and screws (20).
5. Install side panels (WP 0203 00).

HOOD MAINTENANCE (Contd)

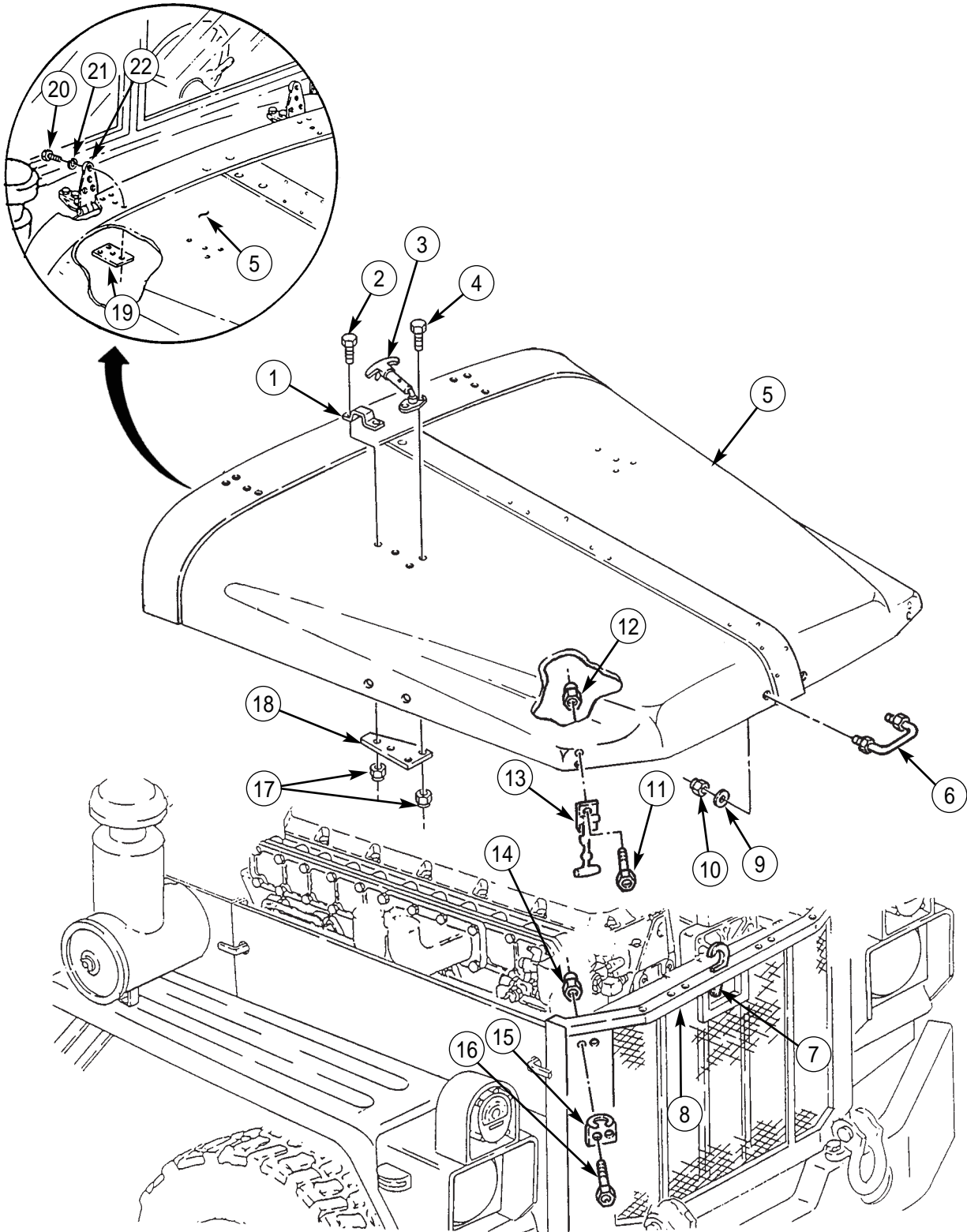

END OF WORK PACKAGE

UNIT MAINTENANCE INSTRUCTIONS

EXTENDED SERVICE PROGRAM (ESP)

TRUCK, CARGO, 2-1/2-TON, 6X6, M44A3 SERIES TRUCKS (DIESEL)

M35A3, W/O WINCH (NSN 2320-01-383-2047); W/WINCH (NSN 2320-01-383-3850);
M35A3C, W/O WINCH (NSN 2320-01-383-2050); W/WINCH (NSN 2320-01-383-2049);
M36A3, W/O WINCH (NSN 2320-01-383-2048); W/WINCH (NSN 2320-01-383-2046).

HOOD HINGES REPLACEMENT

REMOVAL, INSTALLATION

INITIAL SETUP:

Tools and Special Tools

General mechanic's tool kit
(item 30, WP 0394 00)

Materials/Parts

Sixteen lockwashers (item 59, WP 0395 00)

References

TM 9-2320-386-24P

Equipment Condition

Parking brake set (TM 9-2320-386-10).
Glove compartment removed (TM 9-2320-361-20).

HOOD HINGES REPLACEMENT (Contd)

WARNING

Keep fingers clear of hood and cowling when replacing hinges.
Failure to do so may result in injury to personnel.

REMOVAL

1. Turn four lockstuds (3) 1/4-turn to left and pull instrument cluster (2) away from instrument panel (1).

NOTE

Assistant will help with steps 2 through 6.

2. Remove eight screws (5), lockwashers (4), and two reinforcements (15) from cowling (16). Discard lockwashers (4).
3. Remove two holddown latches (10) from brackets (13) on brushguard (12).
4. Push hood latch (11) to left and hold, lift hood (9), and release hood latch (11).
5. Remove hood (9) from vehicle.
6. Remove eight screws (7), lockwashers (8), two reinforcements (14), and hinges (6) from hood (9). Discard lockwashers (8).

INSTALLATION

NOTE

Assistant will help with steps 1 through 6.

1. Install two hinges (6) and reinforcements (14) on hood (9) with eight new lockwashers (8) and screws (7). Finger-tighten screws (7).
2. Position hood (9) on vehicle.
3. Push hood latch (11) to left and hold, lower hood (9), and release hood latch (11).
4. Secure two holddown latches (10) to brackets (13) on brushguard (12).
5. Install two hinges (6) and reinforcements (15) on cowling (16) with eight new lockwashers (4) and screws (5).
6. Tighten screws (7).
7. Position instrument cluster (2) on instrument panel (1), and turn four lockstuds (3) 1/4-turn to right.
8. Install glove compartment (TM 9-2320-361-20).

HOOD HINGES REPLACEMENT (Contd)

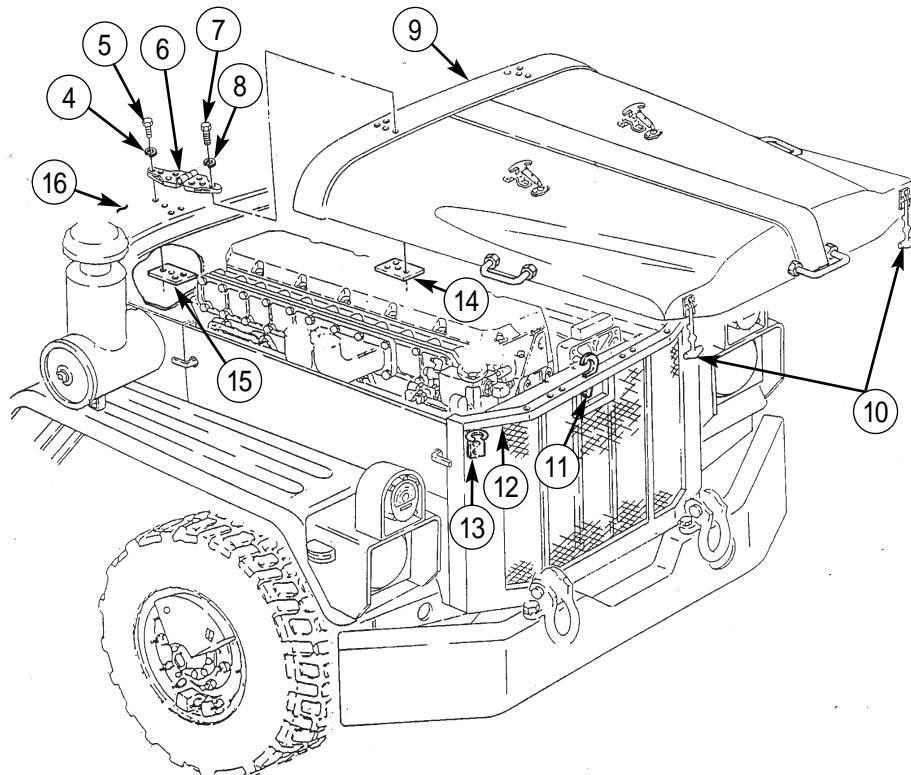
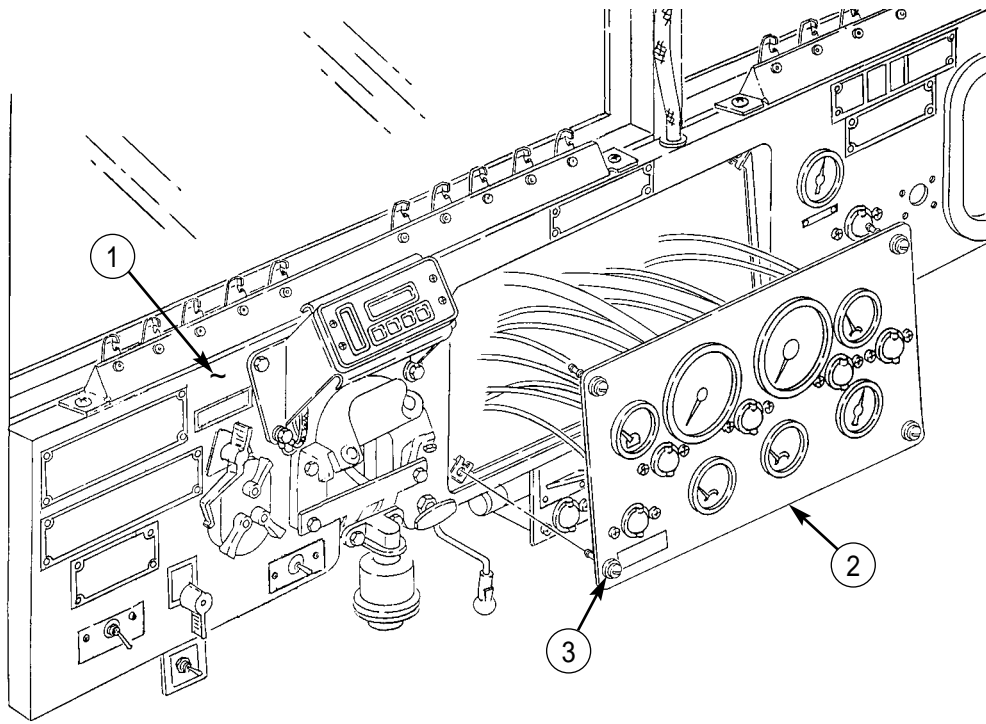

END OF WORK PACKAGE

UNIT MAINTENANCE INSTRUCTIONS

EXTENDED SERVICE PROGRAM (ESP)

TRUCK, CARGO, 2-1/2-TON, 6X6, M44A3 SERIES TRUCKS (DIESEL)

M35A3, W/O WINCH (NSN 2320-01-383-2047); W/WINCH (NSN 2320-01-383-3850);
M35A3C, W/O WINCH (NSN 2320-01-383-2050); W/WINCH (NSN 2320-01-383-2049);
M36A3, W/O WINCH (NSN 2320-01-383-2048); W/WINCH (NSN 2320-01-383-2046).

COMPOSITE HOOD MAINTENANCE (BUILT AFTER SERIAL NO. 504923)

REMOVAL, DISASSEMBLY, INSPECTION AND REPAIR, ASSEMBLY, INSTALLATION

INITIAL SETUP:

Tools and Special Tools

General mechanic's tool kit
(item 30, WP 0394 00)

Materials/Parts

Six locknuts (item 52, WP 0395 00)
Fourteen locknuts (item 14, SP 0395 00)
Sixteen lockwashers (item 303, WP 0395 00)

References

TM 9-2320-386-24P

Equipment Condition

Parking brake set (TM 9-2320-386-10).
Side panels removed (WP 0203 00).

COMPOSITE HOOD MAINTENANCE (BUILT AFTER SERIAL NO. 504923) (Contd)**REMOVAL****NOTE**

Assistant will help with steps 1 and 2.

1. Remove eight screws (24), lockwashers (25), and two reinforcements (23) from hood (7) and two hinges (26). Discard lockwashers (25).
2. Release hood latch (18) and remove hood (7) from vehicle.

DISASSEMBLY

1. Remove six locknuts (13), washers (12), and three handles (11) from hood (7). Discard locknuts (13).
2. Remove insulation from hood (7) (WP 0199 00).
3. Remove four screws (3) and (5), lockwashers (2) and (6), two reinforcements (22), brackets (1), and latch assemblies (4) from hood (7). Discard lockwashers (2) and (6).
4. Remove six locknuts (8), washers (9), and two bumpers (10) from hood (7). Discard locknuts (8).
5. Remove four locknuts (15), screws (14), and two holddown latches (16) from hood (7). Discard locknuts (15).
6. Remove four locknuts (17), screws (21), and two brackets (20) from brushguard (19). Discard locknuts (17).

INSPECTION AND REPAIR

1. Inspect hood (7) for loose or missing pins (27).
2. Replace loose or missing pins (27), notify direct support maintenance.
3. Inspect hood (7) for cracks or damage.
4. Notify direct support maintenance for fiberglass repair.

COMPOSITE HOOD MAINTENANCE (BUILT AFTER SERIAL NO. 504923) (Contd)

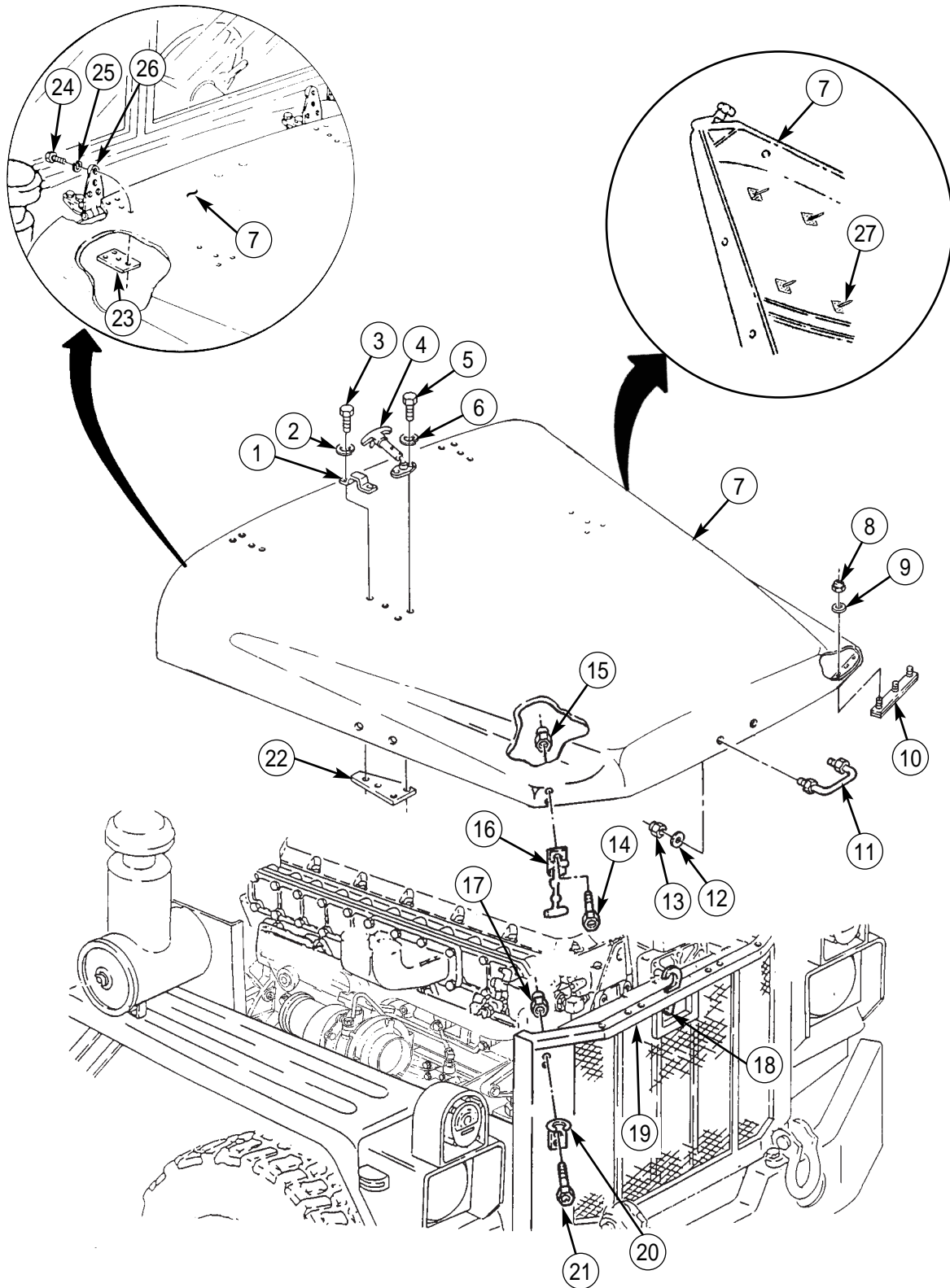

COMPOSITE HOOD MAINTENANCE (BUILT AFTER SERIAL NO. 504923) (Contd)**ASSEMBLY**

1. Install two brackets (20) on brushguard (19) with four screws (21) and new locknuts (17).
2. Install two holddown latches (16) on hood (7) with four screws (14) and new locknuts (15).
3. Install two bumpers (10) on hood (7) with six washers (9) and new locknuts (8).
4. Install two brackets (1), latch assemblies (4), and reinforcements (22) on hood (7) with four new lockwashers (2) and (6) and screws (3) and (5).
5. Install insulation on hood (7) (WP 0199 00).
6. Install three handles (11) on hood (7) with six washers (12) and new locknuts (13).

INSTALLATION**NOTE**

Assistant will help with steps 1 and 2.

1. Position hood (7) on vehicle and secure with hood latch (18).
2. Install two hinges (26) and reinforcements (23) on hood (7) with eight new lockwashers (25) and screws (24).
3. Install side panels (WP 0203 00).

COMPOSITE HOOD MAINTENANCE (BUILT AFTER SERIAL NO. 504923) (Contd)

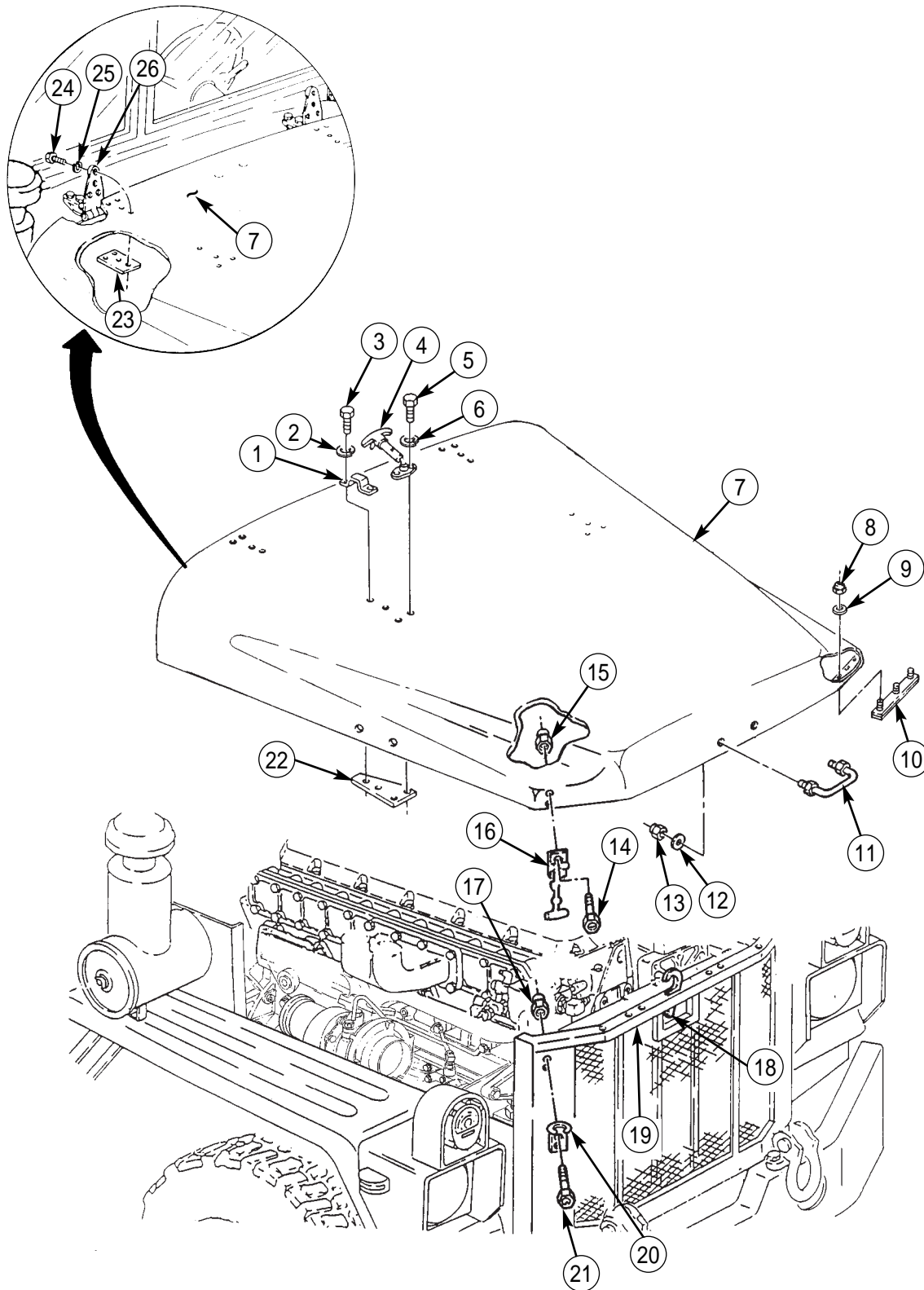

END OF WORK PACKAGE

UNIT MAINTENANCE INSTRUCTIONS

EXTENDED SERVICE PROGRAM (ESP)

TRUCK, CARGO, 2-1/2-TON, 6X6, M44A3 SERIES TRUCKS (DIESEL)

M35A3, W/O WINCH (NSN 2320-01-383-2047); W/WINCH (NSN 2320-01-383-3850);

M35A3C, W/O WINCH (NSN 2320-01-383-2050); W/WINCH (NSN 2320-01-383-2049);

M36A3, W/O WINCH (NSN 2320-01-383-2048); W/WINCH (NSN 2320-01-383-2046).

COMPOSITE HOOD HINGES REPLACEMENT (BUILT AFTER SERIAL NO. 504923)

REMOVAL, INSTALLATION

INITIAL SETUP:

Tools and Special Tools

General mechanic's tool kit
(item 30, WP 0394 00)

Materials/Parts

Sixteen lockwashers (item 59, WP 0395 00)

References

TM 9-2320-386-24P

Equipment Condition

Parking brake set (TM 9-2320-386-10).

Glove compartment removed (TM 9-2320-361-20).

Side panels removed (WP 0203 00).

COMPOSITE HOOD HINGES REPLACEMENT (BUILT AFTER SERIAL NO. 504923) (Contd)**WARNING**

Keep fingers clear of hood and cowling when replacing hinges.
Failure to do so may result in injury to personnel.

REMOVAL

1. Turn four lockstuds (3) 1/4-turn to the left and pull instrument cluster (2) away from instrument panel (1).

NOTE

Assistant will help with steps 2 through 4.

2. Remove eight screws (5), lockwashers (4), and two reinforcements (11) from cowling (12). Discard lockwashers (4).
3. Remove hood (9) from vehicle.
4. Remove eight screws (7), lockwashers (8), two reinforcements (10), and hinges (6) from hood (9). Discard lockwashers (8).

INSTALLATION**NOTE**

Assistant will help with steps 1 through 4.

1. Install two hinges (6) and reinforcements (10) on hood (9) with eight new lockwashers (8) and screws (7). Finger-tighten screws (7).
2. Position hood (9) on vehicle.
3. Install two hinges (6) and reinforcements (11) on cowling (12) with eight new lockwashers (4) and screws (5).
4. Tighten screws (7).
5. Position instrument cluster (2) to instrument panel (1), and install by turning four lockstuds (3) 1/4-turn to the right.
6. Install side panels (WP 0203 00).
7. Install glove compartment (TM 9-2320-361-20).

COMPOSITE HOOD HINGES REPLACEMENT (BUILT AFTER SERIAL NO. 504923) (Contd)

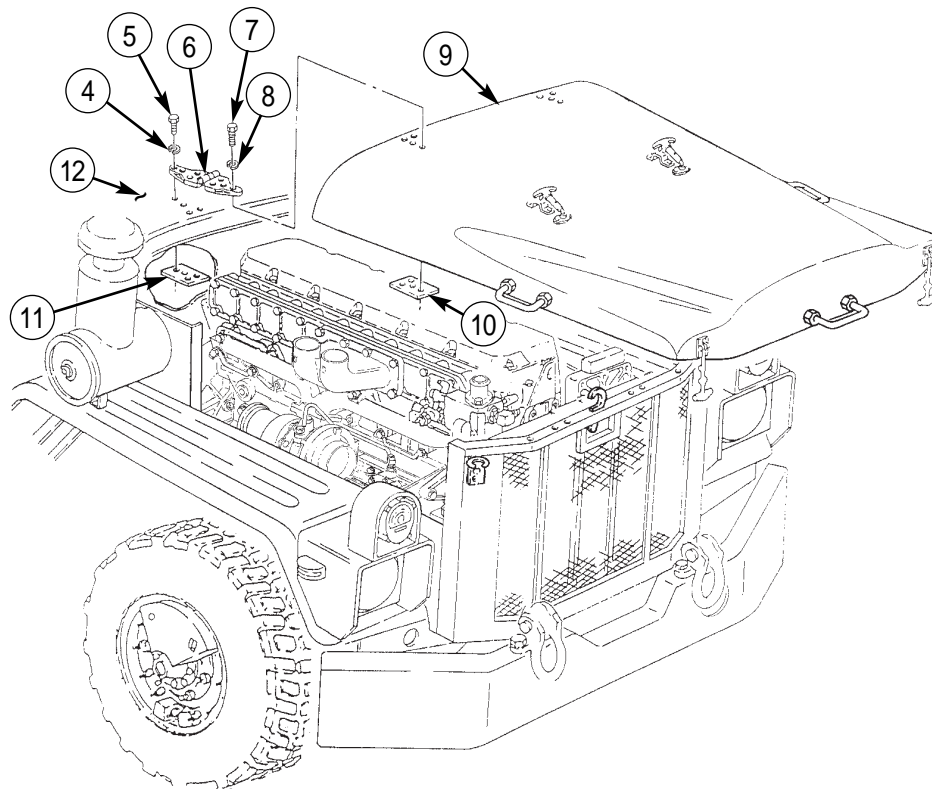
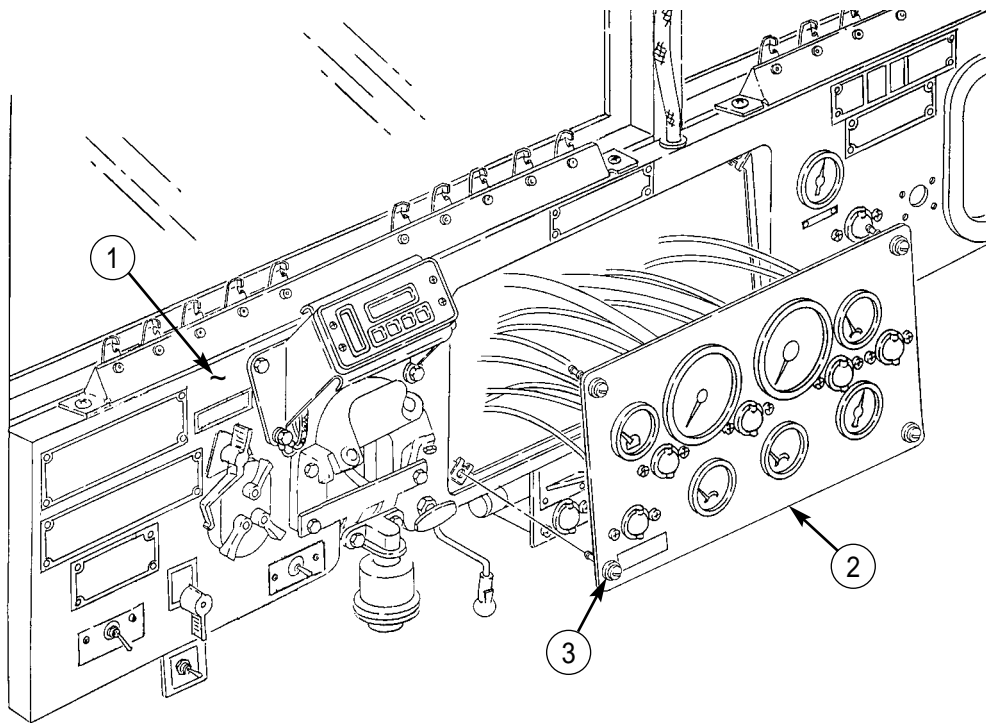

END OF WORK PACKAGE

UNIT MAINTENANCE INSTRUCTIONS

EXTENDED SERVICE PROGRAM (ESP)

TRUCK, CARGO, 2-1/2-TON, 6X6, M44A3 SERIES TRUCKS (DIESEL)

M35A3, W/O WINCH (NSN 2320-01-383-2047); W/WINCH (NSN 2320-01-383-3850);

M35A3C, W/O WINCH (NSN 2320-01-383-2050); W/WINCH (NSN 2320-01-383-2049);

M36A3, W/O WINCH (NSN 2320-01-383-2048); W/WINCH (NSN 2320-01-383-2046).

COMPOSITE HOOD INSULATION REPLACEMENT (BUILT AFTER SERIAL NO. 504923)

REMOVAL, INSTALLATION

INITIAL SETUP:

Tools and Special Tools

General mechanic's tool kit
(item 30, WP 0394 00)

Materials/Parts

Thirty-one caps (item 111, WP 0395 00)

References

TM 9-2320-386-24P

Equipment Condition

Parking brake set (TM 9-2320-386-10).
Composite hood removed (WP 0197 00).

COMPOSITE HOOD INSULATION REPLACEMENT (BUILT AFTER SERIAL NO. 504923) (Contd)**REMOVAL**

Remove thirty-one caps (3), retainers (2), and insulation (4) from pins (5) on hood (1). Discard caps (3).

INSTALLATION

1. Install insulation (4) on pins (5) and hood (1) with thirty-one retainers (2) and new caps (3).
2. Install composite hood (WP 0197 00).

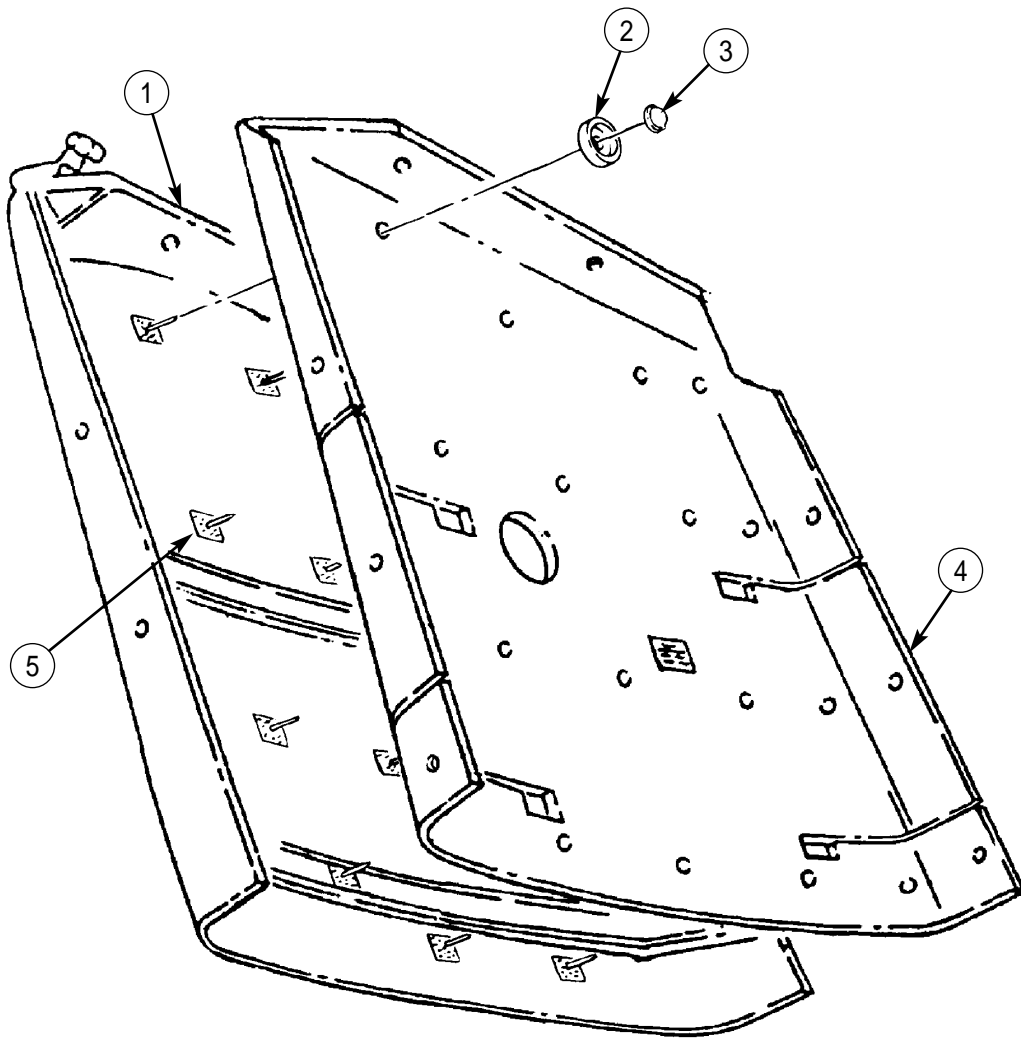

END OF WORK PACKAGE

UNIT MAINTENANCE INSTRUCTIONS

EXTENDED SERVICE PROGRAM (ESP)

TRUCK, CARGO, 2-1/2-TON, 6X6, M44A3 SERIES TRUCKS (DIESEL)

M35A3, W/O WINCH (NSN 2320-01-383-2047); W/WINCH (NSN 2320-01-383-3850);
M35A3C, W/O WINCH (NSN 2320-01-383-2050); W/WINCH (NSN 2320-01-383-2049);
M36A3, W/O WINCH (NSN 2320-01-383-2048); W/WINCH (NSN 2320-01-383-2046).

HOOD AND SIDE PANEL INSULATION REPLACEMENT

REMOVAL, INSTALLATION

INITIAL SETUP:

Tools and Special Tools

General mechanic's tool kit
(item 30, WP 0394 00)

Materials/Parts

Forty-one rivets (item 114, WP 0395 00)

References

TM 9-2320-386-24P

Equipment Condition

Parking brake set (TM 9-2320-386-10).
Hood removed (WP 0195 00).

HOOD AND SIDE PANEL INSULATION REPLACEMENT (Contd)

REMOVAL

1. Remove six rivets (7), retainers (2), and insulation (9) from right side panel (8). Discard rivets (7).
2. Remove eight rivets (5), retainers (3), and insulation (4) from left side panel (6). Discard rivets (5).
3. Remove twenty-seven rivets (10), retainers (11), and insulation (12) from hood (1). Discard rivets (10).

INSTALLATION

1. Install insulation (12) on hood (1) with twenty-seven retainers (11) and new rivets (10).
2. Install insulation (4) on left side panel (6) with eight retainers (3) and new rivets (5).
3. Install insulation (9) on right side panel (8) with six retainers (2) and new rivets (7).
4. Install hood (WP 0195 00).

HOOD AND SIDE PANEL INSULATION REPLACEMENT (Contd)

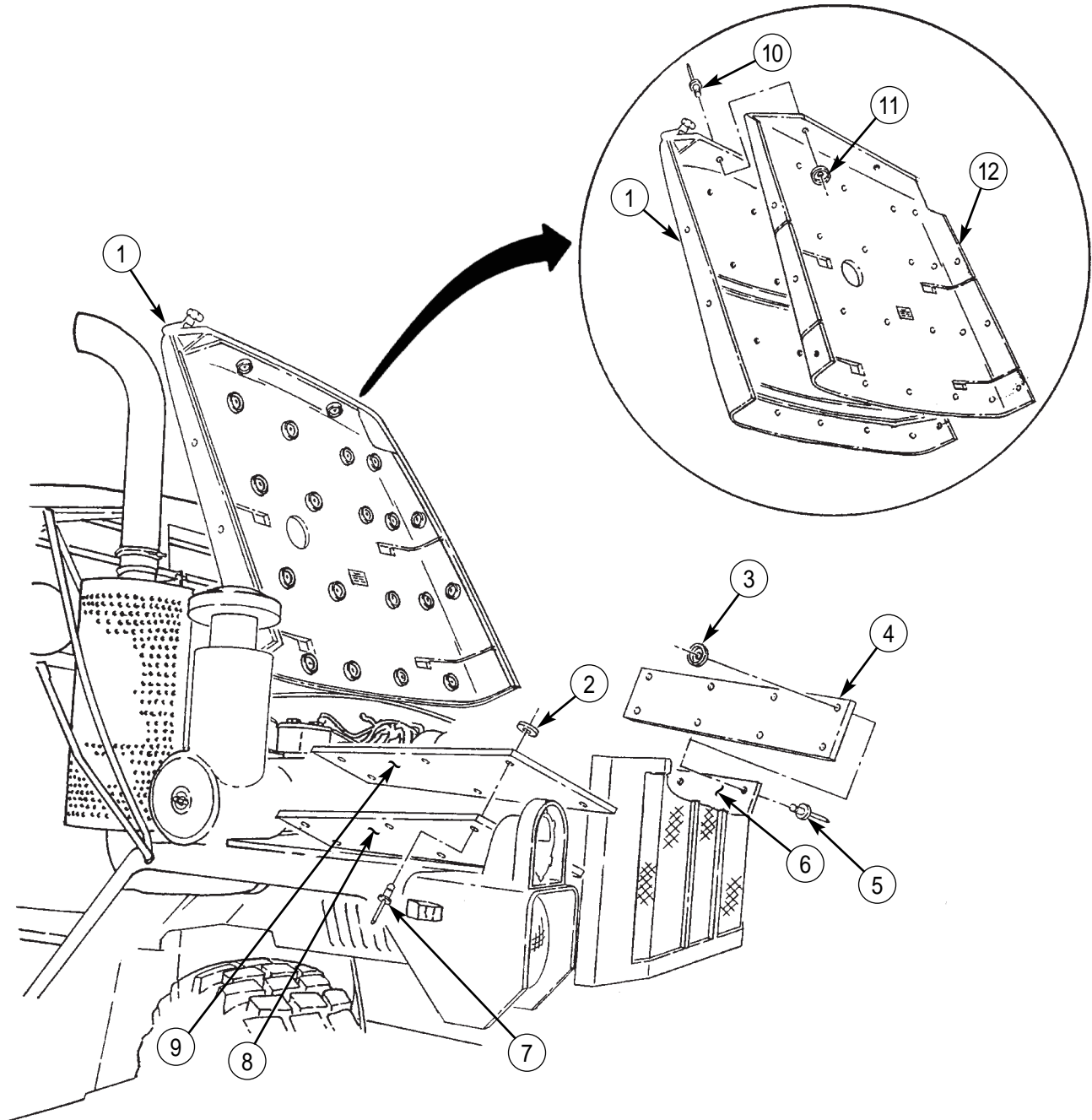

END OF WORK PACKAGE

UNIT MAINTENANCE INSTRUCTIONS

EXTENDED SERVICE PROGRAM (ESP)

TRUCK, CARGO, 2-1/2-TON, 6X6, M44A3 SERIES TRUCKS (DIESEL)

M35A3, W/O WINCH (NSN 2320-01-383-2047); W/WINCH (NSN 2320-01-383-3850);

M35A3C, W/O WINCH (NSN 2320-01-383-2050); W/WINCH (NSN 2320-01-383-2049);

M36A3, W/O WINCH (NSN 2320-01-383-2048); W/WINCH (NSN 2320-01-383-2046).

CAB INSULATION REPLACEMENT

REMOVAL, INSTALLATION

INITIAL SETUP:

Tools and Special Tools

General mechanic's tool kit
(item 30, WP 0394 00)

Equipment Condition

Parking brake set (TM 9-2320-386-10).

References

TM 9-2320-386-24P

CAB INSULATION REPLACEMENT (Contd)***REMOVAL***

1. Remove ten screws (1), two retention straps (7), tunnel insulation (2), and rear tunnel insulation (3) from cab floor tunnel (4).
2. Remove insulation (6) from toeboard cover (5).
3. Remove insulation (8) and (9) from cab floor (10).

INSTALLATION

1. Install insulation (8) and (9) on cab floor (10).
2. Install insulation (6) on toeboard cover (5).
3. Install rear tunnel insulation (3) and front tunnel insulation (2) on cab floor tunnel (4) with two retention straps (7) and ten screws (1).

CAB INSULATION REPLACEMENT (Contd)

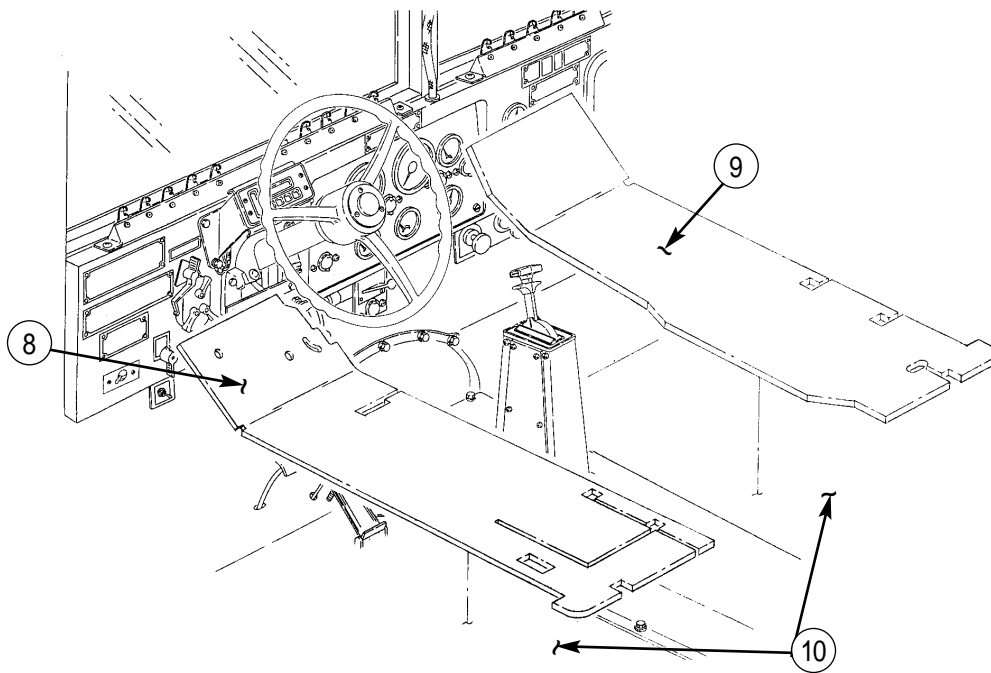
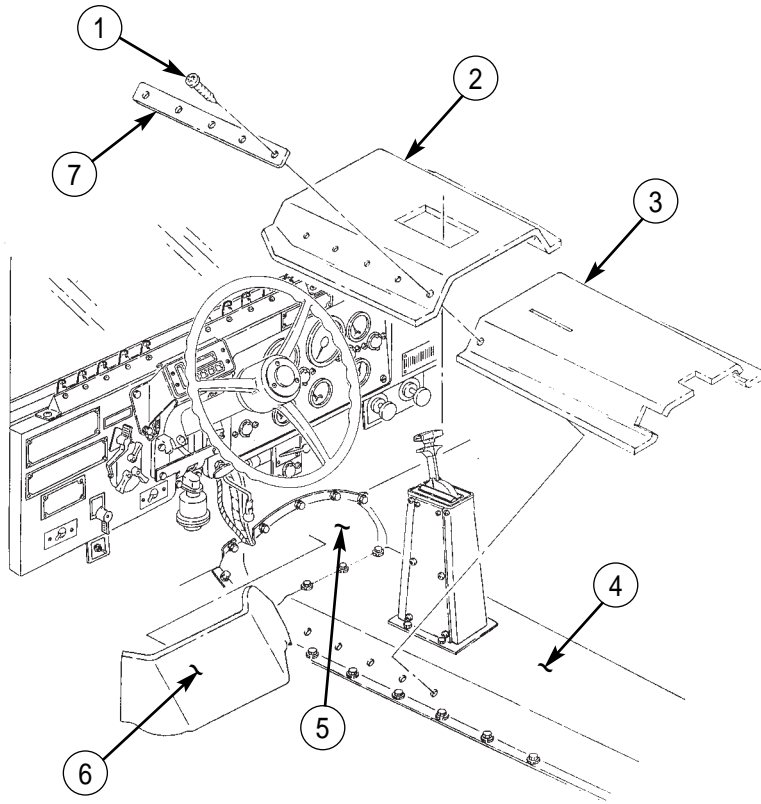

END OF WORK PACKAGE

UNIT MAINTENANCE INSTRUCTIONS

EXTENDED SERVICE PROGRAM (ESP)

TRUCK, CARGO, 2-1/2-TON, 6X6, M44A3 SERIES TRUCKS (DIESEL)

M35A3, W/O WINCH (NSN 2320-01-383-2047); W/WINCH (NSN 2320-01-383-3850);
M35A3C, W/O WINCH (NSN 2320-01-383-2050); W/WINCH (NSN 2320-01-383-2049);
M36A3, W/O WINCH (NSN 2320-01-383-2048); W/WINCH (NSN 2320-01-383-2046).

FIREWALL INSULATION REPLACEMENT

REMOVAL, INSTALLATION

INITIAL SETUP:

Tools and Special Tools

General mechanic's tool kit
(item 30, WP 0394 00)

Materials/Parts

Adhesive (item 5, WP 0393 00)

References

TM 9-2320-386-24P

Equipment Condition

Parking brake set (TM 9-2320-386-10).

FIREWALL INSULATION REPLACEMENT (Contd)

REMOVAL

Remove insulation (1) from cab front firewall (2).

INSTALLATION

1. Apply adhesive to back side insulation (1).
2. Install insulation (1) on cab front firewall (2).

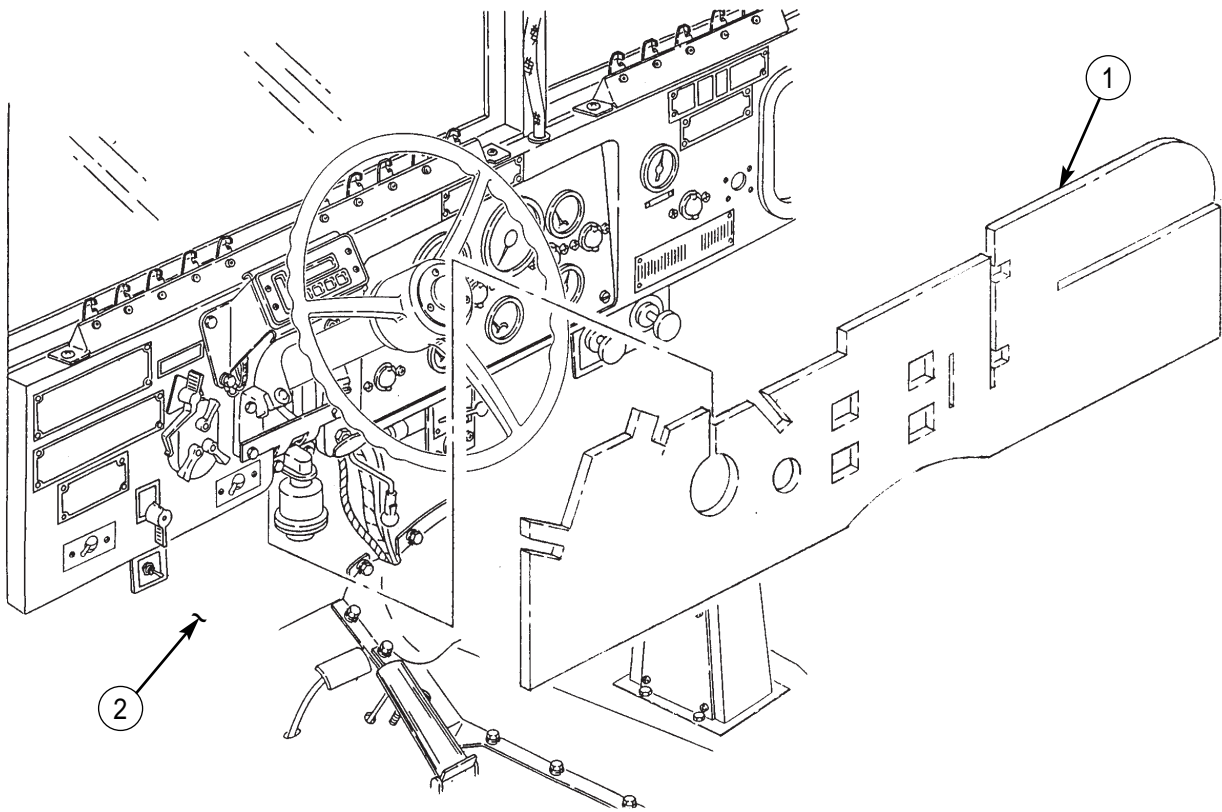

END OF WORK PACKAGE

UNIT MAINTENANCE INSTRUCTIONS

EXTENDED SERVICE PROGRAM (ESP)

TRUCK, CARGO, 2-1/2-TON, 6X6, M44A3 SERIES TRUCKS (DIESEL)

M35A3, W/O WINCH (NSN 2320-01-383-2047); W/WINCH (NSN 2320-01-383-3850);

M35A3C, W/O WINCH (NSN 2320-01-383-2050); W/WINCH (NSN 2320-01-383-2049);

M36A3, W/O WINCH (NSN 2320-01-383-2048); W/WINCH (NSN 2320-01-383-2046).

SIDE PANEL REPLACEMENT

SIDE PANEL REMOVAL, SIDE PANEL HINGES REMOVAL, THUMB CRANKS REMOVAL,
THUMB CRANKS INSTALLATION, SIDE PANEL HINGES INSTALLATION, SIDE PANEL INSTALLATION

INITIAL SETUP:

Tools and Special Tools

General mechanic's tool kit
(item 30, WP 0394 00)

Materials/Parts

Eight locknuts (item 248, WP 0395 00)
Four locknuts (item 344, WP 0395 00)

References

TM 9-2320-386-24P

Equipment Condition

Parking brake set (TM 9-2320-386-10).
Hood raised and secured (TM 9-2320-386-10).

SIDE PANEL REPLACEMENT (Contd)

NOTE

The left and right side panels are replaced basically the same.
This task covers the right side panel.

SIDE PANEL REMOVAL

1. Turn thumb cranks (3) to unlock side panel (2) from fender (16).
2. Raise spring clip (6) and remove side panel (2) from fender (16) by sliding side panel (2) forward until free from vehicle.

SIDE PANEL HINGES REMOVAL

1. Remove four locknuts (8), washers (7), screws (15), washers (14), spring clip (6), and two hinges (5) from side panel (2). Discard locknuts (8).
2. Remove four locknuts (12), washers (11), screws (9), washers (10), and two hinges (13) from fender (16). Discard locknuts (12).

THUMB CRANKS REMOVAL

NOTE

Perform step 1 if side panel has not been removed.

1. Turn thumb cranks (3) to unlock side panel (2) from fender (16).
2. Remove four locknuts (4), screws (1), and two thumb cranks (3) from side panel (2). Discard locknuts (4).

SIDE PANEL REPLACEMENT (Contd)

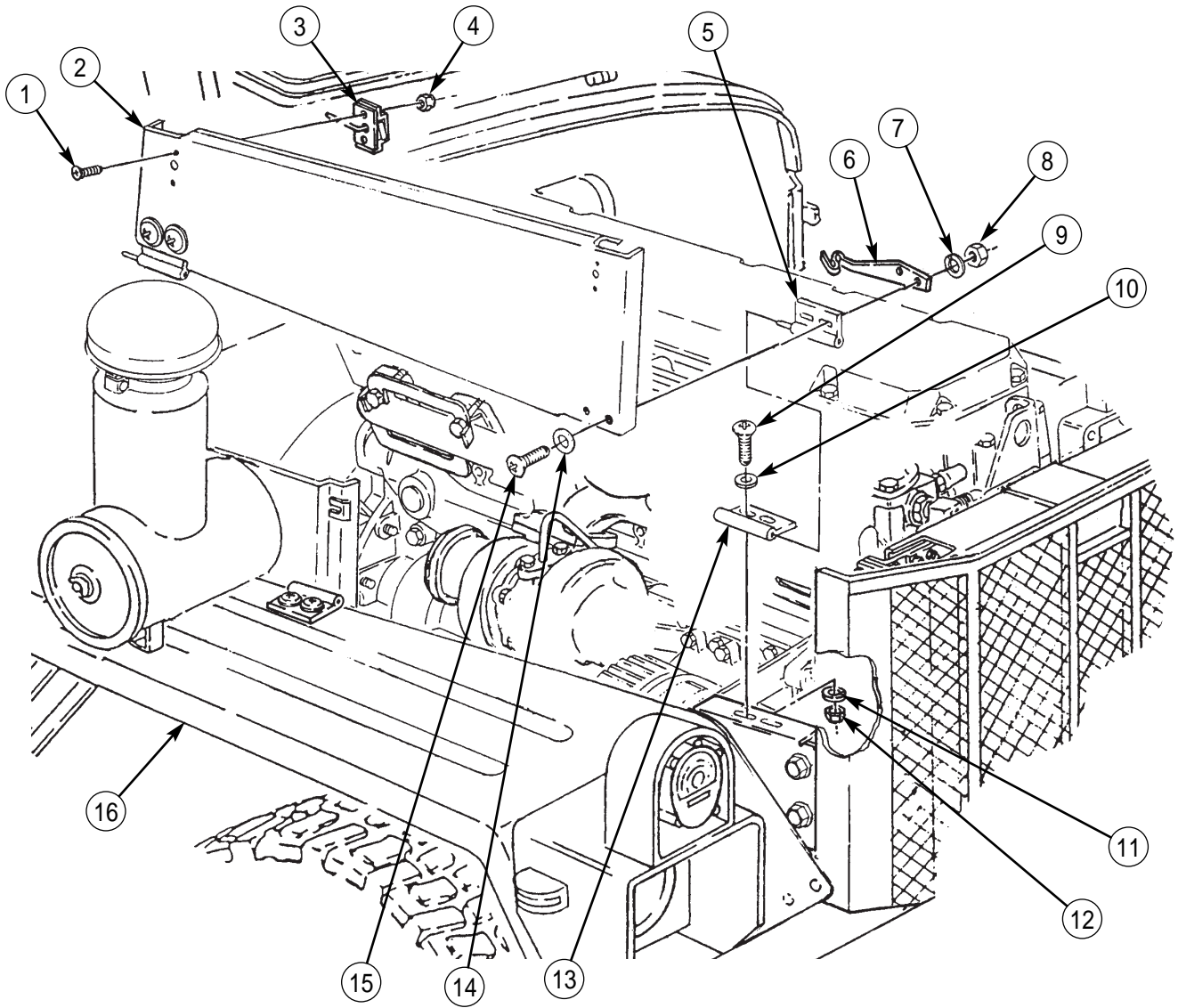

SIDE PANEL REPLACEMENT (Contd)

THUMB CRANKS INSTALLATION

1. Install two thumb cranks (3) on side panel (2) with four screws (1) and new locknuts (4).

NOTE

Perform step 2 if side panel has not been removed.

2. Lock side panel (2) to fender (16) by turning thumb cranks (3).

SIDE PANEL HINGES INSTALLATION

1. Install two hinges (13) on fender (16) with four washers (10), screws (9), washers (11), and new locknuts (12).
2. Install two hinges (5) and spring clip (6) on side panel (2) with four washers (14), screws (15), washers (7), and new locknuts (8).

SIDE PANEL INSTALLATION

1. With hinges (5) and (13) aligned, raise spring clip (6) and install side panel (2) on fender (16) by sliding side panel (2) to the rear until in place.
2. Lock side panel (2) to fender (16) by turning thumb cranks (3).

SIDE PANEL REPLACEMENT (Contd)

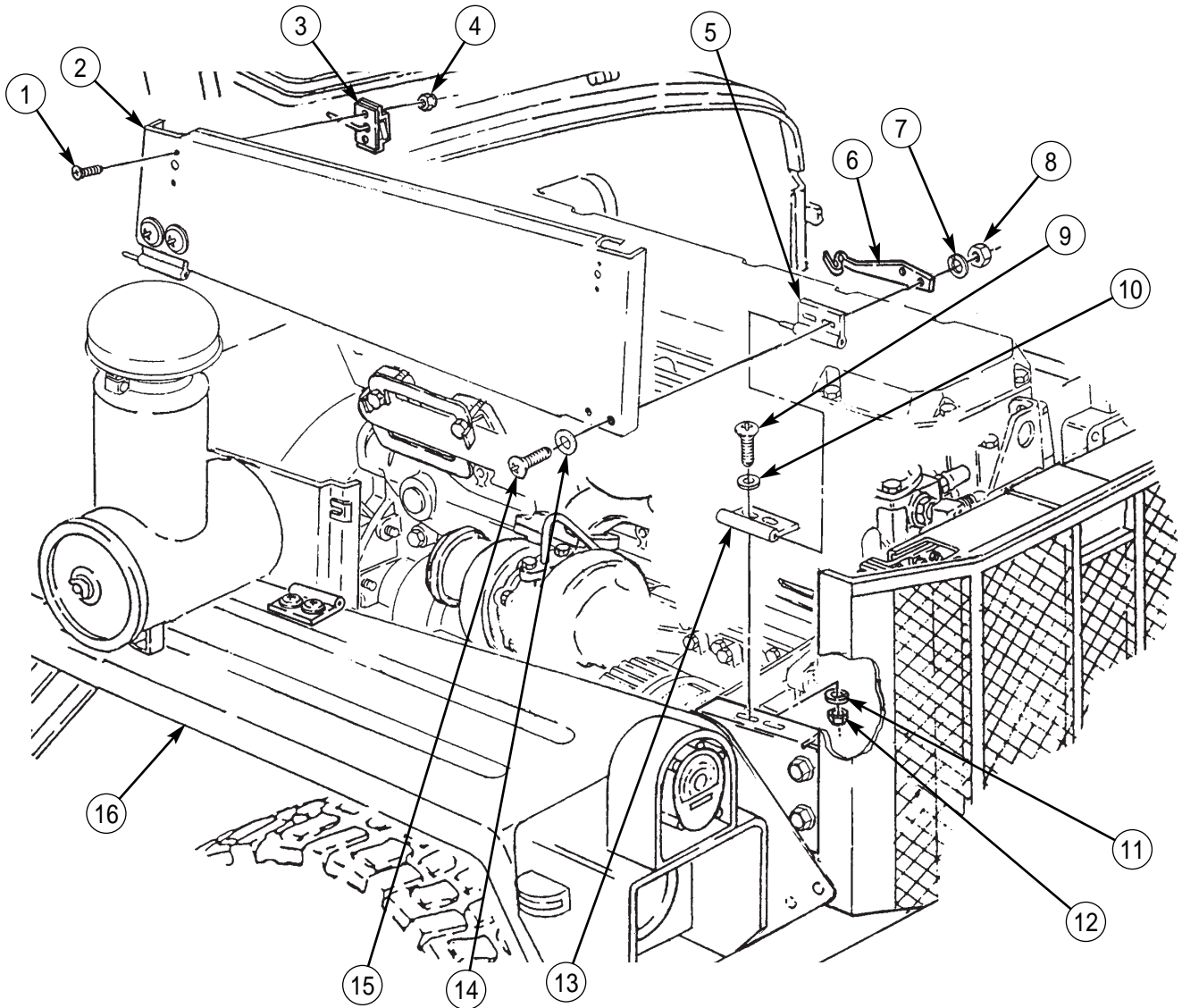

END OF WORK PACKAGE

UNIT MAINTENANCE INSTRUCTIONS

EXTENDED SERVICE PROGRAM (ESP)

TRUCK, CARGO, 2-1/2-TON, 6X6, M44A3 SERIES TRUCKS (DIESEL)

M35A3, W/O WINCH (NSN 2320-01-383-2047); W/WINCH (NSN 2320-01-383-3850);

M35A3C, W/O WINCH (NSN 2320-01-383-2050); W/WINCH (NSN 2320-01-383-2049);

M36A3, W/O WINCH (NSN 2320-01-383-2048); W/WINCH (NSN 2320-01-383-2046).

FRONT FENDER REPLACEMENT

REMOVAL, INSTALLATION

INITIAL SETUP:

Tools and Special Tools

General mechanic's tool kit
(item 30, WP 0394 00)

Materials/Parts

Cotter pin (item 26, WP 0395 00)
Four locknuts (item 184, WP 0395 00)
Locknut (item 86, WP 0395 00)
Two locknuts (item 339, WP 0395 00)
Four locknuts (item 99, WP 0395 00)
Three locknuts (item 83, WP 0395 00)
Three lockwashers (item 60, WP 0395 00)
Two lockwashers (item 50, WP 0395 00)
Two lockwashers (item 51, WP 0395 00)
Three assembled-washer screws
(item 312, WP 0395 00)
Anti-squeak material (item 261, WP 0395 00)

References

TM 9-2320-386-24P

Equipment Condition

Parking brake set (TM 9-2320-386-10).
Side panel removed (WP 0203 00).
Headlight mounting bracket removed (WP 0109 00).
Exhaust system removed (right side only)
(WP 0066 00).
Air cleaner removed (right side only) (WP 0037 00).
Steering assist hoses removed (left side only)
(WP 0186 00).

FRONT FENDER REPLACEMENT (Contd)**NOTE**

Right and left front fenders are replaced basically the same. This procedure covers the left fender.

REMOVAL

1. Remove cotter pin (47) from retaining pin (46). Discard cotter pin (47).
2. Remove retaining pin (46) and brushguard strut rod (45) from mounting bracket (2).
3. Remove locknut (10), washer (9), screw (1), and mounting bracket (2) from fender (4). Discard locknut (10).
4. Remove two nuts (44) and screws (41) from fender (4) and lower side panel (42).
5. Remove two screws (21), lockwashers (20), washers (19), and lower side panel (42) from brushguard (40). Discard lockwashers (20).
6. Remove locknuts (24) and (22), screws (27) and (33), clamps (25) and (32), and wiring harness (16) from fender mounting bracket (23). Discard locknuts (24) and (22).

NOTE

Perform steps 7 and 8 if vehicle is equipped with winch.

7. Remove locknut (37), screw (31), clamp (34), and wiring harness (35) from fender mounting bracket (23). Discard locknut (37).
8. Remove four locknuts (50), washers (51), screws (52), splash guard (49), and splash guard retainer (48) from fender mounting bracket (23). Discard locknuts (50).
9. Remove three nuts (11), lockwashers (12), washers (13), screws (30), six washers (29), three springs (28), and washers (26) from fender (4) and fender mounting bracket (23). Discard lockwashers (12).
10. Remove three assembled-washer screws (5) from fender (4) and cowl (8). Discard assembled-washer screws (5).

NOTE

Assistant will help with step 11.

11. Remove two locknuts (6), washers (7), screws (17), fender (4), and fender mount spacer (43) from fender mounting bracket (23), bracket (18), and cowl (8). Discard locknuts (6).
12. Remove two screws (15), lockwashers (14), and bracket (18) from cowl (8). Discard lockwashers (14).
13. Remove four locknuts (38), screws (36), and fender mounting bracket (23) from rail (39). Discard locknuts (38).
14. Remove anti-squeak material (3) from cowl (8). Discard anti-squeak material (3).

FRONT FENDER REPLACEMENT (Contd)

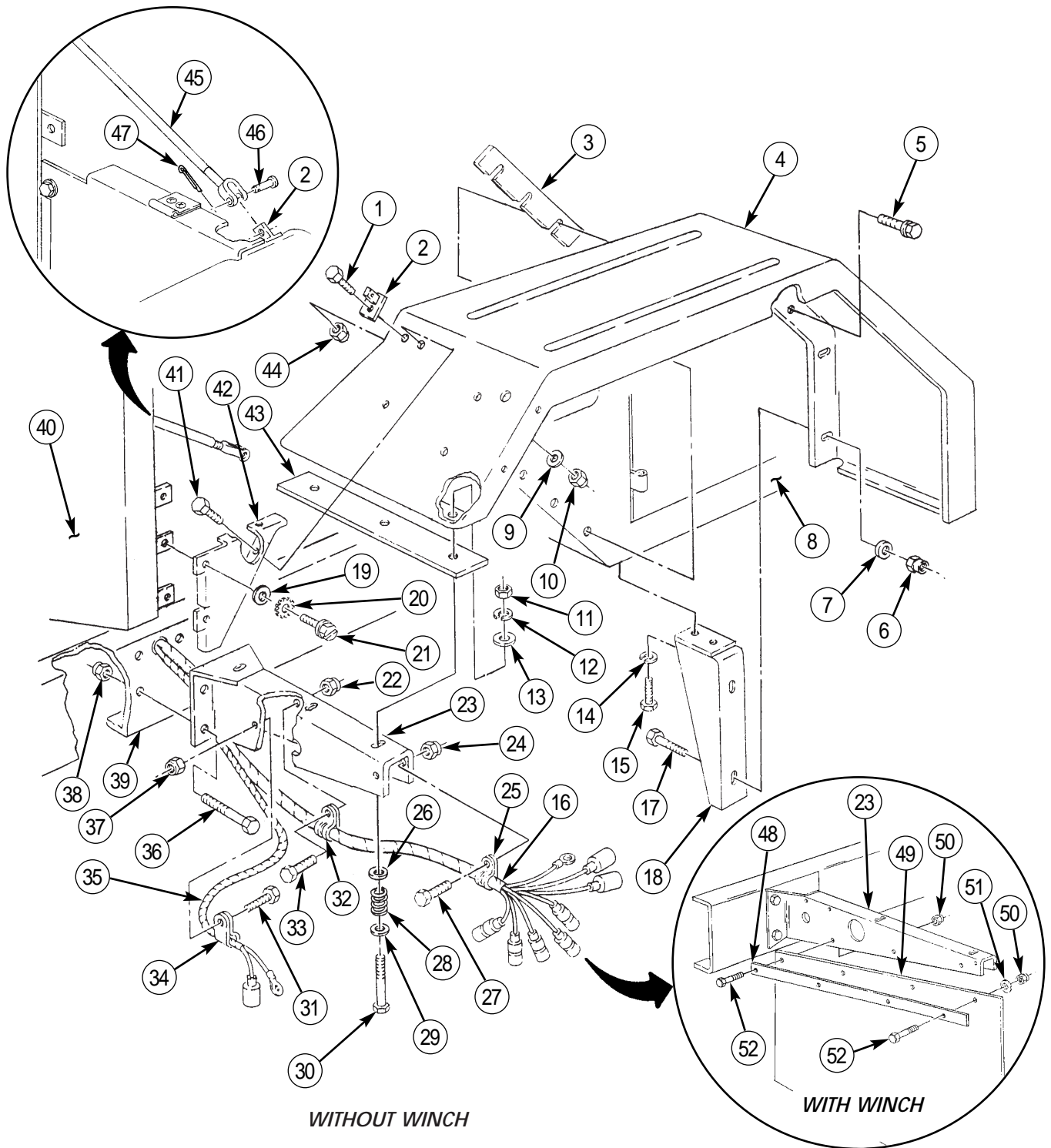

FRONT FENDER REPLACEMENT (Contd)**INSTALLATION**

1. Install fender mounting bracket (23) on rail (39) with four screws (36) and new locknuts (38).
2. Install bracket (18) on cowl (8) with two new lockwashers (14) and screws (15).

NOTE

Assistant will help with step 3.

3. Install new anti-squeak material (3) and fender (4) on cowl (8) and bracket (18) with three new assembled-washer screws (5), two screws (17), washers (7), and new locknuts (6).
4. Install fender mount spacer (43) and fender (4) on fender mounting bracket (23) with three screws (30), six washers (29), three springs (28), washers (26), washers (13), new lockwashers (12), and nuts (11).

NOTE

Perform steps 5 and 6 if vehicle is equipped with winch.

5. Install wiring harness (35) on fender mounting bracket (23) with clamp (34), screw (31), and new locknut (37).
6. Install splash guard (49) and splash guard retainer (48) on fender mounting bracket (23) with four screws (52), washers (51), and new locknuts (50).
7. Install wiring harness (16) on fender mounting bracket (23) with clamps (25) and (32), screws (27) and (33), and new locknuts (24) and (22).
8. Install lower side panel (42) on brushguard (40) with two screws (21), new lockwashers (20), and washers (19).
9. Install lower side panel (42) on fender (4) with two screws (41) and nuts (44).
10. Install mounting bracket (2) on fender (4) with screw (1), washer (9), and new locknut (10).
11. Install brushguard strut rod (45) on mounting bracket (2) with retaining pin (46) and new cotter pin (47).
12. Install steering assist hoses (left side only) (WP 0186 00).
13. Install exhaust system (right side only) (WP 0066 00).
14. Install air cleaner (right side only) (WP 0037 00).
15. Install side panel (WP 0203 00).
16. Install headlight mounting bracket (WP 0109 00).

FRONT FENDER REPLACEMENT (Contd)

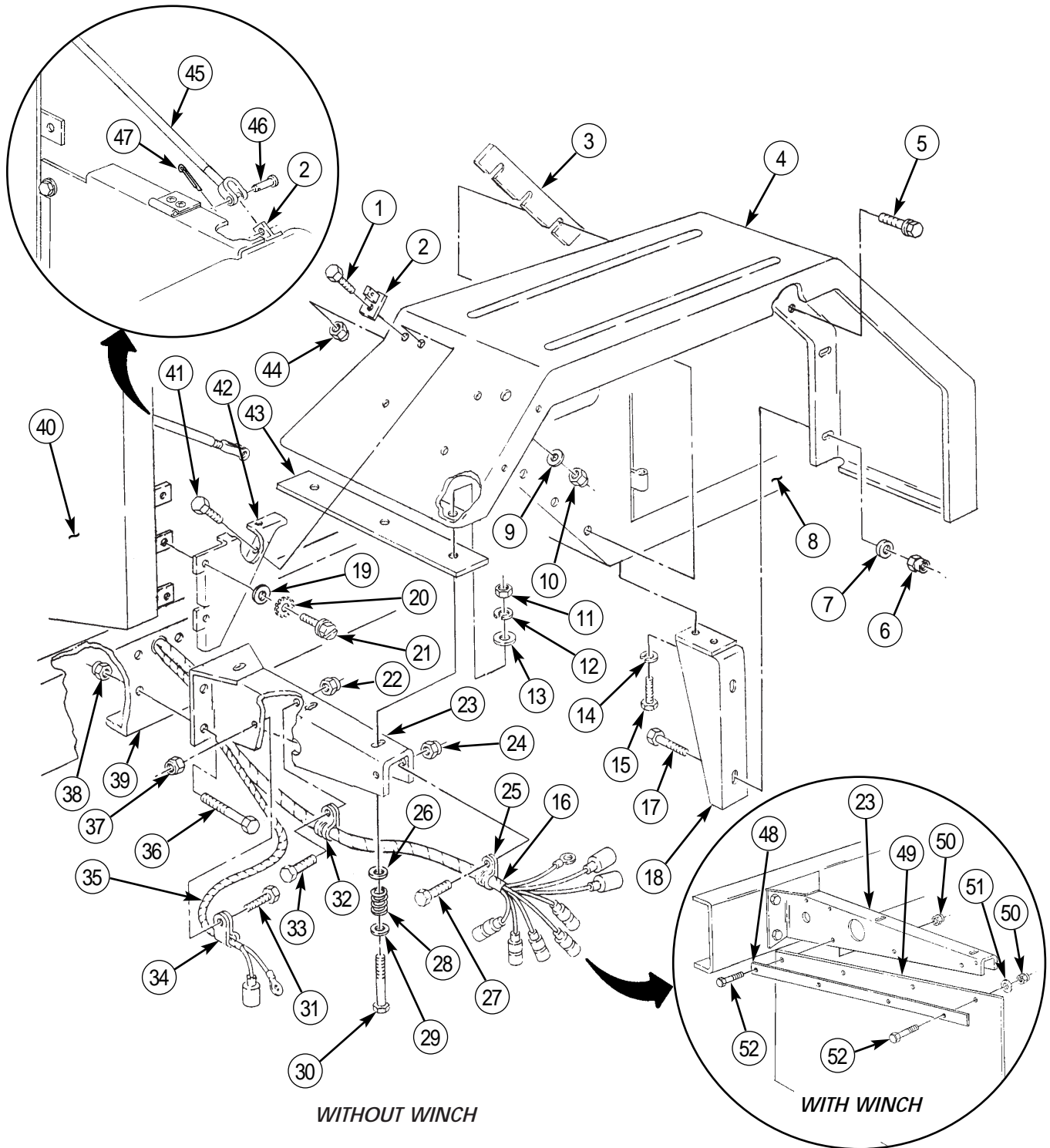

END OF WORK PACKAGE

UNIT MAINTENANCE INSTRUCTIONS

EXTENDED SERVICE PROGRAM (ESP)

TRUCK, CARGO, 2-1/2-TON, 6X6, M44A3 SERIES TRUCKS (DIESEL)

M35A3, W/O WINCH (NSN 2320-01-383-2047); W/WINCH (NSN 2320-01-383-3850);
M35A3C, W/O WINCH (NSN 2320-01-383-2050); W/WINCH (NSN 2320-01-383-2049);
M36A3, W/O WINCH (NSN 2320-01-383-2048); W/WINCH (NSN 2320-01-383-2046).

WINDSHIELD ASSEMBLY MAINTENANCE

REMOVAL, DISASSEMBLY, ASSEMBLY, INSTALLATION

INITIAL SETUP:

Tools and Special Tools

General mechanic's tool kit
(item 30, WP 0394 00)

Materials/Parts

Two locknuts (item 22, WP 0395 00)
Fourteen assembled-washer bolts
(item 330, WP 0395 00)
Two weatherstrips (item 311, WP 0395 00)
Weatherstrip (item 313, WP 0395 00)
Adhesive (item 4, WP 0393 00)

References

TM 9-2320-386-24P

Equipment Condition

Parking brake set (TM 9-2320-386-10).
Cab soft top removed (TM 9-2320-386-10).
Wiper switch, motor, and conlink covers removed
(WP 0232 00).

WINDSHIELD ASSEMBLY MAINTENANCE (Contd)

REMOVAL

1. Remove six assembled-washer bolts (15) and two upper hinges (16) from windshield frame (2) and cab (3). Discard assembled-washer bolts (15).

NOTE

Assistant will help with step 2.

2. Remove windshield frame (2) from cab (3).
3. Remove eight assembled-washer bolts (12) and two lower hinges (11) from cab (3). Discard assembled-washer bolts (12).
4. Remove four screws (4) and two brackets (9) from windshield frame (2).
5. Remove four screws (8), two plates (7), and weatherstrips (6) from brackets (9). Discard weatherstrips (6).
6. Remove weatherstrip (1) from windshield frame (2). Discard weatherstrip (1).
7. Clean weatherstrip remains from windshield frame (2).

DISASSEMBLY

1. Remove two knobs (5) and studs (14) from upper hinges (16).
2. Remove two locknuts (13), hinge bolts (10), and upper hinges (16) from lower hinges (11). Discard locknuts (13).

ASSEMBLY

1. Install two upper hinges (16) on two lower hinges (11) with two hinge bolts (10) and new locknuts (13).
2. Install two studs (14) and knobs (5) on upper hinges (16).

INSTALLATION

1. Apply adhesive to mounting side of new weatherstrip (1) and install weatherstrip (1) on mounting surface of windshield frame (2).
2. Install two new weatherstrips (6) and plates (7) on brackets (9) with four screws (8).
3. Install two brackets (9) on windshield frame (2) with four screws (4).
4. Install upper hinges (16) on windshield frame (2) with six new assembled-washer bolts (15).

NOTE

Assistant will help with step 5.

5. Position windshield frame (2) on cab (3).
6. Install two lower hinges (11) on cab (3) with eight new assembled-washer bolts (12).
7. Install wiper switch, motor, and conlink covers (WP 0232 00).
8. Install cab soft top (TM 9-2320-386-10).

WINDSHIELD ASSEMBLY MAINTENANCE (Contd)

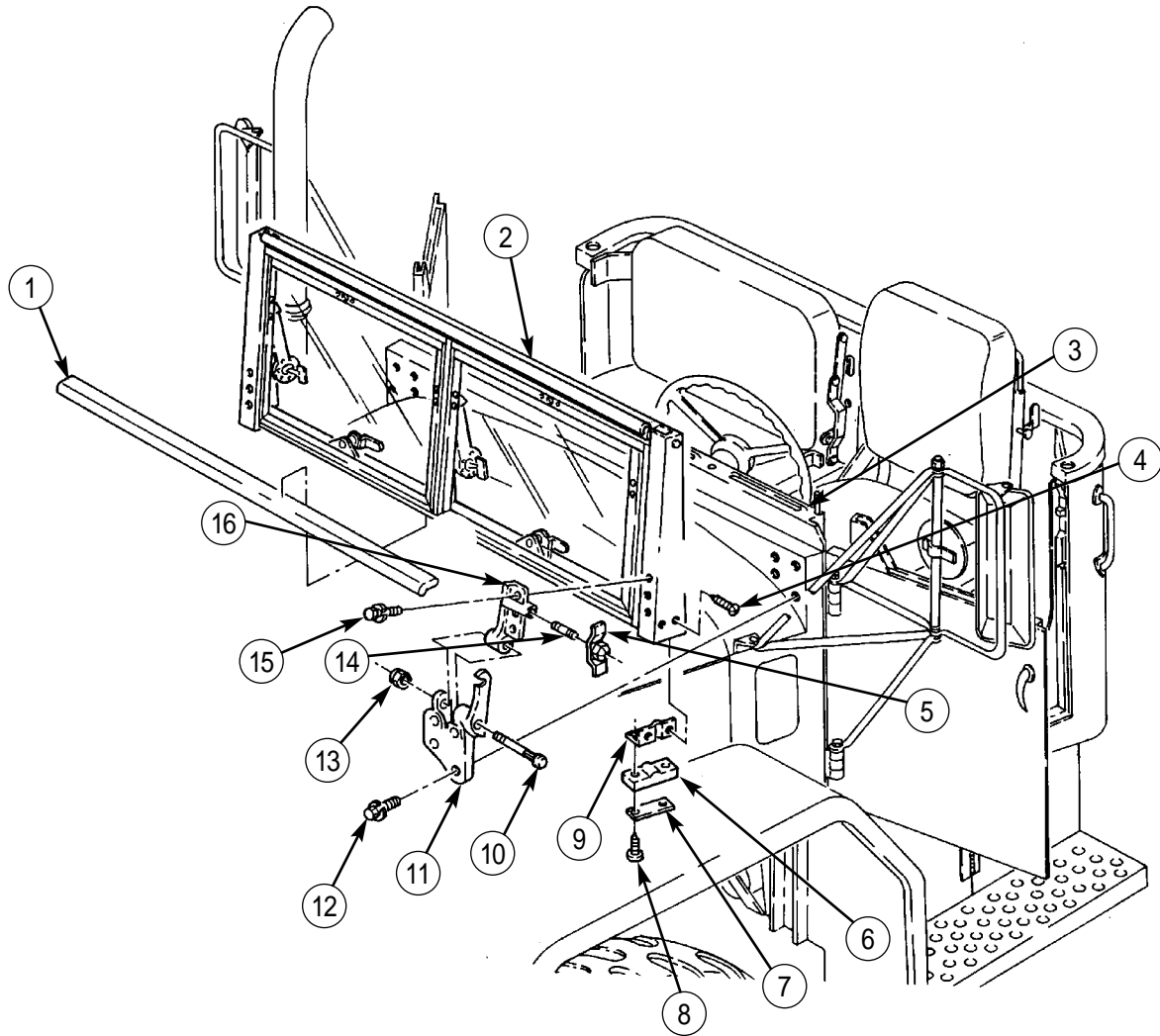

END OF WORK PACKAGE

UNIT MAINTENANCE INSTRUCTIONS

EXTENDED SERVICE PROGRAM (ESP)

TRUCK, CARGO, 2-1/2-TON, 6X6, M44A3 SERIES TRUCKS (DIESEL)

M35A3, W/O WINCH (NSN 2320-01-383-2047); W/WINCH (NSN 2320-01-383-3850);

M35A3C, W/O WINCH (NSN 2320-01-383-2050); W/WINCH (NSN 2320-01-383-2049);

M36A3, W/O WINCH (NSN 2320-01-383-2048); W/WINCH (NSN 2320-01-383-2046).

WINDSHIELD ARM, WINDOW, AND HANDLE REPLACEMENT

ARM REMOVAL, WINDOW REMOVAL, HANDLE REMOVAL,
HANDLE INSTALLATION, WINDOW INSTALLATION, ARM INSTALLATION

INITIAL SETUP:

Tools and Special Tools

General mechanic's tool kit
(item 30, WP 0394 00)

Materials/Parts

Nine assembled-washer bolts
(item 263, WP 0395 00)
Seal (item 165, WP 0395 00)
Seal (item 308, WP 0395 00)
Seal (item 324, WP 0395 00)
Adhesive (item 3, WP 0393 00)

References

TM 9-2320-386-24P

Equipment Condition

Parking brake set (TM 9-2320-386-10).
Wiper switch, motor, and conlink covers removed
(WP 0232 00).

WINDSHIELD ARM, WINDOW, AND HANDLE REPLACEMENT (Contd)

ARM REMOVAL

Remove four screws (8) and spring washers (9) from two arms (11), frame brackets (5), levers (12), and glass frame brackets (10).

WINDOW REMOVAL

1. Remove seven assembled-washer bolts (18) and windshield hinge (3) from windshield outer frame (4). Discard assembled-washer bolts (18).
2. Remove hinge seals (1) and (2) from windshield hinge (3). Remove seal (13) from windshield inner frame (19). Discard seals (1), (2), and (13).

HANDLE REMOVAL

1. Remove two screws (17), nuts (15), and handle (14) from windshield inner frame (19).
2. Remove bumper (16) from handle (14).
3. Remove two assembled-washer bolts (6) and plate (7) from windshield outer frame (4). Discard assembled-washer bolts (6).

HANDLE INSTALLATION

1. Install bumper (16) in handle (14).
2. Install handle (14) on windshield inner frame (19) with two screws (17) and nuts (15).
3. Install plate (7) on windshield outer frame (4) with two new assembled-washer bolts (6).

WINDOW INSTALLATION

1. Apply adhesive to mounting side of new hinge seals (1) and (2) and on windshield hinge (3).
2. Install hinge seals (1) and (2) on hinge (3).
3. Install new seal (13) on windshield inner frame (19).
4. Install hinge (3) on windshield outer frame (4) with seven new assembled-washer bolts (18).

ARM INSTALLATION

1. Install two arms (11) on frame brackets (5) and levers (12) on glass frame brackets (10) with four spring washers (9) and screws (8).
2. Install wiper switch, motor, and conlink covers (WP 0232 00).

WINDSHIELD ARM, WINDOW, AND HANDLE REPLACEMENT (Contd)

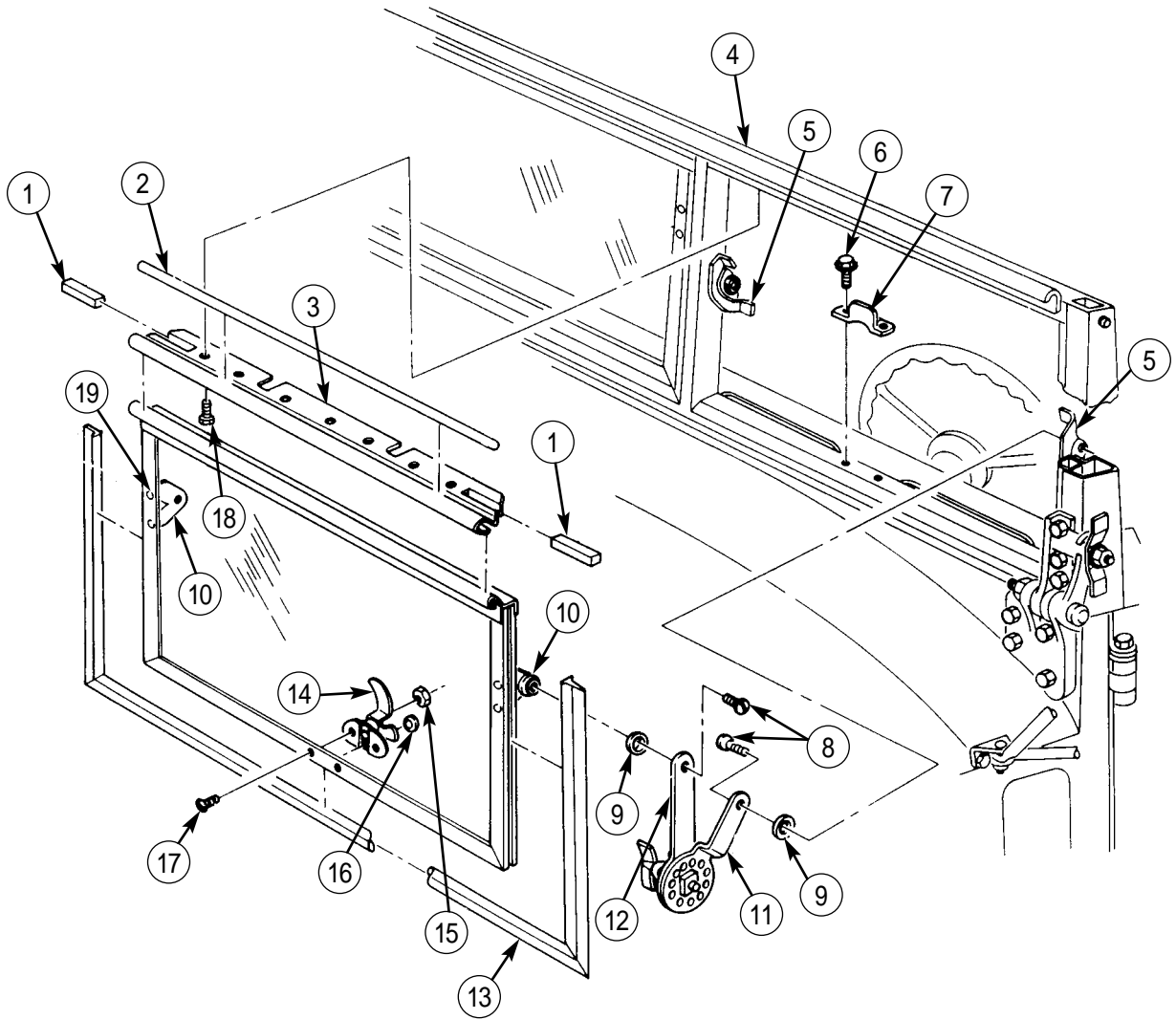

END OF WORK PACKAGE

UNIT MAINTENANCE INSTRUCTIONS

EXTENDED SERVICE PROGRAM (ESP)

TRUCK, CARGO, 2-1/2-TON, 6X6, M44A3 SERIES TRUCKS (DIESEL)

M35A3, W/O WINCH (NSN 2320-01-383-2047); W/WINCH (NSN 2320-01-383-3850);
M35A3C, W/O WINCH (NSN 2320-01-383-2050); W/WINCH (NSN 2320-01-383-2049);
M36A3, W/O WINCH (NSN 2320-01-383-2048); W/WINCH (NSN 2320-01-383-2046).

REAR AND INTERMEDIATE CAB TUNNEL AND TOEBOARD REPLACEMENT

INTERMEDIATE CAB TUNNEL REMOVAL, TOEBOARD REMOVAL, REAR CAB TUNNEL REMOVAL,
REAR CAB TUNNEL INSTALLATION, TOEBOARD INSTALLATION, INTERMEDIATE CAB TUNNEL INSTALLATION

INITIAL SETUP:

Tools and Special Tools

General mechanic's tool kit
(item 30, WP 0394 00)

Materials/Parts

Sixteen assembled-washer bolts
(item 174, WP 0395 00)
Thirteen lockwashers (item 61, WP 0395 00)
Two locknuts (item 338, WP 0395 00)

Equipment Condition

Parking brake set (TM 9-2320-386-10).
Companion seat removed (WP 0208 00).
Transmission select lever removed (for intermediate
cab tunnel replacement only) (WP 0134 00).
Transmission shift tower removed (for intermediate
cab tunnel replacement only) (WP 0133 00).
Remove winch controls, if installed (WP 0223 00).
Remove cab insulation (WP 0201 00).

References

TM 9-2320-386-24P

REAR AND INTERMEDIATE CAB TUNNEL AND TOEBOARD REPLACEMENT (Contd)

INTERMEDIATE CAB TUNNEL REMOVAL

CAUTION

When removing cab tunnel, use care not to damage air lines and hoses.

1. Remove two locknuts (13), screws (5), and cover (6) from cab tunnel (7). Discard locknuts (13).
2. Remove thirteen screws (4), lockwashers (3), and intermediate cab tunnel (7) from cab floor (12), toeboard (1), and rear cab tunnel (10). Discard lockwashers (3).

TOEBOARD REMOVAL

Remove eight assembled-washer bolts (2) and toeboard (1) from cab floor (12). Discard assembled-washer bolts (2).

REAR CAB TUNNEL REMOVAL

1. Remove eight assembled-washer bolts (11) and rear cab tunnel (10) from cab floor (12). Discard assembled-washer bolts (11).
2. Remove four screws (9) and cover (8) from rear cab tunnel (10).

REAR CAB TUNNEL INSTALLATION

1. Install cover (8) on rear cab tunnel (10) with four screws (9).
2. Install rear cab tunnel (10) on cab floor (12) with eight new assembled-washer bolts (11).

TOEBOARD INSTALLATION

Install toeboard (1) on cab floor (12) with eight new assembled-washer bolts (2).

INTERMEDIATE CAB TUNNEL INSTALLATION

CAUTION

When installing cab tunnel, use care not to damage air lines and hoses.

1. Install intermediate cab tunnel (7) on toeboard (1), rear cab tunnel (10), and cab floor (12) with thirteen new lockwashers (3) and screws (4).
2. Install cover (6) on cab tunnel (7) with two screws (5) and new locknuts (13).
3. Install cab insulation (WP 0201 00).
4. Install winch controls, if installed (WP 0223 00).
5. Install transmission shift tower (for intermediate cab tunnel replacement only) (WP 0133 00).
6. Install transmission select lever (for intermediate cab tunnel replacement only) (WP 0134 00).
7. Install companion seat (WP 0208 00).

REAR AND INTERMEDIATE CAB TUNNEL AND TOEBOARD REPLACEMENT (Contd)

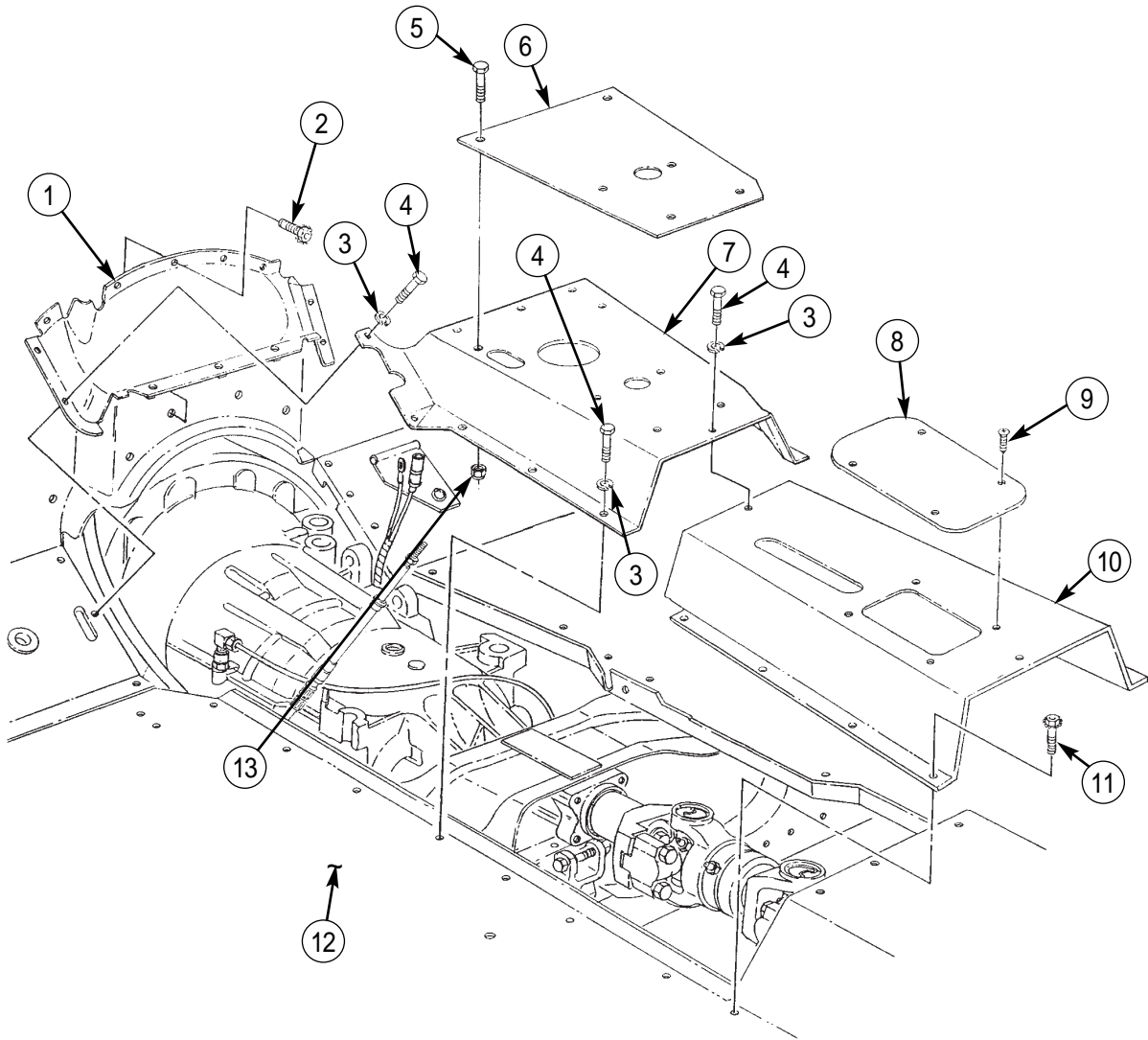

END OF WORK PACKAGE

UNIT MAINTENANCE INSTRUCTIONS

EXTENDED SERVICE PROGRAM (ESP)

TRUCK, CARGO, 2-1/2-TON, 6X6, M44A3 SERIES TRUCKS (DIESEL)

**M35A3, W/O WINCH (NSN 2320-01-383-2047); W/WINCH (NSN 2320-01-383-3850);
M35A3C, W/O WINCH (NSN 2320-01-383-2050); W/WINCH (NSN 2320-01-383-2049);
M36A3, W/O WINCH (NSN 2320-01-383-2048); W/WINCH (NSN 2320-01-383-2046).**

DRIVER'S AND COMPANION SEAT REPLACEMENT

**COMPANION SEAT REMOVAL, DRIVER'S SEAT REMOVAL,
DRIVER'S SEAT INSTALLATION, COMPANION SEAT INSTALLATION**

INITIAL SETUP:

Tools and Special Tools

General mechanic's tool kit
(item 30, WP 0394 00)
Common No. 1 tool kit
(item 15, WP 0394 00)

References

TM 9-2320-386-24P

Equipment Condition

Parking brake set (TM 9-2320-386-10).

Materials/Parts

Six assembled-washer screws
(item 141, WP 0395 00)

DRIVER'S AND COMPANION SEAT REPLACEMENT (Contd)

COMPANION SEAT REMOVAL

Remove four assembled-washer screws (5) and companion seat (1) from cab floor (6). Discard assembled-washer screws (5).

DRIVER'S SEAT REMOVAL

1. Remove screw (13), driver's seatbelt (14), tether (12), and washer (11) from driver's seat (2).
2. Remove screw (8), driver's seatbelt buckle (7), tether (9), and washer (10) from driver's seat (2).
3. Remove two assembled-washer screws (4), driver's seat (2), and base (3) from cab floor (6). Discard assembled-washer screws (4).

DRIVER'S SEAT INSTALLATION

1. Install driver's seat (2) and base (3) on cab floor (6) with two new assembled-washer screws (4).

CAUTION

Ensure seatbelts and tethers are installed on shoulder of screws before tightening.

2. Install driver's seatbelt buckle (7), tether (9), and washer (10) on driver's seat (2) with screw (8). Tighten screw (8) 30-35 lb-ft (41-47 N•m).
3. Install driver's seatbelt (14), tether (12), and washer (11) on driver's seat (2) with screw (13). Tighten screw (13) 30-35 lb-ft (41-47 N•m).

COMPANION SEAT INSTALLATION

Install companion seat (1) on cab floor (6) with four new assembled-washer screws (5).

DRIVER'S AND COMPANION SEAT REPLACEMENT (Contd)

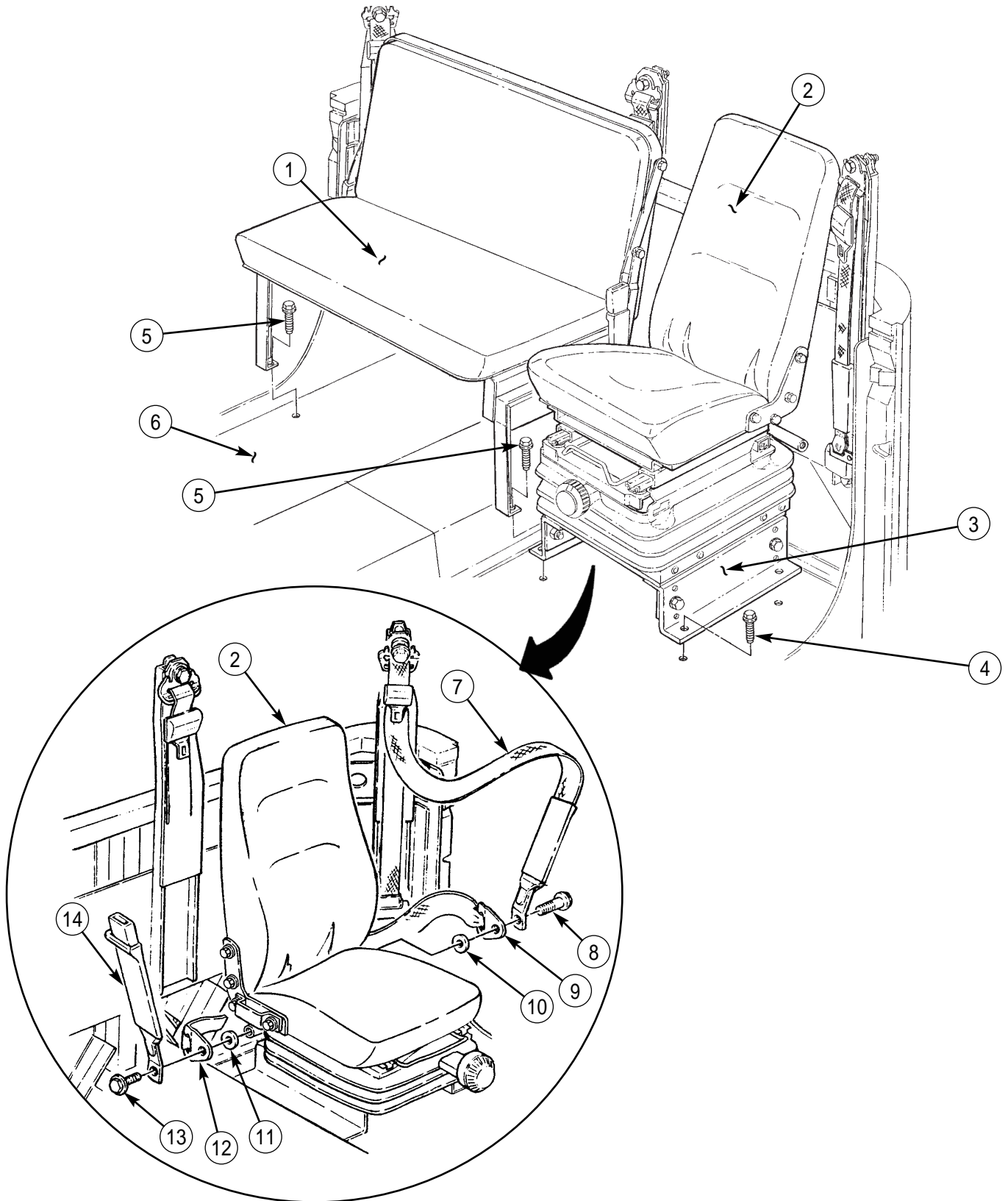

END OF WORK PACKAGE

UNIT MAINTENANCE INSTRUCTIONS

EXTENDED SERVICE PROGRAM (ESP)

TRUCK, CARGO, 2-1/2-TON, 6X6, M44A3 SERIES TRUCKS (DIESEL)

M35A3, W/O WINCH (NSN 2320-01-383-2047); W/WINCH (NSN 2320-01-383-3850);

M35A3C, W/O WINCH (NSN 2320-01-383-2050); W/WINCH (NSN 2320-01-383-2049);

M36A3, W/O WINCH (NSN 2320-01-383-2048); W/WINCH (NSN 2320-01-383-2046).

DRIVER'S SEAT REPAIR

DISASSEMBLY, ASSEMBLY

INITIAL SETUP:

Tools and Special Tools

General mechanic's tool kit
(item 30, WP 0394 00)

Materials/Parts

Eighteen upholstery clips
(item 239, WP 0395 00)
Ten retaining rings (item 273, WP 0395 00)
Ten lockwashers (item 60, WP 0395 00)
Shock absorber kit (item 351, WP 0395 00)

Materials/Parts (Contd)

Six locknuts (item 136, WP 0395 00)
Sealing compound (item 46, WP 0393 00)

References

TM 9-2320-386-24P

Equipment Condition

Driver's and companion seat removed
(WP 0208 00).

DRIVER'S SEAT REPAIR (Contd)**DISASSEMBLY**

1. Remove four nuts (11), lockwashers (10), washers (9), and seat assembly (5) from seat support plate (8). Discard lockwashers (10).
2. Remove four screws (1), washers (2), and seat backrest (6) from right and left side support brackets (4).
3. Remove four screws (1), washers (2), seatbelt bracket (3), and right and left side support brackets (4) from seat cushion (31).
4. If replacement is necessary, remove eighteen upholstery clips (30) and seat cushion upholstery from seat cushion (31). Discard upholstery clips (30).
5. If replacement is necessary, remove ten retaining rings (7) and seat backrest upholstery from seat backrest (6). Discard retaining rings (7).
6. Remove four locknuts (29), screws (26), washers (27), seat support plate (8), and four spacers (28) from slide adjuster assemblies (15). Discard locknuts (29).
7. Remove two locknuts (43), four screws (32), contact washers (51), slide adjuster assemblies (15), and four spacers (50) from seat support mechanism assembly (12). Discard locknuts (43).
8. Remove two screws (14) and seatbelt bar (13) from seat support mechanism assembly (12).
9. Remove pin (25), weight adjuster knob (24), and cover (23) from weight adjuster shaft (22).
10. Remove two push pins (34), four U-clips (33), push pins (49), and boot (21) from seat support mechanism assembly (12).
11. Remove four screws (17), lockwashers (18), washers (19), seat riser (16), and four spacers (20) from seat support mechanism assembly (12). Discard lockwashers (18).
12. Remove two nuts (42), lockwashers (41), and stop bumpers (40) from seat support mechanism assembly (12). Discard lockwashers (41).

NOTE

Shock absorber is supplied as a kit. Perform steps 13 through 16 only if shock absorber is damaged.

13. Remove locknut (35) and screw (38) from bottom support bracket (39) and shock absorber (36). Discard locknut (35).
14. Remove locknut (48), pry spring (45) back, and slide screw (46) out from upper support bracket (44) and shock absorber (36). Discard locknut (48).
15. Remove shock absorber (36) from seat support mechanism assembly (12) and slide inserts (37) and (47) out from ends of shock absorber (36). Discard inserts (37) and (47) and shock absorber (36).

DRIVER'S SEAT REPAIR (Contd)

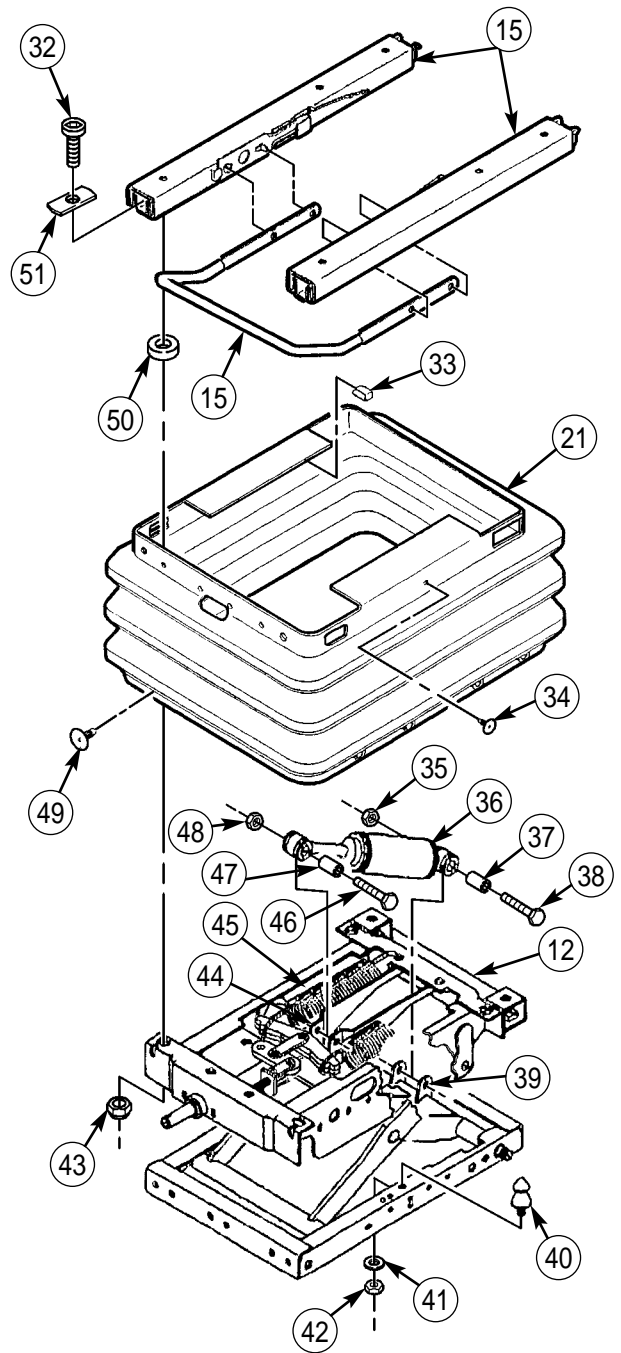
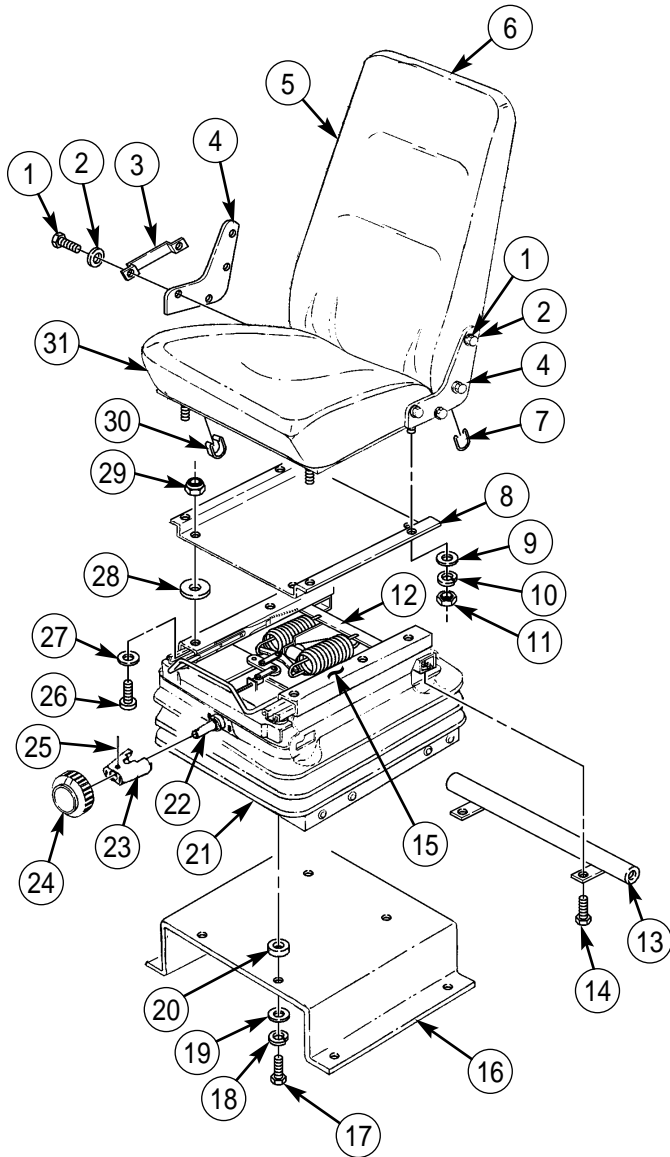

DRIVER'S SEAT REPAIR (Contd)**ASSEMBLY****NOTE**

Perform steps 1 and 2 if shock absorber was removed.

1. If shock absorber (7) was removed, install inserts (8) and (19) on ends of new shock absorber (7) and position shock absorber (7) on upper support bracket (16), pry spring (17) back, and slide screw (18) through upper support bracket (16) and shock absorber (7).
2. Install other end of shock absorber (7) on lower support bracket (11) and slide screw (9) through lower support bracket (11) and shock absorber (7). Install and tighten new locknuts (6) and (20).
3. Install two stop bumpers (12) on seat support mechanism assembly (10) with two new lockwashers (13) and nuts (14).
4. Install four spacers (41) and seat riser (37) on seat support mechanism assembly (10) with four washers (40), new lockwashers (39), and screws (38).
5. Install boot (4) on seat support mechanism assembly (10) with four push pins (21), U-clips (3), and two push pins (5).
6. Install cover (43) and weight adjuster knob (44) on weight adjuster shaft (42) with pin (45).
7. Apply sealing compound to threads of screws (36) and install seatbelt bar (35) on seat support mechanism assembly (10) with two screws (36).
8. Install four spacers (22) and slide adjuster assemblies (2) on seat support mechanism assembly (10) with four contact washers (23), screws (1), and two new locknuts (15).
9. Install four spacers (48) and seat support plate (31) on slide adjuster assemblies (2) with four washers (47), screws (46), and new locknuts (49).
10. If seat backrest upholstery was removed, install seat backrest upholstery on seat backrest (29) with ten new retaining rings (30).
11. If seat cushion upholstery was removed, install seat cushion upholstery on seat cushion (51) with eighteen new upholstery clips (50).
12. Install right seatbelt bracket (26) and right and left side support brackets (27) on seat cushion (51) with four washers (25) and screws (24).
13. Install seat backrest (29) between right and left side support brackets (27) with four washers (25) and screws (24).
14. Install seat assembly (28) on seat support plate (31) with four washers (32), new lockwashers (33), and nuts (34).
15. Install driver's and companion seats (WP 0208 00).

DRIVER'S SEAT REPAIR (Contd)

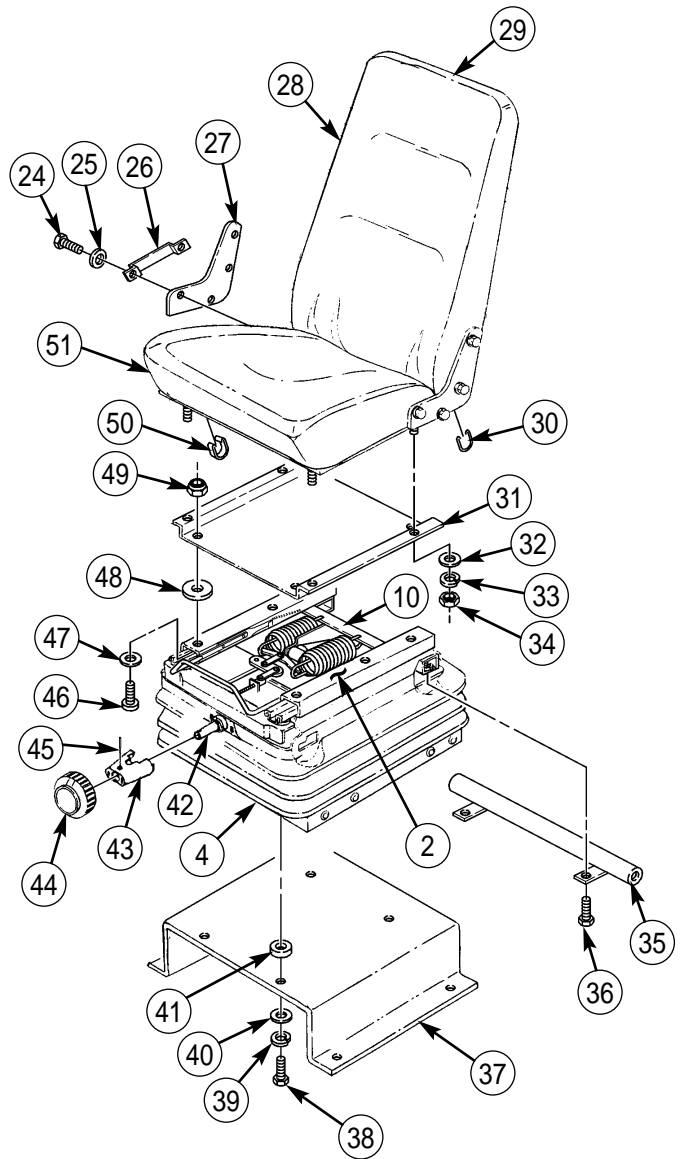
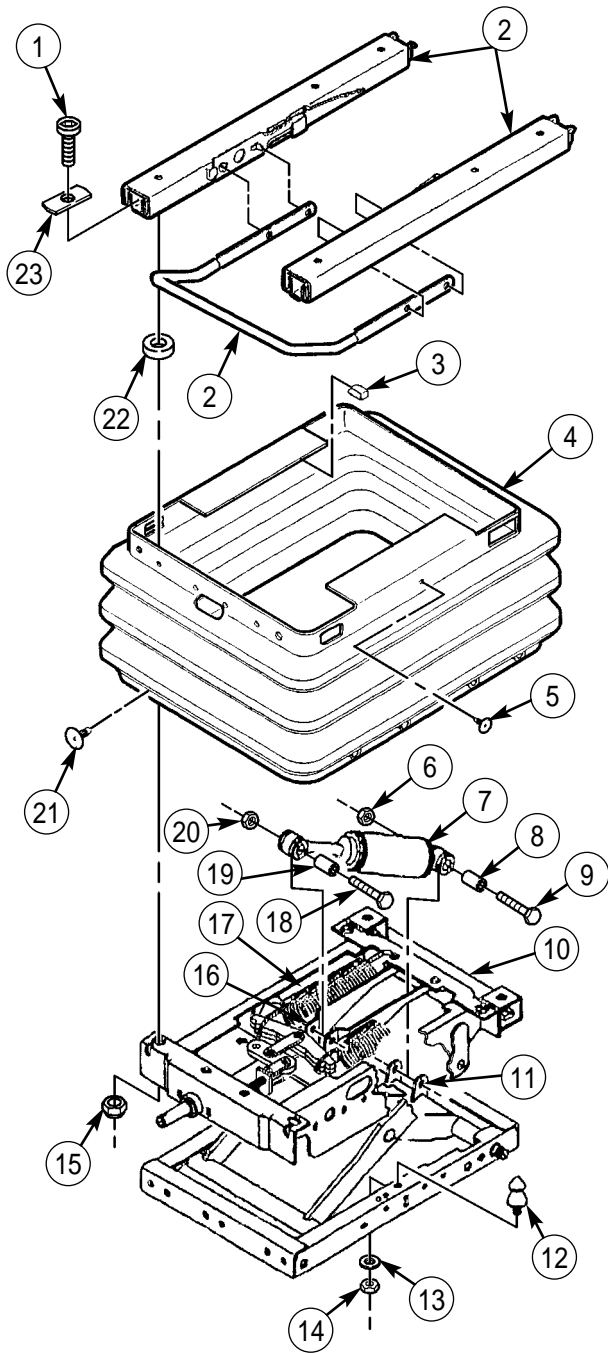

END OF WORK PACKAGE

UNIT MAINTENANCE INSTRUCTIONS

EXTENDED SERVICE PROGRAM (ESP)

TRUCK, CARGO, 2-1/2-TON, 6X6, M44A3 SERIES TRUCKS (DIESEL)

M35A3, W/O WINCH (NSN 2320-01-383-2047); W/WINCH (NSN 2320-01-383-3850);
M35A3C, W/O WINCH (NSN 2320-01-383-2050); W/WINCH (NSN 2320-01-383-2049);
M36A3, W/O WINCH (NSN 2320-01-383-2048); W/WINCH (NSN 2320-01-383-2046).

SEATBELT POSTS AND BRACKETS REPLACEMENT

REMOVAL, INSTALLATION

INITIAL SETUP:

Tools and Special Tools

General mechanic's tool kit
(item 30, WP 0394 00)
Common No. 1 tool kit
(item 15, WP 0394 00)

Materials/Parts

Twenty locknuts (item 337, WP 0395 00)
Six locknuts (item 345, WP 0395 00)
Three locknuts (item 347, WP 0395 00)
Two locknuts (item 15, WP 0395 00)

Materials/Parts (Contd)

Two locknuts (item 336, WP 0395 00)
Plain-assembled nut (item 348, WP 0395 00)

References

TM 9-2320-386-24P

Equipment Condition

Parking brake set (TM 9-2320-386-10).
Driver's and companion seatbelts removed
(WP 0211 00).

SEATBELT POSTS AND BRACKETS REPLACEMENT (Contd)**REMOVAL**

1. Remove locknut (18), washer (13), support bracket (17), screw (14), washer (13), tether (15), and sleeve (16) from left center reinforcement bracket (19). Discard locknut (18).
2. Remove locknut (18), washer (13), support bracket (17), screw (14), washer (13), support bracket (17), and sleeve (16) from right center reinforcement bracket (20). Discard locknut (18).
3. Remove sixteen locknuts (29), washers (11), two upper reinforcement plates (30), lower reinforcement plates (28), sixteen screws (12), washers (11), and left and right center reinforcement brackets (19) and (20) from rear cab wall (6). Discard locknuts (29).
4. Remove two locknuts (4), washers (5), screws (8), and washers (5) from upper holes of center seatbelt post (7) and rear cab wall (6). Discard locknuts (4).
5. Remove six screws (10), washers (9), and center post (7) from rear cab wall (6).
6. Remove two locknuts (22), screws (3), and reinforcement plate (21) from rear cab wall (6). Discard locknuts (22).
7. Remove plain-assembled nut (1), washer (2), screw (23), and resilient mount (24) from support bracket (32). Discard plain-assembled nut (1).
8. Remove two locknuts (31), screws (25), and support bracket (32) from rear cab wall (6). Discard locknuts (31).
9. Remove two locknuts (31), screws (27), and NBC bracket (26) from rear cab wall (6). Discard locknuts (31).

NOTE

Left and right seatbelt post removal is the same. Steps 10 through 14 cover the left side.

10. Remove locknut (48), washer (44), sleeve (47), screw (43), washer (44), and tether (51) from left reinforcement bracket (50). Discard locknut (48).
11. Remove four locknuts (49), screws (45), washers (46), and left reinforcement bracket (50) from rear cab wall (6). Discard locknuts (49).
12. Remove two locknuts (36), washers (37), screws (40), and washers (37) from upper holes of left seatbelt post (39) and left gusset bracket (33). Discard locknuts (36).
13. Remove eight screws (42), washers (41), and left seatbelt post (39) from rear cab wall (6).
14. Remove two screws (35), washers (34), and gusset bracket (33) from rear cab wall (6) and left reinforcement plate (38).

SEATBELT POSTS AND BRACKETS REPLACEMENT (Contd)

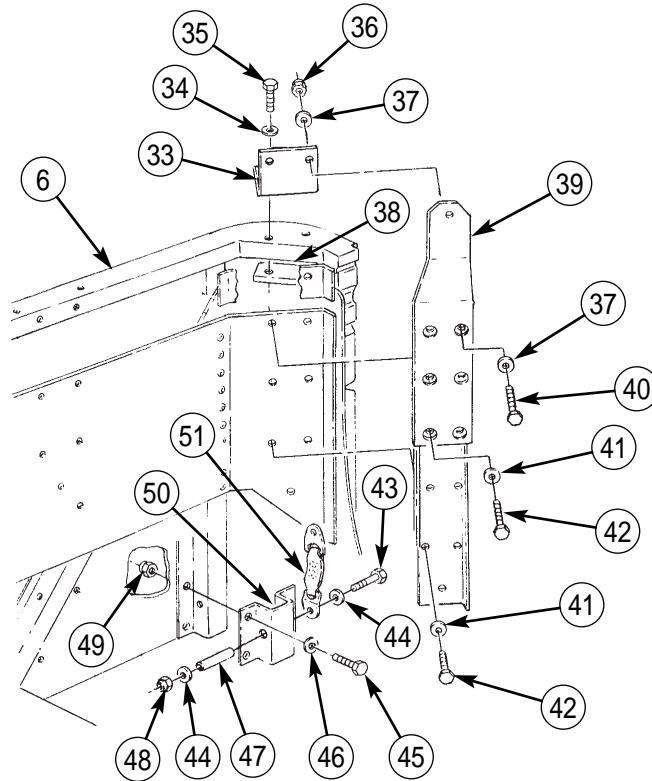
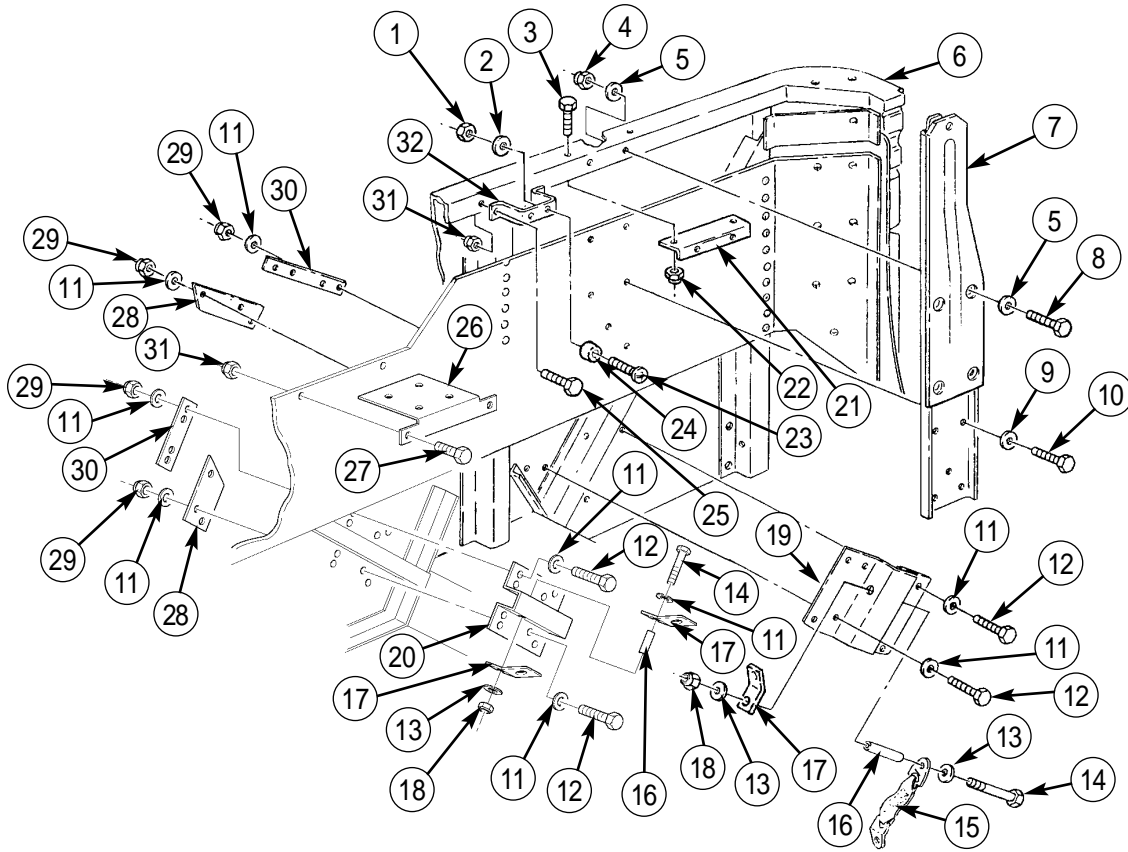

SEATBELT POSTS AND BRACKETS REPLACEMENT (Contd)**INSTALLATION****NOTE**

Left and right seatbelt post installation is the same. Steps 1 through 5 cover the left side.

1. Install left gusset bracket (2) on left reinforcement plate (7) and rear cab wall (1) with two washers (3) and screws (4).
2. Install left seatbelt post (8) on rear cab wall (1) with eight washers (10) and screws (11).
3. Install two washers (6), screws (9), washers (6), and new locknuts (5) in upper holes of left seatbelt post (8) and left gusset bracket (2).
4. Install left reinforcement bracket (19) on rear cab wall (1) with four washers (15), screws (14), and new locknuts (18).

NOTE

Ensure straight portion of tether is installed on left reinforcement bracket with bent portion facing toward driver's door.

5. Install tether (20) and sleeve (16) on left reinforcement bracket (19) with washer (13), screw (12), washer (13), and new locknut (17). Tighten screw (12) 20-25 lb-ft (27-34 N•m).
6. Install support bracket (52) on rear cab wall (1) with two screws (44) and new locknuts (51).
7. Install resilient mount (43) on reinforcement bracket (52) with screw (42), washer (22), and new plain-assembled nut (21).
8. Install reinforcement plate (40) on rear cab wall (1) with two screws (23) and new locknuts (41).
9. Install center post (26) on rear cab wall (1) with six washers (28) and screws (29).
10. Install two washers (25), screws (27), washers (25), and new locknuts (24) in upper holes of center post (26) and rear cab wall (1).
11. Install two upper reinforcement plates (49), lower reinforcement plates (47), and left and right center reinforcement brackets (38) and (39) on rear cab wall (1) with sixteen washers (30), screws (31), washers (30), and new locknuts (48).

NOTE

Ensure straight portion of tether is installed on center reinforcement bracket with bent portion facing outward.

12. Install support bracket (36), sleeve (35), and tether (34) on left center reinforcement bracket (38) with washer (33), screw (32), washer (33), and locknut (37). Tighten screw (32) 20-25 lb-ft (27-34 N•m).
13. Install two support brackets (36) and sleeve (35) on right center reinforcement bracket (39) with washer (30), screw (32), washer (33) and new locknut (37).
14. Install NBC bracket (45) on rear cab wall (1) with two screws (46) and new locknuts (50).
15. Install driver's and companion seatbelts (WP 0211 00).

SEATBELT POSTS AND BRACKETS REPLACEMENT (Contd)

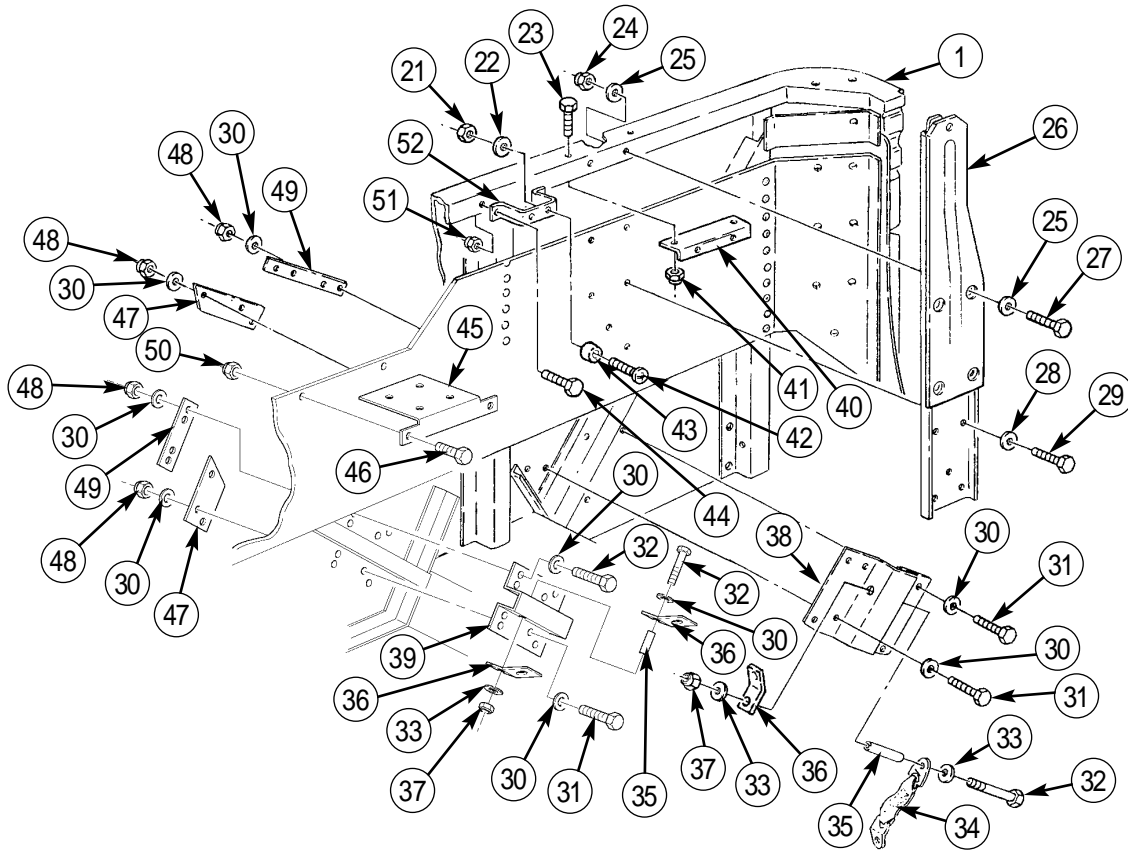
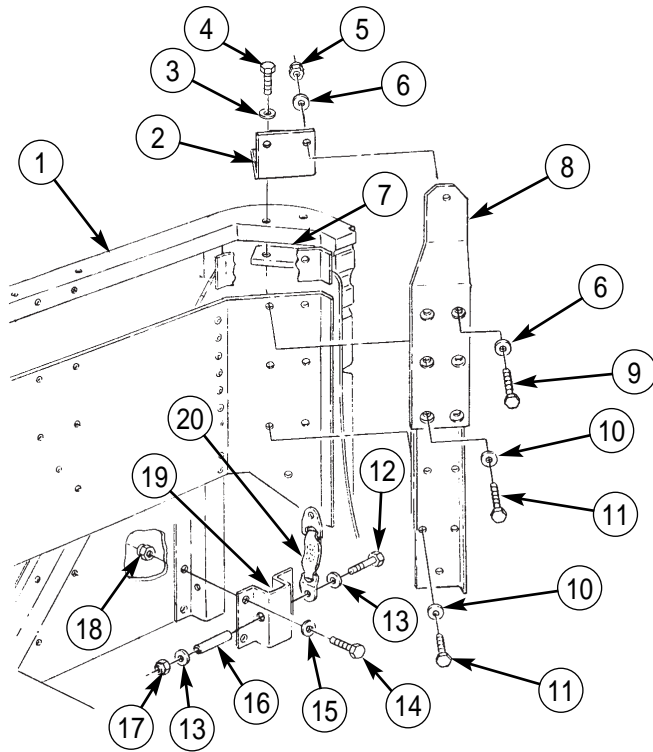

END OF WORK PACKAGE

UNIT MAINTENANCE INSTRUCTIONS

EXTENDED SERVICE PROGRAM (ESP)

TRUCK, CARGO, 2-1/2-TON, 6X6, M44A3 SERIES TRUCKS (DIESEL)

M35A3, W/O WINCH (NSN 2320-01-383-2047); W/WINCH (NSN 2320-01-383-3850);
M35A3C, W/O WINCH (NSN 2320-01-383-2050); W/WINCH (NSN 2320-01-383-2049);
M36A3, W/O WINCH (NSN 2320-01-383-2048); W/WINCH (NSN 2320-01-383-2046).

SEATBELTS MAINTENANCE

DRIVER'S SEATBELT REMOVAL, COMPANION SEATBELTS REMOVAL,
CLEANING AND INSPECTION, COMPANION SEATBELTS INSTALLATION, DRIVER'S SEATBELT INSTALLATION

INITIAL SETUP:

Tools and Special Tools

General mechanic's tool kit
(item 30, WP 0394 00)
Common No. 1 tool kit
(item 15, WP 0394 00)

References

TM 9-2320-386-24P

Equipment Condition

Parking brake set (TM 9-2320-386-10).

Materials/Parts

Seven locknuts (item 346, WP 0395 00)
Two locknuts (item 14, WP 0395 00)

SEATBELTS MAINTENANCE (Contd)

DRIVER'S SEATBELT REMOVAL

1. Remove locknut (1), washer (2), screw (4), driver's seatbelt (5), and washer (3) from top of left seatbelt post (14). Discard locknut (1).
2. Remove screw (7), washer (6), and driver's seatbelt (5) from bottom of left seatbelt post (14).
3. Remove screw (12), driver's seatbelt buckle (13), tether (10), and washer (9) from right support bracket (8).
4. Remove sleeve (11) from driver's seatbelt buckle (13).
5. Remove screw (16), driver's seatbelt (5), tether (18), and washer (19) from left support bracket (15).
6. Remove sleeve (17) from driver's seatbelt (5).

SEATBELTS MAINTENANCE (Contd)

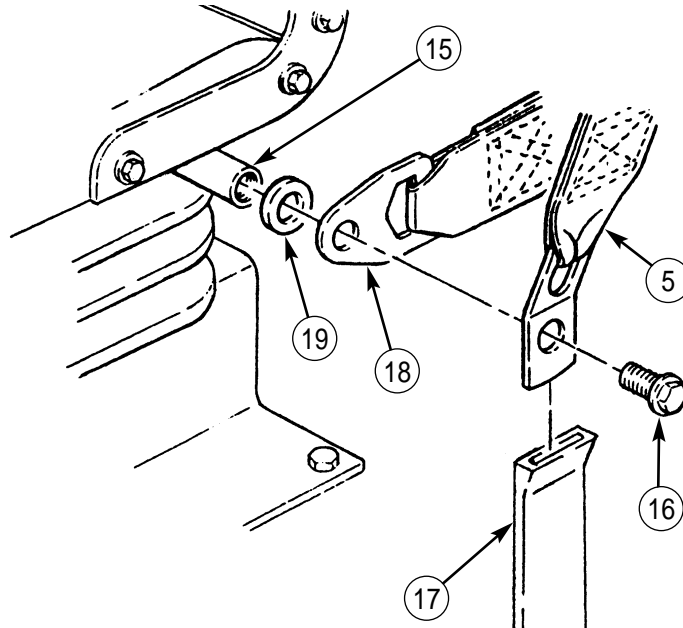
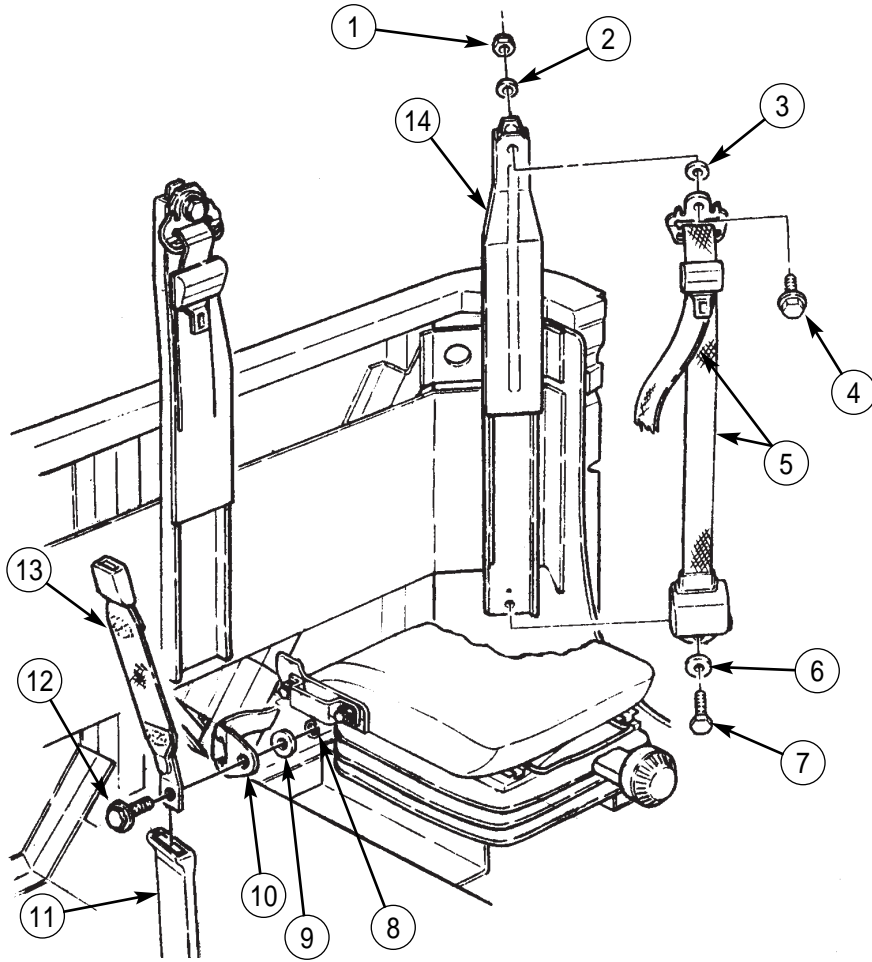

SEATBELTS MAINTENANCE (Contd)

COMPANION SEATBELTS REMOVAL

1. Remove two locknuts (2), screws (5), clips (1), and retainer (3) from companion seat frame (4). Discard locknuts (2).
2. Remove screw (12), washer (11), and left companion seatbelt (10) from bottom of center seatbelt post (33).
3. Remove locknut (6), washer (7), screw (9), left companion seatbelt (10), and washer (8) from top of center seatbelt post (33). Discard locknut (6).
4. Remove locknut (17), washer (16), screw (13), left companion seatbelt (10), and washer (14) from bracket (18). Discard locknut (17).
5. Remove sleeve (15) from left companion seatbelt (10).
6. Remove locknut (20), washer (21), screw (24), left companion seatbelt buckle (25), and washer (26) from bracket (22). Discard locknut (20).
7. Remove sleeve (23) from left companion seatbelt buckle (25).
8. Remove locknut (27), washer (28), screw (32), right companion seatbelt buckle (31), and washer (30) from bracket (29). Discard locknut (27).
9. Remove sleeve (19) from right companion seatbelt buckle (31).
10. Remove locknut (34), washer (35), screw (46), right companion seatbelt (45), and washer (47) from top of right seatbelt post (36). Discard locknut (34).
11. Remove screw (41), washer (42), and right companion seatbelt (45) from bottom of right seatbelt post (36).
12. Remove locknut (44), washer (43), screw (38), right companion seatbelt (45), and washer (40) from cab wall (37). Discard locknut (44).
13. Remove sleeve (39) from right companion seatbelt (45).

CLEANING AND INSPECTION

1. For general cleaning instructions, refer to WP 0383 00.
2. Inspect seatbelts for frayed or torn material on buckles. Replace if material on buckles is frayed or torn.
3. Ensure seatbelts are operating properly. Replace if not operating properly.

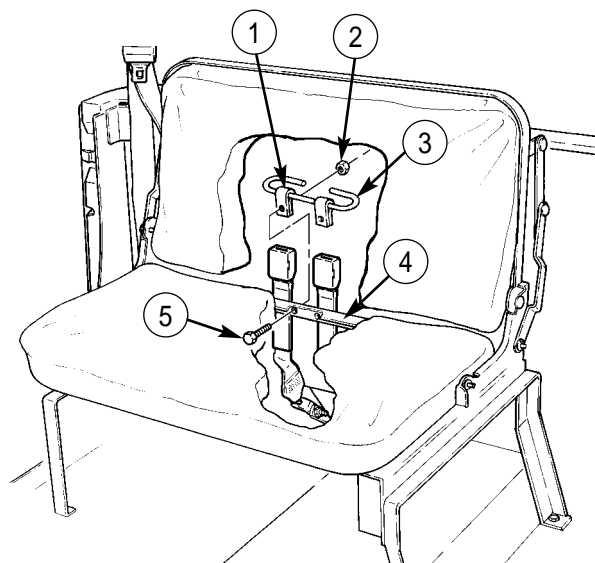

SEATBELTS MAINTENANCE (Contd)

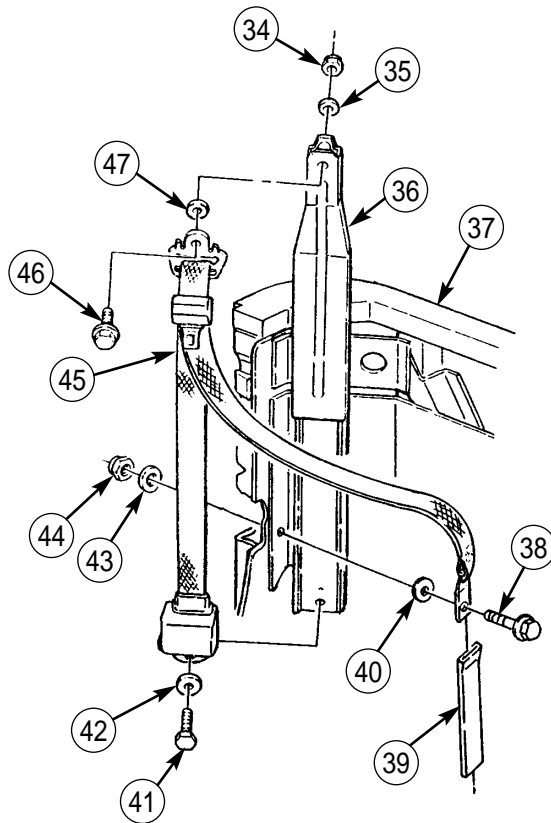
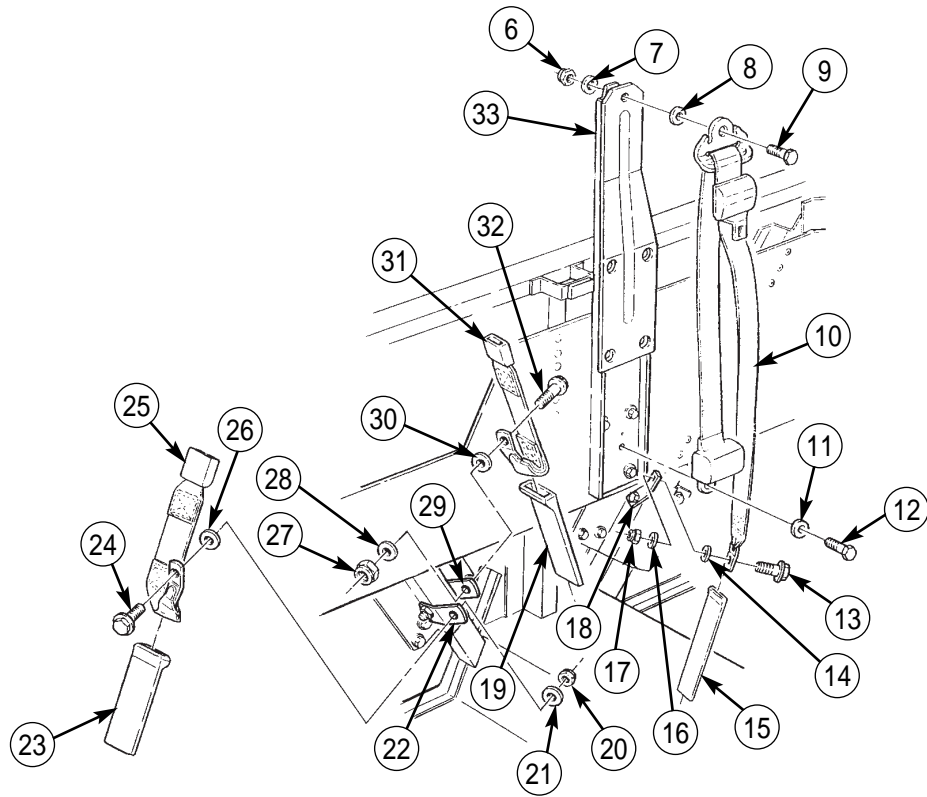

SEATBELTS MAINTENANCE (Contd)**COMPANION SEATBELTS INSTALLATION**

1. Install sleeve (6) on right companion seatbelt (12).
2. Install right companion seatbelt (12) on cab wall (4) with washer (7), screw (5), washer (10), and new locknut (11).
3. Install right companion seatbelt (12) on bottom of right seatbelt post (3) with washer (9) and screw (8).
4. Install right companion seatbelt (12) on top of right seatbelt post (3) with washer (14), screw (13), washer (2), and new locknut (1).
5. Install sleeve (28) on right companion seatbelt buckle (40).
6. Install right companion seatbelt buckle (40) on bracket (38) with washer (39), screw (41), washer (37), and new locknut (36).
7. Install sleeve (32) on left companion seatbelt buckle (34).
8. Install left companion seatbelt buckle (34) on bracket (31) with washer (35), screw (33), washer (30), and new locknut (29).
9. Install sleeve (24) on left companion seatbelt (19).
10. Install left companion seatbelt (19) on bracket (27) with washer (20), screw (23), washer (25), and new locknut (26).
11. Install left companion seatbelt (19) on top of center seatbelt post (42) with washer (17), screw (18), washer (16), and new locknut (15).
12. Install left companion seatbelt (19) on bottom of center seatbelt post (42) with washer (21) and screw (22).
13. Install retainer (45) and two clips (43) on companion seat frame (46) with two screws (47) and new locknuts (44).

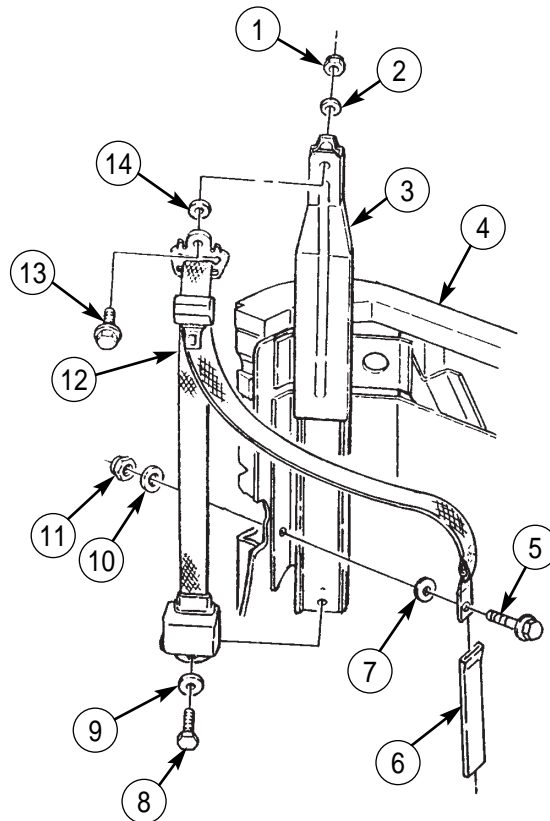

SEATBELTS MAINTENANCE (Contd)

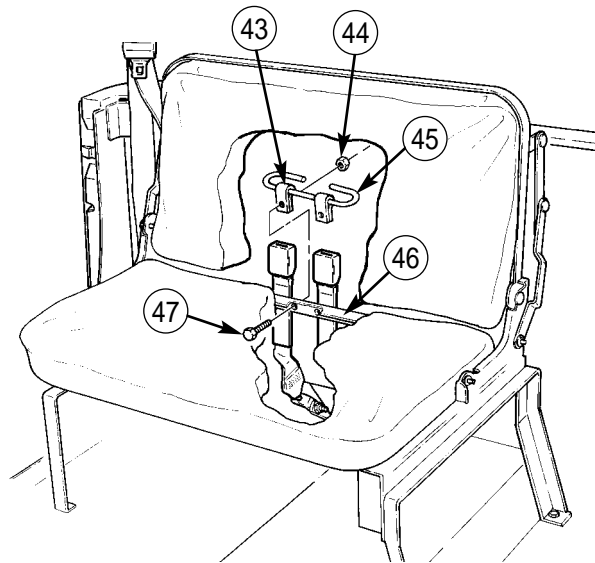
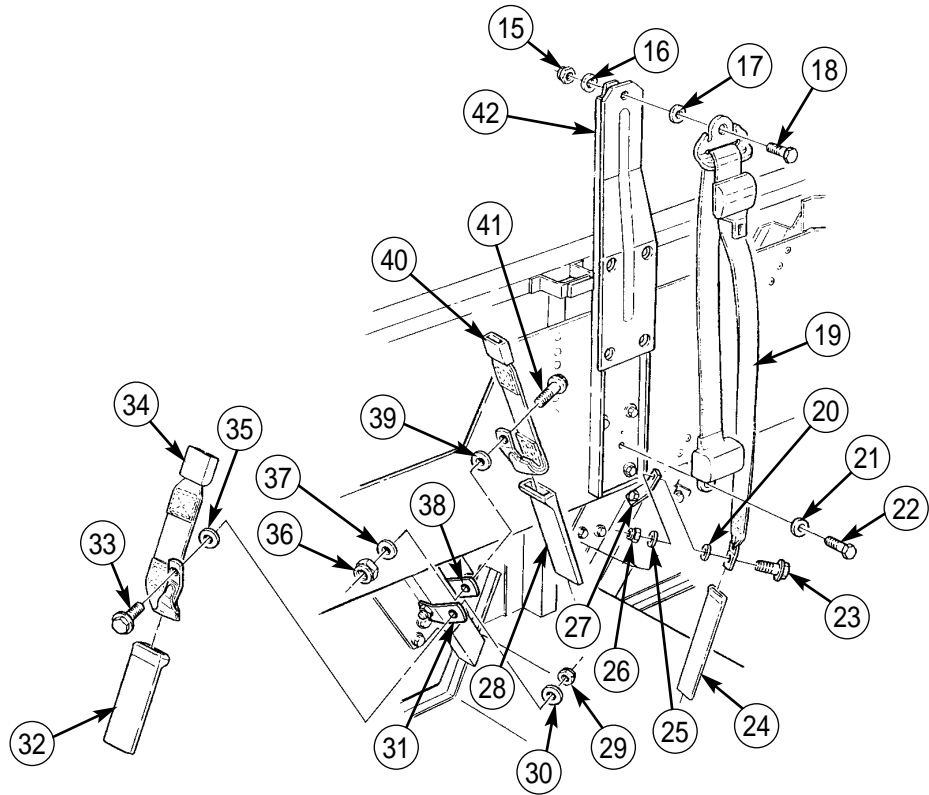

SEATBELTS MAINTENANCE (Contd)**DRIVER'S SEATBELT INSTALLATION**

1. Install sleeve (4) on driver's seatbelt (2).
2. Install driver's seatbelt (2) and tether (5) on left support bracket (1) with washer (6) and screw (3). Tighten screw (3) 30-35 lb-ft (41-47 N•m).
3. Install sleeve (16) on driver's seatbelt buckle (18).
4. Install driver's seatbelt buckle (18) and tether (15) on right support bracket (13) with washer (14) and screw (17). Tighten screw (17) 30-35 lb-ft (41-47 N•m).
5. Install driver's seatbelt (2) on top of left seatbelt post (19) with washer (9), screw (10), washer (8), and new locknut (7).
6. Install driver's seatbelt (2) on bottom of left seatbelt post (19) with washer (11) and screw (12).

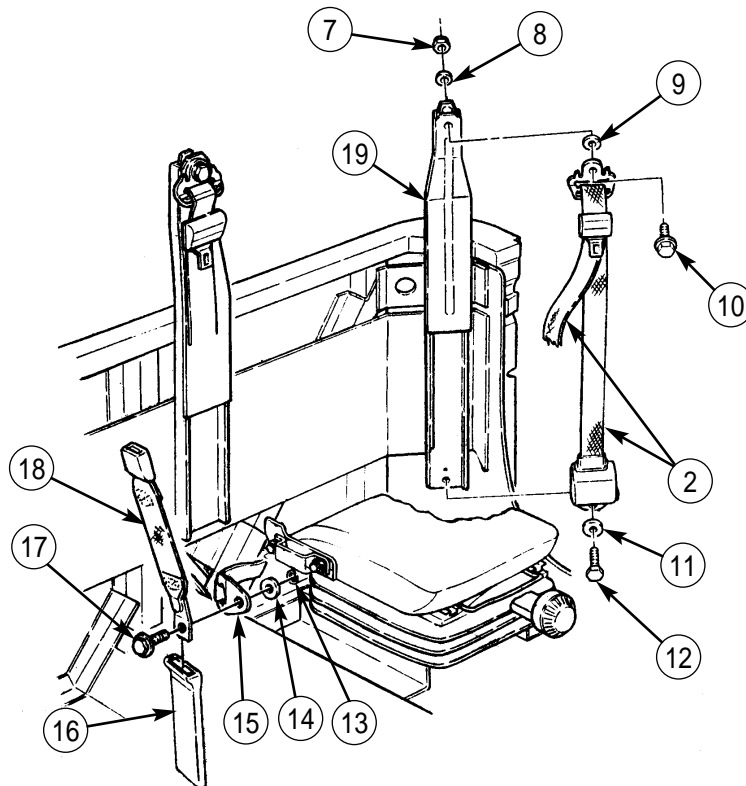
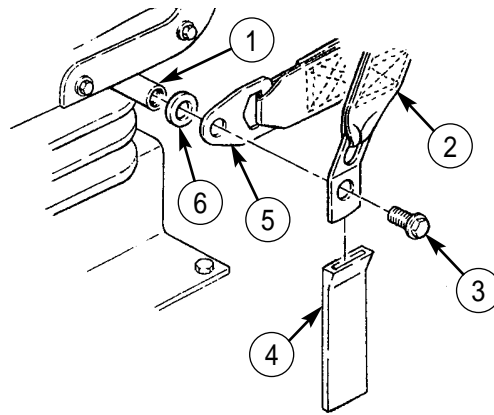

END OF WORK PACKAGE

UNIT MAINTENANCE INSTRUCTIONS

*EXTENDED SERVICE PROGRAM (ESP)
 TRUCK, CARGO, 2-1/2-TON, 6X6, M44A3 SERIES TRUCKS (DIESEL)
 M35A3, W/WINCH (NSN 2320-01-383-3850);
 M35A3C, W/WINCH (NSN 2320-01-383-2049);
 M36A3, W/WINCH (NSN 2320-01-383-2046).*

**Section XIX. FRONT WINCH MAINTENANCE
 TABLE OF CONTENTS**

<i>WP Title</i>	<i>WP Sequence No.-Page No.</i>
Front Winch Hydraulic System Servicing	0213 00-1
Front Winch Hydraulic Oil Filter Replacement	0214 00-1
Front Winch Hydraulic Oil Filter Base Replacement	0215 00-1
Front Winch AOAP Valve Replacement	0216 00-1
Front Winch Hydraulic Vent Valve Maintenance	0217 00-1
Front Winch Hydraulic Control Valve Maintenance	0218 00-1
Front Winch Hydraulic Oil Reservoir Maintenance	0219 00-1
Front Winch Hydraulic Motor Maintenance	0220 00-1
Front Winch Hydraulic Hoses Replacement	0221 00-1
Front Winch Hydraulic Pump Replacement	0222 00-1
Front Winch Controls Replacement	0223 00-1
Front Winch Cable Maintenance	0224 00-1
Front Winch Maintenance	0225 00-1

END OF WORK PACKAGE

UNIT MAINTENANCE INSTRUCTIONS

EXTENDED SERVICE PROGRAM (ESP)

TRUCK, CARGO, 2-1/2-TON, 6X6, M44A3 SERIES TRUCKS (DIESEL)

M35A3, W/WINCH (NSN 2320-01-383-3850);

M35A3C, W/WINCH (NSN 2320-01-383-2049);

M36A3, W/WINCH (NSN 2320-01-383-2046).

FRONT WINCH HYDRAULIC SYSTEM SERVICING

DRAIN SYSTEM, FILL SYSTEM

INITIAL SETUP:

Tools and Special Tools

General mechanic's tool kit
(item 30, WP 0394 00)

References

TM 9-2320-386-24P

Materials/Parts

Gasket (item 73, WP 0395 00)
Lubricating oil (item 32, WP 0393 00)

Equipment Condition

Parking brake set (TM 9-2320-386-10).

FRONT WINCH HYDRAULIC SYSTEM SERVICING (Contd)**DRAIN SYSTEM****WARNING**

Accidental or intentional introduction of liquid contaminants into the environment is in violation of state, federal, and military regulations. Refer to Army POL (WP 0001 00) for information concerning storage, use, and disposal of these liquids. Failure to do so may result in injury or death.

NOTE

Have drainage container ready to catch oil.

1. Remove cap (1) from lockplate (2).
2. Remove drainplug (4) and gasket (5) from reservoir (3). Discard gasket (5).

NOTE

Allow reservoir to drain completely before performing step 3.

3. Inspect sight glass (6). Replace if damaged.
4. Install new gasket (5) and drainplug (4) on reservoir (3).
5. Install cap (1) on lockplate (2).

FILL SYSTEM

1. Remove cap (1) from lockplate (2).

NOTE

Correct oil level can be verified by checking the sight glass.

2. Add oil (WP 0023 00) to reservoir (3), filling system until oil level is centered in sight glass (6).
3. Install cap (1) on lockplate (2).
4. Operate winch (TM 9-2320-386-10), as follows:
 - a. Unwind cable 32-48 ft (10-15 m).
 - b. Rewind and stow cable.
5. Add oil to reservoir (3) to obtain correct oil level, if necessary.

FRONT WINCH HYDRAULIC SYSTEM SERVICING (Contd)

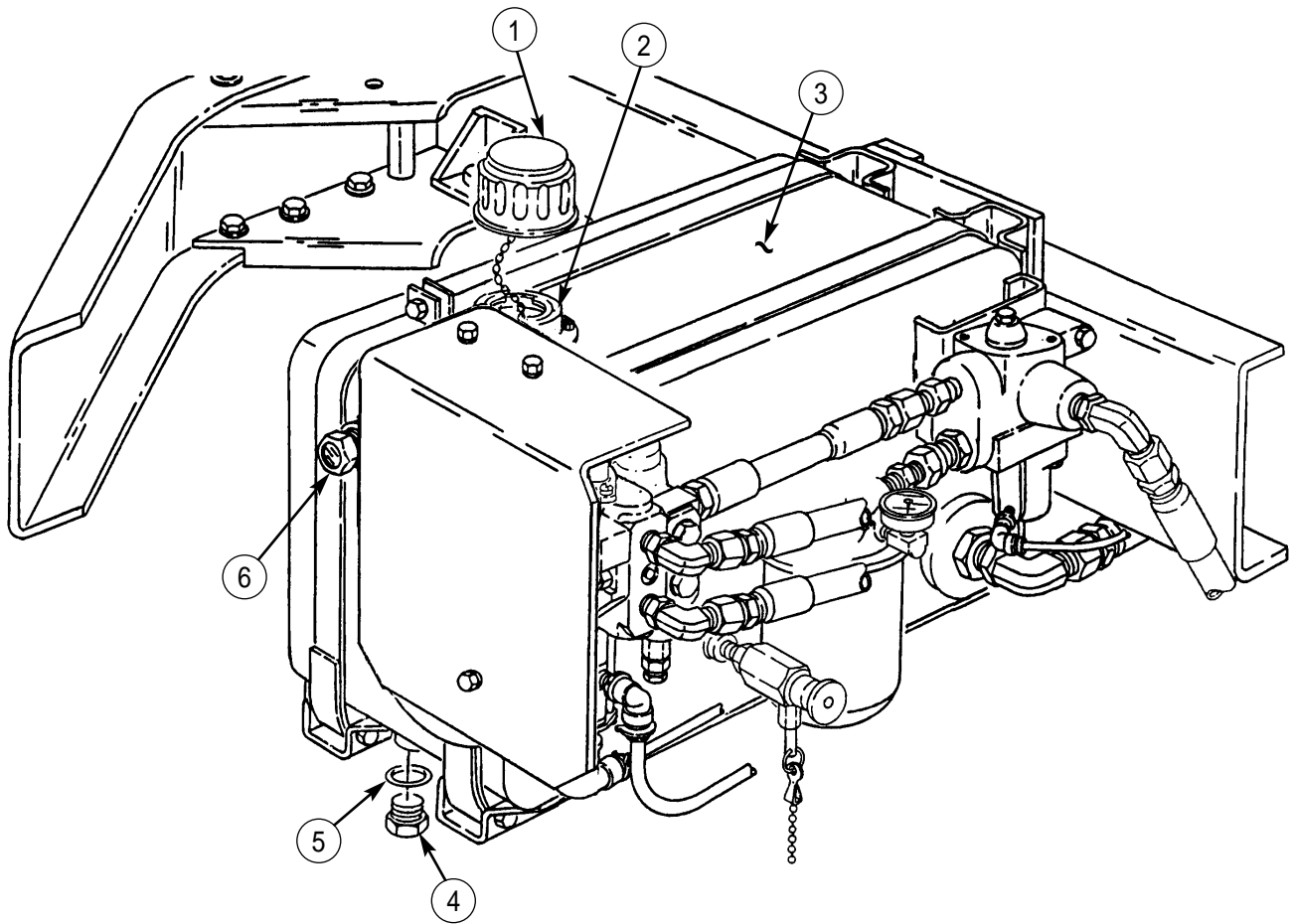

END OF WORK PACKAGE

UNIT MAINTENANCE INSTRUCTIONS

EXTENDED SERVICE PROGRAM (ESP)
TRUCK, CARGO, 2-1/2-TON, 6X6, M44A3 SERIES TRUCKS (DIESEL)
M35A3, W/WINCH (NSN 2320-01-383-3850);
M35A3C, W/WINCH (NSN 2320-01-383-2049);
M36A3, W/WINCH (NSN 2320-01-383-2046).

FRONT WINCH HYDRAULIC OIL FILTER REPLACEMENT

REMOVAL, INSTALLATION

INITIAL SETUP:

Tools and Special Tools

General mechanic's tool kit
(item 30, WP 0394 00)

Materials/Parts

Oil filter (item 112, WP 0395 00)
Lubricating oil (item 32, WP 0393 00)

References

TM 9-2320-386-24P

Equipment Condition

Parking brake set (TM 9-2320-386-10).
Hydraulic oil reservoir drained (WP 0213 00).

FRONT WINCH HYDRAULIC OIL FILTER REPLACEMENT (Contd)**REMOVAL****NOTE**

Have drainage container ready to catch oil.

Remove oil filter (2) from oil filter base (1). Discard oil filter (2).

INSTALLATION

1. Apply lubricating oil to seal of new oil filter (2).
2. Install oil filter (2) on oil filter base (1). Tighten oil filter (2) until it contacts oil filter base (1), then tighten an additional 7/8 to 1 full turn.
3. Fill hydraulic oil reservoir to proper level (WP 0213 00).

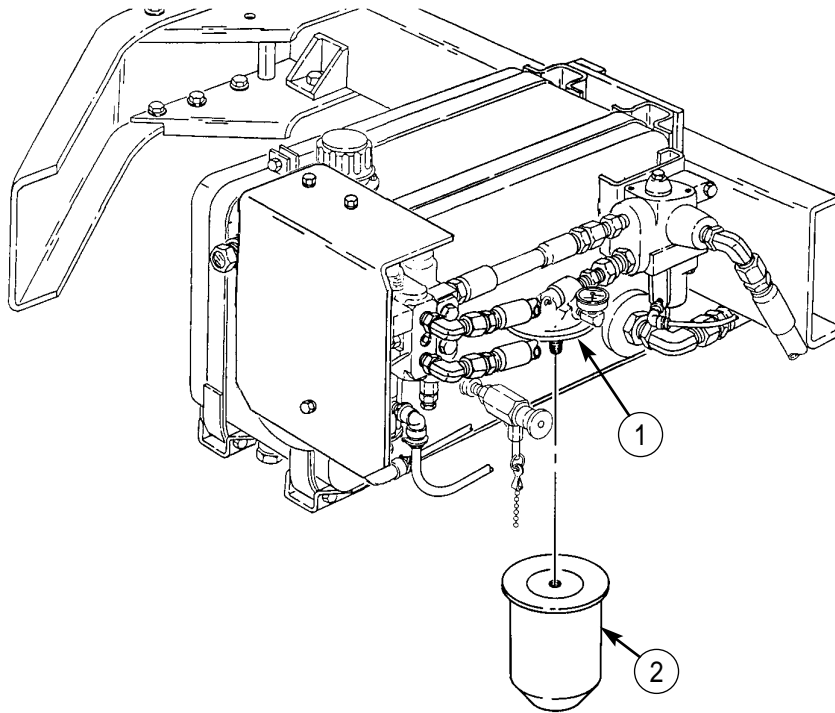

END OF WORK PACKAGE

UNIT MAINTENANCE INSTRUCTIONS

EXTENDED SERVICE PROGRAM (ESP)

TRUCK, CARGO, 2-1/2-TON, 6X6, M44A3 SERIES TRUCKS (DIESEL)

M35A3, W/WINCH (NSN 2320-01-383-3850);

M35A3C, W/WINCH (NSN 2320-01-383-2049);

M36A3, W/WINCH (NSN 2320-01-383-2046).

FRONT WINCH HYDRAULIC OIL FILTER BASE REPLACEMENT

REMOVAL, INSTALLATION

INITIAL SETUP:

Tools and Special Tools

General mechanic's tool kit
(item 30, WP 0394 00)
Common No. 1 tool kit
(item 15, WP 0394 00)
Wrench (item 79, WP 0394 00)

Materials/Parts

O-ring (item 190, WP 0395 00)
O-ring (item 188, WP 0395 00)
O-ring (item 189, WP 0395 00)
O-ring (item 35, WP 0395 00)

Materials/Parts (Contd)

Oil filter (item 112, WP 0395 00)
Teflon pipe sealant (item 41, WP 0393 00)
Lubricating oil (item 32, WP 0393 00)

References

TM 9-2320-386-24P

Equipment Condition

Parking brake set (TM 9-2320-386-10).
Hydraulic oil reservoir drained (WP 0213 00).

FRONT WINCH HYDRAULIC OIL FILTER BASE REPLACEMENT (Contd)**REMOVAL**

1. Loosen two hose connectors (2) and remove hose (5), fitting (3), and O-rings (1) and (4) from control valve (16) and vent valve (5). Discard O-rings (1) and (4).
2. Remove oil filter (12) from oil filter base (11). Discard oil filter (12).
3. Remove reducer (9), fitting (8), and O-ring (7) from vent valve (6) and oil filter base (11). Discard O-ring (7).
4. Remove oil filter base (11) with elbow connector (13) from fitting (14).
5. Remove fitting (14) and O-ring (15) from reservoir (17). Discard O-ring (15).
6. Remove elbow connector (13) from oil filter base (11).
7. Remove gauge (10) from oil filter base (11).

INSTALLATION

1. Apply sealant to male threads of hose connectors (2), fittings (3), (8), and (14), reducer (9), elbow connector (13), and gauge (10).
2. Install gauge (10) on oil filter base (11).
3. Install reducer (9) and elbow connector (13) on oil filter base (11).
4. Install new O-ring (15) and fitting (14) on reservoir (17).
5. Install new O-ring (7) and fitting (8) on vent valve (6).
6. Install oil filter base (11) with elbow connector (13) and reducer (9) on fitting (14) and fitting (8).
7. Apply lubricating oil to seal of new oil filter (12).
8. Install oil filter (12) on oil filter base (11). Tighten oil filter (12) until it contacts oil filter base (11), then tighten an additional 7/8- to 1-full turn.
9. Install O-rings (1) and (4), fitting (3), and hose (5) on vent valve (6) and control valve (16) and tighten hose connectors (2).
10. Fill hydraulic oil reservoir to proper level (WP 0213 00).

FRONT WINCH HYDRAULIC OIL FILTER BASE REPLACEMENT (Contd)

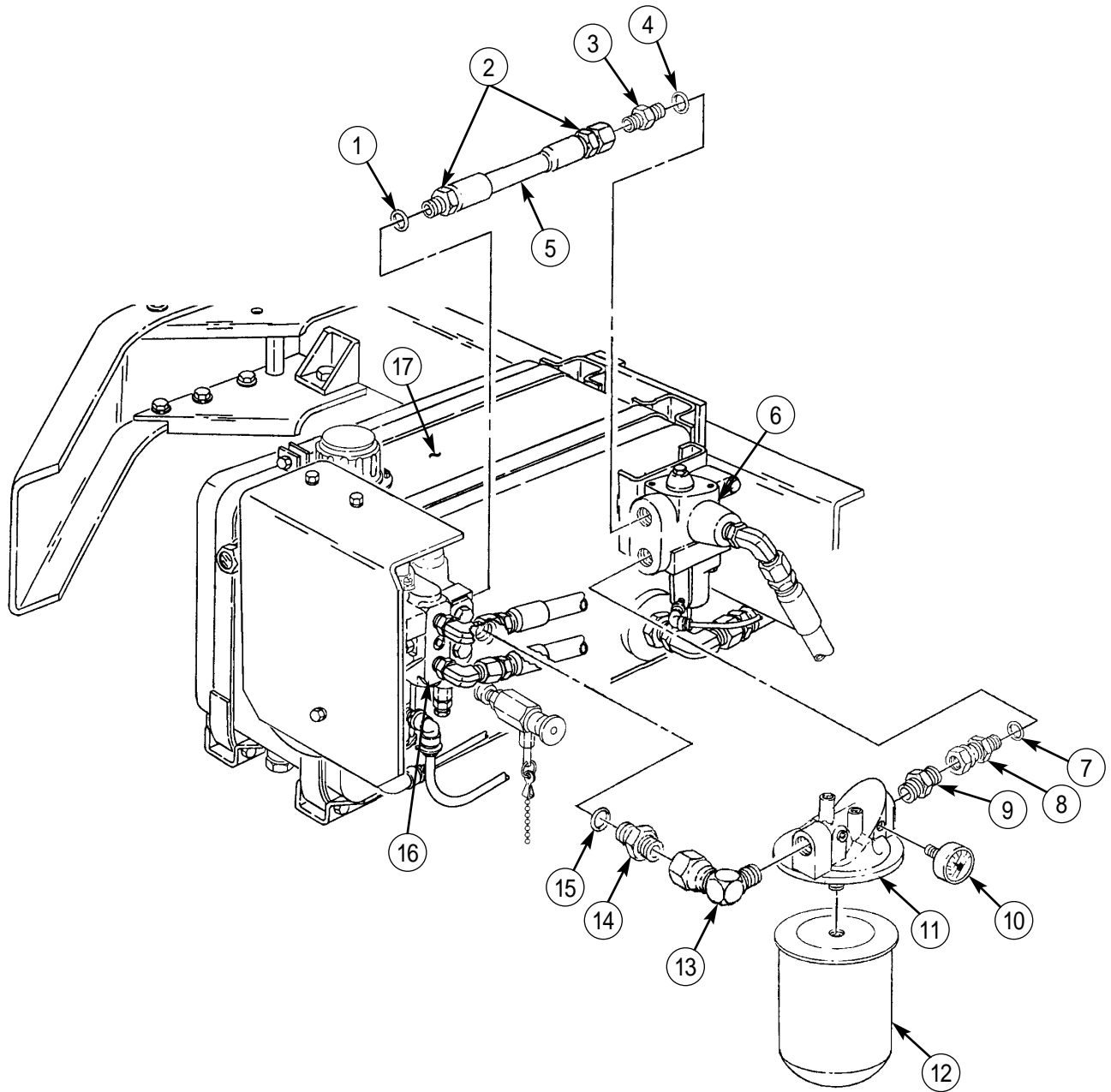

END OF WORK PACKAGE

UNIT MAINTENANCE INSTRUCTIONS

EXTENDED SERVICE PROGRAM (ESP)

TRUCK, CARGO, 2-1/2-TON, 6X6, M44A3 SERIES TRUCKS (DIESEL)

M35A3, W/WINCH (NSN 2320-01-383-3850);

M35A3C, W/WINCH (NSN 2320-01-383-2049);

M36A3, W/WINCH (NSN 2320-01-383-2046).

FRONT WINCH AOAP VALVE REPLACEMENT

REMOVAL, INSTALLATION

INITIAL SETUP:

Tools and Special Tools

General mechanic's tool kit
(item 30, WP 0394 00)

Materials/Parts

Teflon pipe sealant (item 41, WP 0393 00)
Cap and plug set (item 14, WP 0393 00)

References

TM 9-2320-386-24P

Equipment Condition

Parking brake set (TM 9-2320-386-10).
Hydraulic oil reservoir drained (WP 0213 00).

FRONT WINCH AOAP VALVE REPLACEMENT (Contd)**REMOVAL****CAUTION**

Plug all openings immediately after removing valve to prevent dirt and dust from entering hydraulic system. Contamination of the hydraulic system may result in damage to equipment. Remove plugs before installation.

NOTE

Have drainage container ready to catch oil.

Remove AOAP valve (2) from hydraulic oil reservoir (1).

INSTALLATION

1. Apply sealant to male threads of AOAP valve (2).
2. Install AOAP valve (2) on hydraulic oil reservoir (1).
3. Fill hydraulic oil reservoir to proper level (WP 0213 00).

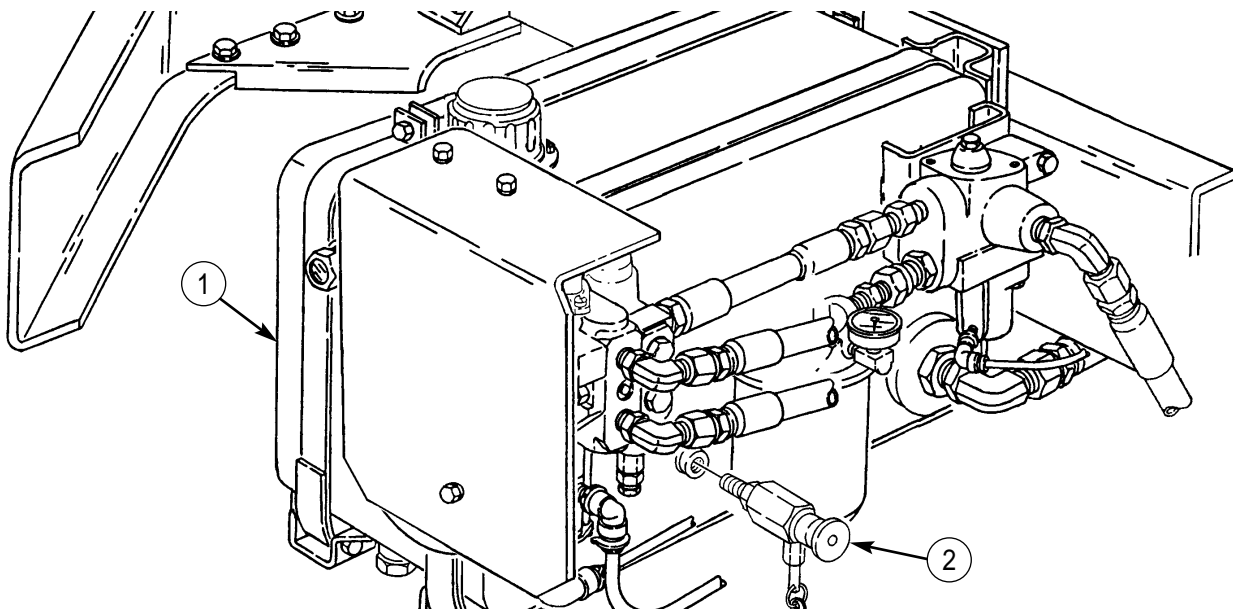

END OF WORK PACKAGE

UNIT MAINTENANCE INSTRUCTIONS

EXTENDED SERVICE PROGRAM (ESP)

TRUCK, CARGO, 2-1/2-TON, 6X6, M44A3 SERIES TRUCKS (DIESEL)

M35A3, W/WINCH (NSN 2320-01-383-3850);

M35A3C, W/WINCH (NSN 2320-01-383-2049);

M36A3, W/WINCH (NSN 2320-01-383-2046).

FRONT WINCH HYDRAULIC VENT VALVE MAINTENANCE

REMOVAL, INSPECTION, INSTALLATION

INITIAL SETUP:

Tools and Special Tools

General mechanic's tool kit
(item 30, WP 0394 00)

Common No. 1 tool kit
(item 15, WP 0394 00)

Materials/Parts

Two locknuts (item 88, WP 0395 00)
O-ring (item 188, WP 0395 00)
Two O-rings (item 189, WP 0395 00)
Cap and plug set (item 14, WP 0393 00)
Teflon pipe sealant (item 41, WP 0393 00)
Four locknuts (item 184, WP 0395 00)

References

TM 9-2320-386-24P

Equipment Condition

Parking brake set (TM 9-2320-386-10).
Hydraulic oil reservoir drained (WP 0213 00).

FRONT WINCH HYDRAULIC VENT VALVE MAINTENANCE (Contd)**REMOVAL****CAUTION**

Plug all openings immediately after disconnecting hoses and fittings to prevent dirt and dust from entering hydraulic system. Contamination of the hydraulic system may result in damage to equipment. Remove plugs before installation.

1. Remove four locknuts (21), washers (22), screws (17), splash guard (19), and splash guard retainer (18) from fender mounting bracket (20). Discard locknuts (21).
2. Remove hose connector (5) from elbow (6).
3. Remove hose connector (13) from fitting (14).
4. Remove snapping (8) and tube (7) from elbow (9).
5. Remove two locknuts (1) and screws (3) from vent valve (10) and bracket (2). Discard locknuts (1).
6. Remove connector (12) and vent valve (10) from fitting (15).
7. Remove elbow (6) and O-ring (4) from vent valve (10). Discard O-ring (4).
8. Remove fitting (14) and O-ring (16) from vent valve (10). Discard O-ring (16).
9. Remove elbow (9) from vent valve (10).
10. Remove connector (12) and O-ring (11) from vent valve (10). Discard O-ring (11).

INSPECTION

Check vent valve (10) body casting for cracks and internal threads for damage. Replace vent valve (10) if damaged.

INSTALLATION

1. Apply sealant to male threads of fittings (14) and (15), connector (12), and elbows (6) and (9).
2. Install new O-ring (11) and connector (12) on vent valve (10).
3. Install elbow (9) on vent valve (10).
4. Install new O-ring (16) and fitting (14) on vent valve (10).
5. Install new O-ring (4) and elbow (6) on vent valve (10).
6. Install connector (12) and vent valve (10) on fitting (15).
7. Install vent valve (10) on bracket (2) with two screws (3) and new locknuts (1).
8. Install tube (7) on elbow (9) with snapping (8).
9. Install hose connector (13) on fitting (14).
10. Install hose connector (5) on elbow (6).
11. Fill hydraulic oil reservoir to proper level (WP 0213 00).
12. Operate winch (TM 9-2320-386-10) and check for leaks.
13. Install splash guard (19) and splash guard retainer (18) on fender mounting bracket (20) with four screws (17), washers (22), and new locknuts (21).

FRONT WINCH HYDRAULIC VENT VALVE MAINTENANCE (Contd)

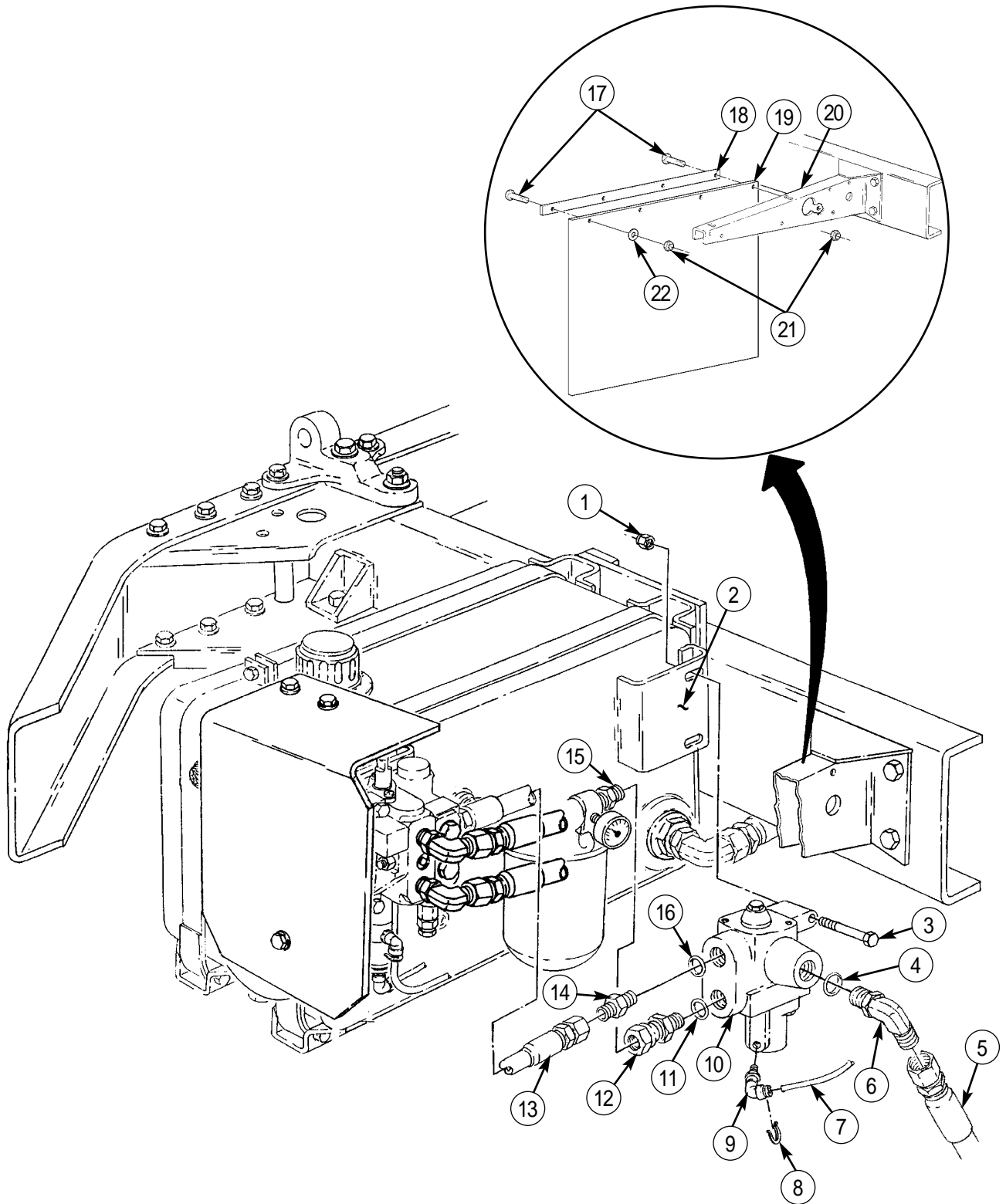

END OF WORK PACKAGE

UNIT MAINTENANCE INSTRUCTIONS

EXTENDED SERVICE PROGRAM (ESP)

TRUCK, CARGO, 2-1/2-TON, 6X6, M44A3 SERIES TRUCKS (DIESEL)

M35A3, W/WINCH (NSN 2320-01-383-3850);

M35A3C, W/WINCH (NSN 2320-01-383-2049);

M36A3, W/WINCH (NSN 2320-01-383-2046).

FRONT WINCH HYDRAULIC CONTROL VALVE MAINTENANCE

REMOVAL, INSPECTION, INSTALLATION

INITIAL SETUP:

Tools and Special Tools

General mechanic's tool kit
(item 30, WP 0394 00)

Common No. 1 tool kit
(item 15, WP 0394 00)

Materials/Parts

O-ring (item 188, WP 0395 00)
Two O-rings (item 191, WP 0395 00)
Cap and plug set (item 14, WP 0393 00)
Teflon pipe sealant (item 41, WP 0393 00)

References

TM 9-2320-386-24P

Equipment Condition

Parking brake set (TM 9-2320-386-10).
Front winch hydraulic oil filter base removed
(WP 0215 00).

FRONT WINCH HYDRAULIC CONTROL VALVE MAINTENANCE (Contd)**REMOVAL****CAUTION**

Plug all openings immediately after disconnecting hoses and fittings to prevent dirt and dust from entering hydraulic system. Contamination of the hydraulic system may result in damage to equipment. Remove plugs before installation.

1. Remove three screws (2), washers (3), and angle bracket (1) from reservoir (4).

NOTE

Tag all hoses for installation.

2. Remove snapping (18) and tube (17) from elbow (19).
3. Remove snapping (13) and tube (14) from elbow (15).
4. Remove elbows (15) and (19) from control valve (5).
5. Remove hose connector (8) from elbow (7).
6. Remove hose connector (9) from elbow (10).
7. Remove elbows (7) and (10) and O-rings (6) and (16) from control valve (5). Discard O-rings (6) and (16).
8. Remove hose connector (20) from elbow (21).
9. Remove elbow (21) and O-ring (22) from control valve (5). Discard O-ring (22).
10. Remove two screws (12), screw (11), control valve (5), and plate (23) from reservoir (4).

INSPECTION

Check control valve (5) body casting for cracks, leaks, and condition of internal threads. Replace control valve (5) if damaged.

INSTALLATION

1. Apply sealant to male threads of elbows (7), (10), (15), (19), and (21).
2. Install control valve (5) and plate (23) on reservoir (4) with two screws (12) and screw (11).
3. Install new O-ring (22) and elbow (21) on control valve (5).
4. Install hose connector (20) on elbow (21).
5. Install new O-rings (6) and (16) and elbows (7) and (10) on control valve (5).
6. Install hose connector (9) on elbow (10).
7. Install hose connector (8) on elbow (7).
8. Install elbows (15) and (19) on control valve (5).
9. Install tube (14) on elbow (15) with snapping (13).
10. Install tube (17) on elbow (19) with snapping (18).
11. Install angle bracket (1) on reservoir (4) with three washers (3) and screws (2).
12. Install front winch hydraulic oil filter base (WP 0215 00).

FRONT WINCH HYDRAULIC CONTROL VALVE MAINTENANCE (Contd)

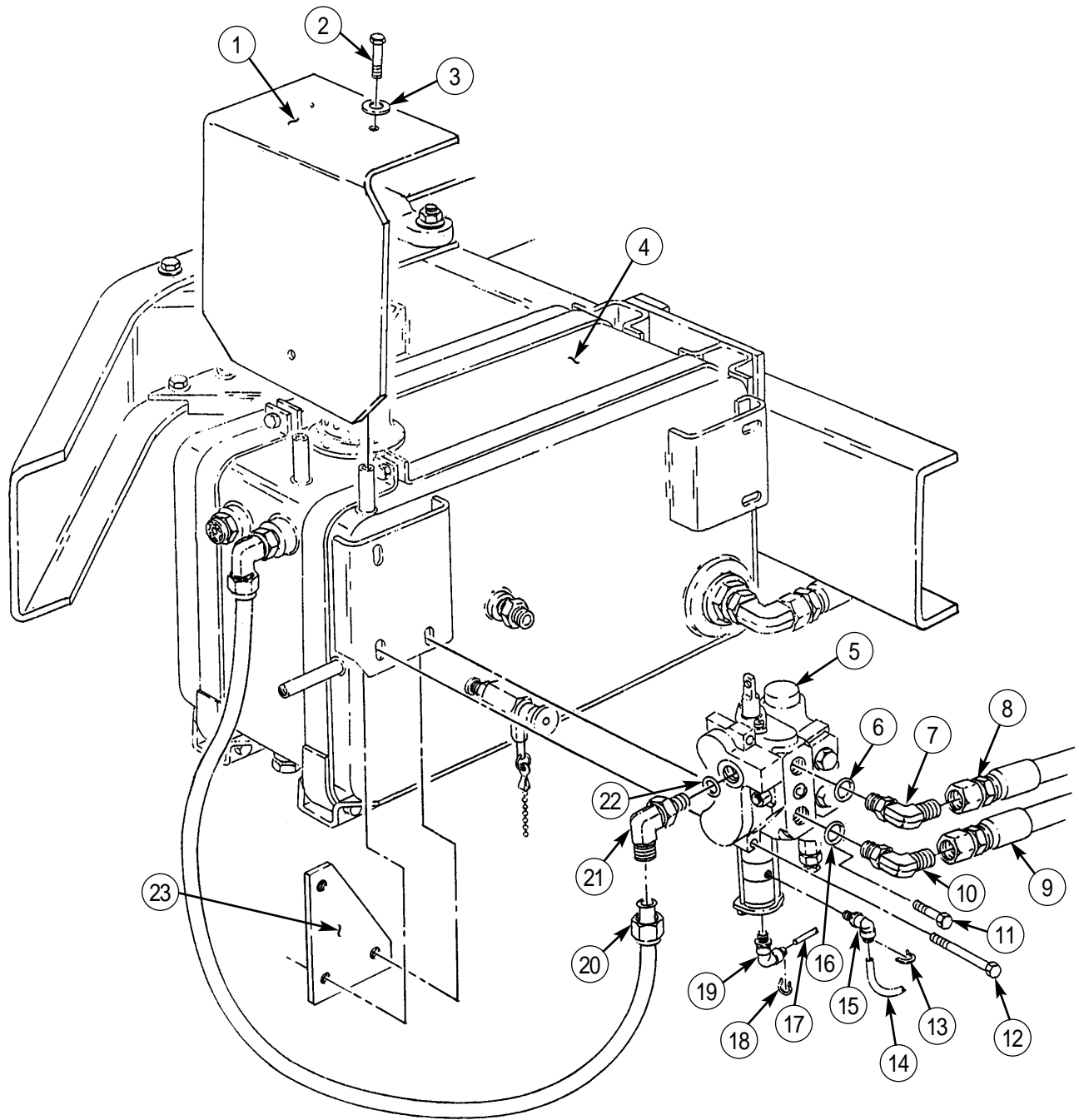

END OF WORK PACKAGE

UNIT MAINTENANCE INSTRUCTIONS

EXTENDED SERVICE PROGRAM (ESP)

TRUCK, CARGO, 2-1/2-TON, 6X6, M44A3 SERIES TRUCKS (DIESEL)

M35A3, W/WINCH (NSN 2320-01-383-3850);

M35A3C, W/WINCH (NSN 2320-01-383-2049);

M36A3, W/WINCH (NSN 2320-01-383-2046).

FRONT WINCH HYDRAULIC OIL RESERVOIR MAINTENANCE

REMOVAL, CLEANING AND INSPECTION, INSTALLATION

INITIAL SETUP:

Tools and Special Tools

General mechanic's tool kit
(item 30, WP 0394 00)
Common No. 1 tool kit
(item 15, WP 0394 00)

Materials/Parts

Two locknuts (item 19, WP 0395 00)
Four locknuts (item 345, WP 0395 00)
Four locknuts (item 107, WP 0395 00)
Gasket (item 73, WP 0395 00)
O-ring (item 188, WP 0395 00)
O-ring (item 212, WP 0395 00)
Adhesive (item 3, WP 0393 00)
Teflon pipe sealant (item 41, WP 0393 00)
Adhesive silicone (item 8, WP 0393 00)

Materials/Parts (Contd)

Crocus cloth (item 49, WP 0393 00)
Mineral spirits (item 33, WP 0393 00)
Cloth (item 18, WP 0393 00)

References

TM 9-2320-386-24P

Equipment Condition

Parking brake set (TM 9-2320-386-10).
Hydraulic oil reservoir drained (WP 0213 00).
Front winch hydraulic control valve removed
(WP 0218 00).
Front winch AOAP valve removed (WP 0216 00).
Front winch hydraulic vent valve removed
(WP 0217 00).

FRONT WINCH HYDRAULIC OIL RESERVOIR MAINTENANCE (Contd)**REMOVAL**

1. Remove hose (2), elbow (3), and O-ring (4) from reservoir (5). Discard O-ring (4).
2. Remove tube (6), elbow (7), and O-ring (1) from reservoir (5). Discard O-ring (1).
3. Remove two locknuts (9) and screws (8) from retaining straps (32) and (11). Discard locknuts (9).
4. Move two retaining straps (32) and (11) away from reservoir (5) and remove reservoir (5) from support bracket (27).
5. Remove two locknuts (29), screws (28), and retaining straps (32) from support bracket (27). Discard locknuts (29).
6. Remove two locknuts (10), screws (12), and retaining straps (11) from support bracket (27). Discard locknuts (10).
7. Remove locknut (18), screw (30), and clamp (17) from rail (19) and wiring harness (16). Discard locknut (18).
8. Remove three locknuts (14), screws (31), and support bracket (27) from rail (19) and rail extension (13). Discard locknuts (14).
9. Remove sight glass (26) from reservoir (5).
10. Remove drainplug (24) and gasket (25) from reservoir (5). Discard gasket (25).
11. Remove filter (23) from reservoir (5).

NOTE

It is not necessary to disconnect cap from chain or chain from lockplate.

12. Remove cap (15) from lockplate (21).
13. Remove six screws (20), lockplate (21), and screen (22) from reservoir (5).

FRONT WINCH HYDRAULIC OIL RESERVOIR MAINTENANCE (Contd)**CLEANING AND INSPECTION****WARNING**

Volatile mineral spirits burn easily and fumes can explode. Do not smoke or allow flames nearby when using volatile mineral spirits. Failure to do so may cause serious injury to personnel.

1. Clean all metallic parts with mineral spirits and dry with a lint-free rag.
2. Inspect all metallic parts for wear, scratches, grooves, and burrs. Remove scratches and burrs with crocus cloth. Replace any parts that show visible signs of being either worn or grooved.
3. Inspect webbing (24) and (28). Remove and replace any webbing (24) and (28) with visible signs of wear or damage.

INSTALLATION**NOTE**

If webbing was removed during cleaning and inspection, perform steps 1 through 4.

1. Cut new webbing (28) approximately 15.25 in. (38.7 cm) for retaining straps (4) and (27).
2. Apply adhesive to two retaining straps (4) and (27). Position new webbing (28) .25 in. (0.6 cm) from end and centered on retaining straps (4) and (27).
3. Cut four pieces of new webbing (24) approximately 28-30 in. (71-76 cm) for support bracket (21).
4. Apply adhesive to support bracket (21). Position new webbing (24) 4 in. (10 cm) from end and centered on support bracket (21).
5. Apply silicone adhesive to mating surface of screen (15) and lockplate (14) and install screen (15) and lockplate (14) on reservoir (17) with six screws (13).
6. Install cap (8) on lockplate (14).
7. Apply sealant to male threads of sight glass (20) and filter (16).
8. Install filter (16) on reservoir (17).
9. Install new gasket (19) and drainplug (18) on reservoir (17).
10. Install sight glass (20) on reservoir (17).
11. Install support bracket (21) on rail (12) and rail extension (6) with three screws (26) and new locknuts (7).
12. Install wiring harness (9) on rail (12) with clamp (10), screw (25), and new locknut (11).
13. Install two retaining straps (4) on support bracket (21) with two screws (5) and new locknuts (3).
14. Install two retaining straps (27) on support bracket (21) with two screws (22) and new locknuts (23).
15. Position reservoir (17) on support bracket (21).
16. Connect two retaining straps (4) and (27) with screws (1) and new locknuts (2).
17. Install new O-ring (31), elbow (30), and hose (29) on reservoir (17).
18. Install new O-ring (34), elbow (33), and tube (32) on reservoir (17).
19. Install front winch hydraulic control valve (WP 0218 00).
20. Install front winch AOAP valve (WP 0216 00).
21. Install front winch hydraulic vent valve (WP 0217 00).
22. Fill hydraulic oil reservoir to proper level (WP 0213 00).

FRONT WINCH HYDRAULIC OIL RESERVOIR MAINTENANCE (Contd)

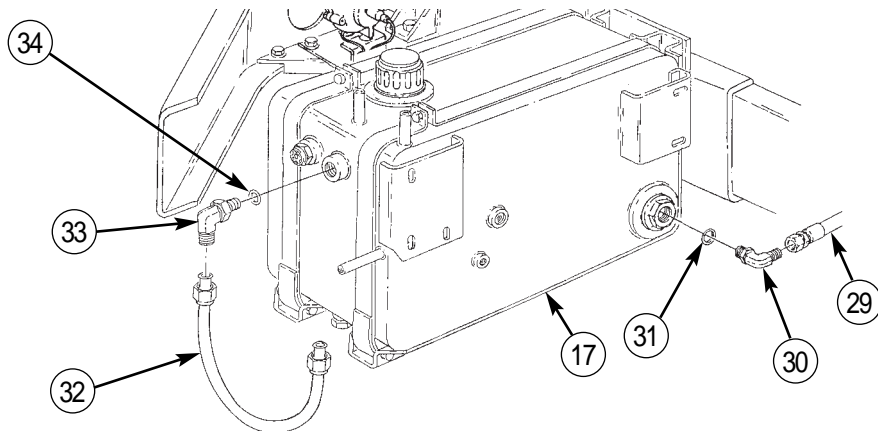
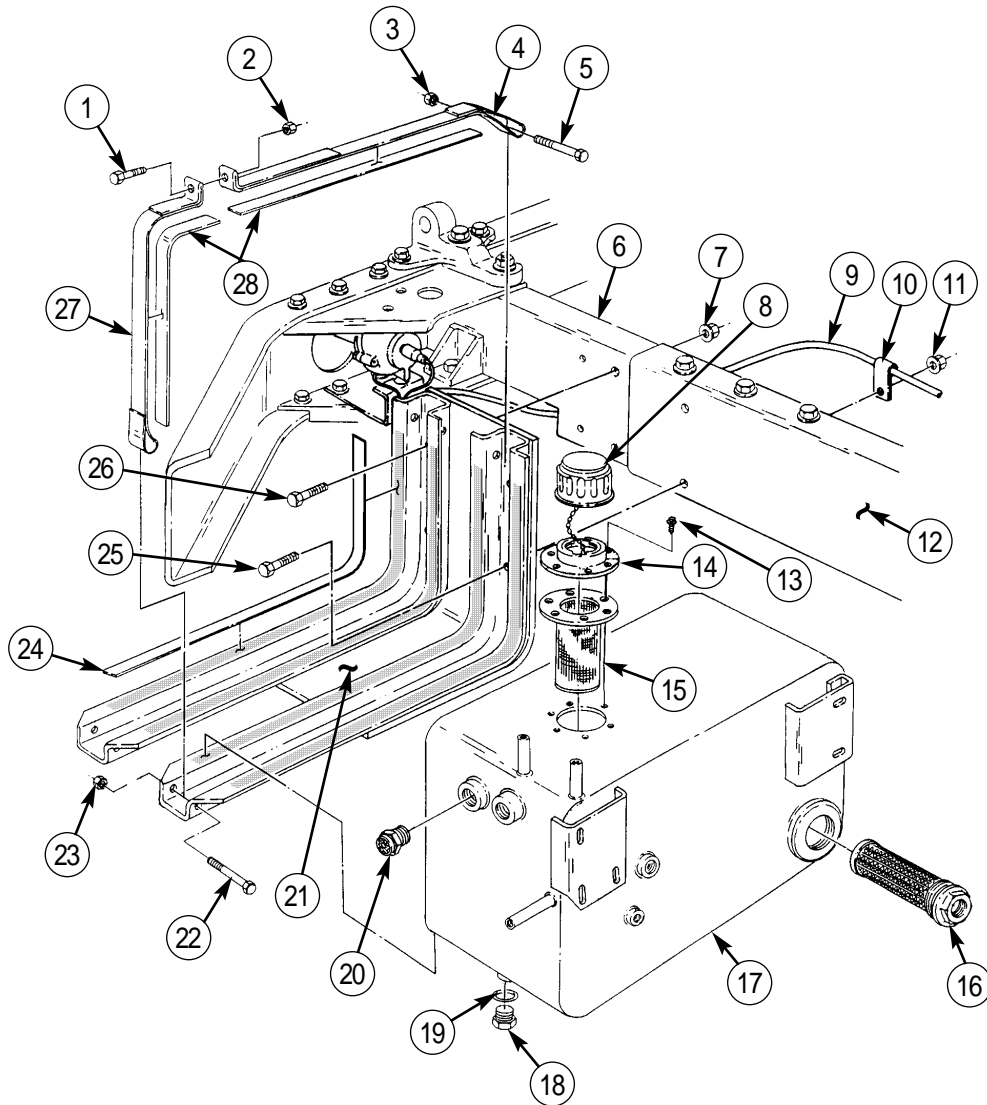

END OF WORK PACKAGE

UNIT MAINTENANCE INSTRUCTIONS

EXTENDED SERVICE PROGRAM (ESP)

TRUCK, CARGO, 2-1/2-TON, 6X6, M44A3 SERIES TRUCKS (DIESEL)

M35A3, W/WINCH (NSN 2320-01-383-3850);

M35A3C, W/WINCH (NSN 2320-01-383-2049);

M36A3, W/WINCH (NSN 2320-01-383-2046).

FRONT WINCH HYDRAULIC MOTOR MAINTENANCE

REMOVAL, INSPECTION, INSTALLATION

INITIAL SETUP:

Tools and Special Tools

General mechanic's tool kit
(item 30, WP 0394 00)

Materials/Parts

Two cotter pins (item 25, WP 0395 00)
Two lockwashers (item 62, WP 0395 00)
Four lockwashers (item 186, WP 0395 00)
Two O-rings (item 191, WP 0395 00)
Teflon pipe sealant (item 41, WP 0393 00)
Cap and plug set (item 14, WP 0393 00)
Woodruff key (item 172 WP 0395 00)

References

TM 9-2320-386-24P

Equipment Condition

Parking brake set (TM 9-2320-386-10).
Hydraulic oil reservoir drained (WP 0213 00).

FRONT WINCH HYDRAULIC MOTOR MAINTENANCE (Contd)

REMOVAL

CAUTION

Plug all openings immediately after disconnecting hoses and fittings to prevent dirt and dust from entering hydraulic system. Contamination of the hydraulic system may result in damage to equipment. Remove plugs before installation.

NOTE

Have drainage container ready to catch oil.
Tag hoses for installation.

1. Remove two hose connectors (14) from elbows (13).
2. Remove two screws (1), lockwashers (2), washers (3), and motor (16) from adapter housing (5). Discard lockwashers (2).
3. Remove woodruff key (17) from output shaft (4). Discard woodruff key (17).
4. Remove four screws (12), lockwashers (11), and adapter housing (5) from winch (8). Discard lockwashers (11).
5. Remove two cotter pins (6) from drive pin (7). Discard cotter pins (6).
6. Remove drive pin (7) and coupling (10) from front winch input shaft (9).
7. Remove two elbows (13) and O-rings (15) from motor (16). Discard O-rings (15).

INSPECTION

Check winch motor (16) for leaks, cracks in casting, and condition of internal threads. Replace if damaged.

INSTALLATION

1. Apply sealant to male threads of two elbows (13).
2. Install two new O-rings (15) and elbows (13) on motor (16).
3. Install coupling (10) on front winch input shaft (9) with drive pin (7) and two new cotter pins (6).
4. Install adapter housing (5) on winch (8) with four new lockwashers (11) and screws (12).
5. Install new woodruff key (17) on output shaft (4).
6. Align woodruff key (17) and output shaft (4) with keyway of coupling (10) and install motor (16) on adapter housing (5) with two new lockwashers (2), washers (3), and screws (1).
7. Install two hose connectors (14) on elbows (13).
8. Fill hydraulic oil reservoir to proper level (WP 0213 00).
9. Operate winch (TM 9-2320-386-10) and check for leaks.

FRONT WINCH HYDRAULIC MOTOR MAINTENANCE (Contd)

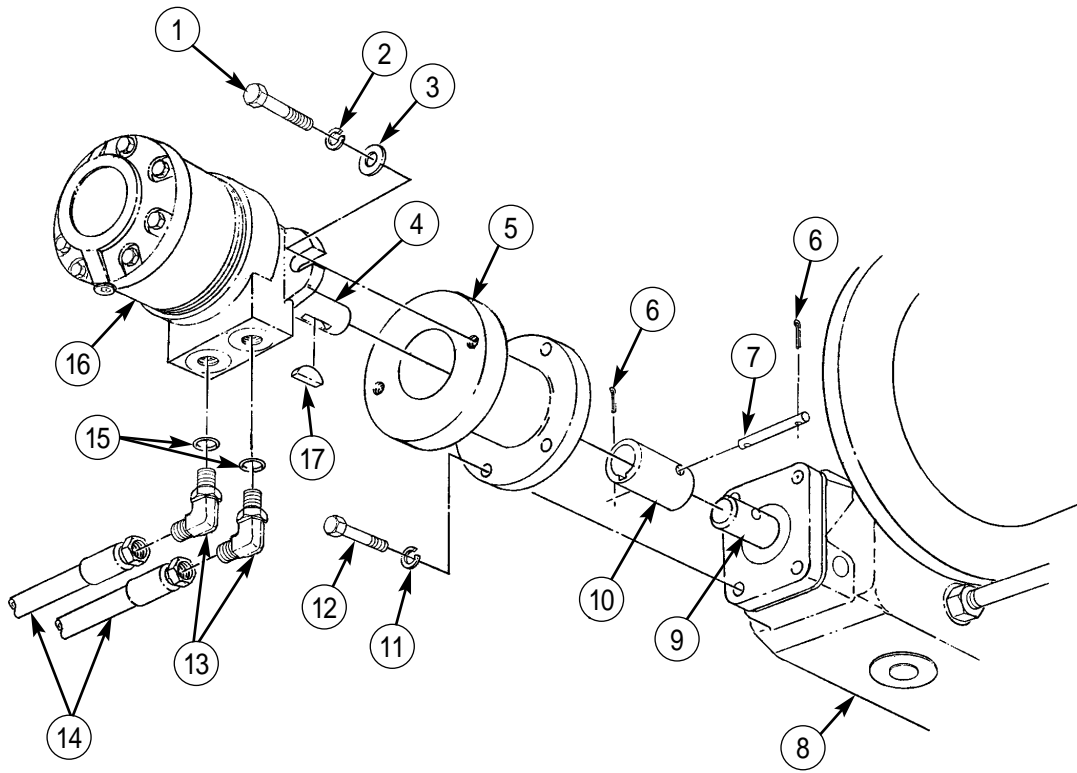

END OF WORK PACKAGE

UNIT MAINTENANCE INSTRUCTIONS

EXTENDED SERVICE PROGRAM (ESP)

TRUCK, CARGO, 2-1/2-TON, 6X6, M44A3 SERIES TRUCKS (DIESEL)

M35A3, W/WINCH (NSN 2320-01-383-3850);

M35A3C, W/WINCH (NSN 2320-01-383-2049);

M36A3, W/WINCH (NSN 2320-01-383-2046).

FRONT WINCH HYDRAULIC HOSES REPLACEMENT

REMOVAL, INSTALLATION

INITIAL SETUP:

Tools and Special Tools

General mechanic's tool kit
(item 30, WP 0394 00)

Common No. 1 tool kit
(item 15, WP 0394 00)

Materials/Parts

Two O-rings (item 189, WP 0395 00)
Locknut (item 338, WP 0395 00)
Locknut (item 345, WP 0395 00)
Cap and plug set (item 14, WP 0393 00)
Teflon pipe sealant (item 41, WP 0393 00)

References

TM 9-2320-386-24P

Equipment Condition

Parking brake set (TM 9-2320-386-10).
Hydraulic oil reservoir drained (WP 0213 00).

FRONT WINCH HYDRAULIC HOSES REPLACEMENT (Contd)**REMOVAL****CAUTION**

Plug all openings immediately after disconnecting hoses and fittings to prevent dirt and dust from entering hydraulic system. Contamination of the hydraulic system may result in damage to equipment. Remove plugs before installation.

NOTE

Have drainage container ready to catch oil.
Tag all hoses for installation.

1. Remove hose (7) from elbow (17).
2. Remove hose (5) from fitting (4).
3. Remove fitting (4) from elbow (3).
4. Remove elbow (3) and O-ring (2) from pump (1). Discard O-ring (2).
5. Remove elbow (17) and O-ring (18) from pump (1). Discard O-ring (18).
6. Remove hose (5) from elbow (13).
7. Remove hose (7) from elbow (14).
8. Remove locknut (9), screw (15), and mounting bracket (10) from crossmember (16). Discard locknut (9).
9. Remove locknut (12), screw (6), and clamps (8) and (11) from mounting bracket (10). Discard locknut (12).
10. Remove clamp (11) from hose (7).
11. Remove clamp (8) from hose (5).

INSTALLATION

1. Apply sealant to male threads of elbows (3), (13), (14) and (17), and fitting (4).
2. Install new O-ring (18) and elbow (17) on pump (1).
3. Install new O-ring (2) and elbow (3) on pump (1).
4. Install fitting (4) on elbow (3).
5. Install hose (5) on fitting (4).
6. Install hose (7) on elbow (17).
7. Route hoses (5) and (7) to elbows (13) and (14).
8. Install hose (5) on elbow (13).
9. Install hose (7) on elbow (14).
10. Install mounting bracket (10) on crossmember (16) with screw (15) and new locknut (9).
11. Position clamp (8) on hose (5).
12. Position clamp (11) on hose (7).
13. Install clamps (8) and (11) on mounting bracket (10) with screw (6) and new locknut (12).
14. Fill hydraulic oil reservoir to proper level (WP 0213 00).
15. Operate winch (TM 9-2320-386-10) and check for leaks.

FRONT WINCH HYDRAULIC HOSES REPLACEMENT (Contd)

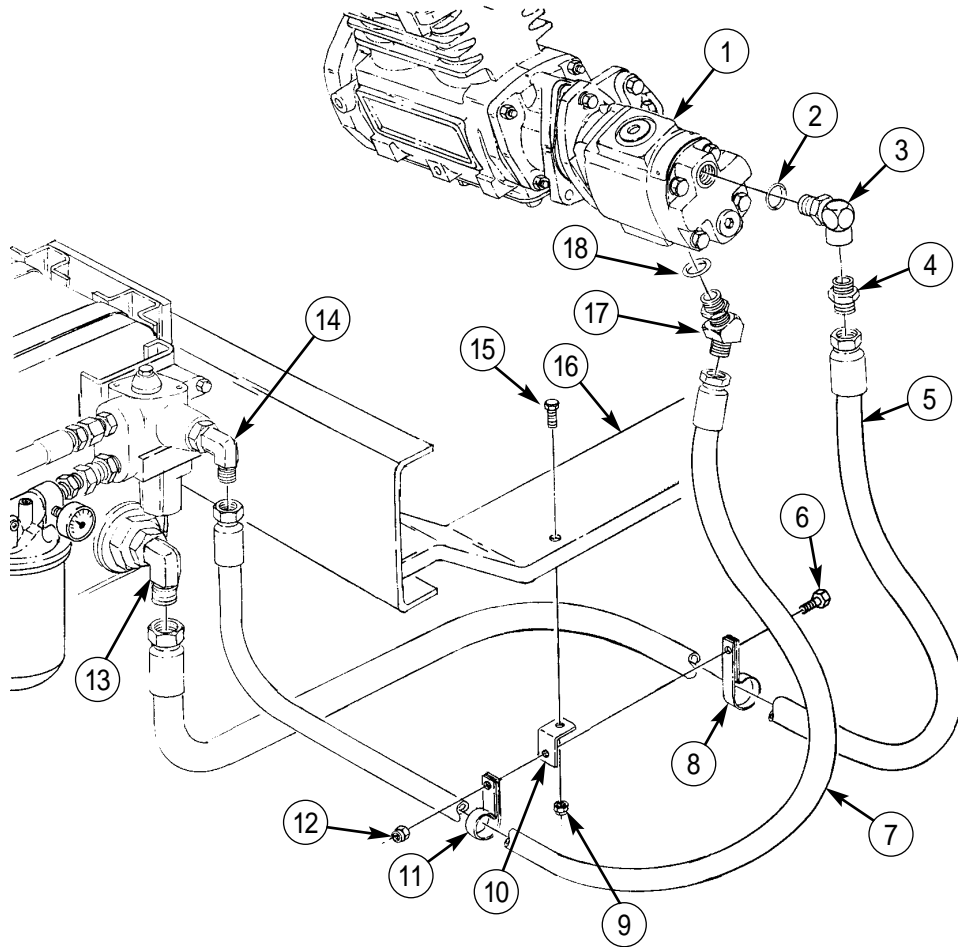

END OF WORK PACKAGE

UNIT MAINTENANCE INSTRUCTIONS

EXTENDED SERVICE PROGRAM (ESP)

TRUCK, CARGO, 2-1/2-TON, 6X6, M44A3 SERIES TRUCKS (DIESEL)

M35A3, W/WINCH (NSN 2320-01-383-3850);

M35A3C, W/WINCH (NSN 2320-01-383-2049);

M36A3, W/WINCH (NSN 2320-01-383-2046).

FRONT WINCH HYDRAULIC PUMP REPLACEMENT

REMOVAL, INSTALLATION

INITIAL SETUP:

Tools and Special Tools

General mechanic's tool kit
(item 30, WP 0394 00)

Common No. 1 tool kit
(item 15, WP 0394 00)

Materials/Parts

Two lockwashers (item 270, WP 0395 00)
Two O-rings (item 189, WP 0395 00)
Gasket (item 264, WP 0395 00)
Cap and plug set (item 14, WP 0393 00)
Teflon pipe sealant (item 41, WP 0393 00)

References

TM 9-2320-386-24P

Equipment Condition

Parking brake set (TM 9-2320-386-10).
Hood raised and secured (TM 9-2320-386-10).
Air reservoirs drained (TM 9-2320-386-10).
Hydraulic oil reservoir drained (WP 0213 00).
Remove air compressor governor (WP 0170 00).

FRONT WINCH HYDRAULIC PUMP REPLACEMENT (Contd)**REMOVAL****CAUTION**

Plug all openings immediately after disconnecting hoses and fittings to prevent dirt and dust from entering hydraulic system. Contamination of the hydraulic system may result damage to equipment. Remove plugs before installation.

1. Disconnect leads 25 and 26 (5) from air solenoid (6).

WARNING

Do not disconnect air lines before draining air reservoirs. Small parts under pressure may shoot out with high velocity, causing injury to personnel.

Eyeshields must be worn when releasing compressed air. Failure to do this may result in injury to personnel.

2. Disconnect air line (9) from elbow (4).
3. Remove two nuts (1), washers (2), screws (7), and air horns (8) from mounting bracket (3).

NOTE

Have drainage container ready to catch oil.

4. Remove hose connector (17) from fitting (16).
5. Remove hose connector (18) from elbow (19).
6. Remove fitting (16) from elbow (15).
7. Remove elbow (15) and O-ring (14) from pump (13). Discard O-ring (14).
8. Remove two screws (12), lockwashers (11), pump (13), and gasket (10) from air compressor (21). Discard lockwashers (11) and gasket (10).
9. Remove elbow (19) and O-ring (20) from pump (13). Discard O-ring (20).

FRONT WINCH HYDRAULIC PUMP REPLACEMENT (Contd)

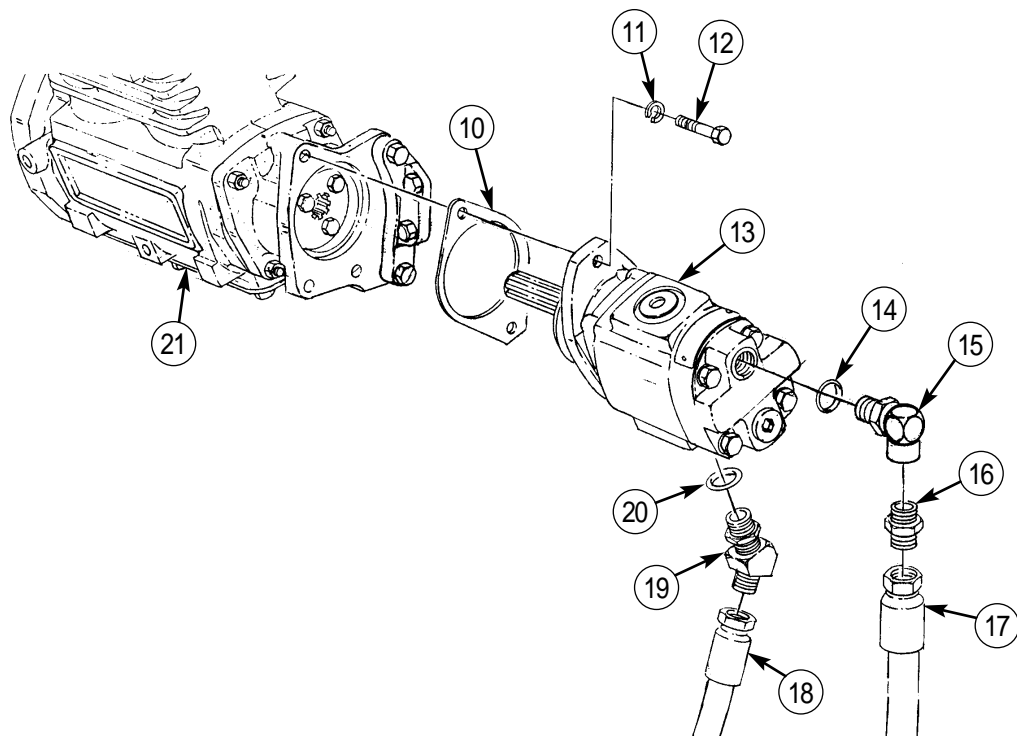
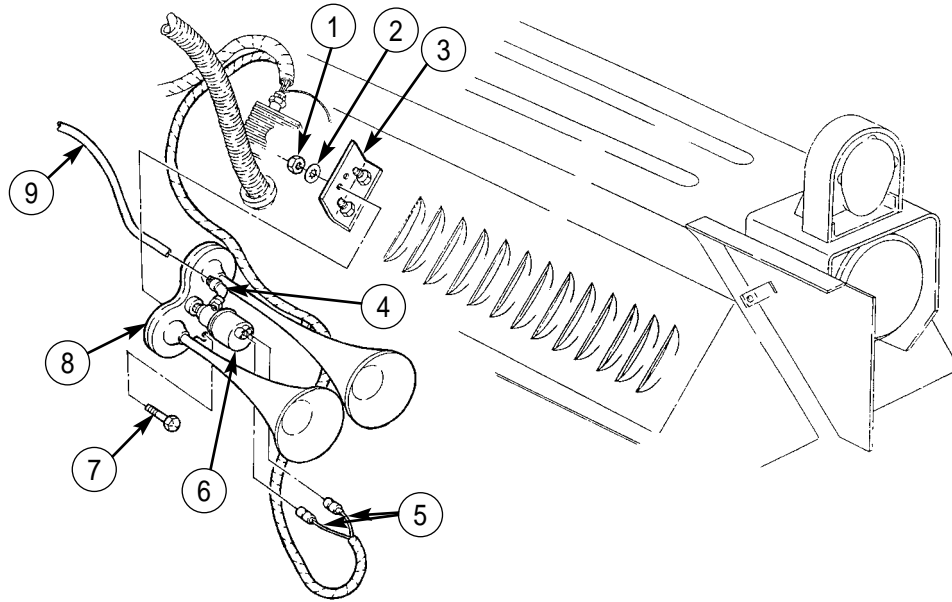

FRONT WINCH HYDRAULIC PUMP REPLACEMENT (Contd)**INSTALLATION**

1. Apply sealant to male threads of elbows (7) and (11) and fitting (8).
2. Install new O-ring (12) and elbow (11) on pump (5).
3. Install new O-ring (6) and elbow (7) on pump (5).
4. Install fitting (8) on elbow (7).
5. Install new gasket (2) and pump (5) on air compressor (1) with two new lockwashers (3) and screws (4).
6. Install hose connector (10) on elbow (11).
7. Install hose connector (9) on fitting (8).
8. Install air horns (20) on mounting bracket (15) with two screws (19), washers (14), and nuts (13).
9. Connect air line (21) to elbow (16).
10. Connect leads 25 and 26 (17) to air solenoid (18).
11. Install air compressor governor (WP 0170 00).
12. Fill hydraulic oil reservoir to proper level (WP 0213 00).

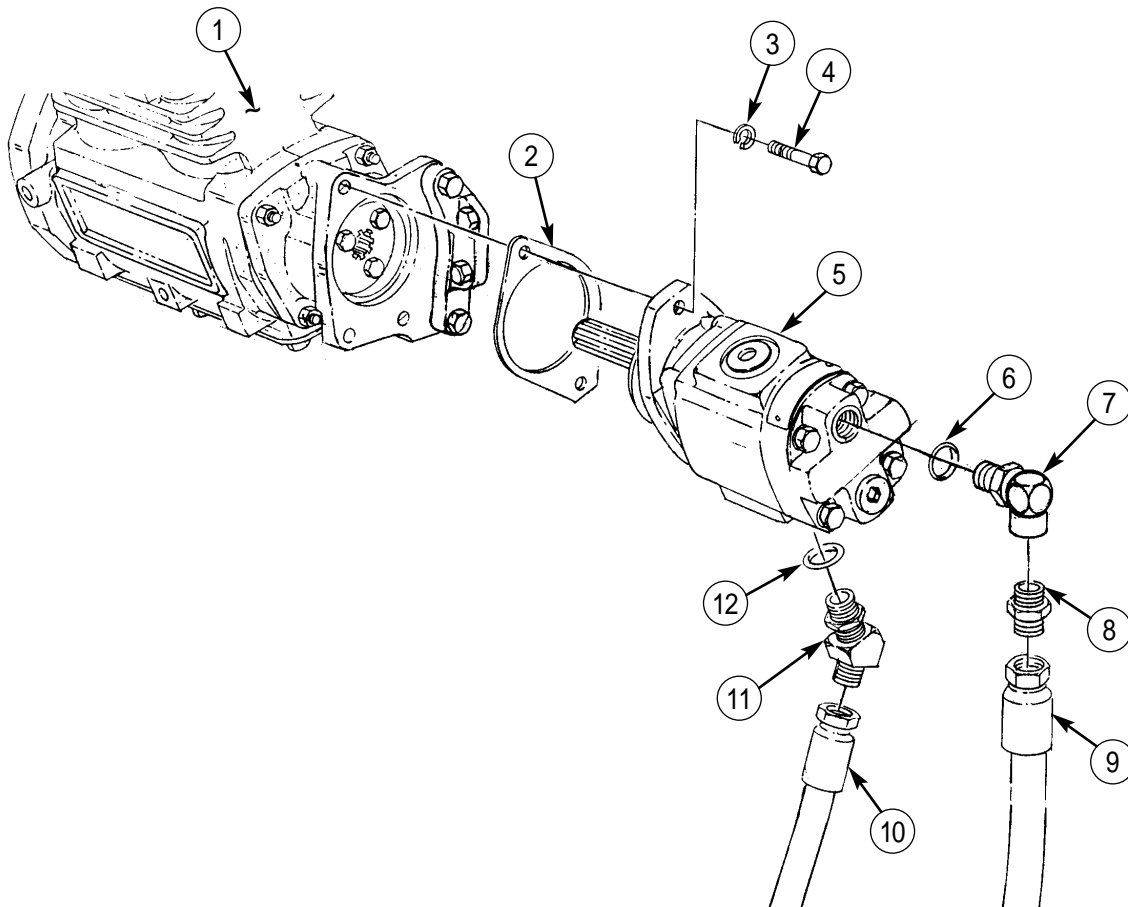

FRONT WINCH HYDRAULIC PUMP REPLACEMENT (Contd)

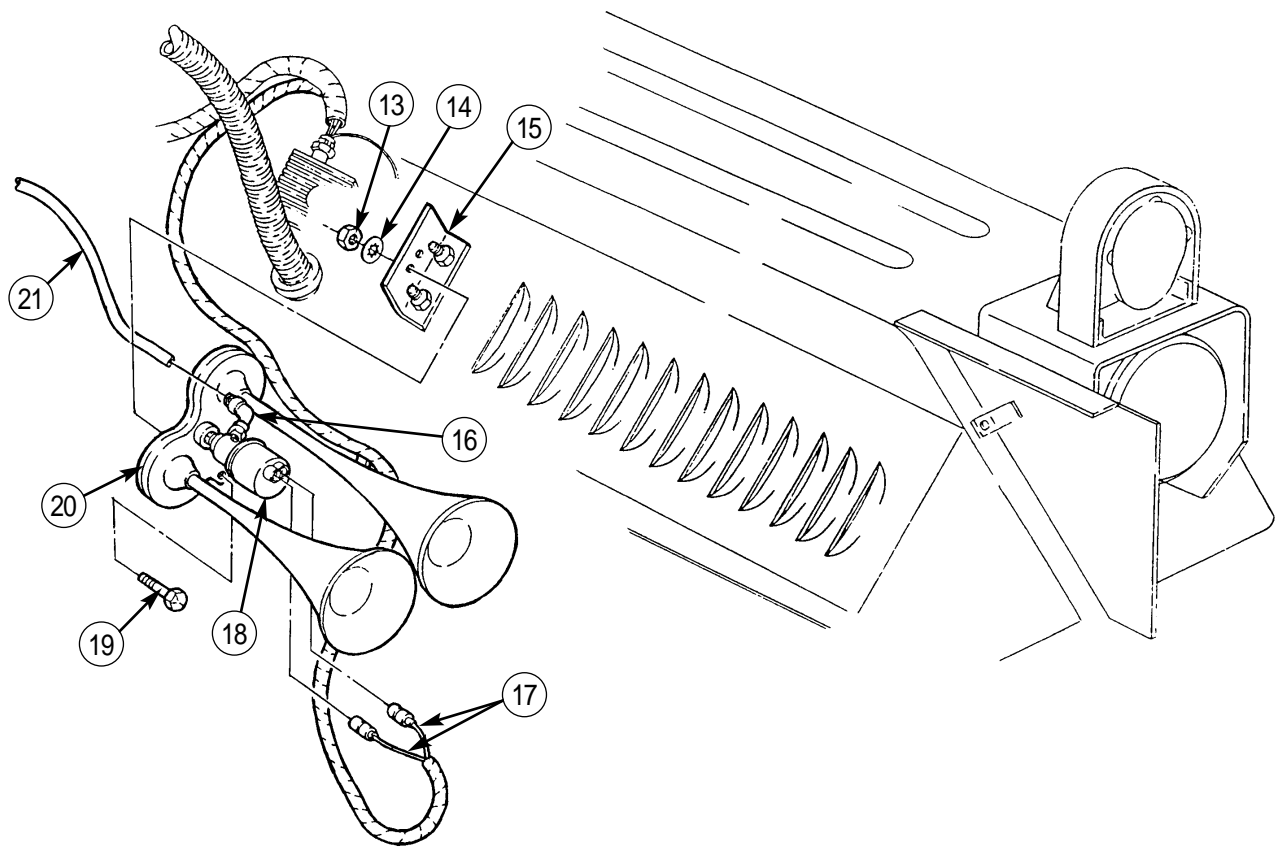

END OF WORK PACKAGE

UNIT MAINTENANCE INSTRUCTIONS

EXTENDED SERVICE PROGRAM (ESP)

TRUCK, CARGO, 2-1/2-TON, 6X6, M44A3 SERIES TRUCKS (DIESEL)

M35A3, W/WINCH (NSN 2320-01-383-3850);

M35A3C, W/WINCH (NSN 2320-01-383-2049);

M36A3, W/WINCH (NSN 2320-01-383-2046).

FRONT WINCH CONTROLS REPLACEMENT

REMOVAL, INSTALLATION

INITIAL SETUP:

Tools and Special Tools

General mechanic's tool kit
(item 30, WP 0394 00)

Materials/Parts

Four locknuts (item 246, WP 0395 00)
Lockwasher (item 45, WP 0395 00)
Teflon pipe sealant (item 41, WP 0393 00)
Cap and plug set (item 14, WP 0393 00)

References

TM 9-2320-386-24P

Equipment Condition

Parking brake set (TM 9-2320-386-10).
Air reservoirs drained (TM 9-2320-386-10).

FRONT WINCH CONTROLS REPLACEMENT (Contd)

REMOVAL

1. Remove six screws (1) and cover (2) from tower (6).

WARNING

Do not disconnect tubes before draining air reservoirs. Small parts under pressure may shoot out with high velocity, causing injury to personnel.

Eyeshields must be worn when releasing compressed air. Failure to do this may result in injury to personnel.

CAUTION

Plug all openings immediately after disconnecting tubes and fittings to prevent dirt and dust from entering compressed air system. Contamination of the compressed air system may result in damage to equipment. Remove plugs before installation.

NOTE

Tag hoses for installation.

2. Remove tube (12) from fitting (23).
3. Remove tube (14) from tee (15).
4. Remove fitting (23) from control (9).
5. Remove tee (15) from control (9).
6. Remove four locknuts (22), screws (10), and control (9) from tower (6). Discard locknuts (22).
7. Remove nut (8), lockwasher (7), and switch (4) from tower (6). Discard lockwasher (7).
8. Remove nut (17), sleeve (18), and tube (13) from elbow (19).
9. Remove nut (21), sleeve (20), and tube (11) from elbow (5).
10. Remove elbows (19) and (5) from switch (4).
11. Remove tube (16) from tee (15) and swivel elbow (3).
12. Remove swivel elbow (3) from switch (4).

INSTALLATION

1. Apply sealant to male threads of swivel elbow (3), elbows (5) and (19), fitting (23), and tee (15).
2. Install swivel elbow (3) on switch (4).
3. Install tube (16) on tee (15) and swivel elbow (3).
4. Install elbows (19) and (5) on switch (4).
5. Install sleeve (18), nut (17), and tube (13) on elbow (19).
6. Install sleeve (20), nut (21), and tube (11) on elbow (5).
7. Install switch (4) on tower (6) with new lockwasher (7) and nut (8).
8. Install control (9) on tower (6) with four screws (10) and new locknuts (22).
9. Install tee (15) on control (9).
10. Install fitting (23) on control (9).
11. Install tube (14) on tee (15).
12. Install tube (12) on fitting (23).
13. Install cover (2) on tower (6) with six screws (1).
14. Start engine (TM 9-2320-386-10) and check controls for proper operation.

FRONT WINCH CONTROLS REPLACEMENT (Contd)

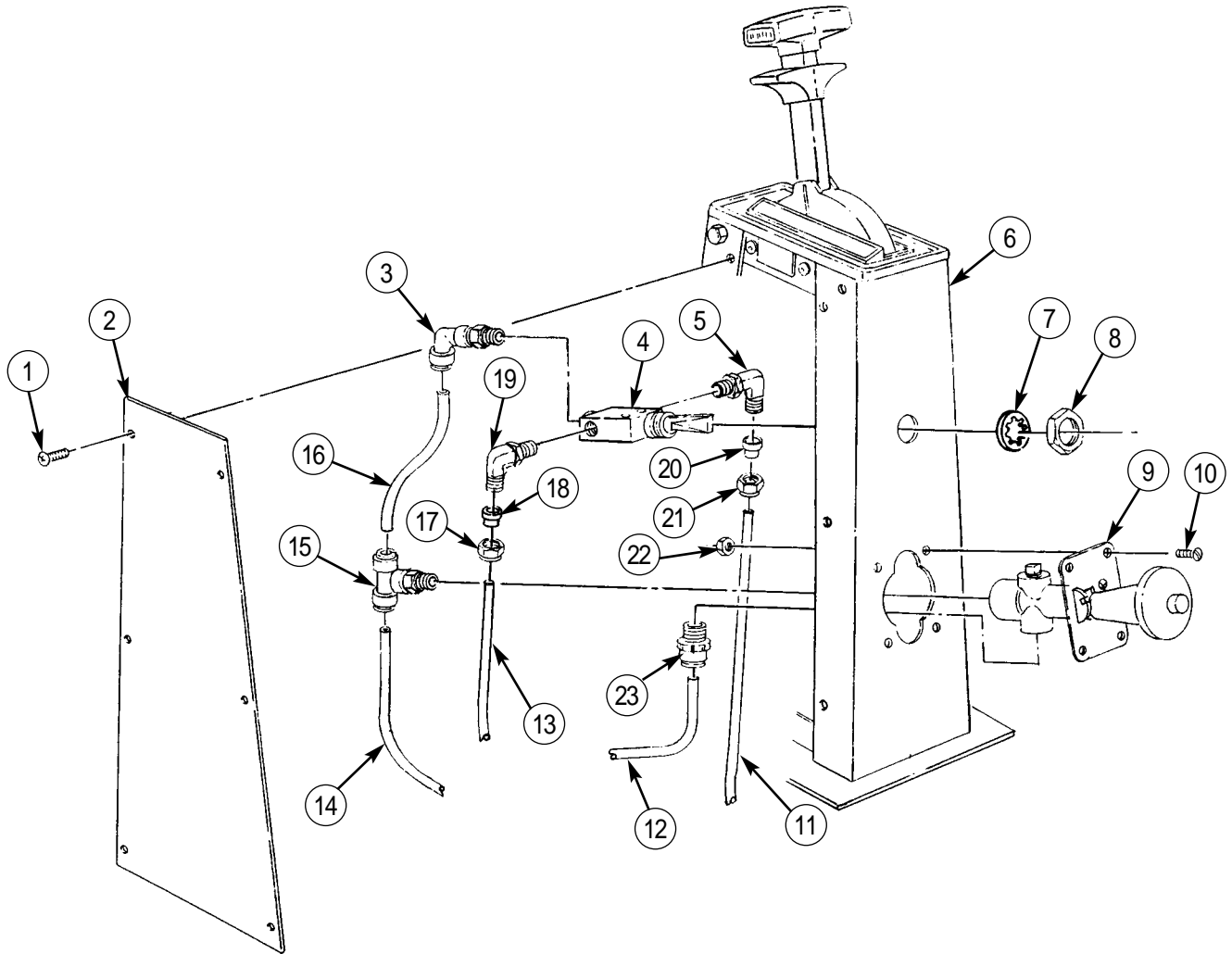

END OF WORK PACKAGE

UNIT MAINTENANCE INSTRUCTIONS

EXTENDED SERVICE PROGRAM (ESP)

TRUCK, CARGO, 2-1/2-TON, 6X6, M44A3 SERIES TRUCKS (DIESEL)

M35A3, W/WINCH (NSN 2320-01-383-3850);

M35A3C, W/WINCH (NSN 2320-01-383-2049);

M36A3, W/WINCH (NSN 2320-01-383-2046).

FRONT WINCH CABLE MAINTENANCE

REMOVAL, CLEANING AND INSPECTION, INSTALLATION

INITIAL SETUP:

Tools and Special Tools

General mechanic's tool kit
(item 30, WP 0394 00)

Personnel Required

Assistant (1)

Materials/Parts

Lubricating oil (item 32, WP 0393 00)
Wiping rags (item 35, WP 0393 00)

References

TM 9-2320-386-24P

Equipment Condition

Parking brake set (TM 9-2320-386-10).

WARNING

Wear leather gloves when handling cable. Do not let cable run through hands. Broken or rusty wires may cause injury to personnel.

Direct all personnel to stand clear of winch cable during winch operation. A snapped winch cable may result in injury to personnel.

Do not exceed 1500 rpm engine speed during winch operation. Use hand throttle to avoid erratic engine speed that could cause injury to personnel.

CAUTION

Do not proceed with front winch operation if oil level is low. Damage to internal components may result.

FRONT WINCH CABLE MAINTENANCE (Contd)**REMOVAL**

1. Place transmission gear shift lever (10) in NEUTRAL.
2. Pull out and rotate drum lock knob (8) clockwise a quarter turn, and release into shallow slot on nut (9).
3. Move winch clutch control lever (1) to OUT position (toward center of vehicle).

NOTE

If cable chain hook will not pass through lifting shackle, disassemble lifting shackle to remove cable chain hook.

4. Remove winch cable chain hook (5) from right lifting shackle (6), pass hook (5) through left lifting shackle (2), and pull winch cable (3) from drum (13).
5. Loosen setscrew (14) and remove front winch cable (3) from drum (13).
6. Remove nut (15), screw (17), and chain (16) from clevis (18).
7. Remove cap (20), winch cable (3), and plug (19) from clevis (18).
8. Remove plug (19) and cap (20) from winch cable (3).

CLEANING AND INSPECTION**WARNING**

Eye protection is required when using a wire brush for cleaning. Failure to do this may result in injury to personnel.

1. Soak winch cable (3) in lubricating oil (TM 9-2320-386-10). Clean winch cable (3) with wire brush.
2. Inspect cable (3) and parts for breaks and wear. Replace cable (3) and/or parts if broken or worn.
3. Lubricate winch drum (14) and winch cable (3) with lubricating oil (WP 0023 00).

INSTALLATION

1. Position cap (20) on winch cable (3) and install plug (19) on winch cable (3).

WARNING

Cable end must be properly assembled on clevis. Failure to do this may cause cable to separate resulting in injury to personnel.

NOTE

When properly assembled, cable end must be visible through inspection hole in clevis.

2. Install plug (19), winch cable (3), and cap (20) on clevis (18).
3. Install chain (16) on clevis (18) with screw (17) and nut (15).
4. Connect winch cable (3) to drum (13) and tighten setscrew (14).
5. Move winch clutch control lever (1) to IN position (toward passenger side of vehicle).
6. Start engine (TM 9-2320-386-10).
7. Place winch control valve lever (12) in ENGAGE position.
8. Hold winch control switch (11) in PAY IN position.

NOTE

Ensure first layer of winch cable goes onto drum in order and that each additional layer starts back across the drum. If necessary, use a wooden block to assist in cable alignment.

9. When winch cable (3) is fully wound on drum, release winch control switch (11) and place winch control valve lever (12) in DISENGAGE position.

NOTE

If cable chain hook will not pass through lifting shackle, disassemble lifting shackle to install cable chain hook.

FRONT WINCH CABLE MAINTENANCE (Contd)

10. Position cable chain (16) under front bumper (7), through left lifting shackle (2), across top of bumper (7), and attach hook (5) to right lifting shackle (6).
11. Move winch clutch control lever (1) to OUT position, toward center of vehicle to release drum.
12. Pull out and rotate drum lock knob (8) counterclockwise a quarter turn, and release drum lock knob (8) into deep slot on nut (9).
13. Rotate drum (13) until drum lock knob (8) plunger slips into nearest hole on drum flange (4).
14. Lubricate winch cable (WP 0023 00).

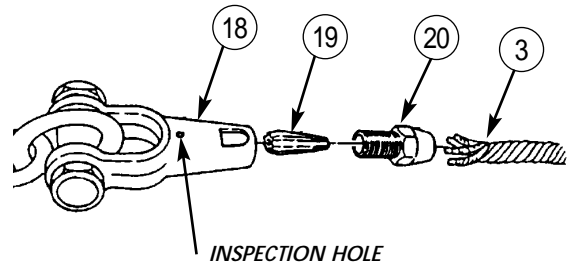
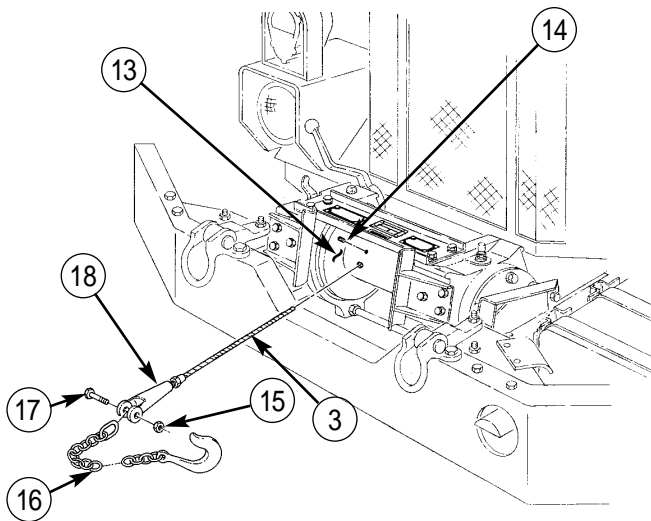
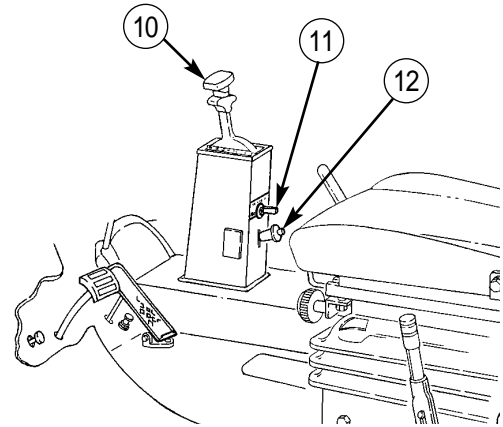
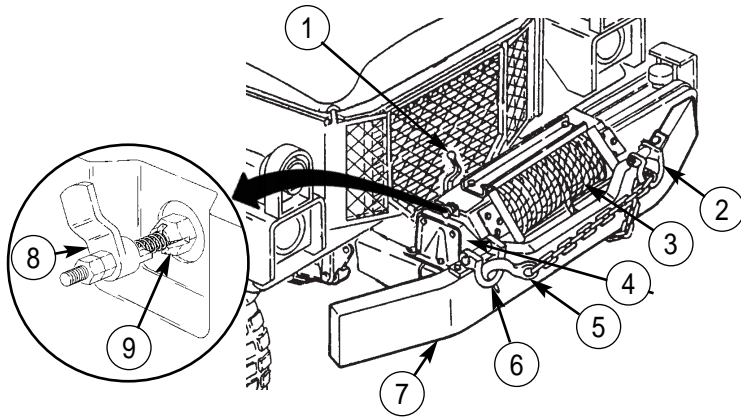

END OF WORK PACKAGE

UNIT MAINTENANCE INSTRUCTIONS

*EXTENDED SERVICE PROGRAM (ESP)
TRUCK, CARGO, 2-1/2-TON, 6X6, M44A3 SERIES TRUCKS (DIESEL)*

W/WINCH (NSN 2320-01-383-3850);

W/WINCH (NSN 2320-01-383-2049);

W/WINCH (NSN 2320-01-383-2046).

FRONT WINCH MAINTENANCE

*REMOVAL, INSTALLATION, DRAG BRAKE TESTING, DRAG BRAKE ADJUSTMENT,
AUTOMATIC WINCH BRAKE TESTING, AUTOMATIC WINCH BRAKE ADJUSTMENT*

INITIAL SETUP:

Tools and Special Tools

General mechanic's tool kit
(item 30, WP 0394 00)
Lifting device
Chain
Support devices

Materials/Parts

Six locknuts (item 107, WP 0395 00)
Four lockwashers (item 186, WP 0395 00)
Two lockwashers (item 62, WP 0395 00)
Two O-rings (item 191, WP 0395 00)
Six lockwashers (item 65, WP 0395 00)
Twelve lockwashers (item 64, WP 0395 00)
Two cotter pins (item 25, WP 0395 00)
Cap and plug set (item 14, WP 0393 00)
Woodruff key (item 172, WP 0395 00)

References

TM 9-2320-386-24P

Equipment Condition

Parking brake set (TM 9-2320-386-10).
Hydraulic oil reservoir drained (WP 0213 00).
Front winch cable removed (WP 0224 00).
Bumper removed (WP 0227 00).
Brushguard removed (WP 0230 00).

FRONT WINCH MAINTENANCE (Contd)**REMOVAL****CAUTION**

Plug all openings immediately after disconnecting hoses to prevent dirt and dust from entering hydraulic system. Contamination of the hydraulic system may result in damage to equipment. Remove plugs before installation.

NOTE

Tag all lines and hoses for installation.
Have drainage container ready to catch oil.

1. Remove two hose connectors (14) from elbows (13).
2. Remove two elbows (13) and O-rings (15) from hydraulic motor (16). Discard O-rings (15).
3. Install chains around winch (8) and on lifting device.
4. Remove six locknuts (26), screws (27), and two support brackets (21) from rail extensions (25). Discard locknuts (26).

WARNING

All personnel must stand clear during lifting operations. A snapped chain, shifting or swinging load may cause injury to personnel.

NOTE

Assistant will help with step 5.

5. Raise winch (8) from vehicle and lower winch (8) onto supporting devices.
6. Remove chains from winch (8) and lifting device.
7. Remove twelve screws (24), lockwashers (23), washers (22), and two support brackets (21) from winch (8). Discard lockwashers (23).
8. Remove six screws (18), lockwashers (19), and two cable guards (20) from winch (8). Discard lockwashers (19).
9. Remove two screws (1), lockwashers (2), washers (3), and hydraulic motor (16) from adapter housing (5). Discard lockwashers (2).
10. Remove woodruff key (17) from output shaft (4). Discard woodruff key (17).
11. Remove four screws (12), lockwashers (11), and adapter (5) from winch (8). Discard lockwashers (11).
12. Remove two cotter pins (6), drive pin (7), and coupling (10) from winch input shaft (9). Discard cotter pins (6).

FRONT WINCH MAINTENANCE (Contd)

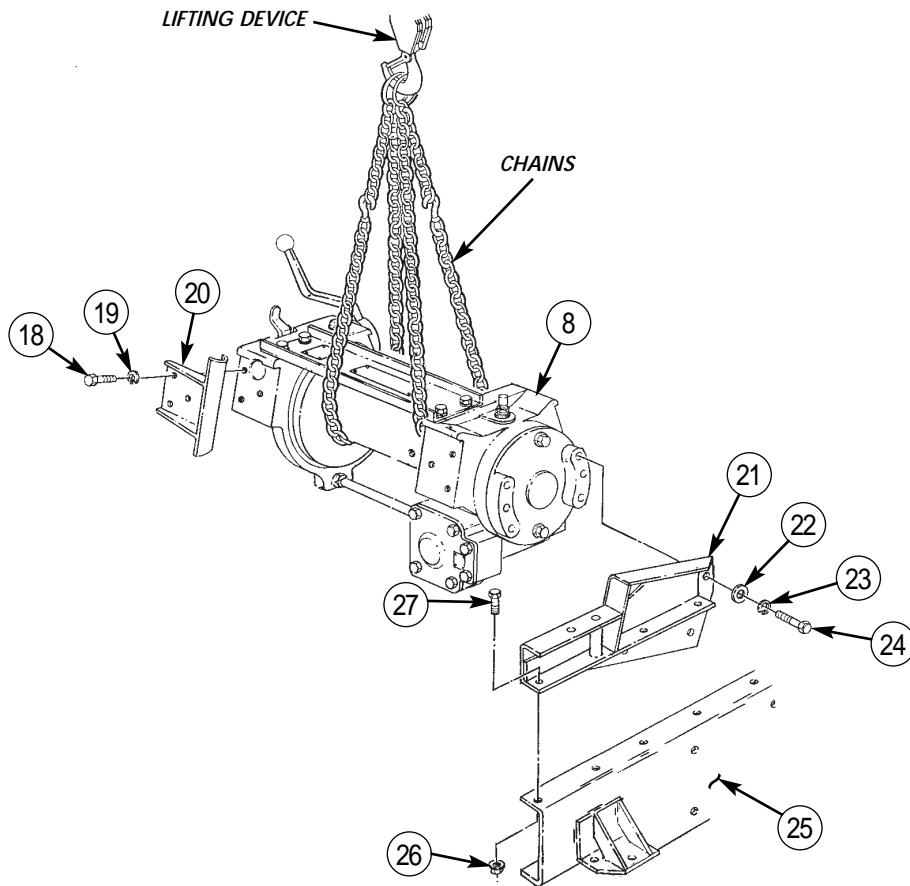
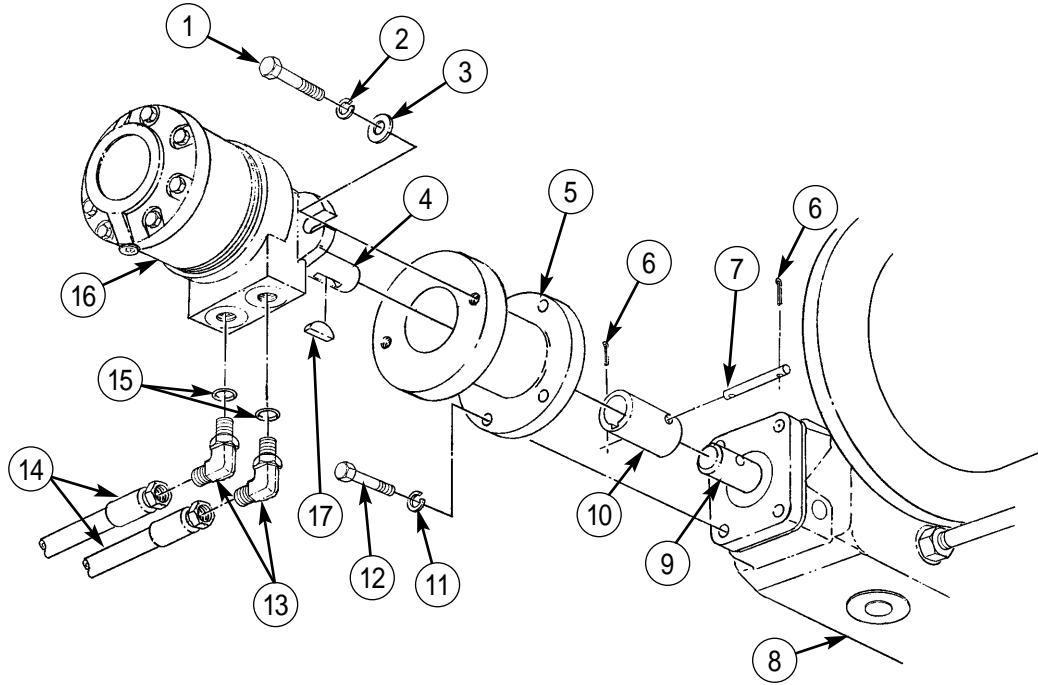

FRONT WINCH MAINTENANCE (Contd)**INSTALLATION**

1. Install coupling (20) on winch input shaft (19) with drive pin (18) and two new cotter pins (17).
2. Install adapter housing (16) on winch (4) with four new lockwashers (21) and screws (22).
3. Install new woodruff key (23) on output shaft (15) .
4. Align woodruff key (23) and output shaft (15) with keyway of coupling (20) and install hydraulic motor (27) on adapter housing (16) with two washers (14), new lockwashers (13), and screws (12).
5. Install two cable guards (3) on winch (4) with six new lockwashers (2) and screws (1).

NOTE

Six screws on left are longer than the six screws on right.

6. Install two support brackets (5) on winch (4) with twelve washers (6), new lockwashers (7), and screws (8).
7. Install chains around winch (4) and on lifting device.

WARNING

All personnel must stand clear during lifting operations. A snapped chain, shifting or swinging load may cause injury to personnel.

NOTE

Assistant will help with step 8.

8. Raise winch (4) from supporting device and position winch (4) on vehicle.
9. Install two support brackets (5) with winch (4) on rail extensions (9) with six screws (11) and new locknuts (10).
10. Remove chains from winch (4) and lifting devices.
11. Install two new O-rings (26) and elbows (24) on hydraulic motor (27).
12. Install two hose connectors (25) on elbows (24).
13. Install brushguard (WP 0230 00).
14. Install bumper (WP 0227 00).
15. Fill hydraulic oil reservoir to proper level (WP 0213 00) before continuing with maintenance operations.
16. Install front winch cable (WP 0224 00).

FRONT WINCH MAINTENANCE (Contd)

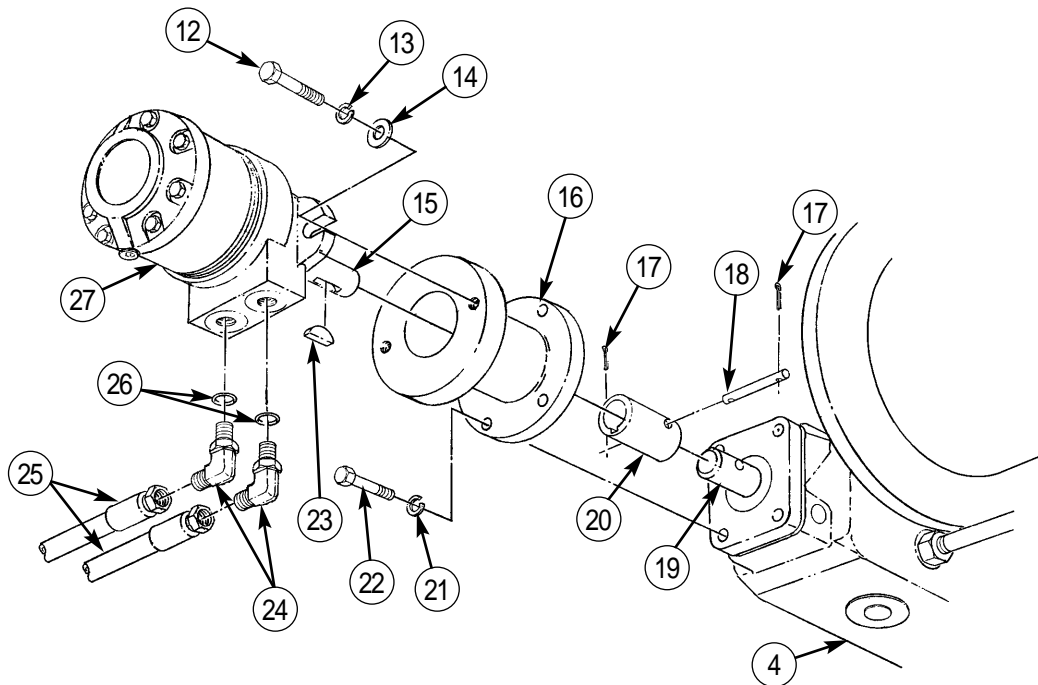
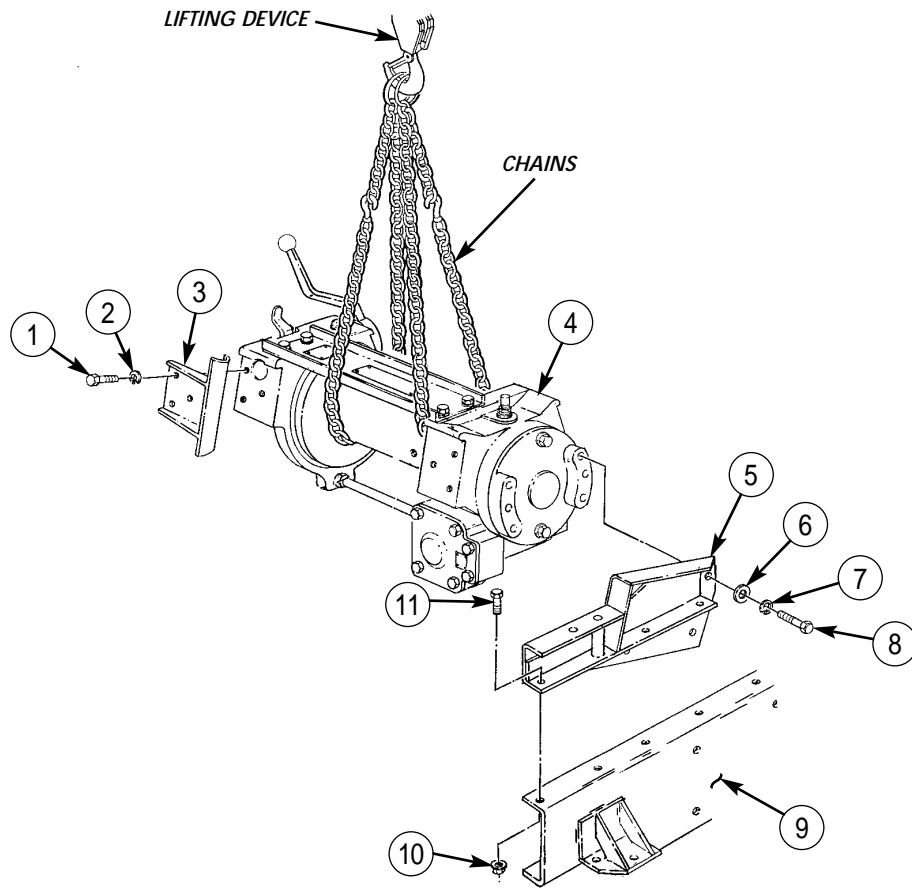

FRONT WINCH MAINTENANCE (Contd)**WARNING**

Wear leather gloves when handling winch cable. Do not let cable run through hands. Broken or rusty wires can cause injury to personnel.

DRAG BRAKE TESTING

1. Pull out and rotate drum lock knob (10) 1/4-turn clockwise, and release into shallow slot on nut (11).
2. Move winch clutch control lever (1) to OUT position (toward center of vehicle).

NOTE

If winch cable chain hook will not pass through lifting shackle, disassemble lifting shackle to remove cable chain hook.

3. Remove winch cable chain hook (6) from right lifting shackle (7), and pass hook (6) through left lifting shackle (2).
4. Pull winch cable (3) out three to four feet. Winch drum (5) should stop turning when cable (3) is released. If drum (5) does not stop turning, adjust drag brake.

DRAG BRAKE ADJUSTMENT**WARNING**

Do not exceed 1500 rpm engine speed during winch operation. Use hand throttle to avoid erratic engine speed that could cause injury to personnel.

CAUTION

Do not proceed with front winch operation if oil level is low. Damage to internal components may result.

NOTE

When performing step 1, adjusting screw is to be turned in 1/2-turn increments until proper drag adjustment is accomplished.

1. Turn adjustment screw (16) clockwise to increase drag.
2. Repeat drag test to make sure drag is adjusted correctly.

NOTE

When proper drag adjustment is accomplished, perform steps 3 through 8.

3. Move winch clutch control lever (1) to IN position (toward passenger side of vehicle).
4. Start engine (TM 9-2320-386-10).
5. Place transmission gear shift lever (12) in NEUTRAL and pull parking brake lever (15) up to apply parking brake.
6. Place winch control valve lever (14) to ENGAGE position.
7. Hold winch control switch (13) in PAY IN position.
8. When winch cable (3) is fully wound on drum (5), release winch control switch (13) and place winch control valve lever (14) in DISENGAGE position.

NOTE

If winch cable chain hook will not pass through lifting shackle, disassemble lifting shackle to install cable chain hook.

9. Position winch cable chain (4) under front bumper (9), through left lifting shackle (2), across top of bumper (9), and attach hook (6) to right lifting shackle (7).

FRONT WINCH MAINTENANCE (Contd)

10. Move winch clutch control lever (1) to OUT position (toward center of vehicle) to release drum (5).
11. Pull out and rotate drum lock knob (10) 1/4-turn counterclockwise, and release drum lock knob (10) into deep slot on nut (11).
12. Rotate drum (5) until plunger of drum lock knob (10) slips into nearest hole on drum flange (8).

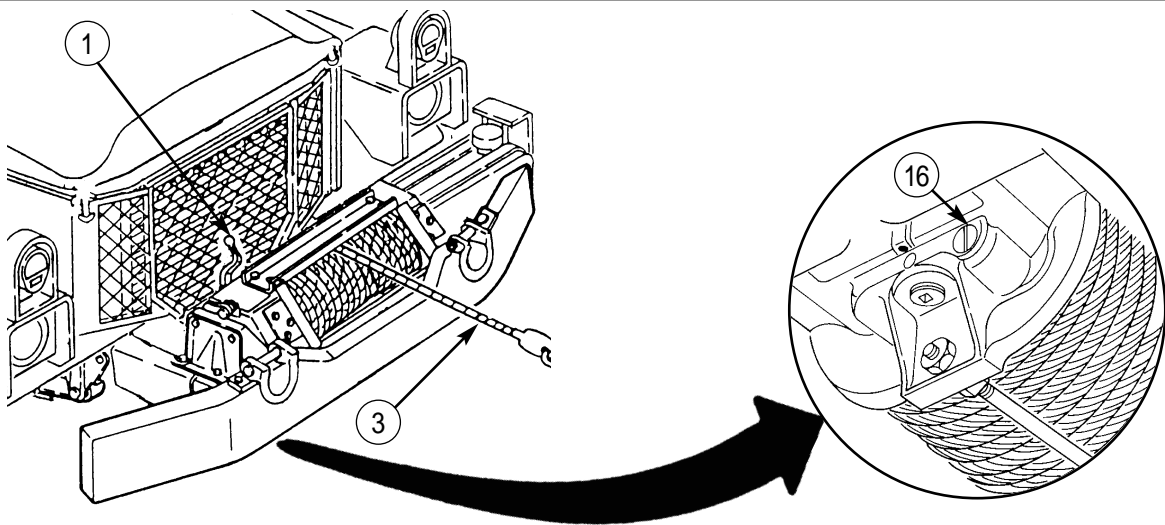
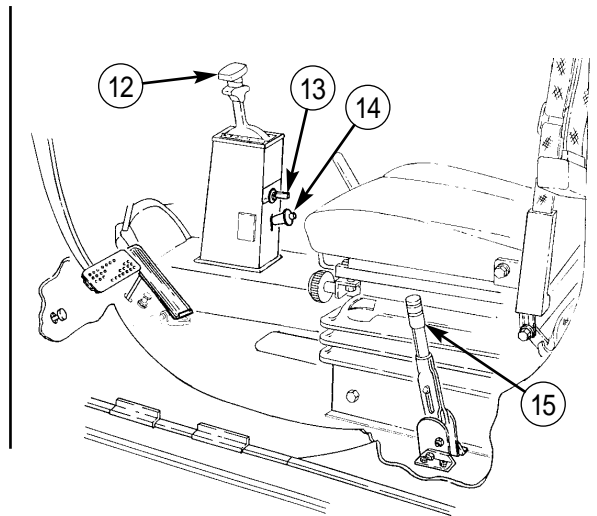
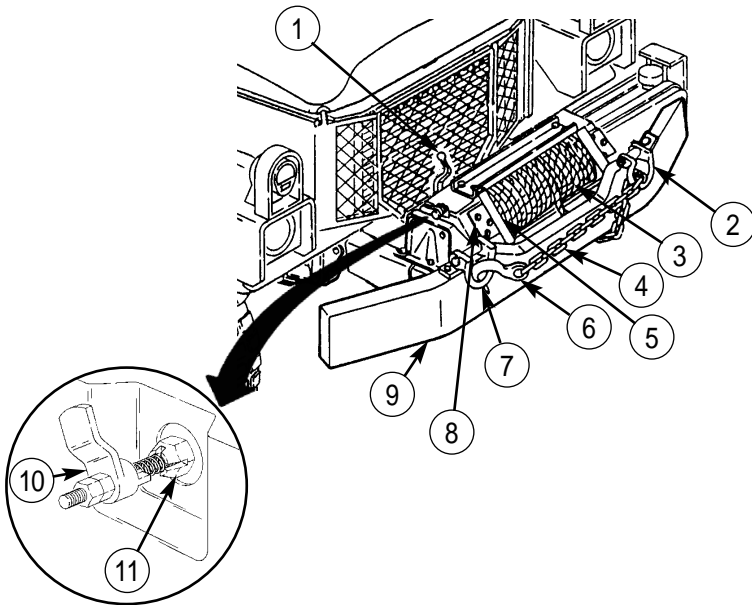

FRONT WINCH MAINTENANCE (Contd)**AUTOMATIC WINCH BRAKE TESTING****NOTE**

Assistant is needed to perform the following procedure.

1. Park test vehicle (1) at top of steep grade facing downhill, place gear shift lever (10) in NEUTRAL, pull parking brake lever (13) to apply parking brake, and chock wheels (TM 9-2320-386-10).

NOTE

Perform steps 2 and 3 only when new winch is installed in order to burnish brake and lubricate gears.

2. Pay out winch cable (2) for 5 minutes at engine idle (TM 9-2320-386-10).
3. Allow brake band to cool for approximately 1-1/2 hours.
4. Park secondary vehicle (3) at bottom of steep grade facing test vehicle (1).

WARNING

Wear leather gloves when handling cable. Do not let cable run through hands. Broken or rusty wires can cause injury to personnel.

Never stand between test vehicles during winch operations. Assistant must remain in secondary vehicle to engage service brake if cable snaps or automatic brake fails. Failure to do this may result in injury to personnel.

Direct all personnel to stand clear of winch cable during winch operation. A snapped winch cable may result in injury to personnel.

Do not exceed 1,500 rpm engine speed during winch operation. Use hand throttle to avoid erratic engine speed that could cause injury to personnel.

CAUTION

Do not proceed with front winch operation if oil level is low. Damage to internal components may result

Do not use front winch to pay out line loads greater than 3,000 lb (1,362 kg) for any distance greater than 10 ft (3.1 m). Damage to equipment may result.

5. Pull out and rotate drum lock knob (8) 1/4-turn clockwise, and release into shallow slot on nut (9).

NOTE

If winch cable chain hook will not pass through lifting shackle, disassemble lifting shackle to remove winch chain hook.

6. Remove winch cable chain hook (6) from right lifting shackle (7), and pass hook (6) through left lifting shackle (5).

WARNING

When hooking up for winching operations, position throat (open part) of hook upward in case overloading straightens out hook. Failure to do so may result in injury to personnel.

CAUTION

Refer to TM 9-2320-386-10 for safe working loads.

7. Move winch clutch control lever (4) to OUT position (toward center of vehicle). Unwind winch cable (2) and fasten winch cable (2) to secondary vehicle (3).
8. Place transmission lever of secondary vehicle (3) in NEUTRAL position, and disengage parking brake.
9. Move winch clutch control lever (4) of test vehicle (1) to IN position (toward passenger side of vehicle).

FRONT WINCH MAINTENANCE (Contd)

10. Start engine (TM 9-2320-386-10).
11. Place winch control valve lever (12) in ENGAGE position.
12. Hold winch control switch (11) in PAY IN position, and pull secondary vehicle (3) halfway up grade.
13. Release winch control switch (11).
14. Place winch control valve lever (12) in DISENGAGE position. If secondary vehicle (3) rolls back down grade, adjust automatic winch brake.
15. If secondary vehicle (3) does not roll back automatic winch is properly adjusted.

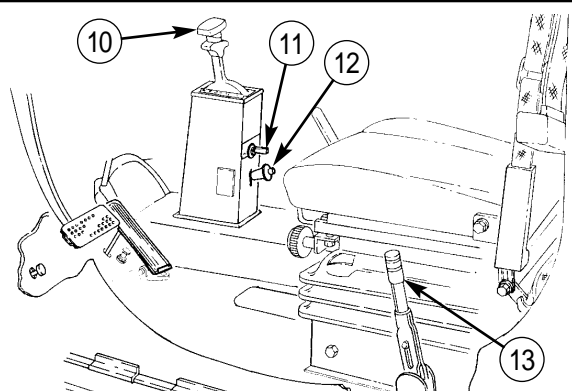
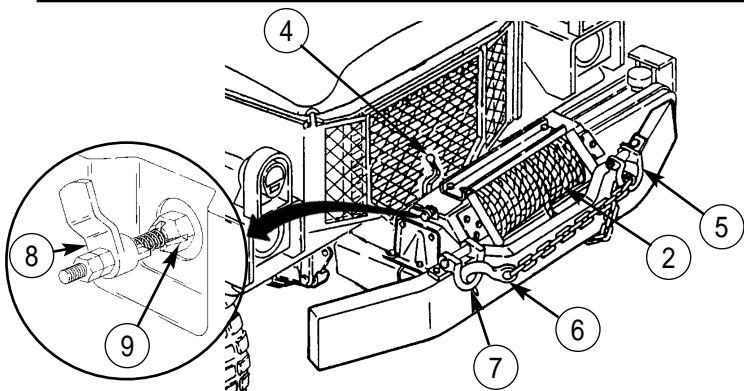
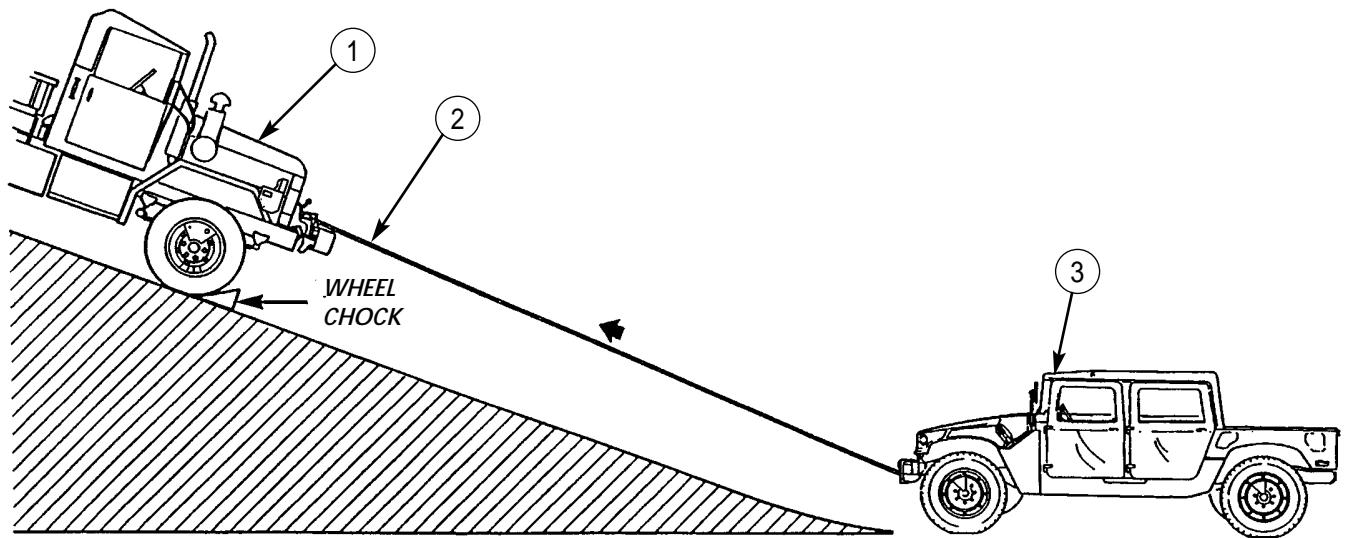

FRONT WINCH MAINTENANCE (Contd)**AUTOMATIC WINCH BRAKE ADJUSTMENT**

1. Place winch control valve lever (2) in ENGAGE position.
2. Hold winch control switch (1) in PAY OUT position, unwind secondary vehicle (6) back to level ground, and set parking brake.
3. Release winch control switch (1).
4. Place winch control valve lever (2) in DISENGAGE position.
5. Move winch clutch control lever (3) to OUT position (toward center of vehicle) to release drum (4).
6. Adjust brake band by turning adjusting screw (5) in 1/2-turn clockwise increments to increase braking action.
7. Repeat testing and adjustment until correct adjustment is obtained.
8. Store front winch cable on front winch drum (TM 9-2320-386-10).

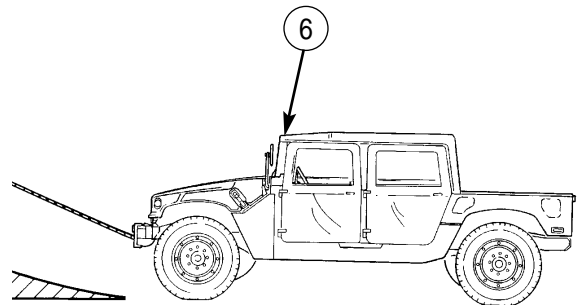
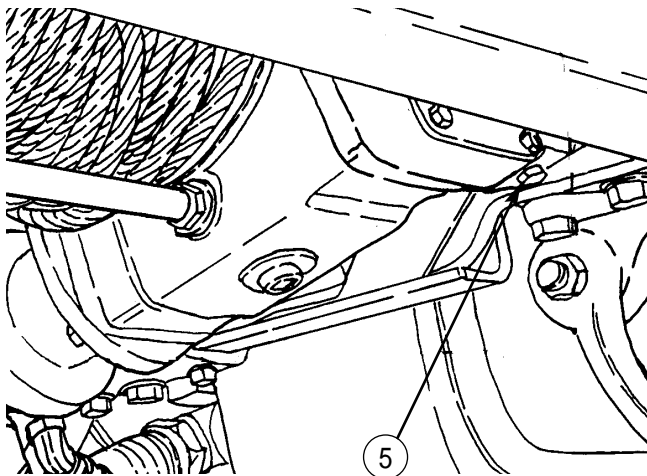
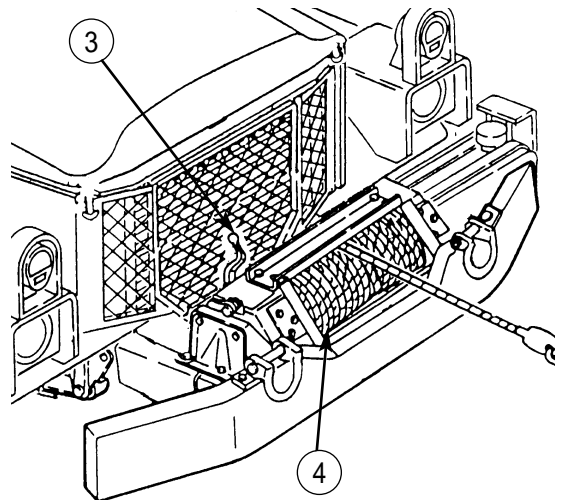
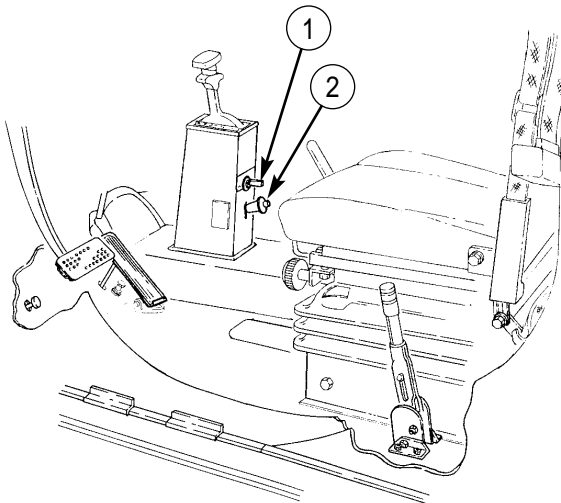
**END OF WORK PACKAGE**

UNIT MAINTENANCE INSTRUCTIONS

EXTENDED SERVICE PROGRAM (ESP)

TRUCK, CARGO, 2-1/2-TON, 6X6, M44A3 SERIES TRUCKS (DIESEL)

M35A3, W/O WINCH (NSN 2320-01-383-2047); W/WINCH (NSN 2320-01-383-3850);

M35A3C, W/O WINCH (NSN 2320-01-383-2050); W/WINCH (NSN 2320-01-383-2049);

M36A3, W/O WINCH (NSN 2320-01-383-2048); W/WINCH (NSN 2320-01-383-2046).

Section XX. BUMPER AND GUARDS MAINTENANCE

TABLE OF CONTENTS

<i>WP Title</i>	<i>WP Sequence No.-Page No.</i>
Front Bumper Replacement	0227 00-1
Rear Bumperette Replacement	0228 00-1
Brushguard Strut Rods and Mounting Brackets Replacement	0229 00-1
Brushguard Replacement	0230 00-1

END OF WORK PACKAGE

UNIT MAINTENANCE INSTRUCTIONS

EXTENDED SERVICE PROGRAM (ESP)

TRUCK, CARGO, 2-1/2-TON, 6X6, M44A3 SERIES TRUCKS (DIESEL)

M35A3, W/O WINCH (NSN 2320-01-383-2047); W/WINCH (NSN 2320-01-383-3850);
M35A3C, W/O WINCH (NSN 2320-01-383-2050); W/WINCH (NSN 2320-01-383-2049);
M36A3, W/O WINCH (NSN 2320-01-383-2048); W/WINCH (NSN 2320-01-383-2046).

FRONT BUMPER REPLACEMENT

REMOVAL, INSTALLATION

INITIAL SETUP:

Tools and Special Tools

General mechanic's tool kit
(item 30, WP 0394 00)

Materials/Parts

Two locknuts (item 84, WP 0395 00)
Ten locknuts (item 107, WP 0395 00)

References

TM 9-2320-386-24P

Equipment Condition

Parking brake set (TM 9-2320-386-10).
Front upper and lower shackles and brackets
removed (w/winch, WP 0189 00) or (w/o winch,
WP 0188 00).

FRONT BUMPER REPLACEMENT (Contd)**NOTE**

Left and right side of bumper is removed the same. This task covers the right side of bumper.

REMOVAL**NOTE**

Assistant will help with step 1.

1. Remove two locknuts (1), screws (4), and bumper (3) from frame (2). Discard locknuts (1).

NOTE

Mark bumper support brackets for installation.

2. Remove six locknuts (10), screws (5), and two upper bumper support brackets (9) from bumper (3). Discard locknuts (10).
3. Remove four locknuts (7), screws (6), and two lower bumper support brackets (8) from bumper (3). Discard locknuts (7).

INSTALLATION

1. Install two lower plates (8) on bumper (3) with four screws (6) and new locknuts (7).
2. Install two upper plates (9) on bumper (3) with six screws (5) and new locknuts (10).

NOTE

Assistant will help with step 3.

3. Install bumper (3) on frame (2) with two screws (4) and new locknuts (1).
4. Install front upper and lower shackles and brackets (w/winch, WP 0189 00) or (w/o winch, WP 0188 00).

FRONT BUMPER REPLACEMENT (Contd)

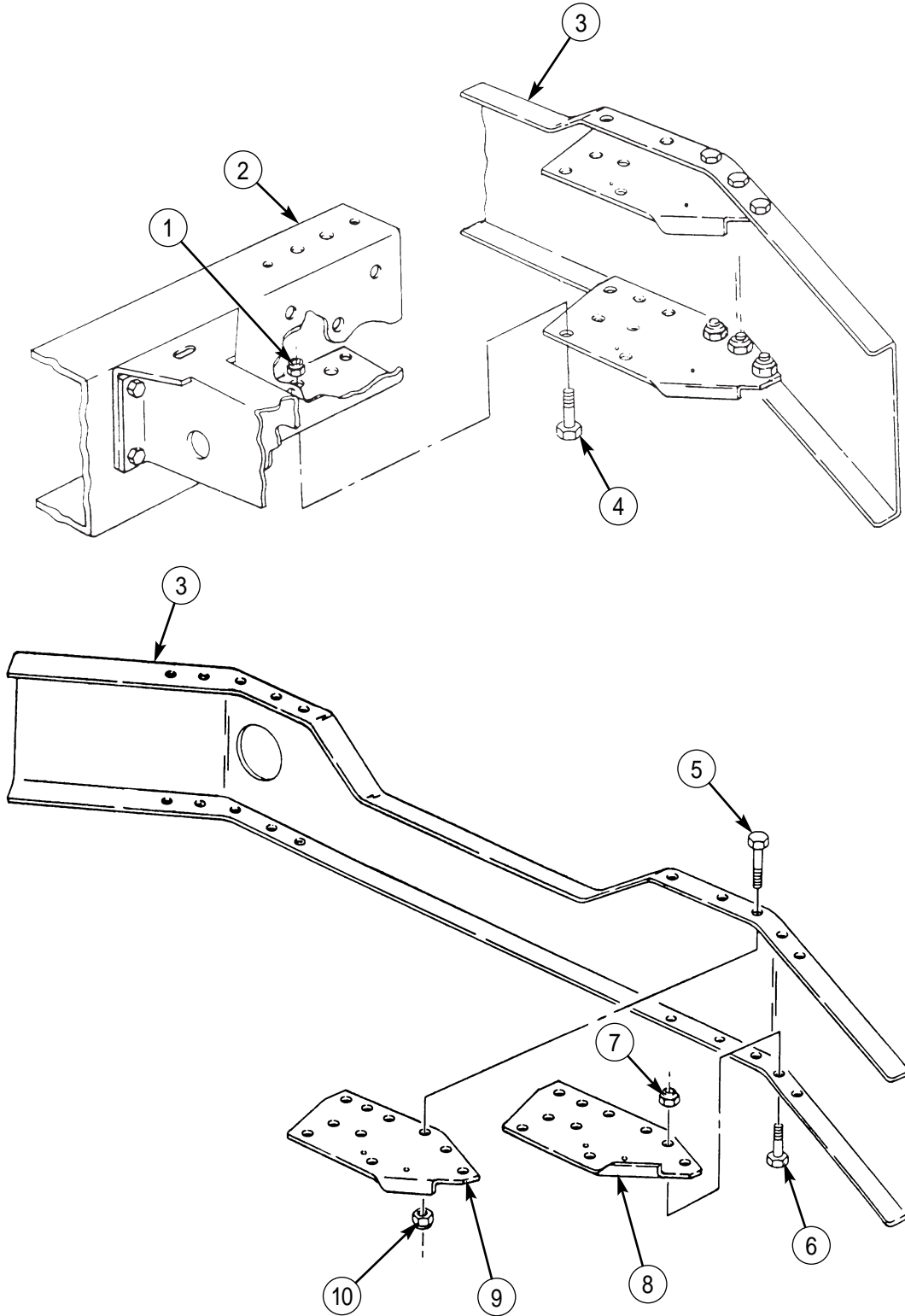

END OF WORK PACKAGE

UNIT MAINTENANCE INSTRUCTIONS

EXTENDED SERVICE PROGRAM (ESP)

TRUCK, CARGO, 2-1/2-TON, 6X6, M44A3 SERIES TRUCKS (DIESEL)

M35A3, W/O WINCH (NSN 2320-01-383-2047); W/WINCH (NSN 2320-01-383-3850);
M35A3C, W/O WINCH (NSN 2320-01-383-2050); W/WINCH (NSN 2320-01-383-2049);
M36A3, W/O WINCH (NSN 2320-01-383-2048); W/WINCH (NSN 2320-01-383-2046).

REAR BUMPERETTE REPLACEMENT

REMOVAL, INSTALLATION

INITIAL SETUP:

Tools and Special Tools

General mechanic's tool kit
(item 30, WP 0394 00)

Materials/Parts

Twelve locknuts (item 107, WP 0395 00)

References

TM 9-2320-386-24P

Equipment Condition

Parking brake set (TM 9-2320-386-10).
Rear composite light removed (WP 0106 00).
Trailer air coupling removed (WP 0164 00).

REAR BUMPERETTE REPLACEMENT (Contd)**NOTE**

Left and right rear bumperettes are replaced the same way. This task covers the left rear bumperette.

REMOVAL

1. Remove two locknuts (2) and screws (4) from crossmember (3) and rear bumperette (5). Discard locknuts (2).

NOTE

Wiring harness clamp is located on left side only.

2. Remove four locknuts (1), screws (7), composite light bracket (6), clamp (9), and rear bumperette (5) from frame (8). Discard locknuts (1).

INSTALLATION

1. Install rear bumperette (5) on rear crossmember (3) with two screws (4) and new locknuts (2).

NOTE

Wiring harness clamp is located on left side only.

2. Install composite light bracket (6) and clamp (9) on bumperette (5) and frame (8) with four screws (7) and new locknuts (1).
3. Install trailer air coupling (WP 0164 00).
4. Install rear composite light (WP 0106 00).

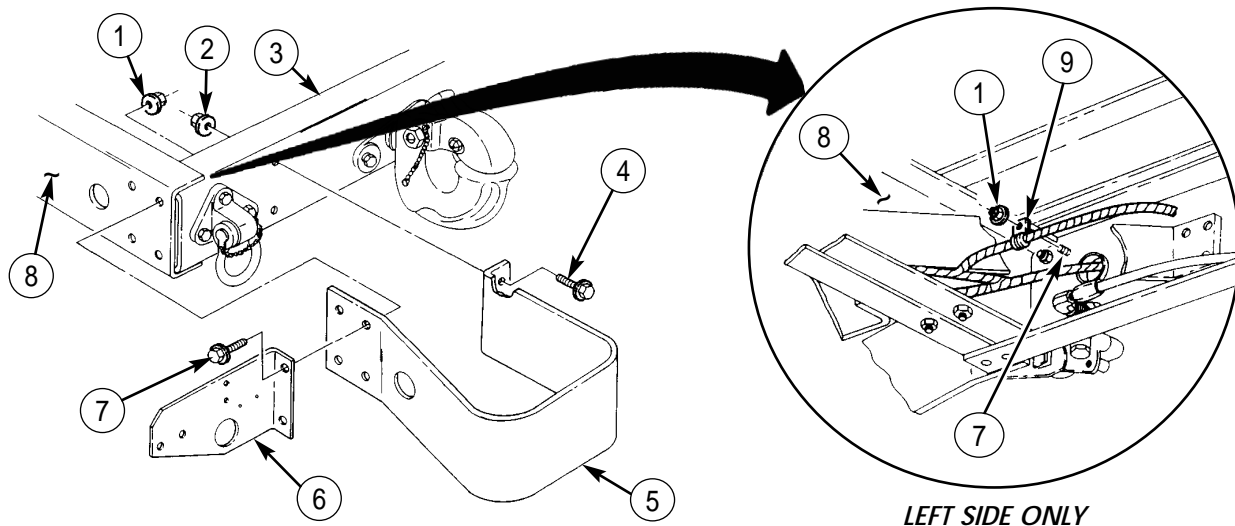

END OF WORK PACKAGE

UNIT MAINTENANCE INSTRUCTIONS

EXTENDED SERVICE PROGRAM (ESP)

TRUCK, CARGO, 2-1/2-TON, 6X6, M44A3 SERIES TRUCKS (DIESEL)

M35A3, W/O WINCH (NSN 2320-01-383-2047); W/WINCH (NSN 2320-01-383-3850);
M35A3C, W/O WINCH (NSN 2320-01-383-2050); W/WINCH (NSN 2320-01-383-2049);
M36A3, W/O WINCH (NSN 2320-01-383-2048); W/WINCH (NSN 2320-01-383-2046).

BRUSHGUARD STRUT RODS AND MOUNTING BRACKETS REPLACEMENT

REMOVAL, INSTALLATION

INITIAL SETUP:

Tools and Special Tools

General mechanic's tool kit
(item 30 WP 0394 00)

Materials/Parts

Two cotter pins (item 26, WP 0395 00)
Locknut (item 338, WP 0395 00)

References

TM 9-2320-386-24P

Equipment Condition

Parking brake set (TM 9-2320-386-10).
Hood raised and secured (TM 9-2320-386-10).

BRUSHGUARD STRUT RODS AND MOUNTING BRACKETS REPLACEMENT (Contd)**NOTE**

Right and left brushguard strut rods and mounting brackets are replaced the same. This task covers the left brushguard strut rod.

REMOVAL

1. Remove two cotter pins (6), retaining pins (2), and strut rod (3) from mounting bracket (5) and brushguard (1). Discard cotter pins (6).
2. Remove clevis (4) from strut rod (3).
3. Remove locknut (9), screw (7), and mounting bracket (5) from fender (8). Discard locknut (9).

INSTALLATION

1. Install mounting bracket (5) on fender (8) with screw (7) and new locknut (9).
2. Install clevis (4) on strut rod (3).

NOTE

Length of strut rod and angle of clevis can be adjusted by turning strut rod clevis clockwise or counterclockwise.

3. Install strut rod (3) on brushguard (1) and mounting bracket (5) with two retaining pins (2) and new cotter pins (6).

BRUSHGUARD STRUT RODS AND MOUNTING BRACKETS REPLACEMENT (Contd)

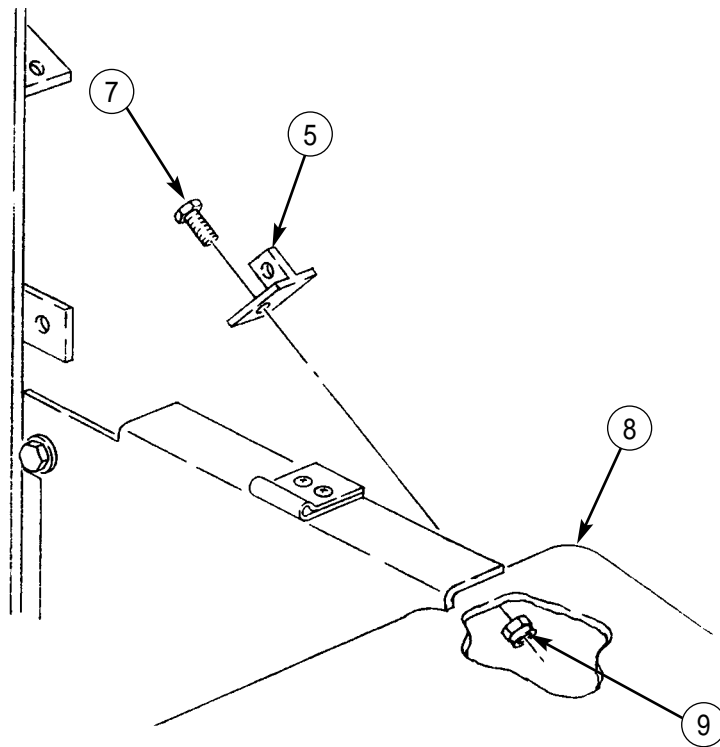
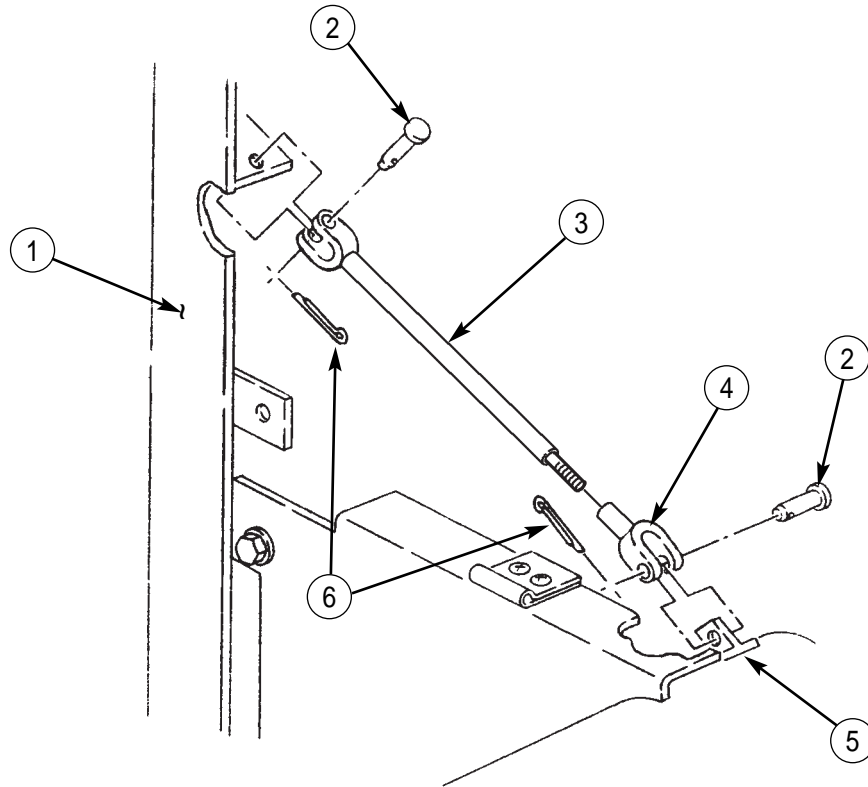

END OF WORK PACKAGE

UNIT MAINTENANCE INSTRUCTIONS

EXTENDED SERVICE PROGRAM (ESP)

TRUCK, CARGO, 2-1/2-TON, 6X6, M44A3 SERIES TRUCKS (DIESEL)

M35A3, W/O WINCH (NSN 2320-01-383-2047); W/WINCH (NSN 2320-01-383-3850);
M35A3C, W/O WINCH (NSN 2320-01-383-2050); W/WINCH (NSN 2320-01-383-2049);
M36A3, W/O WINCH (NSN 2320-01-383-2048); W/WINCH (NSN 2320-01-383-2046).

BRUSHGUARD REPLACEMENT

REMOVAL, INSTALLATION

INITIAL SETUP:

Tools and Special Tools

General mechanic's tool kit
(item 30, WP 0394 00)

Materials/Parts

Two cotter pins (item 26, WP 0395 00)
Four lockwashers (item 50, WP 0395 00)
Two lockwashers (item 186, WP 0395 00)
Four locknuts (item 175, WP 0395 00)
Four locknuts (item 86, WP 0395 00)
Eight rivets (item 155, WP 0395 00)
Cap and plug set (item 14, WP 0393 00)

References

TM 9-2320-386-24P

Equipment Condition

Parking brake set (TM 9-2320-386-10).
Hood raised and secured (TM 9-2320-386-10).
Quick-start mounting brackets removed (for vehicles
built after serial No. 504923 only) (WP 0061 00).

BRUSHGUARD REPLACEMENT (Contd)**REMOVAL**

1. Unlock two side panels (5), open and slide panels (5) forward while depressing catch on front hinges (7). Remove panels (5) from hinges (7).
2. Remove four screws (12), lockwashers (11), and washers (10) from brushguard (1) and two lower side panels (13). Discard lockwashers (11).
3. Remove four locknuts (9), washers (8), screws (4), and two lower side panels (13) from fenders (6). Discard locknuts (9).
4. Remove two cotter pins (14), retaining pins (2), and disconnect two strut rods (3) from brushguard (1). Discard cotter pins (14).
5. Remove two nuts (18), lockwashers (19), washers (20), and brushguard (1) from two studs (21). Discard lockwashers (19).

CAUTION

When disconnecting lines and hoses, plug all openings to prevent dirt from entering and causing damage to internal parts. Remove all plugs prior to installation.

NOTE

Brushguard may require lifting and tilting prior to disconnecting of auxiliary oil cooler lines.

6. Remove oil line (22) from elbow (27) on radiator (26), and oil filter line (25) from elbow (24) on auxiliary oil cooler (23).
7. Remove four locknuts (15), screws (16), and two baffles (17) from brushguard (1). Discard locknuts (15).
8. Remove brushguard (1) from vehicle.
9. Remove four screws (32), washers (31), and auxiliary oil cooler (23) with four rubber mounts (30) from brushguard (1).
10. Remove eight rivets (29) and two bumpers (28) from brushguard (1). Discard rivets (29).

BRUSHGUARD REPLACEMENT (Contd)

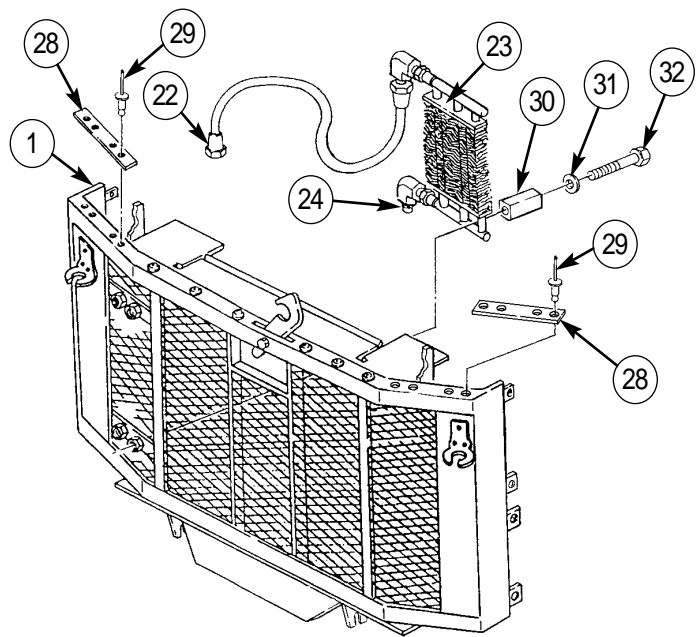
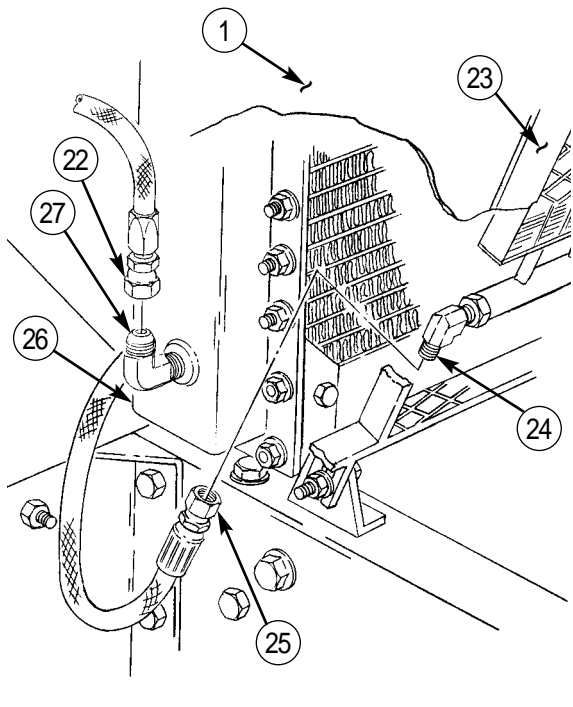
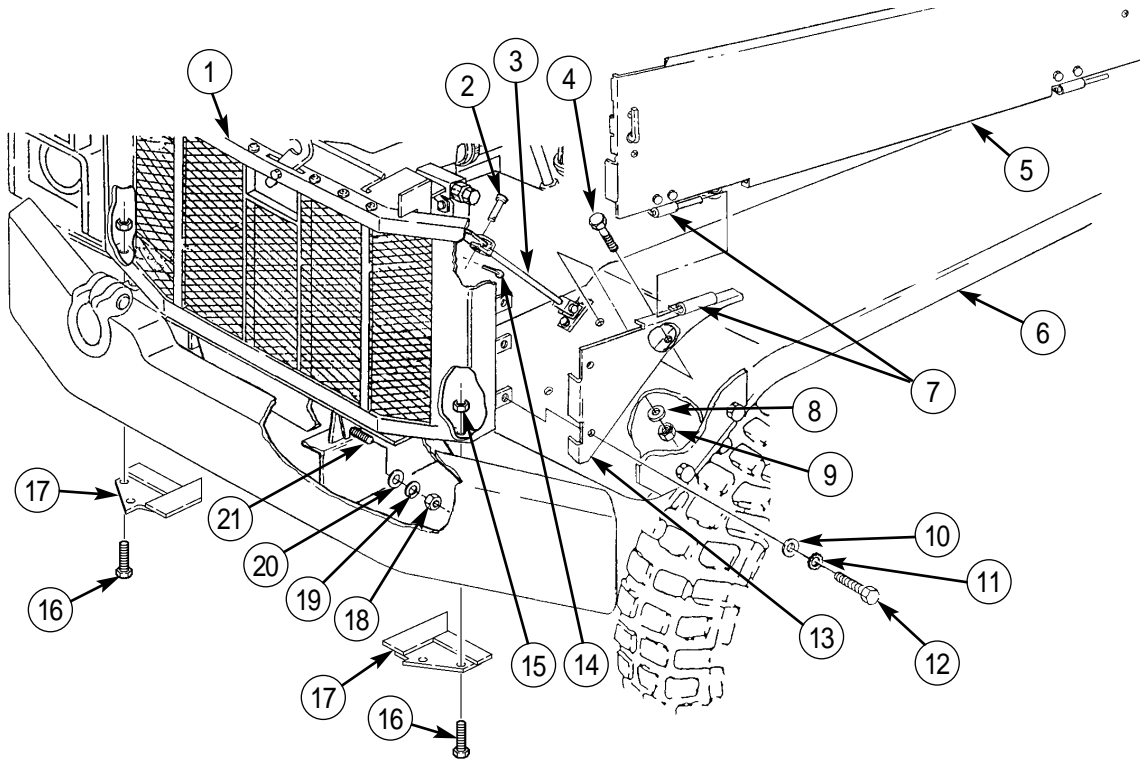

BRUSHGUARD REPLACEMENT (Contd)**INSTALLATION****CAUTION**

When installing auxiliary oil cooler, do not compress rubber mounts more than the thickness of the oil cooler.

1. Install two bumpers (28) on brushguard (1) with eight new rivets (29).
2. Install auxiliary oil cooler (23) on brushguard (1) with four rubber mounts (30), washers (31), and screws (32).
3. Position brushguard (1) on vehicle.
4. Install two baffles (17) on brushguard (1) with four screws (16) and new locknuts (15).
5. Install brushguard (1) on studs (21) with two washers (20), new lockwashers (19), and nuts (18).
6. Install oil line (22) on elbow (27), and oil filter line (25) on elbow (24).
7. Install two strut rods (3) on brushguard (1) with retaining pins (2) and new cotter pins (14).
8. Install two lower side panels (13) on fenders (6) with four screws (4), washers (8), and new locknuts (9).
9. Install two lower side panels (13) on brushguard (1) with four washers (10), new lockwashers (11), and screws (12).
10. Install two upper side panels (5) on hinges (7) and slide panels (5) rearward into position. Close and lock side panels (5).
11. Install quick-start mounting brackets (for vehicles built after serial No. 504923 only) (WP 0061 00).
12. Ensure brushguard is properly aligned with hood (WP 0229 00).

BRUSHGUARD REPLACEMENT (Contd)

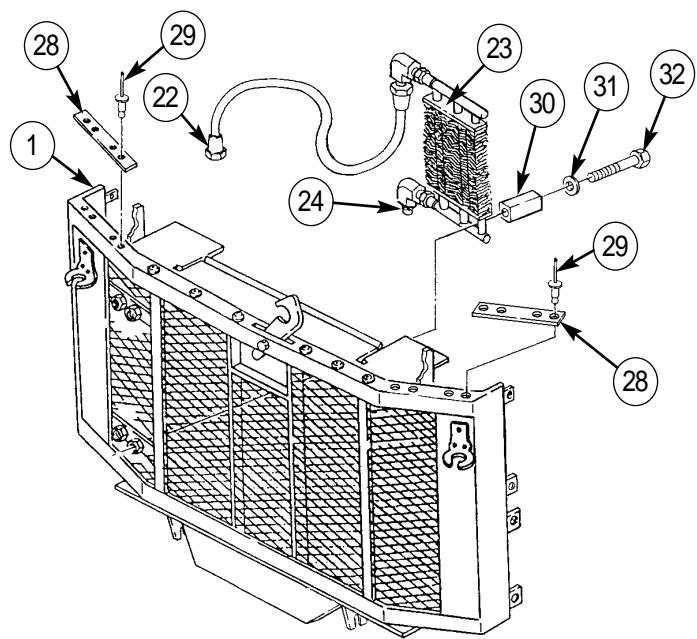
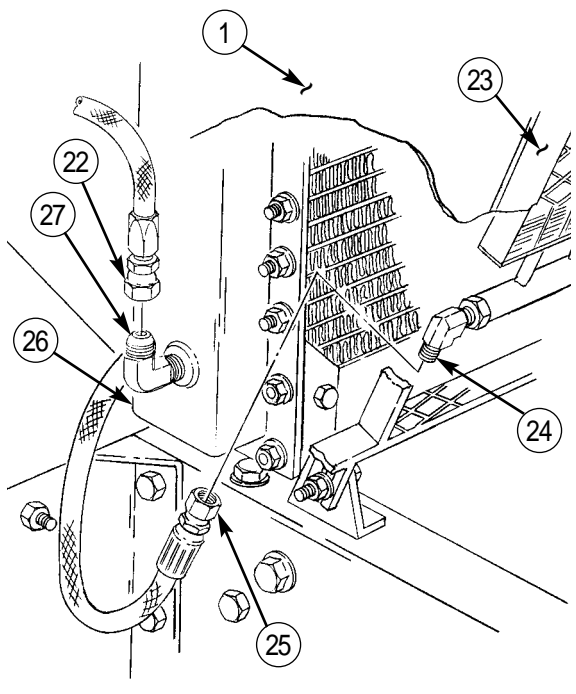
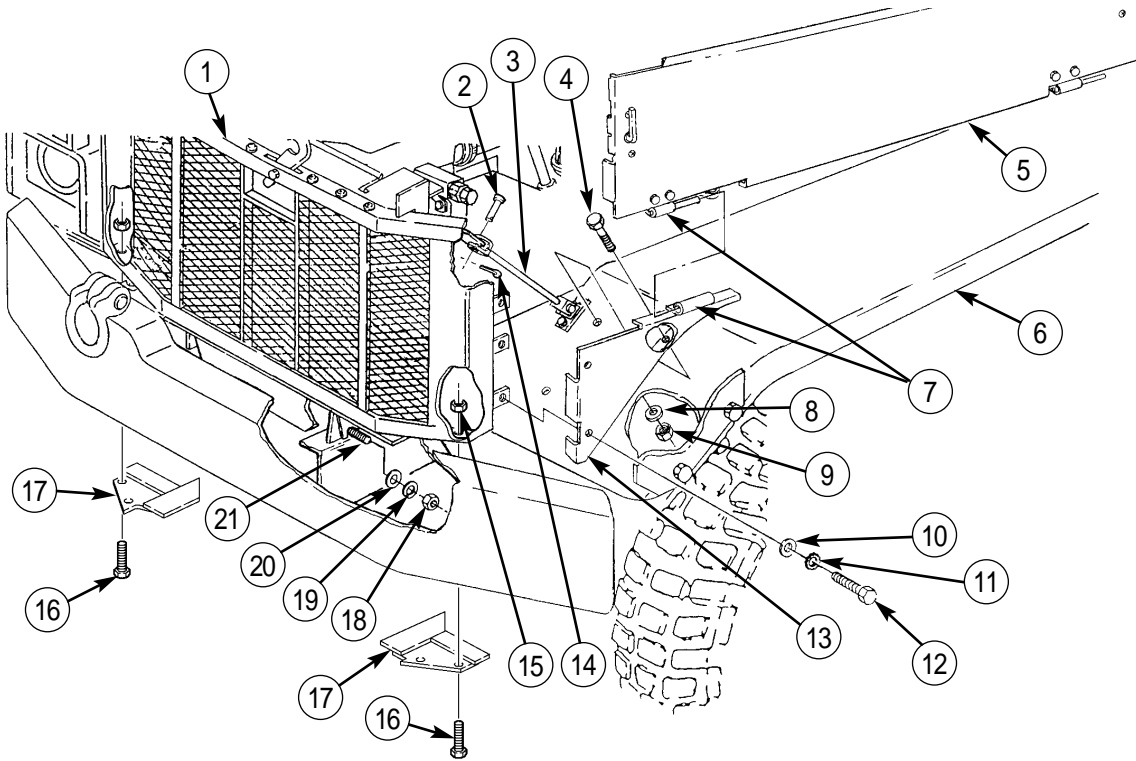

END OF WORK PACKAGE

UNIT MAINTENANCE INSTRUCTIONS

EXTENDED SERVICE PROGRAM (ESP)

TRUCK, CARGO, 2-1/2-TON, 6X6, M44A3 SERIES TRUCKS (DIESEL)

M35A3, W/O WINCH (NSN 2320-01-383-2047); W/WINCH (NSN 2320-01-383-3850);

M35A3C, W/O WINCH (NSN 2320-01-383-2050); W/WINCH (NSN 2320-01-383-2049);

M36A3, W/O WINCH (NSN 2320-01-383-2048); W/WINCH (NSN 2320-01-383-2046).

Section XXI. ACCESSORIES MAINTENANCE

TABLE OF CONTENTS

<i>WP Title</i>	<i>WP Sequence No.-Page No.</i>
Windshield Wiper Switch, Motor, and Conlink Covers Replacement	0232 00-1
Left and Right Conlinks Maintenance	0233 00-1
Windshield Wiper Idler Shaft and Housing Replacement	0234 00-1
Windshield Wiper Blade and Arm Replacement	0235 00-1
Mirrors and Brackets Replacement	0236 00-1

END OF WORK PACKAGE

UNIT MAINTENANCE INSTRUCTIONS

EXTENDED SERVICE PROGRAM (ESP)

TRUCK, CARGO, 2-1/2-TON, 6X6, M44A3 SERIES TRUCKS (DIESEL)

M35A3, W/O WINCH (NSN 2320-01-383-2047); W/WINCH (NSN 2320-01-383-3850);
M35A3C, W/O WINCH (NSN 2320-01-383-2050); W/WINCH (NSN 2320-01-383-2049);
M36A3, W/O WINCH (NSN 2320-01-383-2048); W/WINCH (NSN 2320-01-383-2046).

WINDSHIELD WIPER SWITCH, MOTOR, AND CONLINK COVERS REPLACEMENT

REMOVAL, INSTALLATION

INITIAL SETUP:

Tools and Special Tools

General mechanic's tool kit
(item 30, WP 0394 00)
Common No. 1 tool kit
(item 15, WP 0394 00)

Materials/Parts

Three locknuts (item 338, WP 0395 00)
Locknut (item 331, WP 0395 00)
Four lockwashers (item 176, WP 0395 00)
Two Lockwashers (item 77, WP 0395 00)
Lockwasher (item 42, WP 0395 00)
Six lockwashers (item 82, WP 0395 00)

References

TM 9-2320-386-24P

Equipment Condition

Parking brake set (TM 9-2320-386-10).
Battery ground cable disconnected (WP 0121 00).

WINDSHIELD WIPER SWITCH, MOTOR, AND CONLINK COVERS REPLACEMENT (Contd)**REMOVAL**

1. Remove four screws (3), lockwashers (4), washers (2), two screws (7), and lockwashers (8) from left conlink cover (1), right conlink cover (9), and windshield frame (11). Discard lockwashers (4) and (8).
2. Disconnect harness leads 27 and 71 (19) from wiper switch (18).
3. Remove screw (21), lockwasher (22), ground (GND) wire 57 (20), and lockwasher (23) from wiper motor (27). Discard lockwashers (22) and (23).
4. Remove screw (16) and lockwasher (15) from mounting bracket (10) and windshield frame (11). Discard lockwasher (15).
5. Remove left (1) and right (9) conlink covers, wiper motor (27), wiper switch (18), and mounting bracket (10) from windshield frame (11) as an assembly.
6. Remove three locknuts (12), screws (5), lockwashers (6), left conlink cover (1), and right conlink cover (9) from wiper motor (27) and mounting bracket (10). Discard locknuts (12) and lockwashers (6).
7. Remove locknut (14), retainer bracket (13), and wiper motor (27) from mounting bracket (10). Discard locknut (14).
8. Disconnect wiper switch lead (17) from wiper motor (27).
9. Depress retaining clip on knob (26) and remove knob (26), nut (25), lockwasher (24), and wiper switch (18) from wiper motor (27). Discard lockwasher (24).

INSTALLATION

1. Install wiper switch (18) on wiper motor (27) with new lockwasher (24) and nut (25). Tighten nut (25) 35 lb-in. (4 N•m).
2. Depress retaining clip on knob (26) and install knob (26) on wiper switch (18).
3. Connect wiper switch lead (17) to wiper motor (27).
4. Install wiper motor (27) and retainer bracket (13) on mounting bracket (10) with new locknut (14).
5. Install left conlink cover (1) and right conlink cover (9) on wiper motor (27) and mounting bracket (10) with three new lockwashers (6), screws (5), and new locknuts (12).
6. Position left conlink cover (1) and right conlink cover (9), wiper motor (27), wiper switch (18), and mounting bracket (10) on windshield frame (11) as an assembly.
7. Install four washers (2), new lockwashers (4), screws (3), two new lockwashers (8), and screws (7) on left conlink cover (1), right conlink cover (9), and windshield frame (11).
8. Install mounting bracket (10) and wiper motor (27) on windshield frame (11) with new lockwasher (15) and screw (16).
9. Install new lockwasher (23), ground (GND) wire 57 (20), new lockwasher (22), and screw (21) on wiper motor (27).
10. Connect harness leads 27 and 71 (19) to wiper switch (18).
11. Connect battery ground cable (WP 0121 00).

WINDSHIELD WIPER SWITCH, MOTOR, AND CONLINK COVERS REPLACEMENT (Contd)

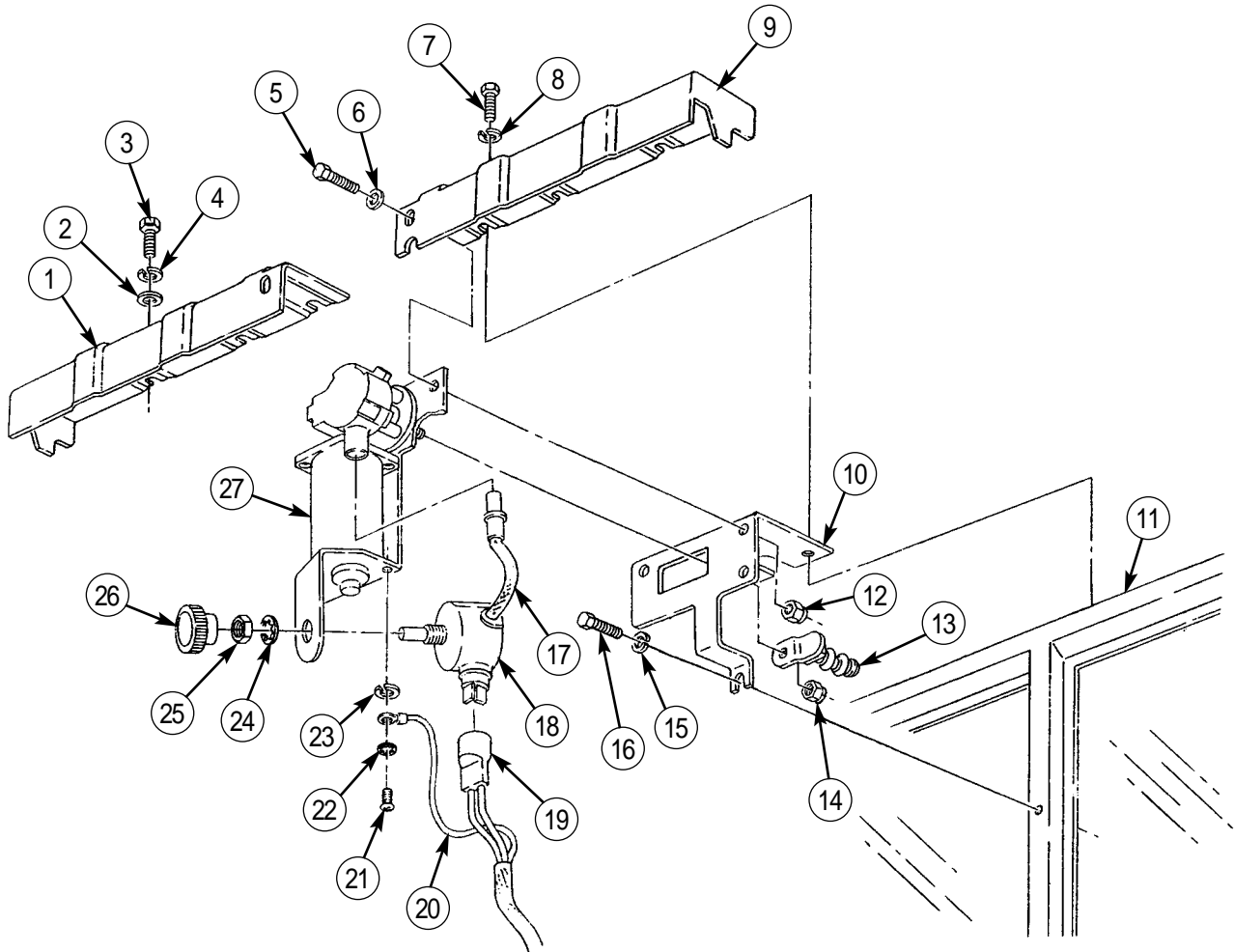

END OF WORK PACKAGE

UNIT MAINTENANCE INSTRUCTIONS

EXTENDED SERVICE PROGRAM (ESP)

TRUCK, CARGO, 2-1/2-TON, 6X6, M44A3 SERIES TRUCKS (DIESEL)

**M35A3, W/O WINCH (NSN 2320-01-383-2047); W/WINCH (NSN 2320-01-383-3850);
M35A3C, W/O WINCH (NSN 2320-01-383-2050); W/WINCH (NSN 2320-01-383-2049);
M36A3, W/O WINCH (NSN 2320-01-383-2048); W/WINCH (NSN 2320-01-383-2046).**

LEFT AND RIGHT CONLINKS MAINTENANCE

REMOVAL, INSTALLATION, ADJUSTMENT

INITIAL SETUP:

Tools and Special Tools

General mechanic's tool kit
(item 30, WP 0394 00)

Materials/Parts

Two lockwashers (item 6, WP 0395 00)

References

TM 9-2320-386-24P

Equipment Condition

Parking brake set (TM 9-2320-386-10).
Conlink covers removed (WP 0232 00).

LEFT AND RIGHT CONLINKS MAINTENANCE (Contd)**REMOVAL**

1. Remove two nuts (8), lockwashers (7), left conlink (4), and right conlink (2) from idler shaft links (6). Discard lockwashers (7).
2. Remove left conlink (4) and right conlink (2) from wiper motor drive link (3).

INSTALLATION**CAUTION**

The right conlink is longer than the left conlink. Ensure conlinks are installed in the correct locations. Failure to do so will result in damage to equipment.

Install left conlink (4) and right conlink (2) on wiper motor drive link (3).

ADJUSTMENT

1. Position wiper arms (9) approximately 2 in. (5 cm) from edge of windshield frame (10).
2. Loosen two jamnuts (1) on locking ball joints (5) and on right conlink (2) and left conlink (4).
3. Shorten or lengthen locking ball joints (5) until they align with holes in idler shaft links (6).

NOTE

Check operation of windshield wipers to ensure correct wiper travel and linkage is free of binding.

4. Tighten jamnuts (1) on right conlink (2) and left conlink (4).
5. Install left conlink (4) and right conlink (2) on two idler shaft links (6) with two new lockwashers (7) and nuts (8).
6. Install conlink covers (WP 0232 00).

LEFT AND RIGHT CONLINKS MAINTENANCE (Contd)

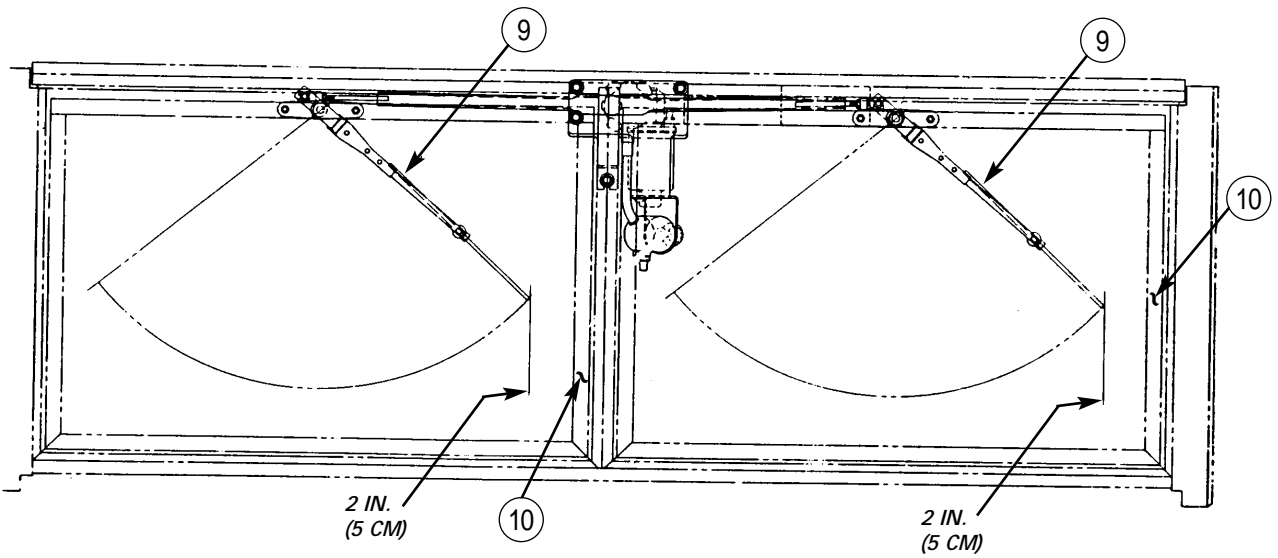
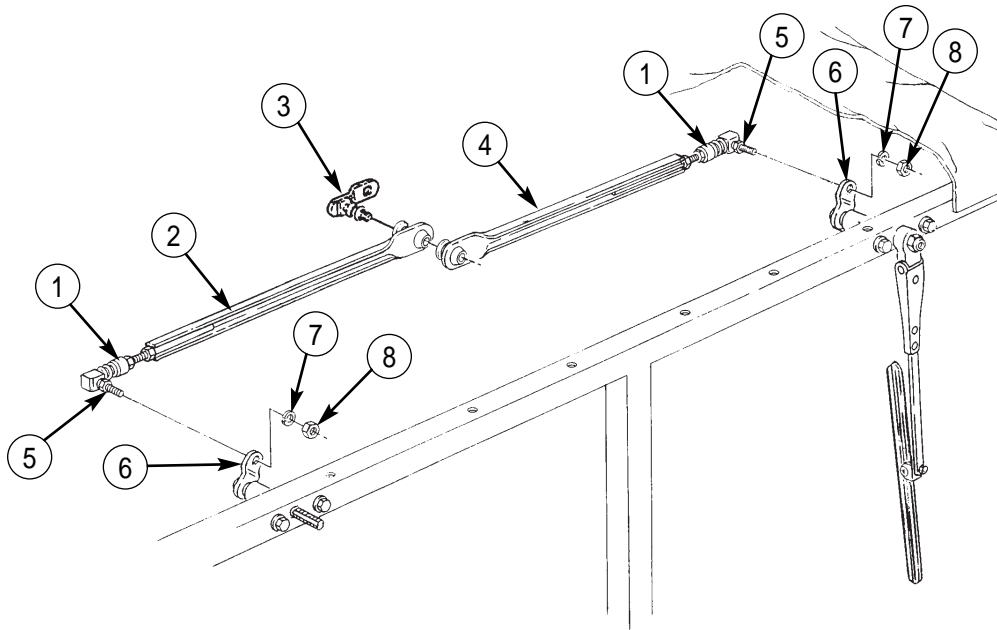

END OF WORK PACKAGE

UNIT MAINTENANCE INSTRUCTIONS

EXTENDED SERVICE PROGRAM (ESP)

TRUCK, CARGO, 2-1/2-TON, 6X6, M44A3 SERIES TRUCKS (DIESEL)

M35A3, W/O WINCH (NSN 2320-01-383-2047); W/WINCH (NSN 2320-01-383-3850);
M35A3C, W/O WINCH (NSN 2320-01-383-2050); W/WINCH (NSN 2320-01-383-2049);
M36A3, W/O WINCH (NSN 2320-01-383-2048); W/WINCH (NSN 2320-01-383-2046).

WINDSHIELD WIPER IDLER SHAFT AND HOUSING REPLACEMENT

REMOVAL, INSTALLATION

INITIAL SETUP:

Tools and Special Tools

General mechanic's tool kit
(item 30, WP 0394 00)

Materials/Parts

Two locknuts (item 316, WP 0395 00)
Grease (item 22, WP 0393 00)

References

TM 9-2320-386-24P

Equipment Condition

Parking brake set (TM 9-2320-386-10).
Wiper blade and arm removed (WP 0235 00).
Left and right conlinks removed (WP 0233 00).

WINDSHIELD WIPER IDLER SHAFT AND HOUSING REPLACEMENT (Contd)**NOTE**

The replacement procedure for the left and right idler shaft and housing assembly is basically the same. This procedure covers the left idler shaft and housing assembly.

REMOVAL

Remove two screws (4), locknuts (1), and idler shaft and housing assembly (2) from windshield frame (5). Discard locknuts (1).

INSTALLATION

1. Apply grease to surface of shaft (3).
2. Install idler shaft and housing assembly (2) on windshield frame (5) with two screws (4) and new locknuts (1).
3. Install left and right conlinks (WP 0233 00)
4. Install wiper blade and arm (WP 0235 00).

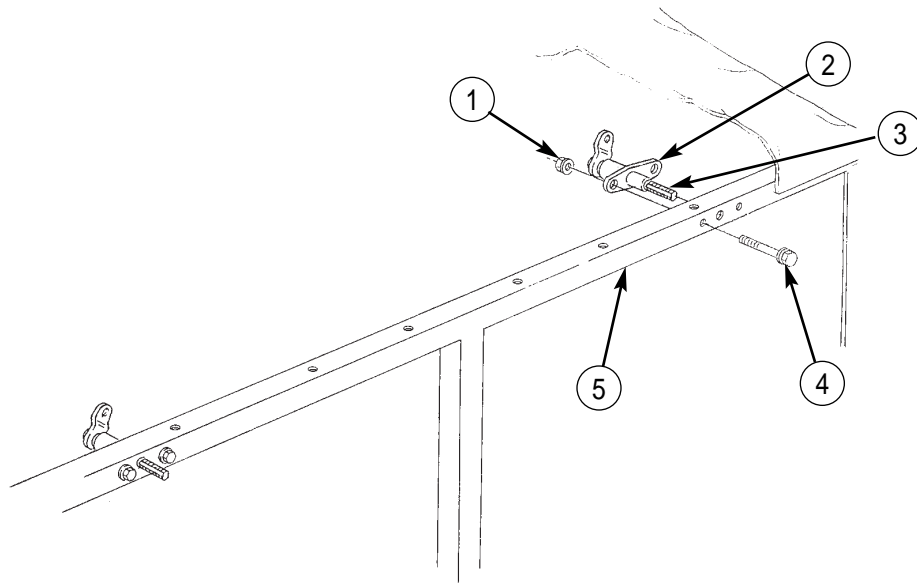

END OF WORK PACKAGE

UNIT MAINTENANCE INSTRUCTIONS

EXTENDED SERVICE PROGRAM (ESP)

TRUCK, CARGO, 2-1/2-TON, 6X6, M44A3 SERIES TRUCKS (DIESEL)

M35A3, W/O WINCH (NSN 2320-01-383-2047); W/WINCH (NSN 2320-01-383-3850);

M35A3C, W/O WINCH (NSN 2320-01-383-2050); W/WINCH (NSN 2320-01-383-2049);

M36A3, W/O WINCH (NSN 2320-01-383-2048); W/WINCH (NSN 2320-01-383-2046).

WINDSHIELD WIPER BLADE AND ARM REPLACEMENT

REMOVAL, INSTALLATION

INITIAL SETUP:

Tools and Special Tools

General mechanic's tool kit
(item 30, WP 0394 00)

Common No. 1 tool kit
(item 15, WP 0394 00)

References

TM 9-2320-386-24P

Equipment Condition

Parking brake set (TM 9-2320-386-10).

Materials/Parts

Locknut (item 11, WP 0395 00)

Locknut (item 5, WP 0395 00)

WINDSHIELD WIPER BLADE AND ARM REPLACEMENT (Contd)**NOTE**

Left and right windshield wiper blades and arms are replaced the same. This procedure covers left windshield wiper blade and arm.

REMOVAL

1. Remove locknut (5), screw (6), and wiper blade (7) from wiper arm (4). Discard locknut (5).
2. Remove locknut (3), wiper arm (4), and arm driver (2) from idler shaft (1). Discard locknut (3).

INSTALLATION**NOTE**

Install wiper arm in line with idler shaft link.

1. Install arm driver (2) and wiper arm (4) on idler shaft (1) with new locknut (3). Tighten locknut (3) 90-110 lb-in. (10-12 N•m).
2. Install wiper blade (7) on wiper arm (4) with screw (6) and new locknut (5). Tighten locknut (5) 15-20 lb-in. (1.7-2.3 N•m).

WINDSHIELD WIPER BLADE AND ARM REPLACEMENT (Contd)

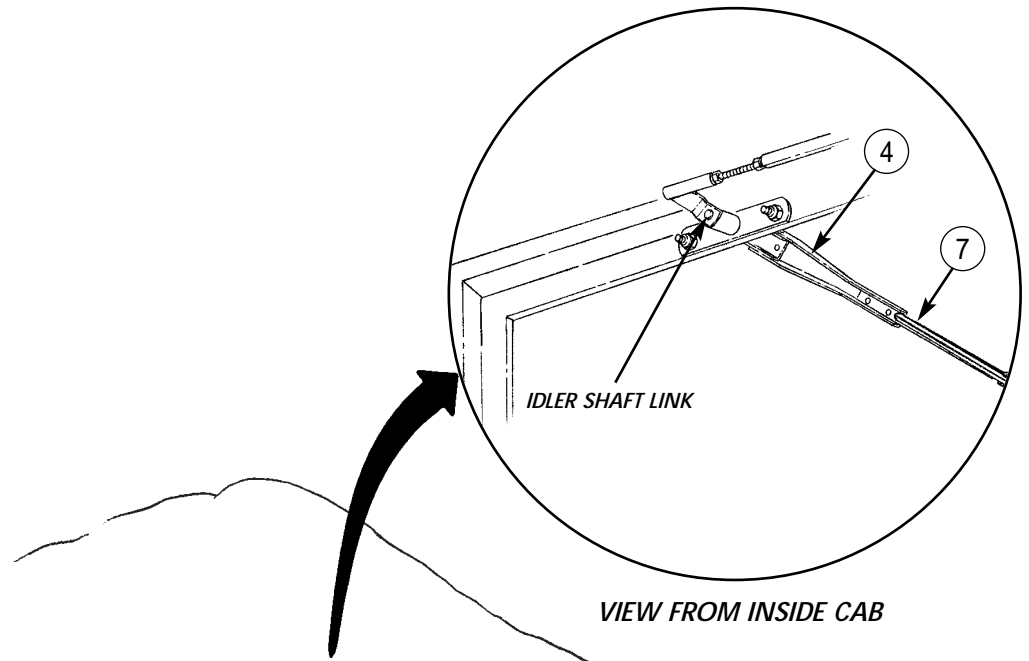

VIEW FROM INSIDE CAB

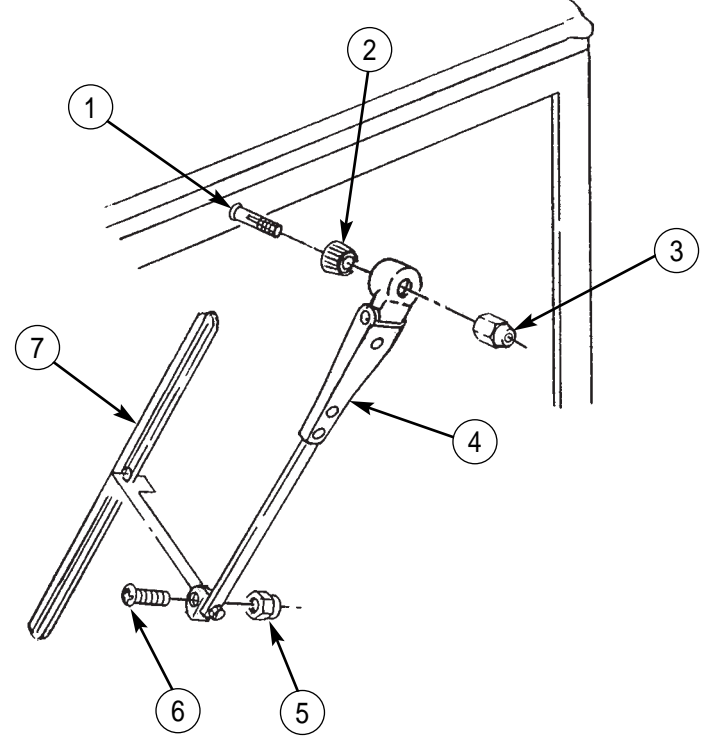

END OF WORK PACKAGE

UNIT MAINTENANCE INSTRUCTIONS

EXTENDED SERVICE PROGRAM (ESP)

TRUCK, CARGO, 2-1/2-TON, 6X6, M44A3 SERIES TRUCKS (DIESEL)

M35A3, W/O WINCH (NSN 2320-01-383-2047); W/WINCH (NSN 2320-01-383-3850);
M35A3C, W/O WINCH (NSN 2320-01-383-2050); W/WINCH (NSN 2320-01-383-2049);
M36A3, W/O WINCH (NSN 2320-01-383-2048); W/WINCH (NSN 2320-01-383-2046).

MIRROR AND BRACKETS REPLACEMENT

LEFT MIRROR AND BRACKET REMOVAL, LEFT MIRROR AND BRACKET INSTALLATION,
RIGHT MIRROR AND BRACKET REMOVAL, RIGHT MIRROR AND BRACKET INSTALLATION

INITIAL SETUP:

Tools and Special Tools

General mechanic's tool kit
(item 30, WP 0394 00)

Materials/Parts

Thirteen locknuts (item 86, WP 0395 00)
Four locknuts (item 15, WP 0395 00)
Two lockwashers (item 59, WP 0395 00)
Two assembled-washer bolts
(item 245, WP 0395 00)
Three locknuts (item 87, WP 0395 00)

Personnel Required

Assistant (1)

References

TM 9-2320-386-24P
TM 9-2320-361-20P

Equipment Condition

Parking brake set (TM 9-2320-386-10).

MIRROR AND BRACKETS REPLACEMENT (Contd)

LEFT MIRROR AND BRACKET REMOVAL

1. Remove assembled-washer bolt (26), left convex mirror (17), locknut (16), lockwasher (15), screw (25), and two brackets (23) from brace (24). Discard locknut (16), assembled-washer bolt (26), and lockwasher (15).
2. Remove two locknuts (18), washers (19), left mirror (21), and two spacers (20) from brace (22). Discard locknuts (18).
3. Remove two locknuts (10), washers (11) and (14), rod (30), and braces (24) and (22) from braces (12), (13), (29), (28), and (27). Discard locknuts (10).
4. Remove locknut (7), washer (6), hinge bolt (9), and braces (13) and (27) from upper door hinge (5). Discard locknut (7).
5. Install hinge bolt (9) in upper door hinge (5).
6. Remove locknut (32), washer (36), hinge bolt (31), and brace (29) from top of lower door hinge (33). Discard locknut (32).
7. Install hinge bolt (31) in left lower door hinge (33).
8. Remove locknut (34), washer (35), screw (8), and braces (12) and (28) from clip (4). Discard locknut (34).
9. Remove two locknuts (1), plate (2), two screws (37), and clip (4) from cowling (3). Discard locknuts (1).

LEFT MIRROR AND BRACKET INSTALLATION

1. Install clip (4) and plate (2) on cowling (3) with two screws (37) and new locknuts (1).
2. Install braces (28) and (12) on clip (4) with screw (8), washer (35), and new locknut (34).
3. Remove hinge bolt (31) from lower door hinge (33).
4. Install brace (29) on top of lower door hinge (33) with hinge bolt (31), washer (36), and new locknut (32).
5. Remove hinge bolt (9) from upper door hinge (5).
6. Install braces (13) and (27) on upper door hinge (5) with hinge bolt (9), washer (6), and new locknut (7).
7. Install braces (22) and (24) on braces (13), (12), (27), (28), and (29) with rod (30), two washers (11) and (14), and new locknuts (10).
8. Install two spacers (20) on left mirror (21) and install mirror (21) on brace (22) with two washers (19) and new locknuts (18).
9. Install left convex mirror (17) on brace (24) with two brackets (23), screw (25), new lockwasher (15), new locknut (16), and new assembled-washer bolt (26).

MIRROR AND BRACKETS REPLACEMENT (Contd)

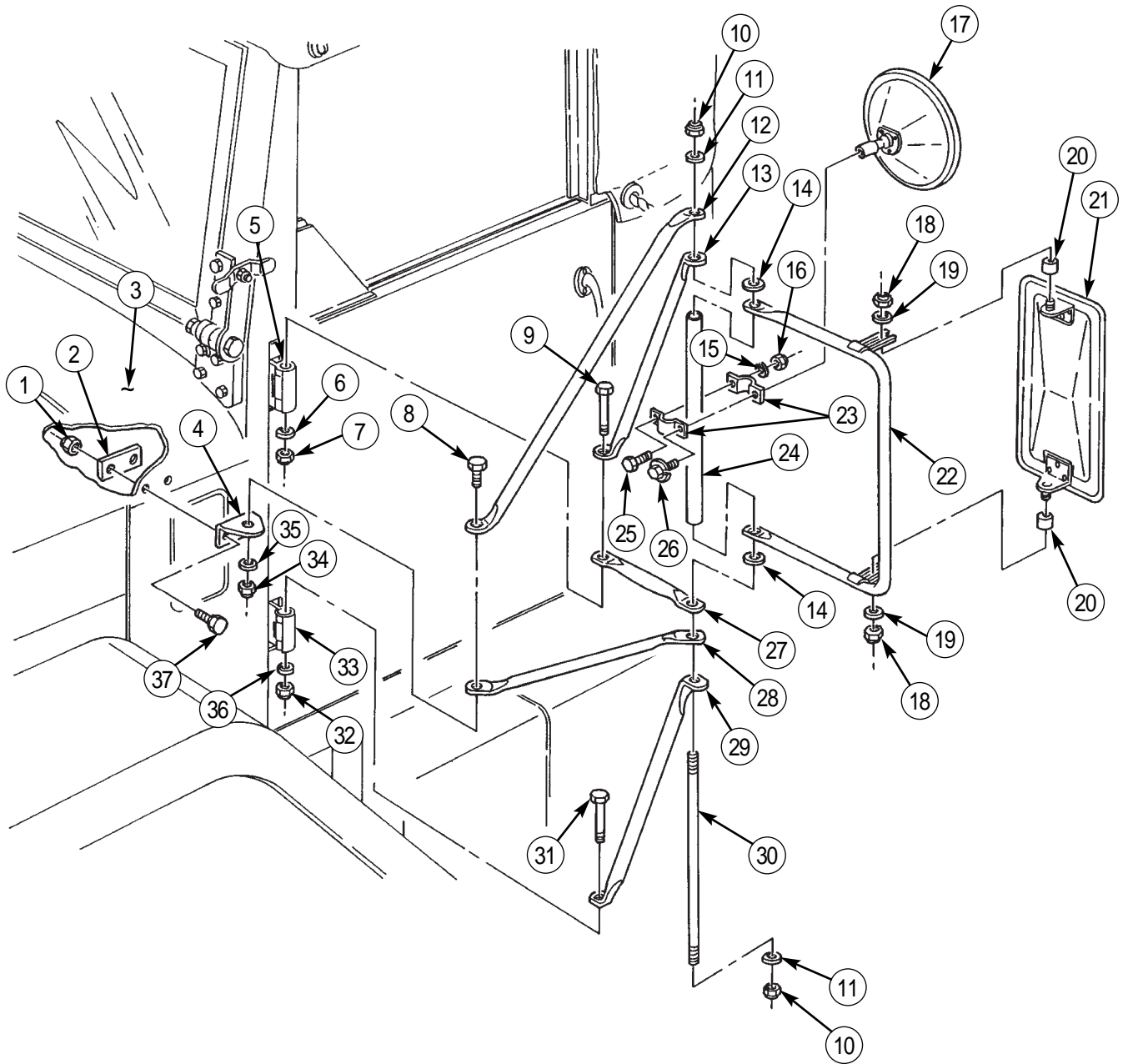

MIRROR AND BRACKETS REPLACEMENT (Contd)

RIGHT MIRROR AND BRACKET REMOVAL

1. Remove assembled-washer bolt (15), right convex mirror (36), locknut (38), lockwasher (39), screw (14), and two brackets (16) from brace (37). Discard locknut (38), lockwasher (39), and assembled-washer bolt (15).
2. Remove two locknuts (9), washers (10), right side mirror (13), and two spacers (11) from brace (12). Discard locknuts (9).
3. Remove two locknuts (1), washers (2), washers (7), rod (3), brace (37), and brace (12) from braces (4), (41), (25), (31), and (32). Discard locknuts (1).
4. Remove locknut (33), washer (34), hinge bolt (40), and braces (32) and (41) from top of upper door hinge (35). Discard locknut (33).
5. Install hinge bolt (40) in upper door hinge (35).
6. Remove locknut (27), washer (26), hinge bolt (29), and brace (25) from top of lower door hinge (28). Discard locknut (27).
7. Install hinge bolt (29) in lower door hinge (28).
8. Remove locknut (30), screw (17), washer (18), and brace (31) from brace (19). Discard locknut (30).
9. Remove locknut (42), screw (6), washer (5), and brace (4) from brace (8). Discard locknut (42).
10. Remove locknut (23), plate (22), screw (21), washer (20), and braces (8) and (19) from fender (24). Discard locknut (23).

RIGHT MIRROR AND BRACKET INSTALLATION

1. Install braces (8) and (19) on fender (24) with washer (20), screw (21), plate (22), and new locknut (23).
2. Install brace (4) on brace (8) with washer (5), screw (6), and new locknut (42).
3. Install brace (31) to brace (19) with washer (18), screw (17), and new locknut (30).
4. Remove hinge bolt (29) from lower door hinge (28).
5. Install brace (25) on top of lower door hinge (28) with hinge bolt (29), washer (26), and new locknut (27).
6. Remove hinge bolt (40) from upper door hinge (35).
7. Install braces (32) and (41) on top of upper door hinge (35) with hinge bolt (40), washer (34), and new locknut (33).
8. Install braces (12) and (37) on braces (41), (4), (32), (31), and (25) with rod (3), two washers (2), washers (7), and two new locknuts (1).
9. Install right side mirror (13) on brace (12) with two spacers (11), washers (10), and new locknuts (9).
10. Install right convex mirror (36) on brace (37) with two brackets (16), screw (14), new lockwasher (39), new locknut (38), and new assembled-washer bolt (15).

MIRROR AND BRACKETS REPLACEMENT (Contd)

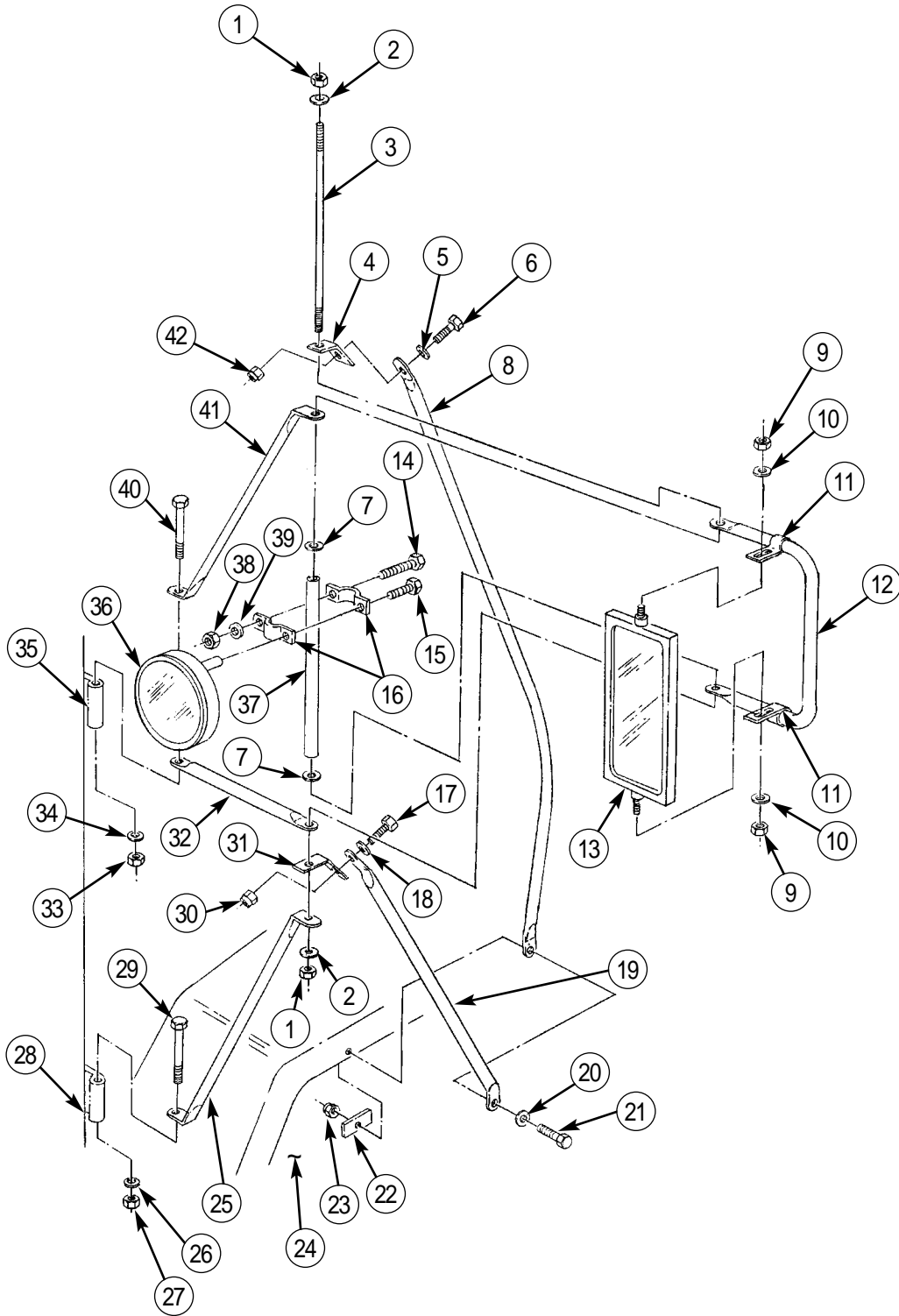

END OF WORK PACKAGE

UNIT MAINTENANCE INSTRUCTIONS

EXTENDED SERVICE PROGRAM (ESP)

TRUCK, CARGO, 2-1/2-TON, 6X6, M44A3 SERIES TRUCKS (DIESEL)

M35A3, W/O WINCH (NSN 2320-01-383-2047); W/WINCH (NSN 2320-01-383-3850);

M35A3C, W/O WINCH (NSN 2320-01-383-2050); W/WINCH (NSN 2320-01-383-2049);

M36A3, W/O WINCH (NSN 2320-01-383-2048); W/WINCH (NSN 2320-01-383-2046).

Section XXII. PERSONNEL HOT WATER HEATER MAINTENANCE

TABLE OF CONTENTS

<i>WP Title</i>	<i>WP Sequence No.-Page No.</i>
Personnel Hot Water Heater Hoses Replacement	0238 00-1
Personnel Hot Water Heater Maintenance	0239 00-1
Personnel Hot Water Heater Ducts Replacement	0240 00-1
Personnel Hot Water Heater Diverter Replacement	0241 00-1
Personnel Hot Water Heater Control Cables Replacement	0242 00-1
Personnel Hot Water Heater Switch Replacement	0243 00-1
Personnel Hot Water Heater Deflectors Replacement	0244 00-1

END OF WORK PACKAGE

UNIT MAINTENANCE INSTRUCTIONS

EXTENDED SERVICE PROGRAM (ESP)

TRUCK, CARGO, 2-1/2-TON, 6X6, M44A3 SERIES TRUCKS (DIESEL)

M35A3, W/O WINCH (NSN 2320-01-383-2047); W/WINCH (NSN 2320-01-383-3850);

M35A3C, W/O WINCH (NSN 2320-01-383-2050); W/WINCH (NSN 2320-01-383-2049);

M36A3, W/O WINCH (NSN 2320-01-383-2048); W/WINCH (NSN 2320-01-383-2046).

PERSONNEL HOT WATER HEATER HOSES REPLACEMENT

REMOVAL, INSTALLATION

INITIAL SETUP:

Tools and Special Tools

General mechanic's tool kit
(item 30, WP 0394 00)

Materials/Parts

Teflon pipe sealant (item 41, WP 0393 00)
Three lockwashers (item 82, WP 0395 00)
O-ring (item 215, WP 0395 00)

References

TM 9-2320-386-24P

Equipment Condition

Parking brake set (TM 9-2320-386-10).
Hood raised and secured (TM 9-2320-386-10).
Cooling system drained (WP 0068 00)
Coolant quick-start temperature switch removed
(WP 0078 00).

PERSONNEL HOT WATER HEATER HOSES REPLACEMENT (Contd)**REMOVAL****NOTE**

Tag all hoses for installation.

Have drainage container ready to catch excess engine coolant.

1. Remove clamps (2) and (34), supply hose (5), and return hose (32) from personnel hot water heater (1).
2. Remove supply hose (5), return hose (32), and grommets (4) and (33) from firewall (3).
3. Remove screw (9), lockwasher (10), clamp (8), and brass return line (11) from engine (12). Discard lockwasher (10).
4. Remove clamp (6) and return hose (32) from brass return line (11).
5. Remove brass return line (11), adapter (13), and tee (14) from thermostat housing (15).
6. Remove screw (30), lockwasher (29), clamp (28), and supply hose (5) from engine (12). Discard lockwasher (29).
7. Remove two clamps (27) and supply hoses (5) and (21) from water shutoff valve (31).
8. Remove screw (26), lockwasher (25), clamp (24), and supply hose (21) from engine (12). Discard lockwasher (25).
9. Remove screw (22), clamp (23), and supply hose (21) from fender (17).
10. Remove clamp (20) and supply hose (21) from connector (19).
11. Remove connector (19), adapter (18), and O-ring (7) from water pump (16). Discard O-ring (7).

INSTALLATION

1. Apply sealant to male threads of adapters (18) and (13).
2. Install new O-ring (7), adapter (18), and connector (19) on water pump (16).
3. Install supply hoses (5) and (21) on water shutoff valve (31) with two clamps (27).
4. Install supply hose (21) on connector (19) with clamp (20).
5. Insert supply hose (5) through hole in firewall (3) and install on personnel hot water heater (1) with clamp (2).
6. Install tee (14), adapter (13), and brass return line (11) on thermostat housing (15).
7. Install return hose (32) on brass return line (11) with clamp (6).
8. Place grommets (33) and (4) on return hose (32) and supply hose (5) and install on firewall (3).
9. Insert return hose (32) through hole in firewall (3) and install on personnel hot water heater (1) with clamp (34).
10. Install supply hose (21) on fender (16) with clamp (23) and screw (22).
11. Install supply hose (21) on engine (12) with clamp (24), new lockwasher (25), and screw (26).
12. Install supply hose (5) on engine (12) with clamp (28), new lockwasher (29), and screw (30).
13. Install brass return line (11) on engine (12) with clamp (8), new lockwasher (10), and screw (9).
14. Install coolant quick-start temperature switch (WP 0078 00).
15. Fill cooling system (WP 0068 00).

PERSONNEL HOT WATER HEATER HOSES REPLACEMENT (Contd)

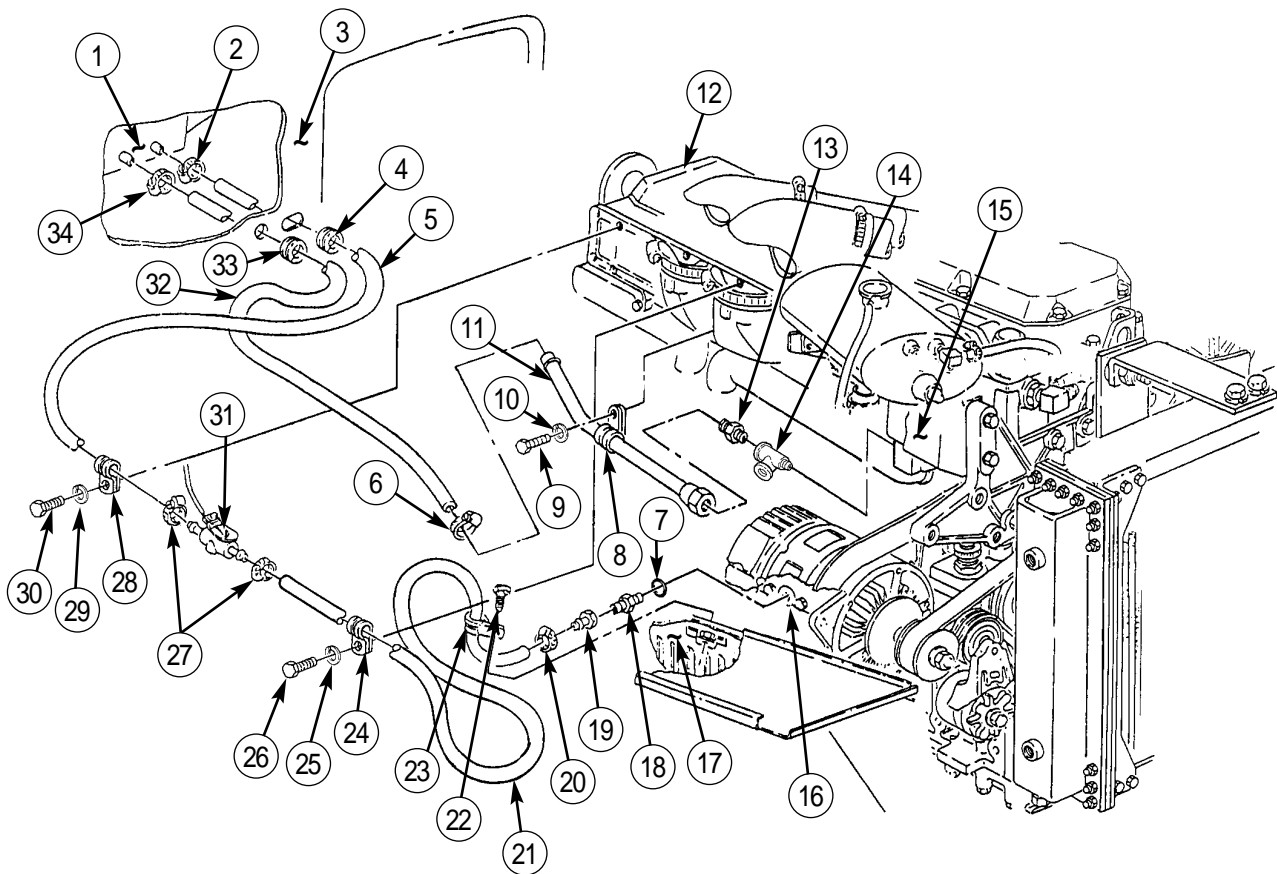

END OF WORK PACKAGE

UNIT MAINTENANCE INSTRUCTIONS

EXTENDED SERVICE PROGRAM (ESP)

TRUCK, CARGO, 2-1/2-TON, 6X6, M44A3 SERIES TRUCKS (DIESEL)

M35A3, W/O WINCH (NSN 2320-01-383-2047); W/WINCH (NSN 2320-01-383-3850);

M35A3C, W/O WINCH (NSN 2320-01-383-2050); W/WINCH (NSN 2320-01-383-2049);

M36A3, W/O WINCH (NSN 2320-01-383-2048); W/WINCH (NSN 2320-01-383-2046).

PERSONNEL HOT WATER HEATER MAINTENANCE

REMOVAL, CLEANING AND INSPECTION, INSTALLATION

INITIAL SETUP:

Tools and Special Tools

General mechanic's tool kit
(item 30, WP 0394 00)

Materials/Parts

Locknut (item 248, WP 395 00)
Four lockwashers (item 40, WP 395 00)
Lockwasher (item 227, WP 395 00)
Adhesive (item 8, WP 393 00)
Skysol-100 (item 17, WP 393 00)
Wiping rag (item 35, WP 393 00)

References

TM 9-2320-386-24P

Equipment Condition

Parking brake set (TM 9-2320-386-10).
Battery ground cable disconnected (WP 0121 00).
Drain cooling system (WP 0068 00).

PERSONNEL HOT WATER HEATER MAINTENANCE (Contd)**REMOVAL****NOTE**

Tag all hoses for installation.

Have drainage container ready to catch excess engine coolant.

1. Remove ten screws (2) and glove box (1) from instrument panel (34).
2. Disconnect lead 400A (10) from hot water heater fan motor plug (11).
3. Remove nut (15), lockwasher (14), GND terminal (13), and nut (16) from fan motor housing (12). Discard lockwasher (14).
4. Loosen clamp (26) and remove hot air duct (25) from adapter (30).

NOTE

Support hot water heater while performing steps 5 through 9.

5. Remove screw (4) from mounting bracket (17) and support bracket (6).
6. Remove screw (5) from support bracket (6) and mounting bracket (7).
7. Remove screw (27) from mounting bracket (21) and insert (3).
8. Remove locknut (32) and screw (33) from mounting bracket (31) and instrument panel (34). Discard locknut (32).
9. Loosen two clamps (22) and disconnect water supply hose (24) and water return hose (23) from hot water heater (20).
10. Remove hot water heater (20) from vehicle.
11. Remove two screws (19) from heater air intake adapter (18) and heater fan motor housing (12).
12. Remove four screws (28), lockwashers (29), and adapter (30) from hot water heater (20). Discard lockwashers (29).
13. Remove four screws (9), washers (8), and mounting brackets (7), (17), (21), and (31) from hot water heater (20).

CLEANING AND INSPECTION

Clean and remove all silicone rubber adhesive from mating surfaces of heater air intake adapter (18) and heater fan motor housing (12).

PERSONNEL HOT WATER HEATER MAINTENANCE (Contd)

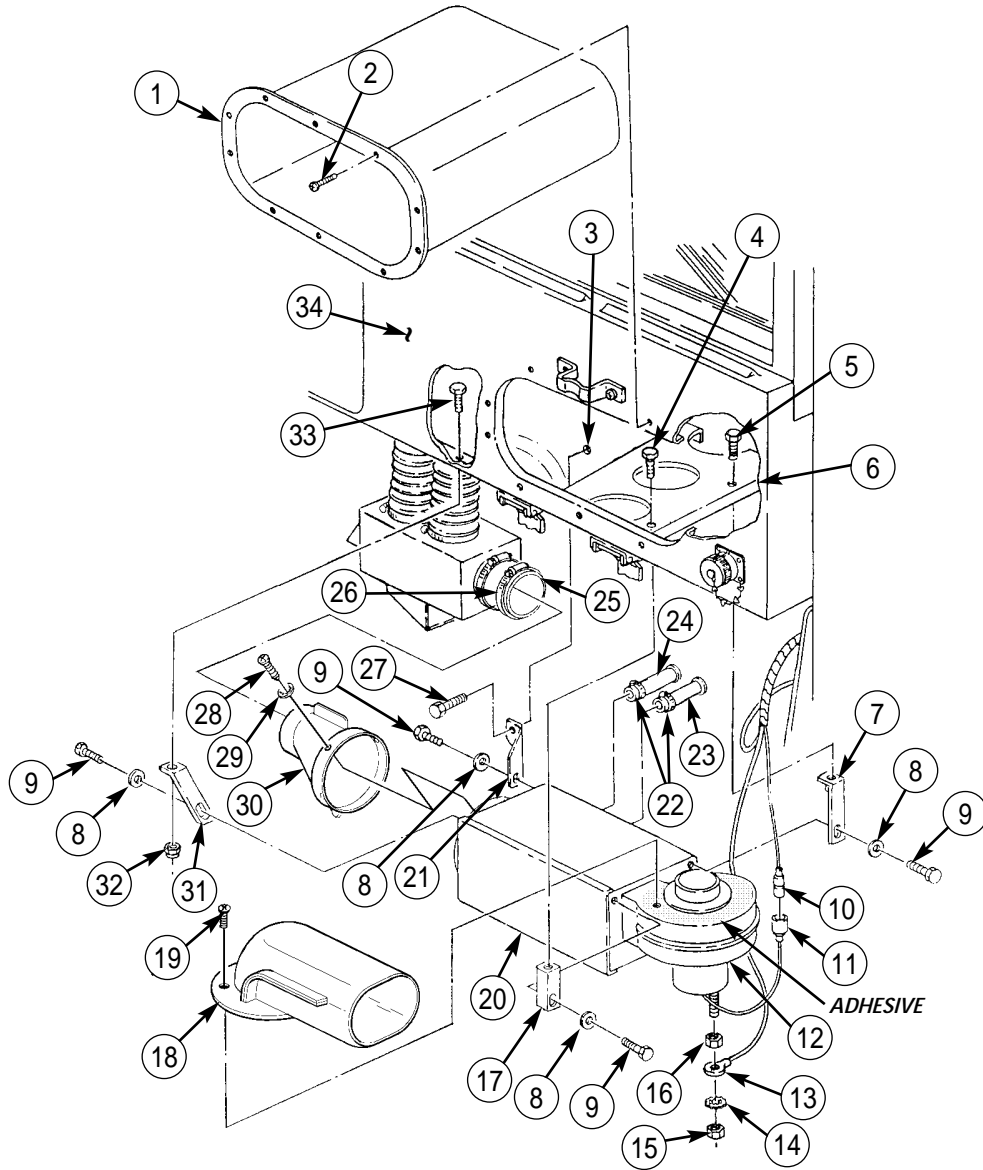

PERSONNEL HOT WATER HEATER MAINTENANCE (Contd)**INSTALLATION**

1. Install mounting brackets (10), (20), (22), and (26) on hot water heater (21) with four washers (11) and screws (12).
2. Install silicone rubber adhesive to mounting surface of heater air intake adapter (23) and surface of heater fan motor housing (14) and install heater air intake adapter (23) on heater fan motor housing (14) with two screws (24).
3. Install adapter (27) on hot water heater (21) with four new lockwashers (28) and screws (29).
4. Install hot water heater (21) and mounting bracket (26) on instrument panel (34) with screw (33) and new locknut (25).
5. Install water supply hose (7) and water return hose (8) on hot water heater (21) and tighten two clamps (9).
6. Install mounting bracket (22) on insert (3) with screw (30).
7. Install mounting bracket (10) on support bracket (6) with screw (5).
8. Install mounting bracket (20) on support bracket (6) with screw (4).
9. Install hot air duct (32) on adapter (27) and tighten clamp (31).
10. Install nut (19), GND terminal (16), new lockwasher (17), and nut (18) on heater fan motor housing (14).
11. Connect lead 400A (13) to hot water heater fan motor plug (15).
12. Install glove box (1) on instrument panel (34) with ten screws (2).
13. Fill cooling system (WP 0068 00).
14. Connect battery ground cable (WP 0121 00).

PERSONNEL HOT WATER HEATER MAINTENANCE (Contd)

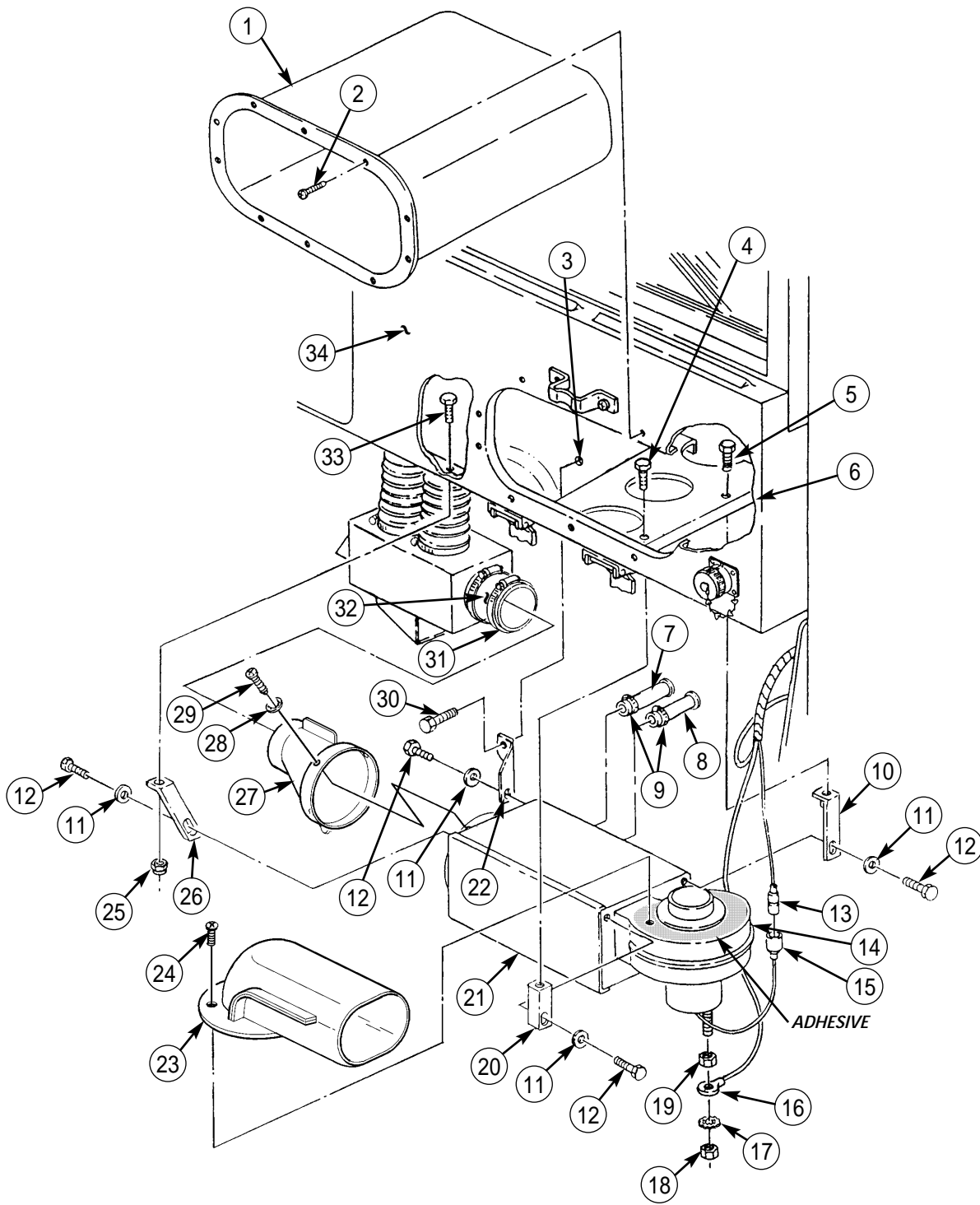

END OF WORK PACKAGE

UNIT MAINTENANCE INSTRUCTIONS

EXTENDED SERVICE PROGRAM (ESP)

TRUCK, CARGO, 2-1/2-TON, 6X6, M44A3 SERIES TRUCKS (DIESEL)

**M35A3, W/O WINCH (NSN 2320-01-383-2047); W/WINCH (NSN 2320-01-383-3850);
M35A3C, W/O WINCH (NSN 2320-01-383-2050); W/WINCH (NSN 2320-01-383-2049);
M36A3, W/O WINCH (NSN 2320-01-383-2048); W/WINCH (NSN 2320-01-383-2046).**

PERSONNEL HOT WATER HEATER DUCTS REPLACEMENT

REMOVAL, INSTALLATION

INITIAL SETUP:

Tools and Special Tools

General mechanic's tool kit
(item 30, WP 0394 00)

Equipment Condition

Parking brake set (TM 9-2320-386-10).

References

TM 9-2320-386-24P

PERSONNEL HOT WATER HEATER DUCTS REPLACEMENT (Contd)**REMOVAL**

1. Remove two clamps (2) and ducts (1) from diverter (5).
2. Remove two clamps (3) and ducts (1) from defrost ducts (4).

INSTALLATION

1. Install two ducts (1) on defrost ducts (4) with clamps (3).
2. Install two ducts (1) on diverter (5) with clamps (2).

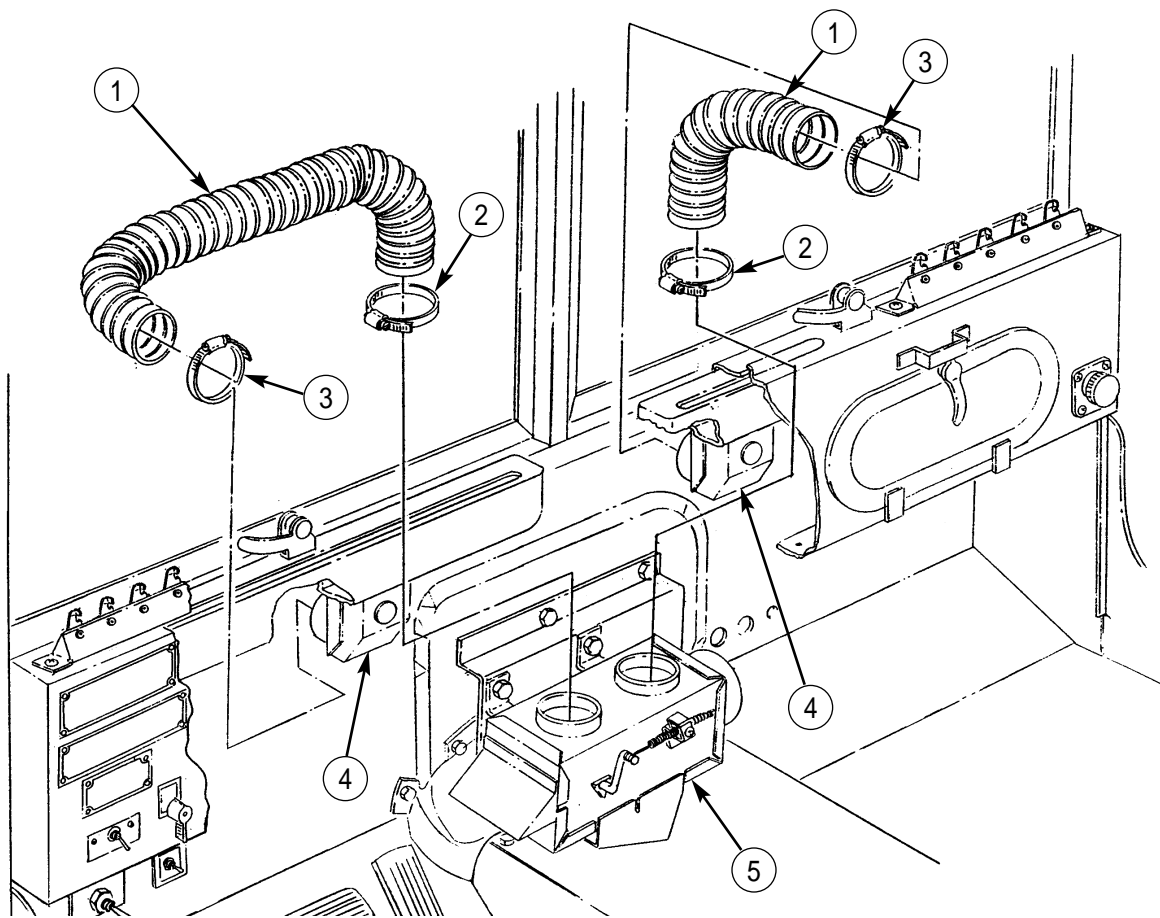

END OF WORK PACKAGE

UNIT MAINTENANCE INSTRUCTIONS

EXTENDED SERVICE PROGRAM (ESP)

TRUCK, CARGO, 2-1/2-TON, 6X6, M44A3 SERIES TRUCKS (DIESEL)

**M35A3, W/O WINCH (NSN 2320-01-383-2047); W/WINCH (NSN 2320-01-383-3850);
M35A3C, W/O WINCH (NSN 2320-01-383-2050); W/WINCH (NSN 2320-01-383-2049);
M36A3, W/O WINCH (NSN 2320-01-383-2048); W/WINCH (NSN 2320-01-383-2046).**

PERSONNEL HOT WATER HEATER DIVERTER REPLACEMENT

REMOVAL, INSTALLATION

INITIAL SETUP:

Tools and Special Tools

General mechanic's tool kit
(item 30, WP 0394 00)

Equipment Condition

Parking brake set (TM 9-2320-386-10).

References

TM 9-2320-386-24P

PERSONNEL HOT WATER HEATER DIVERTER REPLACEMENT (Contd)**REMOVAL**

1. Remove two clamps (14) and ducts (1) from diverter (12).
2. Disconnect defroster control cable (7) from shaft lever (10).
3. Loosen screw (8) and remove defroster control cable (7) from clamp (9) and diverter (12).
4. Remove four screws (11) and diverter (12) from mounting bracket (13).
5. Loosen two clamps (5) and remove diverter (12), duct (6), and two clamps (5) from heater (3).
6. Remove four screws (4) and mounting bracket (13) from firewall (2).

INSTALLATION

1. Install mounting bracket (13) on firewall (2) with four screws (4).
2. Install duct (6) and diverter (12) on heater (3) with two clamps (5).
3. Install diverter (12) on mounting bracket (13) with four screws (11).
4. Install two ducts (1) on diverter (12) with clamps (14).
5. Insert defroster control cable (7) through clamp (9) and install on shaft lever (10).
6. Tighten screw (8) and clamp (9).

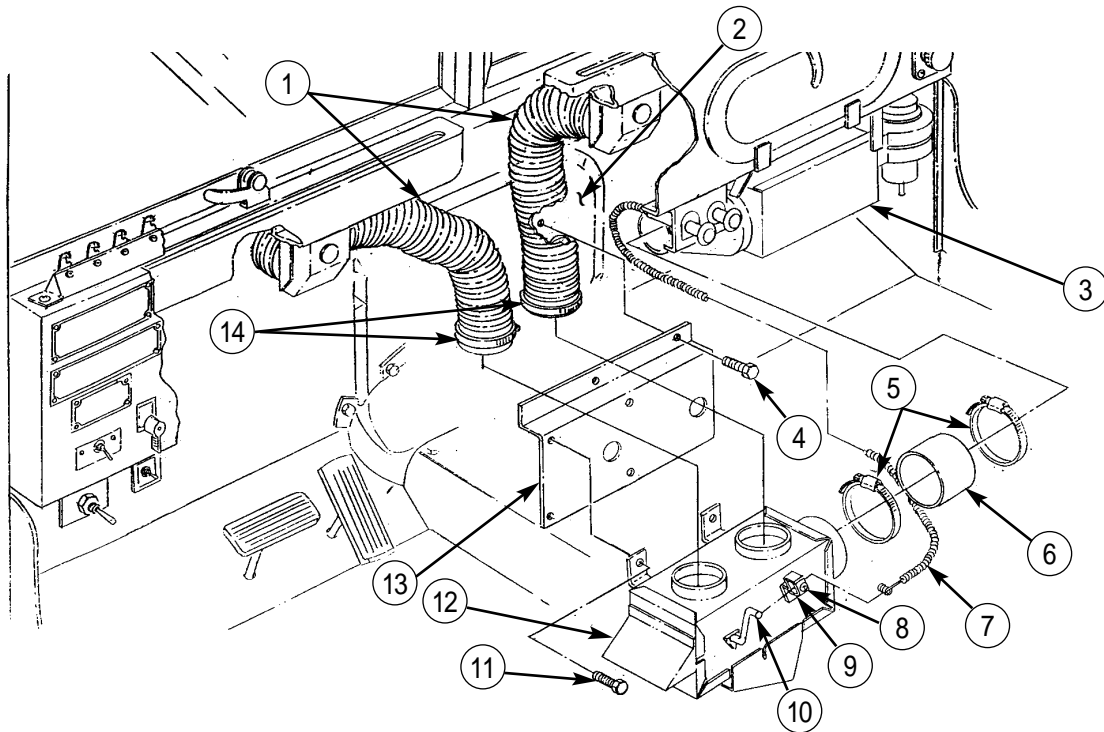
**END OF WORK PACKAGE**

UNIT MAINTENANCE INSTRUCTIONS

EXTENDED SERVICE PROGRAM (ESP)

TRUCK, CARGO, 2-1/2-TON, 6X6, M44A3 SERIES TRUCKS (DIESEL)

M35A3, W/O WINCH (NSN 2320-01-383-2047); W/WINCH (NSN 2320-01-383-3850);
M35A3C, W/O WINCH (NSN 2320-01-383-2050); W/WINCH (NSN 2320-01-383-2049);
M36A3, W/O WINCH (NSN 2320-01-383-2048); W/WINCH (NSN 2320-01-383-2046).

PERSONNEL HOT WATER HEATER CONTROL CABLES REPLACEMENT

REMOVAL, INSTALLATION

INITIAL SETUP:

Tools and Special Tools

General mechanic's tool kit
(item 30, WP 0394 00)

Materials/Parts

Two lockwashers (item 58, WP 0395 00)
Two lockwashers (item 61, WP 0395 00)

References

TM 9-2320-386-24P

Equipment Condition

Parking brake set (TM 9-2320-386-10).
Hood raised and secured (TM 9-2320-386-10).

PERSONNEL HOT WATER HEATER CONTROL CABLES REPLACEMENT (Contd)**REMOVAL**

1. Loosen screw (3) and clamp (2) on water shutoff valve (5).
2. Disconnect damper control cable (1) from lever (4) and remove from clamp (2) and water shutoff valve (5).
3. Remove grommet (9) and damper control cable (1) from firewall (6).
4. Loosen screw (17) and clamp (18) on diverter (19).
5. Disconnect defroster control cable (12) from shaft lever (20) and remove defroster control cable (12) from diverter (19) and clamp (18).
6. Remove two nuts (7), lockwashers (8), screws (14), and bracket (13) from instrument panel (21). Discard lockwashers (8).
7. Remove nut (10), lockwasher (11), and damper control cable (1) from bracket (13). Discard lockwasher (11).
8. Remove nut (16), lockwasher (15), and defroster control cable (12) from bracket (13). Discard lockwasher (15).

INSTALLATION

1. Insert defroster control cable (12) through bracket (13) and install with new lockwasher (15) and nut (16).
2. Insert damper control cable (1) through bracket (13) and install with new lockwasher (11) and nut (10).
3. Install bracket (13) on instrument panel (21) with two screws (14), new lockwashers (8), and nuts (7).
4. Insert defroster control cable (12) through clamp (18) and install on shaft lever (20).
5. Tighten screw (17) and clamp (18) on diverter (19).
6. Install grommet (9) on damper control cable (1) and hole in firewall (6).
7. Insert damper control cable (1) through hole in firewall (6).
8. Route damper control cable (1) to water shutoff valve (5) and install on lever (4).
9. Tighten screw (3) and clamp (2) on damper control cable (1).

PERSONNEL HOT WATER HEATER CONTROL CABLES REPLACEMENT (Contd)

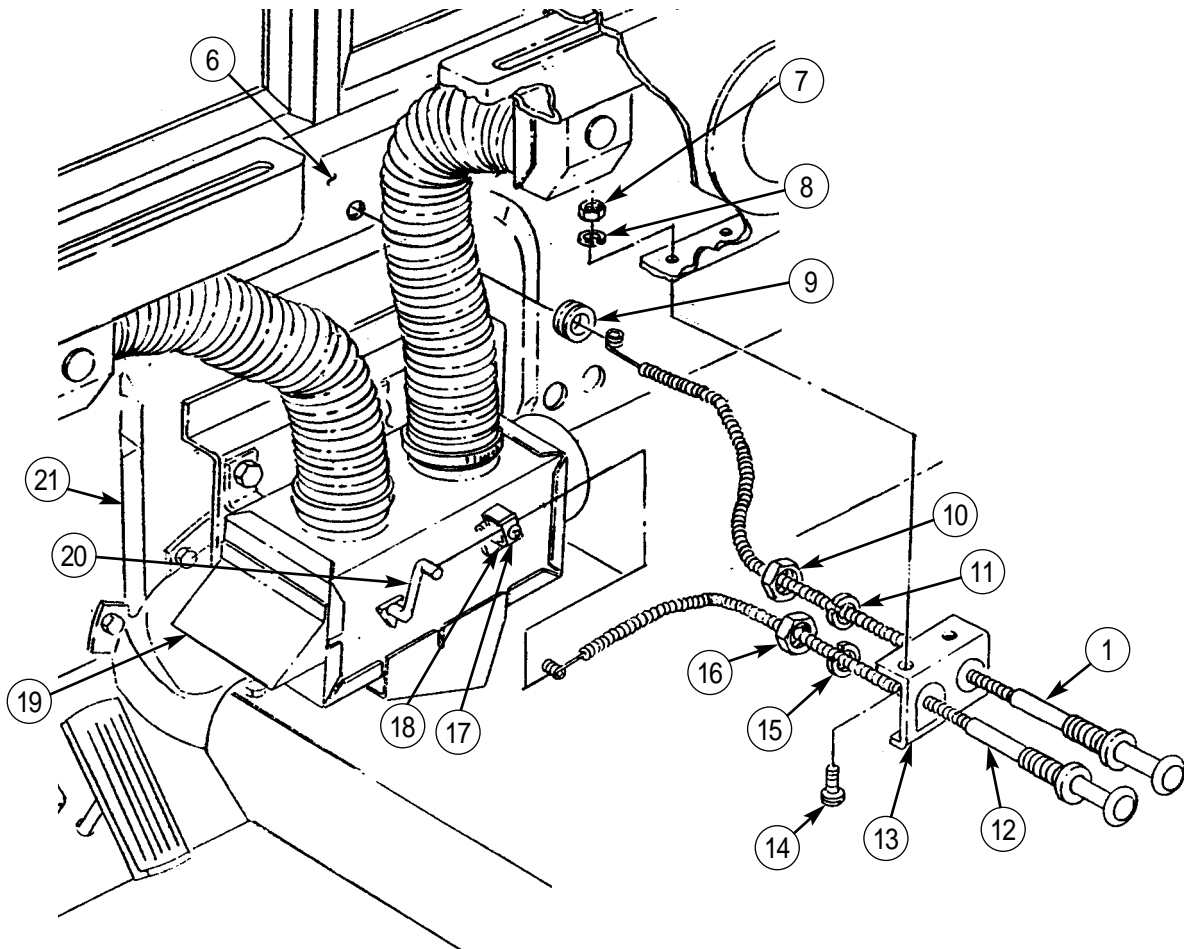
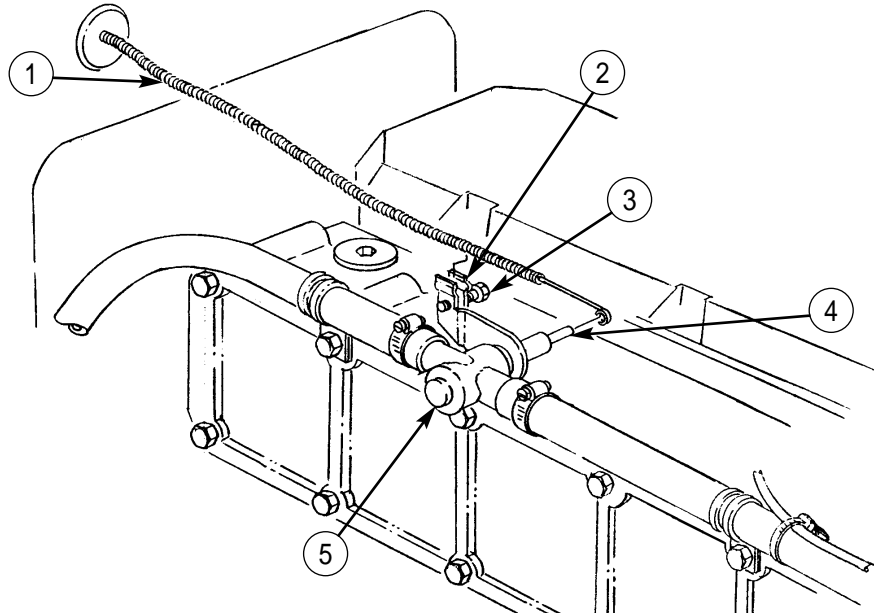

END OF WORK PACKAGE

UNIT MAINTENANCE INSTRUCTIONS

EXTENDED SERVICE PROGRAM (ESP)

TRUCK, CARGO, 2-1/2-TON, 6X6, M44A3 SERIES TRUCKS (DIESEL)

M35A3, W/O WINCH (NSN 2320-01-383-2047); W/WINCH (NSN 2320-01-383-3850);
M35A3C, W/O WINCH (NSN 2320-01-383-2050); W/WINCH (NSN 2320-01-383-2049);
M36A3, W/O WINCH (NSN 2320-01-383-2048); W/WINCH (NSN 2320-01-383-2046).

PERSONNEL HOT WATER HEATER SWITCH REPLACEMENT

REMOVAL, INSTALLATION

INITIAL SETUP:

Tools and Special Tools

General mechanic's tool kit
(item 30, WP 0394 00)

Materials/Parts

Two lockwashers (item 59, WP 0395 00)
Three assembled-washer screws
(item 325, WP 0395 00)
Lockwasher (item 46, WP 0395 00)

References

TM 9-2320-386-24P

Equipment Condition

Parking brake set (TM 9-2320-386-10).
Battery ground cable disconnected (WP 0121 00).

PERSONNEL HOT WATER HEATER SWITCH REPLACEMENT (Contd)**REMOVAL****NOTE**

Locking hardware in step 1 is provisioned with switch.

1. Remove nut (9), lockwasher (8), locking ring (7), plate (6), and switch (11) from mounting bracket (5).

NOTE

Tag leads for installation.

2. Remove three assembled-washer screws (14), resistor lead wire-low (12), lead wire 400A (13), lead wire 400 (15), and resistor lead wire-high (4) from switch (11). Discard assembled-washer screws (14).
3. Remove two nuts (2), lockwashers (1), screws (10), and mounting bracket (5) from instrument panel (3). Discard lockwashers (1).

INSTALLATION

1. Install mounting bracket (5) on instrument panel (3) with two screws (10), new lockwashers (1), and nuts (2).
2. Install resistor lead wire-high (4) on top position, lead wire 400 (15) on center position, and lead wire 400A (13) and resistor lead wire-low (12) on lower position of switch (11) with three new assembled-washer screws (14).
3. Install plate (6) and switch (11), with resistor lead wire-high (4) at top position, on mounting bracket (5) with locking ring (7), lockwasher (8), and nut (9).
4. Connect battery ground cable (WP 0121 00).
5. Check heater switch for proper operation (TM 9-2320-386-10).

PERSONNEL HOT WATER HEATER SWITCH REPLACEMENT (Contd)

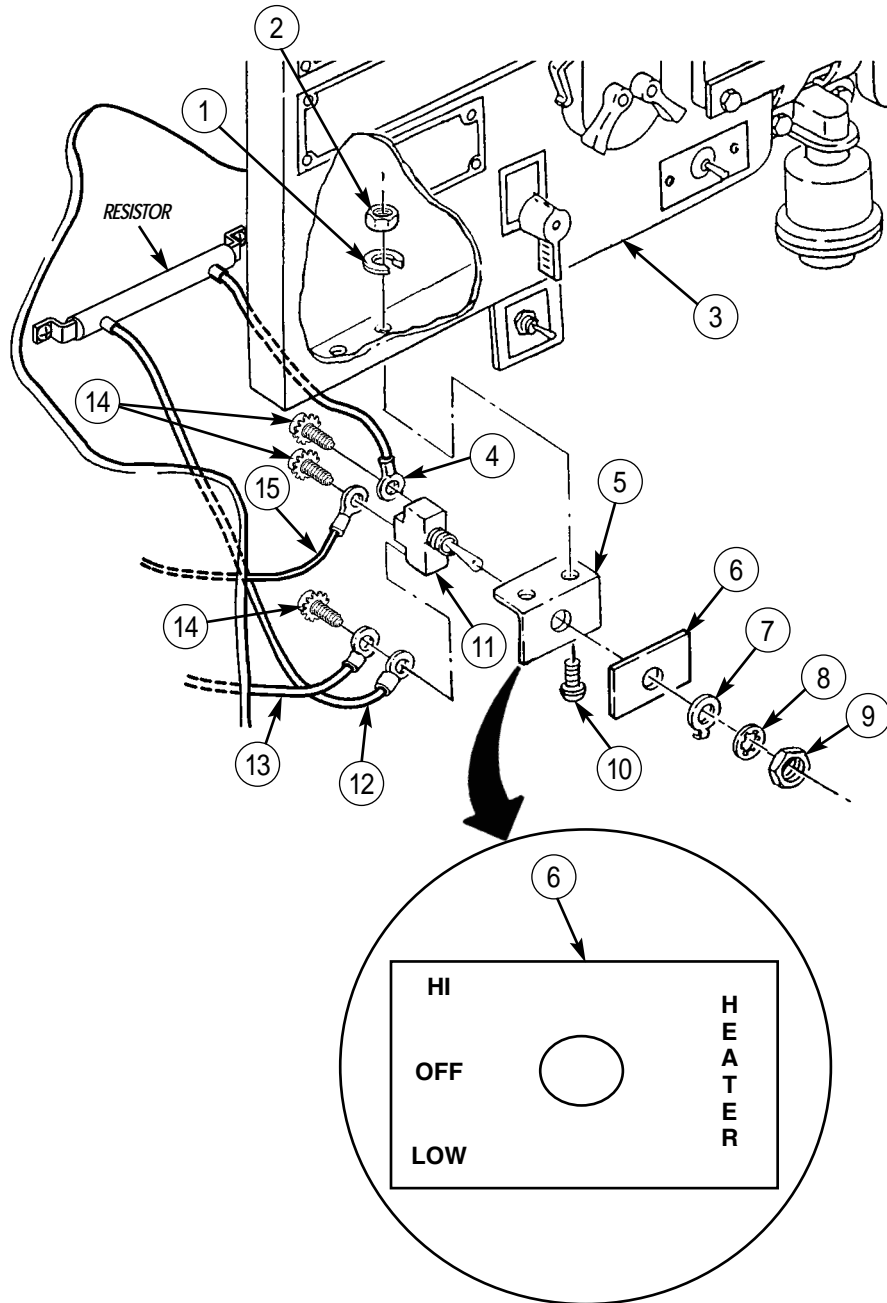

END OF WORK PACKAGE

UNIT MAINTENANCE INSTRUCTIONS

EXTENDED SERVICE PROGRAM (ESP)

TRUCK, CARGO, 2-1/2-TON, 6X6, M44A3 SERIES TRUCKS (DIESEL)

M35A3, W/O WINCH (NSN 2320-01-383-2047); W/WINCH (NSN 2320-01-383-3850);

M35A3C, W/O WINCH (NSN 2320-01-383-2050); W/WINCH (NSN 2320-01-383-2049);

M36A3, W/O WINCH (NSN 2320-01-383-2048); W/WINCH (NSN 2320-01-383-2046).

PERSONNEL HOT WATER HEATER DEFLECTORS REPLACEMENT

REMOVAL, INSTALLATION

INITIAL SETUP:

Tools and Special Tools

General mechanic's tool kit
(item 30, WP 0394 00)

Equipment Condition

Parking brake set (TM 9-2320-386-10).

References

TM 9-2320-386-24P

PERSONNEL HOT WATER HEATER DEFLECTORS REPLACEMENT (Contd)**REMOVAL**

1. Remove two screws (1) and deflector (2) from instrument panel (5).
2. Remove four screws (4) and two deflectors (3) from instrument panel (5).

INSTALLATION

1. Install two deflectors (3) on instrument panel (5) with four screws (4).
2. Install deflector (2) on instrument panel (5) with two screws (1).

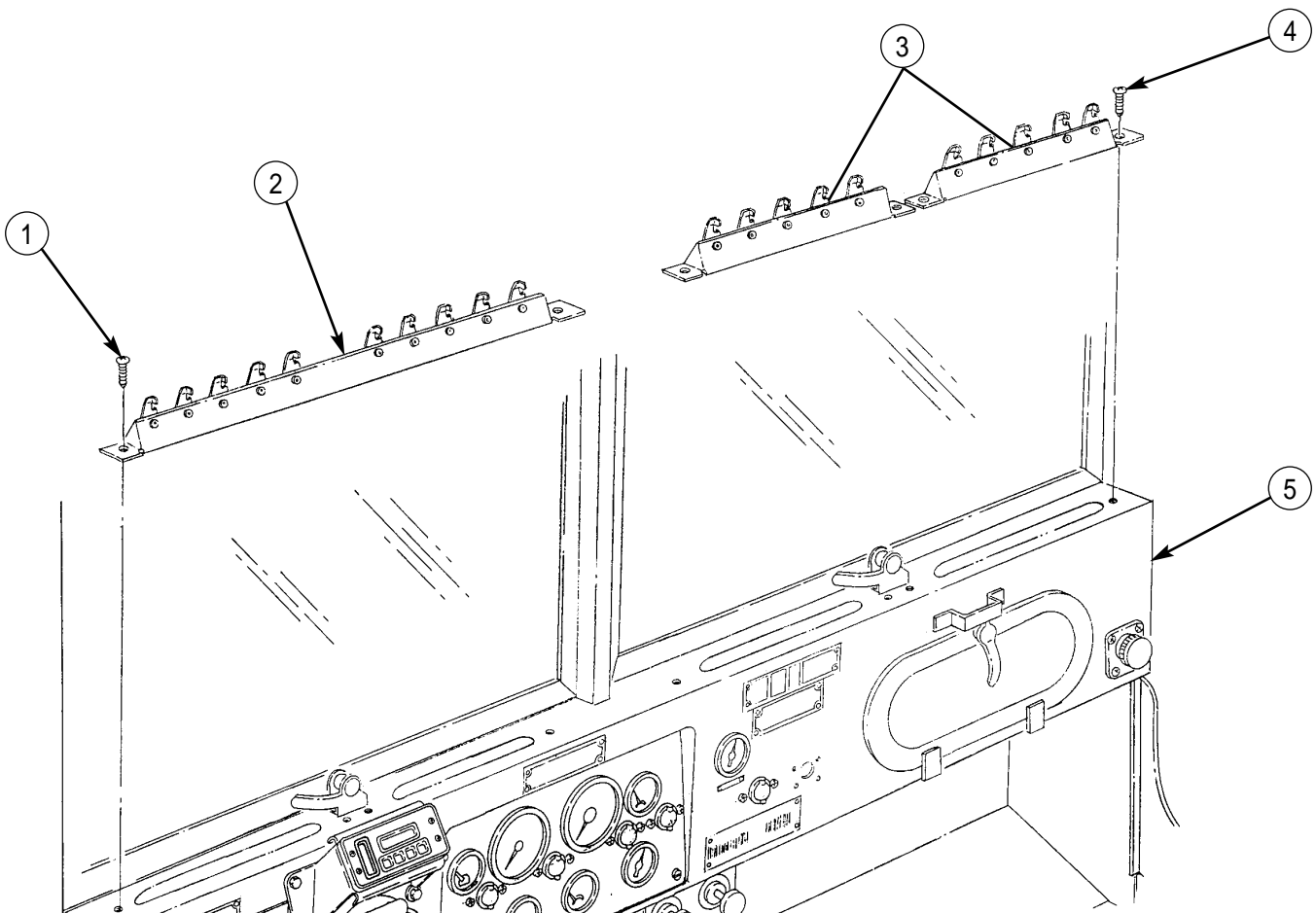
**END OF WORK PACKAGE**

UNIT MAINTENANCE INSTRUCTIONS

EXTENDED SERVICE PROGRAM (ESP)

TRUCK, CARGO, 2-1/2-TON, 6X6, M44A3 SERIES TRUCKS (DIESEL)

M35A3, W/O WINCH (NSN 2320-01-383-2047); W/WINCH (NSN 2320-01-383-3850);

M35A3C, W/O WINCH (NSN 2320-01-383-2050); W/WINCH (NSN 2320-01-383-2049);

M36A3, W/O WINCH (NSN 2320-01-383-2048); W/WINCH (NSN 2320-01-383-2046).

Section XXIII. ARCTIC WINTERIZATION KITS MAINTENANCE

TABLE OF CONTENTS

<i>WP Title</i>	<i>WP Sequence No.-Page No.</i>
Winterfront Radiator Cover Replacement	0246 00-1
Fuel Burning Personnel Heater Replacement	0247 00-1
Personnel Heater Control Box Replacement	0248 00-1
Personnel Heater Fuel Pump Replacement	0249 00-1
Personnel Heater Fuel Filter Replacement	0250 00-1
Personnel Heater Exhaust Tube Replacement	0251 00-1
Oil Pan Shroud and Exhaust Tube Replacement	0252 00-1
Engine Coolant Heater Replacement	0253 00-1
Engine Coolant Heater Harness Replacement	0254 00-1
Battery Box Heater Pad Replacement	0255 00-1

END OF WORK PACKAGE

UNIT MAINTENANCE INSTRUCTIONS

EXTENDED SERVICE PROGRAM (ESP)

TRUCK, CARGO, 2-1/2-TON, 6X6, M44A3 SERIES TRUCKS (DIESEL)

M35A3, W/O WINCH (NSN 2320-01-383-2047); W/WINCH (NSN 2320-01-383-3850);

M35A3C, W/O WINCH (NSN 2320-01-383-2050); W/WINCH (NSN 2320-01-383-2049);

M36A3, W/O WINCH (NSN 2320-01-383-2048); W/WINCH (NSN 2320-01-383-2046).

WINTERFRONT RADIATOR COVER REPLACEMENT

REMOVAL, INSTALLATION

INITIAL SETUP:

Tools and Special Tools

General mechanic's tool kit
(item 30, WP 0394 00)

Materials/Parts

Rivets (item 12, WP 0395 00)

References

TM 9-2320-386-24P

Equipment Condition

Parking brake set (TM 9-2320-386-10).

WINTERFRONT RADIATOR COVER REPLACEMENT (Contd)**REMOVAL**

1. Turn twelve clasps (1) one-quarter turn counterclockwise and remove radiator cover (3) from brushguard (4).

NOTE

Perform step 2 if clasp(s) are damaged.

All clasps are removed the same.

2. Remove two rivets (2) and clasp (1) from brushguard (4). Discard rivets (2).

INSTALLATION**NOTE**

Perform step 1 if clasp(s) were removed.

All clasps are installed the same.

1. Install clasp (1) on brushguard (4) with two new rivets (2).
2. Install radiator cover (3) on brushguard (4) and turn clasps (1) clockwise to hold radiator cover (3) in place.

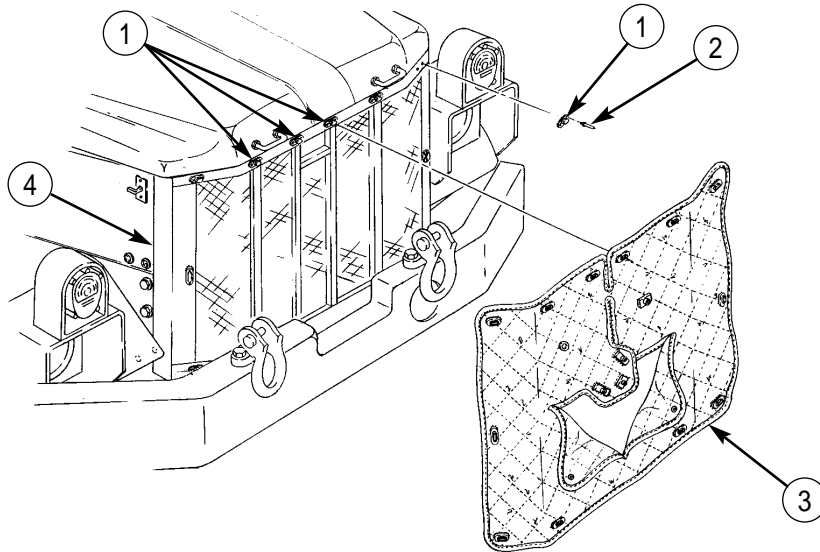

END OF WORK PACKAGE

UNIT MAINTENANCE INSTRUCTIONS

EXTENDED SERVICE PROGRAM (ESP)

TRUCK, CARGO, 2-1/2-TON, 6X6, M44A3 SERIES TRUCKS (DIESEL)

**M35A3, W/O WINCH (NSN 2320-01-383-2047); W/WINCH (NSN 2320-01-383-3850);
M35A3C, W/O WINCH (NSN 2320-01-383-2050); W/WINCH (NSN 2320-01-383-2049);
M36A3, W/O WINCH (NSN 2320-01-383-2048); W/WINCH (NSN 2320-01-383-2046).**

FUEL BURNING PERSONNEL HEATER REPLACEMENT

REMOVAL, INSTALLATION

INITIAL SETUP:

Tools and Special Tools

General mechanic's tool kit
(item 30, WP 0394 00)

Materials/Parts

Cotter pin (item 32, WP 0395 00)
Four lockwashers (item 74, WP 0395 00)
Teflon pipe sealant (item 41, WP 0393 00)

References

TM 9-2320-386-24P

Equipment Condition

Parking brake set (TM 9-2320-386-10).
Hood raised and secured (TM 9-2320-386-10).
Battery ground cable disconnected (WP 0121 00).

FUEL BURNING PERSONNEL HEATER REPLACEMENT (Contd)**REMOVAL**

1. Disconnect wiring harness (1) from personnel heater (2).
2. Remove fuel line (4) from elbow (3) on personnel heater (2).
3. Remove elbow (3) from personnel heater (2).
4. Remove cotter pin (9), and disconnect exhaust tube (10) from personnel heater (2). Discard cotter pin (9).
5. Remove four screws (6), lockwashers (7), and adapter (5) from personnel heater (2). Discard lockwashers (7).
6. Remove two clamps (8) and personnel heater (2) from mount (11).

INSTALLATION

1. Install personnel heater (2) on mount (11) with two clamps (8).
2. Install adapter (5) on personnel heater (2) with four new lockwashers (7) and screws (6).
3. Apply sealant to male threads of elbow (3).
4. Install elbow (3) on personnel heater (2).
5. Connect exhaust tube (10) to personnel heater (2), and insert new cotter pin (9) through tube (10) and personnel heater (2).
6. Install fuel line (4) on elbow (3).
7. Connect wiring harness (1) to personnel heater (2).
8. Connect battery ground cable (WP 0121 00).
9. Start heater and check operation (TM 9-2320-386-10).

FUEL BURNING PERSONNEL HEATER REPLACEMENT (Contd)

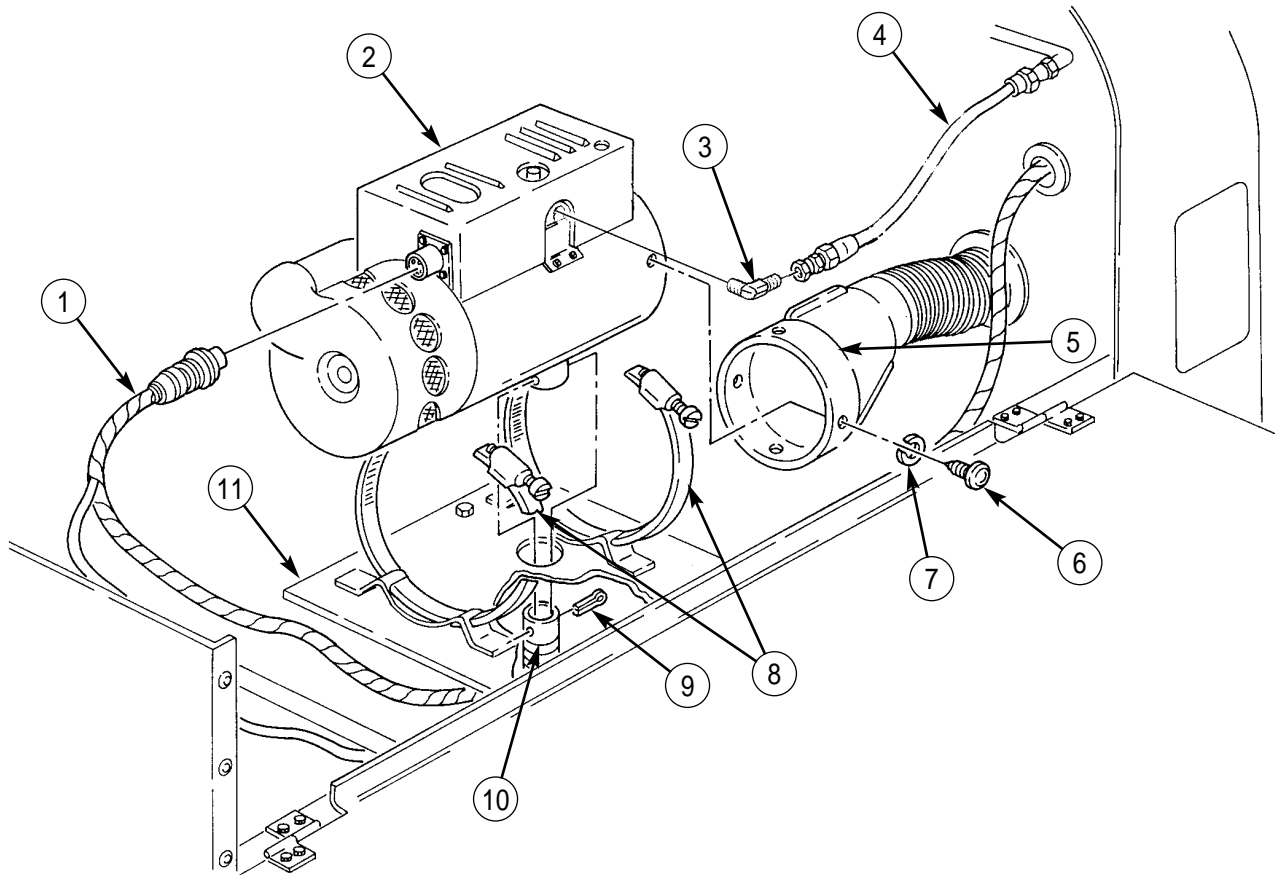

END OF WORK PACKAGE

UNIT MAINTENANCE INSTRUCTIONS

EXTENDED SERVICE PROGRAM (ESP)

TRUCK, CARGO, 2-1/2-TON, 6X6, M44A3 SERIES TRUCKS (DIESEL)

M35A3, W/O WINCH (NSN 2320-01-383-2047); W/WINCH (NSN 2320-01-383-3850);
M35A3C, W/O WINCH (NSN 2320-01-383-2050); W/WINCH (NSN 2320-01-383-2049);
M36A3, W/O WINCH (NSN 2320-01-383-2048); W/WINCH (NSN 2320-01-383-2046).

PERSONNEL HEATER CONTROL BOX REPLACEMENT

REMOVAL, INSTALLATION

INITIAL SETUP:

Tools and Special Tools

General mechanic's tool kit
(item 30, WP 0394 00)

References

TM 9-2320-386-24P

Materials/Parts

Two lockwashers (item 52, WP 0395 00)

Equipment Condition

Parking brake set (TM 9-2320-386-10).
Battery ground cable disconnected (WP 0121 00).

PERSONNEL HEATER CONTROL BOX REPLACEMENT (Contd)**NOTE**

This procedure is the same for the engine coolant heater control box.

REMOVAL

1. Disconnect wiring harness (4) from control box (7).
2. Disconnect wire 400 (6) from wire 400 (5).
3. Remove two nuts (2), lockwashers (1), and control box (7) from bracket (3). Discard lockwashers (1).

INSTALLATION

1. Install control box (7) on bracket (3) with two new lockwashers (1) and nuts (2).
2. Connect wire 400 (6) to wire 400 (5).
3. Connect wiring harness (4) to control box (7).
4. Connect battery ground (GND) cable (WP 0121 00).

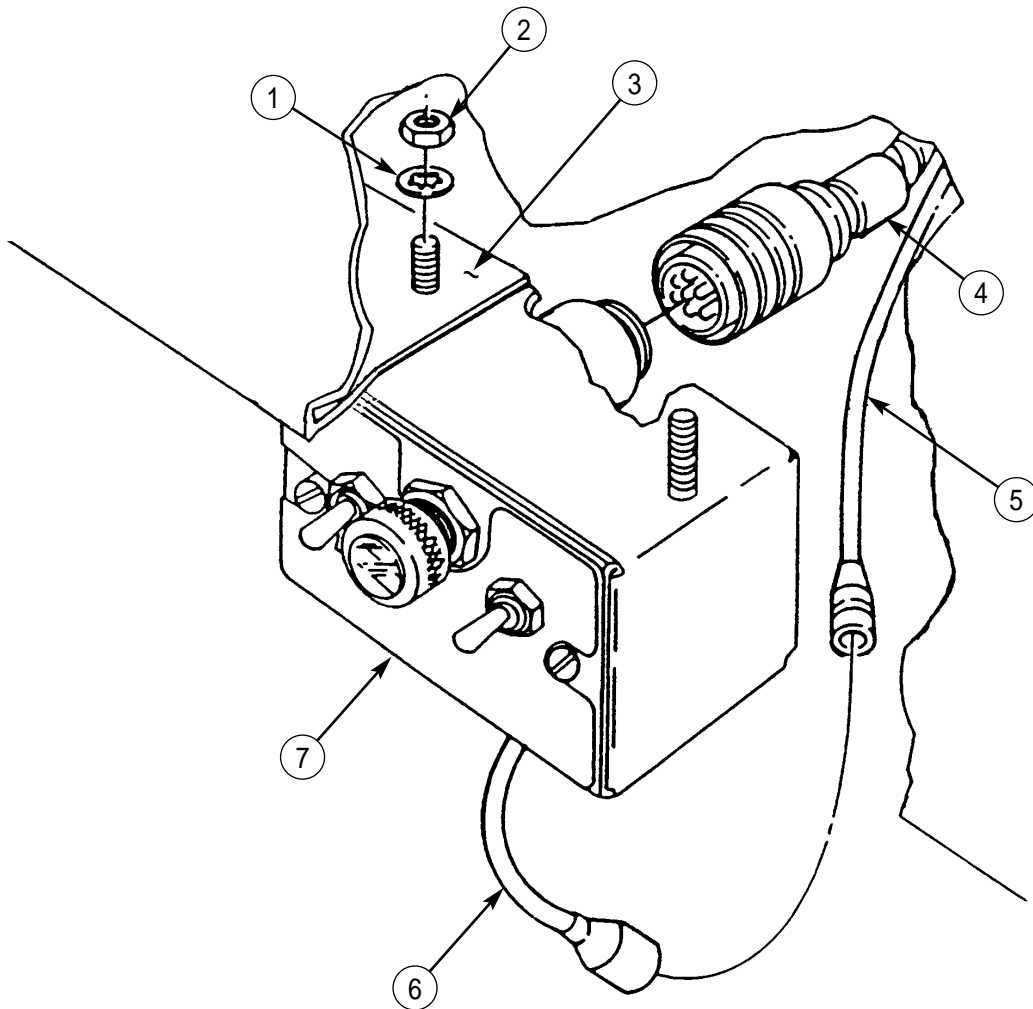

END OF WORK PACKAGE

UNIT MAINTENANCE INSTRUCTIONS

EXTENDED SERVICE PROGRAM (ESP)

TRUCK, CARGO, 2-1/2-TON, 6X6, M44A3 SERIES TRUCKS (DIESEL)

**M35A3, W/O WINCH (NSN 2320-01-383-2047); W/WINCH (NSN 2320-01-383-3850);
M35A3C, W/O WINCH (NSN 2320-01-383-2050); W/WINCH (NSN 2320-01-383-2049);
M36A3, W/O WINCH (NSN 2320-01-383-2048); W/WINCH (NSN 2320-01-383-2046).**

PERSONNEL HEATER FUEL PUMP REPLACEMENT

REMOVAL, INSTALLATION

INITIAL SETUP:

Tools and Special Tools

General mechanic's tool kit
(item 30, WP 0394 00)

Materials/Parts

Two lockwashers (item 77, WP 0395 00)
Cap and plug set (item 14, WP 0393 00)
Teflon pipe sealant (item 41, WP 0393 00)

References

TM 9-2320-386-24P

Equipment Condition

Parking brake set (TM 9-2320-386-10).
Battery ground cable disconnected (WP 0121 00).

PERSONNEL HEATER FUEL PUMP REPLACEMENT (Contd)**WARNING**

Do not perform this procedure while smoking or near sparks or open flame. Fuel is flammable and can explode easily, causing injury or death to personnel and damage to equipment.

REMOVAL

1. Disconnect wire (6) from wire 401 (5).

CAUTION

Cap or plug all hoses, connections, and openings immediately after disconnection to prevent contamination. Remove caps or plugs prior to installation. Failure to do so may result in damage to equipment.

2. Disconnect inlet line (3) from fuel pump (11).
3. Disconnect outlet line (1) from elbow (2).
4. Remove elbow (2) from fuel pump (11).
5. Remove two screws (7), lockwashers (8), clamp (10), ground wire (9), and fuel pump (11) from plate (4). Discard lockwashers (8).

INSTALLATION

1. Apply sealant to male threads of elbow (2).
2. Install fuel pump (11), ground wire (9), and clamp (10) on plate (4) with two new lockwashers (8) and screws (7).
3. Install elbow (2) on fuel pump (11).
4. Connect outlet line (1) to elbow (2).
5. Connect inlet line (3) to fuel pump (11).
6. Connect wire (6) to wire 401 (5).
7. Connect battery ground (GND) cable (WP 0121 00)

PERSONNEL HEATER FUEL PUMP REPLACEMENT (Contd)

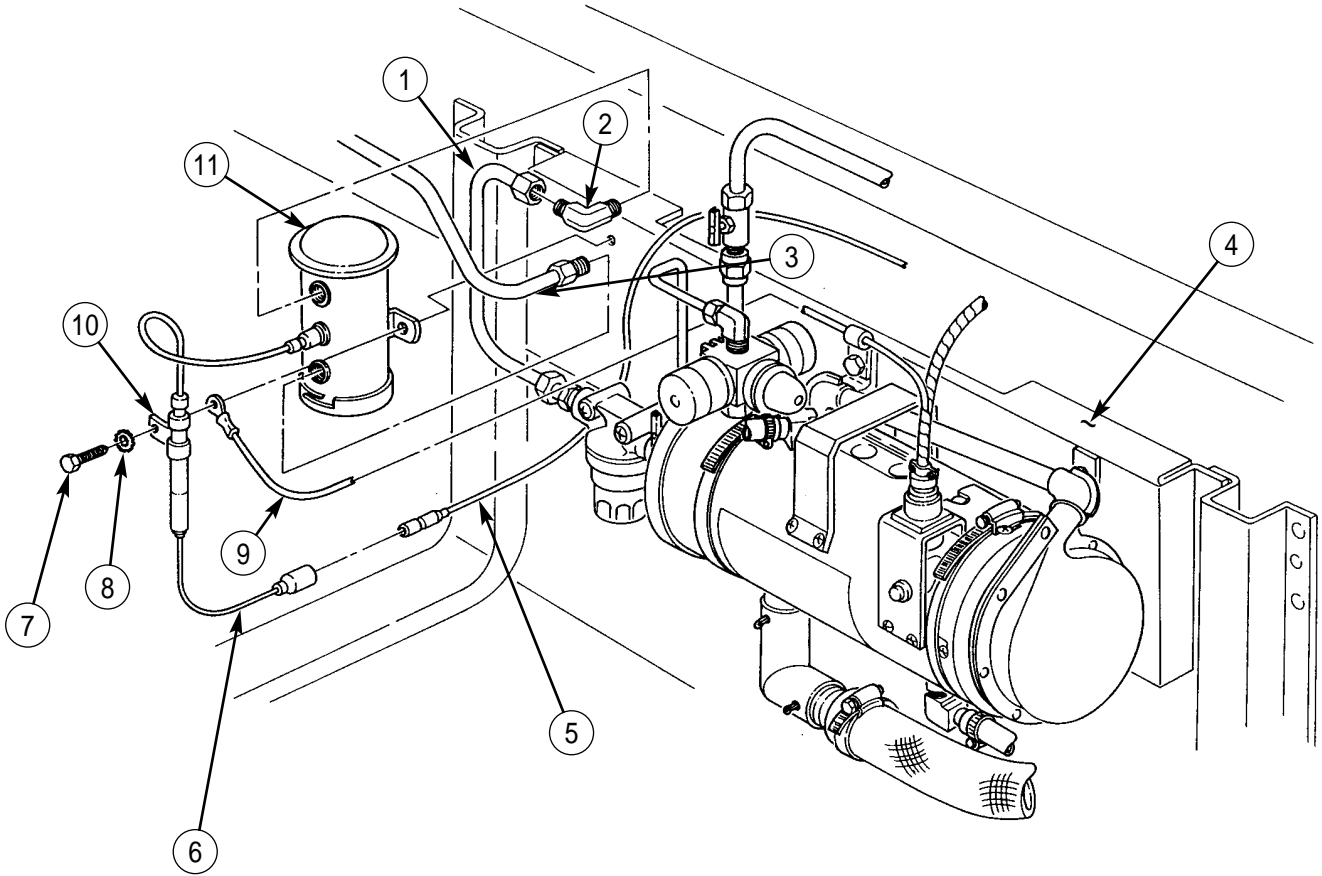

END OF WORK PACKAGE

UNIT MAINTENANCE INSTRUCTIONS

EXTENDED SERVICE PROGRAM (ESP)

TRUCK, CARGO, 2-1/2-TON, 6X6, M44A3 SERIES TRUCKS (DIESEL)

M35A3, W/O WINCH (NSN 2320-01-383-2047); W/WINCH (NSN 2320-01-383-3850);

M35A3C, W/O WINCH (NSN 2320-01-383-2050); W/WINCH (NSN 2320-01-383-2049);

M36A3, W/O WINCH (NSN 2320-01-383-2048); W/WINCH (NSN 2320-01-383-2046).

PERSONNEL HEATER FUEL FILTER REPLACEMENT

REMOVAL, INSTALLATION

INITIAL SETUP:

Tools and Special Tools

General mechanic's tool kit
(item 30, WP 0394 00)

Materials/Parts

Two lockwashers (item 49, WP 0395 00)
Teflon pipe sealant (item 41, WP 0393 00)

References

TM 9-2320-386-24P

Equipment Condition

Parking brake set (TM 9-2320-386-10).
Hood raised and secured (TM 9-2320-386-10).

PERSONNEL HEATER FUEL FILTER REPLACEMENT (Contd)**REMOVAL**

1. Disconnect tube (11) from fuel pump elbow (1) and adapter (10).
2. Disconnect fuel line (3) from tube (4).
3. Disconnect tube (4) from elbow (5).
4. Remove elbow (5) from tee (6).

NOTE

Perform step 5 if vehicle is equipped with engine coolant heater.

5. Disconnect fuel line (12) from tee (6).
6. Remove tee (6) from fuel filter (7).
7. Remove two screws (8), lockwashers (9), and fuel filter (7) from plate (2). Discard lockwashers (9).
8. Remove adapter (10) from fuel filter (7).

INSTALLATION

1. Apply sealant to male threads of elbow (5), fuel line (3), tube (4), tee (6), and adapter (10).
2. Install adapter (10) on fuel filter (7).
3. Install fuel filter (7) on plate (2) with two new lockwashers (9) and screws (8).
4. Install tee (6) on fuel filter (7).
5. Install elbow (5) on tee (6).
6. Connect tube (4) to elbow (5).

NOTE

Perform step 7 if vehicle is equipped with engine coolant heater.

7. Connect fuel line (12) to tee (6).
8. Connect fuel line (3) to tube (4).
9. Connect tube (11) to fuel pump elbow (1) and adapter (10).

PERSONNEL HEATER FUEL FILTER REPLACEMENT (Contd)

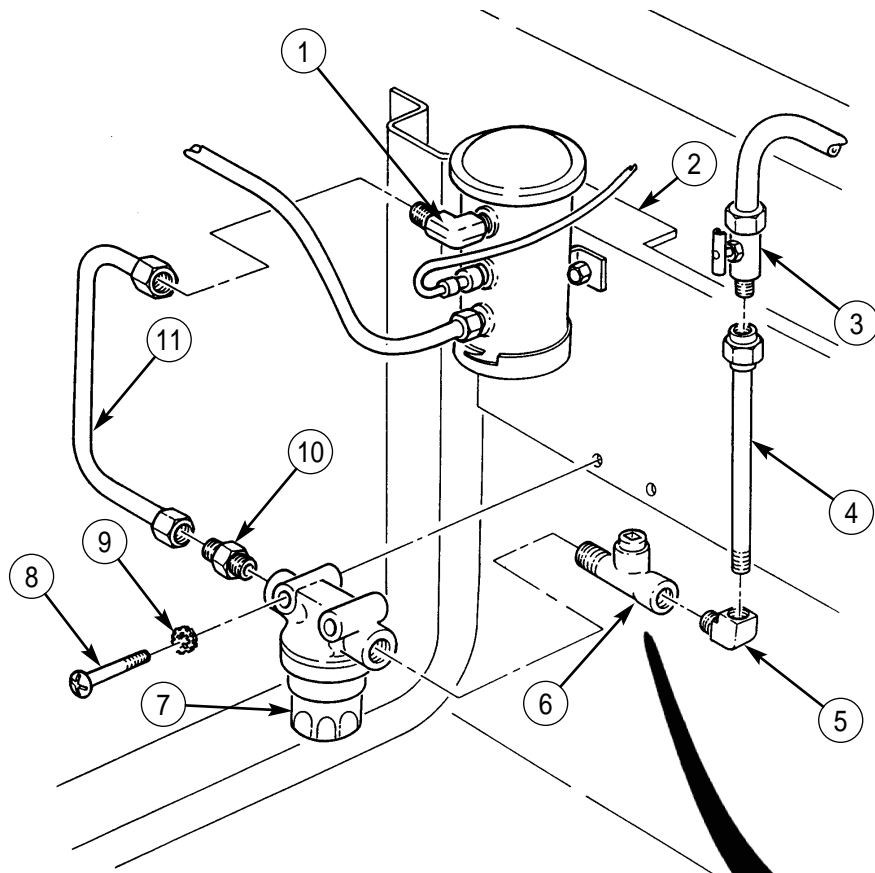

W/O ENGINE COOLANT HEATER

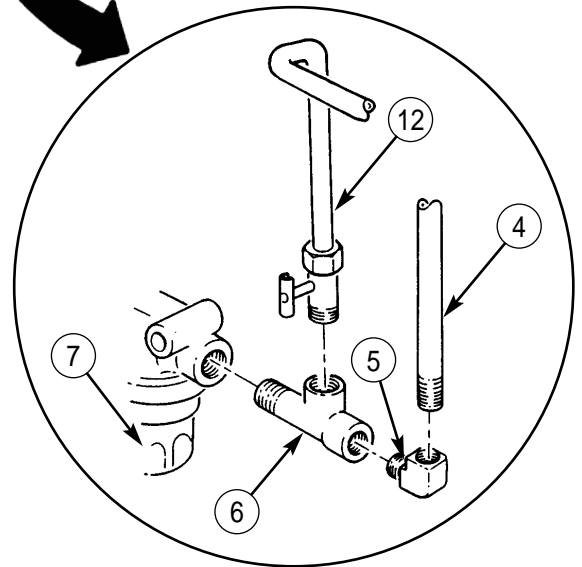

W/ENGINE COOLANT HEATER

END OF WORK PACKAGE

UNIT MAINTENANCE INSTRUCTIONS

EXTENDED SERVICE PROGRAM (ESP)

TRUCK, CARGO, 2-1/2-TON, 6X6, M44A3 SERIES TRUCKS (DIESEL)

**M35A3, W/O WINCH (NSN 2320-01-383-2047); W/WINCH (NSN 2320-01-383-3850);
M35A3C, W/O WINCH (NSN 2320-01-383-2050); W/WINCH (NSN 2320-01-383-2049);
M36A3, W/O WINCH (NSN 2320-01-383-2048); W/WINCH (NSN 2320-01-383-2046).**

PERSONNEL HEATER EXHAUST TUBE REPLACEMENT

REMOVAL, INSTALLATION

INITIAL SETUP:

Tools and Special Tools

General mechanic's tool kit
(item 30, WP 0394 00)

Materials/Parts

Cotter pin (item 32, WP 0395 00)
Locknut (item 15, WP 0395 00)

References

TM 9-2320-386-24P

Equipment Condition

Parking brake set (TM 9-2320-386-10).

PERSONNEL HEATER EXHAUST TUBE REPLACEMENT (Contd)**REMOVAL****WARNING**

Do not touch hot exhaust system components with bare hands.
Injury to personnel may result.

1. Remove cotter pin (2) and exhaust tube (7) from personnel heater (1). Discard cotter pin (2).
2. Remove two nuts (5), screws (3), clamps (4), and exhaust tube (7) from left front fender (6).
3. Remove locknut (8), screw (10), clamp (9), and exhaust tube (7) from splash shield (11). Discard locknut (8).
4. Remove exhaust tube (7) from vehicle.

INSTALLATION

1. Install exhaust tube (7) on personnel heater (1) with new cotter pin (2).
2. Install exhaust tube (7) on left front fender (6) with two clamps (4), screws (3), and nuts (5).
3. Install exhaust tube (7) on splash shield (11) with clamp (9), screw (10), and new locknut (8).

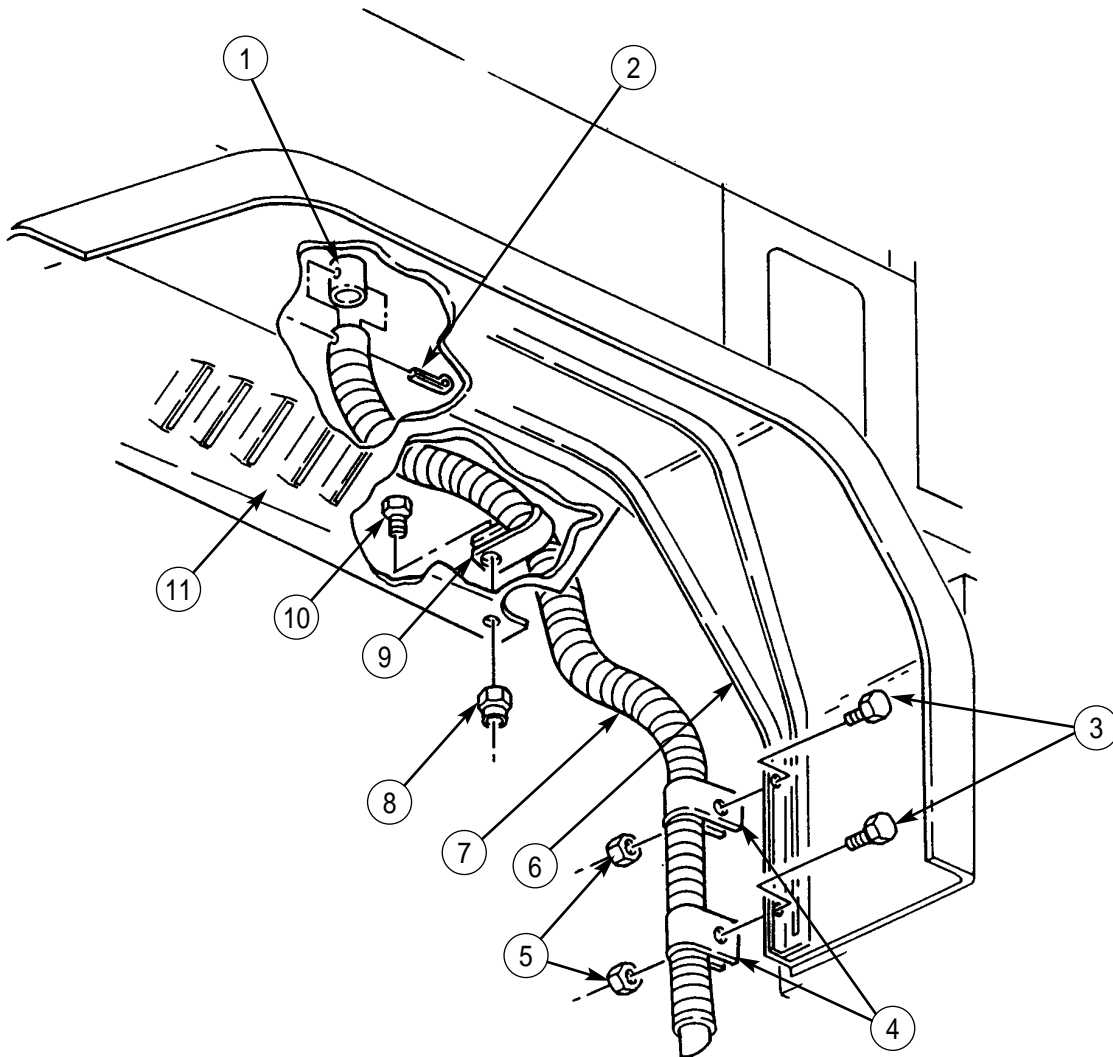

END OF WORK PACKAGE

UNIT MAINTENANCE INSTRUCTIONS

EXTENDED SERVICE PROGRAM (ESP)

TRUCK, CARGO, 2-1/2-TON, 6X6, M44A3 SERIES TRUCKS (DIESEL)

M35A3, W/O WINCH (NSN 2320-01-383-2047); W/WINCH (NSN 2320-01-383-3850);

M35A3C, W/O WINCH (NSN 2320-01-383-2050); W/WINCH (NSN 2320-01-383-2049);

M36A3, W/O WINCH (NSN 2320-01-383-2048); W/WINCH (NSN 2320-01-383-2046).

OIL PAN SHROUD AND EXHAUST TUBE REPLACEMENT

REMOVAL, INSTALLATION

INITIAL SETUP:

Tools and Special Tools

General mechanic's tool kit
(item 30, WP 0394 00)

Materials/Parts

Three cotter pins (item 33, WP 0395 00)
Four lockwashers (item 133, WP 0395 00)
Locknut (item 15, WP 0395 00)

References

TM 9-2320-386-24P

Equipment Condition

Parking brake set (TM 9-2320-386-10).

OIL PAN SHROUD AND EXHAUST TUBE REPLACEMENT (Contd)

REMOVAL

WARNING

Do not touch hot exhaust system components with bare hands.
Injury to personnel may result.

1. Remove cotter pin (9) and exhaust tube (10) from oil pan shroud (6). Discard cotter pin (9).
2. Remove two cotter pins (12), elbow (13), and exhaust tube (10) from heater (14). Discard cotter pins (12).
3. Remove locknut (1), screw (3), clamp (2), and exhaust tube (10) from splash shield (4). Discard locknut (1).
4. Remove exhaust tube (10) from vehicle.
5. Remove four screws (8), lockwashers (7), and oil pan shroud (6) from engine oil pan (5). Discard lockwashers (7).

INSTALLATION

1. Install oil pan shroud (6) on engine oil pan (5) with four new lockwashers (7) and screws (8).
2. Install exhaust tube (10) on oil pan shroud (6) with new cotter pin (9).
3. Insert exhaust tube (10) through hole (11) in toolbox (15).
4. Install elbow (13) and exhaust tube (10) on heater (14) with two new cotter pins (12).
5. Install exhaust tube (10) on splash shield (4) with clamp (2), screw (3), and new locknut (1).

OIL PAN SHROUD AND EXHAUST TUBE REPLACEMENT (Contd)

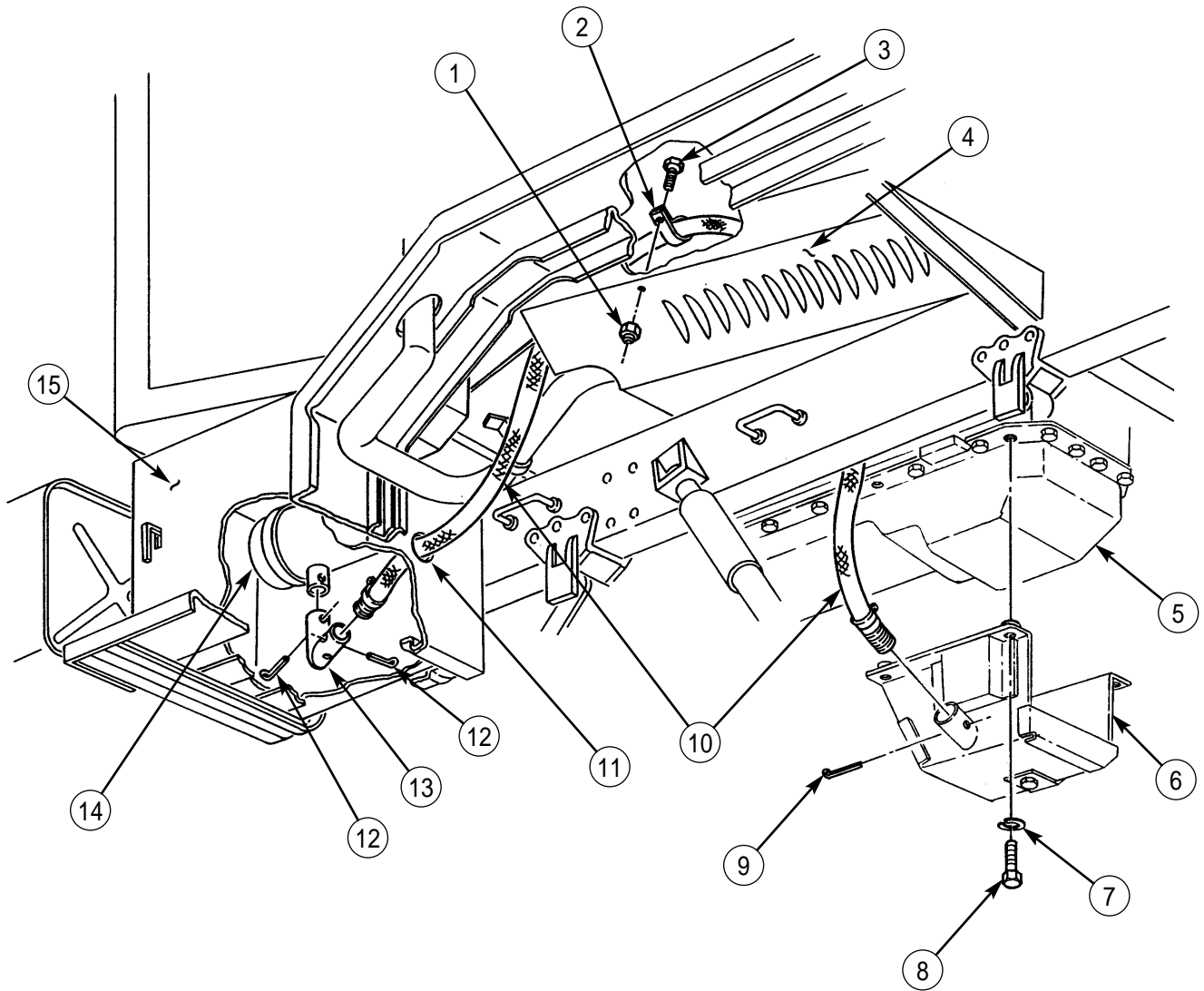

END OF WORK PACKAGE

UNIT MAINTENANCE INSTRUCTIONS

EXTENDED SERVICE PROGRAM (ESP)

TRUCK, CARGO, 2-1/2-TON, 6X6, M44A3 SERIES TRUCKS (DIESEL)

**M35A3, W/O WINCH (NSN 2320-01-383-2047); W/WINCH (NSN 2320-01-383-3850);
M35A3C, W/O WINCH (NSN 2320-01-383-2050); W/WINCH (NSN 2320-01-383-2049);
M36A3, W/O WINCH (NSN 2320-01-383-2048); W/WINCH (NSN 2320-01-383-2046).**

ENGINE COOLANT HEATER REPLACEMENT

REMOVAL, INSTALLATION

INITIAL SETUP:

Tools and Special Tools

General mechanic's tool kit
(item 30, WP 0394 00)

Materials/Parts

Cotter pin (item 33, WP 0395 00)

References

TM 9-2320-386-24P

Equipment Condition

Parking brake set (TM 9-2320-386-10).
Battery ground cable disconnected (WP 0121 00).

ENGINE COOLANT HEATER REPLACEMENT (Contd)**REMOVAL****NOTE**

Prior to removal, close fuel shutoff, engine oil, and water manifold valves.

Have drainage container ready to catch coolant.

1. Disconnect harness (3) from heater (4).
2. Disconnect fuel line (1) from elbow (14).
3. Remove clamp (13) and hose (12) from elbow (11).
4. Remove cotter pin (10) and elbow (8) from heater (4). Discard cotter pin (10).
5. Remove clamp (6) and hose (5) from elbow (7).
6. Remove two clamps (9) and heater (4) from saddle brackets (2).

INSTALLATION

1. Install heater (4) on two saddle brackets (2) with clamps (9).
2. Install hose (5) on elbow (7) with clamp (6).
3. Install elbow (8) on heater (4) with new cotter pin (10).
4. Install hose (12) on elbow (11) with clamp (13).
5. Connect fuel line (1) to elbow (14).
6. Connect harness (3) to heater (4).
7. Connect battery ground cable (WP 0121 00).

ENGINE COOLANT HEATER REPLACEMENT (Contd)

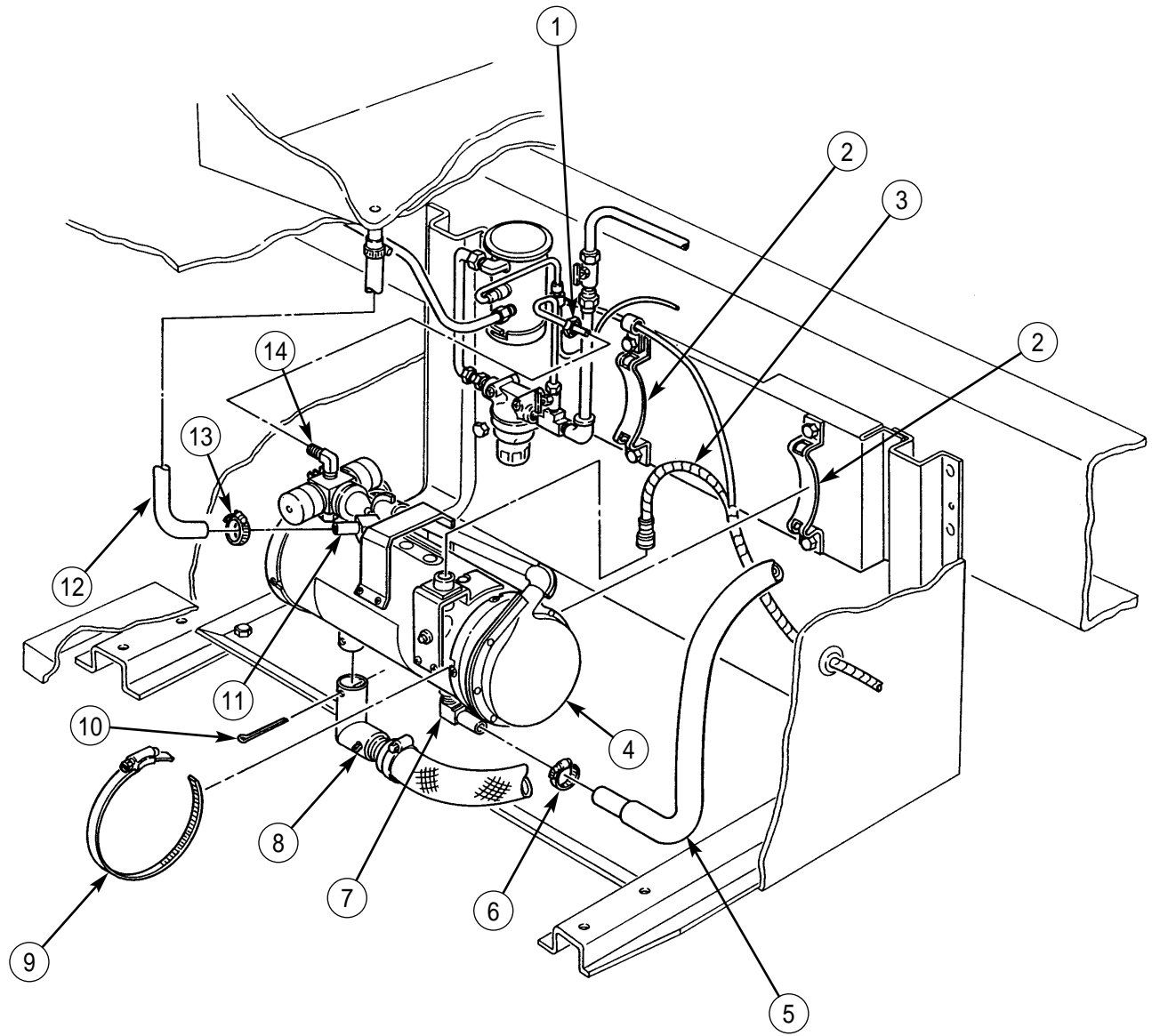

END OF WORK PACKAGE

UNIT MAINTENANCE INSTRUCTIONS

EXTENDED SERVICE PROGRAM (ESP)

TRUCK, CARGO, 2-1/2-TON, 6X6, M44A3 SERIES TRUCKS (DIESEL)

M35A3, W/O WINCH (NSN 2320-01-383-2047); W/WINCH (NSN 2320-01-383-3850);
M35A3C, W/O WINCH (NSN 2320-01-383-2050); W/WINCH (NSN 2320-01-383-2049);
M36A3, W/O WINCH (NSN 2320-01-383-2048); W/WINCH (NSN 2320-01-383-2046).

ENGINE COOLANT HEATER HARNESS REPLACEMENT

REMOVAL, INSTALLATION

INITIAL SETUP:

Tools and Special Tools

General mechanic's tool kit
(item 30, WP 0394 00)

Materials/Parts

Two lockwashers (item 77, WP 0395 00)

References

TM 9-2320-386-24P

Equipment Condition

Parking brake set (TM 9-2320-386-10).
Disconnect battery ground cable (WP 0121 00).

ENGINE COOLANT HEATER HARNESS REPLACEMENT (Contd)

REMOVAL

CAUTION

Use care when routing harness. Snagging may result, and forceful pulling may cause damage to harness.

1. Remove screw (10), lockwasher (11), clamp (12), and ground (GND) lead (13) from right side of fuel pump (16). Discard lockwasher (11).
2. Remove screw (8), lockwasher (9), clamp (7), and ground (GND) lead (13) from saddle bracket (17). Discard lockwasher (9).
3. Disconnect harness (6) from heater (14).
4. Remove grommet (18) and pull harness (6) from toolbox (15).
5. From under instrument panel (2), disconnect harness lead 25 (3) from diode box wire 402 (1).
6. Disconnect harness (6) from heater control box (19).
7. Remove grommet (4) and pull harness (6) from firewall (5).
8. Remove harness (6) from vehicle.

INSTALLATION

1. Insert harness (6) through firewall (5).
2. From under instrument panel (2), connect harness (6) to heater control box (19).
3. Connect harness lead 25 (3) to diode box wire 402 (1).
4. Insert harness (6) through battery box (15) and connect to heater (14).
5. Install ground (GND) lead (13), clamp (12), new lockwasher (11), and screw (10) on the right side of fuel pump (16).
6. Install ground (GND) lead (13) on saddle bracket (17) with clamp (7), new lockwasher (9), and screw (8).
7. Install grommets (4) and (18) on firewall (5) and toolbox (15).
8. Connect battery ground (GND) cable (WP 0121 00).

ENGINE COOLANT HEATER HARNESS REPLACEMENT (Contd)

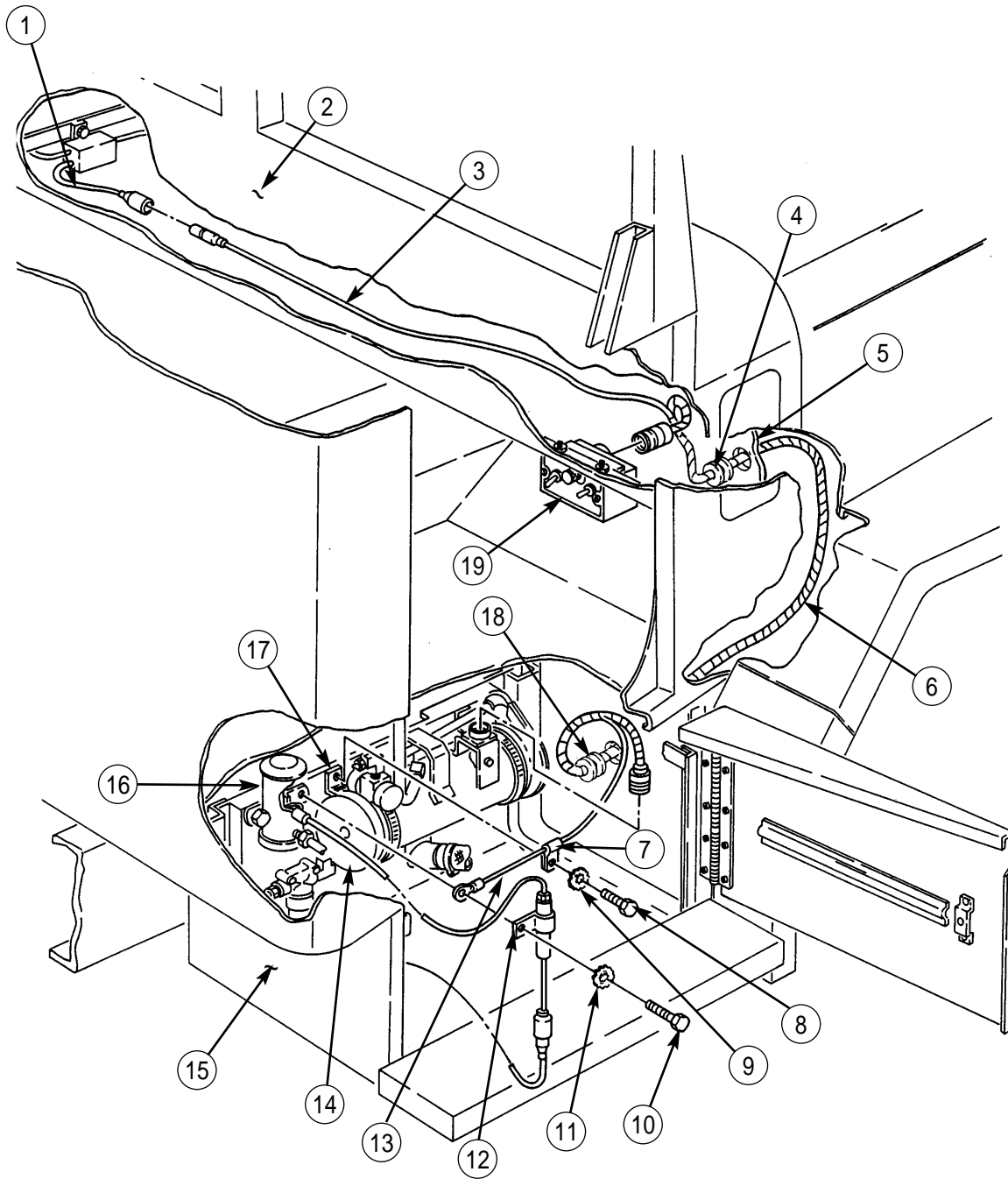

END OF WORK PACKAGE

UNIT MAINTENANCE INSTRUCTIONS

EXTENDED SERVICE PROGRAM (ESP)

TRUCK, CARGO, 2-1/2-TON, 6X6, M44A3 SERIES TRUCKS (DIESEL)

M35A3, W/O WINCH (NSN 2320-01-383-2047); W/WINCH (NSN 2320-01-383-3850);

M35A3C, W/O WINCH (NSN 2320-01-383-2050); W/WINCH (NSN 2320-01-383-2049);

M36A3, W/O WINCH (NSN 2320-01-383-2048); W/WINCH (NSN 2320-01-383-2046).

BATTERY BOX HEATER PAD REPLACEMENT

REMOVAL, INSTALLATION

INITIAL SETUP:

Tools and Special Tools

General mechanic's tool kit
(item 30, WP 0394 00)

References

TM 9-2320-386-24P

Equipment Condition

Parking brake set (TM 9-2320-386-10).
Batteries removed (WP 0122 00).
Companion seat removed (WP 0257 00).

BATTERY BOX HEATER PAD REPLACEMENT (Contd)**REMOVAL****NOTE**

Prior to removal, close water manifold valve.

Have drainage container ready to catch coolant.

1. Loosen two clamps (3) and remove exhaust inlet hose (4) and outlet hose (2) from heater pad (1).
2. Remove heater pad (1) from battery box (5).

INSTALLATION

1. Install heater pad (1) in battery box (5).
2. Install exhaust inlet hose (4) and outlet hose (2) on heater pad (1) and tighten two clamps (3).
3. Install batteries (WP 0122 00).
4. Install companion seat (WP 0257 00).

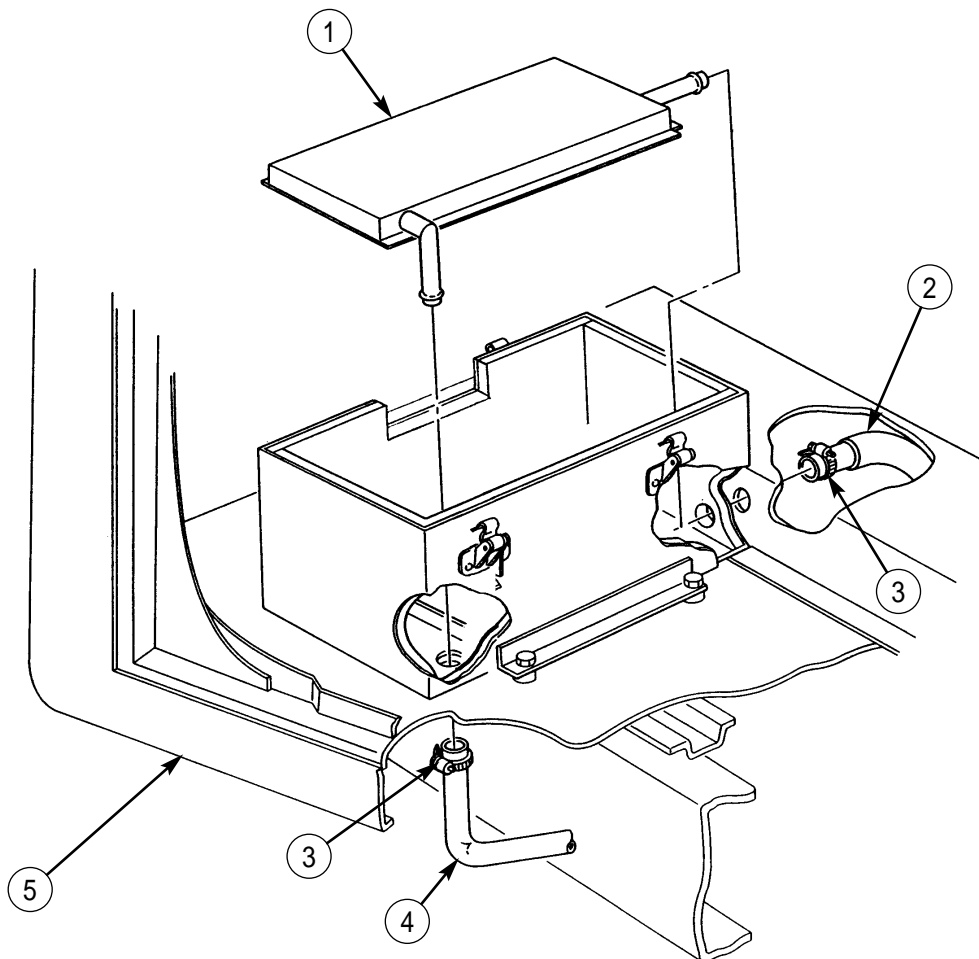

END OF WORK PACKAGE

UNIT MAINTENANCE INSTRUCTIONS

EXTENDED SERVICE PROGRAM (ESP)

TRUCK, CARGO, 2-1/2-TON, 6X6, M44A3 SERIES TRUCKS (DIESEL)

M35A3, W/O WINCH (NSN 2320-01-383-2047); W/WINCH (NSN 2320-01-383-3850);

M35A3C, W/O WINCH (NSN 2320-01-383-2050); W/WINCH (NSN 2320-01-383-2049);

M36A3, W/O WINCH (NSN 2320-01-383-2048); W/WINCH (NSN 2320-01-383-2046).

SECTION XXIV. SWINGFIRE HEATER KIT MAINTENANCE

TABLE OF CONTENTS

<i>WP Title</i>	<i>WP Sequence No.-Page No.</i>
Companion Seat and Leg Extensions Replacement	0257 00-1
Swingfire Heater and Mounting Brackets Replacement	0258 00-1
Swingfire Heater Battery Box Heater Tube Replacement	0259 00-1
Swingfire Heater Water Jacket Replacement	0260 00-1
Swingfire Heater Water Hoses Replacement	0261 00-1
Swingfire Heater Water Jacket Brackets Replacement	0262 00-1
Swingfire Heater Wiring Harness and Receptacle Replacement	0263 00-1

END OF WORK PACKAGE

UNIT MAINTENANCE INSTRUCTIONS

EXTENDED SERVICE PROGRAM (ESP)

TRUCK, CARGO, 2-1/2-TON, 6X6, M44A3 SERIES TRUCKS (DIESEL)

M35A3, W/O WINCH (NSN 2320-01-383-2047); W/WINCH (NSN 2320-01-383-3850);
M35A3C, W/O WINCH (NSN 2320-01-383-2050); W/WINCH (NSN 2320-01-383-2049);
M36A3, W/O WINCH (NSN 2320-01-383-2048); W/WINCH (NSN 2320-01-383-2046).

COMPANION SEAT AND LEG EXTENSIONS REPLACEMENT

REMOVAL, INSTALLATION

INITIAL SETUP:

Tools and Special Tools

General mechanic's tool kit
(item 30, WP 0394 00)

Materials/Parts

Four lockwashers (item 59, WP 0395 00)
Four locknuts (item 18, WP 0395 00)
Four locknuts (item 339, WP 0395 00)

References

TM 9-2320-386-24P

Equipment Condition

Parking brake set (TM 9-2320-386-10).

COMPANION SEAT AND LEG EXTENSIONS REPLACEMENT (Contd)**REMOVAL**

1. Remove four screws (10) and companion seat assembly (1) from vehicle floor (4).
2. Remove four locknuts (2), screws (6), and inner support leg (3) from seat frame (5). Discard locknuts (2).
3. Remove four locknuts (7), lockwashers (8), screws (11), and two leg extensions (9) from seat frame (5). Discard locknuts (7) and lockwashers (8).

INSTALLATION

1. Install two leg extensions (9) on seat frame (5) with four screws (11), new lockwashers (8), and new locknuts (7).
2. Install inner support leg (3) on seat frame (5) with four screws (6) and new locknuts (2).
3. Install companion seat assembly (1) on vehicle floor (4) with four screws (10).

COMPANION SEAT AND LEG EXTENSIONS REPLACEMENT (Contd)

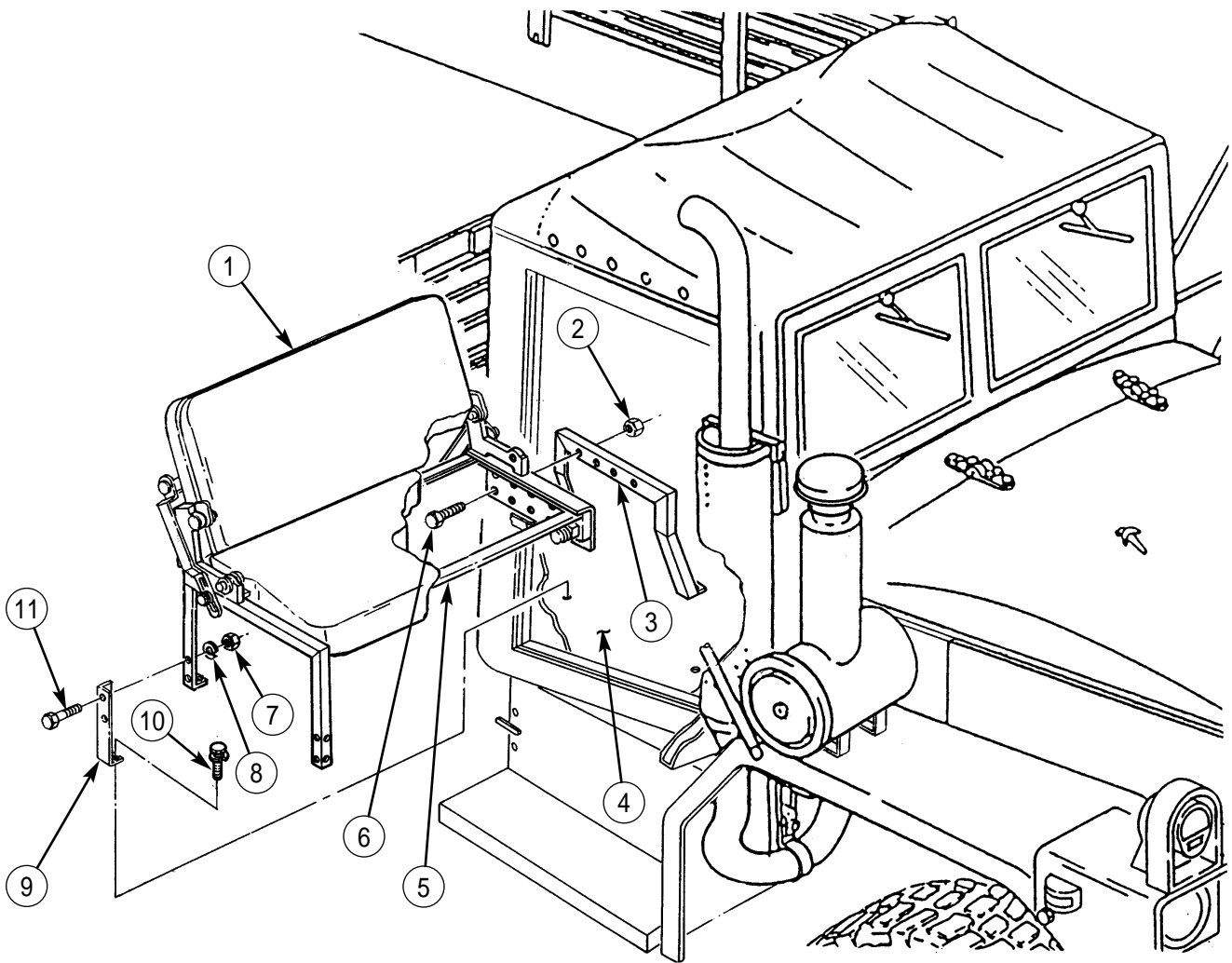

END OF WORK PACKAGE

UNIT MAINTENANCE INSTRUCTIONS

EXTENDED SERVICE PROGRAM (ESP)

TRUCK, CARGO, 2-1/2-TON, 6X6, M44A3 SERIES TRUCKS (DIESEL)

M35A3, W/O WINCH (NSN 2320-01-383-2047); W/WINCH (NSN 2320-01-383-3850);

M35A3C, W/O WINCH (NSN 2320-01-383-2050); W/WINCH (NSN 2320-01-383-2049);

M36A3, W/O WINCH (NSN 2320-01-383-2048); W/WINCH (NSN 2320-01-383-2046).

SWINGFIRE HEATER AND MOUNTING BRACKETS REPLACEMENT

REMOVAL, INSTALLATION

INITIAL SETUP:

Tools and Special Tools

General mechanic's tool kit
(item 30, WP 0394 00)

References

TM 9-2320-386-24P

Materials/Parts

Fourteen lockwashers (item 61, WP 0395 00)
Fourteen locknuts (item 99, WP 0395 00)

Equipment Condition

Parking brake set (TM 9-2320-386-10).
Companion seat removed (WP 0257 00).

SWINGFIRE HEATER AND MOUNTING BRACKETS REPLACEMENT (Contd)**REMOVAL**

1. Unlock clamp handle (3) from clip (9) and remove clamp (2) and swingfire heater (1) from stowage brackets (14) and (5).
2. Remove four locknuts (11), lockwashers (10), screw (13), three screws (6), and stowage bracket (14) from floor (12). Discard lockwashers (10) and locknuts (11).
3. Remove two locknuts (8), lockwashers (7), screws (4), and stowage bracket (5) from floor (12). Discard locknuts (8) and lockwashers (7).
4. Unlock clips (17) and (20), open clamps (16) and (19), and remove swingfire barrel (15) from stowage brackets (18) and (23).
5. Remove eight locknuts (22), lockwashers (21), screws (24), and stowage brackets (18) and (23) from floor (12). Discard locknuts (22) and lockwashers (21).

INSTALLATION

1. Install stowage brackets (23) and (18) on floor (12) with eight screws (24), new lockwashers (21), and new locknuts (22).
2. Install swingfire barrel (15) on stowage brackets (18) and (23) with clamps (16) and (19) and lock clips (17) and (20).
3. Install stowage bracket (5) on floor (12) with two screws (4), new lockwashers (7), and new locknuts (8).
4. Install stowage bracket (14) on floor (12) with screw (13), three screws (6), four new lockwashers (10), and new locknuts (11).
5. Install swingfire heater (1) on stowage brackets (14) and (5) with clamp (2) and lock clamp handle (3) to clip (9).
6. Install companion seat (WP 0257 00).

SWINGFIRE HEATER AND MOUNTING BRACKETS REPLACEMENT (Contd)

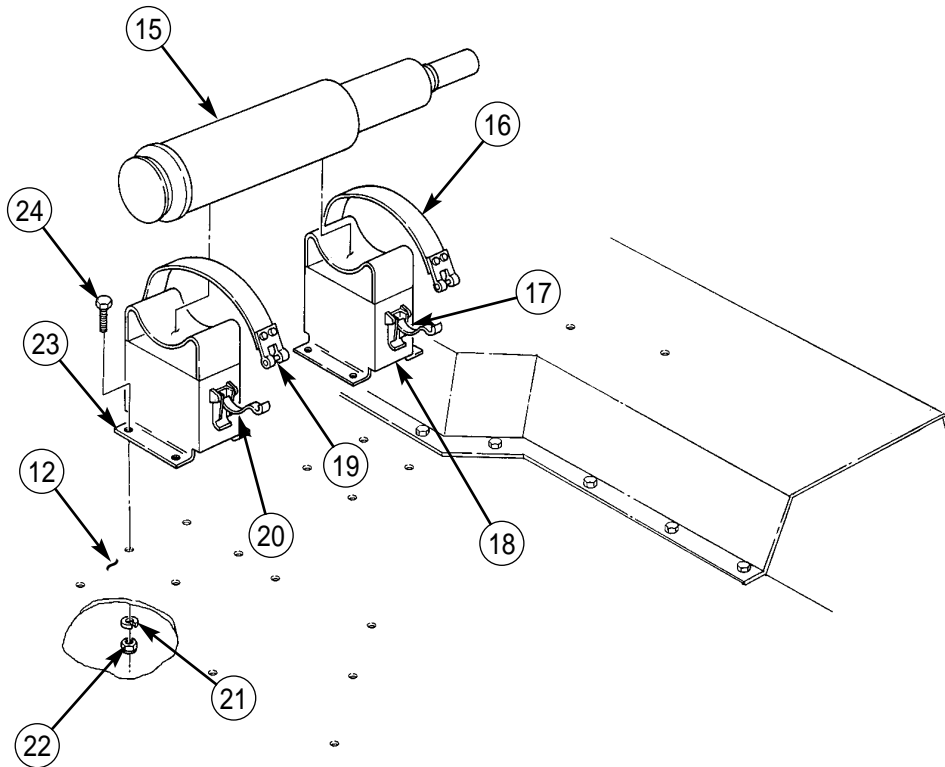
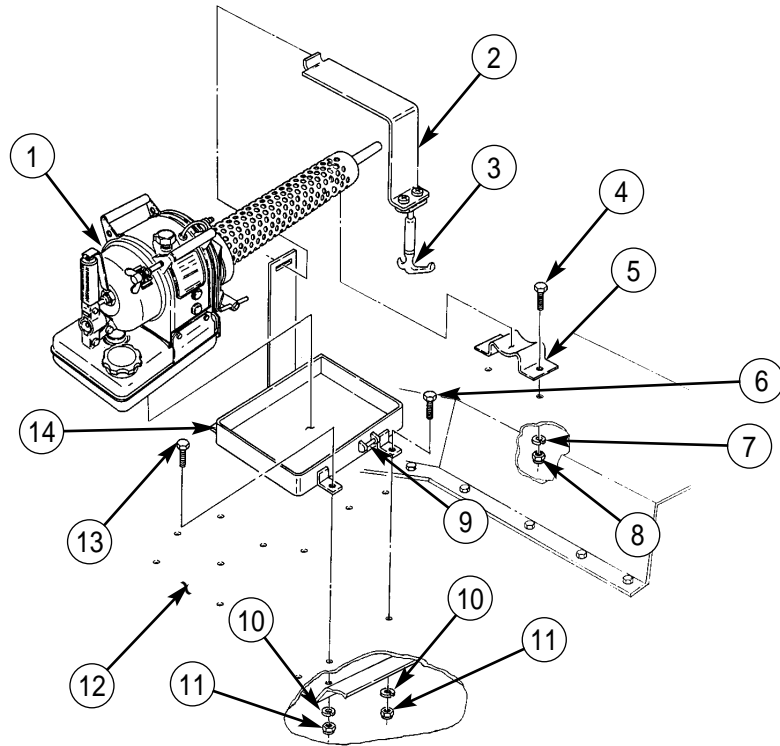

END OF WORK PACKAGE

UNIT MAINTENANCE INSTRUCTIONS

EXTENDED SERVICE PROGRAM (ESP)

TRUCK, CARGO, 2-1/2-TON, 6X6, M44A3 SERIES TRUCKS (DIESEL)

M35A3, W/O WINCH (NSN 2320-01-383-2047); W/WINCH (NSN 2320-01-383-3850);
M35A3C, W/O WINCH (NSN 2320-01-383-2050); W/WINCH (NSN 2320-01-383-2049);
M36A3, W/O WINCH (NSN 2320-01-383-2048); W/WINCH (NSN 2320-01-383-2046).

SWINGFIRE HEATER BATTERY BOX HEATER TUBE REPLACEMENT

REMOVAL, INSTALLATION

INITIAL SETUP:

Tools and Special Tools

General mechanic's tool kit
(item 30, WP 0394 00)

Materials/Parts

Six locknuts (item 15, WP 0395 00)
Four locknuts (item 99, WP 0395 00)
Two lockwashers (item 61, WP 0395 00)

References

TM 9-2320-386-24P

Equipment Condition

Parking brake set (TM 9-2320-386-10).
Battery box removed (WP 0123 00).
STE/ICE-R shunt removed (WP 0124 00).

SWINGFIRE HEATER BATTERY BOX HEATER TUBE REPLACEMENT (Contd)**REMOVAL**

1. Remove two nuts (11), lockwashers (10), screws (7), clamp (9), and exhaust tube (8) from exhaust elbow (16). Discard lockwashers (10).
2. Remove four locknuts (13) and screws (15) from battery support plate (2) and running board supports (6) and (14). Discard locknuts (13).
3. Remove pan assembly (1), with insulation (3), and battery support plate (2) from baffle plate (5).
4. Remove six locknuts (12), screws (4), and baffle plate (5) from running board supports (6) and (14). Discard locknuts (12).

INSTALLATION

1. Install baffle plate (5) on running board supports (6) and (14) with six screws (4) and new locknuts (12).
2. Install pan assembly (1), with insulation (3), and battery support plate (2) on baffle plate (5).
3. Install battery support plate (2) on running board supports (6) and (14) with four screws (15) and new locknuts (13).
4. Install exhaust tube (8) and clamp (9) on exhaust elbow (16) with two screws (7), new lockwashers (10), and nuts (11).
5. Install STE/ICE-R shunt (WP 0124 00).
6. Install battery box (WP 0123 00).

SWINGFIRE HEATER BATTERY BOX HEATER TUBE REPLACEMENT (Contd)

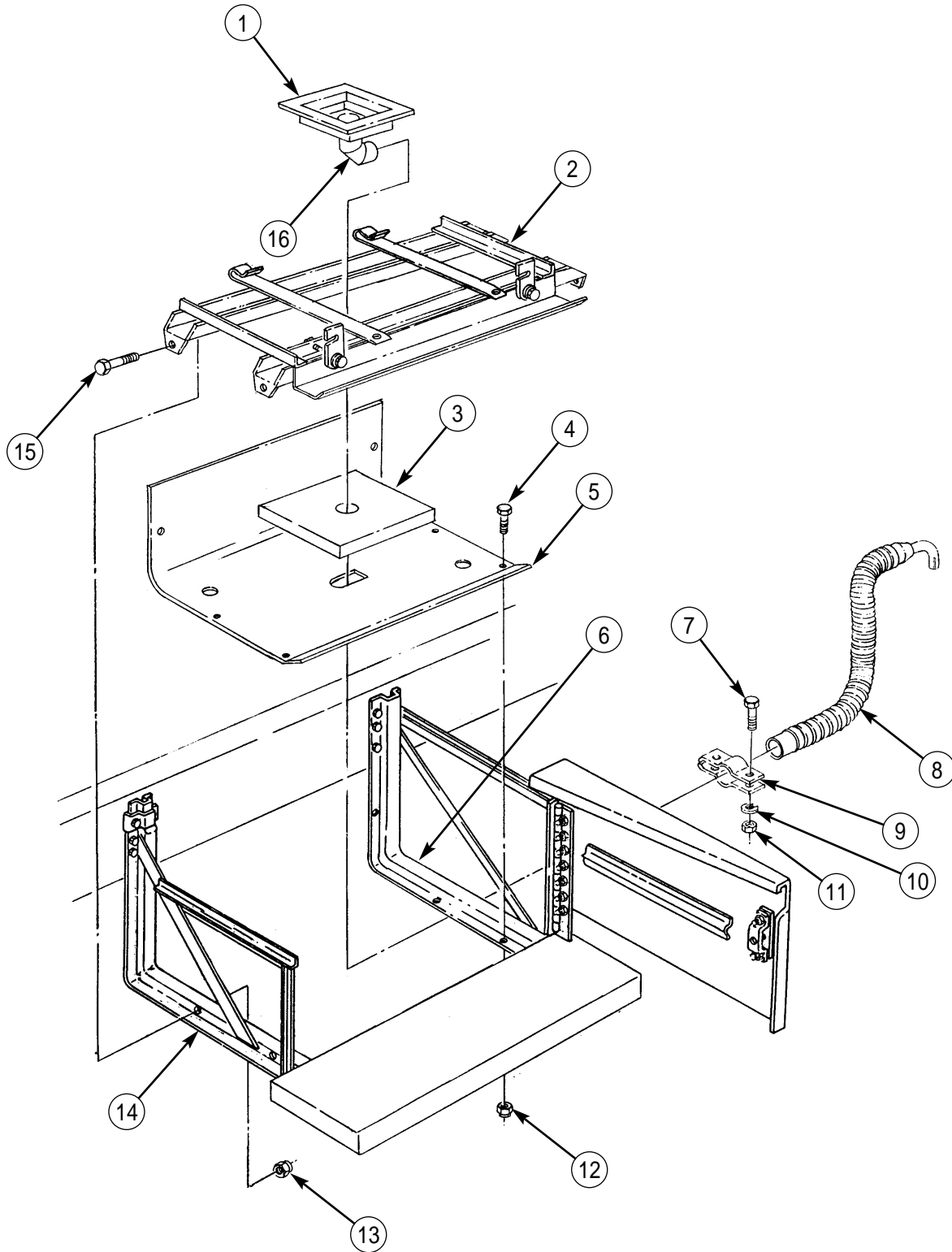

END OF WORK PACKAGE

UNIT MAINTENANCE INSTRUCTIONS

EXTENDED SERVICE PROGRAM (ESP)

TRUCK, CARGO, 2-1/2-TON, 6X6, M44A3 SERIES TRUCKS (DIESEL)

M35A3, W/O WINCH (NSN 2320-01-383-2047); W/WINCH (NSN 2320-01-383-3850);

M35A3C, W/O WINCH (NSN 2320-01-383-2050); W/WINCH (NSN 2320-01-383-2049);

M36A3, W/O WINCH (NSN 2320-01-383-2048); W/WINCH (NSN 2320-01-383-2046).

SWINGFIRE HEATER WATER JACKET REPLACEMENT

REMOVAL, INSTALLATION

INITIAL SETUP:

Tools and Special Tools

General mechanic's tool kit
(item 30, WP 0394 00)

References

TM 9-2320-386-24P

Materials/Parts

Two locknuts (item 333, WP 0395 00)
Two lockwashers (item 61, WP 0395 00)
Teflon pipe sealant (item 41, WP 0393 00)

Equipment Condition

Parking brake set (TM 9-2320-386-10).
Cooling system drained (WP 0068 00).

SWINGFIRE HEATER WATER JACKET REPLACEMENT (Contd)**REMOVAL****NOTE**

Have clean drainage container ready to catch coolant.

1. Remove drainplug (5) and drain coolant from water jacket (4).
2. Remove two nuts (14), lockwashers (15), screws (17), clamp (16), and exhaust tube (13) from exhaust port (18). Discard lockwashers (15).
3. Loosen clamps (7) and (12), and remove inlet hose (11) from inlet port (1) and outlet hose (6) from outlet port (3).
4. Remove two locknuts (9), screws (2), and water jacket (4) from brackets (8) and (10). Discard locknuts (9).

INSTALLATION

1. Install water jacket (4) on brackets (8) and (10) with two screws (2) and new locknuts (9).
2. Install inlet hose (11) on inlet port (1) and outlet hose (6) on outlet port (3) and tighten clamps (12) and (7).
3. Install exhaust tube (13) on exhaust port (18) with two screws (17), new lockwashers (15), and nuts (14).
4. Apply sealant to male threads of drainplug (5).
5. Install drainplug (5) on water jacket (4).
6. Fill cooling system to proper level (WP 0068 00).

SWINGFIRE HEATER WATER JACKET REPLACEMENT (Contd)

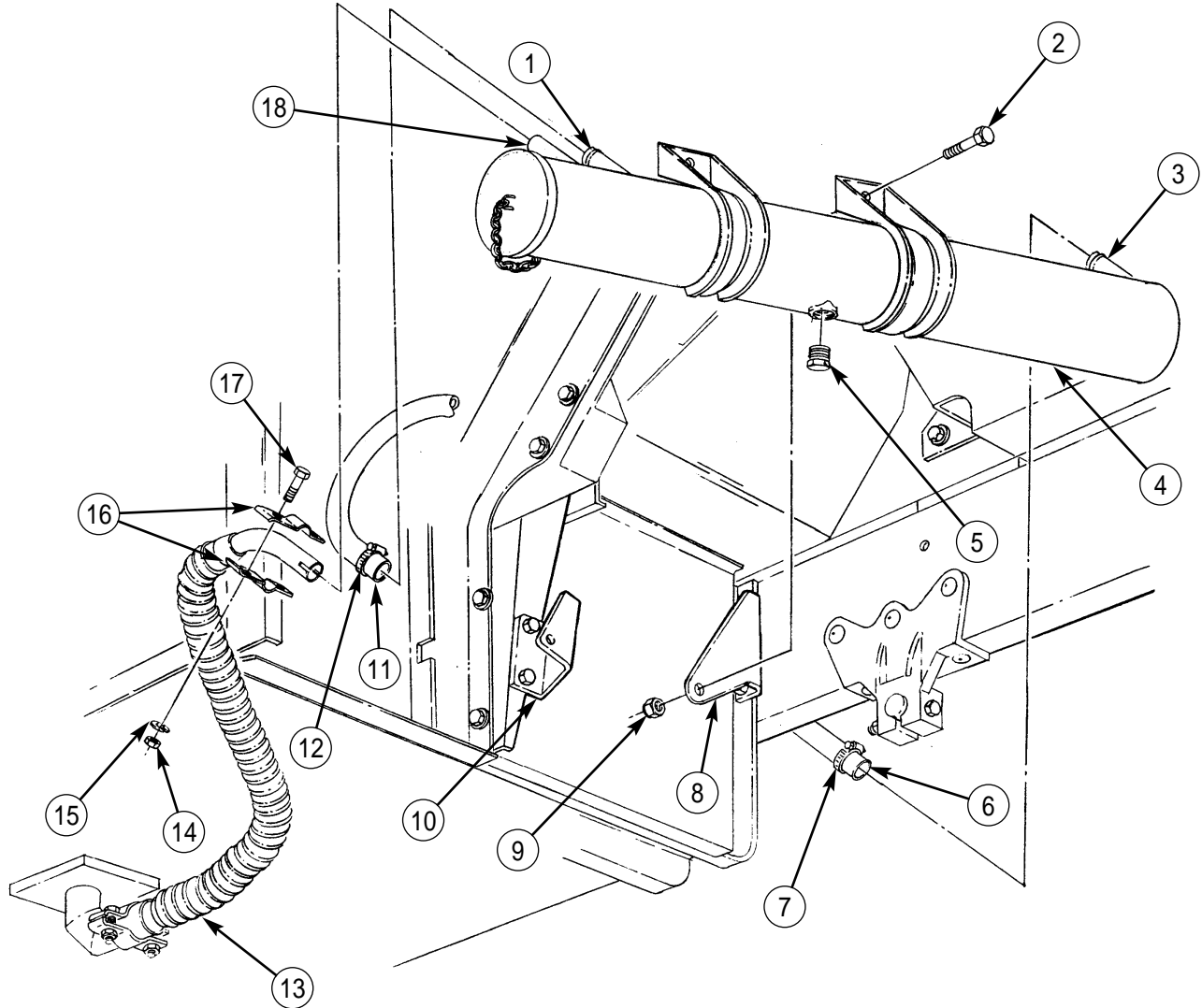

END OF WORK PACKAGE

UNIT MAINTENANCE INSTRUCTIONS

EXTENDED SERVICE PROGRAM (ESP)

TRUCK, CARGO, 2-1/2-TON, 6X6, M44A3 SERIES TRUCKS (DIESEL)

M35A3, W/O WINCH (NSN 2320-01-383-2047); W/WINCH (NSN 2320-01-383-3850);
M35A3C, W/O WINCH (NSN 2320-01-383-2050); W/WINCH (NSN 2320-01-383-2049);
M36A3, W/O WINCH (NSN 2320-01-383-2048); W/WINCH (NSN 2320-01-383-2046).

SWINGFIRE HEATER WATER HOSES REPLACEMENT

REMOVAL, INSTALLATION

INITIAL SETUP:

Tools and Special Tools

General mechanic's tool kit
(item 30, WP 0394 00)

References

TM 9-2320-386-24P

Materials/Parts

Two locknuts (item 99, WP 0395 00)
O-ring (item 213, WP 0395 00)
O-ring (item 215, WP 0395 00)
Teflon pipe sealant (item 41, WP 0393 00)

Equipment Condition

Parking brake set (TM 9-2320-386-10).
Hood raised and secured (TM 9-2320-386-10).
Cooling system drained (WP 0068 00).
Swingfire heater water jacket drained
(WP 0260 00).

SWINGFIRE HEATER WATER HOSES REPLACEMENT (Contd)**REMOVAL**

1. Remove clamps (3) and (7), outlet hose (2), and inlet hose (1) from inlet port (4) and outlet port (6) on water jacket (5).
2. Remove clamp (19) and outlet hose (1) from adapter (18).
3. Remove two locknuts (21), screws (23), clamps (20), and outlet hose (1) from fender (22). Discard locknuts (21).
4. Remove clamp (8) and inlet hose (2) from adapter (9).
5. Remove adapter (9) from elbow (10).
6. Loosen jamnut (11) and remove elbow (10) and O-ring (12) from engine (13). Discard O-ring (12).
7. Remove adapter (18) from fitting (17).
8. Loosen jamnut (16) and remove fitting (17) and O-ring (15) from water pump housing (14). Discard O-ring (15).

INSTALLATION

1. Apply sealant to male threads of adapters (9) and (18).
2. Install new O-ring (15) and fitting (17) on water pump housing (14) and tighten jamnut (16).
3. Install adapter (18) on fitting (17).
4. Install new O-ring (12) and elbow (10) on engine (13) and tighten jamnut (11).
5. Install adapter (9) on elbow (10).
6. Install inlet hose (2) on adapter (9) with clamp (8).
7. Install outlet hose (1) on adapter (18) with clamp (19).
8. Install outlet hose (1) and two clamps (20) on fender (22) with two screws (23) and new locknuts (21).
9. Install outlet hose (1) on outlet port (6) on water jacket (5) with clamp (7).
10. Install inlet hose (2) on inlet port (4) on water jacket (5) with clamp (3).
11. Fill cooling system to proper level (WP 0068 00).

SWINGFIRE HEATER WATER HOSES REPLACEMENT (Contd)

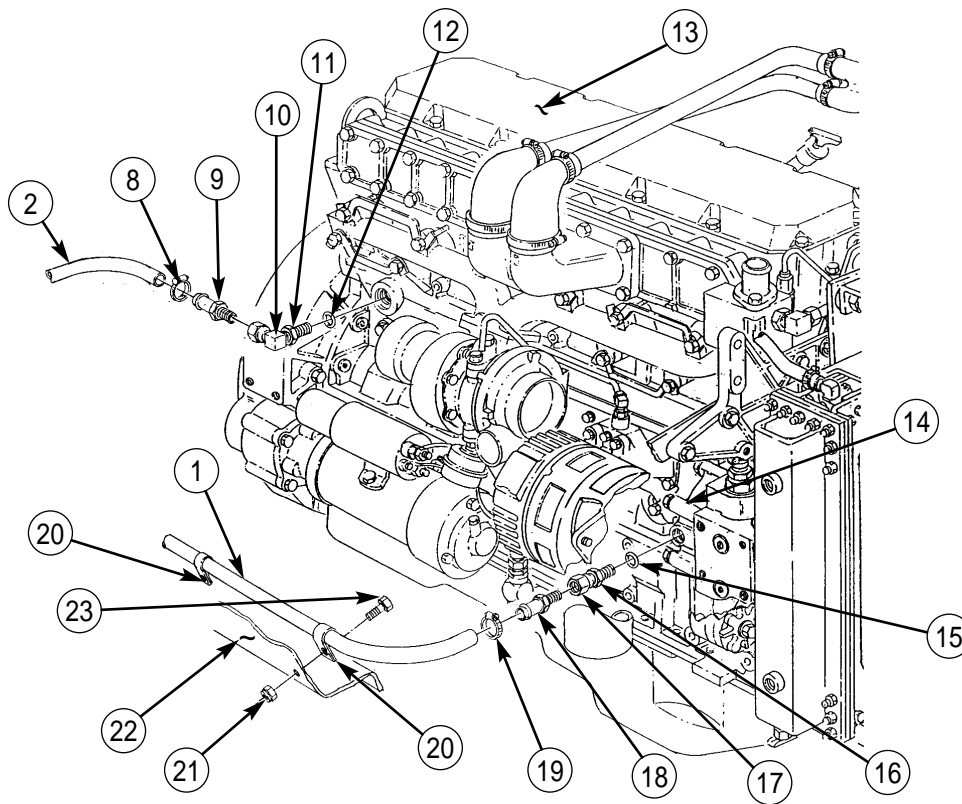
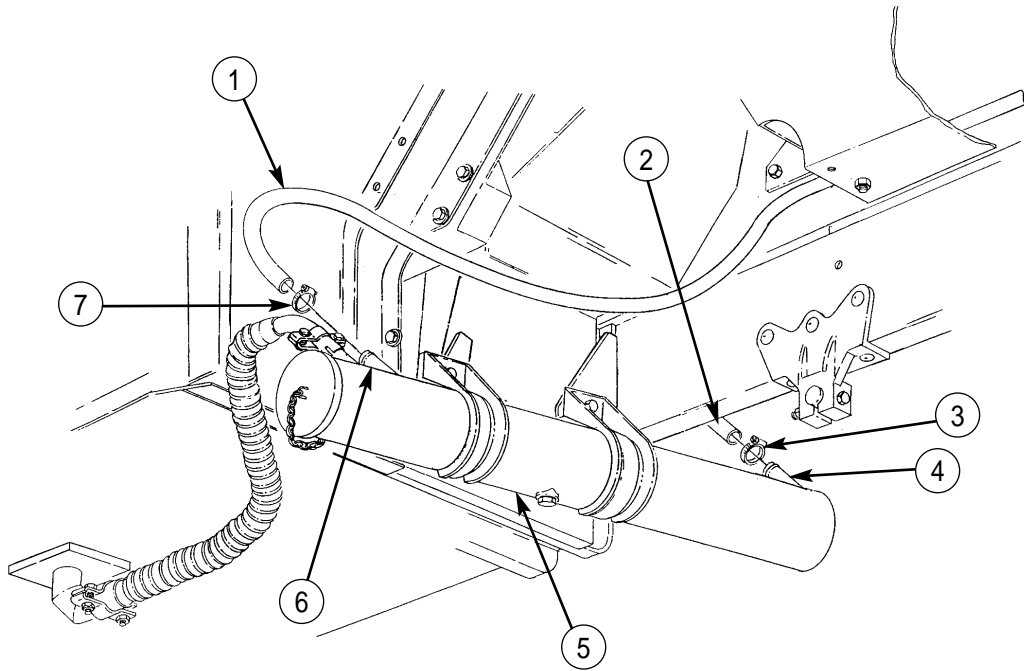

END OF WORK PACKAGE

UNIT MAINTENANCE INSTRUCTIONS

EXTENDED SERVICE PROGRAM (ESP)

TRUCK, CARGO, 2-1/2-TON, 6X6, M44A3 SERIES TRUCKS (DIESEL)

M35A3, W/O WINCH (NSN 2320-01-383-2047); W/WINCH (NSN 2320-01-383-3850);
M35A3C, W/O WINCH (NSN 2320-01-383-2050); W/WINCH (NSN 2320-01-383-2049);
M36A3, W/O WINCH (NSN 2320-01-383-2048); W/WINCH (NSN 2320-01-383-2046).

SWINGFIRE HEATER WATER JACKET BRACKETS REPLACEMENT

REMOVAL, INSTALLATION

INITIAL SETUP:

Tools and Special Tools

General mechanic's tool kit
(item 30, WP 0394 00)

References

TM 9-2320-386-24P

Materials/Parts

Two locknuts (item 333, WP 0395 00)
Two locknuts (item 19, WP 0395 00)

Equipment Condition

Parking brake set (TM 9-2320-386-10).
Swingfire heater water jacket removed
(WP 0260 00).

SWINGFIRE HEATER WATER JACKET BRACKETS REPLACEMENT (Contd)**REMOVAL**

1. Remove two locknuts (7), screws (1), and bracket (2) from fender brace (8). Discard locknuts (7).
2. Remove two locknuts (5), screws (3), and bracket (4) from running board support (6). Discard locknuts (5).

INSTALLATION

1. Install bracket (4) on running board support (6) with two screws (3) and new locknuts (5).
2. Install bracket (2) on fender brace (8) with two screws (1) and new locknuts (7).
3. Install swingfire heater water jacket (WP 0260 00).

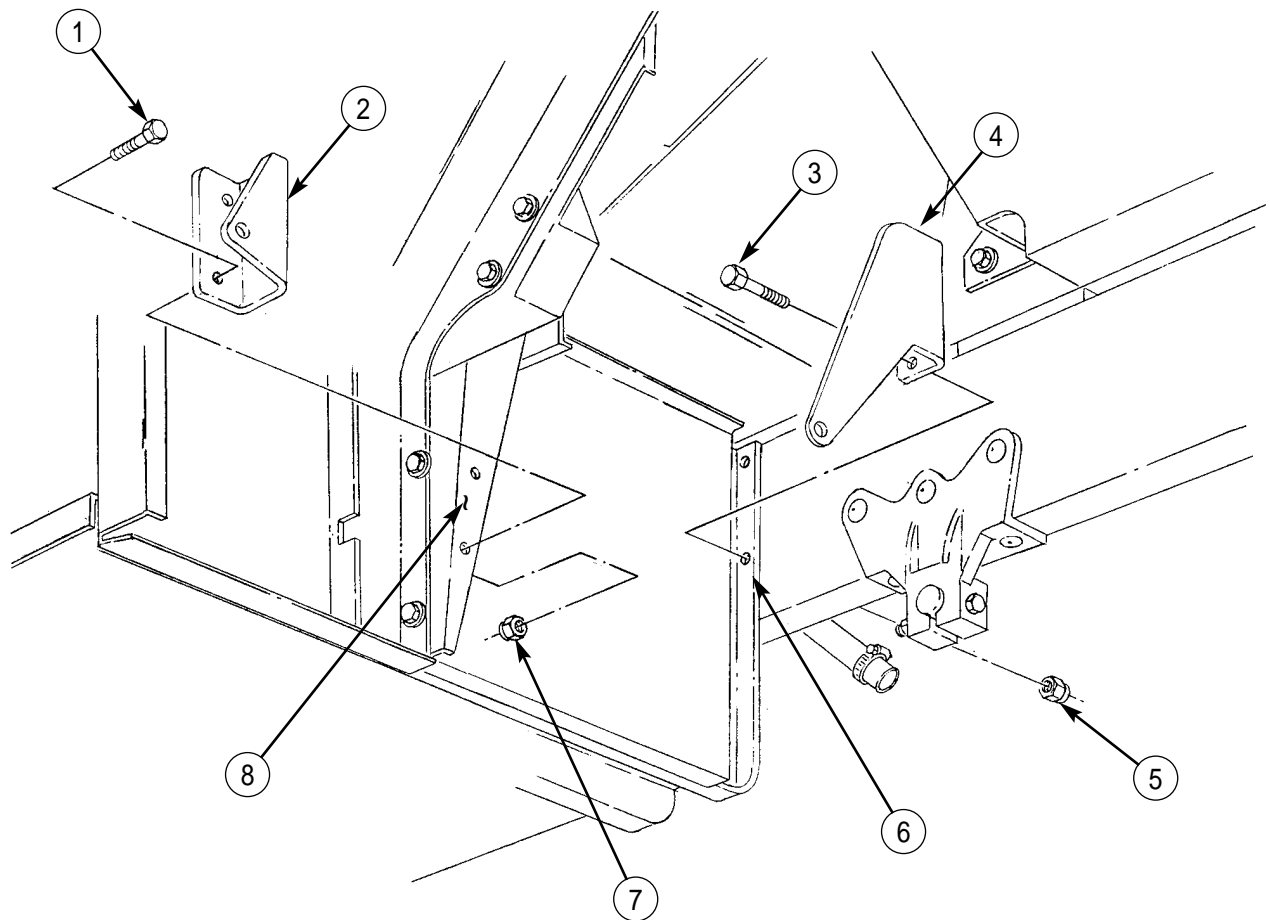
**END OF WORK PACKAGE**

UNIT MAINTENANCE INSTRUCTIONS

EXTENDED SERVICE PROGRAM (ESP)

TRUCK, CARGO, 2-1/2-TON, 6X6, M44A3 SERIES TRUCKS (DIESEL)

M35A3, W/O WINCH (NSN 2320-01-383-2047); W/WINCH (NSN 2320-01-383-3850);
M35A3C, W/O WINCH (NSN 2320-01-383-2050); W/WINCH (NSN 2320-01-383-2049);
M36A3, W/O WINCH (NSN 2320-01-383-2048); W/WINCH (NSN 2320-01-383-2046).

SWINGFIRE HEATER WIRING HARNESS AND RECEPTACLE REPLACEMENT

REMOVAL, INSTALLATION

INITIAL SETUP:

Tools and Special Tools

General mechanic's tool kit
(item 30, WP 0394 00)

References

TM 9-2320-386-24P

Materials/Parts

Twenty tiedown straps (item 38, WP 0395 00)
Locknut (item 86, WP 0395 00)

Equipment Condition

Parking brake set (TM 9-2320-386-10).
Hood raised and secured (TM 9-2320-386-10).
Battery ground cable disconnected (WP 0121 00).

SWINGFIRE HEATER WIRING HARNESS AND RECEPTACLE REPLACEMENT (Contd)**REMOVAL**

1. Loosen screw (7) and remove lead (5) from receptacle (6).

NOTE

Locking hardware is provisioned with receptacle.

2. Remove nut (3), lockwasher (4), and receptacle (6) from side panel (8).
3. Remove twenty tiedown straps (17) from lighting harness (10) and lead 10A (9). Discard tiedown straps (17).
4. Disconnect plug (1) from connector (2) and remove lead (5).
5. Disconnect plug (12) from circuit breaker (11).
6. Remove locknut (15), screw (13), clamp (14), and lead (9) from lighting harness (10) and support (16). Discard locknut (15).

INSTALLATION

1. Install lead 10A (9) on lighting harness (10) with twenty new tiedown straps (17).
2. Install lighting harness (10), lead 10A (9), and clamp (14) on support (16) with screw (13) and new locknut (15).
3. Connect plug (12) to circuit breaker (11).
4. Connect plug (1) to connector (2) on lead (5).
5. Install receptacle (6) on side panel (8) with lockwasher (4) and nut (3).
6. Install lead (5) on receptacle (6) and tighten screw (7).
8. Connect battery ground (GND) cable (WP 0121 00).

SWINGFIRE HEATER WIRING HARNESS AND RECEPTACLE REPLACEMENT (Contd)

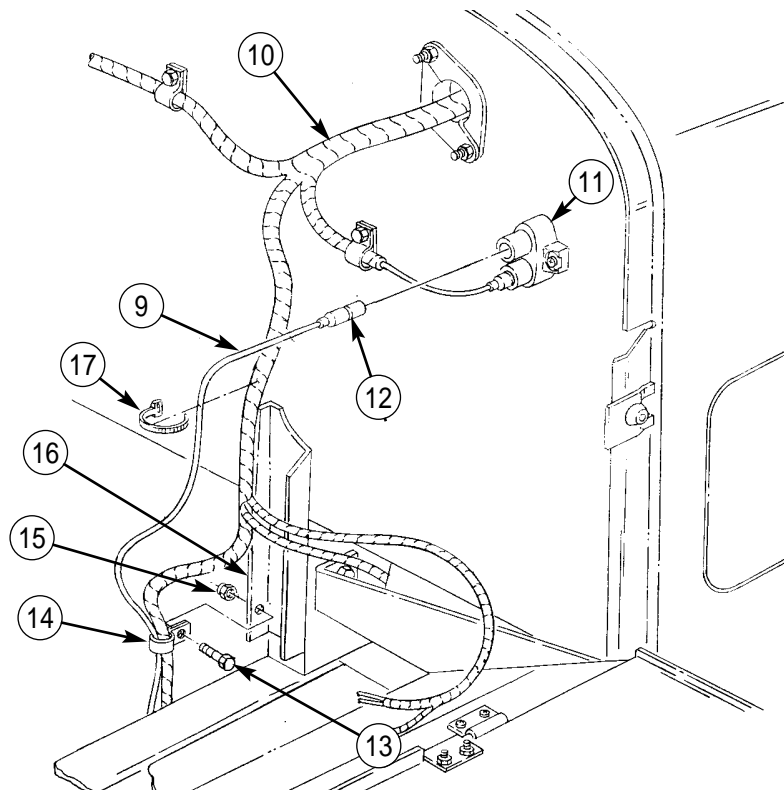
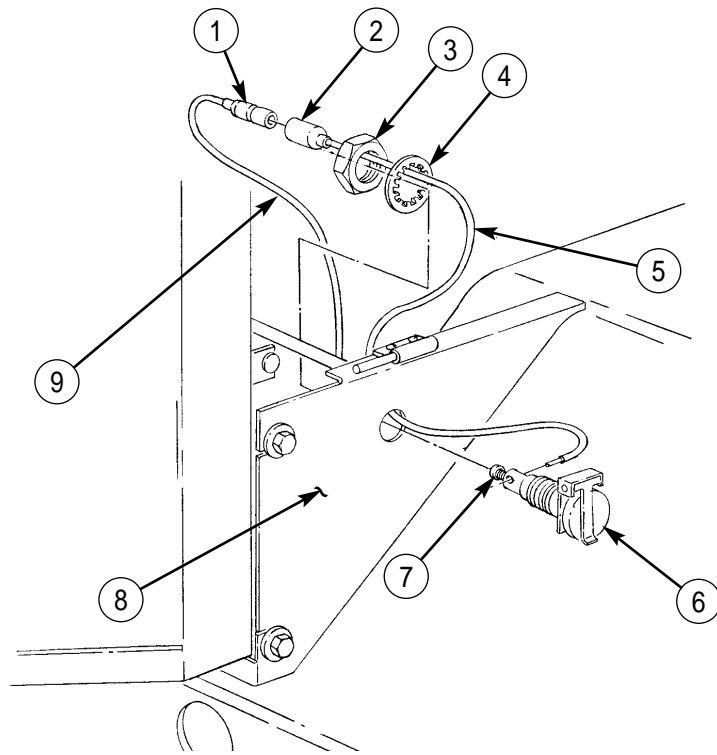

END OF WORK PACKAGE

UNIT MAINTENANCE INSTRUCTIONS

EXTENDED SERVICE PROGRAM (ESP)

TRUCK, CARGO, 2-1/2-TON, 6X6, M44A3 SERIES TRUCKS (DIESEL)

M35A3, W/O WINCH (NSN 2320-01-383-2047); W/WINCH (NSN 2320-01-383-3850);

M35A3C, W/O WINCH (NSN 2320-01-383-2050); W/WINCH (NSN 2320-01-383-2049);

M36A3, W/O WINCH (NSN 2320-01-383-2048); W/WINCH (NSN 2320-01-383-2046).

SECTION XXV. DEEPWATER FORDING KIT MAINTENANCE

TABLE OF CONTENTS

<i>WP Title</i>	<i>WP Sequence No.-Page No.</i>
Crankcase Breather Hose Replacement	0265 00-1
Winch Reservoir Breather Replacement	0266 00-1
Front Axle Breathers Replacement	0267 00-1
Transfer Case Breather Replacement	0268 00-1
Front-Rear and Rear-Rear Axle Breather Replacement	0269 00-1

END OF WORK PACKAGE

UNIT MAINTENANCE INSTRUCTIONS

EXTENDED SERVICE PROGRAM (ESP)

TRUCK, CARGO, 2-1/2-TON, 6X6, M44A3 SERIES TRUCKS (DIESEL)

**M35A3, W/O WINCH (NSN 2320-01-383-2047); W/WINCH (NSN 2320-01-383-3850);
M35A3C, W/O WINCH (NSN 2320-01-383-2050); W/WINCH (NSN 2320-01-383-2049);
M36A3, W/O WINCH (NSN 2320-01-383-2048); W/WINCH (NSN 2320-01-383-2046).**

CRANKCASE BREATHER HOSE REPLACEMENT

REMOVAL, INSTALLATION

INITIAL SETUP:

Tools and Special Tools

General mechanic's tool kit
(item 30, WP 0394 00)

References

TM 9-2320-386-24P

Materials/Parts

Tiedown strap (item 38, WP 0395 00)

Equipment Condition

Parking brake set (TM 9-2320-386-10).
Hood raised and secured (TM 9-2320-386-10).

CRANKCASE BREATHER HOSE REPLACEMENT (Contd)

REMOVAL

1. Remove clamp (2) and breather hose (6) from crankcase breather (1).
2. Remove two clamps (3) and breather hoses (6) and (4) from tube adapter (5).
3. Remove tiedown strap (9) and breather hose (4) from firewall (8). Discard tiedown strap (9).
4. Remove two clamps (13), breather hose (4), and grommet (12) from air cleaner (10) and air cleaner panel (11).
5. Remove clamp (14) and breather (7) from breather hose (4).

INSTALLATION

1. Install breather (7) on breather hose (4) with clamp (14).
2. Install breather hose (4) through air cleaner panel (11) and grommet (12) and install breather hose (4) on air cleaner (11) with two clamps (13).
3. Install breather hoses (4) and (6) on tube adapter (5) with two clamps (3).
4. Install breather hose (6) on crankcase breather (1) with clamp (2).
5. Install hose (4) on firewall (8) with new tiedown strap (9).

CRANKCASE BREATHER HOSE REPLACEMENT (Contd)

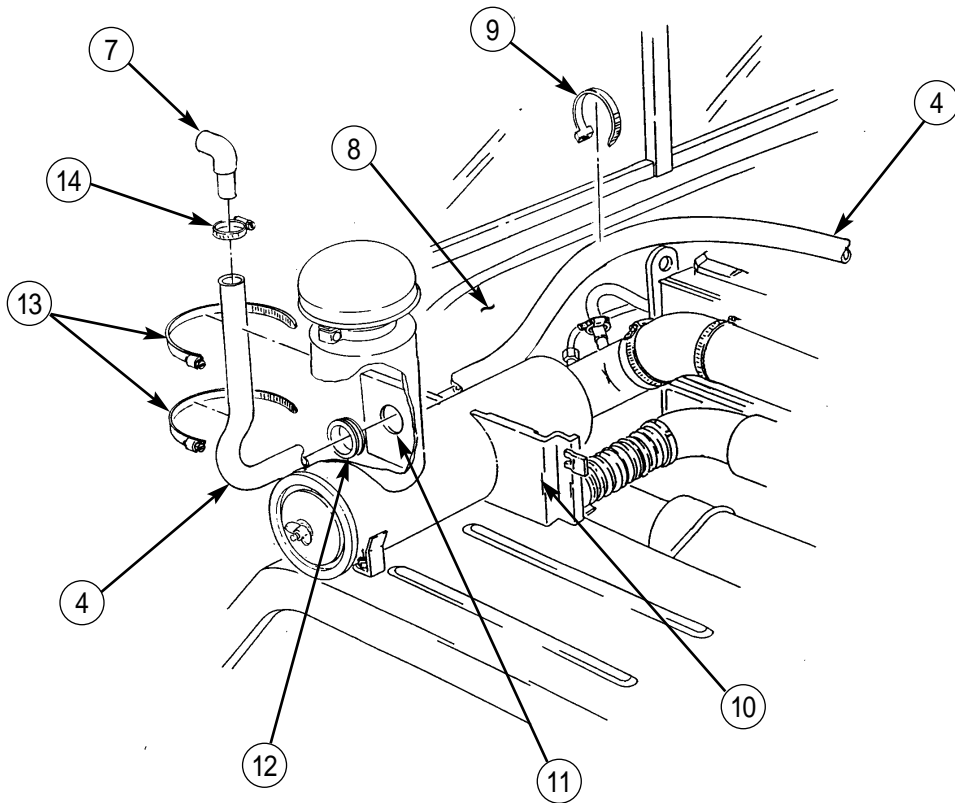
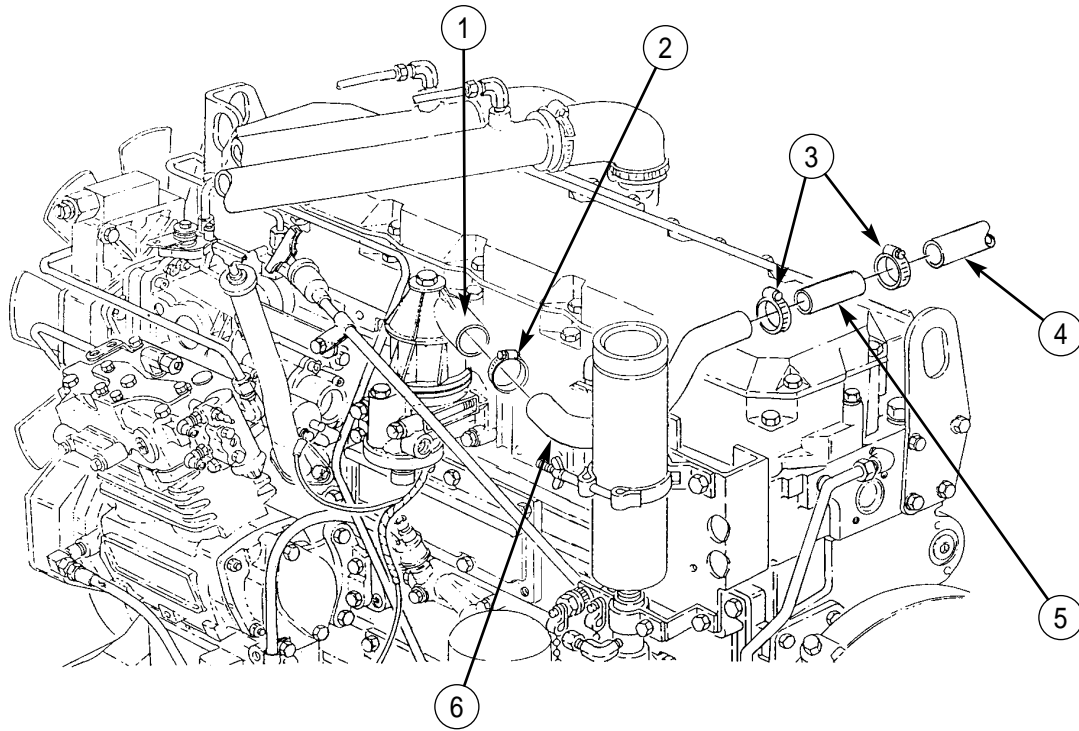

END OF WORK PACKAGE

UNIT MAINTENANCE INSTRUCTIONS

EXTENDED SERVICE PROGRAM (ESP)

TRUCK, CARGO, 2-1/2-TON, 6X6, M44A3 SERIES TRUCKS (DIESEL)

M35A3, W/O WINCH (NSN 2320-01-383-2047); W/WINCH (NSN 2320-01-383-3850);
M35A3C, W/O WINCH (NSN 2320-01-383-2050); W/WINCH (NSN 2320-01-383-2049);
M36A3, W/O WINCH (NSN 2320-01-383-2048); W/WINCH (NSN 2320-01-383-2046).

WINCH RESERVOIR BREATHER REPLACEMENT

REMOVAL, INSTALLATION

INITIAL SETUP:

Tools and Special Tools

General mechanic's tool kit
(item 30, WP 0394 00)

References

TM 9-2320-386-24P

Materials/Parts

Teflon pipe sealant (item 41, WP 0393 00)
Adhesive, silicone rubber (item 8, WP 0393 00)

Equipment Condition

Parking brake set (TM 9-2320-386-10).
Air reservoirs drained (TM 9-2320-386-10).

WINCH RESERVOIR BREATHER REPLACEMENT (Contd)**REMOVAL**

1. Remove breather tube (3) from elbow (1).
2. Remove elbow (1) and reducer (6) from plate (5).
3. Remove six screws (2) and plate (5) from reservoir tank (4).

INSTALLATION

1. Apply sealant to male threads of elbow (1) and reducer (6).
2. Install reducer (6) and elbow (1) on plate (5).
3. Apply silicone rubber adhesive to mating surface of plate (5) and reservoir tank (4).
4. Install plate (5) on reservoir tank (4) with six screws (2).
5. Install tube (3) on elbow (1).

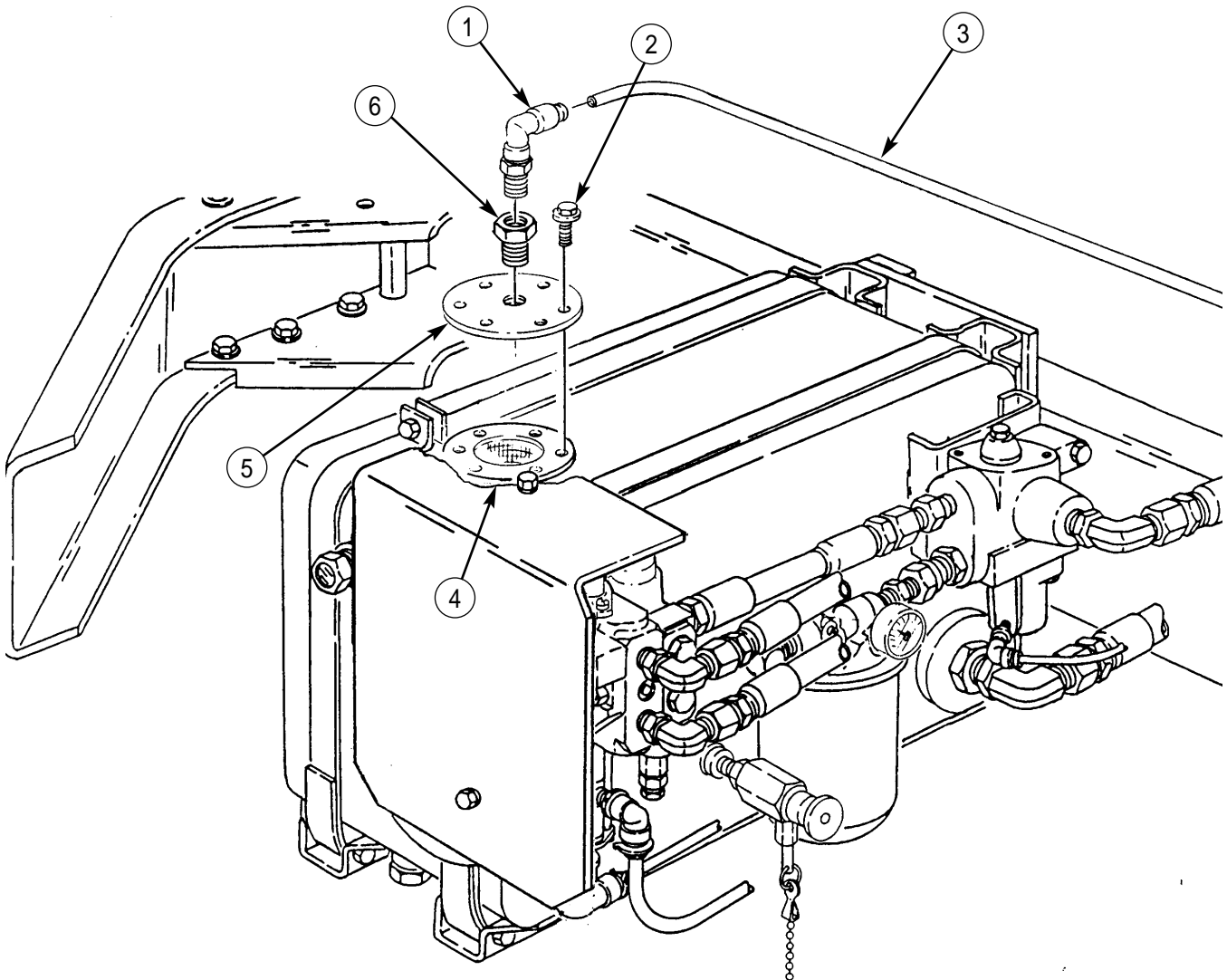

END OF WORK PACKAGE

UNIT MAINTENANCE INSTRUCTIONS

EXTENDED SERVICE PROGRAM (ESP)

TRUCK, CARGO, 2-1/2-TON, 6X6, M44A3 SERIES TRUCKS (DIESEL)

M35A3, W/O WINCH (NSN 2320-01-383-2047); W/WINCH (NSN 2320-01-383-3850);
M35A3C, W/O WINCH (NSN 2320-01-383-2050); W/WINCH (NSN 2320-01-383-2049);
M36A3, W/O WINCH (NSN 2320-01-383-2048); W/WINCH (NSN 2320-01-383-2046).

FRONT AXLE BREATHERS REPLACEMENT

REMOVAL, INSTALLATION

INITIAL SETUP:

Tools and Special Tools

General mechanic's tool kit
(item 30, WP 0394 00)

References

TM 9-2320-386-24P

Materials/Parts

Teflon pipe sealant (item 41, WP 0393 00)

Equipment Condition

Parking brake set (TM 9-2320-386-10)

FRONT AXLE BREATHERS REPLACEMENT (Contd)**REMOVAL**

1. Remove winch breather tube (3) from tee (2).
2. Remove manifold tube (1) from tee (2).
3. Remove manifold tube (12) from tees (11) and (2).
4. Remove breather tubes (10) and (8) from tees (11) and (7).
5. Remove breather tube (10) from elbow (9).
6. Remove breather tube (5) from tee (7) and elbow (4).
7. Remove elbows (4) and (9) and tee (7) from front axle housing (6).

INSTALLATION

1. Apply sealant to male threads of elbows (4) and (9) and tee (7).
2. Install elbows (4) and (9) and tee (7) on front axle housing (6).
3. Install breather tube (5) on elbow (4) and tee (7).
4. Install breather tube (8) on tees (7) and (11).
5. Install breather tube (10) on elbow (9).
6. Install manifold tube (12) on tees (11) and (2).
7. Install manifold tube (1) on tee (2).
8. Install winch breather tube (3) on tee (2).

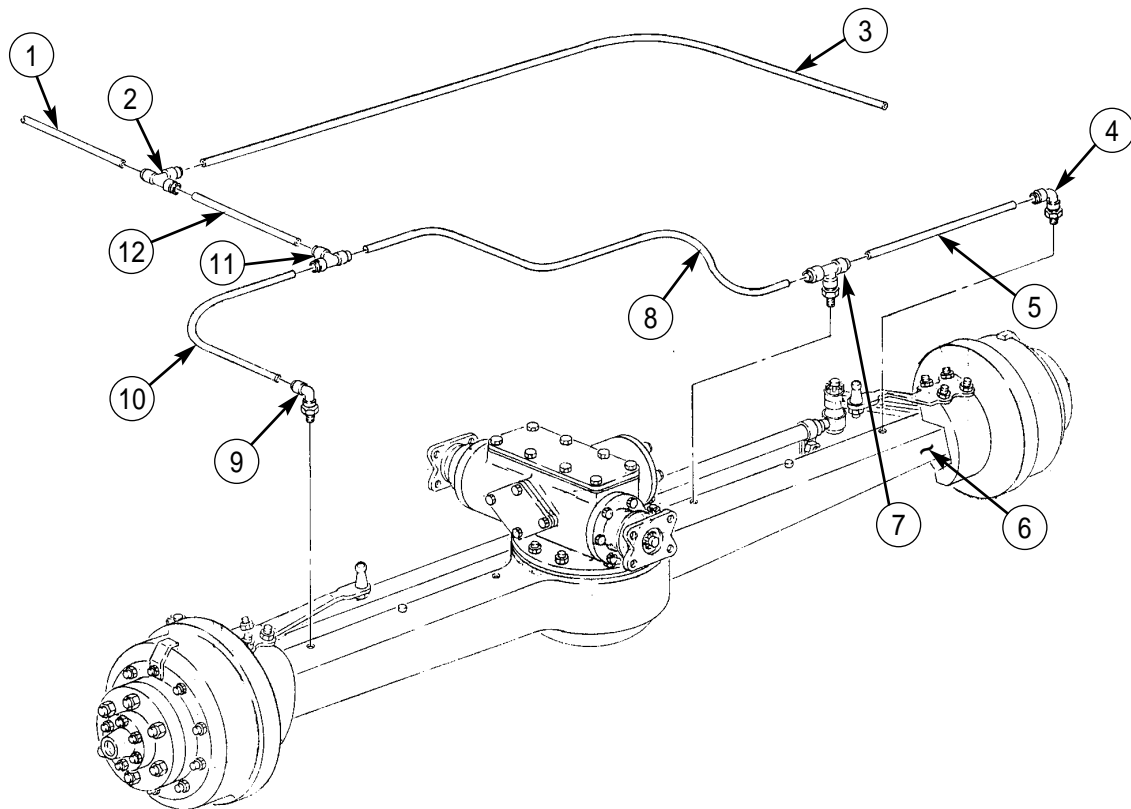
**END OF WORK PACKAGE**

UNIT MAINTENANCE INSTRUCTIONS

EXTENDED SERVICE PROGRAM (ESP)

TRUCK, CARGO, 2-1/2-TON, 6X6, M44A3 SERIES TRUCKS (DIESEL)

M35A3, W/O WINCH (NSN 2320-01-383-2047); W/WINCH (NSN 2320-01-383-3850);
M35A3C, W/O WINCH (NSN 2320-01-383-2050); W/WINCH (NSN 2320-01-383-2049);
M36A3, W/O WINCH (NSN 2320-01-383-2048); W/WINCH (NSN 2320-01-383-2046).

TRANSFER CASE BREATHER REPLACEMENT

REMOVAL, INSTALLATION

INITIAL SETUP:

Tools and Special Tools

General mechanic's tool kit
(item 30, WP 0394 00)

Materials/Parts

Teflon pipe sealant (item 41, WP 0393 00)

References

TM 9-2320-386-24P

Equipment Condition

Parking brake set (TM 9-2320-386-10).

TRANSFER CASE BREATHER REPLACEMENT (Contd)***REMOVAL***

1. Remove breather tube (3) from elbow (2) and tee (5).
2. Remove elbow (2) from transfer case (1).
3. Remove tee (5) from two manifold tubes (4).

INSTALLATION

1. Install tee (5) on two manifold tubes (4).
2. Apply sealant to male threads of elbow (2).
3. Install elbow (2) on transfer case (1).
4. Install breather tube (3) on tee (5) and elbow (2).

TRANSFER CASE BREATHER REPLACEMENT (Contd)

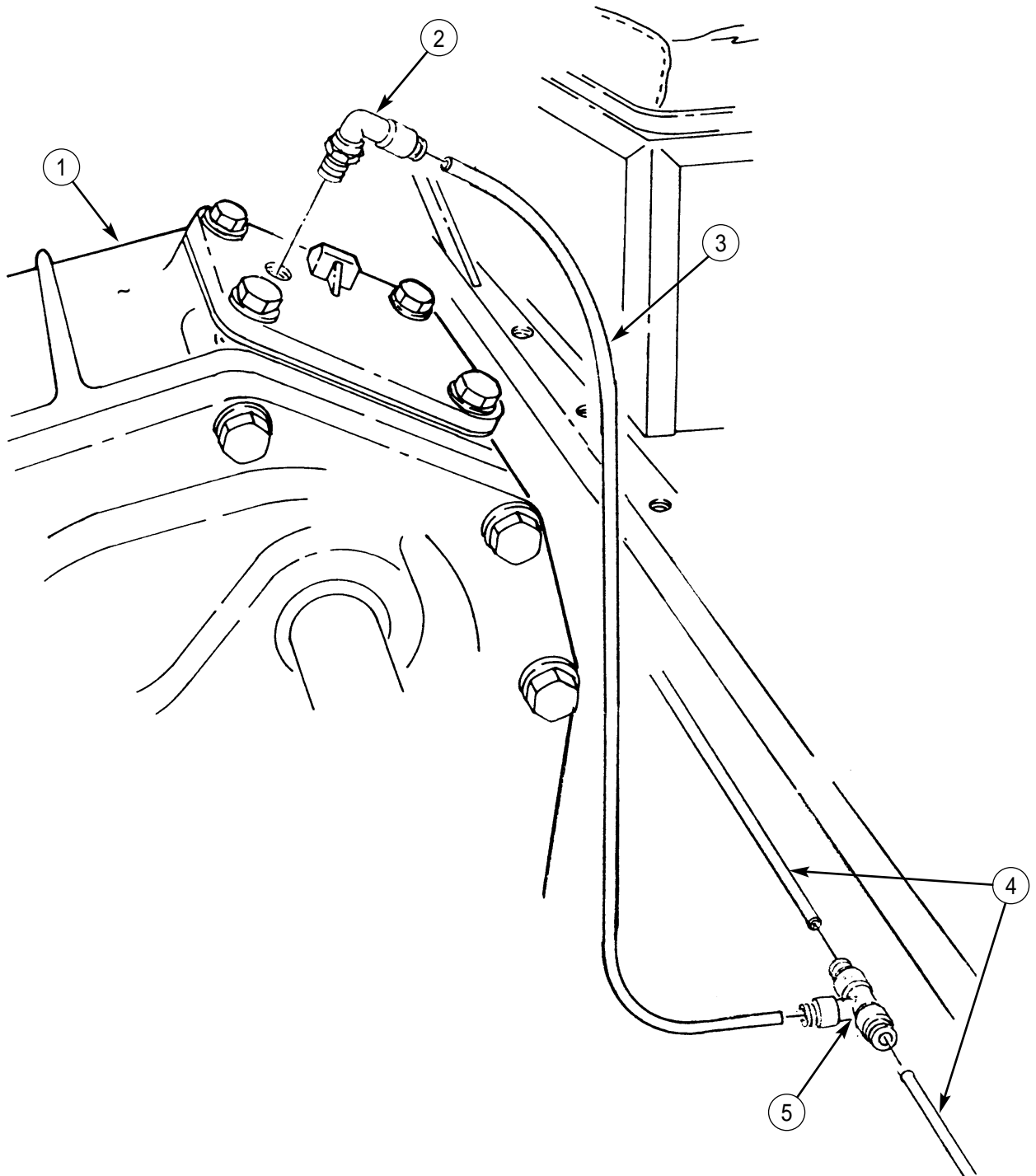

END OF WORK PACKAGE

UNIT MAINTENANCE INSTRUCTIONS

EXTENDED SERVICE PROGRAM (ESP)

TRUCK, CARGO, 2-1/2-TON, 6X6, M44A3 SERIES TRUCKS (DIESEL)

M35A3, W/O WINCH (NSN 2320-01-383-2047); W/WINCH (NSN 2320-01-383-3850);

M35A3C, W/O WINCH (NSN 2320-01-383-2050); W/WINCH (NSN 2320-01-383-2049);

M36A3, W/O WINCH (NSN 2320-01-383-2048); W/WINCH (NSN 2320-01-383-2046).

FRONT-REAR AND REAR-REAR AXLE BREATHER REPLACEMENT

REMOVAL, INSTALLATION

INITIAL SETUP:

Tools and Special Tools

General mechanic's tool kit
(item 30, WP 0394 00)

Materials/Parts

Teflon pipe sealant (item 41, WP 0393 00)

References

TM 9-2320-386-24P

Equipment Condition

Parking brake set (TM 9-2320-386-10).

FRONT-REAR AND REAR-REAR AXLE BREATHER REPLACEMENT (Contd)**REMOVAL**

1. Remove manifold tubes (1) and (3) from tee (2).
2. Remove breather tube (4) from tee (2) and elbow (5) on front-rear axle housing (6).
3. Remove breather tube (3) from elbow (7) on rear-rear axle housing (8).
4. Remove elbow (5) from front-rear axle housing (6).
5. Remove elbow (7) from rear-rear axle housing (8).

INSTALLATION

1. Apply sealant to male threads of elbows (5) and (7).
2. Install elbow (5) on front-rear axle housing (6).
3. Install elbow (7) on rear-rear axle housing (8).
4. Install breather tube (4) on elbow (5) and tee (2).
5. Install manifold tubes (1) and (3) on tee (2).
6. Install manifold tube (3) on elbow (7) on rear-rear axle housing (8).

FRONT-REAR AND REAR-REAR AXLE BREATHER REPLACEMENT (Contd)

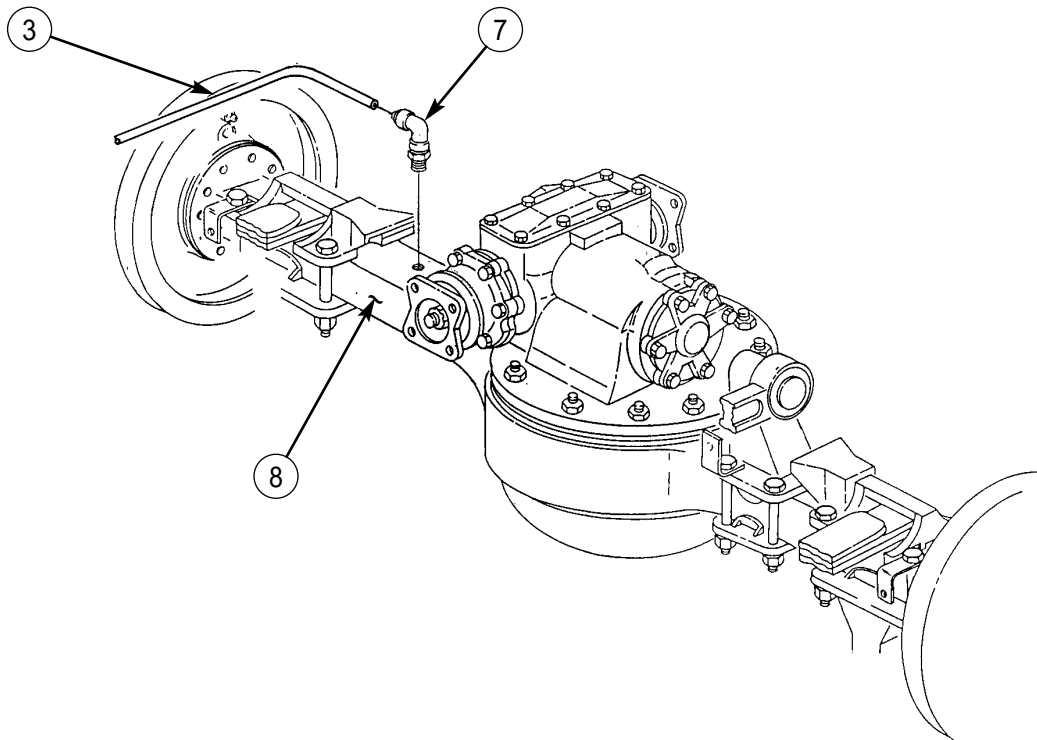
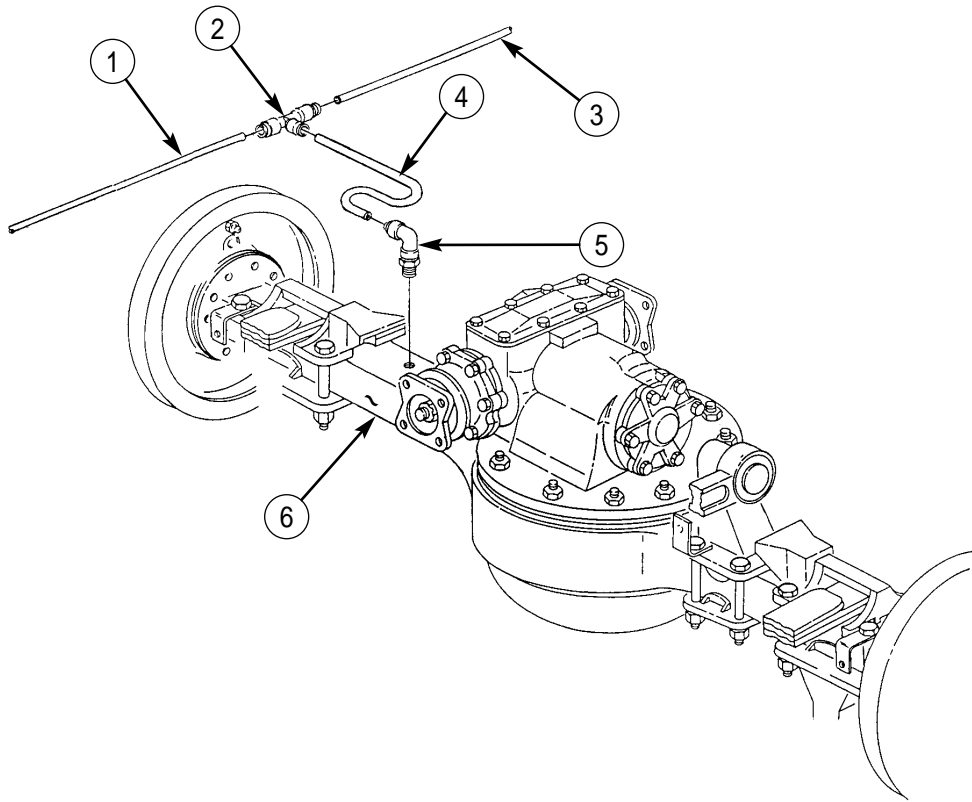

END OF WORK PACKAGE

UNIT MAINTENANCE INSTRUCTIONS

EXTENDED SERVICE PROGRAM (ESP)

TRUCK, CARGO, 2-1/2-TON, 6X6, M44A3 SERIES TRUCKS (DIESEL)

M35A3, W/O WINCH (NSN 2320-01-383-2047); W/WINCH (NSN 2320-01-383-3850);

M35A3C, W/O WINCH (NSN 2320-01-383-2050); W/WINCH (NSN 2320-01-383-2049);

M36A3, W/O WINCH (NSN 2320-01-383-2048); W/WINCH (NSN 2320-01-383-2046).

Section XXVI. CHEMICAL AGENT ALARM MOUNTING KIT REPLACEMENT

TABLE OF CONTENTS

WP Title

WP Sequence No.-Page No.

Chemical Agent Alarm Mounting Kit Replacement	0271 00-1
---------------------------------------------------------	-----------

END OF WORK PACKAGE

UNIT MAINTENANCE INSTRUCTIONS

EXTENDED SERVICE PROGRAM (ESP)

TRUCK, CARGO, 2-1/2-TON, 6X6, M44A3 SERIES TRUCKS (DIESEL)

M35A3, W/O WINCH (NSN 2320-01-383-2047); W/WINCH (NSN 2320-01-383-3850);
M35A3C, W/O WINCH (NSN 2320-01-383-2050); W/WINCH (NSN 2320-01-383-2049);
M36A3, W/O WINCH (NSN 2320-01-383-2048); W/WINCH (NSN 2320-01-383-2046).

CHEMICAL AGENT ALARM MOUNTING KIT REPLACEMENT

REMOVAL, INSTALLATION

INITIAL SETUP:

Tools and Special Tools

General mechanic's tool kit
(item 30, WP 0394 00)

Materials/Parts

Four tiedown straps (item 36, WP 0395 00)
Five locknuts (item 339, WP 0395 00)
Two locknuts (item 336, WP 0395 00)
Two locknuts (item 23, WP 0395 00)
Two lockwashers (item 77, WP 0395 00)
Locknut (item 15, WP 0395 00)
Locknut (item 83, WP 0395 00)

References

TM 9-2320-386-24P

Equipment Condition

Parking brake set (TM 9-2320-386-10).
Hood raised and secured (TM 9-2320-386-10).
Battery ground cable disconnected (WP 0121 00).
M43 detector and M42 alarm unit removed
(TM 3-6665-225-12).

CHEMICAL AGENT ALARM MOUNTING KIT REPLACEMENT (Contd)**REMOVAL**

1. Remove nut (3) and harness receptacle (27) from bracket (2).
2. Remove four locknuts (10), support (9), two screws (1) and (5), clamp (6), harness (7), and detector unit bracket (4) from left front fender (8). Discard locknuts (10).
3. Remove locknut (11), screw (26), clamp (12), and harness (7) from left front fender (8). Discard locknut (11).
4. Disconnect leads 25 (18), 25 (20), and lead 25 (21) from connector (19).
5. Disconnect lead 25 (25) from connector (24).
6. Remove locknut (14), lockwasher (15), screw (23), harness ground (GND) wire (22), ground strap (17), and lockwasher (16) from right side of turn signal flasher box (13). Discard locknut (14) and lockwashers (15) and (16).
7. Remove four tiedown straps (36) from main wiring harness (35). Discard tiedown straps (36).

NOTE

Assistant will help with steps 8 through 14.

8. Remove locknut (39), screw (38), and clamp (37) from firewall (34). Discard locknut (39).
9. Remove two screws (42), clamps (43), and harness (7) from frame (44).
10. Remove grommet (46) from cab floor hole (45).
11. Remove screw (41) and clamp (47) from rear cab panel (29).
12. Remove two locknuts (33), screws (30), and clamps (31) from alarm unit bracket (32). Discard locknuts (33).
13. Remove harness (7) from firewall (34), cab floor hole (45), and rear cab panel (29).
14. Remove two locknuts (28), screws (40), and alarm unit bracket (32) from rear cab panel (29). Discard locknuts (28).

CHEMICAL AGENT ALARM MOUNTING KIT REPLACEMENT (Contd)

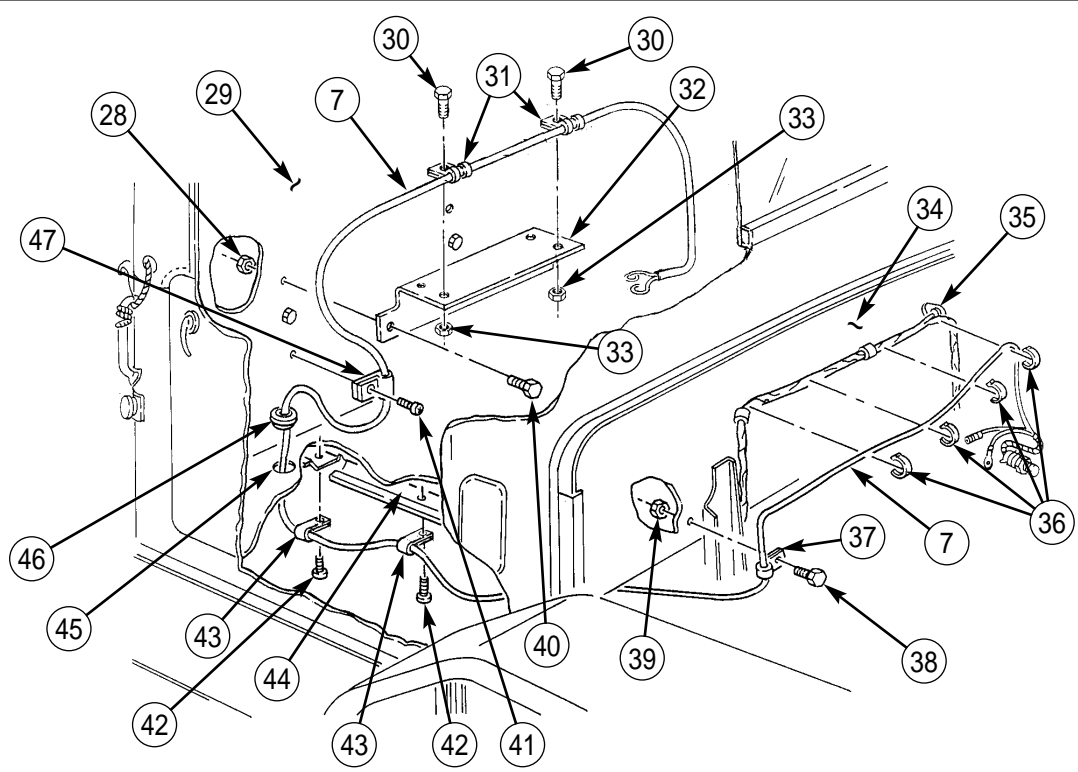
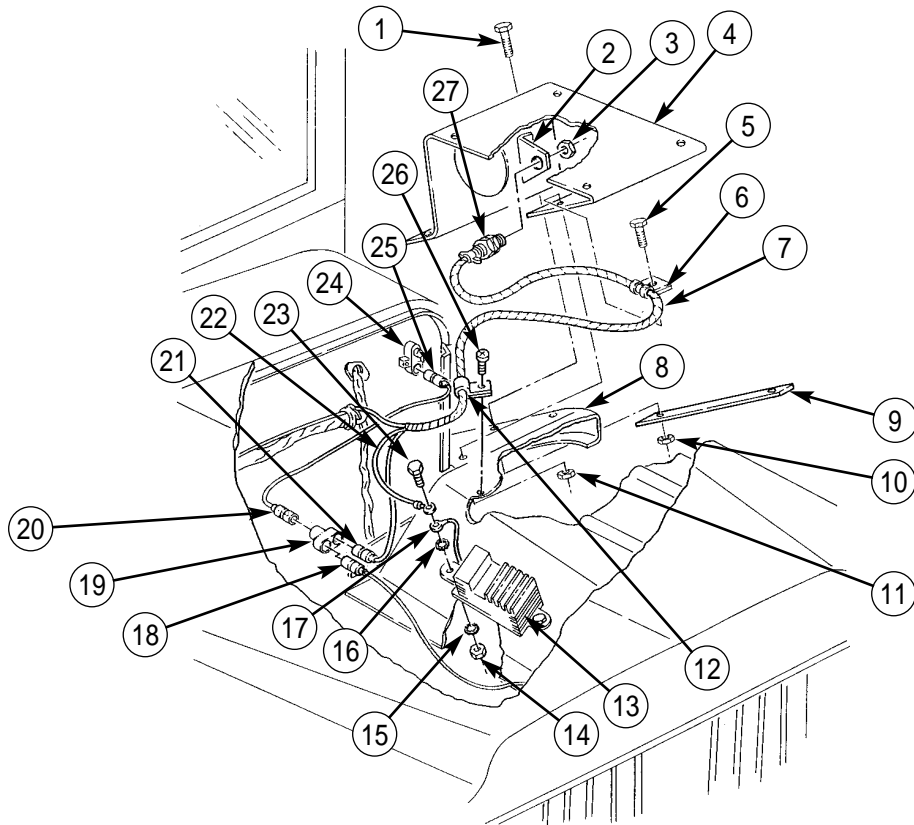

CHEMICAL AGENT ALARM MOUNTING KIT REPLACEMENT (Contd)**INSTALLATION****NOTE**

Assistant will help with steps 1 through 5.

1. Install alarm unit bracket (5) on rear cab panel (1) with two screws (13) and new locknuts (21).
2. Insert harness (2) in grommet (19) and install grommet (19) in cab floor hole (18).
3. Install harness (2) on frame (17) with two clamps (16) and screws (15).
4. Install harness (2) on main wiring harness (8) with four new tiedown straps (9).
5. Install harness (2) on firewall (7) with clamp (10), screw (11), and new locknut (12).
6. Install harness (2) on rear cab panel (1) with clamp (20) and screw (14).
7. Install harness (2) on alarm unit bracket (5) with two clamps (4), screws (3), and new locknuts (6).
8. Install new lockwasher (36), ground (GND) terminal (37), and harness ground (GND) wire (42) on right side of turn signal flasher box (33) with screw (43), new lockwasher (35), and new locknut (34).
9. Connect lead 25 (45) to connector (44).
10. Connect leads 25 (38), 25 (40), and 25 (41) to connector (39).
11. Install harness (2) on left front fender (28) with clamp (32), screw (46), and new locknut (31).
12. Install detector unit bracket (25), support (29), and harness (2) on left front fender (28) with two screws (22) and (26), clamp (27), and four new locknuts (30).
13. Install harness receptacle (47) on bracket (23) with nut (24).
14. Install M43 detector and M42 alarm unit (TM 3-6665-225-12).

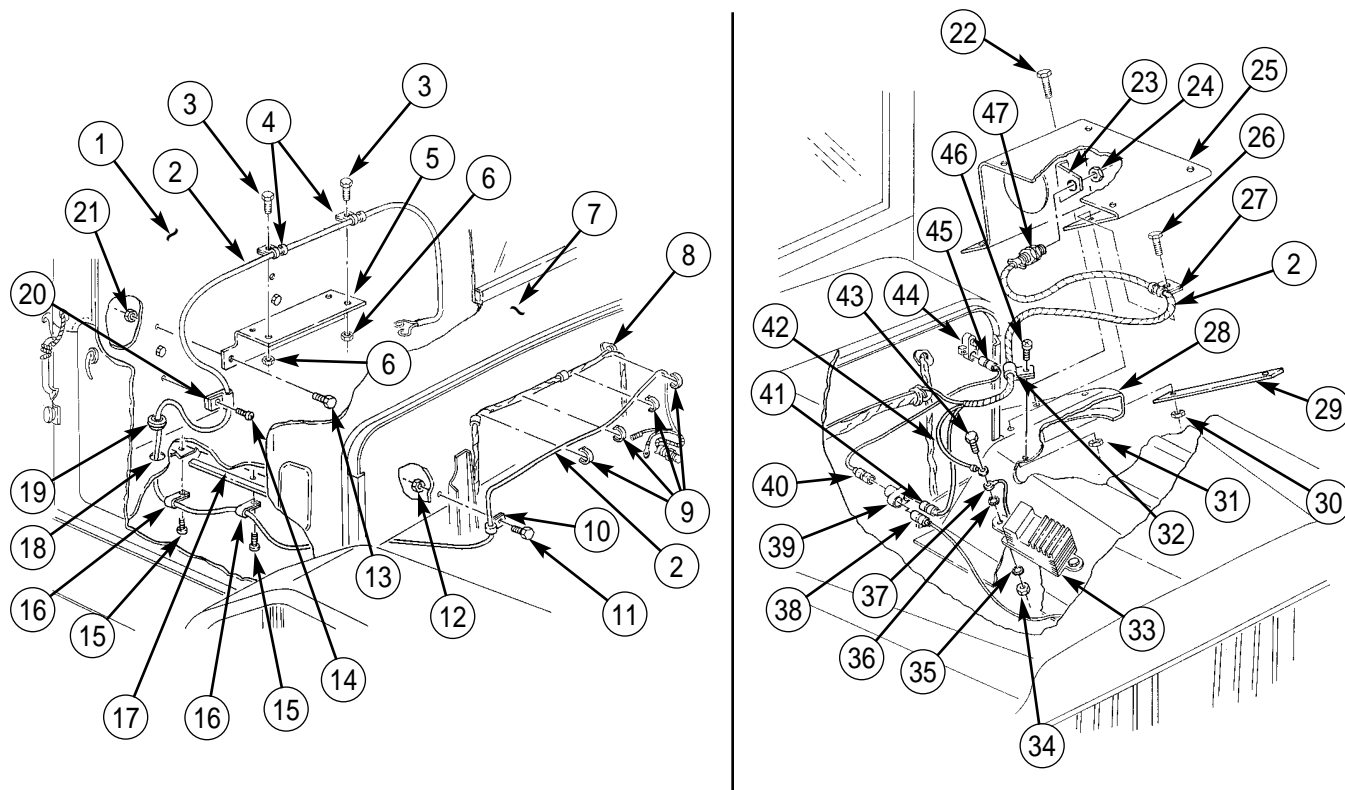

END OF WORK PACKAGE

UNIT MAINTENANCE INSTRUCTIONS

EXTENDED SERVICE PROGRAM (ESP)

TRUCK, CARGO, 2-1/2-TON, 6X6, M44A3 SERIES TRUCKS (DIESEL)

M35A3, W/O WINCH (NSN 2320-01-383-2047); W/WINCH (NSN 2320-01-383-3850);

M35A3C, W/O WINCH (NSN 2320-01-383-2050); W/WINCH (NSN 2320-01-383-2049);

M36A3, W/O WINCH (NSN 2320-01-383-2048); W/WINCH (NSN 2320-01-383-2046).

Section XXVII. AIR BRAKE TRAILER KIT MAINTENANCE

TABLE OF CONTENTS

<i>WP Title</i>	<i>WP Sequence No.-Page No.</i>
Air Brake Rotary Valve and Air Line Replacement	0273 00-1
Air Brake Electrical Harness Replacement	0274 00-1
Air Brake Check Valve, Pressure Switch, and Air Line Replacement	0275 00-1

END OF WORK PACKAGE

UNIT MAINTENANCE INSTRUCTIONS

EXTENDED SERVICE PROGRAM (ESP)

TRUCK, CARGO, 2-1/2-TON, 6X6, M44A3 SERIES TRUCKS (DIESEL)

M35A3, W/O WINCH (NSN 2320-01-383-2047); W/WINCH (NSN 2320-01-383-3850);
M35A3C, W/O WINCH (NSN 2320-01-383-2050); W/WINCH (NSN 2320-01-383-2049);
M36A3, W/O WINCH (NSN 2320-01-383-2048); W/WINCH (NSN 2320-01-383-2046).

AIR BRAKE ROTARY VALVE AND AIR LINE REPLACEMENT

REMOVAL, INSTALLATION

INITIAL SETUP:

Tools and Special Tools

General mechanic's tool kit
(item 30, WP 0394 00)

Materials/Parts

Tiedown strap (item 36, WP 0395 00)
Two lockwashers (item 59, WP 0395 00)
Adhesive (item 8, WP 0393 00)
Cap and plug set (item 14, WP 0393 00)

References

TM 9-2320-386-24P

Equipment Condition

Parking brake set (TM 9-2320-386-10).
Hood raised and secured (TM 9-2320-386-10).
Air reservoir drained (TM 9-2320-386-10).

AIR BRAKE ROTARY VALVE AND AIR LINE REPLACEMENT (Contd)**REMOVAL****WARNING**

Do not disconnect air lines before draining air reservoirs. Small parts under pressure may shoot out with high velocity, causing injury to personnel.

Eyeshields must be worn when releasing compressed air. Failure to do so may result in injury to personnel.

CAUTION

When disconnecting air lines and hoses, plug all openings to prevent dirt from entering and causing damage to internal parts. Remove plugs prior to installation.

NOTE

Tag air lines for installation.

1. Remove tiedown strap (36) from air lines (16) and (17). Discard tiedown strap (36).
2. Loosen nuts (5), (15), and (37) and remove air lines (4), (16), and (17), with inserts (6), (7), and (14), from three straight adapters (8).
3. Loosen nuts (3), (18), and (21) and remove other end of air lines (4), (16), and (17), with inserts (2), (19), and (22), from elbows (1), (20), and (23).
4. Remove elbows (20) and (23) from fittings (24).
5. Loosen nuts (34) and (30) and remove air lines (35) and (29), with inserts (33) and (31), from elbow (32) and straight adapter (28).
6. Remove straight adapter (28) and elbow (32) from fittings (24).

NOTE

Locking hardware in step 7 is provisioned with fitting.

7. Remove two nuts (27), lockwashers (26), and fittings (24) from firewall (25).
8. Remove two screws (12), lockwashers (11), clamp (10), and rotary valve (9) from steering column (13). Discard lockwashers (11).
9. Remove three straight adapters (8) from rotary valve (9).

AIR BRAKE ROTARY VALVE AND AIR LINE REPLACEMENT (Contd)

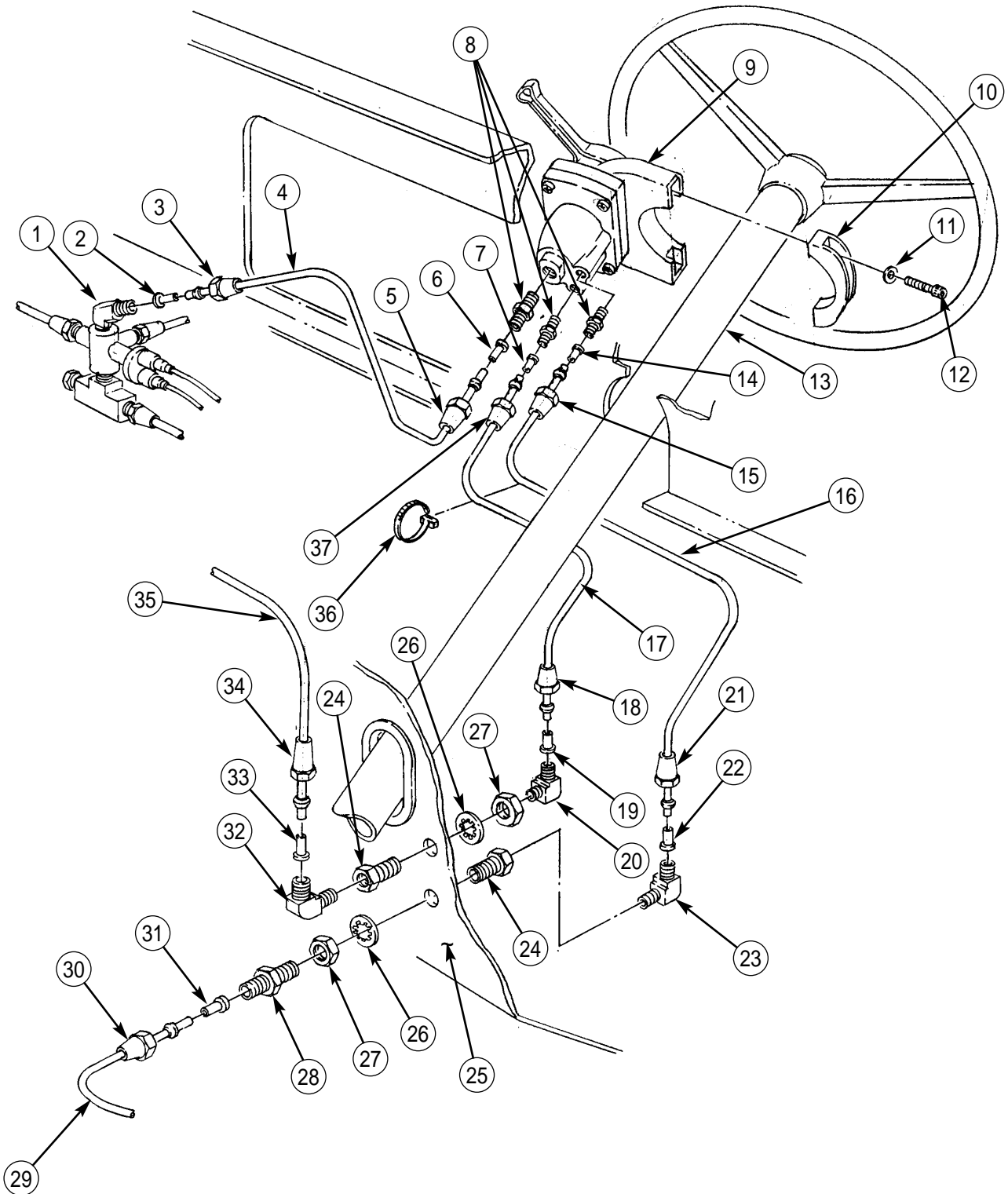

AIR BRAKE ROTARY VALVE AND AIR LINE REPLACEMENT (Contd)

INSTALLATION

1. Apply adhesive to male threads of elbows (1), (20), (23), (32), three straight adapters (8), and straight adapter (28).
2. Install three straight adapters (8) on rotary valve (9).
3. Install rotary valve (9) and clamp (10) on steering column (13) with two new lockwashers (11) and screws (12).
4. Install two fittings (24), lockwashers (26), and nuts (27) on firewall (25).
5. Install elbow (32) and straight adapter (28) on fittings (24).
6. Install air lines (35) and (29), with inserts (33) and (31), on elbow (32) and straight adapter (28) and tighten nuts (34) and (30).
7. Install elbows (20) and (23) on fittings (24).
8. Install air lines (4), (16), and (17), with inserts (2), (19), and (22), on elbows (1), (20), and (23) and tighten nuts (3), (18), and (21).
9. Install other end of air lines (4), (16), and (17), with inserts (6), (7), and (14), on straight adapters (8) and tighten nuts (5), (15), and (37).
10. Install new tiedown strap (36) on air lines (16) and (17).
11. Start engine (TM 9-2320-386-10) and check for leaks and proper operation.

AIR BRAKE ROTARY VALVE AND AIR LINE REPLACEMENT (Contd)

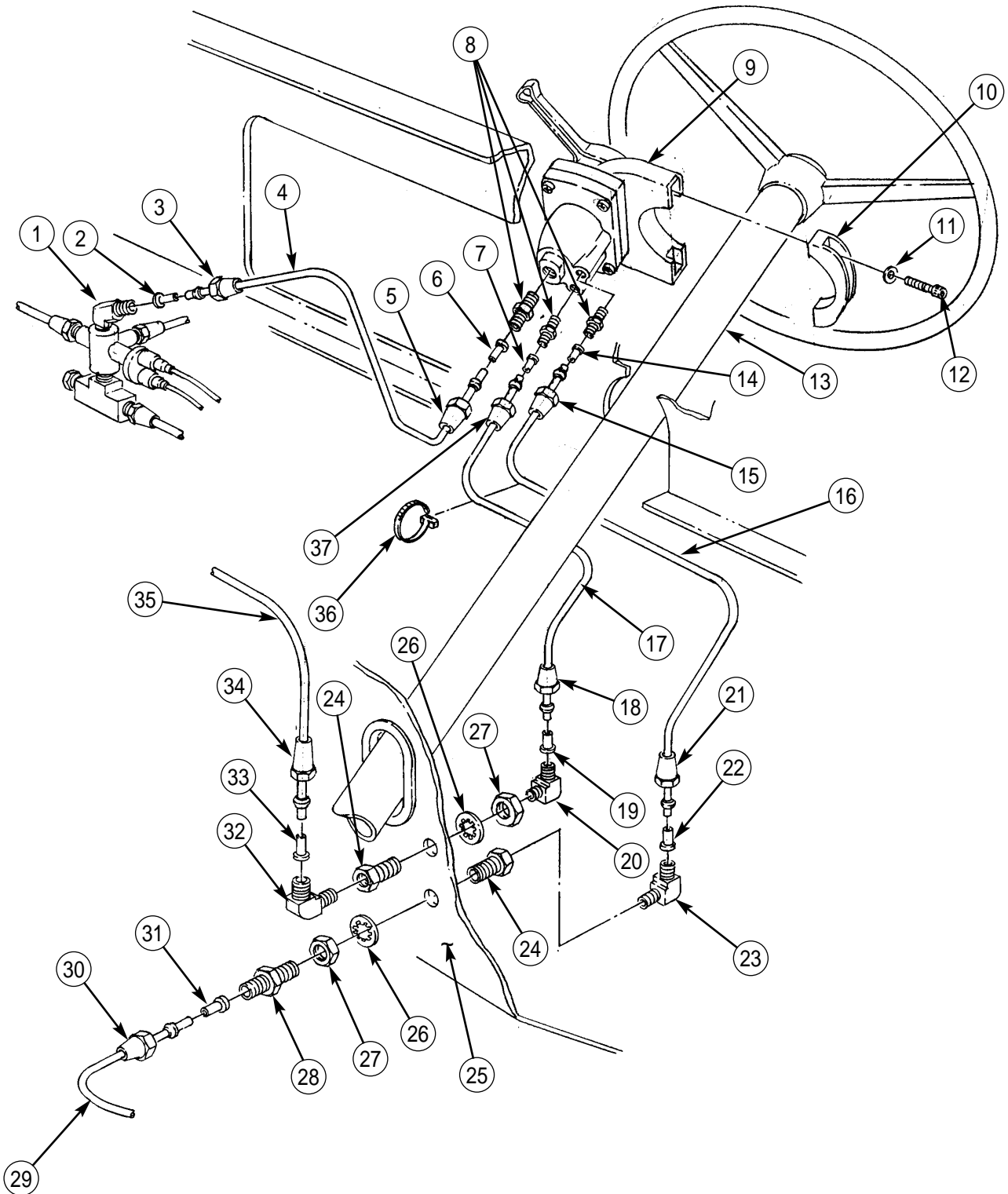

END OF WORK PACKAGE

UNIT MAINTENANCE INSTRUCTIONS

EXTENDED SERVICE PROGRAM (ESP)

TRUCK, CARGO, 2-1/2-TON, 6X6, M44A3 SERIES TRUCKS (DIESEL)

**M35A3, W/O WINCH (NSN 2320-01-383-2047); W/WINCH (NSN 2320-01-383-3850);
M35A3C, W/O WINCH (NSN 2320-01-383-2050); W/WINCH (NSN 2320-01-383-2049);
M36A3, W/O WINCH (NSN 2320-01-383-2048); W/WINCH (NSN 2320-01-383-2046).**

AIR BRAKE ELECTRICAL HARNESS REPLACEMENT

REMOVAL, INSTALLATION

INITIAL SETUP:

Tools and Special Tools

General mechanic's tool kit
(item 30, WP 0394 00)

Materials/Parts

Three tiedown straps (item 36, WP 0395 00)

References

TM 9-2320-386-24P

Equipment Condition

Parking brake set (TM 9-2320-386-10).
Battery ground cable disconnected (WP 0121 00).

AIR BRAKE ELECTRICAL HARNESS REPLACEMENT (Contd)

REMOVAL

1. Remove three tiedown straps (6) from air brake electrical harness (2) and main harness (7). Discard tiedown straps (6).
2. Disconnect two leads 75 (5) from pressure switch (4) on crossmember (3).
3. Disconnect two leads 75 (11) from booster stoplight switch (12).
4. Disconnect two leads 75 (10) from terminal plugs (9) on main harness (7).
5. Remove air brake electrical harness (2) from frame rail (1) and crossmember (8).

INSTALLATION

1. Install air brake electrical harness (2) on main harness (7) on frame rail (1) and crossmember (8) with three new tiedown straps (6).
2. Connect two leads 75 (10) to terminal plugs (9) on main harness (7).
3. Connect two leads 75 (11) on booster stoplight switch (12).
4. Connect two leads 75 (5) on pressure switch (4) on crossmember (3).
5. Connect battery ground (GND) cable (WP 0121 00).

AIR BRAKE ELECTRICAL HARNESS REPLACEMENT (Contd)

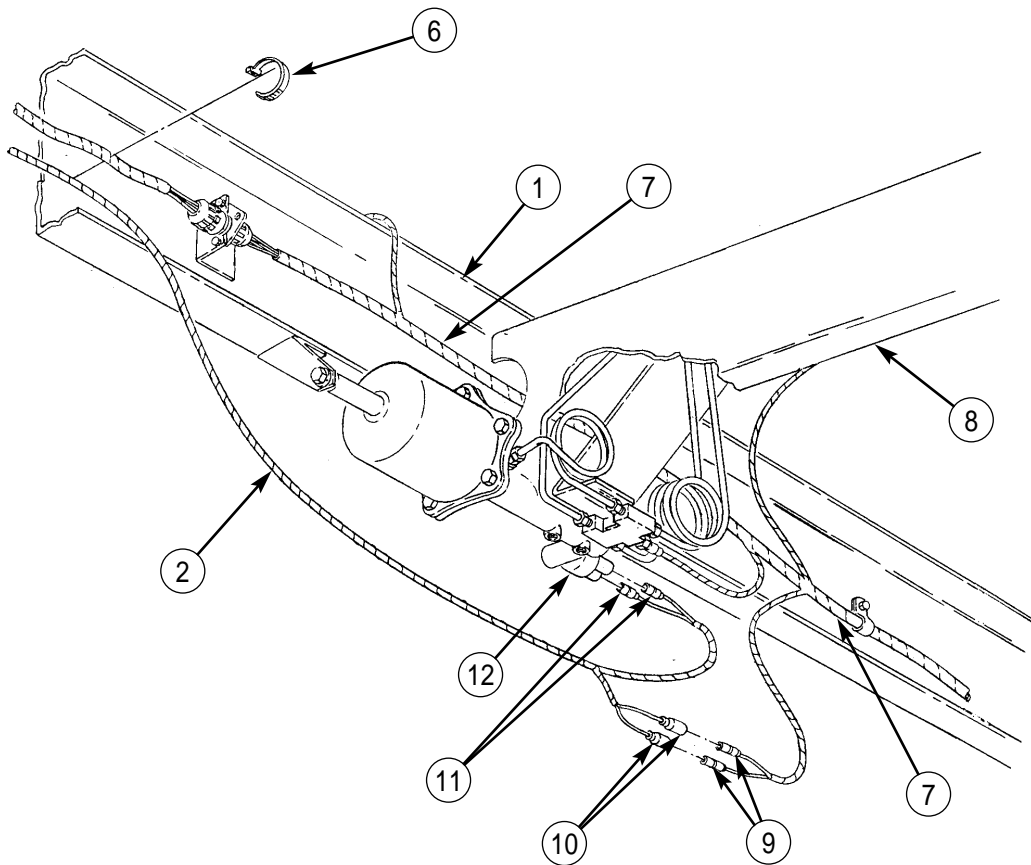
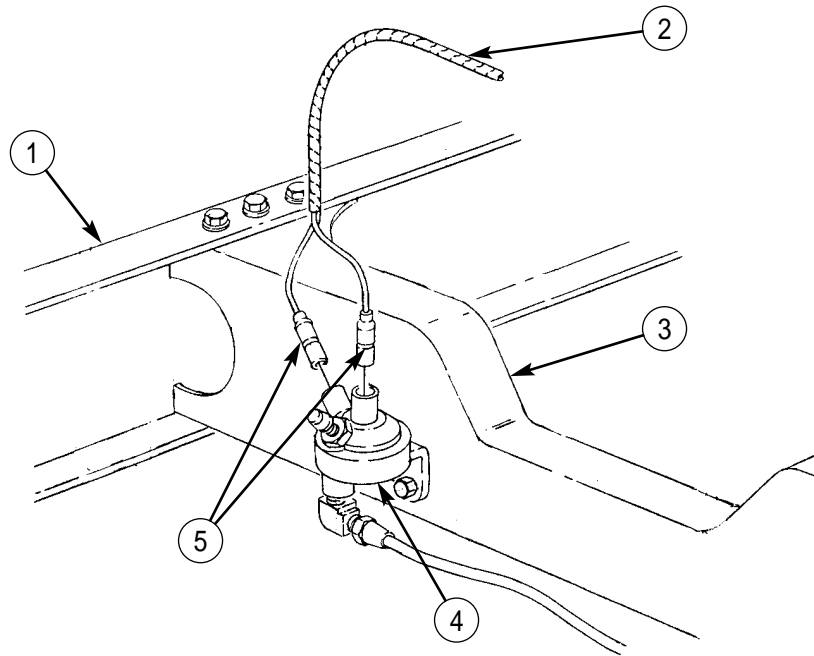

END OF WORK PACKAGE

UNIT MAINTENANCE INSTRUCTIONS

EXTENDED SERVICE PROGRAM (ESP)

TRUCK, CARGO, 2-1/2-TON, 6X6, M44A3 SERIES TRUCKS (DIESEL)

M35A3, W/O WINCH (NSN 2320-01-383-2047); W/WINCH (NSN 2320-01-383-3850);
M35A3C, W/O WINCH (NSN 2320-01-383-2050); W/WINCH (NSN 2320-01-383-2049);
M36A3, W/O WINCH (NSN 2320-01-383-2048); W/WINCH (NSN 2320-01-383-2046).

AIR BRAKE CHECK VALVE, PRESSURE SWITCH, AND AIR LINE REPLACEMENT

REMOVAL, INSTALLATION

INITIAL SETUP:

Tools and Special Tools

General mechanic's tool kit
(item 30, WP 0394 00)

Materials/Parts

Two locknuts (item 259, WP 0395 00)
Locknut (item 58, WP 0395 00)
Four tiedown straps (item 280, WP 0395 00)
Cap and plug set (item 14, WP 0393 00)
Adhesive (item 8, WP 0393 00)

References

TM 9-2320-386-24P

Equipment Condition

Parking brake set (TM 9-2320-386-10).
Hood raised and secured (TM 9-2320-386-10).
Air reservoir drained (TM 9-2320-386-10).

AIR BRAKE CHECK VALVE, PRESSURE SWITCH, AND AIR LINE REPLACEMENT (Contd)**REMOVAL****WARNING**

Do not disconnect air lines before draining air reservoirs. Small parts under pressure may shoot out with high velocity, causing injury to personnel.

Eyeshields must be worn when releasing compressed air. Failure to do so may result in injury to personnel.

CAUTION

When disconnecting air lines and hoses, plug all openings to prevent dirt from entering and causing damage to internal parts. Remove plugs prior to installation.

NOTE

Tag air lines for installation.

1. Disconnect two leads 75 (46) of air brake electrical harness (1) from pressure switch (45).
2. Remove four tiedown straps (21) from air lines (2), (7), (9), (20), and (30). Discard tiedown straps (21).
3. Loosen nuts (3), (8), (29), and (37) and remove air lines (2), (7), (30), and (9), with inserts (44), (40), (28), and (36), from elbows (43) and (38) and tee (35).
4. Loosen nut (31) and remove air line (30), with insert (32), from elbow (33).
5. Remove locknut (39), screw (41), and check valve (42) from crossmember (4). Discard locknut (39).
6. Remove elbows (38) and (43) from check valve (42).
7. Remove tee (35) from check valve (42).
8. Remove two locknuts (6), washers (5), screws (34), and pressure switch (45) from crossmember (4). Discard locknuts (6).
9. Remove elbow (33) from pressure switch (45).
10. Loosen nut (19) and remove air line (20), with insert (18), from elbow (16).
11. Remove elbow (16) from check valve (17).
12. Loosen nuts (10) and (14) and remove air lines (9) and (15), with inserts (11) and (13), from union (12).
13. Loosen nuts (22) and (26) and remove air lines (7) and (27), with inserts (23) and (25), from union (24).

AIR BRAKE CHECK VALVE, PRESSURE SWITCH, AND AIR LINE REPLACEMENT (Contd)

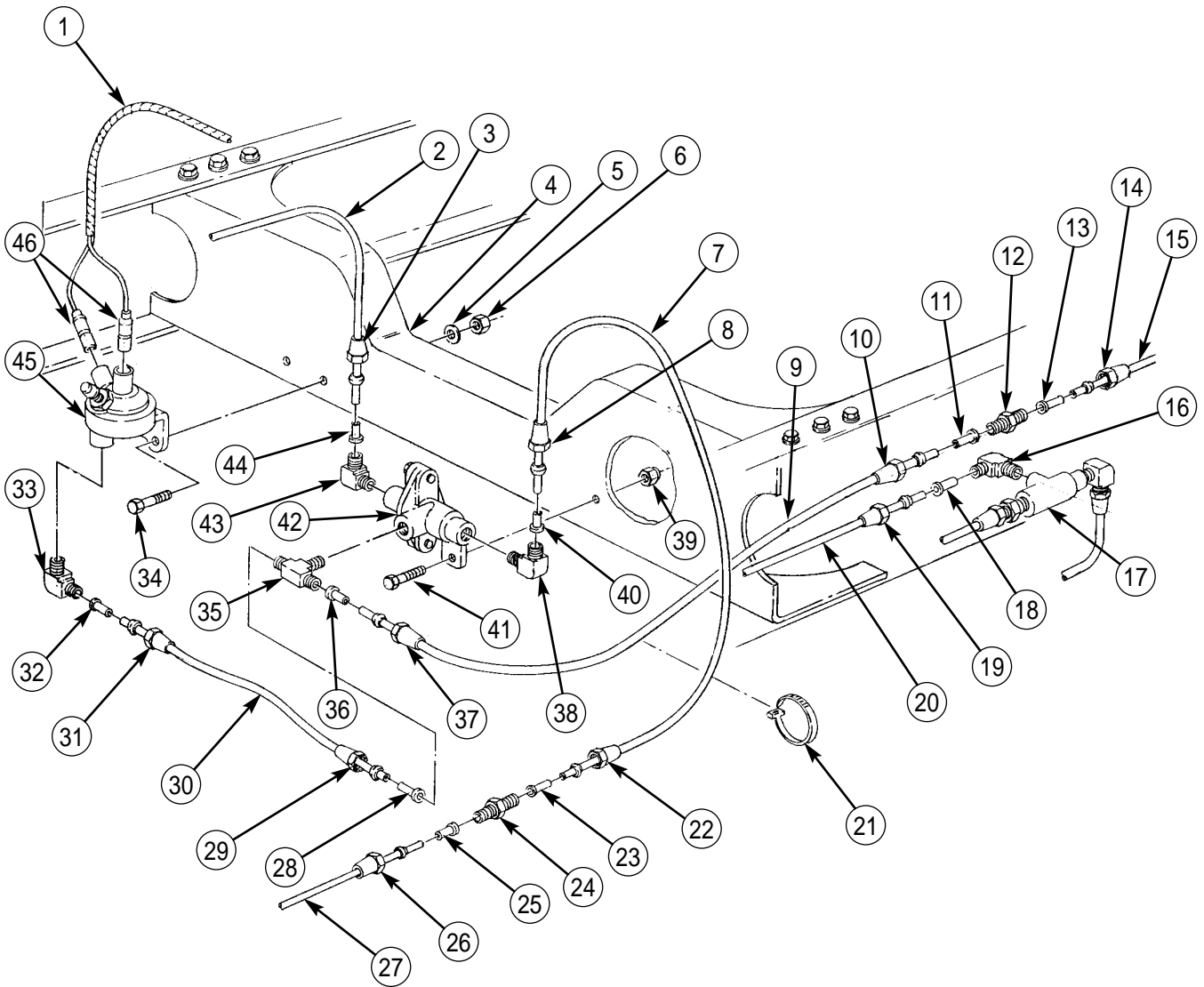

AIR BRAKE CHECK VALVE, PRESSURE SWITCH, AND AIR LINE REPLACEMENT (Contd)**INSTALLATION**

1. Apply adhesive to male threads of elbows (16), (33), (38), and (43), unions (12) and (24), and tee (35).
2. Install air lines (7) and (27), with inserts (23) and (25), on union (24) and tighten nuts (22) and (26).
3. Install air lines (9) and (15), with inserts (11) and (13), on union (12) and tighten nuts (10) and (14).
4. Install elbow (16) on check valve (17).
5. Install air line (20), with insert (18), on elbow (16) and tighten nut (19).
6. Install elbow (33) on pressure switch (45).
7. Install pressure switch (45) on crossmember (4) with two screws (34), washers (5), and new locknuts (6).
8. Install tee (35) on check valve (42).
9. Install elbows (38) and (43) on check valve (42).
10. Install check valve (42) on crossmember (4) with screw (41) and new locknut (39).
11. Install air line (30), with insert (32), on elbow (33) and tighten nut (31).
12. Install air lines (9), (30), (7), and (2), with inserts (36), (28), (40), and (44), on tee (35) and elbows (38) and (43) and tighten nuts (37), (29), (8), and (3).
13. Install four new tiedown straps (21) on air lines (30), (20), (9), (7), and (2).
14. Connect two leads 75 (46) of air brake electrical harness (1) to pressure switch (45).

AIR BRAKE CHECK VALVE, PRESSURE SWITCH, AND AIR LINE REPLACEMENT (Contd)

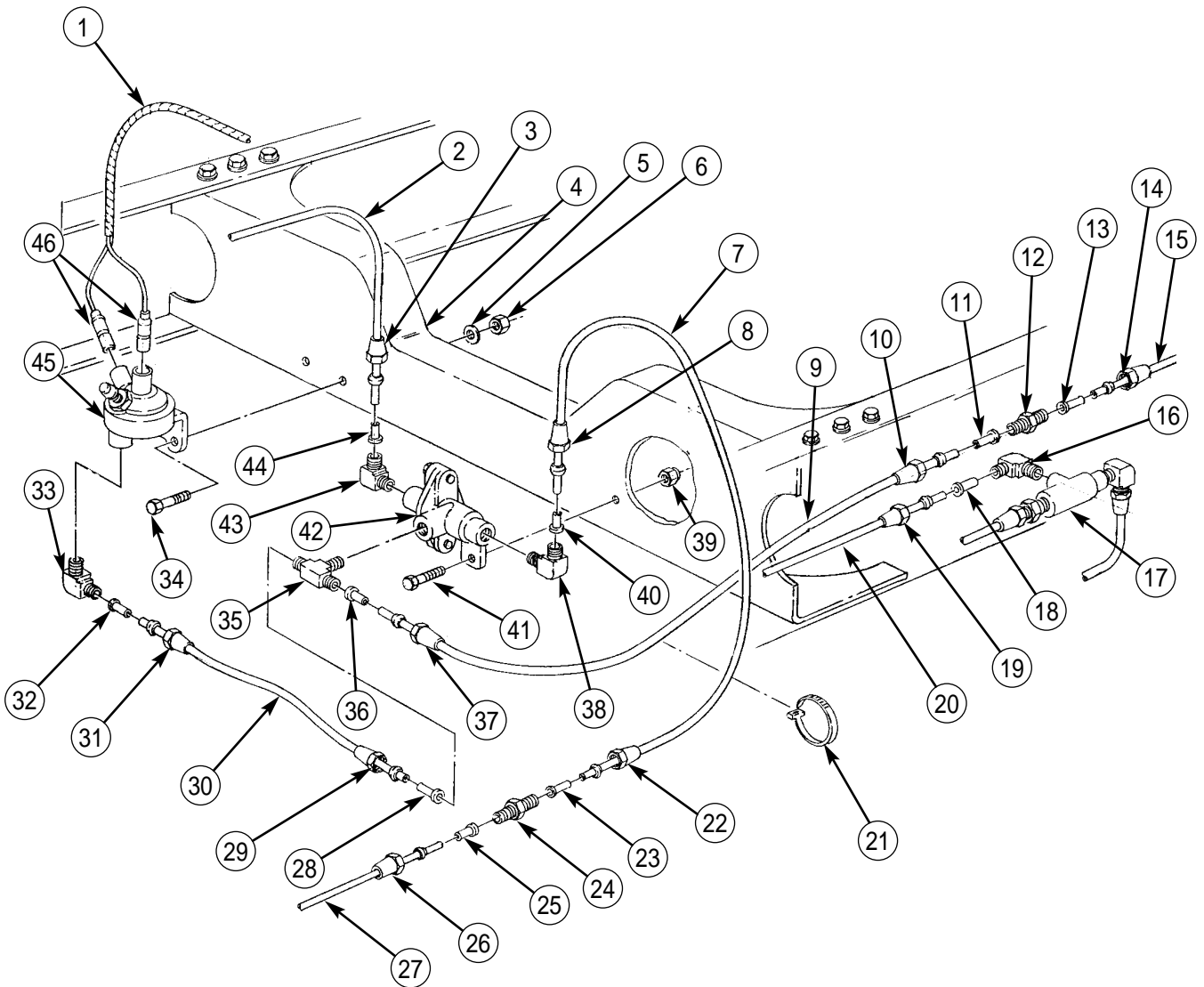

END OF WORK PACKAGE

UNIT MAINTENANCE INSTRUCTIONS

EXTENDED SERVICE PROGRAM (ESP)

TRUCK, CARGO, 2-1/2-TON, 6X6, M44A3 SERIES TRUCKS (DIESEL)

M35A3, W/O WINCH (NSN 2320-01-383-2047); W/WINCH (NSN 2320-01-383-3850);

M35A3C, W/O WINCH (NSN 2320-01-383-2050); W/WINCH (NSN 2320-01-383-2049);

M36A3, W/O WINCH (NSN 2320-01-383-2048); W/WINCH (NSN 2320-01-383-2046).

Section XXVIII. 100-AMP ALTERNATOR KIT MAINTENANCE

TABLE OF CONTENTS

<i>WP Title</i>	<i>WP Sequence No.-Page No.</i>
100-Amp Alternator Replacement	0277 00-1
100-Amp Alternator Cable and Harness Replacement	0278 00-1
100-Amp Alternator Regulator Replacement	0279 00-1

END OF WORK PACKAGE

UNIT MAINTENANCE INSTRUCTIONS

EXTENDED SERVICE PROGRAM (ESP)

TRUCK, CARGO, 2-1/2-TON, 6X6, M44A3 SERIES TRUCKS (DIESEL)

M35A3, W/O WINCH (NSN 2320-01-383-2047); W/WINCH (NSN 2320-01-383-3850);
M35A3C, W/O WINCH (NSN 2320-01-383-2050); W/WINCH (NSN 2320-01-383-2049);
M36A3, W/O WINCH (NSN 2320-01-383-2048); W/WINCH (NSN 2320-01-383-2046).

100-AMP ALTERNATOR REPLACEMENT

REMOVAL, INSTALLATION

INITIAL SETUP:

Tools and Special Tools

General mechanic's tool kit
(item 30, WP 0394 00)
Mechanical puller kit (item 41, WP 0394 00)

Materials/Parts

Three lockwashers (item 62, WP 0395 00)
Two lockwashers (item 130, WP 0395 00)
Two locknuts (item 90, WP 0395 00)
Locknut (item 24, WP 0395 00)
Woodruff key (item 71, WP 0395 00)

References

TM 9-2320-386-24P

Equipment Condition

Parking brake set (TM 9-2320-386-10).
Hood raised and secured (TM 9-2320-386-10).
Battery ground cable disconnected (WP 0121 00).
Fan drivebelt removed (WP 0084 00).

100-AMP ALTERNATOR REPLACEMENT (Contd)

REMOVAL

1. Disconnect cable plug (1) from connector (2) on alternator (3).
2. Remove screw (18) and lockwasher (17) from bracket (4) and alternator (3). Discard lockwasher (17).
3. Remove two screws (9), lockwashers (8), and alternator (3) from bracket (13). Discard lockwashers (8).
4. Remove two locknuts (5), screws (7), and bracket (4) from engine (6). Discard locknuts (5).
5. Remove two screws (15), lockwashers (14), and bracket (13) from water pump housing (19). Discard lockwashers (14).
6. Remove locknut (11) and washer (12) from alternator (3) and pulley (10). Discard locknut (11).
7. Using puller, remove pulley (10) and woodruff key (16) from alternator (3). Discard woodruff key (16).

100-AMP ALTERNATOR REPLACEMENT (Contd)

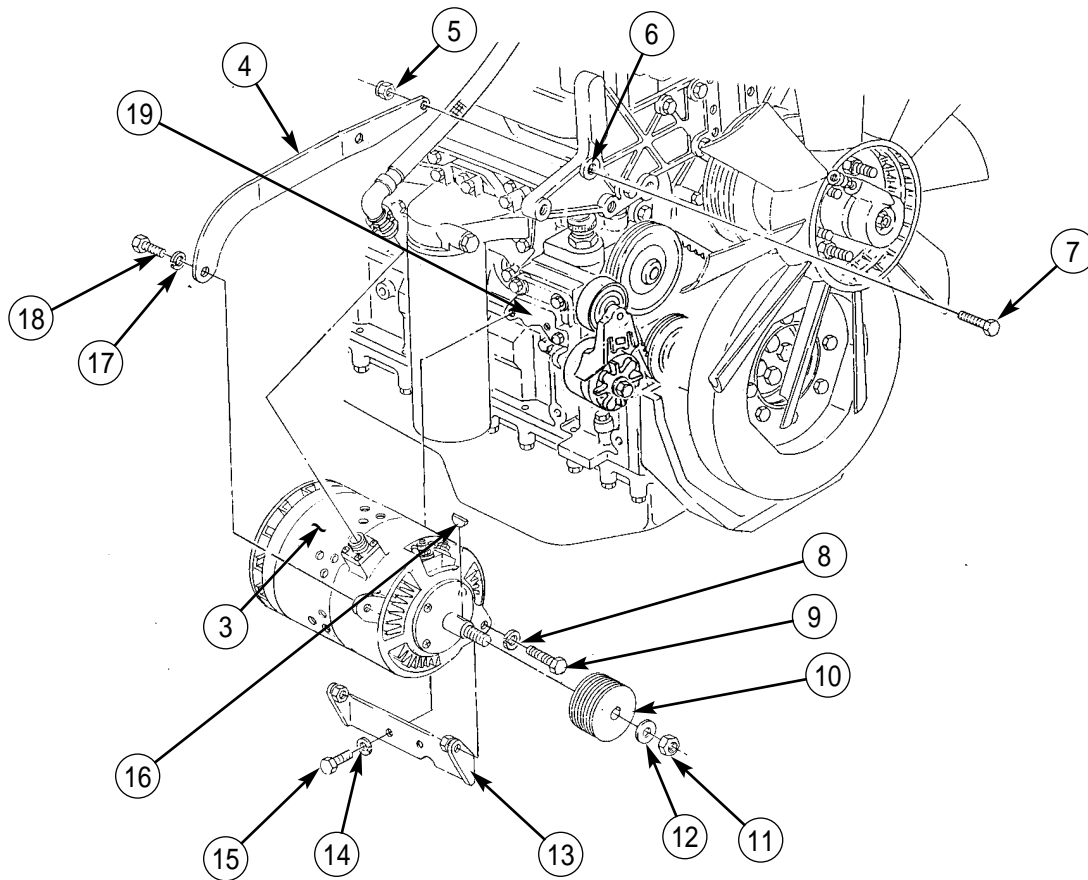
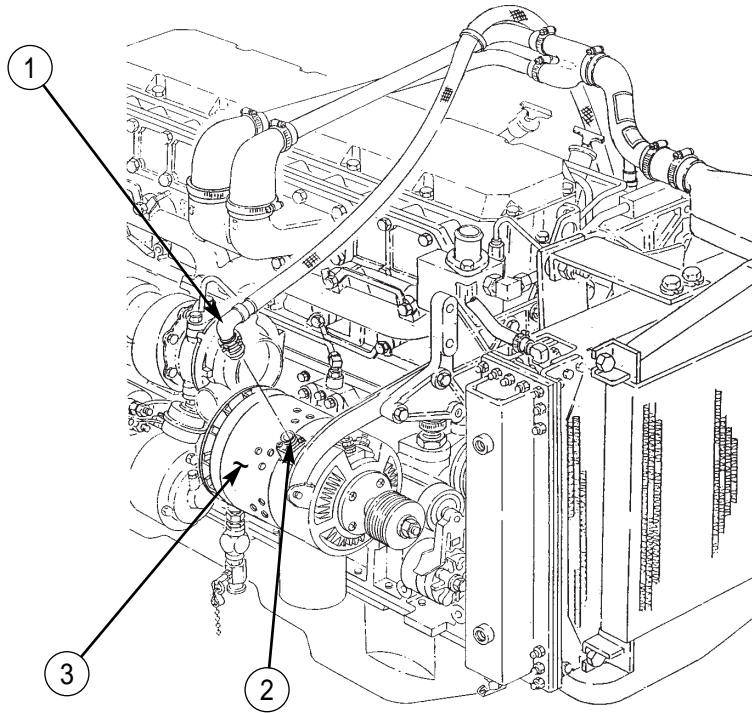

100-AMP ALTERNATOR REPLACEMENT (Contd)

INSTALLATION

1. Install new woodruff key (14) and pulley (8) on alternator (16) with washer (10) and new locknut (9).
2. Install bracket (11) on water pump housing (19) with two new lockwashers (12) and screws (13).
3. Install alternator (16) on bracket (11) with two new lockwashers (6) and screws (7). Finger-tighten screws (7).
4. Install bracket (1) on engine (4) with two screws (5) and new locknuts (2).
5. Install alternator (16) on bracket (1) with new lockwasher (17) and screw (18).
6. Tighten screws (7).
7. Connect cable plug (3) to connector (15) on alternator (16).
8. Install fan drivebelt (WP 0084 00).
9. Connect battery ground (GND) cable (WP 0121 00).

100-AMP ALTERNATOR REPLACEMENT (Contd)

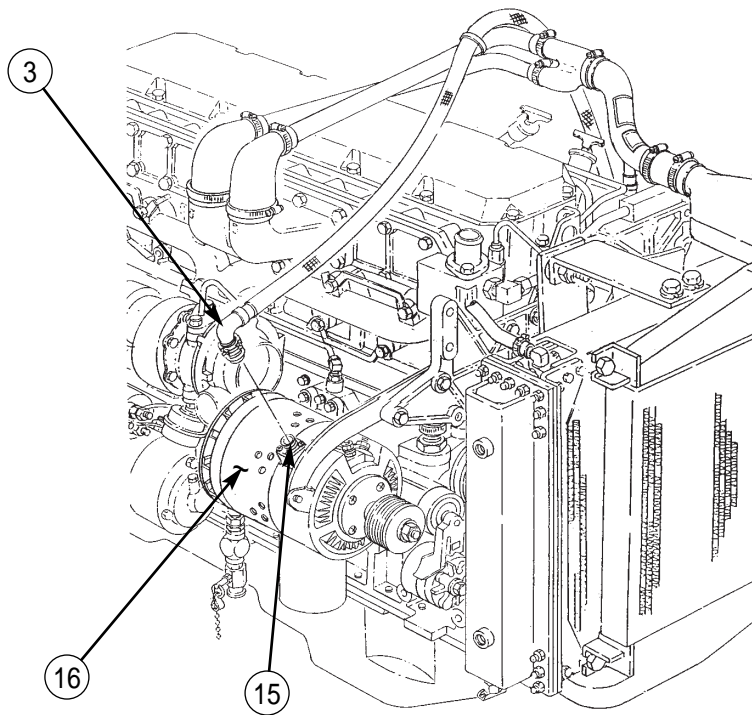
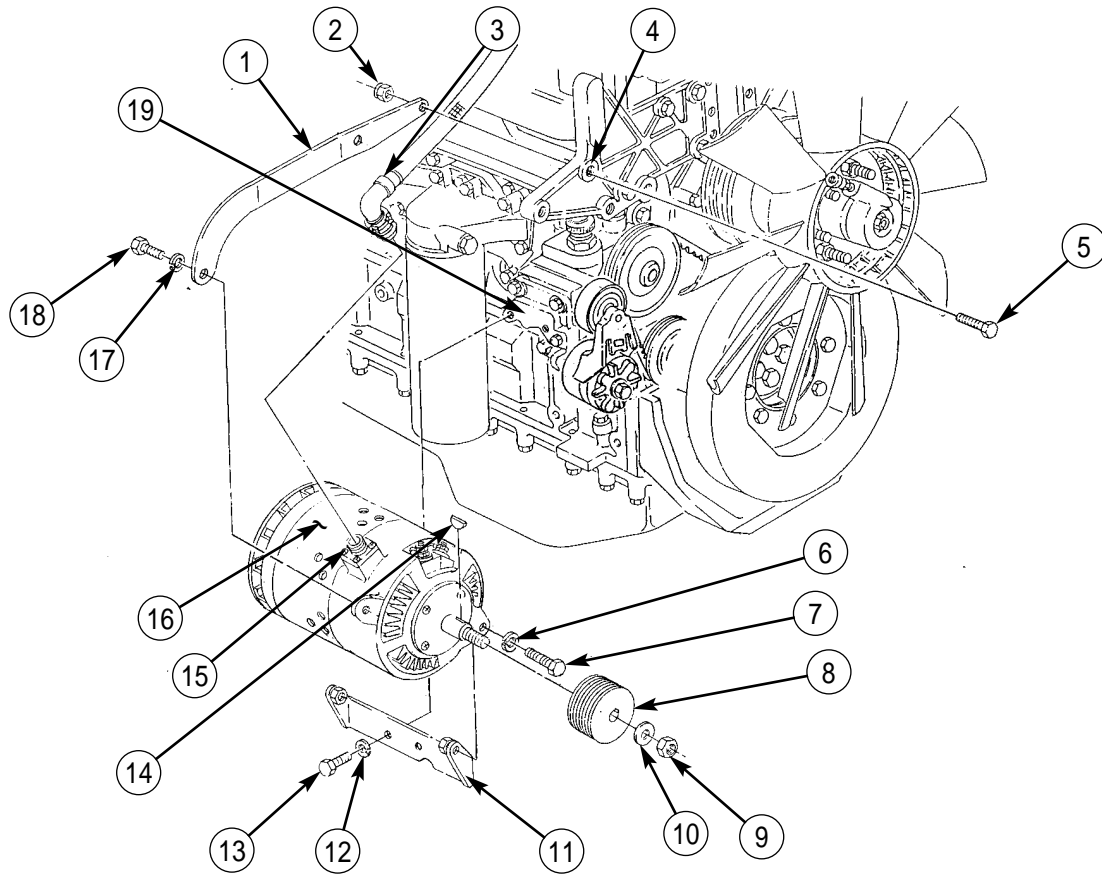

END OF WORK PACKAGE

UNIT MAINTENANCE INSTRUCTIONS

EXTENDED SERVICE PROGRAM (ESP)

TRUCK, CARGO, 2-1/2-TON, 6X6, M44A3 SERIES TRUCKS (DIESEL)

M35A3, W/O WINCH (NSN 2320-01-383-2047); W/WINCH (NSN 2320-01-383-3850);

M35A3C, W/O WINCH (NSN 2320-01-383-2050); W/WINCH (NSN 2320-01-383-2049);

M36A3, W/O WINCH (NSN 2320-01-383-2048); W/WINCH (NSN 2320-01-383-2046).

100-AMP ALTERNATOR CABLE AND HARNESS REPLACEMENT

REMOVAL, INSTALLATION

INITIAL SETUP:

Tools and Special Tools

General mechanic's tool kit
(item 30, WP 0394 00)

Materials/Parts

Twelve tiedown straps (item 36, WP 0395 00)
Two lockwashers (item 186, WP 0395 00)

References

TM 9-2320-386-24P

Equipment Condition

Parking brake set (TM 9-2320-386-10).
Hood raised and secured (TM 9-2320-386-10).
Battery ground cable disconnected (WP 0121 00).

100-AMP ALTERNATOR CABLE AND HARNESS REPLACEMENT (Contd)

REMOVAL

NOTE

Tag all leads for installation.

1. Remove nut (7), lockwasher (8), and lead 93 (9) from negative post (10) on starter motor (12). Discard lockwasher (8).
2. Remove nut (6), lockwasher (5), and leads 6 (4), 2 (3), and 14 (2) from positive post (1) on starter solenoid (1). Discard lockwasher (5).
3. Disconnect cable plug (13) from connector (14) on alternator (15).
4. Remove tiedown strap (17) and cable (13) from tube (16). Discard tiedown strap (17).
5. Disconnect cable plug (18) and remove cable (13) from voltage regulator (19).
6. Disconnect harness plug (20) and remove harness (3) from voltage regulator (19).
7. Disconnect lead 10 (21) from lead 10 (33).
8. Disconnect lead 1 (22) from lead 1 (24).
9. Disconnect leads 10 (33) and (34) from connector (32).
10. Disconnect lead 10 (31) from connector (32) and circuit breaker (30).
11. Disconnect leads 1 (24) and 27 (26) from connector (29).
12. Disconnect lead 27 (27) from connector (29) and switch (28).
13. Remove eleven tiedown straps (23), harness (3), and leads 10 (21) and 1 (22) from front main wiring harness (25). Discard tiedown straps (23).

INSTALLATION

1. Install harness (3) and leads 10 (21) and 1 (22) on front main wiring harness (25) with eleven new tiedown straps (23).
2. Connect lead 27 (27) to connector (29) and switch (28).
3. Connect leads 1 (24) and 27 (26) to connector (29).
4. Connect lead 10 (31) to connector (32) and circuit breaker (30).
5. Connect leads 10 (33) and (34) to connector (32).
6. Connect lead 1 (22) to lead 1 (24).
7. Connect lead 10 (21) to lead 10 (33).
8. Connect harness plug (20) to voltage regulator (19).
9. Connect cable plug (18) to voltage regulator (19) and cable plug (13) to connector (14) on alternator (15).
10. Install cable (13) on tube (16) with new tiedown strap (17).
11. Install leads 14 (2), 2 (3), and 6 (4) to positive post (1) on starter solenoid (1) with new lockwasher (5) and nut (6).
12. Install lead 93 (9) to negative post (10) on starter motor (12) with new lockwasher (8) and nut (7).
13. Connect battery ground (GND) cable (WP 0121 00).

100-AMP ALTERNATOR CABLE AND HARNESS REPLACEMENT (Contd)

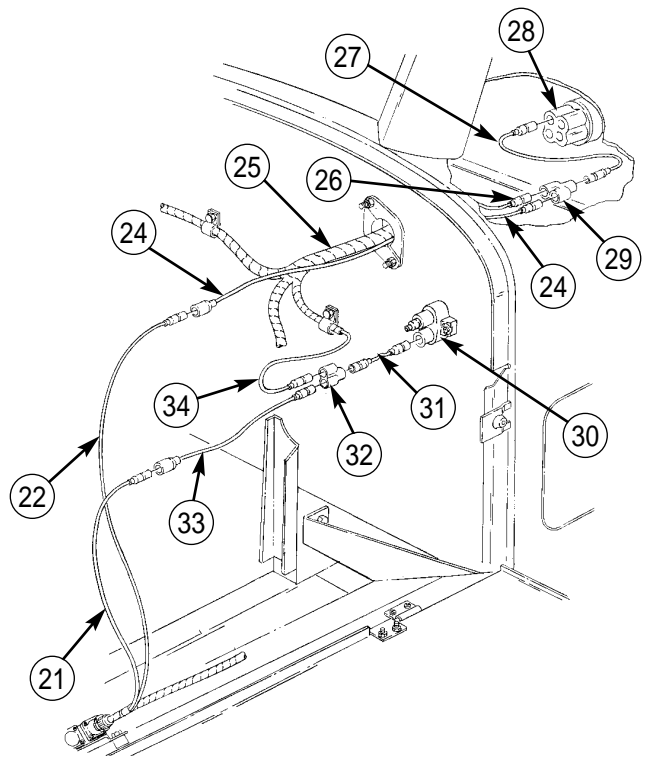
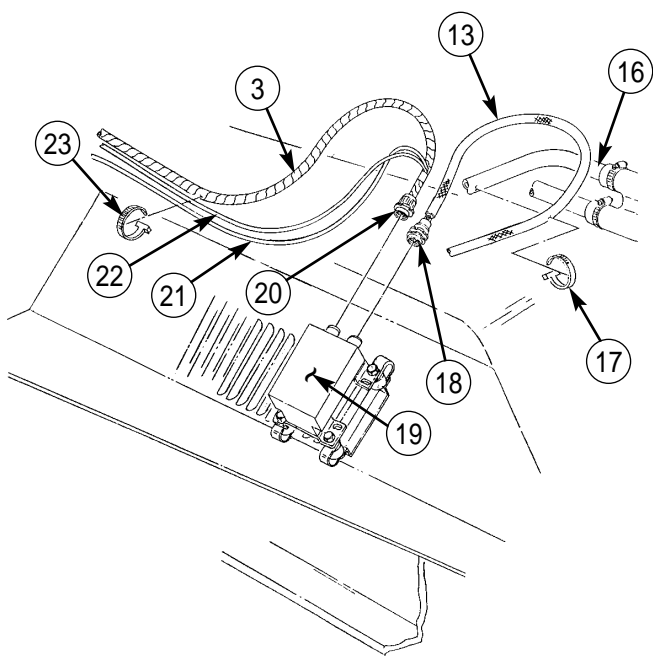
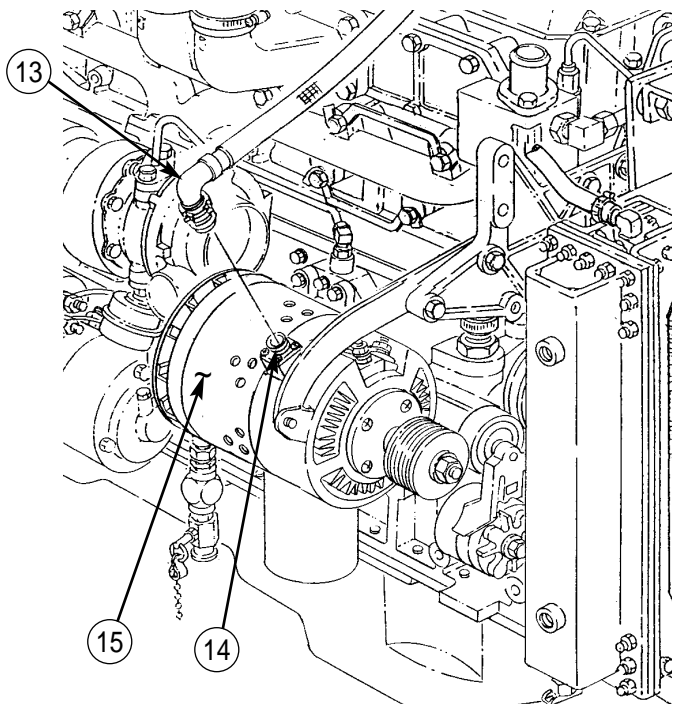
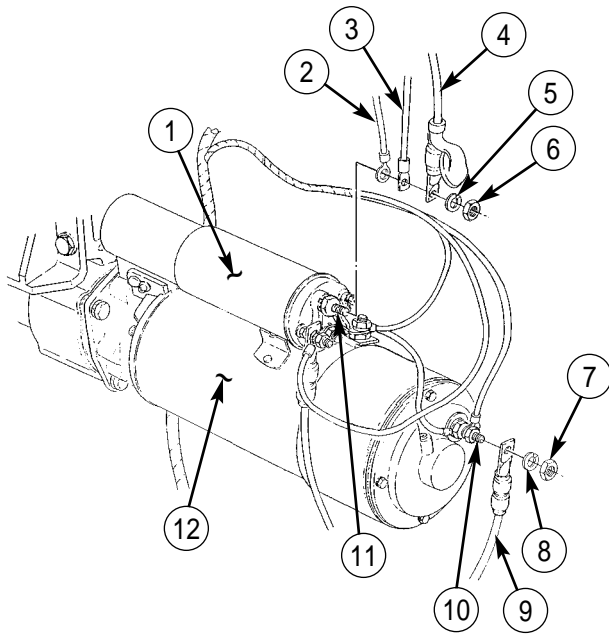

END OF WORK PACKAGE

UNIT MAINTENANCE INSTRUCTIONS

EXTENDED SERVICE PROGRAM (ESP)

TRUCK, CARGO, 2-1/2-TON, 6X6, M44A3 SERIES TRUCKS (DIESEL)

M35A3, W/O WINCH (NSN 2320-01-383-2047); W/WINCH (NSN 2320-01-383-3850);
M35A3C, W/O WINCH (NSN 2320-01-383-2050); W/WINCH (NSN 2320-01-383-2049);
M36A3, W/O WINCH (NSN 2320-01-383-2048); W/WINCH (NSN 2320-01-383-2046).

100-AMP ALTERNATOR REGULATOR REPLACEMENT

REMOVAL, INSTALLATION

INITIAL SETUP:

Tools and Special Tools

General mechanic's tool kit
(item 30, WP 394 00)

Materials/Parts

Twelve lockwashers (item 77, WP 0395 00)
Four lockwashers (item 49, WP 0395 00)
Four locknuts (item 15, WP 0395 00)

References

TM 9-2320-386-24P

Equipment Condition

Parking brake set (TM 9-2320-386-10).
Hood raised and secured (TM 9-2320-386-10).
Battery ground cable disconnected (WP 0121 00).

100-AMP ALTERNATOR REGULATOR REPLACEMENT (Contd)

REMOVAL

1. Disconnect cable (2) and harness (1) from regulator (3).
2. Remove four nuts (15), lockwashers (14), and regulator (3) from four shock mounts (12). Discard lockwashers (14).
3. Remove four screws (16), lockwashers (17), and two frame reinforcements (4) from regulator (3). Discard lockwashers (17).

NOTE

Assistant will help with step 4.

4. Remove four locknuts (9), lockwashers (8), screws (5), and two brackets (6) from fender (7). Discard locknuts (9) and lockwashers (8).
5. Remove four nuts (10), lockwashers (11), shock mounts (12), and ground straps (13) from two brackets (6). Discard lockwashers (11).

INSTALLATION

1. Install four ground straps (13) and shock mounts (12) on two brackets (6) with four new lockwashers (11) and nuts (10).

NOTE

Assistant will help with step 2.

2. Install two brackets (6) on fender (7) with four screws (5), new lockwashers (8), and new locknuts (9).
3. Install two frame reinforcements (4) on regulator (3) with four new lockwashers (17) and screws (16).
4. Install regulator (3) on four shock mounts (12) with four new lockwashers (14) and nuts (15).
5. Connect cable (2) and harness (1) to regulator (3).
6. Connect battery ground cable (WP 0121 00).

100-AMP ALTERNATOR REGULATOR REPLACEMENT (Contd)

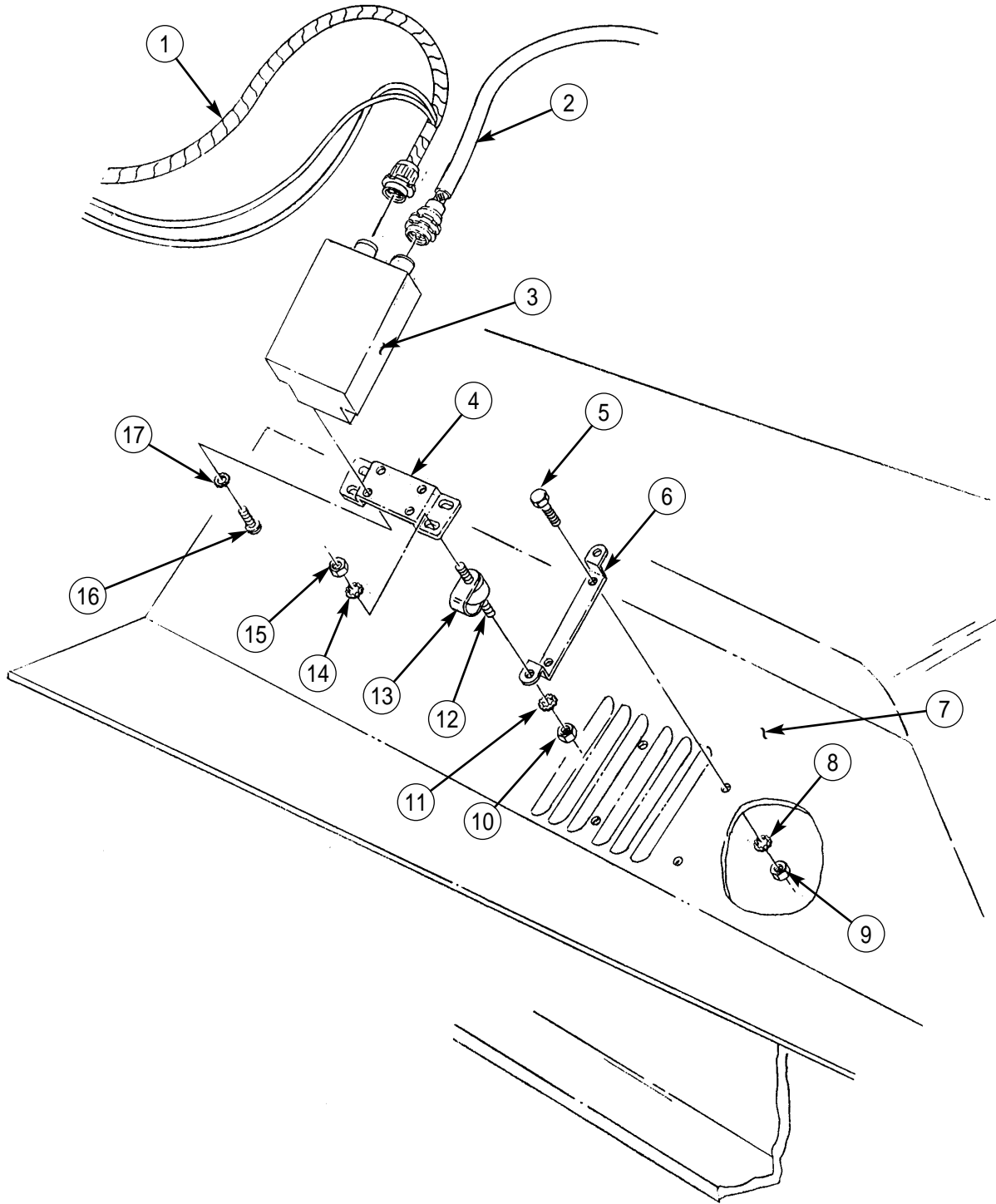

END OF WORK PACKAGE

UNIT MAINTENANCE INSTRUCTIONS

EXTENDED SERVICE PROGRAM (ESP)

TRUCK, CARGO, 2-1/2-TON, 6X6, M44A3 SERIES TRUCKS (DIESEL)

M35A3, W/O WINCH (NSN 2320-01-383-2047); W/WINCH (NSN 2320-01-383-3850);

M35A3C, W/O WINCH (NSN 2320-01-383-2050); W/WINCH (NSN 2320-01-383-2049);

M36A3, W/O WINCH (NSN 2320-01-383-2048); W/WINCH (NSN 2320-01-383-2046).

SECTION XXIX. CENTRAL TIRE INFLATION SYSTEM (CTIS) MAINTENANCE

TABLE OF CONTENTS

<i>WP Title</i>	<i>WP Sequence No.-Page No.</i>
Air Dryer and Air Dryer Heater Maintenance	0281 00-1
CTIS Manifold and Exhaust Replacement	0282 00-1
CTIS Electronic Control Unit (ECU)/Bracket Replacement	0283 00-1
CTIS Overspeed Signal Generator Replacement	0284 00-1

END OF WORK PACKAGE

UNIT MAINTENANCE INSTRUCTIONS

EXTENDED SERVICE PROGRAM (ESP)

TRUCK, CARGO, 2-1/2-TON, 6X6, M44A3 SERIES TRUCKS (DIESEL)

**M35A3, W/O WINCH (NSN 2320-01-383-2047); W/WINCH (NSN 2320-01-383-3850);
M35A3C, W/O WINCH (NSN 2320-01-383-2050); W/WINCH (NSN 2320-01-383-2049);
M36A3, W/O WINCH (NSN 2320-01-383-2048); W/WINCH (NSN 2320-01-383-2046).**

AIR DRYER AND AIR DRYER HEATER MAINTENANCE

**AIR DRYER REMOVAL, DESICCANT AND COALESCING FILTER REMOVAL,
DESICCANT AND COALESCING FILTER INSPECTION, DESICCANT AND COALESCING FILTER INSTALLATION,
AIR DRYER INSTALLATION, OPERATIONAL CHECK, AIR DRYER HEATER REMOVAL, AIR DRYER HEATER INSTALLATION**

INITIAL SETUP:

Tools and Special Tools

General mechanic's tool kit
(item 30, WP 0394 00)
Common No. 1 tool kit
(item 15, WP 0394 00)
Strap wrench (item 79, WP 0394 00)

Materials/Parts

Lockwasher (item 77, WP 0395 00)
Lockwasher (item 61, WP 0395 00)
Air dryer filter kit (item 113, WP 0395 00)
Air dryer heater kit (item 8, WP 0395 00)
Cap and plug set (item 14, WP 0393 00)
Teflon pipe sealant (item 41, WP 0393 00)
Lubricating oil (item 32, WP 0393 00)

References

TM 9-2320-386-24P

Equipment Condition

Parking brake set (TM 9-2320-386-10).
Air reservoirs drained (TM 9-2320-386-10).
Battery ground cable disconnected (WP 0121 00).

AIR DRYER AND AIR DRYER HEATER MAINTENANCE (Contd)**NOTE**

For schematic representation of air line locations and routing, refer to WP 0386 00 of this manual.

AIR DRYER REMOVAL**WARNING**

Do not disconnect air lines before draining air reservoirs. Small parts under pressure may shoot out at high velocity, causing injury to personnel.

Eyeshields must be worn when releasing compressed air. Failure to do so may result in injury to personnel.

CAUTION

When disconnecting air lines and hoses, plug all openings to prevent dirt from entering and causing damage to internal parts. Remove all plugs prior to installation.

NOTE

Tag air lines for installation.

1. Loosen nut (10) and remove tube (9) from air dryer outlet port elbow (11).
2. Loosen nut (19) and remove tube (16) from air dryer control port elbow (12).
3. Loosen nut (3) and remove tube (4) from air dryer inlet port elbow (8).
4. Disconnect wire harness connector 27 (18) from air dryer heater connector (17).
5. Remove nut (15), lockwasher (14), clamp (13), and jamnut (20) from clamp (1). Discard lockwasher (14).
6. Remove screw (6) and lockwasher (5) from air dryer (7) and mounting bracket (2). Discard lockwasher (5).
7. Remove air dryer (7) from clamp (1) and mounting bracket (2).

AIR DRYER AND AIR DRYER HEATER MAINTENANCE (Contd)

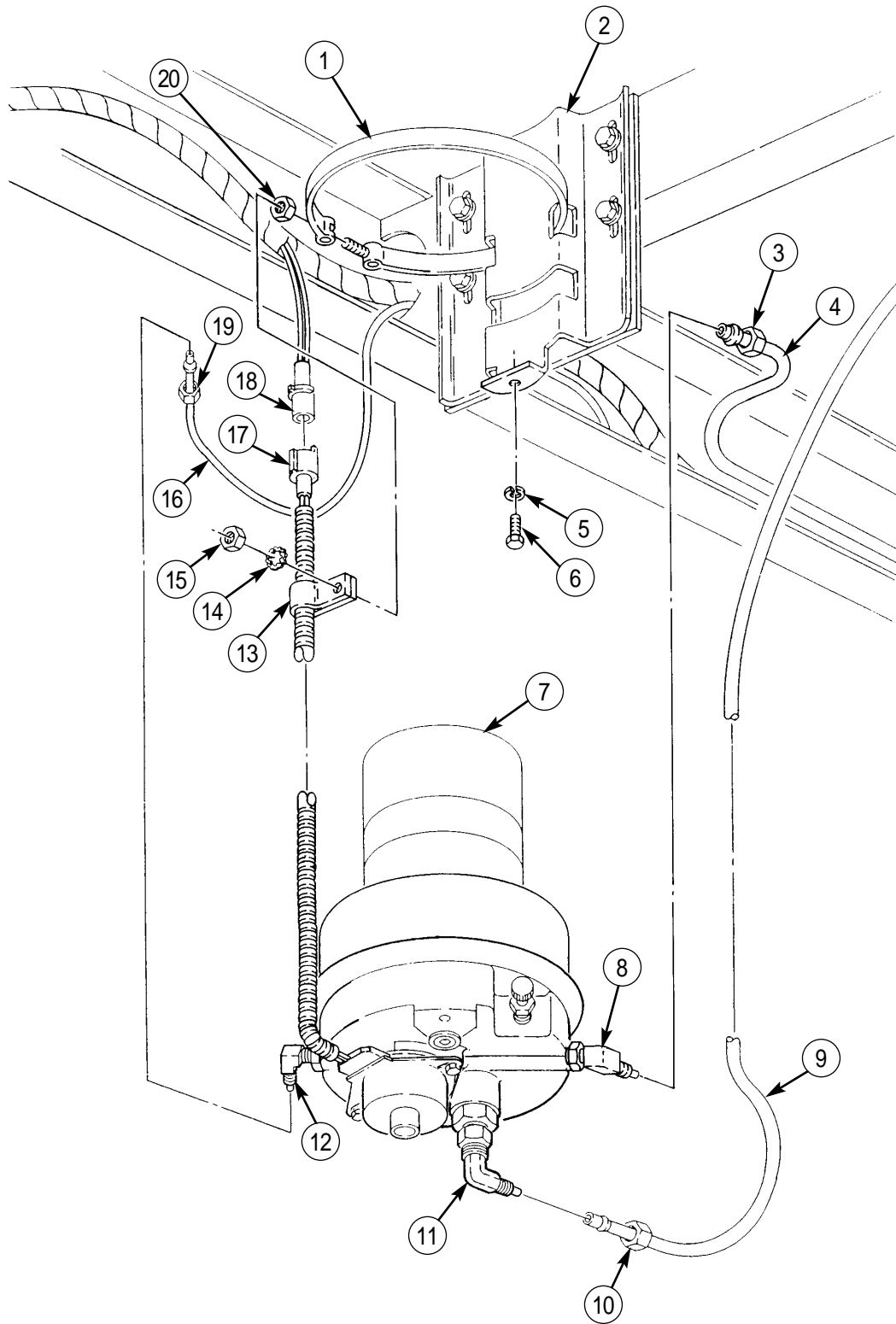

AIR DRYER AND AIR DRYER HEATER MAINTENANCE (Contd)

8. Remove elbow (3) and adapter (4) from inlet port (2) of air dryer (1).
9. Remove elbow (7), adapter (6), and bushing (5) from outlet port (8) of air dryer (1).
10. Remove elbow (10) and bushing (9) from control port (11) of air dryer (1).
11. Remove four nuts (15), screws (12), washers (13), mounting bracket (17), and mounting plate (16) from crossmember (14).

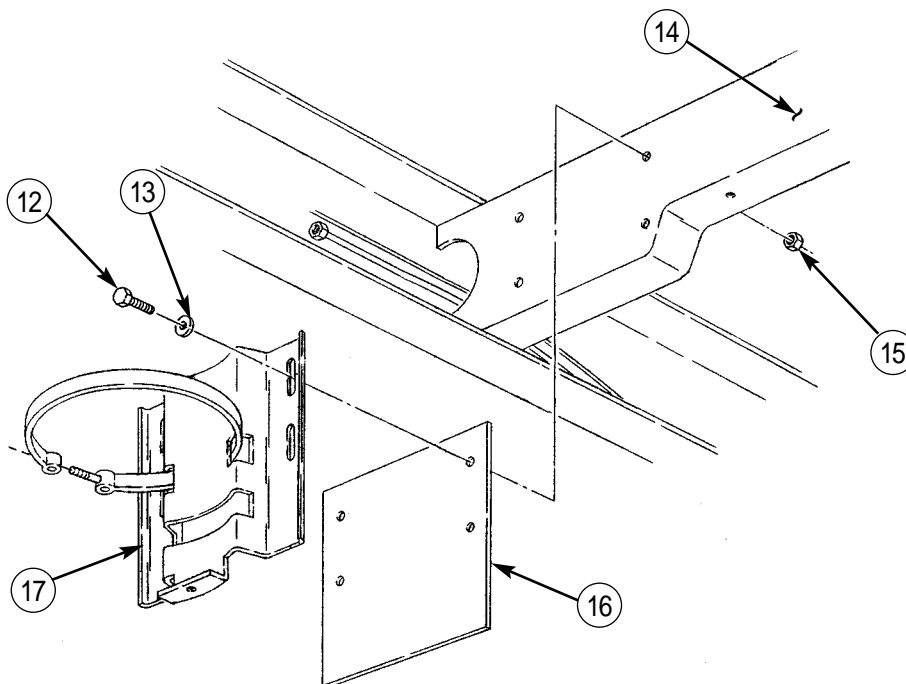
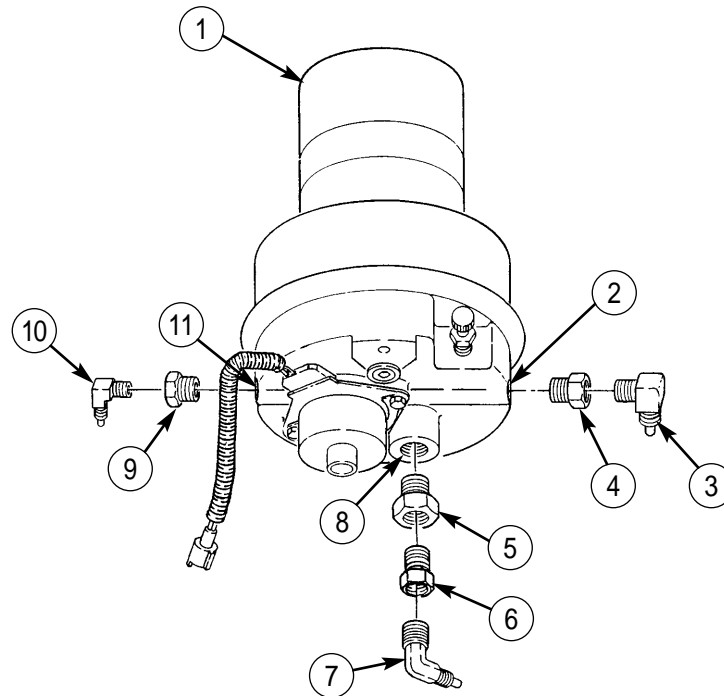

AIR DRYER AND AIR DRYER HEATER MAINTENANCE (Contd)

DESICCANT AND COALESCING FILTER REMOVAL

1. Using strap wrench, remove desiccant canister (18) and canister gasket (19) from air dryer housing (22). Discard desiccant canister (18) and gasket (19).
2. Remove coalescing filter (20) and O-ring (21) from air dryer housing (22). Discard coalescing filter (20) and O-ring (21).

DESICCANT AND COALESCING FILTER INSPECTION

1. Inspect desiccant canister (18) for grime or oil. Replace desiccant canister (18) if grime or oil is present.
2. Inspect coalescing filter (20). Replace if there is any evidence of grime or oil, or if it is plugged.

DESICCANT AND COALESCING FILTER INSTALLATION

1. Apply a light coat of oil to new O-ring (21) and new gasket (19) prior to installation.
2. Install new O-ring (21) and new coalescing filter (20) into air dryer housing (22).
3. Install new gasket (19) and new desiccant canister (18) on air dryer housing (22). Hand-tighten desiccant canister (18). Using strap wrench, tighten desiccant canister (18) an additional 3/4-turn.
4. Inspect desiccant and coalescing filter (20) for air leaks at gasket (19).

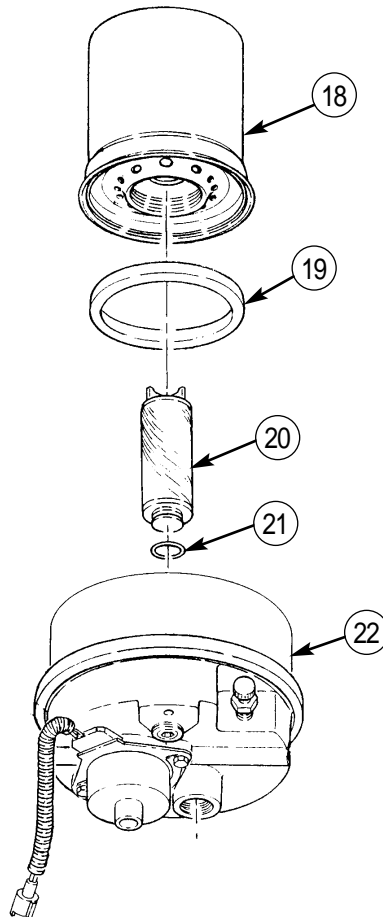

AIR DRYER AND AIR DRYER HEATER MAINTENANCE (Contd)**AIR DRYER INSTALLATION**

1. Install mounting plate (5) and mounting bracket (6) on crossmember (3) with four washers (2), screws (1), and nuts (4).
2. Apply sealant to male threads of elbows (9), (13), and (16), adapters (10) and (12), and bushings (11) and (15).
3. Install bushing (15) on control port (17) of air dryer (7).
4. Install elbow (16) on bushing (15).
5. Install adapter (10) and elbow (9) on inlet port (8) of air dryer (7).
6. Install bushing (11), adapter (12), and elbow (13) on outlet port (14) of air dryer (7).
7. Position air dryer (7) on mounting bracket (6) and clamp (18) and install jamnut (32).
8. Install new lockwasher (21) and screw (22) on mounting bracket (6) and air dryer (7). Tighten screw (22) 20-35 lb-ft (27-47 N•m).
9. Install clamp (25) with air dryer heater connector (29) on clamp (18) with new lockwasher (26) and nut (27).
10. Connect wire harness connector 27 (30) to air dryer heater connector (29).
11. Install tube (20) on air dryer inlet port elbow (9) and tighten nut (19).
12. Install tube (23) on air dryer outlet port elbow (13) and tighten nut (24).
13. Install tube (28) on air dryer control port elbow (16) and tighten nut (31).

OPERATIONAL CHECK

Once the unit is installed, start engine, build up pressure to 100 psi, and shut off engine. Check for air leaks at inlet and outlet of dryer. Correct any leakage problem. Restart engine and build up pressure to compressor cutout pressure. At cutout pressure the dryer purge valve opens and immediately expels a large volume of air, followed by a slow flow of air lasting approximately thirty seconds.

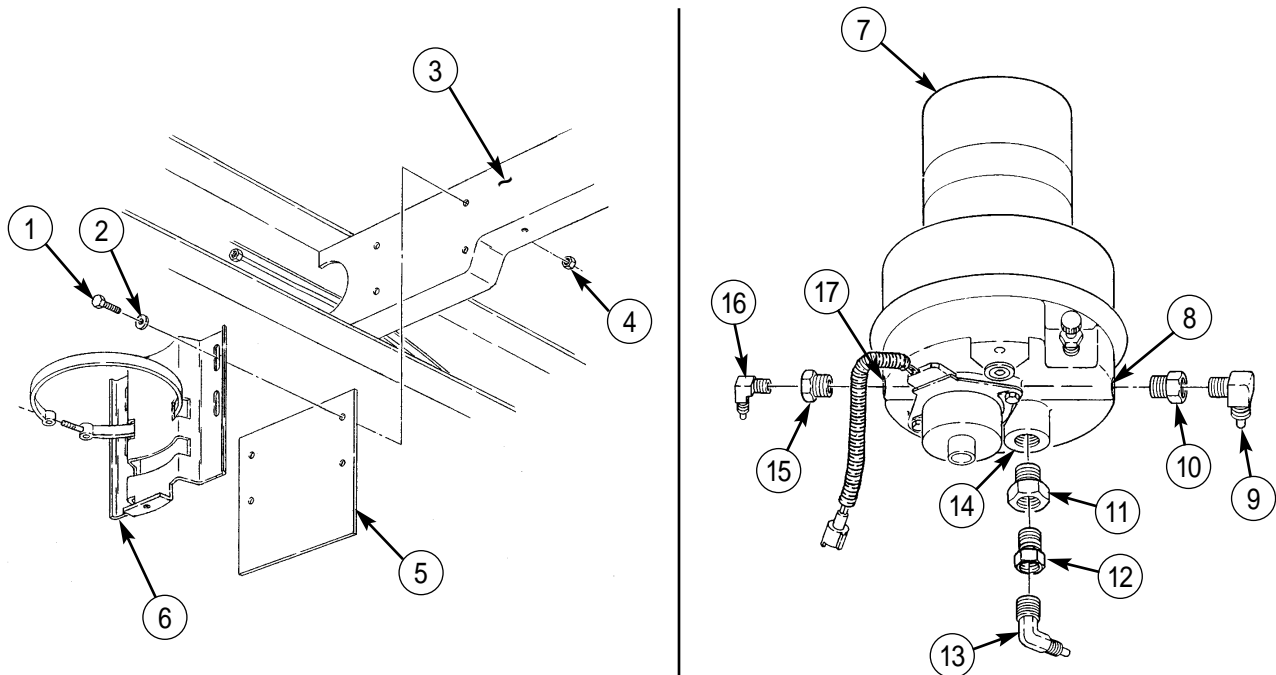

AIR DRYER AND AIR DRYER HEATER MAINTENANCE (Contd)

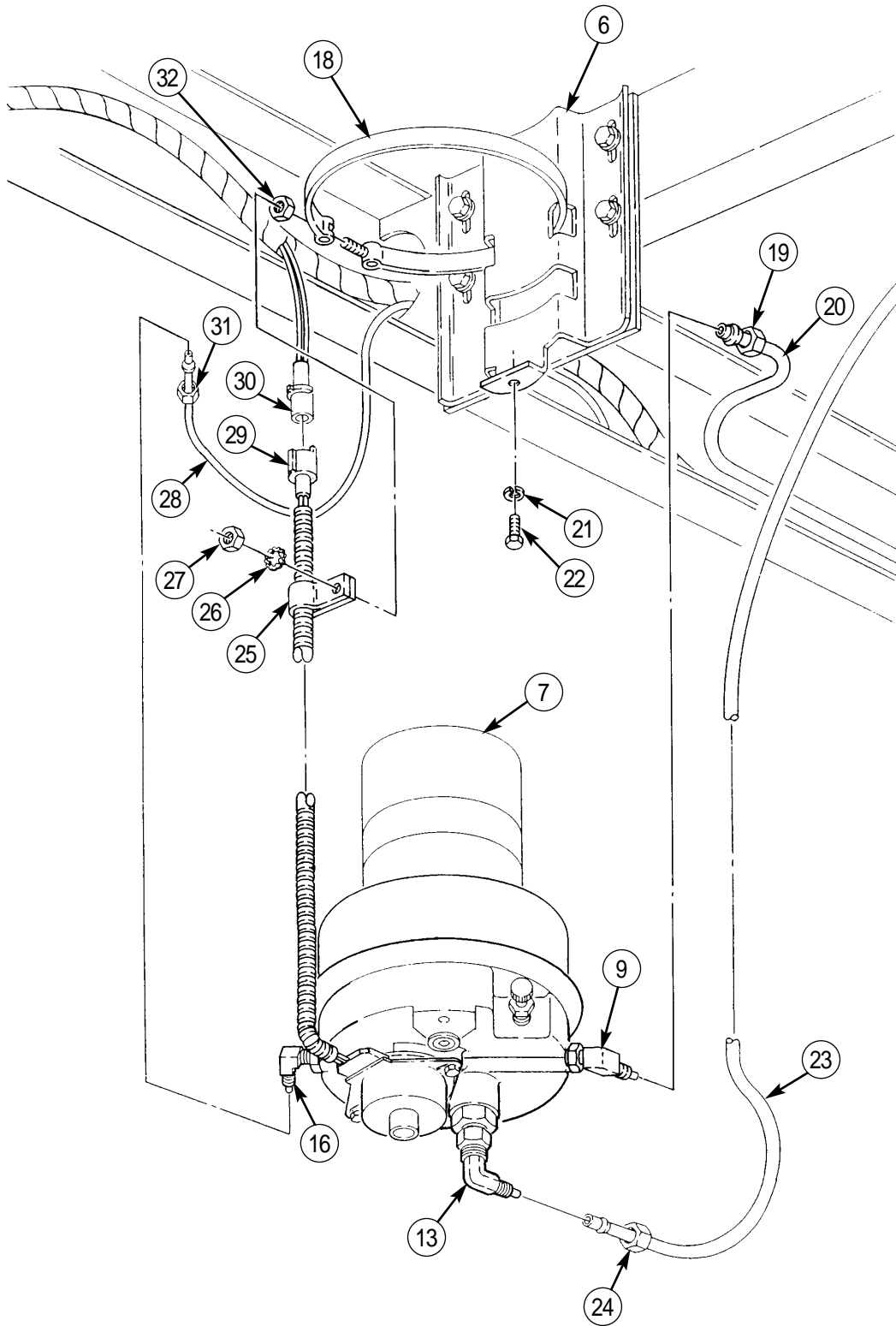

AIR DRYER AND AIR DRYER HEATER MAINTENANCE (Contd)

AIR DRYER HEATER REMOVAL

1. Remove nut (10), lockwasher (9), and clamp (8) with air dryer heater connector (11) from clamp (2). Discard lockwasher (9).
2. Disconnect air dryer heater connector (11) from wiring harness connector 27 (12) and remove clamp (8) from wire (7).
3. Remove three screws (4), retainer plate (3), and purge shield (5) from air dryer (1).
4. Remove air dryer heater (6) from air dryer (1).

AIR DRYER HEATER INSTALLATION

1. Apply small amount of conductive lubricant supplied in kit to temperature sensor (13) on air dryer heater (6).
2. Position air dryer heater (6) on air dryer (1).
3. Install purge shield (5) and retainer plate (3) on air dryer (1) with three screws (4). Tighten screws (4) 30-50 lb-in. (3-6 N•m).
4. Install clamp (8) on wire (7) and connect air dryer heater connector (11) to wiring harness connector 27 (12).
5. Install clamp (8) with air dryer heater connector (11) on clamp (2) with new lockwasher (9) and nut (10).
6. Connect battery cables (WP 0121 00).
7. Start engine (TM 9-2320-386-10) and allow air pressure to build up to normal operating pressure. Check heater operation if temperature is 40°F (4°C) or below.

AIR DRYER AND AIR DRYER HEATER MAINTENANCE (Contd)

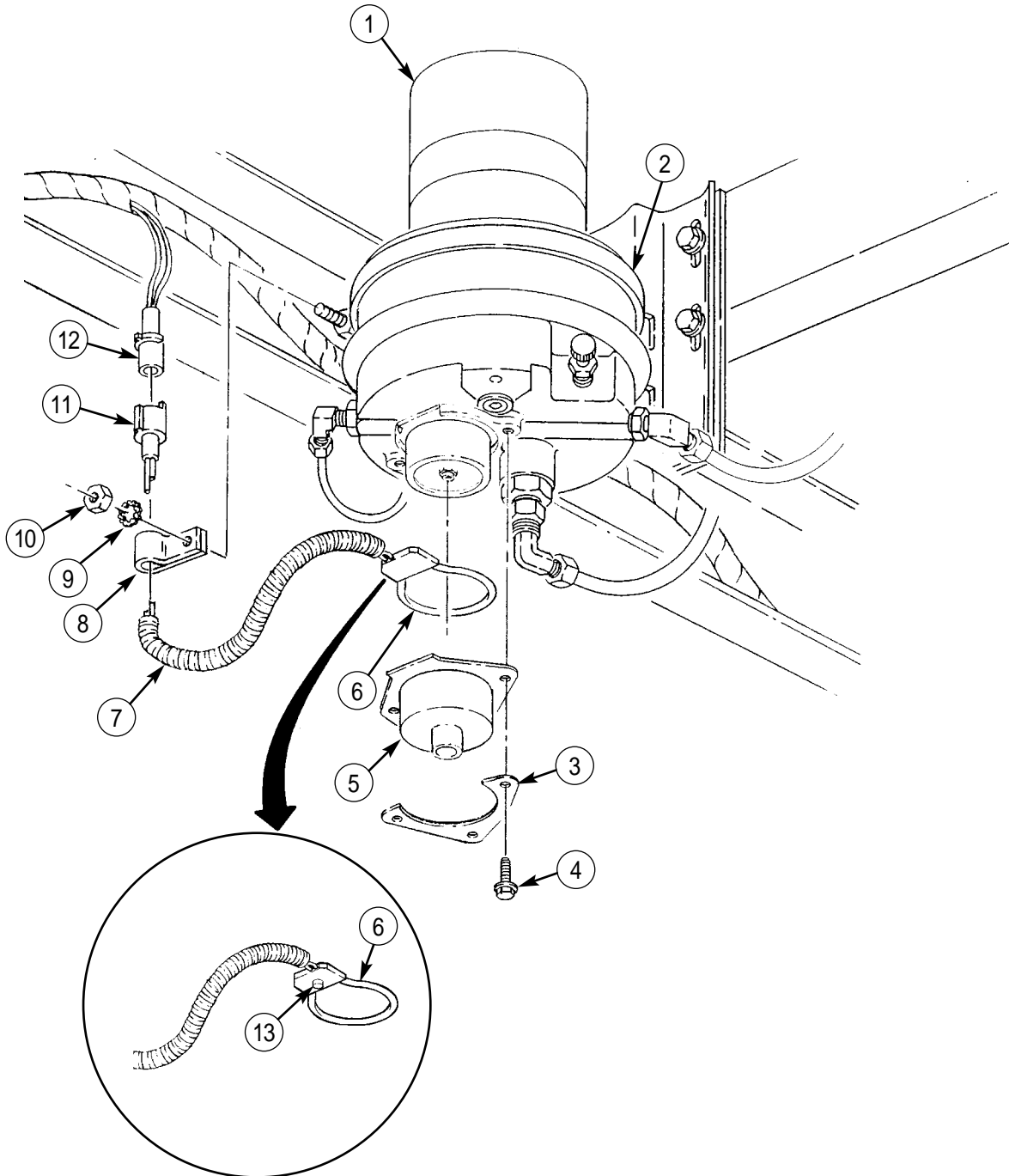

END OF WORK PACKAGE

UNIT MAINTENANCE INSTRUCTIONS

EXTENDED SERVICE PROGRAM (ESP)

TRUCK, CARGO, 2-1/2-TON, 6X6, M44A3 SERIES TRUCKS (DIESEL)

M35A3, W/O WINCH (NSN 2320-01-383-2047); W/WINCH (NSN 2320-01-383-3850);
M35A3C, W/O WINCH (NSN 2320-01-383-2050); W/WINCH (NSN 2320-01-383-2049);
M36A3, W/O WINCH (NSN 2320-01-383-2048); W/WINCH (NSN 2320-01-383-2046).

CTIS MANIFOLD AND EXHAUST REPLACEMENT

REMOVAL, INSTALLATION

INITIAL SETUP:

Tools and Special Tools

General mechanic's tool kit
(item 30, WP 0394 00)

Materials/Parts

Four locknuts (item 85, WP 0395 00)
Four locknuts (item 89, WP 0395 00)
Lockwasher (item 47, WP 0395 00)
Five tiedown straps (item 36, WP 0395 00)
Teflon pipe sealant (item 41, WP 0393 00)

References

TM 9-2320-386-24P

Equipment Condition

Parking brake set (TM 9-2320-386-10).
Air reservoirs drained (TM 9-2320-386-10).
Battery ground cable disconnected (WP 0121 00).

CTIS MANIFOLD AND EXHAUST REPLACEMENT (Contd)**REMOVAL****WARNING**

Do not disconnect air lines and fittings before draining air reservoirs. Small parts under pressure may shoot out with high velocity, causing injury to personnel.

Eyeshields must be worn when releasing compressed air. Failure to do so may result in injury to personnel.

1. Remove crimp nut (11), sleeve (10), elbow (9), and bushing (12) from manifold (2).
2. Remove three tubes (14), elbows (13), and bushings (15) from manifold (2).
3. Remove plug (1) from manifold (2).
4. Remove priority pressure switch tube (5), elbow (4), and elbow (3) from manifold (2).
5. Remove air intake tube (6), elbow (7), and elbow (8) from manifold (2).
6. Remove tiedown straps (22) as necessary. Discard tiedown straps (22).
7. Disconnect CTIS control harness (18) from manifold (2).
8. Remove screw (19), lockwasher (20), and three ground (GND) leads (21) from manifold (2). Discard lockwasher (20).
9. Disconnect lead 27 (16) from plug (17).
10. Remove four locknuts (24), washers (25), screws (26), washers (25), and manifold (2) from mounting bracket (23). Discard locknuts (24).

CAUTION

Place a jack stand under fuel tank to prevent equipment damage.

NOTE

Leave four screws in frame rail to support weight of fuel tank.

11. Remove four locknuts (27), washers (28), and manifold mounting bracket (23) from screws (29) and frame rail (30). Discard locknuts (27).

CTIS MANIFOLD AND EXHAUST REPLACEMENT (Contd)

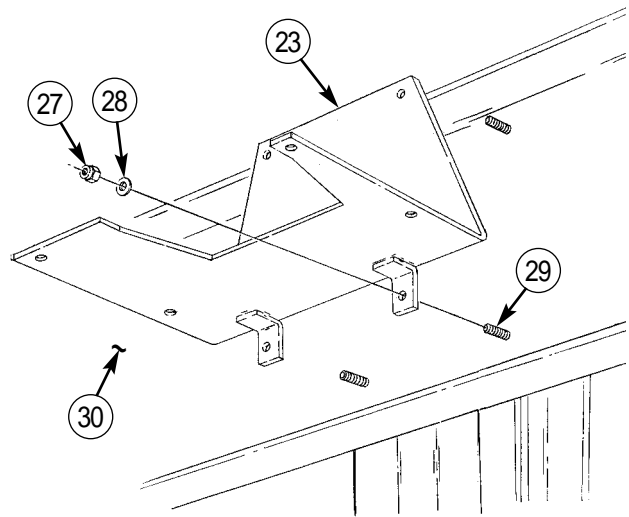
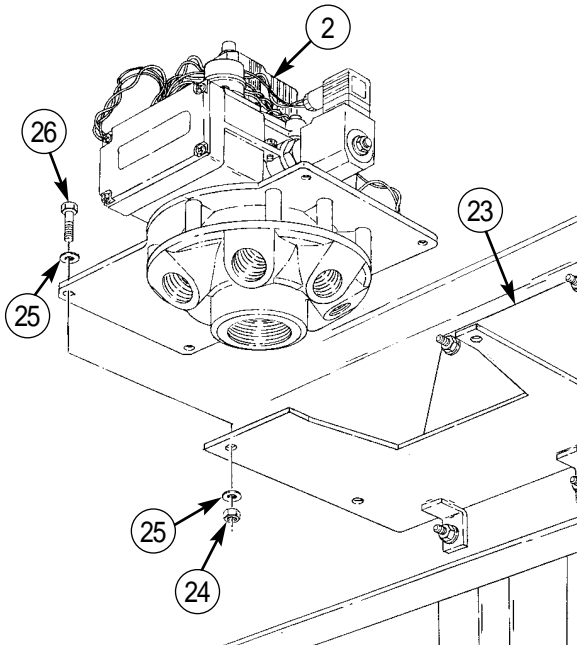
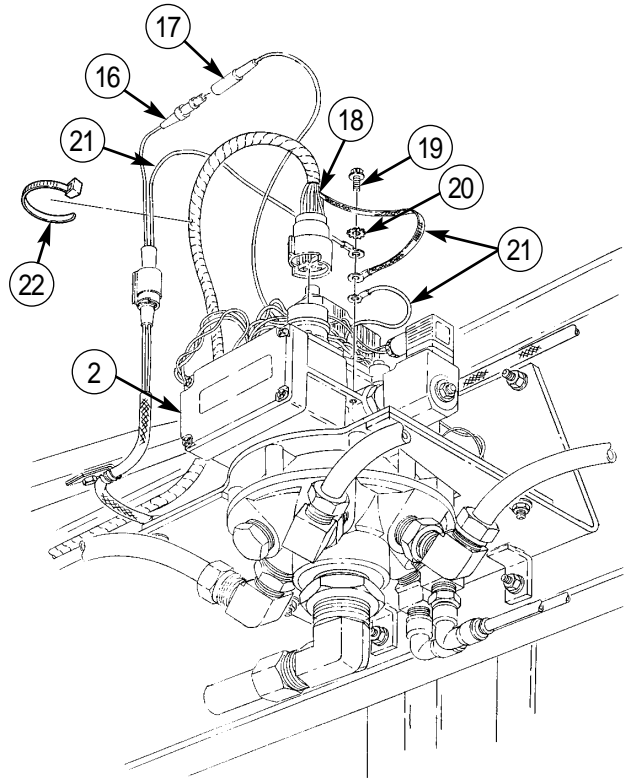
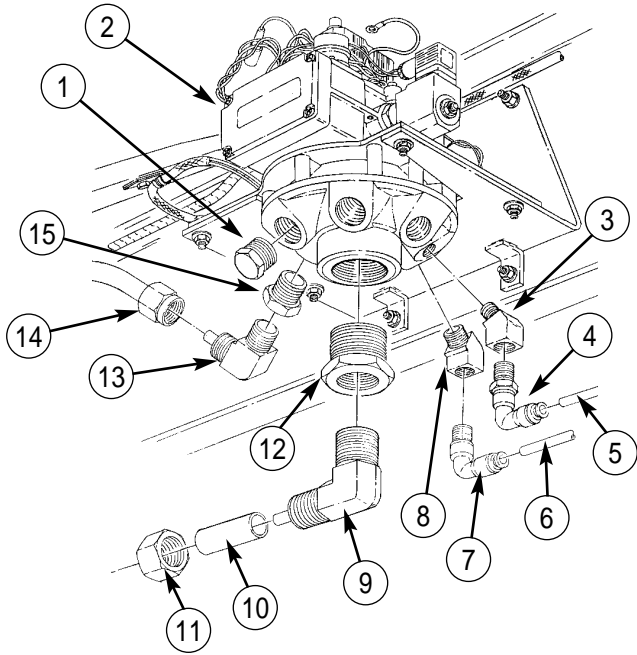

CTIS MANIFOLD AND EXHAUST REPLACEMENT (Contd)**INSTALLATION**

1. Install manifold mounting bracket (3) on frame rail (5) and screws (4) with four washers (2) and new locknuts (1).
2. Install manifold (6) on mounting bracket (3) with four washers (8), screws (9), washers (8), and new locknuts (7).
3. Apply sealant to male threads on bushings (22) and (19), plug (23), elbows (10), (12), (14), (15), and (20) prior to installation.
4. Install three bushings (22), elbows (20), and tubes (21) on manifold (6).
5. Install plug (23) on manifold (6).
6. Install elbows (10) and (12) and air intake tube (11) on manifold (6).

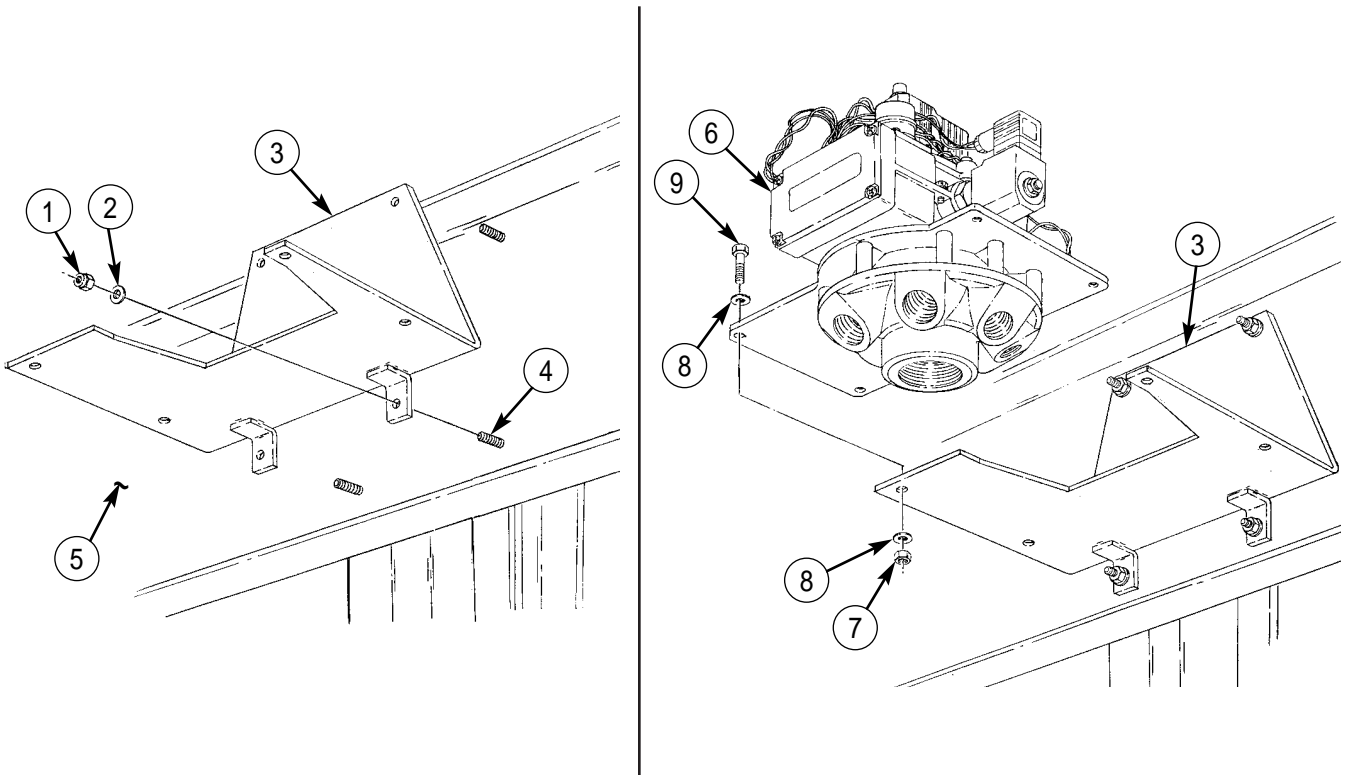

CTIS MANIFOLD AND EXHAUST REPLACEMENT (Contd)

7. Install elbows (15) and (14) and tube (13) on manifold (6).
8. Install bushing (19), elbow (16), sleeve (17), and crimp nut (18) on manifold (6).
9. Connect CTIS control harness (25) to manifold (6) and lead 27 (30) to plug (24).
10. Install three ground (GND) leads (28) on manifold (6) with new lockwasher (27) and screw (26).
11. Install new tiedown straps (29) as necessary to secure CTIS control harness (25), lead 27 (30), and ground (GND) leads (28).
12. Connect battery ground cable (WP 0121 00).

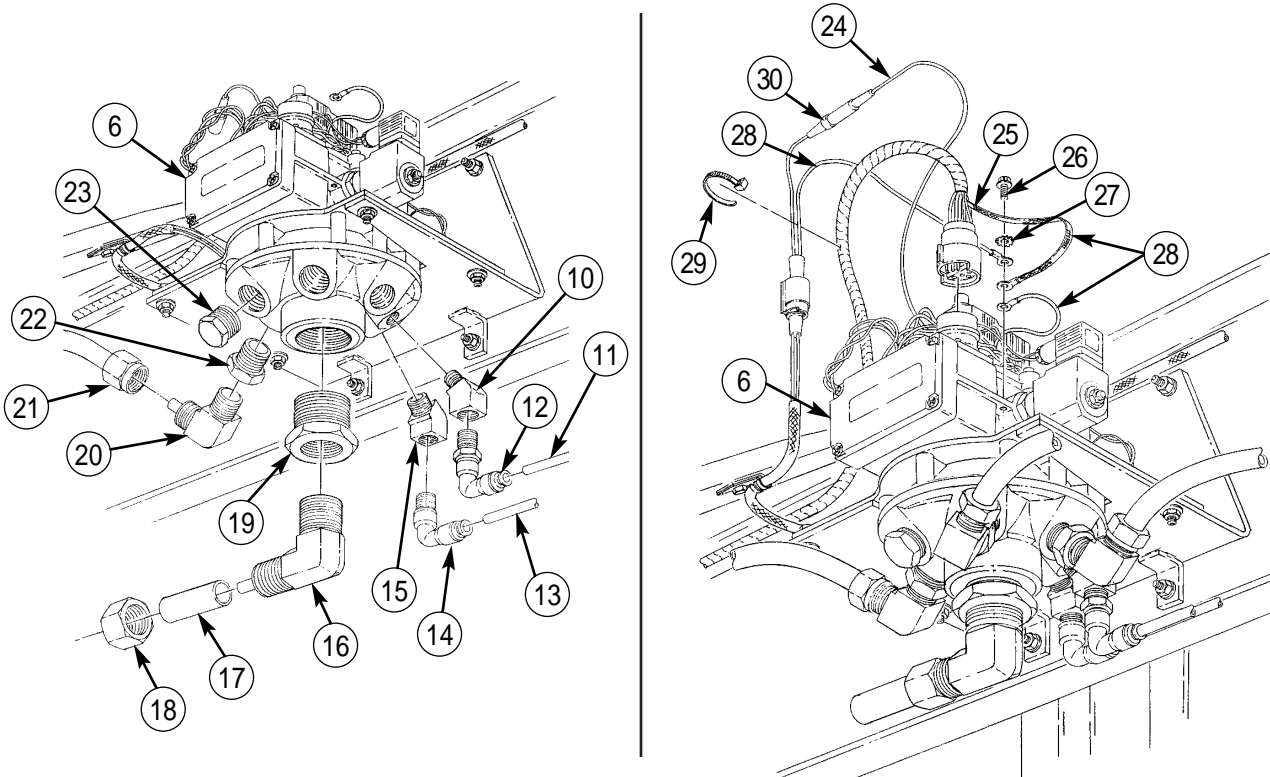

END OF WORK PACKAGE

UNIT MAINTENANCE INSTRUCTIONS

EXTENDED SERVICE PROGRAM (ESP)

TRUCK, CARGO, 2-1/2-TON, 6X6, M44A3 SERIES TRUCKS (DIESEL)

M35A3, W/O WINCH (NSN 2320-01-383-2047); W/WINCH (NSN 2320-01-383-3850);

M35A3C, W/O WINCH (NSN 2320-01-383-2050); W/WINCH (NSN 2320-01-383-2049);

M36A3, W/O WINCH (NSN 2320-01-383-2048); W/WINCH (NSN 2320-01-383-2046).

CTIS ELECTRONIC CONTROL UNIT (ECU)/BRACKET REPLACEMENT

REMOVAL, INSTALLATION

INITIAL SETUP:

Tools and Special Tools

General mechanic's tool kit
(item 30, WP 0394 00)

Materials/Parts

Four lockwashers (item 146, WP 0395 00)
Four lockwashers (item 42, WP 0395 00)
Lockwasher (item 77, WP 0395 00)

References

TM 9-2320-386-24P

Equipment Condition

Parking brake set (TM 9-2320-386-10).
Battery ground cable disconnected
(WP 0121 00).

CTIS ELECTRONIC CONTROL UNIT (ECU)/BRACKET REPLACEMENT (Contd)**REMOVAL**

1. Remove four screws (10) and faceplate (9) from ECU (6).
2. Remove four screws (8), lockwashers (7), and ECU (6) from ECU mounting bracket (14). Discard lockwashers (7).
3. Remove screw (18), ground (GND) strap (4), and jumper ground (GND) lead (5) from ECU (6).
4. Disconnect cannon plugs (2) and (3) from ECU (6).
5. Remove two screws (15), lockwashers (16), washers (17), jumper ground (GND) lead (5), and lockwasher (19) from ECU mounting bracket (14) and instrument panel (1). Discard lockwashers (16) and (19).
6. Remove two screws (13), lockwashers (12), washers (11), and ECU mounting bracket (14) from instrument panel (1). Discard lockwashers (12).

INSTALLATION**NOTE**

Jumper ground (GND) lead is installed on lower left corner of ECU mounting bracket.

1. Install ECU mounting bracket (14) and jumper ground (GND) lead (5) on instrument panel (1) with new lockwasher (19), two washers (17), new lockwashers (16), and screws (15).
2. Install ECU mounting bracket (14) on instrument panel (1) with two washers (11), new lockwashers (12), and screws (13).
3. Connect cannon plugs (2) and (3) to ECU (6).
4. Install jumper ground (GND) lead (5) and ground (GND) strap (4) on ECU (6) with screw (18).
5. Install ECU (6) on mounting bracket (14) with four new lockwashers (7) and screws (8).
6. Install faceplate (9) on ECU (6) with four screws (10).
7. Connect battery ground cable (WP 0121 00).

CTIS ELECTRONIC CONTROL UNIT (ECU)/BRACKET REPLACEMENT (Contd)

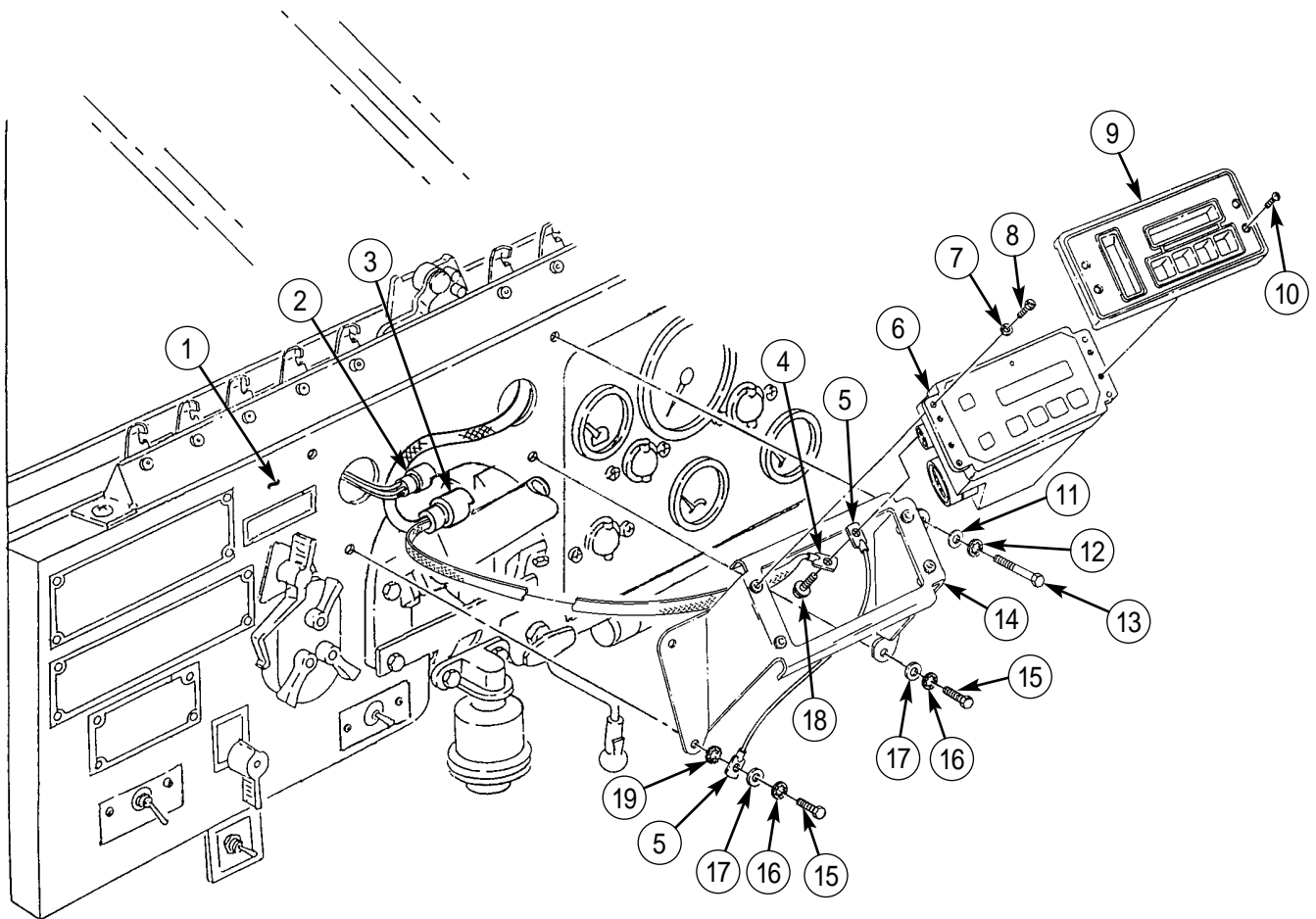

END OF WORK PACKAGE

UNIT MAINTENANCE INSTRUCTIONS

EXTENDED SERVICE PROGRAM (ESP)

TRUCK, CARGO, 2-1/2-TON, 6X6, M44A3 SERIES TRUCKS (DIESEL)

**M35A3, W/O WINCH (NSN 2320-01-383-2047); W/WINCH (NSN 2320-01-383-3850);
M35A3C, W/O WINCH (NSN 2320-01-383-2050); W/WINCH (NSN 2320-01-383-2049);
M36A3, W/O WINCH (NSN 2320-01-383-2048); W/WINCH (NSN 2320-01-383-2046).**

CTIS OVERSPEED SIGNAL GENERATOR REPLACEMENT

REMOVAL, INSTALLATION

INITIAL SETUP:

Tools and Special Tools

General mechanic's tool kit
(item 30, WP 0394 00)

Equipment Condition

Parking brake set (TM 9-2320-386-10).
Battery ground cable disconnected
(WP 0121 00).

References

TM 9-2320-386-24P

CTIS OVERSPEED SIGNAL GENERATOR REPLACEMENT (Contd)**REMOVAL**

1. Disconnect leads 432 and 431 (1) from overspeed signal generator leads (2).
2. Remove overspeed signal generator (3) from adapter (4) on transfer case (5).

INSTALLATION

1. Install overspeed signal generator (3) on adapter (4) on transfer case (5).
2. Connect leads 432 and 431 (1) to overspeed signal generator leads (2).
3. Connect battery ground cable (WP 0121 00).

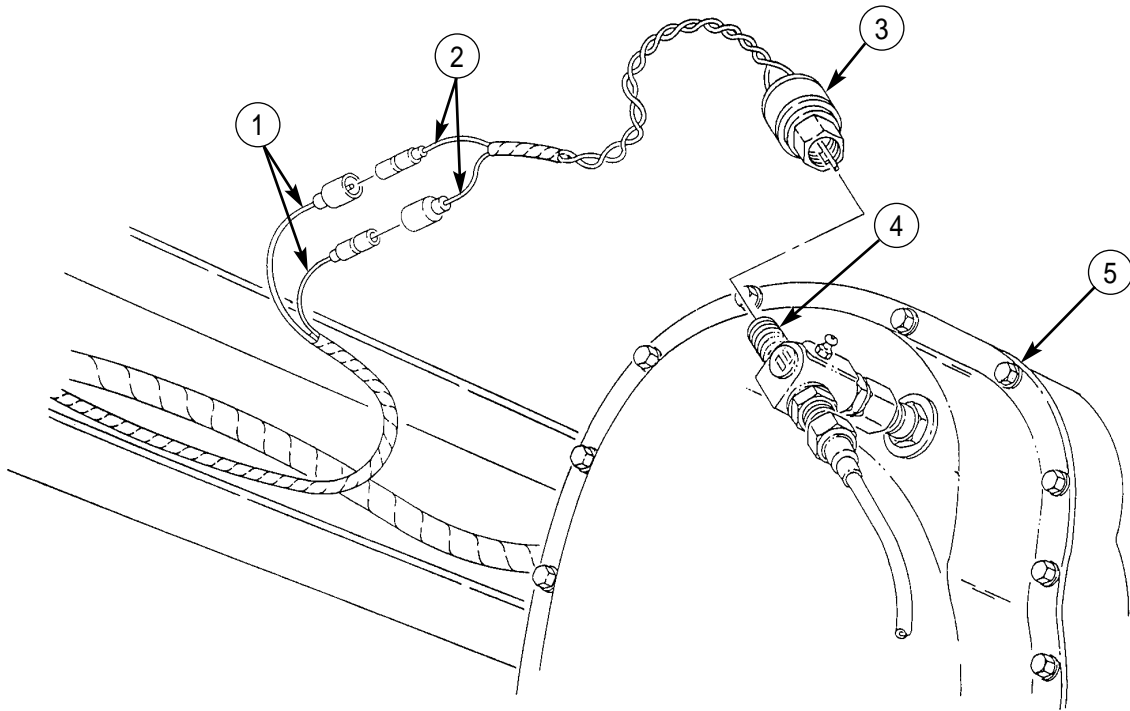

END OF WORK PACKAGE

UNIT MAINTENANCE INSTRUCTIONS

EXTENDED SERVICE PROGRAM (ESP)

TRUCK, CARGO, 2-1/2-TON, 6X6, M44A3 SERIES TRUCKS (DIESEL)

M35A3, W/O WINCH (NSN 2320-01-383-2047); W/WINCH (NSN 2320-01-383-3850);

M35A3C, W/O WINCH (NSN 2320-01-383-2050); W/WINCH (NSN 2320-01-383-2049);

M36A3, W/O WINCH (NSN 2320-01-383-2048); W/WINCH (NSN 2320-01-383-2046).

SECTION XXX. NON-ELECTRICAL GAUGES MAINTENANCE

TABLE OF CONTENTS

<i>WP Title</i>	<i>WP Sequence No.-Page No.</i>
Speedometer Replacement	0286 00-1
Speedometer Driveshaft Adapter Replacement	0287 00-1
Speedometer Driveshaft Replacement	0288 00-1

END OF WORK PACKAGE

UNIT MAINTENANCE INSTRUCTIONS

EXTENDED SERVICE PROGRAM (ESP)

TRUCK, CARGO, 2-1/2-TON, 6X6, M44A3 SERIES TRUCKS (DIESEL)

M35A3, W/O WINCH (NSN 2320-01-383-2047); W/WINCH (NSN 2320-01-383-3850);

M35A3C, W/O WINCH (NSN 2320-01-383-2050); W/WINCH (NSN 2320-01-383-2049);

M36A3, W/O WINCH (NSN 2320-01-383-2048); W/WINCH (NSN 2320-01-383-2046).

SPEEDOMETER REPLACEMENT

REMOVAL, INSTALLATION

INITIAL SETUP:

Tools and Special Tools

General mechanic's tool kit
(item 30, WP 0394 00)

Equipment Condition

Parking brake set (TM 9-2320-386-10).
Battery ground cable disconnected
(WP 0121 00).

References

TM 9-2320-386-24P

SPEEDOMETER REPLACEMENT (Contd)**NOTE**

Appropriate locking hardware is provisioned with gauge.

REMOVAL

1. Turn four lockstuds (2) 1/4-turn to left and pull instrument mounting panel (3) away from instrument panel (1).
2. Disconnect speedometer driveshaft (4) from speedometer (5).
3. Remove two nuts (9), lockwashers (8), wire harness (6), bracket (7), and speedometer (5) from instrument mounting panel (3).

INSTALLATION

1. Install speedometer (5), bracket (7), and wire harness (6) on instrument mounting panel (3) with two lockwashers (8) and nuts (9).
2. Connect speedometer driveshaft (4) to speedometer (5).
3. Position instrument mounting panel (3) on instrument panel (1) and install by turning four lockstuds (2) 1/4-turn to right.
4. Connect battery ground cable (WP 0121 00).
5. Start engine (TM 9-2320-386-10) and road test vehicle to check speedometer for proper operation.

SPEEDOMETER REPLACEMENT (Contd)

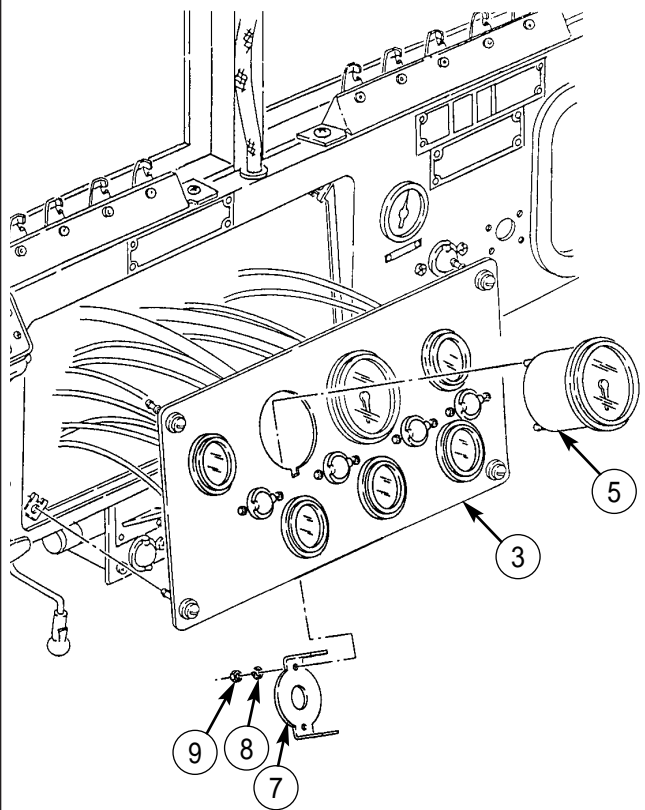
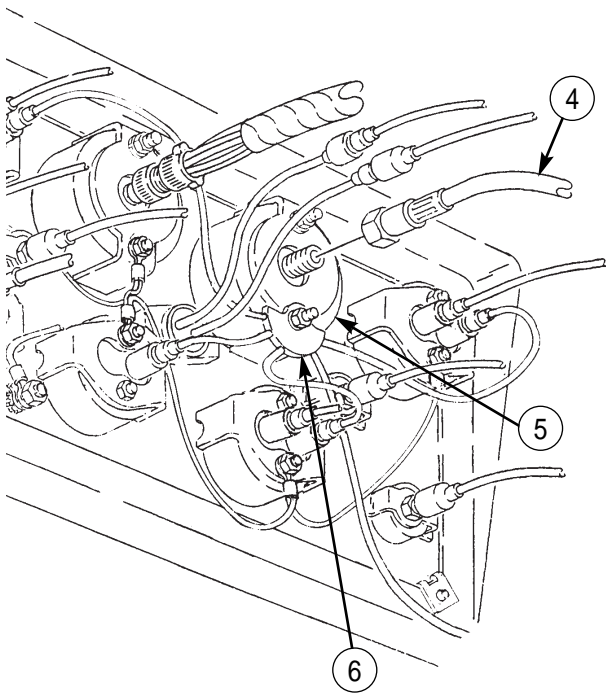
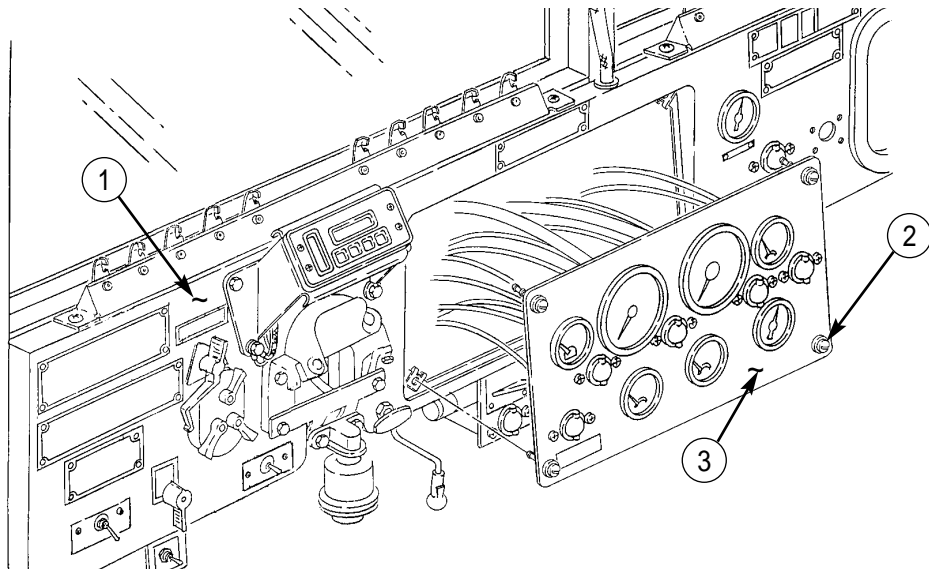

END OF WORK PACKAGE

UNIT MAINTENANCE INSTRUCTIONS

EXTENDED SERVICE PROGRAM (ESP)

TRUCK, CARGO, 2-1/2-TON, 6X6, M44A3 SERIES TRUCKS (DIESEL)

M35A3, W/O WINCH (NSN 2320-01-383-2047); W/WINCH (NSN 2320-01-383-3850);

M35A3C, W/O WINCH (NSN 2320-01-383-2050); W/WINCH (NSN 2320-01-383-2049);

M36A3, W/O WINCH (NSN 2320-01-383-2048); W/WINCH (NSN 2320-01-383-2046).

SPEEDOMETER DRIVESHAFT ADAPTER REPLACEMENT

REMOVAL, INSTALLATION

INITIAL SETUP:

Tools and Special Tools

General mechanic's tool kit
(item 30, WP 0394 00)

References

TM 9-2320-386-24P

Materials/Parts

Teflon pipe sealant (item 41, WP 0393 00)

Equipment Condition

Parking brake set (TM 9-2320-386-10).
Battery ground cable disconnected
(WP 0121 00).

SPEEDOMETER DRIVESHAFT ADAPTER REPLACEMENT (Contd)**REMOVAL**

1. Remove speedometer driveshaft (7) from driveshaft adapter (8).
2. Remove signal generator (1) from driveshaft adapter (8).
3. Remove sleeve and seal assembly (3) from driveshaft adapter (8).
4. Remove sleeve and seal assembly (3) from port (6) on transfer case (5).
5. Remove drive adapter (4) from sleeve and seal assembly (3).
6. Remove lube fitting (2) from driveshaft adapter (8).

INSTALLATION

1. Apply sealant to male threads of lube fitting (2).
2. Install lube fitting (2) on driveshaft adapter (8).
3. Install drive adapter (4) in sleeve and seal assembly (3)
4. Install sleeve and seal assembly (3) in port (6) on transfer case (5).
5. Install driveshaft adapter (8) to sleeve and seal assembly (3).
6. Install signal generator (1) on driveshaft adapter (8).
7. Install speedometer driveshaft (7) to driveshaft adapter (8).
8. Lubricate fitting (WP 0023 00).
9. Connect battery ground cable (WP 0121 00).

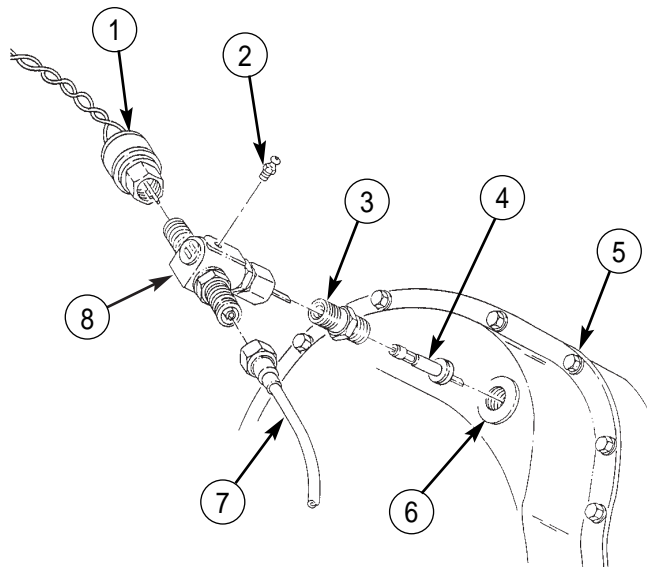
**END OF WORK PACKAGE**

UNIT MAINTENANCE INSTRUCTIONS

EXTENDED SERVICE PROGRAM (ESP)

TRUCK, CARGO, 2-1/2-TON, 6X6, M44A3 SERIES TRUCKS (DIESEL)

M35A3, W/O WINCH (NSN 2320-01-383-2047); W/WINCH (NSN 2320-01-383-3850);
M35A3C, W/O WINCH (NSN 2320-01-383-2050); W/WINCH (NSN 2320-01-383-2049);
M36A3, W/O WINCH (NSN 2320-01-383-2048); W/WINCH (NSN 2320-01-383-2046).

SPEEDOMETER DRIVESHAFT REPLACEMENT

REMOVAL, INSTALLATION

INITIAL SETUP:

Tools and Special Tools

General mechanic's tool kit
(item 30, WP 0394 00)

Personnel Required

Assistant (1)

Materials/Parts

Two locknuts (item 99, WP 0395 00)
Locknut (item 90, WP 0395 00)
Eight assembled-washer bolts
(item 174, WP 0395 00)
Four lockwashers (item 61, WP 0395 00)

References

TM 9-2320-386-24P

Equipment Condition

Parking brake set (TM 9-2320-386-10).
Battery ground cable disconnected
(WP 0121 00).

SPEEDOMETER DRIVESHAFT REPLACEMENT (Contd)

REMOVAL

1. Pull back floor insulation to gain access to cab floor (18).
2. Remove eight assembled-washer bolts (5), four screws (7), lockwashers (8), and toeboard (6) from cab floor (18), cab tunnel (15), and firewall (20). Discard assembled-washer bolts (5) and lockwashers (8).
3. Turn four lockstuds (3) 1/4-turn left and pull instrument mounting panel (2) away from instrument panel (4).
4. Remove speedometer driveshaft (10) from speedometer (1).
5. Remove two locknuts (19), screws (16), clamps (17), and speedometer driveshaft (10) from firewall (20) and cab floor (18). Discard locknuts (19).
6. Remove locknut (14), clamp (11), screw (13), and speedometer driveshaft (10) from crossmember (12). Discard locknut (14).
7. Remove speedometer driveshaft (10) from adapter (9) and vehicle.

INSTALLATION

1. Install speedometer driveshaft (10) on adapter (9).
2. Install speedometer driveshaft (10) on crossmember (12) with screw (13), clamp (11), and new locknut (14).
3. Install speedometer driveshaft (10) on firewall (20) and cab floor (18) with two clamps (17), screws (16), and new locknuts (19).
4. Install speedometer driveshaft (10) on speedometer (1).
5. Install instrument mounting panel (2) on instrument panel (4) and turn four lockstuds (3) 1/4-turn right.
6. Install toeboard (6) on cab floor (18), cab tunnel (15), and firewall (20) with eight new assembled-washer bolts (5), four new lockwashers (8), and screws (7).
7. Lubricate fitting (WP 0023 00).
8. Connect battery ground cable (WP 0121 00).

SPEEDOMETER DRIVESHAFT REPLACEMENT (Contd)

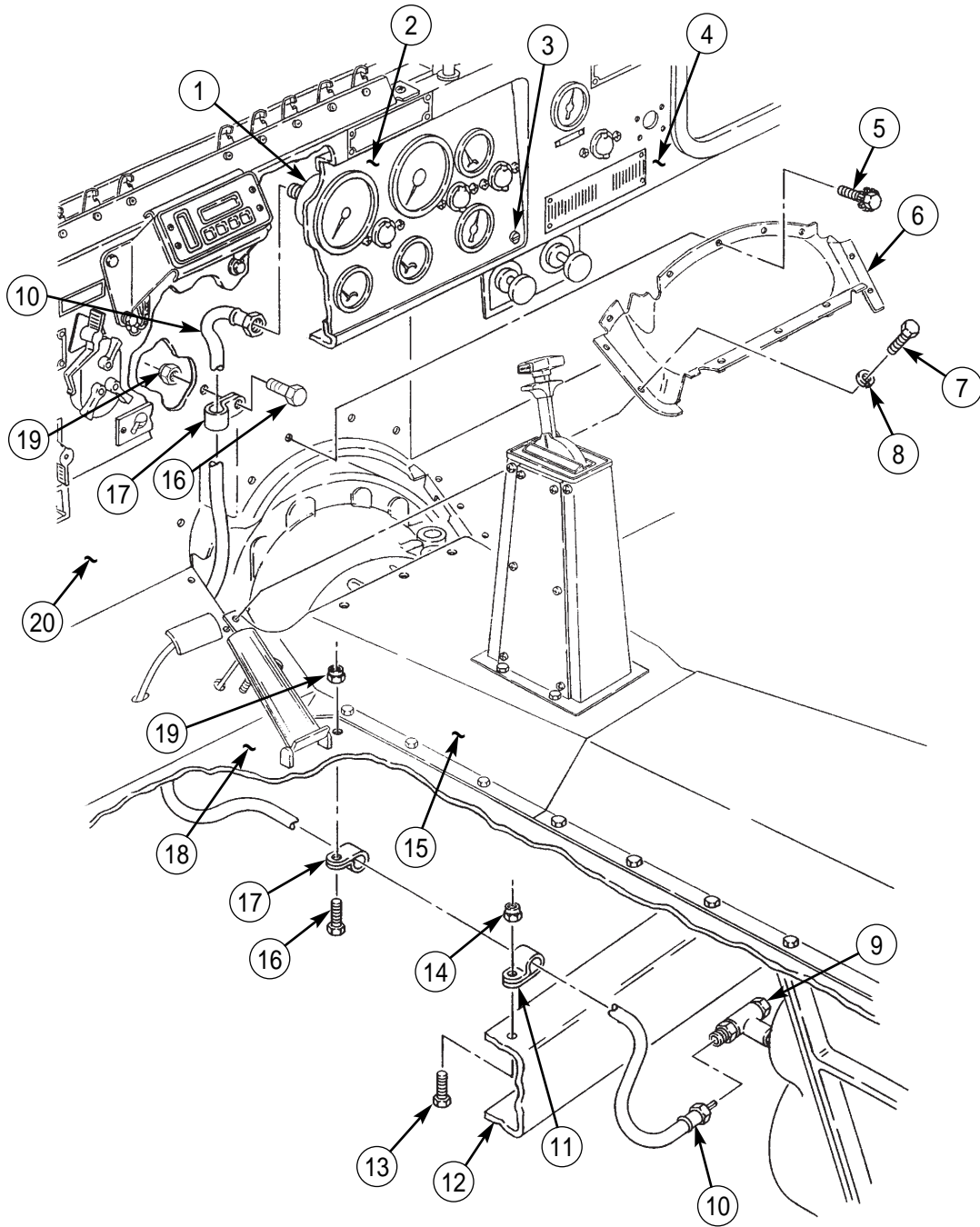

END OF WORK PACKAGE

INDEX

<u>Subject</u>	<u>WP Sequence No.-Page No.</u>
A	
Abbreviations, list of	0001 00-2
Accelerator cable maintenance:	
Adjustment	0064 00-4
Installation	0064 00-4
Removal	0064 00-2
Accelerator pedal and brackets replacement:	
Installation	0063 00-2
Removal	0063 00-2
Actuator, fan, replacement:	
Installation	0085 00-2
Removal	0085 00-2
Actuator tube, fan, maintenance:	
Inspection	0086 00-2
Installation	0086 00-2
Removal	0086 00-2
Adapter, ring, rear wheel, maintenance:	
Cleaning, inspection, and repair	0347 00-4
Installation	0347 00-4
Leak test	0347 00-5
Removal	0347 00-2
Adapter, speedometer driveshaft, replacement:	
Installation	0287 00-2
Removal	0287 00-2
Adjustment, toe-in check and:	
Adjustment	0179 00-6
Check	0179 00-2
Air brake check valve, pressure switch, and air line replacement:	
Installation	0275 00-4
Removal	0275 00-2
Air brake electrical harness replacement:	
Installation	0274 00-2
Removal	0274 00-2
Air brake rotary valve and air line replacement:	
Installation	0273 00-4
Removal	0273 00-2
Air cleaner element maintenance:	
Installation	0040 00-2
Removal	0040 00-2
Service	0040 00-2
Air cleaner hoses replacement:	
Installation	0038 00-2
Removal	0038 00-2
Air cleaner indicator and tube maintenance:	
Cleaning and inspection	0041 00-4
Installation	0041 00-4
Removal	0041 00-2
Testing	0041 00-2
Air cleaner replacement:	
Installation	0037 00-2
Removal	0037 00-2

INDEX (Contd)

<u>Subject</u>	<u>WP Sequence No.-Page No.</u>
<i>A (Contd)</i>	
Air compressor coolant lines replacement:	
Installation	0168 00-2
Removal	0168 00-2
Air compressor governor maintenance:	
Check and adjustment	0170 00-2
Installation	0170 00-2
Removal	0170 00-2
Air compressor replacement:	
Installation	0169 00-4
Removal	0169 00-2
Air coupling, trailer, replacement:	
Installation	0164 00-2
Removal	0164 00-2
Air dryer and air dryer heater maintenance:	
Air dryer installation	0281 00-6
Air dryer removal	0281 00-2
Air dryer heater installation	0281 00-8
Air dryer heater removal	0281 00-8
Desiccant and coalescing filter	
Inspection	0281 00-5
Desiccant and coalescing filter	
installation	0281 00-5
Desiccant and coalescing filter	
removal	0281 00-5
Operational check	0281 00-6
Air horn replacement:	
Installation	0119 00-2
Removal	0119 00-2
Air-hydraulic booster brake lines replacement:	
Left booster brake line installation	0158 00-4
Left booster brake line removal	0158 00-2
Right booster brake line installation	0158 00-4
Right booster brake line removal	0158 00-2
Air-hydraulic booster replacement:	
Installation	0157 00-4
Removal	0157 00-2
Air-hydraulic booster vent line replacement:	
Installation	0159 00-2
Removal	0159 00-2
Air inlet elbow, manifold cover, and manifold replacement:	
Installation	0316 00-4
Removal	0316 00-2
Air line, air brake check valve, pressure switch, and, replacement:	
Installation	0275 00-4
Removal	0275 00-2
Air line, air brake rotary valve and, replacement:	
Installation	0273 00-4
Removal	0273 00-2
Air lines, compressed, replacement and repair:	
Damage at endpoint	0167 00-2
Damage at point between fittings	0167 00-2
Damage to section between fittings	0167 00-4
Air reservoir replacement:	
Installation	0165 00-4
Removal	0165 00-2

INDEX (Contd)

<u>Subject</u>	<u>WP Sequence No.-Page No.</u>
<i>A (Contd)</i>	
Air reservoir drainvalves replacement:	
Installation	0166 00-2
Removal	0166 00-2
Air valve, shutterstat, replacement:	
Installation	0083 00-2
Removal	0083 00-2
Alternator, 100-Amp, replacement:	
Installation	0277 00-4
Removal	0277 00-2
Alternator (Leece-Neville) maintenance:	
Adjustment	0090 00-4
Installation	0090 00-4
Removal	0090 00-2
Alternator (Prestolite) maintenance:	
Adjustment	0089 00-4
Installation	0089 00-4
Removal	0089 00-2
100-Amp alternator cable and harness replacement:	
Installation	0278 00-2
Removal	0278 00-2
100-Amp alternator regulator replacement:	
Installation	0279 00-2
Removal	0279 00-2
100-Amp alternator replacement:	
Installation	0277 00-4
Removal	0277 00-2
Arm, pitman, maintenance:	
Inspection	0180 00-3
Installation	0180 00-4
Removal	0180 00-2
Arm, windshield wiper blade and, replacement:	
Installation	0235 00-2
Removal	0235 00-2
Army petroleum, oil and lubricants (POL):	0001 00-3
Assembly, general	0383 00-6
Atomizers, quick-start, replacement:	
Installation	0057 00-2
Removal	0057 00-2
Axle breather maintenance:	
Cleaning	0151 00-2
Installation	0151 00-2
Removal	0151 00-2
Axle, forward-rear and rear-rear, replacement:	
Installation	0344 00-6
Removal	0344 00-2
Axle, front, replacement:	
Installation	0343 00-8
Removal	0343 00-2
<i>B</i>	
Backup lights and lamps replacement:	
Backup light installation	0110 00-2
Backup light removal	0110 00-2
Lamp installation	0110 00-2
Lamp removal	0110 00-2

INDEX (Contd)

<u>Subject</u>	<u>WP Sequence No.-Page No.</u>
<i>B (Contd)</i>	
Baffles, radiator, replacement:	
Installation	0076 00-2
Removal	0076 00-2
Base, engine crankcase breather and, maintenance:	
Cleaning	0029 00-2
Installation	0029 00-2
Removal	0029 00-2
Base, engine oil filter, maintenance:	
Cleaning and inspection	0315 00-2
Installation	0315 00-2
Removal	0315 00-2
Base, transmission external oil filter and, replacement:	
Oil filter base installation	0142 00-2
Oil filter base removal	0142 00-2
Oil filter installation	0142 00-2
Oil filter removal	0142 00-2
Battery box heater pad replacement:	
Installation	0255 00-2
Removal	0255 00-2
Battery box maintenance:	
Inspection	0123 00-2
Installation	0123 00-2
Removal	0123 00-2
Repair	0123 00-2
Battery cable and clamps replacement:	
Battery cable servicing	0121 00-2
Connect battery ground cable	0121 00-2
Disconnect battery ground cable	0121 00-2
Installation	0121 00-4
Removal	0121 00-4
Battery maintenance:	
Inspection	0122 00-2
Installation	0122 00-2
Removal	0122 00-2
Testing	0122 00-2
Bearing, transmission output shaft seal and, replacement:	
Installation	0382 00-2
Removal	0382 00-2
Blackout drive lamp and housing replacement:	
Lamp installation	0105 00-2
Lamp removal	0105 00-2
Light installation	0105 00-2
Light removal	0105 00-2
Bleeding, service brake system:	
Bleeding air-hydraulic cylinders	0154 00-3
Bleeding wheel cylinders	0154 00-4
Filling master cylinder	0154 00-2
Body, cargo, replacement:	
Installation	0353 00-6
Removal	0353 00-2
Box, battery, maintenance:	
Inspection	0123 00-2
Installation	0123 00-2
Removal	0123 00-2
Repair	0123 00-2

INDEX (Contd)

<u>Subject</u>	<u>WP Sequence No.-Page No.</u>
<i>B (Contd)</i>	
Bracket, CTIS electronic control unit (ECU), replacement:	
Installation	0283 00-2
Removal	0283 00-2
Bracket, fuel/water separator and, replacement:	
Installation	0053 00-2
Removal	0053 00-2
Bracket, headlight mounting, replacement:	
Installation	0109 00-2
Removal	0109 00-2
Bracket, rear lights, replacement:	
Installation	0112 00-2
Removal	0112 00-2
Bracket, rear marker light, replacement:	
Installation	0113 00-2
Removal	0113 00-2
Brackets, accelerator pedal and, replacement:	
Installation	0063 00-2
Removal	0063 00-2
Brackets, front upper and lower shackles and, (wo/winch) replacement:	
Removal	0188 00-2
Installation	0188 00-2
Brackets, front upper and lower shackles and, (w/winch) replacement:	
Lower shackles and brackets installation	0189 00-4
Lower shackles and brackets removal	0189 00-4
Upper shackles and brackets installation	0189 00-6
Upper shackles and brackets removal	0189 00-2
Brackets, mirror and, replacement:	
Left mirror and bracket installation	0236 00-2
Left mirror and bracket removal	0236 00-2
Right mirror and bracket installation	0236 00-4
Right mirror and bracket removal	0236 00-4
Brackets, rear shackles and, replacement:	
Installation	0190 00-2
Removal	0190 00-2
Brackets, seatbelt posts, and, replacement:	
Installation	0210 00-4
Removal	0210 00-2
Brackets, swingfire heater water jacket, replacement:	
Installation	0262 00-2
Removal	0262 00-2
Brake line, hydraulic, front axle replacement:	
Installation	0161 00-4
Removal	0161 00-2
Brake lines, air-hydraulic booster, replacement:	
Left booster brake line installation	0158 00-4
Left booster brake line removal	0158 00-2
Right booster brake line installation	0158 00-4
Right booster brake line removal	0158 00-2
Brake lines, hydraulic, forward-rear and rear-rear axle, replacement:	
Installation	0162 00-2
Removal	0162 00-2
Brake pedal maintenance:	
Installation	0163 00-2
Removal	0163 00-2
Adjustment	0163 00-4

INDEX (Contd)

<u>Subject</u>	<u>WP Sequence No.-Page No.</u>
<i>B (Contd)</i>	
Brake system bleeding, service:	
Bleeding air-hydraulic cylinders	0154 00-3
Bleeding wheel cylinders	0154 00-4
Filling master cylinder	0154 00-2
Breather, axle, maintenance:	
Cleaning	0151 00-2
Installation	0151 00-2
Removal	0151 00-2
Breather, front-rear and rear-rear axle, replacement:	
Installation	0269 00-2
Removal	0269 00-2
Breathers, front axle, replacement:	
Installation	0267 00-2
Removal	0267 00-2
Breather, transfer case, replacement:	
Installation	0268 00-2
Removal	0268 00-2
Brushguard replacement:	
Installation	0230 00-4
Removal	0230 00-2
Brushguard strut rods and mounting brackets replacement:	
Installation	0229 00-2
Removal	0229 00-2
Bumperette, rear, replacement:	
Installation	0228 00-2
Removal	0228 00-2
Bumper, front, replacement:	
Installation	0227 00-2
Removal	0227 00-2
<i>C</i>	
Cab insulation replacement:	
Installation	0201 00-2
Removal	0201 00-2
Cable, accelerator, maintenance:	
Adjustment	0064 00-4
Installation	0064 00-4
Removal	0064 00-2
Cable, front winch, maintenance:	
Cleaning and inspection	0224 00-2
Installation	0224 00-2
Removal	0224 00-2
Cable, throttle control, replacement:	
Installation	0062 00-2
Removal	0062 00-2
Camshaft bearing sleeves maintenance:	
Cleaning and inspection	0360 00-2
Installation	0360 00-2
Removal	0360 00-2
Camshaft maintenance:	
Cleaning and inspection	0359 00-2
Installation	0359 00-4
Removal	0359 00-2

INDEX (Contd)

<u>Subject</u>	<u>WP Sequence No.-Page No.</u>
<i>C (Contd)</i>	
Camshaft roller followers and covers maintenance:	
Cleaning and inspection	0308 00-4
Installation	0308 00-4
Removal	0308 00-2
Cargo body replacement:	
Installation	0353 00-6
Removal	0353 00-2
Center support maintenance:	
Assembly	0378 00-6
Cleaning and inspection	0378 00-4
Disassembly	0378 00-4
Installation	0378 00-8
Removal	0378 00-2
Central tire inflation system (CTIS) operation:	0005 00-2
Charged air cooler replacement:	
Installation	0072 00-2
Removal	0072 00-2
Charged air cooler tubes replacement:	
Installation	0073 00-2
Removal	0073 00-2
Check valve, fuel, replacement:	
Installation	0046 00-2
Removal	0046 00-2
Chemical agent alarm mounting kit replacement:	
Installation	0271 00-4
Removal	0271 00-2
Clamps, battery cable and, replacement:	
Battery cable servicing	0121 00-2
Connect battery ground cable	0121 00-2
Disconnect battery ground cable	0121 00-2
Installation	0121 00-4
Removal	0121 00-4
Cleaning, general	0383 00-1
Cleaner, air, replacement:	
Installation	0037 00-2
Removal	0037 00-2
Clearance and rear side marker lights and lamps replacement:	
Lamp installation	0111 00-2
Lamp removal	0111 00-2
Light installation	0111 00-2
Light removal	0111 00-2
Cluster, instrument, maintenance:	
Assembly	0094 00-4
Disassembly	0094 00-4
Installation	0094 00-6
Removal	0094 00-2
Clutch, first, maintenance:	
Cleaning and inspection	0381 00-6
Installation	0381 00-8
Removal	0381 00-2
Clutch, forward, and turbine shaft maintenance:	
Assembly	0375 00-6
Cleaning and inspection	0375 00-4
Disassembly	0375 00-2
Installation	0375 00-8
Removal	0375 00-2

INDEX (Contd)

<u>Subject</u>	<u>WP Sequence No.-Page No.</u>
<i>C (Contd)</i>	
Clutch, fourth, maintenance:	
Assembly	0376 00-4
Cleaning and inspection	0376 00-4
Disassembly	0376 00-2
Installation	0376 00-5
Removal	0376 00-2
Clutch, second, maintenance:	
Cleaning and inspection	0380 00-2
Installation	0380 00-4
Removal	0380 00-2
Clutch, third, maintenance:	
Cleaning and inspection	0377 00-2
Installation	0377 00-2
Removal	0377 00-2
Common tools and equipment:	0001 00-3
Companion seat and leg extensions replacement:	
Installation	0257 00-2
Removal	0257 00-2
Composite hood hinges replacement (built after serial no. 504923):	
Installation	0198 00-2
Removal	0198 00-2
Composite hood insulation replacement (built after serial no. 504923):	
Installation	0199 00-2
Removal	0199 00-2
Composite hood maintenance (built after serial no. 504923):	
Assembly	0197 00-4
Disassembly	0197 00-2
Inspection and repair	0197 00-2
Installation	0197 00-4
Removal	0197 00-2
Compressed air and brake system troubleshooting	0014 00-1
Compressed air and brake system troubleshooting symptom index	0013 00-1
Compressed air system operation	0005 00-1
Compressed air lines replacement and repair:	
Damage at endpoint	0167 00-2
Damage at point between fittings	0167 00-2
Damage to section between fittings	0167 00-4
Compressor, air, replacement:	
Installation	0169 00-4
Removal	0169 00-2
Conlink covers, windshield wiper switch, motor, and, replacement:	
Installation	0232 00-2
Removal	0232 00-2
Conlinks, left and right, maintenance:	
Adjustment	0233 00-2
Installation	0233 00-2
Removal	0233 00-2
Connecting rods, pistons and, maintenance:	
Assembly	0361 00-4
Cleaning and inspection	0361 00-4
Disassembly	0361 00-2
Installation	0361 00-4
Removal	0361 00-2

INDEX (Contd)

<u>Subject</u>	<u>WP Sequence No.-Page No.</u>
<i>C (Contd)</i>	
Container, engine and, replacement:	
Installation	0296 00-4
Removal	0296 00-2
Control box, personnel heater, replacement:	
Installation	0248 00-2
Removal	0248 00-2
Control cables, personnel hot water heater, replacement:	
Installation	0242 00-2
Removal	0242 00-2
Controls and linkage, transfer case, maintenance:	
Cleaning and inspection	0141 01-2
Installation	0141 01-2
Removal	0141 01-2
Control cable, transmission modulator, maintenance:	
Adjustment	0135 00-2
Installation	0135 00-2
Removal	0135 00-2
Control linkage, fuel injection, maintenance:	
Cleaning and inspection	0320 00-4
Installation	0320 00-4
Removal	0320 00-2
Control valve, front winch hydraulic, maintenance:	
Inspection	0218 00-2
Installation	0218 00-2
Removal	0218 00-2
Control valve, transmission, replacement:	
Installation	0371 00-2
Removal	0371 00-2
Controls, front winch, replacement:	
Installation	0223 00-2
Removal	0223 00-2
Converter, torque, maintenance:	
Cleaning and inspection	0368 00-2
Installation	0368 00-4
Removal	0368 00-2
Testing	0368 00-4
Coolant temperature quick-start switch replacement:	
Installation	0078 00-2
Removal	0078 00-2
Cooler, charged air, replacement:	
Installation	0072 00-2
Removal	0072 00-2
Cooling system operation	0005 00-2
Cooling tubes, piston, replacement:	
Installation	0362 00-2
Removal	0362 00-2
Corrosion prevention and control (CPC):	0001 00-1
Cover, air inlet elbow, and manifold, manifold replacement:	
Installation	0316 00-4
Removal	0316 00-2
Cover, timing gear, replacement:	
Installation	0310 00-2
Removal	0310 00-2

INDEX (Contd)

<u>Subject</u>	<u>WP Sequence No.-Page No.</u>
<i>C (Contd)</i>	
Cover, valve, replacement:	
Installation	0028 00-2
In-vehicle finishing	0028 00-2
In-vehicle prep.	0028 00-2
Removal	0028 00-2
Crankcase breather hose replacement:	
Installation	0265 00-2
Removal	0265 00-2
Crankshaft and bearing sleeves maintenance:	
Cleaning and inspection	0364 00-4
Installation	0364 00-4
Removal	0364 00-2
Crankshaft pulley and front oil seal maintenance:	
Cleaning and inspection	0304 00-2
Installation	0304 00-2
Removal	0304 00-2
Crankshaft rear seal cover maintenance:	
Cleaning and inspection	0306 00-2
Installation	0306 00-2
Removal	0306 00-2
Crankshaft rear seal maintenance:	
Cleaning and inspection	0305 00-2
Installation	0305 00-2
Removal	0305 00-2
CTIS control harness replacement:	
Installation	0129 00-2
Removal	0129 00-2
CTIS controller-to-signal generator wiring harness replacement:	
Installation	0128 00-2
Removal	0128 00-2
CTIS electronic control unit (ECU)/bracket replacement:	
Installation	0283 00-2
Removal	0283 00-2
CTIS manifold and exhaust replacement:	
Installation	0282 00-4
Removal	0282 00-2
CTIS manifold power harness replacement:	
Installation	0130 00-2
Removal	0130 00-2
CTIS overspeed signal generator replacement:	
Installation	0284 00-2
Removal	0284 00-2
CTIS troubleshooting	0019 00-1
CTIS troubleshooting symptom index	0018 00-1
CTIS wheel valve and filter maintenance:	
In-line filter inspection and cleaning.	0176 00-2
Installation	0176 00-4
Removal	0176 00-2
CTIS wheel valve repair:	
Assembly	0177 00-4
Cleaning and inspection	0177 00-4
Disassembly	0177 00-4
Installation	0177 00-6
Removal	0177 00-2

INDEX (Contd)

<u>Subject</u>	<u>WP Sequence No.-Page No.</u>
<i>C (Contd)</i>	
Cylinder and valve, quick-start, replacement (built before serial no. 504924):	
Installation	0055 00-2
Removal	0055 00-2
Cylinder head (in-vehicle) maintenance:	
Assembly	0302 00-19
Cleaning and inspection	0302 00-19
Disassembly	0302 00-19
Installation	0302 00-20
Removal	0302 00-2
Cylinder head repair:	
Assembly	0356 00-2
Cleaning and inspection	0356 00-2
Disassembly	0356 00-2
Cylinder, master, replacement:	
Installation	0155 00-4
Removal	0155 00-2
Cylinder, steering assist, maintenance:	
Adjustment	0183 00-6
Installation	0183 00-4
Removal	0183 00-2
Cylinder, valve, and jumper harness, quick-start, replacement (built after serial no. 504923):	
Installation	0059 00-2
Removal	0059 00-2
<i>D</i>	
Damper, vibration, replacement:	
Installation	0303 00-2
Removal	0303 00-2
Data plates, location and description of	0003 00-9
Deflectors, personnel hot water heater, replacement:	
Installation	0244 00-2
Removal	0244 00-2
Description of major components, location and	0003 00-4
Destruction of army materiel to prevent enemy use	0001 00-2
Differences between models	0003 00-6
Disassembly, general	0383 00-6
Diverter, personnel hot water heater, replacement:	
Installation	0241 00-2
Removal	0241 00-2
Drag link maintenance:	
Adjustment	0181 00-6
Installation	0181 00-4
Removal	0181 00-2
Drainvalves, air reservoir, replacement:	
Installation	0166 00-2
Removal	0166 00-2
Drivebelt, fan, maintenance:	
Inspection	0084 00-2
Installation	0084 00-2
Removal	0084 00-2
Drivebelt, water pump, maintenance:	
Adjustment	0081 00-2
Inspection	0081 00-2
Installation	0081 00-2
Removal	0081 00-2
Driveshaft, speedometer, replacement:	
Installation	0288 00-2
Removal	0288 00-2

INDEX (Contd)

<u>Subject</u>	<u>WP Sequence No.-Page No.</u>
<i>D (Contd)</i>	
Driver's and companion seat replacement:	
Companion seat installation	0208 00-2
Companion seat removal	0208 00-2
Driver's seat installation	0208 00-2
Driver's seat removal	0208 00-2
Driver's seat repair:	
Assembly	0209 00-4
Disassembly	0209 00-2
Dryer, air, and air dryer heater maintenance:	
Air dryer installation	0281 00-6
Air dryer removal	0281 00-2
Air dryer heater installation	0281 00-8
Air dryer heater removal	0281 00-8
Desiccant and coalescing filter inspection	0281 00-5
Desiccant and coalescing filter installation	0281 00-5
Desiccant and coalescing filter removal	0281 00-5
Operational check	0281 00-6
Ducts, personnel hot water heater, replacement:	
Installation	0240 00-2
Removal	0240 00-2
Durable items, expendable and, list:	
Explanation of columns	0393 00-1
Introduction	0393 00-1
Table 1. Expendable and durable items list	0393 00-2
Dust ejector hose replacement:	
Installation	0039 00-2
Removal	0039 00-2
<i>E</i>	
Electrical system operation	0005 00-3
Electrical troubleshooting	0012 00-1
Electrical troubleshooting symptom index, unit	0011 00-1
Electrical wiring harness repair:	
Connector cable repair	0125 00-3
Lead repair (female plug)	0125 00-2
Lead repair (male plug)	0125 00-2
Terminal cable repair	0125 00-2
Element, air cleaner, maintenance:	
Installation	0040 00-2
Removal	0040 00-2
Service	0040 00-2
Engine and container replacement:	
Installation	0296 00-4
Removal	0296 00-2
Engine and transmission ground straps replacement:	
Engine ground strap installation	0101 00-2
Engine ground strap removal	0101 00-2
Transmission ground strap installation	0101 00-2
Transmission ground strap removal	0101 00-2
Engine coolant heater harness replacement:	
Installation	0254 00-2
Removal	0254 00-2
Engine coolant heater replacement:	
Installation	0253 00-2
Removal	0253 00-2

INDEX (Contd)

<u>Subject</u>	<u>WP Sequence No.-Page No.</u>
<i>E (Contd)</i>	
Engine cooling system servicing:	
Cleaning and flushing system	0068 00-2
Drain system	0068 00-2
Fill system	0068 00-2
Engine crankcase breather and base maintenance:	
Cleaning	0029 00-2
Installation	0029 00-2
Removal	0029 00-2
Engine drivebelt tensioner replacement:	
Installation	0087 00-2
Removal	0087 00-2
Engine mounting pad, front, replacement:	
Installation	0027 00-2
Removal	0027 00-2
Engine mounts and support replacement:	
Installation	0301 00-2
Removal	0301 00-2
Engine oil cooler replacement:	
Installation	0314 00-2
Removal	0314 00-2
Engine oil dipstick and tube replacement:	
Installation	0030 00-2
Removal	0030 00-2
Engine oil filler tube replacement:	
Installation	0031 00-2
Removal	0031 00-2
Engine oil filter base maintenance:	
Cleaning and inspection	0315 00-2
Installation	0315 00-2
Removal	0315 00-2
Engine oil filter maintenance:	
Cleaning	0033 00-2
Draining oil	0033 00-2
Filter installation	0033 00-2
Filter removal	0033 00-2
Engine oil manifold maintenance:	
Assembly	0032 00-2
Disassembly	0032 00-2
Installation	0032 00-2
Removal	0032 00-2
Engine oil pan maintenance:	
Cleaning and inspection	0312 00-2
Installation	0312 00-2
Removal	0312 00-2
Engine oil pressure transducer replacement:	
Installation	0100 00-2
Removal	0100 00-2
Engine oil pump maintenance:	
Assembly	0313 00-4
Disassembly	0313 00-2
Inspection	0313 00-4
Installation	0313 00-4
Removal	0313 00-2

INDEX (Contd)

<u>Subject</u>	<u>WP Sequence No.-Page No.</u>
<i>E (Contd)</i>	
Engine oil sampling valve replacement:	
Installation	0034 00-2
Removal	0034 00-2
Engine, preparing replacement, for installation in vehicle:	
Installation	0297 00-4
Removal	0297 00-2
Engine rear mounting pads replacement:	
Installation	0300 00-4
Removal	0300 00-2
Engine, starting repaired or replaced:	
In-chassis run-in	0298 00-2
Priming lubrication	0298 00-2
Engine system operation	0005 00-1
Engine temperature transmitter replacement:	
Installation	0114 00-2
Removal	0114 00-2
Equipment characteristics, capabilities, and features:	0003 00-1
Equipment, common tools and	0001 00-3
Equipment data	0003 00-7
Equipment description and data:	0003 00-1
Exhaust, CTIS manifold and, replacement:	
Installation	0282 00-4
Removal	0282 00-2
Exhaust manifold replacement:	
Installation	0317 00-2
Removal	0317 00-2
Exhaust system replacement:	
Installation	0066 00-2
Removal	0066 00-2
Exhaust tube, oil pan shroud and, replacement:	
Installation	0252 00-2
Removal	0252 00-2
Exhaust tube, personnel heater, replacement:	
Installation	0251 00-2
Removal	0251 00-2
Exhaust valve, intake and, clearance check and adjustment:	
Adjustment	0311 00-4
Check	0311 00-2
Expendable and durable items list:	
Explanation of columns	0393 00-1
Introduction	0393 00-1
Table 1. Expendable and durable items list	0393 00-2
Extensions, companion seat and leg, replacement:	
Installation	0257 00-2
Removal	0257 00-2
<i>F</i>	
Fan actuator replacement:	
Installation	0085 00-2
Removal	0085 00-2
Fan actuator tube maintenance:	
Inspection	0086 00-2
Installation	0086 00-2
Removal	0086 00-2

INDEX (Contd)

<u>Subject</u>	<u>WP Sequence No.-Page No.</u>
<i>F (Contd)</i>	
Fan and fan clutch replacement:	
Installation	0082 00-2
Removal	0082 00-2
Fan drivebelt maintenance:	
Inspection	0084 00-2
Installation	0084 00-2
Removal	0084 00-2
Fan drive pulley replacement:	
Installation	0035 00-2
Removal	0035 00-2
Fender, front, replacement:	
Installation	0204 00-4
Removal	0204 00-2
Fiberglass hood repair (built after serial no. 504923):	
Inspection	0351 00-2
Repair	0351 00-2
Filter, CTIS wheel valve and, maintenance:	
In-line filter inspection and cleaning	0176 00-2
Installation	0176 00-4
Removal	0176 00-2
Filter, fuel, maintenance:	
Cleaning and inspection	0054 00-2
Draining	0054 00-2
Installation	0054 00-2
Removal	0054 00-2
Filter, transmission oil pan and, replacement:	
Installation	0370 00-2
Removal	0370 00-2
Firewall insulation replacement:	
Installation	0202 00-2
Removal	0202 00-2
First clutch maintenance:	
Cleaning and inspection	0381 00-6
Installation	0381 00-8
Removal	0381 00-2
Flexplate and hub, transmission, replacement:	
Installation	0337 00-2
Removal	0337 00-2
Flywheel housing maintenance:	
Cleaning and inspection	0307 00-2
Installation	0307 00-2
Removal	0307 00-2
Followers and covers, camshaft roller, maintenance:	
Cleaning and inspection	0308 00-4
Installation	0308 00-4
Removal	0308 00-2
Forward clutch and turbine shaft maintenance:	
Assembly	0375 00-6
Cleaning and inspection	0375 00-4
Disassembly	0375 00-2
Installation	0375 00-8
Removal	0375 00-2
Forward-rear and rear-rear axle hydraulic brake lines replacement:	
Installation	0162 00-2
Removal	0162 00-2

INDEX (Contd)

<u>Subject</u>	<u>WP Sequence No.-Page No.</u>
<i>F (Contd)</i>	
Forward-rear and rear-rear axle replacement:	
Installation	0344 00-6
Removal	0344 00-2
Fourth clutch maintenance:	
Assembly	0376 00-4
Cleaning and inspection	0376 00-4
Disassembly	0376 00-2
Installation	0376 00-5
Removal	0376 00-2
Front and rear composite lights and lamps replacement:	
Front composite light installation	0106 00-7
Front composite light removal	0106 00-4
Front lamp installation	0106 00-9
Front lamp removal	0106 00-2
Rear composite light angle bracket installation	0106 00-6
Rear composite light angle bracket removal	0106 00-6
Rear composite light installation	0106 00-8
Rear composite light removal	0106 00-5
Rear lamp installation	0106 00-10
Rear lamp removal	0106 00-3
Front and rear differential oil seal replacement:	
Installation	0345 00-2
Removal	0345 00-2
Front axle breathers replacement:	
Installation	0267 00-2
Removal	0267 00-2
Front axle hydraulic brake line replacement:	
Installation	0161 00-4
Removal	0161 00-2
Front axle oil seal replacement:	
Installation	0152 00-2
Removal	0152 00-2
Front axle replacement:	
Installation	0343 00-8
Removal	0343 00-2
Front bumper replacement:	
Installation	0227 00-2
Removal	0227 00-2
Front engine mounting pad replacement:	
Installation	0027 00-2
Removal	0027 00-2
Front fenders replacement:	
Installation	0204 00-4
Removal	0204 00-2
Front-rear and rear-rear axle breather replacement:	
Installation	0269 00-2
Removal	0269 00-2
Front side marker lights and lamps replacement:	
Installation	0108 00-2
Removal	0108 00-2
Front spring replacement:	
Installation	0193 00-4
Removal	0193 00-2

INDEX (Contd)

<u>Subject</u>	<u>WP Sequence No.-Page No.</u>
<i>F (Contd)</i>	
Front upper and lower shackles and brackets (wo/winch) replacement:	
Removal	0188 00-2
Installation	0188 00-2
Front upper and lower shackles and brackets (w/winch) replacement:	
Lower shackles and brackets installation	0189 00-4
Lower shackles and brackets removal	0189 00-4
Upper shackles and brackets installation	0189 00-6
Upper shackles and brackets removal	0189 00-2
Front wheel hub maintenance:	
Assembly	0172 00-6
Cleaning and inspection	0172 00-5
Disassembly	0172 00-4
Installation	0172 00-8
Removal	0172 00-2
Front wheel drive lock-in switch, air lines, and indicator replacement:	
Installation	0145 00-4
Removal	0145 00-2
Front winch AOAP valve replacement:	
Installation	0216 00-2
Removal	0216 00-2
Front winch cable maintenance:	
Cleaning and inspection	0224 00-2
Installation	0224 00-2
Removal	0224 00-2
Front winch controls replacement:	
Installation	0223 00-2
Removal	0223 00-2
Front winch hydraulic control valve maintenance:	
Inspection	0218 00-2
Installation	0218 00-2
Removal	0218 00-2
Front winch hydraulic hoses replacement:	
Installation	0221 00-2
Removal	0221 00-2
Front winch hydraulic motor maintenance:	
Inspection	0220 00-2
Installation	0220 00-2
Removal	0220 00-2
Front winch hydraulic oil filter base replacement:	
Installation	0215 00-2
Removal	0215 00-2
Front winch hydraulic oil filter replacement:	
Installation	0214 00-2
Removal	0214 00-2
Front winch hydraulic oil reservoir maintenance:	
Cleaning and inspection	0219 00-4
Installation	0219 00-4
Removal	0219 00-2
Front winch hydraulic pump replacement:	
Installation	0222 00-4
Removal	0222 00-2
Front winch hydraulic system servicing:	
Drain system	0213 00-2
Fill system	0213 00-2

INDEX (Contd)

Subject

WP Sequence No.-Page No.

F (Contd)

Front winch hydraulic vent valve maintenance:	
Inspection	0217 00-2
Installation	0217 00-2
Removal	0217 00-2
Front winch maintenance:	
Automatic winch brake adjustment	0225 00-10
Automatic winch brake testing	0225 00-8
Drag brake adjustment	0225 00-6
Drag brake testing	0225 00-6
Installation	0225 00-4
Removal	0225 00-2
Front winch operation	0005 00-3
Front wiring harness replacement:	
Installation	0330 00-18
Removal	0330 00-2
Fuel burning personnel heater replacement:	
Installation	0247 00-2
Removal	0247 00-2
Fuel check valve replacement:	
Installation	0046 00-2
Removal	0046 00-2
Fuel filter maintenance:	
Cleaning and inspection	0054 00-2
Draining	0054 00-2
Installation	0054 00-2
Removal	0054 00-2
Fuel filter, personnel heater, replacement:	
Installation	0250 00-2
Removal	0250 00-2
Fuel injection control linkage maintenance:	
Cleaning and inspection	0320 00-4
Installation	0320 00-4
Removal	0320 00-2
Fuel injector replacement:	
Installation	0319 00-4
Removal	0319 00-2
Fuel injector synchronization maintenance:	
Testing	0321 00-2
Fuel injector timing maintenance:	
Adjustment	0322 00-2
Locating top center position for no. 1 piston	0322 00-2
Fuel level sending unit replacement:	
Installation	0115 00-2
Removal	0115 00-2
Fuel pressure transducer replacement:	
Installation	0116 00-2
Removal	0116 00-2
Fuel pump, personnel heater, replacement:	
Installation	0249 00-2
Removal	0249 00-2
Fuel setting adjustment:	
Adjustment	0323 00-2
Fuel shutoff solenoid replacement:	
Installation	0050 00-2
Removal	0050 00-2

INDEX (Contd)

<u>Subject</u>	<u>WP Sequence No.-Page No.</u>
<i>F (Contd)</i>	
Fuel shutoff switch replacement:	
Installation	0103 00-2
Removal	0103 00-2
Fuel system operation	0005 00-1
Fuel tank filler cap and sleeve replacement:	
Installation	0047 00-2
Removal	0047 00-2
Fuel tank lines replacement:	
Installation	0048 00-4
Removal	0048 00-2
Fuel tank and retaining straps replacement:	
Installation	0045 00-2
Removal	0045 00-2
Fuel, timing, injector, maintenance:	
Adjustment	0322 00-2
Locating top center position for No. 1 piston	0322 00-2
Fuel transfer pump repair:	
Assembly	0324 00-4
Cleaning and inspection	0324 00-4
Disassembly	0324 00-2
Fuel vent line replacement:	
Installation	0049 00-2
Removal	0049 00-2
Fuel/water separator and bracket replacement:	
Installation	0053 00-2
Removal	0053 00-2
<i>G</i>	
Gear, steering, adjustment:	
Adjustment	0182 00-2
Gear, steering, replacement:	
Installation	0349 00-6
Removal	0349 00-2
General inspection and servicing instructions	0021 00-1
General maintenance procedures	0383 00-1
General service and inspection procedures	0024 00-1
Generator, CTIS overspeed signal, replacement:	
Installation	0284 00-2
Removal	0284 00-2
Glass, windshield, replacement:	
Installation	0352 00-2
Removal	0352 00-2
Glossary	Glossary 1
Governor, air compressor, maintenance:	
Check and adjustment	0170 00-2
Installation	0170 00-2
Removal	0170 00-2
Governor fuel and oil lines replacement:	
Fuel return tube installation	0051 00-2
Fuel return tube removal	0051 00-2
Governor oil line installation	0051 00-2
Governor oil line removal	0051 00-2
Ratio control line installation	0051 00-2
Ratio control line removal	0051 00-2
Governor low idle speed adjustment:	
Adjustment	0052 00-2

INDEX (Contd)

<u>Subject</u>	<u>WP Sequence No.-Page No.</u>
<i>G (Contd)</i>	
Governor replacement:	
Installation	0326 00-6
Removal	0326 00-2
Governor, transmission, maintenance:	
Cleaning and inspection	0369 00-2
Installation	0369 00-2
Removal	0369 00-2
Ground straps, engine and transmission, replacement:	
Engine ground strap installation	0101 00-2
Engine ground strap removal	0101 00-2
Transmission ground strap installation	0101 00-2
Transmission ground strap removal	0101 00-2
Guide, valve, maintenance:	
Inspection	0357 00-2
Installation	0357 00-2
Reaming	0357 00-2
Removal	0357 00-2
<i>H</i>	
Handle, windshield arm, window, and, replacement:	
Arm installation	0206 00-2
Arm removal	0206 00-2
Handle installation	0206 00-2
Handle removal	0206 00-2
Window installation	0206 00-2
Window removal	0206 00-2
Hand receipt	0001 00-1
Harness, air brake electrical, replacement:	
Installation	0274 00-2
Removal	0274 00-2
Harness, 100-Amp alternator cable and, replacement:	
Installation	0278 00-2
Removal	0278 00-2
Harness, CTIS control, replacement:	
Installation	0129 00-2
Removal	0129 00-2
Harness, CTIS manifold power, replacement:	
Installation	0130 00-2
Removal	0130 00-2
Harness, CTIS controller-to-signal generator wiring, replacement:	
Installation	0128 00-2
Removal	0128 00-2
Harness, electrical wiring, repair:	
Connector cable repair	0125 00-3
Lead repair (female plug)	0125 00-2
Lead repair (male plug)	0125 00-2
Terminal cable repair	0125 00-2
Harness, engine coolant heater, replacement:	
Installation	0254 00-2
Removal	0254 00-2
Harness, wiper motor wiring, replacement:	
Installation	0127 00-2
Removal	0127 00-2

INDEX (Contd)

<u>Subject</u>	<u>WP Sequence No.-Page No.</u>
<i>H (Contd)</i>	
Head, cylinder, (in-vehicle) maintenance:	
Assembly	0302 00-19
Cleaning and inspection	0302 00-19
Disassembly	0302 00-19
Installation	0302 00-20
Removal	0302 00-2
Head, cylinder, repair:	
Assembly	0356 00-2
Cleaning and inspection	0356 00-2
Disassembly	0356 00-2
Headlight mounting bracket replacement:	
Installation	0109 00-2
Removal	0109 00-2
Headlights and headlamps maintenance:	
Alignment	0107 00-4
Headlight installation	0107 00-2
Headlight removal	0107 00-2
Lamp installation	0107 00-2
Lamp removal	0107 00-2
Heater, engine coolant, replacement:	
Installation	0253 00-2
Removal	0253 00-2
Heater pad, battery box, replacement:	
Installation	0255 00-2
Removal	0255 00-2
Heater, personnel hot water, maintenance:	
Cleaning and inspection	0239 00-2
Installation	0239 00-4
Removal	0239 00-2
Heater tube, swingfire heater battery box, replacement:	
Installation	0259 00-2
Removal	0259 00-2
Hood and side panel insulation replacement:	
Installation	0200 00-2
Removal	0200 00-2
Hood hinges, composite, replacement (built after serial no. 504923):	
Installation	0198 00-2
Removal	0198 00-2
Hood hinges replacement:	
Installation	0196 00-2
Removal	0196 00-2
Hood, composite, maintenance (built after serial no. 504923):	
Assembly	0197 00-4
Disassembly	0197 00-2
Inspection and repair	0197 00-2
Installation	0197 00-4
Removal	0197 00-2
Hood insulation, composite, replacement (built after serial no. 504923):	
Installation	0199 00-2
Removal	0199 00-2
Hood, fiberglass, repair (built after serial no. 504923):	
Inspection	0351 00-2
Repair	0351 00-2

INDEX (Contd)

<u>Subject</u>	<u>WP Sequence No.-Page No.</u>
<i>H (Contd)</i>	
Hood maintenance:	
Assembly	0195 00-4
Disassembly	0195 00-2
Inspection and repair	0195 00-2
Installation	0195 00-4
Removal	0195 00-2
Horn, air, replacement:	
Installation	0119 00-2
Removal	0119 00-2
Hose, crankcase breather, replacement:	
Installation	0265 00-2
Removal	0265 00-2
Hose, steering assist, replacement:	
Installation	0186 00-2
Removal	0186 00-2
Hoses, air cleaner, replacement:	
Installation	0038 00-2
Removal	0038 00-2
Hoses, dust ejector, replacement:	
Installation	0039 00-2
Removal	0039 00-2
Hoses, front winch hydraulic , replacement:	
Installation	0221 00-2
Removal	0221 00-2
Hoses, personnel hot water heater, replacement:	
Installation	0238 00-2
Removal	0238 00-2
Hoses, radiator, replacement:	
Installation	0070 00-2
Removal	0070 00-2
Hoses, transmission oil cooler, replacement:	
Installation	0139 00-2
Removal	0139 00-2
Housing, blackout drive lamp and, replacement:	
Lamp installation	0105 00-2
Lamp removal	0105 00-2
Light installation	0105 00-2
Light removal	0105 00-2
Housing, flywheel, maintenance:	
Cleaning and inspection	0307 00-2
Installation	0307 00-2
Removal	0307 00-2
Housing, water regulator, replacement:	
Installation	0079 00-2
Removal	0079 00-2
Housing, windshield wiper idler shaft and, replacement:	
Installation	0234 00-2
Removal	0234 00-2
Hub, front wheel, maintenance:	
Assembly	0172 00-6
Cleaning and inspection	0172 00-5
Disassembly	0172 00-4
Installation	0172 00-8
Removal	0172 00-2

INDEX (Contd)

<u>Subject</u>	<u>WP Sequence No.-Page No.</u>
<i>H (Contd)</i>	
Hub, rear wheel, maintenance:	
Assembly	0173 00-4
Cleaning and inspection	0173 00-3
Disassembly	0173 00-2
Installation	0173 00-6
Removal	0173 00-2
Hub, transmission flexplate and, replacement:	
Installation	0337 00-2
Removal	0337 00-2
Hydraulic, air, booster replacement:	
Installation	0157 00-4
Removal	0157 00-2
/	
Idler gear, timing gear housing and, replacement:	
Installation	0363 00-2
Removal	0363 00-2
Illustrated list of manufactured items:	
Explanation of the illustrations of manufactured items	0384 00-1
How to use the index of manufactured items	0384 00-1
Scope	0384 00-1
Indicator and tube, air cleaner, maintenance:	
Cleaning and inspection	0041 00-4
Installation	0041 00-4
Removal	0041 00-2
Testing	0041 00-2
Indicator, front wheel drive lock-in switch, and, air lines replacement:	
Installation	0145 00-4
Removal	0145 00-2
Injector, fuel, replacement:	
Installation	0319 00-4
Removal	0319 00-2
Injector, fuel, synchronization maintenance:	
Testing	0321 00-2
Inspection, general	0383 00-3
Inspection procedures, general services and:	0024 00-1
Instrument cluster maintenance:	
Assembly	0094 00-4
Disassembly	0094 00-4
Installation	0094 00-6
Removal	0094 00-2
Insulation, cab, replacement:	
Installation	0201 00-2
Removal	0201 00-2
Insulation, composite hood, replacement (built after serial no. 504923):	
Installation	0199 00-2
Removal	0199 00-2
Insulation, firewall, replacement:	
Installation	0202 00-2
Removal	0202 00-2
Insulation, hood and side panel, replacement:	
Installation	0200 00-2
Removal	0200 00-2

INDEX (Contd)

<u>Subject</u>	<u>WP Sequence No.-Page No.</u>
<i>I (Contd)</i>	
Intake and exhaust valve clearance check and adjustment:	
Adjustment	0311 00-4
Check	0311 00-2
Intermediate propeller shaft maintenance (M36A3):	
Assembly	0148 00-4
Cleaning and inspection	0148 00-4
Disassembly	0148 00-2
Installation	0148 00-4
Removal	0148 00-2
Intermediate, rear and, cab tunnel and toeboard replacement:	
Intermediate cab tunnel removal	0207 00-2
Intermediate cab tunnel installation	0207 00-2
Rear cab tunnel installation	0207 00-2
Rear cab tunnel removal	0207 00-2
Toeboard installation	0207 00-2
Toeboard removal	0207 00-2
Internal oil filter, transmission maintenance:	
Cleaning and inspection	0143 00-2
Oil filter installation	0143 00-2
Oil filter removal	0143 00-2
Introduction to troubleshooting:	0007 00-1
<i>L</i>	
Lamps, backup lights and, replacement:	
Backup light installation	0110 00-2
Backup light removal	0110 00-2
Lamp installation	0110 00-2
Lamp removal	0110 00-2
Lamps, clearance and rear side marker lights and, replacement:	
Lamp installation	0111 00-2
Lamp removal	0111 00-2
Light installation	0111 00-2
Light removal	0111 00-2
Lamps, front and rear composite lights and, replacement:	
Front composite light installation	0106 00-7
Front composite light removal	0106 00-4
Front lamp installation	0106 00-9
Front lamp removal	0106 00-2
Rear composite light angle bracket installation	0106 00-6
Rear composite light angle bracket removal	0106 00-6
Rear composite light installation	0106 00-8
Rear composite light removal	0106 00-5
Rear lamp installation	0106 00-10
Rear lamp removal	0106 00-3
Lamps, front side marker lights and, replacement:	
Installation	0108 00-2
Removal	0108 00-2
Left and right conlinks maintenance:	
Adjustment	0233 00-2
Installation	0233 00-2
Removal	0233 00-2
Lighting wiring harness, rear, replacement:	
Installation	0126 00-4
Removal	0126 00-2

INDEX (Contd)

<u>Subject</u>	<u>WP Sequence No.-Page No.</u>
<i>L (Contd)</i>	
Light switch, transmission backup, replacement:	
Installation	0099 00-2
Removal	0099 00-2
Lines, air compressor coolant, replacement:	
Installation	0168 00-2
Removal	0168 00-2
Lines, fuel tank, replacement:	
Installation	0048 00-4
Removal	0048 00-2
Linkage, transfer case controls and, maintenance:	
Cleaning and inspection	0141 01-2
Installation	0141 01-2
Removal	0141 01-2
Link, drag, maintenance:	
Adjustment	0181 00-6
Installation	0181 00-4
Removal	0181 00-2
List of abbreviations	0001 00-2
Location and description of data plates	0003 00-9
Location and description of major components	0003 00-4
Low air pressure switch replacement:	
Installation	0118 00-2
Removal	0118 00-2
Lower radiator shroud and pivot mount replacement:	
Installation	0075 00-2
Removal	0075 00-2
Low idle speed adjustment, governor:	
Adjustment	0052 00-2
Lubrication instructions:	0023 00-1
Table 1. Fluid capacities and lubricant requirements	0023 00-3
Table 2. Lubrication interval	0023 00-4
<i>M</i>	
Magnetic speed sensor replacement:	
Installation	0097 00-2
Removal	0097 00-2
Maintenance allocation chart	
Table 1. Maintenance allocation chart	0392 00-1
Table 2. Tools and test equipment	0392 00-15
Table 3. Remarks	0392 00-20
Maintenance allocation chart (MAC) introduction:	
General	0391 00-1
Explanation of columns in remarks	0391 00-3
Explanation of columns in the MAC	0391 00-2
Explanation of columns in tool and test equipment requirements	0391 00-3
Maintenance functions	0391 00-1
Maintenance forms, records, and reports:	0001 00-1
Mandatory replacement parts list:	
Explanation of columns	0395 00-1
Introduction	0395 00-1
Table 1. Mandatory replacement parts	0395 00-2

INDEX (Contd)

<u>Subject</u>	<u>WP Sequence No.-Page No.</u>
<i>M (Contd)</i>	
Manifold, air inlet elbow, manifold cover, and, replacement:	
Installation	0316 00-4
Removal	0316 00-2
Manifold, exhaust, replacement:	
Installation	0317 00-2
Removal	0317 00-2
Manual shutoff valve replacement:	
Installation	0185 00-2
Removal	0185 00-2
Master cylinder replacement:	
Installation	0155 00-4
Removal	0155 00-2
Master cylinder reservoir replacement:	
Installation	0156 00-2
Removal	0156 00-2
Mechanical troubleshooting, unit	0010 00-1
Mechanical troubleshooting symptom index, unit.	0009 00-1
Mechanical troubleshooting, direct support	0293 00-1
Mechanical troubleshooting symptom index, direct support	0292 00-1
Mirror and brackets replacement:	
Left mirror and bracket installation	0236 00-2
Left mirror and bracket removal	0236 00-2
Right mirror and bracket installation	0236 00-4
Right mirror and bracket removal	0236 00-4
Modulator valve maintenance:	
Assembly	0372 00-2
Cleaning and inspection	0372 00-2
Disassembly	0372 00-2
Installation	0372 00-2
Removal	0372 00-2
Motor, front winch hydraulic, maintenance:	
Inspection	0220 00-2
Installation	0220 00-2
Removal	0220 00-2
Mount, pivot, lower radiator shroud and, replacement:	
Installation	0075 00-2
Removal	0075 00-2
Mounting bracket, headlight, replacement:	
Installation	0109 00-2
Removal	0109 00-2
Mounting bracket, quick-start, replacement (built before serial no. 504924) :	
Installation	0058 00-2
Removal	0058 00-2
Mounting bracket, quick-start, replacement (built after serial no. 504923) :	
Installation	0061 00-2
Removal	0061 00-2
Mounting brackets, brushguard strut rods and, replacement:	
Installation	0229 00-2
Removal	0229 00-2
Mounting brackets, radiator and, replacement:	
Installation	0069 00-4
Removal	0069 00-2

INDEX (Contd)

<u>Subject</u>	<u>WP Sequence No.-Page No.</u>
<i>M (Contd)</i>	
Mounting brackets, surge tank and, replacement:	
Installation	0071 00-2
Removal	0071 00-2
Mounting brackets, swingfire heater and, replacement:	
Installation	0258 00-2
Removal	0258 00-2
Mounting kit, chemical agent alarm, replacement:	
Installation	0271 00-4
Removal	0271 00-2
Mounting pad, front engine, replacement:	
Installation	0027 00-2
Removal	0027 00-2
Mounting pads, engine rear, replacement:	
Installation	0300 00-4
Removal	0300 00-2
Mounting transmission on holding fixture:	
Installation	0367 00-2
Removal	0367 00-2
Mounts and support, engine replacement:	
Installation	0301 00-2
Removal	0301 00-2
<i>N</i>	
NATO slave receptacle replacement:	
Installation	0120 00-2
Removal	0120 00-2
<i>O</i>	
Oil cooler, engine, replacement:	
Installation	0314 00-2
Removal	0314 00-2
Oil cooler, transmission auxiliary, replacement:	
Installation	0140 00-2
Removal	0140 00-2
Oil drainage, transmission:	
Drainage	0137 00-2
Oil drain tube, turbocharger, maintenance:	
Assembly	0042 00-2
Disassembly	0042 00-2
Installation	0042 00-2
Removal	0042 00-2
Oil filter base, hydraulic, front winch, replacement:	
Installation	0215 00-2
Removal	0215 00-2
Oil filter, engine, maintenance:	
Cleaning	0033 00-2
Draining oil	0033 00-2
Filter installation	0033 00-2
Filter removal	0033 00-2
Oil filter, hydraulic, front winch, replacement:	
Installation	0214 00-2
Removal	0214 00-2
Oil inlet tube, turbocharger, replacement:	
Installation	0043 00-2
Removal	0043 00-2

INDEX (Contd)

<u>Subject</u>	<u>WP Sequence No.-Page No.</u>
<i>O (Contd)</i>	
Oil lines, governor fuel and, replacement:	
Fuel return tube installation	0051 00-2
Fuel return tube removal	0051 00-2
Governor oil line installation	0051 00-2
Governor oil line removal	0051 00-2
Ratio control line installation	0051 00-2
Ratio control line removal	0051 00-2
Oil manifold, engine, maintenance:	
Assembly	0032 00-2
Disassembly	0032 00-2
Installation	0032 00-2
Removal	0032 00-2
Oil pan and filter, transmission replacement:	
Installation	0370 00-2
Removal	0370 00-2
Oil pan, engine, maintenance:	
Cleaning and inspection	0312 00-2
Installation	0312 00-2
Removal	0312 00-2
Oil pan shroud and exhaust tube replacement:	
Installation	0252 00-2
Removal	0252 00-2
Oil pump, transmission, maintenance:	
Assembly	0374 00-8
Cleaning and inspection	0374 00-6
Disassembly	0374 00-4
Installation	0374 00-10
Removal	0374 00-2
Oil reservoir, front winch hydraulic, maintenance:	
Cleaning and inspection	0219 00-4
Installation	0219 00-4
Removal	0219 00-2
Oil sampling valve, transmission, replacement:	
Installation	0141 00-2
Removal	0141 00-2
Oil seal, crankshaft pulley and front, maintenance:	
Cleaning and inspection	0304 00-2
Installation	0304 00-2
Removal	0304 00-2
Oil seal, front and rear differential replacement:	
Installation	0345 00-2
Removal	0345 00-2
Oil seal, front axle, replacement:	
Installation	0152 00-2
Removal	0152 00-2
Oil seal, transmission (in-vehicle) output, replacement:	
Installation	0338 00-2
Removal	0338 00-2
<i>P</i>	
Pad, mounting, front engine, replacement:	
Installation	0027 00-2
Removal	0027 00-2

INDEX (Contd)

<u>Subject</u>	<u>WP Sequence No.-Page No.</u>
<i>P (Contd)</i>	
Parking brake light switch replacement:	
Installation	0102 00-2
Removal	0102 00-2
Parts, mandatory replacement:	
Explanation of columns	0395 00-1
Introduction	0395 00-1
Table 1. Mandatory replacement parts	0395 00-2
Parts, repair	0001 00-3
Pedal, brake, maintenance:	
Installation	0163 00-2
Removal	0163 00-2
Adjustment	0163 00-4
Panel, side, replacement:	
Side panel hinges installation	0203 00-4
Side panel installation	0203 00-4
Side panel hinges removal	0203 00-2
Side panel removal	0203 00-2
Thumb cranks installation	0203 00-4
Thumb cranks removal	0203 00-2
Personnel heater control box replacement:	
Installation	0248 00-2
Removal	0248 00-2
Personnel heater exhaust tube replacement:	
Installation	0251 00-2
Removal	0251 00-2
Personnel heater, fuel burning, replacement:	
Installation	0247 00-2
Removal	0247 00-2
Personnel heater fuel filter replacement:	
Installation	0250 00-2
Removal	0250 00-2
Personnel heater fuel pump replacement:	
Installation	0249 00-2
Removal	0249 00-2
Personnel hot water heater control cables replacement:	
Installation	0242 00-2
Removal	0242 00-2
Personnel hot water heater deflectors replacement:	
Installation	0244 00-2
Removal	0244 00-2
Personnel hot water heater diverter replacement:	
Installation	0241 00-2
Removal	0241 00-2
Personnel hot water heater ducts replacement:	
Installation	0240 00-2
Removal	0240 00-2
Personnel hot water heater hoses replacement:	
Installation	0238 00-2
Removal	0238 00-2
Personnel hot water heater maintenance:	
Cleaning and inspection	0239 00-2
Installation	0239 00-4
Removal	0239 00-2

INDEX (Contd)

<u>Subject</u>	<u>WP Sequence No.-Page No.</u>
<i>P (Contd)</i>	
Personnel hot water heater switch replacement:	
Installation	0243 00-2
Removal	0243 00-2
Piston cooling tubes replacement:	
Installation	0362 00-2
Removal	0362 00-2
Pistons and connecting rods maintenance:	
Assembly	0361 00-4
Cleaning and inspection	0361 00-4
Disassembly	0361 00-2
Installation	0361 00-4
Removal	0361 00-2
Pitman arm maintenance:	
Inspection	0180 00-3
Installation	0180 00-4
Removal	0180 00-2
Pivot mount, lower radiator shroud and, replacement:	
Installation	0075 00-2
Removal	0075 00-2
Planetary gearing maintenance:	
Assembly	0379 00-6
Cleaning and inspection	0379 00-4
Disassembly	0379 00-2
Installation	0379 00-6
Removal	0379 00-2
PMCS procedures, specific:	0025 00-1
Power plant replacement:	
Installation	0295 00-20
Removal	0295 00-2
Power steering assist system operation:	0005 00-3
Preparation for storage or shipment:	0001 00-2
Preparing replacement engine for installation in vehicle:	
Installation	0297 00-4
Removal	0297 00-2
Preventive maintenance checks and services	0025 00-1
Table 1. Preventative maintenance checks and services	0025 00-3
Table 2. Semiannual (6000 mile) mandatory replacement parts list	0025 00-18
Table 3. Annual (12,000 mile) or biennial (24,000 mile) mandatory replacement parts list	0025 00-18
Preventive maintenance checks and services introduction	0024 00-1
Propeller shaft, intermediate, maintenance (M36A3):	
Assembly	0148 00-4
Cleaning and inspection	0148 00-4
Disassembly	0148 00-2
Installation	0148 00-4
Removal	0148 00-2
Propeller shaft maintenance:	
Assembly	0147 00-4
Cleaning and inspection	0147 00-2
Disassembly	0147 00-2
Installation	0147 00-4
Removal	0147 00-2
Proportional valve replacement:	
Installation	0160 00-2
Removal	0160 00-2

INDEX (Contd)

<u>Subject</u>	<u>WP Sequence No.-Page No.</u>
<i>P (Contd)</i>	
Pulley, fan drive, replacement:	
Installation	0035 00-2
Removal	0035 00-2
Pump, front winch hydraulic, replacement:	
Installation	0222 00-4
Removal	0222 00-2
Pump, fuel transfer, repair:	
Assembly	0324 00-4
Cleaning and inspection	0324 00-4
Disassembly	0324 00-2
Pump, water, repair:	
Assembly	0328 00-2
Cleaning and inspection	0328 00-2
Disassembly	0328 00-2
Pump, water, replacement:	
Installation	0080 00-6
Removal	0080 00-2
Pushrod, rocker arm assembly and, maintenance:	
Adjustment	0309 00-4
Assembly	0309 00-4
Cleaning and inspection	0309 00-4
Disassembly	0309 00-4
Installation	0309 00-4
Removal	0309 00-2
<i>Q</i>	
Quick-start atomizers replacement:	
Installation	0057 00-2
Removal	0057 00-2
Quick-start cylinder and valve replacement (built before serial no. 504924):	
Installation	0055 00-2
Removal	0055 00-2
Quick-start cylinder, valve, and jumper harness replacement (built after serial no. 504923):	
Installation	0059 00-2
Removal	0059 00-2
Quick-start mounting bracket replacement (built after serial no. 504923):	
Installation	0061 00-2
Removal	0061 00-2
Quick-start mounting bracket replacement (built before serial no. 504924):	
Installation	0058 00-2
Removal	0058 00-2
Quick-start switch replacement:	
Installation	0104 00-2
Removal	0104 00-2
Quick-start tubes replacement (built after serial no. 504923):	
Installation	0060 00-2
Removal	0060 00-2
Quick-start tubes replacement (built before serial no. 504924):	
Installation	0056 00-2
Removal	0056 00-2

INDEX (Contd)

<u>Subject</u>	<u>WP Sequence No.-Page No.</u>
<i>R</i>	
Radiator and mounting brackets replacement:	
Installation	0069 00-4
Removal	0069 00-2
Radiator baffles replacement:	
Installation	0076 00-2
Removal	0076 00-2
Radiator cover, winterfront replacement:	
Installation	0246 00-2
Removal	0246 00-2
Radiator hoses replacement:	
Installation	0070 00-2
Removal	0070 00-2
Radiator shroud, lower, and pivot mount replacement:	
Installation	0075 00-2
Removal	0075 00-2
Rear and intermediate cab tunnel and toeboard replacement:	
Intermediate cab tunnel removal	0207 00-2
Intermediate cab tunnel installation	0207 00-2
Rear cab tunnel installation	0207 00-2
Rear cab tunnel removal	0207 00-2
Toeboard installation	0207 00-2
Toeboard removal	0207 00-2
Rear bumperette replacement:	
Installation	0228 00-2
Removal	0228 00-2
Rear lighting wiring harness replacement:	
Installation	0126 00-4
Removal	0126 00-2
Rear lights bracket replacement:	
Installation	0112 00-2
Removal	0112 00-2
Rear marker light bracket replacement:	
Installation	0113 00-2
Removal	0113 00-2
Rear shackles and brackets replacement:	
Installation	0190 00-2
Removal	0190 00-2
Rear wheel hub maintenance:	
Assembly	0173 00-4
Cleaning and inspection	0173 00-3
Disassembly	0173 00-2
Installation	0173 00-6
Removal	0173 00-2
Rear wheel ring adapter maintenance:	
Cleaning, inspection and repair	0347 00-4
Installation	0347 00-4
Leak test	0347 00-5
Removal	0347 00-2
Rear wiring harness replacement:	
Installation	0332 00-6
Removal	0332 00-2
Receptacle, swingfire heater wiring harness and, replacement:	
Installation	0263 00-2
Removal	0263 00-2

INDEX (Contd)

<u>Subject</u>	<u>WP Sequence No.-Page No.</u>
<i>R (Contd)</i>	
References:	
Field manuals	0390 00-1
Forms	0390 00-1
Other publications	0390 00-3
Publications index	0390 00-1
Scope	0390 00-1
Technical bulletins	0390 00-3
Technical manuals	0390 00-2
Regulator, 100-Amp alternator, replacement:	
Installation	0279 00-2
Removal	0279 00-2
Regulator, steering assist, replacement:	
Installation	0184 00-2
Removal	0184 00-2
Regulator, water housing, replacement:	
Installation	0079 00-2
Removal	0079 00-2
Relay, starter, replacement:	
Installation	0092 00-2
Removal	0092 00-2
Repair, general	0383 00-4
Repair parts	0001 00-3
Replacement, parts, mandatory:	
Explanation of columns	0395 00-1
Introduction	0395 00-1
Table 1. Mandatory replacement parts	0395 00-2
Reporting equipment improvement recommendations (EIR'S):	0001 00-1
Reporting repairs	0024 00-1
Reservoir, air, replacement:	
Installation	0165 00-4
Removal	0165 00-2
Reservoir, master cylinder, replacement:	
Installation	0156 00-2
Removal	0156 00-2
Rocker arm assembly and pushrod maintenance:	
Adjustment	0309 00-4
Assembly	0309 00-4
Cleaning and inspection	0309 00-4
Disassembly	0309 00-4
Installation	0309 00-4
Removal	0309 00-2
S	
Sampling valve, engine oil, replacement:	
Installation	0034 00-2
Removal	0034 00-2
Seal, crankshaft rear, cover maintenance:	
Cleaning and inspection	0306 00-2
Installation	0306 00-2
Removal	0306 00-2
Seal, crankshaft rear, maintenance:	
Cleaning and inspection	0305 00-2
Installation	0305 00-2
Removal	0305 00-2

INDEX (Contd)

<u>Subject</u>	<u>WP Sequence No.-Page No.</u>
<i>S (Contd)</i>	
Seal, transmission manual select shaft and, replacement:	
Installation	0373 00-2
Removal	0373 00-2
Seal, transmission output shaft, and bearing replacement:	
Installation	0382 00-2
Removal	0382 00-2
Seatbelt posts and brackets replacement:	
Installation	0210 00-4
Removal	0210 00-2
Seatbelts maintenance:	
Cleaning and inspection	0211 00-4
Companion seatbelts installation	0211 00-6
Companion seatbelts removal	0211 00-4
Driver's seatbelt installation	0211 00-8
Driver's seatbelt removal	0211 00-2
Seat, driver's and companion, replacement:	
Companion seat installation	0208 00-2
Companion seat removal	0208 00-2
Driver's seat installation	0208 00-2
Driver's seat removal	0208 00-2
Seat, driver's, repair:	
Assembly	0209 00-4
Disassembly	0209 00-2
Seat, valve, maintenance:	
Cleaning and inspection	0358 00-2
Grinding	0358 00-2
Installation	0358 00-2
Removal	0358 00-2
Second clutch maintenance:	
Cleaning and inspection	0380 00-2
Installation	0380 00-4
Removal	0380 00-2
Select lever, transmission, maintenance:	
Assembly	0134 00-4
Disassembly	0134 00-2
Installation	0134 00-4
Removal	0134 00-2
Sending unit, fuel level, replacement:	
Installation	0115 00-2
Removal	0115 00-2
Sensor, transmission oil temperature, replacement:	
Installation	0117 00-2
Removal	0117 00-2
Service brake system bleeding:	
Bleeding air-hydraulic cylinders	0154 00-3
Bleeding wheel cylinders	0154 00-4
Filling master cylinder	0154 00-2
Service upon receipt	0021 00-1
Servicing, engine cooling system:	
Cleaning and flushing system	0068 00-2
Drain system	0068 00-2
Fill system	0068 00-2

INDEX (Contd)

<u>Subject</u>	<u>WP Sequence No.-Page No.</u>
<i>S (Contd)</i>	
Shackles and brackets, rear, replacement:	
Installation	0190 00-2
Removal	0190 00-2
Shaft, forward clutch and turbine, maintenance:	
Assembly	0375 00-6
Cleaning and inspection	0375 00-4
Disassembly	0375 00-2
Installation	0375 00-8
Removal	0375 00-2
Shaft, propeller, intermediate, maintenance (M36A3):	
Assembly	0148 00-4
Cleaning and inspection	0148 00-4
Disassembly	0148 00-2
Installation	0148 00-4
Removal	0148 00-2
Shaft, propeller, maintenance:	
Assembly	0147 00-4
Cleaning and inspection	0147 00-2
Disassembly	0147 00-2
Installation	0147 00-4
Removal	0147 00-2
Shift cable, transmission, maintenance:	
Adjustment	0132 00-2
Installation	0132 00-2
Removal	0132 00-2
Shift tower, transmission, replacement:	
Installation	0133 00-2
Removal	0133 00-2
Shipment and limited storage instructions:	
General preparation of vehicle for shipment	0387 00-1
Loading and movement of vehicle	0388 00-1
Limited storage	0389 00-1
Shroud, upper radiator, replacement:	
Installation	0074 00-2
Removal	0074 00-2
Shunt, STE/ICE-R, replacement:	
Installation	0124 00-2
Removal	0124 00-2
Shutoff valve, manual, replacement:	
Installation	0185 00-2
Removal	0185 00-2
Shutterstat air valve replacement:	
Installation	0083 00-2
Removal	0083 00-2
Side panel replacement:	
Side panel hinges installation	0203 00-4
Side panel installation	0203 00-4
Side panel hinges removal	0203 00-2
Side panel removal	0203 00-2
Thumb cranks installation	0203 00-4
Thumb cranks removal	0203 00-2
Simplified test equipment/internal combustion engines - reprogrammable (STE-ICE-R)	0005 00-3
Slave receptacle, NATO, replacement:	
Installation	0120 00-2
Removal	0120 00-2

INDEX (Contd)

<u>Subject</u>	<u>WP Sequence No.-Page No.</u>
<i>S (Contd)</i>	
Sleeves, camshaft bearing, maintenance:	
Cleaning and inspection	0360 00-2
Installation	0360 00-2
Removal	0360 00-2
Sleeves, crankshaft and bearing, maintenance:	
Cleaning and inspection	0364 00-4
Installation	0364 00-4
Removal	0364 00-2
Sleeve, fuel tank filler cap and, replacement:	
Installation	0047 00-2
Removal	0047 00-2
Solenoid, fuel shutoff, replacement:	
Installation	0050 00-2
Removal	0050 00-2
Spare tire carrier maintenance:	
Assembly	0191 00-2
Disassembly	0191 00-2
Inspection	0191 00-2
Installation	0191 00-2
Removal	0191 00-2
Special tools, TMDE, and support equipment.	0001 00-3
Specific inspection and servicing instructions.	0021 00-2
Specific PMCS procedures.	0025 00-1
Speedometer replacement:	
Installation	0286 00-2
Removal	0286 00-2
Speedometer driveshaft adapter replacement:	
Installation	0287 00-2
Removal	0287 00-2
Speedometer driveshaft replacement:	
Installation	0288 00-2
Removal	0288 00-2
Speed sensor, magnetic, replacement:	
Installation	0097 00-2
Removal	0097 00-2
Split air-hydraulic brake system operation.	0005 00-3
Spring, front, replacement:	
Installation	0193 00-4
Removal	0193 00-2
Starter motor replacement:	
Installation	0091 00-2
Removal	0091 00-2
Starter relay replacement:	
Installation	0092 00-2
Removal	0092 00-2
Starter switch replacement:	
Installation	0093 00-2
Removal	0093 00-2
Starting repaired or replaced engine:	
In-chassis run-in	0298 00-2
Priming lubrication system	0298 00-2
Steering assist cylinder maintenance:	
Adjustment	0183 00-6
Installation	0183 00-4
Removal	0183 00-2

INDEX (Contd)

<u>Subject</u>	<u>WP Sequence No.-Page No.</u>
<i>S (Contd)</i>	
Steering assist hose replacement:	
Installation	0186 00-2
Removal	0186 00-2
Steering assist regulator replacement:	
Installation	0184 00-2
Removal	0184 00-2
Steering gear adjustment:	
Adjustment	0182 00-2
Steering gear replacement:	
Installation	0349 00-6
Removal	0349 00-2
STE/ICE-R shunt replacement:	
Installation	0124 00-2
Removal	0124 00-2
STE-ICE-R troubleshooting (GO chain tests):	0016 00-1
STE-ICE-R troubleshooting introduction:	0015 00-1
STE-ICE-R troubleshooting (NO-GO chain tests) :	0017 00-1
STE/ICE-R wiring harness replacement:	
Installation	0331 00-8
Removal	0331 00-2
Support, center, maintenance:	
Assembly	0378 00-6
Cleaning and inspection	0378 00-4
Disassembly	0378 00-4
Installation	0378 00-8
Removal	0378 00-2
Support equipment, special tools, TMDE and:	0001 00-3
Surge tank and mounting brackets replacement:	
Installation	0071 00-2
Removal	0071 00-2
Swingfire heater and mounting brackets replacement:	
Installation	0258 00-2
Removal	0258 00-2
Swingfire heater battery box heater tube replacement:	
Installation	0259 00-2
Removal	0259 00-2
Swingfire heater water hoses replacement:	
Installation	0261 00-2
Removal	0261 00-2
Swingfire heater water jacket brackets replacement:	
Installation	0262 00-2
Removal	0262 00-2
Swingfire heater water jacket replacement:	
Installation	0260 00-2
Removal	0260 00-2
Swingfire heater wiring harness and receptacle replacement:	
Installation	0263 00-2
Removal	0263 00-2
Switch, transmission backup light, replacement:	
Installation	0099 00-2
Removal	0099 00-2
Switch, coolant temperature quick-start, replacement:	
Installation	0078 00-2
Removal	0078 00-2

INDEX (Contd)

<u>Subject</u>	<u>WP Sequence No.-Page No.</u>
<i>S (Contd)</i>	
Switch, fuel shutoff, replacement:	
Installation	0103 00-2
Removal	0103 00-2
Switch, low air pressure, replacement:	
Installation	0118 00-2
Removal	0118 00-2
Switch, parking brake light, replacement:	
Installation	0102 00-2
Removal	0102 00-2
Switch, personnel hot water heater, replacement:	
Installation	0243 00-2
Removal	0243 00-2
Switch, quick-start, replacement:	
Installation	0104 00-2
Removal	0104 00-2
Switch, starter, replacement:	
Installation	0093 00-2
Removal	0093 00-2
Switch, transmission neutral safety, replacement:	
Installation	0098 00-2
Removal	0098 00-2
System bleeding, service brake:	
Bleeding air-hydraulic cylinders	0154 00-3
Bleeding wheel cylinders	0154 00-4
Filling master cylinder	0154 00-2
System servicing, front winch hydraulic:	
Drain system	0213 00-2
Fill system	0213 00-2
<i>T</i>	
Tachometer replacement:	
Installation	0095 00-2
Removal	0095 00-2
Tank and retaining straps, fuel, replacement:	
Installation	0045 00-2
Removal	0045 00-2
Temperature gauge, transmission oil, replacement:	
Installation	0096 00-2
Removal	0096 00-2
Tensioner, engine drivebelt, replacement:	
Installation	0087 00-2
Removal	0087 00-2
Theory of operation:	0005 00-1
Thermostat replacement:	
Installation	0077 00-2
Removal	0077 00-2
Third clutch maintenance:	
Cleaning and inspection	0377 00-2
Installation	0377 00-2
Removal	0377 00-2
Throttle control cable replacement:	
Installation	0062 00-2
Removal	0062 00-2

INDEX (Contd)

<u>Subject</u>	<u>WP Sequence No.-Page No.</u>
<i>T (Contd)</i>	
Timing gear cover replacement:	
Installation	0310 00-2
Removal	0310 00-2
Timing gear housing and idler gear replacement:	
Installation	0363 00-2
Removal	0363 00-2
Tire and wheel repair:	
Assembly	0175 00-4
Cleaning, inspection, and repair	0175 00-4
Disassembly	0175 00-2
Tire and wheel replacement:	
Installation	0174 00-3
Removal	0174 00-2
Tire carrier, spare, maintenance:	
Assembly	0191 00-2
Disassembly	0191 00-2
Inspection	0191 00-2
Installation	0191 00-2
Removal	0191 00-2
Toeboard, rear and intermediate cab tunnel and, replacement:	
Intermediate cab tunnel removal	0207 00-2
Intermediate tunnel installation	0207 00-2
Rear cab tunnel installation	0207 00-2
Rear cab tunnel removal	0207 00-2
Toeboard installation	0207 00-2
Toeboard removal	0207 00-2
Toe-in check and adjustment:	
Adjustment	0179 00-6
Check	0179 00-2
Tool identification list:	
Explanation of columns	0394 00-1
Scope	0394 00-1
Table 1. Tool identification list	0394 00-2
Torque converter maintenance:	
Cleaning and inspection	0368 00-2
Installation	0368 00-4
Removal	0368 00-2
Testing	0368 00-4
Torque limits:	
Conversion formula	0385 00-7
General	0385 00-1
How to use torque table	0385 00-1
Table 1. Torque limits for dry fasteners	0385 00-2
Table 2. Torque limits for wet fasteners	0385 00-3
Table 3. Torque limits for metric fasteners	0385 00-4
Torque tables	0385 00-1
Torque wrench adapters	0385 00-6
Tubing application tightening assembly instructions	0385 00-5
Trailer air coupling replacement:	
Installation	0164 00-2
Removal	0164 00-2
Transducer, engine oil pressure, replacement:	
Installation	0100 00-2
Removal	0100 00-2

INDEX (Contd)

<u>Subject</u>	<u>WP Sequence No.-Page No.</u>
<i>T (Contd)</i>	
Transducer, fuel pressure, replacement:	
Installation	0116 00-2
Removal	0116 00-2
Transfer case breather replacement:	
Installation	0268 00-2
Removal	0268 00-2
Transfer case controls and linkage maintenance:	
Cleaning and inspection	0141 01-2
Installation	0141 01-2
Removal	0141 01-2
Transfer case maintenance:	
Inspection and repair	0340 00-7
Installation	0340 00-8
Removal	0340 00-2
Transmission and container replacement:	
Installation	0334 00-4
Removal	0334 00-2
Transmission auxiliary oil cooler replacement:	
Installation	0140 00-2
Removal	0140 00-2
Transmission backup light switch replacement:	
Installation	0099 00-2
Removal	0099 00-2
Transmission control valve replacement:	
Installation	0371 00-2
Removal	0371 00-2
Transmission external oil filter and base replacement:	
Oil filter base installation	0142 00-2
Oil filter base removal	0142 00-2
Oil filter installation	0142 00-2
Oil filter removal	0142 00-2
Transmission flexplate and hub replacement:	
Installation	0337 00-2
Removal	0337 00-2
Transmission governor maintenance:	
Cleaning and inspection	0369 00-2
Installation	0369 00-2
Removal	0369 00-2
Transmission internal oil filter maintenance:	
Cleaning and inspection	0143 00-2
Oil filter installation	0143 00-2
Oil filter removal	0143 00-2
Transmission (in-vehicle) output oil seal replacement:	
Installation	0338 00-2
Removal	0338 00-2
Transmission (in-vehicle) replacement:	
Installation	0335 00-10
Removal	0335 00-2
Transmission manual select shaft and seal replacement:	
Installation	0373 00-2
Removal	0373 00-2
Transmission modulator control cable maintenance:	
Adjustment	0135 00-2
Installation	0135 00-2
Removal	0135 00-2

INDEX (Contd)

<u>Subject</u>	<u>WP Sequence No.-Page No.</u>
<i>T (Contd)</i>	
Transmission, mounting, on holding fixture:	
Installation	0367 00-2
Removal	0367 00-2
Transmission neutral safety switch replacement:	
Installation	0098 00-2
Removal	0098 00-2
Transmission oil cooler hoses replacement:	
Installation	0139 00-2
Removal	0139 00-2
Transmission oil dipstick tube replacement:	
Installation	0138 00-2
Removal	0138 00-2
Transmission oil drainage:	
Drainage	0137 00-2
Transmission oil pan and filter replacement:	
Installation	0370 00-2
Removal	0370 00-2
Transmission oil pump maintenance:	
Assembly	0374 00-8
Cleaning and inspection	0374 00-6
Disassembly	0374 00-4
Installation	0374 00-10
Removal	0374 00-2
Transmission oil sampling valve replacement:	
Installation	0141 00-2
Removal	0141 00-2
Transmission oil temperature gauge replacement:	
Installation	0096 00-2
Removal	0096 00-2
Transmission oil temperature sensor replacement:	
Installation	0117 00-2
Removal	0117 00-2
Transmission (out-of-vehicle) replacement:	
Installation	0336 00-4
Removal	0336 00-2
Transmission output shaft seal and bearing replacement:	
Installation	0382 00-2
Removal	0382 00-2
Transmission select lever maintenance:	
Assembly	0134 00-4
Disassembly	0134 00-2
Installation	0134 00-4
Removal	0134 00-2
Transmission shift cable maintenance:	
Adjustment	0132 00-2
Installation	0132 00-2
Removal	0132 00-2
Transmission shift tower replacement:	
Installation	0133 00-2
Removal	0133 00-2
Transmission vent line replacement:	
Transmission vent line installation	0136 00-2
Transmission vent line removal	0136 00-2

INDEX (Contd)

<u>Subject</u>	<u>WP Sequence No.-Page No.</u>
<i>T (Contd)</i>	
Transmitter, engine temperature, replacement:	
Installation	0114 00-2
Removal	0114 00-2
Troubleshooting, compressed air and brake system	0014 00-1
Troubleshooting, CTIS	0019 00-1
Troubleshooting, electrical	0012 00-1
Troubleshooting, introduction to (direct support)	0290 00-1
Troubleshooting, introduction to (unit)	0007 00-1
Troubleshooting, mechanical (direct support)	0293 00-1
Troubleshooting, mechanical (unit)	0010 00-1
Troubleshooting symptom index, mechanical, unit	0009 00-1
Troubleshooting symptom index, mechanical, direct support	0292 00-1
Tube, air cleaner indicator and, maintenance:	
Cleaning and inspection	0041 00-4
Installation	0041 00-4
Removal	0041 00-2
Testing	0041 00-2
Tube, engine oil dipstick and, replacement:	
Installation	0030 00-2
Removal	0030 00-2
Tube, engine oil filler, replacement:	
Installation	0031 00-2
Removal	0031 00-2
Tube, fan actuator, maintenance:	
Inspection	0086 00-2
Installation	0086 00-2
Removal	0086 00-2
Tubes, charged air cooler, replacement:	
Installation	0073 00-2
Removal	0073 00-2
Tubes, piston cooling, replacement:	
Installation	0362 00-2
Removal	0362 00-2
Tubes, quick-start, replacement (built after serial no. 504923):	
Installation	0060 00-2
Removal	0060 00-2
Tubes, quick-start, replacement (built before serial no. 504924):	
Installation	0056 00-2
Removal	0056 00-2
Tube, transmission oil dipstick, replacement:	
Installation	0138 00-2
Removal	0138 00-2
Turbine shaft, forward clutch and, maintenance:	
Assembly	0375 00-6
Cleaning and inspection	0375 00-4
Disassembly	0375 00-2
Installation	0375 00-8
Removal	0375 00-2
Turbocharger oil drain tube maintenance:	
Assembly	0042 00-2
Disassembly	0042 00-2
Installation	0042 00-2
Removal	0042 00-2
Turbocharger oil inlet tube replacement:	
Installation	0043 00-2
Removal	0043 00-2

INDEX (Contd)

<u>Subject</u>	<u>WP Sequence No.-Page No.</u>
<i>T (Contd)</i>	
Turbocharger replacement:	
Installation	0325 00-2
Removal	0325 00-2
<i>U</i>	
Unit troubleshooting procedures	0009 00-1
Unit mechanical troubleshooting symptom index	0009 00-1
Unit electrical troubleshooting symptom index	0011 00-1
Universal joint maintenance:	
Assembly	0149 00-4
Cleaning and inspection	0149 00-4
Disassembly	0149 00-2
Upper radiator shroud replacement:	
Installation	0074 00-2
Removal	0074 00-2
Use of the metric system	0001 00-2
<i>V</i>	
Valve, front winch AOAP, replacement:	
Installation	0216 00-2
Removal	0216 00-2
Valve cover replacement:	
Installation	0028 00-2
In-vehicle finishing	0028 00-2
In-vehicle prep	0028 00-2
Removal	0028 00-2
Valve guide maintenance:	
Inspection	0357 00-2
Installation	0357 00-2
Reaming	0357 00-2
Removal	0357 00-2
Valve maintenance:	
Cleaning and inspection	0355 00-4
Facing	0355 00-4
Installation	0355 00-6
Removal	0355 00-2
Valve, modulator, maintenance:	
Assembly	0372 00-2
Cleaning and inspection	0372 00-2
Disassembly	0372 00-2
Installation	0372 00-2
Removal	0372 00-2
Valve, quick-start, and jumper harness replacement (built after serial no. 504923):	
Installation	0059 00-2
Removal	0059 00-2
Valve, proportional, replacement:	
Installation	0160 00-2
Removal	0160 00-2
Valve seat maintenance:	
Cleaning and inspection	0358 00-2
Grinding	0358 00-2
Installation	0358 00-2
Removal	0358 00-2

INDEX (Contd)

<u>Subject</u>	<u>WP Sequence No.-Page No.</u>
<i>V (Contd)</i>	
Valve, wheel, CTIS, repair:	
Assembly	0177 00-4
Cleaning and inspection	0177 00-4
Disassembly	0177 00-4
Installation	0177 00-6
Removal	0177 00-2
Vent line, transmission, replacement:	
Transmission vent line installation	0136 00-2
Transmission vent line removal	0136 00-2
Vent lines, fuel, replacement:	
Installation	0049 00-2
Removal	0049 00-2
Vent valve, front winch hydraulic, maintenance:	
Inspection	0217 00-2
Installation	0217 00-2
Removal	0217 00-2
Vibration damper replacement:	
Installation	0303 00-2
Removal	0303 00-2
<i>W</i>	
Warranty information	0001 00-2
Water hoses, swingfire heater, replacement:	
Installation	0261 00-2
Removal	0261 00-2
Water jacket, swingfire heater, replacement:	
Installation	0260 00-2
Removal	0260 00-2
Water pump drivebelt maintenance:	
Adjustment	0081 00-2
Inspection	0081 00-2
Installation	0081 00-2
Removal	0081 00-2
Water pump repair:	
Assembly	0388 00-2
Cleaning and inspection	0388 00-2
Disassembly	0388 00-2
Water pump replacement:	
Installation	0080 00-6
Removal	0080 00-2
Water regulator housing replacement:	
Installation	0079 00-2
Removal	0079 00-2
Wheel, tire and, repair:	
Assembly	0175 00-4
Cleaning, inspection, and repair	0175 00-4
Disassembly	0175 00-2
Wheel, tire and, replacement:	
Installation	0174 00-3
Removal	0174 00-2

INDEX (Contd)

<u>Subject</u>	<u>WP Sequence No.-Page No.</u>
<i>W (Contd)</i>	
Wheel valve, CTIS, repair:	
Assembly	0177 00-4
Cleaning and inspection	0177 00-4
Disassembly	0177 00-4
Installation	0177 00-6
Removal	0177 00-2
Winch, front, maintenance:	
Automatic winch brake adjustment	0225 00-10
Automatic winch brake testing	0225 00-8
Drag brake adjustment	0225 00-6
Drag brake testing	0225 00-6
Installation	0225 00-4
Removal	0225 00-2
Winch, front, operation	0005 00-3
Winch reservoir breather replacement:	
Installation	0266 00-2
Removal	0266 00-2
Windshield arm, window, and handle replacement:	
Arm installation	0206 00-2
Arm removal	0206 00-2
Handle installation	0206 00-2
Handle removal	0206 00-2
Window installation	0206 00-2
Window removal	0206 00-2
Windshield assembly maintenance:	
Assembly	0205 00-2
Disassembly	0205 00-2
Installation	0205 00-2
Removal	0205 00-2
Windshield glass replacement:	
Installation	0352 00-2
Removal	0352 00-2
Windshield wiper blade and arm replacement:	
Installation	0235 00-2
Removal	0235 00-2
Windshield wiper idler shaft and housing replacement:	
Installation	0234 00-2
Removal	0234 00-2
Windshield wiper switch, motor, and conlink covers replacement:	
Installation	0232 00-2
Removal	0232 00-2
Winterfront radiator cover replacement:	
Installation	0246 00-2
Removal	0246 00-2
Wiper motor wiring harness replacement:	
Installation	0127 00-2
Removal	0127 00-2
Wiring diagrams introduction	0386 00-1
Wiring harness, front, replacement:	
Installation	0330 00-18
Removal	0330 00-2
Wiring harness, rear lighting, replacement:	
Installation	0126 00-4
Removal	0126 00-2

INDEX (Contd)

Subject

WP Sequence No.-Page No.

W (Contd)

Wiring harness, rear, replacement:

Installation 0332 00-6
Removal 0332 00-2

Wiring harness, STE/ICE-R, replacement:

Installation 0331 00-8
Removal 0331 00-2



THEN . . . JOT DOWN THE DOPE ABOUT IT ON THIS FORM. CAREFULLY TEAR IT OUT. FOLD IT AND DROP IT IN THE MAIL!

SOMETHING WRONG

WITH THIS PUBLICATION?

FROM: (PRINT YOUR UNIT'S COMPLETE ADDRESS)

596th Mt
CMR 440
APO AE 09175

DATE SENT

4-1-01

PUBLICATION NUMBER

TM 9-2320-386-24-1-1

PUBLICATION DATE

1 MAY 01

PUBLICATION TITLE

UNIT, DS AND GS 2-1/2-TON,
6X6, M44A3 (ESP)

BE EXACT. . . PIN-POINT WHERE IT IS

IN THIS SPACE TELL WHAT IS WRONG AND WHAT SHOULD BE DONE ABOUT IT:

PAGE NO.	PARA-GRAPH	FIGURE NO.	TABLE NO.
----------	------------	------------	-----------

010600-1 WP
0106 00

Materials / Parts problem
 In the Materials / Parts section of the initial setup, the incorrect amount of lockwashers is listed. There is an additional lockwasher not listed in the list that is used between the angle bracket and rear composite light.
 Corrective Action
 Add the necessary lockwasher to the Materials / list.

SAMPLE

PRINTED NAME, GRADE OR TITLE, AND TELEPHONE NUMBERS

John Doe, SSG 348-6549

SIGN HERE:

John Doe

SAMPLE

FILL IN YOUR
UNIT'S ADDRESS



FOLD BACK

DEPARTMENT OF THE ARMY

TEAR ALONG PERFORATED LINE

AMSTA-LC-CI/TECH PUBS, TACOM-RI
1 ROCK ISLAND ARSENAL
ROCK ISLAND, IL 61299-7630

FILL IN YOUR
UNIT'S ADDRESS



FOLD BACK

DEPARTMENT OF THE ARMY

TEAR ALONG PERFORATED LINE

AMSTA-LC-CI/TECH PUBS, TACOM-RI
1 ROCK ISLAND ARSENAL
ROCK ISLAND, IL 61299-7630

By Order of the Secretary of the Army:

ERIC K. SHINSEKI
General, United States Army
Chief of Staff

Official:

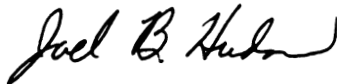

JOEL B. HUDSON
Administrative Assistant to the
Secretary of the Army
0001802

By Order of the Secretary of the Air Force:

RONALD R. FOGLEMAN
General, United States Air Force
Chief of Staff

Official:

HENRY VICCELLIO, JR.
General, United States Air Force
Commander, Air Force Materiel Command

Distribution:

To be distributed in accordance with the initial distribution number (IDN) 381005, requirements for TM 9-2320-386-24-1-1.

THE METRIC SYSTEM AND EQUIVALENTS

LINEAR MEASURE

- 1 Centimeter = 10 Millimeters = 0.01 Meters = 0.3937 Inches
- 1 Meter = 100 Centimeters = 1,000 Millimeters = 39.37 Inches
- 1 Kilometer = 1,000 Meters = 0.621 Miles

SQUARE MEASURE

- 1 Sq Centimeter = 100 Sq Millimeters = 0.155 Sq Inches
- 1 Sq Meter = 10,000 Sq Centimeters = 10.76 Sq Feet
- 1 Sq Kilometer = 1,000,000 Sq Meters = 0.386 Sq Miles

CUBIC MEASURE

- 1 Cu Centimeter = 1,000 Cu Millimeters = 0.06 Cu Inches
- 1 Cu Meter = 1,000,000 Cu Centimeters = 35.31 Cu Feet

LIQUID MEASURE

- 1 Milliliter = 0.001 Liters = 0.0338 Fluid Ounces
- 1 Liter = 1,000 Milliliters = 33.82 Fluid Ounces

TEMPERATURE

- $5/9 (^{\circ}\text{F} - 32) = ^{\circ}\text{C}$
- 212° Fahrenheit is equivalent to 100° Celsius
- 90° Fahrenheit is equivalent to 32.2° Celsius
- 32° Fahrenheit is equivalent to 0° Celsius
- $9/5 ^{\circ}\text{C} + 32 = ^{\circ}\text{F}$

WEIGHTS

- 1 Gram = 0.001 Kilograms = 1,000 Milligrams = 0.035 Ounces
- 1 Kilogram = 1,000 Grams = 2.2 Lb
- 1 Metric Ton = 1,000 Kilograms = 1 Megagram = 1.1 Short Tons

APPROXIMATE CONVERSION FACTORS

<i>TO CHANGE</i>	<i>TO</i>	<i>MULTIPLY BY</i>
Inches	Centimeters	2.540
Feet	Meters	0.305
Yards	Meters	0.914
Miles	Kilometers	1.609
Square Inches	Square Centimeters	6.451
Square Feet	Square Meters	0.093
Square Yards	Square Meters	0.836
Square Miles	Square Kilometers	2.590
Acres	Square Hectometers	0.405
Cubic Feet	Cubic Meters	0.028
Cubic Yards	Cubic Meters	0.765
Fluid Ounces	Milliliters	29.573
Pints	Liters	0.473
Quarts	Liters	0.946
Gallons	Liters	3.785
Ounces	Grams	28.349
Pounds	Kilograms	0.454
Short Tons	Metric Tons	0.907
Pound-Feet	Newton-Meters	1.356
Pounds Per Square Inch	Kilopascals	6.895
Miles Per Gallon	Kilometers Per Liter	0.425
Miles Per Hour	Kilometers Per Hour	1.609
<i>TO CHANGE</i>	<i>TO</i>	<i>MULTIPLY BY</i>
Centimeters	Inches	0.394
Meters	Feet	3.280
Meters	Yards	1.094
Kilometers	Miles	0.621
Square Centimeters	Square Inches	0.155
Square Meters	Square Feet	10.764
Square Meters	Square Yards	1.196
Square Kilometers	Square Miles	0.386
Square Hectometers	Acres	2.471
Cubic Meters	Cubic Feet	35.315
Cubic Meters	Cubic Yards	1.308
Milliliters	Fluid Ounces	0.034
Liters	Pints	2.113
Liters	Quarts	1.057
Liters	Gallons	0.264
Grams	Ounces	0.035
Kilograms	Pounds	2.205
Metric Tons	Short Tons	1.102
Newton-Meters	Pound-Feet	0.738
Kilopascals	Pounds Per Square Inch	0.145
Kilometers Per Liter	Miles Per Gallon	2.354
Kilometers Per Hour	Miles Per Hour	0.621

