

***TM 5-5420-202-10**

TECHNICAL MANUAL

OPERATOR'S MANUAL

FOR

**LAUNCHER, M48A5 TANK CHASSIS
NSN 5420-01-076-6096 (EIC: ARE)
LAUNCHER, M60A1 TANK CHASSIS
NSN 5420-00-889-2020 (EIC: ARC)
TRANSPORTING FOR BRIDGE
ARMORED-VEHICLE LAUNCHED:
SCISSORING-TYPE, CLASS 60 OR CLASS 70**



*Supersedes TM 5-5420-202-10, 30 August 1985, including all changes.

DISTRIBUTION STATEMENT A – Approved for public release, distribution is unlimited.

HEADQUARTERS, DEPARTMENT OF THE ARMY

DECEMBER 2009

WARNING SUMMARY

INTRODUCTION

The following safety and hazardous materials warnings appear throughout this manual. Review these warnings to ensure that you understand them and can apply them during operation and maintenance of the equipment. Failure to comply may result in personnel injury or death.

FIRST AID

For first aid, refer to FM 4-25.11, First Aid.

WARNING SUMMARY - CONTINUED

EXPLANATION OF GENERAL SAFETY WARNING ICONS



EAR PROTECTION – Headphones over ears shows that noise level will harm ears.



ELECTRICAL – Electrical wire to arm with electricity symbol running through human body shows that shock hazard is present.



ELECTRICAL – Electrical wire to hand with electricity symbol running through hand shows that shock hazard is present.



FALLING PARTS – Arrow bouncing off human shoulder and head shows that falling parts present a danger to life or limb.



FLYING PARTICLES – Arrows bouncing off face shows that particles flying through the air will harm face.



FLYING PARTICLES – Arrows bouncing off face with face shield shows that particles flying through the air will harm face.



FORDING – Human figure in water level over mouth shows a risk of drowning.



HEAVY OBJECT – Human figure stooping over heavy object shows physical injury potential from improper lifting technique.



HEAVY PARTS – Hand with heavy object on top shows that heavy parts can crush and harm.

WARNING SUMMARY - CONTINUED



HEAVY PARTS – Foot with heavy object on top shows that heavy parts can crush and harm.



HEAVY PARTS – Heavy object on human figure shows that heavy parts present a danger to life or limb.



HEAVY PARTS – Heavy object pinning human figure against wall shows that heavy, moving parts present a danger to life or limb.



HELMET PROTECTION – Arrow bouncing off head with helmet shows that falling parts present a danger.



HOT AREA – Hand over object radiating heat shows that part is hot and can burn.



MOVING PARTS – Human figure with an arm caught between gears shows that the moving parts of the equipment present a danger to life or limb.



MOVING PARTS – Hand with fingers caught between gears shows that the moving parts of the equipment present a danger to life or limb.



MOVING PARTS – Hand with fingers caught between rollers shows that the moving parts of the equipment present a danger to life or limb.

WARNING SUMMARY - CONTINUED



SHARP OBJECT – Pointed object in hand shows that a sharp object presents a danger to limb.



SHARP OBJECT – Pointed object in foot shows that a sharp object presents a danger to limb.

GENERAL SAFETY WARNING DESCRIPTION

WARNING



Entering water over 4 ft deep may cause water to enter the crew compartment causing electrical shock hazard and drowning hazard. DO NOT enter water over 4 ft deep. If vehicle is accidentally submerged, exit vehicle immediately. Notify field maintenance. Failure to comply may result in personnel injury or death, or equipment damage.

WARNING



- The cupola cover is heavy. Personnel may be injured if the cover is allowed to move freely during vehicle movement. Ensure that the cover is locked in the open or closed position during vehicle movement. Do not release the safety latch when the vehicle is moving. Failure to comply may result in personnel injury or death.
- If the cupola cover is closed, personnel may hit their head on the cover while raising the seat. Raise the seat slowly when the cupola cover is closed. Failure to comply may result in personnel injury or death.

WARNING



Escape hatch is heavy and may drop if control lever is moved. Do not move control lever clockwise or counterclockwise (open position). Failure to comply may result in personnel injury or death.

WARNING SUMMARY - CONTINUED

WARNING



Vehicle may move suddenly if brakes are not applied when shifting out of N (Neutral). Apply brakes when shifting out of N to another range. Failure to comply may result in personnel injury or death.

WARNING



Commander may be thrown from seat when navigating an obstruction. When approaching an obstruction, warn commander to brace for possible impact and adjust vehicle speed and direction so that vehicle can meet the obstruction as squarely as possible. Failure to comply may result in personnel injury or death.

WARNING



Hearing loss may occur with repeated exposure to high noise levels. Personnel must wear hearing protection when the engine is running. Double hearing protection (helmet and earplugs) is required when operating the vehicle at speeds of 15 mph and above. Failure to comply may result in personnel injury.

WARNING



Excessive towing speed is hazardous and may cause loss of vehicle control. DO NOT exceed speed limit when towing vehicle with tow bar or tow cables. Loss of vehicle control may result. Failure to comply may result in personnel injury or death.

WARNING SUMMARY - CONTINUED

WARNING



Vehicle will become unstable and may overturn or roll if driven on a grade exceeding 30 percent. DO NOT attempt to drive the vehicle on a grade exceeding 30 percent. Failure to comply may result in personnel injury or death.

WARNING

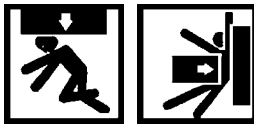

Shifting from L (Low) to R (Reverse) or from R to L while the vehicle is in motion may cause transmission/engine damage and result in steering loss. DO NOT shift transmission from L to R or from R to L while the vehicle is in motion. Failure to comply may result in personnel injury or death, or equipment damage.

WARNING



Exceeding slope limits during bridge launch may cause the vehicle to become unstable and overturn or roll. DO NOT exceed uphill, downhill, or side slope limits when launching the bridge. Failure to comply may result in personnel injury or death, or equipment damage.

WARNING



Actuating ejection cylinders with the bridge improperly positioned could result in failure of the bridge. Ensure bridge is properly positioned before attempting to launch. Failure to comply may result in personnel injury, death, or equipment damage.

WARNING SUMMARY - CONTINUED

WARNING



- If vehicle is operated with cupola cover open, operator may be hit or decapitated by moving hatch. During bridge launch and retrieval operations the operator must be inside the vehicle with the cupola cover closed. Failure to comply may result in personnel injury or death.
- Bridge may shift or fall if a system failure occurs. All personnel must stand clear of the vehicle during launch and retrieval. Failure to comply may result in personnel injury or death.

WARNING



Grille doors are heavy and may cause injury to personnel. Keep feet clear of grille doors when opening. Failure to comply may result in personnel injury.

WARNING



Rear exhaust doors, exhaust pipes, and shroud may be hot. Allow engine to cool a minimum of one hour before opening rear exhaust doors, removing exhaust pipes, or removing transmission shroud. Failure to comply may result in personnel injury or death.

WARNING



Transmission shroud is 80 lb (36.3 kg). To prevent injury, two persons are required to lift shroud. Failure to comply may result in personnel injury or death.

WARNING SUMMARY - CONTINUED

WARNING



A high-pressure oil stream may pierce body and cause injury. When connecting or disconnecting quick-disconnect couplings or relieving pressure from couplings, wear protective goggles and cover coupling with a rag to control spray. Failure to comply may result in personnel injury or death.

WARNING



Grease could spray from relief valve pin when lifted. Wear protective goggles and cover relief valve pin and screwdriver with rag to prevent grease from getting into eyes. Failure to comply may result in personnel injury.

WARNING



Compressed air used for cleaning purposes must not exceed 30 psi (207 kPa). Use only with effective chip guarding and personal protective equipment (goggles/shield, gloves, etc.). Failure to comply may result in personnel injury or death.

WARNING



Final drive hubs, roadwheel or compensating idler wheel hubs, and track support hubs may be hot. Use caution when checking the hubs. Gloves should be used when touching or handling hubs. Failure to comply may result in personnel injury.

WARNING SUMMARY - CONTINUED

WARNING



Track may suddenly separate when lifting with crowbar. Crew member holding up track with crowbar must stand to side of track, not in front of track. DO NOT allow personnel in front of track. Track may suddenly separate. Failure to comply may result in personnel injury or death.

WARNING



- Escape hatch is heavy and may fall. Never crawl under vehicle when removing escape hatch. Keep clear of vehicle when hatch is being raised or lowered. Hatch may fall. Failure to comply may result in personnel injury or death.
- DO NOT work on hatch when supported only by lift jack. Always use blocks or proper stands to support hatch prior to any work. Failure to comply may result in personnel injury or death.

WARNING



Personnel may be struck or pinned by moving vehicle when performing vehicle maintenance. Ensure personnel are clear of vehicle. Use ground guide to direct movement of track. Failure to comply may result in personnel injury or death.

WARNING



Electrical shock or death could occur when removing an antenna during a storm. DO NOT attempt to remove antenna during a storm. Failure to comply may result in personnel injury or death.

WARNING SUMMARY - CONTINUED

WARNING



Personnel may be struck or pinned by uncontrolled vehicle movement. Block vehicle tracks with chock blocks to prevent uncontrolled vehicle movement. Failure to comply may result in personnel injury or death.

WARNING



Overcharged batteries could explode. If battery-generator indicator is showing in bright red, immediately stop engine. Failure to comply may result in personnel injury or death.

WARNING



An installed battery can overheat and may explode when vehicle power is used. Remove viewer battery from viewer and store in viewer stowage box before connecting power cable. Failure to comply may result in personnel injury or death.

WARNING



A flooded heater can explode. DO NOT attempt to restart heater more than one time with ON-LO switch, heater may be flooded. Failure to comply may result in personnel injury or death.

WARNING



Electrical shock may occur when slave starting vehicles if any battery is missing or damaged or cables are defective. DO NOT attempt to slave start vehicle if any battery is missing or damaged. DO NOT use defective cables for slave starting. Failure to comply may result in personnel injury or death, or equipment damage.

WARNING SUMMARY - CONTINUED

WARNING



Discharging of grenades could occur if grenades are present in dischargers. Ensure grenades are not present in grenade dischargers to prevent injury by accidental discharge. Failure to comply may result in personnel injury or death.

WARNING



Smoke grenades contain red phosphorous (RP) and are explosive. If grenades are dropped, heated, thrown, tumbled, or dragged, an explosion may result. Follow standard weapon-loading procedures when handling and loading smoke grenades. Have a manned fire extinguisher handy. Do not allow flames or sparks within area while stowing ammunition. Disassembly of ammunition is not authorized. Failure to comply may result in personnel injury or death, or equipment damage.

WARNING



The explosive in primers and fuses is sensitive to shock and high temperatures. If ammunition is dropped, heated, thrown, tumbled, or dragged, an explosion may result. Ammunition-carrying explosives must be handled with care at all times. Keep ammunition away from heaters. Disassembly of ammunition is not authorized. Failure to comply may result in personnel injury or death, or equipment destruction.

WARNING



An explosion may occur if discharger or grenade contains sand, mud, moisture, frost, snow, ice, grease, or other foreign matter. Before loading grenade into the discharger, ensure each part is free of sand, mud, moisture, frost, snow, ice, grease, or other foreign matter. Failure to comply may result in personnel injury or death.

WARNING SUMMARY - CONTINUED

WARNING



An explosion or discharge may occur when loading discharger. Ensure grenade power switch is OFF (lamp not lit) before loading discharger. DO NOT place any part of body in front of dischargers when loading grenades or when dischargers are loaded. Failure to comply may result in personnel injury, death, or equipment destruction.

WARNING



Damaged grenades may explode. DO NOT use grenades that have external cracks, dents, or other deformities. Disassembly of grenades is not authorized. Place damaged grenades in storage/shipping containers and dispose of in accordance with local regulations. Failure to comply may result in personnel injury or death, or equipment destruction.

WARNING



A misfire or dud has the potential to explode. DO NOT touch a dud smoke grenade. When a misfire or dud occurs, all personnel must remain a minimum of 219 yd (200 m) from vehicle for a minimum of 5 minutes after final attempt to fire. Crew must remain in vehicle with hatches closed. Notify Explosive Ordnance Disposal (EOD) personnel and give type, quantity, and precise location of dud grenades. Failure to comply may result in personnel injury or death.

WARNING



Fire may cause early explosion of explosive ammunition. Cover must be taken immediately. All personnel must remain a minimum of 657 yd (600 m) from grenade pile for a minimum of 5 minutes after attempt to destroy grenades. Failure to comply may result in personnel injury or death, or equipment damage.

WARNING SUMMARY—Continued

WARNING



If fired into gusty winds, particles of a detonated L8A1 grenade may blow back into the vehicle and cause a fire. Crew must remain in vehicle with hatch closed. Failure to comply may result in personnel injury or death, or equipment damage.

WARNING



Firing grenades while launching bridge could cause the grenade to strike the bridge and launching mechanism, causing a fire. DO NOT fire smoke grenades while launching bridge. Failure to comply may result in personnel injury or death, or equipment damage.

WARNING



Frostbite to cheekbone area of face may be experienced by wearers of the M25A1 protective mask from subfreezing air delivered by gas particulate filter unit. DO NOT connect protective mask to filter unit hose unless existing air temperature is well above freezing. Failure to comply may result in personnel injury or death.

WARNING



Leaking fuel could cause a fire. If fuel leak or exhaust leak is present, do not operate personnel heater until repairs are made. Failure to comply may result in personnel injury or death.

WARNING SUMMARY - CONTINUED

EXPLANATION OF HAZARDOUS MATERIALS ICONS



BIOLOGICAL – Abstract symbol bug shows that a material may contain bacteria or viruses that present a danger to life or health.



CHEMICAL – Drops of liquid on hand shows that the material will cause burns or irritation to human skin or tissue.



CRYOGENIC – Hand in block of ice shows that the material is extremely cold and can injure human skin or tissue.



EXPLOSION – Rapidly expanding symbol shows that the material may explode if subjected to high temperatures, sources of ignition, or high pressure.



EXPLOSION – Rapidly expanding symbol shows that the material may explode if subjected to high temperatures, sources of ignition, or high pressure.



EYE PROTECTION – Person with goggles shows that the material will injure the eyes.



FIRE – Flames shows that a material may ignite and cause burns.



RADIATION – Three circular wedges shows that the material emits radioactive energy and can injure human tissue.



VAPOR – Human figure in a cloud shows that material vapors present a danger to life or health.

WARNING SUMMARY - CONTINUED**HAZARDOUS MATERIALS WARNING DESCRIPTION****WARNING**

- Battery acid (electrolyte) and corrosion can cause serious burns. Safety goggles and acid resistant rubber gloves must be worn when working around batteries. If electrolyte or corrosion make contact with skin, eyes, or clothing, immediately flush contacted area with water and obtain medical attention. Failure to comply may result in personnel injury or death.
- Batteries may give off explosive gasses. DO NOT smoke, use open flame, make sparks, or create other ignition sources around the battery. Failure to comply may result in personnel injury or death.
- Personnel may be burned if jewelry or a tool contacts a battery terminal. Remove all jewelry such as rings, ID tags, watches, etc. Failure to comply may result in personnel injury or death.

WARNING

- Carbon monoxide is a colorless, odorless, deadly poisonous gas which, when breathed, deprives the body of oxygen and causes suffocation. Exposure to carbon monoxide produces symptoms of headache, dizziness, loss of muscular control, apparent drowsiness, and coma. Permanent brain damage and death may result.
- Carbon monoxide occurs in exhaust fumes and can become dangerously concentrated under conditions of inadequate ventilation. The following precautions must be observed during operation of the AVL B:
 - DO NOT operate heater or engine in enclosed areas.
 - DO NOT drive the vehicle with inspection plates or cover plates removed.
 - DO NOT sleep in the vehicle with the heater running or the engine idling.
 - BE ALERT for exhaust fumes and symptoms of carbon monoxide exposure. If either is present evacuate the vehicle and ventilate the personnel compartments.
 - BE AWARE the gas particulate filter and M25A1 tank mask WILL NOT protect against carbon monoxide poisoning.

WARNING SUMMARY - CONTINUED

WARNING



Degreasing solvent (MIL-PRF-680) is flammable and may cause irritation to the eyes or skin. Use in well-ventilated areas and keep away from heat and open flame. Wear protective goggles and clothing. If solvent comes in contact with eyes, flush immediately with water. If solvent comes in contact with skin, wash with soap and water. Failure to comply may result in personnel injury, illness, or death.

WARNING



FRH fluid may cause irritation to the eyes and skin. Avoid contact with eyes, skin, and clothing. Wear protective goggles, gloves, and clothing. If FRH comes in contact with eyes or skin, flush area with water. Failure to comply may result in personnel injury or illness.

WARNING



- Fuel is very flammable and can explode easily. Do not work on fuel system when engine is hot. Fuel can be ignited by a hot engine. Keep fuel away from open flame or spark (ignition source). Keep a B-C fire extinguisher within easy reach when working with fuel or on a fuel system. Failure to comply may result in personnel injury or death.
- Clean fuel tank to purge any flammable liquid or vapors before welding, grinding, or using any heat-producing device near the fuel tank. Post "NO SMOKING WITHIN 50 FEET" signs when working with open fuel, fuel lines, or fuel tanks. Failure to comply may result in personnel injury or death.
- When refueling, stop vehicle, shut down engine, and apply parking brake. Ensure no open flame is near area. DO NOT smoke. Never add fuel with engine running. DO NOT have driver seated when adding fuel. After fuel is added, securely close reservoir cap. A loose cap can cause a fuel leak and is a fire hazard. Before starting vehicle, check that no fuel is spilled on or around vehicle. Fuel and oil are slippery and can cause falls. To avoid injury, wipe up spilled fuel or oil with rags. Failure to comply may result in personnel injury or death.

WARNING SUMMARY - CONTINUED

WARNING



Fire extinguisher agent, carbon dioxide (CO₂) will irritate eyes and throat. Wear protective goggles and avoid contact with fire extinguisher agent. Failure to comply may result in personnel injury or death.

WARNING



Frostbite to cheekbone area of face may be experienced by wearers of the M25A1 protective mask from subfreezing air delivered by gas particulate filter unit. DO NOT connect protective mask to filter unit hose unless existing air temperature is well above freezing. Failure to comply may result in personnel injury or death.

WARNING



Nuclear-Biological-Chemical (NBC) contaminated air filters must be handled and disposed of only by authorized and trained personnel. The unit commander or senior officer in charge of maintenance personnel must ensure that prescribed protective clothing (FM 3-11.4) is used and prescribed safety measures and decontamination procedures (FM 3-11.5) are followed. The local unit SOP is responsible for final disposal of contaminated air filters. Failure to comply may result in personnel injury or death.

WARNING



Silicone compounds are harmful to skin and clothing, can burn easily, and may give off a harmful vapor. If compounds contact eyes, wash immediately with water. Wash with soap and water if compounds contact skin. Use adhesives, solvents, sealing, and insulating compounds in well-ventilated areas away from open flame. Failure to comply may result in personnel injury or death.

LIST OF EFFECTIVE PAGES/WORK PACKAGES

NOTE: This manual supersedes TM 5-5420-202-10 dated 30 August 1985. Zero in the "Change No." column indicates an original page or work package.

Date of issue for original manual is:

Original 30 December 2009

TOTAL NUMBER OF PAGES FOR FRONT AND REAR MATTER IS 52 AND THE TOTAL NUMBER OF WORK PACKAGES IN THIS MANUAL IS 79, CONSISTING OF THE FOLLOWING:

Page/WP No.	Change	Page/WP No.	Change
Front Cover.....	0	WP 0035 (2 pgs)	0
Blank	0	WP 0036 (6 pgs)	0
Warning Summary (18 pgs).....	0	WP 0037 (2 pgs)	0
i-xvi	0	WP 0038 (6 pgs)	0
Chp 1 title page	0	Chp 3 title page	0
Blank	0	Blank	0
WP 0001 (4 pgs)	0	WP 0039 (2 pgs)	0
WP 0002 (14 pgs)	0	WP 0040 (8 pgs)	0
WP 0003 (2 pgs)	0	WP 0041 (2 pgs)	0
Chp 2 title page	0	WP 0042 (2 pgs)	0
Blank	0	WP 0043 (4 pgs)	0
WP 0004 (18 pgs)	0	WP 0044 (2 pgs)	0
WP 0005 (4 pgs)	0	WP 0045 (2 pgs)	0
WP 0006 (2 pgs)	0	WP 0046 (4 pgs)	0
WP 0007 (4 pgs)	0	Chp 4 title page	0
WP 0008 (6 pgs)	0	Blank	0
WP 0009 (2 pgs)	0	WP 0047 (2 pgs)	0
WP 0010 (4 pgs)	0	WP 0048 (72 pgs)	0
WP 0011 (12 pgs)	0	Chp 5 title page	0
WP 0012 (4 pgs)	0	Blank	0
WP 0013 (6 pgs)	0	WP 0049 (6 pgs)	0
WP 0014 (4 pgs)	0	WP 0050 (4 pgs)	0
WP 0015 (8 pgs)	0	WP 0051 (4 pgs)	0
WP 0016 (4 pgs)	0	WP 0052 (2 pgs)	0
WP 0017 (10 pgs)	0	WP 0053 (4 pgs)	0
WP 0018 (10 pgs)	0	WP 0054 (4 pgs)	0
WP 0019 (2 pgs)	0	WP 0055 (6 pgs)	0
WP 0020 (10 pgs)	0	WP 0056 (6 pgs)	0
WP 0021 (2 pgs)	0	WP 0057 (8 pgs)	0
WP 0022 (6 pgs)	0	WP 0058 (6 pgs)	0
WP 0023 (10 pgs)	0	WP 0059 (4 pgs)	0
WP 0024 (4 pgs)	0	WP 0060 (4 pgs)	0
WP 0025 (4 pgs)	0	WP 0061 (6 pgs)	0
WP 0026 (2 pgs)	0	WP 0062 (10 pgs)	0
WP 0027 (2 pgs)	0	WP 0063 (4 pgs)	0
WP 0028 (2 pgs)	0	WP 0064 (4 pgs)	0
WP 0029 (4 pgs)	0	WP 0065 (4 pgs)	0
WP 0030 (2 pgs)	0	WP 0066 (12 pgs)	0
WP 0031 (4 pgs)	0	WP 0067 (6 pgs)	0
WP 0032 (10 pgs)	0	WP 0068 (2 pgs)	0
WP 0033 (8 pgs)	0	WP 0069 (2 pgs)	0
WP 0034 (12 pgs)	0	WP 0070 (4 pgs)	0

LIST OF EFFECTIVE PAGES/WORK PACKAGES - CONTINUED

Page/WPNo.	Change
WP 0071 (4 pgs)	0
WP 0072 (6 pgs)	0
WP 0073 (6 pgs)	0
WP 0074 (16 pgs)	0
Chp 6 title page	0
Blank	0
WP 0075 (6 pgs)	0
Chp 7 title page	0
Blank	0
WP 0076 (2 pgs)	0
WP 0077 (22 pgs)	0
WP 0078 (2 pgs)	0
WP 0079 (4 pgs)	0
Index 1-Index 4	0
Blank	0
Metric conversion chart	0
Back cover	0

HEADQUARTERS, DEPARTMENT OF THE ARMY
WASHINGTON, D.C., 30 DECEMBER 2009

TECHNICAL MANUAL

OPERATOR'S MANUAL

FOR

LAUNCHER, M48A5 TANK CHASSIS

NSN 5420-01-076-6096 (EIC: ARE)

LAUNCHER, M60A1 TANK CHASSIS

NSN 5420-00-889-2020 (EIC: ARC)

**TRANSPORTING FOR BRIDGE ARMORED-VEHICLE LAUNCHED: SCISSORING-TYPE,
CLASS 60 OR CLASS 70**

REPORTING ERRORS AND RECOMMENDING IMPROVEMENTS

You can help improve this publication. If you find any errors or if you would like to recommend any improvements to the procedures in this publication, please let us know. The preferred method is to submit your DA Form 2028 (Recommended Changes to Equipment Technical Publications), through the Internet, on the Army Electronic Product Support (AEPS) website. The Internet address is <https://aeeps.ria.army.mil>. The DA Form 2028 is located under the Public Applications section in the AEPS Public Home Page. Fill out the form and click on SUBMIT. Using this form on the AEPS will enable us to respond more quickly to your comments and better manage the DA Form 2028 program. You may also mail, fax, or mail your comments or DA Form 2028 directly to the U.S. Army TACOM Life Cycle Management Command. The postal mail address is U.S. Army TACOM Life Cycle Management Command, ATTN: AMSTA-LCL-MPP / TECH PUBS, 1 Rock Island Arsenal, Rock Island, IL 61299-7630. The email address is tacomlcmc.daform2028@us.army.mil. The fax number is DSN 793-0726. The commercial number is (309) 782-0726.

CURRENT AS OF 15 JULY 2009

*Supersedes TM 5-5420-202-10, 30 August 1985, including all changes.

DISTRIBUTION STATEMENT—Approved for public release, distribution is unlimited.

TABLE OF CONTENTS

Page No.
WP Sequence No.

HOW TO USE THIS MANUAL

CHAPTER 1. GENERAL INFORMATION, EQUIPMENT DESCRIPTION AND THEORY OF OPERATION

GENERAL INFORMATION	WP 0001-1
Figure 1. M48A5 AVLB.	WP 0001-1
Figure 2. M60A1 AVLB.	WP 0001-1
Table 1. List of Abbreviations and Acronyms.	WP 0001-3
EQUIPMENT DESCRIPTION AND DATA	WP 0002-2
Figure 1. Location of AVLB Major Components.	WP 0002-3
Figure 2. Location of AVLB Major Components.	WP 0002-3
Figure 3. Location of AVLB Major Components.	WP 0002-4
Figure 4. Location of AVLB Major Components.	WP 0002-5
Figure 5. Location of AVLB Major Components.	WP 0002-6
Figure 6. M60A1 AVLB Transportation Nameplate.	WP 0002-8
Figure 7. M48A1 AVLB Transportation Nameplate.	WP 0002-9
Figure 8. M60A1 AVLB Transportation Nameplate.	WP 0002-10
Figure 9. M48A5 AVLB Launcher Nameplate.	WP 0002-11
Table 1. AVLB Major Components	WP 0002-2
Table 2. AVLB Major Components	WP 0002-3
Table 3. AVLB Major Components	WP 0002-4
Table 4. AVLB Major Components	WP 0002-5
Table 5. AVLB Major Components	WP 0002-6
Table 6. Equipment Data.	WP 0002-12
THEORY OF OPERATION	WP 0003-1
Figure 1. Armored Vehicle Launched Bridge (AVLB).	WP 0003-1

CHAPTER 2. OPERATOR INSTRUCTIONS

DESCRIPTION AND USE OF OPERATOR'S CONTROLS AND INDICATORS	WP 0004-1
Figure 1. Operator's Controls and Indicators.	WP 0004-1
Figure 2. Operator's Controls and Indicators.	WP 0004-2
Figure 3. Operator's Controls and Indicators.	WP 0004-3
Figure 4. Operator's Controls and Indicators.	WP 0004-4
Figure 5. Operator's Controls and Indicators.	WP 0004-5
Figure 6. Escape Hatch and Drain Valve Levers.	WP 0004-6
Figure 7. Domelight and Ventilation Switches.	WP 0004-6
Figure 8. Fire Extinguisher and Heater Controls M60A1 AVLB	WP 0004-7
Figure 9. Fire Extinguisher and Heater Controls M48A5 AVLB	WP 0004-7
Figure 10. Cupola Cover M60/M48.	WP 0004-8
Figure 11. Night Viewer.	WP 0004-9
Figure 12. Bridge Launching Controls.	WP 0004-10
Figure 13. Indicator Panel.	WP 0004-11
Figure 14. Indicator Panel.	WP 0004-12
Figure 15. Master Control Panel.	WP 0004-13
Figure 16. Master Control Panel.	WP 0004-14
Figure 17. Master Control Panel.	WP 0004-15
Figure 18. Smoke Grenade Launcher Controls.	WP 0004-16
Figure 19. Periscope Door Assembly.	WP 0004-17
Figure 20. Hydraulic Reservoir.	WP 0004-17
Figure 21. Reservoir Filter Indicator.	WP 0004-18

TABLE OF CONTENTS - CONTINUED

	Page No.
	<u>WP Sequence No.</u>
OPERATION UNDER USUAL CONDITIONS - CUPOLA COVER	WP 0005-1
Figure 1. Open/Close Cupola Cover from Outside.	WP 0005-2
Figure 2. Open/Close Cover from Inside.	WP 0005-3
OPERATION UNDER USUAL CONDITIONS - ADJUST SEAT	WP 0006-1
Figure 1. Seat Adjustment.	WP 0006-2
OPERATION UNDER USUAL CONDITIONS - FIXED FIRE EXTINGUISHERS	WP 0007-1
Figure 1. Fire Extinguisher Handles and Switch.	WP 0007-2
Figure 2. Exterior Shot Handles.	WP 0007-3
OPERATION UNDER USUAL CONDITIONS - SERVICE DRIVE LIGHTS	WP 0008-1
Figure 1. Service Drive Lights.	WP 0008-2
Figure 2. High or Low Headlight Beam.	WP 0008-2
Figure 3. Service Stoplight.	WP 0008-3
Figure 4. Blackout Marker Lamps.	WP 0008-3
Figure 5. Blackout Drive Lights.	WP 0008-4
Figure 6. Panel Lights.	WP 0008-5
Figure 7. Dome Lights.	WP 0008-6
OPERATION UNDER USUAL CONDITIONS - DRAIN VALVES	WP 0009-1
Figure 1. Engine and Crew Compartment Drain Valves.	WP 0009-2
OPERATION UNDER USUAL CONDITIONS - PERSONNEL HEATER	WP 0010-1
Figure 1. Personnel Heater.	WP 0010-3
Figure 2. Personnel Heater.	WP 0010-3
OPERATION UNDER USUAL CONDITIONS - AN/VVS-2 NIGHT VISION VIEWER.	WP 0011-1
Figure 1. Night Vision Door.	WP 0011-2
Figure 2. Stowage Box.	WP 0011-2
Figure 3. Snap-On Lens Cover.	WP 0011-3
Figure 4. Viewer.	WP 0011-3
Figure 5. Viewer Installation.	WP 0011-4
Figure 6. Using Vehicle Power.	WP 0011-5
Figure 7. Using Battery Power.	WP 0011-6
Figure 8. Operating AN/VVS-2 Viewer.	WP 0011-7
Figure 9. Removing Night Vision Viewer.	WP 0011-8
Figure 10. Disengaging Viewer.	WP 0011-9
Figure 11. Installing Lens Cover.	WP 0011-9
Figure 12. Stowing Viewer.	WP 0011-10
Figure 13. Night Vision Door.	WP 0011-11
OPERATION UNDER USUAL CONDITIONS - PARKING BRAKE	WP 0012-1
Figure 1. Parking Brake.	WP 0012-2
Figure 2. Parking Brake.	WP 0012-3
OPERATION UNDER USUAL CONDITIONS - SHIFTING TRANSMISSION	WP 0013-1
Figure 1. Neutral.	WP 0013-2
Figure 2. Reverse.	WP 0013-3
Figure 3. Park.	WP 0013-4
Figure 4. Low.	WP 0013-5
Figure 5. High.	WP 0013-5

TABLE OF CONTENTS - CONTINUED

	Page No.
	WP Sequence No.
OPERATION UNDER USUAL CONDITIONS - STEERING VEHICLE	WP 014-1
Figure 1. Forward Left Turn.	WP 014-2
Figure 2. Forward Right Turn.	WP 014-3
Figure 3. Reverse Right Turn.	WP 014-3
Figure 4. Reverse Left Turn.	WP 014-4
Figure 5. Right/Left Pivot Turn.	WP 014-4
OPERATION UNDER USUAL CONDITIONS - STARTING AND STOPPING ENGINE	WP 0015-1
Figure 1. Starting Instructions.	WP 015-2
Figure 2. Powerplant Warning Light.	WP 0015-3
Figure 3. Purge Pump Handle.	WP 015-3
Figure 4. Normal and Cold Weather Starting.	WP 015-4
Figure 5. Manifold Heater Switch.	WP 015-4
Figure 6. Shifting Transmission and Checking Engine Oil Pressure.	WP 0015-5
Figure 7. Engine Indicators.	WP 015-6
Figure 8. Battery-Generator Indicators.	WP 015-7
Figure 9. Air Cleaner Indicator.	WP 015-7
Figure 10. Air Cleaner Indicator.	WP 0015-7
Figure 11. Engine Fuel Shutoff.	WP 0015-8
Figure 12. Drain Valves.	WP 015-8
OPERATION UNDER USUAL CONDITIONS - PLACING VEHICLE IN MOTION AND STOPPING VEHICLE	WP 016-1
Figure 1. Release Parking Brake.	WP 016-2
Figure 2. Steering Vehicle.	WP 016-2
Figure 3. Stopping Vehicle.	WP 016-3
OPERATION UNDER USUAL CONDITIONS - DRIVING VEHICLE.	WP 0017-1
Figure 1. Flat Ground.	WP 017-2
Figure 2. Crossing Ditches, Shell Holes, and Trenches.	WP 0017-3
Figure 3. Operator's Compartment.	WP 017-3
Figure 4. Operator's Compartment.	WP 017-4
Figure 5. Going Over Obstructions.	WP 017-5
Figure 6. Accelerating Uphill.	WP 0017-7
Figure 7. Going Downhill.	WP 0017-8
OPERATION UNDER USUAL CONDITIONS - LAUNCHING BRIDGE	WP 0018-1
Figure 1. Maximum Slope for Bridge Launching.	WP 0018-2
Figure 2. Operator's Controls.	WP 018-3
Figure 3. Launching Bridge and Operator's Controls.	WP 0018-4
Figure 4. Opening Bridge and Partially Extended Bridge.	WP 0018-5
Figure 5. Launching Bridge.	WP 0018-6
Figure 6. Freeing Vehicle of Bridge.	WP 018-7
Figure 7. Retract Ejection Cylinders.	WP 018-8
Figure 8. Clutch Lever.	WP 018-8
Figure 9. Launching Hydraulic Control Levers.	WP 0018-9
Figure 10. Installing Locking Pin.	WP 0018-9
OPERATION UNDER USUAL CONDITIONS - CROSSING BRIDGE	WP 019-1
Figure 1. Crossing Bridge.	WP 019-1

TABLE OF CONTENTS - CONTINUED

	Page No.
	<u>WP Sequence No.</u>
OPERATION UNDER USUAL CONDITIONS - RETRIEVING BRIDGE	WP 0020-1
Figure 1. Locking Pin.	WP 020 -2
Figure 2. Pintle Sockets.	WP 0020-3
Figure 3. Locking Pins.	WP 020 -3
Figure 4. Cap Assemblies.	WP 020 -4
Figure 5. Crew Compartment.	WP 020 -4
Figure 6. Extending Outrigger.	WP 020 -5
Figure 7. Pintle Sockets.	WP 0020-5
Figure 8. Accelerator Locking Lever.	WP 020 -6
Figure 9. Release Handles.	WP 020 -6
Figure 10. Lock Couplings.	WP 020 -7
Figure 11. Retracting Bridge.	WP 020 -8
Figure 12. Locking Pin.	WP 020 -9
Figure 13. Overhead Lever.	WP 020 -9
Figure 14. Turnbuckles.	WP 0020-9
Figure 15. Accelerator Lock.	WP 0020-10
OPERATION UNDER USUAL CONDITIONS - PREVENTING GHOST LAUNCHING OF TONGUE AND OVERHEAD CYLINDER	WP 021 -1
Figure 1. Overhead and Tongue Cylinder Control Levers.	WP 0021-2
OPERATION UNDER USUAL CONDITIONS - AUXILIARY EQUIPMENT	WP 0022-1
Figure 1. Master Battery Switch.	WP 0022-2
Figure 2. Radio Trans Switch.	WP 0022-3
Figure 3. Master Battery Switch.	WP 0022-3
Figure 4. Intercom Set C-2298/VRC.	WP 0022-4
Figure 5. Removing Fire Extinguisher Safety Wire.	WP 0022-5
Figure 6. Empty Fire Extinguisher.	WP 0022-6
OPERATION UNDER USUAL CONDITIONS - M239 SMOKE GRENADE LAUNCHER	WP 0023-1
Figure 1. Grenade Power Switch.	WP 0023-2
Figure 2. Grenade Stowage Box.	WP 023 -3
Figure 3. Loading Dischargers.	WP 023 -4
Figure 4. Grenade Power Switch.	WP 0023-5
Figure 5. Firing Pattern.	WP 023 -6
Figure 6. Fire Smoke Left/Right Pushbuttons.	WP 023 -7
Figure 7. Master Battery Switch.	WP 023 -8
Figure 8. Grenade Stowage Boxes and Dischargers.	WP 0023-9
Figure 9. Ammunition Stowage Boxes and Dischargers.	WP 0023-9
Table 1. Left Pushbutton Pattern.	WP 023 -6
Table 2. Right Pushbutton Pattern	WP 023 -6
OPERATION UNDER USUAL CONDITIONS - ANTENNA REMOVAL AND INSTALLATION	WP 0024-1
Figure 1. Antenna Removal	WP 024 -2
Figure 2. Antenna Installation.	WP 024 -3
OPERATION UNDER USUAL CONDITIONS - TOP DECK GRILLE DOORS.	WP 0025-1
Figure 1. Grille Doors.	WP 0025-2
Figure 2. Grille Doors.	WP 0025-3
OPERATION UNDER UNUSUAL CONDITIONS - EXTREME COLD WEATHER	WP 0026-1
OPERATION UNDER UNUSUAL CONDITIONS - HOT, HUMID, OR SALTY AREAS	WP 0027-1
OPERATION UNDER UNUSUAL CONDITIONS - DUSTY OR SANDY AREAS	WP 0028-1

TABLE OF CONTENTS - CONTINUED

	Page No.
	<u>WP Sequence No.</u>
OPERATION UNDER UNUSUAL CONDITIONS - ENGINE AIR CLEANER INTAKES	WP 0029-1
Figure 1. Removing Air Intake Cover.	WP 0029-2
Figure 2. Installing Air Intake Cover.	WP 0029-3
OPERATION UNDER UNUSUAL CONDITIONS - STOPPING VEHICLE WHEN BRAKES FAIL	WP 0030-1
OPERATION UNDER UNUSUAL CONDITIONS - FORDING	WP 0031-1
Figure 1. Installing Exhaust Plug.	WP 0031-2
Figure 2. Closing Hatches.	WP 0031-2
Figure 3. Engine Air Cleaner Intakes.	WP 0031-3
Figure 4. Master Heater/Battery Switches.	WP 0031-3
OPERATION UNDER UNUSUAL CONDITIONS - SLAVE STARTING.	WP 0032-1
Figure 1. Slave Receptacle Protective Caps.	WP 0032-2
Figure 2. One-Contact and Two-Contact Receptacles.	WP 0032-3
Figure 3. Slave Cables.	WP 0032-3
Figure 4. Vehicle Batteries.	WP 0032-5
Figure 5. Master Battery Switch.	WP 0032-6
Figure 6. Protective Caps.	WP 0032-7
Figure 7. Receptacles.	WP 0032-7
Figure 8. Starter Switch.	WP 0032-8
Figure 9. Battery Indicators.	WP 0032-9
Figure 10. Slave Cable Adapter.	WP 0032-9
Figure 11. Protective Caps.	WP 0032-10
Figure 12. Slave Cables.	WP 0032-10
OPERATION UNDER UNUSUAL CONDITIONS - TOWING A DISABLED VEHICLE	WP 0033-1
Figure 1. Opening Rear Grille Doors/Removing Exhaust Elbow.	WP 0033-3
Figure 2. Quick Disconnect Ring.	WP 0033-5
Figure 3. Universal Joints.	WP 0033-6
Figure 4. Installing Transmission Shroud.	WP 0033-7
Figure 5. Connecting Towing Vehicle.	WP 0033-7
OPERATION UNDER UNUSUAL CONDITIONS - SLAVE-STARTING HYDRAULIC SYSTEM	WP 0034-1
Figure 1. Commander's Cupolas Side by Side.	WP 0034-2
Figure 2. Clutch Lever.	WP 0034-3
Figure 3. Hydraulic Control Levers.	WP 0034-3
Figure 4. Location of Slave Hose Assemblies.	WP 0034-4
Figure 5. Slave Hose Connections.	WP 0034-4
Figure 6. Disconnecting Inlet and Return Hoses on Non-Operating Vehicle.	WP 0034-5
Figure 7. Connecting Slave Hoses on Non-Operating Vehicle.	WP 0034-6
Figure 8. Connecting Slave Hoses on Operating Vehicle.	WP 0034-7
Figure 9. Starting Engine on Operating Vehicle.	WP 0034-7
Figure 10. Setting Accelerator Lock Lever.	WP 0034-8
Figure 11. Disconnecting Slave Hoses on Non-Operating Vehicle.	WP 0034-9
Figure 12. Connecting Return Hose on Non-Operating Vehicle.	WP 0034-10
Figure 13. Connecting Return Hose on Operating Vehicle.	WP 0034-10
Figure 14. Disconnecting Female Inlet Slave Hose on Operating Vehicle.	WP 0034-11
Figure 15. Connecting Inlet Hose on Operating Vehicle.	WP 0034-11
Figure 16. Installing Dust Caps.	WP 0034-12
Figure 17. Stowing Slave Hoses on Vehicle.	WP 0034-12
OPERATION UNDER UNUSUAL CONDITIONS - STORAGE OF SCISSORING BRIDGE	WP 0035-1

TABLE OF CONTENTS - CONTINUED

	Page No.
	<u>WP Sequence No.</u>
OPERATION UNDER UNUSUAL CONDITIONS - GAS PARTICULATE FILTER UNIT	WP 0036-1
Figure 1. Gas Particulate Unit.	WP 0036-3
Figure 2. Gas Particulate Switch.	WP 0036-3
Figure 3. Gas Particulate Filter Unit Hose Connection.	WP 0036-4
Figure 4. Gas Particulate Switch.	WP 0036-5
Figure 5. Master Battery Switch.	WP 0036-5
Figure 6. Disconnecting Particulate Filter Unit Hoses.	WP 0036-6
OPERATION UNDER UNUSUAL CONDITIONS - GAS AND PARTICULATE FILTER CHANGE CRITERIA	WP 0037-1
STOWAGE AND DECAL/DATA PLATE GUIDE	WP 0038-1
Figure 1. M60A1/M48A5 AVLB - Side View.	WP 0038-2
Figure 2. M60A1/M48A5 AVLB - Top View.	WP 0038-3
Figure 3. M60A1/M48A5 AVLB - Operator's Station.	WP 0038-3
Figure 4. M60A1/M48A5 AVLB - Operator's Station.	WP 0038-4
Figure 5. M60A1/ M48A5 AVLB - Commander's Station.	WP 0038-5
 CHAPTER 3. TROUBLESHOOTING PROCEDURES	
TROUBLESHOOTING SYMPTOM INDEX	WP 0039-1
ENGINE TROUBLESHOOTING PROCEDURES.	WP 0040-1
Figure 1. Oil Cooler Screen Location.	WP 0040-5
Figure 2. Dust Detector Warning Lamp	WP 0040-7
Figure 3. Dust Detector Pressure Switches.	WP 0040-1
Table 1. Engine.	WP 0040-1
BRAKES TROUBLESHOOTING PROCEDURES	WP 0041-1
Figure 1. Bellcrank.	WP 0041-2
Table 1. Brakes.	WP 0040-1
VOLTAGE REGULATOR TROUBLESHOOTING PROCEDURES	WP 0042-1
Table 1. Voltage Regulator.	WP 0040-1
LIGHTS TROUBLESHOOTING PROCEDURES	WP 0043-1
Figure 1. Headlight Harness.	WP 0043-1
Figure 2. Taillight Assembly Electrical Connectors.	WP 0043-3
Table 1. Lights	WP 0040-1
STEERING TROUBLESHOOTING PROCEDURES	WP 0044-1
Table 1. Steering	WP 0040-1
PERSONNEL HEATER TROUBLESHOOTING PROCEDURES	WP 0045-1
Figure 1. Heater Master Switch.	WP 0045-1
Figure 2. Airflow Ducts.	WP 0045-1
Table 1. Personnel Heater	WP 0040-1
AUXILIARY SYSTEMS AND CONTROLS PROCEDURES	WP 0046-1
Table 1. Auxiliary Systems and Controls.	WP0040-1
 CHAPTER 4. MAINTENANCE PROCEDURE	
PREVENTIVE MAINTENANCE CHECKS AND SERVICES (PMCS) INTRODUCTION	WP 0047-1

TABLE OF CONTENTS - CONTINUED

	Page No.
	<u>WP Sequence No.</u>
PREVENTIVE MAINTENANCE CHECKS AND SERVICES (PMCS) INSTRUCTIONS	WP 0048-1
Figure 1. External Fire Extinguisher Safety Wire/Lead Seals.	WP 0048-2
Figure 2. Inspect for Hydraulic Fluid Leaks.. . . .	WP 0048-3
Figure 3. Operator's Hatch.. . . .	WP 0048-5
Figure 4. Driver's Escape Hatch.	WP 0048-6
Figure 5. Fire Extinguisher Handle Seal.	WP 0048-7
Figure 6. Internal Fire Extinguisher Cylinders.	WP 0048-7
Figure 7. Control Valve Lead Seal and Shrink Tubing.	WP 0048-8
Figure 8. Seat Adjustment.	WP 0048-8
Figure 9. Brake Pedal.	WP 0048-9
Figure 10. Brake Master Cylinder.	WP 0048-10
Figure 11. Transmission Shift Control Lock.	WP 0048-10
Figure 12. Steering Control.. . . .	WP 0048-11
Figure 13. Gas Particulate Filter.. . . .	WP 0048-12
Figure 14. Powerplant Warning Lamp.	WP 0048-13
Figure 15. Air Cleaner.	WP 0048-14
Figure 16. Accelerator Pedal.	WP 0048-15
Figure 17. Powerplant Warning Lamp.	WP 0048-16
Figure 18. Air Restrictor Indicator.	WP 0048-17
Figure 19. Commander's Hatch.. . . .	WP 0048-18
Figure 20. Commander's Seat.	WP 0048-19
Figure 21. Operator Panel Gauges.	WP 0048-19
Figure 22. Monitor Switch.	WP 0048-20
Figure 23. M60A2 AVLB Personnel Heater.	WP 0048-21
Figure 24. Operator's Controls.	WP 0048-22
Figure 25. Hydraulic Pump Ball Valve (HEU).	WP 0048-22
Figure 26. Interior Hydraulic System.. . . .	WP 0048-24
Figure 27. Launcher Controls.	WP 0048-25
Figure 28. Hold-Down Cylinder.	WP 0048-26
Figure 29. Overhead Cylinder.. . . .	WP 0048-27
Figure 30. Ejection Cylinders.	WP 0048-29
Figure 31. Tongue Cylinder.	WP 0048-30
Figure 32. Locking Plug.	WP 0048-31
Figure 33. Reservoir Air Breather.	WP 0048-32
Figure 34. Filler Cap Removal.	WP 0048-34
Figure 35. Top Deck Grille Doors.	WP 0048-35
Figure 36. MICLIC Support Bracket.	WP 0048-35
Figure 37. Air Cleaner Hoses.	WP 0048-36
Figure 38. Dust Detector Pressure Switch.	WP 0048-37
Figure 39. Engine and Transmission Oil Coolers.	WP 0048-38
Figure 40. Hydraulic Fittings and Hoses.	WP 0048-38
Figure 41. Sprockets.	WP 0048-39
Figure 42. Roadwheels No. 1 and No. 6.	WP 0048-40
Figure 43. Roadwheels.	WP 0048-41
Figure 44. Roadwheel Arm.	WP 0048-42
Figure 45. Shock Absorber.	WP 0048-42
Figure 46. Track Support Roller.	WP 0048-43
Figure 47. Compensating Idler Wheel.	WP 0048-44
Figure 48. Track Center Guides.. . . .	WP 0048-45
Figure 49. Track Pads.	WP 0048-46
Figure 50. End Connectors.. . . .	WP 0048-47
Figure 51. Track Links.	WP 0048-48

TABLE OF CONTENTS - CONTINUED

	Page No.
	<u>WP Sequence No.</u>
Figure 52. End Connector Repair.	WP 0048-48
Figure 53. End Connector Locations.	WP 0048-49
Figure 54. Compensating Idler Wheel.	WP 0048-50
Figure 55. Track Pad.	WP 0048-50
Figure 56. Track Adjusting Link.	WP 0048-51
Figure 57. Grease-Actuated Track Adjusting Link.	WP 0048-52
Figure 58. Pressure Relief Valve.	WP 0048-52
Figure 59. Cylinder Pins and Retaining Rings.	WP 0048-53
Figure 60. Battery Retainer.	WP 0048-55
Figure 61. Checking Battery Electrolyte Level.	WP 0048-57
Figure 62. Fuel Shutoff Handle.	WP 0048-58
Figure 63. Gas Particulate Filter Unit.	WP 0048-59
Figure 64. Gas Particulate Filter Unit Spring Clip.	WP 0048-60
Figure 65. Blackout Marker and Service Drive Headlights.	WP 0048-61
Figure 66. High Beam Indicator.	WP 0048-62
Figure 67. Taillights.	WP 0048-63
Figure 68. Blackout Markers.	WP 0048-64
Figure 69. Sprocket Wear.	WP 0048-65
Figure 70. Portable Fire Extinguisher.	WP 0048-65
Figure 71. Filter Element.	WP 0048-67
Figure 72. Bridge Seat and Pads.	WP 0048-68
Figure 73. Grenade Launcher Power Box.	WP 0048-69
Figure 74. Grenade Launcher.	WP 0048-70
Figure 75. Grenade Launcher.	WP 0048-71
Table 1. Preventive Maintenance Checks and Services	WP 0048-1

CHAPTER 5. MAINTENANCE PROCEDURES

TRACK END CONNECTOR REMOVAL AND INSTALLATION	WP 0049-1
Figure 1. End Connector Hardware.	WP 0049-2
Figure 2. End Connector Removal.	WP 0049-3
Figure 3. Track Fixture Removal.	WP 0049-4
Figure 4. End Connector Installation.	WP 0049-5
TRACK CENTER GUIDE REMOVAL AND INSTALLATION	WP 0050-1
Figure 1. Track Center Guide Removal.	WP 0050-2
Figure 2. Center Guide Installation.	WP 0050-3
TRACK LINK REMOVAL AND INSTALLATION	WP 0051-1
Figure 1. Defective Link.	WP 0051-1
Figure 2. Removing Defective Track Link.	WP 0051-2
Figure 3. Track Link Installation.	WP 0051-2
Figure 4. End Connector Installation.	WP 0051-3
T-142 TRACK PAD REMOVAL AND INSTALLATION	WP 0052-1
Figure 1. Track Pad Removal.	WP 0052-1
Figure 2. Track Pad Removal/Installation.	WP 0052-2
LOOSENING TRACK TENSION - CONVENTIONAL TRACK ADJUSTING LINK	WP 0053-1
Figure 1. Track Adjusting Link.	WP 0053-2
Figure 2. Loosening Track Tension.	WP 0053-2
Figure 3. Measuring Track Drive Sprocket Wear.	WP 0053-3
LOOSENING TRACK TENSION - GREASE-ACTUATED ADJUSTING LINK.	WP 0054-1
Figure 1. Grease-Actuated Adjusting Link.	WP 0054-2
Figure 2. Release Threaded Locking Collar.	WP 0054-3

TABLE OF CONTENTS - CONTINUED

	Page No.
	<u>WP Sequence No.</u>
BREAKING AND CONNECTING TRACK	WP 0055-1
Figure 1. Center Guide and End Connectors.	WP 0055-2
Figure 2. Removing Track Fixture.	WP 0055-3
Figure 3. Lifting Track.	WP 0055-3
Figure 4. Connecting Track.	WP 0055-4
Figure 5. Adjusting Track Fixtures.	WP 0055-4
Figure 6. Remove Center Guide Nut.	WP 0055-5
Figure 7. Engine Fuel Shutoff Switch.	WP 0055-5
Figure 8. Center Guide Nut.	WP 0055-6
TRACK TENSION ADJUSTMENT	WP 0056-1
Figure 1. Positioning Twine Over End Connectors.	WP 0056-2
Figure 2. Wooden Block Placement.	WP 0056-3
Figure 3. Distance Between Bottom of Twine and Top of Marked End Connector.	WP 0056-4
Figure 4. Adjusting Link Locking Screw.	WP 0056-4
Figure 5. Locking Screw Removal.	WP 0056-5
Figure 6. Adjusting Track Tension.	WP 0056-5
Figure 7. Final Track Link Adjustment.	WP 0056-6
THROWN TRACK INSTALLATION	WP 0057-1
Figure 1. Track and Drive Sprocket.	WP 0057-2
Figure 2. FUEL SHUTOFF and MASTER BATTERY Switches.	WP 0057-3
Figure 3. Driving Vehicle onto Track.	WP 0057-3
Figure 4. Stopping Vehicle on Sixteenth Link.	WP 0057-4
Figure 5. Attaching Rope to Center of Link Pin.	WP 0057-4
Figure 6. Pulling Track Using Rope.	WP 0057-5
Figure 7. Guiding Track onto Drive Sprocket.	WP 0057-6
Figure 8. Releasing Brake.	WP 0057-6
Figure 9. Removing Rope from Track.	WP 0057-7
REAR FENDER REMOVAL AND INSTALLATION	WP 0058-1
Figure 1. Removing Fender Angle.	WP 0058-2
Figure 2. Removing Fender and Shield.	WP 0058-3
Figure 3. Installing Fender and Shield.	WP 0058-4
Figure 4. Installing Fender Angle.	WP 0058-5
REFUELING FROM PRESSURIZED SOURCE	WP 0059-1
Figure 1. Fuel Cover.	WP 0059-2
Figure 2. Fuel Filler Cap.	WP 0059-3
Figure 3. Securing Fuel Cover Locking Pin.	WP 0059-3
EMERGENCY REFUELING	WP 0060-1
Figure 1. Fuel Filler Cover Removal.	WP 0060-3
FUEL FILLER CAP MAINTENANCE	WP 0061-1
Figure 1. Fuel Cover.	WP 0061-2
Figure 2. Fuel Filler Cap.	WP 0061-3
Figure 3. Fuel Filler Cap.	WP 0061-3
Figure 4. Fuel Filler Cap.	WP 0061-4
Figure 5. Fuel Filler Cap.	WP 0061-5
Figure 6. Fuel Cover Locking Pin.	WP 0061-5

TABLE OF CONTENTS - CONTINUED

	Page No.
	<u>WP Sequence No.</u>
ISOLATING FUEL TANKS	WP 062-1
Figure 1. Removing and Installing Access Covers.	WP 0062-3
Figure 2. Exhaust Elbow Exploded View.	WP 0062-4
Figure 3. Transmission Shroud Removal.	WP 0062-5
Figure 4. Unlock Left Side Powerplant Guide.	WP 0062-6
Figure 5. Fuel Selector Valve.	WP 0062-6
Figure 6. Lock Left Side Powerplant Guide.	WP 0062-7
Figure 7. Transmission Shroud Installation.	WP 0062-8
Figure 8. Exhaust Pipe Elbow Exploded View.	WP 0062-9
BATTERY MAINTENANCE	WP 0063-1
Figure 1. Battery Retaining Strap and Cover Removal.	WP 0063-2
Figure 2. Battery Electrolyte Inspection.	WP 0063-3
Figure 3. Battery Retaining Strap and Cover Installation.	WP 0063-4
ESCAPE HATCH (M48A5) REMOVAL AND INSTALLATION.	WP 0064-1
Figure 1. Escape Hatch Removal.	WP 0064-2
Figure 2. Escape Hatch Installation.	WP 0064-3
ESCAPE HATCH (M60A1) REMOVAL AND INSTALLATION.	WP 0065-1
Figure 1. Escape Hatch Removal.	WP 0065-2
Figure 2. Escape Hatch Installation.	WP 0065-3
HEADLIGHT, BLACKOUT MARKER, AND TAILLIGHT LAMP REPLACEMENT	WP 0066-1
Figure 1. Headlight Cover Screw Removal.	WP 0066-2
Figure 2. Headlight Cover and Seal Removal.	WP 0066-2
Figure 3. Headlamp Lens Retainer Removal.	WP 0066-3
Figure 4. Headlamp Lens Removal.	WP 0066-3
Figure 5. Headlamp Removal.	WP 0066-4
Figure 6. Headlamp Gasket Removal.	WP 0066-4
Figure 7. Blackout Drive Lamp and Blackout Marker Lamp Removal.	WP 0066-5
Figure 8. Taillight Removal.	WP 0066-6
Figure 9. Headlamp Seal Inspection.	WP 0066-7
Figure 10. Headlamp Installation.	WP 0066-7
Figure 11. Blackout Drive Lamp and Blackout Marker Lamp Installation.	WP 0066-8
Figure 12. Headlamp Lens and Retainer Installation.	WP 0066-9
Figure 13. Headlight Cover and Seal Installation.	WP 0066-9
Figure 14. Headlight Cover Screw Removal.	WP 0066-10
Figure 15. Taillight Installation.	WP 0066-11
MASTER CONTROL PANEL, INSTRUMENT CLUSTER, AND POWERPLANT WARNING LAMP REPLACEMENT.	WP 0067-1
Figure 1. Master Control Panel Lamp Replacement.	WP 0067-2
Figure 2. Instrument Cluster Panel Lamp Replacement.	WP 0067-3
Figure 3. Powerplant Warning Lamp Replacement.	WP 0067-3
Figure 4. Master Control Panel Lamp Replacement.	WP 0067-4
Figure 5. Instrument Cluster Panel Lamp Replacement.	WP 0067-5
Figure 6. Powerplant Warning Lamp Replacement.	WP 0067-5
DUST DETECTOR WARNING LAMP REPLACEMENT	WP 0068-1
Figure 1. Dust Detector Lamp Replacement.	WP 0068-2
SMOKE GRENADE LAUNCHER POWER BOX LAMP REPLACEMENT	WP 0069-1
Figure 1. Smoke Grenade Launcher Power Box Lamp Replacement.	WP 0069-2

TABLE OF CONTENTS - CONTINUED

	<u>Page No.</u>
	<u>WP Sequence No.</u>
HEADLIGHT REMOVAL, STOWAGE, AND INSTALLATION	WP 0070-1
Figure 1. Headlight Removal.	WP 0070-2
Figure 2. Headlight Stowage.	WP 0070-3
Figure 3. Headlight Removal from Stowage.	WP 0070-3
Figure 4. Headlight Installation.	WP 0070-4
ENGINE AIR CLEANER INDICATOR MAINTENANCE	WP 0071-1
Figure 1. Air Cleaner Indicator.	WP 0071-2
Figure 2. Air Cleaner Inspection.. . . .	WP 0071-3
M239 SMOKE GRENADE LAUNCHER MAINTENANCE	WP 0072-1
Figure 1. Smoke Grenade Launcher Power Switch.	WP 0072-2
Figure 2. Discharger Barrels.	WP 0072-2
Figure 3. Cleaning Discharger Barrels.	WP 0072-3
Figure 4. Grenade Discharger Cover.	WP 0072-3
Figure 5. Ammunition Storage Box.	WP 0072-4
Figure 6. Grenade Stowage Box.	WP 0072-5
MAINTENANCE UNDER ADVERSE CONDITIONS	WP 0073-1
Figure 1. Brake Controls.	WP 0073-4
Figure 2. Air Cleaner.	WP 0073-5
LUBRICATION INSTRUCTIONS	WP 0074-1
Figure 1. Launcher, Engine, and Transmission Location.	WP 0074-3
Figure 2. Launcher Hydraulic Level and Fill.	WP 0074-4
Figure 3. Engine Oil Level Dipstick Location.	WP 0074-5
Figure 4. Oil Level Dipstick.	WP 0074-5
Figure 5. Installing Engine Oil Level Dipstick.	WP 0074-6
Figure 6. Transmission Oil Level Dipstick Location.	WP 0074-7
Figure 7. Grenade Launchers, Breather Filter, and Cylinder Plug Location.	WP 0074-8
Figure 8. Tow Cables Location.	WP 0074-10
Figure 9. Hatch Cover Swing and Safety Latch Location.	WP 0074-11
Figure 10. Launcher Tongue and Overhead Cylinder Clevis Location.	WP 0074-12
Figure 11. Launcher Tongue and Overhead Mounting Location.	WP 0074-13
Figure 12. Oil Can Points Location.	WP 0074-14
Table 1. Launcher, Engine, and Transmission Lubricant.	WP 0074-3
Table 2. Grenade Launchers, Breather Filter, and Cylinder Plug Lubricant.	WP 0074-8
Table 3. Tow Cables Lubricant.	WP 0074-10
Table 4. Hatch Cover Swing and Safety Latch Lubricant.	WP 0074-11
Table 5. Launcher Tongue and Overhead Cylinder Clevis Lubricant.	WP 0074-12
Table 6. Launcher Tongue and Overhead Mounting Lubricant.. . . .	WP 0074-13
Table 7. Oil Can Points Lubricant.	WP 0074-14
 CHAPTER 6. AMMUNITION MAINTENANCE	
SMOKE GRENADES - IDENTIFICATION, HANDLING, AND DESTRUCTION	WP 0075-1
Figure 1. Smoke Grenade.	WP 0075-2
Figure 2. Ammunition Markings.	WP 0075-3
 CHAPTER 7. SUPPORTING INFORMATION	
REFERENCES	WP 0076-1
COMPONENTS OF END ITEM (COEI) AND BASIC ISSUE ITEMS (BII) LISTS	WP 0077-1
Table 1. COEI	WP 0077-1
Table 2. BII	WP 0077-6

TABLE OF CONTENTS - CONTINUED

	Page No.
	<u>WP Sequence No.</u>
ADDITIONAL AUTHORIZATION LIST (AAL)	WP 078-1
Table 1. Additional Authorization List.	WP 0078-1
EXPENDABLE AND DURABLE ITEMS LIST	WP 0077-1
Table 1. Expendable and Durable Items List	WP 0079-1
INDEX	Index-1

HOW TO USE THIS MANUAL

INTRODUCTION

You must familiarize yourself with the entire contents of a maintenance task before starting the step-by-step maintenance procedures.

This manual provides general information, operator instructions, and maintenance procedures for the M48A5 and M60A1 Armored Vehicle Launched Bridge (AVLB). It is presented in seven chapters.

A Warning Summary appears at the beginning of this manual. These warnings are repeated at appropriate points throughout the manual. Become familiar with these warnings before using or performing maintenance on the AVLB.

Each chapter is divided into work packages, which are identified by a four-digit number (e.g., 0001, 0002) printed in the upper right corner of each page.

A front cover table of contents is provided for quick reference to chapters and work packages that will be used.

WARNING, CAUTION, and NOTE headings, subject headings, and other essential information are printed in bold type making them easier to see.

Chapter 1 of this manual describes General Information, Equipment Description, and Theory of Operation of the AVLB.

Chapter 2 of this manual covers Operator Instructions including Operator's Controls and Indicators, Operation Under Usual Conditions, and Operation Under Unusual Conditions procedures.

Chapter 3 of this manual covers Troubleshooting Procedures including symptom, malfunction, and corrective action.

Chapter 4 of this manual provides Preventive Maintenance Instructions, including Preventive Maintenance Checks and Services (PMCS), and maintenance procedures.

Chapter 5 of this manual covers Maintenance Instructions.

Chapter 6 of this manual provides Ammunition Maintenance Instructions.

Chapter 7 of this manual covers Supporting Information, including References, Components of End Item (COEI) and Basic Issue Item (BII) lists, Additional Authorization List (AAL), and Expandable/Durable Items List.

The rear matter of this manual contains the Index, Recommended Changes to Equipment Technical Publications DA Form 2028, an Authentication Page, and a Metric Conversion Chart.

All references to other portions of this manual are by work package number. All references to data in other technical manuals (TM) are by TM number only. Take a few minutes to look through this manual. We've designed this manual to make it easier for you to find and perform the procedures required.

Follow these guidelines when using this manual.

The operator must read through this manual and become familiar with the contents before attempting to operate the AVLB.

Read all WARNINGS, CAUTIONS, and NOTES prior to performing any procedure.

CHAPTER 1

**GENERAL INFORMATION, EQUIPMENT DESCRIPTION AND THEORY OF
OPERATION**

FOR

**M48A5 AND M60A1 LAUNCHER AND TANK CHASSIS TRANSPORTING FOR
BRIDGE ARMORED-VEHICLE LAUNCHED: SCISSORING-TYPE, CLASS 60
OR CLASS 70**

OPERATOR MAINTENANCE**GENERAL INFORMATION**

INTRODUCTION

This manual is for use in operating and maintaining the M48A5 Armored Vehicle Launched Bridge (AVLB) and the M60A1 AVLB. These heavily armored vehicles are used for launching and retrieving a scissoring-type Class 60 or Class 70 bridge. The two crew member team consists of an operator and a commander.

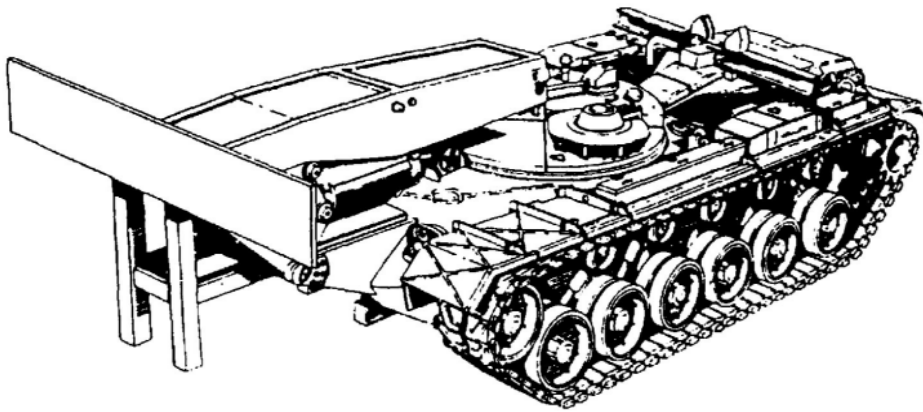

AVLBD002

Figure 1. M48A5 AVLB.

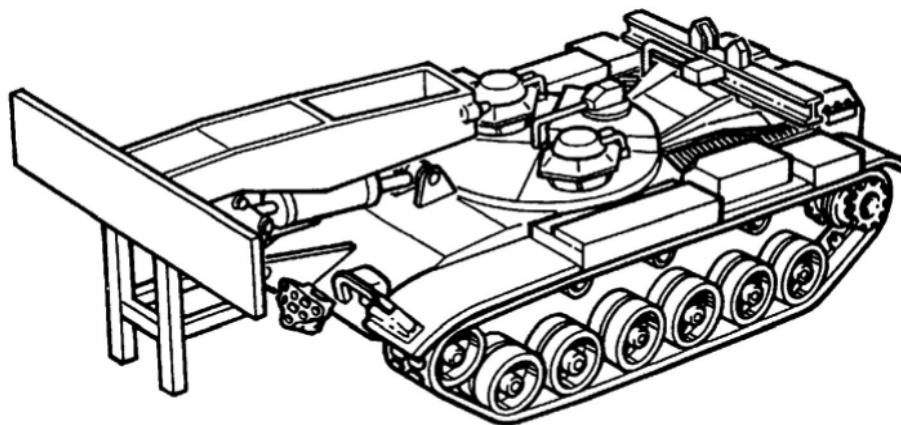

AVLBD001

Figure 2. M60A1 AVLB.

MAINTENANCE FORMS, RECORDS, AND REPORTS

Department of the Army forms and procedures used for equipment maintenance will be those prescribed by PAM 750-8, The Army Maintenance Management System (TAMMS) Users Manual, or AR 700-138, Army Logistics Readiness and Sustainability. A list of forms referenced in this manual is included in WP 0076.

REPORTING EQUIPMENT IMPROVEMENT RECOMMENDATIONS (EIR)

If your AVLB needs improvement, let us know. Send us an EIR. You, the user, are the only one who can tell us what you don't like about your equipment. Let us know why you don't like the design or performance. If you have Internet access, the easiest and fastest way to report problems or suggestions is to go to <https://aeps.ria.army.mil/aepspublic.cfm> (scroll down and choose the "Submit Quality Deficiency Report" bar). The Internet form lets you choose to submit an Equipment Improvement Recommendation (EIR), a Product Quality Deficiency Report (PQDR), or a Warranty Claim Action (WCA). You may also submit your information using an SF 368 (Product Quality Deficiency Report). You can send your SF 368 via e-mail, regular mail, or facsimile using the addresses/facsimile numbers specified in PAM 750-8, The Army Maintenance Management System (TAMMS) Users Manual. We will send you a reply.

CORROSION PREVENTION AND CONTROL (CPC)

Corrosion Prevention and Control (CPC) of Army materiel is a continuing concern. It is important that any corrosion problems with this item be reported so that the problem can be corrected and improvements can be made to prevent the problem in future items.

Corrosion specifically occurs with metals. It is an electrochemical process that causes the degradation of metals. It is commonly caused by exposure to moisture, acids, bases, or salts. An example is the rusting of iron. Corrosion damage in metals can be seen, depending on the metal, as tarnishing, pitting, fogging, surface residue, and/or cracking.

Plastics, composites, and rubbers can also degrade. Thermal (heat), oxidation (oxygen), solvation (solvents), or photolytic (light, typically ultraviolet (UV)) processes cause degradation. Degradation is caused by thermal (heat), oxidation (oxygen), solvation (solvents), or photolytic (light, typically UV) processes. The most common exposures are excessive heat or light. Damage from these processes will appear as cracking, softening, swelling, and/or breaking. SF 368, Product Quality Deficiency Report, should be submitted to the address specified in PAM 750-8, The Army Maintenance Management System (TAMMS) Users Manual.

OZONE DEPLETING SUBSTANCES (ODS)

The use of Class 1 ozone depleting substances (ODS) for new acquisitions has been curtailed by Section 326 of the National Defense Authorization Act of Fiscal Year 1993 (Public Law 102, 484) and related Army policy. Ozone depleting substances are listed in Title VI of the Clean Air Act. For systems procured and fielded prior to the effectiveness of the above law (June 1993) that use a Class 1 ODS, a listing of those substances required to operate and maintain the system shall be included in the manual. This requirement applies to any system procured or fielded after June 1993 that requires the use of a Class 1 ODS, where the use of the ODS has been properly documented and waived. The procuring activity will provide a list of Class 1 ODS on request.

DESTRUCTION OF ARMY MATERIAL TO PREVENT ENEMY USE

Refer to TM 750-244-6 for instructions on destruction of Army materiel to prevent enemy use.

PREPARATION FOR SHIPPING OR STORAGE

Administrative storage procedures shall be in accordance with DA PAM 700-32, Packaging of Army Materiel. The placement of the test set in administrative storage for short periods of time, up to six months, requires no special care or maintenance.

LIST OF ABBREVIATIONS/ACRONYMS

The following alphabetical list gives definitions for the abbreviations and acronyms used in this manual.

Table 1. List of Abbreviations and Acronyms.

AC	Hydrogen Cyanide
AEPS	Army Electronic Product Support
amp	Ampere
AOAP	Army Oil Analysis Program
AVLB	Armored Vehicle Launched Bridge
BII	Basic Issue Items
BO	Blackout
BX	Box
CBR	Chemical-Biological-Radiation
CK	Cyanogen Chloride
CPC	Corrosion Prevention and Control
CTA	Common Table of Allowance
DA	Department of the Army
DDS	Dust Detector System
DIA	Diameter
DR	Drive
EA	Each
EIR	Equipment Improvement Recommendations
EOD	Explosive Ordnance Disposal
FM	Field Manual
gal.	Gallon
GAA	Grease, Automotive Artillery
GMTK	General Mechanic's Tool Kit
gpm	Gallons per Mile
HEU	Hydraulic Electrical Unit
hp	Horsepower
in.	Inch
kPa	Kilopascals
kph	Kilometers per Hour
l	Liter
L	Low
lb	Pound
LO	Lubrication Order
lpm	Liters per Mile
m	Meter
MICLIC	Mine-Clearing Line Charge
MTOE	Modified Table of Organization and Equipment
N	Neutral
NBC	Nuclear-Biological-Chemical
ODS	Ozone Depleting Substances
P	Park
PMCS	Preventive Maintenance Checks and Services
PQDR	Product Quality Deficiency Report
pr	Pair
psi	Pounds per Square Inch
PTO	Power Take-Off
R	Reverse
RP	Red Phosphorous
RPM	Revolutions per Minute

LIST OF ABBREVIATIONS/ACRONYMS - CONTINUED**Table 1. List of Abbreviations and Acronyms - Continued.**

SIG	Signal
SINCGARS	Single Channel Ground and Airborne Radio System
T	Ton
TAMMS	The Army Maintenance Management System
TB	Technical Bulletin
TDA	Table of Distribution and Allowance
TOE	Table of Organization and Equipment
UV	Ultraviolet
VDC	Volts Direct Current
VEDES	Vehicle Exhaust Dust Ejector System
WCA	Warranty Claim Action

END OF WORK PACKAGE

OPERATOR MAINTENANCE
EQUIPMENT DESCRIPTION AND DATA

EQUIPMENT CHARACTERISTICS, CAPABILITIES, AND FEATURES**CHARACTERISTICS**

M60A1 Armored Vehicle Launched Bridge (AVLB) and the M48A5 AVLB launch, retrieve, and transport the scissoring-type bridge.

Capabilities

1. Can be operated in nuclear, biological, or chemical environments.
2. Can be operated on rough ground.
3. Can be forded in water up to 4 ft (1.2 m) deep without special equipment.
4. Can launch or retrieve bridge on uphill or downhill slope of 15 percent or side slope of 8 percent.

Features

1. Quick launch (2 to 5 minutes).
2. Only two persons needed for launch/retrieval of bridge.
3. Heavy armor protection for personnel.

NOTE

If vehicle is equipped with mine-clearing line charge (MICLIC), refer to TM 9-1375-215-13&P for operating instructions.

LOCATION AND DESCRIPTIONS OF MAJOR COMPONENTS**Description**

The vehicles are divided into two sections – hull and launching mechanism. The hull contains the following components:

1. Crew compartment with all controls for operating the launching mechanism.
2. Engine compartment with engine and transmission, which supplies power for operating hull and launching mechanism.
3. Operator and commander cupolas to enter crew compartment.
4. Cupola vision blocks and periscopes for visual operation when openings (hatches) are closed.
5. Bridge seat on which bridge rests during transport.

The launcher mechanism contains the following components:

1. Hydraulic system – pump, fluid, cylinders, hoses, and other parts for moving the bridge, outrigger, and tongue during launch and retrieval.
2. Outrigger – steadies vehicle during bridge launch and retrieval.
3. Tongue – connects vehicle to bridge.

LOCATION AND DESCRIPTIONS OF MAJOR COMPONENTS - CONTINUED

Location

NOTE

Figures 1 through 5 illustrate the M60 AVLB. The M48 is similar because all components detailed in the tables are in the same locations.

The locations of major components are shown in Figure 1 through Figure 5.

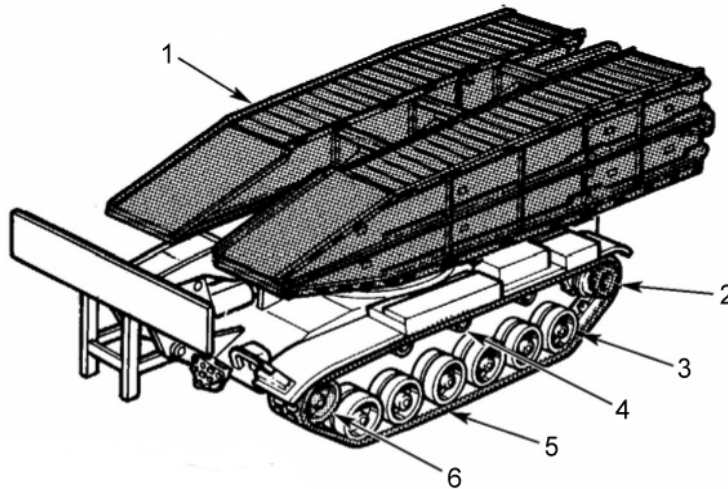

AVLBD003

Figure 1. Location of AVLB Major Components.

Table 1. AVLB Major Components.

ITEM	COMPONENT
1	Bridge
2	Final Drive Sprocket
3	Roadwheel
4	Support Roller (either three or five)
5	Track
6	Compensating Idler Wheel

LOCATION AND DESCRIPTIONS OF MAJOR COMPONENTS - CONTINUED

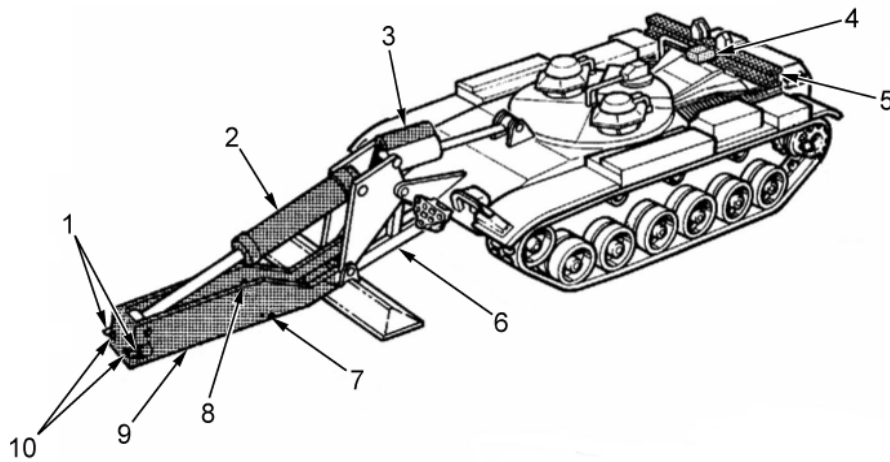

AVLBD004

Figure 2. Location of AVLB Major Components.

Table 2. AVLB Major Components.

ITEM	COMPONENT
1	Pintles
2	Tongue Cylinder
3	Overhead Cylinder
4	Holddown Cylinder
5	Bridge Seat
6	Boom and Outrigger
7	Guide Pin
8	Locking Cylinder
9	Tongue
10	Ejection Cylinders

LOCATION AND DESCRIPTIONS OF MAJOR COMPONENTS - CONTINUED

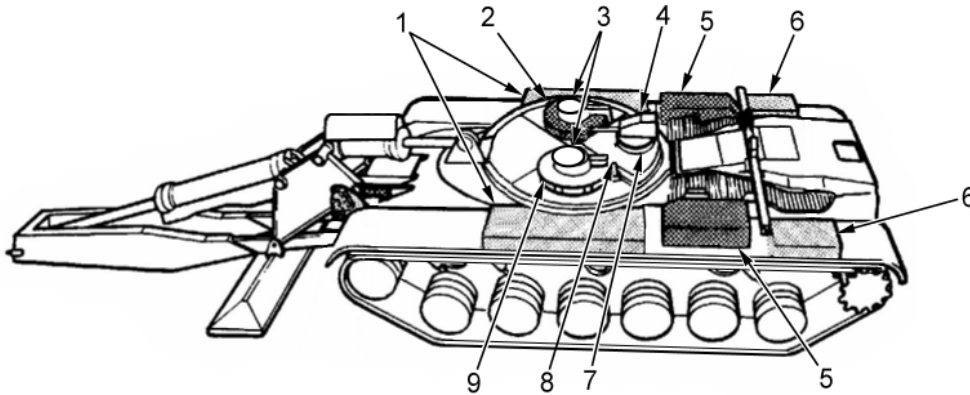

AVLBD005

Figure 3. Location of AVLB Major Components.

Table 3. AVLB Major Components.

ITEM	COMPONENT
1	Front Fender Stowage Boxes
2	Commander's Cupola
3	Hatches
4	Antenna Mount
5	Engine Air Cleaners
6	Rear Fender Stowage Boxes
7	Ventilating Blower Cover
8	Hydraulic Oil Reservoir
9	Operator's Cupola

LOCATION AND DESCRIPTIONS OF MAJOR COMPONENTS - CONTINUED

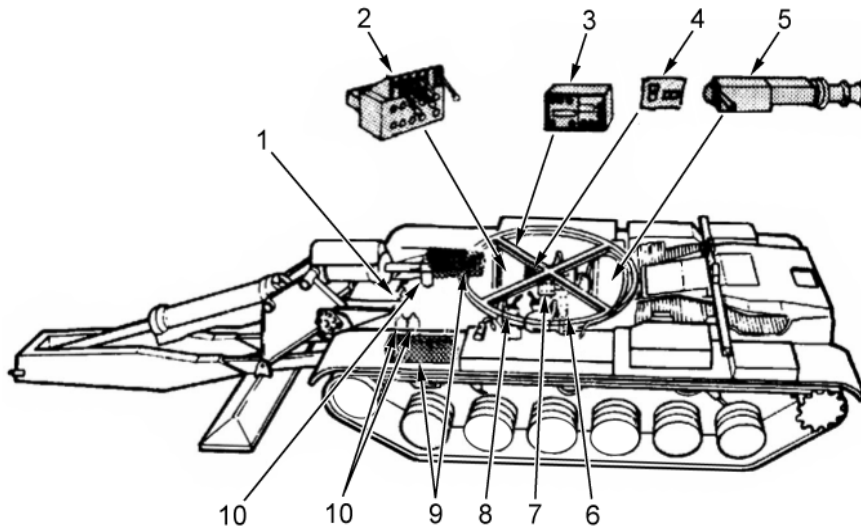

AVLBD006

Figure 4. Location of AVLB Major Components.

Table 4. AVLB Major Components.

ITEM	COMPONENT
1	Personnel Heater
2	Valve Bank Control
3	Radio
4	Grenade Launcher Controls (if equipped)
5	Power Take-Off (PTO), Pump Clutch Assembly, Pump-Ball Valve (Hydraulic Electrical Upgrade (HEU))
6	Operator's Master Control Panel
7	Indicator Panel
8	Night Vision Viewer
9	Batteries (six)
10	Fire Extinguishers (three)

LOCATION AND DESCRIPTIONS OF MAJOR COMPONENTS - CONTINUED

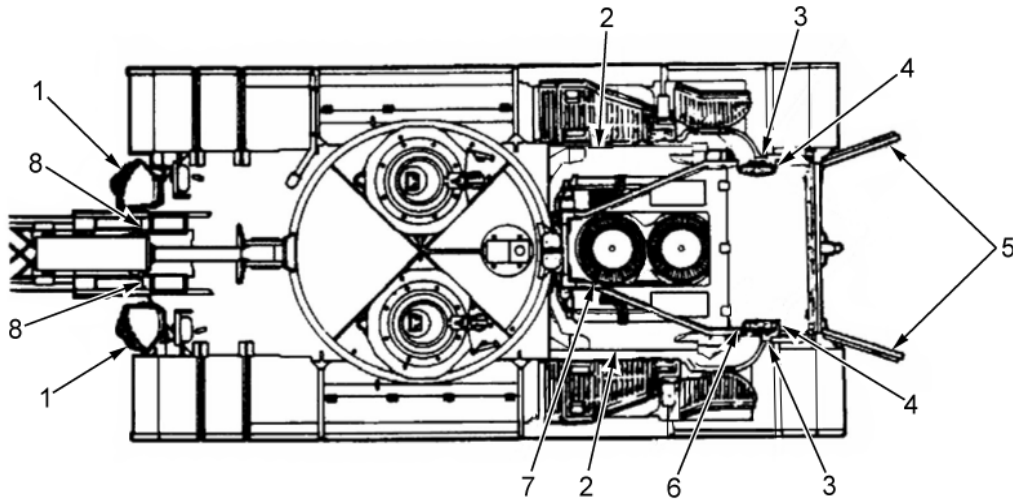

AVLBD007

Figure 5. Location of AVLB Major Components.

Table 5. AVLB Major Components.

ITEM	COMPONENT
1	Smoke Grenade Dischargers (if equipped)
2	Fuel Tanks
3	Final Drives
4	Universal Joints
5	Grille Doors
6	Transmission
7	Engine
8	Smoke Grenade Stowage Boxes (if equipped)

DIFFERENCES BETWEEN MODELS

There are several M60A1 AVLB equipment variations. This manual covers the following variations:

- Armored top-loading engine air cleaner or aluminum top-loading engine air cleaner
- Driver's AN/VVS-2 night vision viewer or periscope, M24
- Smoke grenade launcher
- Vehicle Exhaust Dust Ejector System (VEDES) and Dust Detector System (DDS)
- Mechanical track adjusting link or grease actuated track adjusting link
- AVDS 1790-2D or AVDS 1790-2DA engine
- Upgraded hydraulic/electrical system (HEU)
- 650 amp generator (HEU)

There are several M48A5 AVLB equipment variations. Most M48A5 launchers have five support rollers. Some have three support rollers. This manual covers the following:

- Operator and commander cupolas
- AN/VVS-2 night vision viewer or periscope, M24
- Smoke grenade launcher
- Vehicle Exhaust Dust Ejector System (VEDES) and Dust Detector System (DDS)
- AVDS 1790-2D or AVDS 1790-2DA engine
- Upgraded hydraulic/electrical system (HEU)
- 650 amp generator (HEU)

TRANSPORTATION NAMEPLATE

The transportation nameplate for the M60A1 AVLB is shown in Figure 6. The transportation nameplate for the M48A5 AVLB is shown in Figure 7.

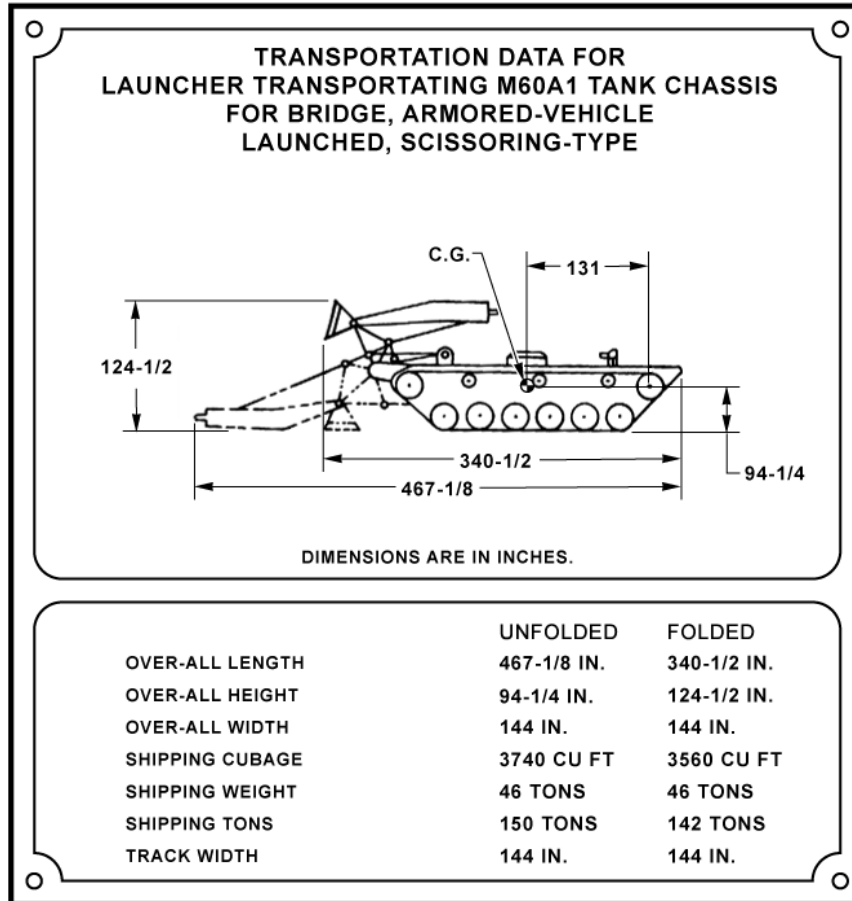

AVLBD009

Figure 6. M60A1 AVLB Transportation Nameplate.

TRANSPORTATION NAMEPLATE - CONTINUED

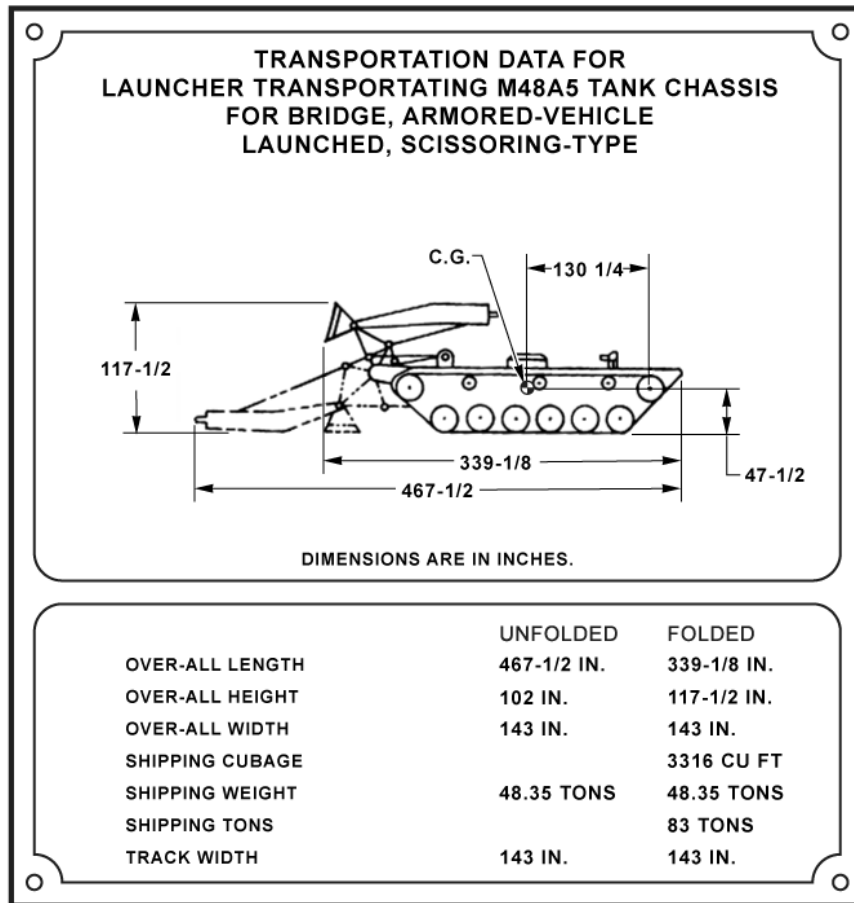

AVLBD010

Figure 7. M48A1 AVL B Transportation Nameplate.

LAUNCHER NAMEPLATE

The launcher nameplate for the M60A1 AVLB is shown in Figure 8. The launcher nameplate for the M48A5 AVLB is shown in Figure 9.

LAUNCHER TRANSPORTATING M60A1 TANK CHASSIS FOR BRIDGE, ARMORED-VEHICLE LAUNCHED, SCISSORING-TYPE NSN 5420-00-889-2020	
SERIAL NO.	<input type="text"/>
REGISTRATION NO.	<input type="text"/>
MFGR'S NAME & ADDRESS	
<input type="text"/>	
MODEL NO.	M-60-A1
ACCEPTANCE DATE	<input type="text"/>
WARRANTY 1 YEAR	
PURCHASE ORDER	<input type="text"/>
INSPECTED WEIGHT (TONS)	<input type="text"/>
U.S.	

AVLBD011

Figure 8. M60A1 AVLB Transportation Nameplate.

LAUNCHER NAMEPLATE - CONTINUED

LAUNCHER TRANSPORTING M48A5 TANK CHASSIS FOR BRIDGE, ARMORED VEHICLE LAUNCHED, SCISSORING TYPE NSN 5420-01-076-6096	
SERIAL NO.	<input type="text"/>
REGISTRATION NO.	<input type="text"/>
MFGR'S NAME & ADDRESS	
<input type="text"/>	
MODEL NO. M-48-A5	
ACCEPTANCE DATE	<input type="text"/>
WARRANTY 1 YEAR	
PURCHASE ORDER	<input type="text"/>
INSPECTED WEIGHT (TONS)	<input type="text"/>
U. S.	

AVLBD012

Figure 9. M48A5 AVLB Launcher Nameplate.

EQUIPMENT DATA

Table 6. Equipment Data.

Equipment Data	M60A1 AVLB	M48A5 AVLB
Capacities (Fuel and Oil):		
Fuel tanks (total)	375 gal. (1419 l)	385 gal. (1604.2 l)
Engine crankcase (ref II)	14.5 gal. (54.9 l)	17 gal. (64.4 l)
Transmission (ref II)	17 gal. (64.3 l)	17 gal. (64.4 l)
Final drives	11 qts (10.4 l)	11 qts (10.4 l)
Hydraulic system w/bridge	135 gal. (511 l)	145 gal. (549 l)
Hydraulic system w/o bridge	115 gal. (435.3 l)	
Controls:		
Brakes	Hydraulic-mechanical foot pedal	Hydraulic-mechanical foot pedal
Steering type	Hydraulic mechanical	Hydraulic mechanical
Turning capability	360-degree pivot	360-degree pivot
Transmission type	CD850-6A, 2 speed forward, 1 reverse	CD850-6A, 2 speed forward, 1 reverse
Operation	Mechanical lever, 5 positions (P, N, L, H, R)	Mechanical lever, 5 positions (P, N, L, H, R)
Dimensions (Travel Position):		
Length (w/o bridge)	28.3 ft (8.64 m)	28.3 ft (8.64 m)
(w/bridge)	37.0 ft (11.28m)	37.0 ft (11.28 m)
Height (w/o bridge)	10.0 ft (3.0 m)	9.9 ft (3.0 m)
(w/bridge)	12.8 ft (3.9 m)	12.7 ft (3.84 m)
Width (w/o bridge)	12.0 ft (3.6 m)	11.9 ft (3.65 m)
(w/bridge)	13.2 ft (4 m)	13.2 ft (4 m)
Ground clearance	14 in. (35.6 cm)	15 in. (38 cm)
Engine:		
Model	AVDS 1790-2D, -2DA, or -2DA	AVDS 1790-2D, -2DA, or -2CB
Type	V-12, turbo supercharged	V-12, turbo supercharged
Governed Speed:		
Full load	2400 RPM	2400 RPM
No load	2650 RPM	2650 RPM
Idle	700 to 750 RPM	700 to 750 RPM
Fuel:		
20° to 115°F (-7° to 46°C)	40 cetane, regular grade, DF-2	40 cetane, regular grade, DF-2
20° to 115°F (-7° to 46°C)	45 cetane, grade JP8	45 cetane, grade JP8
-25° to 20°F (-32° to -7°C)	40 cetane, regular grade, DF-1	40 cetane, regular grade, DF-1
-65° to -25°F (-55° to -32°C)	40 cetane, regular grade, DF-A	40 cetane, regular grade, DF-A
Cooling system (engine and oil)	Air-cooled	Air-cooled
Fuel consumption	1.13 gpm (gal. per mile) (4.3 lpm)	1.13 gpm (gal. per mile) (4.3 lpm)
Electrical System:		
Input	24 VDC	24 VDC
Batteries, type	12 VDC, wet-cell	12 VDC, wet-cell
Number	6	6
Capacity	100 ampere-hours	100 ampere-hours
Charging System Type:		
	Generator	Generator

EQUIPMENT DATA - CONTINUED

Table 6. Equipment Data - Continued.

Equipment Data	M60A1 AVLB	M48A5 AVLB
Output	300 amp (max); 650 amp (upgraded electrical only)	300 amp (max); 650 amp (upgraded electrical only)
Regulator	Relay (electro-mechanical)	Relay (electro-mechanical)
Land Performance:		
Speeds (max)		
Low	10 mph (16 kph)	10 mph (16 kph)
High	30 mph (48 kph)	30 mph (48 kph)
Reverse	5 mph (8 kph)	5 mph (8 kph)
Towing speeds (max)		
Transmission connected	3 mph (5 kph)	3 mph (5 kph)
Transmission disconnected	12 mph (20 kph)	12 mph (20 kph)
Grade (max), transporting		
Uphill or downhill	30 percent	30 percent
Side slope	15 percent	15 percent
Grade (max), launching/retrieving		
Uphill or downhill	15 percent	15 percent
Side slope	8 percent	8 percent
Obstacle height vehicle will climb (max)		
Uphill or downhill	30 percent	30 percent
Side slope	15 percent	15 percent
Uphill or downhill	30 percent	30 percent
Side slope	15 percent	15 percent
Forward	18 in. (46.2 cm)	
Uphill or downhill	30 percent	30 percent
Side slope	15 percent	15 percent
Ditch width vehicle will cross	84 in. (214.8 cm)	84 in. (214.8 cm)
Weight:		
Vehicle (w/o bridge)	92,200 lb (46.1 tons), 41,859 kg (42 metric tons)	97,200 lb (48.6 tons), 44,090 kg (44.1 metric tons)
Vehicle (w/bridge)	121,700 lb (61 tons), 55,252 kg (55.3 metric tons)	126,700 lb (63.4 tons), 47,471 kg (57.5 metric tons)
Ground Pressure:		
Vehicle (w/o bridge)	9.0 psi (lb/sq in.) (62.1 kpa)	9.0 psi (lb/sq in.) (62.1 kpa)
Vehicle (w/bridge)	12.2 psi (84.12 kpa)	14.4 psi (99.26 kpa)
Bridge (TM 5-5420-203-13):		
Night viewer (if equipped)	Scissoring-type, class 60 or 70 AN/VVS-2 night vision	Scissoring-type, class 60 or 70 AN/VVS-2 night vision
Communications System:		
Radio set	AN/VRC-46, AN/VRC-53, AN/VRC-64, or SINCGARS	AN/VRC-46, AN/VRC-53, AN/VRC-64, or SINCGARS
Intercom set	AN/VIC-1	AN/VIC-1
Gas-Particulate Filter Unit:		
Personnel protection	4 (or less) per unit	4 (or less) per unit
Type	M8A3	M8A3
Protective mask	M25 or M25A1	M25 or M25A1

EQUIPMENT DATA - CONTINUED**Table 6. Equipment Data - Continued.**

Equipment Data	M60A1 AVLB	M48A5 AVLB
Smoke Grenade Launcher (if equipped):	L8 series smoke grenades	L8 series smoke grenades
Ammunition	UK L8A1 RP (red phosphorous) smoke grenade	UK L8A1 RP (red phosphorous) smoke grenade

END OF WORK PACKAGE

OPERATOR MAINTENANCE**THEORY OF OPERATION**

INTRODUCTION

The Armored Vehicle Launched Bridge (AVLB) was designed to launch and retrieve a Class 60 or Class 70 bridge. The main body is based on either the M60A1 or the M48A5 tank assembly. An AVLB transports a folding portable bridge on the top of a tank chassis. The AVLB carries a crew of two and is powered by a 750 horsepower diesel engine.

The AVLB consists of three major sections: the launcher, the hull, and the bridge. The launcher is mounted as an integral part of the chassis. The bridge, when emplaced, is capable of supporting tracked and wheeled vehicles with military load bearing capacity up to Class 60 or 70. To extend the bridge for use, hydraulic cylinders are used: one to raise the bridge from the chassis and then lower it to the ground, and another to unfold the structure. The roadway width of the AVLB is 12 feet, 6 inches. Bridge emplacement can be accomplished in 2 to 5 minutes, and retrieval can be accomplished in 10 minutes under armor protection. When unfolded, it can span up to 60 feet. The bridge can be retrieved from either end.

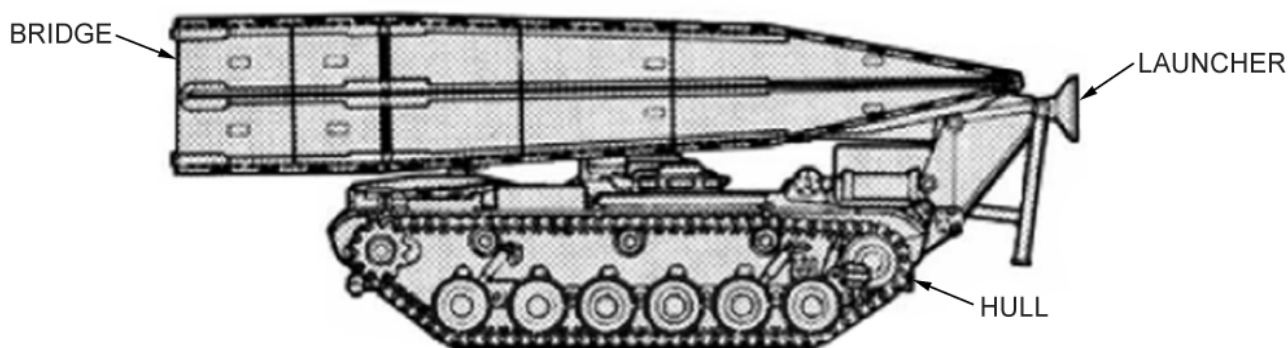

AVLBD521

Figure 1. Armored Vehicle Launched Bridge (AVLB).

END OF WORK PACKAGE

CHAPTER 2

OPERATOR INSTRUCTIONS

FOR

**M48A5 AND M60A1 LAUNCHER AND TANK CHASSIS TRANSPORTING FOR
BRIDGE ARMORED-VEHICLE LAUNCHED: SCISSORING-TYPE, CLASS 60
OR CLASS 70**

OPERATOR MAINTENANCE**DESCRIPTION AND USE OF OPERATOR'S CONTROLS AND INDICATORS**

INTRODUCTION

The following illustrations and text provide the description and use of the controls and indicators pertaining to the M48A5 Armored Vehicle Launched Bridge (AVLB) and the M60A1 AVLB.

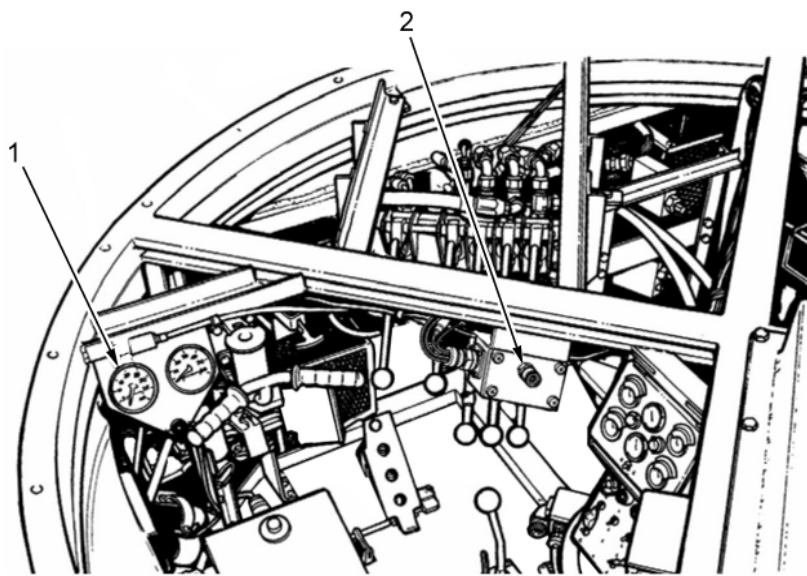

AVLBD013A

Figure 1. Operator's Controls and Indicators.

OPERATOR'S CONTROLS AND INDICATORS

TACHOMETER (Figure 1, Item 1) displays engine speed in revolutions per minute (RPM) and hourmeter registers total equivalent number of hours operated for one clock hour at 2,025 RPM.

DUST DETECTOR WARNING LAMP (if equipped) (Figure 1, Item 2) lights if engine dust detector switch has tripped.

OPERATOR'S CONTROLS AND INDICATORS - CONTINUED

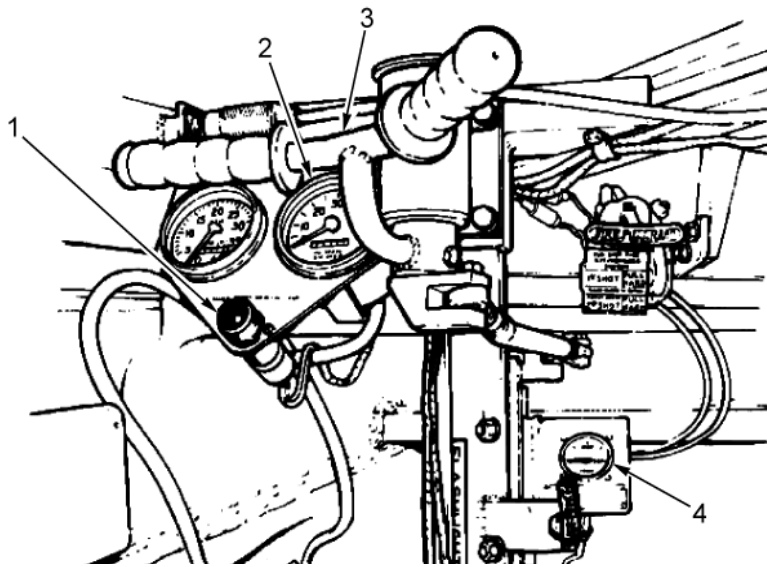

AVLBD014

Figure 2. Operator's Controls and Indicators.

POWERPLANT WARNING LAMP (Figure 2, Item 1) lights if engine oil pressure, engine oil temperature, transmission oil temperature, or transmission oil pressure are not normal or if engine dust detector switch has tripped (if equipped).

SPEEDOMETER (Figure 2, Item 2) displays speed in miles per hour (mph) and **ODOMETER** (Figure 2, Item 2) displays distance traveled in miles and tenths of a mile from 0 to 99,999.9.

STEERING CONTROL (Figure 2, Item 3) steers vehicle.

BRAKE PRESSURE GAUGE (Figure 2, Item 4) shows hydraulic pressure in brake line.

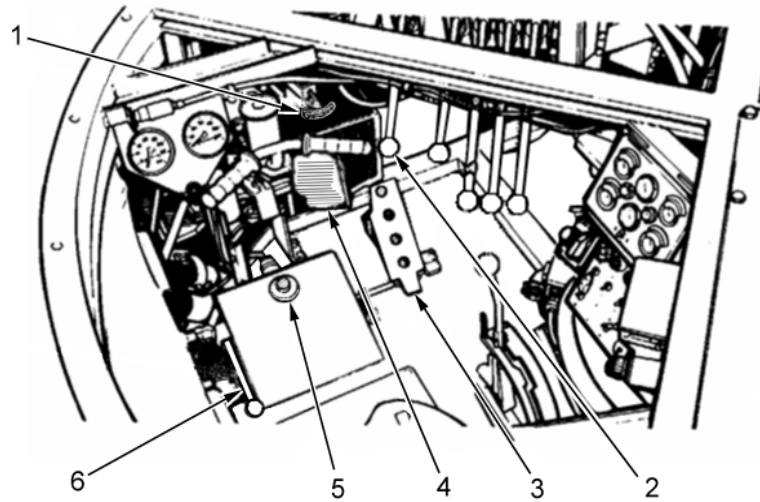
OPERATOR'S CONTROLS AND INDICATORS - CONTINUED

AVLBD015

Figure 3. Operator's Controls and Indicators.

FIXED FIRE EXTINGUISHER CONTROLS (Figure 3, Item 1) discharges fixed fire extinguishers.

OPERATOR'S BRIDGE LAUNCHING CONTROLS (Figure 3, Item 2) fixed fire extinguishers used to put out fire in the engine compartment.

ACCELERATOR PEDAL (Figure 3, Item 3) controls engine speed.

BRAKE PEDAL (Figure 3, Item 4) applies brakes to control and stop vehicle.

DIMMER SWITCH (Figure 3, Item 5) selects either high or low headlight beam when pressed and released.

ACCELERATOR LOCKING LEVER (Figure 3, Item 6) locks accelerator pedal in preset position.

OPERATOR'S CONTROLS AND INDICATORS - CONTINUED

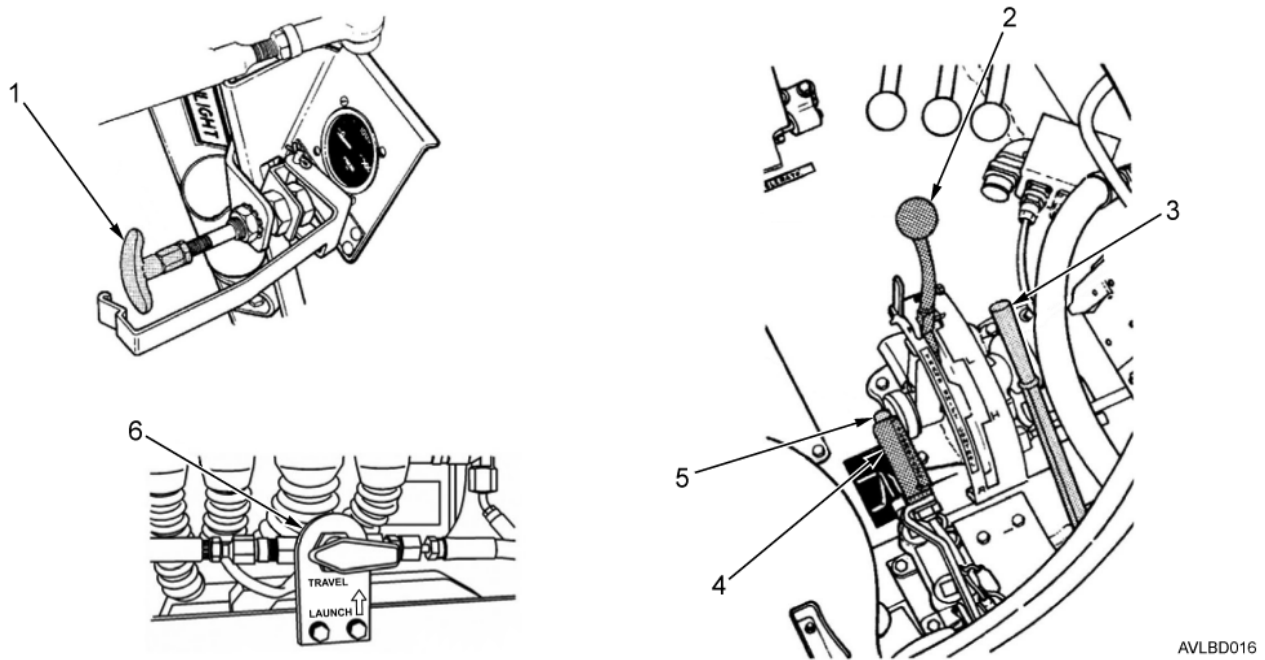

Figure 4. Operator's Controls and Indicators.

MANUAL FUEL SHUTOFF HANDLE (Figure 4, Item 2) controls transmission operating range. Locks brakes when in P (park) position.

TRANSMISSION SHIFT LEVER (Figure 4, Item 1) controls fuel to engine.

PUMP CLUTCH LEVER (Figure 4, Item 3) controls hydraulic pump clutch.

PURGE PUMP CONTROL HANDLE (Figure 4, Item 4) forces air from engine fuel system. Pumps fuel to manifold heaters.

MANIFOLD HEATER SWITCH (Figure 4, Item 5) controls fuel and power to manifold heaters.

HYDRAULIC PUMP BALL VALVE (HYDRAULIC/ELECTRICAL UPGRADE (HEU)) (Figure 4, Item 6) controls hydraulic pump.

OPERATOR'S CONTROLS AND INDICATORS - CONTINUED

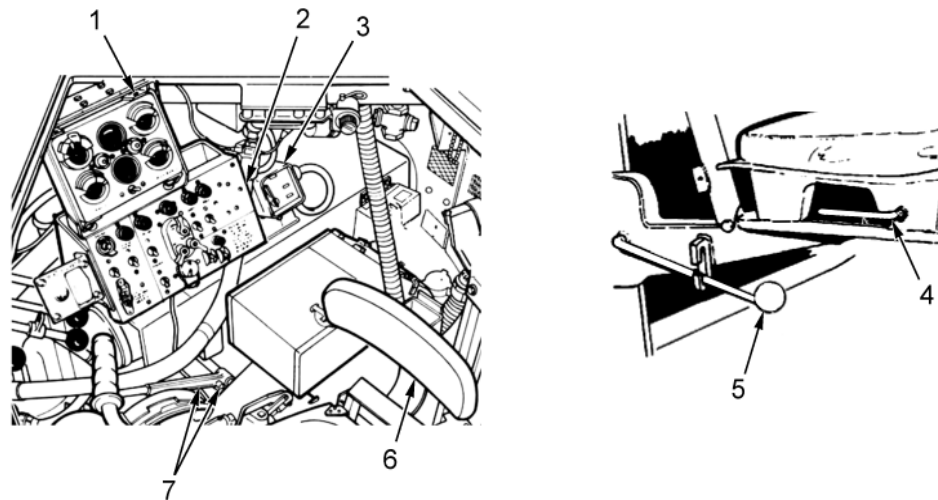

AVLBD017

Figure 5. Operator's Controls and Indicators.

INDICATOR PANEL (Figure 5, Item 1) provides operator with operating controls and indicators.

MASTER CONTROL PANEL (Figure 5, Item 2) provides operator with operating controls and indicators.

INTERCOM CONTROL PANEL (Figure 5, Item 3) provides voice communication selection and volume control.

SEAT CONTROL HANDLE (Figure 5, Item 4) releases seat for forward or rearward adjustment. Locks seat at desired position.

HEIGHT ADJUSTMENT LEVER (Figure 5, Item 5) releases seat for height adjustment. Locks seat at desired height.

OPERATOR'S SEAT (Figure 5, Item 6) controls position of operator.

PUMP CLUTCH LEVER ASSEMBLY/PUMP BALL VALVE ASSEMBLY (FOR VEHICLES WITH HYDRAULIC/ELECTRICAL UPGRADE (HEU)) (Figure 5, Item 7) provides power to hydraulic pump and pressure for hydraulic system.

OPERATOR'S CONTROLS AND INDICATORS - CONTINUED

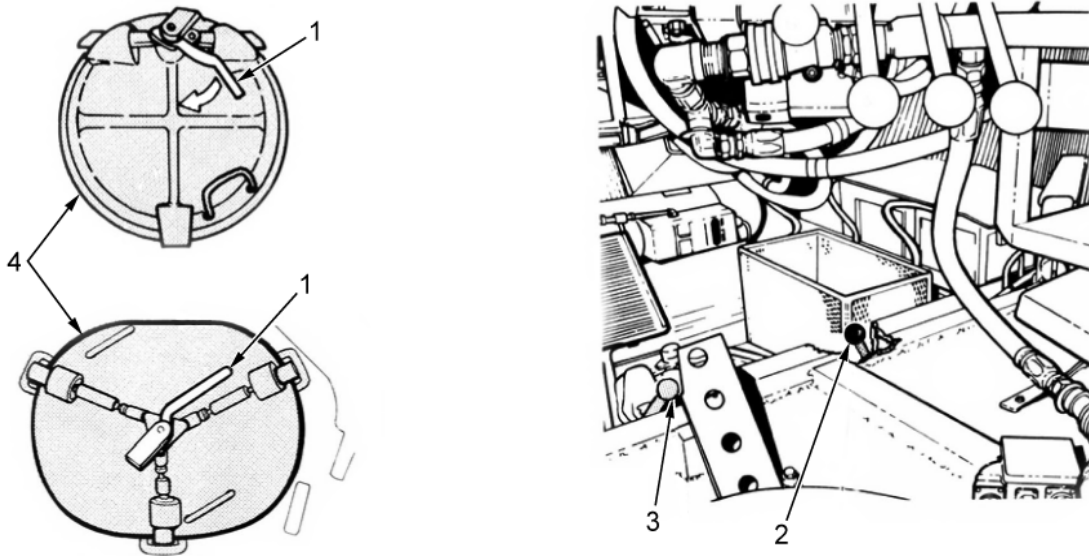

AVLBD018

Figure 6. Escape Hatch and Drain Valve Levers.

ESCAPE HATCH LEVER (Figure 6, Item 1) releases escape hatch from hull.

ENGINE COMPARTMENT DRAIN VALVE LEVER (Figure 6, Item 2) controls engine compartment drain valve.

CREW COMPARTMENT DRAIN VALVE LEVER (Figure 6, Item 3) controls crew compartment drain valve.

ESCAPE HATCH (Figure 6, Item 4) allows emergency exit from vehicle.

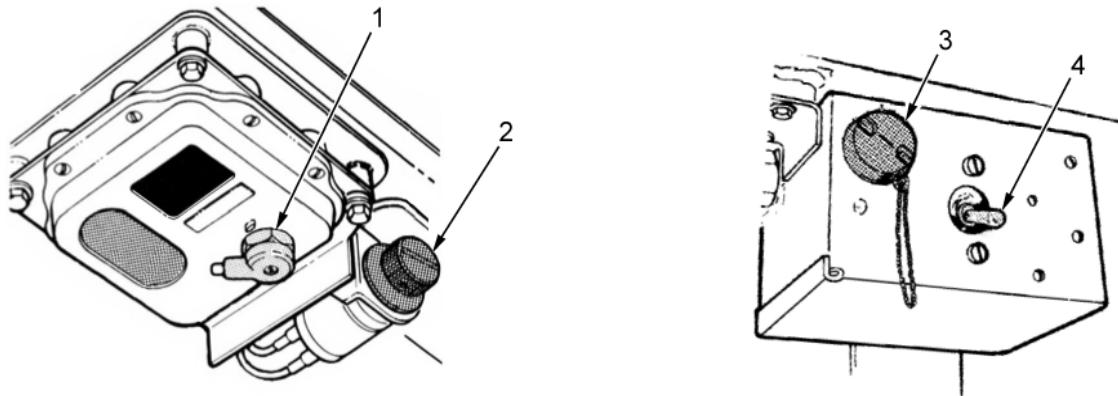

AVLBD019

Figure 7. Domelight and Ventilation Switches.

DOMELIGHT SWITCH (Figure 7, Item 1) turns domelight on or off. Selects red or white light.

RHEOSTAT KNOB (Figure 7, Item 2) controls brightness of domelight.

UTILITY OUTLET (Figure 7, Item 3) provides connection for 24 VDC.

VENTILATING BLOWER SWITCH (Figure 7, Item 4) controls ventilating blower.

OPERATOR'S CONTROLS AND INDICATORS - CONTINUED

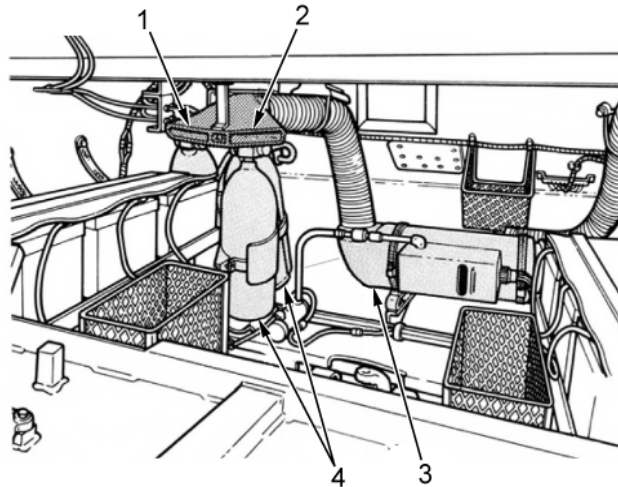

AVLBD020

Figure 8. Fire Extinguisher and Heater Controls - M60A1 AVLB.

OPERATOR'S HEATER VENT (Figure 8, Item 1) directs air from personnel heater toward operator's area.

COMMANDER'S HEATER VENT (Figure 8, Item 2) directs air from personnel heater toward commander's area.

PERSONNEL HEATER (Figure 8, Item 3) provides heated air for vehicle.

FIRE EXTINGUISHERS (2) (Figure 8, Item 4) contain chemicals (under pressure) for putting out fires in engine compartment.

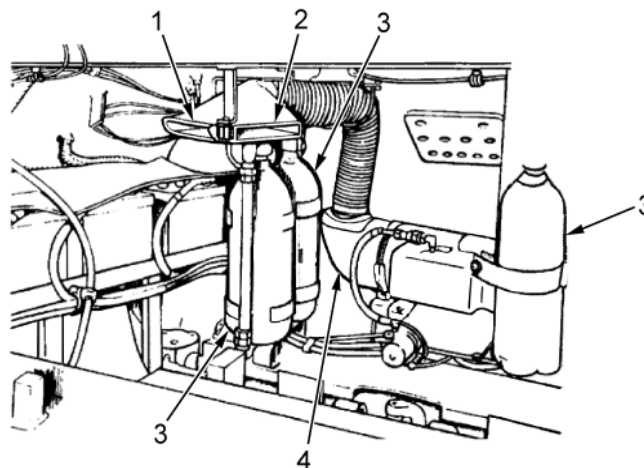

AVLBD021

Figure 9. Fire Extinguisher and Heater Controls - M48A5 AVLB.

OPERATOR'S HEATER VENT (Figure 9, Item 1) directs air from personnel heater toward operator's area.

COMMANDER'S HEATER VENT (Figure 9, Item 2) directs air from personnel heater toward commander's area.

FIRE EXTINGUISHERS (3) (Figure 9, Item 3) contain chemicals (under pressure) for putting out fires in engine compartment.

PERSONNEL HEATER (Figure 9, Item 4) provides heated air for vehicle.

OPERATOR'S CONTROLS AND INDICATORS - CONTINUED

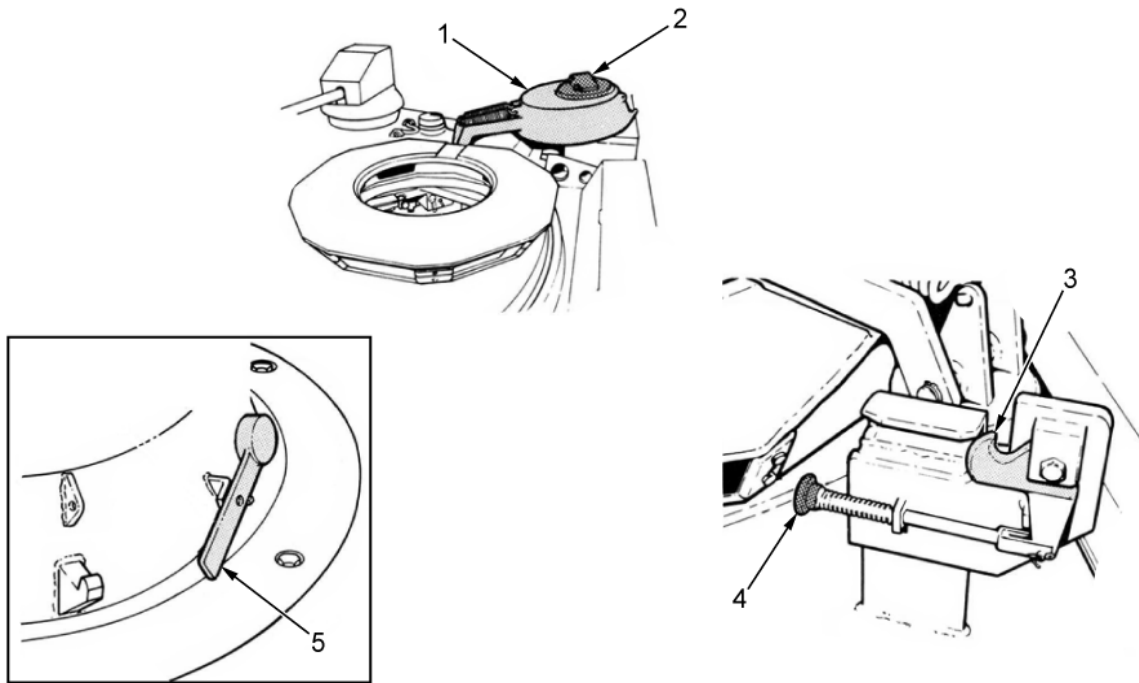

AVLBD023

Figure 10. Cupola Cover M60/M48.

CUPOLA COVER (Figure 10, Item 1) covers hatch opening.

PERISCOPE DOOR ASSEMBLY OR NIGHT VIEWER MOUNT (Figure 10, Item 2) supports periscope or night viewer.

SAFETY LATCH (Figure 10, Item 3) holds cover when open.

RELEASE KNOB (Figure 10, Item 4) releases safety latch when pushed.

CUPOLA COVER HANDLE (Figure 10, Item 5) handles secures cover when closed.

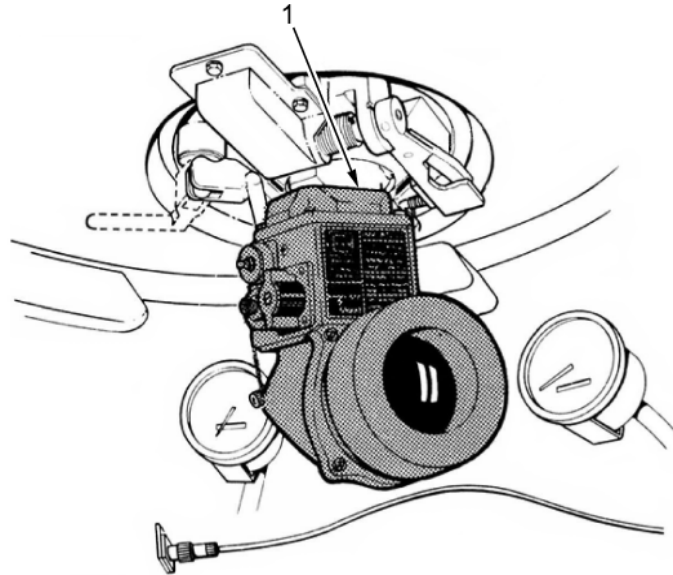
OPERATOR'S CONTROLS AND INDICATORS - CONTINUED

AVLBD026

Figure 11. Night Viewer.

AN/VVS-2 NIGHT VISION VIEWER (Figure 11, Item 1) is used when driving at night under blackout conditions.

OPERATOR'S CONTROLS AND INDICATORS - CONTINUED

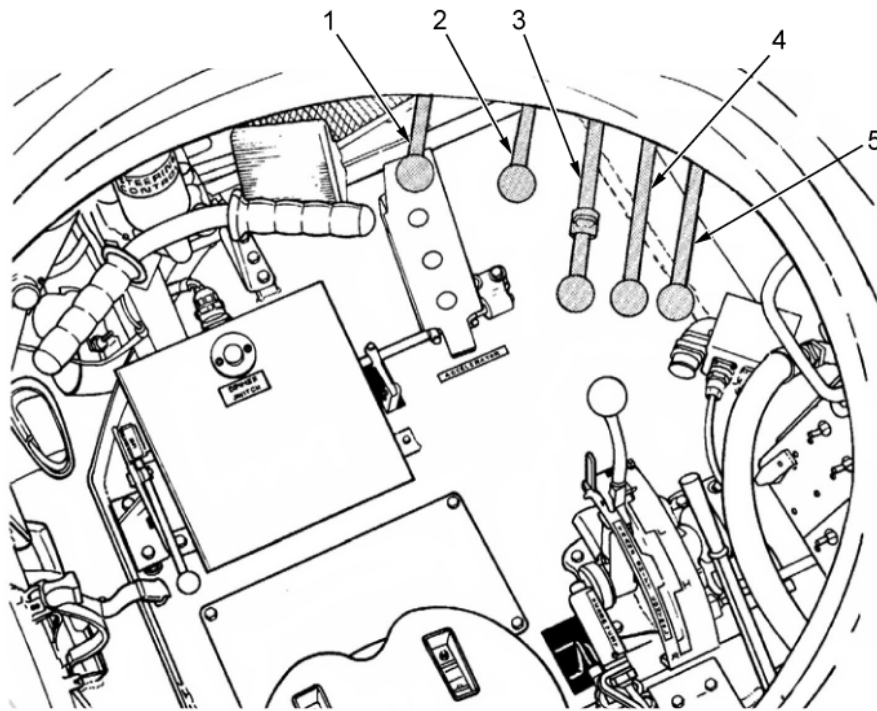

AVLBD027

Figure 12. Bridge Launching Controls.

EJECT LEVER (Figure 12, Item 1) controls ejection cylinders.

LOCK LEVER (Figure 12, Item 2) controls locking cylinder.

SCISSORS LEVER (Figure 12, Item 3) controls bridge scissors cylinder.

TONGUE LEVER (Figure 12, Item 4) controls tongue.

OVERHEAD LEVER (Figure 12, Item 5) controls overhead and hold-down cylinders.

OPERATOR'S CONTROLS AND INDICATORS - CONTINUED

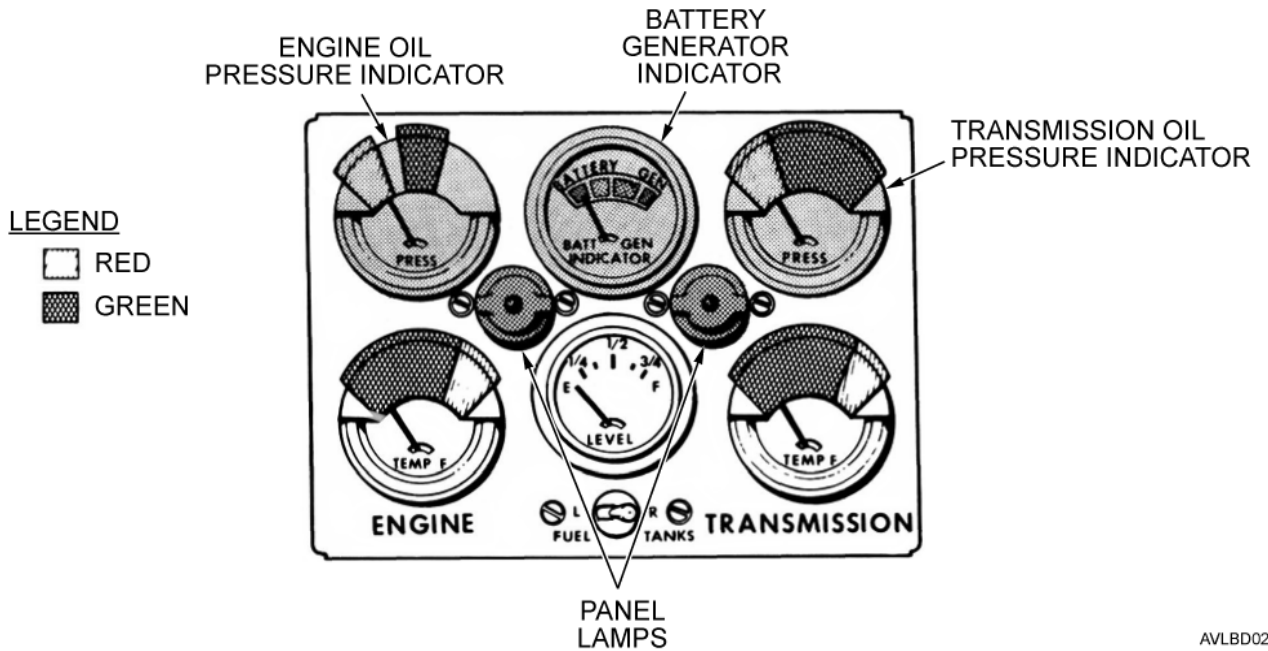

AVLBD028

Figure 13. Indicator Panel.

ENGINE OIL PRESSURE (Figure 13) shows operating pressure. Green – normal; red – low.

BATTERY-GENERATOR (Figure 13). Engine off – shows condition of batteries. Engine running – shows rate of charge.

TRANSMISSION OIL PRESSURE (Figure 13) shows operating pressure. Green – normal; red – low.

PANEL LAMPS (Figure 13) light panel.

OPERATOR'S CONTROLS AND INDICATORS - CONTINUED

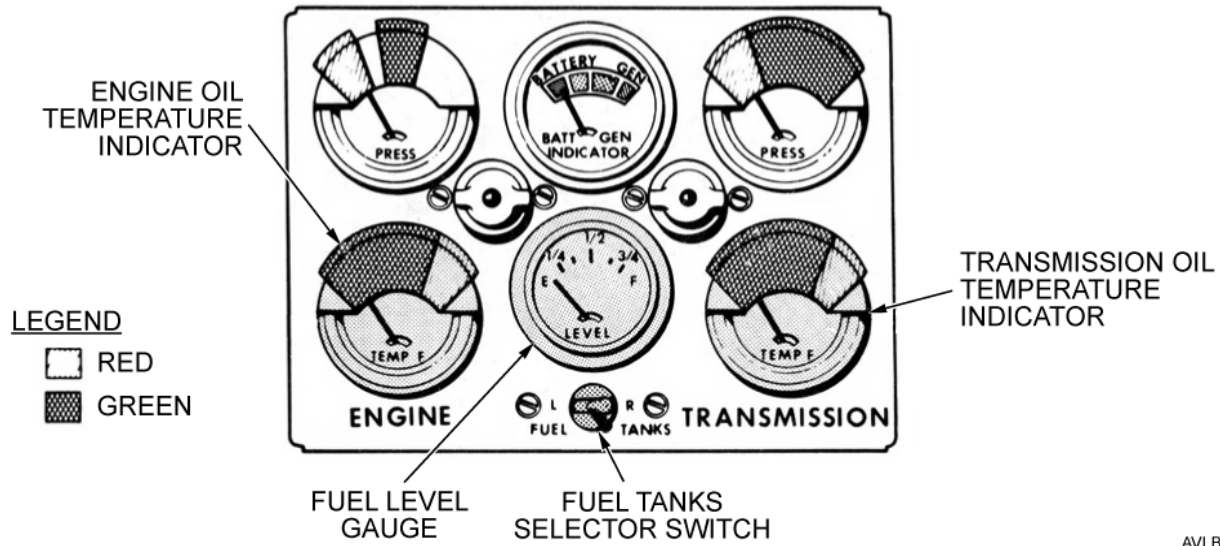

AVLBD029

Figure 14. Indicator Panel.

ENGINE OIL TEMPERATURE (Figure 14) shows operating temperature. Green – normal, red – high.

TRANSMISSION OIL TEMPERATURE (Figure 14) shows operating temperature. Green – normal, red – high.

FUEL TANKS SELECTOR SWITCH (Figure 14) connects fuel level indicator to either fuel tank (L or R).

FUEL LEVEL GAUGE (Figure 14) indicates fuel level in tank selected.

OPERATOR'S CONTROLS AND INDICATORS - CONTINUED

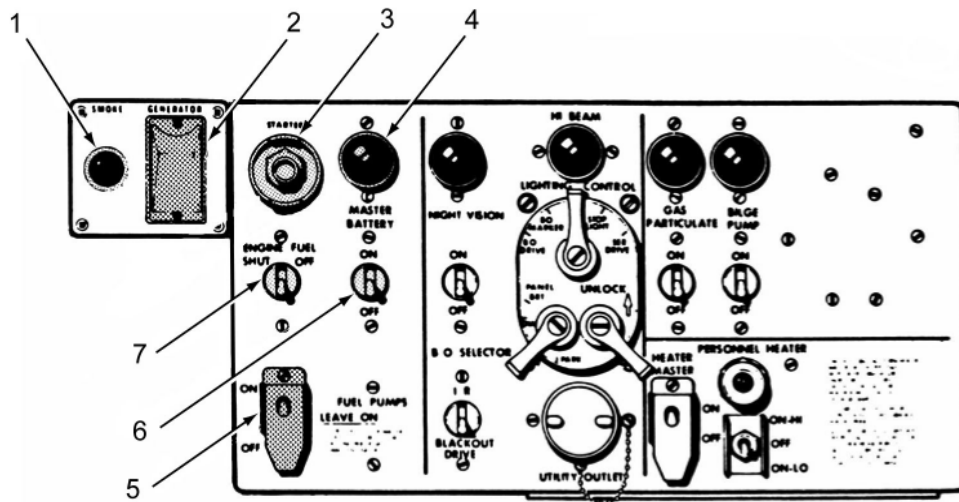

AVLBD030

Figure 15. Master Control Panel.

SMOKE GENERATOR INDICATOR (if equipped) (Figure 15, Item 1) controls power to smoke generator system (deactivated).

SMOKE GENERATOR SWITCH (if equipped) (Figure 15, Item 2) controls power to smoke generator system (deactivated).

STARTER SWITCH (Figure 15, Item 3) controls engine starter.

MASTER BATTERY INDICATOR (Figure 15, Item 4) lights when master battery switch is on.

FUEL PUMPS SWITCH (Figure 15, Item 5) controls in-vehicle fuel pumps.

MASTER BATTERY SWITCH (Figure 15, Item 6) controls power to vehicle electrical system.

ENGINE FUEL SHUTOFF SWITCH (Figure 15, Item 7) controls engine fuel.

OPERATOR'S CONTROLS AND INDICATORS - CONTINUED

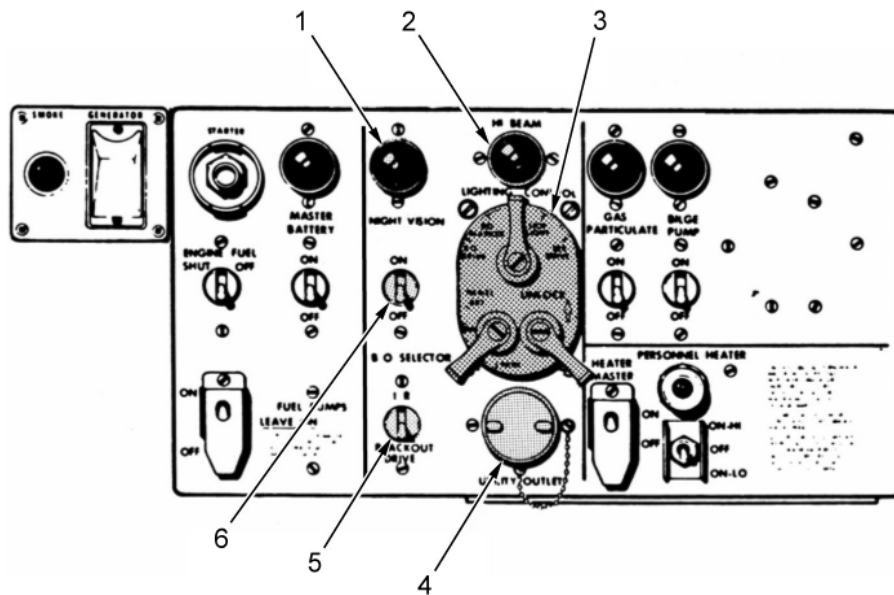

Figure 16. Master Control Panel.

AVLBD031

NIGHT VISION INDICATOR (Figure 16, Item 1) lights when night vision switch is on.

HIGH BEAM INDICATOR (Figure 16, Item 2) lights when headlights are on high beam.

LIGHTING CONTROL SWITCH (Figure 16, Item 3) controls outside lights and panel lights.

UTILITY OUTLET (Figure 16, Item 4) provides 24 VDC power for accessories.

BLACKOUT SELECTOR SWITCH (Figure 16, Item 5) selects either infrared (IR) headlights or blackout (BO) drive lights.

NIGHT VISION SWITCH (Figure 16, Item 6) controls night vision.

OPERATOR'S CONTROLS AND INDICATORS - CONTINUED

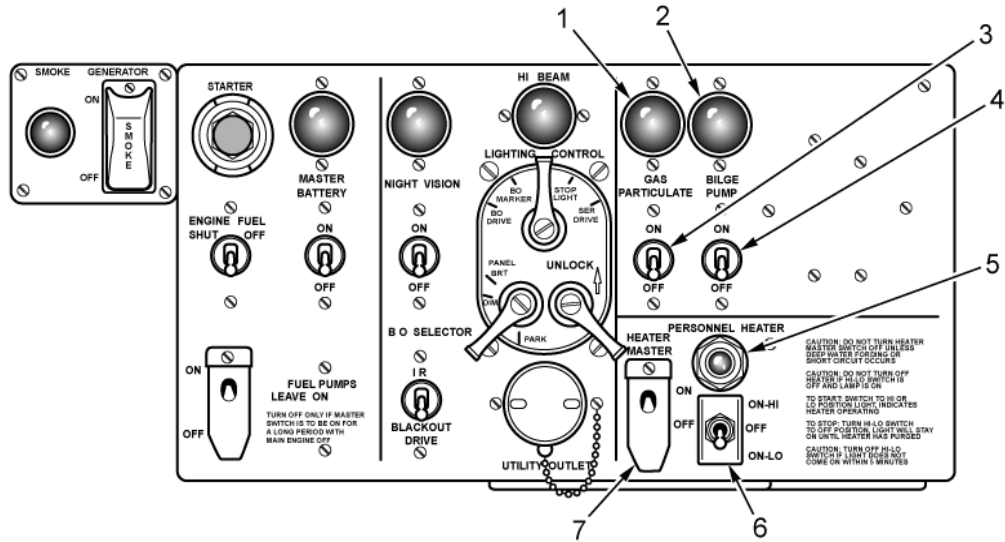

Figure 17. Master Control Panel.

AVLBD032

GAS-PARTICULATE INDICATOR (Figure 17, Item 1) lights when gas-particulate switch is on.

BILGE PUMP INDICATOR (Figure 17, Item 2) is not used.

GAS-PARTICULATE SWITCH (Figure 17, Item 3) controls gas-particulate filter unit power.

BILGE PUMP SWITCH (Figure 17, Item 4) is not used.

PERSONNEL HEATER INDICATOR (Figure 17, Item 5) lights when heater is running.

PERSONNEL HEATER SWITCH (Figure 17, Item 6) controls heater power and provides temperature control.

HEATER MASTER SWITCH (Figure 17, Item 7) controls power to personnel heater switch.

OPERATOR'S CONTROLS AND INDICATORS - CONTINUED

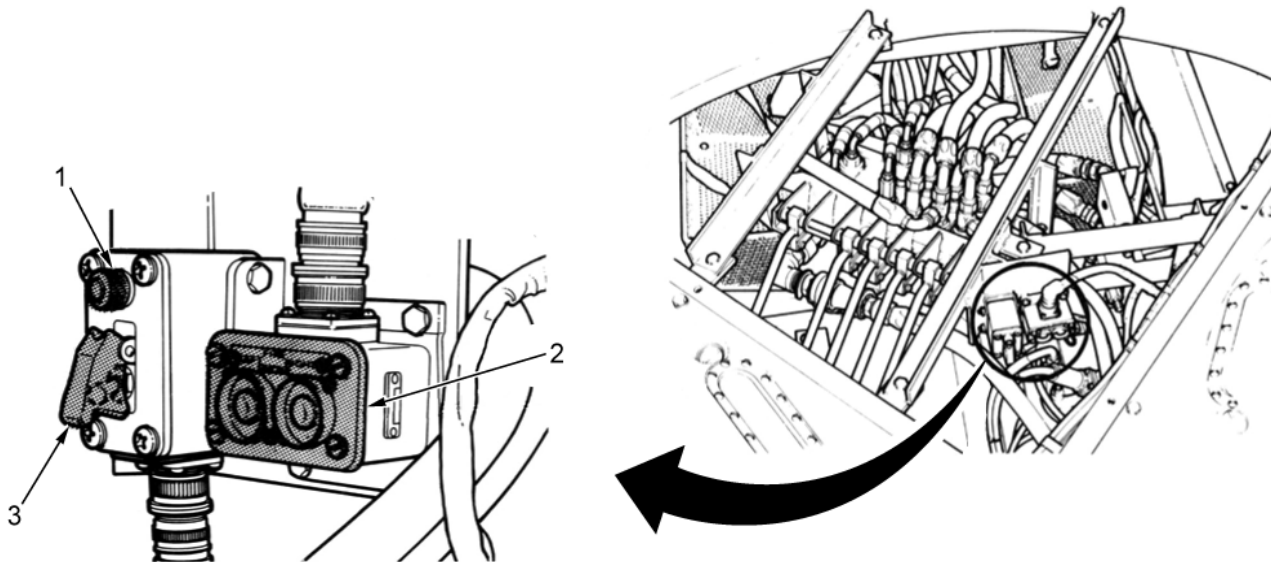

AVLBD033

Figure 18. Smoke Grenade Launcher Controls.

POWER LAMP (Figure 18, Item 1) lights when smoke grenade launcher system power is on.

PUSHBUTTON UNIT (Figure 18, Item 2) controls firing of left and right dischargers when grenade launcher system power is on.

POWER SWITCH (Figure 18, Item 3) controls power to smoke grenade launcher system.

OPERATOR'S CONTROLS AND INDICATORS - CONTINUED

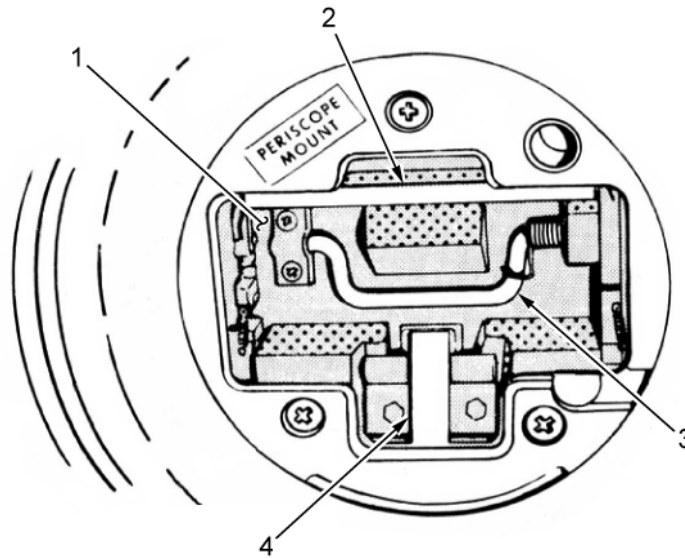

AVLBD034

Figure 19. Periscope Door Assembly.

LID (Figure 19, Item 1) covers periscope opening (spring-loaded to open position).

LOCKING HANDLE (Figure 19, Item 2) locks periscope in place.

LID HANDLE (Figure 19, Item 3) Provides lid grip.

LOCKING LATCH (Figure 19, Item 4) locks lid in closed position.

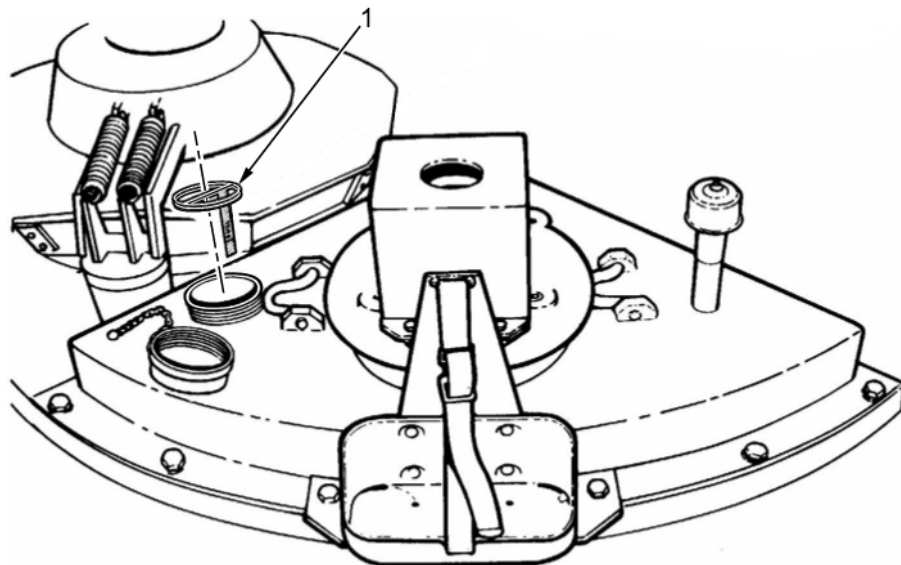

AVLBD035

Figure 20. Hydraulic Reservoir.

DIPSTICK (Figure 20, Item 1) shows hydraulic fluid level in reservoir.

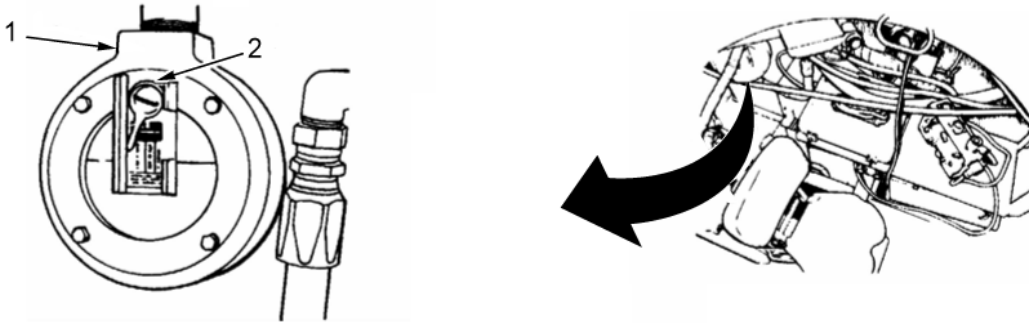
OPERATOR'S CONTROLS AND INDICATORS - CONTINUED

AVLBD036

Figure 21. Reservoir Filter Indicator.

RESERVOIR FILTER (Figure 21, Item 1) filters hydraulic fluid passing from reservoir to hydraulic system.

FILTER INDICATOR (Figure 21, Item 2) indicates filter status: Filter is Clean, Needs Cleaning, or Bypassed.

END OF WORK PACKAGE

OPERATOR MAINTENANCE
OPERATION UNDER USUAL CONDITIONS - CUPOLA COVER

INITIAL SETUP:

NOT APPLICABLE

GENERAL

This work package provides instructions for operating the cupola cover for the M48A5 Armored Vehicle Launched Bridge (AVLB) and M60A1 AVLB under usual/normal conditions. If equipment will not work, notify field maintenance.

OPERATE CUPOLA COVER**WARNING**

- The cupola cover is heavy. Personnel may be injured if the cover is allowed to move freely during vehicle movement. Ensure that the cover is locked in the open or closed position during vehicle movement. Do not release the safety latch when the vehicle is moving. Failure to comply may result in personnel injury or death.
- If the cupola cover is closed, personnel may hit their head on the cover while raising the seat. Raise the seat slowly when the cupola cover is closed. Failure to comply may result in personnel injury or death.

Open Cover from Outside

1. Use key to open and remove padlock (Figure 1, Item 1) from cover handle (Figure 1, Item 2).
2. Pull up handle (Figure 1, Item 2) and swing cover (Figure 1, Item 3) away from cupola (Figure 1, Item 6).
3. Secure cover (Figure 1, Item 3) in open position with safety latch (Figure 1, Item 5). Pull knob (Figure 1, Item 5) to lock safety latch (Figure 1, Item 4).

END OF TASK**Close Cover from Outside**

1. Push in knob (Figure 1, Item 5) to release safety latch (Figure 1, Item 4) and swing cover (Figure 1, Item 3) forward.
2. Push cover (Figure 1, Item 3) down on cupola (Figure 1, Item 6).
3. Push cover handle (Figure 1, Item 2) down to lock in position and lock with padlock (Figure 1, Item 1).

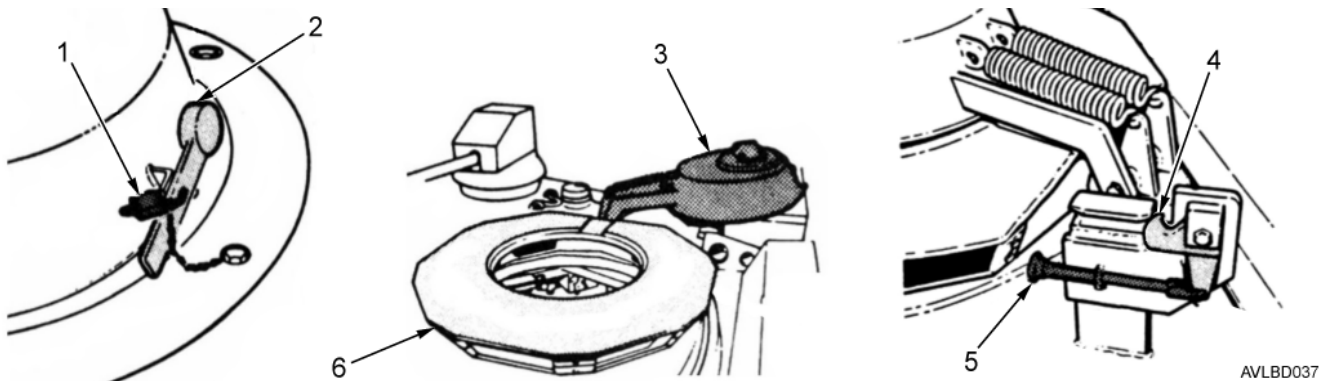

Figure 1. Open/Close Cupola Cover from Outside.

END OF TASK

OPERATE CUPOLA COVER - CONTINUED**Open Cover from Inside**

1. Grasp handle (Figure 2, Item 1) to hold down cover (Figure 2, Item 3).
2. Rotate locking handle (Figure 2, Item 2) counterclockwise and let cover (Figure 2, Item 3) spring up.
3. Swing cover (Figure 2, Item 3) to rear and secure cover in open position with safety latch (Figure 2, Item 4).
4. Lock cover (Figure 2, Item 3) open by pulling knob (Figure 2, Item 5).

END OF TASK**Close Cover from Inside****WARNING**

- The cupola cover is heavy. Personnel may be injured if the cover is allowed to move freely during vehicle movement. Ensure that the cover is locked in the open or closed position during vehicle movement. Do not release the safety latch when the vehicle is moving. Failure to comply may result in personnel injury or death.
- If the cupola cover is closed, personnel may hit their head on the cover while raising the seat. Raise the seat slowly when the cupola cover is closed. Failure to comply may result in personnel injury or death.

1. Push in knob (Figure 2, Item 5) to release safety latch (Figure 2, Item 4).
2. Swing cover (Figure 2, Item 3) forward and grasp handle (Figure 2, Item 1) inside cover.
3. Pull down and hold cover (Figure 2, Item 3) against cupola (Figure 2, Item 6) and rotate locking handle (Figure 2, Item 2) clockwise to lock cover closed.

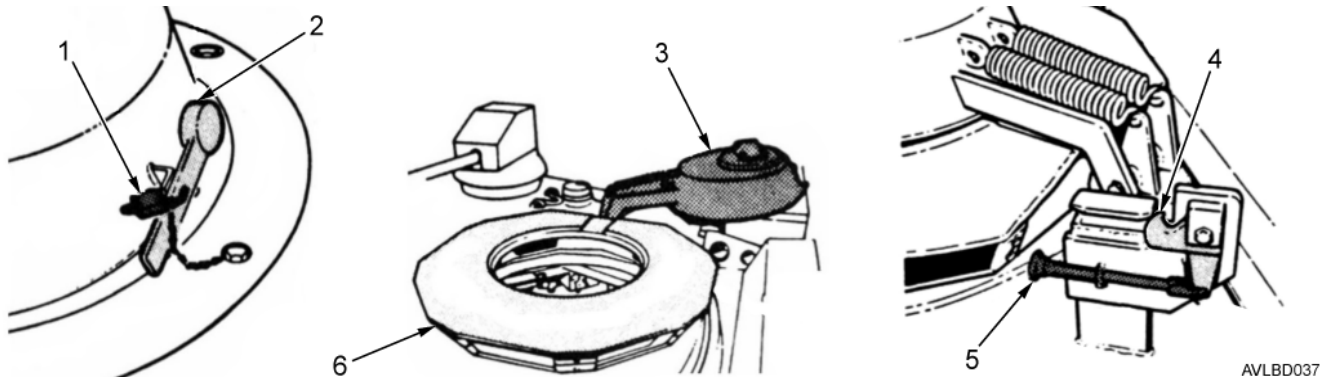

Figure 2. Open/Close Cover from Inside.

END OF TASK**END OF WORK PACKAGE**

OPERATOR MAINTENANCE**OPERATION UNDER USUAL CONDITIONS - ADJUST SEAT**

INITIAL SETUP:

NOT APPLICABLE

GENERAL

This work package provides instructions for operating the operator's and commander's seat for the M48A5 Armored Vehicle Launched Bridge (AVLB) and M60A1 AVLB under usual/normal conditions. If equipment will not work, notify field maintenance.

ADJUST SEAT**Up or Down****WARNING**

- The cupola cover is heavy. Personnel may be injured if the cover is allowed to move freely during vehicle movement. Ensure that the cover is locked in the open or closed position during vehicle movement. Do not release the safety latch when the vehicle is moving. Failure to comply may result in personnel injury or death.
- If the cupola cover is closed, personnel may hit their head on the cover while raising the seat. Raise the seat slowly when the cupola cover is closed. Failure to comply may result in personnel injury or death.

1. Sit in seat (Figure 1, Item 1) and lift up and hold height adjustment lever (Figure 1, Item 3).
2. Raise or lower seat (Figure 1, Item 1) to desired position and release seat control handle (Figure 1, Item 2).

END OF TASK**Forward or Backward**

1. Sit in seat (Figure 1, Item 1) and pull and hold seat control handle (Figure 1, Item 2) toward seat.
2. Move seat (Figure 1, Item 1) forward or backward to desired position and release seat control handle (Figure 1, Item 2).

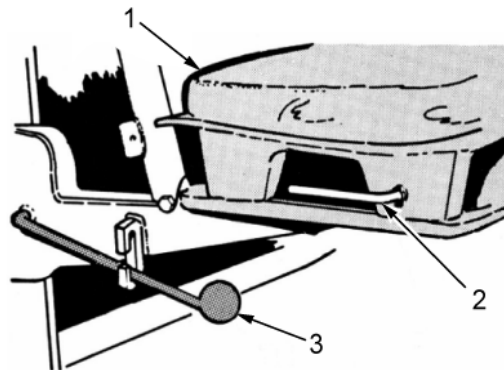

AVLBD045

Figure 1. Seat Adjustment.

END OF TASK**END OF WORK PACKAGE**

OPERATOR MAINTENANCE**OPERATION UNDER USUAL CONDITIONS - FIXED FIRE EXTINGUISHERS**

INITIAL SETUP:**Equipment Conditions**

Vehicle stopped (WP 0015)

GENERAL

This work package provides instructions for operating the fixed fire extinguishers for the M48A5 Armored Vehicle Launched Bridge (AVLB) and M60A1 AVLB under usual/normal conditions. If equipment will not work, notify field maintenance.

OPERATE FIXED FIRE EXTINGUISHERS

NOTE

In the event of fire, pulling handle releases first shot and shuts off engine fuel.

1. Pull handle (Figure 1, Item 1) and release.
2. If engine continues to run, pull up on fuel shutoff handle (Figure 1, Item 2).
3. If fire is not extinguished in 20 seconds, push handle (Figure 1, Item 1) in. Pull handle and release. This will release second shot.
4. If both shots are released, exit vehicle and move upwind from vehicle.
5. If first or second shot did not release, push up and hold ENGINE FUEL SHUTOFF switch (Figure 1, Item 3) for 6 to 10 seconds, or pull up on fuel shutoff handle (Figure 1, Item 2).

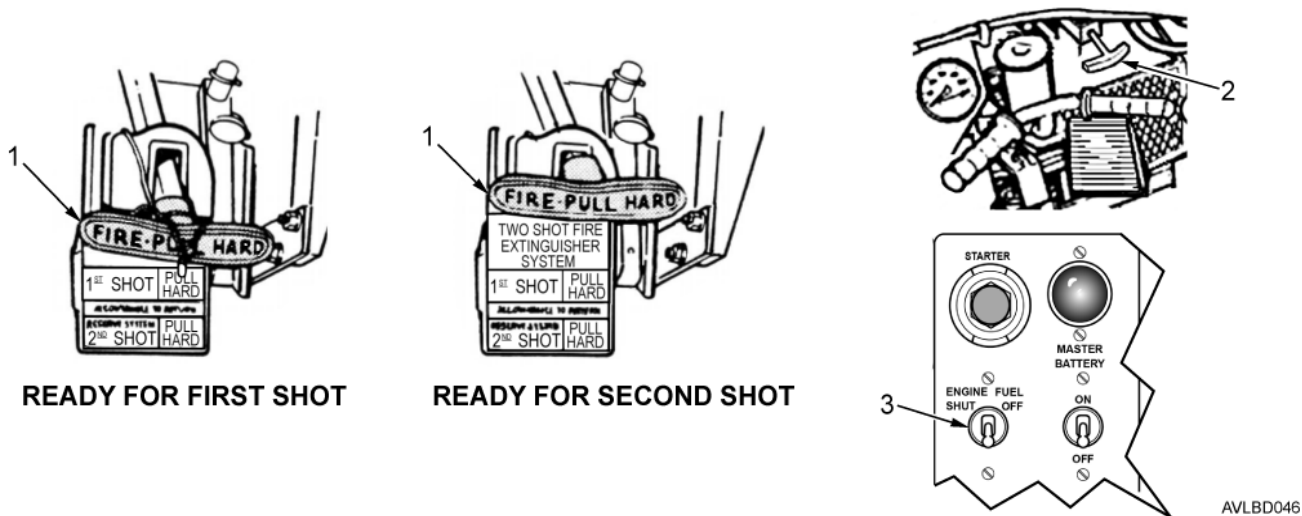

AVLBD046

Figure 1. Fire Extinguisher Handles and Switch.

6. If first or second shot did not release, exit vehicle and move to left front of vehicle.

OPERATE FIXED FIRE EXTINGUISHERS - CONTINUED

7. Pull first SHOT handle (Figure 2, Item 1) and wait 20 seconds.
8. Pull second SHOT handle (Figure 2, Item 2) and move away and upwind of vehicle.

CAUTION

If the fixed fire extinguisher has been used, notify field maintenance. Do not operate vehicle until the cause of the fire has been determined and necessary repairs have been completed. Empty fire extinguisher cylinders must be replaced. Failure to comply may result in equipment damage.

9. Notify field maintenance about fire and fire extinguisher usage.

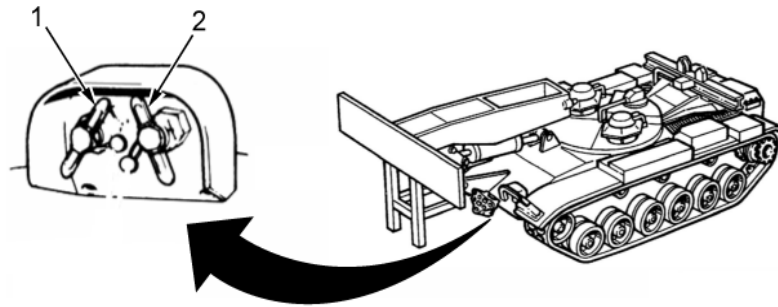

AVLBD504

Figure 2. Exterior Shot Handles.

END OF TASK**END OF WORK PACKAGE**

OPERATOR MAINTENANCE**OPERATION UNDER USUAL CONDITIONS - SERVICE DRIVE LIGHTS**

INITIAL SETUP:**References**WP 0043

GENERAL

This work package provides instructions for operating the service drive lights for the M48A5 Armored Vehicle Launched Bridge (AVLB) and M60A1 AVLB under usual/normal conditions. If equipment will not operate, refer to Lights Troubleshooting Procedures (WP 0043).

OPERATE SERVICE DRIVE LIGHTS

On

1. Turn on MASTER BATTERY switch (Figure 1, Item 1).
2. Raise and hold UNLOCK lever (Figure 1, Item 3).
3. Turn lever (Figure 1, Item 2) to SER DRIVE.
4. Release UNLOCK lever (Figure 1, Item 3). Check to see if headlights and taillights are on.

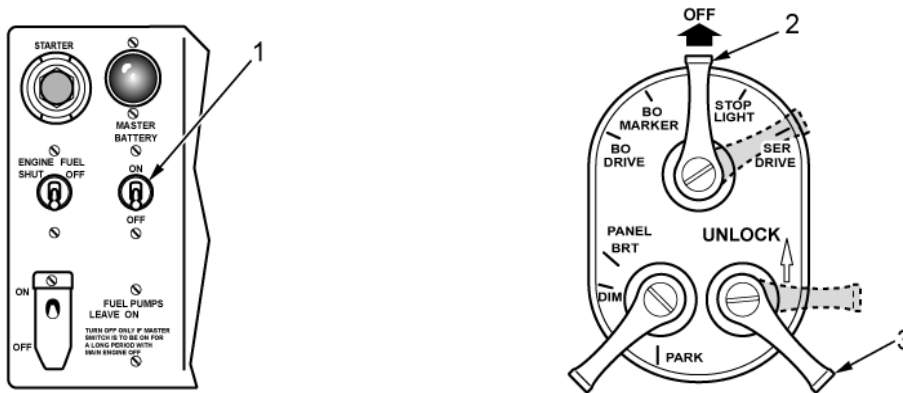

AVLBD049

Figure 1. Service Drive Lights.

END OF TASK

High or Low Headlight Beam

NOTE

HI BEAM indicator (Figure 2, Item 1) lights if headlights are on high beam.

Off

Press and release dimmer switch (Figure 2, Item 2) to select high or low beam and turn UNLOCK lever (Figure 2, Item 3) to OFF.

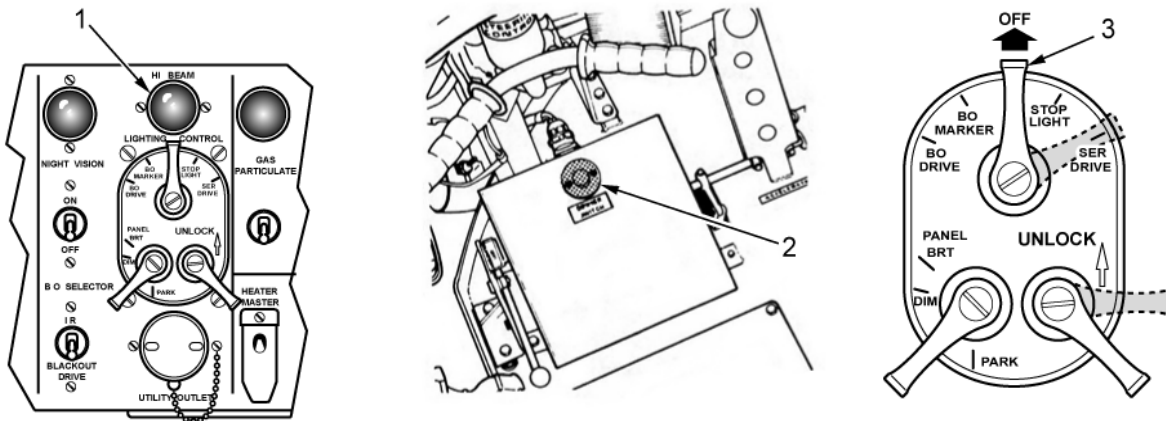

AVLBD050

Figure 2. High or Low Headlight Beam.

END OF TASK

OPERATE SERVICE STOPLIGHT**On**

1. Raise and hold UNLOCK lever (Figure 3, Item 2).
2. Move lever (Figure 3, Item 1) to STOPLIGHT.
3. Release UNLOCK lever (Figure 3, Item 2) and press brake pedal to operate stoplight.

Off

Move lever (Figure 3, Item 1) to OFF to turn off stoplight.

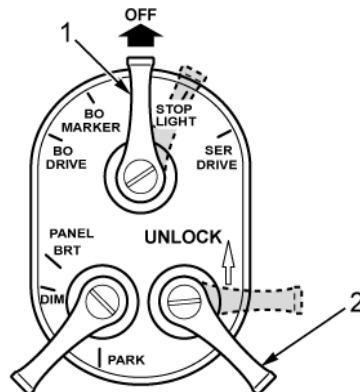

AVLBD051

Figure 3. Service Stoplight.

END OF TASK**OPERATE BLACKOUT MARKER LIGHTS****On**

Move lever (Figure 4, Item 1) to BO MARKER and press brake pedal to operate blackout stoplight.

Off

Move lever (Figure 4, Item 1) to OFF to turn off lights.

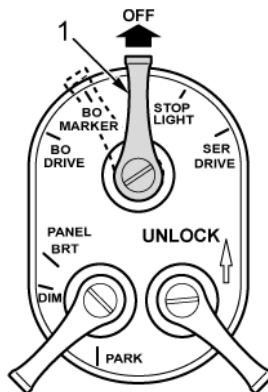

AVLBD052

Figure 4. Blackout Marker Lamps.

END OF TASK

OPERATE BLACKOUT DRIVE LIGHTS

On

1. Set BO SELECTOR switch (Figure 5, Item 1) to BO DRIVE.
2. Raise and hold UNLOCK lever (Figure 5, Item 3).
3. Move lever (Figure 5, Item 2) to BO DRIVE.
4. Release UNLOCK lever (Figure 5, Item 3) and press brake pedal to operate blackout stoplight. Check to ensure blackout stoplight on taillight at rear of vehicle is on.

Off

Move lever (Figure 5, Item 2) to OFF to turn off lights.

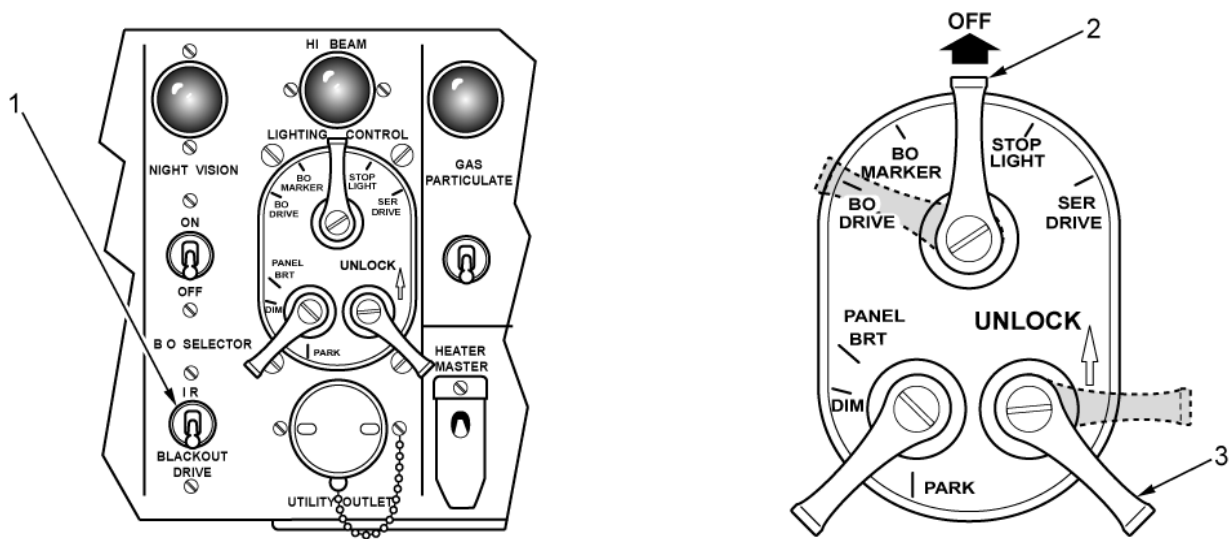

AVLBD053

Figure 5. Blackout Drive Lights.

END OF TASK

OPERATE PANEL LIGHTS

On

NOTE

Lever (Figure 6, Item 1) must be in any position except OFF to move PANEL lever (Figure 6, Item 2).

Move PANEL lever (Figure 6, Item 2) to BRT or DIM.

Off

Move lever (Figure 6, Item 1) to OFF to turn off lights.

END OF TASK

OPERATE PARKING LIGHTS

NOTE

Lever (Figure 6, Item 1) must be in any position except OFF to move PANEL lever (Figure 6, Item 2).

On

Move PANEL lever (Figure 6, Item 2) to PARK.

Off

NOTE

If lever (Figure 6, Item 1) is in SER DRIVE or BO DRIVE, drive lights will come on. If drive lights were on, they will turn off and panel lights will dim.

Move lever (Figure 6, Item 1) to OFF to turn off parking lights.

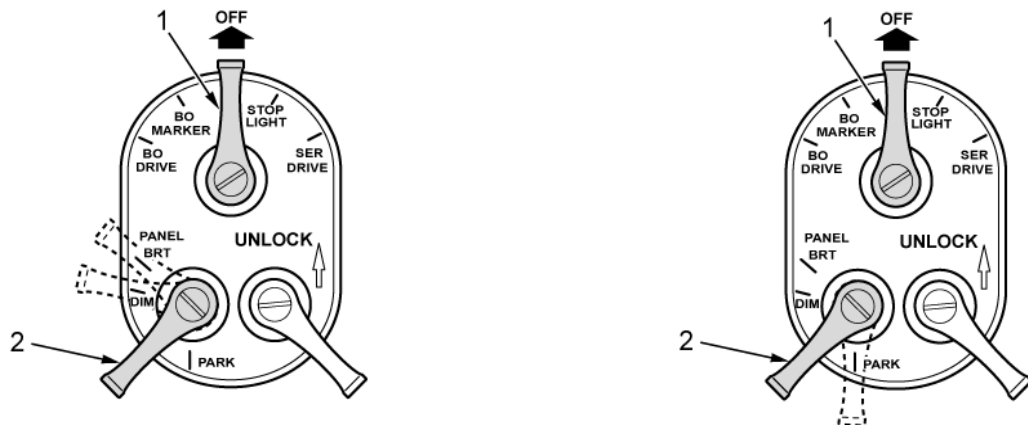

AVLBD056

Figure 6. Panel Lights.

END OF TASK

OPERATE DOME LIGHT**On**

1. Set MASTER BATTERY switch (Figure 7, Item 1) to ON.
2. Press plunger (Figure 7, Item 4) and move switch (Figure 7, Item 2) to right for white light (Figure 7, Item 5).
3. Move switch (Figure 7, Item 2) to left for blackout light (Figure 7, Item 6).
4. Turn knob (Figure 7, Item 3) to change brightness.

Off

Press plunger (Figure 7, Item 4) and move switch (Figure 7, Item 2) to center to turn lights off.

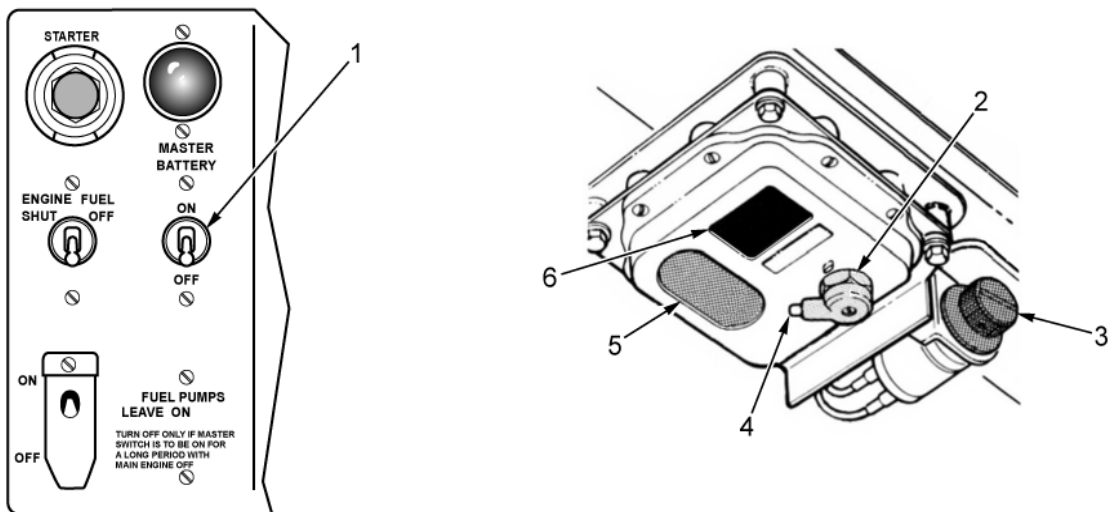

AVLBD468

Figure 7. Dome Lights.

END OF TASK**END OF WORK PACKAGE**

OPERATOR MAINTENANCE
OPERATION UNDER USUAL CONDITIONS - DRAIN VALVES

INITIAL SETUP:

NOT APPLICABLE

GENERAL

This work package provides instructions for operating the engine compartment drain valve for the M48A5 Armored Vehicle Launched Bridge (AVLB) and M60A1 AVLB under usual/normal conditions. If equipment will not operate, notify field maintenance.

OPERATE ENGINE COMPARTMENT DRAIN VALVE**Open**

Push lever (Figure 1, Item 2) down and right into detent to lock open.

Close

Push lever (Figure 1, Item 2) to left out of detent and pull up.

END OF TASK**OPERATE CREW COMPARTMENT DRAIN VALVE****Open**

Push lever (Figure 1, Item 1) to right and rear into detent to lock open.

Close

Push lever (Figure 1, Item 1) forward and left.

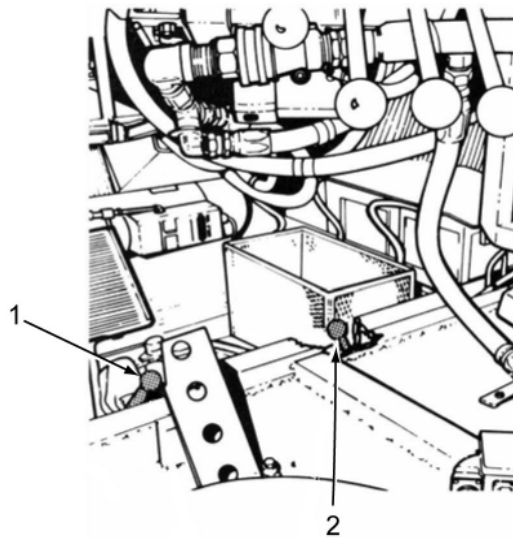

AVLBD057

Figure 1. Engine and Crew Compartment Drain Valves.

END OF TASK**END OF WORK PACKAGE**

OPERATOR MAINTENANCE**OPERATION UNDER USUAL CONDITIONS - PERSONNEL HEATER**

INITIAL SETUP:**References**WP 0045

GENERAL

This work package provides instructions for operating the personnel heater for the M48A5 Armored Vehicle Launched Bridge (AVLB) and M60A1 AVLB under usual/normal conditions. If equipment will not operate, refer to Personnel Heater Troubleshooting Procedures (WP 0045).

OPERATE PERSONNEL HEATER**CAUTION**

- Heater could be damaged if operated with heater exhaust plug. Ensure heater exhaust plug has been removed before operating heater. Failure to comply may result in equipment damage.
- DO NOT turn HEATER MASTER switch off except for deep water fording or electrical trouble. Failure to comply may result in equipment damage.
- DO NOT operate heater less than 5 minutes when deep water fording, or fording may occur and damage heater.

Start Heater

1. Remove exhaust plug (Figure 1, Item 1) from vehicle.
2. Ensure HEATER MASTER switch (Figure 1, Item 4) is in ON position.

NOTE

- Notify field maintenance if ON-HI/OFF/ON-LO switch (Figure 1, Item 3) is off and indicator (Figure 1, Item 2) is lit.
 - DO NOT make more than three attempts to start heater. Indicator (Figure 1, Item 2) will light indicating heater startup. If the heater does not start in three attempts, notify field maintenance.
3. With switch (Figure 1, Item 3) in OFF position, press indicator (Figure 1, Item 2). It should light, indicating it is all right to start heater. If indicator does not light, notify field maintenance.

CAUTION

Leave MASTER BATTERY switch in ON position until heater has purged and stopped. Moving MASTER BATTERY switch to OFF position before heater has purged will damage heater system.

4. Move switch (Figure 1, Item 3) to ON-LO. If heater does not start in 2 minutes, move switch to OFF.
5. After waiting 10 seconds, move switch (Figure 1, Item 3) to ON-LO. If heater does not start in 1 minute, move switch to OFF.
6. After waiting 10 more seconds, move switch (Figure 1, Item 3) to ON-LO. If heater does not start in 1 minute, move switch to OFF and notify field maintenance.
7. Move switch (Figure 1, Item 3) from ON-LO to ON-HI to change air temperature (but not amount of airflow). DO NOT stop switch in OFF position when adjusting air temperature.

OPERATE PERSONNEL HEATER - CONTINUED

Start Heater - Continued

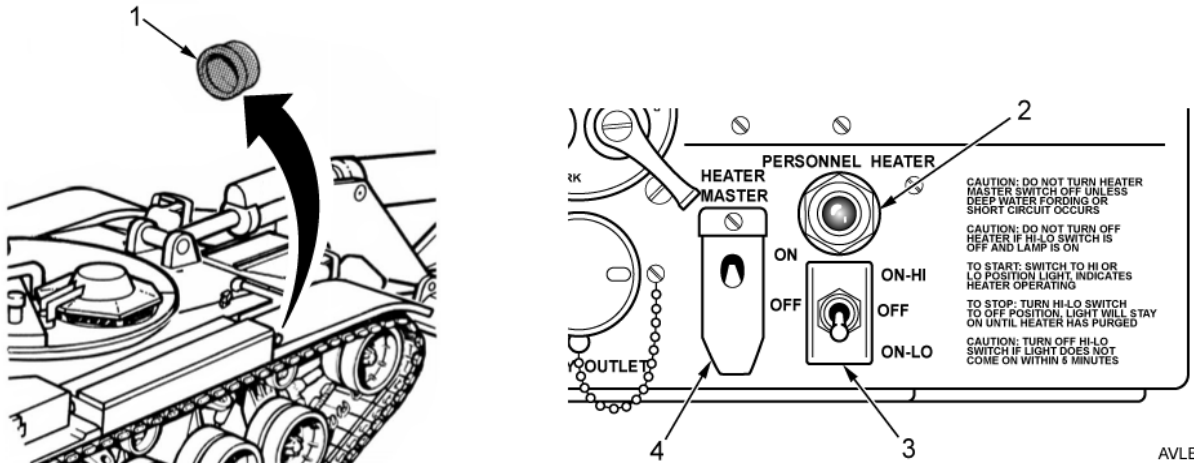

Figure 1. Personnel Heater.

END OF TASK

Stop Heater

1. After heater has run 5 minutes or more, move ON-HIGH/OFF/ON-LO switch (Figure 2, Item 3) to OFF.
2. If indicator (Figure 2, Item 2) does not go out within 5 minutes, notify field maintenance. Install exhaust plug (Figure 2, Item 1) on vehicle.

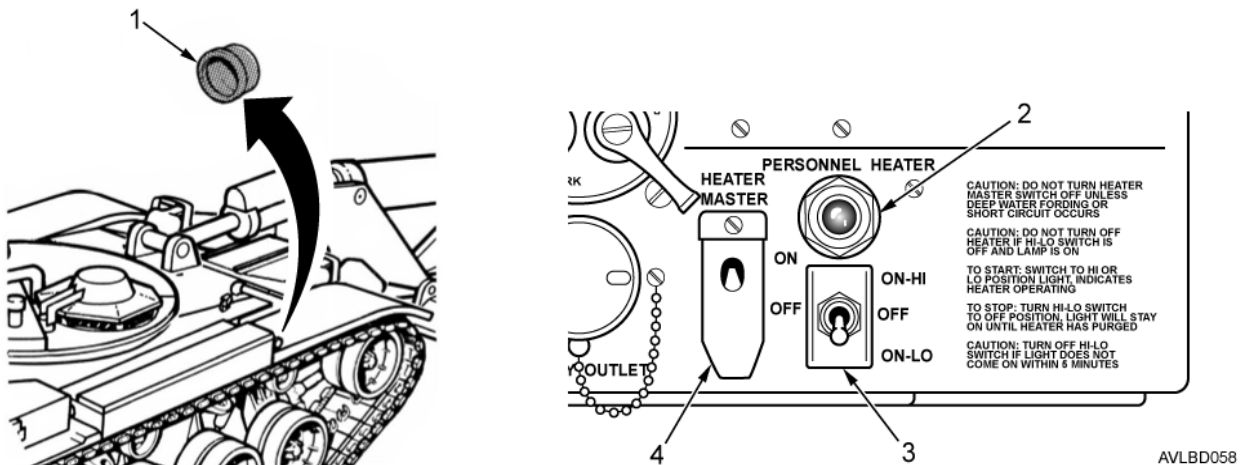

Figure 2. Personnel Heater.

END OF TASK

END OF WORK PACKAGE

OPERATOR MAINTENANCE**OPERATION UNDER USUAL CONDITIONS - AN/VVS-2 NIGHT VISION VIEWER**

INITIAL SETUP:**Materials/Parts**

Battery Driver's Passive Night Viewer
(WP 0079, Table 1, Item 6)
Brush (WP 0079, Item 8)
Rag, Wiping (WP 0079, Item 52)

References

TM 11-5855-249-10
WP 0046

GENERAL

This work package provides instructions for operating the AN/VVS-2 night vision viewer for the M48A5 Armored Vehicle Launched Bridge (AVLB) and M60A1 AVLB under usual/normal conditions. If equipment will not operate, refer to Auxiliary Systems and Controls Troubleshooting (WP 0046).

INSTALLING AN/VVS NIGHT VISION VIEWER**NOTE**

Driver's and commander's hatch must be closed and locked to install night vision viewer.

1. Pivot handle (Figure 1, Item 5) fully downward to raise door (Figure 1, Item 1) above hatch.
2. Rotate handle (Figure 1, Item 5) rearward until door (Figure 1, Item 1) is fully open.
3. Pivot handle (Figure 1, Item 5) upward. Press lever (Figure 1, Item 2) and pull spring-loaded handle (Figure 1, Item 3) down and rearward (180°) until handle locks.
4. Ensure seal (Figure 1, Item 4) is seated in hatch groove and is not hanging loose.

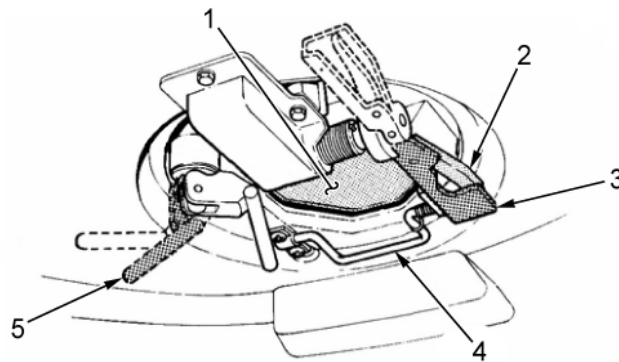

AVLBD060

Figure 1. Night Vision Door.

5. Remove viewer (Figure 2, Item 1) from stowage box (Figure 2, Item 2).

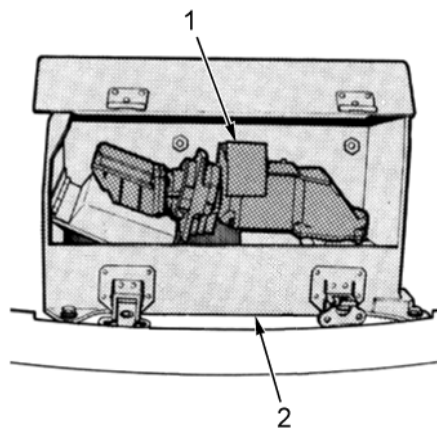

AVLBD061

Figure 2. Stowage Box.

INSTALLING AN/VVS NIGHT VISION VIEWER - CONTINUED

6. Remove snap-on lens cover (Figure 3, Item 1). Stow cover in viewer storage box.

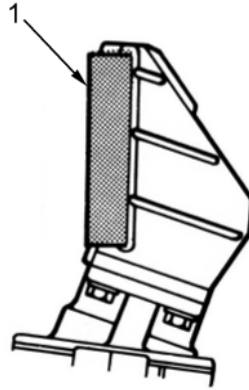

AVLBD062

Figure 3. Snap-On Lens Cover.

7. Rotate mounting plate (Figure 4, Item 1) to position in detent. Sides of mounting plate will be in line with sides of viewer (Figure 4, Item 2).

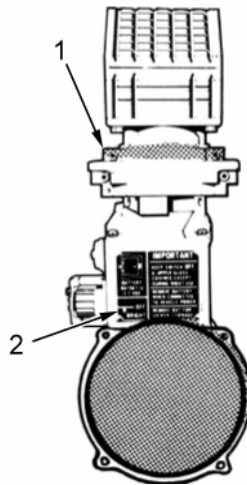

AVLBD469

Figure 4. Viewer.

INSTALLING AN/VVS NIGHT VISION VIEWER - CONTINUED**NOTE**

Viewer weighs approximately 18 lb (8.17 kg).

8. Hold viewer (Figure 5, Item 5) in vertical position and carefully raise viewer head (Figure 5, Item 1) through hatch.
9. Engage front edge of mounting plate (Figure 5, Item 6) with slots (Figure 5, Item 7) at front of hatch (Figure 5, Item 8), and then move rear end of mounting plate upward until viewer is vertical.

CAUTION

Hold handle (Figure 5, Item 3) before depressing lever (Figure 5, Item 2). Handle is spring loaded (30 lb-inch) (3.4 Nm) and will rotate down and forward when lever is depressed exerting excessive force on viewer. Failure to comply may result in damage to viewer.

10. Hold handle (Figure 5, Item 3) and then press lever (Figure 5, Item 2). Allow handle to rotate down and then forward. Push handle up until lever locks. Before releasing viewer, ensure it is seated firmly in place.
11. Remove snap-on eyepiece cover (Figure 5, Item 4). Stow cover in viewer stowage box.

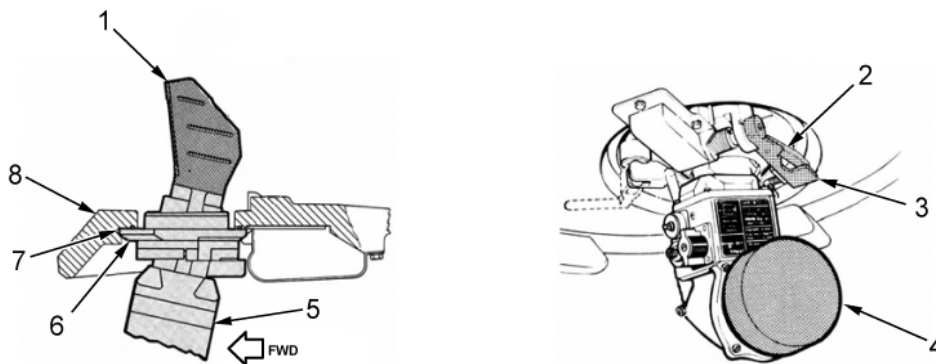

AVLBD063

Figure 5. Viewer Installation.

END OF TASK

USING VEHICLE POWER

WARNING



An installed battery can overheat and may explode when vehicle power is used. Remove viewer battery from viewer and store in viewer stowage box before connecting power cable. Failure to comply may result in personnel injury or death.

NOTE

Viewer may be operated from either vehicle power or battery power. Vehicle power is normally used. When battery power is used, dispose of battery after each night's operation. Normal life of battery in use is 6 to 8 hours.

1. Set NIGHT VISION switch (Figure 6, Item 2) to OFF.
2. Unscrew battery cap (Figure 6, Item 3) and remove battery (if installed). Store battery in viewer stowage box before connecting power cable.
3. Reinstall battery cap (Figure 6, Item 3).
4. Remove cover (Figure 6, Item 8) from viewer receptacle (Figure 6, Item 4).
5. Disconnect power cable connector (Figure 6, Item 6) from dummy receptacle (Figure 6, Item 7).
6. Connect power cable (Figure 6, Item 5) to viewer receptacle (Figure 6, Item 4).
7. Set MASTER BATTERY switch (Figure 6, Item 1) to ON.
8. Set NIGHT VISION switch (Figure 6, Item 2) to ON.

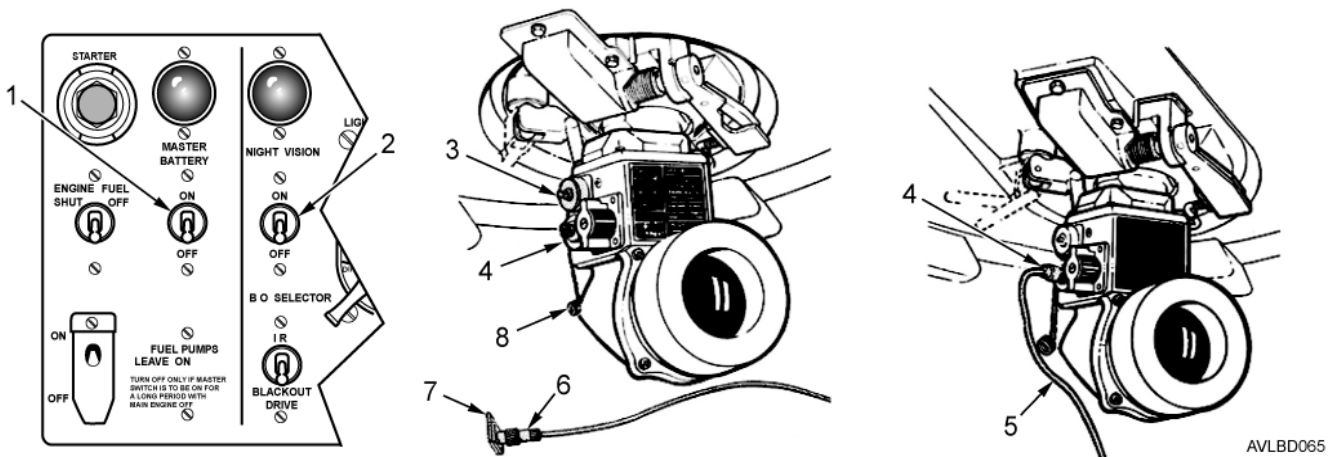

Figure 6. Using Vehicle Power.

END OF TASK

USING BATTERY POWER

NOTE

Joysticks used to control mast assembly functions are spring loaded and return to their neutral positions automatically when released.

1. If vehicle power cable (Figure 7, Item 3) is connected to viewer, set NIGHT VISION switch (Figure 7, Item 1) to OFF.
2. Disconnect power cable (Figure 7, Item 3) from viewer receptacle (Figure 7, Item 2) and connect to dummy receptacle (Figure 7, Item 4).
3. Install cover (Figure 7, Item 5) on viewer receptacle (Figure 7, Item 2).

NOTE

Battery is stowed in viewer carrying case with one spare.

4. Unscrew battery cap (Figure 7, Item 6) and insert battery (refer to WP 0079, Item 6), recessed positive (+) end first.
5. Reinstall battery cap (Figure 7, Item 6).

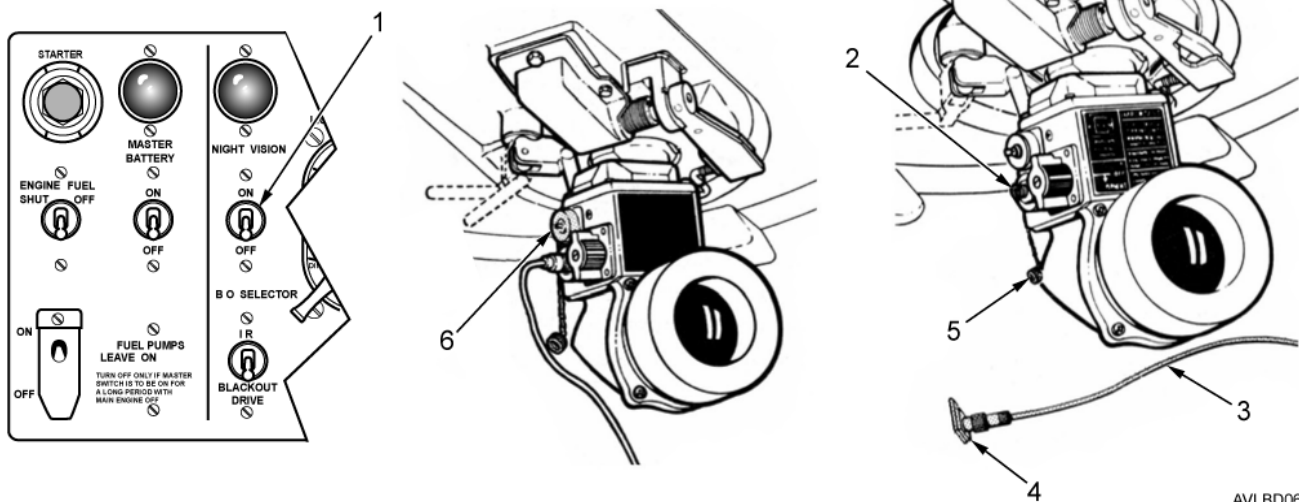

AVLBD067

Figure 7. Using Battery Power.

END OF TASK

OPERATING AN/VVS-2 VIEWER

NOTE

Refer to TM 11-5855-249-10 for additional operating information.

1. Rotate OFF-BRIGHT switch (Figure 8, Item 3) to full BRIGHT.
2. If picture on viewer eyepiece is too bright, rotate OFF-BRIGHT switch (Figure 8, Item 3) slowly toward OFF until viewing is comfortable to eyes.

NOTE

- When viewer is directed toward a bright light source, picture on viewer eyepiece may normally flash or briefly go blank.
 - Viewer range and picture may be improved by turning on the vehicle headlights when operating under very low light conditions.
3. For normal driving, set viewer (Figure 8, Item 2) in straight forward (detent) position. Rotate viewer right or left to increase terrain coverage.
 4. When viewer is installed and not being used, rotate OFF-BRIGHT switch (Figure 8, Item 3) to OFF. Set NIGHT VISION switch (Figure 8, Item 1) to OFF if vehicle power was being used.

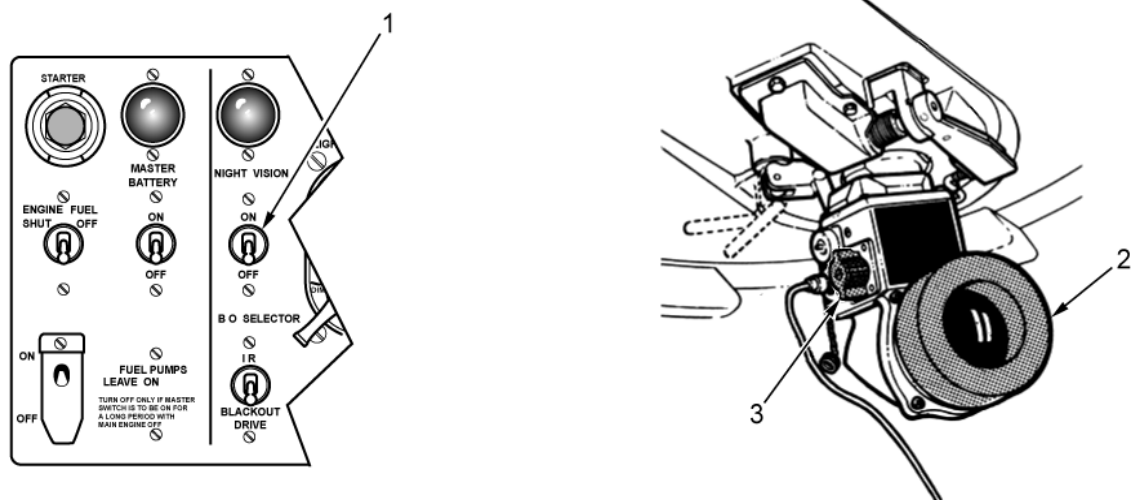

AVLBD069

Figure 8. Operating AN/VVS-2 Viewer.

END OF TASK

CLEANING DURING OPERATION

NOTE

During bad weather conditions such as blowing dust, rain, or snow, outside lens of viewer may require cleaning to get a clear picture. Clean lens as instructed in the following steps.

1. Remove loose dust with lens dusting brush.
2. To remove stubborn dirt or smudges, use a white cotton rag. Gently wipe lens using a circular motion starting at the center and working toward the edge. Dry lens with white cotton rag, using the same circular motions.

END OF TASK

REMOVAL AND STOWAGE

1. If vehicle power was being used, set NIGHT VISION switch (Figure 9, Item 1) to OFF. If battery power was used, remove battery.
2. Rotate OFF-BRIGHT switch knob (Figure 9, Item 3) to OFF.
3. Disconnect power cable (Figure 9, Item 9) from viewer and connect to dummy receptacle (Figure 9, Item 7).
4. Install viewer receptacle cap (Figure 9, Item 8).
5. If battery was used, unscrew battery cap (Figure 9, Item 2). Remove and discard battery.
6. Reinstall battery cap (Figure 9, Item 2).
7. Turn viewer to straight forward (detent) position.
8. Install snap-on eyepiece cover (Figure 9, Item 6).
9. While supporting viewer with your left hand, press lever (Figure 9, Item 4) and pull handle (Figure 9, Item 5) rearward (180°) until it locks.

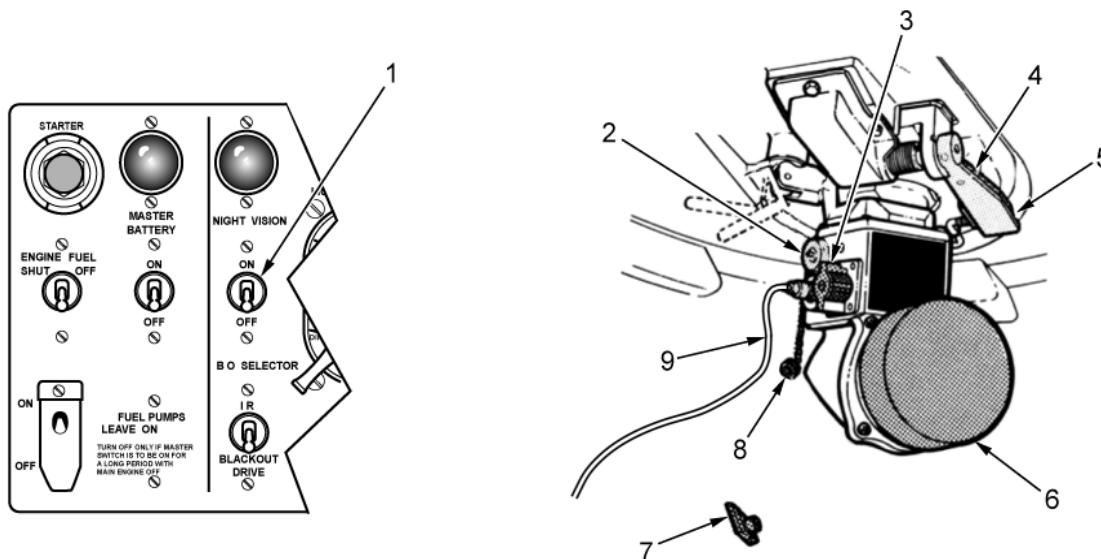

AVLBD070

Figure 9. Removing Night Vision Viewer.

REMOVAL AND STOWAGE - CONTINUED**NOTE**

Viewer weighs approximately 18 lb (8.17 kg).

10. Lower rear end of viewer (Figure 10, Item 2) downward to clear locking plunger (Figure 10, Item 3). Slide viewer rearward to disengage forward mount (Figure 10, Item 1) and carefully lower from hatch.

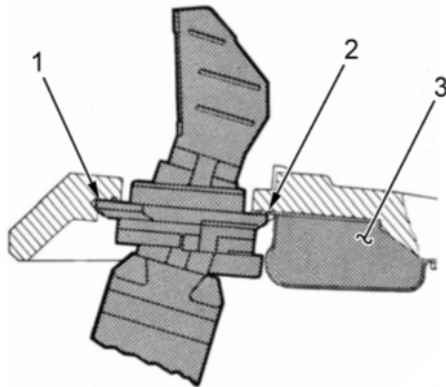

Figure 10. Disengaging Viewer.

AVLBD072

NOTE

Snap-on lens cover is stowed in viewer stowage box.

11. Install snap-on lens cover (Figure 11, Item 1) on viewer.

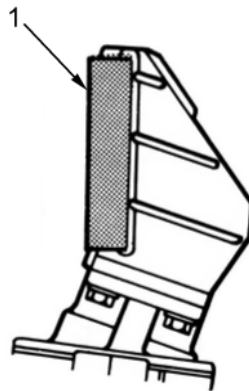
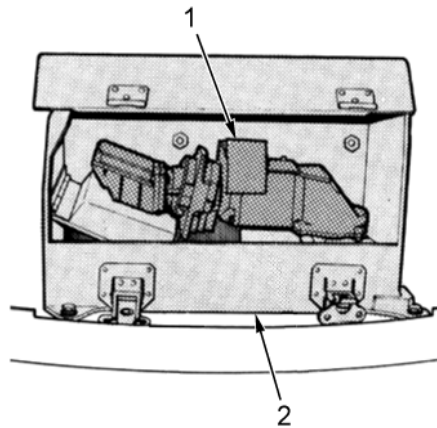

Figure 11. Installing Lens Cover.

AVLBD062

REMOVAL AND STOWAGE - CONTINUED

12. Stow viewer (Figure 12, Item 1) in stowage box (Figure 12, Item 2).



AVLBD073

Figure 12. Stowing Viewer.

CAUTION

Hold handle (Figure 13, Item 3) before depressing lever (Figure 13, Item 2). Handle is spring loaded (30 lb-inch) (3.4 Nm) and will rotate down and forward when lever is depressed. Failure to comply may result in damage to viewer.

13. Hold handle (Figure 13, Item 3) and then press lever (Figure 13, Item 2) and allow door handle (Figure 13, Item 4) to rotate down and then forward. Push handle up until lever locks in place.

NOTE

Ensure viewer door seal area is free of dirt and debris before closing door.

14. Rotate door handle (Figure 13, Item 4) counterclockwise until door (Figure 13, Item 1) is over hatch opening.

Pivot handle down to drop door into place.

15. Pivot door handle (Figure 13, Item 4) up to lock door closed.

REMOVAL AND STOWAGE - CONTINUED

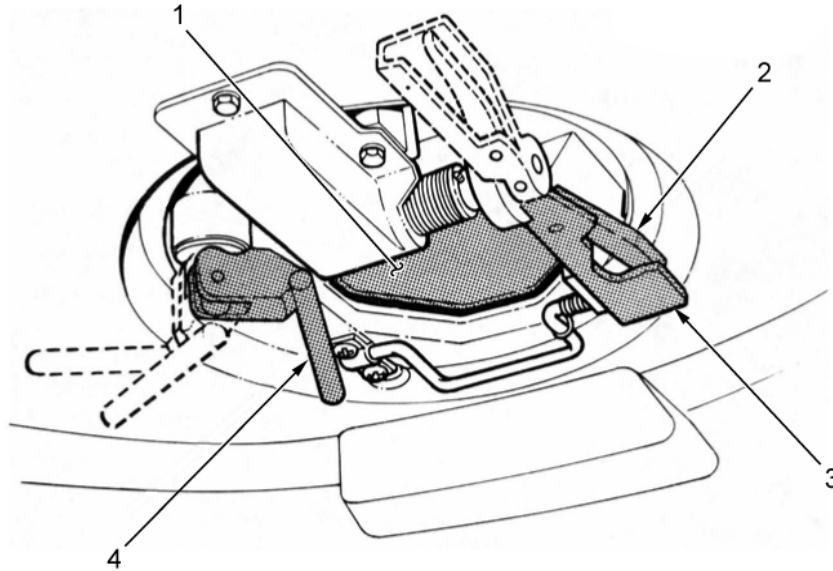

AVLBD074

Figure 13. Night Vision Door.

END OF TASK

END OF WORK PACKAGE

OPERATOR MAINTENANCE
OPERATION UNDER USUAL CONDITIONS - PARKING BRAKE

INITIAL SETUP:**References**

WP 0041

Equipment Conditions

Vehicle stopped (WP 0016)

GENERAL

This work package provides instructions for applying the M48A5 Armored Vehicle Launched Bridge (AVLB) and M60A1 AVLB parking brake under usual/normal conditions. If equipment will not operate, refer to Brakes Troubleshooting Procedures (WP 0041).

OPERATE PARKING BRAKE**Applying Parking Brake****CAUTION**

- DO NOT set parking brake if temperature is at or below freezing (32°F (0°C)). Brakes can be damaged.
- DO NOT attempt to set parking brake before vehicle is stopped. Failure to comply may result in damage to transmission.

1. Press brake pedal (Figure 1, Item 1) once until pressure gauge (Figure 1, Item 4) indicates 750 to 900 psi (5171 kPa to 6205 kPa). If pressure is over 900 psi (6205 kPa), brake may be difficult to release.
2. Move transmission shift lever (Figure 1, Item 2) to P (Park). Set transmission shift lever lock (Figure 1, Item 3).
3. Release brake pedal (Figure 1, Item 1). Parking brake is set.

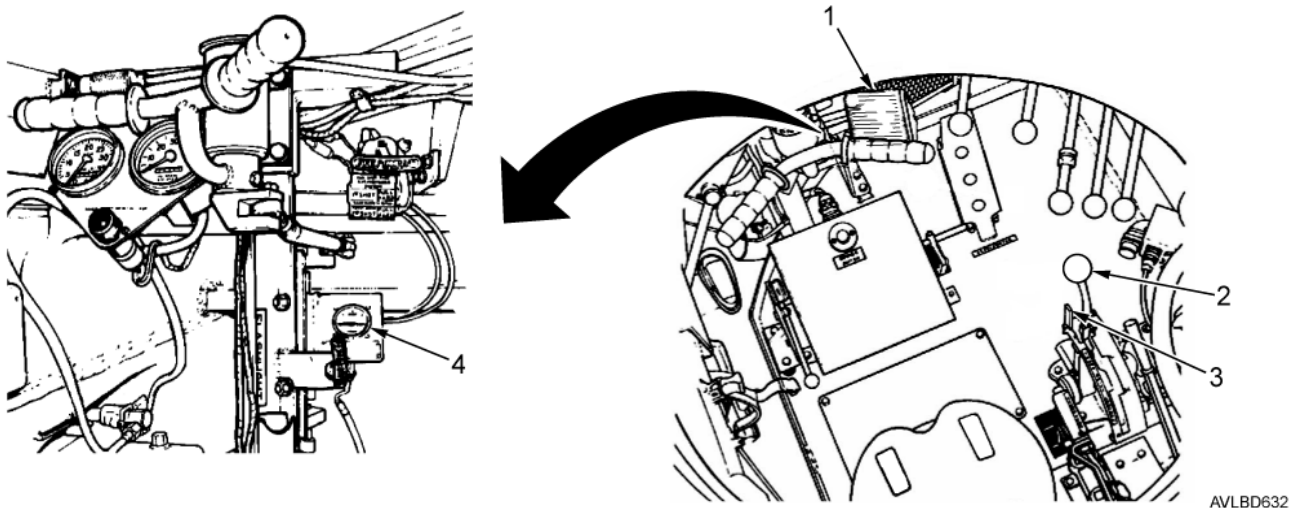

Figure 1. Parking Brake.

END OF TASK

OPERATE PARKING BRAKE - CONTINUED**Releasing Parking Brake****NOTE**

DO NOT pump pedal. This will increase the force necessary to release parking brake from P (Park) position. If pedal has been pumped, release for 1 minute to allow master cylinder to return to unapplied position.

1. Press brake pedal (Figure 2, Item 1).
2. Push transmission shift lever lock (Figure 2, Item 3) forward.
3. Move transmission shift lever (Figure 2, Item 2) to the N (Neutral) position and release brake pedal (Figure 2, Item 1).

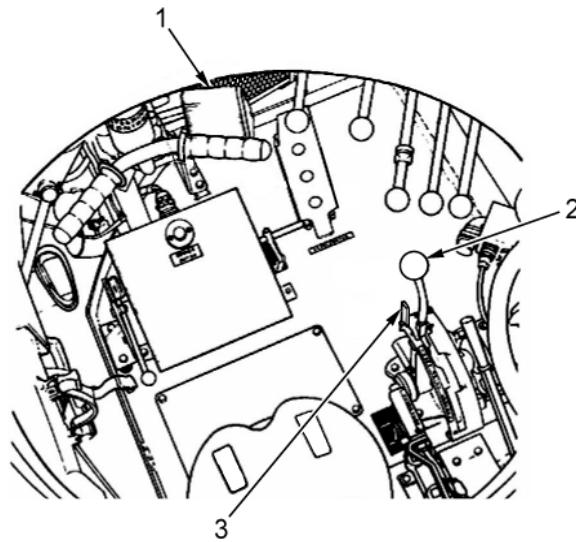

AVLBD626

Figure 2. Parking Brake.

END OF TASK**END OF WORK PACKAGE**

OPERATOR MAINTENANCE**OPERATION UNDER USUAL CONDITIONS - SHIFTING TRANSMISSION**

INITIAL SETUP:NOT APPLICABLE

GENERAL

This work package provides instructions for operating the M48A5 Armored Vehicle Launched Bridge (AVLB) and M60A1 AVLB transmission under usual/normal conditions. If equipment will not operate, notify field maintenance.

SHIFTING TRANSMISSION

WARNING



Vehicle may move suddenly if brakes are not applied when shifting out of N (Neutral). Apply brakes when shifting out of N to another range. Failure to comply may result in personnel injury or death.

CAUTION

- Driving down a slope with the shift lever in N (Neutral) will damage transmission. DO NOT shift from N (Neutral) to L (Low), H (High), or R (Reverse) unless engine is at idle speed (700 to 750 RPM).
- Shifting from N (Neutral) to L (Low), H (High), or R (Reverse) when the engine is not at idle speed will cause transmission to grind. DO NOT shift from N to L, H, or R unless the engine is at idle speed (700 to 750 RPM). Failure to comply may result in equipment damage.
- If engine stalls when driving up an incline, do not allow vehicle to roll backward while transmission shift lever is in a drive range. Damage to engine and transmission will occur. If engine starts to run backward, stop vehicle and shut off engine. Attempt to restart engine. If braking does not stop vehicle, move transmission shift lever to the N position and bring vehicle to a stop with brakes. Then shut off engine.

N (Neutral)

Use N (Neutral) range (Figure 1) when forward or rearward movement is not wanted when making pivot turn.

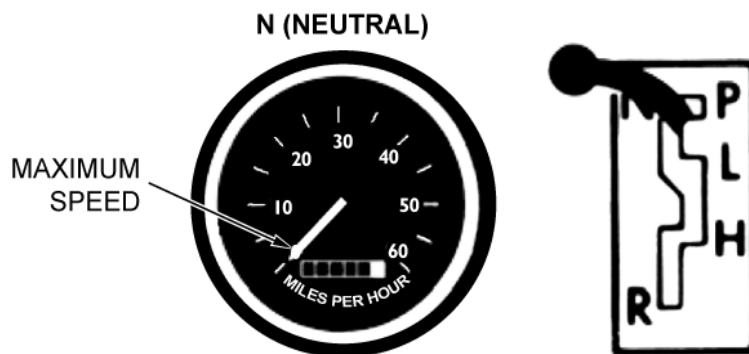

AVLBD078

Figure 1. Neutral.

END OF TASK

SHIFTING TRANSMISSION - CONTINUED**R (Reverse)****WARNING**

Shifting from L (Low) to R (Reverse) or R to L while the vehicle is in motion may cause transmission/engine damage and result in steering loss. DO NOT shift transmission from L to R or from R to L while the vehicle is in motion. Failure to comply may result in personnel injury or death, or equipment damage.

Use R (Reverse) range (Figure 2) for moving vehicle rearward and going up steep grades for maximum engine power.



Figure 2. Reverse.

END OF TASK

SHIFTING TRANSMISSION - CONTINUED

P (Park)

WARNING



Vehicle may move suddenly if brakes are not applied when shifting out of N (Neutral). Apply brakes when shifting out of N to another range. Failure to comply may result in personnel injury or death.

CAUTION

Transmission damage may occur if vehicle is moving when shifting to park. Bring the vehicle to a complete stop before shifting to park. Failure to comply may result in transmission damage.

Move shift lever to P (Park) (Figure 3) to start engine or to lock parking brakes.



Figure 3. Park.

AVLBD079

END OF TASK

L (Low)

CAUTION

When going down steep hills in L (Low) range (vehicle moving forward), keep engine speed below 2,400 RPM by applying brakes as required. Failure to comply may result in equipment damage.

Use L (Low) range (Figure 4) when operating on soft, rough, steeply inclined terrain or when moving forward from a stop.

SHIFTING TRANSMISSION - CONTINUED



AVLBD080

Figure 4. Low.

END OF TASK

H (High)

CAUTION

Starting vehicle moving forward from a stop in H (High) range will damage transmission. DO NOT shift from H to L (Low) if speed is more than 9 mph. DO NOT shift from H to R (Reverse) unless vehicle is stopped and engine is at idle speed (700 to 750 RPM). Failure to comply may result in equipment damage.

Use H (High) range (Figure 5) when driving on firm, smooth, and level ground.



AVLBD081

Figure 5. High.

END OF TASK

END OF WORK PACKAGE

OPERATOR MAINTENANCE
OPERATION UNDER USUAL CONDITIONS - STEERING VEHICLE

INITIAL SETUP:

References

WP 0044

GENERAL

This work package provides instructions for steering the M48A5 Armored Vehicle Launched Bridge (AVLB) and M60A1 AVLB under usual/normal conditions. If equipment will not operate, refer to Steering Troubleshooting Procedures (WP 0044).

STEERING VEHICLE**CAUTION**

- Releasing the steering control and allowing it to return to center may damage the steering control and linkage. DO NOT release the steering control, guide the steering control back to center by hand. Failure to comply may result in equipment damage.
- Abrupt steering can cause a track to be thrown or transmission damage. Apply steering gradually, never steer abruptly. Failure to comply may result in equipment damage.
- Steering side-to-side to slow the vehicle will cause track damage. DO NOT steer from side-to-side to slow the vehicle. Slowly apply brakes to slow vehicle. Failure to comply may result in damage to the track.

NOTE

Turning radius is dependent on how far the steering control is turned, transmission range selected, and engine speed.

1. To turn left while vehicle is moving forward with transmission shift lever in L (Low) or H (High) (Figure 1), turn steering control to right.

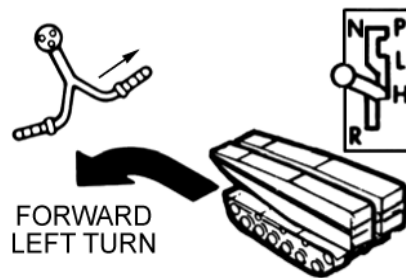

AVLBD082

Figure 1. Forward Left Turn.

STEERING VEHICLE - CONTINUED

NOTE

Operator can make a sharper turn with transmission shift lever in L (Low) than in H (High).

2. To turn right while vehicle is moving forward with transmission shift lever in L (Low) or H (High) (Figure 2), turn steering control to left.

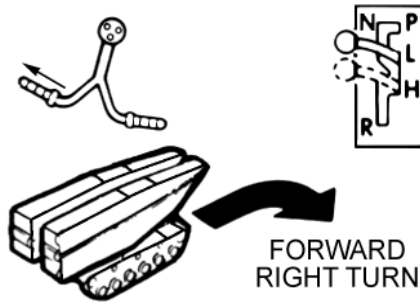

AVLBD083

Figure 2. Forward Right Turn.

3. To turn right while vehicle is moving rearward with transmission shift lever in R (Reverse) (Figure 3), turn steering control to right.

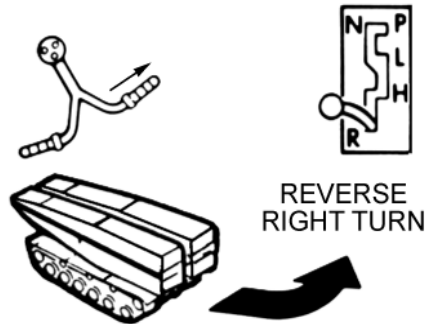

AVLBD084

Figure 3. Reverse Right Turn.

STEERING VEHICLE - CONTINUED

4. To turn left while vehicle is moving rearward with transmission shift lever in R (Reverse) (Figure 4), turn steering control to left.

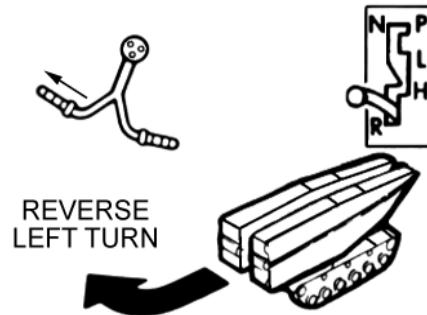

AVLBD085

Figure 4. Reverse Left Turn.

5. To pivot steer with transmission shift lever in N (Neutral) (Figure 5), turn steering control to right for left pivot turn and to left for right pivot turn.

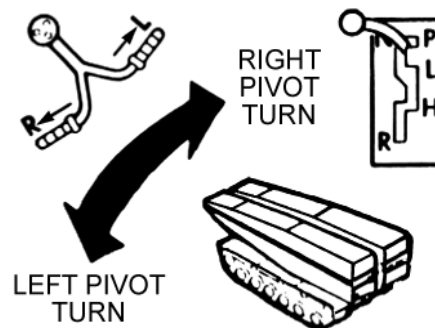

AVLBD086

Figure 5. Right/Left Pivot Turn.

END OF TASK

END OF WORK PACKAGE

OPERATOR MAINTENANCE**OPERATION UNDER USUAL CONDITIONS - STARTING AND STOPPING ENGINE**

INITIAL SETUP:**References**WP 0009
WP 0012**References (cont.)**WP 0040
WP 0048

GENERAL

This work package provides instructions for operating the M48A5 Armored Vehicle Launched Bridge (AVLB) and M60A1 AVLB engine under usual/normal conditions. If equipment will not operate, refer to Engine Troubleshooting Procedures (WP 0040).

STARTING AND STOPPING ENGINE

Starting Engine

WARNING



Hearing loss may occur with repeated exposure to high noise levels. Personnel must wear hearing protection when the engine is running. Double hearing protection (helmet and earplugs) is required when operating the vehicle at speeds of 15 mph and above. Failure to comply may result in personnel injury.

NOTE

Before starting engine or operating vehicle, perform the Preventive Maintenance Checks and Services (PMCS). Refer to WP 0048.

1. Read list of warnings and instructions on plate (Figure 1, Item 3) before starting engine. Where necessary, more details are provided in the following instructions.
2. Apply parking brake. Refer to WP 0012.
3. Close engine compartment drain valve by pushing lever (Figure 1, Item 2) to left, out of detent, and pulling up.
4. Close crew compartment drain valve by moving lever (Figure 1, Item 1) forward and to left.
5. Center steering control (Figure 1, Item 4).
6. Push in manual fuel shutoff handle (Figure 1, Item 5). Ensure transmission shift lever (Figure 1, Item 6) is in P (Park) position.

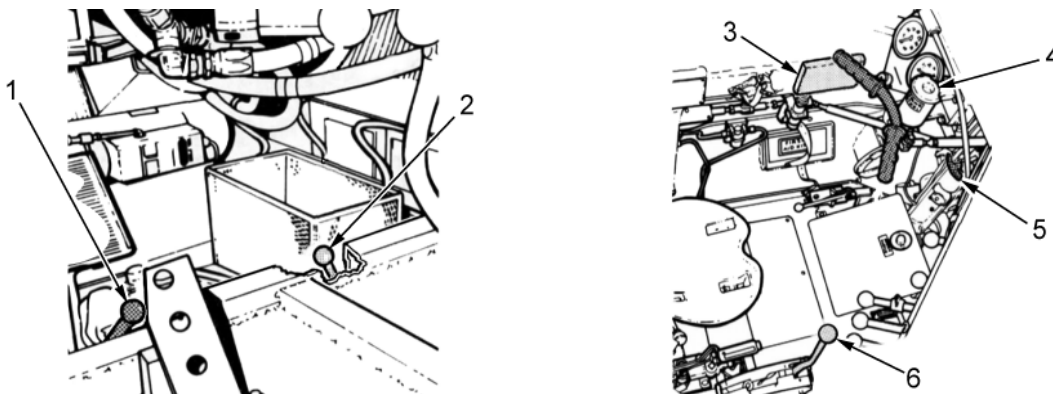

AVLBD087

Figure 1. Starting Instructions.

7. Turn off all electrical switches except FUEL PUMPS (Figure 2, Item 5) and HEATER MASTER (Figure 2, Item 3).
8. Turn off all communications equipment.
9. Ensure FUEL PUMPS switch (Figure 2, Item 5) is ON.
10. Set MASTER BATTERY switch (Figure 2, Item 2) to ON.
11. Ensure MASTER BATTERY LAMP (Figure 2, Item 1) is ON.
12. Ensure POWERPLANT WARNING LAMP (Figure 2, Item 4) is ON.

STARTING AND STOPPING ENGINE - CONTINUED

Starting Engine - Continued

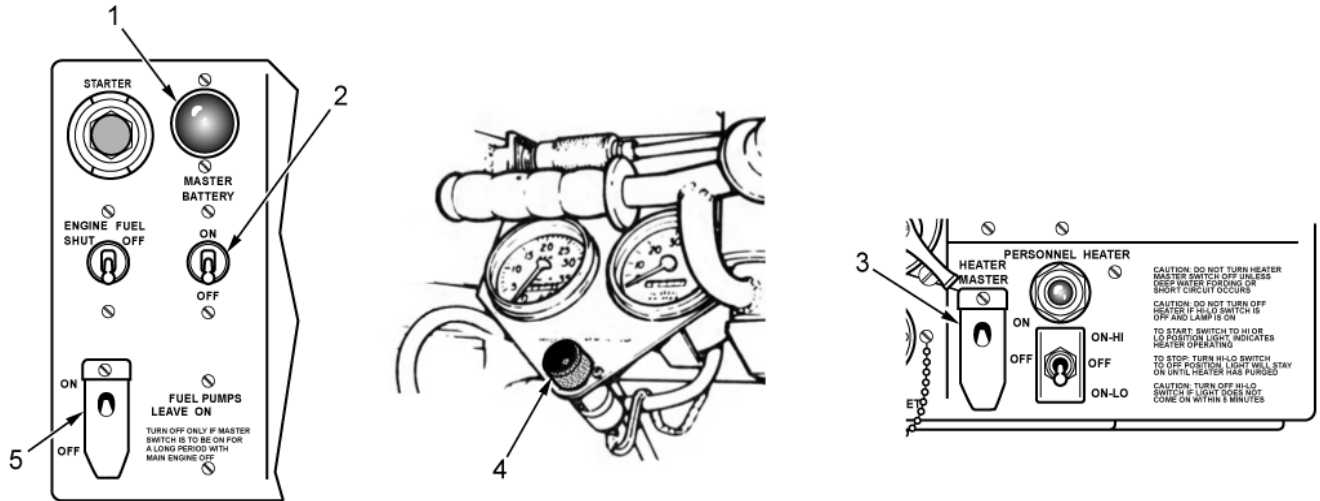

Figure 2. Powerplant Warning Light.

AVLBD088

WARNING



Hearing loss may occur with repeated exposure to high noise levels. Personnel must wear hearing protection when the engine is running. Double hearing protection (helmet and earplugs) is required when operating the vehicle at speeds of 15 mph and above. Failure to comply may result in personnel injury.

13. If engine has not been operated for a week or more, proceed with step 14. If engine has been operated within a week, skip step 14 and proceed with step 15. For cold weather starting, proceed directly to step 18.

14. Purge air from fuel lines by pumping purge pump handle (Figure 3, Item 1) three or four strokes until back pressure is evident.

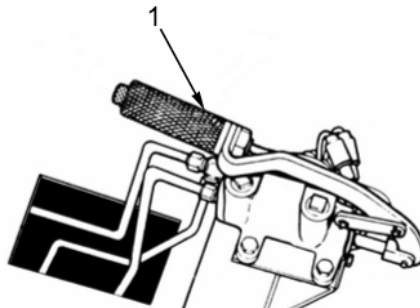

Figure 3. Purge Pump Handle.

AVLBD505

STARTING AND STOPPING ENGINE - CONTINUED**Starting Engine - Continued****CAUTION**

DO NOT start vehicle if radio is being used. Radio damage could result. DO NOT press and hold STARTER switch for more than 30 seconds at a time. Damage to starter could result. Allow at least 2 minutes of cool-off between attempts to start engine.

15. Normal starting. Press accelerator pedal (Figure 4, Item 1) about 2/3 to 3/4 of its travel and press and hold STARTER switch (Figure 4, Item 2).
16. When engine starts, release STARTER switch (Figure 4, Item 2) and proceed to step 21.
17. If engine does not start after a maximum of 30 seconds cranking, release STARTER switch and wait at least 2 minutes before attempting another start. If engine does not start after second attempt, refer to WP 0040.
18. Cold weather starting. Press accelerator pedal (Figure 4, Item 1) about 2/3 or 3/4 of its travel and press and hold STARTER switch (Figure 4, Item 2).

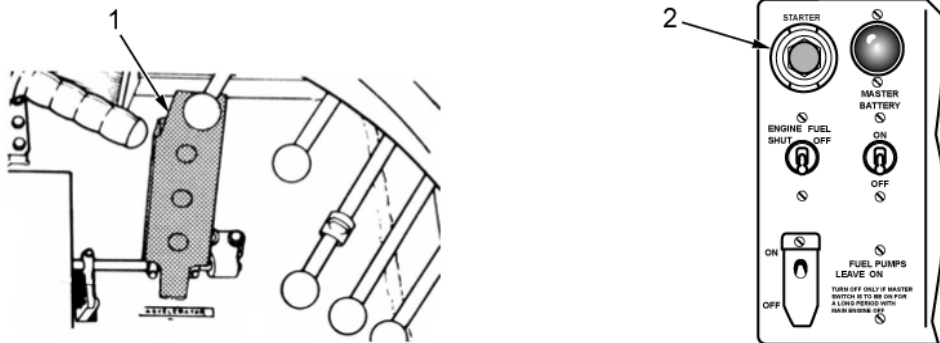

AVLBD091

Figure 4. Normal and Cold Weather Starting.

CAUTION

DO NOT hold manifold heater switch (Figure 5, Item 1) longer than 15 seconds. Damage to manifold heaters may result.

19. While engine is cranking, press manifold heater switch (Figure 5, Item 1) and pump purge pump handle (Figure 5, Item 2).

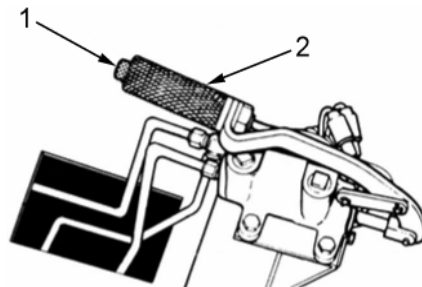

AVLBD090

Figure 5. Manifold Heater Switch.

STARTING AND STOPPING ENGINE - CONTINUED**Starting Engine - Continued**

20. If engine does not start after 30 (maximum) seconds cranking, release STARTER switch and wait at least 2 minutes before attempting another start. If engine does not start after second try, refer to WP 0040.
21. If engine starts and runs on only one bank, depress and hold brake (Figure 6, Item 2) and load engine with transmission by shifting transmission shift lever (Figure 6, Item 5) to H (High) to start other bank.
22. As soon as engine starts, check that ENGINE OIL PRESSURE INDICATOR NEEDLE (Figure 6, Item 4) is in green area and that POWERPLANT WARNING LAMP (Figure 6, Item 7) is OFF. If oil pressure does not come up, shut off engine. Refer to WP 0040.

CAUTION

DO NOT accelerate engine beyond warm-up speeds (1,000 to 1,200 RPM). Damage to engine may result.

23. Press accelerator pedal (Figure 6, Item 3) until TACHOMETER (Figure 6, Item 1) indicates 1,000 to 1,200 RPM (1,200 to 1,800 RPM for 3 to 5 minutes in cold weather).
24. Pull up accelerator lock lever (Figure 6, Item 6).
25. Let engine run for 3 to 5 minutes.

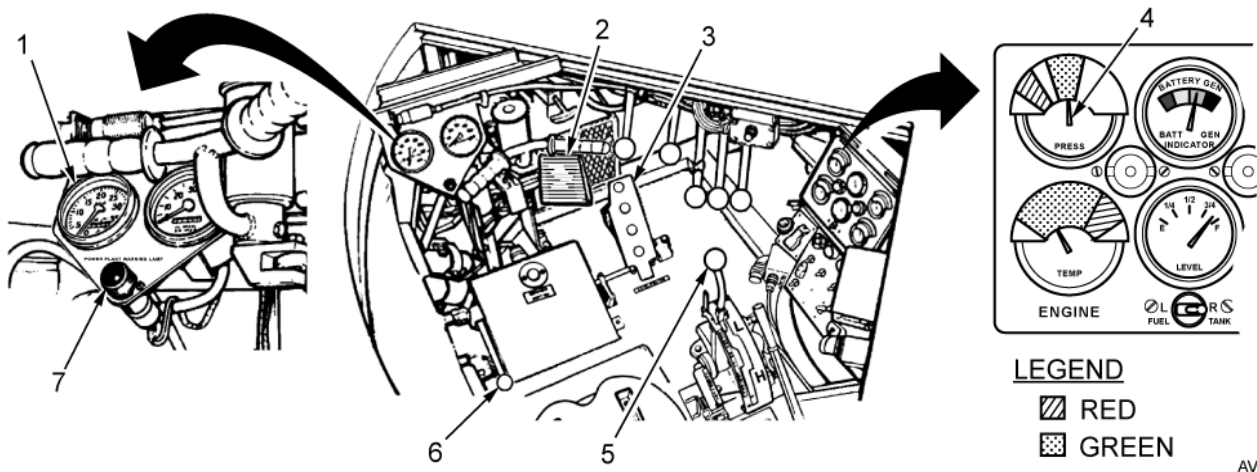

Figure 6. Shifting Transmission and Checking Engine Oil Pressure.

STARTING AND STOPPING ENGINE - CONTINUED

NOTE

- If engine is to be idled for an extended period, set for 1,000 to 1,200 RPM to prevent smoking.
- If vehicle is equipped with 650 amp generator, indicators may fluctuate after initial engine startup.

26. Check indicators are as follows:

ENGINE TEMPERATURE AND PRESSURE OIL INDICATORS (Figure 7): green area.

BATTERY-GENERATOR INDICATOR (Figure 7): green area.

TRANSMISSION TEMPERATURE AND PRESSURE OIL INDICATORS (Figure 8): green area.

POWERPLANT WARNING LAMP (Figure 7): off.

DUST DETECTOR WARNING LAMP (Figure 7) (if equipped): off.

27. If POWERPLANT WARNING LAMP (Figure 7) lights during vehicle operation, repeat step 26 to determine whether engine, transmission, or air intake system is at fault. Stop engine. Refer to WP 0040.

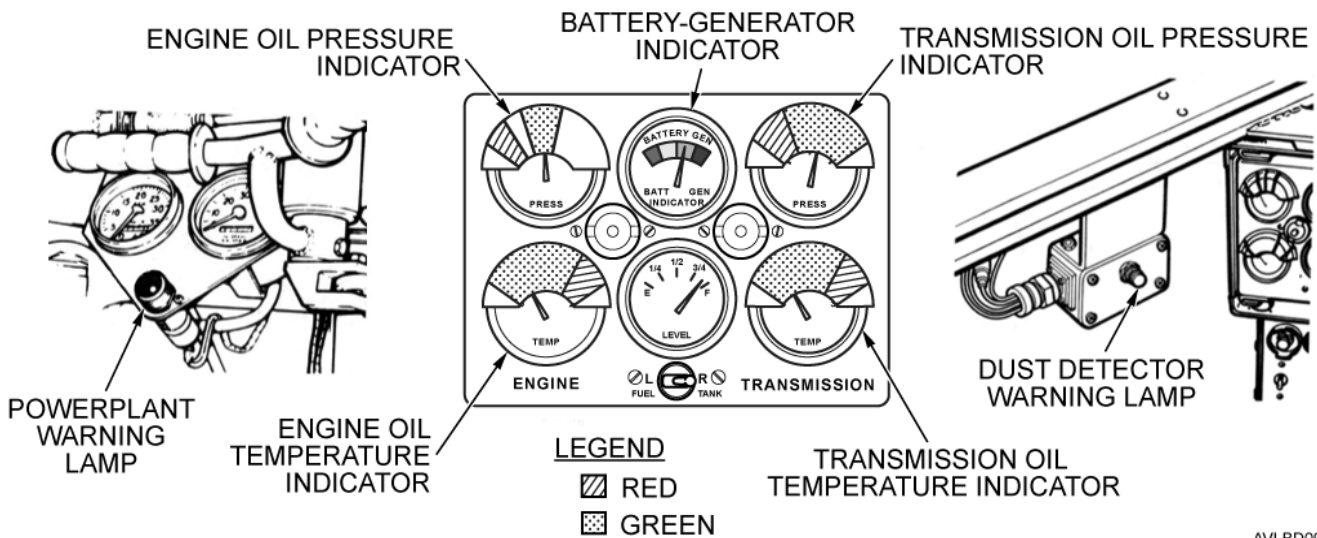

AVLBD094

Figure 7. Engine Indicators.

28. If BATTERY-GENERATOR INDICATOR needle is in yellow or left red area, alternator is not charging (Figure 8). Stop engine and troubleshoot. Refer to WP 0040.
29. If BATTERY-GENERATOR INDICATOR is in right red area, alternator is overcharging (Figure 8). Notify field maintenance.

STARTING AND STOPPING ENGINE - CONTINUED

Starting Engine - Continued



AVLBD096

Figure 8. Battery-Generator Indicators.

30. Inspect air cleaner indicator (Figure 9, Item 1). On indicator with window (Figure 9, Item 2), ensure window is clear (not red).

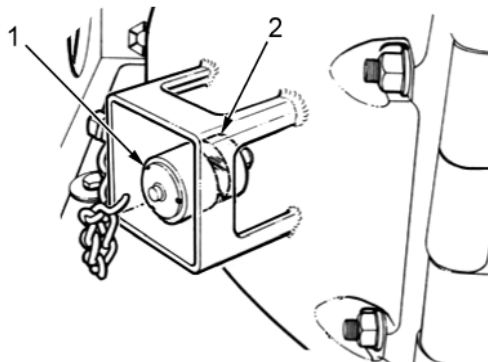

AVLBD097

Figure 9. Air Cleaner Indicator.

31. Inspect air cleaner indicator (Figure 10, Item 1). On indicator with window (Figure 10, Item 2) that measures restriction, ensure window reads less than 30 inches.

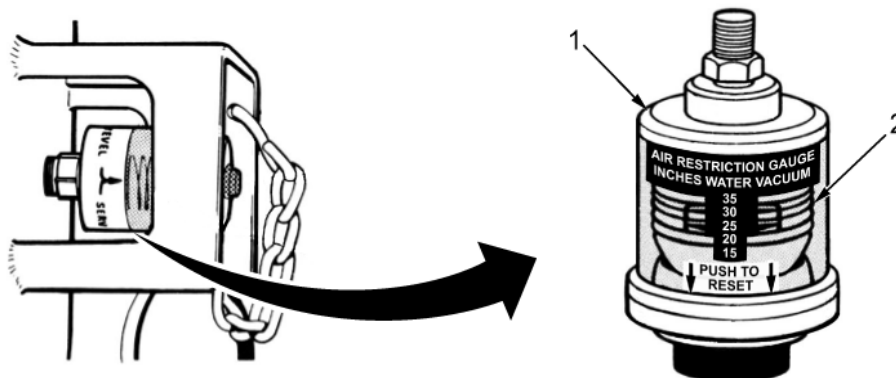

AVLBD631

Figure 10. Air Cleaner Indicator.

END OF TASK

STARTING AND STOPPING ENGINE - CONTINUED

Stopping Engine

1. After stopping vehicle, run engine at 1,000 to 1,200 RPM for several minutes to cool.
2. After running engine at 1,000 to 1,200 RPM to cool, let it idle (700 to 750 RPM).
3. Turn off all electrical equipment.
4. Raise and hold ENGINE FUEL SHUTOFF switch (Figure 11, Item 2) until engine stops.
5. If engine does not stop within 15 seconds, shut off fuel with MANUAL FUEL shutoff handle (Figure 11, Item 1) and increase engine RPM to 1,400. Notify field maintenance if it was necessary to shut off engine with MANUAL FUEL shutoff handle.
6. Turn MASTER BATTERY switch to OFF position (Figure 11, Item 3).
7. If vehicle is to remain parked for a week or more, place MANUAL FUEL shutoff handle (Figure 11, Item 1) in OFF position.

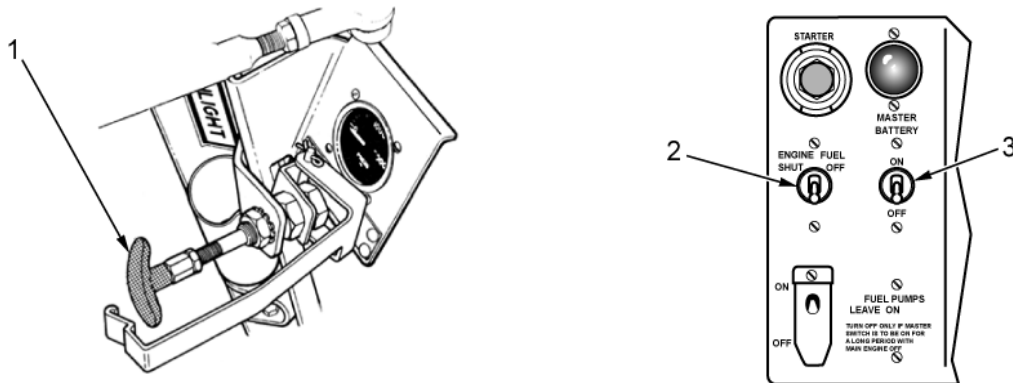

AVLBD101

Figure 11. Engine Fuel Shutoff.

8. Open crew compartment drain valve (Figure 12, Item 1) and engine compartment drain valve (Figure 12, Item 2). Refer to WP 0009.

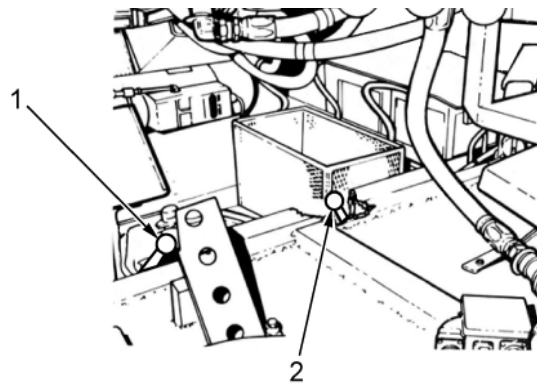

AVLBD102

Figure 12. Drain Valves.

END OF TASK

END OF WORK PACKAGE

OPERATOR MAINTENANCE**OPERATION UNDER USUAL CONDITIONS - PLACING VEHICLE IN MOTION AND STOPPING VEHICLE**

INITIAL SETUP:**References**WP 0008
WP 0012**References (cont.)**WP 0041

GENERAL

This work package provides instructions for placing the M48A5 Armored Vehicle Launched Bridge (AVLB) and M60A1 AVLB in motion and stopping under usual/normal conditions. If equipment will not operate, refer to Brakes Troubleshooting Procedures (WP 0041).

PLACING VEHICLE IN MOTION

1. Turn on service drive lights (Figure 1, Item 1). Refer to WP 0008.
2. Press and release accelerator pedal (Figure 1, Item 3) to release accelerator lock (Figure 1, Item 5). Let engine idle (700 to 750 RPM).

CAUTION

To prevent sudden movement of vehicle and damage to transmission, keep brakes applied when moving shift lever from P (Park) to another range. Stop vehicle before you move shift lever to P (Park). Failure to comply may result in equipment damage.

3. Press brake pedal (Figure 1, Item 2) and move transmission shift lever (Figure 1, Item 4) from P (Park) to N (Neutral) to release parking brake. Refer to WP 0012. If parking brake does not release, refer to WP 0041.

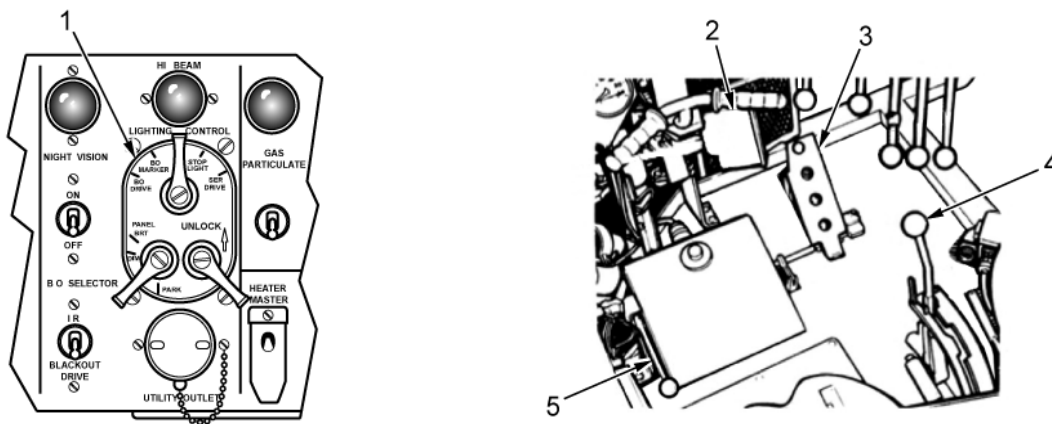

AVLBD098

Figure 1. Release Parking Brake.

4. While maintaining pressure on brake pedal (Figure 2, Item 2), move transmission shift lever (Figure 2, Item 4) to desired range L (Low) or R (Reverse).
5. Release brake pedal (Figure 2, Item 2).
6. Slowly press accelerator pedal (Figure 2, Item 3).
7. Steer vehicle with steering control (Figure 2, Item 1).

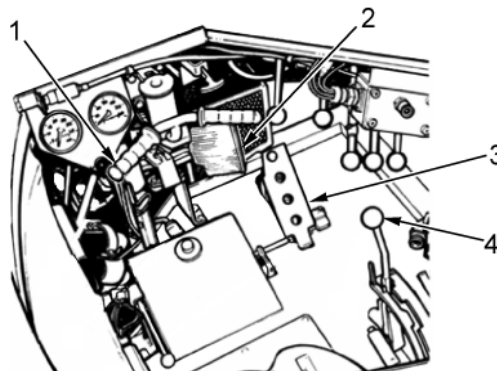

AVLBD099

Figure 2. Steering Vehicle.

END OF TASK

STOPPING VEHICLE

1. Release accelerator pedal (Figure 3, Item 2).
2. Press and hold brake pedal (Figure 3, Item 1) to stop vehicle.
3. Move transmission shift lever (Figure 3, Item 3) to desired range (N, L, or R). If parking vehicle, move transmission shift lever to P (Park) and lock parking brake.
4. Release brake pedal (Figure 3, Item 1).

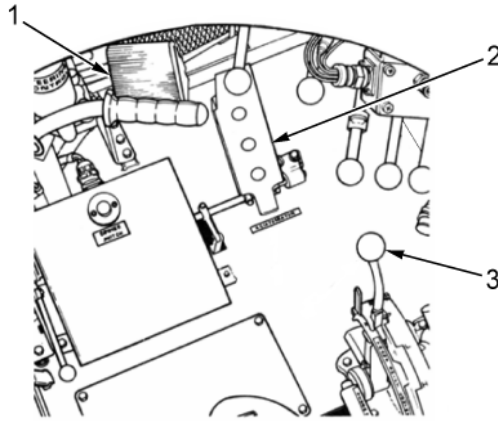

AVLBD100

Figure 3. Stopping Vehicle.

END OF TASK**END OF WORK PACKAGE**

OPERATOR MAINTENANCE
OPERATION UNDER USUAL CONDITIONS - DRIVING VEHICLE

INITIAL SETUP:**References**WP 0013

GENERAL

This work package provides instructions for driving the M48A5 Armored Vehicle Launched Bridge (AVLB) and M60A1 AVLB under usual/normal conditions. If equipment will not operate, notify field maintenance.

DRIVING VEHICLE**Flat Ground****WARNING**

- The cupola cover is heavy. Personnel may be injured if the cover is allowed to move freely during vehicle movement. Ensure that the cover is locked in the open or closed position during vehicle movement. Do not release the safety latch when the vehicle is moving. Failure to comply may result in personnel injury or death.
- If the cupola cover is closed, personnel may hit their head on the cover while raising the seat. Raise the seat slowly when the cupola cover is closed. Failure to comply may result in personnel injury or death.

WARNING

Commander may be thrown from seat when navigating an obstruction. When approaching an obstruction, warn commander to brace for possible impact and adjust vehicle speed and direction so that vehicle can meet the obstruction as squarely as possible. Failure to comply may result in personnel injury or death.

When operating a vehicle on flat ground (Figure 1), your speed depends on:

- a. Surface conditions
- b. Weather
- c. Visibility
- d. Traffic
- e. Speed limits (if posted)
- f. Tactical situation

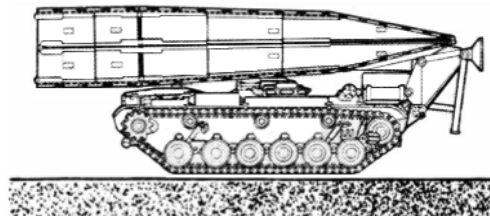

AVLBD103

Figure 1. Flat Ground.

END OF TASK

DRIVING VEHICLE - CONTINUED**Crossing Ditch, Shell Hole, or Trench****CAUTION**

Avoid crossing ditches, shell holes, or trenches that would cause rear fenders to strike or dig into ground. Damage to rear fenders may occur when climbing out of ditches, shell holes, or trenches. Maximum width of ditch that vehicle can cross is 7 ft (2.13 m) (Figure 2). Failure to comply may result in equipment damage.

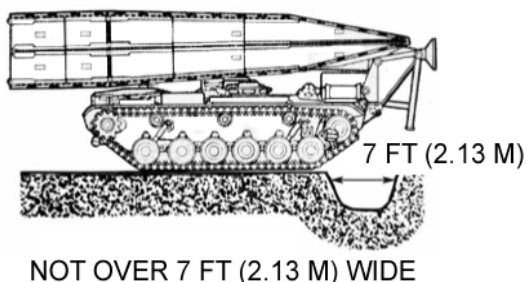

AVLBD104

Figure 2. Crossing Ditches, Shell Holes, and Trenches.

NOTE

Refer to WP 0013 for transmission shifting instructions.

1. Lift foot from accelerator pedal (Figure 3, Item 2) when approaching obstruction.
2. Press brake pedal (Figure 3, Item 1) if necessary.
3. Move transmission shift lever (Figure 3, Item 3) to L (Low).
4. Press accelerator pedal (Figure 3, Item 2) as necessary, especially when climbing out of ditch.

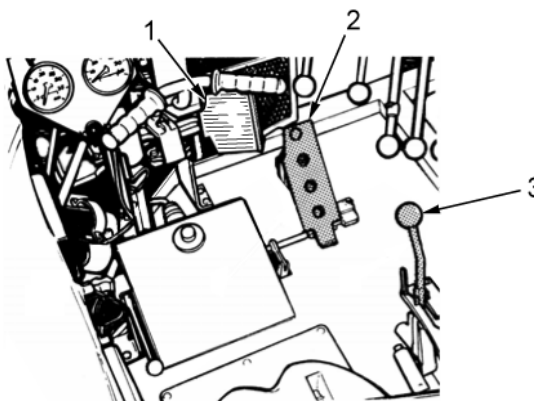

AVLBD105

Figure 3. Operator's Compartment.

END OF TASK

DRIVING VEHICLE - CONTINUED**Going Over Obstruction****WARNING**

Commander may be thrown from seat when navigating an obstruction. When approaching an obstruction, warn commander to brace for possible impact and adjust vehicle speed and direction so that vehicle can meet the obstruction as squarely as possible. Failure to comply may result in personnel injury or death.

CAUTION

Maximum height of obstruction that vehicle will cross is 15 inches (38 cm) (Figure 5) in the forward direction. DO NOT back vehicle over an obstruction. Driving in reverse direction over an obstruction may result in damage to suspension system.

1. Lift foot from accelerator pedal (Figure 4, Item 1) when approaching obstruction.
2. Press accelerator pedal (Figure 4, Item 1) fully when starting over obstruction.
3. Lift foot from accelerator pedal (Figure 4, Item 1) when vehicle is centered on obstruction.
4. Let vehicle glide over crest of obstruction.
5. When front of tracks touch ground, press accelerator pedal (Figure 4, Item 1) and continue.

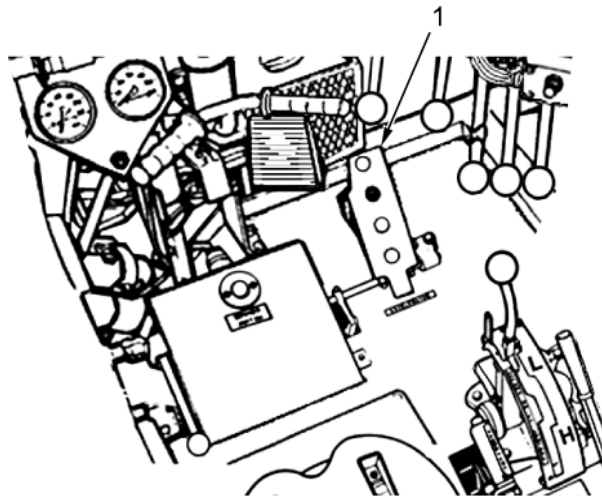

AVLBD523

Figure 4. Operator's Compartment.

DRIVING VEHICLE - CONTINUED

Going Over Obstruction - Continued

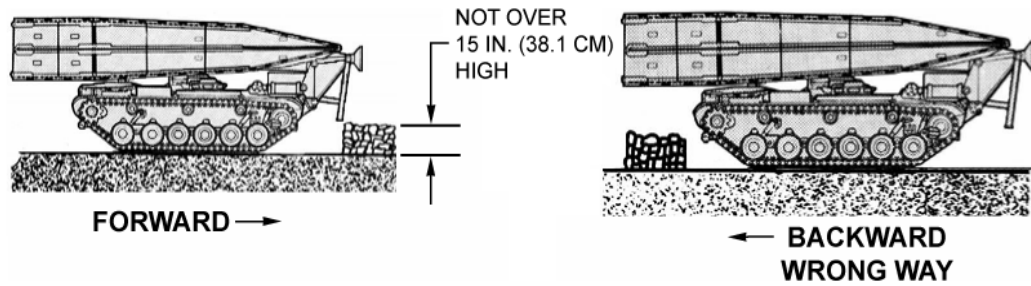

AVLBD106

Figure 5. Going Over Obstructions.

END OF TASK

DRIVING VEHICLE - CONTINUED**Going Uphill****WARNING**

- The cupola cover is heavy. Personnel may be injured if the cover is allowed to move freely during vehicle movement. Ensure that the cover is locked in the open or closed position during vehicle movement. Do not release the safety latch when the vehicle is moving. Failure to comply may result in personnel injury or death.
- Vehicle will become unstable and may overturn or roll if driven on a grade exceeding 30 percent. DO NOT attempt to drive the vehicle on a grade exceeding 30 percent. Failure to comply may result in personnel injury or death.
- Shifting from L (Low) to R (Reverse) or from R to L while the vehicle is in motion may cause transmission/engine damage and result in steering loss. DO NOT shift transmission from L to R or from R to L while vehicle is in motion. Failure to comply may result in personnel injury or death, or equipment damage.

CAUTION

- Transmission may overheat if the accelerator pedal is used to hold vehicle stationary on an incline. DO NOT attempt to hold the vehicle stationary on an incline using the accelerator pedal. Press the brake pedal to hold the vehicle and apply the parking brake. Failure to comply may result in equipment damage.
- If engine stalls while driving uphill, DO NOT allow vehicle to roll backward while transmission shift lever is in L or H. Transmission will drive engine backward and serious damage to engine or air cleaner may result. Operator's compartment may fill with smoke. If engine starts to run backward, stop vehicle and shut off engine and attempt to restart engine. If braking does not stop vehicle, move transmission shift lever to N (Neutral) position, bring vehicle to a stop with brakes, and shut off engine. Failure to comply may result in equipment damage.

DRIVING VEHICLE - CONTINUED**Going Uphill - Continued**

1. Move transmission shift lever (Figure 6, Item 3) to L (Low).
2. Press accelerator pedal (Figure 6, Item 2) as required.
3. If starting from a parked position on a hill, do the following:
 - a. Press and hold brake pedal (Figure 6, Item 1).
 - b. Move transmission shift lever (Figure 6, Item 3) from P (Park) to L (Low).
 - c. Press accelerator pedal (Figure 6, Item 2).
 - d. Release brake pedal (Figure 6, Item 1).

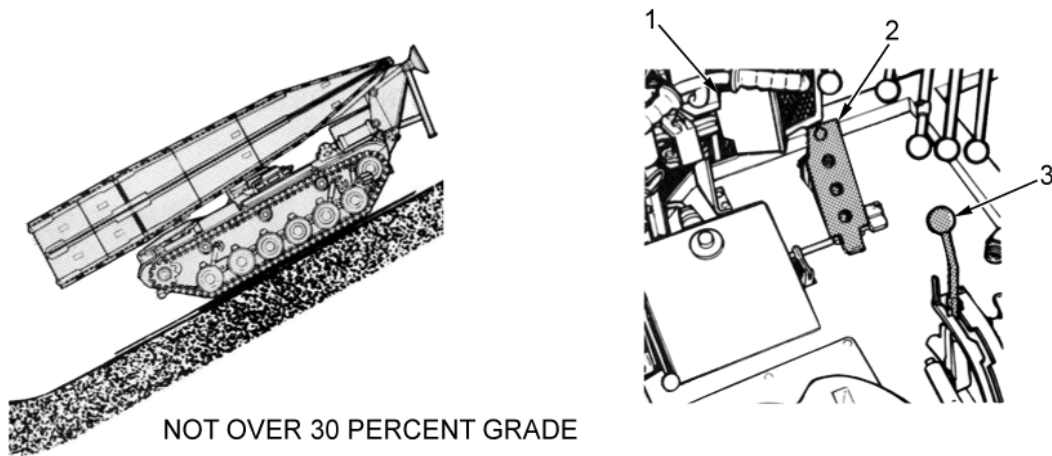

AVLBD107

Figure 6. Accelerating Uphill.

END OF TASK

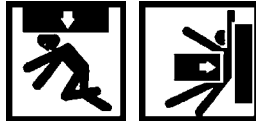
DRIVING VEHICLE - CONTINUED**Going Downhill****WARNING**

- Vehicle will become unstable and may overturn or roll if driven on a grade exceeding 30 percent. DO NOT attempt to drive the vehicle on a grade exceeding 30 percent. Failure to comply may result in personnel injury or death.
- Shifting from L (Low) to R (Reverse) or from R to L while the vehicle is in motion may cause transmission/engine damage and result in steering loss. DO NOT shift transmission from L to R or from R to L while the vehicle is in motion. Failure to comply may result in personnel injury or death, or equipment damage.

NOTE

- The following procedure is to be used only when vehicle is in recommended gear and before beginning descent. This procedure is to be used only in an emergency and when all other actions fail.
 - On ordinary grades, transmission range of L (Low) will normally slow vehicle. Brakes may not be necessary to keep engine speed under 2,400 RPM.
1. Move transmission shift lever to L (Low) before going downhill (Figure 7).
 2. Keep engine speed below 2,400 RPM by applying brakes, if necessary.
 3. At bottom of hill, move transmission shift lever to position desired.

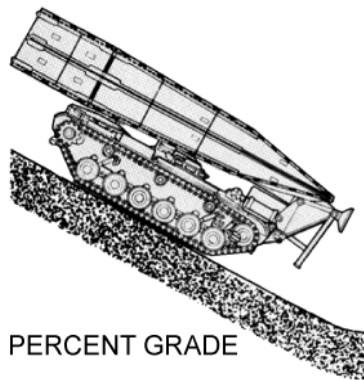

AVLBD108

Figure 7. Going Downhill.

END OF TASK

DRIVING VEHICLE - CONTINUED**Stopping Vehicle When Brakes Fail**

1. If brakes fail to operate on level ground, coast to stop with transmission in L (Low). Put transmission in P (Park), shut off engine, and request recovery.
2. If brakes fail to operate while driving vehicle uphill, drive vehicle forward to a location on level ground or to a position perpendicular to slope of hill. Coast vehicle to a stop, shift transmission from L (Low) to P (Park), shut off engine, and request recovery.
3. If brakes fail to operate while driving vehicle downhill, coast vehicle to a stop on level ground, if possible, or to a position perpendicular to the slope of hill. Shift transmission from L (Low) to P (Park), shut off engine, and request recovery.

END OF TASK**END OF WORK PACKAGE**

OPERATOR MAINTENANCE
OPERATION UNDER USUAL CONDITIONS - LAUNCHING BRIDGE

INITIAL SETUP:

References
WP 0015

References (cont.)
WP 0046

GENERAL

This work package provides instructions for launching the bridge for the M48A5 Armored Vehicle Launched Bridge (AVLB) and M60A1 AVLB under usual/normal conditions. If equipment will not operate, refer to Auxiliary Systems and Controls Procedures (WP 0046).

LAUNCHING BRIDGE

WARNING



Exceeding slope limits (Figure 1) during bridge launch may cause the vehicle to become unstable and overturn or roll. DO NOT exceed uphill, downhill, or side slope limits when launching the bridge. Failure to comply may result in personnel injury or death, or equipment damage.

CAUTION

Far-shore area must be in line with near-shore area and must be 60 ft (18.3 m) or less from near-shore. Area where bridge will rest must be free of trees, boulders, and other objects that will not provide good support. Care in selecting launching site will reduce or eliminate damage to bridge or vehicle and make it easier to disconnect vehicle from bridge.

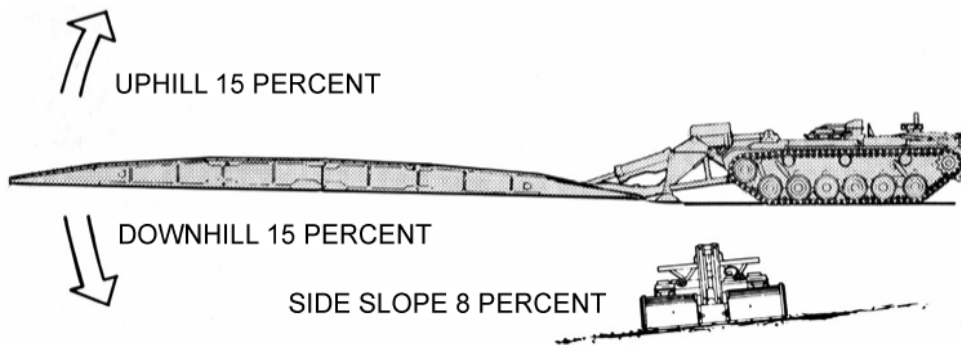

AVLBD109

Figure 1. Maximum Slope for Bridge Launching.

NOTE

In choosing a launching site, consider which end of the bridge will be used for retrieval. This end of the bridge should provide ground support if possible.

1. Start engine and move vehicle into desired position in line with selected site. Refer to WP 0015.
2. Press and hold brake pedal (Figure 2, Item 1).
3. Move transmission shift lever (Figure 2, Item 3) to N (Neutral).

LAUNCHING BRIDGE - CONTINUED**CAUTION**

DO NOT pull up hydraulic clutch pump lever (Figure 2, Item 5) with engine running over 1,000 RPM. For vehicles with hydraulic electrical upgrade (HEU), DO NOT move hydraulic pump ball valve (Figure 2, Item 4) to LAUNCH with engine running over 1,000 RPM. Power take-off (PTO) components may be damaged.

NOTE

A snap can be felt when clutch is properly engaged.

4. On non-hydraulic electrical upgrade (non-HEU) vehicles, pull up hydraulic clutch pump lever (Figure 2, Item 5). For vehicles with HEU, move hydraulic pump ball valve (Figure 2, Item 4) to LAUNCH.
5. Press accelerator pedal (Figure 2, Item 2) until engine is running at 1,800 RPM.
6. Pull up accelerator locking lever (Figure 2, Item 6).

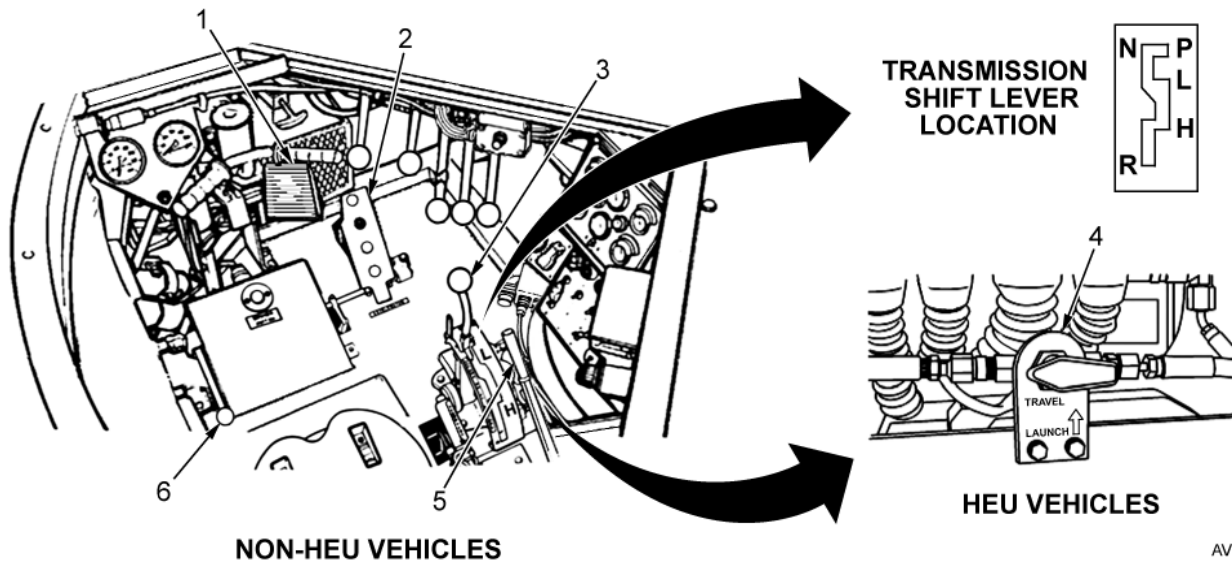

Figure 2. Operator's Controls.

LAUNCHING BRIDGE - CONTINUED

WARNING



- If vehicle is operated with cupola cover open, operator may be hit or decapitated by moving hatch. During bridge launch and retrieval operations the operator must be inside the vehicle with the cupola cover closed. Failure to comply may result in personnel injury or death.
- Bridge may shift or fall if a system failure occurs. All personnel must stand clear of the vehicle during launch and retrieval. Failure to comply may result in personnel injury or death.

NOTE

Hold-down chains are automatically released when operator pushes up overhead cylinder control lever.

7. Ease up on brake pedal (Figure 3, Item 1) while extending overhead cylinder (Figure 3, Item 4) to allow vehicle to ride up on outrigger (Figure 3, Item 5).
8. Pull up overhead lever (Figure 3, Item 2) until overhead cylinder (Figure 3, Item 4) is fully extended, and outrigger (Figure 3, Item 5) is firmly on ground.

NOTE

Listen for change in sound of hydraulic pump. This indicates that overhead cylinder (Figure 3, Item 4) is fully extended. If it is not, bridge will shift when lowered until overhead cylinder bottoms out.

9. Ensure overhead cylinder (Figure 3, Item 4) is fully extended.
10. Press brake pedal (Figure 3, Item 1) and move shift lever (Figure 3, Item 3) to P (Park), engaging parking brake.

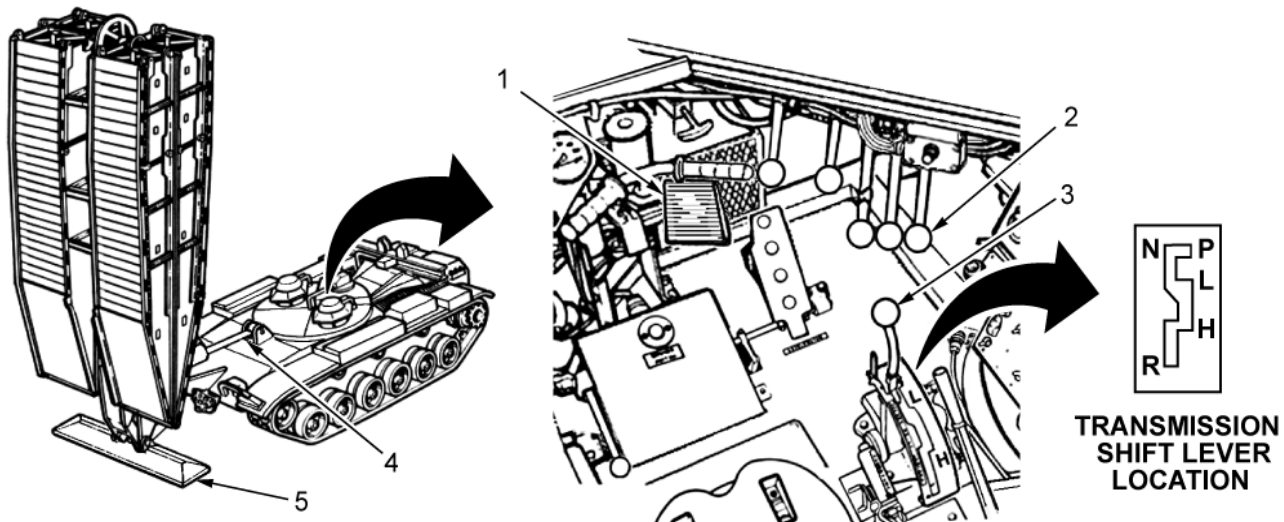

Figure 3. Launching Bridge and Operator's Controls.

LAUNCHING BRIDGE - CONTINUED

11. Pull up tongue lever (Figure 4, Item 3) until bridge starts to lean over and starts to open, then release lever.

NOTE

Moving tongue lever (Figure 4, Item 3) and scissors lever (Figure 4, Item 2) at the same time will open bridge smoothly.

12. Pull up tongue lever (Figure 4, Item 3) and scissors lever (Figure 4, Item 2) to open bridge all the way.

NOTE

Correct position of bridge is about 2 ft (61 cm) aboveground when fully open.

13. Pull up tongue lever (Figure 4, Item 3) until bridge settles on ground.

14. Pull scissors lever (Figure 4, Item 2) down until scissoring cables (Figure 4, Item 1) are slack.

15. Push down accelerator locking lever (Figure 4, Item 6).

16. For non-HEU vehicles, push down hydraulic clutch pump lever (Figure 4, Item 4). For vehicles with HEU, move hydraulic pump ball valve (Figure 4, Item 5) to TRAVEL.

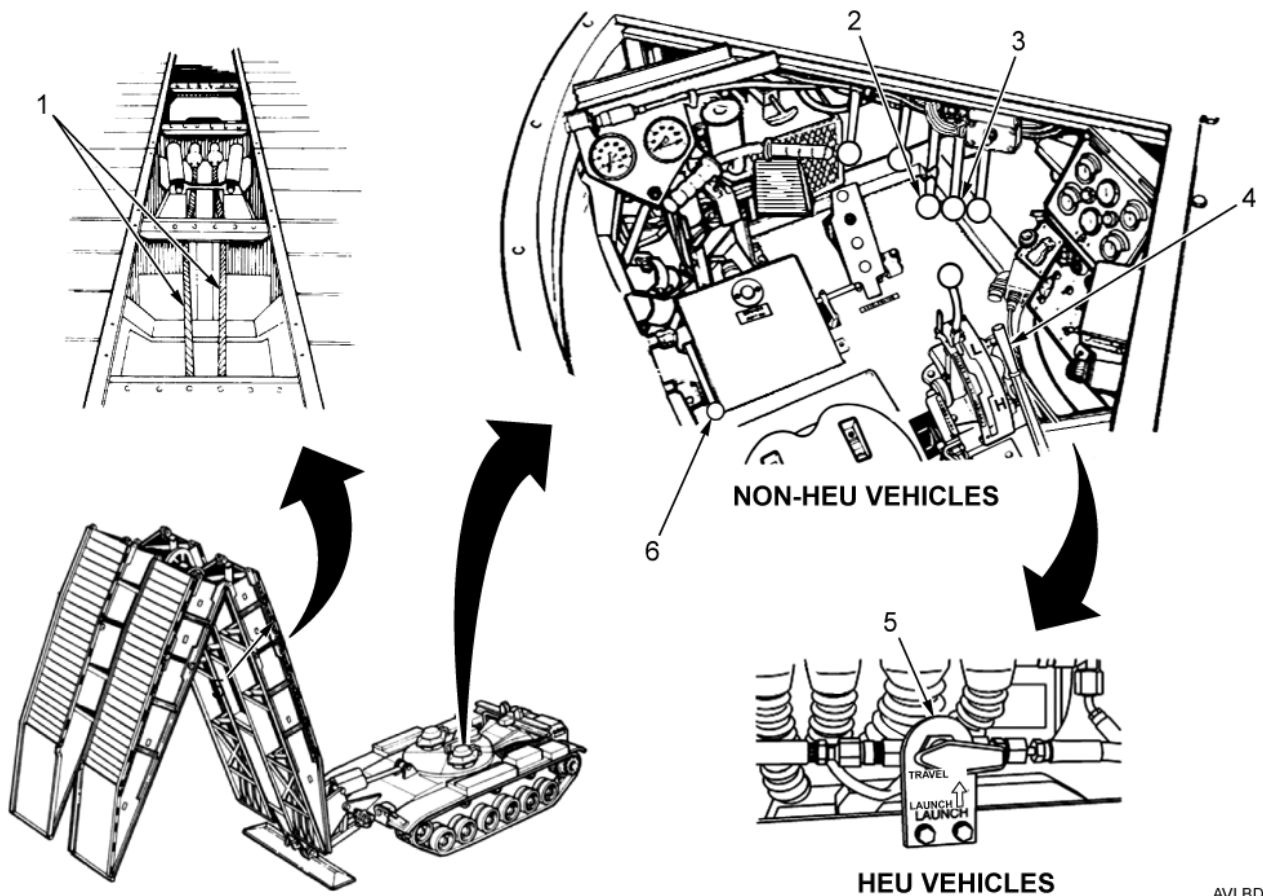

AVLBD642

Figure 4. Opening Bridge and Partially Extended Bridge.

LAUNCHING BRIDGE - CONTINUED

17. Pull overhead lever (Figure 5, Item 4) up and down at least three times to relieve pressure.
18. Pull tongue lever (Figure 5, Item 3) up and down at least three times.
19. On non-HEU vehicles, raise hydraulic clutch pump lever (Figure 5, Item 8). For vehicles with HEU, move hydraulic pump ball valve (Figure 5, Item 7) to LAUNCH.
20. Press accelerator pedal (Figure 5, Item 1) until engine speed is 1,800 RPM.
21. Raise accelerator locking lever (Figure 5, Item 9) and pull up lock lever (Figure 5, Item 2) until locking plugs (Figure 5, Item 5) are retracted in tongue (Figure 5, Item 6).
22. Push down accelerator locking lever (Figure 5, Item 9). For non-HEU vehicles, push down hydraulic clutch pump lever (Figure 5, Item 8). For vehicles with HEU, move hydraulic pump ball valve (Figure 5, Item 7) to TRAVEL.

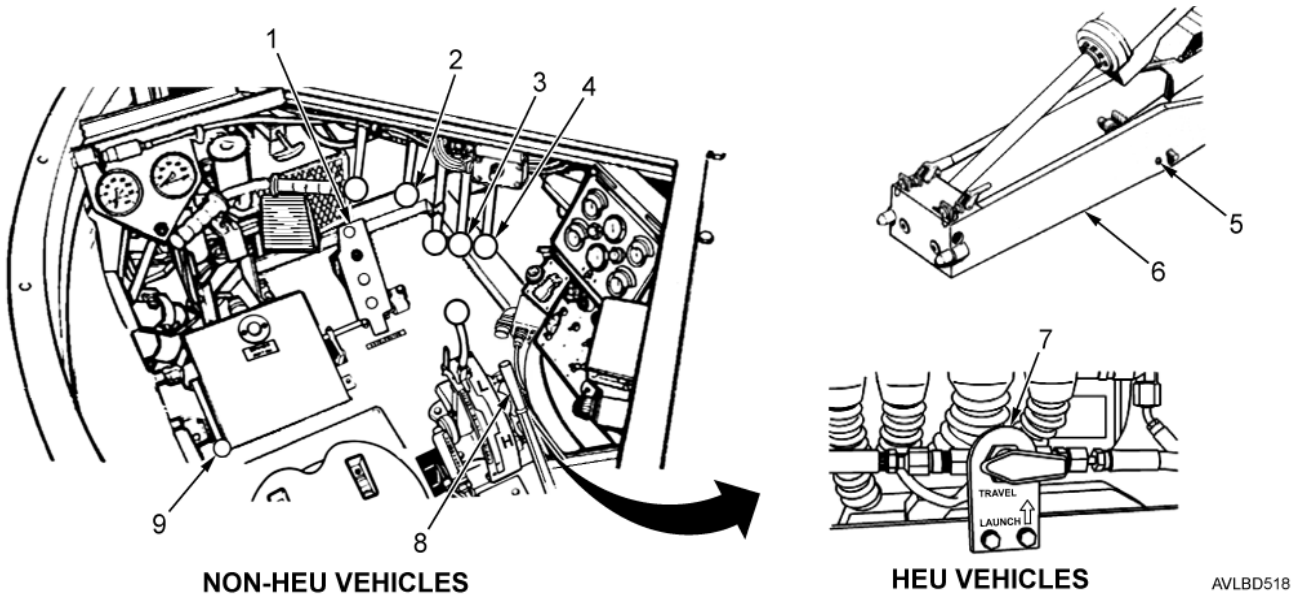

Figure 5. Launching Bridge.

LAUNCHING BRIDGE - CONTINUED

NOTE

Use care in backing vehicle to prevent excessive bulldozer action of outrigger.

23. Move transmission shift lever (Figure 6, Item 3) to R (Reverse) and back vehicle slowly while checking for vehicle separation from bridge.

NOTE

- Quick disconnect fittings between launcher and bridge will disconnect automatically when vehicle is backed away from bridge.
- Perform steps 24 through 32 if vehicle does not come free of bridge.

24. Move transmission shift lever (Figure 6, Item 3) to N (Neutral).
25. On non-HEU vehicles, pull up hydraulic clutch pump lever (Figure 6, Item 5). On vehicles with HEU, move hydraulic pump ball valve (Figure 6, Item 4) to LAUNCH.
26. Press accelerator pedal (Figure 6, Item 2) until engine is running 1,800 RPM.
27. Pull up accelerator locking lever (Figure 6, Item 6).

NOTE

As a safety measure, ejection cylinder control is interlocked with locking cylinder rod end line and operates only when locking cylinder control is held in retracting position.

28. Pull up accelerator locking lever (Figure 6, Item 6) and ejection cylinder lever (Figure 6, Item 1) at same time until vehicle is free of bridge.

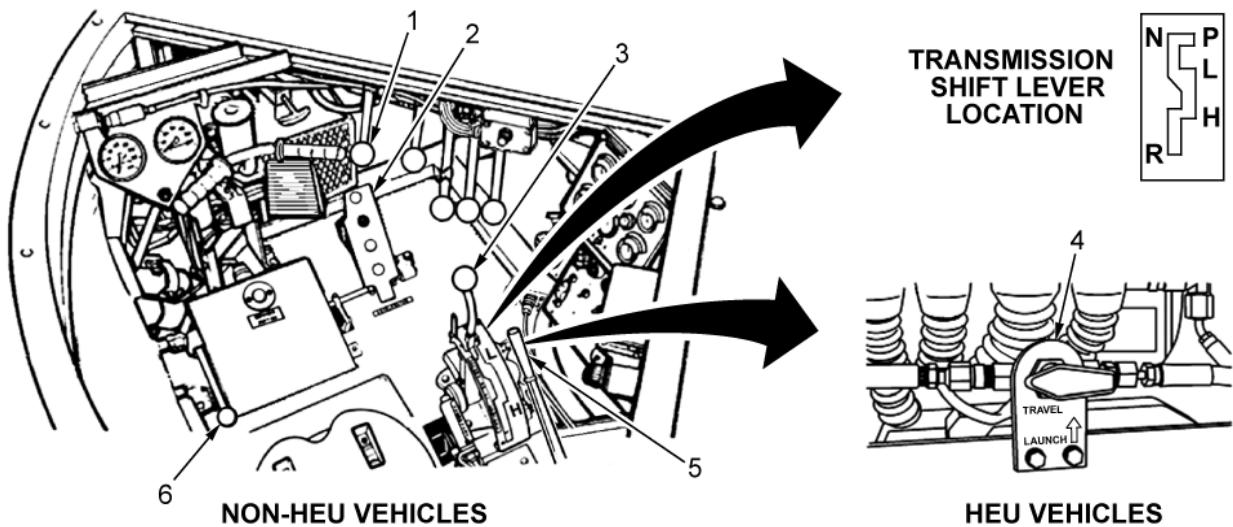

AVLBD116

Figure 6. Freeing Vehicle of Bridge.

LAUNCHING BRIDGE - CONTINUED

29. Pull up locking cylinder lever (Figure 7, Item 2) and push down ejection cylinder lever (Figure 7, Item 1) at same time to retract ejection cylinders (Figure 7, Item 3).

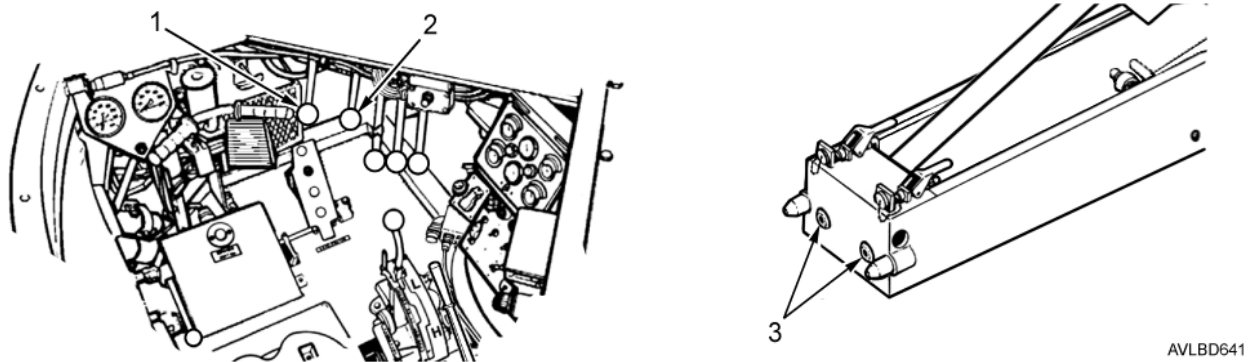

Figure 7. Retract Ejection Cylinders.

30. Push down accelerator locking lever (Figure 8, Item 5).
 31. On non-HEU vehicles, push down hydraulic clutch pump lever (Figure 8, Item 2). For vehicles with HEU, move hydraulic pump ball valve (Figure 8, Item 3) to TRAVEL.

NOTE

Use care in backing vehicle to prevent excessive bulldozer action of outrigger.

32. Move transmission shift lever (Figure 8, Item 1) to R (Reverse) and back vehicle slowly while checking that vehicle is free of bridge.
 33. On non-HEU vehicles, pull up hydraulic clutch pump lever (Figure 8, Item 2). For vehicles with HEU, move hydraulic pump ball valve (Figure 8, Item 3) to LAUNCH.
 34. Press accelerator pedal (Figure 8, Item 4) until engine is running 1,800 RPM.
 35. Pull up accelerator locking lever (Figure 8, Item 5).

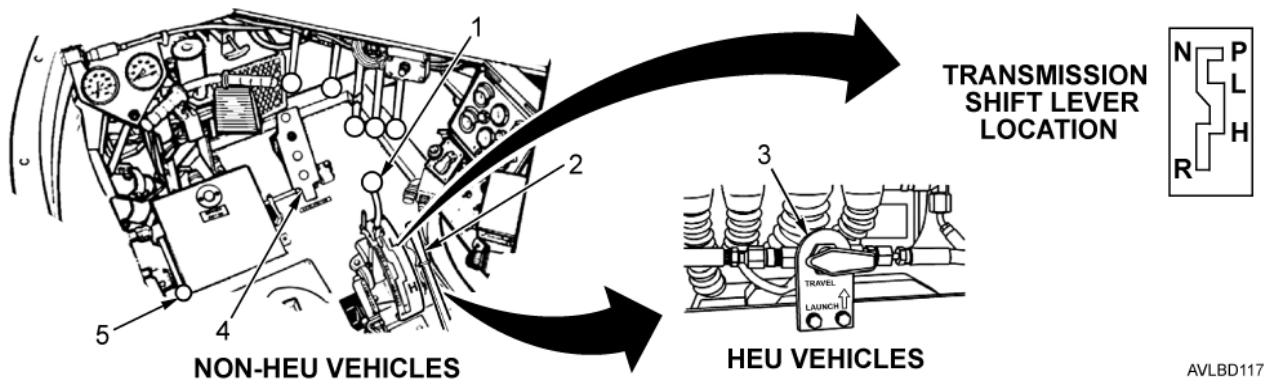
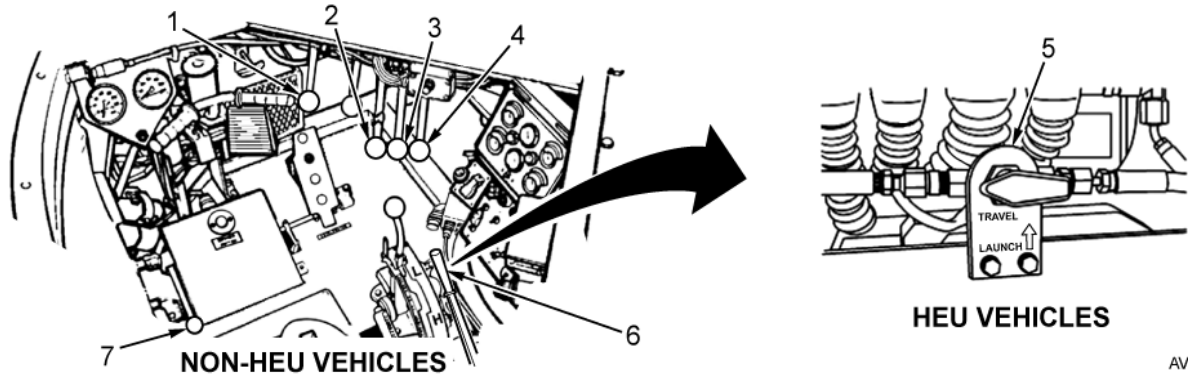

Figure 8. Clutch Lever.

36. Push down tongue lever (Figure 9, Item 3) until tongue is fully retracted.
 37. Push down overhead lever (Figure 9, Item 4) until overhead cylinder is fully retracted.
 38. Push down accelerator locking lever (Figure 9, Item 7).

LAUNCHING BRIDGE - CONTINUED

- 39. On non-HEU vehicles, push down hydraulic clutch pump lever (Figure 9, Item 6). For vehicles with HEU, move hydraulic pump ball valve (Figure 9, Item 5) to TRAVEL.
- 40. Push up and then down on all launching control levers (Figure 9, Item 1, Item 2, Item 3, and Item 4) at least three times each.



AVLBD118

Figure 9. Launching Hydraulic Control Levers.

- 41. Move vehicle to desired location.
- 42. Install cap assembly (Figure 10, Item 5) on coupling (Figure 10, Item 1) on tongue side and cap assembly (Figure 10, Item 4) on coupling (Figure 10, Item 2) on bridge side.
- 43. Insert four locking pins (Figure 10, Item 3) at center of bridge.

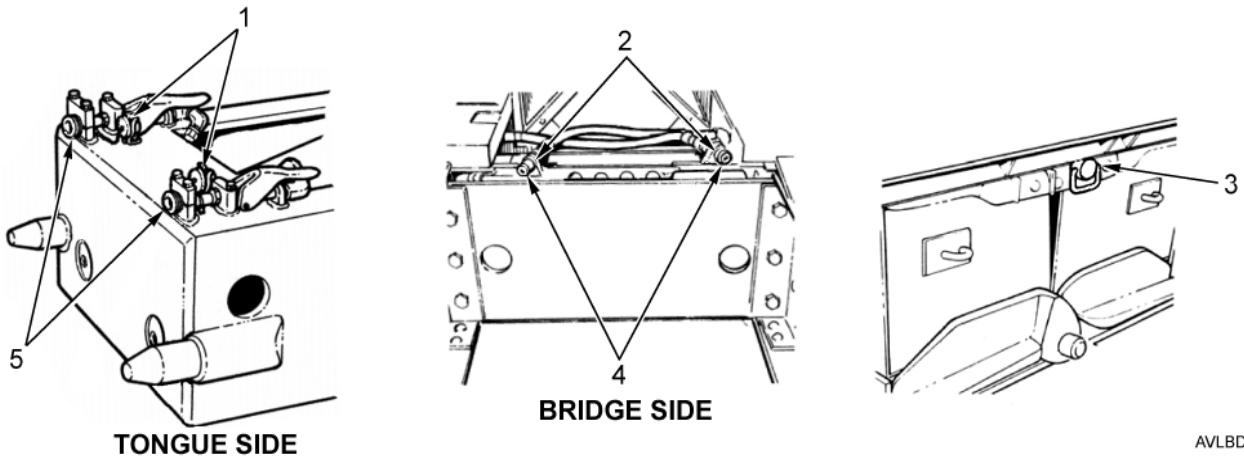

AVLBD119

Figure 10. Installing Locking Pin.

END OF TASK

END OF WORK PACKAGE

OPERATOR MAINTENANCE**OPERATION UNDER USUAL CONDITIONS - CROSSING BRIDGE**

INITIAL SETUP:**Tools and Special Tools**

Pinch Bar (WP 0077, Table 2, Item 5)

ReferencesWP 0046

GENERAL

This work package provides instructions for crossing the bridge for the M48A5 Armored Vehicle Launched Bridge (AVLB) and M60A1 AVLB under usual/normal conditions. If equipment will not operate, refer to Auxiliary Systems and Controls Procedures (WP 0046).

CROSSING BRIDGE**CAUTION**

- DO NOT exceed 8 mph (13 kph) crossing speed. Failure to comply may result in excessive wear and tear to the MLC 60 or MLC 70 bridge.
- Ensure vehicle is in line with bridge while crossing. DO NOT stop, accelerate, or shift gears while crossing bridge. These actions may result in damage to vehicle or bridge.

Proceed across bridge (Figure 1).

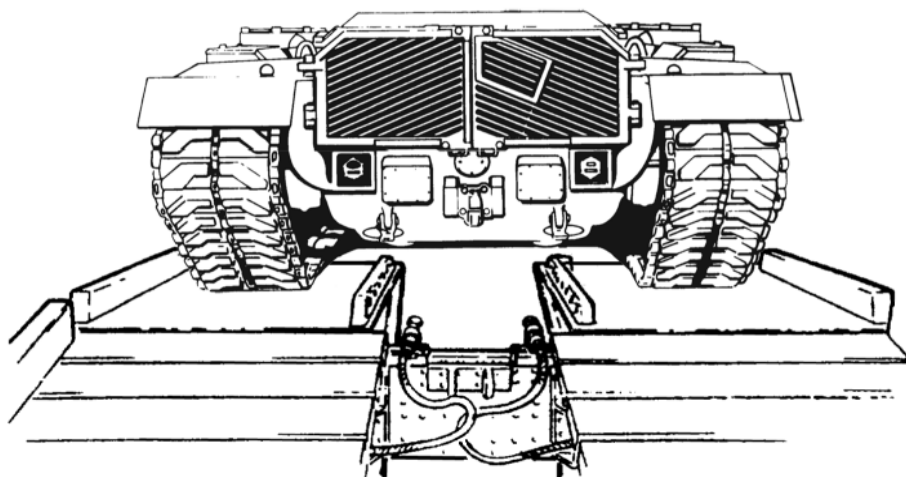

AVLBD522

Figure 1. Crossing Bridge.

END OF TASK**END OF WORK PACKAGE**

OPERATOR MAINTENANCE
OPERATION UNDER USUAL CONDITIONS - RETRIEVING BRIDGE

INITIAL SETUP:**Tools and Special Tools**

Pinch Bar (WP 0077, Table 1, Item 5)

Personnel Required

2

References

WP 0005

References (cont.)

WP 0015

WP 0024

WP 0046

WP 0077

GENERAL

This work package provides instructions for retrieving the bridge for the M48A5 Armored Vehicle Launched Bridge (AVLB) and M60A1 AVLB under usual/normal conditions. If equipment will not operate, refer to Auxiliary Systems and Controls Procedures (WP 0046).

RETRIEVING BRIDGE**CAUTION**

Examine lay of bridge with respect to vehicle. Vehicle must be in line with bridge to pick up bridge. If bridge and vehicle do not line up, raise end of bridge and block up bridge end until they line up. Ensure that vehicle is far enough away from bridge so tongue pintles will not strike bridge diaphragm when tongue is lowered. Failure to comply may result in damage to vehicle or bridge.

NOTE

Two personnel are required for retrieving bridge. One person is needed at vehicle controls and second person is needed outside to direct movements of vehicle.

1. Remove locking pin (Figure 1, Item 1) from bolt (Figure 1, Item 2).
2. Remove nut (Figure 1, Item 5) from bolt (Figure 1, Item 2).
3. Remove bolt (Figure 1, Item 2) and hold-down chain (Figure 1, Item 4) from bracket (Figure 1, Item 3).

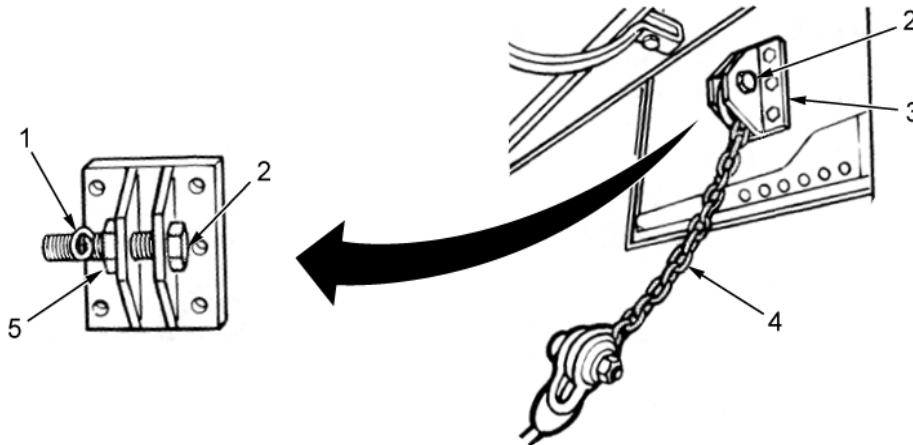

AVLBD508

Figure 1. Locking Pin.

RETRIEVING BRIDGE - CONTINUED

4. Remove any debris from pintle sockets (Figure 2, Item 3), cross pin receiver (Figure 2, Item 2), and locking plug plate (Figure 2, Item 1).

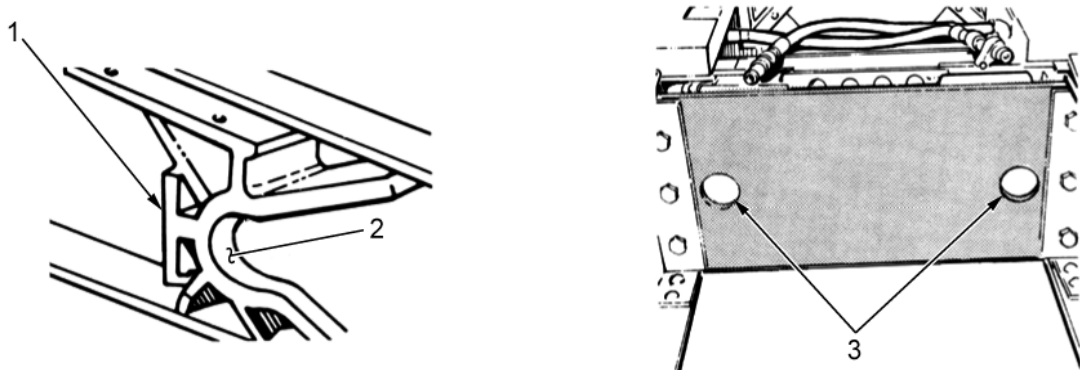

AVBD120

Figure 2. Pintle Sockets.

5. Remove bridge locking pins (Figure 3, Item 1).

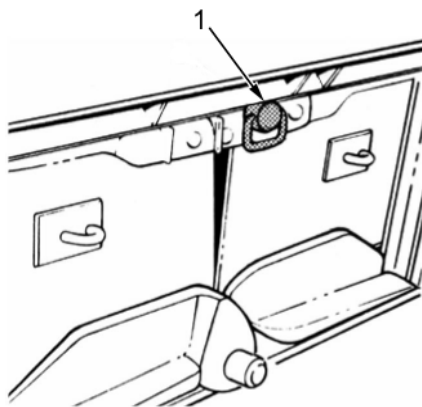

AVLBD122

Figure 3. Locking Pins.

RETRIEVING BRIDGE - CONTINUED

6. Remove cap assembly (Figure 4, Item 3) from coupling (Figure 4, Item 2) on bridge side. Remove cap assembly (Figure 4, Item 4) from coupling (Figure 4, Item 1) on tongue side.

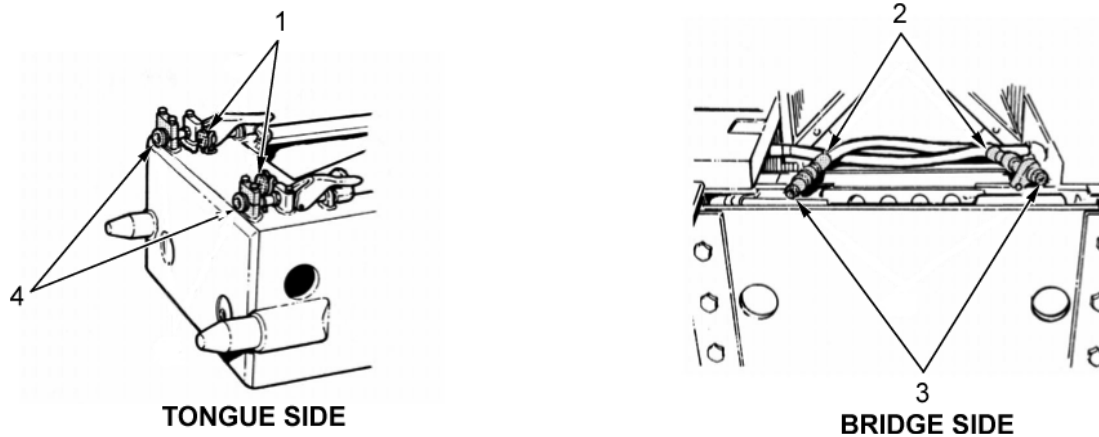

AVLBD123

Figure 4. Cap Assemblies.

7. Start engine (WP 0015) and move vehicle in line with bridge.
8. Move transmission shift lever (Figure 5, Item 2) to N (Neutral).

NOTE

A snap can be felt when clutch is properly engaged.

9. On non-hydraulic electrical upgrade (non-HEU) vehicles, pull up hydraulic clutch pump lever (Figure 5, Item 3). For vehicles with hydraulic electrical upgrade (HEU), move hydraulic pump ball valve (Figure 5, Item 4) to LAUNCH.
10. Press accelerator pedal (Figure 5, Item 1) until engine is running at 1,800 RPM.
11. Pull up accelerator locking lever (Figure 5, Item 5).

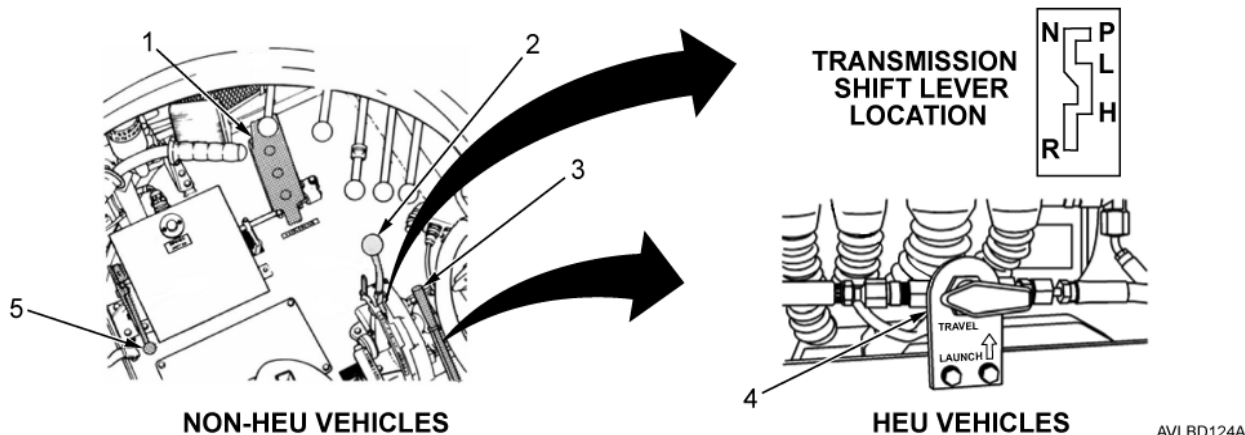

AVLBD124A

Figure 5. Crew Compartment.

12. Pull up overhead lever (Figure 6, Item 5) until outrigger (Figure 6, Item 4) is almost touching ground.
13. Pull up tongue lever (Figure 6, Item 1) until tongue (Figure 6, Item 2) is aligned with bridge diaphragm (Figure 6, Item 3).

RETRIEVING BRIDGE - CONTINUED

NOTE

If pintles do not line up with sockets, reposition vehicle.

14. Pull overhead lever (Figure 6, Item 5) until outrigger (Figure 6, Item 4) is firmly on ground and overhead cylinder is all the way out.

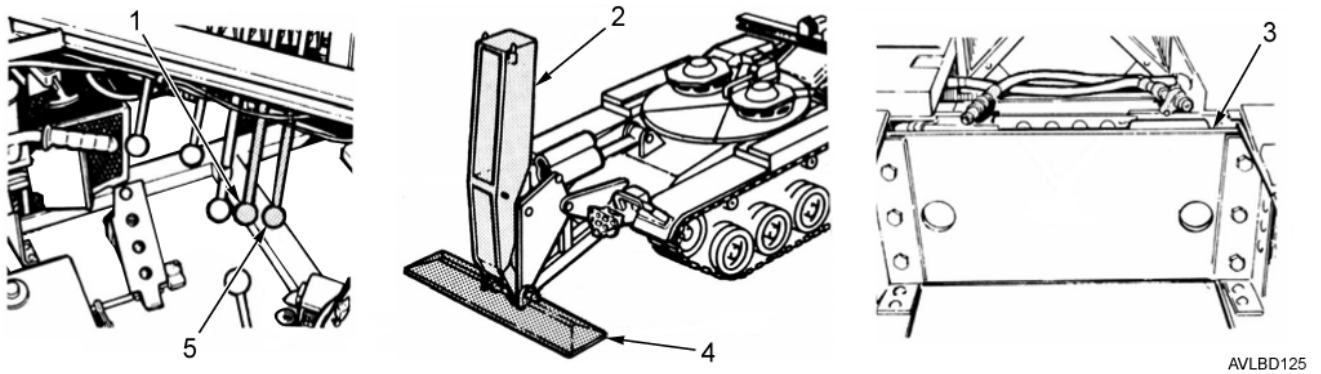

Figure 6. Extending Outrigger.

15. Slowly move vehicle forward and align tongue (Figure 7, Item 1) and pintles (Figure 7, Item 6) with pintle sockets (Figure 7, Item 5).
16. Pull tongue lever (Figure 7, Item 3) up or down until pintles (Figure 7, Item 6) are seated in pintle sockets (Figure 7, Item 5) and tongue (Figure 7, Item 1) fully contacts bridge diaphragm (Figure 7, Item 2).
17. Push lock lever (Figure 7, Item 4) down to extend locking pins.

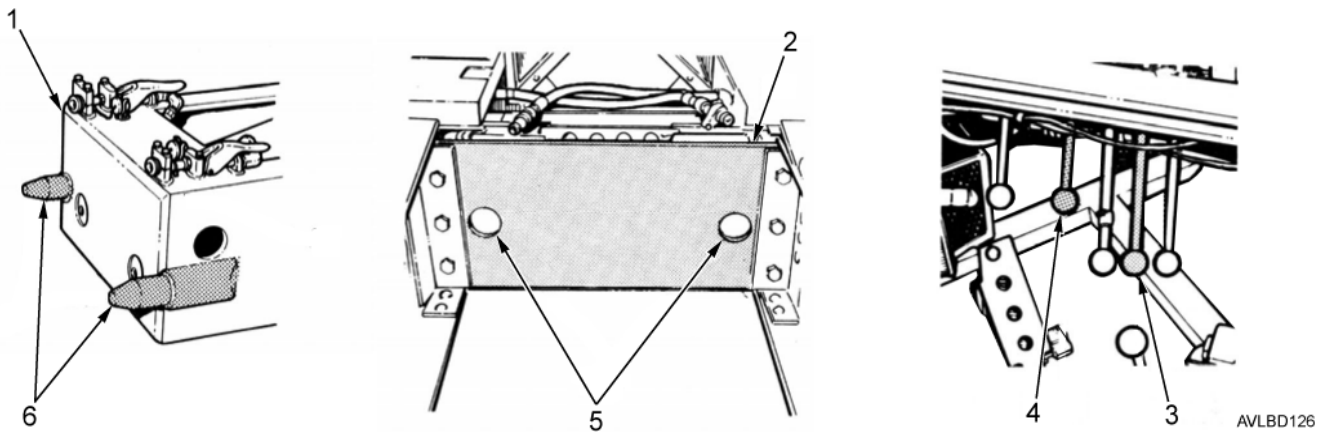
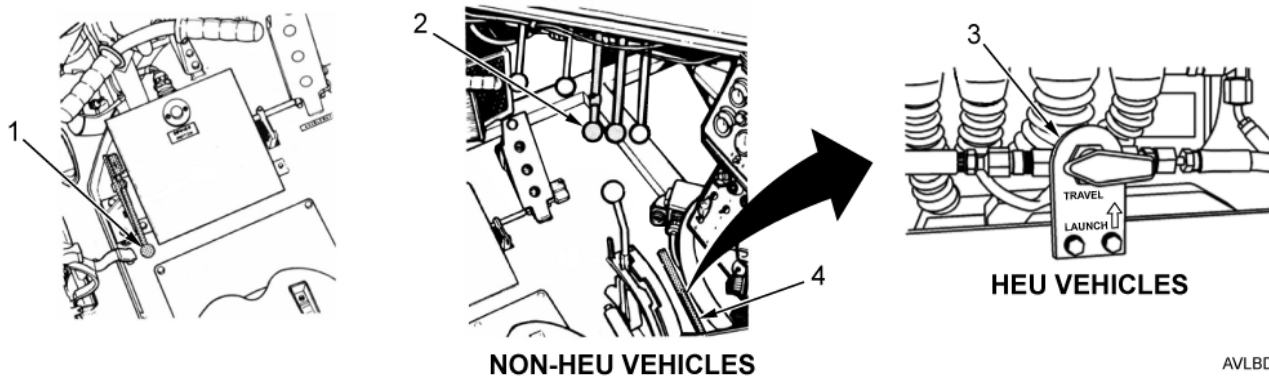

Figure 7. Pintle Sockets.

RETRIEVING BRIDGE - CONTINUED

18. Push down accelerator locking lever (Figure 8, Item 1).
19. On non-HEU vehicles, push down hydraulic clutch pump lever (Figure 8, Item 4). For vehicles with HEU, move hydraulic pump ball valve (Figure 8, Item 3) to TRAVEL.
20. Pull scissors lever (Figure 8, Item 2) up and then down at least three times.



AVLBD127A

Figure 8. Accelerator Locking Lever.

21. Pull up and hold release handles (Figure 9, Item 3).
22. Push coupling (Figure 9, Item 1) on bridge side into coupling (Figure 9, Item 2) on tongue side .
23. Release handles (Figure 9, Item 3) and push coupling on bridge side (Figure 9, Item 1) into coupling (Figure 9, Item 2) on tongue side until couplings retract.
24. Visually check assembly to ensure couplings (Figure 9, Item 1) on bridge side are securely seated in couplings (Figure 9, Item 2) on tongue side.

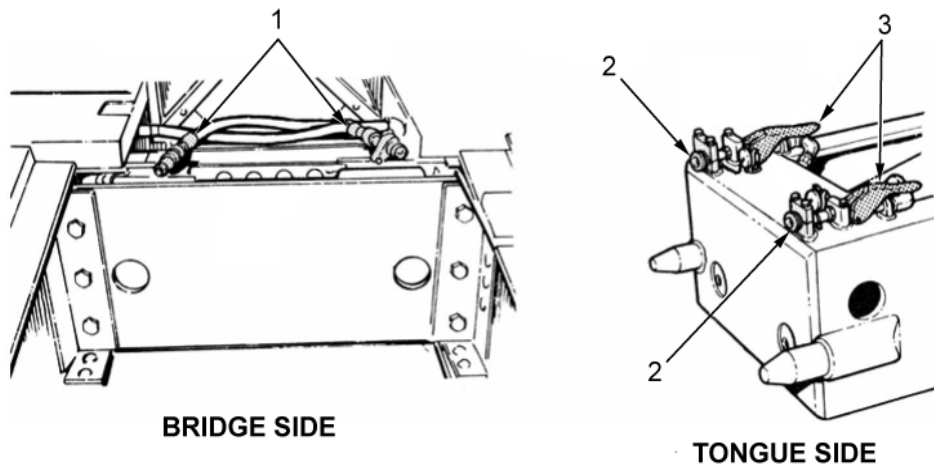

AVLBD128

Figure 9. Release Handles.

RETRIEVING BRIDGE - CONTINUED

NOTE

Perform steps 25 through 30 if couplings will not lock.

25. Open both valves (Figure 10, Item 1) on scissors cylinder (Figure 10, Item 5) to relieve pressure.
26. Pull up and hold release handles (Figure 10, Item 2).
27. Connect couplings (Figure 10, Item 4) on tongue side and couplings (Figure 10, Item 3) on bridge side.
28. Release handles (Figure 10, Item 2) and push coupling (Figure 10, Item 3) on bridge side into coupling (Figure 10, Item 4) on tongue side until couplings retract.
29. Visually check couplings on tongue side (Figure 10, Item 4) and couplings (Figure 10, Item 3) on bridge side to ensure they are fully connected.
30. Close both valves (Figure 10, Item 1) on scissors cylinder (Figure 10, Item 5).
31. Remove radio antenna. Refer to WP 0024.
32. Close and latch operator's cupola cover. Refer to WP 0005.

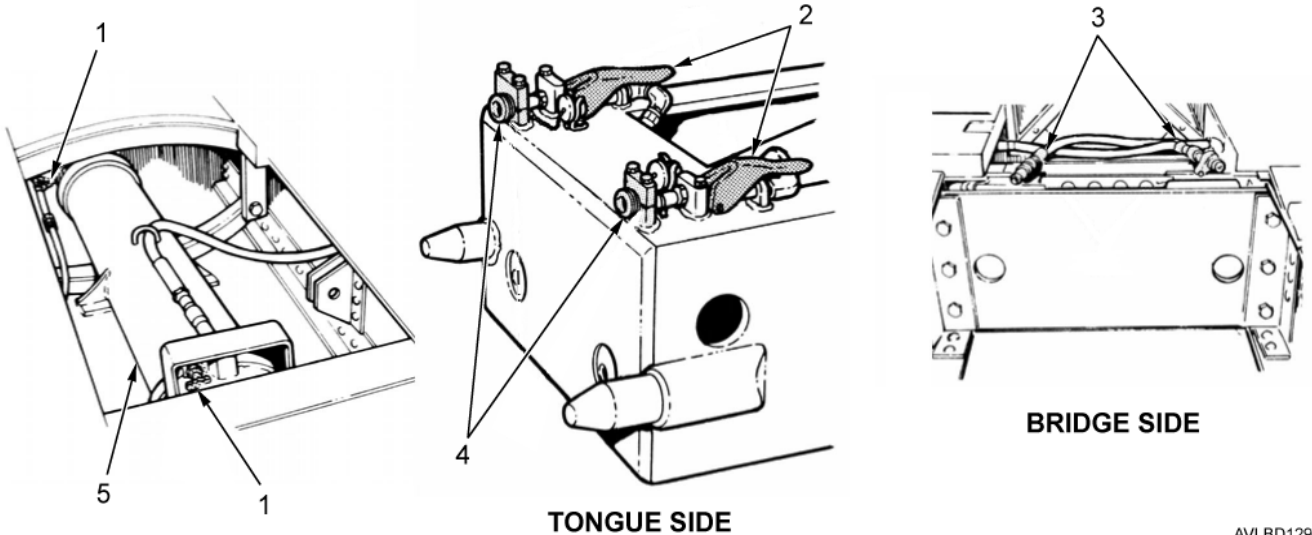

AVLBD129

Figure 10. Lock Couplings.

RETRIEVING BRIDGE - CONTINUED

WARNING



- If vehicle is operated with cupola cover open, operator may be hit or decapitated by moving hatch. During bridge launch and retrieval operations the operator must be inside the vehicle with the cupola cover closed. Failure to comply may result in personnel injury or death.
- Bridge may shift or fall if a system failure occurs. All personnel must stand clear of the vehicle during launch and retrieval. Failure to comply may result in personnel injury or death.

33. On non-HEU vehicles, pull up hydraulic clutch pump lever (Figure 11, Item 7). For vehicles with HEU, move hydraulic pump ball valve (Figure 11, Item 6) to LAUNCH.

34. Press accelerator pedal (Figure 11, Item 1) until engine is running at 1,800 RPM.

35. Pull up accelerator locking lever (Figure 11, Item 8).

NOTE

Free end of bridge should not be more than 2 ft (61 cm) above ground during retrieval.

36. Push up scissors lever (Figure 11, Item 2) until scissors cables are taut. Push down tongue lever (Figure 11, Item 3) and scissors lever until tongue and scissors cylinders are fully retracted with bridge folded and in upright position.

37. Push down overhead lever (Figure 11, Item 4) until bridge is resting on bridge seat (Figure 11, Item 5).

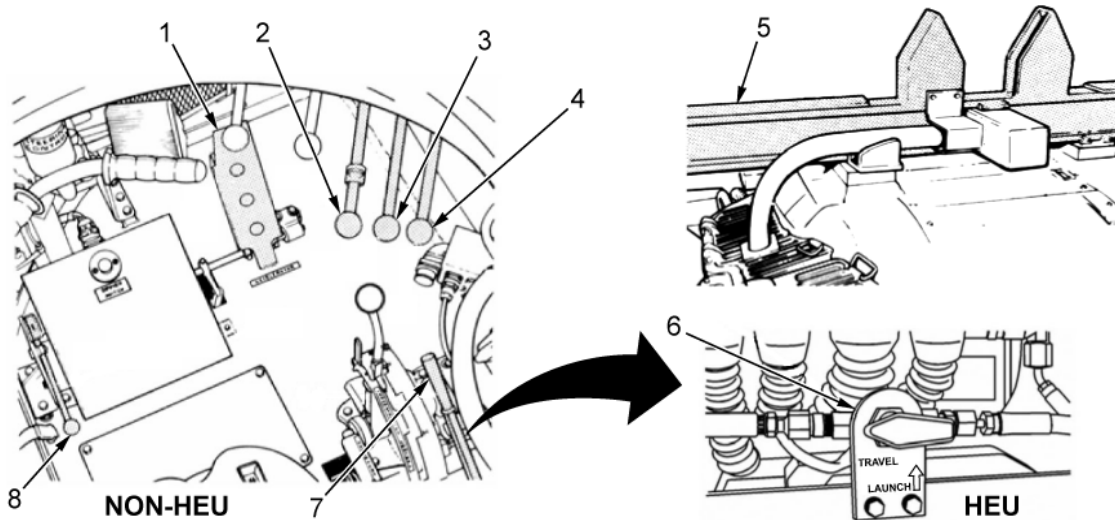

AVLBD131A

Figure 11. Retracting Bridge.

38. Install hold-down chains (Figure 12, Item 5) in bracket (Figure 12, Item 2) using bolt (Figure 12, Item 1).

39. Install nut (Figure 12, Item 4) on bolt (Figure 12, Item 1) finger-tight.

40. Insert locking pin (Figure 12, Item 3) through hole in bolt (Figure 12, Item 1).

RETRIEVING BRIDGE - CONTINUED

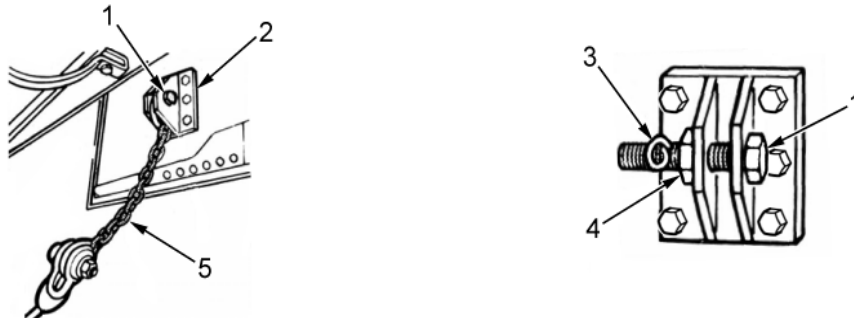

AVLBD132

Figure 12. Locking Pin.

41. Install turnbuckles (Figure 13, Item 3) in opening (Figure 13, Item 1).
42. If hold-down pin (Figure 13, Item 4) is extended, pull up overhead lever (Figure 13, Item 2) until hold-down pin is retracted.
43. Push down overhead lever (Figure 13, Item 2) until hold-down pin (Figure 13, Item 4) extends through turnbuckles (Figure 13, Item 3) completely.

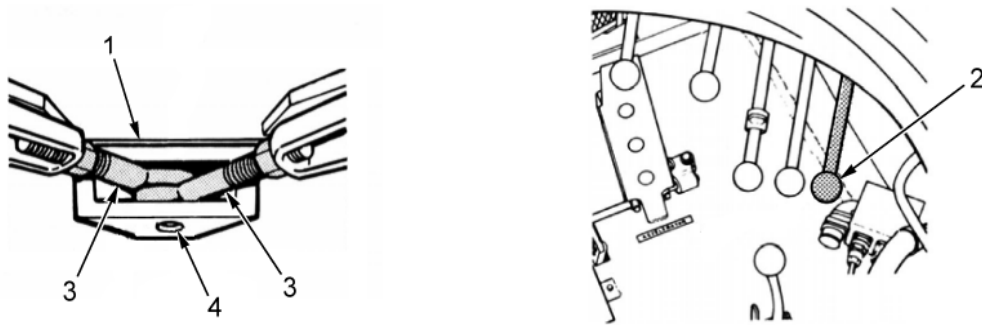

AVLBD134

Figure 13. Overhead Lever.

44. Tighten turnbuckles (Figure 14, Item 1) with pinch bar. Refer to WP 0077.

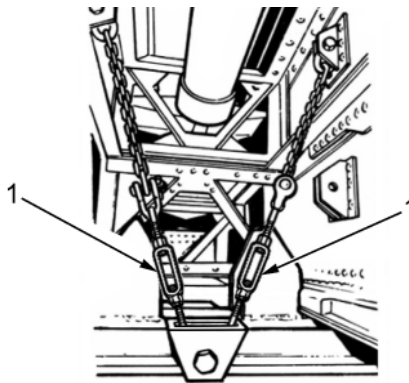

AVLBD133

Figure 14. Turnbuckles.

RETRIEVING BRIDGE - CONTINUED

45. Push down accelerator locking lever (Figure 15, Item 1).
46. On non-HEU vehicles, push down hydraulic clutch pump lever (Figure 15, Item 2). For vehicles with HEU, move hydraulic pump ball valve (Figure 15, Item 3) to LAUNCH.

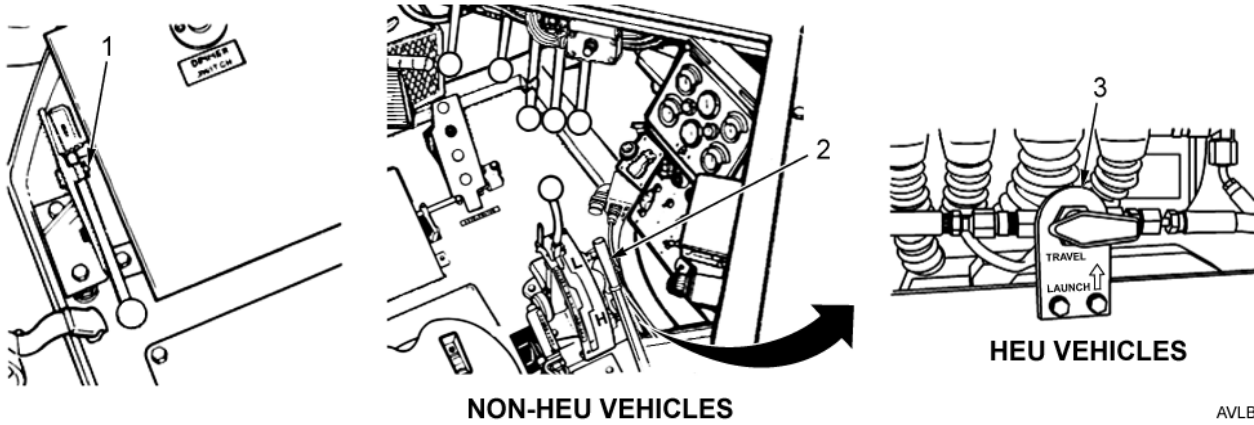

Figure 15. Accelerator Lock.

47. Pull up and then push down on all hydraulic levers a minimum of three times each to release pressure in system.
48. Install radio antenna. Refer to WP 0024.

END OF TASK

END OF WORK PACKAGE

OPERATOR MAINTENANCE**OPERATION UNDER USUAL CONDITIONS - PREVENTING GHOST LAUNCHING OF TONGUE AND OVERHEAD CYLINDER**

INITIAL SETUP:**Equipment Conditions**Engine running (WP 0015)

GENERAL

This work package provides instructions on parking an Armored Vehicle Launched Bridge (AVLB) retro ftted with hydraulic electrical upgrade (HEU) if the vehicle is experiencing ghost launching of the tongue and/or overhead cylinders. This condition can occur on vehicles parked without a bridge. The condition is caused by excessive internal leakage of the overhead and/or tongue cylinders. If equipment will not operate, notify f eld maintenance.

PREVENTING GHOST LAUNCHING OF TONGUE AND OVERHEAD CYLINDER

1. Bring overhead and tongue cylinders to stowed positions.
2. Move overhead control lever (Figure 1, Item 2) up until overhead cylinder rod extends 1/8 in. to 1/2 in. and release lever.
3. Move tongue control lever (Figure 1, Item 1) up until tongue cylinder rod extends 1/8 in. to 1/2 in. and release lever.
4. Move pump pressure control valve (Figure 1, Item 3) to TRAVEL position.
5. Proceed with normal vehicle engine shutdown procedure. Refer to WP 0015.

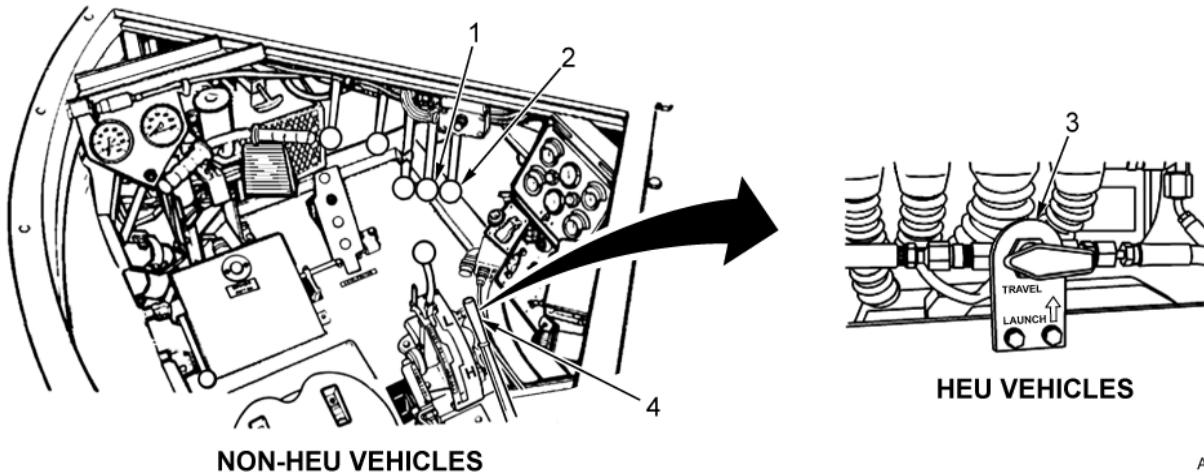

AVLBD625

Figure 1. Overhead and Tongue Cylinder Control Levers.

END OF TASK**END OF WORK PACKAGE**

OPERATOR MAINTENANCE**OPERATION UNDER USUAL CONDITIONS - AUXILIARY EQUIPMENT**

INITIAL SETUP:**References**

TB 43-0129
TM 11-5820-401-10-2

References (cont.)

TM 11-5820-498-12
TM 11-5915-224-14

GENERAL

This work package provides instructions for operating the auxiliary equipment for the M48A5 Armored Vehicle Launched Bridge (AVLB) and M60A1 AVLB under usual/normal conditions. If equipment will not operate, notify field maintenance.

AUXILIARY EQUIPMENT

Communication System

NOTE

- Operation of amplifier AM-1780/VRC and operation of intercom sets are contained in these work packages.
- Refer to TM 11-5820-498-12 for operation of radio sets AN/VRC-53 and AN/VRC-64.
- Refer to TM 11-5820-401-10-2 for operation of radio set AN/VRC-46.
- Refer to TM 11-5915-224-14 for operation of transient suppressor MX-7778A/GRC.
- Notify field maintenance for removal and installation of radio sets.

Amplifier AM-1780/VRC

1. Set MASTER BATTERY switch (Figure 1, Item 1) to ON.

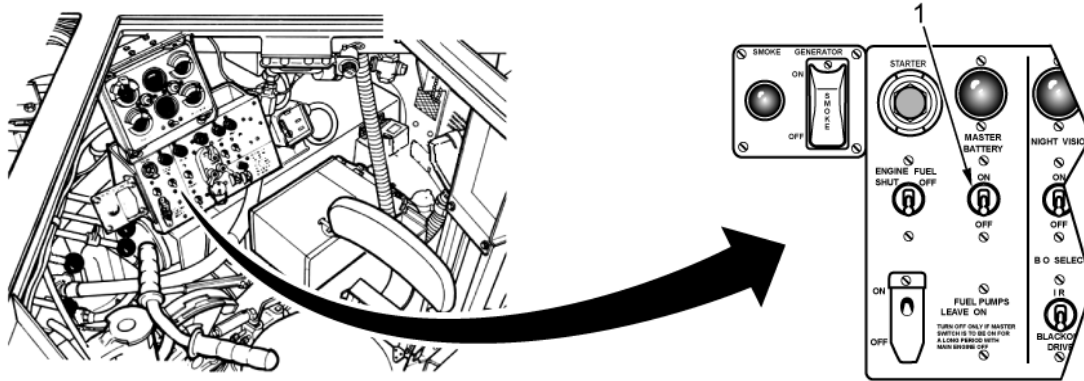

AVLBD136

Figure 1. Master Battery Switch.

2. Set MAIN PWR switch (Figure 2, Item 1) to NORM.
3. Set POWER CKT BKR (Figure 2, Item 4) to ON. POWER indicator (Figure 2, Item 5) will light.

CAUTION

If POWER CKT BKR (Figure 2, Item 4) trips to OFF after reset, move MAIN PWR switch (Figure 2, Item 1) to OFF to prevent damage to amplifier. Notify field maintenance.

4. If POWER CKT BKR (Figure 2, Item 4) trips to OFF, reset to ON.
5. Move INT ACCENT switch (Figure 2, Item 2) to ON or OFF.

NOTE

INT ACCENT (Figure 2, Item 2) OFF: Intercom and radio sound levels are equal. INT ACCENT ON: Radio sound level is lower than intercom.

6. Set RADIO TRANS switch (Figure 2, Item 3) to CDR + CREW, CDR ONLY, or LISTENING SILENCE.
7. Turn off amplifier by moving MAIN PWR switch (Figure 2, Item 1) to OFF.

AUXILIARY EQUIPMENT - CONTINUED

Amplif er AM-1780/VRC - Continued

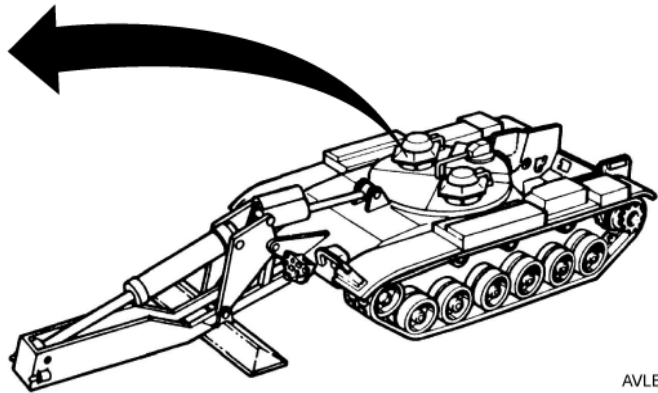
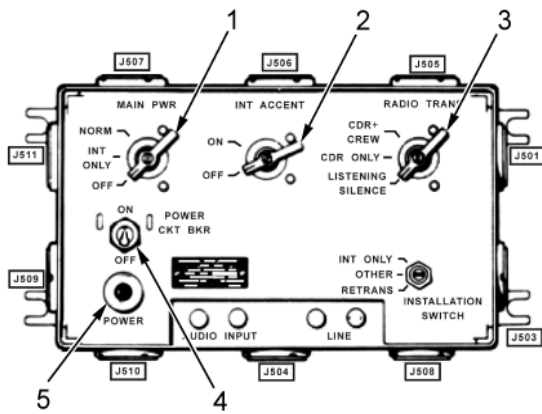

AVLBD137

Figure 2. Radio Trans Switch.

- 8. Set MASTER BATTERY switch (Figure 3, Item 1) to OFF if it is not required for other operations.

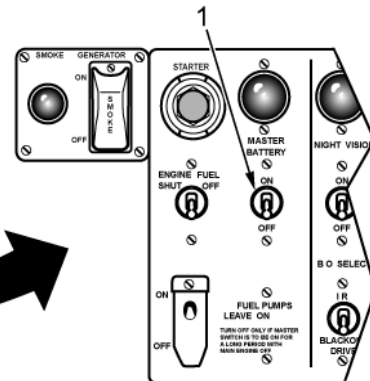
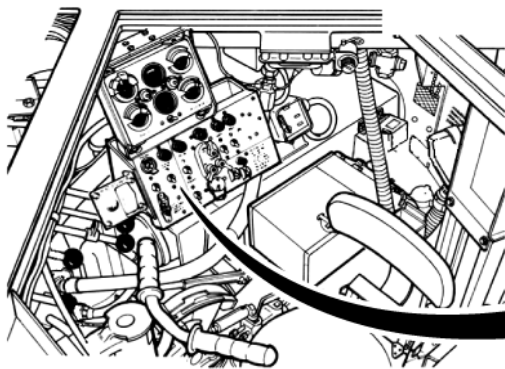

AVLBD136

Figure 3. Master Battery Switch.

END OF TASK

AUXILIARY EQUIPMENT - CONTINUED**Intercom Set C-2298/VRC**

1. Turn on amplifier AM-1780/VRC.
2. Transmit on receiver-transmitter by moving MONITOR switch (Figure 4, Item 1) to ALL, A, or B. Connect communication cords (Figure 4, Item 4) to intercom box (Figure 4, Item 2) and adjust VOLUME knob (Figure 4, Item 5) to desired level. Hold push-to-talk switch (Figure 4, Item 3) forward to transmit.

NOTE

Ensure communication cord with yellow band is connected to the left intercom box connector.

3. Talk on intercom by moving MONITOR switch (Figure 4, Item 1) to INT ONLY. Adjust VOLUME knob (Figure 4, Item 5) to desired level. Set push-to-talk switch (Figure 4, Item 3) rearward to talk.

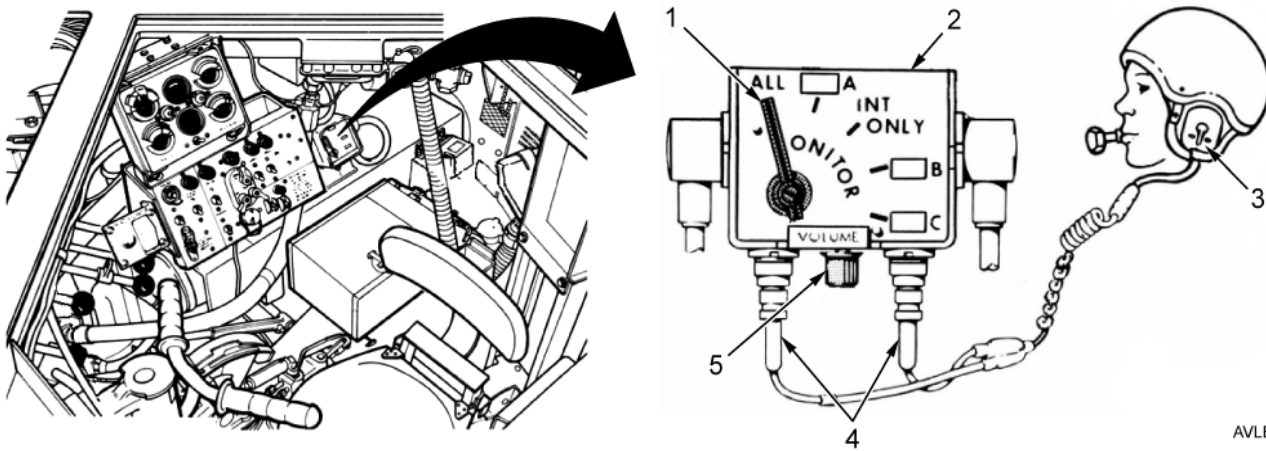

AVLBD138

Figure 4. Intercom Set C-2298/VRC.

4. Turn intercom sets off by turning amplifier AM-1780/VRC off.

END OF TASK**Antenna**

1. Refer to TB 43-0129 for tiedown information.
2. Refer to TB 43-0129 for safety measures to be observed when using whip-type antennas.

END OF TASK

AUXILIARY EQUIPMENT - CONTINUED**Portable Fire Extinguisher****WARNING**

Fire extinguisher agent carbon dioxide (CO₂) will irritate eyes and throat. Wear protective goggles and avoid contact with fire extinguisher agent. Failure to comply may result in personnel injury or death.

1. Remove portable fire extinguisher (Figure 5, Item 3) from bracket behind operator's seat.
2. Break wire (Figure 5, Item 2) and remove pin (Figure 5, Item 1).
3. Pull horn (Figure 5, Item 4) up to level position.
4. Take fire extinguisher (Figure 5, Item 3) as close to fire as possible and point horn (Figure 5, Item 4) directly at base of flames.

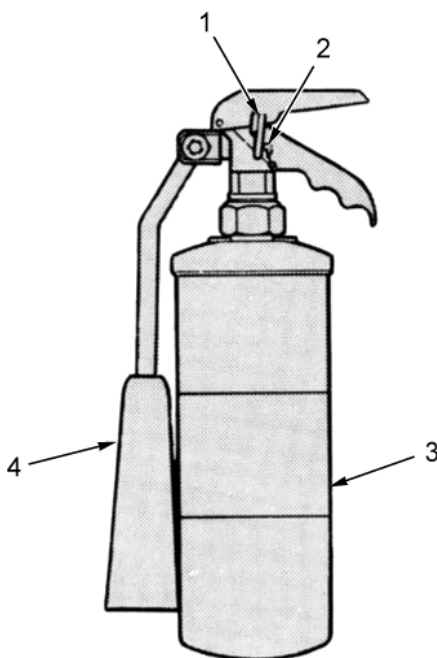

AVLBD139

Figure 5. Removing Fire Extinguisher Safety Wire.

AUXILIARY EQUIPMENT - CONTINUED**Portable Fire Extinguisher - Continued****NOTE**

Fire extinguisher is most efficient when held within 5 ft (1.5 m) of fire.

5. Press down and hold trigger (Figure 6, Item 2) to shoot extinguisher agent at fire.

NOTE

If fire was inside vehicle, open all hatches and let vehicle air out for 5 minutes before continuing operation.

6. Insert pin (Figure 6, Item 1) back into trigger (Figure 6, Item 2).
7. Turn horn (Figure 6, Item 4) down and tag fire extinguisher (Figure 6, Item 3) with the word "empty."
8. Replace empty fire extinguisher (Figure 6, Item 3) as soon as possible.

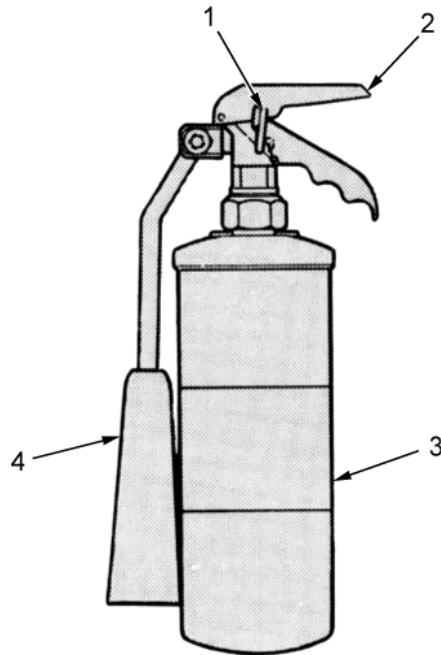

AVLBD509

Figure 6. Empty Fire Extinguisher.

END OF TASK**END OF WORK PACKAGE**

OPERATOR MAINTENANCE**OPERATION UNDER USUAL CONDITIONS - M239 SMOKE GRENADE LAUNCHER**

INITIAL SETUP:**References**

WP 0004

WP 0005

GENERAL

This work package provides instructions for operating the M239 smoke grenade launcher for the M48A5 Armored Vehicle Launched Bridge (AVLB) and M60A1 AVLB under usual/normal conditions. If equipment will not operate, notify field maintenance.

OPERATE M239 SMOKE GRENADE LAUNCHER**Loading****WARNING**

- Smoke grenades contain red phosphorous (RP) and are explosive. If grenades are dropped, heated, thrown, tumbled, or dragged, an explosion may result. Follow standard weapon-loading procedures when handling and loading smoke grenades. Have a manned fire extinguisher handy. Do not allow flames or sparks within area while stowing ammunition. Disassembly of ammunition is not authorized. Failure to comply may result in personnel injury or death, or equipment damage.
- An explosion or discharge may occur when loading discharger. Ensure grenade power switch is OFF (lamp not lit) before loading discharger. DO NOT place any part of body in front of dischargers when loading grenades or when dischargers are loaded. Failure to comply may result in personnel injury, death, or equipment destruction.

1. Ensure grenade power switch (Figure 1, Item 2) is in OFF position. Light (Figure 1, Item 1) is off.

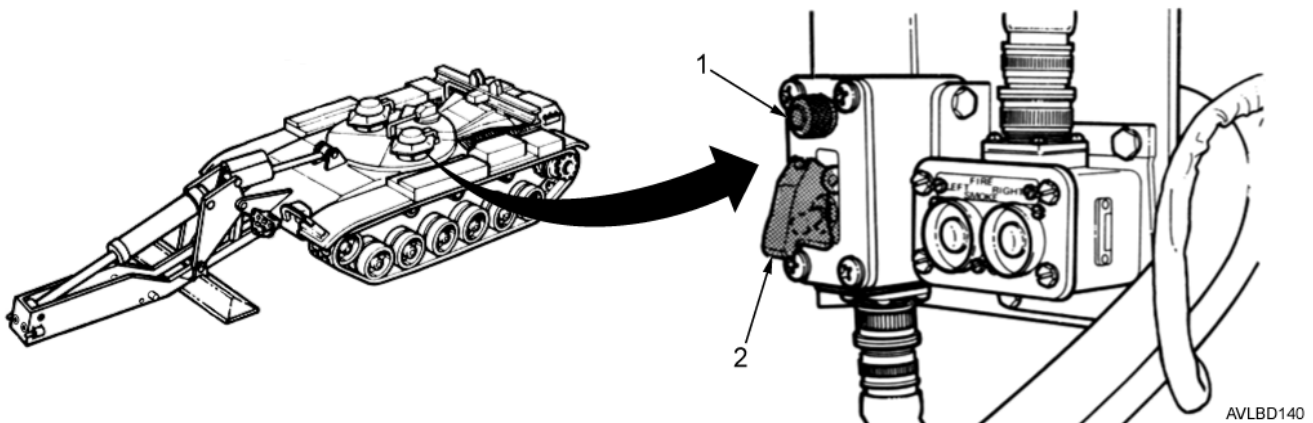

Figure 1. Grenade Power Switch.

2. Set MASTER BATTERY switch to off. Refer to WP 0004.

OPERATE M239 SMOKE GRENADE LAUNCHER - CONTINUED**Loading - Continued****WARNING**

An explosion or discharge may occur when loading discharger. Ensure grenade power switch is OFF (lamp not lit) before loading discharger. DO NOT place any part of body in front of dischargers when loading grenades or when dischargers are loaded. Failure to comply may result in personnel injury, death, or equipment destruction.

3. Remove canvas covers (Figure 2, Item 5) from right and left discharger (Figure 2, Item 4) and stow in fender storage box (Figure 2, Item 3).
4. Ensure all barrels of each discharger are clear and clean.

WARNING

Damaged grenades may explode. DO NOT use grenades that have external cracks, dents, or other deformities. Disassembly of grenades is not authorized. Place damaged grenades in storage/shipping containers and dispose of in accordance with local regulations. Failure to comply may result in personnel injury or death, or equipment destruction.

5. Remove grenades (Figure 2, Item 1) from stowage box (Figure 2, Item 2) (M60A1).

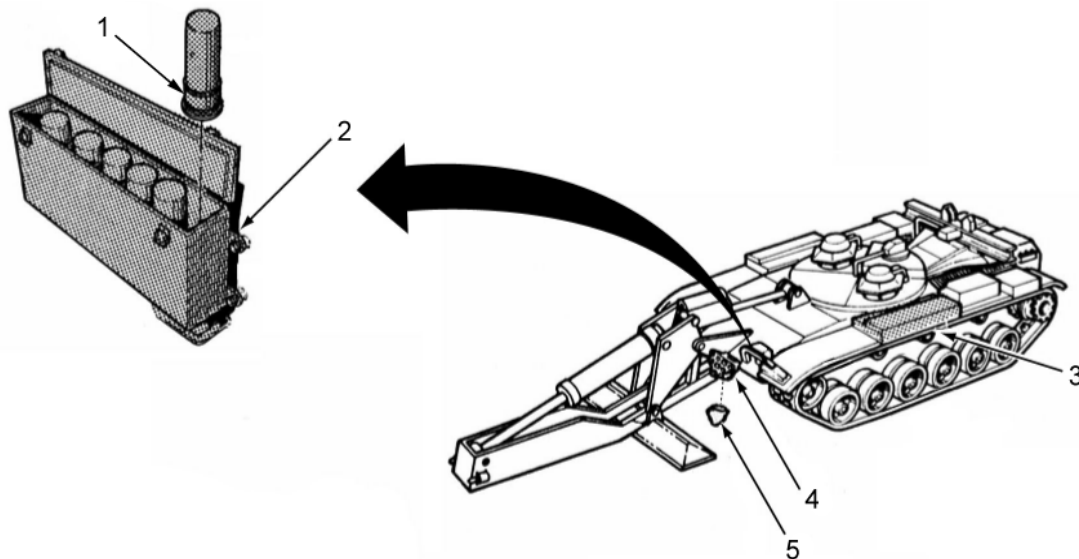

Figure 2. Grenade Stowage Box.

AVLBD141

OPERATE M239 SMOKE GRENADE LAUNCHER - CONTINUED

Loading - Continued

WARNING



An explosion or discharge may occur when loading discharger. Ensure grenade power switch is OFF (lamp not lit) before loading discharger. DO NOT place any part of body in front of dischargers when loading grenades or when dischargers are loaded. Failure to comply may result in personnel injury, death, or equipment destruction.

6. Push six grenades (Figure 3, Item 3), base first, into barrels of each discharger (Figure 3, Item 1). Spring clip (Figure 3, Item 4) on grenade base must engage tip plug (Figure 3, Item 2) at bottom of each barrel.
7. Rotate each grenade (Figure 3, Item 3) 1/4 to 1/2 turn to ensure electrical contact.

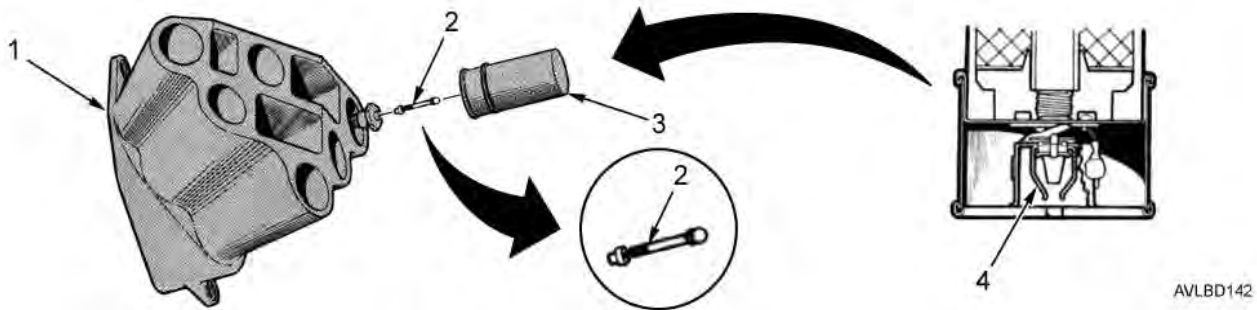

Figure 3. Loading Dischargers.

END OF TASK

Firing

WARNING



- A misfire or dud has the potential to explode. DO NOT touch a dud smoke grenade. When a misfire or dud occurs, all personnel must remain a minimum of 219 yd (200 m) from vehicle for a minimum of 5 minutes after final attempt to fire. Crew must remain in vehicle with hatches closed. Notify Explosive Ordnance Disposal (EOD) personnel and give type, quantity, and precise location of dud grenades. Failure to comply may result in personnel injury or death.
- Firing grenades while launching bridge could cause the grenade to strike the bridge and launching mechanism, causing a fire. DO NOT fire smoke grenades while launching bridge. Failure to comply may result in personnel injury or death, or equipment damage.
- If fired into gusty winds, particles of a detonated L8A1 grenade may blow back into the vehicle and cause a fire. Crew must remain in vehicle with hatch closed. Failure to comply may result in personnel injury or death, or equipment damage.

OPERATE M239 SMOKE GRENADE LAUNCHER - CONTINUED**Firing - Continued**

1. Ensure grenade power switch (Figure 4, Item 2) is in OFF position. Light (Figure 4, Item 1) is off.
2. Ensure all crew members are inside of vehicle with hatches locked. Refer to WP 0005.

WARNING

- A misfire or dud has the potential to explode. DO NOT touch a dud smoke grenade. When a misfire or dud occurs, all personnel must remain a minimum of 219 yd (200 m) from vehicle for a minimum of 5 minutes after final attempt to fire. Crew must remain in vehicle with hatches closed. Notify Explosive Ordnance Disposal (EOD) personnel and give type, quantity, and precise location of dud grenades. Failure to comply may result in personnel injury or death.
 - An explosion may occur if discharger or grenade contains sand, mud, moisture, frost, snow, ice, grease, or other foreign matter. Before loading grenade into the discharger, ensure each part is free of sand, mud, moisture, frost, snow, ice, grease, or other foreign matter. Failure to comply may result in personnel injury or death.
3. Set MASTER BATTERY switch to ON. Refer to WP 0004.
 4. Set grenade power switch (Figure 4, Item 2) to ON and ensure that light (Figure 4, Item 1) is on.

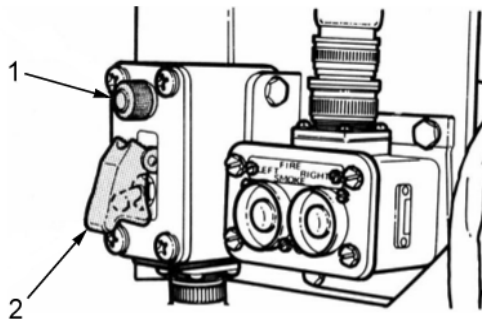

Figure 4. Grenade Power Switch.

AVLBD143

OPERATE M239 SMOKE GRENADE LAUNCHER - CONTINUED

Firing - Continued

NOTE

Smoke grenades can be fired in the following combinations. Figure 5 indicates grenade launch angle.

- a. Right pushbutton pattern.
- b. Left pushbutton pattern.
- c. Salvo (both pushbuttons).

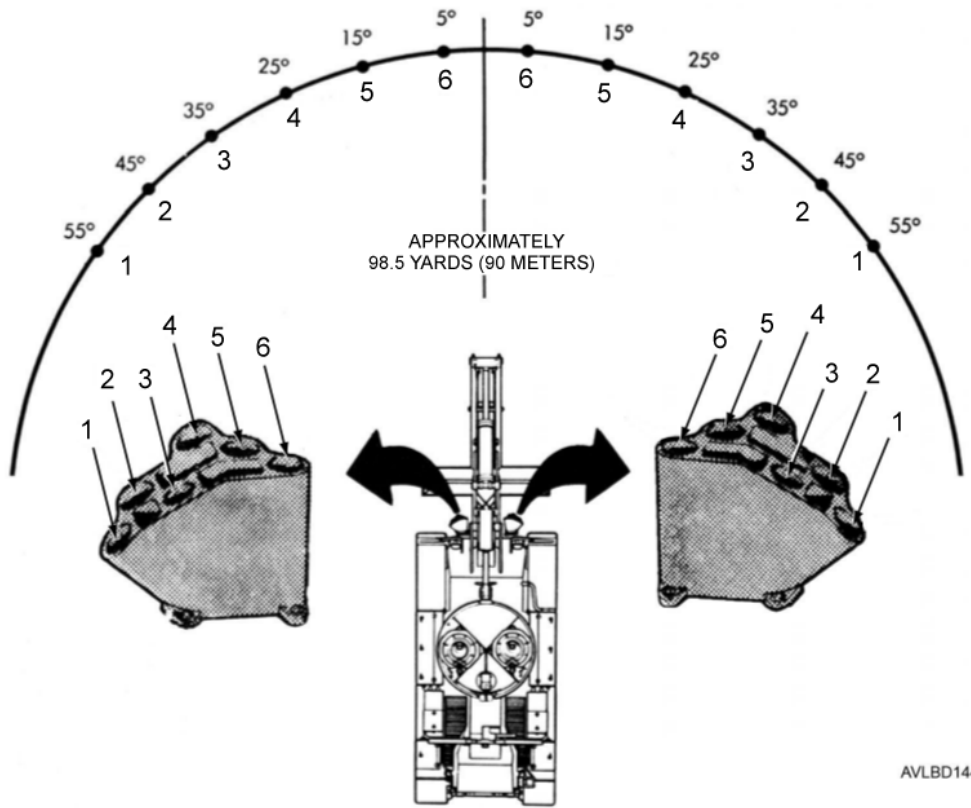

Figure 5. Firing Pattern.

Table 1. Left Pushbutton Pattern.

LEFT DISCHARGER	RIGHT DISCHARGER
1-3-5	6-4-2

Table 2. Right Pushbutton Pattern.

LEFT DISCHARGER	RIGHT DISCHARGER
2-4-6	5-3-1

OPERATE M239 SMOKE GRENADE LAUNCHER - CONTINUED**Firing - Continued**

- When grenade power light (Figure 6, Item 1) comes on, press FIRE SMOKE LEFT pushbutton (Figure 6, Item 2), FIRE SMOKE RIGHT pushbutton (Figure 6, Item 3), or both pushbuttons from dischargers.

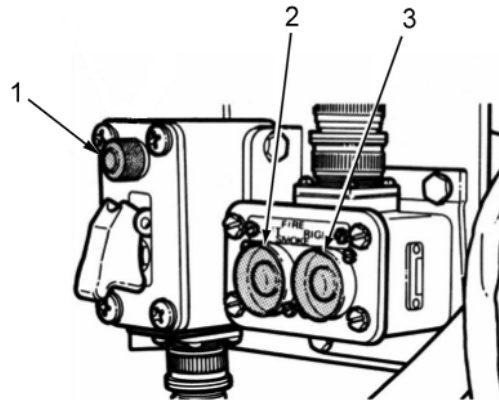

AVLBD145

Figure 6. Fire Smoke Left/Right Pushbuttons.

END OF TASK**Hangfire, Misfire, and Duds****WARNING**

A misfire or dud has the potential to explode. **DO NOT** touch a dud smoke grenade. When a misfire or dud occurs, all personnel must remain a minimum of 219 yd (200 m) from vehicle for a minimum of 5 minutes after final attempt to fire. Crew must remain in vehicle with hatches closed. Notify Explosive Ordnance Disposal (EOD) personnel and give type, quantity, and precise location of dud grenades. Failure to comply may result in personnel injury or death.

- A hangfire smoke grenade is a temporary failure or delay in action of propellant charge. When hangfire occurs, wait 10 seconds and make two additional attempts to fire with 10-second intervals. If grenade still does not fire, wait 5 minutes and treat it as a misfire.
- A misfire is failure of smoke grenade discharger to fire grenades. When misfire occurs, wait 10 seconds and make two additional attempts to fire with 10-second intervals. If grenade still does not fire, wait 5 minutes, remove misfired grenade from discharger, and place it 219 yd (200 m) away from personnel and equipment. Notify EOD personnel and give type, quantity, and precise location of misfired grenades.
- A dud is a smoke grenade that has fired from a discharger but has failed to burst or burn. Wait 15 minutes with hatches closed. Notify EOD personnel and give type and precise location of dud grenade.

END OF TASK

OPERATE M239 SMOKE GRENADE LAUNCHER - CONTINUED

Unloading

1. Ensure grenade power switch (Figure 7, Item 2) is in OFF position.
2. Set MASTER BATTERY switch (Figure 7, Item 1) to OFF.

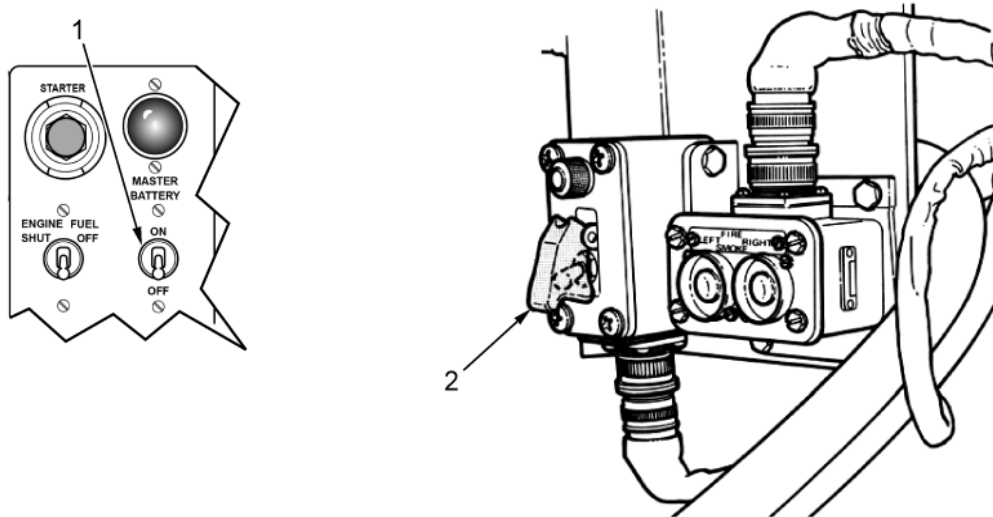

AVLBD146

Figure 7. Master Battery Switch.

WARNING



- Smoke grenades contain red phosphorous (RP) and are explosive. If grenades are dropped, heated, thrown, tumbled, or dragged, an explosion may result. Follow standard weapon-loading procedures when handling and loading smoke grenades. Have a manned fire extinguisher handy. Do not allow flames or sparks within area while stowing ammunition. Disassembly of ammunition is not authorized. Failure to comply may result in personnel injury or death, or equipment damage.
- An explosion or discharge may occur when loading discharger. Ensure grenade power switch is OFF (lamp not lit) before loading discharger. DO NOT place any part of body in front of dischargers when loading grenades or when dischargers are loaded. Failure to comply may result in personnel injury, death, or equipment destruction.

3. Unlatch and open right and left stowage boxes (Figure 8, Item 2).
4. Remove all grenades (Figure 8, Item 1) from both grenade dischargers (Figure 8, Item 3) and both stowage boxes (Figure 8, Item 2).

OPERATE M239 SMOKE GRENADE LAUNCHER - CONTINUED

Unloading - Continued

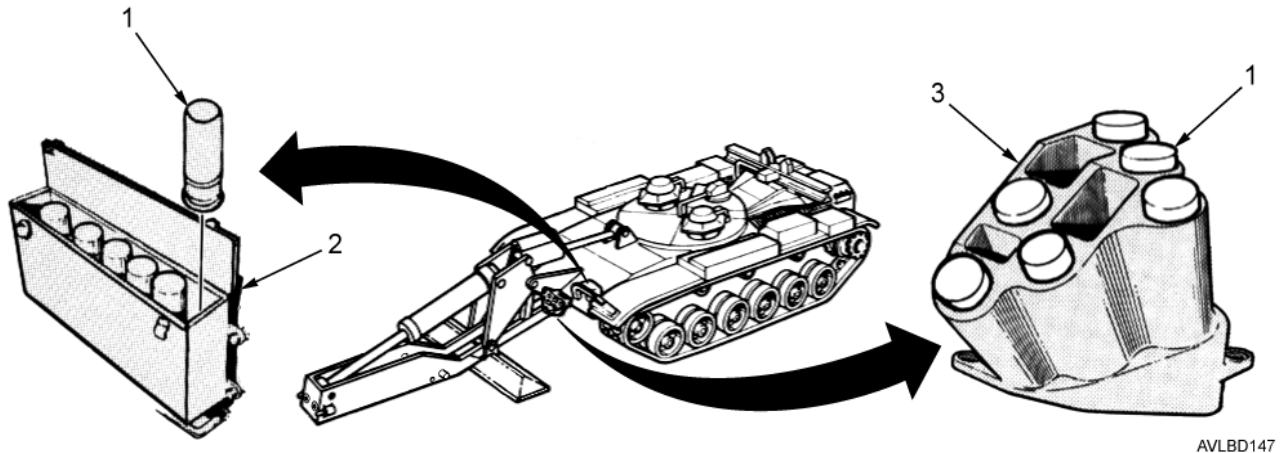

AVLBD147

Figure 8. Grenade Stowage Boxes and Dischargers.

5. Return all grenades (Figure 9, Item 2) to ammunition stowage boxes (Figure 9, Item 3).
6. Close and latch ammunition stowage boxes (Figure 9, Item 3) and place ammunition stowage boxes in right and left fender stowage boxes (Figure 9, Item 1).
7. Remove discharger covers (Figure 9, Item 5), if stowed, from fender stowage box (Figure 9, Item 1) and install discharge covers on left and right grenade dischargers (Figure 9, Item 4).

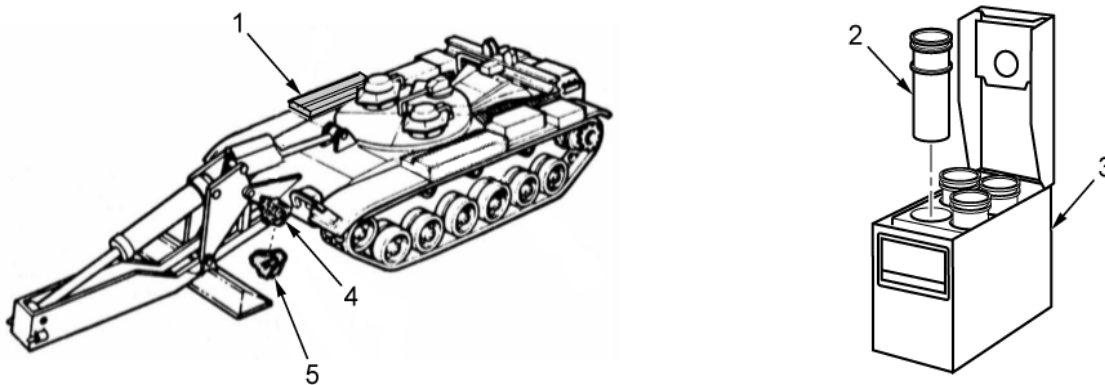

AVLBD148

Figure 9. Ammunition Stowage Boxes and Dischargers.

END OF TASK

END OF WORK PACKAGE

OPERATOR MAINTENANCE**OPERATION UNDER USUAL CONDITIONS - ANTENNA REMOVAL AND INSTALLATION**

INITIAL SETUP:**Tools and Special Tools**

Pliers, Slip-Joint (WP 0077, Table 2, Item 43)
Wrench, Adjustable (WP 0077, Table 2, Item 66)

References

TM 11-5985-262-14
TM 11-5985-262-24P

Materials/Parts

Compound, Silicone (WP 0079, Table 1, Item 21)

Equipment Conditions

MASTER BATTERY switch off (WP 0004)

GENERAL

This work package provides instructions for removing and installing the antenna for the M48A5 Armored Vehicle Launched Bridge (AVLB) and M60A1 AVLB under usual/normal conditions. If equipment will not operate, notify field maintenance.

REMOVAL**WARNING**

Electrical shock or death could occur when removing an antenna during a storm. **DO NOT** attempt to remove antenna during a storm. Failure to comply may result in personnel injury or death.

1. If antenna is tied down to vehicle, remove tiedown (TM 11-5985-262-14 or TM 11-5985-262-24P).
2. Use pliers to remove safety wire (Figure 1, Item 2) from hole in spring mount (Figure 1, Item 3) and antenna (Figure 1, Item 1).
3. Use adjustable wrench to remove antenna (Figure 1, Item 1) from spring mount (Figure 1, Item 3).

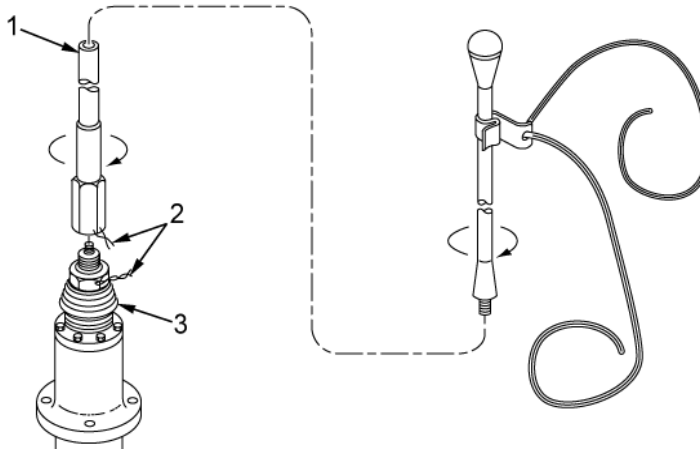

AVLBD636

Figure 1. Antenna Removal.

END OF TASK**INSTALLATION****WARNING**

Electrical shock or death could occur when removing an antenna during a storm. **DO NOT** attempt to remove antenna during a storm. Failure to comply may result in personnel injury or death.

INSTALLATION - CONTINUED

WARNING



Silicone compounds are harmful to skin and clothing, can burn easily, and may give off a harmful vapor. If compounds contact eyes, wash immediately with water. Wash with soap and water if compounds contact skin. Use adhesives, solvents, sealing, and insulating compounds in well-ventilated areas away from open flame. Failure to comply may result in personnel injury or death.

1. Apply silicone compound to threads (Figure 2, Item 5) of spring mount (Figure 2, Item 3).
2. Install preformed packing (Figure 2, Item 4) down around bottom of threads (Figure 2, Item 5) of spring mount (Figure 2, Item 3).
3. Use adjustable wrench to install antenna (Figure 2, Item 1) on spring mount (Figure 2, Item 3).

NOTE

Safety wire prevents antenna from coming loose from spring mount while vehicle is in motion. If antenna will be frequently removed or if vehicle will not be on the road frequently, do not install safety wire.

4. Insert safety wire (Figure 2, Item 2) through hole in spring mount (Figure 2, Item 3).
5. Insert opposite end of safety wire (Figure 2, Item 2) through hole in antenna (Figure 2, Item 1).
6. Use pliers to twist ends of safety wire (Figure 2, Item 2) three to six times to form pigtail.
7. Use pliers to trim excess safety wire (Figure 2, Item 2) and bend pigtail back against hexagonal portion of spring mount (Figure 2, Item 3).
8. Tie down antenna (TM 11-5985-262-14 or TM 11-5985-262-24P).

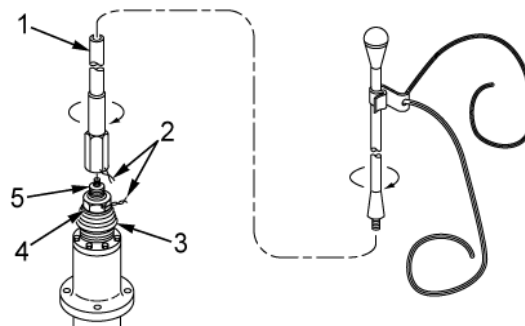

Figure 2. Antenna Installation.

AVLBD633

END OF TASK

END OF WORK PACKAGE

OPERATOR MAINTENANCE**OPERATION UNDER USUAL CONDITIONS - TOP DECK GRILLE DOORS**

INITIAL SETUP:**Tools and Special Tools**

Ratchet, (WP 0077, Table 2, Item 31)

Socket Wrench (WP 0077, Table 2, Item 61)

GENERAL

This work package provides instructions for operating the top deck grille doors for the M48A5 Armored Vehicle Launched Bridge (AVLB) and M60A1 AVLB under usual/normal conditions. If equipment will not operate, notify field maintenance.

TOP DECK GRILLE DOORS OPERATION**Open Doors****WARNING**

Grille doors are heavy and may cause injury to personnel. Keep feet clear of grille doors when opening. Failure to comply may result in personnel injury.

Loosen four screws (Figure 1, Item 2) and open eight grille doors (Figure 1, Item 1).

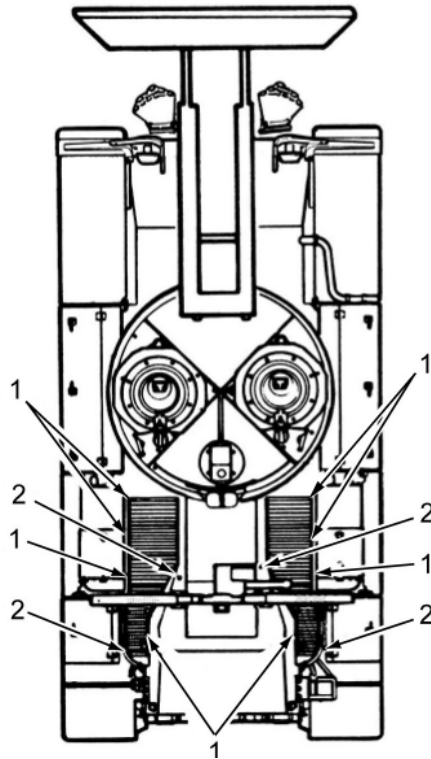

AVLBD433

Figure 1. Grille Doors.

END OF TASK

TOP DECK GRILLE DOORS OPERATION - CONTINUED**Close Doors**

Close eight grille doors (Figure 2, Item 1) and tighten four screws (Figure 2, Item 2).

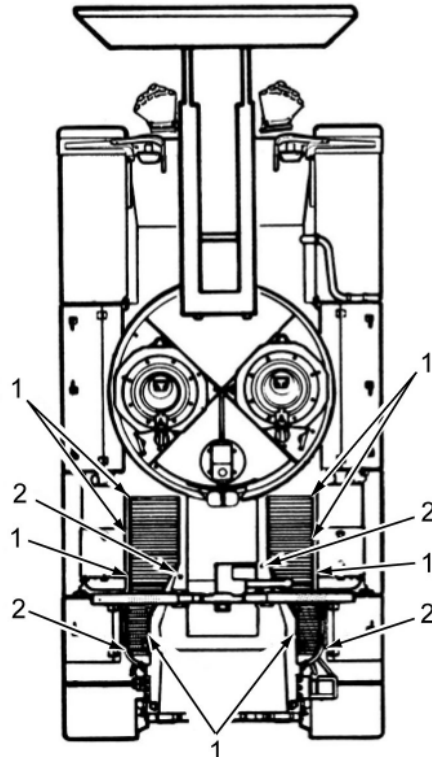

AVLBD433

Figure 2. Grille Doors.

END OF TASK

END OF WORK PACKAGE

OPERATOR MAINTENANCE**OPERATION UNDER UNUSUAL CONDITIONS - EXTREME COLD WEATHER**

INITIAL SETUP:**References**

DA Form 2404
TM 9-6140-200-14

References (cont.)

WP 0015
WP 0048

GENERAL

In addition to performing normal Preventive Maintenance Checks and Services (PMCS) (WP 0048), clean and lubricate equipment more often to compensate for extremes of temperature, humidity, and terrain conditions that are present or expected. Cleaned and lubricated equipment ensures proper operation and guards against excessive wear and failure.

When equipment constantly breaks down due to operating under extreme conditions, report failure(s) using DA Form 2404 (Equipment Inspection and Maintenance Worksheet).

UNUSUAL ENVIRONMENT/WEATHER**Operating In Extreme Cold Weather****CAUTION**

DO NOT suddenly move a sighting instrument from cold to warm temperatures or vice versa. Moisture caused by this change in temperature may cause cloudy optics and rusty internal parts.

1. Prepare equipment when scheduled for operation in extreme cold. Generally, extreme cold will:
 - a. Cause lubricant to thicken.
 - b. Freeze batteries or prevent them from furnishing enough current for starting engine.
 - c. Prevent fuel from vaporizing to form combustible mixture for starting.
 - d. Cause some materials to become hard, brittle, and easy to damage or break. (Cracked insulation can cause electrical short circuits).
2. Always watch for indication of weather effects on equipment.
3. Be cautious when moving vehicle after shutdown. Thick lubricants may cause failure of parts. After warming up engine thoroughly, drive vehicle slowly about 100 yd (91.4 m) to warm up lubricants to point where normal operation can be expected.
4. Monitor temperature and pressure indicators. If readings are abnormal, stop vehicle and investigate cause. Refer to WP 0015. If you cannot find and correct problem, notify field maintenance.
 - a. Always watch for indication of weather effects on equipment.
 - b. Be cautious when moving vehicle after a shutdown. Thick lubricants may cause failure of parts. After warming up engine thoroughly, drive vehicle slowly about 100 yd (91.4 m) to warm up lubricants to point where normal operation can be expected.
 - c. Monitor temperature and pressure indicators. If readings are abnormal, stop vehicle and investigate cause. Refer to WP 0015. If problem cannot be located and corrected, notify field maintenance.

END OF TASK

UNUSUAL ENVIRONMENT/WEATHER - CONTINUED**At Halt and Parking**

1. When stopping for short shutdown periods, park vehicle in sheltered location out of wind. If sheltered location is not available, park so that front of vehicle faces into wind. This keeps rain, snow, and sleet from entering engine compartment through rear grille door. When shut down for long period and unable to locate dry ground, park vehicle on footing of planks or brush to prevent tracks from freezing to ground.
2. Additional actions to perform when preparing to shut down:
 - a. Place control levers in (N) Neutral position to prevent possible freezing in engaged position.
 - b. Cover all grille doors to retain heat and prevent entrance of snow, which will melt and freeze in engine compartment.
 - c. Open hull drain valves to drain melted snow while engine heat is present. After draining, close drain valves to prevent valves freezing in open position.
 - d. Clear mud, snow, and ice from vehicle as soon as possible after stopping.
 - e. If fuel tanks contain excessive water, notify field maintenance.
 - f. To prevent linkage freezing, do not apply parking brake.
 - g. Fill fuel tanks as soon as possible to reduce condensation.
 - h. Refer to TM 9-6140-200-14 for battery care and maintenance.

END OF TASK**END OF WORK PACKAGE**

OPERATOR MAINTENANCE**OPERATION UNDER UNUSUAL CONDITIONS - HOT, HUMID, OR SALTY AREAS**

INITIAL SETUP:**Materials/Parts**

Lubricating Oil, General Purpose (LO 5-5420-202-13)

References

DA Form 2404

References (cont.)

LO 5-5420-202-13

TM 9-6140-200-14

WP 0048

GENERAL

In addition to performing normal Preventive Maintenance Checks and Services (PMCS) (WP 0048), clean and lubricate equipment more often to compensate for extremes of temperature, humidity, and terrain conditions that are present or expected. Cleaned and lubricated equipment ensures proper operation and guards against excessive wear and failure.

When equipment constantly breaks down due to operating under extreme conditions, report failure(s) using DA Form 2404 (Equipment Inspection and Maintenance Worksheet).

OPERATING IN HOT, HUMID, OR SALTY AREAS

1. Operating vehicle for long periods at high speeds, on long hard pulls in L (Low) or R (Reverse), on steep grades, or in soft terrain, may cause engine to overheat. Avoid using L and R for long periods whenever possible. Monitor ENGINE and TRANSMISSION TEMP F indicators. If either indicator indicates in red area, stop vehicle and run engine at 1,000 to 1,200 RPM until indicator is in green area. Resume operation. If temperature does not return to normal or if overheating recurs, shut down engine and notify your supervisor.
2. Frequently check for moisture, corrosion, and fungus growth. Dry all exposed unpainted surfaces and lubricate as prescribed in LO 5-5420-202-13.
3. Shield sighting equipment from direct rays of the sun as much as possible.
4. Weapons require cleaning and lubricating more often when not in use. Cover exposed metal surfaces with film of general purpose lubricating oil, as prescribed in LO 5-5420-202-13, and keep covers in place.
5. Refer to TM 9-6140-200-14 for battery care and maintenance.

END OF TASK**END OF WORK PACKAGE**

OPERATOR MAINTENANCE**OPERATION UNDER UNUSUAL CONDITIONS - DUSTY OR SANDY AREAS**

INITIAL SETUP:**References**

DA Form 2404
FM 90-3
WP 0048

GENERAL

In addition to performing normal Preventive Maintenance Checks and Services (PMCS) (WP 0048), clean and lubricate equipment more often to compensate for extremes of temperature, humidity, and terrain conditions that are present or expected. Cleaned and lubricated equipment ensures proper operation and guards against excessive wear and failure.

When equipment constantly breaks down due to operating under extreme conditions, report failure(s) using DA Form 2404 (Equipment Inspection and Maintenance Worksheet).

OPERATING IN DUSTY OR SANDY AREAS**CAUTION**

DO NOT operate vehicle in dusty or sandy areas without inspection plates or drain plugs. Failure to comply may result in equipment damage.

NOTE

Air cleaners are to be opened and serviced only by field maintenance personnel.

1. Operation in dusty and sandy areas shortens service life of air cleaner. Service inspection parts, air cleaner filter element, and air cleaner box assembly more frequently.
2. When at halt for extended periods, cover entire vehicle with canvas. Where entire vehicle cannot be covered, protect periscopes and other optical surfaces against scratches by wind-blown sand. Protect engine compartment against entry of sand or dust.
3. When extended for crossing, frequently check hydraulic seals, hydraulic lines, and fittings for leaks. Wipe hydraulic cylinder clean after use and cap all hydraulic fittings.
4. Keep scissoring cables clean of sand buildup.
5. Inspect tracks/sprockets often for signs of track guide and sprocket tooth wear.
6. Avoid sharp, high-speed turns in loose or fine sand. Track tension is particularly important in loose or fine sand.
7. Additional information on operating equipment in extreme environmental conditions can be found in FM 90-3, Desert Operations.

END OF TASK**END OF WORK PACKAGE**

OPERATOR MAINTENANCE**OPERATION UNDER UNUSUAL CONDITIONS - ENGINE AIR CLEANER INTAKES**

INITIAL SETUP:**Tools and Special Tools**

Extension, Socket Wrench (WP 0077, Table 2, Item 15)
Handle, Socket Wrench, Ratchet (WP 0077, Table 2, Item 31)
Socket Wrench (WP 0077, Table 2, Item 57)
Socket Wrench (WP 0077, Table 2, Item 58)

Materials/Parts

Washer, Lock (18) (WP 0079, Table 1, Item 40)

References

DA Form 2404
WP 0048

GENERAL

In addition to performing normal Preventive Maintenance Checks and Services (PMCS) (WP 0048), clean and lubricate equipment more often to compensate for extremes of temperature, humidity, and terrain conditions that are present or expected. Cleaned and lubricated equipment ensures proper operation and guards against excessive wear and failure.

When equipment constantly breaks down due to operating under extreme conditions, report failure(s) using DA Form 2404 (Equipment Inspection and Maintenance Worksheet).

ENGINE AIR CLEANER INTAKES

Reversing Intakes to Draw Air from Engine Compartment

NOTE

Under normal and especially dusty conditions, operate vehicle with air cleaner intakes set to draw air from crew compartment. When operating in extreme cold, and if a nuclear, biological, or chemical attack is expected, set intakes to draw air from the engine compartment.

1. Remove four screws (Figure 1, Item 1) and lockwashers (Figure 1, Item 2) from air intake cover (Figure 1, Item 3). Discard lockwashers.

NOTE

A gasket is glued to air intake cover.

2. Remove cover (Figure 1, Item 3) from air intake (Figure 1, Item 4).
3. Remove six nuts (Figure 1, Item 5) and lockwashers (Figure 1, Item 6) from inside of air intake (Figure 1, Item 4). Discard lockwashers.
4. Remove eight nuts (Figure 1, Item 5) and lockwashers (Figure 1, Item 6) from outside of air intake (Figure 1, Item 4). Discard lockwashers.
5. Remove air intake (Figure 1, Item 4) from bulkhead.

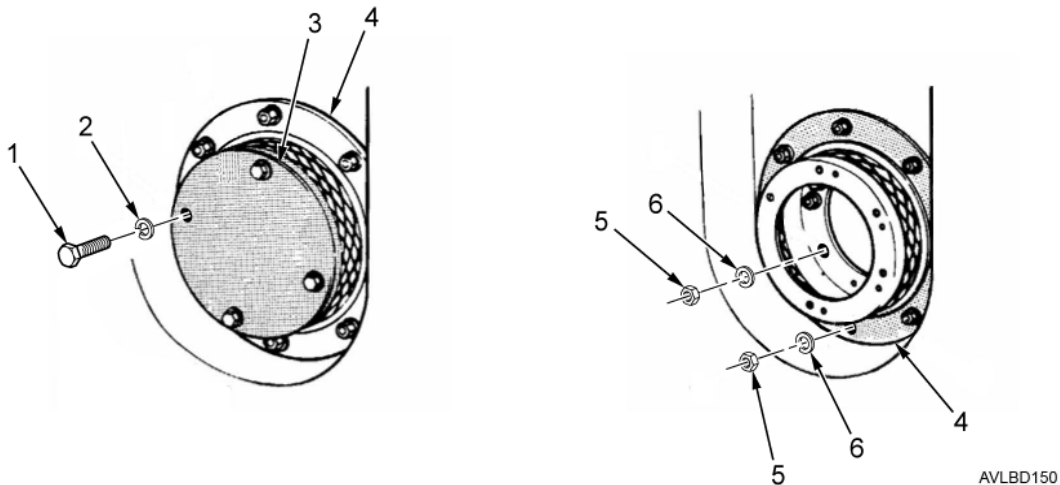
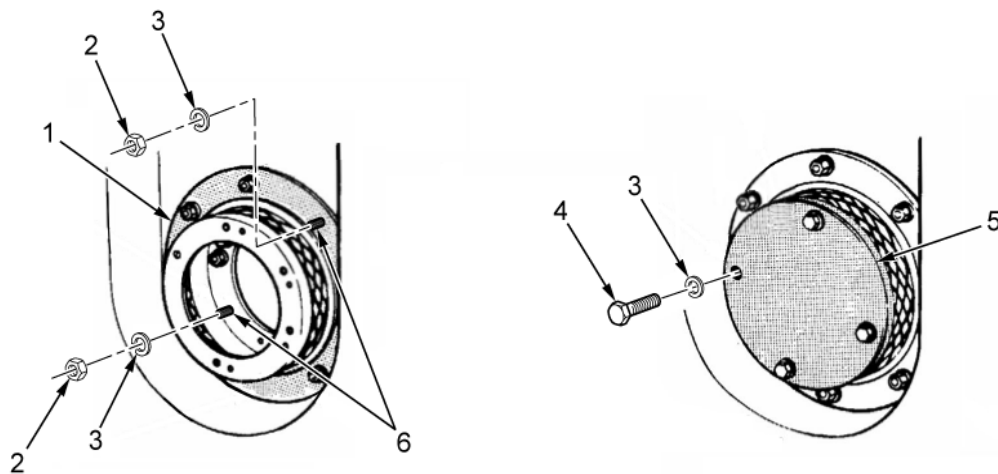

Figure 1. Removing Air Intake Cover.

ENGINE AIR CLEANER INTAKES - CONTINUED**Reversing Intakes to Draw Air from Engine Compartment - Continued**

6. Inspect gasket and air intake (Figure 2, Item 1) for damage. If gasket or intake are damaged, notify field maintenance.
7. Position air intake (Figure 2, Item 1) on flange studs (Figure 2, Item 6) with screen toward engine compartment.
8. Install six nuts (Figure 2, Item 2) and new lockwashers (Figure 2, Item 3) on studs (Figure 2, Item 6) inside air intake (Figure 2, Item 1).
9. Install eight nuts (Figure 2, Item 2) and new lockwashers (Figure 2, Item 3) on studs (Figure 2, Item 6) outside air intake (Figure 2, Item 1).
10. Install air intake cover (Figure 2, Item 5) on air intake (Figure 2, Item 1), and install four hex-head bolts (Figure 2, Item 4) and new lockwashers (Figure 2, Item 3) in air intake cover (Figure 2, Item 5).



AVLBD151

Figure 2. Installing Air Intake Cover.

END OF TASK**END OF WORK PACKAGE**

OPERATOR MAINTENANCE**OPERATION UNDER UNUSUAL CONDITIONS - STOPPING VEHICLE WHEN BRAKES FAIL**

INITIAL SETUP:**References**

DA Form 2404
WP 0048

GENERAL

In addition to performing normal Preventive Maintenance Checks and Services (PMCS) (WP 0048), clean and lubricate equipment more often to compensate for extremes of temperature, humidity, and terrain conditions that are present or expected. Cleaned and lubricated equipment ensures proper operation and guards against excessive wear and failure.

When equipment constantly breaks down due to operating under extreme conditions, report failure(s) using DA Form 2404 (Equipment Inspection and Maintenance Worksheet).

STOPPING VEHICLE WHEN BRAKES FAIL

1. If brakes fail to operate on level ground:
 - a. Coast to a stop with transmission in L (Low).
 - b. Put transmission in P (Park).
 - c. Shut off engine.
 - d. Request recovery.
2. If brakes fail to operate while driving vehicle uphill:
 - a. Drive vehicle forward to a location on level ground or to a position perpendicular to the slope of the hill.
 - b. Coast to a stop.
 - c. Shift transmission from L (Low) to P (Park).
 - d. Shut off engine.
 - e. Request recovery.
3. If brakes fail to operate while driving vehicle downhill:
 - a. Coast vehicle to a stop on level ground or to a position perpendicular to the slope of the hill.
 - b. Shift transmission from L (Low) to P (Park).
 - c. Shut off engine.
 - d. Request recovery.

END OF TASK**END OF WORK PACKAGE**

OPERATOR MAINTENANCE
OPERATION UNDER UNUSUAL CONDITIONS - FORDING

INITIAL SETUP:**References**

DA Form 2404
WP 0005
WP 0009
WP 0015

References (cont.)

WP 0029
WP 0048

GENERAL

In addition to performing normal Preventive Maintenance Checks and Services (PMCS) (WP 0048), clean and lubricate equipment more often to compensate for extremes of temperature, humidity, and terrain conditions that are present or expected. Cleaned and lubricated equipment ensures proper operation and guards against excessive wear and failure.

When equipment constantly breaks down due to operating under extreme conditions, report failure(s) using DA Form 2404 (Equipment Inspection and Maintenance Worksheet).

FORDING

WARNING



Entering water over 4 ft deep may cause water to enter the crew compartment causing electrical shock hazard and drowning hazard. DO NOT enter water over 4 ft deep. If vehicle is accidentally submerged, exit vehicle immediately. Notify field maintenance. Failure to comply may result in personnel injury or death, or equipment damage.

NOTE

Perform the following steps before entering water.

1. Check battery filler caps (Figure 1, Item 3) to ensure they are tight.
2. Plug heater exhaust pipe (Figure 1, Item 1) with cap plug (Figure 1, Item 2).

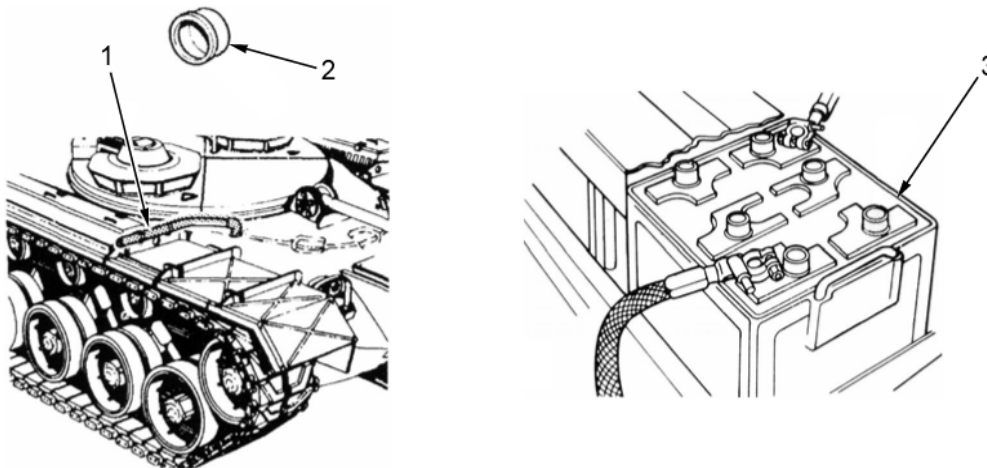

AVLBD152

Figure 1. Installing Exhaust Plug.

3. Close and lock hatches (Figure 2, Item 1). Refer to WP 0005.

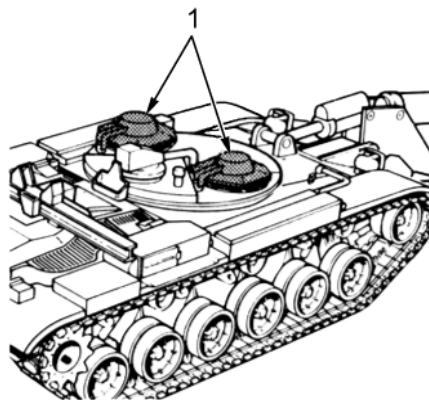

AVLBD153

Figure 2. Closing Hatches.

FORDING - CONTINUED

4. Ensure engine air cleaner intakes (Figure 3, Item 1) are set to draw air from crew compartment intake screen (Figure 3, Item 3) on crew compartment side of bulkhead. If air cleaner intakes are set to draw air from engine compartment, refer to WP 0029 for reversing procedures.
5. Ensure that hull drain valves (Figure 3, Item 2) are closed. Refer to WP 0009.

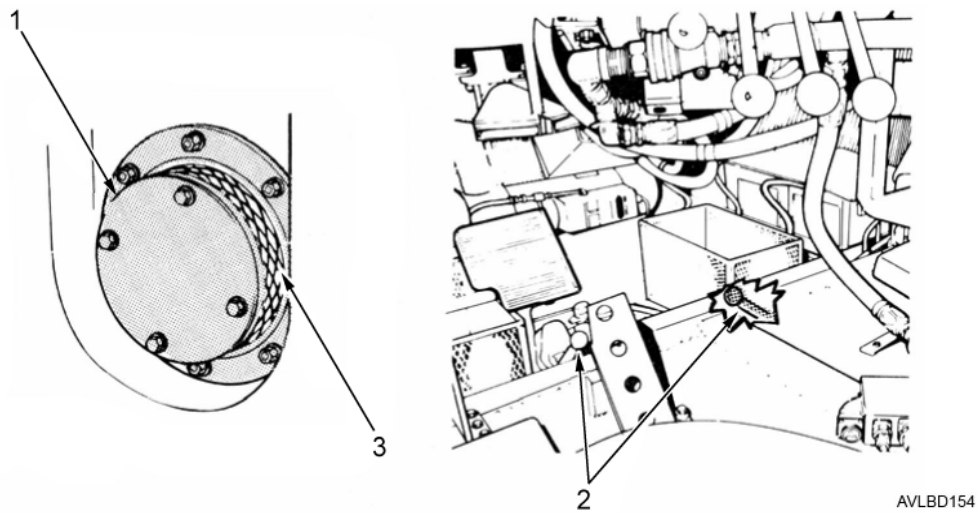

Figure 3. Engine Air Cleaner Intakes.

6. Set HEATER MASTER switch (Figure 4, Item 2) to OFF.
7. Start and warm up engine. Refer to WP 0015.
8. Set MASTER BATTERY switch (Figure 4, Item 1) to OFF.

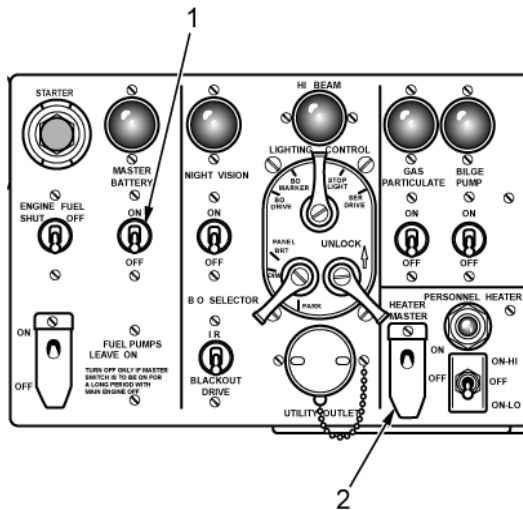

Figure 4. Master Heater/Battery Switches.

FORDING - CONTINUED

9. To avoid a "bow wave," drive slowly into water.
10. Drive at 3 mph to 4 mph (5 kph to 6 kph) while fording. Keep engine speed up to at least 1,000 RPM. Slow vehicle with brake, if necessary, while maintaining 1,000 RPM.

CAUTION

If you accidentally drive into water more than 4 ft (1.22 m) deep, do not stop engine while it is under water. Exhaust pressure will prevent water from entering engine through the exhaust system. If engine stops while it is under water, do not try to restart. Damage to engine may occur. Have vehicle towed from water immediately. If you must stop vehicle while engine is under water, shift transmission to high, apply and hold brakes, and keep engine speed at 1,000 RPM. DO NOT attempt to operate vehicle after submerging until field maintenance has checked it. Failure to comply may damage vehicle.

END OF TASK**END OF WORK PACKAGE**

OPERATOR MAINTENANCE**OPERATION UNDER UNUSUAL CONDITIONS - SLAVE STARTING**

INITIAL SETUP:**Materials/Parts**

Gloves, Rubber (WP 0079, Table 1, Item 25)
Goggles, Industrial (WP 0079, Table 1, Item 26)

Personnel Required

3

References

DA Form 2404
WP 0015
WP 0039
WP 0048

GENERAL

In addition to performing normal Preventive Maintenance Checks and Services (PMCS) (WP 0048), clean and lubricate equipment more often to compensate for extremes of temperature, humidity, and terrain conditions that are present or expected. Cleaned and lubricated equipment ensures proper operation and guards against excessive wear and failure.

When equipment constantly breaks down due to operating under extreme conditions, report failure(s) using DA Form 2404 (Equipment Inspection and Maintenance Worksheet).

SLAVE STARTING

CAUTION

- A field mechanic must be present during slave starting procedures to ensure proper hookup and to preclude damage to equipment.
- DO NOT remove protective caps (Figure 1, Item 3) from slave receptacles (Figure 1, Item 2) until MASTER BATTERY switch (Figure 1, Item 1) is set to OFF. Failure to comply may result in equipment damage.

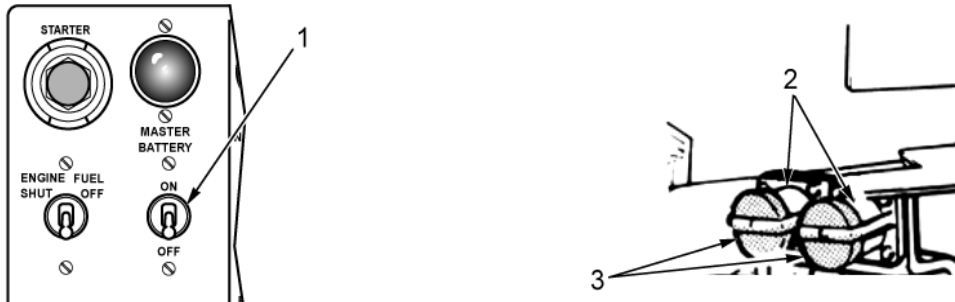

AVLBD156

Figure 1. Slave Receptacle Protective Caps.

NOTE

- A “live” (operational) vehicle is needed to start a “dead” vehicle.
 - Three people are required to perform the slave starting procedures. One person must be stationed in the driver’s station of the live vehicle and one person in the dead vehicle. The third person, a field maintenance mechanic, is stationed outside the vehicles and directs the operation. The only slave cables and slave cable adapters that may be used are those provided in the field maintenance tool sets.
 - For hydraulic electrical upgrade (HEU) vehicles, the NATO slave receptacle is located on the left wall in front of the driver. Like vehicles should be used to perform slave starting procedures.
1. To locate the correct slave cable, first check slave receptacles in both vehicles. Some receptacles (Figure 2, Item 1) have two contacts, others (Figure 2, Item 2) have one contact.

SLAVE STARTING - CONTINUED

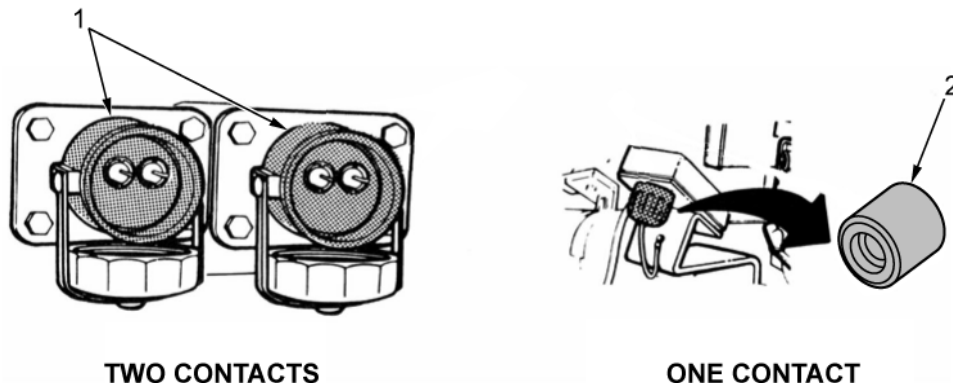

TWO CONTACTS

ONE CONTACT

AVLBD157

Figure 2. One-Contact and Two-Contact Receptacles.

NOTE

There are two types of slave cables. The two-prong cable (Figure 3, Item 1) fits only the two-contact receptacle. The one-prong NATO cable (Figure 3, Item 2) fits the one-contact receptacle. It can also fit the two-contact receptacles using an adapter (Figure 3, Item 3).

- 2. Obtain proper slave cable (Figure 3, Item 1 or Item 2) and adapter (Figure 3, Item 3) if required.

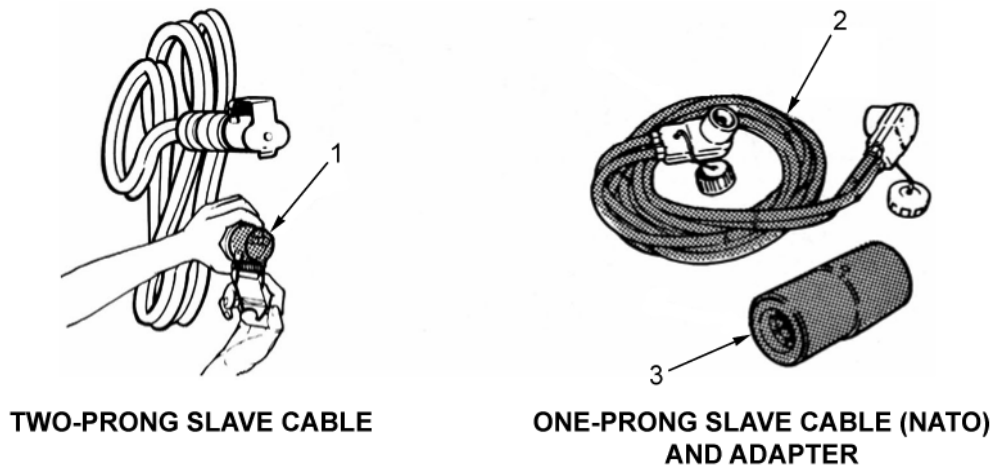

TWO-PRONG SLAVE CABLE

**ONE-PRONG SLAVE CABLE (NATO)
AND ADAPTER**

AVLBD158

Figure 3. Slave Cables.

SLAVE STARTING - CONTINUED**WARNING**

- Electrical shock may occur when slave starting vehicles if any battery is missing or damaged or cables are defective. DO NOT attempt to slave start vehicle if any battery is missing or damaged. DO NOT use defective cables for slave starting. Failure to comply may result in personnel injury or death, or equipment damage.

WARNING

- Battery acid (electrolyte) and corrosion can cause serious burns. Safety goggles and acid resistant rubber gloves must be worn when working around batteries. If electrolyte or corrosion make contact with skin, eyes, or clothing, immediately flush contacted area with water and obtain medical attention. Failure to comply may result in personnel injury or death.
 - Batteries may give off explosive gasses. DO NOT smoke, use open flame, make sparks, or create other ignition sources around the battery. Failure to comply may result in personnel injury or death.
 - Personnel may be burned if jewelry or a tool contacts a battery terminal. Remove all jewelry such as rings, ID tags, watches, etc. Failure to comply may result in personnel injury or death.
3. Inspect cables for defects before use. Inspect for:
 - a. Frayed insulation or exposed wiring.
 - b. Cable connectors and adapter completeness and serviceability.

SLAVE STARTING - CONTINUED

4. Dead vehicle:
 - a. Ensure connections on battery cables, leads, and terminals are clean and tight.
 - b. In cold climates ensure batteries (Figure 4, Item 1) are not frozen. Remove caps (Figure 4, Item 2). If ice or frost is visible inside cell opening (Figure 4, Item 3), batteries are frozen.
 - c. Check for correct electrolyte level in all six batteries (Figure 4, Item 1).
 - d. Notify field maintenance of any defects.

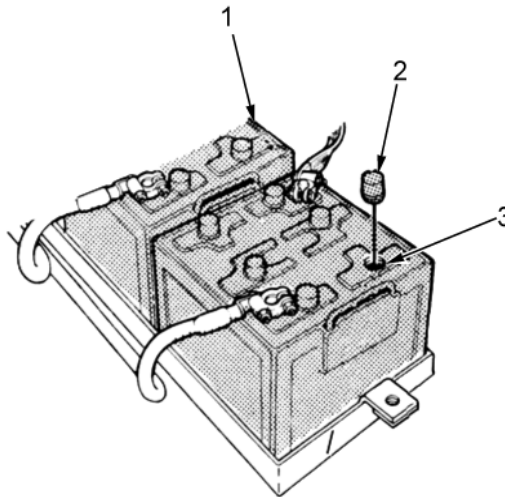

AVLBD159

Figure 4. Vehicle Batteries.

5. Station one person in driver's station of each vehicle. Field mechanic will give directions from the ground.
6. Live vehicle: Start engine. Refer to WP 0015.

SLAVE STARTING - CONTINUED**WARNING**

Personnel may be struck or pinned by moving vehicle when performing vehicle maintenance. Ensure personnel are clear of vehicle. Use ground guide to direct movement of track. Failure to comply may result in personnel injury or death.

7. Live vehicle: Park beside dead vehicle, facing same way. If that is not possible, park live vehicle at right angle to dead vehicle.
8. Ensure that on both vehicles:
 - a. Parking brakes are set.
 - b. Hatches are locked open.
 - c. All electrical equipment is OFF.
9. Dead vehicle: Set MASTER BATTERY switch (Figure 5, Item 1) to OFF.
10. Live vehicle: Set MASTER BATTERY switch (Figure 5, Item 1) to OFF. Keep engine running.

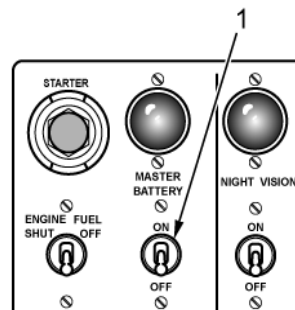

AVLBD161

Figure 5. Master Battery Switch.

CAUTION

DO NOT remove protective caps (Figure 6, Item 3 or Item 8) from slave receptacles (Figure 6, Item 1 or Item 2) until MASTER BATTERY switch is set to OFF. Failure to comply may result in equipment damage.

SLAVE STARTING - CONTINUED

11. Both vehicles: Remove protective caps (Figure 6, Item 3 or Item 8) from slave receptacles (Figure 6, Item 1 or Item 2).
12. Both vehicles: Put one end of cable through driver's hatch.
13. Both vehicles: Remove protective caps (Figure 6, Item 6 or Item 5) from cable (Figure 6, Item 4 or Item 7).

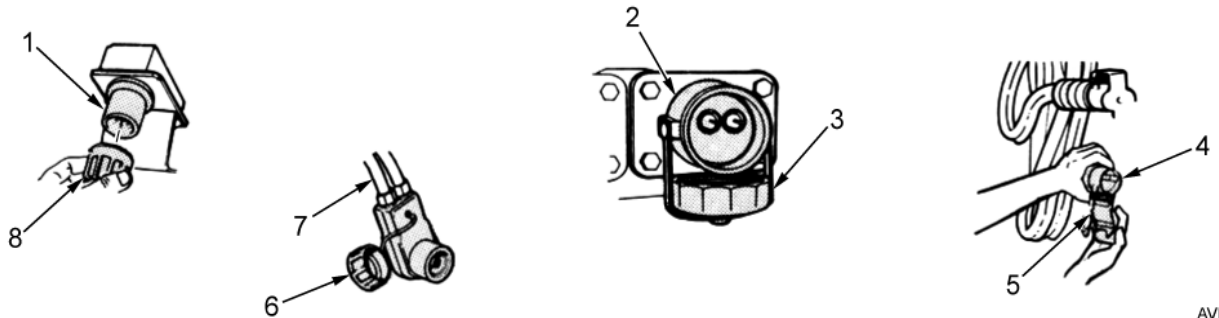

AVLBD162

Figure 6. Protective Caps.

CAUTION

All electrical equipment in both vehicles must be off before slave starting to prevent damage to equipment.

14. Both vehicles: Connect slave cables (Figure 7, Item 4 or Item 5) to slave receptacles (Figure 7, Item 2 or Item 3). Use adapter (Figure 7, Item 7) if connecting cable (Figure 7, Item 6) to two-contact receptacle (Figure 7, Item 1).

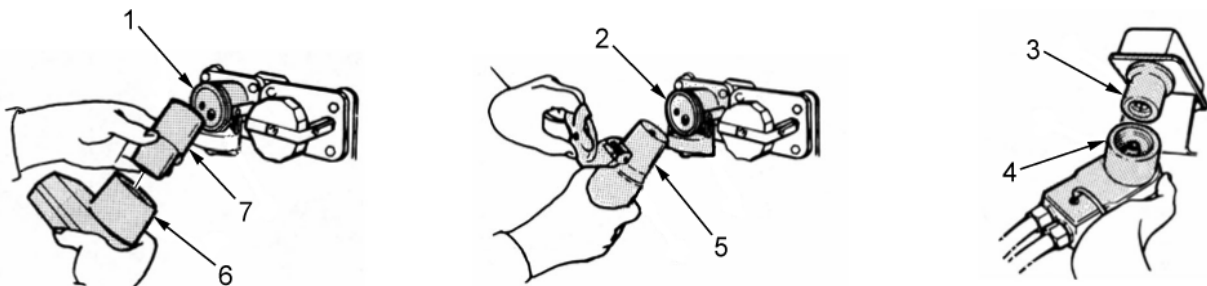

AVLBD163

Figure 7. Receptacles.

SLAVE STARTING - CONTINUED**NOTE**

If tactical situation will not allow time to charge batteries, go to step 16.

15. Charge dead vehicle's batteries:

- a. Live vehicle: Set MASTER BATTERY switch (Figure 8, Item 1) to ON to charge batteries in dead vehicle.
- b. Live vehicle: Set engine to run at 1,000 to 1,200 RPM.
- c. Live vehicle: Let engine run for up to 30 minutes if possible.

CAUTION

When attempting to start dead vehicle, DO NOT hold STARTER switch (Figure 8, Item 2) longer than 15 seconds. Starter may overheat and damage to starter may occur. Wait 3 to 5 minutes before making second attempt to start.

16. Start dead vehicle:

- a. Both vehicles: Set MASTER BATTERY switch (Figure 8, Item 1) to ON.
- b. Live vehicle: Set engine to run at 1,000 to 1,200 RPM.
- c. Dead vehicle: Try to start engine once. If engine starts, go to step 17.

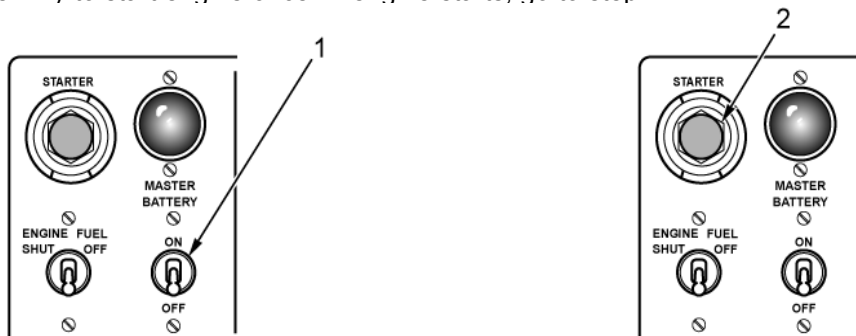

AVLBD164

Figure 8. Starter Switch.

- d. If engine does not start within 15 seconds, release STARTER switch and read BATT GEN INDICATOR (Figure 9, Item 2).
- e. Indicator needle in yellow or green area (Figure 9, Item 1): Wait 3 to 5 minutes and go back to step 16b.
- f. Indicator needle in left red area (Figure 9, Item 4): Go to step 15. If there is insufficient time to charge batteries, go to step 16b.
- g. If batteries will not charge or vehicle will not start after two attempts, refer to Troubleshooting Index (WP 0039).

SLAVE STARTING - CONTINUED

17. Disconnect cables:

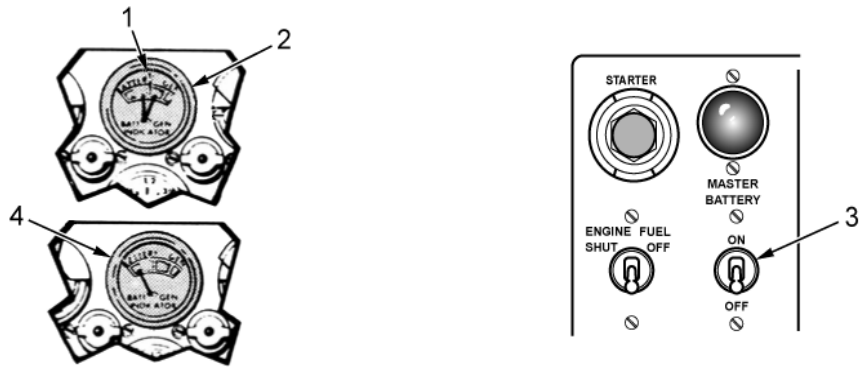

AVLBD165

Figure 9. Battery Indicators.

- a. Both vehicles: When engine is running smoothly, set MASTER BATTERY switch (Figure 9, Item 3) to OFF.
- b. DO NOT remove slave cables (Figure 10, Item 4 or Item 5) from receptacles (Figure 10, Item 1 or Item 3) until MASTER BATTERY switch is set to OFF in both vehicles.
- c. Both vehicles: Disconnect slave cable (Figure 10, Item 4 or Item 5) and adapter (Figure 10, Item 2), if used, from receptacles (Figure 10, Item 1 or Item 3).

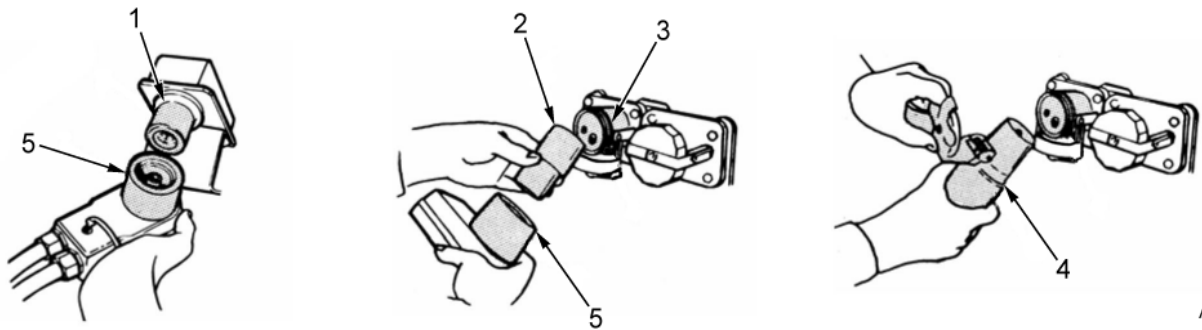

AVLBD167

Figure 10. Slave Cable Adapter.

SLAVE STARTING - CONTINUED

- d. Both vehicles: Install protective caps (Figure 11, Item 3 or Item 4) on slave receptacles (Figure 10, Item 1 or Item 2).
- e. Both vehicles: Install protective caps (Figure 12, Item 1 or Item 2) on cable (Figure 12, Item 3 or Item 4).

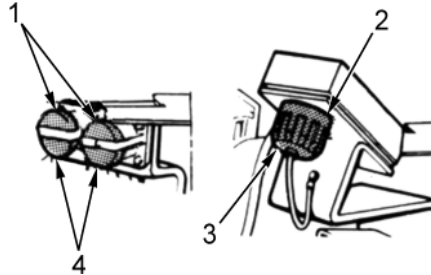

AVLBD168

Figure 11. Protective Caps.

- f. Both vehicles: Remove cable from driver's hatch opening.



AVLBD169

Figure 12. Slave Cables.

END OF TASK**END OF WORK PACKAGE**

OPERATOR MAINTENANCE**OPERATION UNDER UNUSUAL CONDITIONS - TOWING A DISABLED VEHICLE**

INITIAL SETUP:**Tools and Special Tools**

Bar, Pinch (WP 0077, Table 2, Item 4)
Hammer, Machinist (WP 0077, Table 2, Item 26)
Ratchet (WP 0077, Table 2, Item 32)
Pliers (WP 0077, Table 2, Item 44)
Handle, Socket Wrench (WP 0077, Table 2, Item 62)
Wrench, Adjustable (WP 0077, Table 2, Item 67)
Wrench (WP 0077, Table 2, Item 71)

Personnel Required

2

References

DA Form 2404
TM 5-5420-203-13
WP 0012
WP 0048

GENERAL

In addition to performing normal Preventive Maintenance Checks and Services (PMCS) (WP 0048), clean and lubricate equipment more often to compensate for extremes of temperature, humidity, and terrain conditions that are present or expected. Cleaned and lubricated equipment ensures proper operation and guards against excessive wear and failure.

When equipment constantly breaks down due to operating under extreme conditions, report failure(s) using DA Form 2404 (Equipment Inspection and Maintenance Worksheet).

TOWING A DISABLED VEHICLE**WARNING**

Excessive towing speed is hazardous and may cause loss of vehicle control. **DO NOT** exceed speed limit when towing vehicle with tow bar or tow cables. Loss of vehicle control may result. Failure to comply may result in personnel injury or death.

CAUTION

Towing a vehicle with working brakes may damage universal joints. Disconnect universal joints from final drives if engine or transmission is damaged, or if disabled vehicle will be towed more than 1 mile (1.6 km).

NOTE

Tow vehicle only with a V-type bar from the rear. Obtain tow bar from field maintenance. Towing vehicle will control direction of vehicle under tow.

1. Remove bridge from vehicle (TM 5-5420-203-13) and disconnect universal joints from final drive.
2. Chock roadwheels.

WARNING

Rear exhaust doors, exhaust pipes, and shroud may be hot. Allow engine to cool a minimum of one hour before opening rear exhaust doors, removing exhaust pipes, or removing transmission shroud. Failure to comply may result in personnel injury or death.

NOTE

If roadwheels cannot be chocked, connect tow bar before disconnecting final drive.

TOWING A DISABLED VEHICLE - CONTINUED

3. Release parking brake (WP 0012).
4. Use socket and ratchet to remove four screw assemblies (Figure 1, Item 1) securing right and left rear exhaust doors (Figure 1, Item 2) and open doors.
5. Use 7/16-inch wrench to loosen clamp nuts (Figure 1, Item 6) and remove elbows (Figure 1, Item 3) and clamps (Figure 1, Item 4) from exhaust pipe (Figure 1, Item 5).

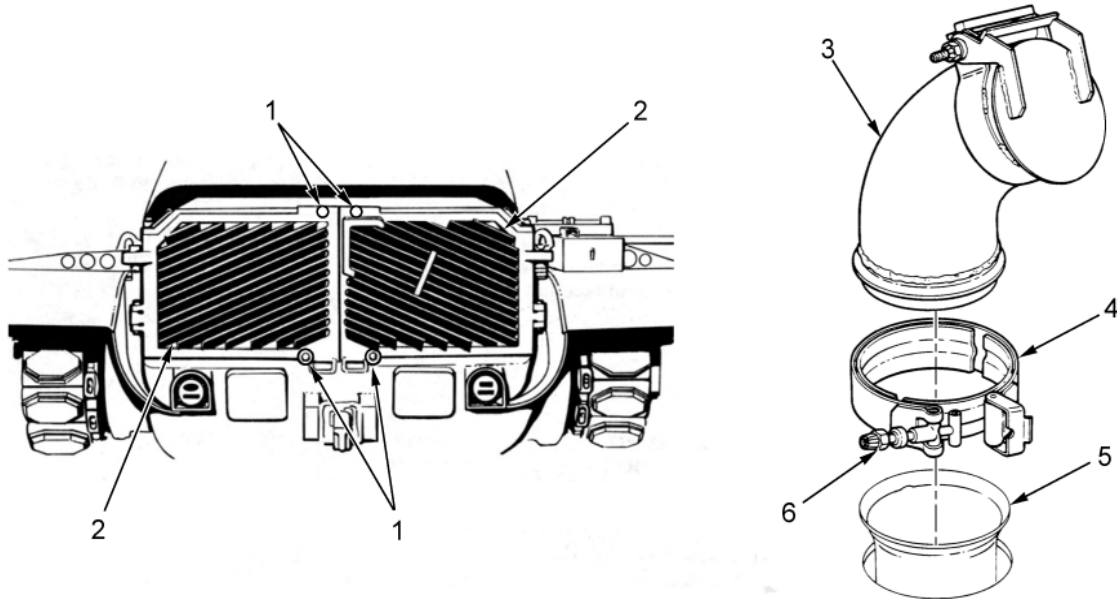

AVLBD171

Figure 1. Opening Rear Grille Doors/Removing Exhaust Elbow.

TOWING A DISABLED VEHICLE - CONTINUED

6. Use adjustable wrench to rotate six cam screws (Figure 2, Item 6) toward center of vehicle.

WARNING

Transmission shroud is 80 lb (36.3 kg). To prevent injury, two persons are required to lift shroud. Failure to comply may result in personnel injury or death.

CAUTION

Remove transmission shroud (Figure 2, Item 2) carefully to avoid damage to shroud seal.

7. With the help of second technician, remove transmission shroud (Figure 2, Item 2) from vehicle brace (Figure 2, Item 1).

NOTE

Rotate quick disconnect ring (Figure 2, Item 3), if necessary, to gain access to screw (Figure 2, Item 5) and lockwire (Figure 2, Item 4).

8. Use pliers to remove lockwire (Figure 2, Item 4) at final drive on both sides of transmission.

NOTE

When removing screw (Figure 2, Item 5), secure quick disconnect ring (Figure 2, Item 3) or it will snap open and fall down into engine compartment.

9. Use adjustable wrench to remove screw (Figure 2, Item 5) from quick disconnect ring (Figure 2, Item 3).

TOWING A DISABLED VEHICLE - CONTINUED

NOTE

Use hammer to tap quick disconnect ring (Figure 2, Item 3).

10. Separate quick disconnect ring (Figure 2, Item 3) and remove from both sides of transmission.

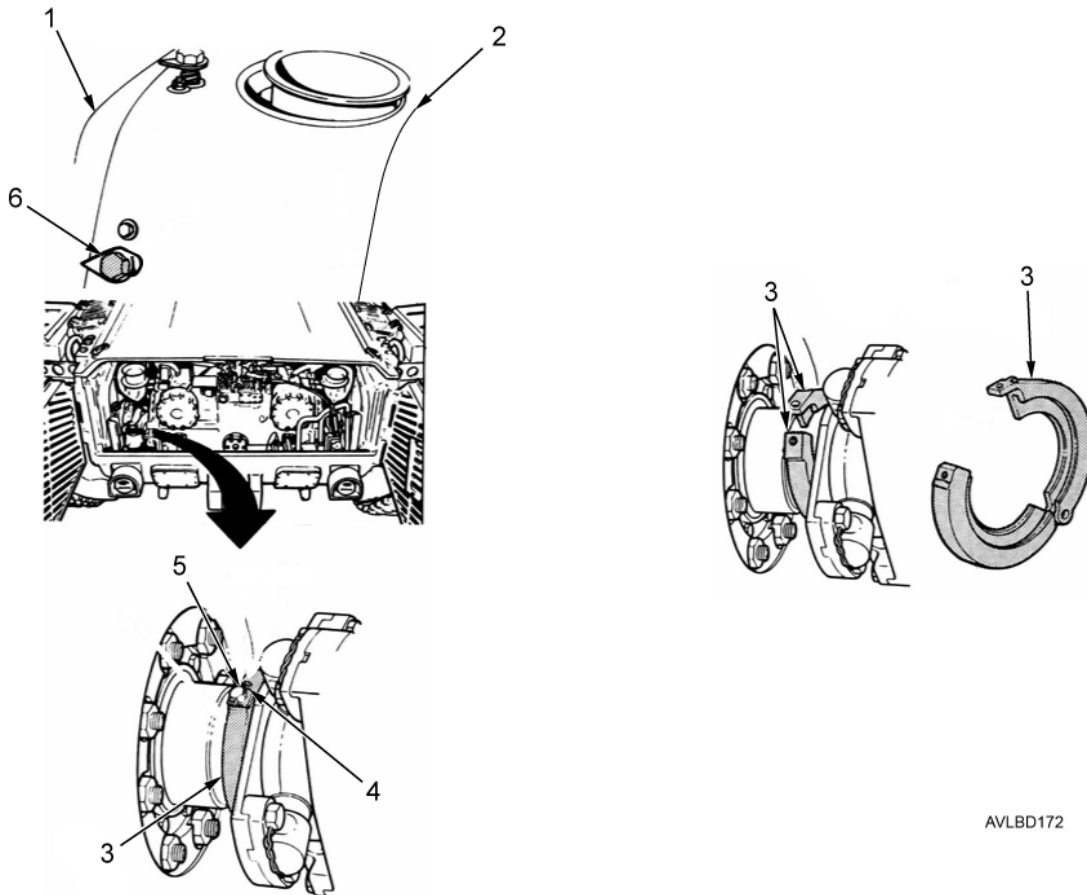

AVLBD172

Figure 2. Quick Disconnect Ring.

TOWING A DISABLED VEHICLE - CONTINUED

11. Insert pinch bar (Figure 3, Item 3), and use hammer to pry final drive adapter (Figure 3, Item 2) toward final drive (Figure 3, Item 1), far enough to free final drive adapter from universal joint (Figure 3, Item 4) on both sides of transmission.

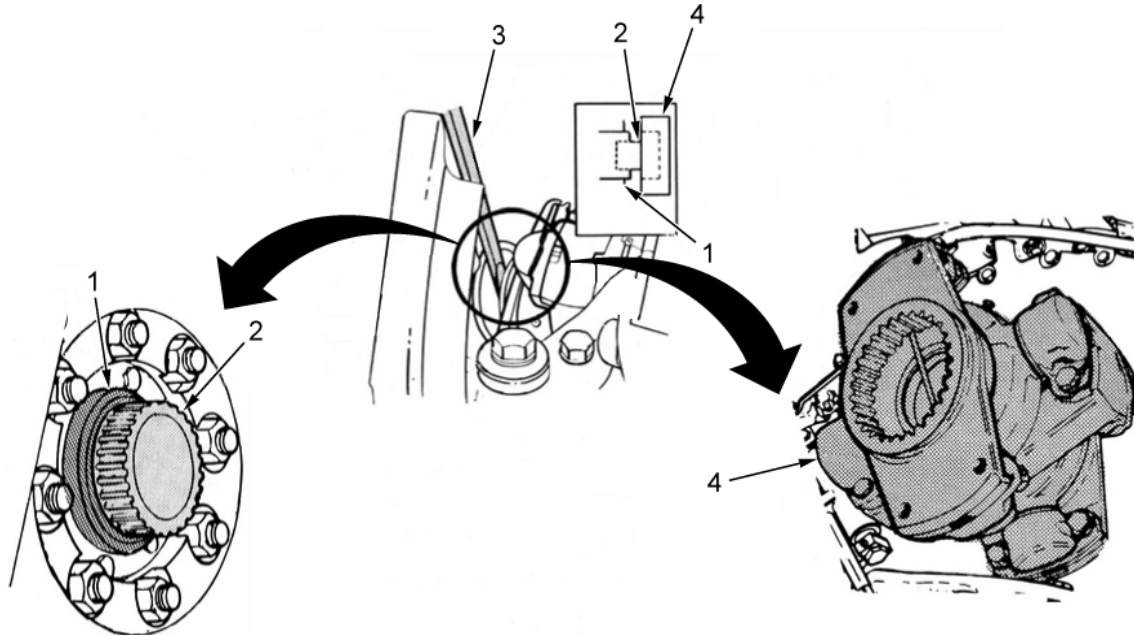

AVLBD173

Figure 3. Universal Joints.

WARNING

Transmission shroud is 80 lb (36.3 kg). To prevent injury, two persons are required to lift shroud. Failure to comply may result in personnel injury or death.

12. Install transmission shroud (Figure 4, Item 1) in vehicle and rotate six cam screws (Figure 4, Item 4) to secure transmission shroud in vehicle.
13. Close rear doors (Figure 4, Item 2) and install four screws (Figure 4, Item 3).

TOWING A DISABLED VEHICLE - CONTINUED

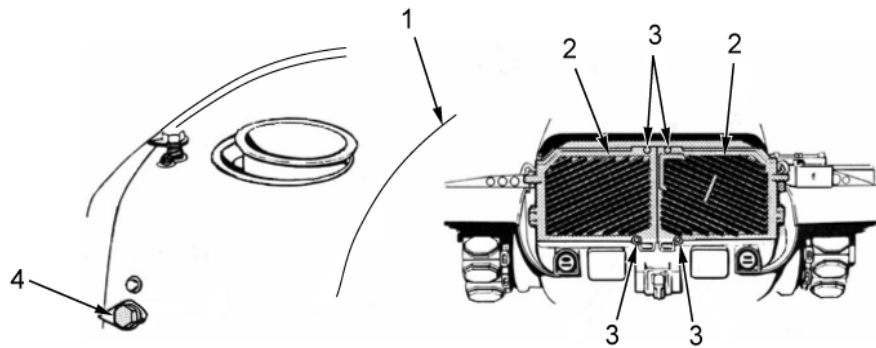

AVLBD174

Figure 4. Installing Transmission Shroud.

14. Connect tow bar (Figure 5, Item 2) to towing eyes (Figure 5, Item 8) of disabled vehicle (Figure 5, Item 1).
15. Remove cotter pin (Figure 5, Item 7) from pintle (Figure 5, Item 6) of towing vehicle (Figure 5, Item 3).
16. Raise latch (Figure 5, Item 4) and lift lock (Figure 5, Item 5).
17. Align pintle (Figure 5, Item 6) with tow bar (Figure 5, Item 2), lower tow bar into pintle, and lower lock (Figure 5, Item 5).

CAUTION

DO NOT exceed 3 mph when towing vehicle with universal joints connected or with tracks removed. Failure to comply may damage universal joints and roadwheels when towing vehicle. DO NOT exceed 8 mph under any conditions.

18. Tow vehicle (Figure 5, Item 1) in a straight line and, when necessary, make wide turns.
19. Upon completion of towing operation, chock roadwheels of disabled vehicle and disconnect tow bar (Figure 5, Item 2).

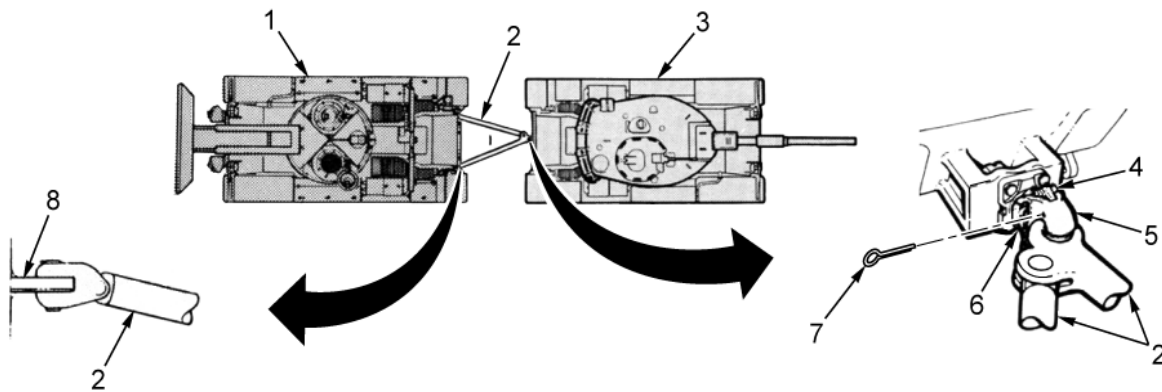

AVLBD634

Figure 5. Connecting Towing Vehicle.

END OF TASK

END OF WORK PACKAGE

OPERATOR MAINTENANCE**OPERATION UNDER UNUSUAL CONDITIONS - SLAVE-STARTING HYDRAULIC SYSTEM**

INITIAL SETUP:**Tools and Special Tools**

Extension, Socket Wrench
(WP 0077, Table 2, Item 15)
Hose Assembly, Hydraulic Slave (2)
(WP 0077, Table 2, Item 33)

References

DA Form 2404
WP 0012
WP 0015
WP 0018
WP 0020
WP 0048

Materials/Parts

Gloves, Rubber (WP 0079, Table 1, Item 25)
Goggles, Industrial (WP 0079, Table 1, Item 26)
Rag, Wiping (WP 0079, Table 1, Item 52)
Solvent, Degreasing (WP 0079, Table 1, Item 58)

GENERAL

In addition to performing normal Preventive Maintenance Checks and Services (PMCS) (WP 0048), clean and lubricate equipment more often to compensate for extremes of temperature, humidity, and terrain conditions that are present or expected. Cleaned and lubricated equipment ensures proper operation and guards against excessive wear and failure.

When equipment constantly breaks down due to operating under extreme conditions, report failure(s) using DA Form 2404 (Equipment Inspection and Maintenance Worksheet).

SLAVE-STARTING HYDRAULIC SYSTEM**WARNING**

Personnel may be struck or pinned by moving vehicle when performing vehicle maintenance. Ensure personnel are clear of vehicle. Use ground guide to direct movement of track. Failure to comply may result in personnel injury or death.

1. On operating vehicle:
 - a. Start engine. Refer to WP 0015.
 - b. Move operating vehicle next to non-operating vehicle (Figure 1). Preferred position is facing in opposite directions with commander's cupolas side by side.

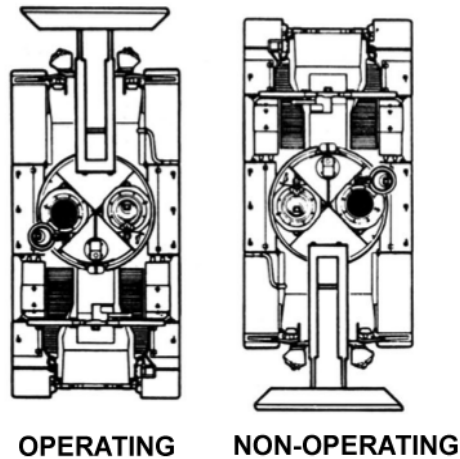

Figure 1. Commander's Cupolas Side by Side.

AVLBD176

- c. Stop engine. Refer to WP 0015.

SLAVE-STARTING HYDRAULIC SYSTEM - CONTINUED

2. On both vehicles:
 - a. Set parking brakes. Refer to WP 0012.
 - b. Push down clutch lever (Figure 2, Item 1).

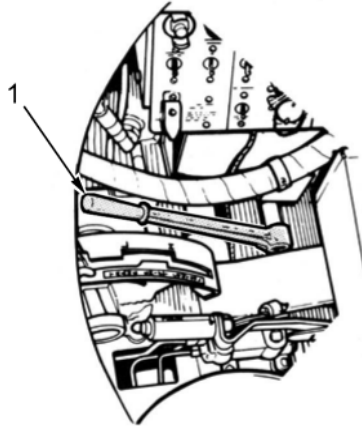

AVLBD510

Figure 2. Clutch Lever.

- c. Pull all hydraulic control levers (Figure 3, Item 1) up and down three times to relieve pressure in system.

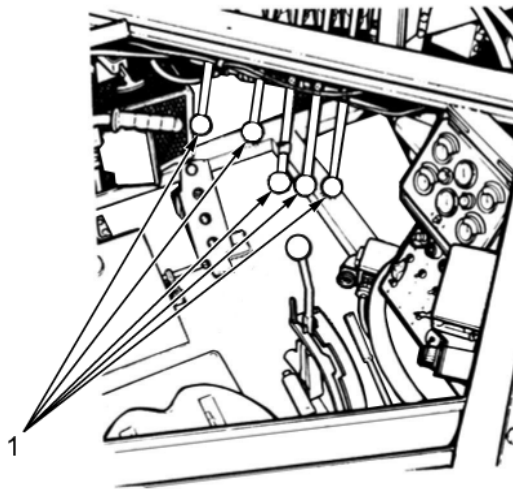

AVLBD177

Figure 3. Hydraulic Control Levers.

SLAVE-STARTING HYDRAULIC SYSTEM - CONTINUED

- d. Open commander's hatches (Figure 4, Item 3).
- e. Remove two slave hose assemblies (Figure 4, Item 2) from left rear fender stowage boxes (Figure 4, Item 1).

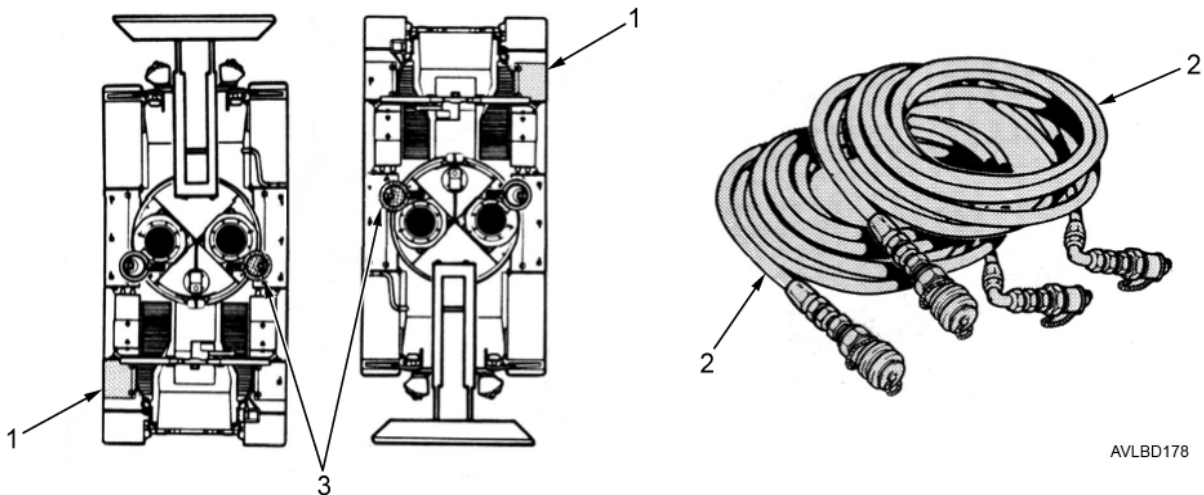

AVLBD178

Figure 4. Location of Slave Hose Assemblies.

- f. Put female coupling (Figure 5, Item 2) of one slave hose assembly and male coupling (Figure 5, Item 1) of the other slave hose assembly through commander's hatch of each vehicle.

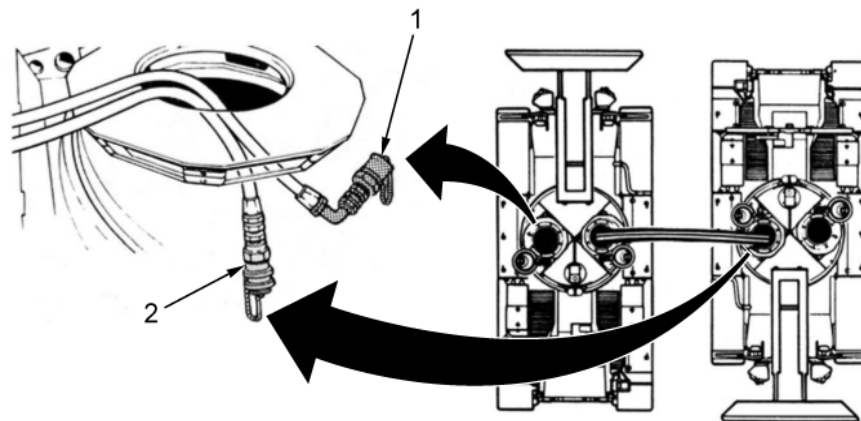

AVLBD179

Figure 5. Slave Hose Connections.

SLAVE-STARTING HYDRAULIC SYSTEM - CONTINUED

WARNING



A high-pressure oil stream may pierce body and cause injury. When connecting or disconnecting quick disconnect couplings or relieving pressure from couplings, wear protective goggles and cover coupling with a rag to control spray. Failure to comply may result in personnel injury or death.

3. On non-operating vehicle:
 - a. Disconnect inlet hose coupling (Figure 6, Item 8) from pump output coupling (Figure 6, Item 7). Cover pump outlet coupling with rag.
 - b. Disconnect return hose coupling (Figure 6, Item 2) from valve outlet coupling (Figure 6, Item 1). Cover valve outlet coupling with rag.
 - c. Remove dust cap (Figure 6, Item 4) from male coupling (Figure 6, Item 3) and dust cap (Figure 6, Item 5) from female coupling (Figure 6, Item 6).

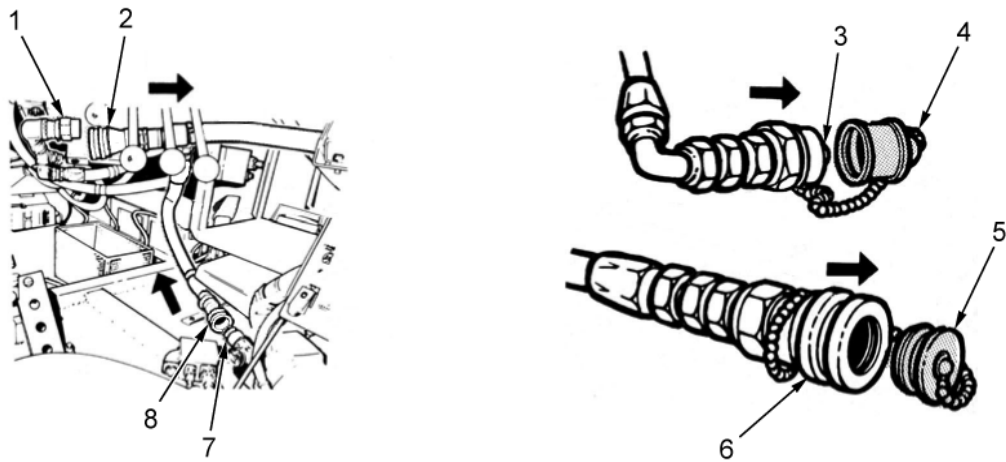

AVLBD180

Figure 6. Disconnecting Inlet and Return Hoses on Non-Operating Vehicle.

SLAVE-STARTING HYDRAULIC SYSTEM - CONTINUED

NOTE

If pressure in slave hoses prevents locking quick disconnect, relieve pressure by performing steps d and e. If quick disconnect locks properly, omit steps d and e.

- d. Insert 5 inch socket extension into female coupling (Figure 7, Item 3).
- e. Push back plunger inside female coupling (Figure 7, Item 3) to bleed excess hydraulic pressure.
- f. Push male coupling (Figure 7, Item 1) of slave hose into inlet hose female coupling (Figure 7, Item 6).
- g. Pull inlet hose (Figure 7, Item 7) and slave hose (Figure 7, Item 5) to ensure connection is secure.
- h. Insert slave hose female coupling (Figure 7, Item 3) onto valve outlet coupling (Figure 7, Item 2).
- i. Pull slave hose (Figure 7, Item 4) to ensure connection is secure.

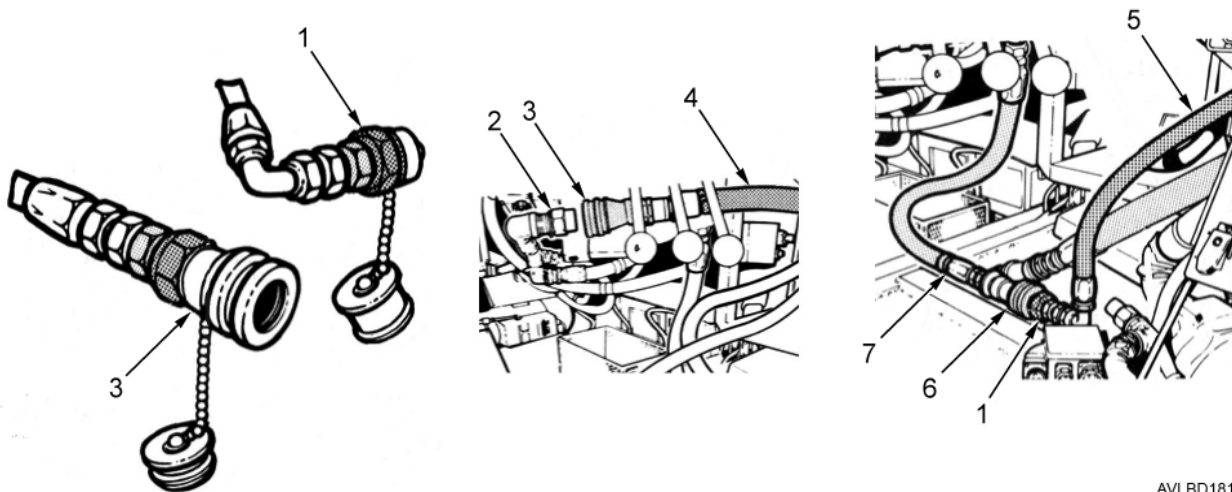

AVLBD181

Figure 7. Connecting Slave Hoses on Non-Operating Vehicle.

4. On operating vehicles:
 - a. Disconnect inlet hose coupling (Figure 8, Item 9) from pump output coupling (Figure 8, Item 8). Cover output coupling with rag.
 - b. Disconnect return hose coupling (Figure 8, Item 2) from valve outlet coupling (Figure 8, Item 1). Cover valve outlet coupling with rag.
 - c. Remove dust caps (Figure 8, Item 4 and Item 7) from slave hose couplings (Figure 8, Item 5 and Item 6).
 - d. Install slave hose male coupling (Figure 8, Item 5) into female coupling (Figure 8, Item 2) of return hose (Figure 8, Item 3).
 - e. Pull return hose (Figure 8, Item 3) to ensure connection is secure.

SLAVE-STARTING HYDRAULIC SYSTEM - CONTINUED

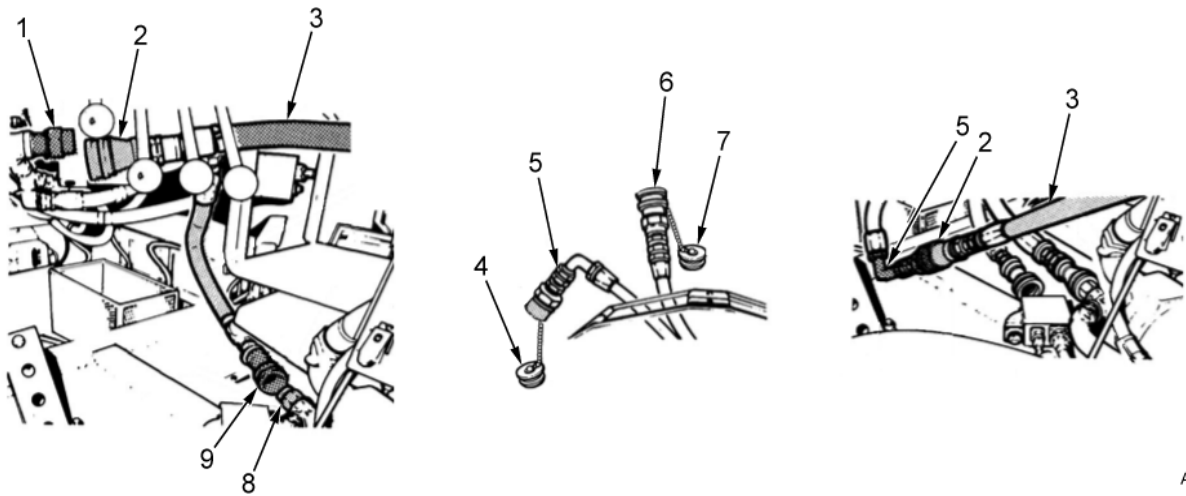

AVLBD183

Figure 8. Connecting Slave Hoses on Operating Vehicle.

- f. Insert female coupling (Figure 9, Item 3) of slave hose (Figure 9, Item 1) on male coupling (Figure 9, Item 2).
- g. Pull slave hose (Figure 9, Item 1) to ensure connection is secure.

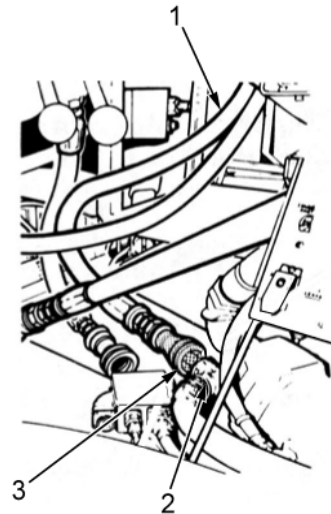

AVLBD185

Figure 9. Starting Engine on Operating Vehicle.

- h. Start engine. Refer to WP 0015.

SLAVE-STARTING HYDRAULIC SYSTEM - CONTINUED

- i. Depress accelerator (Figure 10, Item 1) until engine is running at 1,800 RPM.
- j. Pull up clutch lever (Figure 10, item 2).
- k. Raise accelerator lock lever (Figure 10, Item 3).

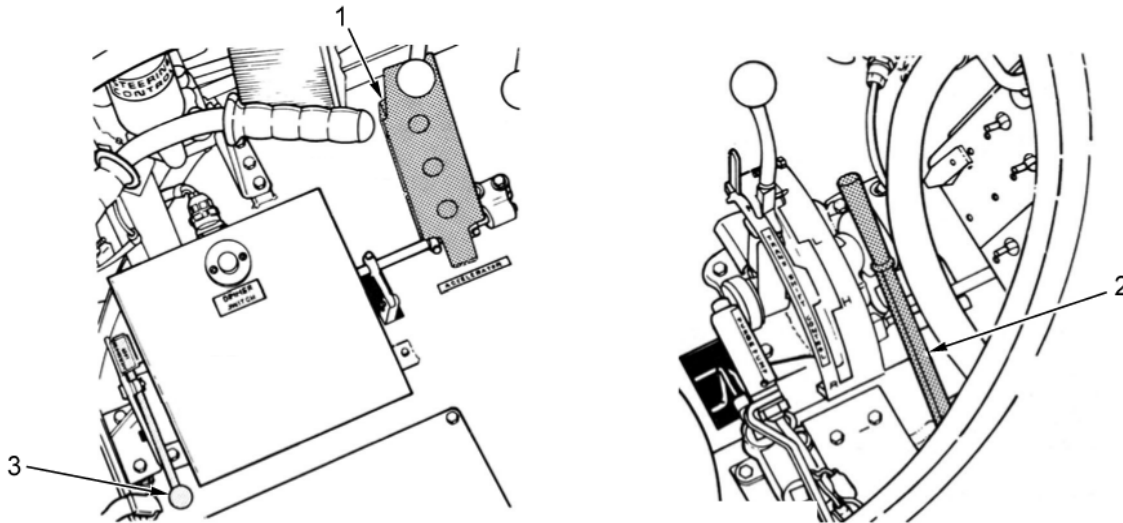

AVLBD186

Figure 10. Setting Accelerator Lock Lever.

5. On non-operating vehicles, use hydraulic controls to launch bridge or retrieve bridge. Refer to WP 0018 or WP 0020.

NOTE

Upon completion of launch or retrieve procedure, perform the following steps to disconnect vehicles.

6. On operating vehicle:
 - a. Push down accelerator lock lever (Figure 11, Item 7).
 - b. Push down clutch lever (Figure 11, Item 2).
 - c. Stop engine. Refer to WP 0015.

SLAVE-STARTING HYDRAULIC SYSTEM - CONTINUED**WARNING**

A high-pressure oil stream may pierce body and cause injury. When connecting or disconnecting quick disconnect couplings or relieving pressure from couplings, wear protective goggles and cover coupling with a rag to control spray. Failure to comply may result in personnel injury or death.

7. On non-operating vehicle:
 - a. Push hydraulic control levers (Figure 11, Item 1) up and down three times to relieve pressure in system.
 - b. Disconnect slave hose male coupling (Figure 11, Item 3) from inlet hose female coupling (Figure 11, Item 5).
 - c. Connect inlet hose female coupling (Figure 11, Item 5) to pump output coupling (Figure 11, Item 4).
 - d. Pull inlet hose (Figure 11, Item 6) to ensure connection is secure.

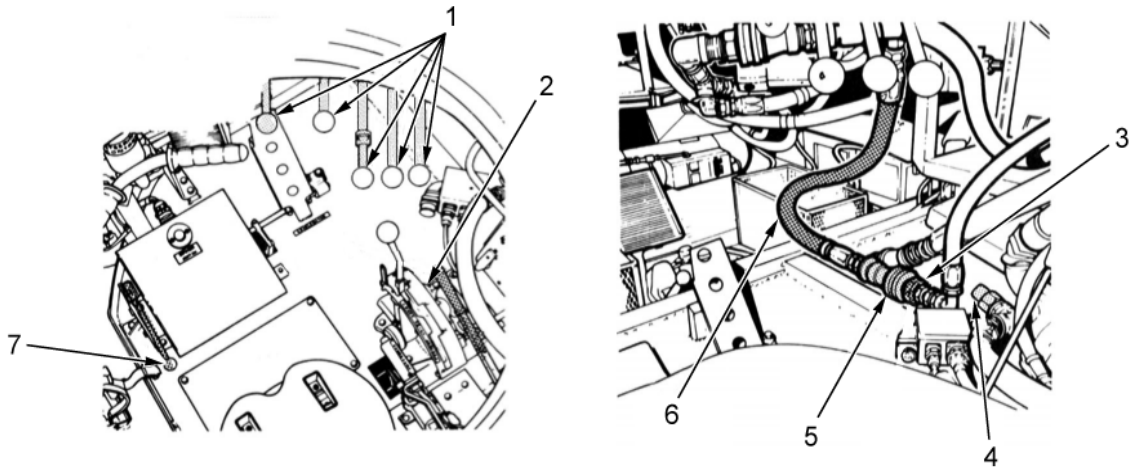

AVLBD187

Figure 11. Disconnecting Slave Hoses on Non-Operating Vehicle.

SLAVE-STARTING HYDRAULIC SYSTEM - CONTINUED

- e. Disconnect slave hose (Figure 12, Item 3) female coupling (Figure 12, Item 2) from valve outlet coupling (Figure 12, Item 1).
- f. Connect return hose coupling (Figure 12, Item 4) to valve outlet coupling (Figure 12, Item 1).
- g. Pull return hose (Figure 12, Item 5) to ensure connection is secure.

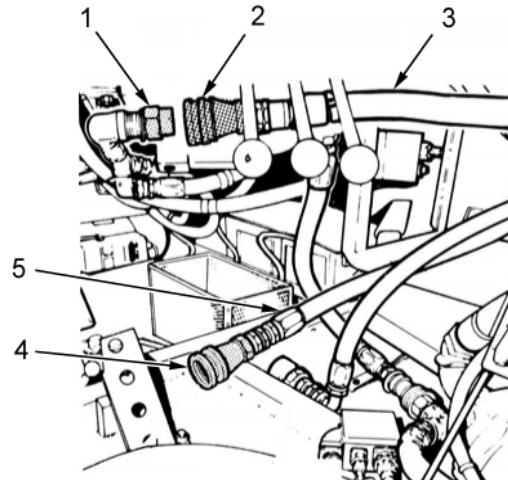

AVLBD189

Figure 12. Connecting Return Hose on Non-Operating Vehicle.

8. On operating vehicle:
 - a. Disconnect slave hose (Figure 13, Item 2) male coupling (Figure 13, Item 5) from return hose coupling (Figure 13, Item 4).
 - b. Connect return hose coupling (Figure 13, Item 4) to valve outlet coupling (Figure 13, Item 1).
 - c. Pull return hose (Figure 13, Item 3) to ensure connection is secure.

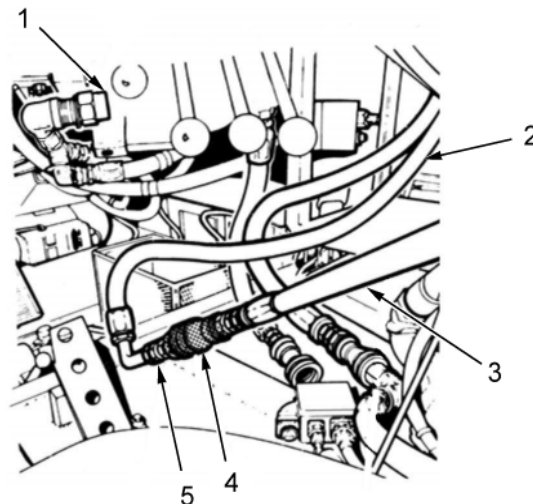

AVLBD190

Figure 13. Connecting Return Hose on Operating Vehicle.

SLAVE-STARTING HYDRAULIC SYSTEM - CONTINUED

- d. Disconnect slave hose female coupling (Figure 14, Item 2) from pump outlet male coupling (Figure 14, Item 1).

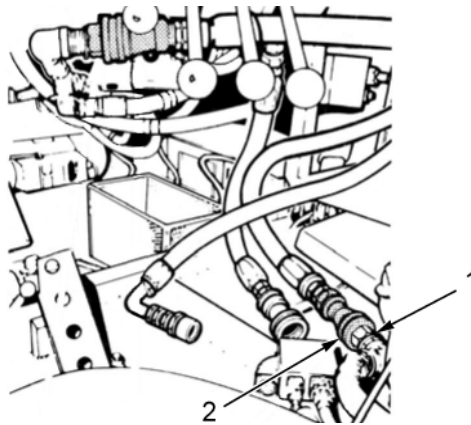

AVLBD191

Figure 14. Disconnecting Female Inlet Slave Hose on Operating Vehicle.

- e. Connect inlet hose female coupling (Figure 15, Item 3) to pump output coupling (Figure 15, Item 2).
f. Pull hose (Figure 15, Item 1) to ensure connection to pump outlet coupling (Figure 15, Item 2) is secure.

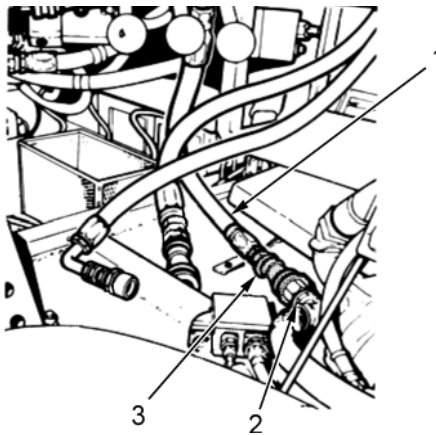

AVLBD192

Figure 15. Connecting Inlet Hose on Operating Vehicle.

- g. Wipe up any spilled hydraulic fluid.

SLAVE-STARTING HYDRAULIC SYSTEM - CONTINUED

WARNING



Degreasing solvent (MIL-PRF-680) is flammable and may cause irritation to the eyes or skin. Use in well-ventilated areas and keep away from heat and open flame. Wear protective goggles and clothing. If solvent comes in contact with eyes, flush immediately with water. If solvent comes in contact with skin, wash with soap and water. Failure to comply may result in personnel injury, illness, or death.

9. Clean both slave hoses (Figure 16, Item 1 and Item 2) thoroughly using solvent and dry hoses.
10. Install dust caps (Figure 16, Item 3 and Item 4) on slave hoses (Figure 16, Item 1 and Item 2).

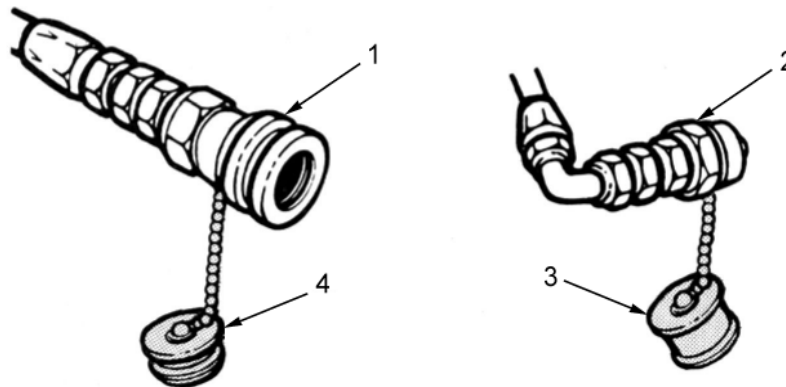

AVLBD193

Figure 16. Installing Dust Caps.

11. Stow one slave hose in the left rear fender storage box (Figure 17, Item 1) of each vehicle.

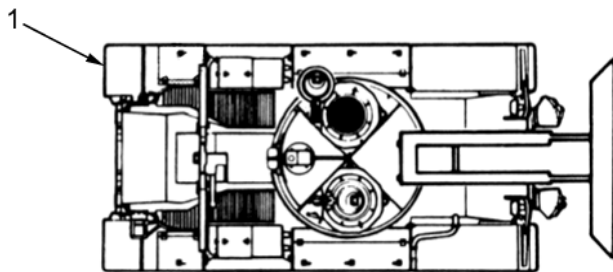

AVLBD194

Figure 17. Stowing Slave Hoses on Vehicle.

END OF TASK

END OF WORK PACKAGE

OPERATOR MAINTENANCE**OPERATION UNDER UNUSUAL CONDITIONS - STORAGE OF SCISSORING BRIDGE**

INITIAL SETUP:**References**

DA Form 2404
WP 0048

GENERAL

In addition to performing normal Preventive Maintenance Checks and Services (PMCS) (WP 0048), clean and lubricate equipment more often to compensate for extremes of temperature, humidity, and terrain conditions that are present or expected. Cleaned and lubricated equipment ensures proper operation and guards against excessive wear and failure.

When equipment constantly breaks down due to operating under extreme conditions, report failure(s) using DA Form 2404 (Equipment Inspection and Maintenance Worksheet).

STORAGE OF SCISSORING BRIDGE**CAUTION**

DO NOT store the bridge in a standing inverted "A" position. Bridge may collapse or fall resulting in damage to bridge.

NOTE

The removal of the bridge for lesser periods or time of storage should be at the discretion of the unit/battalion commander.

1. When vehicle is not needed for extended period (60 days or longer), remove scissoring bridge and store in extended position in suitable flat-surfaced area. If storage space is at premium, bridge may be stored in folded position with cribbing.
2. Exercise hydraulic system monthly as required by PMCS. Refer to WP 0048.

END OF TASK**END OF WORK PACKAGE**

OPERATOR MAINTENANCE**OPERATION UNDER UNUSUAL CONDITIONS - GAS PARTICULATE FILTER UNIT**

INITIAL SETUP:**References**

DA Form 2404
FM 3-11.4
FM 3-11.5
TM 3-4240-280-10
WP 0048

Equipment Conditions

MASTER BATTERY switch on (WP 0004)

GENERAL

In addition to performing normal Preventive Maintenance Checks and Services (PMCS) (WP 0048), clean and lubricate equipment more often to compensate for extremes of temperature, humidity, and terrain conditions that are present or expected. Cleaned and lubricated equipment ensures proper operation and guards against excessive wear and failure.

When equipment constantly breaks down due to operating under extreme conditions, report failure(s) using DA Form 2404 (Equipment Inspection and Maintenance Worksheet).

GAS PARTICULATE FILTER UNIT**Connecting****WARNING**

- Carbon monoxide is a colorless, odorless, deadly poisonous gas which, when breathed, deprives the body of oxygen and causes suffocation. Exposure to carbon monoxide produces symptoms of headache, dizziness, loss of muscular control, apparent drowsiness, and coma. Permanent brain damage and death may result.
- Carbon monoxide occurs in exhaust fumes and can become dangerously concentrated under conditions of inadequate ventilation. The following precautions must be observed during operation of the AVLB:
 - DO NOT operate heater or engine in enclosed areas.
 - DO NOT drive the vehicle with inspection plates or cover plates removed.
 - DO NOT sleep in the vehicle with the heater running or the engine idling.
 - BE ALERT for exhaust fumes and symptoms of carbon monoxide exposure. If either is present, evacuate the vehicle and ventilate the personnel compartments.
 - BE AWARE that the gas particulate filter and M25A1 tank mask WILL NOT protect against carbon monoxide poisoning.

WARNING

Nuclear-Biological-Chemical (NBC) contaminated air filters must be handled and disposed of only by authorized and trained personnel. The unit commander or senior officer in charge of maintenance personnel must ensure that prescribed protective clothing (FM 3-11.4) is used and prescribed safety measures and decontamination procedures (FM 3-11.5) are followed. The local unit SOP is responsible for final disposal of contaminated air filters. Failure to comply may result in personnel injury or death.

GAS PARTICULATE FILTER UNIT - CONTINUED

Connecting - Continued

1. Put on and adjust M25A1 protective mask (not part of filter unit) (TM 3-4240-280-10).

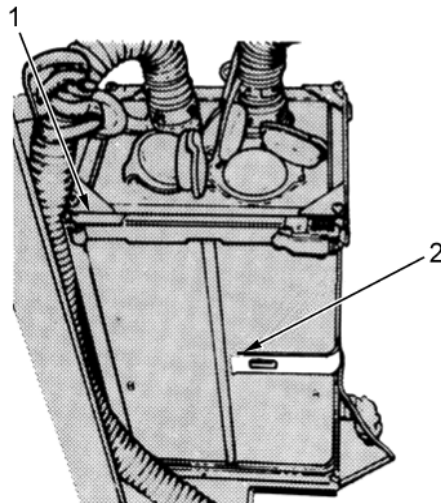

AVLBD201

Figure 1. Gas Particulate Unit.

2. Slide spring clip (Figure 1, Item 2) from air intake openings on precleaner and particulate filter unit assembly (Figure 1, Item 1).
3. Set GAS PARTICULATE switch (Figure 2, Item 1) to ON.

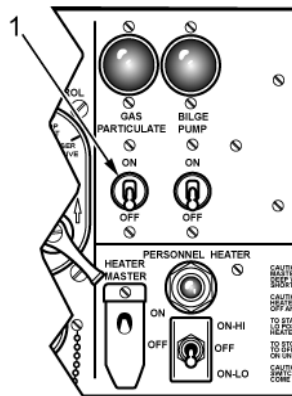

AVLBD202

Figure 2. Gas Particulate Switch.

GAS PARTICULATE FILTER UNIT - CONTINUED**Connecting - Continued****WARNING**

Frostbite to cheekbone area of face may be experienced by wearers of the M25A1 protective mask from subfreezing air delivered by gas particulate filter unit. **DO NOT** connect protective mask to filter unit hose unless existing air temperature is well above freezing. Failure to comply may result in personnel injury or death.

4. Disconnect hose (Figure 3, Item 2) from clip (Figure 3, Item 1).
5. Connect hose (Figure 3, Item 2) to M25A1 protective mask canister (Figure 3, Item 3).

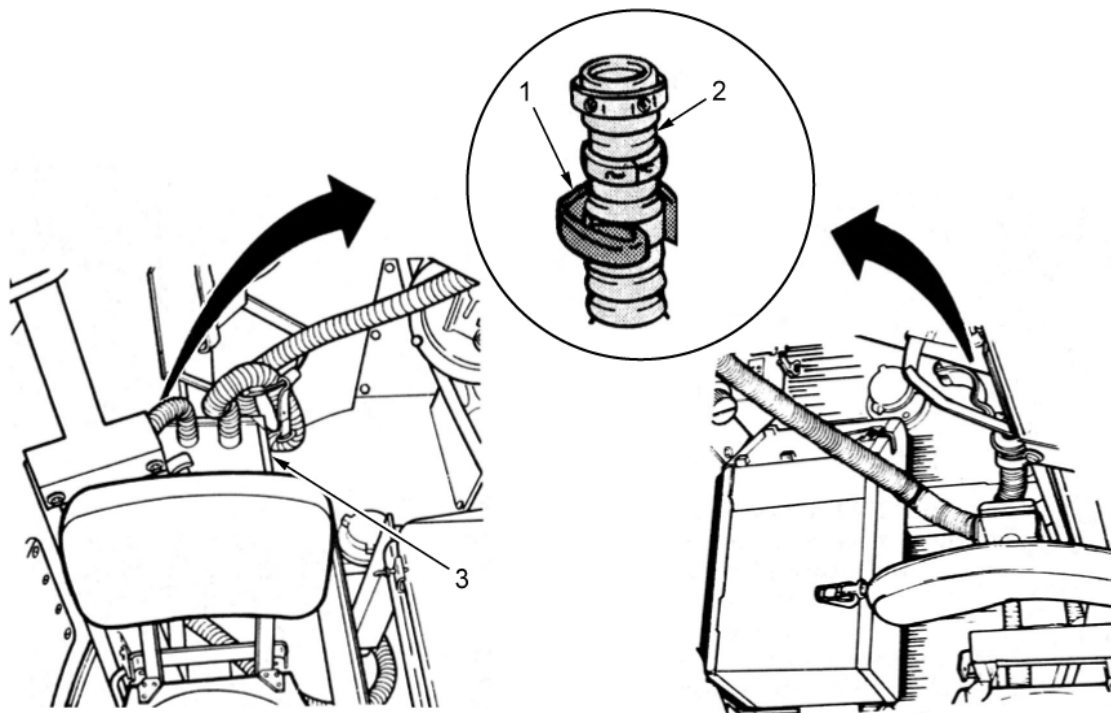

AVLBD203

Figure 3. Gas Particulate Filter Unit Hose Connection.

END OF TASK

GAS PARTICULATE FILTER UNIT - CONTINUED

Stopping Filtered Air

1. Set GAS PARTICULATE switch (Figure 4, Item 1) to OFF.

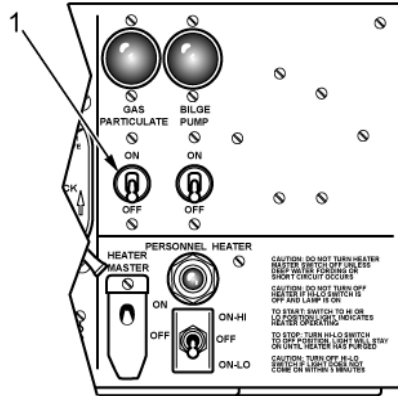

AVLBD204

Figure 4. Gas Particulate Switch.

2. Set MASTER BATTERY switch (Figure 5, Item 1) to OFF if not required for other operation.

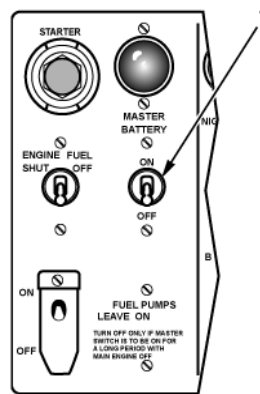

AVLBD205

Figure 5. Master Battery Switch.

GAS PARTICULATE FILTER UNIT - CONTINUED**Stopping Filtered Air - Continued**

3. Remove M25A1 protective mask, disconnect from protective mask canister, and connect hose (Figure 6, Item 2) to clip (Figure 6, Item 1).
4. Press spring clip (Figure 6, Item 4) on particulate filter unit (Figure 6, Item 3) to close air intake openings.

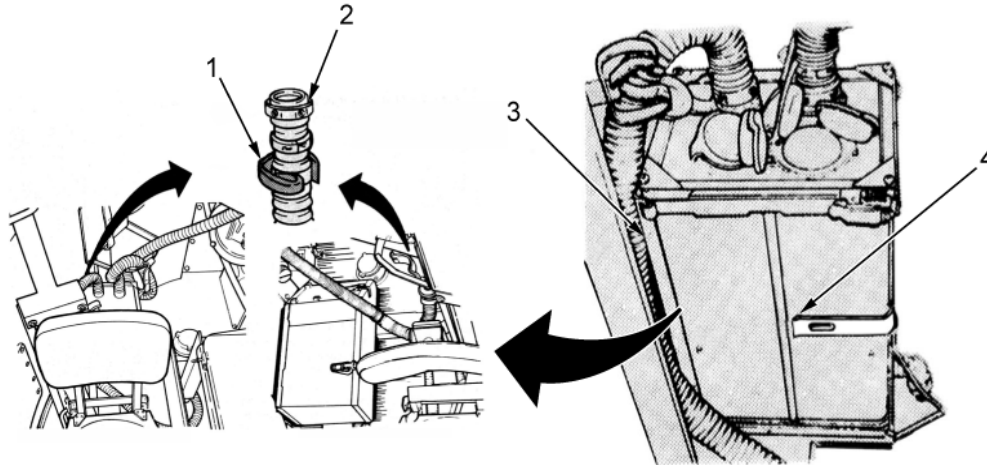

AVLBD206

Figure 6. Disconnecting Particulate Filter Unit Hoses.

END OF TASK**END OF WORK PACKAGE**

OPERATOR MAINTENANCE**OPERATION UNDER UNUSUAL CONDITIONS - GAS AND PARTICULATE FILTER CHANGE CRITERIA**

INITIAL SETUP:**References**

DA Form 2404
FM 3-11.4

References (cont.)

FM 3-11.5
WP 0048

GENERAL

In addition to performing normal Preventive Maintenance Checks and Services (PMCS) (WP 0048), clean and lubricate equipment more often to compensate for extremes of temperature, humidity, and terrain conditions that are present or expected. Cleaned and lubricated equipment ensures proper operation and guards against excessive wear and failure.

When equipment constantly breaks down due to operating under extreme conditions, report failure(s) using DA Form 2404 (Equipment Inspection and Maintenance Worksheet).

GAS AND PARTICULATE FILTER CHANGE CRITERIA**WARNING**

Nuclear-Biological-Chemical (NBC) contaminated air filters must be handled and disposed of only by authorized and trained personnel. The unit commander or senior officer in charge of maintenance personnel must ensure that prescribed protective clothing (FM 3-11.4) is used and prescribed safety measures and decontamination procedures (FM 3-11.5) are followed. The local unit SOP is responsible for final disposal of contaminated air filters. Failure to comply may result in personnel injury or death.

NOTE

For maximum safety, it is vital the gas and particulate filters of filter unit M8A3 be fully serviceable. Field maintenance is responsible for changing filters when notified. Notify field maintenance when one or more of the following conditions exist.

1. Conditions for M12A1 gas filter replacement:
 - a. Physical damage or water immersion.
 - b. Low airflow to masks, determined not to be caused by incorrect hose connections or low electrical power.
 - c. At beginning of combat conditions when use of CK (cyanogen chloride) or AC (hydrogen cyanide) is expected.
 - d. As soon as possible after each AC or CK attack.
 - e. 5,000-mile vehicle overhaul (peacetime).
 - f. 1,500 hours of vehicle operation (approximately 5 months, wartime).
2. Conditions for M13 particulate filter replacement:
 - a. Physical damage occurs.
 - b. M12A1 gas filter is changed.
 - c. Particulate filter becomes clogged, resulting in insufficient airflow.

END OF TASK**END OF WORK PACKAGE**

OPERATOR MAINTENANCE
STOWAGE AND DECAL/DATA PLATE GUIDE

SCOPE

This work package shows the locations for stowage of required equipment and material to be carried on the M48A5 and M60A1 Armored Vehicle Launched Bridge (AVLB).

STOWAGE AND DECAL/DATA PLATE LOCATIONS

The figures in this work package show the location of decals, stencils, and metal signs used on the vehicle. Most of these signs mark the places where equipment should be stowed. Some signs are cautions or information necessary for safe operation of the vehicle.

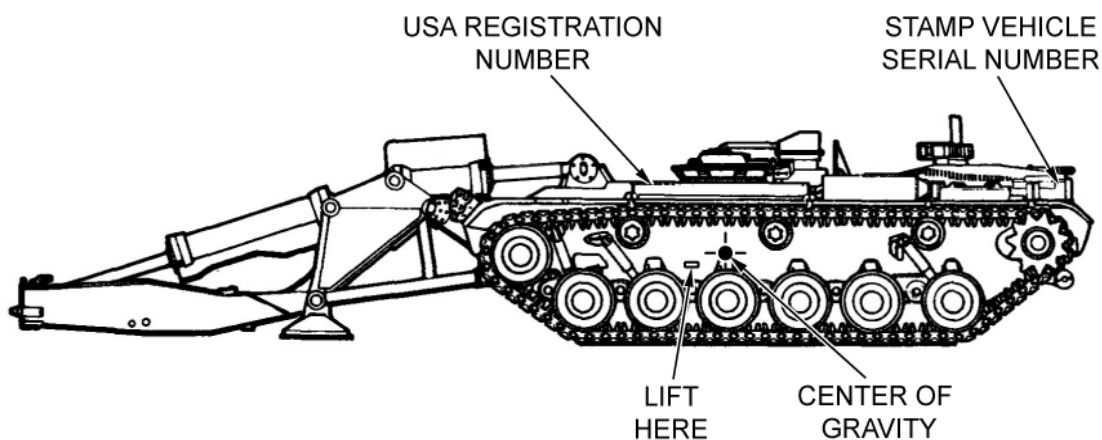

AVLBD210

Figure 1. M60A1/M48A5 AVLB - Side View.

STOWAGE AND DECAL/DATA PLATE LOCATIONS - CONTINUED

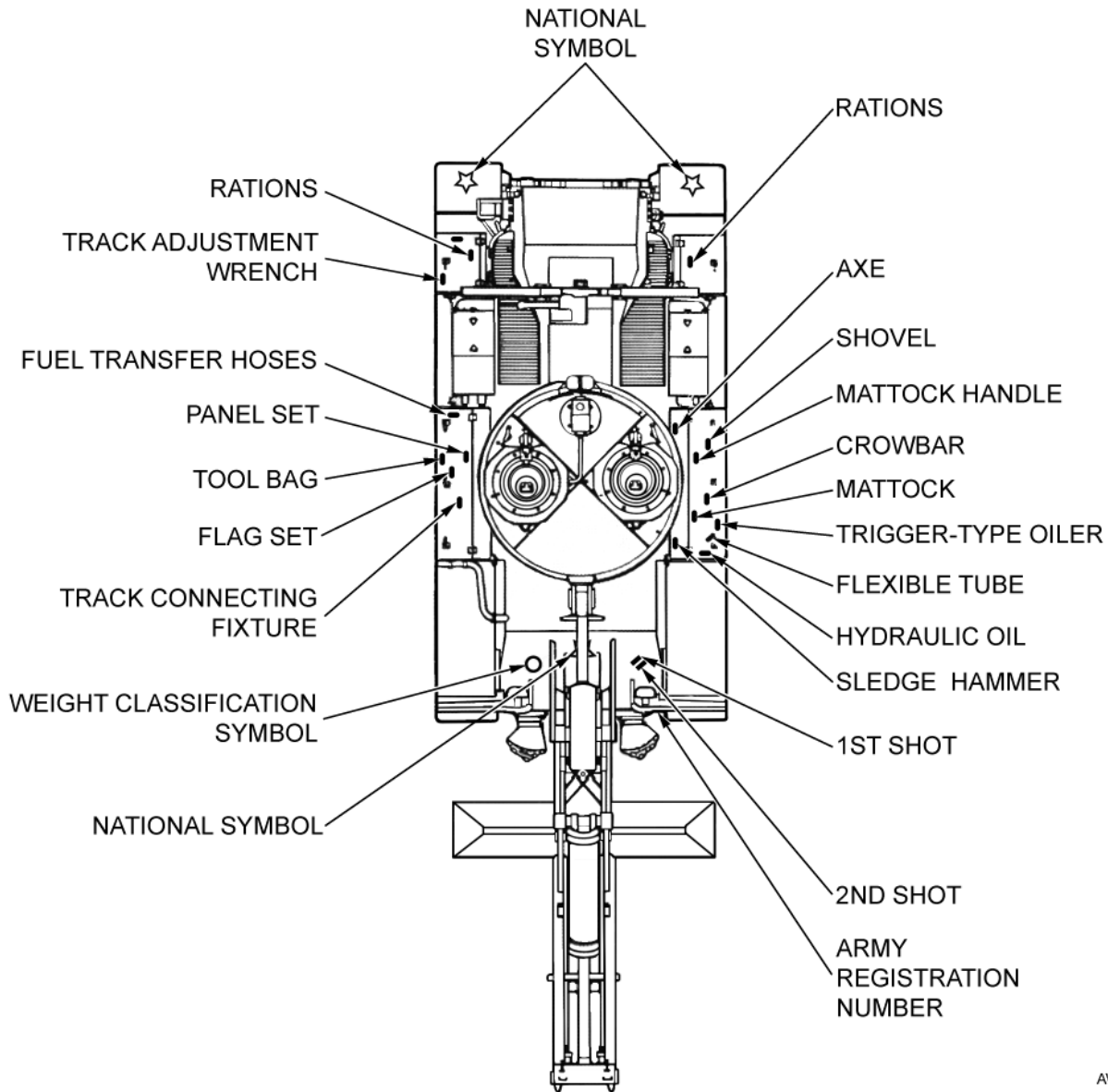

AVLBD211

Figure 2. M60A1/M48A5 AVLB - Top View.

STOWAGE AND DECAL/DATA PLATE LOCATIONS - CONTINUED

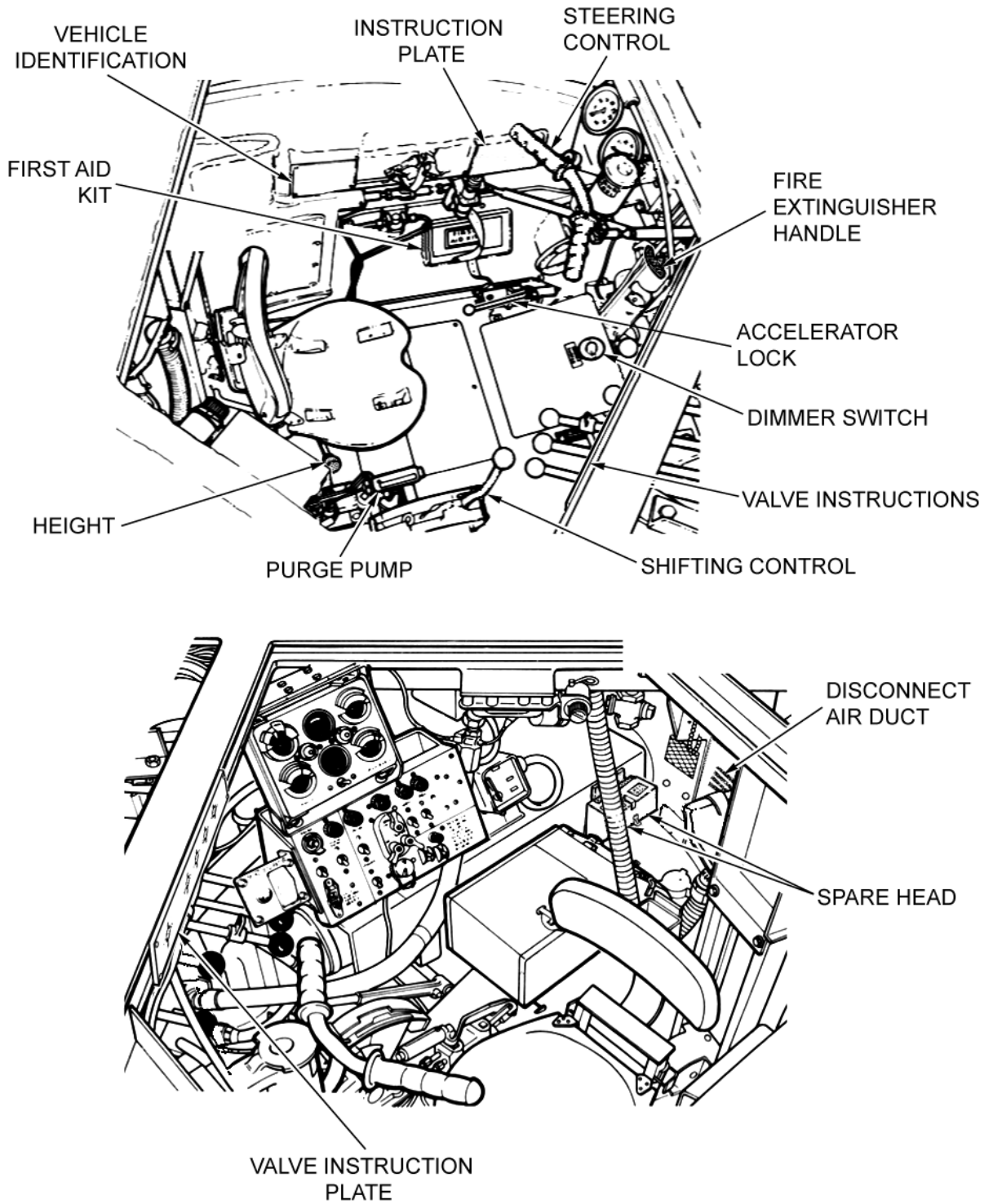
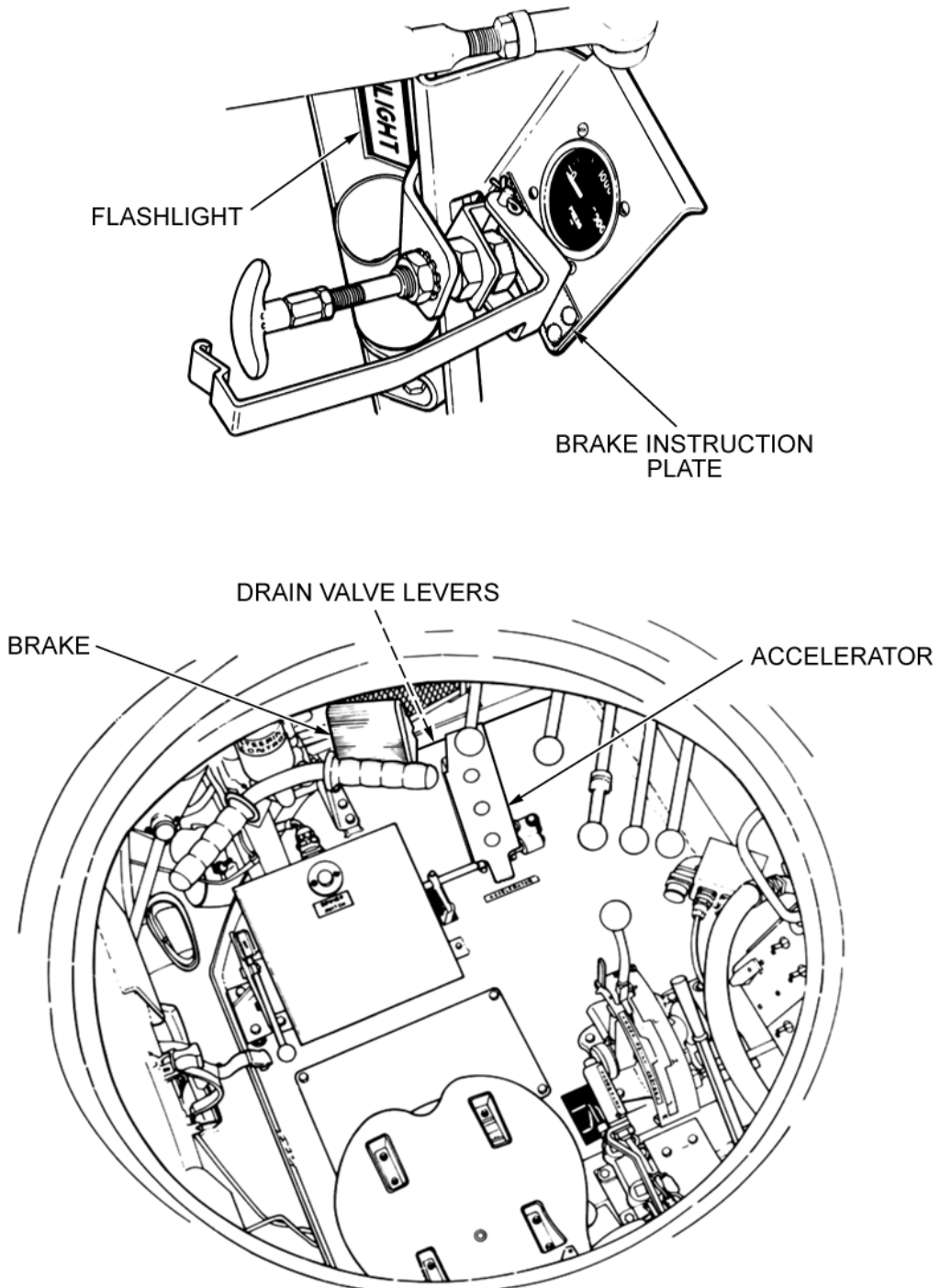

Figure 3. M60A1/M48A5 AVLB - Operator's Station.

AVLBD217

STOWAGE AND DECAL/DATA PLATE LOCATIONS - CONTINUED



AVLBD213

Figure 4. M60A1/M48A5 AVLB - Operator's Station.

STOWAGE AND DECAL/DATA PLATE LOCATIONS - CONTINUED

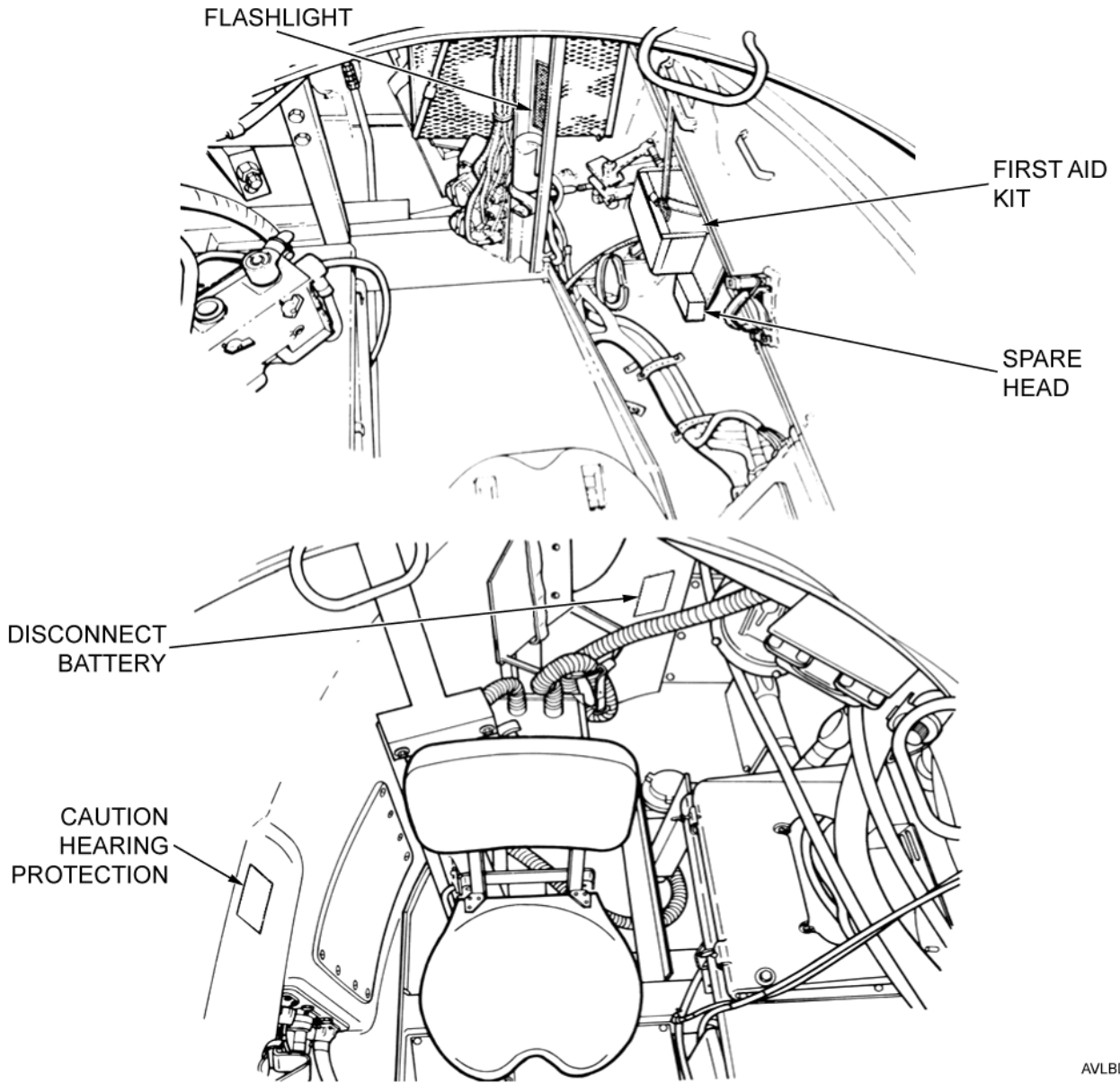

AVLBD214

Figure 5. M60A1/M48A5 AVLB - Commander's Station.

END OF WORK PACKAGE

CHAPTER 3

TROUBLESHOOTING PROCEDURES

FOR

**M45A5 AND M60A1 LAUNCHER AND TANK CHASSIS TRANSPORTING FOR
BRIDGE ARMORED-VEHICLE LAUNCHED: SCISSORING-TYPE, CLASS 60
OR CLASS 70**

OPERATOR MAINTENANCE
TROUBLESHOOTING SYMPTOM INDEX

GENERAL

This work package (WP) lists the common malfunctions that may occur during the operation or maintenance of the Armored Vehicle Launched Bridge (AVLB) or its components. Locate the malfunction/system in the following index and then refer to the corresponding WP for the appropriate troubleshooting procedure.

This manual cannot list all malfunctions that may occur or all tests, inspections, and corrective actions. If a malfunction is not listed or is not corrected by listed corrective actions, notify your supervisor.

If the corrective action requires lubrication or oil, refer to WP 0074 or notify field maintenance.

TROUBLESHOOTING SYMPTOM INDEX

The Troubleshooting Symptom Index lists common malfunctions found during operation of the AVLB. The Troubleshooting Symptom Index is divided into sections. Each section covers malfunctions common to the different systems of the vehicle.

The operator's manual cannot list all possible malfunctions, nor all the tests and inspections required for corrective actions. If a malfunction is not listed, or is not corrected by the listed corrective action, notify your supervisor.

Malfunction/Symptom **Troubleshooting Procedure**

ENGINE

- 1. Engine does not crank WP 0040
- 2. Engine cranks but does not start. WP 0040
- 3. Dark or black smoke blowing through rear grille doors (after warm-up). WP 0040
- 4. Engine runs rough or does not idle properly (after warm-up).. . . . WP 0040
- 5. Powerplant warning light comes on while engine is running above 750 to 800 RPM WP 0040

BRAKES

- 6. Parking brake is stuck. WP 0041

VOLTAGE REGULATOR

- 7. Battery-generator indicator reads in yellow or red when engine is running.. . . . WP 0042

LIGHTS

- 8. Lights are inoperable. WP 0043

STEERING

- 9. Vehicle leads to right or left on flat road.. . . . WP 0044

PERSONNEL HEATER

- 10. Personnel heater will not operate properly. WP 0045

AUXILIARY SYSTEMS AND CONTROLS

- 11. Driver's night vision viewer is inoperative. WP 0046
- 12. Driver's night vision viewer picture quality is poor. WP 0046
- 13. Lack of air in gas-particulate filter unit. WP 0046
- 14. Bridge fails to lift off bridge seat or fails to lift when retrieving bridge.. . . . WP 0046
- 15. Bridge fails to open during launching or fails to close when retrieving. WP 0046
- 16. Launcher does not engage bridge during retrieving. WP 0046
- 17. Launcher does not release bridge. WP 0046

END OF WORK PACKAGE

OPERATOR MAINTENANCE
ENGINE TROUBLESHOOTING PROCEDURES

INITIAL SETUP:**References**

LO 5-5420-202-13
WP 0015
WP 0029
WP 0032

References (cont.)

WP 0063
WP 0071
WP 0074

Table 1. Engine.



SYMPTOM	MALFUNCTION	CORRECTIVE ACTION
Engine does not crank.	ENGINE DOES NOT CRANK WHEN STARTER SWITCH IS DEPRESSED.	<p style="text-align: center;">WARNING</p> <div style="text-align: center;">  </div> <p>Electrical shock may occur when slave starting vehicles if any battery is missing or damaged or cables are defective. DO NOT attempt to slave start vehicle if any battery is missing or damaged. DO NOT use defective cables for slave starting. Failure to comply may result in personnel injury or death, or equipment damage.</p> <p style="text-align: center;">WARNING</p> <div style="text-align: center;">  </div> <ul style="list-style-type: none"> • Battery acid (electrolyte) and corrosion can cause serious burns. Safety goggles and acid resistant rubber gloves must be worn when working around batteries. If electrolyte or corrosion makes contact with skin, eyes, or clothing, immediately flush contacted area with water and obtain medical attention. Failure to comply may result in personnel injury or death. • Batteries may give off explosive gasses. DO NOT smoke, use open flame, make sparks, or create other ignition sources around the battery. Failure to comply may result in personnel injury or death. • Personnel may be burned if jewelry or a tool contacts a battery terminal. Remove all jewelry such as rings, ID tags, watches, etc. Failure to comply may result in personnel injury or death. <p>STEP 1. Move shifting control lever from P (Park) to R (Reverse) and back to P (Park). Attempt to start vehicle. If vehicle does not start, go to step 2.</p>

Table 1. Engine - Continued.

SYMPTOM	MALFUNCTION	CORRECTIVE ACTION
<p>Engine cranks but does not start.</p>	<p>ENGINE CRANKS BUT DOES NOT START.</p>	<p>STEP 2. Remove battery cover assemblies (WP0063). Visually check to see if battery terminals and cables are corroded or damaged. If cables are corroded or damaged, notify field maintenance.</p> <p>STEP 3. Visually check for broken or loose battery connections and posts. If connections are loose, notify field maintenance.</p> <p>STEP 4. Check to see if electrolyte level is above top of plates. Refer to WP 0063. If electrolyte level is low, notify field maintenance.</p> <p>STEP 5. Slave start vehicle. Refer to WP 0032.</p> <p>STEP 6. Allow engine to run 30 minutes to charge batteries.</p> <p>STEP 7. If engine does not start or batteries do not charge, notify field maintenance.</p> <p>STEP 1. Pump purge handle until you feel back pressure. Refer to WP 0015. Air will be purged from fuel lines.</p> <p>STEP 2. Start engine. Refer to WP 0015. If engine does not start, go to step 3.</p> <p style="text-align: center;">CAUTION</p> <p style="text-align: center;">DO NOT hold manifold heater switch longer than 15 seconds. Holding manifold heater switch longer than 15 seconds can damage manifold heaters. Failure to comply may result in equipment damage.</p> <p style="text-align: center;">NOTE</p> <p style="text-align: center;">If temperature is less than 40°F (4°C), go to step 3. If temperature is above 40°F (4°C), go to step 4.</p> <p>STEP 3. While depressing starter switch, press and hold manifold heater switch and pump purge handle for 15 seconds. If engine does not start, go to step 4.</p> <p>STEP 4. Operate fuel shutoff handle three times. Push in fuel shutoff handle and start engine. Refer to WP 0015. If engine does not start, notify field maintenance.</p>

Table 1. Engine - Continued.

SYMPTOM	MALFUNCTION	CORRECTIVE ACTION
Engine smokes.	DARK OR BLACK SMOKE BLOWS THROUGH REAR GRILLE DOORS (AFTER WARM-UP).	<p style="text-align: center;">CAUTION</p> <p>If engine oil pressure indicator shows in red, stop engine. Refer to WP 0015. Continued operation may cause engine damage. Failure to comply may result in equipment damage.</p> <p>STEP 1. Feel rear grille doors for oil. If oil is present, notify field maintenance.</p> <p>STEP 2. Check engine oil level. Refer to WP 0074.</p> <p>STEP 3. If engine oil level is too high (overfull), notify field maintenance.</p> <p>STEP 4. If engine oil level is correct, perform steps 2, 3, and 4 of "Engine runs rough or does not idle properly after warm-up."</p>
Engine runs rough.	ENGINE RUNS ROUGH OR DOES NOT IDLE PROPERLY (AFTER WARM-UP).	<p style="text-align: center;">CAUTION</p> <p>DO NOT push manifold heater switch while operating purge pump handle in step 1. This may damage the intake manifold. Failure to comply may result in equipment damage.</p> <p>STEP 1. Pump purge pump handle until back pressure is felt. If engine still does not run properly, shut down engine. Refer to WP 0015.</p> <p style="text-align: center;">NOTE</p> <p>Armored Vehicle Launched Bridge (AVLB) vehicles may not be equipped with air restriction indicators. If the vehicle does not have air restriction indicators, go to step 3.</p> <p>STEP 2. Visually check both air restriction indicators (WP 0071), if equipped, for condition of air cleaner filters. Air restriction indicators will be either a window that reads clear or red, or a window that measures restriction.</p> <p>STEP 3. If vehicle is equipped with indicator windows that read clear, red, or green, attempt to reset restriction indicators by pushing reset button (WP 0071).</p> <p>STEP 4. If either indicator shows red band after resetting, notify field maintenance.</p> <p>STEP 5. If both indicators show clear, go to step 10.</p> <p>STEP 6. If vehicle is equipped with indicator windows that measure restriction in degrees, and indicators have a reading of 30 inches or more, as shown by red disc, filter elements need to be cleaned. Notify field maintenance.</p>

Table 1. Engine - Continued.

SYMPTOM	MALFUNCTION	CORRECTIVE ACTION
<p>Powerplant warning light comes on.</p>	<p>POWERPLANT WARNING LIGHT COMES ON WHILE ENGINE IS ABOVE 750 TO 800 RPM.</p>	<p style="text-align: center;">NOTE</p> <p>Indicator windows that measure restriction in degrees are not reset until filter element has been cleaned or replaced.</p> <p>STEP 7. Check engine air intakes inside crew compartment or through top deck grille doors for obstruction (WP 0029).</p> <p>STEP 8. Remove any foreign material obstructing air intakes and start engine (WP 0015).</p> <p>STEP 9. If engine does not run properly, notify field maintenance.</p> <p>STEP 10. For vehicles without air restriction indicators, notify field maintenance.</p> <p style="text-align: center;">CAUTION</p> <p>Check ENGINE and TRANSMISSION oil pressure and temperature indicators (gauges). Stop engine if ENGINE or TRANSMISSION indicators show in red (WP 0015). Engine or transmission may overheat and damage to both components may occur. Failure to comply may result in equipment damage.</p> <p>STEP 1. Check right and left top deck grille doors to see if obstruction is blocking airflow.</p> <p>STEP 2. Check engine and transmission oil cooler screens for obstruction by dirt, leaves, or other foreign material (Figure 1). If obstruction is found, notify field maintenance.</p> <div style="text-align: center;">  <p style="text-align: right; font-size: small;">AVLBD610</p> </div> <p style="text-align: center;">Figure 1. Oil Cooler Screen Location.</p>

Table 1. Engine - Continued.

SYMPTOM	MALFUNCTION	CORRECTIVE ACTION
		<p style="text-align: center;">CAUTION</p> <p>Operate engine only long enough to check engine and transmission oil levels. Continued operation with powerplant warning light on could cause severe damage to the engine or transmission.</p> <p>STEP 3. Check engine and transmission oil levels. Refer to LO 5-5420-202-13 for M60A1 AVLB and M48A5 AVLB.</p> <p>STEP 4. If engine or transmission oil is low, add oil. Refer to LO 5-5420-202-13.</p> <p>STEP 5. If powerplant warning light comes on, notify field maintenance.</p> <p>STEP 6. Check dust detector warning lamp (Figure 2, Item 1) if equipped.</p> <div style="text-align: center;">  <p style="text-align: right; margin-right: 20px;">AVLB593</p> </div> <p style="text-align: center;">Figure 2. Dust Detector Warning Lamp.</p> <p>STEP 7. If lamp is on, stop vehicle, open grille doors, and check both dust detector pressure switches (Figure 3, Item 2).</p> <p>STEP 8. A red plunger (Figure 3, Item 1), visible through plastic cover on switch body, indicates dust detector pressure switch (Figure 3, Item 2).</p> <p>STEP 9. If switch (Figure 3, Item 2) has tripped, notify field maintenance.</p>

Table 1. Engine - Continued.

SYMPTOM	MALFUNCTION	CORRECTIVE ACTION
		 <p data-bbox="1388 856 1469 877">AVLBD594</p> <p data-bbox="906 919 1425 955">Figure 3. Dust Detector Pressure Switches.</p>

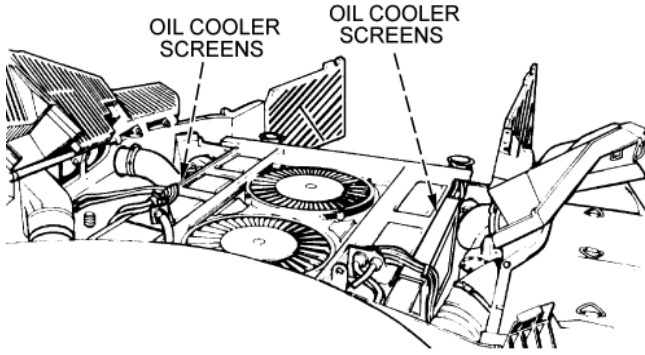
END OF WORK PACKAGE

OPERATOR MAINTENANCE
BRAKES TROUBLESHOOTING PROCEDURES

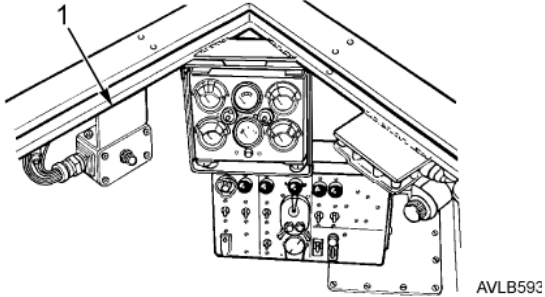
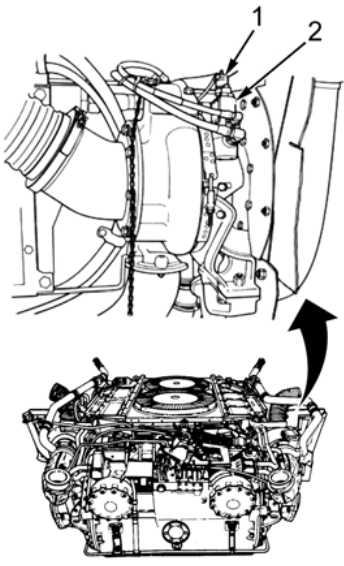
INITIAL SETUP:

References
WP 0013

References (cont.)
WP 0033

Table 1. Brakes.

SYMPTOM	MALFUNCTION	CORRECTIVE ACTION
<p>Parking brake is stuck.</p>	<p>PARKING BRAKE DOES NOT RELEASE.</p>	<p>STEP 1. With transmission shift lever in P (Park), depress brake pedal and increase brake pressure to 1,000 psi (6895 kPa) on brake pressure gauge, and shift transmission to N (Neutral). Refer to WP 0013. If parking brake does not release, go to step 2.</p> <p style="text-align: center;">WARNING</p> <div style="text-align: center;">  </div> <p>Personnel may be struck or pinned by uncontrolled vehicle movement. Block vehicle tracks with chock blocks to prevent uncontrolled vehicle movement. Failure to comply may result in personnel injury or death.</p> <p>STEP 2. Remove transmission shroud. Refer to WP 0033.</p> <p>STEP 3. With transmission shift lever in N (Neutral), manually pry bellcrank (Figure 1, Item 1) (without forcing) and listen for brakes to release.</p>

Table 1. Brakes - Continued.

SYMPTOM	MALFUNCTION	CORRECTIVE ACTION
		 <p data-bbox="1291 898 1372 919">AVLBD595</p> <p data-bbox="954 961 1187 993">Figure 1. Bellcrank.</p> <p data-bbox="764 1003 1325 1062">STEP 4. If parking brakes release, continue to operate and notify field maintenance.</p> <p data-bbox="764 1073 1308 1131">STEP 5. If brakes do not release, notify field maintenance.</p>

END OF WORK PACKAGE

OPERATOR MAINTENANCE
VOLTAGE REGULATOR TROUBLESHOOTING PROCEDURES

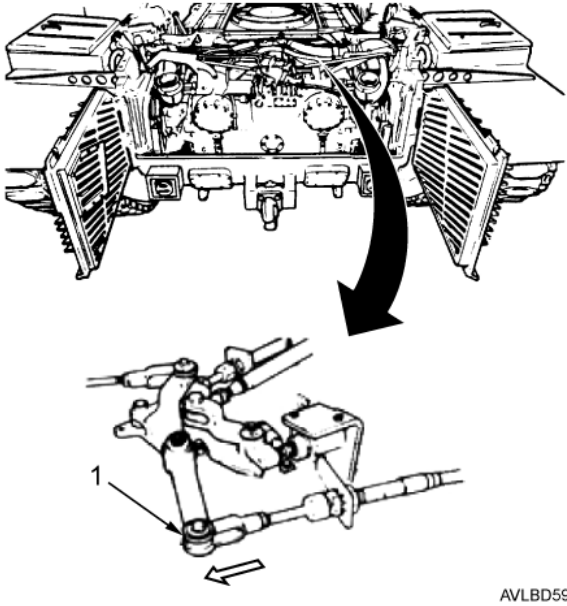
INITIAL SETUP:

References
WP 0015

References (cont.)
WP 0063

Table 1. Voltage Regulator.

SYMPTOM	MALFUNCTION	CORRECTIVE ACTION
Battery-generator indicator reads in yellow or red when engine is running.	BATTERY-GENERATOR INDICATOR POINTER IS IN YELLOW OR LEFT RED WHEN ENGINE IS RUNNING.	<p>STEP 1. Increase engine speed to 1,600 RPM and watch for pointer to move toward green.</p> <p>STEP 2. If pointer moves to green, continue operation and notify field maintenance.</p> <p>STEP 3. If pointer does not move to green, stop engine. Refer to WP 0015 and notify field maintenance.</p>
Battery-generator indicator reads in yellow or red when engine is running.	BATTERY-GENERATOR INDICATOR POINTER IS IN YELLOW OR LEFT RED WHEN ENGINE IS RUNNING.	<p style="text-align: center;">WARNING</p> <div style="text-align: center;">  </div> <p>Overcharged batteries could explode. If battery-generator indicator is showing in bright red, immediately stop engine. Failure to comply may result in personnel injury or death.</p> <p>STEP 1. Check batteries by touching battery case to see if they are hot. Refer to WP 0063.</p> <p>STEP 2. If batteries are hot, stop engine and notify field maintenance.</p>

END OF WORK PACKAGE

OPERATOR MAINTENANCE
LIGHTS TROUBLESHOOTING PROCEDURES

INITIAL SETUP:

References
WP 0008

References (cont.)
WP 0033
WP 0066

Table 1. Lights.

SYMPTOM	MALFUNCTION	CORRECTIVE ACTION
Lights are inoperable.	SERVICE DRIVE HEADLIGHT OR BLACKOUT MARKER LIGHT DOES NOT WORK.	<p>STEP 1. Check headlight mounting connectors of non-operational headlight assembly to see if mounting nut is secured and seated into headlight mount. Refer to WP 0066. If not, secure mounting nut and seat properly.</p> <p>STEP 2. Operate headlights. Refer to WP 0008. If headlights do not work, go to step 3.</p> <p>STEP 3. Check to ensure all electrical connectors (Figure 1, Item 2) in both right and left headlight harness assemblies (Figure 1, Item 1) are connected. If not connected, connect.</p> <p>STEP 4. Operate headlights. Refer to WP 0008. If headlights do not work, replace defective lamps. Refer to WP 0066.</p> <div style="text-align: center;">  <p>The diagram shows a top-down view of a vehicle's headlight assembly with two headlights. Below it, a detailed view of the electrical harness is shown. A curved cable is connected to a main harness. Two specific points are labeled: '1' points to the main harness assembly, and '2' points to a specific electrical connector within the harness.</p> </div> <p style="text-align: right;">AVLBD596</p>

Figure 1. Headlight Harness.

Table 1. Lights - Continued.

SYMPTOM	MALFUNCTION	CORRECTIVE ACTION
	<p>SERVICE DRIVE TAILLIGHT, SERVICE STOPLIGHT, OR BLACKOUT MARKER LIGHT DOES NOT WORK.</p>	<p style="text-align: center;">NOTE</p> <p>Service drive headlights use identical seal beam lamps. Switch lamps until replacement lamp is available.</p> <p>STEP 5. Operate service drive headlights, blackout drive light, or blackout marker light. Refer to WP 0008. If lights do not work, notify field maintenance.</p> <p>STEP 1. Remove transmission shroud. Refer to WP 0033.</p> <p style="text-align: center;">NOTE</p> <p>Right taillight assembly has two electrical connectors and left taillight assembly has three electrical connectors. Connectors are located behind taillights, under the transmission shroud.</p> <p>STEP 2. Check non-operational taillight assembly electrical connectors (Figure 2, Item 1) to ensure they are properly connected. Secure any loose connectors.</p>

Table 1. Lights - Continued.

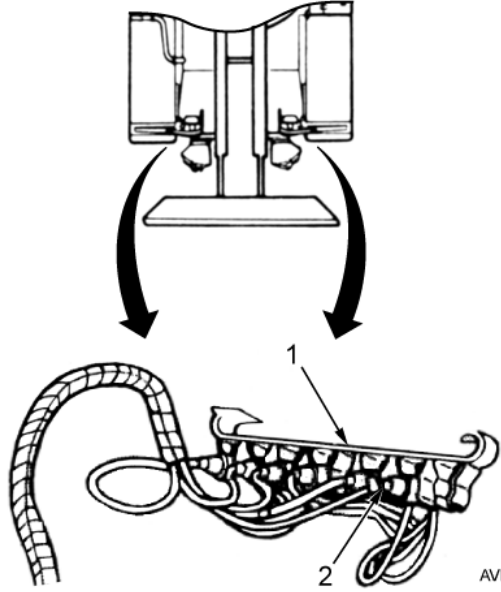
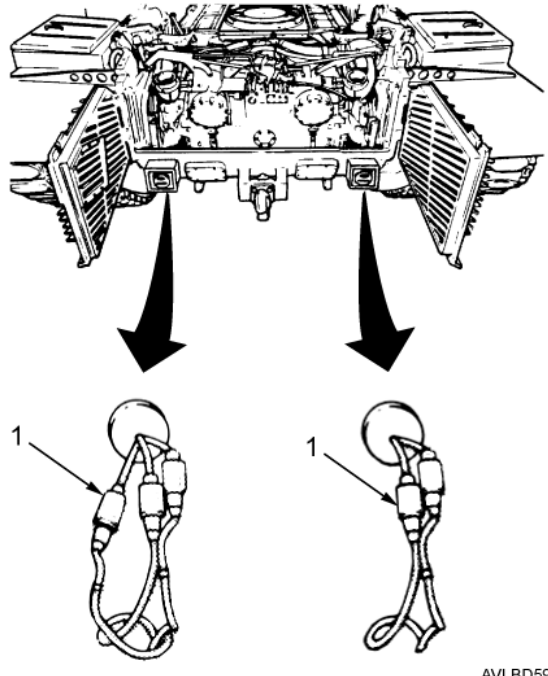
SYMPTOM	MALFUNCTION	CORRECTIVE ACTION
		 <p style="text-align: right; font-size: small;">AVLBD597</p> <p>Figure 2. Taillight Assembly Electrical Connectors.</p> <p>STEP 3. Operate taillights. Refer to WP 0008.</p> <p>STEP 4. If taillights do not operate, replace defective lamps. Refer to WP 0066.</p> <p>STEP 5. If taillights still do not operate, notify field maintenance.</p>

END OF WORK PACKAGE

OPERATOR MAINTENANCE
STEERING TROUBLESHOOTING PROCEDURES

INITIAL SETUP:

References
WP 0056

Table 1. Steering.

SYMPTOM	MALFUNCTION	CORRECTIVE ACTION
Vehicle leads to right or left on f at road.	TRACK TENSION INCORRECTLY ADJUSTED.	STEP 1. Check track tension adjustment. Refer to WP 0056. STEP 2. If adjustment is not as specif ed, adjust track tension. Refer to WP 0056. STEP 3. If adjustment is still incorrect, notify f eld maintenance.

END OF WORK PACKAGE

OPERATOR MAINTENANCE
PERSONNEL HEATER TROUBLESHOOTING PROCEDURES

INITIAL SETUP:

References
WP 0010

Table 1. Personnel Heater.



SYMPTOM	MALFUNCTION	CORRECTIVE ACTION
<p>Personnel heater will not operate properly.</p>	<p>PERSONNEL HEATER STARTS, RUNS SHORT TIME, AND STOPS.</p>	<p style="text-align: center;">NOTE</p> <p>The HEATER MASTER switch (Figure 1, Item 1) should always be set to ON. If heater was turned off with HEATER MASTER switch or operated less than 5 minutes, it may not restart because of flooding.</p> <div style="text-align: center;">  <p style="text-align: right;">AVLBD598</p> </div> <p style="text-align: center;">Figure 1. Heater Master Switch.</p> <p>STEP 1. Check blower air inlet (Figure 2, Item 2) and airflow ducts (Figure 2, Item 1) for anything blocking airflow. Remove anything blocking airflow.</p> <div style="text-align: center;">  <p style="text-align: right;">AVLBD599</p> </div> <p style="text-align: center;">Figure 2. Airflow Ducts.</p>

Table 1. Personnel Heater - Continued.

SYMPTOM	MALFUNCTION	CORRECTIVE ACTION
		<p>STEP 2. Check personnel heater exhaust tube for anything blocking heater exhaust. Refer to WP 0010. Remove anything blocking personnel heater exhaust.</p> <p style="text-align: center;">WARNING</p> <div style="text-align: center;">  </div> <p>A flooded heater can explode. DO NOT attempt to restart heater more than one time with ON-LO switch. Failure to comply may result in personnel injury or death.</p> <p>STEP 3. Attempt to start heater. Refer to WP 0010. If heater does not run, notify field maintenance.</p>

END OF WORK PACKAGE

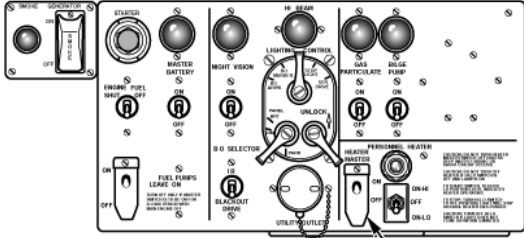
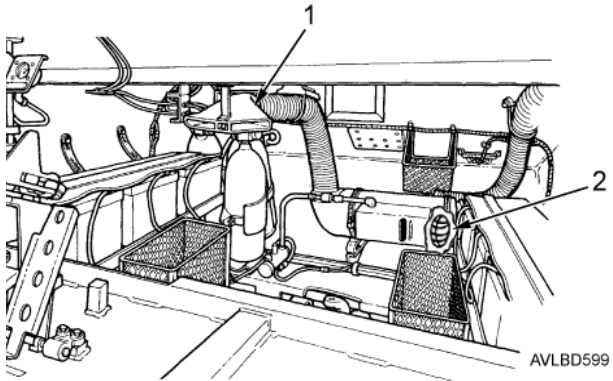
OPERATOR MAINTENANCE
AUXILIARY SYSTEMS AND CONTROLS PROCEDURES

INITIAL SETUP:

References

WP 0011
WP 0018
WP 0020

References (cont.)

WP 0037
WP 0074

Table 1. Auxiliary Systems and Controls.

SYMPTOM	MALFUNCTION	CORRECTIVE ACTION
<p>Driver's night vision viewer is inoperative.</p>	<p>DRIVER'S NIGHT VISION VIEWER DOES NOT OPERATE ON BATTERY POWER (VIEWER OPERATES ON VEHICLE POWER).</p>	<p style="text-align: center;">WARNING</p> <div style="text-align: center;">  </div> <p>An installed battery can overheat and may explode when vehicle power is used. Remove viewer battery from viewer and store in viewer stowage box before connecting power cable. Failure to comply may result in personnel injury or death.</p> <p>STEP 1. Remove viewer battery from viewer. Refer to WP 0011. Store battery in viewer stowage box.</p> <p>STEP 2. Check to see if vehicle power cable is attached to night vision viewer. Refer to WP 0011. If cable is attached, place NIGHT VISION power switch in OFF position, wait 2 minutes, and disconnect vehicle cable.</p> <p>STEP 3. Place night vision viewer OFF/BRIGHT rotary switch in OFF position. Check to see if battery is installed with positive (+) end first in night vision viewer.</p> <p>STEP 4. Night vision viewer battery may be discharged. Replace battery for test. Refer to WP 0011.</p> <p>STEP 5. Check for corrosion or dirt on battery contacts, contact in night vision viewer, or contact in battery compartment cap. If dirty, clean contacts. Refer to WP 0011.</p>

Table 1. Auxiliary Systems and Controls - Continued.

SYMPTOM	MALFUNCTION	CORRECTIVE ACTION
	<p>DRIVER'S NIGHT VISION VIEWER DOES NOT OPERATE ON VEHICLE POWER (VIEWER OPERATES ON BATTERY POWER).</p> <p>DRIVER'S NIGHT VISION VIEWER DOES NOT OPERATE ON VEHICLE POWER OR BATTERY POWER.</p> <p>DRIVER'S NIGHT VISION VIEWER PICTURE QUALITY IS POOR.</p>	<p style="text-align: center;">WARNING</p> <div style="text-align: center;">  </div> <p>An installed battery can overheat and may explode when vehicle power is used. Remove viewer battery from viewer and store in viewer stowage box before connecting power cable. Failure to comply may result in personnel injury or death.</p> <p>STEP 1. Remove battery before connecting vehicle power cable to night vision viewer. Refer to WP 0011.</p> <p>STEP 2. Check if MASTER BATTERY and NIGHT VISION power switches are ON. If not, place both switches ON.</p> <p>STEP 3. Check if vehicle power cable is loose or not connected to night vision viewer. Refer to WP 0011. If not connected, place NIGHT VISION power switch OFF, and connect vehicle power cable to night vision viewer.</p> <p>STEP 4. Place NIGHT VISION power switch in OFF position, and disconnect vehicle power cable from night vision viewer. Check for corrosion or dirt on cable or viewer contacts. If dirty, clean contacts. Refer to WP 0011.</p> <p>STEP 1. Check if outside lens cover is installed. If installed, remove lens cover. Refer to WP 0011.</p> <p>STEP 2. Check if outside conditions are too bright. If terrain or sky is too bright, driver's night vision viewer will automatically shut off. Point viewer at dark scene.</p> <p>STEP 3. Check if OFF/BRIGHT rotary switch is set to OFF. If off, rotate switch to maximum BRIGHT position.</p> <p>STEP 1. Check if OFF/BRIGHT rotary switch is adjusted properly. If not, rotate to maximum BRIGHT position and reduce brightness for best image.</p> <p>STEP 2. Check if lenses are dirty or fogged. If yes, clean outside lens and eyepiece lens. Refer to WP 0011.</p>

Table 1. Auxiliary Systems and Controls - Continued.

SYMPTOM	MALFUNCTION	CORRECTIVE ACTION
		<p style="text-align: center;">WARNING</p> <div style="text-align: center;">  </div> <p>An installed battery can overheat and may explode when vehicle power is used. Remove viewer battery from viewer and store in viewer stowage box before connecting power cable. Failure to comply may result in personnel injury or death.</p> <p>STEP 3. Remove viewer battery from viewer. Refer to WP 0011. Store battery in viewer stowage box before connecting cable.</p> <p>STEP 4. Check if picture quality is better using vehicle power than when using battery power. If yes, replace battery. Refer to WP 0011.</p> <p>STEP 1. Ensure spring clip has been lifted from air intake opening on filter unit. Refer to WP 0037. If not, lift from air intake opening.</p> <p>STEP 2. Check electrical connector at precleaner and filter unit. If connector is loose, tighten.</p> <p>STEP 3. Check if precleaner and filter unit motor is operating by listening for motor noise. If motor is not running, notify field maintenance.</p> <p>STEP 1. Check clutch and ensure it is fully engaged.</p> <p>STEP 2. Check for low level in launcher hydraulic reservoir. Refer to WP 0074.</p> <p>STEP 3. If hydraulic fluid is low, refill reservoir. Refer to WP 0074. Repeat launching or retrieving procedures. Refer to WP 0018 and WP 0020.</p> <p>STEP 4. If launcher hydraulic fluid level is correct and bridge will not raise, notify field maintenance.</p> <p>STEP 1. Check for low level in launcher hydraulic reservoir. Refer to WP 0074. If hydraulic fluid is low, refill reservoir. Refer to WP 0074. Repeat launching or retrieving procedures. Refer to WP 0018 and WP 0020.</p>
<p>Gas particulate filter is inoperative.</p>	<p>LACK OF AIR IN GAS-PARTICULATE FILTER UNIT.</p>	
<p>Bridge inoperative.</p>	<p>BRIDGE FAILS TO LIFT OFF BRIDGE SEAT OR FAILS TO LIFT WHEN RETRIEVING BRIDGE.</p>	
	<p>BRIDGE FAILS TO OPEN DURING LAUNCHING OR FAILS TO CLOSE WHEN RETRIEVING.</p>	

Table 1. Auxiliary Systems and Controls - Continued.

SYMPTOM	MALFUNCTION	CORRECTIVE ACTION
	<p>LAUNCHER DOES NOT ENGAGE BRIDGE DURING RETRIEVING.</p> <p>LAUNCHER DOES NOT RELEASE BRIDGE.</p>	<p>STEP 2. Check that quick disconnect couplings are properly connected.</p> <p>STEP 3. Check for open valves on bridge scissors cylinder. Refer to WP 0020.</p> <p>STEP 4. If valves are open, close valves. If bridge still fails to open or close, notify field maintenance.</p> <p>STEP 1. Check if ejection cylinder plugs retract. Refer to WP 0018 and WP 0020. If ejection cylinder plugs do not retract, notify field maintenance.</p> <p>STEP 1. Check that locking cylinder plugs (WP 0018 and WP 0020) are retracted. If locking cylinder plugs are not retracted, notify field maintenance.</p>

END OF WORK PACKAGE

CHAPTER 4

MAINTENANCE PROCEDURES

FOR

**M48A5 AND M60A1 LAUNCHER AND TANK CHASSIS TRANSPORTING FOR
BRIDGE ARMORED-VEHICLE LAUNCHED: SCISSORING-TYPE, CLASS 60
OR CLASS 70**

OPERATOR MAINTENANCE**PREVENTIVE MAINTENANCE CHECKS AND SERVICES (PMCS) INTRODUCTION**

GENERAL

PMCS means systematic caring, inspecting, and servicing of equipment to keep it in good condition and to prevent breakdowns. Always perform the PMCS in the same order, so it gets to be a habit. Once you have had some practice, you will quickly spot anything wrong. Perform the PMCS as follows:

1. **BEFORE PMCS** - just before you operate the M48A5 and M60A1 Armored Vehicle Launched Bridge (AVLB). Pay attention to WARNINGS, CAUTIONS, and NOTES. Refer to WP 0048.
2. **DURING PMCS** - while you operate the AVLB. During operation means to monitor the AVLB and its related components while it is actually being operated. Pay attention to WARNINGS, CAUTIONS, and NOTES. Refer to WP 0048.
3. **AFTER PMCS** - right after operating the AVLB. Pay attention to WARNINGS, CAUTIONS, and NOTES. Refer to WP 0048.
4. **WEEKLY** - once a week. Refer to WP 0048.
5. **MONTHLY** - once a month. Refer to WP 0048.

Use DA Form 2404 (Equipment Inspection and Maintenance Worksheet) to record any faults that you discover before, during, or after operation, unless you can fix them. You **DO NOT** need to record faults that you fix.

CORROSION PREVENTION AND CONTROL (CPC)

Inspect all external and internal parts and surfaces for corrosion. If corrosion is found, notify field maintenance. Refer to WP 0001 for CPC requirements.

PMCS PROCEDURES

The PMCS table in work package 0048 lists the inspections and care required to keep the AVLB in good operating condition. It is set up so you can perform BEFORE Operation checks as you walk around the AVLB. The PMCS table includes the following columns:

1. The **ITEM NO.** column indicates the number assigned to each PMCS procedure. The procedures are numbered in logical sequence of performance.
2. The **INTERVAL** column indicates when to perform a certain check or service.
3. The **ITEM TO BE CHECKED OR SERVICED** column identifies the vehicle component located where the procedure is to be performed.
4. The **PROCEDURE** column indicates how to do the required checks and services. Carefully follow these instructions. If you do not have tools, or if the procedure tells you to, notify your supervisor.
5. The **EQUIPMENT NOT READY/AVAILABLE IF** column indicates when the AVLB is non-mission capable and why the equipment cannot be used.

If the AVLB does not perform as required, refer to Chapter 3, Troubleshooting. Refer to WP 0039. If anything looks wrong and you cannot fix it, complete a DA Form 2404. **IMMEDIATELY** report the problem to your supervisor.

SPECIAL INFORMATION**NOTE**

Only use those authorized cleaning solvents or agents listed in the Expendable/Durables Items List (WP 0079) in this manual.

1. **Keep It Clean.** Dirt, grease, oil, and debris may cover up a serious problem. Clean as you work and as needed. Use degreasing solvent (WP 0079, Item 58) on all metal surfaces. Use soap and water when you clean rubber or plastic material. Upholstery can be cleaned with soap and water and a clean, damp cloth.

SPECIAL INFORMATION - CONTINUED

2. Rust and Corrosion. Check AVLB body and frame for rust and corrosion. If any bare metal or corrosion exists, clean and apply a thin coat of cleaner and preservative lubricant (WP 0079, Item 42). Report it to your supervisor.
3. Bolts, Nuts, and Screws. Check for obvious looseness and missing, bent, or broken condition. You cannot try them all with a tool, but look for chipped paint, bare metal, or rust around bolt heads. If you find a bolt, nut, or screw you think is loose, tighten it or report it to your supervisor.
4. Welds. Look for loose or chipped paint, rust, or gaps where parts are welded together. If you find a bad weld, report it to your supervisor.
5. Electric Wires and Connectors. Look for cracked, frayed, or broken insulation; bare wires; and loose or broken connectors. Tighten loose connectors. Report any damaged wires to your supervisor.
6. Hoses and Fluid Lines. Look for wear, damage, and leaks, and ensure clamps and fittings are tight. Wet spots indicate leaks, but a stain around a fitting or connector can also mean a leak. If a leak comes from a loose fitting or connector, tighten it. If something is broken or worn out, report it to your supervisor.

When you check for operating condition, look at the component to see if it is serviceable.

When cleaning grease buildup or rust, use a cleaning solvent. Then apply a thin coat of light oil to affected area.

OIL FILTERS

Oil filters shall be serviced/cleaned/changed, as applicable, when:

1. They are known to be contaminated or clogged.
2. Service is recommended by Army Oil Analysis Program (AOAP) laboratory analysis.
3. At prescribed hardtime intervals.

FLUID LEAKAGE**NOTE**

- Equipment operation is allowed with minor leakage (Class I or II). Consideration must be given to fluid capacity in the item/system being checked/inspected. When in doubt, notify your supervisor.
- Class III leaks should be reported immediately to your supervisor using DA Form 2404 (Equipment Inspection and Maintenance Worksheet).

It is necessary for you to know how fluid leakage affects the status of the AVLB. Following are types/classes of leakage you need to know to be able to determine the status of the AVLB. Learn these leakage definitions and remember - when in doubt, notify your supervisor.

When operating with Class I or II leaks, continue to check fluid levels as required in the PMCS.

1. CLASS I - Leakage of fluid (as indicated by wetness or discoloration) not great enough to form drops.
2. CLASS II - Leakage of fluid great enough to form drops but not enough to cause drops to drip from item being checked/inspected.
3. CLASS III - Leakage of fluid great enough to form drops that fall from item being checked/inspected.

END OF WORK PACKAGE

OPERATOR MAINTENANCE**PREVENTIVE MAINTENANCE CHECKS AND SERVICES (PMCS) INSTRUCTIONS**

INITIAL SETUP:**Materials/Parts**

Fluid, Hydraulic (FRH) (WP 0079, Table 1, Item 24)
Grease, Automotive and Artillery (GAA) (14 oz)
(WP 0079, Table 1, Item 28)
Solvent, Degreasing (WP 0079, Table 1, Item 58)

References

FM 3-11.4
FM 3-11.5
TM 5-5420-203-13
WP 0011
WP 0018

References (cont.)

WP 0022
WP 0039
WP 0049
WP 0050
WP 0051
WP 0052
WP 0056
WP 0063
WP 0074

Table 1. Preventive Maintenance Checks and Services (PMCS).

ITEM NO.	INTERVAL	ITEM TO BE CHECKED OR SERVICED	PROCEDURE	EQUIPMENT NOT READY/ AVAILABLE IF:
1	Before	Fire Extinguisher Handles (External)	 <p data-bbox="756 764 1081 810">SAFETY WIRE/ LEAD SEAL AVBD614</p> <p data-bbox="630 842 1146 905">Figure 1. External Fire Extinguisher Safety Wire/Lead Seals.</p> <p data-bbox="613 919 1146 1010">a. Ensure safety wire/lead seals on fire extinguisher external release handles are not missing or broken.</p>	Safety wire/leads seal broken or missing.
2	Before	Grenade Launcher Dischargers	If firing is anticipated, wipe all surfaces dry.	

Table 1. PMCS - Continued.

ITEM NO.	INTERVAL	ITEM TO BE CHECKED OR SERVICED	PROCEDURE	EQUIPMENT NOT READY/ AVAILABLE IF:
3	Before	Hydraulic Fluid Leaks (External)	<p style="text-align: center;">DEPRESSURIZATION MANIFOLD SCISSOR CYLINDER COUNTER BALANCE VALVE</p>  <p style="text-align: right;">ALVBD245</p> <p>Figure 2. Inspect for Hydraulic Fluid Leaks.</p> <p>a. Visually inspect for evidence of hydraulic fluid leaks in the following areas: overhead cylinder, tongue cylinder, locking cylinder, ejection cylinder, and hold-down cylinder cover.</p>	Any Class III leak.

Table 1. PMCS - Continued.

ITEM NO.	INTERVAL	ITEM TO BE CHECKED OR SERVICED	PROCEDURE	EQUIPMENT NOT READY/ AVAILABLE IF:
4	Before	Operator's Hatch	<p style="text-align: center;">WARNING</p>  <ul style="list-style-type: none"> • The cupola cover is heavy. Personnel may be injured if the cover is allowed to move freely during vehicle movement. Ensure that the cover is locked in the open or closed position during vehicle movement. Do not release the safety latch when the vehicle is moving. Failure to comply may result in personnel injury or death. • If the cupola cover is closed, personnel may hit their head on the cover while raising the seat. Raise the seat slowly when the cupola cover is closed. Failure to comply may result in personnel injury or death. <p>a. Check that hatch is not missing.</p>	

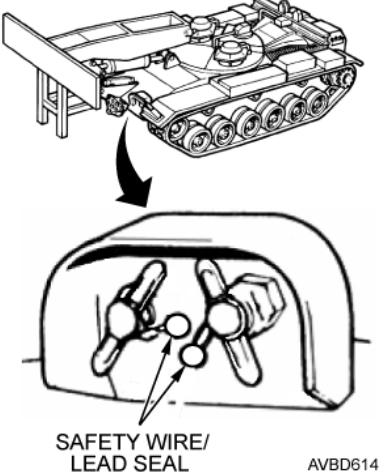
Table 1. PMCS - Continued.

ITEM NO.	INTERVAL	ITEM TO BE CHECKED OR SERVICED	PROCEDURE	EQUIPMENT NOT READY/ AVAILABLE IF:
			 <p data-bbox="813 961 1149 995">Figure 3. Operator's Hatch.</p> <ul style="list-style-type: none"> <li data-bbox="711 1010 1214 1066">b. Check that hatch locks are in open and closed positions. <li data-bbox="711 1087 1252 1144">c. Check that hatch moves smoothly between open and closed positions. 	<p data-bbox="1271 352 1497 443">Hatch is missing or will not lock in open or closed positions.</p>

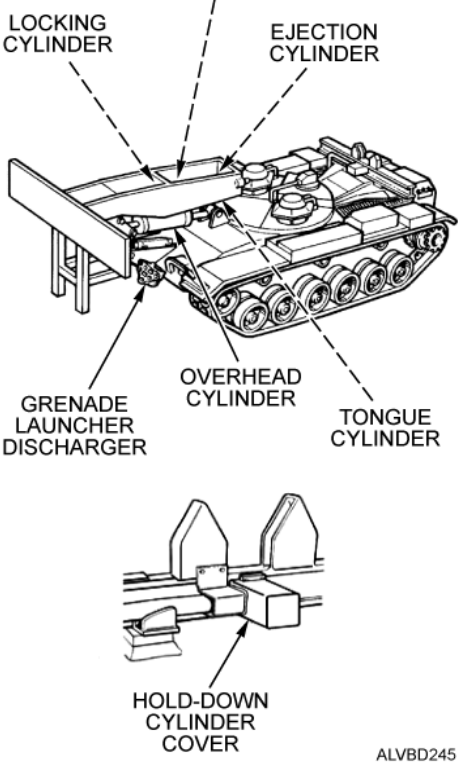
Table 1. PMCS - Continued.



ITEM NO.	INTERVAL	ITEM TO BE CHECKED OR SERVICED	PROCEDURE	EQUIPMENT NOT READY/ AVAILABLE IF:
5	Before	Driver's Escape Hatch	<p style="text-align: center;">WARNING</p> <div style="text-align: center;">  </div> <p>Escape hatch is heavy and may drop if control lever is moved. Do not move control lever clockwise or counterclockwise (open position). Failure to comply may result in personnel injury or death.</p> <div style="text-align: center;">  <p>ROUND ESCAPE HATCH</p>  <p>OVAL ESCAPE HATCH <small>AVLBD247</small></p> </div> <p>Figure 4. Driver's Escape Hatch.</p> <ol style="list-style-type: none"> a. Ensure that escape hatch is in place. b. Ensure two plunger bolts on round escape hatch or three plunger bolts on oval escape hatch extend over edge of hatch opening. 	<p>Escape hatch cover is not installed.</p> <p>Escape hatch lever will not lock.</p>

Table 1. PMCS - Continued.

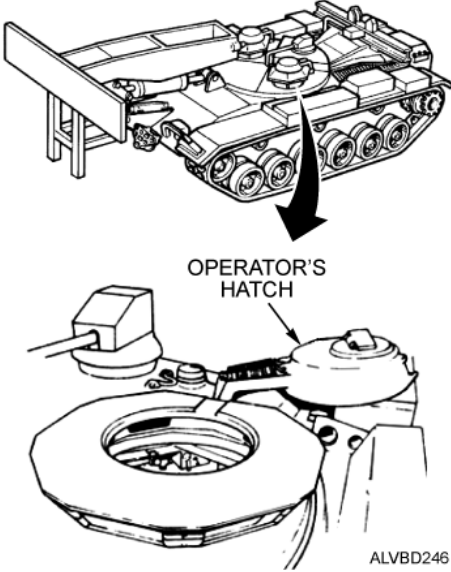
ITEM NO.	INTERVAL	ITEM TO BE CHECKED OR SERVICED	PROCEDURE	EQUIPMENT NOT READY/ AVAILABLE IF:
			<p>c. Ensure manual control lever on round escape hatch is in full closed (counterclockwise) position, or manual control lever on oval escape hatch is in full closed (clockwise) position.</p>	
6	Before	Fire Extinguisher System	<p>NOTE</p> <p>Location of M48A5 and M60A1 fire extinguishers are different. M60A1 fire extinguisher locations are shown.</p>  <p>Figure 5. Fire Extinguisher Handle Seal.</p> <p>a. Ensure internal fire extinguisher handle seal is not broken or missing.</p>  <p>Figure 6. Internal Fire Extinguisher Cylinders.</p> <p>b. Ensure three internal fire extinguisher cylinders (M60A1) and two fire extinguisher cylinders (M48A5) are installed.</p>	<p>Seal on handle broken or missing.</p> <p>Cylinder missing.</p>

Table 1. PMCS - Continued.

ITEM NO.	INTERVAL	ITEM TO BE CHECKED OR SERVICED	PROCEDURE	EQUIPMENT NOT READY/ AVAILABLE IF:
			 <p>Figure 7. Control Valve Lead Seal and Shrink Tubing.</p> <ul style="list-style-type: none"> c. Ensure lead seal on each of three internal fire extinguisher cylinder control valves and pins is not broken or missing. d. Ensure lead seal and shrink tubing on each of the two or three internal fire extinguisher cylinders are not broken or missing. 	<p>Seals on cylinder control valves broken or missing.</p> <p>Shrink tubing broken or missing.</p>
7	Before	Operator's Seat (Adjustment)	 <p>Figure 8. Seat Adjustment.</p> <ul style="list-style-type: none"> a. Adjust operator's seat up and down (height adjustment lever), forward and backward (seat control handle). b. Check that seat moves smoothly and locks in desired position. 	<p>Operator's seat is missing or broken (includes seat back).</p> <p>Operator's seat will not adjust.</p>

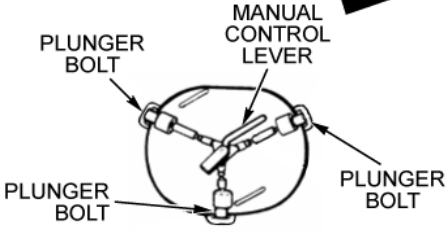
Table 1. PMCS - Continued.

ITEM NO.	INTERVAL	ITEM TO BE CHECKED OR SERVICED	PROCEDURE	EQUIPMENT NOT READY/ AVAILABLE IF:
8	Before	Hydraulic Brake System	<p style="text-align: center;">NOTE</p> <p>Do not allow brake pedal pressure to go over 900 psi (6205 kPa). Brake may become difficult to release.</p> <div style="text-align: center;">  <p style="text-align: center;">ALVBD251</p> </div> <p style="text-align: center;">Figure 9. Brake Pedal.</p> <p>a. Press brake pedal once until pressure gauge indicates 750 to 900 psi (5171 to 6205 kPa). Hold pedal in position for 30 seconds.</p>	750 psi (5171 kPa) cannot be obtained.

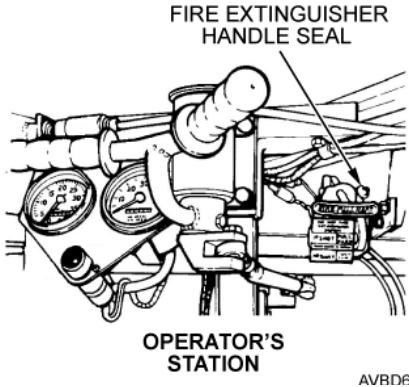
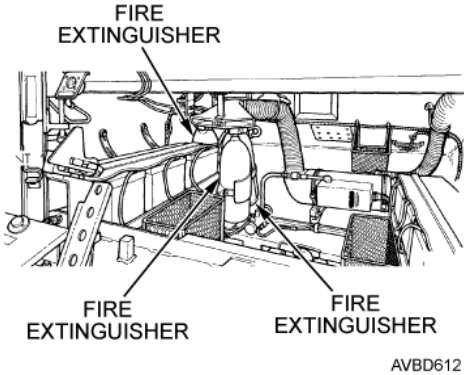
Table 1. PMCS - Continued.

ITEM NO.	INTERVAL	ITEM TO BE CHECKED OR SERVICED	PROCEDURE	EQUIPMENT NOT READY/ AVAILABLE IF:
			f. To release brake, press and hold brake pedal. Push transmission shift control lock forward to unlock position. Place transmission shift control in N (Neutral) position. Release brake pedal.	
9	Before	Linkages, Steering, Shifting, and Accelerator	<p data-bbox="743 533 862 583">STEERING CONTROL</p>  <p data-bbox="781 989 943 1039">ACCELERATOR PEDAL</p> <p data-bbox="1036 989 1214 1039">TRANSMISSION SHIFT CONTROL</p> <p data-bbox="1133 1045 1219 1066">ALVBD253</p> <p data-bbox="808 1100 1166 1129">Figure 12. Steering Control.</p> <ol data-bbox="711 1150 1219 1449" style="list-style-type: none"> Test steering linkage by moving steering control to left and right positions and releasing. Test transmission shift control linkage by shifting transmission control through all positions. Test accelerator linkage by depressing accelerator pedal and allowing pedal to return. 	<p data-bbox="1268 533 1490 625">Steering control does not return to center.</p> <p data-bbox="1268 638 1502 730">Transmission shift control binds or will not shift.</p> <p data-bbox="1268 743 1490 814">Accelerator pedal sticks or binds.</p>

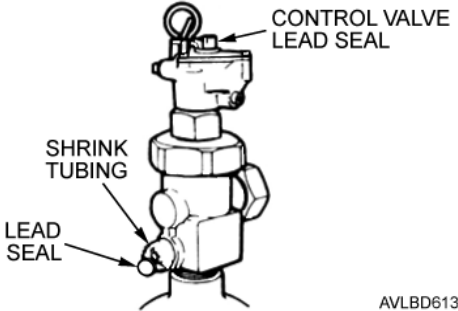
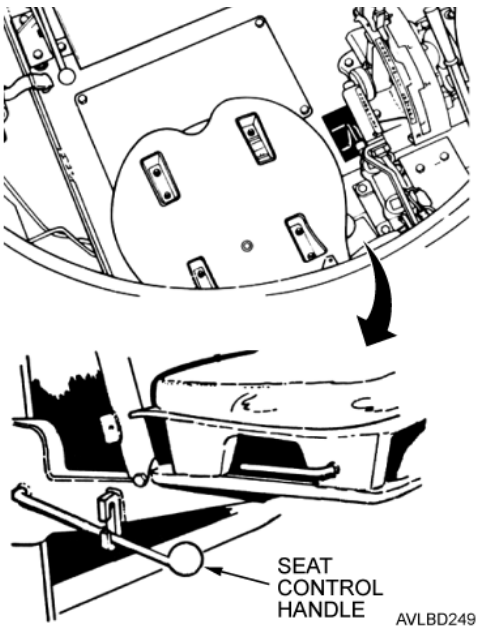
Table 1. PMCS - Continued.

ITEM NO.	INTERVAL	ITEM TO BE CHECKED OR SERVICED	PROCEDURE	EQUIPMENT NOT READY/ AVAILABLE IF:
10	Before	Gas Particulate System	<p style="text-align: center;">WARNING</p> <div style="text-align: center;">  </div> <p>If Nuclear-Biological-Chemical (NBC) exposure is suspected, NBC-contaminated air filters must be handled and disposed of only by authorized and trained personnel. The unit commander or senior officer in charge of maintenance personnel must ensure that prescribed protective clothing (FM 3-11.4) is used, and prescribed safety measures and decontamination procedures (FM 3-11.5) are followed. The local unit standard operating procedure (SOP) is responsible for final disposal of contaminated air filters. Failure to comply may result in personnel injury or death.</p> <div style="text-align: center;">  <p style="text-align: right;">AVLBD254</p> </div> <p style="text-align: center;">Figure 13. Gas Particulate Filter.</p> <p>a. At the initiation of combat operations where use of a blood agent (AC or CK) is expected or after a known blood agent attack, notify field maintenance that gas particulate filters must be replaced.</p>	

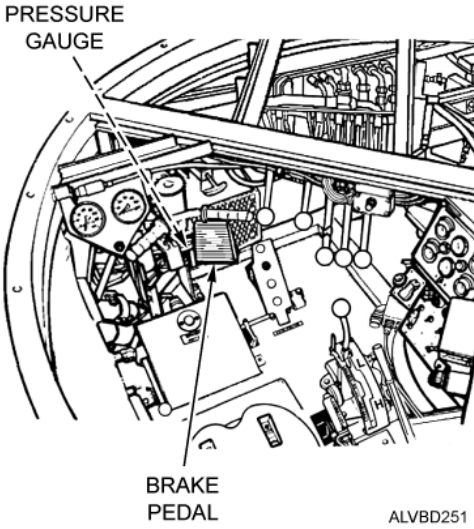
Table 1. PMCS - Continued.

ITEM NO.	INTERVAL	ITEM TO BE CHECKED OR SERVICED	PROCEDURE	EQUIPMENT NOT READY/ AVAILABLE IF:
11	Before	MASTER BATTERY Indicator Lamp and POWER PLANT WARNING Lamp (Engine Not Running)	 <p>Figure 14. Powerplant Warning Lamp.</p> <ol style="list-style-type: none"> Set MASTER BATTERY switch to ON. Check that both MASTER BATTERY lamp and POWER PLANT WARNING lamp light. 	MASTER BATTERY lamp or POWER PLANT WARNING lamp do not light.

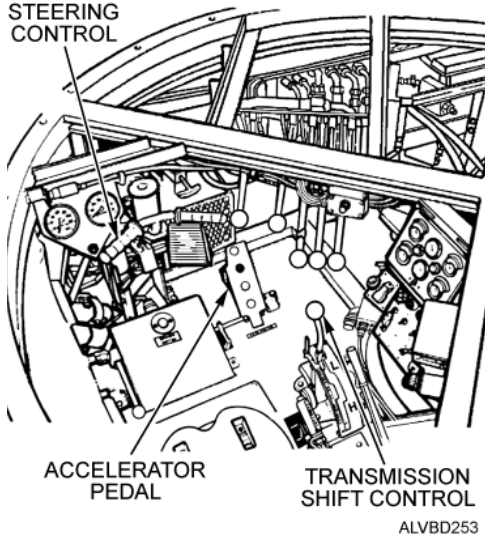
Table 1. PMCS - Continued.

ITEM NO.	INTERVAL	ITEM TO BE CHECKED OR SERVICED	PROCEDURE	EQUIPMENT NOT READY/ AVAILABLE IF:
12	Before	Air Cleaner Housings and Doors (Right and Left Sides)	 <p data-bbox="743 957 1024 989">Figure 15. Air Cleaner.</p> <ol data-bbox="610 1003 1170 1493" style="list-style-type: none"> Check air cleaner door for cracked, damaged, or missing mounting hardware. Check for broken or missing door locking screws. Inspect housing for cracks and dents that would allow dirt to enter. Check baseplate for cracks. Check door and housing hinges for bent, broken, cracked, or missing parts. Check blower motor access plate for cracks and loose or missing mounting bolts. Check that drain plug or inspection plugs are not loose or missing. 	<p data-bbox="1170 331 1403 485">Air cleaner door, locking screws, or mounting hardware is damaged or missing.</p> <p data-bbox="1170 499 1403 562">Housing is cracked or dented.</p> <p data-bbox="1170 577 1403 640">Door hinges are broken or bent.</p> <p data-bbox="1170 655 1403 751">Blower motor access plate missing.</p> <p data-bbox="1170 766 1403 829">Drain or inspection plugs missing.</p>

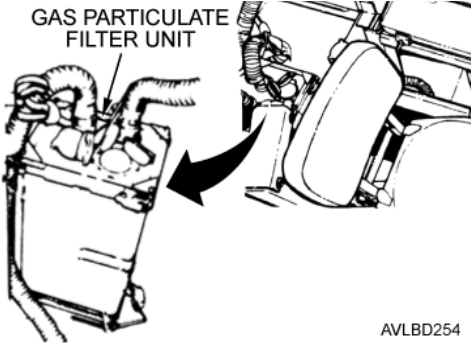
Table 1. PMCS - Continued.

ITEM NO.	INTERVAL	ITEM TO BE CHECKED OR SERVICED	PROCEDURE	EQUIPMENT NOT READY/ AVAILABLE IF:
13	Before	Engine Idle Speed and Accelerator Control (Engine Running)	<p style="text-align: center;">NOTE</p> <p>Engine speed should not surge when accelerator pedal is held steady.</p> <div style="text-align: center;">  </div> <p style="text-align: center;">Figure 16. Accelerator Pedal.</p> <ol style="list-style-type: none"> a. Push down on accelerator lock. Leave transmission shift control in P (Park) position. b. Start engine and check idle speed. Tachometer must indicate 700 to 750 RPM. c. Step on brake pedal once until pressure gauge reads 750 to 900 psi (5171 to 6205 kPa). d. Accelerate engine until tachometer reads 1,600 RPM. Release accelerator pedal. e. Check that accelerator pedal returns freely to idle position and tachometer reads from 700 to 750 RPM. 	<p>Tachometer is inoperative or missing.</p> <p>750 psi (5171 kPa) cannot be obtained.</p> <p>Binding prevents pedal from returning to idle position. Engine surges.</p>

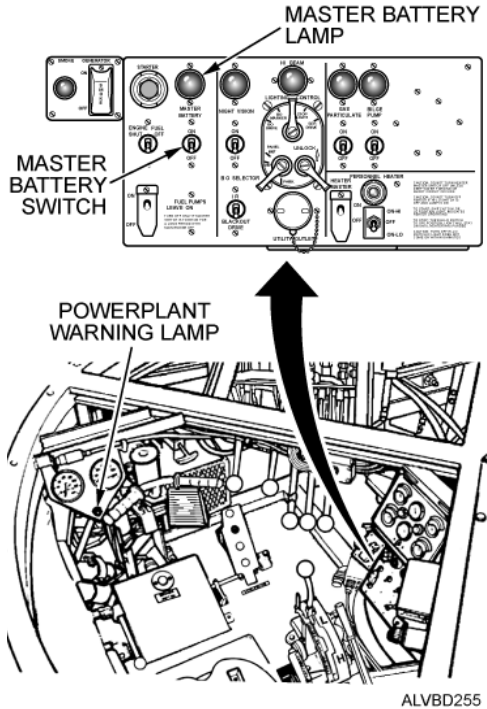
Table 1. PMCS - Continued.

ITEM NO.	INTERVAL	ITEM TO BE CHECKED OR SERVICED	PROCEDURE	EQUIPMENT NOT READY/ AVAILABLE IF:
14	Before	POWER PLANT WARNING LAMP (Engine Running)	 <p data-bbox="651 1178 1117 1209">Figure 17. Powerplant Warning Lamp.</p> <ol data-bbox="613 1224 1166 1541" style="list-style-type: none"> Check lamp frequently to ensure it is not lit. If lamp is lit, immediately check operator's indicator panel ENGINE PRESS, ENGINE TEMP F, TRANSMISSION PRESS, and TRANSMISSION TEMP F gauges for abnormal readings. Check that DUST DETECTOR WARNING LAMP is out. Press lens cap in to check lamp. If lamp does not light, replace lamp. If lamp lights, refer to WP 0039. 	

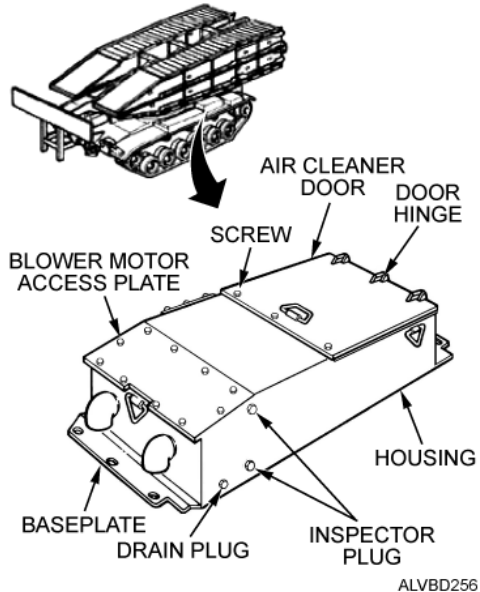
Table 1. PMCS - Continued.

ITEM NO.	INTERVAL	ITEM TO BE CHECKED OR SERVICED	PROCEDURE	EQUIPMENT NOT READY/ AVAILABLE IF:
15	Before	Restriction Indicator (Right and Left Sides)	 <p>Figure 18. Air Restrictor Indicator.</p> <ol style="list-style-type: none"> a. If tactical situations permit, check the following during stops and halts: <ol style="list-style-type: none"> 1. Check that restriction indicator, pipe plug, or indicator guard is not damaged or missing. 2. Indicator windows that read clear, red, or green. Check indicator window. If indicator window shows red, press indicator reset button, and accelerate engine to 2,400 RPM. 3. Check indicator window. 4. Indicator windows that measure restriction in degrees. Check indicator reading. If indicator registers above 30 inches, press indicator reset button and accelerate engine to 2,400 RPM. 5. Check indicator reading. 	<p>Both restriction indicator and pipe plug are missing.</p> <p>Restriction indicator remains red after reset.</p> <p>Indicator reading is 30 inches or more.</p>

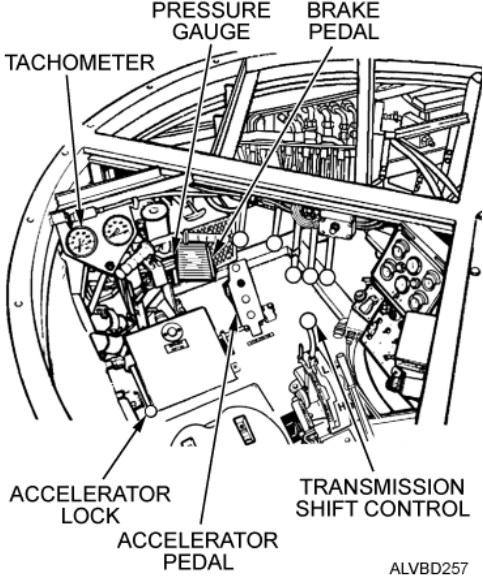
Table 1. PMCS - Continued.

ITEM NO.	INTERVAL	ITEM TO BE CHECKED OR SERVICED	PROCEDURE	EQUIPMENT NOT READY/ AVAILABLE IF:
16	Before	Commander's Hatch	<p style="text-align: center;">WARNING</p>  <ul style="list-style-type: none"> • The cupola cover is heavy. Personnel may be injured if the cover is allowed to move freely during vehicle movement. Ensure that the cover is locked in the open or closed position during vehicle movement. Do not release the safety latch when the vehicle is moving. Failure to comply may result in personnel injury or death. • If the cupola cover is closed, personnel may hit their head on the cover while raising the seat. Raise the seat slowly when the cupola cover is closed. Failure to comply may result in personnel injury or death. <p style="text-align: center;">COMMANDER'S HATCH</p>  <p style="text-align: center;">Figure 19. Commander's Hatch.</p> <ol style="list-style-type: none"> a. Check that hatch is not missing. b. Check that hatch locks in open and closed position. c. Check that hatch moves smoothly between open and closed positions. 	Hatch is missing or will not lock in open or closed positions.

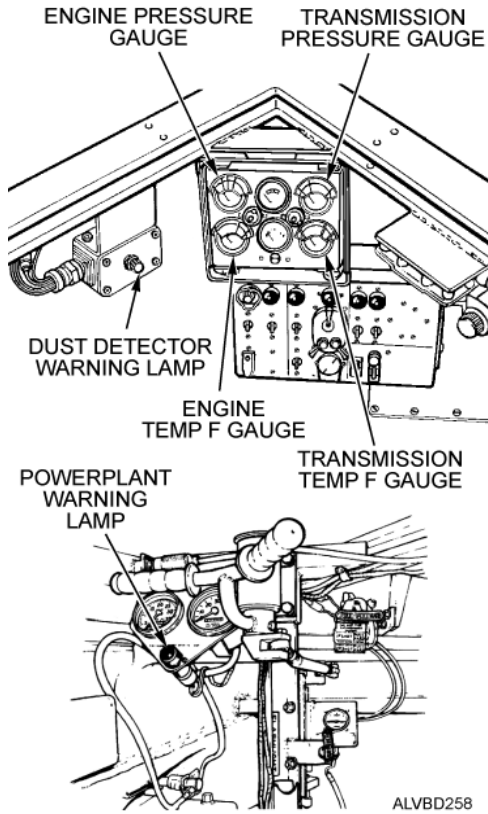
Table 1. PMCS - Continued.

ITEM NO.	INTERVAL	ITEM TO BE CHECKED OR SERVICED	PROCEDURE	EQUIPMENT NOT READY/ AVAILABLE IF:
17	Before	Commander's Seat Adjustment	 <p>Figure 20. Commander's Seat.</p> <ol style="list-style-type: none"> Inspect commander's seat for damage. Adjust commander's seat up and down (height adjustment lever), forward and backward (seat control handle). Check that seat moves smoothly and locks in desired position. 	<p>Commander's seat is missing or broken (includes seat back).</p> <p>Commander's seat will not adjust.</p>
18	Before	Operator's Indicator Panel (Engine Running)	 <p>Figure 21. Operator Panel Gauges.</p> <ol style="list-style-type: none"> Check that BATT GEN indicator reads in green band. Check that ENGINE PRESS gauge reads in green band 15 psi (103 kPa) at idle. Check that ENGINE TEMP F gauge reads in green band (between 180°F (82°C) and 225°F (107°C) when engine is warm). Check that TRANSMISSION PRESS gauge reads in green band, 2 psi (14 kPa) at idle (700 to 750 RPM) or 8 to 40 psi (55 to 276 kPa) when accelerating. 	<p>BATT GEN indicator reads in red band. ENGINE PRESS gauge reads in red band (below 15 psi (103 kPa) or above 70 psi (483 kPa)).</p> <p>ENG TEMP F gauge reads in red band or above 225°F (107°C).</p> <p>TRANSMISSION PRESS gauge reads in red band (below 2 psi (14kPa)).</p> <p>TRANSMISSION TEMP F reads in red band or above 280°F (138°C).</p> <p>DUST DETECTOR WARNING LAMP is on, inoperative, or missing.</p>

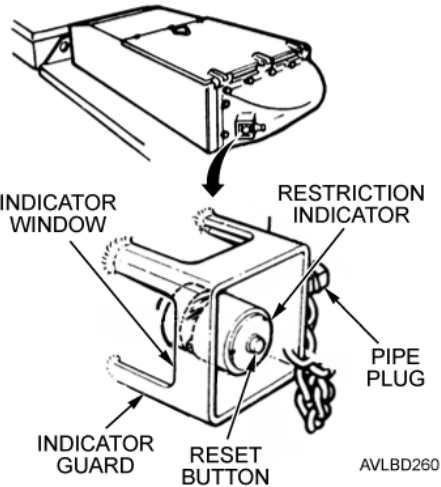
Table 1. PMCS - Continued.

ITEM NO.	INTERVAL	ITEM TO BE CHECKED OR SERVICED	PROCEDURE	EQUIPMENT NOT READY/ AVAILABLE IF:
			d. Check that TRANSMISSION TEMP F reads in green band (between 200°F (93°C) and 280°F (138°C) when engine is warm). e. Check that DUST DETECTOR WARNING LAMP is out.	Any gauge missing or inoperative.
19	Before	Intercom Set C-2298 (Operator and Commander)	 <p style="text-align: center;">Figure 22. Monitor Switch.</p> a. Turn amplifier AM 1780/VRC ON. b. Talk to commander: Move MONITOR switch to INT ONLY and adjust VOLUME control to desired level. c. Check intercom operation. d. Check radio set operation. Refer to WP 0022.	Operator cannot talk with commander. Radio will not transmit or receive.
20	Before	Darkness Check	<p style="text-align: center;">CAUTION</p> <p style="text-align: center;">Perform AN/VVS-2 night vision check during darkness only. Damage to equipment may occur if objective lens on night vision viewer is exposed to direct sunlight or bright light.</p> a. If operating at night, install and operate night vision viewer. Refer to WP 0011.	Night vision viewer is inoperative.

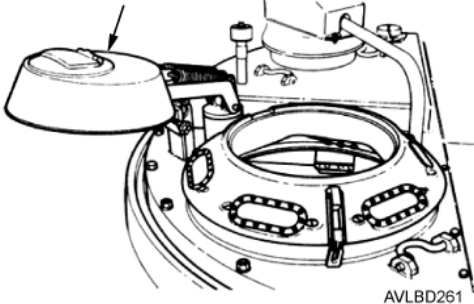
Table 1. PMCS - Continued.

ITEM NO.	INTERVAL	ITEM TO BE CHECKED OR SERVICED	PROCEDURE	EQUIPMENT NOT READY/ AVAILABLE IF:
21	Before	Personnel Heater	<p style="text-align: center;">WARNING</p> <div style="text-align: center;">  </div> <p>Leaking fuel could cause a fire. If fuel leak or exhaust leak is present, do not operate personnel heater until repairs are made. Failure to comply may result in personnel injury or death.</p> <p style="text-align: center;">NOTE</p> <p>The M48A5 and M60A2 AVLB personnel heater locations are different. The M60A2 AVLB personnel heater is shown.</p> <div style="text-align: center;">  <p style="text-align: right; font-size: small;">ALVBD265</p> </div> <p>Figure 23. M60A2 AVLB Personnel Heater.</p> <ol style="list-style-type: none"> a. Check for fuel leaks in area of quick disconnect at personnel heater, fittings, and fuel pump. b. Check for exhaust fumes in area of personnel heater exhaust pipe at hull feed-through pipe coupling. 	<p>Any fuel leak is present.</p> <p>Any exhaust leak is present.</p>
22	During	Steering Control	<ol style="list-style-type: none"> a. Ensure steering control returns to center position and vehicle does not wander to right or left. 	<p>Vehicle wanders or steering control does not center during operation.</p>

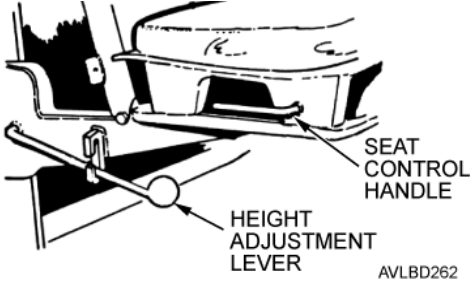
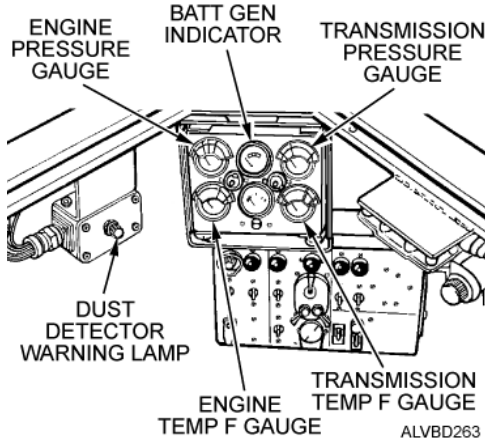
Table 1. PMCS - Continued.

ITEM NO.	INTERVAL	ITEM TO BE CHECKED OR SERVICED	PROCEDURE	EQUIPMENT NOT READY/ AVAILABLE IF:
23	During	Transmission Shift Control	a. When driving, check for proper response when shifting transmission shift control through entire shift pattern. b. Check for binding of transmission shift control or failure of transmission to shift.	Binding of transmission shift control or failure to shift.
24	During	Hydraulic Brake System	 <p style="text-align: center;">STEERING CONTROL BRAKE PEDAL TRANSMISSION SHIFT CONTROL</p> <p style="text-align: right; font-size: small;">ALVBD266</p> <p style="text-align: center;">Figure 24. Operator's Controls.</p> a. Ensure that vehicle stops smoothly and does not pull to one side when brake pedal is pressed.	Vehicle does not stop or pulls to one side.
25	During	Air Induction System	a. Check that exhaust smoke is not excessively black. b. Check for noticeable loss of engine power.	Excessive black smoke or noticeable loss of power.
26	During	Hydraulic Pump Clutch – Non-Hydraulic Electrical Upgrade (Non-HEU) and Universal Joints	 <p style="text-align: center;">HYDRAULIC PUMP CLUTCH LEVER OR HYDRAULIC PUMP BALL VALVE (HEU)</p> <p style="text-align: right; font-size: small;">ALVBD267</p> <p style="text-align: center;">Figure 25. Hydraulic Pump Ball Valve (HEU).</p> a. Check that hydraulic pump clutch engages. If lever is jammed, remove obstruction.	Hydraulic pump clutch fails to engage. Hydraulic pump fails to produce pressure.

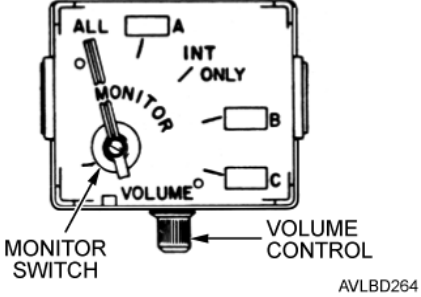
Table 1. PMCS - Continued.

ITEM NO.	INTERVAL	ITEM TO BE CHECKED OR SERVICED	PROCEDURE	EQUIPMENT NOT READY/ AVAILABLE IF:
			b. Check clutch for chatter and odor of overheated oil. c. Check universal joints for any unusual noise or vibration. d. Check that hydraulic pump engages when ball valve is turned.	
27	During	Reservoir Filter – Non-Hydraulic Electrical Upgrade (Non-HEU) (Clutch Engaged) Reservoir Filter – Hydraulic Electrical Upgrade (HEU) (Hydraulics Engaged)	a. Ensure transmission shift control is locked in P (Park) position and brake is set. Set engine speed (throttle) at 1,800 RPM. a. Check that indicators on side of filter manifold are not popped out. If popped out, push indicator in once. If indicator pops out, notify unit maintenance. b. Visually check that filter indicator indicates FILTER IS CLEAN. If not, notify field maintenance.	Filter indicator does not indicate FILTER IS CLEAN.

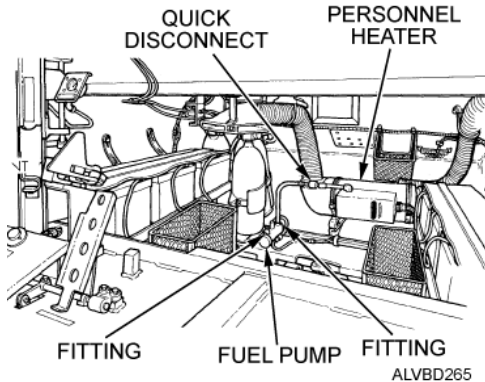
Table 1. PMCS - Continued.

ITEM NO.	INTERVAL	ITEM TO BE CHECKED OR SERVICED	PROCEDURE	EQUIPMENT NOT READY/ AVAILABLE IF:
28	During	Interior Hydraulic System	 <p>The diagram illustrates the interior hydraulic system. At the top left, there is a schematic of hydraulic lines and components. To its right is a rectangular panel with a circular gauge, labeled 'FILTER INDICATOR'. Below these is a detailed view of the 'COMMANDER'S STATION' showing the seat and associated hydraulic controls. An arrow points from the commander's station towards the filter indicator. The text 'AVLBD268' is located at the bottom right of the diagram area.</p>	Any Class III fluid leak is found.

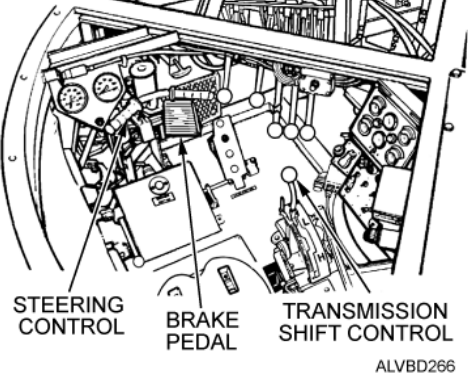
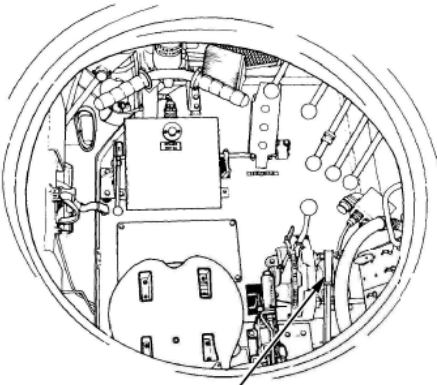
Figure 26. Interior Hydraulic System.
 a. Visually check interior of vehicle for hydraulic fluid leaks.

Table 1. PMCS - Continued.

ITEM NO.	INTERVAL	ITEM TO BE CHECKED OR SERVICED	PROCEDURE	EQUIPMENT NOT READY/ AVAILABLE IF:
29	During	Launcher Control Valve Bank	<p style="text-align: center;">VALVE BANK</p>  <p style="text-align: center;">LAUNCHER CONTROLS</p> <p style="text-align: center;">OPERATOR'S STATION ALVBD269</p> <p style="text-align: center;">Figure 27. Launcher Controls.</p> <ol style="list-style-type: none"> a. Check for hydraulic fluid leaks in area of valve bank. b. Check for proper response of launcher controls during launch or retrieve operations. 	<p>Any Class III fluid leak is found.</p> <p>Fails to complete launch or retrieve operation.</p>

Table 1. PMCS - Continued.

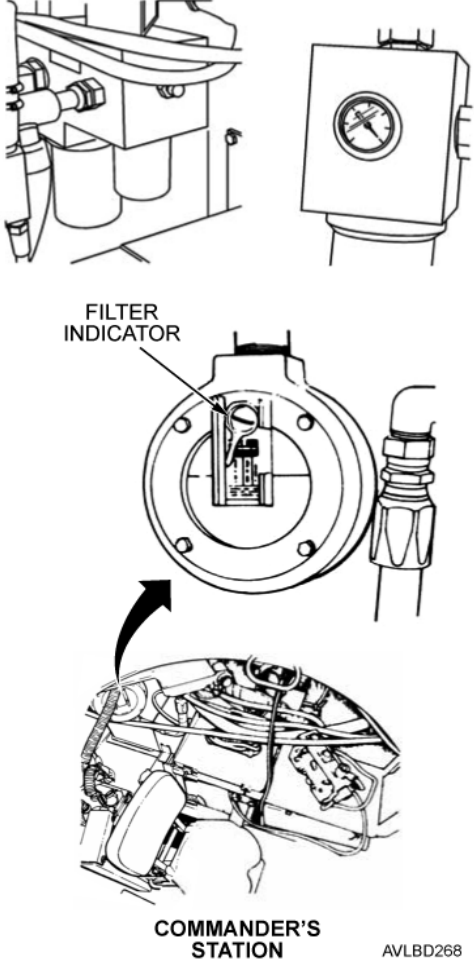

ITEM NO.	INTERVAL	ITEM TO BE CHECKED OR SERVICED	PROCEDURE	EQUIPMENT NOT READY/ AVAILABLE IF:
30	During	Hold-Down Cylinder	<p style="text-align: center;">WARNING</p> <div style="display: flex; justify-content: center; gap: 10px;">    </div> <p>FRH fluid may cause irritation to the eyes and skin. Avoid contact with eyes, skin, and clothing. Wear protective goggles, gloves, and clothing. If FRH comes in contact with eyes or skin, flush area with water. Failure to comply may result in personnel injury or illness.</p> <div style="text-align: center;">  <p>ALVBD270</p> </div> <p>Figure 28. Hold-Down Cylinder.</p> <p>a. Immediately after exercising hydraulic system, wipe residue from cylinder seal area using a clean cloth, and then check for fluid leaks in these areas.</p>	Any Class III fluid leak.

Table 1. PMCS - Continued.

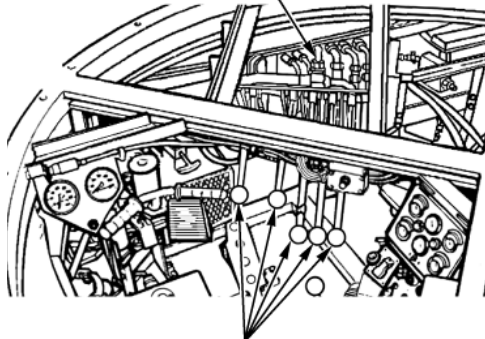

ITEM NO.	INTERVAL	ITEM TO BE CHECKED OR SERVICED	PROCEDURE	EQUIPMENT NOT READY/ AVAILABLE IF:
31	During	Overhead Cylinder	<p style="text-align: center;">WARNING</p> <div style="display: flex; justify-content: center; gap: 10px;">    </div> <p>FRH fluid may cause irritation to the eyes and skin. Avoid contact with eyes, skin, and clothing. Wear protective goggles, gloves, and clothing. If FRH comes in contact with eyes or skin, flush area with water. Failure to comply may result in personnel injury or illness.</p> <div style="text-align: center;">  <p style="text-align: right; margin-right: 50px;">ALVBD270</p> </div> <p>Figure 29. Overhead Cylinder.</p> <p>a. Immediately after exercising hydraulic system, wipe residue from cylinder seal area using a clean cloth, and then check for fluid leaks in these areas.</p>	Any Class III fluid leak.

Table 1. PMCS - Continued.

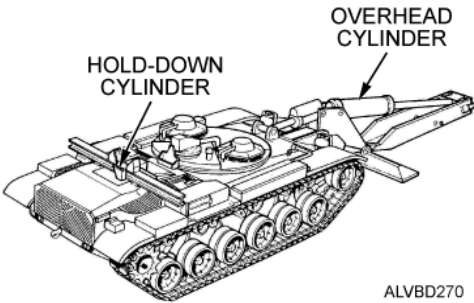

ITEM NO.	INTERVAL	ITEM TO BE CHECKED OR SERVICED	PROCEDURE	EQUIPMENT NOT READY/ AVAILABLE IF:
			<p style="text-align: center;">WARNING</p> <div style="text-align: center;">  </div> <p>Actuating ejection cylinders with the bridge improperly positioned could result in failure of the bridge. Ensure bridge is properly positioned before attempting to launch. Failure to comply may result in personnel injury, death, or equipment damage.</p> <div style="text-align: center;">  </div> <p>FRH fluid may cause irritation to the eyes and skin. Avoid contact with eyes, skin, and clothing. Wear protective goggles, gloves, and clothing. If FRH comes in contact with eyes or skin, flush area with water. Failure to comply may result in personnel injury or illness.</p>	

Table 1. PMCS - Continued.

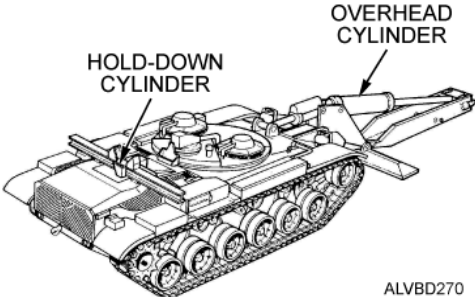
ITEM NO.	INTERVAL	ITEM TO BE CHECKED OR SERVICED	PROCEDURE	EQUIPMENT NOT READY/ AVAILABLE IF:
32	During	Ejection Cylinder	 <p data-bbox="800 1094 1159 1125">Figure 30. Ejection Cylinders.</p> <ol data-bbox="711 1142 1260 1413" style="list-style-type: none"> Immediately after exercising hydraulic system, wipe residue from cylinder seal area using a clean cloth, and then check for fluid leaks in these areas. Visually check that ejection pins extend and retract. Visually check ejection cylinder housing for movement indicating loose housing mount. 	Any Class III fluid leak.
33	During	Tongue Quick Disconnect Dust Caps	<ol data-bbox="711 1423 1203 1478" style="list-style-type: none"> Visually check for damaged or missing quick disconnect dust caps. 	

Table 1. PMCS - Continued.



ITEM NO.	INTERVAL	ITEM TO BE CHECKED OR SERVICED	PROCEDURE	EQUIPMENT NOT READY/ AVAILABLE IF:
34	During	Tongue Cylinder	<p style="text-align: center;">WARNING</p> <div style="display: flex; justify-content: center; gap: 10px;">    </div> <p>FRH fluid may cause irritation to the eyes and skin. Avoid contact with eyes, skin, and clothing. Wear protective goggles, gloves, and clothing. If FRH comes in contact with eyes or skin, flush area with water. Failure to comply may result in personnel injury or illness.</p> <div style="text-align: center;">  </div> <p style="text-align: center;">Figure 31. Tongue Cylinder.</p> <ol style="list-style-type: none"> a. Immediately after exercising hydraulic system, wipe residue from cylinder seal area using a clean cloth, and then check for fluid leaks in these areas. b. Check for proper operation. 	Any Class III fluid leak.

Table 1. PMCS - Continued.

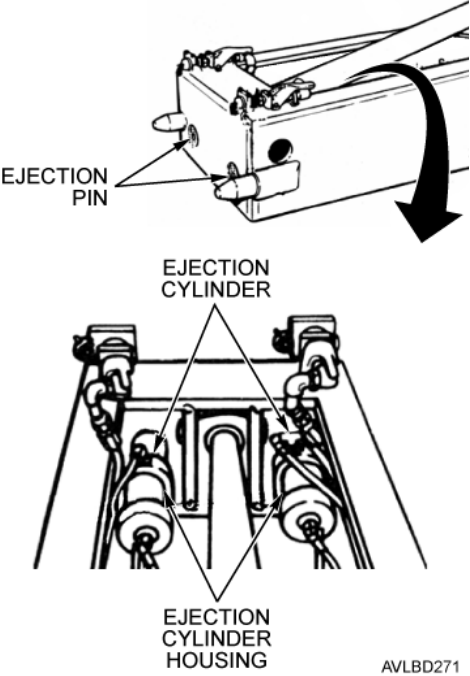

ITEM NO.	INTERVAL	ITEM TO BE CHECKED OR SERVICED	PROCEDURE	EQUIPMENT NOT READY/ AVAILABLE IF:
35	During	Locking Cylinder and Plugs	<p style="text-align: center;">WARNING</p> <div style="display: flex; justify-content: center; gap: 10px;">    </div> <p>FRH fluid may cause irritation to the eyes and skin. Avoid contact with eyes, skin, and clothing. Wear protective goggles, gloves, and clothing. If FRH comes in contact with eyes or skin, flush area with water. Failure to comply may result in personnel injury or illness.</p> <div style="text-align: center;">  <p>Figure 32. Locking Plug.</p> </div> <ol style="list-style-type: none"> a. Immediately after exercising hydraulic system, wipe residue from cylinder seal area using a clean cloth, and then check for fluid leaks in these areas. b. Visually check that locking plugs extend and retract. 	<p>Any Class III fluid leak.</p> <p>Locking plugs will not extend or retract.</p>

Table 1. PMCS - Continued.

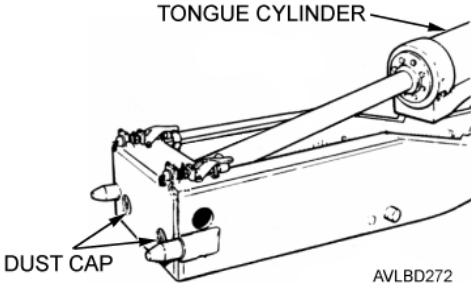
ITEM NO.	INTERVAL	ITEM TO BE CHECKED OR SERVICED	PROCEDURE	EQUIPMENT NOT READY/ AVAILABLE IF:
36	After	Reservoir Air Breather Non-Hydraulic Electrical Upgrade (HEU)	<p style="text-align: center;">NOTE</p> <p>After operations, PMCS tasks are easier to perform with bridge standing in "A" position.</p>  <p style="text-align: center;">Figure 33. Reservoir Air Breather.</p> <ol style="list-style-type: none"> a. Launch bridge to standing "A" position. Refer to WP 0018. b. Check that reservoir air breather is not damaged or missing. c. Check desiccant strip on side of filter. If desiccant strip shows excessive moisture, notify field maintenance. 	

Table 1. PMCS - Continued.



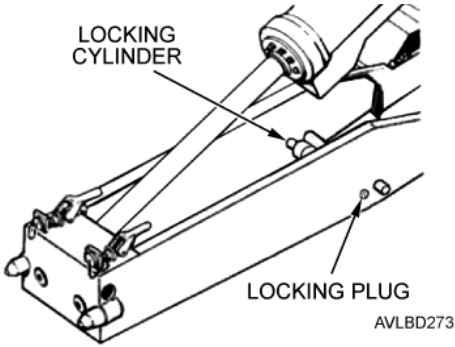

ITEM NO.	INTERVAL	ITEM TO BE CHECKED OR SERVICED	PROCEDURE	EQUIPMENT NOT READY/ AVAILABLE IF:
			<p style="text-align: center;">WARNING</p> <div style="display: flex; justify-content: space-around;">     </div>  <ul style="list-style-type: none"> • FRH fluid may cause irritation to the eyes and skin. Avoid contact with eyes, skin, and clothing. Wear protective goggles, gloves, and clothing. If FRH comes in contact with eyes or skin, flush area with water. Failure to comply may result in personnel injury or illness. • Degreasing solvent (MIL-PRF-680) is flammable and may cause irritation to the eyes or skin. Use in well ventilated areas and keep away from heat and open flame. Wear protective goggles and clothing. If solvent comes in contact with eyes, flush immediately with water. If solvent comes in contact with skin, wash with soap and water. Failure to comply may result in personnel injury, illness, or death. 	

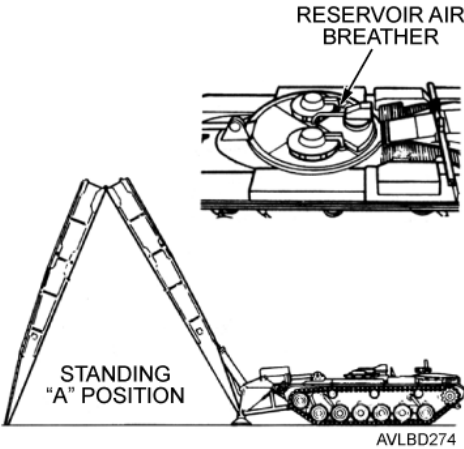
Table 1. PMCS - Continued.

ITEM NO.	INTERVAL	ITEM TO BE CHECKED OR SERVICED	PROCEDURE	EQUIPMENT NOT READY/ AVAILABLE IF:
37	After	Hydraulic Reservoir Fluid and Fluid Strainer	 <p data-bbox="695 940 1117 972">Figure 34. Filler Cap Removal.</p> <ol data-bbox="612 989 1170 1423" style="list-style-type: none"> Unscrew reservoir filler cap. Remove dipstick and fluid strainer from reservoir filler neck. Check for and remove any dirt and debris from fluid strainer. If required, clean fluid strainer in degreasing solvent and dry by shaking. Apply FRH oil to fluid strainer. DO NOT use OE/HDO. Install fluid strainer. Wipe dipstick and insert into filler neck. Remove dipstick and check that fluid level is at or slightly above FULL mark. If fluid is below FULL mark, add fluid as required. Refer to WP 0074. 	
38	After	Engine and Transmission Oil Level (Engine Running)	<ol data-bbox="612 1430 1170 1583" style="list-style-type: none"> Check engine and transmission oil levels. Refer to WP 0074. 	

Table 1. PMCS - Continued.

ITEM NO.	INTERVAL	ITEM TO BE CHECKED OR SERVICED	PROCEDURE	EQUIPMENT NOT READY/ AVAILABLE IF:
39	After	Top Deck Grille Doors (Left and Right)	 <p style="text-align: right; margin-right: 50px;">AVLBD278</p> <p style="text-align: center;">Figure 35. Top Deck Grille Doors.</p> <ol style="list-style-type: none"> a. Check that all doors are present. b. Lift open grille doors starting at rear. c. Look for missing engine heat shroud hardware on grille doors and hinges. 	<p>Any top grille door missing.</p> <p>Engine heat shroud missing.</p>
40	After	Mine-Clearing Line Charge (MICLIC) Support Bracket (If Equipped)	 <p style="text-align: right; margin-right: 50px;">AVLBD279</p> <p style="text-align: center;">Figure 36. MICLIC Support Bracket.</p> <ol style="list-style-type: none"> a. Check that MICLIC support bracket is not damaged. b. Check that MICLIC mounting brackets are not damaged, and mounting screws and nuts are not loose or missing. 	

Table 1. PMCS - Continued.

ITEM NO.	INTERVAL	ITEM TO BE CHECKED OR SERVICED	PROCEDURE	EQUIPMENT NOT READY/ AVAILABLE IF:
41	After	Air Cleaner Elbows, Hoses, and Clamps (Right and Left Sides)	 <p data-bbox="703 999 1068 1031">Figure 37. Air Cleaner Hoses.</p> <ol data-bbox="613 1045 1154 1346" style="list-style-type: none"> Check that air cleaner intake hoses and outlet hoses are not cracked, damaged, or missing. Check that intake hose elbows and outlet hose elbows are not loose, damaged, or missing. Check that intake and outlet hose clamps (two on each hose) are not loose, broken, or missing. 	Intake or outlet hose is damaged or missing. Elbows are loose, damaged, or missing.

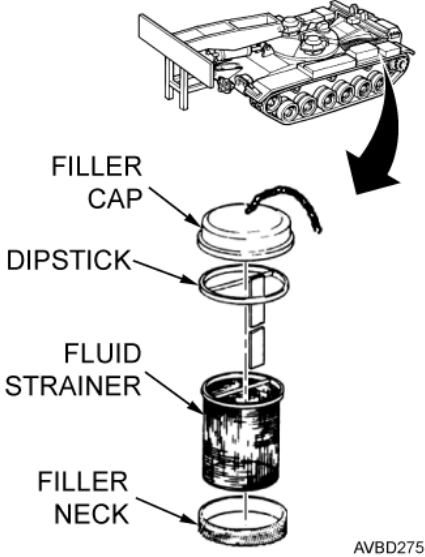
Table 1. PMCS - Continued.

ITEM NO.	INTERVAL	ITEM TO BE CHECKED OR SERVICED	PROCEDURE	EQUIPMENT NOT READY/ AVAILABLE IF:
42	After	Dust Detector Pressure Switch (Right and Left Sides) (If Equipped)	 <p>The diagram shows a close-up of the dust detector pressure switch assembly with labels: HOSE, FITTING, WIRING HARNESS, DUST DETECTOR PRESSURE SWITCH, and FITTING. Below this is a view of the engine with arrows pointing to the locations of the switches on both sides. The reference code AVLBD281 is shown at the bottom right of the diagram.</p> <p>Figure 38. Dust Detector Pressure Switch.</p> <ol style="list-style-type: none"> Check dust detector pressure switch for security of mounting. Check dust detector pressure switch to ensure switch has not been tripped (red plunger is visible through plastic cover). Check that wiring harness is connected. Check that hoses are not damaged or missing. Check that fittings are secure. 	Dust detector switch is tripped.

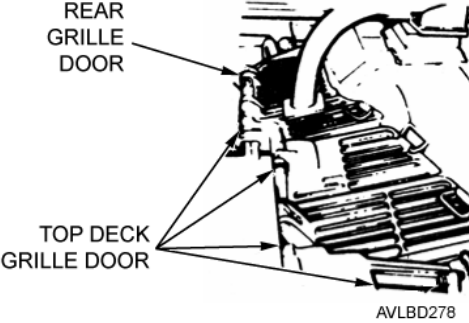
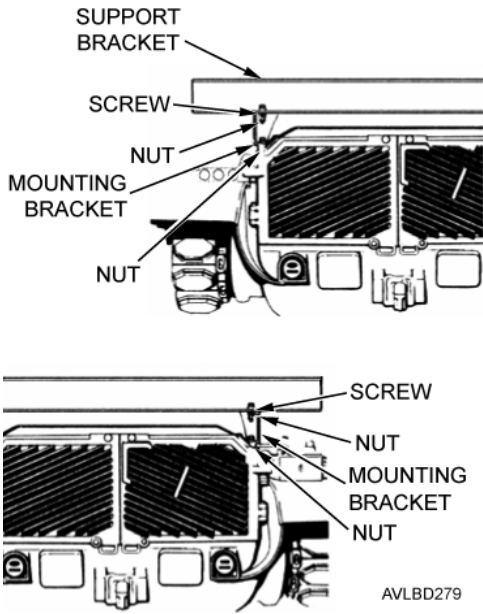
Table 1. PMCS - Continued.

ITEM NO.	INTERVAL	ITEM TO BE CHECKED OR SERVICED	PROCEDURE	EQUIPMENT NOT READY/ AVAILABLE IF:
43	After	Engine Oil and Transmission Oil Coolers (Right and Left Sides)	<div style="text-align: center;">  <p>Figure 39. Engine and Transmission Oil Coolers.</p> <ol style="list-style-type: none"> a. Check screens on engine oil and transmission oil coolers for debris. b. Check coolers for damage and check for leaks. </div>	Damage to oil coolers or oil lines that restrict oil flow. Class III oil leak is found in oil coolers or lines.
44	After	Hydraulic Hoses and Connections (Engine Compartment)	<div style="text-align: center;"> <p>NOTE</p> <p>Check items 44 to 56 during stops and halts other than tactical operations.</p>  <p>Figure 40. Hydraulic Fittings and Hoses.</p> <ol style="list-style-type: none"> a. Check hydraulic hoses and connections in right side of engine compartment for fluid leaks. </div>	Any class fluid leak.

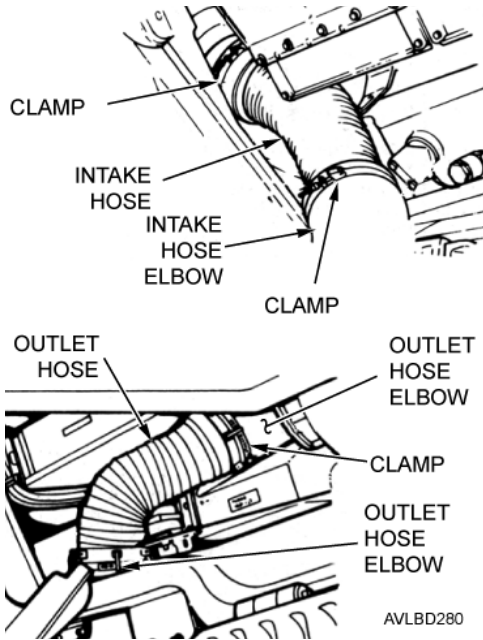
Table 1. PMCS - Continued.

ITEM NO.	INTERVAL	ITEM TO BE CHECKED OR SERVICED	PROCEDURE	EQUIPMENT NOT READY/ AVAILABLE IF:
45	After	Rear Grille Doors	a. Ensure grille doors are secure. b. Check for loose or missing hardware. c. Be sure doors are not damaged or missing.	Rear grille door is missing or cannot be secured.
46	After	Final Drive	a. Cautiously check final drive hubs for overheating. b. Check for Class III oil leakage between final drive and bottom of sprocket. Report Class III fluid leakage to field maintenance. c. Check for sheared mounting studs.	Any final drive hub is overheated. Any Class III fluid leakage. More than two final drive hub studs are sheared on any one final drive.
47	After	Sprockets	<p style="text-align: center;">WARNING</p> <div style="text-align: center;">  <p>Final drive hubs, roadwheel or compensating idler wheel hubs, and track support hubs may be hot. Use caution when checking the hubs. Gloves should be used when touching or handling hubs. Failure to comply may result in personnel injury.</p> </div> <div style="text-align: center;">  <p style="text-align: right; font-size: small;">AVLBD284</p> </div> <p style="text-align: center;">Figure 41. Sprockets.</p> a. Check sprocket for cracks and broken teeth.	Sprocket cracked or has broken teeth.

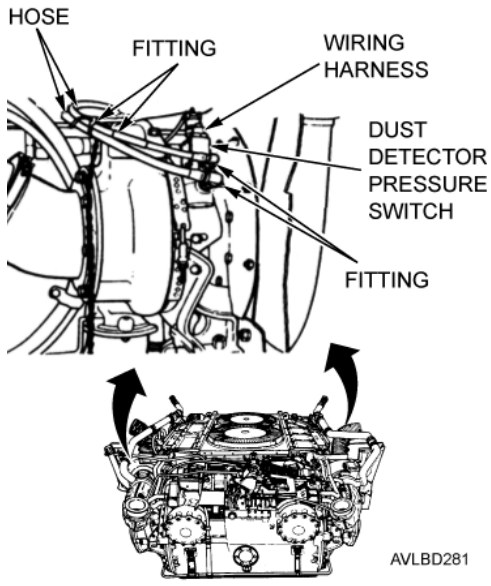
Table 1. PMCS - Continued

ITEM NO.	INTERVAL	ITEM TO BE CHECKED OR SERVICED	PROCEDURE	EQUIPMENT NOT READY/ AVAILABLE IF:
48	After	Torsion Bars for Roadwheels No. 1 and No. 6 (Right and Left Sides)	<div data-bbox="646 365 1130 709" data-label="Image"> <p>The diagram shows a top-down view of the front track assembly of a tank. Labels include: SHOCK ABSORBER SLEEVE (two locations), ROADWHEEL NO. 6 (left side), VOLUTE BUMPER SPRING (center), ROADWHEEL NO. 1 (right side), and FRONT (right side). The diagram is identified as AVLBD285.</p> </div> <p data-bbox="639 751 1130 783">Figure 42. Roadwheels No. 1 and No. 6.</p> <ol data-bbox="610 800 1159 1188" style="list-style-type: none"> Look at roadwheels No. 1 and No. 6 to see if torsion bars are broken or missing. If volute bumper spring bracket is clearly visible above top of roadwheel, and extended shock absorber sleeve is clearly visible above top of roadwheel, torsion bar is operational. If volute bumper spring bracket is barely visible above top of roadwheel, and compressed shock absorber sleeve is barely visible or not visible above top of roadwheel, torsion bar is broken. 	Torsion bars at roadwheels No.1 and/or No. 6 are broken or missing.
			<p data-bbox="802 1213 959 1245">WARNING</p> <div data-bbox="818 1276 940 1398" data-label="Image"> <p>The icon depicts a hand reaching towards a hot surface, with a flame-like effect at the point of contact, indicating a warning of heat.</p> </div> <p data-bbox="699 1423 1073 1696">Final drive hubs, roadwheel or compensating idler wheel hubs, and track support hubs may be hot. Use caution when checking the hubs. Gloves should be used when touching or handling hubs. Failure to comply may result in personnel injury.</p>	

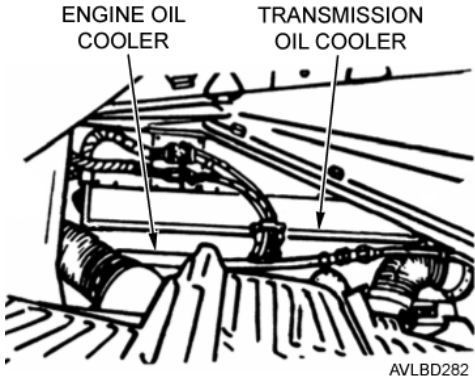
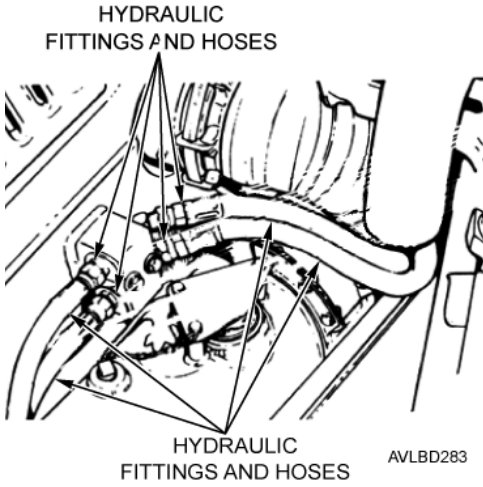
Table 1. PMCS - Continued

ITEM NO.	INTERVAL	ITEM TO BE CHECKED OR SERVICED	PROCEDURE	EQUIPMENT NOT READY/ AVAILABLE IF:
49	After	Roadwheels and Hubs (Right and Left Sides)	 <p data-bbox="836 1077 1128 1108">Figure 43. Roadwheels.</p> <ol data-bbox="711 1125 1258 1547" style="list-style-type: none"> Check inner and outer roadwheels for chunking or separated rubber that would cause thumping during use. Check for worn mounting holes by looking for a shiny area around mounting nuts and washers. Cautiously check hubs for high temperature differences between hubs. Check inside rim for grease spattering. Spattering grease indicates a defective seal. Check for missing roadwheels or compensating idler wheels. 	<p data-bbox="1268 369 1453 514">Any hub is overheated and cannot be corrected by lubrication.</p> <p data-bbox="1268 537 1453 653">One or more roadwheels are missing or unserviceable.</p>

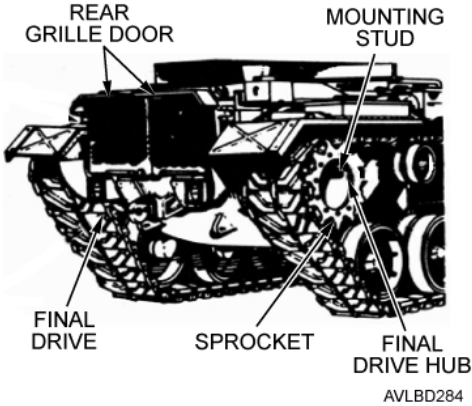
Table 1. PMCS - Continued

ITEM NO.	INTERVAL	ITEM TO BE CHECKED OR SERVICED	PROCEDURE	EQUIPMENT NOT READY/ AVAILABLE IF:
50	After	Roadwheel Arms (Right and Left Sides)	 <p>Figure 44. Roadwheel Arm.</p> <p>a. Ensure that roadwheel arms are not bent, broken, or missing.</p>	
51	After	Shock Absorbers (Right and Left Sides)	 <p>Figure 45. Shock Absorber.</p> <p>a. Check shock absorbers for broken or missing clips/springs and for signs of oil leakage.</p>	Shock absorber at No. 1 or No. 6 roadwheel is broken or missing.

Table 1. PMCS - Continued

ITEM NO.	INTERVAL	ITEM TO BE CHECKED OR SERVICED	PROCEDURE	EQUIPMENT NOT READY/ AVAILABLE IF:
52	After	Track Support Rollers and Hubs (Right and Left Sides)	<p style="text-align: center;">WARNING</p>  <p>Final drive hubs, roadwheel or compensating idler wheel hubs, and track support hubs may be hot. Use caution when checking the hubs. Gloves should be used when touching or handling hubs. Failure to comply may result in personnel injury.</p> <p style="text-align: center;">NOTE</p> <p>Notify field maintenance if tire separation or chunking is more than one-half the width of tire.</p>  <p style="text-align: right; font-size: small;">AVLBD289</p> <p style="text-align: center;">Figure 46. Track Support Roller.</p> <ol style="list-style-type: none"> a. Check for missing or loose track support rollers. b. Check rollers for separation of rubber from metal and chunking. c. Cautiously feel support roller hubs for high temperature differences between other hubs. 	<p>One or more track support roller(s) are missing or loose.</p> <p>Any hub is overheated and cannot be corrected by lubrication.</p>

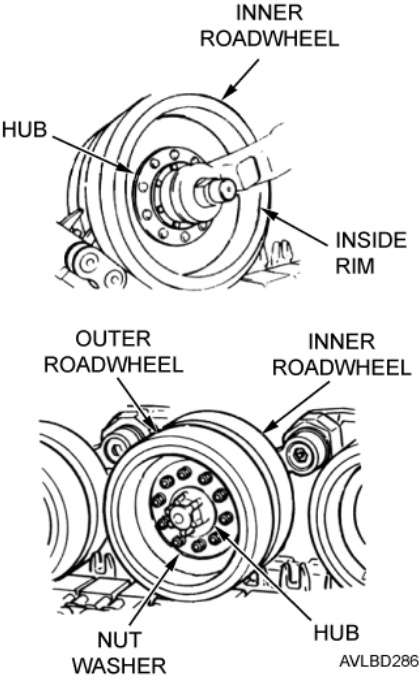
Table 1. PMCS - Continued

ITEM NO.	INTERVAL	ITEM TO BE CHECKED OR SERVICED	PROCEDURE	EQUIPMENT NOT READY/ AVAILABLE IF:
53	After	Track, End Connector, and Wedges, Center Guides, Track Links, and Track Pads (Right and Left Sides)	 <p data-bbox="662 787 1133 819">Figure 47. Compensating Idler Wheel.</p> <ol data-bbox="610 829 1170 1562" style="list-style-type: none"> Adjust track tension. Refer to WP 0056. Look for dead links between track support rollers. Park vehicle on hard, level surface. Remove dirt and mud from track. Have four crew members available (two other AVLB crew members from sister vehicle preferred) to perform track checks. Station driver at operator's station and start engine. Station one crew member in front of vehicle to check left track as it passes over compensating idler wheel. Station two crew members as ground guides. Ground guides direct driver to move vehicle in reverse at creeping speed. Front crew member inspects track as it travels over compensating idler wheel. If defect is found, crew member alerts front ground guide to signal driver to stop vehicle. Crew member marks outboard end connector where defect is located. Corrective action is required. 	

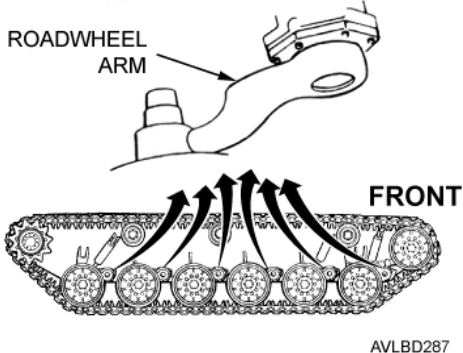
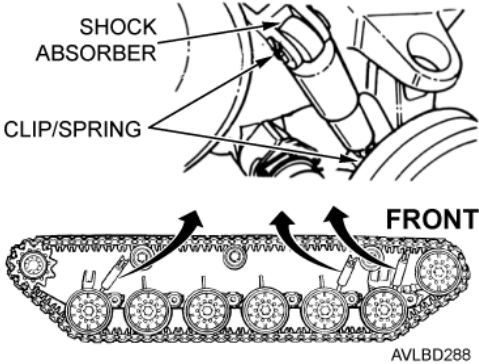
Table 1. PMCS - Continued

ITEM NO.	INTERVAL	ITEM TO BE CHECKED OR SERVICED	PROCEDURE	EQUIPMENT NOT READY/ AVAILABLE IF:
			 <p data-bbox="779 1008 1177 1039">Figure 48. Track Center Guides.</p> <p data-bbox="706 1050 1258 1228">h. Check track for the following:</p> <ol data-bbox="706 1092 1258 1228" style="list-style-type: none"> 1. Missing, bent, cracked, broken, or shiny (loose) center guides. 2. Shiny metal on center guide around mounting bolt (indicates loose center guide). 	<p data-bbox="1266 357 1485 451">One or more missing/broken center guides.</p>

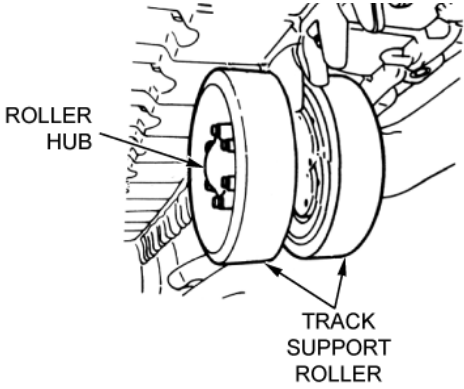
Table 1. PMCS - Continued

ITEM NO.	INTERVAL	ITEM TO BE CHECKED OR SERVICED	PROCEDURE	EQUIPMENT NOT READY/ AVAILABLE IF:
			 <p style="text-align: center;">REQUIRES REPLACEMENT</p> <p style="text-align: center;">NORMAL WEAR <small>ALVBD292</small></p> <p style="text-align: center;">Figure 49. Track Pads.</p> <p>3. Missing or loose track pads/links.</p> <p>4. Excessive wear of track pads/links (indicated by damage to roadway).</p>	

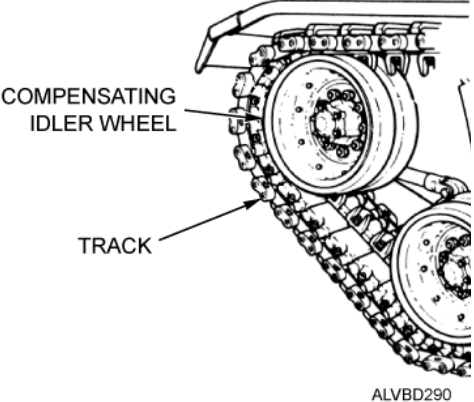
Table 1. PMCS - Continued

ITEM NO.	INTERVAL	ITEM TO BE CHECKED OR SERVICED	PROCEDURE	EQUIPMENT NOT READY/ AVAILABLE IF:
			<div style="display: flex; flex-direction: column; align-items: center;"> <div style="display: flex; justify-content: space-between; width: 100%;"> <div style="text-align: left;">WEDGE NOT SEATED</div> <div style="text-align: center;">  </div> </div> <div style="display: flex; justify-content: space-between; width: 100%; margin-top: 20px;"> <div style="text-align: left;">WEDGE NOTICEABLY HIGHER</div> <div style="text-align: center;">  </div> </div> <div style="display: flex; justify-content: space-between; width: 100%; margin-top: 20px;"> <div style="text-align: left;">BOLT</div> <div style="text-align: center;">  </div> </div> <p style="text-align: right; margin-right: 50px;">ALVBD293</p> <p style="text-align: center;">Figure 50. End Connectors.</p> <ol style="list-style-type: none"> 5. Broken, missing, or loose end connectors (shiny metal around wedge bolt). 6. Missing or improperly seated wedges. 7. Wedges and bolts are missing or broken. </div>	<p>One or more broken/missing wedges.</p>

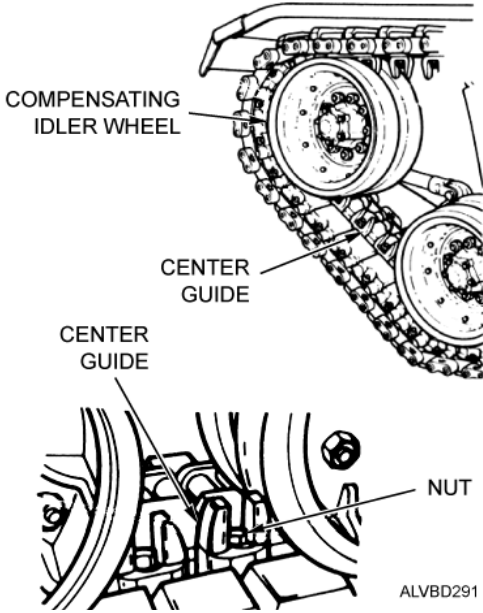
Table 1. PMCS - Continued

ITEM NO.	INTERVAL	ITEM TO BE CHECKED OR SERVICED	PROCEDURE	EQUIPMENT NOT READY/ AVAILABLE IF:
			<p style="text-align: center;">NOTE</p> <p>When track link appears out of line, it indicates a dead link or damaged track pin bushing.</p> <p style="text-align: center;">NOTE</p> <p>After left track has been checked and marked, check right track using same procedures. After both tracks are checked and marked, go to applicable corrective procedure.</p> <div style="text-align: center;">  <p>TRACK LINK</p> <p>DEAD LINK</p> <p>ALVBD294</p> </div> <p style="text-align: center;">Figure 51. Track Links.</p> <p>i. Look for dead links between support rollers.</p> <div style="text-align: center;">  <p>COMPENSATING IDLER WHEEL</p> <p>POSITION LOOSE END CONNECTOR HERE FOR TIGHTENING</p> <p>CENTER GUIDE</p> <p>CENTER GUIDE NUT</p> <p>NO. 1 ROADWHEEL</p> <p>ALVBD295</p> </div> <p style="text-align: center;">Figure 52. End Connector Repair.</p>	

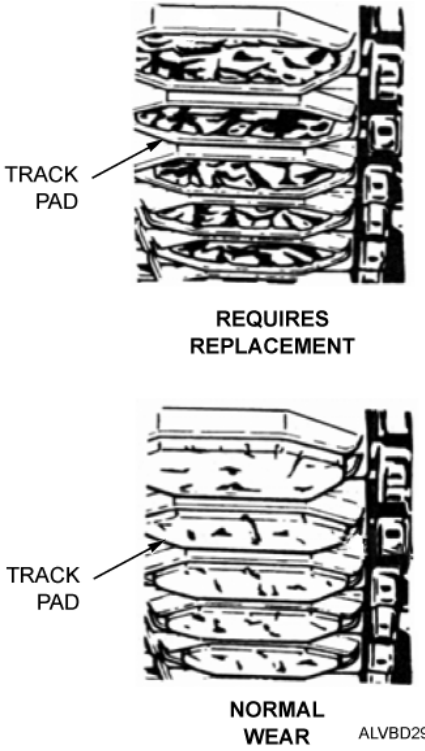
Table 1. PMCS - Continued

ITEM NO.	INTERVAL	ITEM TO BE CHECKED OR SERVICED	PROCEDURE	EQUIPMENT NOT READY/ AVAILABLE IF:
			<p>j. If end connector is loose or unseated, perform the following:</p> <ol style="list-style-type: none"> 1. Loosen track tension. Refer to WP 0056. 2. Loosen center guide nut (left side) on same link that has loose end connector. 3. Move vehicle until loose end connector is midway over compensating idler wheel, and then stop vehicle.  <p>k. Check that wedge is in normal position and does not touch radius. If wedge touches inner or outer radius, reposition end connector (in or out) on pins to properly seat wedge.</p>	

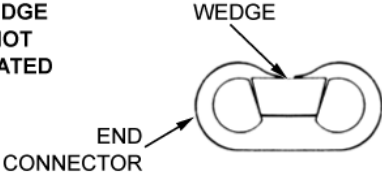
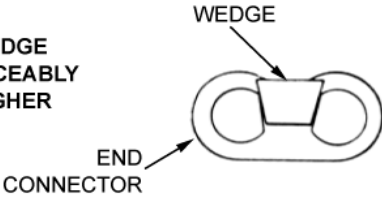
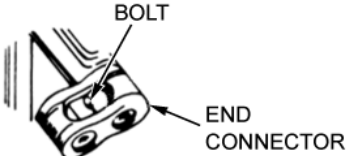
Table 1. PMCS - Continued

ITEM NO.	INTERVAL	ITEM TO BE CHECKED OR SERVICED	PROCEDURE	EQUIPMENT NOT READY/ AVAILABLE IF:
			<p data-bbox="613 342 1112 401">l. Tighten both inboard and outboard end connector bolts.</p> <p data-bbox="613 422 1144 506">m. Tighten center guide nut. If end connector is damaged, replace connector. Refer to WP 0049.</p>  <p data-bbox="651 976 1117 1008">Figure 54. Compensating Idler Wheel.</p> <p data-bbox="613 1024 1166 1083">n. If center guide is loose, perform the following steps:</p> <ol data-bbox="613 1100 1161 1371" style="list-style-type: none"> <li data-bbox="613 1100 1161 1184">1. Move vehicle until defective or loose center guide is between compensating idler wheel and No. 1 roadwheel. <li data-bbox="613 1205 1161 1289">2. Tighten loose center guide nut. (For reference, proper torque is 360 to 380 lb-ft (488.2 to 515.3 Nm.) <li data-bbox="613 1310 1161 1371">3. If center guide is damaged, replace center guide. Refer to WP 0050.  <p data-bbox="748 1833 1019 1864">Figure 55. Track Pad.</p>	

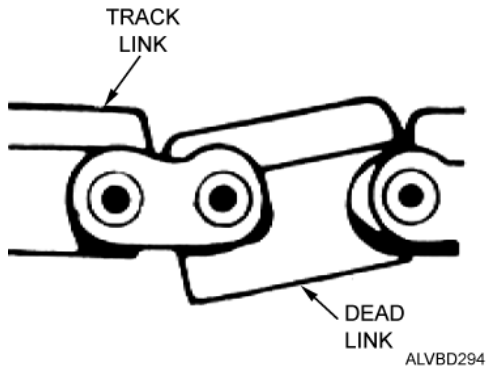
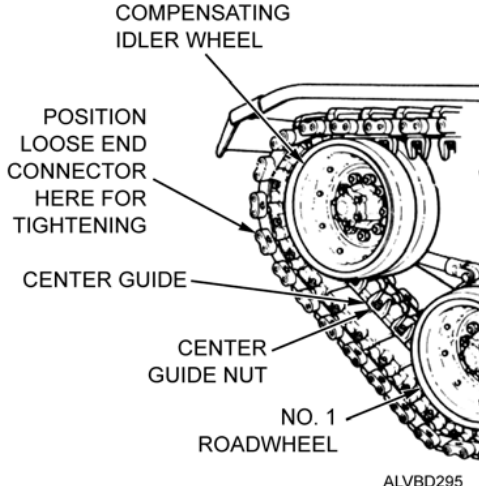
Table 1. PMCS - Continued.

ITEM NO.	INTERVAL	ITEM TO BE CHECKED OR SERVICED	PROCEDURE	EQUIPMENT NOT READY/ AVAILABLE IF:
			<p>o. If track pads are loose, perform the following steps:</p> <ol style="list-style-type: none"> 1. Move vehicle until loose track is between compensating idler wheel and No. 1 roadwheel. 2. Stop vehicle and tighten track pad nut. 3. If track pads are damaged or excessively worn, replace pads. Refer to WP 0052. 4. If track links or pins are damaged, replace track links. Refer to WP 0051. 	
54	After	Track Adjusting Link (Mechanical) (Left and Right Sides)	<p style="text-align: center;">NOTE</p> <p>The track adjusting link procedure applies to the M60A1 only.</p>  <p style="text-align: center;">Figure 56. Track Adjusting Link.</p> <ol style="list-style-type: none"> a. Check that link assembly is not missing or broken. b. Check that cotter pin is not missing or broken. 	Track adjusting link is broken or missing.

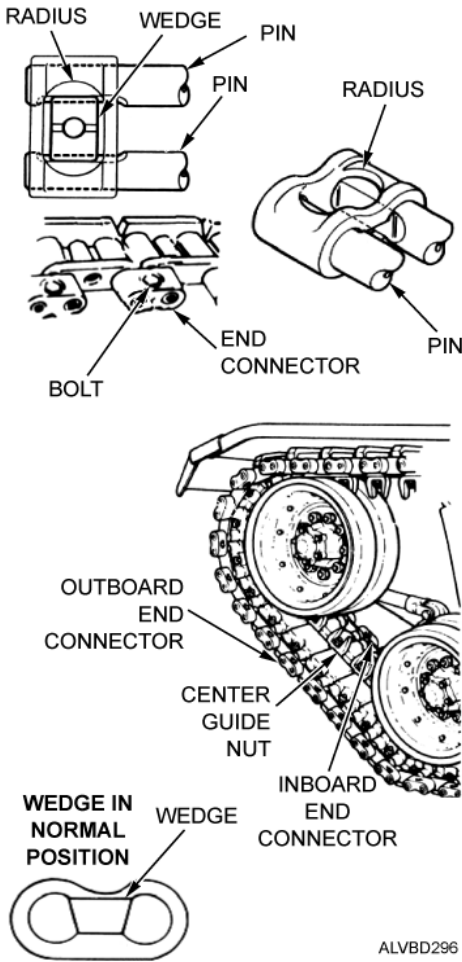
Table 1. PMCS - Continued.

ITEM NO.	INTERVAL	ITEM TO BE CHECKED OR SERVICED	PROCEDURE	EQUIPMENT NOT READY/ AVAILABLE IF:
55	After	Track Adjusting Link (Grease-Actuated) (Left and Right Sides)	 <p>Figure 57. Grease-Actuated Track Adjusting Link.</p> <ol style="list-style-type: none"> Check for missing, broken, or leaking track adjusting link. Check that cotter pin is not missing. Check that collar locking screw is not loose or missing.  <p>Figure 58. Pressure Relief Valve.</p>	Track adjusting link broken, missing, or leaking. Pressure relief valve or plug damaged or missing.

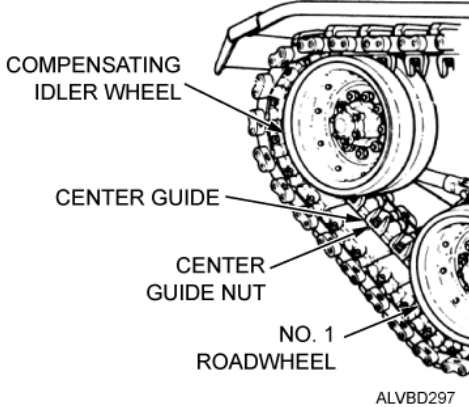
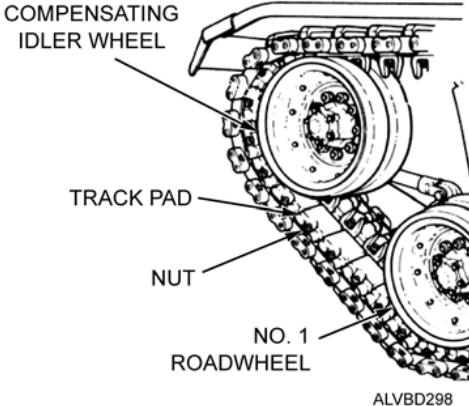
Table 1. PMCS - Continued.

ITEM NO.	INTERVAL	ITEM TO BE CHECKED OR SERVICED	PROCEDURE	EQUIPMENT NOT READY/ AVAILABLE IF:
			d. Check that bearing and pin are not worn. e. Check that bearing-attaching screws are not loose or missing. f. Check that grease fitting, pressure relief valve, and plug are not damaged or missing.	
56	After	Track Tension (Left and Right Sides)	<p style="text-align: center;">CAUTION</p> <ul style="list-style-type: none"> • Track tension must be checked and adjusted when bridge is on vehicle. Proper track tension will prevent track damage and will prevent track from being thrown. • Track tension must be checked and adjusted when bridge is removed and vehicle is to be operated extensively without bridge. Proper track tension will prevent track from being thrown. a. Adjust track tension after all other track inspection and/or faults have been corrected. Refer to WP 0056.	
57	After	Cylinder Pins and Retaining Rings (Left and Right Sides)	 <p>Figure 59. Cylinder Pins and Retaining Rings.</p> a. Check that pins or retaining rings are not missing on boom, tongue, tongue cylinder, and overhead cylinder.	Any pins or retaining rings are missing.

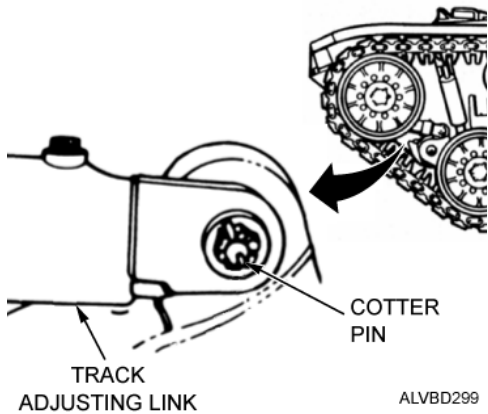
Table 1. PMCS - Continued.

ITEM NO.	INTERVAL	ITEM TO BE CHECKED OR SERVICED	PROCEDURE	EQUIPMENT NOT READY/ AVAILABLE IF:
			<p style="text-align: center;">WARNING</p> <div style="text-align: center;">  </div> <ul style="list-style-type: none"> • Battery acid (electrolyte) and corrosion can cause serious burns. Safety goggles and acid resistant rubber gloves must be worn when working around batteries. If electrolyte or corrosion makes contact with skin, eyes, or clothing, immediately flush contacted area with water and obtain medical attention. Failure to comply may result in personnel injury or death. • Batteries may give off explosive gasses. DO NOT smoke, use open flame, make sparks, or create other ignition sources around the battery. Failure to comply may result in personnel injury or death. • Personnel may be burned if jewelry or a tool contacts a battery terminal. Remove all jewelry such as rings, ID tags, watches, etc. Failure to comply may result in personnel injury or death. 	

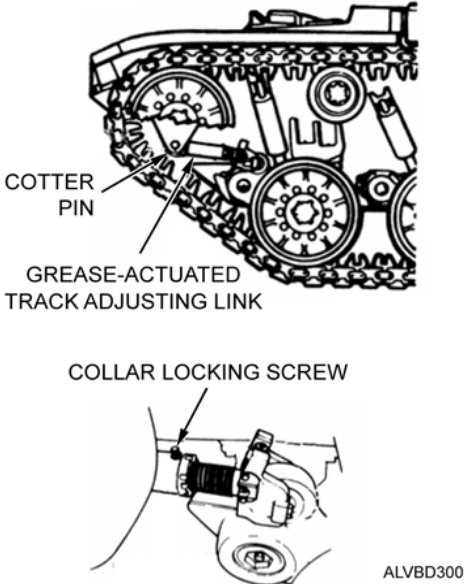
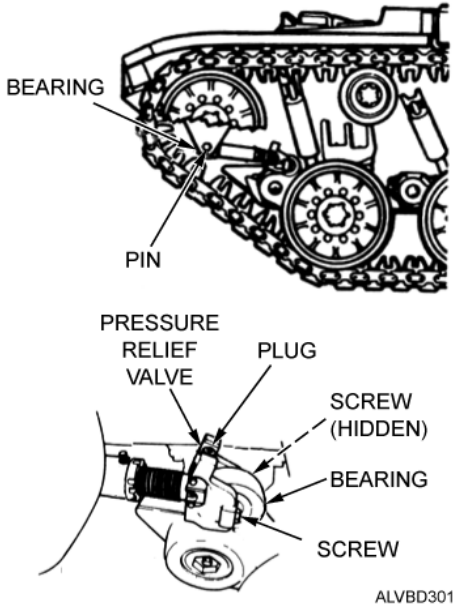
Table 1. PMCS - Continued.

ITEM NO.	INTERVAL	ITEM TO BE CHECKED OR SERVICED	PROCEDURE	EQUIPMENT NOT READY/ AVAILABLE IF:
			<p style="text-align: center;">WARNING</p> <div style="text-align: center;">  </div> <p>Electrical shock may occur when slave starting vehicles if any battery is missing or damaged or cables are defective. DO NOT attempt to slave start vehicle if any battery is missing or damaged. DO NOT use defective cables for slave starting. Failure to comply may result in personnel injury or death, or equipment damage.</p>	
58	Weekly	Batteries (Left and Right Sides)	<div style="text-align: center;">  </div> <p style="text-align: center;">Figure 60. Battery Retainer.</p> <ol style="list-style-type: none"> a. Remove battery retainer. Refer to WP 0063. b. Remove cover. c. Visually check for broken or loose battery connectors and posts. d. Check for corrosion on battery connectors and posts. 	One or more unserviceable batteries.

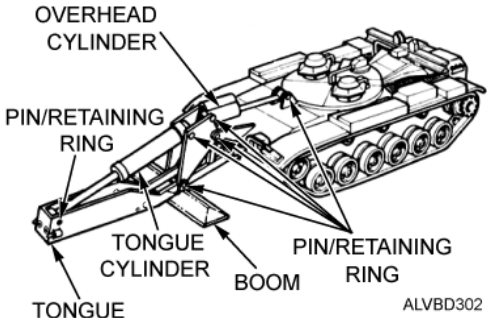
Table 1. PMCS - Continued.

ITEM NO.	INTERVAL	ITEM TO BE CHECKED OR SERVICED	PROCEDURE	EQUIPMENT NOT READY/ AVAILABLE IF:
			e. Wipe connectors and posts with clean cloth, and apply light coat of GAA grease (WP 0079, Table1, Item 28). f. Check battery casings for cracks.	
			<p style="text-align: center;">WARNING</p> <div style="text-align: center;">  </div> <ul style="list-style-type: none"> • Battery acid (electrolyte) and corrosion can cause serious burns. Safety goggles and acid resistant rubber gloves must be worn when working around batteries. If electrolyte or corrosion makes contact with skin, eyes, or clothing, immediately flush contacted area with water and obtain medical attention. Failure to comply may result in personnel injury or death. • Batteries may give off explosive gasses. DO NOT smoke, use open flame, make sparks, or create other ignition sources around the battery. Failure to comply may result in personnel injury or death. • Personnel may be burned if jewelry or a tool contacts a battery terminal. Remove all jewelry such as rings, ID tags, watches, etc. Failure to comply may result in personnel injury or death. 	

Table 1. PMCS - Continued.

ITEM NO.	INTERVAL	ITEM TO BE CHECKED OR SERVICED	PROCEDURE	EQUIPMENT NOT READY/ AVAILABLE IF:
			<p style="text-align: center;">WARNING</p> <div style="text-align: center;">  </div> <p>Electrical shock may occur when slave starting vehicles if any battery is missing or damaged or cables are defective. DO NOT attempt to slave start vehicle if any battery is missing or damaged. DO NOT use defective cables for slave starting. Failure to comply may result in personnel injury or death, or equipment damage.</p> <div style="text-align: center;">  </div> <p style="text-align: right; font-size: small;">ALVBD304</p> <p>Figure 61. Checking Battery Electrolyte Level.</p> <p>g. Remove battery caps from fill holes. Check that electrolyte covers plates or bottom of split ring (if equipped).</p> <p>h. If electrolyte level is low, or if you notice any defects, notify field maintenance.</p>	

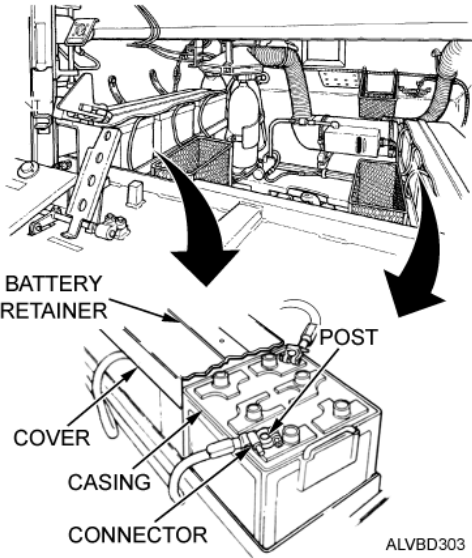
Table 1. PMCS - Continued.



ITEM NO.	INTERVAL	ITEM TO BE CHECKED OR SERVICED	PROCEDURE	EQUIPMENT NOT READY/ AVAILABLE IF:
59	Weekly	Engine Manual Fuel Shutoff	 <p data-bbox="695 766 1079 798">Figure 62. Fuel Shutoff Handle.</p> <ol data-bbox="613 814 1161 995" style="list-style-type: none"> With engine running, release latch and pull manual FUEL SHUTOFF handle. Check that engine stops within 30 seconds. Push manual FUEL SHUTOFF handle in and secure with latch. 	Engine does not shut down.
			<p data-bbox="808 1003 966 1035">WARNING</p>  <p data-bbox="695 1218 1071 1764">Nuclear-Biological-Chemical (NBC) contaminated air filters must be handled and disposed of only by authorized and trained personnel. The unit commander or senior officer in charge of maintenance personnel must ensure that prescribed protective clothing (FM 3-11.4) is used and prescribed safety measures and decontamination procedures (FM 3-11.5) are followed. The local unit SOP is responsible for final disposal of contaminated air filters. Failure to comply may result in personnel injury or death.</p>	

Table 1. PMCS - Continued

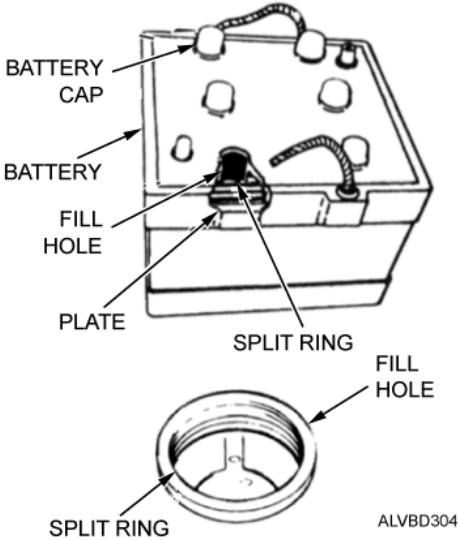
ITEM NO.	INTERVAL	ITEM TO BE CHECKED OR SERVICED	PROCEDURE	EQUIPMENT NOT READY/ AVAILABLE IF:
60	Weekly	Gas Particulate System	 <p>The diagram illustrates the Gas Particulate Filter Unit and its integration into the vehicle's control systems. It shows the unit's location relative to the Commander's Station and Operator's Station. Key components labeled include the Gas Particulate Filter Unit, Spring Clip, Master Battery Switch, and Gas Particulate Switch. The Operator's Station panel features various controls such as the Starter, Master Battery, and Gas Particulate Switch, along with indicator lights and a heater control. The diagram is identified as AVLBD306.</p>	

Figure 63. Gas Particulate Filter Unit.

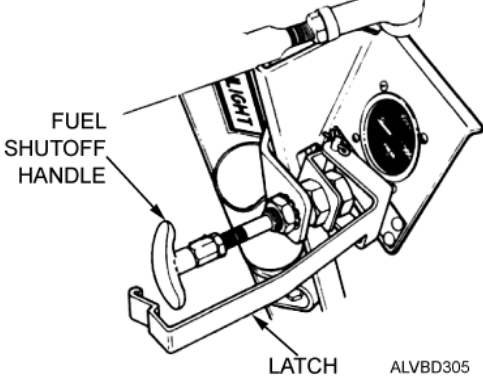
a. Visually inspect filter unit for damage.

Table 1. PMCS - Continued

ITEM NO.	INTERVAL	ITEM TO BE CHECKED OR SERVICED	PROCEDURE	EQUIPMENT NOT READY/ AVAILABLE IF:
			 <p>Figure 64. Gas Particulate Filter Unit Spring Clip.</p> <ol style="list-style-type: none"> Pull and lift spring clip from air intake openings on filter unit. Set MASTER BATTERY switch and GAS PARTICULATE switch to ON. Pull hose outlet from clip at both crew member stations. Check for steady flow of air at hose outlet at both crew member stations. Push hose outlet into clip at both crew member stations. Set GAS PARTICULATE switch to OFF. Press spring clip down on filter unit to cover air intake opening. Set MASTER BATTERY switch to OFF. 	

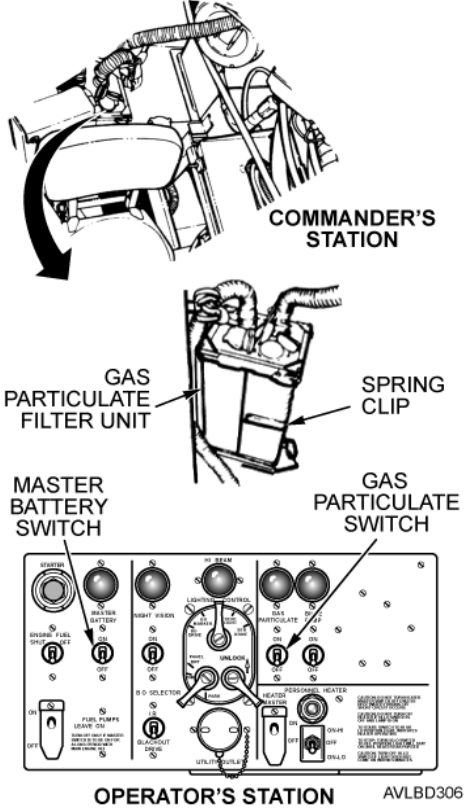
Table 1. PMCS - Continued

ITEM NO.	INTERVAL	ITEM TO BE CHECKED OR SERVICED	PROCEDURE	EQUIPMENT NOT READY/ AVAILABLE IF:
61	Weekly	BO Marker and Service Drive Headlights	 <p>Figure 65. Blackout Marker and Service Drive Headlights.</p> <ol style="list-style-type: none"> Station crew member in front of vehicle to verify headlight checks. Set MASTER BATTERY switch to ON. Place LIGHTING CONTROL lever to blackout (BO) marker. Check that blackout marker lamps light. Set BO SELECTOR switch to BLACKOUT DRIVE. Check that blackout marker lamps light. 	

Table 1. PMCS - Continued.

ITEM NO.	INTERVAL	ITEM TO BE CHECKED OR SERVICED	PROCEDURE	EQUIPMENT NOT READY/ AVAILABLE IF:
			 <p>The diagram illustrates the components for checking the high beam indicator. At the top, a control panel is shown with various indicators and switches. A 'HI BEAM INDICATOR' is labeled with an arrow pointing to a specific light. A 'LIGHTING CONTROL LEVER' is also labeled with an arrow pointing to a lever on the panel. Below the panel, two views of a 'SERVICE DRIVE HEADLIGHT' are shown, with arrows pointing to the lens area. At the bottom, a 'DIMMER SWITCH' is shown on a mechanical assembly, with an arrow pointing to it. The diagram is identified by the code 'AVLBD309'.</p>	
			<p>Figure 66. High Beam Indicator.</p> <ul style="list-style-type: none"> g. Place LIGHTING CONTROL lever to SER DRIVE. h. Check that high and low beams light by pressing and releasing DIMMER SWITCH. i. Ensure HI BEAM indicator lights when high beam service drive lights are lit. 	

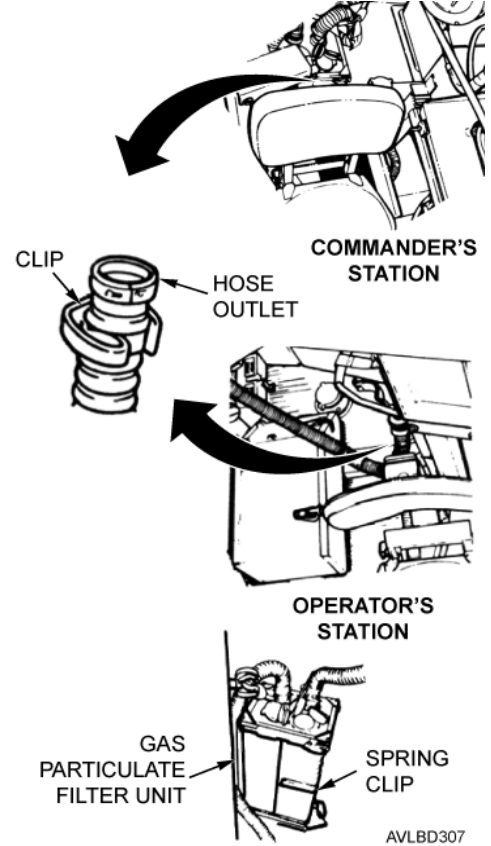
Table 1. PMCS - Continued.

ITEM NO.	INTERVAL	ITEM TO BE CHECKED OR SERVICED	PROCEDURE	EQUIPMENT NOT READY/ AVAILABLE IF:
62	Weekly	Taillights	<p style="text-align: center;">LIGHTING CONTROL LEVER</p>  <p style="text-align: center;">Figure 67. Taillights.</p> <ol style="list-style-type: none"> a. Station crew member at rear of vehicle to verify taillight and stoplight operation. b. Check that service drive taillight lights. c. Press brake pedal. Check that service drive stoplight lights. d. Turn LIGHTING CONTROL lever to STOPLIGHT. e. Press brake pedal. Check that service drive stoplight lights. 	

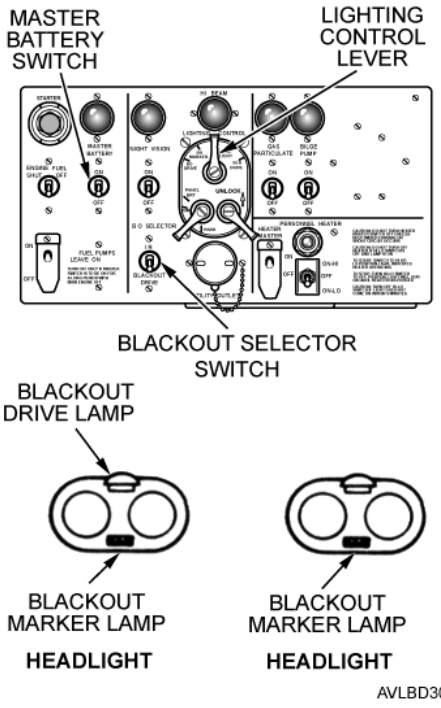
Table 1. PMCS - Continued.

ITEM NO.	INTERVAL	ITEM TO BE CHECKED OR SERVICED	PROCEDURE	EQUIPMENT NOT READY/ AVAILABLE IF:
			<p style="text-align: center;">LIGHTING CONTROL LEVER</p>  <p style="text-align: center;">Figure 68. Blackout Markers.</p> <p>f. Turn LIGHTING CONTROL lever to BO MARKER.</p> <p>g. Check that blackout markers light.</p> <p>h. Press brake pedal. Check that blackout drive stoplight lights.</p> <p>i. Station crew member at rear of vehicle to verify taillight and stoplight checks.</p> <p>j. Turn LIGHTING CONTROL lever to BO DRIVE.</p> <p>k. Check that blackout drive taillights light.</p> <p>l. Press brake pedal.</p> <p>m. Check that blackout stoplight lights.</p> <p>n. Turn LIGHTING CONTROL lever to OFF.</p> <p>o. SET MASTER BATTERY switch to OFF.</p>	

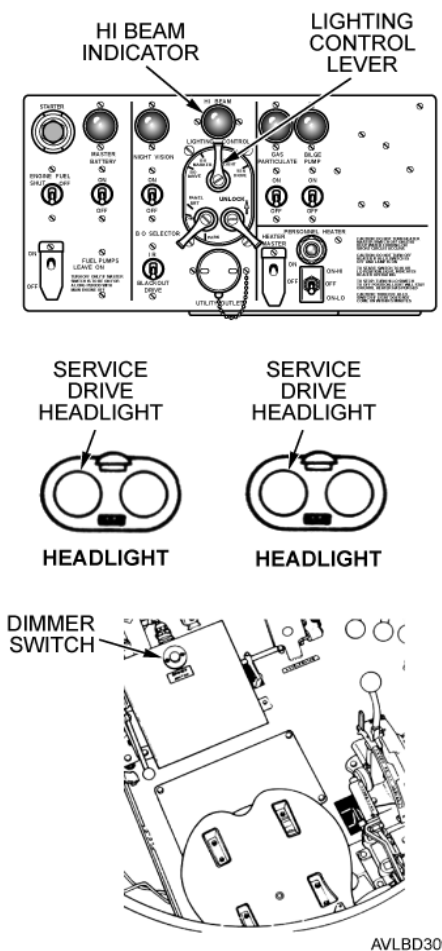
Table 1. PMCS - Continued.

ITEM NO.	INTERVAL	ITEM TO BE CHECKED OR SERVICED	PROCEDURE	EQUIPMENT NOT READY/ AVAILABLE IF:
63	Weekly	Track Drive Sprocket (Right and Left Sides)	 <p>Figure 69. Sprocket Wear.</p> <ol style="list-style-type: none"> Check sprocket for wear by looking at undercut located on two sprocket teeth. Check that undercut area has not been worn away. 	Undercut is completely worn away.
64	Weekly	AN/VVS-2 Night Vision Viewer and Hatch (Night Check)	<p style="text-align: center;">CAUTION</p> <p>Perform AN/VVS-2 night vision check during darkness only. Damage to objective lens on night vision viewer may occur if lens is exposed to direct sunlight or bright light.</p> <ol style="list-style-type: none"> Install and operate night vision viewer. Refer to WP 0011. 	Night vision viewer is inoperative.
65	Weekly	Portable Fire Extinguisher	 <p>Figure 70. Portable Fire Extinguisher.</p> <ol style="list-style-type: none"> Check that extinguisher clamp is secure. Check that safety wire/lead seal has not been broken. 	

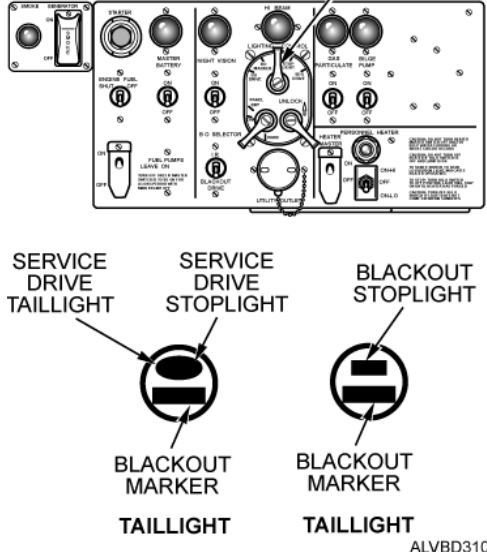
Table 1. PMCS - Continued.



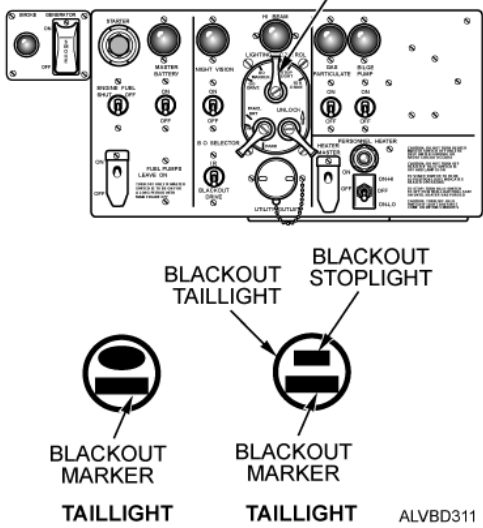

ITEM NO.	INTERVAL	ITEM TO BE CHECKED OR SERVICED	PROCEDURE	EQUIPMENT NOT READY/ AVAILABLE IF:
			<p style="text-align: center;">WARNING</p> <div style="display: flex; justify-content: center; gap: 10px;">     </div> <ul style="list-style-type: none"> • FRH fluid may cause irritation to the eyes and skin. Avoid contact with eyes, skin, and clothing. Wear protective goggles, gloves, and clothing. If FRH comes in contact with eyes or skin, flush area with water. Failure to comply may result in personnel injury or illness. • Degreasing solvent (MIL-PRF-680) is flammable and may cause irritation to the eyes or skin. Use in well ventilated areas and keep away from heat and open flame. Wear protective goggles and clothing. If solvent comes in contact with eyes, flush immediately with water. If solvent comes in contact with skin, wash with soap and water. Failure to comply may result in personnel injury, illness, or death. <p style="text-align: center;">CAUTION</p> <p>Do not clean hydraulic reservoir air breather filter if hydraulic electrical upgrade (HEU) has been applied. Attempting to clean filter will damage it, and it will have to be replaced. Failure to comply may result in equipment damage.</p> <p style="text-align: center;">NOTE</p> <p>One pint of oil loss per operational hour is acceptable.</p>	

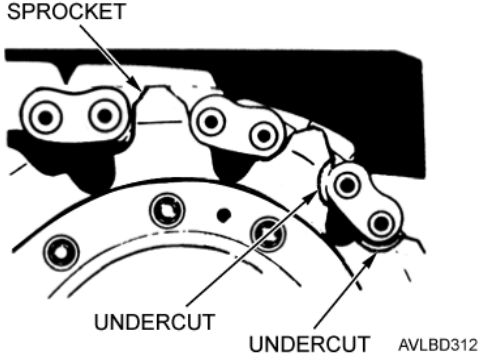
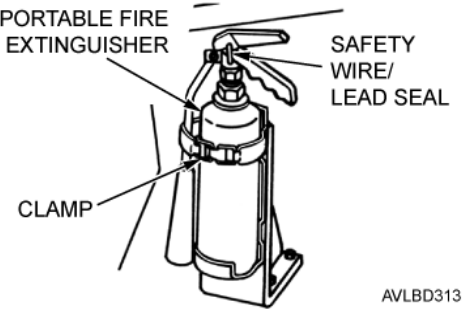
Table 1. PMCS - Continued.

ITEM NO.	INTERVAL	ITEM TO BE CHECKED OR SERVICED	PROCEDURE	EQUIPMENT NOT READY/ AVAILABLE IF:
66	Monthly	Exercising Hydraulic System	 <p style="text-align: center;">Figure 71. Filter Element.</p> <ol style="list-style-type: none"> a. Remove nut, washer, and nameplate securing hydraulic breather filter hood and remove hood. b. Remove filter element and clean with degreasing cleaning solvent (WP 0079, Table 1, Item 58). c. Dip filter element in hydraulic fluid and install on body assembly. d. Position hood on filter element and secure nameplate, washer, and nut. e. (HEU) Check hydraulic reservoir breather filter desiccant. Notify field maintenance if excessive moisture is indicated. f. Check bridge for serviceability. Refer to TM 5-5420-203-13. g. Perform launch and retrieval procedures five times. Refer to WP 0018. h. Immediately after exercising hydraulic system, wipe residue from all cylinder seal areas using a clean cloth, and then check for fluid leaks in these areas. 	<p>Bridge is unserviceable or missing.</p> <p>Any Class III fluid leak.</p>

Table 1. PMCS - Continued.



ITEM NO.	INTERVAL	ITEM TO BE CHECKED OR SERVICED	PROCEDURE	EQUIPMENT NOT READY/ AVAILABLE IF:
67	Monthly	Bridge Seat and Pads	 <p>Figure 72. Bridge Seat and Pads.</p> <ol style="list-style-type: none"> Check for broken welds, loose pad mounting screws, and loose bridge mounting screws. Check for torn or missing pads. 	Any broken welds.
68	Monthly	Hydraulic Brake System	<ol style="list-style-type: none"> Check brake master cylinder fluid level. Refer to WP 0074. 	Brake system leaks.
			<p style="text-align: center;">WARNING</p> <div style="display: flex; justify-content: center; gap: 20px;">   </div> <p>Discharging of grenades could occur if grenades are present in dischargers. Ensure grenades are not present in grenade dischargers to prevent injury by accidental discharge. Failure to comply may result in personnel injury or death.</p>	

Table 1. PMCS - Continued.

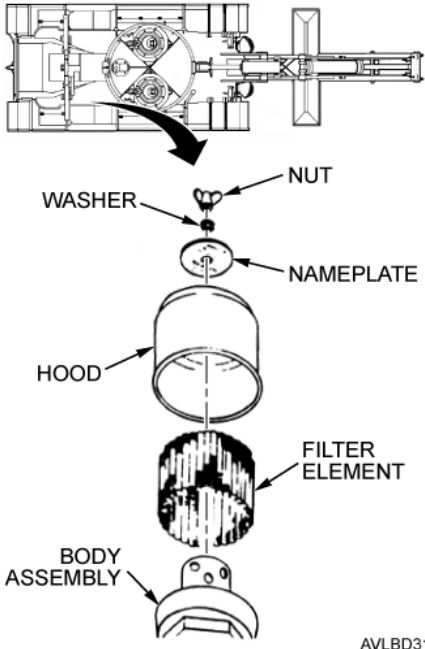
ITEM NO.	INTERVAL	ITEM TO BE CHECKED OR SERVICED	PROCEDURE	EQUIPMENT NOT READY/ AVAILABLE IF:
69	Monthly	Grenade Launcher Power Box	 <p>Figure 73. Grenade Launcher Power Box.</p> <ol style="list-style-type: none"> Ensure MASTER BATTERY switch is set to ON. Set grenade POWER switch to ON. Check that POWER lamp lights. Set POWER switch to OFF. Set MASTER BATTERY switch to OFF. 	

Table 1. PMCS - Continued.

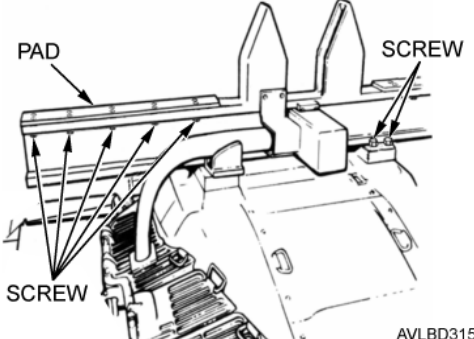
ITEM NO.	INTERVAL	ITEM TO BE CHECKED OR SERVICED	PROCEDURE	EQUIPMENT NOT READY/ AVAILABLE IF:
70	Monthly	Grenade Launcher Discharger, Cover, and Stowage Box (Right and Left Sides)	 <p style="text-align: right;">AVLBD317</p> <p>Figure 74. Grenade Launcher.</p> <ol style="list-style-type: none"> Ensure Master BATTERY switch is set to OFF. Remove cover from discharger and check for tears or damaged canvas. Check discharger for obvious damage and dirty or clogged barrels. <p style="text-align: center;">NOTE</p> <p>Top center drain hole cannot be checked using stiff wire. If drain hole is clogged, notify field maintenance.</p>	

Table 1. PMCS - Continued.

ITEM NO.	INTERVAL	ITEM TO BE CHECKED OR SERVICED	PROCEDURE	EQUIPMENT NOT READY/ AVAILABLE IF:
			 <p style="text-align: right;">AVLBD317</p> <p>Figure 75. Grenade Launcher.</p> <ul style="list-style-type: none"> d. Check that drain holes are clear by inserting stiff wire in holes. e. Check stowage box for damaged hinge and for proper operation of lid and latch. f. Check stowage box for damage and secure mounting. 	

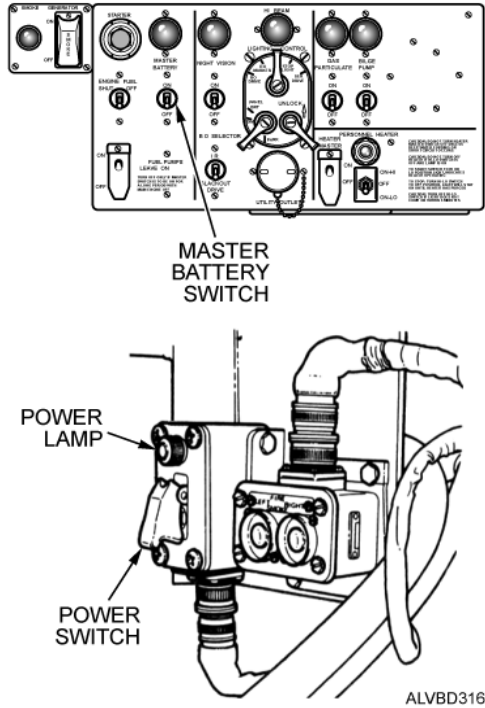
END OF WORK PACKAGE

CHAPTER 5

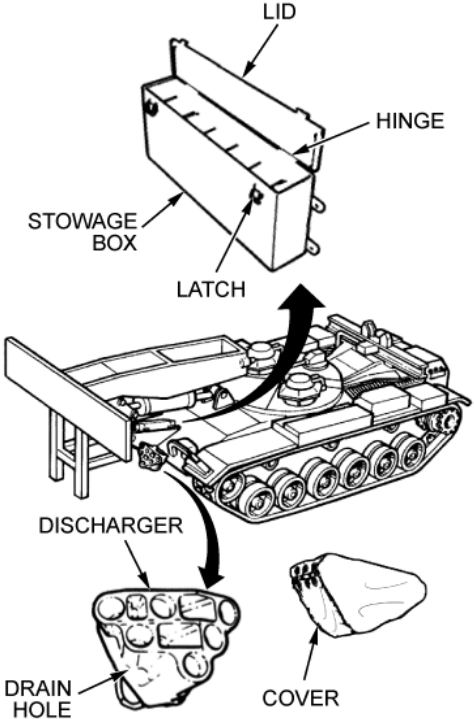
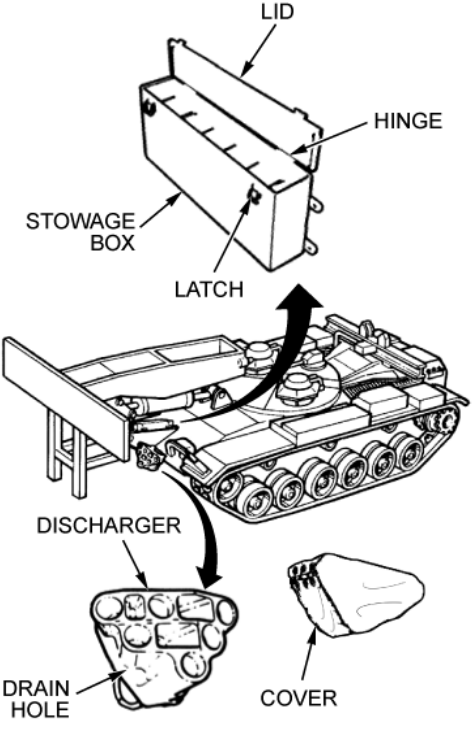
MAINTENANCE PROCEDURES

FOR

**M48A5 AND M60A1 LAUNCHER AND TANK CHASSIS TRANSPORTING FOR
BRIDGE ARMORED-VEHICLE LAUNCHED: SCISSORING-TYPE, CLASS 60
OR CLASS 70**

OPERATOR MAINTENANCE**TRACK END CONNECTOR REMOVAL AND INSTALLATION**

INITIAL SETUP:**Tools and Special Tools**

Fixture, Track Connecting (WP 0077, Table 2, Item 21)
Hammer, Machinist (WP 0077, Table 2, Item 26)
Socket Wrench (WP 0077, Table 2, Item 30)
Socket Wrench (WP 0077, Table 2, Item 32)
Puller, Mechanical (WP 0077, Table 2, Item 45)
Socket Wrench (WP 0077, Table 2, Item 63)

Tools and Special Tools (cont.)

Socket Wrench (WP 0077, Table 2, Item 64)

Equipment Conditions

Vehicle stopped on flat, level ground so end connector to be removed is positioned between compensating idler and front roadwheel (WP 0016)
Track tension loosened (WP 0053 or WP 0054)

GENERAL

This work package contains information on the removal, inspection, and installation of the track end connectors.

REMOVAL**NOTE**

Inner and outer end connectors are removed the same way.

1. Use 15/16 inch socket and 3/4 inch hinged handle to loosen bolt (Figure 1, Item 1).
2. Tap bolt (Figure 1, Item 1) with hammer to loosen wedge (Figure 1, Item 3).
3. Remove bolt (Figure 1, Item 1) and wedge (Figure 1, Item 3) from outer end connector (Figure 1, Item 2).

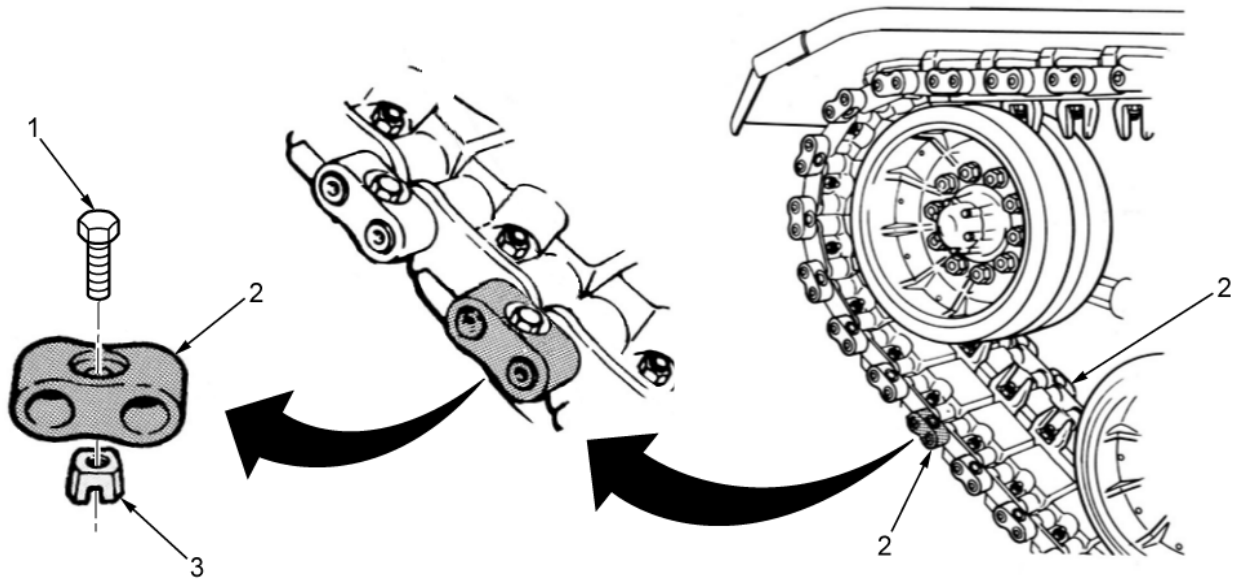

AVLBD324A

Figure 1. End Connector Hardware.

REMOVAL - CONTINUED

4. Install end connector puller (Figure 2, Item 3) on end connector (Figure 2, Item 1).
5. Use 1-1/2 inch socket to tighten two puller screws (Figure 2, Item 2) until 1 inch of track link pins (Figure 2, Item 4) is visible behind end connector (Figure 2, Item 1).

NOTE

It may be necessary to tap seated end connector (Figure 2, Item 1) with hammer to loosen.

6. Remove end connector (Figure 2, Item 1) from track link pins (Figure 2, Item 4).

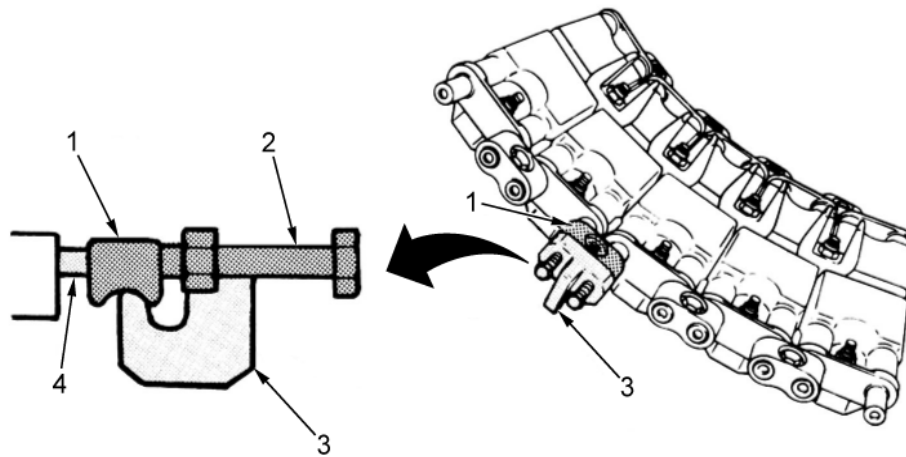

AVLBD325

Figure 2. End Connector Removal.

REMOVAL - CONTINUED**NOTE**

Depending on the vehicle, there are two types of track fixtures available. The new-type track fixture is used for this procedure. The old-type track fixture is equipped with an extension bar used for opening and closing the fixture.

7. Attach track fixture (Figure 3, Item 3) to track pins (Figure 3, Item 2). Use ratchet to turn track fixture tension adjustment (Figure 3, Item 1) counterclockwise to tighten track fixture jaws.

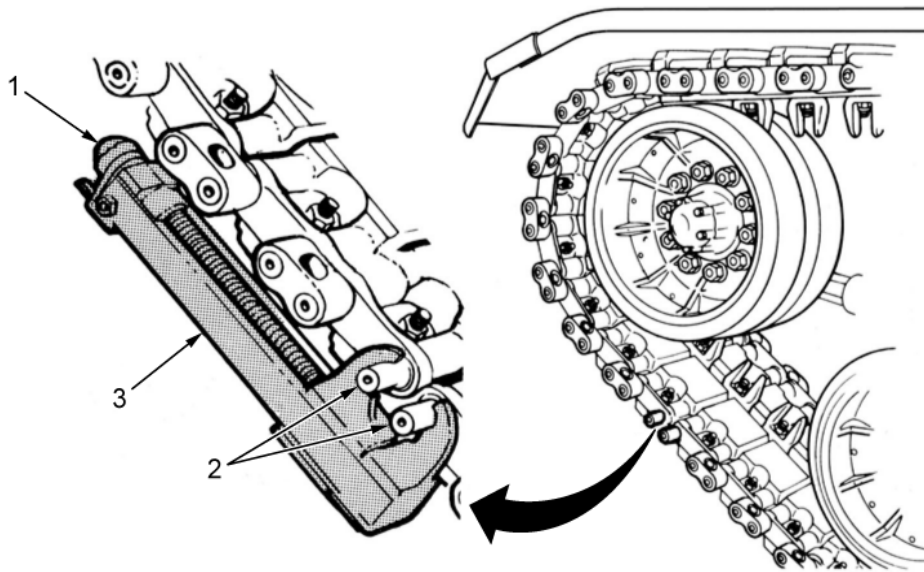

AVLBD337

Figure 3. Track Fixture Removal.

8. To remove inner end connector, repeat steps 1 through 7.

END OF TASK

TEST AND INSPECTION

Inspect attaching hardware, e.g., washers, screws, and bolts, for stripped threads, rust, or corrosion. Replace any hardware that is defective.

END OF TASK

INSTALLATION

1. Use hammer to tap end connector (Figure 4, Item 2) onto link pins (Figure 4, Item 3) until connector contacts track fixture (Figure 4, Item 7).
2. Use ratchet to turn track fixture tension adjustment (Figure 4, Item 1) clockwise until track fixture (Figure 4, Item 7) is loose. Remove track fixture from track (Figure 4, Item 4).
3. Use hammer to tap end connector (Figure 4, Item 2) onto pins (Figure 4, Item 3) until end connector contacts track (Figure 4, Item 4).
4. Insert wedge (Figure 4, Item 6) in end connector (Figure 4, Item 2).

NOTE

Have field mechanic torque bolt. If field mechanic is not available, position track as shown in Breaking and Connecting Track (WP 0055) and tighten bolt. Have field mechanic torque bolt as soon as possible.

5. Use 15/16 inch socket to install bolt (Figure 4, Item 5) in end connector (Figure 4, Item 2) and tighten bolt by turning clockwise.
6. Adjust track tension. Refer to WP 0056.

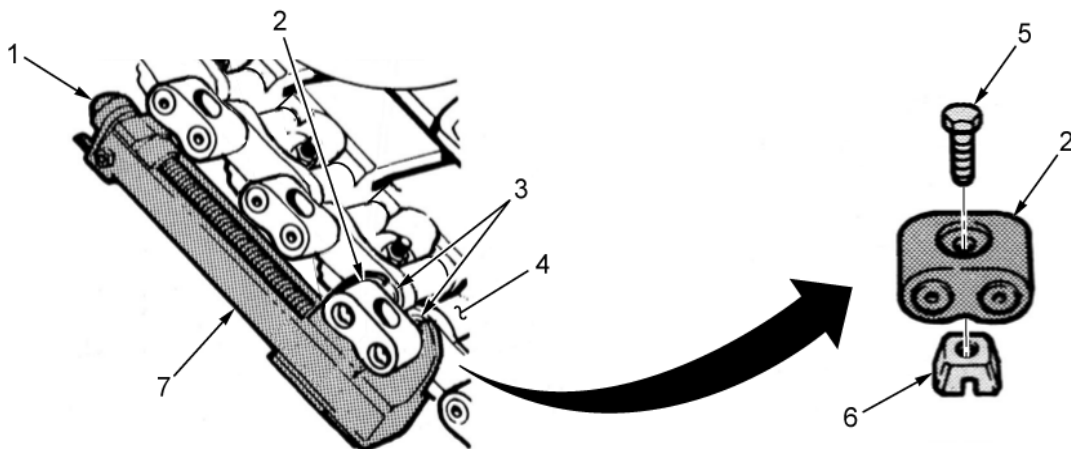

AVLBD338A

Figure 4. End Connector Installation.

END OF TASK

END OF WORK PACKAGE

OPERATOR MAINTENANCE
TRACK CENTER GUIDE REMOVAL AND INSTALLATION

INITIAL SETUP:**Tools and Special Tools**

Socket Wrench (WP 0077, Table 2, Item 17)
Hammer, Machinist (WP 0077, Table 2, Item 26)
Wrench (WP 0077, Table 2, Item 27)
Socket Wrench (WP 0077, Table 2, Item 30)
Socket Wrench (WP 0077, Table 2, Item 54)

Equipment Conditions

Engine off (WP 0015)
Center guide positioned between compensating idler
and number one roadwheel (WP 0016)
Track end connectors removed (WP 0049)
Track tension loosened (WP 0053 or WP 0054)

GENERAL

This work package contains information on the removal, inspection, and installation of the track center guide.

REMOVAL

1. Use 1-5/16 inch socket, 4-5/8 inch socket wrench extension, hinged handle, and extension handle to turn nut (Figure 1, Item 2) counterclockwise until nut is flush with bolt (Figure 1, Item 4).
2. Tap nut (Figure 1, Item 2) and bolt (Figure 1, Item 4) with hammer until cap (Figure 1, Item 3) is loose.
3. Remove nut (Figure 1, Item 2), center guide (Figure 1, Item 1), cap (Figure 1, Item 3), and bolt (Figure 1, Item 4) from track (Figure 1, Item 5).

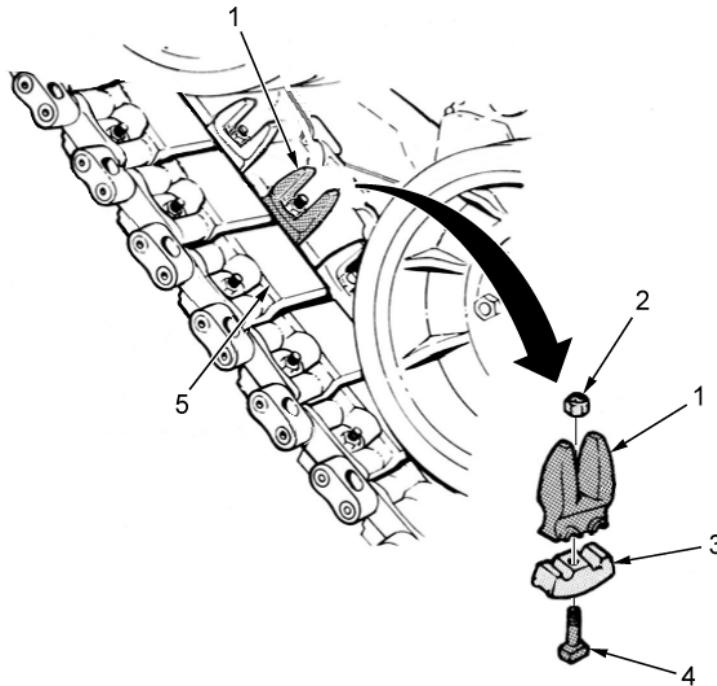

AVLBD329

Figure 1. Track Center Guide Removal.

END OF TASK**INSPECTION OF INSTALLED ITEMS**

Inspect attaching hardware, e.g., washers, screws, and bolts, for stripped threads, rust, or corrosion. Replace any hardware that is defective.

END OF TASK

INSTALLATION

1. Install center guide (Figure 2, Item 1), cap (Figure 2, Item 3), and bolt (Figure 2, Item 4) in track link (Figure 2, Item 5).

NOTE

Have field mechanic torque nut to specification. If field mechanic is not available, tighten nut and have field mechanic torque it as soon as possible.

2. Use 1-5/16 inch socket, 4-5/8 inch socket wrench extension, hinged handle, and extension handle to install nut (Figure 2, Item 2) on bolt (Figure 2, Item 4).
3. Tighten track tension. Refer to WP 0053 or WP 0054.

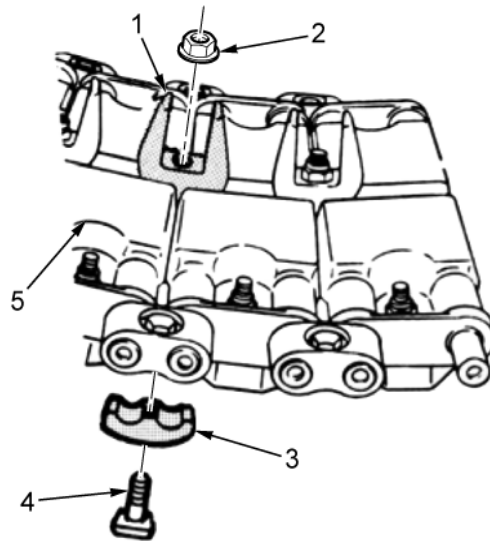

AVLBD340

Figure 2. Center Guide Installation.

END OF TASK**END OF WORK PACKAGE**

OPERATOR MAINTENANCE
TRACK LINK REMOVAL AND INSTALLATION

INITIAL SETUP:**Tools and Special Tools**

- Hammer (WP 0077, Table 2, Item 26)
- Wrench (WP 0077, Table 2, Item 27)
- Socket Wrench (WP 0077, Table 2, Item 30)
- Socket Wrench (WP 0077, Table 2, Item 61)

Personnel Required

2

References

WP 0049

References (cont.)

- WP 0050
- WP 0055

Equipment Conditions

- Center guide positioned between track link and compensating idler wheel (WP 0016)
- Engine off (WP 0015)

GENERAL

This work package contains information on the removal and installation of the track link.

REMOVAL

1. Ensure vehicle is positioned with defective track link (Figure 1, Item 3) between compensating idler wheel (Figure 1, Item 1) and front roadwheel (Figure 1, Item 2).

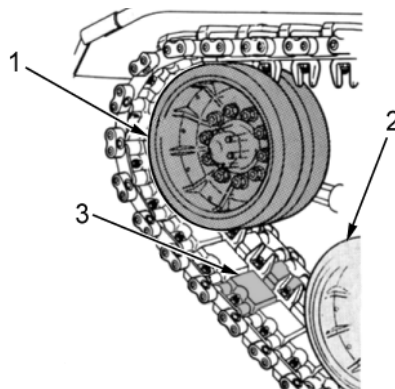

AVLBD333A

Figure 1. Defective Link.

REMOVAL - CONTINUED

2. Remove inner and outer end connectors (Figure 2, Item 3). Refer to WP 0049.

NOTE

Track link will fall free when center guide is removed.

3. Remove center guide (Figure 2, Item 2). Refer to WP 0050.
4. Break track (Figure 2, Item 1). Refer to WP 0055.

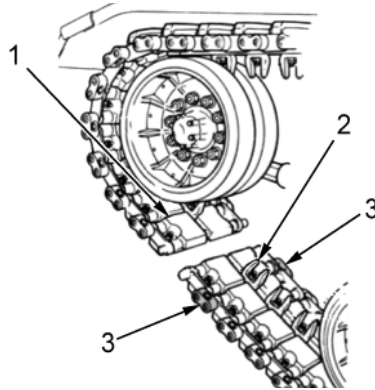

AVLBD511

Figure 2. Removing Defective Track Link.

END OF TASK**INSTALLATION**

1. Place new track link (Figure 3, Item 1) in front of track (Figure 3, Item 2).

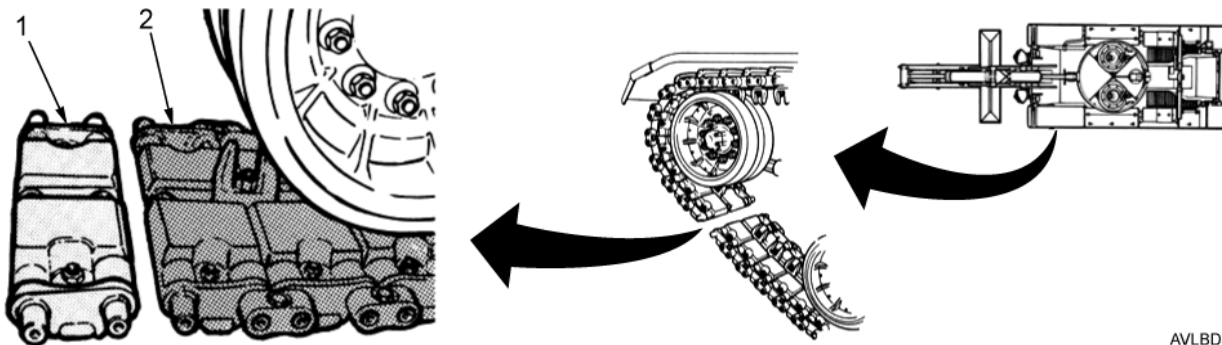

AVLBD335

Figure 3. Track Link Installation.

2. One crew member lines up track link pins (Figure 4, Item 2).
3. Other crew member uses hammer to tap end connectors (Figure 4, Item 1) onto track link pins (Figure 4, Item 2).
4. Install wedge (Figure 4, Item 6) and bolt (Figure 4, Item 3) on end connectors (Figure 4, Item 1). Do not tighten.
5. When end connectors (Figure 4, Item 1) contact track (Figure 4, Item 5), tighten bolts (Figure 4, Item 3).
6. Install center guide (Figure 4, Item 4) (refer to WP 0050) and connect track (Figure 4, Item 5) (refer to WP 0055).

INSTALLATION - CONTINUED

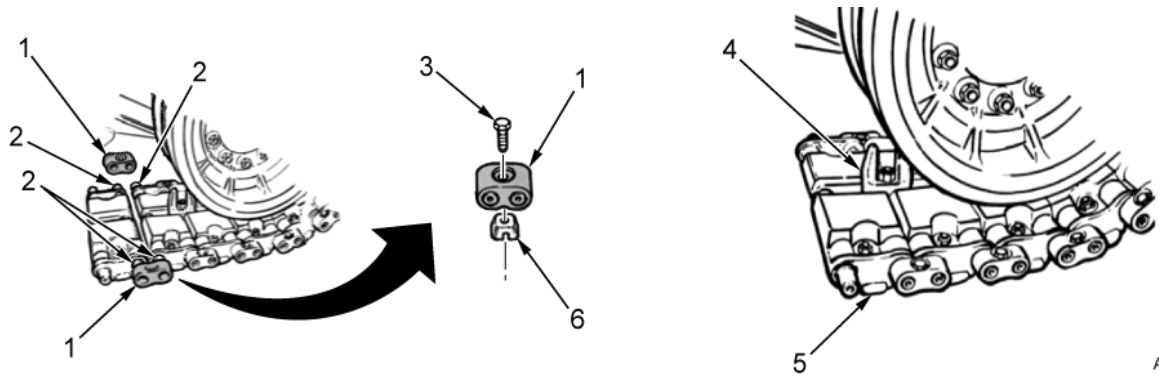

AVLBD336A

Figure 4. End Connector Installation.

END OF TASK

END OF WORK PACKAGE

OPERATOR MAINTENANCE**T-142 TRACK PAD REMOVAL AND INSTALLATION**

INITIAL SETUP:**Tools and Special Tools**

Hammer (WP 0077, Table 2, Item 26)
Wrench (WP 0077, Table 2, Item 27)
Socket Wrench (WP 0077, Table 2, Item 30)
Socket Wrench (WP 0077, Table 2, Item 61)

Equipment Conditions

Track pad positioned between compensating idler wheel and front road wheel (WP 0016)
Engine off (WP 0015)

GENERAL

This work package contains information on the removal and installation of the T-142 track pad.

REMOVAL

1. Ensure vehicle is positioned with defective track pad (Figure 1, Item 3) between compensating idler wheel (Figure 1, Item 1) and front road wheel (Figure 1, Item 2).

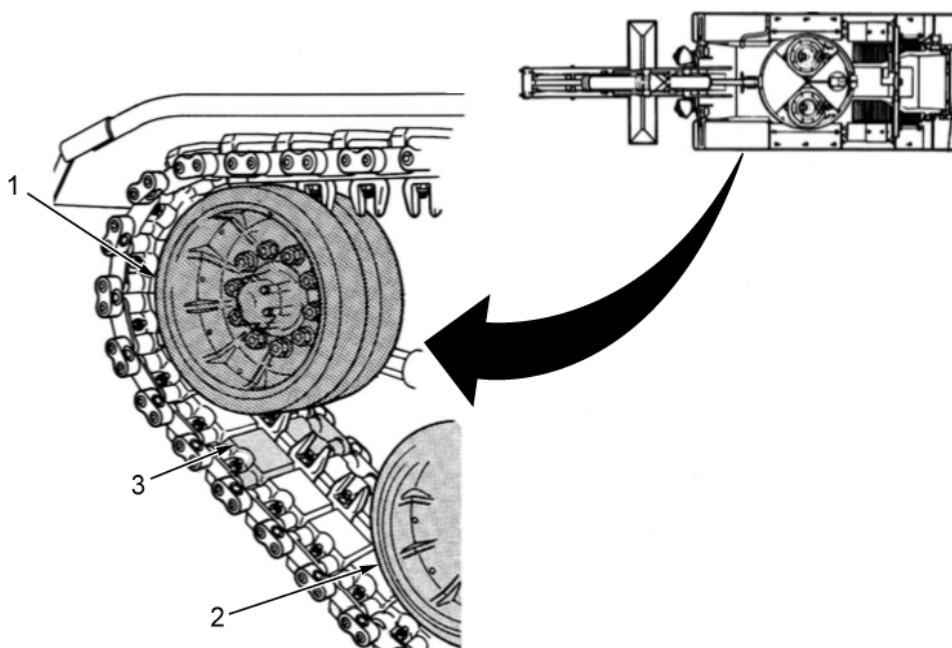

AVLBD347

Figure 1. Track Pad Removal.

REMOVAL - CONTINUED

2. Use socket to remove nut (Figure 2, Item 3) from bolt (Figure 2, Item 4).
3. Tap bolt (Figure 2, Item 4) with hammer to remove pad (Figure 2, Item 1) from link assembly (Figure 2, Item 2).

END OF TASK**INSPECTION OF INSTALLED ITEMS**

Inspect attaching hardware, e.g., washers, screws, and bolts, for stripped threads, rust, or corrosion. Replace any hardware that is defective.

END OF TASK**INSTALLATION**

1. Install pad (Figure 2, Item 1) on link assembly (Figure 2, Item 2) and install nut (Figure 2, Item 3) on bolt (Figure 2, Item 4) using socket.
2. Contact field maintenance to torque nut.

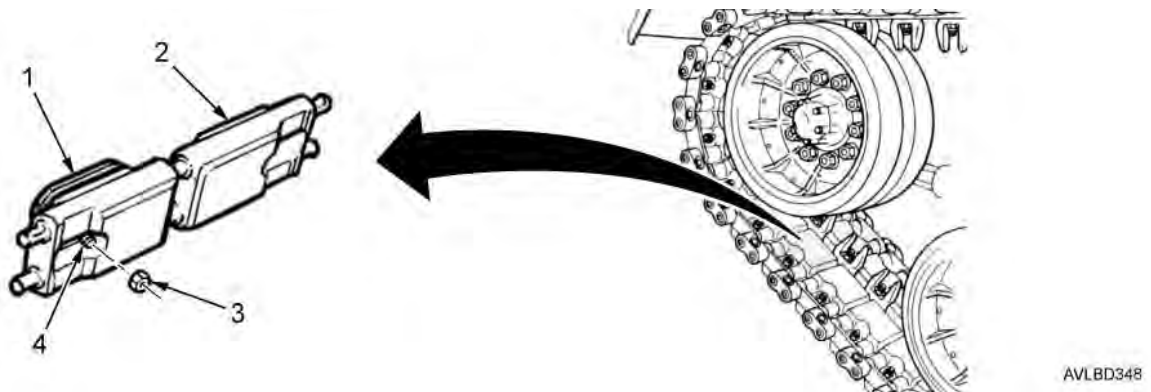

Figure 2. Track Pad Removal/Installation.

END OF TASK**END OF WORK PACKAGE**

OPERATOR MAINTENANCE**LOOSENING TRACK TENSION - CONVENTIONAL TRACK ADJUSTING LINK**

INITIAL SETUP:**Tools and Special Tools**

Wrench, Double Head (WP 0077, Table 2, Item 72)
Wrench, Single Head (WP 0077, Table 2, Item 74)

Equipment Conditions

Vehicle stopped on hard, level surface (WP 0016)
Engine off (WP 0015)

References

WP 0056

GENERAL

This work package contains information on loosening conventional track tension and sprocket inspection.

ADJUSTMENT

1. Remove dirt and mud from locking screw (Figure 1, Item 2) and adjusting link (Figure 1, Item 1).

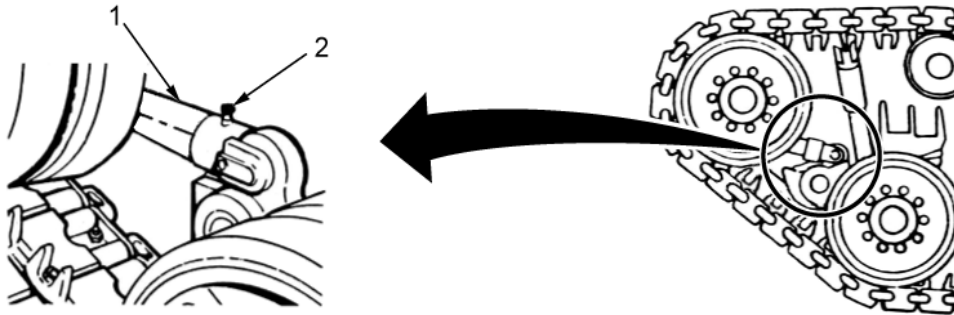

AVLBD318A

Figure 1. Track Adjusting Link.

2. Turn double head wrench (Figure 2, Item 3) counterclockwise and loosen locking screw (Figure 2, Item 4) until adjusting arm (Figure 2, Item 2) moves.

NOTE

On right side of vehicle, rotate down on single head wrench (Figure 2, Item 1) to loosen track tension. On left side of vehicle, rotate up on single head wrench to loosen track tension.

3. Use single head open-end wrench (Figure 2, Item 1) to rotate wrench up or down until track sags.

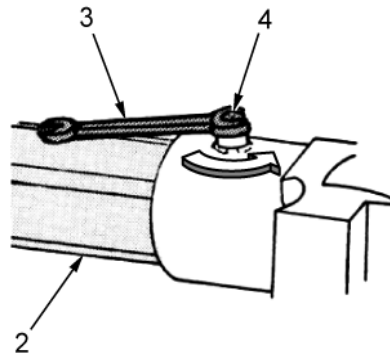
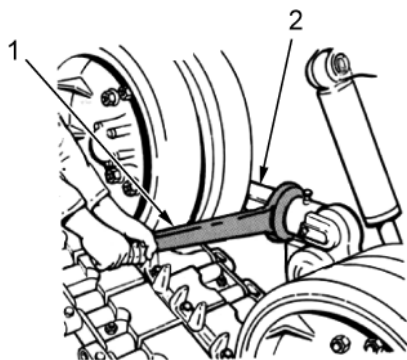

AVLBD319A

Figure 2. Loosening Track Tension.

4. If no further maintenance is required, adjust track tension. Refer to WP 0056.

END OF TASK

TEST AND INSPECTION**NOTE**

- Undercut is located on two teeth only.
- Vehicle may be equipped with drive sprockets having no undercut. In this case, wear will be measured quarterly by field maintenance personnel.

1. Check for undercut (Figure 3, Item 2) on sprocket tooth (Figure 3, Item 1).
2. If wear has eliminated undercut, notify field maintenance.

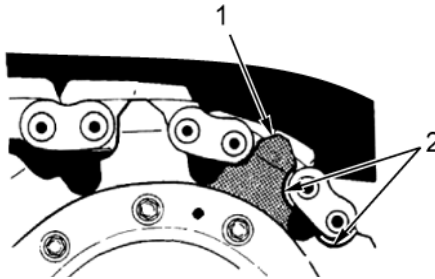

AVLBD320

Figure 3. Measuring Track Drive Sprocket Wear.

END OF TASK**END OF WORK PACKAGE**

OPERATOR MAINTENANCE**LOOSENING TRACK TENSION - GREASE-ACTUATED ADJUSTING LINK**

INITIAL SETUP:**Tools and Special Tools**

Gun, Grease (WP 0077, Table 2, Item 14)
Gun, Lubricating (WP 0077, Table 2, Item 24)
Screwdriver, Flat-Tipped (WP 0077, Table 2, Item 49)
Wrench, Spanner (WP 0077, Table 2, Item 75)

Equipment Conditions

Vehicle moved forward on hard, level surface and
coasted to stop without applying brakes (WP 0016)
Engine off (WP 0015)

Materials/Parts

Rag, Wiping (WP 0079, Table 1, Item 52)

GENERAL

This work package contains information on loosening track tension for grease-actuated adjusting link.

ADJUSTMENT

1. Remove and clean grease, mud, and dirt from pressure relief valve (Figure 1, Item 1), grease fitting (Figure 1, Item 5), threaded shaft (Figure 1, Item 2), thread locking collar (Figure 1, Item 4), and locking screw (Figure 1, Item 3).

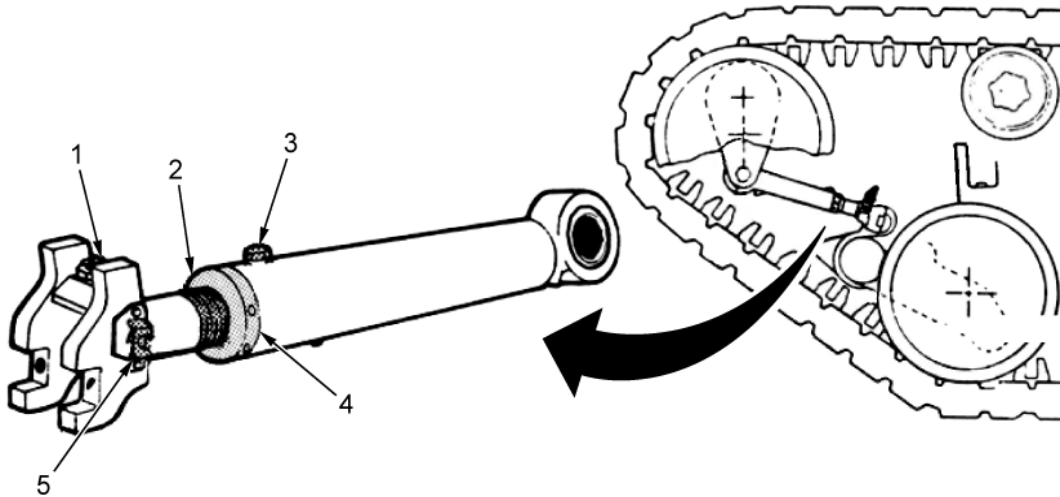

AVLBD321A

Figure 1. Grease-Actuated Adjusting Link.

2. Loosen locking screw (Figure 2, Item 2).
3. Insert lube gun extension (Figure 2, Item 7) into bracket (Figure 2, Item 9) and couple extension with grease fitting (Figure 2, Item 8). Couple grease gun (Figure 2, Item 6) to lube gun extension.

NOTE

Locking collar may first require tightening to break loose trapped dirt prior to loosening collar.

4. Pump grease gun (Figure 2, Item 6) handle to release threaded locking collar (Figure 2, Item 10).
5. Back off locking collar (Figure 2, Item 10) using spanner wrench (Figure 2, Item 1).

ADJUSTMENT**WARNING**

Grease could spray from relief valve pin when lifted. Wear protective goggles and cover relief valve pin and screwdriver with rag to prevent grease from getting into eyes. Failure to comply may result in personnel injury.

CAUTION

DO NOT remove plug (Figure 2, Item 3) to relieve pressure when track is connected. Grease-actuated adjusting link could be damaged. After track is broken, plug may be removed for easy hand collapsing of grease-actuated adjusting link.

6. Relieve link internal pressure by lifting pressure relief valve pin (Figure 2, Item 4) with screwdriver (Figure 2, Item 5).

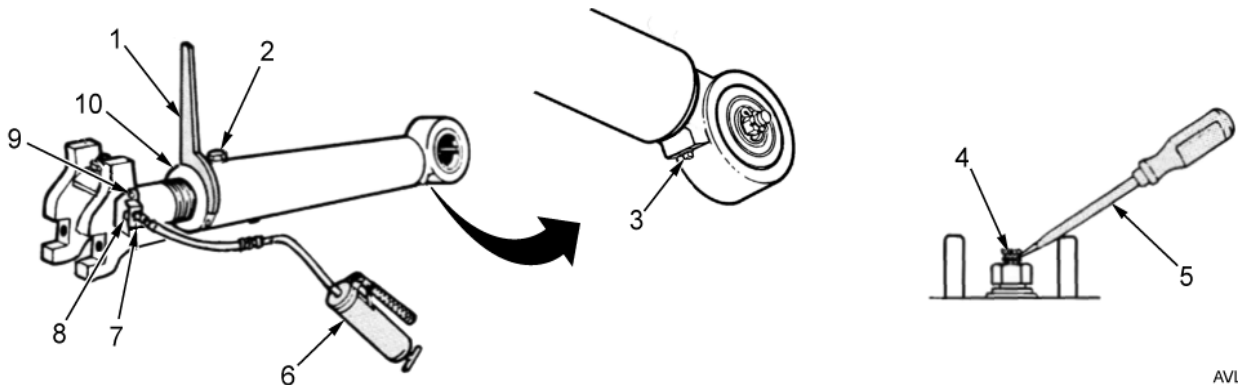

AVLBD322

Figure 2. Release Threaded Locking Collar.

END OF TASK

END OF WORK PACKAGE

OPERATOR MAINTENANCE
BREAKING AND CONNECTING TRACK

INITIAL SETUP:**Tools and Special Tools**

Crowbar (WP 0077, Table 2, Item 11)
Socket Wrench (WP 0077, Table 2, Item 17)
Fixture, Track (WP 0077, Table 2, Item 21)
Wrench (WP 0077, Table 2, Item 27)
Socket Wrench (WP 0077, Table 2, Item 31)

Personnel Required

3

References

WP 0012
WP 0013
WP 0015

References (cont.)

WP 0016
WP 0049
WP 0050
WP 0053
WP 0054
WP 0056

Equipment Conditions

Vehicle on hard, level surface and defective link
break point positioned between compensating idler
and number one roadwheel (WP 0016)
Engine off (WP 0015)

GENERAL

This work package contains information on breaking and connecting track.

DISASSEMBLY

1. Remove center guide (Figure 1, Item 2). Refer to WP 0050.
2. Loosen track tension. Refer to WP 0053 or WP 0054.
3. Remove inner and outer end connectors (Figure 1, Item 1). Refer to WP 0049.

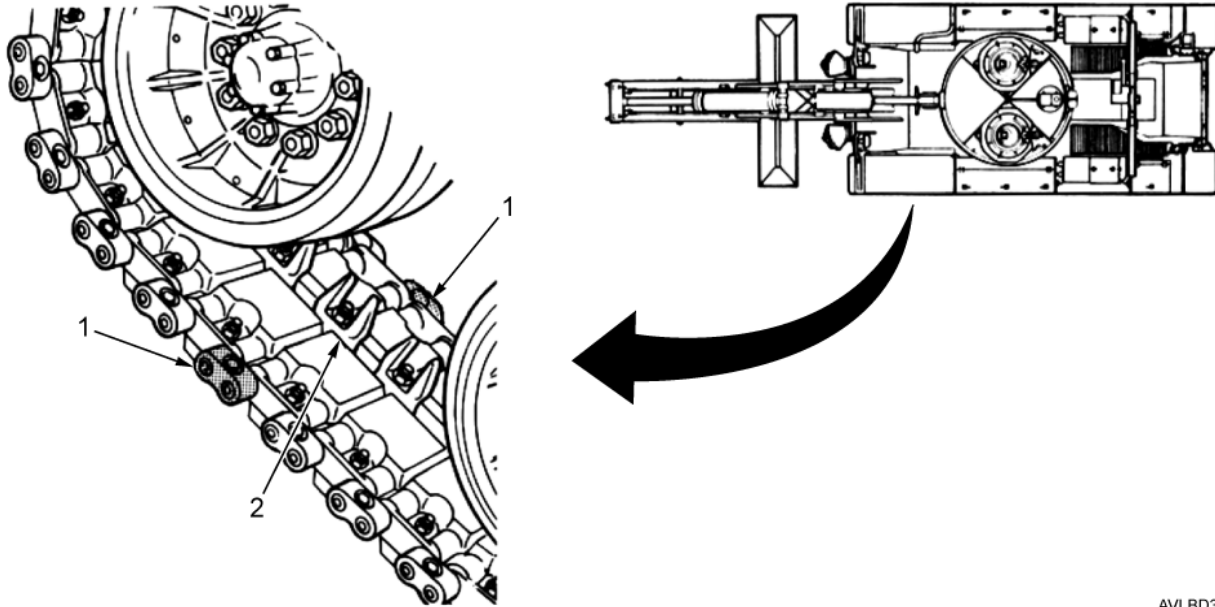

AVLBD330

Figure 1. Center Guide and End Connectors.

WARNING

Track may suddenly separate when lifting with crowbar. Crew member holding up track with crowbar must stand to side of track, not in front of track. DO NOT allow personnel in front of track. Track may suddenly separate. Failure to comply may result in personnel injury or death.

4. One crew member uses crowbar (Figure 2, Item 2) to hold track (Figure 2, Item 1).

NOTE

Depending on the vehicle, there are two types of track fixtures available. The new-type track fixture requires a ratchet for opening or closing fixture jaw and is used for this procedure. The old-type track fixture is equipped with an extension bar used for opening and closing the fixture.

5. Second crew member uses ratchet to turn track fixture tension adjustment (Figure 2, Item 4) clockwise until loose.
6. Remove track fixture (Figure 2, Item 3) and crowbar (Figure 2, Item 2) from track (Figure 2, Item 1) and allow track to fall free.

DISASSEMBLY - CONTINUED

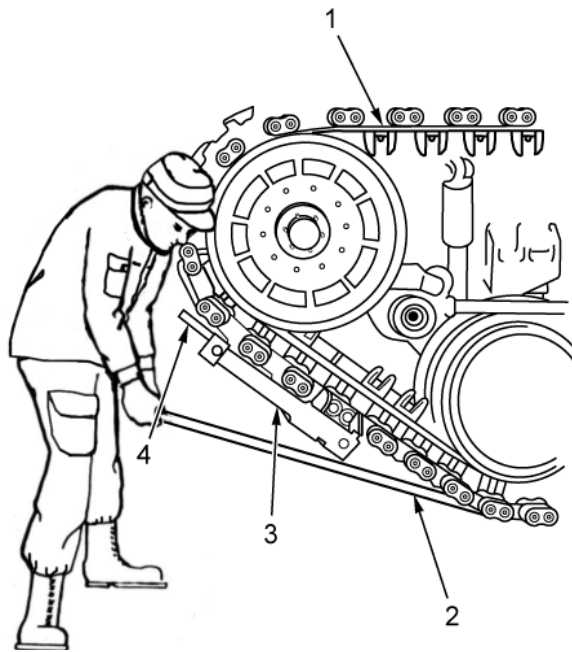

AVLBD331

Figure 2. Removing Track Fixture.

END OF TASK

ASSEMBLY

1. Use crowbar (Figure 3, Item 2) to lift track (Figure 3, Item 1).

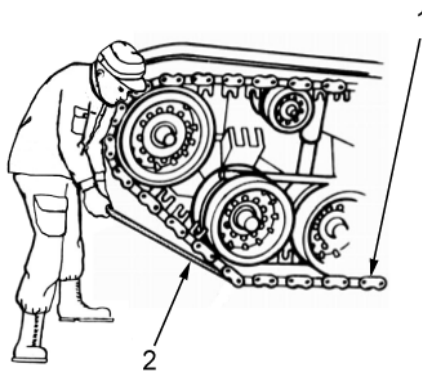

AVLBD341

Figure 3. Lifting Track.

ASSEMBLY - CONTINUED

2. If outer pins (Figure 4, Item 4) are too far apart to attach track fixtures, wedge crowbar (Figure 4, Item 2) between two center guides (Figure 4, Item 3) and groove of compensating idler wheel (Figure 4, Item 1). Pull down on crowbar until track fixtures can be attached.
3. Remove crowbar (Figure 4, Item 2) from track center guide (Figure 4, Item 3).

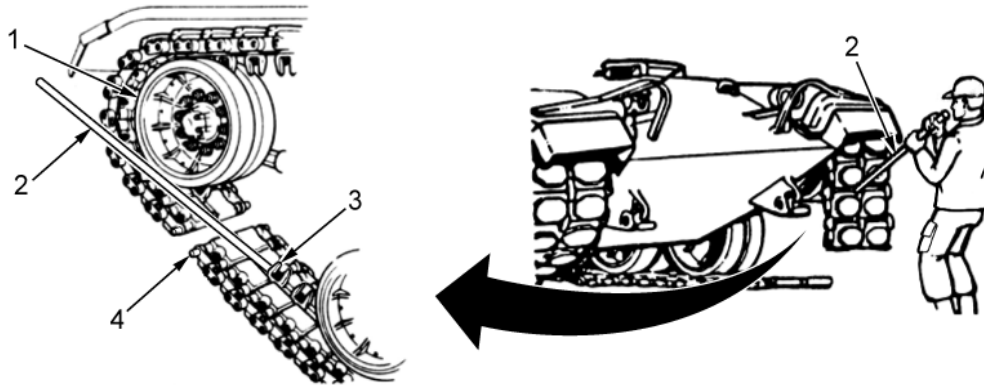

AVLBD501

Figure 4. Connecting Track.

4. Line up track pins (Figure 5, Item 3) on outside of track.
5. Other two crew members attach track fixture (Figure 5, Item 5) to track pins (Figure 5, Item 3), and use ratchet to turn track fixture tension adjustment (Figure 5, Item 1) counterclockwise to tighten.
6. Align track pins (Figure 5, Item 3) on inside of track and attach second track fixture (Figure 5, Item 5) to inner pins.
7. Tighten both track fixtures (Figure 5, Item 5) by turning tension adjustment (Figure 5, Item 1) counterclockwise until track links (Figure 5, Item 4) are almost touching.

NOTE

Use new center guide bolt and nut, if available. If not, replace as soon as possible.

8. Install outer and inner connectors (Figure 5, Item 2) (WP 0049) and center guide. Refer to WP 0050.

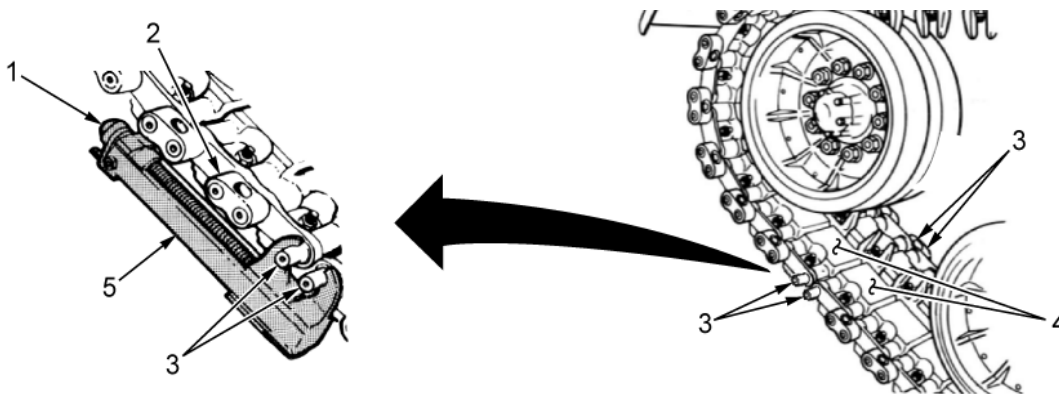

AVLBD343

Figure 5. Adjusting Track Fixtures.

ASSEMBLY - CONTINUED**NOTE**

Field mechanic must torque end connector and center guide bolts to correct torque value. If field mechanic is not available, perform steps 9 through 24. Notify field mechanic to torque end connector and center guide bolts as soon as possible.

9. Turn center guide nut (Figure 6, Item 1) counterclockwise one turn to loosen.
10. Start engine. Refer to WP 0015.
11. Move vehicle until end connector (Figure 6, Item 2) is located at 9 o'clock position in reference to compensating idler wheel (Figure 6, Item 3). Stop vehicle. Refer to WP 0016.
12. Move shift lever to P (Park). Refer to WP 0013.

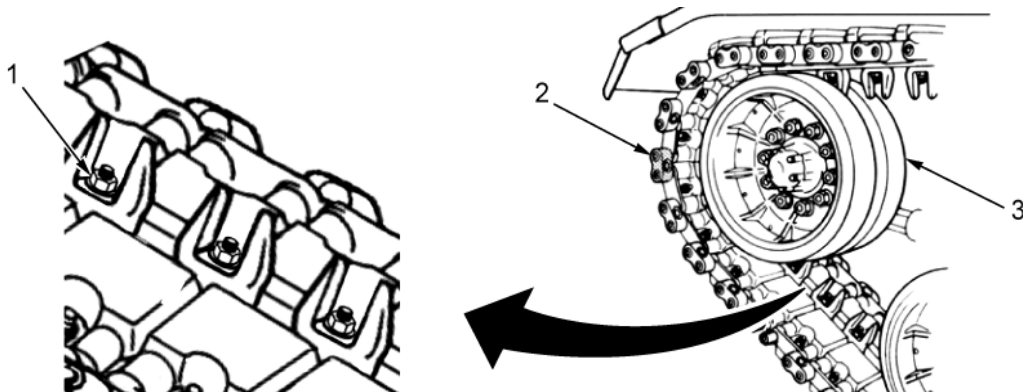

AVLBD344

Figure 6. Remove Center Guide Nut.

13. Raise and hold ENGINE FUEL SHUTOFF switch until engine stops. Refer to WP 0015.
14. Set parking brake. Refer to WP 0012.
15. Tighten inner and outer connector bolts. Refer to WP 0049.
16. Start engine. Refer to WP 0015.
17. Move vehicle until end connector (Figure 7, Item 2) is located at 6 o'clock position in relation to compensating idler wheel (Figure 7, Item 1).

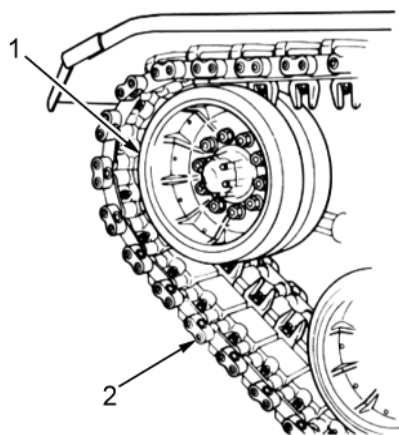

AVLBD345A

Figure 7. Engine Fuel Shutoff Switch.

ASSEMBLY - CONTINUED

18. Move vehicle until end connector (Figure 8, Item 2) is located back at 9 o'clock position in relation to compensating idler wheel (Figure 8, Item 3).
19. Repeat steps 12 through 14.
20. Tighten inner and outer connector bolts. Refer to WP 0049.
21. Start engine. Refer to WP 0015.
22. Move vehicle until center guide (Figure 8, Item 5) is located between compensating idler wheel (Figure 8, Item 3) and number one roadwheel (Figure 8, Item 4).
23. Repeat steps 12 through 14.
24. Tighten center guide bolt (Figure 8, Item 1) and adjust track tension. Refer to WP 0056.

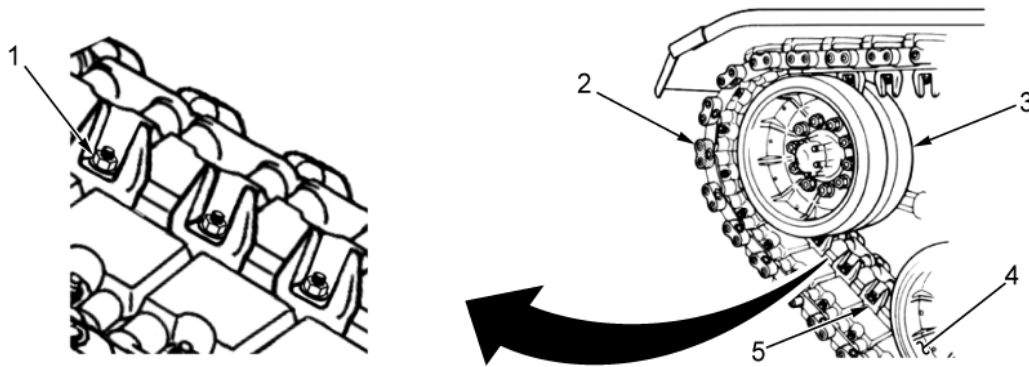

AVLBD346

Figure 8. Center Guide Nut.

END OF TASK**END OF WORK PACKAGE**

OPERATOR MAINTENANCE
TRACK TENSION ADJUSTMENT

INITIAL SETUP:**Tools and Special Tools**

Ruler (General Mechanic's Tool Kit)
Wrench, Double Head (WP 0077, Table 2, Item 72)
Wrench, Single Head (WP 0077, Table 2, Item 74)

Materials/Parts

Lockwasher (WP 0079, Table 1, Item 39)
Twine, Fibrous (WP 0079, Table 1, Item 65)
2 inch x 4 ft Wooden block

References

WP 0013
WP 0051
WP 0054
LO 5-5420-202-13

Equipment Conditions

Vehicle stopped on level ground (WP 0016)

GENERAL

This work package contains procedures for track tension adjustment.

ADJUSTMENT**CAUTION**

Track tension must be checked and adjusted when bridge is on vehicle. Proper track tension will prevent track damage and will prevent track from being thrown.

1. Move vehicle backward two vehicle lengths.
2. Move vehicle forward and allow vehicle to stop without applying brakes.
3. Set shift lever to P (Park) and shut off engine. Refer to WP 0013.
4. Remove dirt and mud from end connectors (Figure 1, Item 2), near compensating idler wheel (Figure 1, Item 1) and first and second support rollers (Figure 1, Item 3).
5. Tie centerguides (Figure 1, Item 4) to each end of twine (Figure 1, Item 5).
6. Position twine (Figure 1, Item 5) over center of end connectors (Figure 1, Item 2).

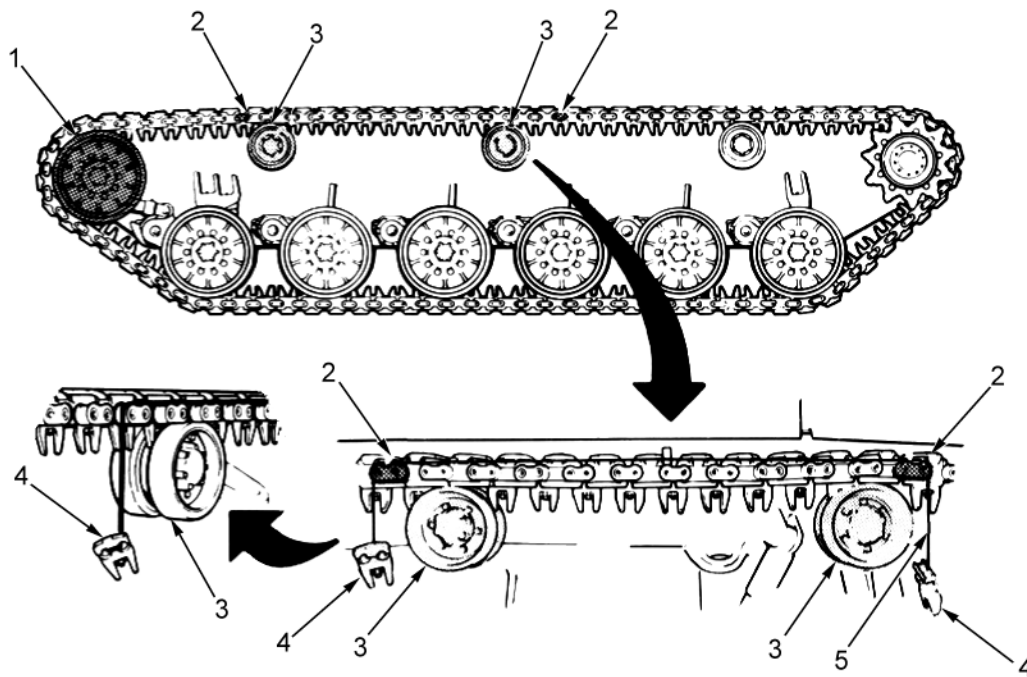

AVLBD349

Figure 1. Positioning Twine Over End Connectors.

ADJUSTMENT - CONTINUED

NOTE

If vehicle is equipped with five support rollers, perform steps 7 and 8. If vehicle is equipped with less than five support rollers, proceed to step 9.

7. Place 2 inch x 4 ft wooden block (Figure 2, Item 6) between center support roller (Figure 2, Item 5) and track (Figure 2, Item 2).
8. Position twine (Figure 2, Item 1) with centerguides (Figure 2, Item 4) on both ends over end connectors (Figure 2, Item 3) over center and front support rollers (Figure 2, Item 5). Position twine in center of end connector. Record measurement between arrows.

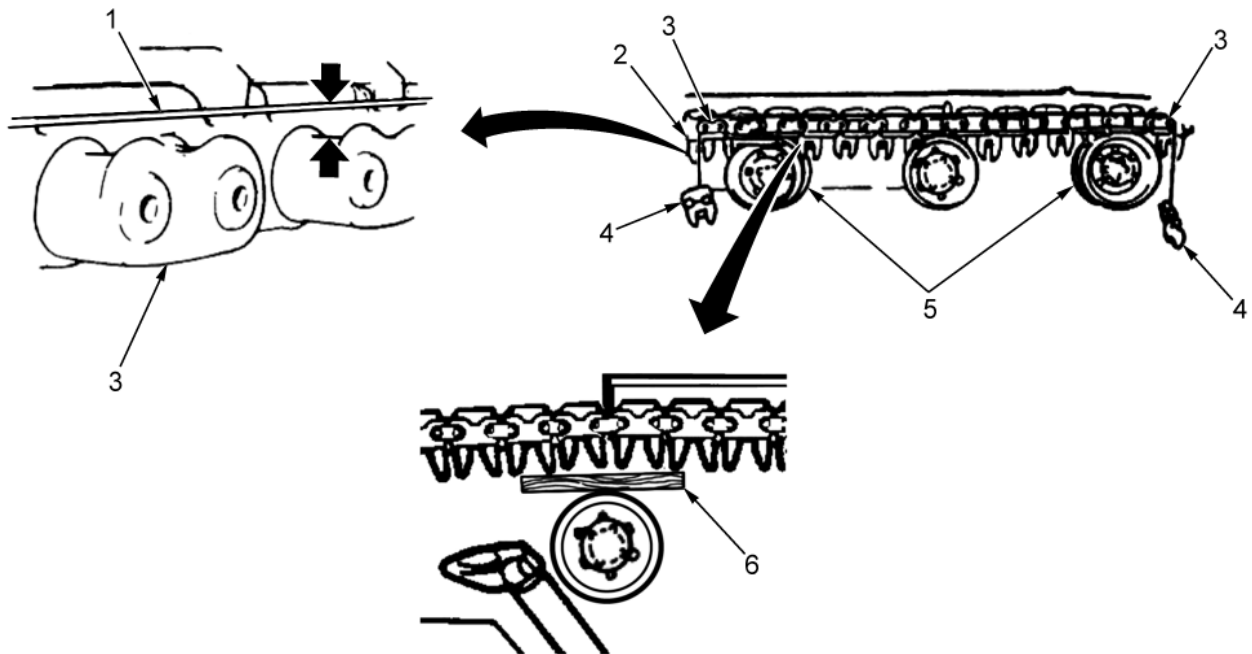

AVLBD350

Figure 2. Wooden Block Placement.

ADJUSTMENT - CONTINUED

NOTE

Once track adjustment is completed, remove wooden block.

9. Find center of twine (Figure 3, Item 1) and place check mark on nearest end connector (Figure 3, Item 2).
10. Using ruler (Figure 3, Item 3), measure distance between bottom of twine (Figure 3, Item 4) and top of check-marked end connector (Figure 3, Item 2).

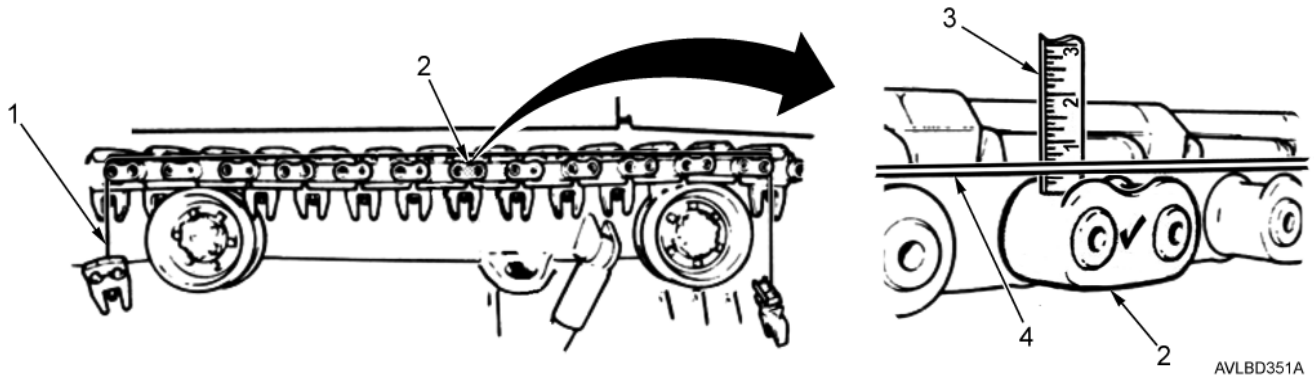

Figure 3. Distance Between Bottom of Twine and Top of Marked End Connector.

NOTE

If space between twine and end connector measures between 3/8 to 9/16 inch (9.5 to 14.3 mm), track tension is acceptable. If measurement is not within specifications, perform steps 11 through 18 for conventional track adjusting link or refer to Grease-Actuating Adjusting Link. Refer to WP 0054.

11. Remove dirt and mud from locking screw (Figure 4, Item 2) and adjusting link (Figure 4, Item 1).

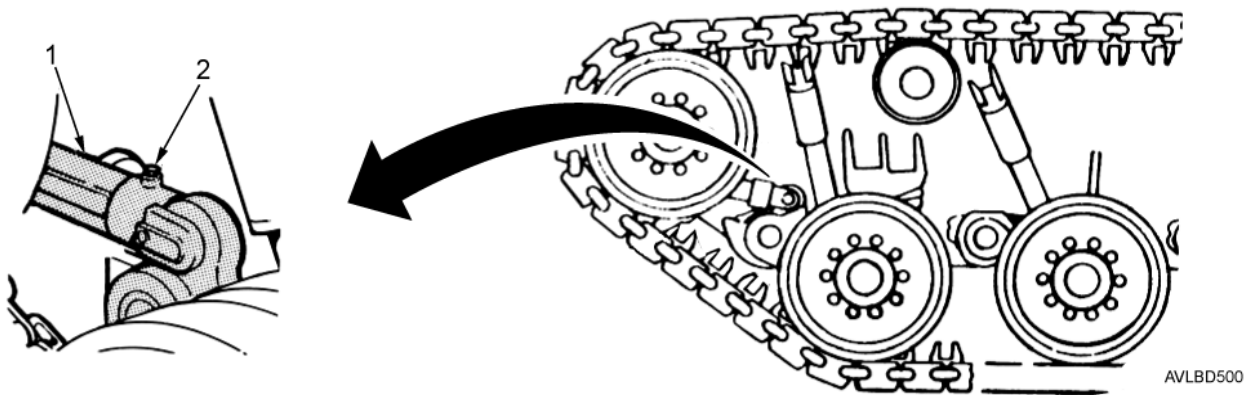
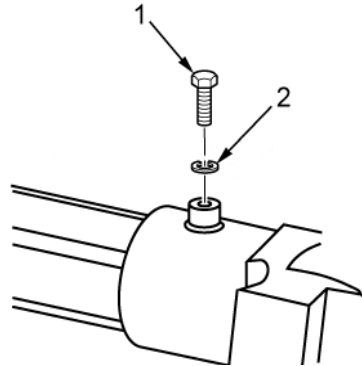

Figure 4. Adjusting Link Locking Screw.

ADJUSTMENT - CONTINUED

12. Use 9/16 inch wrench to remove locking screw (Figure 5, Item 1) and lockwasher (Figure 5, Item 2). Discard lockwasher.



AVLBD512

Figure 5. Locking Screw Removal.

13. Place 3-3/16 inch open end wrench (Figure 6, Item 3) on track adjusting link (Figure 6, Item 2) next to compensating idler wheel (Figure 6, Item 1).

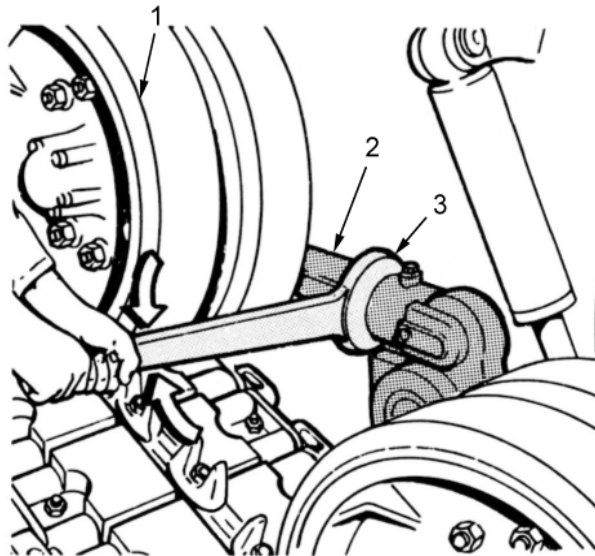

AVLBD353

Figure 6. Adjusting Track Tension.

ADJUSTMENT - CONTINUED**CAUTION**

When increasing track tension, DO NOT move adjusting link beyond groove or red painted groove (M48A5). Damage to adjusting link may occur. If track tension is still loose after groove or red painted groove appears, remove one track link and readjust track tension. Refer to WP 0051. Stow removed track link in fender stowage box. If a track link must be removed when adjusting one side, the opposite side does not have to be shortened.

NOTE

To adjust track tension on right side of vehicle, pull wrench up to increase tension and push down to decrease tension. On left side of track, use opposite directions.

14. Use 3-3/16 inch open end wrench (Figure 7, Item 1) to decrease or increase track tension as required by turning track adjusting link (Figure 7, Item 2).

CAUTION

When increasing track tension, DO NOT move adjusting link beyond groove or red painted groove (M48A5). Damage to adjusting link may occur. If track tension is still loose after groove or red painted groove appears, remove one track link and readjust track tension. Refer to WP 0051. Stow removed track link in fender stowage box. If a track link must be removed when adjusting one side, the opposite side does not have to be shortened.

15. Repeat step 10.

NOTE

When installing lockwasher and tightening locking screw, ensure high side of adjusting link is aligned with locking screw.

16. Install new lockwasher (Figure 7, Item 4) and locking screw (Figure 7, Item 3) on track adjusting link (Figure 7, Item 2).
17. Lubricate adjusting link. Refer to LO 5-5420-202-13.

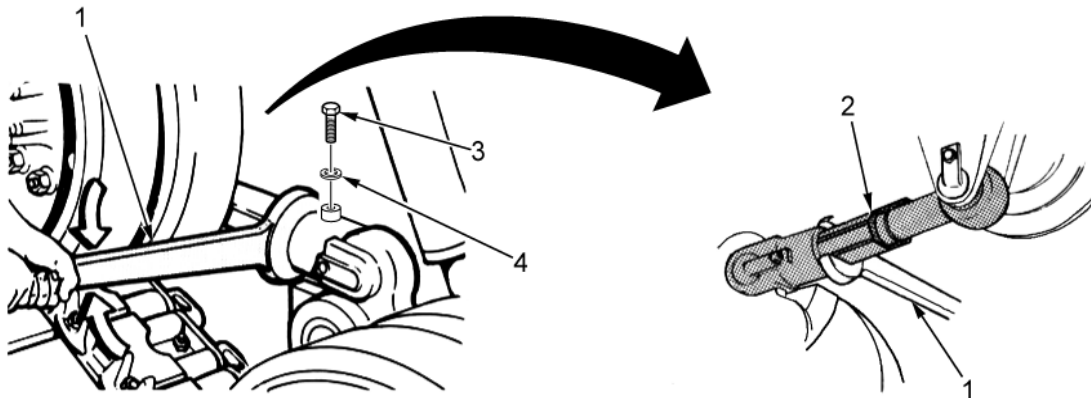

AVLBD354

Figure 7. Final Track Link Adjustment.

END OF TASK

END OF WORK PACKAGE

OPERATOR MAINTENANCE
THROWN TRACK INSTALLATION

INITIAL SETUP:**Tools and Special Tools**

Crowbar (WP 0077, Table 2, Item 11)

Materials/Parts

Rope (WP 0079, Table 1, Item 53)

Wood (2)

Wood Board

Personnel Required

4

References

WP 0012

References (cont.)

WP 0013

WP 0014

WP 0015

WP 0017

WP 0055

WP 0056

WP 0058

Equipment Conditions

Vehicle stopped on level ground (WP 0016)

Engine off (WP 0015)

GENERAL

This work package contains information on installing thrown track.

INSTALLATION**CAUTION**

If vehicle cannot be moved under its own power without causing damage to vehicle or track, **DO NOT** attempt to remove track. Damage to track may occur. Request assistance from field maintenance.

1. Remove rear fender. Refer to WP 0058.
2. Break track (if not already broken). Refer to WP 0055.

WARNING

Personnel may be struck or pinned by moving vehicle when performing vehicle maintenance. Ensure personnel are clear of vehicle. Use ground guide to direct movement of track. Failure to comply may result in personnel injury or death.

3. Start engine, warm up, and let idle. Refer to WP 0015.
4. Drive vehicle rearward slowly until track (Figure 1, Item 2) is free of drive sprocket (Figure 1, Item 1). Refer to WP 0017.

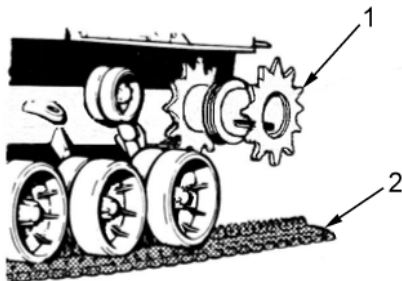

AVLBD359

Figure 1. Track and Drive Sprocket.

5. Move shift lever to P (Park). Refer to WP 0013.
6. Push up and hold ENGINE FUEL SHUTOFF switch (Figure 2, Item 1) until engine stops.
7. Set MASTER BATTERY switch (Figure 2, Item 2) to OFF.
8. Set parking brake. Refer to WP 0012.

INSTALLATION - CONTINUED

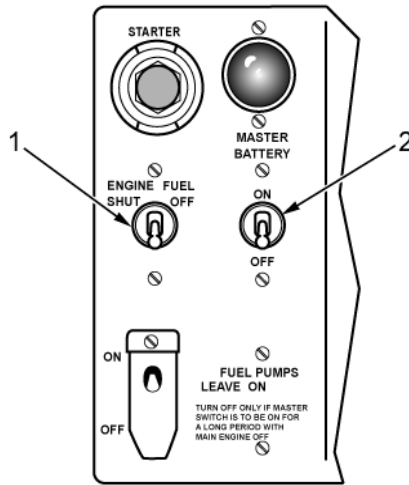

AVLBD360

Figure 2. FUEL SHUTOFF and MASTER BATTERY Switches.

NOTE

If vehicle is completely off track, perform steps 9 through 40. If roadwheels are still resting on track, skip steps 9, 11, and 13.

9. Align track (Figure 3, Item 1) with roadwheel (Figure 3, Item 3) at front or rear of vehicle.
10. Use thick wooden board (Figure 3, Item 4) to drive roadwheel (Figure 3, Item 3) onto track (Figure 3, Item 1). If board is not available, dig hole under track so upper part of track links (Figure 3, Item 2) are even with ground.
11. Start engine, warm up, and let idle. Refer to WP 0015.

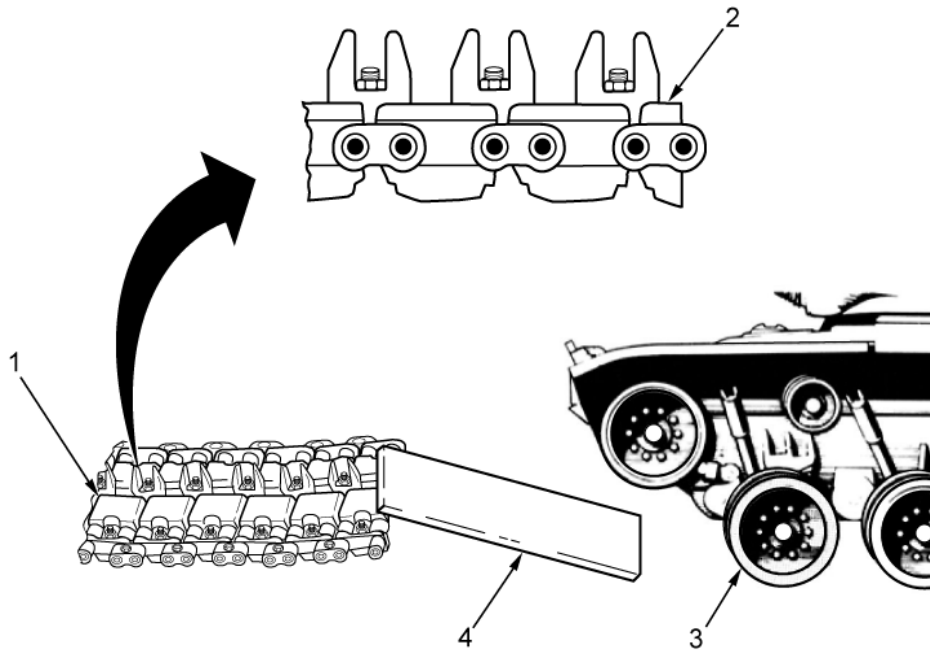

AVLBD361

Figure 3. Driving Vehicle onto Track.

INSTALLATION - CONTINUED

12. Drive vehicle onto track (Figure 4, Item 2). Refer to WP 0017.
13. Stop vehicle when number six (last) roadwheel (Figure 4, Item 1) is resting on sixteenth link (Figure 4, Item 3) from end of track.

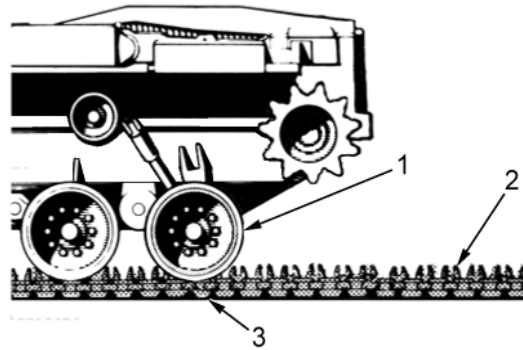

AVLBD362

Figure 4. Stopping Vehicle on Sixteenth Link.

14. Repeat steps 5 through 8.
15. Block front and rear of opposite track with two 3 x 2 inch pieces of wood, each 1 ft long. Use 30-ft piece of rope (Figure 5, Item 3) to move track onto vehicle.
16. Tie rope (Figure 5, Item 3) to center of link pin (Figure 5, Item 4).
17. Pass rope (Figure 5, Item 3) over center guide groove of drive sprocket (Figure 5, Item 2).
18. Pass rope (Figure 5, Item 3) around groove of rear dual support roller (Figure 5, Item 1).

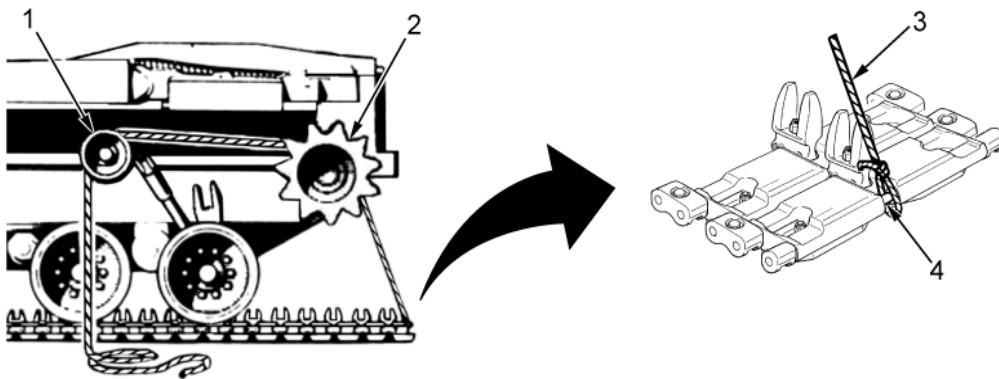

AVLBD363

Figure 5. Attaching Rope to Center of Link Pin.

INSTALLATION - CONTINUED

19. Pass rope (Figure 6, Item 2) under and around outer surface of drive sprocket (Figure 6, Item 1) two times.
20. Pull free end of rope (Figure 6, Item 2) and hold.
21. Remove wood blocks from opposite side.
22. Start engine, warm up, and let idle. Refer to WP 0015.
23. Hold brake. Move shift lever to L (Low). Refer to WP 0013.
24. Steer vehicle slightly away from track. Refer to WP 0014.
25. Slowly release brake.
26. Hold rope (Figure 6, Item 2) at free end while driver accelerates engine until drive sprocket (Figure 6, Item 1) turns slowly.

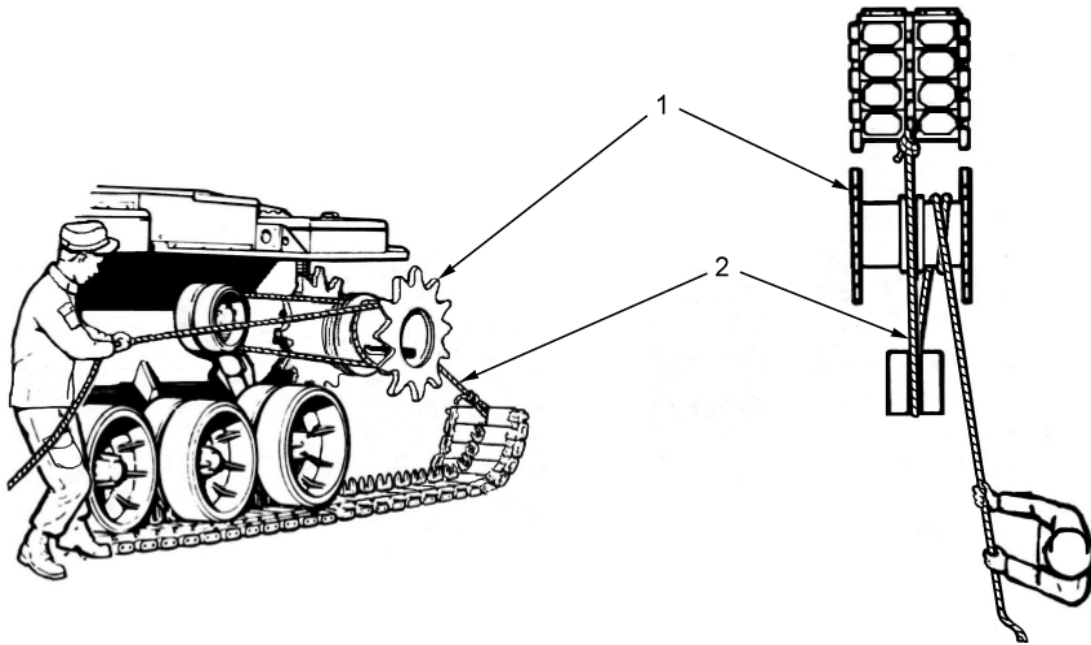

AVLBD364

Figure 6. Pulling Track Using Rope.

INSTALLATION - CONTINUED

27. Guide free end of track (Figure 7, Item 1) onto drive sprocket (Figure 7, Item 2).
28. Stop forward movement of vehicle when three end connectors (Figure 7, Item 3) are on drive sprocket (Figure 7, Item 2).
29. Repeat steps 5 through 8.

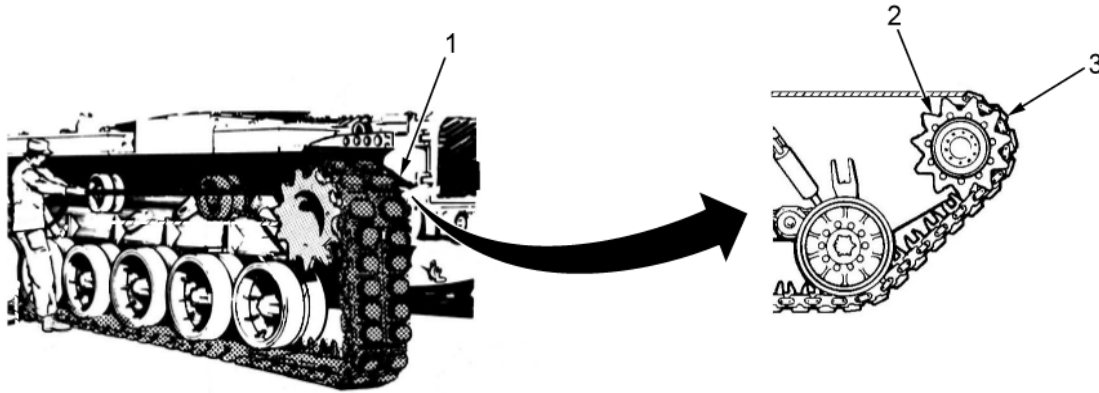

AVLBD365

Figure 7. Guiding Track onto Drive Sprocket.

30. Remove rope (Figure 8, Item 1) from around sprocket (Figure 8, Item 3) and support rollers (Figure 8, Item 2).
31. Pass rope (Figure 8, Item 1) over sprocket (Figure 8, Item 3), support rollers (Figure 8, Item 2), and compensating idler wheel (Figure 8, Item 5). Pull track (Figure 8, Item 4) and hold rope (Figure 8, Item 1) tight.
32. Start engine, warm up, and let idle. Refer to WP 0015.
33. Step on brake and move shift lever to L (Low). Refer to WP 0013.
34. Slowly release brake. Refer to WP 0012.

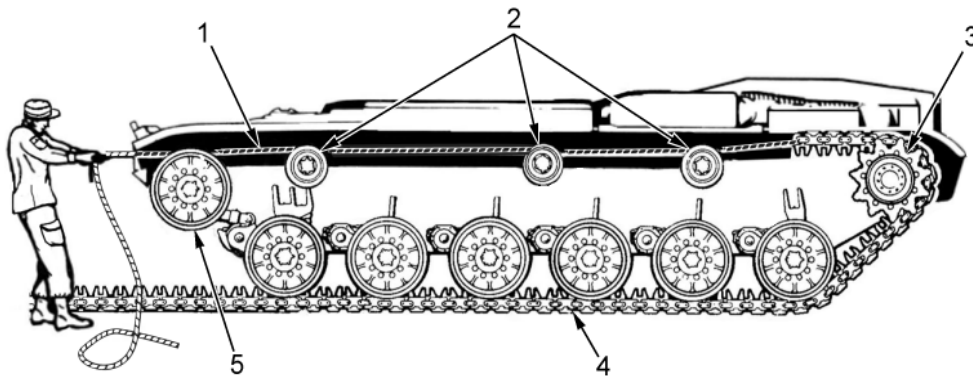

AVLBD366

Figure 8. Releasing Brake.

INSTALLATION - CONTINUED**NOTE**

Free end of track will sometimes drive down toward ground over forward side of drive sprockets. If this happens, place crowbar under track links, with end of crowbar against side of vehicle to keep track moving over support rollers and forward compensating idler wheel.

35. Accelerate engine to slowly turn drive sprocket (Figure 9, Item 2).
36. Continue forward until eight track links (Figure 9, Item 5) pass over compensating idler wheel (Figure 9, Item 1).
37. Repeat steps 5 through 8.
38. Remove rope (Figure 9, Item 3) from track link pin (Figure 9, Item 4) and connect track. Refer to WP 0055.

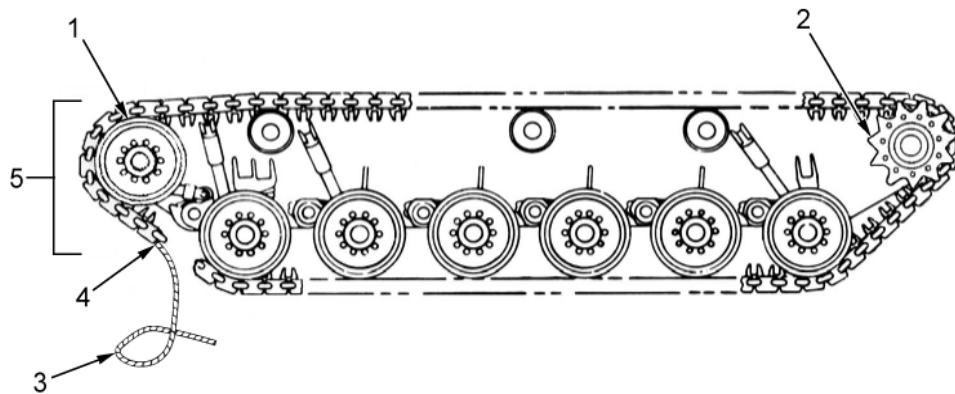

AVLBD367

Figure 9. Removing Rope from Track.

39. Adjust track tension. Refer to WP 0056.
40. Install rear fender. Refer to WP 0058.

END OF TASK**END OF WORK PACKAGE**

OPERATOR MAINTENANCE
REAR FENDER REMOVAL AND INSTALLATION

INITIAL SETUP:**Tools and Special Tools**

Socket Wrench (WP 0077, Table 2, Item 31)
Screwdriver, Cross-Tipped
(WP 0077, Table 2, Item 48)
Socket Wrench (WP 0077, Table 2, Item 58)
Wrench, Double Head (WP 0077, Table 2, Item 71)

Materials/Parts

Lockwasher (12) (WP 0079, Table 1, Item 40)
Nut, Self-locking (12) (WP 0079, Table 1, Item 44)

Materials/Parts (cont.)

Nut, Self-locking (2) (WP 0079, Table 1, Item 45)

Personnel Required

2

Equipment Conditions

Vehicle stopped on level ground (WP 0016)
Engine off (WP 0015)

GENERAL

This work package contains information on removing and installing (M60A1) rear fender.

REMOVAL

Fender Angle

1. Open stowage box cover (Figure 1, Item 2) of rear fender stowage box (Figure 1, Item 1) to access bolts (Figure 1, Item 12).
2. Use open end wrench to remove four self-locking nuts (Figure 1, Item 8), four lockwashers (Figure 1, Item 9), and eight spacers (Figure 1, Item 10). Use ratchet and socket to remove four bolts (Figure 1, Item 12) from stowage box (Figure 1, Item 1). Discard self-locking nuts and lockwashers.
3. Use open end wrench to remove eight self-locking nuts (Figure 1, Item 7), eight lockwashers (Figure 1, Item 6), sixteen flat washers (Figure 1, Item 5) and eight bolts (Figure 1, Item 4) from fender (Figure 1, Item 3). Discard self-locking nuts and lockwashers.
4. Remove angle (Figure 1, Item 11) from fender (Figure 1, Item 3).
5. Close stowage box cover (Figure 1, Item 2) of rear fender stowage box (Figure 1, Item 1).

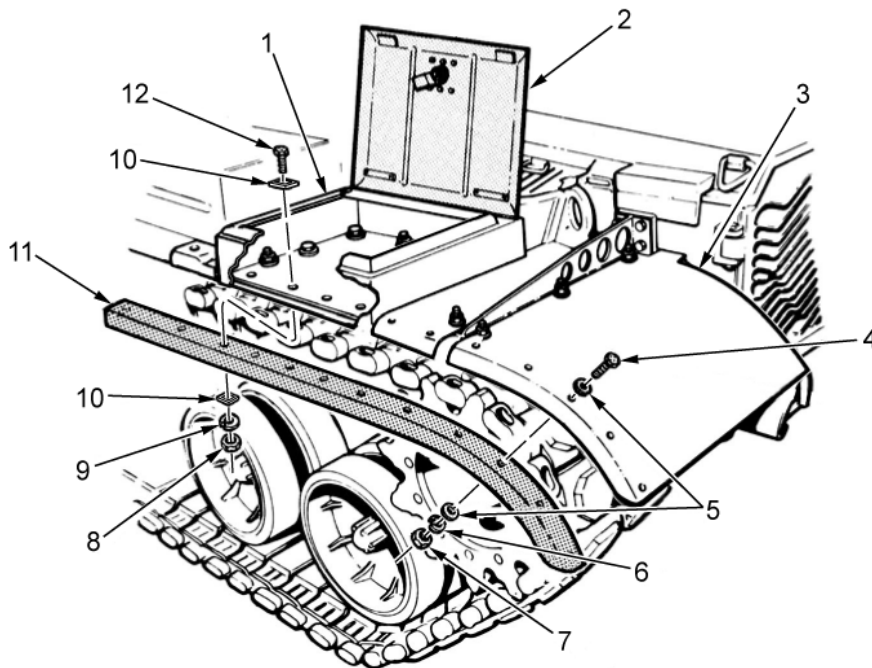

AVLBD373

Figure 1. Removing Fender Angle.

END OF TASK

Fender and Shield

1. Use socket and ratchet to remove three bolts (Figure 2, Item 1) and flat washers (Figure 2, Item 2) from fender (Figure 2, Item 7).
2. Use open end wrench to remove two self-locking nuts (Figure 2, Item 3) and four flat washers (Figure 2, Item 4) from shield (Figure 2, Item 6). Discard self-locking nuts.
3. Use ratchet and socket to remove two bolts (Figure 2, Item 5) from shield (Figure 2, Item 6).
4. Remove fender (Figure 2, Item 7) and shield (Figure 2, Item 6) from support bracket (Figure 2, Item 8).

REMOVAL - CONTINUED

Fender and Shield - Continued

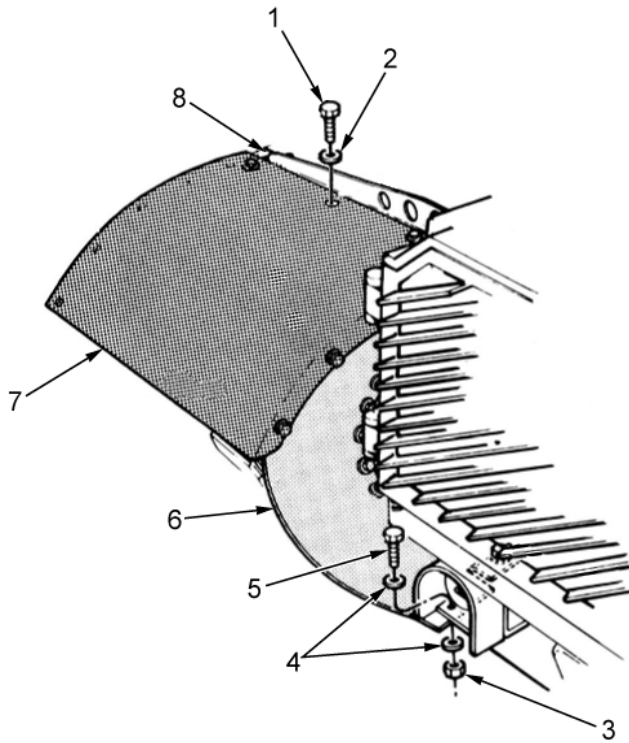

AVLBD370

Figure 2. Removing Fender and Shield.

END OF TASK

INSTALLATION

Fender and Shield

1. Install fender (Figure 3, Item 9) and shield (Figure 3, Item 8) on support bracket (Figure 3, Item 3).
2. Install three flat washers (Figure 3, Item 2) and new self-locking nuts (Figure 3, Item 1) on support bracket studs (Figure 3, Item 4). Hand-tighten self-locking nuts.
3. Install two screws (Figure 3, Item 7), four flat washers (Figure 3, Item 6), and two new self-locking nuts (Figure 3, Item 5) in shield (Figure 3, Item 8). (If necessary, align holes with cross-tip screwdriver). Hand-tighten screws.

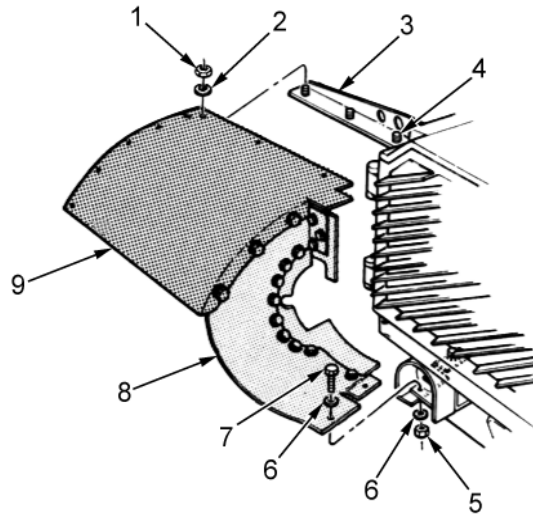

AVLBD372

Figure 3. Installing Fender and Shield.

END OF TASK

Fender Angle

1. Position angle (Figure 4, Item 11) in place against fender (Figure 4, Item 3).
2. Install eight bolts (Figure 4, Item 4), sixteen flat washers (Figure 4, Item 5), eight new lockwashers (Figure 4, Item 6), and eight new self-locking nuts (Figure 4, Item 7) in fender (Figure 4, Item 3) and angle (Figure 4, Item 11). (If necessary, align holes with cross tipped screwdriver). Hand-tighten bolts.
3. Open rear fender stowage box cover (Figure 4, Item 2).
4. Install four bolts (Figure 4, Item 12), eight spacers (Figure 4, Item 10), four new lockwashers (Figure 4, Item 9), and four new self-locking nuts (Figure 4, Item 8) in stowage box (Figure 4, Item 1). Hand-tighten bolts.
5. Use open end wrench and ratchet and socket to tighten bolts (Figure 4, Item 4).
6. Use open end wrench and ratchet and socket to tighten bolts (Figure 4, Item 12).
7. Use open end wrench and ratchet and socket to tighten nuts (Figure 4, Item 7 and Item 8).
8. Close rear fender stowage box cover (Figure 4, Item 2).

INSTALLATION - CONTINUED

Fender Angle - Continued

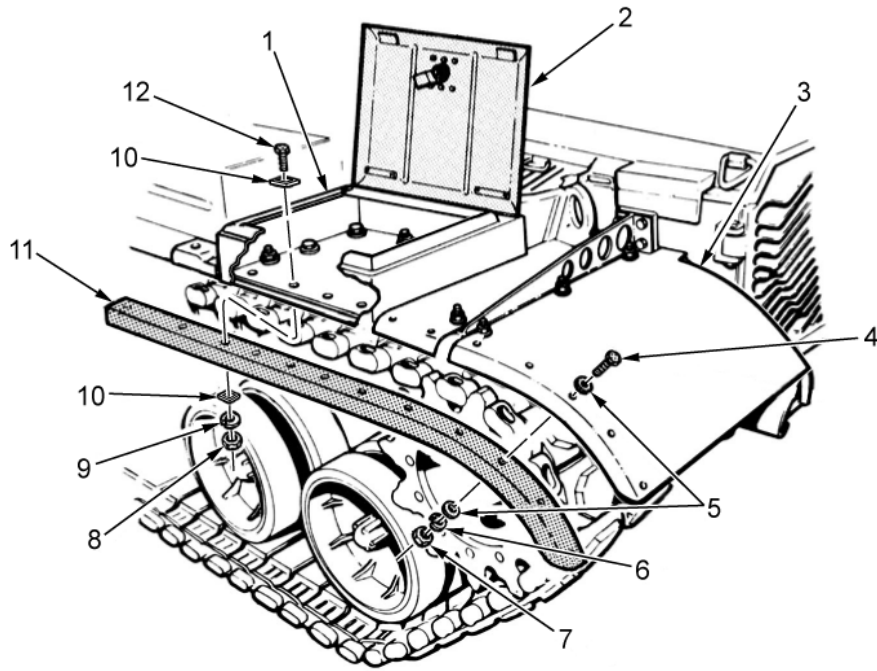

AVLBD373

Figure 4. Installing Fender Angle.

END OF TASK

END OF WORK PACKAGE

OPERATOR MAINTENANCE
REFUELING FROM PRESSURIZED SOURCE

INITIAL SETUP:**Tools and Special Tools**

Wrench, Adjustable (WP 0077, Table 2, Item 67)

Equipment Conditions (cont.)

Vehicle stopped on level ground (WP 0016)

Equipment Conditions

Engine off (WP 0015)

GENERAL

This work package contains information on refueling vehicle from pressurized source.

SERVICE

WARNING



- Fuel is very flammable and can explode easily. DO NOT work on fuel system when engine is hot. Fuel can be ignited by a hot engine. Keep fuel away from open flame or spark (ignition source). Keep a B-C fire extinguisher within easy reach when working with fuel or on a fuel system. Failure to comply may result in personnel injury or death or equipment damage.
 - Clean fuel tank to purge any flammable liquid or vapors before welding, grinding, or using any heat-producing device near the fuel tank. Post "NO SMOKING WITHIN 50 FEET" signs when working with open fuel, fuel lines, or fuel tanks. Failure to comply may result in personnel injury or death, or equipment damage.
 - When refueling, stop vehicle, shut down engine, and apply parking brake. Ensure no open flame is near area. DO NOT smoke. Never add fuel with engine running. DO NOT have driver seated when adding fuel. After fuel is added, securely close reservoir cap. A loose cap can cause a fuel leak and is a fire hazard. Before starting vehicle, check that no fuel is spilled on or around vehicle. Fuel and oil are slippery and can cause falls. To avoid injury, wipe up spilled fuel or oil with rags. Failure to comply may result in personnel injury or death, or equipment damage.
1. Use wrench to loosen lock screw (Figure 1, Item 2), remove lock pin (Figure 1, Item 1), and lift fuel cover (Figure 1, Item 3).

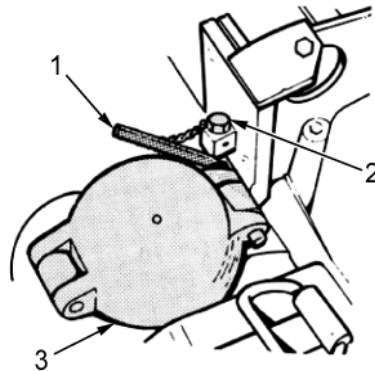

AVLBD377

Figure 1. Fuel Cover.

SERVICE - CONTINUED

2. Turn fuel filler cap (Figure 2, Item 1) and remove from fuel filler neck (Figure 2, Item 3).

NOTE

- During sandy, dusty, or other adverse conditions, cover fuel filler neck to prevent foreign matter from entering fuel tanks.
 - Tank requires 385 gal. (1457 l) for complete ref ll.
3. Insert hose (Figure 2, Item 2) into fuel filler neck (Figure 2, Item 3). Allow for fuel expansion by filling 6 inches below opening. Remove any spilled fuel immediately. Wipe up spilled fuel or oil with rags.
 4. Remove hose (Figure 2, Item 2) from fuel filler neck (Figure 2, Item 3) and replace fuel filler cap (Figure 2, Item 1) on fuel filler neck.

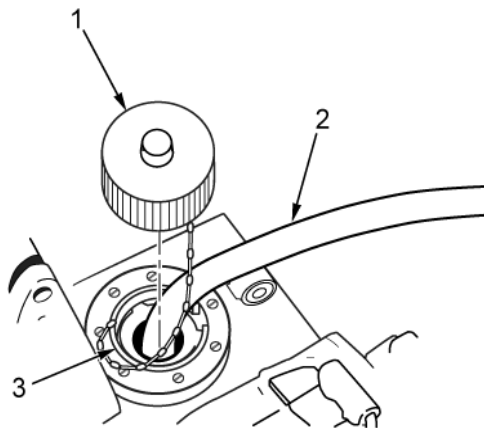

AVLBD498

Figure 2. Fuel Filler Cap.

5. Lower fuel cover (Figure 3, Item 3) and secure with lock pin (Figure 3, Item 1).
6. Use wrench to tighten lock screw (Figure 3, Item 2).

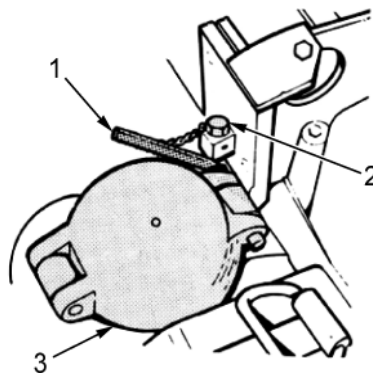

AVLBD377

Figure 3. Securing Fuel Cover Locking Pin.

END OF TASK**END OF WORK PACKAGE****0059-3/4 blank**

OPERATOR MAINTENANCE**EMERGENCY REFUELING**

INITIAL SETUP:**Tools and Special Tools**

Socket Wrench (WP 0077, Table 2, Item 31)
Socket Wrench (WP 0077, Table 2, Item 32)
Pliers, Slip-Joint (WP 0077, Table 2, Item 44)
Socket Wrench (WP 0077, Table 2, Item 56)
Socket Wrench (WP 0077, Table 2, Item 61)

Materials/Parts

Rag, Wiping (WP 0079, Table 1, Item 52)

Equipment Conditions

Vehicle stopped on level ground (WP 0016)
Engine off (WP 0015)

GENERAL

This work package contains information on emergency refueling.

SERVICE**WARNING**

- Fuel is very flammable and can explode easily. DO NOT work on fuel system when engine is hot. Fuel can be ignited by a hot engine. Keep fuel away from open flame or spark (ignition source). Keep a B-C fire extinguisher within easy reach when working with fuel or on a fuel system. Failure to comply may result in personnel injury or death, or equipment damage.
 - Clean fuel tank to purge any flammable liquid or vapors before welding, grinding, or using any heat-producing device near the fuel tank. Post "NO SMOKING WITHIN 50 FEET" signs when working with open fuel, fuel lines, or fuel tanks. Failure to comply may result in personnel injury or death, or equipment damage.
 - When refueling, stop vehicle, shut down engine, and apply parking brake. Ensure no open flame is near area. DO NOT smoke. Never add fuel with engine running. DO NOT have driver seated when adding fuel. After fuel is added, securely close reservoir cap. A loose cap can cause a fuel leak and is a fire hazard. Before starting vehicle, check that no fuel is spilled on or around vehicle. Fuel and oil are slippery and can cause falls. To avoid injury, wipe up spilled fuel or oil with rags. Failure to comply may result in personnel injury or death, or equipment damage.
1. Use 15/16-inch socket and 3/4-inch ratchet to loosen lock screw (Figure 1, Item 1), and open left top deck grille doors (Figure 1, Item 2) to access left fuel tank, emergency fuel filler cover (Figure 1, Item 6).
 2. Use pliers to remove lockwire (Figure 1, Item 5) from eight screws (Figure 1, Item 3).
 3. Use 7/16-inch socket and 1/2-inch ratchet to remove eight screws (Figure 1, Item 3) and washers (Figure 1, Item 4) from fuel filler cover (Figure 1, Item 6).
 4. Remove fuel filler cover (Figure 1, Item 6) and gasket (Figure 1, Item 7) from fuel filler neck (Figure 1, Item 8).

NOTE

During sandy, dusty, or other adverse conditions, cover fuel filler opening with a rag to prevent foreign matter from entering fuel filler neck opening.

5. Insert fuel hose into fuel filler opening (Figure 1, Item 8) and refuel. Remove any spilled fuel immediately. To avoid injury, wipe up spilled fuel or oil with rags.
6. Remove fuel hose from fuel filler neck opening (Figure 1, Item 8).

SERVICE - CONTINUED**NOTE**

Have field maintenance install lockwire on screws as soon as possible.

7. Use 7/16-inch socket and 1/2-inch ratchet to install fuel filler cover (Figure 1, Item 6) and gasket (Figure 1, Item 7) on fuel filler neck (Figure 1, Item 8), and secure with eight screws (Figure 1, Item 3) and washers (Figure 1, Item 4).
8. Use 15/16-inch socket and 3/4-inch ratchet to close top deck grille doors (Figure 1, Item 2) and tighten lock screw (Figure 1, Item 1),

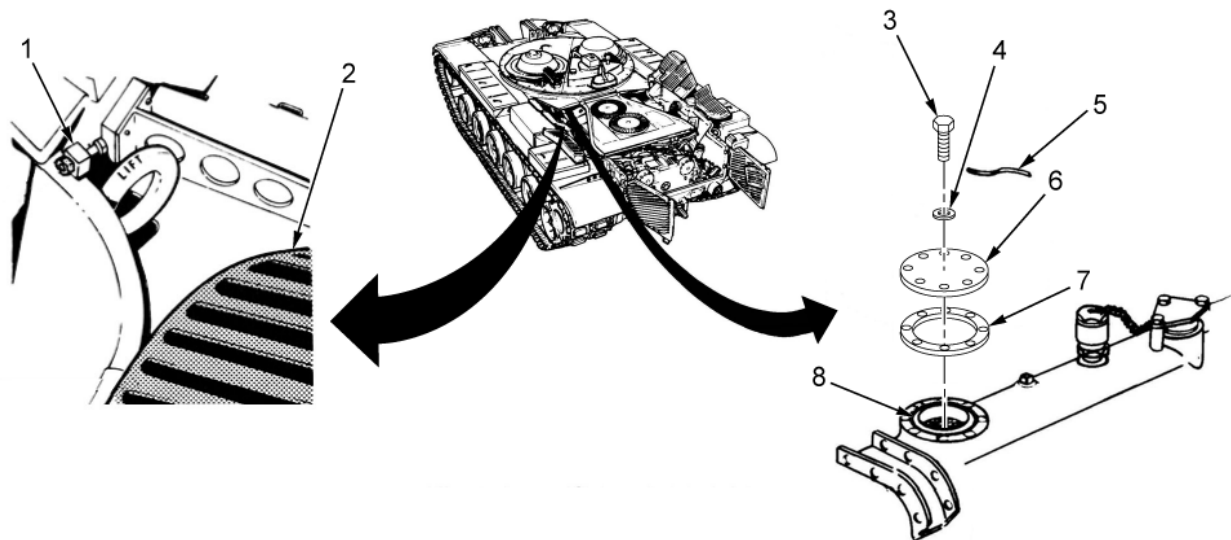

AVLBD378

Figure 1. Fuel Filler Cover Removal.

END OF TASK**END OF WORK PACKAGE**

OPERATOR MAINTENANCE
FUEL FILLER CAP MAINTENANCE

INITIAL SETUP:**Tools and Special Tools**

Pliers, Slip-Joint (WP 0077, Table 2, Item 44)
Wrench, Adjustable (WP 0077, Table 2, Item 67)

Equipment Conditions

Vehicle stopped on level ground (WP 0016)
Engine off (WP 0015)

Materials/Parts

Solvent, Degreasing (WP 0079, Table 1, Item 58)

GENERAL

This work package contains information on servicing fuel filler cap.

REMOVAL

WARNING



- Fuel is very flammable and can explode easily. DO NOT work on fuel system when engine is hot. Fuel can be ignited by a hot engine. Keep fuel away from open flame or spark (ignition source). Keep a B-C fire extinguisher within easy reach when working with fuel or on a fuel system. Failure to comply may result in personnel injury or death, or equipment damage.
 - Clean fuel tank to purge any flammable liquid or vapors before welding, grinding, or using any heat-producing device near the fuel tank. Post "NO SMOKING WITHIN 50 FEET" signs when working with open fuel, fuel lines, or fuel tanks. Failure to comply may result in personnel injury or death, or equipment damage.
 - When refueling, stop vehicle, shut down engine, and apply parking brake. Ensure no open flame is near area. DO NOT smoke. Never add fuel with engine running. DO NOT have driver seated when adding fuel. After fuel is added, securely close reservoir cap. A loose cap can cause a fuel leak and is a fire hazard. Before starting vehicle, check that no fuel is spilled on or around vehicle. Fuel and oil are slippery and can cause falls. To avoid injury, wipe up spilled fuel or oil with rags. Failure to comply may result in personnel injury or death, or equipment damage.
1. Use wrench to loosen lock screw (Figure 1, Item 2), remove lock pin (Figure 1, Item 1), and lift fuel cover (Figure 1, Item 3).

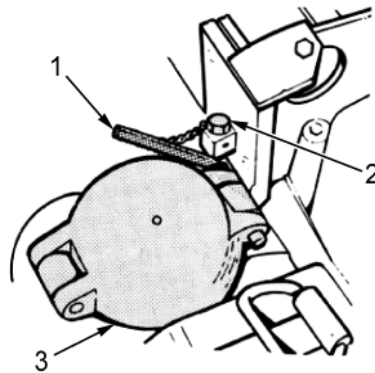

AVLBD377

Figure 1. Fuel Cover.

REMOVAL - CONTINUED

2. Turn fuel filler cap (Figure 2, Item 1) and remove from fuel filler neck (Figure 2, Item 4).
3. Use pliers to remove vent cap (Figure 2, Item 2) from fuel filler cap (Figure 2, Item 1), exposing relief vent (Figure 2, Item 3).
4. Remove chain (Figure 2, Item 5) from base of fuel filler cap (Figure 2, Item 1).

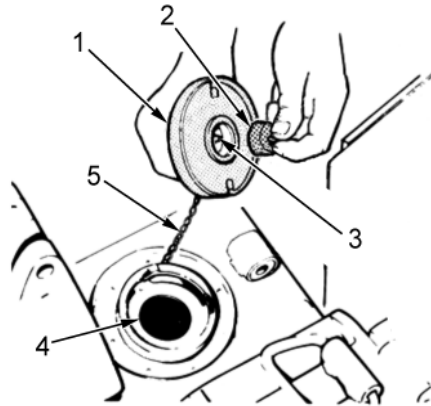

AVLBD627

Figure 2. Fuel Filler Cap.

END OF TASK**INSPECTION**

Inspect vent cap (Figure 3, Item 1) and screen (Figure 3, Item 2) inside of vent cap for foreign particles.

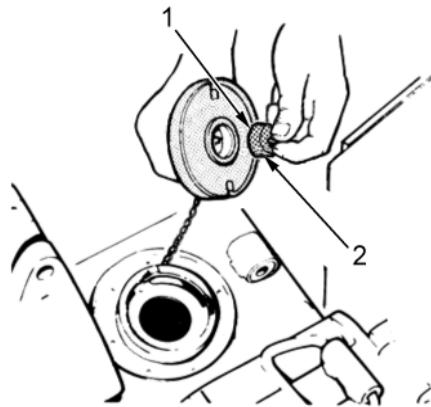

AVLBD643

Figure 3. Fuel Filler Cap.

END OF TASK

CLEANING**WARNING**

Degreasing solvent (MIL-PRF-680) is flammable and may cause irritation to the eyes or skin. Use in well ventilated areas and keep away from heat and open flame. Wear protective goggles and clothing. If solvent comes in contact with eyes, flush immediately with water. If solvent comes in contact with skin, wash with soap and water. Failure to comply may result in personnel injury or death.

Clean screen in degreasing solvent, if necessary.

END OF TASK**INSPECTION/ACCEPTANCE AND REJECTION CRITERIA**

1. With vent cap (Figure 4, Item 2) removed, inspect fuel filler cap (Figure 4, Item 1), float, and ball.

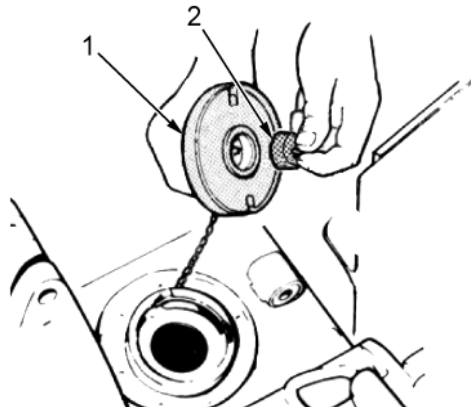

Figure 4. Fuel Filler Cap.

AVLBD628

NOTE

- With fuel filler cap right side up, float point should not appear in relief vent.
- With fuel filler cap upside down, float point should be visible in relief vent.

2. If float is not visible, notify field maintenance.

END OF TASK

INSTALLATION

1. If screen (Figure 5, Item 3) was removed for cleaning, ensure it was placed back into vent cap (Figure 5, Item 2).
2. Manually press vent cap (Figure 5, Item 2) into fuel filler cap (Figure 5, Item 1) and reconnect chain (Figure 5, Item 5) to base of fuel filler cap.
3. Position fuel filler cap (Figure 5, Item 1) on fuel filler neck (Figure 5, Item 4) and tighten.

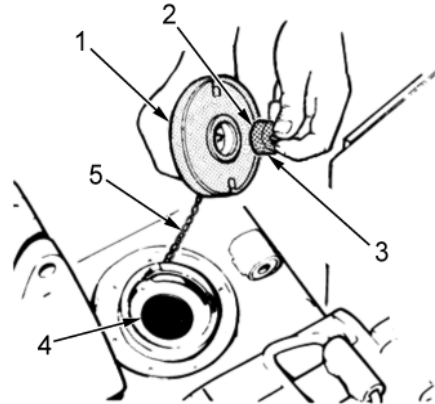

AVLBD644

Figure 5. Fuel Filler Cap.

4. Close fuel cover (Figure 6, Item 3), insert lock pin (Figure 6, Item 1), and use wrench to tighten lock screw (Figure 6, Item 2).

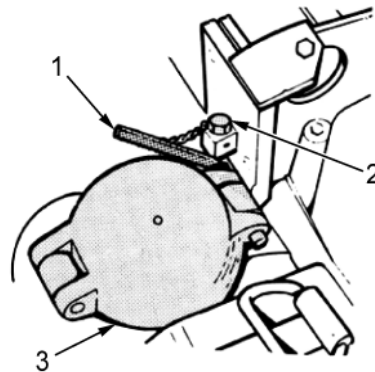

AVLBD377

Figure 6. Fuel Cover Locking Pin.

END OF TASK**END OF WORK PACKAGE**

OPERATOR MAINTENANCE**ISOLATING FUEL TANKS**

INITIAL SETUP:**Tools and Special Tools**

Ratchet (WP 0077, Table 2, Item 31)
Ratchet (WP 0077, Table 2, Item 32)
Pliers, Slip-Joint (WP 0077, Table 2, Item 44)
Screwdriver, Flat-Tipped (WP 0077, Table 2, Item 49)
Socket Wrench (WP 0077, Table 2, Item 56)
Socket Wrench (WP 0077, Table 2, Item 58)
Socket Wrench, (WP 0077, Table 2, Item 64)

Tools and Special Tools (cont.)

Wrench, Double Head, (WP 0077, Table 2, Item 72)

Personnel Required

2

Equipment Conditions

Vehicle stopped on level ground (WP 0016)

Engine off (WP 0015)

GENERAL

This work package contains information on isolating fuel tanks.

REMOVAL**Access Cover****WARNING**

- Fuel is very flammable and can explode easily. DO NOT work on fuel system when engine is hot. Fuel can be ignited by a hot engine. Keep fuel away from open flame or spark (ignition source). Keep a B-C fire extinguisher within easy reach when working with fuel or on a fuel system. Failure to comply may result in personnel injury or death, or equipment damage.
- Clean fuel tank to purge any flammable liquid or vapors before welding, grinding, or using any heat-producing device near the fuel tank. Post "NO SMOKING WITHIN 50 FEET" signs when working with open fuel, fuel lines, or fuel tanks. Failure to comply may result in personnel injury or death, or equipment damage.
- When refueling, stop vehicle, shut down engine, and apply parking brake. Ensure no open flame is near area. DO NOT smoke. Never add fuel with engine running. DO NOT have driver seated when adding fuel. After fuel is added, securely close reservoir cap. A loose cap can cause a fuel leak and is a fire hazard. Before starting vehicle, check that no fuel is spilled on or around vehicle. Fuel and oil are slippery and can cause falls. To avoid injury, wipe up spilled fuel or oil with rags. Failure to comply may result in personnel injury or death, or equipment damage.

NOTE

Removal steps 1 through 4 and installation steps 1 and 2 are performed through crew compartment fuel crossover access.

1. Use 9/16-inch socket, 1/2-inch drive, and 1/2-inch ratchet to remove six bolts (Figure 1, Item 6) and washers (Figure 1, Item 5) from access cover (Figure 1, Item 1), and remove access cover from adjoining cover (Figure 1, Item 7).
2. Use screwdriver to remove 12 screws (Figure 1, Item 8) from crossover access cover plate (Figure 1, Item 9) and remove crossover access cover plate from vehicle floor (Figure 1, Item 10).
3. Use pliers to remove lockwire (Figure 1, Item 3) from crossover butterfly valve (Figure 1, Item 2) and collar (Figure 1, Item 4).
4. Rotate collar (Figure 1, Item 4) clockwise as far as possible.
5. Have field maintenance install new lockwire (Figure 1, Item 3) as soon as possible.

END OF TASK

INSTALLATION**Access Cover**

1. Install crossover access cover plate (Figure 1, Item 9) and manually install 12 screws (Figure 1, Item 8) .
2. Use a fat-tip screwdriver to install 12 screws (Figure 1, Item 8).
3. Position cover and manually install six screws (Figure 1, Item 6) and washers 9 (Figure 1, Item 5).
4. Use a 9/16-inch wrench to tighten six screws (Figure 1, Item 6).

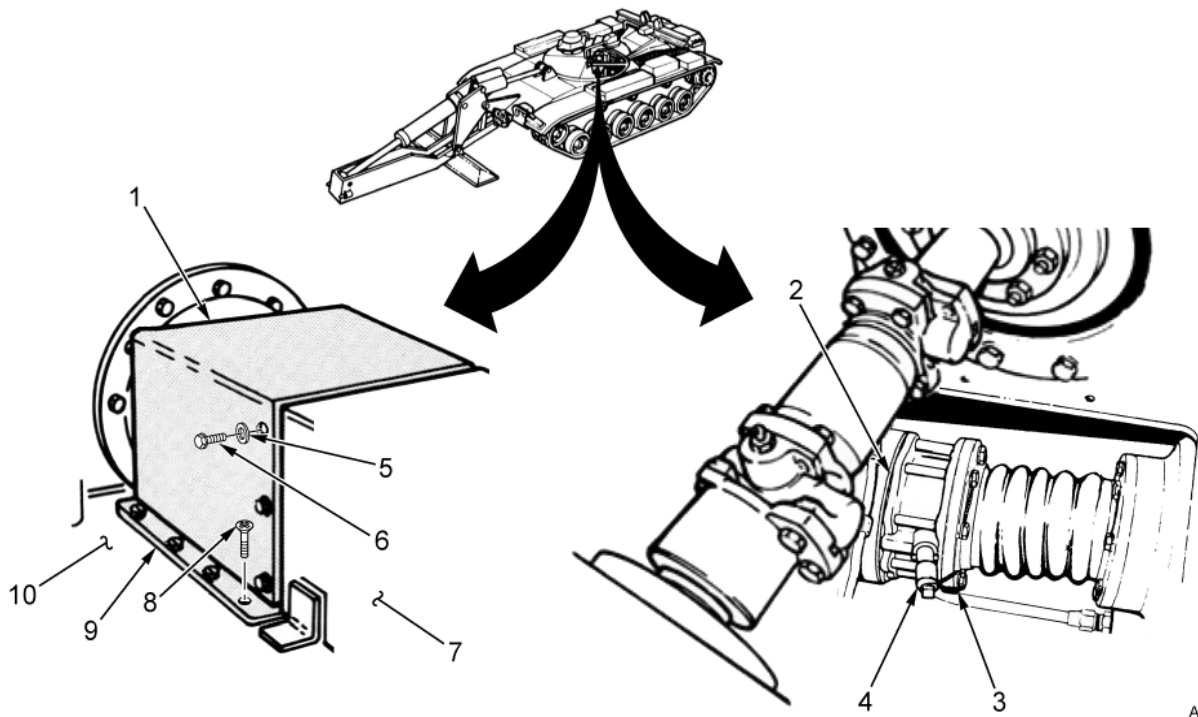

AVLBD379A

Figure 1. Removing and Installing Access Covers.

END OF TASK

REMOVAL

Transmission Shroud

WARNING



Rear exhaust doors, exhaust pipes, and shroud may be hot. Allow engine to cool a minimum of one hour before opening rear exhaust doors, removing exhaust pipes, or removing transmission shroud. Failure to comply may result in personnel injury or death.

1. Use 1-1/8-inch socket and 3/4-inch ratchet to remove four screw assemblies (Figure 2, Item 1) securing rear grille doors (Figure 2, Item 2), and open doors.
2. Use 7/16-inch wrench to loosen nut (Figure 2, Item 6) on clamp (Figure 2, Item 4).
3. Remove exhaust elbow (Figure 2, Item 3) and clamp (Figure 2, Item 4) from exhaust pipe (Figure 2, Item 5) on each side of vehicle.

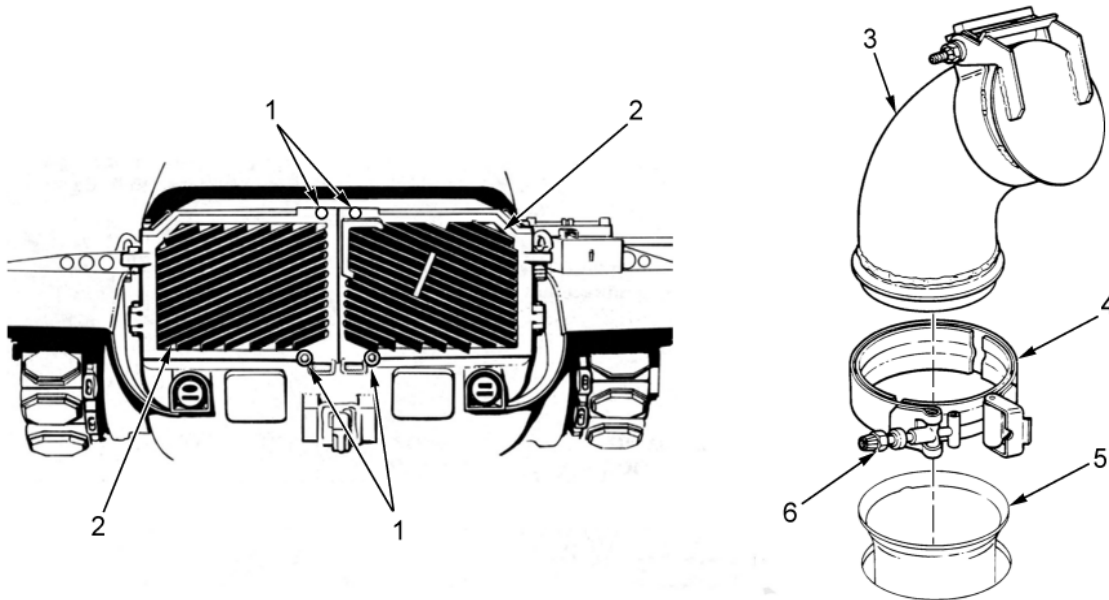

AVLBD381A

Figure 2. Exhaust Elbow Exploded View.

4. Install plastic covers (Figure 3, Item 2) in exhaust pipes (Figure 3, Item 6).

NOTE

Narrow end of turnlock fasteners must be rotated 180 degrees from their original position so fastener points inside engine compartment.

5. Use 3/4-inch open end wrench to unlock six turnlock fasteners (Figure 3, Item 1) while holding transmission shroud (Figure 3, Item 5) to angle bracket (Figure 3, Item 7) on both sides of vehicle.

REMOVAL - CONTINUED**Transmission Shroud - Continued****WARNING**

Transmission shroud is 80 lbs (36.3 kg). To prevent injury, two persons are required to lift shroud. Failure to comply may result in personnel injury or death.

CAUTION

Remove shroud (Figure 3, Item 5) carefully to avoid damage to shroud seal (Figure 3, Item 4).

6. With the help of second technician, grasp lifting handles (Figure 3, Item 3) and remove shroud (Figure 3, Item 5) from vehicle.

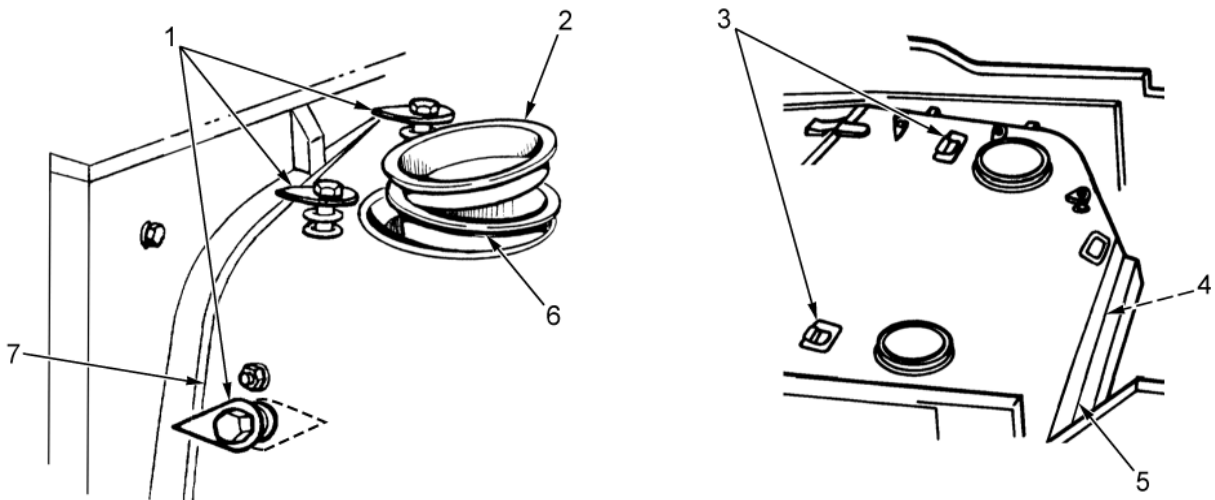

AVLBD475A

Figure 3. Transmission Shroud Removal.

END OF TASK

ADJUSTMENT

Selector Valve

1. Pull out locking (Figure 4, Item 1) to unlock left side powerplant guide (Figure 4, Item 2) and swing powerplant guide backward.

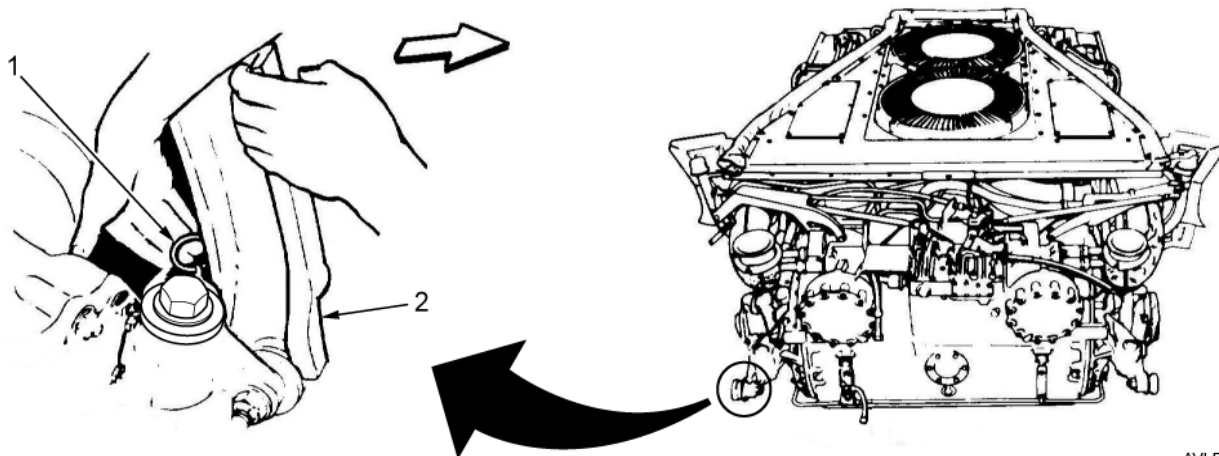

AVLBD383

Figure 4. Unlock Left Side Powerplant Guide.

2. Use pliers to remove lockwire (Figure 5, Item 3) from valve cock (Figure 5, Item 1). Rotate fuel selector valve (Figure 5, Item 2) to LEFT or RIGHT EMERGENCY as required.

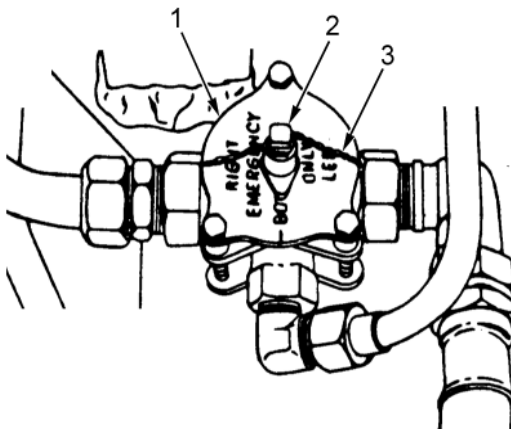

AVLBD477

Figure 5. Fuel Selector Valve.

NOTE

Have field maintenance install lockwire (Figure 5, Item 3) in selector valve (Figure 5, Item 2) as soon as possible.

3. Raise locking (Figure 6, Item 1) and swing the left side powerplant guide (Figure 6, Item 2) forward until guide locks in place.

ADJUSTMENT - CONTINUED

Selector Valve - Continued

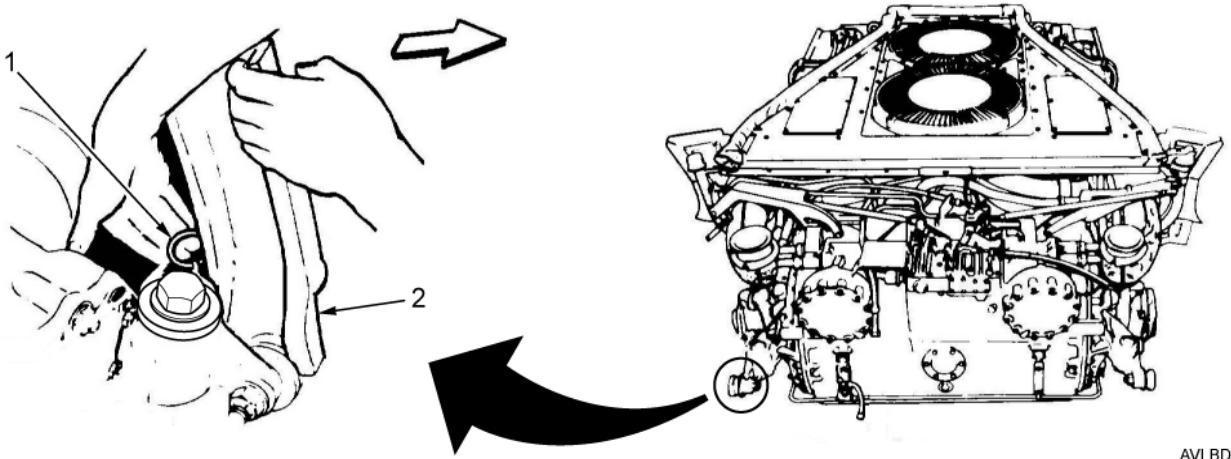

AVLBD383

Figure 6. Lock Left Side Powerplant Guide.

END OF TASK

INSTALLATION

Transmission Shroud

WARNING



Transmission shroud is 80 lbs (36.3 kg). To prevent injury, two persons are required to lift shroud. Failure to comply may result in personnel injury or death.

CAUTION

Position shroud (Figure 7, Item 5) carefully on vehicle to avoid damage to shroud seal (Figure 7, Item 4).

1. With help of second technician, grasp shroud lifting handles (Figure 7, Item 3) and install shroud (Figure 7, Item 5) on vehicle.

NOTE

Narrow end of turnlock fasteners (Figure 7, Item 1) must be rotated 180 degrees to lock.

2. Use 3/4-inch wrench to lock three turnlock fasteners (Figure 7, Item 1) while holding transmission shroud (Figure 7, Item 5) to angle bracket (Figure 7, Item 7) on both sides of vehicle.
3. Remove plastic covers (Figure 7, Item 2) from exhaust pipes (Figure 7, Item 6).

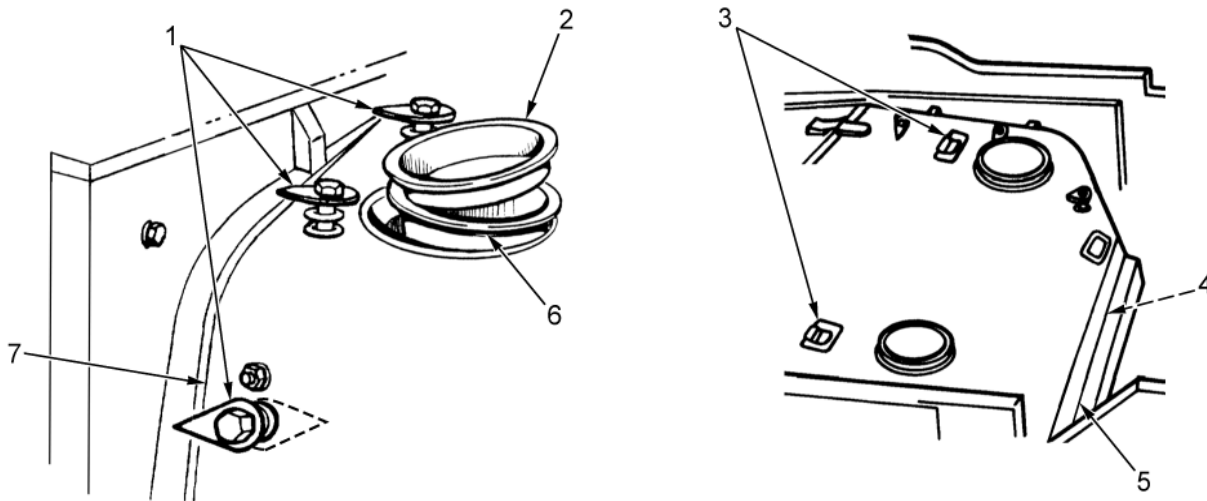

AVLBD475A

Figure 7. Transmission Shroud Installation.

INSTALLATION - CONTINUED**Transmission Shroud - Continued****NOTE**

Position both exhaust elbows at a 45-degree angle toward center of vehicle.

4. Position notch at rear of elbow (Figure 8, Item 3) into notch of exhaust pipe (Figure 8, Item 5).
5. Position clamp (Figure 8, Item 4) on bottom of elbow (Figure 8, Item 3) and exhaust pipe (Figure 8, Item 5).
6. Use 7/16-inch wrench to close clamp (Figure 8, Item 4) and tighten nut (Figure 8, Item 6) on clamp (Figure 8, Item 4).
7. Close rear exhaust doors (Figure 8, Item 2). Use 1-1/8-inch wrench and 3/4-inch socket to install four screw assemblies (Figure 8, Item 1) in rear exhaust doors.

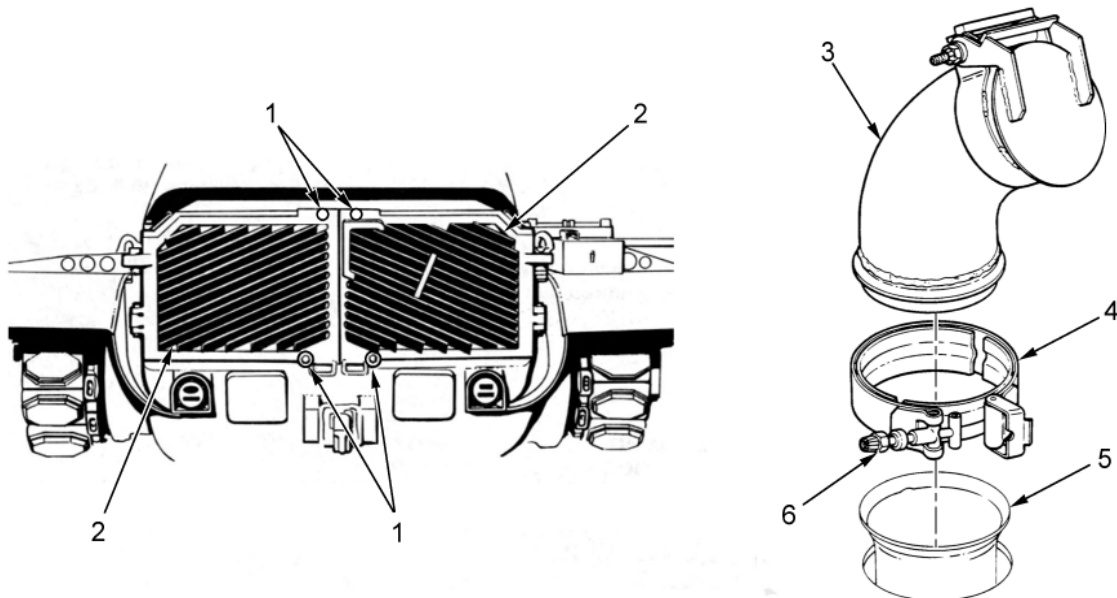

AVLBD171

Figure 8. Exhaust Pipe Elbow Exploded View.

END OF TASK**END OF WORK PACKAGE**

OPERATOR MAINTENANCE**BATTERY MAINTENANCE**

INITIAL SETUP:**Tools and Special Tools**

Wrench, Double Head (WP 0077, Table 2, Item 72)

Materials/Parts

Gloves, Rubber (WP 0079, Item 25)
Goggles, Industrial (WP 0079, Item 26)
Lockwasher (4) (WP 0079, Item 39)

References

TM 9-6140-200-14

Equipment Conditions

Vehicle stopped on level ground (WP 0016)
Engine off (WP 0015)
MASTER BATTERY switch off (WP 0004)

GENERAL

This work package contains information on battery maintenance.

REMOVAL

WARNING



- Battery acid (electrolyte) and corrosion can cause serious burns. Safety goggles and acid resistant rubber gloves must be worn when working around batteries. If electrolyte or corrosion make contact with skin, eyes, or clothing, immediately flush contacted area with water and obtain medical attention. Failure to comply may result in personnel injury or death.
- Batteries may give off explosive gasses. DO NOT smoke, use open flame, make sparks, or create other ignition sources around the battery. Failure to comply may result in personnel injury or death.
- Personnel may be burned if jewelry or a tool contacts a battery terminal. Remove all jewelry such as rings, ID tags, watches, etc. Failure to comply may result in personnel injury or death.
- Electrical shock may occur when slave starting vehicles if any battery is missing or damaged or cables are defective. DO NOT attempt to slave start vehicle if any battery is missing or damaged. DO NOT use defective cables for slaving starting. Failure to comply may result in personnel injury or death, or equipment damage.

CAUTION

DO NOT remove batteries from equipment battery box container for cleaning or inspection purposes. Equipment operator may assist in cleaning operations, but actual battery removal and replacement must be performed by field maintenance. Damage to batteries may occur during removal.

Retaining Strap and Cover Removal

1. Use 9/16 inch wrench to remove four bolts (Figure 1, Item 3) and flat washers (Figure 1, Item 4) from retaining strap (Figure 1, Item 1).
2. Remove retaining strap (Figure 1, Item 1) and rubber cover (Figure 1, Item 2) from batteries (Figure 1, Item 5).

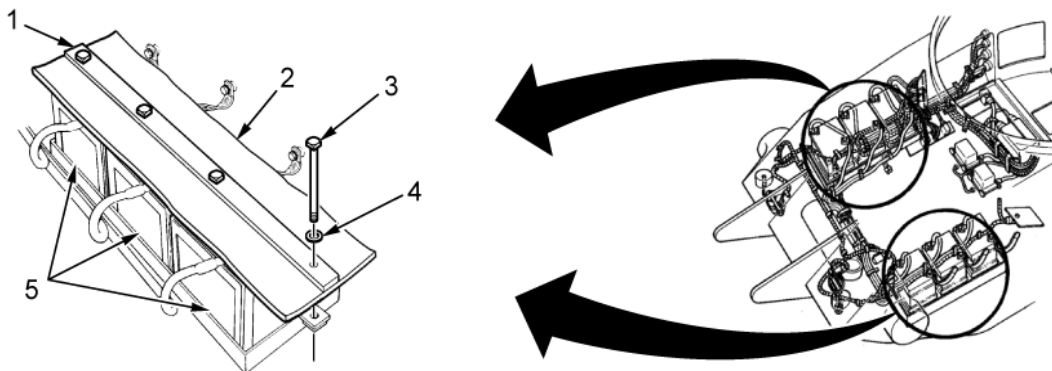

AVLBD385A

Figure 1. Battery Retaining Strap and Cover Removal.

END OF TASK

INSPECTION**Electrolyte Level Inspection****WARNING**

- Battery acid (electrolyte) and corrosion can cause serious burns. Safety goggles and acid resistant rubber gloves must be worn when working around batteries. If electrolyte or corrosion make contact with skin, eyes, or clothing, immediately flush contacted area with water and obtain medical attention. Failure to comply may result in personnel injury or death.
- Batteries may give off explosive gasses. DO NOT smoke, use open flame, make sparks, or create other ignition sources around the battery. Failure to comply may result in personnel injury or death.
- Personnel may be burned if jewelry or a tool contacts a battery terminal. Remove all jewelry such as rings, ID tags, watches, etc. Failure to comply may result in personnel injury or death.

NOTE

For further maintenance, refer to TM 9-6140-200-14.

1. Remove six caps (Figure 2, Item 4) from batteries (Figure 2, Item 3).
2. Inspect battery fill hole (Figure 2, Item 1) for electrolyte level. If batteries are equipped with split ring (Figure 2, Item 2), electrolyte level must be filled to bottom of split ring. If electrolyte level is low or is boiling, notify field maintenance.
3. Install six caps (Figure 2, Item 4) on batteries (Figure 2, Item 3).
4. If electrolyte level was low and water was added, start engine. Run engine for 15 minutes to mix electrolyte with water and charge batteries.
5. Inspect terminal posts (Figure 2, Item 5), clamps (Figure 2, Item 6), cables (Figure 2, Item 7), and batteries (Figure 2, Item 3) for corrosion. If corrosion is present, notify field maintenance to clean and coat parts with metal surface protection.

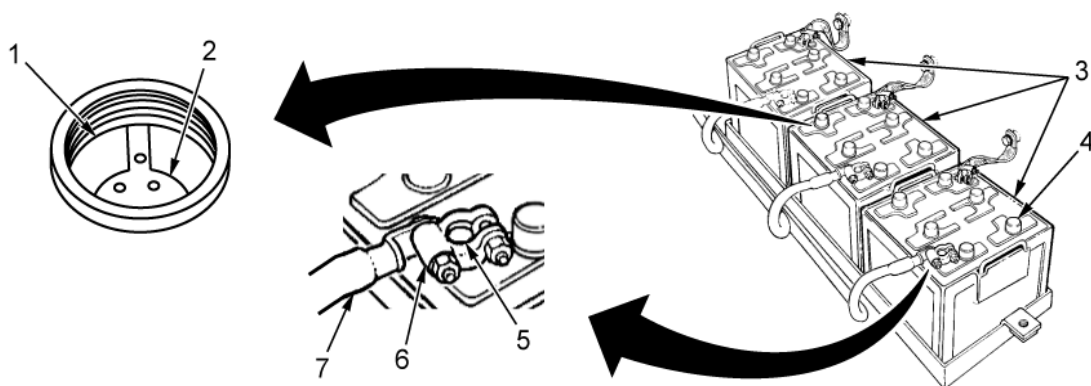
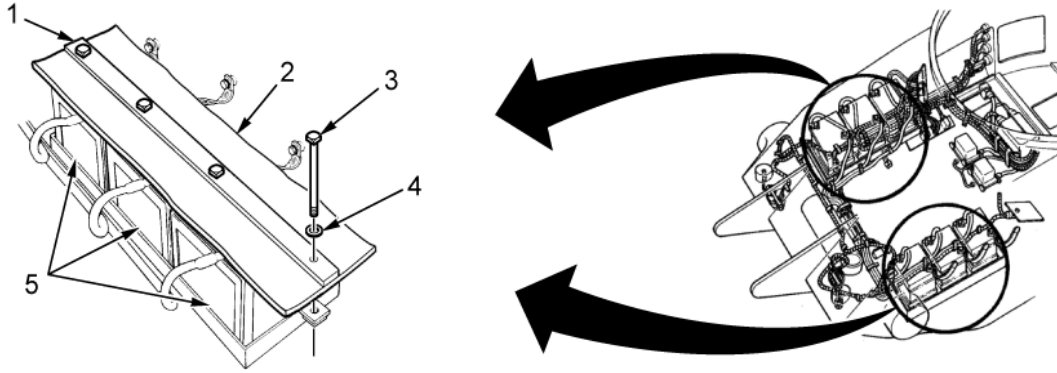

Figure 2. Battery Electrolyte Inspection.

END OF TASK

INSTALLATION**Retaining Strap and Cover Installation**

1. Install rubber cover (Figure 3, Item 2) and retaining strap (Figure 3, Item 1) on batteries (Figure 3, Item 5).
2. Install four bolts (Figure 3, Item 3) and four flat washers (Figure 3, Item 4) in retaining strap (Figure 3, Item 1). Use 9/16 inch open-end wrench to tighten bolts.



AVLBD385A

Figure 3. Battery Retaining Strap and Cover Installation.

END OF TASK**END OF WORK PACKAGE**

OPERATOR MAINTENANCE**ESCAPE HATCH (M48A5) REMOVAL AND INSTALLATION**

INITIAL SETUP:**Tools and Special Tools**

Crowbar (WP 0077, Table 2, Item 11)

Personnel Required

3

Materials/Parts

Compound, Silicone (WP 0079, Table 1, Item 21)

Gloves, Rubber (WP 0079, Table 1, Item 25)

Goggles, Industrial (WP 0079, Table 1, Item 26)

Rag, Wiping (WP 0079, Table 1, Item 52)

Equipment Conditions

Vehicle stopped on level ground (WP 0016)

Engine off (WP 0015)

GENERAL

This work package contains information on the M48A5 escape hatch removal, inspection, and installation.

REMOVAL**WARNING**

- Escape hatch is heavy and may fall. Never crawl under vehicle when removing escape hatch. Keep clear of vehicle when hatch is being raised or lowered. Hatch may fall. Failure to comply may result in personnel injury or death.
- DO NOT work on hatch when supported only by lift jack. Always use blocks or proper stands to support hatch prior to any work. Failure to comply may result in personnel injury or death.

CAUTION

Escape hatch should be removed only for emergency exit from vehicle. Hatch weighs 125 lb (56.8 kg) and will fall to ground when released. Impact with ground could damage hatch.

NOTE

Normally this task is field maintenance responsibility. In an emergency, crew can replace as follows:

- Use hydraulic floor jack, if available, from field maintenance. If not, use three people. Two people will raise cover outside vehicle, and one person will latch cover inside vehicle.
 - Place floor jack against hatch beneath vehicle before removal.
1. Move escape hatch lever (Figure 1, Item 2) clockwise to unlock hatch (Figure 1, Item 1). Hatch will drop out of vehicle.
 2. Use floor jack to slide hatch (Figure 1, Item 1) from under vehicle.

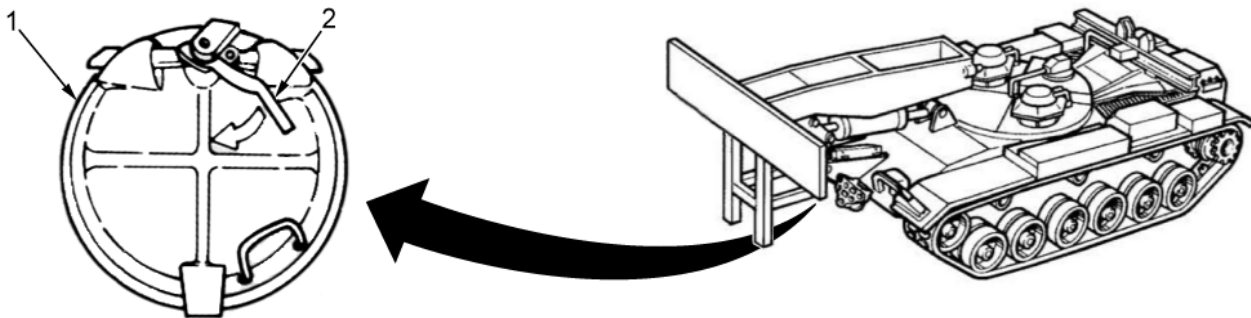

AVLBD496

Figure 1. Escape Hatch Removal.

END OF TASK

CLEANING

Use rags to wipe grease and dirt from edge of hatch and vehicle opening.

END OF TASK**INSTALLATION****WARNING**

Silicone compounds are harmful to skin and clothing, can burn easily, and may give off a harmful vapor. If compounds contact eyes, wash immediately with water. Wash with soap and water if compounds contact skin. Use adhesives, solvents, sealing, and insulating compounds in well-ventilated areas away from open flame. Failure to comply may result in personnel injury or death.

1. Inspect hatch seal for cracks and tears. If seal is defective, notify field maintenance.
2. Apply coating of silicone compound to seal (Figure 2, Item 3).
3. Push latch lever (Figure 2, Item 2) fully clockwise to unlock.
4. Position hatch (Figure 2, Item 4) on jack beneath vehicle in alignment with vehicle opening.
5. Raise jack until hatch (Figure 2, Item 4) is fully seated in vehicle opening.
6. Ensure plungers (Figure 2, Item 1) fully engage hull lugs.

NOTE

If plungers do not fully engage in hull lugs, notify field maintenance.

7. Push latch lever (Figure 2, Item 2) fully counterclockwise to lock hatch (Figure 2, Item 4) in place.
8. Lower jack and remove from under vehicle.

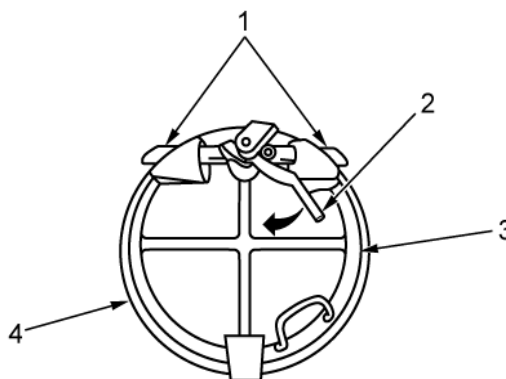

AVLBD502

Figure 2. Escape Hatch Installation.

END OF TASK**END OF WORK PACKAGE**

OPERATOR MAINTENANCE**ESCAPE HATCH (M60A1) REMOVAL AND INSTALLATION**

INITIAL SETUP:**Tools and Special Tools**

Crowbar (WP 0077, Table 2, Item 11)

Personnel Required

2

Materials/Parts

Compound, Silicone (WP 0079, Item 21)

Gloves, Rubber (WP 0079, Item 25)

Goggles, Industrial (WP 0079, Item 26)

Rag, Wiping (WP 0079, Item 52)

Equipment Conditions

Vehicle stopped on level ground (WP 0016)

Engine off (WP 0015)

GENERAL

This work package contains information on the M60A1 escape hatch removal and installation.

REMOVAL**WARNING**

- Escape hatch is heavy and may fall. Never crawl under vehicle when removing escape hatch. Keep clear of vehicle when hatch is being raised or lowered. Hatch may fall. Failure to comply may result in personnel injury or death.
- DO NOT work on hatch when supported only by lift jack. Always use blocks or proper stands to support hatch prior to any work. Failure to comply may result in personnel injury or death.

CAUTION

Escape hatch should be removed only for emergency exit from vehicle. Hatch weighs 125 lb (56.8 kg) and will fall to ground when released. Impact with ground could damage hatch.

NOTE

Normally this task is field maintenance responsibility. In an emergency, crew can replace as follows:

1. Use hydraulic floor jack, if available, from field maintenance. If not, use three persons - two people will raise cover outside vehicle and one person, inside, latches cover.
 2. Place floor jack against hatch beneath vehicle before removal.
1. Move escape hatch lever (Figure 1, Item 1) clockwise to unlock hatch (Figure 1, Item 2). Hatch will drop out of vehicle.
 2. Use floor jack to slide hatch (Figure 1, Item 2) from under vehicle.

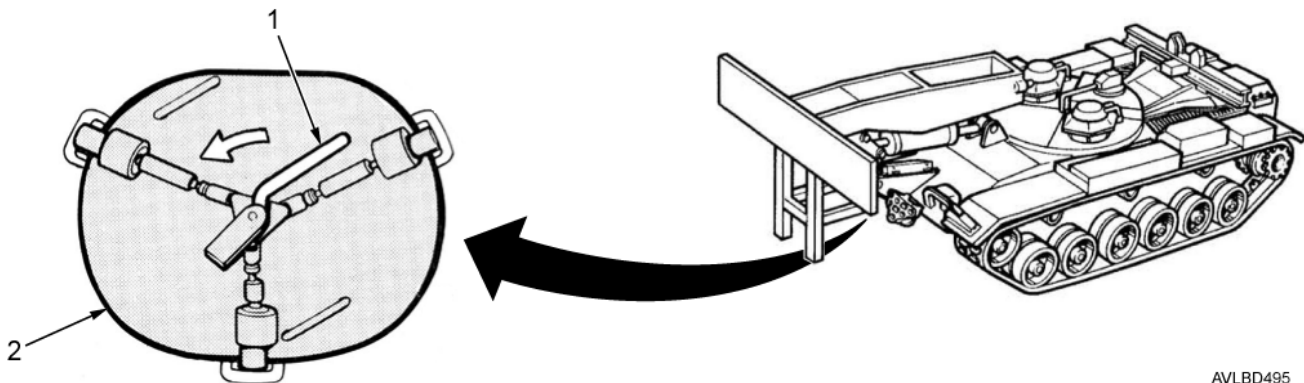

AVLBD495

Figure 1. Escape Hatch Removal.

END OF TASK**CLEANING**

Using rags to wipe grease and dirt from edge of hatch and vehicle opening.

END OF TASK

INSTALLATION**WARNING**

Silicone compounds are harmful to skin and clothing, can burn easily, and may give off a harmful vapor. If compounds contact eyes, wash immediately with water. Wash with soap and water if compounds contact skin. Use adhesives, solvents, sealing, and insulating compounds in well-ventilated areas away from open flame. Failure to comply may result in personnel injury or death.

1. Inspect hatch seal for cracks and tears. If seal is defective, notify field maintenance.
2. Apply coating of silicone compound to seal (Figure 2, Item 1).
3. Push latch lever (Figure 2, Item 2) fully clockwise to unlock.
4. Position hatch (Figure 2, Item 3) on jack beneath vehicle in alignment with vehicle opening.
5. Raise jack until hatch (Figure 2, Item 3) is fully seated in vehicle opening.
6. Ensure locking bolts (Figure 2, Item 4) are fully seated.

NOTE

If locking bolts do not fully engage in hull, notify field maintenance.

7. Push latch lever (Figure 2, Item 2) fully counterclockwise to lock hatch (Figure 2, Item 3) in place.
8. Lower jack and remove from under vehicle.

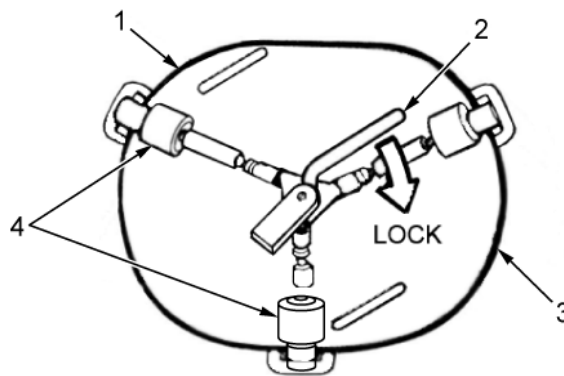

AVLBD503A

Figure 2. Escape Hatch Installation.

END OF TASK**END OF WORK PACKAGE**

OPERATOR MAINTENANCE**HEADLIGHT, BLACKOUT MARKER, AND TAILLIGHT LAMP REPLACEMENT**

INITIAL SETUP:**Tools and Special Tools**

Screwdriver, Flat-Tipped (WP 0077, Table 2, Item 50)
Screwdriver, Cross-Tipped
(WP 0077, Table 2, Item 47)

Materials/Parts

Lamp, Incandescent (WP 0079, Item 33)
Lamp, Incandescent (3) (WP 0079, Item 34)
Lamp, Incandescent (WP 0079, Item 37)
Lamp, Incandescent (2) (WP 0079, Item 38)

Materials/Parts (cont.)

Lockwasher (4) (WP 0079, Item 40)
Rag, Wiping (WP 0079, Item 52)

References

WP 0008

Equipment Conditions

MASTER BATTERY switch off (WP 0004)

GENERAL

This work package contains information on the removal and installation of headlight, blackout marker, and taillight lamps.

REMOVAL**Headlight and Blackout Marker Lamp**

1. Use 6 inch flat-tipped screwdriver to remove four screws (Figure 1, Item 2) and lockwashers (Figure 1, Item 3) from cover (Figure 1, Item 1). Discard lockwashers.

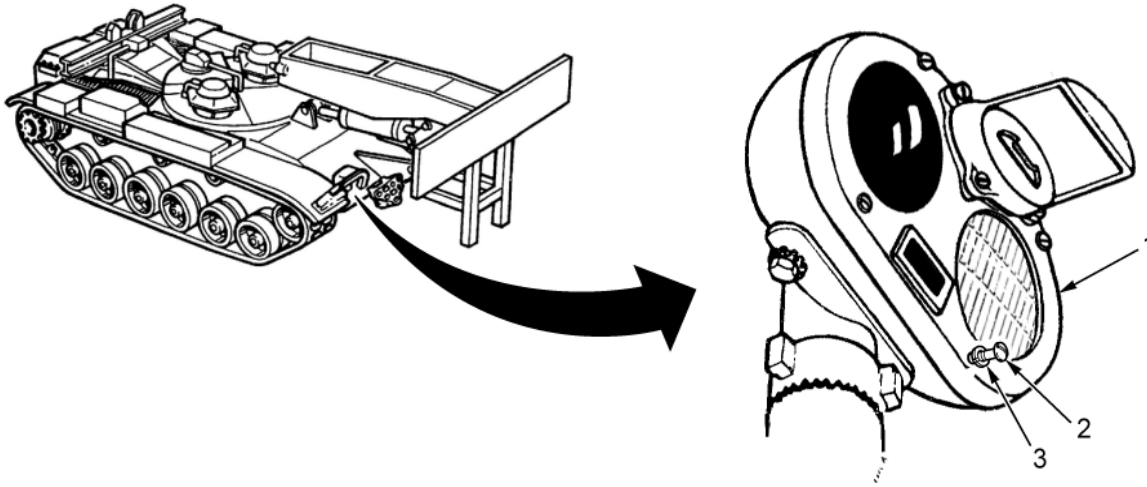

AVLBD488

Figure 1. Headlight Cover Screw Removal.

2. Remove cover (Figure 2, Item 3) and seal (Figure 2, Item 2) by pulling straight from body (Figure 2, Item 1) to avoid damaging guide pin (Figure 2, Item 4).

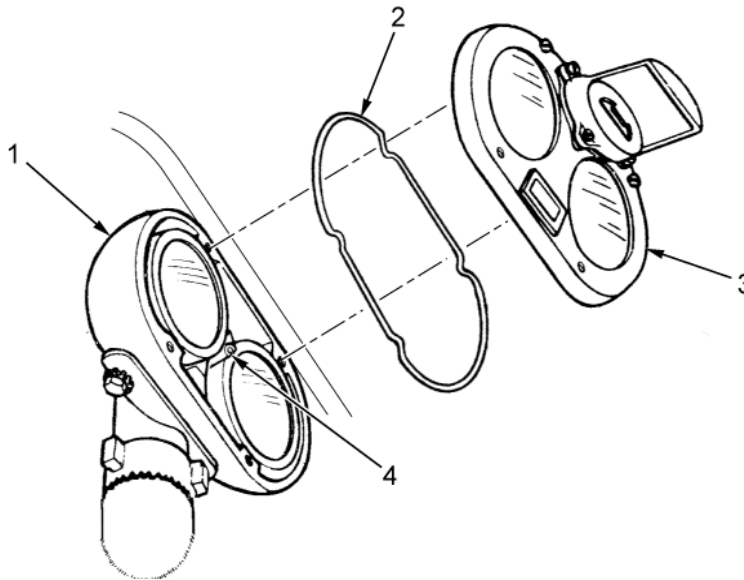

AVLBD387B

Figure 2. Headlight Cover and Seal Removal.

REMOVAL - CONTINUED**Headlight and Blackout Marker Lamp - Continued**

3. Use 8 inch cross-tipped screwdriver to remove six screws (Figure 3, Item 6) and washers (Figure 3, Item 5) from retainers (Figure 3, Item 4).
4. Use 8 inch cross-tipped screwdriver to remove two retainers (Figure 3, Item 4) securing clear lens (Figure 3, Item 2) and red lens (Figure 3, Item 3) from body (Figure 3, Item 1).

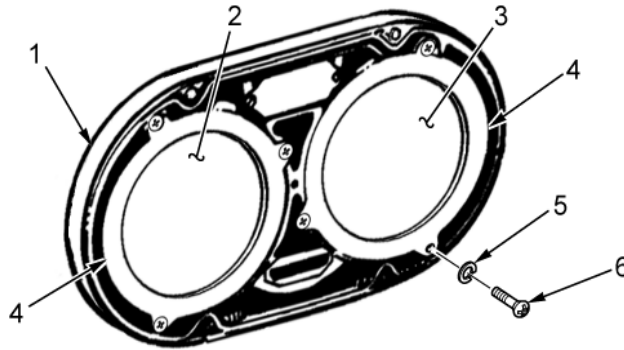

AVLBD388A

Figure 3. Headlamp Lens Retainer Removal.

5. Remove lenses (Figure 4, Item 2 and Item 4) and two gaskets (Figure 4, Item 3) from headlight body (Figure 4, Item 1).

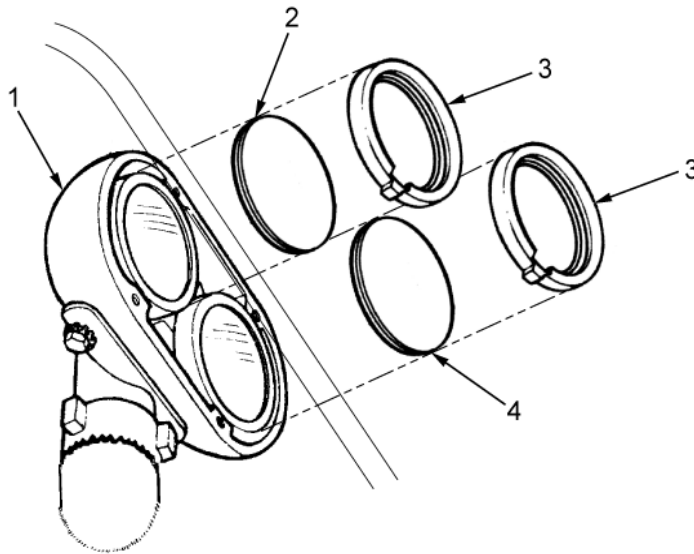

AVLBD479

Figure 4. Headlamp Lens Removal.

REMOVAL - CONTINUED**Headlight and Blackout Marker Lamp - Continued**

6. Remove two headlight lamps (Figure 5, Item 3) and gaskets (Figure 5, Item 4) from headlight body (Figure 5, Item 1).
7. Disconnect lamps (Figure 5, Item 3) from connectors (Figure 5, Item 2).

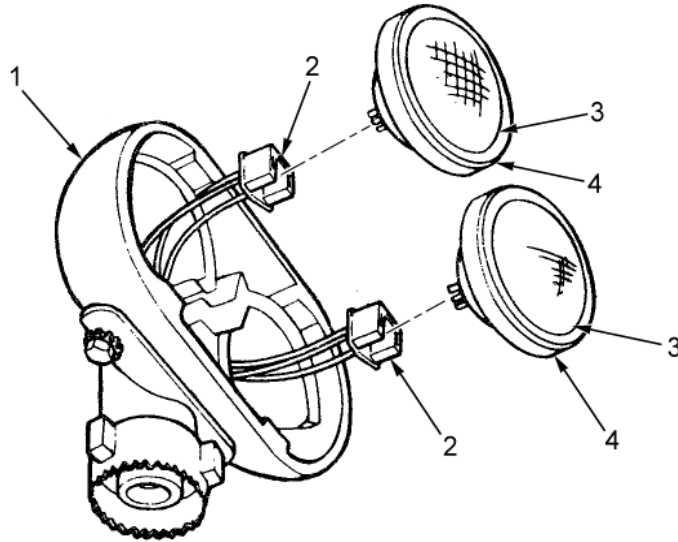

AVLBD480

Figure 5. Headlamp Removal.

8. Remove two gaskets (Figure 6, Item 2) from lamps (Figure 6, Item 1).

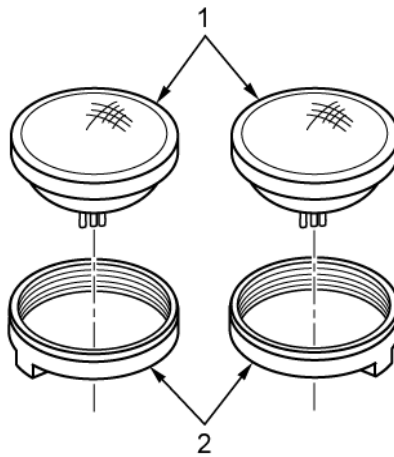

AVLBD481

Figure 6. Headlamp Gasket Removal.

REMOVAL - CONTINUED**Headlight and Blackout Marker Lamp - Continued**

9. Remove blackout drive lamp (Figure 7, Item 2) and blackout marker lamp (Figure 7, Item 3) from body (Figure 7, Item 4) by pressing lamps in and turning counterclockwise. Discard lamps.
10. Remove reflector (Figure 7, Item 1) from body (Figure 7, Item 4).

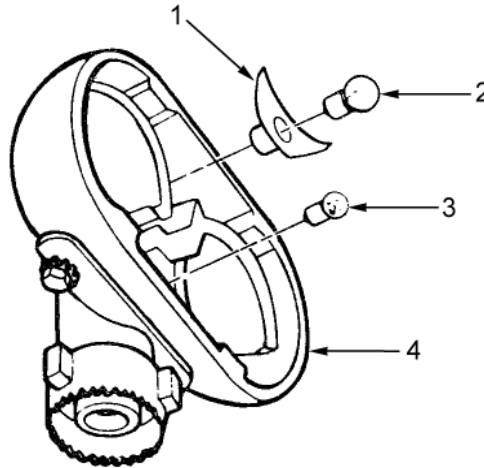

AVLBD482

Figure 7. Blackout Drive Lamp and Blackout Marker Lamp Removal.

END OF TASK

REMOVAL - CONTINUED**Taillight Removal**

1. Use 6 inch flat-tipped screwdriver to loosen six screws (Figure 8, Item 7) from retainer lens (Figure 8, Item 6).
2. Remove retainer lens (Figure 8, Item 6) and retainer rings (Figure 8, Item 8) from housing (Figure 8, Item 1).
3. Remove O-ring (Figure 8, Item 5) from retainer lens (Figure 8, Item 6).
4. Press in and rotate counterclockwise to remove service taillight stoplight lamps (Figure 8, Item 4) from sockets (Figure 8, Item 9) and blackout marker lamp (Figure 8, Item 3) from socket (Figure 8, Item 2). Discard lamps.

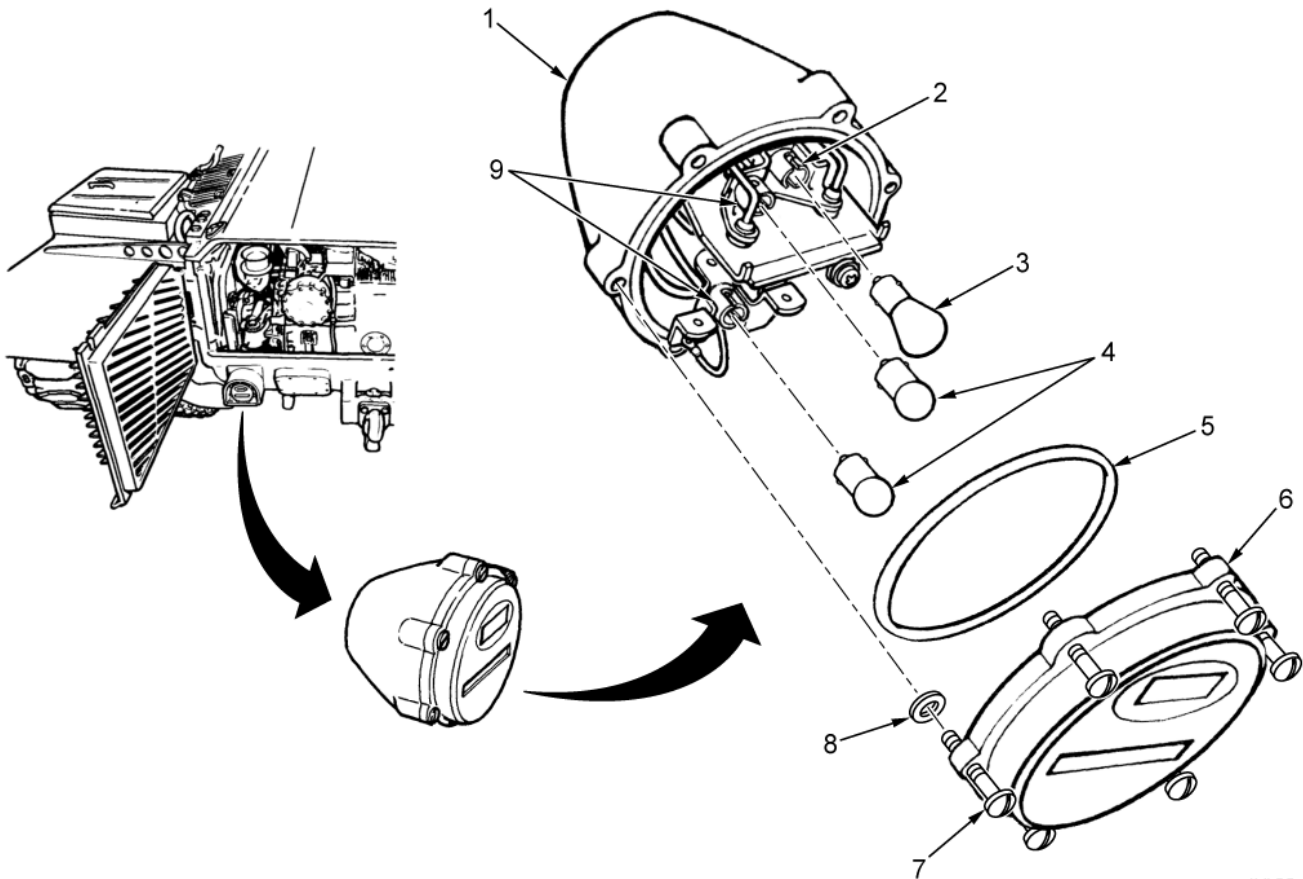

AVLBD490

Figure 8. Taillight Removal.

END OF TASK

INSTALLATION

Headlight and Blackout Marker Lamp

1. Inspect seals (Figure 9, Item 2) for cuts or damage. Notify field maintenance if replacement is required. Align notches on seals and lamps (Figure 9, Item 1) and install two seals on two new lamps.

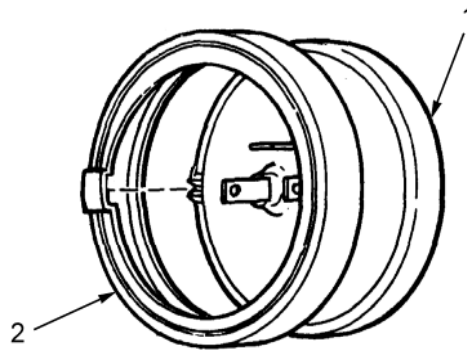

AVLBD483

Figure 9. Headlamp Seal Inspection.

NOTE

Ensure sealed beam is positioned with the word FOG at bottom.

2. Connect lamps (Figure 10, Item 3) to electrical connectors (Figure 10, Item 2) and install lamps in body (Figure 10, Item 1) aligning notches in gaskets (Figure 10, Item 4) with slots in body.

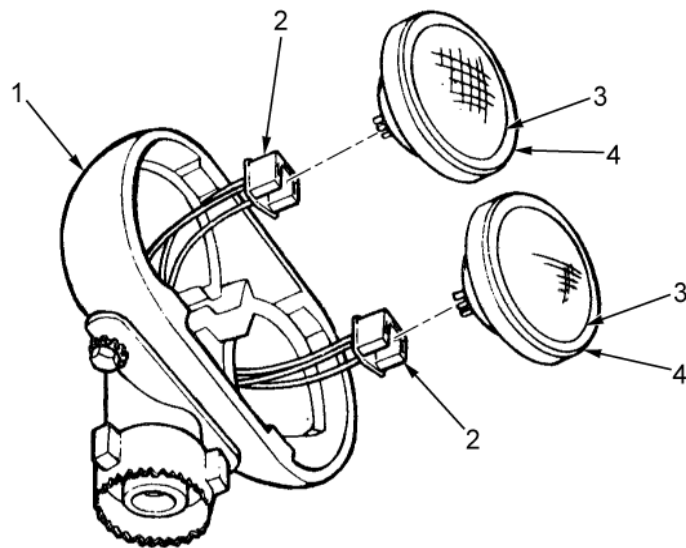

AVLBD484

Figure 10. Headlamp Installation.

INSTALLATION - CONTINUED**Headlight and Blackout Marker Lamp - Continued****NOTE**

Ensure red lens is installed in the outside position.

3. Install reflector (Figure 11, Item 1) in body (Figure 11, Item 4).
4. Install new blackout drive lamp (Figure 11, Item 2) and blackout marker lamp (Figure 11, Item 3) in body (Figure 11, Item 4) by pressing in and turning clockwise.

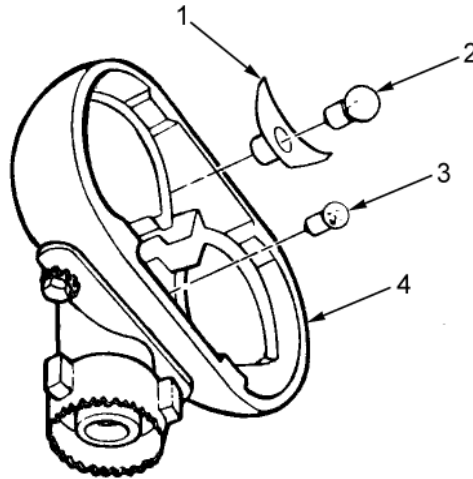

AVLBD485

Figure 11. Blackout Drive Lamp and Blackout Marker Lamp Installation.

NOTE

Use soft cloth to clean lens (Figure 12, Item 8 and Item 9) and glass.

5. Install two seals (Figure 12, Item 1) around clear and red lenses (Figure 12, Item 8 and Item 9). Ensure notches of seals are pointing to inside.
6. Install headlight lens (Figure 12, Item 8 and Item 9) and seals (Figure 12, Item 1) over lamps (Figure 12, Item 3 and Item 4) in notches of body (Figure 12, Item 2) with rounded sides outward.

INSTALLATION - CONTINUED

Headlight and Blackout Marker Lamp - Continued

7. Use 8 inch cross-tipped screwdriver to install two retainers (Figure 12, Item 5) over lens (Figure 12, Item 8 and Item 9).
8. Use 8 inch cross-tipped screwdriver to install six screws (Figure 12, Item 7) and washers (Figure 12, Item 6) in retainers (Figure 12, Item 5).

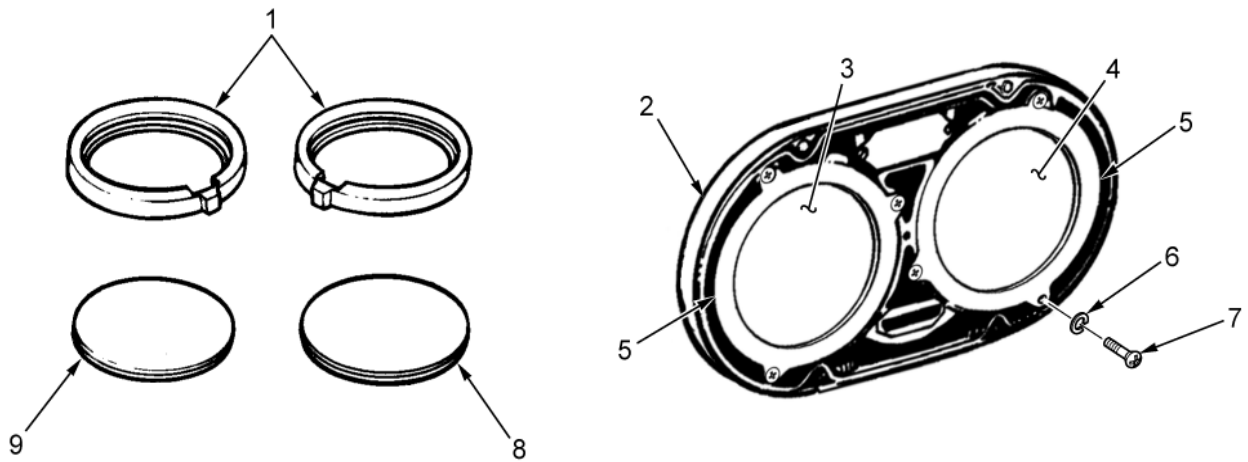

AVLBD486A

Figure 12. Headlamp Lens and Retainer Installation.

9. Inspect cover seal (Figure 13, Item 2) for cuts or damage. Notify field maintenance if replacement is required. Install seal on cover (Figure 13, Item 3).
10. Align cover (Figure 13, Item 3) with guide pin (Figure 13, Item 4) and install cover on body (Figure 13, Item 1).

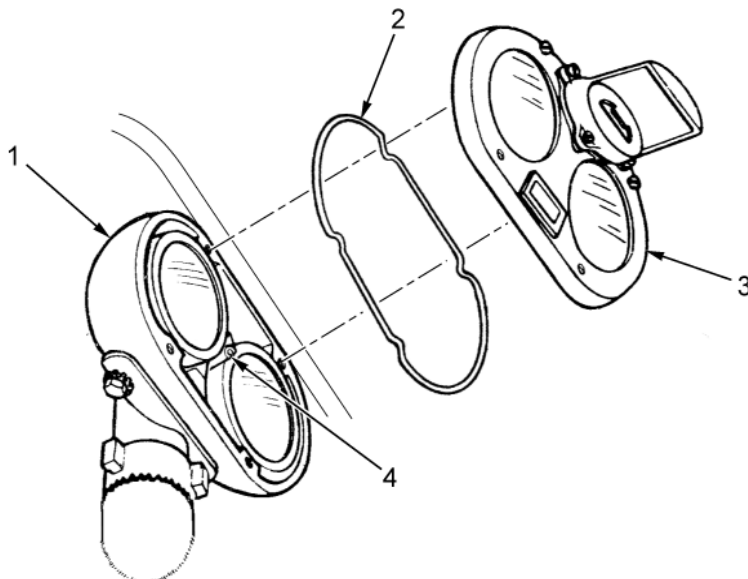

AVLBD387B

Figure 13. Headlight Cover and Seal Installation.

INSTALLATION - CONTINUED**Headlight and Blackout Marker Lamp - Continued**

11. Use 6 inch flat-tipped screwdriver to install four screws (Figure 14, Item 2) and new lockwashers (Figure 14, Item 3) in cover (Figure 14, Item 1).

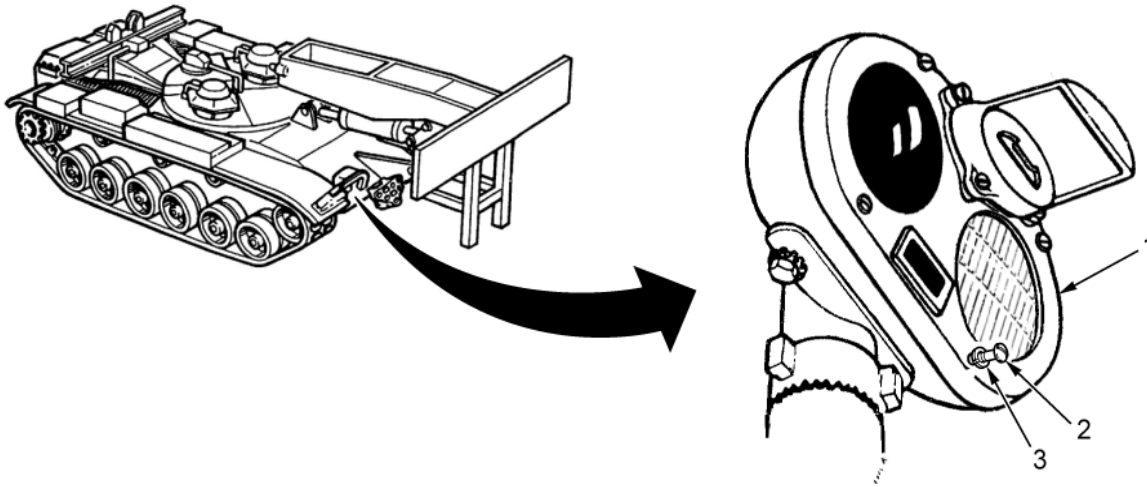

AVLBD488

Figure 14. Headlight Cover Screw Removal.

12. Turn MASTER BATTERY switch ON. Refer to WP 0004.
 13. Check operation of taillights. Refer to WP 0008.

END OF TASK**Taillight Installation**

1. Install new service taillight and stoplight lamps (Figure 15, Item 4) in sockets (Figure 15, Item 9) and blackout marker lamp (Figure 15, Item 3) in socket (Figure 15, Item 2). Press lamps in and turn clockwise to lock.
2. Wipe retainer lens (Figure 15, Item 6) with a clean cloth.
3. Inspect O-ring (Figure 15, Item 5) for cuts or damage. Notify field maintenance if replacement is required. Install O-ring in retainer lens (Figure 15, Item 6).
4. Use 6 inch flat-tipped screwdriver to install retainer lens (Figure 15, Item 6) on housing (Figure 15, Item 1).
5. Use 6 inch flat-tipped screwdriver to tighten six screws (Figure 15, Item 7) and retainer rings (Figure 15, Item 8) in retainer lens (Figure 15, Item 6).
6. Turn MASTER BATTERY switch ON. Refer to WP 0004.
7. Check operation of taillights. Refer to WP 0008.

INSTALLATION - CONTINUED
Taillight Installation - Continued

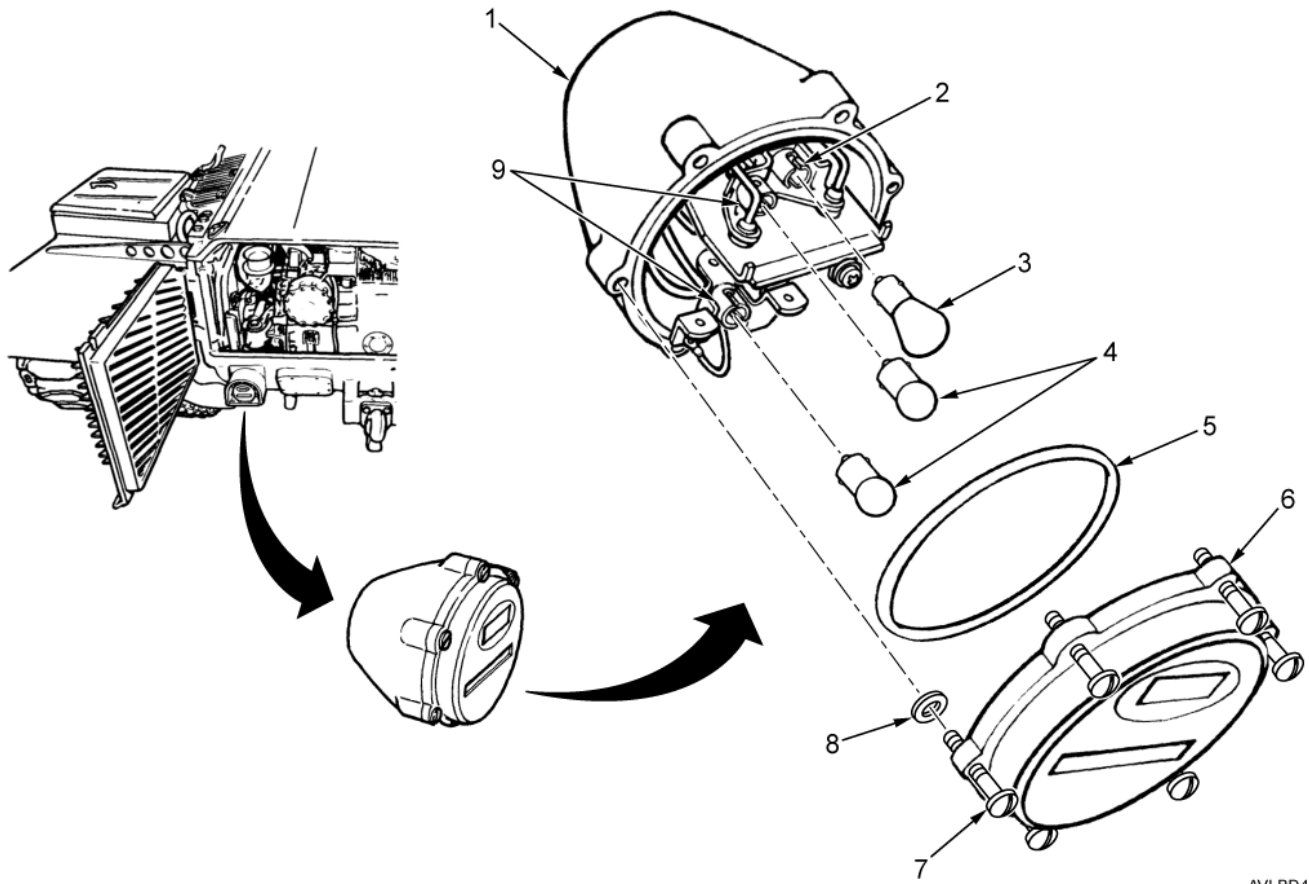

AVLBD490

Figure 15. Taillight Installation.

END OF TASK

END OF WORK PACKAGE

OPERATOR MAINTENANCE**MASTER CONTROL PANEL, INSTRUMENT CLUSTER, AND POWERPLANT WARNING LAMP
REPLACEMENT**

INITIAL SETUP:**Tools and Special Tools**

Wrench, Adjustable (WP 0077, Table 2, Item 67)

References

WP 0008

Materials/Parts

Lamp, Incandescent (4) (WP 0079, Item 36)

Rag, Wiping (WP 0079, Item 52)

Equipment Conditions

MASTER BATTERY switch off (WP 0004)

GENERAL

This work package contains information on master control panel, instrument cluster, and powerplant warning lamp replacement.

REMOVAL**Master Control Panel Lamp**

1. Remove lens (Figure 1, Item 5) from adapter (Figure 1, Item 3).
2. Use adjustable wrench to remove adapter (Figure 1, Item 3) from panel (Figure 1, Item 1).
3. Remove O-ring (Figure 1, Item 4) from adapter (Figure 1, Item 3).
4. Remove lamp (Figure 1, Item 2) from panel (Figure 1, Item 1) by pushing lamp in and turning counterclockwise. Discard lamp.

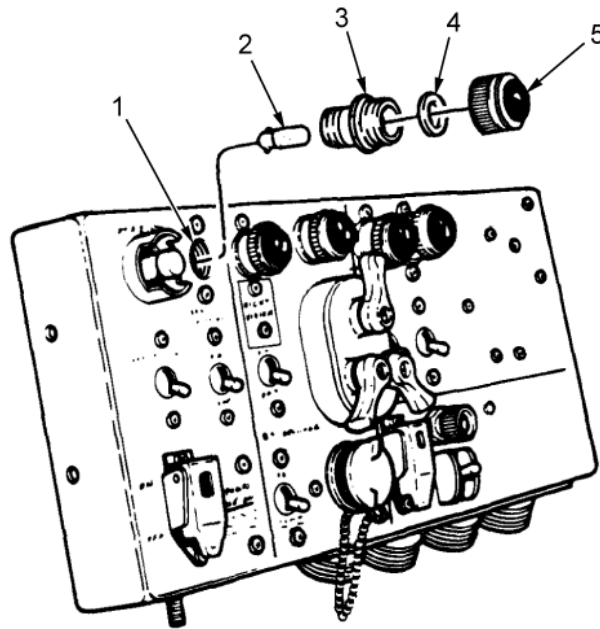

AVLBD393

Figure 1. Master Control Panel Lamp Replacement.

END OF TASK

REMOVAL - CONTINUED**Instrument Cluster Panel Lamp**

1. Remove lens (Figure 2, Item 3) from instrument panel (Figure 2, Item 4).
2. Remove O-ring (Figure 2, Item 2) from lens (Figure 2, Item 3).
3. Remove lamp (Figure 2, Item 1) from instrument panel (Figure 2, Item 4) by pushing in lamp and turning counterclockwise. Discard lamp.

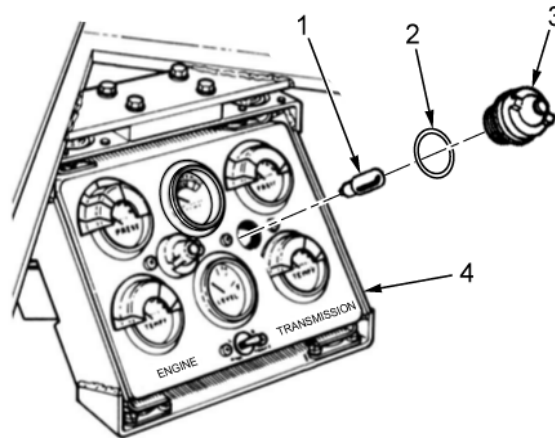

AVLBD399

Figure 2. Instrument Cluster Panel Lamp Replacement.

END OF TASK**Powerplant Warning Lamp**

1. Remove lens (Figure 3, Item 5) from adapter (Figure 3, Item 3).
2. Use adjustable wrench to remove adapter (Figure 3, Item 3) from panel (Figure 3, Item 1).
3. Remove O-ring (Figure 3, Item 4) from adapter (Figure 3, Item 3).
4. Remove lamp (Figure 3, Item 2) from panel (Figure 3, Item 1) by pushing in lamp and turning counterclockwise. Discard lamp.

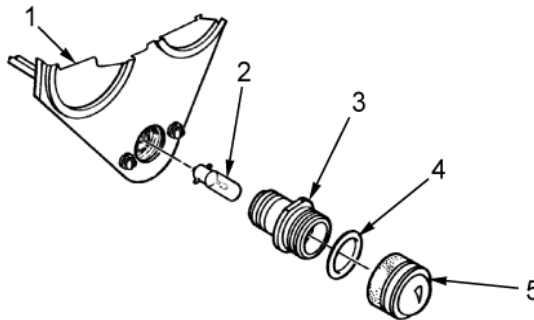

AVLBD394

Figure 3. Powerplant Warning Lamp Replacement.

END OF TASK

INSTALLATION**Master Control Panel Lamp**

1. Install new lamp (Figure 4, Item 2) in panel (Figure 4, Item 1) by pushing lamp in and turning clockwise.
2. Inspect O-ring (Figure 4, Item 4) for cuts or damage. If replacement is required, notify field maintenance.
3. Install O-ring (Figure 4, Item 4) on adapter (Figure 4, Item 3).
4. Use adjustable wrench to install adapter (Figure 4, Item 3) in panel (Figure 4, Item 1).
5. Install lens (Figure 4, Item 5) on adapter (Figure 4, Item 3).
6. Turn MASTER BATTERY switch on. Refer to WP 0004.
7. Check operation of lamp (Figure 4, Item 2). Refer to WP 0008.

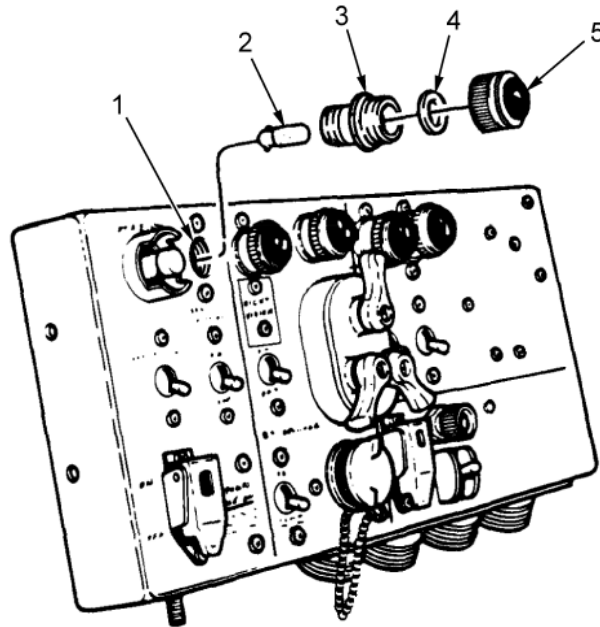

AVLBD393

Figure 4. Master Control Panel Lamp Replacement.

END OF TASK**Instrument Cluster Panel Lamp**

1. Install new lamp (Figure 5, Item 1) in panel (Figure 5, Item 4) by pushing in lamp and turning clockwise.
2. Inspect O-ring (Figure 5, Item 2) for cuts or damage. If replacement is required, notify field maintenance.
3. Install O-ring (Figure 5, Item 2) on lens (Figure 5, Item 3).
4. Install lens (Figure 5, Item 3) in panel (Figure 5, Item 4).
5. Turn MASTER BATTERY switch on. Refer to WP 0004.
6. Check operation of lamp. Refer to WP 0008.

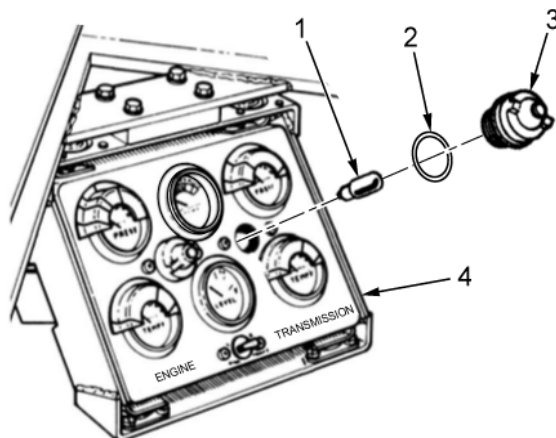
INSTALLATION - CONTINUED**Instrument Cluster Panel Lamp - Continued**

AVLBD399

Figure 5. Instrument Cluster Panel Lamp Replacement.

END OF TASK**Powerplant Warning Lamp**

1. Install new lamp (Figure 6, Item 2) in panel (Figure 6, Item 1) by pushing in lamp and turning clockwise.
2. Inspect O-ring (Figure 6, Item 4) for cuts or damage. If replacement is required, notify field maintenance.
3. Install O-ring (Figure 6, Item 4) on adapter (Figure 6, Item 3).
4. Use adjustable wrench to install adapter (Figure 6, Item 3) in panel (Figure 6, Item 1).
5. Install lens (Figure 6, Item 5) on adapter (Figure 6, Item 3).
6. Turn MASTER BATTERY switch on. Refer to WP 0004.
7. Check operation of lamp (Figure 6, Item 2). Refer to WP 0008.

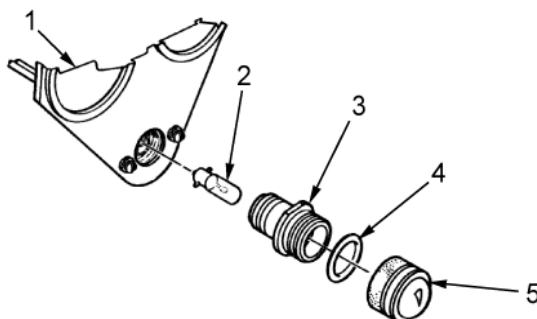

AVLBD394

Figure 6. Powerplant Warning Lamp Replacement.

END OF TASK**END OF WORK PACKAGE**

OPERATOR MAINTENANCE
DUST DETECTOR WARNING LAMP REPLACEMENT

INITIAL SETUP:**Materials/Parts**

Lamp, Incandescent (WP 0079, Item 30)

Equipment Conditions

MASTER BATTERY switch off (WP 0004)

References

WP 0008

GENERAL

This work package contains information on dust detector warning lamp replacement.

REMOVAL

1. Remove lens (Figure 1, Item 4) and O-ring (Figure 1, Item 3) from lamp socket (Figure 1, Item 1).
2. Remove lamp (Figure 1, Item 2) from lamp socket (Figure 1, Item 1). Discard lamp.

END OF TASK**INSPECTION**

Inspect O-ring (Figure 1, Item 3) for cuts or damage. If replacement is required, notify field maintenance.

END OF TASK**INSTALLATION**

1. Install new lamp (Figure 1, Item 2) in lamp socket (Figure 1, Item 1).
2. Install O-ring (Figure 1, Item 3) on lamp socket (Figure 1, Item 1).
3. Install lens (Figure 1, Item 4) on lamp socket (Figure 1, Item 1).
4. Turn Master Battery switch ON. Refer to WP 0004.
5. Check operation of lamp (Figure 1, Item 2). Refer to WP 0008.

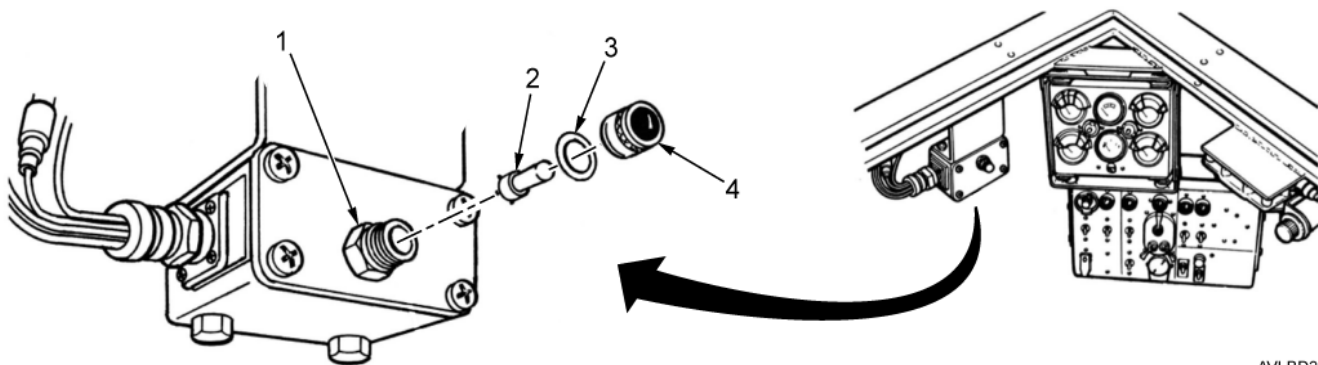

AVLBD398

Figure 1. Dust Detector Lamp Replacement.

END OF TASK**END OF WORK PACKAGE**

OPERATOR MAINTENANCE**SMOKE GRENADE LAUNCHER POWER BOX LAMP REPLACEMENT**

INITIAL SETUP:**Materials/Parts**

Lamp, Incandescent (WP 0079, Table 1, Item 37)

Equipment Conditions

MASTER BATTERY switch off (WP 0004)

References

WP 0004

WP 0008

GENERAL

This work package contains information on smoke grenade launcher power box lamp replacement.

REMOVAL

1. Rotate lens cap (Figure 1, Item 1) counterclockwise and remove from housing (Figure 1, Item 4).
2. Remove lamp (Figure 1, Item 3) from lens cap (Figure 1, Item 1). Discard lamp.

END OF TASK**INSPECTION**

Inspect lens cap (Figure 1, Item 1) and O-ring (Figure 1, Item 2) for cuts or damage. If replacement is required, notify field maintenance.

END OF TASK**INSTALLATION**

1. Install new lamp (Figure 1, Item 3) in lens cap (Figure 1, Item 1).
2. Ensure O-ring (Figure 1, Item 2) is properly installed in lens cap (Figure 1, Item 1) and install lens cap (Figure 1, Item 1) in housing (Figure 1, Item 4).
3. Rotate lens cap (Figure 1, Item 1) clockwise to tighten.
4. Turn MASTER BATTERY switch on. Refer to WP 0004.
5. Check operation of lamp (Figure 1, Item 3). Refer to WP 0008.

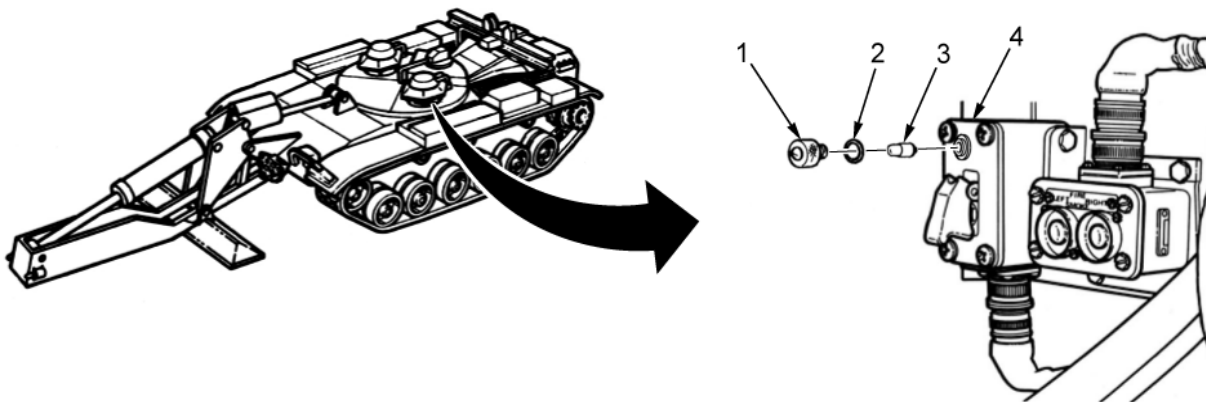

AVLBD396A

Figure 1. Smoke Grenade Launcher Power Box Lamp Replacement.

END OF TASK**END OF WORK PACKAGE**

OPERATOR MAINTENANCE
HEADLIGHT REMOVAL, STOWAGE, AND INSTALLATION

INITIAL SETUP:**Tools and Special Tools**

Hammer, Machinist (WP 0077, Table 2, Item 26)

Equipment Conditions

MASTER BATTERY switch off (WP 0004)

GENERAL

This work package contains information on headlight removal, stowage, and installation.

REMOVAL**NOTE**

- Right and left headlights are identical.
- Some nuts may be too tight to loosen with fingers. Tap rings with hammer, if necessary, and then perform step 1 and step 2.

Turn nut (Figure 1, Item 2) counterclockwise and remove headlight (Figure 1, Item 1) from base assembly (Figure 1, Item 3).

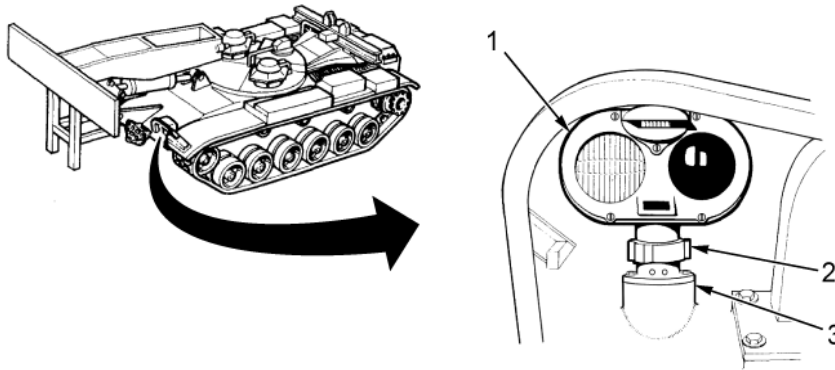

AVLBD638

Figure 1. Headlight Removal.

END OF TASK**STOWAGE****NOTE**

There are two lampholders in the crew compartment. One is located behind operator's seat and one behind commander's seat.

1. Unscrew dust cap (Figure 2, Item 5) from inside stowage mount (Figure 2, Item 4).
2. Position headlight (Figure 2, Item 1) on inside stowage mount (Figure 2, Item 4) and secure with nut (Figure 2, Item 6).
3. Install dust caps (Figure 2, Item 2) on outside mounts (Figure 2, Item 3).

STOWAGE - CONTINUED

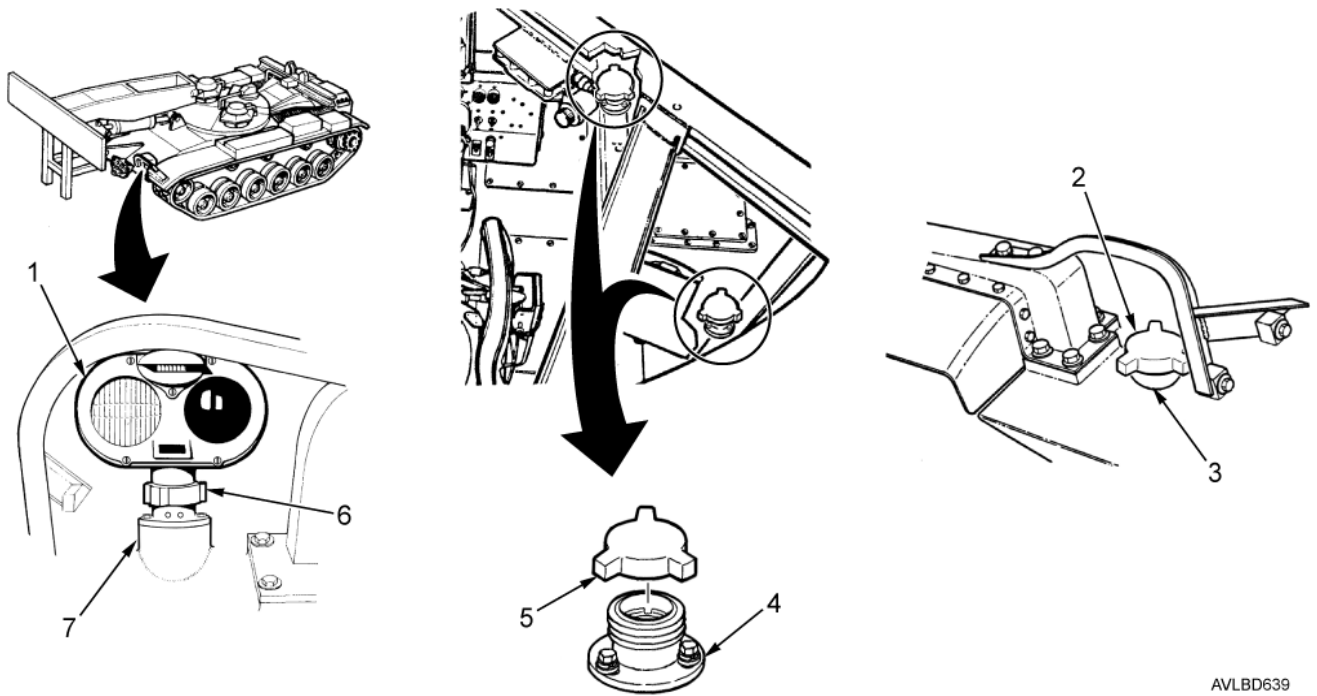

AVLBD639

Figure 2. Headlight Stowage.

END OF TASK

INSTALLATION

1. Turn headlight nut (Figure 3, Item 3) and remove headlight (Figure 3, Item 2) From inside stowage mount (Figure 3, Item 4).
2. Remove dust cap (Figure 3, Item 1) from outside mount (Figure 3, Item 5).

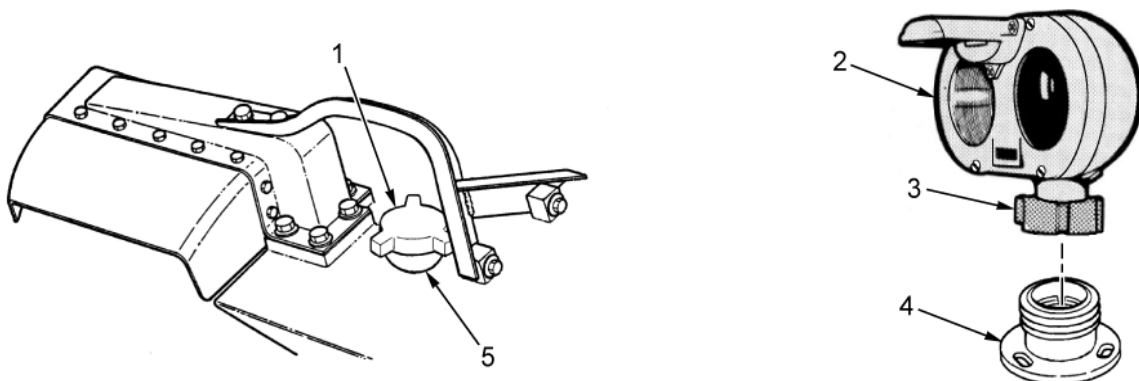

AVLBD208

Figure 3. Headlight Removal from Stowage.

INSTALLATION - CONTINUED

3. Install dust cap (Figure 4, Item 2) on inside stowage mount (Figure 4, Item 3).
4. Install headlight (Figure 4, Item 1) by pushing headlight downward into outside mount (Figure 4, Item 4).
5. Thread nut clockwise (Figure 4, Item 5) onto outside mount (Figure 4, Item 4).

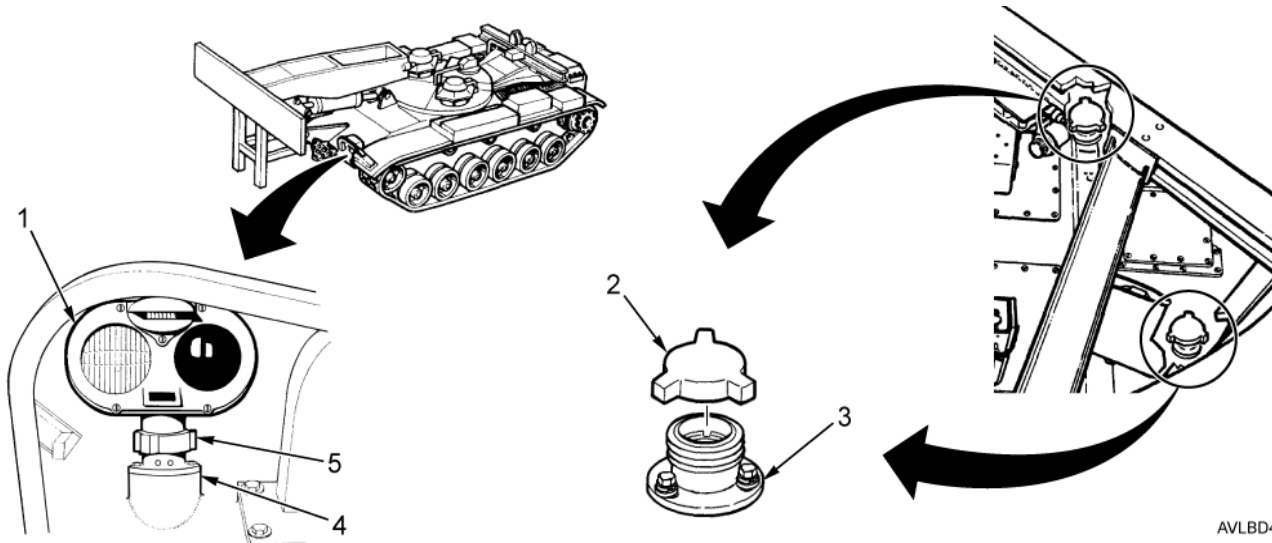

AVLBD493

Figure 4. Headlight Installation.

END OF TASK**END OF WORK PACKAGE**

OPERATOR MAINTENANCE**ENGINE AIR CLEANER INDICATOR MAINTENANCE**

INITIAL SETUP:**Tools and Special Tools**

Flashlight (WP 0077, Table 2, Item 22)
Wrench, Adjustable (WP 0077, Table 2, Item 67)

Equipment Conditions

Engine running (WP 0015)
MASTER BATTERY switch off (WP 0004)

GENERAL

This work package contains information on engine air cleaner indicator maintenance.

INSPECTION/ACCEPTANCE AND REJECTION CRITERIA

NOTE

- Use the following procedure for either top-loading aluminum or armored air cleaners.
 - Air cleaners are normally serviced by field maintenance after every 750 miles of vehicle operation or quarterly, whichever occurs first. Dusty conditions, power loss, or excessive black smoke may indicate the need for more frequent cleaning.
1. If air cleaner is equipped with restriction indicator, check to see if restriction indicator window (Figure 1, Item 5) is clear or red. A clear window indicates normal condition. If indicator window is red, press indicator reset button (Figure 1, Item 1), rev engine to 2,400 RPM maximum, and then recheck indicator window. If window is still red, shut off engine and notify field maintenance.
 2. If air cleaner is equipped with restriction indicator (Figure 1, Item 3), measure amount of restriction created by filter element. The indicator measures amount of restriction (Figure 1, Item 2) created by filter element in 5 inch increments. Reset button (Figure 1, Item 4) is pressed only when filter element is cleaned or replaced. A reading of 30 inches or more indicates that filter element must be cleaned. Shut off engine and notify field maintenance.
 3. If restriction indicator window (Figure 1, Item 5) is red, or restriction indicator window (Figure 1, Item 3) is reading 30 inches or more, but engine power loss is not indicated, continue operations until first opportunity for servicing at next maintenance interval.
 4. If restriction indicator window (Figure 1, Item 5) is red, or restriction indicator window (Figure 1, Item 3) is reading 30 inches or more, and power loss is indicated, notify field maintenance.
 5. If restriction indicator window (Figure 1, Item 5) is clear, proceed to step 6.

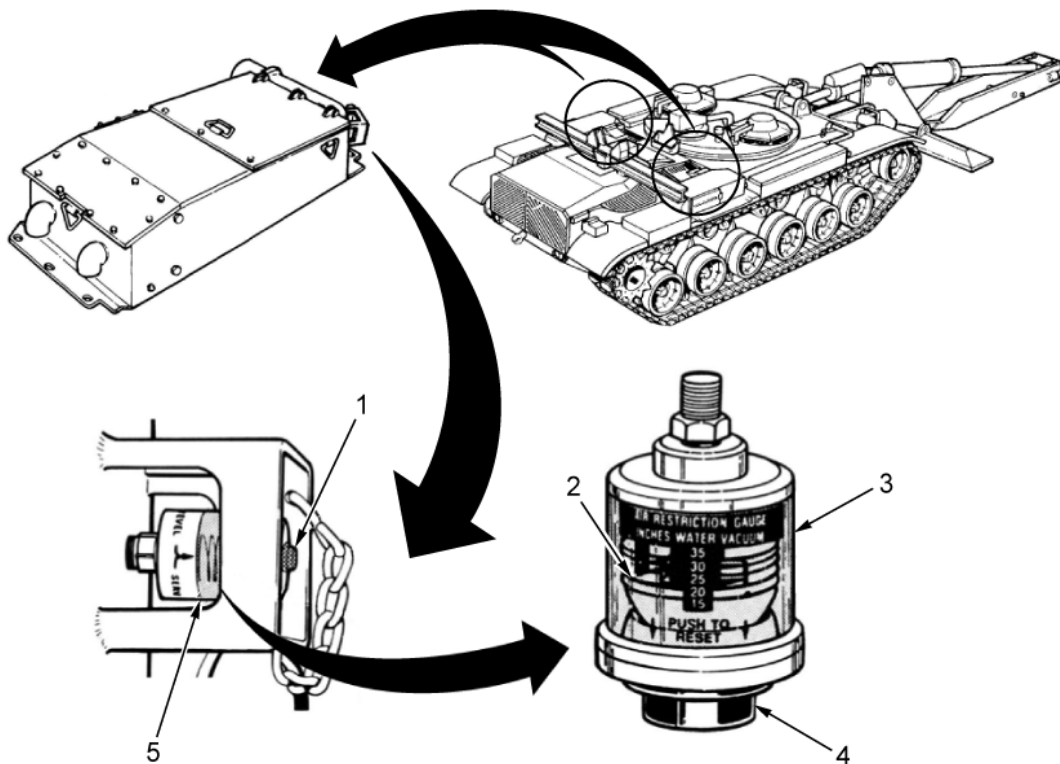

AVLBD425A

Figure 1. Air Cleaner Indicator.

INSPECTION/ACCEPTANCE AND REJECTION CRITERIA - CONTINUED

6. Lift grille doors on right and left sides of vehicle and check for loose or missing air cleaner input and output hose clamps. Tighten loose clamps. If clamps are missing, notify field maintenance and do not start vehicle until clamp is replaced.
7. Remove lower inspection plug (Figure 2, Item 2) from air cleaner (Figure 2, Item 1). Use flashlight to inspect hole. If dust has accumulated above bottom row of tubes, replace plug (Figure 2, Item 2) and notify field maintenance.

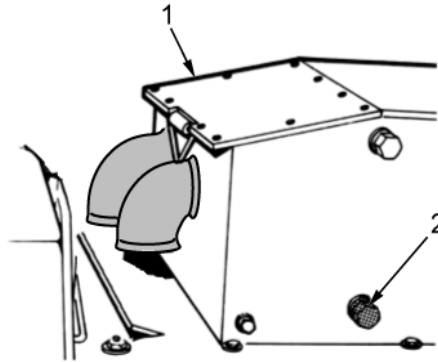

AVLBD426A

Figure 2. Air Cleaner Inspection.

END OF TASK**END OF WORK PACKAGE**

OPERATOR MAINTENANCE**M239 SMOKE GRENADE LAUNCHER MAINTENANCE**

INITIAL SETUP:**Materials/Parts**

Rag, Wiping (WP 0079, Table 1, Item 52)

Equipment Conditions

Grenade launcher covers removed (WP 0023)

Equipment Conditions (cont.)

Grenade launcher dischargers unloaded (WP 0023)

MASTER BATTERY switch off (WP 0004)

GENERAL

This work package contains information on M239 smoke grenade launcher maintenance.

CLEANING

Cleaning Dischargers

1. Turn smoke grenade launcher power switch (Figure 1, Item 1) to OFF position.

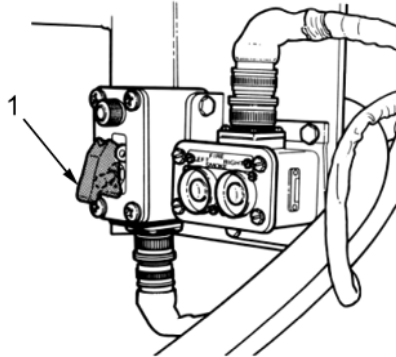

AVLBD428A

Figure 1. Smoke Grenade Launcher Power Switch.

2. Clean debris from grenade discharger barrels (Figure 2, Item 1).

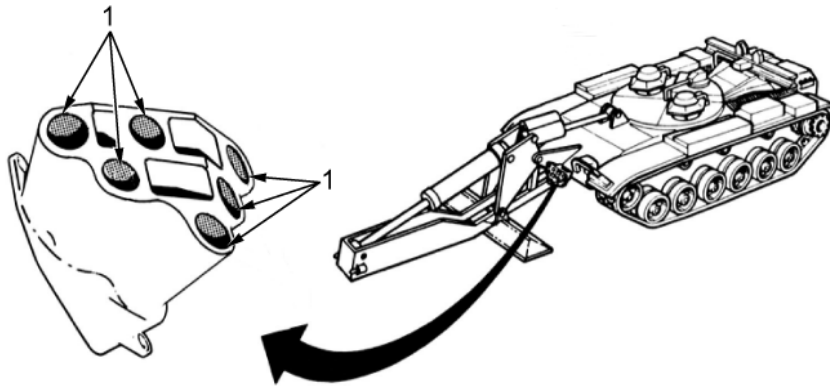

AVLBD429

Figure 2. Discharger Barrels.

NOTE

Top center barrel drain hole cannot be cleaned using steel wire. If barrel drain hole is clogged, notify field maintenance to clean barrel drain hole using compressed air.

3. Use steel wire to ensure drain holes (Figure 3, Item 1) in grenade discharger barrels (Figure 3, Item 2) are clear.

CAUTION

- Barrel tip plugs must be clean and dry. DO NOT oil barrel tip plugs. Oil can foul barrel tip plugs and damage launcher.
- DO NOT step on dischargers. Stepping on dischargers can damage dischargers.
- DO NOT use wire brush or steel wool to clean barrels. Steel wool can score barrel and damage launcher.

CLEANING - CONTINUED**Cleaning Dischargers - Continued**

4. Use rag and rifle bore cleaner or soap and water to clean grenade discharger barrels (Figure 3, Item 2).
5. Use clean rags to remove cleaning solution from grenade discharger barrels (Figure 3, Item 2). Ensure no residue remains around barrel tip plugs (Figure 3, Item 3).

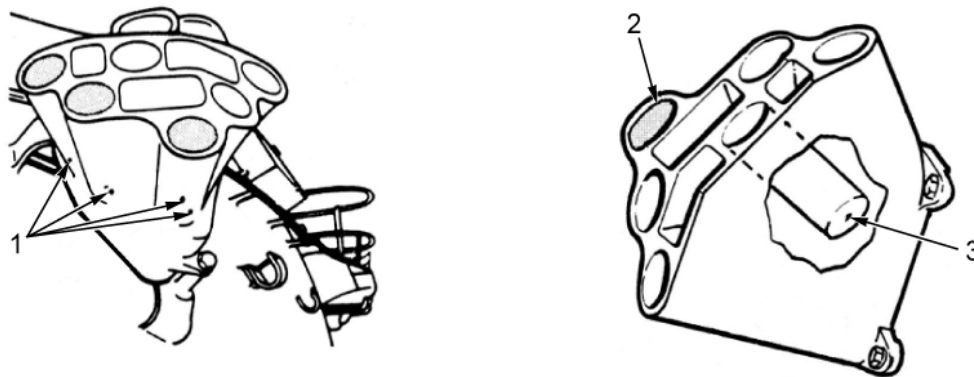

AVLBD430

Figure 3. Cleaning Discharger Barrels.

6. Install grenade discharger covers (Figure 4, Item 1) on smoke grenade dischargers (Figure 4, Item 2).

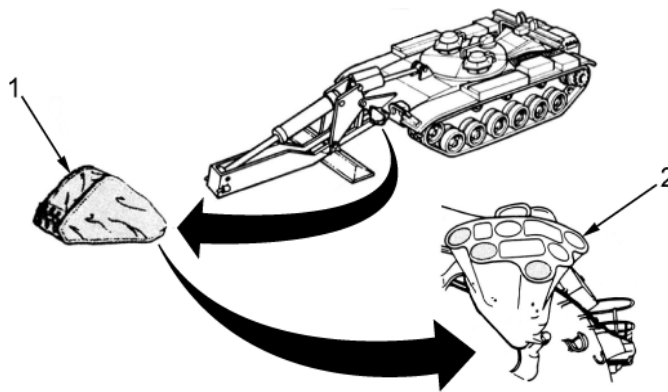

AVLBD431

Figure 4. Grenade Discharger Cover.

END OF TASK

STOWAGE**Stowing Smoke Grenades****WARNING**

Smoke grenades contain red phosphorous (RP) and are explosive. If grenades are dropped, heated, thrown, tumbled, or dragged, an explosion may result. Follow standard weapon-loading procedures when handling and loading smoke grenades. Have a manned fire extinguisher handy. Do not allow flames or sparks within area while stowing ammunition. Disassembly of ammunition is not authorized. Failure to comply may result in personnel injury or death, or equipment damage.

NOTE

One stowage box is located on each side of overhead cylinder.

1. Open ammunition box (Figure 5, Item 2) and remove smoke grenades (Figure 5, Item 1) from ammunition storage box.

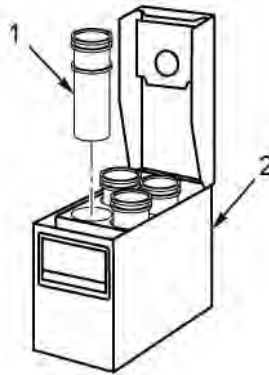

AVLBD513

Figure 5. Ammunition Storage Box.

STOWAGE - CONTINUED**Stowing Smoke Grenades - Continued**

- Put six smoke grenades (Figure 6, Item 1), base first, into each stowage box (Figure 6, Item 3) and close and latch lid (Figure 6, Item 2).

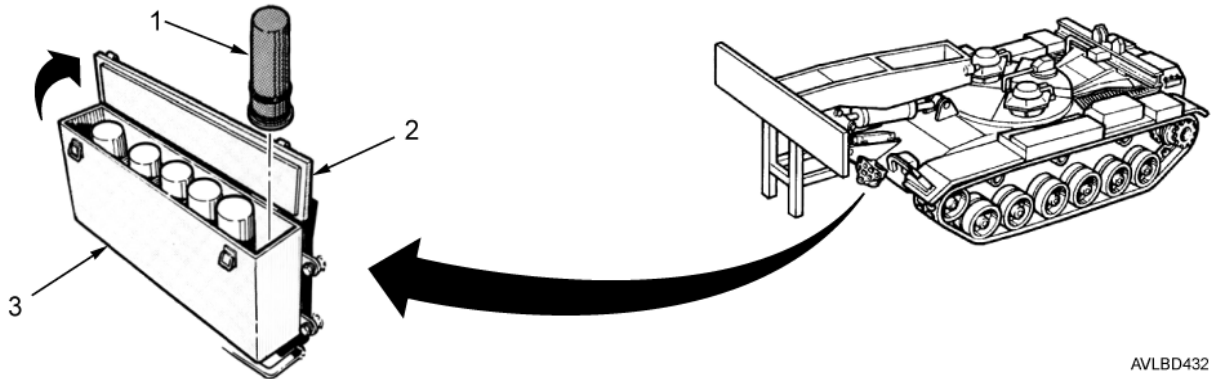

AVLBD432

Figure 6. Grenade Stowage Box.

END OF TASK**END OF WORK PACKAGE**

OPERATOR MAINTENANCE
MAINTENANCE UNDER ADVERSE CONDITIONS

INITIAL SETUP:**Tools and Special Tools**

Handle, Socket Wrench, Ratchet (WP 0077,
Table 2, Item 31)
Socket Wrench (WP 0077, Table 2, Item 58)
Wrench, Adjustable (WP 0077, Table 2, Item 67)

References (cont.)

WP 0009
WP 0048
WP 0063
WP 0074

References

FM 9-207
LO 5-5420-202-13

GENERAL

This work package contains information on maintenance under adverse conditions. In addition to performing normal Preventive Maintenance Checks and Services (PMCS) (WP 0048), use special care in cleaning and lubricating the vehicle where extremes of temperature, humidity, and terrain conditions are present or anticipated. Properly clean and lubricate the vehicle to ensure proper operation, functioning, and guarding against excessive wear of working parts and deterioration of material. Refer to WP 0074. Follow proper procedures for stowage and handling of lubricants and fuels (FM 9-207).

MAINTENANCE UNDER ADVERSE CONDITIONS

Extreme Cold Weather

Typical Problems in Extreme Cold Weather: Maintenance of mechanical equipment in extreme cold conditions is exceptionally difficult in the field. Even shop maintenance cannot be completed with normal speed because equipment must warm up before satisfactory repairs can be made. In the field, maintenance is performed under the most difficult conditions. Bare hands will stick to cold metal. Engine oils, except subzero grades, will not pour at temperatures below -40°F (-4.5°C). Ordinary greases become hard at extremely cold temperatures. These difficulties increase the time required to perform maintenance. At temperatures below -40°F (-4.5°C), procedures require up to five times the normal amount of time. The time required to warm a vehicle so it will start and be operable at temperatures as low as -50°F (-10°C) may approach 2 hours. Complete winterization, diligent maintenance, and well-trained crews are the key to efficient operation of vehicles in extreme cold weather.

Batteries: Extreme cold causes batteries to freeze and prevents them from furnishing sufficient current. See FM 9-207 for methods of protecting batteries from cold, and maintenance of batteries in cold weather.

Tracks and Suspension: If possible, clean mud, snow, and ice from tracks and suspension after stopping. See FM 9-207 for more detailed information about maintenance of tracks and suspension, and effects of cold weather on tracks and suspension.

Canvas Covers: Canvas covers present difficulties in conforming to their intended use due to apparent shrinkage. Shrinkage is usually a result of wrinkles that are extremely difficult to smooth out at subzero temperatures. Whenever possible, warm and unfold canvas in heated enclosures. Clean all snow, mud, and ice from vehicle before covering. Keep ends of canvas off ground to prevent entrance of snow into engine compartment. Snow will melt and later freeze, which may prevent linkage operation.

Metal Parts: Metal parts become brittle at subzero temperatures and cannot withstand shock loads as well as at normal temperatures. Frequently inspect metal parts and components for cracks and breakage.

Plastic and Rubber Parts: Handle any parts made of plastic or rubber carefully. Plastic and rubber parts become brittle in cold weather and may break due to vibration or handling. To prevent insulation from cracking and causing short circuits, warm rubber or plastic insulated cables before bending, and ensure that all cables are properly installed.

Fuel and Lubricants: See FM 9-207 for instructions on storage, handling, and use of fuels and lubricants in cold weather.

Extreme Hot Weather

Typical Problems in Extreme Hot Weather: Extreme heat causes water, lubricants, and fuels to expand and possibly overflow their containers. Perspiration from hands contains acids and salts, which cause corrosion of unprotected metal parts when handled. Engines and transmissions have a greater tendency to overheat. Metal parts can become too hot to handle, and paint can blister. Extreme heat and overexposure in the sun can cause rubber and plastic parts to age and crack.

Batteries: Batteries will self-discharge at a greater rate if left standing for long periods of time in high temperatures. Consider this condition when operating in hot zones. Run vehicle engine periodically to keep batteries charged.

Metal Parts: Remove paint blisters with abrasive paper and spot-paint as required.

Plastic and Rubber Parts: Check plastic and rubber-insulated cables for cracks, which can result in short circuits. Check all plastic and rubber parts for cracks and aging.

Optical Equipment: Do not expose sighting/optical equipment or optical parts to direct rays of sun.

MAINTENANCE UNDER ADVERSE CONDITIONS - CONTINUED

Highly Humid or Salty Atmosphere

Typical Problems in Very Humid or Salty Atmosphere: Corrosive action will occur on all parts that are not properly protected. Evidence of corrosion appears as rust and paint blisters on metal parts, and mildew, mold, or fungus growth on wood, fabrics, or leather. Humid and salty atmospheres have a tendency to deteriorate oil and grease and destroy their rust-preventive qualities.

Metal Surfaces: Remove corrosion from exterior metal surfaces with abrasive paper and apply a protective coating of paint, oil, or suitable rust preventive as required.

Canvas Covers: Clean and dry canvas often to prevent mildew.

Magnesium and Aluminum Parts: Clean all magnesium and aluminum parts and wipe dry to prevent corrosion.

Sand, Dust, or Mud

Typical Problems in Sand, Dust, or Mud: Painted surfaces and sighting optical parts, if not covered, become etched by sand. Lubricants and fuels become contaminated. Service life of air cleaners and filters is shortened.

Sighting Equipment: Keep exposed optical surfaces protected as much as possible to prevent etching by sand or dust.

Engine and Engine Compartment: Clean engine compartment and engine as often as required to prevent accumulation of sand, dust, or mud. Cover engine compartment grilles when parked.

After Fording

General: The following services should be performed on vehicle after fording, especially in saltwater. Perform these services, as soon as tactical situation permits, to halt deterioration and avoid damage before the vehicle is driven extensively in regular service. Heat generated by moving parts during operation of vehicle will evaporate or force out most of the water that may have entered at various points. Any small amount of water that has entered the engine crankcase due to leakage or condensation will usually be evaporated and passed by the ventilating system.

Hull:

1. Open drain valves and allow all water to drain. Refer to WP 0009.
2. If fording was in saltwater, wash all traces of saltwater and salt deposits from vehicle.
3. Clean, dry, and lubricate all exposed surfaces that will affect operation or deterioration due to exposure to water.

Engine, Transmission, and Final Drives: Inspect engine, transmission, and final drive oil for contamination. If evidence of contamination is found, notify field maintenance.

MAINTENANCE UNDER ADVERSE CONDITIONS - CONTINUED**After Fording - Continued**Brake Controls:

1. Use 1/2 inch drive ratchet and 9/16 inch socket to remove six screws (Figure 1, Item 2) and lockwashers (Figure 1, Item 3) securing two rear access covers (Figure 1, Item 4) on underside of hull. Remove two rear access covers and gaskets.
2. Use adjustable wrench to remove drain plug (Figure 1, Item 5) from left and right brake control housings (Figure 1, Item 1). Allow water to drain.
3. Use adjustable wrench to install drain plug (Figure 1, Item 5) in left and right brake control housings (Figure 1, Item 1).
4. Install two rear access covers (Figure 1, Item 4) and gaskets in position and secure with six screws (Figure 1, Item 2) and lockwashers (Figure 1, Item 3).

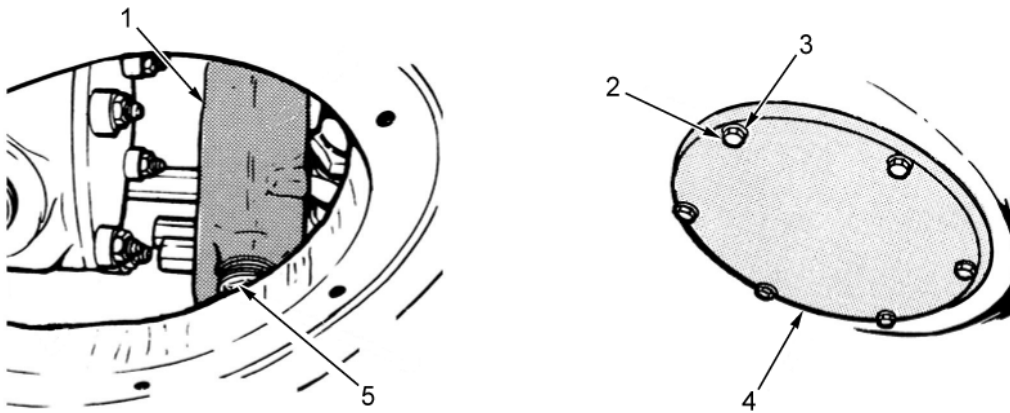

AVLBD434

Figure 1. Brake Controls.

Suspension System: Lubricate all lubrication fittings. Refer to LO 5-5420-202-13.

Air Cleaner:

1. Use adjustable wrench to remove air cleaner drain plug (Figure 2, Item 1).
2. Check for water leakage into air cleaner.
3. If water leakage into air cleaner is evident, notify field maintenance.
4. If no water is present, use wrench and install drain plug (Figure 2, Item 1).

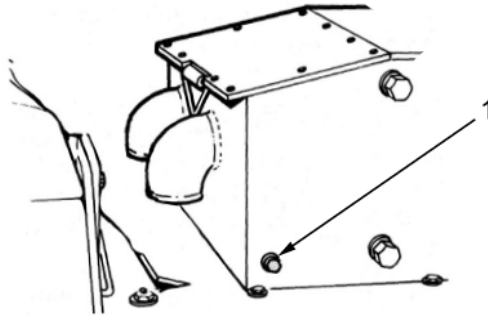
MAINTENANCE UNDER ADVERSE CONDITIONS - CONTINUED**After Fording - Continued**

AVLBD435

Figure 2. Air Cleaner.

Batteries:

1. If an excessive amount of water entered hull (capable of splashing over batteries), check electrolyte level to ensure no water entered batteries through vent caps. Refer to WP 0063.
2. If high fluid levels are evident, notify field maintenance.

END OF TASK**END OF WORK PACKAGE**

OPERATOR MAINTENANCE
LUBRICATION INSTRUCTIONS

INITIAL SETUP:**Tools and Special Tools**

Gun, Lubricating (WP 0077, Table 2, Item 24)

Materials/Parts

Compound, Corrosion Preventive (WP 0079, Table 1, Item 19)
Fluid, Hydraulic (FRH) (WP 0079, Table 1, Item 24)
Lubricant, Cleaner and Preservative (WP 0079, Table 1, Item 42)

Materials/Parts (cont.)

Rag, Wiping (WP 0079, Table 1, Item 52)
Solvent, Degreasing (WP 0079, Table 1, Item 58)

References

FM 90-3
FM 9-207
LO 5-5420-202-13

SCOPE

This work package provides operator lubrication instructions. Lubrication intervals (on-condition or hard/fixed time) are based on normal operation. Lubricate more often during constant use or in severe conditions. Refer to LO 5-5420-202-13.

LUBRICATION INSTRUCTIONS**WARNING**

Degreasing solvent (MIL-PRF-680) is flammable and may cause irritation to the eyes or skin. Use in well-ventilated areas and keep away from heat and open flame. Wear protective goggles and clothing. If solvent comes in contact with eyes, flush immediately with water. If solvent comes in contact with skin, wash with soap and water. Failure to comply may result in personnel injury, illness, or death.

NOTE

- Use clean rag and degreasing solvent to clean grease or oil from all metal surfaces except those exposed to powder fouling. For powder-fouled surfaces, use CLP (MIL-L-63460). Failure to comply may result in personnel injury, illness, or death.
- Hard (fixed) time intervals and the related manhour time are based on normal operation. The manhour time specified is the time you need to do all the services prescribed for a particular interval. Change the interval if your lubricants are contaminated or if you are operating the equipment under adverse conditions, including longer-than-usual operating hours. The interval may be extended during periods of low activity. If extended, adequate preservation precautions must be taken. Interval symbols: B- Before Operation, D - During Operation, A - After Operation, W - Weekly, M - Monthly.
- When checking fluid levels, vehicle must be on level surface.
- Oil filters shall be serviced/cleaned/changed when they are known to be contaminated or clogged, service is recommended by Army Oil Analysis Program (AOAP), or hard time service is required.
- Dispose of used lubricants in accordance with local Standard Operating Procedures (SOPs).
- Lubricate oil can points that become accessible while performing other lubrication tasks. Refer to LO 5-5420-202-13.
- For arctic operation, see FM 9-207.
- For desert operation, see FM 90-3.
- Clean all grease fittings before attaching grease gun.
- When using grease gun, operate until grease appears around seals or out of relief valve, and check escaping grease for contamination. If contamination is found, notify field maintenance.
- If no other treatment is directed, paint or clean and coat unprotected metal surfaces with cleaner/lubricant/preservative (CLP) (WP 0079, Item 42).
- Clean around filler necks/drain plugs/openings before servicing to keep dirt from entering system.

LUBRICATION INSTRUCTIONS - CONTINUED

Launcher, Engine, and Transmission Checks

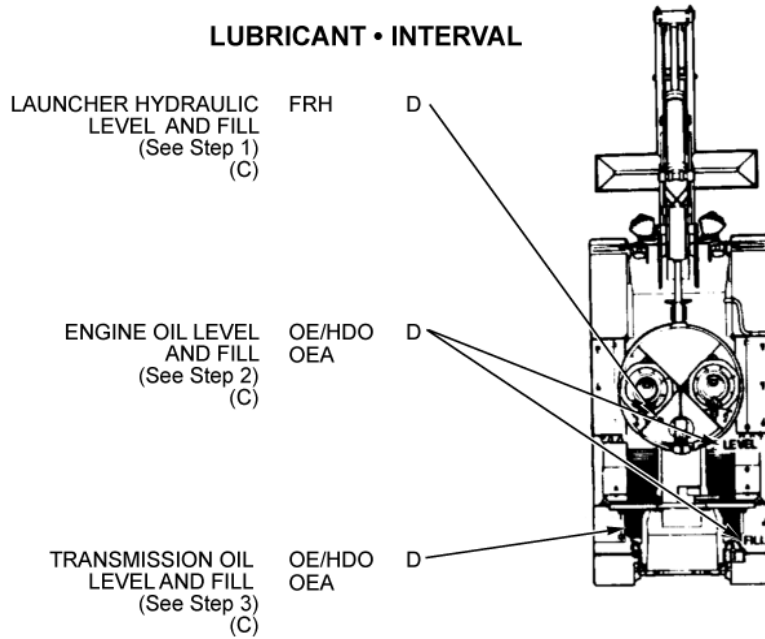

AVLBD617

Figure 1. Launcher, Engine, and Transmission Location.

Table 1. Launcher, Engine, and Transmission Lubricant.

Temperature Range	Lubricant Mil. Symbol (NATO Code) Specification	Capacity	Interval	Manhours
Launcher All Temperatures	FRH (H-544) MIL-PRF-46170	AR	D	0.2
Engine Transmission	OE/HDO-15/40 (O-1236) MIL-PRF-2104	AR	D	0.1
+5°F to +125°F (-15°C to +52°C)		AR	D	0.1
+5°F to -70°F (-15°C to -57°C)	OEA (O-183) MIL-PRF-46167			

LUBRICATION INSTRUCTIONS - CONTINUED**Launcher, Engine, and Transmission Checks - Continued****WARNING**

FRH fluid may cause irritation to the eyes and skin. Avoid contact with eyes, skin, and clothing. Wear protective goggles, gloves, and clothing. If FRH comes in contact with eyes or skin, flush area with water. Failure to comply may result in personnel injury or illness.

1. LAUNCHER HYDRAULIC LEVEL AND FILL. Unscrew reservoir filler cap. Remove dipstick from filler neck. Wipe dipstick and insert fully into filler neck. Remove dipstick and check that fluid level is at or slightly above FULL mark. If fluid is below FULL mark, add fluid as required (Figure 2).

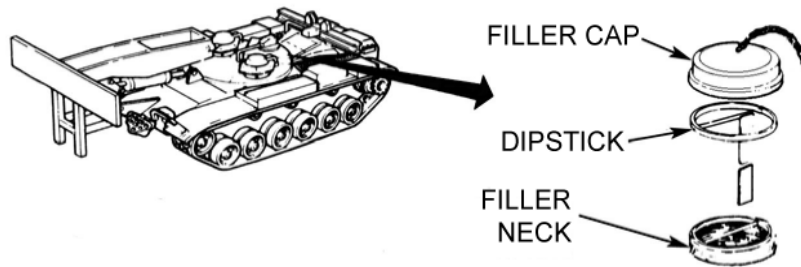

AVLBD438

Figure 2. Launcher Hydraulic Level and Fill.

LUBRICATION INSTRUCTIONS - CONTINUED

Launcher, Engine, and Transmission Checks - Continued

2. ENGINE OIL LEVEL AND FILL. Check engine oil levels daily after operating engine. Vehicle must be parked on level ground to obtain accurate oil level reading. Loosen screw securing outer cover and lift outer cover. Open inner cover and remove dipstick from tube (Figure 3). Wipe dipstick and insert in tube with dipstick loop facing hull.

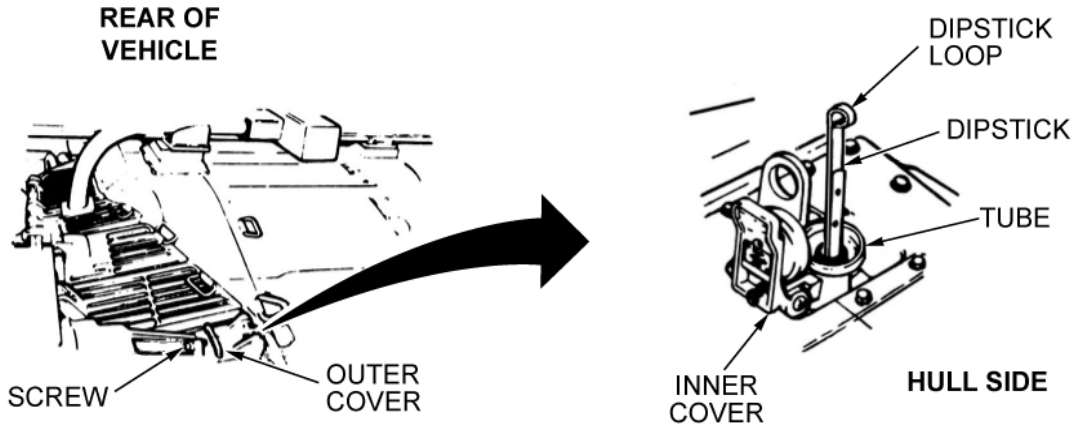

AVLBD439

Figure 3. Engine Oil Level Dipstick Location.

a. Checking procedure for:

- (1) Engine Running, Cold Oil. When oil level is checked after engine has been started, but operated at 700 to 1200 RPM for only 5 to 10 minutes, oil temperature will be below normal operating temperature.
 - (a) Check oil level (with engine idling at 700 to 750 RPM). If level is in IDLING RANGE (between ADD and HOT FULL marks), engine is safe to operate. If oil level is below ADD mark, add oil as necessary to bring level to COLD FULL mark (Figure 4).

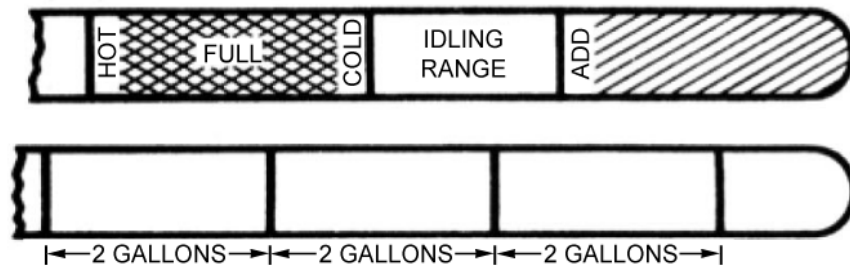

AVLBD440

Figure 4. Oil Level Dipstick.

- (b) On backside of dipstick are four hashmarks. Distance between each mark is 2 gal. (7.6 L). When oil level shows low on dipstick, turn to these marks to determine correct amount of oil to add. Any added oil will not show on dipstick until after engine has been running for several minutes.

LUBRICATION INSTRUCTIONS - CONTINUED**Launcher, Engine, and Transmission Checks - Continued**

(2) Engine Running, Hot Oil Level.

- (a) Check oil level with engine idling at 700 to 750 RPM. After a hot run, oil level will be 2 to 3 inches (5.08 to 7.62 cm) above HOT FULL mark. This would be normal under these conditions due to oil expansion and aeration.
- (b) If tactical situation permits, allow engine to idle to 700 to 750 RPM for 5 to 10 minutes and check level again.
- (c) If oil level is above ADD mark, engine is safe to operate. However, oil may be added pending expected mission duration.
- (d) If oil level is above ADD mark, add oil as necessary to bring level to HOT FULL mark. Install dipstick in tube with dipstick loop facing hull. Close inner cover. Close outer cover and secure with screw (Figure 5).

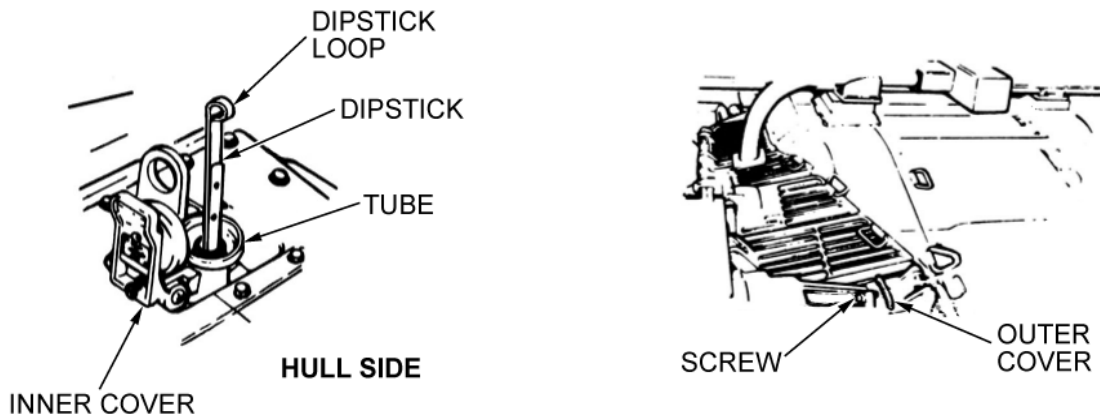

AVLBD441

Figure 5. Installing Engine Oil Level Dipstick.

LUBRICATION INSTRUCTIONS - CONTINUED**Launcher, Engine, and Transmission Checks - Continued**

3. TRANSMISSION OIL LEVEL AND FILL. Set parking brakes with shift lever in PARK. Start engine and run at 1000 to 1200 RPM until transmission oil temperature gauge reads in green band. With engine idling at 700 to 750 RPM, check oil level. Add oil as required to transmission to bring level to FULL mark on transmission dipstick.
 - a. Oil level on transmission dipstick must be at or above ADD mark. Approximately 3 gal. (11.4 L) of oil will raise transmission oil level from ADD to FULL (Figure 6).

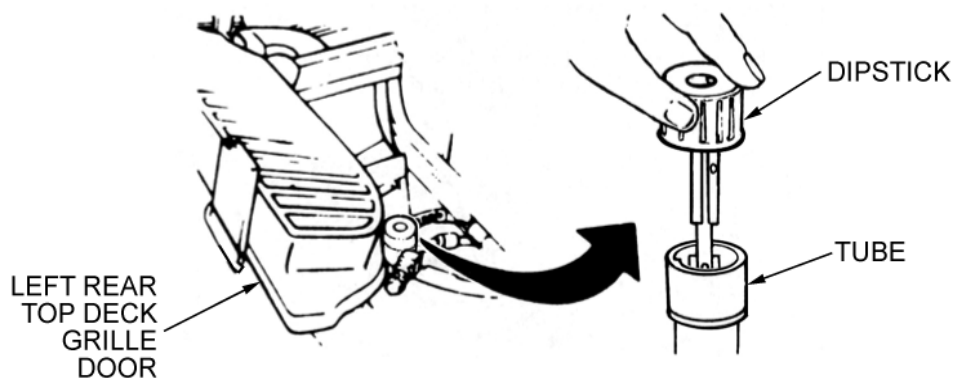

AVLBD442

Figure 6. Transmission Oil Level Dipstick Location.

LUBRICATION INSTRUCTIONS - CONTINUED

Grenade Launchers, Breather Filter, and Cylinder Plug Lubricants

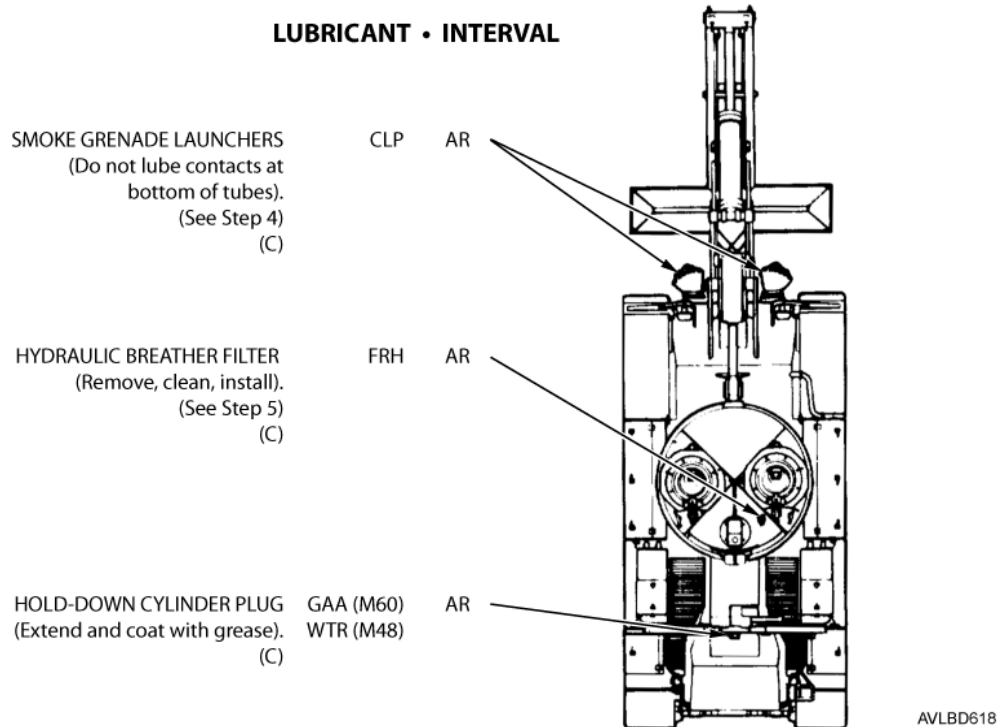

Figure 7. Grenade Launchers, Breather Filter, and Cylinder Plug Location.

Table 2. Grenade Launchers, Breather Filter, and Cylinder Plug Lubricant.

Temperature Range	Lubricant Mil. Symbol (NATO Code) Specification		Capacity	Interval	Manhours
Smoke Grenade Launchers All Temperatures	CLP (S-758) MIL-L-63460		AR	AR	0.2
Hydraulic Breather Filter All Temperatures	FRH (H-544) MIL-H-46170		AR	AR	0.1
Hold-Down Cylinder Plug All Temperatures	GAA (M60) (G-403) MIL-G-10924	WTR (M48) (G-395) MIL-G-81322	AR	AR	0.1

1. SMOKE GRENADE LAUNCHERS.

- a. Before firing: Wipe all surfaces dry.
- b. After firing: Immediately clean with CLP (WP 0079, Item 42) and wipe dry. Apply a light coat of CLP to all surfaces. Ensure all surfaces are coated. DO NOT wipe dry. After firing, repeat process for 2 days.
- c. Inactivity: If not to be fired for extended period, clean quarterly with CLP (WP 0079, Item 42), wipe dry, and apply CLP to all surfaces.

LUBRICATION INSTRUCTIONS - CONTINUED**Hydraulic Breather Filter****WARNING**

- FRH fluid may cause irritation to the eyes and skin. Avoid contact with eyes, skin, and clothing. Wear protective goggles, gloves, and clothing. If FRH comes in contact with eyes or skin, flush area with water. Failure to comply may result in personnel injury or illness.
- Degreasing solvent (MIL-PRF-680) is flammable and may cause irritation to the eyes or skin. Use in well-ventilated areas and keep away from heat and open flame. Wear protective goggles and clothing. If solvent comes in contact with eyes, flush immediately with water. If solvent comes in contact with skin, wash with soap and water. Failure to comply may result in personnel injury, illness, or death.

1. HYDRAULIC BREATHER FILTER. Remove cap. Clean filter in degreasing solvent (MIL-PRF-680), and dry by shaking. Oil the filter using FRH hydraulic fluid (WP 0079, Item 24). DO NOT use OE/HDO oil. In extremely dusty conditions, service more frequently. Every month, remove breather tube, clean with degreasing solvent, and dip in FRH hydraulic fluid. DO NOT use OE/HDO oil.

Tow Cables**WARNING**

Degreasing solvent (MIL-PRF-680) is flammable and may cause irritation to the eyes or skin. Use in well-ventilated areas and keep away from heat and open flame. Wear protective goggles and clothing. If solvent comes in contact with eyes, flush immediately with water. If solvent comes in contact with skin, wash with soap and water. Failure to comply may result in personnel injury or death.

1. TOW CABLES. Clean cables with degreasing solvent (MIL-PRF-680) and coat with corrosion preventive compound (MIL-C-16173, Grade 1).

LUBRICATION INSTRUCTIONS - CONTINUED

Tow Cables -Continued

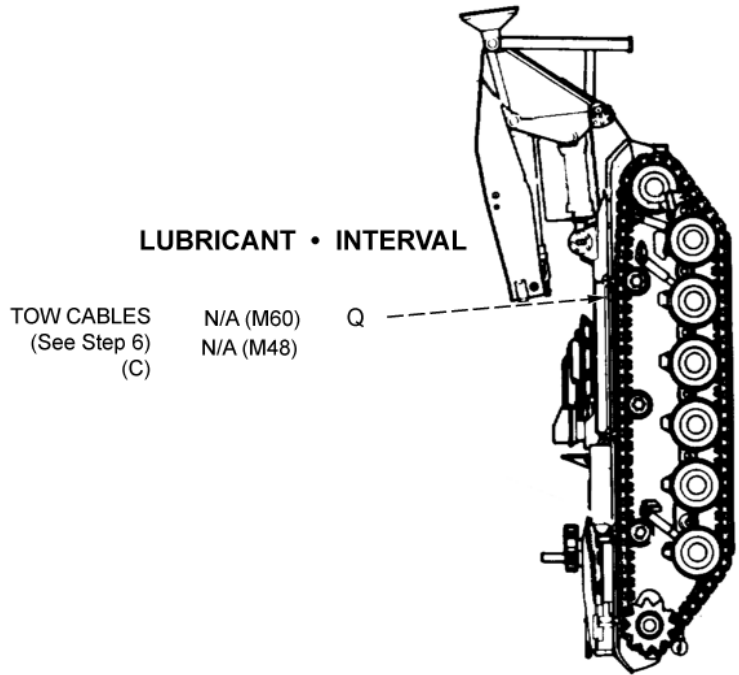

AVLBD619

Figure 8. Tow Cables Location.

Table 3. Tow Cables Lubricant.

Temperature Range	Lubricant Mil. Symbol (NATO Code) Specification	Capacity	Interval	Manhours
Tow Cables All Temperatures	N/A (N/A) MIL-C-16173	AR	Q	0.1

LUBRICATION INSTRUCTIONS - CONTINUED

Hatch Cover Swing and Safety Latch

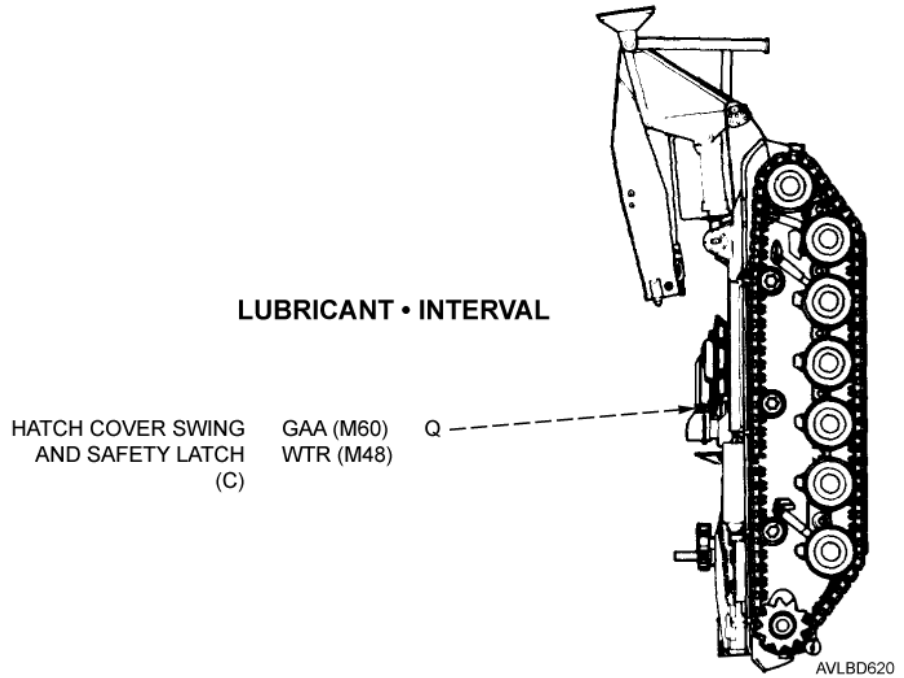

Figure 9. Hatch Cover Swing and Safety Latch Location.

Table 4. Hatch Cover Swing and Safety Latch Lubricant.

Temperature Range	Lubricant Mil. Symbol (NATO Code) Specification		Capacity	Interval	Manhours
Hatch Cover Swing and Safety Latch All Temperatures	GAA (M60) (G-403) MIL-G-10924	WTR (M48) (G-395) MIL-G-81322	AR	Q	0.4

LUBRICATION INSTRUCTIONS - CONTINUED

Launcher Tongue and Overhead Cylinder Clevis

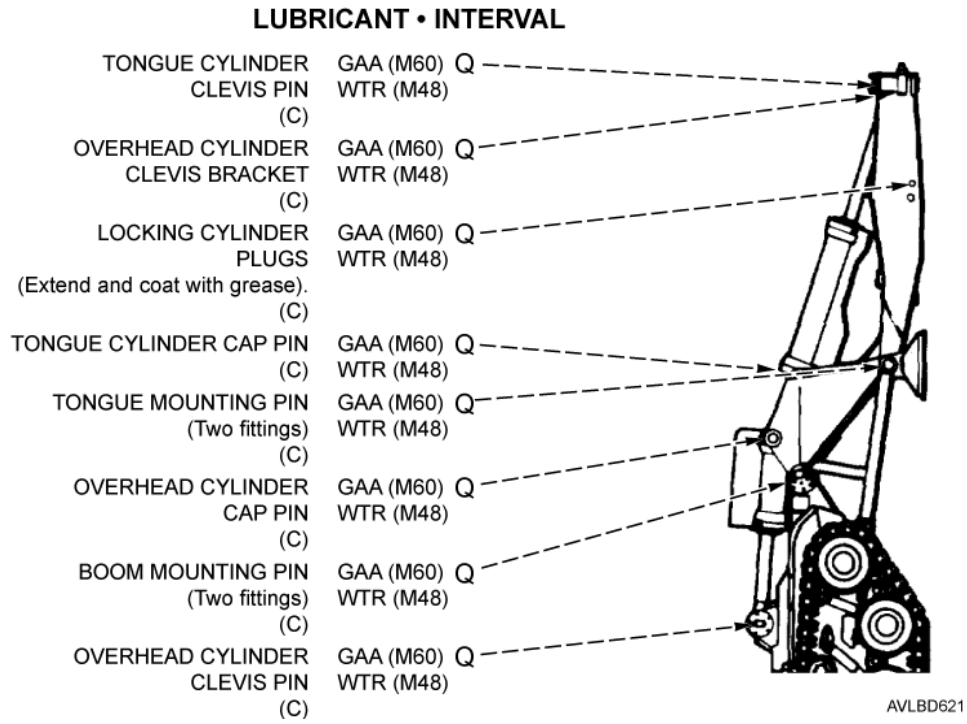

Figure 10. Launcher Tongue and Overhead Cylinder Clevis Location.

Table 5. Launcher Tongue and Overhead Cylinder Clevis Lubricant.

Temperature Range	Lubricant Mil. Code	Symbol (NATO Specif cation)	Capacity	Interval	Manhours
Tongue Cylinder Clevis Pin					
Overhead Cylinder Clevis Bracket					
Locking Cylinder Plugs					
Tongue Cylinder Cap Pin					
Tongue Mounting Pin					
Overhead Cylinder Cap Pin					
Boom Mounting Pin					
Overhead Cylinder Clevis Pin All Temperatures	GAA (M60) (G-403) MIL-G-10924	WTR (M48) (G-395) MIL-G-81322	AR	Q	1.5

LUBRICATION INSTRUCTIONS - CONTINUED

Launcher Tongue and Overhead Mounting

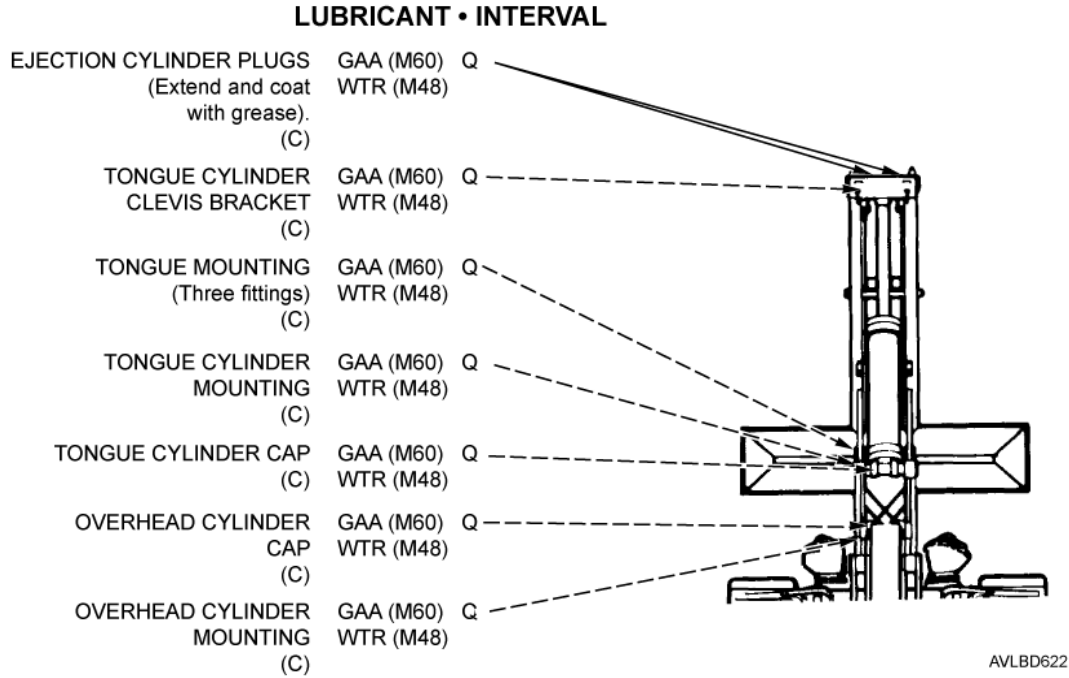

Figure 11. Launcher Tongue and Overhead Mounting Location.

Table 6. Launcher Tongue and Overhead Mounting Lubricant.

Temperature Range	Lubricant Mil. Symbol (NATO Code) Specification		Capacity	Interval	Manhours
Ejection Cylinder Plugs					
Tongue Cylinder Clevis Bracket					
Tongue Mounting					
Tongue Cylinder Mounting					
Tongue Cylinder Cap					
Overhead Cylinder Cap					
Overhead Cylinder Mounting					
All Temperatures	GAA (M60) (G-403) MIL-G-10924	WTR (M48) (G-395) MIL-G-81322	AR	Q	1.5

LUBRICATION INSTRUCTIONS - CONTINUED

Oil Can Points

LUBRICANT • INTERVAL

OIL CAN POINTS
(See Steps 7 and 8)
(C)

OE/HDO Q
OEA

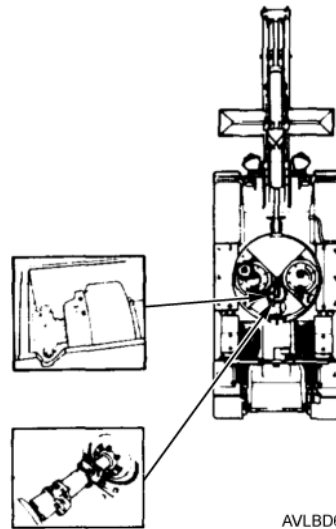

Figure 12. Oil Can Points Location.

Table 7. Oil Can Points Lubricant.

Temperature Range	Lubricant Mil. Symbol (NATO Code) Specification	Capacity	Interval	Manhours
Oil Can Points +5°F to +125°F (-15°C to +52°C)	OE/HDO-15/40 (0-1236) MIL-L-2104	AR	Q	0.4

1. OIL CAN POINTS. Quarterly, lubricate the following items:

- Headlight removal nuts
- Fender stowage box hatches and hinges
- Towing hooks (hinge pin)
- Brake linkage
- Transmission support guide rails and rollers
- Hatch locks and hinges
- Driver's escape hatch (clean and coat pins, plungers, and all unpainted surfaces)
- Grille door hinges
- Control rod clevises
- Driver's and commander's seat moving parts
- Universal joints
- Hatch locks and hinges

LUBRICATION INSTRUCTIONS - CONTINUED**Oil Can Points - Continued**

2. OIL CAN POINTS. DO NOT lubricate the following items:

- Starter solenoid
- Air cleaner blower motor
- Hydraulic powerpack electric motor
- Heater motor
- Ventilator blower motor
- Gas particulate fan motor
- Tracks
- Tachometer driver adapter
- Any item not pointed out in this lubrication order

END OF WORK PACKAGE

CHAPTER 6

AMMUNITION MAINTENANCE

FOR

**M48A5 AND M60A1 LAUNCHER AND TANK CHASSIS TRANSPORTING FOR
BRIDGE ARMORED-VEHICLE LAUNCHED: SCISSORING-TYPE, CLASS 60
OR CLASS 70**

OPERATOR MAINTENANCE**SMOKE GRENADES - IDENTIFICATION, HANDLING, AND DESTRUCTION**

INITIAL SETUP:**References**DA PAM 385-64

GENERAL

This work package provides information for the identification, handling, and destruction of smoke grenades.

SERVICE

Introduction

WARNING



- A misfire or dud has the potential to explode. DO NOT touch a dud smoke grenade. When a misfire or dud occurs, all personnel must remain a minimum of 219 yd (200 m) from vehicle for a minimum of 5 minutes after final attempt to fire. Crew must remain in vehicle with hatches closed. Notify Explosive Ordnance Disposal (EOD) personnel and give type, quantity, and precise location of dud grenades. Failure to comply may result in personnel injury or death.
 - An explosion may occur if discharger or grenade contains sand, mud, moisture, frost, snow, ice, grease, or other foreign matter. Before loading grenade into the discharger, ensure each part is free of sand, mud, moisture, frost, snow, ice, grease, or other foreign matter. Failure to comply may result in personnel injury or death.
1. United Kingdom (UK) L8A1 RP (red phosphorous) screening smoke grenades are used with the M239 grenade launcher. They are filled with a red phosphorous and butyl rubber mix (Figure 1, Item 2). Each grenade is approximately 2.61 inches (6.6 cm) in diameter, 7.28 inches (18.5 cm) long, and weighs approximately 1.5 lb (0.68 kg).
 2. A grenade is propelled from the discharger when electrical current at the firing contact (Figure 1, Item 5) ignites the fuse (Figure 1, Item 4). The fuse ignites the propellant charge (Figure 1, Item 6) and a delay composition within the delay holder (Figure 1, Item 7) and, in turn, the gunpowder and bursting charge (Figure 1, Item 3). This bursts the rubber case (Figure 1, Item 1) and ignites the red phosphorous/butyl rubber composition (Figure 1, Item 2) to produce an immediate smoke cloud.

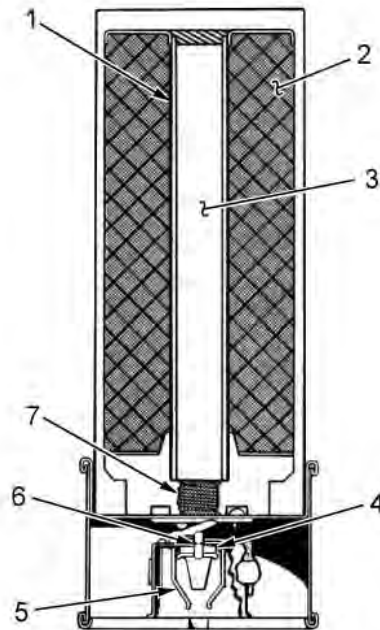

Figure 1. Smoke Grenade.

AVLBD445

END OF TASK

SERVICE - CONTINUED**Identification**

The ammunition is completely identified by the markings at the base of the casing.



AVLBD446

Figure 2. Ammunition Markings.

END OF TASK

SERVICE - CONTINUED**Care, Handling, and Preservation****WARNING**

- The explosive in primers and fuses is sensitive to shock and high temperatures. If ammunition is dropped, heated, thrown, tumbled, or dragged, an explosion may result. Ammunition-carrying explosives must be handled with care at all times. Keep ammunition away from heaters. Disassembly of ammunition is not authorized. Failure to comply may result in personnel injury or death, or equipment destruction.
 - An explosion may occur if discharger or grenade contains sand, mud, moisture, frost, snow, ice, grease, or other foreign matter. Before loading grenade into the discharger, ensure each part is free of sand, mud, moisture, frost, snow, ice, grease, or other foreign matter. Failure to comply may result in personnel injury or death.
1. Ammunition is packed to withstand conditions ordinarily met in the field. Ensure packing boxes do not get broken or damaged. All broken packing boxes must be repaired immediately. Carefully transfer all markings to new packing boxes.
 2. When it is necessary to leave ammunition in an open area, raise ammunition on a platform at least 3 inches (7.6 cm) from ground. Cover ammunition with a double thickness of tarpaulin. Leave 18 inches (46 cm) space for air circulation. Trenches should be dug to prevent water from running under the pile. Ammunition is damaged by moisture and high temperature and should be protected as follows:
 - a. DO NOT break moisture-resistant seal on container until ammunition is to be used.
 - b. Protect ammunition, particularly fuses, from high temperature and direct rays of sun. More uniform firing is obtained if rounds are at the same temperature.
 - c. DO NOT disassemble grenade or any of its parts.
 - d. When loading grenades into stowage box, grasp grenade case with one hand over primer (P), and grasp nose of projectile with other hand.
 - e. Grenades dent easily and should be protected from hard knocks and blows. Dented grenades may result in incomplete seating, jamming in chamber, and difficulty in removal. DO NOT load or fire dented rounds.
 - f. DO NOT handle duds. Duds are extremely dangerous. Their fuses may be armed. Leave them in place for disposal by authorized personnel in accordance with DA PAM 385-64.
 - g. Do not remove protective or safety devices from fuses until just before loading.

END OF TASK

SERVICE - CONTINUED**Destruction of UK L8A1 RP Ammunition to Prevent Enemy Usage**

1. To destroy grenades by burning, stack ammunition in a pile.
2. Place flammable materials such as rags, scrap wood, or brush on the pile.

WARNING

Fire may cause early explosion of explosive ammunition. Cover must be taken immediately. All personnel must remain a minimum of 657 yd (600 m) from grenade pile for a minimum of 5 minutes after attempt to destroy grenades. Failure to comply may result in personnel injury or death, or equipment damage.

3. Ignite by means of an incendiary grenade fired from a safe distance, a combustible train of suitable length, or other appropriate means. Take cover immediately. The danger area for piles being burned in the open is 657 yd (600 m).

END OF TASK**END OF WORK PACKAGE**

CHAPTER 7
SUPPORTING INFORMATION
FOR
M48A5 AND M60A1 LAUNCHER AND TANK CHASSIS TRANSPORTING FOR
BRIDGE, ARMORED-VEHICLE LAUNCHED: SCISSORING-TYPE, CLASS 60
OR CLASS 70

OPERATOR MAINTENANCE
REFERENCES

Scope

This work package lists all forms, technical manuals, and miscellaneous publications referenced in this manual. DA PAM 25-30, Consolidated Index of Army Publications and Blank Forms, should be consulted for information concerning changes, revisions, suppression, or replacement of references listed.

ADMINISTRATIVE PUBLICATIONS

AR 700-138	Army Logistics Readiness and Sustainability
DA PAM 25-30	Consolidated Index of Army Publications and Blank Forms
DA PAM 385-64	Ammunition and Explosives Safety Standards
DA PAM 700-32	Packaging of Army Materiel
PAM 750-8	The Army Maintenance Management System (TAMMS)

FIELD MANUALS

FM 3-11.4	Multiservice Tactics, Techniques, and Procedures for Nuclear, Biological, and Chemical (NBC) Protection
FM 3-11.5	Multiservice Tactics, Techniques, and Procedures for Chemical, Biological, Radiological, and Nuclear Decontamination
FM 4-25.11	First Aid
FM 9-207	Operation and Maintenance of Ordnance Materiel in Cold Weather
FM 90-3	Desert Operations

FORMS

DA Form 2028	Recommended Changes to DA Publications
DA Form 2404	Equipment Inspection and Maintenance Worksheet
SF Form 368	Quality Deficiency Report

TECHNICAL PUBLICATIONS

LO 5-5420-202-13	Launcher, M60A1 and M48A5 Tank Chassis, Transporting: Bridge, Armored Vehicle Launched, Scissoring-Type Class 60 and Class 70
TB 43-0129	Safety Requirements for Use of Antennas and Mast Equipment

TECHNICAL MANUALS

TM 3-4240-280-10	Operator's Manual for Mask, Chemical-Biological: Aircraft ABC-M24 and Accessories and Mask Chemical-Biological: Tank M25A1 and Accessories
TM 5-5420-203-13	Operator and Field Maintenance Manual for Bridge, Armored Vehicle Launched: Scissoring-Type Class 60 (5420-00-522-9599) and Class 70 (5420-01-370-3933) Aluminum 60 Foot Span; for Use With M48A5 and M60A1 Launcher (All Makes and Models)
TM 5-5420-228-24	Launcher Hydraulics System, M60A1 and M48A5 Tank Chassis, Transporting for Bridge, Armored Vehicle Launched Class 60
TM 9-1375-215-13&P	Joint Technical Manual for MK 2 Mod 0, Mine Clearance System and Mine Clearance Line Charge - MICLIC for Operator's, Unit, and Direct Support, Maintenance Manual with Components List, Repair Parts and Special Tools List
TM 9-6140-200-14	Operator's Unit, Direct Support, and General Maintenance Manual for Lead-Acid Storage Batteries
TM 11-5820-401-10-2	Operator's Manual, Radio Sets
TM 11-5820-498-12	Operator's and Organizational Maintenance Manual, Radio Sets
TM 11-5820-890-10	Operator's Manual for SINCGARS Ground Combat Net Radio, ICOM Manpack Radio, AN/PRC-119A

TECHNICAL MANUALS - Cont.

TM 11-5855-249-10	Operator's Manual for Viewers, Driver's Night Vision AN/VVS-2
TM 11-5915-224-14	Operator's Organizational, Direct Support, and General Support Maintenance Manual: Suppressor, Electrical Transient MX-7778A/GRC
TM 11-5985-262-14	Operator's, Organizational, Direct Support, and General Support Maintenance Manual for Antenna, AS-1729/VRC
TM 11-5985-262-24P	Organizational, Direct Support, and General Support Maintenance Repair Parts and Special Tools List (Including Depot Maintenance Repair Parts and Special Tools) for Antenna, AS-1729/VRC
TM 740-90-1	Administrative Storage of Equipment
TM 750-244-6	Procedures for Destruction of Equipment to Prevent Enemy Use

END OF WORK PACKAGE

FIELD MAINTENANCE
COMPONENTS OF END ITEM (COEI) AND BASIC ISSUE ITEMS (BII) LISTS

INTRODUCTION**Scope**

This work package lists COEI and BII for the M48A5/M60A1 Armored Vehicle Launched Bridge (AVLB) to help you inventory items for safe and efficient operation of the equipment.

General

The COEI and BII information is divided into the following lists:

Components of End Item (COEI). This list is for information purposes only and is not authority to requisition replacements. These items are part of the M48A5/M60A1 AVLB. As part of the end item, these items must be with the end item whenever it is issued or transferred between property accounts. Items of COEI are removed and separately packaged for transportation or shipment only when necessary. Illustrations are furnished to help you find and identify the items.

Basic Issue Items (BII). These essential items are required to place the M48A5/M60A1 AVLB in operation, operate it, and do emergency repairs. Although shipped separately packaged, BII must be with the M48A5/M60A1 AVLB during operation and when it is transferred between property accounts. Listing these items is your authority to request/requisition them for replacement based on authorization of the end item by the TOE/MTOE (Table of Organization and Equipment/Modified Table of Organization and Equipment). Illustrations are furnished to help you find and identify the items.

Explanation of Columns in the COEI List and BII List

Column (1) Item Number. Gives you the reference number of the item listed.

Column (2) National Stock Number (NSN) and Illustration. Identifies the stock number of the item to be used for requisitioning purposes and provides an illustration of the item.

Column (3) Description, Part Number/(CAGEC). Identifies the Federal item name (in all capital letters) followed by a minimum description when needed. The stowage location of COEI and BII is also included in this column. The last line below the description is the part number and the Commercial and Government Entity Code (CAGEC) (in parentheses).

Column (4) Usable On Code. When applicable, gives you a code if the item you need is not the same for different models of equipment. These codes are identified below:

<u>Code</u>	<u>Used on</u>
AJE	Model M48A5
BHX	Model M60A1

Column (5) U/I. Unit of Issue (U/I) indicates the physical measurement or count of the item as issued per the National Stock Number shown in column (2).

Column (6) Qty Rqr. Indicates the quantity required.

Table 1. Components of End Item.

(1) Item Number	(2) National Stock Number (NSN) and Illustration	(3) Description, Part Number/(CAGEC)	(4) Usable On Code	(5) U/I	(6) Qty Rqr
1	NSN 5342-01-027-3625  AVLBD524	CAP PROTECTIVE: EYEPIECE DRIVER'S VIEWER (ON VIEWER OR STOWED IN CARRYING CASE) SM-C-771382 (80063)		EA	2
2	NSN 6650-01-196-4667  AVLBD447	CASE, OPTICAL INSTRUMENT: AN/VVS-2, NIGHT VIEWER (1-RIGHT REAR OF DRIVER ON FLOOR, 2-LEFT FRONT OF COMMANDER UNDER RADIO RACK) 11669784 (19207)		EA	1
3	NSN 5855-01-027-1553  AVLBD525	COVER, PROTECTIVE: WINDOW, DRIVER'S VIEWER (ON VIEWER OR STOWED IN CARRYING CASE), SM-C-771364 (80063)		EA	2
4	NSN 4240-00-853-3201  AVLBD534	FILTER UNIT, GAS PARTICULATE, MIL-F-51069 (81349)		EA	1

Table 1. Components of End Item List.

(1) Item Number	(2) National Stock Number (NSN) and Illustration	(3) Description, Part Number/(CAGEC)	(4) Usable On Code	(5) U/I	(6) Qty Rqr
5	NSN 2540-00-706-8219  AVLBD526	HOOK, TOW, CABLE (IN RIGHT FRONT FENDER STOWAGE BOX), 7068219 (19207)		EA	4
6	NSN 1055-01-015-0874  AVLBD616	LAUNCHER, SMOKE GRENADE, M239 (MOUNTED ON CHASSIS), (CONSISTING OF ITEMS 7-12 BELOW), B13-12-32 (81361)		EA	1
7	NSN 2540-01-041-9830  AVLBD592	CONSISTING OF BOX, STOWAGE, FV576789 (K6897)		EA	2
8	NSN 1040-01-042-3861  AVLBD529	COVER, DISCHARGER, LEFT, 13-12-39 (81361)		EA	1

Table 1. Components of End Item List - Continued.

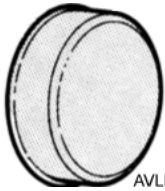
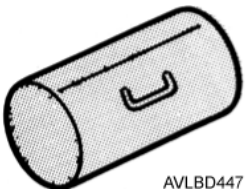
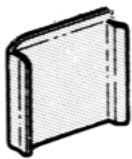
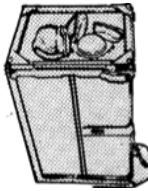

(1) Item Number	(2) National Stock Number (NSN) and Illustration	(3) Description, Part Number/(CAGEC)	(4) Usable On Code	(5) U/I	(6) Qty Rqr
9	NSN 1040-01-043-7896  AVLBD530	COVER, DISCHARGER, RIGHT, 13-12-38 (81361)		EA	1
10	NSN 1040-01-041-9829  AVLBD533	DISCHARGER, LEFT, FV855990 (K6897)		EA	1
11	NSN 1040-01-041-9828  AVLBD532	DISCHARGER, RIGHT, FV855991 (K6897)		EA	1
12	NSN 5930-01-047-8359  AVLBD531	PUSHBUTTON, FIRING, FV861135 (K6897)		EA	1

Table 1. Components of End Item List - Continued.

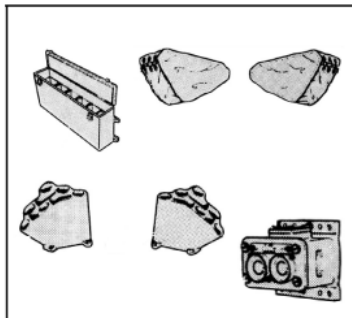
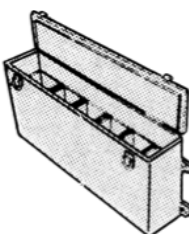
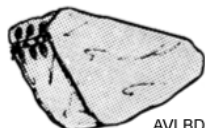

(1) Item Number	(2) National Stock Number (NSN) and Illustration	(3) Description, Part Number/(CAGEC)	(4) Usable On Code	(5) U/I	(6) Qty Rqr
13	NSN 5315-00-706-9195  <small>AVLBD527</small>	PIN, GROOVED, HEADLESS: (IN RIGHT FRONT FENDER STOWAGE BOX), 7069195 (19207)		EA	4
14	NSN 5315-00-350-4326  <small>AVLBD52E</small>	PIN, LOCKING: (IN RIGHT FRONT FENDER STOWAGE BOX), 5213744 (19207)		EA	8
15	NSN 5855-01-096-0871  <small>AVLBD448</small>	VIEWER, NIGHT, AN/VVS-2: (MOUNTED IN HATCH OR STOWED IN CARRYING CASE), SM-D-771480-1 (80063)		EA	2

Table 2. Basic Issue Items List.

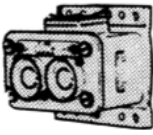

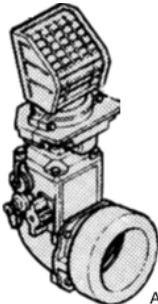

(1) Item Number	(2) National Stock Number (NSN) and Illustration	(3) Description, Part Number/(CAGEC)	(4) Usable On Code	(5) U/I	(6) Qty Rqr
1	NSN 4930-00-288-1511  AVLBD545	ADAPTER, GREASE GUN, 12 INCHES LG, FLEXIBLE (IN TOOL BAG IN RIGHT FRONT FENDER STOWAGE BOX), 6300333 (19207)		EA	1
2	NSN 5110-00-293-2336  AVLBD450	AXE, SINGLE BIT, 4 LB HEAD, 34 INCHES LG HANDLE (IN LEFT FRONT FENDER STOWAGE BOX), 6150925 (19207)		EA	1
3	NSN 2540-00-670-2459  AVLBD539	BAG ASSY, PAMPHLET (IN CREW COMPARTMENT), 11676920 (19207)		EA	1
4	NSN 5140-00-473-6256  AVLBD538	BAG, TOOL: SACHEL (IN RIGHT FRONT FENDER STOWAGE BOX), 11655979 (19207)		SE	1

Table 2. Basic Issue Items List - Continued.



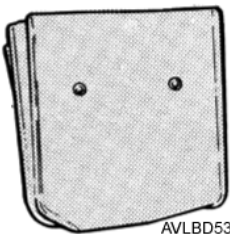

(1) Item Number	(2) National Stock Number (NSN) and Illustration	(3) Description, Part Number/(CAGEC)	(4) Usable On Code	(5) U/I	(6) Qty Rqr
5	NSN 5120-00-526-6044  AVLBD535	BAR, PINCH, 1/2 INCH WIDE 16 INCHES LG (IN TOOL BAG IN RIGHT FRONT FENDER STOWAGE BOX), 5266044 (19204)		EA	1
6	NSN 751000-889-3494  AVLBD536	BINDER, LOOSELEAF, EQUIPMENT LOG BOOK (IN PAMPHLET BAG), 11677003 (19207)		EA	1
7	NSN 7510-00-738-6164  AVLBD537	BINDER, LOOSELEAF, TECHNICAL MANUALS (IN PAMPHLET BAG), 10952007 (19207)		EA	1
8	NSN 5340-00-076-8996  AVLBD542	CAP, PROTECTIVE: DUST AND MOISTURE SEAL, (ON HEATER EXHAUST TUBE OR STOWED IN RIGHT FRONT FENDER STOWAGE BOX), 10934267 (19207) (M48 ONLY)	AJE	EA	1

Table 2. Basic Issue Items List - Continued.





(1) Item Number	(2) National Stock Number (NSN) and Illustration	(3) Description, Part Number/(CAGEC)	(4) Usable On Code	(5) U/I	(6) Qty Rqr
9	NSN 5140-00-261-4994  AVLBD540	CARRIER, TOOL, (IN TOOL BAG IN RIGHT FRONT FENDER STOWAGE BOX), 11655787 (19207)		EA	1
10	NSN 6230-00-378-2053  AVLBD543	CORD, LIGHT, ELECTRICAL, 15 FT LG (IN RIGHT FRONT FENDER STOWAGE BOX), 17-C-35079-33 (19207)		EA	1
11	NSN 5120-00-224-1390  AVLBD541	CROWBAR, PINCH POINT, 60 INCHES LG, 1-1/4 INCH POINT (IN LEFT FRONT FENDER STOWAGE BOX), 11677049-1 (19207)		EA	1
12	NSN 5110-00-595-8229  AVLBD451	CUTTER, BARBED WIRE, INSULATED HANDLES (IN CARRIER, ITEM 9, 5140-00-261-4994), 11655981 (19207)		EA	1

Table 2. Basic Issue Items List - Continued.





(1) Item Number	(2) National Stock Number (NSN) and Illustration	(3) Description, Part Number/(CAGEC)	(4) Usable On Code	(5) U/I	(6) Qty Rqr
13	NSN 2590-00-740-3968  AVLBD545	DIAGRAM, STRAP LOCATION, (IN PAMPHLET BAG, ITEM 2, 2540-00-670-2459), 10934431 (19207)		EA	1
14	NSN 2590-00-740-3968  AVLBD545	EXTENSION, GREASE GUN, 12 INCHES LG, FLEXIBLE (IN TOOL BAG IN RIGHT REAR FENDER STOWAGE BOX), 6300333 (19207)		EA	1
15	NSN 5120-00-243-7326  AVLBD546	EXTENSION, SOCKET WRENCH: 1/2 INCH DR, 5 INCHES LG (IN TOOLBAG IN RIGHT FRONT FENDER STOWAGE BOX), 12810 (08292)		EA	1
16	NSN 5120-00-227-8074  AVLBD547	EXTENSION, SOCKET WRENCH, 1/2 INCH DR, 10 INCHES LG (IN TOOL BAG IN RIGHT FRONT FENDER STOWAGE BOX), 11655788-1 (19207)		EA	1

Table 2. Basic Issue Items List - Continued.



(1) Item Number	(2) National Stock Number (NSN) and Illustration	(3) Description, Part Number/(CAGEC)	(4) Usable On Code	(5) U/I	(6) Qty Rqr
17	NSN 5120-00-273-9208  <small>AVLBD452</small>	EXTENSION, SOCKET WRENCH, 3/4 INCH DR, 4-5/8 INCHES LG (IN TOOL BAG IN RIGHT FRONT FENDER STOWAGE BOX), B107-10 (05047)		EA	1
18	NSN 5120-00-243-7328  <small>AVLBD548</small>	EXTENSION, SOCKET WRENCH, 3/4 INCH DR, 8 INCHES LG (IN TOOLBAG IN RIGHT FRONT FENDER STOWAGE BOX), 41B309-20 (19204)		EA	1
19	NSN 5120-00-227-8079  <small>AVI BD549</small>	EXTENSION, SOCKET WRENCH, 3/4 INCH DR, 16 INCHES LG (IN TOOL BAG IN RIGHT FRONT FENDER STOWAGE BOX), L122 (C7127)		EA	1

Table 2. Basic Issue Items List - Continued.

(1) Item Number	(2) National Stock Number (NSN) and Illustration	(3) Description, Part Number/(CAGEC)	(4) Usable On Code	(5) U/I	(6) Qty Rqr
20	NSN 6830-00-555-8837  AVLBD550	EXTINGUISHER, FIRE, CF, BR3, 2-3/4 LB WITH BRACKET (ON RACK BEHIND OPERATOR'S SEAT), 10916537 (19207)		EA	1
21	NSN 5120-01-016-2149  AVLBD453	FIXTURE, TRACK CONNECTING, (POWER OPERATION), (IN RIGHT FRONT FENDER STOWAGE BOX), 12252120 (19207)		EA	1
22	NSN 6230-00-264-8261  AVLBD551	FLASHLIGHT, (IN CREW COMPARTMENT FLASHLIGHT BRACKETS), MX991-U (D9182)		EA	1
23	NSN 7240-00-527-9868  AVLBD553	FUNNEL, METAL WITH STRAINER, 1 QT CAPACITY (IN RIGHT REAR FENDER STOWAGE BOX), RR-F-800 (81348)		EA	1

Table 2. Basic Issue Items List - Continued.





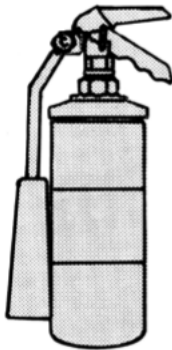
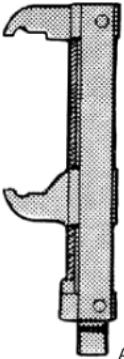
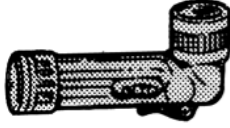
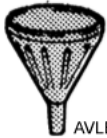

(1) Item Number	(2) National Stock Number (NSN) and Illustration	(3) Description, Part Number/(CAGEC)	(4) Usable On Code	(5) U/I	(6) Qty Rqr
24	NSN 4930-01-133-7143  AVLBD552	GUN, LUBRICATING, HIGH PRESSURE, 21 OZ CAPACITY (IN TOOL BAG IN RIGHT FRONT FENDER STOWAGE BOX), 12312118 (19207)		EA	1
25	NSN 5120-00-243-2957  AVLBD454	HAMMER, ENGINEER, 10 LB SLEDGE, HICKORY WOOD HANDLE (IN LEFT FRONT FENDER STOWAGE BOX), GGG-H-86 (81348)		EA	1
25	NSN 5120-00-900-6097  AVLBD454	HAMMER, ENGINEER, 10 LB SLEDGE, HICKORY WOOD HANDLE (IN LEFT FRONT FENDER STOWAGE BOX), GGG-H-86 (81348)		ALT	1
26	NSN 5120-00-061-8546  AVLBD554	HAMMER, MACHINIST, 2 LB FIBERGLASS HANDLE (IN TOOL BAG IN RIGHT FRONT FENDER STOWAGE BOX), 11677028-3 (19207)		EA	1
27	NSN 5120-00-473-6320  AVLBD555	HANDLE, EXTENSION, WRENCH, 1-1/8 INCH DIA, 36 INCHES LG (IN RIGHT FRONT FENDER STOWAGE BOX), 1756412 (80064)		EA	1
28	NSN 5120-00-288-6574  AVLBD455	HANDLE, MATTOCK, PICK, 36 INCHES LG (IN LEFT FRONT FENDER STOWAGE BOX), 11677021 (19207)		EA	1

Table 2. Basic Issue Items List - Continued.

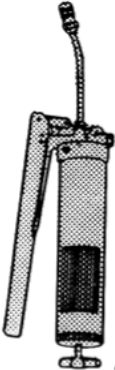



(1) Item Number	(2) National Stock Number (NSN) and Illustration	(3) Description, Part Number/(CAGEC)	(4) Usable On Code	(5) U/I	(6) Qty Rqr
29	NSN 5120-00-236-7590  AVLBD555	HANDLE, SOCKET WRENCH, HINGED, 1/2 INCH DR, 14 INCHES LG (IN TOOL BAG IN RIGHT FRONT FENDER STOWAGE BOX), 11655786-1 (19207)		EA	1
30	NSN 5120-00-221-7959  AVLBD556	HANDLE, SOCKET WRENCH, HINGED, 3/4 INCH DR, 23 INCHES LG (IN TOOL BAG IN RIGHT FRONT FENDER STOWAGE BOX), H377 (45225)		EA	1
31	NSN 5120-00-230-6385  AVLBD556	HANDLE, SOCKET WRENCH, RATCHET, 1/2 INCH DR, 9 INCHES LG (IN TOOL BAG IN RIGHT FRONT FENDER STOWAGE BOX), H41H1505-9 (99993)		EA	1
32	NSN 5120-00-249-1076  AVLBD557	HANDLE, SOCKET WRENCH, RATCHET, 3/4 INCH DR, 17 INCHES LG (IN TOOL BAG IN RIGHT FRONT FENDER STOWAGE BOX), GGG-W-641 (81348)		EA	1
33	NSN 4720-00-498-6291  AVLBD456	HOSE ASSEMBLY, HYDRAULIC SLAVE, (IN LEFT REAR FENDER STOWAGE BOX), 13215E6140 (97403)		EA	1

Table 2. Basic Issue Items List - Continued.





(1) Item Number	(2) National Stock Number (NSN) and Illustration	(3) Description, Part Number/(CAGEC)	(4) Usable On Code	(5) U/I	(6) Qty Rqr
34	NSN 5120-00-198-5390  AVLBD560	KEY, SOCKET HEAD SCREW L-TYPE, SHORT, 3/8 INCH (IN TOOL BAG IN RIGHT FRONT FENDER STOWAGE BOX), 1940722 (80064)		EA	1
35	NSN 5129-00-224-2510  AVLBD457	KEY, SOCKET HEAD SCREW L-TYPE, SHORT, 5/8 INCH (IN TOOL BAG IN RIGHT FRONT FENDER STOWAGE BOX), 1940710 (80064)		EA	1
36	NSN 6545-00-922-1200  AVLBD561	KIT, FIRST AID, (ONE IN CREW COMPARTMENT, ONE IN RIGHT REAR FENDER STOWAGE BOX), 11677011 (19207)		EA	2
37	NSN  AVLBD564	LUBRICATION ORDER, (IN PAMPHLET BAG) LO 5-5420-202-13		EA	1

Table 2. Basic Issue Items List - Continued.

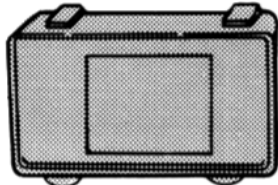

(1) Item Number	(2) National Stock Number (NSN) and Illustration	(3) Description, Part Number/(CAGEC)	(4) Usable On Code	(5) U/I	(6) Qty Rqr
38	NSN  AVLBD562	MANUAL, OPERATOR'S (BRIDGE), (IN PAMPHLET BAG), TM 5-5420- 203-13		EA	1
39	NSN  AVLBD563	MANUAL, OPERATOR'S, (IN PAMPHLET BAG), TM 5-5420-202-10		EA	1
40	NSN 5120-00-243-2395  AVLBD458	MATTOCK, PICK, 5 LB W/O HANDLE (IN LEFT FRONT FENDER STOWAGE BOX), 11677022 (19207)		EA	1

Table 2. Basic Issue Items List - Continued.

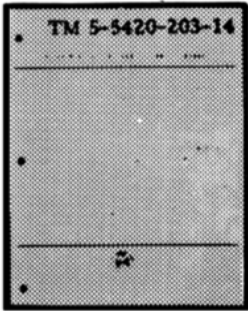
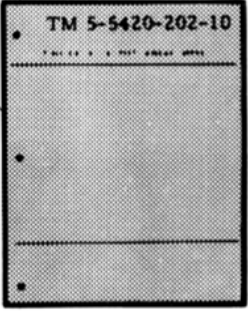

(1) Item Number	(2) National Stock Number (NSN) and Illustration	(3) Description, Part Number/(CAGEC)	(4) Usable On Code	(5) U/I	(6) Qty Rqr
41	NSN 4930-00-262-8868  AVLBD565	OILER, HAND, WITH LEVER PUMP, FLEXIBLE SPOUT (IN LEFT FRONT FENDER STOWAGE BOX), 328 (72798)		EA	1
42	NSN 5340-00-838-5276  AVLBD566	PADLOCK, INDIVIDUAL 2 ON CUPOLA HATCHES, 4 ON FENDER BOXES, MIL-P-17802 (81349)		EA	6
43	NSN 5120-00-278-0350  AVLBD567	PLIERS, SLIP-JOINT, ANGLE NOSE, MULTI-TONGUE AND GROOVE, 5 INCHES LG (IN TOOL BAG IN FRONT FENDER STOWAGE BOX), GGG-P-471TY2LISTA (80244)		EA	1
44	NSN 5120-00-278-0352  AVLBD569	PLIERS, SLIP-JOINT, ANGLE NOSE, MULTI-TONGUE AND GROOVE, 10 INCHES LG (IN TOOL BAG IN FRONT FENDER STOWAGE BOX), GGG-P-471 (81348)		EA	1
45	NSN 5120-01-040-9318  AVLBD568	PULLER, MECHANICAL, TRACK END CONNECTOR (IN RIGHT REAR FENDER STOWAGE BOX), 12252143 (19207)		EA	1

Table 2. Basic Issue Items List - Continued.





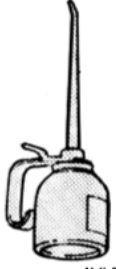

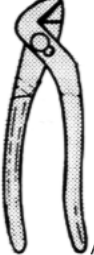
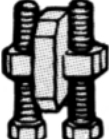
(1) Item Number	(2) National Stock Number (NSN) and Illustration	(3) Description, Part Number/(CAGEC)	(4) Usable On Code	(5) U/I	(6) Qty Rqr
46	NSN 5120-00-234-8913  AVLBD573	SCREWDRIVER, CROSS-TIPPED, PHILLIPS NO. 2, 4 INCH BLADE (IN TOOL BAG IN RIGHT FRONT FENDER STOWAGE BOX), RGP42 (55719)		EA	1
47	NSN 512000-224-7375  AVLBD570	SCREWDRIVER, CROSS-TIPPED, PHILLIPS NO. 4, 8 INCH BLADE (IN TOOL BAG IN RIGHT FRONT FENDER STOWAGE BOX), RGP84 (55719)		EA	1
48	NSN 5120-00-596-8502  AVLBD572	SCREWDRIVER, FLAT-TIPPED, CLOSE QUARTER, 1-1/2 INCH BLADE (IN TOOL BAG IN RIGHT FRONT FENDER STOWAGE BOX), MS15221-2 (96906)		EA	1
49	NSN 5120-00-227-7338  AVLBD571	SCREWDRIVER, FLAT-TIPPED, EXTRA HEAVY DUTY, 5 INCH BLADE (IN TOOL BAG IN RIGHT FRONT FENDER STOWAGE BOX), D339 (77948)		EA	1
50	NSN 5120-00-234-8910  AVLBD459	SCREWDRIVER, FLAT-TIPPED, GENERAL PURPOSE, 6 INCH BLADE (IN TOOL BAG IN RIGHT FRONT FENDER STOWAGE BOX), MS15219-1 (96906)		EA	1
51	NSN 5120-00-293-3336  AVLBD460	SHOVEL, HAND, ROUND POINT, D-HANDLE, SHORT (IN LEFT FRONT FENDER STOWAGE BOX), 11655784 (19207)		EA	1

Table 2. Basic Issue Items List - Continued.







(1) Item Number	(2) National Stock Number (NSN) and Illustration	(3) Description, Part Number/(CAGEC)	(4) Usable On Code	(5) U/I	(6) Qty Rqr
52	NSN 3940-01-110-4432  <small>AVLBD574</small>	SLING, MULTIPLE LEG, 2 LEG, 5/8 INCH X 6 FT CHAIN (IN LEFT FRONT FENDER STOWAGE BOX), 13212E7099 (97403)		EA	2
53	NSN 5120-01-181-6813  <small>AVLBD575</small>	SOCKET, IMPACT WRENCH, 3/4 INCH DR, 15/16 INCH (IN TOOL BAG IN RIGHT FRONT FENDER STOWAGE BOX), A-A-1394 (58536)		EA	1
54	NSN 5130-01-227-6684  <small>AVLBD576</small>	SOCKET, IMPACT WRENCH, 6 PT, 3/4 INCH DR, 1-5/16 INCH (IN TOOL BAG IN RIGHT FRONT FENDER STOWAGE BOX), C67455 (11976)		EA	1
55	NSN 5120-00-237-0982 	SOCKET WRENCH, 12 PT, 1/2 INCH DR, 3/8 INCH (IN TOOL BAG IN RIGHT FRONT FENDER STOWAGE BOX), A-A-1399 (58536)		EA	1
56	<small>AVLBD461</small> NSN 5120-00-189-7924  <small>AVLBD577</small>	SOCKET WRENCH, 12 PT, 1/2 INCH DR, 7/16 INCH (IN TOOL BAG IN RIGHT FRONT FENDER STOWAGE BOX), ST-1214 (65814)		EA	1
57	NSN 5120-00-222-2021  <small>AVLBD578</small>	SOCKET WRENCH, 12 PT, 1/2 INCH DR, 1/2 INCH (IN TOOL BAG IN RIGHT FRONT FENDER STOWAGE BOX), A-A-2486 (58536)		EA	1

Table 2. Basic Issue Items List - Continued.







(1) Item Number	(2) National Stock Number (NSN) and Illustration	(3) Description, Part Number/(CAGEC)	(4) Usable On Code	(5) U/I	(6) Qty Rqr
58	NSN 5120-00-189-7932  AVLBD579	SOCKET WRENCH, 12 PT, 1/2 INCH DR, 9/16 INCH (IN TOOL BAG IN RIGHT FRONT FENDER STOWAGE BOX), 11677025 (19207)		EA	1
59	NSN 5120-00-189-7985  AVLBD462	SOCKET WRENCH, 12 PT, 1/2 INCH DR, 3/4 INCH (IN TOOL BAG IN RIGHT FRONT FENDER STOWAGE BOX), 11677025-4 (19207)		EA	1
60	NSN 5120-00-189-7934  AVLBD580	SOCKET WRENCH, 12 PT, 1/2 INCH DR, 7/8 INCH (IN TOOL BAG IN RIGHT FRONT FENDER STOWAGE BOX), 11677025-5 (19207)		EA	1
61	NSN 5120-00-181-6813  AVLBD581	SOCKET WRENCH, 12 PT, 3/4 INCH DR, 15/16 INCH (IN TOOL BAG IN RIGHT FRONT FENDER STOWAGE BOX), 1230 (24789)		EA	1
62	NSN 5120-00-239-0021  AVLBD582	SOCKET WRENCH, 12 PT, 3/4 INCH DR, 1-1/8 INCH (IN TOOL BAG IN RIGHT FRONT FENDER STOWAGE BOX), GGG-W-641 (81348)		EA	1
63	NSN 5120-00-235-5871  AVLBD583	SOCKET WRENCH, 12 PT, 3/4 INCH DR, 1-1/4 INCH (IN TOOL BAG IN RIGHT FRONT FENDER STOWAGE BOX), GGG-W-641 (81348)		EA	1

Table 2. Basic Issue Items List - Continued.



(1) Item Number	(2) National Stock Number (NSN) and Illustration	(3) Description, Part Number/(CAGEC)	(4) Usable On Code	(5) U/I	(6) Qty Rqr
64	NSN 5120-00-293-0094  AVLBD463	SOCKET WRENCH, 12 PT, 3/4 INCH DR, 1-1/2 INCH (IN TOOL BAG IN RIGHT FRONT FENDER STOWAGE BOX), GGG-W-641 (81348)		EA	1
65	NSN 5130-01-084-6025  AVLBD584	SOCKET WRENCH, POWER DR, 3/4 INCH DR, 1-5/16 INCH (IN TOOL BAG IN RIGHT FRONT FENDER STOWAGE BOX), 10894847-1 (19207)		EA	1
66	NSN 4010-00-202-2425  AVLBD467	WIRE ROPE ASSEMBLY, SINGLE LEG, 1-1/8 INCH DIA, 10 FT LG (IN BRACKETS ON LEFT SIDE OF HULL), 7360553 (19207)		EA	2
67	NSN 5120-00-473-6476  AVLBD585	WRENCH, ADJUSTABLE, AUTOMOTIVE, 11-1/2 INCH HANDLE (IN TOOL BAG IN RIGHT FRONT FENDER STOWAGE BOX), P489 (80212)		EA	1
68	NSN 5120-00-277-1246  AVLBD586	WRENCH, CYLINDER ROD FLATS, 1-1/2 INCH (IN RIGHT FRONT FENDER STOWAGE BOX), MS16382-1 (96906)		EA	1

Table 2. Basic Issue Items List - Continued.

(1) Item Number	(2) National Stock Number (NSN) and Illustration	(3) Description, Part Number/(CAGEC)	(4) Usable On Code	(5) U/I	(6) Qty Rqr
69	NSN 5420-00-050-8745  AVLBD587	WRENCH, CYLINDER ROD FLATS, 4-9/16 INCH (IN RIGHT FRONT FENDER STOWAGE BOX), 13211E3202 (97403)		EA	1
70	NSN 5120-00-277-2307  AVLBD464	WRENCH, DOUBLE HEAD, OPEN END, 5/16 INCH AND 3/8 INCH (IN TOOL BAG IN RIGHT FRONT FENDER STOWAGE BOX), S1012 (55719)		EA	1
71	NSN 5120-00-187-7123  AVLBD588	WRENCH, DOUBLE HEAD, OPEN END, 7/16 INCH AND 1/2 INCH (IN TOOL BAG IN RIGHT FRONT FENDER STOWAGE BOX), S1416 (55719)		EA	1
72	NSN 5120-00-293-2134  AVLBD589	WRENCH, DOUBLE HEAD, OPEN END, 9/16 INCH AND 11/16 INCH (IN TOOL BAG IN RIGHT REAR FENDER STOWAGE BOX), 5323330 (19207)		EA	1
73	NSN 5120-00-224-3102  AVLBD465	WRENCH, DOUBLE HEAD, OPEN END, 5/8 INCH AND 1/2 INCH (IN TOOL BAG IN RIGHT FRONT FENDER BOX) 729 (65814)		EA	1

Table 2. Basic Issue Items List - Continued.

(1) Item Number	(2) National Stock Number (NSN) and Illustration	(3) Description, Part Number/(CAGEC)	(4) Usable On Code	(5) U/I	(6) Qty Rqr
74	NSN 5120-00-563-7342  AVLBD591	WRENCH, SINGLE HEAD, OPEN END, 3-3/16 INCH, 26 INCHES LG (IN RIGHT REAR FENDER STOWAGE BOX), 8708683 (19207)		EA	1
75	NSN 5120-01-100-0391  AVLBD590	WRENCH, SPANNER, TRACK ADJUSTING LINK (IN LEFT FRONT FENDER STOWAGE BOX), 12301553 (19207)		EA	1

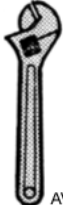
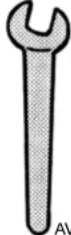
**OPERATOR MAINTENANCE
ADDITIONAL AUTHORIZATION LIST (AAL)**

INTRODUCTION

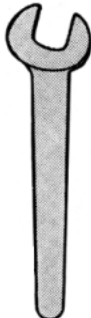
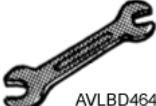
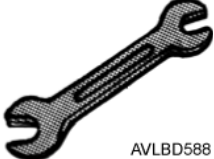
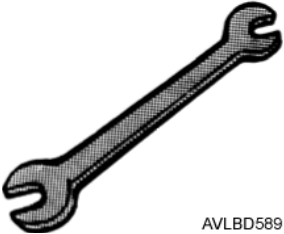
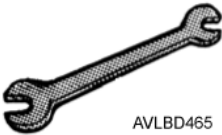
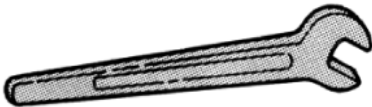
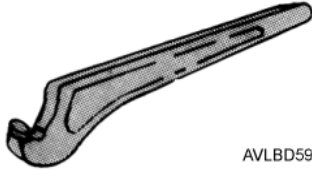
Scope

This work package lists additional items you are authorized for the support of the M48A5/M60A1 Armored Vehicle Launched Bridge (AVLB).

General

This list identifies items that do not have to accompany the M48A5/M60A1 AVLB and that do not have to be turned in with it. These items are all authorized to you by CTA, MTOE, TDA, or JTA.

Explanation of Columns in the AAL

Column (1) National Stock Number (NSN). Identifies the stock number of the item to be used for requisitioning purposes.

Column (2) Description, Commercial and Government Entity Code (CAGEC), and Part Number (P/N). Identifies the Federal item name (in all capital letters) followed by a minimum description when needed. The last line below the description is the CAGEC (in parentheses) and the part number.

Column (3) Usable On Code. When applicable, gives you a code if the item you need is not the same for different models of equipment.

Column (4) Unit of Issue (U/I). Indicates the physical measurement or count of the item as issued per the National Stock Number shown in column (1).

Column (5) Qty Recm. Indicates the quantity recommended.

Table 1. Additional Authorization List.

(1) NATIONAL STOCK NUMBER	(2) DESCRIPTION, CAGEC, AND PART NUMBER	(3) USABLE ON CODE	(4) U/I	(5) QTY RECM
5820-00-938-0214	ACCESSORY KIT, MK-1297-G (USED WITH RADIO SET AN/VRC-46 OR AN/VRC-64) (INSTALLED WITH RADIO SET) (80063) PPL4324		EA	1
7240-00-089-3827	CAN, WATER, MILITARY, PLASTIC, 5 GAL (IN WATER CAN STOWAGE BRACKET) (81349) MIL-C-43613		EA	1
7240-00-242-6153	CAN, WATER, MILITARY, STEEL, 5 GAL (IN WATER CAN STOWAGE BRACKET) (81349) MIL-C-13984T1		EA	1
8345-00-178-8437	CASE, FLAG (81349) MIL-F-40045-CS-90		EA	1
8345-00-227-1406	FLAG (GREEN) (81349) MIL-F-40045-MC-275		EA	1
8345-00-227-1511	FLAG (RED) (81349) MIL-F-40045-MC-273		EA	1
8345-00-227-1405	FLAG (YELLOW) (81349) MIL-F-40045-MC-274		EA	1
8345-00-375-0223	FLAG SET, M238 (IN RIGHT FRONT FENDER STOWAGE BOX) (81349) MIL-F-40045		EA	1
8345-00-174-6865	PANEL, MARKER (81349) MIL-P-40061		EA	1

Table 1. Additional Authorization List - Continued.

(1) NATIONAL STOCK NUMBER	(2) DESCRIPTION, CAGEC, AND PART NUMBER	(3) USABLE ON CODE	(4) U/I	(5) QTY RECM
4930-00-294-5110	PUMP, DISPENSING, HAND, ROTARY (81348) XXD385		EA	1
5820-00-223-7433	RADIO SET, AN/VRC-46 (IN RADIO MOUNT) (80063) PPL4319		EA	1
5820-00-223-7475	RADIO SET, AN/VRC-64 (IN RADIO MOUNT) (80063) PPL4324		EA	1
7240-00-177-6154	SPOUT, FLEXIBLE, 5 GAL CAN (81349) IL-S-1285		EA	2
8345-00-242-3650	STAFF, FLAG (81349) MIL-F-40045-MC-270		EA	1

END OF WORK PACKAGE

**OPERATOR MAINTENANCE
EXPENDABLE AND DURABLE ITEMS LIST**

INTRODUCTION

Scope

This work package lists expendable and durable items that you will need to operate and maintain the Armored Vehicle Launched Bridge (AVLB). This list is for information only and is not authority to requisition the listed items. These items are authorized to you by CTA 50-970, Expendable/Durable Items (Except Medical, Class V Repair Parts, and Heraldic Items), CTA 50-909, Field and Garrison Furnishings and Equipment or CTA 8-100, Army Medical Department Expendable/Durable Items.

Explanation of Columns in the Expendable/Durable Items List

Column (1) Item No. This number is assigned to the entry in the list and is referenced in the narrative instructions to identify the item (e.g., Use brake fluid (WP 0098, Item 5)).

Column (2) Level. This column identifies the lowest level of maintenance that requires the listed item, which is C = Crew.

Column (3) National Stock Number (NSN). This is the NSN assigned to the item which you can use to requisition it.

Column (4) Item Name, Description, Part Number/(CAGEC). This column provides the other information you need to identify the item. The last line below the description is the part number and the Commercial and Government Entity Code (CAGEC) (in parentheses). (*M48A5 only and **M60A1 only).

Column (5) U/I. Unit of Issue (U/I) code shows the physical measurement or count of an item, such as gallon, dozen, gross, etc.

Table 1. Expendable and Durable Items List.

(1) ITEM NUMBER	(2) LEVEL	(3) NATIONAL STOCK NUMBER	(4) ITEM NAME, DESCRIPTION, CAGEC, AND PART NUMBER	(5) U/I
1	C	8040-00-262-9025	ADHESIVE, GENERAL PURPOSE, NATURAL RUBBER (80244) MMM-A-1617 TYPE 1	OZ
2	C	8040-00-262-9028	ADHESIVE, GENERAL PURPOSE, NATURAL RUBBER (19203) 829899	PT
3	C	8040-00-664-4318	ADHESIVE, GENERAL PURPOSE, SYNTHETIC RUBBER (10001) 12Z30300-19	PT
4	C	8040-00-865-8991	ADHESIVE, GENERAL PURPOSE, RTV SILICONE (19207) 12266964	KT
5	C	6135-00-835-7210	BATTERY, FLASHLIGHTS AND INSTRUMENTS (80204) 13A	PG
6	C	6135-00-485-7402	BATTERY, DRIVER'S PASSIVE NIGHT VIEWER (80058) BA1567/U	EA
7	C	8020-00-244-0153	BRUSH, ARTIST, METAL FERRULE FLATPOINT, 7/16 INCH WIDE (80244) 8020-00-244-0153	EA
8	C	8020-00-224-8024	BRUSH, ARTIST, METAL FERRULE, ROUND TAPERED (38536) A-A-3191	EA
9	C	1015-00-615-7208	BRUSH, SECTION, CLEANING, ARTILLERY (19207) 6157208	EA
10	C	7920-00-291-5815	BRUSH, WIRE, SCRATCH (83421) 7920-00-291-5815	EA

Table 1. Expendable and Durable Items List - Continued.

(1) ITEM NUMBER	(2) LEVEL	(3) NATIONAL STOCK NUMBER	(4) ITEM NAME, DESCRIPTION, CAGEC, AND PART NUMBER	(5) U/I
11	C	9150-01-053-6688	CLEANER, LUBRICANT, PRESERVATIVE 1 GAL (81349) MIL-PRF-63460	GL
12	C	5350-00-192-5047	CLOTH, ABRASIVE, 80 GRIT (Z8X80) 00422002	PG
13	C	5350-00-192-5049	CLOTH, ABRASIVE, 120 GRIT (76381) 05144-02458	PG
14	C	5350-00-192-5051	CLOTH, ABRASIVE, 180 GRIT (80204) AN51B74.18	PG
15	C	5350-00-221-0872	CLOTH, ABRASIVE (80204) AN51B74.18	PG
16	C	6850-00-227-1887	COMPOUND, CLEANING, OPTICAL LENS (58536) AA59199-1	QT
17	C	6850-00-282-6770	COMPOUND, CLEANING, ALUMINUM SURFACE (55208) AC-102	CN
18	C	8010-00-141-7838	COMPOUND, WALK WAY OD 1 GAL (58536) AA59166-2-0016-34088	GL
19	C	8030-00-903-0931	COMPOUND, CORROSION PREVENTIVE (81349) MIL-C-16173	PT
20	C	6850-00-174-9672	COMPOUND, CORROSION REMOVING (81349) MIL-C-10578	GL
21	C	6850-00-880-7616	COMPOUND, SILICONE (81343) AS866080ZTU	TU
22	C	7930-00-990-7391	DETERGENT, LAUNDRY (P-D-245) 81348	CO
23	C	9150-01-102-9455	FLUID, BRAKE, AUTOMOTIVE 1 GAL (81349) MIL-PRF-46176	GL
24	C	9150-00-111-6256	FLUID, HYDRAULIC (FRH) (81349) MIL-PRF- 46170	QT
25	C	8415-00-266-8677	GLOVES, RUBBER (81349) MIL-DTL-32066	PR
26	C	4240-00-269-7912	GOGGLES, INDUSTRIAL (80204) AN51Z87.1	PR
27	C	9150-00-961-8995	GREASE, AIRCRAFT AND INSTRUMENT (81349) M1513429	TU
28	C	9150-01-197-7693	GREASE, AUTOMOTIVE AND ARTILLERY 14 OZ (60014) 60226	CA
29	C	9150-01-197-7689	GREASE, AUTOMOTIVE AND ARTILLERY 6.5 LB (81349) MIL-PRF-10924G	CN
30	C	6240-00-155-7836	LAMP, INCANDESCENT (K0673) A259	BX
31	C	6240-00-155-8714	LAMP, INCANDESCENT (96906) MS25231-313	EA
32	C	6240-00-019-3093	LAMP, INCANDESCENT (58536) AA5263-A09	EA
33	C	6240-00-044-6914	LAMP, INCANDESCENT (08108) 1683	BX
34	C	6240-00-295-2668	LAMP, 28V, INCANDESCENT (58536) AA52463-B11	EA
35	C	6240-00-266-9940	LAMP, INCANDESCENT (71744) CM1829-28V	EA

Table 1. Expendable and Durable Items List - Continued.

(1) ITEM NUMBER	(2) LEVEL	(3) NATIONAL STOCK NUMBER	(4) ITEM NAME, DESCRIPTION, CAGEC, AND PART NUMBER	(5) U/I
36	C	6240-00-019-0877	LAMP, INCANDESCENT (58536) AA52463-A08	EA
37	C	6240-00-155-7929	LAMP, INCANDESCENT (08108) 43	EA
38	C	6240-00-368-4972	LAMP, INCANDESCENT (96906**) MS18003-4811	EA
39	C	5310-00-061-1258	LOCKWASHER (96906) MS45904-76	HD
40	C	5310-00-637-9541	LOCKWASHER (59556) 019-00004-42	HD
41	C	5310-00-193-7574	LOCKWASHER (13499) 373-1070-000	HD
42	C	9150-01-054-6453	LUBRICANT, CLEANER AND PRESERVATIVE (B0897) 3058220120	PT
43	C	9150-01-152-4117	LUBRICATING OIL, ENGINE (81349) M2104-1-15W40	QT
44	C	5310-00-087-4652	NUT, SELF-LOCKING EXTENDED WASHER (81349) M45913/1-6CG5C	EA
45	C	5310-00-930-8214	NUT, SELF-LOCKING EXTENDED WASHER (96906) MS51988-7	EA
46	C	5310-00-959-7600	NUT, SELF-LOCKING EXTENDED WASHER (96906) MS51922-5	EA
47	C	5310-00-732-0558	NUT, PLAIN, HEXAGON (96906) MS51967-8	HD
48	C	9150-00-402-4478	OIL, ENGINE LUBRICATING (15445) RIVID TYPE 1	QT
49	C	9150-00-261-7899	PENETRATING OIL (81348) A-A-50493	PT
50	C	4730-01-038-5290	PLUG, PIPE, MAGNETIC (02951) 1000-20	EA
51	C	4730-00-045-9833	PLUG, PIPE, MAGNETIC (58536) AA59432-12	EA
52	C	7920-00-205-1711	RAG, WIPING (64067) 7920-00-205-1711	BE
53	C	4020-00-231-9014	ROPE, FIBROUS (81340) CGS21R4 TYPE M, CLASS 2	CL
54	C	4020-00-689-5688	ROPE, FIBROUS (TR605) 81348*	LG
55	C	8950-00-292-9611	SODA, BAKING	BX
56	C	6850-00-597-9765	SOLVENT, CLEANING COMPOUND (80063) 6G236-6	GL
57	C	6850-00-664-5685	SOLVENT, DRY CLEANING (58536) AA59Q601-1D	BX
58	C	6850-00-281-1985	SOLVENT, DEGREASING (81348*) MIL-PRF-680	BX
59	C	1005-00-288-3565	SWAB, SMALL ARMS (19204**) 5019316	PG
60	C	5970-01-052-4941	TAPE, INSULATION, ELECTRICAL (81349**) MIL-I-23594	RO

Table 1. Expendable and Durable Items List - Continued.

(1) ITEM NUMBER	(2) LEVEL	(3) NATIONAL STOCK NUMBER	(4) ITEM NAME, DESCRIPTION, CAGEC, AND PART NUMBER	(5) U/I
61	C	5970-00-198-8621	TAPE, INSULATION, ELECTRICAL D4514 1.5 INCHES WIDE (81346**)	RO
62	C	7510-00-473-9513	TAPE, PRESSURE SENSITIVE (81349**) MIL-T-23397	RO
63	C	7510-00-551-1245	TAPE, PRESSURE SENSITIVE ADHESIVE (58536**) A-A-884	RO
64	C	8010-00-242-2089	THINNER, PAINT PRODUCTS (H0203) 132251613901	GL
65	C	4020-00-231-5860	TWINE, FIBROUS (58536) A-A-145	CE
66	C	9505-00-684-4843	WIRE, NONELECTRICAL (81346) ASTMA641	LB

END OF WORK PACKAGE

INDEX

<u>Subject</u>	<u>WP Sequence No.–Page No.</u>
A	
Abbreviations, List of	WP 0001–3
Adjust Seat	WP 0006–2
Adjust Track Tension	WP 0056–1
Administrative Publications	WP 0076–1
Ammunition Maintenance	WP 0075–1
Ammunition Service	WP 0075–2
Ammunition Identification	WP 0075–4
Additional Authorization List (AAL)	WP 0078–1
Ammunition Care, Handling, and Preservation	WP 0075–1
AN/VVS-2 Night Vision Viewer Installation	WP 0011–1
Apply Parking Brake	WP 0012–1
Auxiliary Systems and Controls Troubleshooting Procedures	WP 0041–1
B	
Battery Care and Maintenance	WP 0063–1
Brakes Troubleshooting Procedures	WP 0041–1
Breaking and Connecting Track	WP 0055–1
C	
Components of End Item (COEI) and Basic Issue Items (BII) Lists	WP 0077–1
Corrosion Prevention and Control	WP 0001–2
Crossing the Bridge	WP 0019–1
D	
Description and Use of Operator’s Controls and Indicators	WP 0004–1
Destruction of Army Materiel to Prevent Enemy Use	WP 0001–2
Differences Between Models	WP 0002–7
Driving Vehicle	WP 0017–2
Dust Detector Warning Lamp Replacement	WP 0068–1
E	
Emergency Refueling	WP 0060–1
Engine Air Cleaner Intakes	WP 0071–1
Equipment Characteristics, Capabilities, and Features	WP 0002–1
Equipment Data	WP 0002–12
Equipment Description and Data	WP 0002–1
Equipment Improvement Recommendations (EIRs)	WP 0001–2
Escape Hatch (M48A5) Removal and Installation	WP 0064–1
Escape Hatch (M60A1) Removal and Installation	WP 0065–1
Expendable and Durable Items List	WP 0079–1
F	
Field Manuals	WP 0076–1
Fording	WP 0031–1
Forms	WP 0076–1
Fuel Filler Cap Maintenance	WP 0061–1
G	
Gas and Particulate Filter Change Criteria	WP 0037–1

INDEX – CONTINUED

G

General Information WP 0001–1

H

Headlight, Blackout Marker, and Taillight Lamp Replacement WP 0066–1
 Headlight Removal, Stowage, and Installation WP 0070–1
 How to Use This Manual xv

I

Instrument Panel Cluster Assembly Lamp Replacement WP 0067–3
 Isolating Fuel Tanks WP 0062–1

L

Launcher Nameplate - M60A1 WP 0002–8
 Launcher Nameplate - M48A5 WP 0002–9
 Launching Bridge WP 0018–1
 List of Abbreviations WP 0041–3
 Loosening Track Tension - Conventional Track Adjusting Link WP 0053–1
 Location and Description of Major Components WP 0002–2
 Loosening Track Tension - Grease-Actuated Adjusting Link WP 0054–1
 Lubrication Instructions WP 0074–1

M

M239 Smoke Grenade Launcher Maintenance WP 0072–1
 Maintain Track (Adjust Track Tension) WP 0056–1
 Maintain Track (Break Track) WP 0055–1
 Maintain Track (Connect Track) WP 0055–1
 Maintain Track (Install Centerguide) WP 0050–1
 Maintain Track (Install End Connectors) WP 0049–1
 Maintain Track (Install Rear Fender - M60A1) WP 0058–1
 Maintain Track (Install Thrown Track) WP 0057–1
 Maintain Track (Install Track Link) WP 0051–1
 Maintain Track (Loosen Track Tension - Conventional Adjusting Link) WP 0053–1
 Maintain Track (Loosen Track Tension - Grease-Actuated Adjusting Link) WP 0054–1
 Maintain Track (Remove and Install T-142 Track Pad) WP 0052–1
 Maintain Track (Remove Centerguide) WP 0050–1
 Maintain Track (Remove End Connectors) WP 0049–1
 Maintain Track (Remove Rear Fender - M60A1) WP 0058–1
 Maintain Track (Remove Track Link) WP 0051–1
 Maintenance Forms, Records, and Reports WP 0001–2
 Maintenance Under Adverse Conditions WP 0073–1
 Master Control Panel, Instrument Cluster, and Powerplant Warning Lights Lamp Replacement WP 0067–1

O

Operation Under Unusual Conditions - Dusty or Sandy Areas WP 0028–1
 Operation Under Unusual Conditions - Engine Air Cleaner Intakes WP 0029–1
 Operation Under Unusual Conditions - Extreme Cold Weather WP 0026–1
 Operation Under Unusual Conditions - Forging WP 0031–1
 Operation Under Unusual Conditions - Gas and Particulate Filter Change Criteria WP 0037–1
 Operation Under Unusual Conditions - Gas Particulate Filter Unit WP 0036–1
 Operation Under Unusual Conditions - Hot, Humid, or Salty Areas WP 0027–1
 Operation Under Unusual Conditions - Slave Starting WP 0032–1
 Operation Under Unusual Conditions - Slave-Starting Hydraulic System WP 0034–1
 Operation Under Unusual Conditions - Stopping Vehicle When Brakes Fail WP 0030–1

INDEX – CONTINUED

O

Operation Under Unusual Conditions - Storage of Scissoring Bridge	WP 0035-1
Operation Under Unusual Conditions - Towing a Disabled Vehicle	WP 0033-1
Operation Under Usual Conditions - Adjust Seat	WP 0006-1
Operation Under Usual Conditions - AN/VVS-2 Night Vision Viewer	WP 0011-1
Operation Under Usual Conditions - Antenna Removal and Installation	WP 0024-1
Operation Under Usual Conditions - Auxiliary Equipment	WP 0022-1
Operation Under Usual Conditions - Crossing Bridge	WP 0019-1
Operation Under Usual Conditions - Cupola Cover	WP 0005-1
Operation Under Usual Conditions - Drain Valves	WP 0009-1
Operation Under Usual Conditions - Driving Vehicle	WP 0017-1
Operation Under Usual Conditions - Fixed Fire Extinguishers	WP 0007-1
Operation Under Usual Conditions - Launching Bridge	WP 0018-1
Operation Under Usual Conditions - M239 Smoke Grenade Launcher	WP 0023-1
Operation Under Usual Conditions - Parking Brake	WP 0012-1
Operation Under Usual Conditions - Personnel Heater	WP 0010-1
Operation Under Usual Conditions - Placing Vehicle in Motion and Stopping Vehicle	WP 0016-1
Operation Under Usual Conditions - Preventing Ghost Launching of Tongue and Overhead Cylinder	WP 0021-1
Operation Under Usual Conditions - Retrieving Bridge	WP 0020-1
Operation Under Usual Conditions - Service Drive Lights	WP 0008-1
Operation Under Usual Conditions - Shifting Transmission	WP 0013-1
Operation Under Usual Conditions - Starting and Stopping Engine	WP 0015-1
Operation Under Usual Conditions - Steering Vehicle	WP 0014-1
Operation Under Usual Conditions - Top Deck Grille Doors	WP 0025-1
Operator's Controls and Indicators	WP 0004-1
Ozone Depletion Substances (ODS)	WP 0001-2

P

Preventive Maintenance Checks and Services (PMCS) Introduction	WP 0047-1
Preventive Maintenance Checks and Services (PMCS)	WP 0048-1

R

Rear Fender Removal and Installation	WP 0058-1
References	WP 0076-1
Refueling from Pressurized Source	WP 0059-1
Releasing Parking Brake	WP 0012-3
Removing, Stowing, and Installing Headlight	WP 0070-1
Replacing Headlight, Blackout Drive, and Blackout Marker Lamps	WP 0066-1
Replacing Lamp - Dust Detector Warning Lamp	WP 0068-1
Replacing Lamp - Instrument Panel Cluster Assembly	WP 0067-1
Replacing Lamp - Master Control Panel	WP 0067-1
Replacing Lamp - Smoke Generator	WP 0067-1
Replacing Lamp - Powerplant Warning Lights	WP 0067-1
Replacing Lamp - Smoke Grenade Launcher Power Box	WP 0072-1
Replacing Taillight Lamps	WP 0066-1

S

Servicing Engine Air Cleaners Indicators	WP 0071-1
Servicing Fuel Filler Cap	WP 0061-1
Shifting Transmission	WP 0013-1
Slave Starting	WP 0032-1
Slaving Hydraulic System	WP 0032-1
Smoke Grenade Launcher Power Box Lamp Replacement	WP 0072-1
Smoke Grenades - Identification, Handling, and Destruction	WP 0075-1

INDEX – CONTINUED

S

Starting Engine	WP 0015–2
Steering Vehicle	WP 0014–2
Stopping Engine	WP 0015–8
Storage of Scissoring Bridge	WP 0035–1
Stowage and Decal/Data Plate Guide	WP 0038–1
Steering Vehicle	WP 0038–1

T

T-142 Track Pad Removal and Installation	WP 0052–1
Taillight Lamp Replacement	WP 0066–6
Technical Publications	WP 0076–1
Theory of Operation	WP 0003–1
Top Deck Grille Doors Operation	WP 0025–1
Towing a Disabled Vehicle	WP 0033–1
Transportation Nameplate - M48A5	WP 0002–9
Transportation Nameplate - M60A1	WP 0002–8
Troubleshooting Symptom Index - General	WP 0039–1
Troubleshooting Procedure - Auxiliary Systems and Controls	WP 0042–1
Troubleshooting Procedure - Brakes	WP 0041–1
Troubleshooting Procedure - Engine	WP 0040–1
Troubleshooting Procedure - Lights	WP 0043–1
Troubleshooting Procedure - Personnel Heater	WP 0045–1
Troubleshooting Procedure - Steering	WP 0044–1
Troubleshooting Procedures - Voltage Regulator	WP 0042–1

RECOMMENDED CHANGES TO PUBLICATIONS AND BLANK FORMS For use of this form, see AR 25-30; the proponent agency is ODISC4.						Use Part II (reverse) for Repair Parts and Special Tool Lists (RPSTL) and Supply Catalogs/Supply Manuals (SC/SM).	DATE Date you filled out this form.
TO: <i>(Forward to proponent of publication or form) (Include ZIP Code)</i> U.S. Army TACOM Life Cycle Management Command ATTN: AMSTA-LCL-MPP/TECH PUBS 1 Rock Island Arsenal, Rock Island, IL 61299-7630						FROM: <i>(Activity and location) (Include ZIP Code)</i> Your mailing address	
PART I – ALL PUBLICATIONS (EXCEPT RPSTL AND SC/SM) AND BLANK FORMS							
PUBLICATION/FORM NUMBER TM 5-5420-202-10						DATE 30 Dec 09	Title Operator Manual, Launcher, Tank, M48A5, M60A1, for Bridge Armored - Vehicle Launched, Class 60 or 70
ITEM NO.	PAGE NO.	PARA-GRAPH	LINE NO. *	FIGURE NO.	TABLE NO.	RECOMMENDED CHANGES AND REASON (Provide exact wording of recommended changes, if possible).	
SAMPLE							
<i>*Reference to line numbers within the paragraph or subparagraph.</i>							
TYPED NAME, GRADE OR TITLE Your Name				TELEPHONE EXCHANGE/AUTOVON, PLUS EXTENSION		Signature Your Signature	

TO: (Forward direct to addressee listed in publication) U. S. Army TACOM Life Cycle Management Command ATTN: AMSTA-LCL-MPP/TECH PUBS 1 Rock Island Arsenal, Rock Island, IL 61299-7630	FROM: (Activity and location) (Include ZIP Code) Your address	DATE Date you filled out this form
--	---	--

PART II – REPAIR PARTS AND SPECIAL TOOL LISTS AND SUPPLY CATALOGS/SUPPLY MANUALS

PUBLICATION NUMBER TM 5-5420-202-10	DATE 30 Dec 09	TITLE Oper Manual for Launcher, Tank M48A5 and M60A1 for Bridge Armored-Vehicle Class 60 or 70
--	-------------------	---

PAGE NO.	COLM NO.	LINE NO.	NATIONAL STOCK NUMBER	REFERENCE NO.	FIGURE NO.	ITEM NO.	TOTAL NO. OF MAJOR ITEMS SUPPORTED	RECOMMENDED ACTION
SAMPLE								

PART III – REMARKS (Any general remarks or recommendations, or suggestions for improvement of publications and blank forms. Additional blank sheets may be used if more space is needed.)

TYPED NAME, GRADE OR TITLE Your Name	TELEPHONE EXCHANGE/AUTOVON, PLUS EXTENSION	SIGNATURE Your Signature
---	--	-----------------------------

RECOMMENDED CHANGES TO PUBLICATIONS AND BLANK FORMS For use of this form, see AR 25-30; the proponent agency is ODISC4.						Use Part II (reverse) for Repair Parts and Special Tool Lists (RPSTL) and Supply Catalogs/Supply Manuals (SC/SM).	DATE
TO: (Forward to proponent of publication or form)(Include ZIP Code) U.S. Army TACOM Life Cycle Management Command ATTN: AMSTA-LCL-MPP/TECH PUBS 1 Rock Island Arsenal, Rock Island, IL 61299-7630						FROM: (Activity and location) (Include ZIP Code)	
PART I – ALL PUBLICATIONS (EXCEPT RPSTL AND SC/SM) AND BLANK FORMS							
PUBLICATION/FORM NUMBER TM 5-5420-202-10						DATE 30 Dec 09	TITLE Operator Manual for Launcher Tank, M48A5, M60A1 for Bridge Armored-Vehicle, Class 60 or 70
ITEM NO.	PAGE NO.	PARA-GRAPH	LINE NO. *	FIGURE NO.	TABLE NO.	RECOMMENDED CHANGES AND REASON (Provide exact wording of recommended changes, if possible).	
TYPED NAME, GRADE OR TITLE				*Reference to line numbers within the paragraph or subparagraph. TELEPHONE EXCHANGE/AUTOVON, PLUS EXTENSION		SIGNATURE	

TO: (Forward direct to addressee listed in publication) U. S. Army TACOM Life Cycle Management Command ATTN: AMSTA-LCL-MPP/TECH PUBS 1 Rock Island Arsenal, Rock Island, IL 61299-7630	FROM: (Activity and location) (Include ZIP Code)	DATE
--	---	-------------

PART II – REPAIR PARTS AND SPECIAL TOOL LISTS AND SUPPLY CATALOGS/SUPPLY MANUALS

PUBLICATION NUMBER TM 5-5420-202-10				DATE 30 Dec 09			TITLE Operator Manual for Launcher, Tank, M48A5, M60A1 for Bridge Armored-Vehicle, Class 60 or 70	
PAGE NO.	COLM NO.	LINE NO.	NATIONAL STOCK NUMBER	REFERENCE NO.	FIGURE NO.	ITEM NO.	TOTAL NO. OF MAJOR ITEMS SUPPORTED	RECOMMENDED ACTION

PART III – REMARKS (Any general remarks or recommendations, or suggestions for improvement of publications and blank forms. Additional blank sheets may be used if more space is needed.)

TYPED NAME, GRADE OR TITLE	TELEPHONE EXCHANGE/AUTOVON, PLUS EXTENSION	SIGNATURE
----------------------------	--	-----------

RECOMMENDED CHANGES TO PUBLICATIONS AND BLANK FORMS						Use Part II (reverse) for Repair Parts and Special Tool Lists (RPSTL) and Supply Catalogs/Supply Manuals (SC/SM).	DATE
For use of this form, see AR 25-30; the proponent agency is ODISC4.							
TO: (Forward to proponent of publication or form) (Include ZIP Code) U. S. Army TACOM Life Cycle Management Command ATTN: AMSTA-LCL-MPP/TECH PUBS 1 Rock Island Arsenal, Rock Island, IL 61299-7630						FROM: (Activity and location) (Include ZIP Code)	
PUBLICATION/FORM NUMBER TM 5-5420-202-10						DATE 30 Dec 09	TITLE Operator Manual for Launcher, Tank, M48A5, and M60A1 for Bridge Armored-Vehicle, Class 60 or Class 70
ITEM NO.	PAGE NO.	PARA-GRAPH	LINE NO. *	FIGURE NO.	TABLE NO.	RECOMMENDED CHANGES AND REASON (Provide exact wording of recommended changes, if possible).	
<i>*Reference to line numbers within the paragraph or subparagraph.</i>							
TYPED NAME, GRADE OR TITLE					TELEPHONE EXCHANGE/AUTOVON, PLUS EXTENSION		SIGNATURE

TO: (Forward direct to addressee listed in publication) U. S. Army TACOM Life Cycle Management Command ATTN: AMSTA-LCL-MPP/TECH PUBS 1 Rock Island Arsenal, Rock Island, IL 61299-7630	FROM: (Activity and location) (Include ZIP Code)	DATE
--	---	-------------

PART II – REPAIR PARTS AND SPECIAL TOOL LISTS AND SUPPLY CATALOGS/SUPPLY MANUALS

PUBLICATION NUMBER TM 5-5420-202-10	DATE 30 Dec 09	TITLE Operator Manual for Launcher, Tank, M48A5 M60A1 for Bridge Armored-Vehicle, Class 60 or 70
--	-------------------	---

PAGE NO.	COLM NO.	LINE NO.	NATIONAL STOCK NUMBER	REFERENCE NO.	FIGURE NO.	ITEM NO.	TOTAL NO. OF MAJOR ITEMS SUPPORTED	RECOMMENDED ACTION

PART III – REMARKS *(Any general remarks or recommendations, or suggestions for improvement of publications and blank forms. Additional blank sheets may be used if more space is needed.)*

--

TYPED NAME, GRADE OR TITLE	TELEPHONE EXCHANGE/AUTOVON, PLUS EXTENSION	SIGNATURE
----------------------------	--	-----------

RECOMMENDED CHANGES TO PUBLICATIONS AND BLANK FORMS						Use Part II (reverse) for Repair Parts and Special Tool Lists (RPSTL) and Supply Catalogs/Supply Manuals (SC/SM).	DATE
For use of this form, see AR 25-30; the proponent agency is ODISC4.							
TO: (Forward to proponent of publication or form) (Include ZIP Code) U. S. Army TACOM Life Cycle Management Command ATTN: AMSTA-LCL-MPP/TECH PUBS 1 Rock Island Arsenal, Rock Island, IL 61299-7630						FROM: (Activity and location) (Include ZIP Code)	
PUBLICATION/FORM NUMBER TM 5-5420-202-10						DATE 30 Dec 09	TITLE Operator Manual for Launcher, Tank, M48A2 and M60A1 for Bridge Armored-Vehicle, Class 60 or Class 70
ITEM NO.	PAGE NO.	PARA-GRAPH	LINE NO. *	FIGURE NO.	TABLE NO.	RECOMMENDED CHANGES AND REASON (Provide exact wording of recommended changes, if possible).	
<i>*Reference to line numbers within the paragraph or subparagraph.</i>							
TYPED NAME, GRADE OR TITLE					TELEPHONE EXCHANGE/AUTOVON, PLUS EXTENSION		SIGNATURE

TO: (Forward direct to addressee listed in publication) U. S. Army TACOM Life Cycle Management Command ATTN: AMSTA-LCL-MPP/TECH PUBS 1 Rock Island Arsenal, Rock Island, IL 61299-7630	FROM: (Activity and location) (Include ZIP Code)	DATE
--	---	-------------

PART II – REPAIR PARTS AND SPECIAL TOOL LISTS AND SUPPLY CATALOGS/SUPPLY MANUALS

PUBLICATION NUMBER TM 5-5420-202-10	DATE 30 Dec 09	TITLE Operator Manual for Launcher, Tank, M48A5 & M60A1, for Bridge Armored-Vehicle Class 60 or 70
--	-------------------	---

PAGE NO.	COLM NO.	LINE NO.	NATIONAL STOCK NUMBER	REFERENCE NO.	FIGURE NO.	ITEM NO.	TOTAL NO. OF MAJOR ITEMS SUPPORTED	RECOMMENDED ACTION

PART III – REMARKS *(Any general remarks or recommendations, or suggestions for improvement of publications and blank forms. Additional blank sheets may be used if more space is needed.)*

TYPED NAME, GRADE OR TITLE	TELEPHONE EXCHANGE/AUTOVON, PLUS EXTENSION	SIGNATURE
----------------------------	--	-----------

RECOMMENDED CHANGES TO PUBLICATIONS AND BLANK FORMS						Use Part II (reverse) for Repair Parts and Special Tool Lists (RPSTL) and Supply Catalogs/Supply Manuals (SC/SM).	DATE
For use of this form, see AR 25-30; the proponent agency is ODISC4.							
TO: (Forward to proponent of publication or form) (Include ZIP Code) U. S. Army TACOM Life Cycle Management Command ATTN: AMSTA-LCL-MPP/TECH PUBS 1 Rock Island Arsenal, Rock Island, IL 61299-7630						FROM: (Activity and location) (Include ZIP Code)	
PUBLICATION/FORM NUMBER TM 5-5420-202-10						DATE 30 Dec 09	TITLE Operator Manual for Launcher, Tank, M48A5, and M60A1 for Bridge Armored-Vehicle, Class 60 or Class 70
ITEM NO.	PAGE NO.	PARA-GRAPH	LINE NO. *	FIGURE NO.	TABLE NO.	RECOMMENDED CHANGES AND REASON (Provide exact wording of recommended changes, if possible).	
<i>*Reference to line numbers within the paragraph or subparagraph.</i>							
TYPED NAME, GRADE OR TITLE				TELEPHONE EXCHANGE/AUTOVON, PLUS EXTENSION		SIGNATURE	

TO: (Forward direct to addressee listed in publication) U. S. Army TACOM Life Cycle Management Command ATTN: AMSTA-LCL-MPP/TECH PUBS 1 Rock Island Arsenal, Rock Island, IL 61299-7630	FROM: (Activity and location) (Include ZIP Code)	DATE
--	---	-------------

PART II – REPAIR PARTS AND SPECIAL TOOL LISTS AND SUPPLY CATALOGS/SUPPLY MANUALS

PUBLICATION NUMBER TM 5-5420-202-10	DATE 30 Dec 09	TITLE Operator Manual for Launcher, Tank, M48A5 M60A1 for Bridge Armored-Vehicle, Class 60 or 70
--	-------------------	---

PAGE NO.	COLM NO.	LINE NO.	NATIONAL STOCK NUMBER	REFERENCE NO.	FIGURE NO.	ITEM NO.	TOTAL NO. OF MAJOR ITEMS SUPPORTED	RECOMMENDED ACTION

PART III – REMARKS *(Any general remarks or recommendations, or suggestions for improvement of publications and blank forms. Additional blank sheets may be used if more space is needed.)*

TYPED NAME, GRADE OR TITLE	TELEPHONE EXCHANGE/AUTOVON, PLUS EXTENSION	SIGNATURE
----------------------------	--	-----------

By Order of the Secretary of the Army:

Official:



JOYCE E. MORROW
Administrative Assistant to the
Secretary of the Army
0935001

GEORGE W. CASEY, JR.
General, United States Army
Chief of Staff

Distribution:

To be distributed in accordance with the initial distribution number (IDN) 371048,
requirements for TM 5-5420-202-10.

THE METRIC SYSTEM AND EQUIVALENTS

LINEAR MEASURE

1 Centimeter = 10 Millimeter = 0.01 Meters = 0.3937 inches
 1 Meter = 100 Centimeters = 1000 Millimeters = 39.37 inches
 1 Kilometer = 1000 Meters = 0.621 Miles

SQUARE MEASURE

1 Sq. Centimeter = 100 Sq. Millimeter = 0.155 Sq. Inches
 1 Sq. Meter = 10,000 Sq. Centimeters = 10.76 Sq. Inches
 1 Sq. Kilometer = 1,000,000 Sq. Meters = 0.386 Sq. Miles

WEIGHTS

1 Gram = 0.001 Kilograms = 1000 Milligrams = 0.035 Ounces
 1 Kilogram = 1000 Grams = 2.2 lb. 1 Cu. Meter = 1,000,000
 1 Metric Ton = 1000 Kilograms = 1 Megagram = 1.1 Short Tons

CUBIC MEASURE

1 Cu. Centimeter = 1000 Cu. Millimeters = 0.06 Cu. Inches
 1 Cu. Centimeters = 35.31 Cu. Feet

LIQUID MEASURE

1 Millimeter = 0.001 Liters = 0.0338 Fluid Ounces
 1 Liter = 1000 Millimeters = 32.82 Fluid Ounces

TEMPERATURE

$5/9 (^{\circ}\text{F} - 32) = ^{\circ}\text{C}$
 212° Fahrenheit is equivalent to 100° Celsius
 90° Fahrenheit is equivalent to 32.2° Celsius
 32° Fahrenheit is equivalent to 0° Celsius
 $9/5 ^{\circ}\text{C} + 32 = ^{\circ}\text{F}$

APPROXIMATE CONVERSION FACTORS

TO CHANGE	TO	MULTIPLY BY
Inches.....	Centimeters.....	2.540
Feet.....	Meters.....	0.305
Yards.....	Meters.....	0.914
Miles.....	Kilometers.....	1.609
Square Inches.....	Square Centimeters.....	6.451
Square Feet.....	Square Meters.....	0.093
Square Yards.....	Square Meters.....	0.836
Square Miles.....	Square Kilometers.....	2.590
Acres.....	Square Hectometers.....	0.405
Cubic Feet.....	Cubic Meters.....	0.028
Cubic Yards.....	Cubic Meters.....	0.765
Fluid Ounces.....	Milliliters.....	29.573
Pints.....	Liters.....	0.473
Quarts.....	Liters.....	0.946
Gallons.....	Liters.....	3.785
Ounces.....	Grams.....	28.349
Pounds.....	Kilograms.....	0.454
Short Tons.....	Metric Tons.....	0.907
Pound-Feet.....	Newton-Meters.....	1.356
Pounds per Square Inch.....	Kilo pascals.....	6.895
Miles per Gallon.....	Kilometers per Liter.....	0.425
Miles per Hour.....	Kilometers per Hour.....	1.609

TO CHANGE	TO	DIVIDE BY
Centimeters.....	Inches.....	2.540
Meters.....	Feet.....	0.305
Meters.....	Yards.....	0.914
Kilometers.....	Miles.....	1.609
Square Centimeters.....	Square Inches.....	6.451
Square Meters.....	Square Feet.....	0.093
Square Meters.....	Square Yards.....	0.836
Square Kilometers.....	Square Miles.....	2.590
Square Hectometers.....	Acres.....	0.405
Cubic Meters.....	Cubic Feet.....	0.028
Cubic Meters.....	Cubic Yards.....	0.765
Milliliters.....	Fluid Ounces.....	29.573
Liters.....	Pints.....	0.473
Liters.....	Quarts.....	0.946
Liters-Meters.....	Gallons.....	3.785
Grams.....	Ounces.....	28.349
Kilograms.....	Pounds.....	0.454
Metric Tons.....	Short Tons.....	0.907
Newton-Meters.....	Pound-Feet.....	1.356
Kilo pascals.....	Pounds per Square Inch.....	6.895
Kilometers per Liter.....	Miles per Gallon.....	0.425
Kilometers per Hour.....	Miles per Hour.....	1.609

