

TECHNICAL MANUAL

**ORGANIZATIONAL
MAINTENANCE MANUAL**

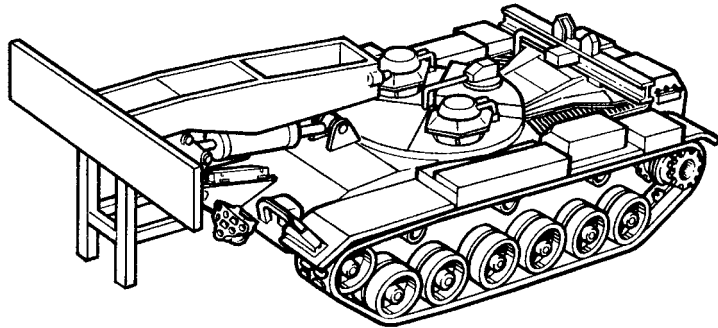

**M60A1 TANK CHASSIS,
TRANSPORTING:
FOR BRIDGE,
ARMORED-VEHICLE-LAUNCHED;
SCISSORING TYPE, CLASS 60
(5420-00-889-2020)**

TABLE OF CONTENTS	i
HULL-INTERIOR MAINTENANCE	17-1
PERSONNEL HEATER MAINTENANCE	18-1
SPEEDOMETER AND TACHOMETER MAINTENANCE	19-1
FIRE EXTINGUISHER SYSTEM MAINTENANCE	20-1
ENGINE SMOKE GENERATOR SYSTEM MAINTENANCE	21-1
SMOKE GRENADE LAUNCHER MAINTENANCE	22-1
REFERENCES	A-1
MAINTENANCE ALLOCATION CHART	B-1
EXPENDABLE SUPPLIES AND MATERIALS	C-1
SCHEMATIC DIAGRAMS	E-1
ILLUSTRATED LIST OF MANUFACTURED ITEMS	F-1
ALPHABETICAL INDEX	Index-1
MAINTENANCE INFORMATION INDEX	

DISTRIBUTION STATEMENT A : Approved for public release; distribution is unlimited.

WARNING**CARBON MONOXIDE POISONING CAN BE DEADLY**

Carbon monoxide is a colorless, odorless, deadly poisonous gas, which when breathed deprives the body of oxygen and causes suffocation. Exposure to air contaminated with carbon monoxide produces symptoms of headache, dizziness, loss of muscular control, apparent drowsiness, and/or coma. Permanent brain damage or death can result from severe exposure. Carbon monoxide occurs in the exhaust fumes of fuel-burning heaters and internal-combustion engines and becomes dangerously concentrated under conditions of inadequate ventilation. The following precautions must be observed to make sure of the safety of personnel whenever the personnel heater, main or auxiliary engine of any vehicle is operated for maintenance purposes or tactical use.

1. DO NOT operate heater or engine of vehicle in an enclosed area unless the area is ADEQUATELY VENTILATED.
2. DO NOT idle engine for long periods without maintaining ADEQUATE VENTILATION in personnel compartments.
3. DO NOT drive any vehicle with inspection plates, cover plates, or engine compartment doors removed unless necessary for maintenance purposes.
4. BE ALERT at all times during vehicle operation for exhaust odors and exposure symptoms. If either are present, IMMEDIATELY VENTILATE personnel compartments. If symptoms persist, remove affected personnel from vehicle and treat as follows: expose to fresh air; keep warm; DO NOT PERMIT PHYSICAL EXERCISE.
For artificial respiration, refer to FM 21-11.

THE BEST DEFENSE AGAINST CARBON MONOXIDE POISONING IS ADEQUATE VENTILATION.

WARNING

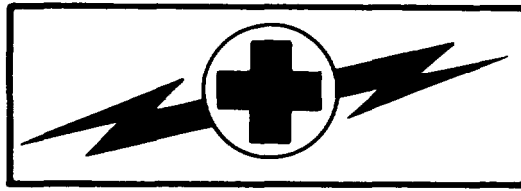

WARNING

HIGH VOLTAGE
Used in the operation of this equipment

DEATH ON CONTACT
May result if personnel fail to observe safety precautions.

Never work on electronic equipment unless there is another person nearby who is familiar with the operation and hazards of the equipment and who is competent in administering first aid. When a technician is aided by operators, he must warn them about dangerous areas.

Whenever possible, the master battery switch and battery ground straps should be either turned off or disconnected before beginning work on the equipment.

Whenever the nature of the operation permits, keep one hand away from the equipment to reduce the hazard of current flowing through vital organs of the body.

Before you work around tracked vehicles, remove rings, bracelets, and wristwatches. These items may be caught on projections and cause injury or may be shorted across an electrical circuit and cause severe burns and electrical shock.

For artificial respiration, refer to FM 21-11.

WARNING

HAZARDOUS NOISE

1. Hearing protection (helmet) required.
2. Double hearing protection (helmet and ear plugs) required on road marches at speeds over 15 mph.

WARNING

The following summary list is adapted from the warnings within this volume. However, all warnings should be observed as noted in the text.

Hold up rear drain valve seat when removing last screw attaching valve seat to hull floor. Valve seat is heavy and can cause injury if it falls.

Hold up front drain valve cage assembly when removing last screw attaching cage to hull. Valve assembly may fall and cause injury if cage is not held up.

Handle charged fire extinguisher cylinders with care. Do not jar or subject cylinders to temperature above 140 degrees F (60 degrees C).

Driver's hatch cover weights approximately 130 pounds. Do not try to lift it alone.

The unit commander or senior officer in charge of maintenance personnel assigned to remove and dispose of contaminated gas filters must prescribe necessary protective clothing to be worn when replacing gas particulate filters. He must also prescribe necessary safety measures to be performed before new gas filters are installed.

Contaminated gas particulate filters must be handled in accordance with FM 21-40 and must be disposed of by trained personnel.

Compressed air used for cleaning purposes will not exceed 30 psi. Use only with effective chip guarding and personal protective equipment (goggles/shield, gloves, etc.)

FRH hydraulic fluid may contain Tricresyl Phosphate which, if taken internally, can produce paralysis. Hydraulic fluid may be absorbed through the skin. Wear long sleeves, gloves, goggles, and face shield. If FRH gets in eyes, wash them immediately and get medical aid immediately. If FRH gets on skin, thoroughly wash with soap and water. Wash hands thoroughly prior to eating or smoking. Application of these measures is considered an effective control of the hazard.

Dry cleaning solvent P-D-680 is toxic and flammable. To prevent personal injury, wear protective goggles and gloves and use only in a well-ventilated area. Avoid contact with skin, eyes, and clothes and don't breathe vapors. Do not use near open flame or excessive heat. The flash point for Type #1 Dry Cleaning Solvent is 100°F (38°C) and for Type #2 is 138°F (50°C). If you become dizzy while using cleaning solvent, get fresh air immediately and get medical aid. If contact with eyes is made, wash your eyes with water and get medical aid immediately.

CHANGE
NO. 6

HEADQUARTERS
DEPARTMENT OF THE ARMY
Washington, D.C., 28 February 2007

**ORGANIZATIONAL
MAINTENANCE**

**M60A1 TANK CHASSIS,
TRANSPORTING:
FOR BRIDGE,
ARMORED-VEHICLE-LAUNCHED;
SCISSORING TYPE, CLASS 60
(5420-00-889-2020)**

TM 5-5420-202-20-4, dated 28 October 1985, is changed as follows:

1. Remove old pages and insert new pages as indicated below.
2. New or changed material is indicated by a vertical bar in the margin of the page.

Remove Pages

None
i thru iv/(vi blank)
B-1 and B-2
B-11 and B-12
B-21 thru B-24
B-27 thru B-30
B-59 and B-60
Index I-1 thru Index I-18
None
None
None
None
2028 Sample and 2028 (Sample Back)
2028-2 Front and 2028-2 Back
2028-2 Front and 2028-2 Back
2028-2 Front and 2028-2 Back
Front Cover (Inside Blank)

Insert Pages

A thru D
i thru v/(vi blank)
B-1 and B-2
B-11 and B-12
B-21 thru B-24
B-27 thru B-30
B-59 and B-60
Index I-1 thru Index I-22
FO-2 (Sheet 1)/blank
FO-2 (Sheet 2)/blank
FO-2 (Sheet 3)/blank
FO-2 (Sheet 4)/blank
2028 Front and 2028 Back
2028 Front and 2028 Back
2028 Front and 2028 Back
None
Front Cover and PIN

DISTRIBUTION STATEMENT A: Approved for public release; distribution is unlimited.

File this change sheet in front of the publication for reference purposes.

By Order of the Secretary of the Army:

PETER J. SCHOOMAKER
General, United States Army
Chief of Staff

Official:



JOYCE E. MORROW
Administrative Assistant to the
Secretary of the Army
0704302

Distribution:

To be distributed in accordance with the initial distribution number (IDN) 990003,
requirements for TM 5-5420-202-20-4.

CHANGE

NO. 5

HEADQUARTERS
DEPARTMENT OF THE ARMY
Washington, D. C., 26 July 1995

**TECHNICAL MANUAL
ORGANIZATIONAL MAINTENANCE**

M60A1 TANK CHASSIS,
TRANSPORTING:
FOR BRIDGE,
ARMORED-VEHICLE-LAUNCHED
SCISSORING TYPE, CLASS 60
(NSN 5420-00-889-2020)

TM 5-5420-202-20-4, dated 28 October 1985, is changed as follows:

1. Remove old pages and insert new pages as indicated below.
2. New or changed information is indicated by a vertical bar in the margin of the page.

Remove Pages

A-1 and A-2

Insert Pages

A-1 thru A-3/(A-4 blank)

Approved for public release; distribution is unlimited.

File this change sheet in front of the publication for reference purposes.

By Order of the Secretary of the Army:

DENNIS J. REIMER
General, United States Army
Chief of Staff

Official:



Handwritten signature of Joel B. Hudson in black ink.

JOEL B. HUDSON

Acting Administrative Assistant to the
Secretary of the Army
00446

DISTRIBUTION:

To be distributed in accordance with DA Form 12-37-E, block 1049, requirements for
TM 5-5420-202-20-4.

CHANGE

NO. 4

HEADQUARTERS
DEPARTMENT OF THE ARMY
Washington D. C., 13 February 1992

TECHNICAL MANUAL

ORGANIZATIONAL MAINTENANCE

M60A1 TANK CHASSIS,
TRANSPORTING:
FOR BRIDGE,
ARMORED-VEHICLE-LAUNCHED;
SCISSORING TYPE, CLASS 60
(5420-00-889-2020)

TM 5-5420-202-20-4, 28 October 1985, is changed as follows:

1. Remove old pages and insert new pages as indicated below.
2. New or changed material is indicated by a vertical bar in the margin of the page.

Remove Pages

18-1 and 18-2
18-5 and 18-6
18-7 thru 18-14
20-1 and 20-2
20-39 thru 20-42
20-55 and 20-56
20-63 thru 20-66
20-75 and 20-76
20-81 and 20-82
A-1 and A-2
F-3 thru F-6
I-11 and I-12
MI-13 and MI-14

Insert Pages

18-1 and 18-2
18-5 and 18-6
None
20-1 and 20-2
20-39 thru 20-42
20-55 and 20-56
20-63 thru 20-66
20-75 and 20-76
20-81 and 20-82
A-1 and A-2
F-3 thru F-6
I-11 and I-12
MI-13 and MI-14

This publication is required for official use or for administrative or operational purposes only. Distribution is limited to U.S. Government Agencies. Other requests for this document must be referred to Commander, AG Publication Center, 2800 Eastern Boulevard, Baltimore, Maryland 21220.

File this change sheet in front of the publication for reference purposes.

By Order of the Secretary of the Army:

Official:

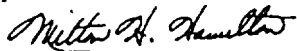

MILTON H. HAMILTON
*Administrative Assistant to the
Secretary of the Army*

00606

GORDON R. SULLIVAN
*General, United States Army
Chief of Staff*

Distribution:

To be distributed in accordance with DA Form 12-37-E, Block 1049, Unit maintenance requirements for TM 5-5420-202-20-4.

CHANGE
NO. 3

HEADQUARTERS
DEPARTMENT OF THE ARMY
Washington, D. C., 2 December 1987

Organizational Maintenance

M60A1 TANK CHASSIS, TRANSPORTING:
FOR BRIDGE, ARMORED-VEHICLE-LAUNCHED;
SCISSORING TYPE, CLASS 60

(5420-00-889-2020)

TM 5-5420-202-20-4, 28 October 1985, is changed as follows:

1. Remove old pages and insert new pages as indicated below.
2. New or changed material is indicated by a vertical bar in the margin of the page.

Remove Pages

D-3/(D-4 blank)
None
1-17 and 1-18
MI-19 and MI-20

Insert Pages

D-3/(D-4 blank)
F-9/(F-10 blank)
I-17 and I-18
MI-19 and MI-20

File this change sheet in front of the publication for reference purposes.

By Order of the Secretary of the Army

Official:

CARL E. VUONO
General, United States Army
Chief of Staff

R.L. DILWORTH
Brigadier General United States Army
The Adjutant General

Distribution:

To be distributed in accordance with DA Form 12-37, Unit Maintenance requirements for Tank, Bridge Launcher, M60A1 (AVLB).

CHANGE
NO.2

HEADQUARTERS
DEPARTMENT OF THE ARMY
Washington, D. C., 8 June 1987

TECHNICAL MANUAL
ORGANIZATIONAL MAINTENANCE

M60A1 TANK CHASSIS, TRANSPORTING: FOR BRIDGE,
ARMORED-VEHICLE-LAUNCHED; SCISSORING TYPE, CLASS 60

(5420-00-889-2020)

TM 5-5420-202-20-4, 28 October 1985, is changed as follows:

1. Remove old pages and insert new pages as indicated below.
2. New or changed material is indicated by a vertical bar in the margin of the page.

Remove Pages

20-51 thru 20-56
A-1 and A-2
B-1 and B-2
D-3/(D-4 blank)
1-5 and 1-6
1-15and I-16

Insert Pages

20-51 thru 20-56
A-1 and A-2
B-1 and B-2
D-3/(D-4 blank)
I-5 and I-6
I-15 and I-16

File this change sheet in front of the publication for reference purposes.

By Order of the Secretary of the Army:

Official:

JOHN A. WICKHAM, JR.
General, United States Army
Chief of Staff

R.L. DILWORTH
Brigadier General, United States Army
The Adjutant General

Distribution:

To be distributed in accordance with DA Form 12-37R, Unit Maintenance requirements for Tank, Bridge Launcher, M60A1 (AVLB).

CHANGE

NO. 1

HEADQUARTERS
DEPARTMENT OF THE ARMY
Washington, D.C., 8 July 1986

**TECHNICAL MANUAL
ORGANIZATIONAL MAINTENANCE**

**M60A1 TANK CHASSIS, TRANSPORTING: FOR BRIDGE,
ARMORED-VEHICLE-LAUNCHED; SCISSORING TYPE, CLASS 60**

(5420-00-889-2020)

TM 5-5420-202-20-4, 28 October 1985, is changed as follows:

1. Remove old pages and insert new pages as indicated below.
2. New or changed material is indicated by a vertical bar in the margin of the page.

Remove Pages

D-3/(D-4 blank)
E-1/(E-2 blank)
I-1 thru I-6
I-9 and I-10
I-13 thru I-16
None

Insert Pages

D-3/(D-4 blank)
E-1/(E-2 blank)
I-1 thru I-6
I-9 and I-10
I-13 thru I-16
FO-2

File this change sheet in front of the publication for reference purposes.

By Order of the Secretary of the Army:

JOHN A. WICKHAM, JR.
General, United States Army
Chief of Staff

Official:

MILDRED E. HEDBERG
Brigadier General, United States Army
The Adjutant General

Distribution:

To be distributed in accordance with DA Form 12-37, Organizational Maintenance requirements for Tank, Bridge, Launcher, M60A1 (AVLB).

LIST OF EFFECTIVE PAGES

INSERT LATEST CHANGED PAGES. DESTROY SUPERSEDED PAGES.

Note: The portion of the text affected by the changes is indicated by a Vertical line or an asterisk.

Dates of issue for original and changed pages are:

Original 0 28 October 1985
 Change 1 08 July 1986
 Change 2 08 June 1987
 Change 3 02 December 1987
 Change 4 13 February 1992
 Change 5 26 July 1995
 Change 6 28 February 2007

TOTAL NUMBER OF PAGES IN THIS PUBLICATION IS 540, CONSISTING OF THE FOLLOWING:

Page No.	*Change No.	Page No.	*Change No.	Page No.	*Change No.
Front Cover	6	17-27	0	17-69	0
PIN	6	17-28	0	17-70 BLANK	0
a	0	17-29	0	18-1	4
b	0	17-30	0	18-2	0
c	0	17-31	0	18-3	0
d BLANK	0	17-32	0	18-4	0
A	6	17-33	0	18-5	0
B	6	17-34	0	18-6	4
C	6	17-35	0	18-7 DELETED	4
D	6	17-36	0	18-8 DELETED	4
i	6	17-37	0	18-9 DELETED	4
ii	6	17-38	0	18-10 DELETED	4
iii	6	17-39	0	18-11 DELETED	4
iv	0	17-40	0	18-12 DELETED	4
v	6	17-41	0	18-13 DELETED	4
vi BLANK	0	17-42	0	18-14 DELETED	4
17-1	0	17-43	0	18-15	0
17-2	0	17-44	0	18-16	0
17-3	0	17-45	0	18-17	0
17-4	0	17-46	0	18-18	0
17-5	0	17-47	0	18-19	0
17-6	0	17-48	0	18-20	0
17-7	0	17-49	0	18-21	0
17-8	0	17-50	0	18-22	0
17-9	0	17-51	0	18-23	0
17-10	0	17-52	0	18-24	0
17-11	0	17-53	0	18-25	0
17-12	0	17-54	0	18-26	0
17-13	0	17-55	0	18-27	0
17-14	0	17-56	0	18-28 BLANK	0
17-15	0	17-57	0	19-1	0
17-16	0	17-58	0	19-2	0
17-17	0	17-59	0	19-3	0
17-18	0	17-60	0	19-4	0
17-19	0	17-61	0	19-5	0
17-20	0	17-62	0	19-6	0
17-21	0	17-63	0	19-7	0
17-22	0	17-64	0	19-8	0
17-23	0	17-65	0	19-9	0
17-24	0	17-66	0	19-10	0
17-25	0	17-67	0	19-11	0
17-26	0	17-68	0	19-12	0

*Zero in this column indicates an original page.

Page No.	*Change No.	Page No.	*Change No.	Page No.	*Change No.
19-13	0	20-36	0	21-9	0
19-14	0	20-37	0	21-10	0
19-15	0	20-38	0	21-11	0
19-16	0	20-39	4	21-12	0
19-17	0	20-40	0	21-13	0
19-18	0	20-41	0	21-14	0
19-19	0	20-42	4	21-15	0
19-20	0	20-43	0	21-16	0
19-21	0	20-44	0	21-17	0
19-22	0	20-45	0	21-18	0
19-23	0	20-46	0	21-19	0
19-24	0	20-47	0	21-20	0
19-25	0	20-48	0	21-21	0
19-26	0	20-49	0	21-22	0
19-27	0	20-50	0	21-23	0
19-28	0	20-51	0	21-24	0
19-29	0	20-52	2	21-25	0
19-30	0	20-53	2	21-26	0
19-31	0	20-54	2	21-27	0
25-32	0	20-55	3	21-28	0
19-33	0	20-56	4	21-29	0
19-34	0	20-57	0	21-30	0
20-1	0	20-58	0	21-31	0
20-2	4	20-59	0	21-32	0
20-3	0	20-60	0	21-33	0
20-4	0	20-61	0	21-34	0
20-5	0	20-62	0	21-35	0
20-6	0	20-63	4	21-36	0
20-7	0	20-64	0	21-37	0
20-8	0	20-65	4	21-38	0
20-9	0	20-66	0	21-39	0
20-10	0	20-67	0	21-40	0
20-11	0	20-68	0	21-41	0
20-12	0	20-69	0	21-42	0
20-13	0	20-70	0	22-1	0
20-14	0	20-71	0	22-2	0
20-15	0	20-72	0	22-3	0
20-16	0	20-73	0	22-4	0
20-17	0	20-74	0	22-5	0
20-18	0	20-75	4	22-6	0
20-19	0	20-76	4	22-7	0
20-20	0	20-77	0	22-8	0
20-21	0	20-78	0	22-9	0
20-22	0	20-79	0	22-10	0
20-23	0	20-80	0	22-11	0
20-24	0	20-81	4	22-12	0
20-25	0	20-82	0	22-13	0
20-26	0	20-83	0	22-14	0
20-27	0	20-84	0	22-15	0
20-28	0	21-1	0	22-16	0
20-29	0	21-2	0	22-17	0
20-30	0	21-3	0	22-18	0
20-31	0	21-4	0	22-19	0
20-32	0	21-5	0	22-20	0
20-33	0	21-6	0	22-21	0
20-34	0	21-7	0	22-22	0
20-35	0	21-8	0	22-23	0

*Zero in this column indicates an original page.

Page No.	*Change No.	Page No.	*Change No.	Page No.	*Change No.
22-24	0	B-44	0	C-4	0
22-25	0	B-45	0	C-5	0
22-26	0	B-46	0	C-6	0
22-27	0	B-47	0	C-7	0
22-28	0	B-48	0	C-8	0
22-29	0	B-49	0	C-9	0
22-30	0	B-50	0	C-10	0
22-31	0	B-51	0	C-11	0
22-32	0	B-52	0	C-12	0
A-1	5	B-53	0	C-13	0
A-2	5	B-54	0	C-14	0
A-3	5	B-55	0	C-15	0
A-4 BLANK	5	B-56	0	C-16	0
B-1	0	B-57	0	C-17	0
B-2	6	B-58	0	C-18	0
B-3	0	B-59	6	C-19	0
B-4	0	B-60	0	C-20	0
B-5	0	B-61	0	C-21	0
B-6	0	B-62	0	C-22	0
B-7	0	B-63	0	C-23	0
B-8	0	B-64	0	C-24	0
B-9	0	B-65	0	C-25	0
B-10	0	B-66	0	C-26	0
B-11	6	B-67	0	C-27	0
B-12	0	B-68	0	C-28	0
B-13	0	B-69	0	C-29	0
B-14	0	B-70	0	C-30	0
B-15	0	B-71	0	C-31	0
B-16	0	B-72	0	C-32	0
B-17	0	B-73	0	C-33	0
B-18	0	B-74	0	C-34	0
B-19	0	B-75	0	D-1	0
B-20	0	B-76	0	D-2	0
B-21	6	B-77	0	D-3	3
B-22	6	B-78	0	D-4 BLANK	3
B-23	6	B-79	0	E-1	1
B-24	0	B-80	0	E-2 BLANK	1
B-25	0	B-81	0	F-1	0
B-26	0	B-82	0	F-2	0
B-27	6	B-83	0	F-3	4
B-28	6	B-84	0	F-4	4
B-29	0	B-85	0	F-5	4
B-30	6	B-86	0	F-6	4
B-31	0	B-87	0	F-7	0
B-32	0	B-88	0	F-8	0
B-33	0	B-89	0	F-9	3
B-34	0	B-90	0	F-10 BLANK	3
B-35	0	B-91	0	I-1	6
B-36	0	B-92	0	I-2	6
B-37	0	B-93	0	I-3	6
B-38	0	B-94	0	I-4	6
B-39	0	B-95	0	I-5	6
B-40	0	B-96 BLANK	0	I-6	6
B-41	0	C-1	0	I-7	6
B-42	0	C-2	0	I-8	6
B-43	0	C-3	0	I-9	6

*Zero in this column indicates an original page.

Page No.	*Change No.	Page No.	*Change No.	Page No.	*Change No.
I-10	6	MI-11	0	BLANK ADDED	6
I-11	6	MI-12	0	FO-2 Sheet 2 ADDED	6
I-12	6	MI-13	0	BLANK ADDED	6
I-13	6	MI-14	4	FO-2 Sheet 3 ADDED	6
I-14	6	MI-15	0	BLANK ADDED	6
I-15	6	MI-16	0	FO-2 Sheet 4 ADDED	6
I-16	6	MI-17	0	BLANK ADDED	6
I-17	6	MI-18	0	Authentication Front	0
I-18	6	MI-19	0	Authentication Back BLANK	0
I-19	6	MI-20	3	2028 Front	6
I-20	6	MI-21	0	2028 Back	6
I-21	6	MI-22 BLANK	0	2028 Front	6
I-22	6	FO-1 Sheet 1	0	2028 Back	6
MI-1	0	FO-1 Sheet 2	0	2028 Front	6
MI-2	0	FO-1 Sheet 3	0	2028 Back	6
MI-3	0	FO-1 Sheet 4	0	Inside Back Cover	0
MI-4	0	FO-1 Sheet 5	0	Back Cover BLANK	0
MI-5	0	BLANK	0		
MI-6	0	FO-2 Sheet 1	6		
MI-7	0				
MI-8	0				
MI-9	0				
MI-10	0				

*Zero in this column indicates an original page.

**ORGANIZATIONAL
MAINTENANCE MANUAL**

**M60A1 TANK CHASSIS,
TRANSPORTING:
FOR BRIDGE,
ARMORED-VEHICLE-LAUNCHED;
SCISSORING TYPE, CLASS 60
(5420-00-889-2020)**

REPORTING ERRORS AND RECOMMENDING IMPROVEMENTS

You can help improve this publication. If you find any mistakes or if you know of a way to improve the procedures, please let us know. Submit your DA Form 2028 (Recommended Changes to Publications and Blank Forms), through the Internet, on the Army Electronic Product Support (AEPS) website. The Internet address is <https://aeprs.ria.army.mil>. The DA Form 2028 is located under the Public Applications section in the AEPS Public Home Page. Fill out the form and click on SUBMIT. Using this form on the AEPS will enable us to respond quicker to your comments and better manage the DA Form 2028 program. You may also mail, fax or e-mail your letter or DA Form 2028 direct to: AMSTA-LC-LPIT/TECH PUBS, TACOM-RI, 1 Rock Island Arsenal, Rock Island, IL 61299-7630. The e-mail address is ROCK-TACOM-TECH-PUBS@conus.army.mil. The fax number is DSN 793-0726 or Commercial (309) 782-0726.

DISTRIBUTION STATEMENT A: Approved for public release; distribution is unlimited.

TABLE OF CONTENTS

		Page
VOLUME 1		
	HOW TO USE THIS MANUAL	iv
CHAPTER 1	INTRODUCTION	1-1
Section I	General Information	1-1
Section II	Equipment Description And Data	1-2

***This manual together with TM 5-5420-202-20-1, TM 5-5420-202-20-2, TM 5-5420-202-20-3 supersedes TM 5-5420-202-20-4, 14 January 1976.**

TABLE OF CONTENTS - Continued

		Page
CHAPTER 2	PRINCIPLES OF OPERATION	2-1
Section I	Functional Description	2-1
Section II	Systems Operations	2-2
CHAPTER 3	HULL MAINTENANCE	3-1
Section I	Repair Parts, Special Tools, TMDE, And Support Equipment	3-1
Section II	Service Upon Receipt	3-6
Section III	Preventive Maintenance Checks And Services (PMCS)	3-7
CHAPTER 4	HULL TROUBLESHOOTING	4-1
VOLUME 2		
CHAPTER 5	POWERPLANT MAINTENANCE	5-1
CHAPTER 6	ENGINE MAINTENANCE	6-1
CHAPTER 7	FUEL SYSTEM MAINTENANCE	7-1
CHAPTER 8	EXHAUST SYSTEM MAINTENANCE	8-1
CHAPTER 9	COOLING SYSTEM MAINTENANCE	9-1
VOLUME 3		
CHAPTER 10	ELECTRICAL SYSTEM MAINTENANCE	10-1
CHAPTER 11	TRANSMISSION AND SHIFTING MAINTENANCE	11-1
CHAPTER 12	FINAL DRIVE AND UNIVERSAL JOINTS MAINTENANCE	12-1
CHAPTER 13	BRAKE SYSTEM MAINTENANCE	13-1
CHAPTER 14	TRACKS AND SUSPENSION SYSTEM MAINTENANCE	14-1
CHAPTER 15	STEERING SYSTEM MAINTENANCE	15-1
CHAPTER 16	HULL-EXTERIOR MAINTENANCE	16-1

TABLE OF CONTENTS - Continued

		Page
VOLUME 4		
CHAPTER 17	HULL-INTERIOR MAINTENANCE	17-1
CHAPTER 18	PERSONNEL HEATER MAINTENANCE	18-1
CHAPTER 19	SPEEDOMETER AND TACHOMETER MAINTENANCE	19-1
CHAPTER 20	FIRE EXTINGUISHER MAINTENANCE	20-1
CHAPTER 21	ENGINE SMOKE GENERATOR SYSTEM MAINTENANCE	21-1
CHAPTER 22	SMOKE GRENADE LAUNCHER MAINTENANCE	22-1
APPENDIX A	REFERENCES	A-1
APPENDIX B	MAINTENANCE ALLOCATION CHART (MAC)	B-1
APPENDIX C	GENERAL MAINTENANCE	C-1
APPENDIX D	EXPENDABLE SUPPLIES AND MATERIALS	D-1
APPENDIX E	SCHEMATIC DIAGRAMS	E-1
APPENDIX F	ILLUSTRATED LIST OF MANUFACTURED ITEMS	F-1
	ALPHABETICAL INDEX	I-1
	MAINTENANCE INFORMATION INDEX	MI-1

HOW TO USE THIS MANUAL:

- Manual is divided into chapters.
- Chapters are by functional group code and are presented in same order as the RPSTL (Repair Parts and Special Tools List).
- Procedure indexes are on procedures that are four pages or more, and indicate how the procedure is set up, i.e., disassembly, removal, cleaning, inspection, etc.
- All references within this technical manual refer to page numbers.
- Steps are numbered and are to be performed in that order.
- Be sure to read all NOTES, WARNINGS, and CAUTIONS.
- Locator views are included wherever necessary. These will help you locate the item which the procedure is referencing.
- Jagged circle (✱) on locator (A) indicates a cutout and means the item is inside the vehicle.
- A (⌒) symbol represents the outside surface (B) of a piece of equipment that cannot be shown in its entirety.
- Callouts are shown by a circle with a letter inside.
- Locator arrows (C) are black, and mechanical motion arrows (D) are white.
- Broken leader arrow (⋯→) indicates the item is either inside or under the vehicle and cannot be seen.

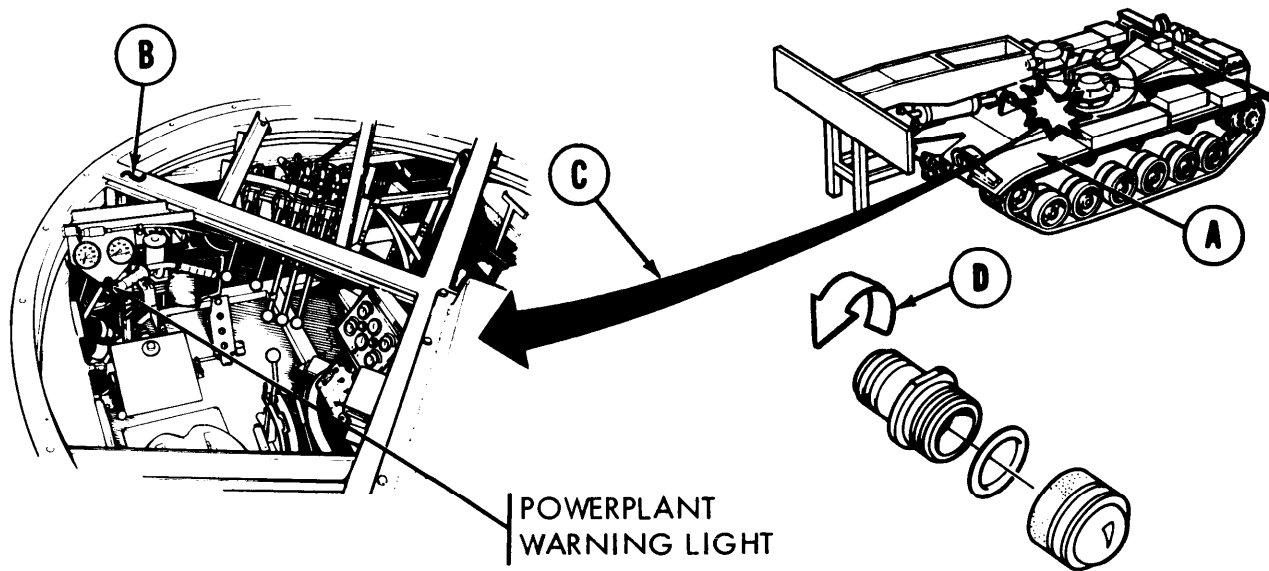

TA247960

HOW TO USE THIS MANUAL - Continued

- An illustrated list of manufactured items includes complete instructions for making items authorized to be manufactured or fabricated and used at organizational maintenance.
- A maintenance information index lists all parts subject to maintenance tasks. It provides the location of all maintenance tasks related to a component in this manual.
- Certain sections of the manual have detailed “how to use” instructions at the beginning of the section - for example troubleshooting.
- As a general maintenance practice, throw away all removed lockwashers, locknuts, o-rings, preformed packings, and cotter pins, and replace with new lockwashers, locknuts, o-rings, preformed packings, and cotter pins at installation.

CHAPTER 17
HULL INTERIOR MAINTENANCE
INDEX

Procedure	Page
Bulkhead Access Cover Replacement	17-2
Commander's Floor Plate Replacement	17-7
Operator's Floor Access Plate Replacement	17-8
Storage Bins and Flashlight Holder Replacement	17-9
Helmet Bracket Replacement.	17-10
Engine Upper Access Cover Replacement	17-11
Engine Lower Access Cover Replacement	17-13
Bulkhead PTO Ring Replacement	17-15
Slipping Box Access Cover Replacement	17-16
Bulkhead Pipe Plug Replacement	17-17
Front Drain Valve Control Lever Replacement	17-18
Front Drain Valve Assembly Replacement	17-19
Rear Drain Valve Control Lever Assembly Replacement	17-24
Rear Drain Valve Rear Rod, Coupling, and Clevis Replacement	17-28
Rear Drain Valve Actuating Lever Replacement.	17-34
Rear Drain Valve Mounting Brackets Replacement.	17-38
Rear Drain Valve Linkage Adjustment	17-40
Rear Drain Valve Assembly Replacement.	17-47
Commander's Seat Backrest Replacement	17-53
Operator's Seat Backrest Replacement.	17-54
Personnel Seat Cushion Replacement	17-55
Personnel Seat and Seat Mount Assembly Replacement	17-56
Personnel Seat Assembly Repair	17-58
Seat and Backrest Mount Assembly Repair	17-63

BULKHEAD ACCESS COVER REPLACEMENT (Sheet 1 of 3)

TOOLS: 9/16 in. socket with 1/2in. drive
Ratchet with 1/2 in. drive
9/16 in. combination box and open end wrench

SUPPLIES: Gasket
Adhesive (Item 4, Appendix D)
Lockwashers (16 required)

NOTE

The following procedure is for replacement of the right bulkhead access cover. Replacement of the left bulkhead access cover is identical.

REMOVAL:

1. Using socket and wrench, remove two screws, nuts, lockwashers, and washers (A) securing seat mount assembly (B) to bracket (C).
2. Using socket, remove two screws, washers, and lockwashers (D) securing rubber bumper (E) and seat mount assembly (B) to floor.
3. Remove seat mount assembly with seat attached.

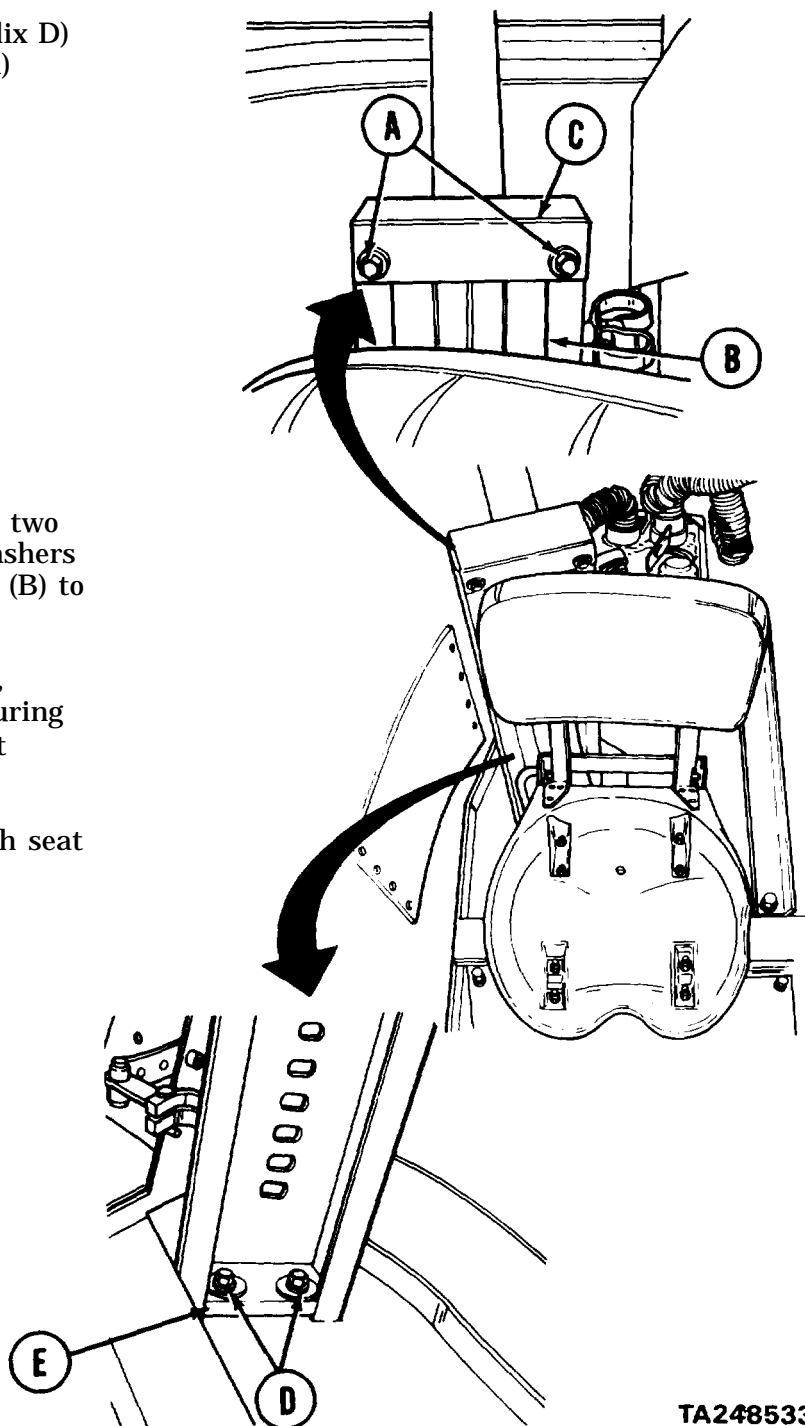

Go on to Sheet 2

TA248533

BULKHEAD ACCESS COVER REPLACEMENT (Sheet 2 of 3)

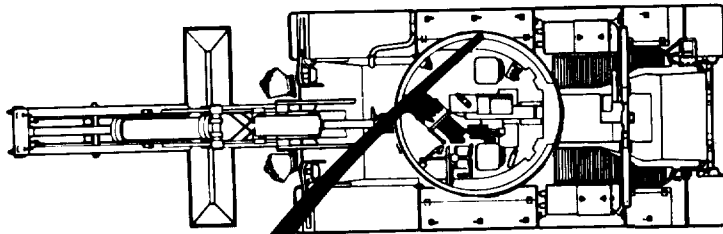

QUADRANTS REMOVED FOR CLARITY

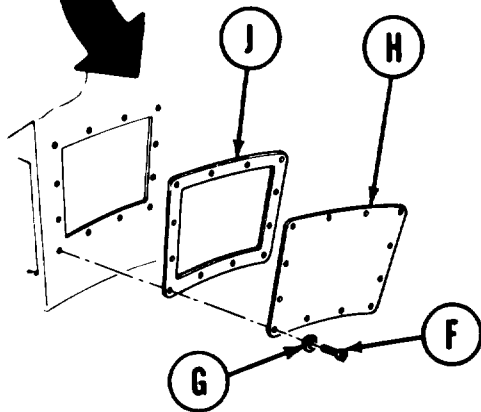

4. Using socket, remove 12 screws (F) and lockwashers (G) securing cover (H) and gasket (J) to vehicle side wall.
5. Remove cover (H) and gasket (J) from side wall. Throw away gasket.

INSTALLATION:

1. Apply adhesive to new gasket (A).
2. Place gasket (A) and cover (B) in Position over bulkhead opening in vehicle side wall.
3. Using socket, install 12 screws (C) and lockwashers (D) to secure cover (B) and gasket (A) to bulkhead.

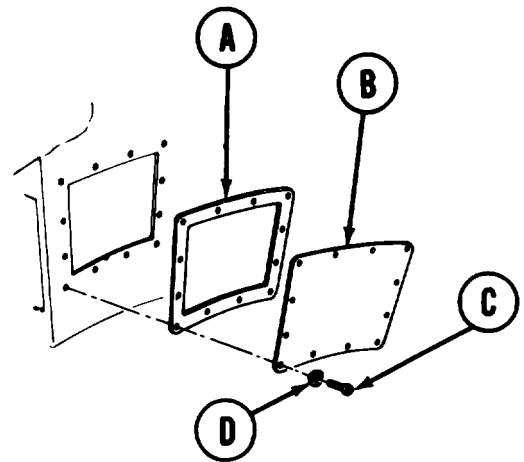

Go on to Sheet 3

TA248534

BULKHEAD ACCESS COVER REPLACEMENT (Sheet 3 of 3)

4. Place seat mount (E), with seat attached, in installed position.
5. Using socket and wrench, install two screws, nuts, lockwashers, and washers (F) and seat mount assembly to bracket.
6. Using socket, install two screws, washers, and lockwashers (H) securing seat mount (E) and rubber bumper (G) to floor.

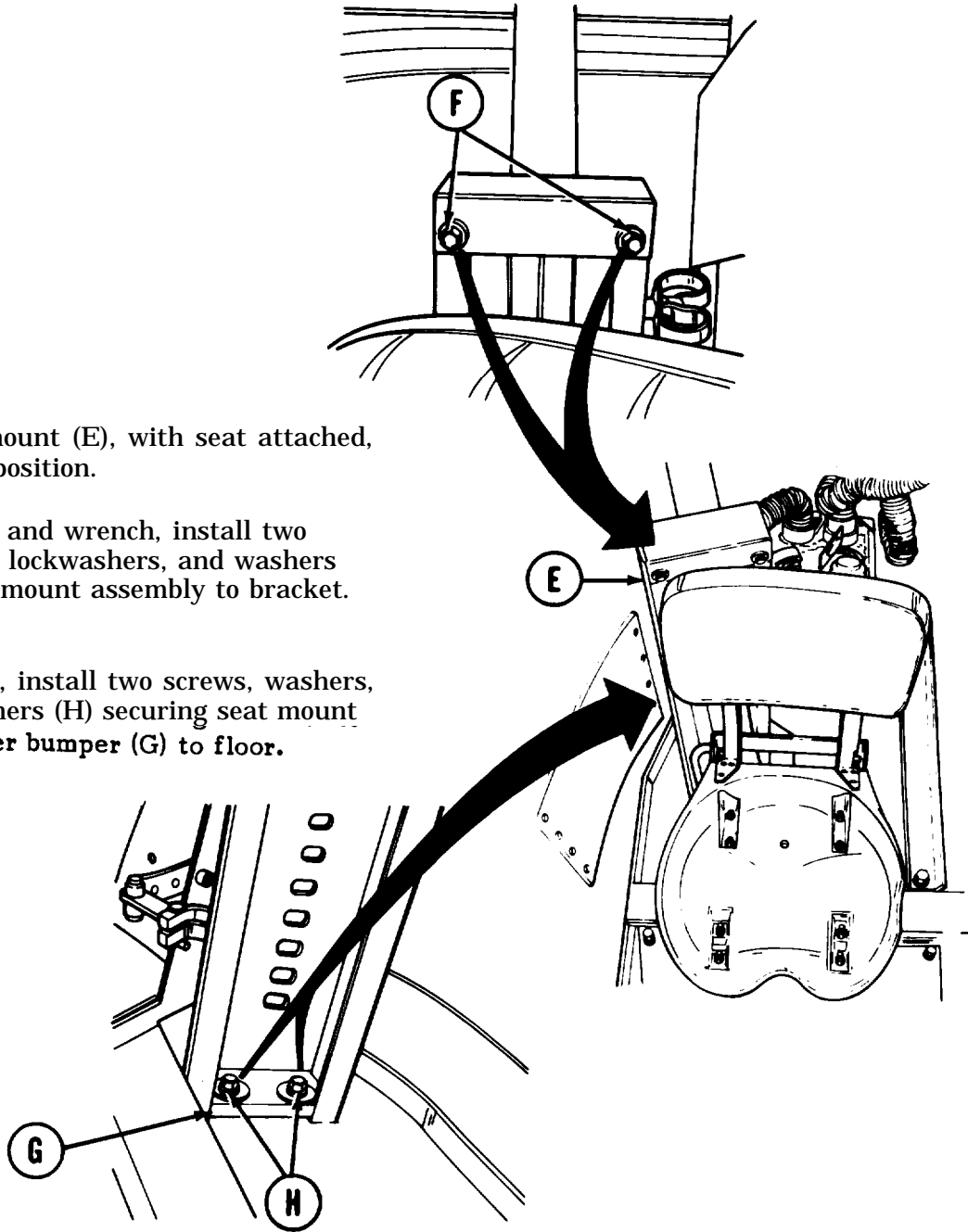

End of Task

TA248535

FLOOR FORWARD ACCESS COVERS REPLACEMENT (Sheet 1 of 2)

TOOLS: 8 in. flat-tip screwdriver
Putty knife

REFERENCE: TM 5-5420-228-24

SUPPLIES: Gasket
Adhesive (Item 4, Appendix D)

PRELIMINARY PROCEDURE: Remove clutch assembly (TM 5-5420-228-24)

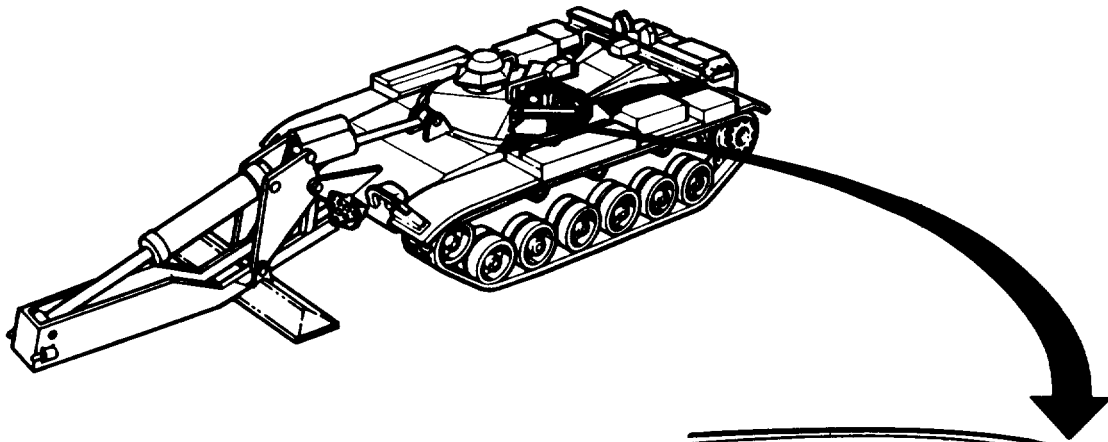

REMOVAL:

NOTE

There are two bulkhead floor forward access covers side-by-side on the bulkhead floor.

1. Using screwdriver, remove 14 screws (A) securing cover (B) and gasket (C) to bulkhead floor.
2. Remove cover (B) and gasket (C). Throw gasket (C) away.
3. Using putty knife, scrape off all gasket (C) and adhesive residue.

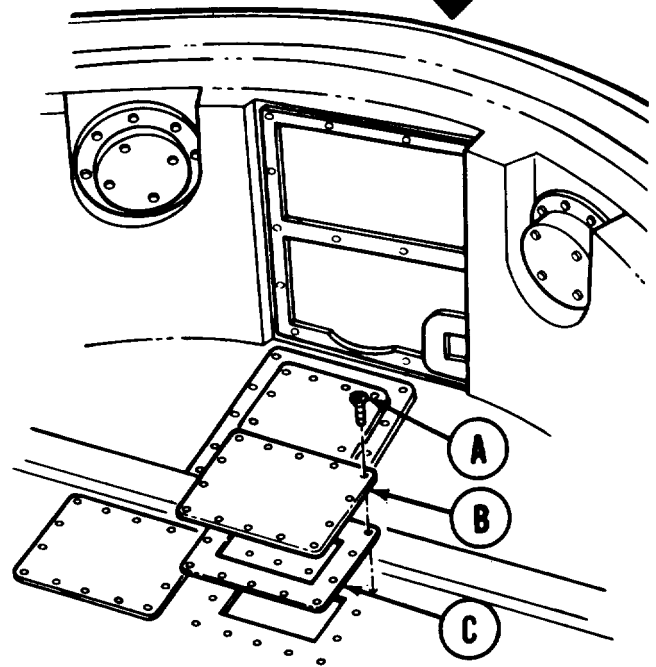

Go on to Sheet 2

FLOOR FORWARD ACCESS COVERS REPLACEMENT (Sheet 2 of 2)

INSTALLATION:

1. Apply adhesive to both sides of new gasket (A).
2. Position gasket (A) and cover (B) on bulkhead floor opening with holes alined.
3. Using screwdriver, install 14 screws (C) securing cover to bulkhead floor.
4. Install clutch assembly (TM 5-5420-228-24).

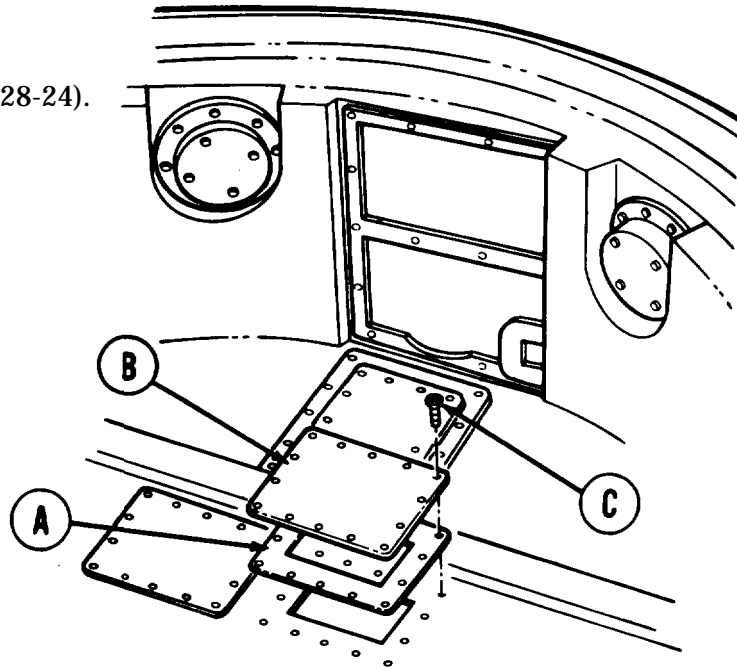

End of Task

TA248537

COMMANDER'S FLOOR PLATE REPLACEMENT (Sheet 1 of 1)

TOOLS: 7/16 in. socket with 1/2 in. drive

Ratchet with 1/2 in. drive

SUPPLIES: Lockwashers (8 required)

REFERENCE: TM 5-5420-228-24

PRELIMINARY PROCEDURES: Remove commander's seat (page 17-56)
Remove commander's periscope stowage box
(TM 5-5420-228-24)

REMOVAL:

1. Using socket, remove eight screws (A), lockwashers (B), and flat washers (C) securing two plates (D) to hull floor.
2. Remove two plates (D) from hull floor.

INSTALLATION:

1. Place two plates (D) in position on hull floor.
2. Using socket, install eight screws (A), lockwashers (B), and flat washers (C) securing two plates (D) to hull floor.
3. Install commander's seat (page 17-57).
4. Install commander's periscope stowage box (TM 5-5420-228-24).

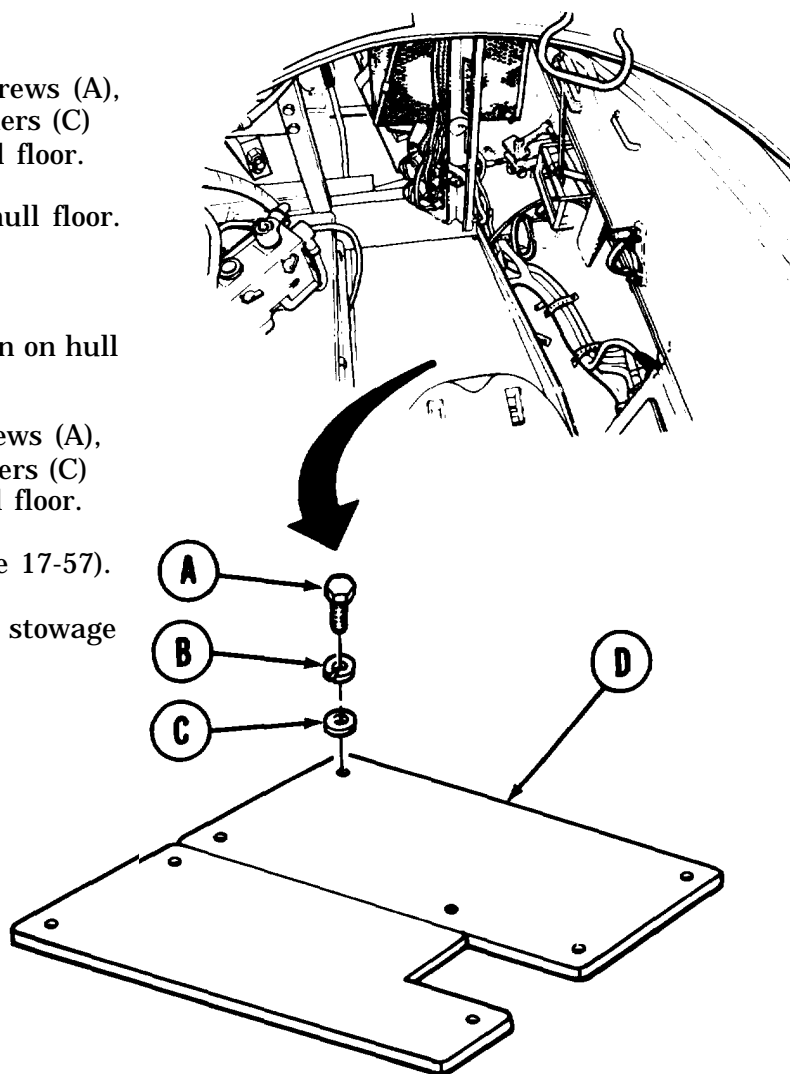

End of Task

TA248538

OPERATOR'S FLOOR ACCESS PLATE REPLACEMENT (Sheet 1 of 1)

TOOLS: Flat-tip screwdriver

SUPPLIES: Gasket

PRELIMINARY PROCEDURE: Remove operator's seat (page 17-2, steps 1 through 3)

REMOVAL:

1. Using screwdriver, remove six screws (A).
2. Remove plate (B) and gasket (C) from hull floor. Throw away gasket.

INSTALLATION:

1. Place new gasket (C) and plate (B) in position on hull floor.
2. Using screwdriver, install six screws (A).
3. Install operator's seat (page 17-3, steps 4 through 6).

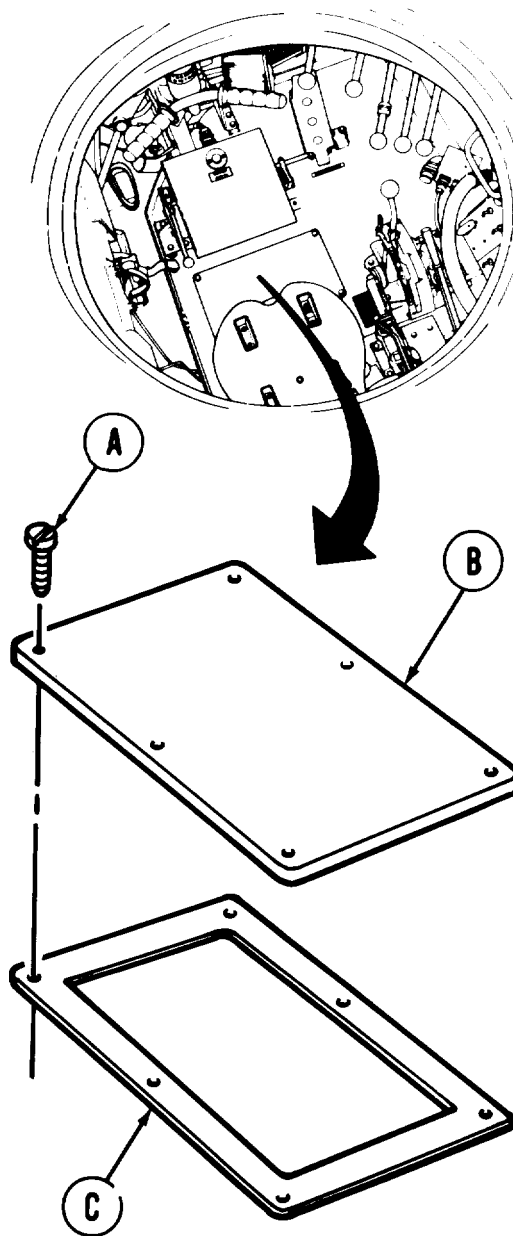

End of Task

TA248539

STORAGE BINS AND FLASHLIGHT HOLDER REPLACEMENT (Sheet 1 of 1)

REMOVAL (Storage Bin):

TOOLS: 7/16 inch combination box and open end wrench (2 required)
 9/16 inch combination box and open end wrench

- Using 9/16 inch wrench, remove four screws (A) four lockwashers (B) and four washers (C), from the inside Of storage bin corners.

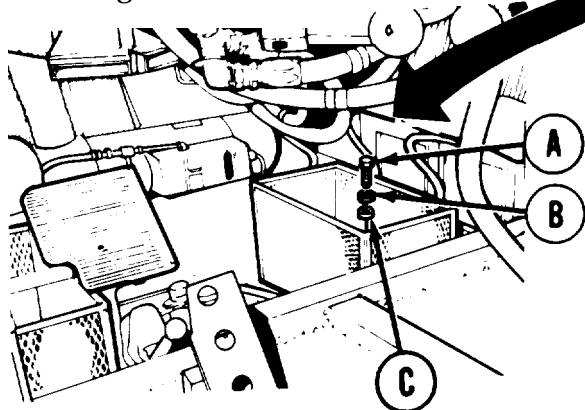

QUADRANTS REMOVED FOR CLARITY

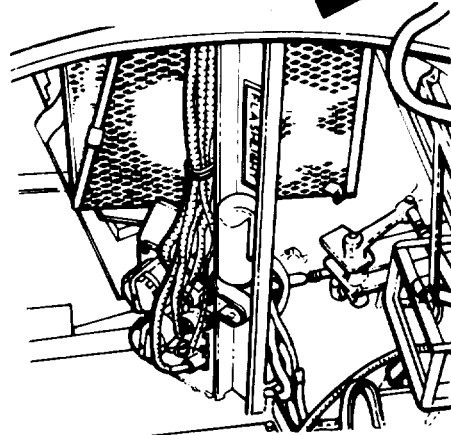
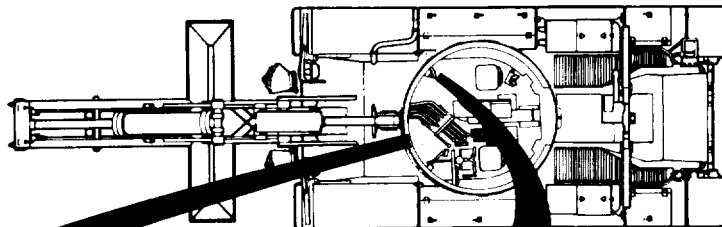

INSTALLATION (Storage Bin):

- Using fingers, install four screws (A), four lockwashers (B), and four washers (C) at the four corners of the storage bin, finger tight.
- Using 9/16 inch wrench, tighten screws (A).

REMOVAL (Flashlight Holder):

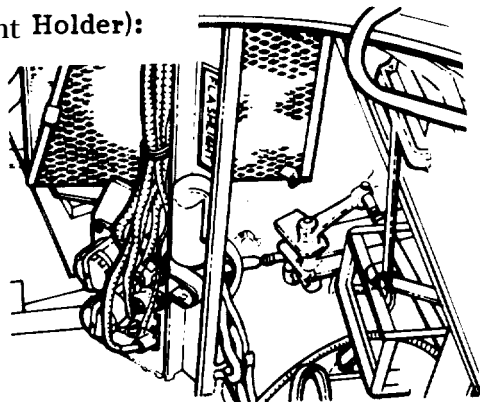

COMMANDER'S STATION

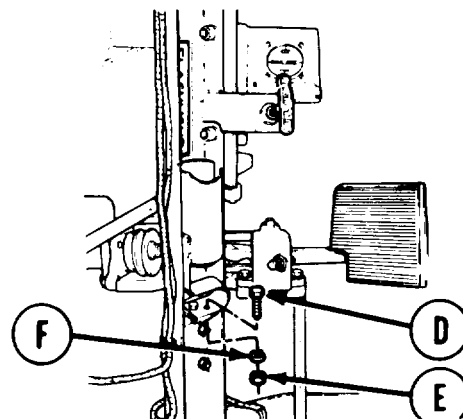

OPERATOR'S STATION

Using two 7/16 inch wrenches, hold two screws (D) with one wrench and remove two nuts (E) and two lockwashers (F) with the other wrench.

INSTALLATION (Flashlight Holder):

Using two 7/16 inch wrenches, hold two screws (D) with one wrench and install two nuts (E) and two lockwashers (F) with the other wrench.

End of Task

TA248540

HELMET BRACKET REPLACEMENT (Sheet 1 of 1)

TOOLS: 7/16 in. open end wrench (2 required)

SUPPLIES: Lockwashers (2 required)

QUADRANTS REMOVED
FOR CLARITY

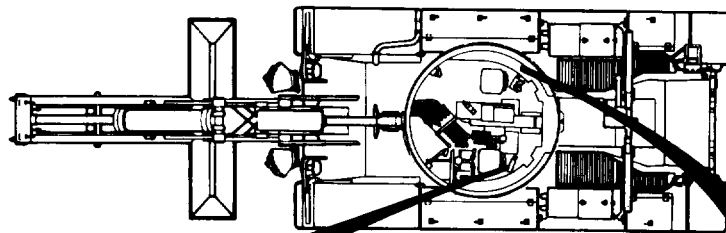

REMOVAL:

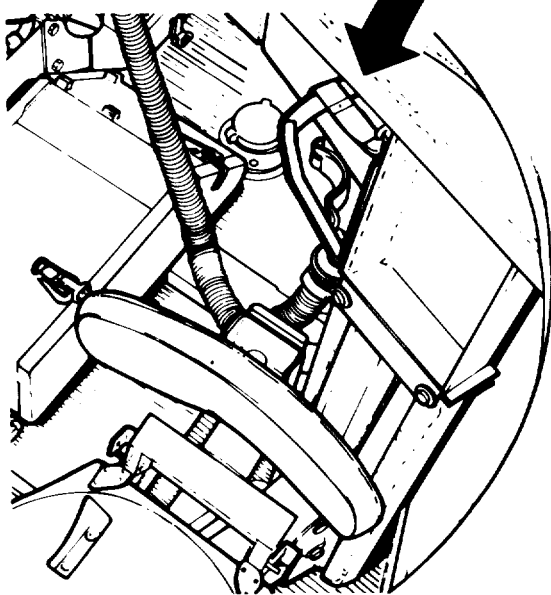

OPERATOR'S STATION

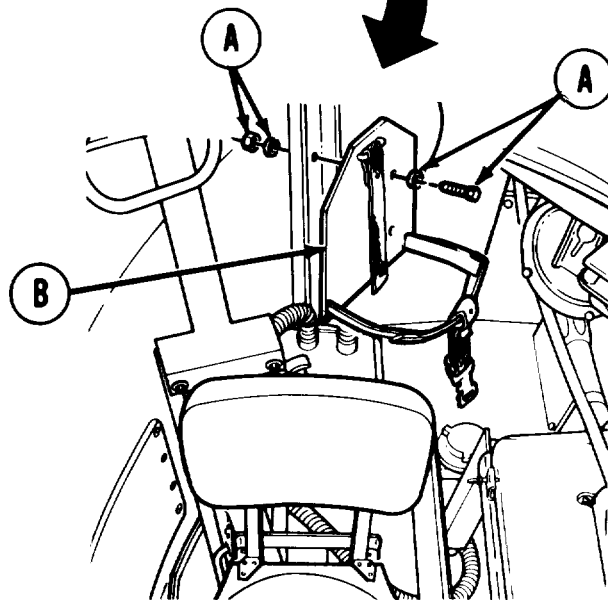

COMMANDER'S STATION

Using 7/16 inch wrenches, remove two screws, lockwashers, and nuts (A) securing helmet brackets (B).

INSTALLATION:

Using 7/16 inch wrenches, install two screws, lockwashers, and nuts (A) into helmet brackets (B).

End of Task

TA248541

ENGINE UPPER ACCESS COVER REPLACEMENT (Sheet 1 of 2)

TOOLS: 9/16 in. socket with 1/2 in. drive
 Ratchet with 1/2 in. drive
 Putty knife

SUPPLIES: Gasket
 Adhesive (Item 4, Appendix D)
 Lockwashers (12 required)

PRELIMINARY PROCEDURE: Remove engine lower access cover (page 17-13)

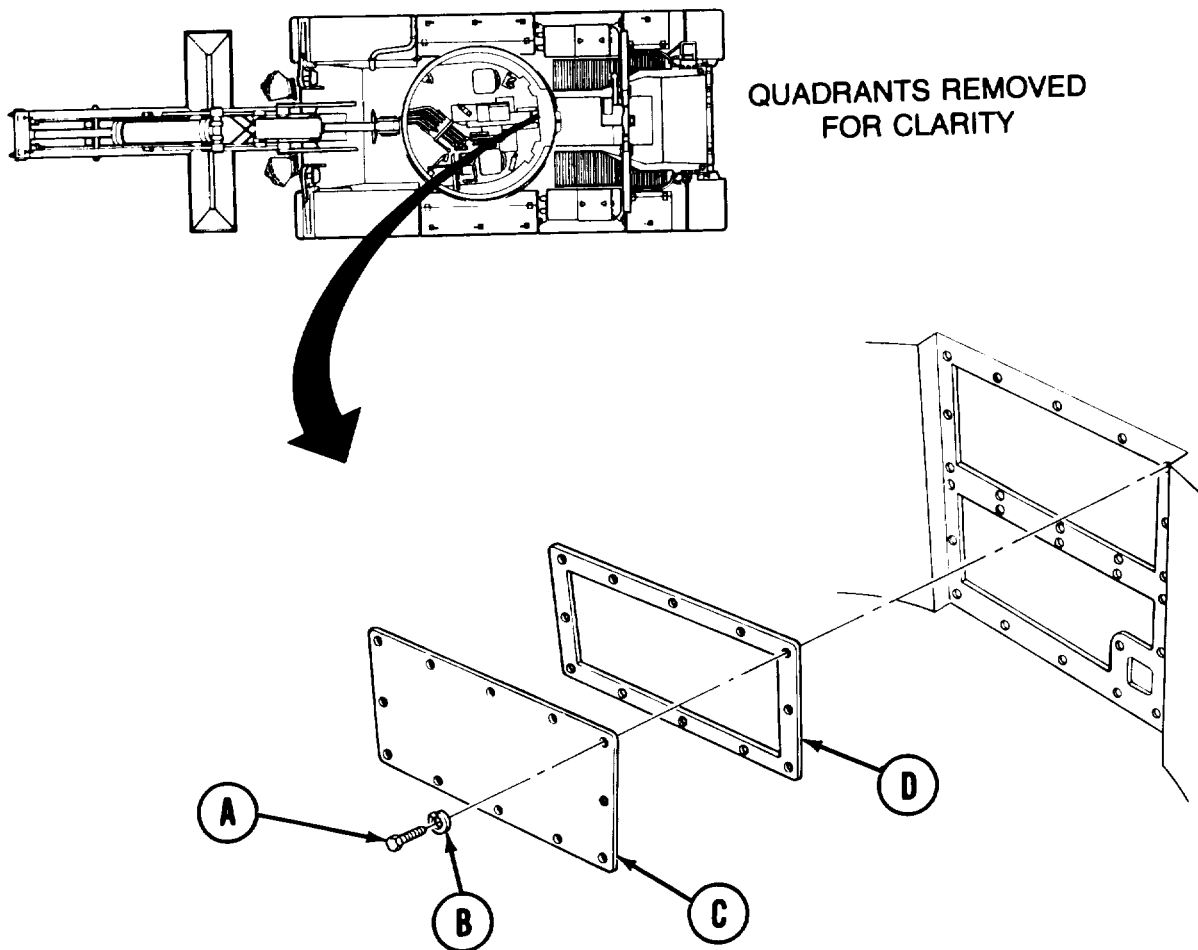

REMOVAL:

1. Using 9/16 inch socket, remove 12 screws (A) and lockwashers (B) securing cover (C) and gasket (D) to bulkhead.
2. Remove cover (C) and gasket (D). Throw gasket away.
3. Using putty knife, scrape off all gasket and adhesive residue from cover and bulkhead.

Go on to Sheet 2

TA248542

ENGINE UPPER ACCESS COVER REPLACEMENT (Sheet 2 of 2)

INSTALLATION:

1. Apply adhesive to new gasket (A).
2. Position new gasket (A) and cover (B) on bulkhead with holes alined.

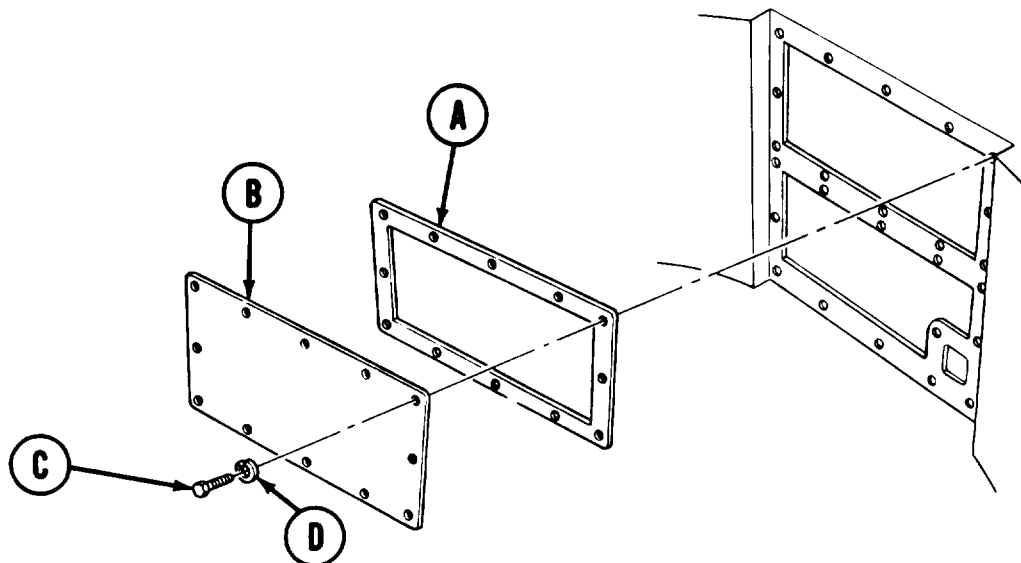

3. Using 9/16 inch socket, install 12 screws (C) and lockwashers (D) securing cover (B) and gasket (A) to bulkhead.
4. Install engine lower access cover (page 17-14).

End of Task

TA248543

ENGINE LOWER ACCESS COVER REPLACEMENT (Sheet 1 of 2)

TOOLS: 9/16 in. socket with 1/2 in. drive
 5 in. extension with 1/2 in. drive
 Ratchet with 1/2 in. drive
 Putty knife

SUPPLIES: Gasket
 Adhesive (Item 4, Appendix D)
 Lockwashers (8 required)

PRELIMINARY PROCEDURE: Remove bulkhead p to ring (page 17-15).

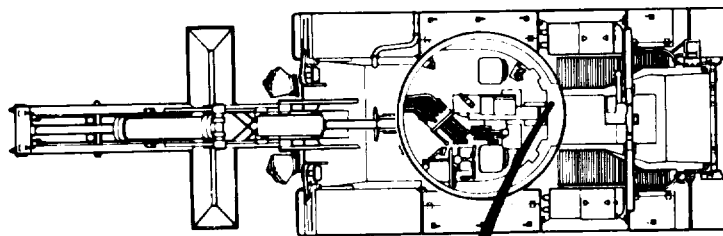

QUADRANTS REMOVED FOR CLARITY

REMOVAL:

1. Using socket, remove eight screws (A) and lockwashers (B) from holes (C).
2. Using socket and extension, remove six screws (D) lockwashers (E), and flat washers (F).
3. Remove cover (G) and gasket (H).
4. Using putty knife, scrape off all gasket and adhesive residue. Throw away gasket.

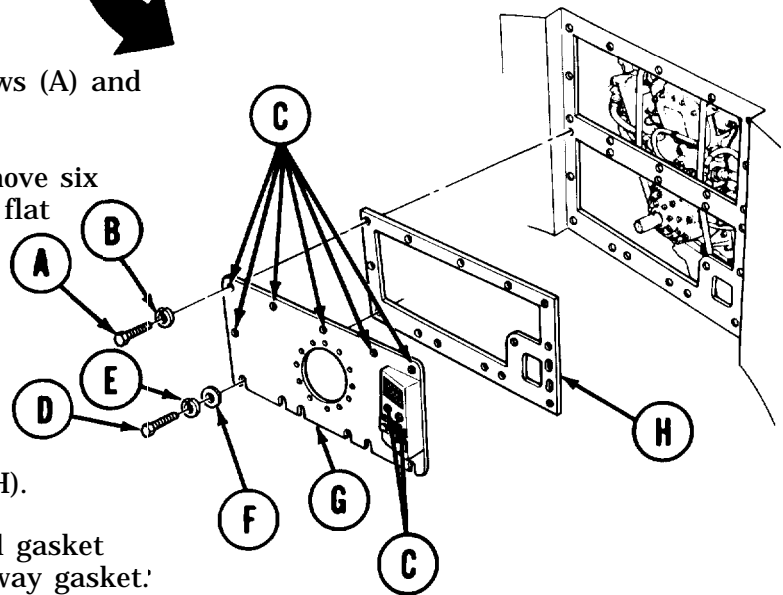

Go on to Sheet 2

TA248544

ENGINE LOWER ACCESS COVER REPLACEMENT (Sheet 2 of 2)

INSTALLATION

1. Apply adhesive to new gasket (A).
2. Position new gasket (A) and cover (B) on bulkhead with holes (C) alined.
3. Using socket, install eight screws (D) and lockwashers (E) in holes (C).
4. Using socket with extension, install six screws (F), lockwashers (G), and flat washers (H).
5. Install bulkhead p to ring (page 17-15).

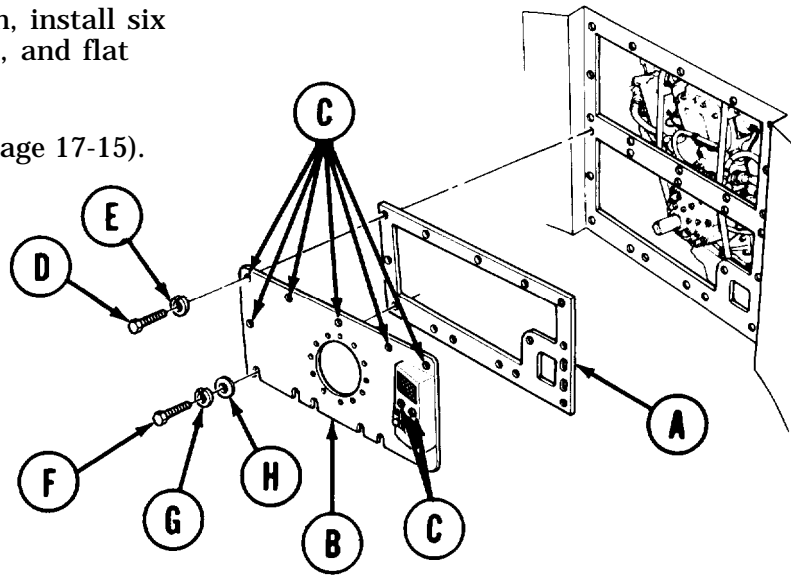

End of Task

TA248545

BULKHEAD P TO RING REPLACEMENT (Sheet 1 of 1)

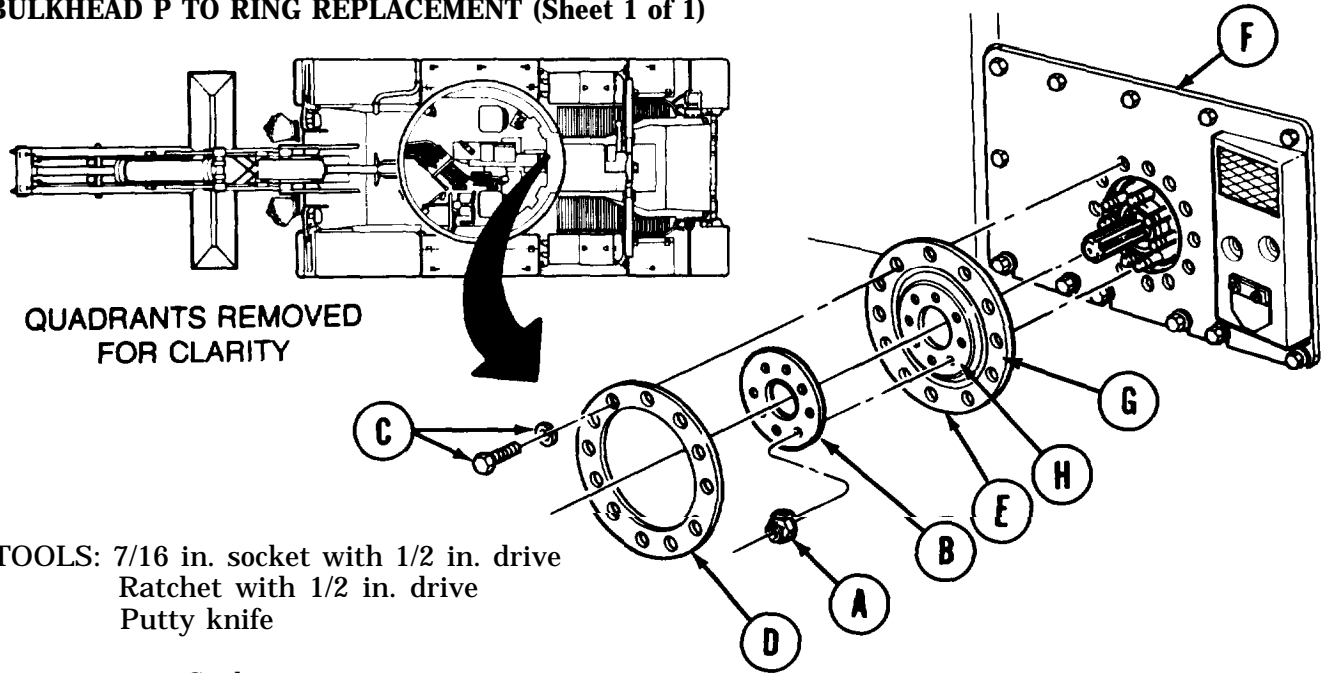

TOOLS: 7/16 in. socket with 1/2 in. drive
 Ratchet with 1/2 in. drive
 Putty knife

SUPPLIES: Gasket
 Adhesive (Item 4, Appendix D)
 Lockwashers (12 required)
 Self-locking nut (8 required)

PRELIMINARY PROCEDURE: Remove universal joint (TM 5-5420-228-24)

REMOVAL

1. Using socket, remove eight self-locking nuts (A) from ring (B).
2. Using socket, remove 12 screws and lockwashers (C), securing ring (D) and gasket (E) to cover (F).
3. Remove rings (B) and (D), and gasket (E). Throw gasket away.
4. Using putty knife, scrape off all gasket and adhesive residue.

INSTALLATION:

1. Apply adhesive to surface (G) and surface (H) of new gasket (E).
2. Position rings (B) and (D), and gasket (E) on cover (F) with holes alined.
3. Using socket, install 12 screws and lockwashers (C) securing ring (D) and gasket (E) to cover (F).
4. Using socket, install eight nuts (A) securing ring (B) and gasket (E) to p to housing.
5. Install universal joint (TM 5-5420-228-24).

End of Task

TA248546

SLIPRING BOX ACCESS COVER REPLACEMENT (Sheet 1 of 1)

TOOLS: 9/16 in. combination box and open end wrench
Putty knife

SUPPLIES: Gasket
Adhesive (Item 4, Appendix D)
Lockwashers (6 required)

PRELIMINARY PROCEDURE: Remove commander's floor plate (page 17-7)

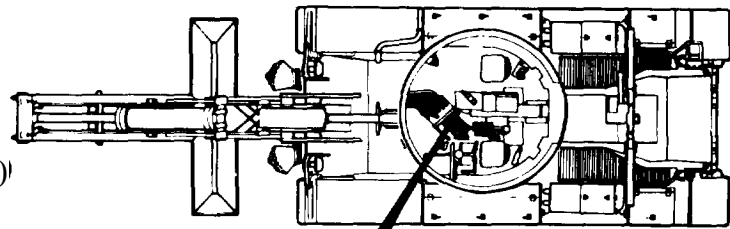

QUADRANTS
REMOVED
FOR CLARITY

REMOVAL:

1. Use wrench to remove six screws (A) and lock washers (B) securing cover (C) and gasket (D).
2. Remove cover (C) and gasket (D). Throw gasket away.
3. Using putty knife, remove all gasket and adhesive residue.

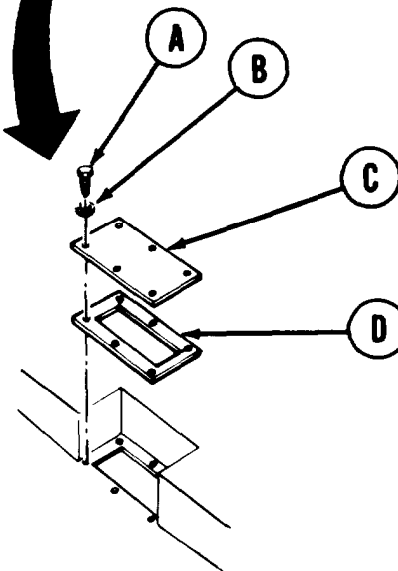

INSTALLATION:

1. Apply adhesive to new gasket (D).
2. Position gasket (D) and cover (C) with holes alined over opening in floor.
3. Reaching through floor plate access opening, use wrench to install six lockwashers (B) and screws (A).
4. Install commander's floor plate (page 17-7).

End of Task

TA248547

BULKHEAD PIPE PLUG REPLACEMENT (Sheet 1 of 1)

TOOLS: 9/16 inch socket head screw key (allen wrench)

REMOVAL: Using allen wrench, remove pipe plug (A) from bulkhead mounting plate (B).

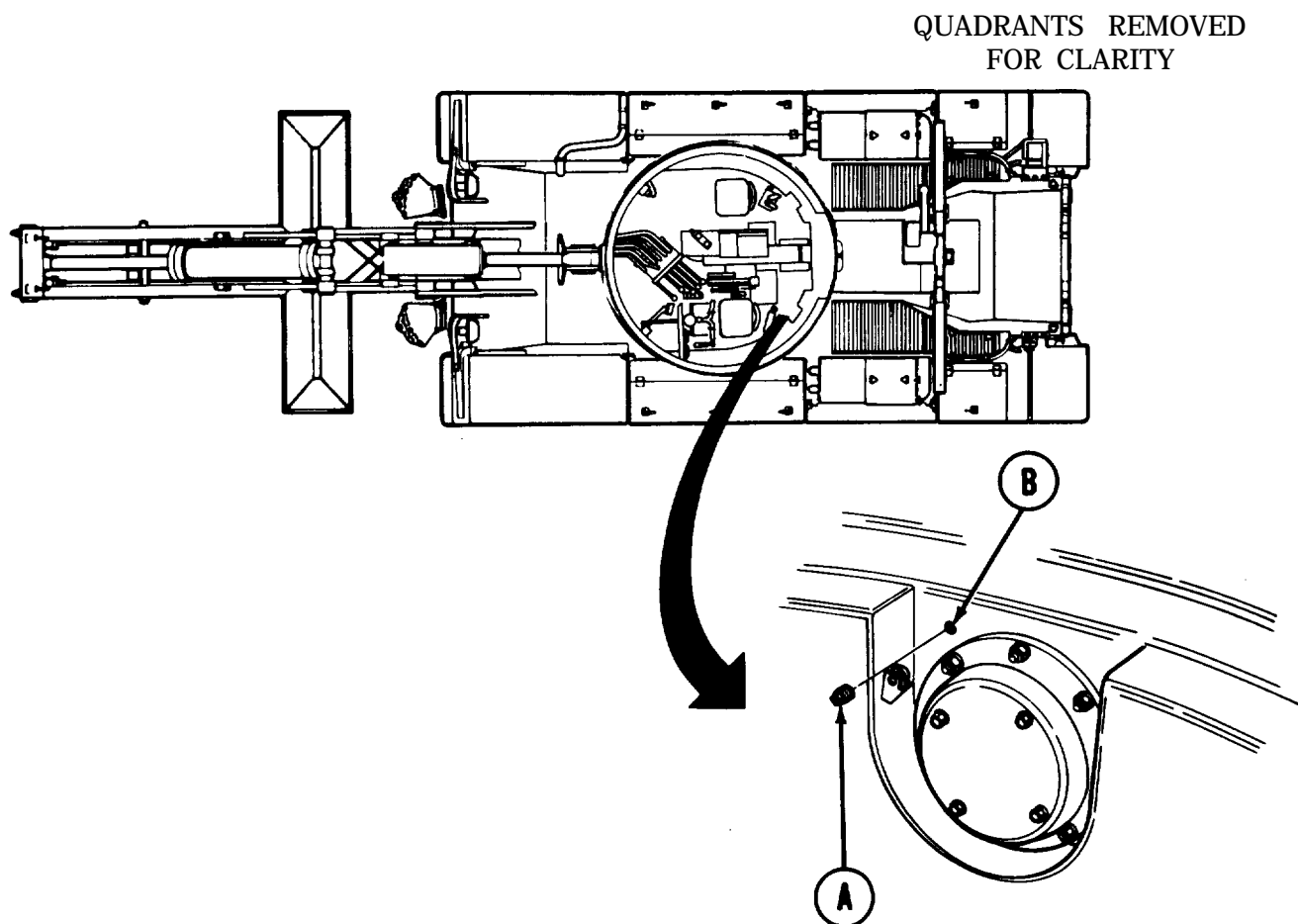

INSTALLATION: Using allen wrench, install pipe plug (A) in bulkhead mounting plate (B).

End of Task

TA248548

FRONT DRAIN VALVE CONTROL LEVER REPLACEMENT (Sheet 1 of 1)

TOOLS: 1/2 in. socket with 1/2 in. drive
Ratchet with 1/2 in. drive

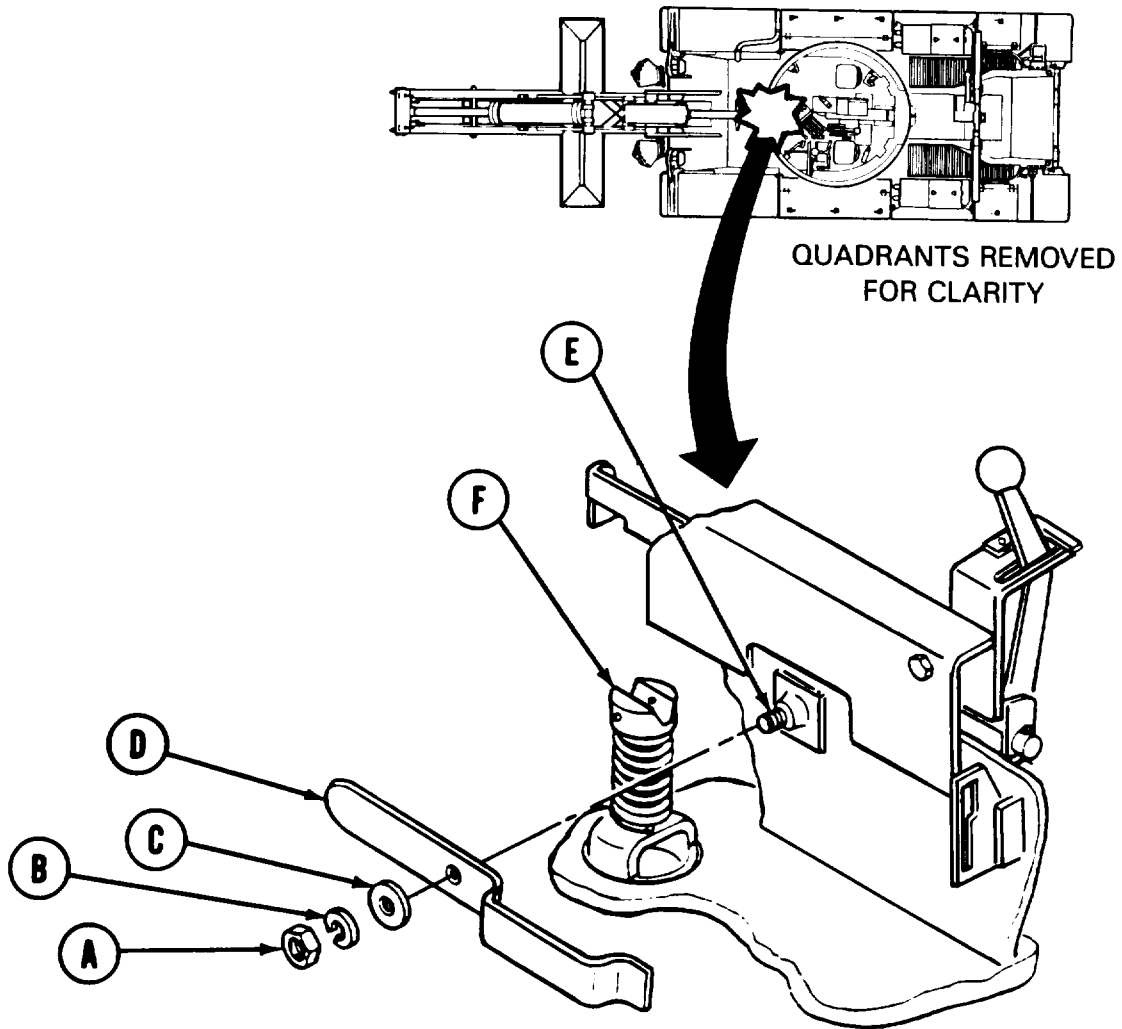

REMOVAL:

Using socket, remove nut (A), lockwasher (B), flat washer (C), and lever (D) from stud (E). Push down on knob (F) and remove lever (D).

INSTALLATION:

1. Put lever (D) on stud (E) and in groove on knob (F). Push down on knob (F) to install lever (D).
2. Using socket, install flat washer (C), lockwasher (B), and nut (A) on stud (E).
3. Operate front drain valve and make sure valve opens and closes smoothly. If lever does not operate smoothly, loosen nut (A) slightly and operate valve again.

End of Task

TA248549

FRONT DRAIN VALVE ASSEMBLY REPLACEMENT (Sheet 1 of 5)

PROCEDURE INDEX

PROCEDURE	PAGE
Removal	17-19
Cleaning and Inspection	17-21
Installation	17-21

TOOLS: Prybar

- 1/2 in. socket with 1/2 in. drive
- Ratchet with 1/2 in. drive
- Hand hammer
- 1/8 in. drive pin punch

Flat-tip screwdriver (2 required)

- 6 or 12 in. ruler
- Putty knife
- Slip joint pliers

SUPPLIES:

- Gasket
- Dry cleaning solvent (Item 55, Appendix D)
- Rags (Item 65, Appendix D)

Lock washers (4 required)

- Gloves (Item 69, Appendix D)
- Goggles (Item 70, Appendix D)

PERSONNEL: Two

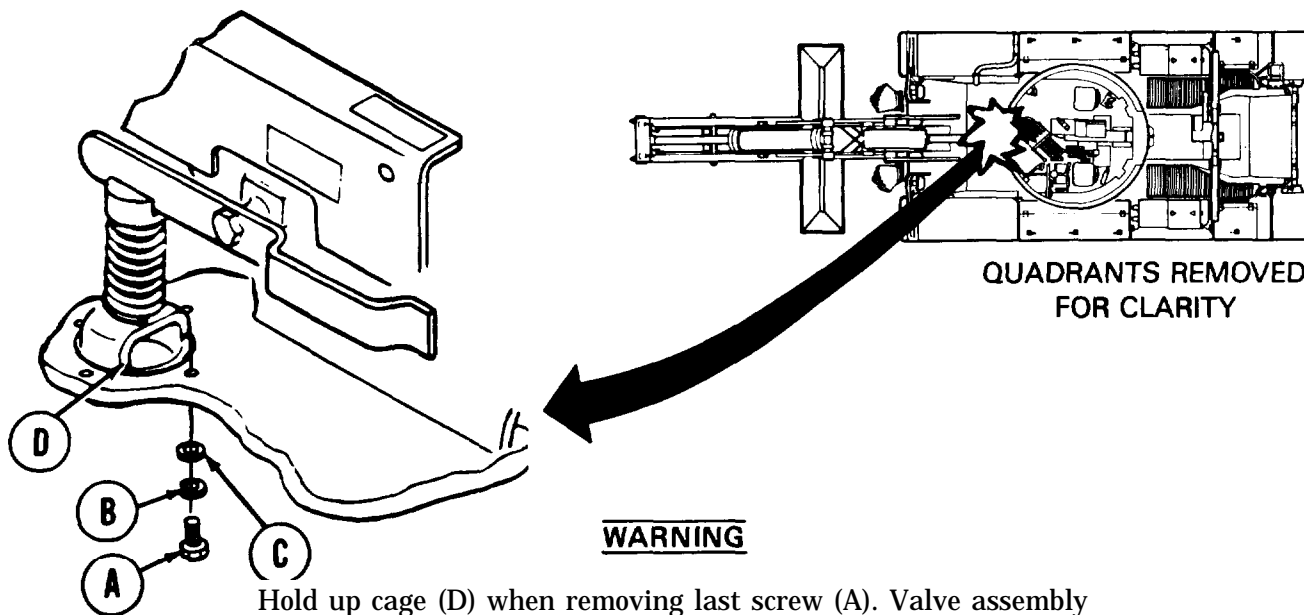

REMOVAL:

1. From underside of vehicle, using socket, remove four screws (A), lockwashers (B), and flat washers (C) from cage (D).

Go on to Sheet 2

TA248550

FRONT DRAIN VALVE ASSEMBLY REPLACEMENT (Sheet 2 of 5)

2. Using prybar, pry cage (D) from bottom of hull (E). If cage (D) will not come off, hit knob (F) inside vehicle with hammer until cage (D) comes out.
3. Using putty knife, scrape gasket (G) from cage (D) and hull (E).
4. Clamp cage (D) in vise.
5. Using hammer and punch, drive pin (H) out of hole in knob (F), while second person holds spring (J) down using two screwdrivers. Throw pin (H) away if damaged.
6. Remove knob (F), spring (J), and valve (K) from cage (D).
7. With valve (K) in vise, using hammer and punch, drive pin (L) out of hole in valve (K). Throw pin (L) away if damaged.

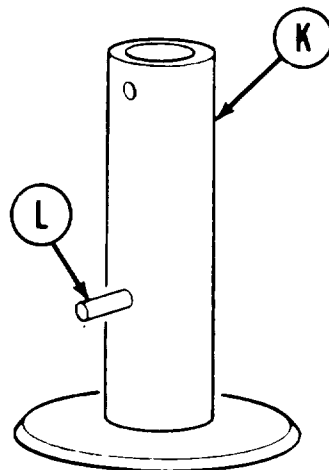
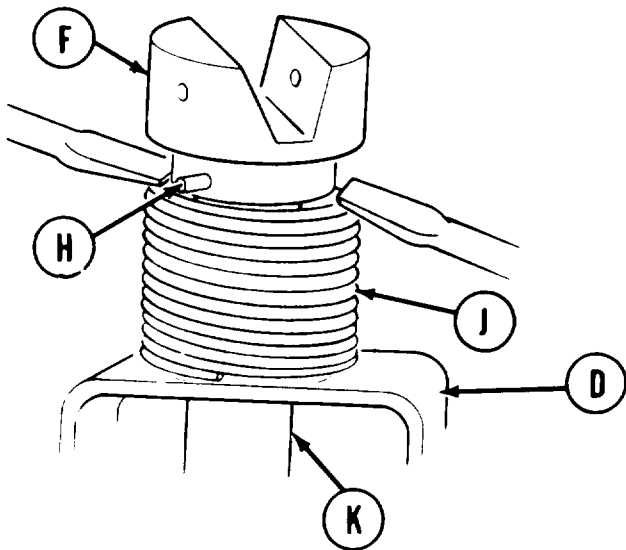
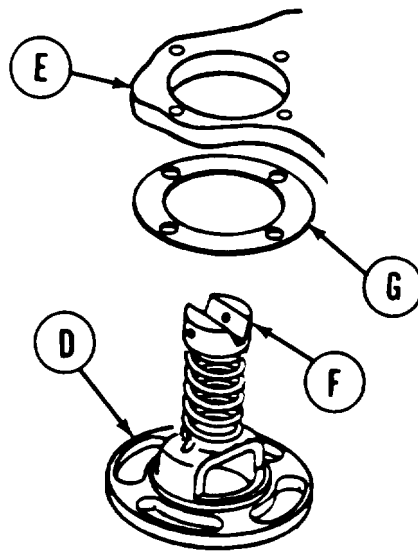

Go on to Sheet 3

TA248551

FRONT DRAIN VALVE ASSEMBLY REPLACEMENT (Sheet 3 of 5)

CLEANING AND INSPECTION:

WARNING

Dry cleaning solvent P-D-680 is toxic and flammable. To prevent personal injury, wear protective goggles and gloves and use only in a well-ventilated area. Avoid contact with skin, eyes, and clothes and don't breathe vapors. Do not use near open flame or excessive heat. The flash point for Type #1 Dry Cleaning Solvent is 100°F (38°C) and for Type #2 is 138°F (50°C). If you become dizzy while using cleaning solvent, get fresh air immediately and get medical aid. If contact with eyes is made, wash your eyes with water and get medical aid immediately.

1. Clean all parts using drycleaning solvent and clean rags.
2. Inspect all parts for cracks, corrosion, damage, or other defects. Replace defective parts.
3. Inspect mating surface of cage (A) and valve (B) for cracks, corrosion, damage, or other defects. Replace cage (A) or valve (B) if defective.

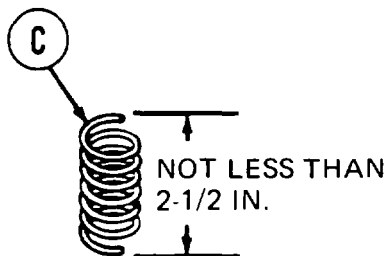
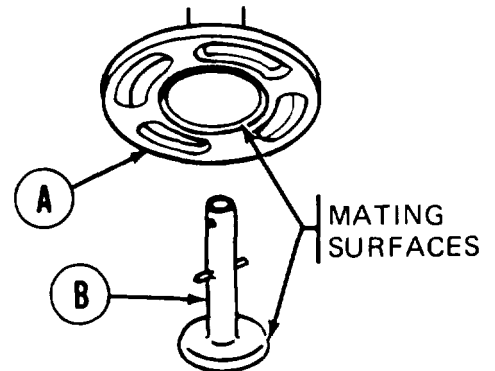

4. Measure length of spring (C). If spring is less than 2-1/2 inches, replace spring.

INSTALLATION:

1. Using pliers, start pin (A) in lower hole in valve (B).
2. With valve (B) in vise, drive pin (A) in hole until pin (A) sticks out an equal amount on both sides of valve (B).
3. Push valve (B) up through cage (C) and turn valve (B) until valve (B) fits all the way up in cage (C).
4. With cage (C) in vise, hold valve (B) in place and install spring (D) and knob (E) on cage (C).

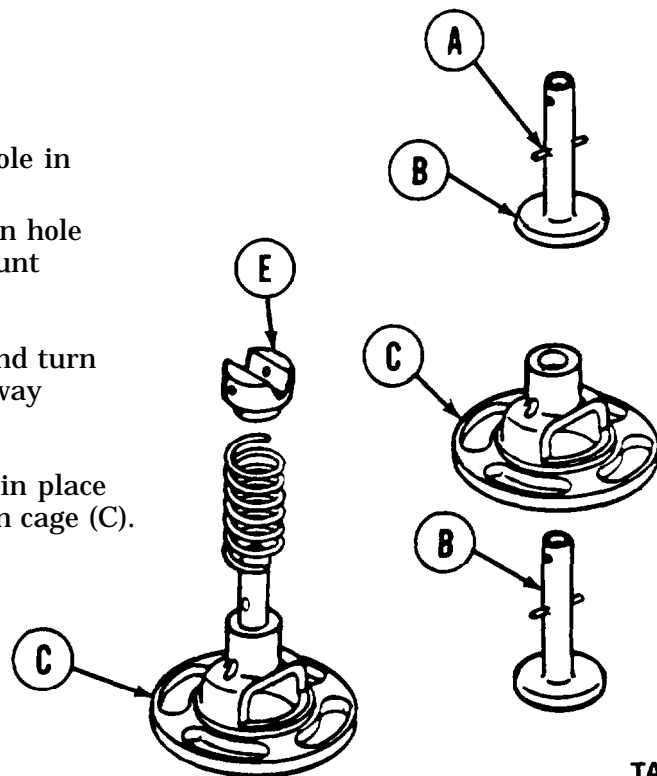

Go on to Sheet 4

TA248552

FRONT DRAIN VALVE ASSEMBLY REPLACEMENT (Sheet 4 of 5)

- Using punch, line up hole in knob (E) and hole in valve (B) while second person holds down spring (D), using two screwdrivers.

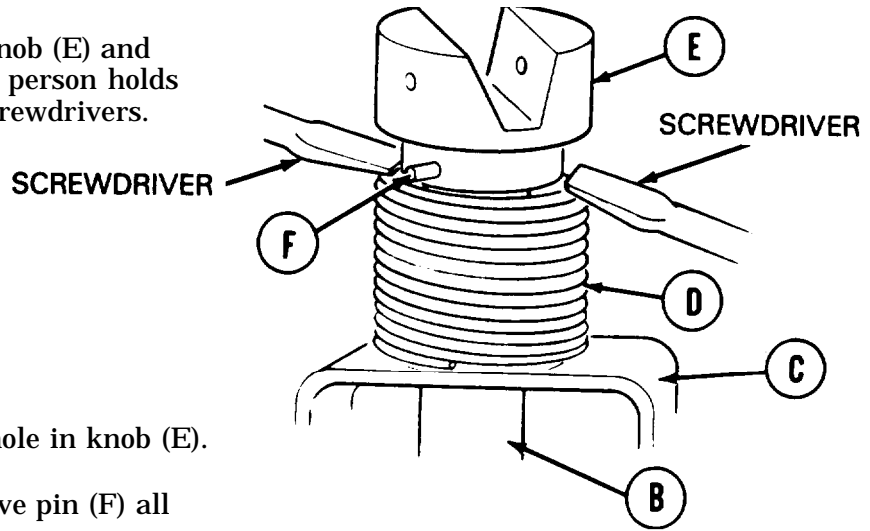

- Using pliers, start pin (F) in hole in knob (E).
- Using hammer and punch, drive pin (F) all the way in hole.

NOTE

Make sure lever (J) fits in center of groove in knob (E) when holes are lined up.

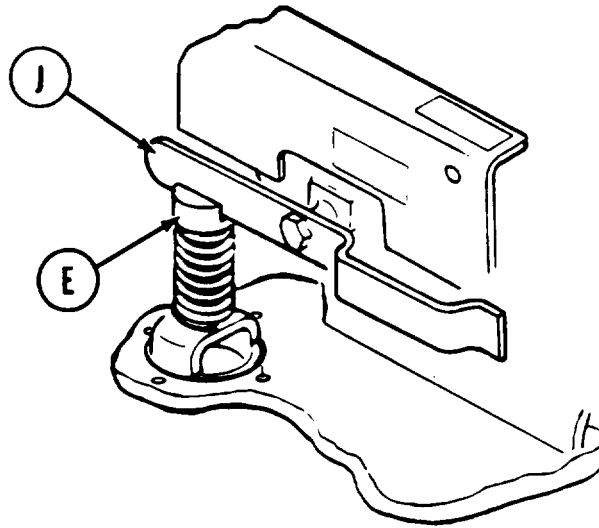
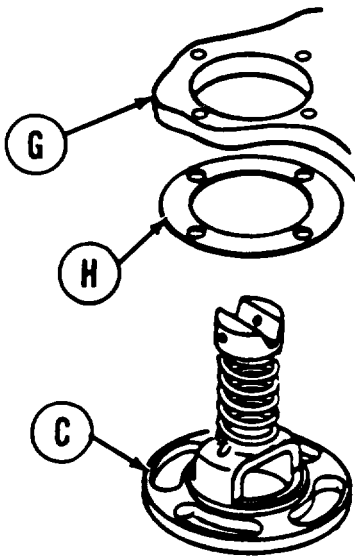

- Line up holes in cage (C), new gasket (H), and hull (G).

Go on to Sheet 5

TA248553

FRONT DRAIN VALVE ASSEMBLY REPLACEMENT (Sheet 5 of 5)

9. Using socket, install four screws (K), lockwashers (L), and flat washers (M) in holes in cage (C) and hull (G).
10. Check front drain valve for proper operation.

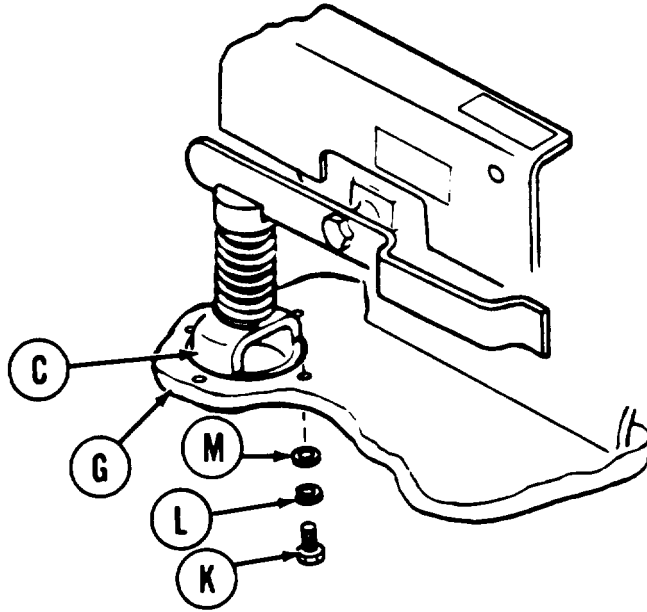

End of Task

TA248554

REAR DRAIN VALVE CONTROL LEVER ASSEMBLY REPLACEMENT (Sheet 1 of 4)

PROCEDURE INDEX

PROCEDURE	PAGE
Removal	17-24
Cleaning and Inspection	17-26
Installation	17-26

TOOLS: Slip joint pliers

Hammer

1/8 in. drive pin punch

5/16 in. combination box and open end wrench

7/16 in. combination box and open end wrench

1/2 in. drive pin punch

SUPPLIES:

Cotter pin

Dry cleaning solvent (Item 55, Appendix D)

Rags (Item 65, Appendix D)

Lockwashers (4 required)

Gloves (Item 69, Appendix D)

Goggles (Item 70, Appendix D)

REFERENCE:

TM 5-5420-202-10

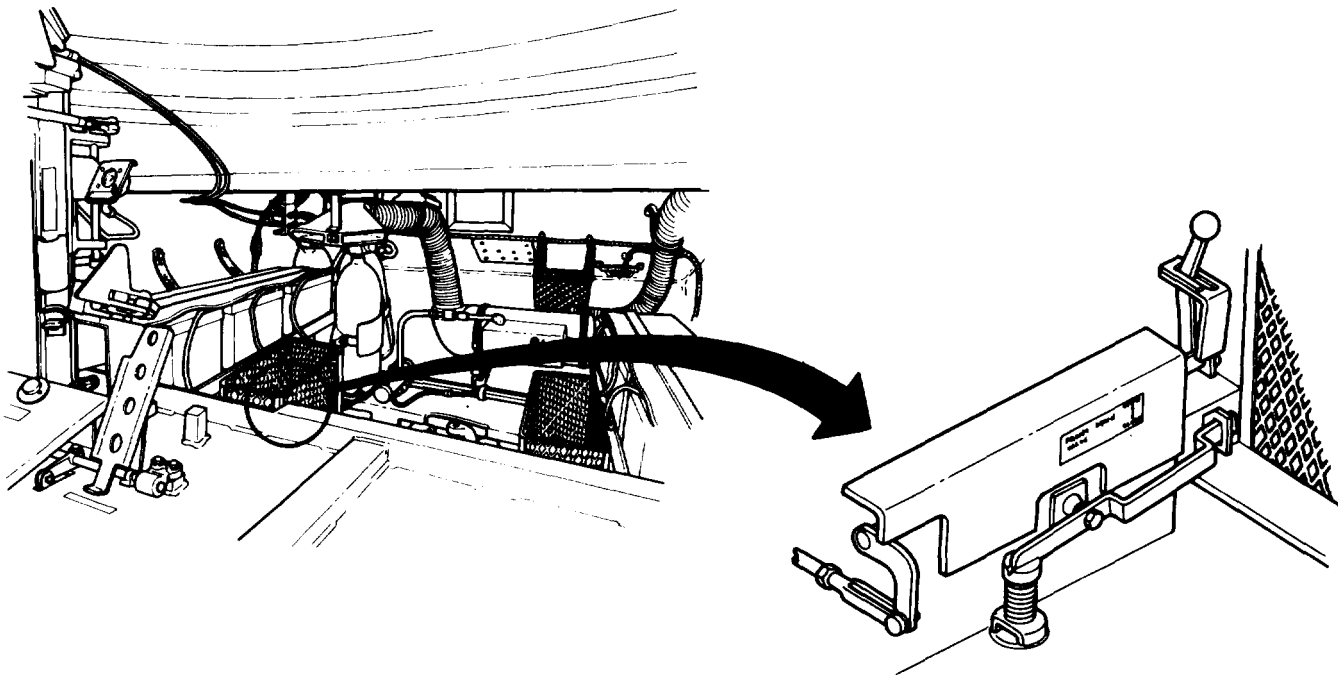

Go on to Sheet 2

TA248555

REAR DRAIN VALVE CONTROL LEVER ASSEMBLY REPLACEMENT (Sheet 2 of 4)

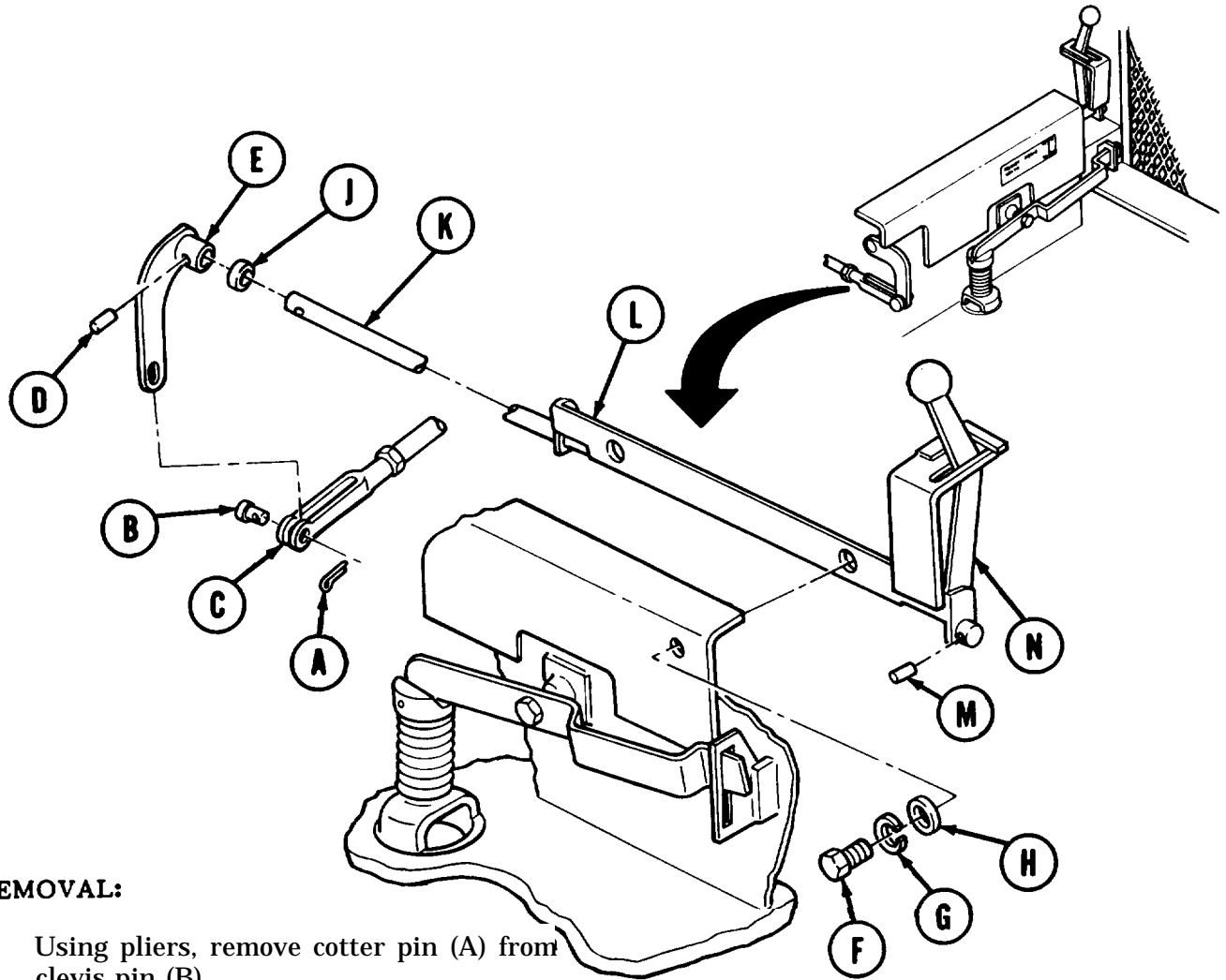

REMOVAL:

1. Using pliers, remove cotter pin (A) from clevis pin (B).
2. Using pliers, remove pin (B) from clevis (C).
3. Using hammer and 1/8 inch punch, drive pin (D) out of lever (E).
4. Using 7/16 inch wrench, remove two screws (F), lockwashers (G), and flat washers (H).

NOTE

It may be necessary to tap lever (E) with hammer for removal.

5. Remove lever (E) and washer (J) from shaft (K).
6. Remove bracket (L) from vehicle.
7. Secure bracket (L) in vise.
8. Using hammer and 1/8 inch punch, drive pin (M) out of control lever (N).

Go on to Sheet 3

TA248556

REAR DRAIN VALVE CONTROL LEVER ASSEMBLY REPLACEMENT (Sheet 3 of 4)

9. Using 5/16 inch wrench, remove two screws (P) and lockwashers (Q). Remove lever stop (R).
10. Pull control lever (N) out of slot in bracket (L).
11. Pull shaft (K) and control lever (N) out of bracket (L).
12. Secure lever (N) in vise and using hammer and 1/2 inch punch, drive shaft (K) from lever (N).

CLEANING AND INSPECTION:

WARNING

Dry cleaning solvent P-D-680 is tixic and flammable. To prevent personal injury, wear protective goggles and gloves and use only in a well-ventilated area. Avoid contact with skin, eyes, and clothes and don't breathe vapors. Do not use near open flame or excessive heat. The flash point for Type #1 Dry Cleaning Solvent is 100°F (38°C) and for Type #2 is 138°F (50°C). If you become dizzy while using cleaning solvent, get fresh air immediately and get medical aid. If contact with eyes is made, wash your-eyes with water and get medical aid immediately.

1. Using dry cleaning solvent and rags, clean all parts.
2. Inspect parts for bends, cracks, or other defects. Replace defective parts.

INSTALLATION:

1. Push shaft (A) through holes in bracket (B) and hole in control lever (C). Make sure control lever (C) is not installed backwards.
2. Push control lever (C) in slot in bracket (B).
3. Line up holes in lever stop (D) and holes in bracket (B).
4. Install two screws (E) and lockwashers (F) attaching lever stop (D) to bracket (B).

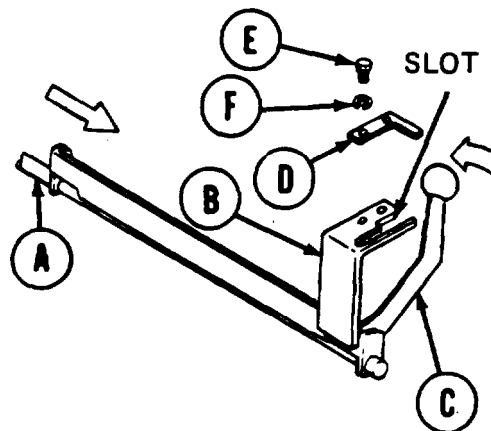

Go on to Sheet 4

TA248557

REAR DRAIN VALVE CONTROL LEVER ASSEMBLY REPLACEMENT (Sheet 4 of 4)

5. Clamp bracket (B) in vise.
6. Using 1/8 inch punch and pliers, line up hole in shaft (A) with hole in control lever (C).
7. Using pliers, start pin (D) in hole in control lever (C).
8. Using hammer and 1/8 inch punch, drive pin (D) all the way in hole.
9. Position bracket (B) in vehicle.

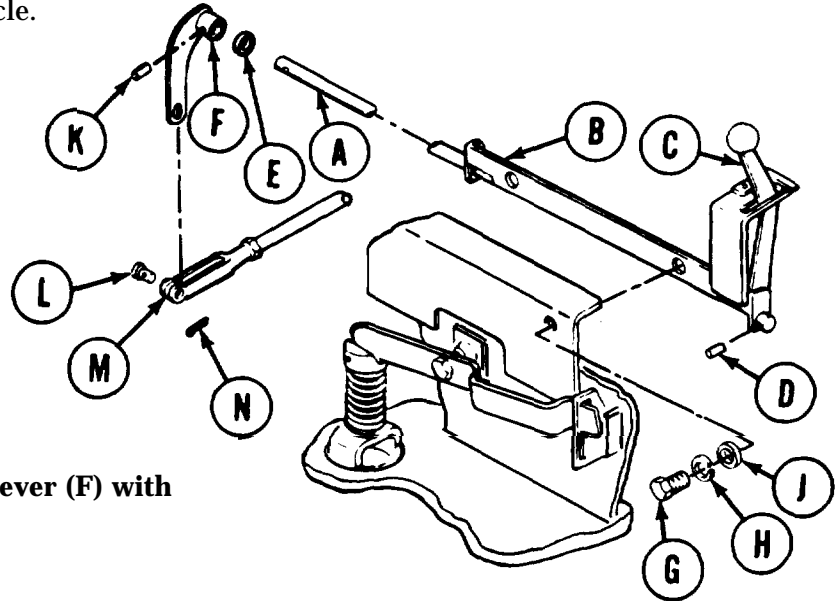
**NOTE**

It may be necessary to tap lever (F) with hammer for installation.

10. Install washer (E) and lever (F) on shaft (A).
11. Using wrench, install two screws (G), lockwashers (H), and flat washers (J) attaching bracket (B).
12. Using 1/8 inch punch, line up hole in shaft (A) with hole in lever (F).
13. Using pliers, start pin (K) in hole in lever (F).
14. Using hammer and 1/8 inch punch, drive pin (K) all the way in hole.
15. Install clevis pin (L) through hole in clevis (M) and hole in lever (F).
16. Install cotter pin (N) in clevis pin (L).
17. Operate rear drain valve and make sure valve opens and closes smoothly. If valve does not open and close properly, check for debris in the way and for missing parts. Clear debris in the way and install missing parts.

End of Task

TA248558

REAR DRAIN VALVE REAR ROD, COUPLING, AND CLEVIS REPLACEMENT

(Sheet 1 of 6)

PROCEDURE INDEX

PROCEDURE	PAGE
Removal	17-28
Installation	17-31

TOOLS: Slip joint pliers
 6 in. steel rule
 9/16 in. combination box and open end wrench (2 required)

SUPPLIES: Cotter pin
 Pencil (Item 71, Appendix D)
 Paper (Item 72, Appendix D)

REFERENCE: TM 5-5420-202-10

PRELIMINARY PROCEDURE: Remove powerplant (page 5-2)

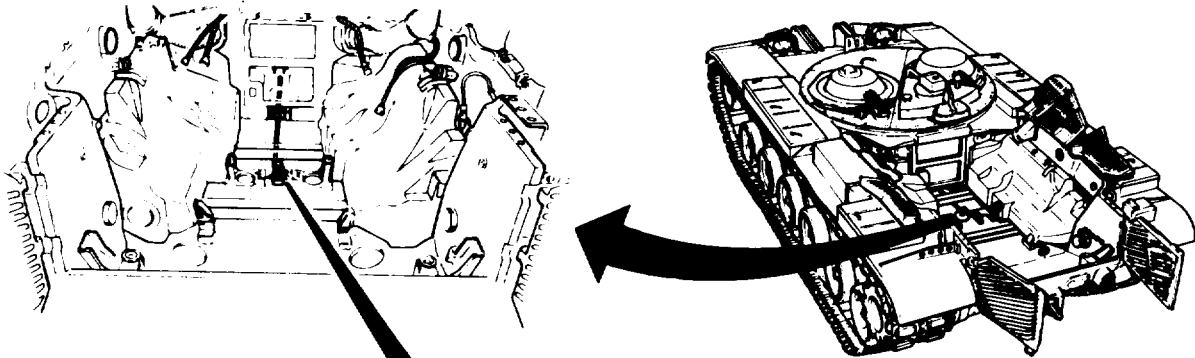

NOTE

Make sure rear drain valve is closed.
 TM 5-5420-202-10).

REMOVAL:

1. Using pliers, remove cotter pin (A) from hole in clevis pin (B).
2. Using pliers, remove clevis pin (B) from clevis (C) and lever (D).

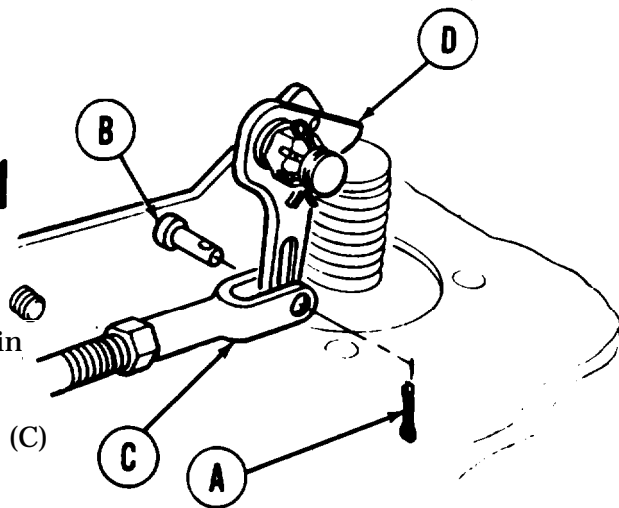

Go on to Sheet 2

TA248559

REAR DRAIN VALVE REAR ROD, COUPLING, AND CLEVIS REPLACEMENT
(Sheet 2 of 6)

NOTE

Be sure to count and write down number of turns needed to unscrew coupling (F) from rear intermediate rod (G).

- Using 9/16 inch wrench, loosen coupling jamnut (E) from coupling (F) while holding coupling (F) with another 9/16 inch wrench.

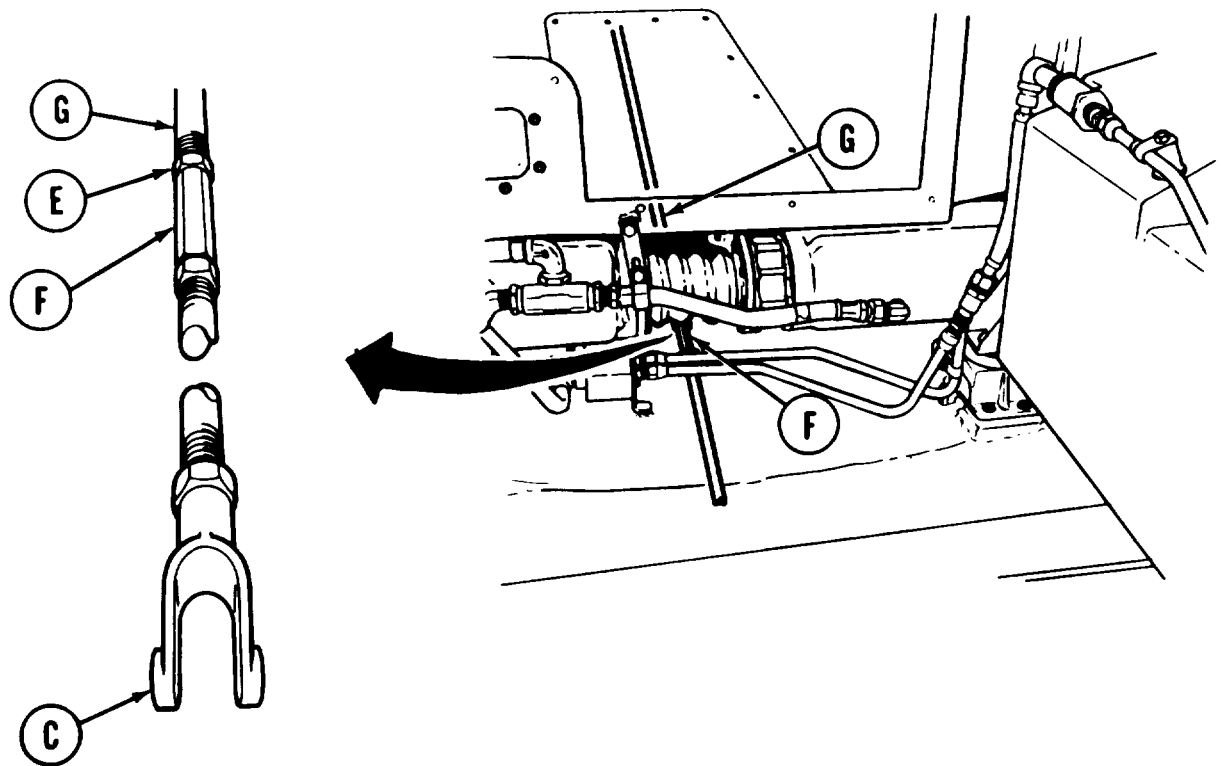

- Open rear drain valve (TM 5-5420-202-10) and turn clevis (C) until coupling (F) unscrews from rear intermediate rod (G).

Go on to Sheet 3

TA248560

REAR DRAIN VALVE REAR ROD, COUPLING, AND CLEVIS REPLACEMENT
(Sheet 3 of 6)

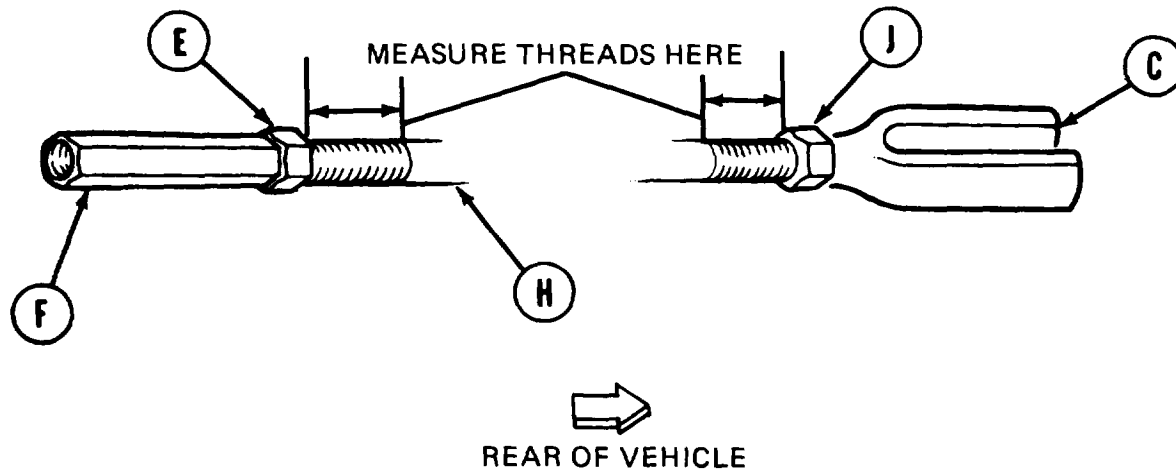

5. Measure and record length of threads on both ends of rod (H).
6. Using 9/16 inch wrench, loosen coupling jamnut (E) while holding coupling (F) with another 9/16 inch wrench.
7. Using 9/16 inch wrench, loosen clevis jamnut (J) while holding clevis (C) with pliers.
8. Using pliers, if necessary, remove clevis (C), clevis jam nut (J), coupling (F), and coupling jamnut (E) from rod (H).
9. Remove parts from vehicle.

Go on to Sheet 4

TA248561

REAR DRAIN VALVE REAR ROD, COUPLING, AND CLEVIS REPLACEMENT (Sheet 4 of 6)

INSTALLATION:

1. Install clevis jamnut (A) and clevis (B) on either end of rod (C).
2. Adjust clevis (B) and clevis jamnut (A) until original length of threads can be measured on rod (C) with clevis jamnut (A) finger tightened against clevis (B) (page 17-30, step 5).
3. using 9/16 inch wrench, tighten clevis jam nut (A) against clevis (B), while holding clevis (B) with pliers.

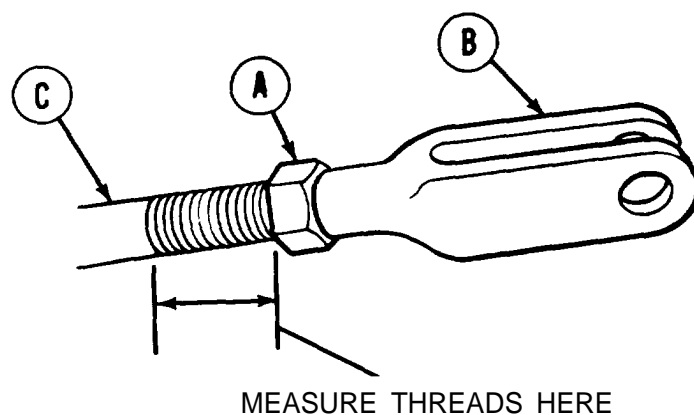

Go on to Sheet 5

TA248562

REAR DRAIN VALVE REAR ROD, COUPLING, AND CLEVIS REPLACEMENT (Sheet 5 of 6)

- Put end of rod (C) through hole in bracket (D).

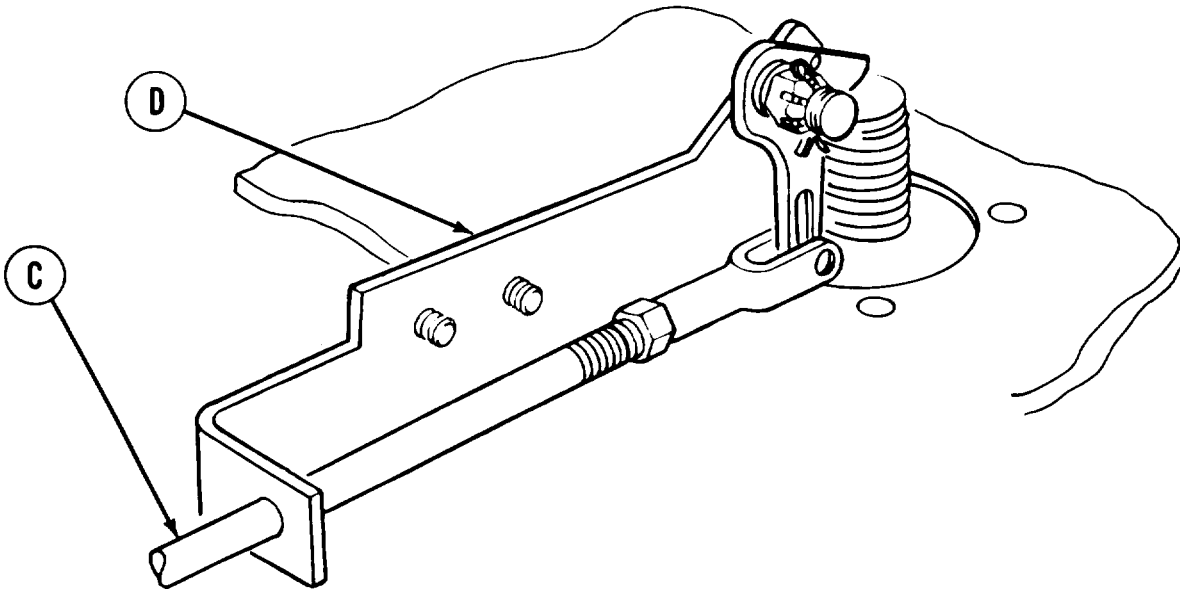

- Install coupling (E) and coupling jamnut (F) on end of rod (C).
- Adjust coupling (E) and coupling jamnut (F) until original length of threads can be measured on rod (C) with coupling jamnut (F) finger tight ened against coupling (E) (page 17-30, step 5).
- Using 9/16 inch wrench, tighten coupling jamnut (F) against coupling (E) while holding coupling (E) with another wrench.
- Line up coupling (E) with rear intermediate control rod (G).

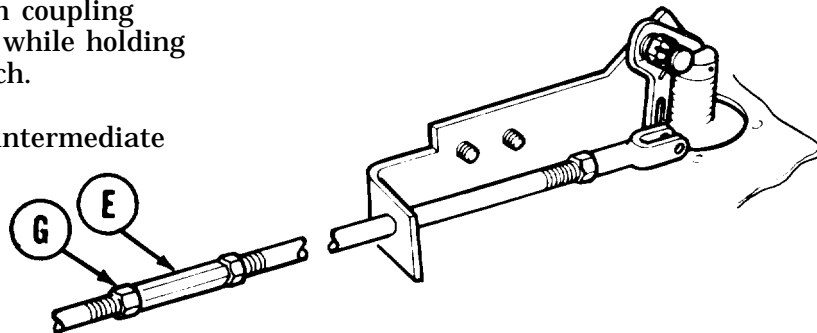
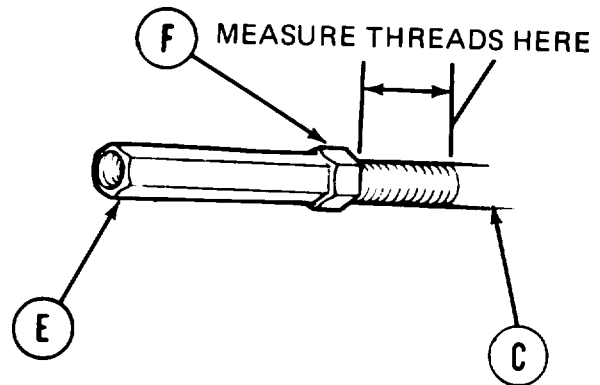

Go on to Sheet 6

TA248563

REAR DRAIN VALVE REAR ROD, COUPLING, AND CLEVIS REPLACEMENT (Sheet 6 of 6)

9. Turn clevis (B) and screw coupling (E) on rear intermediate rod (G) the recorded number of turns (page 17-29, step 4 and NOTE).
10. Close rear drain valve (TM 5-5420-202-10) and install clevis pin (H) through holes in clevis (B) and hole in lever (J).
11. Using pliers, install cotter pin (K) in hole in clevis pin (H).
12. Using 9/16 inch wrench, tighten coupling jamnut (F) against coupling (E) while holding coupling (E) with another wrench.

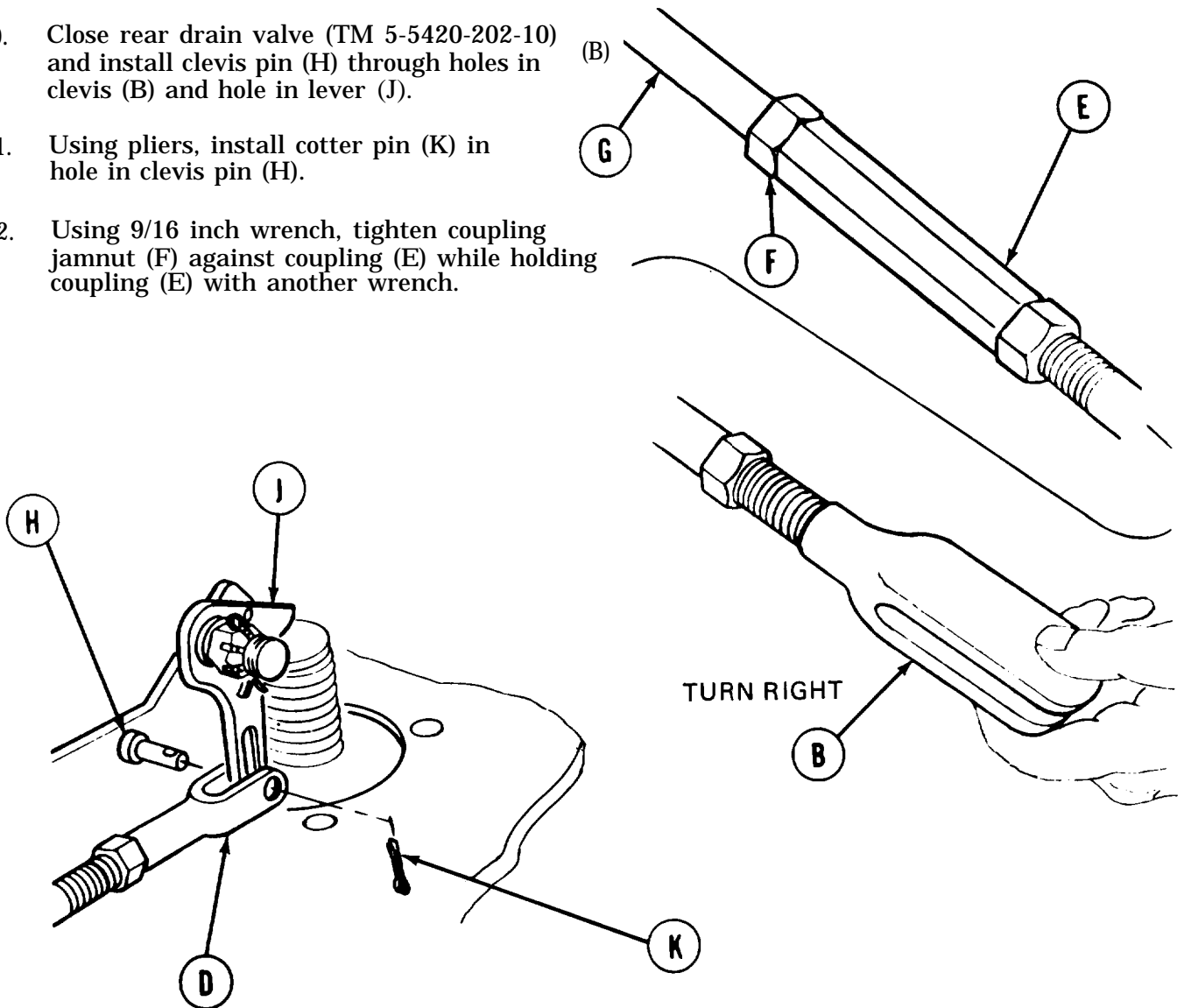

NOTE

If valve does not operate properly, check linkage for obstructions and adjust linkage, if necessary.

13. Operate valve to make sure rear drain valve opens and closes smoothly (TM 5-5420-202-10).
14. Install powerplant (page 5-14).

End of Task

TA248564

REAR DRAIN VALVE ACTUATING LEVER REPLACEMENT (Sheet 1 Of 4)

PROCEDURE INDEX

PROCEDURE	PAGE
Removal	17-34
Installation	17-36

TOOLS: 7/16 in. combination box and open end wrench
 Slip joint pliers
 1/2 in. combination box and open end wrench

SUPPLIES: Cotter pins (2 required)

PRELIMINARY PROCEDURE: Remove powerplant (page 5-2).

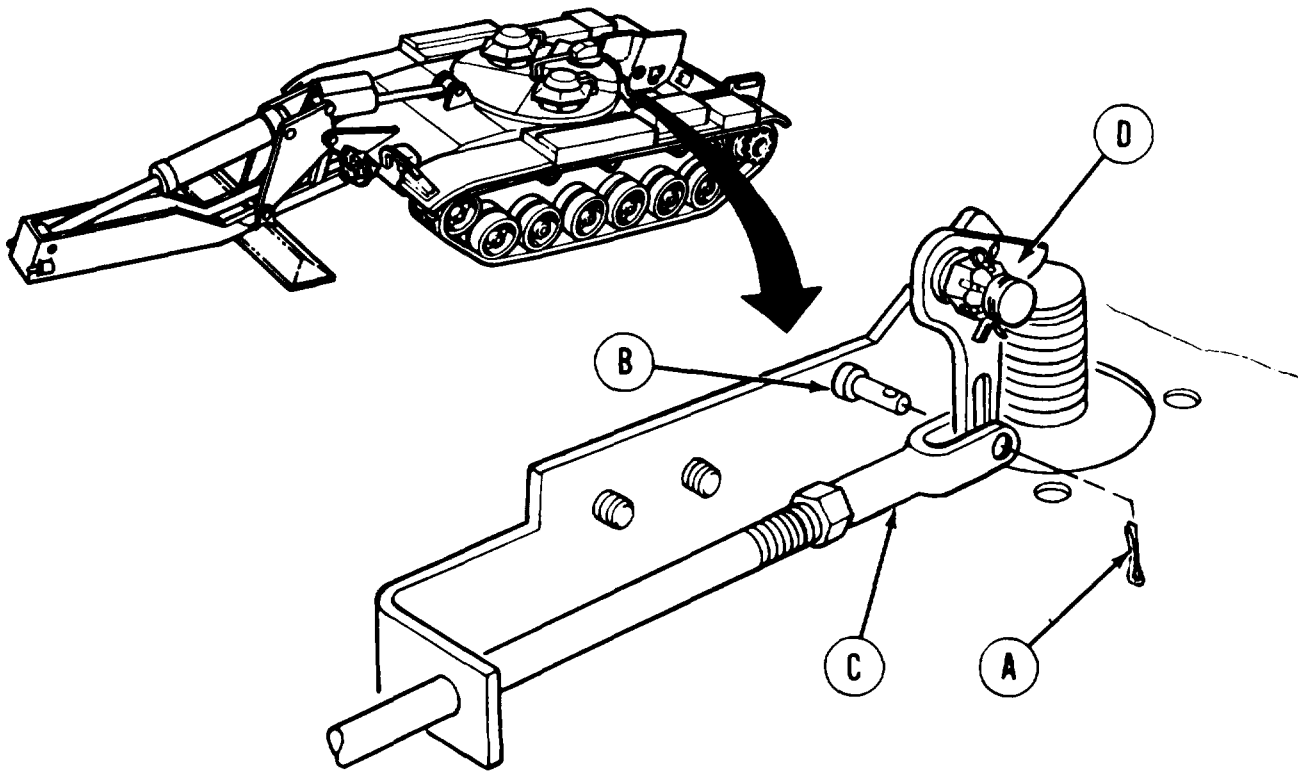

REMOVAL:

1. Using pliers, remove cotter pin (A) from clevis pin (B).
2. Using pliers, pull clevis pin (B) out of holes in clevis (C) and hole in lever (D).

Go on to sheet 2

TA248565

REAR DRAIN VALVE ACTUATING LEVER REPLACEMENT (Sheet 2 of 4)

3. Using pliers, remove cotter pin (E) from bolt (F).
4. Using 7/16 inch wrench on slotted nut (G) and 1/2 inch wrench on bolt (F), remove slotted nut (G), flat washer (H), flat washer (J), lever (D), two flat washers (K), and bolt (F) from bracket (L).

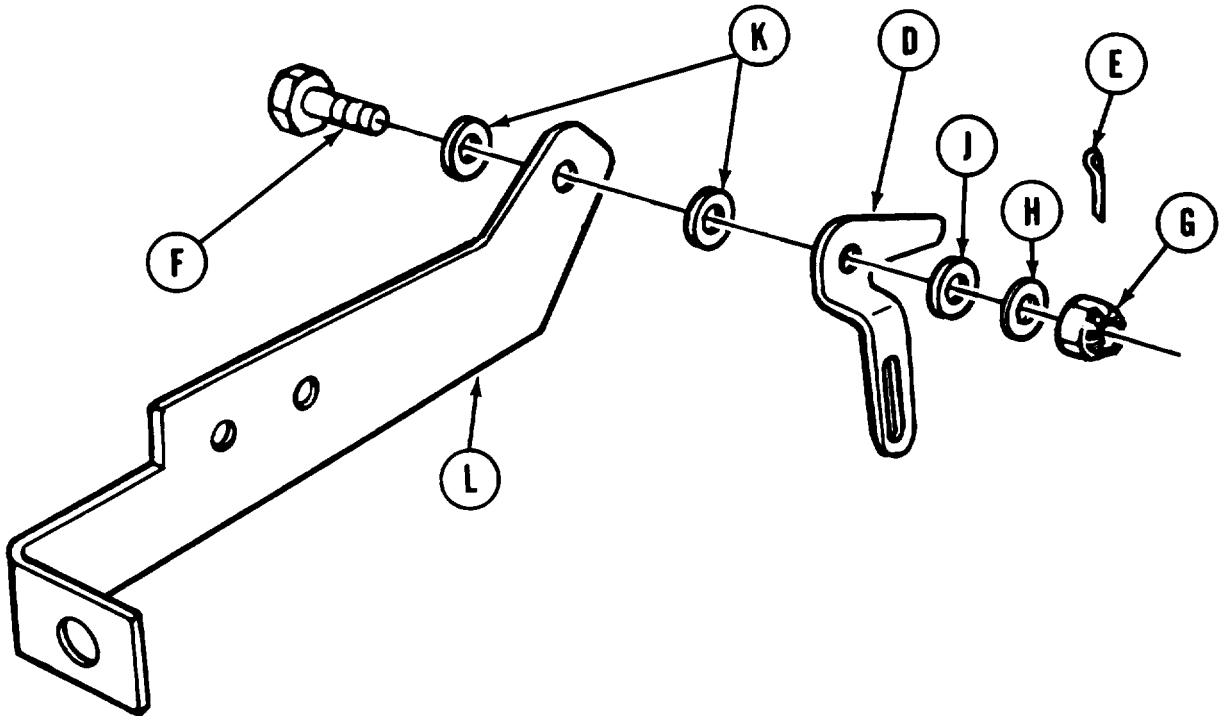

Go on to Sheet 3

TA248566

REAR DRAIN VALVE ACTUATING LEVER REPLACEMENT (Sheet 3 of 4)

INSTALLATION

1. Install bolt (A), two flat washers (B), lever (C), flat washer (D), flat washer (E), and slotted nut (F) on bracket (G).

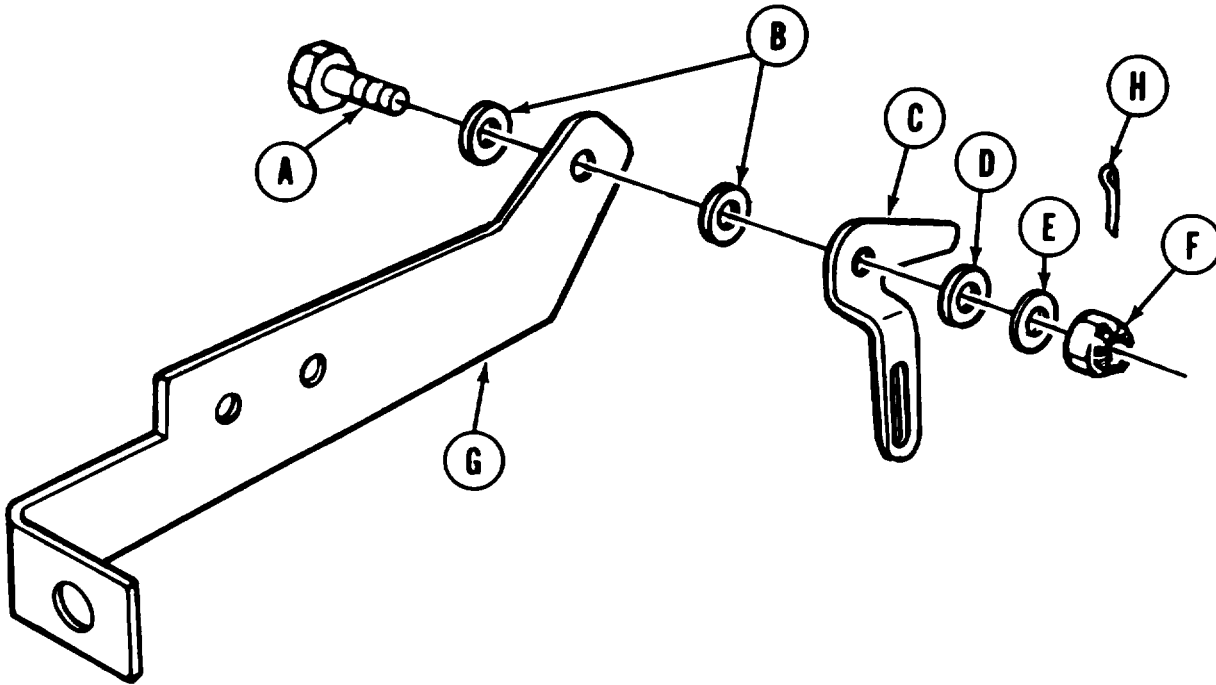

2. Finger tighten slotted nut (F) on bolt (A).
3. Line up hole in bolt (A) with slot in slotted nut (F).
4. Using pliers, install cotter pin (H) in bolt (A).

Go on to Sheet 4

TA248567

REAR DRAIN VALVE ACTUATING LEVER REPLACEMENT (Sheet 4 of 4)

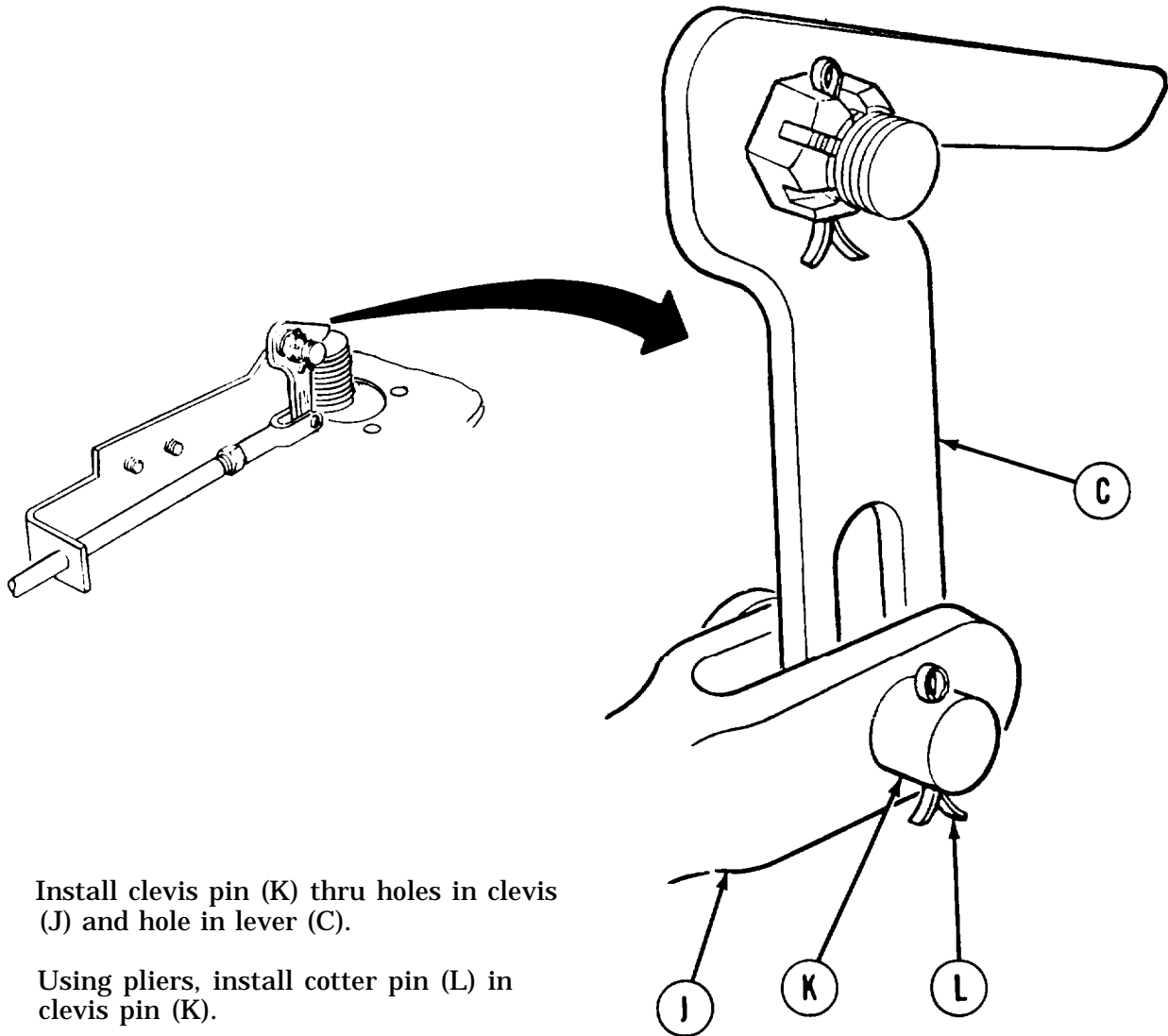

5. Install clevis pin (K) thru holes in clevis (J) and hole in lever (C).
6. Using pliers, install cotter pin (L) in clevis pin (K).
7. Operate rear drain valve and make sure drain valve opens and closes smoothly.
8. Install powerplant (pages 5-14).

End of Task

TA248568

REAR DRAIN VALVE MOUNTING BRACKETS REPLACEMENT (Sheet 1 of 2)

TOOLS: 9/16 in. combination box and open end wrench
Slip joint pliers
Ratchet with 1/2 in. drive
9/16 in. socket with 1/2 in. drive
10 in. pipe wrench

SUPPLIES: Pencil (Item 71, Appendix D)
Paper (Item 72, Appendix D)

REFERENCE: TM 5-5420-202-10

PRELIMINARY PROCEDURE: Remove actuating lever
(page 17-34)

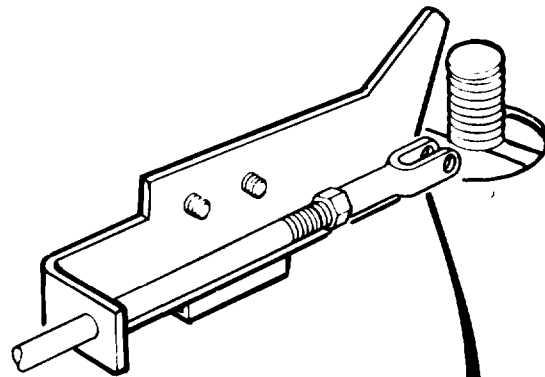
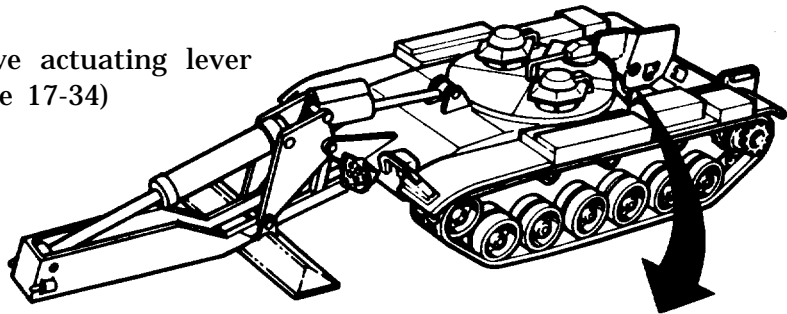

REMOVAL:

1. Using 9/16 inch wrench, loosen jamnut (A) while holding clevis (B) with pliers.

NOTE

Count and write down number of turns needed to unscrew clevis (B) from rod (C).

2. Unscrew clevis (B) and jamnut (A) from rod (C) while holding rod (C) with 10 inch pipe wrench.

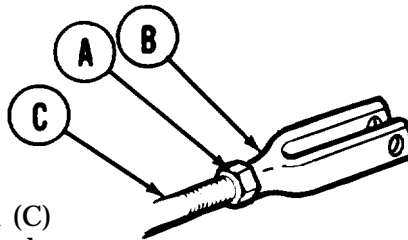

Go on to Sheet 2

TA248569

REAR DRAIN VALVE MOUNTING BRACKETS REPLACEMENT (Sheet 2 of 2)

3. Using socket, remove four screws (D), four lockwashers (E), and two washers (F) attaching large bracket (G) to small bracket (H) and small bracket (H) to hull floor (J) .
4. Slide large bracket (G) off rod (K).

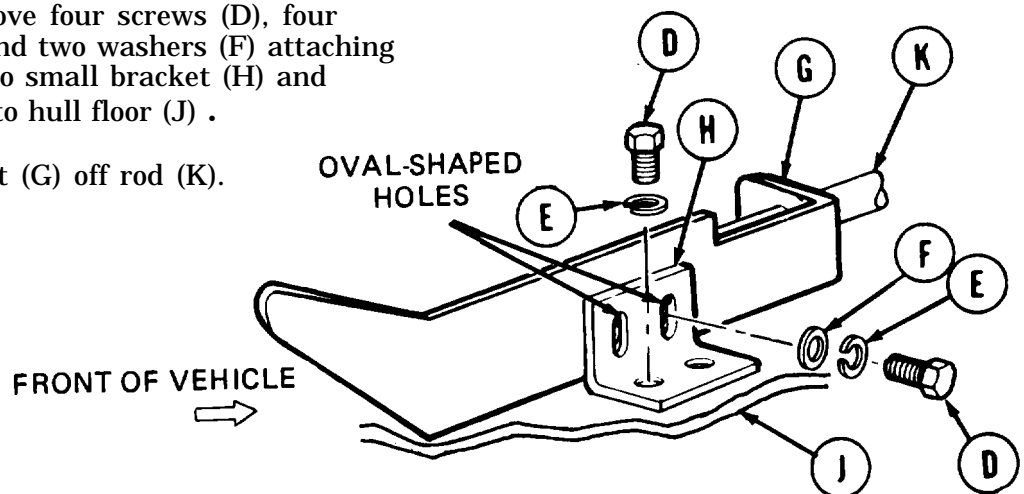

INSTALLATION

1. Using socket, install two screws (A), lockwashers (B), and flat washers (C) through oval-shaped holes in small bracket (D) into holes in large bracket (E).
2. Slide large bracket (E) on rod (F).
3. Using socket, install two screws (G) and lockwashers (H) attaching small bracket (D) to hull floor (J).

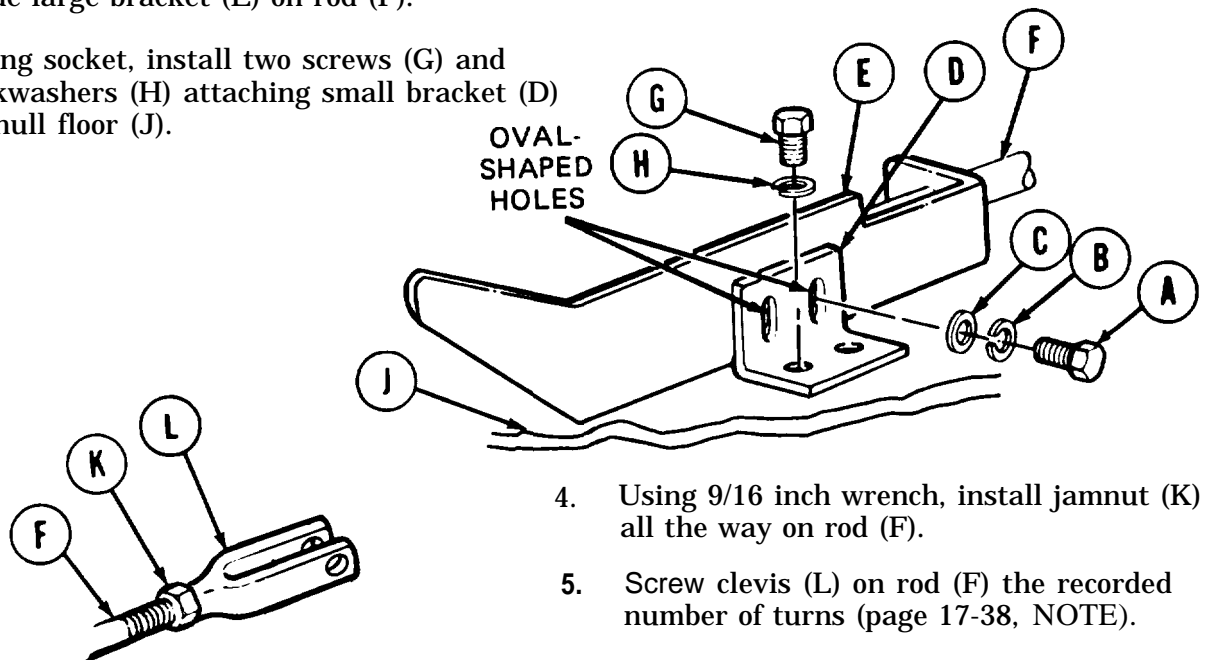

4. Using 9/16 inch wrench, install jamnut (K) all the way on rod (F).
5. Screw clevis (L) on rod (F) the recorded number of turns (page 17-38, NOTE).
6. Using 9/16 inch wrench, tighten jamnut (K) against clevis (L) while holding clevis (L) with pliers.
7. Install actuating lever (page 17-36).

End of Task

TA248570

REAR DRAIN VALVE LINKAGE ADJUSTMENT (Sheet 1 of 7)

TOOLS: 9/16 in. combination box and open end wrench (2 required)
Slip joint pliers
1/8 in. dia. alinement pin (2 in. long)
6 in. steel rule

SUPPLIES: Cotter pins (2 required)

REFERENCE: TM 5-5420-202-10

PRELIMINARY PROCEDURE: Remove powerplant (page 5-2)

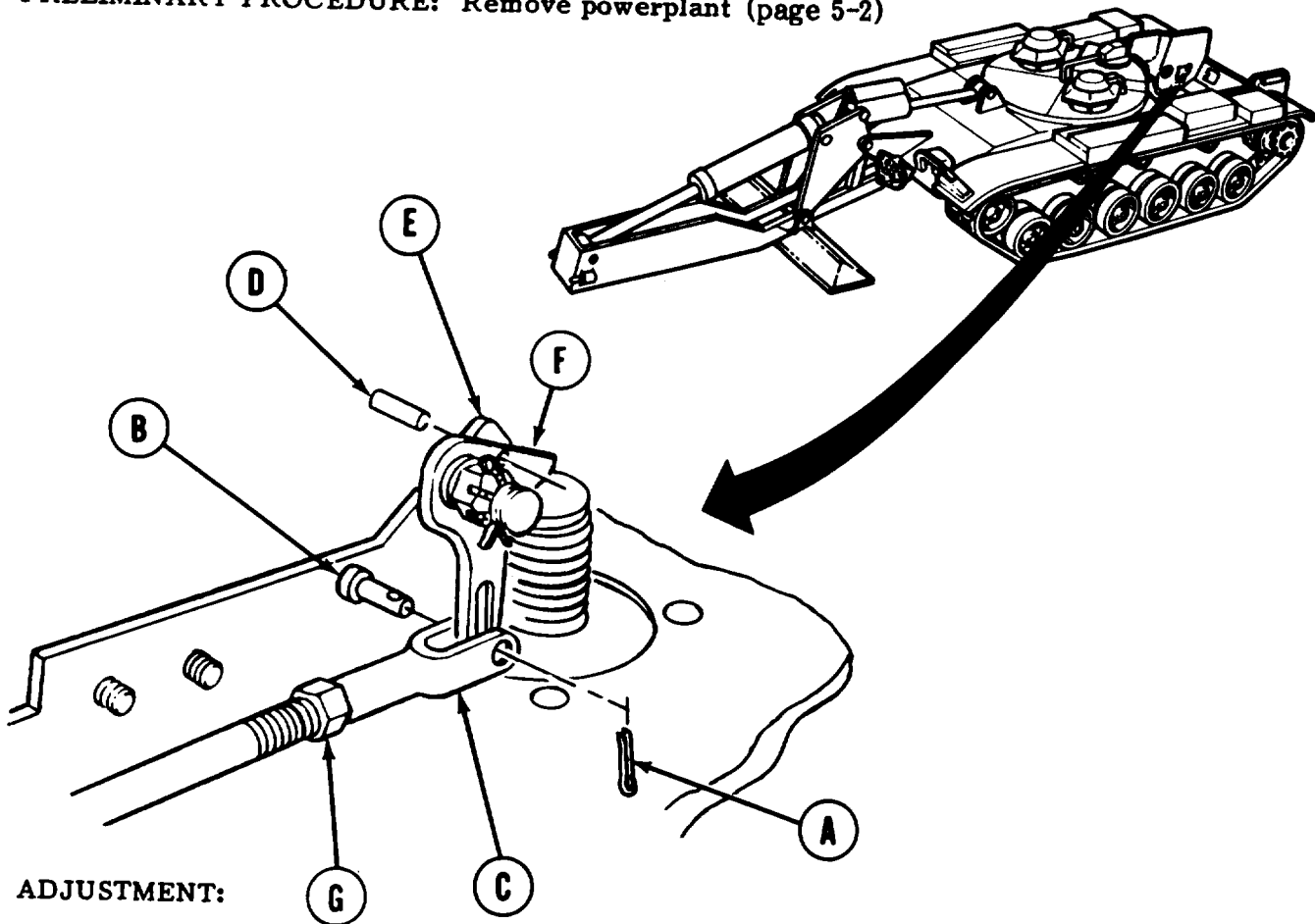

ADJUSTMENT:

1. Using pliers, remove cotter pin (A) from clevis pin (B).
2. Pull clevis pin (B) out of holes in clevis (C).
3. Put alinement pin (D) through hole in bracket (E) and hole in lever (F).
4. Using 9/16 inch wrench, loosen jamnut (G) all the way while holding clevis (C) with pliers.

Go on to Sheet 2

TA248571

REAR DRAIN VALVE LINKAGE ADJUSTMENT (Sheet 2 of 7)

5. Adjust clevis (C) until holes in clevis and hole in lever (F) can be lined up using clevis pin (B).
6. Using fingers, tighten jamnut (G) against clevis (C).
7. Measure threads on rod (H):

If threads measure one inch or less, go to step 14.

If threads are more than one inch, go to step 8.

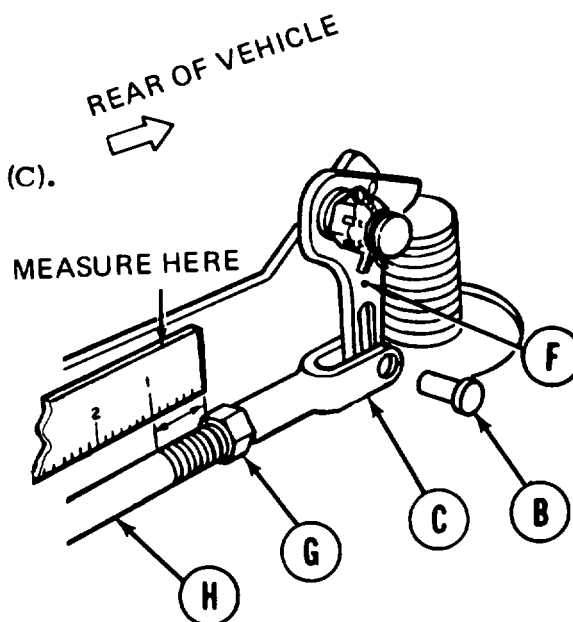

NOTE

Coupling jamnut (J) can be reached from engine compartment. Open or close rear drain valve, if necessary, to put wrench on coupling jam nut (J).

8. Using wrench, loosen coupling jamnut (J) all the way while holding coupling (K) with another wrench.

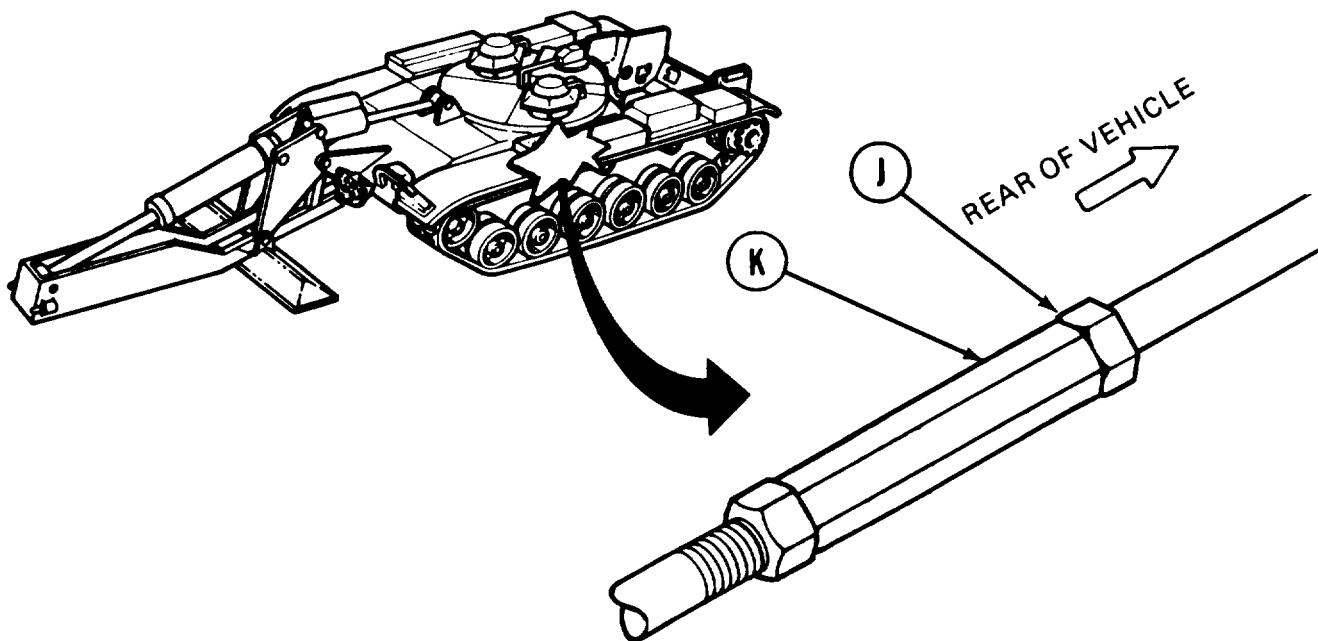

Go on to Sheet 3

TA248572

REAR DRAIN VALVE LINKAGE ADJUSTMENT (Sheet 3 of 7)

9. Adjust clevis (C) and jamnut (G) until one inch of threads can be measured on rod (H).
10. Using wrench, tighten jamnut (G) while holding clevis (C) with pliers.
11. Turn rod (H) by hand until holes in clevis (C) and hole in lever (E) can be lined up using clevis pin (B).
12. Using fingers, push clevis pin (B) through holes in clevis (C) and hole in lever (E).
13. Using wrench, tighten rear coupling jamnut (J) while holding coupling (K) with another wrench.

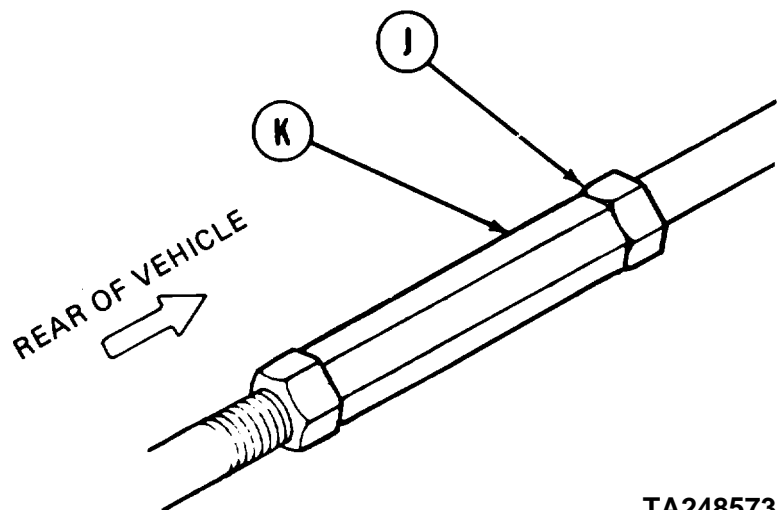
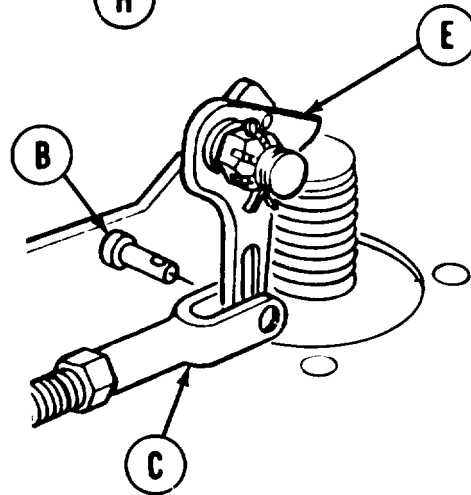
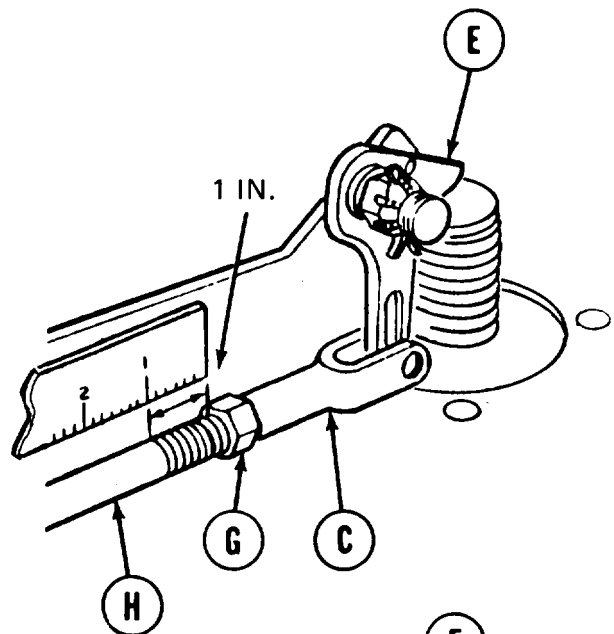

Go on to Sheet 4

TA248573

REAR DRAIN VALVE LINKAGE ADJUSTMENT (Sheet 4 of 7)

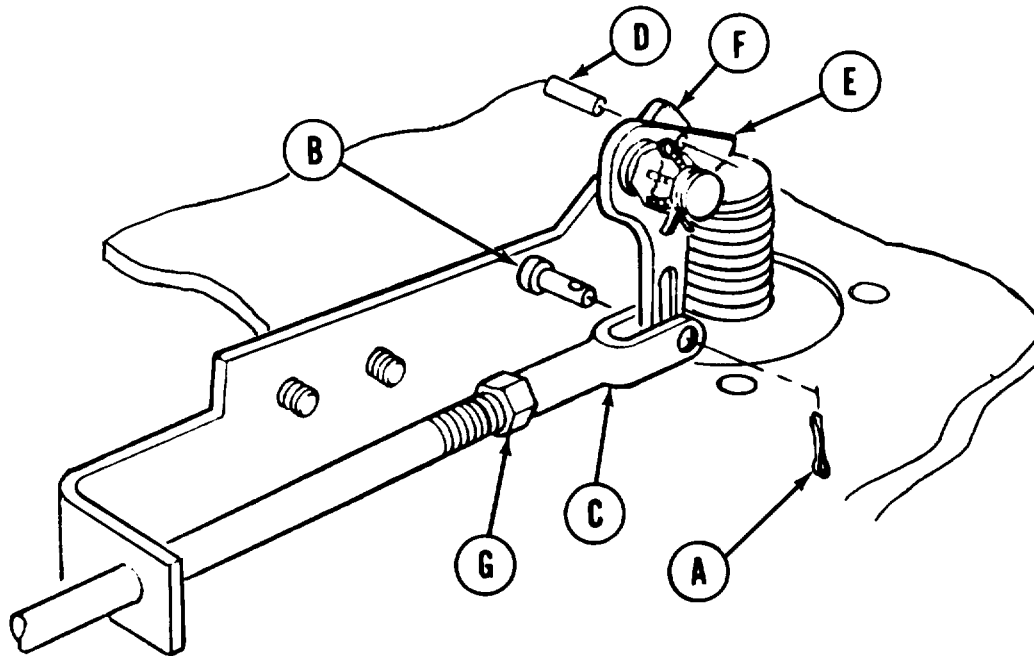

14. If clevis pin (B) was not installed in clevis (C) in step 12, use fingers and install clevis pin (B) in holes in clevis (C) and hole in lever (E).
15. Using pliers, install new cotter pin (A) in clevis pin (B).
16. Pull alignment pin (D) out of hole in lever (E) and hole in bracket (F).
17. If clevis jamnut (G) was not tightened against clevis (C) in step 10, use wrench and tighten jamnut (G) while holding clevis (C) with pliers.
18. Make sure drain valve (M) opens when control lever (N) is in open position (TM 5-5420-202-10).

If valve (M) does not open, perform steps 19 through 30.

If valve (M) opens, go to step 31 (page 17-46).

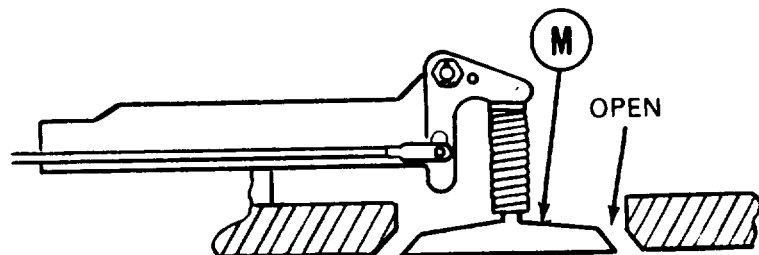
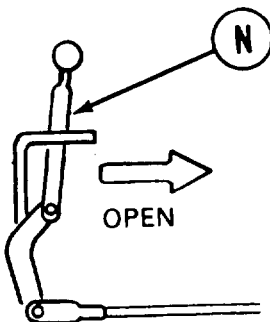

Go on to Sheet 5

TA248574

REAR DRAIN VALVE LINKAGE ADJUSTMENT (Sheet 5 of 7)

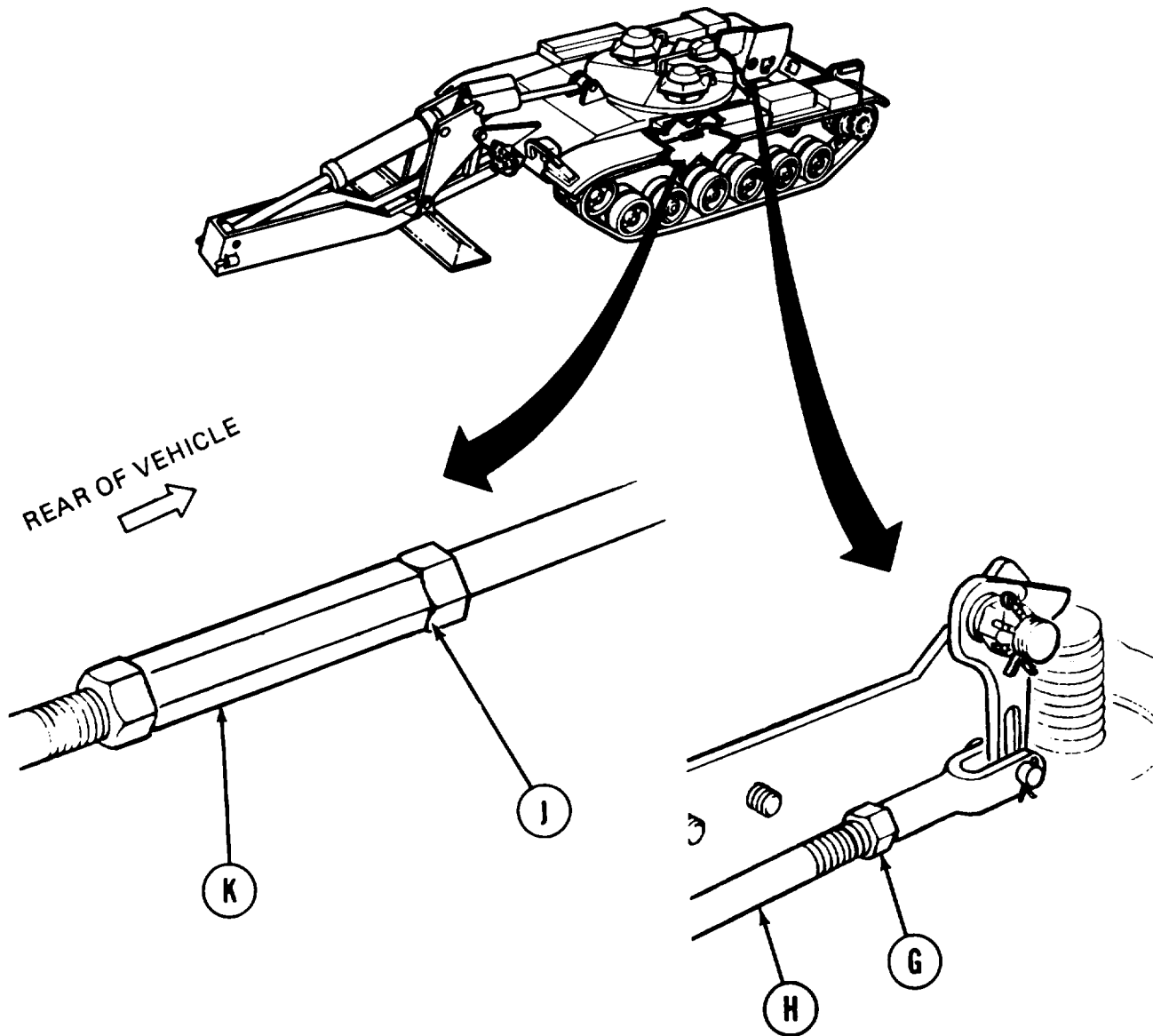

19. Close rear drain valve (TM 5-5420-202-10).
20. Using wrench, loosen rear coupling jamnut (J) all the way while holding coupling (K) with another wrench.
21. Using wrench, loosen clevis jamnut (G) all the way while holding rod (H) with pliers.

Go on to Sheet 6

TA240576

REAR DRAIN VALVE LINKAGE ADJUSTMENT (Sheet 6 of 7)

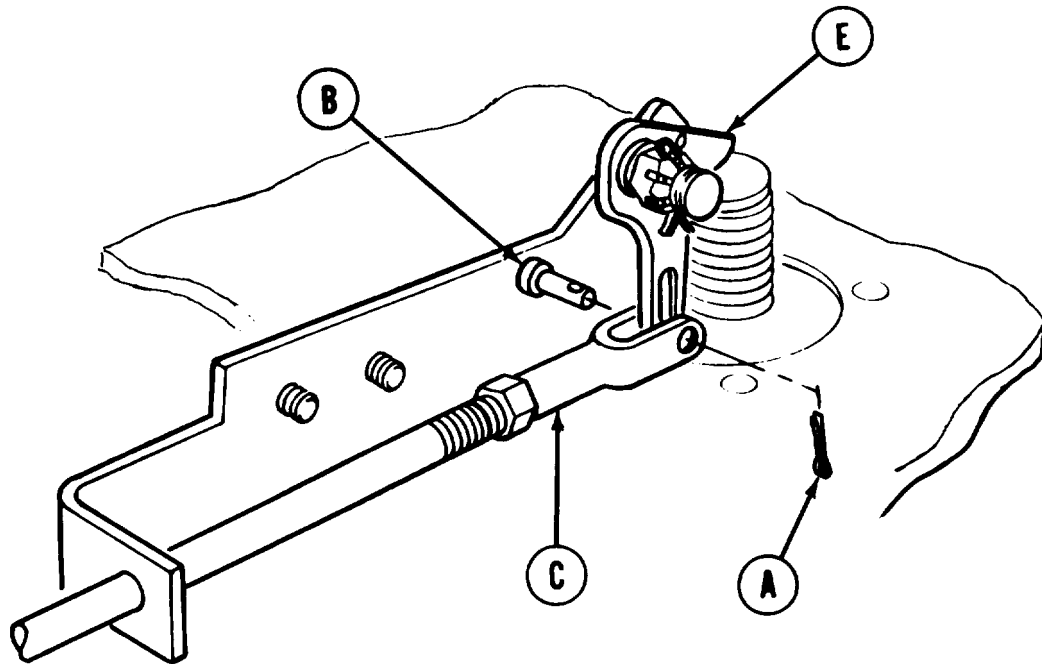

22. Using pliers, remove cotter pin (A) from clevis pin (C).
23. Using fingers, pull clevis pin (B) from clevis (C).
24. Hold clevis (C) and turn clockwise five complete turns.
25. Line up holes in clevis (C) with hole in lever (E).
26. Using fingers, push clevis pin (B) through holes in clevis (C) and hole in lever (E).
27. Using pliers, install new cotter pin (A) in hole in clevis pin (B).

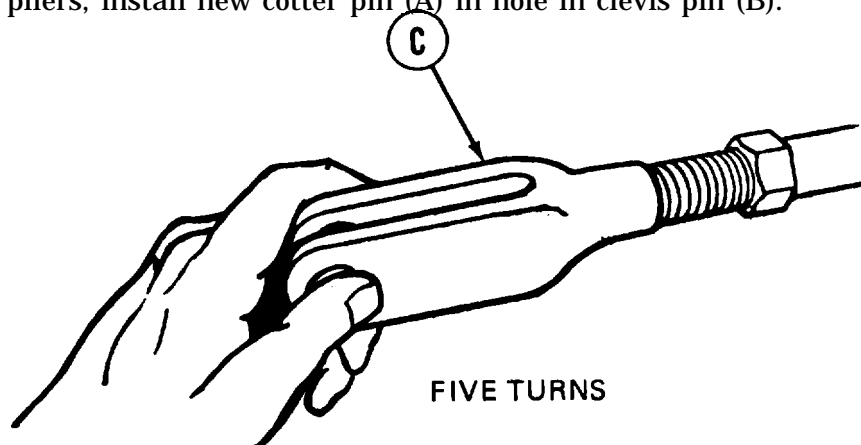

Go on to Sheet 7

TA248576

REAR DRAIN VALVE LINKAGE ADJUSTMENT (Sheet 7 of 7)

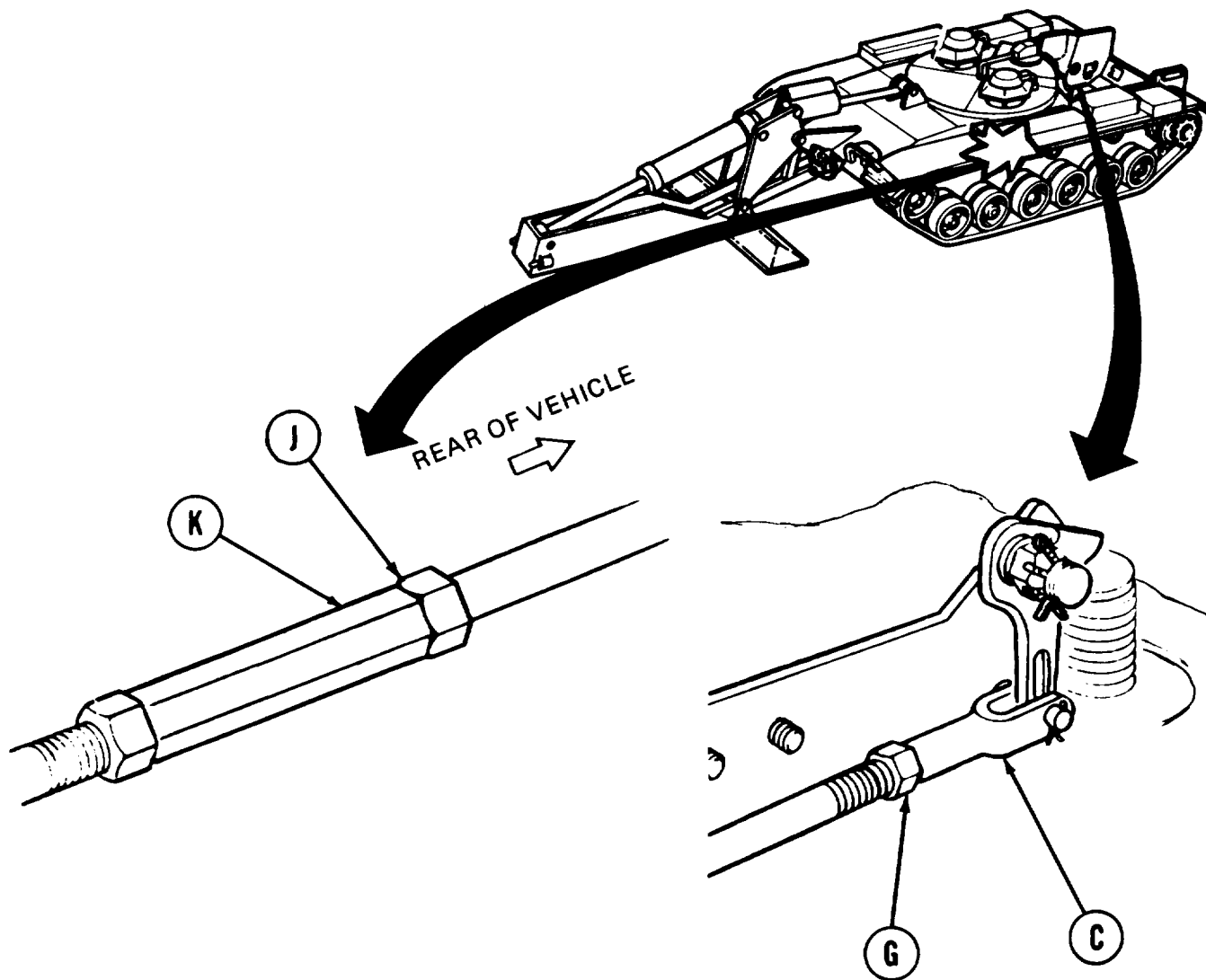

28. Using wrench, tighten rear coupling jamnut (J) while holding coupling (K) with wrench.
29. Using wrench, tighten clevis jamnut (G) while holding clevis (C) with pliers.
30. Make sure drain valve opens when control lever is in open position (step 18).
 - If drain valve does not open, repeat steps 19 through 30.
 - If drain valve opens, go to step 31.
31. Install powerplant (page 5-14).

End of Task

TA248577

REAR DRAIN VALVE ASSEMBLY REPLACEMENT (Sheet 1 of 6)

PROCEDURE INDEX

PROCEDURE	PAGE
Removal	17-47
Cleaning and Inspection	17-50
Installation	17-51

TOOLS: Slip joint pliers
 Ratchet with 1/2 in. drive
 3/4 in. socket with 1/2 in. drive
 Hammer
 1/8 in. drive pin punch
 6 in. steel rule
 Putty knife
 Flat-tip screwdriver (2 required)

SUPPLIES: Dry cleaning solvent (Item 55, Appendix D)
 Gasket
 Rags (Item 65, Appendix D)

Block of wood, approx.
 2 in. x 4 in.
 Gloves (Item 69, Appendix D)
 Goggles (Item 70, Appendix D)

PERSONNEL: Two

Go on to Sheet 2

REAR DRAIN VALVE ASSEMBLY REPLACEMENT (Sheet 2 of 6)

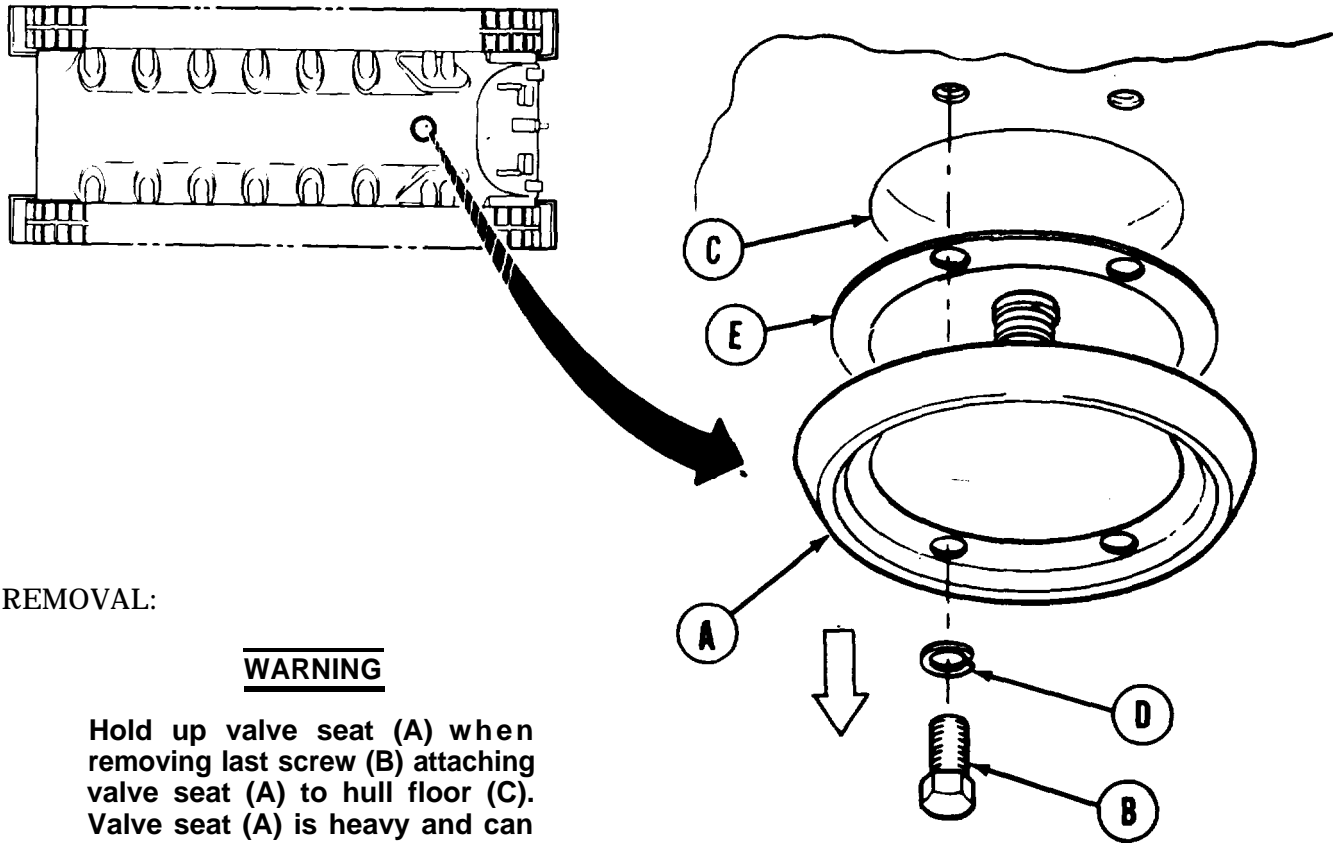

REMOVAL:

WARNING

Hold up valve seat (A) when removing last screw (B) attaching valve seat (A) to hull floor (C). Valve seat (A) is heavy and can cause injury if it falls.

1. Using socket, remove four screws (B) and lockwashers (D) holding valve seat (A) and gasket (E) to hull floor (C).
2. While holding valve seat (A), use screwdriver and pry valve seat (A) from hull floor (C).
3. Using putty knife, scrape gasket (E) from hull floor (C) and valve seat (A).

Go on to Sheet 3

TA246679

REAR DRAIN VALVE ASSEMBLY REPLACEMENT (Sheet 3 of 6)

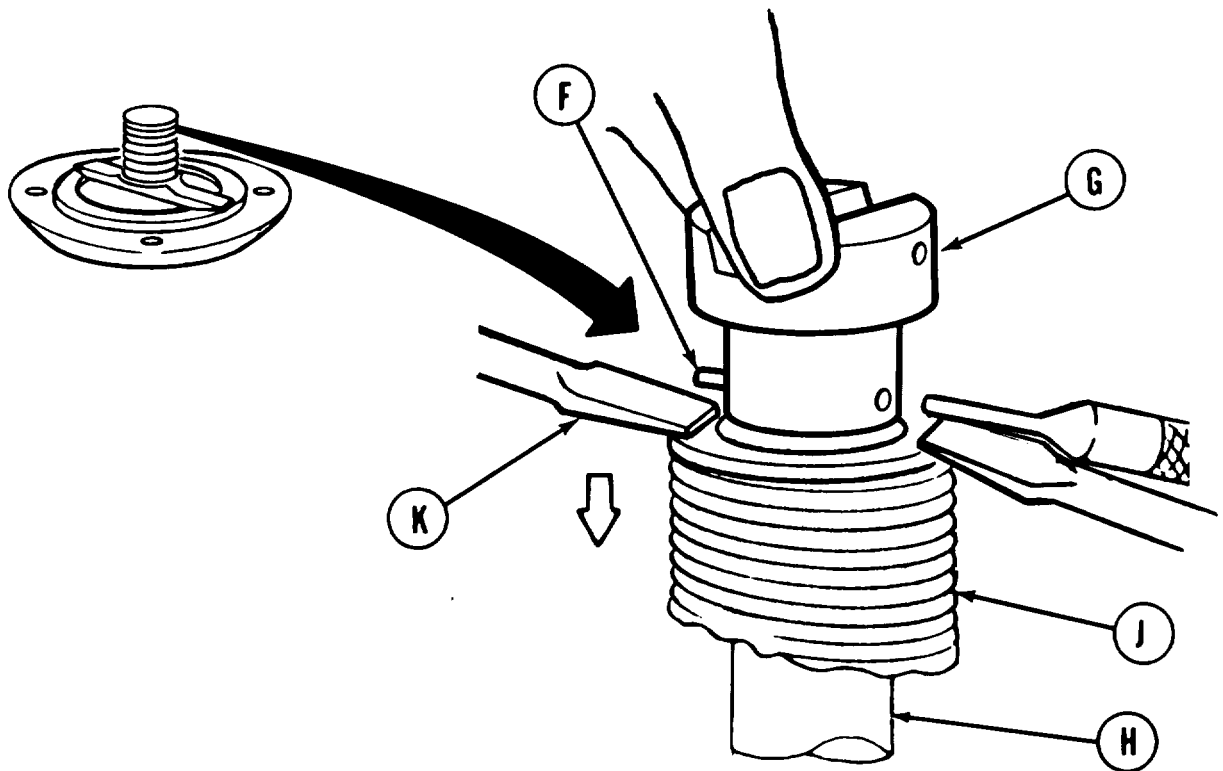

4. Using hammer and punch, drive pin (F) out of knob (G) and valve (H) while second person holds down spring (J) and ferrule (K) using two screwdrivers.
5. Remove knob (G), ferrule (K), spring (J), and valve (H) from valve seat (A).

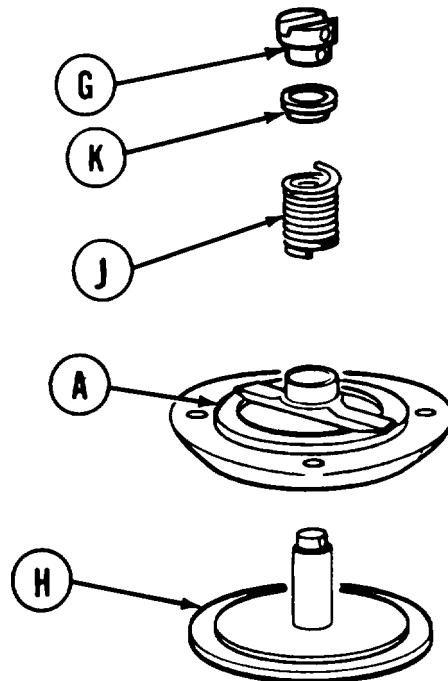

Go on to Sheet 4

TA248580

REAR DRAIN VALVE ASSEMBLY REPLACEMENT (Sheet 4 of 6)

CLEANING AND INSPECTION:

WARNING

Dry cleaning solvent P-D-680 is toxic and flammable. To prevent personal injury, wear protective goggles and gloves and use only in a well-ventilated area. Avoid contact with skin, eyes, and clothes and don't breathe vapors. Do not use near open flame or excessive heat. The flash point for Type #1 Dry Cleaning Solvent is 100°F (38°C) and for Type #2 is 138°F (50°C). If you become dizzy while using cleaning solvent, get fresh air immediately and get medical aid. If contact with eyes is made, wash your eyes with water and get medical aid immediately.

1. Using drycleaning solvent and clean rags, clean all parts.
2. Inspect removed parts for cracks, nicks, burrs, or other defects. Replace defective parts.
3. Measure length of spring (A). If spring (A) measures less than 2-1/2 inches, replace spring (A).
4. Inspect mating surface of valve (B) and valve seat (C) for nicks, cracks, burrs, rust, or other defects. If defects are found, replace defective part.

REAR DRAIN VALVE ASSEMBLY REPLACEMENT (Sheet 5 of 6)

INSTALLATION:

1. Assemble knob (A), ferrule (B), spring (C), and valve (D) on valve seat (E).

NOTE

Use block of wood to support valve (D) in the closed Position.

2. With second person pressing down on ferrule (B) with two screwdrivers, use punch to line up hole in knob (A) and hole in valve (D).
3. Using pliers, start pin (F) in hole in knob (A).
4. Using hammer and punch, drive pin (F) all the way in hole.

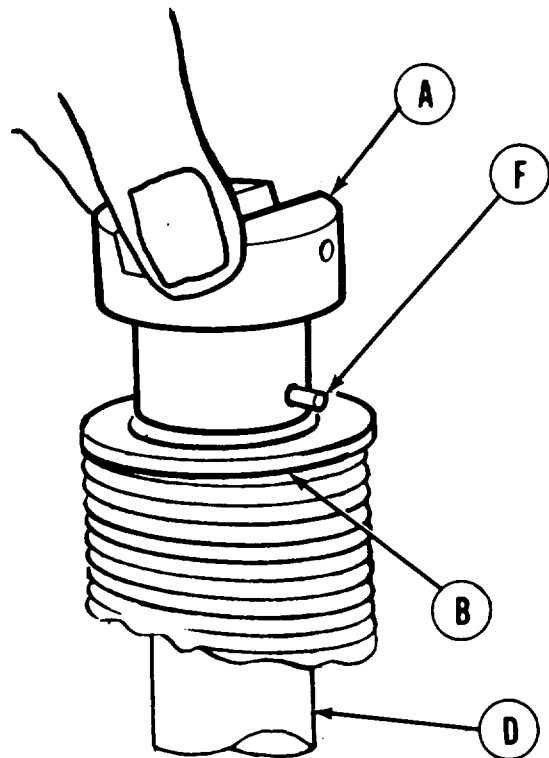
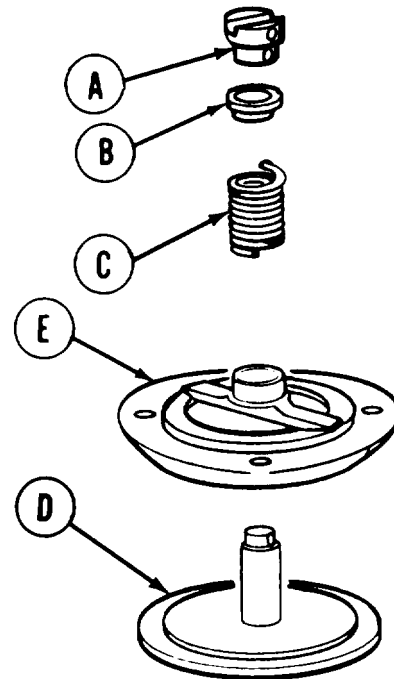

Go on to Sheet 6

TA248582

REAR DRAIN VALVE ASSEMBLY REPLACEMENT (Sheet 6 of 6)

5. Line up four holes in valve seat (E), new gasket (G), and hull floor (H) under vehicle.
6. Using socket, install four screws (J) and lockwashers (K) holding valve seat (E) and gasket (G) to hull floor (H).
7. Operate rear drain valve to make sure valve opens and closes smoothly. If valve does not open or close properly, remove, inspect, and install valve assembly again.

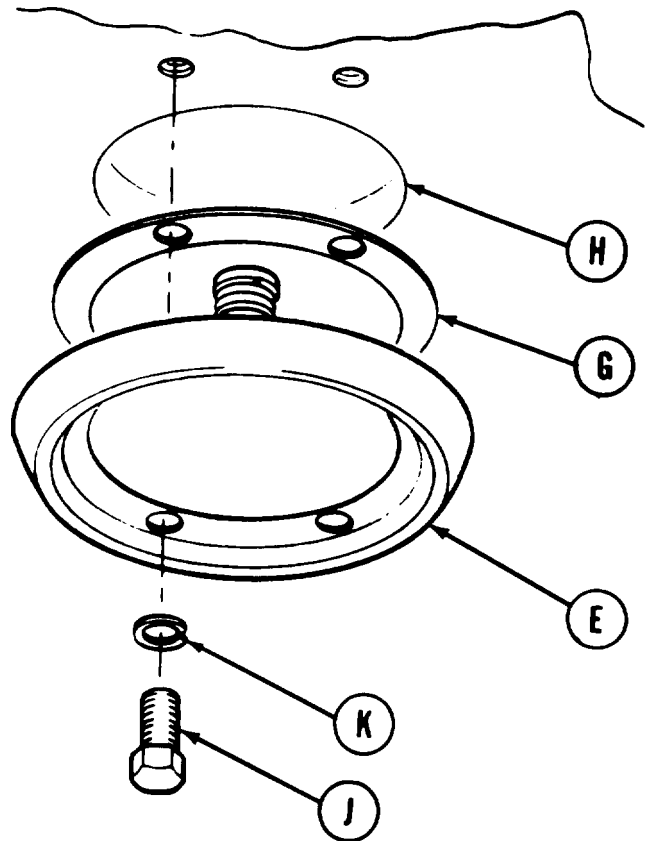

End of Task

TA248583

COMMANDER'S SEAT BACKREST REPLACEMENT (Sheet 1 of 1)

TOOLS: 7/16 in. combination box and open end wrench

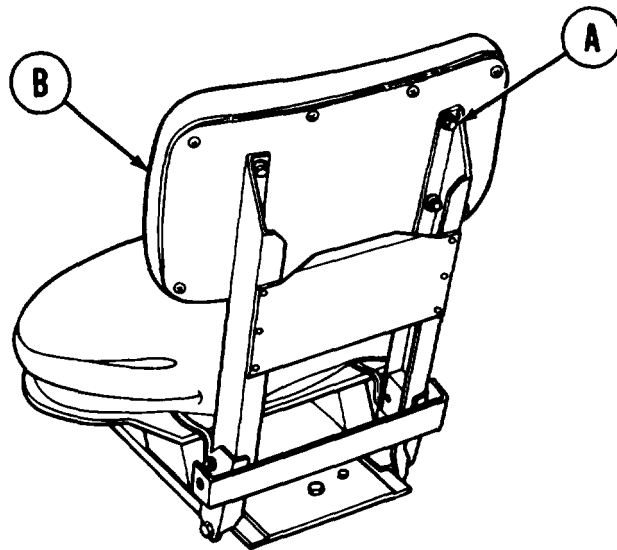
**REMOVAL:**

1. Using wrench, remove four screws and flat washers (A) from backrest (B).
2. Remove backrest (B).

INSTALLATION:

1. Position backrest (B) with holes alined.
2. Using wrench, install four flat washers and screws (A).

End of Task

TA248584

OPERATOR'S SEAT BACKREST REPLACEMENT (Sheet 1 of 1)

TOOLS: Slip joint pliers

REMOVAL:

1. Using fingers, pull pin (A) from backrest (B) and support (C).
2. Using pliers, remove two hooks (D) and chain (E).
3. Untie cord (F) and remove pad (G).

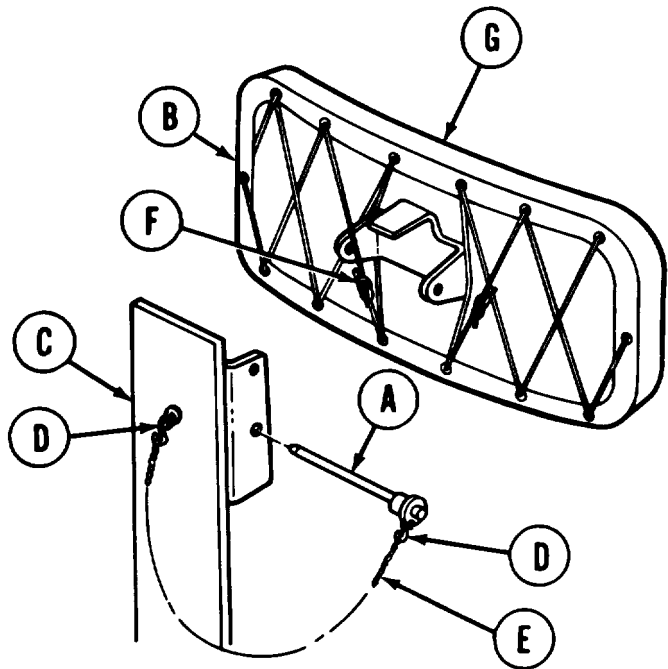

INSTALLATION:

1. Place pad (G) in position on backrest (B).
2. Lace cord (F) through pad (G) and tie securely.
3. Using pliers, install two hooks (D) and chain (E) to support (C) and pin (A).
4. Place backrest (B) in position on support (C).
5. Push pin (A) into place through support (C) and backrest (B).

End of Task

TA248585

PERSONNEL SEAT CUSHION REPLACEMENT (Sheet 1 of 1)

TOOLS: Slip joint pliers

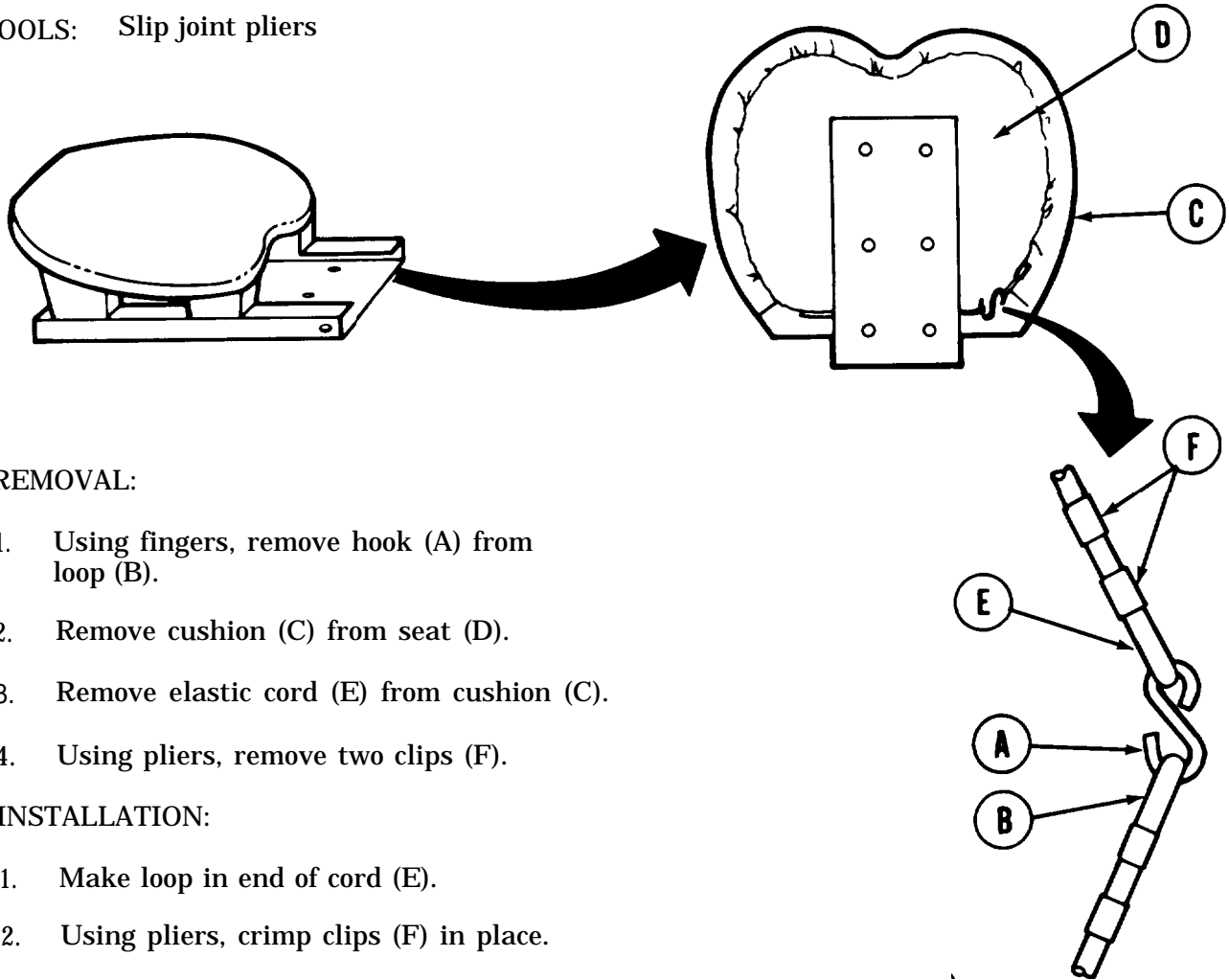
**REMOVAL:**

1. Using fingers, remove hook (A) from loop (B).
2. Remove cushion (C) from seat (D).
3. Remove elastic cord (E) from cushion (C).
4. Using pliers, remove two clips (F).

INSTALLATION:

1. Make loop in end of cord (E).
2. Using pliers, crimp clips (F) in place.
3. Using fingers, thread elastic cord (E) through channel in cushion (C).
4. Position cushion (C) on seat (D).
5. Using fingers, install hook (A) in loop (B).

End of Task

TA248586

PERSONNEL SEAT AND SEAT MOUNT ASSEMBLY REPLACEMENT (Sheet 1 of 2)

TOOLS: 7/16 in. combination box and open end wrench
 1/2 in. combination box and open end wrench (2 required)
 9/16 in. open end wrench
 7/16 in. socket with 1/2 in. drive
 Ratchet with 1/2 in. drive
 Putty knife

SUPPLIES: Adhesive (Item 4, Appendix D)

NOTE

This procedure covers the replacement of the commander's seat and seat mount assembly. Replacement of the driver's seat and seat mount assembly is similar.

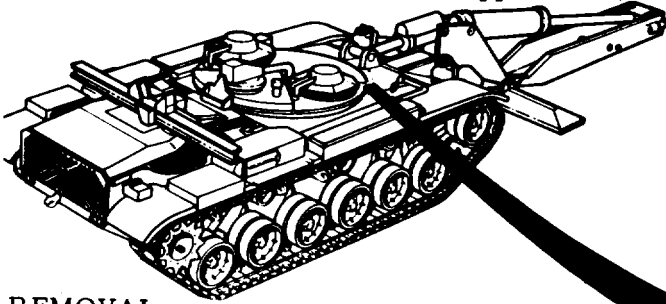

REMOVAL:

1. Using two 1/2 inch wrenches, remove two bolts, flat washers, lockwashers, and nuts (A).
2. Using putty knife, remove pad (B).
3. Using 9/16 inch wrench, remove two screws, lockwashers and washers (C).

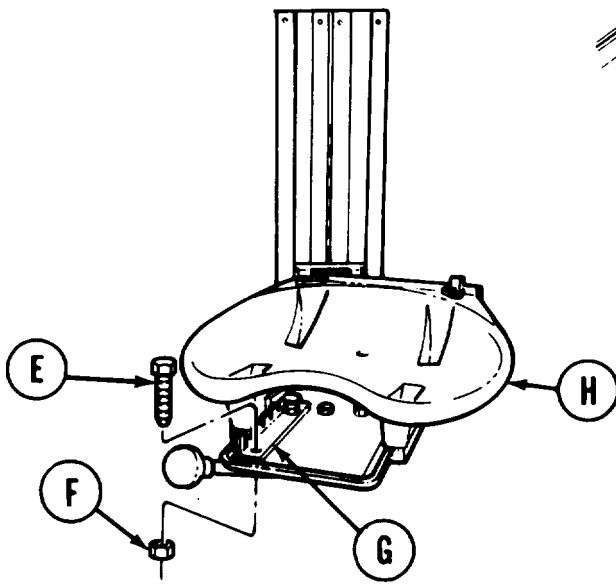
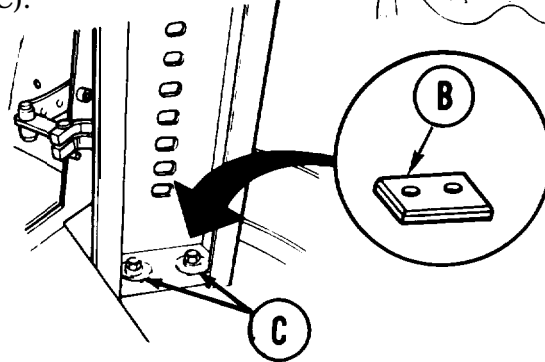
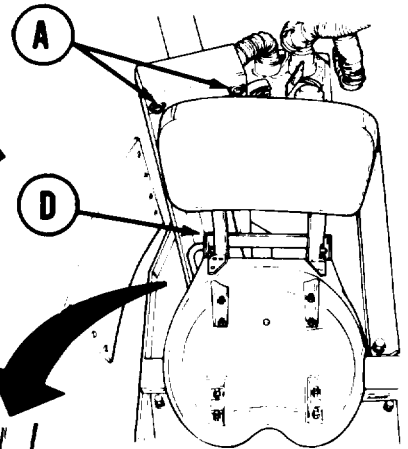

4. Remove seat and seat mount assembly (D) from vehicle.
5. Using 7/16 inch wrench and socket, remove two screws (E) and nuts (F) securing rack (G).
6. Remove rack (G) and seat (H).

Go on to Sheet 2

TA248587

PERSONNEL SEAT AND SEAT MOUNT ASSEMBLY REPLACEMENT (Sheet 2 of 2)

INSTALLATION:

1. Slide seat (A) on support (B).
2. Position rack (C) on support (B).
3. Using 7/16 inch wrench and socket, install screw (D) and nut (E) securing rack (C) to support (B).

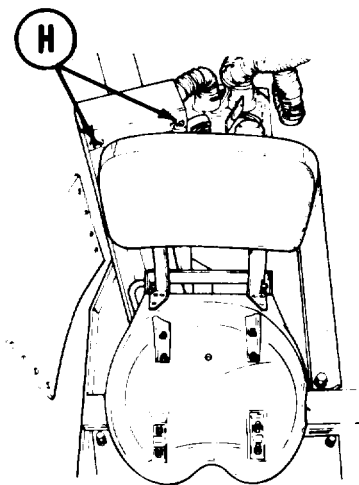
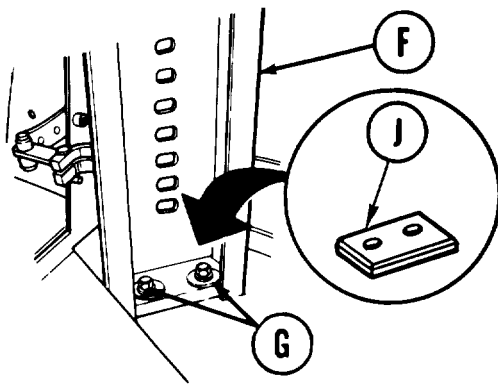
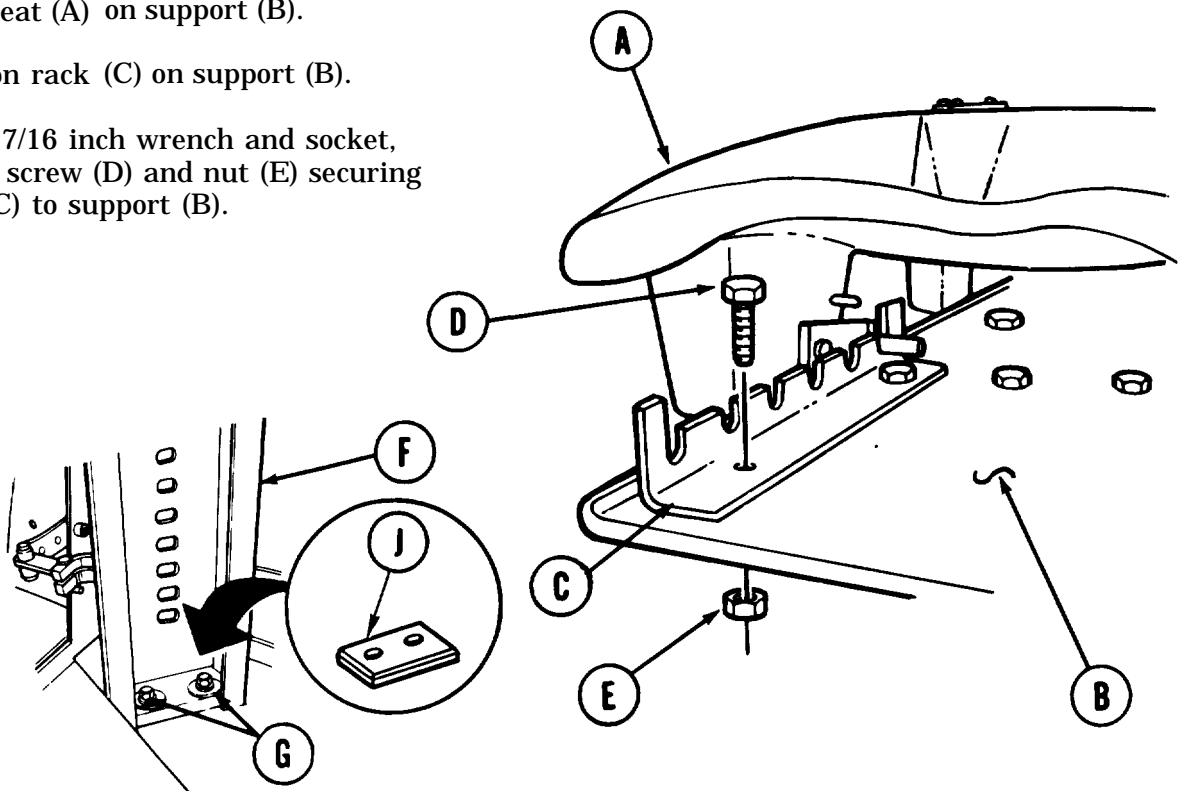

4. Position seat and support (F) in vehicle with holes aligned.
5. Using 9/16 inch wrench, install two screws, lockwashers, and washers (G).
6. Using two 1/2 inch wrenches, install two bolts, flat washers, lockwashers, and nuts (H).
7. Apply adhesive to pad (J), and install pad (J).

End of Task

TA248588

PERSONNEL SEAT ASSEMBLY REPAIR (Sheet 1 of 5)

PROCEDURE INDEX

PROCEDURE	PAGE
Disassembly	17-58
Assembly	17-60

- TOOLS:** Hammer, machinist's
 Punch, drive pin, 1/8 in.
 Screwdriver, flat-tip
 Screwdriver, cross-tip
 5/16 in. combination box and open end wrench
 Punch, drive pin, 1/4 in.
 7/16 in. socket with 1/2 in. drive
 Ratchet wrench with 1/2 in. drive
 Slip joint pliers
 Punch, drive pin, 3/8 in.

- SUPPLIES:** Short spring pins (2 required)
 Long spring pin (2 required)

PRELIMINARY PROCEDURE: Remove seat assembly from vehicle (page 17-56)

PERSONNEL SEAT ASSEMBLY REPAIR (Sheet 2 of 5)

DISASSEMBLY:

1. Using cross-tip screwdriver and 5/16 inch wrench, remove six screws, washers, and nuts (A) from clips (B).
2. Remove two clips (B).
3. Using 7/16 inch socket, remove two screws, washers, and spacers (C) from support (D).
4. Remove support (D) and back assembly (E).

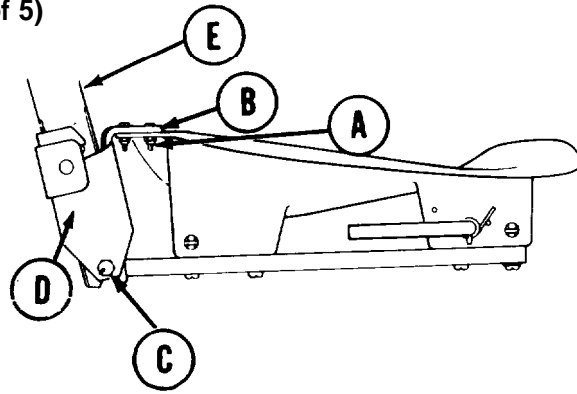

5. Using flat-tip screwdriver, remove eight screws (F).
6. Remove brace (G).
7. Remove two rails (H).
8. Using hammer, 1/8 inch punch, and pliers, remove two long pins (J) from seat (K).
9. Throw pins (J) away.

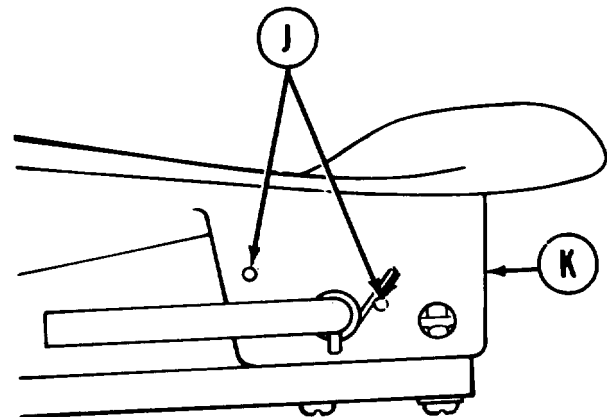
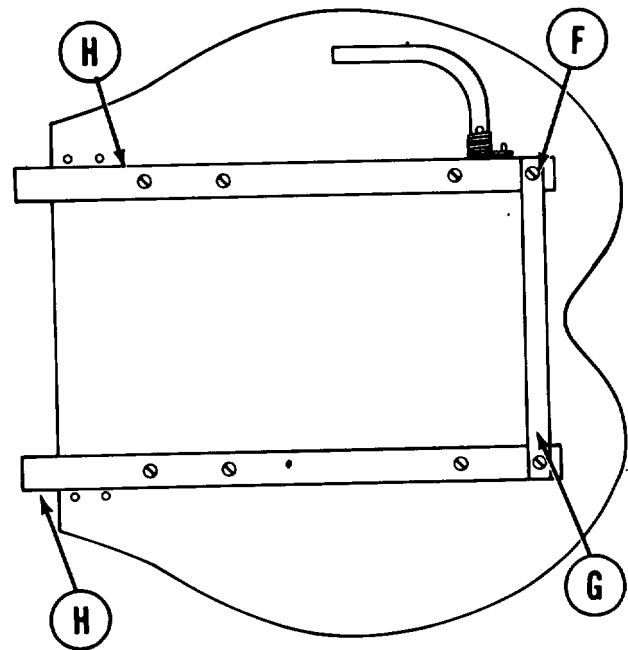

Go on to Sheet 3

TA248590

PERSONNEL SEAT ASSEMBLY REPAIR (Sheet 3 of 5)

10. Using hammer and 1/8 inch punch, remove two short pins (L) from handle (M).
11. Remove handle (M), latch (N), and spring (P).
12. Using hammer and 1/4 inch punch, drive out eight nuts (Q).
13. **Inspect all parts** for damage or wear; replace parts as required.

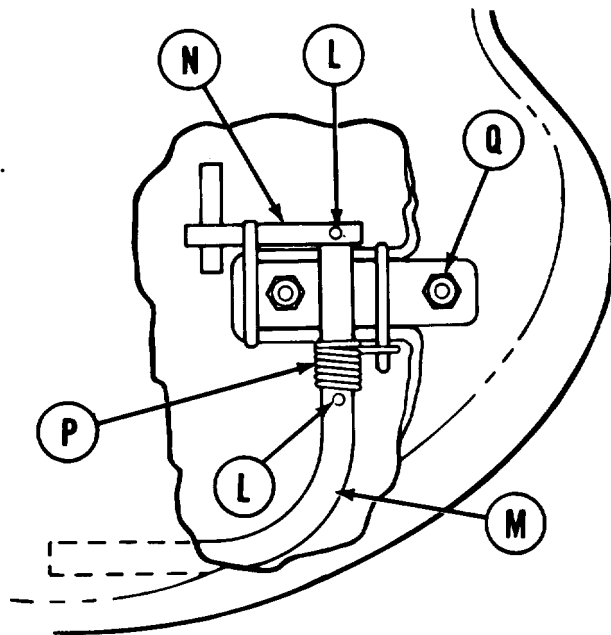

ASSEMBLY:

1. Using hammer and 1/8 inch punch, install eight nuts (A).
2. Using hammer, install new short pin (B) in handle (C).
3. " Position spring (D) on handle (C)..
4. Position handle (C) through hole in seat (E).
5. Position latch (F) on handle (C) with holes alined.
6. Using hammer and punch, install new short pin (G) in handle (C).

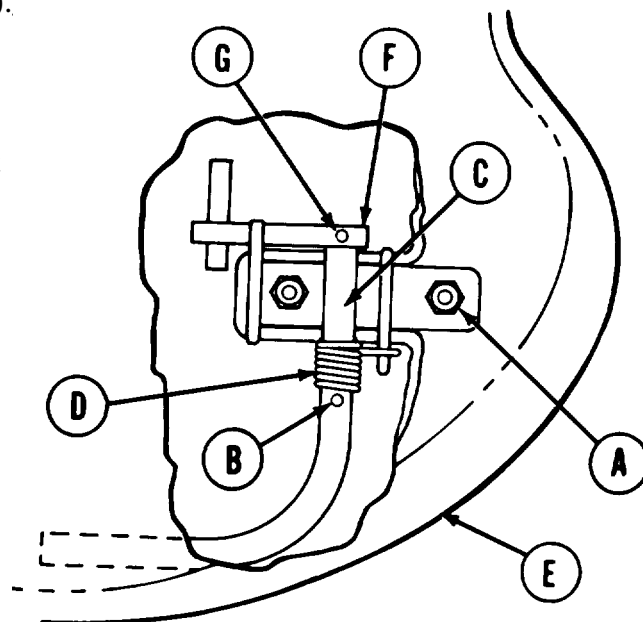

Go on to Sheet 4

TA248591

PERSONNEL SEAT ASSEMBLY REPAIR (Sheet 4 of 5)

7. Position rails (H) on seat (E) with holes a lined.
8. Position brace (J) on rails (H) with holes a lined.
9. Using flat-tip screwdriver, install eight screws (K).
10. Position support (L) and back assembly (M) to seat (E).
11. Using 7/16 inch socket, install two screws, washers, and spacers (N).
12. Position two clips (P) to seat (E) with holes alined.
13. Using cross-tip screwdriver and 5/16 inch wrench, install six screws, washers, and nuts (Q).

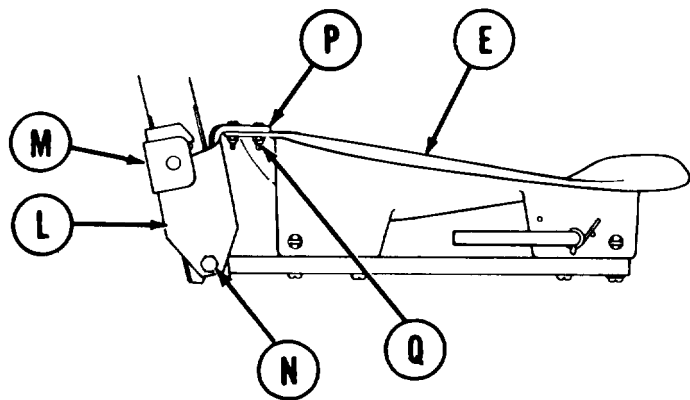
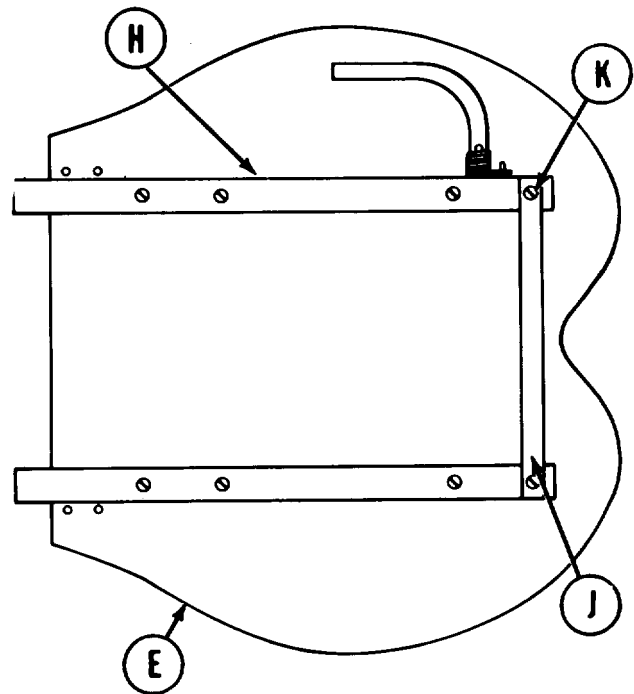

Go on to Sheet 5

TA248592

PERSONNEL SEAT ASSEMBLY REPAIR (Sheet 5 of 5)

14. Using hammer, install two long pins (R) in seat (E) as shown.
15. Install seat assembly in vehicle (page 17-57).

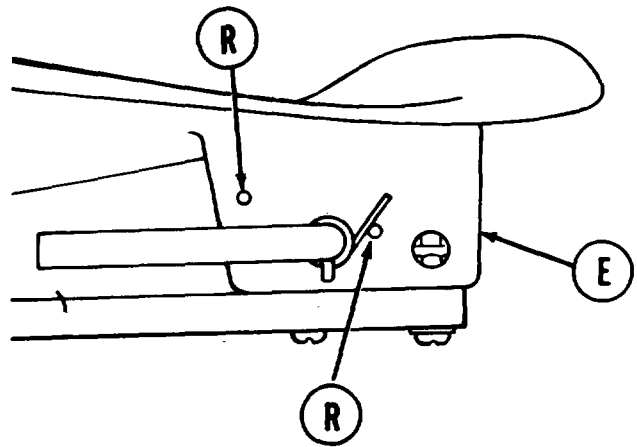

End of Task

TA248593

SEAT AND BACKREST MOUNT ASSEMBLY REPAIR (Sheet 1 of 7)

PROCEDURE INDEX

PROCEDURE	PAGE
Disassembly	17-63
Assembly	17-67

TOOLS: Pliers, long round nose (needle nose)
 1/8 in. drive pin punch
 Hammer
 Cross-tip screwdriver
 7/16 in. socket with 1/2 in. drive
 Ratchet with 1/2 in. drive
 Snap ring pliers
 1/4 in. drive punch
 3/4 in. drive punch (brass drift)
 3/4 in. open end wrench

PERSONNEL: Two

SUPPLIES: Cotter pin
 Spring pin (4 required)

PRELIMINARY PROCEDURE: Remove seat and seat mount assembly (page 17-56)

DISASSEMBLY:

1. Using socket, remove four screws (A).
2. Remove plate (B).
3. Using 3/4 inch wrench, loosen jamnut (C) on crank (D).
4. Using fingers, remove knob (E).
5. Using 3/4 inch wrench, remove jamnut (C).

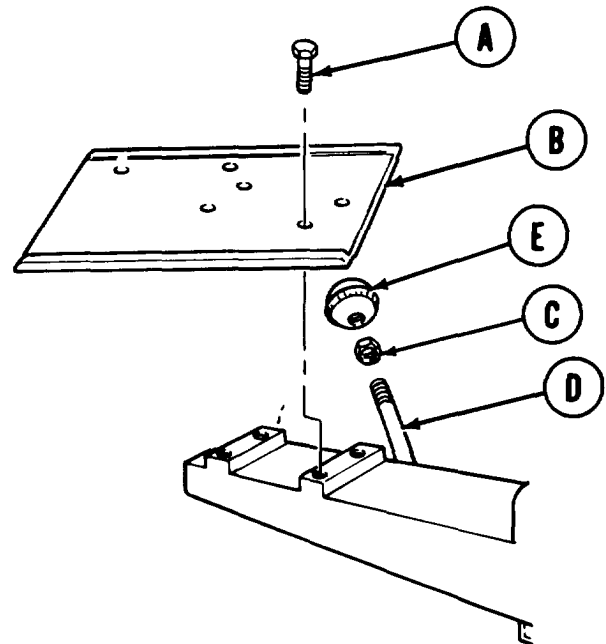

Go on to Sheet 2

TA248594

SEAT AND BACKREST MOUNT ASSEMBLY REPAIR (Sheet 2 of 7)

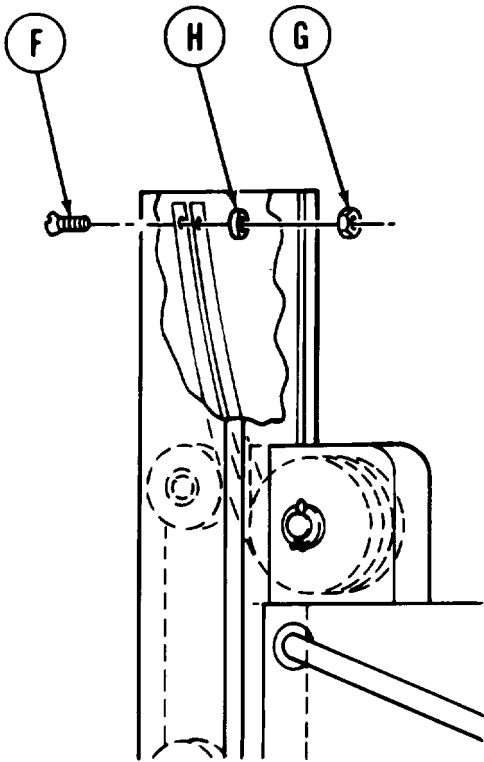

6. Holding two screws (F) with screwdriver, use socket to remove two nuts (G).
7. Remove two screws (F) and washers (H).

8. Lift support (J) up and out of post (K).
9. Using socket, remove screw (L).
10. Lift off cover (M).

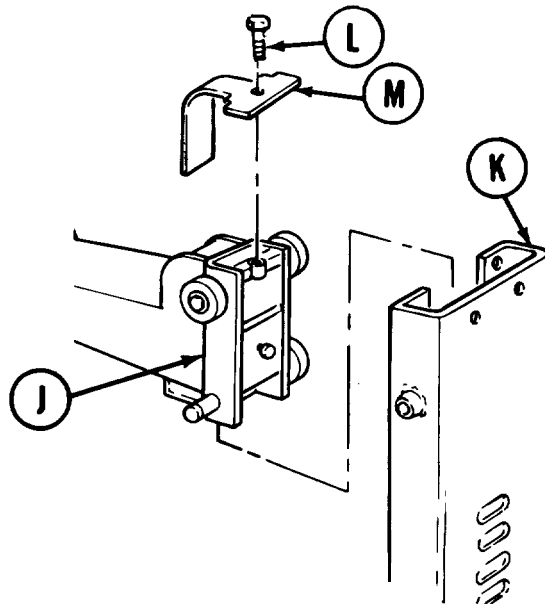

Go on to Sheet 3

TA248595

SEAT AND BACKREST MOUNT ASSEMBLY REPAIR (Sheet 3 of 7)

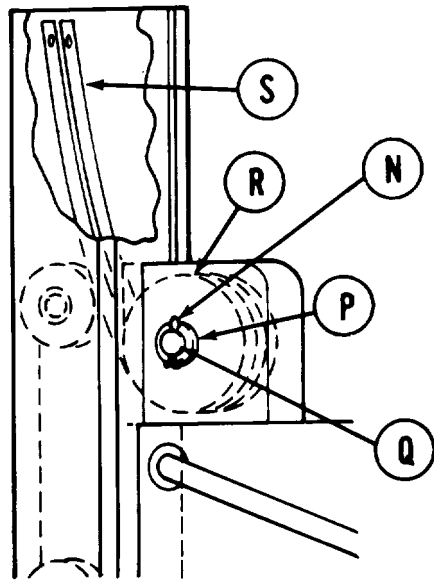

11. Using pliers, remove cotter pin (N).
12. Remove washers (P) and headed pin (Q).
13. Remove spool (R).
14. Remove two springs (S) from spool (R) .

15. Using snap ring pliers, remove four snap rings (T).
16. Remove four rollers (U).
17. Using 1/4 inch punch and hammer, drive out four nuts (V).

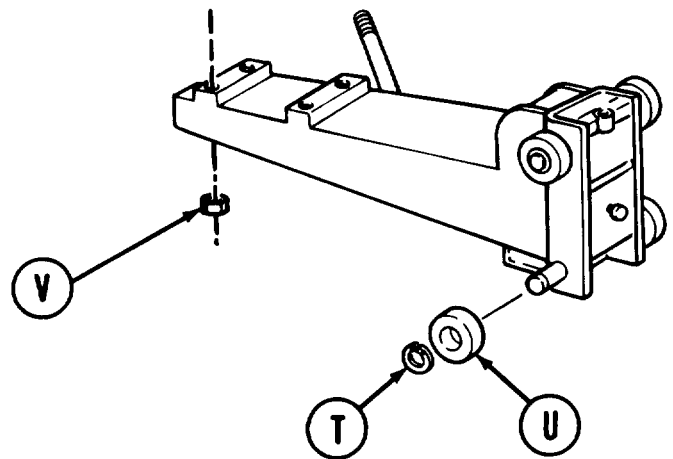

Go on to Sheet 4

TA246596

SEAT AND BACKREST MOUNT ASSEMBLY REPAIR (Sheet 4 of 7)

18. Using 1/8 inch punch and hammer, drive out two spring pins (W).

19. Pull out crank (X).

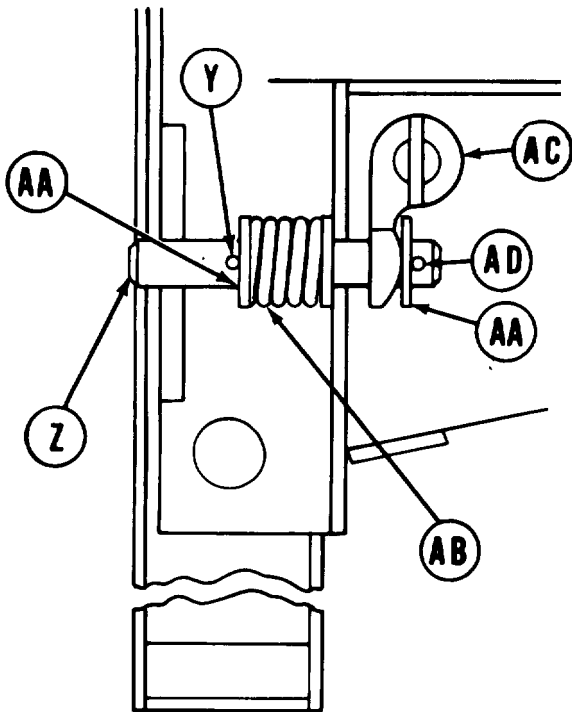
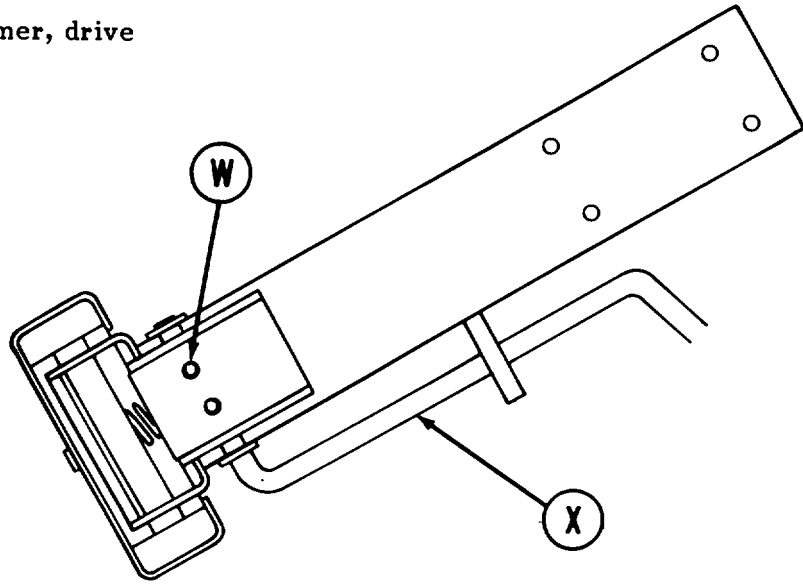

20. Using 1/8 inch punch and hammer, drive out spring pin (Y).

21. Remove pin (Z), two washers (AA), spring (AB), and cam (AC).

22. Using 1/8 inch punch and hammer, drive out spring pin (AD).

Go on to Sheet 5

TA248597

SEAT AND BACKREST MOUNT ASSEMBLY REPAIR (Sheet 5 of 7)

ASSEMBLY:

1. Using hammer, drive in new spring pin (A).
2. Position pin (B), two washers (C), spring (D), and cam (E) as shown in support (F).
3. Using hammer and 1/4 inch punch, drive in new spring pin (G).

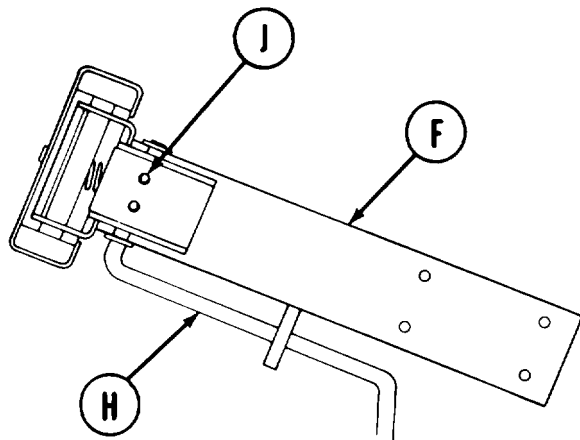
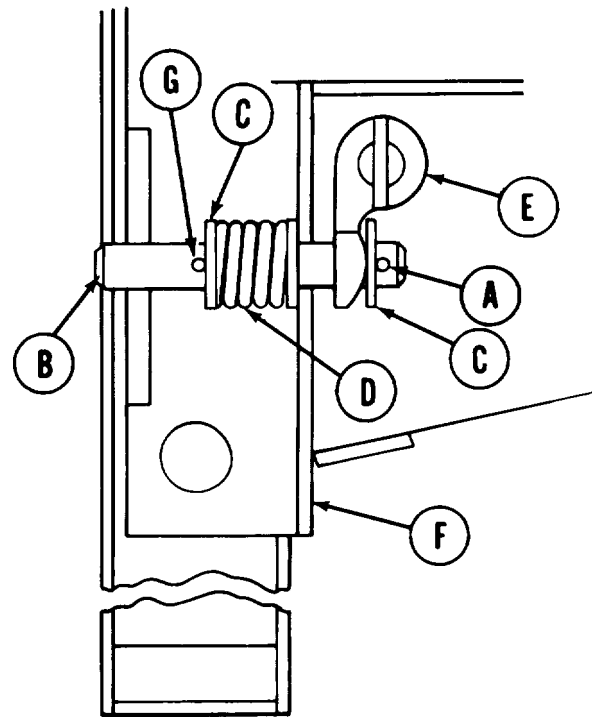

4. Insert crank (H) in support (F).
5. Using hammer and 1/4 inch punch, install two spring pins (J).

6. Using hammer and brass drift, install four nuts (K).
7. Place four rollers (L) in position on support (F).
8. Using snap ring pliers, install four snap rings (M).

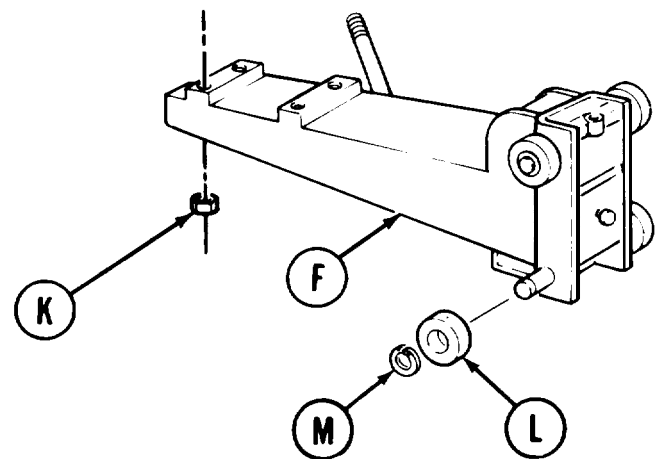

Go on to Sheet 6

TA248598

SEAT AND BACKREST MOUNT ASSEMBLY REPAIR (Sheet 6 of 7)

9. Install two springs (N) on spool (P).
10. Place spool (P) in position on support (F).
11. Install headed pin (Q) and washer R through spool (P).
12. Using pliers, install cotter pin (S),
13. Lower support (F) into position in post (T).

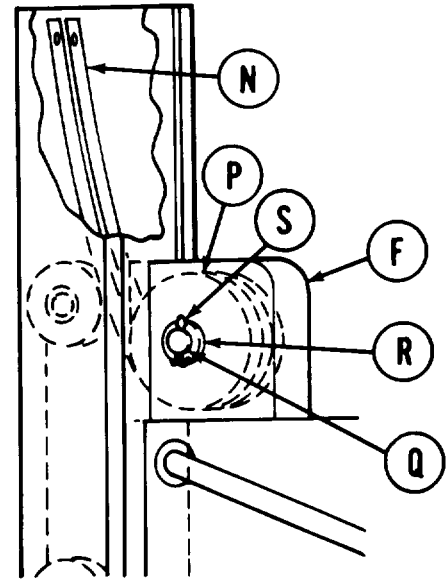

NOTE

Steps 14 through 16 must be performed by two people.

14. Place two springs (N) in position on post (T) .

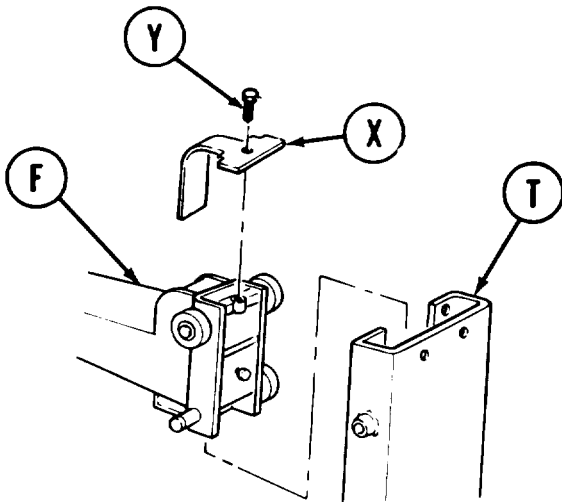

15. Install two screws (U), washers (V), and nuts (W) through two springs (N).
16. Holding two screws (U) with screwdriver, use socket to tighten two nuts (W).
17. Place cover (X) in position on support (F).
18. Using socket, install screw (Y).

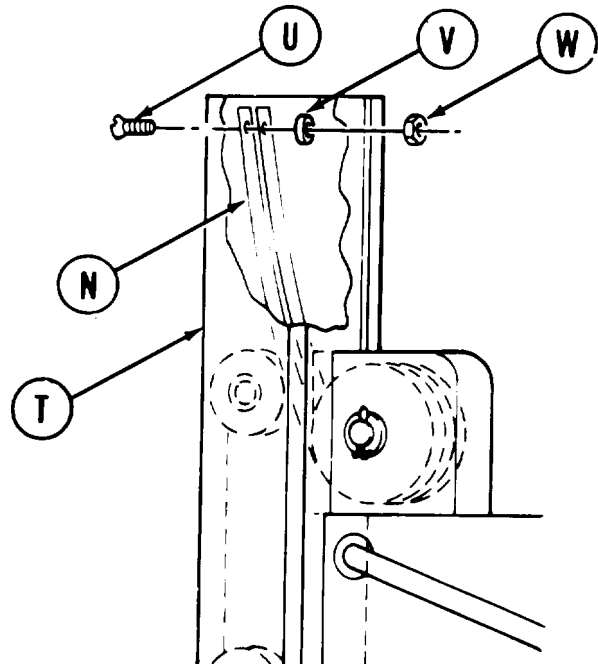

Go on to Sheet 7

TA248599

SEAT AND BACKREST MOUNT ASSEMBLY REPAIR (Sheet 7 of 7)

19. Using fingers, install jamnut (Z) on crank (H).
20. Using fingers, install knob (AA) on crank (H).
21. Using 3/4 inch open end wrench, tighten jamnut (Z) against knob (AA).
22. Place plate (AB) in position on support (F).
23. Using socket, install four screws (AC) securing plate (AB) to support (F).
24. Install seat and seat mount assembly (page 17-57).

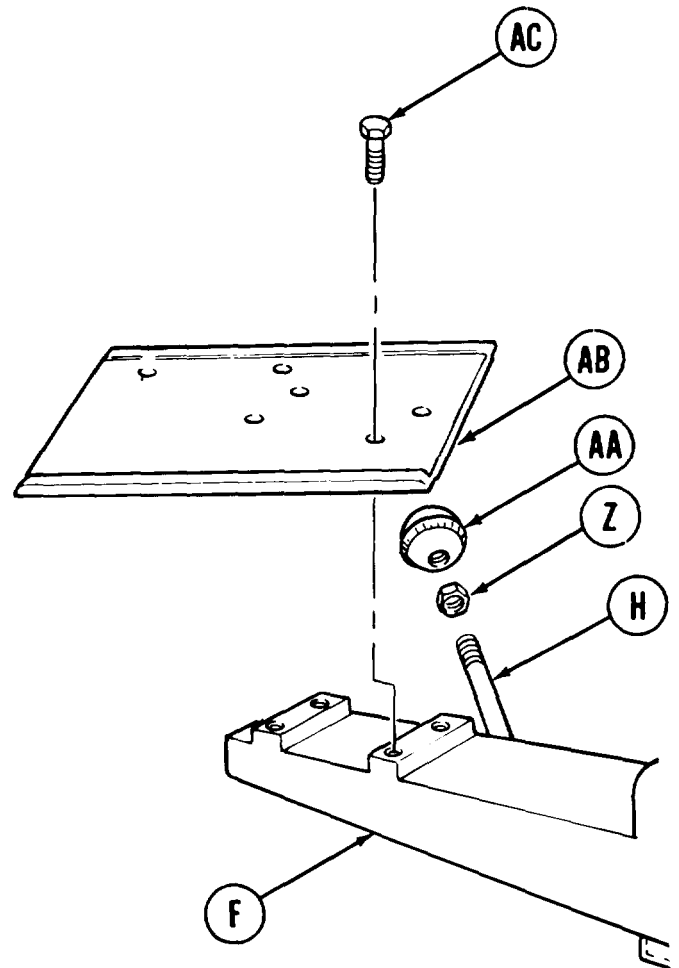

End of Task

TA248600

17-69/(17-70 blank)

CHAPTER 18
 PERSONNEL HEATER MAINTENANCE
 INDEX

Procedure	Page
Personnel Heater Assembly Replacement	18-2
Personnel Heater Mounting Clamp Replacement	18-15
Personnel Heater Mount Replacement	18-16
Personnel Heater Air Duct Outlet Hose and Deflector Replacement	18-17
Inner Exhaust Pipe Replacement	18-20
Outer Exhaust Tube Replacement	18-22
Heater Fuel Pump Replacement	18-23
Personnel Heater Fuel Line Hose and Quick-Disconnect Coupling Assembly Replacement	18-26

PERSONNEL HEATER ASSEMBLY REPLACEMENT (Sheet 1 of 5)

PROCEDURE INDEX

PROCEDURE	PAGE
Removal	18-2
Installation	18-5

TOOLS: 7/16 in. socket with 1/2 in. drive
 Torque wrench with 1/2 in. drive (0-175 lb-ft)
 Adjustable pipe wrench
 7/16 in. combination box and open end wrench
 Cross-tip screwdriver
 5 in. extension with 1/2 in. drive
 Flat-tip screwdriver

SUPPLIES: Rags (Item 65, Appendix D)
 Drain pan
 Lockwashers (4 required)

REFERENCE: TM 5-5420-202-10

PRELIMINARY PROCEDURE Set MASTER HEATER switch to OFF (TM 5-5420-202-10)

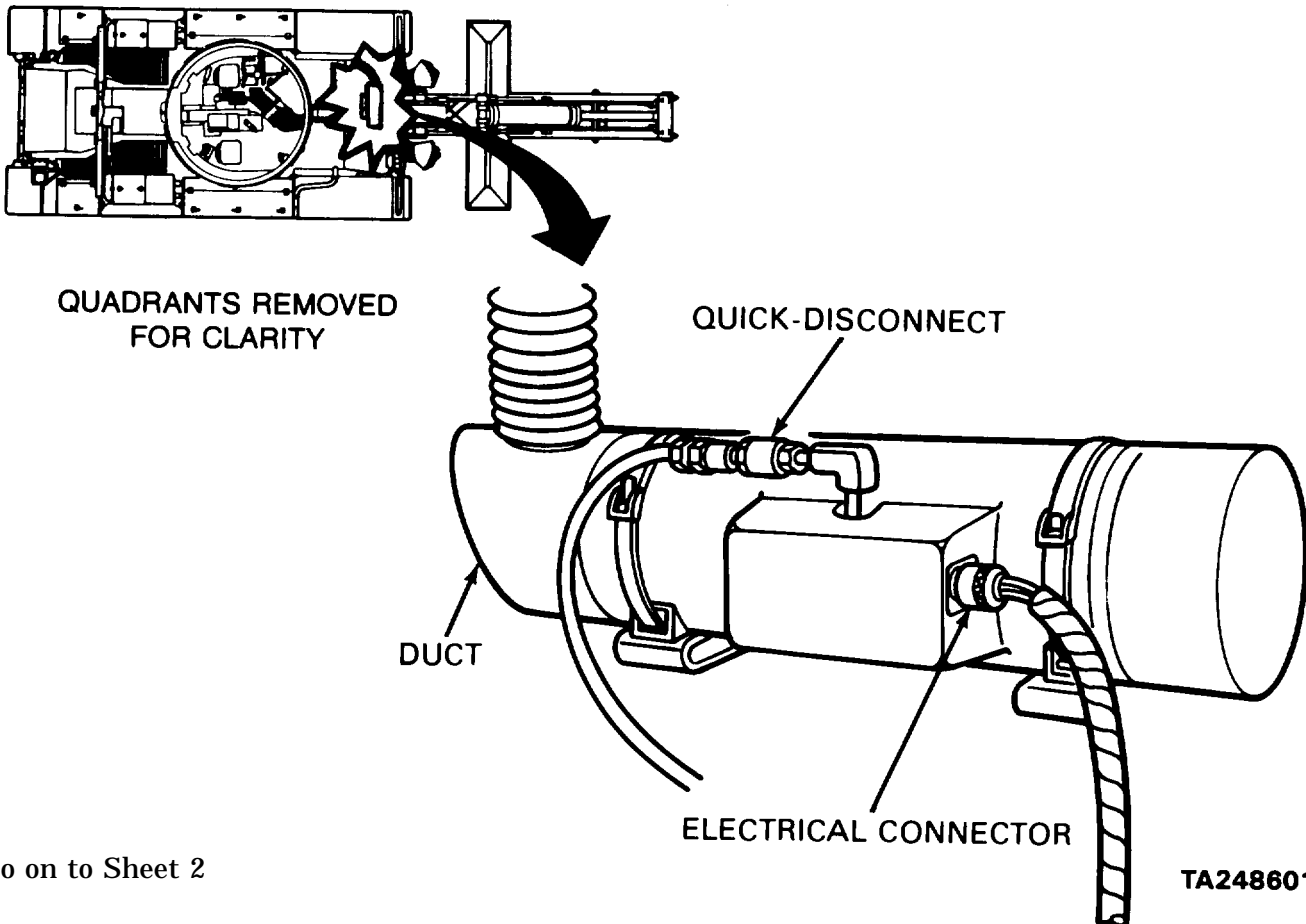

Go on to Sheet 2

PERSONNEL HEATER ASSEMBLY REPLACEMENT (Sheet 2 of 5)

REMOVAL:

1. Locate electrical connection (A) at cover on personnel heater.
2. Disconnect cable (B).

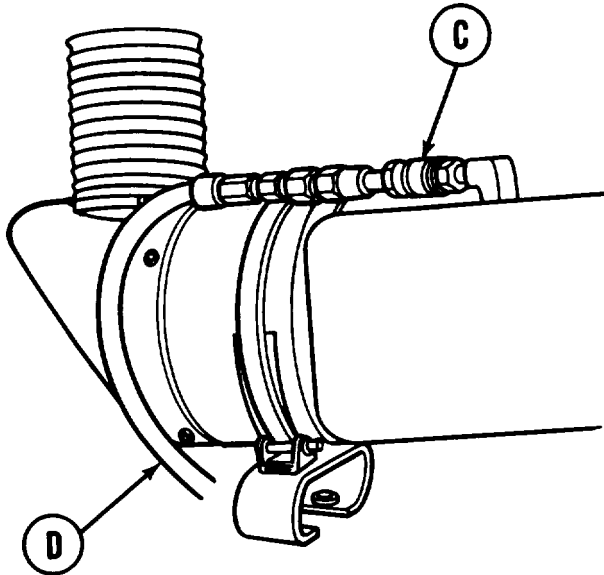
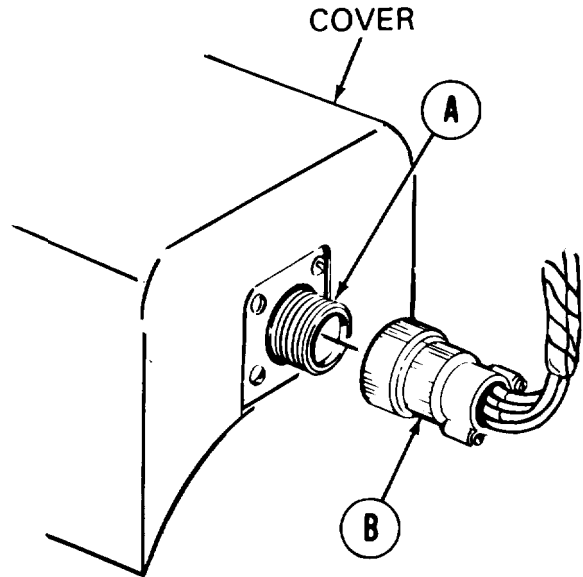

3. Push and pull quick-disconnect coupler (C) to disconnect hose (D). Position drain pan to catch fuel from hose, if necessary.

4. Using 7/16 inch wrench, loosen coupling clamp (E) securing exhaust pipe (F).
5. Remove clamp (E).
6. Separate pipe (F) from heater.

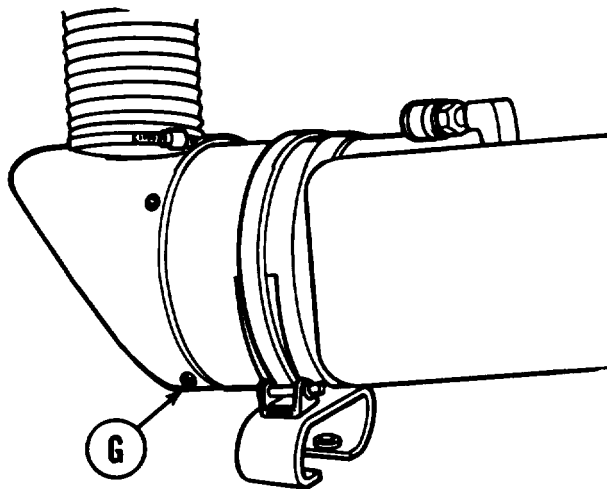
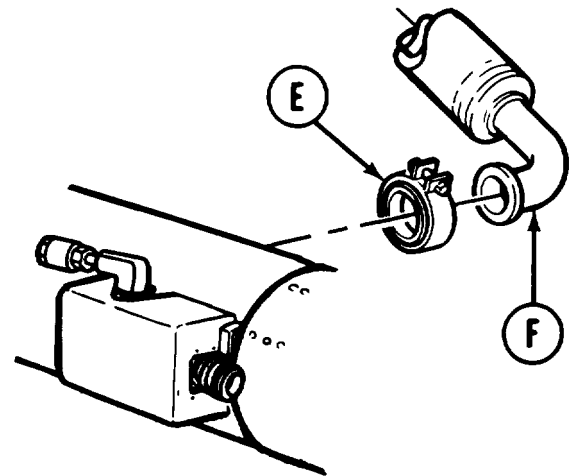

NOTE

It may be necessary to move heater left or right to remove remaining two screws and lock-washers.

7. Using cross-tip screwdriver, remove four screws and lockwashers (G) securing heater to duct.

Go on to Sheet 3

TA248602

PERSONNEL HEATER ASSEMBLY REPLACEMENT (Sheet 3 of 5)

8. Using flat-tip screwdriver, remove two clamps (H) from heater mounting bracket (J).
9. Separate heater (K) from duct (L).

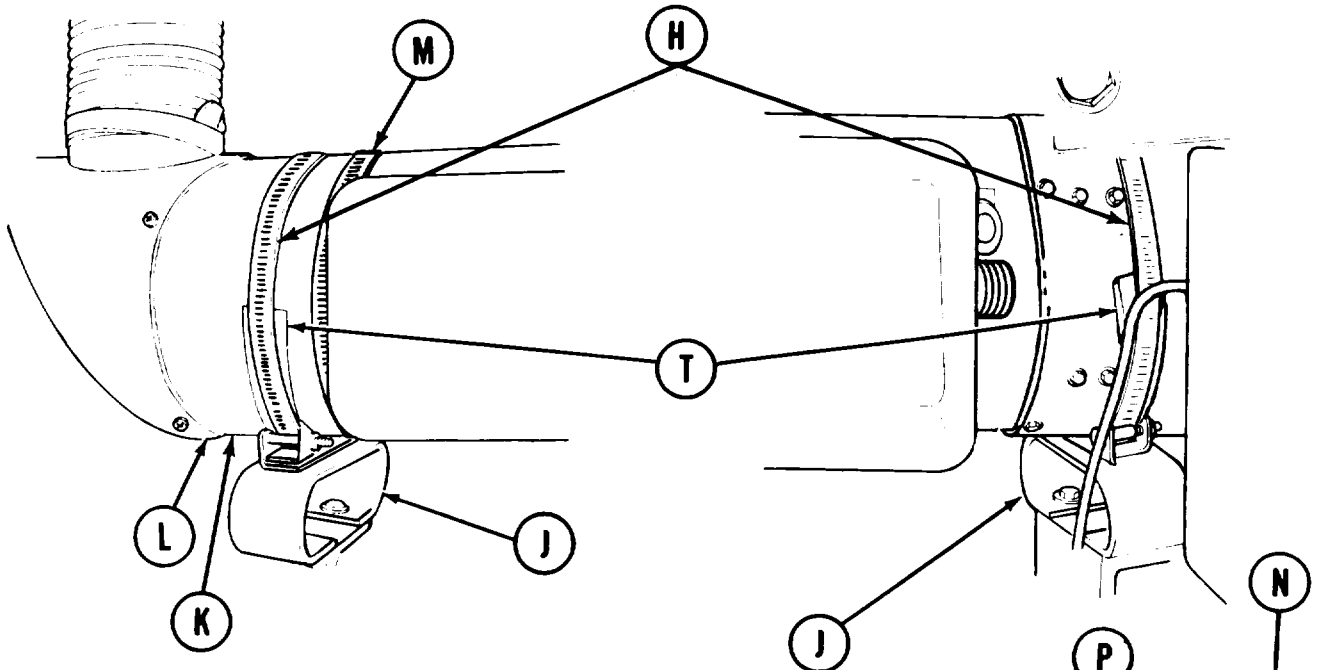

10. Using flat-tip screwdriver, remove clamp (M), sleeve (N), and exhaust tube retainer (P).

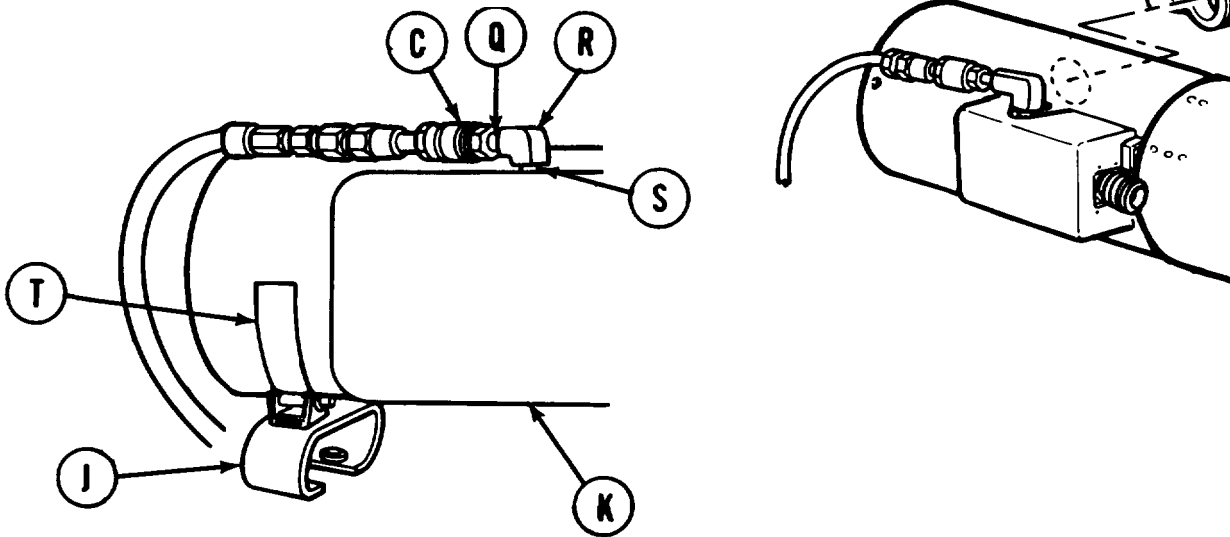

11. Using pipe wrench, remove nipple (Q), quick-disconnect (C), elbow (R), and nipple (S).
12. Remove personnel heater (K) from vehicle. Make sure segments (T) remain with bracket (J) and are not stuck to heater.

Go on to Sheet 4

TA248603

PERSONNEL HEATER ASSEMBLY REPLACEMENT (Sheet 4 of 5)

INSTALLATION:

1. Using pipe wrench, install nipple (A), elbow (B), and nipple (C) on heater (D).
2. Using pipe wrench, install quick-disconnect (E) to nipple (C).
3. Using flat-tip screwdriver, install clamp (F), sleeve (G), and exhaust tube retainer (H).

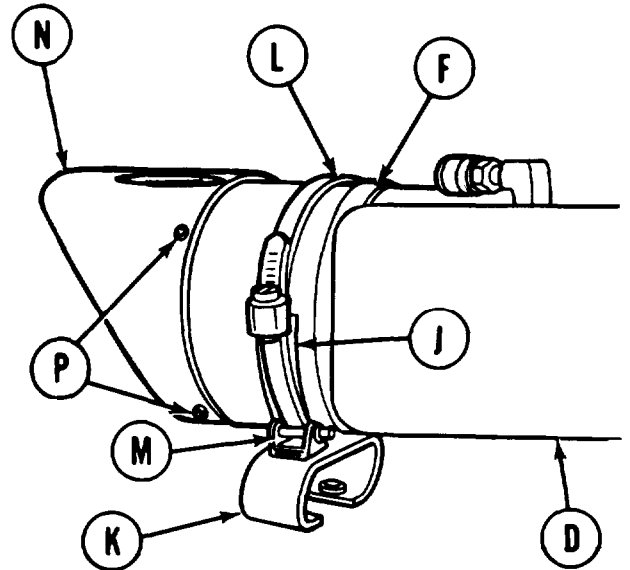
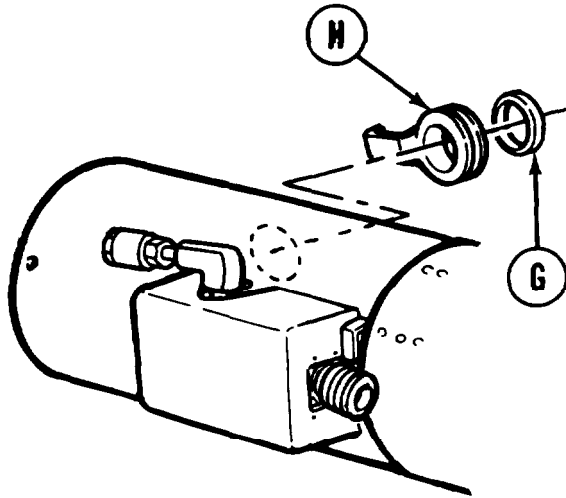
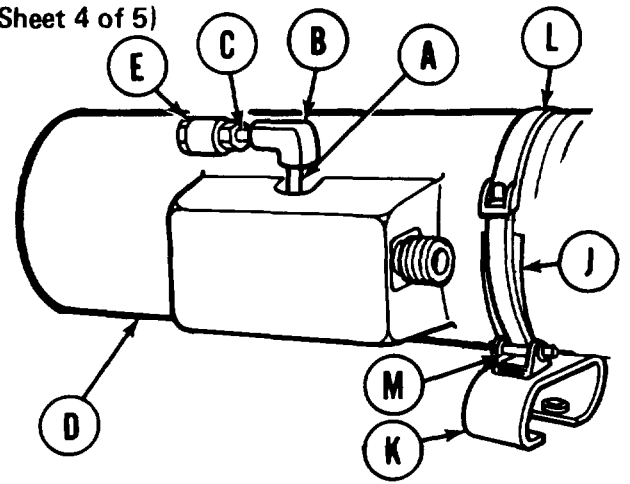

4. Make sure segment (J) is in place on each bracket (K). Position heater (D) on mounting brackets (K) and slide both clamps (L) thru bracket arms (M). Do not tighten clamps (L) at this time.
5. Position heater (D) to duct (N) and align screw holes.
6. Using cross-tip screwdriver, install bottom rear and top front screws and lockwashers (P). (Do not tighten screws completely down.)

NOTE

It may be necessary to move heater left or right to install remaining two screws and lockwashers.

7. Using cross-tip screwdriver, install top rear and bottom front screws and lockwashers (P).
8. Using cross-tip screwdriver, tighten four screws (P).

Go on to Sheet 5

TA248604

PERSONNEL HEATER ASSEMBLY REPLACEMENT (Sheet 5 of 5)

9. Position coupling (Q) and coupling clamp (R) on heater (D).
10. Close coupling clamp (R) and, using 7/16 inch wrench, tighten nut to secure exhaust pipe to heater (D).
11. Using torque wrench with extension, tighten clamp (R) nut to 60 lb-ft (81 N-m).
12. Using flat-tip screwdriver, tighten two clamps (L) securing heater (D) in bracket (K).

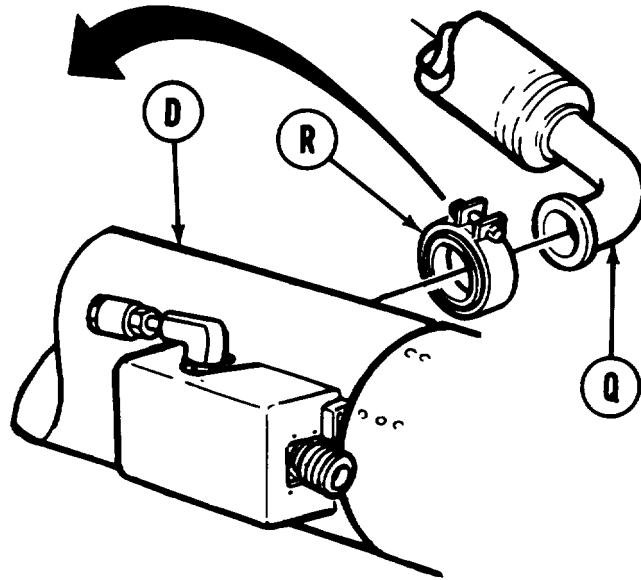
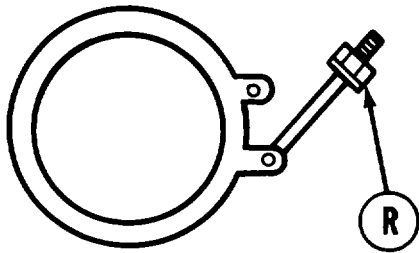

13. Make sure all personnel heater connections, especially exhaust pipe, are tight and secure.
14. Push quick-disconnect coupling (S) into fuel hose line (T) to connect line to heater.

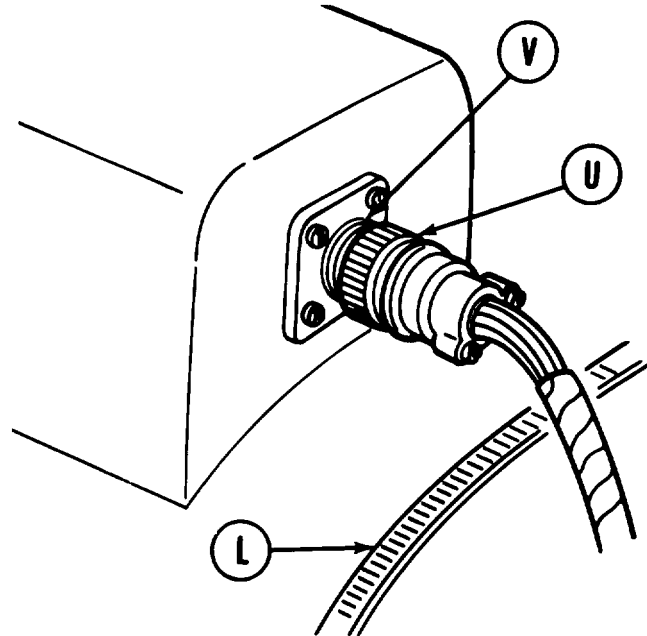
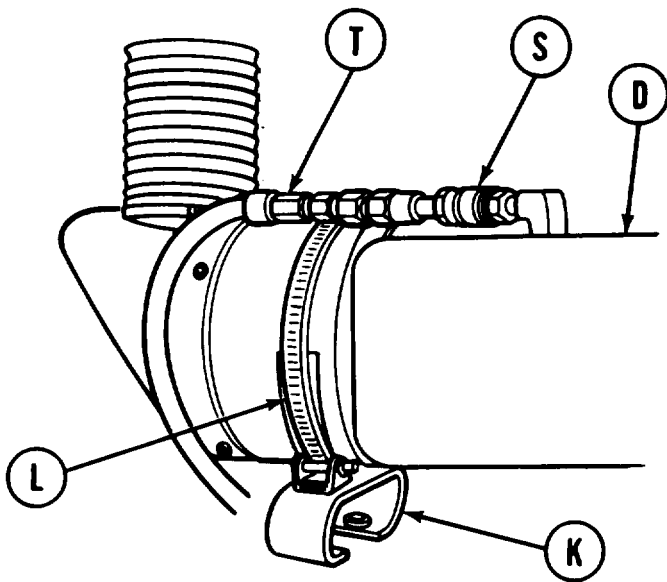

15. Connect harness cable connector (U) to heater connector (V).

End of Task

All data on pages 18-7 thru 18-14 deleted.

PERSONNEL HEATER REPAIR (Sheet 1 of 8)

PROCEDURE INDEX

PROCEDURE	PAGE
Heater Igniter Replacement	18-7
Heater Flame Detector Switch Replacement	18-11
Ignition Control Replacement	18-13

Heater Igniter Replacement (Sheet 1 of 4)

PROCEDURE INDEX

PROCEDURE	PAGE
Removal	18-7
Inspection	18-8
Installation	18-9
Test	18-10

TOOLS: Flat-tip screwdriver, 1-3/4 in. long
 Flat-tip screwdriver, 8 in. long
 Slip joint pliers

SUPPLIES: Flashlight (Item 73, Appendix D)

PRELIMINARY PROCEDURES: Disconnect battery ground cables (page 10-268).
 Remove right fixed fire extinguisher cylinder (page 20-52)

REFERENCE: TM 5-5420-202-10

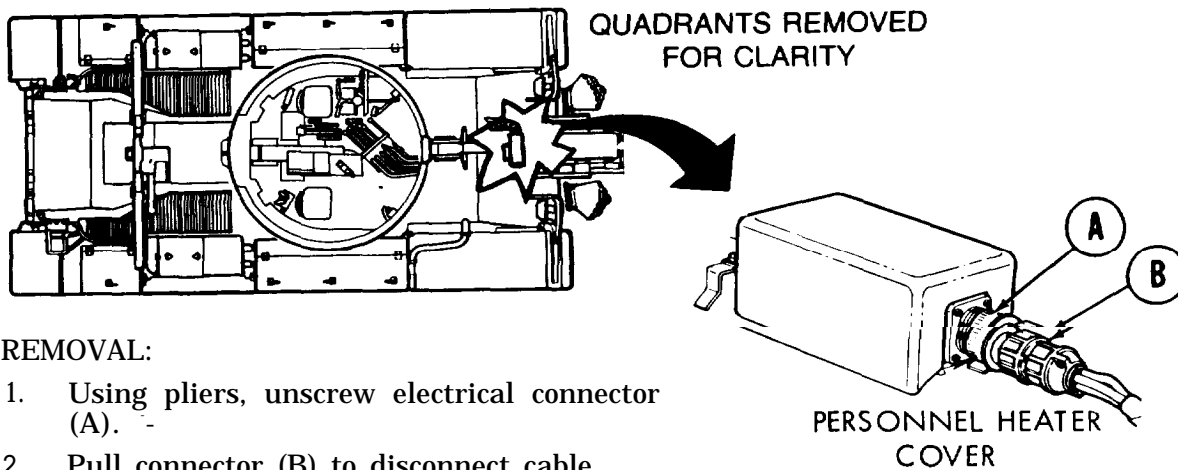

REMOVAL:

1. Using pliers, unscrew electrical connector (A).
2. Pull connector (B) to disconnect cable.

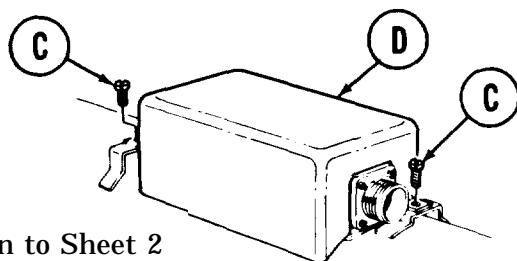

Go on to Sheet 2

NOTE
 Some covers have only one screw on top.

3. Using screwdriver, remove two screws (C).
4. Lift cover (D) off heater.

TA248606

PERSONNEL HEATER REPAIR (Sheet 2 of 8)

Heater Igniter Replacement (Sheet 2 of 4)

- Using screwdriver, turn two captive screws (E) 1/4-turn counterclockwise.

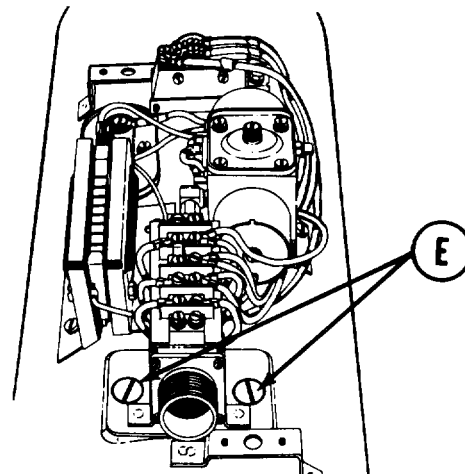
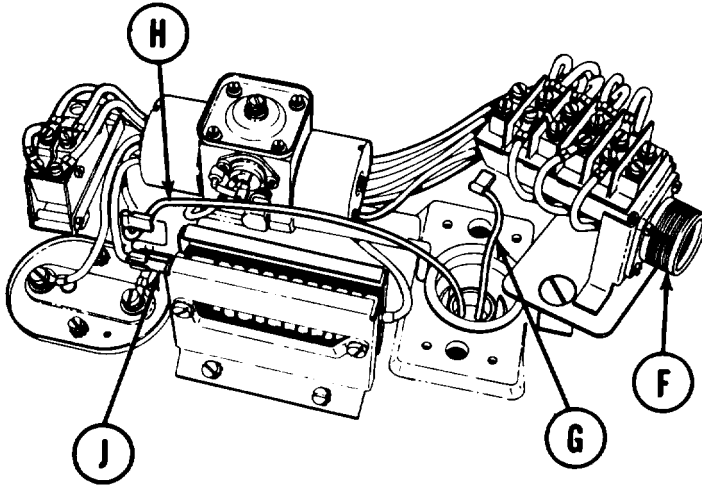

Move electrical inlet connection (F) aside.

Disconnect white igniter ground lead (G) (shorter lead).

Disconnect white lead (H) (longer lead) at igniter control (J).

- Push down on igniter (K). Rotate it 1/8-turn counterclockwise.
- Lift igniter (K) out of tube (L).

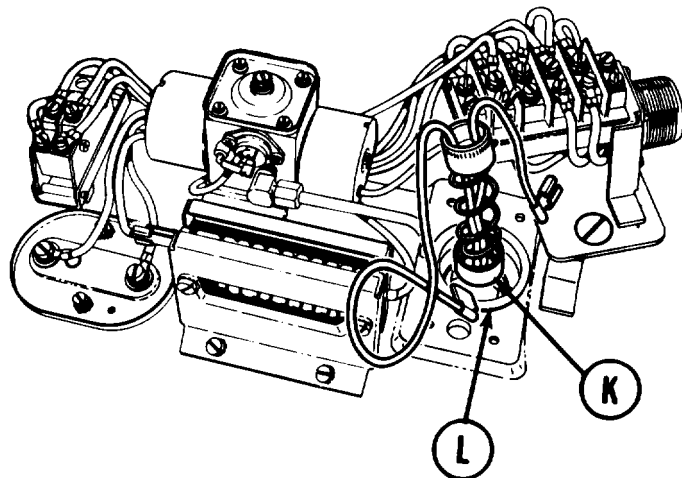

INSPECTION OF IGNITOR WICK:

- Using a flashlight, look into igniter tube (L) at wick. The yarn (fiber material) should be dry, unbroken and white.
- If strands of yarn (fiber material) seem thin (less than 1/16 inch thick) or are broken, notify support maintenance.
- If wick is wet, burner is flooded.
- If burner is flooded, go to TEST procedures at end of this task.
- If burner is not flooded, go on to INSTALLATION.

Go on to Sheet 3

TA248607

PERSONNEL HEATER REPAIR (Sheet 3 of 8)

Heater Igniter Replacement (Sheet 3 of 4)
INSTALLATION:

1. Install igniter (A) into tube.
2. Using hand, press down on igniter (A), and using screwdriver on pin (B), turn igniter (A) clockwise to secure in tube (C).

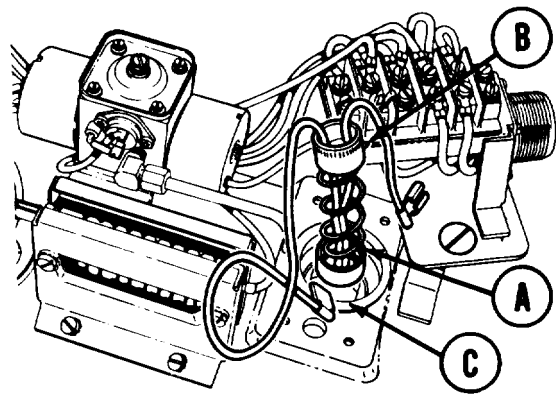

3. Connect shorter lead (D) to ground terminal (E).
4. Connect longer white lead (F) to igniter control (G).

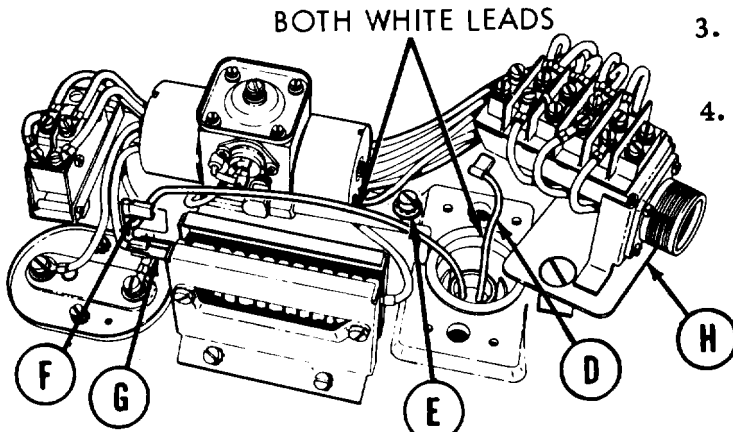

5. Place electrical inlet connection (H) in position on personnel heater.
6. Using screwdriver, turn two captive screws (J) 1/4-turn clockwise to secure inlet connection (H) to personnel heater.

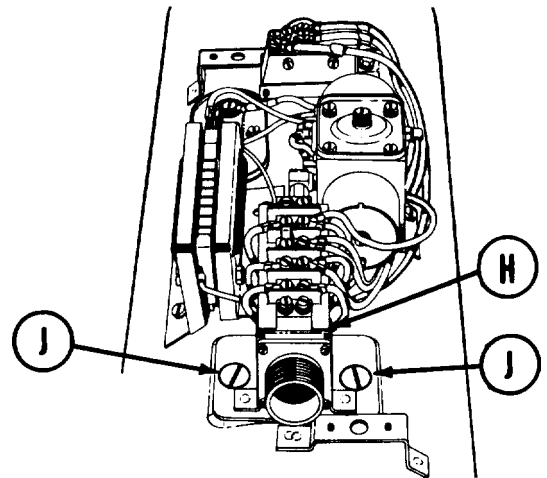

7. Mount cover (K) on personnel heater.

NOTE

Some covers have only one screw on top.

8. Using screwdriver, install two screws (L) to secure cover (K).

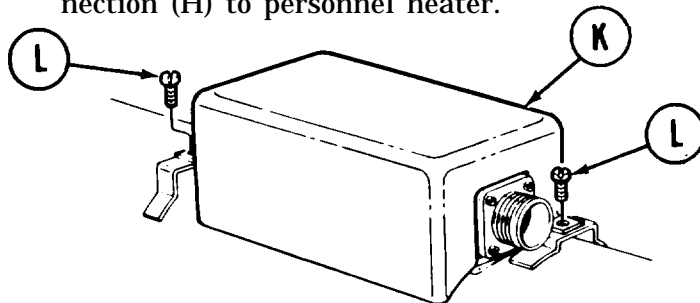

9. Connect electrical connector (M) to perso heater electrical connector (H).
10. Screw coupling (N) over connection (H).
11. Connect battery ground cables (10-268).
12. Check heater operation (TM 5-5420-202-10).

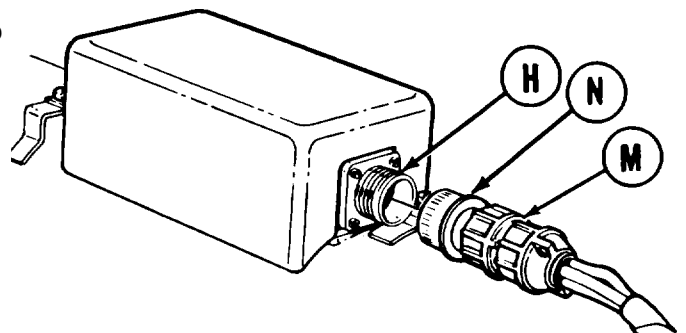

Go on to Sheet 4

TA248608

PERSONNEL HEATER REPAIR (Sheet 4 of 8)
Heater Igniter Replacement (Sheet 4 of 4)

TEST:

1. If burner is flooded (see INSPECTION OF IGNITOR WICK), disconnect lead (A) at normally open (N.O.) terminal on flame detector switch (B).

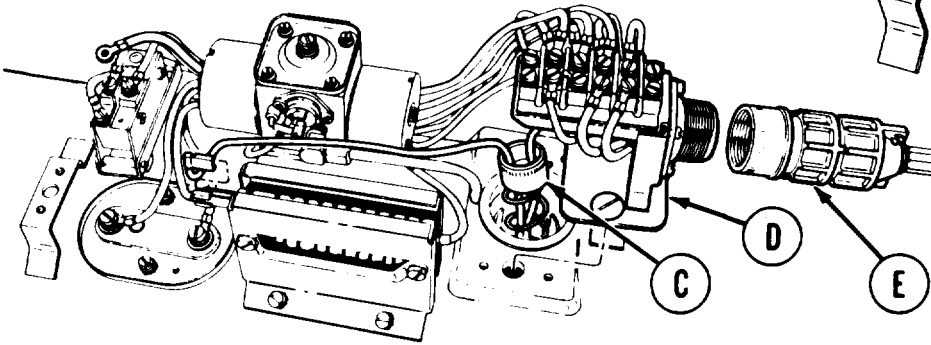
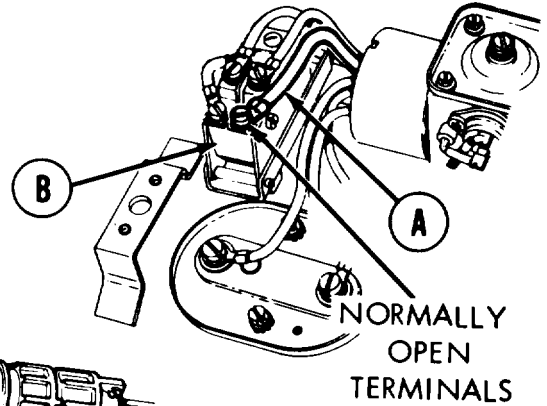

2. Install personnel heater igniter (C), electrical inlet connection (D), and electrical connector (E). See INSTALLATION procedure.

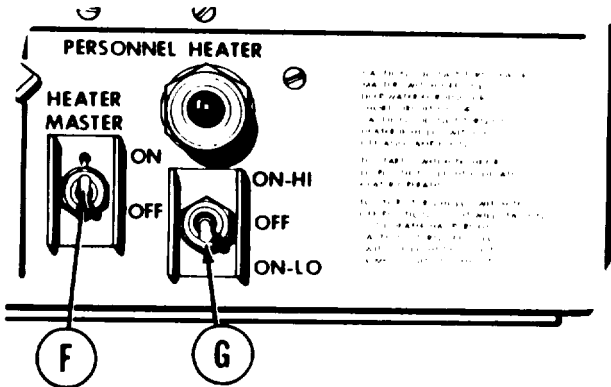

3. Turn PERSONNEL HEATER HEATER MASTER switch (F) ON.
4. Set PERSONNEL HEATER ON-HI OFF ON-LO switch (G) to ON-LO.
5. A white, smoke-like fuel vapor will flow out of exhaust tube at front of vehicle.
6. When personnel heater ignites, wait for black-grey exhaust smoke to clear up.

7. Once this has happened, connect lead (A) to flame detector switch (B).
8. Install personnel heater cover (page 18-9, steps 6 and 7).
9. Let personnel heater run for 5 minutes.

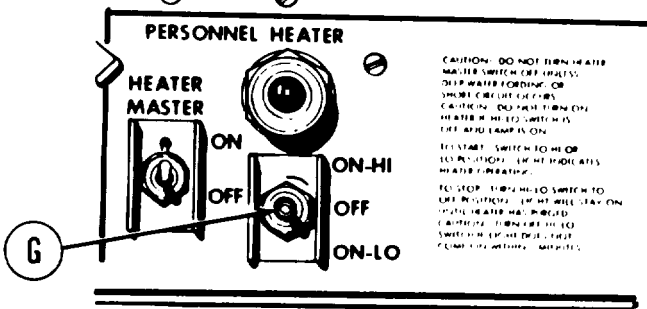
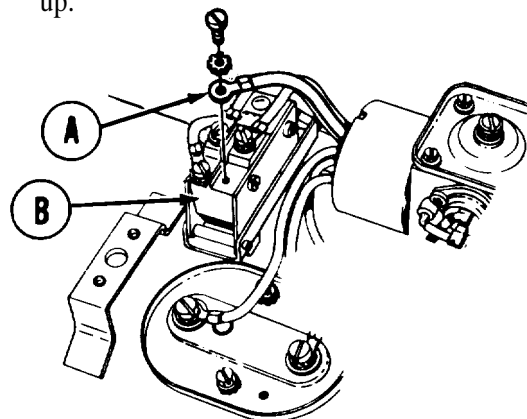

10. Turn PERSONNEL HEATER ON-HI OFF ON-LO switch (G) to OFF.

Fan will continue to run until fuel is purged from personnel heater.

End of Task

TA248609

PERSONNEL HEATER REPAIR (Sheet 5 of 8)
Heater Flame Detector Switch Replacement (Sheet 1 of 2)

TOOLS: Flat-tip screwdriver, 4 in. long blade
 5/16 in. combination box and open end wrench

SUPPLIES: Lockwashers (6 required)

REFERENCE TM 5-5420-202-20-10

PRELIMINARY PROCEDURES: Set HEATER MASTER switch to OFF (TM 5-5420-202-10)
 Disconnect electrical connector (page 18-7)
 Remove heater cover (page 18-7)
 Disconnect fuel inlet at quick-disconnect (page 18-26)

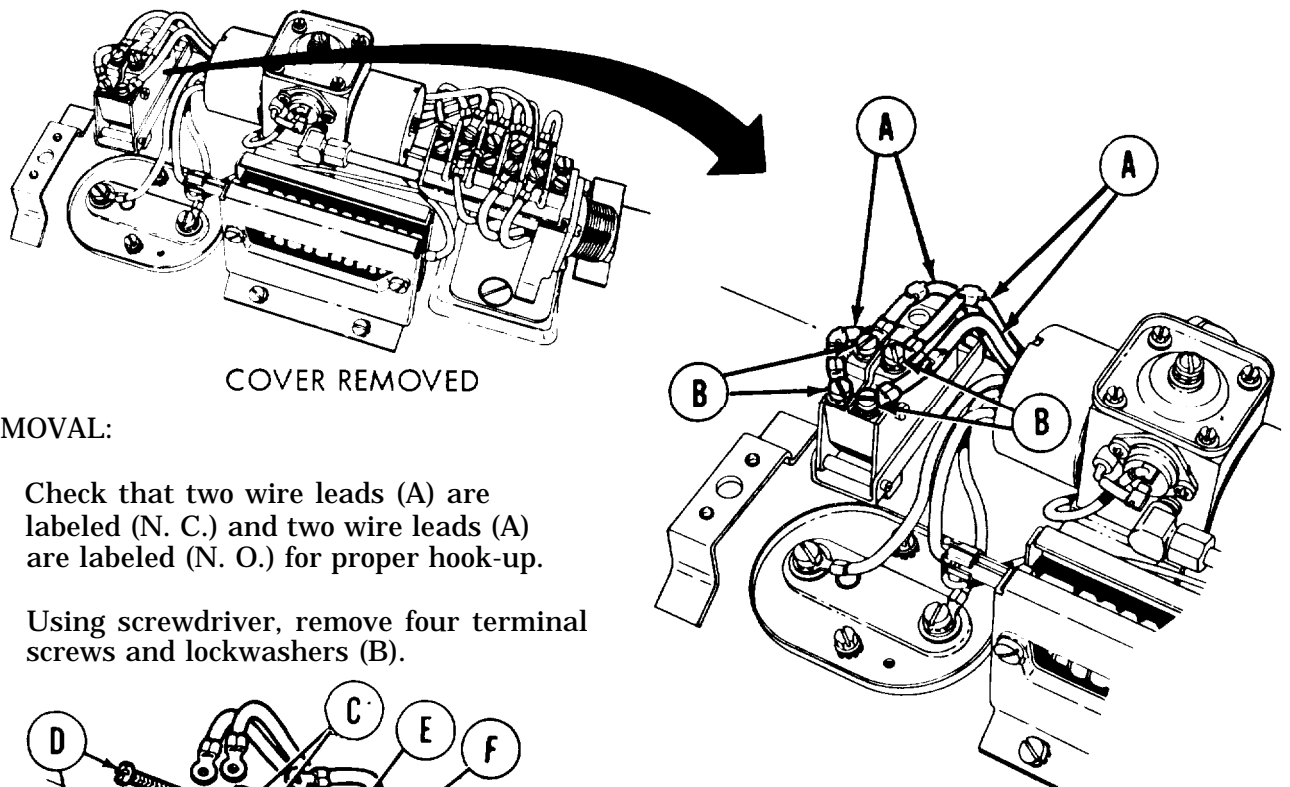

REMOVAL:

1. Check that two wire leads (A) are labeled (N. C.) and two wire leads (A) are labeled (N. O.) for proper hook-up.
2. Using screwdriver, remove four terminal screws and lockwashers (B).

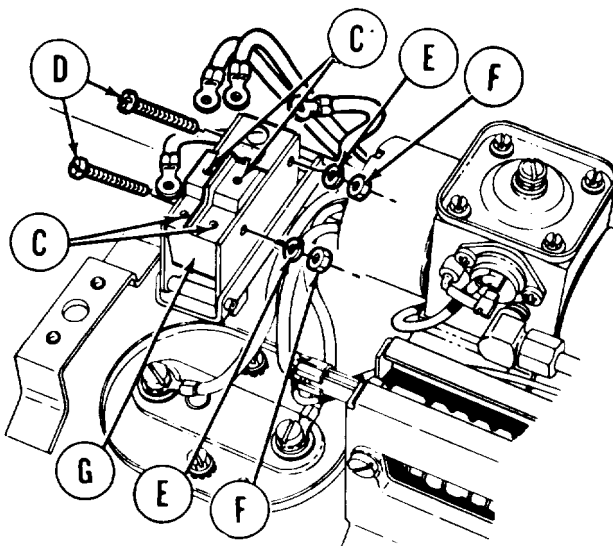

3. Disconnect four leads at terminals (C).
4. Using screwdriver and wrench, remove two screws (D), lockwashers (E), and nuts (F).
5. Remove flame detector switch (G).

Go on to Sheet 2

TA248610

PERSONNEL HEATER REPAIR (Sheet 6 of 8)
Heater Flame Detector Switch Replacement (Sheet 2 of 2)

INSTALLATION:

1. Mount flame detector switch (A) to personnel heater.
2. Using screwdriver and wrench, install two screws (B), lockwashers (C), and nuts (D).

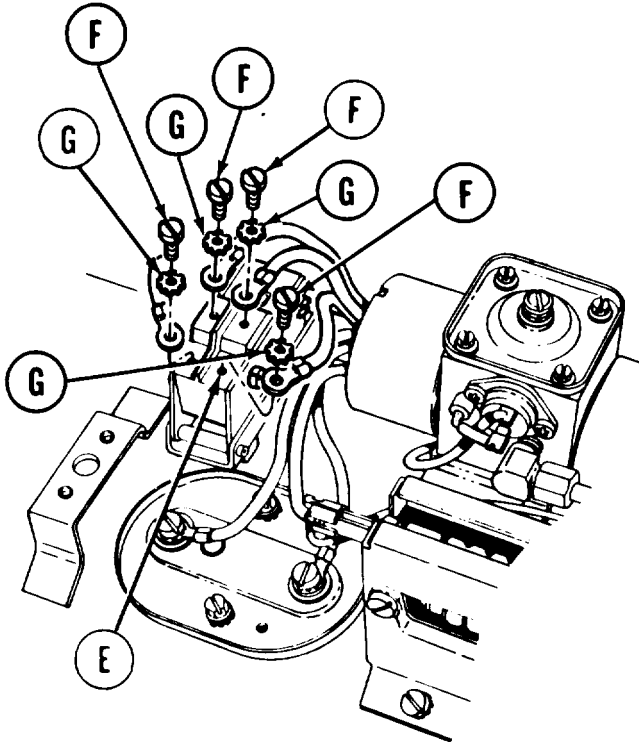
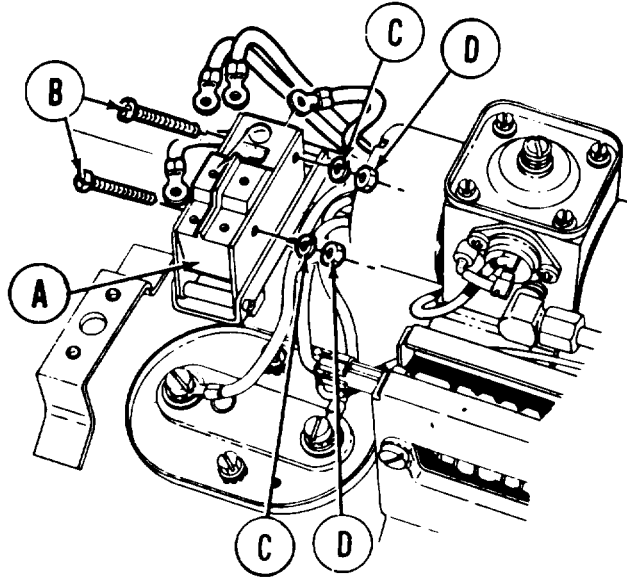

3. Connect four leads to four terminals (E). (two to N.O. (normally open), two to N.C. (normally closed) switch terminals (E)) with four screws (F) and lockwashers (G).

4. Make sure all labels (H) are to proper terminals.
5. Using screwdriver, tighten four screws (F).
6. Install heater cover (page 18-9, steps 7 and 8).
7. Connect electrical connector (page 18-9, steps 9 and 10).
8. Connect fuel inlet line to quick-disconnect (page 18-27).
9. Check heater for proper operation (TM 5-5420-202-10).

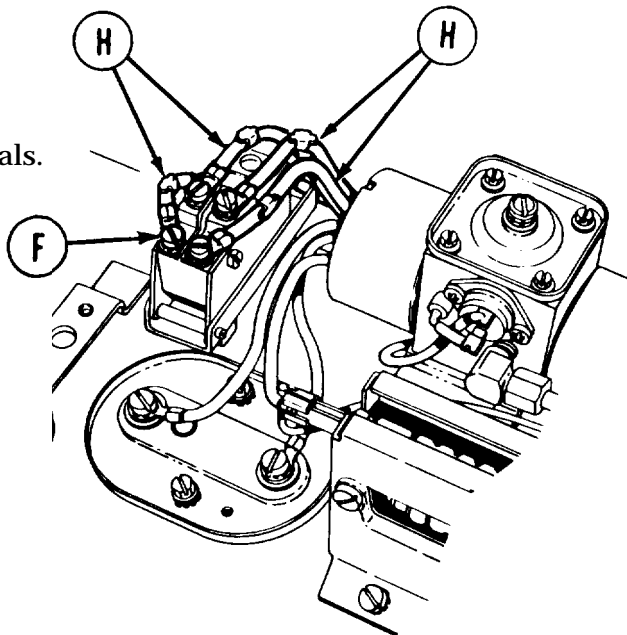

End of Task

TA248611

PERSONNEL HEATER REPAIR (Sheet 7 of 8)
Ignition Control Replacement (Sheet 1 of 2)

TOOLS: Flat-tip screwdriver

REFERENCE: TM 5-5420-202-20-10

PRELIMINARY PROCEDURES: Set HEATER MASTER switch to OFF (TM 5-5420-202-10)
 Disconnect electrical connector (page 18-7)
 Remove heater cover (page 18-7)

REMOVAL:

1. Disconnect two leads (A and B).
2. Using screwdriver, remove screw and lockwasher (C) securing third lead (D) (N. O.) to flame detector switch (E).
3. Disconnect lead (D) from switch (E).

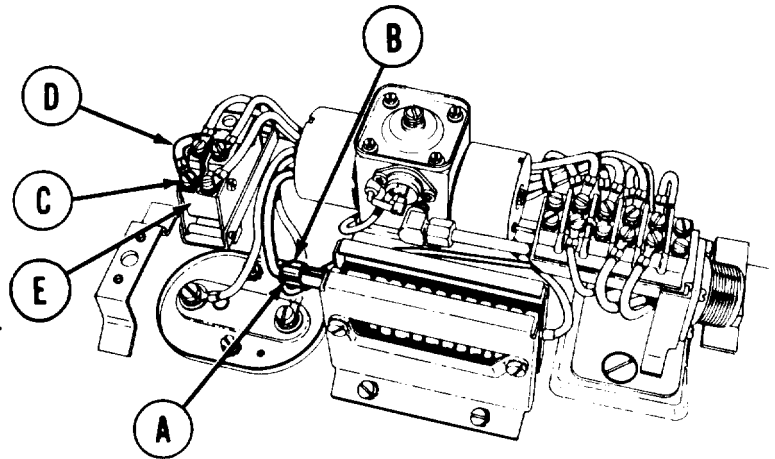

4. Using screwdriver, loosen (do not remove) two screws (F) at slotted mounting holes.

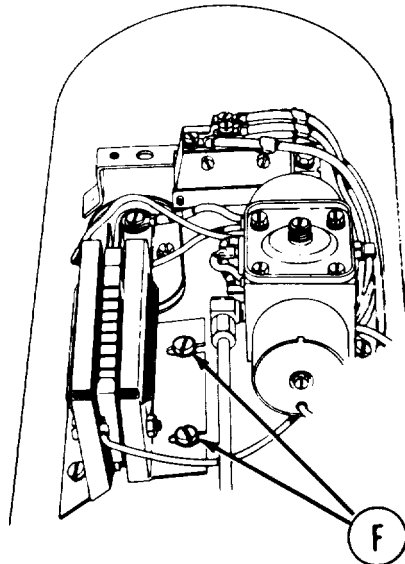

5. Remove plastic band (G) by pulling apart.
6. Using screwdriver, remove two screws and lockwashers (H).
7. Remove ignition control (J) from personnel heater.

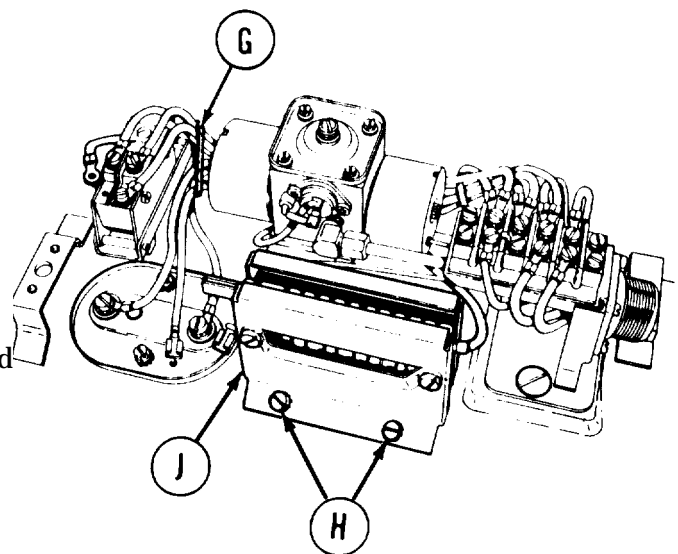

Go on to Sheet 2

TA248612

PERSONNEL HEATER REPAIR (Sheet 8 of 8)
Personnel Ignition Control Replacement (Sheet 2 of 2)

INSTALLATION:

1. Mount ignition control assembly (A) to heater, and install two screws and lockwashers (B).
2. Using screwdriver tighten four screws (B) to secure ignition control (A) to heater.

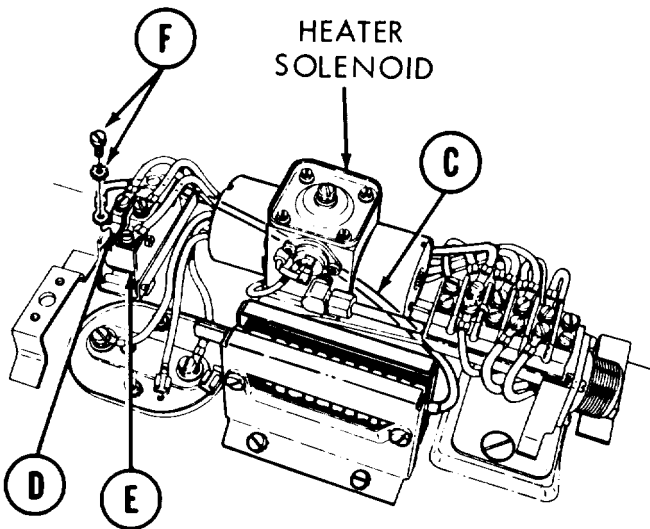
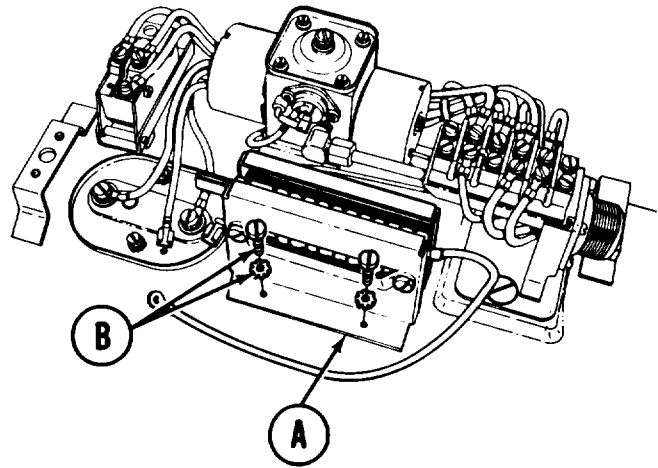

3. Route lead (C) under heater solenoid to terminal (N.O.) (D) on flame detector switch (E).
4. Install screw and lockwasher (F) securing lead (C) to flame detector switch.(E).
5. Using screwdriver, tighten screw (F).

6. Connect two leads (G) and (H) to ignition control (A).
7. Install plastic band (J).
8. Install heater cover (page 18-9, steps 7 and 8).
9. Connect electrical connector (page 18-9, steps 9 and 10).
10. Check heater operation (TM 5-5420-202-10)

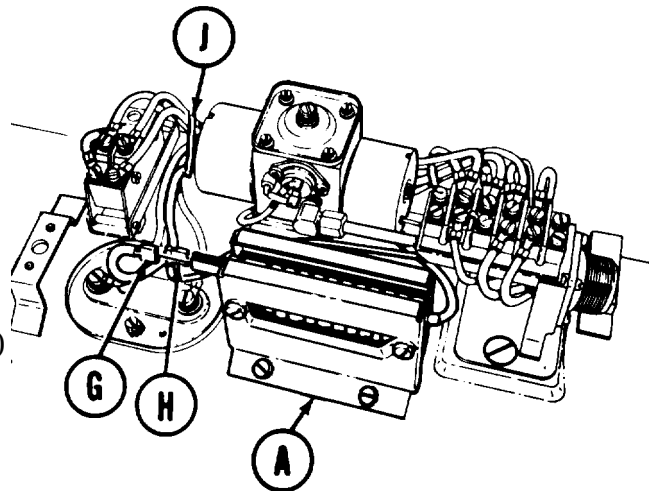

End of Task

TA248613

PERSONNEL HEATER MOUNTING CLAMP REPLACEMENT (Sheet 1 of 1)

TOOLS: Flat-tip screwdriver
Metal cutting shears

PRELIMINARY PROCEDURE: Set MASTER HEATER switch to OFF (TM 5-5420-202-10)

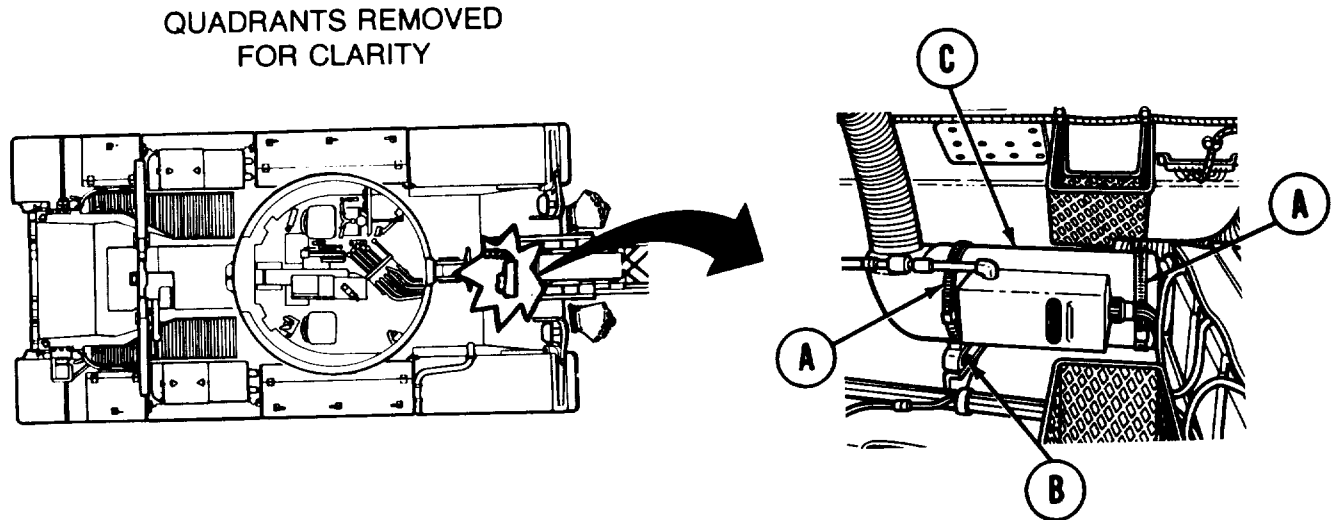

REMOVAL:

1. Using screwdriver, remove either one or all three clamps (A), as necessary.
2. If clamps are too rusted or old to remove, use screwdriver and pry clamp away from mounting bracket (B) or heater (C). Then, using shears, cut clamp free.

INSTALLATION:

1. Install new clamp (A) around mounting brackets (B) or heater (C), as necessary.
2. Using screwdriver, tighten clamp (A).

End of Task

TA248614

PERSONNEL HEATER MOUNT REPLACEMENT (Sheet 1 of 1)

TOOLS: 7/16 in. combination box and open end wrench
9/16 in. combination box and open end wrench (2 required)

SUPPLIES: Lockwashers (4 required)

PRELIMINARY PROCEDURE: Remove personnel heater assembly (page 18-2)

REMOVAL:

1. Using 7/16 inch wrench, remove two screws (A) and lockwashers (B) securing two clamps (C) to mount (D).
2. Remove two clamps (C) and segment (E) from mount (D).

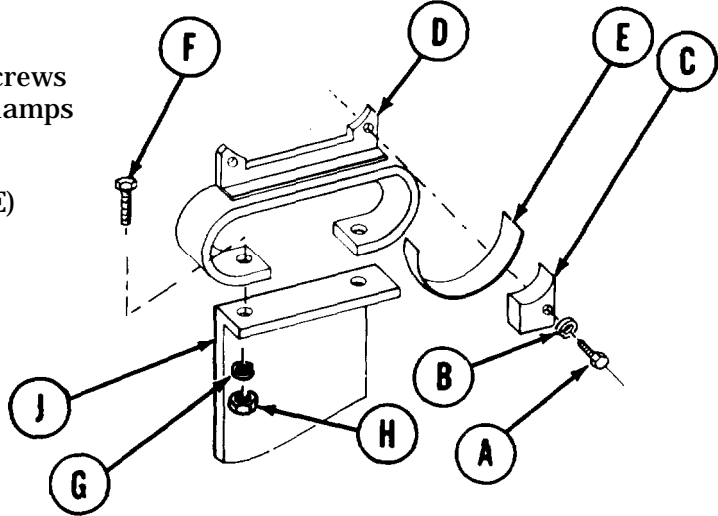

3. Using two 9/16 inch wrenches, remove two screws (F), lockwashers (G) and nuts (H) securing mount (D) to support (J).
4. Remove mount (D).

INSTALLATION:

1. Place mount (D) in position on support (J).
2. Using two 9/16 inch wrenches, install two screws (F), lockwashers (G) and nuts (H) securing mount (D) to support (J).
3. Place two clamps (C) and segment (E) in position on mount (D).
4. Using fingers, install two screws (A) and lockwashers (B) securing clamps (C) to mount (D).
5. Using 7/16 inch wrench, tighten screws (A).
6. Install personnel heater assembly (page 18-5).

End of Task

TA248615

PERSONNEL HEATER AIR DUCT OUTLET HOSE AND DEFLECTOR REPLACEMENT (Sheet 1 of 3)

TOOLS: 9/16 in. combination box and open end wrench
 9/16 in. socket with 1/2 in. drive
 7/16 in. socket with 1/2 in. drive
 Ratchet with 1/2 in. drive
 7/16 in. open end wrench
 Flat-tip screwdriver

SUPPLIES: Lockwashers (7 required)

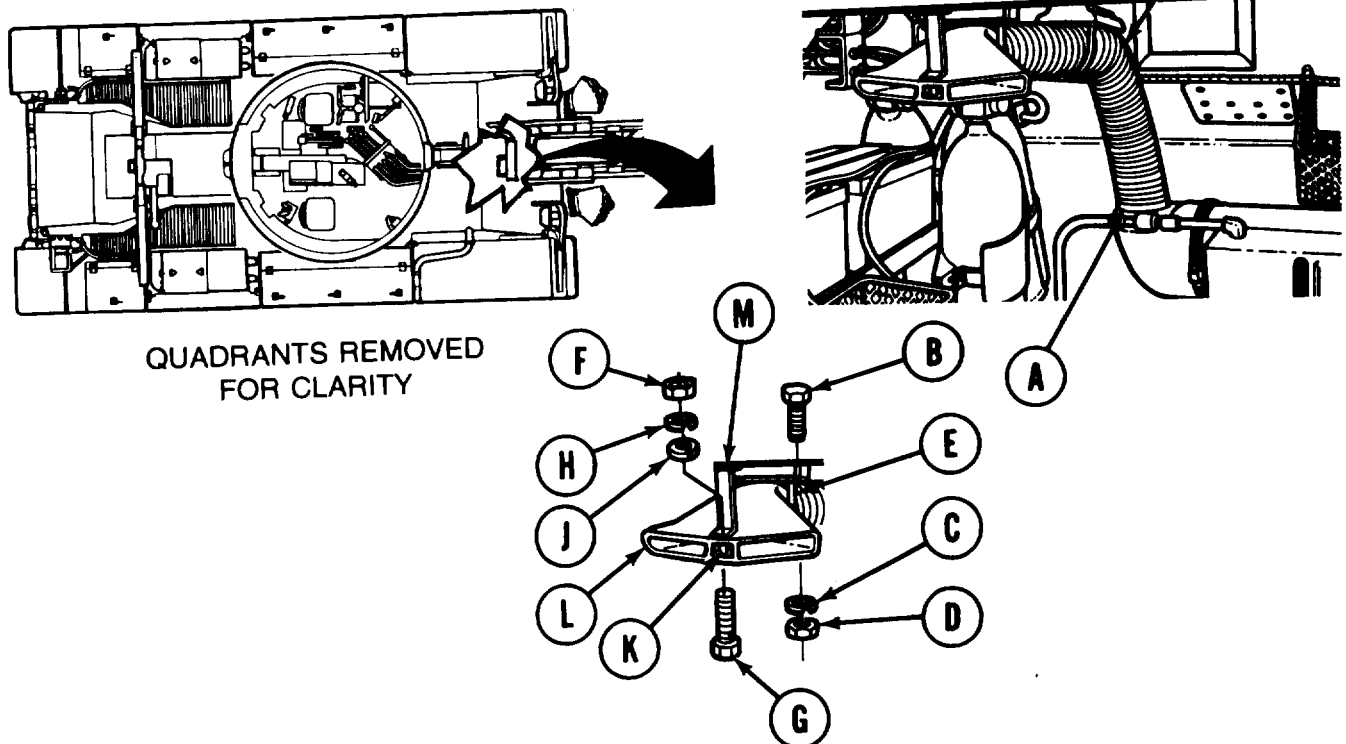

REMOVAL:

1. Using screwdriver, loosen hose clamp (A).
2. Using 9/16 inch socket, remove two screws (B), lockwashers (C), and nuts (D) securing clamp (E) to pads.
3. Remove clamp (E).
4. Hold nut (F) with 7/16 inch wrench. Use 7/16 inch socket to remove screw (G), lockwasher (H), washer (J), and spacer (K) securing deflector (L) to bracket (M).
5. Pull deflector (L) from hose (N).

TA248616

Go on to Sheet 2

PERSONNEL HEATER AIR DUCT OUTLET HOSE AND DEFLECTOR
(Sheet 2 of 3)

REPLACEMENT

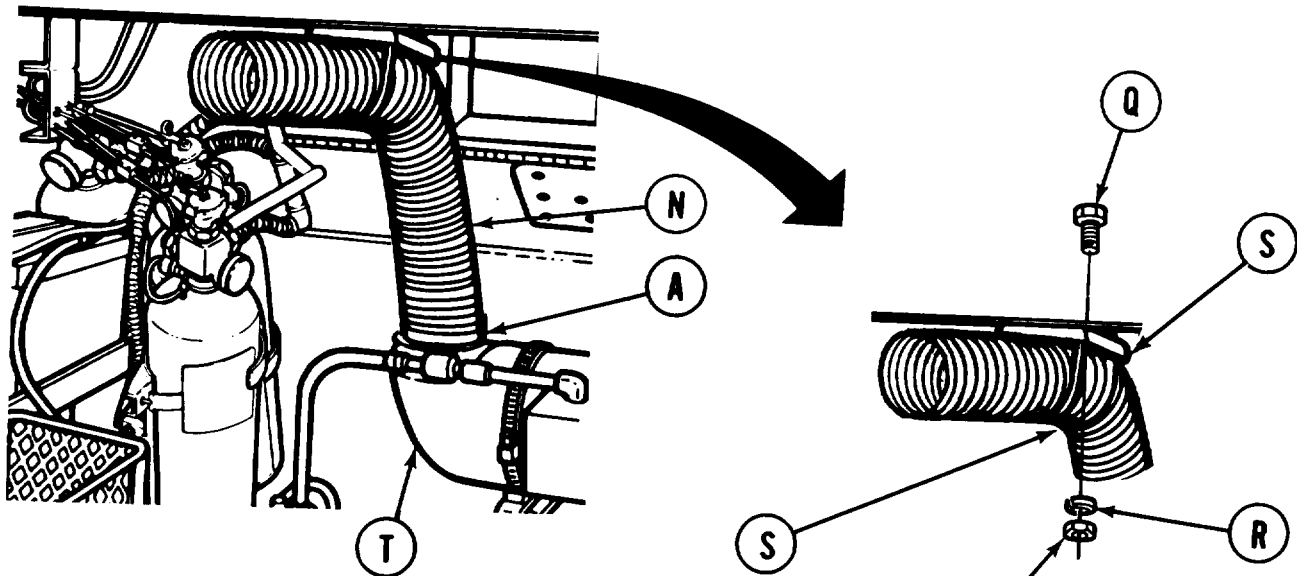

6. Holding nuts (P) with 9/16 inch wrench, use 9/16 inch socket to remove four screws (Q), lockwashers (R) and nuts (P) securing two clamps (S) to hull brackets.
7. Remove two clamps (S).
8. Gently pull hose (N) free of heater elbow (T).
9. Remove hose clamp (A) from hose (N).

INSTALLATION

1. Place clamp (A) loosely over hose (B).
2. Install hose (B) loosely on heater elbow (C).
3. Place clamps (D) over hose (B) and position on hull bracket (E).
4. Using 9/16 inch socket, install four screws (F), lockwashers (G), and nuts (H) securing clamps (D) to hull bracket (E).

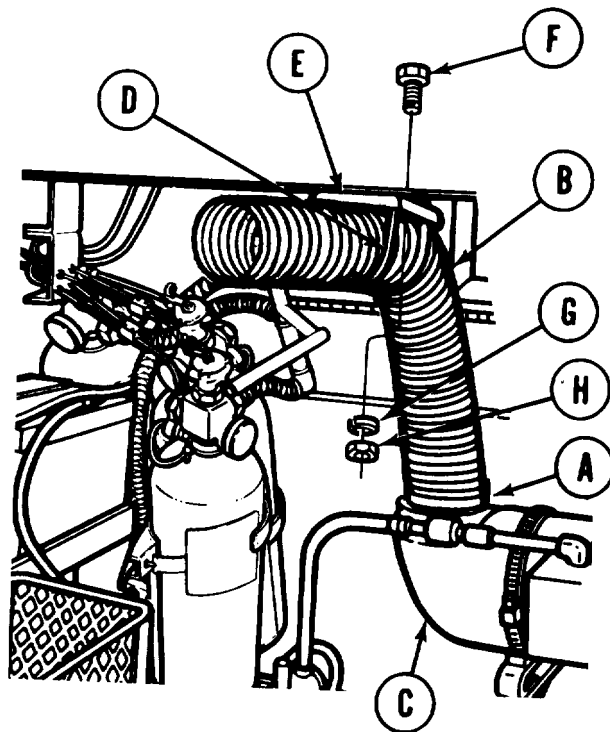

Go on to Sheet 3

TA248617

PERSONNEL HEATER AIR DUCT OUTLET HOSE AND DEFLECTOR REPLACEMENT
 (Sheet 3 of 3)

5. Place clamp (J) in position on hose (B) and bracket (K).
6. Hold two nuts (L) with 9/16 inch wrench. Use 9/16 inch socket to install two screws (M) and lockwashers (N) securing clamp (J) to bracket (K).
7. Place deflector (P) in position on hose (B).

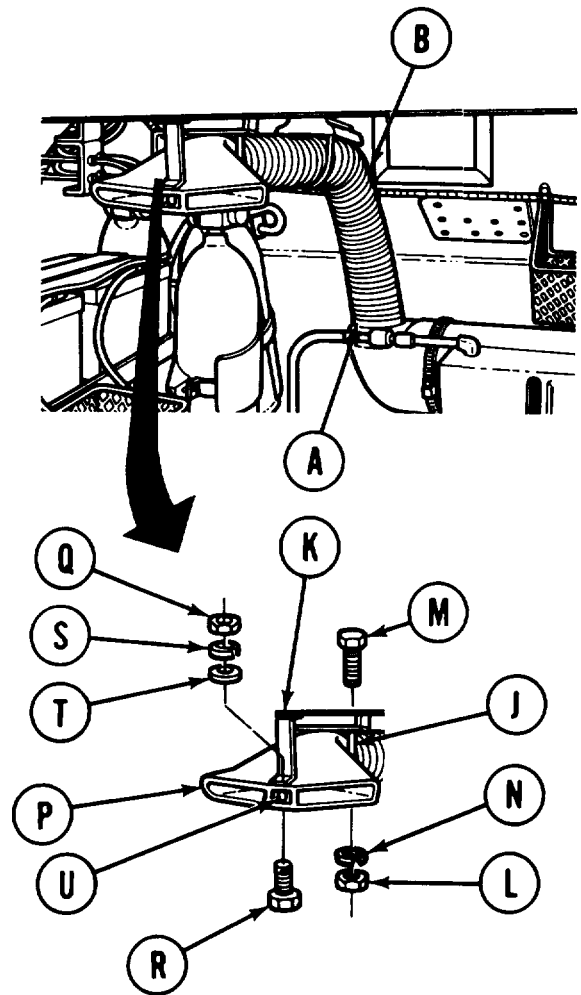

8. Hold nut (Q) with 7/16 inch wrench. Use 7/16 inch socket to install screw (R), lockwasher (S), washer (T), and spacer (U) securing deflector (P) to bracket (K).
9. Using screwdriver, tighten clamp (A).

End of Task

TA248618

INNER EXHAUST PIPE REPLACEMENT (Sheet 1 of 2)

TOOLS: 5 in. extension with 1/2 in. drive
Ratchet with 1/2 in. drive
7/16 in. combination box and open end wrench
Hammer
Chisel
9/16 in. socket with 1/2 in. drive

SUPPLIES Lockwasher

PRELIMINARY PROCEDURE: Remove personnel heater (page 18-2)

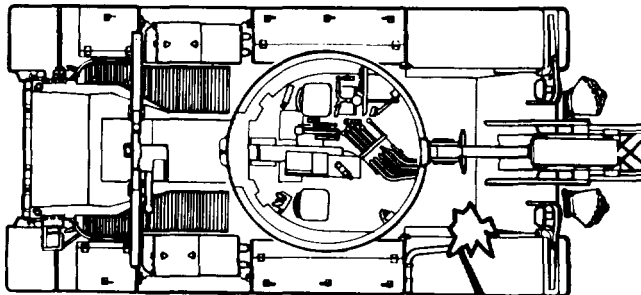

QUADRANTS REMOVED FOR CLARITY

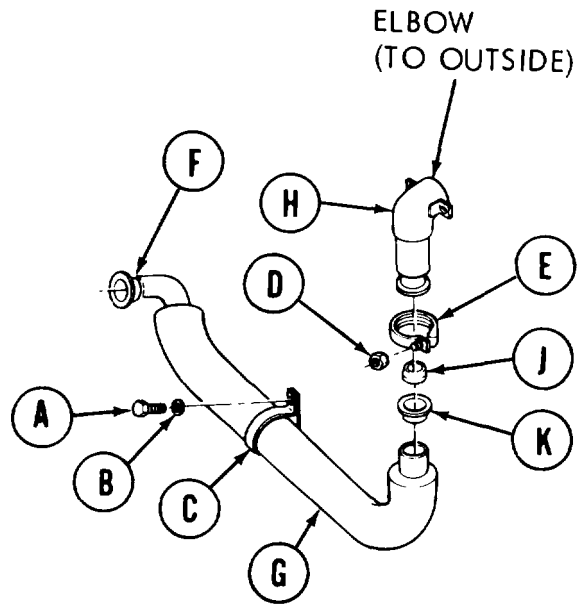

REMOVAL:

1. Using socket with extension, remove screw (A) and lockwasher (B) securing clamp (C) to hull.
2. Using wrench, remove nut (D) from coupling clamp (E). Remove clamp (E).
3. Remove pipe (F) with insulation (G) from elbow (H).

NOTE

If sleeve (J) and flange (K) "freeze" on pipes, throw entire assembly away.

4. Using hammer and chisel, drive sleeve (J) and flange (K) off exhaust elbow end of pipe (F).
5. Remove clamp (C) and insulation (G) from pipe (F).

Go on to Sheet 2

TA248619

INNER EXHAUST PIPE REPLACEMENT (Sheet 2 of 2)

INSTALLATION:

1. Install insulation (A) over hose part of pipe (B).
2. Slide clamp (C) into position on pipe (B).
3. Using hammer, lightly tap flange (D) onto exhaust elbow end of pipe (B).
4. Using hammer and chisel, tap sleeve (E), with tapered end of sleeve away from flange (D), onto pipe (B).

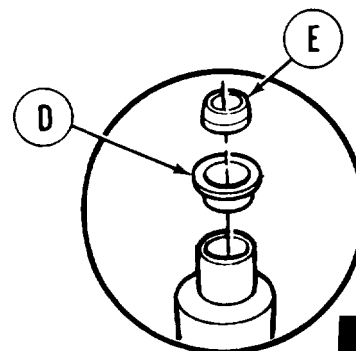

NOTE

Sleeve (E) butts UP to flange (D) to hold flange in place. It may be necessary to use hammer and punch to aid in mating the two flanges.

5. Position heater pipe (B) to exhaust elbow (F) so flange (D) mates to flange on elbow.
6. Slide coupling clamp (G) over mating flanges. Install nut (H) onto coupling clamp (G). Using wrench, tighten nut (H).

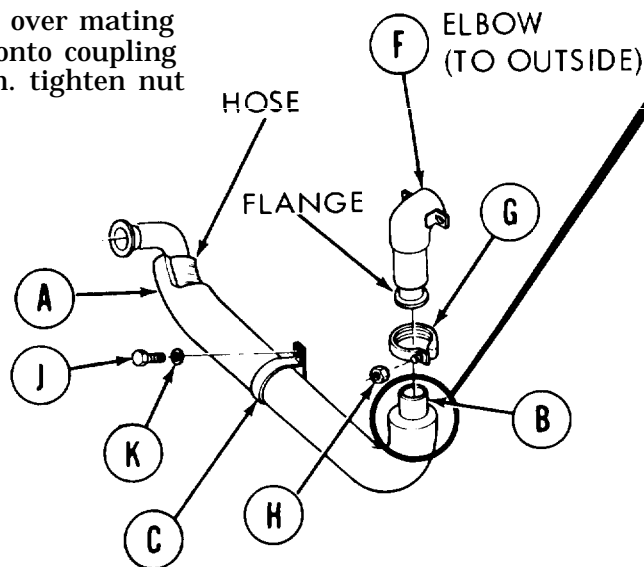

Using socket with extension, install screw (J) with lockwasher (K) securing clamp (C) to hull.

Install personnel heater (page 18-5).

End of Task

TA248620

OUTER EXHAUST TUBE REPLACEMENT (Sheet 1 of 1)

TOOLS: 9/16 in. combination box and open end wrench
 9/16 in. socket with 1/2 in. drive
 Ratchet with 1/2 in. drive

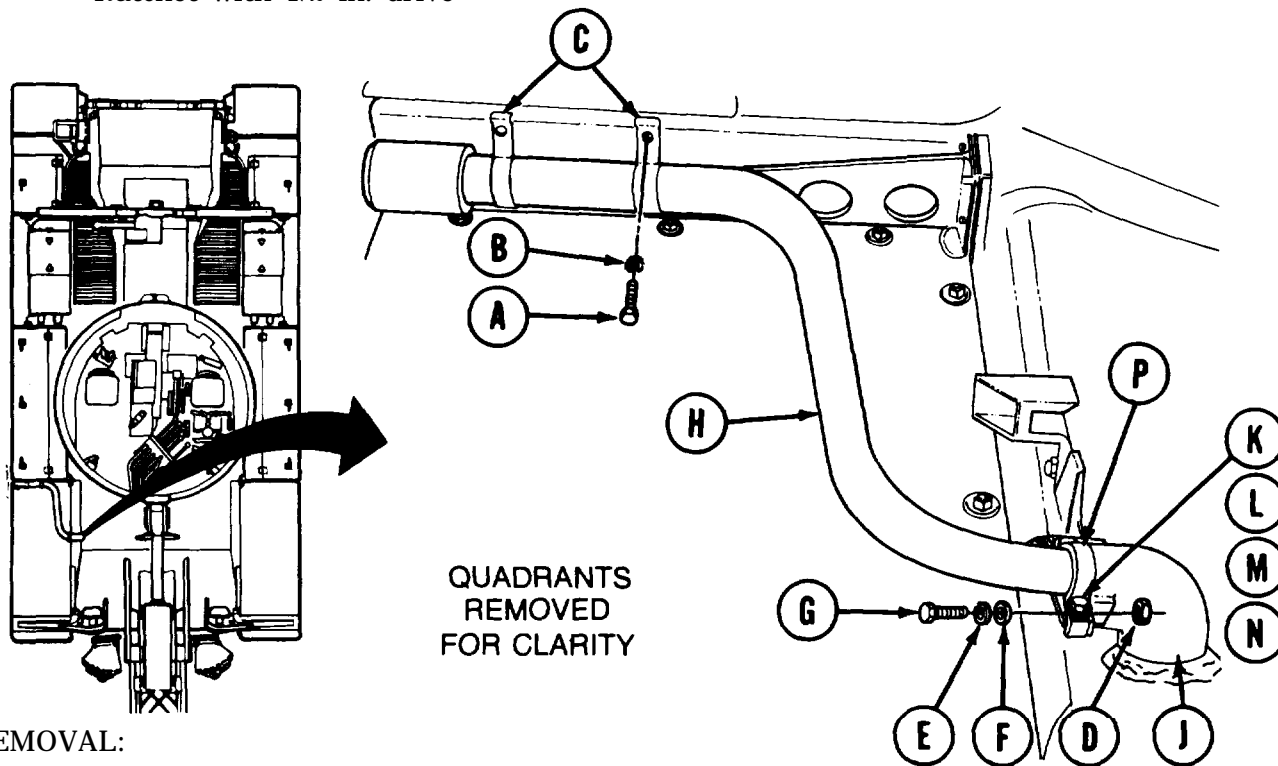

REMOVAL:

1. Using socket, remove two screws (A) and lockwashers (B), securing two clamps (C) to hull.
2. Using socket and wrench, remove two nuts (D), lockwashers (E), washers (F), and screws (G).
3. Using hands, pull exhaust tube (H) from elbow (J).
4. Using hands, spread and remove two clamps (C) from exhaust tube (H).
5. Using socket and wrench, remove two nuts (K), lockwashers (L), washers (M), screws (N), and clamp (P) from exhaust tube (H).

INSTALLATION:

1. Using hands, squeeze two clamps (C) into position on exhaust tube (H).
2. Using hands, push exhaust tube (H) into position in elbow (J).
3. Using socket and wrench, install clamp (P), two screws (N), washers (M), lockwashers (L), and nuts (K).
4. Using socket and wrench, install two screws (G), washers (F), lockwashers (E), and nuts (D).
5. Using socket, install two screws (A) and lockwashers (B) securing two clamps (C) to hull.

End of Task

TA248621

HEATER FUEL PUMP REPLACEMENT (Sheet 1 of 3)

TOOLS: 9/16 in. combination box and open end wrench
 5/8 in. combination box and open end wrench
 7/16 in. socket with 1/2 in. drive
 7/16 in. combination box and open end wrench

Ratchet with 1/2 in. drive
 5 in. extension with 1/2 in. drive
 8 in. adjustable wrench

SUPPLIES: Plastic plugs
 Container

REFERENCE: TM 5-5420-202-10

PRELIMINARY PROCEDURE: Turn HEATER MASTER switch to OFF (TM 5-5420-202-10)

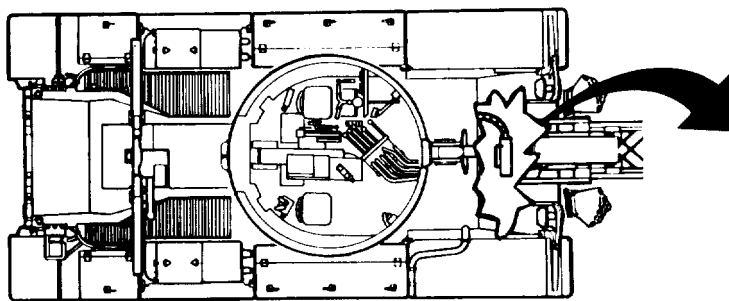

QUADRANTS REMOVED FOR CLARITY

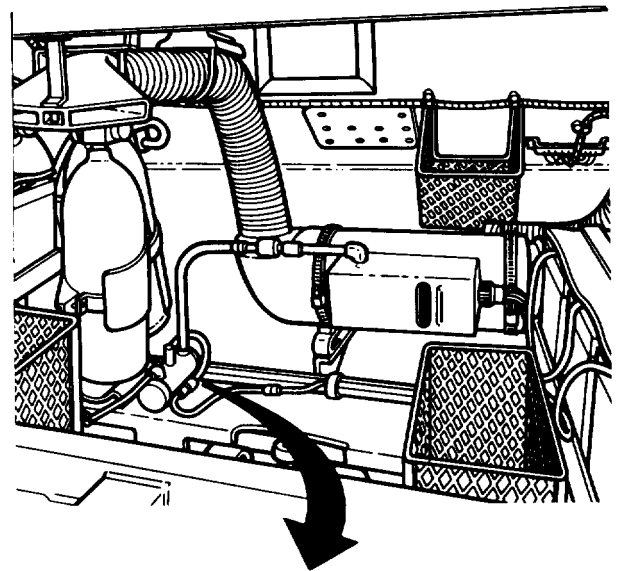

REMOVAL:

1. Pull electrical plug (A) from harness connector (B).
2. Using 5/8 inch open end wrench, loosen tube nut (C).
3. Disconnect tube nut (C) from elbow (D).
4. Catch any excess fuel in container.
5. Using 9/16 inch open end wrench, loosen hose nut (E).
6. Disconnect hose nut (E) from pump (F).
7. Plug both fuel lines (C) and (E).

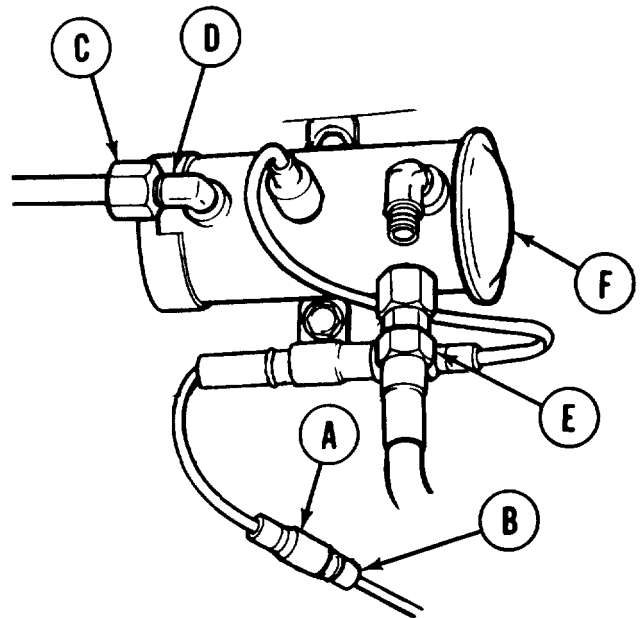

Go on to Sheet 2

TA248622

HEATER FUEL PUMP REPLACEMENT (Sheet 2 of 3)

8. Using socket with extension and 7/16 inch wrench remove two screws, lockwashers, and washers (G) securing fuel pump (F) to hull.
9. Remove fuel pump (F) from vehicle.

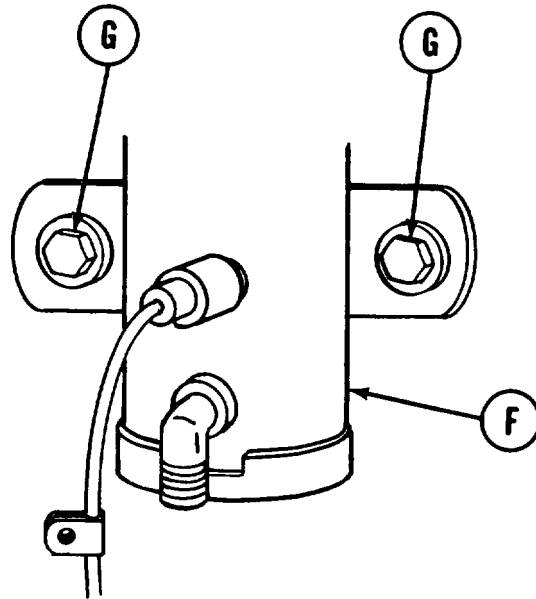
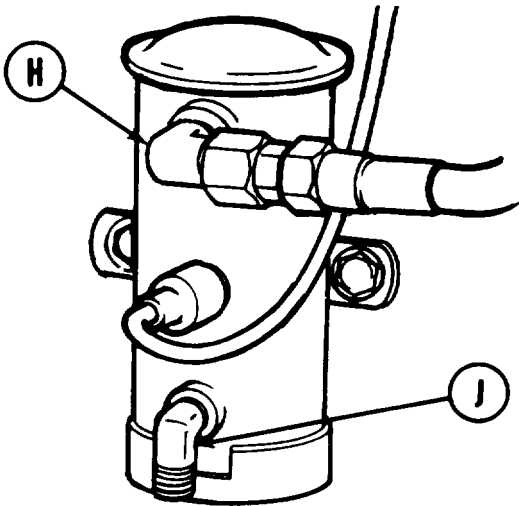

10. Using adjustable wrench, remove elbow (H) and adapter (J).

INSTALLATION:

1. Using adjustable wrench, install adapter (A) and elbow (B) into pump (C).

NOTE

When installing heater pump, make sure cable condenser bracket is secured with pump mounting bracket.

2. Mount condenser bracket (D) and fuel pump (C) to hull.

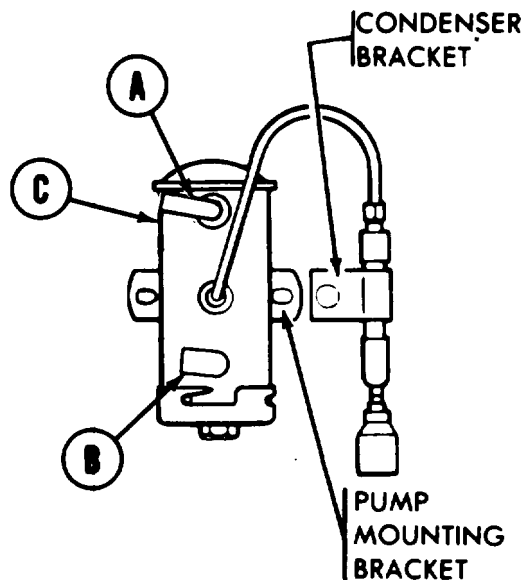

Go on to Sheet 3

TA248623

HEATER FUEL PUMP REPLACEMENT (Sheet 3 of 3)

3. Using socket and extension, install two screws, lockwashers, and washers (E) securing fuel pump (C) to hull.
4. Remove two plugs from fuel lines (F) and (G).
5. Using 9/16 inch wrench, install line (F) to pump (C).
6. Using 5/8 inch wrench, install tube nut (H) to elbow (B).
7. Connect electrical connector (J) to harness connector (K).
8. Test heater for operation (TM 5-5420-202-10).

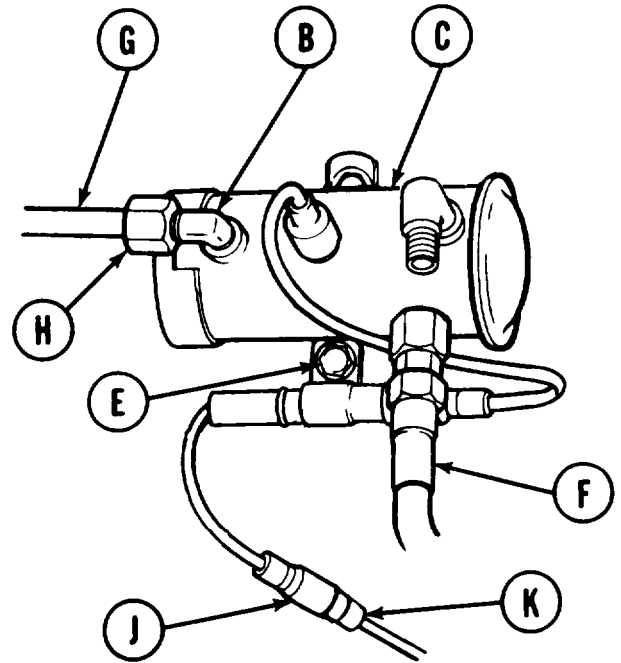

End of Task

TA248624

**PERSONNEL HEATER FUEL LINE HOSE AND QUICK-DISCONNECT COUPLING ASSEMBLY
REPLACEMENT (Sheet 1 of 2)**

TOOLS: 5/8 in. openend wrench (2 required)

SUPPLIES: Plugs
Rags (Item 65, Appendix D)
Container

PRELIMINARY PROCEDURE: Close fuel shutoff valve (TM 5-5420-202-10)

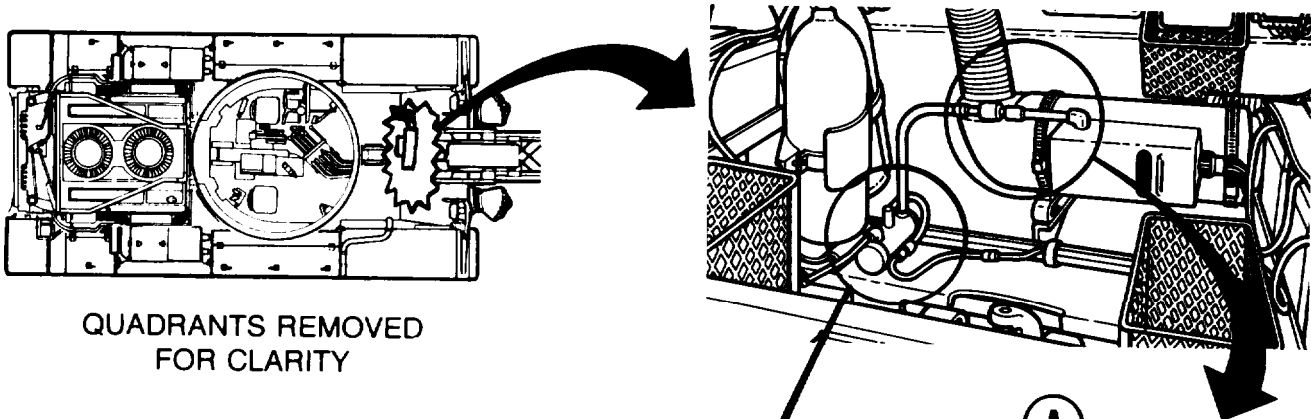

QUADRANTS REMOVED
FOR CLARITY

REMOVAL:

1. Push and pull on quick-disconnect coupler nut (A) to disconnect hose (B) at heater.
2. Using Wrench, loosen nut(C) to disconnect hose(B) at fuel pump adapter(D). Plug adapter (D).
3. Using container to catch fuel, remove hose (B).
4. Using two wrenches, disconnect coupling assembly (E) from hose assembly (B). Plug hose (B).

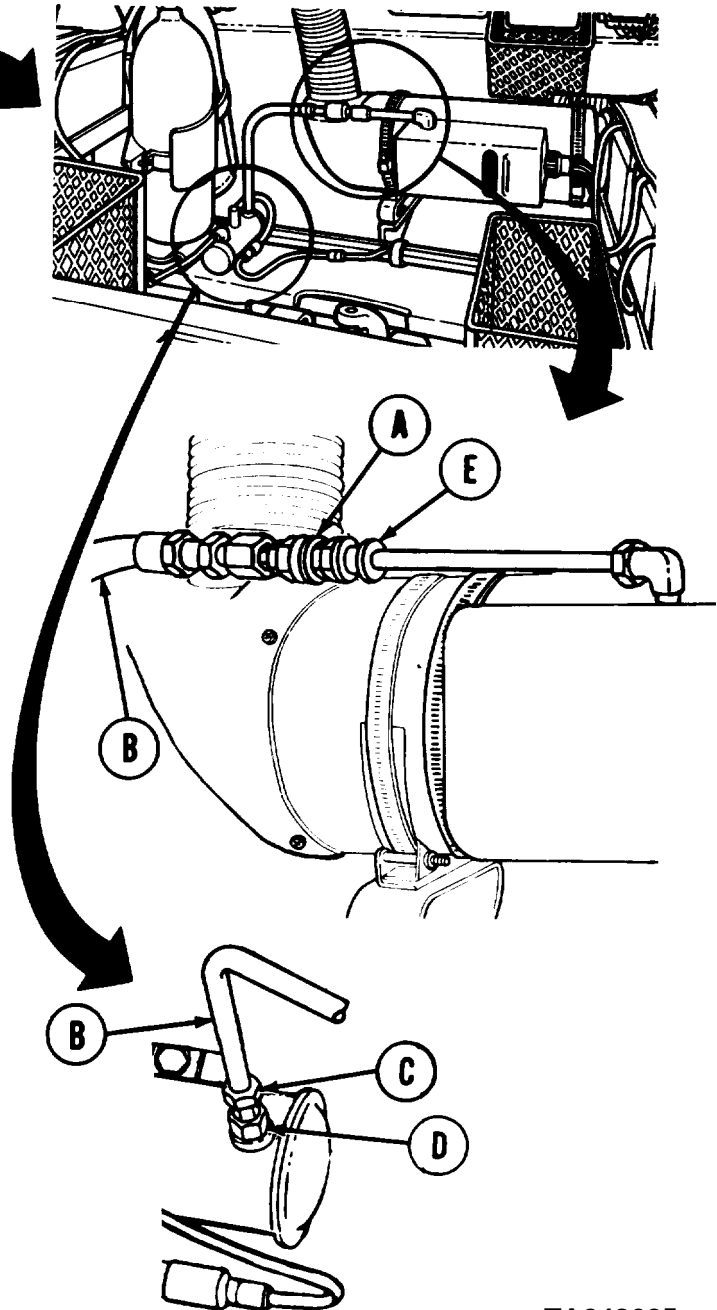

Go on to Sheet 2

TA248625

PERSONNEL HEATER FUEL LINE HOSE AND QUICK-DISCONNECT COUPLING ASSEMBLY REPLACEMENT (Sheet 2 of 2)**INSTALLATION:**

1. Using two wrenches, install coupling assembly (A) on hose (B).
2. Install hose nut (C) on fuel pump adapter (D).
3. Using wrench, tighten hose nut (C).
4. Push quick-disconnect coupling assembly (E) into elbow on heater assembly.
5. Open fuel shutoff valve (TM 5-5420-202-10).

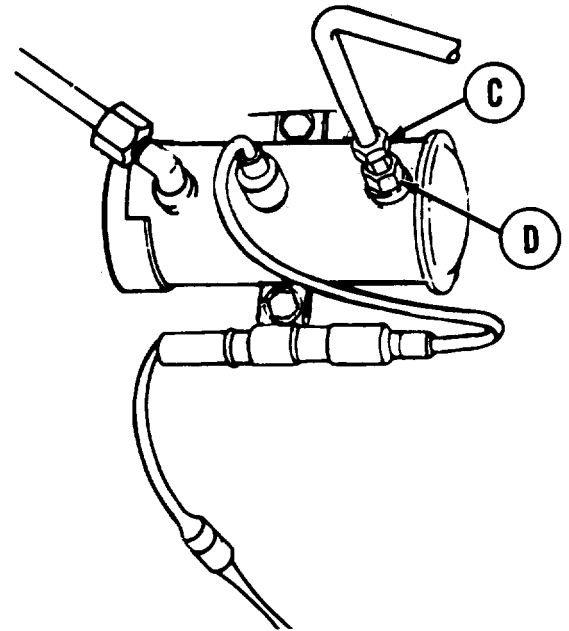
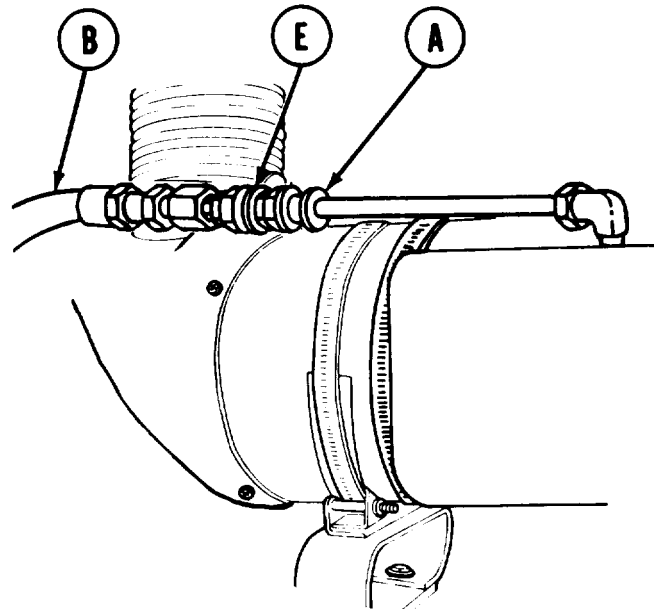

End of Task

TA248626

18-27/18-28 blank)

CHAPTER 19

SPEEDOMETER AND TACHOMETER MAINTENANCE

INDEX

Procedure	Page
Speedometer Replacement	19-2
Speedometer Flexible Shaft Assembly Replacement	19-5
Speedometer Flexible Shaft Assembly Repair	19-7
Speedometer Adapter Rotating Bracket Assembly Replacement	19-9
Speedometer Shaft Adapter Assembly Replacement	19-11
Speedometer Shaft Adapter Assembly Repair	19-13
Tachometer Replacement	19-14
Tachometer Bulkhead Shaft Adapter Replacement	19-17
Tachometer Front Flexible Shaft Assembly Replacement	19-20
Tachometer Front Flexible Shaft Repair	19-23
Tachometer Rear Flexible Shaft Replacement	19-25
Tachometer Rear Flexible Shaft Adapter Replacement	19-31
Tachometer Rear Flexible Shaft Adapter Repair	19-33
Speedometer-Tachometer Mounting Bracket Replacement	19-34

SPEEDOMETER REPLACEMENT (Sheet 1 of 3)

PROCEDURES INDEX

PROCEDURES	PAGE
Removal	19-2
Installation	19-3

TOOLS: 3/8 in. combination box and open end wrench
3/4 in. combination box and open end wrench

REFERENCE: TM 5-5420-202-10

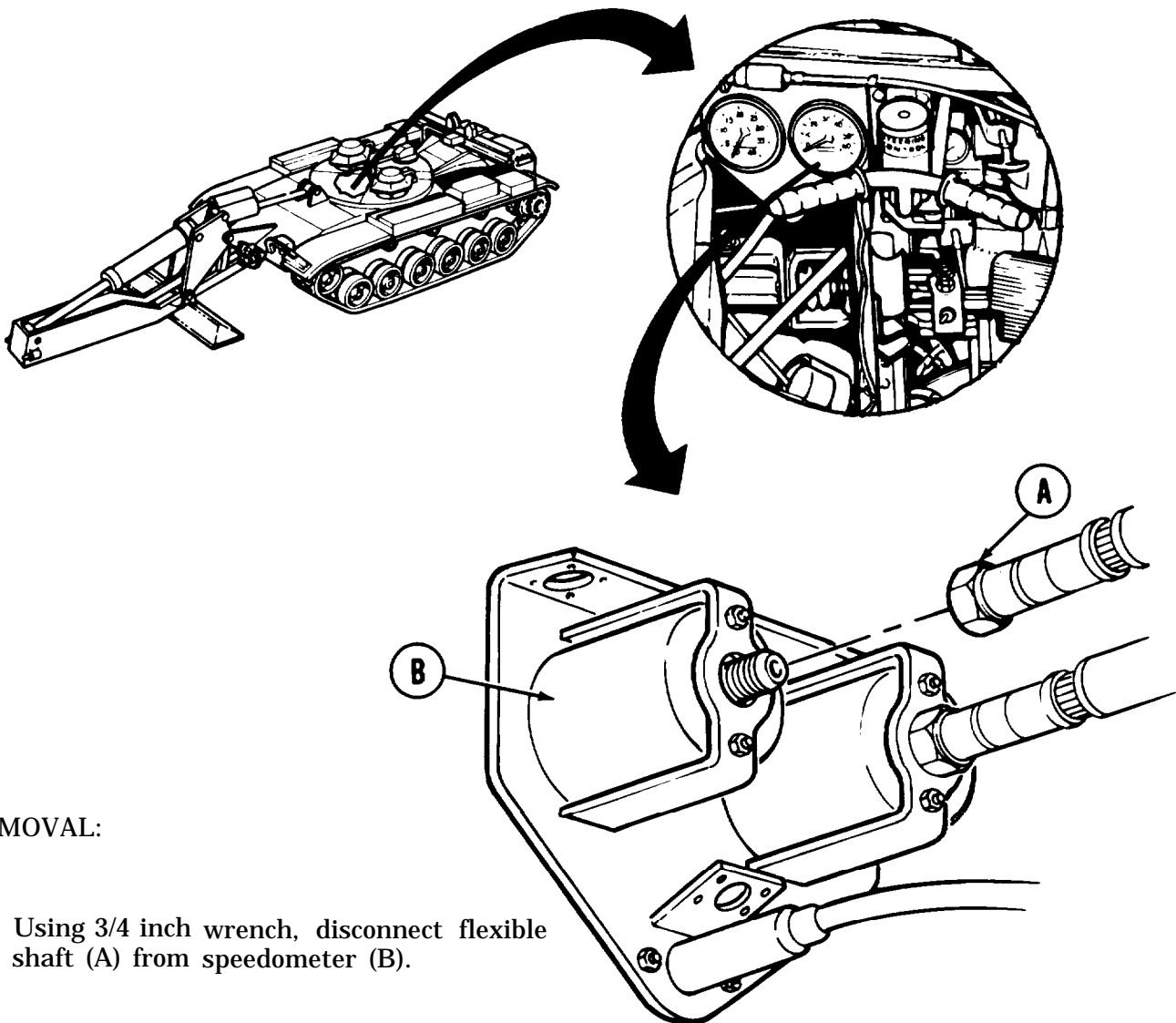

REMOVAL:

1. Using 3/4 inch wrench, disconnect flexible shaft (A) from speedometer (B).

Go on to Sheet 2

TA248627

SPEEDOMETER REPLACEMENT (Sheet 2 of 3)

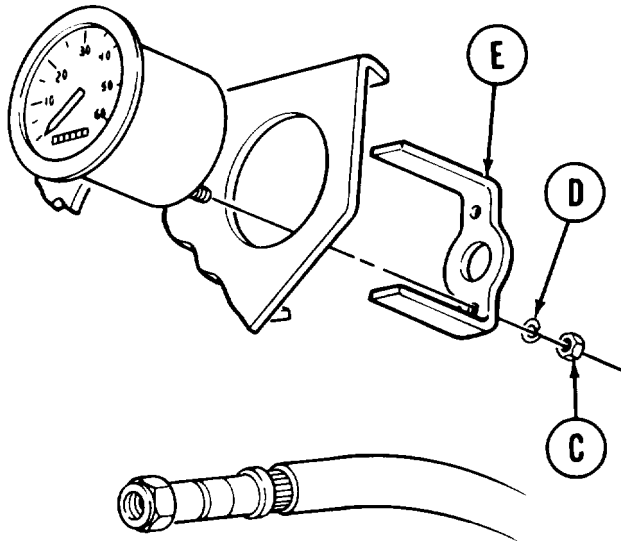

2. Using 3/8 inch wrench, remove two nuts (C) and lockwashers (D) securing retainer (E).
3. Remove retainer (E).

4. Remove speedometer (B) from mounting bracket (F).

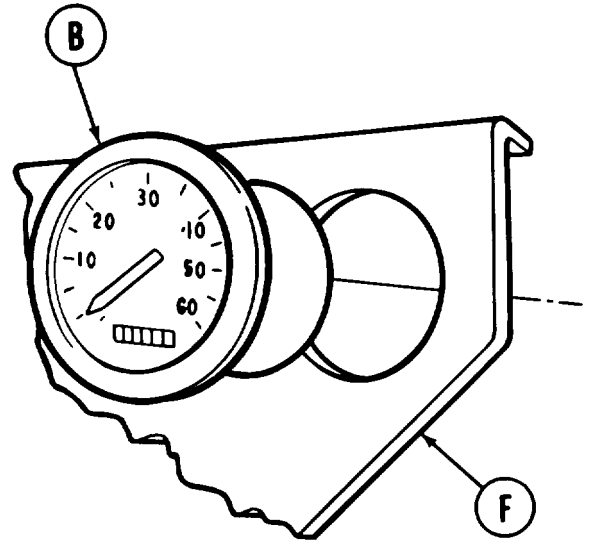

INSTALLATION:

1. Place speedometer (A) in position in mounting bracket (B).

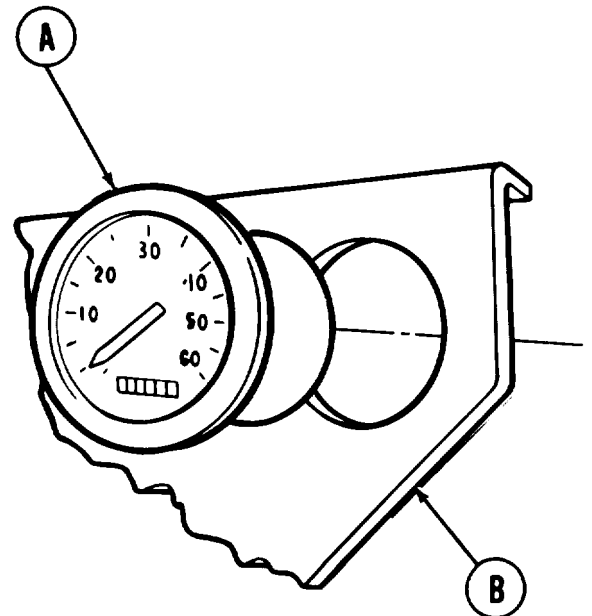

Go on to Sheet 3

TA248628

SPEEDOMETER REPLACEMENT (Sheet 3 of 3)

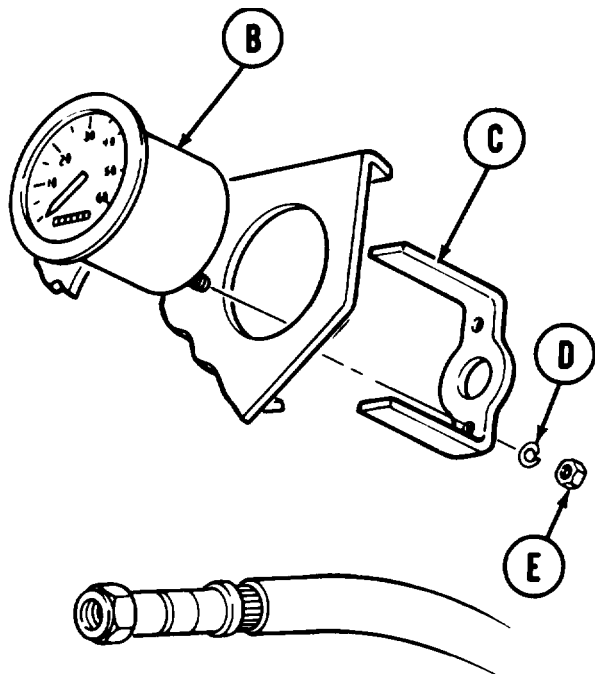

2. Place retainer (C) in position on speedometer (B).
3. Position two lockwashers (D).
4. Using 3/8 inch wrench, install two nuts (E).

5. Using 3/4 inch wrench, install flexible cable (F) on speedometer (B).

6. Check operation of speedometer (TM 5-5420-202-10).

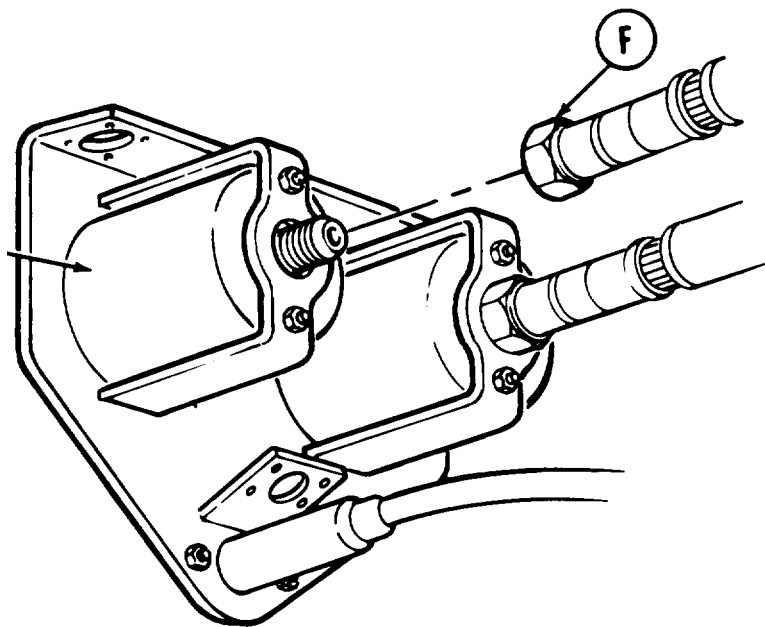

End of Task

TA248629

SPEEDOMETER FLEXIBLE SHAFT ASSEMBLY REPLACEMENT (Sheet 1 of 2)

TOOLS: 3/4 in. open end wrench
 1 in. open end wrench

REFERENCE: TM 5-5420-202-10

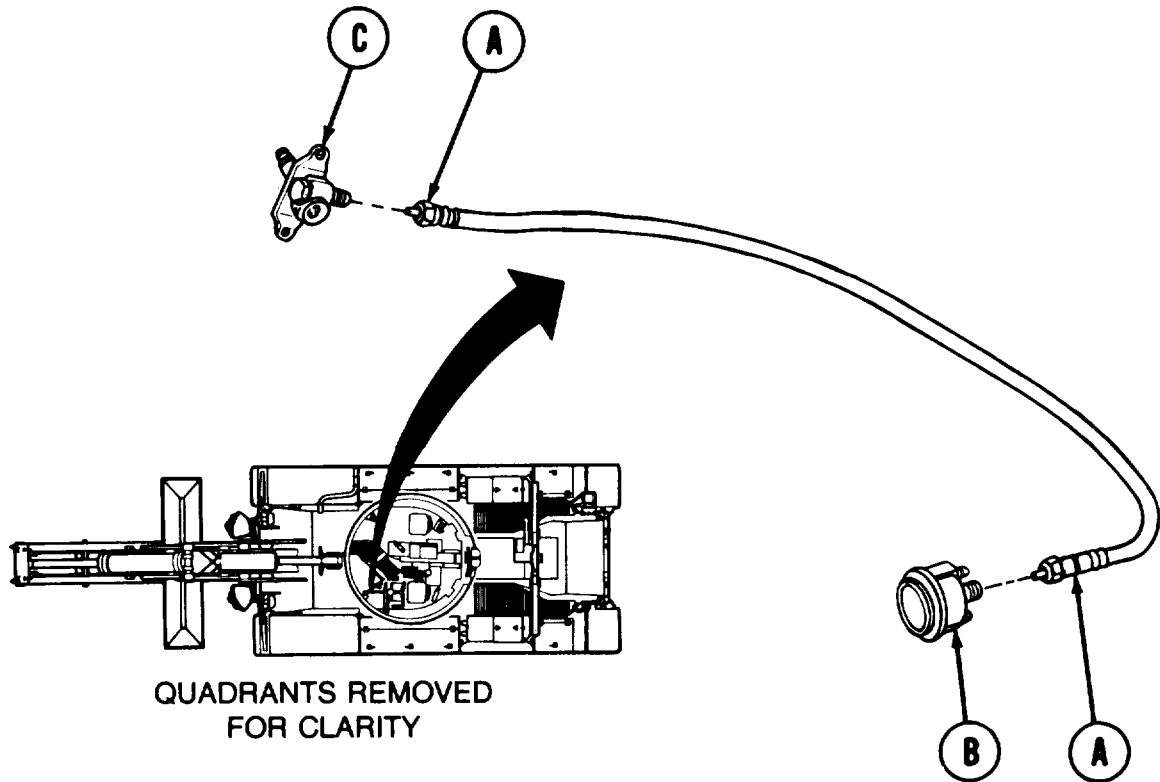

REMOVAL:

1. Using 3/4 inch wrench, remove end of flexible shaft (A) from speedometer (B).
2. Using 1 inch wrench, remove end of flexible shaft (A) from adapter assembly (C).

Go on to Sheet 2

TA248630

SPEEDOMETER FLEXIBLE SHAFT ASSEMBLY REPLACEMENT (Sheet 2 of 2)

INSTALLATION:

NOTE

Be sure to aline flexible shaft key with speedometer and adapter.

1. Place flexible shaft (A) in position.
2. Using 1 inch wrench, install end of flexible shaft (A) on adapter (B).

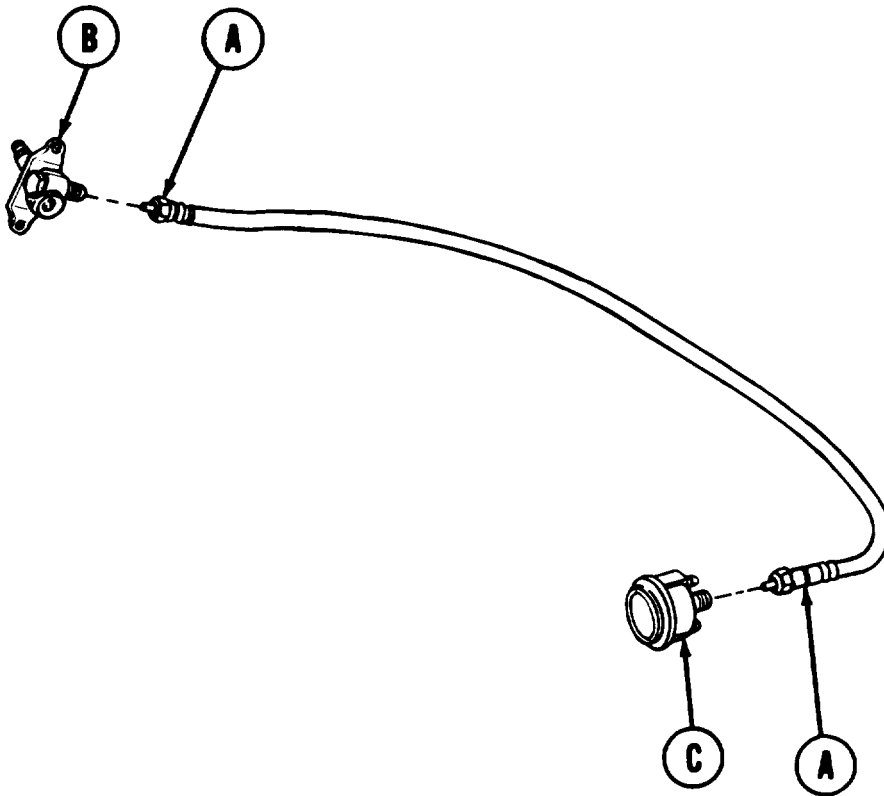

3. Using 3/4 inch wrench, install other end of flexible shaft (A) to speedometer (C).
4. Check operation of speedometer (TM 5-5420-202-10).

End of Task

TA248631

SPEEDOMETER FLEXIBLE SHAFT ASSEMBLY REPAIR (Sheet 1 of 2)

TOOLS: Slip joint pliers
Long round nose pliers (needle nose)

PRELIMINARY PROCEDURE: Remove speedometer flexible shaft assembly (page 19-5)

DISASSEMBLY:

1. Using slip joint pliers, pull out core (A) as far as possible from right angle drive adapter end (B) of flexible shaft (C).
2. Using needle nose pliers, remove slotted washer (D).
3. Remove one gasket (E) from each end of shaft (C).
4. Using pliers, pull out core (A) from speedometer end (F) of shaft (C).

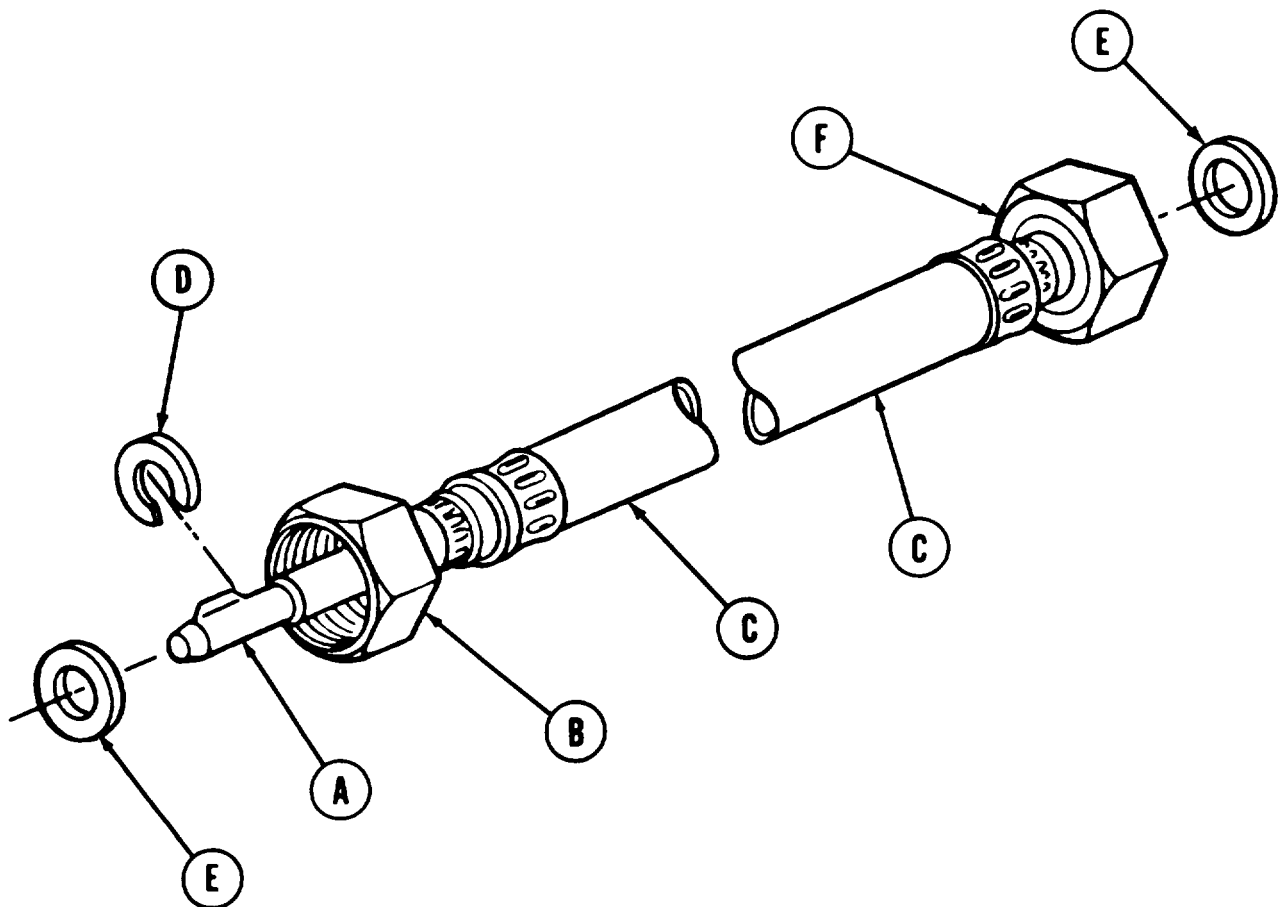

Go on to Sheet 2

TA248632

SPEEDOMETER FLEXIBLE SHAFT ASSEMBLY REPAIR (Sheet 2 of 2)

ASSEMBLY:

1. Install one gasket (A) onto each end of shaft (B).
2. Install core (C) in speedometer end (D) of flexible shaft (B).
3. Using slip joint pliers, pull out core (C) as far as possible from right angle drive adapter end (E) of shaft (B).
4. Using needle nose pliers, install slotted washer (F) on core (C).
5. Push core (C) back into flexible shaft (B) until seated.
6. Install speedometer flexible shaft assembly (page 19-6).

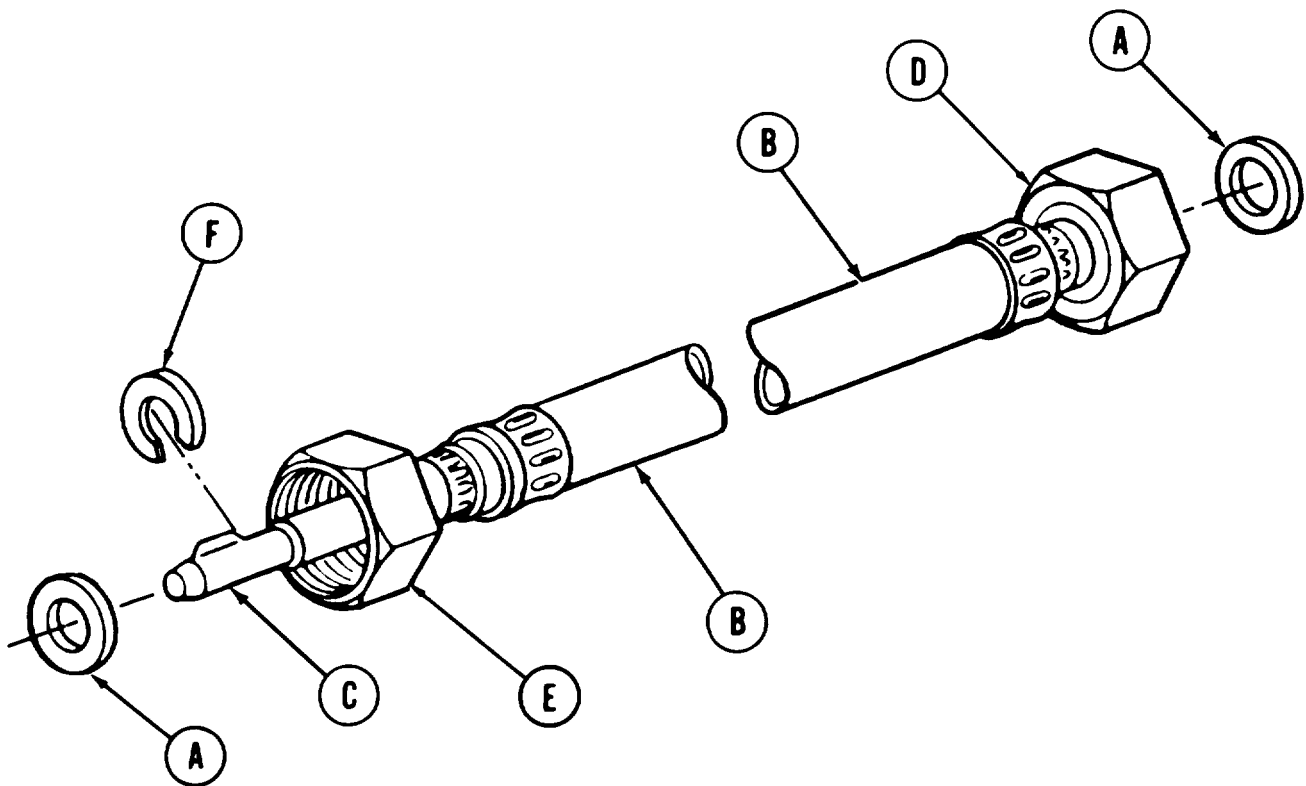

End of Task

TA248633

SPEEDOMETER ADAPTER ROTATING BRACKET ASSEMBLY REPLACEMENT (Sheet 1 of 2)

TOOLS: Diagonal cutting pliers
 Slip joint pliers
 Ratchet with 1/2 in. drive
 7/16 in. socket with 1/2 in. drive
 5 in. extension with 1/2 in. drive

SUPPLIES: Lockwire (Item 61, Appendix D)
 Lockwashers (4 required)

PRELIMINARY PROCEDURE: Remove speedometer shaft adapter assembly
 (page 19-11)

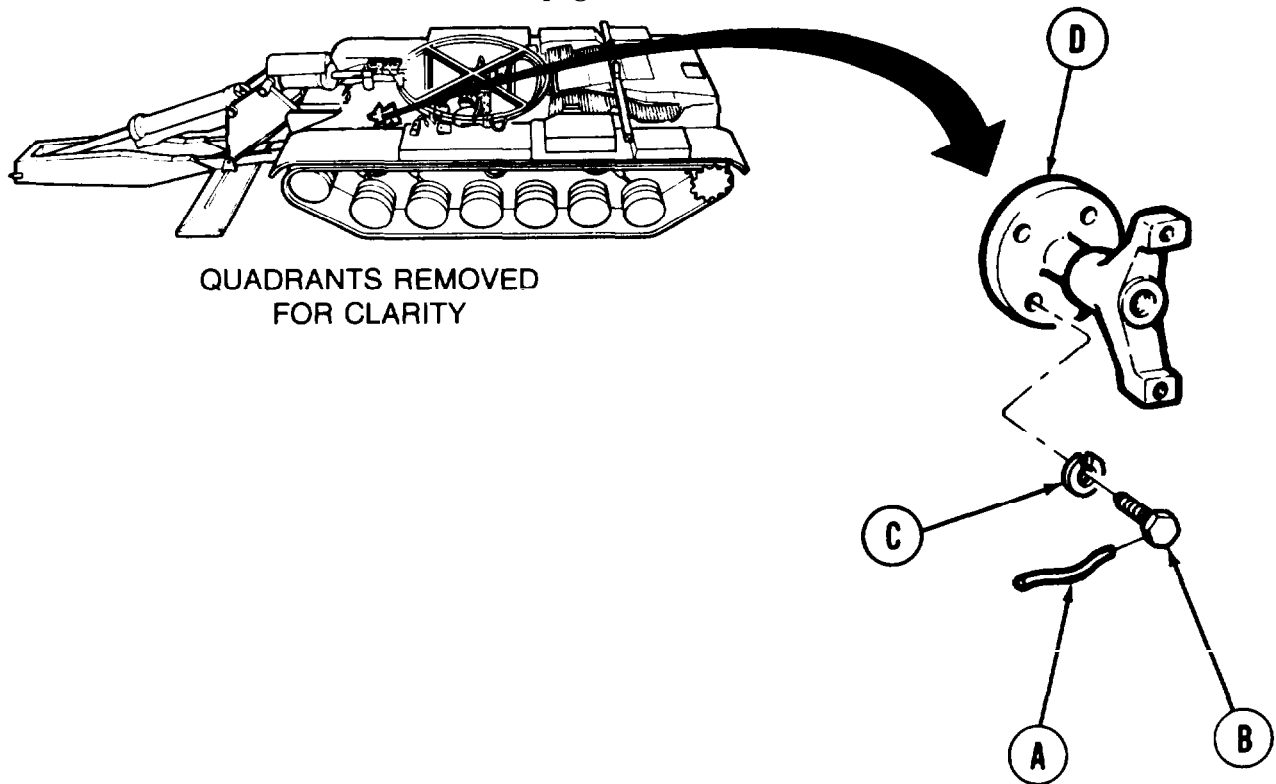

REMOVAL:

1. Using cutting pliers, remove lockwire (A) from four screws (B). Throw lockwire away.
2. Using socket and extension, remove four screws (B) and lockwashers (C).
3. Remove rotating bracket assembly (D).

Go on to Sheet 2

TA248634

SPEEDOMETER ADAPTER ROTATING BRACKET ASSEMBLY REPLACEMENT Sheet 2 of 2)

INSTALLATION:

1. Place rotating bracket (A) in position on hull wall.
2. Using socket and extension, install four screws (B) and lockwasher (C).
3. Using slip joint pliers, install new lockwire (D).
4. Install speedometer shaft adapter assembly (page 19-12).

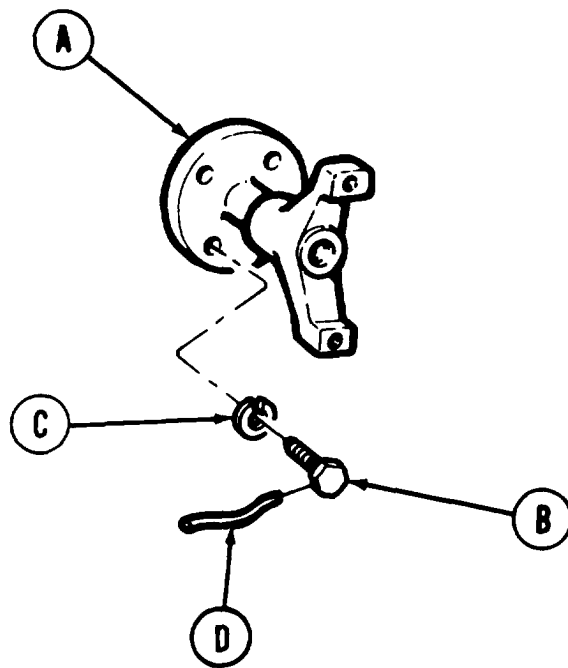

End of Task

TA248635

SPEEDOMETER SHAFT ADAPTER ASSEMBLY REPLACEMENT {Sheet 1 of 2}

TOOLS: 7/16 in. socket with 1/2 in. drive
1 in. combination box and open end wrench
Ratchet with 1/2 in. drive
5 in. extension with 1/2 in. drive

SUPPLIES: Lockwashers (2 required)

REFERENCE TM 5-5420-202-10

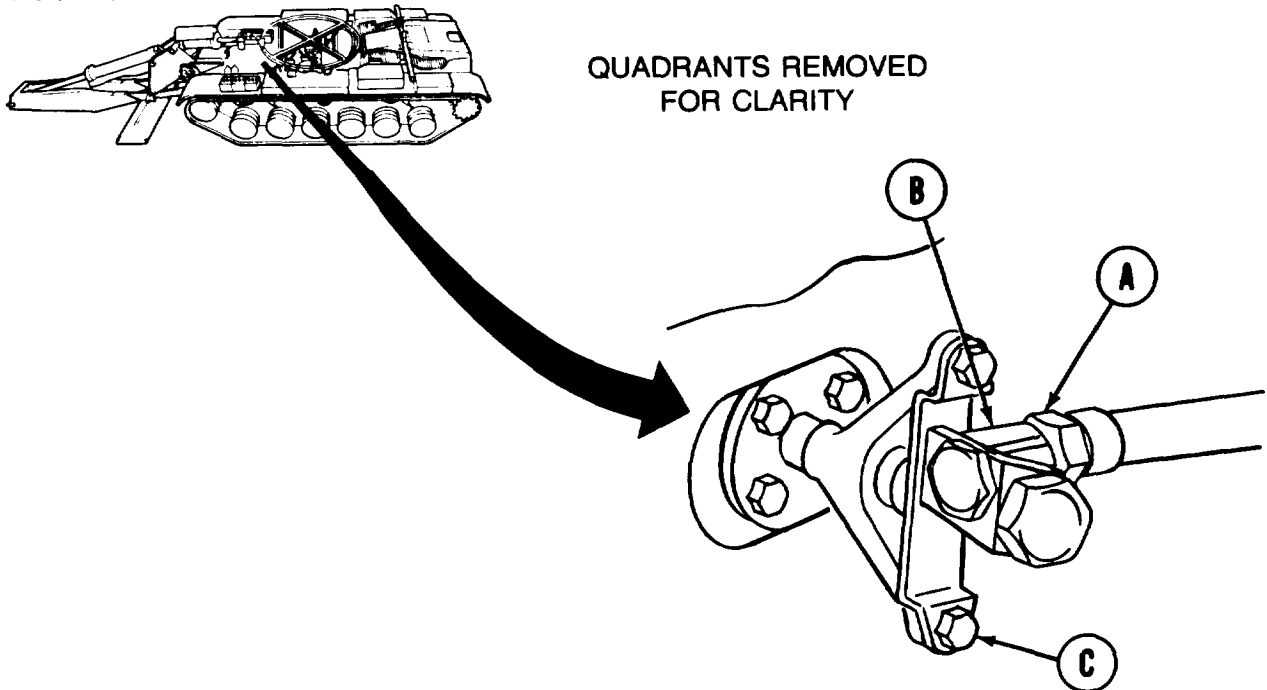
REMOVAL:

1. Using 1 inch wrench, disconnect flexible shaft assembly (A) from speedometer shaft adapter (B).
2. Using 7/16 inch socket and extension, remove two screws and lockwashers (C).
3. Remove speedometer shaft adapter assembly (B).

Go on to Sheet 2

TA248636

SPEEDOMETER SHAFT ADAPTER ASSEMBLY REPLACEMENT (Sheet 2 of 2)

INSTALLATION:

NOTE

When placing shaft adapter in position, make sure to align adapter and cable.

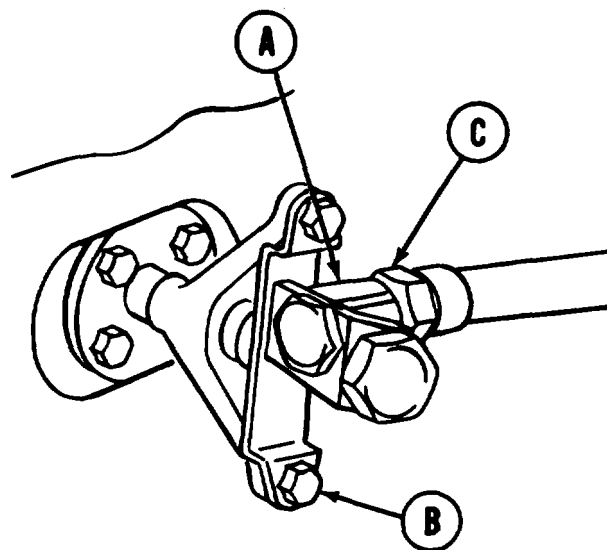

1. Place speedometer shaft adapter (A) in position.
2. Using 7/16 inch socket and extension, install two screws and lock washer (B).
3. Using 1 inch wrench, connect flexible shaft assembly (C) to shaft adapter (A).
4. Check operation of speedometer (TM 5-5420-202-10).

End of Task

TA248637

SPEEDOMETER SHAFT ADAPTER ASSEMBLY REPAIR (Sheet 1 of 1)

TOOLS: 1-1/4 in. box end wrench
Flat-tip screwdriver

SUPPLIES: Grease (Item 37, Appendix D)
Preformed packing

PRELIMINARY PROCEDURE: Remove speedometer shaft adapter assembly (page 19-11)

DISASSEMBLY:

1. Using wrench, remove adapter plug (A) from speedometer shaft adapter assembly (B).
2. Using screwdriver, remove two preformed packings (C).
3. Throw preformed packings away.

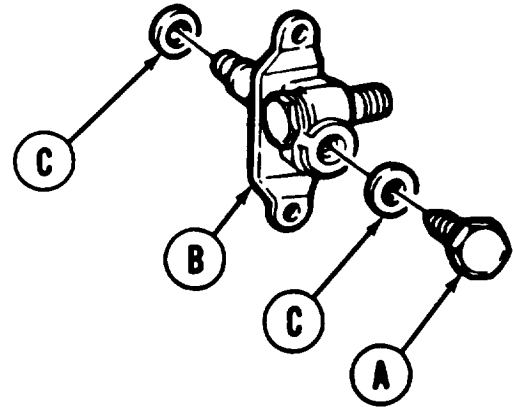

ASSEMBLY:

1. Lightly grease two new preformed packings (C).
2. Place two preformed packings (C) in position on speedometer shaft adapter assembly (B).
3. Using wrench, install adapter plug (A) in speedometer shaft adapter assembly (B).
4. Install speedometer shaft adapter assembly in vehicle (page 19-12).

End of Task

TA248638

TACHOMETER REPLACEMENT (Sheet 1 of 3)

PROCEDURE INDEX

PROCEDURE	PAGE
Removal	19-14
Installation	19-15

TOOLS: 3/8 in. combination box and open end wrench
3/4 in. combination box and open end wrench

SUPPLIES Lockwashers (2 required)

REFERENCE TM 5-5420-202-10

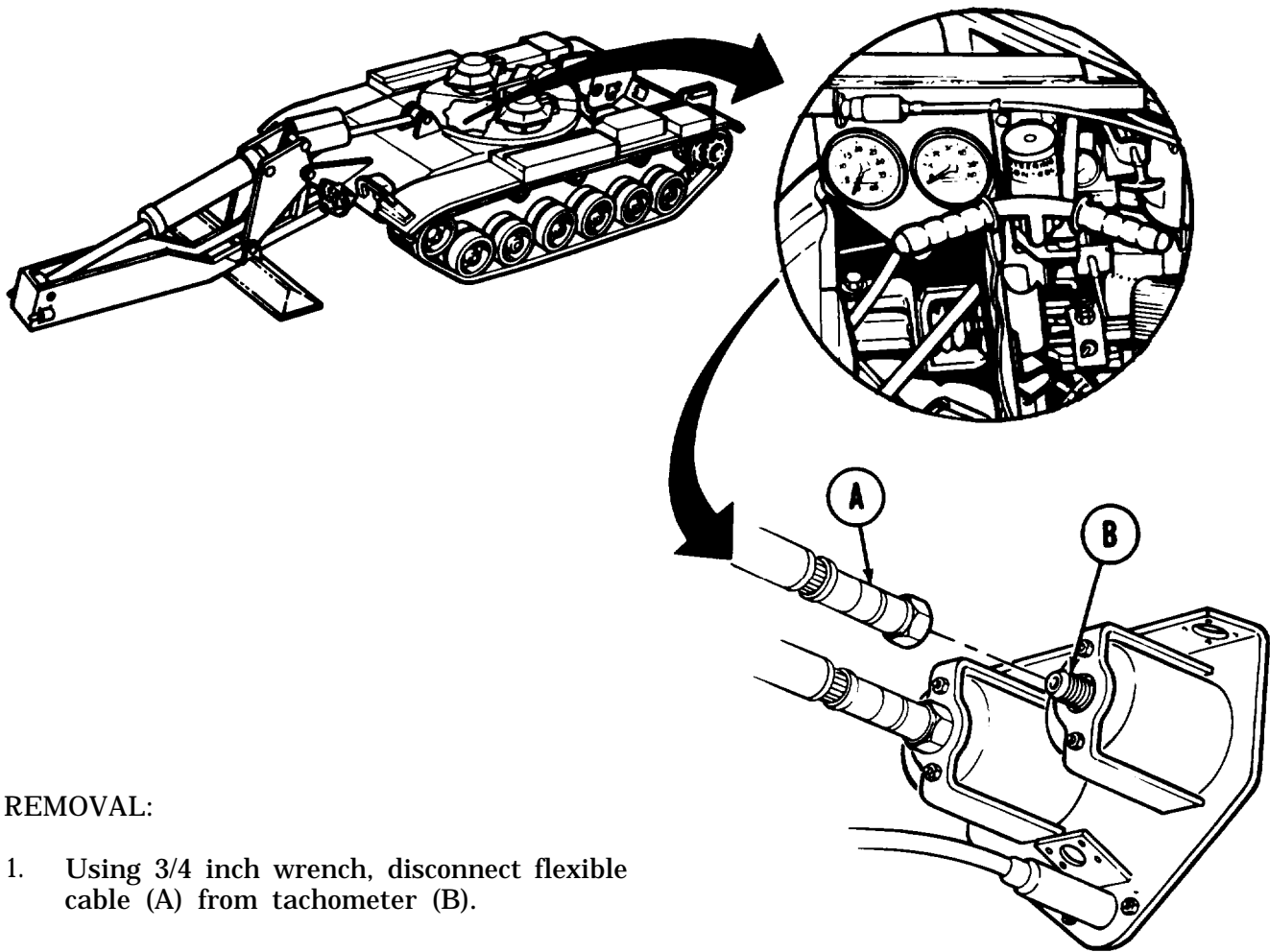

REMOVAL:

1. Using 3/4 inch wrench, disconnect flexible cable (A) from tachometer (B).

Go on to Sheet 2

TA248639

TACHOMETER REPLACEMENT (Sheet 2 of 3)

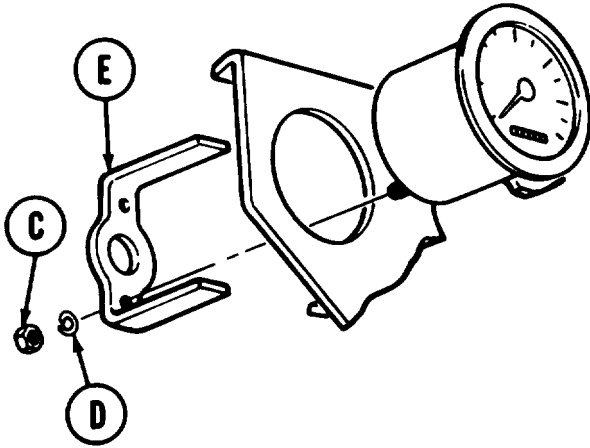

2. Using 3/8 inch wrench, remove two nuts (C) and lockwashers (D) securing retainer (E).

3. Remove retainer (E).

4. Remove tachometer (B) from mounting bracket (F).

INSTALLATION:

1. Place tachometer (A) in position in mounting bracket (B).

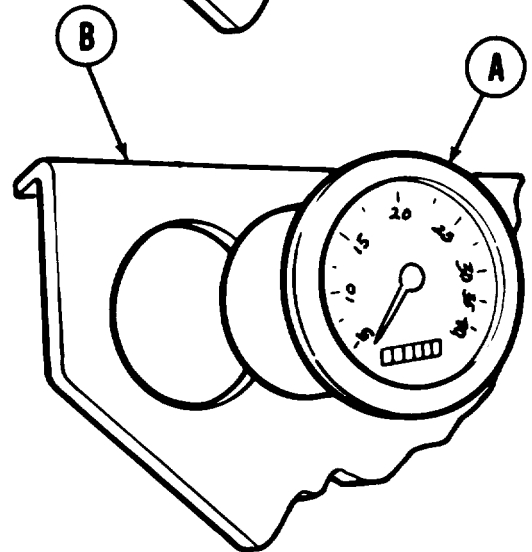
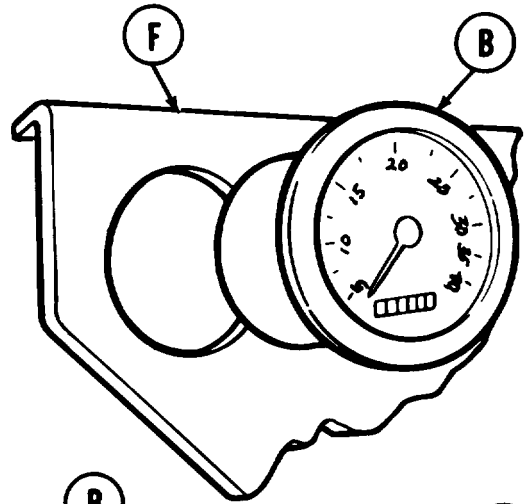

Go on to Sheet 3

TA248640

TACHOMETER REPLACEMENT (Sheet 3 of 3)

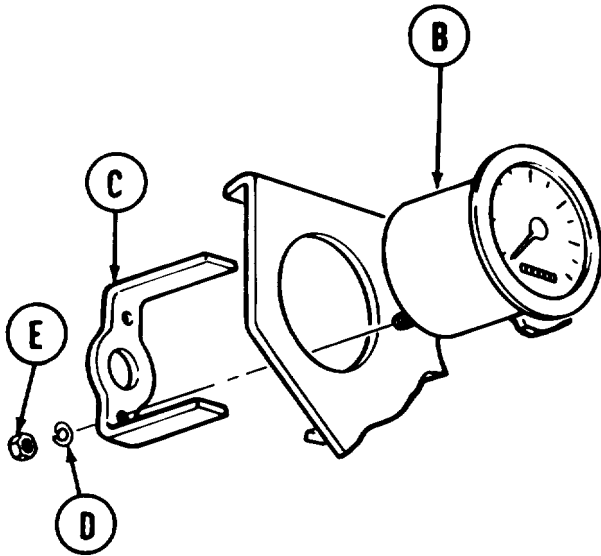

2. Place retainer (C) in position on tachometer (B).
3. Position two lockwashers (D).
4. Using 3/8 inch wrench, install two nuts (E).
5. Using 3/4 inch wrench, install flexible cable (F) on tachometer (E).

6. Start engine (TM5-5420-202-10).

7. Make sure tachometer operates.

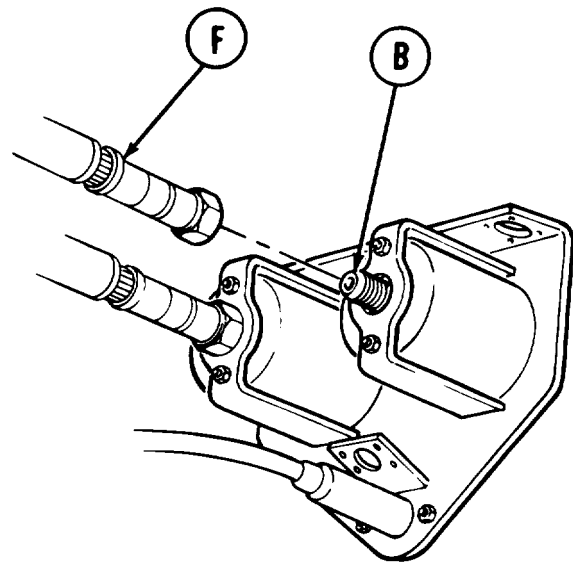

End of Task

TA248641

TACHOMETER BULKHEAD SHAFT ADAPTER REPLACEMENT (Sheet 1 of 3)

TOOLS: Adjustable wrench, 10 in.
Screwdriver, cross-tip

REFERENCE: TM 5-5420-202-10

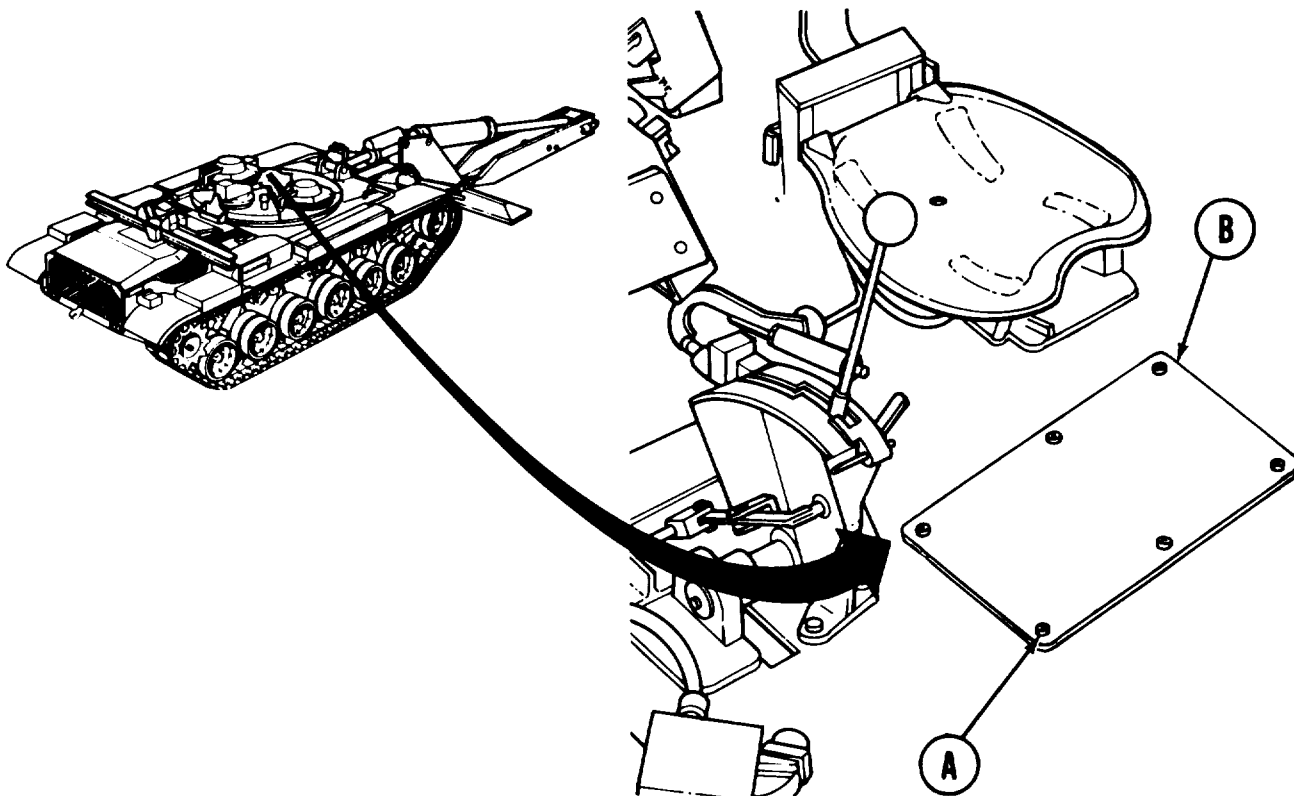

REMOVAL:

1. Using screwdriver, remove six screws (A) from floor plate (B) in driver's compartment floor.
2. Remove floor plate (B).

Go on to Sheet 2

TA248642

TACHOMETER BULKHEAD SHAFT ADAPTER REPLACEMENT (Sheet 2 of 3)

3. Using wrench, remove front flexible shaft assembly (C) from underside of floor plate.
4. Using wrench, remove rear flexible shaft assembly (D).
5. Using wrench, loosen nut (E).
6. Remove adapter (F) from mounting bracket (G).

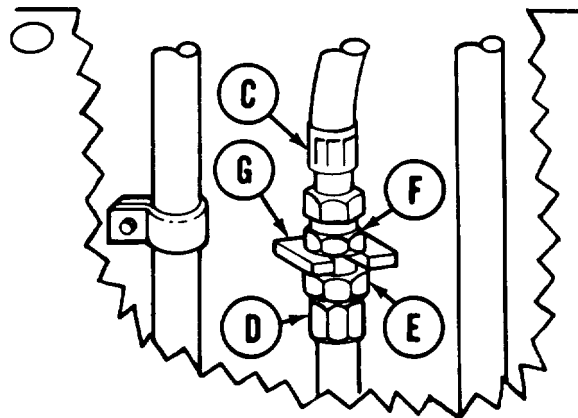

INSTALLATION:

1. Place adapter (A) in position on mounting bracket (B).
2. Using wrench, tighten nut (C).
3. Using fingers, install front flexible shaft (D) and rear flexible shaft (E).
4. Using wrench, tighten shafts (B) and (E).

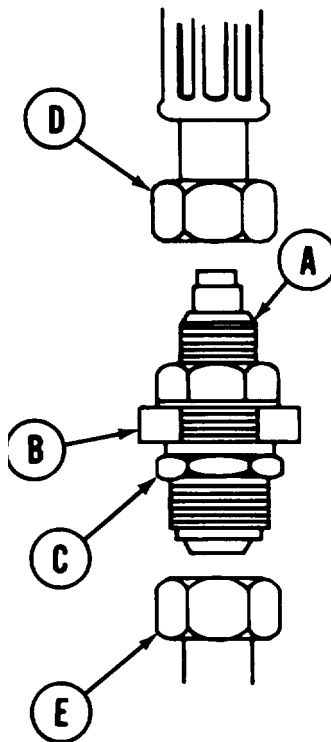

Go on to Sheet 3

TA248643

5. Position floor plate (F) with holes alined.
6. Using screwdriver, install six screws (G).
7. Start engine (TM 5-5420-202-10).
8. Make sure tachometer works.

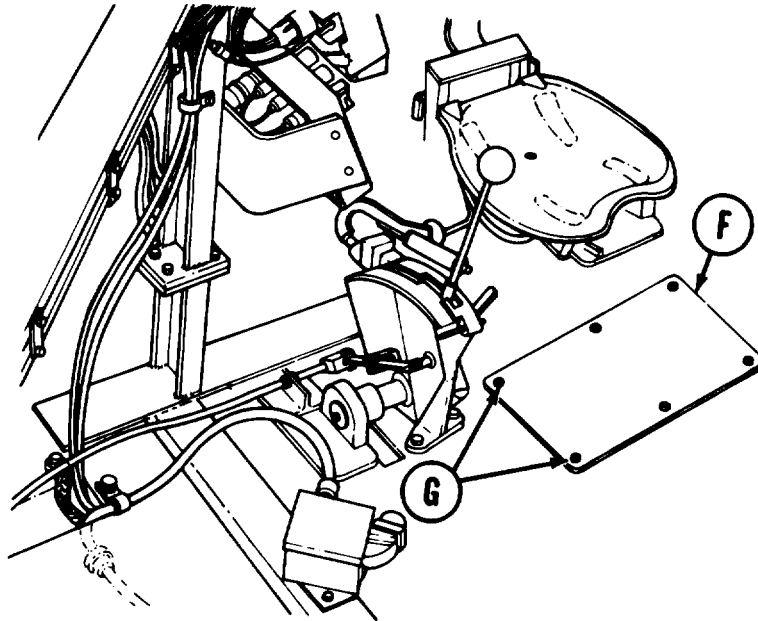

End of Task

TA248644

TACHOMETER FRONT FLEXIBLE SHAFT ASSEMBLY REPLACEMENT (Sheet 1 of 3)

TOOLS: 7/16 in. combination box and open end wrench
3/4 in. Combination box and open end wrench
1 in. combination box and open end wrench
Screwdriver, cross-tip

REFERENCE: TM 5-5420-202-10

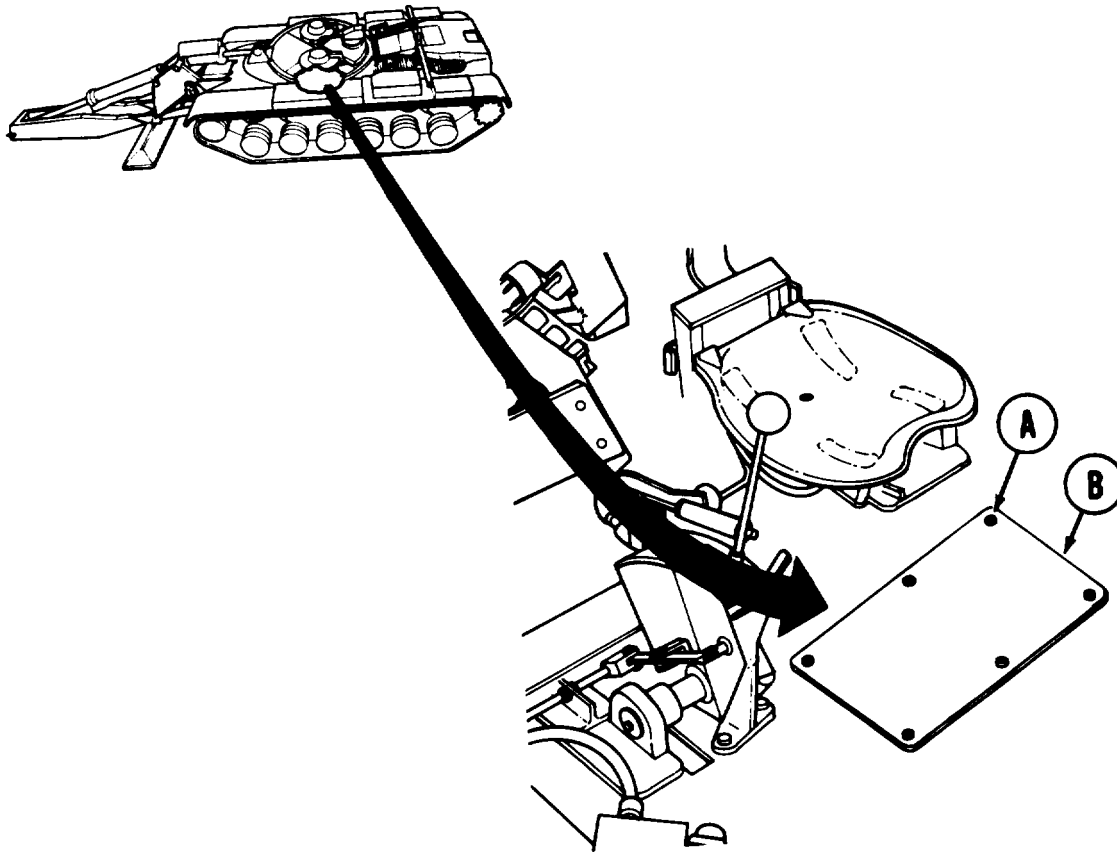

REMOVAL:

1. Using screwdriver, remove six screws (A) from floor plate (B).
2. Remove floor plate (E).

TA248645

Go on to Sheet 2

TACHOMETER FRONT FLEXIBLE SHAFT ASSEMBLY REPLACEMENT (Sheet 2 of 3)

- Using 3/4 inch wrench, remove end of shaft (C) from tachometer (D) in driver's compartment.

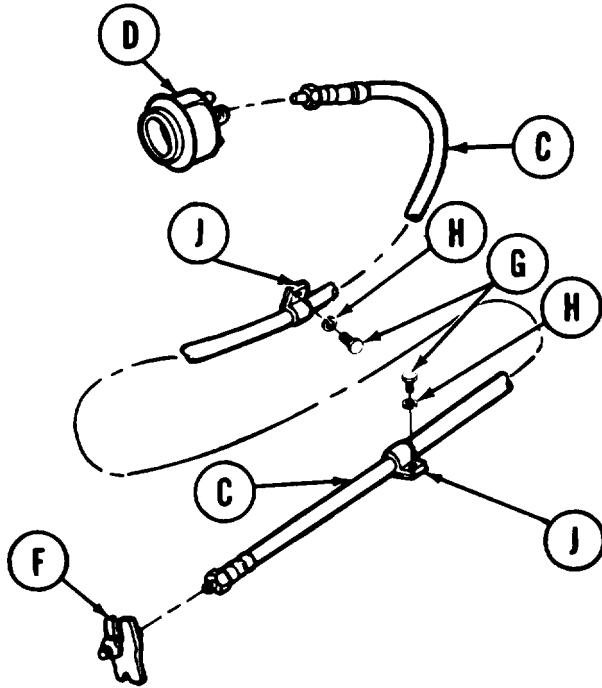

- Using 1 inch wrench, remove end of shaft (C) from tachometer shaft adapter (F) under floor plate.
- Using 7/16 inch wrench, remove two screws (G), and lockwashers (H), and clamps (J).
- Remove front flexible shaft (C).

INSTALLATION :

NOTE

Be sure to aline flexible shaft key with slot in adapter.

Go on to Sheet 3

TA248646

TACHOMETER FRONT FLEXIBLE SHAFT ASSEMBLY REPLACEMENT (Sheet 3 of 3)

1. Place shaft (A) in position.
2. Using 1 inch wrench, install end of shaft (A) on tachometer shaft adapter (B).
3. Using 3/4 inch wrench, install other end of shaft (A) to tachometer (C).
4. Using 7/16 inch wrench, install two clamps (D), screws (E), and lockwashers (F).
5. Position floor plate (F) with holes alined.
6. Using screwdriver, install six screws (G).

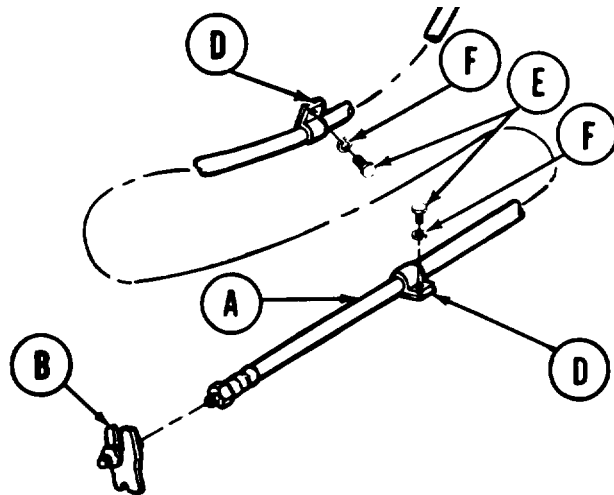

7. Start engine (TM 5-5420-202-10).
8. Make sure tachometer works.

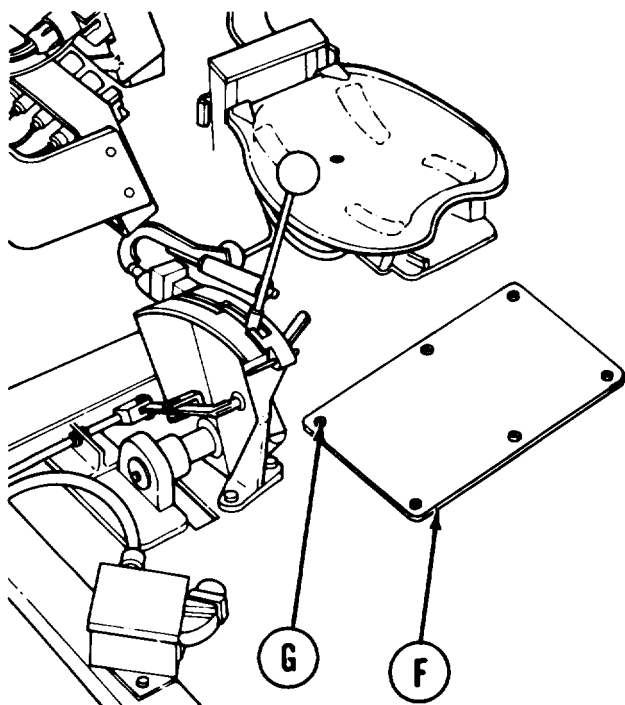

End of Task

TA248647

TACHOMETER FRONT FLEXIBLE SHAFT REPAIR (Sheet 1 of 2)

TOOLS: Slip joint pliers
Long round nose pliers (needle nose)

REFERENCE: TM 5-5420-202-10

PRELIMINARY PROCEDURE: Remove tachometer shaft assembly from vehicle (page 19-20)

DISASSEMBLY:

1. Using needle nose pliers, remove gasket (A).
2. Using slip joint pliers, pull out core (B) from tachometer shaft adapter end (C) of flexible cable (D) as far as possible.
3. While holding core (B) with pliers, use needle nose pliers to remove slotted washer (E).
4. Using slip joint pliers, pull out core (B) from tachometer end (F) of flexible shaft (C).
5. Using needle nose pliers, remove flat washer (G) from shaft end.

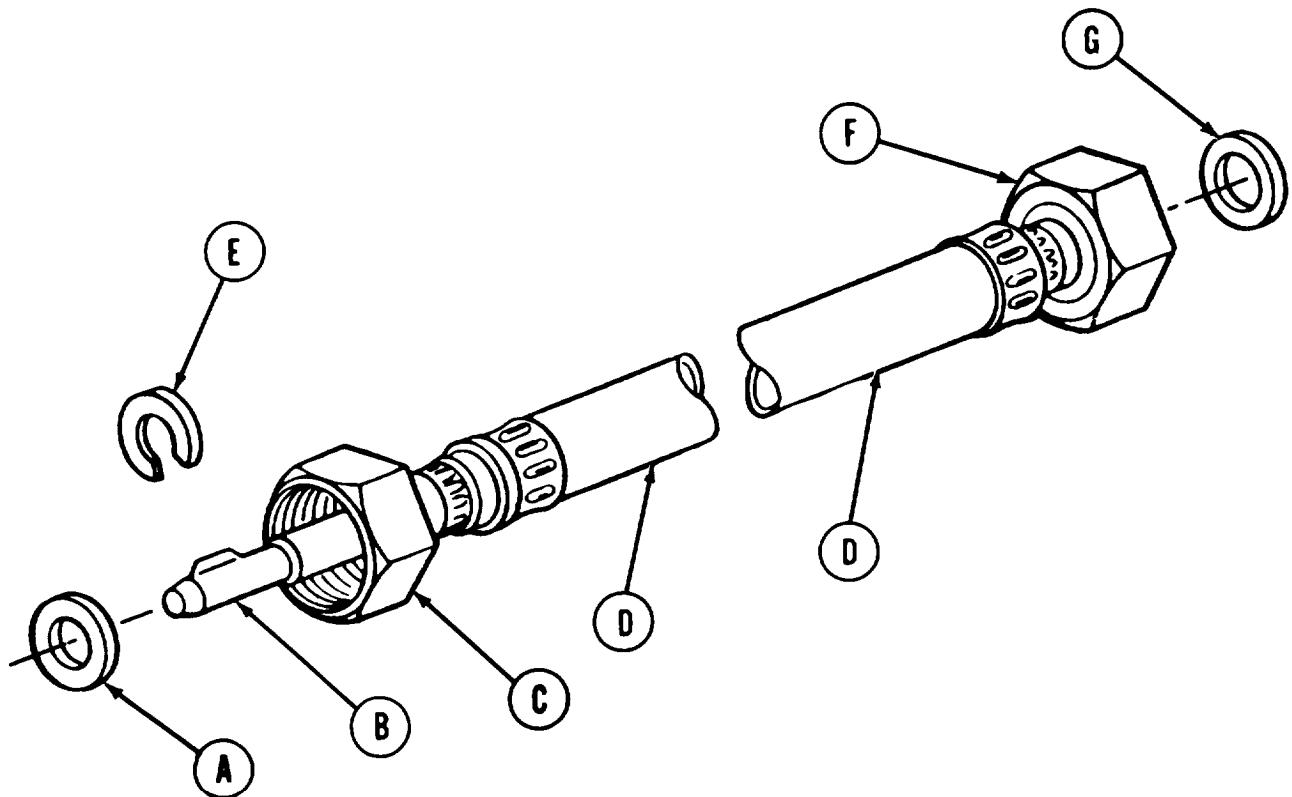

Go on to Sheet 2

TA248648

TACHOMETER FRONT FLEXIBLE SHAFT REPAIR (Sheet 2 of 2)

ASSEMBLY:

1. Install flat washer (A) onto shaft end.
2. Install core (B) through tachometer end (C) of flexible shaft (D).
3. Using slip joint pliers, pull out core (B) from tachometer shaft adapter end (E) as far as it will go.
4. Using needle nose pliers, install slotted washer (F).
5. Using needle nose pliers, install gasket (G) onto end of shaft (D).
6. Push core (B) back into flexible shaft (D) until seated.
7. Install shaft in vehicle (Page 19-21).
8. Start engine (TM 5-5420-202-10).
9. Make sure tachometer works.

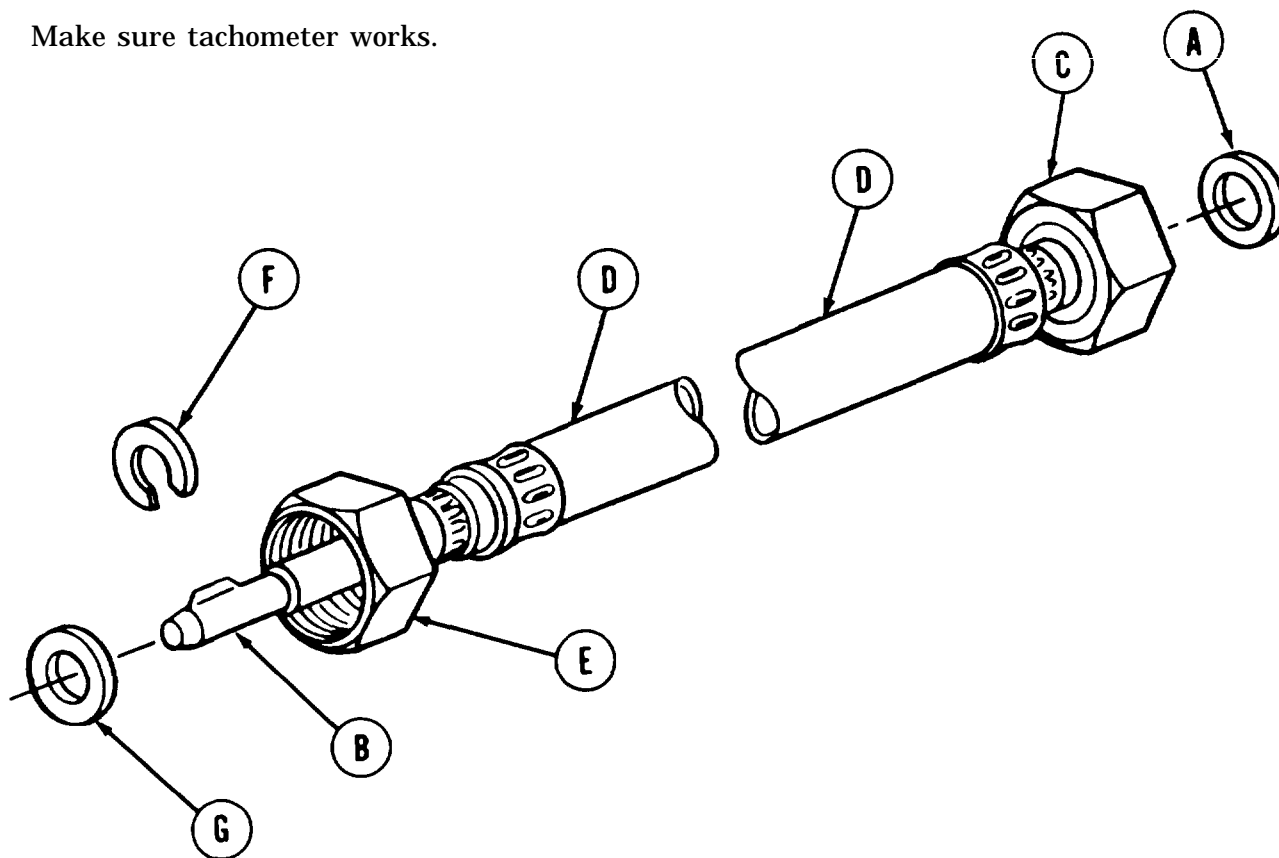

End of Task

TA248649

TACHOMETER REAR FLEXIBLE SHAFT REPLACEMENT (Sheet 1 of 6)

PROCEDURE INDEX

PROCEDURE	PAGE
Removal	19-25
Disassembly	19-27
Cleaning and Inspection	19-28
Assembly	19-28
Installation	19-29

TOOLS: 12 in. adjustable wrench
 Slip joint pliers
 Flat-tip screwdriver
 6 in. steel rule
 Long round nose pliers
 Cross-tip screwdriver

SPECIAL TOOLS: Heat gun (Item 36, Chapter 3, Section I)

SUPPLIES: Shrink tubing (Item 60, Appendix D)
 Adhesive (Item 4, Appendix D)
 Electrical tape (Item 59, Appendix D)
 8 ft. wire (Item 61, Appendix D)

Dry cleaning solvent
 (Item 55, Appendix D)
 Rags (Item 65, Appendix D)
 Gloves (Item 69, Appendix D)
 Goggles (Item 70, Appendix D)

PERSONNEL: Two

REFERENCE: TM 5-5420-202-10

PRELIMINARY PROCEDURES: Remove engine upper access cover (page 17-11).
 Remove powerplant (page 5-2).

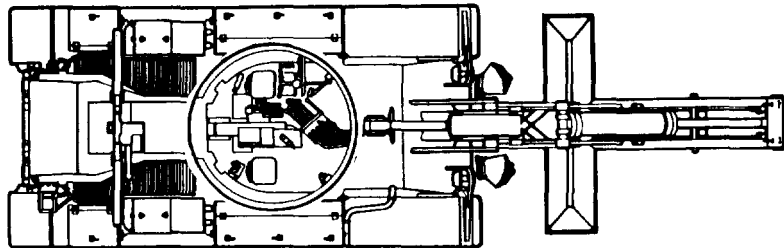

Go on to Sheet 2

TA248650

TACHOMETER REAR FLEXIBLE SHAFT REPLACEMENT (Sheet 2 of 6)

REMOVAL:

1. Using cross-tip screwdriver, remove six screws (A) from floor plate (B).
2. Remove floor plate (B).
3. Using wrench, disconnect rear tachometer shaft (C) from adapter (D).

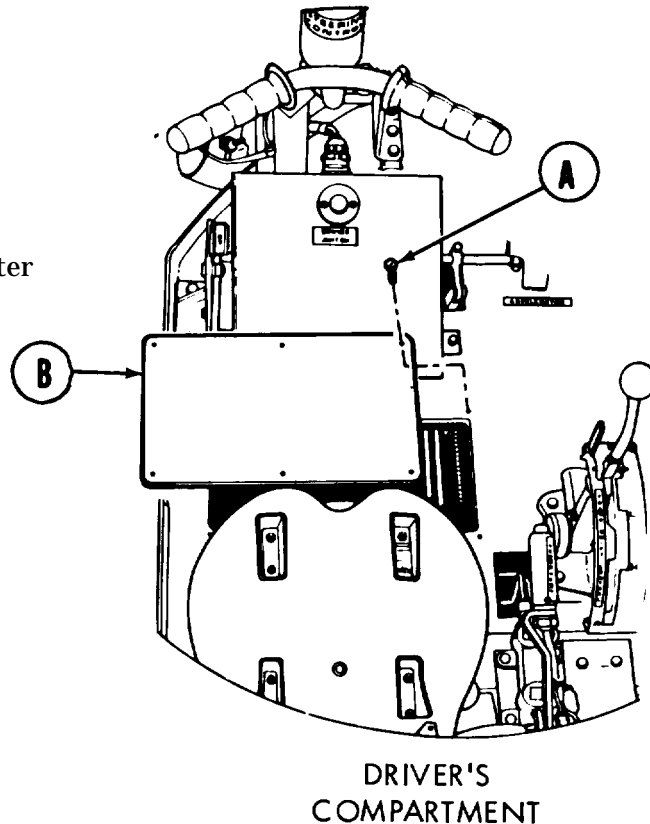
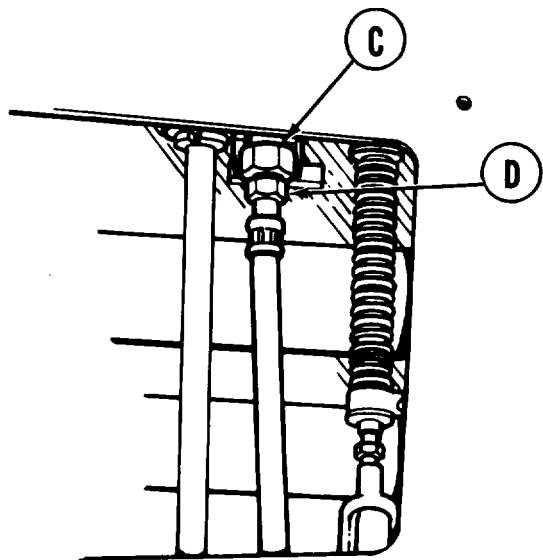

4. Locate where shaft (C) goes into bulkhead (E).
5. Using flat-tip screwdriver, loosen clamp (F) on grommet (G), slip off clamp.
6. Using flat-tip screwdriver and pliers, pry out rubber bushing (H) from under grommet (E). Remove bushing from shaft assembly.

NOTE

Grommet (G) is bonded to bulkhead. If the grommet does not have to be replaced, go to step 8.

7. Using screwdriver and pliers, pry out grommet (G) from bulkhead (E).

Go on to Sheet 3

TA248651

TACHOMETER REAR FLEXIBLE SHAFT REPLACEMENT (Sheet 3 of 6)

8. While one person holds shaft (C) in crew compartment, other person locates other end of shaft (C) through engine upper access opening.
9. Attach wire to crew compartment end of shaft (C).
10. Person at engine upper access opening remove shaft (C) by pulling out.
11. Remove wire from shaft (C) leaving wire in place for installation.

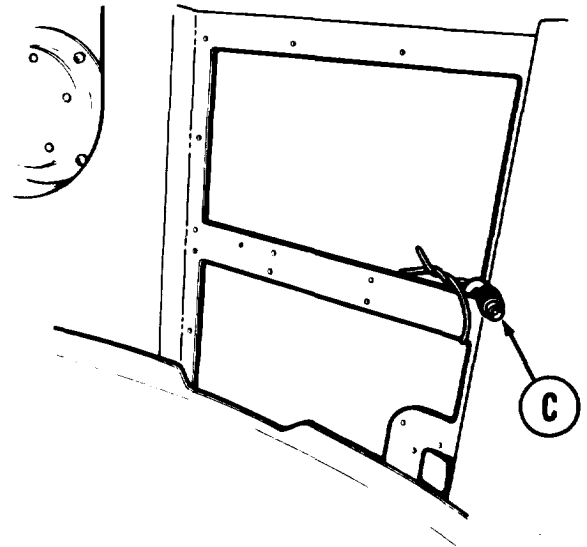

DISASSEMBLY:

1. Using slip joint pliers, pull out core (A) approximately 2 inches from tachometer drive adapter end (B).
2. Using long round nose pliers, remove slotted washer (C) and gasket (D).
3. Using slip joint pliers, pull out core (A) from tachometer adapter end (E).
4. Remove flat washer (F) from adapter end (E).

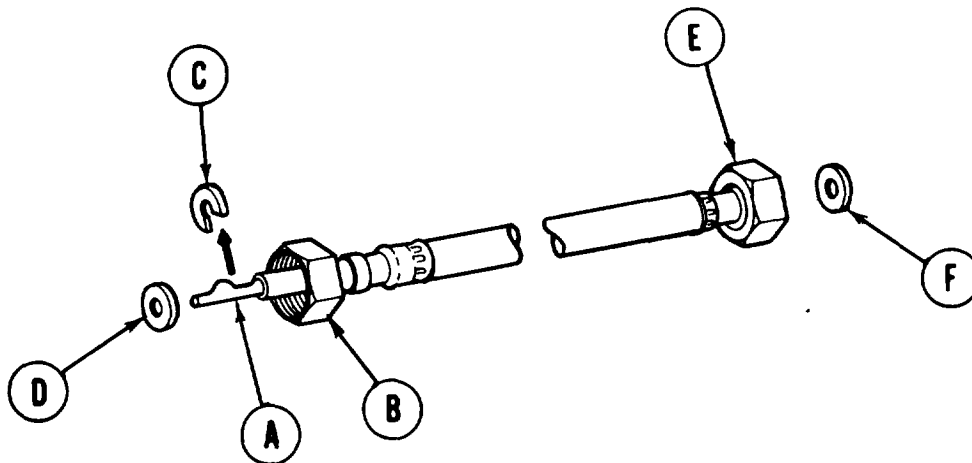

Go on to Sheet 4

TA248652

TACHOMETER REAR FLEXIBLE SHAFT REPLACEMENT (Sheet 4 of 6)

CLEANING AND INSPECTION:

WARNING

Dry cleaning solvent P-D-680 is toxic and flammable. To prevent personal injury, wear protective goggles and gloves and use only in a well-ventilated area. Avoid contact with skin, eyes and clothes and don't breathe vapors. Do not use near open flame or excessive heat. The flash point for Type #1 Dry Cleaning Solvent is 100° (38°C) and for Type #2 is 138°F (50°C). If you become dizzy while using cleaning solvent, get fresh air immediately and get medical aid. If contact with eyes is made, wash your eyes with water and get medical aid immediately.

1. Using dry cleaning solvent and rags, clean all component parts.
2. Inspect all component parts for damage or wear, replace as required.

ASSEMBLY:

1. Install flat washer (A) into tachometer adapter end (B).
2. Install core (C) through adapter end (B).
3. Using slip joint pliers, pull core (C) approximately 2 inches from tachometer drive end (D).
4. Install slotted washer (E) and gasket (F).
5. Push core (C) back into flexible shaft (G) until seated.

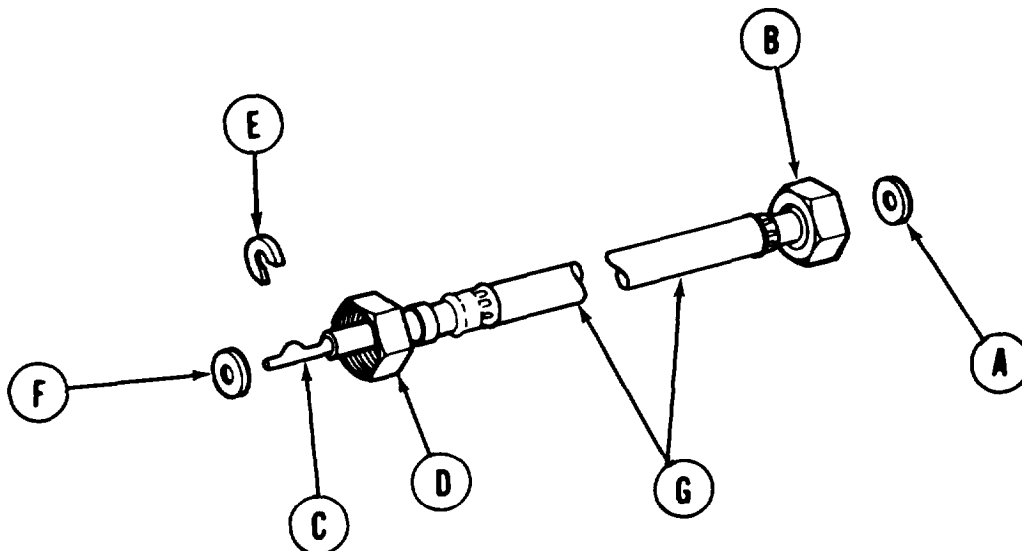

NOTE

If replacing or installing plastic tubing on flexible shaft (G), do steps 6 thru 9 below. If not, go directly to installation.

Go on to Sheet 5

TA248653

TACHOMETER REAR FLEXIBLE SHAFT REPLACEMENT (Sheet 5 of 6)

6. Using steel rule, measure back approximately 10 inches from tachometer adapter end (B).
7. From 10 inch mark, wrap shaft (G) with tape 5 inches to the rear until shaft (G) is approximately 5/8 inch in diameter.

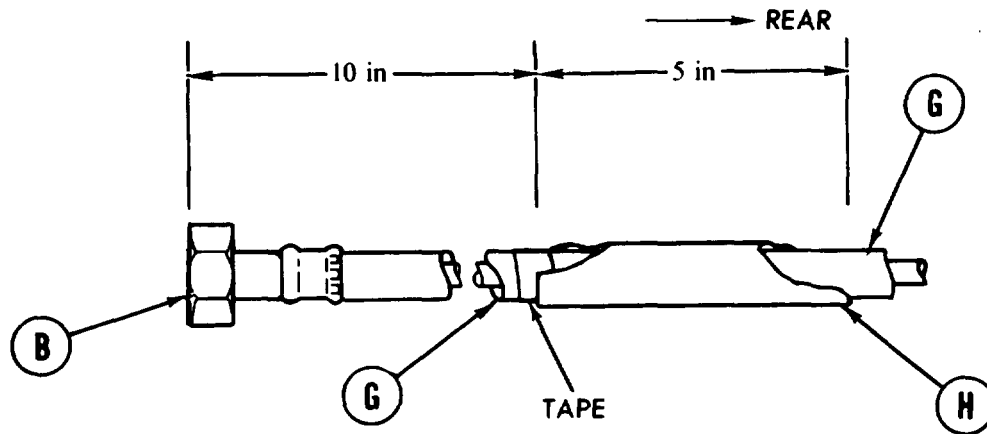

8. Place heat shrink plastic tubing (H) over tape.

NOTE

Avoid overheating in one spot as plastic tubing melts easily.

9. Using heat gun, shrink tubing by moving hot air back and forth over entire length of tubing.

INSTALLATION:

1. Person in powerplant compartment, attach wire to powerplant end of shaft (A).
2. Person in crew compartment, pull on wire to thread shaft (A) back into position.
3. Remove wire from shaft (A).

Go on to Sheet 6

TA248654

TACHOMETER REAR FLEXIBLE SHAFT REPLACEMENT (Sheet 6 of 6)

NOTE

If grommet (B) was not removed from bulkhead, go to step 6.

4. Slide grommet (B) over shaft (A).
5. Apply adhesive to grommet (B).
6. Install grommet (B) in position in bulkhead (c).
7. Slide clamp (D) over shaft (A) in position on grommet (B).
8. Install rubber bushing (E) in position.

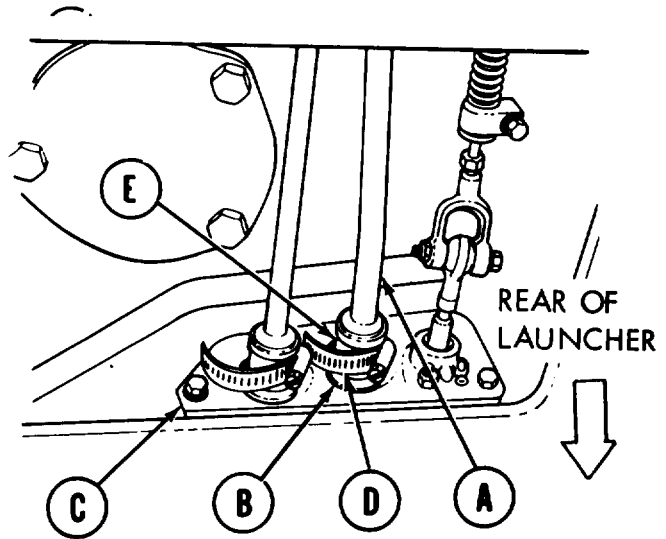

9. Locate tachometer shaft adapter (F) under driver's compartment floor plate (G).
10. Using fingers, connect shaft (A) to shaft adapter (F).
11. Using screwdriver, tighten clamp (D) on grommet (B).

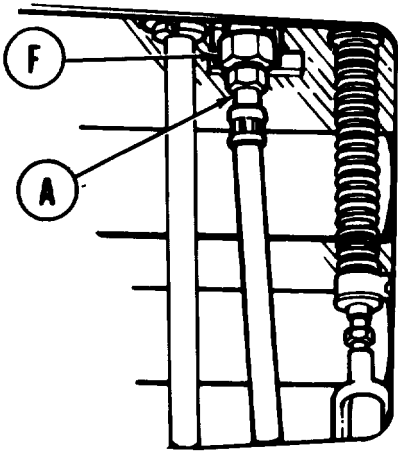

12. Using wrench, tighten shaft (A) to tachometer shaft adapter (F).
13. Position floor plate (G) with holes alined.
14. Using screwdriver, install six screws (H).
15. Install powerplant (page 5-14).
16. Start engine (TM 5-5420-202-10).
17. Make sure tachometer works.
18. Install engine upper access cover (page 17-12).

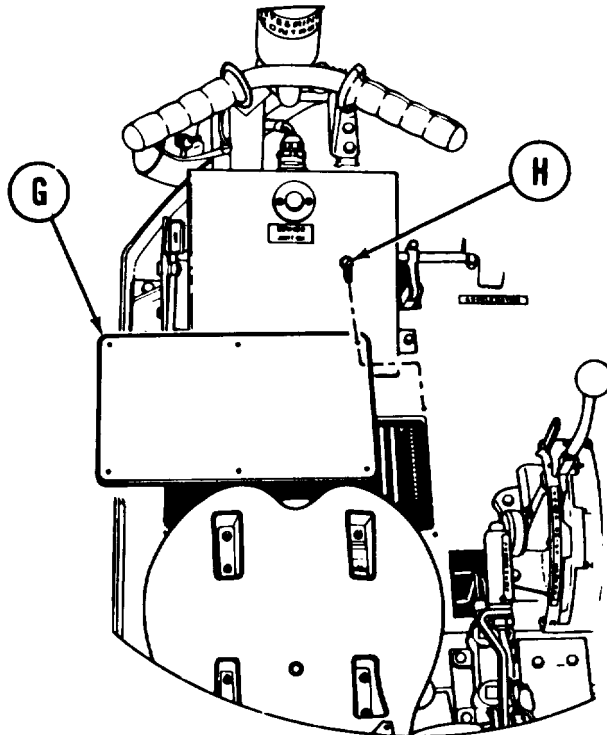

End of Task

TA248655

TACHOMETER REAR FLEXIBLE SHAFT ADAPTER REPLACEMENT (Sheet 1 of 2)

TOOL: 1 in. combination box and open end wrench

REFERENCE: TM 5-5420-202-10

PRELIMINARY PROCEDURE: Remove engine upper access cover (page 17-11).

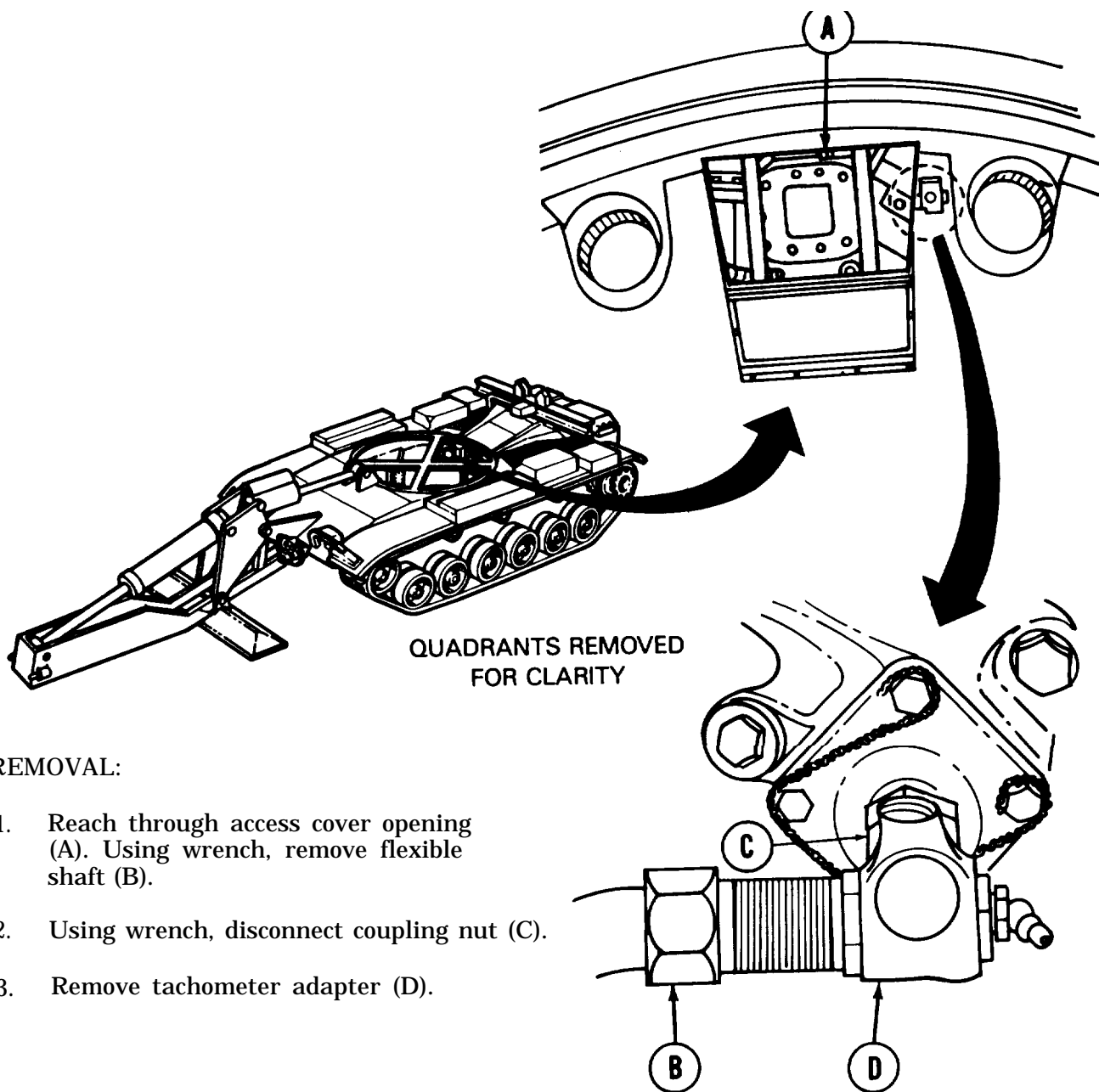

REMOVAL:

1. Reach through access cover opening (A). Using wrench, remove flexible shaft (B).
2. Using wrench, disconnect coupling nut (C).
3. Remove tachometer adapter (D).

Go on to Sheet 2

TA248656

TACHOMETER REAR FLEXIBLE SHAFT ADAPTER REPLACEMENT (Sheet 2 of 2)

INSTALLATION:

1. Reach through access cover opening and place tachometer drive adapter (A) in position.
2. Using wrench, install coupling nut (B).
3. Using wrench, install flexible shaft (C).

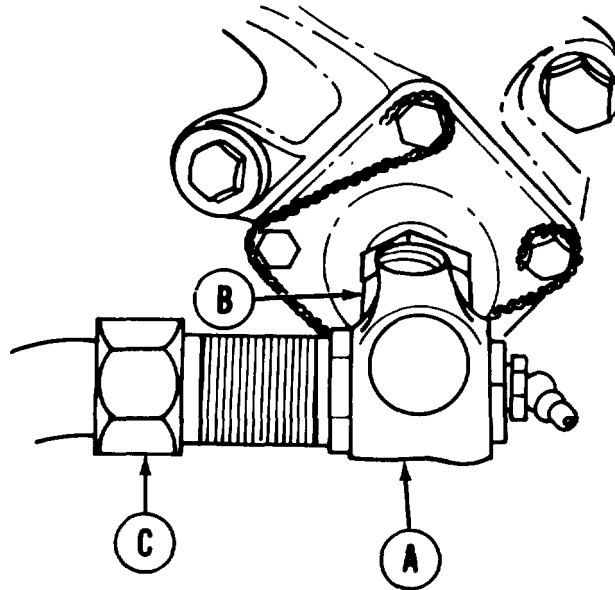

4. Start engine (TM 5-5420-202-10).
5. Make sure tachometer operates.
6. Install engine upper access cover (page 17-12).

End of Task

TA248657

TACHOMETER REAR FLEXIBLE SHAFT ADAPTER REPAIR (Sheet 1 of 1)

TOOL: Long round nose pliers

SUPPLIES: Gasket

PRELIMINARY PROCEDURE: Remove tachometer rear flexible shaft adapter
(page 19-31)

DISASSEMBLY:

Using pliers, remove gasket (A).
Throw gasket away.

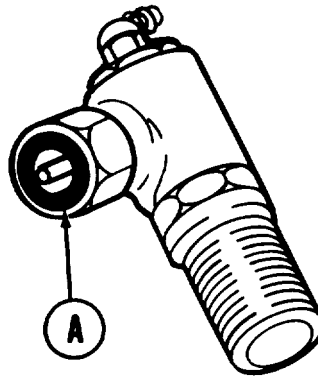
**ASSEMBLY:**

1. Using fingers, install new gasket (A).
2. Install shaft adapter (page 19-32).

End of Task

TA248658

SPEEDOMETER - TACHOMETER MOUNTING BRACKET REPLACEMENT (Sheet 1 of 1)

TOOLS: Cross-tip screwdriver
5/16 in. open end wrench
Flat-tip screwdriver

SUPPLIES: Lock washers (15 required)

PRELIMINARY PROCEDURES: Remove speedometer (page 19-2)
Remove tachometer (page 19-14)
Remove powerplant warning light (page 10-189)

REMOVAL:

1. Using cross-tip screwdriver and wrench, remove three screws (A), lockwashers (B), and nuts (C) securing bracket (D) to mount.
2. Using flat-tip screwdriver, remove 12 lockwasher screws (E) securing 3 cushions (F) to bracket (D).

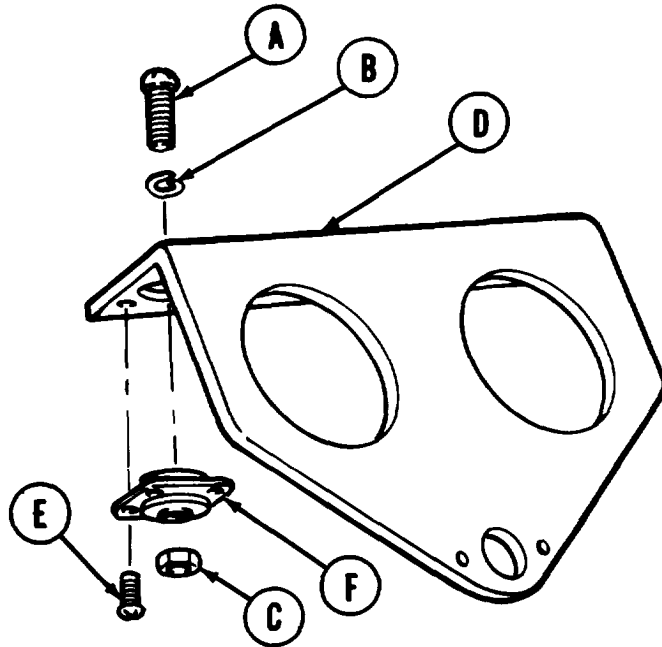

INSTALLATION:

1. Place three cushions (F) in position on bracket (D).
2. Using flat-tip screwdriver, install 12 lockwasher screws (E) securing 3 cushions (F) to bracket (D).
3. Place bracket (D) in position in vehicle.
4. Using cross-tip screwdriver and wrench, install three screws (A), lockwashers (B), and nuts (C) securing bracket (D) to mounts.
5. Install speedometer (page 19-3).
6. Install tachometer (page 19-15).
7. Install powerplant warning light (page 10-190).

End of Task

TA248659

CHAPTER 20

FIRE EXTINGUISHER SYSTEM MAINTENANCE

INDEX

<u>Procedure</u>	<u>Page</u>
Fixed Fire Extinguisher Control Valve Replacement	20-2
Fixed Fire Extinguisher Interior Release Mechanism Control Assembly Replacement	20-16
Fixed Fire Extinguisher Interior Release Mechanism and Mounting Bracket Replacement	20-23
Interior Release Mechanism Repair	20-28
Exterior Release Handle Body Assembly Replacement	20-39
Exterior Release Handle Body Assembly Repair	20-43
Fixed Fire Extinguisher Outside Release Handle Control Assembly Replacement	20-44
Exterior Release Handle Mounting Bracket Replacement	20-48
Control Valve Assembly Repair	20-50
Fixed Fire Extinguisher Cylinder Replacement	20-52
Fixed Fire Extinguisher Delay Bottle and Tubes Replacement	20-56
Fixed Fire Extinguisher Mounting Bracket Repair	20-62
Fixed Fire Extinguisher Manifold Replacement	20-63
Upper Discharge Valve, Tubes, and Related Parts Replacement	20-65
Right Discharge Valve, Tubes, and Related Parts Replacement	20-71
Left Discharge Valve, Tubes, and Related Parts Replacement	20-76
Engine Compartment Discharge Manifold Replacement	20-81

FIXED FIRE EXTINGUISHER CONTROL VALVE REPLACEMENT (Sheet 1 of 14)

PROCEDURE INDEX

PROCEDURE	PAGE
Removal	20-2
Disassembly	20-5
Cleaning and Inspection	20-8
Assembly	20-8
Installation	20-14

- TOOLS:**
- Spring scale (150 lb.)
 - 7/16 in. open end wrench
 - 9/16 in. open end wrench
 - 1-1/2 in. open end wrench
 - Flat-tip screwdriver
 - 3/32 in. socket head screw key (allen wrench)
 - 1/16 in. socket head screw key (allen wrench)
 - 1-1/2 in. crowfoot wrench
 - 7/16 in. crowfoot wrench
 - Torque wrench with 3/8 in. drive (0-200 lb-in)
 - Torque wrench with 1/2 in. drive (0-175 lb-ft)
 - 5 in. extension with 1/2 in. drive
 - 10 in. adjustable wrench (two required)
 - Diagonal cutting pliers
 - Long round nose pliers
 - Slip joint pliers
 - 9/16 in. crowfoot wrench

- SUPPLIES:**
- Zinc chromate primer (Item 51, Appendix D)
 - Sealant (Item 24, Appendix D)
 - Lead seal
 - 1/16 in. rod
 - Goggles (Item 70, Appendix D)
 - Dry cleaning solvent (Item 55, Appendix D)
 - Sealant (Item 30, Appendix D)
 - Rags (Item 65, Appendix D)
 - Gloves (Item 69, Appendix D)

PRELIMINARY PROCEDURE: Remove personnel heater air duct (page 18-17)

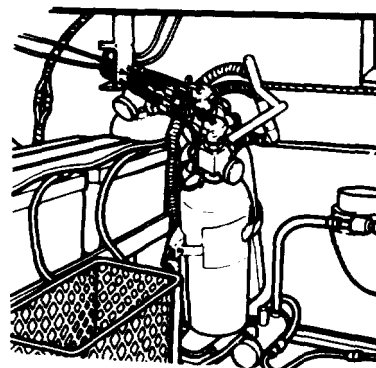
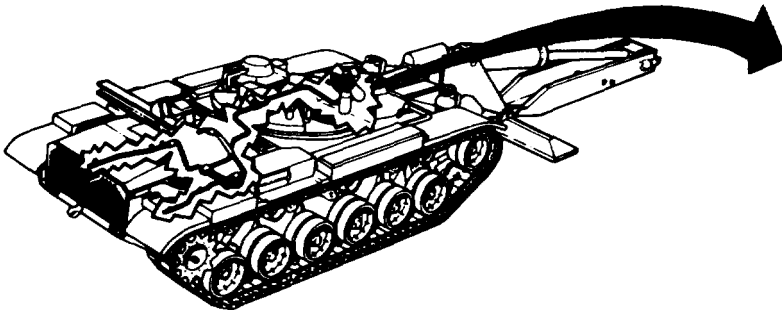

Go on to Sheet 2

FIXED FIRE EXTINGUISHER CONTROL VALVE REPLACEMENT (Sheet 2 of 14)**REMOVAL:****CAUTION**

You must remove both control valves to prevent accidental discharge, even if only one control valve is to be replaced.

Do not pull on control cables as valves are being removed or cylinder will discharge.

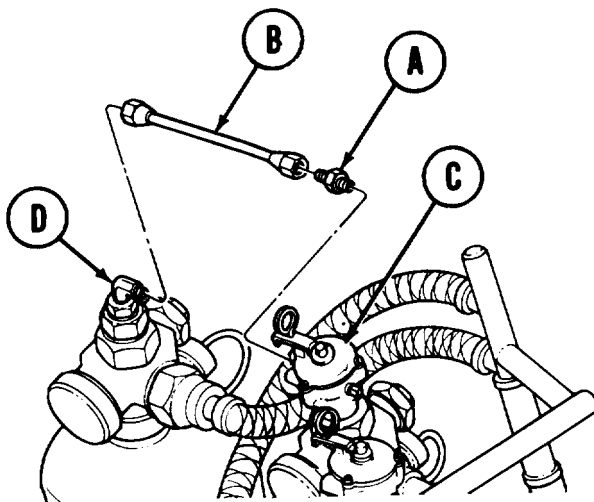

1. Using 7/16 inch wrench to hold adapter (A), use 9/16 inch wrench to remove tube (B) from adapter (A).
2. Using 7/16 inch wrench, remove adapter (A) from control valve (C).
3. Using 9/16 inch wrench, remove tube (B) from elbow (D).

Go on to Sheet 3

TA246661

FIXED FIRE EXTINGUISHER CONTROL VALVE REPLACEMENT (Sheet 3 of 14)

- Using adjustable wrench, remove elbow (D) from pressure head (E).

CAUTION

Immediately after removing each discharge line, install protective cap to cover exposed part. Use protective caps stowed on dummy plugs at neck of cylinder.

NOTE

Pressure head (E) must be removed as one part even though it can be disassembled.

- Using 1-1/2 inch wrench, remove pressure head (E) and washer (F) from port (G) on cylinder (H).
- Using slip joint pliers if necessary, remove protective cap (J) from dummy plug (K). Using hands only, install and tighten protective cap (J) on port (G).

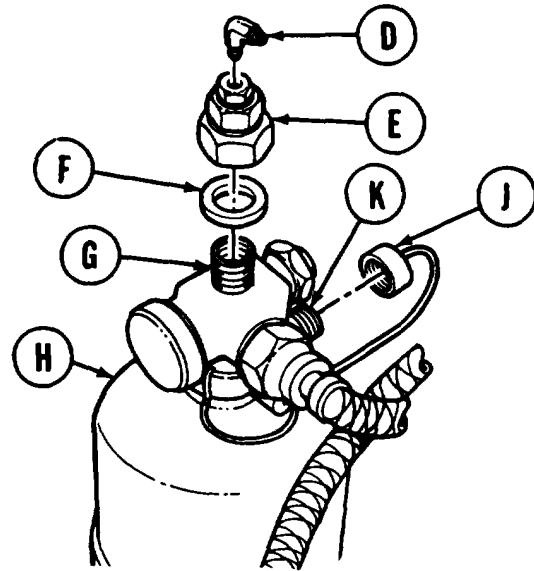

CAUTION

Make sure bottle does not turn and pull on discharge cable. Fire extinguisher will discharge.

- Using 1-1/2 inch wrench, remove control valve (L) and washer (M) from port (N) on cylinder (P).
- Using slip joint pliers if necessary, remove protective cap (Q) from dummy plug (R). Using hands only, install and tighten protective cap (Q) on port (N).
- Remove control valve (C) and washer (S) from cylinder (T) using the same procedure as step 7.
- Using slip joint pliers if necessary, remove protective cap (U) from dummy plug (V). Using hands only, install and tighten protective cap (U) on port (W).

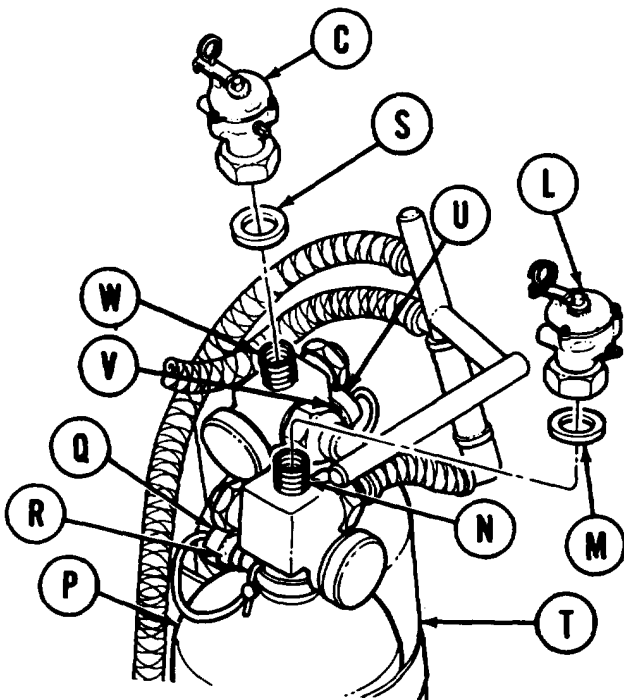

Go on to Sheet 4

TA248662

FIXED FIRE EXTINGUISHER CONTROL VALVE REPLACEMENT (Sheet 4 of 14)

DISASSEMBLY:

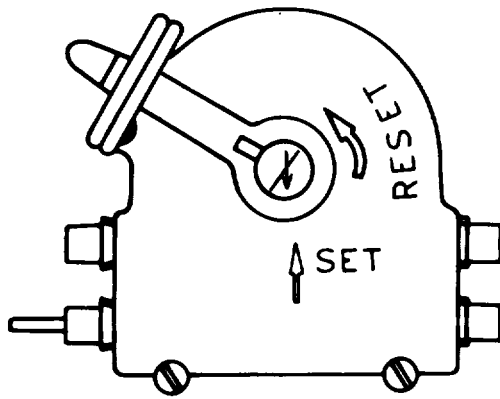

FOUR-PORT VALVE

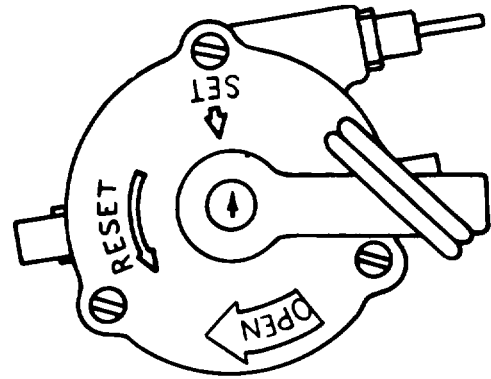

THREE-PORT VALVE

NOTE

Steps 1 through 10 describe the disassembly of four-port valve. Steps 11 through 18 describe the disassembly of three-port valve. Although the four-port valve is the latest model, there are some three-port valves on current vehicles.

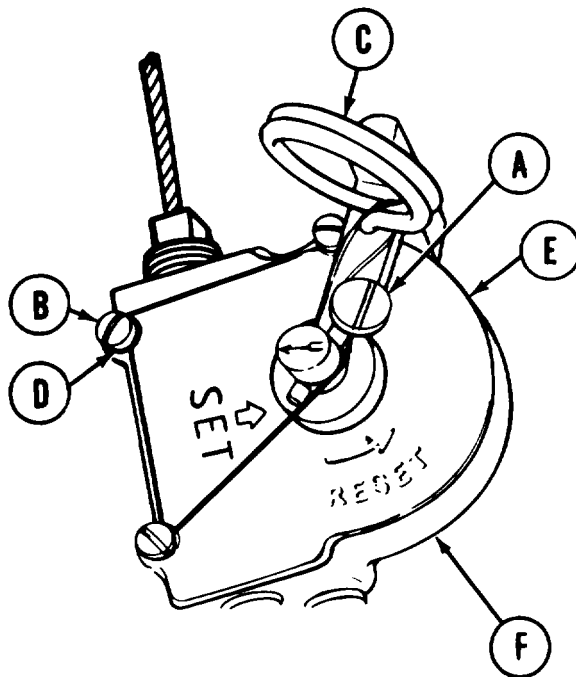

1. Using diagonal cutting pliers, remove lead seal (A).
2. Using fingers, remove wire from three screws (B) and pin (C).
3. Using screwdriver, remove three screws (B) and washers (D) securing cover (E) to housing (F).
4. Remove cover (E) from housing (F).

Go on to Sheet 5

TA248663

FIXED FIRE EXTINGUISHER CONTROL VALVE REPLACEMENT (Sheet 5 of 14)

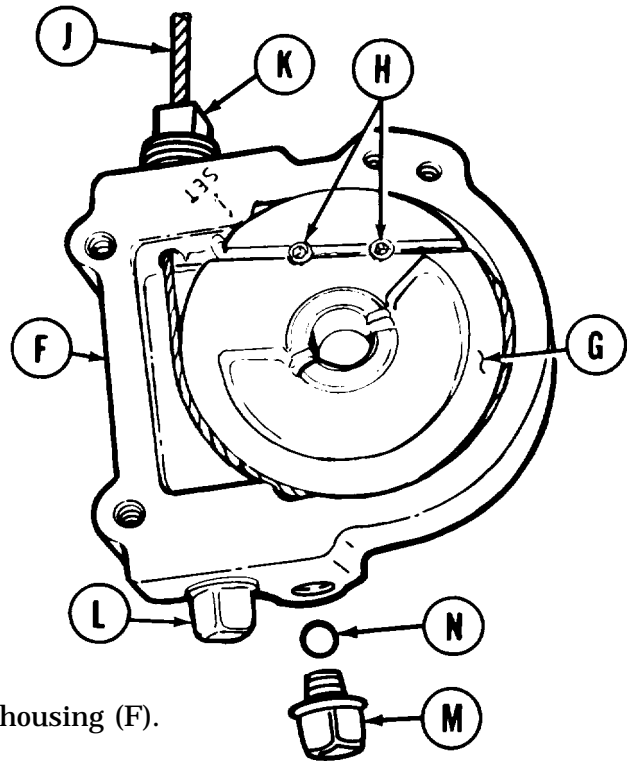

5. Remove sheave (G) from housing (F).
6. Using 1/16 inch allen wrench, remove two screws (H) securing cable (J) to sheave (G).
7. Pull cable (J) out of housing (F) through hole in plug (K).
8. Using adjustable wrench, remove plug (K) from housing (F).
9. Using adjust able wrench, remove plug (L) from housing (F).
10. Using adjustable wrench, remove plug (M) and ball (N) from housing (F).

NOTE

The following steps describe the disassembly of three-port valve.

Go on to Sheet 6

TA248664

FIXED FIRE EXTINGUISHER CONTROL VALVE REPLACEMENT (Sheet 6 of 14)

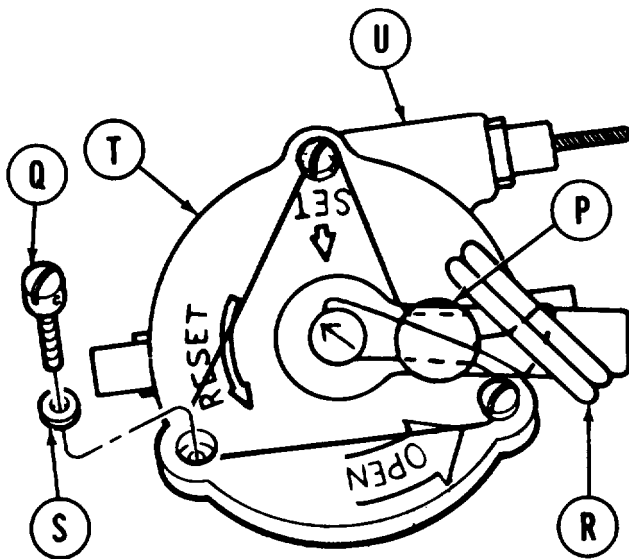

11. Using diagonal cut ting pliers, remove lead seal (P).
12. Using fingers, remove wire from three screws (Q) and pin (R).
13. Using screwdriver, remove three screws (Q) and washers (S) securing cover (T) to housing (U).
14. Remove cover (T) from housing (U).

15. Using 3/32 inch allen wrench, remove two screws (V) from retainer (W).
16. Remove sheave (X) and retainer (W) from housing (U).
17. Remove cable (Y) from housing (U) through hole in plug (Z).
18. Using adjustable wrench, remove plug (Z) from housing (U).

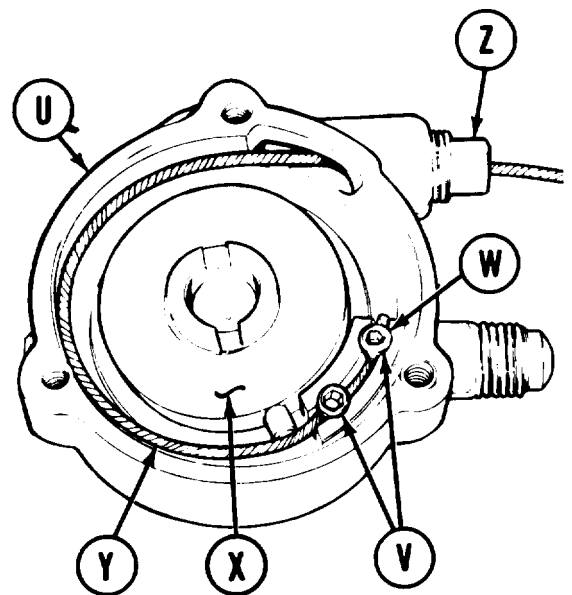

Go on to Sheet 7

TA248665

FIXED FIRE EXTINGUISHER CONTROL VALVE REPLACEMENT (Sheet 7 of 14)

CLEANING AND INSPECTION:

WARNING

Dry cleaning solvent P-D-680 is toxic and flammable. To prevent personal injury, wear protective goggles and gloves and use only in a well-ventilated area. Avoid contact with skin, eyes, and clothes and don't breathe vapors. Do not use near open flame or excessive heat. The flash point for Type #1 Dry Cleaning Solvent is 100° (38°C) and for Type #2 is 138 (50°C). If you become dizzy while using cleaning solvent, get fresh air immediately and get medical aid. If contact with eyes is made, wash your eyes with water and get medical aid immediately.

1. Using rags and dry cleaning solvent, clean all parts.
2. Inspect valves and related parts for nicks, burrs, and cracks.
3. Replace damaged parts.

ASSEMBLY:

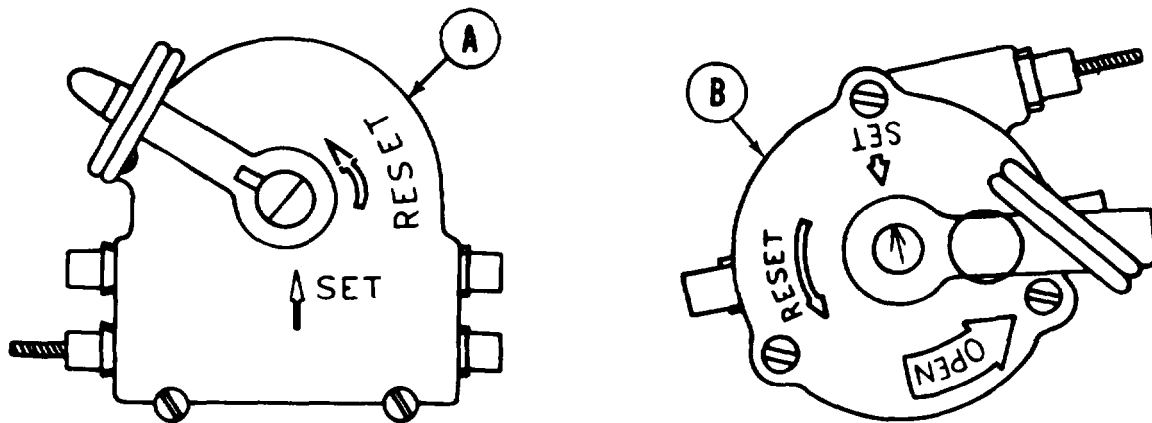

NOTE

Steps 1 through 18 describe assembly of four-port valve (A). Steps 19 through 34 describe assembly of three-port valve (B). Although the four-port valve is the latest model, both valves are used on current vehicles. If three-port valve is used in system, proceed to step 19.

Go on to Sheet 8

TA248666

FIXED FIRE EXTINGUISHER CONTROL VALVE REPLACEMENT (Sheet 8 of 14)

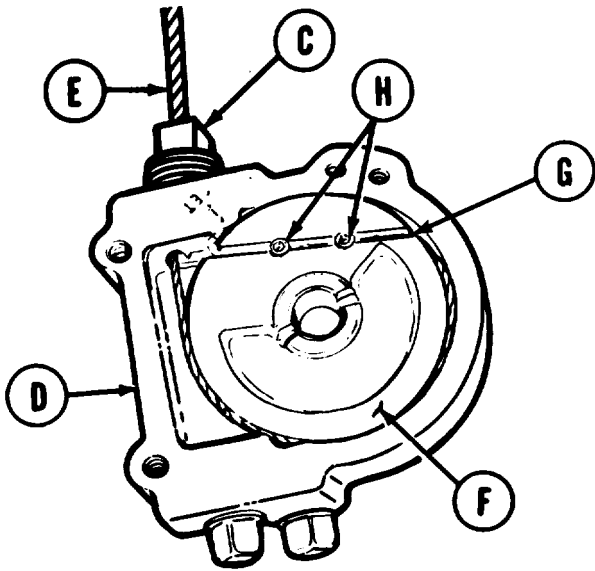

1. Using adjustable wrench, install plug (C) in housing (D).
 2. Using fingers, push cable (E) through plug (C) and around sheave (F).
 3. Lay cable (E) in groove around sheave (F) and lay in slot (G).
 4. Extend cable (E) full length of slot (G) and no further.
 5. Coat threads of two screws (H) with sealant.
-
6. Using 1/16 inch allen wrench, install two screws (H) in sheave (F).
 7. Using spring scale, pull sheave (F) against cable (E) with about 150 pounds of force to make sure cable (E) is secured by screws (H).
 8. Place sheave (F) in housing (D).
 9. Wind cable (E) around sheave (F) until stop on bottom of sheave is behind peg in housing (D).

Go on to Sheet 9

TA248667

FIXED FIRE EXTINGUISHER CONTROL VALVE REPLACEMENT (Sheet 9 of 14)

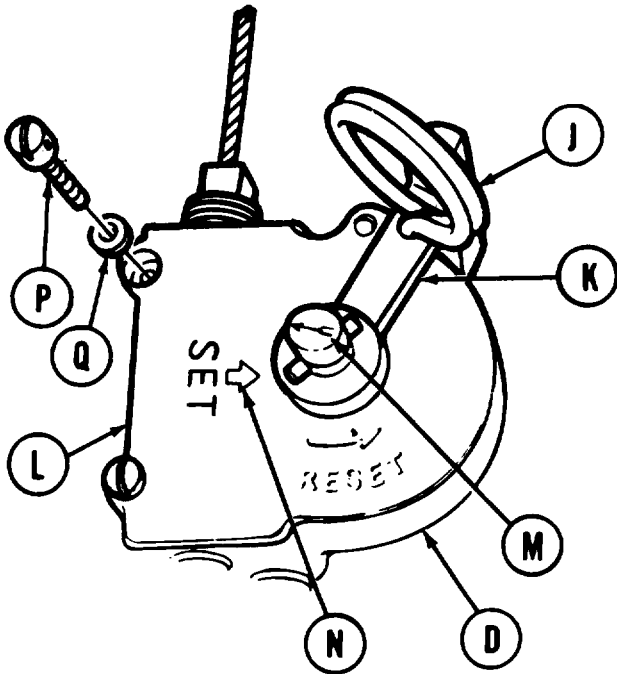

10. Install pin (J) through handle (K) and cover (L).

11. Using 1/16 inch rod, turn cover shaft (M) until arrow points at SET arrow (N) on cover (L).

12. Place cover (L) on housing (D).

13. Using screwdriver, install three screws (P) and washers (Q) securing cover (L) to housing (D).

14. Using rod, reset valve by turning shaft (M) counterclockwise to align arrow on shaft (M) with SET arrow (N) on cover.

Go on to Sheet 10

TA248668

FIXED FIRE EXTINGUISHER CONTROL VALVE REPLACEMENT (Sheet 10 of 14)

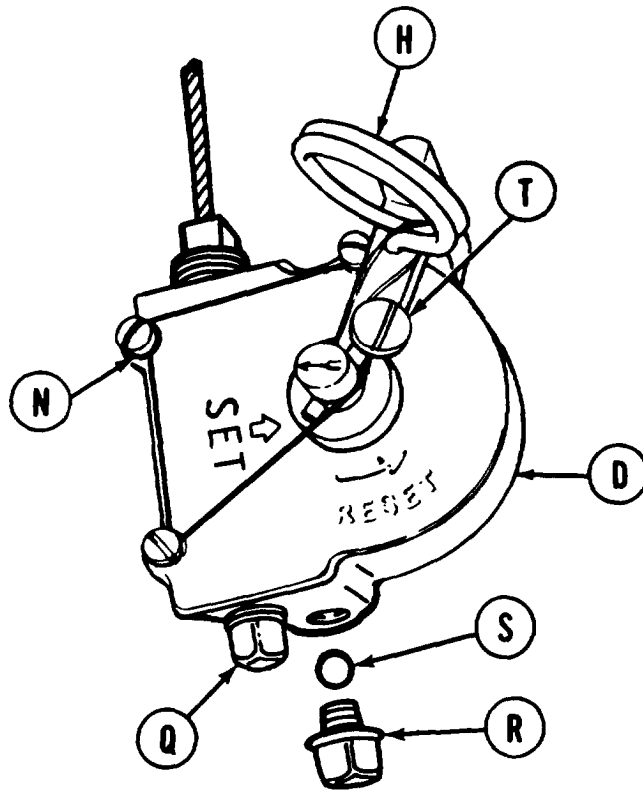

15. Check operation of valve by pulling cable, resetting with rod, releasing with handle, and resetting several times. Verify that pin in bottom of valve is released and retracted each time. Leave in SET condition.
16. Coat plugs (Q) and (R) with sealant.
17. Using adjustable wrench, install plug (R) and ball (S) in housing (D).
18. Using adjustable wrench, install plug (Q) in housing (D).
19. Using long round nose pliers, install lead seal (T) through three screws (N) and pin (H).

NOTE

Steps 20 through 34 apply to three-port valve.

Go on to Sheet 11

TA248669

FIXED FIRE EXTINGUISHER CONTROL VALVE REPLACEMENT (Sheet 11 of 14)

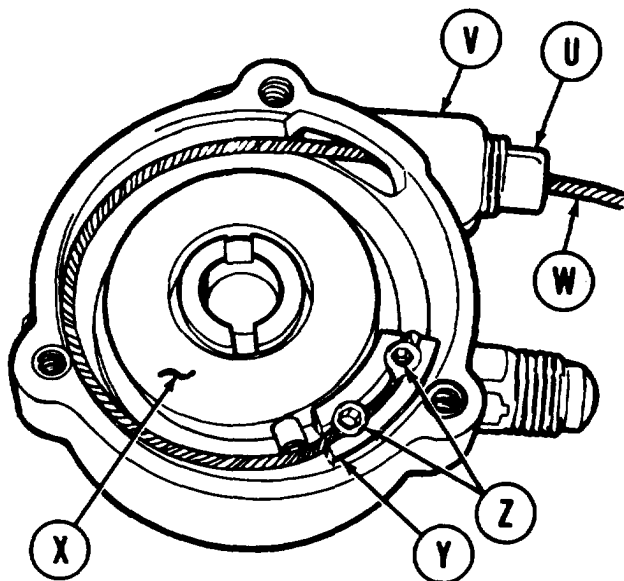

20. Using adjustable wrench, install plug (U) in housing (V).
21. Push cable (W) through plug (U) and around sheave (X).
22. Lay cable (W) in retainer (Y).
23. Extend cable (W) full length of retainer (Y) and no further.

24. Coat threads of two screws (Z) with sealant.
25. Using 3/32 inch allen wrench, install two screws (Z) securing cable (W) in retainer (Y).
26. Place sheave (X), cable (W), and retainer (Y) in housing (V) in approximately the position shown. Cable end of retainer (Y) must be against pin on sheave (X).
27. Using spring scale, pull against cable (W) with about 150 pounds of force to make sure cable (W) is secured by screws (Z).

Go on to Sheet 12

TA246670

FIXED FIRE EXTINGUISHER CONTROL VALVE REPLACEMENT (Sheet 12 of 14)

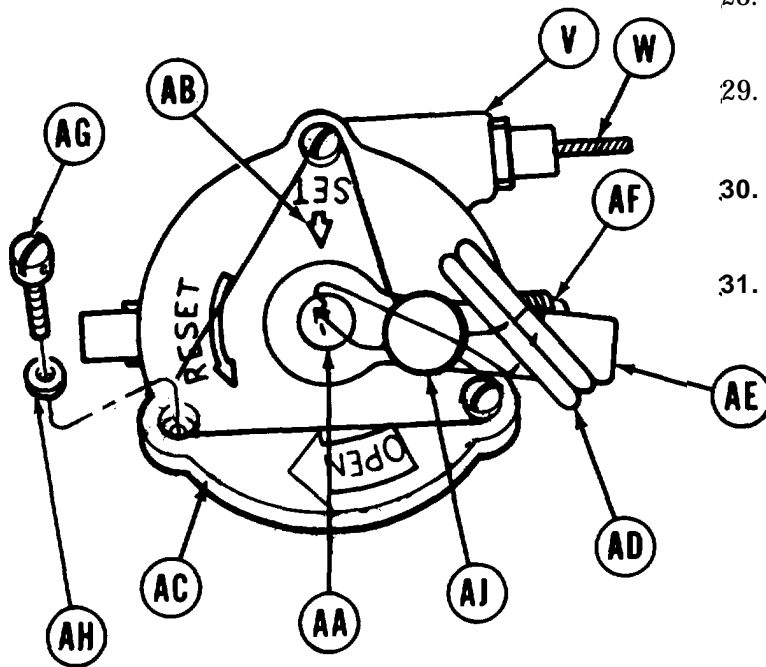

28. Aline arrow on shaft (AA) with SET arrow (AB) on cover (AC).
29. Install pin (AD) through handle (AE) and cover (AC)..
30. Position cover (AC) on housing (T) with handle (AE) over adapter (AF).
31. Using screwdriver, install three screws (AG) and washers (AH) securing cover (AC) to housing (V).

32. Check operation of valve by pulling cable (W) and making sure pin releases and retracts with movement of cable (W).
33. Using rod, reset valve by turning counterclockwise and alining arrow on shaft (AA) with SET arrow (AB) on cover (AC).
34. Using long round nose pliers, install lead seal (AJ) through three screws (AG), pin (AD), and shaft (AA).

Go on to Sheet 13

TA248671

FIXED FIRE EXTINGUISHER CONTROL VALVE REPLACEMENT (Sheet 13 of 14)

INSTALLATION:

Actuating pins on bottoms of valves must be fully retracted before valves are installed on cylinders or cylinders will discharge during installation.

Do not pull on cables as valves are being installed or cylinders will discharge.

NOTE

Apply primer to all male pipe threads before installing threaded parts.

1. Using 7/16 inch wrench, install adapter (A) on valve (B).
2. Using 3/8 inch drive torque wrench and 7/16 inch crow foot wrench, tighten adapter (A) to 135-150 lb-in (13.5-17 N-m).
3. Using hands, remove protective cap (C) from port of cylinder (D) and stow on dummy coupling (E).
4. Using 1-1/2 inch wrench, install valve (B) and washer (F) on cylinder (D).
5. Using hands, remove protective cap (G) from port on cylinder (H) and stow on dummy coupling (J).
6. Using 1-1/2 inch wrench, install valve (K) and washer (L) on cylinder (H).

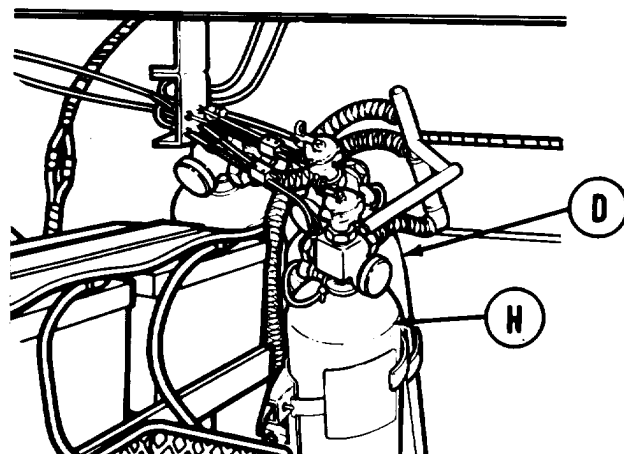
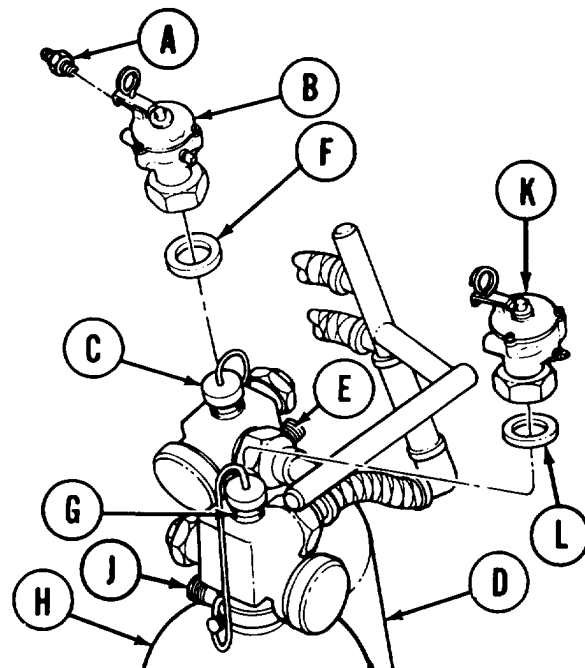

Go on to Sheet 14

TA248672

FIXED FIRE EXTINGUISHER CONTROL VALVE REPLACEMENT (Sheet 14 of 14)

7. Using hands, remove protective cap (M) from port (N) of cylinder (P) and stow on dummy plug (Q).
8. Using two adjustable wrenches, install elbow (R) on pressure head (S).
9. Using hands, install pressure head(s) and washer (T) on Port (N) .
10. Using 9/16-inch wench, install tube (U) on elbow (R) and valve adapter (A).
11. Using 3/8 inch drive torque wrench and 9/16-inch crow foot wrench, tighten tube (U) to 135-150 lb-in (13.5 -17 N-m).

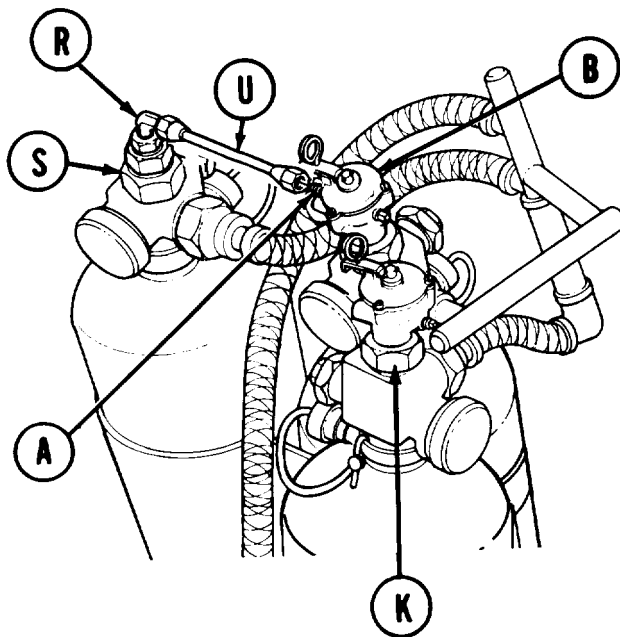
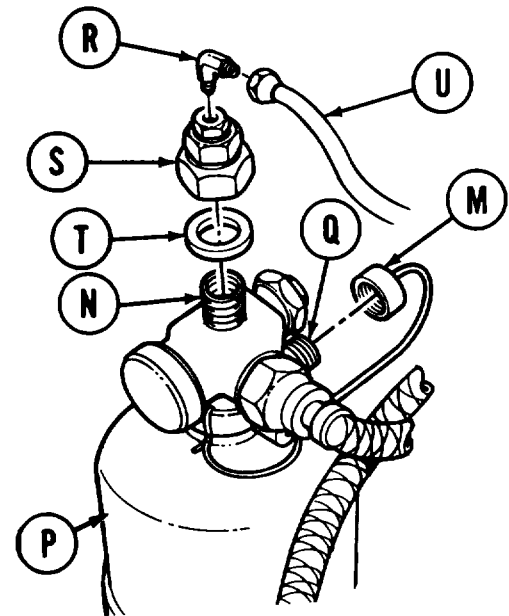

12. Using 1-1/2 inch wrench, tighten pressure head (S) and valves (B) and (K).
13. Using 1/2-inch drive torque wrench, tighten pressure head(s) and valves (B) and (K) to 105-130 lb-ft (142-176 N-m).
14. Do semi-annual check (page 3-52).
15. Install personnel heater air duct (page 18-18).

End of Task

TA248673

**FIXED FIRE EXTINGUISHER INTERIOR RELEASE MECHANISM CONTROL ASSEMBLY
REPLACEMENT (Sheet 1 of 7)**

PROCEDURE INDEX

PROCEDURE	PAGE
Removal	20-16
Inspection	20-19
Installation	20-20

TOOLS: 9/16 in. open end wrench
 1/2 in. open end wrench
 3/8 in. open end wrench
 5/16 in. flat-tip screwdriver
 3/32 in. hex socket key

7/16 in. socket with 1/2 in. drive
 1/2 in. socket with 1/2 in. drive
 Ratchet with 1/2 in. drive
 Spring scale (150 lbs.)

SUPPLIES: Lockwashers (2 required)

PRELIMINARY PROCEDURE: Remove control valves (page 20-2)

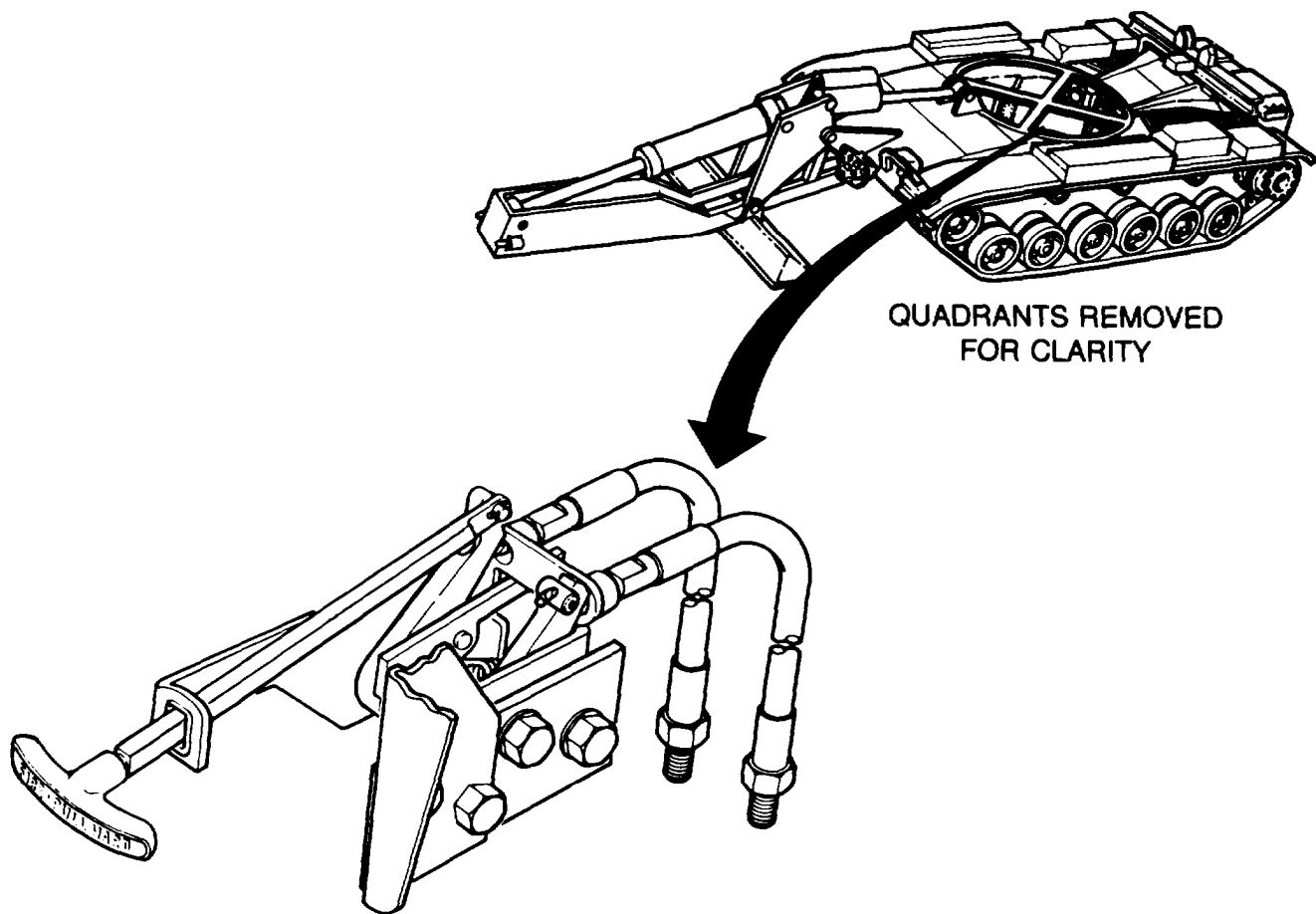

Go on to Sheet 2

TA248874

**FIXED FIRE EXTINGUISHER INTERIOR RELEASE MECHANISM CONTROL ASSEMBLY
REPLACEMENT (Sheet 2 of 7)**

REMOVAL:

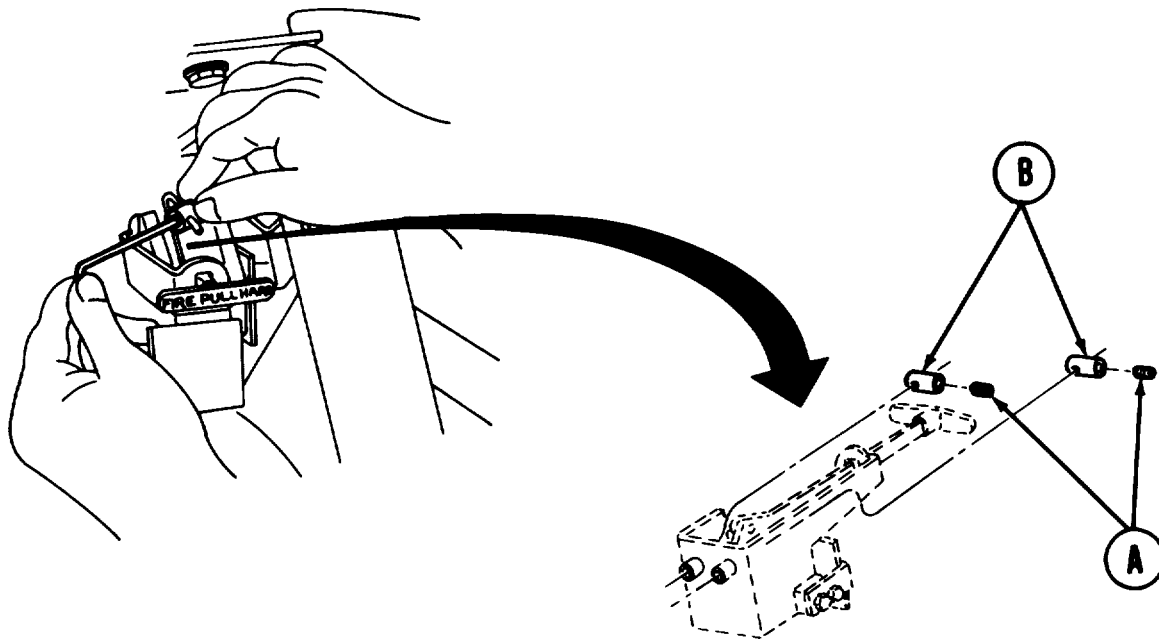

1. Using hex socket key, loosen two setscrews (A) in cable stops (B) until cable is free.
2. Remove two stops (B) and setscrews (A).
3. Using screwdriver, remove four screws (C) securing clamps (D) to control assemblies on end closest to fire extinguisher cylinders.

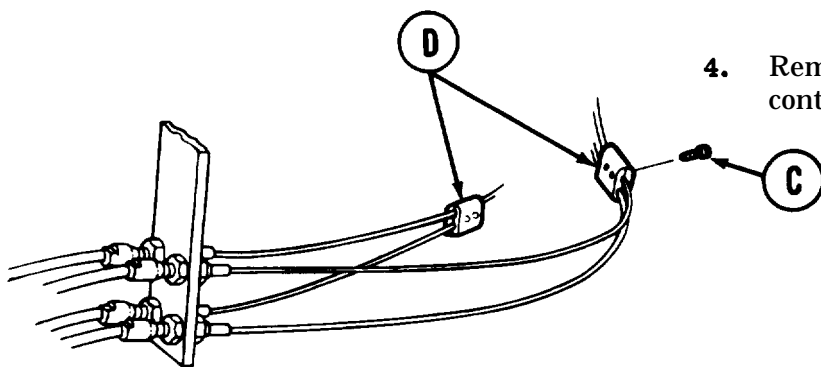

4. Remove two sets of clamps (D) from control assemblies.

Go on to Sheet 3

TA248675

**FIXED FIRE EXTINGUISHER INTERIOR RELEASE MECHANISM CONTROL ASSEMBLY
REPLACEMENT (Sheet 3 of 7)**

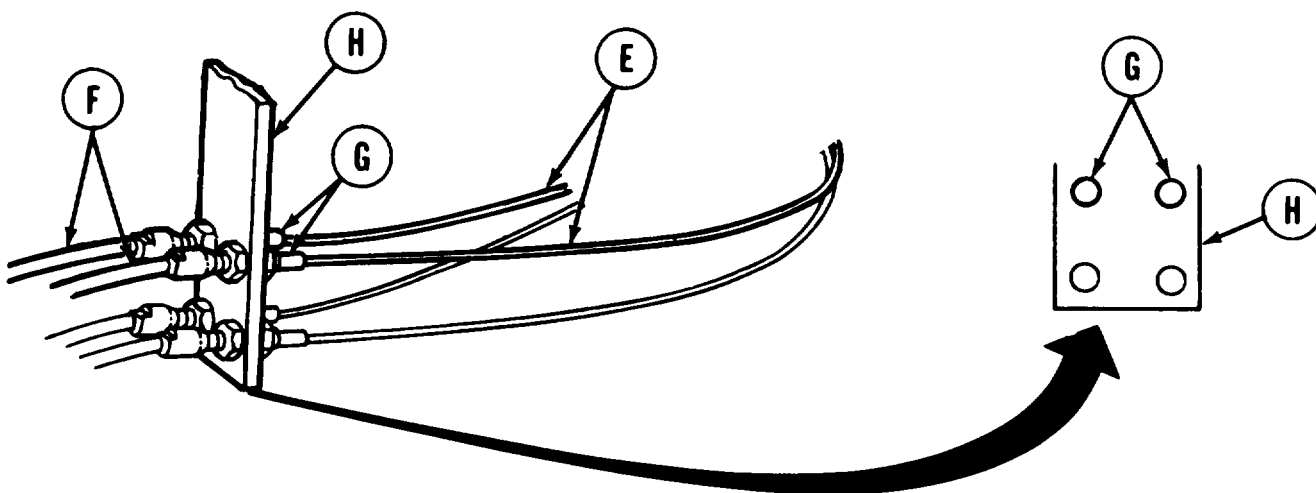

5. Using fingers, grasp two cables (E) and pull out of control assemblies (F).
6. Using 9/16 inch wrench, remove two nuts (G) from bracket (H).
7. Use 1/2 inch end wrench to hold two screws (J) and using 1/2 inch socket and ratchet, remove two nuts (M) and lockwashers (N). Remove screws (J), two clamps (L), and washers (K) from two control assemblies (F).

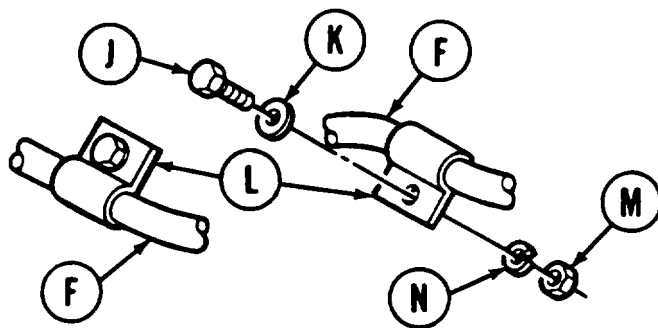

8. Using fingers, grasp two control assemblies (F) on side of bracket (H) away from fire extinguisher cylinders and pull out of bracket (H).

Go on to Sheet 4

TA248676

**FIXED FIRE EXTINGUISHER INTERIOR RELEASE MECHANISM CONTROL ASSEMBLY
REPLACEMENT (Sheet 4 of 7)**

9. Using 9/16 inch wrench, remove two remaining nuts (P) from two control assemblies (F).
10. Using 3/8 inch wrench on flats (Q) of two control assemblies (F), remove two control assemblies (F) from release mechanism (R).

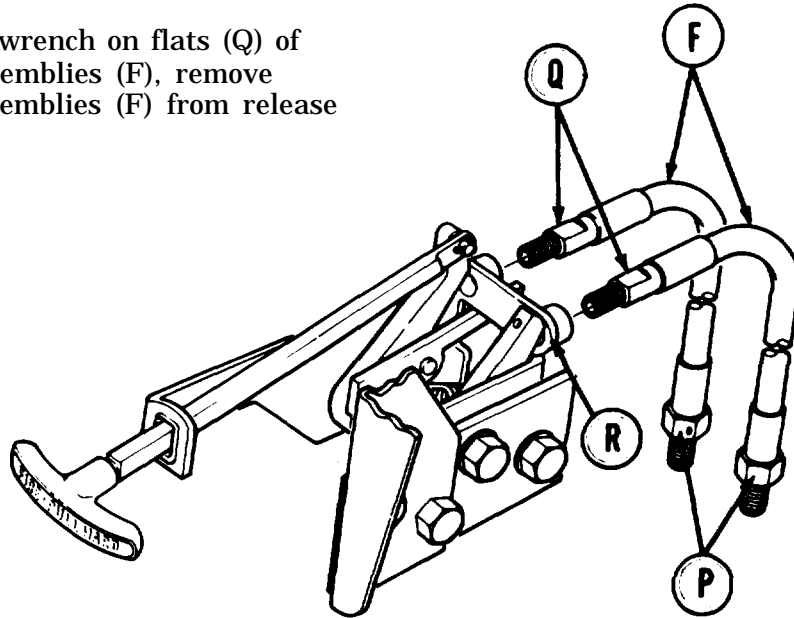
**INSPECTION:**

1. Check all parts for signs of wear or damage.
2. Replace all worn or damaged parts.

Go on to Sheet 5

TA248677

**FIXED FIRE EXTINGUISHER INTERIOR RELEASE MECHANISM CONTROL ASSEMBLY
REPLACEMENT (Sheet 5 of 7)**

INSTALLATION:

1. Thread cables (A) through two control assemblies (B).

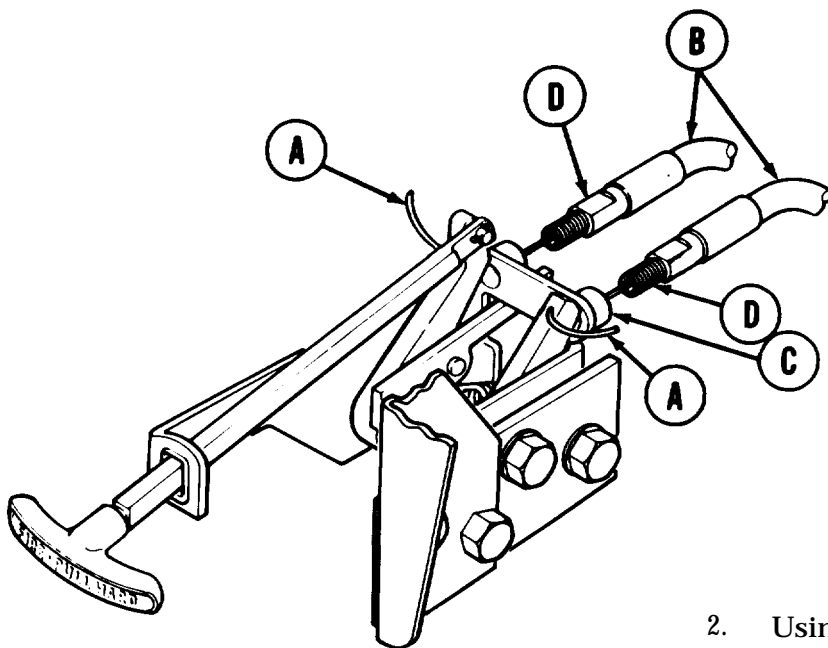
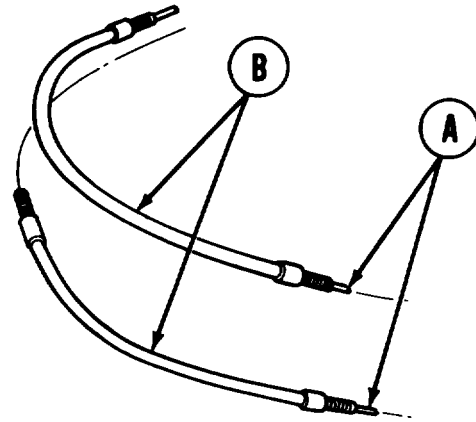

2. Using fingers, place two control assemblies (B) in position on release mechanism (C), making sure two cables (A) are threaded through holes in release mechanism (C).

3. Using 3/8 inch wrench on flats (D) of two control assemblies (B), tighten two control assemblies (B) into place on release mechanism (C).

Go on to Sheet 6

TA248678

FIXED FIRE EXTINGUISHER INTERIOR RELEASE MECHANISM CONTROL ASSEMBLY REPLACEMENT (Sheet 6 of 7)

4. Insert two cables (A) into cable stops (E).
5. Using hex socket key, tighten setscrews (F) into two cable stops (E).
6. Using spring scale, check that cable (A) in stops (E) can withstand 150 lbs. of force.
7. Using 9/16 inch wrench, install two nuts (G) on ends of two interior control assemblies (B).

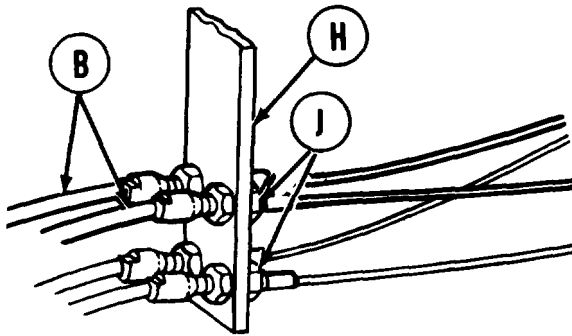
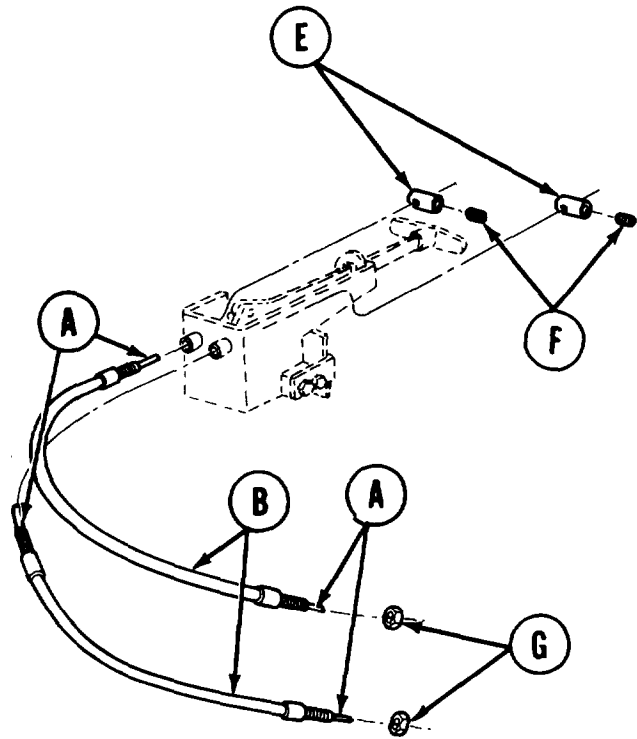

8. Using fingers, insert ends of two control assemblies (B) in bracket (H) from left to right, making sure cable (A) extends through bracket (H).
9. Using 9/16 inch wrench, tighten, two nuts (J) securing two control assemblies (B) to bracket (H).

Go on to Sheet 7

TA248679

**FIXED FIRE EXTINGUISHER INTERIOR RELEASE MECHANISM CONTROL ASSEMBLY
REPLACEMENT (Sheet 7 of 7)**

10. Using screwdriver, install four screws (K) in block clamps (L) on right side of bracket (H).

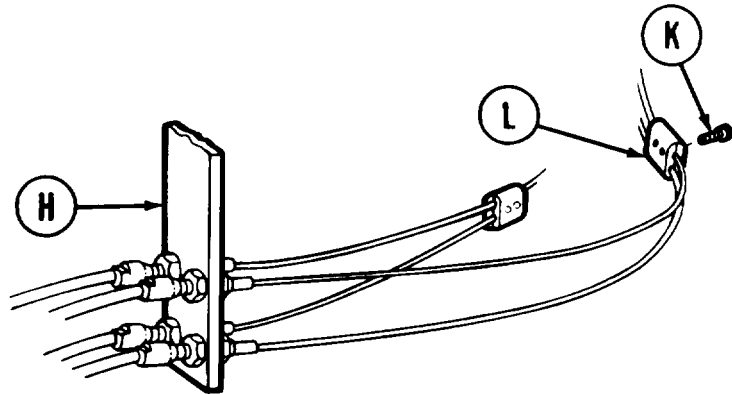

11. Using fingers, position two clamps (M) on two control assemblies (B) and attach loosely to the hull with two screws (N), washers (P), lockwashers (Q), and nuts (R).
12. Using 1/2 inch end wrench to hold two screws (N) use 1/2 inch socket and ratchet to tighten nuts (R).

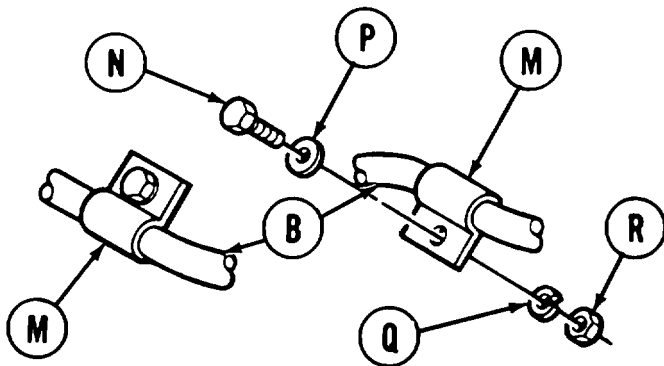

13. Install control valves (page 20-14).

End of Task

TA248680

FIXED FIRE EXTINGUISHER INTERIOR RELEASE MECHANISM AND MOUNTING BRACKET REPLACEMENT (Sheet 1 of 5)

PROCEDURE INDEX

PROCEDURE	PAGE
Removal	20-23
Installation	20-25

TOOLS: 1/2 in. open end wrench (2 required)
Diagonal cutting pliers

SUPPLIES: Lead seal
Lockwashers (4 required)

PRELIMINARY PROCEDURE: Remove interior release mechanism control assemblies (page 20-16)

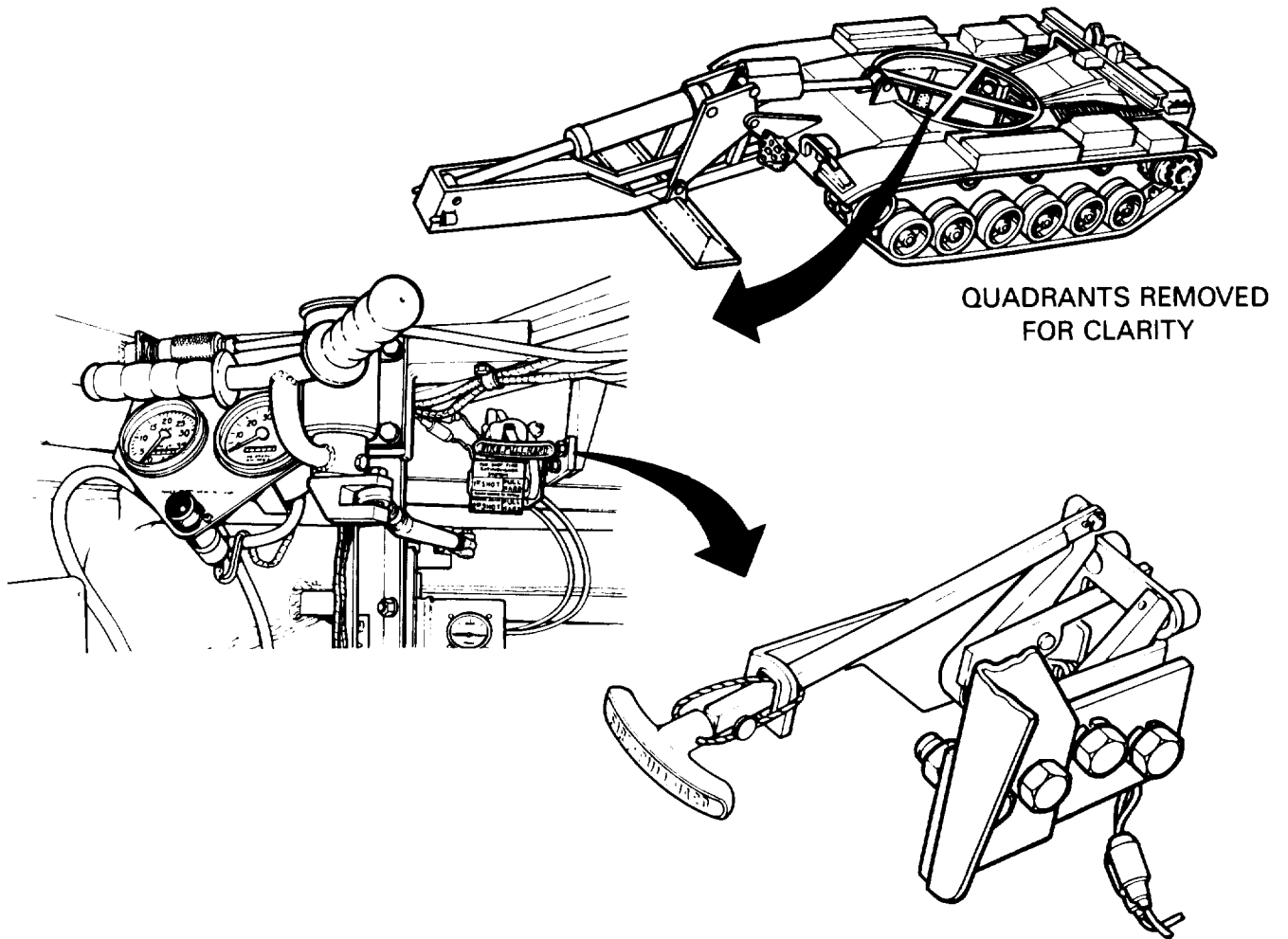

Go on to Sheet 2

TA248681

FIXED FIRE EXTINGUISHER INTERIOR RELEASE MECHANISM AND MOUNTING BRACKET REPLACEMENT (Sheet 2 of 5)

REMOVAL:

1. Disconnect two fuel shutoff electrical connectors (A) by pulling apart.
2. Using wrench, remove two bolts (B) and lockwashers (C) securing mechanism to bracket (D).
3. Remove mechanism from bracket (D).
4. Using pliers, remove safety wire (E).

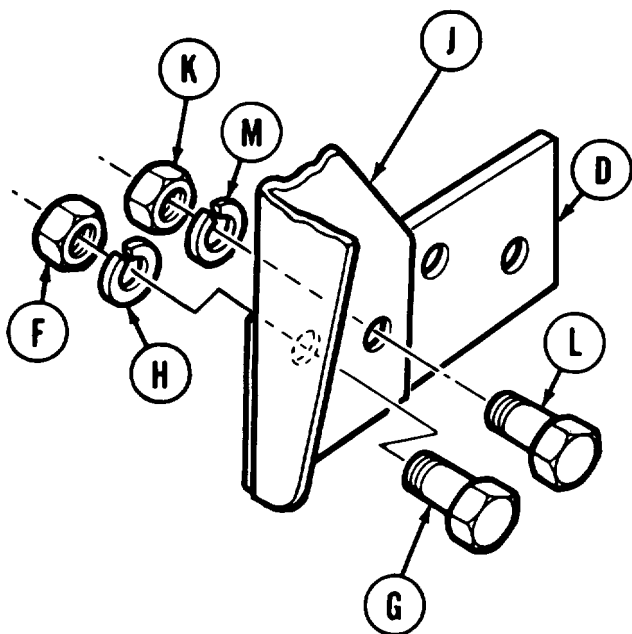
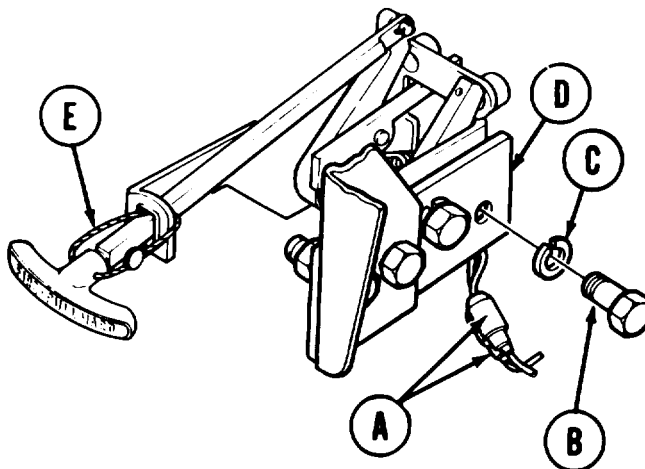

5. Using one wrench to hold nut (F), use other wrench to remove screw (G) and lockwasher (H) securing bracket (D) to bracket (J).
6. Using one wrench to hold nut (K), use other wrench to remove screw (L) and lockwasher (M) securing bracket (D) to bracket (J).
7. Remove bracket (D).

Go on to Sheet 3

TA248682

FIXED FIRE EXTINGUISHER INTERIOR RELEASE MECHANISM AND MOUNTING BRACKET REPLACEMENT (Sheet 3 of 5)

INSTALLATION:

1. Pull handle (A) of release mechanism forward.
2. Push pawl (B) downward.

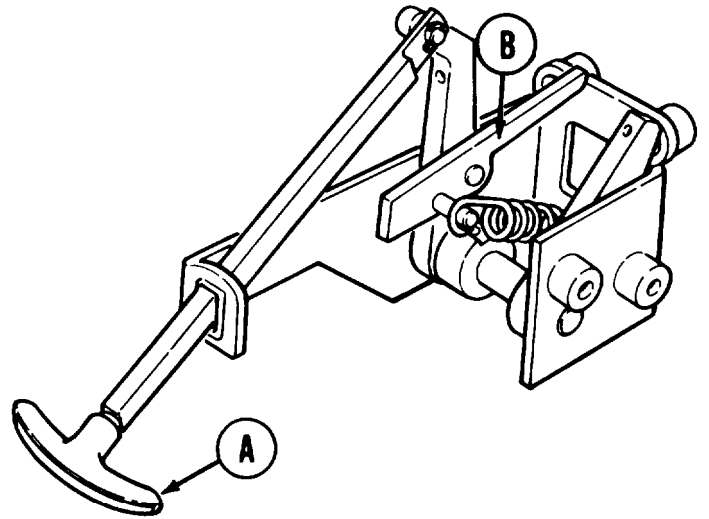

3. While pushing handle (A) rearward, guide pawl (B) into rear opening on bracket (C).

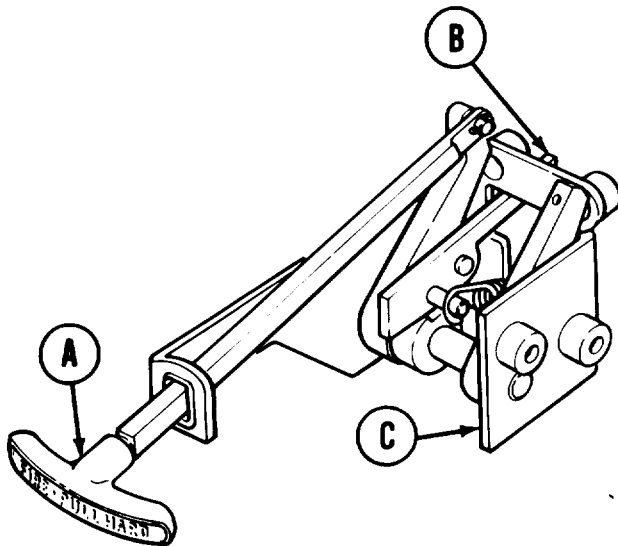

4. Place bracket (D) in position on bracket (E).
5. Using fingers, install two screws (F) and (G), new lockwashers (H), and nuts (J) and (K) securing bracket (D) to bracket (E).

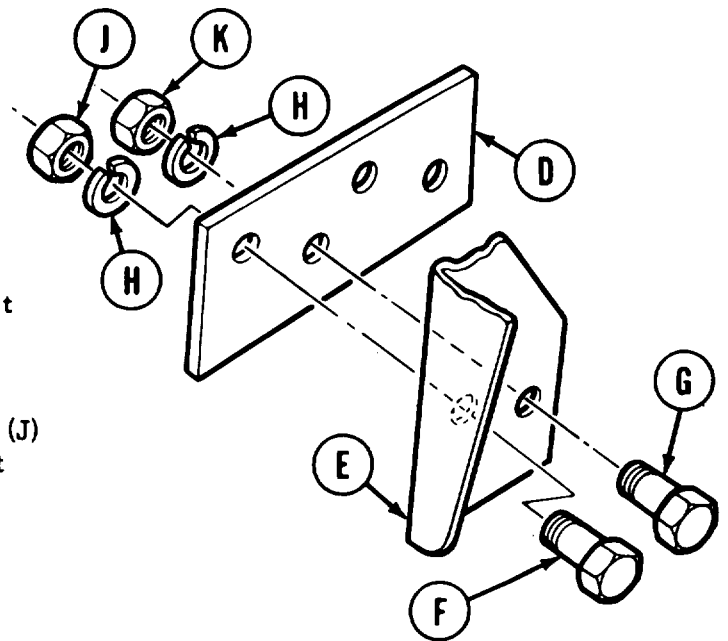

Go on to Sheet 4

TA248683

**FIXED FIRE EXTINGUISHER INTERIOR RELEASE MECHANISM AND MOUNTING BRACKET
REPLACEMENT (Sheet 4 of 5)**

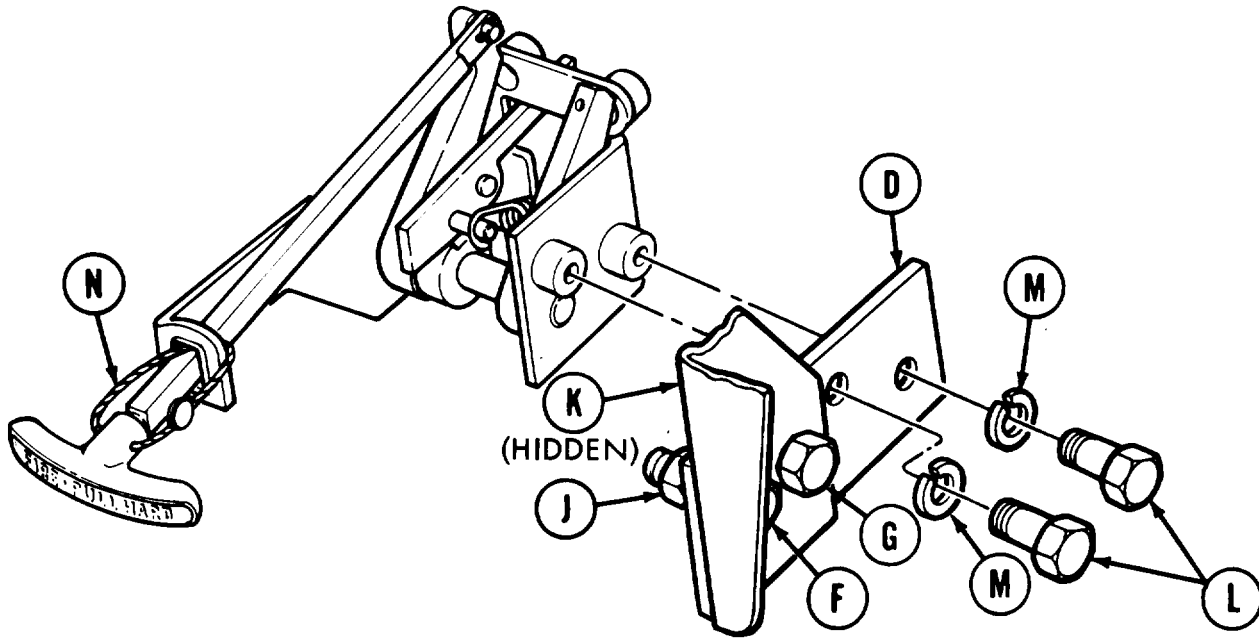

6. Holding nut (J) with wrench, use other wrench to tighten screw (F).
7. Holding nut (K) with wrench, use other wrench to tighten screw (G).
8. Place mechanism in position on bracket (D).
9. Using wrench, install two screws (L) and new lockwashers (M) securing mechanism to bracket (D).
10. Install lead seal (N) as shown.

Go on to Sheet 5

TA248684

**FIXED FIRE EXTINGUISHER INTERIOR RELEASE MECHANISM AND MOUNTING BRACKET
REPLACEMENT (Sheet 5 of 5)**

11. Connect two fuel shutoff electrical connectors (P) by pushing together.
12. Install interior release mechanism control assemblies (page 20-20).

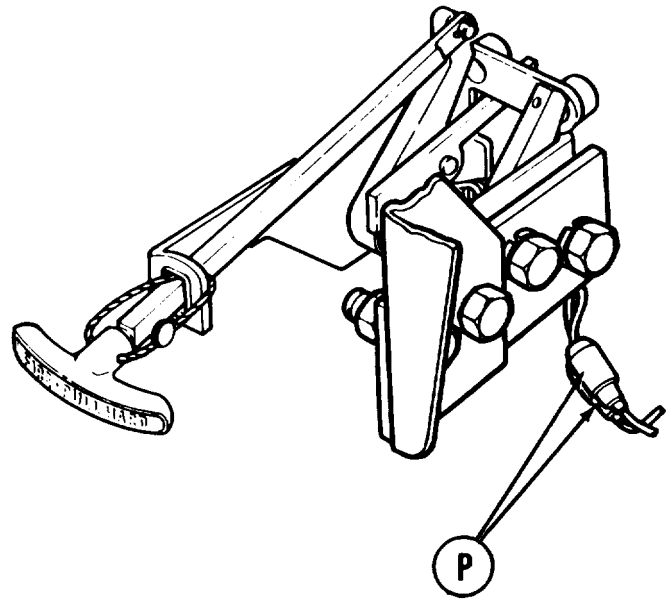

End of Task

TA248685

INTERIOR RELEASE MECHANISM REPAIR (Sheet 1 of 11)

PROCEDURE INDEX

PROCEDURE	PAGE
Disassembly	20-28
Cleaning and Inspection	20-32
Assembly	20-32

TOOLS: Pliers
 5/16 in. combination box and open end wrench
 Flat-tip screwdriver
 Long round nose pliers (needle nose)
 Ball peen hammer
 3/32 in. drive punch
 3/16 in. drive punch
 Vice

SUPPLIES: Spring pins (five)
 Dry cleaning solvent (Item 55, Appendix D)
 Cleaning fluid (Item 36, Appendix D)
 Cooking stove
 Water
 Gloves (Item 69, Appendix D)
 Cotter pins
 Goggles (Item 70, Appendix D)

PRELIMINARY PROCEDURES: Remove interior release mechanism and mounting bracket (page 20-23).

NOTE

Position interior release mechanism in vise as necessary to accomplish disassembly and assembly.

DISASSEMBLY:

- Using wrench, remove two screws (A) holding bracket (B) to release mechanism (C). Remove bracket (B), fuel shutoff switch (D), and instruction plate (E) from release mechanism (C).

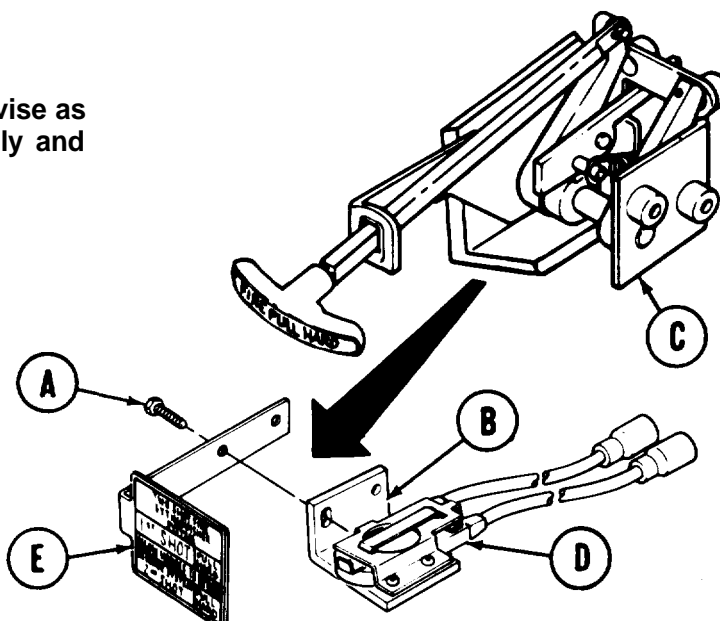

Go on to Sheet 2

TA248686

INTERIOR RELEASE MECHANISM REPAIR (Sheet 2 of 11)

2. Using screwdriver, remove two screws (F) and lockwashers (G) from bracket (B). Separate retainer (H) from switch assembly (D).

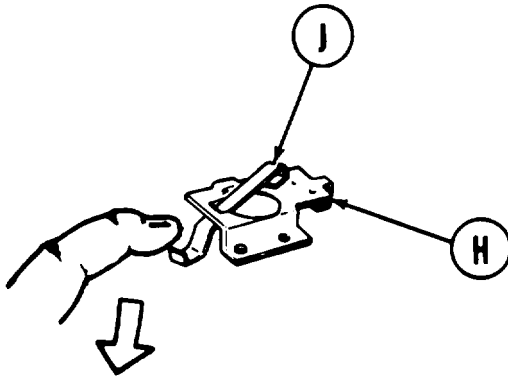
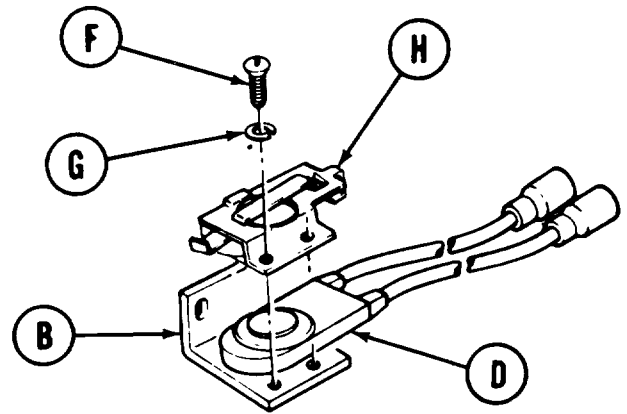

3. Using finger, push down and, separate switch guard (J) from retainer (H).

4. Using long nose pliers, remove antipilferage seal (K) from release mechanism (C). Using pliers, remove spring (L) from pawl (M) and release mechanism (C).

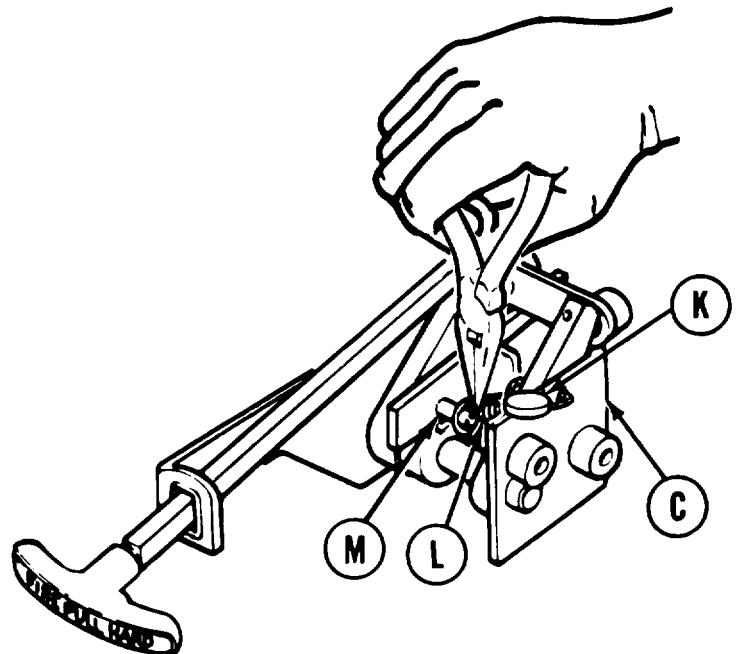

Go on to Sheet 3

TA248687

INTERIOR RELEASE MECHANISM REPAIR (Sheet 3 of 11)

5. Using pliers, remove cotter pin (N) from lever (P).

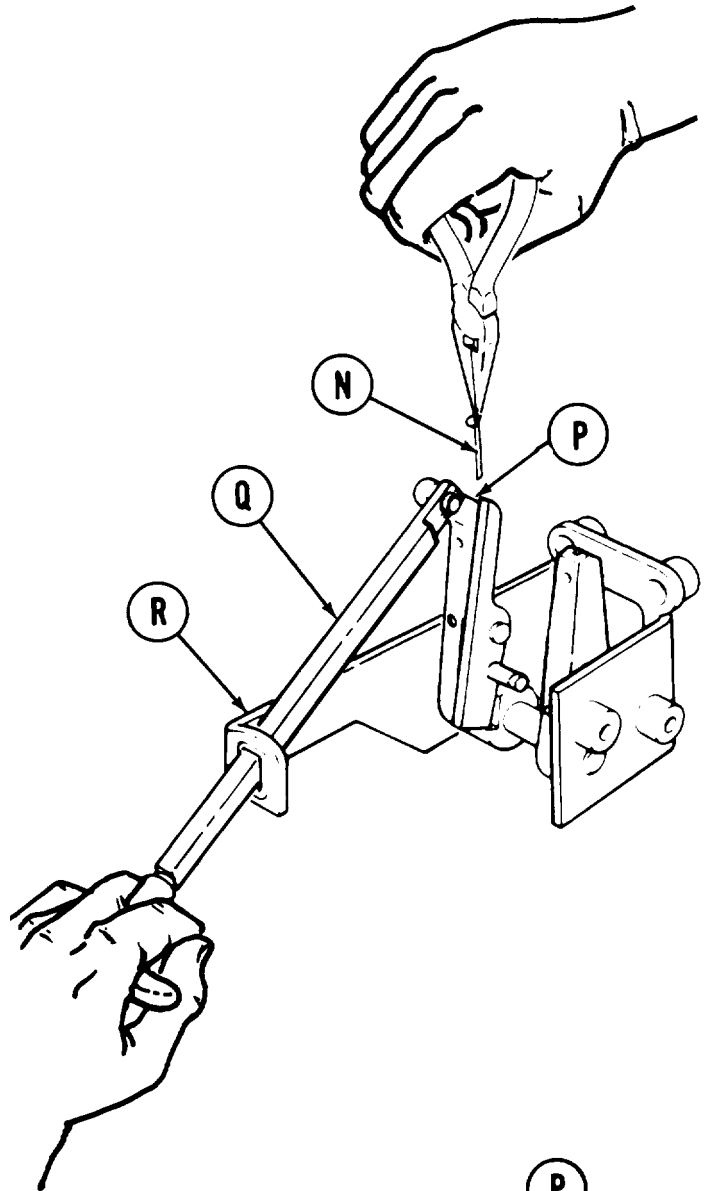

6. Push shaft (Q) off lever (P) and pull out of bracket (R).

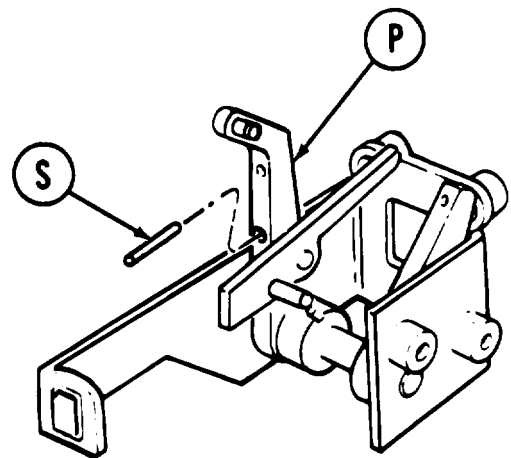

7. Using 3/32 inch punch and hammer, remove spring pin (S) from lever (P). Throw spring pin (S) away.

Go on to Sheet 4

TA248688

INTERIOR RELEASE MECHANISM REPAIR (Sheet 4 of 11)

8. Using 3/16 inch punch and hammer, remove straight pin (T), bushing (U), spacer (V), and pawl (W) from bracket (R).
9. Using 3/16 inch punch and hammer, drive spring pin (X) out of cam (Y). Throw spring pin (X) away.

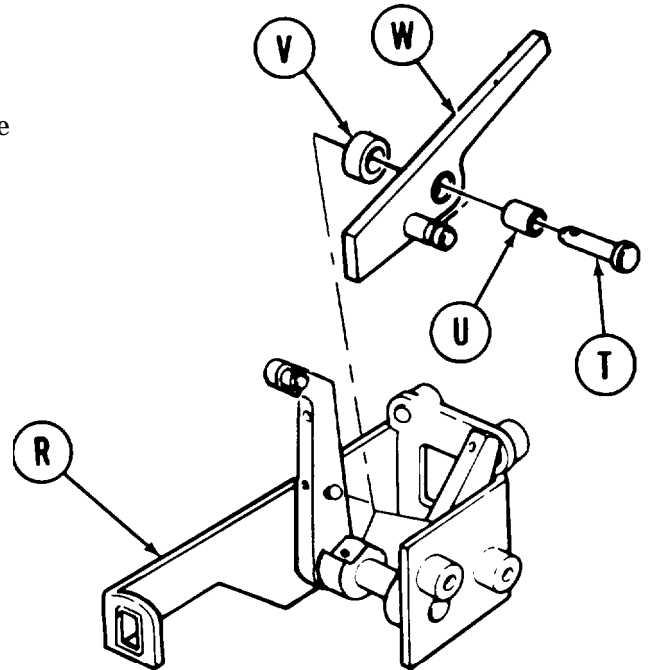

10. Using 3/16 inch punch and hammer, drive spring pin (Z) out of lever (AA). Throw spring pin (Z) away.
11. Pull lever pin (AB) out of bracket (R). Remove two thrust washers (AC), lever (AA), cam (Y), and lever (P).
12. Remove plastic grommet (AD) from bracket (R) if cracked or worn or does not fit properly.

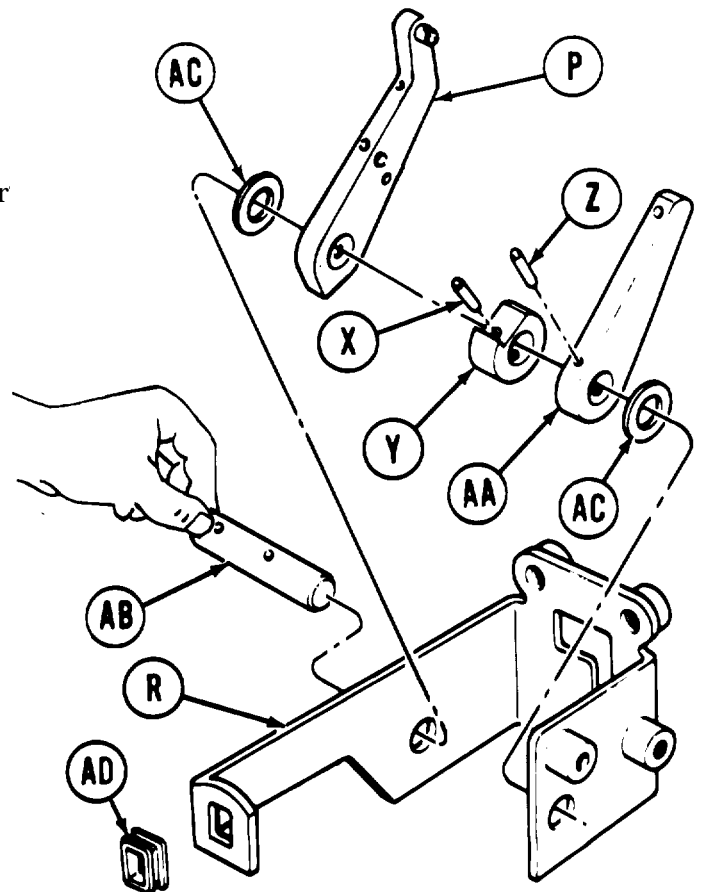

Go on to Sheet 5

TA248689

INTERIOR RELEASE MECHANISM REPAIR (Sheet 5 of 11)

13. Using 3/32 inch punch and hammer, drive spring pin (AE) out of shaft (Q). Throw spring pin (AE) away.
14. Pull handle (AF) off shaft (Q).

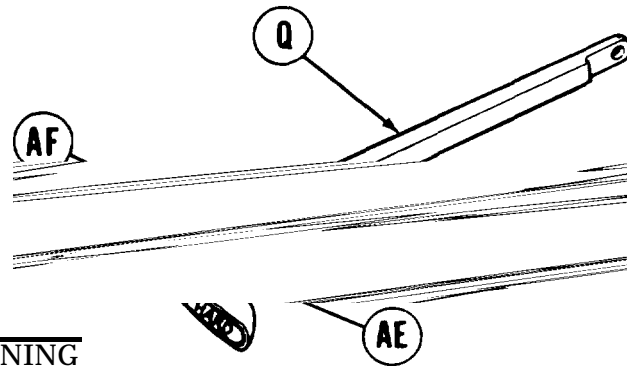

CLEANING AND INSPECTION:

Dry cleaning solvent P-D-680 is toxic and flammable. To prevent personal injury, wear protective goggles and gloves and use only in a wall-ventilated area. Avoid contact with skin, eyes, and clothes and don't breathe vapors. Do not use near open flame or excessive heat. The flash point for Type #1 Dry Cleaning Solvent is 100° (38°C) and for Type #2 is 138° (50°C). If you become dizzy while using cleaning solvent, get fresh air immediately and get medical aid. If contact with eyes is made, wash your eyes with water and medical aid immediately.

1. Using dry cleaning solvent, clean metal parts.
2. Using cleaning fluid, clean switch assembly and switch connectors.
3. Check metal parts for cracks.
4. Check levers, pins, pawl, and handle shaft for bends or breaks.
5. Check brackets for bends, elongated holes, or damaged points.
6. Check spring wire for nicks and grooves at contact points.
7. Replace all defective parts.

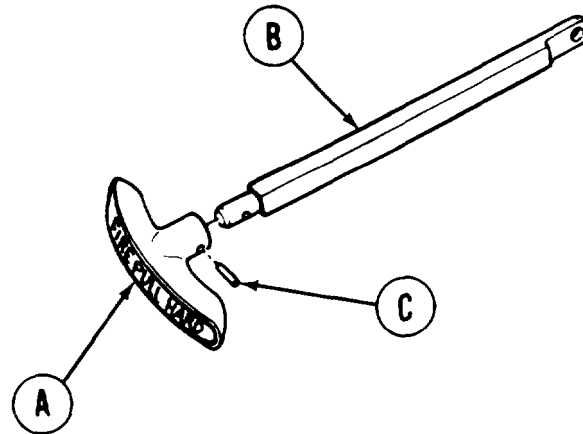

ASSEMBLY:

1. Push handle (A) onto shaft (B). Aline spring pin hole of handle (A) with hole of shaft (B).
2. Using hammer, install new spring pin (C) into handle (A) and shaft (B).

Go on to Sheet 6

TA248690

INTERIOR RELEASE MECHANISM REPAIR (Sheet 6 of 11)

NOTE

Before installing new grommet (D) into bracket (E), it will be necessary to place grommet (D) in boiling water, using cooking stove, for 2-3 minutes.

3. If grommet (D) was removed, using pliers and wearing rubber gloves, quickly remove grommet (D) from boiling water and snap it in place into bracket (E).

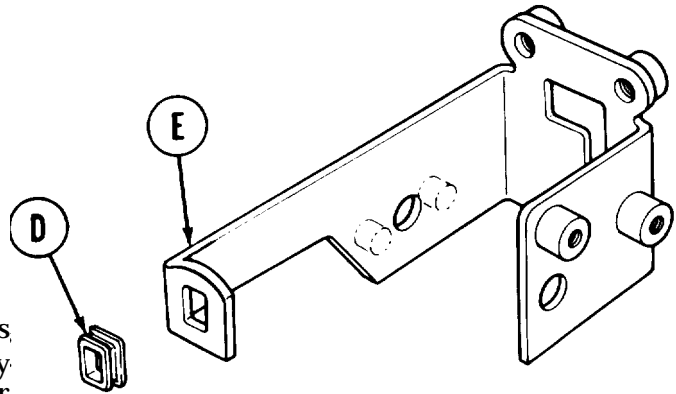

4. Position lever pin (F) partially into hole in left side of bracket (E).
5. Position thrust washer (G), lever (H), cam (J), lever (K), and another thrust washer (G) onto lever pin (F).
6. Push lever pin (F) through right hole of bracket (E) so that both ends of pin (F) are flush with outside of bracket (E).

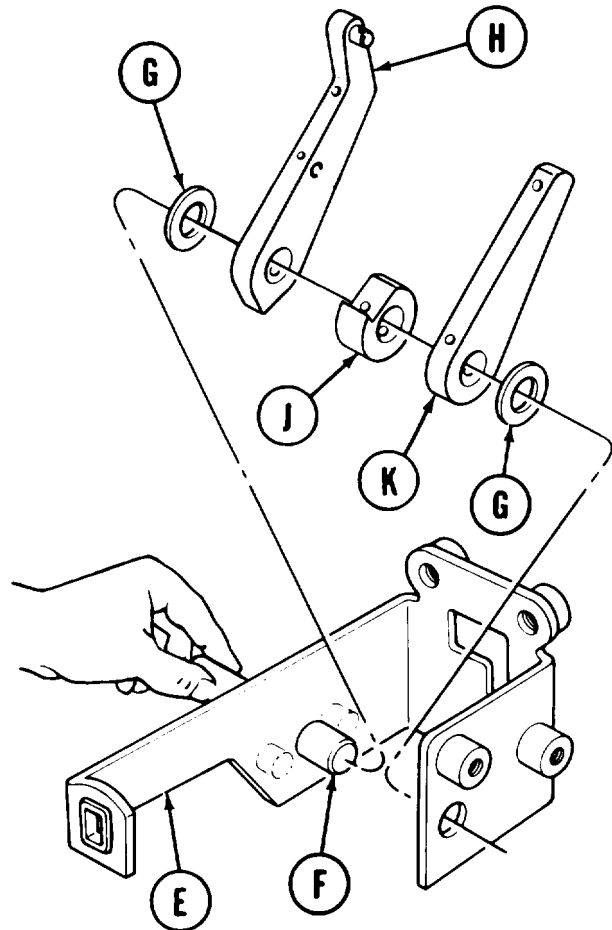

Go on to Sheet 7

TA248691

INTERIOR RELEASE MECHANISM REPAIR (Sheet 7 of 11)

7. Aline pin hole of cam (J) with pin hole of lever pin (F).
8. Using hammer and 3/16 inch punch, tap new short spring pin (L) into cam (J) and lever pin (F).
9. Aline pin hole of lever (K) with pin hole of lever pin (F).
10. Using hammer and punch, tap new long spring pin (M) into lever (K) and lever pin (F).

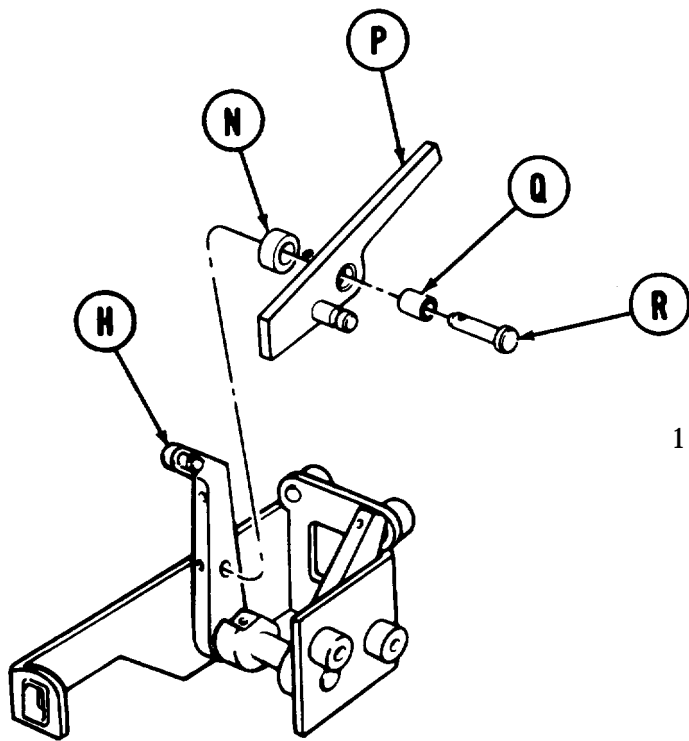
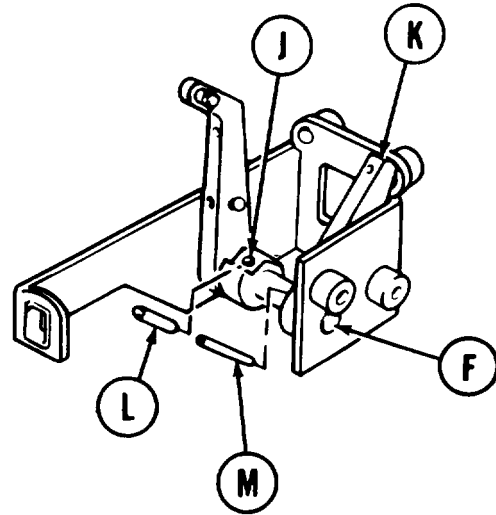

11. Install spacer (N), pawl (P), bushing (Q), and straight pin (R) onto lever (H).

Go on to Sheet 8

TA248692

INTERIOR RELEASE MECHANISM REPAIR (Sheet 8 of 11)

12. Using pliers, align pinhole of straight pin (R) with pin hole of lever (H).
13. Using hammer and 3/16 inch punch, tap new spring pin (S) into lever (H) and pin (R).

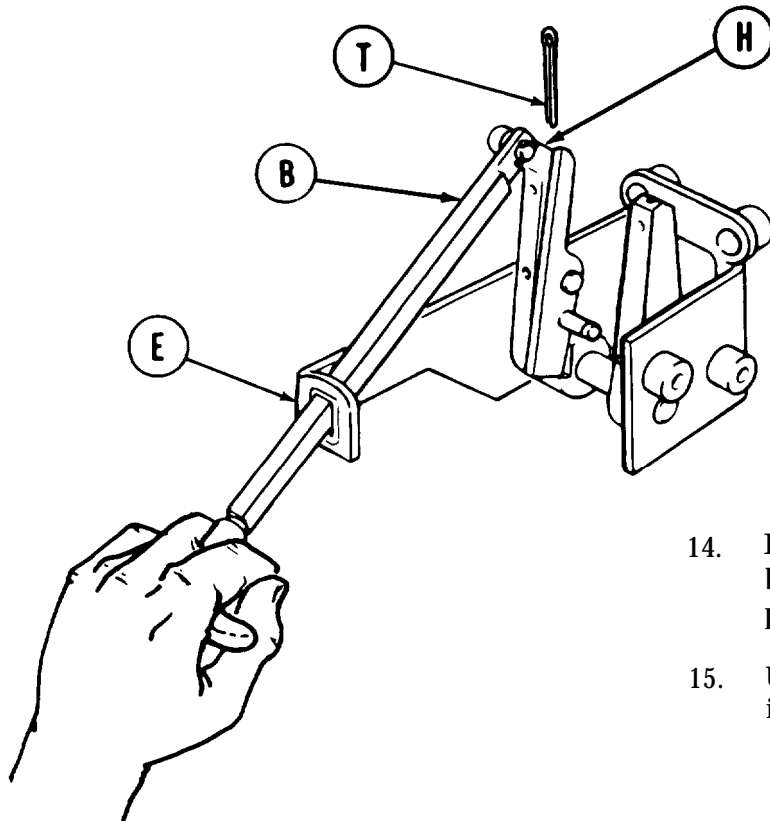
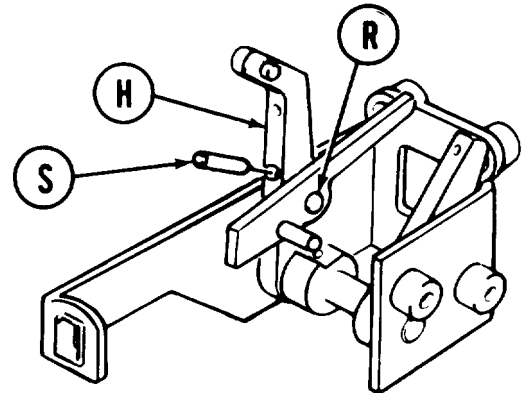

14. Insert shaft (B) through front hole of bracket (E). Push end of shaft (B) onto pin of lever (H).
15. Using pliers, install cotter pin (T) into retaining pin of lever (H).

Go on to Sheet 9

TA248693

INTERIOR RELEASE MECHANISM REPAIR (Sheet 9 of 11)

16. Insert end of spring (U) through hole in rear of bracket (E). Install antipilferage seal.
17. Using pliers, connect and seat other end of spring (U) onto connecting pin (V) of pawl (P).
18. Move handle (A) forward and rearward to check for proper operation.

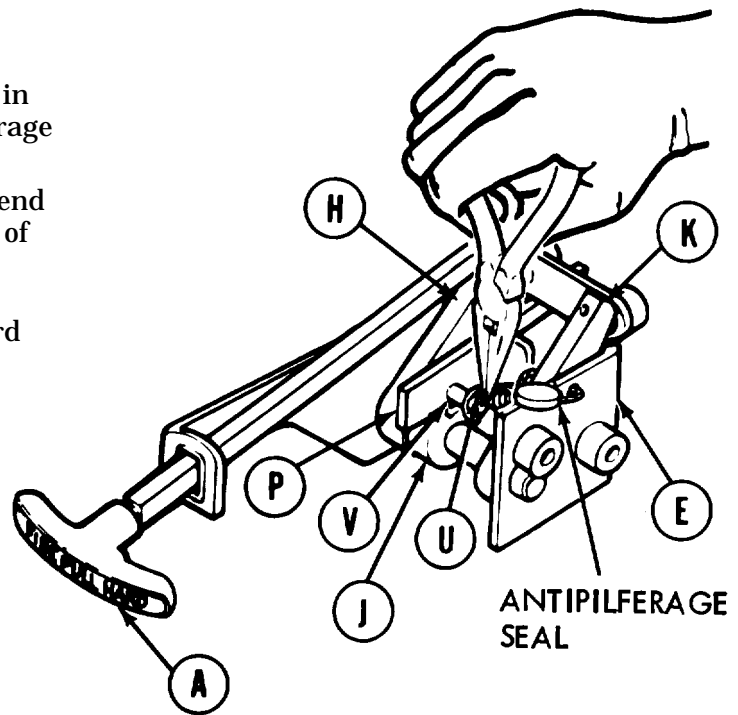

NOTE

Make sure pawl lever (P) snaps downward on forward stroke and engages cam (J) on rearward stroke. Also, this check will cause lever (K) to move at same time as lever (H) when activated.

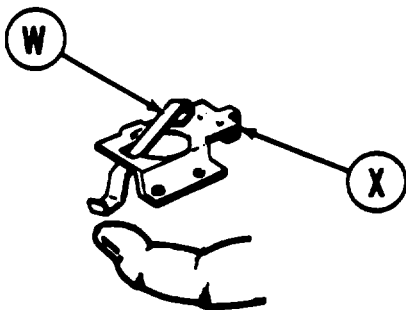

19. Insert switch guard (W) up through center hole of retainer (X) and connect to retainer (x).

Go on to Sheet 10

TA248694

INTERIOR RELEASE MECHANISM REPAIR (Sheet 10 of 11)

20. Place fuel shutoff switch (Y) on mounting bracket (Z).
21. Place retainer (X) on top of switch (Y) on bracket (Z).
22. Insert two lockwashers (AA) and screws (AB) through retainer (X) and bracket (Z). Do not tighten screws (AB) completely.
23. Make sure fuel shutoff switch (Y) touches switch guard (W). Using screwdriver, tighten screws (AB) to bracket (Z).
24. Insert two screws (AC) through instruction plate (AD) into bracket (Z) and secure in mounting holes on left side of bracket (E).
25. Using wrench, tighten screws (AC).

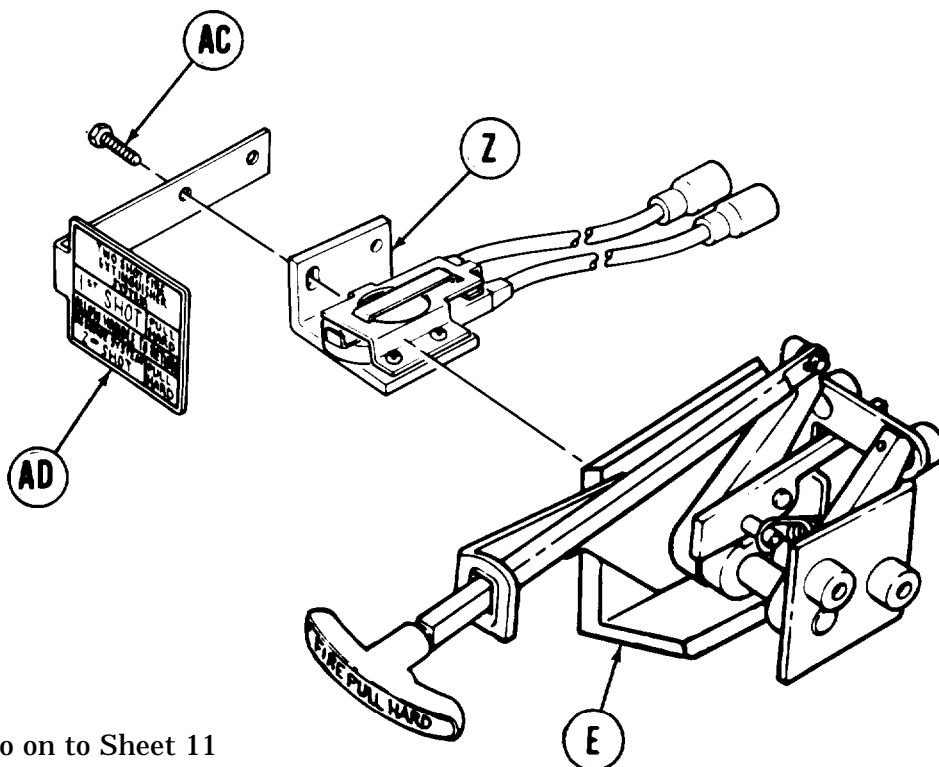
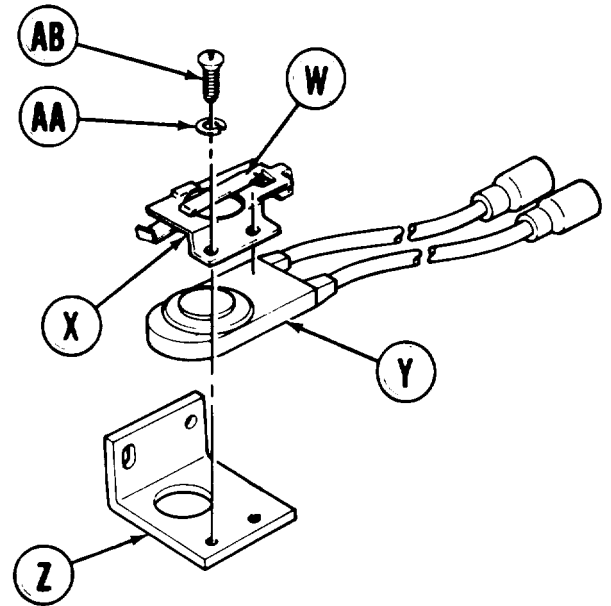

Go on to Sheet 11

TA246695

INTERIOR RELEASE MECHANISM REPAIR (Sheet 11 of 11)

26. Pull handle (A) forward to check fuel shutoff switch for clicking sound. If clicking sound is not heard, adjust fuel shutoff switch guard (W) to make sure it touches fuel shutoff switch (Y). If switch (Y) cannot be actuated, replace switch (page 20-28).

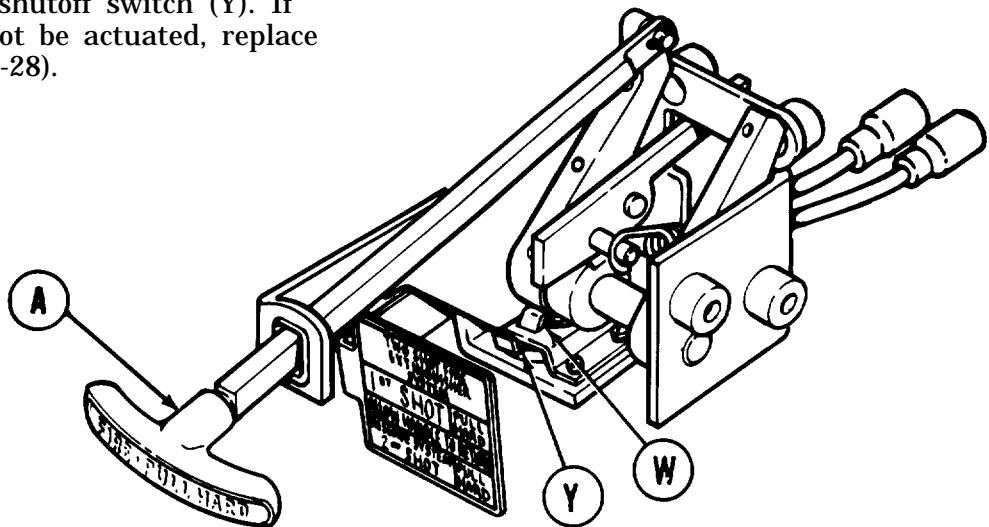

27. Install interior release mechanism and mounting bracket assembly (page 20-25).

End of Task

TA248696

EXTERIOR RELEASE HANDLE BODY ASSEMBLY REPLACEMENT (Sheet 1 of 4)

PROCEDURE INDEX

PROCEDURE	PAGE
Removal	20-39
Installation	20-41

TOOLS: Diagonal cutting pliers
 1/2 in. combination box and open end wrench
 Slip joint pliers

SUPPLIES: Antipilferage seal

PRELIMINARY PROCEDURE: Remove control valves (page 20-2).

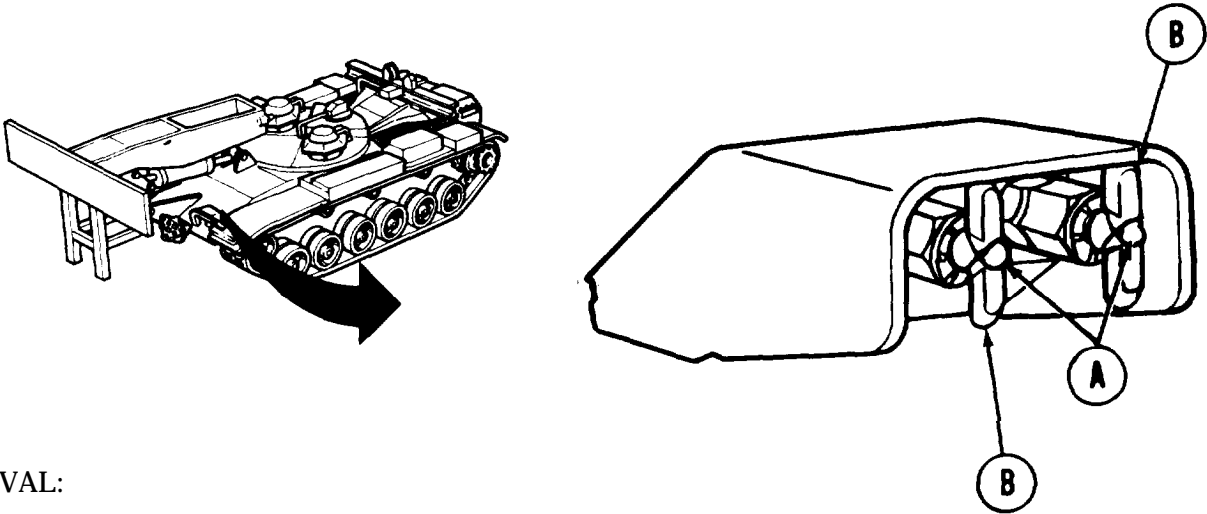

REMOVAL:

1. Using cutting pliers, remove lead seals (A) from body assemblies (B).

NOTE

These instructions describe removal of either body assembly.

Go on to Sheet 2

EXTERIOR RELEASE HANDLE BODY ASSEMBLY REPLACEMENT (Sheet 2 of 4)

2. Pull body assembly (B) out of mounting bracket (C) until fastener (D) is exposed.
3. Using 1/2 inch wrench, unscrew fastener (D) from body assembly (B).

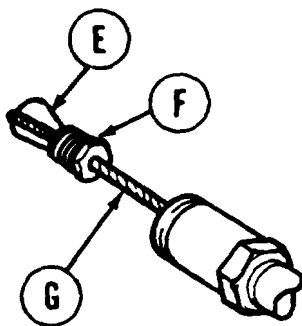
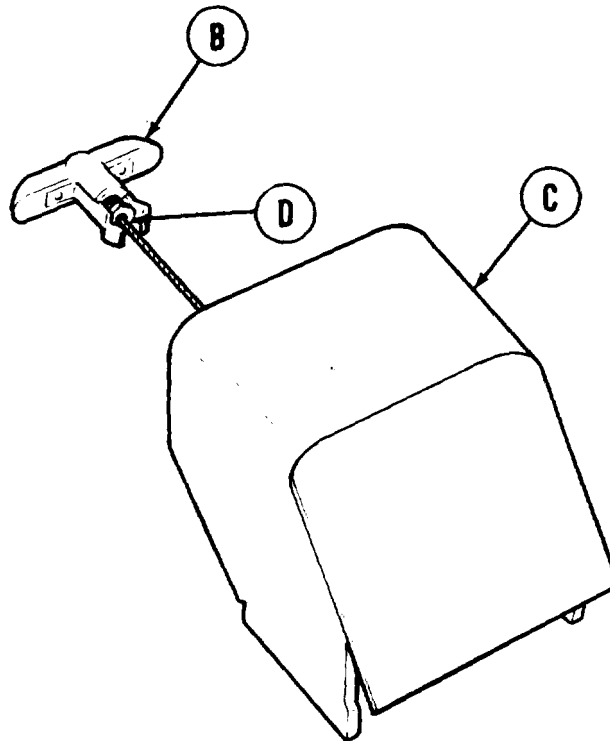

NOTE

Plug (E) does not separate from socket (F) in step 4.

4. Using pliers, loosen plug (E) in socket (F) until cable (G) is unlocked and can be removed from plug (E).
5. Remove cable (G) from plug (E).

Go on to Sheet 3

TA248698

EXTERIOR RELEASE HANDLE BODY ASSEMBLY REPLACEMENT (Sheet 3 of 4)

NOTE

These instructions describe installation of either body assembly.

INSTALLATION:

1. Thread cable (A) into socket (B).
2. Lay cable (A) in groove around plug (C). Allow a minimum of 1/8 inch of cable extending beyond plug (C).

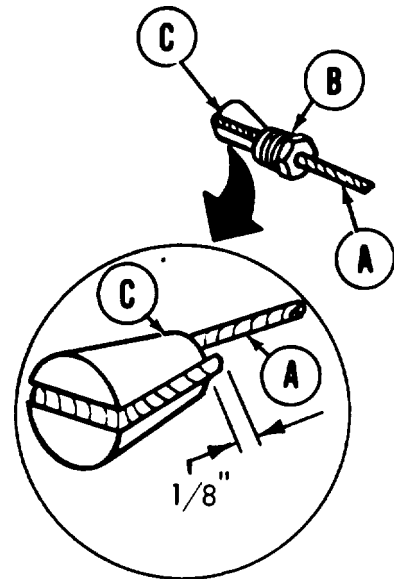

3. Using pliers, seat plug (C) into socket (B).

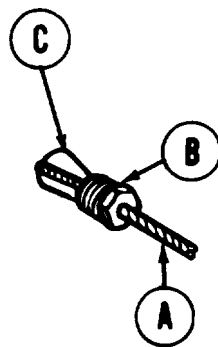

4. Install fastener assembly (D) into body assembly (E).
5. Using 1/2 inch wrench, tighten fastener assembly (D) into body assembly (E).

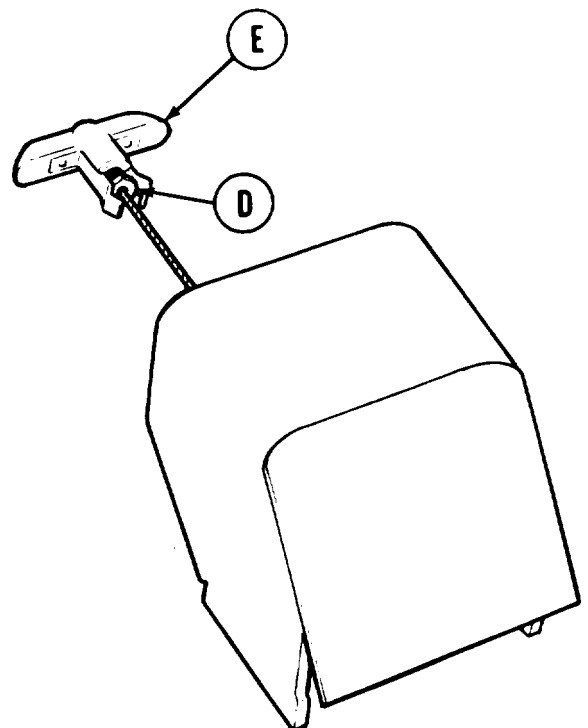

Go on to Sheet 4

TA248699

EXTERIOR RELEASE HANDLE BODY ASSEMBLY REPLACEMENT (Sheet 4 of 4)

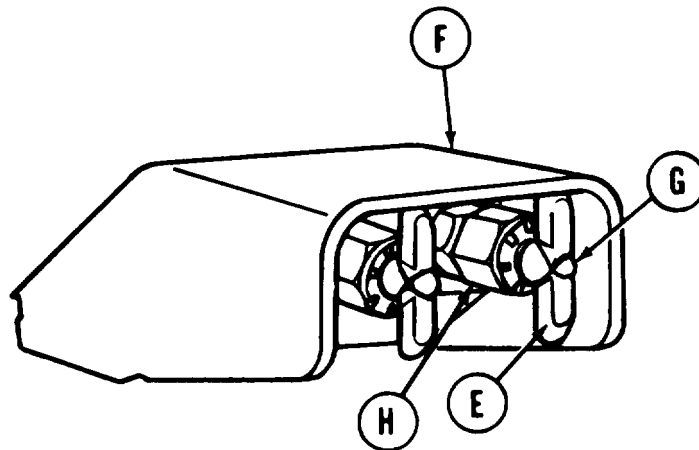

6. Squeeze spring clips on body assembly (E) and insert body assembly (E) into bracket (F).

7. Install antipilferage seal (G) as shown. Position seal (G). Wrap wire from seal (G) around coupling (H), cross over body assembly handle (E), and thread end of wire through seal (G).

8. Using slip joint pliers, crimp seal (G) onto wire.

9. Replace control valves (page 20-14).

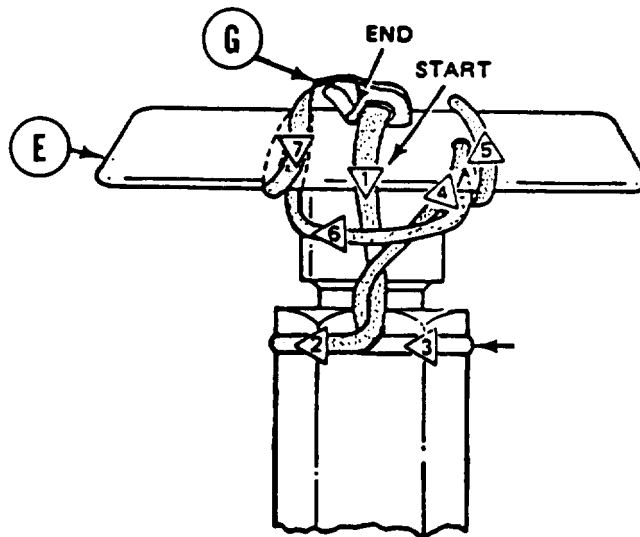

End of Task

EXTERIOR RELEASE HANDLE BODY ASSEMBLY REPAIR (Sheet 1 of 1)

TOOLS: Ball peen hammer
1/8 in. flat-tip screwdriver (pocket screwdriver)
1/2 inch drive punch

SUPPLIES: Drive screws (2 required)

PRELIMINARY PROCEDURE: Remove release handle body assembly (page 20-39).

DISASSEMBLY:

1. Using screwdriver, pry two drive screws (A) from body (B).
2. Remove two clip springs (C).
3. Replace defective parts as required.

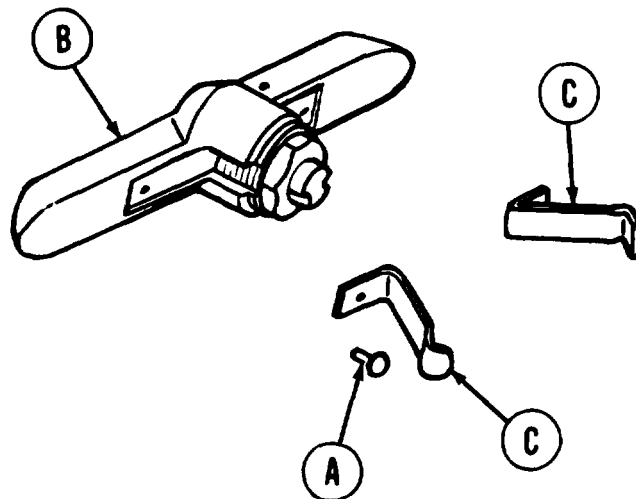
**ASSEMBLY:**

1. Place body (B) on flat surface.
2. Position clip springs (C) onto body (B).
3. Using hammer and punch, tap new drive screws (A) into body (B).
4. Install release handle body assembly (page 20-41).

End of Task

TA248701

**FIXED FIRE EXTINGUISHER OUTSIDE RELEASE HANDLE CONTROL ASSEMBLY
REPLACEMENT (Sheet 1 of 4)**

PROCEDURE INDEX

PROCEDURE	PAGE
Removal	20-44
Cleaning and Inspection	20-46
Installation	20-46

TOOLS: 7/64 in. socket head screw key (allen wrench)
 5/16 in. open end wrench
 9/16 in. open end wrench
 Pliers, diagonal cutting
 Pliers, long round nose

SUPPLIES: Seal, anti-pilferage (two required)

PRELIMINARY PROCEDURE: Remove release handle body assembly (page 20-39).

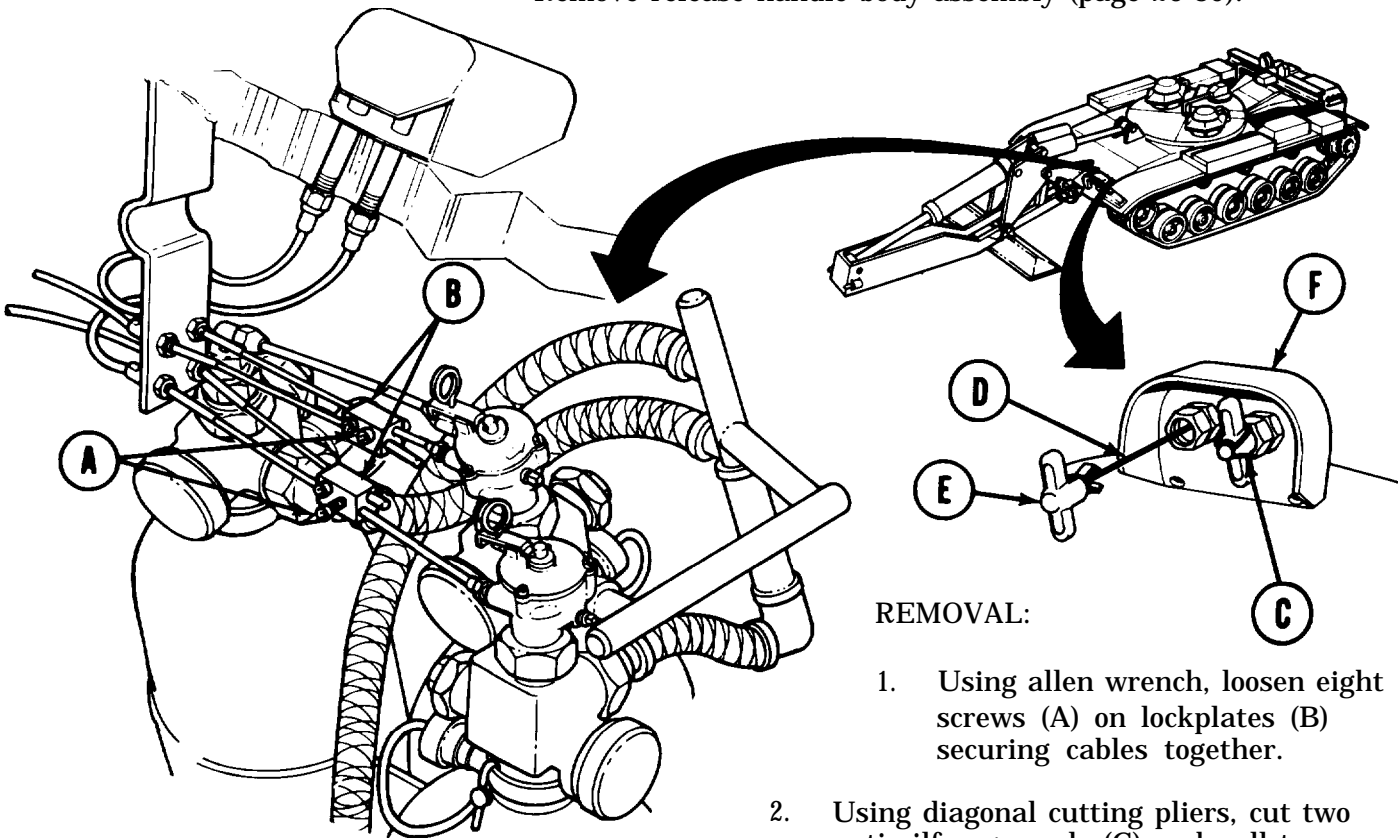

REMOVAL:

1. Using allen wrench, loosen eight screws (A) on lockplates (B) securing cables together.
2. Using diagonal cutting pliers, cut two anti-pilferage seals (C) and pull two cables (D) with release handle assemblies (E) out of bracket (F).

Go on to Sheet 2

TA248702

FIXED FIRE EXTINGUISHER OUTSIDE RELEASE HANDLE CONTROL ASSEMBLY REPLACEMENT (Sheet 2 of 4)

3. Using 9/16 inch wrench, remove two nuts (G) securing two control assemblies (H) to bracket (J).
4. Pull two control assemblies (H) out of bracket (J).
5. Using 5/16 inch wrench on flats (K) of two control assemblies (H), remove two control assemblies (H), from hull.

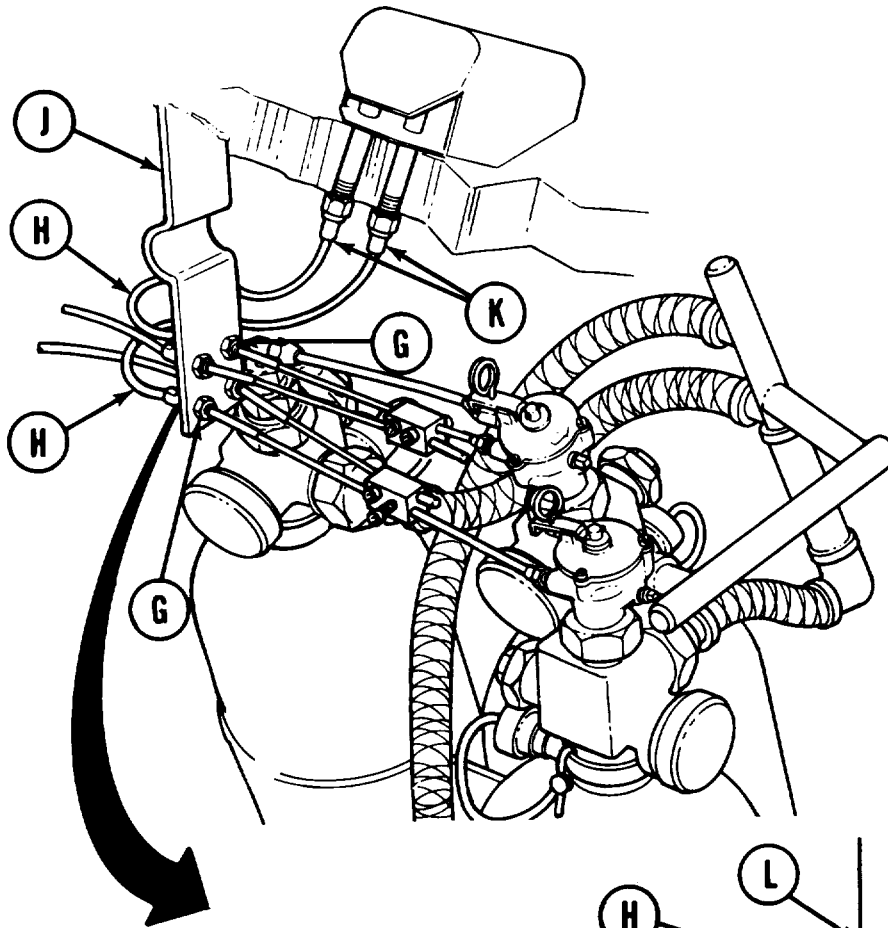

6. Using 9/16 inch wrench, remove two nuts (L) from two control assemblies (H).

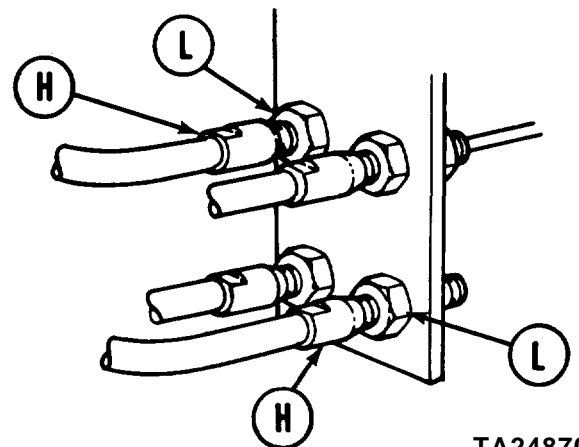

Go on to Sheet 3

TA248703

**FIXED FIRE EXTINGUISHER OUTSIDE RELEASE HANDLE CONTROL ASSEMBLY
REPLACEMENT (Sheet 3 of 4)**

INSPECTION:

1. Inspect cables (A) for kinks and frayed areas.
2. Replace cables if kinked or frayed.
3. Examine exterior control assembly (B) for cracks.
4. Replace exterior control assembly (B) if damaged.

INSTALLATION:

NOTE

Control assembly mounted toward center of vehicle is first shot.

1. Using 9/16 inch wrench, screw two nuts (C) onto two control assemblies (B).
2. Using 5/16 inch wrench on flats (D) of two control assemblies (B), install two control assemblies (B) on hull.
3. Thread cables (A) with release handle assemblies (E) from outside of vehicle, through handle mounting bracket and through two control assemblies (B).

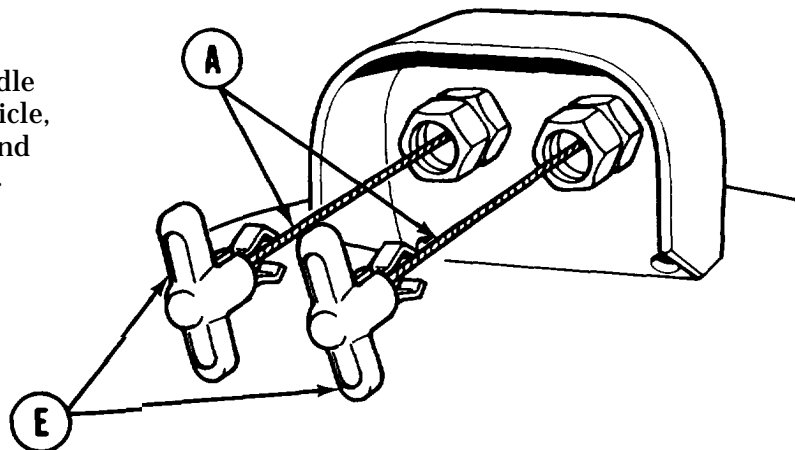
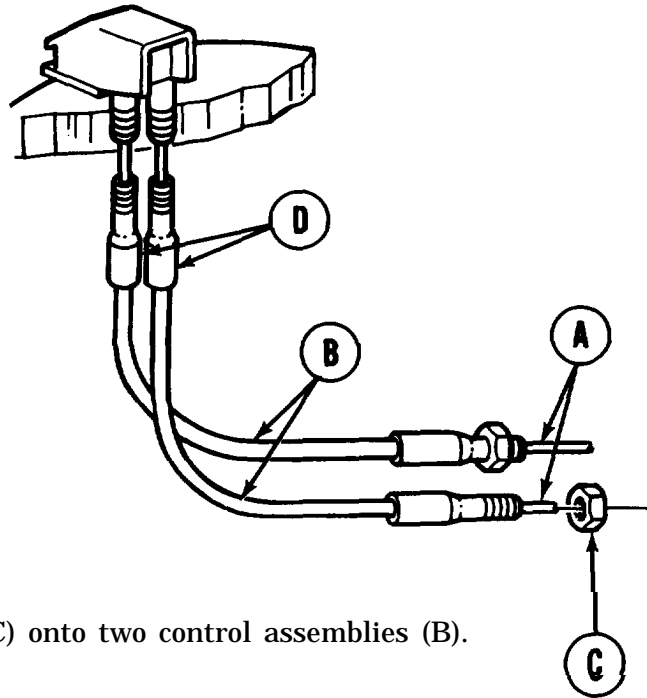

Go on to Sheet 4

TA248704

FIXED FIRE EXTINGUISHER OUTSIDE RELEASE HANDLE CONTROL ASSEMBLY REPLACEMENT (Sheet 4 of 4)

4. Install first shot control assembly (F) in position (G) on bracket (H).
5. Install second shot control assembly (J) in position (K) on bracket (H).
6. Using 9/16 inch wrench, install two nuts (L) securing two control assemblies (F) and (J) to bracket (H).
7. Insert two cables (A) in locking plates (M).
8. Using allen wrench, install screws (N) securing two cables (A) in locking plates (M).

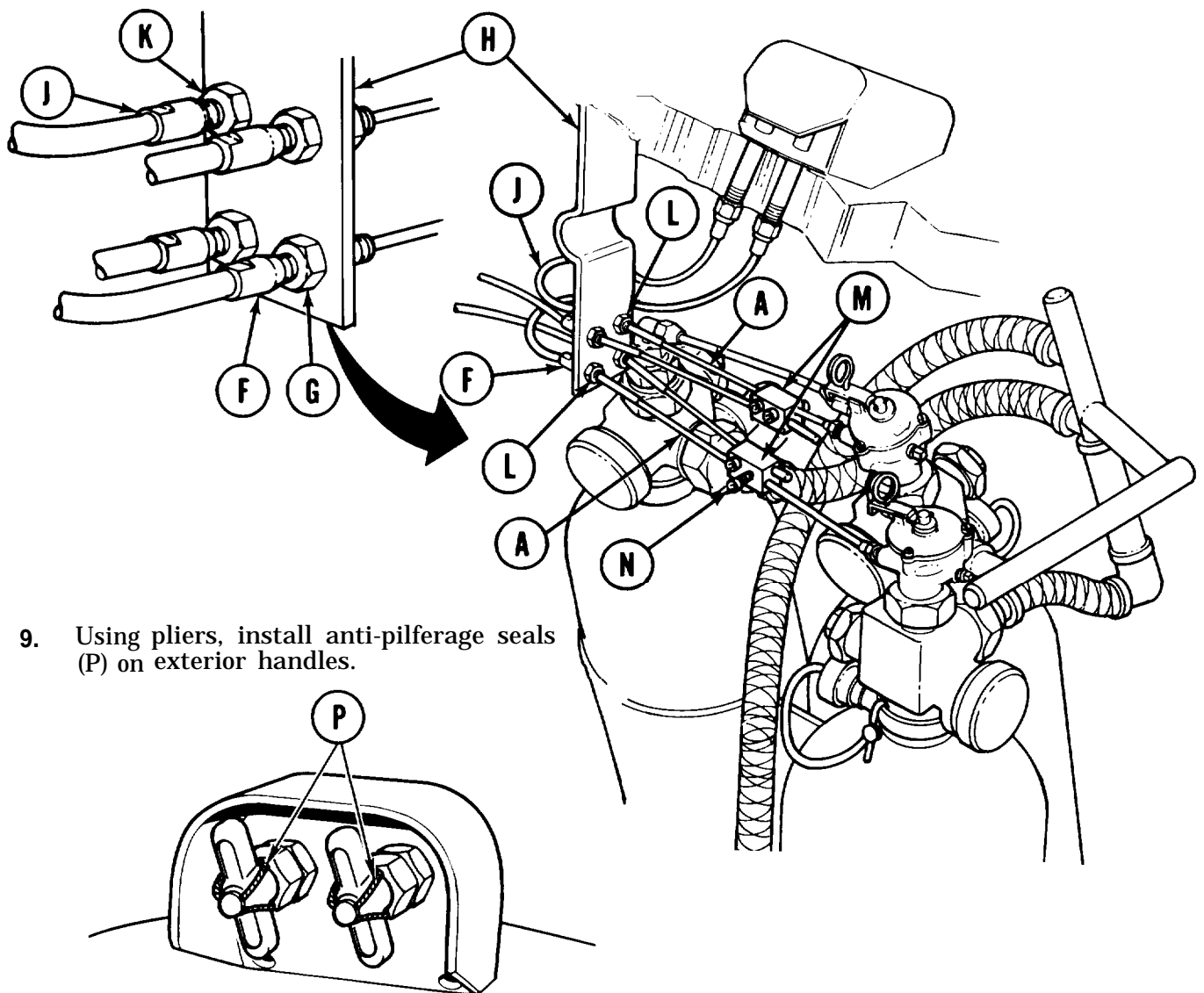

9. Using pliers, install anti-pilferage seals (P) on exterior handles.

10. Install release handle body assembly (page 20-41).

End of Task

TA248705

EXTERIOR RELEASE HANDLE MOUNTING BRACKET REPLACEMENT (Sheet 1 of 2)

TOOLS: 1-1/8 in. combination box and open end wrench
 1 in. combination box and open end wrench
 Flat-tip screwdriver with 5/16 in. blade

SUPPLIES: Preformed packing (two)

PRELIMINARY PROCEDURES:

Remove exterior release handle body assemblies
 (page 20-39)
 Remove outside release handle control assemblies
 (page 20-44)

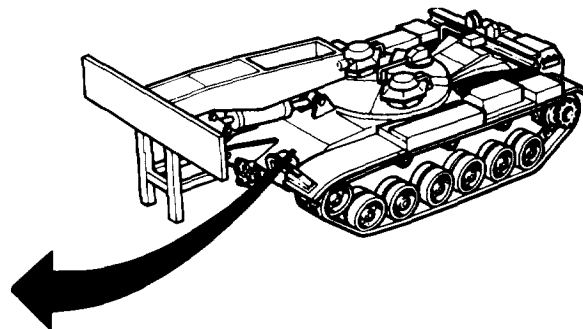
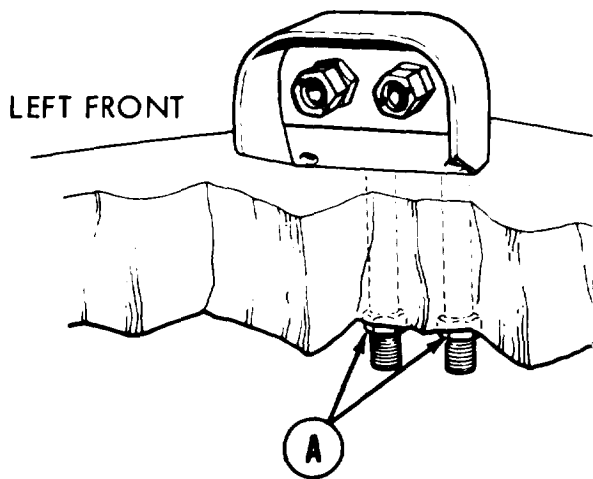

REMOVAL:

1. Using 1-1/8 inch wrench, remove two nuts (A) from inside hull.
2. Remove mounting bracket (B) from vehicle.
3. Using hands, remove preformed packings (C). Throw packings away.

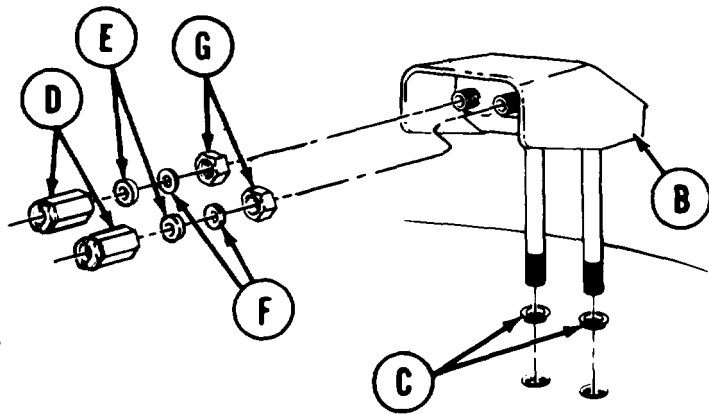

NOTE

When removing couplings (D) in next step, bushings (E) and washers (F) will remain with couplings (D).

4. Using 1 inch wrench, remove couplings (D) from mounting bracket (B).
5. Using 1-1/8 inch wrench, remove nuts (G) from mounting bracket (B).
6. Using screwdriver, remove washers (F) and bushings (E) from couplings (D).

Go on to Sheet 2

TA248706

EXTERIOR RELEASE HANDLE MOUNTING BRACKET REPLACEMENT (Sheet 2 of 2)

INSTALLATION:

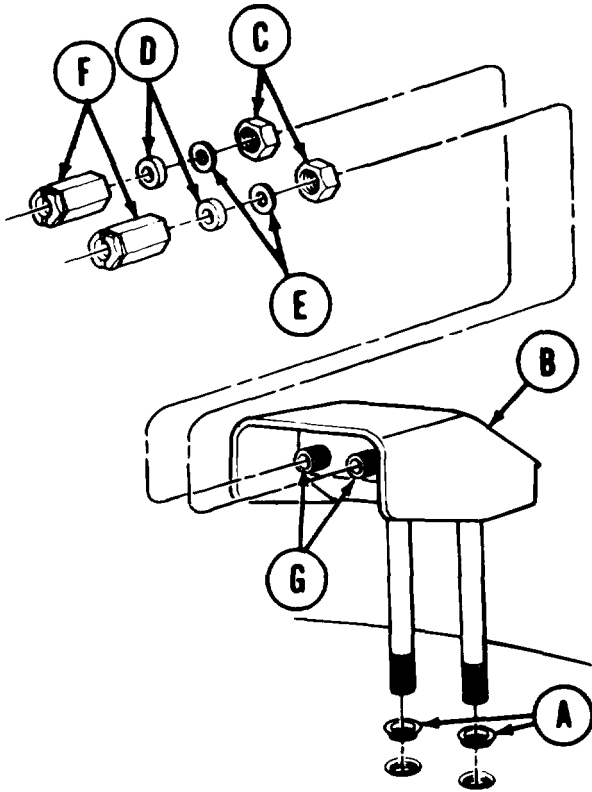

1. Using hands, install new preformed packings (A) onto bracket (B).
2. Using 1-1/8 inch wrench, screw nuts (C) all the way down onto bracket (B).
3. Press bushings (D) and washers (E) into couplings (F).
4. Tighten couplings (F) finger tight to bracket (B).

CAUTION

Be sure not to overtighten couplings (F) or tubes (G) will collapse.

5. Using 1 inch wrench to hold coupling (F), use 1-1/8 inch wrench and tighten nuts (C) against coupling (F).
6. Place mounting bracket (B) onto vehicle.
7. Screw two nuts (G) to mounting bracket (B) (inside hull).
8. Using 1-1/8 inch wrench, tighten two nuts (H).
9. Install outside release handle control assemblies (page 20-46).
10. Install exterior release handle body assemblies (page 20-41).

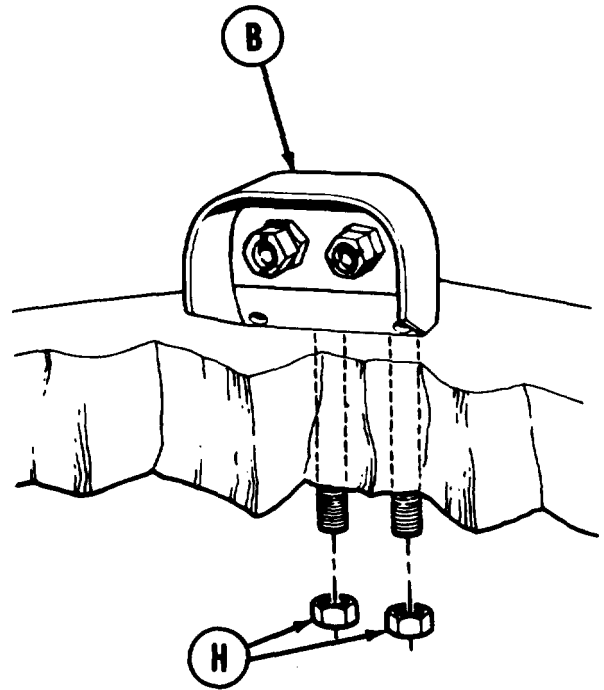

End of Task

TA248707

CONTROL VALVE ASSEMBLY REPAIR (Sheet 1 of 2)

TOOLS: Bench vise
8 in. adjustable wrench

SUPPLIES: Plug

PRELIMINARY PROCEDURE: Remove control valve (page 20-2)

DISASSEMBLY:

1. Secure control valve in vise with vent plug (A) up.
2. Using adjustable wrench, remove vent plug (A) from valve (B) and throw plug away.
3. Holding hand over hole where plug (A) was removed, remove valve (B) from vise. Turn plug hole down and remove ball (C) from valve (B).

INSPECTION:

Inspect plug hole and ball (C) for nicks and burrs. If damaged, replace damaged part.

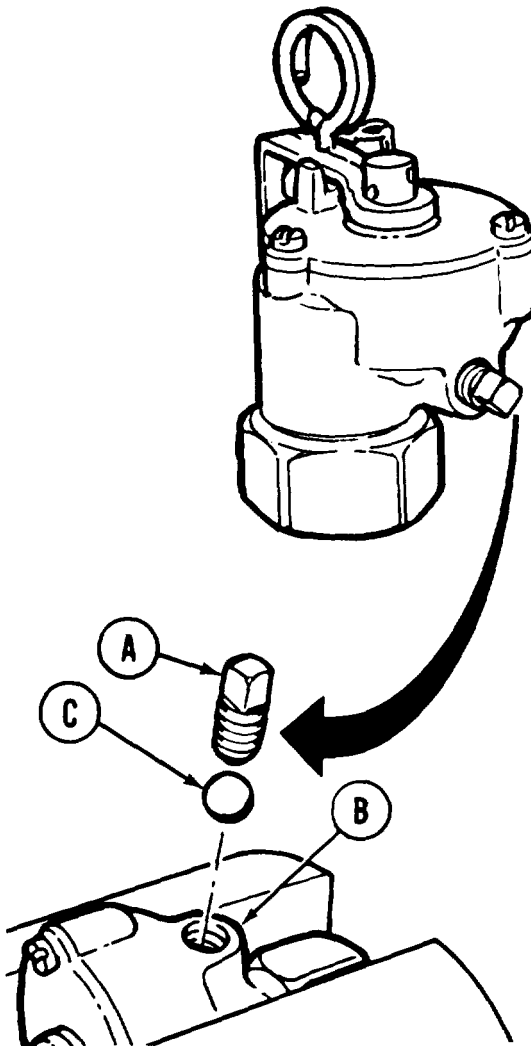

Go on to Sheet 2

TA248708

CONTROL VALVE ASSEMBLY REPAIR (Sheet 2 of 2)

ASSEMBLY:

1. Secure valve (A) in vise with hole up.
2. Place ball (B) in hole in valve (A).
3. Using adjustable wrench, install new plug (c) into valve (A).
4. Remove valve (A) from vise.
5. Install control valve (page 20-14).

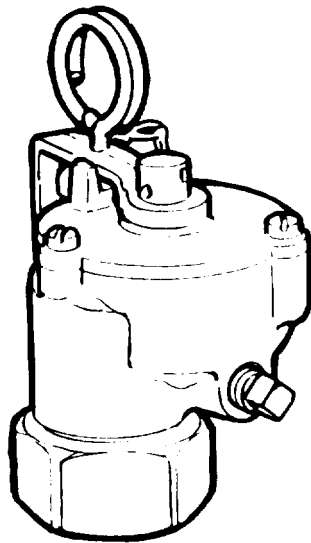
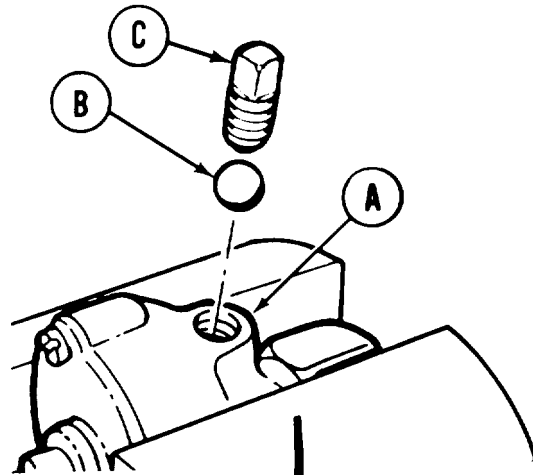

End of Task

TA248709

20-51

FIXED FIRE EXTINGUISHER CYLINDER REPLACEMENT (Sheet 1 of 4)

PROCEDURE INDEX

PROCEDURE	PAGE
Removal	20-52
Inspection	20-53
Repair	20-55
Installation	20-54

Tools: Flat tip screwdriver

Pliers

SPECIAL TOOLS: Heat Gun (Item 36, Chapter 3, Section I

SUPPLIES: Tubing (Item 81, Appendix D)

Seal

PRELIMINARY PROCEDURES: Remove control valves (page 20-2)
Remove extinguisher manifold (page 20-63)

REMOVAL:

1. Using screwdriver, release latch (A) of bracket (B).
2. Using hands, lift first shot cylinder (C) out of bracket (D).
3. Using screwdriver, release latch (E).
4. Using hands, lift one or both second shot cylinders (F) out of bracket (G).

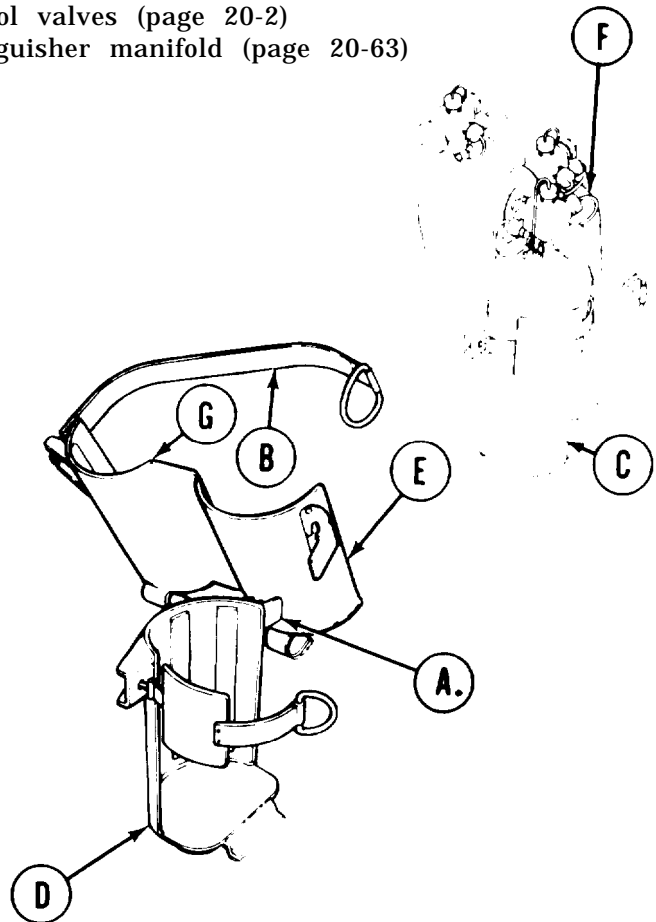

Go on to Sheet 2

FIXED FIRE EXTINGUISHER CYLINDER REPLACEMENT (Sheet 2 of 4)

INSPECTION:

CAUTION

Anytime CO₂ cylinders are not fully installed, install protective caps to cover the exposed ports. Use protective caps stowed on dummy plugs on the neck of cylinder.

1. If protective cap (A) or diffuser cap (B) is lost or damaged, replace (see Repair procedure.)
2. Weigh removed cylinder(s). A cylinder must be recharged if its weight loss exceeds 10% of the difference between the full and empty weight marked on the cylinder. Replace cylinder if hydrostatic test date (stamped on neck) has exceeded five years.
3. To recharge and pressure test cylinders, report to support maintenance.
4. Inspect cylinder for plastic safety release indicator (C). If damaged or missing, install new indicator (C).
5. Remove any remaining pieces of damaged indicator (C), safety wire lead seal (D), etc.

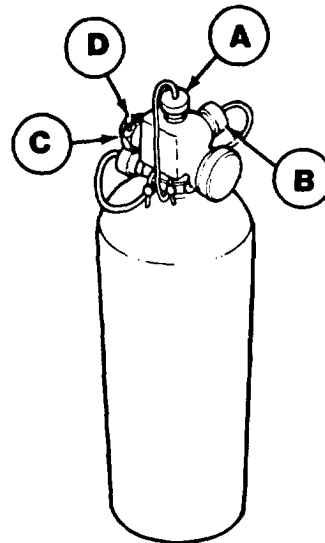

FIXED FIRE EXTINGUISHER CYLINDER REPLACEMENT (Sheet 3 of 4)

6. From a piece of 1-inch diameter insulation tubing (E), (Heat shrink tubing), cut off a 3/8-inch long piece. Ends of the piece should be straight and square and at right angles to the centerline of the tubing.
7. Place the round part of the shrink tubing over the safety release vent nut (F). Make, sure that the shrink tubing is pushed tightly against the main part of the valve.
8. Using heat gun, carefully warm tubing tightly around the head of the vent nut (F). USE CARE-Keep the heat moving around the tubing or it will scorch, burn, or split open.
9. Allow shrink tubing (E) to cool until it no longer feels warm to the touch.

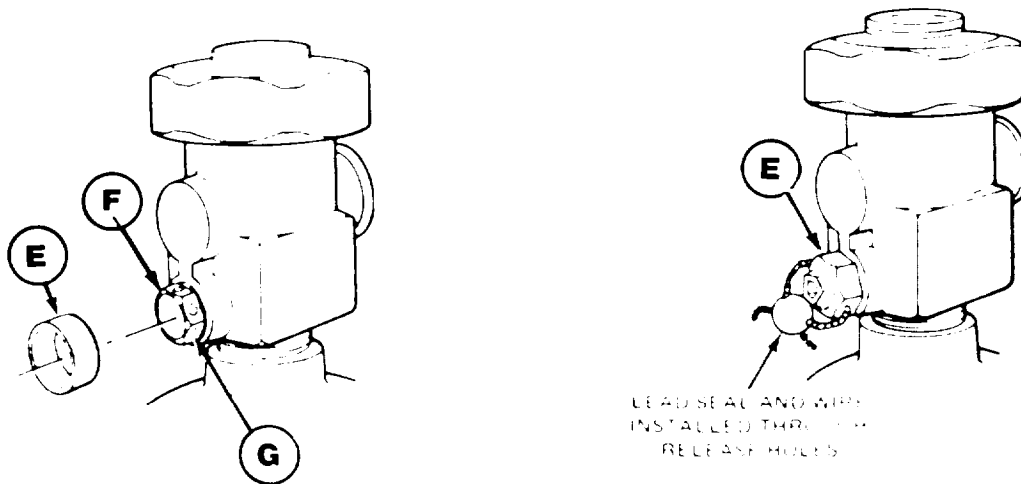

NOTE

Heat the end of a piece of wire (Using a match or lighter) to pierce the tubing.

10. Carefully pierce a small hole in the shrink tubing, in line with one set of opposite existing holes in vent nut (F).
11. Push the wire of the lead seal through the shrink tubing (E) and two opposite in-line release holes (G) in the vent nut (F). Route the wire across the top of the vent nut (F) and back through the lead seal. Pull tight.
12. Using large pliers, crimp the lead seal tightly around the wires going through it.
13. Trim any excess length of wire, 1/4 to 3/8 inch from the lead seal.

Go on to Sheet 4

FIXED FIRE EXTINGUISHER CYLINDER REPLACEMENT (Sheet 4 of 4)

REPAIR:

1. Using screwdriver, release clamp (A) on neck of cylinder (B).
2. Using fingers, slide clamp (A) out of diffusers plug (C), protective cap plug (D), and two straps (E).
3. Using fingers, remove protective cap (F) from port (G) and diffuser cap (H) from port (J).
4. Replace any damaged or missing parts in reverse order and in the position illustrated.

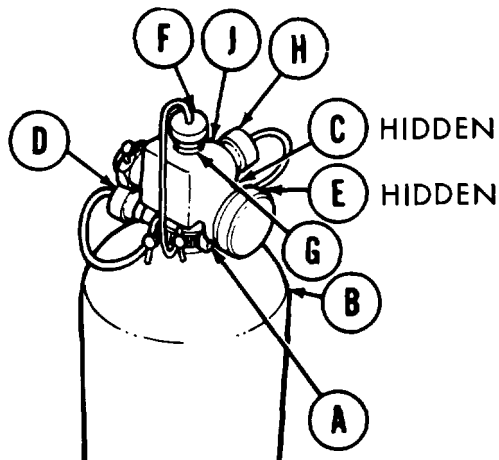

INSTALLATION:

1. Place cylinders (A) and (B) in position on bracket (C).
2. Using fingers, hook and close latch (D).

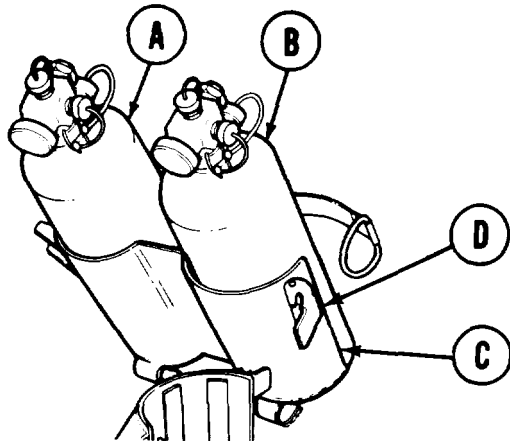

FIXED FIRE EXTINGUISHER DELAY BOTTLE AND TUBES REPLACEMENT (Sheet 1 of 6)

PROCEDURE INDEX

PROCEDURE	PAGE
Removal	20-57
Inspection	20-59
Installation	20-59

- TOOLS: 1-3/8 in. open end wrench
9/16 in. socket with 1/2 in. drive
1-1/4 in. open end wrench
1-1/16 in. open end wrench (2 required)
9/16 in. open end wrench
Torque wrench with 1/2 in. drive (0-175 lb-ft)
Ratchet with 1/2 in. drive
1-3/8 in. crowfoot wrench

SUPPLIES: Lockwashers (3 required)

- PRELIMINARY PROCEDURE: Remove control valves (page 20-2)
 Remove floor plate (page 17-8)

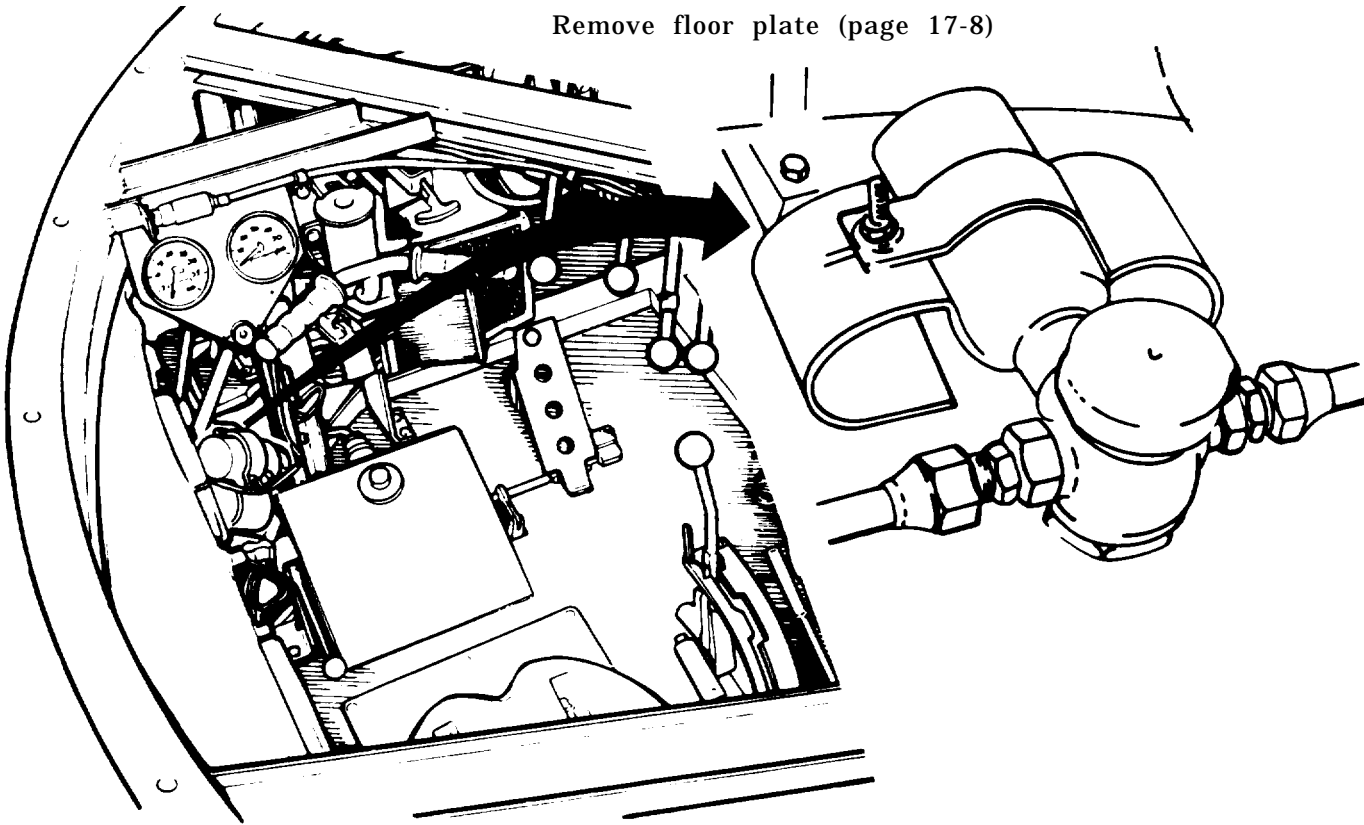

Go on to Sheet 2

FIXED FIRE EXTINGUISHER DELAY BOTTLE AND TUBES REPLACEMENT (Sheet 2 of 6)

REMOVAL:

1. Holding manifold (A) with 1-1/16 inch wrench, use 3/8 inch wrench to remove tube assembly (B).

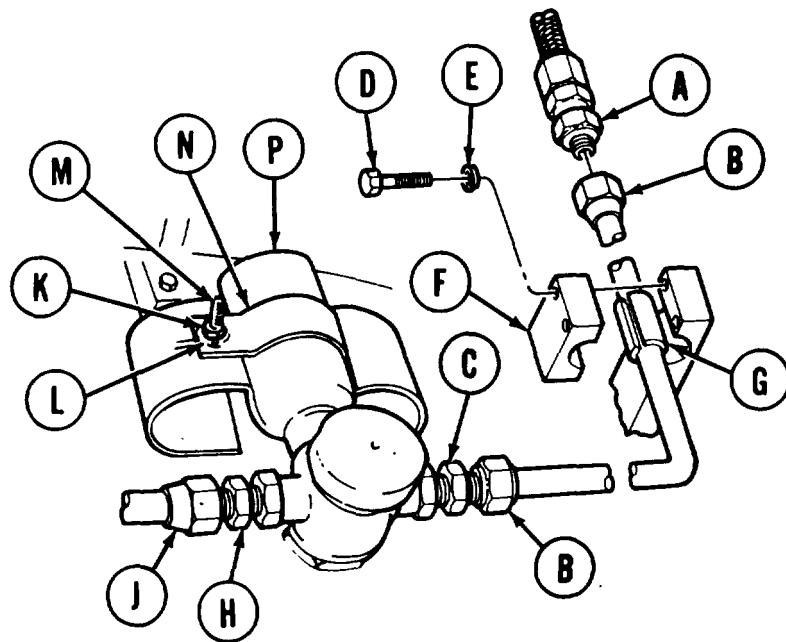

2. Holding adapter (C) with 1-1/16 inch wrench, use 1-3/8 inch wrench to remove tube assembly (B) from adapter (C).
3. If tube assembly (B) is to be removed use 9/16 inch socket and ratchet to remove two screws (D) and lockwashers (E)
4. Using fingers, remove support cap (F) and cushion (G). Remove tube assembly (B).
5. Holding adapter (H) with 1-1/16 inch wrench, use 1-1/4 inch wrench to remove rear tube assembly (J).
6. Using 9/16 inch wrench, remove nut (K) lockwasher (L) and bolt (M) to strap (N).
7. Remove delay bottle (P) from strap (N).

Go on to Sheet 3

TA248715

FIXED FIRE EXTINGUISHER DELAY BOTTLE AND TUBES REPLACEMENT (Sheet 3 of 6)

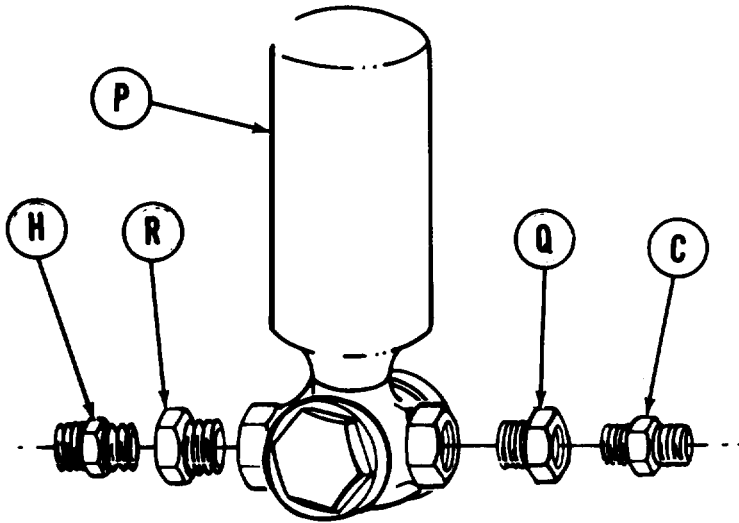

8. Holding bushing (Q) with 1-1/16 inch wrench, use another 1-1/16 inch wrench to remove adapter (C).
9. Holding bushing (R) with 1-1/16 inch wrench, use another 1-1/16 inch wrench to remove adapter (H).
10. Using 1-1/16 inch wrench, remove two bushings (Q) and (R) from delay bottle (P).
11. Using 1-1/4 inch wrench, remove rear tube assembly (J) from elbow (S).
12. Remove rear tube assembly (J) by pulling through from driver's compartment.

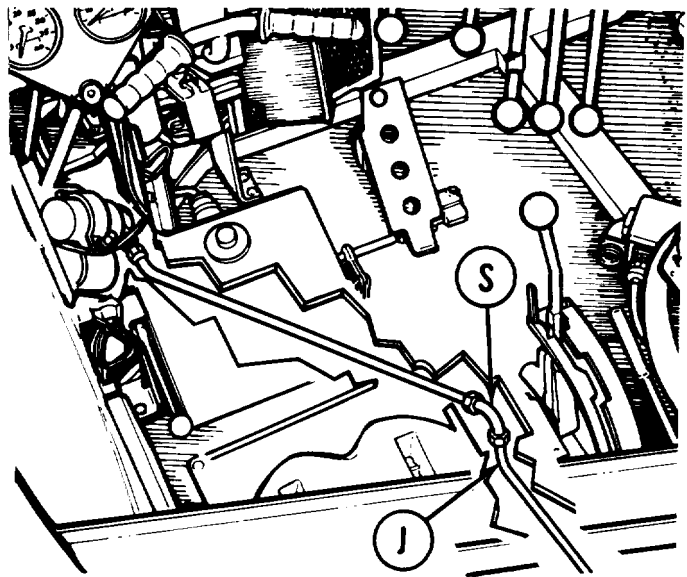

Go on to Sheet 4

TA248716

FIXED FIRE EXTINGUISHER DELAY BOTTLE AND TUBES REPLACEMENT (Sheet 4 of 6)

INSPECTION:

1. Check all parts for wear and damage.
2. Replace damaged or worn parts.

INSTALLATION:

1. Using 1-1/16 inch wrench, install two bushings (A) in delay bottle (B).
2. Using 1-1/16 inch wrench, install two adapters (C) and (D) in two bushings (A).

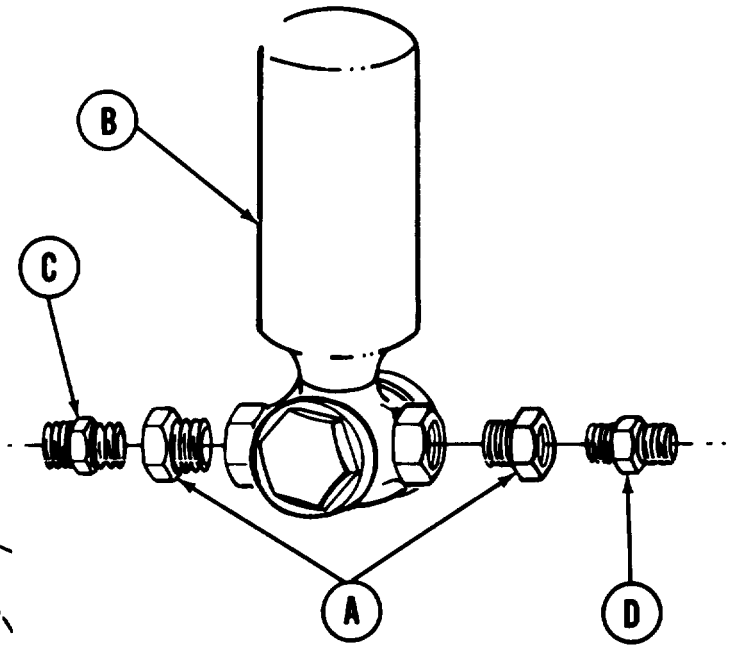
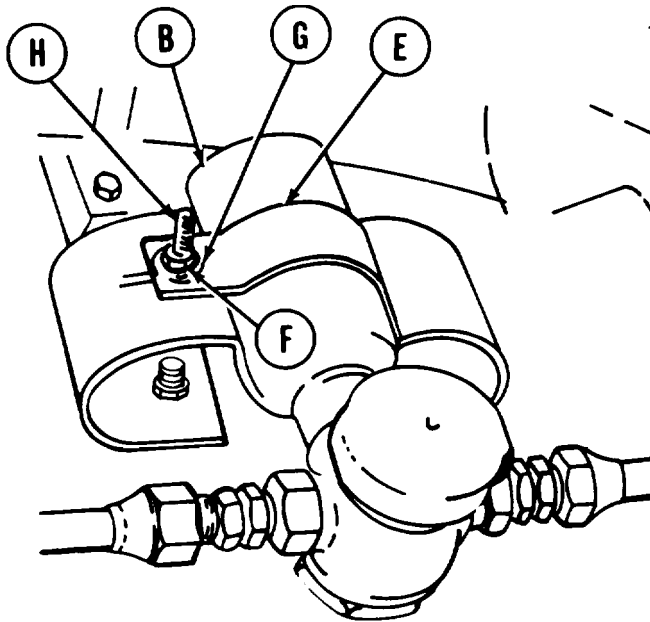

3. Place delay bottle (B) in position.
4. Place strap (E) in position on delay bottle (B).
5. Attach strap (E) with nut (F), washer (G), and bolt (H).

Go on to Sheet 5

TA248717

FIXED FIRE EXTINGUISHER DELAY BOTTLE AND TUBES REPLACEMENT (Sheet 5 of 6)

6. Place rear tube assembly (J) in position under subfloor by pushing through from forward hull compartment.

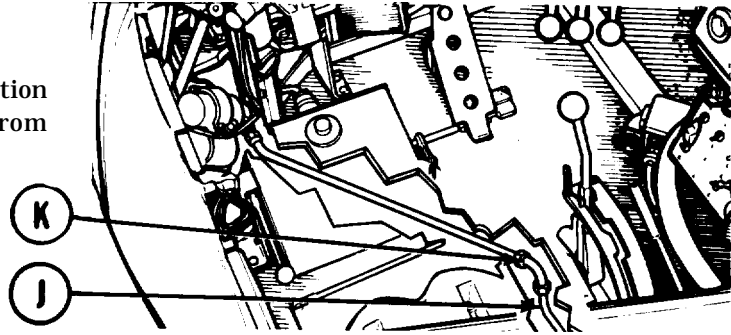

7. Using 1-1/4 inch wrench, install rear tube assembly (J) on elbow (K).
8. Using torque wrench and 1-1/4 inch crowfoot wrench tighten nut on rear tube assembly (J) to 40-55 lb-ft (54.2-74.5 N-m).
9. Place front tube assembly (L) in position under stowage basket.

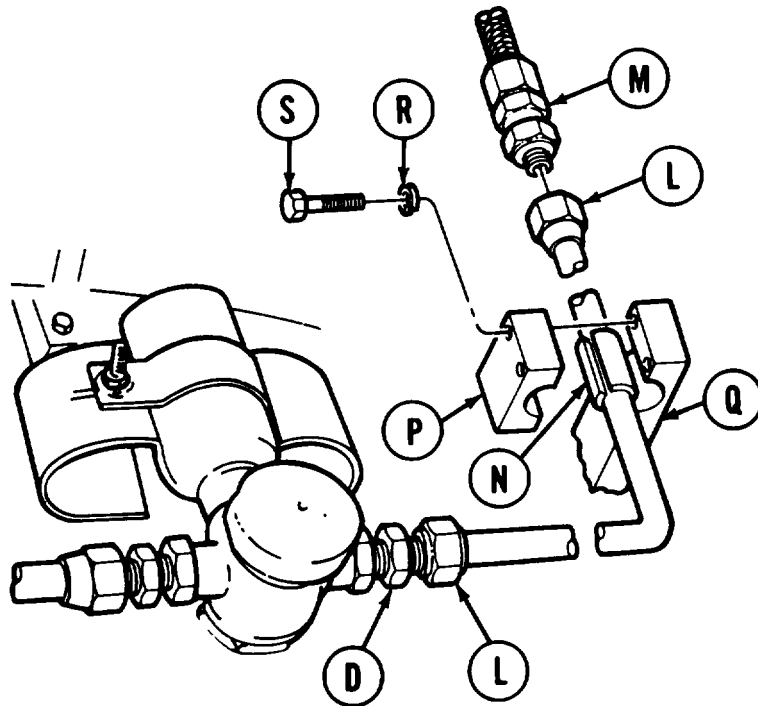

10. Using fingers, attach tube (L) to manifold (M) and adapter (D). Do not tighten at this time.
11. Using fingers, install cushion (N) and cap (P) on tube (L) and position on support (Q). Using 9/16 inch socket and ratchet, secure parts with two screws (S) and lockwashers (R).

Go on to Sheet 6

TA248718

FIXED FIRE EXTINGUISHER DELAY BOTTLE AND TUBES REPLACEMENT (Sheet 6 of 6)

12. Using 1-1/16 inch wrench to hold adapters (D) and (M), use 1-3/8 inch wrench to tighten nuts on tube assembly (L) to a snug fit.
13. Using torque wrench and 1-3/8 inch crow foot wrench, tighten nuts on tube assembly (L) to 40-55 lb-ft (54.2-74.5 N-m.)

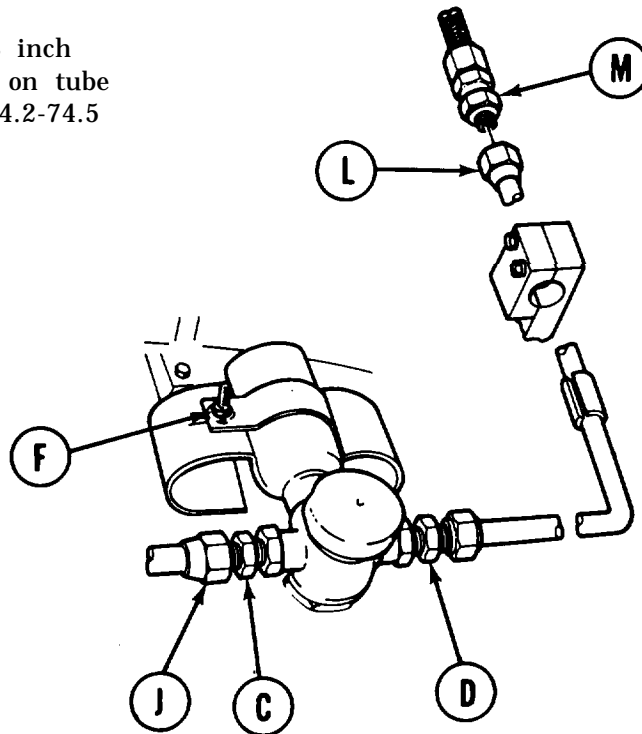

14. Attach tube (J) to adapter (C) in a similar manner to tube (L). Using 1-1/4 inch wrench, repeat steps 10, 12, and 13.
15. Using 9/16 inch wrench, tighten nut (F).
16. Install control valves (page 20-14).
17. Install floor plate (page 17-8).

End of Task

TA248719

FIXED FIRE EXTINGUISHER MOUNTING BRACKET REPAIR (Sheet 1 of 1)

TOOLS: Needle nose pliers

PRELIMINARY PROCEDURE: Remove cylinders (page 20-52)

NOTE

Repair procedures for first short bracket and second shot bracket are the same. Second shot bracket is shown.

DISASSEMBLY:

1. Using pliers, remove cotter pin (A) holding straight pin (B) in mounting bracket (C).
2. Using fingers, remove straight pin (B) securing latch (D) to mounting bracket (C).
3. Remove latch (D) from mounting bracket (C).

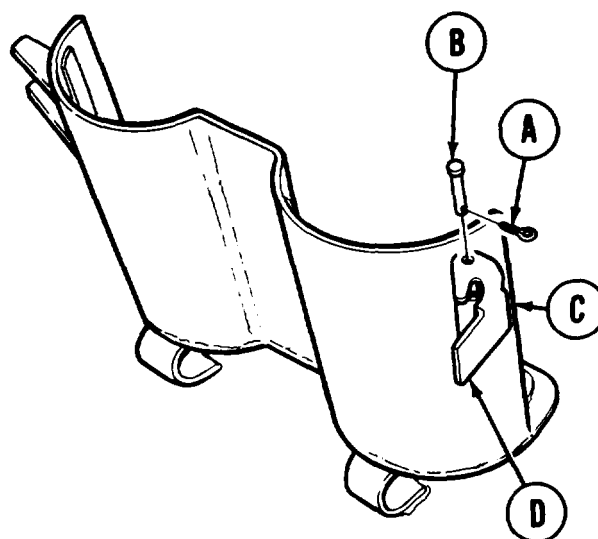

ASSEMBLY:

1. Place latch (D) in position on mounting bracket (C).
2. Insert straight pin (B) through latch (D) and mounting bracket (C).
3. Using pliers, install new cotter pin (A) through straight pin (B).
4. Install cylinders (page 20-54).

End of Task

TA248720

**FIXED FIRE EXTINGUISHER MANIFOLD REPLACEMENT
(Sheet 1 of 2)**

TOOLS: 1-5/8 in. open end wrench
 1-1/16 in. open end wrench
 1-1/4 in. open end wrench
 Torque wrench with 1/2 in. drive
 10 in. extension with 1/2 in. drive
 1-1/4 in. crowfoot wrench
 1-5/8 in. crowfoot wrench

REMOVAL:

CAUTION

Immediately after removing each discharge line, install protective cap to cover exposed part. Use protective caps stowed on dummy plugs at neck of cylinder.

1. Using 1-5/8 inch wrench, remove three nuts (A) attaching manifold assembly (B) to three cylinders (C).
2. Using hands, remove protective cap (D) from dummy plug (E) and install on each of the three cylinders (C).
3. Using 1-1/16 inch wrench and 1-1/4 inch wrench, hold fitting (F) and remove tube nut (G).
4. Using hands, lift manifold assembly (B) from the area.

INSPECTION:

1. Check manifold assembly (B) and nuts (A) for cracks or wear.

NOTE

To check threads on cylinders for wear, it will be necessary to remove protective caps (D).

2. Check threads on cylinder (C) for wear.
3. Replace necessary parts.

Go on to Sheet 2

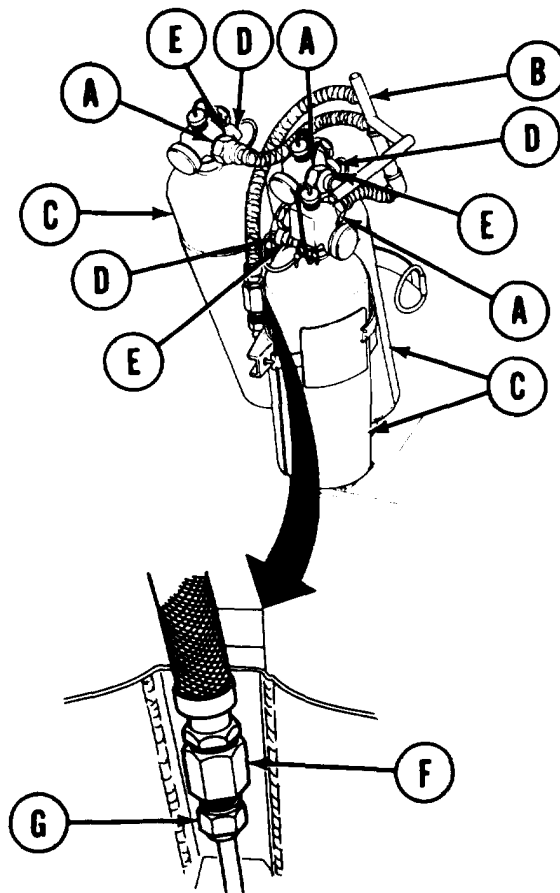

**FIXED FIRE EXTINGUISHER MANIFOLD REPLACEMENT
(Sheet 2 of 2)**

INSTALLATION:

1. Using hands, remove the protective cap (A) from each of the three cylinders (B). Stow caps (A) on dummy plugs (C).
2. Position manifold (D) on top of three cylinders (B).
3. Using fingers, start tube nut (E) on manifold fitting (F).
4. Using fingers, start three manifold nuts (G) on cylinders (B).
5. Using 1-1/16 inch wrench, hold fitting (F) and use 1-1/4 inch wrench to tighten nut (E) to a snug fit.
6. Using 1-1/4 inch crowfoot wrench, extension, and torque wrench, torque nut (E) to 40-55 lb-ft (54-75 N m).
7. Using 1-5/8 inch wrench, tighten three nuts (G) to a snug fit.
8. Using 1-5/8 inch crowfoot wrench and torque wrench, torque nuts (G) to 70-90 lb-ft (95-102 N-m).
9. Replace control valves (page 20-14)

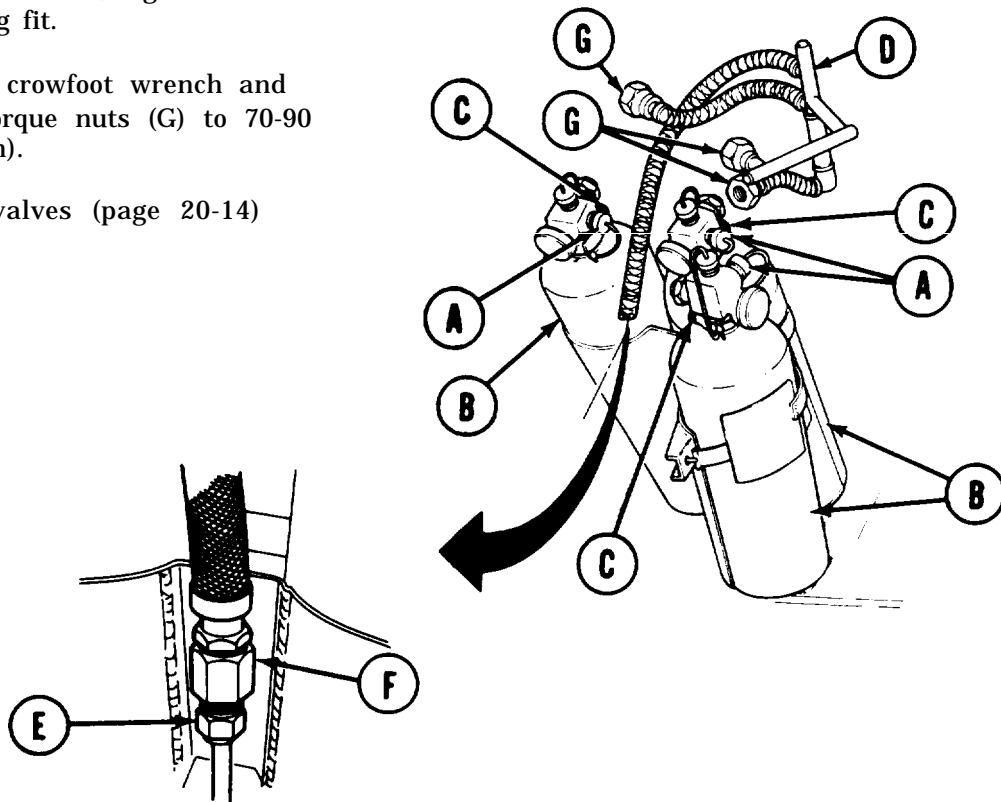

TA248722

**UPPER DISCHARGE VALVE, TUBES, AND RELATED PARTS REPLACEMENT
(FIXED FIRE EXTINGUISHER) (Sheet 1 of 6)**

PROCEDURE INDEX

PROCEDURE	PAGE
Removal	20-65
Disassembly	20-66
Inspection	20-67
Assembly	20-67
Installation	20-69

- TOOLS:**
- | | |
|---|--|
| <ul style="list-style-type: none"> 1 in. combination box and open end wrench 7/8 in. combination box and open end wrench (2 required) 3/4 in. combination box and open end wrench 1/2 in. combination box and open end wrench Ratchet with 1/2 in. drive 1/2 in. socket with 1/2 in. drive 7/8 in. crowfoot wrench | <ul style="list-style-type: none"> 10 in. pipe wrench (2 required) 1-1/8 in. socket with 1/2 in. drive 15/16 in. socket with 1/2 in. drive 1-1/8 in. combination box and open end wrench 15/16 in. combination box and open end wrench Vise Torque wrench with 1/2 in. drive (0-175 lb-ft) 3/4 in. deep well socket with 1/2 in. drive |
|---|--|

SUPPLIES: Zinc chromate primer (Item 51, Appendix D)

PRELIMINARY PROCEDURE: Remove powerplant (page 5-2)

REMOVAL:

QUADRANTS REMOVED FOR CLARITY

1. Using 1/2 inch socket and ratchet, remove screw (A), washer (B), and clamp (C) from bracket (D).
2. Using 1/2 inch wrench, remove screw (E) and washer (F) holding bracket (D) to hull.
3. Remove bracket (D).

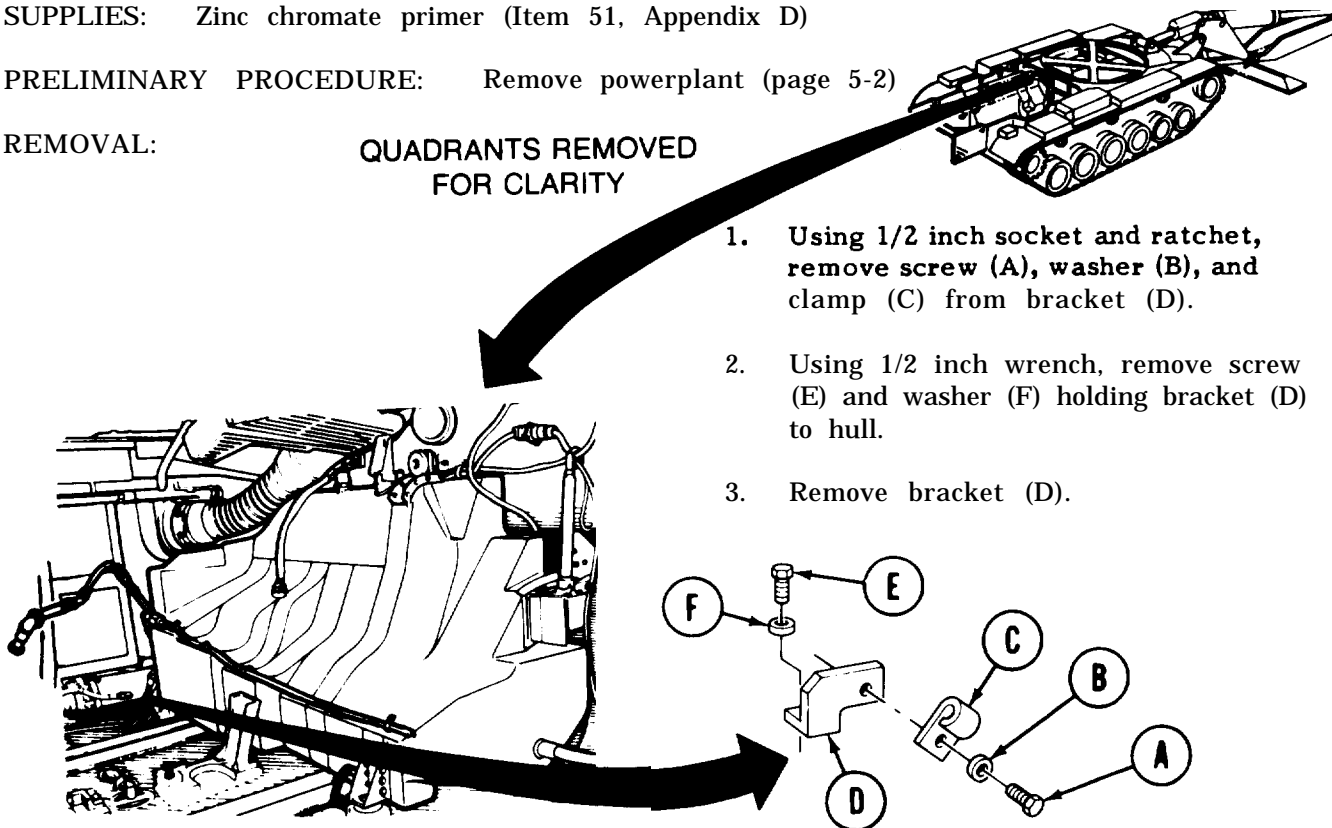

Go on to Sheet 2

**UPPER DISCHARGE VALVE, TUBES, AND RELATED PARTS REPLACEMENT
(FIXED FIRE EXTINGUISHER) (Sheet 2 of 6)**

- Using 3/4 inch wrench to hold adapter (G), use 7/8 inch wrench to remove connector on tube (H) from adapter (G). Lay tube (H) aside.

NOTE

Tag tube (J) during removal for proper installation.

- Using 3/4 inch wrench to hold adapter (K), use 7/8 inch wrench to remove connector on tube (J) from adapter (K).
- Using 3/4 inch wrench, remove adapter (K) from manifold (L).
- Remove assembled line (J) from vehicle to bench.

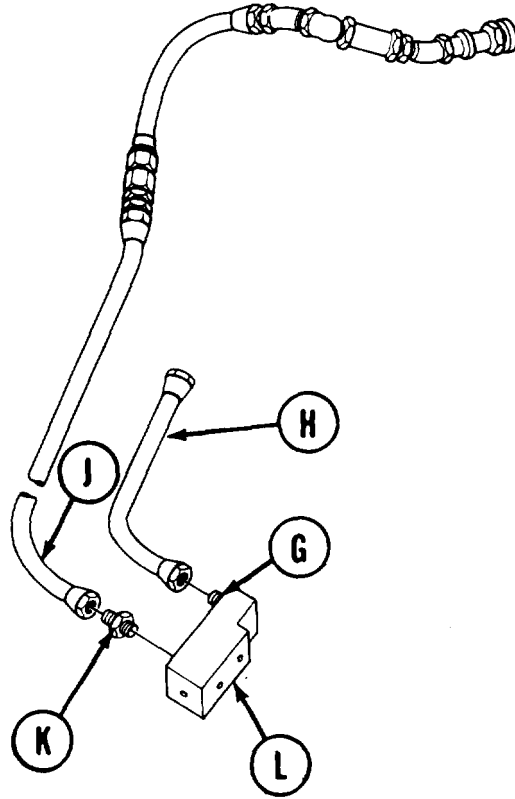

DISASSEMBLY: NOTE

Position assembled line in vise as necessary for disassembly.

- Using 3/4 inch wrench to hold adapter (A) and 7/8 inch wrench on tube (B), remove tube (B) from adapter (A).
- Using 1 inch wrench to hold tube (C) and 1-1/8 inch wrench on bushing (D), remove bushing (D), bushing (E), and adapter (A) from tube (C).

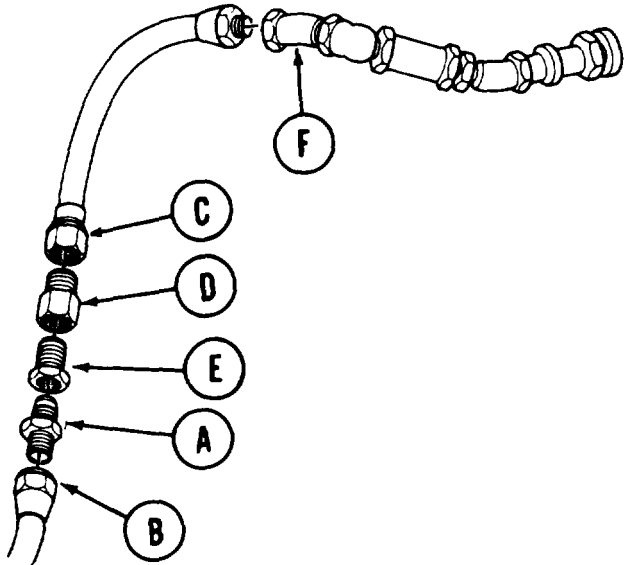

- Using 15/16 inch wrench to hold bushing (E), use 3/4 inch wrench to remove adapter (A) from bushing (E).
- Using 1-1/8 inch wrench to hold adapter (D), use 15/16 inch wrench to remove bushing (E) from adapter (D).
- Using pipe wrench to hold elbow (F) and 7/8 inch wrench on tube (C), remove tube (C) from elbow (F).

Go on to Sheet 3

TA248724

**UPPER DISCHARGE VALVE, TUBES, AND RELATED PARTS REPLACEMENT
(FIXED FIRE EXTINGUISHER) (Sheet 3 of 6)**

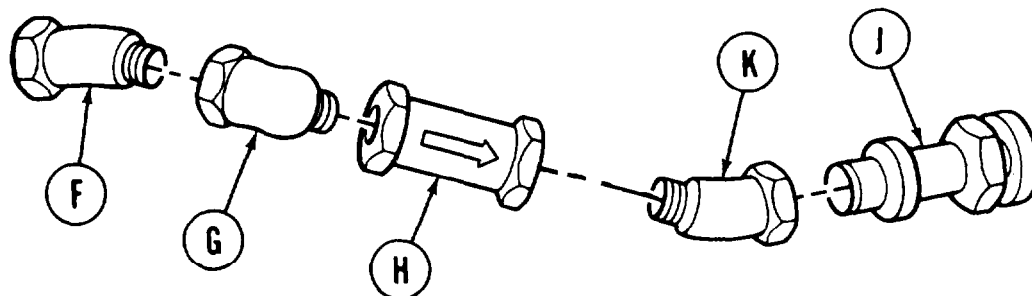

6. Using one pipe wrench to hold elbow (G), use other pipe wrench to remove elbow (F) from elbow (G).
7. Using pipe wrench, remove elbow (G) from valve (H).
8. Using pipe wrench to hold elbow (K), use 1 inch wrench to remove self-sealing socket (J) from elbow (K).
9. Place valve (H) in a vise.
10. Using pipe wrench, remove elbow (K) from valve (H).

INSPECTION:

Make sure all connections and seating surfaces are free of nicks, burrs, or other defects that could cause leakage. Replace any damaged parts.

ASSEMBLY:

NOTE

Apply zinc chromate primer to all threads prior to installation of threaded tube/hose connections.

NOTE

Secure tubes and related parts in vise as necessary to accomplish assembly.

**UPPER DISCHARGE VALVE, TUBES, AND RELATED PARTS REPLACEMENT
(FIXED FIRE EXTINGUISHER) (Sheet 4 of 6)**

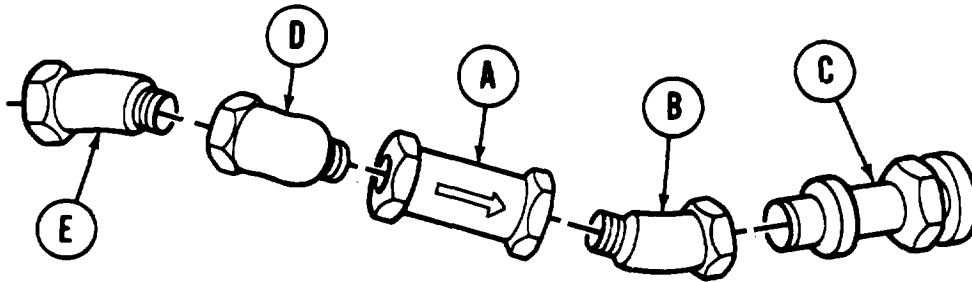

1. Install valve (A) in vise.
2. Using pipe wrench, install elbow (B) into valve (A), making sure that arrow on valve (A) is pointed towards elbow (B).
3. Using 1 inch wrench, install self-sealing socket (C) into elbow (B).
4. Using pipe wrench, install elbow (D) into valve (A).
5. Using pipe wrench, install elbow (E) into elbow (D).
6. Remove valve (A) and connecting parts from vise.
7. Using 7/8 inch wrench, install tube (F) into elbow (E). Using pipe wrench to hold elbow (E), use torque wrench and crow foot wrench to tighten tube (F) to 40-50 lb-ft (54-75 N m).
8. Using 1 inch wrench to hold tube (F) and 1-1/8 inch wrench on bushing (G), install bushing (G) into tube (F). Using 1 inch wrench to hold tube (F), use torque wrench and 1-1/8 inch socket to tighten bushing (G) to 40-50 lb-ft (54-75 N m).

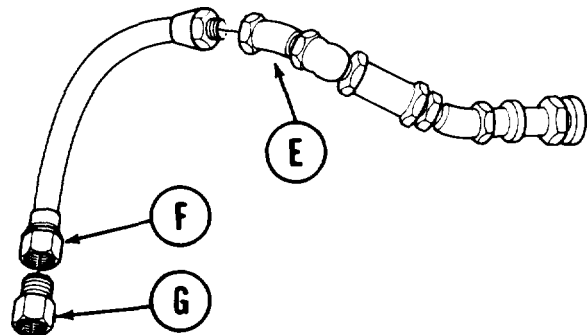

Go on to Sheet 5

TA248726

**UPPER DISCHARGE VALVE, TUBES, AND RELATED PARTS REPLACEMENT
(FIXED FIRE EXTINGUISHER) (Sheet 5 of 6)**

9. Using 1-1/8 inch wrench to hold bushing (G) and 15/16 inch wrench on bushing(H), install bushing (H) into bushing (G). Using 1-1/8 inch wrench to hold bushing (G), use torque wrench and 15/16 inch socket to tighten bushing (H) to 40-50 lb-ft (54-75 N m).
10. Using 15/16 inch wrench to hold bushing (H) and 3/4 inch wrench on adapter (J), install adapter (J) into bushing (H). Using 15/16 inch wrench to hold bushing (H), use torque wrench and 3/4 inch deep well socket to tighten adapter (J) to 40-50 lb-ft (54-75 N m).
11. Using 3/4 inch wrench to hold adapter (J) and 7/8 inch wrench on tube (K), install tube (K) on adapter (J). Do not tighten tube (K) on adapter (J).

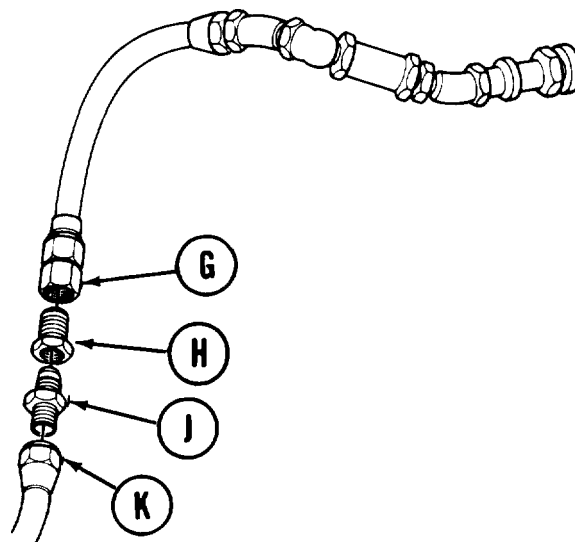

INSTALLATION:

1. Position assembled line in installation location in vehicle.

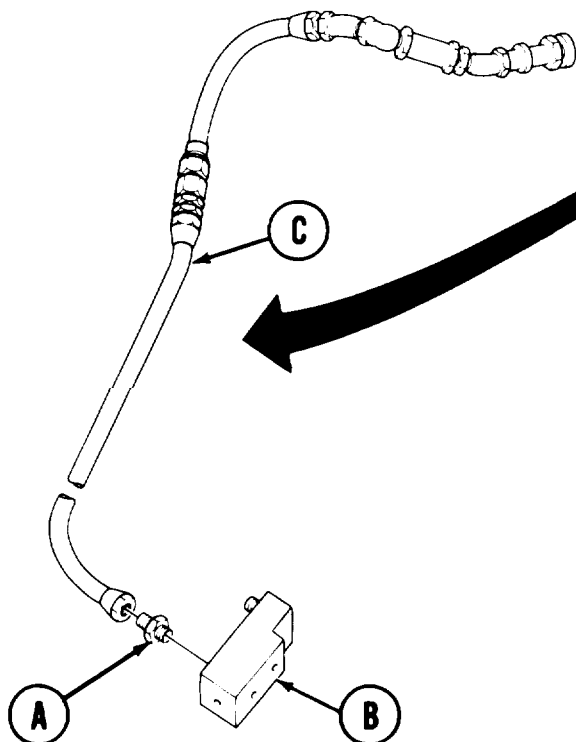

2. Using 3/4 inch wrench, install adapter (A) into manifold (B). Using torque wrench and 3/4 inch deep well socket, tighten adapter (A) to 40-50 lb-ft (54-75 N m).

Using 7/8 inch wrench, install connector on tube (C) to adapter (A). Using 3/4 inch wrench to hold adapter (A), use torque wrench and 7/8 inch crowfoot to tighten

Go on to Sheet 6

TA248727

**UPPER DISCHARGE VALVE, TUBES, AND RELATED PARTS REPLACEMENT
(FIXED FIRE EXTINGUISHER) (Sheet 6 of 6)**

4. Using 7/8 inch wrench, install connector on tube (D) to adapter (E). Using 3/4 inch wrench to hold adapter (E), use torque wrench and 7/8 inch crowfoot to tighten tube (D) to 40-50 lb-ft (54-75 N m).
5. Using 1/2 inch wrench, install bracket (F) to hull of vehicle with screw (G) and washer (H).
6. Using 1/2 inch socket, secure tube (C) to bracket (F) with clamp (J), screw (K), and washer (L).

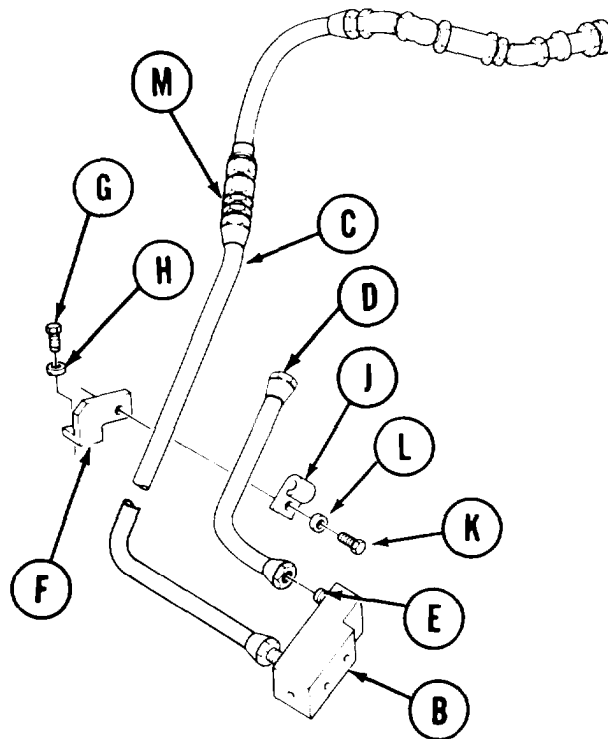

7. Position assembled line as needed.
8. Using 3/4 inch wrench to hold adapter (M), use torque wrench and 7/8 inch crowfoot to tighten tube (C) to 40-50 lb-ft (54-75 N m).
9. Install powerplant (page 5-14).

End of Task

TA248728

RIGHT DISCHARGE VALVE, TUBES, AND RELATED PARTS REPLACEMENT (FIXED FIRE EXTINGUISHER) (Sheet 1 of 5)

PROCEDURE INDEX

PROCEDURE	PAGE
Removal	20-71
Disassembly	20-72
Inspection	20-73
Assembly	20-74
Installation	20-75

TOOLS:

- 3/4 in. combination box and open end wrench
- 7/8 in. combination box and open end wrench
- 1/2 in. socket with 1/2 in. drive
- Ratchet with 1/2 in. drive
- 10 in. pipe wrench (2 each)
- Bench vise
- 1 in. combination box and open end wrench
- 3/4 in. deep well socket

SUPPLIES: Zinc chromate primer (Item 51, Appendix D)

PRELIMINARY PROCEDURE: Remove powerplant (page 5-2)

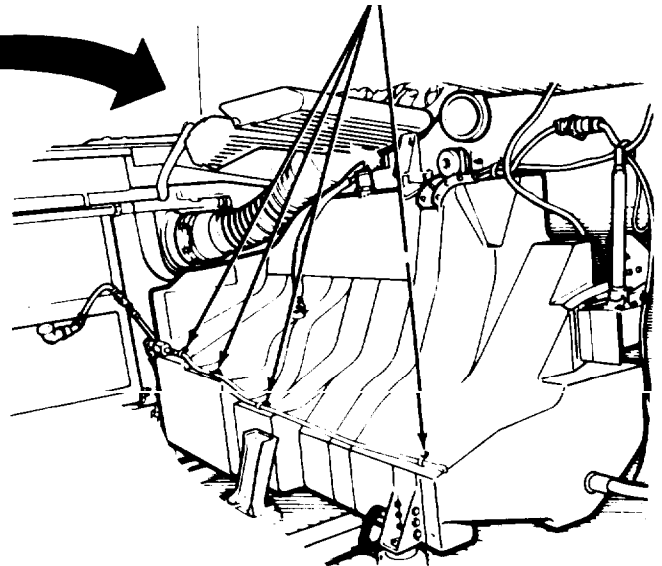
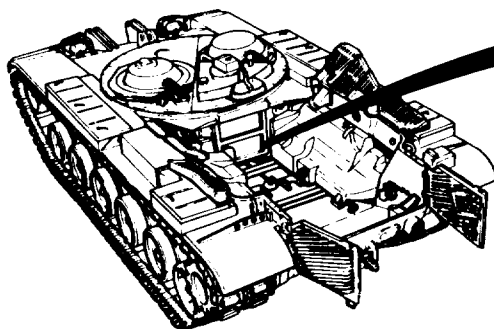
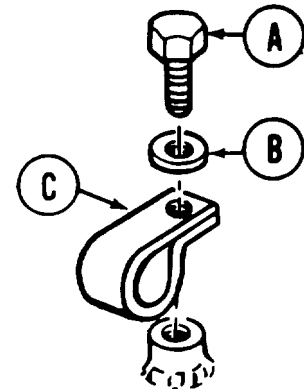

REMOVAL:

1. Using 1/2 inch socket, remove four screws (A), washers (B), and clamps (C) that secure line to fuel tank.

Go on to Sheet 2

TA248729

RIGHT DISCHARGE VALVE, TUBES, AND RELATED PARTS REPLACEMENT (FIXED FIRE EXTINGUISHER) (Sheet 2 of 5)

2. Using 3/4 inch wrench to hold adapter (D), use 7/8 inch wrench to remove connector on tube (E) from adapter (D).
3. Using 3/4 inch deep well socket, remove adapter (D) from manifold (F).
4. Remove assembled line and adapter from vehicle to bench.

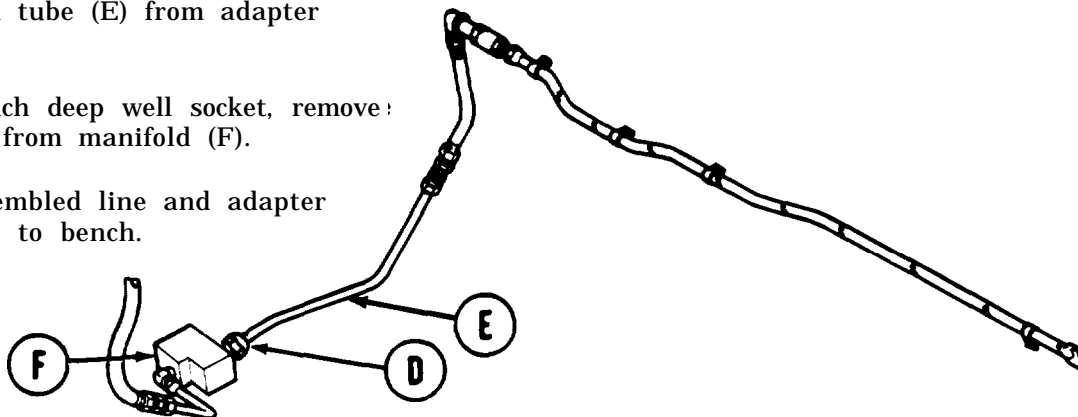

NOTE

Place assembled line in vise as necessary to accomplish disassembly.

DISASSEMBLY:

1. Using 7/8 inch wrench on tube (A) and 3/4 inch wrench on tube (B), remove tube (A) from tube (B).

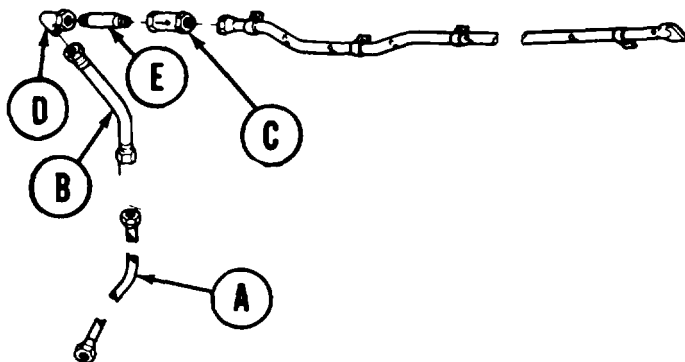

2. Position valve (C) in vise.
3. Using pipe wrench to hold elbow (D), use 1-inch wrench to remove tube (B).
4. Using two pipe wrenches, hold nipple (E) and remove elbow (D) from nipple (E).

TA248730

RIGHT DISCHARGE VALVE, TUBES, AND RELATED PARTS REPLACEMENT (FIXED FIRE EXTINGUISHER) (Sheet 3 of 5)

5. Using pipe wrench, remove nipple(E) from valve (C).
6. Using 3/4 inch wrench to hold adapter (F), use 7/8 inch wrench to remove tube (G) from adapter (F).
7. Using 7/8 inch wrench to hold bushing (H), use 3/4 inch wrench to remove adapter (F) from bushing (H).
8. Using 7/8 inch wrench, remove bushing (H) from valve (C).
9. Remove valve (C) from vise.

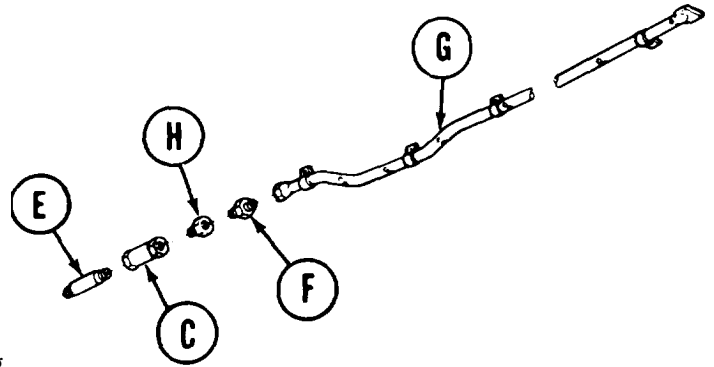

INSPECTION:

Make sure that all connections and seating surfaces are free of nicks, burrs, or other defects that could cause leakage. Replace any damaged parts.

RIGHT DISCHARGE VALVE, TUBES, AND RELATED PARTS REPLACEMENT (FIXED FIRE EXTINGUISHER) (Sheet 4 of 5)

ASSEMBLY:

NOTE

- Position tubes, valves, and related parts in vise as necessary to accomplish assembly.
- Apply zinc chromate primer to all male pipe threads before installing threaded connections.

1. Using vise, secure new valve (A).
2. Using 7/8 inch wrench, install bushing (B) into valve (A), making sure that arrow on valve (A) is pointing toward bushing (B).
3. Using 3/4 inch wrench, install adapter (C) into bushing (B).
4. Using 7/8 inch wrench, install tube (D) onto adapter (C). Do not tighten at this time.
5. Using pipe wrench, install nipple (E) into valve (A).
6. Using pipe wrench, install elbow (F) onto nipple (E).
7. Using 1-inch wrench, install tube (G) onto elbow (F).
8. Using 1 inch wrench on tube (G) and 7/8 inch wrench on tube (H), install tube (H) onto tube (G). Do not tighten at this time.

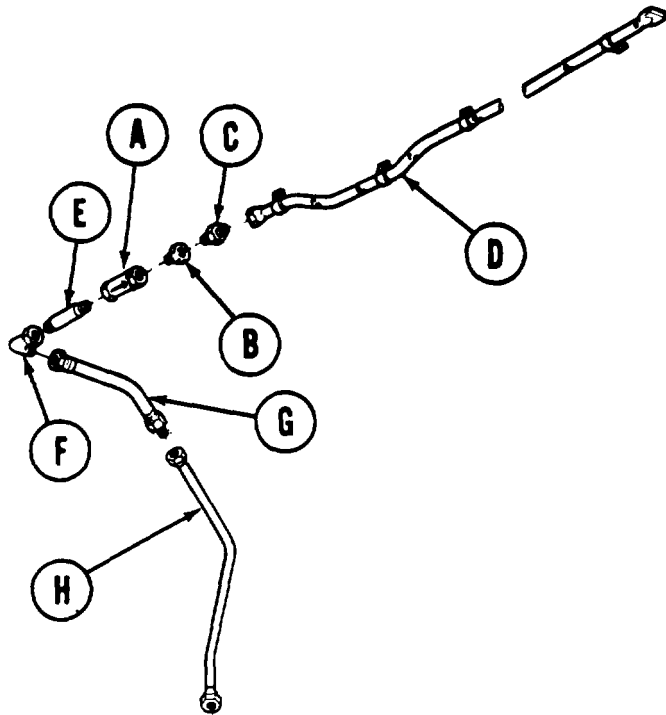

RIGHT DISCHARGE VALVE, TUBES, AND RELATED PARTS REPLACEMENT (FIXED FIRE EXTINGUISHER) (Sheet 5 of 5)

INSTALLATION:

1. Position assembled line (A) to hull of vehicle.
2. Using 1/2 inch socket, install four clamps (B), screws (C), and washers (D).

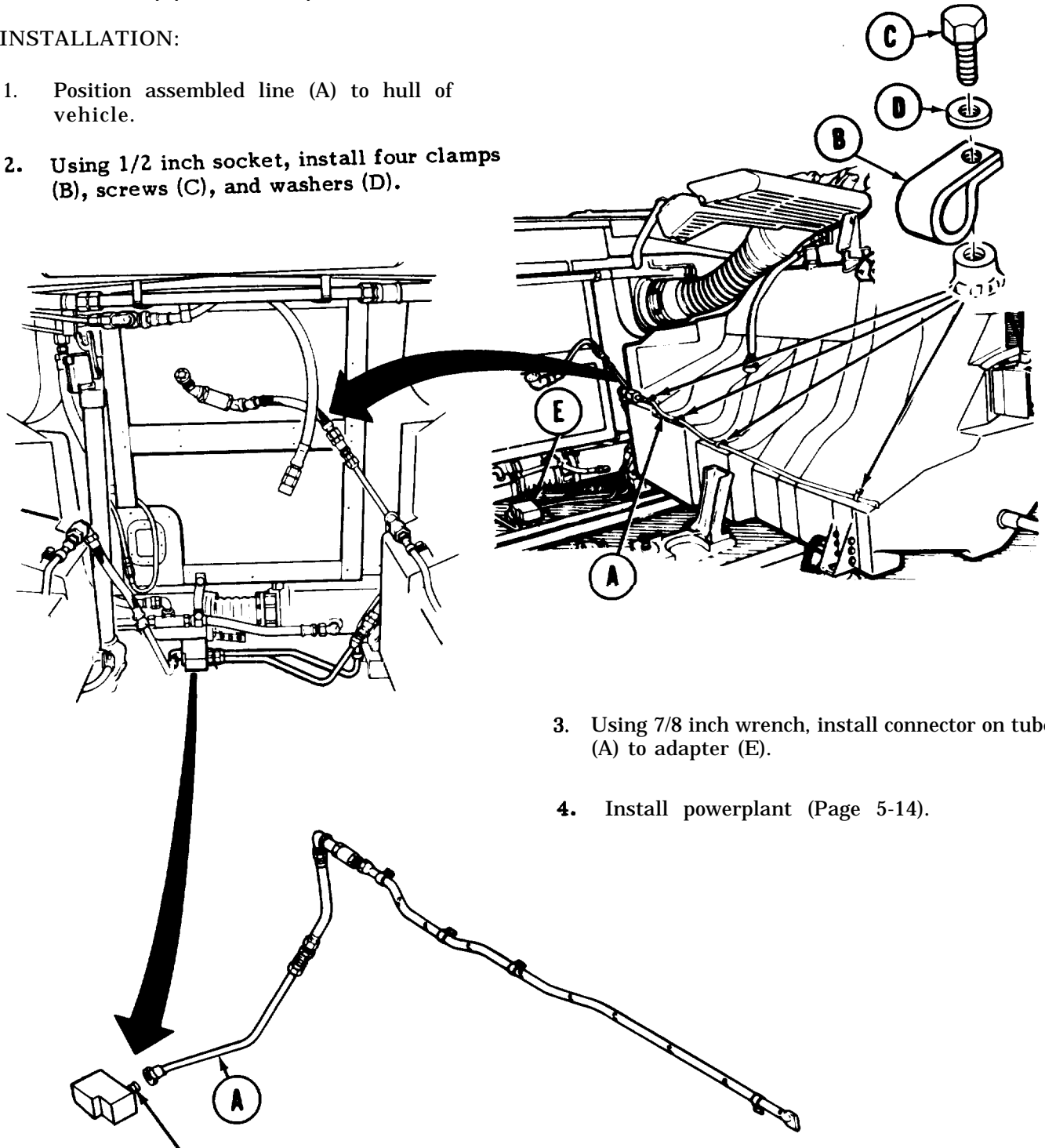

3. Using 7/8 inch wrench, install connector on tube (A) to adapter (E).
4. Install powerplant (Page 5-14).

End of Task

**LEFT DISCHARGE VALVE, TUBES, AND RELATED PARTS REPLACEMENT
(FIXED FIRE EXTINGUISHER) (Sheet 1 of 5)**

PROCEDURE INDEX

PROCEDURE	PAGE
Removal	20-76
Disassembly	20-77
Inspection	20-78
Assembly	20-78
Installation	20-79

- TOOLS:**
- Torque wrench with 1/2 in. drive (0-175 lb-ft)
 - 15/16 in. socket with 1/2 in. drive
 - 3/4 in. socket with 1/2 in. drive
 - 3/4 in. combination box and open end wrench
 - 7/8 in. combination box and open end wrench (2 required)
 - 10 in. pipe wrench
 - 1/2 in. socket with 1/2 in. drive
 - Ratchet with 1/2 in. drive
 - Bench vise
 - 1-1/8 in. combination box and open end wrench
 - 15/16 in. combination box and open end wrench
 - 4 in. flat-tip screwdriver
 - 5 in. extension with 1/2 in. drive
 - 1 in. combination box and open end wrench
 - 7/8 in. crowfoot wrench
 - 1-1/8 in. crowfoot wrench

SUPPLIES: Zinc chromate primer (Item 51, Appendix D)

PRELIMINARY PROCEDURE: Remove powerplant (page 5-2)

REMOVAL:

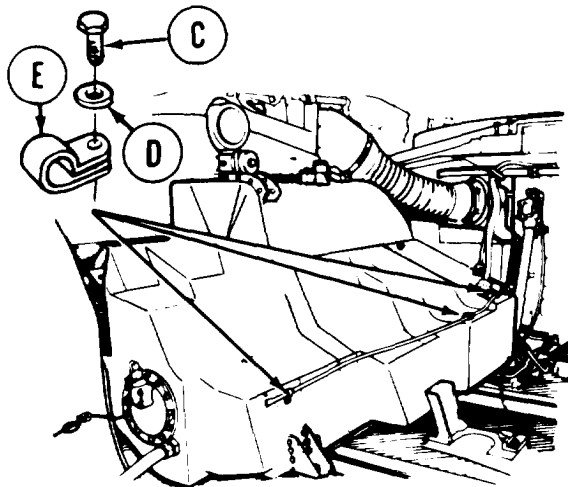
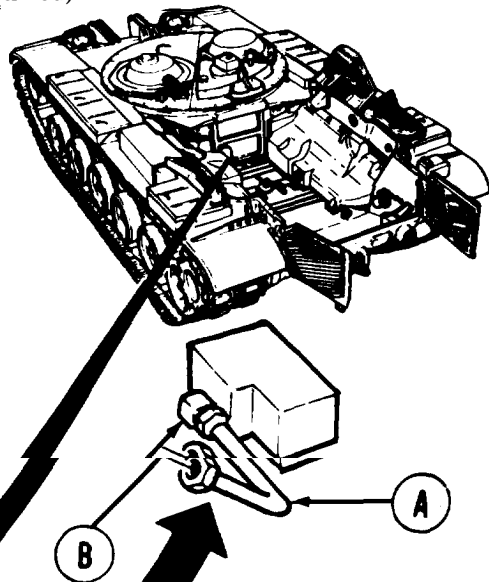

NOTE

Since two types of discharge tube assemblies are used on this vehicle, this procedure will cover both types.

1. Using 7/8 or 1-1/8 inch wrench, remove connector on tube (A) from elbow (B).
2. Using 1/2 inch socket and ratchet, remove three screws (C), washers (D), and clamps (E) securing tube to fuel tank.

Go on to Sheet 2

LEFT DISCHARGE VALVE, TUBES, AND RELATED PARTS REPLACEMENT (FIXED FIRE EXTINGUISHER) (Sheet 2 of 5)

3. Remove assembled line from vehicle.

DISASSEMBLY:

1. Secure check valve (A) in vise.

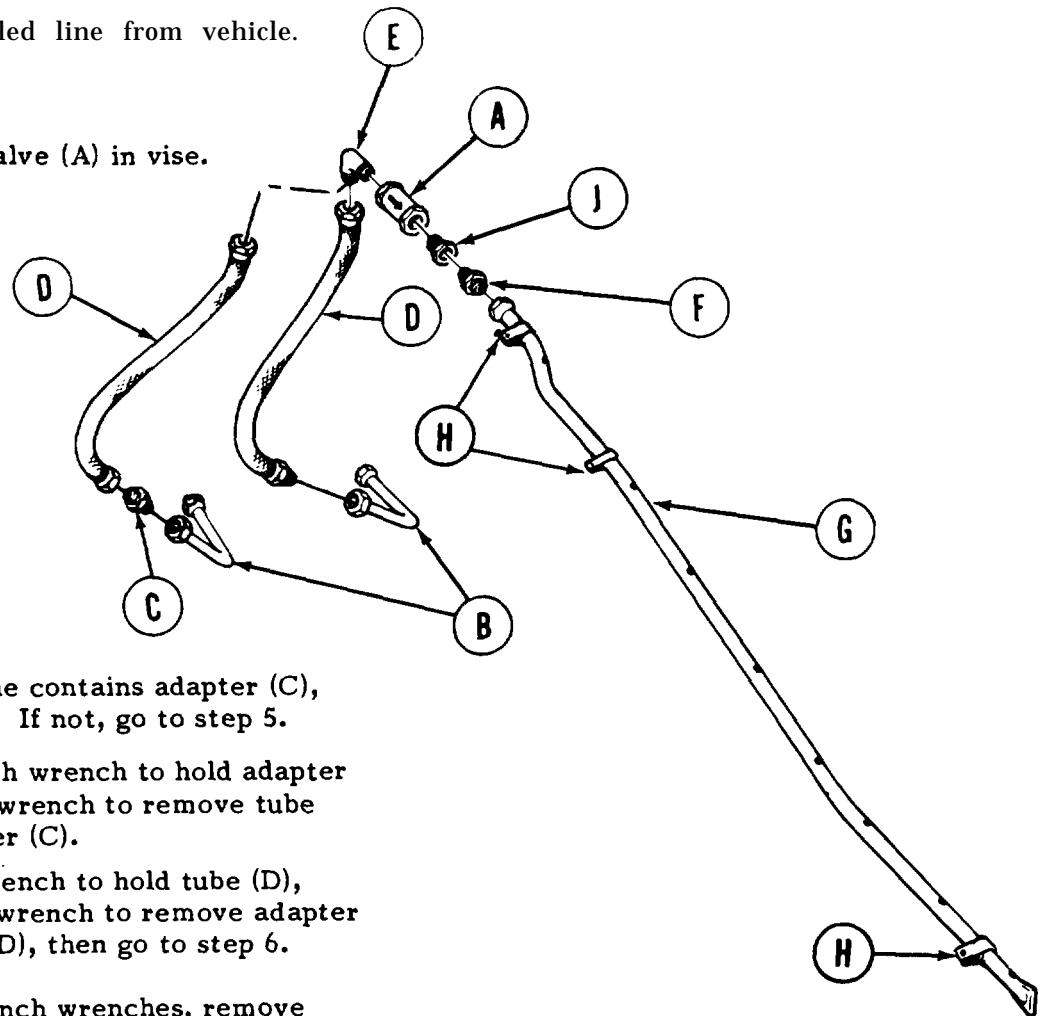

2. If assembled line contains adapter (C), go on to step 3. If not, go to step 5.

3. Using 15/16 inch wrench to hold adapter (C), use 1 inch wrench to remove tube (B) from adapter (C).

4. Using 1 inch wrench to hold tube (D), use 15/16 inch wrench to remove adapter (C) from tube (D), then go to step 6.

5. Using two 7/8 inch wrenches, remove tube (B) from tube (D).

6. Using 7/8 inch wrench, remove tube (D) from elbow (E).

7. Using pipe wrench, remove elbow (E) from check valve (A).

8. Using 3/4 inch wrench to hold adapter (F), use 7/8 inch wrench to remove tube (G) from adapter (F).

9. Using screwdriver, remove three clamps (H) from tube (G).

10. Using 15/16 inch wrench to hold bushing (J), use 3/4 inch wrench to remove adapter (F) from bushing (J).

11. Using 15/16 inch wrench, remove bushing (J) from check valve (A).

Go on to Sheet 3

T'A248735

LEFT DISCHARGE VALVE, TUBES, AND RELATED PARTS REPLACEMENT (FIXED FIRE EXTINGUISHER) (Sheet 3 of 5)

INSPECTION:

Make sure all connections and seating surfaces are free of nicks, burrs, or other defects that could cause leakage. Replace any damaged part.

NOTE

Apply zinc chromate primer to all threads prior to installation of threaded tube/hose connectors:

ASSEMBLY:

1. Secure check valve (A) in vise.
2. Using 15/16 inch wrench, install bushing (B) into free flow end of check valve (A). Using 15/16 inch socket, ratchet, and torque wrench, tighten bushing (B) to 40-50 lb-ft (54-75 N•m).
3. Using 3/4 inch wrench, install adapter (C) into bushing (B). Using 3/4 inch socket, ratchet, and torque wrench, tighten adapter (C) to 40-50 lb-ft (54-75 N•m).
4. Using 7/8 inch wrench, install tube (D) loosely onto adapter (C). Tube (D) must remain loose for positioning during installation.

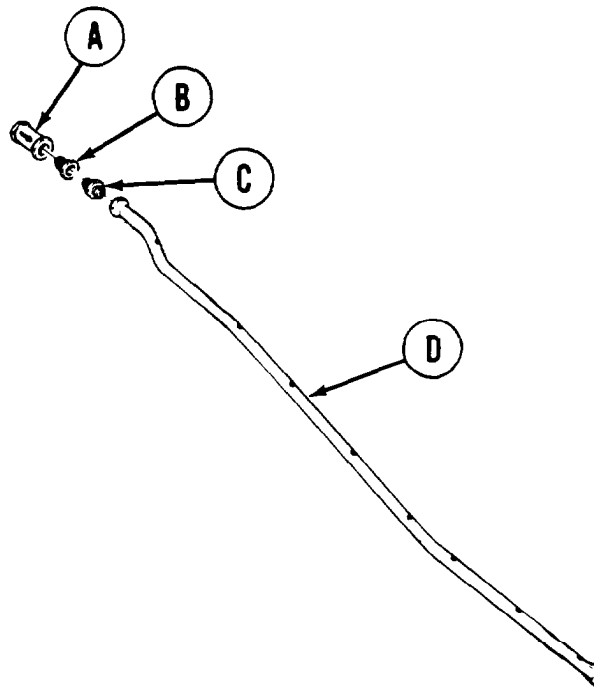

Go on to Sheet 4

TA248736

LEFT DISCHARGE VALVE, TUBES, AND RELATED PARTS REPLACEMENT (FIXED FIRE EXTINGUISHER) (Sheet 4 of 5)

5. Using pipe wrench, install elbow (E) into check valve (A).
6. If line assembly contains adapter (F), go on to step 7. If not, go to step 9.
7. Using 15/16 inch wrench on adapter (F) and 1 inch wrench on tube (G), install adapter (F) into tube (G). Using 1 inch wrench to hold tube (G), use 15/16 inch socket, ratchet, and torque wrench to tighten adapter (F) to 40-50 lb-ft (54-75 N•m).
8. Using 15/16 inch wrench on adapter (F) and 1 inch wrench on tube (H), install tube (H) loosely onto adapter (F). Tube (H) must remain loose for positioning during installation; then go to step 11.
9. Using 7/8 inch wrench, install tube (G) onto elbow (E). Using 7/8 inch crowfoot and torque wrench, tighten tube (G) to 40-50 lb-ft (54-75 N•m).
10. Using two 7/8 inch wrenches, install tube (H) loosely onto tube (G). Tube (H) must remain loose for positioning during installation.
11. Using hands, position three clamps (J) on tube (D).

INSTALLATION:

1. Position assembled line in position in hull of vehicle.

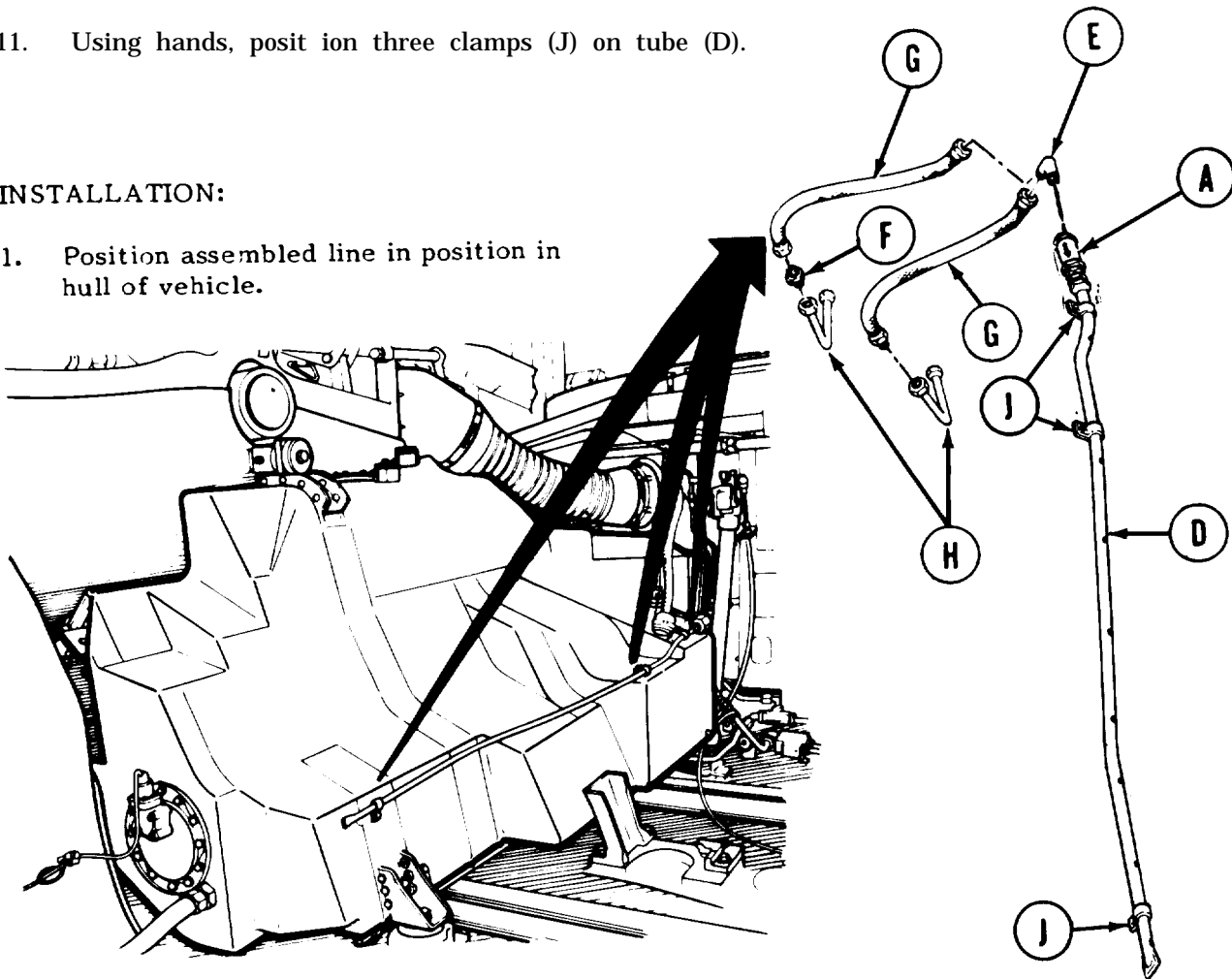

Go on to Sheet 5

TA248737

**LEFT DISCHARGE VALVE, TUBES, AND RELATED PARTS REPLACEMENT
(FIXED FIRE EXTINGUISHER) (Sheet 5 of 5)**

NOTE

When installing clamps in step 2, position clamps down.

2. Using socket, loosely install three clamps (A), screws (B), and washers (C) securing line (D) to left fuel tank (clamps must remain loose for positioning during installation)

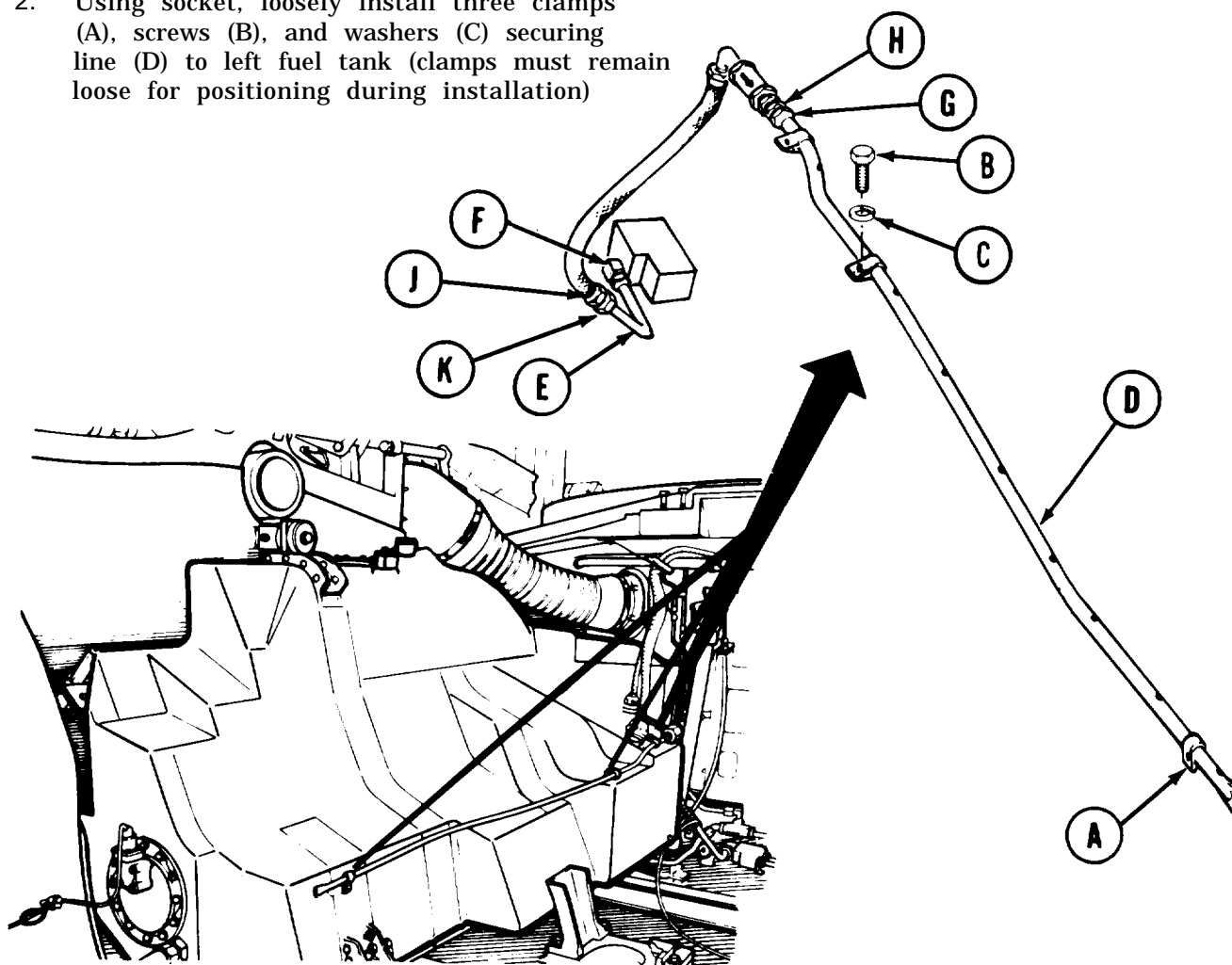

3. Using 7/8 or 1-1/8 inch wrench, install connector on tube (E) to elbow (F). Using 7/8 or 1-1/8 inch crowfoot, extension and torque wrench, tighten tube (E) to 40-50 lb-ft (54-75 N m).
4. Using socket, tighten three screws (B) securing clamps (A) to fuel tank.
5. Holding adapter (G) with 3/4 inch wrench and using 7/8 inch crowfoot adapter and torque wrench, tighten connector (G) onto adapter (H) to 40-50 lb-ft (54-75 N m).
6. Using 7/8 or 1-1/8 inch wrench to hold connector (J), use torque wrench and 7/8 or 1-1/8 inch crowfoot to tighten connector (K) to 40-50 lb-ft (54-75 N m).
7. Install powerplant (page 5-14).

End of Task

TA248738

**ENGINE COMPARTMENT DISCHARGE MANIFOLD REPLACEMENT
(FIXED FIRE EXTINGUISHER) (Sheet 1 of 4)**

PROCEDURE INDEX

PROCEDURE	PAGE
Removal	20-81
Inspection	20-83
Installation	20-83

- TOOLS:**
- 1/2 in. box end wrench
 - 3/4 in. deep style socket with 1/2 in. drive
 - 3/4 in. combination box and open end wrench
 - 7/8 in. combination box and open end wrench
 - Bench vise
 - 5 in. extension with 1/2 in. drive
 - 1-1/4 in. combination box and open end wrench
 - 1-1/16 in. combination box and open end wrench
 - Torque wrench with 1/2 in. drive (0-175 lb-ft)
 - 1-1/8 in. combination box and open end wrench
 - 1-1/16 in. deep style socket with 1/2 in. drive
 - 1-1/4 in. crowfoot wrench
 - 7/8 in. crowfoot wrench
 - 1-1/8 in. crowfoot wrench

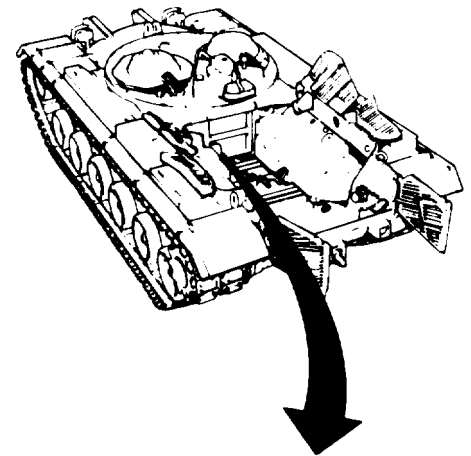

SUPPLIES: Zinc chromate primer (Item 51, Appendix D)

PRELIMINARY PROCEDURES:

- Remove powerplant (page 5-2)
- Remove crew compartment rear floor access plate (TM 5-5420-228-24).

REMOVAL:

1. Using 3/4 inch wrench to hold adapter (A), use 7/8 inch wrench and loosen connector on tube (B) from adapter (A).

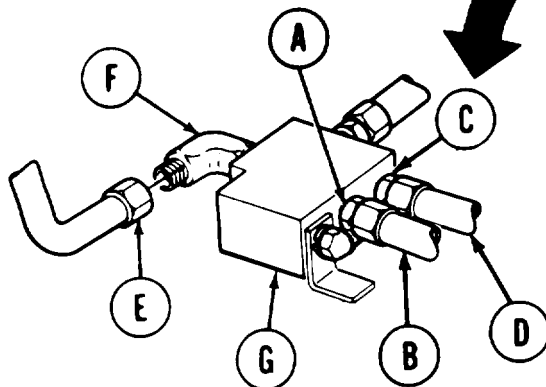
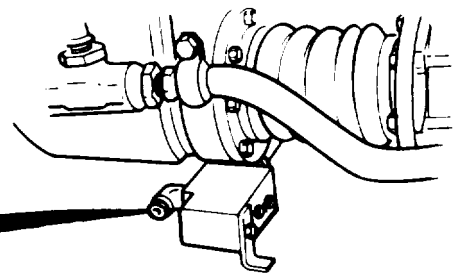

2. Using 3/4 inch wrench to hold adapter (C), use 7/8 inch wrench and loosen connector on tube (D) from adapter (C).
3. Using 1-1/8 inch wrench, remove connector (E) from elbow (F) on manifold (G).

Go on to Sheet 2

**ENGINE COMPARTMENT DISCHARGE MANIFOLD REPLACEMENT
(FIXED FIRE EXTINGUISHER) (Sheet 2 of 4)**

4. Using 1/2 inch wrench, remove screw (H) and washer (J) from manifold (G).
5. Go to crew compartment for the following steps.
6. Locate manifold (G) and tube (K) through center subfloor access plate.
7. Using 1-1/16 inch wrench to hold adapter (L), use 1-1/4 inch wrench and loosen connector (K) from adapter (L).
8. Using 1/2 inch wrench, remove screw (M) and washer (N) from manifold (G).
- 9* Remove manifold (G) from vehicle.
10. Secure manifold (G) in vise.
11. Using 7/8 inch wrench, remove elbow (F) from manifold (G).
12. Using 3/4 inch wrench, remove adapters (A) and (C) from manifold (G).
13. Using 1-1/16 inch wrench, remove adapter (L) from manifold (G).

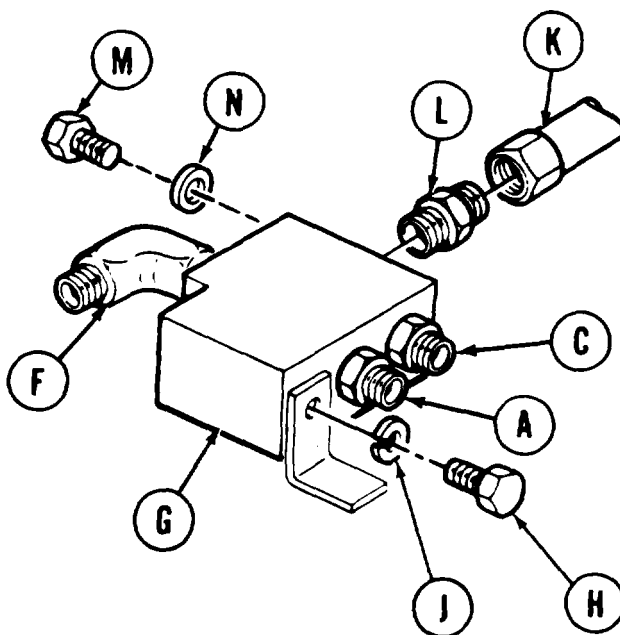

Go on to Sheet 3

TA248740

ENGINE COMPARTMENT DISCHARGE MANIFOLD REPLACEMENT (FIXED FIRE EXTINGUISHER) (Sheet 3 of 4)

INSPECTION:

Make sure that all connections and seating surfaces are free of nicks, burrs, or other defects that could cause leakage. Replace any damaged parts.

NOTE

Apply zinc chromate primer to all threads prior to installation of threaded tube/hose connections.

INSTALLATION:

1. Secure manifold (A) in vise.
2. Using 7/8 inch wrench, install elbow (B) into manifold (A).

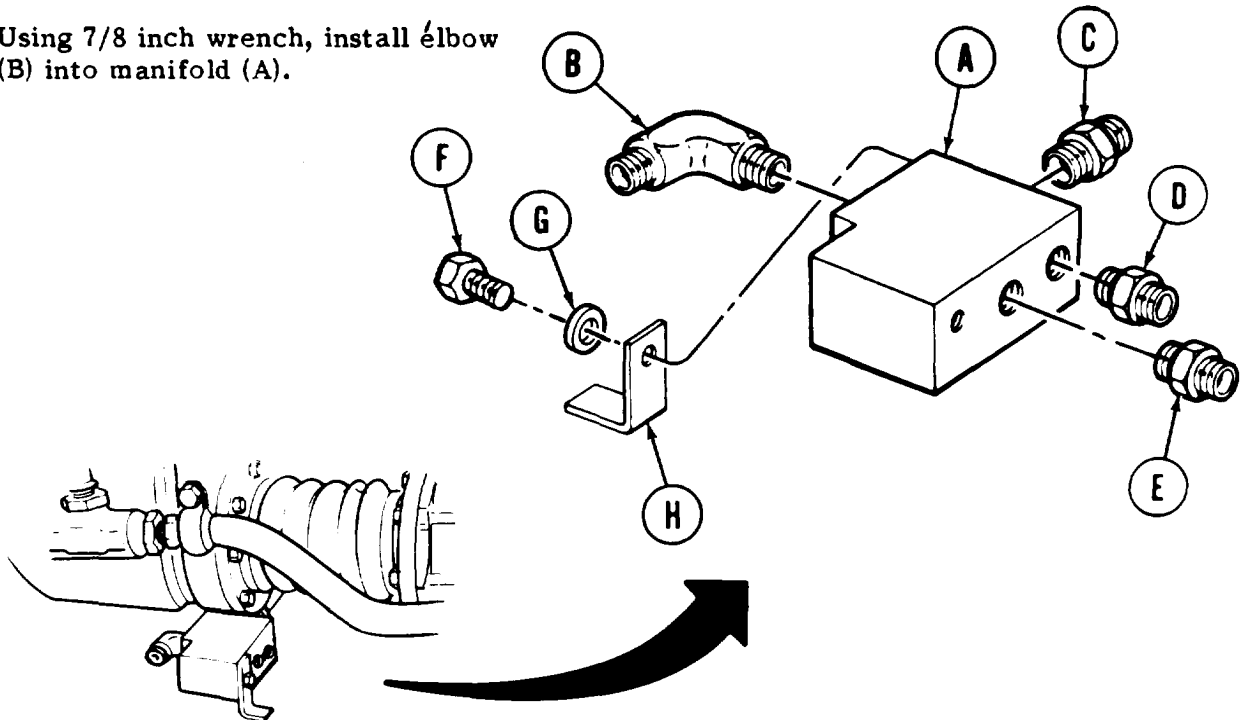

3. Using 1-1/16 inch wrench, install adapter (C) into manifold (A). Using torque wrench and 1-1/16 inch socket, tighten adapter (C) to 40-50 lb-ft (54-75 N·m).
4. Using 3/4 inch wrench, install adapters (D) and (E) into manifold (A). Using torque wrench and 3/4 inch socket, tighten adapters (D) and (E) to 40-50 lb-ft (54-75 N·m).

NOTE

When manifold (A) is positioned in vehicle, make sure tubes are positioned onto adapters (C) and (D).

5. Remove manifold (A) from vise and position in vehicle.
6. Using 1/2 inch wrench, install screw (F) and washer (G) through bracket (H) into manifold (A).

Go on to Sheet 4

TA248741

**ENGINE COMPARTMENT DISCHARGE MANIFOLD REPLACEMENT
(FIXED FIRE EXTINGUISHER) (Sheet 4 of 4)**

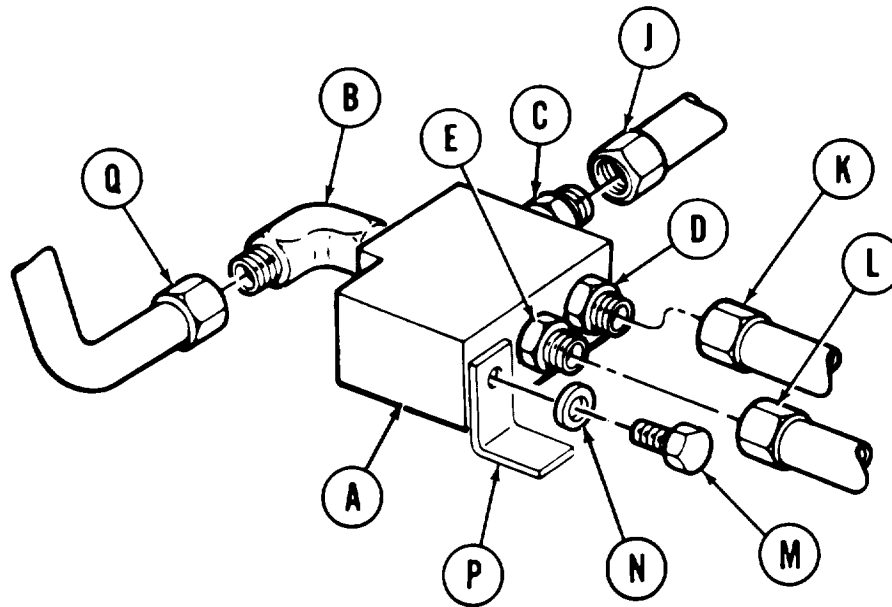

7. Using 1-1/4 inch wrench, install connector (J) to adapter (C). Using 1-1/16 inch wrench to hold adapter (C), use torque wrench and 1-1/4 inch crowfoot to tighten connector (J) to 40-50 lb-ft (54-75 N·m).
8. Using 7/8 inch wrench, install connector (K) onto adapter (D). Using 3/4 inch wrench to hold adapter (D) and 7/8 inch crowfoot and torque wrench on connector (K), tighten connector (K) to 40-50 lb-ft (54-75 N·m).
9. Go to engine compartment and position connector (L) onto adapter (E).
10. Using 7/8 inch wrench, install connector (L) onto adapter (E). Using 3/4 inch wrench to hold adapter (E) and 7/8 inch crow foot and torque wrench on connector (L), tighten connector (L) to 40-50 lb-ft (54-75 N·m).
11. Using 1/2 inch wrench, install screw (M) and washer (N) through bracket (P) into manifold (A).
12. Using 1-1/8 inch wrench, install connector (Q) onto elbow (B). Using 1-1/8 inch crowfoot and torque wrench, tighten connector (Q) to 40-50 lb-ft (54-75 N·m).
13. Install crew compartment rear floor access plate (TM 5-5420-228-24).
14. Install powerplant (page 5-14).

End of Task

TA248742

CHAPTER 21
SMOKE GENERATOR MAINTENANCE

INDEX

Procedure	Page
Smoke Generator Switch Or Guard Replacement	21-2
Smoke Generator Switch Cover Replacement	21-4
Smoke Generator Indicator Light Replacement.	21-5
Smoke Generator Switch And Indicator Light Mounting Bracket Replacement	21-8
Smoke Generator Wiring Harness To Bulkhead Lead Replacement	21-10
Smoke Generator Hull Wiring Harness Replacement	21-11
Smoke Generator Intermediate Fuel Hose Replacement	21-16
Smoke Generator Fuel Shut-Off Valve Replacement	21-21
Smoke Generator Solenoid Replacement	21-25
Smoke Generator Elbow-To-Solenoid Fuel Hose Replacement.	21-30
Smoke Generator Solenoid Output Fuel Hose Replacement	21-32
Smoke Generator Tee-To-Turbosupercharger Tube Assembly Replacement	21-34
Smoke Generator Front Engine Fuel Hose Replacement	21-39

SMOKE GENERATOR SWITCH OR GUARD REPLACEMENT (Sheet 1 of 2)

TOOLS: Cross-tip screwdriver

SUPPLIES: Lockwashers (2 required)

REFERENCE TM 5-5420-202-10

QUADRANTS
REMOVED
FOR CLARITY

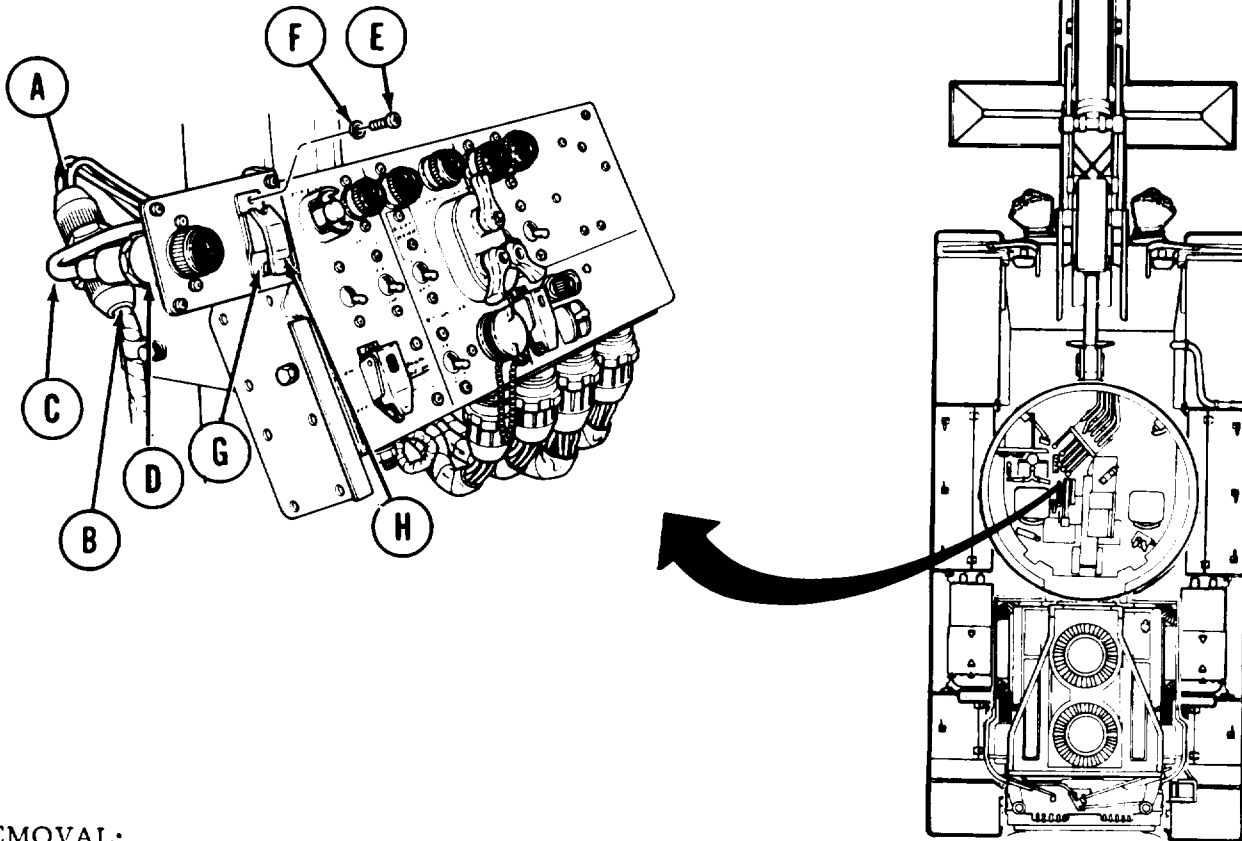

REMOVAL:

1. Make sure MASTER BATTERY switch is set to OFF (TM 5-5420-202-)
2. Disconnect switch connector (A) from wiring harness connector (B).
3. Disconnect switch-to-indicator light lead (C) from indicator light (D).
4. Using screwdriver, remove two screws (E) and lockwashers (F) from switch (G) and guard (H).
5. Remove switch (G) and guard (H).
6. Replace switch (G) or guard (H) as required.

Go on to Sheet 2

TA248743

SMOKE GENERATOR SWITCH OR GUARD REPLACEMENT (Sheet 2 of 2)**INSTALLATION:**

1. Be sure ON position is up and position switch (A) to backside of mounting bracket (B).
2. Position guard (C) over switch (A). Be sure toggle lever on switch is down.
3. Using screwdriver, install two screws and lockwashers (D) to secure guard (C) and switch (A) to bracket (B).
4. Connect switch-to-light indicator lead (E) to light indicator connector (F).

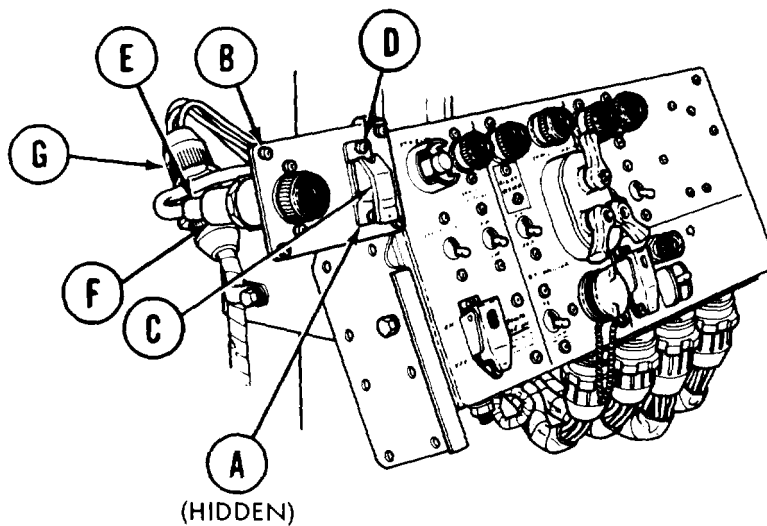

5. Connect switch connector (G) to harness connector.
6. Start engine (TM 5-5420-202-10) and run until normal operating temperatures are attained. Run engine at 1600 rpm.
7. Place SMOKE GENERATOR switch (A) to ON.
8. Observe operation of smoke generator.
9. Place SMOKE GENERATOR switch (A) to OFF.
10. Shut down engine (TM 5-5420-202-10).

End of Task

TA248744

SMOKE GENERATOR SWITCH COVER REPLACEMENT (Sheet 1 of 1)

TOOLS: Cross-tip screwdriver
11/32 in. open end wrench

SUPPLIES Lockwashers (4 required)

PRELIMINARY PROCEDURE: Remove smoke generator switch and guard (page 21-2)
Remove smoke generator indicator light (page 21-5)

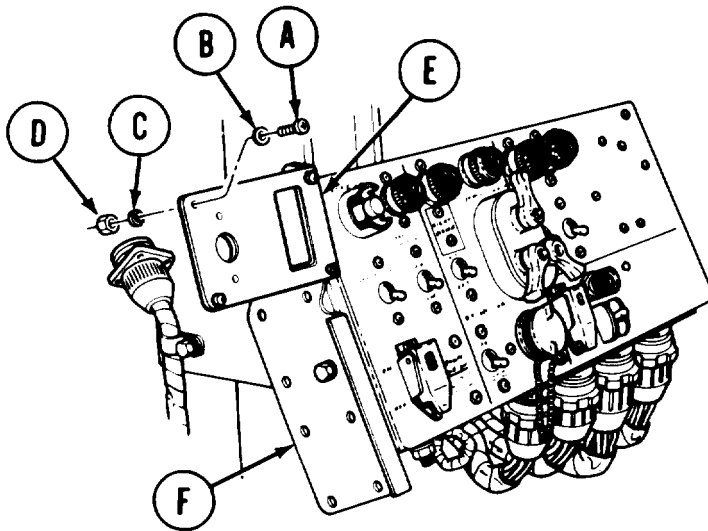

REMOVAL:

1. Using screwdriver and 11/32 inch wrench, remove four screws (A), flat washers (B), lockwashers (C), and nuts (D) securing cover (E) to mounting bracket (F).
2. Remove cover (E).

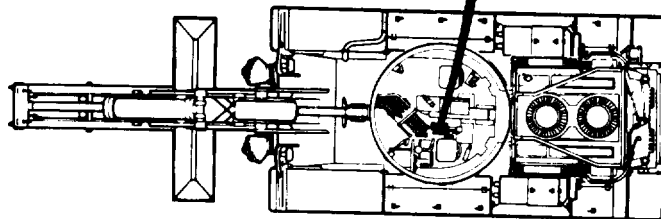

INSTALLATION:

1. Position cover (E) on mounting bracket (F).
2. Using screwdriver and 11/32 inch wrench, install and tighten four screws (A), (B), lockwashers (C), and nuts (D) securing cover (E) to mounting bracket (F). flat washers
3. Install smoke generator indicator light (page 21-7).
4. Install smoke generator switch and guard (page 21-3).

End of Task

TA248745

SMOKE GENERATOR INDICATOR LIGHT REPLACEMENT (Sheet 1 of 3)

TOOLS: 1-1/8 in. open end wrench
Cross-tip screwdriver

SUPPLIES: Lint-free cloth (Item 12, Appendix D)
Steel wool (Item 56, Appendix D)
Silicone compound (Item 32, Appendix D)
Preformed packing
Lockwashers (2 required)

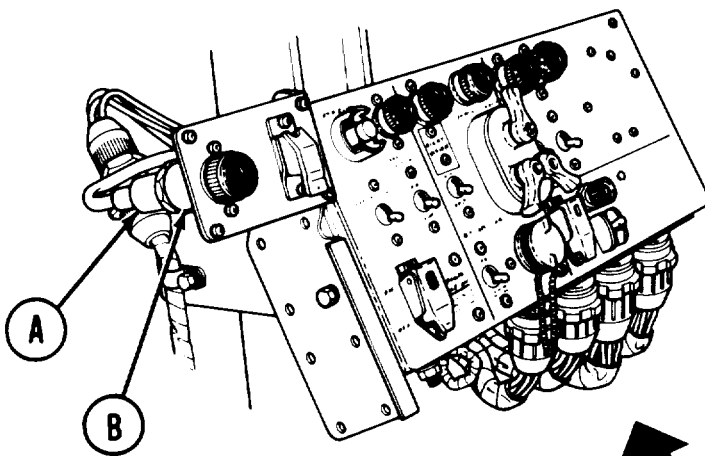
REMOVAL:

1. Manually disconnect electrical lead (A) from rear of light assembly (B).

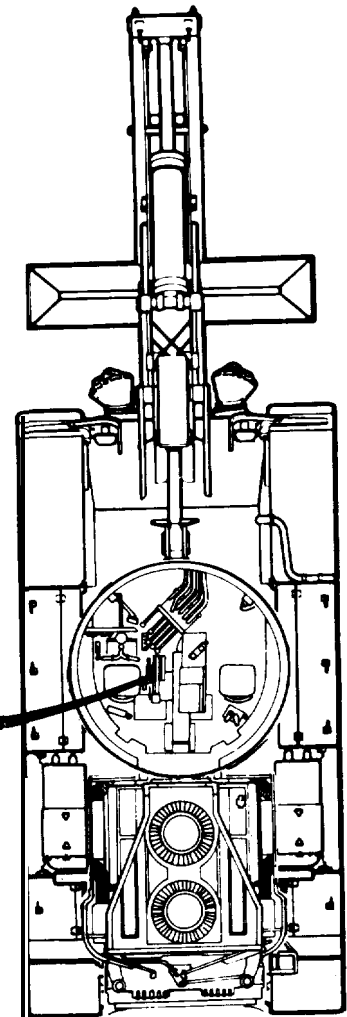

QUADRANTS
REMOVED
FOR CLARITY

Go on to Sheet 2

TA248746

SMOKE GENERATOR INDICATOR LIGHT REPLACEMENT (Sheet 2 of 3)

2. Unscrew and remove lens (C).
3. Remove preformed packing (D) from adapter (E). Throw preformed packing (D) away.
4. Using wrench, remove adapter (E).
5. Push in and turn lamp (F) counterclockwise. Remove lamp.
6. Using screwdriver, remove two screws (G) and lockwashers (H) securing base assembly (J) to mounting bracket (K).
7. Remove base assembly (J).

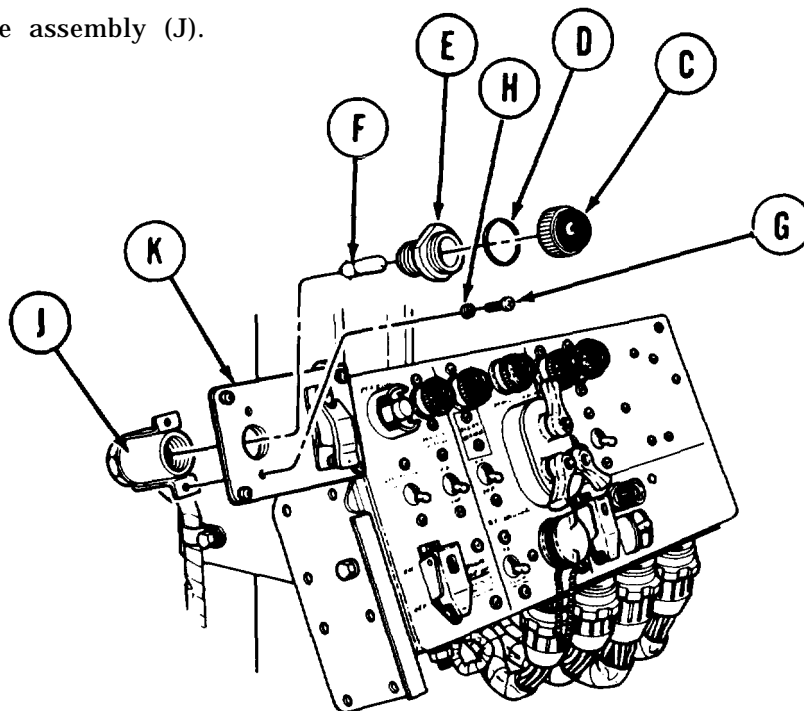

CLEANING AND INSPECTION:

1. Clean lens (C) with moist, lint-free cloth.
2. Using steel wool, remove any corrosion from connector terminals and lamp socket of base assembly (J).
3. Inspect lens (C) for cracks or deep scratches. Replace if any are found.

Go on to Sheet 3

TA248747

SMOKE GENERATOR INDICATOR LIGHT REPLACEMENT (Sheet 3 of 3)

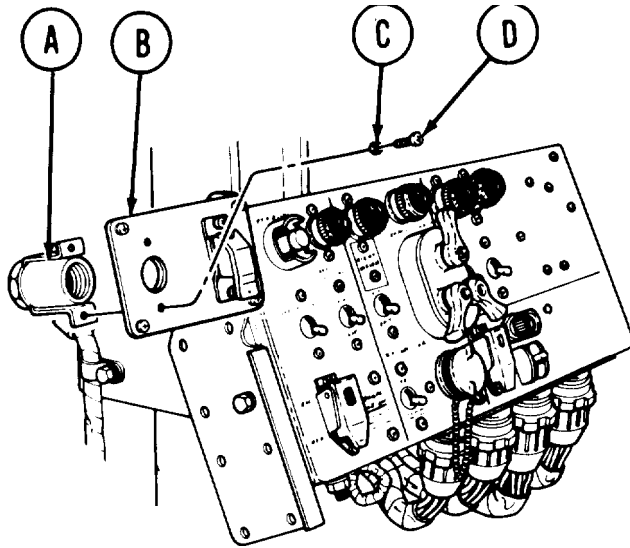

INSTALLATION:

1. Position base assembly (A) to rear of mounting bracket (B).
2. Using screwdriver, install two lockwashers (C) and screws (D) to secure base assembly (A) to mounting bracket (B).

3. Insert lamp (E) into base assembly (A). Push lamp in and turn clockwise and release.
4. Install adapter (F) into base assembly (A). Using wrench, tighten adapter (F).
5. Install new preformed packing (G) onto adapter (F).
6. Install lens (H) onto adapter (F) and tighten.

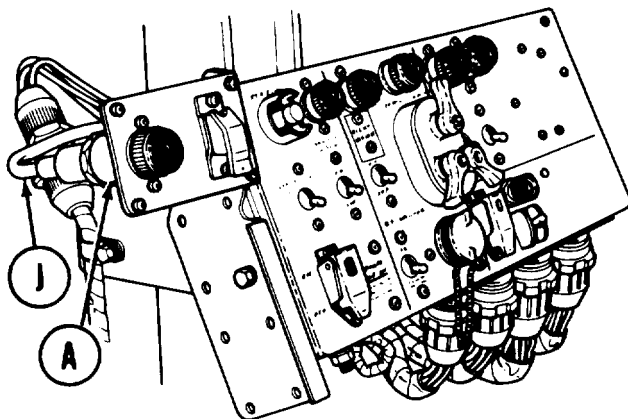
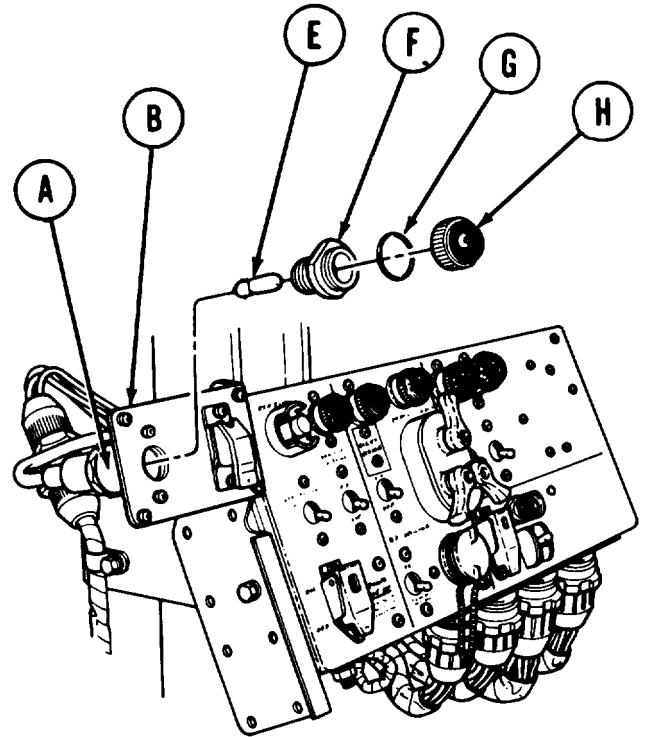

7. Connect electrical lead (J) from switch to base assembly (A) connector.

End of Task

TA248748

SMOKE GENERATOR SWITCH AND INDICATOR LIGHT MOUNTING BRACKET REPLACEMENT (Sheet 1 of 2)

TOOLS: 7/16 in. combination box and open end wrench

SUPPLIES: Lockwashers (2 required)

PRELIMINARY PROCEDURES: Remove switch and guard (page 21-2)
Remove indicator light (page 21-5)
Remove cover (page 21-4)

REMOVAL:

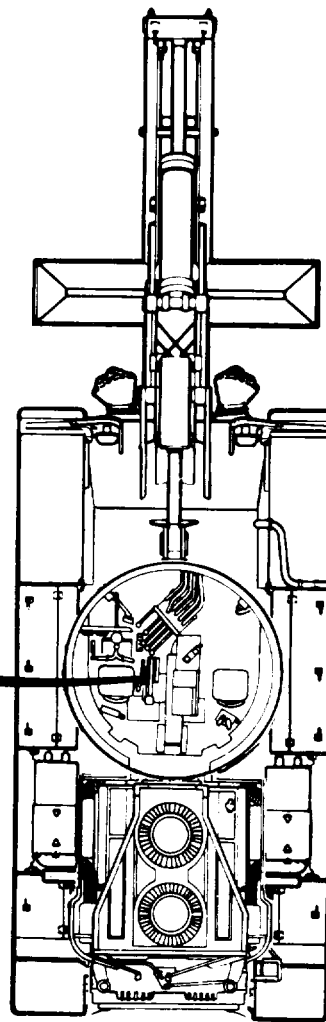
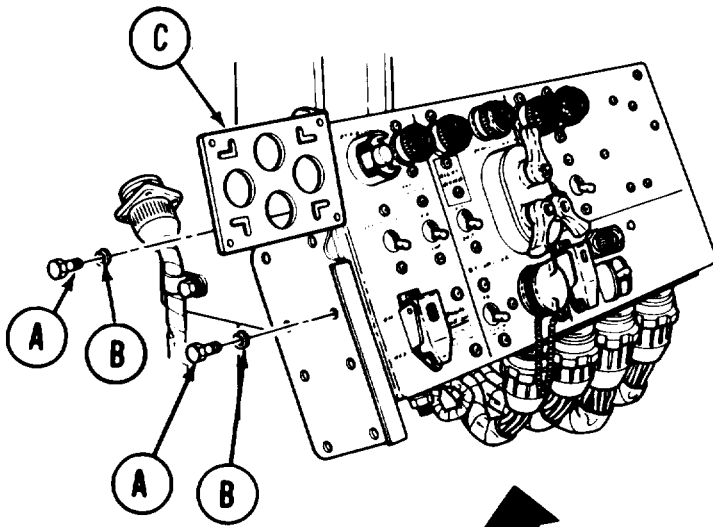

QUADRANTS
REMOVED

1. Using wrench, remove two screws (A) and lockwashers (B) securing mounting bracket (C) to mounting plate.
2. Remove mounting bracket (C).

Go on to Sheet 2

TA248749

SMOKE GENERATOR SWITCH AND INDICATOR LIGHT MOUNTING BRACKET REPLACEMENT (Sheet 2 of 2)

INSTALLATION:

1. Position mounting bracket (A) to mounting plate.
2. Using wrench, install and tighten two screws (B) and lockwashers (C) securing mounting bracket (A) to mounting plate.
3. Install cover (page 21-4).
4. Install indicator light (page 21-7).
5. Install switch and guard (page 21-3).

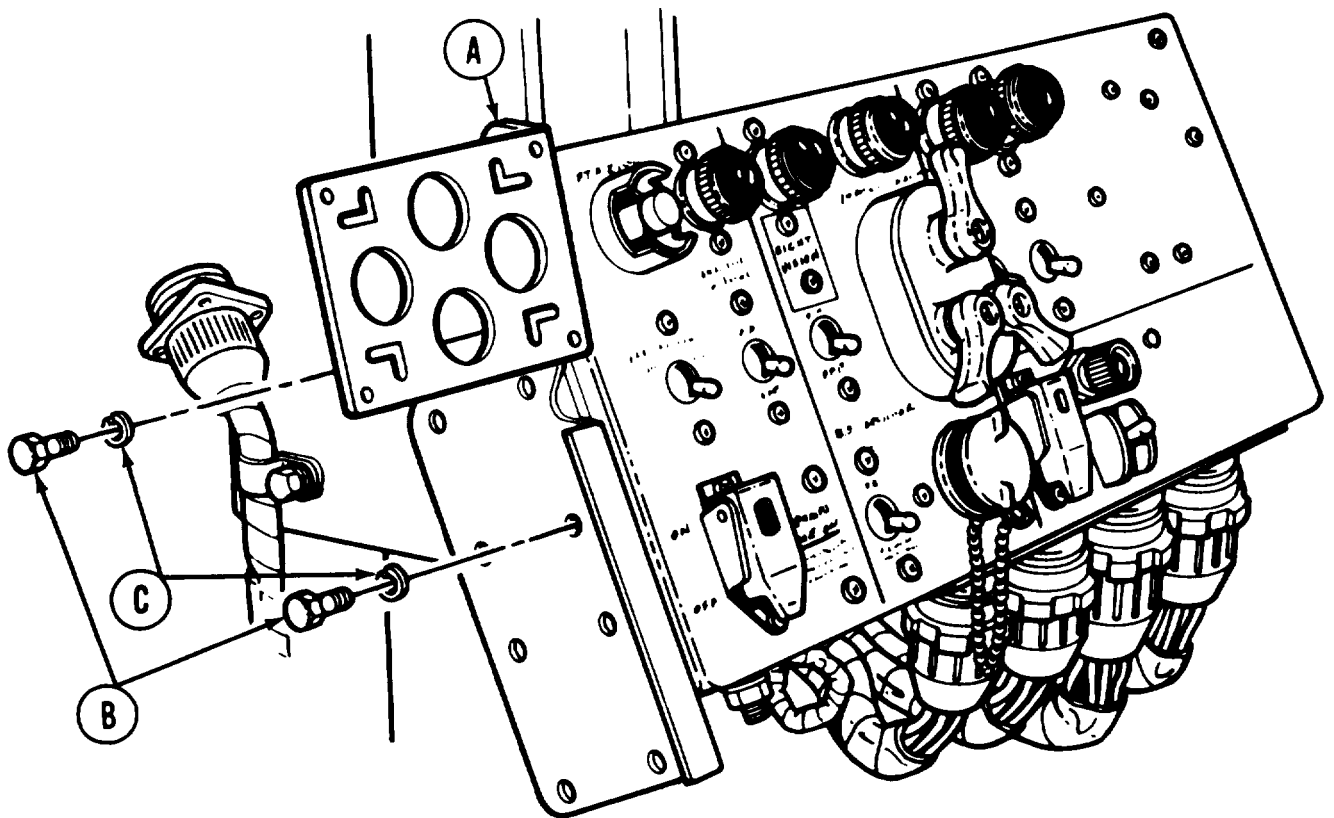

End of Task

TA248750

SMOKE GENERATOR WIRING HARNESS TO BULKHEAD LEAD REPLACEMENT (Sheet 1 of 1)

TOOLS: Electrical connector repair tool kit
Long nosed pliers (needle nose)
Slip joint pliers

REFERENCE: TM 5-5420-202-10

PRELIMINARY PROCEDURES: Remove ground terminals from batteries (page 10-268)
Remove starter harness bulkhead cable disconnect (page 10-269).

REMOVAL:

1. Manually pull apart connectors (A and B).
2. Using slip joint pliers, unscrew nut (C) from plug assembly (D).
3. Using remover, push out pin from position "A" in plug assembly (D).
4. Remove lead (E) from nut (C). Throw lead (E) away.

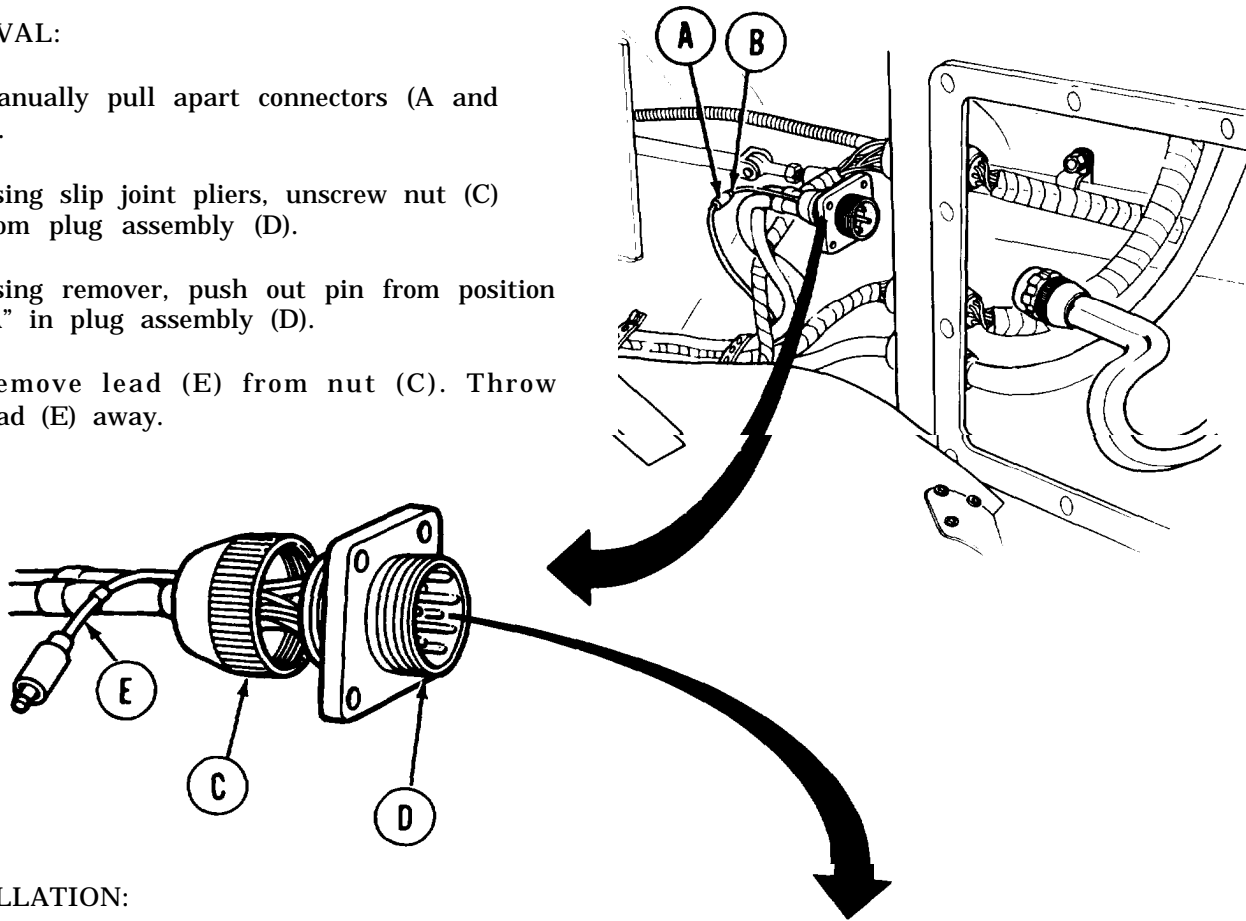

INSTALLATION:

1. Thread new lead (E) through nut (C).
2. Using needle nose pliers, insert lead (E) pin into position "A" in plug assembly (D).
3. Using slip joint pliers, tighten nut (C) onto plug assembly (D).
4. Install starter harness bulkhead cable disconnect (page 10-270).
5. Connect ground terminals to batteries (page 10-268).

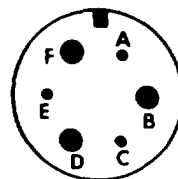

End of Task

TA248751

SMOKE GENERATOR HULL WIRING HARNESS REPLACEMENT (Sheet 1 of 5)

PROCEDURE INDEX

PROCEDURE	PAGE
Removal	21-11
Installation	21-14

TOOLS: 7/16 in. socket with 1/2 in. drive
 3 in. extension with 1/2 in. drive
 Ratchet with 1/2 in. drive
 Spanner wrench
 7/16 in. combination wrench

SUPPLIES: Lockwashers (5 required)

REFERENCES: TM 5-5420-202-10
 TM 5-5420-228-24

PRELIMINARY PROCEDURE: Remove hull interior floor plate (TM 5-5420-228-24)

REMOVAL

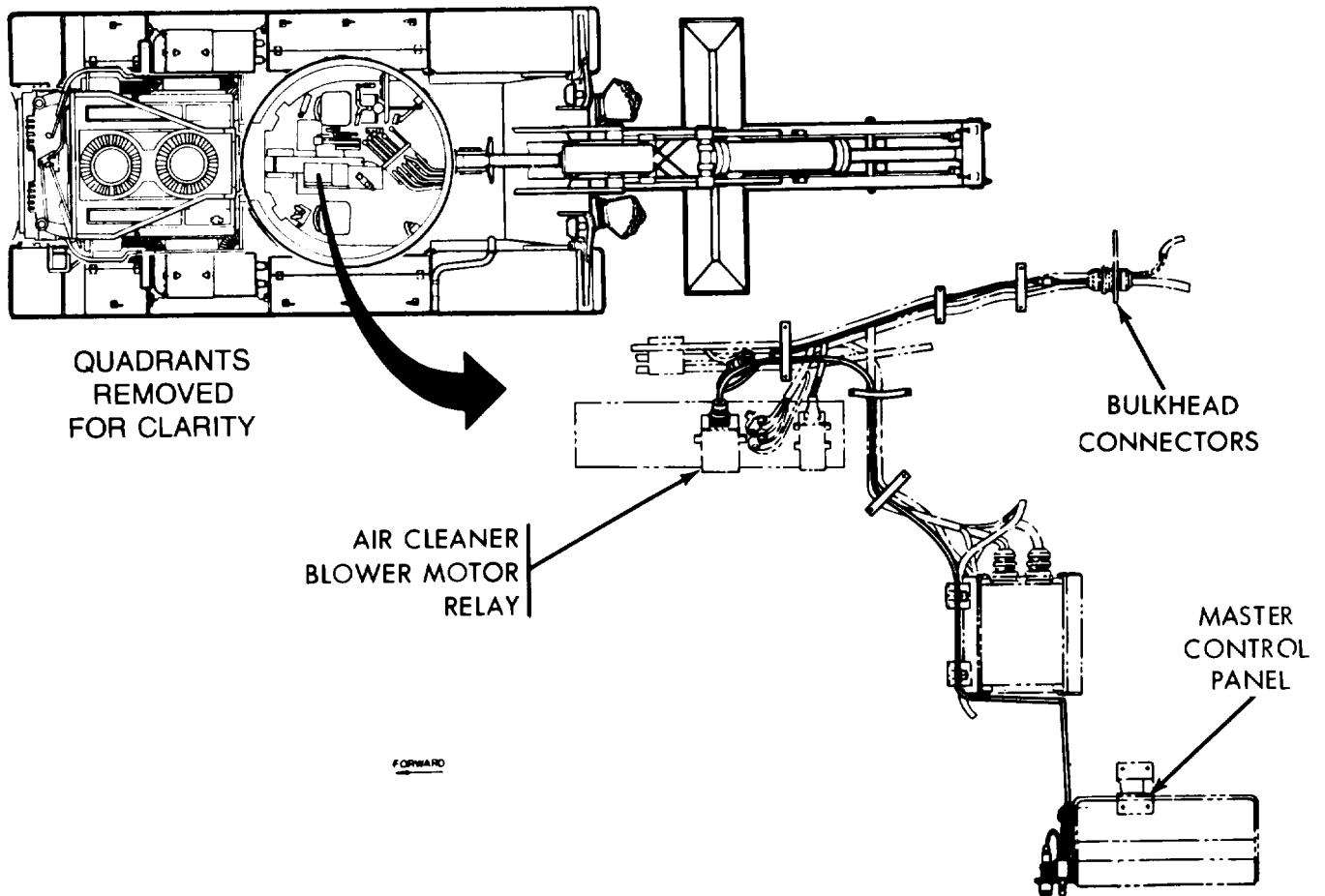

TA248752

Go on to Sheet 2

SMOKE GENERATOR HULL WIRING HARNESS REPLACEMENT (Sheet 2 of 5)

1. Disconnect smoke generator switch connector (A) from wiring harness connector (B).
2. Using 7/16 inch wrench to hold nut (C), use socket to remove screw (D) and lockwasher (E).
3. Remove clamp (F) from wiring harness (B).
4. Using socket and extension, remove screws (G), washers (H), and lockwashers (J) to release one end on each of five straps (K).

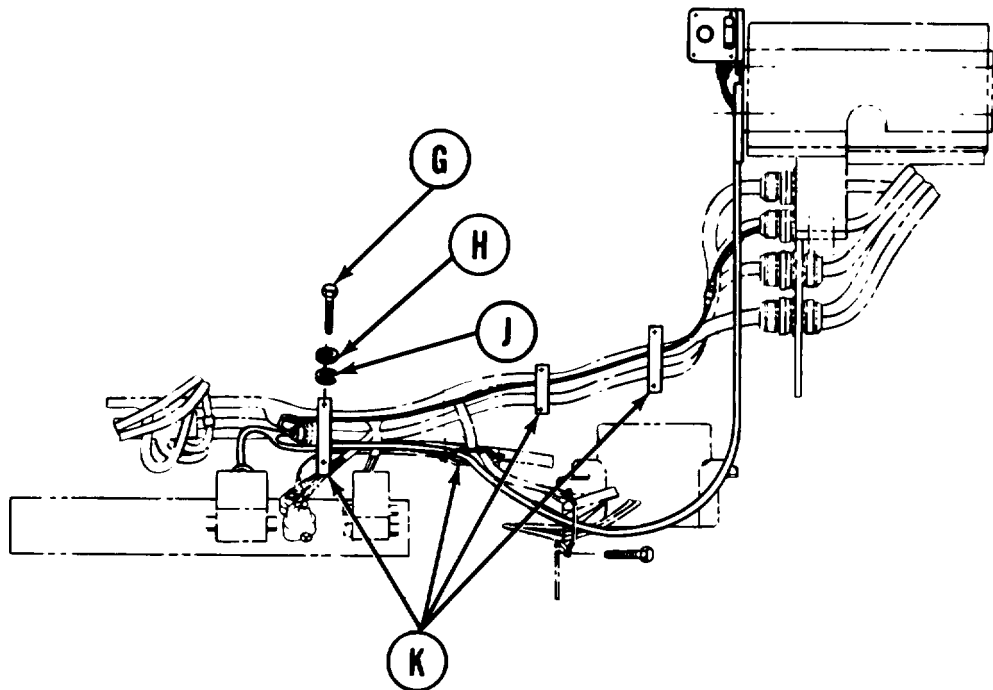
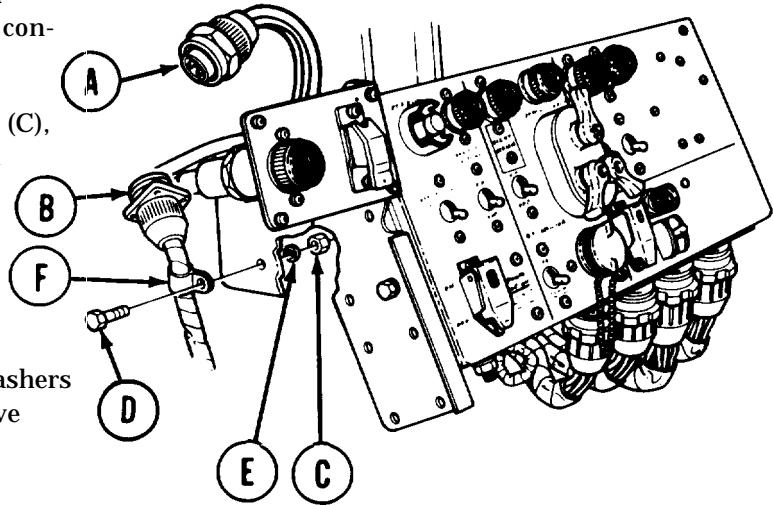

Go on to Sheet 3

TA248753

SMOKE GENERATOR HULL WIRING HARNESS REPLACEMENT (Sheet 3 of 5)

5. Using spanner wrench, disconnect connector (L) from air cleaner blower motor relay (M).
6. Using spanner wrench, disconnect connector (N) from wiring harness connector (P).

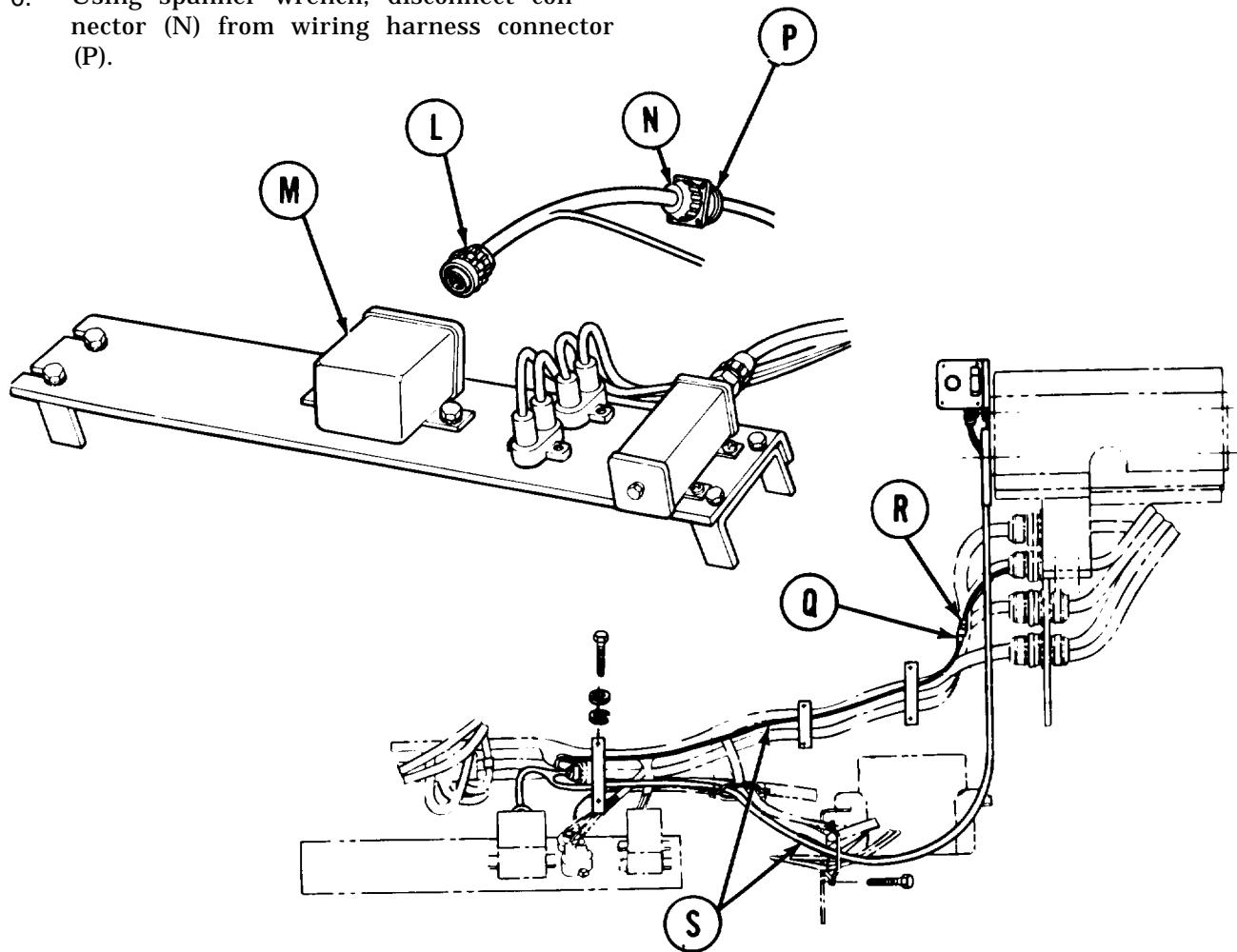

7. Disconnect wiring harness connector (Q) from lead connector (R).
8. Note routing and remove wiring harness (S) from hull.

Go on to Sheet 4

TA248754

SMOKE GENERATOR HULL WIRING HARNESS REPLACEMENT (Sheet 4 of 5)

INSTALLATION:

1. Position and route wiring harness (A) along hull.

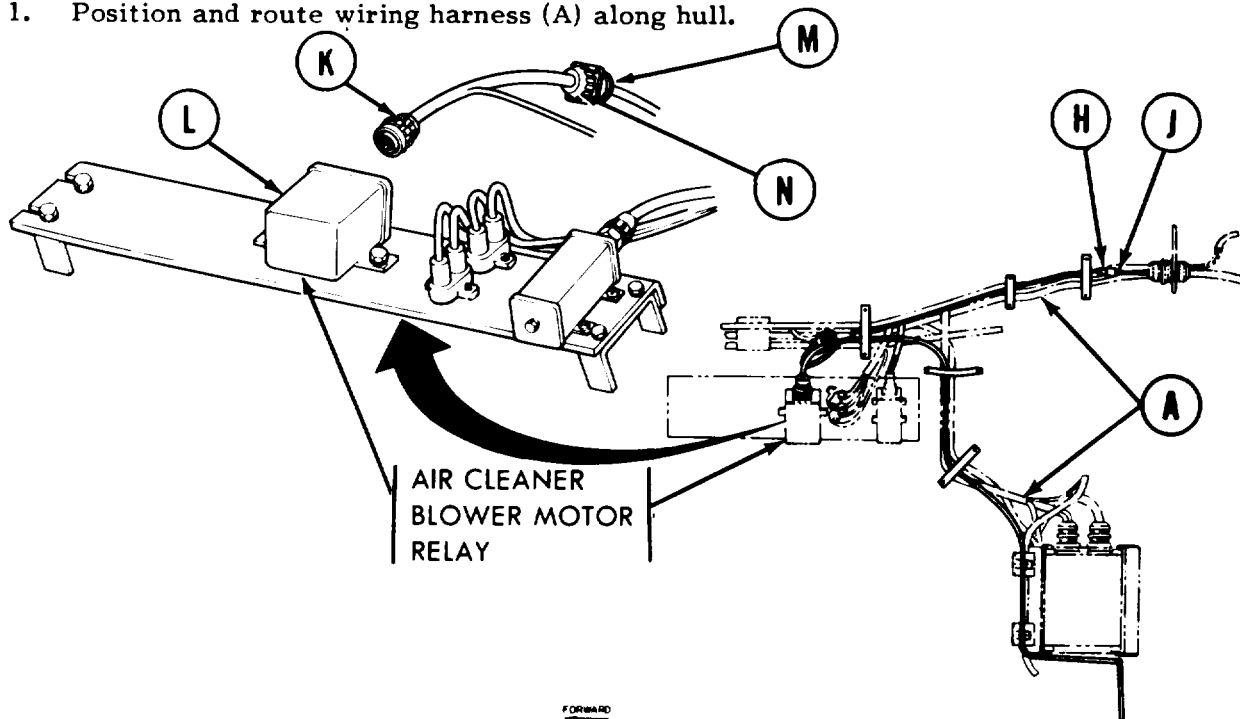

2. Connect smoke generator switch connector (B) to wiring harness connector (C).
3. Place clamp (D) on wiring harness (A).
4. Manually install screw (E) through clamp (D) and support (F).
5. Install lockwasher and nut (G) on screw (E).
6. Using socket and 7/16 inch wrench, tighten screw (E).
7. Connect wiring harness connector (H) to lead connector (J).
8. Manually connect connector (K) to air cleaner blower motor relay (L).
9. Use spanner wrench to tighten connector (K).
10. Connect connector (M) to wiring harness connector (N).

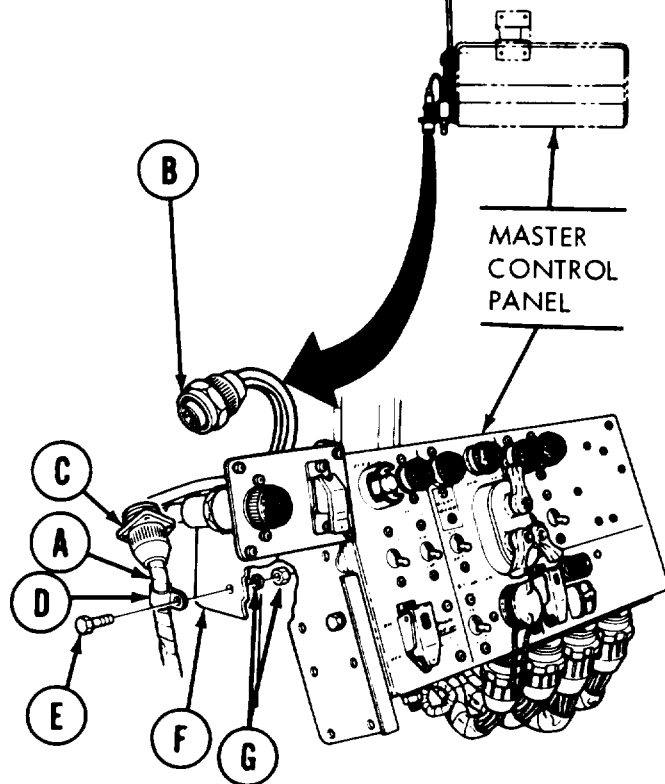

Go on to Sheet 5

TA248755

SMOKE GENERATOR HULL WIRING HARNESS REPLACEMENT (Sheet 5 of 5)

11. Position wiring harness (A) under five straps (P).
12. Using socket, install and tighten five screws (Q), washers (R), and lockwashers (S) to secure ends of straps (P).

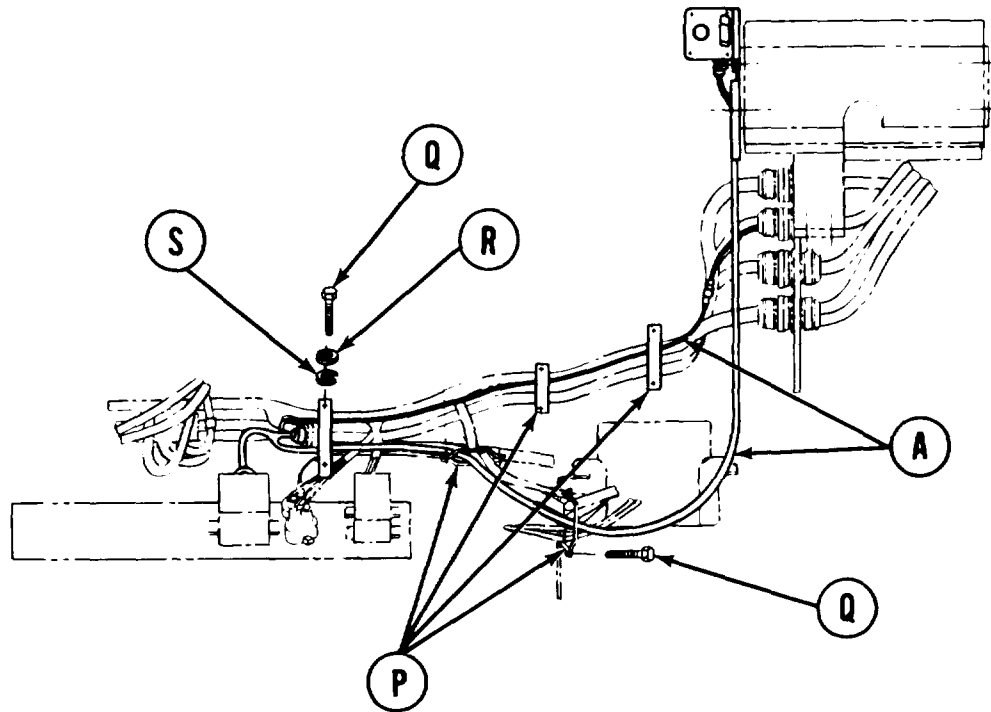

13. Start engine (TM 5-5420-202-10) and run until normal operating temperatures are attained. Run engine at 1600 rpm and activate smoke generator. Observe operation. Shut off smoke generator. Shut down engine.
14. Install hull interior floor plate. (TM 5-5420-228-24).

End of Task

TA248756

SMOKE GENERATOR INTERMEDIATE FUEL HOSE REPLACEMENT (Sheet 1 of 5)

PROCEDURE INDEX

PROCEDURE	PAGE
Removal	21-16
Installation	21-19

TOOLS: 7/8 in. combination box and open end wrench
 1/2 in. socket with 1/2 in. drive
 Ratchet with 1/2 in. drive
 3/4 in. combination box and open end wrench
 1 in. combination box and open end wrench

SUPPLIES: Container
 Lint-free cloth (Item 12, Appendix D)

REFERENCE: TM 5-5420-202-10

PRELIMINARY PROCEDURE: Remove engine shroud (page 9-30)

REMOVAL.:

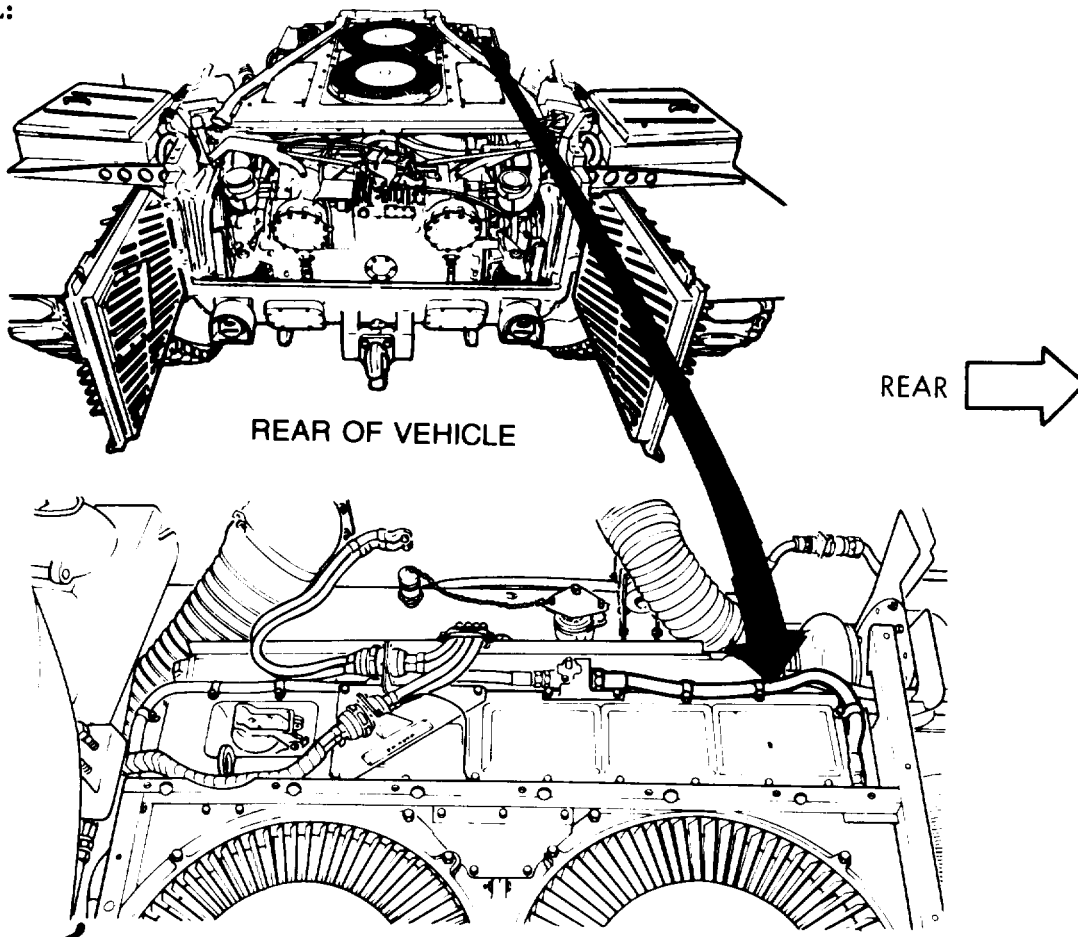

Go on to Sheet 2

TA248757

SMOKE GENERATOR INTERMEDIATE FUEL HOSE REPLACEMENT (Sheet 2 of 5)

NOTE

Use suitable container to catch fuel whenever any fuel line connection is loosened or disconnected. Cap all openings to prevent contamination of fuel.

1. Using socket, remove three assembled washer screws (A) securing clamps (B) to engine.
2. Using 7/8 inch wrench, disconnect intermediate fuel hose (C) from output port of fuel shut-off valve (D).
3. Using 7/8 inch wrench, disconnect intermediate fuel hose (C) from elbow (E) in shroud.

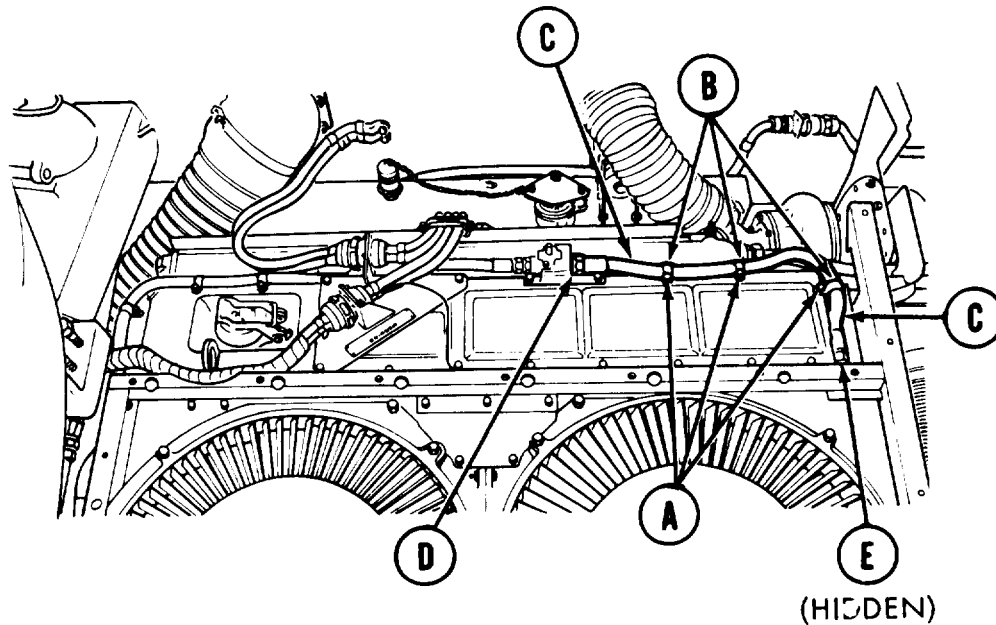

4. Remove intermediate fuel hose (C) and clamps (B) from engine.
5. Remove clamps (B) from intermediate fuel hose (C).

Go on to Sheet 3

TA248758

SMOKE GENERATOR INTERMEDIATE FUEL HOSE REPLACEMENT (Sheet 3 of 5)

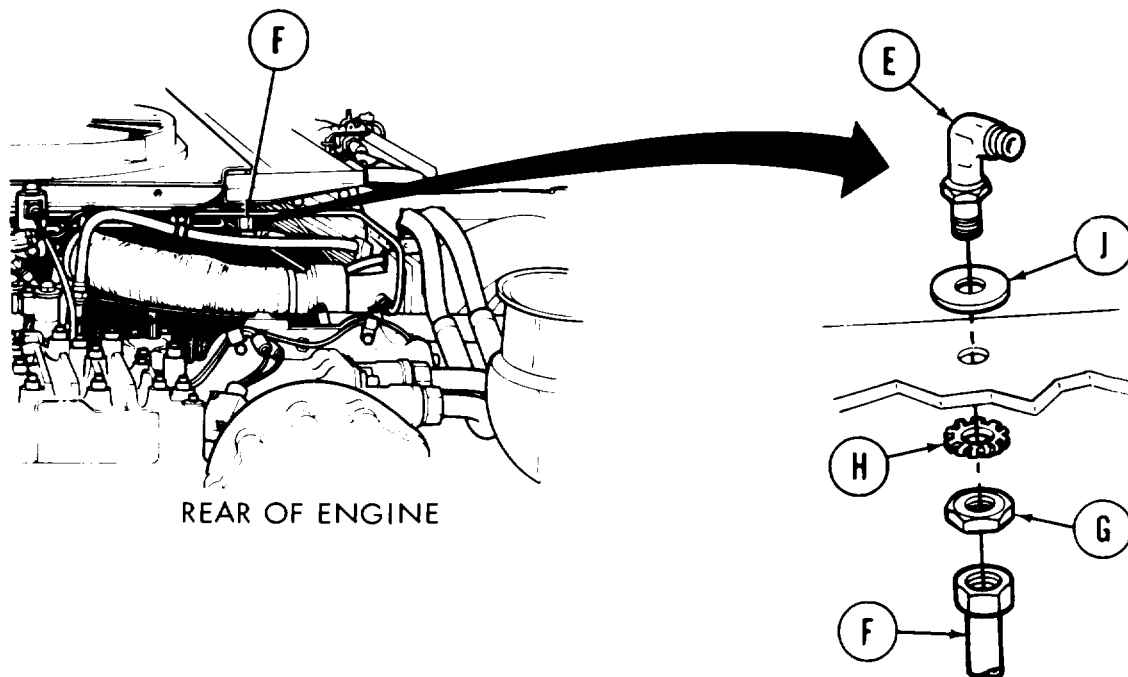

6. Using 7/8 inch wrench, disconnect elbow-to-solenoid fuel hose (F) from elbow (E) in shroud.
7. Using 3/4 inch wrench to hold elbow (E) and 1 inch wrench on nut (G), remove nut (G) and lockwasher (H).
8. Remove elbow (E) and flat washer (J).
9. Inspect elbow (E) for cracks and damage to threads. If elbow is cracked or threads damaged replace elbow.

Go on to Sheet 4

TA248759

SMOKE GENERATOR INTERMEDIATE FUEL HOSE REPLACEMENT (Sheet 4 of 5)

INSTALLATION:

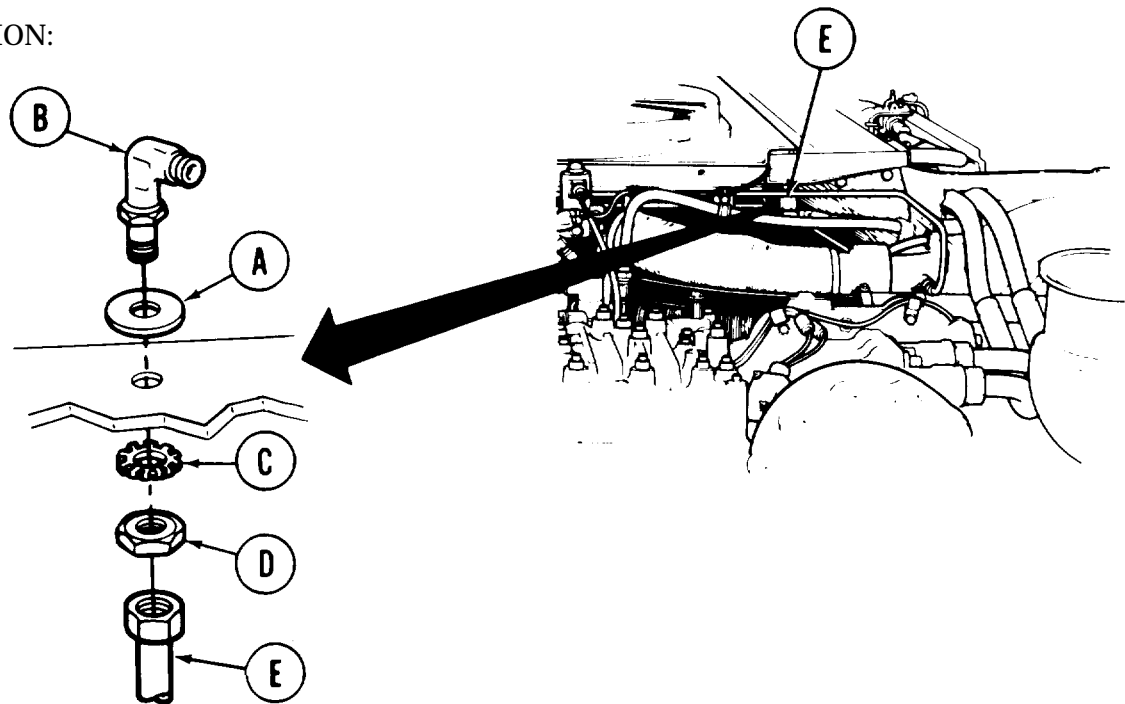

1. Install flat washer (A) and elbow (B) into shroud.
2. Install lockwasher (C) and nut (D) onto elbow (B) to secure elbow to shroud.
3. Position elbow (B) to face toward right side of engine. Using 3/4 inch wrench to hold elbow (B), use 1 inch wrench and tighten nut (D).
4. Connect elbow-to-solenoid fuel hose (E) to elbow (B). Using 7/8 inch wrench, tighten hose (E) connector to elbow (B).

Go on to Sheet 5

TA248760

SMOKE GENERATOR INTERMEDIATE FUEL HOSE REPLACEMENT (Sheet 5 of 5)

5. Install three clamps (F) onto intermediate fuel hose (G).
6. Position intermediate fuel hose (G) along top right side of engine and connect to output port of fuel shut-off valve (H) and elbow (B) in shroud.
7. Using 7/8 inch wrench, tighten hose connections.

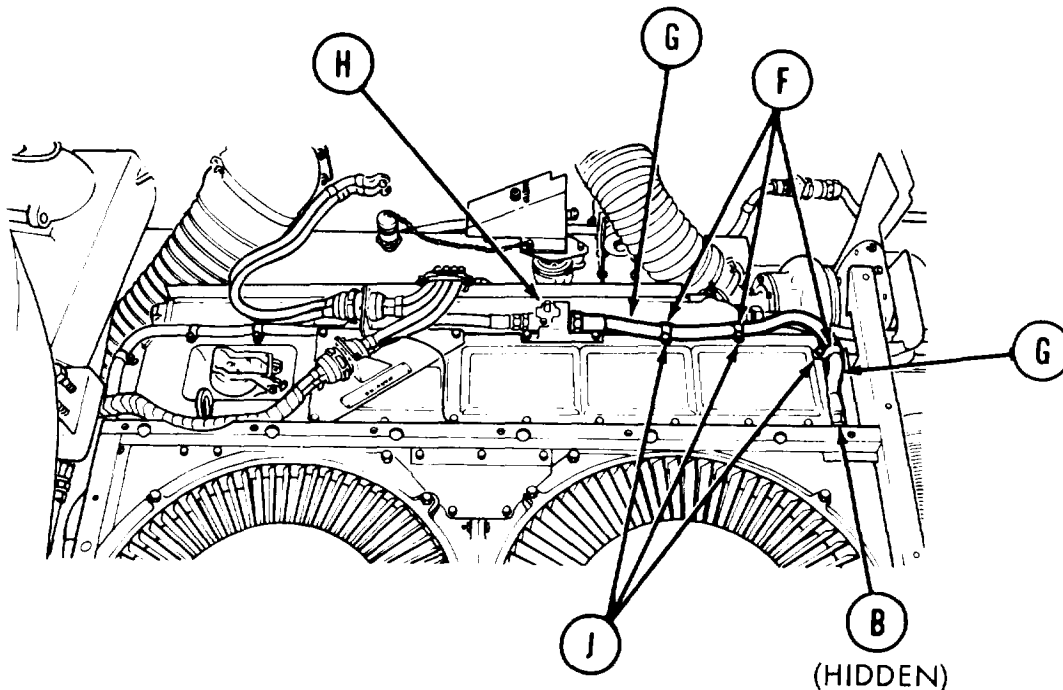

8. Using socket, install and tighten three assembled washer screws (J) to secure clamps (F) to engine.

WARNING

Do not activate smoke generator in a building or closed area or with personnel near.

CAUTION

Always be aware of wind direction and speed when using smoke generator.

9. Start engine (TM 5-5420-202-10) and run until normal operating temperatures are attained. Run engine at 1600 rpm and activate smoke generator. Observe operation. Shut off smoke generator. Shut down engine.
10. Check smoke generator lines for leaks. Correct as necessary.
11. Install engine shroud (page 9-31).

End of Task

TA248761

SMOKE GENERATOR FUEL SHUT-OFF VALVE REPLACEMENT (Sheet 1 of 4)

PROCEDURE INDEX

PROCEDURE	PAGE
Removal	21-21
Installation	21-23

TOOLS: 1/2 in. socket with 1/2 in. drive
 7/16 in. socket with 1/2 in. drive
 Ratchet with 1/2 in. drive
 7/8 in. combination box and open end wrench
 7/16 in. combination box and open end wrench
 1 in. combination box and open end wrench
 1-1/4 in. open end wrench

SUPPLIES: Container
 Lint-free cloth (item 12, Appendix D)
 Self-locking nuts (2 required)
 Preformed packings (2 required)

REFERENCE: TM 5-5420-202-10

PRELIMINARY PROCEDURE: Remove engine shroud (page 9-30)

REMOVAL:

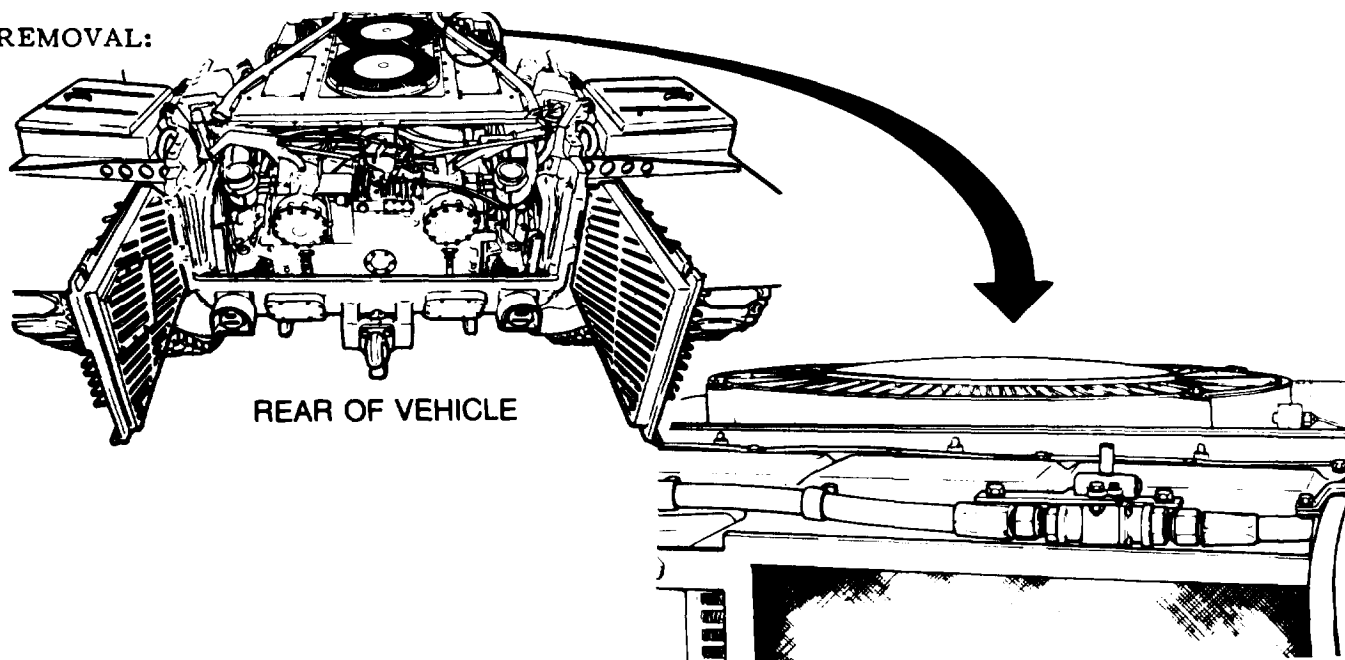

NOTE
 Use suitable container to catch fuel whenever any fuel line connection is loosened or disconnected. Cap all openings to prevent contamination of fuel.

Go on to Sheet 2

TA248762

SMOKE GENERATOR FUEL SHUT-OFF VALVE REPLACEMENT (Sheet 2 of 4)

1. Using 7/8 inch wrench, disconnect fuel hoses (A and B) from fuel shut-off valve (C).
2. Using 1/2 inch socket, remove two assembled washer screws (D) securing mounting bracket (E) with fuel shut-off valve (C) to engine.
3. Remove mounting bracket (E) and fuel shut-off valve (C) as a unit.

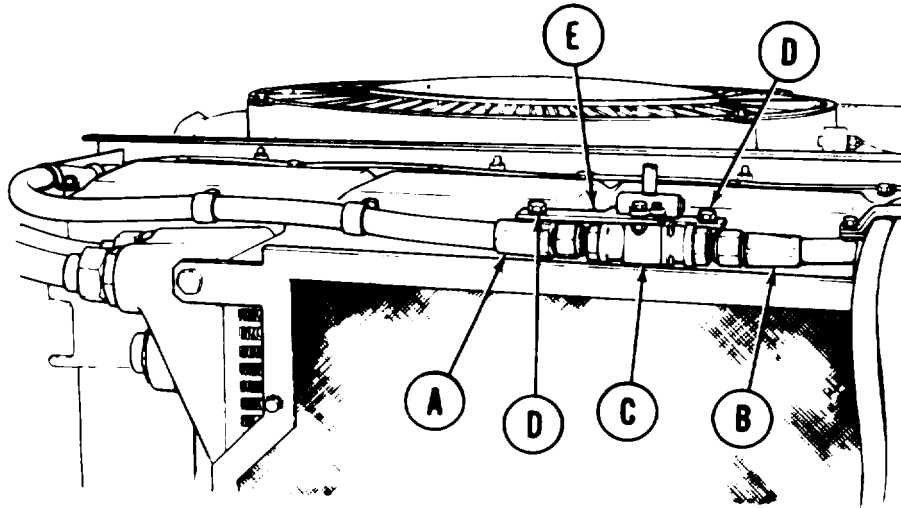

4. Using 7/16 inch wrench to hold nuts, use 7/16 inch socket and remove two screws (F) and nuts (G) securing shutoff valve (C) to mounting bracket (E). Throw nuts (G) away.
5. Using 1-1/4 inch wrench to hold shut-off valve (C), use 1 inch wrench and remove two adapters (H) and preformed packings (J) from valve.
6. Throw preformed packings (J) and valve (C) away.

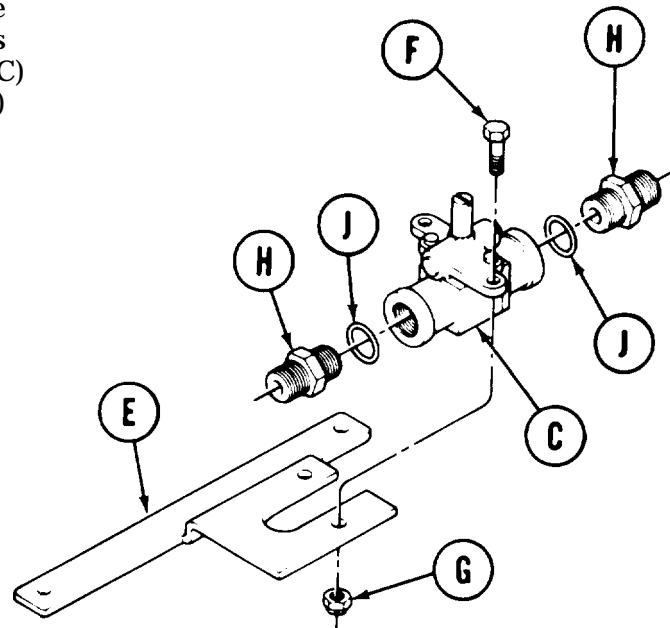

Go on to Sheet 3

TA248763

SMOKE GENERATOR FUEL SHUT-OFF VALVE REPLACEMENT (Sheet 3 of 4)**INSTALLATION:**

1. Install new preformed packings (A) on two adapters (B).
2. Using 1-1/4 inch wrench to hold fuel shut-off valve (C), manually install adapters (B) with preformed packings (A) into ports of fuel shut-off valve.
3. Using 1 inch wrench, tighten adapters. (B).

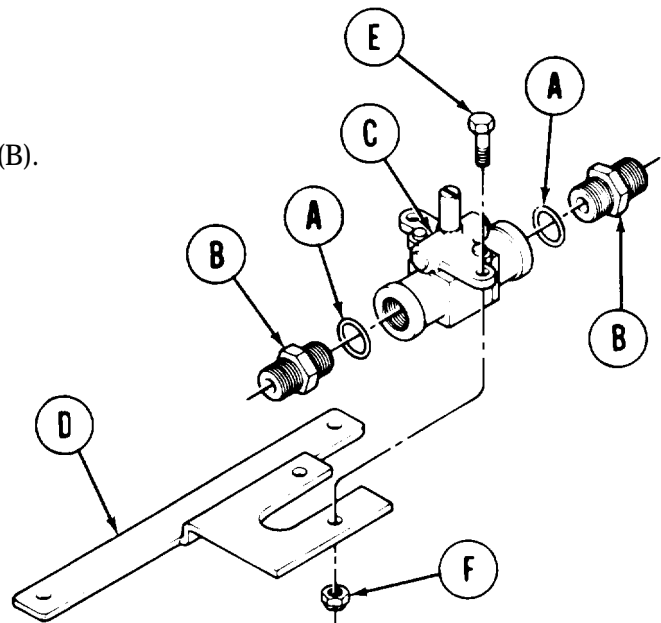

4. Position assembled fuel shut-off valve (C) to mounting bracket (D) and install two screws (E) and new nuts (F).
5. Using 7/16 inch wrench to hold nuts (F), use 7/16 inch socket and tighten screws (E).

Go on to Sheet 4

TA248764

SMOKE GENERATOR FUEL SHUT-OFF VALVE REPLACEMENT (Sheet 4 of 4)

6. Position assembled fuel shut-off valve (C) and mounting bracket (D) onto engine.
7. Using 1/2 inch socket, install and tighten two assembled washer screws (G) to secure mounting bracket (D) to engine.
8. Connect fuel hose (H and J) to fuel shut-off valve (C). Using 7/8 inch wrench, tighten hose connectors to shut-off valve.

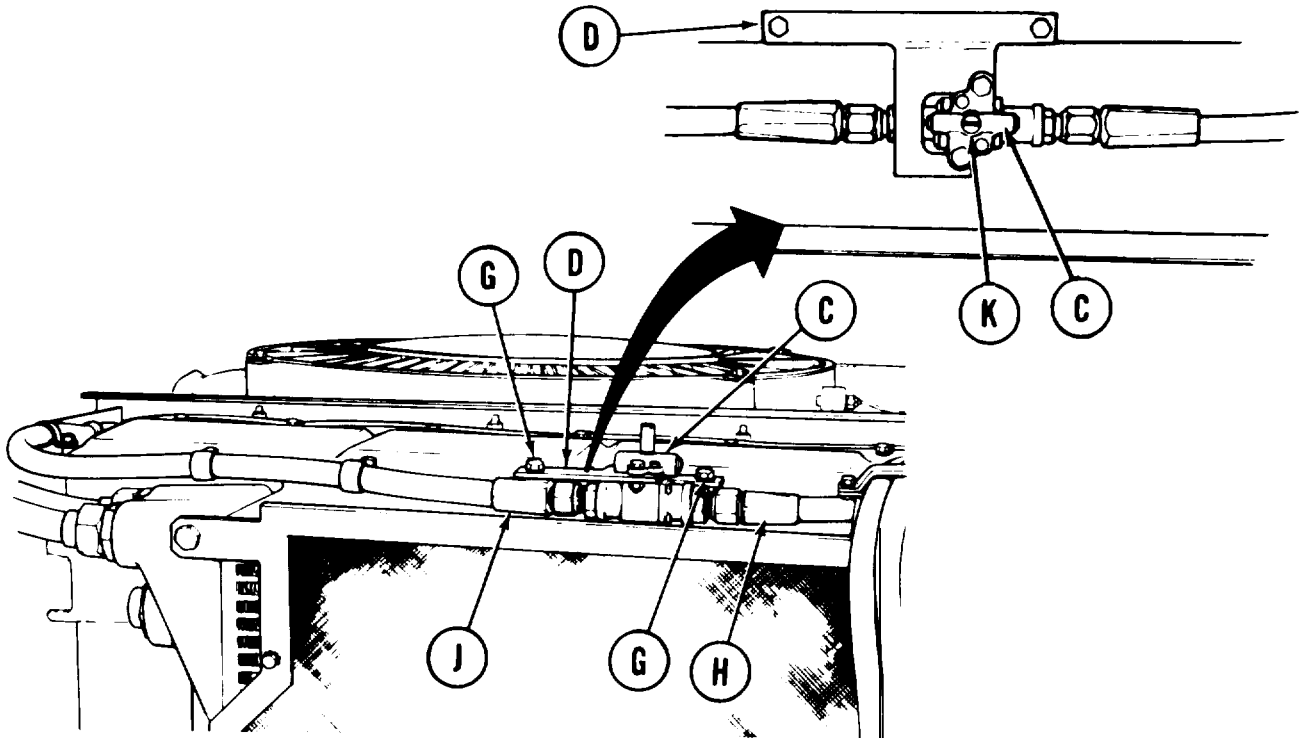

9. Be sure that fuel shut-off valve is in open position. (Index line (K) atop shaft of fuel shut-off valve (C) will be in line with two ports of valve.)

WARNING

Do not activate smoke generator in a building or closed area or with personnel near.

CAUTION

Always be aware of wind direction and speed when using smoke generator.

10. Start engine (TM 5-5420-202-10) and run until normal operating temperatures are attained. Run engine at 1600 rpm and activate smoke generator. Observe operation. Shut off smoke generator. Shut down engine.
11. Check smoke generator lines for leaks. Correct as necessary.
12. Install engine shroud (page 9-31).

End of Task

TA248765

SMOKE GENERATOR SOLENOID REPLACEMENT (Sheet 1 of 5)

PROCEDURE INDEX

PROCEDURE	PAGE
Removal	21-25
Installation	21-27

TOOLS: 5/16 in. combination box and open end wrench
 7/16 in. combination box and open end wrench
 9/16 in. combination box and open end wrench
 5/8 in. combination box and open end wrench
 3/4 in. combination box and open end wrench
 7/8 in. combination box and open end wrench
 7/16 in. socket with 1/2 in. drive
 3/4 in. socket with 1/2 in. drive
 Ratchet with 1/2 in. drive
 Diagonal cutting pliers
 5 in. extension with 1/2 in. drive
 3/4 in. socket with 3/8 in. drive
 11/16 in. combination box and open end wrench
 Torque wrench 0-200 in-lb with 3/8 in. drive

SUPPLIES: Container
 Lint-free cloth (Item 12, Appendix D)
 Lockwire (Item 61, Appendix D)
 Oil (Item 44, Appendix D)
 Lockwashers (4 required)

REFERENCE TM 5-5420-202-10

PRELIMINARY PROCEDURE: Remove engine shroud (page 9-30)

REMOVAL:

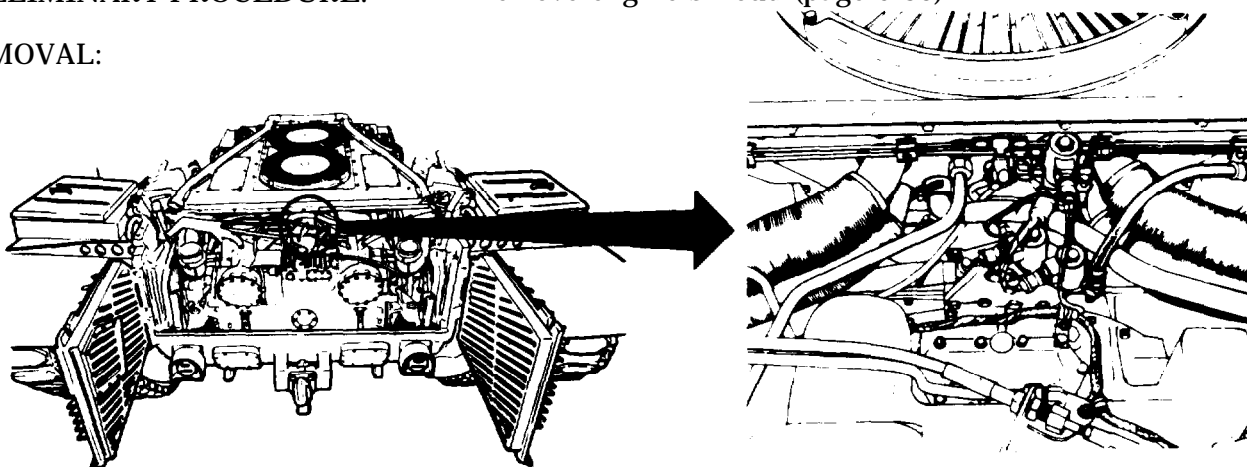

Go on to Sheet 2

TA248766

SMOKE GENERATOR SOLENOID REPLACEMENT (Sheet 2 of 5)

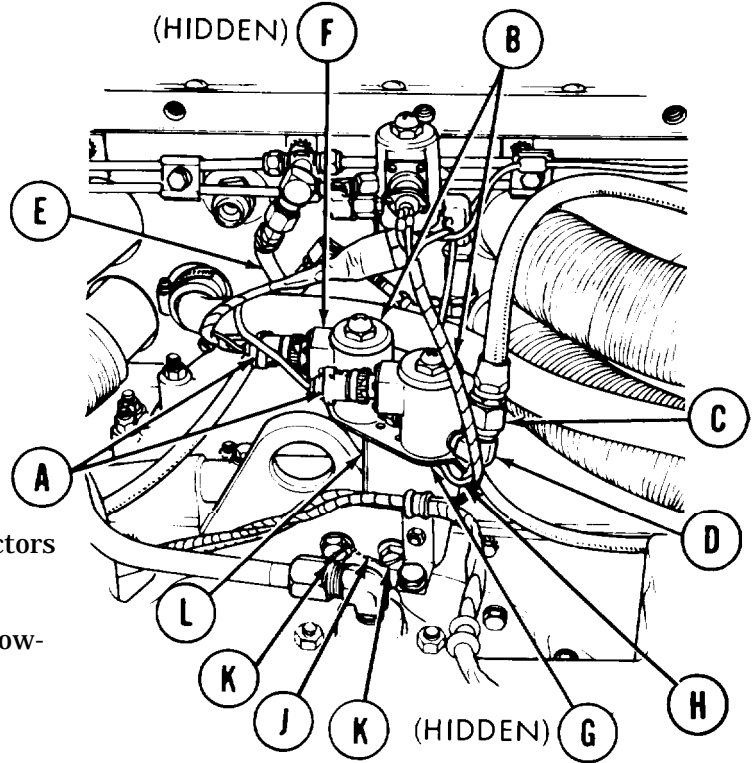

1. Manually disconnect electrical connectors (A) from solenoids(B).
2. Using 7/8 inch wrench, disconnect elbow-to-solenoid hose (C) from 90-degree elbow (D).
3. Using 11/16 inch wrench, disconnect output fuel hose (E) from 45-degree elbow (F).
4. Using 7/16 inch wrench to hold screw and 7/16 inch socket and extension on nut, remove nut and screw (G) and remove ground wire (H) from bracket.
5. Using pliers, cut and remove lockwire (J). Throw lockwire away.
6. Using 3/4 inch socket, remove two screws (K) securing bracket (L) to engine.
7. Remove bracket (L) and attached solenoids (B) with fittings as a unit.

Go on to Sheet 3

TA248767

SMOKE GENERATOR SOLENOID REPLACEMENT (Sheet 3 of 5)

8. Using 5/16 inch wrench, remove four screws (M), lockwashers (N), and flat washers (P) securing solenoid valves (B) to bracket (L).
9. Remove solenoid valves (B) with fittings as a unit.
10. Using 3/4 inch wrench, remove 90-degree elbow (Q) from input port of solenoid (B).
11. Using 9/16 inch wrench, remove 45-degree elbow (R) from output port of solenoid (B).
12. Using 5/8 inch wrench, remove nipple (S) from solenoid valves (B).

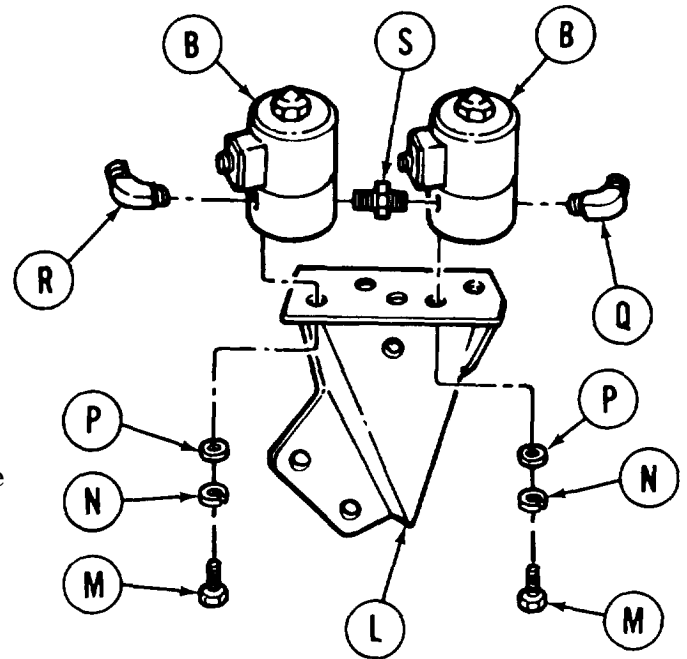

INSTALLATION:

1. Check position of electrical connector on solenoid valves. Hold valve with outlet port to your left. Electrical connector must be 45 degrees from outlet port and pointing toward you. If connector must be repositioned, place valve in soft-jawed vise. Loosen acorn nut on top of valve and rotate connector to correct position. Using 3/4 inch socket and torque wrench, tighten acorn nut to 50 in-lb (5-6 N•m).

Go on to Sheet 4

TA248768

SMOKE GENERATOR SOLENOID REPLACEMENT (Sheet 4 of 5)

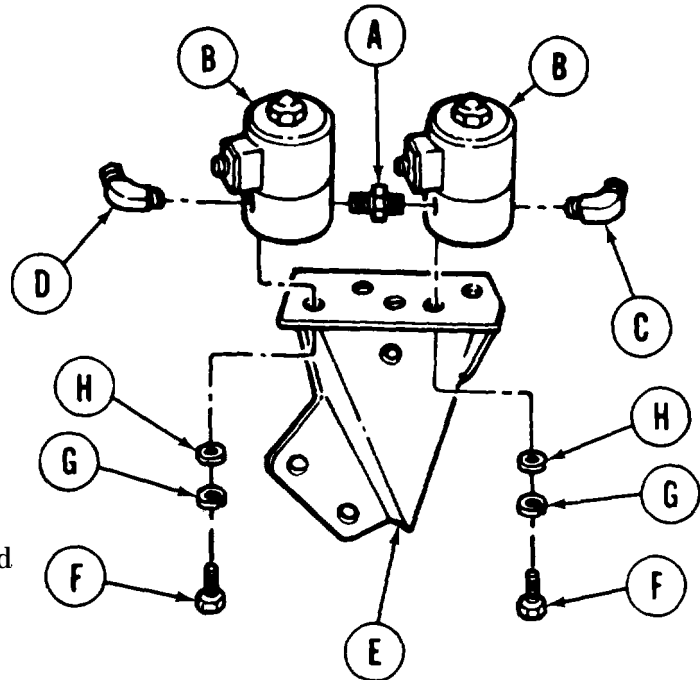

2. Lightly coat threads of nipple (A) with oil.
3. Using 5/8 inch wrench, install nipple (A) into input port of one solenoid (B) and into outlet port of the other solenoid (B).
4. Tighten valves securely onto nipple and adjust valves (B) so their bottoms are even with each other.
5. Lightly coat threads of 90-degree elbow (C) and 45-degree elbow (D) with oil.
6. Holding solenoids (B) and nipple (A) assembly in your hand with connector facing toward you, install 90-degree elbow (C) into inlet port of the solenoid (B) on your right. Using 3/4 inch wrench, tighten 90-degree elbow (C) to the approximate one o'clock position.
7. Install 45-degree elbow (D) into outlet port of the solenoid on your left. Using 9/16 inch wrench, tighten 45-degree elbow (D) to the approximate eight o'clock position.
8. Position assembled solenoids (B) and fittings onto bracket (E) with connectors facing toward you.
9. Using 5/16 inch wrench, install and tighten four screws (F), lockwashers (G), and flat washers (H) to secure solenoids (B) to bracket (E).

SMOKE GENERATOR SOLENOID REPLACEMENT (Sheet 5 of 5)

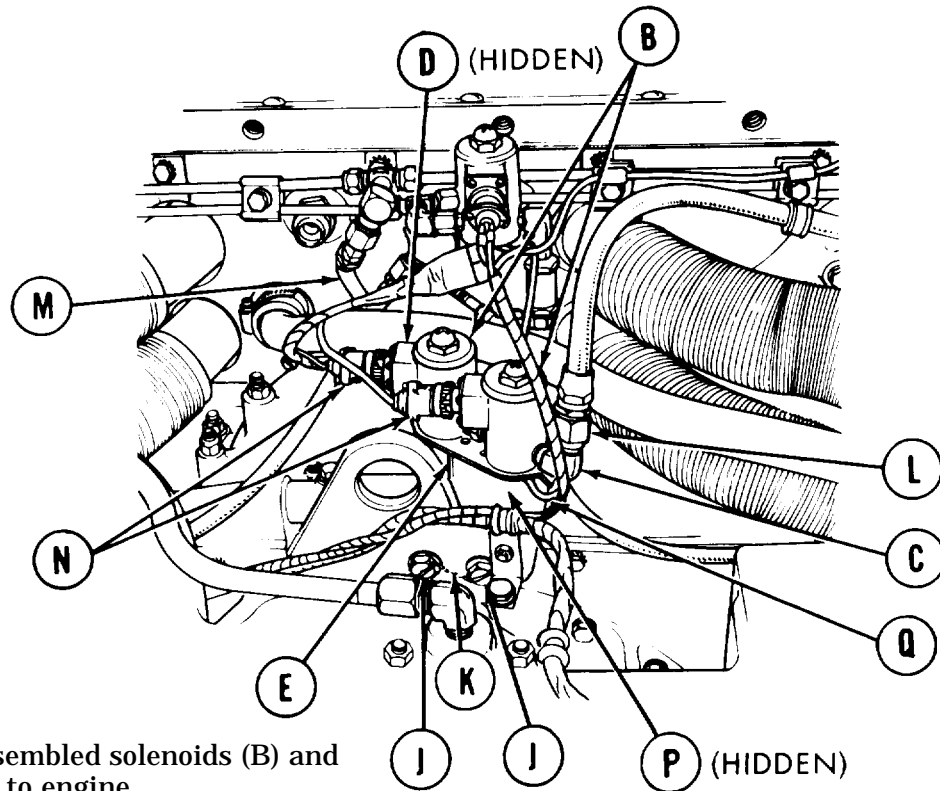

10. Position assembled solenoids (B) and bracket (E) to engine.
11. Using 3/4 inch socket, install and tighten two screws (J) to secure bracket (E) to engine.
12. Install lockwire (K).
13. Using 7/8 inch wrench, connect elbow-to-solenoid hose (L) to 90-degree elbow (c).
14. Using 11/16 inch wrench, connect output fuel hose (M) to 45-degree elbow (D).
15. Manually connect electrical connectors (N) to solenoids (B).
16. Using 7/16 inch wrench and 7/16 inch socket, install nut and screw (P) to secure ground wire (Q) to bracket (E).
17. Start engine (TM 5-5420-202-10). Run engine until normal operating temperatures are reached. Run engine at 1600 rpm and activate smoke generator. Observe operation. Shut down smoke generator. Shut down engine.
18. Check system for any possible fuel leaks. Correct leaks as necessary.
19. Install engine shroud (page 9-3 1).

End of Task

TA248770

SMOKE GENERATOR ELBOW-TO-SOLENOID FUEL HOSE REPLACEMENT (Sheet 1 of 2)

TOOLS: 7/16 in. combination box and open end wrench (2 required)
7/8 in. combination box and open end wrench

SUPPLIES: Container
Lint-free cloth (Item 12, Appendix D)
Lockwasher

REFERENCE: TM 5-5420-202-10

PRELIMINARY PROCEDURE: Remove engine shroud (page 9-30)

REMOVAL:

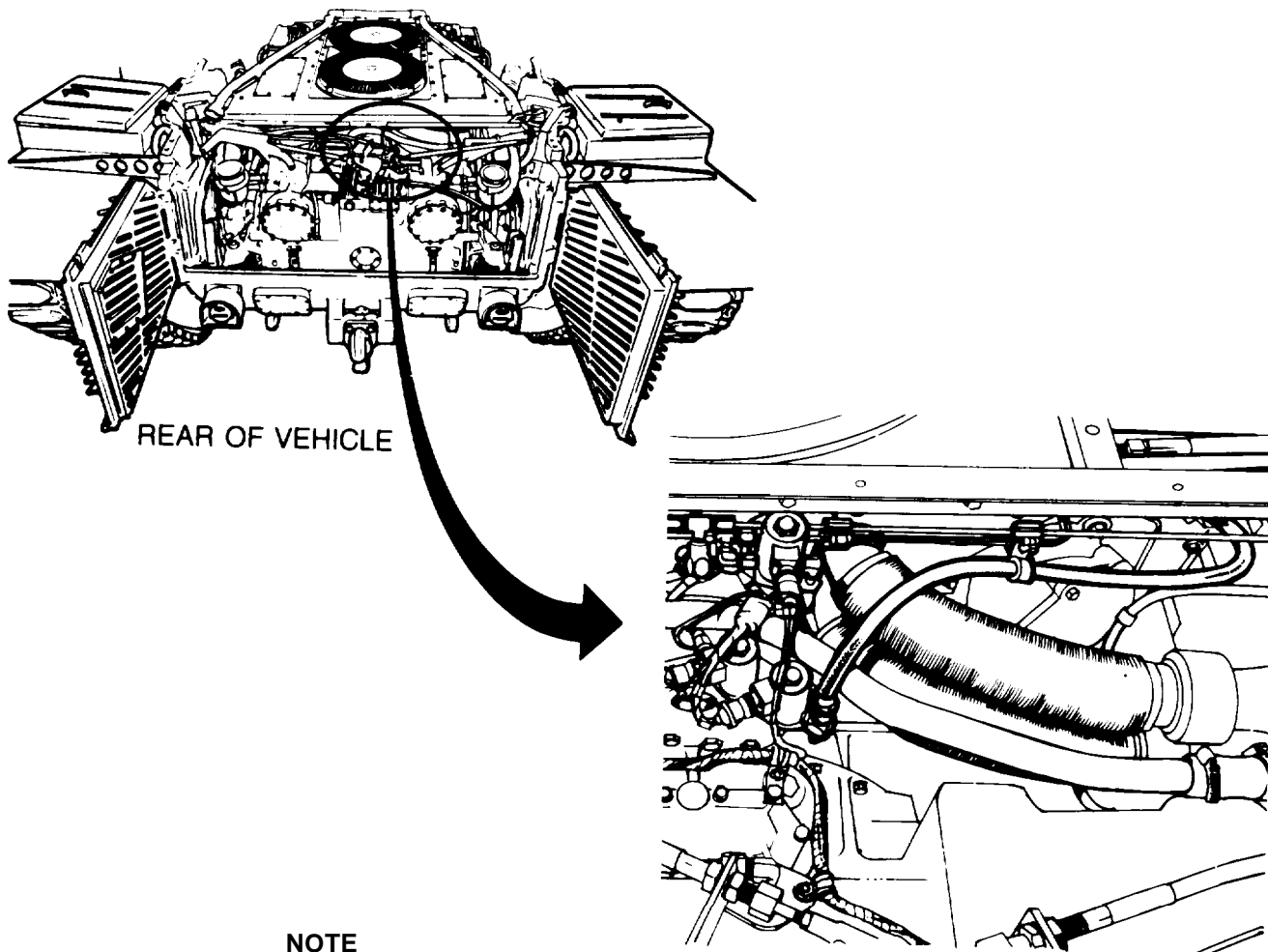

NOTE

Use suitable container to catch fuel whenever any fuel line connection is loosened or disconnected. Cap all openings to prevent contamination of fuel.

Go on to Sheet 2

TA248771

SMOKE GENERATOR ELBOW-TO-SOLENOID FUEL HOSE REPLACEMENT (Sheet 2 of 2)

- Using 7/16 inch wrench to hold nut (A) and 7/16 inch wrench on screw (B), remove nut (A), lockwasher (C), and screw (B) securing retaining straps (D), pads (E), and clamps (F and G).
- Remove retaining straps (D), pads (E), and clamps (F and G).

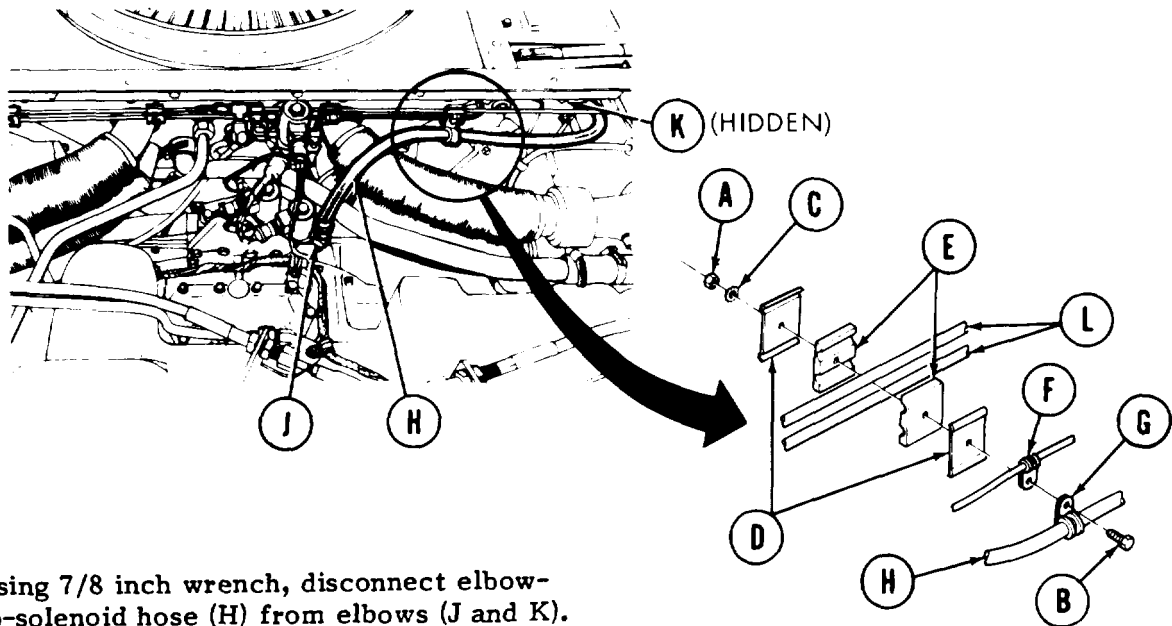

- Using 7/8 inch wrench, disconnect elbow-to-solenoid hose (H) from elbows (J and K).
- Remove elbow-to-solenoid hose (H). Remove clamp (G) from hose (H).

INSTALLATION:

- Install clamp (G) onto elbow-to-solenoid hose (H).
- Position and connect elbow-to-solenoid hose (H) to elbows (J and K). Using 7/8 inch wrench, tighten hose (H) connections to elbows (J and K).
- Install pads (E), retaining straps (D), and clamps (F and G) to tube assemblies (L).
- Install screw (B), lockwasher (C), and nut (A) to tube assemblies. Using 7/16 inch wrench to hold nut (A) and 7/16 inch wrench on screw, tighten screw (B).

WARNING

Do not activate smoke generator in a building or closed area or with personnel near.

CAUTION

Always be aware of wind direction and speed when using smoke generator.

- Start engine (TM 5-5420-202-10) and run until normal operating temperatures are attained. Run engine at 1600 rpm and activate smoke generator. Observe operation. Shut off smoke generator. Shut down engine.
- Check smoke generator lines for leaks. Correct as necessary.
- Install engine shroud (page 9-3).

End of Task

TA248772

SMOKE GENERATOR SOLENOID OUTPUT FUEL HOSE REPLACEMENT (Sheet 1 of 2)

TOOLS: 11/16 in. combination box and open end wrench
3/4 in. combination box and open end wrench

SUPPLIES: Container
Lint-free cloth (Item 12, Appendix D)

REFERENCE: TM 5-5420-202-10

PRELIMINARY PROCEDURE: Remove engine shroud (page 9-30)

REMOVAL:

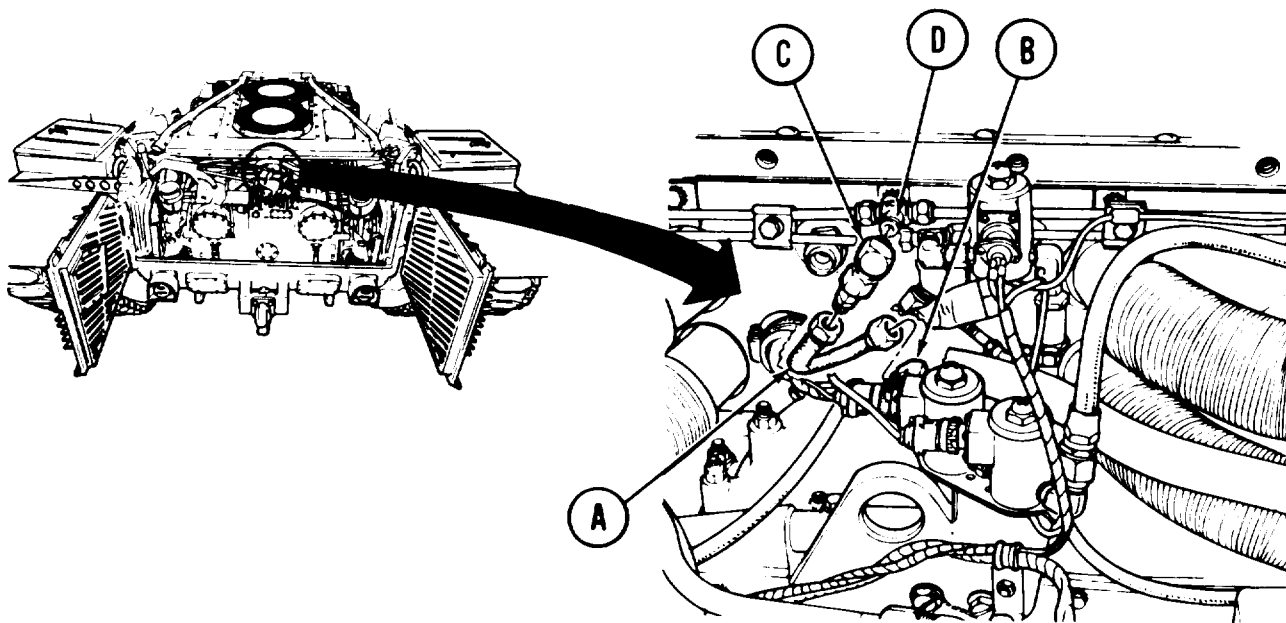

1. Using 11/16 inch wrench, disconnect output fuel hose (A) from 45-degree elbow (B) and 90-degree elbow (C).
2. Remove hose (A).
3. Inspect 90-degree elbow (C) for cracks or damaged threads.
4. If damaged or defective, using 3/4 inch wrench, remove 90-degree elbow (C) from tee (D) and throw it away.

Go on to Sheet 2

TA248773

SMOKE GENERATOR SOLENOID OUTPUT FUEL HOSE REPLACEMENT (Sheet 2 of 2)**INSTALLATION:**

1. Using 3/4 inch wrench, install 90-degree elbow (A) to tee (B). Adjust elbow to face engine.
2. Position and manually connect hose (C) to 90-degree elbow (A) and 45-degree elbow (D).
3. Using 11/16 inch wrench, tighten hose (C) connectors to elbows (A) and (D).

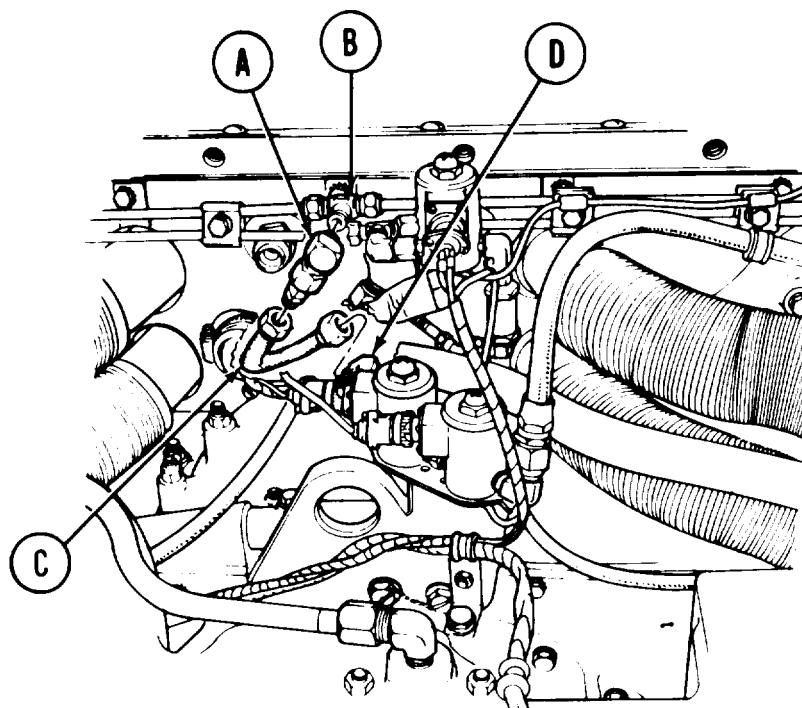
**WARNING**

Do not activate smoke generator in a building or closed area or with personnel near,

CAUTION

Always be aware of wind direction and speed when using smoke generator.

4. Start engine (TM 5-5420-202-10) and run until normal operating temperatures are attained. Run engine at 1600 rpm and activate smoke generator. Observe operation. Shut off smoke generator. Shut down engine.
5. Check smoke generator lines for leaks. Correct as necessary.
6. Install engine shroud (page 9-31).

End of Task

TA248774

SMOKE GENERATOR TEE-TO-TURBOSUPERCHARGER TUBE ASSEMBLY REPLACEMENT
 (Sheet 1 of 5)

PROCEDURE INDEX

PROCEDURE	PAGE
Removal	21-34
Installation	21-37

TOOLS: 7/16 in. combination box and open end wrench (2 required)
 1/2 in. combination box and open end wrench
 9/16 in. combination box and open end wrench (2 required)
 11/16 in. combination box and open end wrench
 3/4 in. combination box and open end wrench

SUPPLIES: Container
 Lint-free cloth (Item 12, Appendix D)
 Lockw asher

REFERENCE. TM 5-5420-202-10

PRELIMINARY PROCEDURE: Remove engine shroud (page 9-30)

REM OVAL:

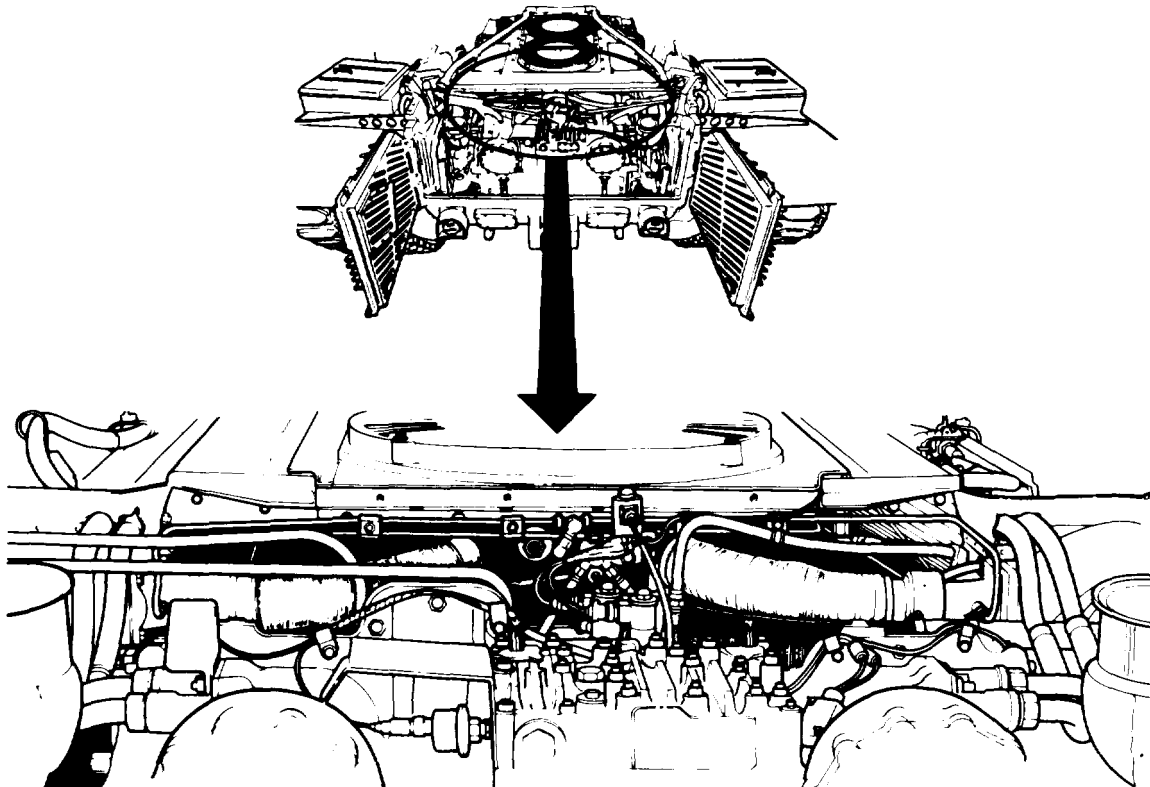

Go on to Sheet 2

TA248775

SMOKE GENERATOR TEE-TO-TURBOSUPERCHARGER TUBE ASSEMBLY REPLACEMENT

(Sheet 2 of 5)

NOTE

Replacement of left or right tube assembly is similar, except as noted. Replacement of right tube assembly is shown.

NOTE

Use suitable container to catch fuel whenever any fuel line connection is loosened or disconnected.

- Using 7/16 inch wrench to hold nut (A) and 7/16 inch wrench on screw (B), remove screw (B), lockwasher (C), and nut (A) securing retaining straps (D), cushions (E), and clamps (F and G) (two places).

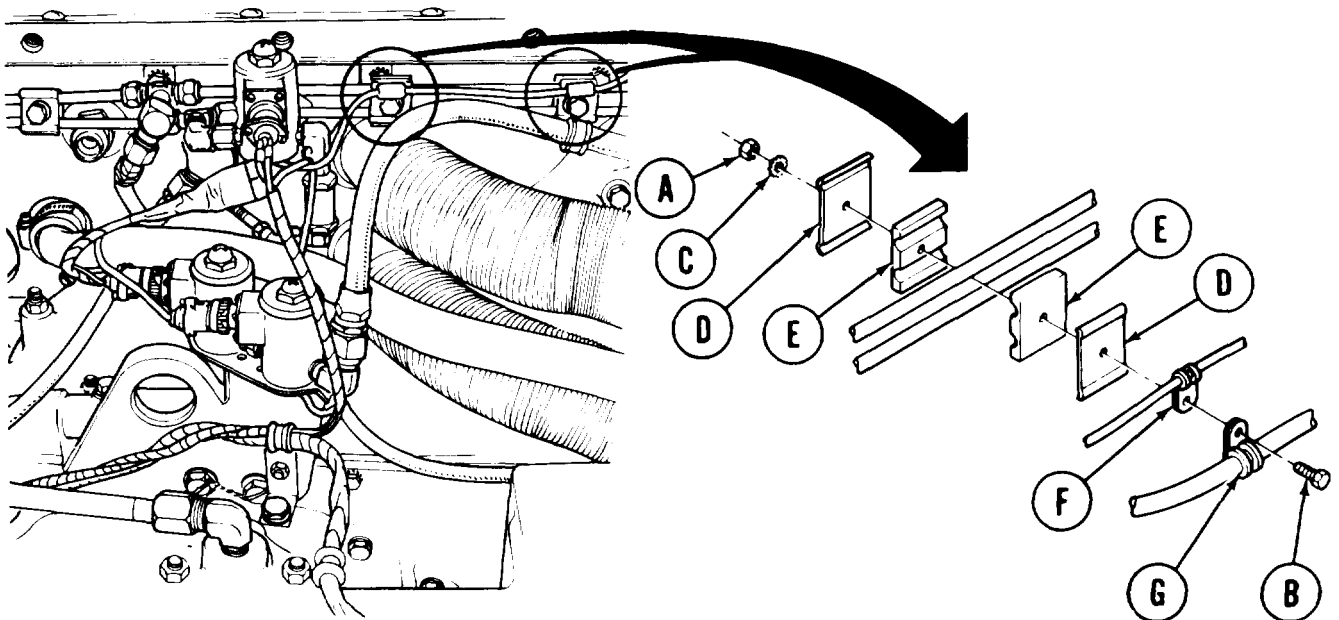

- Remove two retaining straps (D), two cushions (E), and clamps (F and G) if present.

NOTE

One clamp is used at inner position, two clamps at outer position for right tube installation. No clamps are used on left tube installation.

Go on to Sheet 3

TA248776

SMOKE GENERATOR TEE-TO-TURBOSUPERCHARGER TUBE ASSEMBLY REPLACEMENT

(Sheet 3 of 5)

3. Using 11/16 inch wrench, disconnect solenoid output fuel hose (H) from 90-degree elbow (J).
4. Using 3/4 inch wrench, remove 90-degree elbow (J) from tee(K).
5. Using 9-16 inch wrench to hold tee (K), use 9/16 inch wrench and disconnect tubes(L) from tee (K).
6. Remove tee (K).

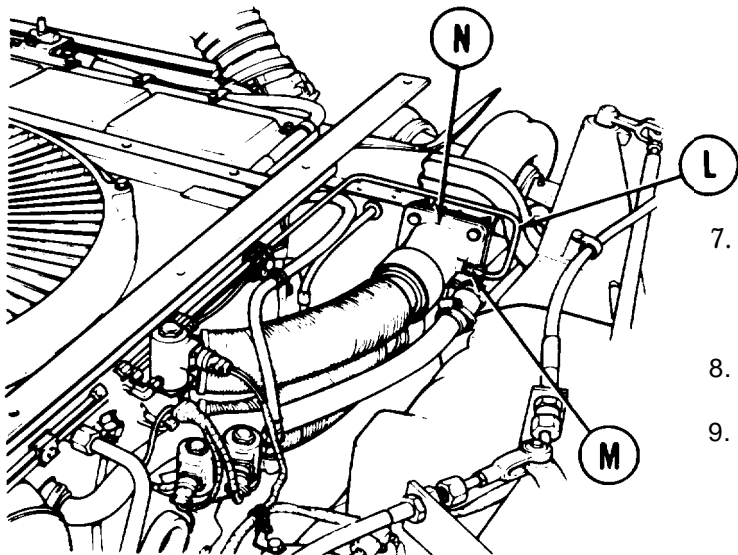
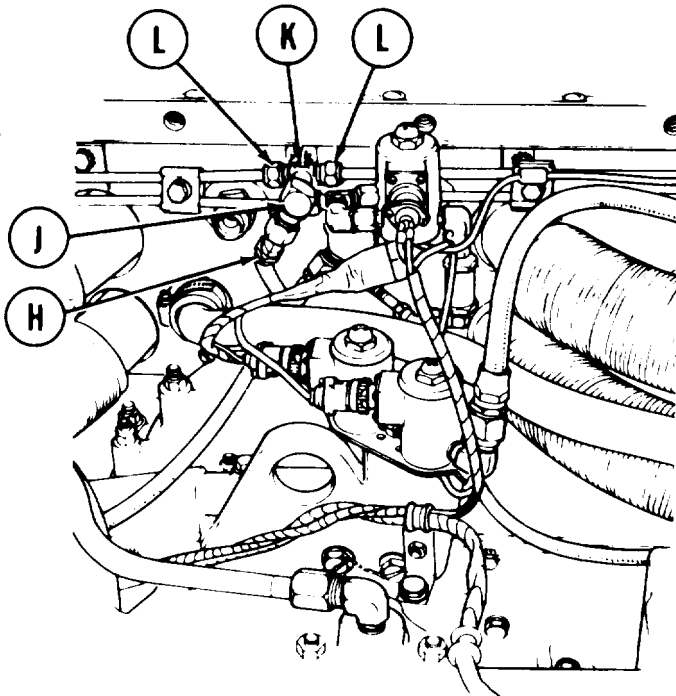

7. Using 1/2 inch wrench to hold adapter (M), use 9/16 inch wrench and disconnect tube (L) from adapter (M).
8. Remove tube (L).
9. Inspect adapter (M) in turbosupercharger elbow (N) for cracks or damaged threads. If defective, use 1/2 inch wrench and remove adapter (M) and throw it away.

Go on to Sheet 4

TA248777

SMOKE GENERATOR TEE-TO-TURBOSUPERCHARGER TUBE ASSEMBLY REPLACEMENT (Sheet 4 of 5)

INSTALLATION:

1. If adapter (A) was removed from turbosupercharger elbow (B), remove adapter (A) from replacement tube and, using 1/2 inch wrench, install adapter (A) to turbosupercharger elbow (B).
2. If adapter (A) was not removed from turbosupercharger elbow, remove adapter (A) from replacement tube and return adapter to supply.
3. Position tube (C) to engine and manually connect it to adapter (A).

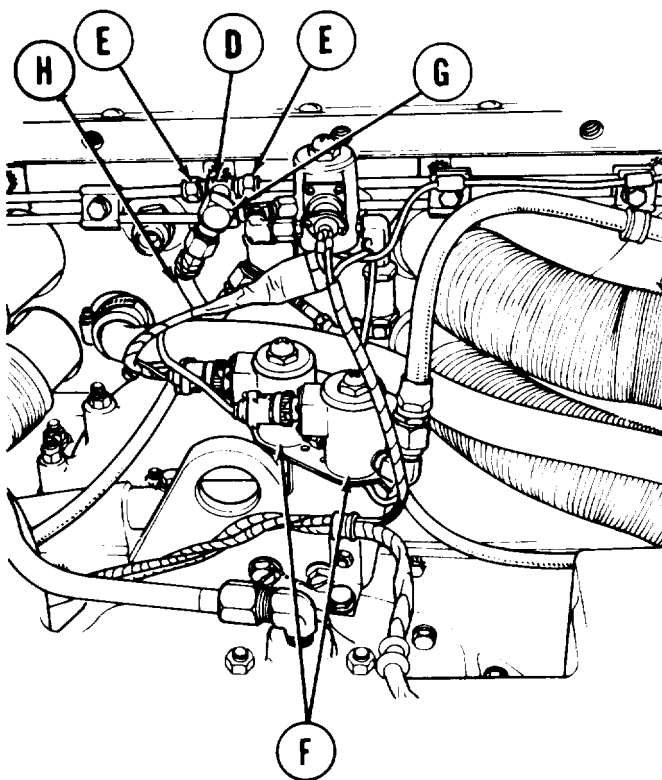
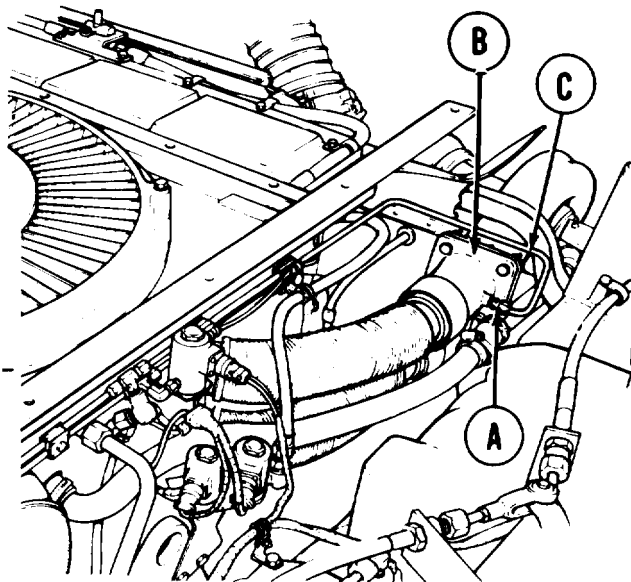

4. Position tee (D) and manually connect tube nuts (E) to tee (D).
5. Position tee (D) so the open port points toward solenoid valves (F).
6. Using 9/16 inch wrench, tighten tube nuts (E) onto tee (D).
7. Using 3/4 inch wrench, install 90-degree elbow (G) to tee (D). Position elbow open port down.
8. Using 11/16 inch wrench, connect solenoid output fuel hose (H) to 90-degree elbow (G).
9. Using 1/2 inch wrench to hold adapter (A) in turbosupercharger elbow (B), use 9/16 inch wrench to tighten tube (C) onto adapter (A).

Go on to Sheet 5

TA248778

SMOKE GENERATOR TEE-TO-TURBOSUPERCHARGER TUBE ASSEMBLY REPLACEMENT

(Sheet 5 of 5)

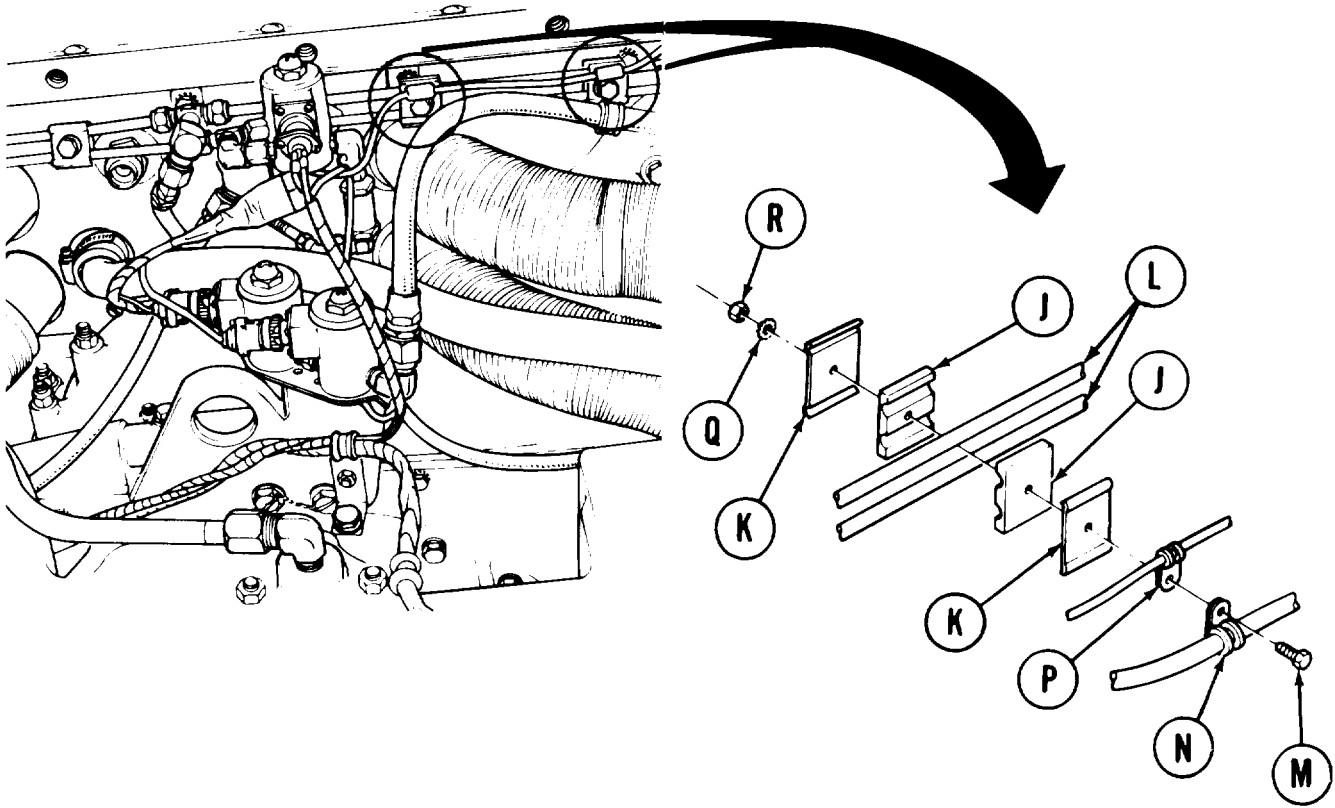

10. Position two cushions (J) and two retaining straps (K) over tubes (L) (two places).
11. Install screw (M) through clamps (N and P), cushions (J), retaining straps (K), lockwasher and nut (R).
12. Using 7/16 inch wrench to hold nut (R), use 7/16 inch wrench to tighten screw (M) to secure clamps, cushions, and retaining straps.

WARNING

Do not activate smoke generator in a building or closed area or with personnel near.

CAUTION

Always be aware of wind direction and speed when using smoke generator.

13. Start engine (TM 5-5420-202-10) and run until normal operating temperatures and Run engine at 1600 rpm and activate smoke generator. Observe operation. Shut smoke generator. Shut down engine. attained.
14. Check smoke generator lines for leaks. Correct as necessary.
15. Install engine shroud (page 9-31).

End of Task

TA248779

SMOKE GENERATOR FRONT ENGINE FUEL HOSE REPLACEMENT (Sheet 1 of 4)

PROCEDURE INDEX

PROCEDURE	PAGE
Removal	21-39
Installation	21-41

TOOLS: 7/8 in. combination box and open end wrench
 1/2 in. socket with 1/2 in. drive
 Ratchet with 1/2 in. drive

SUPPLIES: Container
 Lint-free cloth (Item 12, Appendix D)

REFERENCE: TM 5-5420-202-10

PRELIMINARY PROCEDURES: Remove upper engine access cover (page 17- 11)
 Remove engine shroud (page 9-30)

REMOVAL:

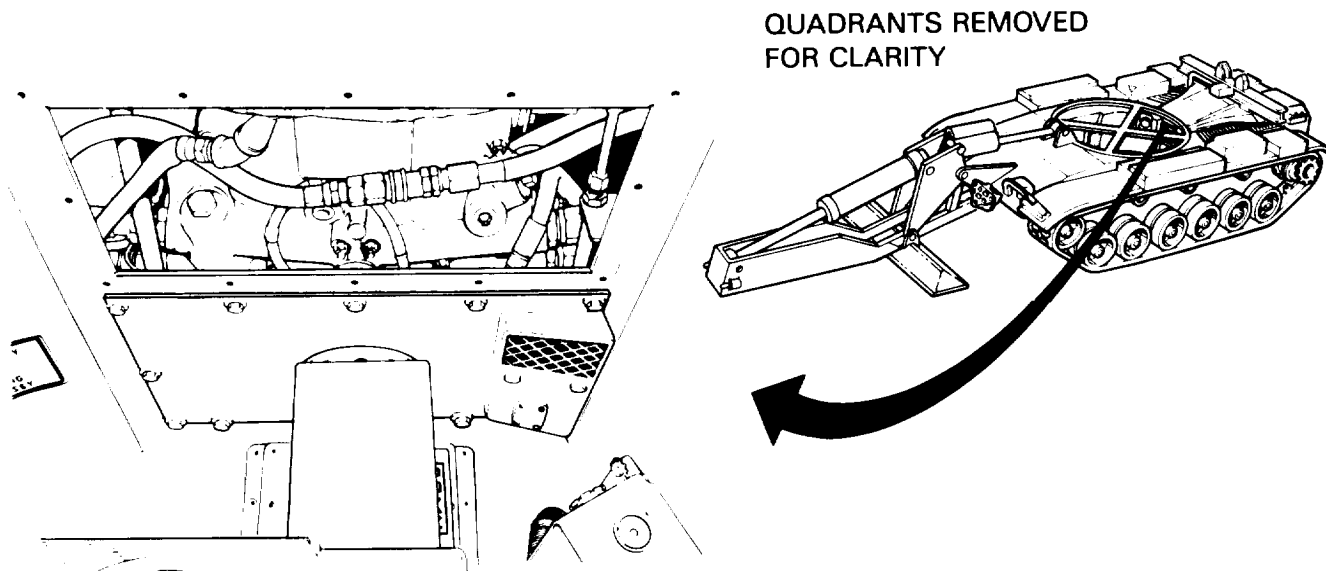

NOTE

Use suitable container to catch fuel whenever any fuel line connection is loosened or disconnected. Cap all openings to prevent contamination of fuel.

NOTE

Steps 1 thru 5 are performed from inside of crew compartment.

Go on to Sheet 2

TA248780

SMOKE GENERATOR FRONT ENGINE FUEL HOSE REPLACEMENT (Sheet 2 of 4)

1. Using wrench, disconnect smoke generator fuel hose (A) from tee (B).
2. Using wrench, disconnect fuel water separator hose (C) from tee (B).
3. Using wrench, disconnect tee (B) from bulkhead elbow (D).

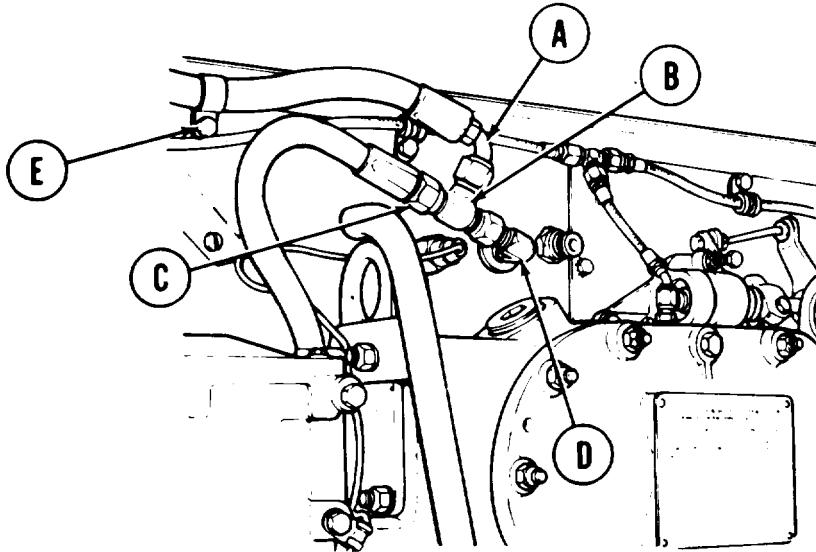

4. Inspect threads on tee (B). If damaged in any way, replace.
5. Using socket, remove assembled washer screw (E).

NOTE

Steps 6 thru 9 are performed from outside and atop engine.

Go on to Sheet 3

TA248781

SMOKE GENERATOR FRONT ENGINE FUEL HOSE REPLACEMENT (Sheet 3 of 4)

6. Using socket, remove three assembled washer screws (F) securing clamps (G) to engine.
7. Using wrench, disconnect smoke generator fuel hose (A) from fuel shut-off valve (B).
8. Remove smoke generator fuel hose (A) from engine.
9. Remove three clamps from hose (G) and throw hose away.

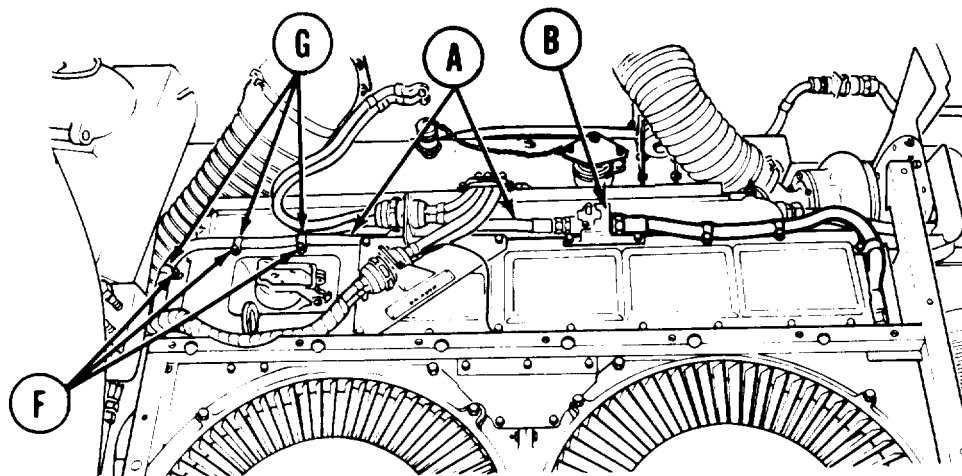
**INSTALLATION:**

1. Install three clamps (A) onto smoke generator fuel hose (B).
2. Position smoke generator fuel hose (B) under electrical cables and along edge of shroud as indicated.
3. Position clamps (A) along hose (B) and, using socket, install assembled washer screws (C).
4. Remove cap from inlet port of fuel shut-off valve (D) and manually connect smoke generator fuel hose (B) to inlet port of fuel shut-off valve (D). Using wrench, tighten hose (B) to fuel shut-off valve (D).

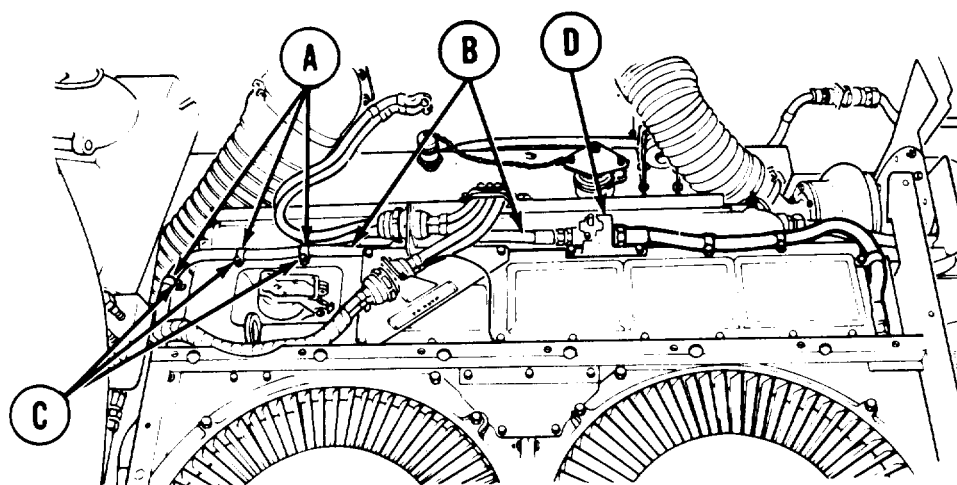

Go on to Sheet 4

TA248782

SMOKE GENERATOR FRONT ENGINE FUEL HOSE REPLACEMENT (Sheet 4 of 4)

5. Manually install tee(E) onto bulkhead elbow (F).
6. Manually connect fuel water separator hose (G) onto tee (E).
7. Manually connect smoke generator fuel hose (B) to tee (E).
8. Adjust positions of tee (E) and hoses (B and G) to avoid interference with other parts. Using wrench, tighten tee (E) to elbow (F) and hoses (B and G) to tee (E).

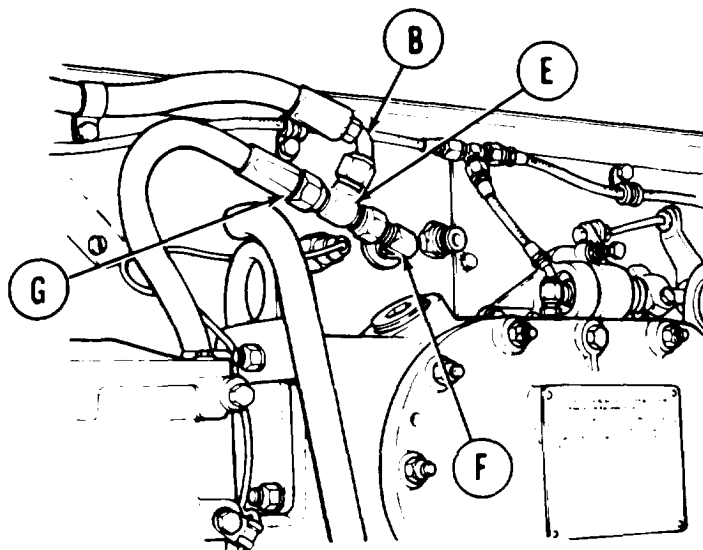

WARNING

Do not activate smoke generator in a building or closed area or with personnel near.

CAUTION

Always be aware of wind direction and speed when using smoke generator.

9. Start engine (TM 5-5420-202-10) and run until normal operating temperatures are attained. Run engine at 1600 rpm and activate smoke generator. Observe operation. Shut off smoke generator. Shut down engine.
10. Check smoke generator fuel lines for leaks. Correct as necessary.
11. Install upper bulkhead engine access cover (page 17-12).
12. Install engine shroud (page 9-31).

End of Task

TA248783

CHAPTER 22
SMOKE GRENADE LAUNCHER MAINTENANCE
INDEX

Procedure	Page
Smoke Grenade Power Box Replacement	22-2
Smoke Grenade Pushbutton Unit Replacement	22-4
Smoke Grenade Crew Compartment Wiring Harness Assembly Replacement	22-6
Smoke Grenade Hull Compartment Wiring Harness Assembly Replacement	22-12
Smoke Grenade Discharger Replacement	22-23
Smoke Grenade Discharger Wiring Harness Assembly Replacement	22-25
Smoke Grenade Discharger Bracket Dummy Receptacle Replacement	22-27
Smoke Grenade Stowage Box Replacement	22-29
Smoke Grenade Launcher Functional Check	22-30

SMOKE GRENADE POWER BOX REPLACEMENT (Sheet 1 of 2)

TOOLS: 7/16 in. combination box and open end wrench (2 required)
Slip joint pliers, conduit style, with plastic jaw inserts

SUPPLIES: Lockwashers (2 required)

REMOVAL:

WARNING

Make sure there are no smoke grenades in dischargers. Accidental firing of grenade could hurt or kill you.

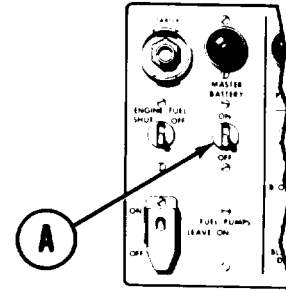

OPERATOR'S STATION

1. Set MASTER BATTERY switch (A) to OFF.
2. Using pliers, disconnect electrical connector (B) from power box (C).
3. Using one wrench to hold screw (D) and other wrench to turn nut (E), remove two screws (D), lockwashers (F), and nuts (E) securing box (C) to bracket (G).
4. Remove box (C) from bracket (G).

Go on to Sheet 2

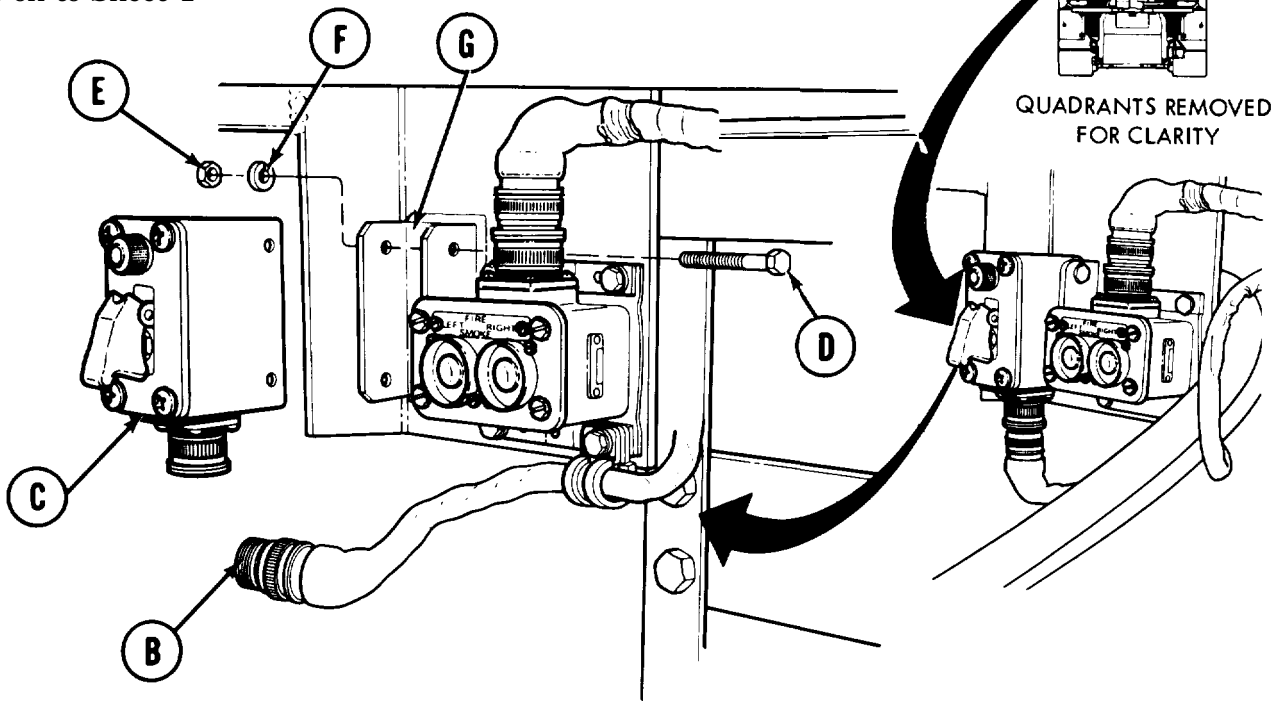

TA248784

SMOKE GRENADE POWER BOX REPLACEMENT (Sheet 2 of 2)

INSTALLATION:

WARNING

Make sure there are no smoke grenades -in dischargers. Accidental firing of grenade could hurt or kill you.

1. Put box (A) in position on bracket (B). Aline holes in box (A) with holes in bracket (B).
2. Using one wrench to hold screw (C) and other wrench to turn nut (D), install and tighten two screws (C), lockwashers (E), and nuts (D).
3. Connect electrical connector (F) to box (A).
4. Perform smoke grenade launcher functional check (page 22-30).

End of Task

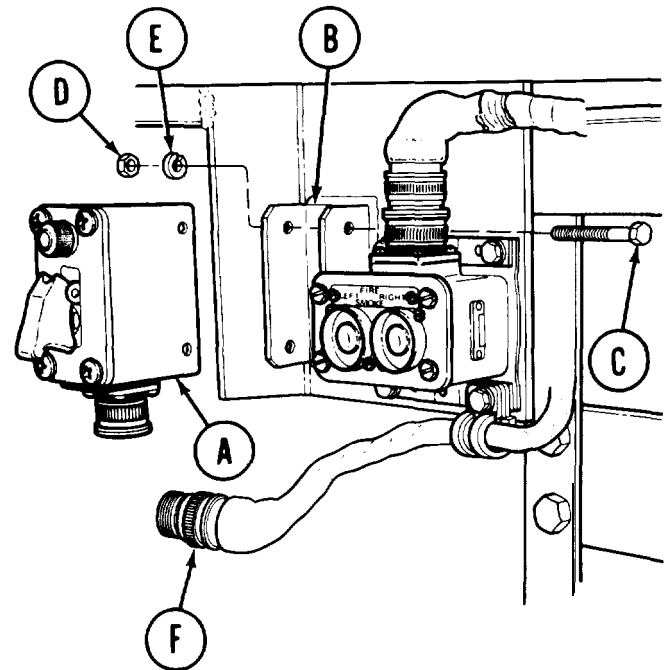

TA248785

SMOKE GRENADE PUSHBUTTON UNIT REPLACEMENT (Sheet 1 of 2)

TOOLS: 7/16 in. socket with 3/8 in. drive
 5 in. extension with 3/8 in. drive
 Ratchet with 3/8 in. drive
 Slip joint pliers, conduit style, with plastic jaw inserts

SUPPLIES: Lockwashers (4 required)

REMOVAL:

WARNING

Make sure there are no smoke grenades in dischargers. Accidental firing of grenade could hurt or kill you.

1. Set MASTER BATTERY switch (A) to OFF.
2. Using pliers, disconnect electrical connector (B) from pushbutton unit (C).
3. Using socket and extension, remove screw (D) and lockwasher (E) securing clamp (F) and harness lead (G) to pushbutton unit (C) and bracket (H). Remove three other screws (D) and lockwashers (E) securing unit (C) to bracket (H).
4. Remove unit (C) from bracket (H).

Go on to Sheet 2

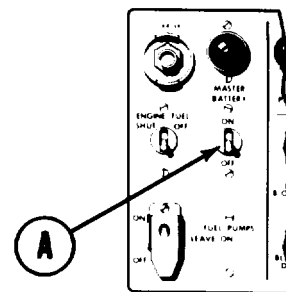

OPERATOR'S STATION

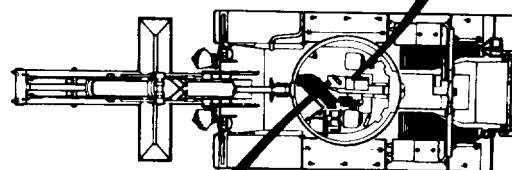

QUADRANTS REMOVED FOR CLARITY

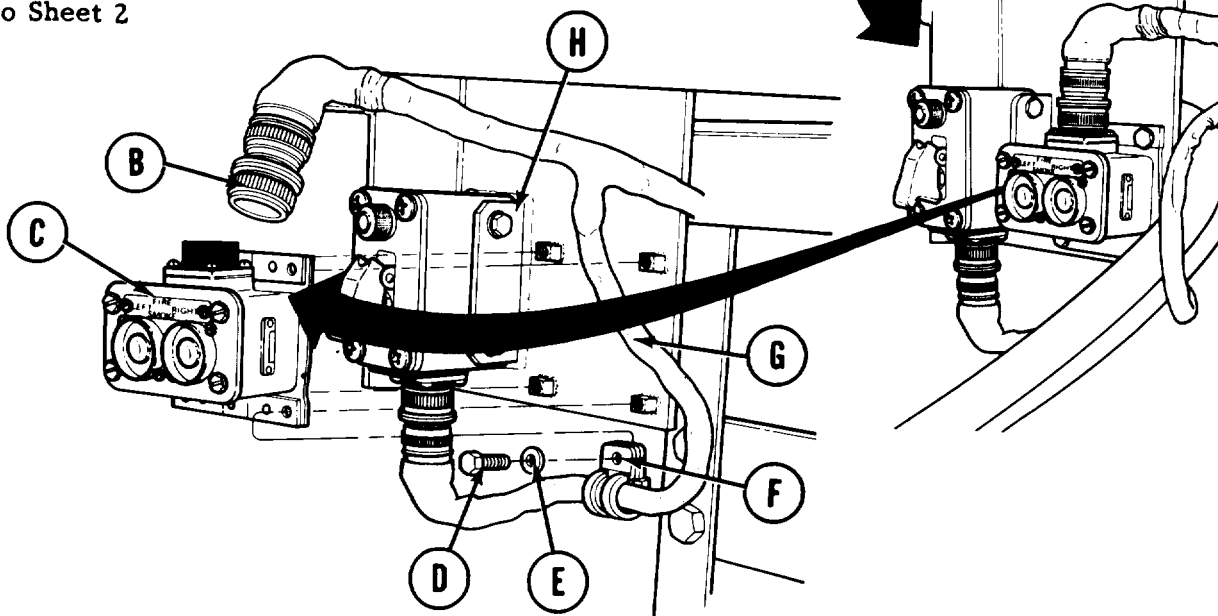

TA248786

SMOKE GRENADE PUSHBUTTON UNIT REPLACEMENT (Sheet 2 of 2)

INSTALLATION:

WARNING

Make sure there are no smoke grenades in dischargers. Accidental firing of grenade could hurt or kill you.

1. Put pushbutton unit (A) in position on bracket (B). Aline unit mounting holes with bracket mounting holes.
2. Using socket and extension, put in but do not tighten screw (C) and lockwasher (D) securing clamp (E) and harness lead (F) to pushbutton unit (A) and bracket (B). Put in other three screws (C) and lockwashers (D). Tighten all four screws (C).
3. Connect electrical connector (G) to pushbutton unit (A).
4. Perform smoke grenade launcher functional check (page 22-30).

End of Task

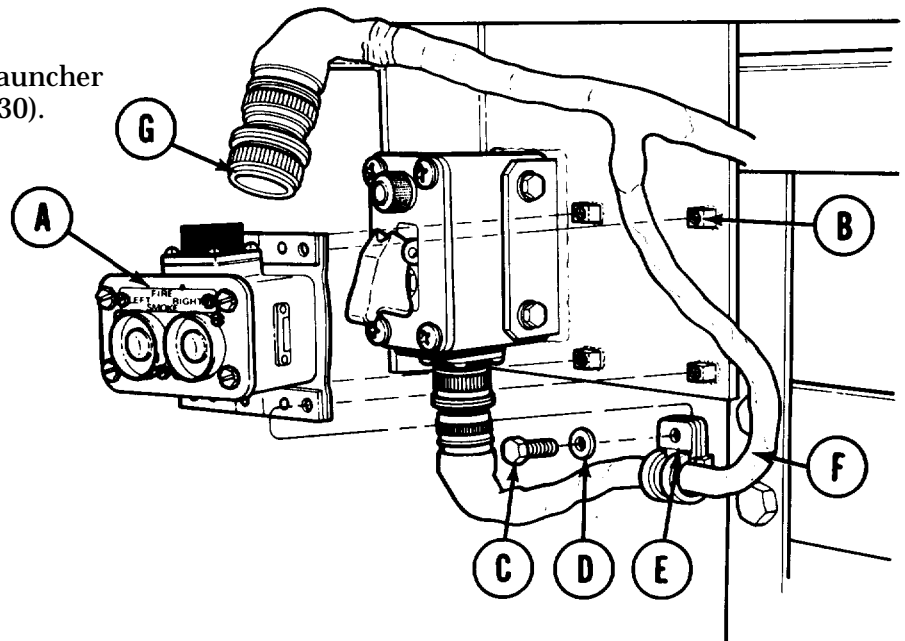

TA248787

**SMOKE GRENADE CREW COMPARTMENT WIRING HARNESS ASSEMBLY REPLACEMENT
(Sheet 1 of 6)**

PROCEDURE INDEX

PROCEDURE	PAGE
Removal	22-6
Installation	22-9

TOOLS: 7/16 in. socket with 3/8 in. drive
 5 in. extension with 3/8 in. drive
 Ratchet with 3/8 in. drive
 Slip joint pliers, conduit style, with plastic jaw inserts

SUPPLIES: Lockwashers (17 required)

REMOVAL:

WARNING

Make sure there are no smoke grenades in dischargers. Accidental firing of grenade could hurt or kill you.

1. Set MASTER BATTERY switch (A) to OFF.
2. Using socket, extension, and ratchet, remove screw (B) and lockwasher (C) securing clamp (D) and crew compartment harness assembly (E) to pushbutton unit (C).
3. Using pliers, disconnect electrical connector (G) from pushbutton unit (F) and electrical connector (H) from power box (J).

Go on to Sheet 2

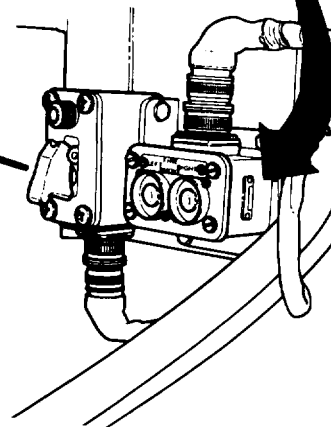
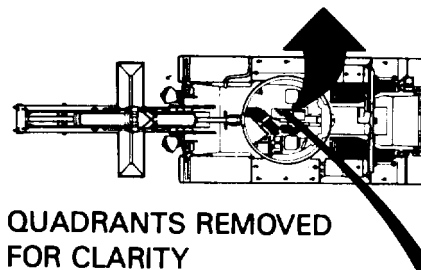
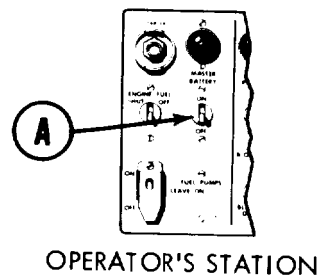
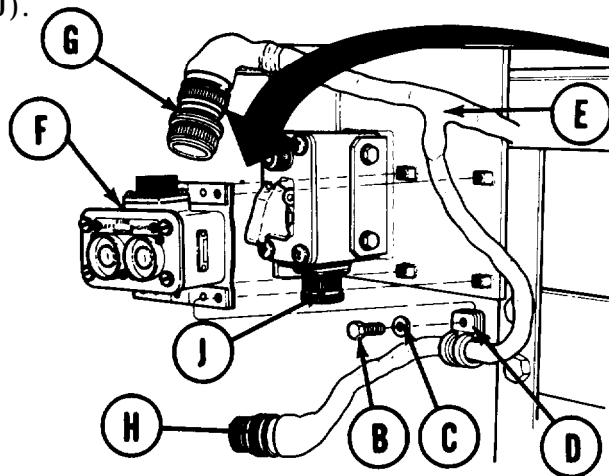

TA248788

SMOKE GRENADE CREW COMPARTMENT WIRING HARNESS ASSEMBLY REPLACEMENT (Sheet 2 of 6)

4. Using pliers, disconnect electrical connector (K) of crew compartment harness assembly (E) from basket disconnect (L).
5. Using fingers, disconnect lead (M) of harness (E) from lead (N) of dome-light rheostat (P). Disconnect harness lead (Q) from CKT 138 power lead (R).
6. Using socket and extension, remove screw (S) and two lockwashers (T) securing clamp (U), ground lead (V), and leads (M) and (Q) of harness (E) to overhead crossbeam (W) and support column (X).

Go on to Sheet 3

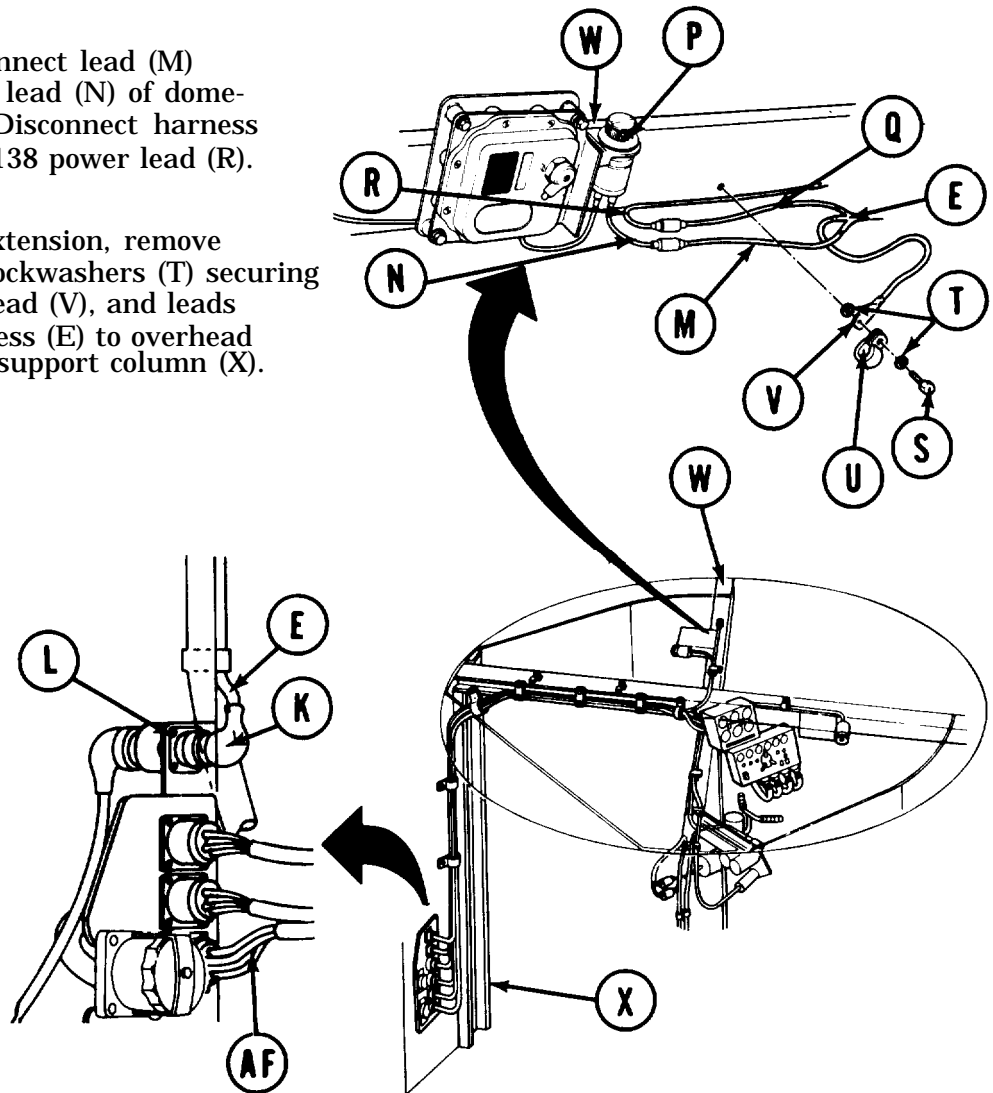

TA248789

SMOKE GRENADE CREW COMPARTMENT WIRING HARNESS ASSEMBLY REPLACEMENT
(Sheet 3 of 6)

7. Using socket and extension, remove three screws (Y), lockwashers (Z), and washers (AA) securing clamps (AB) and harness (E) to overhead crossbeam (W) at three existing straps (AC).
8. Using socket and extension, remove one screw (AD) and lockwasher (AE) securing clamp (AF) and harness (E) to overhead crossbeam (W). Remove three screws (AD) and lockwashers (AE) securing three clamps (AF) and harness (E) to support column (X).
9. Take crew compartment harness (E) out of vehicle.

Go on to Sheet 4

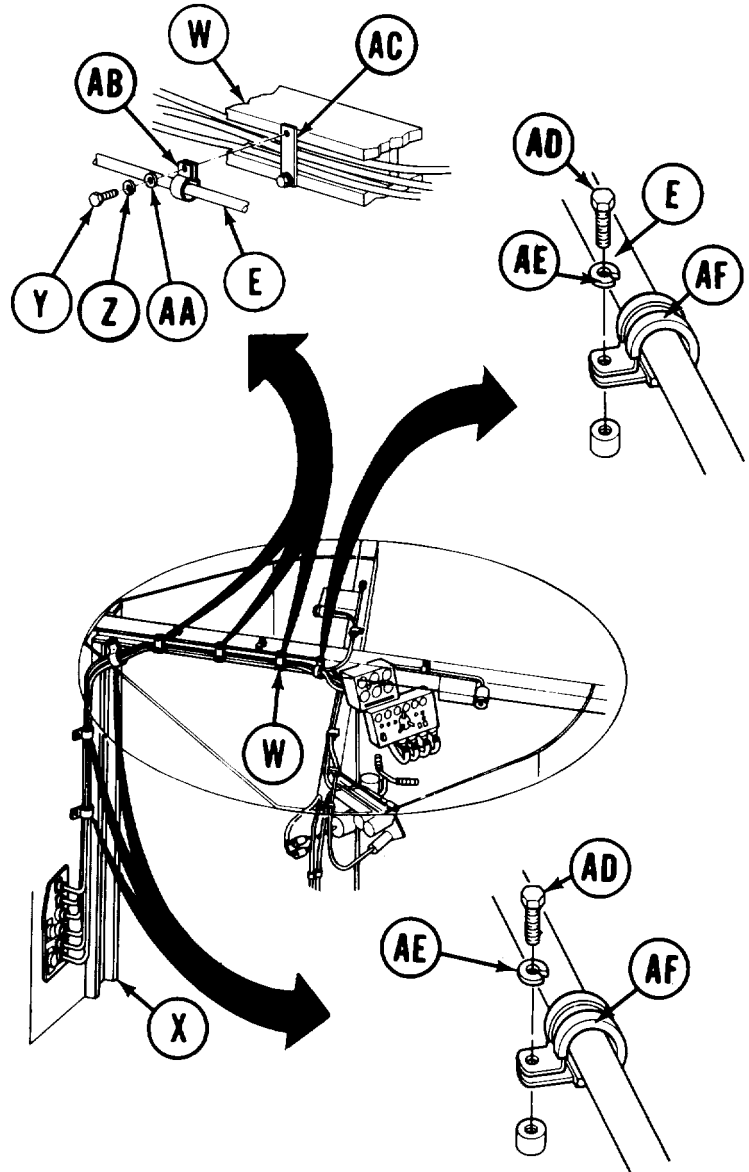

TA248790

SMOKE GRENADE CREW COMPARTMENT WIRING HARNESS ASSEMBLY REPLACEMENT (Sheet 4 of 6)

INSTALLATION:

WARNING

Make sure there are no smoke grenades in dischargers. Accidental firing of grenade could hurt or kill you.

1. Put three clamps (A) on crew compartment harness assembly (B). Using socket and extension, screw in but do not tighten three screws (C), lockwashers (D), and washers (E) securing clamps (A) to overhead crossbeam (F) at three existing straps (G).
2. Put one clamp (H) around harness (B) at overhead crossbeam (F) and three clamps (H) around harness (B) at support column (J). Using socket and extension, screw in but do not tighten four screws (K) and four lockwashers (L) securing clamps (H) to overhead crossbeam (F) and to support column (J).

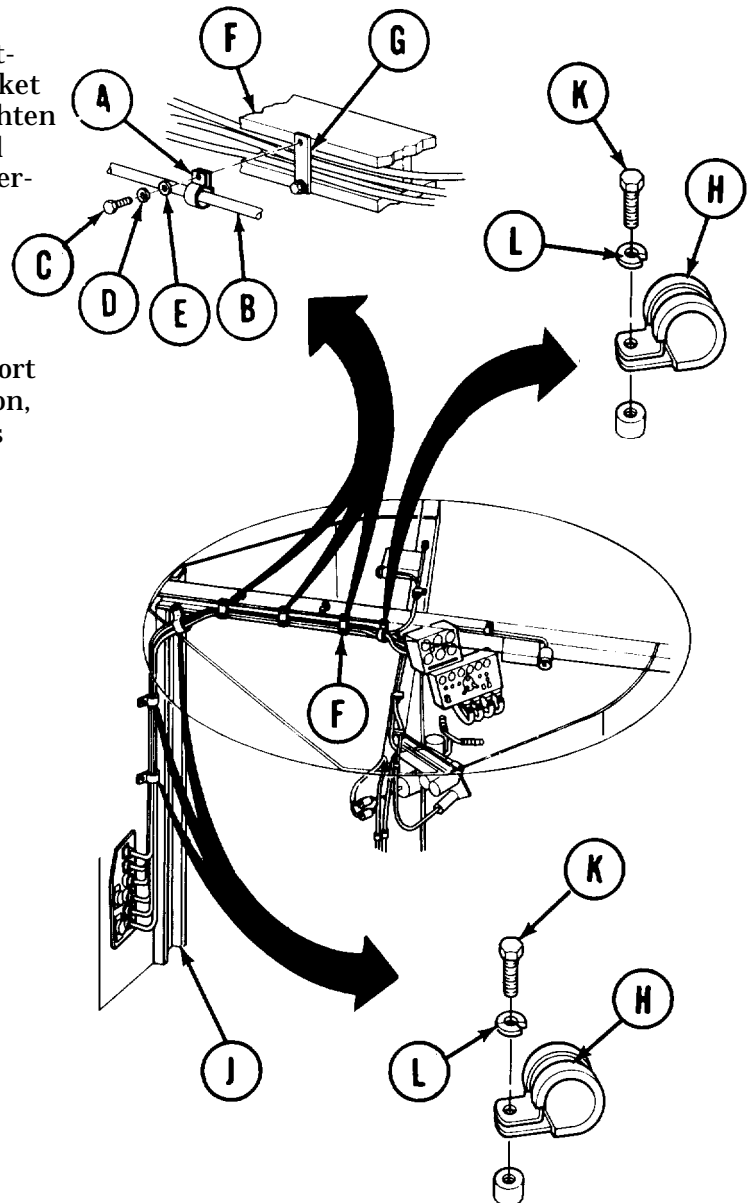

Go on to Sheet 4

TA248791

**SMOKE GRENADE CREW COMPARTMENT WIRING HARNESS ASSEMBLY REPLACEMENT
(Sheet 5 of 6)**

3. Connect lead (M) of harness (B) to lead (N) of dome light rheostat (P). Connect lead (Q) of harness (B) to CKT 138 power lead (R).
4. Put clamp (S) around leads (M) and (Q). Screw in but do not tighten screw (T) and two lockwashers (U) securing clamp (S) and ground lead (V) of harness (B) to overhead crossbeam (F).
5. Connect electrical connector (W) of harness (B) to basket disconnect (X).
6. Using socket and extension, tighten all screws securing harness (B) to overhead crossbeam (F) and support column (J).

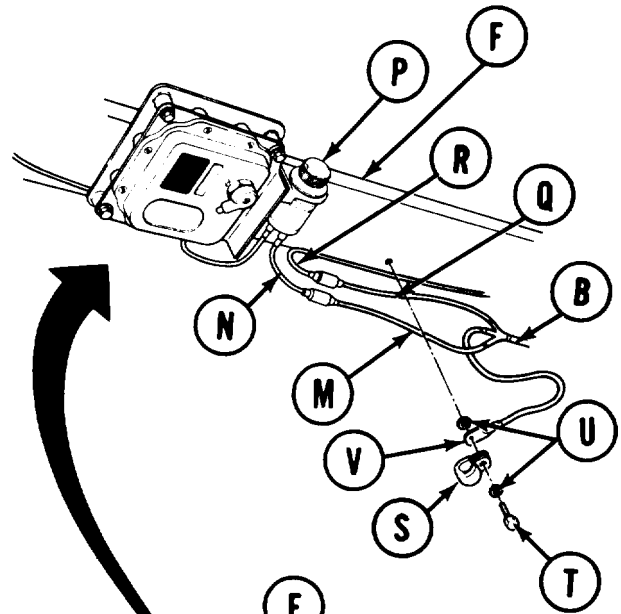

Go on to Sheet 6

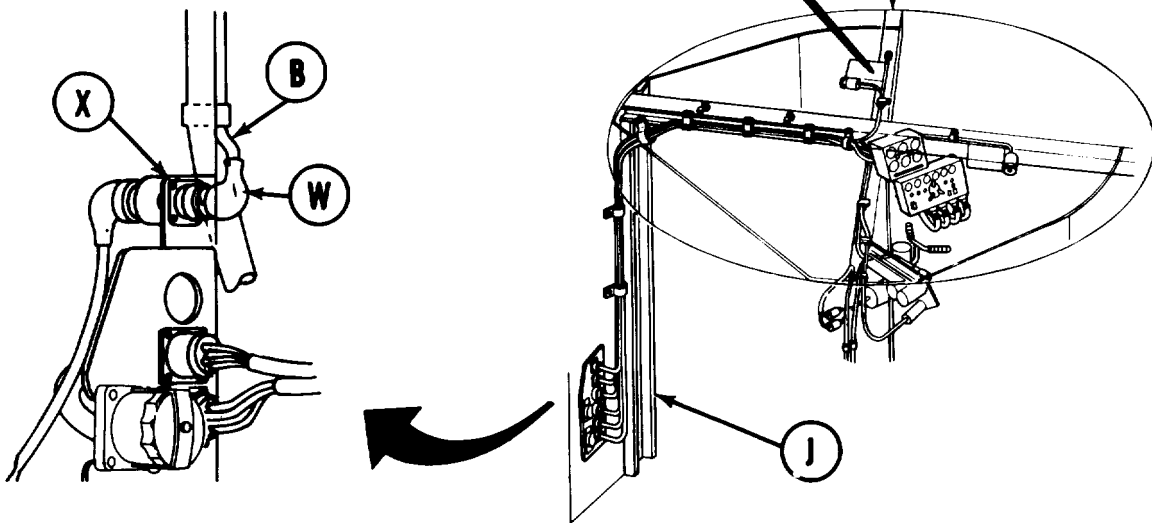

TA248792

SMOKE GRENADE CREW COMPARTMENT WIRING HARNESS ASSEMBLY REPLACEMENT
 (Sheet 6 of 6)

7. Connect electrical connector (Y) of harness (B) to pushbutton unit (Z).
8. Connect electrical connector (AA) of harness (B) to power box (AB).
9. Put clamp (AC) on power box lead (AD) of harness (B). Using socket and extension, install and tighten screw (AE) and lockwasher (AF) to secure clamp (AC) and lead (AD) to pushbutton unit (Z).
10. Perform smoke grenade launcher functional check (page 22-30)

End of Task

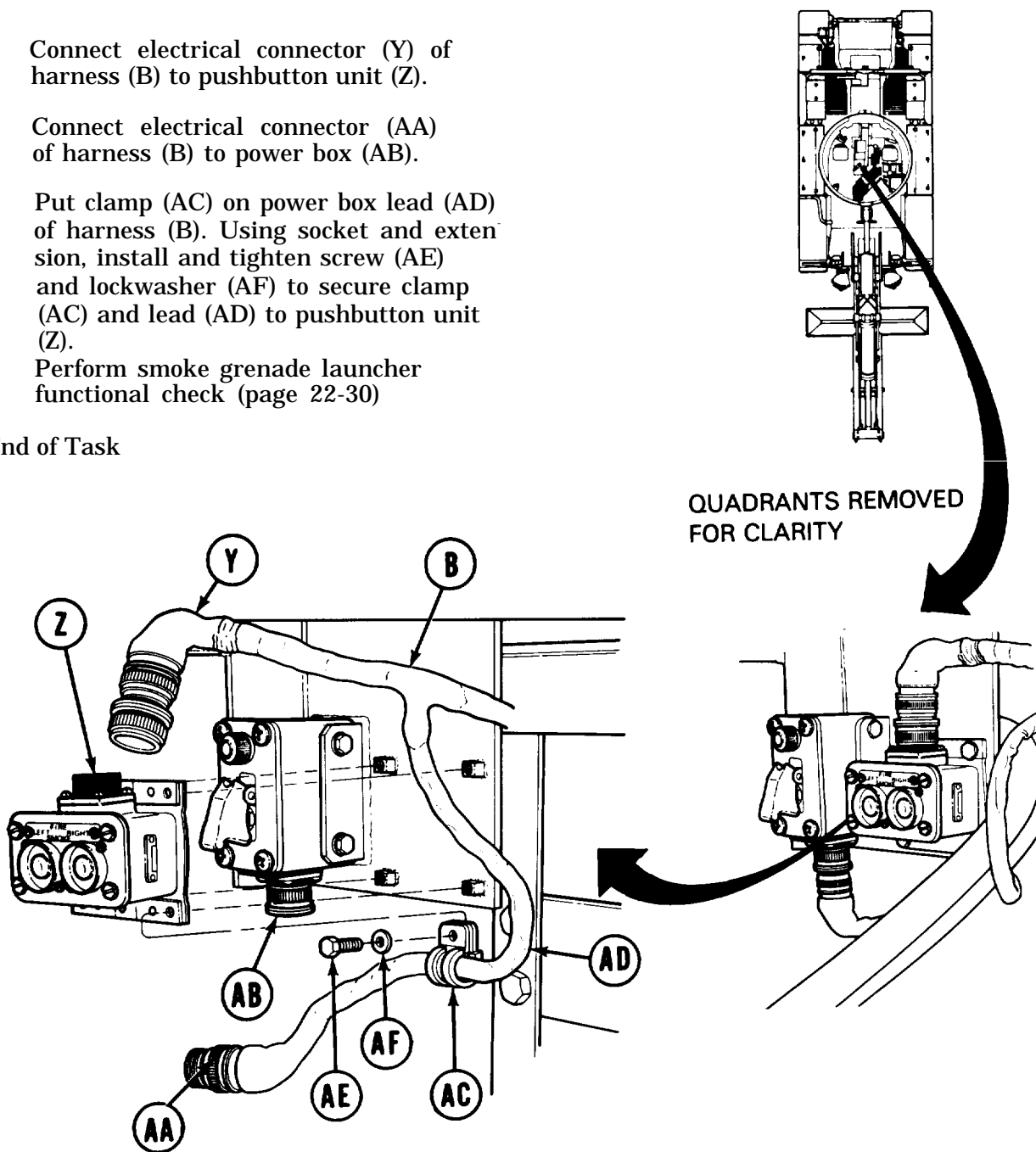

TA248793

**SMOKE GRENADE HULL COMPARTMENT WIRING HARNESS ASSEMBLY REPLACEMENT
(Sheet 1 of 11)**

PROCEDURE INDEX

PROCEDURE	PAGE
Removal	22-14
Installation	22-17

TOOLS: 7/16 in. socket with 3/8 in. drive
 5 in. extension with 3/8 in. drive
 Ratchet with 3/8 in. drive
 Slip joint pliers, conduit style, with plastic jaw inserts
 Flat-tip screwdriver
 Socket insert/extract tool

SUPPLIES: Lockwashers
 Gaskets
 Silicone lubricating compound (Item 32, Appendix D)

REMOVAL:

WARNING

Make sure there are no smoke grenades in dischargers. Accidental firing of grenade could hurt or kill you.

1. Set MASTER BATTERY switch (A) to OFF.
2. Using pliers, disconnect electrical connector (B) of smoke grenade hull compartment wiring harness (C) from back side of basket disconnect (D).
3. Using socket and extension, remove two top screws (E), lockwashers (F), and washers (G) securing two harness bundle straps (H) to hull.

Go on to Sheet 2

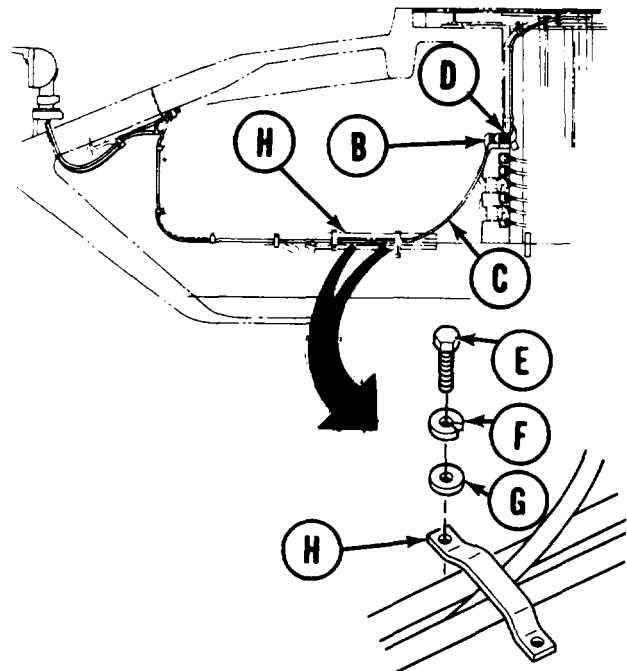
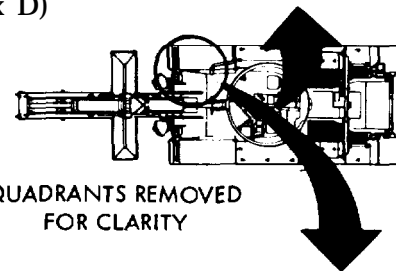
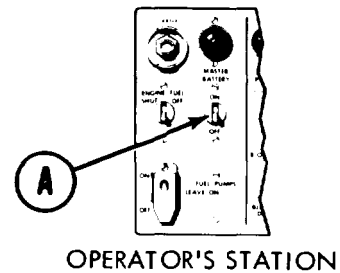

TA248794

**SMOKE GRENADE HULL COMPARTMENT WIRING HARNESS ASSEMBLY REPLACEMENT
(Sheet 2 of 11)**

4. Using socket and extension, remove screw (J) and lockwasher (K) securing harness bundle clamp (L) to hull.
5. Using socket and extension, remove three screws (M) and lockwashers (N) securing three harness bundle clamps (P) to hull.

Go on to Sheet 3

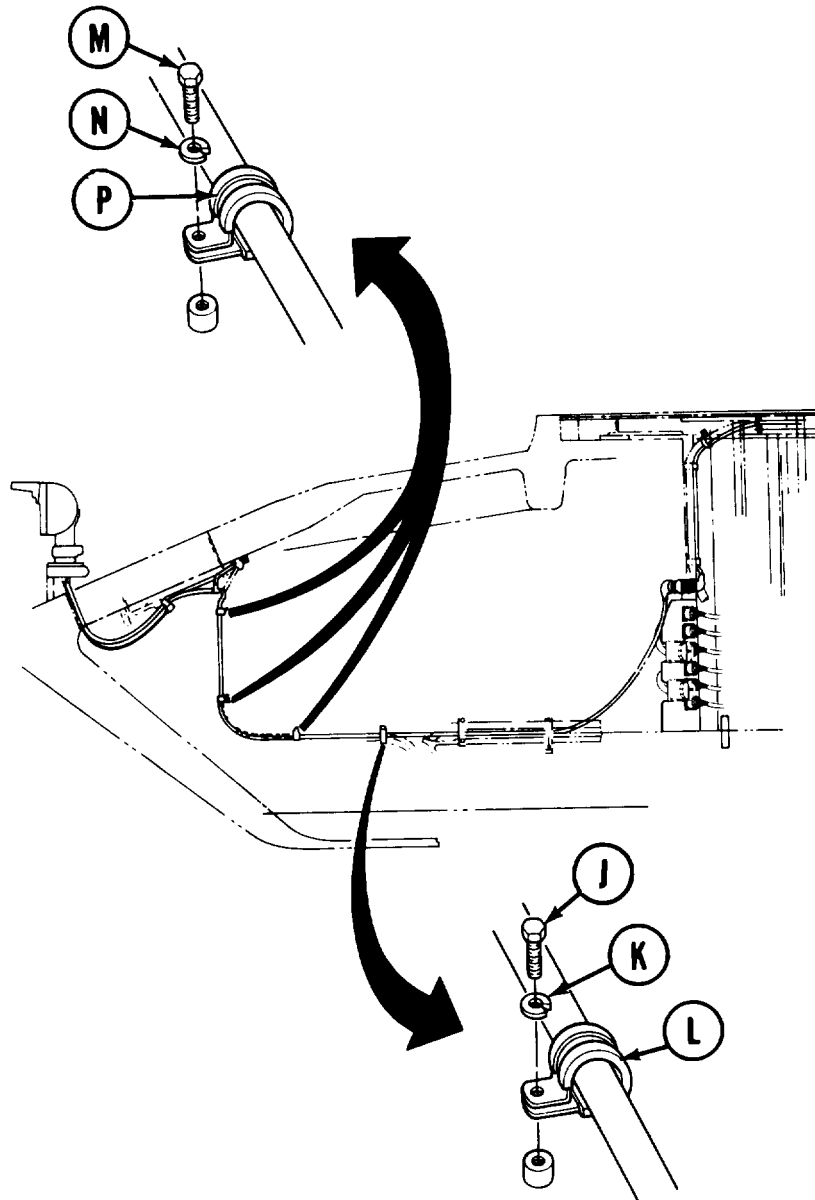

TA248795

**SMOKE GRENADE HULL COMPARTMENT WIRING HARNESS ASSEMBLY REPLACEMENT
(Sheet 3 of 11)**

6. Using socket and extension, remove screw (Q) and lockwasher (R) securing harness bundle clamp (S) to hull.
7. Using socket and extension, remove screw (T) and two lockwashers (U) securing harness bundle clamp (V) and right ground lead (N) of wiring harness (C) to hull.
8. Using socket and extension, remove screw (X) and lockwasher (Y) securing harness bundle clamp (Z) to hull in four places.
9. Using socket and extension, remove screw (AA) and lockwasher (AB) securing harness bundle clamp (AC) to hull.
10. Using socket and extension, remove screw (AD) and two lockwashers (AE) securing harness bundle clamp (AF) and left ground lead (AG) of harness (C) to-hull.

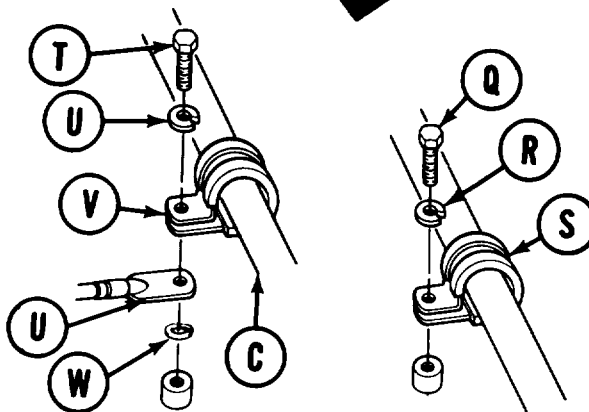
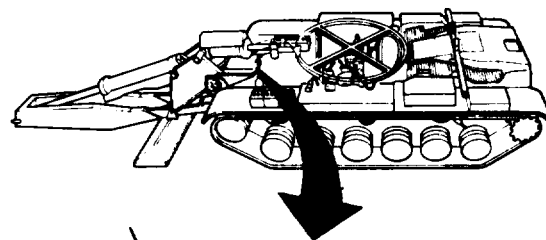

Go on to Sheet 4

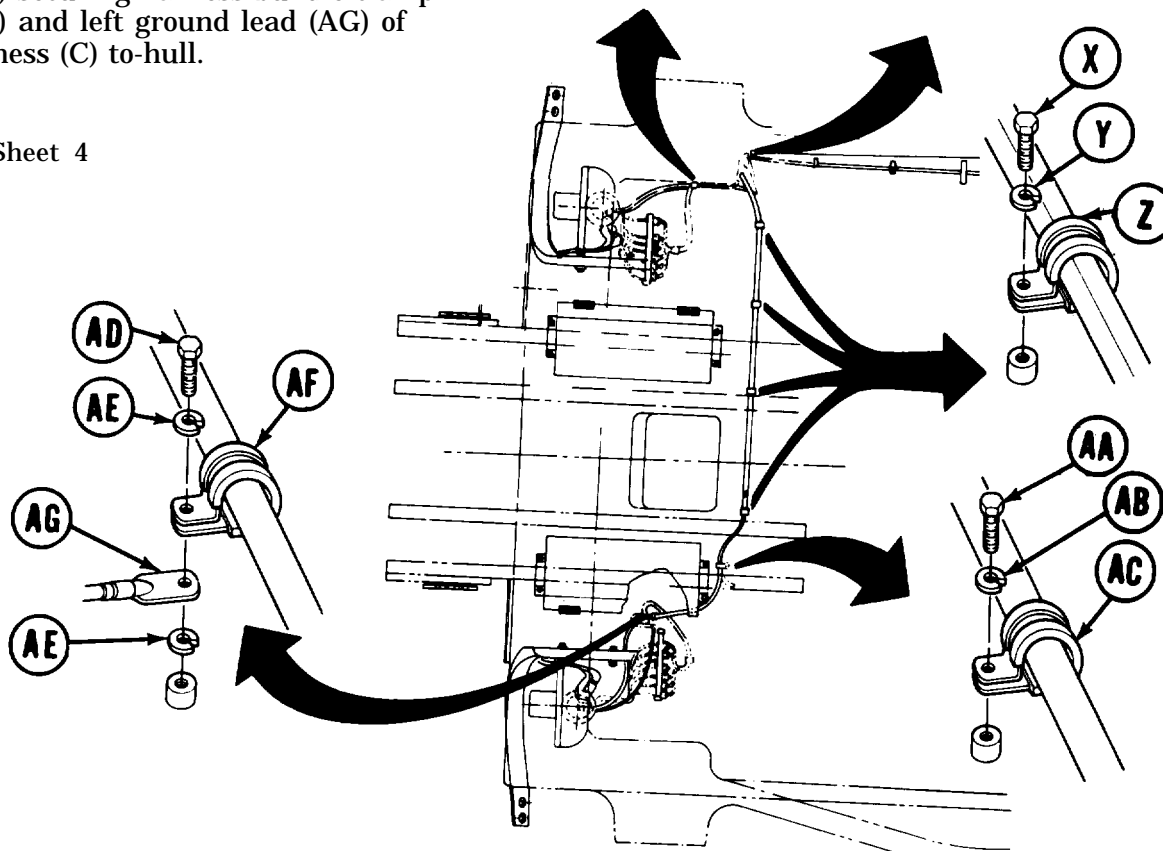

TA248796

**SMOKE GRENADE HULL COMPARTMENT WIRING HARNESS ASSEMBLY REPLACEMENT
(Sheet 4 of 11)**

NOTE

The following step (11 through 20) apply to removal of the harness from both the left and right headlights assemblies.

11. Remove and disconnect six headlight connectors (AH) from six vehicle harness connectors (AJ) at bracket (AK).
12. Using screwdriver, remove screw (AL) and two lockwashers (AM) securing headlight ground wire (AN) to bracket (AK).
13. Outside vehicle, using pliers, disconnect electrical connector (AP) of discharger harness (AQ) from headlight adapter receptacle (AR).
14. Loosen ring nut (AS) of headlight assembly (AT).

Go on to Sheet 5

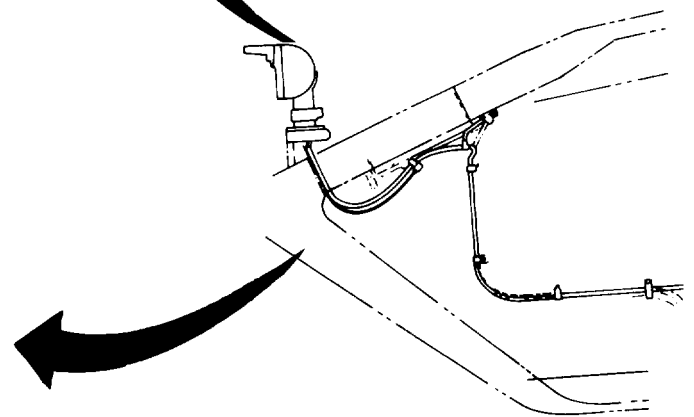
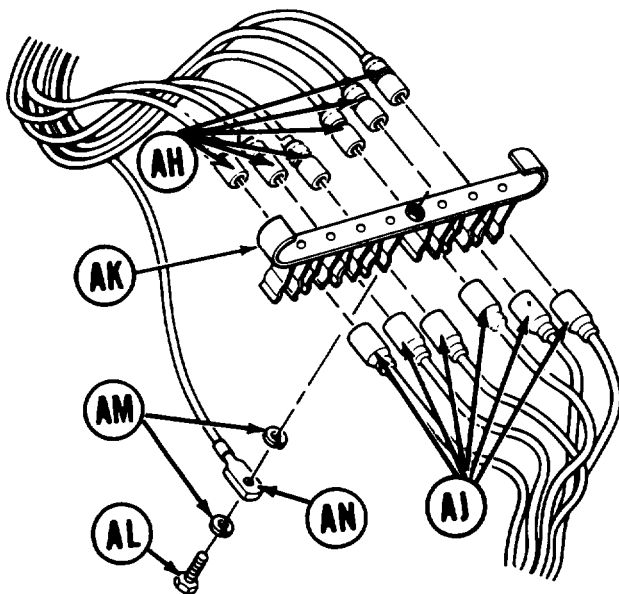
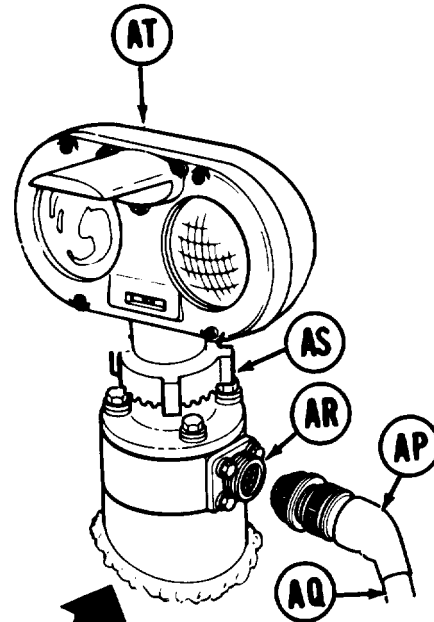

TA248797

**SMOKE GRENADE HULL COMPARTMENT WIRING HARNESS ASSEMBLY REPLACEMENT
(Sheet 5 of 11)**

15. Take headlight assembly (AT) off base (AU).
16. Using socket and extension, remove three screws (AV), lockwashers (AW), and washers (AX) securing base (AU), two gaskets (AY), and adapter (AZ) to headlight mounting boss (BA).
17. Using screwdriver, remove four screws (BB) and lockwashers (BC) securing receptacle (BD) and gasket (BE) to adapter (AZ).
18. Pull receptacle (BD), with smoke grenade wiring harness (C) attached, away from adapter (AZ).
19. Using socket insert/extract tool, take four socket contacts (BF) of harness (C) out of receptacle (BD).
20. Take smoke grenade hull compartment wiring harness (C) out of vehicle.

Go on to Sheet 6

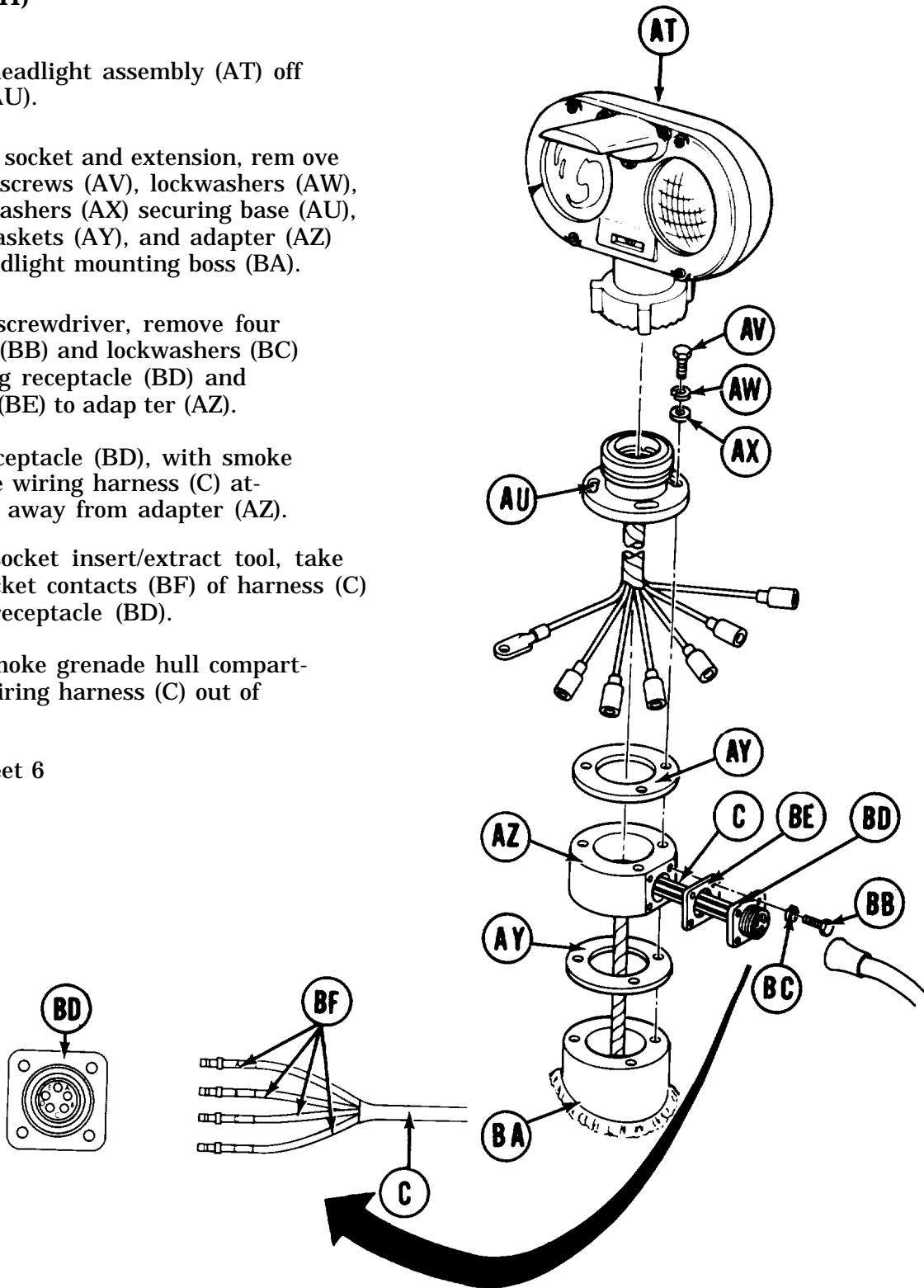

TA248798

SMOKE GRENADE HULL COMPARTMENT WIRING HARNESS ASSEMBLY REPLACEMENT
(Sheet 6 of 11)

INSTALLATION:

WARNING

Make sure there are no smoke grenades in dischargers. Accidental firing of grenade could hurt or kill you.

1. Lay smoke grenade hull compartment wiring harness (A) in position along right side of hull.
2. At back side of basket disconnect (B), connect connector (C) of harness (A) to smoke grenade crew compartment wiring harness (D).

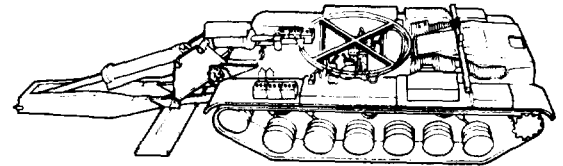

3. Route harness (A) with existing harnesses behind two straps (E). Using socket and extension, secure straps (E) to hull with two screws (F), lockwashers (G), and washers (H).
4. Put harness (A) in clamp (J) with existing harnesses. Secure clamp (J) to hull with screw (K) and new lockwasher (L).
5. Put harness (A) in three clamps (M) with existing harnesses. Secure clamps (M) to hull with three screws (N) and lockwashers (P).

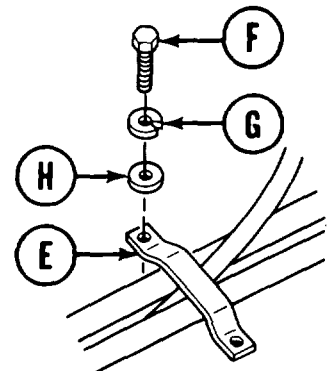
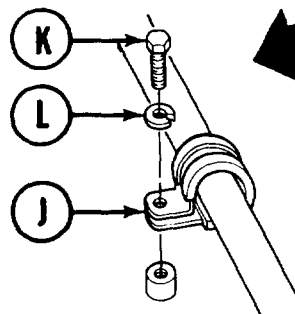
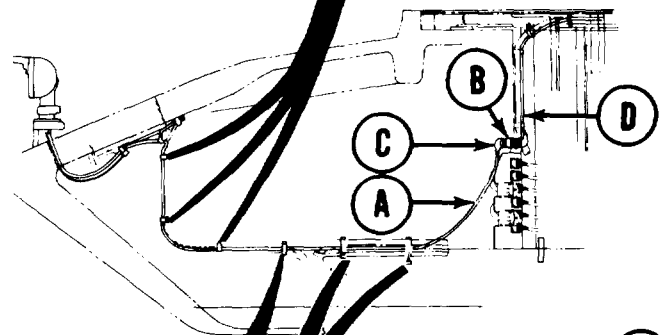
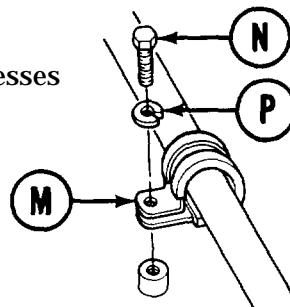

Go on to Sheet 7

TA248799

**SMOKE GRENADE HULL COMPARTMENT WIRING HARNESS ASSEMBLY REPLACEMENT
(Sheet 7 of 11)**

6. Put harness (A) in clamp (Q) with existing harness. Using socket and extension, secure clamp (Q) to hull with screw (R) and lockwasher (S).
7. Route short branch of harness (A) to right headlight of opening. Put short branch of harness (A) in clamp (T) with existing harness. Secure clamp (T) and ground lead (U) of harness (A) to hull with screw (V) and two star lockwashers (W).
8. Route long branch of harness (A) across hull to left headlight opening. Put left branch of harness (A) in four clamps (X) and secure clamps (X) to hull overhead with four screws (Y) and lockwashers (Z).

Go on to Sheet 8

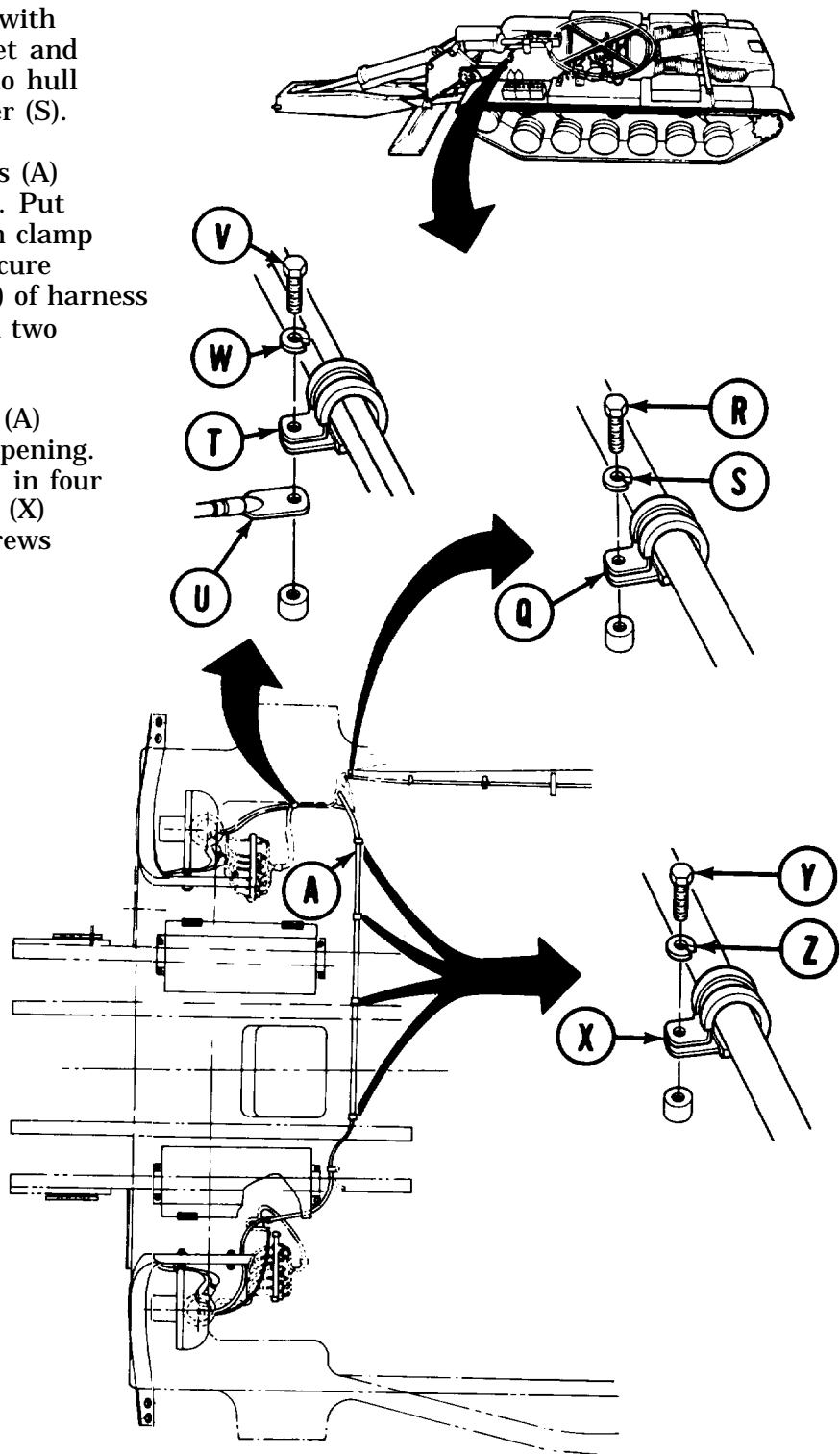

TA248800

SMOKE GRENADE HULL COMPARTMENT WIRING HARNESS ASSEMBLY REPLACEMENT (Sheet 8 of 11)

9. Put harness (A) in clamp (AA) with existing harness. Secure clamp (AA) to hull with screw (AB) and lockwasher (AC).
10. Put harness (A) in clamp (AD) with existing harness. Secure clamp (AD) and ground lead (AE) of harness (A) to hull with screw (AF) and two star lockwashers (AG).

Go on to Sheet 9

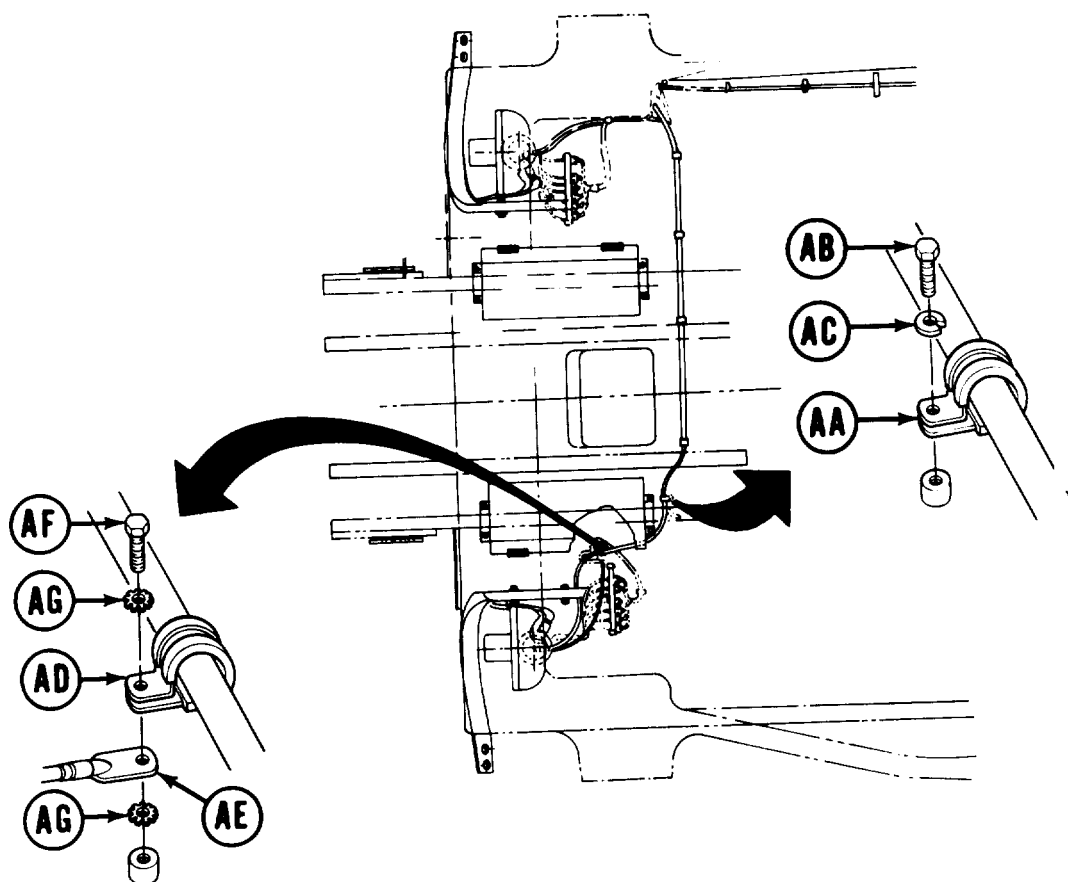

TA248801

**SMOKE GRENADE HULL COMPARTMENT WIRING HARNESS ASSEMBLY REPLACEMENT
(Sheet 9 of 11)**

NOTE

The following steps (11 through 21) apply to installation of both the left and right headlight assemblies.

11. Put one new gasket (AH) and adapter (AJ) on headlight mounting boss (AK) with harness (A) routed through hole in side of adapter (AJ).
12. Put receptacle gasket (AL) on receptacle (AM). Using insert/extract tool, put four marked lead socket contacts (AN) of harness (A) in corresponding holes of receptacle (AM).

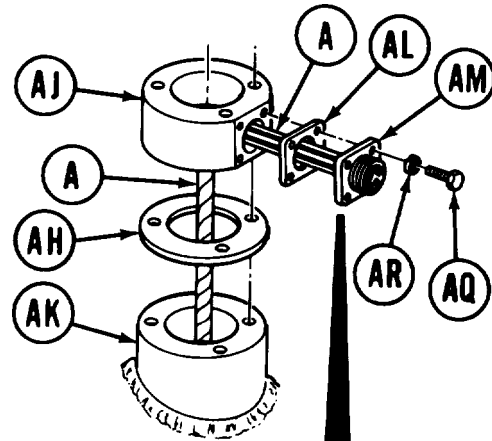

NOTE

Receptacle hole position D (AP) is not used. Put dummy socket in position D to prevent entry of water and dirt.

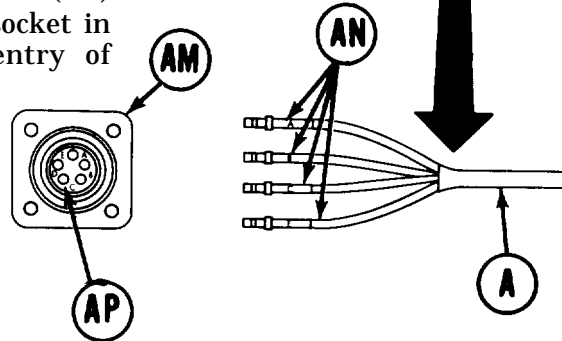

13. Make sure hole in side of adapter (AJ) faces center of vehicle. Put receptacle (AM) and gasket (AL) on adapter (AJ) with receptacle keyway forward. Using screwdriver, secure receptacle (AM) and gasket (AL) to adapter (AJ) with four screws (AQ) and lockwashers (AR).

Go on to Sheet 10

SMOKE GRENADE HULL COMPARTMENT WIRING HARNESS ASSEMBLY REPLACEMENT (Sheet 10 of 11)

14. Put new gasket (AH) in position on adapter (AJ).
15. Insert wires (AS) through opening in adapter (AJ) and position headlight base (AT) on adapter (AJ) with headlight base keyway to the rear.
16. Using socket and extension, secure base assembly (AT) and adapter (AJ) to headlight mounting boss (AK) with three screws (AU), lockwashers (AV), and washers (AW). Make sure receptacle (AM) faces center of vehicle and that receptacle keyway is forward.
17. Put headlight assembly (AX) on base (AT) and, while pressing down on headlight, tighten ring nut (AY).

Go on to Sheet 11

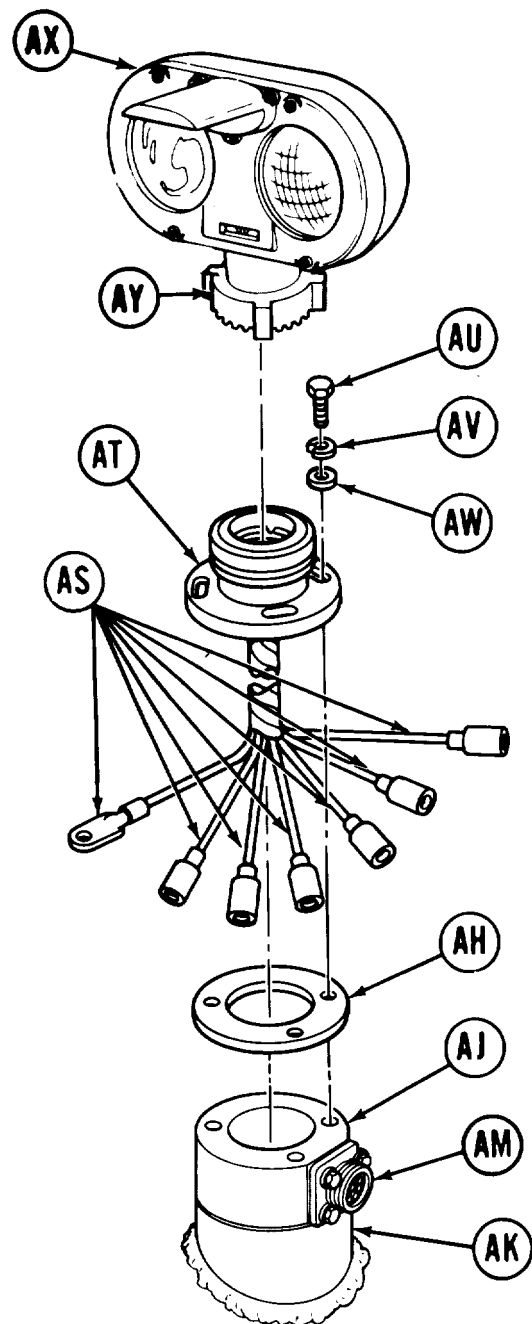

TA248803

SMOKE GRENADE HULL COMPARTMENT WIRING HARNESS ASSEMBLY REPLACEMENT (Sheet 11 of 11)

18. Connect electrical connector (AZ) of discharger harness (BA) to headlight adapter receptacle (BB).
19. Inside vehicle, using screwdriver, secure headlight ground wire (BC) to bracket (BD) with screw (BE) and two lockwashers (BF).
20. Spray six connectors (BG) with silicone compound. Connect to six corresponding vehicle harness connectors (BH). Put connectors in bracket (BD).
21. Perform smoke grenade launcher functional check (page 22-30).

End of Task

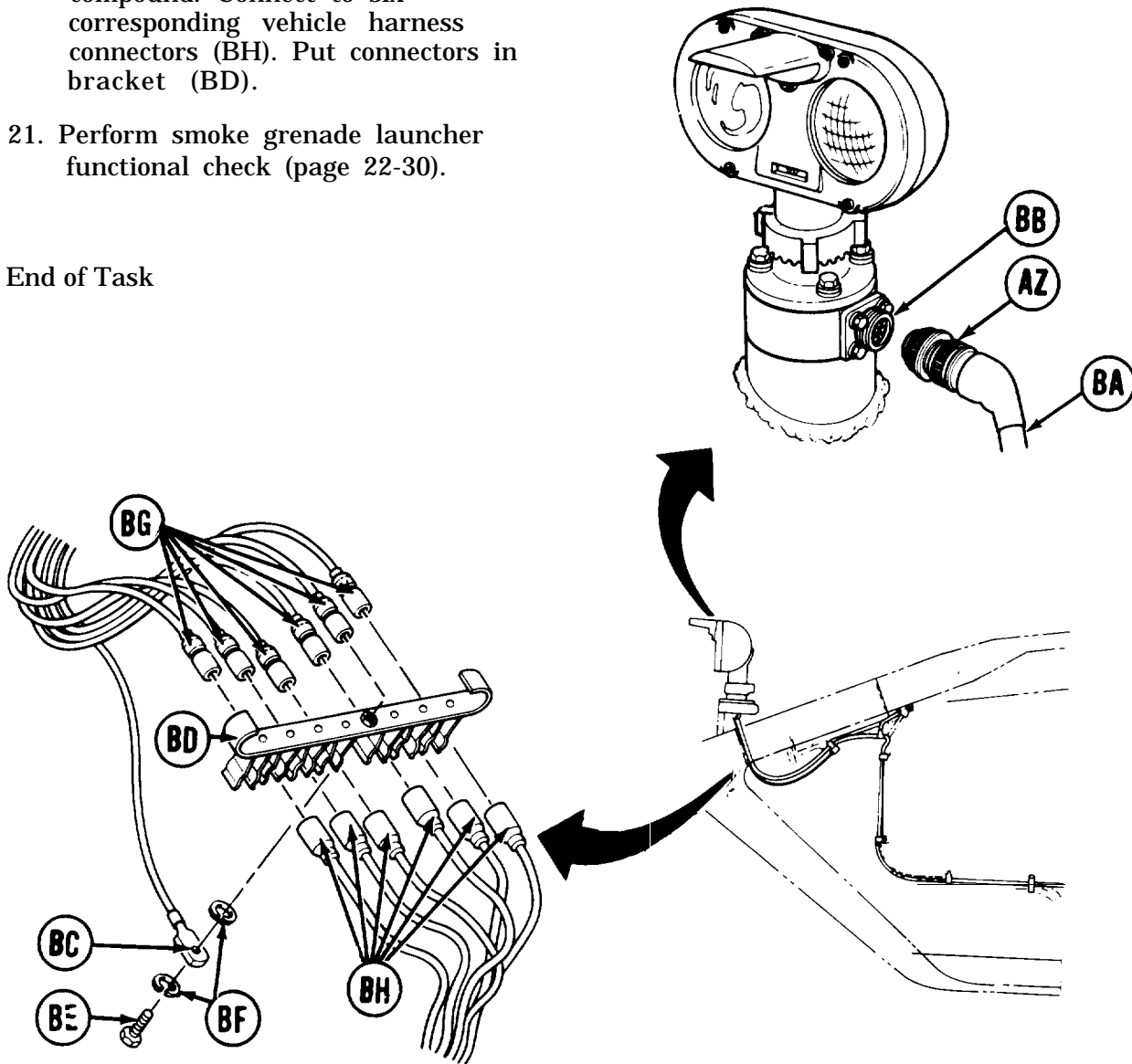

TA248804

SMOKE GRENADE DISCHARGER REPLACEMENT (Sheet 1 of 2)

TOOLS: 3/4 in. socket with 1/2 in. drive
 6 in. extension with 1/2 in. drive
 Ratchet with 1/2 in. drive
 Slip joint pliers, conduit style, with plastic jaw inserts
 Torque wrench with 1/2 in. drive (0-175 lb-ft)

SUPPLIES: Locking compound (Item 15, Appendix D)
 Lockwashers (3 required)

REMOVAL:

WARNING

Make sure there are no smoke grenades in dischargers. Accidental firing of grenade could hurt or kill you.

NOTE

Removal procedure is the same for both the right and left dischargers.

1. Using pliers, disconnect wiring harness connector (A) from receptacle on back of discharger (B).
2. Using socket, extension, and ratchet, remove three screws (C) and washers (D) securing discharger (B) to bracket (E).
3. Take discharger (B) off vehicle.

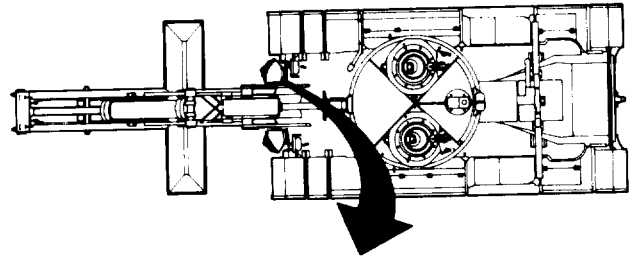

Go on to Sheet 2

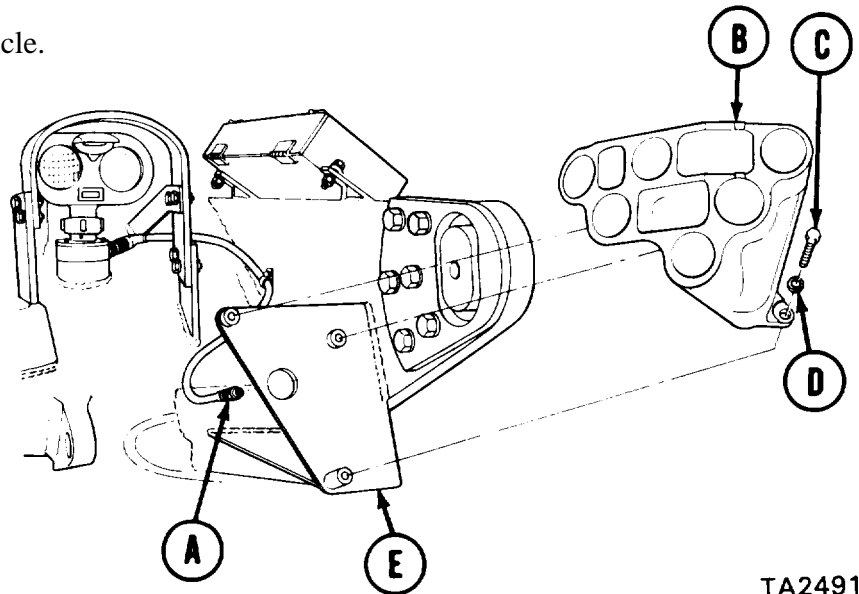

TA249164

SMOKE GRENADE DISCHARGER REPLACEMENT (Sheet 2 of 2)

REPAIR: Refer to TM 3-1040-266-20&P for procedure to repair Smoke Grenade discharger.

INSTALLATION:

WARNING

Make sure there are no smoke grenades in dischargers. Accidental firing of grenade could hurt or kill you.

NOTE

Installation procedure is the same for both the right and left dischargers

1. Apply two to three drops of locking compound (Item 15, Appendix D) to threads of three screws (A).
2. Put discharger (B) in position on bracket (C). Using socket, extension, and torque wrench, secure discharger (B) to bracket (C) with three screws (A) and washers (D). Tighten screws (A) to **55-74 lb-ft (75-100 N•m)**.
3. Connect electrical connector (E) of discharger harness to receptacle on back of discharger (B).
4. **Perform smoke grenade launcher function check (page 22-30).**

End of Task

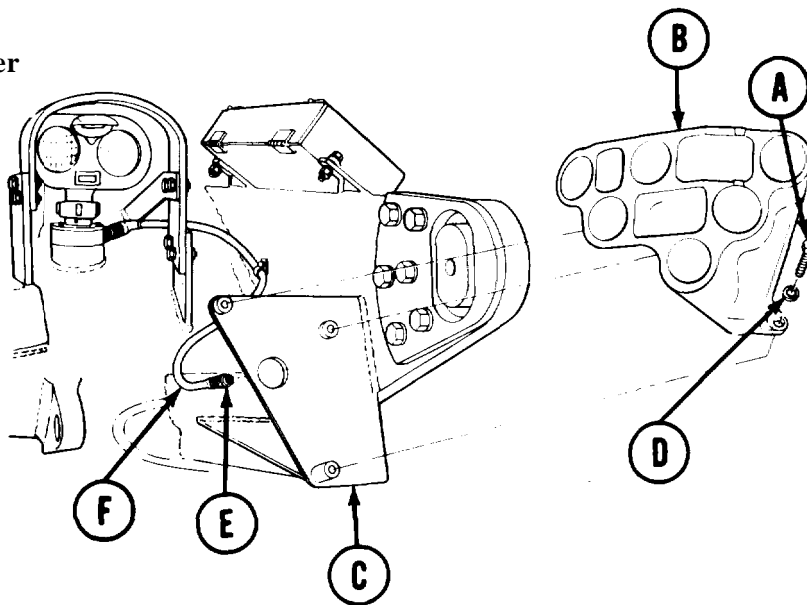

TA249165

SMOKE GRENADE DISCHARGER WIRING HARNESS ASSEMBLY REPLACEMENT (Sheet 1 of 2)

TOOLS: 7/16 in. socket with 3/8 in. drive
 Ratchet with 3/8 in. drive
 Slip joint pliers, conduit style, with plastic jaw inserts

SUPPLIES: Lockwashers (2 required)

REMOVAL:

WARNING

Make sure there are no smoke grenades in dischargers. Accidental firing of grenade could hurt or kill you.

NOTE

Replacement of the discharger wiring harness is the same for both the right and left sides. Replacement of the left side harness is shown.

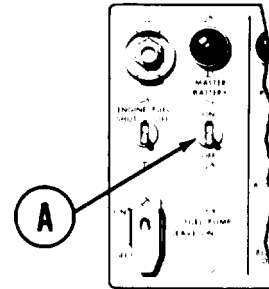

DRIVER'S STATION

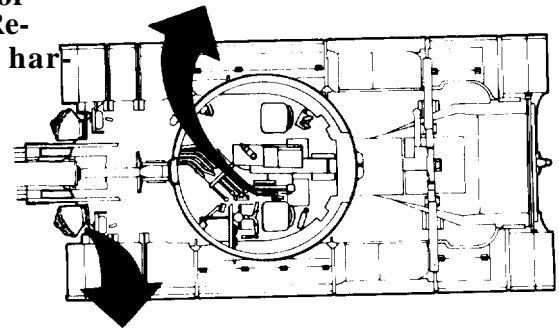

1. Set MASTER BATTERY switch (A) to OFF.
2. Using pliers, disconnect electrical connector (B) from discharger unit receptacle (C) and disconnect electrical connector (D) from headlight adapter receptacle (E).
3. Using socket and ratchet, remove screw (F) and lockwasher (G) securing clamp (H) and harness (J) to headlamp boom pivot mount (K).
4. Take clamp (H) off harness (J). Take harness (J) off vehicle.

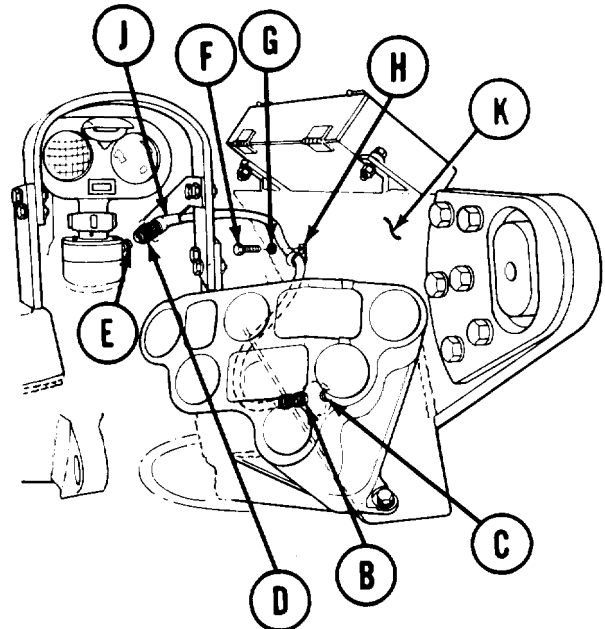

Go on to Sheet 2

SMOKE GRENADE DISCHARGER WIRING HARNESS ASSEMBLY REPLACEMENT (Sheet 2 of 2)

INSTALLATION:

WARNING

Make sure there are no smoke grenades in dischargers. Accidental firing of grenade could hurt or kill you.

1. Connect electrical connector (A) of harness (B) to headlight adapter receptacle (C). Connect electrical connector (D) to discharger unit receptacle (E).
2. Put clamp (F) on harness (B).
3. Using socket and ratchet, install and tighten screw (G) and lockwasher (H) to secure clamp (F) and harness (B) to boom pivot mount (J).
4. Perform smoke grenade launcher functional check (page 22-30).

End of Task

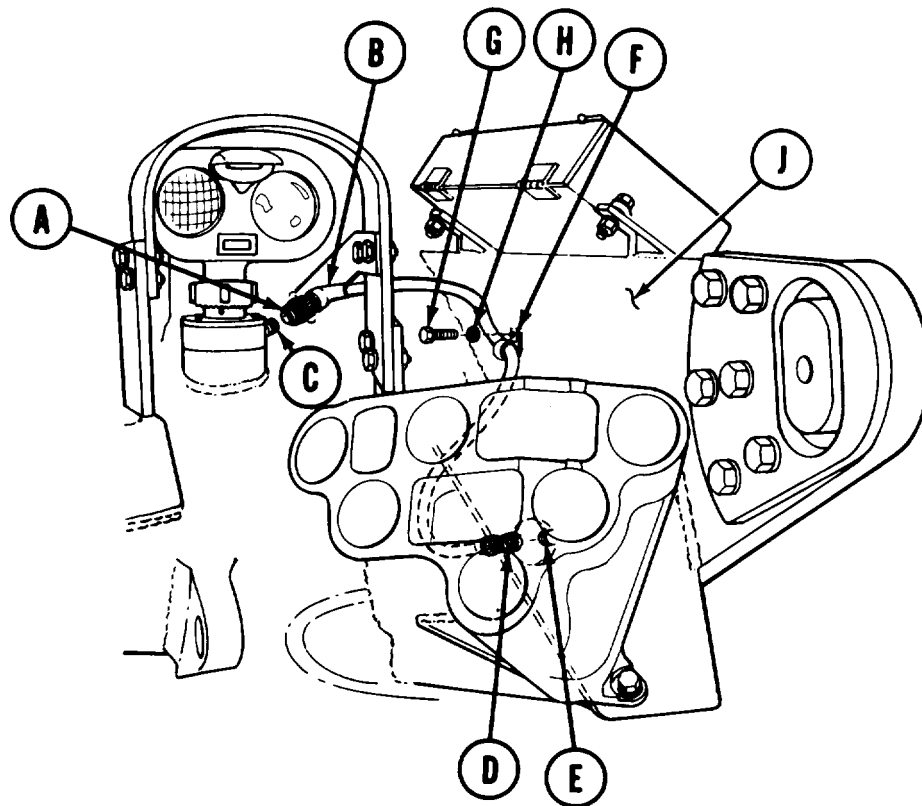

TA249167

SMOKE GRENADE DISCHARGER BRACKET DUMMY RECEPTACLE REPLACEMENT (Sheet 1 of 2)

TOOLS: Slip joint pliers, conduit style, with plastic jaw inserts
Flat-tip screwdriver

SUPPLIES: Lockwashers (4 required)
Gasket

REMOVAL:

WARNING

Make sure there are no smoke grenades in dischargers. Accidental firing of grenade could hurt or kill you.

NOTE

Removal procedures are the same for both the left and right dummy receptacles.

1. Using pliers, disconnect electrical connector (A) of discharger harness (B) from back of discharger (C).
2. Using screwdriver, remove four screws (D) and lockwashers (E) securing dummy receptacle (F) and gasket (G) to discharger bracket (H).
3. Take dummy receptacle (F) and gasket (G) off discharger bracket (H). Discard gasket.

Go on to Sheet 2

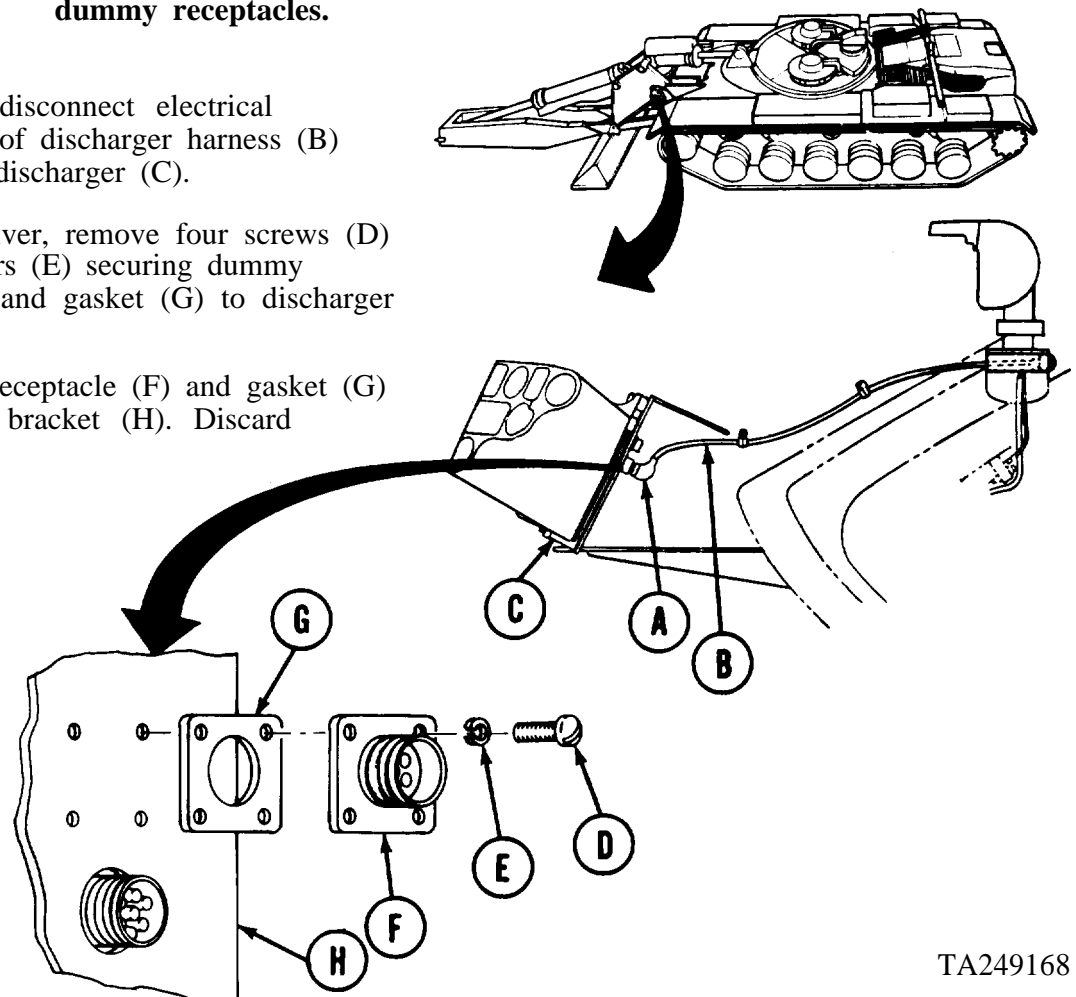

TA249168

SMOKE GRENADE DISCHARGER BRACKET DUMMY RECEPTACLE REPLACEMENT
(Sheet 2 of 2)

INSTALLATION:

WARNING

Make sure there are no smoke grenades in dischargers. Accidental firing of grenade could hurt or kill you.

NOTE

Installation procedures are the same for both the left and right dummy receptacles.

1. Put dummy receptacle (A) and new gasket (B) in position on back of discharger bracket (C).
2. Using screwdriver, secure receptacle (A) and gasket (B) to discharger bracket (C) with four screws (D) and new lockwashers (E).
3. Connect electrical connector (F) of discharger harness (G) to receptacle (H) at back of discharger (J).
4. **Perform smoke grenade launcher functional check (page 22-30).**

End of Task

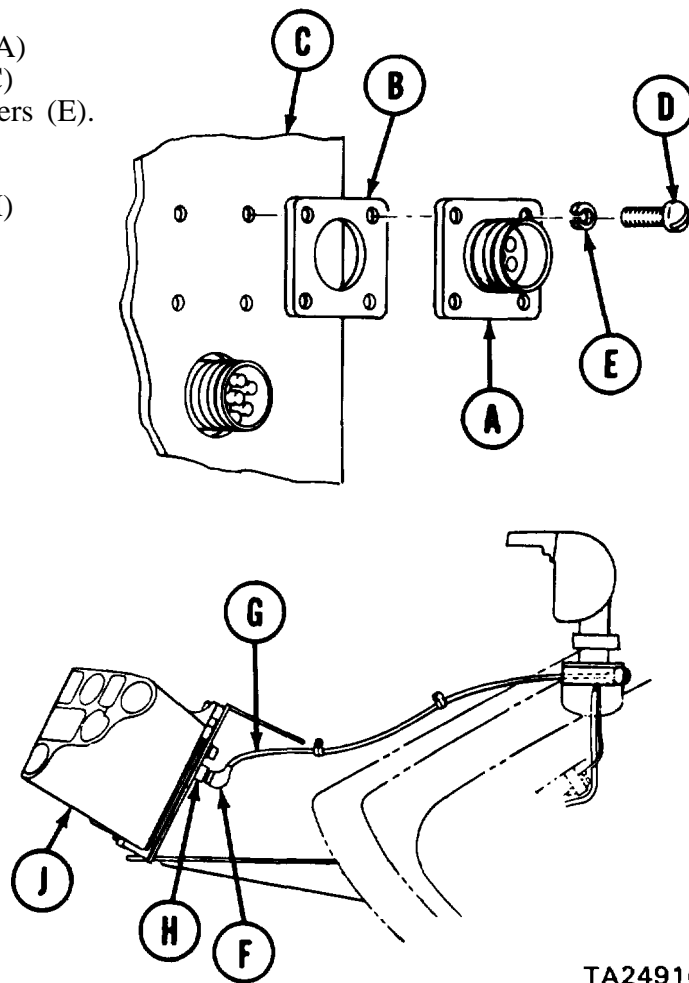

TA249169

SMOKE GRENADE STOWAGE BOX REPLACEMENT (Sheet 1 of 1)**TOOLS: 9/16 in. combination box and open end wrench (2 required)****SUPPLIES: Lockwashers (4 required)****WARNING**

Make sure smoke grenade stowage box is empty before you replace it. Accidental discharge of smoke grenades could hurt or kill you.

NOTE

Replacement procedure is the same for both 'the left and right stowage boxes.

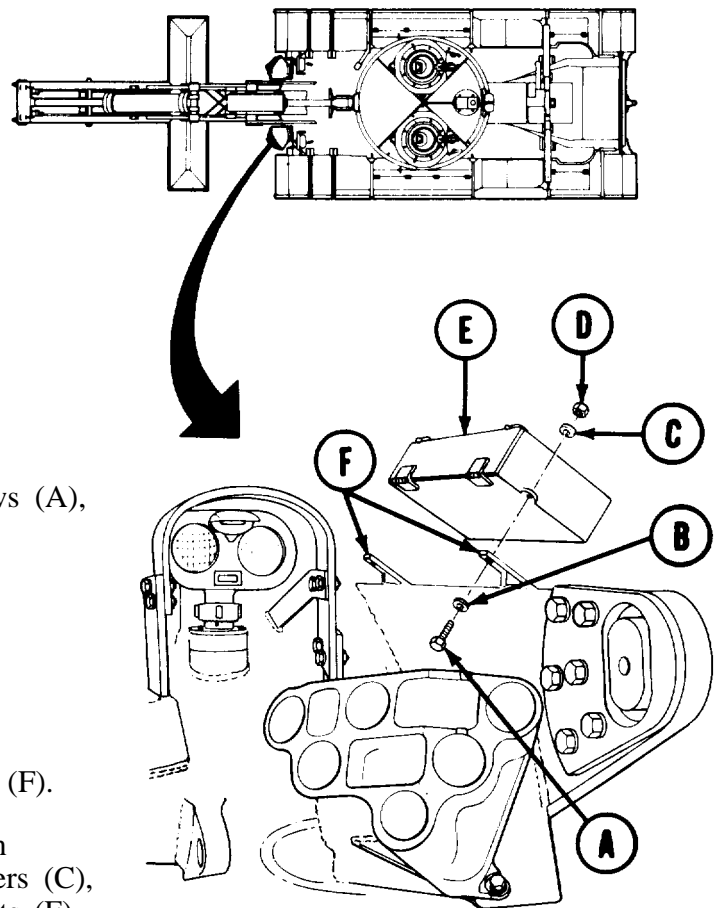
**REMOVAL:**

1. Using two wrenches, remove four screws (A), washers (B), lockwashers (C), and nuts (D) securing stowage box (E) to brackets (F).
2. Take box (E) off brackets (F).

INSTALLATION:

1. Put box (E) in position on two brackets (F).
2. Using two wrenches, install and tighten four screws (A), washers (B), lockwashers (C), and nuts (D) securing box (E) to brackets (F).

End of Task

TA249170

SMOKE GRENADE LAUNCHER FUNCTIONAL CHECK (Sheet 1 of 3)

TEST EQUIPMENT. Multimeter

Personnel: Two

WARNING

Make sure grenade dischargers (A) are not loaded before you perform functional check. Be sure MASTER BATTERY switch (B) and grenade power switch (C) are in OFF position before you unload the dischargers. Never put your body in front of discharger while unloading. Accidental firing of grenades could hurt or kill you.

1. Set MASTER BATTERY switch (B) to ON.
2. Set grenade power switch (C) to ON. Indicator light (D) should come on.

NOTE

Have a helper inside crew compartment operate FIRE SMOKE LEFT RIGHT pushbutton switches (E) during functional check.

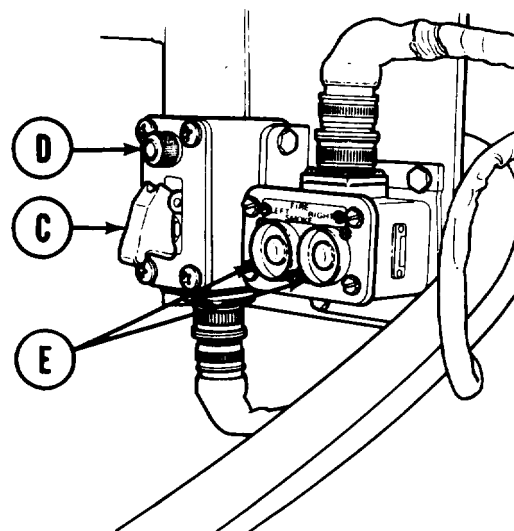
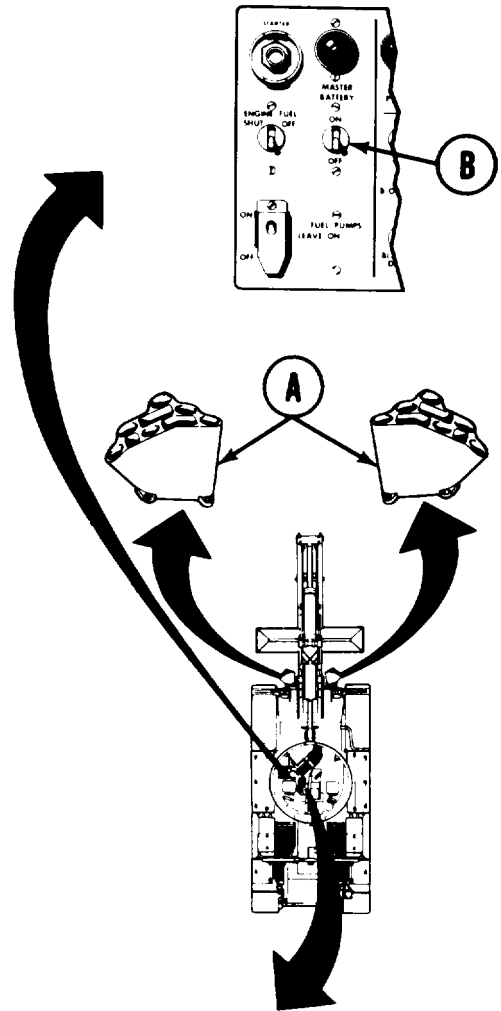

TA248805

SMOKE GRENADE LAUNCHER FUNCTIONAL CHECK (Sheet 2 of 3)

- Set multimeter to 0-50 VDC scale.

NOTE

During following checks, hold multimeter negative test probe to ground (vehicle or discharger) and touch positive test probe to tip of plug (F) at bottom center of each discharger (G, H) barrel.

CAUTION

Do not short circuit multimeter probe from barrel contact to ground. Arcing will result,

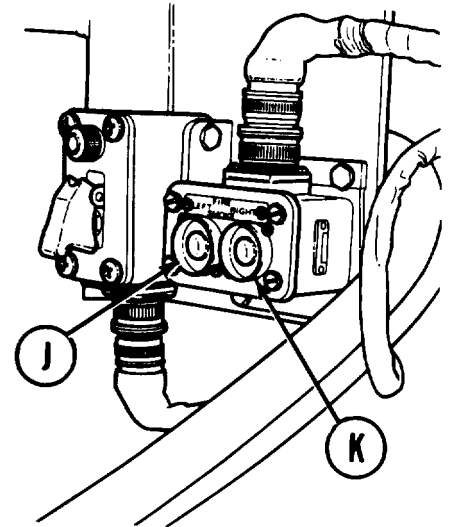

- Press and hold FIRE SMOKE LEFT pushbutton switch (J).
- At left side discharger (G), check that vehicle voltage (24 ± 6 VDC) is present at barrels 3, 4, 6 and is not present at barrels 1, 2, 5.
- Press and hold FIRE SMOKE RIGHT pushbutton switch (K).
- At left side discharger (G), check that vehicle voltage (24 ± 6 VDC) is present at barrels 1, 2, 5 and is not present at barrels 3, 4, 6.

Go on to Sheet 3

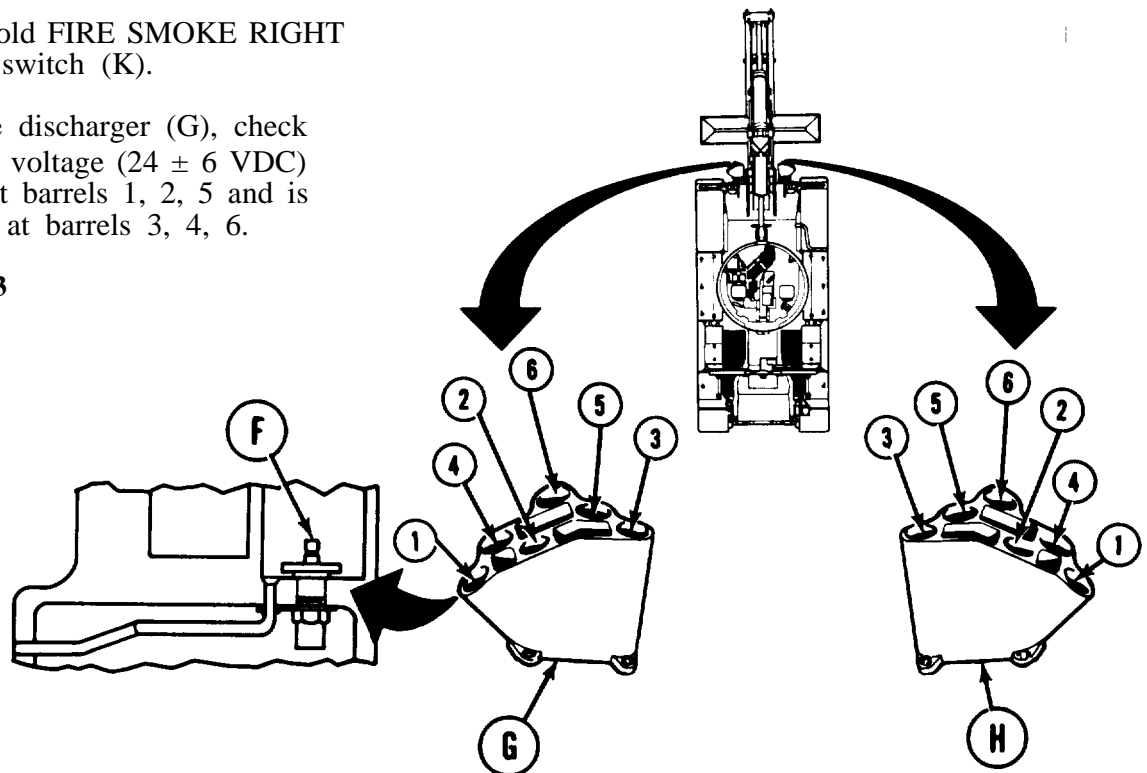

TA248806

SMOKE GRENADE LAUNCHER FUNCTIONAL CHECK (Sheet 3 of 3)

8. Press and hold FIRE SMOKE LEFT pushbutton switch (J).
9. At right side discharger (H), check that vehicle voltage (24 ± 6 VDC) is present at barrels 3, 4, 6 and is not present at barrels 1, 2, 5.
10. Press and hold FIRE SMOKE RIGHT pushbutton switch (K).
11. At right side discharger (H), check that vehicle voltage (24 ± 6 VDC) is present at barrels 1, 2, 5 and is not present at barrels 3, 4, 6.

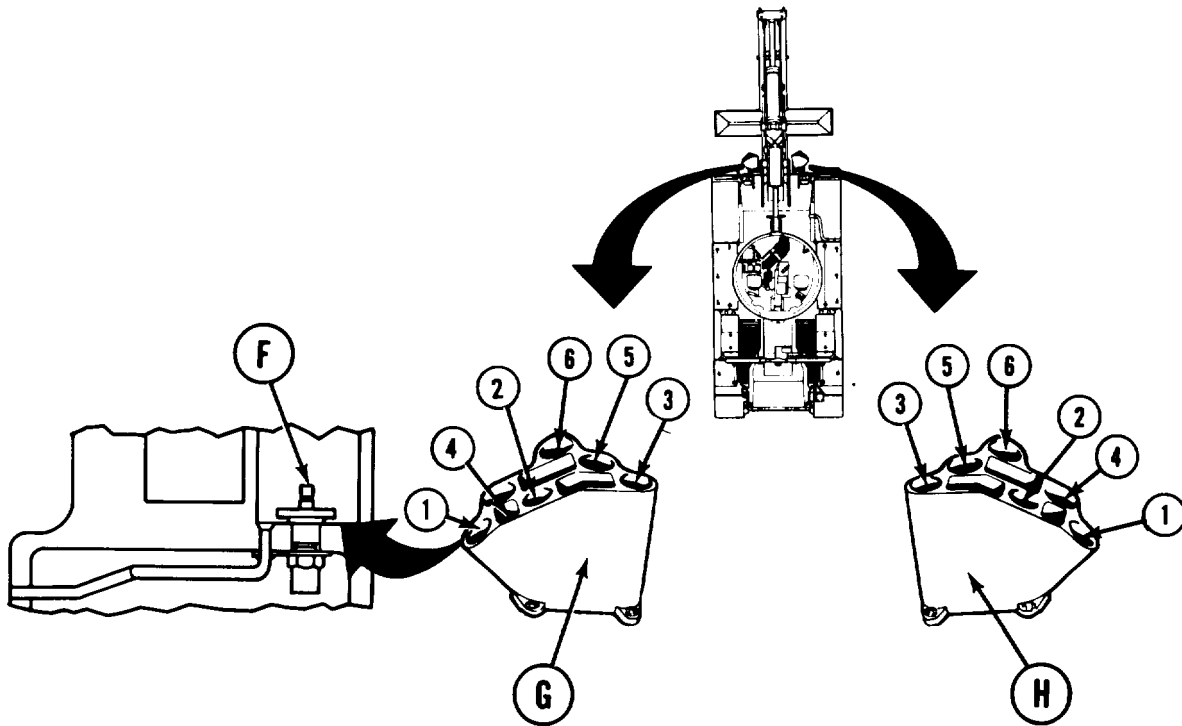
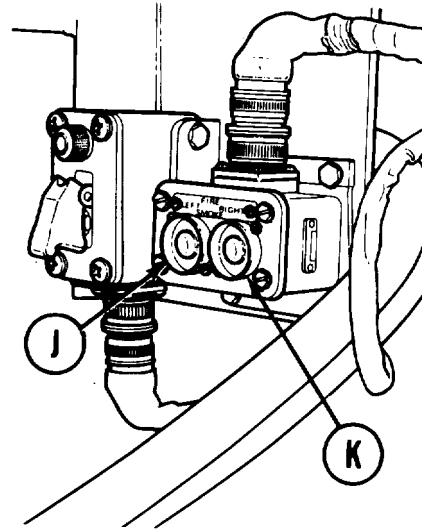

End of Task

TA249171

APPENDIX A**REFERENCES**

A-1 Publication Index

The following index should be consulted frequently for latest changes or revisions of references given in this Appendix and for new publications relating to material covered in this Technical Manual:

DA PAM 25-30 Consolidated Index of Army Publications and Blank Forms

A-2 Maintenance Forms and Records

DA Form 2028 Recommended Changes to Publications and Blank Forms
 DA Form 2404 Equipment Inspection and Maintenance Worksheet
 DA Form 2407 Maintenance Request
 DA Form 2407-1 Maintenance Request - Continuation Sheet

DA PAM 750-8 The Army Maintenance Management System (TAMMS)

DD Form 1397 Processing and Reprocessing Record for Shipment, Storage and
 Issue of Vehicles and Spare Engines
 SF368 Quality Deficiency Report

A-3 Regulations

AR 75-1 Malfunctions Involving Ammunition and Explosives
 AR 385-40 Accident Reporting and Records
 AR 746- 1 Color, Marking, and Preparation of Equipment for Shipment

A-4 Lubrication

LO 5-5420-202-12 Launcher and M60A1 Tank Chassis, Transporting for Bridge,
 Armored-Vehicle-Launched, Scissoring Type, Class 60 (NSN
 5420-00-889-2020)

A-5 Technical Manuals

TB 43-0213 Corrosion Prevention and Control Including Rustproofing
 Procedures for Tactical Vehicles and Trailers
 TB 746-93-1 Color and Marking of Military Vehicles, Construction
 Equipment, and Materials Handling Equipment

TM 5-5420-202-20-4

TB MED 269	Carbon Monoxide: Symptoms, Etiology, Treatment and Prevention of Overexposure
TB MED 524	Occupational and Environmental Health Control of Hazards to Health from Laser Radiation
TM 3-1040-266-20&P	Organizational Maintenance Manual (Including Repair Parts and Special Tools Lists): Launcher, Grenade, Smoke: Screening, RP, M239 (NSN 1040-01-015-0874)
TM 9-214	Inspection, Care, and Maintenance of Antifriction Bearings
TM 9-237	Operator's Manual: Welding Theory and Application
TM 9-238	Deepwater Forging of Ordnance Materiel
TM 9-243	Use and Care of Handtools and Measuring Tools
TM 9-247	Materials Used for Cleaning, Preserving, Abrading, and Cementing Ordnance Materiel and Related Materials Including Chemicals
TM 9-2530-200-24	Standards for Inspection and Classification of Tracks, Track Components and Solid-Rubber Tires (FSC 2530)
TM 9-1375-215-14&P	Operator, Unit, Direct Support & General Support Maintenance Manual Including Repair Parts and Special Tools List for Demolition Kit, Mine Clearing Line Charge (MICLIC)
TM 9-2540-205-24&P	Organizational, Direct Support and General Support Maintenance Manual (Including Repair Parts and Special Tools) for Heaters, Vehicular Compartment (Stewart Warner Model 10560M) (NSN 2540-01-071-0651), (Model 10560M24B1) (2540-01-169-5159), (Model 10560C) (2540-01-083-0691) and (Model 8460C24) (2540-00-854-4449); (Hupp Model MF510A) (2540-00-930-8938), (model Mf510B) (2540-01-071-0652) and (Model MF510C (2540-01-162-3834) and (Espar Model V7S) (2540-01-114-7688)
TM 9-4910-571-12&P	Operator's and Organizational Maintenance Manual Including Repair Parts and Special Tools List: Simplified Test Equipment for Internal Combustion Engines - Reprogrammable (STE/ICE-R)
TM 9-6140-200-14	Operator and Organizational Maintenance Manual for Lead-Acid Storage Batteries
TM 10-277	Chemical, Toxicological, and Missile Fuel Handlers Protective Clothing
TM 11-5820-401-12	Operator's and Organizational Maintenance Manual(Including Repair Parts and Special Tools List): Radio Set AN/VRC-12, AN/VRC-43, AN/VRC-44, ANVRC-45, AN/VRC-46, AN/VRC-47, AN/VRC-48, AN/VRC-49, AN/VRC-54, and AN/VRC-55 MOUNTING MT-1029/VRC and MT-1898/VRC; ANTENNA AT-912;/VRC; Control Frequency Selector C-2742/VRC and Control Radio Set C-2299/VRC
TM 11-5855-249-10	Operator's Manual for Viewer, Driver's Night Vision AN/VVS-2(V) 1

TM 11-5855-249-23	Organizational and Direct Support Maintenance Manual - Viewer, Driver's Night Vision AN/VVS-2(V) 1
TM 11-5855-249-23P	Organizational and Direct Support Maintenance Repair Parts and Special Tools List (Including Depot Maintenance Repair Parts and Special Tools) for Viewer, Driver's Night Vision AN/VVS-2(V) 1
TM 43-0139	Painting Instructions for Field Use
TM 55-2350-215-10-15	Transportability Guidance Tank, Combat, Full-Track, M60 Series
TM 740-90-1	Administrative Storage of Equipment
TM 750-244-6	Procedures for Destruction of Tank - Automotive Equipment to Prevent Enemy Use (U.S. Army Tank-Automotive Command)

A-5 Vehicle Manuals

TM 5-5420-202-10	Operator's Manual Launcher and M60A1 Tank Chassis, Transporting: for Bridge, Armored-Vehicle-Launched, Scissoring Type, Class 60 (5420-00-889-2020)
TM 5-5420-202-24P	Unit, Direct Support and General Support Maintenance Repair Parts and Special Tools Lists (Including Depot Maintenance Repair Parts) for Launcher and M60A1 Tank Chassis, Transporting: for Bridge, Armored-Vehicle-Launched, Scissoring Type, Class 60 (5420-00-889-2020)
TM5-5420-228-24	Organizational, Direct Support and General Support Maintenance Instructions for Launcher, M60A1 Tank Chassis, Transporting for Bridge, Armored-Vehicle-Launched, Scissoring Type, Class 60 (NSN 5420-00-889-2020)

A-6 Supply Catalogs

SC 4910-95-A31	Shop Equipment, Automotive Maintenance and Repair: Field Maintenance, Basic, Less Power (4910-754-0705) (Line Item T24660) and Shop Equipment, Automotive Maintenance and Repair: Field Maintenance, Basic, MAP only (4910-919-0076)
SC 4940-95-CL-A21	Shop Set, Contact and Emergency Repair: Field Maintenance, Less Power (NSN 4940-00-754-0737) (LIN T26030) and Map Only (4940-00-919-0111)

A-7 Field Manuals

FM 3-5	NBC Decontamination
FM 5-20	Camouflage
FM 5-25	Explosives and Demolitions
FM 9-207	Operation and Maintenance of Ordnance Materiel in Cold Weather (0° to -65°F) (-18° to -54°C)
FM 21-11	First Aid for Soldiers
FM 21-40	Chemical, Biological, Radiological and Nuclear Defense

APPENDIX B
MAINTENANCE ALLOCATION CHART
Section I. INTRODUCTION

B-1 General

a. This section provides a general explanation of all maintenance and repair functions authorized at various maintenance levels.

b. The Maintenance Allocation Chart (MAC) in Section II designates overall responsibility for the performance of maintenance functions on the identified end item or component. The implementation of the maintenance functions upon the end item or component will be consistent with the assigned maintenance functions.

c. Section III lists the special tools and test equipment required for each maintenance function as referenced from section II.

d. Section IV contains supplemental instructions and explanatory notes for a particular maintenance function.

B-2 Maintenance Functions

a. **Inspect.** To determine the serviceability of an item by comparing its physical, mechanical and/or electrical characteristics with established standards through examination.

b. **Test.** To verify serviceability and detect incipient failure by measuring the mechanical or electrical characteristics of an item and comparing these characteristics with prescribed standards.

c. **Service.** Operations required

periodically to keep an item in proper operating condition, i.e., to clean (decontaminate), to preserve, to drain, to paint, or to replenish fuel, lubricants, hydraulic fluids, or compressed air supplies.

d. **Adjust.** To maintain, within prescribed limits, by bringing into proper or exact position, or by setting the operating characteristics to specified parameters.

e. **Align.** To adjust specified variable elements of an item to bring about optimum or desired performance.

f. **Calibrate.** To determine and cause corrections to be made or to be adjusted on instruments or test measuring and diagnostic equipment used in precision measurement. Consists of comparisons of two instruments, one of which is a certified standard of known accuracy, to detect and adjust any discrepancy in the accuracy of the instrument being compared.

g. **Install.** The act of emplacing, seating, or fixing into position an item, part, or module (component or assembly) in a manner to allow the proper functioning of an equipment or system.

h. **Replace.** The act of substituting a serviceable like part, subassembly, or module (component or assembly) for an un-serviceable counterpart.

i. **Repair.** The application of maintenance services¹, including fault location/troubleshooting², removal/installation, and disassembly/assembly³ procedures, and maintenance actions⁴ to identify troubles

¹ Services - inspect, test, service, adjust, align, calibrate, and/or replace.

² Fault locate/troubleshoot - The process of investigating and detecting the cause of equipment malfunctioning; the act of isolating a fault within a system or unit under test (UUT).

³ Disassemble/assemble - encompasses the step-by-step taking apart (or breakdown) of a spare/functional group coded item to the level of its least component identified as maintenance significant (i.e., assigned and SMR code) for the category of maintenance under consideration.

⁴ Actions - welding, grinding, riveting, straightening, facing, remachining, and/or resurfacing.

and restore serviceability to an item by correcting specific damage, fault, malfunction, or failure in a part, subassembly, module (component or assembly), end item, or **system**.

J. Overhaul. That maintenance effort (services/actions) necessary to restore an item to a completely serviceable/operational condition as prescribed by maintenance standards (i.e., DMWR) in appropriate technical publications. Overhaul is normally the highest degree of maintenance performed by the Army. Overhaul does not normally return an item to like new condition.

k. Rebuild. Consists of those services/actions necessary for the restoration of unserviceable equipment to a like new condition in accordance with original manufacturing standards. Rebuild is the highest degree of materiel maintenance applied to Army equipment. The rebuild operation includes the act of returning to zero those age measurements (hours/miles, etc.) considered in classifying Army equipments/components.

B-3. Explanation of Columns in the MAC, Section II.

a. Column 1. Group Number. Column 1 lists group numbers, the purpose of which is to identify components, assemblies, subassemblies, and modules with the next higher assembly.

b. Column 2. Component/Assembly. Column 2 contains the names of components, assemblies, subassemblies, and modules for which maintenance is authorized.

5 This maintenance category is not included in Section II, column (4) of the Maintenance Allocation Chart. To identify functions to this category of maintenance, enter a work time figure in the "H" column of Section II, column (4), and use an associated reference code in the Remarks column (6). Key the code to Section IV, Remarks, and explain the SRA complete repair application there. The explanatory remark(s) shall reference the specific Repair Parts and Special Tools List (RPSTL) TM which contains additional SRA criteria and the authorized spare/repair parts.

Column 3. Maintenance Functions.

Column 3 lists the functions to be performed on the item listed in column 2. (For detailed explanation of these functions, see para B-2.)

d. Column 4. Maintenance Level.

This column specifies the average total manhours required to do the job. For example, if it takes two people five hours to complete the job, the figure would be ten (manhours). This figure represents the time required to perform the job at the lowest indicated category of maintenance and restore the item to a serviceable condition. It includes disassembly, troubleshooting, quality assurance and assembly. The symbol designations for the various maintenance levels are as follows:

- C** Operator or crew
- O** Organization maintenance
- F** Direct support maintenance
- H** General support maintenance
- L** Specialized repair activity (SRA)⁵
- D** Depot maintenance

A # symbol after the manhour figure identifies a maintenance function performed on Hydraulic/Electrical Upgraded (HEU) vehicles.

e. Column 5. Tools and Equipment. Column 5 specifies, by code, **those common** tool sets (not individual tools) and special tools, TM DE, and support equipment required to perform the designated function.

f. Column 6. Remarks. This column shall, when applicable, contain a letter code, in alphabetic order, which shall be keyed to the remarks contained in Section IV.

B-4. Explanation of Columns in Tool and Test Equipment Requirements, Section III.

a. Column 1. Reference Code. The tool and TMDE reference code correlates with a code used in the MAC, Section 11, Column 5.

b. Column 2. Maintenance Level. The lowest level of maintenance

authorized to use the tool or test equipment.

c. Column 3. Nomenclature. Name or identification of the tool or test equipment.

d. Column 4. National Stock Number.

The National stock number of the tool or TMDE.

e. Column 5. Tool Part Number. The manufacturer's part number.

B-5. Explanation of Columns in Remarks Section IV.

a. Reference Code. The code recorded in column 6, section II.

b. Remarks. This column lists information pertinent to the maintenance function being performed as indicated in the MAC, section II.

SECTION II. MAINTENANCE ALLOCATION CHART - CONT.

(1) Group Number	(2) Component Assembly	(3) Maintenance Function	(4) Maintenance Category					(5) Tools and Equipment	(6) Remarks
			C	O	F	H	D		
0100	Engine and Trans- mission Assy, Power Pack	Inspect Test	0.3	0.3 0.3					OT OU
		Service Adjust Replace Repair	0.2	0.5 0.5 9.0 2.0	12.0			168 59, 130, 168 130, 168, 176 130, 168, 171, 176	AW AW OR, OV
0100		Engine Diesel Models AVDS- -1790-2D (1168400)	Inspect Test			0.3 1.5			13, 25, 36, 40, 42, 46-48, 53, 120-123, 126- 129, 168, 169, 171, 178, 180
		Adjust Replace Repair			1.0 12.0			171, 176 61, 64, 67, 70, 169, 176	
		Overhaul		2.2	2.0	4.0		1-23, 25-27, 31-38, 40-44, 47-58, 121- 124, 126, 127, 130-143, 169, 171, 172, 176	NK, OK
0100	Guide Power Plant, Rear - Left and Right (11645840-1, 11645840-2)	Inspect Replace Repair		0.1 0.3 0.8				168, 176 168, 176	
0100	Support Assy (11645839-1, 11645839-2)	Replace Repair		1.5 0.5				177 176	

SECTION II. MAINTENANCE ALLOCATION CHART - CONT.

(1) Group Number	(2) Component Assembly	(3) Maintenance Function	(4) Maintenance Category					(5) Tools and Equipment	(6) Remarks
			C	O	F	H	D		
0101	Engine Block (11684108)	Replace Repair				0.9 0.2		169, 176, 179 169	
0101	Cylinder Head (10951304)	Replace Repair Overhaul				2.1 1.5		15, 16, 25, 26, 42, 51, 52, 176 2-5, 29, 30, 33, 34, 37, 38, 49, 50, 169	NK, OK
0102	Crankshaft (8682734)	Replace Repair				4.0		8-10, 28, 35, 169, 176	OK
0102	Housing Assy, Crankshaft Damper (11684077)	Replace Repair				0.8 0.2		169, 176 169	
0104	Connecting Rod Piston (11683934)	Replace Repair				0.5 0.2		169, 176 169	
0105	Adapter, Crankshaft Drive (8682540)	Replace Repair				0.8 0.2		19, 169 169	
0105	Support, Camshaft End Cover (8682751)	Replace Repair				0.5 0.2		169, 176 176	
0105	Housing, Mech. Drive Camshaft Gear Assy. (L.B.) (11682701)	Replace Repair				0.2 0.2	169	169, 176	

SECTION II. MAINTENANCE ALLOCATION CHART - CONT.

(1) Group Number	(2) Component Assembly	(3) Maintenance Function	(4) Maintenance Category					(5) Tools and Equipment	(6) Remarks
			C	O	F	H	D		
0105	Housing, Mech. Drive Camshaft Gear Assy. (R.B.) (11682703)	Replace Repair				0.2 0.2		169, 176 169	
0105	Gearshaft Assy, Accessory Camshaft Drive Bevel (10865393)	Replace Repair				0.5 0.2		169, 176 19, 169	
0106	Frame, Engine, Engine Oil Cooler Support Right (11684048)	Replace Repair		0.4	2.2 0.1			176 164, 176	
0106	Frame, Engine Oil Cooler Support, Left (11684041)	Replace Repair		4.0	3.0			176 164, 176	
0106	Cooler, Engine Oil (11668989)	Inspect Replace Repair	0.1	0.3 12.0		3.0		174 164, 165	
0106	Oil Pan Engine Crankcase (11683998)	Inspect Replace Repair		0.1		3.0 4.0		169, 176 169	
0106	Cooler, Fluid Transmission (11684103)	Inspect Replace Repair	0.1	0.1 12.0		3.0		174 164, 165	

SECTION II. MAINTENANCE ALLOCATION CHART - CONT.

(1) Group Number	(2) Component Assembly	(3) Maintenance Function	(4) Maintenance Category					(5) Tools and Equipment	(6) Remarks
			C	O	F	H	D		
0106	Cover Access, Engine (Upper Shroud Left Bank) (11683985)	Replace Repair		0.2	0.1			176 164, 177	
0106	Cover Access, Engine (Upper Shroud Right Bank) (11684246)	Replace Repair		0.2	0.1			176 164, 177	
0106	Adapter Assy, Fuel Pump (10882611)	Replace Repair				0.5 0.2		176 169	
0106	Filler Neck: Oil Filler Tube, Upper (11641922)	Replace Repair		0.1 0.1				176 176	
0106	Cap Assy, Oil Lever Filler Tube (8761109)	Replace Repair		0.1 0.1				176 176	
0106	Pump Assy, Oil Engine Lube (11683982)	Replace Repair				1.4 1.6		169, 176 169, 176	
0106	Cap, Filler, Neck, Gage Rod Tube (10935623)	Replace Repair		0.1 0.1				176 176	
0106	Cap Assy, Oil Level Gage Rod Tube (8761109)	Replace Repair		0.1 0.1				176 176	
0108	Manifold, Air Intak (8761045)	Replace Repair			2.7 0.2			169, 176 169	

SECTION II. MAINTENANCE ALLOCATION CHART - CONT.

(1) Group Number	(2) Component Assembly	(3) Maintenance Function	(4) Maintenance Category					(5) Tools and Equipment	(6) Remarks
			C	O	F	H	D		
0108	Elbow, Engine Manifold, Intake (8761156)	Replace Repair			2.0 0.2			169, 176 169	
0108	Tube Assy, Metal Intake Manifold (8761082)	Replace Repair			1.0 0.2			176 169	
0109	Base, Accessory Drive Housing (8761206)	Replace Repair				1.1 0.2		176 169	
0109	Housing Ass, Accessory Drive (11642121-1)	Replace Repair				2.3 0.2		31, 176 169	
0301	Nozzle and Holder Assy, Fuel Injector (10912452-2)	Replace Repair			0.2 0.5			53, 176 47, 48, 171, 176	
0302	Pump Assy, Fuel Injector (11684129-1)	Replace Repair Overhaul			2.0	3.8		25, 169, 176 135-138, 140, 141, 143, 169, 171, 178	DL, DN, DO NK, OK
0302	Cover Assy, Tank Fuel Pump (11637072)	Replace Repair		1.0 1.0				178 178	
0302	Pump Assy, Engine Fuel (10882763-1)	Replace Repair	0.4	0.7				176 176	
0302	Coupling, Shaft, Injection Pump (7323990)	Replace Repair			0.5 0.5			169, 176 176	

SECTION II. MAINTENANCE ALLOCATION CHART - CONT.

(1) Group Number	(2) Component Assembly	(3) Maintenance Function	(4) Maintenance Category					(5) Tools and Equipment	(6) Remarks
			C	O	F	H	D		
0302	Pump Assy, Engine Fuel (10882763-1)	Replace Repair			0.4 0.7			176 176	
0304	Air Cleaner Assy, Left and Right Side Loader, Top Loader and Armored Top Loader (11655320-1, 11655320-2, 12251922-1, 12251922-2, 10949233-1, 10940233-2, 11675951-1, 11675951-2)	Inspect Service Replace Repair	0.1 0.5 2.7	0.8	0.8			150 164, 169, 176, 177	
0304	Filter Assy, Air Cleaner (8762850)	Replace Repair		0.3 0.5				168	
0304	Fan, Centrifugal Air Cleaner (10905010)	Replace Repair		0.8 0.4				168 176	
0304	Motor, Direct Current (12270348, 10905006)	Replace Repair		0.4	0,8			176 169	
0304	Lead Assy, Ground-Blower Motor (10863589)	Replace Repair		0.1 0.2				176 168	
0304	Door Assy, Armored Top Loading A/C (12251910)	Replace Repair		0.3			0.2 0.3	162, 176 176	

SECTION II. MAINTENANCE ALLOCATION CHART - CONT.

(1) Group Number	(2) Component Assembly	(3) Maintenance Function	(4) Maintenance Category					(5) Tools and Equipment	(6) Remarks
			C	O	F	H	D		
0304	Door Assy, Alum. Side Loading A/C (10933774)	Replace		0.2				168, 176	
		Repair		0.2				168, 176	
0304	Door Assy, Alum. Top Loading A/C (11659645)	Replace		0.2				168, 176	
		Repair		0.2				168, 176	
0304	Hose Assembly, Outlet Assy. (12270440, 12271067)	Inspect	0.1						
		Replace		0.3				176	
		Repair			0.3			176	
0304	Hose Assy, Outlet (11655240, 12271066)	Replace		0.3				176	
		Repair			0.3			176	
0304	Air Hose Outlet Assy. (11599544)	Inspect	0.1						
		Replace		0.3				176	
		Repair			0.3			176	
0304	Plug Assy, Restriction Indicator Replacement Top Loading Air Cleaner (12252413)	Inspect	0.1						
		Replace		0.1				176	
		Repair			0.1			176	
0305	Turbo Super-charger Assy, Diesel Eng., Right and Left Bank (11669107-1, 11669107-2, 11668377-1, 11668377-2)	Replace			1.4			39, 176	
		Repair					3.5	131, 132, 133, 134, 169, 176	
0305	Base Assy, Turbo-supercharger (8761086)	Replace			0.3			176	
		Repair			0.2			169	

SECTION II. MAINTENANCE ALLOCATION CHART - CONT.

(1) Group Number	(2) Component Assembly	(3) Maintenance Function	(4) Maintenance Category					(5) Tools and Equipment	(6) Remarks
			C	O	F	H	D		
0306	Plug, Fuel Tank Relief (11615361)	Replace		0.3				178	
		Repair		0.3				178	
0306	Seal, Filler Neck - Right Fuel Tank (7398886)	Replace		0.5				178	
		Repair		1.0				178	
0306	Tank, Fuel, Engine, Right (10911722)	Inspect		0.3					
		Service	0.5						
		Replace Repair		18.0# 12.0	18.0			169 130, 168, 176, 178	
0306	Tank, Fuel, Engine, Left (11673739)	Inspect		0.3					
		Service	0.5						
		Replace Repair		18.0# 12.0	18.0			169 130, 168, 176, 178	
0306	Handle Assy, Fuel Shutoff (10951808)	Inspect	0.1						
		Replace		0.3				176	
		Repair		0.5				176	
0309	Filter, Fluid Pressure - Fuel Inlet (MS51085-1)	Replace		0.5				178	
		Repair		0.6				178	
0309	Filter, Fluid Pressure, Primary Fuel (12254221)	Inspect		1.0					
		Service	0.3					176	
		Replace Repair		9.0 0.3				176 176	
0309	Filter, Fluid Pressure, Fuel/ Water Separator (11602063)	Inspect		1.0					
		Test		0.2				167	
		Service	0.1	0.4				176	
		Replace		0.9				176	
		Repair		0.2				176	

SECTION II. MAINTENANCE ALLOCATION CHART - CONT.

(1) Group Number	(2) Component Assembly	(3) Maintenance Function	(4) Maintenance Category					(5) Tools and Equipment	(6) Remarks
			C	O	F	H	D		
0309	Filter, Fluid Pressure, Intake Manifold Heater (7416350)	Inspect		0.1					
		Service		0.1				176	
		Replace		0.2				176	
		Repair		0.1				176	
0309	Bracket, Fuel/Water Separator (10951434)	Replace		0.2				176	
		Repair			0.2			169	
0311	Heater, Manifold, Air Left and Right Bank (7062195, 7062197)	Inspect		0.1					
		Replace		0.3				176	
		Repair		0.1				176	
0311	Plug, Ignition Manifold Heater (E089D)	Replace		0.1				176	
		Repair		0.1				176	
0311	Pump Assy, Fuel Primer (Purge) (10863692)	Inspect		0.3					
		Replace		1.0				176	
		Repair		1.0	2.0			169, 171, 178	
0311	Valve Assy, Inlet Fuel Primer Pump (7703662)	Replace			0.5			178	
		Repair			0.5			178	
0311	Valve Assy, Outlet Fuel Primer Pump (7703663)	Replace			0.5			178	
		Repair			0.5			178	
0311	Rod Assy, Pump Piston-Fuel Primer (7703661)	Replace			0.6			178	
		Repair			0.6			178	
0311	Rod Assy, Primer, Fuel (7703653)	Replace			0.4			178	
		Repair			0.4			178	

SECTION II. MAINTENANCE ALLOCATION CHART - CONT.

(1) Group Number	(2) Component Assembly	(3) Maintenance Function	(4) Maintenance Category					(5) Tools and Equipment	(6) Remarks
			C	O	F	H	D		
0312	Bearing Unit Plain, Accelerator and Throttle (10863743-1)	Service Replace Repair		0.1 0.4 0.1				168 168, 176 168, 176	AW
0312	Lever, Manual Control Rod- Accelerator (10870699)	Service Replace Repair		0.1 0.2 0.1				168 168, 176 168, 176	AW
0312	Flange Assy, Bulkhead, Accelerator Control (11610566)	Service Replace Repair		0.1 0.1	0.3 0.3			168 169 169, 176	AW OQ
0312	Linkage Assy, Accelerator Control Engine Compartment (11610828)	Inspect Service Replace Repair		0.2 0.3	0.7 1.0			168 169, 176 169, 176	AW
0312	Connecting Link Assy to Clevis (11610565)	Replace Repair			0.5 0.2			169, 176 176	
0312	Connecting Link Riser Linkage Assy (11610762)	Replace Repair			0.4 0.2			169, 176 176	
0311	Control, Auto Fuel Injection (12254217)	Replace Repair				0.5 1.8		169, 176 169	
0401	Cap Assembly Engine Exhaust Outlet Protector (10940879)	Replace Repair		.5 .5				176 176	
0502	Bracket, Shroud Support, Front Engine (8762980)	Replace Repair		2.0 0.7				176 176	

SECTION II. MAINTENANCE ALLOCATION CHART - CONT.

(1) Group Number	(2) Component Assembly	(3) Maintenance Function	(4) Maintenance Category					(5) Tools and Equipment	(6) Remarks
			C	O	F	H	D		
0502	Support, Shroud Rear Engine (10863502)	Replace		1.2				176	
		Repair		0.7				176	
0502	Shroud Assy, Engine (11673825, 10863514)	Replace		1.0				176	
		Repair		2.5				176, 177	
0502	Cover Assy, Engine Access- Left (8762919)	Replace		0.5				176,	
		Repair		0.8				176, 177	
0502	Cover Assy, Engine Access- Right (8762920)	Replace		0.5				176	
		Repair		0.8				176, 177	
0502	Shroud Assy, Engine Cooling Fan (11684088)	Replace		2.1				176	
		Repair			0.1			164, 177	
0502	Plate, Shroud, Engine Left Bank Damper End (11684089)	Replace		1.3				176	
		Repair			0.2			176	
0502	Shroud Plate Turbo Left Bank Inner (10865268)	Replace		0.7				176	
		Repair		0.1	0.2			164, 176	
0502	Shroud Plate Turbo Right Bank Inner (10865267)	Replace		0.7				176	
		Repair		0.1	0.2			164, 176	
0502	Shroud, Cooling Left Bank Lower (11684264)	Replace		0.4				176	
		Repair			0.2			176	
0502	Bracket, Angle, Left Engine Shroud (8762977)	Replace		1.4				176	
		Repair		0.7				176	

SECTION II. MAINTENANCE ALLOCATION CHART - CONT.

(1) Group Number	(2) Component Assembly	(3) Maintenance Function	(4) Maintenance Category					(5) Tools and Equipment	(6) Remarks
			C	O	F	H	D		
0502	Support, Shroud Engine, Right (8762976)	Replace Repair		1.4 0.7				176 176	JC
0502	Bracket Assembly Transmission Shroud Support (11591420-1, 11591420-2)	Replace Repair		1.0 1.0				176 176	
0502	Shroud Assembly Transmission (10864055, 12257232)	Replace Repair		1.0 1.0				176 176	
0505	Fan Tower Assy, Engine Cooling (10935541-1)	Replace Repair				1.1 0.2		176 169	
0505	Housing Assy, Mech. Drive Cooling Fan Base Forward (8761155-1)	Replace Repair				1.2 0.2		176 169	
0505	Clutch Assy, Friction Fan Drive (10951075)	Replace Repair			1.4 1.1			1, 24, 169, 176 169, 176	
0505	Retainer Seal Assy, Fan Drive (8761062)	Replace Repair		0.5 0.1				1, 176 176	
0505	Mount Baffle, Air Flow Cooling Fan Housing Fly-wheel End (8682682)	Replace Repair		0.7		0.2		176 169	
0505	Housing, Engine, Cooling Fan Damper End (8682785)	Replace Repair		0.7		0.2		176 169	

SECTION II. MAINTENANCE ALLOCATION CHART - CONT.

(1) Group Number	(2) Component Assembly	(3) Maintenance Function	(4) Maintenance Category					(5) Tools and Equipment	(6) Remarks
			C	O	F	H	D		
0601	Generator, Engine Accessory 300 Amp (10889713)	Inspect Replace Repair Overhaul		0.1 1.3	1.8			45, 176 171, 176	DR NK, OK
0601	End Bell, Electrical Brush and Bearing Holder Assembly (8344709)	Replace Repair			0.5 0.2			176 171	
0601	Brush Holder Assembly (G22-44)	Replace Repair			0.1 0.1			176 176	
0601	Fan, Tube Axial (10898759)	Replace Repair			0.6 0.1			176 176	
0601	Motor, Fan (10898760)	Replace Repair			0.6 0.2			171, 176 176	
0601	Cradle, Generator (10882774)	Replace Repair		0.2 0.1				176 176	
0602	Regulator, Voltage Control-300A Solid State (12257823)	Replace Repair		1.3			1.0	176	NK
0603	Starter, Engine, Electric (8712242)	Inspect Replace Repair Overhaul		0.1 0.8	1.2	2.5		17, 176 166, 176 166, 171, 176	DT
0603	Relay/Solenoid Assy, Starter (7748640)	Replace Repair		0.2	0.5			176 176	

SECTION II. MAINTENANCE ALLOCATION CHART .CONT.

(1) Group Number	(2) Component Assembly	(3) Maintenance Function	(4) Maintenance Category					(5) Tools and Equipment	(6) Remarks
			C	O	F	H	D		
0603	Plate, Commutator End (1953226)	Replace Repair			0.3 0.1			176 176	
0603	Plate, Commutator End (1953227)	Replace Repair			0.3 0.2			176 176	
0603	Plate, Commutator (1953228)	Replace Repair			0.3 0.1			176 176	
0603	Holder Assembly, Electrical (7748633)	Replace Repair			0.3 0.1			176 176	
0603	Housing, Engine Drive Starter (1949606)	Replace Repair			0.2 0.2			176 169	
0603	Housing Assy, Lever Starter (1953223)	Replace Repair			0.3 0.2			176 169	
0607	Cluster Assembly (Gage Indicator Panel) (10915377)	Replace Repair		0.3 4.0				176 176	
0607	Wiring Harness Branched Instru- ment Panel (10915380)	Replace Repair		1.5 2.5				176 167, 175	
0607	Connector, Receptacle (7722353)	Replace Repair		1.0 1.0				176 167	
0607	Cable Assy, Fuel Tank Selector Switch-Instru- ment (8762440)	Replace Repair		0.2 0.2				167	

SECTION II. MAINTENANCE ALLOCATION CHART .CONT.

(1) Group Number	(2) Component Assembly	(3) Maintenance Function	(4) Maintenance Category					(5) Tools and Equipment	(6) Remarks
			C	O	F	H	D		
0607	Light Indicator, Gage Illumination Instrument Panel (8376500)	Replace Repair	0.1	0.4 0.5				176 176	KQ
0607	Control Panel Assy, Master (Driver's) (12251968)	Inspect Test Repair	0.3 0.1	0.3 4.0				176 175, 176	KQ
0607	Lamp Assy, Personnel Heater Indicator (10883766)	Replace Repair		0.5 0.8				176 167, 176	
0607	Utility Outlet Assy, Master Control Panel (10905682)	Replace Repair		0.3 0.3				176 167, 176	
0607	Lamp Holder (8376359)	Replace Repair		0.2 0.2				176 167, 176	
0607	Base Assy, Indicator Bilge Pump, CBR, IR Pwr, Master Battery, Master Control Panel (10933573)	Replace Repair		0.3 0.2				176 176	
0607	Wiring Harness, Branched, Fuel (Pump) Switches to CB Shut-off Master Control Panel (10911164)	Replace Repair		0.2 0.3				167	

SECTION II. MAINTENANCE ALLOCATION CHART - CONT.

(1) Group Number	(2) Component Assembly	(3) Maintenance Function	(4) Maintenance Category					(5) Tools and Equipment	(6) Remarks
			C	O	F	H	D		
0607	Cable Assy, Gas Particulate and Bilge Pump Switches to Common CB, Master Control Panel (10933669)	Replace Repair		0.2 0.2				167	
0607	Lamp Assy, High Beam Indicator, Master Control Panel (8737689)	Replace Repair		0.3 0.3				176 176	
0607	Wiring Harness, Branched, Heater and Starter Push Button Switches (11655748)	Replace Repair		1.5 1.0				176 167	
0607	Connector, Receptacle, (7971515)	Replace Repair		0.5 0.5				167 167	
0607	Wiring Harness, Branched, Master Battery (10911166)	Replace Repair		0.7 0.6				176 167	
0607	Connector, Receptacle (7722354)	Replace Repair		0.4 0.4				167 167	
0607	Wiring Harness, Branched, Accessories, Master Control Panel (11655749)	Replace Repair		1.0 2.0				176 167, 175	
0607	Connector, Receptacle (7716794)	Replace Repair		0.8 0.8				167 167	

SECTION II. MAINTENANCE ALLOCATION CHART - CONT.

(1) Group Number	(2) Component Assembly	(3) Maintenance Function	(4) Maintenance Category					(5) Tools and Equipment	(6) Remarks
			C	O	F	H	D		
0607	Wiring Harness, Branched, Personnel Heater, Master Control Panel (10911163)	Replace Repair		0.5 0.5				176 167, 175	
0607	Connector, Receptacle (7716785)	Replace Repair		0.4 0.4				167 167	
0607	Cable Assy, Circuit 516 to both IR Power Packs (10934317)	Replace Repair		0.6 0.3				176 167	
0607	Connector (8724199)	Replace Repair		0.3 0.2				167 167	
0607	Wiring Harness, Foot Dimmer and Fire Extinguisher Switches (10934309)	Replace Repair		1.2 1.0				176 167	
0607	Connector Assy (8724244)	Replace Repair		0.7 0.5				167 167	
0607	Connector, Rcpt (7722353)	Replace Repair		0.8 0.5				167 167	

SECTION II. MAINTENANCE ALLOCATION CHART - CONT.

(1) Group Number	(2) Component Assembly	(3) Maintenance Function	(4) Maintenance Category					(5) Tools and Equipment	(6) Remarks
			C	O	F	H	D		
0607	Wiring Harness, Battery to Heater and Fuel Shut-off CB (10934389, 12304151)	Replace Repair		0.4 0.2				176 167	
0607	Lead Assy Intermediate Cable to Heater Fuel Pump (10934402)	Replace Repair		0.3 0.2				176 167	
0607	Cable Assembly, Basket Disconnect-to-Indicator Panel (10934286)	Replace Repair		1.3# 0.7	1.3 1.3			176 167	KR
0607	Connector, Rcpt Basket, Basket-to-Indicator Panel Wiring Harness (7722353)	Replace Repair		0.7 0.4				167 167	
0607	Connector Assembly, Panel, Basket-to-Indicator Panel Wiring Harness (8724244)	Replace Repair		0.5 0.4				167 167	
0607	Cable Assembly, Heater, Basket-to Master Control Panel (10934300)	Replace Repair		1.3# 0.9	1.3 1.0			176 167	KR
0607	Connector, Rcpt, Basket, Basket-to-Master Control Panel Heater Wiring Harness (7716785)	Replace Repair		0.7 0.4				167 167	

SECTION II. MAINTENANCE ALLOCATION CHART - CONT.

(1) Group Number	(2) Component Assembly	(3) Maintenance Function	(4) Maintenance Category					(5) Tools and Equipment	(6) Remarks
			C	O	F	H	D		
0607	Connector Assembly, Panel, Basket-to-Master Control Panel Heater Wiring Harness (8724245)	Replace Repair		0.5 0.3				167 167	
0607	Cable Assembly, Accessories, Basket-to-Master Control Panel (10934322)	Replace Repair		1.2# 0.8	1.2 1.0			176 167	KR
0607	Connector, Basket, Accessories, Basket-to-Master Control Panel Wiring Harness (7716794)	Replace Repair		0.8 0.4				167 167	
0607	Connector Assembly, Panel, Accessories, Basket-to-Master Control Panel Wiring Harness (8724257)	Replace Repair		0.7 0.4				167 167	
0607	Wiring Harness, Basket-to-Light Switch (10934323)	Replace Repair		1.1# 0.7	1.1 0.9			176 167	KR
0607	Connector, Basket, Basket-to-Light Switch Wiring Harness (7716793)	Replace Repair		0.6 0.4				167 167	
0607	Connector, Light Switch, Basket-to-Light Switch Wiring Harness (8724258)	Replace Repair		0.8 0.6				167 167	

SECTION II. MAINTENANCE ALLOCATION CHART - CONT.

(1) Group Number	(2) Component Assembly	(3) Maintenance Function	(4) Maintenance Category					(5) Tools and Equipment	(6) Remarks
			C	O	F	H	D		
0607	Wiring Harness, Basket-to-Master Control Panel, Starting (10934301) (12326536)	Replace Repair		0.9# 0.5	0.9 0.5			176 167	KR
0607	Connector, Rcpt, Basket, Basket-to-Master Control Panel, Starting Wiring Harness (7722354)	Replace Repair		0.5 0.4				167 167	
0607	Connector, Panel Basket-to-Master Panel, Starting Wiring Harness (8724243)	Replace Repair		0.4 0.4				167 167	
0607	Cable Assembly, Basket-to-Master Control Panel, Power (10934308)	Replace Repair		1.4# 0.4	1.4 0.7			176 167	KR
0607	Connector, Rcpt, Basket, Basket-to-Master Control Panel, Power Wiring Harness (7971515)	Replace Repair		0.4 0.3				167 167	
0607	Connector Plug, Panel, Basket-to-Master Control Panel, Power Wiring Harness (8724240)	Replace Repair		0.3 0.3				167 167	
0607	Lead Electrical, Interconnecting Box-to-Hull Power Wiring Harness (10952058)	Replace Repair		0.5 0.3				176 167	

SECTION II. MAINTENANCE ALLOCATION CHART - CONT.

(1) Group Number	(2) Component Assembly	(3) Maintenance Function	(4) Maintenance Category					(5) Tools and Equipment	(6) Remarks
			C	O	F	H	D		
0607	Connector, Box Assembly, Interconnecting Box-to-Hull Power Wiring Harness (8724242)	Replace Repair		0.4 0.3				167 167	
0607	Receptacle Assembly, Harness Connection, Interconnecting Box-to-Hull Power Wiring Harness (7716780)	Replace Repair		0.5 0.3				167 167	
0608	Power Supply, IR High Voltage Drivers (7978752)	Replace Repair		0.5 0.8	2.0			176 167	KR, NK
0608	Power Supply, High Voltage (7355743)	Replace Repair		1.0	2.0			167	NK
0608	Relay Solenoid, Starter (10946920)	Replace Repair			1.4 1.4			176 176	
0608	Plate Mouting, Electric Equipment (10934298-1)	Replace Repair		0.3 0.4				176 176	
0608	Harness Assembly, IR Power Pack to IR Periscope (10934298-1)	Replace Repair		0.8 0.4				176 167	
0608	Connector, Plug (11654592)	Replace Repair		0.3 0.3				167 167	

SECTION II. MAINTENANCE ALLOCATION CHART - CONT.

(1) Group Number	(2) Component Assembly	(3) Maintenance Function	(4) Maintenance Category					(5) Tools and Equipment	(6) Remarks
			C	O	F	H	D		
0608	Panel, Relay Mounting (11591055)	Replace		0.2				176	
		Repair		0.2				176	
0608	Box, Special Purpose, Venti- lation Blower and Radio (10940180)	Replace		0.3				176	
		Repair		0.6				176	
0608	Receptacle Assem- bly, Power, Inter- connecting Box (7751500-1)	Replace		0.4				175	
		Repair		0.2				175	
0608	Connector, Power, Interconnecting Box (7388320)	Replace		0.3				167	
		Repair		0.2				167	
0608	Receptacle Assem- bly, Blower, Inter- connecting Box (7972770)	Replace		0.5				175	
		Repair		0.4				175	
0608	Receptacle, Blower, Inter- connecting Box (7722225SMR)	Replace		0.3				167	
		Repair		0.2				167	
0608	Lead Assembly, Interconnecting Box (10940176)	Replace		0.6				175	
		Repair		0.3				175	
0608	Connector, Recep. (7388319)	Replace		0.3				167	
		Repair		0.3				167	
0609	Resistor Assembly, Variable (10893854)	Replace		0.3				176	
		Repair		0.2				167	
0609	Light, Dome Driver's (7064671)	Inspect	0.1						KQ
		Replace		0.7				176	
		Repair	0.2	1.0				168, 175, 176	

SECTION II. MAINTENANCE ALLOCATION CHART . CONT.

(1) Group Number	(2) Component Assembly	(3) Maintenance Function	(4) Maintenance Category					(5) Tools and Equipment	(6) Remarks
			C	O	F	H	D		
0609	Headlight Assy, Left and Right (7972325)	Inspect	0.3						
		Service		0.3				176	
		Adjust		0.5				176	
		Replace		0.5				176	
		Repair	0.2	2.0			168, 175, 176	KQ	
0609	Base Assembly, Headlight Left and Right (7972347)	Replace		0.5				176	
		Repair		0.5				167	
0609	Base Headlight Mounting (7972352)	Replace		0.4				167, 176	
		Repair		0.4				167, 176	
0609	Stop Light - Taillight, Left (8378785)	Inspect	0.3						
		Service		0.3				176	
		Adjust		0.5				176	
		Replace		0.3				176	
		Repair	0.2	1.0			168, 175, 176	KQ	
0609	Door Assy, Left Taillight - Stop Light (7526020)	Replace		0.3				176	
		Repair		0.4				176	
0609	Stop Light, Taillight Right (8378786)	Inspect	0.3						
		Service		0.3				176	
		Adjust		0.5				176	
		Replace		0.3				176	
		Repair	0.2	1.0			168, 175, 176	KQ	
0609	Door Assy, Right Taillight - Stop Light (7526018)	Replace		0.3				176	
		Repair		0.4				176	
0612	Battery, Storage, 12V Type (MS35000-3)	Inspect	0.4					BII	
		Test		0.3				168	
		Service		0.4				168, 176	
		Replace		1.5				176	
		Repair			0.5		176		

SECTION II. MAINTENANCE ALLOCATION CHART - CONT.

(1) Group Number	(2) Component Assembly	(3) Maintenance Function	(4) Maintenance Category					(5) Tools and Equipment	(6) Remarks
			C	O	F	H	D		
0612	Cable Assembly, Battery Jumper (10934307)	Replace Repair		0.7 0.4				176 167, 175	
0613	Wiring Harness, Starter Feed, Bulkhead to Engine Disconnect (10863758, 11655553, 11615531)	Replace Repair		2.0# 0.3	2.0 0.7			176 167, 181	
0613	Connector Plug (8395480)	Replace Repair		0.3 0.3				167 167	
0613	Connector Plug (8724404)	Replace Repair		0.3 0.3				167 167	
0613	Wiring Harness, Starter Feed, Engine Disconnect to Starter (11655450)	Replace Repair		0.3 0.1				167, 176 167, 176	
0613	Cable, Receptacle, Wiring Harness, Starter Feed, Engine Disconnect (7388353)	Replace Repair		0.1 0.1				167, 176 167, 176	
0613	Wiring Harness, Branched, Heater Control, (10911265)	Replace Repair		2.0# 0.4	2.0 1.0			176 167, 181	KR
0613	Connector Assy (8724245)	Replace Repair		0.4 0.3				167 167	

SECTION II. MAINTENANCE ALLOCATION CHART - CONT.

(1) Group Number	(2) Component Assembly	(3) Maintenance Function	(4) Maintenance Category					(5) Tools and Equipment	(6) Remarks
			C	O	F	H	D		
0613	Wiring Harness, Branched, Rear Accessory (10951788, 11615537, 12326537)	Replace		3.0#	3.0			176	KR
		Repair		0.6	2.0			167, 181	
0613	Connector, Plug (8724258)	Replace		0.6				167	
		Repair		0.4				167	
0613	Wiring Harness Assy, Hull Power (11676288, 12304153)	Replace		2.0#	2.0			176	KR
		Repair		1.0	1.8			167, 181	
0613	Connector, Plug (8724242)	Replace		0.3				167	
		Repair		0.3				167	
0613	Connector, Plug (8724406)	Replace		0.3				167	
		Repair		0.3				167	
0613	Connector, Plug (8724240)	Replace		0.4				167	
		Repair		0.3				167	
0613	Wiring Harness, Branched, Master (11590678, 11626171, 12304152)	Replace		4.5#	4.5			176	KR
		Repair		1.0	4.0			167, 181	
0613	Connector, Assembly (8724199)	Replace		0.2				167	
		Repair		0.2				167	
0613	Shell Assembly (8724231)	Replace		0.3				167	
		Repair		0.3				167	
0613	Connector, Plug (8724243)	Replace		0.7				167	
		Repair		0.6				167	

SECTION II. MAINTENANCE ALLOCATION CHART - CONT.

(1) Group Number	(2) Component Assembly	(3) Maintenance Function	(4) Maintenance Category					(5) Tools and Equipment	(6) Remarks
			C	O	F	H	D		
0613	Connector, Assembly (8724244)	Replace Repair		0.3 0.3				167 167	
0613	Connector, Assembly (8724257)	Replace Repair		0.7 0.6				167 167	
0613	Shell Assembly (8724238)	Replace Repair		0.3 0.3				167 167	
0613	Connector, Plug (8724258)	Replace Repair		0.9 0.7				167 167	
0613	Connector, Plug (8724405)	Replace Repair		0.6 0.4				167 167	
0613	Receptacle Assy (7716780)	Replace Repair		0.6 0.3				167, 176 167	
0613	Connector, Receptacle (7716793)	Replace Repair		1.0 0.6				167, 176 167	
0613	Connector, Receptacle (7716794)	Replace Repair		1.0 0.7				167, 176 167	
0613	Cable Assy Start Relay to Bulkhead (10911212)	Replace Repair		0.6 0.4				176 167, 176	
0613	Receptacle Assembly (8395481)	Replace Repair		0.4 0.2				167 167	
0613	Connector, Plug (8395480)	Replace Repair		0.4 0.2				167 167	

SECTION II. MAINTENANCE ALLOCATION CHART - CONT.

(1) Group Number	(2) Component Assembly	(3) Maintenance Function	(4) Maintenance Category					(5) Tools and Equipment	(6) Remarks
			C	O	F	H	D		
0613	Cable Assy, Battery Slave (10934318, 12290743)	Replace Repair		2.5# 0.4	2.5 2.0			176 167, 181	KR
0613	Connector, Assy (7321299)	Replace Repair		0.3 0.2				167 167	
0613	Connector, Plug (8724242)	Replace Repair		0.3 0.3				167 167	
0613	Wiring Harness (11682726)	Replace Repair		0.8 0.1				167, 176 167, 176	
0613	Connector (7716793)	Replace Repair		0.1 0.1				167, 176 167, 176	
0613	Connector Plug, Electrical: Starter, Low Voltage Pro- tection, Engine Electrical (8724240)	Replace Repair		0.1 0.1				167, 176 167, 176	
0613	Connector, Plug Fuel Shut-off Cable, Engine Electrical (8724199)	Replace Repair		0.1 0.1				167, 176 167, 176	
0613	Connector, Rcpt, Transmission Dis- connect Engine Electrical (7722353)	Replace Repair		0.1 0.1				167, 176 167, 176	

SECTION II. MAINTENANCE ALLOCATION CHART - CONT.

(1) Group Number	(2) Component Assembly	(3) Maintenance Function	(4) Maintenance Category					(5) Tools and Equipment	(6) Remarks
			C	O	F	H	D		
0613	Lead Electrical, Generator-to-Engine Disconnect (11682723)	Replace Repair		0.3 0.1				167, 176 167, 176	
0613	Connector Assembly, Receptacle, Engine Disconnect, Generator Lead Assembly (7716781)	Replace Repair		0.1 0.1				167, 176 167, 176	
0613	Lead Assembly, Electrical, Generator Blower (11682724)	Replace Repair		0.1 0.1				167, 176 167, 176	
0613	Connector Plug, Electrical, Generator Blower (8724233)	Replace Repair		0.1 0.1				167, 176 167, 176	
0613	Wiring Harness, Branched, Engine Accessory Control (11655653)	Replace Repair		1.0	2.0 1.8			176 167, 181	KR
0613	Connector, Plug (8724257)	Replace Repair		1.0 0.8				167 167	
0613	Connector, Plug (8724258)	Replace Repair		1.0 0.7				167 167	
0613	Cable Assembly, Special, BHD to Engine Disconnect (Left Side) (11655654)	Replace Repair		0.3	1.0 0.6			176 167	OX KR, OX

SECTION II. MAINTENANCE ALLOCATION CHART - CONT.

(1) Group Number	(2) Component Assembly	(3) Maintenance Function	(4) Maintenance Category					(5) Tools and Equipment	(6) Remarks
			C	O	F	H	D		
0613	Connector (8724242)	Replace Repair		0.4 0.3				167 167	
0613	Connector (8724241)	Replace Repair		0.3 0.2				167 167	
0613	Lead Assembly, Engine Disconnect to Starter Ground (10863699)	Replace Repair		0.8 0.5				176 167	
0613	Connector, Plug (8724403)	Replace Repair		0.3 0.3				167 167	
0613	Wiring Harness, Smoke Generator (12270526)	Replace Repair		1.5 1.0				176 167	
0613	Receptacle Assy, (7720485)	Replace Repair		0.6 0.3				167, 176 167	
0613	Receptacle Assy, (7722351)	Replace Repair		0.6 0.3				167, 176 167	
0613	Connector (8724238)	Replace Repair		0.4 0.3				167, 176 167	
0615	Capacitor and Housing Assy, (7061046)	Replace Repair		0.5 0.5				178 178	
0615	Connector Assy, Capacitor (7018245)	Replace Repair		0.4 0.3				178 178	

SECTION II. MAINTENANCE ALLOCATION CHART - CONT.

(1) Group Number	(2) Component Assembly	(3) Maintenance Function	(4) Maintenance Category					(5) Tools and Equipment	(6) Remarks
			C	O	F	H	D		
0615	Cable and Adapter Assy, Fuel Tank Pump Power Left (7061058-1, 7061059)	Replace		0.4				178	
		Repair		0.4				178	
0615	Cable and Adapter Assy, Fuel Tank Pump Power Right (7061058)	Replace		0.5				178	
		Repair		0.5				178	
0616	Blower Assy, Ventilating (7974293)	Inspect		0.1					
		Replace		2.0				167, 176	
		Repair			0.8			169, 176	
0616	Motor, Turret Vent (7727524)	Replace			0.4			176	
		Repair			1.5			176	
0616	Box Assy, Ventilating Blower (8335333)	Replace		0.4				176	
		Repair		0.6				176	
0616	Utility, Outlet Assy (8734796, 10905682)	Replace		0.4				176	
		Repair		0.3				176	
0616	Connector (8338560)	Replace		0.2				167	
		Repair		0.2				167	
0616	Lamp Holder (8376359)	Replace		0.2				167	
		Repair		0.2				167	
0616	Connector (8335304)	Replace		0.6				176	
		Repair		0.3				167	
0616	Receptacle (7720485)	Replace		0.3				167	
		Repair		0.3				167	

SECTION II. MAINTENANCE ALLOCATION CHART - CONT.

(1) Group Number	(2) Component Assembly	(3) Maintenance Function	(4) Maintenance Category					(5) Tools and Equipment	(6) Remarks
			C	O	F	H	D		
0616	Connector (8338560)	Replace Repair		0.2 0.2				167 167	
0616	Cable Assy, Control (8733955)	Replace Repair		0.6 0.3				176 167	
0616	Connector (7722348)	Replace Repair		0.2 0.2				167 167	
0616	Lead, Electrical (8734051)	Replace Repair		0.6 0.3				176 167	
0616	Connector (7722347)	Replace Repair		0.2 0.2				167 167	
0705	Seal Assy, Compartment Link Assy Shield (10864295)	Replace Repair		1.0 0.8				176 168	
0705	Bell Crank, Intermediate Shifting Control (10870167)	Replace Repair			0.7 1.0			176 163	
0705	Rod Assy, Engine Compartment (10870275)	Replace Repair			1.0 0.4			176 176	
0705	Connecting Link, Bulkhead Inter- mediate Rod (10870423)	Replace Repair			2.0 0.4			176 163, 176	
0705	Bracket, Shifting, Shift Link Assy, Mounting (10934254)	Replace Repair		1.4 1.0				176 176	

SECTION II. MAINTENANCE ALLOCATION CHART - CONT.

(1) Group Number	(2) Component Assembly	(3) Maintenance Function	(4) Maintenance Category					(5) Tools and Equipment	(6) Remarks
			C	O	F	H	D		
0705	Bracket Assy, Transmission Control Rod (10887630)	Replace Repair		1.2 0.7				176 176	
0705	Link Assy, Shift Control, Engine Compartment, Rear Control Rod to Rise Rod (10912028)	Replace Repair		2.5 0.9				176 176	
0705	Bracket Assy, Engine Compartment, Link Mounting (10915269)	Replace Repair		1.8 0.8				176 176	
0705	Pivot Assy, Shifting Control Hand Lever (10915822)	Replace Repair		1.0 0.3				176 176	
0705	Base, Control, Lever Pivot (12290520)	Replace Repair		1.2 0.6				176 176	
0705	Guard, Linkage Control Engine Compartment, Rear Control Rod (11654810)	Replace Repair			1.3 1.0			176 163, 176, 177	
0705	Link, Shift, Control Rod to Riser (7953921, 12291352)	Replace Repair		1.8 0.8				176 176, 177	
0708	Stator Assembly, Converter, first and second stages (7710822)	Replace Repair				0.3 1.5		172 172	

SECTION II. MAINTENANCE ALLOCATION CHART - CONT.

(1) Group Number	(2) Component Assembly	(3) Maintenance Function	(4) Maintenance Category					(5) Tools and Equipment	(6) Remarks	
			C	O	F	H	D			
0708	Stator Assembly, second (7373561)	Replace				0.3		172		
		Repair				1.0		172		
0708	Stator Assembly, first (7909884)	Replace				0.2		172		
		Repair				1.0		172		
0708	Cover Assembly, Converter turbine (8350580)	Replace				1.0		64, 172		
		Repair				0.5		172		
0710	Transmission Assy, CD850-6A (8355830)	Replace			8.0			61, 64, 67, 70, 163		OF
		Repair			7.0	25.5		59, 61-67, 70, 72-76, 79-82, 125, 169, 170, 172		
		Overhaul					**	59-89		NK, OK
0710	Housing Assembly, Converter (7767664)	Replace				5.3		64, 172		
		Repair				0.3		172		
0710	Housing Assembly, Front and Rear, Studding (8355833)	Replace				2.0		64, 80, 172		
		Repair				2.0		64, 172		
0710	Housing Assembly, Front and Rear, Machined (8355832)	Replace				2.0		64, 172		
		Repair				1.0		169, 172		
0710	Housing Assembly, Transmission Front Subassembly, Studding (8355831)	Replace				1.0		64, 172		
		Repair					**		NK, OK	
0710	Screen Assembly, Center, Oil (7707218)	Replace				0.8		169		
		Repair				0.8		169		

SECTION II. MAINTENANCE ALLOCATION CHART - CONT.

(1) Group Number	(2) Component Assembly	(3) Maintenance Function	(4) Maintenance Category					(5) Tools and Equipment	(6) Remarks
			C	O	F	H	D		
0710	Unit Assembly, Input Gear, Converter and Steering (8350530)	Replace Repair				2.5 5.3		64, 176 72, 169, 172	
0710	Plate Assembly, Reaction (7708121)	Replace Repair				1.0 1.0		64, 172 172	
0710	Bushing Assembly (7709396)	Replace Repair				1.0 0.5		172 169, 172	
0710	Gear Set, Bevel, Matched, Input Gear (7710834)	Replace Repair				1.0 1.0		67, 70, 172 67, 70, 172	
0710	Carrier Assembly, Bevel Gear (7710933)	Replace Repair				1.5 1.5		172 172	
0710	Carrier Assembly, Bevel Gear (8355736)	Replace Repair				1.0 1.0		172 172	
0710	Carrier Assembly, Bevel Gear (7710934)	Replace Repair				1.0 1.0		172 172	
0710	Hub Assembly, Steering, Clutch Bearing (7709440)	Replace Repair				1.0 1.0		172 172	
0710	Carrier Assembly, Steering Differential Planetary (7539886)	Replace Repair				1.0 1.0		172 172	
0710	Gear Assembly, Reverse, Sun (7767602)	Replace Repair				0.2 1.0		169, 172	

SECTION II. MAINTENANCE ALLOCATION CHART - CONT.

(1) Group Number	(2) Component Assembly	(3) Maintenance Function	(4) Maintenance Category					(5) Tools and Equipment	(6) Remarks
			C	O	F	H	D		
0710	Carrier Assembly, Reverse, Planetary (7767597)	Replace Repair				0.2 1.0		169, 172	
0710	Carrier, Reverse (7767601)	Replace Repair				0.2 1.0		172 169, 172	
0710	Hub Assembly, Reverse and Output Ring Gear (7767603)	Replace Repair				0.2 1.0		172	
0710	Shaft Assembly, Main Crossdrive (7709548)	Replace Repair				0.2 1.0		72, 172	
0710	End Cover Assembly, Right and Left (8348320, 8348319)	Replace Repair			3.0 1.0		8.0	63, 79, 82, 172 63, 65, 66, 72-75, 82, 85, 172	
0710	Carrier Assembly, Output Planetary (7709550)	Replace Repair			0.5		2.0	62, 169 172	
0710	Carrier, Output Planetary (7709695)	Replace Repair				0.5 2.0		172 66, 172	
0710	Piston Assembly (7710806)	Replace Repair			0.5 1.0			169 169	
0710	Cover Assembly, Left or Right (7709402, 7709403)	Replace Repair			3.8 0.3		0.7	79, 82, 169 169, 172	
0710	Lever Assembly, Brake Apply (7540472, 7540473)	Replace Repair			0.1 0.4			76, 79 169	

SECTION II. MAINTENANCE ALLOCATION CHART - CONT.

(1) Group Number	(2) Component Assembly	(3) Maintenance Function	(4) Maintenance Category					(5) Tools and Equipment	(6) Remarks
			C	O	F	H	D		
0710	Carrier Assembly, Low Range Planetary (7767647)	Replace Repair				0.2 1.0		169, 172	
0710	Gear Assembly, Low Range Ring (7767575)	Replace Repair				0.2 2.0		169, 172	
0710	Piston Assembly, High Range Clutch (8351058)	Replace Repair				0.2 0.3		172 169, 172	
0713	Housing Assembly, Steering Clutch (7709429)	Replace Repair				1.5 0.6		64, 172 169, 172	
0713	Cover Assembly, Steering Clutch Housing (7709412)	Replace Repair				1.5 1.0		172 169, 172	
0713	Hub Assembly, Steering Clutch (7709449)	Replace Repair				0.2 0.7		172 169, 172	
0714	Band Assembly, Reverse (8350561)	Replace Repair				0.2 0.5	**	172	NK, OK
0714	Band Assembly, Low Range (8350561)	Replace Repair				0.2 0.5	**	172	NK, OK
0714	Valve Assembly, Control (8355809)	Replace Repair			1.5 1.0			169 169	
0714	Body Assembly, Control Valve (7708258)	Replace Repair			1.0 2.0			172 76, 172	

SECTION II. MAINTENANCE ALLOCATION CHART - CONT.

(1) Group Number	(2) Component Assembly	(3) Maintenance Function	(4) Maintenance Category					(5) Tools and Equipment	(6) Remarks
			C	O	F	H	D		
0721	Pump Assembly, Input Oil (11649924)	Replace Repair				0.2 0.3		172 169, 172	
0721	Oil Strainer Assy, Side (8350689)	Service Replace Repair		0.8 0.8 0.8				169 169 169	AW
0721	Filter Assembly, Top Oil Filter (8348730)	Replace Repair			1.0 0.4			130, 169 169	
0721	Body Assembly, Top Oil Filter (7767817)	Replace Repair			1.0 0.4			169 169	
0721	Pump Assembly, Output Oil (7768072)	Replace Repair				0.2. 0.3		172 169, 172	
0721	Filter, Side Oil (8351025)	Inspect Replace Repair		0.4 0.2	0.3			176 169, 176	
0721	Oil Level Indicator Assembly, (8350969)	Replace Repair		0.1 0.1					
0721	Filter Assembly, Main Oil (7720937-1)	Service Replace Repair		0.6 0.4	0.8			176 176 169	AW
0721	Screen Assy, Side Oil (7707225)	Service Replace Repair			0.8 0.8 0.8			169 169 169	AW

SECTION II. MAINTENANCE ALLOCATION CHART - CONT.

(1) Group Number	(2) Component Assembly	(3) Maintenance Function	(4) Maintenance Category					(5) Tools and Equipment	(6) Remarks
			C	O	F	H	D		
0801	Drive Assy, Final (12251724)	Inspect	0.2	0.2				176	AW
		Service		0.3				105, 167, 168,	
		Replace		1.5				176	
		Repair		0.2	10.3			104, 105, 106,	OG
							112, 116, 163, 167, 170, 174, 176, 180		
		Overhaul					16.0	104, 105, 106, 112, 116, 163, 167, 170, 174, 176, 180	OH
0801	Shaft Assy, Final Drive Output (12251723)	Replace			7.6			104, 105, 112, 116, 163, 169, 170, 174, 176, 180	OG
		Repair			0.2			169	
0801	Case and Carrier Assy, Final Drive (8689176)	Replace			8.2			104, 105, 112, 116, 163, 169, 170, 174, 176, 180	OG
		Repair			0.2			168	
0801	Seal Assy (12304107)	Replace			8.8			104, 112, 116, 163, 170, 176	OG
		Repair			0.2			170	
0900	Universal Joint, Final Drive (5591570)	Inspect		0.1					
		Service		0.2				168	
		Replace		0.4				176	
		Repair		0.7				176	
0900	Spider Assy (11645013)	Replace		0.7				176	
		Repair		0.1				168	

SECTION II. MAINTENANCE ALLOCATION CHART - CONT.

(1) Group Number	(2) Component Assembly	(3) Maintenance Function	(4) Maintenance Category					(5) Tools and Equipment	(6) Remarks
			C	O	F	H	D		
1204	Lever, Assembly: Linkage Guide (Hydraulic Brake) (10915246)	Inspect Service Adjust Replace Repair		0.3 0.5 0.5 1.5 0.5				BII 176 176 176	AW
1204	Lever, Linkage Cam (Hydraulic Brake) (10915657)	Inspect Service Adjust Replace Repair		0.3 0.5 0.5 1.0 1.0				BII 176 176 176	AW
1204	Cylinder Assy, Master Brake (Hydraulic Brake) (10916089)	Inspect Service Replace Repair	0.3	0.3 0.5 1.0		1.0		176 176 168, 176 169	AW
1204	Cylinder Assy, (Hydraulic Brake) Slave Tube (11675894)	Replace Repair		1.0		1.5		168, 176 169	
1206	Housing Assy, Engine Compart- ment, Brake Lever, Left (10916175-1, 12290725-1)	Replace Repair		0.8 0.5				176 167, 176	
1206	Housing Assy, Engine Compart- ment, Brake Lever, Right (10916175-2, 12290725-2)	Replace Repair		0.8 0.5				176 167, 176	
1206	Lever Assy, Parking Brake Lock, Left (10940387-1)	Replace Repair		1.0 0.4				176 176	

SECTION II. MAINTENANCE ALLOCATION CHART - CONT.

(1) Group Number	(2) Component Assembly	(3) Maintenance Function	(4) Maintenance Category					(5) Tools and Equipment	(6) Remarks
			C	O	F	H	D		
1206	Lever Assy, Parking Brake Lock, Right (10940387-2)	Replace Repair		1.0 0.4				176 176	
1206	Bell Crank Brake Control SPRT BRKT (11626368)	Replace Repair		0.7 0.4				176 176	
1301	Wheel, Solid Rubber 1 thru 6, Left and Right (7013976, 12290876)	Inspect	0.2						OD
1301	Hub and Arm Assembly No. 1 Left and Right Roadwheel (10905986-1, 10905986-2)	Inspect Service Adjust Replace Repair	0.2	0.2 0.5 1.5 1.5				168 119, 167, 168, 174, 176 90, 91, 93, 94, 95, 96, 97, 101, 119, 167, 168, 176 93, 95, 97, 101, 119, 156, 167, 168, 176	AW
1301	Arm Assembly, Roadwheel No. 1 Left and Right (10905983-1, 10905983-2)	Replace Repair		1.5 1.0		1.0		93, 95, 97, 101, 119, 156, 167, 168, 176 92, 93, 95, 101, 114, 119, 164, 167, 168, 169, 176	
1301	Seal Assy, Hub and Arm (7364672)	Replace Repair		4.0 4.5				93, 95, 97, 101, 119, 167, 168, 176 176	

SECTION II. MAINTENANCE ALLOCATION CHART - CONT.

(1) Group Number	(2) Component Assembly	(3) Maintenance Function	(4) Maintenance Category					(5) Tools and Equipment	(6) Remarks	
			C	O	F	H	D			
1301	Hub, Wheel, Hub and Arm Assy. (8763016)	Replace		1.5				93, 95, 97, 101, 167, 168, 176		
		Repair		1.5						93, 95, 97, 101, 119, 167, 168, 176
1301	Hub and Arm Assy, No. 2 Left and Right Roadwheel (10915602-1, 10915602-2)	Inspect	0.2	0.2				168 119, 167, 168, 174, 176	AW	
		Service		0.5						
		Adjust								
		Replace			1.5					
		Repair		1.5				90, 91, 93, 94, 95, 97, 101, 167, 168, 176		
1301	Arm Assembly, Roadwheel, No. 2 Left and Right (10915603-1, 10915603-2)	Replace		1.5				93, 95, 97, 101, 119, 167, 168, 169, 176		
		Repair		1.0	1.0					
1301	Seal Assy, Hub and Arm (7364672)	Replace		1.5				93, 95, 97, 101, 167, 168, 176		
		Repair		0.2						
1301	Hub, Wheel, Hub and Arm Assy (8763016)	Replace		1.5				93, 95, 97, 101, 167, 168, 176		
		Repair		1.5						93, 95, 97, 101, 119, 167, 168, 176

SECTION II. MAINTENANCE ALLOCATION CHART - CONT.

(1) Group Number	(2) Component Assembly	(3) Maintenance Function	(4) Maintenance Category					(5) Tools and Equipment	(6) Remarks
			C	O	F	H	D		
1301	Hub and Arm Assy, No's. 3, 4 and 5 Right and Left Roadwheel (11590673-1, 11590673-2)	Inspect Service Adjust	0.2	0.2 0.5				168 119, 167, 168, 174, 176	AW
		Replace		1.5				90, 91, 93, 94, 95, 97, 101, 167, 168, 176	
		Repair		1.5				93, 95, 97, 101, 119, 167, 168, 176	
1301	Arm Assembly, Roadwheel No's. 3 4 and 5 Right and Left (11590672-1, 11590672-2)	Replace		1.5				93, 95, 97, 101, 119, 156, 167, 168, 176	
		Repair		1.0	1.0			93, 95, 101, 114, 119, 164, 167, 168, 169, 176	
1301	Seal Assy, Hub and Arm (7364672)	Replace		1.5				93, 95, 97, 101, 167, 168, 176	
		Repair		0.2				176	
1301	Hub, Wheel, Hub and Arm Assy (8763016)	Replace		1.5				93, 95, 97, 101, 167, 168, 176	
		Repair		1.5				93, 95, 97, 101, 119, 167, 168, 176	

SECTION II. MAINTENANCE ALLOCATION CHART - CONT.

(1) Group Number	(2) Component Assembly	(3) Maintenance Function	(4) Maintenance Category					(5) Tools and Equipment	(6) Remarks
			C	O	F	H	D		
1301	Hub and Arm Assy, No. 6 Left and Right Roadwheel (10905988-1, 10905988-2)	Inspect	0.2	0.2				168 119, 167, 168, 174, 176 90, 91, 93, 94, 95, 97, 101, 167, 168, 176 93, 95, 97, 101, 119, 167, 168, 176	
Service		0.5							
Adjust									
Replace		1.5							
	Arm Assembly, Roadwheel No. 6 Left and Right (10905985-1, 10905985-2)	Repair		1.5				93, 95, 97, 101, 119, 156, 167, 168, 176 93, 95, 101, 114, 119, 164, 167, 168, 169, 176	
1301		Replace		1.5					
	Seal Assy, Hub and Arm (7364672)	Repair		1.0	1.0			93, 95, 97, 101, 167, 168, 176	
1301		Replace		1.5					
	Hub, Wheel, Hub and Arm Assy. (8763016)	Repair		1.5				93, 95, 97, 101, 167, 168, 176 93, 95, 97, 101, 119, 167,	
1301		Replace		1.5					
	Cover, Access, Left and Right Torsion Bar No. 1 thru 6 Roadwheels (7058039, 10952230)	Repair		0.5				167, 168, 176 168	
1301		Replace		0.5					

SECTION II. MAINTENANCE ALLOCATION CHART - CONT.

(1) Group Number	(2) Component Assembly	(3) Maintenance Function	(4) Maintenance Category					(5) Tools and Equipment	(6) Remarks
			C	O	F	H	D		
1301	Housing Assy, Roadwheel - No. 2 thru 6 Torsion Bar, Left and Right (7953933)	Replace		0.7				90, 91, 94, 97 167, 168, 176 167, 168, 176	
		Repair		0.3					
1301	Housing Assy, Roadwheel No. 1 Torsion Bar Left and Right (8762181, 8762180)	Replace		0.7				90, 91, 94, 97, 167, 168, 176 167, 168, 176	
		Repair		0.3					
1302	Roller Assembly, Track Support Roller No. 1 Left (12251861)	Inspect	0.1					168 109, 168, 174, 176 109, 168, 174, 176 90, 97, 109, 168, 174, 176	AW
		Service		0.2					
		Adjust		0.5					
		Replace		2.0					
1302	Wheel and Hub Assy, Track Support Roller (12251859)	Replace		1.5				109, 168, 174, 176 174, 176	
		Repair		0.5					
1302	Hub Assy, Track Support Roller (8763023)	Replace		0.5				174, 176 98, 99, 103, 169	
		Repair		0.3	0.3				
1302	Spindle, Wheel, Nondrive, Track Support Roller, No. 1 Left (8762156)	Replace Repair		0.5		0.5		90, 97, 176 163, 164, 169	

SECTION II. MAINTENANCE ALLOCATION CHART - CONT.

(1) Group Number	(2) Component Assembly	(3) Maintenance Function	(4) Maintenance Category					(5) Tools and Equipment	(6) Remarks
			C	O	F	H	D		
1302	Roller Assy, Track Support, Left No. 2 and 3 Right No. 1 thru 3 (12251872)	Inspect	0.1	0.2				168	AW
		Service		2.0				109, 168, 174, 176	AW
		Replace							
		Repair		2.0				90, 97, 109, 168, 174, 176	AW
1302	Wheel and Hub Assy, Track Support Roller (12251859)	Replace		1.5				109, 168, 174, 176	
		Repair		0.5				174, 176	
1302	Hub Assy, Track Support Roller (8763023)	Replace		1.5				174, 176	
		Repair		0.3	0.3			98, 99, 103, 169	
1302	Spindle, Wheel, Nondrive, No. 2 and 3 Left, No. 1 thru 3 Right (8762157)	Replace		0.5				90, 97, 176	
		Repair			0.5			163, 164, 169	
1303	Hub and Arm Assy, Compensating Idler Left and Right (11674372, 10905982)	Inspect	0.2	0.2				168	AW
		Service		0.5				119, 167, 168, 174, 176	
		Adjust							
		Replace		1.0			168		
		Repair		1.5			95, 98, 100, 101, 103, 107, 119, 168, 176		
1303	Arm Assy, Pivot, Compensating Idler (11674373, 10905981)	Replace		1.5				95, 98, 100, 101, 103, 107, 119, 168, 176	
		Repair		1.0	1.0			95, 98, 100, 101, 103, 107, 119, 164, 167, 168, 169, 176	

SECTION II. MAINTENANCE ALLOCATION CHART - CONT.

(1) Group Number	(2) Component Assembly	(3) Maintenance Function	(4) Maintenance Category					(5) Tools and Equipment	(6) Remarks
			C	O	F	H	D		
1303	Hub, Wheel, Compensating Idler (8763016)	Replace		1.5				95, 98, 100, 101, 103, 107, 119, 168, 176	
		Repair		1.5					
1303	Seal Assy, Compensating Idler (7364672)	Replace		1.5				95, 98, 100, 101, 103, 107, 119, 168, 176	
		Repair		0.2					
1303	Link Assy, Adjusting, Left and Right (8335109, 8335110)	Inspect	0.3					90, 97, 113, 167, 168, 176	AW
		Service Replace	0.3	1.0					
1304	Sprocket, Wheel (11637173)	Inspect		0.3				108	OD
			0.1						
1305	Track Assembly, Left and Right Type T97 and T142 (10916170, 11645124)	Inspect	0.5					110, 111 BII	HS
		Adjust	0.5						
1305	Track Shoe Set, Vehicle Track Assy, Type T97 and T142 (12257551, 10916159)	Replace		1.5				BII, 115, 117, 118, 168	JX, OL, OM, ON
		Repair		1.5					
1305	Track Shoe Set, Vehicle Track Assy, Type T97 and T142 (12257551, 10916159)	Replace		1.5				BII, 117, 118, 168	OP
		Repair		0.8					

SECTION II. MAINTENANCE ALLOCATION CHART - CONT.

(1) Group Number	(2) Component Assembly	(3) Maintenance Function	(4) Maintenance Category					(5) Tools and Equipment	(6) Remarks
			C	O	F	H	D		
1305	Track Shoe, Vehicular Track Assy, Type T142 (11645125)	Replace Repair		1.5 0.8				BII, 168 BII, 168	ON OP
1305	Link Assy (11645126)	Replace Repair		0.5			**	168	OK
1401	Lever Assy Steering (10952273)	Replace Repair		1.0 0.1				176 176	
1401	Shaft Assy, Intermediate Rod to Engine Compartment Front Rod (10864129)	Replace Repair			1.5 0.4			176 176	
1401	Sleeve Assy, Steering Control Bulkhead (10864132)	Replace Repair			0.7 0.7			176 163	
1401	Link Steering Control Engine Compartment Rise to Transmission Connector Link (8762127)	Replace Repair		0.8 0.5				176 176	
1401	Connecting Link Assy, Engine Compartment Rod to Riser Rod (8762291)	Replace Repair		1.0 0.6				176 176	
1401	Mount Assy, Steering Control Sleeve (11676078)	Replace Repair		1.0	0.8			176 163	

SECTION II. MAINTENANCE ALLOCATION CHART - CONT.

(1) Group Number	(2) Component Assembly	(3) Maintenance Function	(4) Maintenance Category					(5) Tools and Equipment	(6) Remarks
			C	O	F	H	D		
1401	Handle Steering Control (11590653)	Replace		0.7				176	
		Repair		0.3				176	
1503	Pintle and Sleeve Assy. (8694383)	Inspect	0.1					BII	AW
		Service	0.1					168, 176	
		Replace Repair		0.7 1.0				168, 176	
1503	Pintle Assy. (8710630)	Service	0.2					BII	AW
		Replace		0.5				167	
		Repair		0.8				167	
1503	Pin, Straight, Headless (7069195)	Service	0.1					BII	OD, AW
1601	Spring, Volute Roadwheel Arm, Front and Rear, Left and Right (8370079)	Inspect	0.1	0.1				176	OD
		Replace		0.2					
1604	Shock Absorber Assy, Direct Action (11654535, 11645792)	Inspect	0.1	0.1				168, 176 114, 168, 176	
		Replace		0.3					
		Repair		0.3					
1801	Screw Assy, Rear Exhaust Doors, Top Deck Grille (11674324)	Replace		0.2				176	
		Repair		0.3				176	
1801	Cover, Fuel Filler. Hull (10915265)	Inspect	0.1					168, 176 168, 176 168, 176, 177	AW
		Service	0.3	0.5					
		Replace		2.0					
		Repair		1.5					

SECTION II. MAINTENANCE ALLOCATION CHART - CONT.

(1) Group Number	(2) Component Assembly	(3) Maintenance Function	(4) Maintenance Category					(5) Tools and Equipment	(6) Remarks
			C	O	F	H	D		
1801	Cover Assy, Engine Access Lower (12290632)	Inspect Service Replace Repair	0.1 0.3	0.5 0.6 1.5				168, 176 168, 176 168, 176, 177	AW
1801	Cap, Retainer, Fuel Tank (6200399)	Replace Repair		0.5 0.5				176 176	
1801	Hull Body Assembly (10934175)	Replace Repair					80.0 60.0		NK NK
1801	Frame Assy (10864100)	Replace Repair		2.5 3.0				130, 168, 176 168, 177	
1801	Door Assy, Intake Engine Access (10863964, 10863965, 10864205, 10864206, 11654555, 11626427, 10864147, 10864146, 10864043, 10924454)	Inspect Service Replace Repair	0.3 0.3	0.5 0.5 0.8				130, 168, 176 168, 176 177	AW
1801	Cover Assy, Access (10863865, 10863928, 7972027)	Inspect Service Replace Repair	0.3 0.3	0.5 0.4 0.5				168, 176 168, 176 177	AW
1801	Block Assy (7970529)	Replace Repair		0.7 0.3				177 176, 177	

SECTION II. MAINTENANCE ALLOCATION CHART - CONT.

(1) Group Number	(2) Component Assembly	(3) Maintenance Function	(4) Maintenance Category					(5) Tools and Equipment	(6) Remarks
			C	O	F	H	D		
1801	Door Assy, Rear Exhaust (10864135, 10893777)	Replace Repair		1.5 1.0				176 177	
1801	Bracket Assy (7364583)	Replace Repair		0.7 0.3				177 176	
1803	Cover Assy, Driver's Escape Hatch (10911409)	Inspect Service Adjust Replace Repair	0.2 0.2	0.5 1.5 2.0 1.5				168, 176 176 167 167, 177	AW
1803	Cupola Quadrant Assy (13211E3170), 13211E3171, 13220E8296, 13220E8297)	Replace Repair		1.5 1.4				167, 169, 176 167, 169, 176	
1803	Hatch Assy, Right and Left Sides (10951781)	Inspect Service Replace Repair	0.1 0.1	0.2 0.5 0.5				BII 176 176	AW
1803	Lid Assy, Right and Left Side (11591176)	Replace Repair		0.5 0.5				176 176	
1803	Cupola Body Assy, Right and Left Side (13211E3150, 13220E8285)	Inspect Adjust Replace Repair	1.0	0.5 1.4 0.8				167, 176 167, 176	
1803	Block, Direct Vision (6300790)	Replace Repair		0.4				176	NK

SECTION II. MAINTENANCE ALLOCATION CHART - CONT.

(1) Group Number	(2) Component Assembly	(3) Maintenance Function	(4) Maintenance Category					(5) Tools and Equipment	(6) Remarks
			C	O	F	H	D		
1803	Cupola Quadrant Subassembly (13211E3157, 13211E3158, 13220E8298, 13220E8299)	Replace Repair		1.0 1.0				169, 176 177	AY
1803	Quadrant, Front (13211E3168)	Replace Repair		1.0 1.0				169, 176 173	
1804	Valve Assy, Drain (8724469)	Inspect Replace Repair	0.2	0.4 0.2				176 168	
1806	Seat Assy, Driver's (10952286)	Inspect Service Replace Repair	0.1 0.1	0.1 1.0 0.2				BII 176 176	AW
1806	Pin, Driver's Seat (11599875-4)	Replace Repair		0.2 0.3				176 176	
1806	Cushion, Seat Driver's (11610838)	Replace Repair		0.2 0.4				176	
1806	Mount Assembly, Driver's Seat (10934367-1)	Inspect Service Replace Repair	0.1 0.1	0.2 0.7 0.6				BII 176 176	AW
1806	Seat Assembly, Commander's (10865725, 11645325)	Inspect Service Replace Repair	0.1 0.1	0.1 1.0 0.3				BII 176 176	AW

SECTION II. MAINTENANCE ALLOCATION CHART - CONT.

(1) Group Number	(2) Component Assembly	(3) Maintenance Function	(4) Maintenance Category					(5) Tools and Equipment	(6) Remarks
			C	O	F	H	D		
1806	Cushion, Seat (10865882, 11645301)	Replace Repair		0.3 0.3				176 176	
1806	Mount Assembly, Commander's Seat (10934367-2)	Inspect Service Replace Repair	0.1 0.1	0.2 0.7 0.6				BII 176 176	
1806	Bracket Assy (11626509)	Replace Repair		0.3 0.4				176 168, 176	
1806	Stowage Bin (11626508, 11676497)	Replace Repair		0.5 0.5				176 168, 176	
1808	Box, Fender, Assemblies (10873779, 10923988, 10873799)	Inspect Service Replace Repair	0.2 0.2	1.0 0.4				BII 176 168, 177	AW
1808	Cover, Box, Stowage, Left Rear (10873794)	Replace Repair		0.5 0.5				176 168, 177	
1808	Cover, Box, Stowage, Right Rear (10873795)	Replace Repair		0.5 0.5				176 168, 177	
1808	Latch Assy, Stowage Box, Cover Locking (Left) (6312712)	Service Replace Repair	0.1	0.2 0.3 0.2				BII 176 176	AW
1808	Latch Assy, Stowage Box, Cover Locking (Right) (7324021)	Service Replace Repair	0.1	0.2 0.3 0.2				BII 176 176	AW

SECTION II. MAINTENANCE ALLOCATION CHART - CONT.

(1) Group Number	(2) Component Assembly	(3) Maintenance Function	(4) Maintenance Category					(5) Tools and Equipment	(6) Remarks
			C	O	F	H	D		
1808	Cover, Box Stowage (Left and Right) (10915630)	Replace Repair		0.7 0.6				176 168, 177	
1808	Bracket Assy (MS53052-1)	Replace Repair		0.3 0.3				167, 176	
1808	Tow Cable, Stowage Bracket (13215E8564)	Replace Repair		0.3 0.3				176 176	
2002	Power Take-off (10935502-1)	Replace Repair			0.7 0.8			176 176	
2002	Adapter (10935495)	Replace Repair			0.4 0.2			176 169	
2002	Housing (10935501-1)	Replace Repaire			0.8 0.2			176 169	
2002	Tube Assembly (10865100-12)	Replace Repair		0.1 0.2				176 176	
2202	Heater, Vehicular Personnel (Combustion Multifuel) (11669496)	Inspect Replace Repair Overhaul	0.3	2.0 0.4	1.0		*	168, 176 168, 175, 176	NK
2202	Motor, Direct Current (CPR109627)	Replace Repair			1.0 0.7			176 182	

SECTION II. MAINTENANCE ALLOCATION CHART - CONT.

(1) Group Number	(2) Component Assembly	(3) Maintenance Function	(4) Maintenance Category					(5) Tools and Equipment	(6) Remarks
			C	O	F	H	D		
2202	Switch Thermo- static No. 2 Person- ell Heater (CPR109628)	Replace Repair			0.5 0.4			176 182	
2202	Valve, Fuel Regulator, Control Valve No. 2 Person- ell Heater (CPR109629)	Replace Repair			0.5 0.7			176 182	
2202	Intercom AN/VIC-1 (393851)	Test	0.1						OD
2400	Pin Cap, Tongue Cylinder (13222E3737-1)	Service	0.1					BII	OD, AW
2400	Pin Cap, Over- head Cylinder (13222E3737-2)	Service	0.1					BII	OD, AW
2400	Pin Clevis Over- head Cylinder (13222E3735)	Service	0.1					BII	OD, AW
2400	Pin, Tongue Mounting (13222E3736)	Service	0.1					BII	OD, AW
2400	Pin, Boom Mounting (13222E3738)	Service	0.1					BII	AW
2400	Plug, Holddown Cylinder (13211E3005)	Service	0.1					BII	OD, AW
2400	Boom Outrigger Assembly (13211E3190)	Inspect Service Replace Repair	0.1 0.1		3.0 6.0			BII 163, 169, 176 164, 169, 170	AW

SECTION II. MAINTENANCE ALLOCATION CHART - CONT.

(1) Group Number	(2) Component Assembly	(3) Maintenance Function	(4) Maintenance Category					(5) Tools and Equipment	(6) Remarks
			C	O	F	H	D		
2400	Tongue Assembly (13211E3200)	Inspect	0.1					BII 163, 169, 176 164, 169, 173, 176	AW KR
		Service	0.1						
		Replace			3.0				
		Repair		0.5	6.0				
2400	Seat Assy Bridge (13211E3106)	Inspect	0.1					169, 176 173, 176	
		Replace		2.0					
		Repair		0.8					
2400	Beam, Bridge Seat (13213E4361)	Replace		0.7				176 164, 168, 173, 176	
		Repair			0.4				
2401	Clutch (13211E3124, 18251)	Inspect		0.1				BII 176 176 169, 176	AW NK
		Service		0.1					
		Adjust		0.5					
		Replace			1.5				
		Repair			4.0				
		Overhaul					8.0		
2401	Yoke Assembly (A167)	Replace			1.7			169, 176 176	
		Repair			0.3				
2401	Cone Assembly (C310)	Replace			0.5			169, 176 176	
		Repair			0.3				
2401	Collar (117C10)	Replace			0.3			176 176	
		Repair			0.2				
2401	Spider, Clutch (X8151-3BB)	Replace			1.8			169, 176 169, 176	
		Repair			0.7				

SECTION II. MAINTENANCE ALLOCATION CHART - CONT.

(1) Group Number	(2) Component Assembly	(3) Maintenance Function	(4) Maintenance Category					(5) Tools and Equipment	(6) Remarks
			C	O	F	H	D		
2401	Pump, Hydraulic (13211E3126, PF2020-23-21LH)	Inspect Replace Repair Overhaul	0.1		3.0	5.0	8.0	169, 176 169, 176	OF
	(12326774)(HEU)	Repair		3.0#					NK
2401	Shaft, Drive (112051)	Replace Repair				2.0 0.5		169, 176 169, 176	
2401	Piston & Rod & Bearing Assy (90909)	Replace Repair				0.3 0.3		169, 176 169, 176	
2401	Piston & Rod & Bearing Subassy (90934)	Replace Repair				0.3 0.3		169, 176 169, 176	
2401	Universal Link & Pin (90910)	Replace Repair				1.8 0.2		169, 176 176	
2041	Universal Joint (13211E3169)	Inspect Service Replace Repair		0.1 0.1 0.7 0.6				BII 176 167, 176	AW
2401	Lever, Hand (13211E3128)	Replace Repair		0.4 0.2				176 176	
2401	Yoke, Throw Out (13211E3129)	Replace Repair			0.6 0.2			176 176	
2402	Valve Bank Control (13211E3255)	Inspect Replace Repair Overhaul		0.1	8.0 1.0		4.0 8.0	169, 176 169, 170	NK

SECTION II. MAINTENANCE ALLOCATION CHART - CONT.

(1) Group Number	(2) Component Assembly	(3) Maintenance Function	(4) Maintenance Category					(5) Tools and Equipment	(6) Remarks
			C	O	F	H	D		
2402	Valve, Sequence (13211E3216)	Replace Repair			0.7			176	NK
2402	Body Assembly (512068, 512119, 981153)	Replace Repair						0.2 0.2	NK NK
2402	Valves, Check, Flow & Relief (512079)	Adjust Replace Repair		0.5				0.4 1.4	NK NK
2402	Manifold Sequence Valve (512098)	Replace Repair						0.5 0.2	NK NK
2406	Filter (13211E3203)	Service Replace Repair	0.2	0.2 0.2 0.4				176 169, 176 169, 176	
2406	Filter, Air (13211E3254)	Replace Repair		0.2 0.4				169, 176 169, 176	
2407	Cylinder, Over-head (13214E0070)	Inspect Service Replace Repair Overhaul	0.1 0.1	4.0	6.0			BII 169, 176 169, 172, 176	AW NK
2407	Cylinder, Tongue (13214E0080)	Inspect Service Replace Repair Overhaul	0.1 0.1	3.0	3.0			BII 169, 176 169, 172, 176	AW
								4.0	

SECTION II. MAINTENANCE ALLOCATION CHART - CONT.

(1) Group Number	(2) Component Assembly	(3) Maintenance Function	(4) Maintenance Category					(5) Tools and Equipment	(6) Remarks
			C	O	F	H	D		
2407	Cylinder, Hydraulic, Ejection (13211E3140)	Inspect Replace Repair Overhaul	0.1	2.0	1.4		4.0	169, 176 169, 172, 176	NK
2407	Cylinder, Hold Down (13211E3020)	Inspect Replace Repair Overhaul	0.1	1.6	1.5		5.0	169, 176 169, 172, 176	NK
2407	Cylinder, Locking (13211E3130)	Inspect Replace Repair Overhaul	0.1	1.5	1.8		1.5	169, 176 169, 172, 176,	NK
2407	Armor, Ovhd Cylinder (13211E3114)	Inspect Replace Repair		0.1 0.5 0.3				169, 176 169, 176	
2407	Armor, Tongue Cyl (13211E3113)	Inspect		0.1				176	OD
2407	Armor, Hold Down Cyl (13211E3011)	Inspect		0.1					OD
2407	Clevis, Rod End (13211E3107)	Replace Repair		0.7	0.4			176 169, 176	
2408	Reservoir Quadrant (13211E3247)	Inspect Replace Repair	0.1		4.0 4.0			170, 176 163, 164	AY

SECTION II. MAINTENANCE ALLOCATION CHART - CONT.

(1) Group Number	(2) Component Assembly	(3) Maintenance Function	(4) Maintenance Category					(5) Tools and Equipment	(6) Remarks
			C	O	F	H	D		
3401	Pushbutton Unit, Smoke Grenade Discharge (13-12-37)	Inspect	0.1						OY
		Replace		0.3				176	
		Repair		0.5				176	
3401	Discharge Smoke Grenade, Left (13-12-34, FV855990)	Inspect	0.1						OY
		Service	0.2						AW
		Replace		0.6				176	
		Repair		1.0				176	
3401	Discharge Smoke Grenade, Right (13-12-34, FV855991)	Inspect	0.1						OY
		Service	0.2						AW
		Replace		0.6				176	
		Repair		1.0				176	
3401	Switch Box Assy, Grenade Discharge Power (12257456)	Inspect	0.1						OY
		Replace		0.2				176	
		Repair	0.1		0.4			176	KQ
3403	Periscope, M24, Driver's I.R. (Old) (8293676)	Remove/ Inst	0.1						MN,
		Replace		0.1					
		Repair			10.0		10.0	176	NK
		Overhaul					20.0	183, 184, 186, 187, 189, 191, 223-228	
3403	Objective Assy (11746830)	Replace					1.0		NK
		Repair					2.0		NK
3403	Body Assy (8293689)	Replace					1.5		NK
		Repair					2.0		NK

SECTION II. MAINTENANCE ALLOCATION CHART - CONT.

(1) Group Number	(2) Component Assembly	(3) Maintenance Function	(4) Maintenance Category					(5) Tools and Equipment	(6) Remarks
			C	O	F	H	D		
3403	Headrest, Optical (7635912)	Replace			0.5			176	
		Repair			1.0			176	
3403	Lock, Elevation (8293678)	Replace			0.3			176	
		Repair			1.0			176	
3403	Eye Lens Assy (7688770)	Replace					1.0		NK
		Repair					2.0		NK
3403	Periscope Assy, Driver's IR, M24 (New) (11747127)	Install	0.1						MP
		Replace		0.1					
		Repair			10.0		10.0	176	NK
		Overhaul					20.0	183, 184, 186, 187, 189, 191, 223-229	NK
34-3	Objective Assy (11747130)	Replace					1.0		NK
		Repair					2.0		NK
3403	Cell Assy (11747132)	Replace					1.0		NK
		Repair					1.5		NK
3403	Body, Periscope (11748061)	Replace					1.5		NK
		Repair					2.0		NK
3403	Headrest, Optical (7635912)	Replace			0.5			176	
		Repair			1.0			176	
3403	Lock, Elevation (8293678)	Replace			0.3			176	
		Repair			1.0			176	
3403	Eye Lens Assy (7688770)	Replace					1.0		NK
		Repair					2.0		NK

SECTION II. MAINTENANCE ALLOCATION CHART - CONT.

(1) Group Number	(2) Component Assembly	(3) Maintenance Function	(4) Maintenance Category					(5) Tools and Equipment	(6) Remarks
			C	O	F	H	D		
3403	Viewer Assy, Driver's Night Vision AN/VVS-2(V) 1A (SM-D-771480-1, SM-D-771324-1)	Inspect	0.1					BII 175 175, 179 144-149, 175, 179, 190-206, 144-149, 175, 179, 190-206	MQ NM, AW
		Service	0.1						
		Remove/ Inst	0.1						
		Replace		0.1					
		Repair		0.2	4.2		0.5		
	Overhaul					3.0			
3403	Mount Assy, Viewer (SM-D-771210-1)	Replace			0.3			144, 146, 147, 175, 179, 192 144-149, 175, 179, 190-218	
		Repair			0.5		1.0		
3403	Tube and Magnifier (SM-D-771212-1)	Replace			0.8			144, 175, 179, 228 216-223	
		Repair					1.0		
3403	Image Intensifier Night Vision MX-9644/UV (SM-D-850310-1)	Replace					0.5		NK NK
		Repair					0.8		
3403	Housing Assy, Eyepiece (SM-D-771327-1)	Replace			0.3			144, 175, 179 144, 175, 179, 190, 195, 196, 201, 202, 209, 210, 215, 222	
		Repair			0.4		1.7		
3403	Entrance Window and Mirror (SM-D-771333-1)	Replace			0.3			144, 175, 179, 190 144, 175, 179	
		Repair			0.3				

SECTION II. MAINTENANCE ALLOCATION CHART - CONT.

(1) Group Number	(2) Component Assembly	(3) Maintenance Function	(4) Maintenance Category					(5) Tools and Equipment	(6) Remarks
			C	O	F	H	D		
3403	Barrel Assy, Lens, Objective (SM-D-771334-1)	Replace			0.5			144, 145, 175, 179	
		Repair					1.8	190, 194, 195, 203, 204, 208, 209, 210, 216	
3403	Housing Assy, Main, Viewer (SM-D-771335-1)	Replace			1.1			144-149, 175, 179, 190 192	
		Repair					1.0	144-149, 175, 179, 190-192, 196, 199, 200	
3403	Adapter Assy, Power (SM-C-771200-1)	Replace			0.5			144, 175, 179, 228	
		Repair		0.2	0.7			175, 179	
3403	Battery Case and Cap Assy (SM-D-771325-1)	Replace			0.3			175, 179	
		Repair		0.2	0.3			175, 179	
3403	Knob Assy, Control, Brightness (SM-D-771326-1)	Inspect	0.1					175	
		Replace			0.5			175, 179	
		Repair			0.8			175, 179	
4701	Speedometer and Drive Components (MS39021-2)	Replace		0.3				176	
		Repair		0.2				176	
4701	Shaft Assy, Flexible Speedometer (MS51071-3)	Replace		0.6				176	
		Repair		0.1				176	
4701	Adapter Assy, Speedometer Shaft Assy (8337231)	Replace		0.4				176	
		Repair		0.1				176	

SECTION II. MAINTENANCE ALLOCATION CHART - CONT.

(1) Group Number	(2) Component Assembly	(3) Maintenance Function	(4) Maintenance Category					(5) Tools and Equipment	(6) Remarks
			C	O	F	H	D		
4701	Tachometer Mechanical (MS35916-2)	Replace		0.3				176	
		Repair		0.2				176	
4701	Adapter Assy, Tachometer Rear Flexible Shaft (MS39130-25, MS39130-27)	Replace		0.4				176	
		Repair		0.1				176	
4701	Shaft Assy, Flexible, Tachometer Front Drive (MS51071-9)	Replace		0.8				176	
		Repair		0.1				176	
4701	Shaft Assy, Tachometer Rear (12252200-3, 12252200-4)	Replace		0.6				176	
		Repair		0.5				167, 176	
4701	Shaft Assy, Flexible Tachometer, Rear (MS52116-12, MS52116-13)	Replace		0.5				176	
		Repair		0.2				176	
6714	Antenna Base Armor (13211E3168)	Inspect		0.1				176	OD
7639	Extinguisher, Fire, Fixed, First and Second Shot, (12257169, 7714476)	Inspect	0.5						
		Test		1.5				168, 176	
		Service			3.0			169	
	Replace			3.0				151-154, 159, 161, 167, 176	
	Repair			0.2	0.3		*	167, 176	KI, NK

SECTION II. MAINTENANCE ALLOCATION CHART - CONT.

(1) Group Number	(2) Component Assembly	(3) Maintenance Function	(4) Maintenance Category					(5) Tools and Equipment	(6) Remarks
			C	O	F	H	D		
7639	Body Assy, Release Handle, Fixed Fire Ex- tinguisher (7355053)	Inspect Test Adjust Replace Repair	0.2	0.2 0.2 0.5 0.3				176 176 176	
7639	Control, Fire Extinguisher Exterior Release Mechanism, Fixed Fire Extinguisher (11608379)	Inspect Test Adjust Replace Repair	0.2	0.2 0.2 3.0 0.3				176 168, 176 167, 176	
7639	Release Mechanism Assy, Inside Control - Fixed Fire Extinguisher (12252586)	Inspect Test Adjust Replace Repair	0.2	0.2 0.2 3.0 1.5				176 168, 176 168, 176	
7639	Valve, Fire Ex- tinguisher, Fixed (12252284, 12290439)	Inspect Replace Repair		0.1 0.5 0.5				151-161, 167, 176 151-161, 167, 176	
7639	Valve, Fire Ex- tinguisher (8386355, 11669032)	Replace Repair		0.5 0.3				151-161, 167, 176 151-161, 167, 176	
7639	Bracket Assy (10864312)	Replace Repair		0.4 0.5				176 176	
7639	Bracket Assy, Cylinder (11590888)	Replace Repair		0.4 0.5					

SECTION III. TOOL AND TEST EQUIPMENT REQUIREMENTS - CONT.

(1) Tool and Test Equipment Ref. Code	(2) Maintenance Category	(3) Nomenclature	(4) National/NATO Stock Number	(5) Tool Number
		CHASSIS TOOLS, Engine		
1	O	Puller, Screw: Fan Drive Oil Seal Retainer or Vibration Damper	1520-00-473-7222	5379997
2	H	Reamer, Hand: Roughing Exhaust Valve, Guide: Used w/5110-00-003-1010 bushing	5110-00-708-3696	7083696
3	H	Reamer, Hand: Finishing, Exhaust Valve Guide: Used w/5110-00-003-1010 bushing	5110-00-708-3697	7083697
4	H	Reamer, Hand: Roughing Intake Valve Guide: Used w/5110-00-460-5831 bushing	5110-00-708-3698	7083698
5	H	Reamer, Hand: Intake Valve Guide: Used w/5110-00-460-5831 busing	5110-00-708-3699	7083699
6	H	Extractor, Coil Thread Insert: Cylinder to Crankcase 7/16 in. to 1 in. diameter inserts	5120-00-251-1527	7751056
7	H	Remover and Replacer, Piston Ring	5120-00-494-1846	7950177
8	H	Adapter, Mechanical Puller Crankshaft Main Bearing: Used w/puller 5210-00-310-4668 and spreader 5120-00-575-7767. Accessory Drive Second Idler Gear Spindle: Used w/5120-00-473-7372 puller	5120-00-837-5091	8375091

SECTION III. TOOL AND TEST EQUIPMENT REQUIREMENTS - CONT.

(1) Tool and Test Equipment Ref. Code	(2) Maintenance Category	(3) Nomenclature	(4) National/NATO Stock Number	(5) Tool Number
		CHASSIS TOOLS, Engine (Cont'd)		
9	H	Puller, Mechanical: Generator and Starter Idler Gear Shaft or Crankshaft Main Bearing: Used w/5120-00-837-5091 Adapter and 5120-00-575-7767 Spreader	5120-00-310-4668	8708712
10	H	Spreading Tool, Crankcase	5120-00-575-7767	8708361
11	H	Stand, Valve, Removing & Inserting, Cylinder Assembly: Used w/lifter 5120-00-678- 5285	4910-00-554-1317	8708419
12	H	Insertor, Coil Thread Insert: Screwlock 3/8-24	5120-00-710-7437	8375324
13	F	Adapter: Used w/compression checking gage 4910-00-870- 6283 to engine	4910-00-795-7961	8743025
14	H	Lifter Assembly, Valve Spring: Used w/4910-00- 554-1317 stand	5120-00-678-5285	8761535
15	H	Wrench Box: Torquing Cylinder Hold Down Nuts	5120-00-678-5287	8761561
16	H	Wrench, Box: Torquing Cylinder Hold Down Nuts	5120-00-475-5414	8761562
17	O	Wrench, Open End Fixed: Starter Mounting Nuts	5120-00-678-5288	8761568
18	H	Insertor, Coil Thread Insert: Screwlock 1/2-20	5120-00-672-8897	8761582

SECTION III. TOOL AND TEST EQUIPMENT REQUIREMENTS - CONT.

(1) Tool and Test Equipment Ref. Code	(2) Maintenance Category	(3) Nomenclature	(4) National/NATO Stock Number	(5) Tool Number
		CHASSIS TOOLS, Engine (Cont'd)		
19	H	Puller, Mechanical: Cam- shaft Drive Quill	5120-00-678-5282	8761297
20	F	Blade, Thickness Gage: Valve Tappet Adjusting (.010 gap)	5210-00-793-7898	10882615
21	F	Blade, Thickness Gage: Valve Tappet Adjusting (0.25 gap)	5210-00-793-7899	10882616
22	F	Blade, Thickness Gage: Valve Tappet Adjusting (.100 gap)	5210-00-793-7897	10882617
23	O	Spacer, Fan Rotor Hub	4910-00-795-7952	10882651
24	H	Wrench, Spanner: Cooling Fan, Rotor Clutch	5120-00-793-7896	10882653
25	F	Wrench, Splined: Engine Turning	5120-00-793-7895	10882747
26	H	Protector Crankcase Bore: Cylinder Mounting Pads (1 required per cylinder)	4910-00-795-7951	10882790
27	H	Compressor and Gage: Piston Ring	4910-00-795-7956	10882888
28	D	Compressor and Gage: Piston ¹ Ring (0.010 and 0.020 over- size)	5120-00-005-3001	10882888-1
29	H	Bushing, Reamer: ² Pilot Bushing for Reaming Exhaust Valve Guide: Used w/5110- 00-108-3696 reamer and 5110- 00-708-3697	4910-00-795-7957	10882891

SECTION III. TOOL AND TEST EQUIPMENT REQUIREMENTS - CONT.

(1) Tool and Text Equipment Ref. Code	(2) Maintenance Category	(3) Nomenclature	(4) National/NATO Stock Number	(5) Tool Number
		CHASSIS TOOLS, Engine (Cont'd)		
30	H	Bushing, Reamer, Pilot: ² for Reaming Intake Valve Guides: Used with reamer 5110-00-708-3699 and 5110- 00-708-3698	3910-00-795-7950	10882892
31	H	Sling, Fan Drive and Advance Unit Hsg.	1910-00-795-7954	10882945
32	F	Cutter, Carbon, Nozzle Seat: Removing Tool	4910-00-795-7958	10882949
33	H	Puller, Mechanical: Intake Valve Guide	5120-00-448-0400	10882953
34	H	Puller, Mechanical: Exhaust Valve Guide	5120-00-448-0401	10882954
35	H	Sling, Crankshaft and Con- necting Rods	4910-00-795-7955	10882958
36	F	Tube, Attaching Nozzle: Fuel Injector Nozzle Connector: Used w/tester 4910-00-255- 8641	4910-00-795-7953	10882963
37	H	Replacer, Valve Guide: Intake	5120-00-448-0402	10883052
38	H	Replacer, Valve Guide: Exhaust	5120-00-448-7993	10883053
39	F	Wrench, Open End, Fixed: ² Turbo Charger Oil Line to Engine	5120-00-448-0404	10883075

SECTION III. TOOL AND TEST EQUIPMENT REQUIREMENTS - CONT.

(1) Tool and Test Equipment Ref. Code	(2) Maintenance Category	(3) Nomenclature	(4) National/NATO Stock Number	(5) Tool Number
		CHASSIS TOOLS, Engine (Cont'd)		
40	F	Gage Assembly, Compression Testing: Used w/4910-00- 795-7961 adapter	4910-00-870-6283	10899180
41	H	Test Stand (Advance Unit) Fuel Injector Pump	4910-00-986-9873	10898928
42	H	Stand, Maintenance Auto- motive Engine	4910-00-856-4137	10912260
43	H	Gage, Ring, Plain: Piston Ring (standard and 0.020 oversize)	5220-00-988-8774	10912589
44	H	Gage, Ring, Plain: Piston ³ Ring (standard and 0.040 oversize)	5220-01-005-3002	10912589-2
45	O	Wrench, Box: Generator ⁴ Mounting Nuts	5120-00-789-4881	10935476
46	F	Wrench, Socket, Crowfoot Attachment Torquing Fuel Injector Tube Nuts: Used w/torque wrench 5120-00- 221-7947	5120-00-078-3809	10935497
47	F	Puller, Fuel Injector Nozzle	5120-00-873-6943	11610150
48	F	Socket Wrench, Fuel Injector Nozzle	5120-00-875-9551	11610171
49	H	Bushing, Reamer: Pilot ³ Bushing for Remaining Intake Valve Guide: Used w/5110- 00-708-3698 reamer and 5110- 00-708-3699 reamer	5110-00-460-5831	11642088

SECTION III. TOOL AND TEST EQUIPMENT REQUIREMENTS - CONT.

(1) Tool and Test Equipment Ref. Code	(2) Maintenance Category	(3) Nomenclature	(4) National Stock Number	(6) Tool Number
		CHASSIS TOOLS, Engine (Cont'd)		
50	H	Bushing, Reamer: Pilot' Bushing for Reaming Exhaust Valve Guide: Used w/5110- 00-708-3697 reamer	5110-00-003-1010	11642089
51	H	Wrench Box: Torquing No. 11 left and right cylinder, holddown nuts	5120-00-466-5948	11684130-1
52	H	Wrench, Box: Torquing No. 11 left and right cylinder, holddown nuts	5120-01-018-8690	11684130-2
53	F	Crowfoot Attachment Wrench, Fuel Injector Nozzle	5120-01-039-2809 or 5120-00-871-7198	12254244 or 11617167
54	H	Pliers Retaining Ring: Fan Drive Retaining Ring	5120-00-752-9755	GGG-P-480A, Type 11, Class 3, Style B, Size 22
55	H	Insertor, Coil Thread Insert: (screwlock 7/16-20)	5120-00-797-2407	MIL-T-21309, Type 111, Class 1, Style A
56	H	Extractor, Coil Thread Insert: Cylinder Head to Valve Rocker Cover (No. 10 to 3/8 in. diameter inserts)	5120-00-723-6833	MIL-T-21309, Table VIII, Type 5, Size 2
57	H	Insertor, Coil Thread Insert: (screwlock 5/16-24)	5120-00-797-2405	MIL-T-21309, Type 111, Class 1, Style A

SECTION III. TOOL AND TEST EQUIPMENT REQUIREMENTS - CONT.

(1) Tool and Test Equipment Ref. Code	(2) Maintenance Category	(3) Nomenclature	(4) National/NATO Stock Number	(5) Tool Number
		CHASSIS TOOLS, Engine (Cont'd)		
58	F	Bolt Eye: Flywheel Lifting	5306-00-017-6143	MS51937-7
		CHASSIS TOOLS, Transmission		
59	O	Socket, Socket Wrench: Band Adjusting Screw Locknut	5120-00-626-1842	7003946
60	D	Adapter, Hoisting Front Housing Unit Assembly: Lifting package unit into front housing	4910-00-473-7031	7031501
61	F	Wrench, Pinion Turning: Hold- ing Input Driving Bevel Gear or Turning Engine thru Trans- mission Input Driving Bevel Gear	5120-00-708-1564	7081564
62	F	Eye, Lifting, Output Planetary Assy. & Brake Drum	4910-00-408-1573	7081573
63	F	Sling, Lifting: Left end Cover Assembly	4910-00-708-1580	7081580
64	F	Sling, Lifting: Transmission Assembly	4910-00-473-7556	7081593
65	F	Thimble, Installing, Parking Brake Oil Seal	4910-00-708-1614	7081614
66	F	Handle, Remover and Replacer	5120-00-708-2196	7082196
67	F	Puller, Attachment, Mech- anical: Slide Hammer Type (used w/adapter)	5120-00-473-735	7082201

SECTION III. TOOL AND TEST EQUIPMENT REQUIREMENTS - CONT.

(1) Tool and Test Equipment Ref. Code	(2) Maintenance Category	(3) Nomenclature	(4) National/NATO Stock Number	(5) Tool Number
		CHASSIS TOOLS, Transmission (Cont'd)		
68	D	Remover and Replacer, Main Shaft Needle Bearing: Used w/5120-00-473-7121 handle	5120-00-473-7388	7082426
69	D	Replacer, Gear: Rear Housing Servo Lever Needle Bearing	5120-00-473-7460	7082480
70	F	Adapter, Mechanical Puller: Input Shaft: Used w/5120-00- 473-7352 Puller	5120-00-708-2774	7082774
71	D	Sling, Lifting: Package Unit	4910-00-708-2787	7082787
72	F	Handle, Remover and Replacer	5120-00-473-7123	7082881
73	F	Replacer, Bearing, Brake: Apply Shaft Bracket Assembly	5120-00-708-2980	7082980
74	F	Replacer, Bearing, Brake: Apply Outer Lever Trunnion Bearing	5120-00-708-2981	7082981
75	F	Replacer, Bearing: Brake: Apply Shaft Bearing into End Cover	5120-00-708-2982	7082982
76	F	Remover, Lead Seal: Control Valve Body Stud Lead Washers	5120-00-708-3514	7083514
77	D	Adapter, Remover: Package Unit to Rear Housing Locat- ing Dowel Pin: Used w/5120- 00-473-7352 Puller	5120-00-708-3673	7083673
78	D	Sling, Lifting: Front Housing Steering, Clutch Housing Reaction Plate Assembly, Torque Converter Housing Driving Bevel Gear Carrier Assembly	4910-00-708-3778	7083778

SECTION III. TOOL AND TEST EQUIPMENT REQUIREMENTS - CONT.

(1) Tool and Test Equipment Ref. Code	(2) Maintenance Category	(3) Nomenclature	(4) National/NATO Stock Number	(6) Tool Number
		CHASSIS TOOLS, Transmission (Cont'd)		
79	F	Puller, Screw: End Cover	5120-00-708-3894	7083894
80	F	Bolt, Machine: Front & Rear Housing	5306-00-773-7292	7737292
81	O	Gage, Pressure, Dial Indica- ting Transmission Oil Pres- sure	6620-00-795-0330	7950330
82	F	Adapter, Hoisting, Transmis- sion End Cover: Lifting right hand end cover assy	4910-00-610-5963	8350448
83	D	Socket Wrench, Face Spanner: Transfer Driver Gear Locknut or Input Driving Bevel Gear Locknut	5120-00-658-2257	8350702
84	D	Socket Wrench, Face Spanner: Torque Converter Input Shaft Nut	5126-00-658-2258	8350703
85	D	Replacer, Bushing Cover: Output Flange Bushing or End Cover to Output Shaft Bushing	5120-00-658-2256	8350746
86	D	Fixture, Backlash Setting: Input Drive Bevel Gears	4910-00-084-0797	8355779
87	D	Puller Assembly: Low Drum	4910-00-070-4888	8356051
88		Adapter, Mech. Puller: Accessory Drive Second Idler Gear Spindle: Used w/5120-00-473-7352 Puller	5120-00-837-5091	8375091

SECTION III. TOOL AND TEST EQUIPMENT REQUIREMENTS - CONT.

(1) Tool and Test Equipment Ref. Code	(2) Maintenance Category	(3) Nomenclature	(4) National/NATO Stock Number	(5) Tool Number
		CHASSIS TOOLS, Transmission (Cont'd)		
89	D	Wrench, Spanner: Converter Output Shaft Flange	5120-00-0920-9069	8390286
		CHASSIS TOOLS, Suspension		
90	O	Puller, Slide Hammer Type: Used w/adapter 5120-00-322- 5953	5120-00-557-3615	5573615
91	O	Lifter, Roadwheel Arm	5120-00-611-7137	7010355
92	O	Remover and Replacer Assy., Compensating Link Bearing	5120-00-614-1454	7027414
93	O	Replacer, Oil Seal: Road- wheel Arm Support Spindle Outer Bearing Oil Seal (used w/5120-00-473-7121 Handle)	5120-00-473-745	7078973
94	O	Wrench, Plug: Roadwheel Arm Torsion Bar End Plug	5120-00-473-7716	7078976
95	O	Replacer, Oil Seal: Compen- sating Arm Spindle, Road- wheel Arm Spindle, Inner Bearing Oil Seal (used w/5120-00-473-7121 Handle)	5120-00-473-7494	7078977
96	O	Wrench, Hook Spanner: Used on Roadwheel Arm Assy. Retaining Nut	5120-00-473-7761	7078980
97	O	Adapter, Roadwheel Arm: Used w/5120-00-557-3615 Puller	5120-00-473-6927	7080285

SECTION III. TOOL AND TEST EQUIPMENT REQUIREMENTS - CONT.

(1) Tool and Test Equipment Ref. Code	(2) Maintenance Category	(3) Nomenclature	(4) National/NATO Stock Number	(5) Tool Number
		CHASSIS TOOLS, Suspension (Cont'd)		
98	O	Remover and Replacer: Roadwheel Track Support Roller Wheel, and Compensating Idler Wheel Hub Outer Bearing Cups (used w/5120-00-708-3883 Handle)	5120-00-473-7374	7082834
99	O	Remover and Replacer: Track Support Roller Wheel Hub Inner Bearing Cup (used w/5120-00-708-3883 Handle)	5120-00-473-7372	7082863
100	O	Remover and Replacer: Roadwheel or Compensating Idler Hub Inner Bearing Cup (used w/5120-00-708- 3883 Handle)	5120-00-473-7373	7082876
101	O	Handle, Remover and Replacer	5120-00-473-7121	7082881
102	O	Replacer, Oil Seal: Track Support Roller Wheel Inner Bearing Oil Seal	5120-00-473-7471	7082882
103	O	Handle, Remover and Replacer	5120-00-708-3883	7083883
104	F	Thimble, Final Drive Out- put Shaft Seal Installing	5120-00-977-5581	8355822
105	O	Sling Assembly, Single Leg: Final Drive Hub and Sprocket Assy	4010-00-383-3681	8366458
106	O	Remover, Final Drive: Sprocket Hub Split Tapered Dowel	5120-00-034-8445	8390335

SECTION III. TOOL AND TEST EQUIPMENT REQUIREMENTS - CONT.

(1) Tool and Test Equipment Ref. Code	(2) Maintenance Category	(3) Nomenclature	(4) National/NATO Stock Number	(6) Tool Number
		CHASSIS TOOLS, Suspension (Cont'd)		
107	O	Replacer, Oil Seal and Retainer: Compensating Arm Oil Seal and Retainer Assy.	5120-00-592-3672	8708188
108	O	Gage, Sprocket	5210-00-563-7320	8708388
109	O	Wrench, Spanner: Roadwheel Track Support Roller, or Compensating Idler Wheel Bearing Adjusting Nut	5120-00-588-4808 or 5120-01-048-8640	8708459 12257561
110	F	Wrench, Open End, Fixed: Track Tension Adjusting	5120-00-563-7342	8708683
111	O	Gage, Wear: End Connector	4910-00-795-7960	10873933
112	F	Tool and Case Assy., Bearing Final Drive Out- put Shaft Bearing Seal and Inner Bearing	4910-00-906-1065	10933875
113	O	Remover and Replacer Tool, Track Adjusting Link Pin: Used w/5120-00-557-3615	5120-00-113-5265	11645917
114	O	Tool Assembly, Shock Absor- ber Bearing	5120-00-279-8325	11654533
115	O	Adapter, Mechanical Puller: Torsion Bar Track Adjusting Pin (used w/5120-00-557-3615 Puller)	5120-01-017-5328	12251805

SECTION III. TOOL AND TEST EQUIPMENT REQUIREMENTS - CONT.

(1) Tool and Test Equipment Ref. Code	(2) Maintenance Category	(3) Nomenclature	(4) National/NATO Stock Number	(5) Tool Number
		CHASSIS TOOLS, Suspension (Cont'd)		
116	F	Wrench, Box: Final Drive Output Shaft Nut	5120-01-050-2070	12251988
117	F	Fixture, Track Connecting Full Tracked Vehicle (used w/5120-00-632-5797 adapter, socket wrench)	5120-01-016-2149	12252120
118	F	Puller, Mechanical Two Leg Type: Track End Connector	5120-01-040-9318	12252143
119	O	Wrench, Spanner	5120-01-086-1603	12284929
		CHASSIS TOOLS, Powerplant		
120	O	Stall Check Kit, Engine and Transmission: Used to Stall Check Powerplant while out of Vehicle	4910-00-740-0064	8351307
121	O	Cable Assembly, Generator ⁴ Armature PPTR	4910-00-092-9131	8366463
122	O	Cable Assembly, Accessories: PPTR	2590-00674-8736	10864166
123	O	Cable Assembly, Starter: PPTR	2590-00-674-8737	10864169
124	O	Cable Assembly, Ground: PPTR	2590-00-674-8738	10864170

SECTION III. TOOL AND TEST EQUIPMENT REQUIREMENTS - CONT.

(1) Tool and Test Equipment Ref. Code	(2) Maintenance Category	(3) Nomenclature	(4) National/NATO Stock Number	(6) Tool Number
		CHASSIS TOOLS, Powerplant (Cont'd)		
125	O	Tool Assy., Mechanical: To Remove Resilient Mount from Transmission Mounting Brackets	5120-00-463-7302	10933782
126	O	Hose Assembly, Non-Metal- lic: Engine Primer (Power- plant Test Run)	5130-00-891-7865	11591102
127	O	Hose Assembly, Non-Metal- lic: Main Fuel Line and Fuel Injector Return (Power- plant Test Run)	5130-00-891-7864	11591103
128	O	Cable Assembly, ⁵ Alternator: PPTR	6150-00-628-1160	11674344
129	O	Test Harness, Electrical Generating System	4910-00-628-1157	11674369
130	O	Sling, Lifting: Powerplant or Grille Cover	4910-00-048-8706	12257229
		CHASSIS TOOLS, Turbosuper- charger		
131	H	Wrench, Box: Bearing ³ Housing	5120-00-323-4875	8708189
132	H	Gage: Ring Groove Width	4910-00-793-5030	10882675
133	H	Sleeve, Installing ³	4910-00-870-2122	10899149

SECTION III. TOOL AND TEST EQUIPMENT REQUIREMENTS - CONT.

(1) Tool and Test Equipment Ref. Code	(2) Maintenance Category	(3) Nomenclature	(4) National/NATO Stock Number	(5) Tool Number
134	H	CHASSIS TOOLS, Turbosuper- charger (Cont'd) Pliers, Retaining Ring3	5120-00-792-8624	10935598
135	H	CHASSIS TOOLS, Fuel Injector Pump Puller, Mechanical: Weight and Spider Assy.	5120-00-793-5048	10882818
136	H	Wrench, Spanner: Access Plug	5120-00-793-5045	10882851
137	H	Gage, Spring Governor: Weight and Spider Springs	49100-00-793-5040	10882854
138	H	Remover and Replacer: Weight and Spider Assy.	5120-00-793-5055	10882856
139	H	Wrench, Spanner; Clutch Troque Checking	5120-00-615-8843	10882857
140	H	Fixture, Positioning Plunger	4910-00-793-5039	10882859
141	H	Compressor, Spring Seat	5120-00-793-5049	10882862
142	H	Wrench, Turning and Holding: Pronged Typed, Clutch Torque	5120-00-793-5046	10882889
143	H	Wrench, Shaft Turning and Holding	5120-00-793-5057	10882894

SECTION III. TOOL AND TEST EQUIPMENT REQUIREMENTS - CONT.

(1) Tool and Test Equipment Ref. Code	(2) Maintenance Category	(2) Nomenclature	(4) National/NATO Stock Number	(5) Tool Number
		VIEWER, DRIVER'S NIGHT VISION TOOLS		
144	F	Wrench and Adapted Assy., Purging	5855-01-027-1566	SMD771384-1
145	F	Wrench Assy., Spanner Focusing	5855-01-027-1568	SMD771387-1
146	F	Plate Assy., Torque Viewer	5855-01-027-1571	SMD771391-1
147	F	Adapter Assy., Viewer Torque Wrench	5855-014-027-1570	SMD771392-1
148	F	Cable Assy., Special Purpose	5955-01-027-3320	SMD771395-1
149	F	Test Target	5855-01-027-1567	SMD771396
		CHASSIS TOOLS - Miscellane- ous		
150	O	Vacuum Cleaner: Clean Air Cleaner Housing	7910-00-807-3704	A1626

SECTION III. TOOL AND TEST EQUIPMENT REQUIREMENTS - CONT.

(1) Tool and Test Equipment Ref. Code	(2) Maintenance Category	(3) Nomenclature	(4) National/NATO Stock Number	(5) Tool Number
		CHASSIS TOOLS, Miscellaneous (Cont'd)		
151	O	Crowfoot Attachment, Socket Wrench, 7/16 in. flat, 3/8 dr.	5120-00-184-8383	GGG-C-001507 Type 1
152	O	Crowfoot Attachment, Socket Wrench, 1/2 in. flat, 3/8 dr.	5120-00-184-8384	GGG-C-001507 Type 11
153	O	Crowfoot Attachment, Socket Wrench, 9/16 in. flat, 3/8 dr.	5120-00-184-8397	GGG-C-001507 Type 11
154	O	Crowfoot Attachment, Socket Wrench, 1-1/4 in. Hex. flat, 1/2 dr.	5720-00-181-6759	GGG-C-001507 Type 1
155	O	Crowfoot Attachment, Socket Wrench, 1-1/16 in. Hex. flat, 3/8 dr.	5120-00-181-6764	GGG-C-001507 Type 1
156	O	Crowfoot Attachment, Socket Wrench, 3/4 in. Hex, 3/8 dr.	5120-00-189-7898	GGG-C-001507 Type 1
157	O	Crowfoot Attachment, Socket Wrench, 3/4 in. flat, 3/8 dr.	5120-00-184-8400	GGG-W-641 Type IV, Class 1
158	O	Crowfoot Attachment, Socket Wrench, 1 in. flat, 1/2 dr.	5120-00-293-1282	GGG-C-001507 Type 11
159	O	Crowfoot Attachment, Socket Wrench, 7/8 in. flat, 1/2 dr.	5120-00-293-1284	GGG-C-101507 Type 11
160	O	Crowfoot Attachment, Socket Wrench, 7/8 in. flat, 3/8 dr.	5120-00-541-4071	GGG-C-001507 Type 11

SECTION III. TOOL AND TEST EQUIPMENT REQUIREMENTS - CONT.

(1) Tool and Test Equipment Ref. Code	(2) Maintenance Category	(3) Nomenclature	(4) National/NATO Stock Number	(5) Tool Number
		CHASSIS TOOLS, Miscellaneous (Cont'd)		
161	O	Crowfoot Attachment, Socket Wrench, 1-1/8 in. flat, 3/8 dr.	5120-00-517-7021	GGG-C-001507 Type 11
162	D	Gage Assy: Used for Air Cleaner Door Assy	TBD	TBD
		COMMON TOOL SETS		
163	F	Shop Equipment, Machine Shop FM	3470-00-754-0708	
164	F	Shop Equipment, Welding, FM	3470-00-357-7268	
165	O	Shop Equipment, Radiator Test and Repair, Field Maintenance, Composite, Shop A	4910-00-071-0746	
166	F	Shop Set, Fuel & Electric System, FM. Supplemental #1	4910-00-390-7774	
167	O	Shop Equipment, Automotive Maintenance, OM, Common #2	4910-00-754-0650	
168	O	Shop Equipment, Automotive Maintenance, OM, Common #1	4910-00-754-0654	
169	F	Shop Equipment, Automotive Maintenance, FM, Basic	4910-00-754-0705	

SECTION III. TOOL AND TEST EQUIPMENT REQUIREMENTS - CONT.

(1) Tool and Test Equipment Ref. Code	(2) Maintenance Category	(3) Nomenclature	(4) National/NATO Stock Number	(5) Tool Number
		COMMON TOOL SETS (Cont'd)		
170	O	Shop Equipment, Automotive Repair, FM, Supplement #1	4910-00-754-0706	
171	O	Shop Set, Fuel & Electric System, FM	4910-00-754-0714	
172	O	Shop Equipment, General	4940-00-287-4894	
173	O	Shop Equipment, Contact Maint.	4940-00-294-9518	
174	O	Tool Set Vehicle. Full	4940-00-754-0743	

SECTION III. TOOL AND TEST EQUIPMENT REQUIREMENTS - CONT.

(1) Tool and Test Equipment Ref. Code	(2) Maintenance Category	(3) Nomenclature	(4) National/NATO Stock Number	(5) Tool Number
		COMMON TOOL SETS (Cont'd)		
182	F	Tool Kit, Electronic Equip- ment, TK-100G	5180-00-605-0079	
		PERSCOPE TOOLS, DRIVER'S		
183	F	Wrench, Clip: to remove retaining clips on head assembly	5120-00-338-3742	7631861
184	F	Gun, Sealing Hand	4930-00-764-8117	7648117
185	F	Gun, Hydraulic, Sealing	4931-00-764-8134	76418134
186	F	Dioptometer	4931-00-536-5557	7680631
187	D	Wrench, Insulated Adjusting: to hold and adjust prism	5120-00-508-5475	7680822
188	D	Wrench, Collimating Assy: used to adjust inner and outer eccentrics of periscope	5120-00-508-5476	7680834
189	D	Tester, Tube (Check Image Intensifier Tube M35E1 and M36E1)	4931-00-053-3644	8566309
190	O	Kit, Purging	4931-00-064-1110	
191	F	Power Supply PP-3940/G	6130-00-953-7500	
192	F	Torque Wrench	5120-00-541-3001	
193	D	Test Set, Viewer, Drivers, Night Vision		
194	D	Test Station Assy, Optical Prime Item		

SECTION III. TOOL AND TEST EQUIPMENT REQUIREMENTS - CONT.

(1) Tool and Test Equipment Ref. Code	(2) Maintenance Category	(3) Nomenclature	(4) National/NATO Stock Number	(5) Tool Number
		PERSCOPE TOOLS, DRIVER'S (Cont'd)		
195	D	Helium Leak Detector, Varian Vacuum Corp.		Model 925-40
196	D	Bell Jar Assy		
197	D	Viewer Stand Assy		
198	D	Test Set Assy, Electronic		
199	D	Plate Assy Kit, Sealing Test	5120-00-541-3301	
200	D	Plate Assy Kit, Main Housing Interface		
201	D	Photometer, Pritchard		Model UBD-1
202	D	Plate Assy, Test, Trans- mission		
203	D	Adapter Assy, Mount, Torque Wrench		
204	D	Plate Assy Kit, Mount Immersion		
205	D	Plate Assy, Sealing Test, Window Housing		
206	D	Fixture Assy, Objective Lens		
207	D	Odetta Spatial Frequency Analyzer		Model 28
208	D	Gauge Kit, Objective Lens		
209	D	Fixture Assy, Eyepiece Lens		

SECTION III. TOOL AND TEST EQUIPMENT REQUIREMENTS - CONT.

(1) Tool and Test Equipment Ref. Code	(2) Maintenance Category	(3) Nomenclature	(4) National/NATO Stock Number	(5) Tool Number
		PERSCOPE TOOLS, DRIVER'S (Cont'd)		
210	D	Adapter Assy, Sealing, Test Eyepiece		
211	D	Fixture Assy, Window Housing		
212	D	Fixture Assy, Viewer Handling		
213	D	Wrench, Spanner, Eyepiece		
214	D	Wrench, Spanner, Objective		
215	D	Fixture Assy, Eyepiece Holding		
216	D	Tool, Objective Insertion		
217	D	Tool, Magnifier Barrel Release		
218	D	Fixture Assy, Image Inten- sifier Assy Magnifier		
219	D	Gage, Interface		
220	D	Fixture Assy, D-Ring		
221	D	Fixture Assy, Knob Sealing		
222	D	Helium Technical Grade		
223	D	Adapter: Used w/Fixture 4931-00-508-5441	4931-00-561-0789	7297922
224	D	Adapter, Vibration: Used w/Vibrator Tester 4931-00- 536-5555	4931-00-346-9091	756-0099
225	D	Power Supply, High Voltage	4931-00-536-5556	7561204

SECTION III. TOOL AND TEST EQUIPMENT REQUIREMENTS I CONT.

(1) Tool and Test Equipment: Ref. Code	(2) Maintenance Category	(3) Nomenclature	(4) National/NATO Stock Number	(5) Tool Number
225	D	PERSCOPE TOOLS, DRIVER'S (Cont'd) Tester, Tube		7560125
227	D	Transformer, Power, Voltage: To Regulate Voltage for Light Source of Tester, Tube 4931-00-053-3644	5950-00-647-8517	7284975
228	F	Multimeter AN/USM-223	6625-00-999-7465	

SECTION IV. REMARKS

Reference Code	Remarks
AW	Task Authorized by L.O.
AY	Repair by welding.

SECTION IV. REMARKS
FOR
M48/M60 SERIES VEHICLES
SECTION IV. B. - REMARKS, TECHNICAL MANUAL REFERENCES

Reference Code	Remarks
TM-DJ	9-2815-220-34
DK	9-2815-220-34P
DL	9-2910-212-34
DN	9-2910-213-34
DO	9-2910-213-34P
DR	9-2920-224-34
DT	9-2920-232-34&P
DV	9-2990-200-34
HS	9-2530-200-34 Standards for Inspection and Classification of Tracks, Track Components and Solid Rubber Tires.

**SECTION IV. REMARKS
FOR
M48/M60 SERIES VEHICLES
SECTION IV. C. - REMARKS, INFORMATIONAL**

Reference Code	Remarks
JC	Mod 2A Engine only.
JX	Only individual shoes or 8 link sections available.
KI	Specialized repair activity.
KQ	Crew (C) - Light bulbs only.
KR	Organizational (O) - Replaces repair parts stocked at "O" and/or does minor repair (e.g., straighten pins, install protective taps).
MN	Old M24 Periscope per ARRCOM PMR date 7/22/82.
MP	New M24 Periscope per ARRCOM PMR date 7/22/82.
MQ	All Night Vision Viewer data obtained from U.S. Army Communications Electronics Command (CECOM) PMR.
NK	Tools and Test Equipment in accordance with DMWR.
NM	MAC data from TM 11-5855-249-20. MAC data for all Night Vision Viewer subassemblies are from TM 11-5855-249-20.

**SECTION IV. REMARKS
FOR
M48/M60 SERIES VEHICLES
SECTION IV. C. - REMARKS, INFORMATIONAL**

Reference Code	Remarks
OD	Maintenance Significant Item.
OF	PN13211E3126 replaced by PF2020-23-21LH.
OG	Those maintenance actions necessary to restore serviceability to an item by correcting specific damage, fault, malfunction, or failure.
OH	Those maintenance actions necessary to restore an item to a completely serviceable/operational condition to include, when prescribed, inspection with dye penetrants (zyglo), magnaflux, "and/or" measurements for comparison to acceptable standards.
OK	**Indicates work time/man hours and tools required.
OL	Crew is responsible for installing a thrown track.
OM	Organizational maintenance is responsible for torquing hardware.
ON	Organizational maintenance is responsible for replacing track assembly. Crew is authorized to replace track assembly under supervision of organizational maintenance.
OP	Crew is authorized to perform track repair under supervision of organizational maintenance.
OQ	Organizational maintenance repairs by replacing grease fitting.
OR	All repair and replacement of parts performed by organizational maintenance is limited to authorized items listed in TM 9-2350-260-20P-1.
OT	Inspection by crew level personnel is limited to a visual inspection.
OU	Test is performed with powerplant installed in vehicle.

**SECTION IV. REMARKS
 FOR
 M48/M60 SERIES VEHICLES
SECTION IV. C. - REMARKS, INFORMATIONAL**

Reference Code	Remarks
OV	Direct support repair to the powerplant consists of replacing the engine or transmission.
OX	To replace and repair the bulkhead-to-engine disconnect (left side) wiring harness, it is necessary to remove powerplant.

APPENDIX C

GENERAL MAINTENANCE

INDEX

Inspection and Repair of Welds.	C-2
Inspection, Care, and Maintenance of Antifriction Bearings	C-2
Inspection and Repair of Cast Parts and Machined Surfaces	C-3
Inspection and Repair of Splines	C-5
Cleaning Threads and Nuts...	C-7
Loosening and Removing Nuts	C-8
Cutting Nuts	C-9
Bolt Removal	C-10
Removal of Studs Broken at Surface	C-11
Removal of Studs Broken Below Surface.	C-14
Removal of Studs Broken Above Surface	C-17
Installation of New Studs...	C-18
Dowel Pin Removal	C-19
Dowel Pin Installation	C-20
Spring Pin Removal	C-21
Spring Pin Installation	C-22
Hand Lubrication of Bearings.	C-23
Wheel Bearing Packer Lubrication of Bearings	C-24
Inspection and Repair of Gears.	C-27
Safety Wiring Procedures.	C-28
Single Fastener Double-Twist Safety Wiring	C-30
Castellated Nuts on Undrilled Stud Double-Twist Safety Wiring.	C-31
Multiple Fastener Double-Twist Safety Wiring	C-32
External Snap Ring Single Wire Safety Wiring	C-33
Small Screws in Closely Spaced, Closed Geometrical Pattern Single Wire Safety Wiring	C-34

GENERAL MAINTENANCE (Sheet 1 of 33)

Inspection and Repair of Welds (Sheet 1 of 1)

1. **Inspect and repair welds in accordance with TM 9-237.**
2. **Military specifications referenced in this manual will be used as mandatory guidelines beyond the scope of TM 9-237 during welding processes.**
3. **When welding requirements are beyond organizational capabilities, notify support maintenance personnel.**

End of Task

Inspection, Care, and Maintenance of Antifriction Bearings. Refer to TM 9-214

End of Task

GENERAL MAINTENANCE (Sheet 2 of 33)

Inspection and Repair of Cast Parts and Machined Surfaces (Sheet 1 of 2)

SUPPLIES: Dry cleaning solvent (Item 55, Appendix D)
 Rubber gloves
 Crocus cloth (Item 14, Appendix D)

1. Check interior of cast parts and machined surfaces for scoring, burring, and pitting.

WARNING

Cleaning agent specified is flammable. Use only in well ventilated areas. Keep away from flames, sparks, or heat. Do not smoke while using. Prevent contact with eyes, mouth, and/or skin. Wear rubber gloves when performing cleaning procedures.

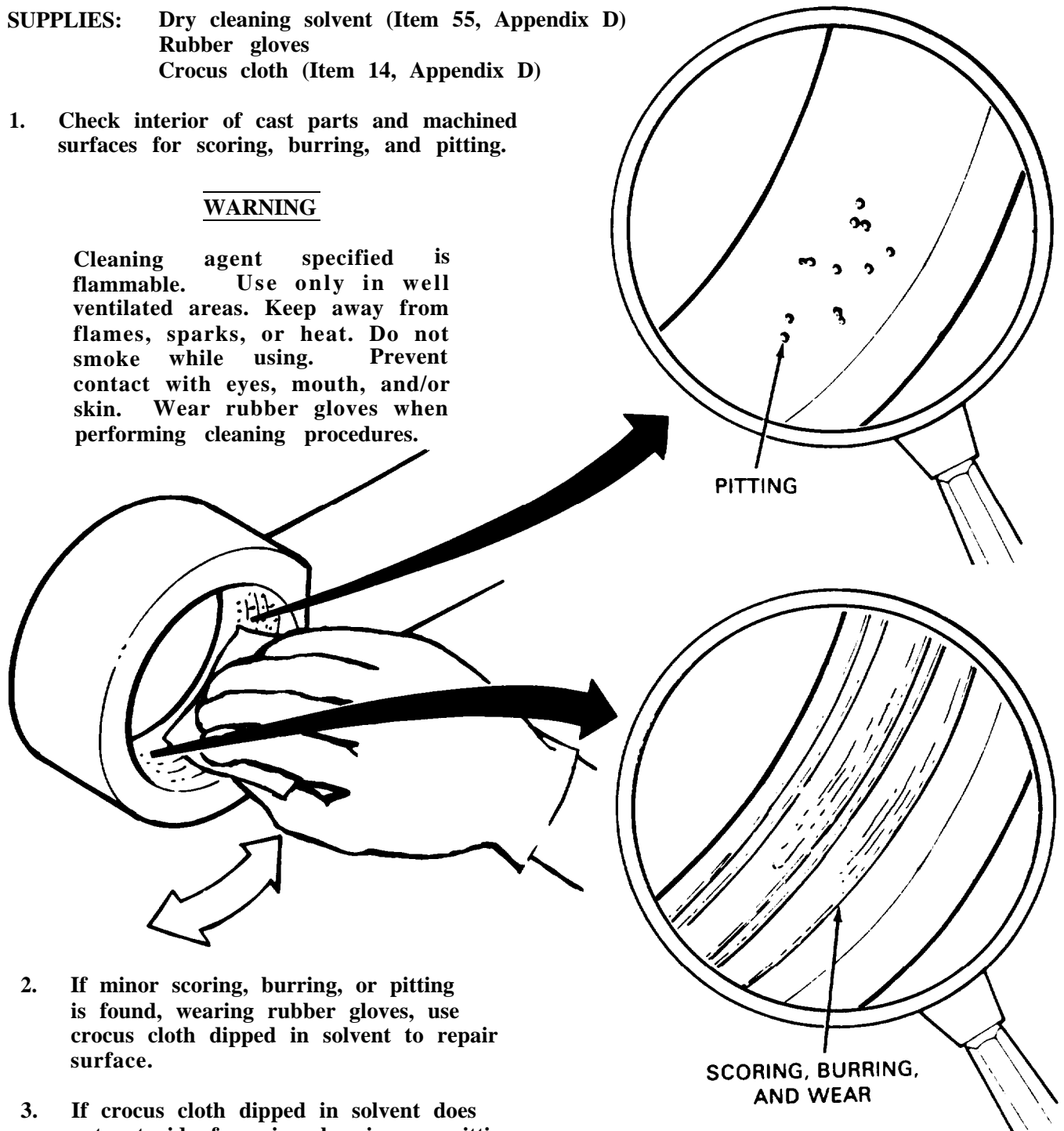

2. If minor scoring, burring, or pitting is found, wearing rubber gloves, use crocus cloth dipped in solvent to repair surface.
3. If crocus cloth dipped in solvent does not get rid of scoring, burring, or pitting, or if part is excessively scored, worn, pitted, or burred, throw part away.

Go on to Sheet 2

TA248900

Check exterior parts and machined surfaces for cracks, chipping, and corrosion.

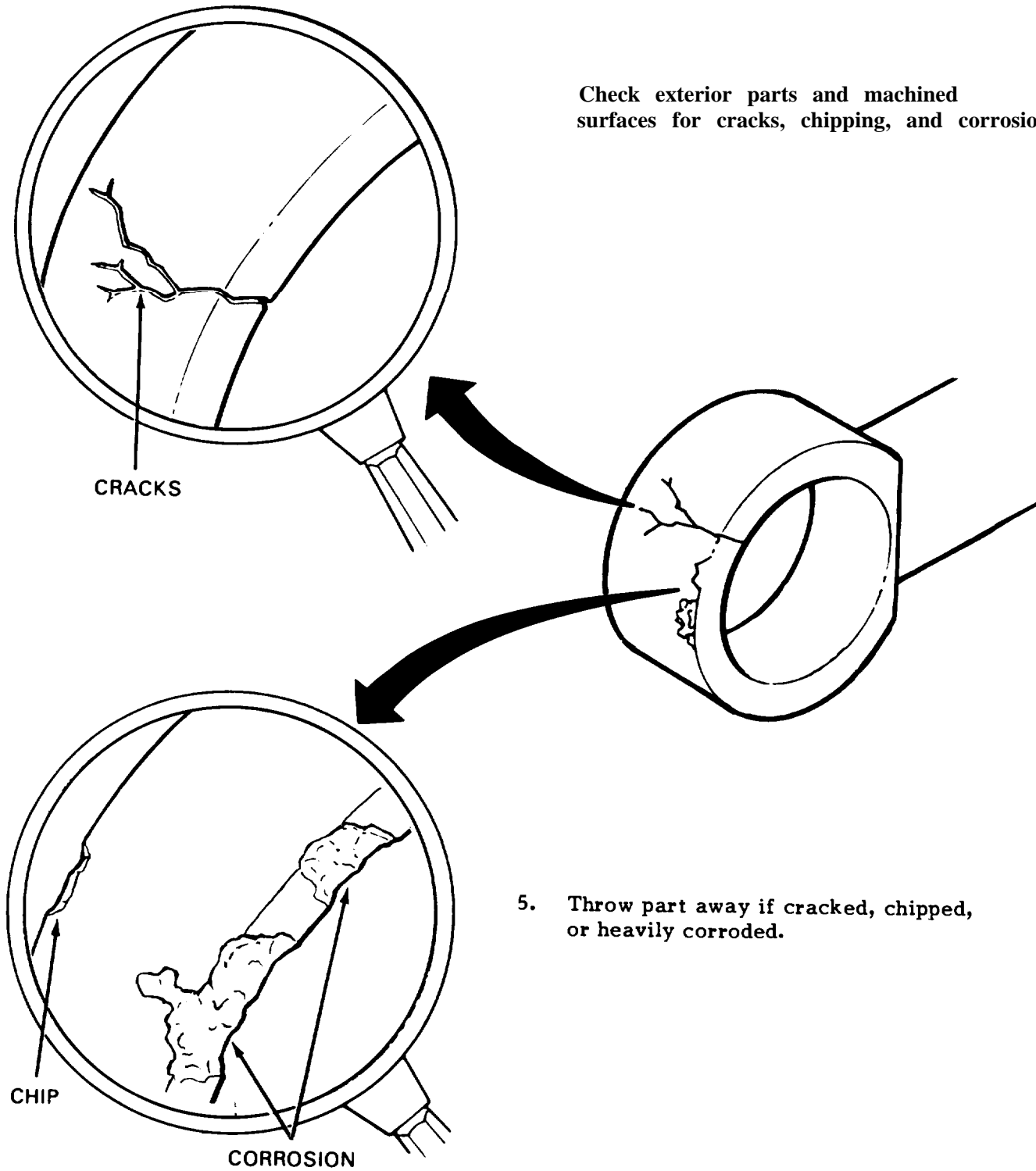

5. Throw part away if cracked, chipped, or heavily corroded.

End of Task

TA248901

GENERAL MAINTENANCE (Sheet 4 of 33)

Inspection and Repair of Splines (Sheet 1 of 2)

TOOLS: Hand file
Hand oiler
1/4 in. paint brush

SUPPLIES: Dry cleaning solvent (Item 55, Appendix D)
Rubber gloves
Crocus cloth (Item 14, Appendix D)
Clean rags
Lubricating oil (Item 44, Appendix D)
protective wrapping (if required)

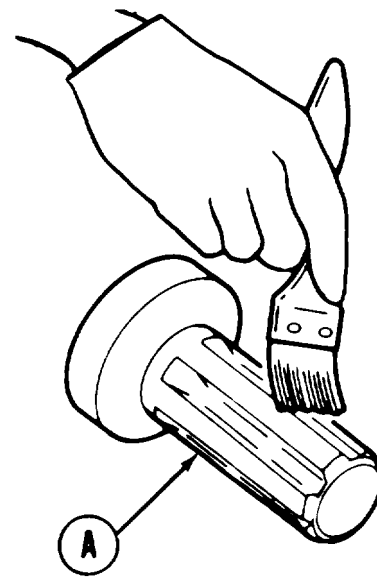

WARNING

Cleaning agent specified is flammable. Use only in well ventilated areas. Keep away from flames, sparks, or heat. Do not smoke while using. Prevent contact with eyes, mouth, and/or skin. Wear rubber gloves when performing cleaning procedures.

1. Wearing gloves, use dry cleaning solvent and brush to clean spline (A). Make sure all traces of grease and dirt are gone.

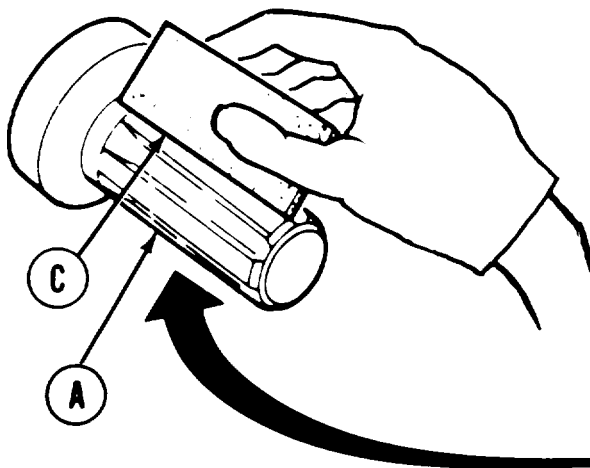

2. Using clean rag, wipe spline (A) dry.
3. Check spline (A) for signs of rust (B).
4. Using crocus cloth (C), rub rust (B) off spline (A).

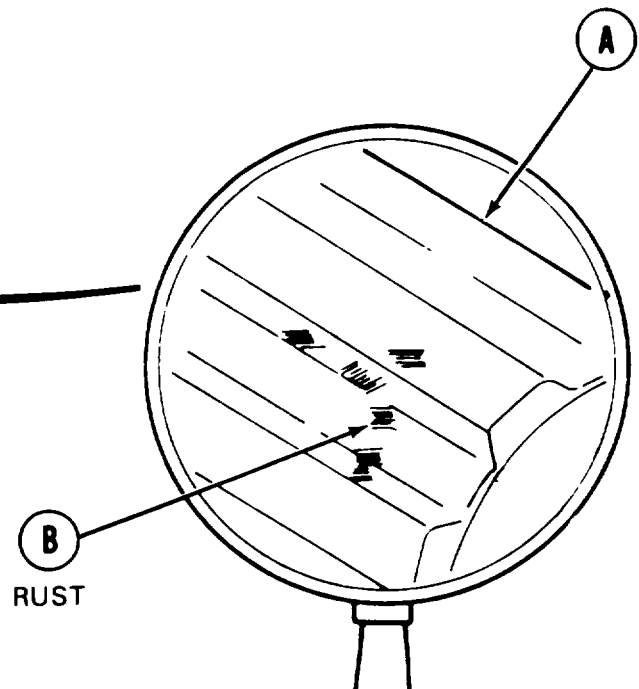

Go on to Sheet 2

TA248902

GENERAL MAINTENANCE (Sheet 5 of 33)

Inspection and Repair of Splines (Sheet 2 of 2)

5. Check for chipped teeth (D) and gouging (E) on face of spline (A).
6. Using hand file, get rid of sharp edges or light gouging (E).
7. Using rag dampened with dry cleaning solvent, wipe metal chips and metal dust from spline (A).

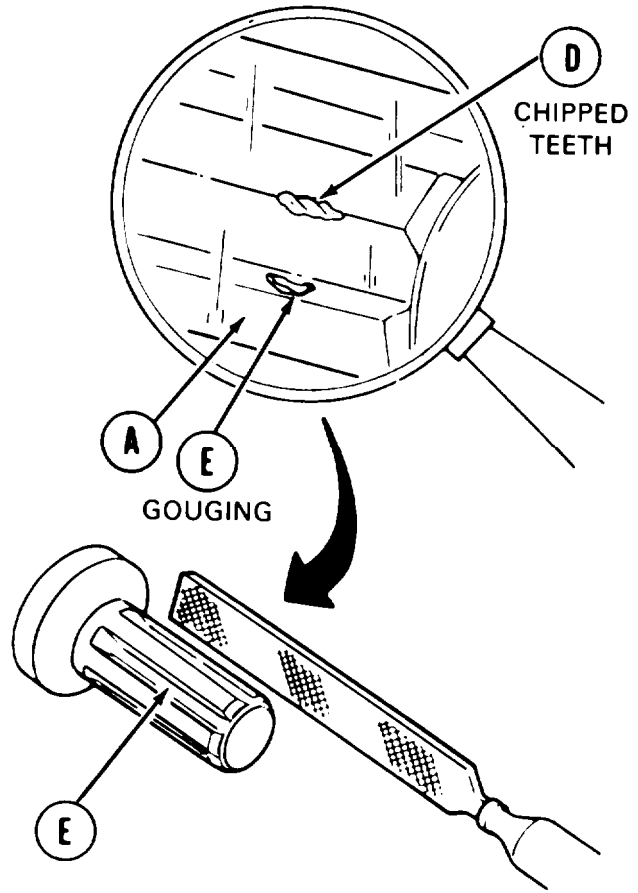
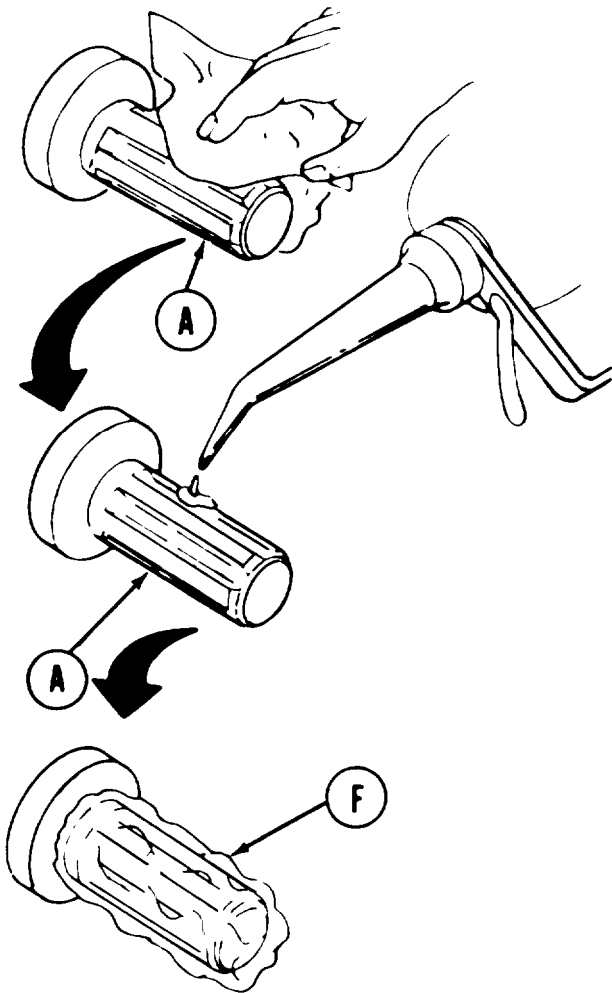

NOTE

Only if spline (A) will not be used right away, do steps 8 and 9.

8. Using oil, coat spline (A).
9. Using protective wrapping (F), wrap spline (A).

End of Task

TA248903

GENERAL MAINTENANCE (Sheet 6 of 33)

Cleaning Threads and Nuts (Sheet 1 of 1)

TOOLS: Wire brush
1/4 in. paint brush
Hand oiler

SUPPLIES: Dry cleaning solvent (Item 55, Appendix D)
Penetrating oil (Item 43, Appendix D)
Rubber gloves

WARNING

Cleaning agent specified is flammable. Use only in well ventilated areas. Keep away from flames, sparks, or heat. Do not smoke while using. Prevent contact with eyes, mouth, and/or skin. Wear rubber gloves when performing cleaning procedures.

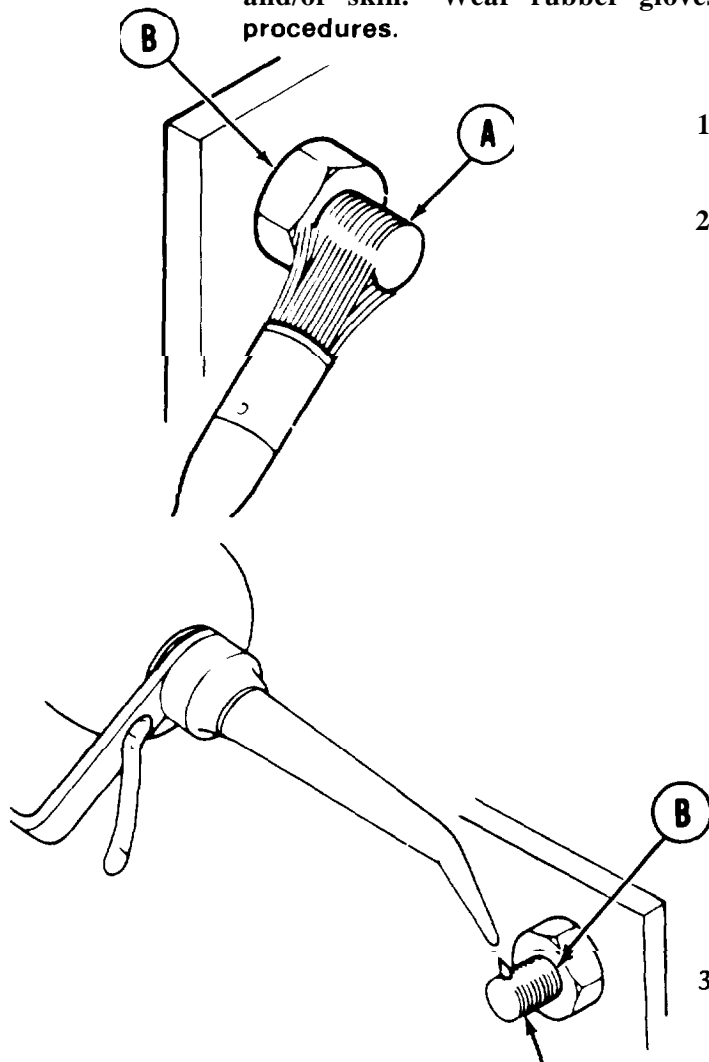

1. Wearing gloves, use dry cleaning solvent and brush to clean threads (A) and nut (B).
2. Using wire brush, clean threads (A) and nut (B). Make sure all traces of rust and dirt are removed.

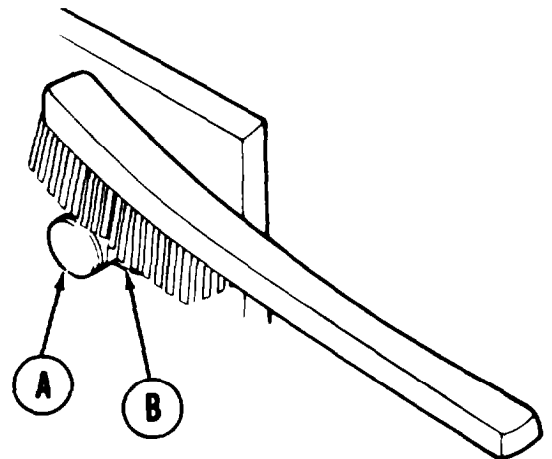

3. Using penetrating oil, lube threads (A) and nut (B). Let oil seep between threads (A) and nut (B).

End of Task

TA248904

GENERAL MAINTENANCE (Sheet 7 of 33)

Loosening and Removing Nuts (Sheet 1 of 1)

TOOLS: Ball peen hammer
Wire Brush
Socket

1. Using socket, try to remove nut (A).
2. If nut (A) will not turn, clean threads and nut (page C-7).
3. Using hammer, gently tap nut (A).
4. Using socket wrench handle with socket attempt to free nut.

NOTE

If nut (A) cannot be freed by step 3 above, go to page C-9.

4. Take off and throw away nut (A). If nut (A) was attached to a bolt, replace bolt.

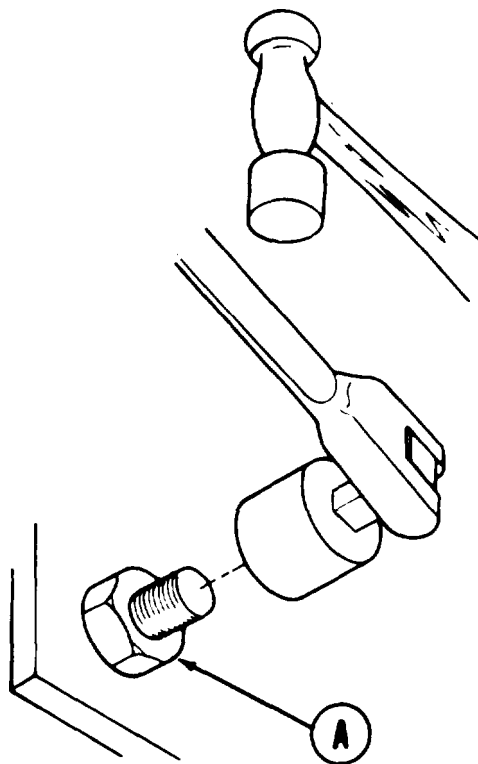

End of Task

TA248905

GENERAL MAINTENANCE (Sheet 8 of 33)

Cutting Nuts (Sheet 1 of 1)

TOOLS: Cape chisel
 Screw threading set
 Ball peen hammer
 Adjustable wrench

1. Using hammer and cape chisel, cut flat side of nut (A).

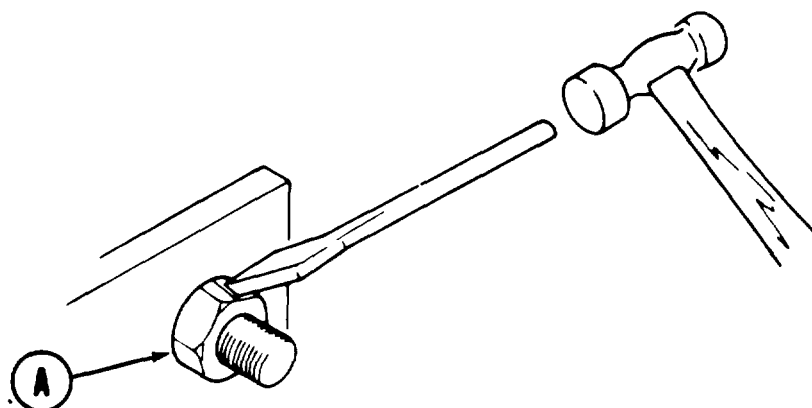

2. Stop cutting when nut (A) spreads apart (B).

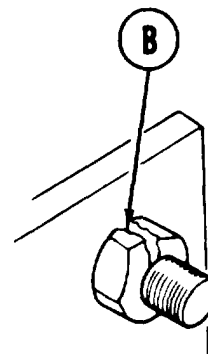

3. Using adjustable wrench remove nut (A).

NOTE

If nut (A) was removed from end of a bolt, throw bolt away if damaged. If nut (A) was removed from a stud or threaded shaft, do step 4.

4. Using die (C) from screw threading set, clean up threads (D).

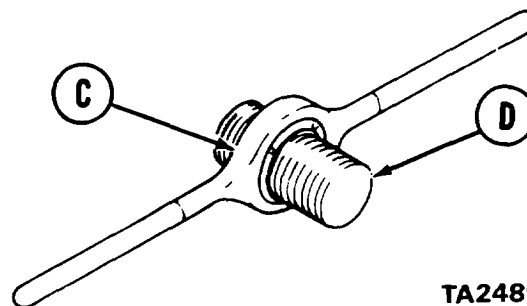

End of Task

TA248906

GENERAL MAINTENANCE (Sheet 9 of 33)

Bolt Removal (Sheet 1 of 1)

TOOLS: Ball peen hammer
Wire brush
Hand oiler

SUPPLIES: Penetrating oil (Item 43, Appendix D)

1. Using wire brush, clean head of bolt (A) and nearby area.

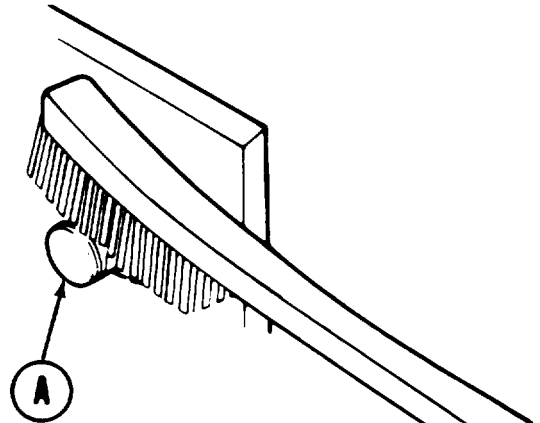

2. Using penetrating oil around head of bolt (A), allow oil to seep into threads.

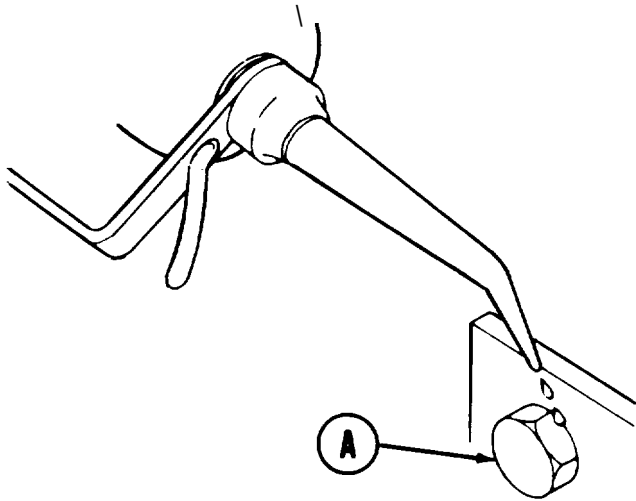

3. Using hammer, lightly tap head of bolt (A).

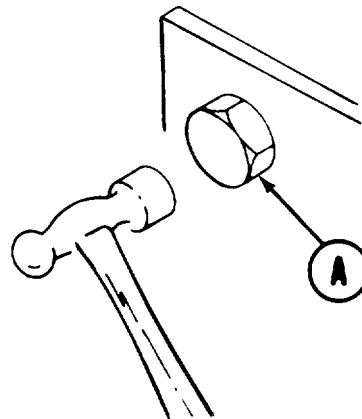

4. Using socket wrench handle with socket, remove bolt (A). Throw away bolt (A) if damaged.

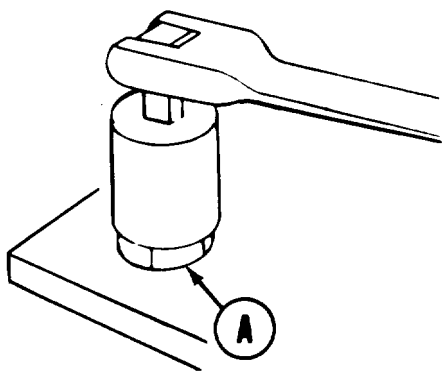

End of Task

TA248907

GENERAL MAINTENANCE (Sheet 10 of 33)

Removal of Studs Broken at Surface (Sheet 1 of 3)

TOOLS: Screw threading set
 Portable electric drill
 Twist drill set
 Screw extractor set
 Ball peen hammer
 Prick punch
 Hand oiler

SUPPLIES: Penetrating oil (Item 43, Appendix D)
 Clean rags
 Safety glasses

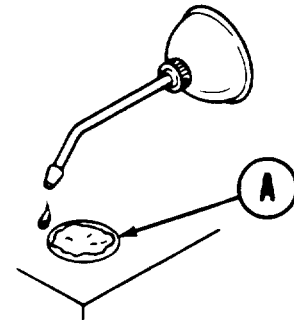

1. Using penetrating oil, lube thread area (A).

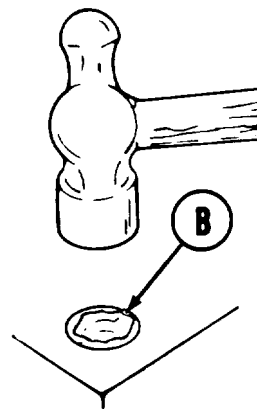

2. Using hammer, lightly tap stud (B).

NOTE

It is very important to drill out broken stud on exact center line.

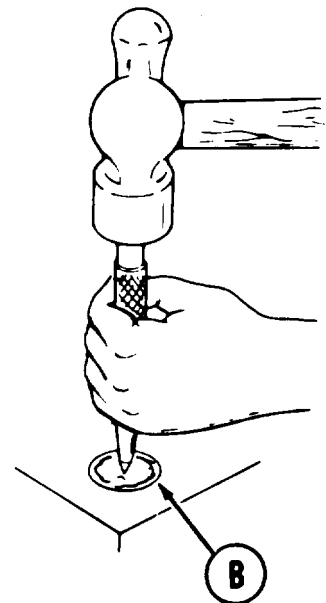

3. Using punch and hammer, punch center of broken stud (B).

Go on to Sheet 2

TA248908

GENERAL MAINTENANCE (Sheet 11 of 33)

Removal of Studs Broken at Surface (Sheet 2 of 3)

WARNING

Safety glasses must be worn when using drill to prevent injury to eyes.

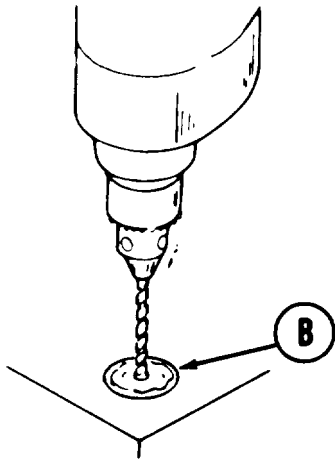

4. Using electric drill with pilot twist drill, drill center of stud (B).

5. Using electric drill with twist drill slightly smaller than extractor, drill into stud (B).

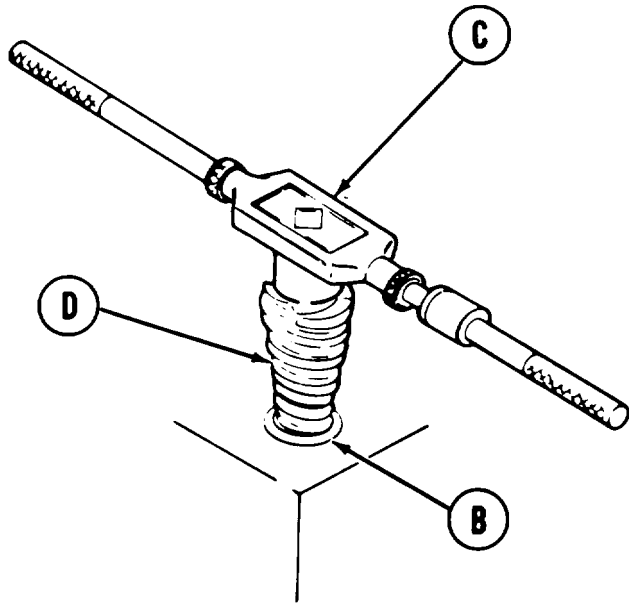
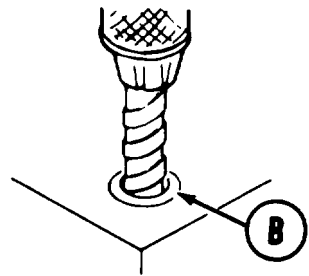

6. Using tap wrench handle (C) with screw extractor (D), turn tap wrench handle (C) counterclockwise to screw extractor (D) into stud (B).

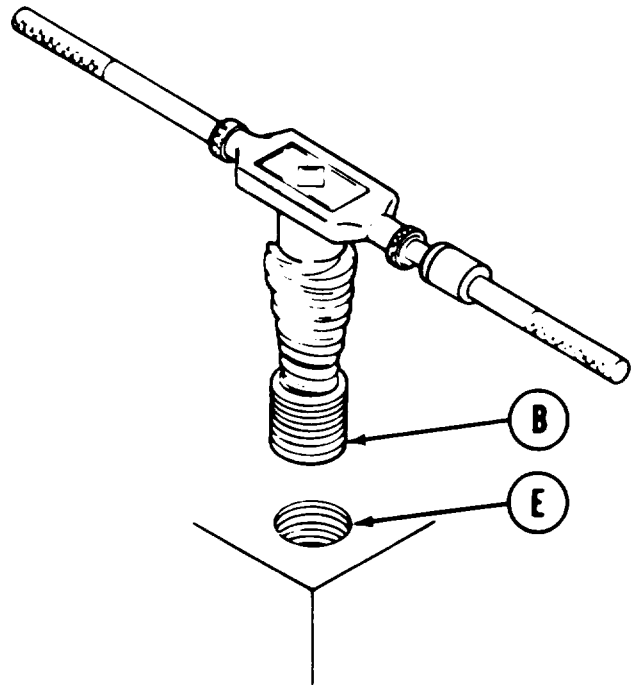

Go on to Sheet 3

TA248909

GENERAL MAINTENANCE (Sheet 12 of 33)

Removal of Stud Broken at Surface (Sheet 3 of 3)

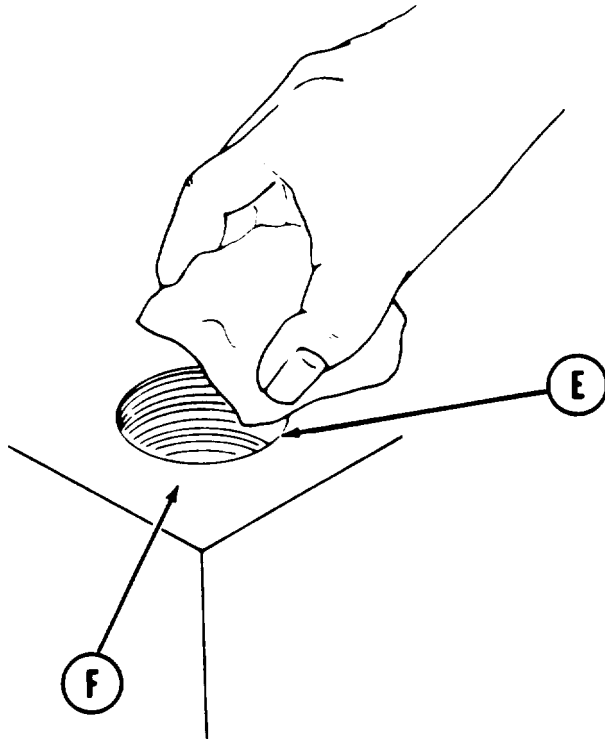

7. Keep turning extractor counterclockwise until stud (B) is removed from threaded hole (E).
8. Using clean rag, wipe out threaded hole (E) and surface (F).
9. Using bottoming tap, chase internal threads.

End of Task

TA248910

GENERAL MAINTENANCE (Sheet 13 of 33)

Removal of Studs Broken Below Surface (Sheet 1 of 3)

TOOLS: Screw extractor set
Portable electric drill
Twist drill set
Hand oiler
Ball peen hammer

SUPPLIES: Penetrating oil (Item 43, Appendix D)
Clean rags
Safety glasses

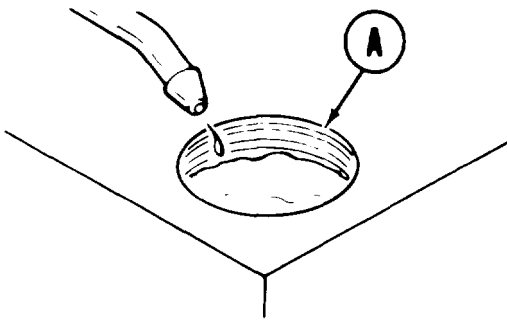

1. Using penetrating oil, lube thread area (A).

NOTE

It is very important to drill out broken stud on exact center line.

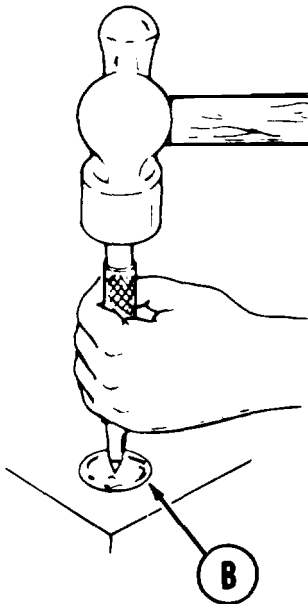

2. Using punch and hammer, punch center of broken stud (B).

Go on to Sheet 2

TA248911

GENERAL MAINTENANCE (Sheet 14 of 33)

Removal of Studs Broken Below Surface (Sheet 2 of 3)

WARNING

Safety glasses must be worn when using drill to prevent injury to eyes.

- Using electric drill with twist drill slightly smaller than extractor, drill into stud (B).

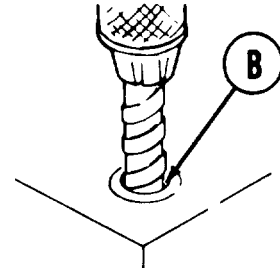

NOTE

Make sure all metal chips are removed from hole (C) before using extractor.

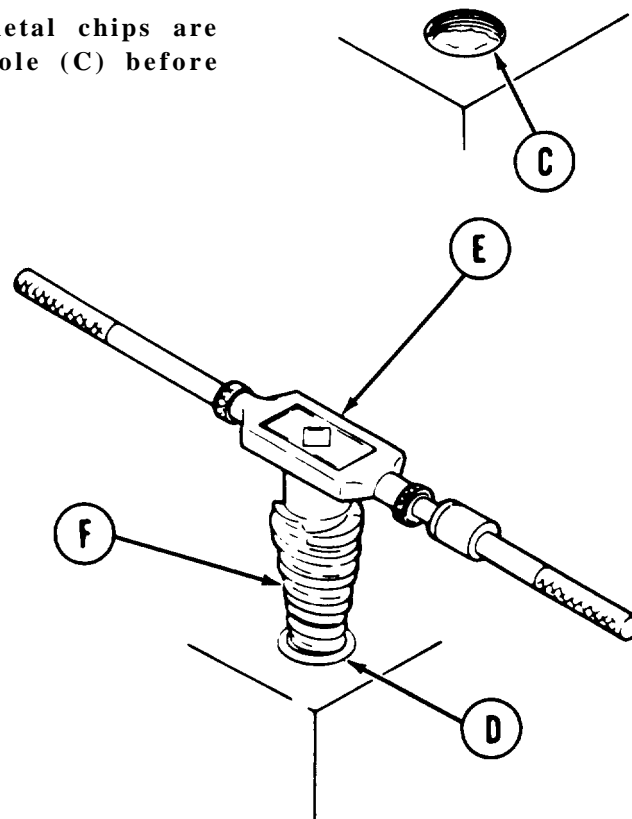

- Using tap wrench handle (E) with screw extractor (F), turn tap wrench handle (E) counterclockwise to screw extractor (F) into stud (D).

Go on to Sheet 3

TA248912

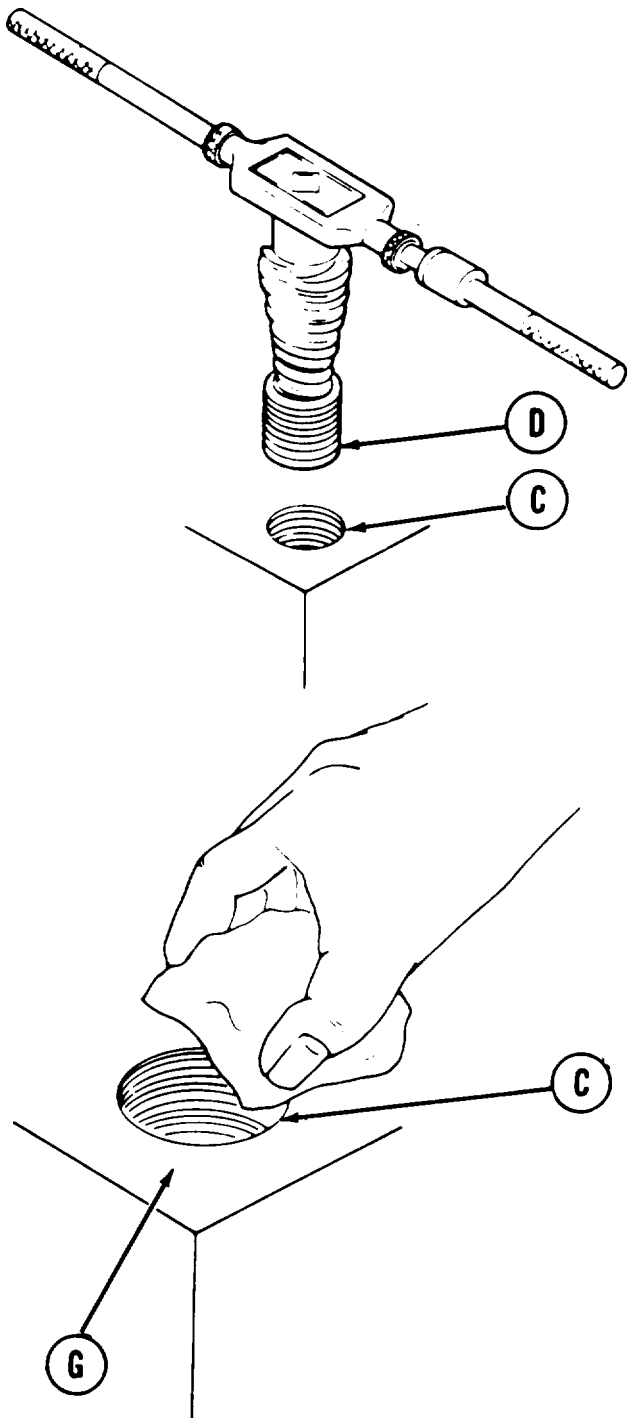

5. Keep turning extractor counterclockwise until stud (D) is removed from threaded hole (C).

6. Using clean rag, wipe out threaded hole (C) and surface (G).
7. Using a bottoming tap, chase internal threads.

End of Task

TA248913

GENERAL MAINTENANCE (Sheet 16 of 33)

Removal of Studs Broken Above Surface (Sheet 1 of 1)

TOOLS: Ball peen hammer
Screw extractor set
Hand oiler
Wrench

SUPPLIES: Penetrating oil (Item 43, Appendix D)
Clean rags

1. Using penetrating oil, lube threaded area (A).

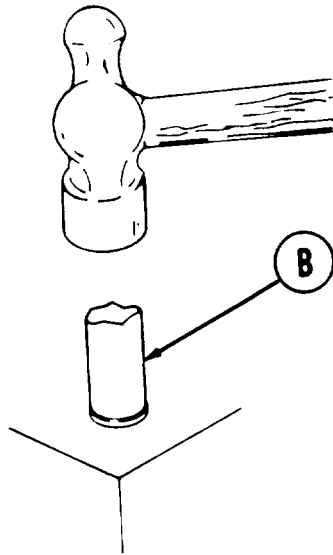
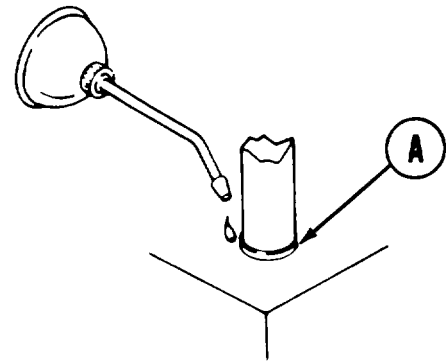

2. Using hammer, lightly tap stud (B).

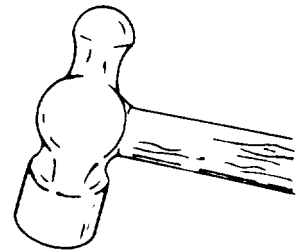

3. Using hammer, tap stud remover (C) onto stud (B).

4. Using wrench, turn stud remover (C) to the left.

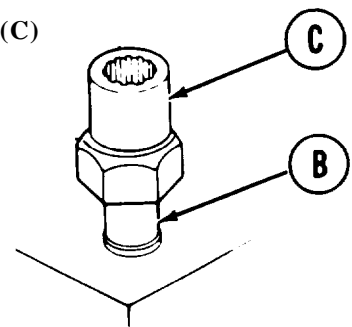

5. Using wrench, keep turning stud remover (c) to the left until stud (B) is removed from threaded hole (D).

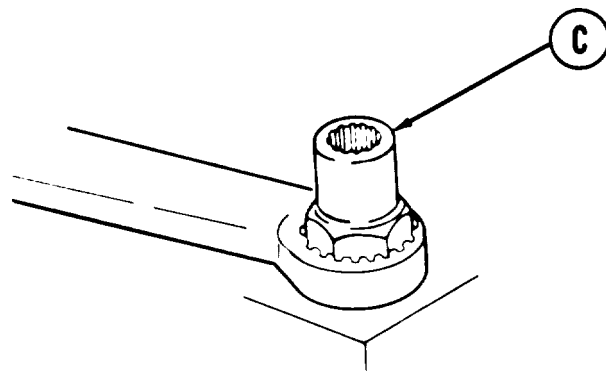

6. Using clean rag, wipe out threaded hole (D) and surf ace (E).

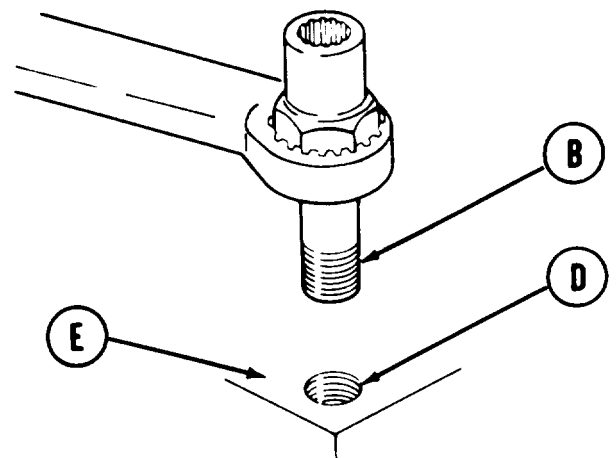

7. Using a bottoming tap, chase internal threads.

End of Task

TA248914

GENERAL MAINTENANCE (Sheet 17 of 33)

Installation of New Studs (Sheet 1 of 1)

TOOLS: Wrench, torque
Screw threading set
Combination box and open end wrench (2 required)
Socket

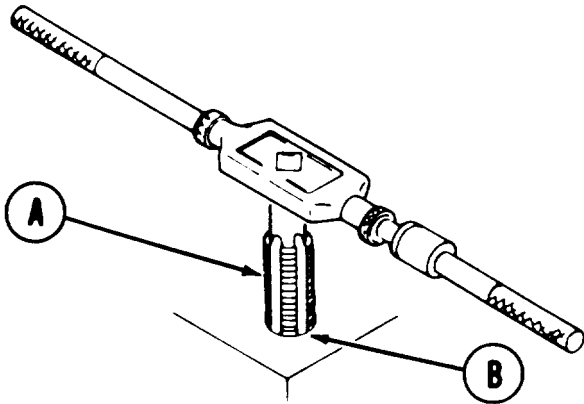

1. Using bottoming tap (A), clean out threads in hole (B).
2. Using two wrenches, install and jam two nuts (C) onto end of new stud (D).

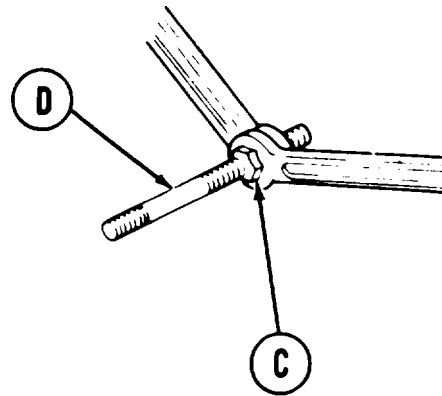

3. Using socket, install new stud (D) into hole (B).

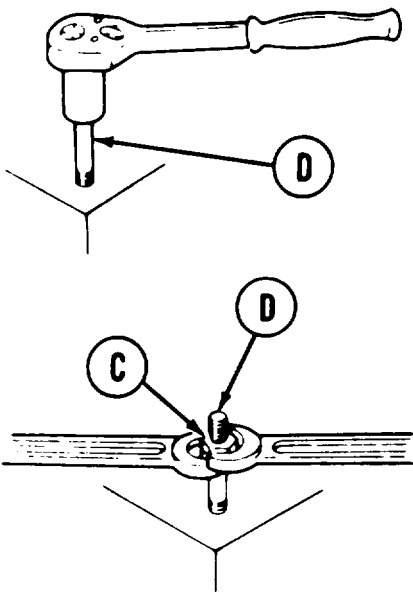

4. Using torque wrench, tighten new stud (D) to required value (refer to specific maintenance procedure).

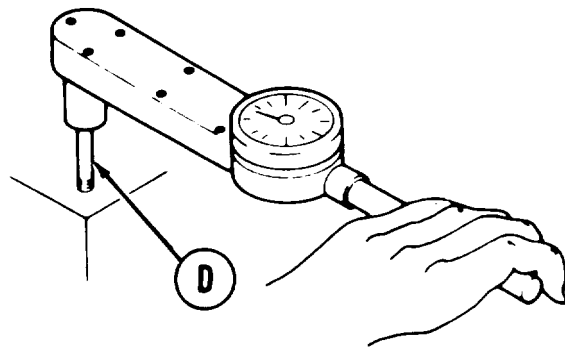

5. Using two wrenches, remove two nuts (C) from new stud (D).

End of Task

TA248915

GENERAL MAINTENANCE (Sheet 18 of 33)

Dowel Pin Removal (Sheet 1 of 1)

TOOLS: Slip joint pliers
 Portable electric hand grinder (if required)
 Portable electric drill (if required)
 Twist drill set

1. Using pliers, grip pin (A).
2. Using pliers, pull out pin (A) with twisting motion.

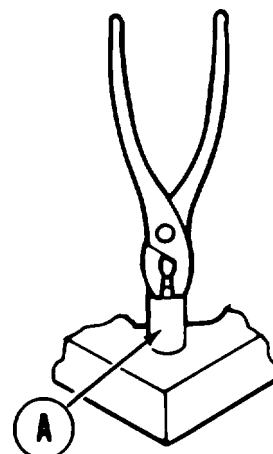

WARNING

Safety glasses must be worn when using grinder or drill to prevent injury to eyes.

3. If unable to pull out pin (A) with pliers, using hand grinder, grind pin (A) off flush with surface (B).

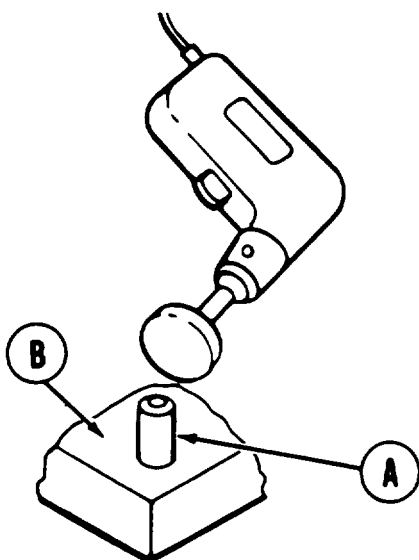

4. Using electric drill and twist drill, drill out rest of pin (A).

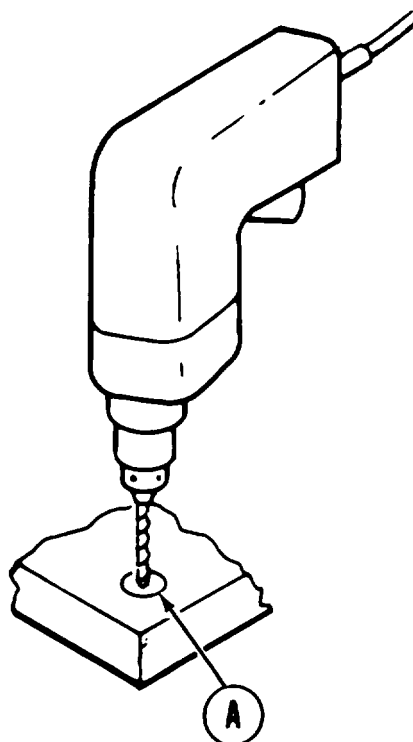

End of Task

TA248916

GENERAL MAINTENANCE (Sheet 19 of 33)

Dowel Pin Installation (Sheet 1 of 1)

TOOLS: Ball peen hammer

SUPPLIES: Hard wood block

1. Place pin (A) into hole (B), keeping pin (A) as straight as possible.

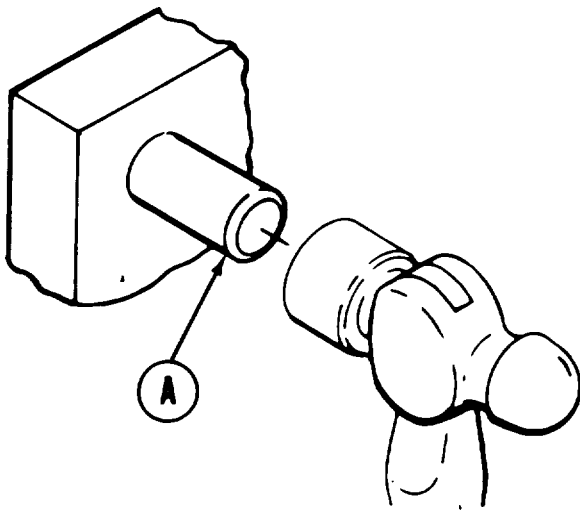
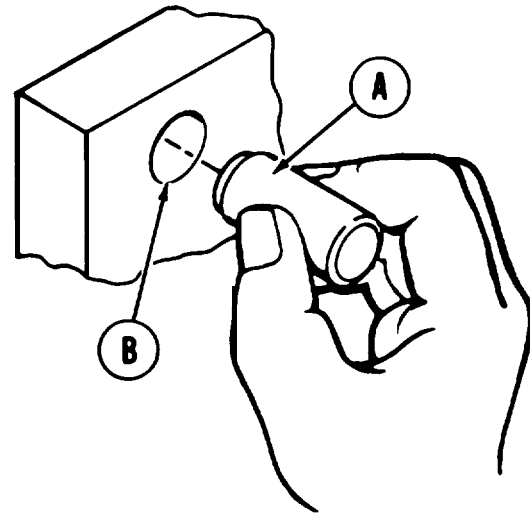

CAUTION

If pin (A) is tapped too hard, end will flatten out and pin (A) will not properly seat.

2. Using hammer, lightly tap in pin (A) until seated.
3. If pin (A) cannot be driven by lightly tapping with hammer, put wooden block (C) against pin (A) and hit with hammer until pin (A) is seated.

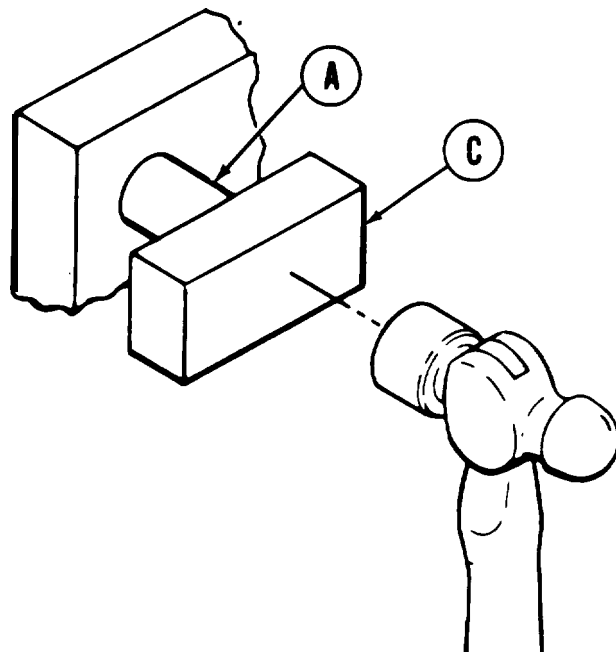

End of Task

TA248917

GENERAL MAINTENANCE (Sheet 20 of 33)

Spring Pin Removal (Sheet 1 of 1)

TOOLS: Ball peen hammer
Drive pin punch

NOTE

Drive pin punch used to remove spring pin must be about 1/32 inch smaller than pin hole.

1. Put drive pin punch into spring hole and center on pin (A).

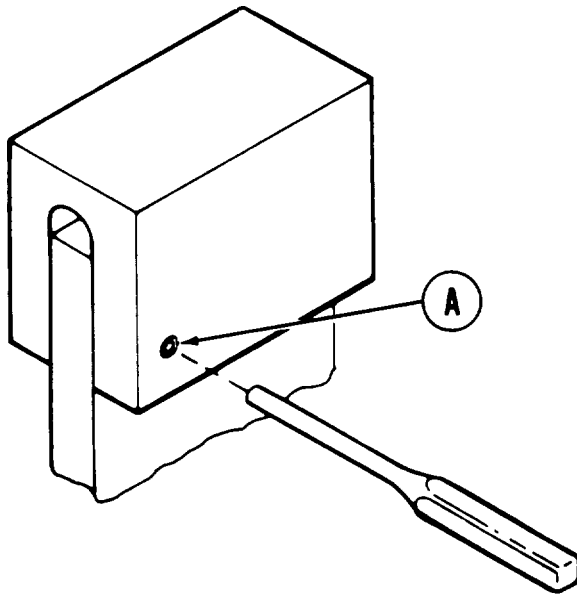

2. Using hammer, lightly tap drive pin punch until pin (A) is driven out of hole.

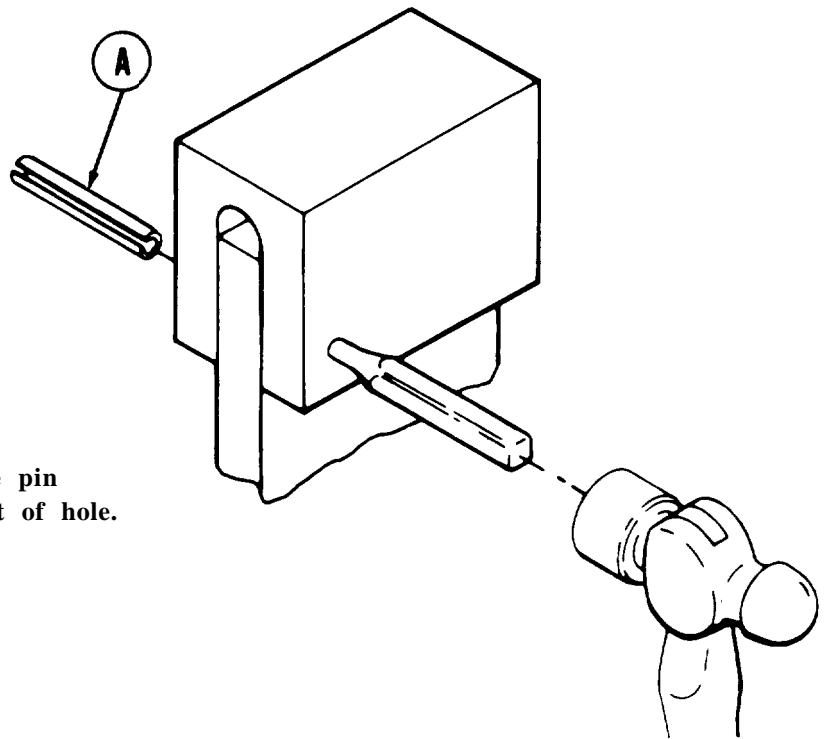

End of Task

TA248918

GENERAL MAINTENANCE (Sheet 21 of 33)

Spring Pin Installation (Sheet 1 of 1)

TOOLS: Ball peen hammer
Hand oiler

SUPPLIES: Lubricating oil (Item 44, Appendix D)
Hard wood block

1. Using oil, lightly lube pin (A).

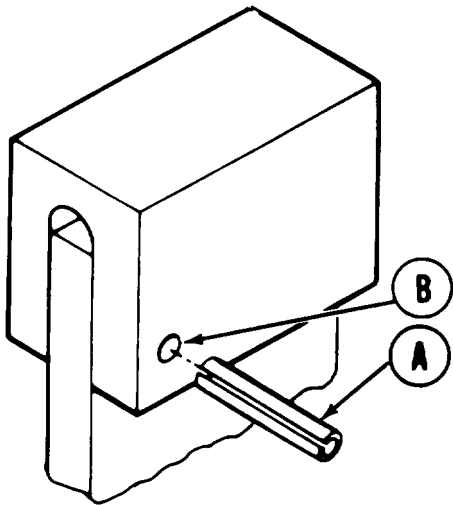
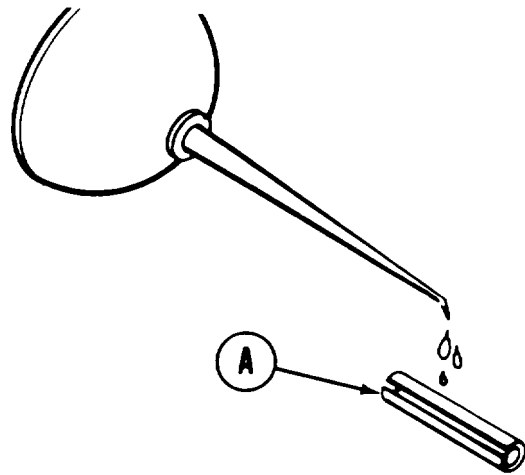

2. Putting spring pin (A) into hole (B), keep it as straight as possible.
3. Using hammer, tap pin (A) until flush with surface (C).

NOTE

If structure is not sturdy, support opposite end of hole with wooden block (D) while tapping pin (A) into place.

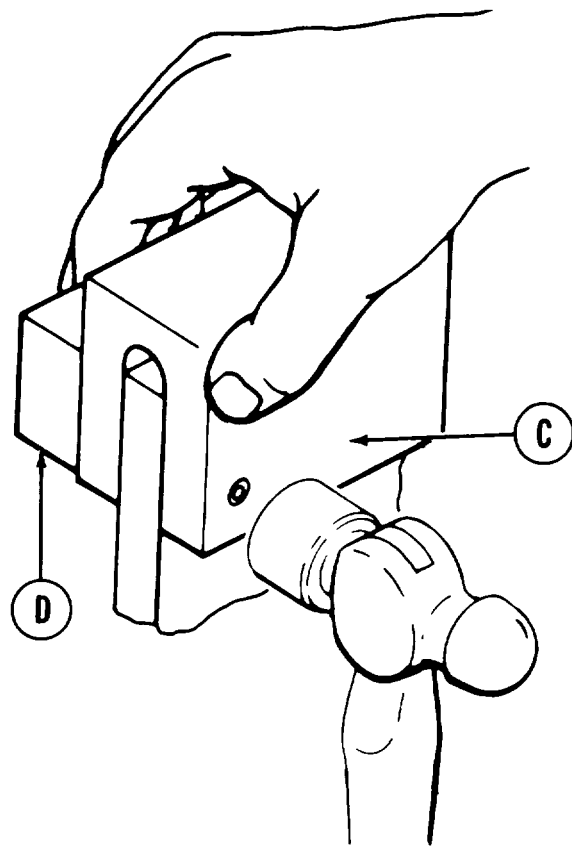

End of Task

TA248919

GENERAL MAINTENANCE (Sheet 22 of 33)

Hand Lubrication of Bearings (Sheet 1 of 1)

SUPPLIES: Grease (Item 37, Appendix D)
Clean rags

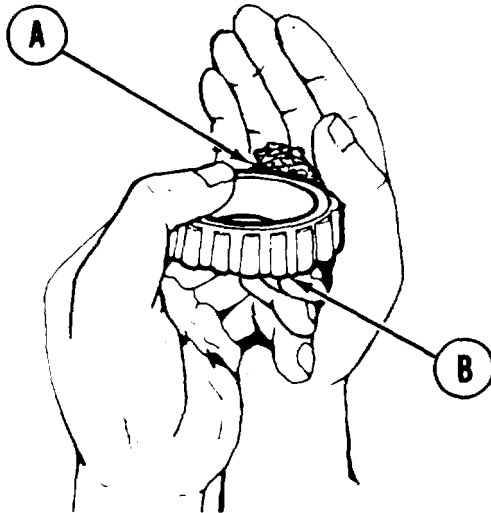

1. Place about 1 ounce of grease (A) into palm of one hand.
2. Holding bearing (B) in other hand, force grease (A) between inner race and cage.
3. Press bearing (B) into grease until grease (A) appears on other side of bearing (B).

4. Turning bearing (B) over, repeat steps 1, 2, and 3.
5. Using light film of grease (A), lube rollers (C).
6. Using clean rags, cover bearing (B) until ready for assembly.

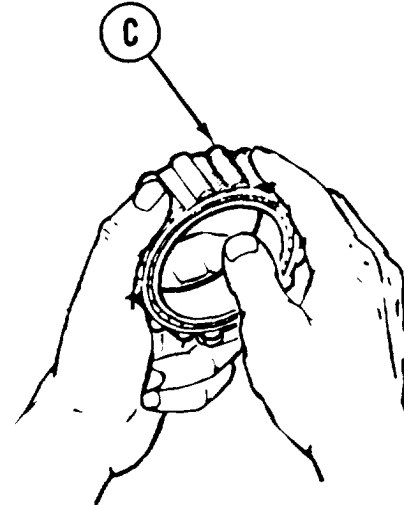

End of Task

TA248920

GENERAL MAINTENANCE (Sheet 23 of 33)

Wheel Bearing Packer Lubrication of Bearings (Sheet 1 of 3)

TOOLS: Wheel bearing packer
Hand grease gun

SUPPLIES: Grease (Item 37, Appendix D)
Clean rags

1. Take cover (A) off base (B).

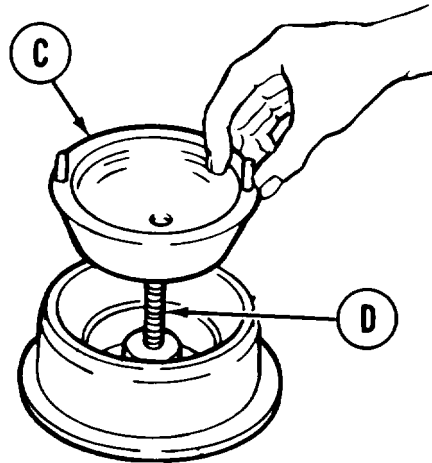
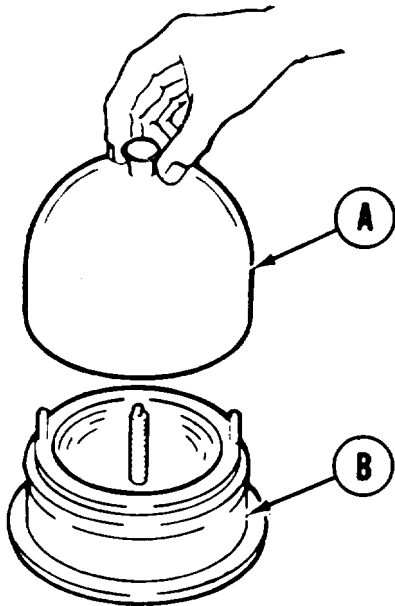

2. Unscrew cap (C) from center post (D).

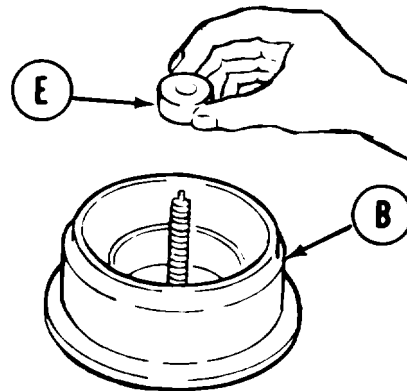

3. Take insert (E) from base (B).

4. Put bearing (F) into base (B).

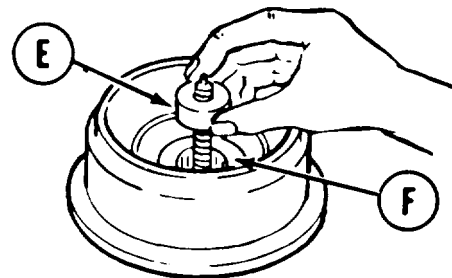
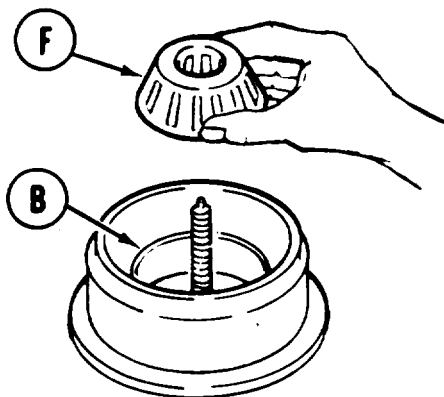

5. Put insert (E) in center of bearing (F) to act as filler.

Go on to Sheet 2

TA248921

GENERAL MAINTENANCE (Sheet 24 of 33)

Wheel Bearing Packer Lubrication of Bearings (Sheet 2 of 3)

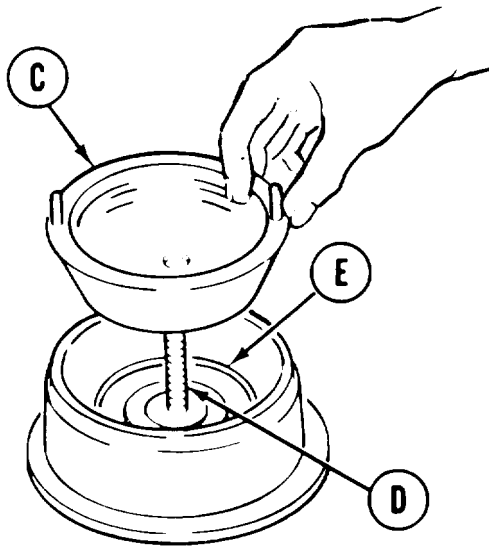

6. Screw cap (C) onto center post (D) to hold bearing (E) in position.

7. Using grease gun, pump grease into fitting (G) until resistance is felt.

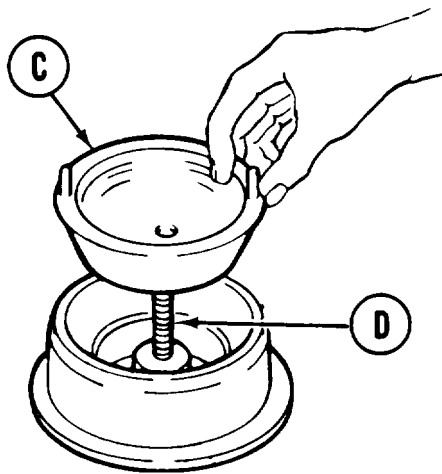
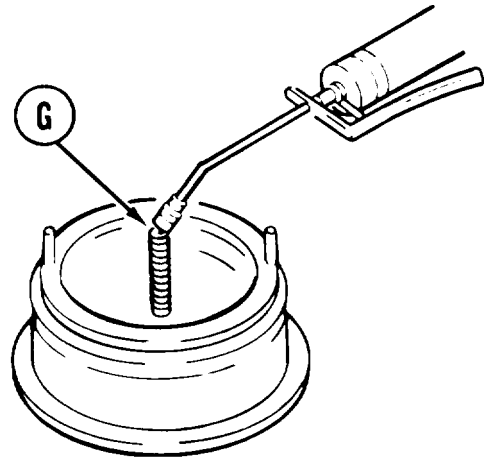

8. Unscrew cap (C) from center post (D).

9. Take insert (E) from base (B).

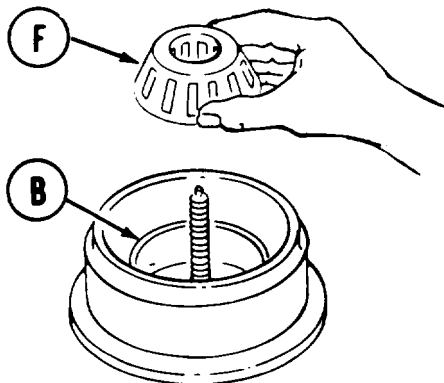
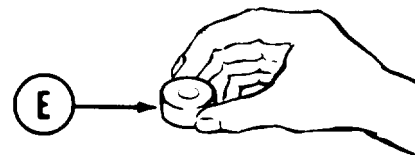

10. Remove bearing (F) from base (B).

Go on to Sheet 3

TA248922

11. Put insert (E) into base (B).

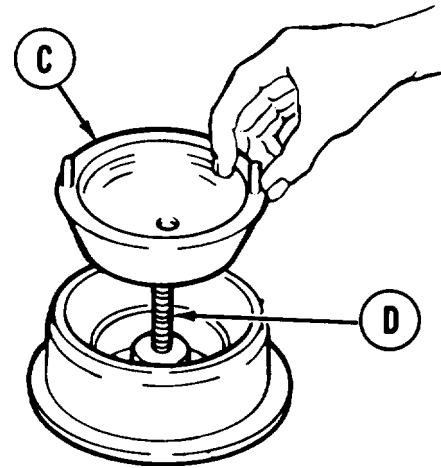
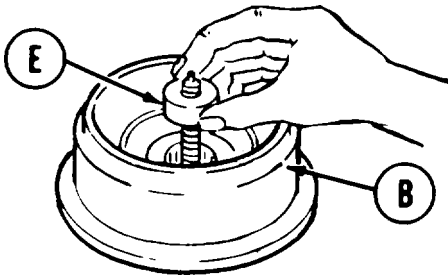

12. Screw cap (C) onto center post (D).

13. Put cover (A) onto base (B).

14. Place clean rags over bearing until ready for assembly.

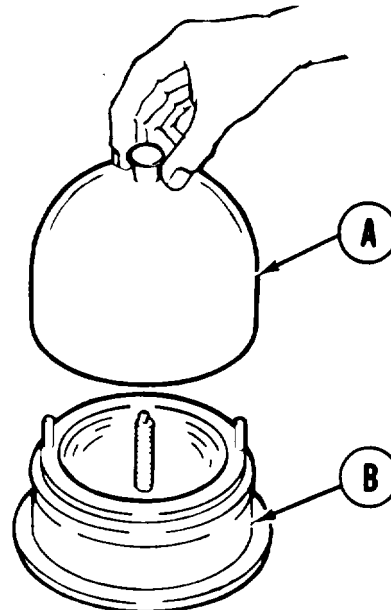

End of Task

TA248923

GENERAL MAINTENANCE (Sheet 26 of 33)

Inspection and Repair of Gears (Sheet 1 of 1)

SUPPLIES: Crocus cloth (Item 14, Appendix D)

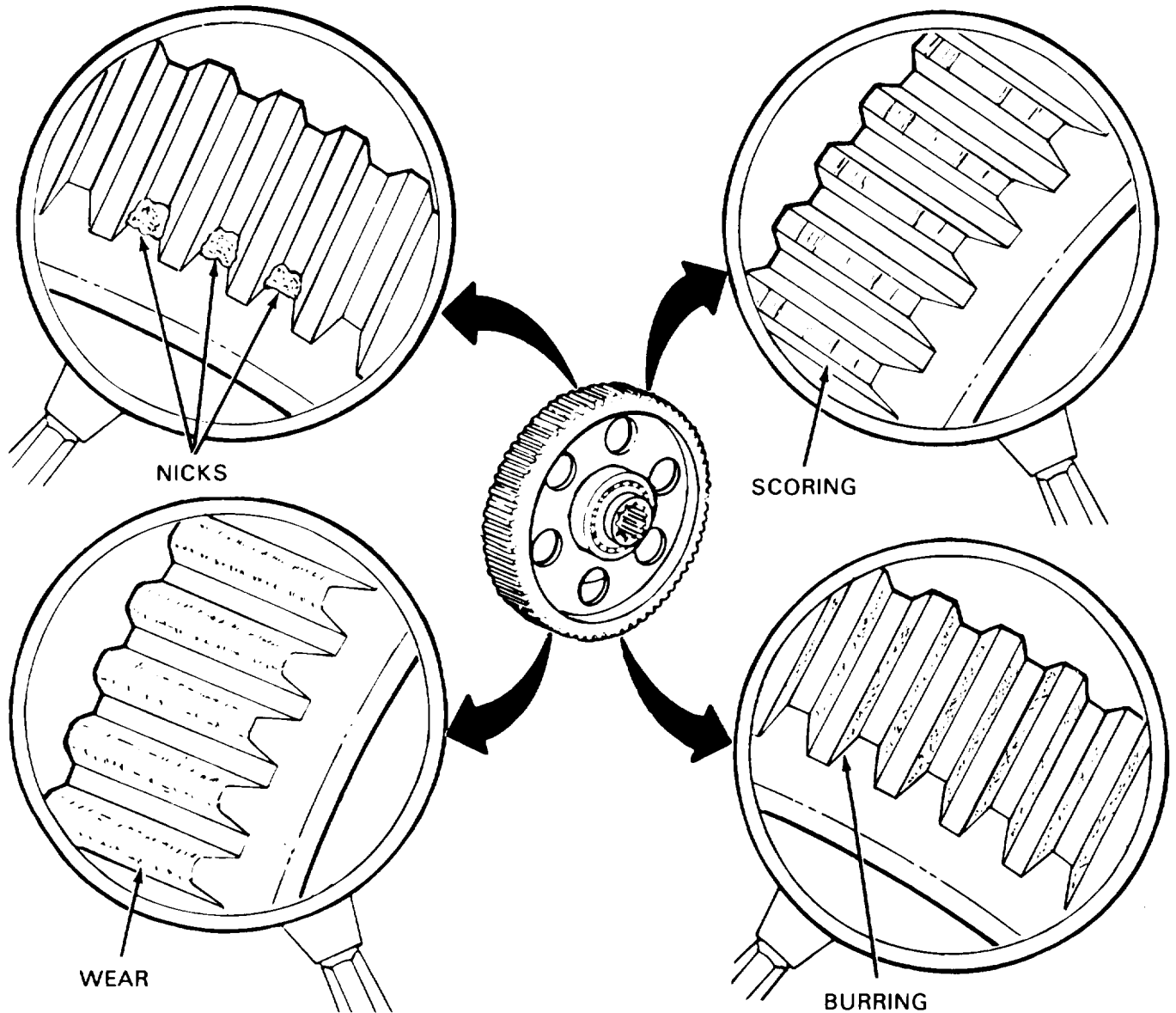

1. Check gears for wear, nicks, scoring, and burring.
2. Using crocus cloth, try to get rid of minor nicks or burring.
3. If minor nicks or burring cannot be removed with crocus cloth, or if any other damage is seen, replace gears.

End of Task

TA248924

GENERAL MAINTENANCE (Sheet 27 of 33)

Safety Wiring Procedures (Sheet 1 of 2)

NOTE

The double-twist method of safety wiring is used as the common method of safety wiring. Use the double-twist method for screws in closed geometric patterns which secure hydraulic or air seals, hold hydraulic pressure, or are used in critical areas of clutch mechanisms.

NOTE

When safety wiring widely spaced multiple groups (fastenings from 4 to 60 inches apart) by the double-twist method, three units are the maximum number that may be wired in series. When safety wiring multiple groups, the maximum number of units that may be safety wired is limited to the number that can be wired with a 24 inch length of wire.

NOTE

The single-wire method is used in a closely spaced (maximum of 2 inches between centers), closed geometric pattern (triangle, square, rectangle, circle, etc.) on parts in electrical systems and in similar places that would make the single-wire method more feasible. Use the single wire method for shear and seal wiring applications.

NOTE

Use copper wire only for securing emergency devices and install so that it can be easily broken when required.

Go on to Sheet 2

GENERAL MAINTENANCE (Sheet 28 of 33)

Safety Wiring Procedures (Sheet 2 of 2)

NOTE

Always use new lockwire.

NOTE

Drilled head bolts and screws installed with self-locking nuts or lockwashers usually do not require safety wiring.

NOTE

Do not use lockwire to secure fasteners or fittings together that are spaced more than 6 inches apart.

NOTE

Use care when installing lockwire to be sure it is tight but not overstressed.

NOTE

When safety wiring castellated nuts on drilled studs, tighten nut to low side of torque range (unless otherwise specified) and continue tightening until a slot aligns with hole.

NOTE

Safety wire drain plugs and cocks to adjacent (less than 6 inches away) bolts, nuts, or parts having a free lockhole.

NOTE

Safety wire electrical connectors which have threaded coupling rings or plugs which have screws to fasten the individual parts of the plug together. Safety wire connectors and plugs individually.

End of Task

GENERAL MAINTENANCE (Sheet 29 of 33)

Single Fastener Double-Twist Safety Wiring (Sheet 1 of 1)

TOOLS: Slip joint pliers
Diagonal cutting pliers

SUPPLIES: Lockwire

1. Using diagonal cutting pliers, cut piece of lockwire about 24 inches long.

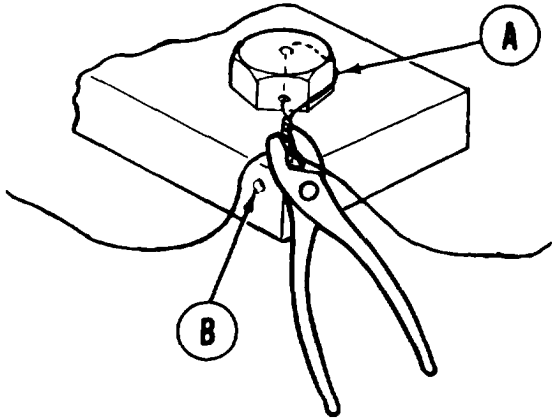

2. Run wire through drilled bolt head (A), keeping length of free wire ends the same.
3. Using slip joint pliers, twist wire until wire twist almost reaches drilled hole (B) in plate.

4. Run one leg of wire through drilled hole (B) in plate.
5. Using slip joint pliers, twist wire at least six times.
6. Using diagonal cutting pliers, cut wire leaving a pigtail from 1/4 to 1/2 inch long.

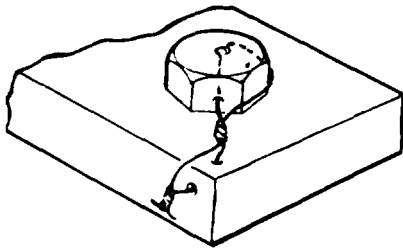
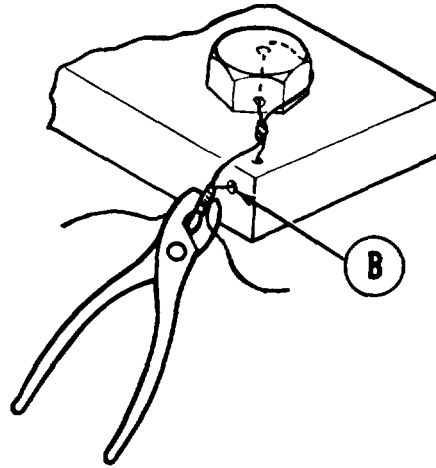

7. Bend pigtail back under to prevent it from becoming a snag.

End of Task

TA248925

GENERAL MAINTENANCE (Sheet 30 of 33)

Castellated Nuts on Undrilled Stud Double-Twist Safety Wiring (Sheet 1 of 1)

TOOLS: Slip joint pliers
Diagonal cutting pliers

SUPPLIES: Lockwire

1. Using diagonal cutting pliers, cut piece of lockwire about 24 inches long.
2. Run wire through nut (A), keeping length of free wire ends the same.
3. Using slip joint pliers, twist wire until wire twist almost reaches next nut (B).
4. Run one leg of wire through nut (B).

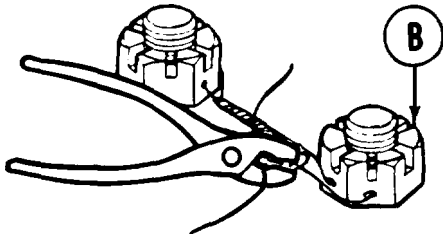
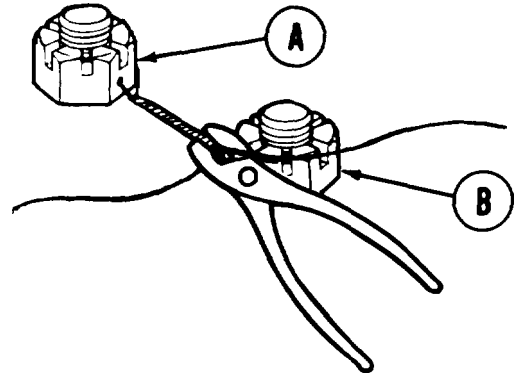

5. Using slip joint pliers, twist wire at least six times.

6. Using diagonal cutting pliers, cut wire leaving a pigtail from 1/4 to 1/2 inch long.
7. Bend pigtail back under to prevent it from becoming a snag.

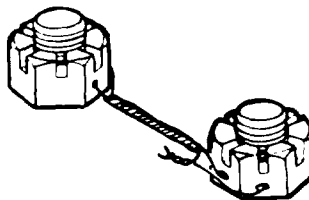

End of Task

TA248926

GENERAL MAINTENANCE (Sheet 31 of 33)

Multiple Fastener Double-Twist Safety Wiring (Sheet 1 of 1)

TOOLS: Slip joint pliers
Diagonal cutting pliers

SUPPLIES: Lockwire

1. Using diagonal cutting pliers, cut piece of lockwire about 24 inches long.

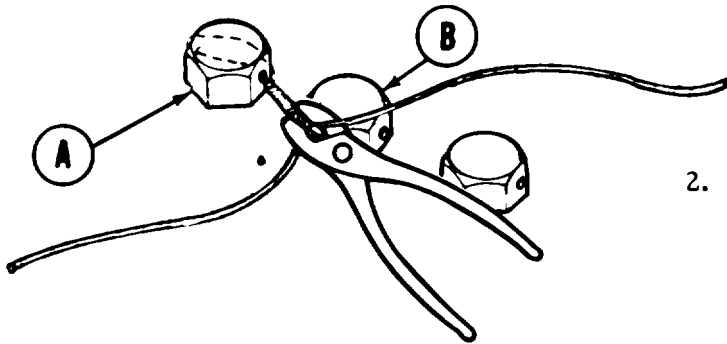

2. Run wire through drilled bolt (A), keeping length of free wire ends the same.

3. Using slip joint pliers, twist wire until wire twist almost reaches next bolt head (B).

4. Run one leg of wire through bolt head (B).

5. Using slip joint pliers, twist wire until wire twist almost reaches next bolt head (C).

6. Run one leg of wire through bolt head (C).

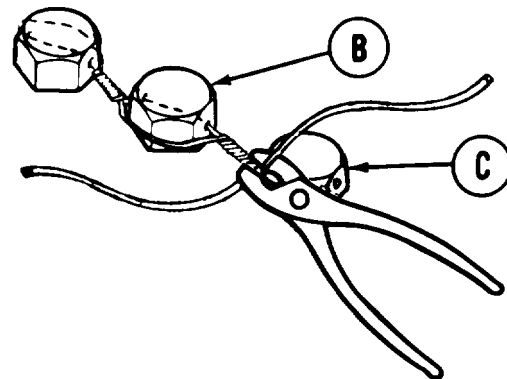

7. Using slip joint pliers, twist wire at least six times.

8. Using diagonal cutting pliers, cut wire leaving a pigtail from 1/4 to 1/2 inch long.

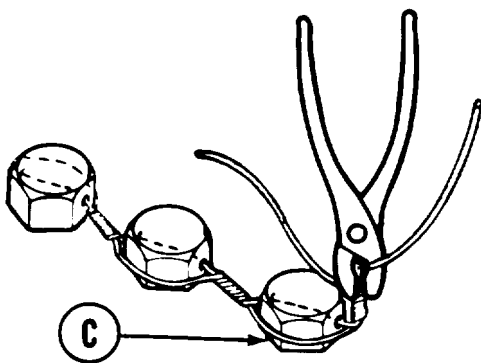

9. Bend pigtail back under to prevent it from becoming a snag.

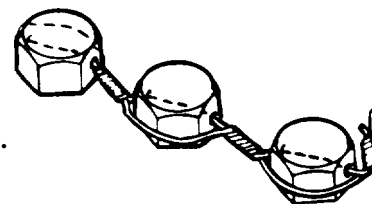

End of Task

TA248927

GENERAL MAINTENANCE (Sheet 32 of 33)

External Snap Ring Single Wire Safety Wiring (Sheet 1 of 1)

TOOLS: Slip joint pliers
Diagonal cutting pliers

SUPPLIES: Lock wire

NOTE

Do not safety wire internal snap rings.

1. Using diagonal cutting pliers, cut piece of lock wire about 12 inches long.

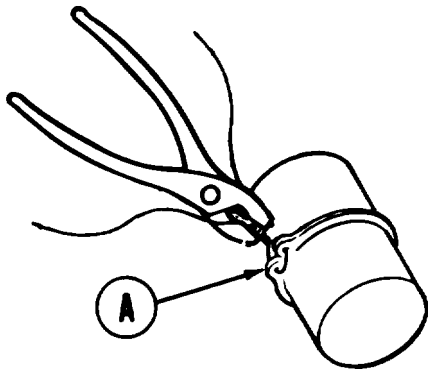

2. Run wire through two holes in external snap ring (A), keeping length of free wire ends the same.
3. Using slip joint pliers, twist wire at least six times.

4. Using diagonal cutting pliers, cut wire leaving a pigtail from 1/4 to 1/2 inch long.
5. Bend pigtail back under to prevent it from becoming a snag.

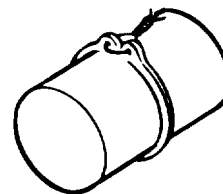

End of Task

TA248928

GENERAL MAINTENANCE (Sheet 33 of 33)

Small Screws in Closely Spaced, Closed Geometrical Pattern Single Wire Safety Wiring (Sheet 1 of 1)

TOOLS: Slip joint pliers
Diagonal cutting pliers

SUPPLIES: Lockwire

1. Using diagonal cutting pliers, cut piece of lockwire long enough to hold the screws in the pattern being wired.
2. Using slip joint pliers, run wire through nuts, leaving enough wire pigtailling from nut (A) so completed lacing may be secured by twisting.

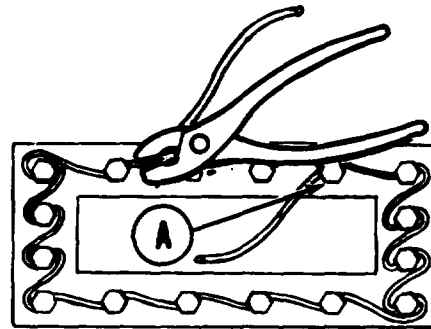
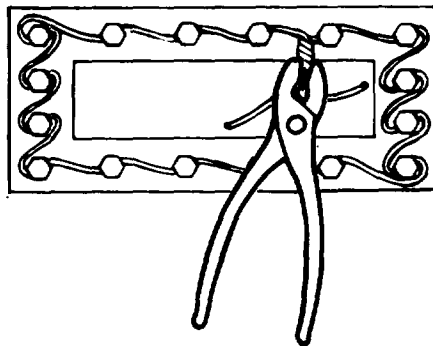

3. Using slip joint pliers, twist wire at least six times.

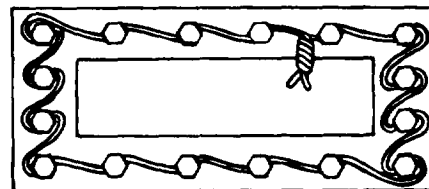

4. Using diagonal cutting pliers, cut wire leaving a pigtail from 1/4 to 1/2 inch long.
5. Bend pigtail back under to prevent it from becoming a snag.

End of Task

TA248929

APPENDIX D

EXPENDABLE SUPPLIES AND MATERIALS LIST

Section 1. INTRODUCTION

Scope.

This appendix lists expendable supplies and materials you will need to operate and maintain the M60A1 AVLB chassis. These items are authorized to you by CTA 50-970, Expendable Items (Except Medical, Class V, Repair Parts, and Heraldic Items).

Explanation of Columns.

- a. Column 1-Item Number. This number is assigned to the entry in the listing and is referenced in the narrative instructions to identify the material, e.g., use sealer compound, (Item 15, Appendix D).
- b. Column 2- Level. This column identifies the lowest level of maintenance that requires the listed item.
 - C - Operator/Crew
 - O - organizational Maintenance
 - F - Direct Support Maintenance
 - H - General Support Maintenance
- c. Column 3- National Stock Number. This is the National Stock Number assigned to the item; use it to request or requisition the item.
- d. Column 4- Description. Indicates the Federal item name and, if required, a description to identify the item. The last line for each item indicates the part number followed by the Federal Supply Code for Manufacturer (FSCM) in parentheses if applicable.
- e. Column 5- Unit of Measure (U/M). Indicates the measure used in performing the actual maintenance function. This measure is expressed by a two-character alphabetical abbreviation (e.g., ea., in., pr). If the unit of measure differs from the unit of issue, requisition the lowest unit of issue that will satisfy your requirements.

Section II. EXPENDABLE SUPPLIES AND MATERIALS LIST

ITEM	LEVEL	NATIONAL STOCK NUMBER	DESCRIPTION	U/M
1	o	8040-01-027-4900	Adhesive (MIL-A-25457)	PT
2	0	8040-00-262-9025	Adhesive (MIL-A-5092, Type II)	PT
3	0		Adhesive (MIL-A-1154)	PT
4	0	8040-00-664-4318	Adhesive (MMM-A-1617, Type II), Rubber	PT
5	0	8040-00-118-2695	Adhesive (MIL-A46146, Type I)	PT
6	0		Adhesive, Sealing (MIL-A-3562)	OZ
7	0	8040-00-149-0136	Adhesive, Silicone (SR-529)	OZ
8	0	6810-00-286-5435	Alcohol (TT-I-735, Grade A)	QT
9	0	5330-00-942-4728	Asbestos, Sheet	FT
10	0	7920-00-255-7529	Brush, Adhesive	EA
11	0	7510-00-223-6701	Chalk, White	EA
12	c	8305-00-286-5451	Cloth, Lint Free	YD

EXPENDABLE SUPPLIES AND MATERIALS LIST- Continued

ITEM	LEVEL	NATIONAL STOCK NUMBER	DESCRIPTION	U/M
13	C	6640-00-240-5851	Cloth, Soft, Lens Cleaning (NNN-P-40)	EA
14	C	5350-00-221-0872	Cloth, Crocus (P-C-458)	SH
15	O	8030-00-148-9833	Compound, Locking (MIL-S-46163, Type II, Grade N)	CC
16	O	8030-01-014-5869	Compound, Locking (MIL-S-46163, Type II, Grade O)	PT
17	O		Compound, Locking (MIL-S-46163, Type XI, Grade M)	PT
18	O		Compound, Locking (MIL-S-46164)	PT
19	O		Compound, Sealing (MIL-A-1617)	PT
20	O		Compound, Sealing (MIL-A-1617, Type II)	PT
21	O		Compound, Sealing (MIL-A-12274, Type III)	PT
22	O	9150-01-018-8960	Compound, Sealing (MIL-G-4343)	PT
23	O	8030-00-088-7818	Compound, Sealing (MIL-S-7916)	OZ
24	O	8030-00-275-8110	Compound, Sealing (MIL-S-11031)	PT
25	O	8030-00-081-2340	Compound, Sealing (MIL-S-22473, Grade AA)	PT
26	O	8030-00-081-2337	Compound, Sealing (MIL-S-22473, Grade AY)	QT
27	O	8030-00-964-7537	Compound, Sealing (MIL-S-22473, Grade C)	OZ
28	O	8030-00-081-2330	Compound, Sealing (MIL-S-22473, Grade CV)	BT
29	O	8030-00-081-2327	Compound, Sealing (MIL-S-22473, Grade E)	PT
30	O	8030-00-081-2325	Compound, Sealing (MIL-S-22473, Grade HV)	BT
31	O	8030-01-067-6198	Compound, Sealing (MIL-S-22473, Grade N, Form R)	PT
32	C	6850-00-880-7616	Compound, Silicone (MIL-S-8660)	OZ
33	O	7390-00-990-7391	Detergent, Liquid	DR
34	C	9150-00-190-0932	Fluid, Brake (VV-B-680)	GA
35	C	9150-00-265-9407	Fluid, Brake Hydraulic (MIL-H-13919) (Arctic Conditions)	QT
36	O		Fluid, Cleaning (MIL-C-8130B, Type II)	BT
37	C	9150-00-935-1017	Grease, GAA (MIL-G-10924)	LB
38	C	9150-00-965-2003	Grease, GMD (MIL-G-21164)	LB
39	O	8010-00-823-8046	Glyptol (MLL-E-22118)	OZ
40	C	9150-00-190-0932	Hydraulic Fluid, HB, Non Petroleum Base (VV-B-680)	GA
41	C	9150-00-231-2361	Lubricant (MIL-L-3150)	QT
42	O	9330-00-580-6718	Plastic Sheet	SH
43	O	9150-00-2234119	Oil, Penetrating (VV-P-216)	QT
44	O	9150-00-265-9425	Oil, Lubricating, Grade 10 (OE/HDO10) (MIL-S-2104)	QT
45	O	8030-01-041-1602	Paint, Acid Resistant, Black (MIL-P-20689)	
46	O	8030-01-041-1600	Paint, Acid, Resistant (MIL-P-22750)	QT
47	O	8010-01-050-2555	Paint, Forest Green (MIL-E-52798)	QT
48	O	8010-00-286-7725	Paint, White (TT-E-489)	QT

SECTION II. EXPENDABLE SUPPLIES AND MATERIALS LIST (Cont'd)

I T E M	L E V E L	NATIONAL STOCK NUMBER	DESCRIPTION	U/M
49	O	8030-00-963-0930	Primer (MIL-S-22743, Type T)	QT
50	O		Primer, Paint (TT-P-646)	QT
51	O	8010-00-899-0931	Primer, Zinc Chromate (TT-P-1757)	QT
52	O	5350-00-264-3489	Paper, Abrasive	SH
53	O	8040-00-426-0652	Sealant (MIL-A-46146, Type I)	OZ
54	O	8030-00-837-5885	Sealant (MIL-S-45180, Type II)	OZ
55	C	6850-00281-1985	Solvent, Dry Cleaning (PD-680, Type II, SD-2)	GA
56	C	5350-00-242-4405	Steel Wool	EA
57	C	7510-00-266-6713	Tape, Masking 1/4 inch	RL
58	C	7510-00-290-2023	Tape, Masking 1/2 inch	RL
59	C	5970-00-419-3164	Tape, Electricians (MIL-I-24391)	RL
60	O		Tubing, Heat Shrink (MIL-R-46846)	FT
61	O	9505-00-191-3680	Wire, Steel, Carbon (QQ-W-461)	RL
62	O	9505-00-248-9849	Wire, Steel, Carbon (MS-20995-F41)	RL
63	O	9505-00-293-4208	Wire, nonelectric (safety wire)	LB
64	O	8030-00-275-8110	Accelerator and Sealer (Kit)	EA
65	C	7920-00-205-1711	Rag, Wiping, Cotton, White (DDR-30 GB)	LB
66	C	4020-00-689-5688	Rope, Manila, 3/4 in. (81348) TR605	FT
67	O	3439-00-307-7333	Solder, Tin Alloy, Lead-Tin Alloy and Lead Alloy	RL
68	O		Wire, Electrical (M13486/1-3)	RL
69	O	8415-00-641-4601	Gloves, Rubber	PR
70	O	4240-00-816-3819	Goggles, Industrial	PR
71	O	7510-00-189-7881	Pencil, Wiring (SS-P-1605)	EA
72	O	7530-00-285-5836	Paper, Writing (UU-P-121)	EA
73	C	6320-00-264-8261	Flashlight (MS991/V)	EA
74	O	8040-00-851-0211	Adhesive, Loctite, 593-45	OZ
75	O	9920-00-292-9946	Cleaner Pipe	EA
76	O	8415-00-634-4658	Gloves, Leather	PR
77	O	4240-00-542-2048	Shield, Face	EA
78	O	4720-00-964-1433	Tubing, Nonmetallic	FT
79	O	8020-00-297-6657	Brush, Paint	EA
80	O	3439-00-204-2555	Brazing Alloy, Copper	LB
81	O	3439-00-255-4577	Flux, Welding	LB

APPENDIX E

SCHEMATIC DIAGRAMS

Refer to FO-1 and FO-2 in the back of this manual for the hull electrical system schematic diagrams.

APPENDIX F

ILLUSTRATED LIST OF MANUFACTURED ITEMS

This appendix includes complete instructions for making items authorized to be manufactured or fabricated at organizational maintenance.

MATERIAL		
STOCK SIZE	DESCRIPTION	FABRICATING REQUIREMENT
11 to 16 Gauge	Sheet Metal	1. Bend 90 degrees 2. Tolerance +0 -1/4 Inch

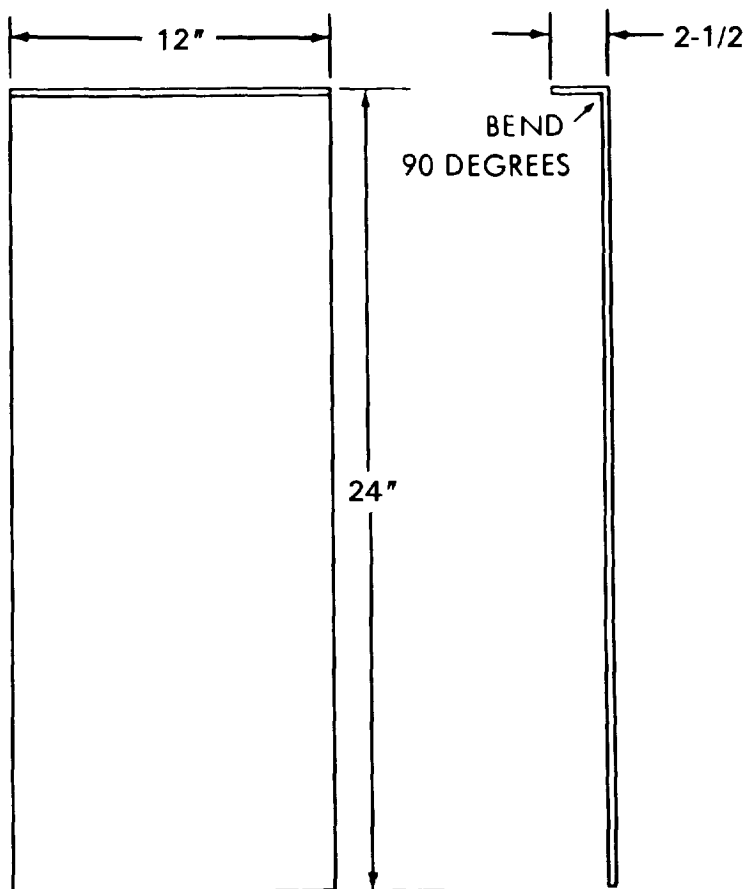

NOTE: 2 EACH REQUIRED.

Figure F-1. Final drive guide shield.

TA248933

MATERIAL		
STOCK	DESCRIPTION	FABRICATING REQUIREMENT
MS35916	Tachometer	Assembly Shaft
MS52116-1	Shaft Assembly	Assembly to Tachometer

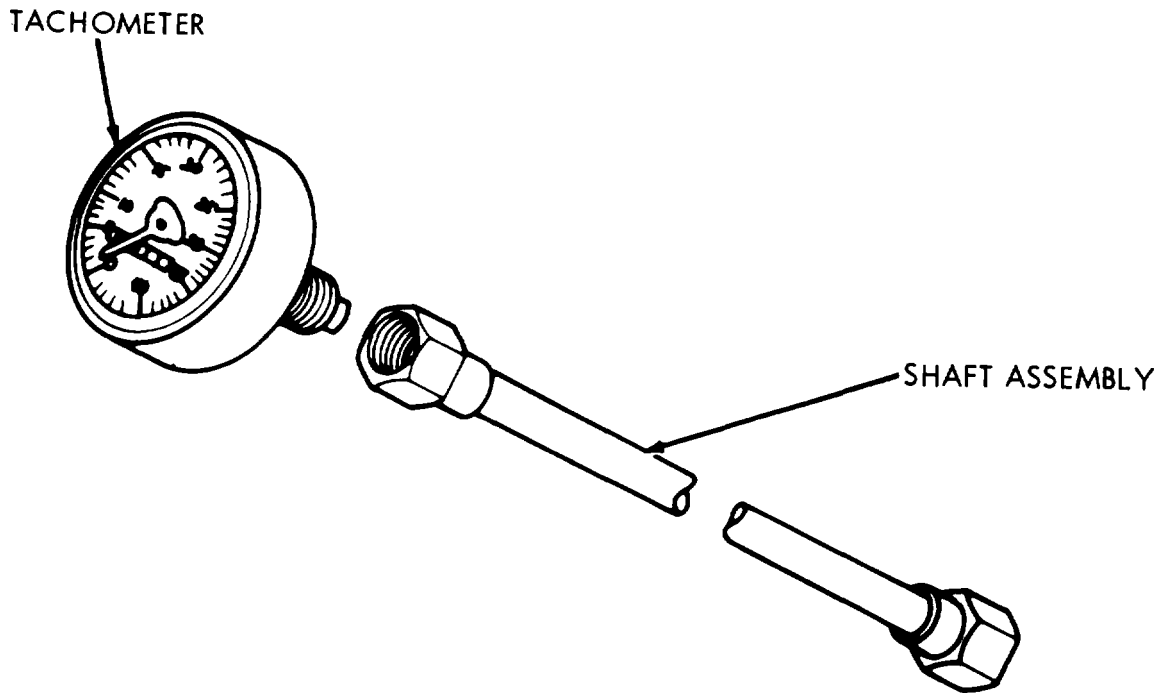

Figure F-2. Tachometer assembly.

TA248934

MATERIAL		
STOCK SIZE	DESCRIPTION	FABRICATING REQUIREMENT
1010 to 1025	Steel Rod, 3/16 in. dia.	<ol style="list-style-type: none"> 1. Grind one end as shown. 2. Bend rod as shown. 3. Remove burrs and break sharp edges. 4. Tolerance: +1/16 inch

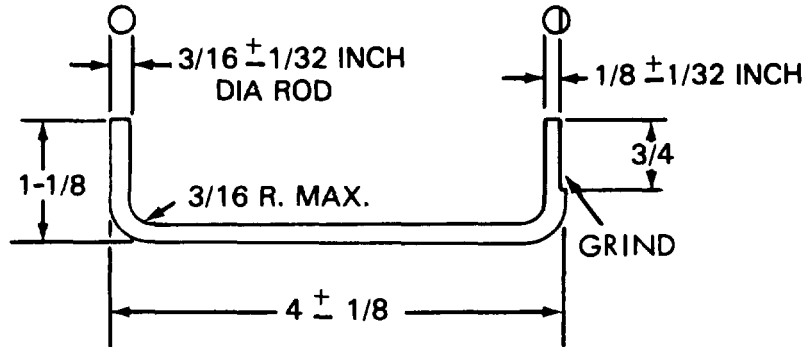

Figure F-3. Throttle linkage adjusting go-no go gage.

MATERIAL		
STOCK	DESCRIPTION	FABRICATING REQUIREMENT
P/N: 7379233 NSN: 2520-00-737-9233 NOTE: MAY BE SALVAGED FLANGE. P/N: 10904402 NSN: 2510-00-020-2331 NOTE: CLIPS MAY BE MADE FROM ANGLE IRON OR FORMED FROM 1/4" STEEL.	1 EA QUICK DISCONNECT FLANGE 6 EA DECK CLIP	1. CUT EARS OFF QUICK DISCONNECT FLANGE 1/4" OUTSIDE LIP (6.5" DIA). 2. MACHINE FLAT SIDE UNTIL TOOL THICKNESS IS APPROXIMATELY 1" TO 1-5/32". (THIS STEP OPTIONAL IF MACHINE SHOP SERVICES ARE NOT AVAILABLE.) 3. CUT RING IN THREE PLACES SO THAT EACH LARGE PIECE HAS 14 SPLINE TEETH. 4. DEBURR SPLINE TEETH EDGES WITH WIRE BRUSH OR WIRE WHEEL IF NECESSARY. 5. USING BENCH GRINDER OR EQUIVALENT, GRIND APPROXIMATELY 3" RADIUS INTO SHORT ARM OF DECK CLIP. DEBURR EDGES. 6. CUT OFF DECK CLIP TO A LENGTH OF 1-5/16". 7. IF US IN ANGLE IRON. FABRICATE GUIDE CLIPS GRIND AS IN STEP 4.

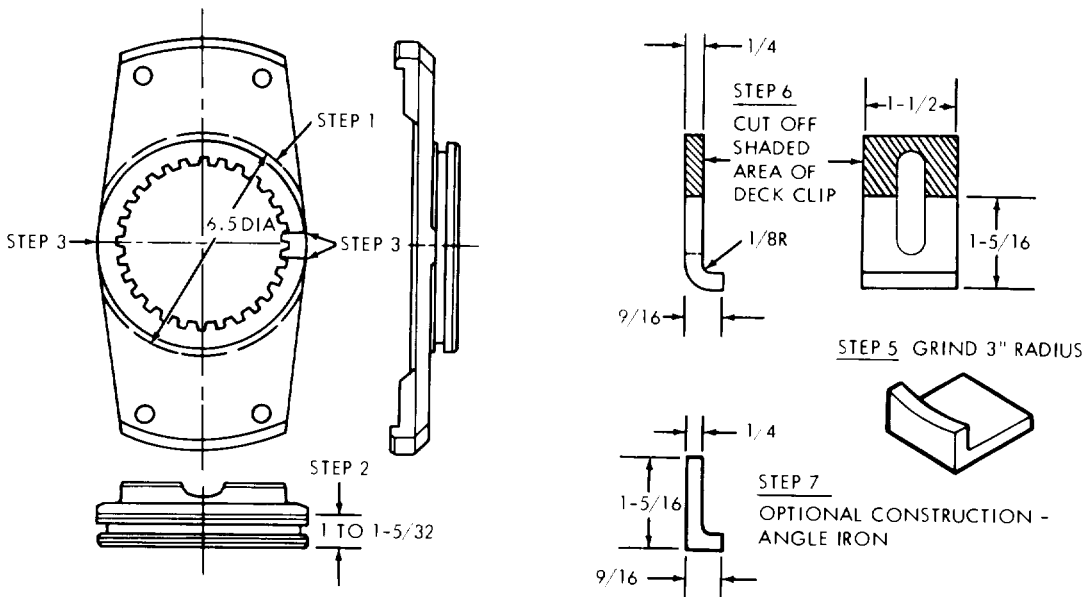

Figure F-4. Final drive adapter hook-up tool (Sheet 1 of 2).

MATERIAL		
STOCK	DESCRIPTION	FABRICATING REQUIREMENT
		<p>8. GRIND OR FILE APPROXIMATELY 1/8" OFF THE TWO INSIDE CORNERS OF THE CLIPS AT EACH END, TO AID TOOL ENGAGEMENT.</p> <p>9. WELD THREE GUIDE CLIPS TO EACH SEMI CIRCULAR FLANGE PIECE.</p> <p>NOTE THE TWO CLIPS ON THE ENDS SHOULD BE ANGLED OUT SLIGHTLY.</p> <p>10. WELD APPROXIMATELY 48" OF SMALL LINK CHAIN (WITH AN EYE AT THE FREE END) TO THE CENTER CLIP.</p>

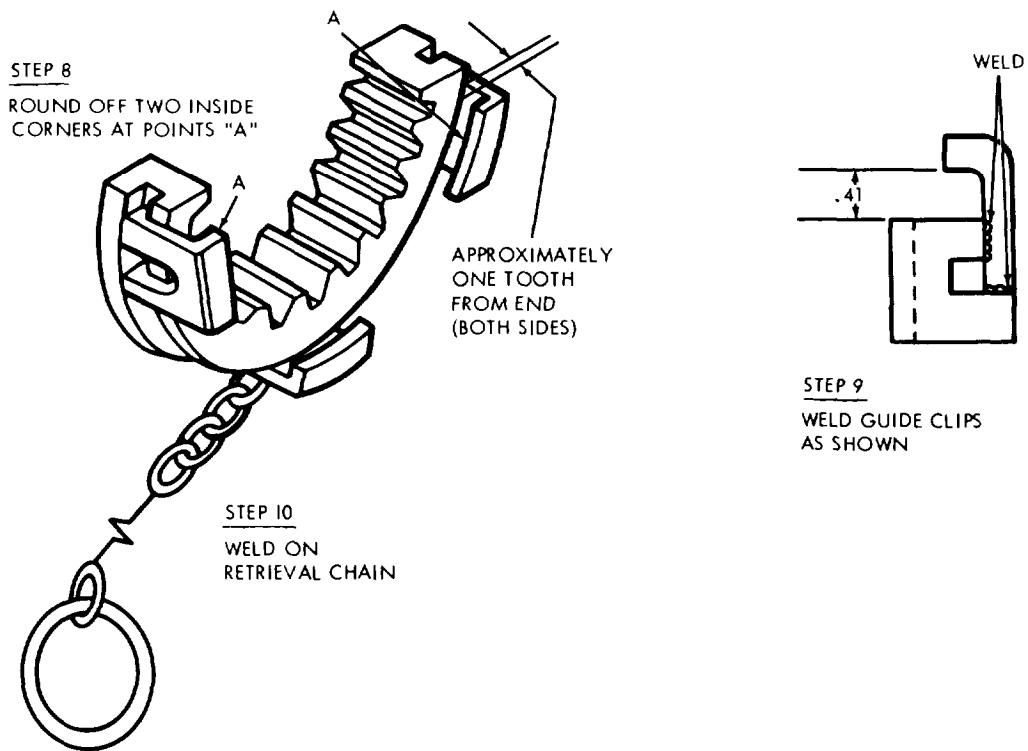

Figure F-4. Final drive adapter hook-up tool (Sheet 2 of 2).

MATERIAL		
STOCK	DESCRIPTION	FABRICATING REQUIREMENT
1010 to 1025 Steel	Bar stock: 1 x 1-1/8 x 3/4 } (New) 1 x 15/16 x 3/4 } (old) 1 x 3/16 x 3/4	1. Remove burrs and sharp edges. 2. Tolerance: $\pm 1/32$ in.

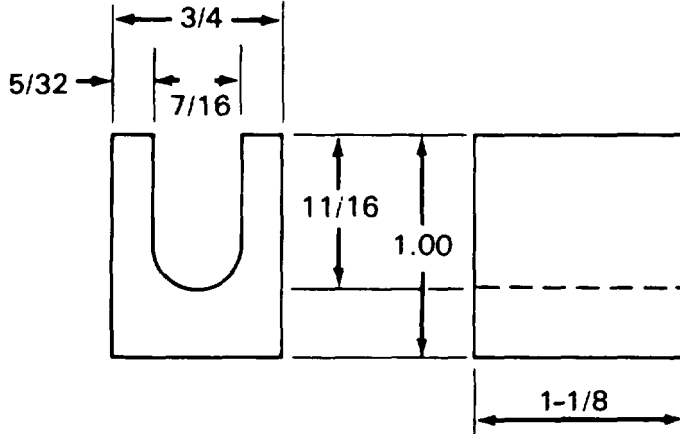

Figure F-5. Parking brake adjusting tool.

MATERIAL		
STOCK	DESCRIPTION	FABRICATING REQUIREMENT
1 x 8 N.C. 2 in. I.D. MS27183-28 5146158	A. Nut, 1-1/2 in. flats B. Pipe, 3-1/2 in. lg. C. Flat washer 1-1/4 I.D. x 2-1/2 O.D. x 3/16 in. D. Nut, 2-1/2 in. flats	Weld parts as shown.

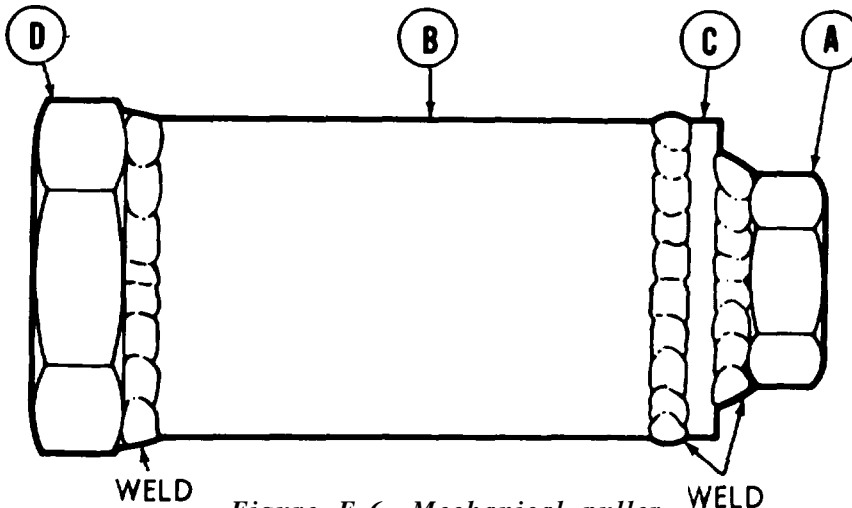

Figure F-6. Mechanical puller.

MATERIAL		
STOCK SIZE	DESCRIPTION	FABRICATING REQUIREMENT
MS3106R10SL4SC	Connector, electrical	<ol style="list-style-type: none"> 1. If using 20 ft. wire, cut in 10 ft. lengths and connect to connector. 2. If using optional wire, connect one black wire and one red wire to connector. 3. Wrap electrician's tape around both wires at connector. 4. Cut two 3 inch long pieces of heat shrink tubing and slide one piece onto each wire. 5. Solder one lug terminal to each wire. 6. Connect lug terminals to power clips with screws and bend ears of power clips over wires. 7. Slide heat shrink tubing onto power clip connection and using heat gun, shrink tubing.
M1348611-3	Wire, black, electrical 16 ga., 20 ft. lg	
(OPT) M227591/1616-0	Wire, black, electrical 16 ga., 10 ft. lg	
(OPT) M22759/16-16-2	Wire, red, electrical 16 ga., 10 ft. lg	
(OPT) M81044/12-16-0	Wire, black, electrical 16 ga., 10 ft. lg	
(OPT) M81044/12-16-2	Wire, red, electrical 16 ga., 10 ft. lg	
W-C-440B Type PC4	Power clip (2 required)	
8/32 UNC-2A X 1/4 lg	Screw (2 required)	
MILR-46846, Type V 7056709	Heat shrink tubing, 1 ft. lg Lug Terminal	
NSN 3439-00-307-7333	Solder (Item 67, Appendix D)	
NSN 5970-00-419-3164	Electricians tape (Item 59, Appendix D)	

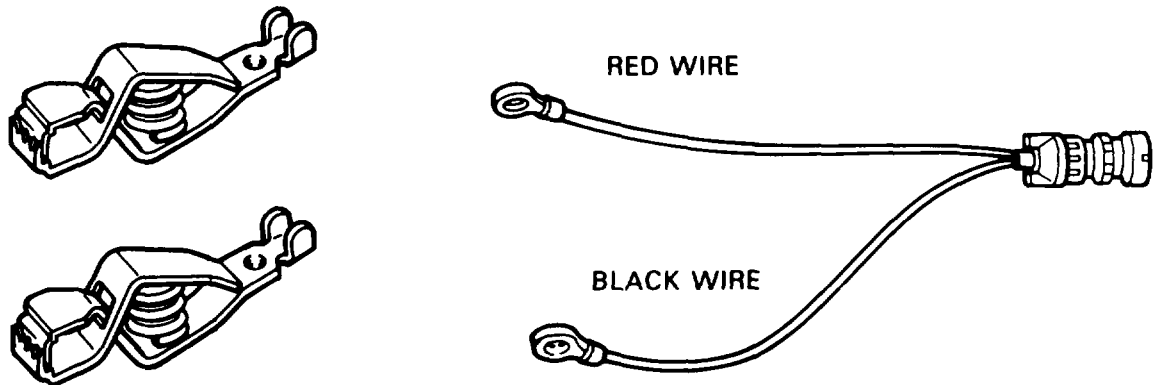

Figure F-7. Fuel- Water Separator Test Cable

TA248939

MATERIAL		
STOCK	DESCRIPTION	FABRICATING REQUIREMENT
M13486/1-3	Wire, electrical 16 gage, 3-5 ft. lg	<ol style="list-style-type: none"> 1. Cut heat shrink tubing into two equal lengths and slide onto wire. 2. Solder lug terminals to each end of wire. 3. Connect lug terminals to power clips with screws, Bend tabs of power clips over wire. 4. Shrink tubing over ends of lug terminal and wire connections.
W-C-440B Type PC4	Power clip (2 required)	
7056709	Lug Terminal (2 required)	
8/32 UNC-2A X 1/4 lg.	Screw (2 required)	
NSN 3439-00-307-7333	Solder (Item 67, Appendix D)	
MIL-R-46846, Type V	Heat shrink tubing, 6 in. lg (Item 60, Appendix D)	

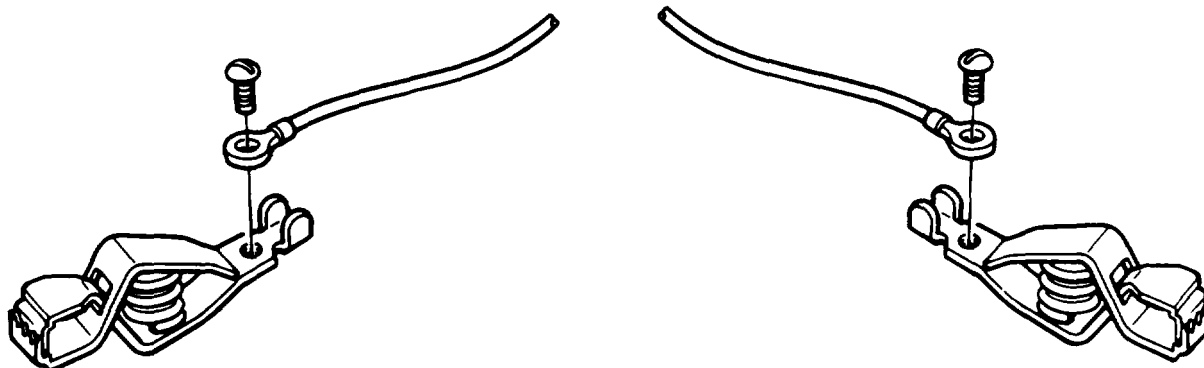

Figure F-8. Fuel-Water Separator Test Cable

TA248940

MATERIAL		
STOCK	DESCRIPTION	FABRICATING REQUIREMENTS
5120-00-293-3509	Center punch	Grind point as shown.

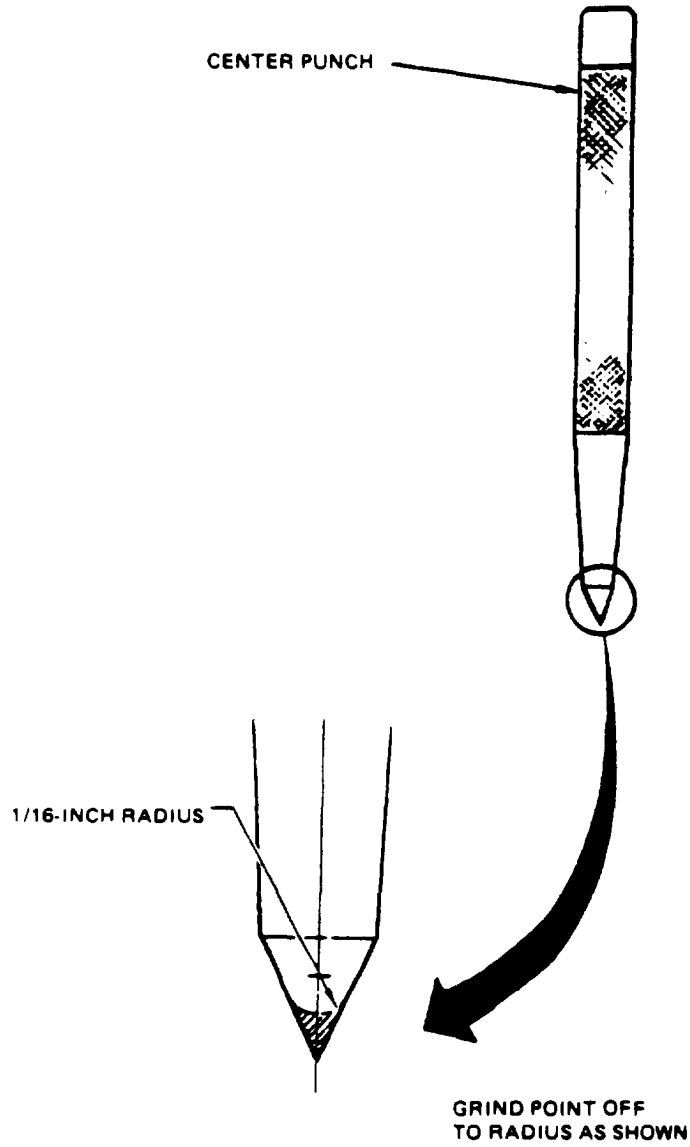

Figure F-9. Center Punch

ALPHABETICAL INDEX

Subject, Page

Subject, Page

A

Acceleration Control Rod, 7-308
 Cleaning and Inspection, 7-310
 Installation, 7-311
 Removal, 7-308
 Accelerator Linkage Adjustment, 7-300
 Accelerator Linkage Bulkhead Flange,
 7-324
 Installation, 7-325
 Removal, 7-324
 Accelerator Linkage Engine Control, 7-322
 Cleaning and Inspection, 7-323
 Installation, 7-323
 Removal, 7-322
 Accelerator Pedal Assembly, 7-306
 Installation, 7-307
 Removal, 7-306
 Accelerator Pedal Return Spring Adjustment,
 7-298
 Accelerator Throttle Linkage, 7-313
 Cleaning and Inspection, 7-317
 Installation, 7-318
 Removal, 7-313
 Accessories Wiring Harness (Master Control
 Panel), 10-91
 Air Cleaner, 7-88
 Installation, 7-92
 Removal, 7-88
 Accessory Harness, Front, 10-296.88
 Installation, 10-296.95
 Removal, 10-296.88
 Accessory Wiring, Rear, 10-296.18
 Installation, 10-296.22
 Remove, 10-296.19
 Air Cleaner (Aluminum) Centrifugal Fan Cover
 and Gasket, 7-106
 Installation, 7-108
 Removal, 7-106
 Air Cleaner (Armored) Centrifugal Fan Cover
 and Gasket, 7-103
 Installation, 7-105
 Removal, 7-103

A - continued

Air Cleaner (Aluminum) Centrifugal Fan,
 7-120
 Installation, 7-122
 Removal, 7-120
 Air Cleaner (Armored) Centrifugal Fan,
 7-111
 Installation, 7-114
 Removal, 7-111
 Air Cleaner Centrifugal Fan Ground Lead,
 7-126
 Installation, 7-127
 Removal, 7-126
 Air Cleaner (Aluminum) Centrifugal Fan Hose,
 7-110
 Installation, 7-110
 Removal, 7-110
 Air Cleaner (Armored) Centrifugal Fan Hose,
 7-109
 Installation, 7-109
 Removal, 7-109
 Air Cleaner (Aluminum) Centrifugal Fan Power
 Lead, 7-80
 Installation, 7-82
 Removal, 7-80
 Air Cleaner (Armored) Centrifugal Fan Power
 Lead, 7-77
 Installation, 7-79
 Removal, 7-77
 Air Cleaner (Aluminum) Circuit Breaker,
 7-125
 Installation, 7-125
 Removal, 7-125
 Air Cleaner (Armored) Circuit Breaker,
 7-124
 Installation, 7-124
 Removal, 7-124
 Air Cleaner Door, 7-128
 Installation, 7-129
 Removal, 7-128

Subject, Page

A - continued

Air Cleaner Filter Element Cleaning or Replacement, 7-96
 Cleaning and Inspection, 7-98
 Installation, 7-99
 Removal, 7-96
 Air Cleaner Intake and Hose, 7-65
 Installation, 7-68
 Removal, 7-65
 Air Cleaner Intake Elbow, 7-71
 Installation, 7-73
 Removal, 7-71
 Air Cleaner Manifold and Gasket, 7-130.1
 Installation, 7-130.2
 Removal, 7-130.1
 Air Cleaner Manifold and Related Parts 7-130.3
 Installation, 7-130.5
 Removal, 7-130.4
 Air Cleaner Motor Solenoid Relay, 10-163
 Installation, 10-164
 Removal, 10-163
 Air Cleaner Outlet Elbow, 7-101
 Installation, 7-102
 Removal, 7-101
 Air Cleaner Outlet Hose, 7-84
 Inspection, 7-85
 Installation, 7-86
 Removal, 7-84
 Air Cleaner Plug, 7-70
 Installation, 7-70
 Removal, 7-70
 Air Cleaner Restriction Indicator (Left or Right), 7-87
 Installation, 7-87
 Removal, 7-87
 Air Cleaner Turbocharger Elbow, 7-74
 Installation, 7-76
 Removal, 7-74
 Air Pressure Hose Assemblies, 7-130.16
 Installation, 7-130.17
 Removal, 7-130.16

Subject, Page

B

Basket Harness, Heater, 10-296.52
 Installation, 10-296.55
 Removal, 10-296.53
 Basket Wiring Harness, 10-296.69
 Installation, 10-296.71
 Removal, 10-296.70
 Basket/Control Panel Accessories Harness, 10-296.34
 Installation,, 10-296.37
 Removal, 10-296.34
 Basket/Control Panel Power Harness, 10-296.25
 Installation,, 10-296.27
 Removal, 10-296.25
 Basket/Control Panel Heater Harness, 10-296.48
 Installation,, 10-296.50
 Removal, 10-296.48
 Basket/Control Panel Starting Harness, 10-296.29
 Installation,, 10-296.32
 Removal, 10-296.29
 Basket/Gage Indicator Panel Harness, 10-296.57
 Installation, 10-296.60
 Remove, 10-296.57
 Basket/Light Switch Harness, 10-296.39
 Installation,, 10-296.44
 Removal, 10-296.40
 Battery and Battery Cover, 10-253
 Installation, 10-256
 Removal, 10-253
 Battery Generator Indicator (Cluster Assembly), 10-117
 Battery Ground Strap, 10-263
 Installation, 10-266
 Removal, 10-263
 Battery Jumper Cable Assembly, 10-245
 Installation, 10-248
 Removal, 10-245
 Battery Terminal Lug, 10-251
 Installation, 10-252
 Removal, 10-251
 Battery Testing, 10-258

Subject, Page

B - continued

Bell Crank, 13-128
 Installation, 13-130
 Removal, 13-128
 Bilge Pump Switch and Indicator Light (Master Control Panel), 10-66
 Installation, 10-68
 Removal, 10-66
 Blackout Selector Switch (Master Control Panel), 10-58
 Installation, 10-59
 Removal, 10-58
 Bleed Hydraulic Brake System, 13-86
 Bracket Assembly (Shifting), 11-40
 Assembly, 11-40
 Disassembly, 11-40
 Brakes Adjustment, 13-78
 Brake Control Housing, 13-64
 Cleaning and Inspection, 13-70
 Installation, 13-70
 Removal, 13-64
 Brake Foot Pedal Lever Mounting Bracket, 13-11
 Cleaning and Inspection, 13-13
 Installation, 13-14
 Removal, 13-11
 Brake Left Hand Slave Cylinder and Tube Assembly, 13-54
 Cleaning and Inspection, 13-56
 Installation, 13-56
 Removal, 13-54
 Brake Master Cylinder, 13-2
 Cleaning and Inspection, 13-6
 Installation, 13-7
 Removal, 13-2
 Brake Pedal Adjustment, 13-17
 Brake Pressure Gage Tube Assembly, Reducer and Gasket, 13-35
 Cleaning and Inspection, 13-38
 Installation, 13-39
 Removal, 13-35

Subject, Page

B - continued

Brake Quick-Disconnect and Hose Assembly, 13-47
 Cleaning and Inspection, 13-50
 Installation, 13-50
 Removal, 13-47
 Brake Right Hand Slave Cylinder and Tube Assembly, 13-58
 Cleaning and Inspection, 13-60
 Installation, 13-61
 Removal, 13-58
 Brake Switch (Stoplight), 13-31
 Cleaning and Inspection, 13-32
 Installation, 13-33
 Removal, 13-31
 Breather Line, 7-153
 Inspection, 7-155
 Installation, 7-156
 Removal, 7-153
 Bulkhead Access Cover, 17-2
 Installation, 17-3
 Removal, 17-2
 Bulkhead Cable Disconnect, 10-269
 Installation, 10-270
 Removal, 10-269
 Bulkhead Pipe Plug, 17-17
 Installation, 17-17
 Removal, 17-17
 Bulkhead PTO Ring, 17-15
 Installation, 17-15
 Removal, 17-15

C

Cable Assembly, Power Relay, 10-296.13
 Installation, 10-296.15
 Remove, 10-296.13
 Cap Assembly, 8-14
 Installation, 8-16
 Removal, 8-14
 Centrifugal Fan Housing, 9-64
 Installation, 9-65
 Removal, 9-64

Subject, Page

C - continued

Check Valve (Manifold Heater - Return Fuel),
7-263
 Cleaning and Inspection, 7-264
 Installation, 7-265
 Removal, 7-263
Circuit Breaker Replacement (Master Control
Panel), 10-70
 Installation, 10-71
 Removal, 10-70
Commander's Floor Plate, 17-7
 Installation, 17-7
 Removal, 17-7
Commander's Seat Backrest, 17-53
 Installation, 17-53
 Removal, 17-53
Compensating Idler Arm Assembly, 14-65
 Assembly, 14-67
 Cleaning and Inspection, 14-67
 Disassembly, 14-65
Compensating Idler Hub and Arm, 14-62
 Installation, 14-64
 Removal, 14-62
Compensating Idler Wheel and Roadwheel,
14-50
 Cleaning and Inspection, 14-53
 Installation, 14-53
 Removal, 14-50
Condensate Relief Valve (Left or Right),
7-131
 Cleaning and Inspection, 7-132
 Installation, 7-132
 Removal, 7-130
Connecting Link (Steering), 15-24
 Installation, 15-25
 Removal, 15-24
Control Panel Accessories Harness, Basket,
10-296.34
 Installation,, 10-296.37
 Removal, 10-296.34
Control Panel Harness, Power/Master,
10-296.73
 Installation, 10-296.77
 Removal, 10-296.74

Subject, Page

C - continued

Control Panel Heater Harness, Basket,
10-296.48
 Installation,, 10-296.50
 Removal, 10-296.48
Control Panel Power Harness, Basket,
10-296.25
 Installation,, 10-296.27
 Removal, 10-296.25
Control Panel Starting Harness, Basket,
10-296.29
 Installation,, 10-296.32
 Removal, 10-296.29
Control Valve Assembly, 20-50
 Assembly, 20-51
 Disassembly, 20-50
Cooling Fan Shroud, 9-47
 Installation, 9-51
 Removal, 9-47
Cover Assembly (Escape Hatch) (Early Model),
16-42
 Assembly, 16-46
 Cleaning and Inspection, 16-46
 Disassembly, 16-45
 Installation, 16-43
 Removal, 16-42
Cover Assembly (Escape Hatch) (Late Model),
16-35
 Adjustment, 16-49
 Assembly, 16-39
 Cleaning and Inspection, 16-39
 Disassembly, 16-37
 Installation, 16-36
 Removal, 16-35
Crankcase Breather Tee and Rear Tube,
6-97
 Installation, 6-100
 Removal, 6-98
Cylinder Head and Oil Pan Drain Tubes (Left
and Right), 6-135
 Installation, 6-137
 Removal 6-135

Subject, Page

D

Disconnect Battery Ground Straps, 10-268
 Connect, 10-268

Domelight Assembly, 10-191
 Assembly, 10-197
 Disassembly, 10-193
 Installation, 10-192
 Removal, 10-191

Domelight Resistor Assembly, 10-201
 Installation, 10-202
 Removal, 10-201

Domelight Resistor Assembly Bracket, 10-203
 Installation, 10-203
 Removal, 10-203

Drain Engine Oil, 6-12

Draining Fuel Tanks, 7-206

Dust Detector Engine Wiring Harness, 10-298
 Installation, 10-298.4
 Removal, 10-298.1

Dust Detector Filter Strip and Cover, 7-130.11
 Installation, 7-130.13
 Removal, 7-130.11

Dust Detector Filter Strip, Service, 7-130.14

Dust Detector Hull Intermediate Lead Assembly, 10-298.8
 Installation, 10-298.10
 Removal, 10-298.8

Dust Detector Operational Test, 10-298.17

Dust Detector Pressure Switch and Bracket, 7-130.7
 Installation, 7-130.9
 Removal, 7-130.7

Dust Detector Warning Light Box Assembly and Mounting Bracket, 10-298.14
 Installation, 10-298.15
 Removal, 10-298.14

Subject, Page

D - continued

Dust Detector Warning Light Harness Assembly, 10-298.12
 Installation, 10-298.13
 Removal, 10-298.12

E

Electrical Wiring Harness and Cable Connector Repair, 10-298.20

Electrical Wiring Harness and Cable Connector Repair, 10-298

Engine Access Covers (Left Bank), 6-112
 Installation, 6-115
 Removal, 6-112

Engine Access Covers (Right Bank), 6-107
 Installation, 6-110
 Removal, 6-107

Engine Access Panel Seal, 16-31
 Installation, 16-32
 Removal, 16-31

Engine Accessory Relay, HEU, 10-166.1
 Installation, 10-166.1
 Removal, 10-166.1

Engine Compartment Discharge Manifold, 20-81
 Installation, 20-83
 Removal, 20-81

Engine Cooling Fan, 9-55
 Installation, 9-57
 Removal, 9-55

Engine Disconnect Wiring Harness, 10-296.7
 Installation, 10-296.10
 Removal, 10-296.7

Engine Fuel Injection Pump: Fuel Shutoff Lead, 10-28
 Installation, 10-31
 Removal, 10-28

Engine Fuel Pump, 7-37
 Cleaning and Inspection, 7-38
 Installation, 7-39
 Removal, 7-37

Subject, Page

E - continued

Engine Fuel Return Hose Assembly (Left Side), 7-167
 Installation, 7-168
 Removal, 7-167
 Engine Fuel Return Hose, 7-169
 Installation, 7-170
 Removal, 7-169
 Engine Fuel Return Tube, 7-234
 Installation, 7-235
 Removal, 7-234
 Engine Fuel Return Selector Cock, 7-163
 Inspection, 7-165
 Installation, 7-165
 Removal, 7-163
 Engine Fuel Return Tube Assembly, 7-294
 Installation, 7-296
 Removal, 7-294
 Engine Fuel Shutoff and Fuel Pump Switch (Master Control Panel), 10-47
 Installation, 10-48
 Removal, 10-47
 Engine Generator, 10-6
 Installation, 10-10
 Removal, 10-6
 Engine Generator Regulator, 10-18
 Installation, 10-19
 Removal, 10-18
 Engine Generator Regulator Mounting Bracket, 10-20
 Installation, 10-20
 Removal, 10-20
 Engine High Oil Pressure Transmitter, 10-221
 Installation, 10-223
 Removal, 10-221
 Engine Idle Adjustment, 7-297
 Engine Low Oil Pressure Switch, 10-242
 Installation, 10-243
 Removal, 10-242
 Engine Lower Access Cover, 17-13
 Installation, 17-14
 Removal, 17-13
 Engine Mounts (Left and Right), 6-5
 Installation, 6-7
 Removal, 6-5

Subject, Page

E - continued

Engine Oil Cooler (Left and Right), 6-19
 Installation, 6-22
 Removal, 6-19
 Engine Oil Cooler Bypass Valve Assembly, 6-55
 Installation, 6-56
 Removal, 6-55
 Engine Oil Cooler Fluid Pump Connector, 6-57
 Installation, 6-59
 Removal, 6-57
 Engine Oil Cooler Screen, 6-51
 Installation, 6-52
 Removal, 6-51
 Engine Oil Coolers - Cleaning, 6-48
 Engine Oil Filter Cap, 6-81
 Installation, 6-83
 Removal, 6-81
 Engine Oil Filter Element, 6-76
 Installation, 6-79
 Removal, 6-76
 Engine Oil High Temperature Thermostatic Switch, 10-219
 Installation, 10-220
 Removal, 10-219
 Engine Oil Pressure Indicator (Cluster Assembly), 10-115
 Engine Oil Temperature Indicator (Cluster Assembly), 10-123
 Engine Oil Temperature Transmitter, 10-224
 Installation, 10-225
 Removal, 10-224
 Engine Regulator, HEU, 10-20.1
 Installation, 10-20.2
 Removal, 10-20.1
 Engine Shroud, 9-30
 Installation, 9-31
 Removal, 9-30
 Engine Shroud Repair Off Engine, 9-32
 Assembly, 9-33
 Disassembly, 9-32
 Engine Shroud Repair on the Engine, 9-34
 Assembly, 9-36
 Disassembly, 9-34

Subject, Page

E - continued

Engine Shroud Support, 9-39
 Installation, 9-40
 Removal, 9-39
 Engine Starter Wiring Harness, 10-274
 Installation, 10-277
 Removal, 10-274
 Engine Upper Access Cover, 17-11
 Installation, 17-12
 Removal, 17-11
 Engine Wiring Harness, 10-286
 Installation, 10-292
 Removal, 10-286
 Equipment Description and Data, 1-2
 Exhaust Doors, 16-17
 Installation, 16-19
 Removal, 16-17
 Exhaust Pipe (Left Side), 8-5
 Installation, 8-7
 Removal, 8-5
 Exhaust Pipe (Right Side), 8-9
 Installation, 8-11
 Removal, 8-9
 Exhaust Pipe Cap Assembly, 8-2
 Installation, 8-4
 Removal, 8-2
 Exterior Release Handle Body Assembly
 Repair, 20-43
 Assembly, 20-43
 Disassembly, 20-43
 Exterior Release Handle Body Assembly,
 20-39
 Installation, 20-41
 Removal, 20-39
 Exterior Release Handle Mounting Bracket,
 20-48
 Installation, 20-49
 Removal, 20-48

F

Fan Drive Oil Seal, 9-59
 Installation, 9-61
 Removal, 9-59

Subject, Page

F - continued

Fender and Shield (Rear), 16-69
 Installation, 16-72
 Removal, 16-69
 Fender Extension (Left), 16-65
 Inspection, 16-66
 Installation, 16-67
 Removal, 16-65
 Fender Support No. 3 (Left and Right), 16-50
 Cleaning and Inspection, 16-52
 Installation, 16-52
 Removal, 16-50
 Fender Support No. 4 (Left and Right), 16-54
 Cleaning and Inspection, 16-56
 Installation, 16-56
 Removal, 16-54
 Final Drive Adapter Assembly and Oil Seal,
 12-7
 Installation, 12-8
 Removal, 12-7
 Final Drive Air Pressure Relief Valve (Left
 and Right), 12-6
 Installation, 12-6
 Removal, 12-6
 Final Drive Magnetic Plug, 12-9
 Installation, 12-9
 Removal, 12-9
 Final Drive Stud, 12-10
 Installation, 12-11
 Removal, 12-10
 Fire Extinguisher Relay and Master Relay
 Circuit Breaker, 10-141
 Installation, 10-142
 Removal, 10-141
 Fire Extinguisher Solenoid
 Relay, 10-158
 Installation, 10-159
 Removal, 10-158
 Fixed Fire Extinguisher Control Valve, 20-2
 Assembly, 20-8
 Cleaning and Inspection, 20-8
 Disassembly, 20-5
 Installation, 20-14
 Removal, 20-2

Subject, Page

F - continued

Fixed Fire Extinguisher (Cylinder) 20-52
 Installation, 20-55
 Removal, 20-52
 Fixed Fire Extinguisher Delay Bottle and
 Tubes, 20-56
 Installation, 20-59
 Removal, 20-56
 Fixed Fire Extinguisher Interior Release
 Mechanism Control Assembly, 20-16
 Installation, 20-20
 Removal, 20-16
 Fixed Fire Extinguisher Interior Release
 Mechanism and Mounting Bracket, 20-23
 Installation, 20-25
 Removal, 20-23
 Fixed Fire Extinguisher Outside Release
 Handle Control Assembly, 20-44
 Installation, 20-46
 Removal, 20-44
 Fixed Fire Extinguisher Manifold, 20-63
 Installation, 20-64
 Removal, 20-63
 Fixed Fire Extinguisher Mounting Bracket
 Repair, 20-62
 Assembly, 20-62
 Disassembly, 20-62
 Floor Forward Access Covers, 17-5
 Installation, 17-6
 Removal, 17-5
 Forward Inboard Bell Crank Assembly,
 11-16
 Installation, 11-17
 Removal, 11-16
 Forward Outboard Lever Assembly, 11-18
 Installation, 11-19
 Removal, 11-18
 Front Accessory Harness, 10-296.88
 Installation, 10-296.95
 Removal, 10-296.88
 Front Drain Valve Assembly, 17-19
 Cleaning and Inspection, 17-21
 Installation, 17-21
 Removal, 17-19

Subject, Page

F - continued

Front Drain Valve Control Lever, 17-18
 Installation, 17-18
 Removal, 17-18
 Front Fender (Center, Left and Right) Stowage
 Box, 16-76
 Assembly, 16-79
 Disassembly, 16-79
 Installation, 16-77
 Removal, 16-76
 Front Fender (Center, Left and Right) Stowage
 Box Cover, 16-80
 Assembly, 16-82
 Cleaning and Inspection, 16-82
 Disassembly, 16-80
 Front Fenders, Headlight Guards, Fender
 Support, 16-58
 Installation, 16-62
 Removal, 16-58
 Front Harness, HEU, 10-296.102
 Installation, 10-296.106
 Removal, 10-296.102
 Front Powerplant Guide (Left or Right)
 Replacement, 6-4
 Installation, 6-4
 Removal, 6-4
 Front Steering Control Tube, 15-13
 Installation, 15-15
 Removal, 15-13
 Fuel Backflow Valve, 7-25
 Cleaning and Inspection, 7-27
 Installation, 7-27
 Removal, 7-25
 Fuel Filler Cover Assembly, 16-8
 Installation, 16-9
 Removal, 16-8
 Fuel Inlet Fluid Pressure Filter Repair,
 7-243
 Assembly, 7-244
 Disassembly, 7-243
 Fuel Injection Pump Inlet to Bulkhead Elbow
 Tube Assembly, 7-29
 Cleaning and Inspection, 7-31
 Installation, 7-31
 Removal, 7-29

Subject, Page

F - continued

Fuel Injector Nozzles and Holders Inspection, 7-62
 Fuel Line Insulator, 7-42
 Installation, 7-47
 Removal, 7-42
 Fuel Pump-to-Fuel Water Separator Hose Assembly, 7-20
 Inspection, 7-22
 Installation, 7-23
 Removal, 7-20
 Test, 7-22
 Fuel Pump - Left Fuel Tank, 7-11
 Installation, 7-16
 Removal, 7-11
 Fuel Pump - Right Fuel Tank, 7-5
 Installation, 7-8
 Removal, 7-5
 Fuel Return Hose (Right Tank), 7-161
 Installation, 7-162
 Removal, 7-161
 Fuel Return Lines, 7-2
 Cleaning and Inspection, 7-56
 Installation, 7-57
 Removal, 7-52
 Fuel Shutoff Handle, 7-171
 Installation, 7-172
 Removal, 7-171
 Fuel Shutoff and Personnel Heater Circuit Breakers, 10-165
 Installation, 10-166
 Removal, 10-165
 Fuel Shutoff Wiring Harness (Master Control Panel), 10-109
 Fuel Tank Repair, 7-331
 Fuel Tank Butterfly Valve, 7-145
 Installation, 7-148
 Removal, 7-145
 Fuel Tank Capacitor and Housing Assembly, 10-326
 Assembly, 10-326
 Disassembly, 10-326

Subject, Page

F - continued

Fuel Tank Capacitor and Housing Assembly (Left), 10-321
 Installation, 10-324
 Removal, 10-321
 Fuel Tank Capacitor and Housing Assembly (Right), 10-316
 Installation, 10-318
 Removal, 10-316
 Fuel Tanks Condensate
 Removal, 7-178
 Condensate Removal, 7-181
 Installing Hand Pump, 7-178
 Removing Hand Pump, 7-181
 Fuel Tanks (Left and Right) Drain Plug, 7-186
 Cleaning and Inspection, 7-186
 Installation, 7-186
 Removal, 7-186
 Fuel Tanks (Left and Right) Level Gage Transmitter, 7-141
 Installation, 7-143
 Removal, 7-141
 Fuel Tank Liquid Quantity Indicator (Cluster Assembly), 10-125
 Installation, 10-126
 Removal, 10-125
 Fuel Tank Selector Switch (Cluster Assembly), 10-130
 Fuel Tank Selector Switch Cable Assembly (Cluster Assembly), 10-136
 Fuel-Water Separator Control Assembly, 7-209
 Cleaning and Inspection, 7-212
 Installation, 7-213
 Removal, 7-209
 Fuel-Water Separator Drain Lines, 7-217
 Installation, 7-221
 Removal, 7-217
 Fuel-Water Separator Drain Solenoid Valve, 7-214
 Installation, 7-216
 Removal, 7-214

Subject, Page

F - continued

- Fuel-Water Separator Filter Element, 7-196
 - Cleaning and Inspection, 7-198
 - Installation, 7-198
 - Removal, 7-196
- Fuel-Water Separator Fluid Pressure Filter Assembly, 7-202
 - Cleaning and Inspection, 7-206
 - Installation, 7-208
 - Removal, 7-202
- Fuel-Water Separator Fuel Filter Outlet Hose Assembly, 7-34
 - Cleaning and Inspection, 7-35
 - Installation, 7-35
 - Removal, 7-34
- Fuel-Water Separator Operational Tests
 - Automatic Drain Test, 7-226
 - Manual Drain Test, 7-223
 - Sequential Drain Test, 7-230
 - 15-Second Drain Test, 7-228

G

- Gage Illumination Indicator Light (Cluster Assembly), 10-121
 - Installation, 10-122
 - Removal, 10-121
- Gas Particulate and Bilge Pump Lead Assembly (Master Control Panel), 10-108
- Gas Particulate Switch and Indicator Light (Master Control Panel), 10-62
- General Information, 1-1
- Generator Air Exhaust Pipe and Hose, 10-14
 - Installation, 10-16
 - Removal, 10-14
- Generator Air Intake Tube Assembly, 10-3
 - Installation, 10-5
 - Removal, 10-3
- Generator, HEU, 10-12.2
 - Installation, 10-13
 - Removal, 10-12.2
- Ground Hop Powerplant, 5-25

Subject, Page

H

- Harness, Basket/Gage Indicator Panel, 10-296.57
 - Installation, 10-296.60
 - Remove, 10-296.57
- Headlight Adjustment, 10-217
- Headlight Assembly (Left and Right), 10-172
 - Assembly, 10-177
 - Disassembly, 10-173
 - Installation, 10-172
 - Removal, 10-172
- Headlight Beam Selector Switch Assembly, 10-169
 - Installation, 10-170
 - Removal, 10-169
- Headlight Beam Selector Switch Assembly Mounting Bracket, 10-171
 - Installation, 10-171
 - Removal, 10-171
- Headlight Guard, 10-185
 - Installation, 10-185
 - Removal, 10-185
- Headlight Harness Base Assembly, 10-181
 - Installation, 10-183
 - Removal, 10-181
- Headlight Harness Base Assembly Shell, 10-186
 - Installation, 10-186
 - Removal, 10-186
- Headlight Stowage Lampholder, 10-187
 - Assembly, 10-188
 - Disassembly, 10-188
 - Installation, 10-187
 - Removal, 10-187
- Heater Fuel Pump, 18-23
 - Installation, 18-24
 - Removal, 18-23
- Heater Harness, Basket/Control Panel, 10-296.48
 - Installation,, 10-296.50
 - Removal, 10-296.48
- Heater/Basket Harness, 10-296.52
 - Installation, 10-296.55
 - Removal, 10-296.53
- Helmet Bracket, 17-10
 - Installation, 17-10
 - Removal, 17-10

Subject, Page

Subject, Page

H - continued

I

HEU Engine Accessory Relay, 10-166.1
 Installation, 10-166.1
 Removal, 10-166.1
 HEU Engine Regulator, 10-20.1
 Installation, 10-20.2
 Removal, 10-20.1
 HEU Front Harness, 10-296.102
 Installation, 10-296.106
 Removal, 10-296.102
 HEU Generator, 10-12.2
 Installation, 10-13
 Removal, 10-12.2
 HEU Main Power Wiring Harness, 10-296.81
 Installation, 10-296.85
 Removal, 10-296.81
 HEU Slave Receptacle, 10-268.3
 Installation, 10-268.3
 Removal, 10-268.3
 HEU Slave Receptacle Cover, 10-268.1
 Installation, 10-268.1
 Removal, 10-268.1
 HEU Slave Receptacle Ground Strap, 10-268.2
 Installation, 10-268.2
 Removal, 10-268.2
 High Voltage IR Power Supply and Shock
 Mount Assembly, 10-152
 Installation, 10-155
 Removal, 10-152
 Hose Assembly (To Primary Fuel Filter),
 7-173
 Installation, 7-174
 Removal, 7-173
 Hose Assembly (To Purge Line), 7-175
 Installation, 7-176
 Removal, 7-175
 How to Use This Manual, iv
 Hub Assembly, 14-15
 Assembly, 14-18
 Cleaning and Inspection, 14-17
 Disassembly, 14-15
 Hull Maintenance, 3-1
 Hydraulic Brake System Bleeding, 13-86

Infrared Stowage Receptacle Assembly,
 10-160
 Installation, 10-160
 Removal, 10-160
 Inner Exhaust Pipe, 18-20
 Installation, 18-21
 Removal, 18-20
 Instrument Panel Cluster Assembly, 10-111
 Installation, 10-112
 Removal, 10-111
 Repair, 10-114
 Instrument Panel Cluster Assembly Mounting
 Support and Cushion, 10-137
 Installation, 10-137
 Removal, 10-137
 Instrument Panel Wiring Harness (Cluster
 Assembly), 10-132
 Installation, 10-134
 Removal, 10-132
 Intake Grille Door No. 1 (Left and Right), 16-10
 Installation, 16-10
 Removal, 16-10
 Intake Grille Door No. 2 (Left and Right), 16-11
 Installation, 16-11
 Removal, 16-11
 Intake Grille Door No. 3 (Left and Right), 16-12
 Installation, 16-13
 Removal, 16-12
 Intake Grille Door No. 4 (Left and Right), 16-14
 Installation, 16-14
 Removal, 16-14
 Intake Grille Door No. 5 (Left and Right), 16-15
 Installation, 16-16
 Removal, 16-15
 Intake Tube and Hoses, 8-13
 Installation, 8-13
 Removal, 8-13
 Interconnecting Box Assembly, 10-143
 Assembly, 10-147
 Disassembly, 10-144
 Installation, 10-143
 Removal, 10-143

Subject, Page

I - continued

Interconnecting Box Cable Assembly, 10-285
 Installation, 10-285
 Removal, 10-285
 Interior Release Mechanism, 20-28
 Assembly, 20-32
 Cleaning and Inspection, 20-32
 Disassembly, 20-28
 Intermediate Scavenger Tube, 8-17
 Installation, 8-19
 Removal, 8-17
 Inter-Tank Swing Check Valve, 7-238
 Cleaning and Inspection, 7-240
 Installation, 7-240
 Removal, 7-238
 Introduction, 1-1

L

Left Discharge Valve, Tubes, and Related Parts, 20-76
 Assembly, 20-78
 Disassembly, 20-77
 Installation, 20-79
 Removal, 20-76
 Left Exhaust Ejector Tube, 8-21
 Installation, 8-23
 Removal, 8-21
 Left Fuel Tank Emergency Filler, 7-139
 Cleaning and Inspection, 7-140
 Installation, 7-140
 Removal, 7-139
 Left Fuel Tank Jettison Pipe Plug, 7-152
 Installation, 7-152
 Removal, 7-152
 Left and Right Final Drive, 12-2
 Installation, 12-4
 Removal, 12-2
 Left Outer and Inner Engine to Transmission Oil Line Tube Assemblies, 6-68
 Installation, 6-70
 Removal, 6-68
 Left or Right Front Powerplant Guide, 6-4
 Installation, 6-4
 Removal, 6-4

Subject, Page

L - continued

Left or Right Rear Powerplant Guide, 6-2
 Installation, 6-3
 Removal, 6-2
 Left Taillight - Stoplight Assembly, 10-204
 Assembly, 10-209
 Disassembly, 10-207
 Installation, 10-205
 Removal, 10-204
 Light Control Switch and Hi Beam Indicator Light (Master Control Panel), 10-54
 Installation, 10-56
 Removal, 10-54
 Light Switch Harness, Basket, 10-296.39
 Installation, 10-296.44
 Removal, 10-296.40
 Link Assembly (Steering), 15-21
 Installation, 15-23
 Removal, 15-21
 Linkage Adjustment Accelerator, 7-300
 Drain Valve, Linkage, 17-43
 Shift Linkage, 11-53
 Steering Control Linkage, 15-31
 Lower Oil Filler Tube and Hose, 6-88
 Installation, 6-89
 Removal, 6-88

M

Main Fuel Feed Hose, 7-236
 Installation, 7-237
 Removal, 7-236
 Main Power Wiring Harness, HEU, 10-296.81
 Installation, 10-296.85
 Removal, 10-296.81
 Male Connector Repair, 10-302
 Male Plug Repair, 10-299
 Master Battery Switch and Indicator Light (Master Control Panel), 10-43
 Installation, 10-45
 Removal, 10-43
 Master Battery Wiring Harness (Master Control Panel), 10-97
 Installation, 10-99
 Removal, 10-97

Subject, Page

M - continued

Master Brake Cylinder Mounting Bracket Tie Rod, Push Rod, Clevis and Boot, 13-19
 Cleaning and Inspection, 13-24
 Installation, 13-25
 Removal, 13-19

Master Cylinder and Pedal Lever Mount Assembly, 13-28
 Installation, 13-30
 Removal, 13-28

Master Brake Cylinder-to-Bulkhead Tube Assembly, 13-42
 Cleaning and Inspection, 13-44
 Installation, 13-45
 Removal, 13-42

Master Control Panel, 10-34
 Installation, 10-36
 Removal, 10-34
 Repair, 10-38

Master Control Panel Displacement, 10-33
 Installation, 10-33
 Removal, 10-33

Master Control Panel Repair Index, 10-38
 Accessories Wiring Harness, 10-91
 Bilge Pump Lead Assembly, 10-108
 Bilge Pump Switch and Indicator Light, 10-66
 Blackout Selector Switch, 10-58
 Engine Fuel Shutoff and Fuel Pump Switch, 10-47
 Fuel Shutoff Wiring Harness, 10-109
 Gas Particulate Switch Lead Assembly, 10-108
 Gas Particulate Switch and Indicator Light, 10-62
 IR (Night Vision), Fuel Pump/Gas Particulate Fuel Shutoff, Bilge Pump and Utility Outlet Circuit Breaker, 10-70
 IR Power Switch and Indicator Light, 10-50
 Lighting Control Switch and Hi Beam Indicator, 10-54

Master Battery Switch and Indicator Light, 10-43

Subject, Page

M - continued

Master Battery Wiring Harness, 10-97

Master Control Panel Wiring Harness, 10-101

Master Heater Circuit Breaker, 10-70

Master Heater Hi-Lo Switch and Indicator Light, 10-77
 Personnel Heater Wiring Harness, 10-85
 Starter Switch, 10-41
 Utility Outlet, 10-60

Master Control Panel Wiring Harness, 10-101

Master Relay Assembly, 10-138
 Installation, 10-139
 Removal, 10-138

Master Relay Mounting Plate and Bracket, 10-161
 Installation, 10-162
 Removal, 10-161

Manifold Heater (Left and Right), 7-276
 Installation, 7-278
 Removal, 7-276

Manifold Heater Fuel Filter and Input Fuel Line, 7-245

Manifold Heater Fuel Return Hose Assembly, 7-290
 Cleaning and Inspection, 7-291
 Installation, 7-292
 Removal, 7-290

Manifold Heater Fuel Return Solenoid Valve, 7-282
 Inspection, 7-284
 Installation, 7-285
 Removal, 7-282

Manifold Heater Fuel Return Tube Assembly (Left and Right Bank), 7-266
 Cleaning and Inspection, 7-269
 Installation, 7-270
 Removal, 7-266

Manifold Heater Ignition Coil and Cable, 7-279
 Installation, 7-281
 Removal, 7-279

Manifold Heater Input Solenoid Valve and Fuel Line, 7-253

Subject, Page

M - continued

- Manifold Heater Nozzle, 7-273
 - Installation, 7-275
 - Removal, 7-273
- Manifold Heater Operational Check, 7-288
- Manifold Heater Spark Plug, 7-287
 - Installation, 7-287
 - Removal, 7-287
- Master Heater Switch, Hi-Lo Switch, and Indicator Light (Master Control Panel), 10-77
- Multiple Fluid Pressure Line Connector, 6-101
 - Installation, 6-103
 - Removal, 6-101

N

- Night viewer power harness, 10-298.19
 - Installation, 10-298.23
 - Removal, 10-298.19
- Neutral Shift Switch Adjustment, 11-80
- Neutral Shift Switch Assembly, 10-236
 - Installation, 10-237
 - Removal, 10-236
- Night Vision (IR) Switch and Indicator Light (Master Control Panel), 10-50

O

- Oil Damper Housing Straight Tube Hose Adapter, 6-72
 - Installation, 6-74
 - Removal, 6-72
- Oil Pressure Transmitter Guard Plate, 10-240
 - Installation, 10-241
 - Removal, 10-240
- Operator's Floor Access Plate, 17-8
 - Installation, 17-8
 - Removal, 17-8
- Operator's Seat Backrest, 17-54
 - Installation, 17-54
 - Removal, 17-54
- Outer Exhaust Tube, 18-22
 - Installation, 18-22
 - Removal, 18-22

Subject, Page

O - continued

- Oil Cooler Vent Hoses and Fittings, 6-61
 - Installation, 6-63
 - Removal, 6-61

P

- Parking Brake Cable Adjustment, 13-132
- Parking Brake Control Assembly (Engine Compartment), 13-107
 - Installation, 13-114
 - Removal, 13-107
- Parking Brake Control Assembly and Linkage, 13-90
 - Installation, 13-98
 - Removal, 13-90
- Parking Brake Control Assembly Replacement, 13-122
 - Installation, 13-125
 - Removal, 13-122
- Parking Brake Pawl and Bell Crank Adjustment, 13-136
- Periscope Cable, Infrared, 10-296.63
 - Installation, 10-296.66
 - Removal, 10-296.63
- Personnel Heater Air Duct Outlet Hose and Deflector, 18-17
 - Installation, 18-18
 - Removal, 18-17
- Personnel Heater Assembly, 18-2
 - Installation, 18-5
 - Removal, 18-2
- Personnel Heater Fuel Line Hose and Quick-Disconnect Coupling Assembly, 18-26
 - Installation, 18-27
 - Removal, 18-26
- Personnel Heater Mount, 18-16
 - Installation, 18-16
 - Removal, 18-16
- Personnel Heater Mounting Clamp, 18-15
 - Installation, 18-15
 - Removal, 18-15
- Personnel Heater Wiring Harness (Master Control Panel), 10-85

Subject, Page

P - continued

Personnel Seat Assembly, 17-58
 Assembly, 17-60
 Disassembly, 17-59
 Personnel Seat Cushion, 17-55
 Installation, 17-55
 Removal, 17-55
 Personnel Seat and Seat Mount Assembly, 17-56
 Installation, 17-57
 Removal, 17-56
 Power Relay Cable Assembly, 10-296.13
 Installation, 10-296.15
 Remove, 10-296.13
 Powerplant, 5-2
 Installation, 5-14
 Removal, 5-2
 Powerplant Left Bank Oil Cooler Frame and Brackets, 6-126
 Installation, 6-131
 Removal, 6-126
 Powerplant Right Bank Oil Cooler Frame and Brackets, 6-117
 Installation, 6-121
 Removal, 6-117
 Powerplant Tests (Ground Hop), 5-25
 Test Hookup, 5-27
 Idle Test, 5-30
 Governed No-Load Test, 5-31
 Stall Test, 5-33
 Engine Fuel Leak Test, 5-38
 After-Test Disconnect, 5-40
 Powerplant Warning Light, 10-189
 Assembly, 10-190
 Disassembly, 10-189
 Power Takeoff Disconnect, 5-23
 Power/Master Control Panel Harness, 10-296.73
 Installation, 10-296.77
 Removal, 10-296.74
 Preventative Maintenance Checks and Services (PMCS), 3-7

Subject, Page

P - continued

Primary Fuel Filter, 7-192
 Installation, 7-194
 Removal, 7-192
 Primary Fuel Filter Outlet to Fuel Backflow Valve Hose, 7-40
 Cleaning and Inspection, 7-40
 Installation, 7-41
 Removal, 7-40
 Primary Fuel Filter Element, 7-187
 Cleaning and Inspection, 7-189
 Installation, 7-189
 Removal, 7-187
 Principles of Operation, 2-1
 Purge Fuel System, 7-63

R

Rear Drain Valve Assembly, 17-47
 Cleaning and Inspection, 17-50
 Installation, 17-51
 Removal, 17-47
 Rear Drain Valve Actuating Lever, 17-34
 Installation, 17-36
 Removal, 17-34
 Rear Drain Valve Control Lever Assembly, 17-24
 Cleaning and Inspection, 17-26
 Installation, 17-26
 Removal, 17-25
 Rear Drain Valve Linkage Adjustment, 17-40
 Rear Drain Valve Mounting Brackets, 17-38
 Installation, 17-39
 Removal, 17-38
 Rear Drain Valve Rear Rod, Coupling and Clevis, 17-28
 Installation, 17-31
 Removal, 17-28
 Rear Fender (Left and Right) Stowage Box, 16-84
 Assembly, 16-87
 Disassembly, 16-87
 Installation, 16-85
 Removal, 16-84

Subject, Page

R - continued

Rear Fender (Left and Right) Stowage Box Cover, 16-88
 Assembly, 16-90
 Cleaning and Inspection, 16-90
 Disassembly, 16-88
 Rear Powerplant Guide (Left and Right), 6-2
 Installation, 6-3
 Removal, 6-2
 Rear Transmission Access Cover, 16-33
 Installation, 16-33
 Removal, 16-33
 Receptacle Mounting Plate and Gasket, 10-272
 Installation, 10-273
 Removal, 10-272
 Relay and Circuit Breaker Mounting Panel, 10-167
 Installation, 10-168
 Removal, 10-167
 Repair Parts, Special Tools, TMDE, and Support Equipment, 3-1
 Right Discharge Valve, Tubes, and Related Parts, 20-71
 Assembly, 20-74
 Disassembly, 20-72
 Installation, 20-75
 Removal, 20-71
 Right Exhaust Ejector Tube, 8-25
 Installation, 8-27
 Removal, 8-25
 Right Fuel Tank Filler, 7-133
 Cleaning and Inspection, 7-136
 Installation, 7-137
 Removal, 7-133
 Right Fuel Tank Return Tube Assembly, 7-158
 Cleaning and Inspection, 7-160
 Installation, 7-160
 Removal, 7-158
 Right Outer and Inner Engine to Transmission Oil Line Tube Assemblies, 6-64
 Installation, 6-66
 Removal, 6-64

Subject, Page

R - continued

Right Side Engine Disconnect Ground Lead Assembly, 10-271
 Installation, 10-271
 Removal, 10-271
 Right Taillight - Stoplight Assembly, 10-210
 Assembly, 10-215
 Disassembly, 10-213
 Installation, 10-212
 Removal, 10-210
 Ring (Quick-Disconnect) Assembly, 12-12
 Installation, 12-14
 Removal, 12-13
 Roadwheel Arm Repair, 14-9
 Cleaning and Inspection, 14-11
 Assembly, 14-12
 Disassembly, 14-10
 Roadwheel Arm Replacement, 14-2
 Installation, 14-6
 Removal, 14-4
 Roadwheel Support Housing Assembly, 14-22
 Installation, 14-23
 Removal, 14-22
 Rod End, 15-26
 Installation, 15-26
 Removal, 15-26

S

Seat and Backrest Mount Assembly, 17-63
 Assembly, 17-67
 Disassembly, 17-63
 Service Dust Detector Filter Strip, 7-130.14
 Servobands Adjustment, 11-83
 Shift Linkage Adjustment, 11-52
 Shifting Control Bracket Assembly and Connecting Link, 11-38
 Installation, 11-39
 Removal, 11-38

Subject, Page

S - continued

- Shifting Control Bracket and Link Assembly, 11-41
 - Assembly, 11-47
 - Disassembly, 11-44
 - Inspection, 11-46
 - Installation, 11-49
 - Removal, 11-41
- Shifting Control to Forward Inboard Bell Crank and Rod Assembly, 11-25
 - Adjustment, 11-28
 - Assembly, 11-27
 - Disassembly, 11-27
 - Inspection, 11-27
 - Installation, 11-29
 - Removal, 11-25
- Shifting Control Rear Rod and Levers, 11-34
 - Installation, 11-36
 - Removal, 11-34
- Shifting Control and Related Parts, 11-2
 - Assembly, 11-9
 - Cleaning and Inspection, 11-7
 - Disassembly, 11-5
 - Installation, 11-13
 - Removal, 11-2
- Shifting Forward Cross Tube, 11-21
 - Assembly, 11-23
 - Cleaning and Inspection, 11-23
 - Disassembly, 11-23
 - Installation, 11-24
 - Removal, 11-21
- Shifting Forward Outboard Rod, 11-30
 - Adjustment, 11-32
 - Assembly, 11-31
 - Disassembly, 11-31
 - Inspection, 11-31
 - Installation, 11-33
 - Removal, 11-30
- Shock Absorber, 14-93
 - Assembly, 14-96
 - Disassembly, 14-95
 - Installation, 14-94
 - Removal, 14-93

Subject, Page

S - continued

- Slave Receptacle, HEU, 10-268.3
 - Installation, 10-268.3
 - Removal, 10-268.3
- Slave Receptacle Cover, HEU, 10-268.1
 - Installation, 10-268.1
 - Removal, 10-268.1
- Slave Receptacle Ground Strap, HEU, 10-268.2
 - Installation, 10-268.2
 - Removal, 10-268.2
- Slipring Box Access Cover, 17-16
 - Installation, 17-16
 - Removal, 17-16
- Smoke Generator Elbow-to-Solenoid Fuel Hose, 21-30
 - Installation, 21-31
 - Removal, 21-30
- Smoke Generator Front Engine Fuel Hose, 21-39
 - Installation, 21-41
 - Removal, 21-39
- Smoke Generator Fuel Shutoff Valve, 21-21
 - Installation, 21-23
 - Removal, 21-21
- Smoke Generator Hull Wiring Harness, 21-11
 - Installation, 21-12
 - Removal, 21-11
- Smoke Generator Indicator Light, 21-5
 - Cleaning and Inspection, 21-6
 - Installation, 21-7
 - Removal, 21-5
- Smoke Generator Intermediate Fuel Hose, 21-16
 - Installation, 21-19
 - Removal, 21-16
- Smoke Generator Solenoid, 21-25
 - Installation, 21-27
 - Removal, 21-25
- Smoke Generator Solenoid Output Fuel Hose, 21-32
 - Installation, 21-33
 - Removal, 21-32

Subject, Page

S - continued

Smoke Generator Switch Cover, 21-4
 Installation, 21-4
 Removal, 21-4
 Smoke Generator Switch or Guard, 21-2
 Installation, 21-3
 Removal, 21-2
 Smoke Generator Switch and Indicator Light
 Mounting Bracket, 21-8
 Installation, 21-9
 Removal, 21-8
 Smoke Generator Tee-to-Turbosupercharger
 Tube Assembly, 21-34
 Installation, 21-37
 Removal, 21-34
 Smoke Generator Wiring Harness to Bulkhead
 Lead, 21-10
 Installation, 21-10
 Removal, 21-10
 Smoke Grenade Power Box, 22-2
 Installation, 22-3
 Removal, 22-2
 Smoke Grenade Pushbutton Unit, 22-4
 Installation, 22-5
 Removal, 22-4
 Smoke Grenade Crew Compartment Wiring
 Harness Assembly, 22-6
 Installation, 22-9
 Removal, 22-6
 Smoke Grenade Hull Compartment Wiring
 Harness Assembly, 22-12
 Installation, 22-17
 Removal, 22-12
 Smoke Grenade Launcher Functional Check
 22-23
 Speedometer, 19-2
 Installation, 19-3
 Removal, 19-2
 Speedometer Adapter Rotating Bracket
 Assembly, 19-9
 Installation, 19-10
 Removal, 19-9

Subject, Page

S - continued

Speedometer Flexible Shaft Assembly, 19-5
 Installation, 19-6
 Removal, 19-5
 Speedometer Flexible Shaft Assembly Repair.
 19-7
 Assembly, 19-8
 Disassembly, 19-7
 Speedometer Shaft Adapter Assembly, 19-11
 Installation, 19-12
 Removal, 19-11
 Speedometer Shaft Adapter Assembly Repair.
 19-13
 Assembly, 19-13
 Disassembly, 19-13
 Speedometer and Tachometer Mounting
 Bracket, 19-34
 Installation, 19-34
 Removal, 19-34
 Starter, 10-21
 Installation, 10-25
 Removal, 10-21
 Starter Feed Wiring Harness, 10-296.2
 Installation, 10-296.4
 Removal, 10-296.2
 Starter Low Voltage Relay Solenoid, 10-227
 Installation, 10-228
 Removal, 10-227
 Starter Switch (Master Control Panel), 10-41
 Steering Control Bracket, 15-27
 Installation, 15-28
 Removal, 15-27
 Steering Control Clevis and Stud, 15-16
 Installation, 15-18
 Removal, 15-16
 Steering Control Extension Stud, 15-29
 Installation, 15-30
 Removal, 15-29
 Steering Control Handle Assembly, 15-2
 Installation, 15-3
 Removal, 15-2

Subject, Page

Subject, Page

S - continued

T - continued

Steering Control Handle, Mount and Sleeve.
15-4
 Installation, 15-5
 Removal, 15-4
Steering Control Lever Assembly, 15-9
 Installation, 15-12
 Removal, 15-9
Steering Control Linkage Adjustment. 15-31
Steering Control Rod, 15-6
 Installation, 15-8
 Removal, 15-6
Steering Control to Transmission Shaft
Connecting Link, 15-19
 Installation, 15-20
 Removal, 15-19
Storage Bins and Flashlight Holder, 17-9
 Installation, 17-9
 Removal, 17-9
Suspension Torsion Bar, 14-24
 Installation, 14-27
 Removal, 14-24
Systems Operation, 2-2
Service Upon Receipt, 3-6

Tachometer Rear Flexible Shaft, 19-25
 Assembly, 19-28
 Cleaning and Inspection, 19-28
 Disassembly, 19-27
 Installation, 19-29
 Removal, 19-25
Tachometer Rear Flexible Shaft Adapter,
19-31
 Installation, 19-32
 Removal, 19-31
Tachometer Rear Flexible Shaft Adapter
Repair, 19-33
 Assembly, 19-33
 Disassembly, 19-33
Taillight Grommet, 10-216
 Installation, 10-216
 Removal, 10-216 Test
Dust Detector Operation 10-298.6
Idle Test 5-30
Governed No. Load Test 5-31
Stall Test. 5-33
Engine Fuel Leak Test. 5-38
Tests
 Dust Detector Operation, 10-298.16
Thermostatic Engine Oil Cooler Valve
Assembly (Left and Right), 6-15
 Installation, 6-18
 Removal, 6-15
Thermostatic Transmission Oil Cooler Valve
Assembly (Left Side) Test and Replacement,
6-25
 Installation, 6-29
 Removal, 6-25
Thermostatic Transmission Oil Cooler Valve
Assembly (Right Side) Test and Replacement,
6-32
 Installation, 6-36
 Removal, 6-32

T

Tachometer, 19-14
 Installation, 19-15
 Removal, 19-14
Tachometer Bulkhead Shaft Adapter, 10-17
 Installation, 19-18
 Removal, 19-17
Tachometer Front Flexible Shaft Assembly,
19-20
 Installation, 19-21
 Removal, 19-20
Tachometer Front Flexible Shaft Repair, 19-23
 Assembly, 19-24
 Disassembly, 19-23

Subject, Page

T - continued

Throttle Control Handle Assembly, 7-327
 Cleaning and Inspection, 7-328
 Installation, 7-329
 Removal, 7-327
 Thrust Washer Bearing Seal
 Installation, 11-86.1
 Removal, 11-86
 Top Deck Frame Assembly, 16-21
 Top Deck, 16-21
 Installation, 16-23
 Removal, 16-21
 Top Deck Door Panels, 16-25
 Installation, 16-26
 Removal, 16-25
 Top Deck Insulator Panels, 16-27
 Installation, 16-29
 Removal, 16-27
 Torsion Bar Anchor, 14-31
 Installation, 14-32
 Removal, 14-31
 Tow Cable Hook, 16-7
 Installation, 16-7
 Removal, 16-7
 Towing Pintle, 16-2
 Assembly, 16-4
 Cleaning and Inspection, 16-4
 Disassembly, 16-3
 Installation, 16-6
 Removal, 16-2
 Track Adjusting Link, Grease Actuated, 14-99
 Assembly, 14-108
 Disassembly, 14-107
 Inspection, 14-108
 Installation, 14-103
 Removal, 14-100
 Track Adjusting Link, Mechanical, 14-54
 Assembly, 14-60
 Disassembly, 14-59
 Installation, 14-57
 Removal, 14-54

Subject, Page

T - continued

Track Assembly, 14-79
 Installation, 14-82
 Removal, 14-79
 Track Drive Sprocket, 14-70
 Assembly, 14-75
 Disassembly, 14-73
 Installation, 14-77
 Inspection, 14-75
 Removal, 14-70
 Track Link, 14-90
 Installation, 14-92
 Removal, 14-90
 Track Shoe Pad, 14-89
 Installation, 14-89
 Removal, 14-89
 Track Support Roller, 14-34
 Assembly, 14-48
 Disassembly, 14-45
 Installation, 14-40
 Removal, 14-35
 Transmission Drain Access Cover, 16-34
 Installation, 16-34
 Removal, 16-34
 Transmission Main Oil Filter Element, 11-89
 Cleaning and Inspection, 11-92
 Installation, 11-93
 Removal, 11-89
 Transmission Mounts (Left and Right), 6-8
 Installation, 6-10
 Removal, 6-8
 Transmission Oil Breather Tube, 11-86
 Installation, 11-88
 Removal, 11-86
 Transmission Oil Cooler, 6-38
 Installation, 6-43
 Removal, 6-38
 Transmission Oil Coolers Screen, 6-53
 Installation, 6-54
 Removal, 6-53

Subject, Page

T - continued

Transmission Oil Pressure Indicator (Cluster Assembly), 10-119
 Transmission Oil Pressure Transmitter, 10-231
 Installation, 10-233
 Removal, 10-231
 Transmission Oil Temperature Indicator (Cluster Assembly), 10-128
 Transmission Oil Temperature Transmitter, 10-234
 Installation, 10-235
 Removal, 10-234
 Transmission Oil Temperature Transmitter Protector, 10-229
 Installation, 10-230
 Removal, 10-229
 Transmission Shroud, 9-2
 Assembly, 9-13
 Cleaning and Inspection, 9-12
 Disassembly, 9-9
 Installation, 9-6
 Removal, 9-2
 Transmission Shrouds, 9-22
 Left Intermediate Shroud Installation, 9-29
 Left Intermediate Shroud Removal, 9-29
 Lower Shroud Installation, 9-28
 Lower Shroud Removal, 9-27
 Right Intermediate Shroud Installation, 9-25
 Right Intermediate Shroud Removal, 9-22
 Transmission Stroud Supports (Left and Right), 9-15
 Assembly, 9-19
 Disassembly, 9-16
 Installation, 9-15
 Removal, 9-15
 Transmission Side Oil Strainer Assembly, 11-96
 Assembly, 11-100
 Cleaning and Inspection, 11-99
 Disassembly, 11-99
 Installation, 11-101
 Removal, 11-96

Subject, Page

T - continued

Transmission Wiring Harness, 10-281
 Installation, 10-283
 Removal, 10-281
 Troubleshooting, 4-1
 Troubleshooting System Index, 4-20
 Turbocharger Shrouds, 9-41
 Inner Shroud Installation, 9-43
 Inner Shroud Removal, 9-41
 Outer Shroud Installation, 9-45
 Outer Shroud Removal, 9-45
 Upper Shroud Installation, 9-46
 Upper Shroud Removal, 9-46
 Turbosupercharger Oil Drain Tube (Left Bank), 6-94
 Installation, 6-95
 Removal, 6-94
 Turbosupercharger Oil Drain Tube (Right Bank), 6-90
 Installation, 6-92
 Removal, 6-90

U

Universal Joint, 12-15
 Assembly, 12-23
 Disassembly, 12-22
 Inspection, 12-18
 Installation, 12-18.2
 Removal, 12-16
 Upper Discharge Valve, Tubes, and Related Parts, 20-65
 Assembly, 20-67
 Disassembly, 20-66
 Installation, 20-69
 Removal, 20-65
 Upper Oil Filler Tube, 6-84
 Installation, 6-86
 Removal, 6-84
 Utility Outlet (Master Control Panel), 10-60

Subject, Page

Subject, Page

V

Volute Spring, 14-97
Installation, 14-98
Removal, 14-97

W

Wiring Harness

Accessories Wiring Harness, 10-91
■ Basket Wiring Harness, 10-296.69
Electrical Wiring Harness Repair,
10-298
■ Engine Disconnect Wiring Harness,
10-296.7
Engine Starter Wiring Harness, 10-274
Engine Wiring Harness, 10-286
Fuel Shutoff Wiring Harness, 10-109
■ HEU Main Power Wiring Harness,
10-296.81
Instrument Panel Wiring Harness, 10-132
Master Battery Wiring Harness, 10-97
Master Control Panel Wiring Harness,
10-101
Personnel Heater Wiring Harness, 10-85
Smoke Generator Wiring Harness
Hull Wiring Harness, 21-11
to Bulkhead Lead, 21-10
■ Starter Feed Wiring Harness, 10-296.2
Transmission Wiring Harness, 10-281
■ Wiring, Rear Accessory, 10-296.18
Installation, 10-296.22
Removal, 10-296.19

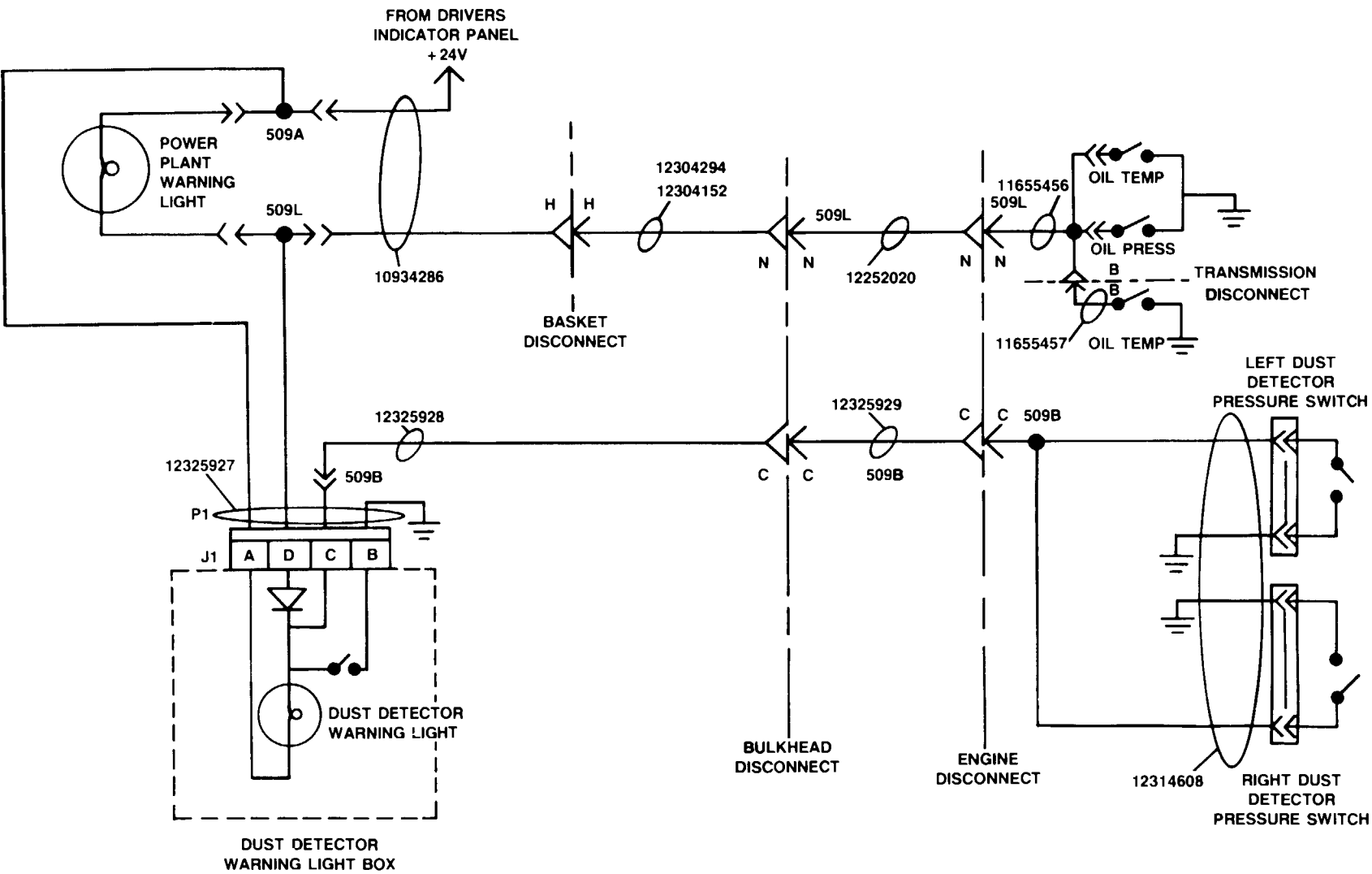

FO-2.

Dust Detector Schematic Diagram For
Vehicles Equipped With 2DA Engine.

Change 1

MAINTENANCE INFORMATION INDEX

A	Adjust	Disassemble	Clean	Inspect	Repair	Remove	Install	Assemble Test
Accelerator Control Rod			7-310	7-310		7-308	7-311	
Accelerator Linkage	7-300							
Accelerator Linkage Bulkhead Flange						7-324	7-325	
Accelerator Linkage Engine Control			7-323	7-323		7-322 7-306	7-323 7-307	
Accelerator Pedal Assembly								
Accelerator Pedal Return Spring	7-298							
Accelerator Throttle Linkage			7-317	7-317		7-313	7-318	
Accessories Wiring Harness (Master Control Panel)						10-91 7-88	10-94 7-92	
Air Cleaner								
Air Cleaner (Aluminum) Centrifugal Fan Cover and Gasket						7-106	7-108	
Air Cleaner (Armored) Centrifugal Fan Cover and Gasket						7-103	7-105	
Air Cleaner (Aluminum) Centrifugal Fan						7-120	7-122	
Air Cleaner (Armored) Centrifugal Fan						7-111	7-114	
Air Cleaner Centrifugal Fan Ground Lead						7-126	7-127	
Air Cleaner (Aluminum) Centrifugal Fan Hose						7-110	7-110	
Air Cleaner (Armored) Centrifugal Fan Hose						7-109	7-109	
Air Cleaner (Aluminum) Centrifugal Fan Power Lead						7-80	7-82	
Air Cleaner (Armored) Centrifugal Fan Power Lead						7-77	7-79	
Air Cleaner (Aluminum) Circuit Breaker						7-125	7-125	
Air Cleaner (Armored) Circuit Breaker						7-124 7-128	7-124 7-129	
Air Cleaner Door								

MAINTENANCE INFORMATION INDEX

B - Continued	Adjust	Disassemble	Clean	Inspect	Repair	Remove	Install	Assemble Test
Brake Pressure Gage Tube Assembly, Reducer and Gasket			13-38	13-38		13-35	13-39	
Brake Quick Disconnect and Hose Assembly			13-50	13-50		13-47	13-50	
Brake Right Hand Slave Cylinder and Tube Assembly			13-60	13-60		13-58	13-61	
Brake Switch (Stoplight)			13-32	13-32		13-31	13-33	
Breather Line				7-155		7-153	7-156	
Bulkhead Access Cover						17-2	17-3	
Bulkhead Cable Disconnect						10-269	10-270	
Bulkhead Pipe Plug						17-17	17-17	
Bulkhead PTO Ring						17-15	17-15	
C								
Centrifugal Fan Housing						9-64	9-65	
Check Valve (Manifold Heater- Return Fuel)			7-264	7-264		7-263	2-265	
Circuit Breaker (Master Control Panel)						10-70	10-71	
Commander's Floor Plate						17-7	17-7	
Commander's Seat Backrest						17-53	17-53	
Compensating Idler Hub and Arm						14-62	14-64	
Compensating Idler Wheel			14-53	14-53		14-50	14-53	
Condensate Relief Valve (Left or Right)			7-132	7-132		7-130	7-132	
Connecting Link (Steering).						15-24	15-25	
Control Valve Assembly		20-50						20-51
Cooling Fan Shroud						9-47	9-51	
Cover Assembly (Escape Hatch) (Early Model)		16-45	16-46	16-46		16-42	16-43	16-46
Cover Assembly (Escape Hatch) (Late Model)	16-35	16-37				16-35	16-36	16-39
Crankcase Breather Tee and Rear Tube						6-97	6-99	
Cylinder Head and Oil Pan Drain Tubes (Left and Right)						6-135	6-137	

	Adjust	Disassemble	Clean	Inspect	Repair	Remove	Install	Assemble	Test
D									
Disconnect Battery Ground Straps						10-268	10-268		
Domelight Assembly		10-193	10-197	10-197		10-191	10-192	10-197	
Domelight Resistor Assembly						10-201	10-202		
Domelight Resistor Assembly Bracket						10-203	10-203		
E									
Electrical Wiring Harness and Cable Connector					10-298				
Engine Access Covers (Left Bank)						6-112	6-115		
Engine Access Covers (Right Bank)						6-107	6-110		
Engine Access Panel Seal						16-31	16-32		
Engine Compartment Discharge Manifold						20-81	20-83		
Engine Cooling Fan						9-55	9-57		
Engine Fuel Injection Pump: Fuel Shutoff Lead						10-28	10-31		
Engine Fuel Pump		7-38	7-38			7-37	7-39		
Engine Fuel Return Hose Assembly (Left Side)						7-167	7-168		
Engine Fuel Return Hose						7-169	7-170		
Engine Fuel Return Line Tube						7-234	7-235		
Engine Fuel Return Selector Cock				7-165		7-163	7-165		
Engine Fuel Return Tube Assembly						7-294	7-296		
Engine Fuel Shutoff and Fuel Pump Switch (Master Control Panel)						10-47	10-48		
Engine Generator						10-6	10-10		
Engine Generator Regulator						10-18	10-19		
Engine Generator Regulator Mounting Bracket						10-20	10-20		
Engine High Oil Pressure Transmitter						10-221	10-223		
Engine Idle	7-297								
Engine Low Oil Pressure Switch						10-242	10-243		

MAINTENANCE INFORMATION INDEX

E - Continued	Adjust	Disassemble	Clean	Inspect	Repair	Remove	Install	Assemble	Test
Engine Lower Access Cover						17-13	17-14		
Engine Mounts (Left and Right)						6-5	6-7		
Engine Oil Cooler (Left and Right)						6-19	6-22		
Engine Oil Cooler Bypass Valve Assembly						6-55	6-56		
Engine Oil Cooler Fluid Pump Connector						6-57	6-59		
Engine Oil Cooler Screen						6-51	6-52		
Engine Oil Coolers			6-48						
Engine Oil Filler Cap						6-81	6-83		
Engine Oil Filter Element						6-76	6-79		
Engine Oil High Temperature Thermostatic Switch						10-219	10-220		
Engine Oil Pressure Indicator (Cluster Assembly)						10-115	10-116		
Engine Oil Temperature Indicator (Cluster Assembly)						10-123	10-124		
Engine Oil Temperature Transmitter						10-224	10-225		
Engine Shroud						9-30	9-31		
Engine Shroud (Off Engine)		9-32							9-33
Engine Shroud (On Engine)		9-34							9-36
Engine Shroud Support						9-39	9-40		
Engine Starter Wiring Harness						10-274	10-277		
Engine Upper Access Cover						17-11	17-12		
Engine Wiring Harness						10-286	10-292		
Exhaust Doors						16-17	16-19		
Exhaust Pipe (Left Side)						8-5	8-7		
Exhaust Pipe (Right Side)						8-9	8-11		
Exhaust Pipe Cap Assembly						8-2	8-4		
Exterior Release Handle Body Assembly		20-43			20-43	20-39	20-41	20-43	
Exterior Release Handle Mounting Bracket						20-48	20-49		

MAINTENANCE INFORMATION INDEX

F	Adjust	Disassemble	Clean	Inspect	Repair	Remove	Install	Assemble	Test
Fan Drive Oil Seal						9-59	9-61		
Fender and Shield (Rear)						16-69	16-72		
Fender Extension (Left)				16-66		16-65	16-67		
Fender Support No. 3 (Left and Right)			16-52	16-52		16-50	16-52		
Fender Support No. 4 (Left and Right)			16-56	16-56		16-54	16-56		
Final Drive Adapter Assembly and Oil Seal						12-7	12-8		
Final Drive Air Pressure Relief Valve (Left and Right)						12-6	12-6		
Final Drive Magnetic Plug						12-9	12-9		
Final Drive Stud						12-10	12-11		
Fire Extinguisher Relay and Master Relay Circuit Breaker						10-141	10-142		
Fire Extinguisher Solenoid Relay						10-158	10-159		
Fixed Fire Extinguisher Control Valve	20-5		20-8	20-8		20-2	20-14	20-8	
Fixed Fire Extinguisher Cylinder						20-52	20-54		
Fixed Fire Extinguisher Delay Bottle and Tubes						20-56	20-59		
Fixed Fire Extinguisher Interior Release Mechanism Control Assembly						20-16	20-21		
Fixed Fire Extinguisher Interior Release Mechanism and Mounting Bracket						20-23	20-25		
Fixed Fire Extinguisher Outside Release Handle Control Assembly						20-44	20-46		
Fixed Fire Extinguisher Manifold						20-63	20-64		
Fixed Fire Extinguisher Mounting Bracket Repair						20-62	20-62		
Floor Forward Access Covers						17-5	17-6		
Forward Inboard Bell Crank Assembly						11-16	11-17		
Forward Outboard Lever Assembly						11-18	11-19		

MAINTENANCE INFORMATION INDEX

F - Continued	Adjust	Disassemble	Clean	Inspect	Repair	Remove	Install	Assemble	Test
Front Drain Valve Assembly			17-21	17-21		17-19	17-21		
Front Drain Valve Control Lever						17-18	17-18		
Front Fender (Center, Left and Right) Stowage Box		16-79				16-76	16-77	16-79	
Front Fender (Center, Left and Right) Stowage Box Cover		16-80	16-82	16-82				16-82	
Front Fenders, Headlight Guards, and Fender Support						16-58	16-62		
Front Powerplant Guide (Left or Right)						6-4	6-4		
Front Steering Control Tube						15-13	15-15		
Fuel Backflow Valve			7-27	7-27		7-25	7-27		
Fuel Filler Cover Assembly						16-8	16-9		
Fuel Inlet Fluid Pressure Filter Repair		7-243							7-244
Fuel Injection Pump Inlet to Bulkhead Elbow Tube Assembly			7-31	7-31		7-29	7-31		
Fuel Injector Nozzles and Holders				7-62					
Fuel Line Insulator						7-42	7-47		
Fuel Pump-to-Fuel Water Separator Hose				7-22		7-20	7-23		7-22
Fuel Pump - Left Fuel Tank						7-11	7-16		
Fuel Pump - Right Fuel Tank						7-5	7-8		
Fuel Return Hose (Right Tank)						7-161	7-162		
Fuel Return Lines			7-56	7-56		7-52	7-57		
Fuel Shutoff Handle						7-171	7-172		
Fuel Shutoff and Personnel Heater Circuit Breakers						10-165	10-166		
Fuel Shutoff Wiring Harness (Master Control Panel)						10-109	10-110		
Fuel Tank					7-331				
Fuel Tank Butterfly Valve						7-145	7-148		
Fuel Tank Capacitor and Housing Assembly		10-326						10-326	

MAINTENANCE INFORMATION INDEX

	Adjust	Disassemble	Clean	Inspect	Repair	Remove	Install	Assemble	Test
F - Continued									
Fuel Tank Capacitor and Housing Assembly (Left)						10-321	10-324		
Fuel Tank Capacitor and Housing Assembly (Right)						10-316	10-318		
Fuel Tanks Condensate Removal						7-178			
Fuel Tanks (Left and Right) Drain Plug			7-186	7-186		7-186	7-186		
Fuel Tanks (Left and Right) Level Gage Transmitter						7-141	7-143		
Fuel Tanks Liquid Quantity Indicator (Cluster Assembly)						10-125	10-126		
Fuel Tank Selector Switch (Cluster Assembly)						10-130	10-130		
Fuel Tank Selector Switch Cable Assembly (Cluster Assembly)						10-136	10-136		
Fuel-Water Separator Control Assembly			7-212	7-212		7-209	7-213		
Fuel-Water Separator Drain Lines						7-217	7-221		
Fuel-Water Separator Drain Solenoid Valve						7-214	7-216		
Fuel-Water Separator Filter Element			7-198	7-198		7-196	7-198		
Fuel-Water Separator Fluid Pressure Filter Assembly			7-206	7-206		7-202	7-208		
Fuel-Water Separator Fuel Filter Outlet Hose Assembly			7-35	7-35		7-34	7-35		
Fuel-Water Separator Operational Tests									
Automatic Drain Test									7-226
Manual Drain Test									7-223
Sequential Drain Test									7-230
15 - Second Drain Test									7-228
G									
Gage Illumination Indicator Light (Cluster Assembly)						10-121	10-122		

MAINTENANCE INFORMATION INDEX

G - Continued	Adjust	Disassemble	Clean	Inspect	Repair	Remove	Install	Assemble	Test
Gas Particulate and Bilge Pump Lead Assembly (Master Control Panel)						10-108	10-108		
Gas Particulate Switch and Indicator Light (Master Control Panel)						10-62	10-62		
Generator Air Exhaust Pipe and Hose						10-14	10-16		
Generator Air Intake Tube Assembly						10-3	10-5		
H									
Headlight	10-217								
Headlight Assembly (Left and Right)		10-173				10-172	10-172	10-177	
Headlight Harness Base Assembly Shell						10-186	10-186		
Headlight Beam Selector Switch Assembly						10-169	10-170		
Headlight Beam Selector Switch Assembly Mounting Bracket						10-171	10-171		
Headlight Guard						10-185	10-185		
Headlight Harness Base Assembly						10-181	10-183		
Headlight Stowage Lampholder		10-188				10-187	10-187	10-188	
Heater Fuel Pump						18-23	18-24		
Helmet Bracket						17-10	17-10		
High Voltage IR Power Supply and Shock Mount Assembly						10-152	10-155		
Hose Assembly (To Primary Fuel Filter)						7-173	7-174		
Hose Assembly (To Purge Line)						7-175	7-176		
Hub Assembly		14-15		14-17	14-17				14-18

MAINTENANCE INFORMATION INDEX

	Adjust	Disassemble	Clean	Inspect	Repair	Remove	Install	Assemble	Test
I									
Infrared Stowage Receptacle Assembly						10-160	10-160		
Inner Exhaust Pipe						18-20	18-21		
Instrument Panel Cluster Assembly					10-114	10-111	10-112		
Instrument Panel Cluster Assembly Mounting Support and Cushion						10-137	10-137		
Instrument Panel Wiring Harness (Cluster Assembly)						10-132	10-134		
Intake Grille Door No. 1 (Left and Right)						16-10	16-10		
Intake Grille Door No. 2 (Left and Right)						16-11	16-11		
Intake Grille Door No. 3 (Left and Right)						16-12	16-13		
Intake Grille Door No. 4 (Left and Right)						16-14	16-14		
Intake Grille Door No. 5 (Left and Right)						16-15	16-16		
Interconnecting Box Assembly	10-144					10-143	10-143	10-147	
Interconnecting Box Cable Assembly						10-285	10-285		
Interior Release Mechanism	20-28							20-32	
Inter-Tank Swing Check Valve			7-240	7-242		7-238	7-240		
L									
Left Discharge Valve, Tubes, and Related Parts	20-77					20-76	20-79	20-78	
Left Fuel Tank Emergency Filler			7-140	7-140		7-139	7-140		
Left Fuel Tank Jettison Pipe Plug						7-152	7-152		
Left and Right Final Drive						12-2	12-4		
Left Outer and Inner Engine to Transmission Oil Line Tube Assemblies						6-68	6-70		
Left or Right Front Powerplant Guide						6-4	6-4		

MAINTENANCE INFORMATION INDEX

L - Continued	Adjust	Disassemble	Clean	Inspect	Repair	Remove	Install	Assemble	Test
Left or Right Rear Powerplant Guide						6-2	6-3		
Left Taillight - Spotlight Assembly		10-207				10-204	10-205	10-209	
Lighting Control Switch and Hi Beam Indicator Light (Master Control Panel)						10-54 15-21	10-56 15-23		
Link Assembly (Steering)									
Linkage Adjustment									
Accelerator	7-300								
Drain Valve, Rear Linkage	17-43								
Shift Linkage	11-53								
Steering Control Linkage	15-31								
Lower Oil Filler Tube and Hose						6-88	6-89		
M									
Male Connector Repair					10-302				
Male Plug Repair					10-299				
Main Fuel Feed Hose						7-236	7-237		
Master Battery Switch and Indicator Light (Master Control Panel)						10-43	10-45		
Master Battery Wiring Harness (Master Control Panel)						10-97	10-99		
Master Brake Cylinder Mounting Bracket Tie Rod, Push Rod, Clevis and Boot			13-24	13-24		13-19	13-25		
Master Brake Cylinder and Pedal Lever Mount Assembly						13-28	13-30		
Master Brake Cylinder-to-Bulkhead Tube Assembly			13-44	13-44		13-42	13-45		
Master Control Panel					10-38	10-34	10-36		
Master Control Panel Displacement						10-33	10-33		
Master Control Panel Repair Index						10-91	10-94		
Accessories Wiring Harness									

MAINTENANCE INFORMATION INDEX

M - Continued	Adjust	Disassemble	Clean	Inspect	Repair	Remove	Install	Assemble	Test
Bilge Pump Lead Assembly						10-108	10-108		
Bilge Pump Switch and Indicator Light						10-66	10-68		
Blackout Selector Switch						10-58	10-59		
Engine Fuel Shutoff and Fuel Pump Switch						10-47	10-48		
Fuel Shutoff Wiring Harness						10-109	10-110		
Gas Particulate Switch Lead Assembly						10-108	10-108		
Gas Particulate Switch and Indicator Light						10-62	10-64		
IR (Night Vision), Fuel Pump/ Gas Particulate Fuel Shutoff, Bilge Pump, and Utility Outlet Circuit Breaker						10-70	10-71		
IR Power Switch and Indicator Light						10-50	10-52		
Lighting Control Switch and Hi Beam Indicator						10-54	10-56		
Master Battery Switch and Indicator Light						10-43	10-45		
Master Battery Wiring Harness						10-97			
Master Control Panel Wiring Harness						10-101	10-105		
Master Heater Hi-Lo Switch and Indicator Light						10-77	10-81		
Personnel Heater Wiring Harness						10-85	10-89		
Starter Switch						10-41	10-42		
Utility Outlet						10-60	10-61		
Master Control Panel Wiring Harness						10-101	10-105		
Master Relay Assembly						10-138	10-139		
Master Relay Mounting Plate and Bracket						10-161	10-162		

MAINTENANCE INFORMATION INDEX

M - Continued	Adjust	Disassemble	Clean	Inspect	Repair	Remove	Install	Assemble	Test
Manifold Heater (Left and Right)						7-276	7-278		
Manifold Heater Fuel Filter and Input Fuel Line						7-245	7-248		
Manifold Heater Fuel Return Hose Assembly			7-291	7-291		7-290	7-292		
Manifold Heater Fuel Return Solenoid Valve				7-284		7-282	7-285		
Manifold Heater Fuel Return Tube Assembly (Left and Right Bank)			7-269	7-269		7-266	7-270		
Manifold Heater Ignition Coil and Cable						7-279	7-281		
Manifold Heater Input Solenoid Valve and Fuel Line						7-253	7-256		
Manifold Heater Nozzle						7-273	7-275		
Manifold Heater Spark Plug						7-287	7-287		
Master Heater Switch, Hi-Lo Switch, and Indicator Light (Master Control Panel)						10-77	10-81		
Multiple Fluid Pressure Line Connector						6-101	6-103		
N									
Neutral Shift Switch	11-80								
Neutral Shift Switch Assembly						10-236	10-237		
Night Vision (IR) Switch and Indicator Light (Master Control Panel)						10-50	10-52		
O									
Oil Cooler Vent Hoses and Fittings						6-61	6-63		
Oil Damper Housing Straight Tube Hose Adapter						6-72	6-74		

MAINTENANCE INFORMATION INDEX

O - Continued

Oil Pressure Transmitter Guard Plate
 Operator's Floor Access Plate
 Operator's Seat Backrest
 Outer Exhaust Tube

Adjust	Disassemble	Clean	Inspect	Repair	Remove	Install	Assemble	Test
					10-240	10-241		
					17-8	17-8		
					17-54	17-54		
					18-22	18-22		

P

Parking Brake Cable
 Parking Brake Control Assembly (Engine Compartment)
 Parking Brake Control Assembly and Linkage
 Parking Brake Control Assembly
 Parking Brake Pawl and Bell Crank
 Personnel Heater Air Duct Outlet Hose and Deflector
 Personnel Heater Assembly
 Personnel Heater Fuel Line Hose and Quick-Disconnect Coupling Assembly
 Personnel Heater Mount
 Personnel Heater Mounting Clamp
 Personnel Heater Wiring Harness (Master Control Panel)
 Personnel Seat Assembly
 Personnel Seat Cushion
 Personnel Seat and Seat Mount Assembly
 Powerplant

13-132								
					13-107	13-114		
					13-90	13-98		
					13-122	13-125		
13-136								
					18-17	18-18		
					18-2	18-5		
					18-26	18-27		
					18-16	18-16		
					18-15	18-15		
					10-85	10-89		
	17-58							17-59
					17-55	17-55		
					17-56	17-57		
					5-2	5-14		

MAINTENANCE INFORMATION INDEX

P - Continued	Adjust	Disassemble	Clean	Inspect	Repair	Remove	Install	Assemble	Test
Powerplant Left Bank Oil Cooler Frame and Brackets						6-126	6-131		
Powerplant Right Bank Oil Cooler Frame and Brackets						6-117	6-121		
Powerplant Tests (Ground Hop)									5-25
Powerplant Warning Light	10-189							10-190	
Power Takeoff Disconnect						5-23			
Primary Fuel Filter						7-192	7-194		
Primary Fuel Filter Backflow Valve			7-40	7-40		7-40	7-41		
Primary Fuel Filter Element			7-189	7-189		7-187	7-189		
R									
Rear Drain Valve Assembly			17-50	17-50		17-47	17-51		
Rear Drain Valve Actuating Lever						17-34	17-36		
Rear Drain Valve Control Lever			17-26	17-26		17-25	17-26		
Rear Drain Valve Linkage	17-40								
Rear Drain Mounting Brackets						17-38	17-39		
Rear Drain Valve Rear Rod, Coupling and Clevis						17-28	17-31		
Rear Fender (Left and Right) Stowage Box		16-87				16-84	16-85	16-87	
Rear Fender (Left and Right) Stowage Box Cover			16-90	16-90		16-88	16-90		
Rear Powerplant Guide (Left or Right)						6-2	6-3		
Rear Transmission Access Cover						16-33	16-33		
Receptacle Mounting Plate and Gasket						10-272	10-273		
Relay and Circuit Breaker Mounting Panel						10-167	10-168		
Right Discharge Valve, Tubes, and Related Parts		20-72				20-71	20-75	20-74	

MAINTENANCE INFORMATION INDEX

	Adjust	Disassemble	Clean	Inspect	Repair	Remove	Install	Assemble	Test
R - Continued									
Right Fuel Tank Filler			7-136	7-136		7-133	7-137		
Right Fuel Tank Return Tube Assembly			7-160	7-160		7-158	7-160		
Right Outer and Inner Engine to Transmission Oil Line Tube Assemblies						6-64	6-66		
Right Side Engine Disconnect Ground Lead Assembly						10-271	10-271		
Right Taillight Stoplight Assembly		10-213				10-210	10-212	10-215	
Ring (Quick-Disconnect) Assembly						12-13	12-14		
Roadwheel Arm Repair	14-10		14-11	14-11	14-9			14-12	
Roadwheel Arm Replacement						14-4	14-6		
Roadwheel Support Housing Assembly						14-22	14-23		
Rod End						15-26	15-26		
S									
Seat and Backrest Mount Assembly						17-63	17-67		
Servobands	11-83								
Shift Linkage	11-52								
Shifting Control Bracket Assembly and Connecting Link						11-38	11-39		
Shifting Control Bracket and Link Assembly		11-44		11-46		11-41	11-49	11-47	
Shifting Control - Forward Inboard Bell Crank and Rod Assembly	11-28	11-27		11-27		11-25	11-29	11-27	
Shifting Control Rear Rod and Levers						11-34	11-36		
Shifting Control and Related Parts		11-5	11-7	11-7		11-2	11-13	11-9	
Shifting Forward Cross Tube		11-23	11-23	11-23		11-21	11-24	11-23	
Shifting Forward Outboard Rod	11-32	11-31		11-31		11-30	11-33	11-31	

MAINTENANCE INFORMATION INDEX

S - Continued	Adjust	Disassemble	Clean	Inspect	Repair	Remove	Install	Assemble Test
Shock Absorber		14-95				14-93	14-94	14-96
Slipring Box Access Cover						17-16	17-16	
Smoke Generator Elbow-to-Solenoid Fuel Hose						21-30	21-31	
Smoke Generator Front Engine Fuel Hose						21-39	21-41	
Smoke Generator Fuel Shutoff Valve						21-21	21-23	
Smoke Generator Hull Wiring Harness						21-11	21-12	
Smoke Generator Indicator Light			21-6	21-6		21-5	21-7	
Smoke Generator Intermediate Fuel Hose						21-16	21-19	
Smoke Generator Solenoid						21-25	21-27	
Smoke Generator Solenoid Output Fuel Hose						21-32	21-33	
Smoke Generator Switch Cover						21-4	21-4	
Smoke Generator Switch or Guard						21-2	21-3	
Smoke Generator Switch and Indicator Light Mounting Bracket						21-8	21-9	
Smoke Generator Tee-to-Turbo-supercharger Tube Assembly						21-34	21-37	
Smoke Generator Wiring Harness to Bulkhead Lead						21-10	21-10	
Smoke Grenade Power Box						22-2	22-3	
Smoke Grenade Pushbutton Unit						22-4	22-5	
Smoke Grenade Crew Compartment Wiring Harness Assembly						22-6	22-9	
Smoke Grenade Hull Compartment Wiring Harness Assembly						22-12	22-17	
Smoke Grenade Launcher Functional Check								22-23
Speedometer						19-2	19-3	
Speedometer Adapter Rotating Bracket Assembly						19-9	19-10	

MAINTENANCE INFORMATION INDEX

S - Continued	Adjust	Disassemble	Clean	Inspect	Repair	Remove	Install	Assemble	Test
Speedometer Flexible Shaft Assembly		19-7			9-7	19-5	19-6	19-8	
Speedometer Shaft Adapter Assembly		19-13			19-13	19-11	19-12	19-13	
Speedometer and Tachometer Mounting Bracket						19-34	19-34		
Starter						10-21	10-25		
Starter Low Voltage Relay Solenoid						10-227	10-228		
Starter Switch (Master Control Panel)						10-41	10-42		
Steering Control Bracket						15-27	15-28		
Steering Control Clevis and Stud						15-16	15-18		
Steering Control Extension Stud						15-29	15-30		
Steering Control Handle Assembly						15-2	15-3		
Steering Control Handle, Mount, and Sleeve						15-4	15-5		
Steering Control Lever Assembly						15-9	15-12		
Steering Control Linkage	15-31								
Steering Control Rod						15-6	15-8		
Steering Control to Transmission Shaft Connecting Link						15-19	15-20		
Stowage Bins and Flashlight Holder						17-9	17-9		
Suspension Torsion Bar						14-24	14-27		
T									
Tachometer						19-14	19-15		
Tachometer Bulkhead Shaft Adapter						19-17	19-18		
Tachometer Front Flexible Shaft Assembly		19-23			19-23	19-20	19-21	19-24	
Tachometer Rear Flexible Shaft		19-27	19-28	19-28		19-25	19-29	19-28	
Tachometer Rear Flexible Shaft Adapter		19-33			19-33	19-31	19-32	19-33	

MAINTENANCE INFORMATION INDEX

T - Continued	Adjust	Disassemble	Clean	Inspect	Repair	Remove	Install	Assemble	Test
Taillight Grommet						10-216	10-216		
Thermostatic Engine Oil Cooler Valve Assembly (Left and Right)						6-15	6-18		
Thermostatic Transmission Oil Cooler Valve Assembly (Left Side Test) and Replacement						6-25	6-29		
Thermostatic Transmission Oil Cooler Valve Assembly (Right Side Test) and Replacement						6-32	6-36		
Throttle Control Handle Assembly			7-328	7-328		7-327	7-329		
Top Deck Frame Assembly									
Top Deck						16-21	16-23		
Top Deck Door Panels						16-25	16-26		
Top Deck Insulator Panel						16-27	16-29		
Torsion Bar Anchor						14-31	14-32		
Tow Cable Hook						16-7	16-7		
Towing Pintle	16-3		16-4	16-4		16-2	16-6	16-4	
Track Adjusting Link, Mechanical	14-59					14-54	14-57	14-60	
Track Adjusting Link, Grease Actuated	14-107			14-108		14-100	14-103	14-108	
Track Assembly						14-79	14-82		
Track Drive Sprocket	14-73			14-75		14-70	14-77	14-75	
Track Link						14-90	14-92		
Track Shoe Pad						14-89	14-89		
Track Support Roller	14-45					14-35	14-40	14-48	
Transmission Drain Access Cover						16-34	16-34		
Transmission Main Oil Filter Element			11-92	11-92		11-89	11-93		
Transmission Mounts (Left and Right)						6-8	6-10		
Transmission Oil Breather Tube						11-86	11-88		
Transmission Oil Cooler						6-38	6-43		
Transmission Oil Coolers Screen						6-53	6-54		
Transmission Oil Pressure Indicator (Cluster Assembly)						10-119	10-120		
Transmission Oil Pressure Transmitter						10-231	10-233		

MAINTENANCE INFORMATION INDEX

T - Continued

	Adjust	Disassemble	Clean	Inspect	Repair	Remove	Install	Assemble	Test
Transmission Oil Temperature Indicator (Cluster Assembly)						10-128	10-128		
Transmission Oil Temperature Transmitter						10-234	10-235		
Transmission Oil Temperature Transmitter Protector						10-229	10-230		
Transmission Shroud	9-9		9-12	9-12		9-2	9-6	9-13	
Transmission Shrouds									
Left Intermediate Shroud						9-29	9-29		
Lower Shroud						9-27	9-28		
Right Intermediate Shroud						9-22	9-25		
Transmission Shroud Supports (Left and Right)	9-16					9-15	9-15	9-19	
Transmission Side Oil Strainer Assembly	11-99		11-99	11-99		11-96	11-101	11-100	
Transmission Wiring Harness						10-281	10-283		
Turbocharger Shrouds									
Inner Shroud						9-41	9-43		
Outer Shroud						9-45	9-45		
Upper Shroud						9-46	9-46		
Turbosupercharger Oil Drain Tube (Left Bank)						6-94	6-95		
Turbosupercharger Oil Drain Tube (Right Bank)						6-90	6-92		

U

■ Universal Joint	12-22			12-18		12-16	12-18.2	12-23	
Upper Discharge Valve, Tubes, and Related Parts	20-66					20-65	20-69	20-67	
Upper Oil Filler Tube						6-84	6-86		
Utility Outlet (Master Control Panel)						10-60	10-61		

V

Volute Spring						14-97	14-98		
---------------	--	--	--	--	--	-------	-------	--	--

MAINTENANCE INFORMATION INDEX

W	Adjust	Disassemble	Clean	Inspect	Repair	Remove	Install	Assemble	Test
Wiring Harnesses									
Accessories Wiring Harness						10-91	10-94		
Electrical Wiring Harness					10-298				
Engine Starter Wiring Harness					10-274	10-274	10-277		
Engine Wiring Harness						10-286	10-292		
Fuel Shutoff Wiring Harness						10-109	10-110		
Instrument Panel Wiring Harness						10-132	10-134		
Master Battery Wiring Harness						10-97	10-99		
Master Control Panel Wiring Harness						10-101	10-105		
Personnel Heater Wiring Harness						10-85	10-89		
Smoke Generator Wiring Harness									
Hull Wiring Harness						21-11	21-14		
To Bulkhead Lead						21-10	21-10		
Transmission Wiring Harness						10-281	10-283		

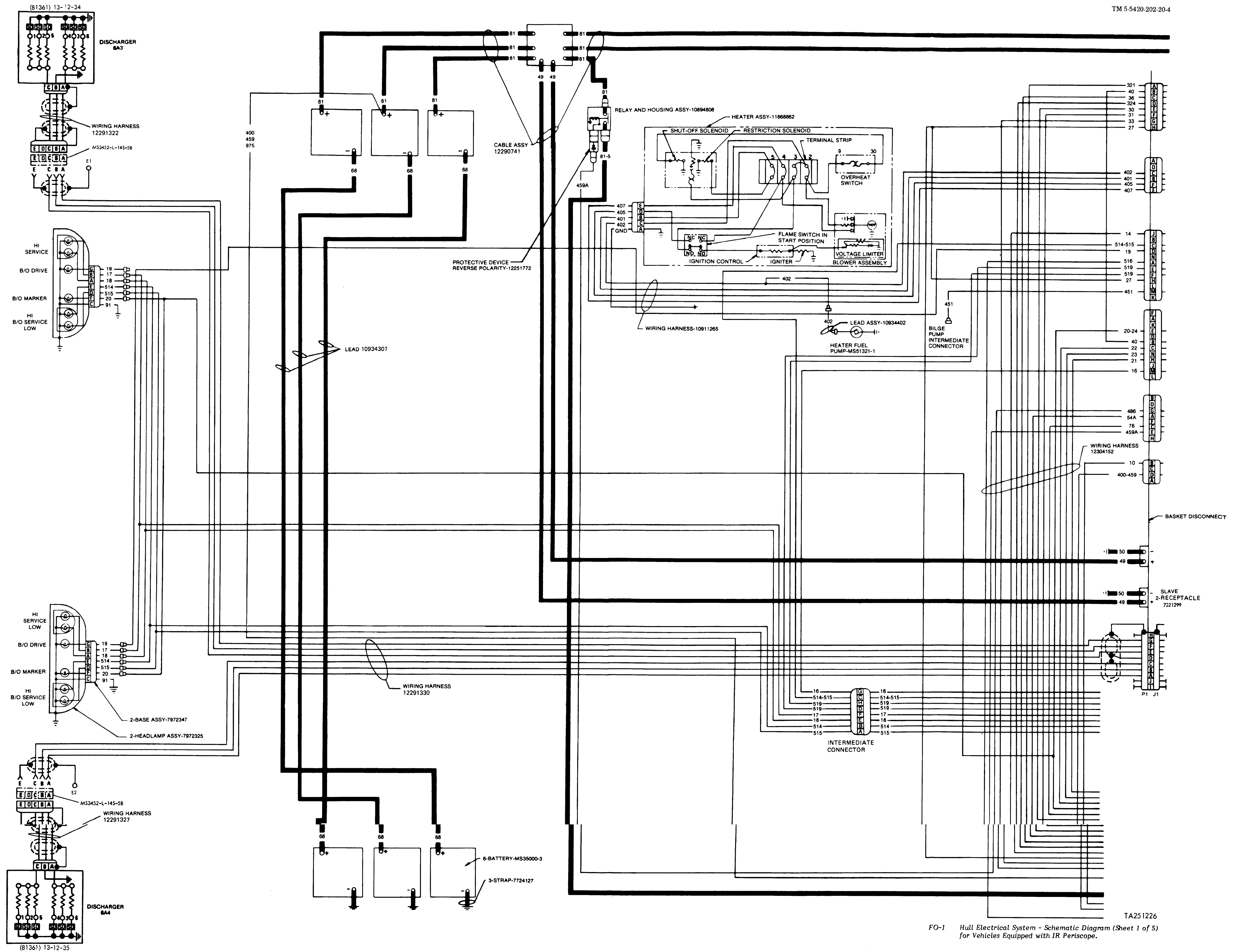

(81361) 13-12-35

TA251226

FO-1 Hull Electrical System - Schematic Diagram (Sheet 1 of 5) for Vehicles Equipped with IR Periscope.

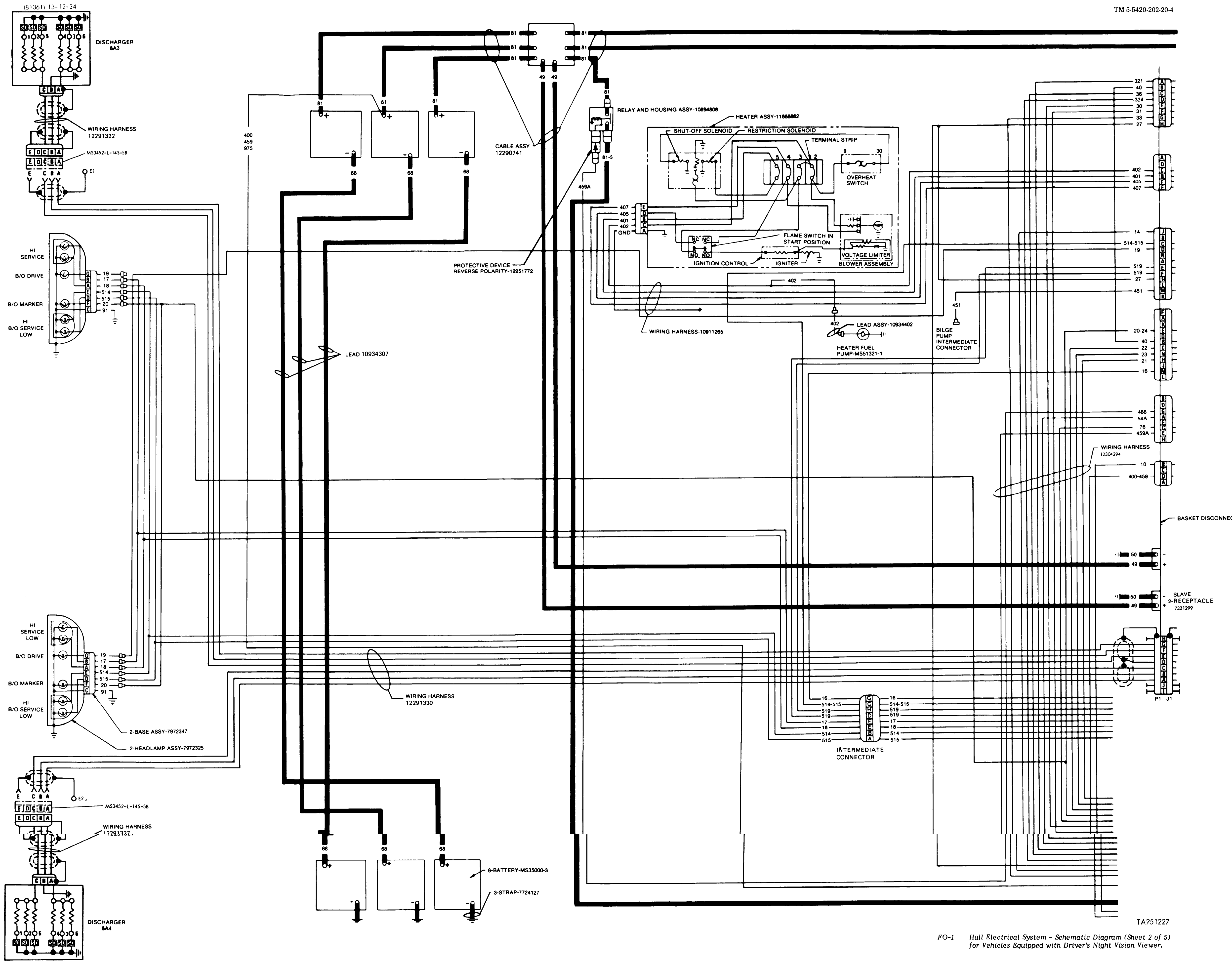

(81361) 13-12-34

(81361) 13-12-35

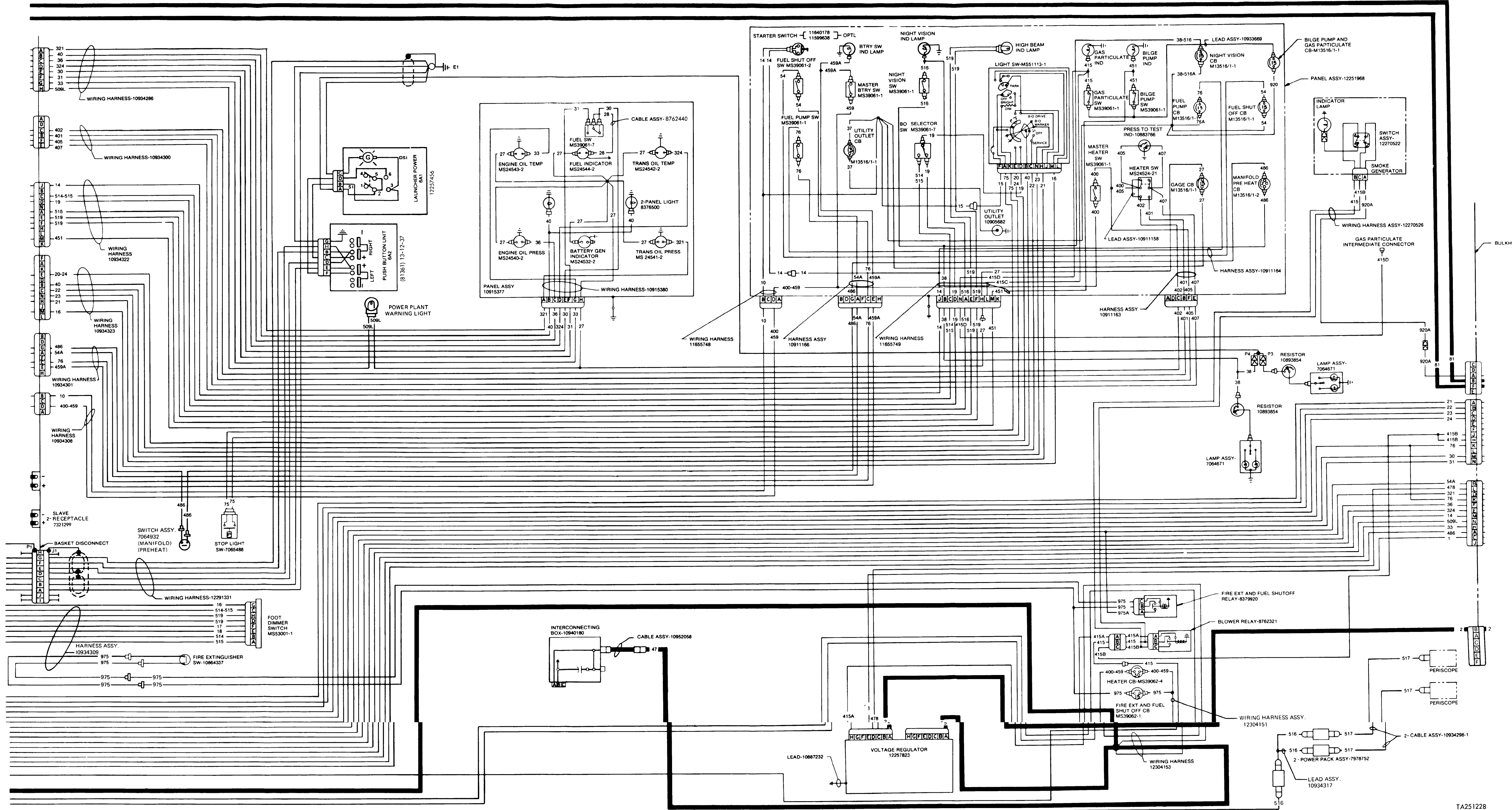

FO-1 Hull Electrical System - Schematic Diagram (Sheet 3 of 5) for Vehicles Equipped with IR Periscope.

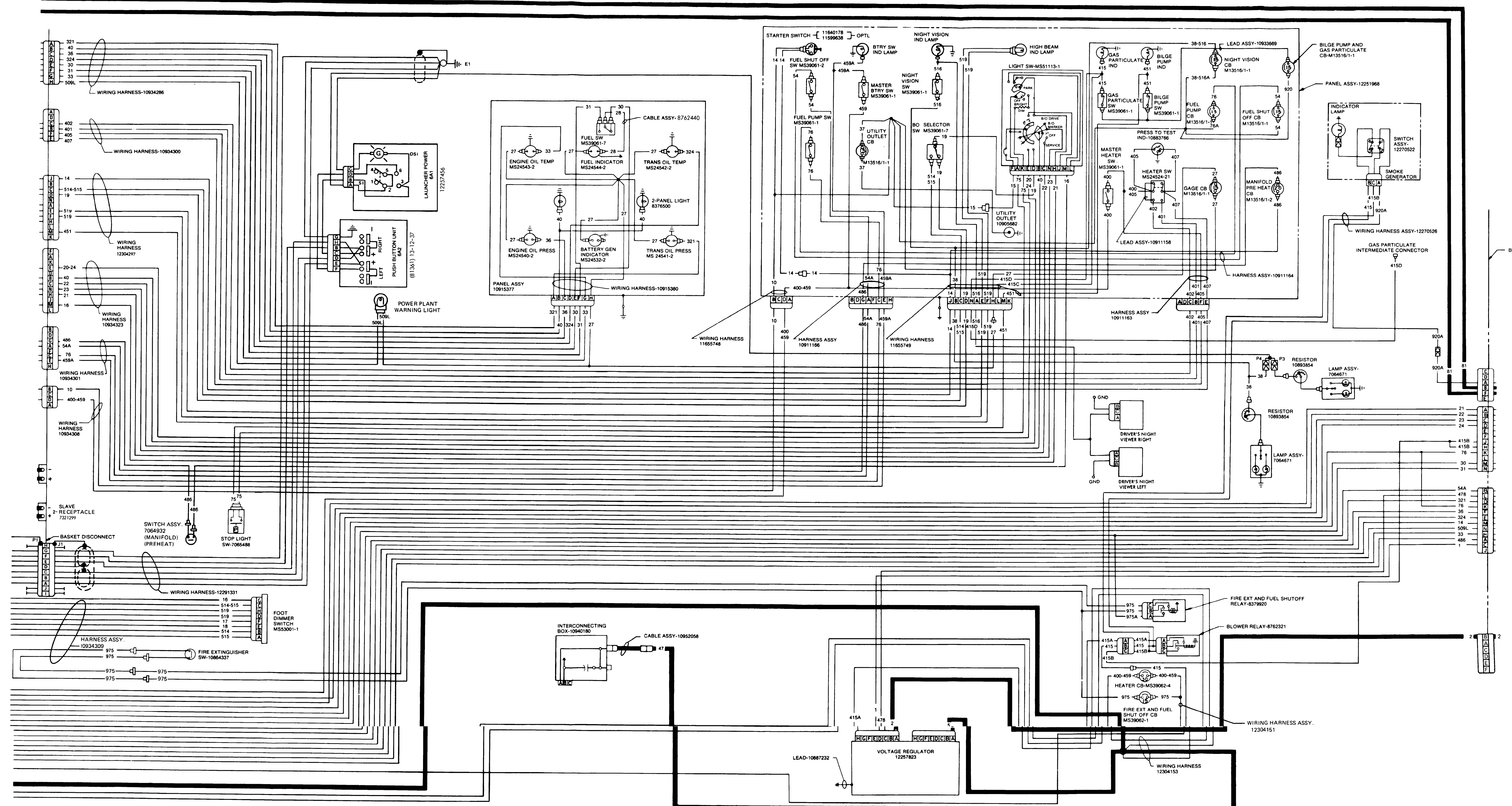

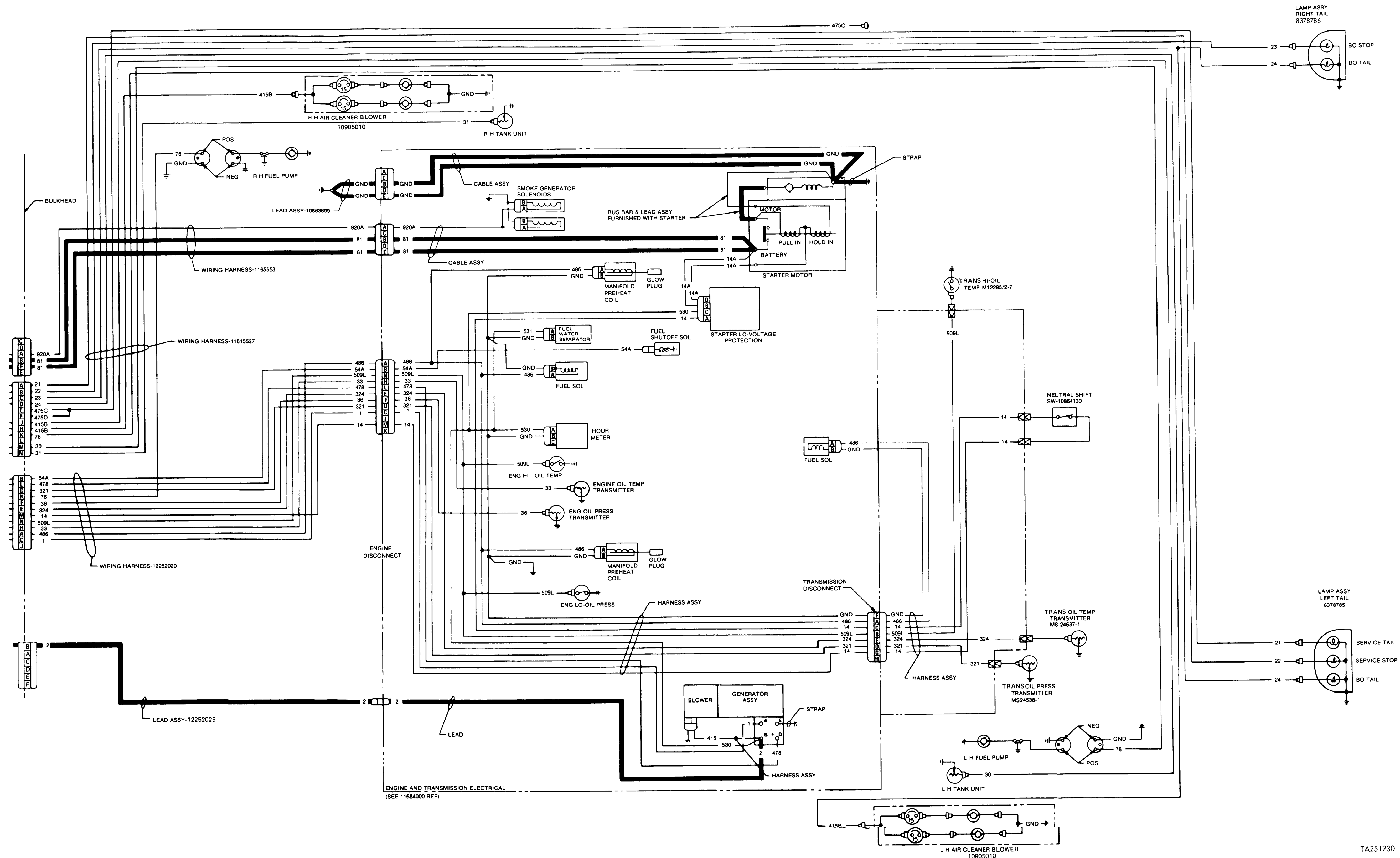

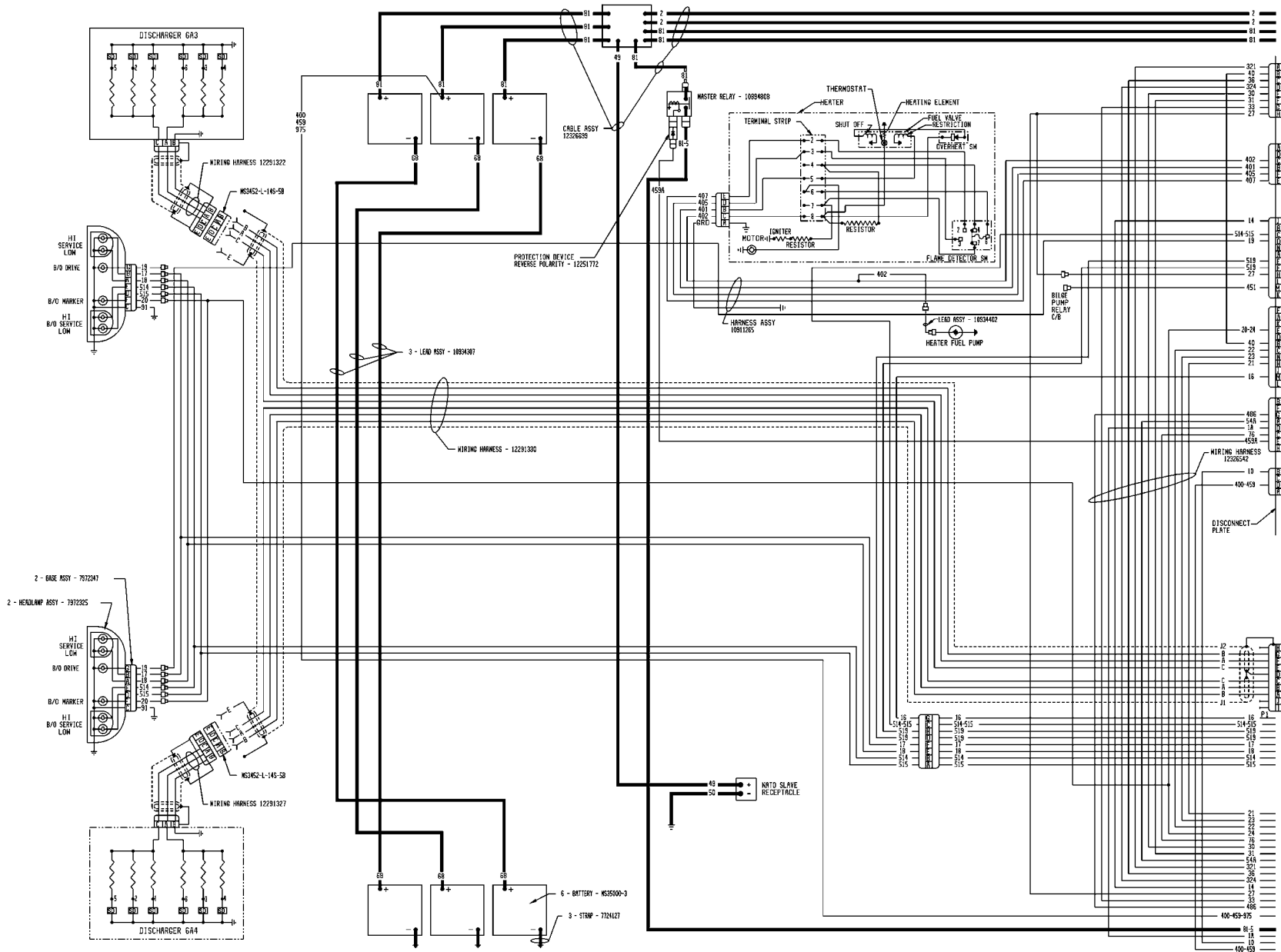

HYDRAULIC/ELECTRICAL
UPGRADED (HEU) VEHICLES
FOR VEHICLES EQUIPPED WITH
650 VDC ALTERNATOR

FO-2 Hull Electrical System -
Schematic Diagram
(Sheet 1 of 4)

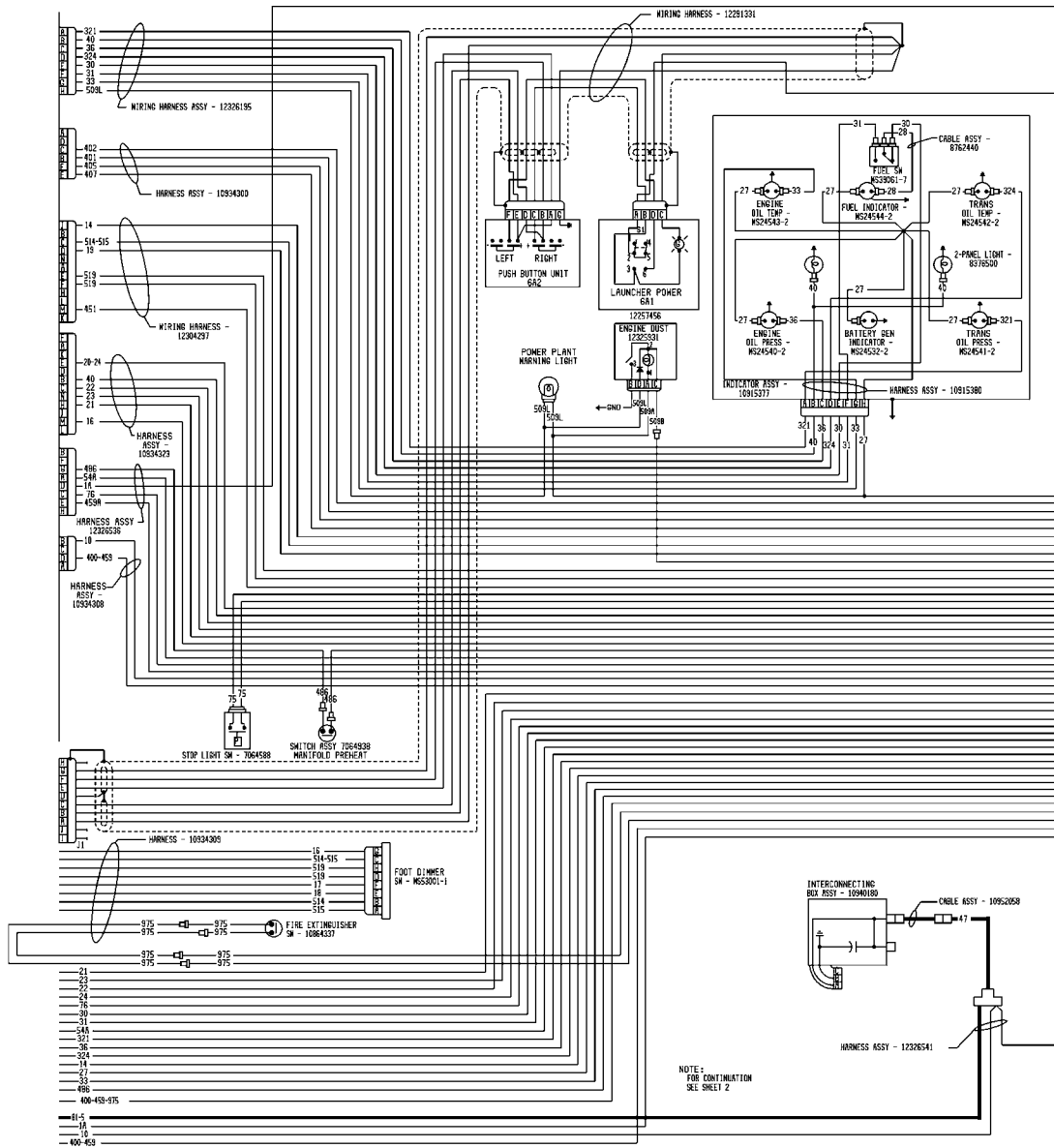

HYDRAULIC/ELECTRICAL
UPGRADED (HEU) VEHICLES

FOR VEHICLES EQUIPPED WITH
650 VDC ALTERNATOR

FO-2 Hull Electrical System -
Schematic Diagram
(Sheet 2 of 4)

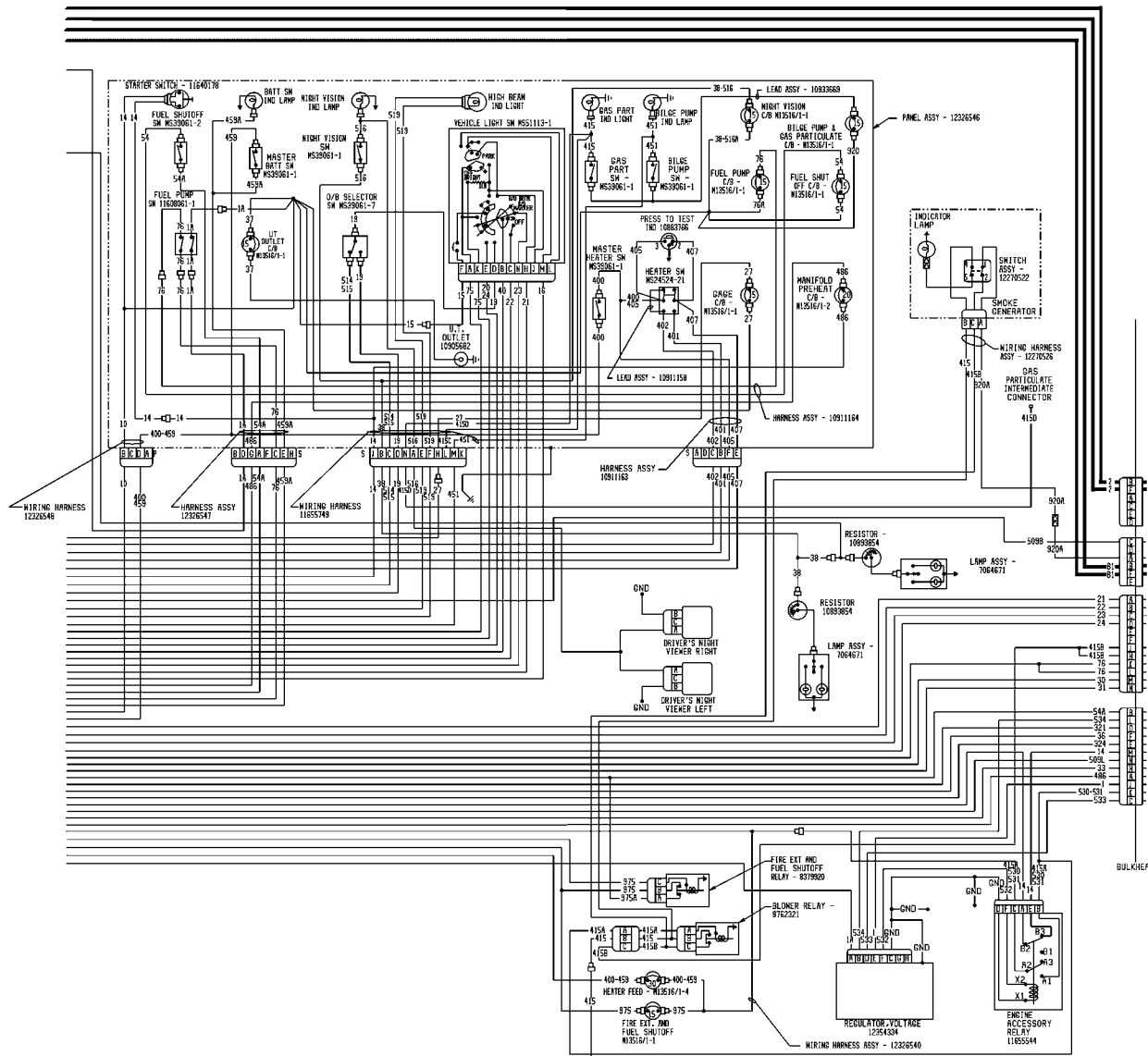

HYDRAULIC/ELECTRICAL
UPGRADED (HEU) VEHICLES

FOR VEHICLES EQUIPPED WITH
650 VDC ALTERNATOR

FO-2 Hull Electrical System -
Schematic Diagram
(Sheet 3 of 4)

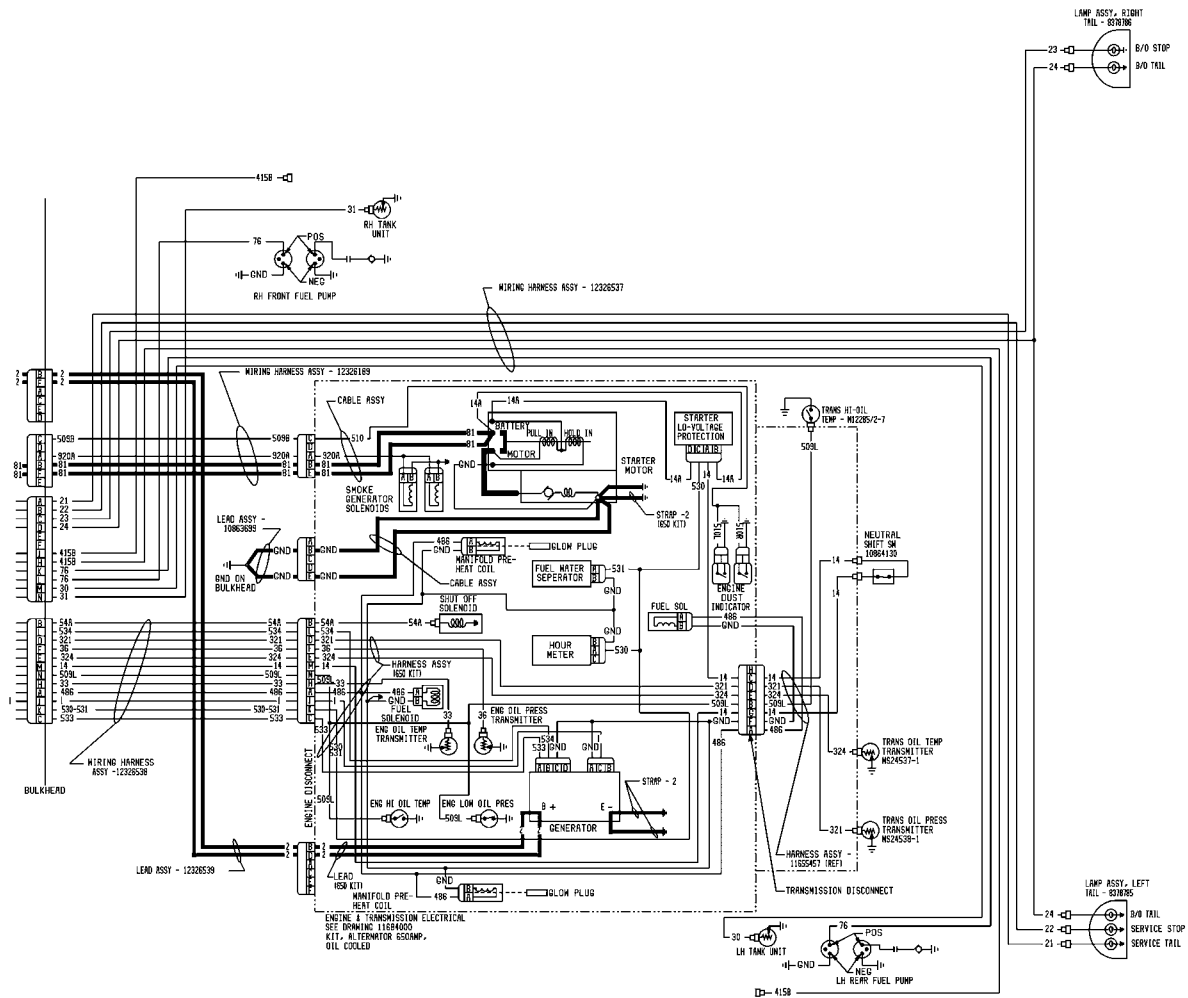

HYDRAULIC/ELECTRICAL
UPGRADED (HEU) VEHICLES

FOR VEHICLES EQUIPPED WITH
650 VDC ALTERNATOR

FO-2 Hull Electrical System -
Schematic Diagram
(Sheet 4 of 4)

By Order of the Secretary of the Army

JOHN A. WICKHAM, JR.
General United States Army
Chief of Staff

Official:

MILDRED E. HEDBERG
Brigadier General United States Army
The Adjutant General

Distribution

To be distributed in accordance with DA Form 12-37, Organizational Maintenance Requirements for Tank, Bridge Launcher, M60A1, (AVLB).

RECOMMENDED CHANGES TO PUBLICATIONS AND BLANK FORMS For use of this form, see AR 25-30; the proponent agency is ODISC4.						Use Part II (<i>reverse</i>) for Repair Parts and Special Tool Lists (RPSTL) and Supply Catalogs/Supply Manuals (SC/SM).	DATE
TO: (<i>Forward to proponent of publication or form</i>) (<i>Include ZIP Code</i>) AMSTA-LC-LPIT / TECH PUBS, TACOM-RI 1 Rock Island Arsenal Rock Island, IL 61299-7630						FROM: (<i>Activity and location</i>) (<i>Include ZIP Code</i>)	
PART I - ALL PUBLICATIONS (EXCEPT RPSTL AND SC/SM) AND BLANK FORMS							
PUBLICATION/FORM NUMBER TM 5-5420-202-20-4						DATE 28 OCTOBER 1985	TITLE M60A1 TANK CHASSIS, TRANSPORTING: FOR BRIDGE, SCISSORING TYPE, CLASS 60
ITEM NO.	PAGE NO.	PARA-GRAPH	LINE NO. *	FIGURE NO.	TABLE NO.	RECOMMENDED CHANGES AND REASON (<i>Provide exact wording of recommended changes, if possible.</i>)	
<i>*Reference to line numbers within the paragraph or subparagraph.</i>							
TYPED NAME, GRADE OR TITLE					TELEPHONE EXCHANGE/AUTOVON, PLUS EXTENSION		SIGNATURE

TO: <i>(Forward direct to addressee listed in publication)</i> AMSTA-LC-LPIT / TECH PUBS, TACOM-RI 1 Rock Island Arsenal Rock Island, IL 61299-7630	FROM: <i>(Activity and location) (Include ZIP Code)</i>	DATE
--	---	------

PART II – REPAIR PARTS AND SPECIAL TOOL LISTS AND SUPPLY CATALOGS/SUPPLY MANUALS

PUBLICATION NUMBER TM 5-5420-202-20-4	DATE 28 OCTOBER 1985	TITLE M60A1 TANK CHASSIS, TRANSPORTING: FOR BRIDGE, SCISSORING TYPE, CLASS 60
--	-------------------------	---

PAGE NO.	COLM NO.	LINE NO.	NATIONAL STOCK NUMBER	REFERENCE NO.	FIGURE NO.	ITEM NO.	TOTAL NO. OF MAJOR ITEMS SUPPORTED	RECOMMENDED ACTION

PART III – REMARKS *(Any general remarks or recommendations, or suggestions for improvement of publications and blank forms. Additional blank sheets may be used if more space is needed.)*

TYPED NAME, GRADE OR TITLE	TELEPHONE EXCHANGE/AUTOVON, PLUS EXTENSION	SIGNATURE
----------------------------	--	-----------

RECOMMENDED CHANGES TO PUBLICATIONS AND BLANK FORMS						Use Part II (<i>reverse</i>) for Repair Parts and Special Tool Lists (RPSTL) and Supply Catalogs/Supply Manuals (SC/SM).	DATE
For use of this form, see AR 25-30; the proponent agency is ODISC4.							
TO: (<i>Forward to proponent of publication or form</i>) (<i>Include ZIP Code</i>) AMSTA-LC-LPIT / TECH PUBS, TACOM-RI 1 Rock Island Arsenal Rock Island, IL 61299-7630						FROM: (<i>Activity and location</i>) (<i>Include ZIP Code</i>)	
PART I - ALL PUBLICATIONS (EXCEPT RPSTL AND SC/SM) AND BLANK FORMS							
PUBLICATION/FORM NUMBER TM 5-5420-202-20-4				DATE 28 OCTOBER 1985	TITLE M60A1 TANK CHASSIS, TRANSPORTING: FOR BRIDGE, SCISSORING TYPE, CLASS 60		
ITEM NO.	PAGE NO.	PARA-GRAPH	LINE NO. *	FIGURE NO.	TABLE NO.	RECOMMENDED CHANGES AND REASON (<i>Provide exact wording of recommended changes, if possible.</i>)	
<i>*Reference to line numbers within the paragraph or subparagraph.</i>							
TYPED NAME, GRADE OR TITLE				TELEPHONE EXCHANGE/AUTOVON, PLUS EXTENSION		SIGNATURE	

TO: <i>(Forward direct to addressee listed in publication)</i> AMSTA-LC-LPIT / TECH PUBS, TACOM-RI 1 Rock Island Arsenal Rock Island, IL 61299-7630	FROM: <i>(Activity and location) (Include ZIP Code)</i>	DATE
--	---	------

PART II - REPAIR PARTS AND SPECIAL TOOL LISTS AND SUPPLY CATALOGS/SUPPLY MANUALS

PUBLICATION NUMBER TM 5-5420-202-20-4	DATE 28 OCTOBER 1985	TITLE M60A1 TANK CHASSIS, TRANSPORTING: FOR BRIDGE, SCISSORING TYPE, CLASS 60
--	-------------------------	---

PAGE NO.	COLM NO.	LINE NO.	NATIONAL STOCK NUMBER	REFERENCE NO.	FIGURE NO.	ITEM NO.	TOTAL NO. OF MAJOR ITEMS SUPPORTED	RECOMMENDED ACTION

PART III - REMARKS *(Any general remarks or recommendations, or suggestions for improvement of publications and blank forms. Additional blank sheets may be used if more space is needed.)*

TYPED NAME, GRADE OR TITLE	TELEPHONE EXCHANGE/AUTOVON, PLUS EXTENSION	SIGNATURE
----------------------------	--	-----------

RECOMMENDED CHANGES TO PUBLICATIONS AND BLANK FORMS For use of this form, see AR 25-30; the proponent agency is ODISC4.						Use Part II (<i>reverse</i>) for Repair Parts and Special Tool Lists (RPSTL) and Supply Catalogs/Supply Manuals (SC/SM).	DATE
TO: (<i>Forward to proponent of publication or form</i>) (<i>Include ZIP Code</i>) AMSTA-LC-LPIT / TECH PUBS, TACOM-RI 1 Rock Island Arsenal Rock Island, IL 61299-7630						FROM: (<i>Activity and location</i>) (<i>Include ZIP Code</i>)	
PART I - ALL PUBLICATIONS (EXCEPT RPSTL AND SC/SM) AND BLANK FORMS							
PUBLICATION/FORM NUMBER TM 5-5420-202-20-4						DATE 28 OCTOBER 1985	TITLE M60A1 TANK CHASSIS, TRANSPORTING: FOR BRIDGE, SCISSORING TYPE, CLASS 60
ITEM NO.	PAGE NO.	PARA-GRAPH	LINE NO. *	FIGURE NO.	TABLE NO.	RECOMMENDED CHANGES AND REASON (<i>Provide exact wording of recommended changes, if possible.</i>)	
<i>*Reference to line numbers within the paragraph or subparagraph.</i>							
TYPED NAME, GRADE OR TITLE				TELEPHONE EXCHANGE/AUTOVON, PLUS EXTENSION		SIGNATURE	

TO: <i>(Forward direct to addressee listed in publication)</i> AMSTA-LC-LPIT / TECH PUBS, TACOM-RI 1 Rock Island Arsenal Rock Island, IL 61299-7630	FROM: <i>(Activity and location) (Include ZIP Code)</i>	DATE
--	---	------

PART II - REPAIR PARTS AND SPECIAL TOOL LISTS AND SUPPLY CATALOGS/SUPPLY MANUALS

PUBLICATION NUMBER TM 5-5420-202-20-4	DATE 28 OCTOBER 1985	TITLE M60A1 TANK CHASSIS, TRANSPORTING: FOR BRIDGE, SCISSORING TYPE, CLASS 60
--	-------------------------	---

PAGE NO.	COLM NO.	LINE NO.	NATIONAL STOCK NUMBER	REFERENCE NO.	FIGURE NO.	ITEM NO.	TOTAL NO. OF MAJOR ITEMS SUPPORTED	RECOMMENDED ACTION

PART III - REMARKS *(Any general remarks or recommendations, or suggestions for improvement of publications and blank forms. Additional blank sheets may be used if more space is needed.)*

TYPED NAME, GRADE OR TITLE	TELEPHONE EXCHANGE/AUTOVON, PLUS EXTENSION	SIGNATURE
----------------------------	--	-----------

THE METRIC SYSTEM AND EQUIVALENTS

LINEAR MEASURE

1 Centimeter = 10 Millimeters = 0.01 Meters = 0.3937 Inches
 1 Meter = 100 Centimeters = 1000 Millimeters = 39.37 Inches
 1 Kilometer = 1000 Meters = 0.621 Miles

WEIGHTS

1 Gram = 0.001 Kilograms = 1000 Milligrams = 0.035 Ounces
 1 Kilogram = 1000 Grams = 2.2 Lb.
 1 Metric Ton = 1000 Kilograms = 1 Megagram = 1.1 Short Tons

LIQUID MEASURE

1 Milliliter = 0.001 Liters = 0.0338 Fluid Ounces
 1 Liter = 1000 Milliliters = 33.82 Fluid Ounces

SQUARE MEASURE

1 Sq. Centimeter = 100 Sq. Millimeters = 0.155 Sq. Inches
 1 Sq. Meter = 10,000 Sq. Centimeters = 10.76 Sq. Feet
 1 Sq. Kilometer = 1,000,000 Sq. Meters = 0.386 Sq. Miles

CUBIC MEASURE

1 Cu. Centimeter = 1000 Cu. Millimeters = 0.06 Cu. Inches
 1 Cu. Meter = 1,000,000 Cu. Centimeters = 35.31 Cu. Feet

TEMPERATURE

$\frac{5}{9}(\text{°F} - 32) = \text{°C}$
 212° Fahrenheit is equivalent to 100° Celsius
 90° Fahrenheit is equivalent to 32.2° Celsius
 32° Fahrenheit is equivalent to 0° Celsius
 $\frac{9}{5} \text{°C} + 32 = \text{°F}$

APPROXIMATE CONVERSION FACTORS

TO CHANGE	TO	MULTIPLY BY
Inches	Centimeters	2.540
Feet	Meters	0.305
Yards	Meters	0.914
Miles	Kilometers	1.609
Square Inches	Square Centimeters	6.451
Square Feet	Square Meters	0.093
Square Yards	Square Meters	0.836
Square Miles	Square Kilometers	2.590
Acres	Square Hectometers	0.405
Cubic Feet	Cubic Meters	0.028
Cubic Yards	Cubic Meters	0.765
Fluid Ounces	Milliliters	29.573
Pints	Liters	0.473
Quarts	Liters	0.946
Gallons	Liters	3.785
Ounces	Grams	28.349
Pounds	Kilograms	0.454
Short Tons	Metric Tons	0.907
Pound-Feet	Newton-Meters	1.356
Pounds per Square Inch	Kilopascals	6.895
Miles per Gallon	Kilometers per Liter	0.425
Miles per Hour	Kilometers per Hour	1.609

TO CHANGE	TO	MULTIPLY BY
Centimeters	Inches	0.394
Meters	Feet	3.280
Meters	Yards	1.094
Kilometers	Miles	0.621
Square Centimeters	Square Inches	0.155
Square Meters	Square Feet	10.764
Square Meters	Square Yards	1.196
Square Kilometers	Square Miles	0.386
Square Hectometers	Acres	2.471
Cubic Meters	Cubic Feet	35.315
Cubic Meters	Cubic Yards	1.308
Milliliters	Fluid Ounces	0.034
Liters	Pints	2.113
Liters	Quarts	1.057
Liters	Gallons	0.264
Grams	Ounces	0.035
Kilograms	Pounds	2.205
Metric Tons	Short Tons	1.102
Newton-Meters	Pound-Feet	0.738
Kilopascals	Pounds per Square Inch	0.145
Kilometers per Liter	Miles per Gallon	2.354
Kilometers per Hour	Miles per Hour	0.621

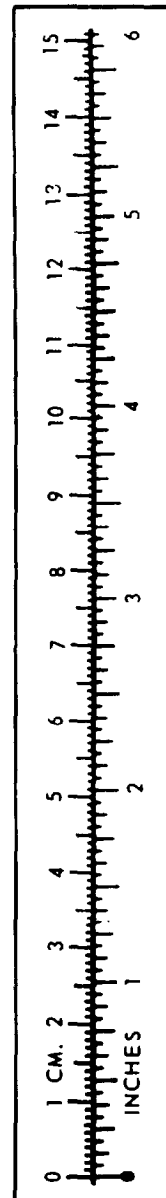

TA089991