

SUPERSEDES COPY DATED
18 DECEMBER 1981

**TECHNICAL MANUAL
DIRECT SUPPORT AND GENERAL
SUPPORT MAINTENANCE MANUAL**

**HULL AND
RELATED COMPONENTS
RECOVERY VEHICLE,
FULL TRACKED: LIGHT,
ARMORED, M578
(2350-00-439-6242) (EIC:3LA)**

DIRECT SUPPORT TROUBLESHOOTING	PAGE 2-3
-----------------------------------	----------

DIRECT SUPPORT MAINTENANCE PROCEDURES	PAGE 2-32
---	-----------

GENERAL SUPPORT TROUBLESHOOTING	PAGE 3-1
------------------------------------	----------

GENERAL SUPPORT MAINTENANCE PROCEDURES	PAGE 3-5
--	----------

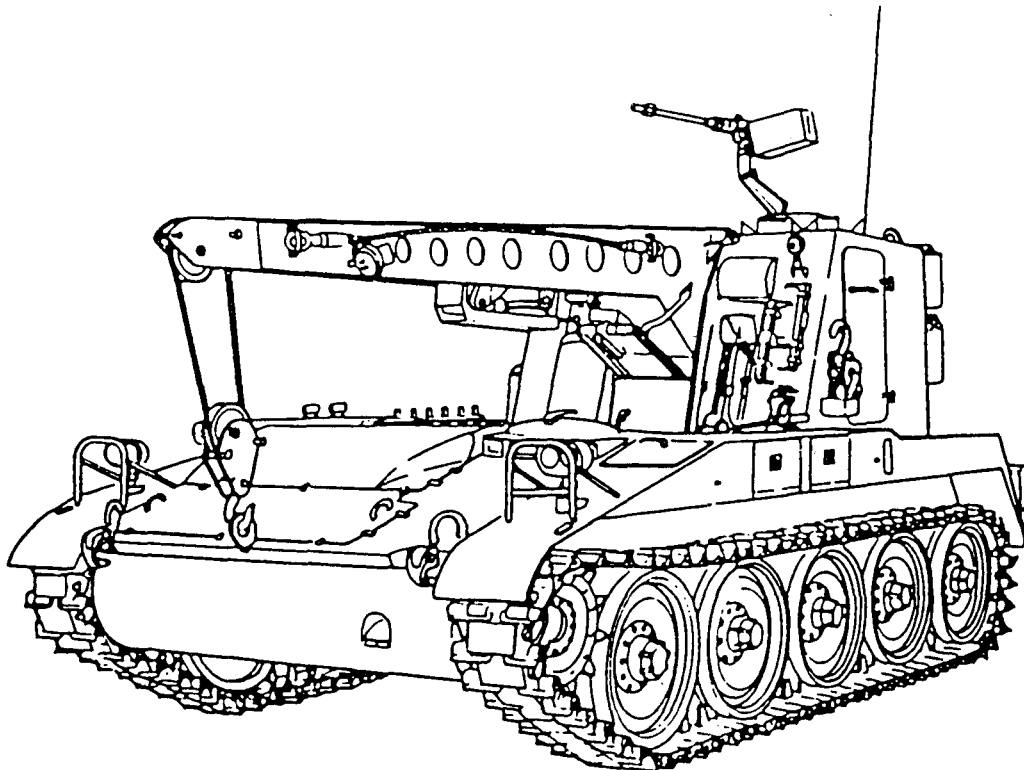

Distribution: Statement A: Approved for public release; distribution is unlimited

This Manual supersedes hull and related components portions of
TM 9-2350-238-34-1, dated 18 December 1981, including all changes

**HEADQUARTERS, DEPARTMENT OF THE ARMY
31 MARCH 1994**

WARNING

RADIATION HAZARD



T R I T I U M (H₃)

Rules and Regulations

Copies of the following rules and regulations are maintained at HQ, AMCCOM Rock Island, IL 61299-6000. Copies may be requested or information obtained by contacting the AMCCOM Radiological Protection Officer (RPO), AUTOVON 793-2964, Commercial (309) 782-2964.

10CFR Part 19--Notices, Instructions, and Reports to Workers; Inspections.

10CFR Part 20--Standards for Protection Against Radiation.

NRC license, license condition, and license application.

Safety Precautions

The radioactive material used in these instruments is tritium gas (H₃) sealed in pyrex tubes. It poses no significant hazard to the repair person when intact. These sources illuminate the instrumentation for night operations. Tampering with or removal of the sources in the field is prohibited by Federal law. In the event there is no illumination, notify the local RPO. Do not attempt to repair or replace the instrument in the field. If skin contact is made with any area contaminated with tritium, immediately wash with nonabrasive soap and water.

Identification

Radioactive self-luminous sources are identified by means of radioactive warning labels (as above). These labels should not be defaced or removed and should be replaced immediately when necessary. Refer to the local RPO or the AMCCOM RPO for instructions on handling, storage, or disposal.

Storage and Shipping

All radioactively illuminated instruments or modules which are defective will be evacuated to a depot maintenance activity. These items must be placed in a plastic bag and packaged in the shipping container from which the replacement was taken before evacuation to a higher echelon is made. Spare equipment must be stored in the shipping container, as received, until installed on the weapon. Storage of these items is recommended to be in an outdoor shed-type storage or unoccupied building.

GENERAL

Dry cleaning solvent (SD2) is toxic and flammable. Wear protective goggles and gloves and use only in well-ventilated areas.

Solvent vapors are toxic. Do not use solvent in a confined space. Avoid long periods of breathing solvent vapors and/or contact with skin.

Prolonged breathing of fuel vapors can be fatal. If eyes or skin become irritated by diesel fuel, flush with water.

WARNING (CONT)

Prolonged breathing of fuel vapors can be fatal. Do not enter fuel cells until they have been thoroughly cleaned.

Fuel cells that are not entirely free of fuel or fuel vapors must not be welded or exposed to heat, flame, or sparks. Welding or the use of power sanders, chisels, and chipping hammers shall be preceded by removal of the fabric fuel cell and by thorough cleaning.

Failure to reduce pressure to zero before removing fuel filler cap may cause injury.

Unusable CARC mixtures are considered hazardous waste and will require disposal in accordance with Federal, state, DOD, DA, and local installation waste regulations. Consult the installation environmental office for proper disposal guidance. Mixed CARC is extremely flammable-use only in well-ventilated areas and keep away from open flames, heat, sparks, and other ignition sources.

- For brush/roller painting in confined spaces, an airline respirator is required, unless an air sampling shows exposure to be below standards. If the air sampling is below standards, either chemical cartridge or airline respirators are required.
- Spot painters applying CARC paint by brush or roller must wear clothing and gloves affording full coverage.
- Do not use water, alcohol, or amine-based solvents to thin or remove CARC paints. Use of these solvents with CARC paints can produce chemical reactions resulting in nausea, disease, burns, or severe illness to personnel.
- Do not use paint solvents to remove paint/coating from your skin.
- Mix paint/coating in a well-ventilated mixing room or spraying area away from open flames. Personnel mixing paint/coating should wear eye protection.
- Use paint/coating with adequate ventilation.
- Personnel grinding or sanding on painted equipment should use high efficiency air purifying respirators.
- Do not weld or cut CARC-coated metal. Substances causing skin or respiratory irritation may be released. Before applying heat, sand or grind paint down to bare metal on area four inches to either side of the area you plan to weld or cut.

HYDRAULICS

Hydraulic fluid is under high pressure. Relieve pressure and drain system before removing connections or components.

Hydraulic system is under high pressure. Follow safety procedures to prevent injury. Wipe up spilled hydraulic fluid.

WARNING (CONT)

MASTER SWITCH

Make sure MASTER switch is OFF before repairing electrical components. Failure to observe this warning could result in injury to personnel.

BATTERIES

Failure to remove or disconnect the batteries before removing or installing any electrical wiring harness or lead may result in injury or damaged equipment.

FIRST AID

Refer to FM 21-11, First Aid for Soldiers.

TECHNICAL MANUAL

No. 9-2350-238-34-1

HEADQUARTERS
DEPARTMENT OF THE ARMY
WASHINGTON, DC , 31 March 1994

DIRECT SUPPORT AND GENERAL SUPPORT MAINTENANCE MANUAL

HULL AND RELATED COMPONENTS
RECOVERY VEHICLE, FULL TRACKED:
LIGHT, ARMORED, M578
(2350-00-439-6242) (EIC:3LA)

DISTRIBUTION STATEMENT A. Approved for public release; distribution is unlimited.

REPORTING ERRORS AND RECOMMENDING IMPROVEMENTS

You can help improve this manual. If you find any mistakes or if you know of a way to improve the procedures, please let us know. Mail your letter, DA Form 2028 (Recommended Changes to Publications and Blank Forms), or DA Form 2028-2 located in the back of this manual direct to Commander, US Army Tank-Automotive Command, Attn: AMSTA-MB, Warren, MI 48597-5000. A reply will be furnished to you.

Table of Contents

	Page
HOW TO USE THIS MANUAL	ii
 CHAPTER 1. INTRODUCTION	
Section I. General Information	1-1
Section II. Equipment Description and Data.	1-3
 CHAPTER 2. DIRECT SUPPORT MAINTENANCE INSTRUCTIONS	
Section I. Repair Parts, Special Tools, TMDE, and Support Equipment	2-2
Section II. Direct Support Troubleshooting	2-3
Section III. Maintenance of Hydraulic Lines and Fittings	2-19
Section IV. Wiring Harness and Cable Repair.	2-21
Section V. Direct Support General Maintenance Procedures	2-28
Section VI. Direct Support Maintenance Procedures	2-32
 CHAPTER 3. GENERAL SUPPORT MAINTENANCE INSTRUCTIONS	
Section 1. General Support General Maintenance Procedures	3-1
Section II. General Support Troubleshooting	3-1

*This manual supersedes TM 9-2350-238-34-1, dated 18 December 1981

Table of Contents (cont)

Page

Section III. General Support Maintenance Procedures	3 -4
Section IV. Preparation for Storage or Shipment	3 -55
APPENDIX A. REFERENCES	A -1
APPENDIX B. EXPENDABLE/DURABLE SUPPLIES AND MATERIALS LIST	B -1
APPENDIX C. ILLUSTRATED LIST OF MANUFACTURED ITEMS	C -1
APPENDIX D. TORQUE VALUES	D -1
APPENDIX E. SPECIAL TOOLS AND EQUIPMENT	E -1
ALPHABETICAL INDEX	Index -1

HOW TO USE THIS MANUAL

This manual (TM 9-2350-238-34-1) contains direct support and general support maintenance procedures for the hull and related components of the M578 full tracked recovery vehicle. This manual is to be used in conjunction with TM 9-2350-238-20-1 and TM 9-2340-238-24P-1. Chapter 1 contains general information; information concerning repair parts special tools, TMDE, and support equipment; and equipment description and data. Chapter 2 contains direct support troubleshooting and direct support maintenance procedures. Chapter 3 contains general support maintenance procedures and information concerning preparation for storage or shipment.

Be sure to read and understand maintenance instructions before beginning any maintenance task. Also, read and understand information in Chapter 1 and general maintenance procedures on page 2-28 before beginning any maintenance task.

M578 ARMORED LIGHT, FULL TRACKED RECOVERY VEHICLE

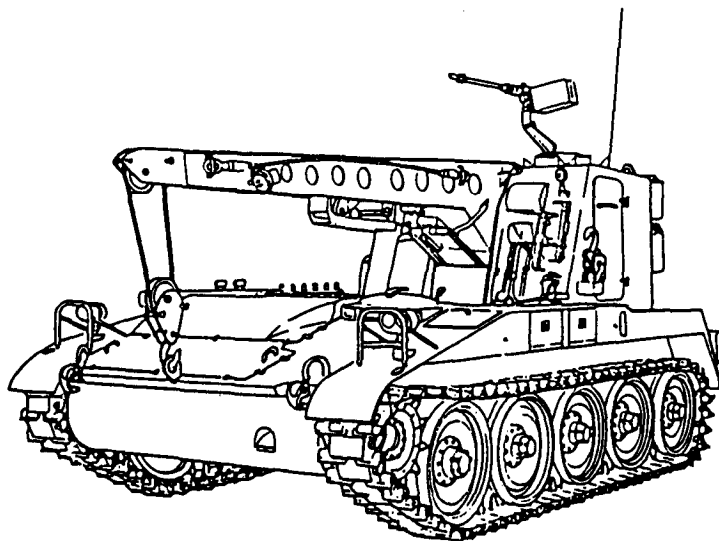

CHAPTER 1

INTRODUCTION

CHAPTER INDEX

	Page
Corrosion Prevention and Control (CPC)	1- 3
Destruction of Army Materiel to Prevent Enemy Use	1 - 2
Equipment Characteristics, Capabilities, and Features	1- 4
Equipment Data	1- 4
Location and Description of Major Components	1 - 4
Maintenance Forms, Records, and Reports	1 - 2
Official Nomenclature, Names, and Designations	1- 3
Preparation for Storage or Shipment	1 -2
Reporting Equipment improvement Recommendations (EIR)	1- 3
Scope	1- 2

Section I. GENERAL INFORMATION

1-1. SCOPE.

- a. *Type of Manual:* Direct support and general supported maintenance.
- b. *Model Number and Equipment Name:* M578 armored light full tracked recovery vehicle.
- c. *Purpose of Equipment:* M578 armored light full tracked recovery vehicle is used to pick up or tow disabled mechanized equipment.

1-2. MAINTENANCE FORMS, RECORDS, AND REPORTS. Department of the Army forms and procedures used for equipment maintenance will be those prescribed by DA PAM 738-750, The Army Maintenance Management System (TAMMS).

1-3. DESTRUCTION OF ARMY MATERIEL TO PREVENT ENEMY USE.

a. *Tactical Situations.* Situations may arise in which it is necessary to abandon equipment in the combat zone. All abandoned equipment must be destroyed to prevent its use by the enemy. The destruction of equipment subject to capture or abandonment in the combat zone will be undertaken only upon authority delegated by a division or higher commander.

b. *Plans.*

(1) Plans for destruction of equipment must be adequate, uniform, and easily carried out in the field.

1-3. DESTRUCTION OF ARMY MATERIEL TO PREVENT ENEMY USE (CONT).

(2) Destruction must be as complete as the available time, equipment, and personnel will permit. Since complete destruction requires considerable time, priorities must be established so the more essential parts are destroyed first.

(3) The same essential parts must be destroyed on all like units to prevent the enemy from constructing a complete unit from undamaged parts.

(4) Spare parts and accessories must be given the same priority as parts installed on the equipment.

c. *Methods.* To destroy equipment adequately and uniformly, all personnel of the unit must know the plan and priority of destruction and be trained in the methods of destruction.

d. *References.* Read TM 750-244-6 for information on destruction of mechanical equipment. Read TM 750-244-5-1 for information on destruction of ammunition.

1-4. PREPARATION FOR STORAGE OR SHIPMENT. Administrative storage is restricted to 90 days and must not be extended. Refer to TM 9-2350-238-20-1 for detailed instructions on administrative storage.

1-5. OFFICIAL NOMENCLATURE, NAMES, AND DESIGNATIONS.

Nomenclature Cross-Reference List.

<i>Common Name</i>	<i>Official Nomenclature</i>
Compression spring	Outer contact set compression spring
Crossover vent tube	Metallic bent tube
Fuel filler neck cap	Fuel filler neck assembly cap
Fuel level transmitter	Fuel sending unit liquid quantity transmitter
Insulating ring	Cover contact set insulating plus
Left fabric fuel cell	Left hand fuel cell
Lockwire	Nonelectrical wire
Plug connector	Plug shell assembly
Right fabric fuel cell	Engine fuel tank
Snap ring spacer	Receptacle to terminal board snap ring spacer
Upper insulating ring	Upper insulating plus

1-6. REPORTING EQUIPMENT IMPROVEMENT RECOMMENDATIONS (EIR). If your M578 vehicle needs improvement, let us know. Send us an EIR. You, the user, are the only one who can tell us what you don't like about your equipment. Let us know why you don't like the design. Put it on an SF 368 (Product Quality Deficiency Report). Mail it to us at Commander, US Army Tank-Automotive Command, ATTN: AMSTA-Q, Warren, MI 48397-5000. We will send you a reply.

1-7. CORROSION PREVENTION AND CONTROL (CPC).

a. General. Corrosion Prevention and Control (CPC) of Army materiel is a continuing concern. It is important that any corrosion problems with this item be reported so that the problem can be corrected and improvements can be made to prevent the problem in the future.

b. Corrosion. While corrosion is typically associated with rusting of metals, it can also include deterioration of other materials such as rubber and plastic. Unusual cracking, softening, swelling, or breaking of these materials maybe a corrosion problem.

c. Reporting. If a corrosion problem is identified, it can be reported using SF 368, Product Quality Deficiency Report. Use of key words such as "corrosion," "rust," "deterioration," or "cracking" will assure that the information is identified as a CPC problem.

d. Forms. The form should be submitted to: Commander, US Army Tank-Automotive Command, ATTN: AMSTA-Q/Customer Feedback Center, Warren, MI 48397-5000.

Section II EQUIPMENT DESCRIPTION AND DATA**1-8. EQUIPMENT CHARACTERISTICS, CAPABILITIES, AND FEATURES.**

a. Purpose. The M578 vehicle is used to pickup or tow disabled mechanized equipment, as a crane at repair bases, and as a carrying platform for spare parts and maintenance personnel.

b. Capabilities and Features.

CAUTION

Do not ford water which exceeds 42.0 in. (106.7 cm) in depth. Check for soft mud or sandy bottoms.

(1) The M578 vehicle is a light, full tracked, self-propelled, diesel-powered vehicle with a 30,000-lb (13,614-kg) boom winch and a 60,000-lb (27,228-kg) tow winch mounted in an armored cab. It is highly mobile, maneuverable, and may be air transported. The vehicle is capable of long-range, high-speed operation on improved roads. It can traverse rough terrain, muddy or marshy ground, sand, and snow or ice. The M578 vehicle can ford streams up to 42.0 in. (106.7 cm) deep without auxiliary fording equipment.

(2) A suspension lockout system and spade assembly provide a stable platform and increase the lifting and winching capabilities of the vehicle. The suspension lockout system, boom, winches, cab, and spade are hydraulically powered.

(3) A machine gun mount support is installed on the rigger/gunner cupola to accommodate a Browning M2 caliber .50 machine gun.

1-9. LOCATION AND DESCRIPTION OF MAJOR COMPONENTS. Refer to TM 9-2350-238-20-1.

1-10. EQUIPMENT DATA. Necessary equipment data not furnished in this manual can be found in TM 9-2350-238-10 or TM 9-2350-238-20-1.

a. Engine.



Do not let engine speed exceed 2300 RPM under any circumstances.

- (1) Type Two-cycle, V-8, turbocharged
compression-ignition, diesel, liquid cooled
- (2) Model 8V71T
- (3) Weight, dry (as installed) 2442 lb(1108 kg)
- (4) Number of cylinders 8
- (5) Displacement 568 cu in. (9308 cm³)
- (6) Bore 4.25 in. (10.80 cm)
- (7) Stroke 5.0 in. (12.7 cm)
- (8) Compression ratio 17:1
- (9) Maximum, gross brake horsepower (at 2300 rpm) 405 (302kW)
- (10) Maximum, net brake horsepower. 345 (257kW)
- (11) Maximum, rpm (governed):
 - (a) No load 2300 rpm
 - (b) Hydraulic pump engaged 1350 rpm
- (12) Idle speed 650 to 700 rpm
- (13) Crankshaft rotation (viewed from front of engine) Clockwise
- (14) Firing order 1L-3R-3L-4R-4L-2R-2L-1R

b. Power Takeoff.

- (1) Dimensions 19.00 in. lg x 10.75 in. h x 8.50 in. w
(48.26 cm lg x 27.30 cm h x 21.59 cm w)
- (2) Engine rpm to power takeoff output ratio. 1.32:1

c. Final Drives.

- (1) Type Front drive sprocket
- (2) Final drive ratio..... 5.35:1
- (3) Weight, dry:
 - (a) Left 718 lb (326 kg)
 - (b) Right 633 lb (287 kg)

d. Transmission.

- (1) Type Crossdrive, torque converter, planetary gear, all-torque shifting
- (2) Model XTG-411-2A
- (3) Transmission Hydraulic and mechanical
- (4) Weight, dry (as installed) 2390 1b(1084 kg)
- (5) Overall length 61.386 in. (155.920 cm)
- (6) Overall height 26.07 in. (66.22 cm)
- (7) Overall width (between output drive-to-hull mounting faces) 83 in. (211 cm)
- (8) Torque converter type Hydraulic, single stage, polyphase, (three element, with automatic lockup clutch)
- (9) Clutches Multiplate wet, hydraulically applied
- (10) Range selector Four forward speeds, two reverse speeds
- (11) Oil screen Reusable, disk-type
- (12) Lubrication pressure 18 to 45 psi (124 to 310 kPa) at 1835 to 1900 engine rpm (minimum 10 psi (69 kPa) at 1000 engine rpm)
- (13) Gear ratios:
 - (a) 1st 4.69:1
 - (b) 2nd 3.18:1
 - (c) 3rd 1.59:1
 - (d) 4th 0.794:1
 - (e) R1 5.60:1
 - (f) R2 3.79:1
- (14) Maximum rating:
 - (a) Input torque 880 ft-lb (1193 N-m)
 - (b) Input power (net) 360 hp (269 kW)
 - (c) Input speed 2300 rpm
- (15) Steering system:
 - (a) Clutches applied by Oil pressure
 - (b) Clutches released by Spring pressure
 - (c) Steering brakes applied by Oil pressure
 - (d) Brakes (service and parking) Multiplate, wet, mechanically applied, sintered bronze on steel
 - (e) Oil pumps 5 pumps
 - (f) Type of pump Gear, positive displacement

e. Auxiliary Drive Assembly.

- (1) Weight 191 lb (87 kg)
- (2) Input to generator output shaft ratio 1:3.48
- (3) Input fan sheave output shaft ratio 1:0.69
- (4) Magnetic clutch:
 - (a) Voltage 24 V dc
 - (b) Ampere at 25 °C (77 °F) 4.76
 - (c) Resistance at 25 °C (77°F) 5.04 ohms

1-10. EQUIPMENT DATA (CONT).

f. Radiators.

- (1) Dimensions 39.25 in. h x 24.00 in. w x 5.00 in. deep
(99.70 cm h x 60.96 cm w x 12.70 cm deep)
- (2) Coolant flow (each radiator)70 gpm (265 l/min)
- (3) Top tank temperature210 °F(99 °C)
- (4) Weight (each).....73 lb(33 kg)

g. Coolant Fan.

- (1) Design and construction data:
 - (a) Outside diameter27.0 in.(68.6cm)
 - (b) Overall length15.0 in. (38.1 cm)
 - (c) Weight120.0 lb(53.4 kg)
- (2) Direction of rotation (viewed from pulley end) Clockwise
- (3) Direction of airflow Through fan, into engine compartment
- (4) Number of mounting holes16
- (5) Bolt circle diameter25.75 in. (65.41 cm)

h. Hydraulic Rotary Pump.

- (1) Type Dual Vane
- (2) Rate output pressure2000 psi (13,790 kPa)
- (3) Rated flow at 2000 psi7.6 gpm(28.8 l/min)
- (4) Maximum operating rpm1350 rpm

i. Lockout Cylinder.

- (1) Length:
 - (a) Retracted25.94 in. (65.89 cm)
 - (b) Extended35.47 in. (90.09 cm)
- (2) Outside diameter6.00 in. (15.24 cm)
- (3) Weight, dry82 lb (37 kg)
- (4) Operating pressure150 psi (1034kPa)

CHAPTER 2

DIRECT SUPPORT MAINTENANCE INSTRUCTIONS

CHAPTER INDEX

	Page
Cleaning	2-29
Common Tools and Equipment.	2-2
General	2-19, 2-21, 2-28
Lubrication	2-30
Maintenance of Air Cleaner Access Door	2-153
Maintenance of Air Cleaner Blower Access Door Assembly	2-150
Maintenance of Air Cleaner Centrifugal Fan	2-43
Maintenance of Air Deflector Assembly	2-187
Maintenance of Auxiliary Drive Assembly	2-95
Maintenance of Auxiliary Drive Assembly (Clutch Drive)	2-110
Maintenance of Auxiliary Drive Assembly (Generator Drive)	2-116
Maintenance of Auxiliary Drive Assembly (input Drive)'	2-131
Maintenance of Auxiliary Drive Assembly (Vehicular Drive)	2-101
Maintenance of Auxiliary Driveling Ball Bearing Unit	2-146
Maintenance of Battery Access Cover	2-151
Maintenance of Driver's Hatch Cover	2-157
Maintenance of Driver's Instrument Panel Assembly (Gage and Indicator)	2-72
Maintenance of Engine and Related Parts, and Transmission Assembly	2-32
Maintenance of Engine Blower Assembly (Heater installation Kit)	2-173
Maintenance of Engine Fuel Filter Access Door	2-155
Maintenance of External Oil Lines and Fittings (Lower Engine) and Scavenger Reservoir	2-41
Maintenance of Fabric Fuel Cell installation and Fabric Fuel Cell Filler Blocks	2-46
Maintenance of Heater Electrical Control Box (Heater installation Kit)	2-176
Maintenance of Hydraulic Cylinder Assembly	2-164
Maintenance of impact Wrench Regulator Ball Valve	2-139
Maintenance of Oil Drain Tube Assembly	2-137
Maintenance of Oil Filler Neck.	2-136
Maintenance of Power Takeoff installation	2-163
Maintenance of Radiator Cooling Vaneaxial Fan	2-68
Maintenance of Slip Ring Electrical Brush Connector Assembly	2-90
Maintenance of Slip Ring Electrical Contact Set Assembly	2-84
Maintenance of Slip Ring Electrical Components, Slip Ring Disconnect to interior Disconnect Wiring Harness, and Slip Ring to 24-Volt Feed Electrical Lead,	2-73
Maintenance of Spade Hydraulic Control Valves, Lines, and Fittings and Direct Linear Valve....	2-169
Maintenance of Turret Slip Ring Cover	2-80
Maintenance of Transfer Assembly.	2-93

CHAPTER INDEX (CONT)

	Page
Maintenance of Vehicular Window and Crane Window Assembly	2-183
Maintenance of Vehicular Window (Driver's and Crane Operator's Windshield)	2-182
Maintenance of Windshield Wiper Motor Assembly (Driver's Windshield Enclosure Kit)	2-185
Nonskid Areas2-31
Painting Instructions	2-30
Repair Methods	2-28
Repair Parts2-2
Replacing Cable Terminals and Shell Connectors	2-27
Restenciling Vehicle Markings..	2-31
Special Tools, TMDE, and Support Equipment	2-2
Straight Adapter to Tube Fitting	2-20
Torque Values2-29
Touchup and Recoating,2-31
Troubleshooting Information2-3
Tube Elbow toTube Fitting2-19
Tube Nipple to Tube Fitting2-20
Tube Reducer to Tube Fitting2-20
Tube Tee to Tube Fitting2-19
Typical Female-Type Panel Mounting Receptacle Connector	2-21, 2-23
Typical Female-Type Plug Connector	2-25
Typical Male-Type Panel Mounting Receptacle Connector	2-22, 2-24
Typical Male-Type Plug Connector2-26

**Section I. REPAIR PARTS, SPECIAL TOOLS, TMDE,
AND SUPPORT EQUIPMENT**

2-1. COMMON TOOLS AND EQUIPMENT. For authorized common tools and equipment, refer to the Modified Table of Organization (MTOE) applicable to your unit.

2-2. SPECIAL TOOLS, TMDE, AND SUPPORT EQUIPMENT. Tools, special tools, and test equipment necessary to maintain the M578 vehicle are listed in TM 9-2350-238-24P-1, TM9-2815-202-24P, and appendix B of TM 9-2350-238-20-1. For an illustrated list of special tools and equipment, refer to appendix E of this manual.

2-3. REPAIR PARTS. Repair parts are listed in TM 9-2350-238-24P-1 and TM 9-2815-202-24P, covering unit, direct support, general support, and depot maintenance for this equipment.

Section II. DIRECT SUPPORT TROUBLESHOOTING

2-4. TROUBLESHOOTING INFORMATION.

a. The symptom index can be used as a quick guide to troubleshooting. Common malfunctions are listed in alphabetical order under each major assembly, which appear in MAC order, with a page number reference to the troubleshooting table where a test or inspection and corrective action are provided.

b. The direct support troubleshooting table lists the malfunction, the test or inspection indicating the malfunction, and the necessary corrective action.

c. If the malfunction still exists after all listed direct support maintenance corrective actions have been performed, notify general support maintenance.

d. This manual cannot list all malfunctions that may occur, nor all tests or inspections and corrective actions. If a malfunction is not listed or is not corrected by listed corrective actions, notify your supervisor.

DIRECT SUPPORT SYMPTOM INDEX

	Troubleshooting Procedure Page
ENGINE	
Engine cranks but does not start	2-5
Engine cranks slowly but does not start	2-5
Engine is not getting enough air...	2-6
Engine labors, runs unevenly, smokes too much, lacks power, or uses too much oil	2-6
Starter fails to crank engine when start switch is pressed	2-4
FUEL SYSTEM	
Engine does not get enough fuel...	2-7
Engine leaks	2-8
EXHAUST	
Burned areas exist around exhaust manifold	2-9
Engine smokes too much	2-9
RADIATOR COOLING VANEAXIAL FAN	
Radiator cooling vaneaxial fan does not operate	2-9
GENERATOR	
Generator does not operate	2-10

2-4. TROUBLESHOOTING INFORMATION (CONT).

DIRECT SUPPORT SYMPTOM INDEX (CONT)

	Troubleshooting Procedure Page
TRANSMISSION	
Transmission does not shift properly..2-13
Transmission oil temperature is too high2-12
Transmission stalls or does not operate in all ranges	2-14
Vehicle does not brake properly2-12
Vehicle does not steer properly2-13
AUXILIARY DRIVE AND POWER TAKEOFF	
Auxiliary drive or power takeoff makes too much noise	2-15
Vehicular drive does not operate2-14
HYDRAULIC SUSPENSION LOCKOUT CYLINDER ASSEMBLY	
Hydraulic suspension lockout cylinder assembly does not actuate	2-16
Hydraulic suspension lockout cylinder assembly does not lock	2-17
Hydraulic suspension lockout cylinder assembly does not unlock	2-17
SPADE	
Spade does not raise or lower.2-17
IMPACT WRENCH	
Impact wrench does not operate2-18

Table 2-1. DIRECT SUPPORT TROUBLESHOOTING

MALFUNCTION

TEST OR INSPECTION

CORRECTIVE ACTION

ENGINE

1. STARTER FAILS TO CRANK ENGINE WHEN START SWITCH IS PRESSED.

Step1. Check batteries for low charge.

Charge batteries, refer to TM 9-6140-200-14; or replace batteries, refer to TM 9-2350-238-20-1.

Table 2-1. DIRECT SUPPORT TROUBLESHOOTING (CONT)

MALFUNCTION**TEST OR INSPECTION****CORRECTIVE ACTION**

Step 2. Check for proper setting of neutral position switch.

2-4. TROUBLESHOOTING INFORMATION (CONT).

Table 2-1. DIRECT SUPPORT TROUBLESHOOTING (CONT)

MALFUNCTION

TEST OR INSPECTION

CORRECTIVE ACTION

Step 2. Check engine shutdown handle.

Push engine shutdown handle against hull.

Step 3. Check for water in primary and secondary fuel filters.

Drain water from fuel filters, refer to TM 9-2350-238-10; or replace dirty fuel filters, refer to TM 9-2350-238-20-1.

Step 4. Check operation of air box heater by feeling air box heater on top of engine,

a. If air box heater is not warm, troubleshoot air box heater. Refer to TM 9-2350-238-20-1.

b. If air box heater is warm, troubleshoot engine fuel system. Refer to TM 9-2815-202-34.

Step 5. Check for faulty engine parts.

Troubleshoot engine fuel system and check engine compression. Refer to TM 9-2815-202-34.

4. ENGINE LABORS, RUNS UNEVENLY, SMOKES TOO MUCH, LACKS POWER, OR USES TOO MUCH OIL.

Check for faulty engine systems.

Troubleshoot engine. Refer to TM 9-2815-202-34.

5. ENGINE IS NOT GETTING ENOUGH AIR.

Step 1. Check for clogged or dirty air cleaner filter elements.

Clean clogged or dirty air cleaner filter elements, refer to TM 9-2350-238-10; or replace air cleaner filter elements and seal assemblies, refer to TM 9-2350-238-20-1.

Table 2-1. DIRECT SUPPORT TROUBLESHOOTING (CONT)

MALFUNCTION	TEST OR INSPECTION	CORRECTIVE ACTION
	<p><i>Step 2.</i> Check forward and aft air separator centrifugal fan exhaust ports for air movement.</p>	<p>a. If forward or aft air cleaner centrifugal fan is not operating, troubleshoot air cleaner centrifugal fan circuits. Refer to TM 9-2350-238-20-1.</p> <p>b. Repair damaged air cleaner centrifugal fan, refer to page 2-43; or replace damaged air cleaner centrifugal fan, refer to TM 9-2350-238-20-1.</p>
	<p><i>Step 3.</i> Check for dirt buildup in forward and aft air cleaner separators.</p>	<p>Clean and repair dirty air cleaner separators. Refer to TM 9-2350-238-20-1.</p>
	<p><i>Step 4.</i> Check air intake ducts and screen assembly for damaged or clogged parts.</p>	<p>Repair or replace damaged parts. Refer to TM 9-2350-238-20-1.</p>
	<p><i>Step 5.</i> Check turbocharger for damaged or clogged parts.</p>	<p>Troubleshoot turbocharger. Refer to TM 9-2815-202-34.</p>
NOTE		
	<p>Step 6 applies to engine model 7083-7398.</p>	
	<p><i>Step 6.</i> Check turbocharger regulator for damaged bypass valve.</p>	<p>Troubleshoot turbocharger regulator. Refer to TM 9-2815-202-34.</p>

FUEL SYSTEM

6. ENGINE DOES NOT GET ENOUGH FUEL.

Step 1. Check fuel filler neck cap vent.

Turn fuel filler neck cap vent to OPEN.

2-4. TROUBLESHOOTING INFORMATION (CONT).

Table 2-1. DIRECT SUPPORT TROUBLESHOOTING (CONT)

MALFUNCTION

TEST OR INSPECTION

CORRECTIVE ACTION

Step 2. Check fuel level indicator for fuel level.

Fill fabric fuel cell. Refer to TM 9-2350-238-10.

Step 3. Check for dirty fuel filters.

Replace filter elements. Refer to TM 9-2350-238-20-1.

Step 4. Check for damaged engine fuel pump or clogged lines.

Perform fuel flow test. Refer to TM 9-2350-238-20-1.

Step 5. Check for damaged or dirty fuel injectors.

Troubleshoot fuel injectors. Refer to TM 9-2815-202-34.

7. ENGINE LEAKS.

Step 1. Check for leaking or loose fuel drain plugs.

Tighten or replace fuel drain plugs and preformed packings. Refer to page 2-46.

Step 2. Check fuel supply and return tubes, hoses, and fittings for leaks.

a. Tighten loose connections.

b. Replace all damaged tubes, hoses, and fittings. Refer to TM 9-2350-238-20-1.

Step 3. Check for fuel leaks around hull fuel compartment.

Tighten screws to stop leaks, or replace fabric fuel cells. Refer to page 2-46.

Step 4. Check for internal leaks in fuel pump.

Troubleshoot fuel pump. Refer to TM 9-2815-202-34.

Table 2-1. DIRECT SUPPORT TROUBLESHOOTING (CONT)

MALFUNCTION	TEST OR INSPECTION	CORRECTIVE ACTION
-------------	--------------------	-------------------

EXHAUST

8. BURNED AREAS EXIST AROUND EXHAUST MANIFOLD.

CAUTION

Exhaust manifold lugs must be aligned properly to prevent breakage.

Step 1. Check for loose exhaust manifold.

Tighten exhaust manifold. Refer to TM 9-2815-202-34.

Step 2. Check for cracked exhaust manifold and damaged exhaust manifold gasket.

Troubleshoot exhaust manifold and exhaust manifold gasket. Refer to TM 9-2815-202-34.

9. ENGINE SMOKES TOO MUCH.

Step 7. Check for stuck or damaged exhaust valves.

Replace stuck or damaged exhaust valves. Refer to TM 9-2815-202-34.

Step 2. Check for clogged engine air intake.

Troubleshoot ENGINE. Refer to malfunction 5, page 2-6.

Step 3. Check for engine misfire or low compression if smoke is white. Check to see if oil bypasses cylinders if smoke is blue. Check for dirty or damaged fuel injectors if smoke is black or gray.

Troubleshoot engine. Refer to TM 9-2815-202-34.

RADIATOR COOLING VANEAXIAL FAN

10. RADIATOR COOLING VANEAXIAL FAN DOES NOT OPERATE.

Step 1. Check for broken V-belt.

If V-belt is not broken, go to step 3.

2-4. TROUBLESHOOTING INFORMATION (CONT).

Table 2-1. DIRECT SUPPORT TROUBLESHOOTING (CONT)

MALFUNCTION

TEST OR INSPECTION

CORRECTIVE ACTION

Step 2. Check for seized or damaged radiator cooling vaneaxial fan bearings. Check radiator cooling vaneaxial fan housing for scratches or gouges from impeller. Move impeller fore and aft by hand, checking for too much play or looseness.

- a. If impeller has hit housing, is loose, or will not turn, remove radiator cooling vaneaxial fan. Refer to TM 9-2350-238-20-1.
- b. Repair radiator cooling vaneaxial fan bearings. Refer to page 2-68.
- c. Install and adjust new V-belt. Refer to TM 9-2350-238-20-1.
- d. If fan belt tensioner is damaged, repair fan belt tensioner. Refer to TM 9-2350-238-20-1.

Step 3. Remove V-belt, refer to TM 9-2350-238-20-1. Start engine. Check clutch fan sheave for rotation. Stop engine.

If clutch fan sheave did not rotate, refer to malfunction 11, steps 3 and 4, page 2-11.

GENERATOR

11. GENERATOR DOES NOT OPERATE.

Step 1. Check for faulty or damaged voltage regulator.

Troubleshoot voltage regulator. Refer to TM 9-2350-238-20-1.

Table 2-1. DIRECT SUPPORT TROUBLESHOOTING (CONT)

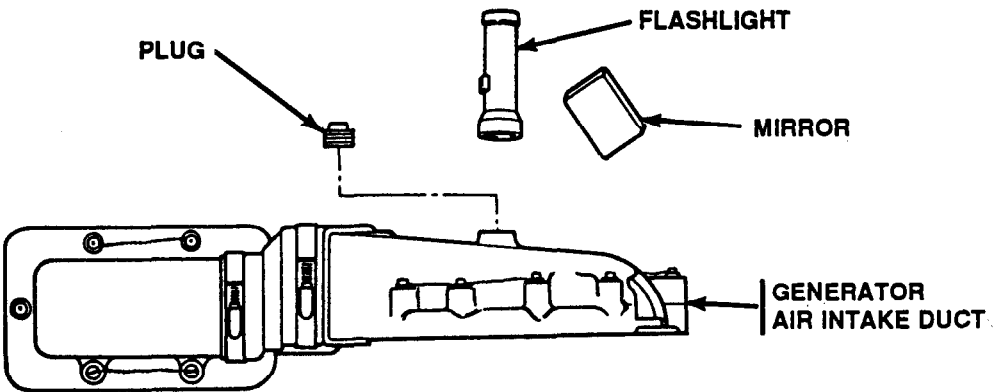
MALFUNCTION	TEST OR INSPECTION	CORRECTIVE ACTION
<p><i>Step 2.</i> Check for faulty or damaged generator. Remove engine deck. Remove plug from generator air intake duct. Start engine. Using mirror and flashlight, look through air duct hole and check if generator is turning. Stop engine.</p>	<p>If generator turned, troubleshoot generator. Refer to TM 9-2350-238-20-1. If generator did not turn, go to step 3.</p>	
<p><i>Step 3.</i> Install plug in generator air intake duct. Check for worn or damaged drive shaft or universal joints. Enter right hull tunnel and turn power takeoff to auxiliary drive shaft back and forth.</p>	<p>If any play is in drive line, repair worn or damaged universal joints. Refer to TM 9-2350-238-20-1.</p>	
<p><i>Step 4.</i> Check for damaged or faulty power source. Start engine. Check power takeoff to auxiliary drive shaft for rotation. Stop engine.</p>	<p>a. If power takeoff to auxiliary drive shaft rotated, remove auxiliary drive. Refer to TM 9-2350-238-20-1. Repair or replace auxiliary drive. Refer to page 2-95.</p> <p>b. If power takeoff to auxiliary drive shaft did not rotate, remove powerplant. Refer to TM 9-2350-238-20-1. Replace power takeoff, refer to page 2-163; or repair power takeoff, refer to page 3-45.</p>	

2-4. TROUBLESHOOTING INFORMATION (CONT).

Table 2-1. DIRECT SUPPORT TROUBLESHOOTING (CONT)

MALFUNCTION	TEST OR INSPECTION	CORRECTIVE ACTION
-------------	--------------------	-------------------

TRANSMISSION

12. TRANSMISSION OIL TEMPERATURE IS TOO HIGH.

Step 1. Check transmission oil level.

Add or drain oil to proper level. Refer to TM 9-2350-238-20-1.

Step 2. Check for dirty or clogged transmission oil filter.

Clean transmission oil filter. Refer to TM 9-2350-238-20-1.

Step 3. Check for damaged or faulty transmission warning light and temperature indicator circuits.

Troubleshoot transmission warning light and temperature indicator circuits. Refer to TM 9-2350-238-20-1.

Step 4. Check for low main oil pressure, damaged oil pump, internal binding, and clutch slippage.

Troubleshoot transmission. Refer to TM 9-2520-234-35.

13. VEHICLE DOES NOT BRAKE PROPERLY.

Step 1. Check brake linkage adjustment. Check for damaged or worn linkage.

Adjust or replace brake linkage components. Refer to TM 9-2350-238-20-1.

Step 2. Check adjustment of transmission brakes.

Adjust transmission brakes. Refer to TM 9-2350-238-20-1.

Step 3. Check hydraulic operating pressure in left and right transmission brakes. Refer to TM 9-2520-234-35.

If pressure is wrong, troubleshoot transmission oil pump. Refer to TM 9-2520-234-35.

Table 2-1. DIRECT SUPPORT TROUBLESHOOTING (CONT)

MALFUNCTION**TEST OR INSPECTION****CORRECTIVE ACTION**

Step 4. Check transmission for worn or damaged brake plates.

Troubleshoot transmission brakes. Refer to TM 9-2520-234-35.

14. VEHICLE DOES NOT STEER PROPERLY.

Step 1. Check steering linkage adjustment. Check for damaged or worn steering linkage.

Adjust or replace steering linkage components. Refer to TM 9-2350-238-20-1.

Step 2. Check left and right geared steer clutch and left and right output clutch hydraulic operating pressure. Refer to TM 9-2520-234-35.

If pressure is wrong, troubleshoot transmission oil pump. Refer to TM 9-2520-234-35.

Step 3. Check transmission internal steering.

Troubleshoot transmission internal steering. Refer to TM 9-2520-234-35.

15. TRANSMISSION DOES NOT SHIFT PROPERLY.

Step 1. Check shifting linkage adjustment. Check for damaged or worn linkage.

Adjust or replace shifting linkage components. Refer to TM 9-2350-238-20-1.

Step 2. Check transmission shift hydraulic operating pressure. Refer to TM 9-2520-234-35.

If pressure is wrong, troubleshoot transmission oil pump. Refer to TM 9-2520-234-35.

Step 3. Check transmission internal shifting components.

Troubleshoot transmission. Refer to TM 9-2520-234-35.

2-4. TROUBLESHOOTING INFORMATION (CONT).

Table 2-1. DIRECT SUPPORT TROUBLESHOOTING (CONT)

MALFUNCTION

TEST OR INSPECTION

CORRECTIVE ACTION

16. TRANSMISSION STALLS OR DOES NOT OPERATE IN ALL RANGES.

Step 1. Check transmission hydraulic operating pressures. Refer to TM 9-2520-234-35.

If pressures are wrong, troubleshoot transmission oil pump. Refer to TM 9-2520-234-35.

Step 2. Check transmission for internal wear or damage.

Troubleshoot transmission. Refer to TM 9-2520-234-35.

AUXILIARY DRIVE AND POWER TAKEOFF

17. VEHICULAR DRIVE DOES NOT OPERATE.

Step 1. Start engine. Set HYD PUMP/PTO CLUTCH switch ON. Check radiator cooling vaneaxial fan and vehicular drive drive shaft for rotation. Set HYD PUMP/PTO CLUTCH switch OFF. Stop engine.

a. If radiator cooling vaneaxial fan rotated and vehicular drive did not, troubleshoot HYD PUMP/PTO CLUTCH switch. Refer to TM 9-2350-238-20-1.

b. If radiator cooling vaneaxial fan did not rotate, troubleshoot GENERATOR, steps 3 and 4. Refer to page 2-11.

Step 2. Remove auxiliary drive. Refer to TM 9-2350-238-20-1. Check for damaged drive shaft between auxiliary drive and vehicular drive.

If drive shaft is damaged, repair drive shaft. Refer to page 2-101.

Step 3. Check vehicular drive for worn or damaged plates.

If vehicular drive plates are worn or damaged, repair vehicular drive. Refer to page 2-101.

Table 2-1. DIRECT SUPPORT TROUBLESHOOTING (CONT)

MALFUNCTION

TEST OR INSPECTION

CORRECTIVE ACTION

18. AUXILIARY DRIVE OR POWER TAKEOFF MAKES TOO MUCH NOISE.

Step 1. Check auxiliary drive oil level.

Add oil to FULL mark on gage. Refer to TM 9-2350-238-10.

Step 2. Check for worn or damaged universal joints in drive shaft.

Enter right hull tunnel and turn power takeoff to auxiliary drive shaft back and forth. If any play is in drive line, repair worn or damaged universal joints. Refer to TM 9-2350-238-20-1.

Step 3. Isolate noise in auxiliary drive or power takeoff. Remove exhaust pipes.

Refer to TM 9-2350-238-20-1. Disconnect drive shaft at power takeoff. Pull drive shaft coupling from power takeoff and lower drive shaft to hull bottom. Install exhaust pipes. Start engine. Listen for noise. Stop engine.

a. If noise was not present, replace auxiliary drive, refer to TM 9-2350-238-20-1; or repair auxiliary drive, refer to page 2-95.

b. If noise was present, replace power takeoff, refer to TM 9-2350-238-20-1; or repair power takeoff, refer to page 2-163.

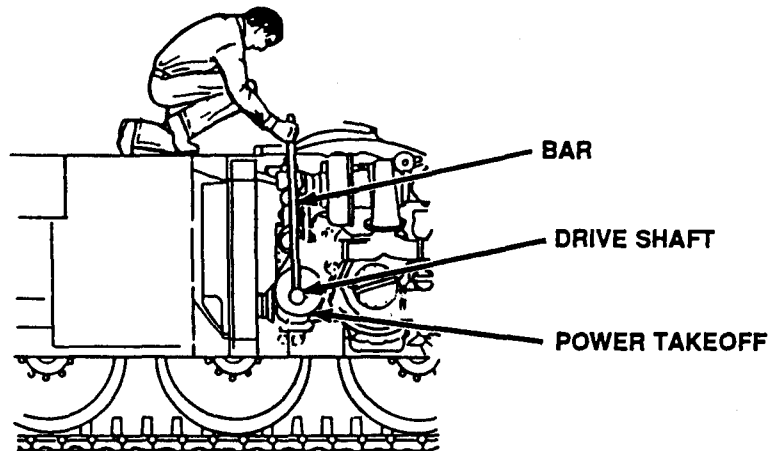

2-4. TROUBLESHOOTING INFORMATION (CONT).

Table 2-1. DIRECT SUPPORT TROUBLESHOOTING (CONT)

MALFUNCTION	TEST OR INSPECTION	CORRECTIVE ACTION
-------------	--------------------	-------------------

HYDRAULIC SUSPENSION LOCKOUT CYLINDER ASSEMBLY

19. HYDRAULIC SUSPENSION LOCKOUT CYLINDER ASSEMBLY DOES NOT ACTUATE.

Step 1. Check for low hydraulic pressure near pump and slip ring using pressure gage. Start engine and set HYD PUMP/PTO CLUTCH switch ON.

- a. If pressure gage indicates about 450 psi, go to step 7.
- b. If pressure gage indicates less than 450 psi, go to step 2. Set HYD PUMP/PTO CLUTCH switch OFF. Stop engine. Remove pressure gage.

Step 2. Check for open impact wrench manual shut-off valve.

If open, close impact wrench manual shut-off valve.

Step 3. Check for damaged or faulty impact wrench manual shut-off valve.

If damaged or faulty, replace impact wrench manual shut-off valve. Refer to TM 9-2350-238-20-1.

Step 4. Check for damaged or faulty impact wrench control check valve.

If damaged or faulty, replace impact wrench control check valve. Refer to TM 9-2350-238-20-1.

Step 5. Check for damaged or faulty hull hydraulic relief valve.

If damaged or faulty, replace hull hydraulic relief valve. Refer to TM 9-2350-238-20-1.

Step 6. If problem still exists, notify general support maintenance.

Step 7. Install pressure gage to lockout cylinder manifold test port. Start engine and set HYD PUMP/PTO CLUTCH switch ON.

If pressure gage indicates a minimum of 450 psi, replace lockout pressure reducing valve. Refer to TM 9-2350-238-20-1. Set HYD PUMP/PTO CLUTCH switch OFF. Stop engine. Remove pressure gage.

Table 2-1. DIRECT SUPPORT TROUBLESHOOTING (CONT)

MALFUNCTION**TEST OR INSPECTION****CORRECTIVE ACTION**

Step 8. Check for damaged or faulty lockout cylinder check valve.

If damaged or faulty, replace lockout cylinder check valve. Refer to TM 9-2350-238-20-1.

20. HYDRAULIC SUSPENSION LOCKOUT CYLINDER ASSEMBLY DOES NOT LOCK.

Step 1. Check for leaks and damaged or clogged tubes, hoses, and fittings.

a. Tighten all loose connections.

b. Replace leaking or damaged components. Refer to TM 9-2350-238-20-1.

Step 2. If problem still exists, notify general support maintenance.

21. HYDRAULIC SUSPENSION LOCKOUT CYLINDER ASSEMBLY DOES NOT UNLOCK.

Step 1. Check for damaged or faulty lockout cylinder manifold check valve.

If damaged or faulty, replace lockout cylinder manifold check valve. Refer to TM 9-2350-238-20-1.

Step 2. If problem still exists, notify general support maintenance.

SPADE

22. SPADE DOES NOT RAISE OR LOWER.

Step 7. Remove rear hydraulic access cover for access to spade hydraulic components. Refer to TM 9-2350-238-20-1. Check for leaks and damaged or clogged hoses and fittings.

a. Tighten all loose connections.

b. Replace all leaking or damaged components. Refer to TM 9-2350-238-20-1.

2-4. TROUBLESHOOTING INFORMATION (CONT).

Table 2-1. DIRECT SUPPORT TROUBLESHOOTING (CONT)

MALFUNCTION

TEST OR INSPECTION

CORRECTIVE ACTION

Step 2. Check for damaged or faulty hull hydraulic relief valve.

If damaged or faulty, replace hull hydraulic relief valve. Refer to TM 9-2350-238-20-1.

Step 3. Check for damaged or faulty spade control valve.

If damaged or faulty, replace spade control valve. Refer to TM 9-2350-238-20-1.

Step 4. Check for damaged or faulty spade relief valve.

If damaged or faulty, replace spade relief valve. Refer to TM 9-2350-238-20-1.

IMPACT WRENCH

23. IMPACT WRENCH DOES NOT OPERATE.

Step 1. Check for open impact wrench manual shut-off valve.

If open, close impact wrench manual shut-off valve.

Step 2. Check for damaged or faulty impact wrench manual shut-off valve.

If damaged or faulty, replace impact wrench manual shut-off valve. Refer to TM 9-2350-238-20-1.

SECTION III. MAINTENANCE OF HYDRAULIC LINES AND FITTINGS

2-5. GENERAL.

a. This section contains instructions on repair of hydraulic lines and fittings. Repair of hydraulic lines and fittings consists of replacement of preformed packings, tube fitting locknuts, lockwashers, and defective sleeve spacers and washers. Pages 2-19 and 2-20 show exploded views of typical hydraulic lines and fittings used on the vehicle and give procedures for disassembly and reassembly of fittings. For complete inspection procedures, refer to b. and c. below. Refer to TM 9-2350-238-24P-1 for ordering of authorized parts. Ensure hydraulic pressure is relieved before performing any disassembly of hydraulic lines and fittings.

b. Inspect all unions, nipples, tees, reducers, plugs, elbows, and parts on which end fittings are used for thread damage, fractures, corrosion, distortion, slivers, restrictions, sealing surface scratches, and mutilation. Hex corners shall not be rounded.

c. Inspect tube assemblies for kinks, fractures, cracks, thread damage, restrictions, corrosion, and mutilation. Tube ends shall be squared, deburred inside and out, unprimed, and unpainted from sleeve flange to tube end. Tubes, 1/4 to 3/8 in. (6.35 to 9.53 mm) in diameter, shall show no deformation of sleeves as a result of over application of torque. Repair is by replacement of authorized parts (TM 9-2350-238-24P-1) which do not meet inspection criteria.

2-6. TUBE ELBOW TO TUBE FITTING.

DISASSEMBLY

Remove tube fitting locknut (1), sleeve spacer (2), tube elbow (3), tube fitting locknut (4), flat washer (5), and preformed packing (6).

REASSEMBLY

Install new preformed packing (6), flat washer (5), new tube fitting locknut (4), tube elbow (3), sleeve spacer (2), and new tube fitting locknut (1).

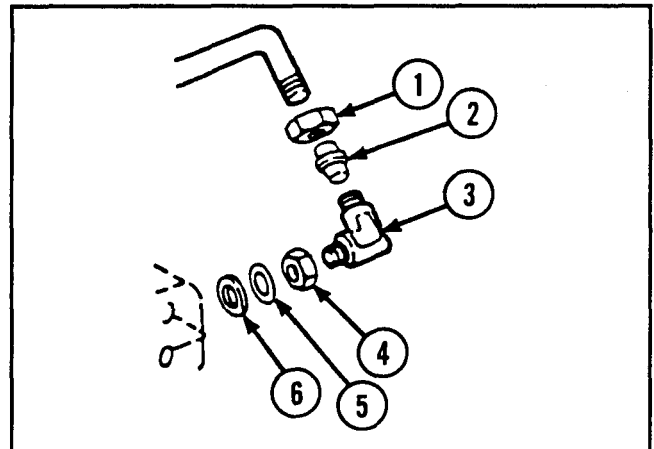

2-7. TUBE TEE TO TUBE FITTING.

DISASSEMBLY

1 Remove tube fitting locknut (1), flat washer (2), and preformed packing (3).

2 Disconnect tube assemblies from tube tee (4) and remove tube tee.

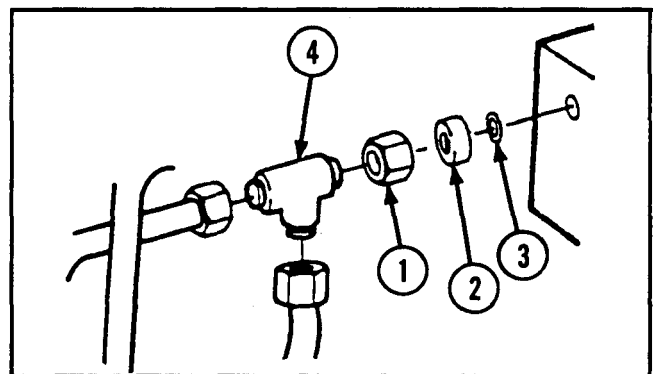

2-7. TUBE TEE TO TUBE FITTING (CONT).

REASSEMBLY

Install tube tee (4), new preformed packing (3), flat washer (2), and new tube fitting locknut (1).

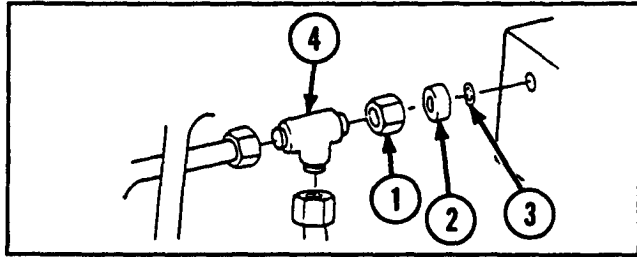

2-8. TUBE REDUCER TO TUBE FITTING.

DISASSEMBLY

Disconnect tube assembly, and remove tube reducer (1) and preformed packing (2).

REASSEMBLY

Install new preformed packing (2) and tube reducer (1), and connect tube assembly.

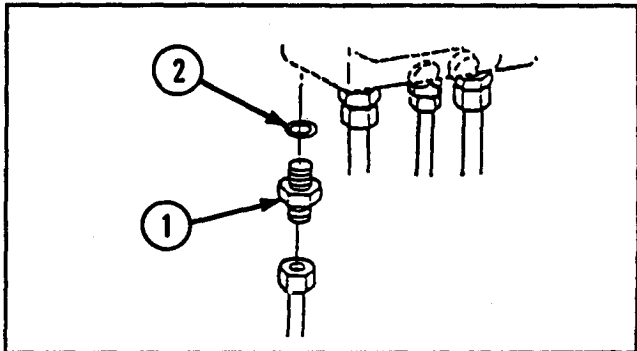

2-9. TUBE NIPPLE TO TUBE FITTING.

DISASSEMBLY

Disconnect tube fitting (1), and remove tube nipple (2), and preformed packing (3).

REASSEMBLY

Install new preformed packing (3) and tube nipple (2), and connect tube fitting (1).

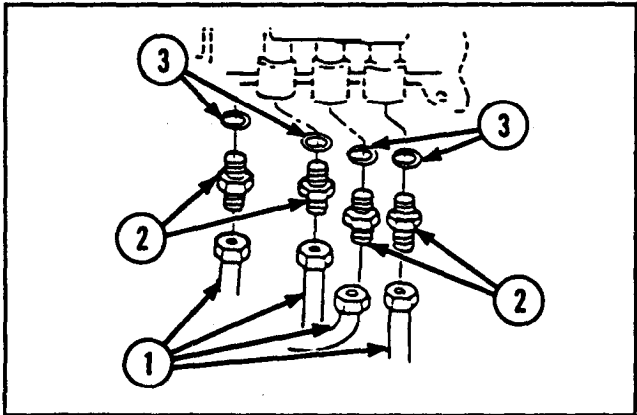

2-10. STRAIGHT ADAPTER TO TUBE FITTING.

DISASSEMBLY

Remove tube fitting locknut (1), sleeve spacer (2), and straight adapter (3).

REASSEMBLY

Install straight adapter (3), sleeve spacer (2), and new tube fitting locknut (1).

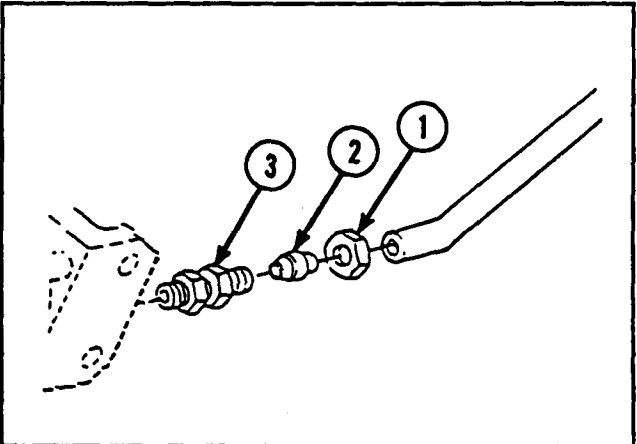

Section IV. WIRING HARNESS AND CABLE REPAIR

2-11. GENERAL. This section contains instructions on repair of wiring harnesses and cables (leads). Repair of wiring harnesses and cables consists of replacement of defective connectors, shells, and terminals, or taping cut or worn insulation and exposed wire conductors. Pages 2-21 thru 2-28 show exploded views of typical harness and cable connectors used on the vehicle, and give procedures for disassembly and assembly of connectors. When soldering is required, procedures in TB-SIG-222 must be followed.

INITIAL SETUP

Tools and Special Tools

Automotive maintenance and repair shop equipment: field maintenance, basic, less power (SC 4910-95-A31)

- Electric soldering iron
- Electrical repair tool kit

Materials/Parts

Solder (item 28, appx B)

NOTE

Label cables on multiple receptacles during disassembly to ensure proper order during reassembly.

2-12. TYPICAL FEMALE-TYPE PANEL MOUNTING RECEPTACLE CONNECTOR.

DISASSEMBLY

- 1 Drive socket contacts (1) out through rear of insert (2) with pin extractor.
- 2 Unsolder cable leads from solder wells on socket contacts (1).
- 3 Slide insert out through rear of shell assembly (3).

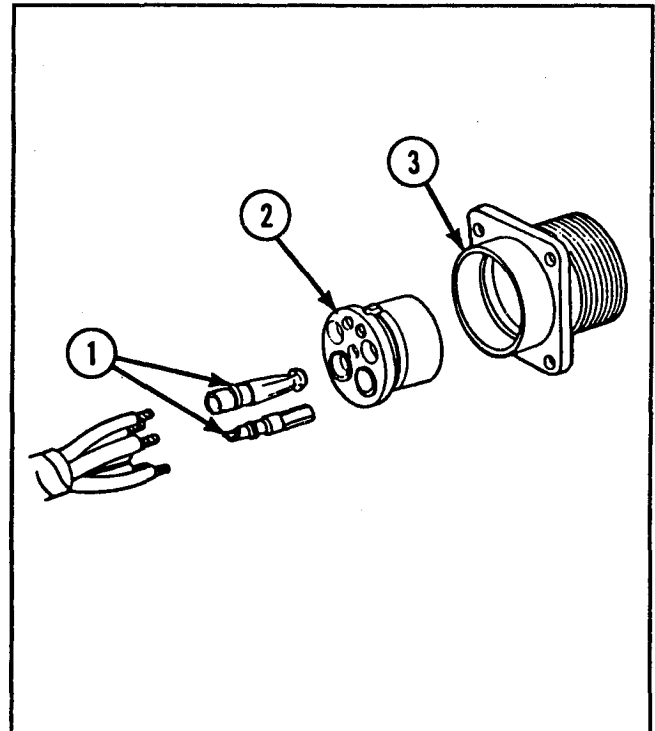

2-12. TYPICAL FEMALE-TYPE PANEL MOUNTING RECEPTACLE CONNECTOR (CONT).

REASSEMBLY

- 1 Strip cable insulation equal to depth of solder wells of socket contacts (1).
- 2 Insert cable leads into solder wells of socket contacts (1) and solder.
- 3 Push insert (2) into shell assembly (3) from rear until seated. Groove (4) in insert must be aligned with guide in shell assembly (3) to ensure proper fit.
- 4 Push socket contacts (1) into insert (2) from rear until seated.

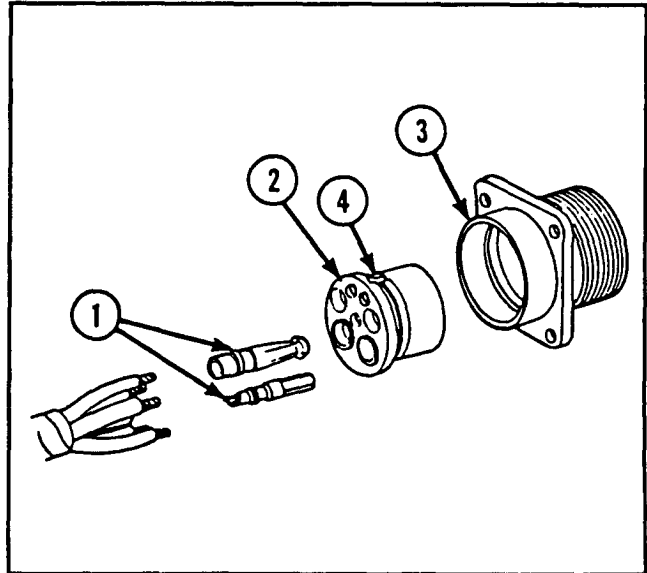

2-13. TYPICAL MALE-TYPE PANEL MOUNTING RECEPTACLE CONNECTOR.

DISASSEMBLY

- 1 Drive pin contacts (1) out through rear of insert (2) with pin extractor.
- 2 Unsolder cable leads (3) from solder wells on pin contacts (1).
- 3 Slide insert (2) out through rear of shell assembly (4).

REASSEMBLY

- 1 Strip cable insulation equal to depth of solder wells of pin contacts (1).
- 2 Insert cable leads (3) into solder wells of pin contacts (1) and solder.
- 3 Push insert (2) into shell assembly (4) from rear until seated. Groove (5) in insert must be aligned with guide in shell assembly (4) to ensure proper fit.
- 4 Push pin contacts (1) into insert (2) from rear until seated.

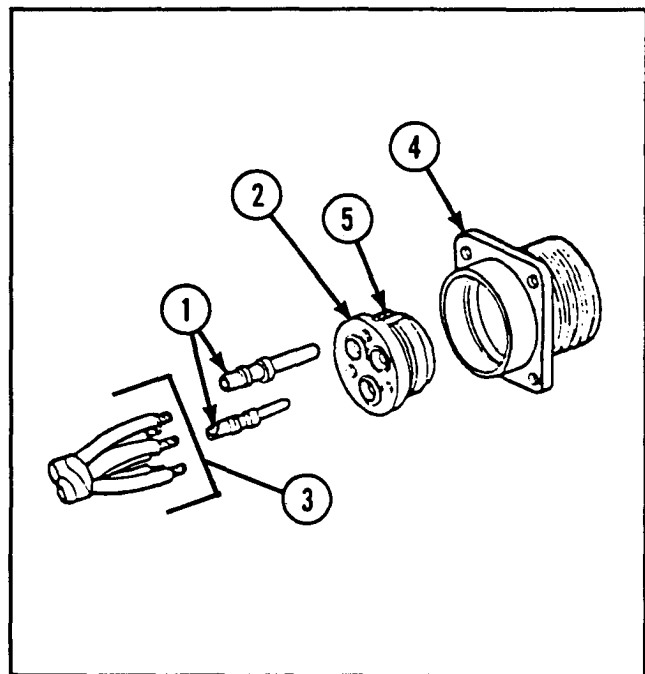

2-14. TYPICAL FEMALE-TYPE PANEL MOUNTING RECEPTACLE CONNECTOR.

DISASSEMBLY

- 1 Unscrew nut (1) from shell assembly (2) and slide back on cable (3).
- 2 Slide grommet (4) back on cable leads (5).
- 3 Drive socket contacts (6) out through front of insert (7) with pin extractor.
- 4 Unsolder lead from socket contacts (6).
- 5 Push insert (7) out through rear of shell assembly (2).

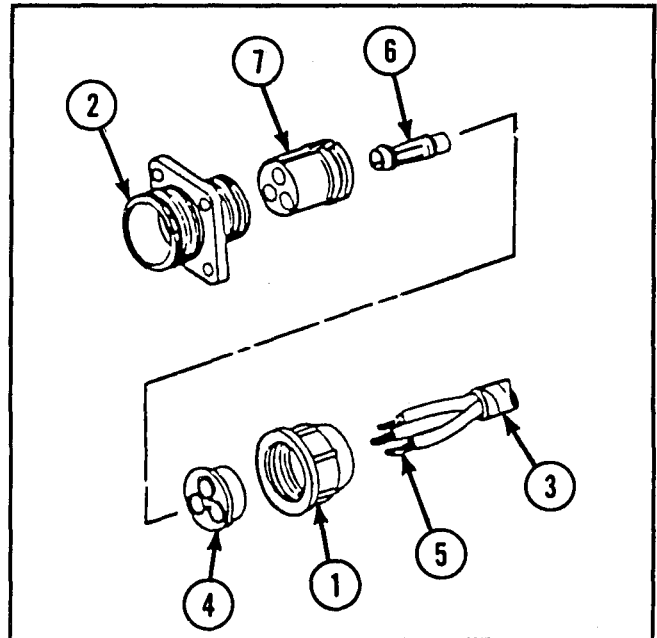

REASSEMBLY

- 1 Strip cable insulation to depth of solder wells of socket contacts (1).
- 2 Slide nut (2) over cable (3).
- 3 Slide grommet (4) over cable leads (5).
- 4 Insert cable leads (5) into solder wells of socket contacts (1) and solder.
- 5 Push insert (6) into shell assembly (7) from rear until seated. Groove (8) in insert (6) must be aligned with guide in shell assembly (7) to ensure proper fit.
- 6 Push socket contacts (1) into insert (6) from rear until seated.
- 7 Push grommet (4) down cable leads (5) and over solder wells of socket contacts (1).
- 8 Screw nut (2) onto shell assembly (7).

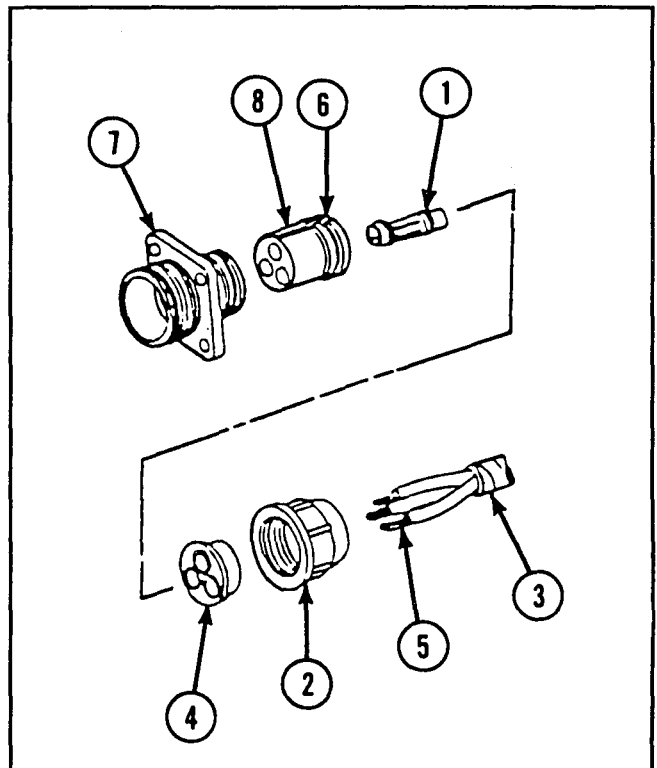

2-15. TYPICAL MALE-TYPE PANEL MOUNTING RECEPTACLE CONNECTOR.

DISASSEMBLY

- 1 Unscrew nut (1) from shell assembly (2) and slide back on cable (3).
- 2 Push grommet (4) back on cable leads (5).
- 3 Drive pin contacts (6) out through rear of insert (7) with pin extractor.
- 4 Push insert (7) out through rear of shell assembly (2).
- 5 Unsolder cable leads (5) from pin contacts (6).

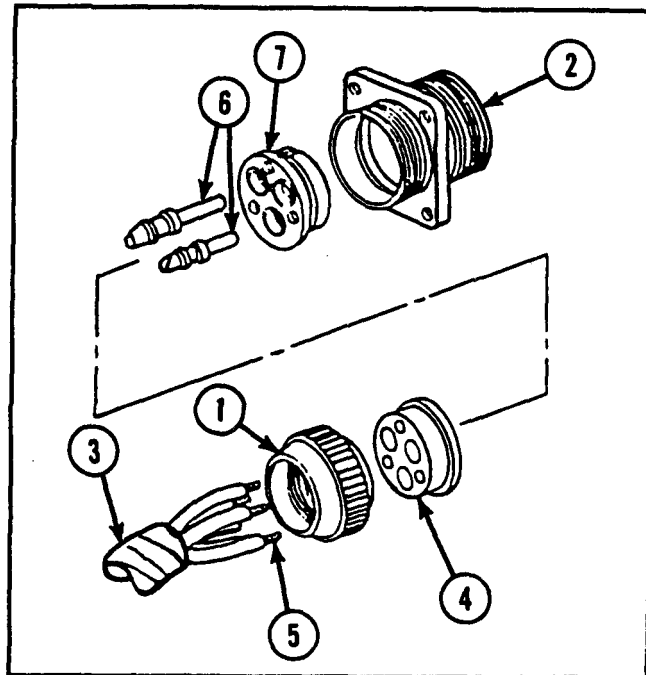

REASSEMBLY

- 1 Strip cable insulation equal to depth of solder wells of pin contacts (1).
- 2 Slide nut (2) onto cable (3).
- 3 Slide grommet (4) over cable leads (5).
- 4 Insert cable leads (5) into solder wells of pin contacts (1) and solder.
- 5 Push insert (6) into shell assembly (7) from rear until seated. Groove (8) in insert (6) must be aligned with guide in shell assembly (7) to ensure proper fit.
- 6 Push pin contacts (1) into insert (6) from rear until seated.
- 7 Push grommet (4) down cable leads (5) and over solder wells of pin contacts (1).
- 8 Screw nut (2) onto shell assembly (7).

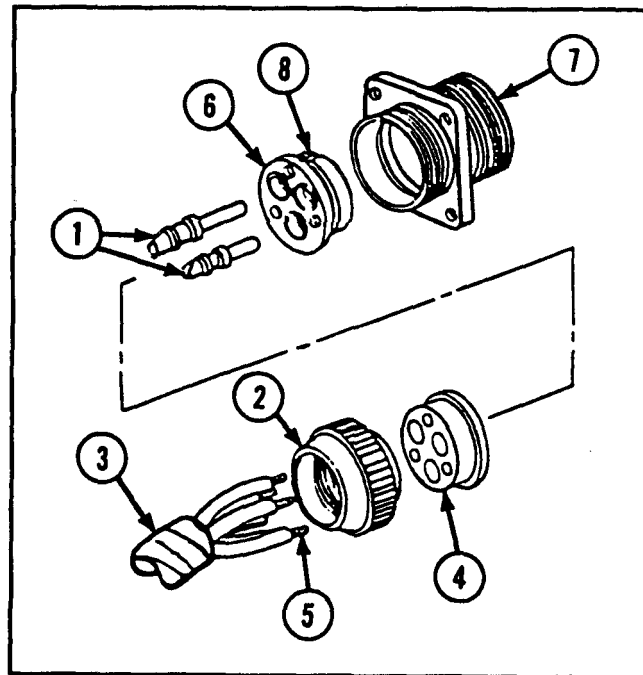

2-16. TYPICAL FEMALE-TYPE PLUG CONNECTOR.

DISASSEMBLY

- 1 Unscrew nut (1) from shell assembly (2) and slide back on cable (3).
- 2 Slide grommet (4) back on cable leads (5).
- 3 Slide coupling (6) off shell assembly (2).
- 4 Drive socket contacts (7) out through rear of insert (8) with pin extractor.
- 5 Push insert (8) out through rear of shell assembly (2).
- 6 Unsolder cable leads (5) from socket contacts (7).

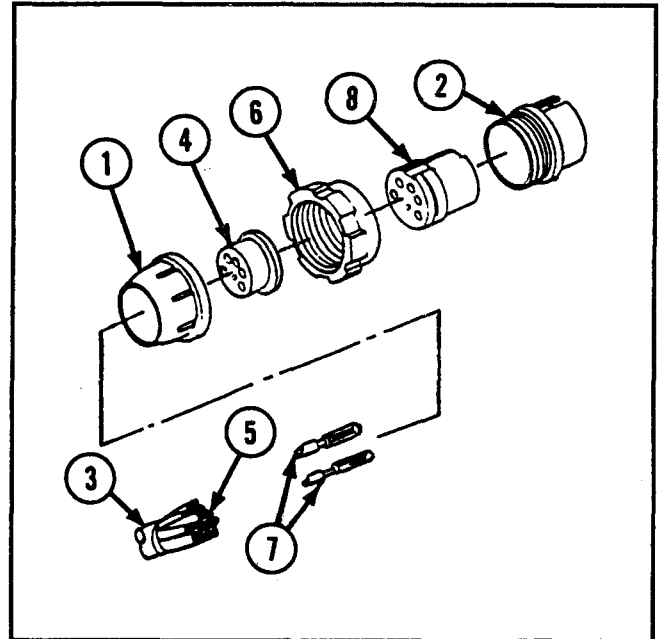

REASSEMBLY

- 1 Strip cable insulation equal to depth of solder wells of socket contacts (1).
- 2 Slide nut (2) over cable (3).
- 3 Slide grommet (4) over cable leads (5).
- 4 Insert cable leads (5) into solder wells of socket contacts (1) and solder.
- 5 Push insert (6) into shell assembly (7) from rear until seated. Groove (8) in insert (6) must be aligned with guide in shell assembly (7) to ensure proper fit.
- 6 Push socket contacts (1) into insert (6) from rear until seated.
- 7 Slide coupling (9) onto shell assembly (7).
- 8 Push grommet (4) down cable leads (5) and over solder wells of socket contacts (1).
- 9 Screw nut (2) onto shell assembly (7).

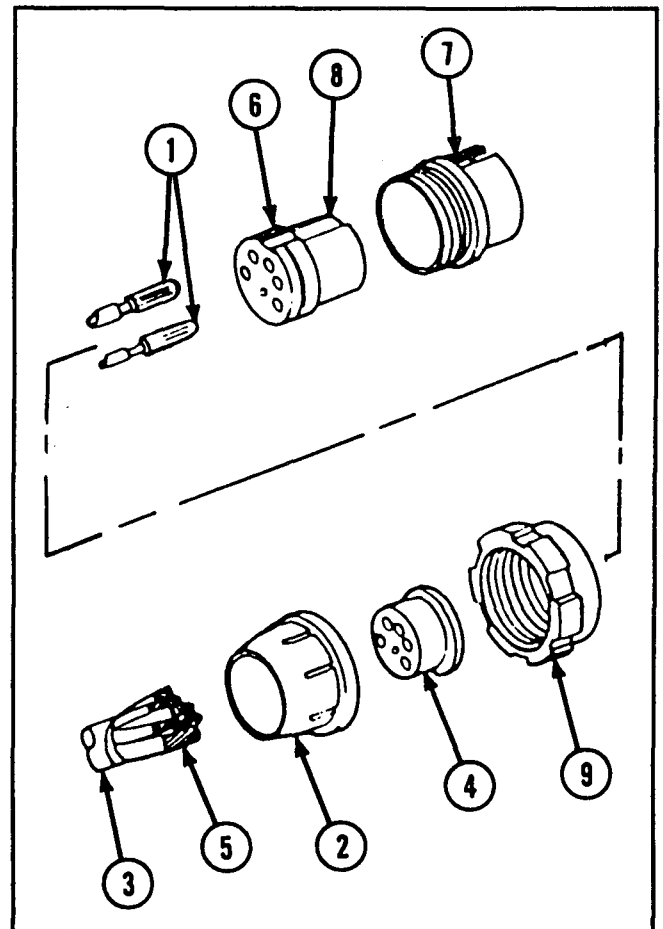

2-17. TYPICAL MALE-TYPE PLUG CONNECTOR.

DISASSEMBLY

- 1 Unscrew nut (1) from shell assembly (2) and slide back on cable (3).
- 2 Slide grommet (4) back on cable leads (5).
- 3 Slide coupling (6) off shell assembly (2).
- 4 Drive pin contacts (7) out through rear of insert (8) with pin extractor.
- 5 Push insert (8) out through rear of shell assembly (2).
- 6 Unsolder cable leads (5) from pin contacts (7).

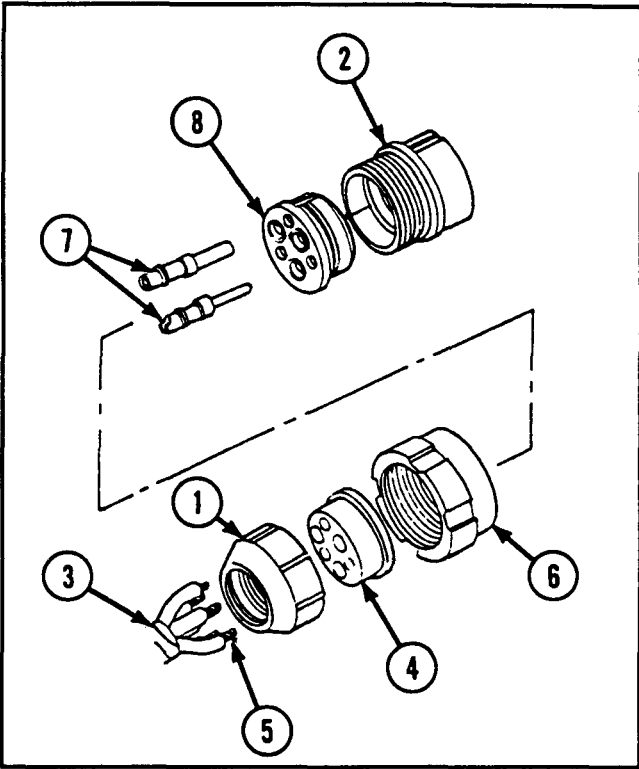

REASSEMBLY

- 1 Strip cable of insulation equal to depth of solder wells of pin contacts (1).
- 2 Slide nut (2) over cable (3).
- 3 Slide grommet (4) over cable leads (5).
- 4 Insert cable leads (5) into solder wells of pin contacts (1) and solder.
- 5 Push insert (6) into shell assembly (7) from rear until seated. Groove (8) in insert (6) must be aligned with guide in shell assembly (7) to ensure proper fit.
- 6 Push pin contacts (1) into insert (6) from rear until seated.
- 7 Slide coupling (9) onto shell assembly (7).
- 8 Push grommet (4) down cable leads (5) and over solder wells of pin contacts (1).
- 9 Screw nut (2) onto shell assembly (7).

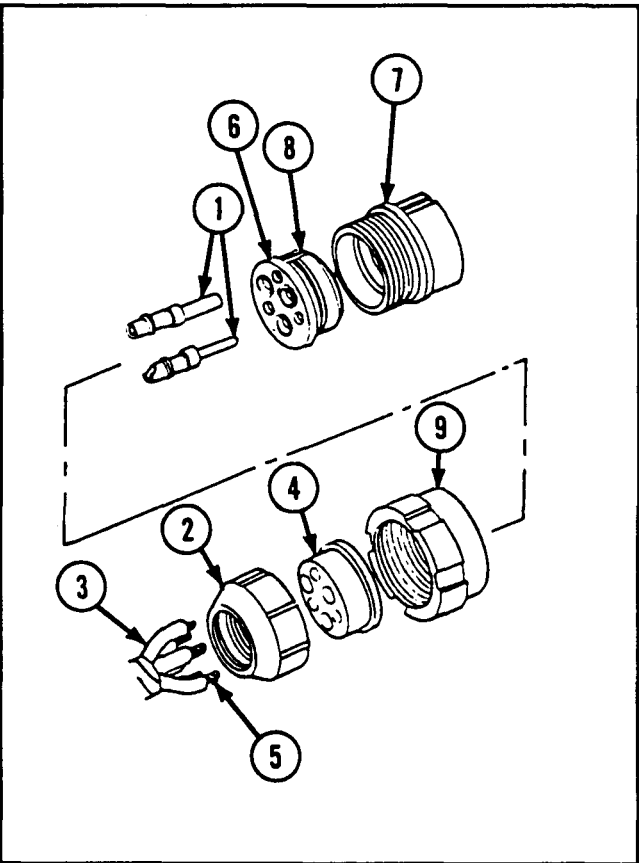

2-18. REPLACING CABLE TERMINALS AND SHELL CONNECTORS.

TERMINAL-TYPE CABLE CONNECTORS

- 1 Strip cable insulation equal to depth of terminal well (1).
- 2 Slide insulator (2) over cable (3).
- 3 Insert cable (3) into terminal well (1) and crimp.
- 4 Slide insulator (2) over crimped end of terminal (4).

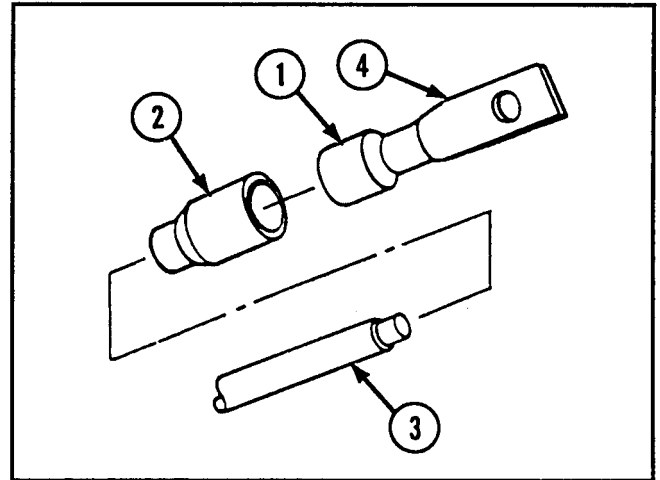

MALE CABLE SHELL CONNECTOR

- 1 Strip cable insulation equal to depth of ferrule well (1).
- 2 Slide shell assembly (2) over cable (3).
- 3 Insert cable (3) into ferrule well (1) and crimp.
- 4 Place C-washer (4) over cable (3) at crimped junction and slide shell assembly (2) over C-washer (4) and ferrule (5).

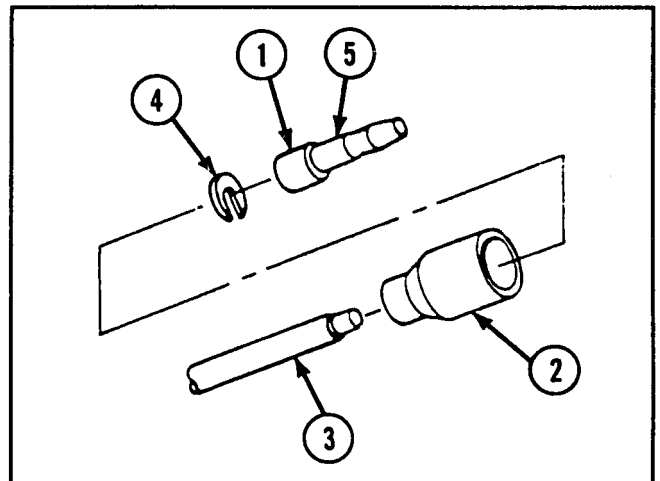

FEMALE CABLE SHELL CONNECTOR (WITH WASHER)

- 1 Strip cable insulation approximately 1/8 in. (0.318 cm).
- 2 Slide shell assembly (1) and washer (2) over cable (3).
- 3 Place cable (3) in cylindrical end of terminal (4) and crimp.
- 4 Slide shell assembly (1) and washer (2) over terminal (4).

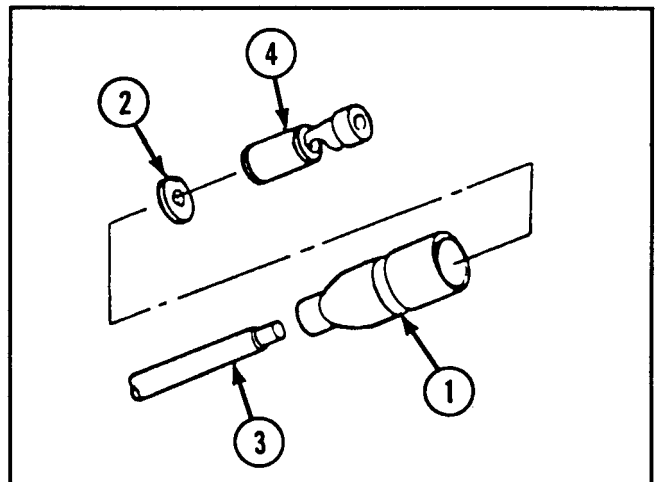

2-18. REPLACING CABLE TERMINALS AND SHELL CONNECTORS (CON).

**FEMALE CABLE SHELL CONNECTOR
(WITH SLEEVE)**

- 1 Strip cable insulation approximately 1/8 in. (0.318 cm).
- 2 Slide shell assembly (1) and sleeve (2) over cable (3).
- 3 Place cable (3) in cylindrical end of terminal (4) and crimp.
- 4 Slide shell assembly (1) and sleeve (2) over terminal (4).

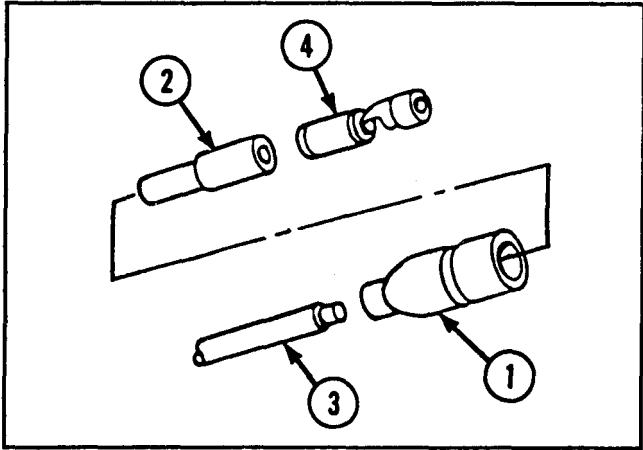

Section V. DIRECT SUPPORT GENERAL MAINTENANCE PROCEDURES

2-19. GENERAL. This section contains general repair methods and cleaning procedures. Special repair and cleaning procedures are provided, as required, in the individual maintenance instructions.

2-20. REPAIR METHODS.

- 1 Complete disassembly is not always necessary to make a repair. Exercise good judgment to keep disassembly and assembly to a minimum.
- 2 Repair or replace unserviceable parts and hardware. Always replace preformed packings, gaskets, seals, and cotter pins with new parts.
- 3 Remove burrs with a stone or file. Remove burrs on closely fitted mating surfaces by lapping the surfaces with abrasive grade compound (item 19, appx B).
- 4 Remove corrosion or rust with sandblasting, vapor blast cleaning, or crocus cloth (item 8, appx B). Use the method that will not damage the surface being cleaned. Crocus cloth should be used to remove corrosion and rust from polished surfaces. Make sure that critical dimensions are not changed when using crocus cloth.
- 5 Repair damaged threads with a thread chaser, or by chasing in a lathe or die.
- 6 When welding is authorized, procedures in TM 9-237 must be followed. Welds must be inspected for cracks.
- 7 Bearings should be inspected and maintained per TM 9-214.
- 8 Some components of the M578 vehicle require special repair or disposition. The following table lists the components needing special handling and the action to be taken.

Table 2-2. ITEMS FOR SPECIAL REPAIR OR HANDLING.

COMPONENT NAME	SPECIAL REPAIR/HANDLING
Engine Coolant Radiator	For limited repair, refer to TM 750-254.
Engine Generator	For repair, refer to TM 9-2815-202-34.
Fire Extinguisher	Recharge fire extinguisher.
Generator Cooling Air Tube Fan	For repair, refer to TM 9-2920-224-34&P.
Magnetic Clutch	For disposition and repair, notify Depot maintenance.
Storage Battery	For disposition and limited repair, refer to TM 9-6140-200-14.
Transmission	For repair, refer to TM 9-2520-234-35.

2-21. TORQUE VALUES.

- 1 Follow torque values given throughout this manual. When no torque value is given, follow the torque limits guide, provided in appendix D of this manual, to prevent damaged parts.
- 2 The guide is based on using clean, dry threads. Reduce original torque requirements by amount specified under the following conditions:
 - a. Ten percent when engine oil is used as a lubricant.
 - b. Twenty percent when new screws are used.
 - c. Thirty percent when threading screws into aluminum, unless inserts are used.

2-22. CLEANING.

- 1 Wire brush metal parts to remove rust and corrosion.

WARNING

Solvent vapors are toxic. Do not use solvent in a confined space. Avoid long periods of breathing solvent vapors and/or contact with skin.

2-22. CLEANING (CONT).

- 2 Clean metal parts with dry cleaning solvent (item 11, appx B). Metal or fiber brushes may be used to apply cleaning solvent and to remove softened or dissolved materials. Hand scraping with metal scrapers may be used to remove soft coatings or deposits.
- 3 Soak very oily or greasy metal parts in a tank containing dry cleaning solvent (item 11, appx B). The time parts must be in solvent varies with the type and amount of material to be removed.
- 4 Do not use solvent to clean electrical insulation, wires, cables, or wiring harnesses. Clean these parts by wiping with a damp cloth (item 8, appx B). Use a solution of mild soap (item 27, appx B) if necessary. Dry immediately with clean, dry cloths (item 8, appx B). Clean contact points with flint abrasive paper (item 21, appx B) and dust thoroughly after cleaning.
- 5 Do not use solvent to clean rubber parts. Clean rubber parts by washing with mild solution of soap (item 27, appx B) and water.
- 6 Dry parts by blowing with low-pressure compressed air or wiping with clean lint-free cloths (item 8, appx B).
- 7 Bearings should be cleaned according to procedures in TM 9-214.
- 8 Paint metal surfaces after repair as required. Sand and paint damaged areas. Apply one coat of rust inhibitor primer (item 22, appx B). Allow primer to dry for 30 minutes minimum before applying enamel. Paint with enamel to match existing color; use white enamel (item 14, appx B) or olive drab enamel (item 13, appx B).

2-23. LUBRICATION. Keep a light coat of lubricating oil (item 20, appx B) on parts during repair procedures to prevent rusting. Lubricate parts during repair and assembly as required by TM 9-2350-238-20-1.

2-24. PAINTING INSTRUCTIONS. Complete painting is authorized for and done by general support maintenance personnel or higher. Spot painting and restenciling vehicle markings is done by unit maintenance personnel. Instructions for materiel preparation, priming, and finish are given in TM 43-0139.

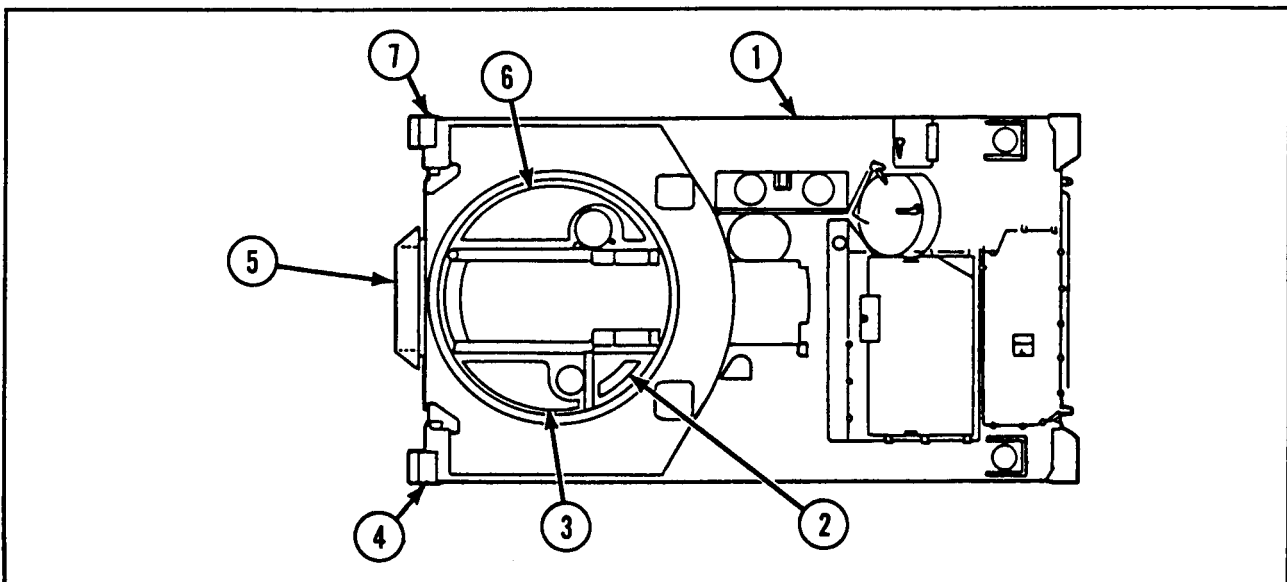

2-25. NONSKID AREAS. Nonslip paint (item 9, appx B) will be used to coat deck areas where personnel walk. The seven areas (1 thru 7) to be coated with nonslip paint are shown in the figure on page 2-30.

2-26. TOUCHUP AND RECOATING.



Unusable CARC mixtures are considered hazardous waste and will require disposal in accordance with Federal, state, DOD, DA, and local installation waste regulations. Consult the installation environmental office for proper disposal guidance. Mixed CARC is extremely flammable—use only in well-ventilated areas and keep away from open flames, heat, sparks, and other ignition sources.

- For brush/roller painting in confined spaces, an airline respirator is required, unless an air sampling shows exposure to be below standards. If the air sampling is below standards, either chemical cartridge or airline respirators are required.
- Spot painters applying CARC paint by brush or roller must wear clothing and gloves affording full coverage.
- Do not use water, alcohol, or amine-based solvents to thin or remove CARC paints. Use of these solvents with CARC paints can produce chemical reactions resulting in nausea, disease, burns, or severe illness to personnel.
- Do not use paint solvents to remove paint/coating from your skin.
- Mix paint/coating in a well-ventilated mixing room or spraying area away from open flames. Personnel mixing paint/coating should wear eye protection.
- Use paint/coating with adequate ventilation.
- Personnel grinding or sanding on painted equipment should use high efficiency air purifying respirators.
- Do not weld or cut CARC-coated metal because substances causing skin or respiratory irritation may be released. Before applying heat, sand or grind paint down to bare metal on area four inches to either side of the area you plan to weld or cut.

When touching up damaged areas, the procedure should be as similar to the original method of finishing as possible; a clean surface is imperative. Where general disintegration of the surface is evident, or the under surface is corroded, the coating must be stripped clean from the part. Corrosion must be removed or neutralized by mechanical or chemical treatment, or both, and the surface metal must be pretreated, primed, and then top coated.

2-27. RESTENCILING VEHICLE MARKINGS. Refer to TM 9-2350-238-20-1.

Section VI. DIRECT SUPPORT MAINTENANCE PROCEDURES

2-28. MAINTENANCE OF ENGINE AND RELATED PARTS, AND TRANSMISSION ASSEMBLY.

This task covers:	a. Removal	b. Inspection/Repair	c. Installation
INITIAL SETUP			
<p>Tools and Special Tools</p> <p>Automotive maintenance and repair shop equipment: field maintenance, basic, less power (SC 4910-95-A31)</p> <ul style="list-style-type: none"> ● Plier wire twister <p>Engine sling (item 21, appx E)</p> <p>Hoist</p> <p>Transmission sling mounting bracket (item 2, appx E)</p> <p>Transmission sling (item 22, appx E)</p> <p>Waste oil drain unit (figure 86, item 8- TM 9-2815-202-24P)</p> <p>Materials/Parts</p> <p>Cotter pin</p> <p>Flywheel housing gasket</p>		<p>LockWasher(14)</p> <p>LockWasher (6)</p> <p>Lockwire (item 32, appx B)</p> <p>Self-locking bolt (12)</p> <p>References</p> <p>TM 9-2350-238-20-1</p> <p>TM 9-2350-238-24P-1</p> <p>TM 9-2520-234-35</p> <p>TM 9-2815-202-24P</p> <p>Equipment Conditions</p> <p>Powerplant removed (TM 9-2350-238-20-1)</p>	

REMOVAL

- 1 Ensure powerplant is properly supported on engine maintenance stand or blocks.
- 2 Disconnect oil filter cooler hose assembly (1) and engine oil filter hose assembly (2).
- 3 Disconnect two transmission-to-oil cooler hose assemblies (3).

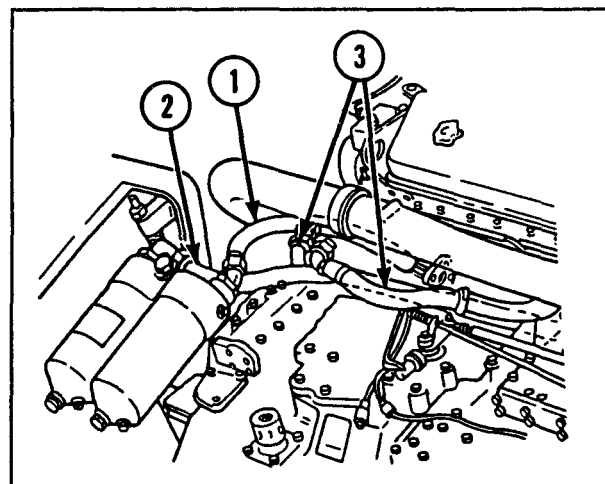

- 4 Disconnect transfer case drain hose (4).
- 5 Remove pipe-to-tube elbow (5) and pipe bushing (6).

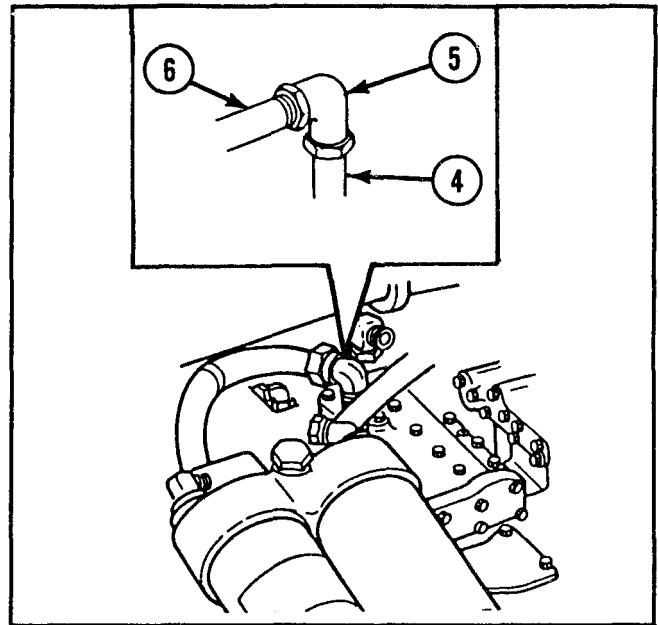

- 6 Disconnect governor throttle control rod (7) by removing cotter pin (8) and straight pin (9).

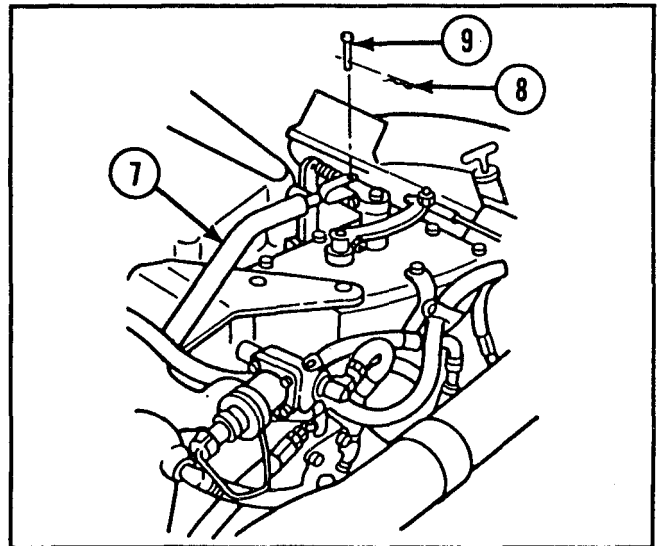

- 7 Disconnect transmission oil pressure transmitter electrical lead (10).
- 8 Remove two loop clamps (11) securing tachometer cable (12) and electrical lead (13).
- 9 Pull tachometer cable (12) and electrical lead (13) free of transmission and place on engine.

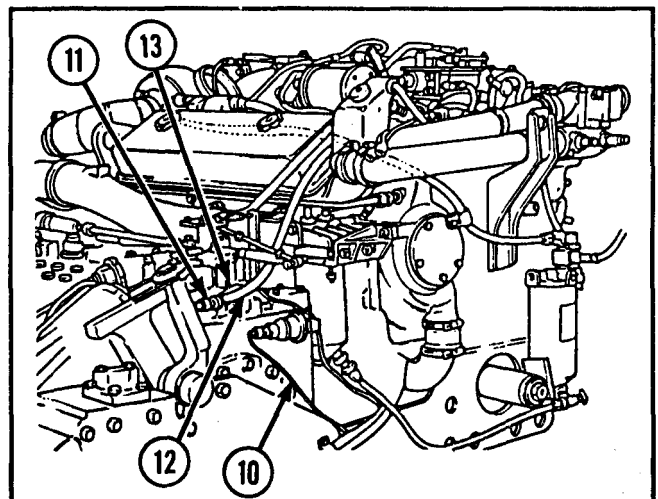

2-28. MAINTENANCE OF ENGINE AND RELATED PARTS, AND TRANSMISSION ASSEMBLY (CONT).

REMOVAL (CONT)

- 10 Disconnect two electrical leads (14) from neutral position sensitive switch (15).

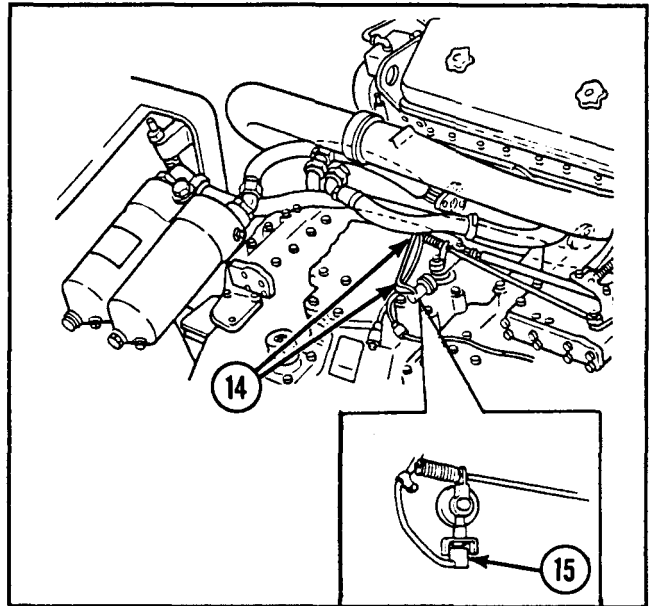

- 11 Loosen two nuts (16) and remove two exhaust pipe clamps (17).

NOTE

Steps 12 and 13 are written and illustrated for engine model 7083-7398 only.

- 12 Disconnect air regulator hose assembly (18) from turbocharger (19).
- 13 Disconnect two air regulator hose clamps (20) from turbocharger (19). Remove two air regulator hose clamps and hose (21).
- 14 Remove lockwire (22), four screws (23), and four washers (24) securing turbocharger (19) to transmission transfer assembly.

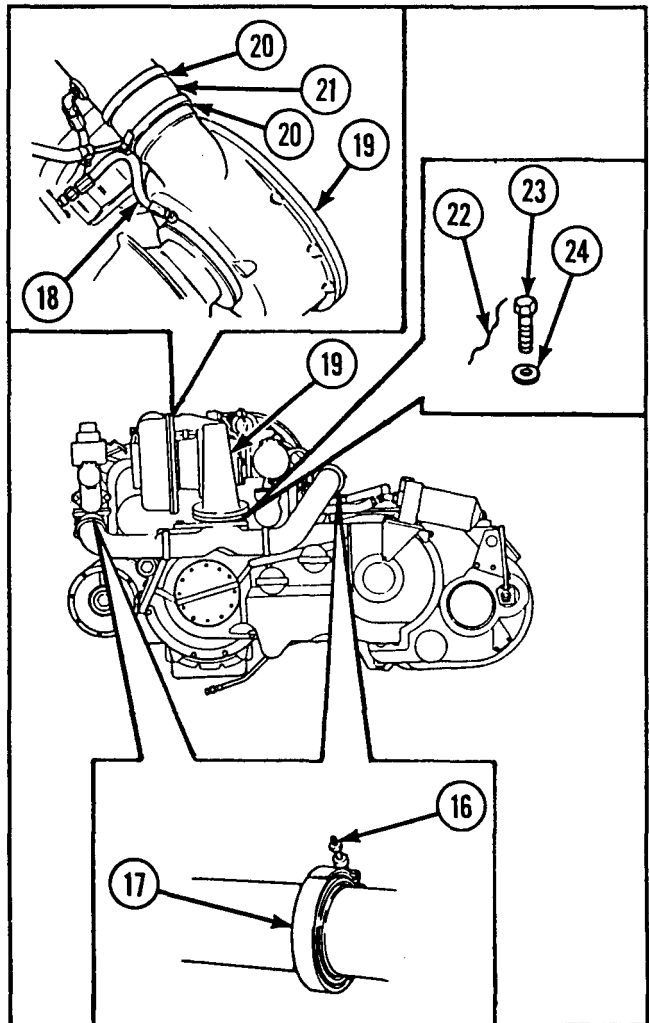

- 15 Attach hoist to turbocharger lifting eye (25). Lift turbocharger (19) from diesel engine.

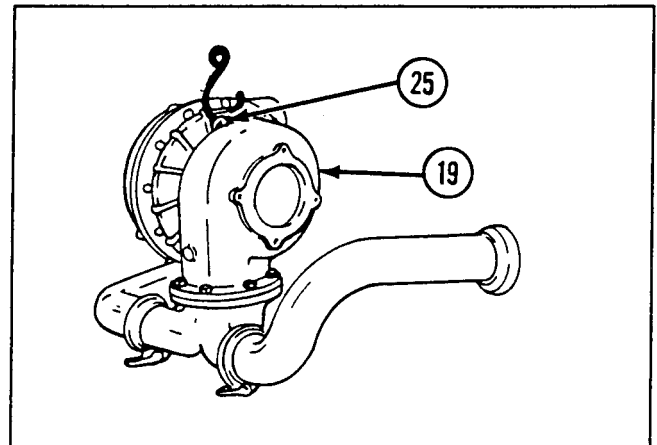

- 16 Attach engine sling to diesel engine (26). Attach hoist to engine sling. Remove slack from sling cables.

NOTE

If transmission is to be moved, attach transmission lifting bracket. Attach transmission sling to transmission lifting bracket. Attach second hoist to sling and remove slack.

- 17 Remove six hexagon head capscrews (27) and six lockwashers (28) securing engine-to-transmission support (29) to transmission assembly (30).

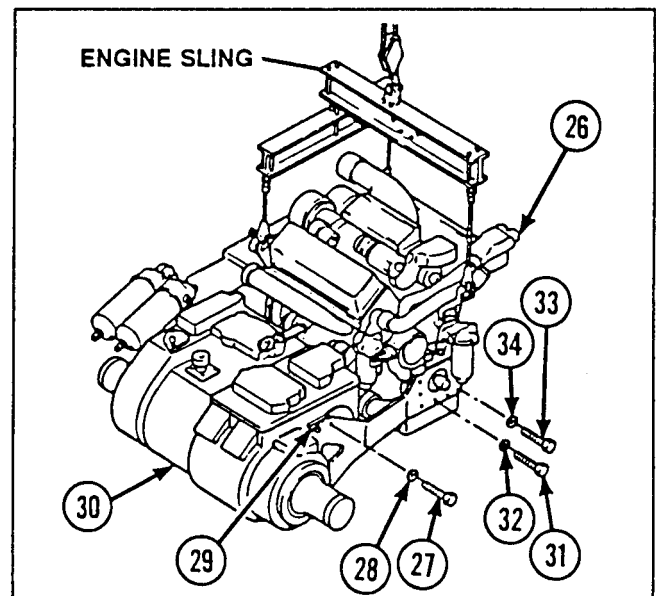

NOTE

Tag all capscrews in steps 18 and 19 to ensure proper installation.

- 18 Remove two 1-1/8-in. hexagon head capscrews (31), two lockwashers (32), four 4-in. hexagon head capscrews (33), four lockwashers (34), and engine-to-transmission support (29) from diesel engine (26).

- 19 Remove nine 1-1/2-in. hexagon head capscrews (35), three 2-1/4-in. hexagon head capscrews (36), two 3-1/2-in. capscrews (37), and 14 lockwashers (38) securing transfer assembly (39) to diesel engine (26).

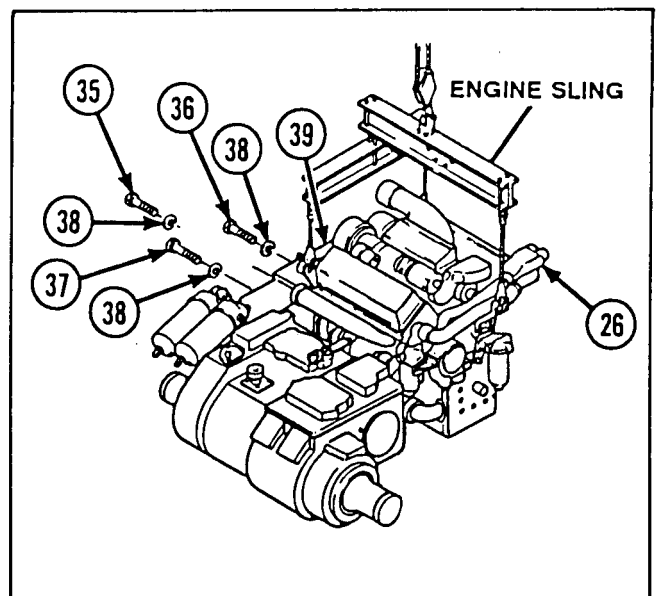

2-28. MAINTENANCE OF ENGINE AND RELATED PARTS, AND TRANSMISSION ASSEMBLY (CONT).

REMOVAL (CONT)

- 20 Carefully swing and lift diesel engine (26) from transmission assembly (30) and transfer assembly (39).
- 21 Place diesel engine on suitable supports for removal of accessories, using waste oil drain unit per TM 9-2815-202-24P.

NOTE

Retainer is not an authorized repair part. Use care to ensure retainer is not lost or damaged during maintenance of diesel engine.

- 22 Remove retainer (40), 12 self-locking bolts (41), preformed packing (42), and flexible coupling shaft (43) from diesel engine (26).
- 23 Remove flywheel housing gasket (44) from diesel engine (26).

NOTE

If transmission coupling shaft was removed with diesel engine, remove shaft from engine and install in assembly.

- 24 Remove transfer assembly from transmission assembly, refer to page 2-93.

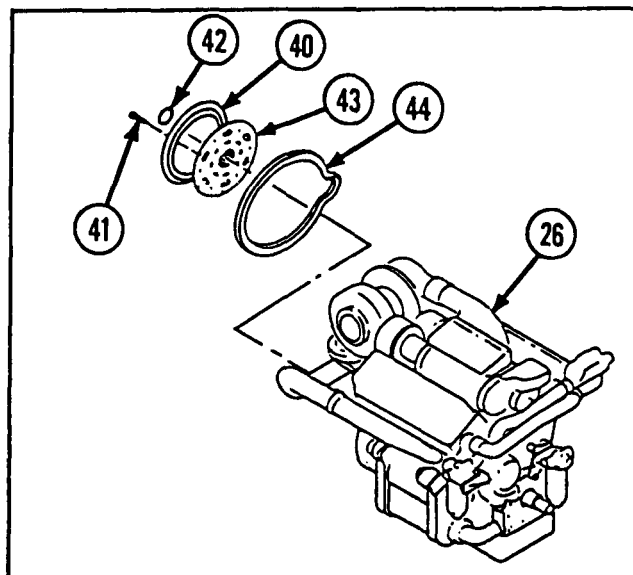
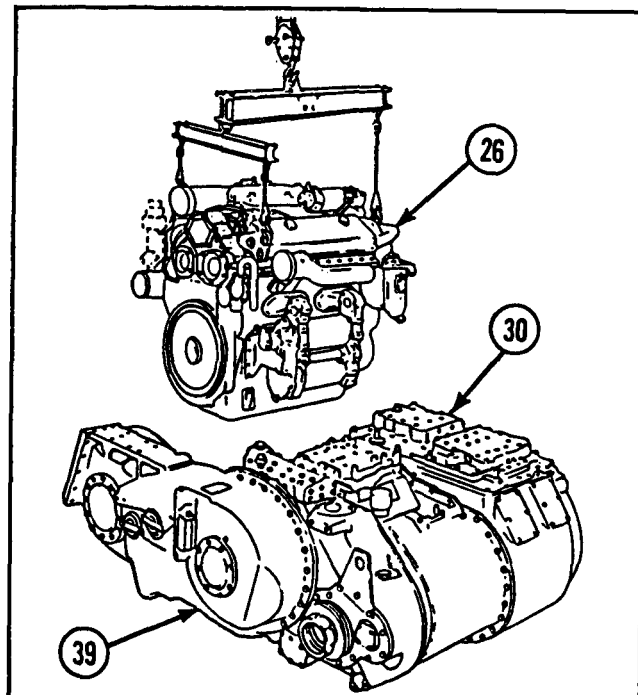

INSPECTION/REPAIR

- 1 Inspect for broken, damaged, or missing parts.
- 2 If diesel engine is damaged, refer to TM 9-2815-202-24P.
- 3 For repair of transmission, refer to TM 9-2520-234-35.

- 4 If transmission is damaged beyond repair, replace entire transmission and container.
- 5 Repair is by replacement of authorized parts (TM 9-2350-238-24P-1) which do not meet inspection criteria.

INSTALLATION

NOTE

When installing new engine, use exhaust pipes from old engine.

- 1 install transfer assembly (1) on transmission assembly (2), refer to page 2-93.
- 2 Install new flywheel housing gasket (3) on diesel engine (4).
- 3 Install flexible shaft coupling (5), new preformed packing (6), 12 new self-locking bolts (7), and retainer (8) on diesel engine (4).
- 4 Lift and carefully swing engine from support. install diesel engine (4) to transmission and transfer assemblies (2 and 1).

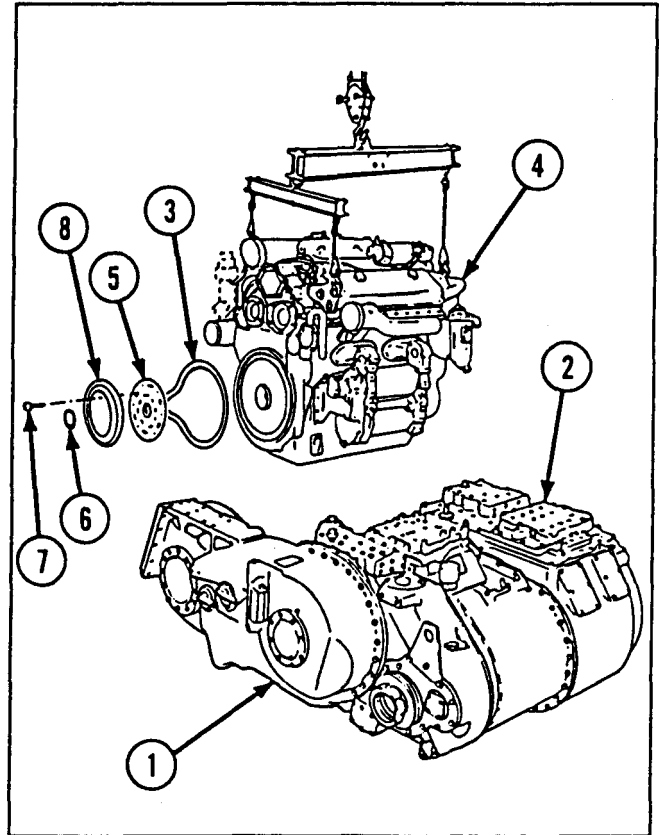

- 5 Install 14 new lockwashers (9), nine 1-1/2-in. hexagon head capscrews (10), three 2-1/4-in. hexagon head capscrews (11), and two 3-1/2-in. hexagon head capscrews (12) securing diesel engine (4) to transfer assembly (1).

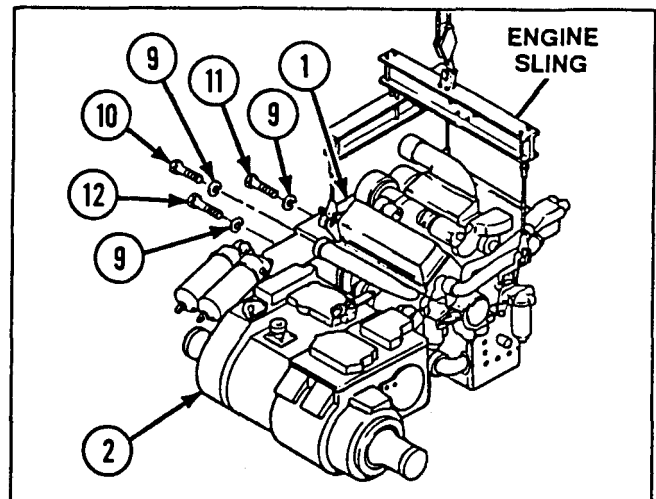

2-28. MAINTENANCE OF ENGINE AND RELATED PARTS, AND TRANSMISSION ASSEMBLY (CONT).

INSTALLATION (CONT)

6 Install engine-to-transmission support (13) on transmission assembly (2) and secure with six new lockwashers (14) and six hexagon head capscrews (15).

7 Install four new lockwashers (16), four 4-in. hexagon head capscrews (17), two new lockwashers (18), and two 1-1/8-in. hexagon head capscrews (19) to secure engine-to-transmission support (13) to diesel engine (4).

NOTE

If transmission was moved, remove transmission sling mounting bracket, transmission sling, and hoist.

8 Remove engine sling from diesel engine (4). Remove hoist from engine sling.

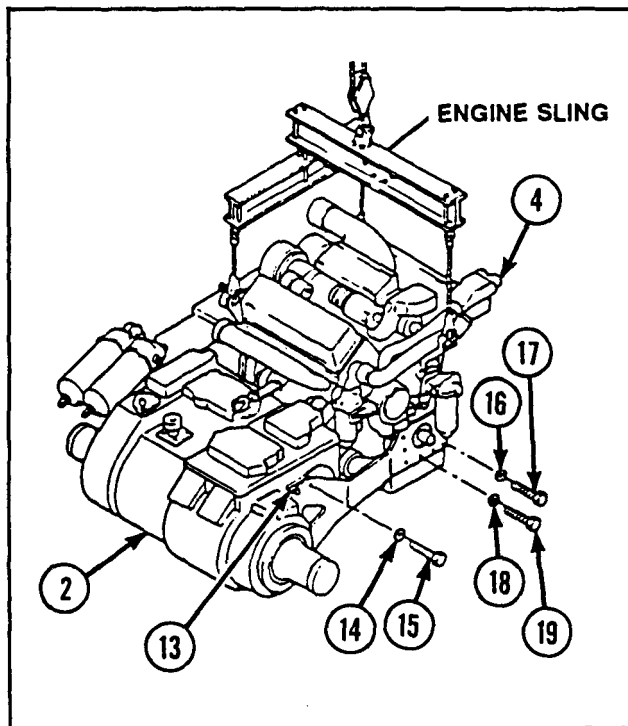

9 Using hoist, install turbocharger (20) to diesel engine. Remove hoist from turbocharger lifting eye (21).

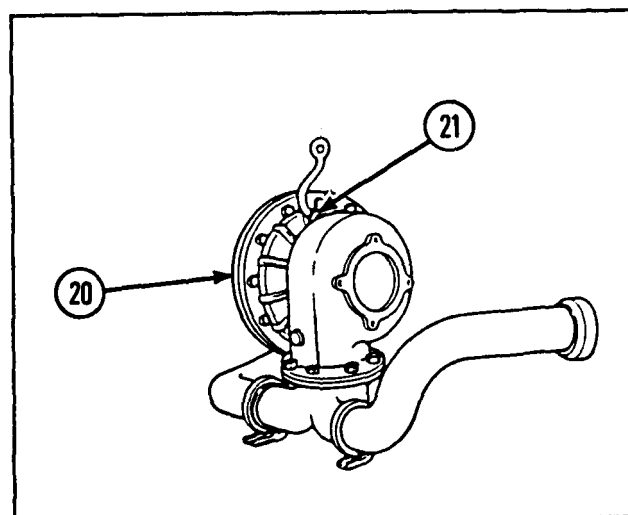

- 10 Install four washers (22), four screws (23), and new lockwire (24) securing turbocharger (20) to transfer assembly.

NOTE

Steps 11 and 12 are written for engine model 7083-7398 only.

- 11 Connect two air regulator hose clamps (25) and hose (26) to turbocharger (20).
- 12 Connect air regulator hose assembly (27) to turbocharger (20).
- 13 Install two exhaust pipe clamps (28) and tighten two nuts (29).

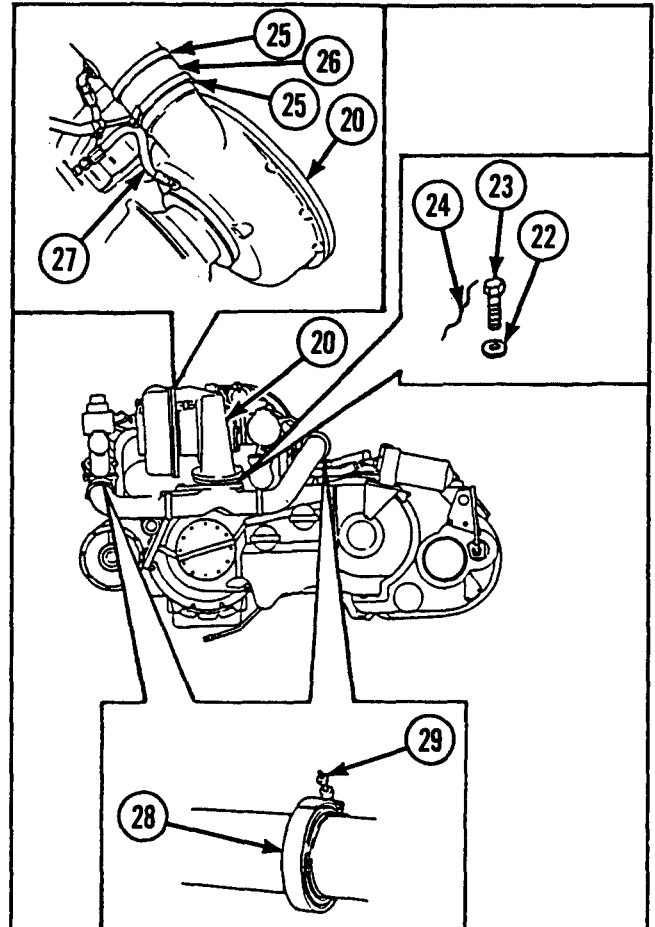

- 14 Connect two electrical leads (30) to neutral position sensitive switch (31).

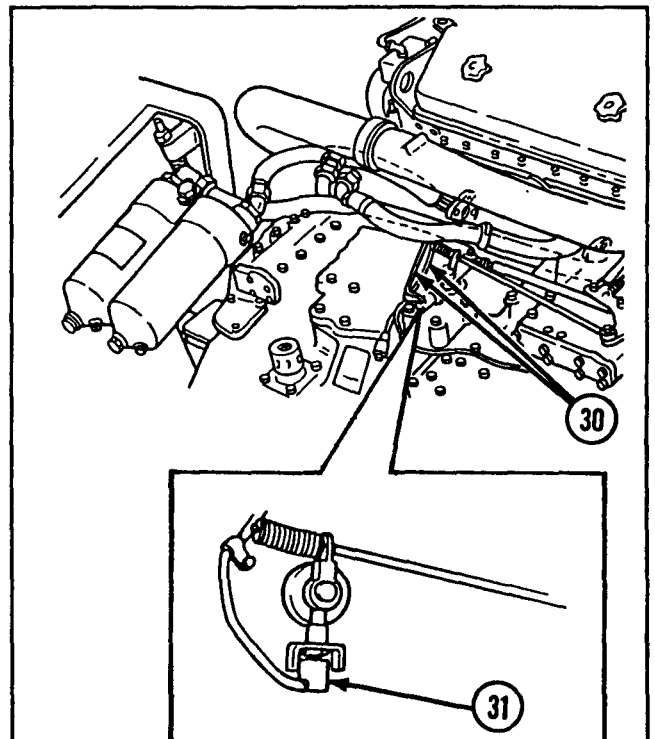

2-28. MAINTENANCE OF ENGINE AND RELATED PARTS, AND TRANSMISSION ASSEMBLY (CONT).

INSTALLATION (CONT)

15 Install electrical lead (32) and tachometer cable (33), and secure with two clamps (34).

16 Connect transmission oil pressure transmitter electrical lead (35).

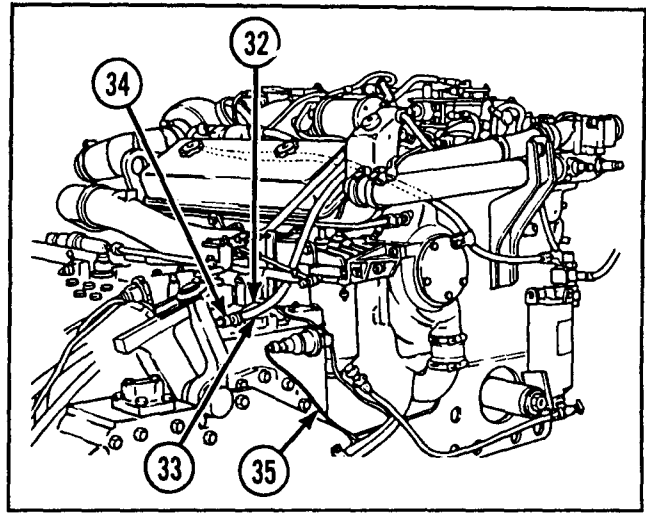

17 Install straight pin (36) and new cotter pin (37) securing governor throttle control rod (38).

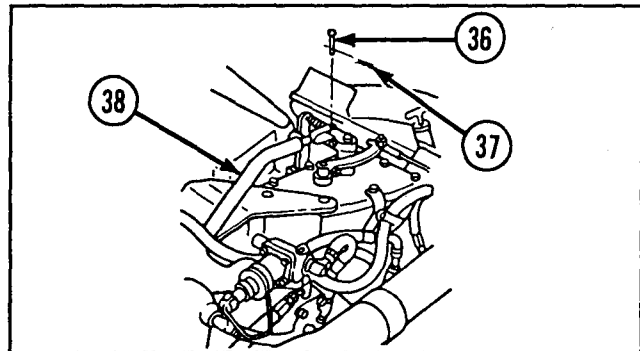

18 Install pipe bushing (39) and pipe-to-tube elbow (40).

19 Connect transfer case drain hose (41).

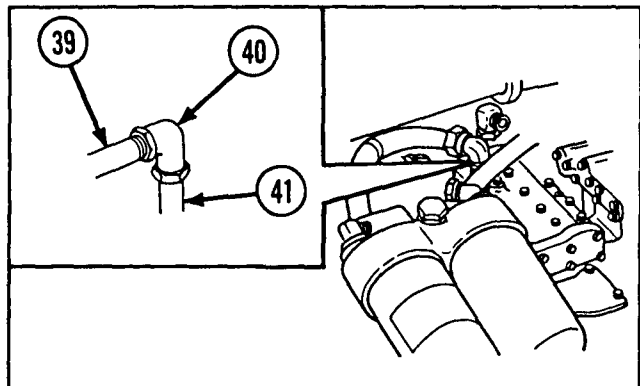

20 Connect two transmission-to-oil cooler hose assemblies (42).

21 Connect engine oil filter hose assembly (43) and oil filter cooler hose assembly (44).

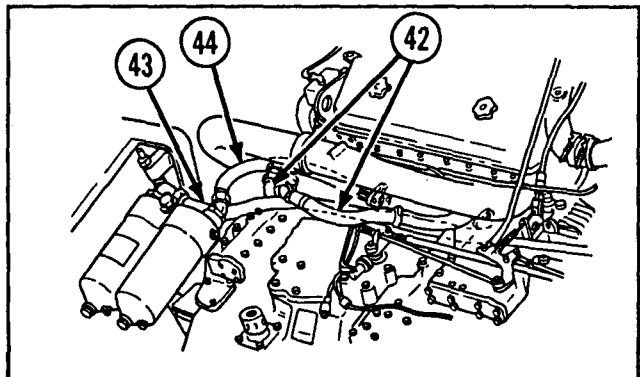

2-29. MAINTENANCE OF EXTERNAL OIL LINES AND FITTINGS (LOWER ENGINE) AND SCAVENGER RESERVOIR.

This task covers:	a. Removal	b. Inspection/Repair	c. Installation
INITIAL SETUP			
<p>Tools and Special Tools</p> <p>Automotive maintenance and repair shop equipment: field maintenance, basic, less power (SC 4910-95-A31)</p> <ul style="list-style-type: none"> ● Plier wire twister 	<p>Equipment Conditions</p> <p>2-32 Engine removed</p>		
<p>Materials/Parts</p> <p>LockWasher (2)</p> <p>LockWire (item 32, appx B)</p> <p>Preformed packing (3)</p>	<p>General Safety Instructions</p> <div style="border: 2px solid black; padding: 5px; text-align: center; margin: 10px 0;">WARNING</div> <p>Wipe up any spilled hydraulic fluid to prevent injury to personnel.</p>		
<p>References</p> <p>TM 9-2350-238-24P-1</p>			

REMOVAL

WARNING

Wipe up any spilled hydraulic fluid to prevent injury to personnel.

- 1 Disconnect governor to solenoid nonmetallic hose assembly (1) and remove preformed packing (2) from tube reducer (3).
- 2 Disconnect transmission to solenoid nonmetallic hose assembly (4) and remove preformed packing (5) from tube reducer (6).
- 3 Disconnect transmission to solenoid nonmetallic hose assembly (7) and remove preformed packing (8) from tube reducer (9).

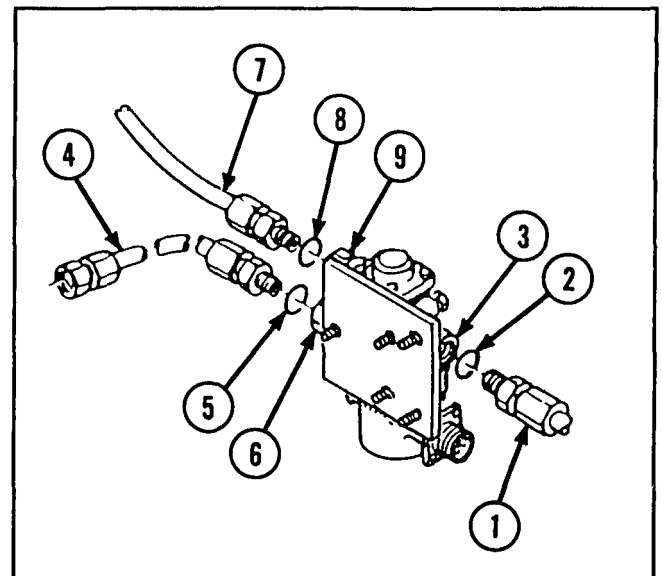

2-29. MAINTENANCE OF EXTERNAL OIL LINES AND FITTINGS (LOWER ENGINE) AND SCAVENGER RESERVOIR (CONT).

REMOVAL (CONT)

- 4 Remove three tube reducers (3, 6, and 9) from bypass return solenoid direct linear valve (10).
- 5 Remove lockwire (11), three hexagon head capscrews (12), and bypass return solenoid direct linear valve (10).
- 6 Remove two hexagon head capscrews (13), two lockwashers (14), and bypass solenoid valve mounting plate (15).

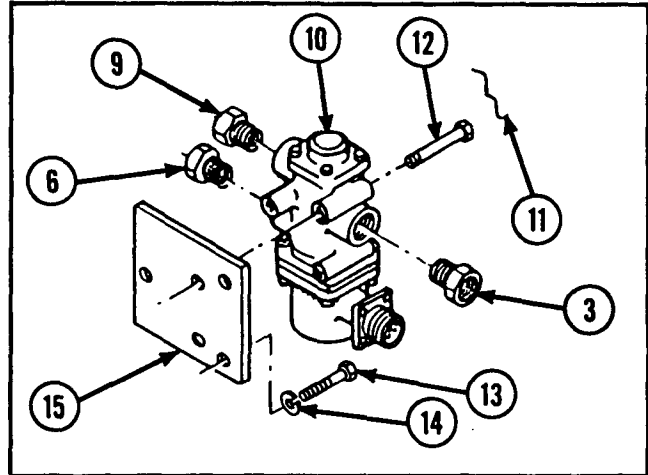

INSPECTION/REPAIR

- 1 Inspect for broken, damaged, or missing parts.
- 2 Repair is by replacement of authorized parts (TM 9-2350-238-24P-1).

INSTALLIZATION

- 1 Install bypass solenoid valve mounting plate (1), two new lockwashers (2), and two hexagon head capscrews (3).
- 2 Install bypass return solenoid direct linear valve (4), three hexagon head capscrews (5), and secure with new lockwire (6).
- 3 Install three tube reducers (7) in bypass return solenoid direct linear valve (4).
- 4 install new preformed packing (8) and connect transmission to solenoid nonmetallic hose assembly (9) to tube reducer (7).
- 5 Install new preformed patting (10) and connect transmission to solenoid nonmetallic hose assembly (11) to tube reducer (7).
- 6 Install new preformed packing (12) and connect governor to bypass solenoid nonmetallic hose assembly (13) to tube reducer (7).

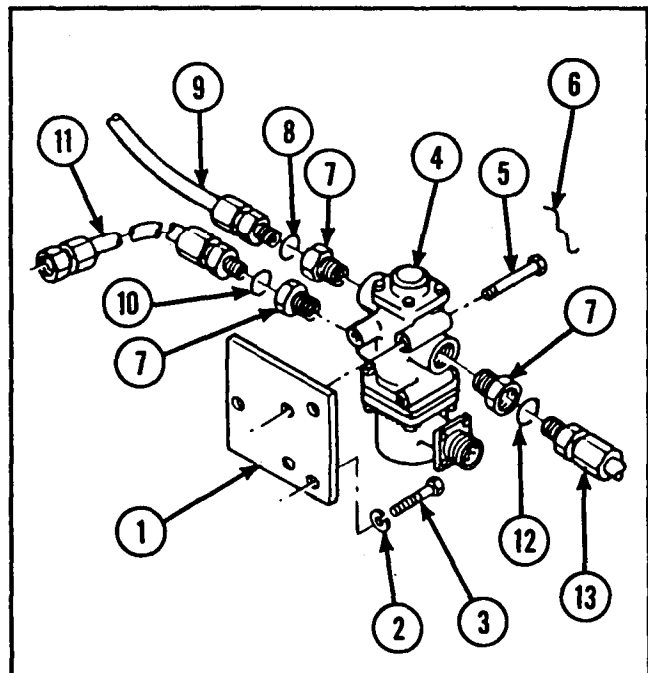

2-30. MAINTENANCE OF AIR CLEANER CENTRIFUGAL FAN.

This task covers:	a. Disassembly	b. Inspection/Repair	c. Reassembly
-------------------	----------------	----------------------	---------------

INITIAL SETUP

Materials/Parts

- Air cleaner blower parts kit
- Lockwasher (4)
- LockWasher (11)
- LockWasher (1)
- Preformed packing
- Preformed packing
- Self-locking nut
- Spring pin

References

- TM 9-2350-238-20-1
- TM 9-2350-238-24P-1

Equipment Conditions

Air cleaner centrifugal fan removed (TM 9-2350-238-20-1)

DISASSEMBLY

- 1 Remove machine screw (1), lockwasher (2), retaining strap (3), and electrical lead (4) from centrifugal blower motor housing (5).
- 2 Remove ten machine screws (6), ten lockwashers (7), and electric motor cover (8) from centrifugal blower motor housing (5).
- 3 Remove screw (9) and lockwasher (10) securing electrical lead (11) to rear of motor. Disconnect electrical lead and capacitor (12).
- 4 Pull direct current electric motor (13) from centrifugal blower motor housing (5). Remove preformed packing (14). Pull electrical leads (11 and 12) from groove under motor packing flange.
- 5 Remove four machine screws (15), four lockwashers (16), and lead and capacitor (12) from centrifugal blower motor housing (5).

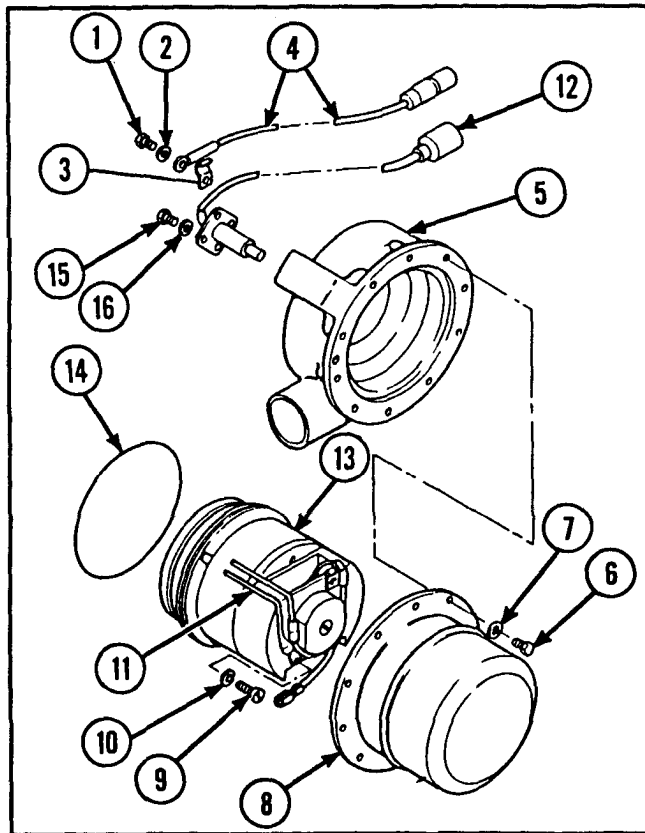

2-30. MAINTENANCE OF AIR CLEANER CENTRIFUGAL FAN (CONT).

DISASSEMBLY (CONT)

- 6 Remove self-locking nut (17), flat washer (18), centrifugal fan impeller (19), and flat washer (20) from direct current electric motor (13).
- 7 Remove preformed packing (21) from direct current electric motor (13).
- 8 If damaged, remove spring pin (22) from centrifugal blower motor housing (5).
- 9 If damaged, remove terminal (23) and insulation sleeving (24) from electrical lead (25).

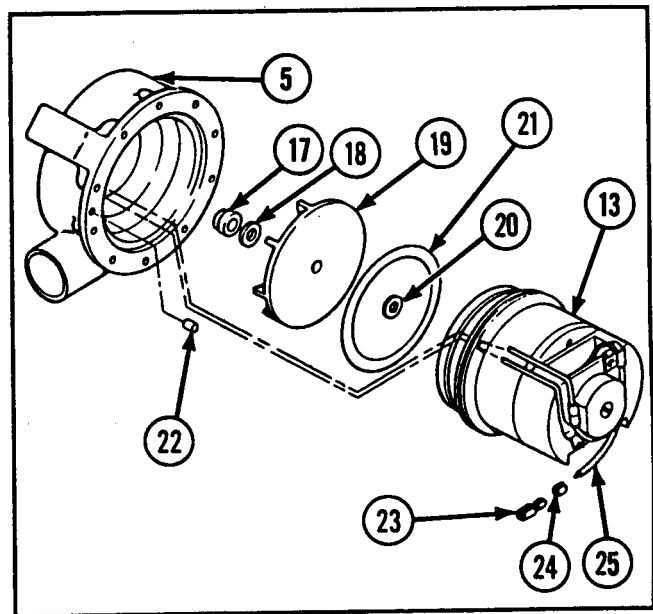

INSPECTION/REPAIR

- 1 Inspect for broken, damaged, or missing parts.
- 2 If any kit component is damaged, replace entire air cleaner blower parts kit.
- 3 Repair is by replacement of authorized parts (TM 9-2350-2-8-24P-1) which do not meet inspection criteria.

REASSEMBLY

- 1 If removed, install new insulation sleeving (1) and terminal (2) on electrical lead (3).
- 2 If removed, install new spring pin (4) in centrifugal blower motor housing (5).
- 3 Install new preformed packing (6) in groove on direct current electric motor (7).

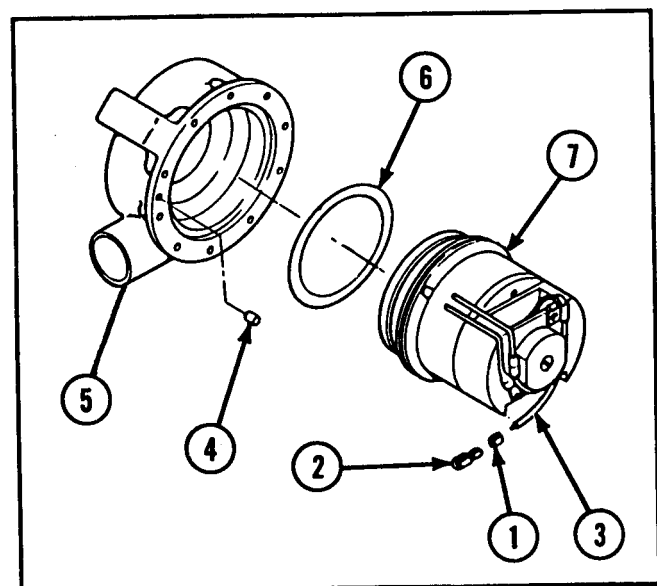

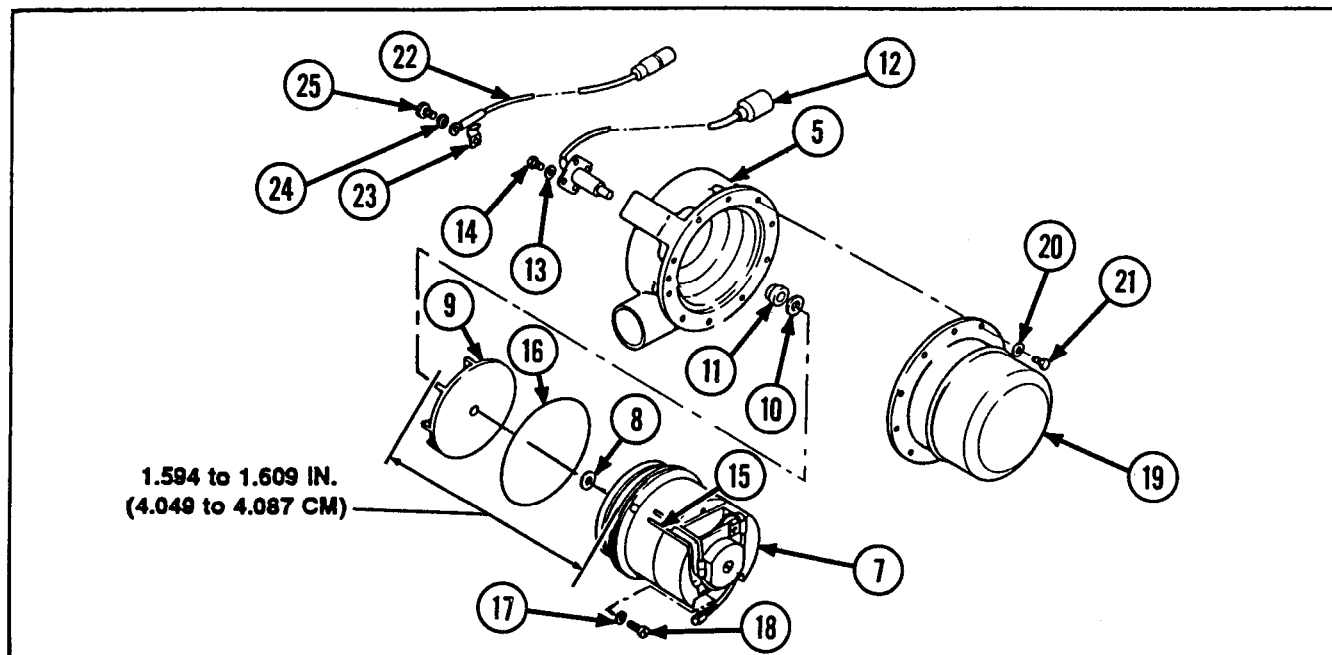

- 4 Install flat washer (8), centrifugal fan impeller (9), flat washer (10), and new self-locking nut (11) to direct current electrical motor (7). Measure distance between forward edge of centrifugal fan impeller and forward edge of motor packing flange. Add or remove flat washers (8) until measurement is 1.594 to 1.609 in. (4.049 to 4.087 cm).
- 5 Install lead and capacitor (12) through centrifugal blower motor housing (5) with four new lockwashers (13) and four machine screws (14).
- 6 Insert leads (12 and 15) through groove under motor packing flange. Install new preformed packing (16) to direct current electric motor (7). Install direct current electric motor to centrifugal blower motor housing (5).
- 7 Secure electrical lead (15) to rear of motor with new lockwasher (17) and screw (18). Connect lead and capacitor (12) at connector.
- 8 Install electric motor cover (19), ten new lockwashers (20), and ten machine screws (21) to centrifugal blower motor housing (5).
- 9 Install electrical lead (22), retaining strap (23), new lockwasher (24), and machine screw (25) to centrifugal blower motor housing (5).

2-31. MAINTENANCE OF FABRIC FUEL CELL INSTALLATION AND FABRIC FUEL CELL FILLER BLOCKS.

This task covers:	a. <i>Fabric Fuel Cell Draining</i> b. <i>Removal</i> c. <i>Cleaning</i>	d. <i>Inspection/Repair</i> e. <i>Installation</i> f. <i>Test</i>
-------------------	--	---

INITIAL SETUP

Tools and Special Tools

Automotive maintenance and repair shop equipment: field maintenance, basic, less power (SC 4910-95-A31)

- Hand pump
- Pressure gage, 0 to 10 psi (0 to 69 kPa)
- Sparkproof extension light
- Spray gun
- Torque wrench (0 to 300 in.-lb)

Materials/Parts

Cleaning compound (item 6, appx B)
 Compressed air (90 to 100 psi)
 Gasket (2)
 Grease (item 17, appx B)
 Liquid soap (item 27, appx B)
 Lockwasher (18)
 Lockwasher (40)
 Masking tape (item 29, appx B)
 Paint thinner (item 30, appx B)
 Preformed packing (2)
 Rags (item 23, appx B)
 Rubber hose (figure C-1, appx C)
 Sealing compound (item 24, appx B)
 Silicone adhesive sealant (item 2, appx B)

References

TM 9-2350-238-20-1
 TM 9-2350-238-24P-1

Equipment Conditions

Fan well deck removed
 (TM 9-2350-238-20-1)

General Safety Instructions



- Prolonged breathing of fuel vapors can be fatal. Do not enter fuel cells until they have been thoroughly cleaned. If eyes or skin become irritated by diesel fuel, flush with water.
- Fuel cells that are not entirely free of fuel or fuel vapors must not be welded or exposed to heat, flames, or sparks. Welding or the use of power sanders, chisels, and chipping hammers shall be preceded by removal of the fabric fuel cell and by thorough cleaning.
- Failure to reduce pressure to zero before removing cap may cause injury.

FABRIC FUEL CELL DRAINING

- 1 Use hand pump to remove as much fuel as possible. Place suitable containers for fuel under two fabric fuel cell drains (1) (fuel capacity is 260 gal. (984 l)).
- 2 Remove two drain plugs (2) and two pre-formed packings (3) and drain fabric fuel cell. Allow 24 hours for the fabric fuel cell to drip, if possible.

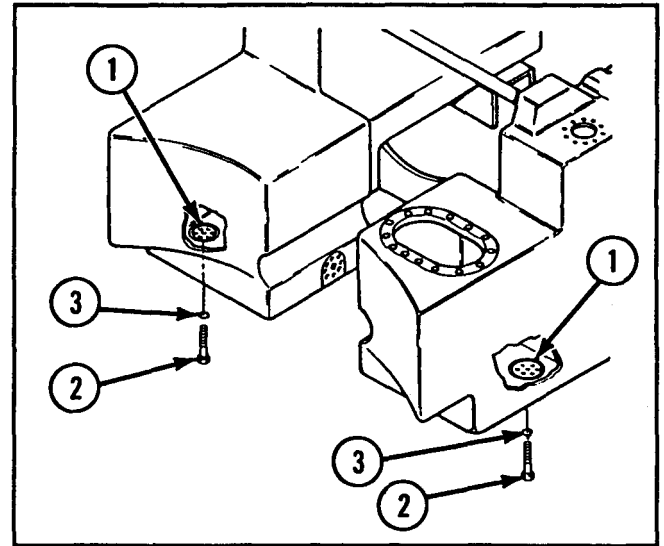

R E M O V A L

NOTE

Steps 1 and 2 are written and illustrated for left fuel cell access cover but apply to both the left and right fuel cell access covers.

- 1 Remove 20 capscrews (1), 20 lockwashers (2), and left fuel cell access cover (3).
- 2 Remove two capscrews (4) and access cover gasket (5). Reinstall capscrews (4) and hand tighten.

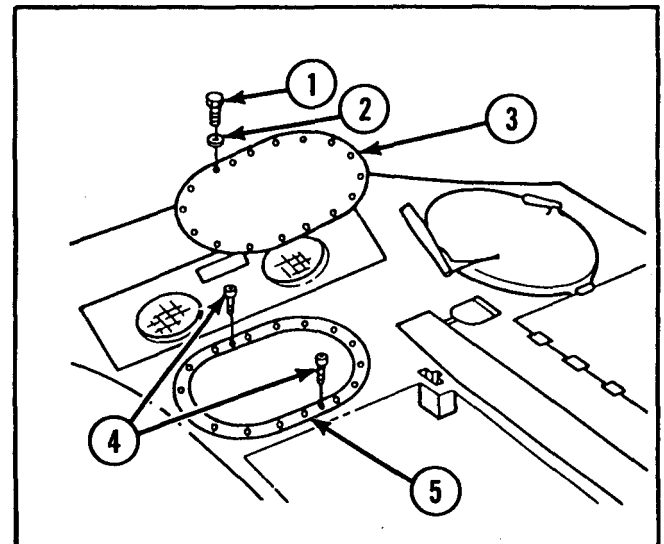

2-31. MAINTENANCE OF FABRIC FUEL CELL INSTALLATION AND FABRIC FUEL CELL FILLER BLOCKS (CONT).

REMOVAL (CONT)

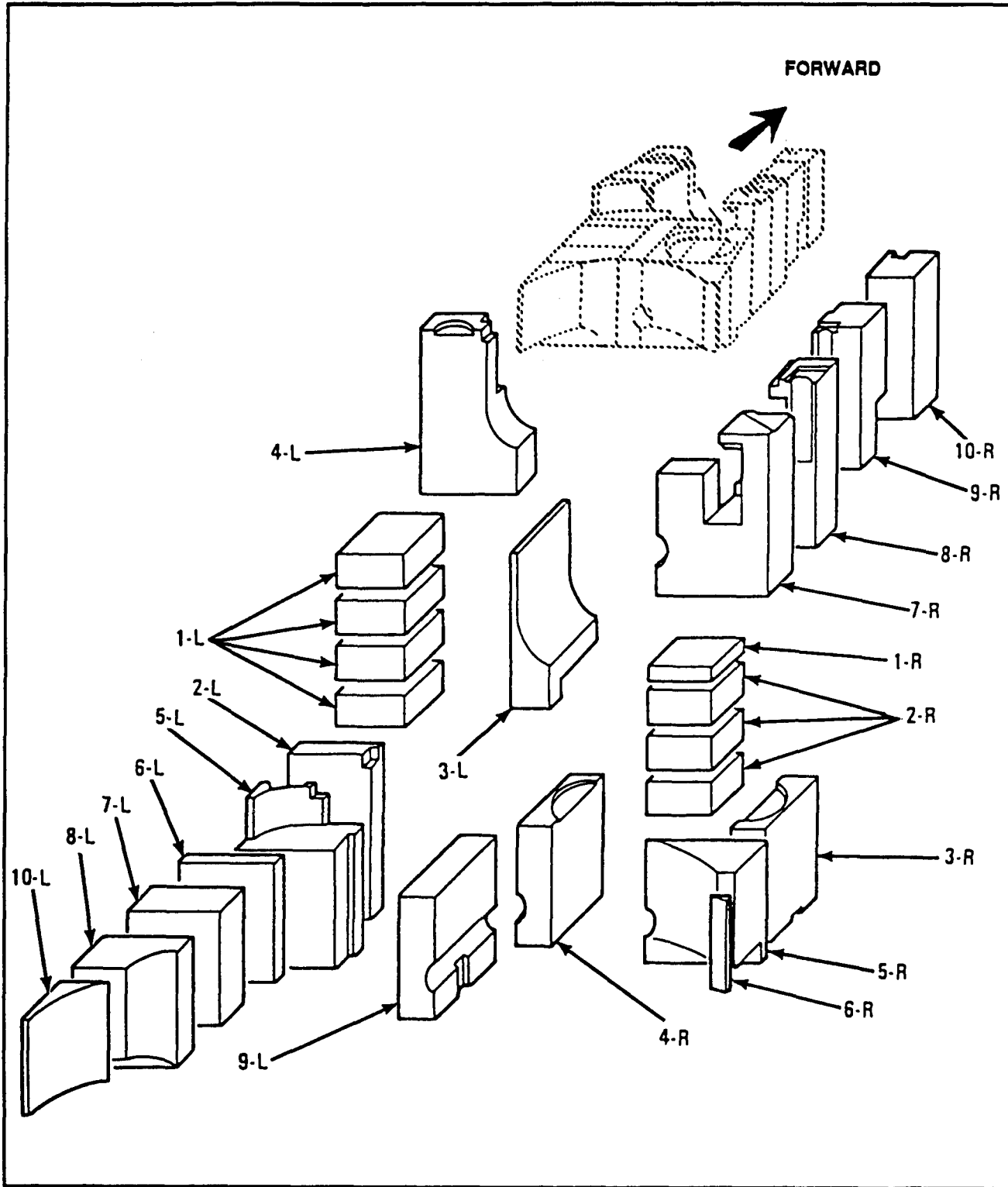

WARNING

Prolonged breathing of fuel vapors can be fatal. If eyes or skin become irritated by diesel fuel, flush with water.

CAUTION

Filler blocks are saturated with diesel fuel. Running water must be available to flush eyes and sensitive skin areas that may be irritated by fuel. If possible, wear coveralls and protective covers on hands and arms.

NOTE

The fabric fuel cells are filled with 25 foam filler blocks shaped to fit one way inside the fuel compartments. The filler blocks may have painted manufacturer's numbers that should be disregarded. Tag and number each filler block as it is removed for easy identification.

- 3 Ensure fuel level transmitter and fuel filler neck and strainer element have been removed (TM 9-2350-238-20-1).
- 4 Provide suitable containers to hold filler blocks and catch dripping diesel fuel.
- 5 Start at right fabric fuel cell access opening. Remove and tag filler blocks in sequence 1-R thru 10-R as shown.
- 6 Start at left fabric fuel cell access opening. Remove and tag filler blocks in sequence 1-L thru 10-L as shown.

WARNING

- Prolonged breathing of vapors can be fatal. Do not enter fuel cells until they have been thoroughly cleaned.
 - Fuel compartments that are not entirely free of fuel or fuel vapors must not be welded or exposed to heat, flames, or sparks. Welding or the use of power sanders, chisels, and chipping hammers shall be preceded by removal of the fabric fuel cell and by thorough cleaning.
- 7 Perform fabric fuel cell cleaning procedures, refer to page 2-53.

2-31. MAINTENANCE OF FABRIC FUEL CELL INSTALLATION AND FABRIC FUEL CELL FILLER BLOCKS (CONT).

REMOVAL (CONT)

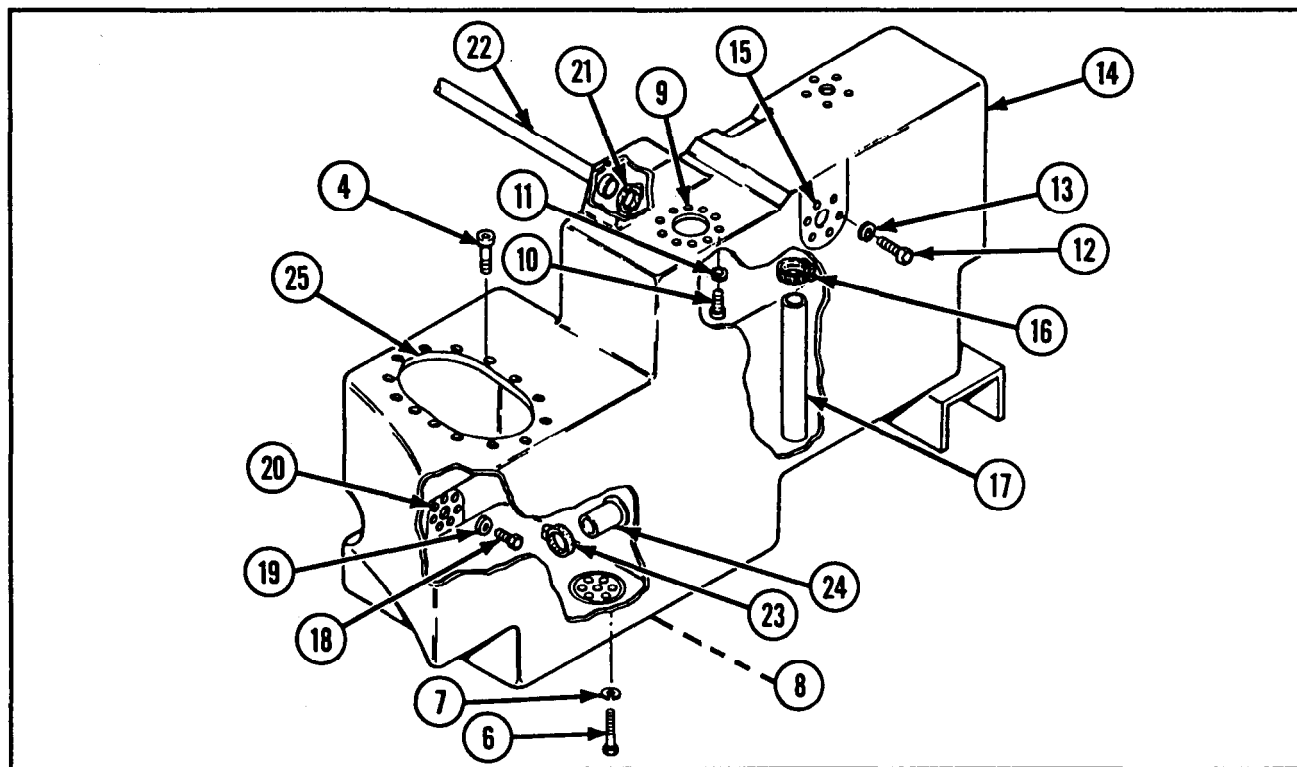

- 8 Remove six capscrews (6) and six lockwashers (7) securing right fuel drain nut ring (8) to hull.
- 9 Reach through fuel filler neck and strainer element access (9) and remove ten capscrews (10) and ten flat washers (11).
- 10 Enter right vehicle tunnel and remove six capscrews (12) and six lockwashers (13) securing right fabric fuel cell (14) to coolant heater fuel intake (15).
- 11 Enter right fabric fuel cell (14) and remove hose clamp (16) and rubber hose (17).
- 12 Remove eight capscrews (18) and eight flat washers (19) at interconnect (20).
- 13 Remove hose clamp (21) securing nipple to crossover vent tube (22). Pull right fabric fuel cell free of fitting. Plug or cap crossover vent tube (22).
- 14 Remove hose clamp (23) securing nipple to fuel intake tube (24). Pull right fabric fuel cell free of fitting. Plug or cap fuel intake tube (24).
- 15 Remove two capscrews (4) securing right fabric fuel cell (14) to right fabric fuel cell access opening (25).

CAUTION

Do not enter fuel compartment until all sharp objects are removed from clothing and shoes are wrapped with rags to prevent damage to fabric fuel cells.

CAUTION

Do not cut or damage fabric fuel cell when separating from hull.

NOTE

Fabric fuel cells are sealed with sealant at hull attaching points.

- 16 Use putty knife or dull screwdriver to separate right fabric fuel cell (14) from hull at the following points: right fabric cell access opening (25); fuel level transmitter access (26); fuel filler neck and strainer element access (9); and coolant heater fuel intake (15).
- 17 Pull right fabric fuel cell (14) down and free of fuel intake tube (24).
- 18 Fold right fabric fuel cell (14) down and roll back to gain access to fuel drain (27). Separate right fabric fuel cell (14) from hull.

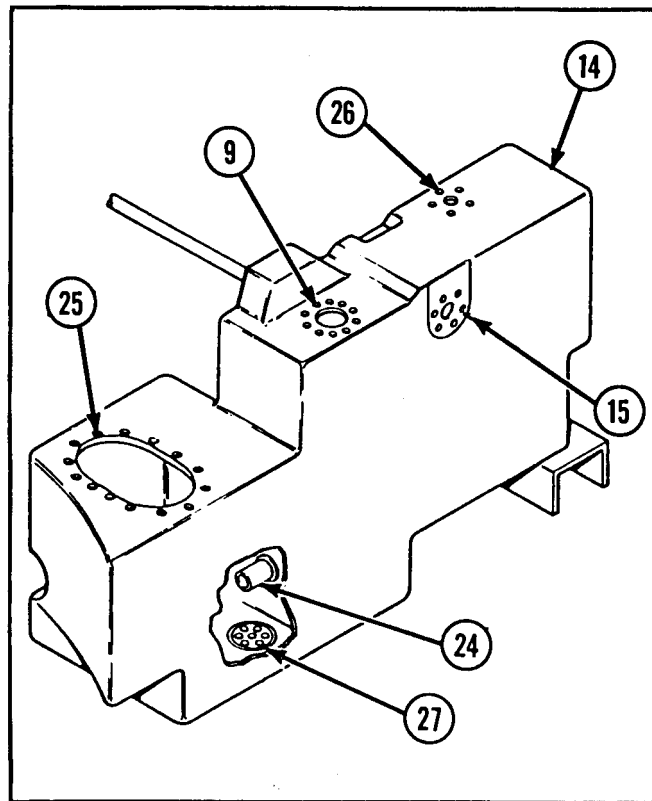

- 19 Fold and remove right fabric fuel cell (14) from hull through right fabric fuel cell access opening (25).

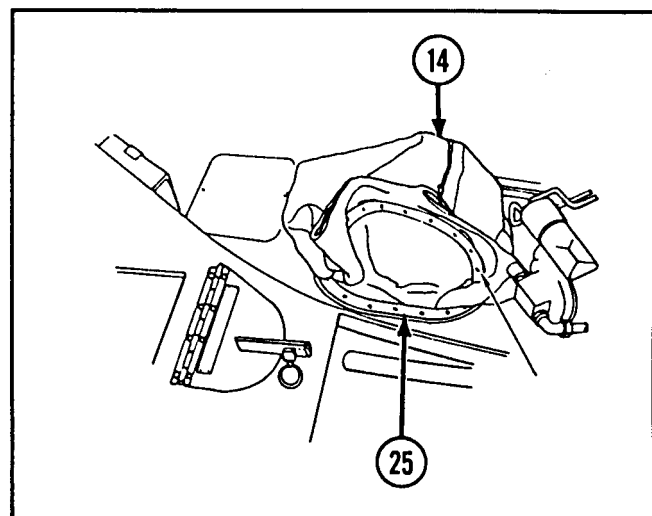

2-31. MAINTENANCE OF FABRIC FUEL CELL INSTALLATION AND FABRIC FUEL CELL FILLER BLOCKS (CONT).

REMOVAL (CONT)

- 20 Remove six capscrews (28) and six lockwashers (29) securing left fuel drain nut ring (30) to hull.
- 21 Remove hose clamp (31) securing nipple to crossover vent tube (22). Pull left fabric fuel cell (32) free of crossover vent tube.
- 22 Remove hose clamp (33) securing left fabric fuel cell (32) to fuel return adapter (34). Pull left fabric fuel cell (32) free of fuel return adapter (34).
- 23 Remove two capscrews (4) securing left fabric fuel cell (32) to left fabric fuel cell access opening (35).
- 24 Use putty knife or dull screwdriver to separate left fabric fuel cell (32) from left fabric fuel cell access opening (35).
- 25 Fold left fabric fuel cell (32) down and roll back to gain access to fuel drain (36). Separate left fabric fuel cell (32) from hull.
- 26 Fold and remove left fabric fuel cell (32) from hull through left fabric fuel cell access opening (35).
- 27 Remove crossover vent tube (22) through left fabric fuel cell access opening (35).
- 28 Remove left front fuel cell support (37).
- 29 Remove right front fuel cell support (38).
- 30 Remove fuel tank support (39).
- 31 Remove fuel return adapter (34).
- 32 Clean right and left fuel compartments. Refer to general cleaning procedures, page 2-29.

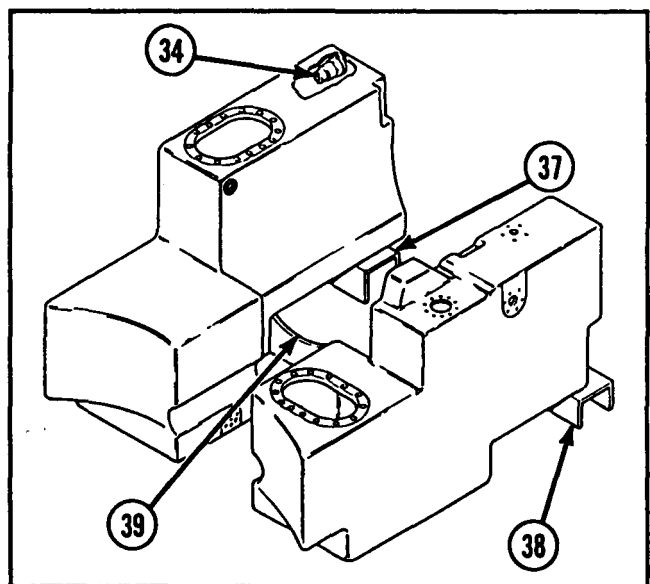
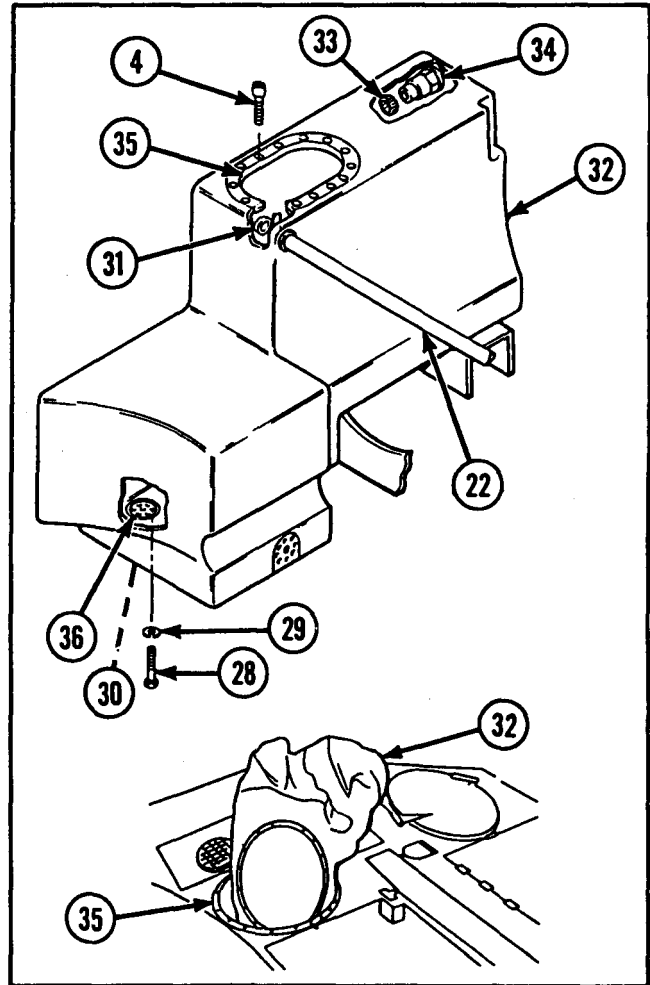

CLEANING

- 1 The following materials are needed to clean the fabric fuel cells:
 - a. Pressurized hot water at 100 to 160 °F (38 to 71 °C) and a hose long enough to reach vehicle top deck.
 - b. Cleaning compound.
 - c. Paint thinner.
 - d. Liquid soap.
 - e. Compressed air (90 to 100 psi (621 to 690 kPa)).
 - f. Sparkproof extension light.
 - g. Spray gun with nozzle and connections for air and water.
- 2 Prepare cleaning solution of one part cleaning compound and nine parts paint thinner. Mix solution well. Fill spray gun cup and attach gun to air pressure.
- 3 Ensure drained fuel has been removed from under vehicle and provision has been made for disposal of cleaning solution.
- 4 Spray fabric fuel cells with cleaning solution. Cracks will retain residual fuel. Ensure all surfaces are covered.
- 5 Allow cleaning solution to remain on surfaces for 15 minutes minimum.
- 6 Fill spray gun cup with liquid soap and attach to pressurized hot water.
- 7 Rinse fabric fuel cells with soap solution for 5 minutes minimum. Allow rinse to drain holes.
- 8 Thoroughly rinse fabric fuel cells with clean warm water.

CAUTION

Do not enter fuel compartments until all sharp objects are removed from clothing and shoes are wrapped with rags to prevent damage to fabric fuel cells.

- 9 Dry fabric fuel cells with clean, dry, absorbent rags,
- 10 Test cleanliness of fabric fuel cells, using 12.0 in. (30.5 cm) x 2.0 in. (5.1 cm) wide masking tape. If tape sticks to fabric fuel cell, the fabric fuel cell is clean. If tape does not stick, repeat cleaning procedures.

2-31. MAINTENANCE OF FABRIC FUEL CELL INSTALLATION AND FABRIC FUEL CELL FILLER BLOCKS (CONT).

INSPECTION/REPAIR

- 1 Inspect for broken, damaged, or missing parts.
- 2 Filler blocks are part of left fuel cell kit or right fuel cell kit. If filler blocks are broken, damaged, or missing, order applicable fuel cell kit for replacement.
- 3 Inspect fabric fuel cells for tears or holes which will cause leaks. Repair small holes and tears using silicone adhesive sealant.
- 4 Rubber hose is a manufactured item, refer to appendix C.
- 5 Repair is by replacement of authorized parts (TM 9-2350-238-24P-1) which do not meet inspection criteria.

INSTALLATION

- 1 Make sure left and right fuel compartments are clean. Refer to general cleaning procedures, page 2-29. Remove all debris and sharp objects.
- 2 Clean fuel return tube threads (1) and apply sealing compound. Install fuel return adapter (2).

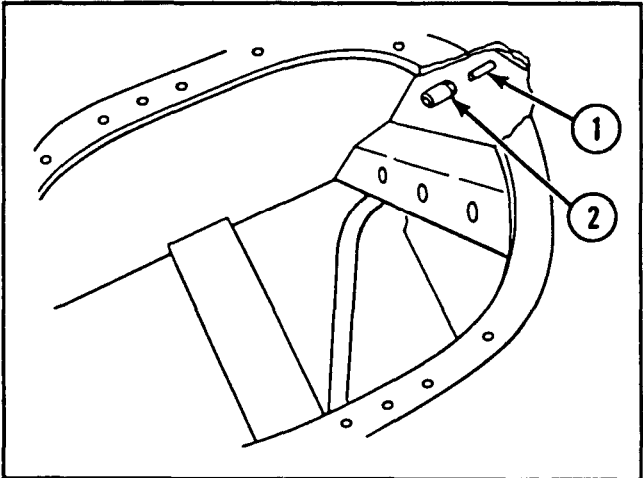

- 3 Install left front fuel cell support (3). Elevate inboard side of support when inserting to aid positioning,

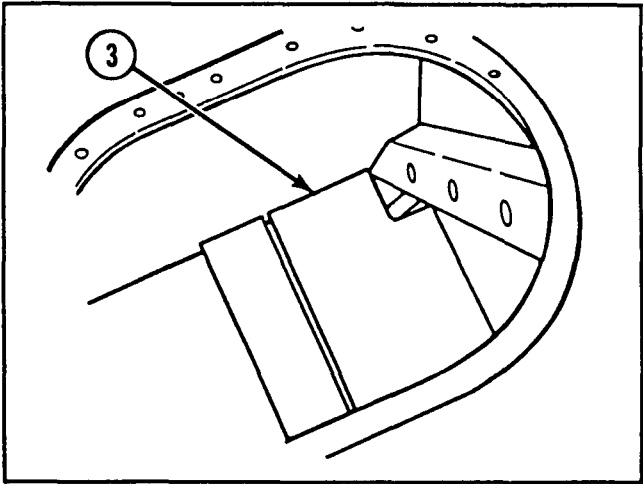

- 4 Install right front fuel cell support (4). Elevate inboard side of support when inserting to aid positioning.

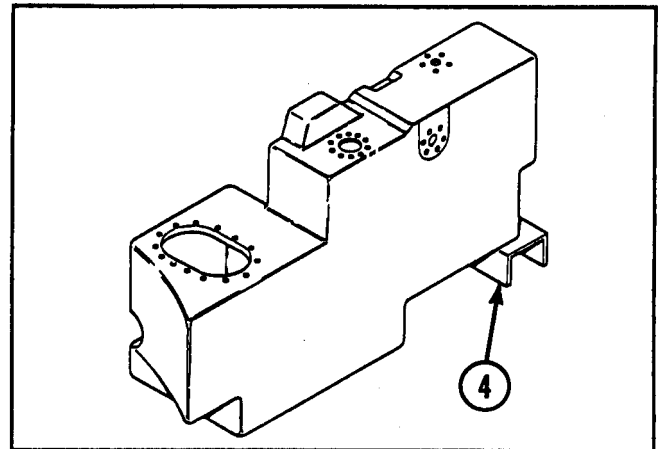

- 5 Install fuel tank support (5). Make sure fuel intake tube (6) extends through fuel tank support.

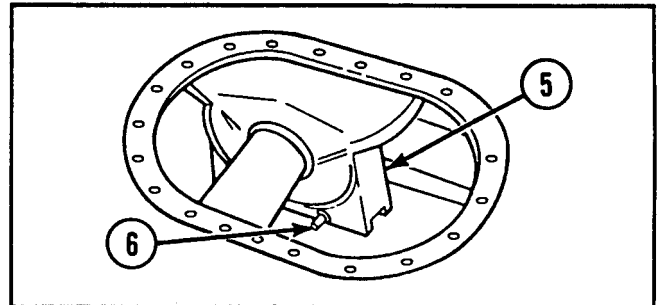

- 6 Fold right fabric fuel cell (7). Insert forward part into right fabric fuel cell access opening (8).

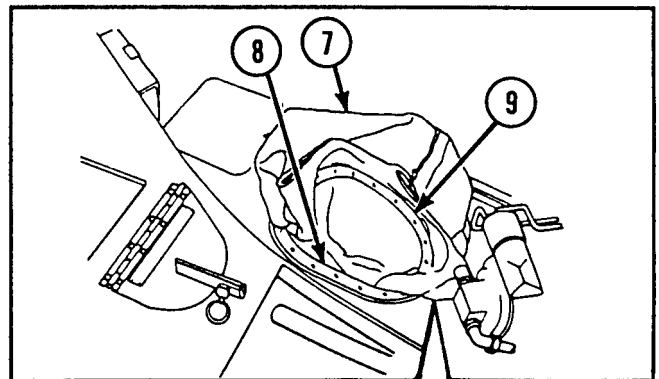

- 7 Turn right fabric fuel cell (7) and install right fabric fuel cell nut ring (9) and remainder of right fabric fuel cell through right fabric fuel cell access opening (8).

- 8 Unfold right fabric fuel cell (7) inside right fuel compartment.

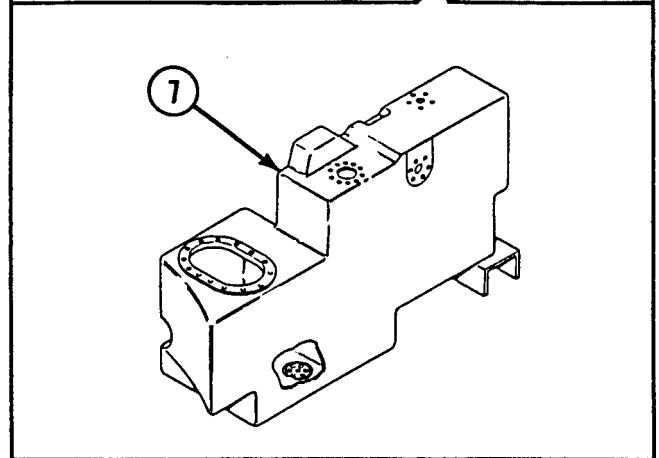

2-31. MAINTENANCE OF FABRIC FUEL CELL INSTALLATION AND FABRIC FUEL CELL FILLER BLOCKS (CONT).

INSTALLATION (CONT)

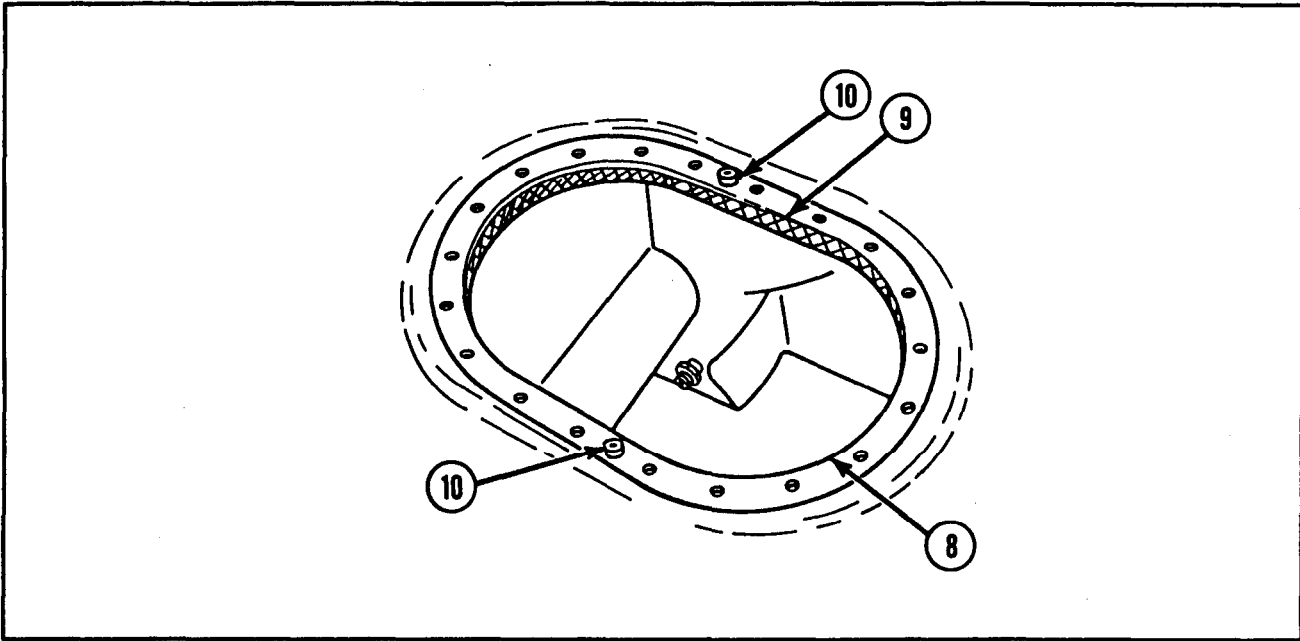

WARNING

Apply silicone adhesive sealant only in a well-ventilated area. Keep away from heat, sparks, and open flame.

NOTE

- Silicone adhesive sealant should cure until a skin coat is formed before mating surfaces are placed together.
- Hand tighten capscrews during installation. Tighten screws to torque specifications after fabric fuel cell installation is complete. Allow 6 hours minimum drying time before adding fuel. Take care not to apply silicone adhesive sealant to tube connections.

9 Secure right fabric fuel cell nut ring (9) to right fabric fuel cell access opening (8) with two capscrews (10) through odd-spaced holes offset from centerline. Hand tighten two capscrews (10).

CAUTION

Do not enter fuel compartment until all sharp objects are removed from clothing and shoes are wrapped with rags to prevent damage to fabric fuel cell.

10 Enter right fuel compartment and smooth right fabric fuel cell to contours of right fuel compartment.

11 Fold down forward right side of right fabric fuel cell. Clean mating surfaces and apply a liberal amount of silicone adhesive sealant to drain nut ring (11) and hull, and to coolant heater fuel intake (12). Allow silicone adhesive sealant to form a skin coat.

12 Slide right fabric fuel cell over coolant heater fuel intake tube (13) and press against hull.

13 Enter right vehicle tunnel (14). Apply sealing compound to six capscrews (15). Secure right fabric fuel cell (7) to coolant heater fuel intake (16) with six new lockwashers (17) and six capscrews (15). Hand tighten capscrews.

14 Install rubber hose (18). Secure rubber hose with hose clamp (19).

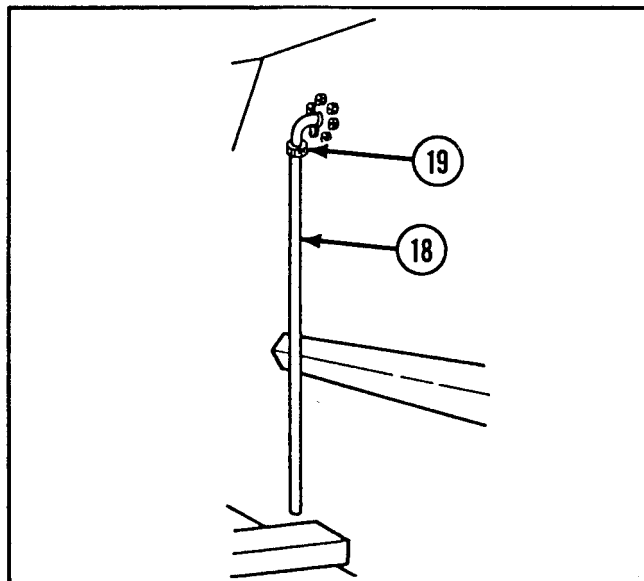
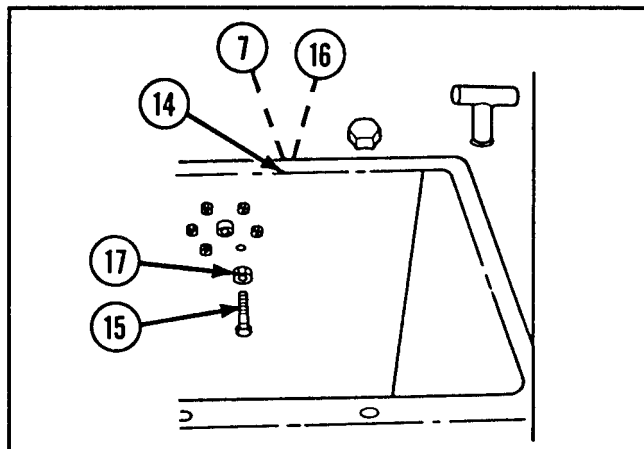
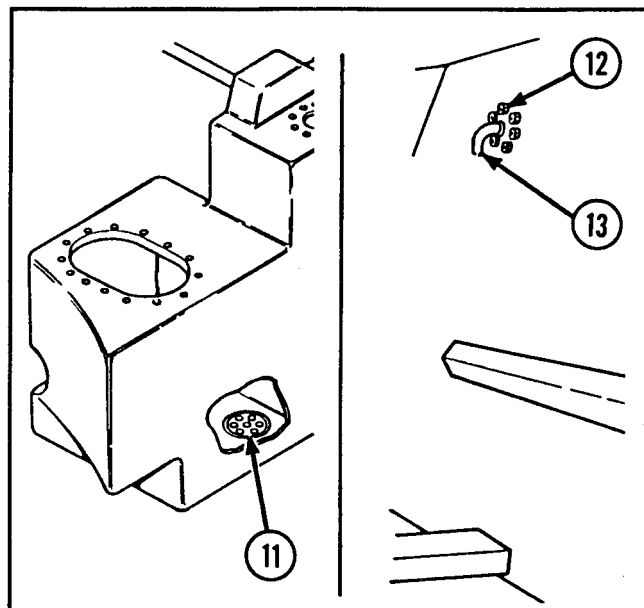

2-31. MAINTENANCE OF FABRIC FUEL CELL INSTALLATION AND FABRIC FUEL CELL FILLER BLOCKS (CONT).

INSTALLATION (CONT)

15 Remove two capscrews (10) securing right fabric fuel cell to right fabric fuel cell access opening (8).

16 Clean mating surfaces and apply a liberal amount of silicone adhesive sealant to right fabric fuel cell access opening (8) and right fabric fuel cell nut ring (9). Allow silicone adhesive sealant to form a skin coat.

17 Secure right fabric fuel cell nut ring (9) to right fabric fuel cell access opening (8) with two capscrews (10) through odd-spaced holes offset from centerline. Hand tighten capscrews.

18 Work right fabric fuel cell nipple over fuel intake tube (6) until tube protrudes through nipple. Secure right fabric fuel cell with hose clamp (20).

19 Clean mating surfaces and apply a liberal amount of silicone adhesive sealant to nut ring (21) and underside of hull at fuel filler neck and strainer element access (22). Allow silicone adhesive sealant to form a skin coat.

20 Apply sealing compound to ten capscrews (23). Secure right fabric fuel cell (7) to hull with ten flat washers (24) and ten capscrews (23) installed through right fabric fuel cell into hull. Hand tighten capscrews.

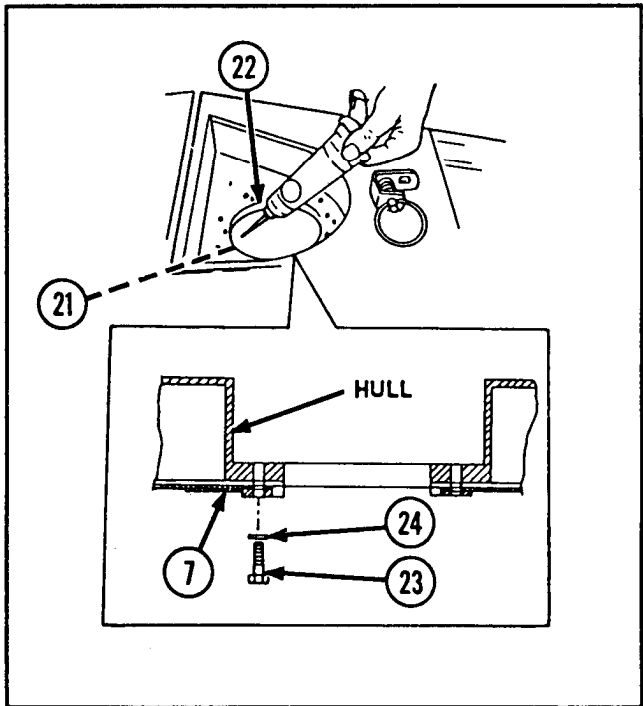
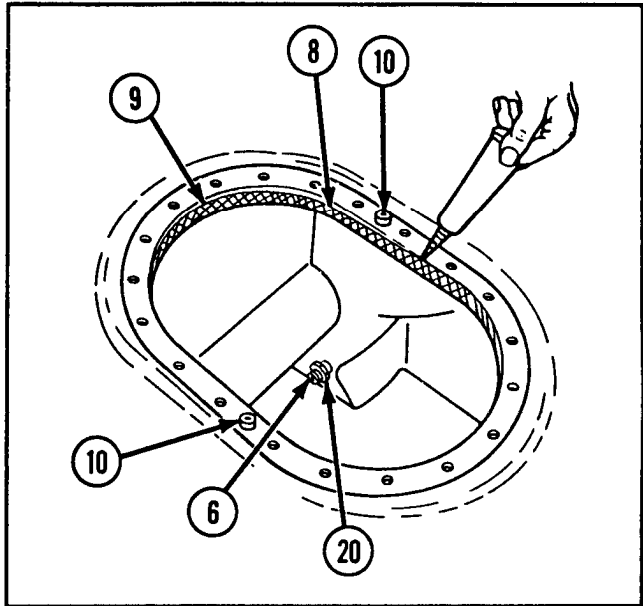

- 21 Align fuel drain nut ring (25) with hull. Hold in place with one capscrew (26) with only one- or two-thread engagements. While right fabric fuel cell (7) is lifted from inside, work from underside of hull and apply a liberal amount of silicone adhesive sealant to mating surfaces of fuel drain nut ring (25) and hull. Allow silicone adhesive sealant to form a skin coat.
- 22 Apply sealing compound to six capscrews (26). Secure fuel drain nut ring (25) to hull with six new lockwashers (27) and six capscrews (26). Hand tighten six capscrews.
- 23 Install new preformed packing (28) and drain plug (29).

CAUTION

Pushing tube too far may damage right fabric fuel cell.

- 24 Lightly lubricate crossover vent tube (30) with grease. Install crossover vent tube through left fabric fuel cell access opening (31) into hull vent flange (32). As tube projects into right fabric fuel cell, work right nipple over tube until tube protrudes through nipple. Push tube through right nipple until end of crossover vent tube is nearly flush with hull vent flange in left fuel compartment.

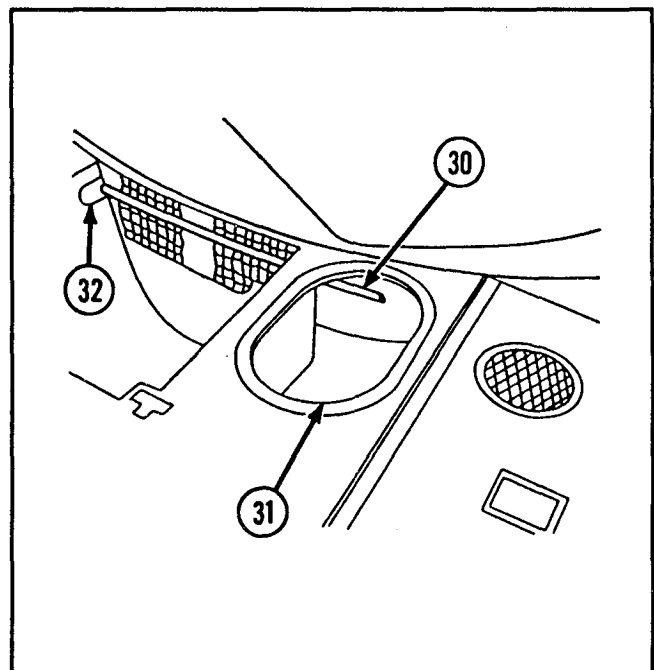
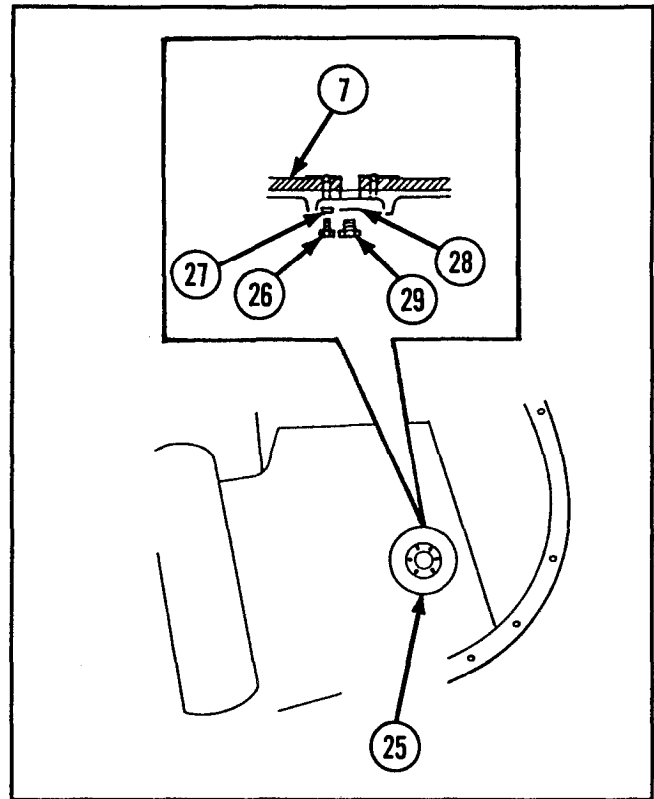

2-31. MAINTENANCE OF FABRIC FUEL CELL INSTALLATION AND FABRIC FUEL CELL FILLER BLOCKS (CONT).

INSTALLATION (CONT)

NOTE

Do not clamp hull vent tube to right nipple at this time.

- 25 Fold left fabric fuel cell (33). Insert forward part into left fabric fuel cell access opening (31).
- 26 Turn left fabric fuel cell (33) and install left fuel cell nut ring (34) and remainder of left fabric fuel cell through left fabric fuel cell access opening (31).
- 27 Unfold left fabric fuel cell (33) inside left fuel compartment.
- 28 Secure left fuel cell nut ring (34) to left fabric fuel cell access opening (31) with two capscrews (35) through odd-spaced holes offset from centerline. Hand tighten two capscrews.

CAUTION

Do not enter fuel compartment until all sharp objects are removed from clothing and shoes are wrapped with rags to prevent damage to fabric fuel cell.

- 29 Enter left fuel compartment and smooth left fabric fuel cell to contours of left fuel compartment.
- 30 Remove two capscrews (35) securing left fabric fuel cell (33) to left fabric fuel cell access opening (31).

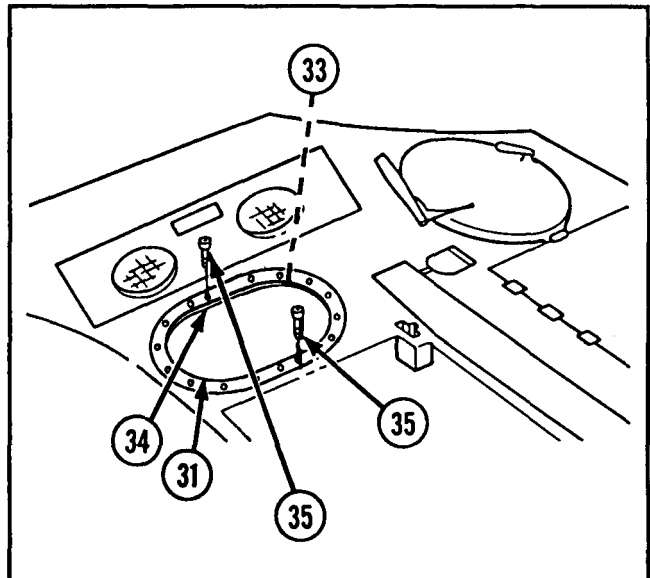
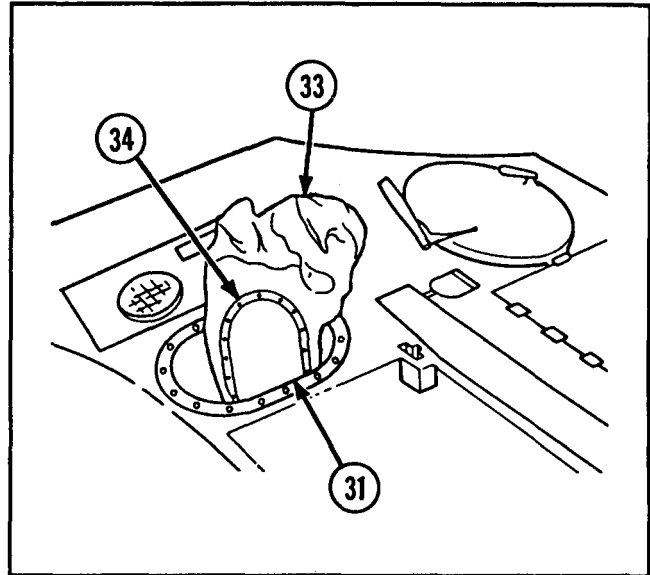

- 31 Pull fabric fuel cell away from hull. Apply a liberal amount of silicone adhesive sealant to mating surfaces of left and right fabric fuel cell interconnects (36). Allow silicone adhesive sealant to form a skin coat.
- 32 From inside right fabric fuel cell (7), apply sealing compound to eight capscrews (37). Secure interconnects with eight flat washers (38) and eight capscrews (37). Hand tighten eight capscrews.

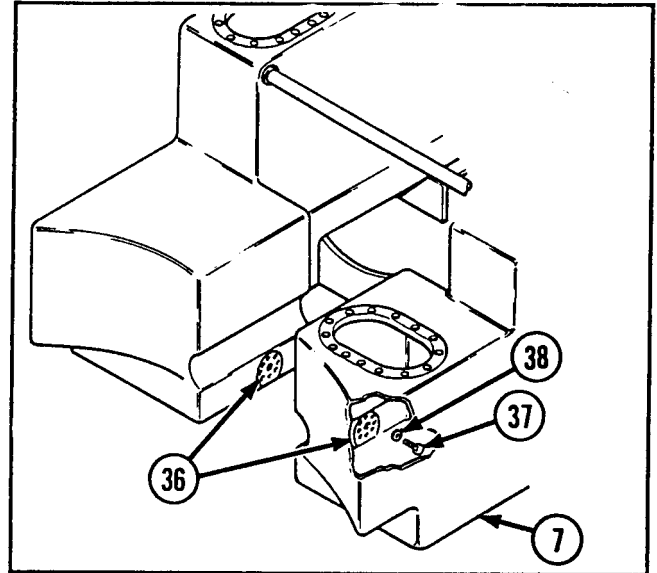

- 33 Clean mating surfaces and apply a liberal amount of silicone adhesive sealant to left fabric fuel cell access opening (31) and left fuel cell nut ring (34). Allow silicone adhesive sealant to form a skin coat.
- 34 Secure left fuel cell nut ring (34) to left fabric fuel cell access opening (31) with two capscrews (35) through odd-spaced holes offset from centerline. Hand tighten capscrews.

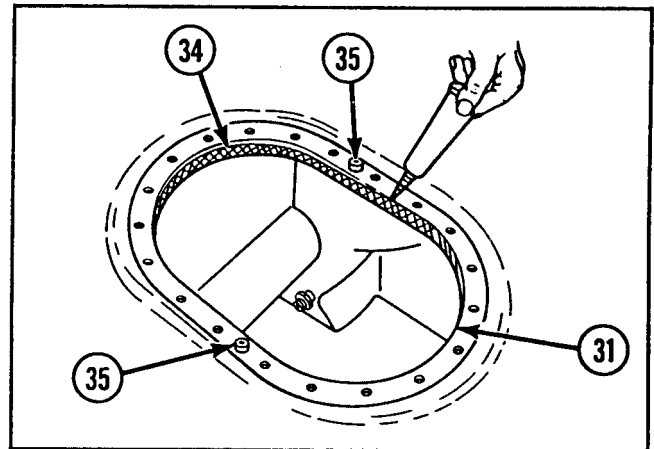

- 35 Align left fuel drain nut ring (39) with hull. Hold in place with one capscrew (40) with only one-or-two thread engagements. While left fabric fuel cell (33) is lifted from inside, work from underside of hull and apply a liberal amount of silicone adhesive sealant to mating surfaces of left fuel drain nut ring (39) and hull. Allow silicone adhesive sealant to form a skin coat.
- 36 Apply sealing compound to six capscrews (40). Secure left fuel drain nut ring (39) to hull with six new lockwashers (41) and six capscrews (40). Hand tighten capscrews.
- 37 Install new preformed packing (42) and drain plug (43).

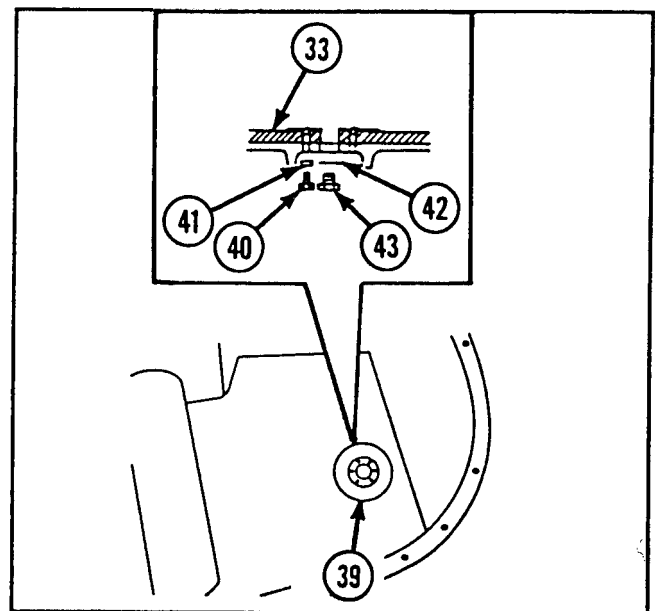

2-31. MAINTENANCE OF FABRIC FUEL CELL INSTALLATION AND FABRIC FUEL CELL FILLER BLOCKS (CONT).

INSTALLATION (CONT)

38 From inside right fabric fuel cell, push crossover vent tube (30) toward left fabric fuel cell. Work fabric fuel cell nipples (44) over hull vent flange (32) until crossover vent tube is evenly spaced in both right and left fabric fuel cells. Secure crossover vent tube (30) to right and left nipples with hose clamps (45),

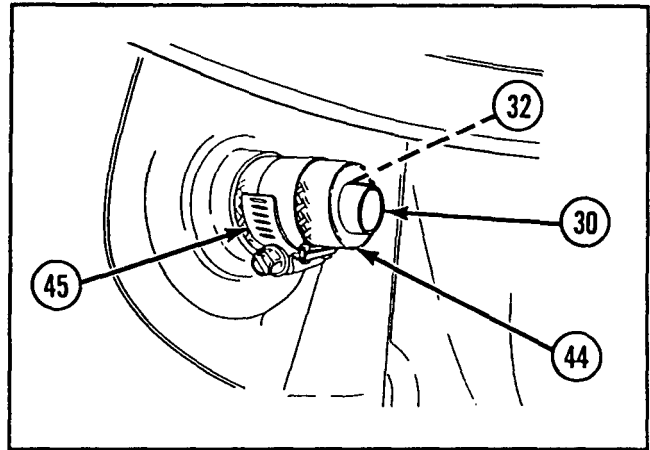

39 Under left fabric fuel cell access opening, work left fabric fuel cell over fuel return adapter (2). Extend fuel return adapter through right fabric fuel cell nipple (44). Secure right fabric fuel cell nipple with hose clamp (46).

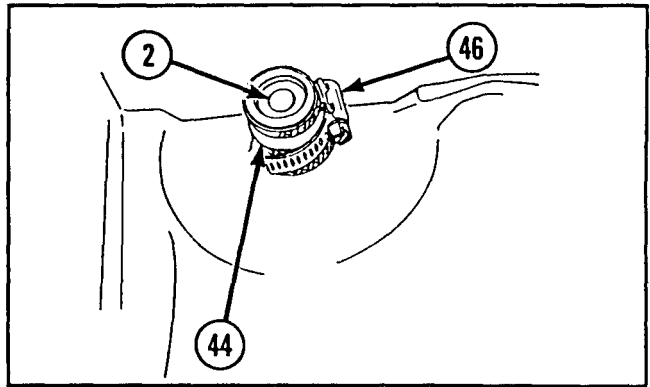

40 Torque the following capscrews to 108.0 to 120.0 in.-lb (12.2 to 13.6 N-m):

- a. six capscrews (15) securing right fabric fuel cell (7) to coolant heater fuel intake (16).
- b. ten capscrews (23) securing nut ring (21) to underside of hull at fuel filler neck and strainer element access (22). Fill top of ten capscrew holes with sealing compound.
- c. six capscrews (26) securing right fuel drain nut ring (25) to hull.
- d. eight capscrews (37) securing right and left fabric fuel cell interconnects (36).
- e. six capscrews (40) securing left fuel drain nut ring (39) to hull.

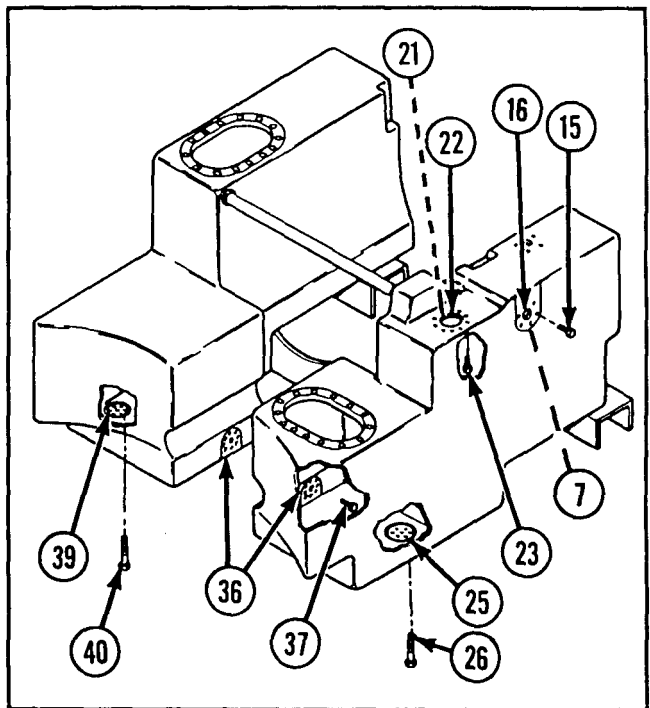

- 41 Make sure all hose clamps are securely tightened.

NOTE

Filler blocks support the fabric fuel cell in areas where fabric fuel cells are not attached to the hull. Make sure each filler block is in place before installing the next block. Assembling the blocks in an open area prior to installation will help in identification, location, and installation of the blocks.

- 42 Install block 10-R (47) into front of right fabric fuel cell.
- 43 Install block 9-R (48) into front of right fabric fuel cell. Make sure coolant heater fuel intake hose is in filler block slot.

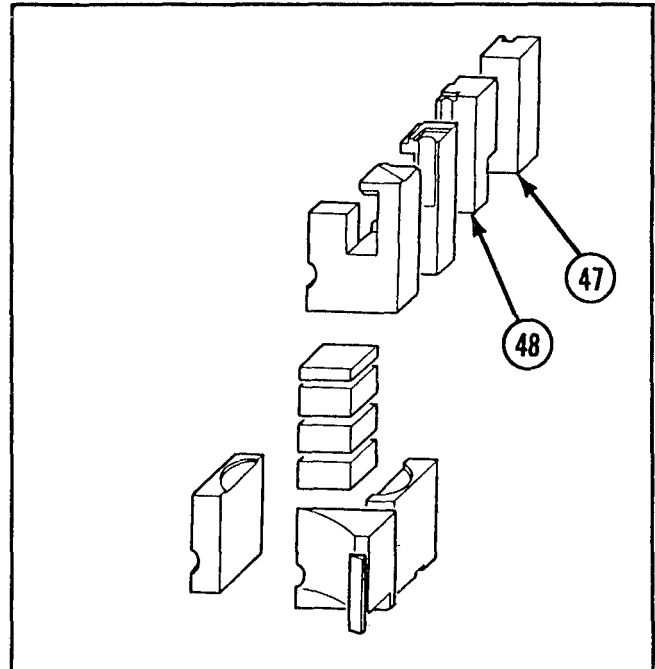

- 44 Install fuel level transmitter. Refer to TM 9-2350-238-20-1.
- 45 Adjust block 9-R (48) until fuel level transmitter float (49) has complete freedom of movement.

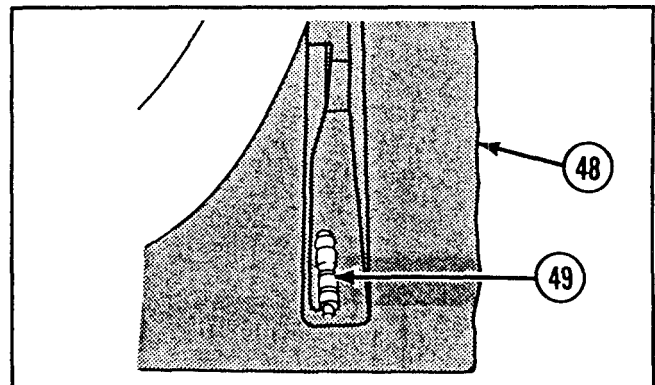

- 46 Install block 8-R (50) into forward part of ceil. Align cutout with fuel filler hole to allow installation of fuel filler neck and fuel filler neck strainer element.
- 47 Install fuel filler neck strainer element and fuel filler neck cap. Refer to TM 9-2350-238-20-1.

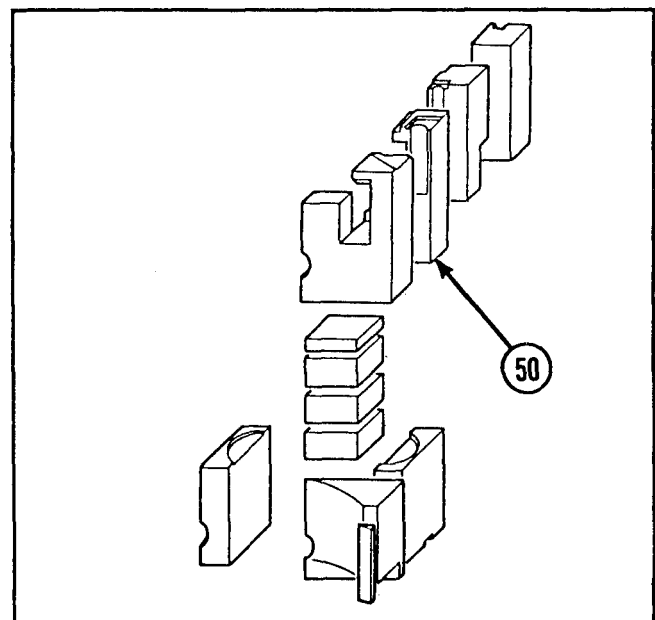

2-31. MAINTENANCE OF FABRIC FUEL CELL INSTALLATION AND FABRIC FUEL CELL FILLER BLOCKS (CONT).

INSTALLATION (CONT)

- 4 8 Adjust block 8-R (50) to fit around fuel filler neck strainer element (51).

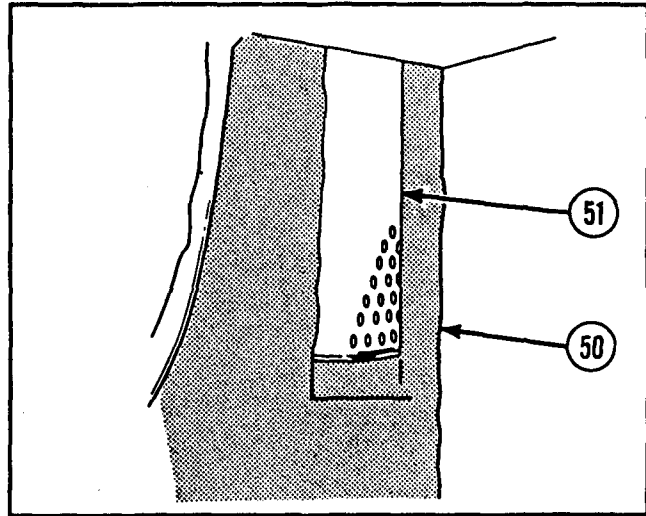

- 4 9 Install block 7-R (52) into forward part of right fabric fuel cell.
- 5 0 Install block 6-R (53) into right rear corner of right fabric fuel cell.
- 5 1 Install block 5-R (54) into rear part of right fabric fuel cell.
- 5 2 Install block 4-R (55) into inboard side of right fabric fuel cell.
- 5 3 Install block 3-R (56) into outboard side of right fabric fuel cell.
- 5 4 Install three blocks 2-R (57), one on top of another, into bottom of right fabric fuel cell.
- 5 5 Install block 1-R (58) into right fabric fuel cell on top of block 2-R (57).

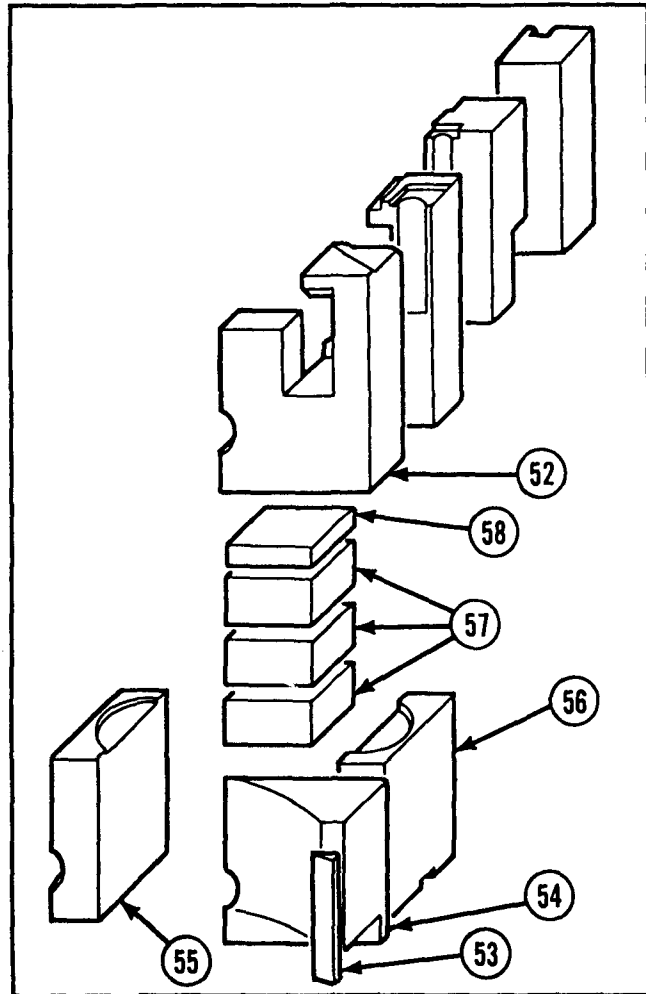

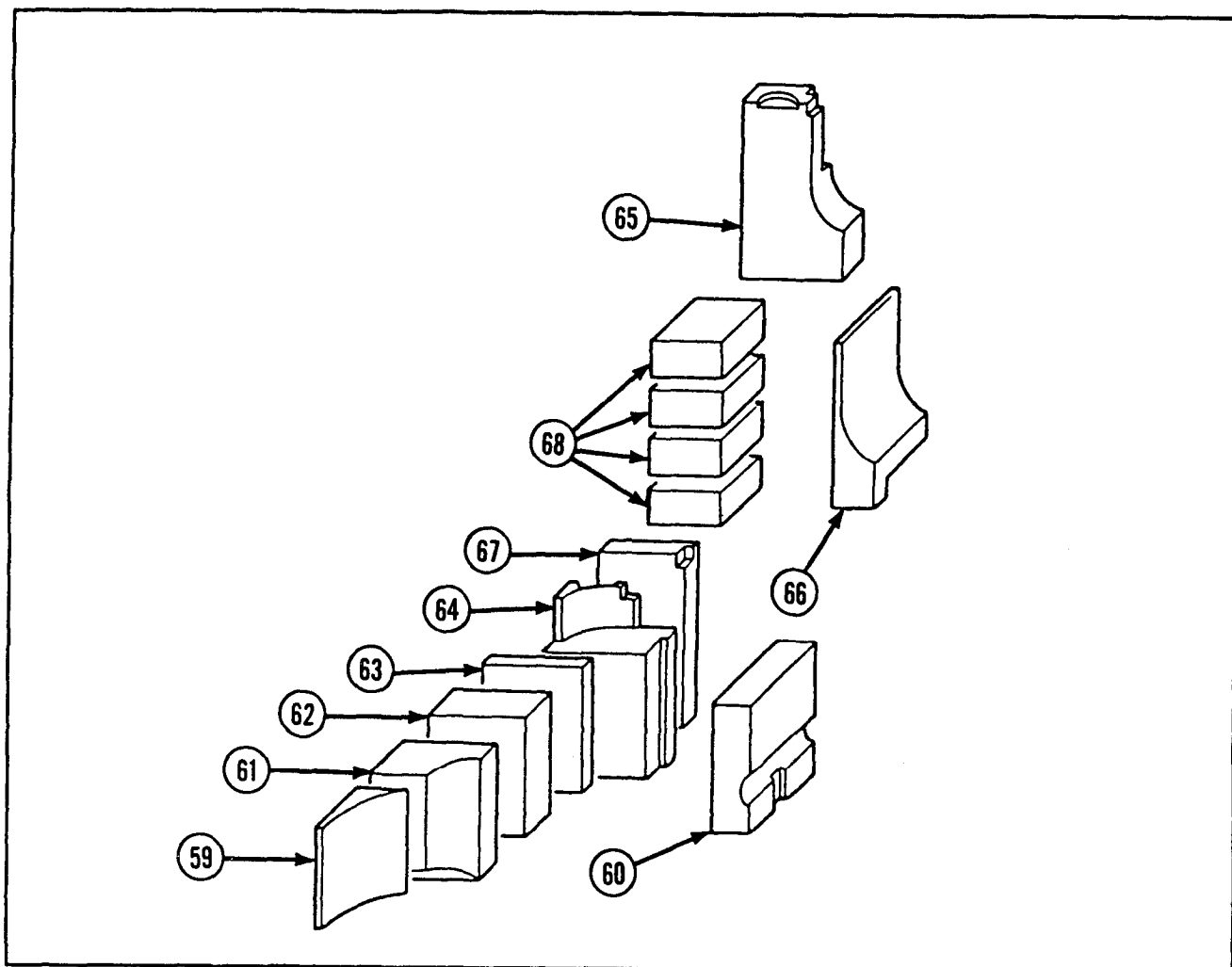

- 56 Install block 10-L (59) into rear corner of left fabric fuel cell.
- 57 Install block 9-L (60) into rear inboard side of left fabric fuel cell.
- 58 Install block 8-L (61) into rear outboard side of left fabric fuel cell.
- 59 Install block 7-L (62) into rear outboard side of left fabric fuel cell.
- 60 Install block 6-L (63) into rear of left fabric fuel cell.
- 61 Install block 5-L (64) into rear of left fabric fuel cell.
- 62 Install block 4-L (65) into front of left fabric fuel cell.
- 63 Install block 3-L (66) into inboard side of left fabric fuel cell.
- 64 Install block 2-L (67) into rear of left fabric fuel cell.
- 65 Install four blocks 1-L (68), one on top of another, into bottom of left cell.

2-31. MAINTENANCE OF FABRIC FUEL CELL INSTALLATION AND FABRIC FUEL CELL FILLER BLOCKS (CONT).

INSTALLATION (CONT)

NOTE

Steps 66 thru 68 are written and illustrated for left fabric fuel cell access cover but apply to both left and right fabric fuel cell access covers.

- 66 Remove two capscrews (35) securing left fabric fuel cell nut ring (34) to left fabric fuel cell access opening (31).
- 67 Place access cover gasket (69) on access ring. Apply sealing compound to two capscrews (35). Secure access cover gasket (69) and left fabric fuel cell nut ring (34) to left fabric fuel cell access opening (31) with two capscrews (35). Torque capscrews to 108.0 to 120.0 in.-lb (12.2 to 13.6 N-m).
- 68 Apply sealing compound to 20 capscrews (70). Secure fuel cell access cover (71) and left fabric fuel cell nut ring (34) to hull with 20 new lockwashers (72) and 20 capscrews (70). Torque all capscrews to 120.0 to 130.0 in.-lb (13.6 to 14.7 N-m).
- 69 Install fan well cover. Refer to TM 9-2350-238-20-1.

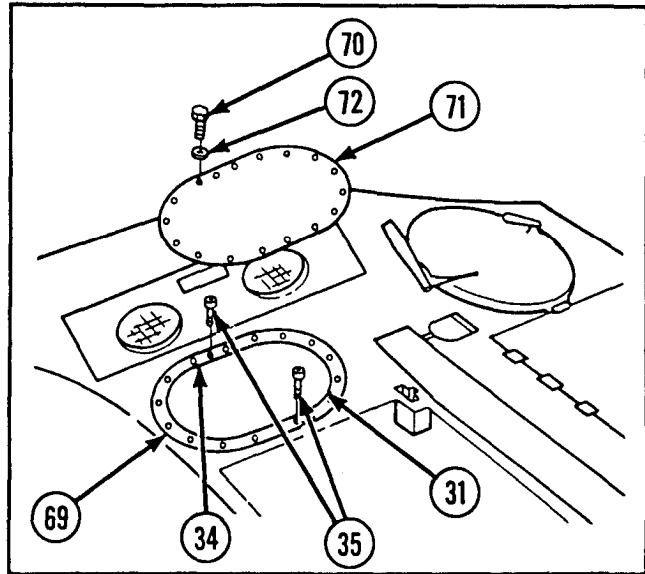

TEST

- 1 Remove fuel filler neck cap. Turn cap vent valve, on underside of cap, to CLOSED position. Install fuel filler neck cap and tighten.
- 2 Remove plug from coolant heater fuel intake line (1). Install nipple (2) into fuel intake line. Connect hose (3) to nipple (2).

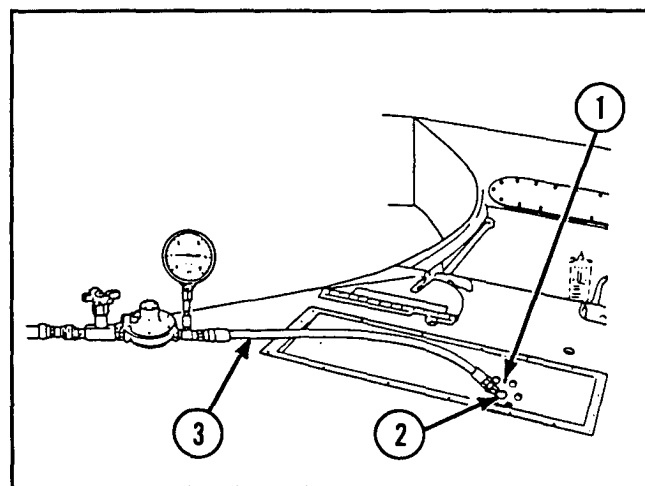

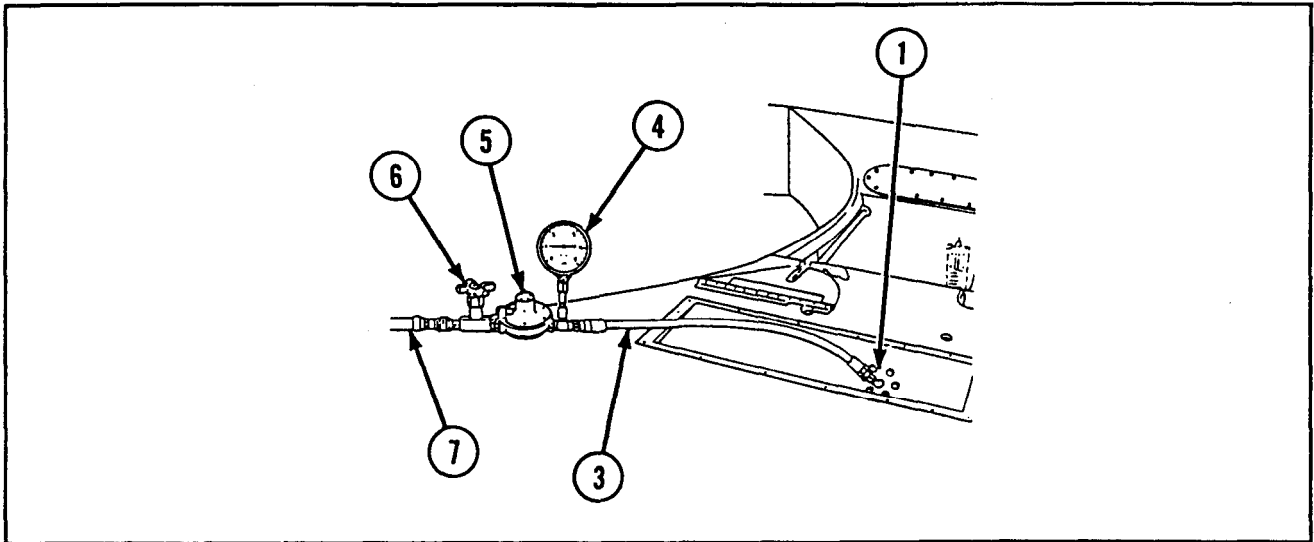

3 Connect 0 to 10 psi (0 to 69 kPa) pressure gage (4), pressure regulator valve (5), and shutoff valve (6) to hose (3). Connect shutoff valve to compressed air source (7).

4 Set pressure regulator valve (5) to 3 psi (21 kPa). Pressurize fabric fuel cell for 5 minutes minimum. Observe gage for any pressure drop.

5 Check for air leakage with soap solution at the following places:

- a. access covers.
- b. fuel level transmitter.
- c. fuel filler neck.
- d. fuel drain plugs.
- e. coolant heater fuel intake.
- f. fuel supply and return line quick disconnects.

6 Tighten capscrews, if required, to stop leaks. No leakage is permissible. If leakage cannot be stopped by tightening capscrews, disassemble the fabric fuel cell to the extent necessary to reseal leaking area.

WARNING

Failure to reduce pressure to zero before removing fuel filler neck cap may cause injury.

7 Reduce fabric fuel cell pressure to zero and remove test equipment. Install plug in coolant heater fuel intake (1).

8 Remove fuel filler neck cap and turn cap vent valve to OPEN position. Install fuel filler neck cap.

9 Install right tunnel access cover.

10 Allow 6 hours minimum drying time for sealants, then fill fabric fuel cell with diesel fuel.

2-32. MAINTENANCE OF RADIATOR COOLING VANEAXIAL FAN.

This task covers: a. <i>Disassembly</i> b. <i>Inspection/Repair</i> c. <i>Reassembly</i>		
INITIAL SETUP		
<p>Tools and Special Tools</p> <p>Automotive maintenance and repair shop equipment field maintenance, basic, less power (SC 4910-95-A31)</p> <ul style="list-style-type: none"> ● Arbor press ● Bearing puller 	<p>References</p> <p>TM 9-2350-238-20-1</p> <p>TM 9-2350-238-24P-1</p>	<p>Equipment Conditions</p> <p>Radiator cooling vaneaxial fan removed (TM 9-2350-238-20-1)</p>
<p>Materials/Parts</p> <p>Grease (GAA) (item 17, appx B)</p> <p>Vaneaxial fan repair parts kit</p>		

DISASSEMBLY

1 Remove seven screws (1) and ring assembly (2) from housing (3).

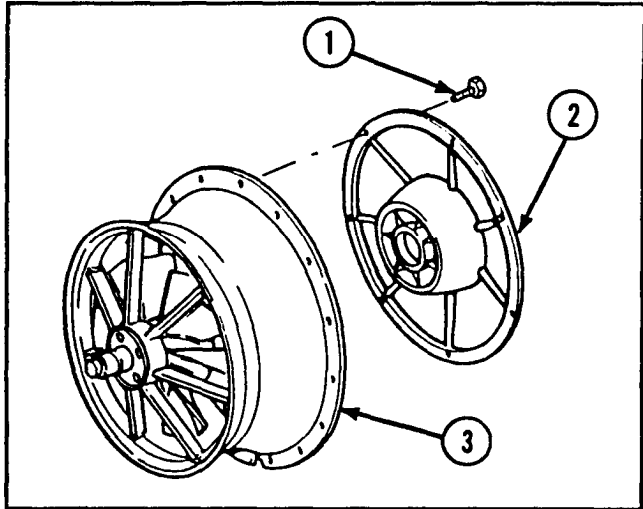

2 Remove four machine screws (4), four nuts (5), plate (6), felt (7), and plate (8) from housing (3).

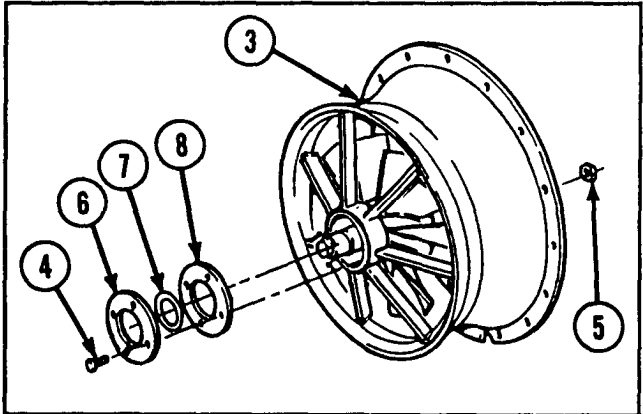

- 3 Remove impeller and shaft assembly (9) from housing (3).
- 4 Using bearing puller, remove bearing (10) from impeller and shaft assembly (9).

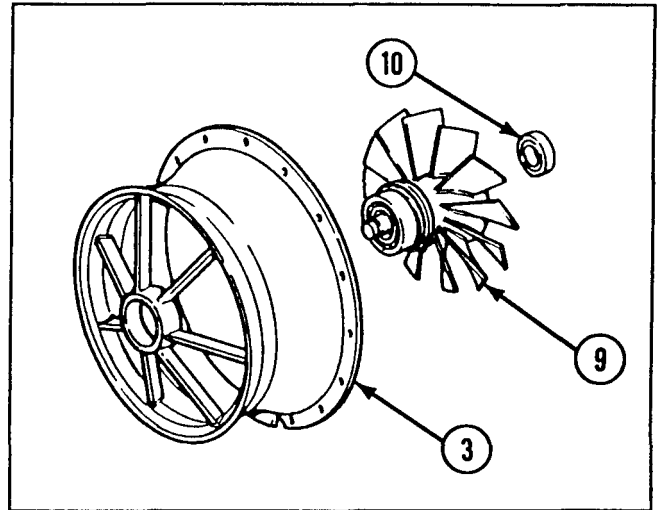

- 5 Remove spacer (11) from impeller and shaft assembly (9).
- 6 Using bearing puller, remove bearing (12) from impeller and shaft assembly (9).
- 7 Remove plate (13), felt (14), and plate assembly (15) from impeller and shaft assembly (9).
- 8 Remove spacer (16) from impeller and shaft assembly (9).
- 9 If necessary, remove spacer (17) from impeller and shaft assembly (9).

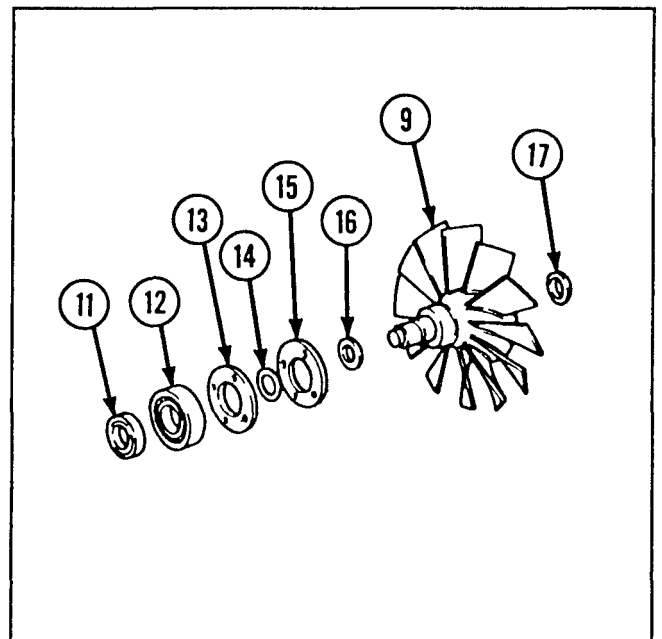

2-32. MAINTENANCE OF RADIATOR COOLING VANEAXIAL FAN (CONT).

INSPECTION/REPAIR

- 1 Inspect for broken, damaged, or missing parts.
- 2 If any kit component is damaged, replace entire vaneaxial fan repair parts kit.

CAUTION

Do not attempt repair of impeller and shaft assembly. It is a balanced unit and must be replaced if damaged.

- 3 If impeller and shaft assembly, ring assembly, or housing are damaged, replace entire radiator cooling vaneaxial fan.
- 4 Repair is by replacement of authorized parts (TM 9-2350-238-24P-1) which do not meet inspection criteria.

REASSEMBLY

- 1 If removed, install spacer (1) to impeller and shaft assembly (2).
- 2 Install spacer (3) to impeller and shaft assembly (2).
- 3 Install plate assembly (4), felt (5), and plate (6) to impeller and shaft assembly (2).
- 4 Pack bearing (7) with grease.
- 5 Using arbor press, install bearing (7) to impeller and shaft assembly (2).
- 6 Install spacer (8) to impeller and shaft assembly (2).

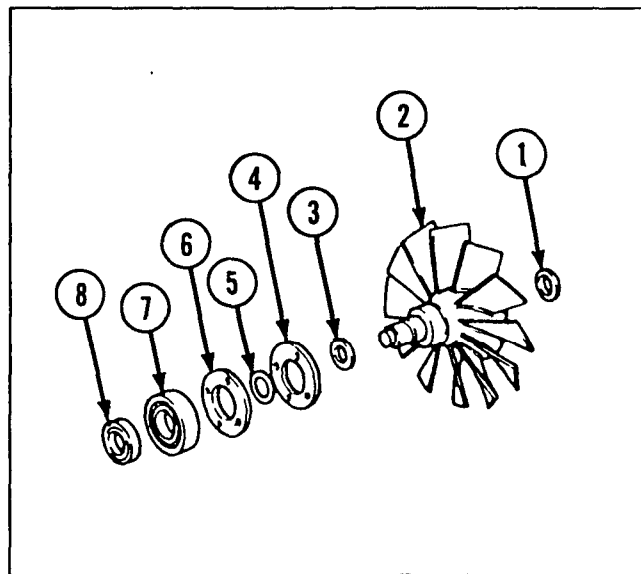

7 Pack bearing (9) with grease.

8 Using arbor press, install bearing (9) to impeller and shaft assembly (2).

9 install impeller and shaft assembly (2) to housing (10).

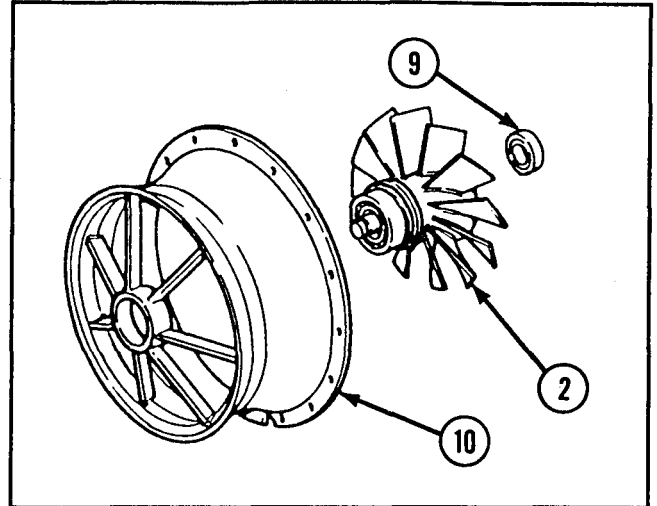

10 Align mounting holes in plates (11 and 12) and housing (10). Install plate (11), felt (13), plate (12), four nuts (14), and four machine screws (15) to housing (10).

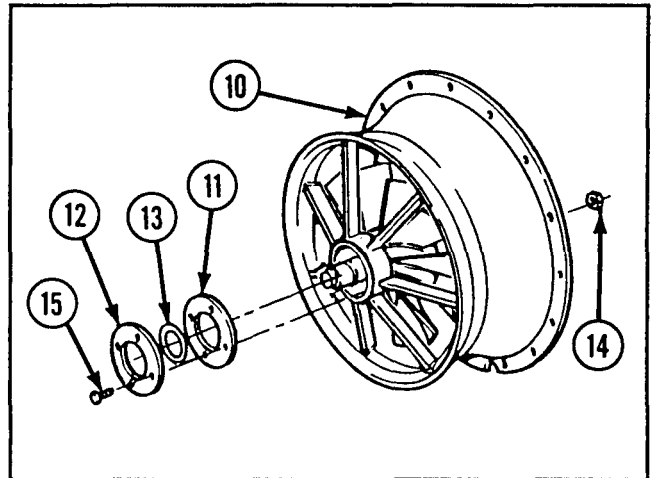

11 Align mounting holes in ring assembly (16) and housing (10). Install ring assembly and seven screws (17) to housing.

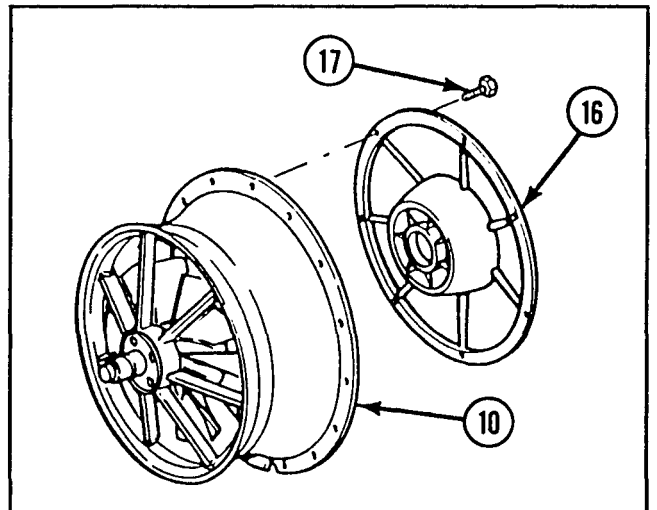

2-33. MAINTENANCE OF DRIVER'S INSTRUMENT PANEL ASSEMBLY (GAGE AND INDICATOR).

This task covers: a. *Disassembly* b. *Inspection/Repair* c. *Reassembly*

INITIAL SETUP

References

TM 9-2350-238-20-1

TM 9-2350-238-24P-1

Equipment Conditions

Driver's instrument panel assembly removed and partially disassembled (TM 9-2350-238-20-1)

DISASSEMBLY

If necessary, remove 12 solid rivets (1) and 3 instrument panel mounting cushions (2) from instrument panel (3).

INSPECTION/REPAIR

- 1 Inspect for broken, damaged, or missing parts.
- 2 Repair is by replacement of authorized parts (TM 9-2350-238-24P-1).

REASSEMBLY

If removed, install 3 instrument panel mounting cushions (2), and secure to instrument panel (3) with 12 new solid rivets (1).

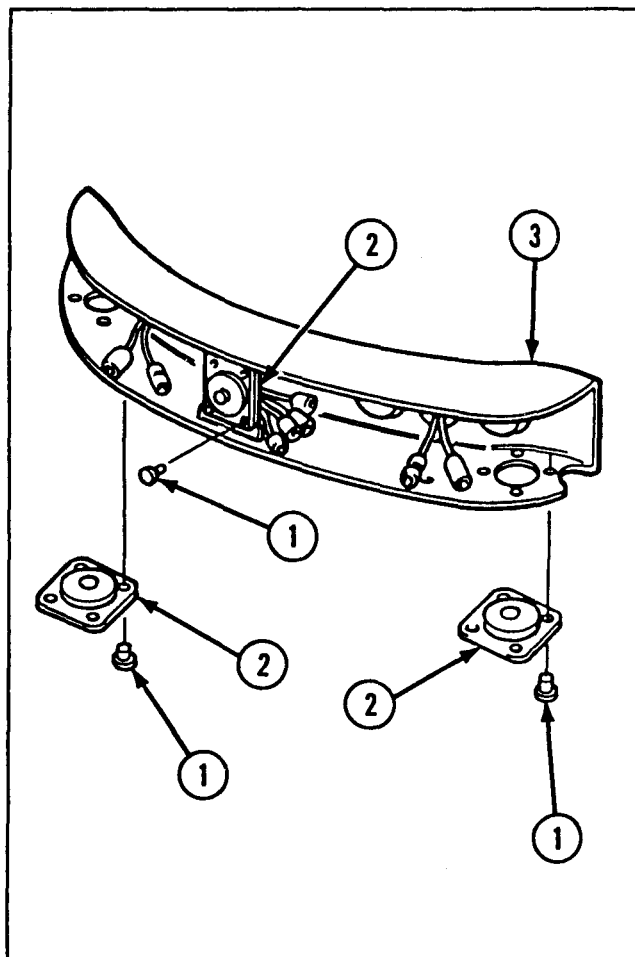

2-34. MAINTENANCE OF SLIP RING ELECTRICAL COMPONENTS, SLIP RING DISCONNECT TO INTERIOR DISCONNECT WIRING HARNESS, AND SLIP RING TO 24-VOLT FEED ELECTRICAL LEAD.

This task covers: a. *Removal* b. *Inspection/Repair* c. *Installation*

INITIAL SETUP

Tools and Special Tools

Automotive maintenance and repair shop equipment: field maintenance, basic, less power (SC 491-0-95-A31)

- Plier wire twister

References

TM 9-2350-238-24P-1

Equipment Conditions

Power OFF

Materials/Parts

- Cover assembly plain stud (8)
- Grease (item 17, appx B)
- Lint-free cloth (item 8, appx B)
- Lockwasher
- Lockwire (item 33, appx B)
- Preformed packing
- Sealing compound (item 26, appx B)
- Self-locking nut (8)
- Shell gasket
- Shell gasket
- Slip ring electrical brush connector assembly parts kit
- Slip ring electrical contact set assembly parts kit

- 1 Disconnect two wiring harnesses (1 and 2) from turret slip ring cover (3).
- 2 Disconnect two wiring harnesses (4 and 5) from slip ring (6).

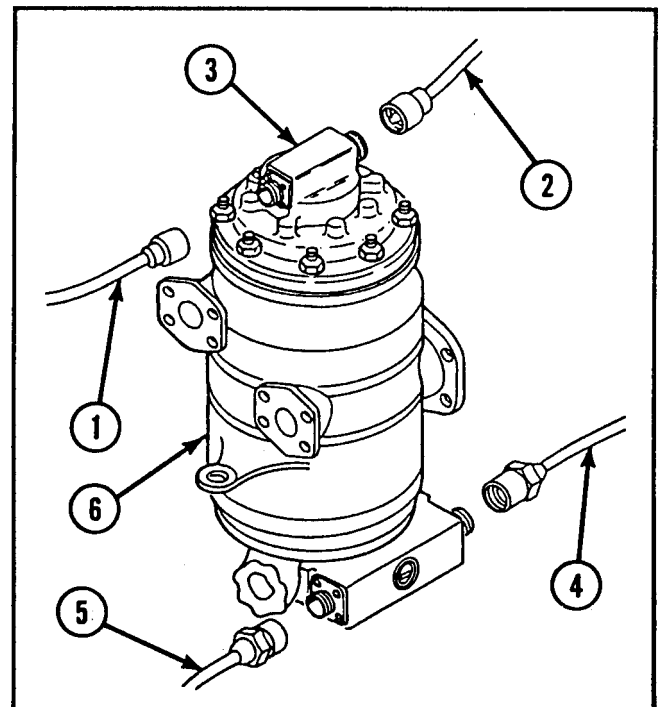

2-36. MAINTENANCE OF SLIP RING ELECTRICAL COMPONENTS, SLIP RING DISCONNECT TO INTERIOR DISCONNECT WIRING HARNESS, AND SLIP RING TO 24-VOLT FEED ELECTRICAL LEAD (CONT).

REMOVAL (CONT)

- 3 Remove eight self-locking nuts (7) from eight cover assembly plain studs (8).
- 4 Remove turret slip ring cover (3) from slip ring (6).

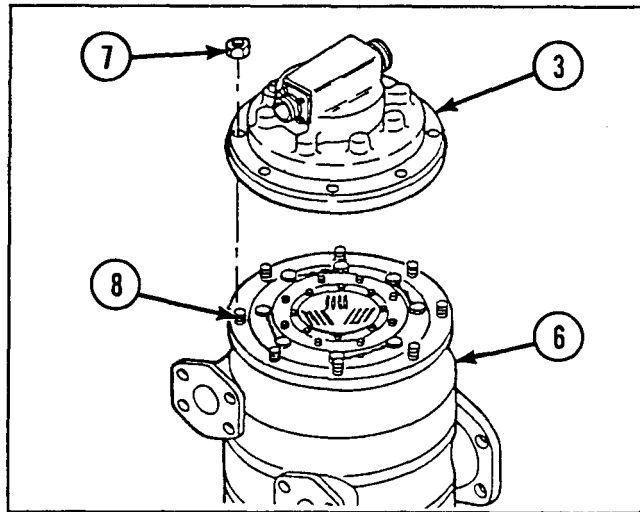

- 5 Lift slip ring electrical brush connector assembly (9) straight up and out of slip ring electrical contact set assembly (10).
- 6 Remove 12 springs (11) from slip ring electrical contact set assembly (10).
- 7 Disconnect slip ring disconnect to interior disconnect wiring harness (12) from slip ring electrical brush connector assembly (9).

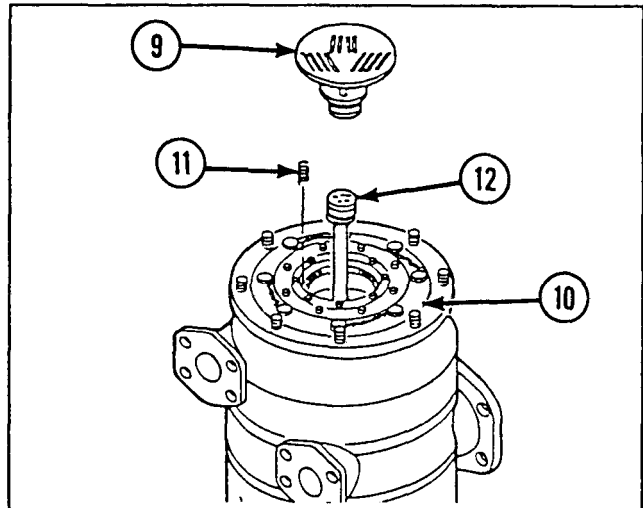

- 8 Remove lockwire (13) and eight hexagon head capscrews (14) from slip ring electrical contact set assembly (10).

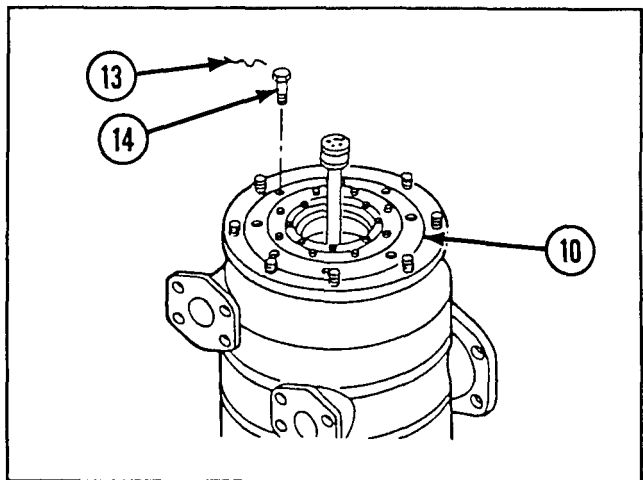

9 Lift contact set (10) from slip ring (6), and remove hexagon plain nut (15), lock-washer (16), and hexagon head capscrew (17). Remove contact set (10) from slip ring to 24-volt feed cable assembly (18).

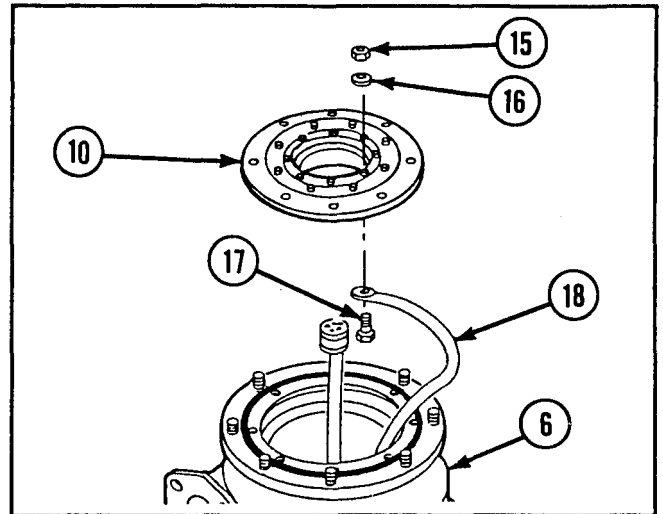

10 Remove preformed packing (19) from slip ring (6).

11 If damaged, remove eight cover assembly plain studs (8) from slip ring (6).

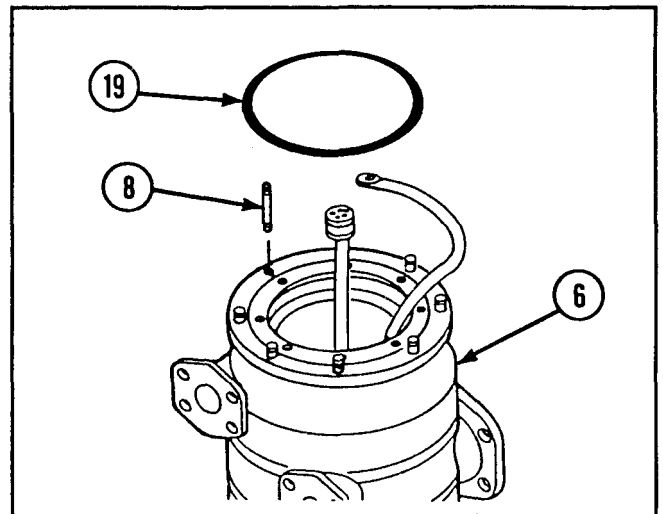

12 Remove lockwire (20) and four socket head capscrews (21).

13 Remove slip ring disconnect to interior disconnect wiring harness (12) and shell gasket (22) from slip ring (6).

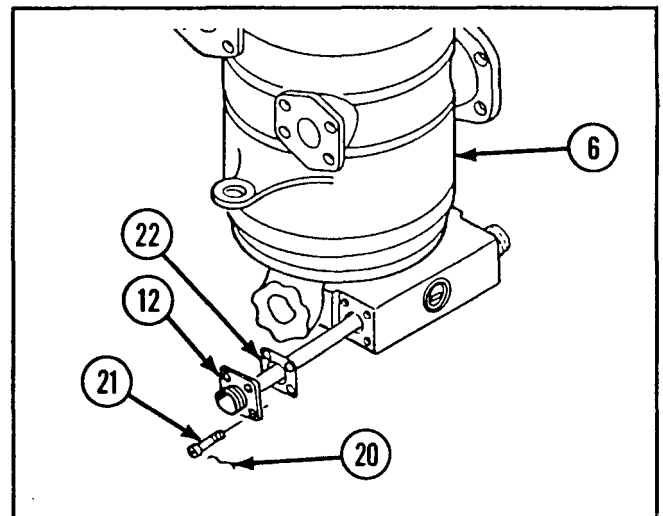

2-34. MAINTENANCE OF SLIP RING ELECTRICAL COMPONENTS, SLIP RING DISCONNECT TO INTERIOR DISCONNECT WIRING HARNESS, AND SLIP RING TO 24-VOLT FEED ELECTRICAL LEAD (CONT).

REMOVAL (CONT)

- 14 Remove lockwire (23) and four socket head capscrews (24).
- 15 Remove slip ring to 24-volt feed electrical lead (18) and shell gasket (25) from slip ring (6).

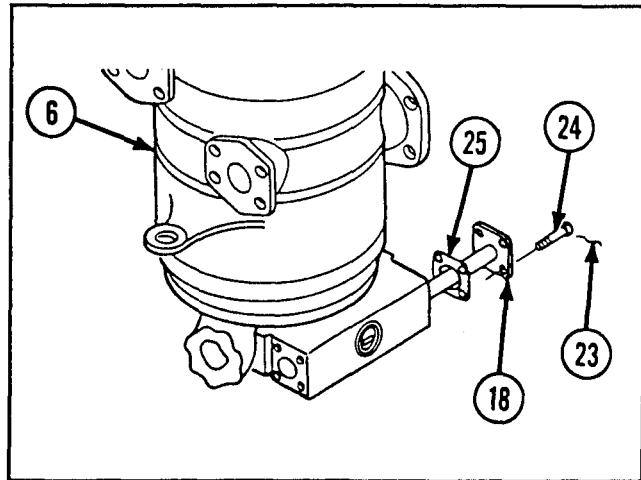

INSPECTION/REPAIR

- 1 Inspect for broken, damaged, or missing parts.
- 2 For repair of slip ring disconnect to interior disconnect wiring harness and slip ring to 24-volt feed electrical lead, refer to general maintenance, page 2-19.
- 3 Turret slip ring cover is a repairable assembly. Refer to page 2-80.
- 4 Slip ring electrical brush connector assembly is a repairable assembly. Refer to page 2-90.
- 5 Slip ring electrical contact set assembly is a repairable assembly. Refer to page 2-84.
- 6 If any kit component requires replacement, replace entire slip ring contact set assembly parts kit or slip ring electrical brush connector assembly parts kit.
- 7 Repair is by replacement of authorized parts (TM 9-2350-238-24P-1) which do not meet inspection criteria.

INSTALLATION

- 1 Install new shell gasket (1) and slip ring to 24-volt feed electrical lead (2) to slip ring (3), and secure with four socket head capscrews (4) and new lockwire (5). Pull slip ring to 24-volt feed electrical lead (2) up through top of slip ring.

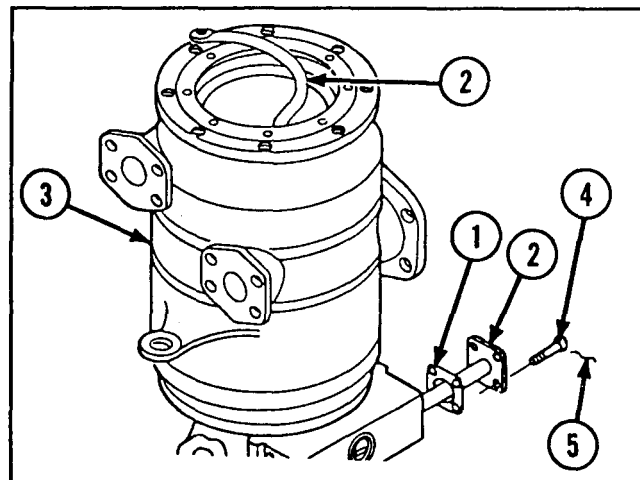

- 2 Install new shell gasket (6) and slip ring disconnect to interior disconnect wiring harness (7) to slip ring (3), and secure with four socket head capscrews (8) and new lockwire (9). Pull slip ring disconnect to interior disconnect wiring harness (7) up through top of slip ring.

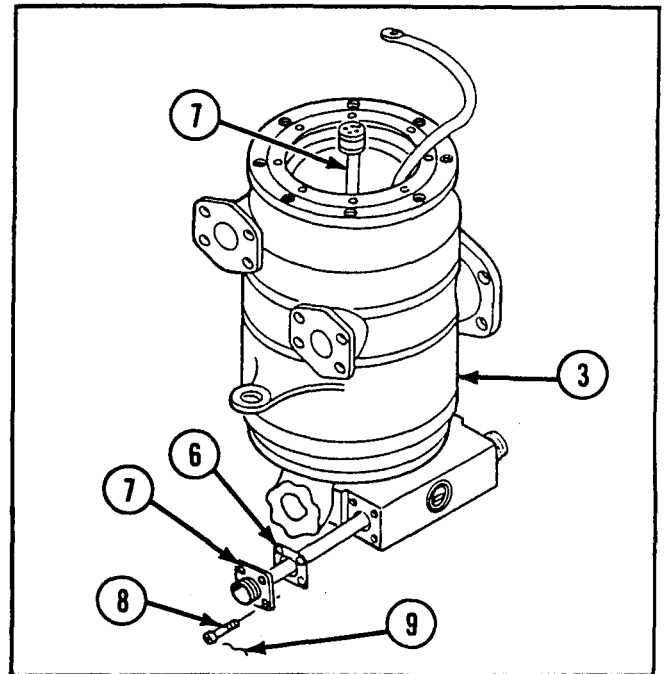

- 3 If removed, install eight new cover assembly plain studs (10) to slip ring (3).
- 4 Wipe top of slip ring (3) with lint-free cloth to remove dirt or dust.
- 5 Install new preformed packing (11) in top flange of slip ring (3).

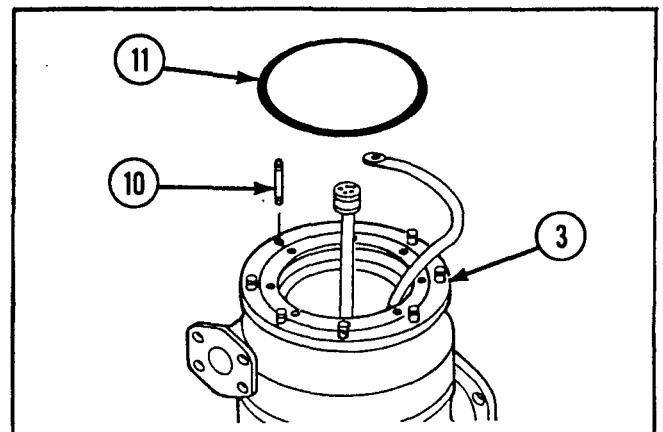

- 6 Apply thin, even coat of grease to mating surface of new slip ring electrical contact set assembly (12) in slip ring (3).
- 7 Connect slip ring to 24-volt feed electrical lead (2) to slip ring electrical contact set assembly (12), and secure with hexagon head capscrew (13), new lockwasher (14), and hexagon plain nut (15).

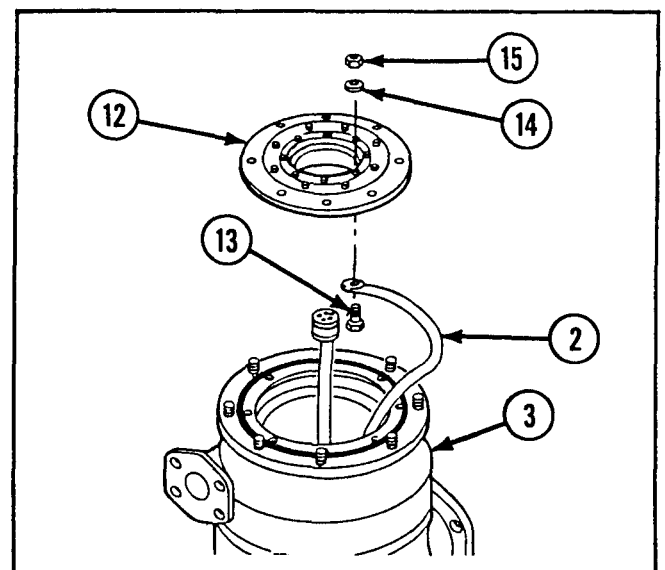

2-34. MAINTENANCE OF SLIP RING ELECTRICAL COMPONENTS, SLIP RING DISCONNECT TO INTERIOR DISCONNECT WIRING HARNESS, AND SLIP RING TO 24-VOLT FEED ELECTRICAL LEAD (CONT).

INSTALLATION (CONT)

- 8 Install slip ring electrical contact set assembly (12) in slip ring (3). Align mounting holes.
- 9 Install eight new hexagon head capscrews (16) to slip ring electrical contact set assembly (12) and slip ring (3), and secure with new lockwire (17).

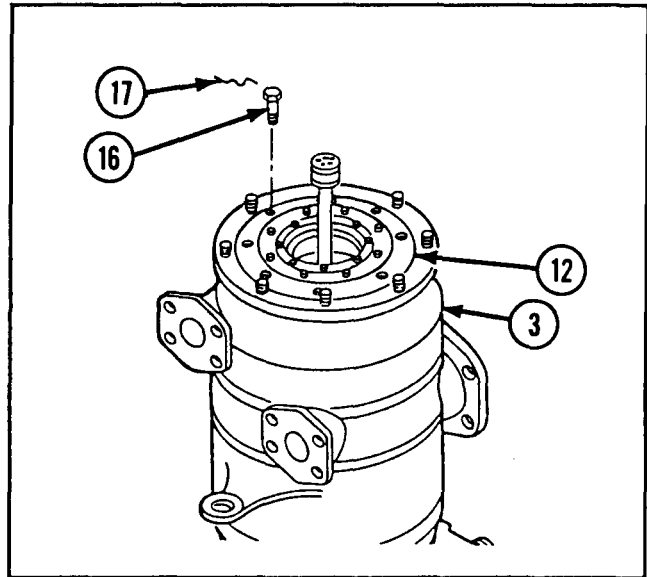

- 10 Connect slip ring electrical brush connector assembly (18) to slip ring disconnect to interior disconnect wiring harness (7).

CAUTION

Use care not to drop any compression springs into slip ring.

- 11 Install 12 new compression springs (19) to slip ring electrical contact set assembly (12).
- 12 Install slip ring electrical brush connector assembly (18) into slip ring electrical contact set assembly (12) using care not to lose any compression springs (19).

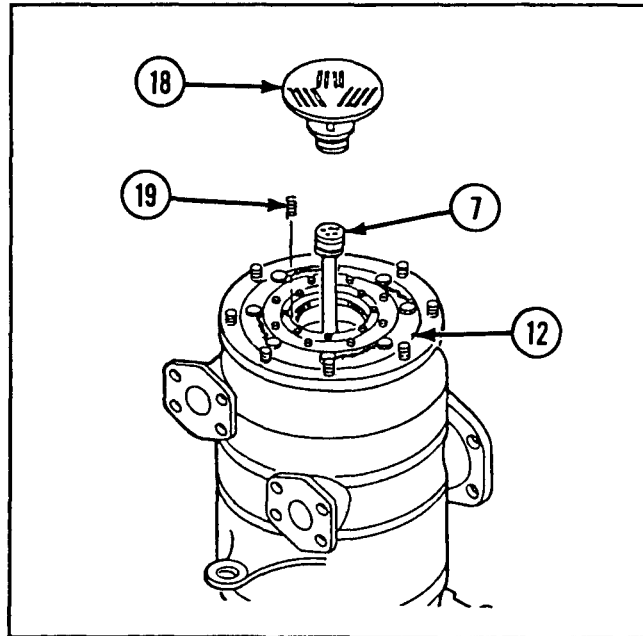

- 13 Clean all electrical contacts with a lint-free cloth to remove dirt, dust, and grease.

CAUTION

Avoid too much movement of slip ring cover when installing to slip ring to prevent damage to electrical contacts.

NOTE

Inspect all electrical contacts for even contact and free brush movement.

- 14 Install slip ring cover (20) on slip ring (3) and eight cover assembly plain studs (10).
- 15 Coat threads of eight cover assembly plain studs (10) with sealing compound.
- 16 Install eight new self-locking nuts (21) to eight cover assembly plain studs (10).

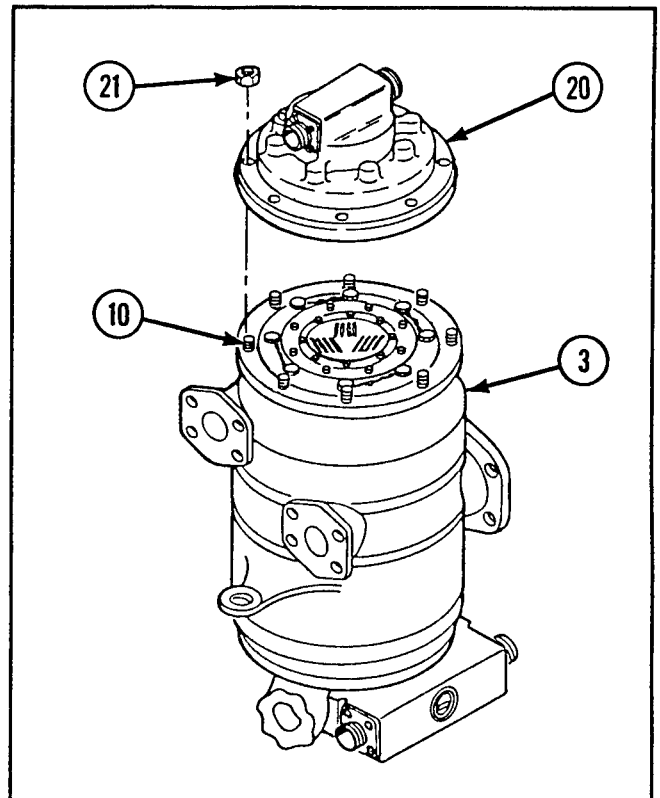

- 17 Connect two wiring harnesses (22 and 23) to slip ring (3).
- 18 Connect two wiring harnesses (24 and 25) to turret slip ring cover (20).

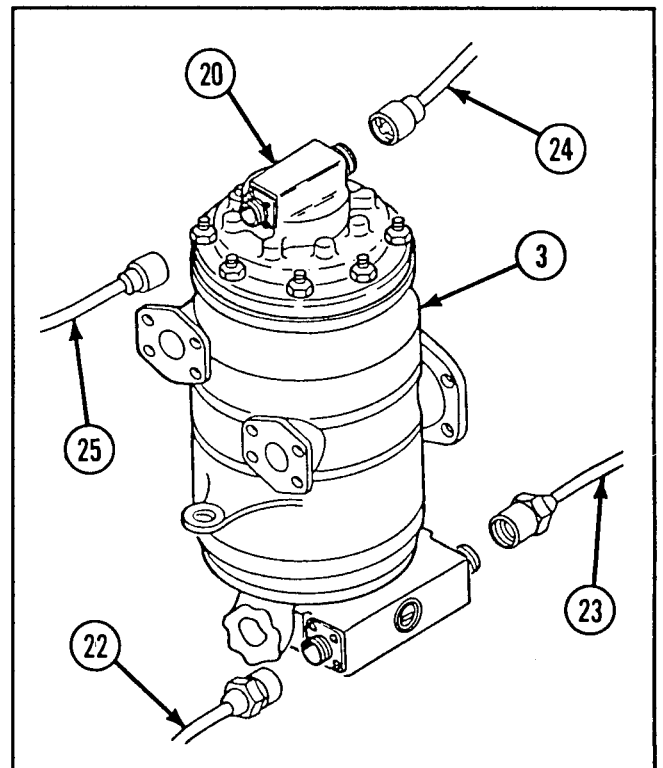

2-35. MAINTENANCE OF TURRET SLIP RING COVER.

This task covers:		
a. <i>Disassembly</i>	b. <i>Inspection/Repair</i>	c. <i>Reassembly</i>
INITIAL SETUP		
Tools and Special Tools Automotive maintenance and repair shop equipment: field maintenance, basic, less power (SC 4910-95-A31) <ul style="list-style-type: none"> ● Plier wire twister ● Soldering gun 		References TB SIG-222 TM 9-2350-238-24P-1 Equipment Conditions 2-73 Turret slip ring cover removed
Materials/Parts Lockwire (item 33, appx B) Sealing compound (item 26, appx B) Shell gasket Shell gasket Solder (item 28, appx B)		

DISASSEMBLY

NOTE

Slip ring cover should be disassembled only when there is known damage to the assembly.

1 Remove assembled washer screw (1) from slip ring cover (2).

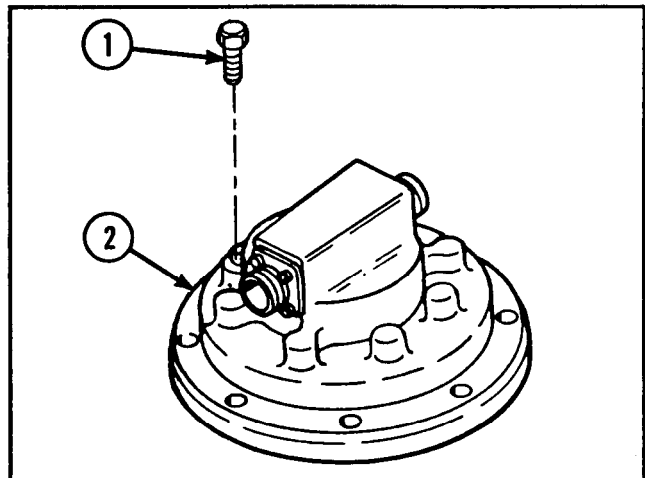

2 Remove lockwire (3) and four socket head capscrews (4) from electrical receptacle connector (5) and slip ring cover (2).

3 Remove lockwire (6) and four socket head capscrews (7) from waterproof receptacle (8) and slip ring cover (2).

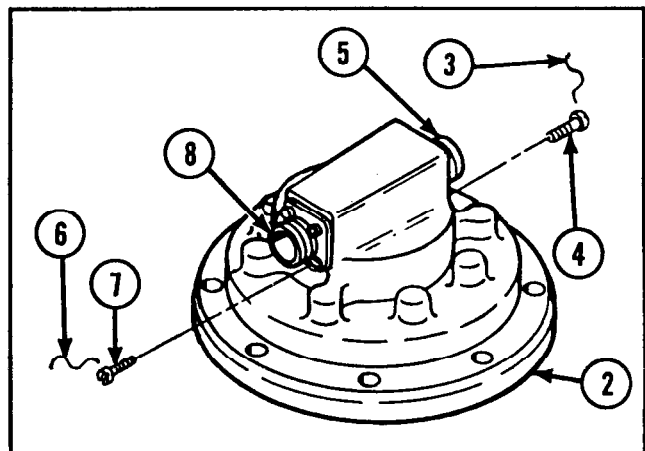

NOTE

Tag all electrical leads during disassembly to aid reassembly.

- 4 Pull waterproof receptacle (8) and electrical receptacle connector (5) from slip ring cover (2). Tag and unsolder 14 electrical leads from electrical receptacle connector and one lead from waterproof receptacle.

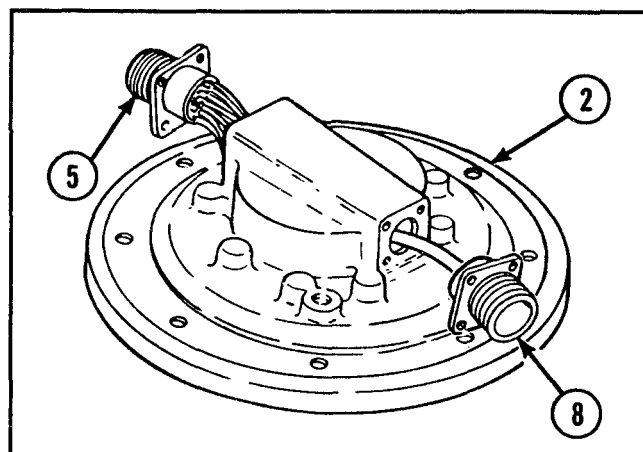

- 5 Remove shell gasket (9) and shell gasket (10) from slip ring cover (2).

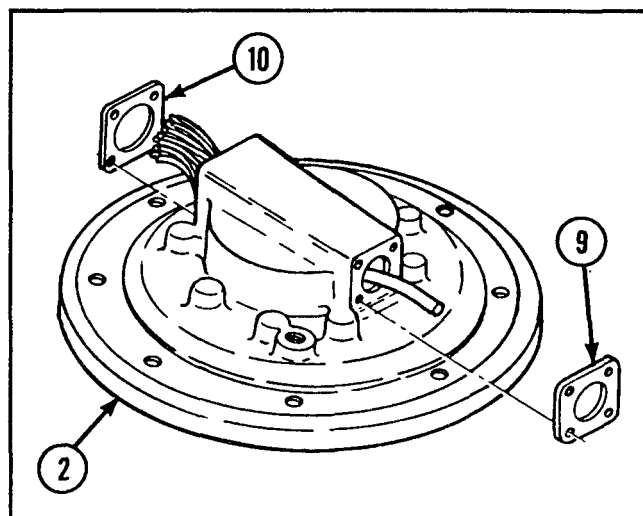

- 6 Remove lockwire (11) and eight socket head capscrews (12) from electrical contact ring (13) and slip ring cover (2).

CAUTION

Mating surface of electrical contact ring is bonded to slip ring cover with sealing compound. Be careful not to damage slip ring cover or electrical contact ring when separating.

- 7 Remove electrical contact ring (13), insulating ring (14), and collector ring slip ring cover (15) from slip ring cover (2).

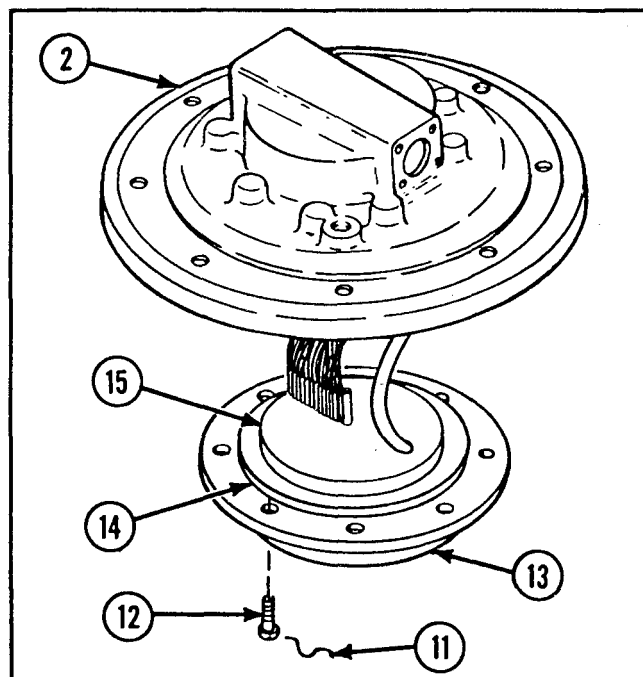

2-35. MAINTENANCE OF TURRET SLIP RING COVER (CONT).

DISASSEMBLY (CONT)

- 8 Separate electrical contact ring (13) and insulating ring (14) from collector ring slip ring cover (15).
- 9 Separate electrical contact ring (13) from insulating ring (14).

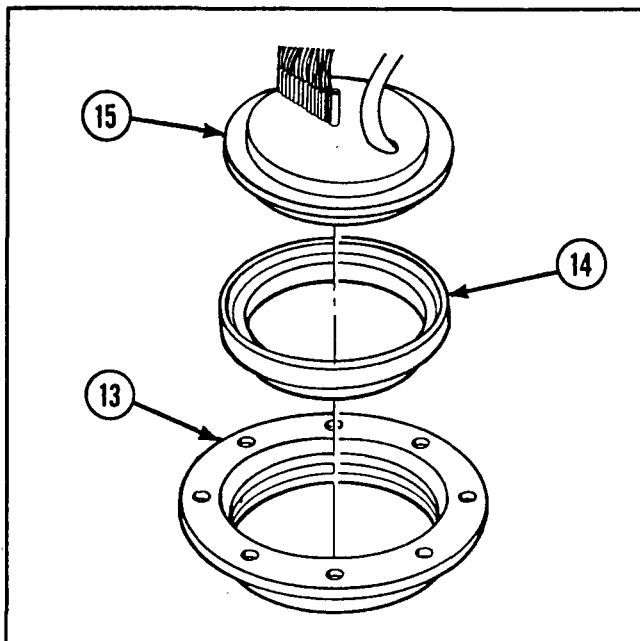

INSPECTION/REPAIR

- 1 Inspect for broken, damaged, or missing parts.
- 2 If slip ring cover or electrical contact ring is broken, damaged, or missing, repair is by replacement of next higher assembly.
- 3 Repair is by replacement of authorized parts (TM 9-2350-238-24P-1) which do not meet inspection criteria.

REASSEMBLY

- 1 Install collector ring slip ring cover (1) into insulating ring (2).
- 2 Install collector ring slip ring cover (1) and insulating ring (2) into electrical contact ring (3).

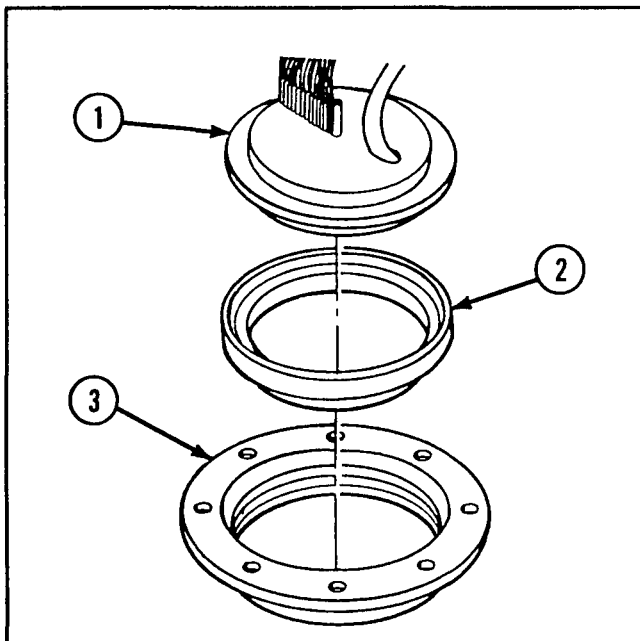

- 3 Coat mating surfaces of electrical contact ring (3) and slip ring cover (4) with sealing compound.
- 4 Insert 14 electrical leads through electrical receptacle connector mount and one electrical lead through waterproof receptacle mount in slip ring cover (4).
- 5 Install assembled electrical contact ring (3) to slip ring cover (4). Align mounting holes.
- 6 Install eight socket head capscrews (5) to electrical contact ring (3) and slip ring cover (4), and secure with new lockwire (6).

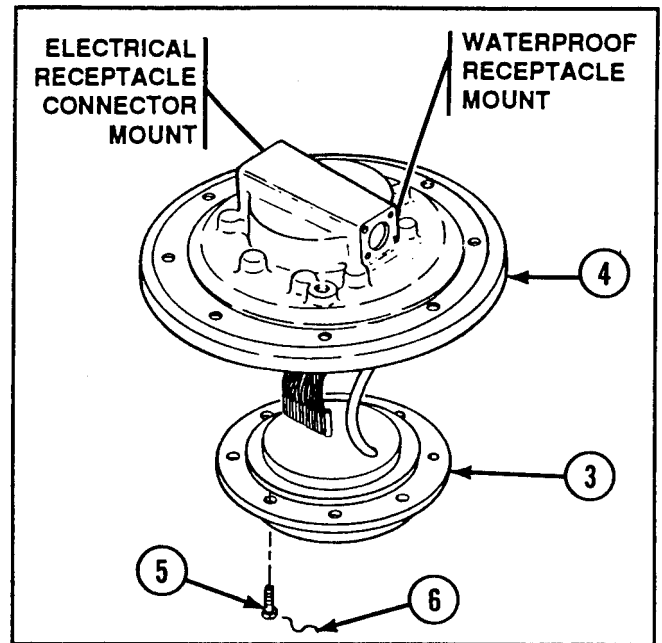

- 7 Install new shell gasket (7) and new shell gasket (8) over electrical leads in receptacle openings in slip ring cover (4).
- 8 Solder and untag 14 leads to electrical receptacle connector (9) and one electrical lead to waterproof receptacle (10) per TB SIG-222.

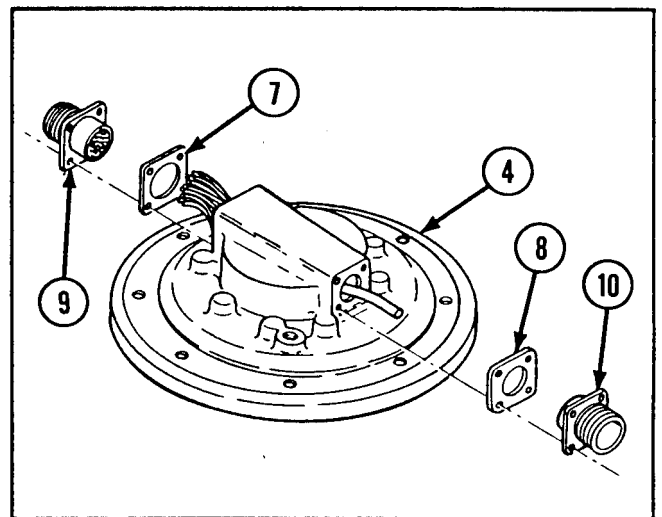

- 9 Install electrical receptacle connector (9) and waterproof receptacle (10) to slip ring cover (4).
- 10 Install four socket head capscrews (11) to electrical receptacle connector (9) and four socket head capscrews (12) to waterproof receptacle (10), and secure with new lockwire (13).

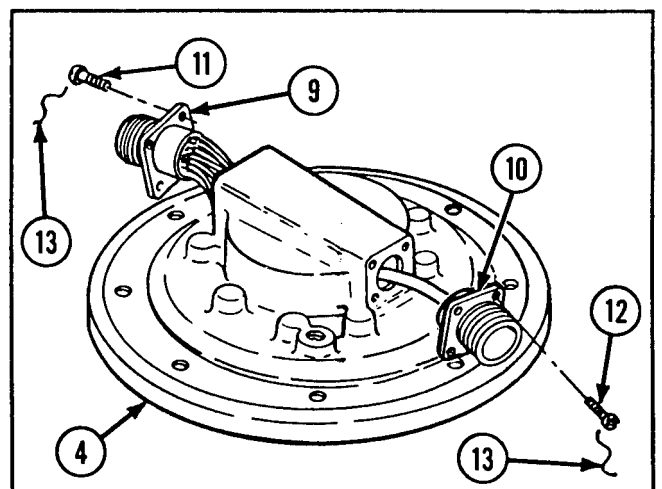

2-35. MAINTENANCE OF TURRET SLIP RING COVER (CONT).

REASSEMBLY (CONT)

11 Install assembled washer screw (14) to slip ring cover (4).

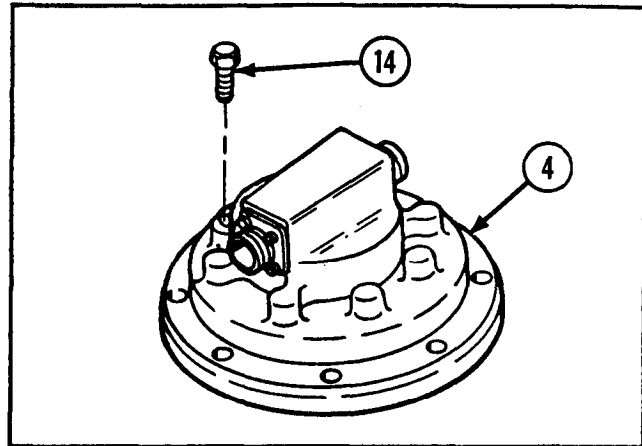

2-36. MAINTENANCE OF SLIP RING ELECTRICAL CONTACT SET ASSEMBLY.

This task covers: a. *Disassembly* b. *Inspection/Repair* c. *Reassembly*

INITIAL SETUP

Tools and Special Tools

- Automotive maintenance and repair shop equipment: field maintenance, basic, less power (SC 4910-95-A31)
 - Plier wire twister
 - Soldering gun
- Wood block (2)

References

- TB SIG-222
- TM 9-2350-238-24P-1

Equipment Conditions

- 2-73 Slip electrical ring contact set assembly removed

Materials/Pads

- Brush (16)
- Contact set outer compression spring (16)
- Lockwire (item 33, appx B)
- Sealing compound (item 26, appx B)
- Solder (item 28, appx B)

DISASSEMBLY

1 Remove lockwire (1) and eight machine screws (2) from holder housing (3) and outer contact set holder (4).

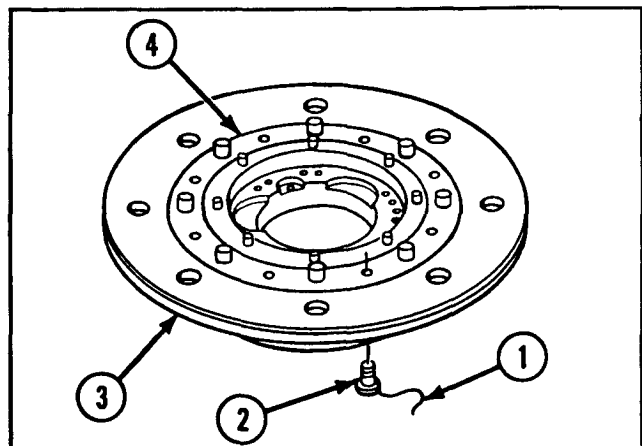

CAUTION

Mating edge of outer contact set holder and inner edge of holder housing are bonded together with sealing compound. When separating, use extreme care to avoid damage.

- 2 Place two wood blocks under holder housing (3) with outer contact set holder (4) facing down.
- 3 Using hammer and soft block, lightly tap inner contact set holder (5) until inner contact set holder and outer contact set holder (4) separate from holder housing (3).

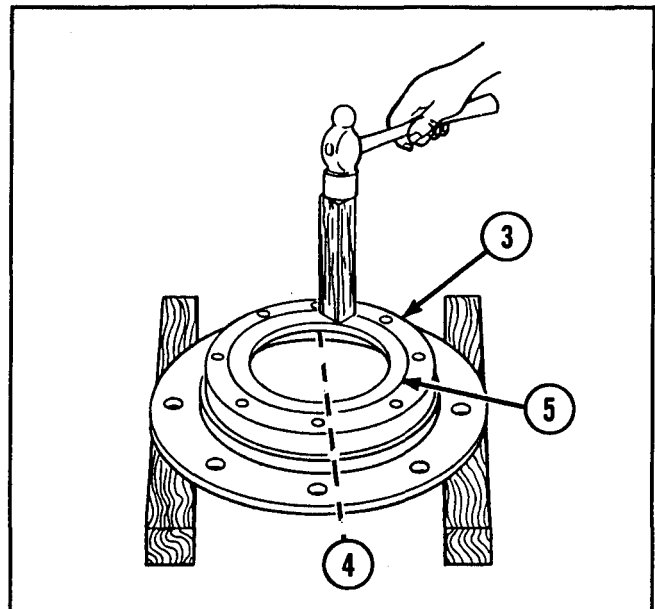

- 4 Remove inner insulating ring (6) from inner contact set holder (5).

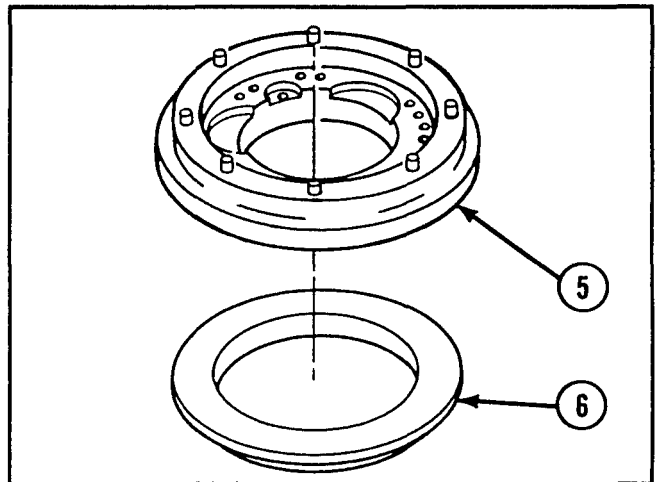

- 5 Remove upper insulating ring (7) from outer contact set holder (4).

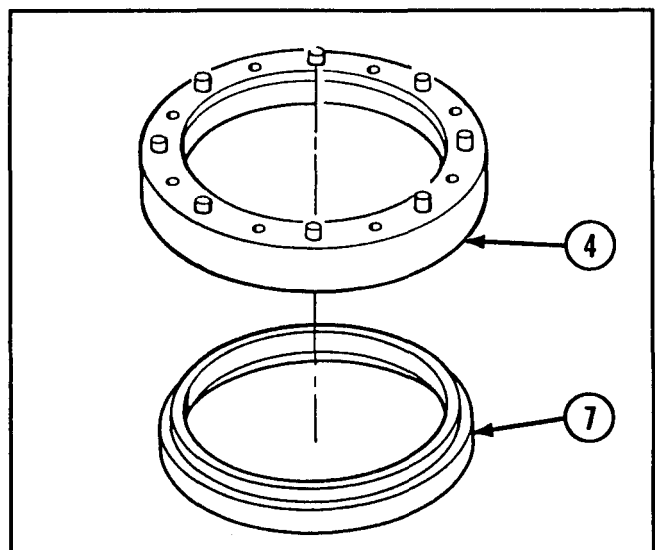

2-36. MAINTENANCE OF SLIP RING ELECTRICAL CONTACT SET ASSEMBLY (CONT).

DISASSEMBLY (CONT)

6 Unsolder and remove eight brushes (8) from inner contact set holder (5).

7 Remove eight compression springs (9) from inner contact set holder (5).

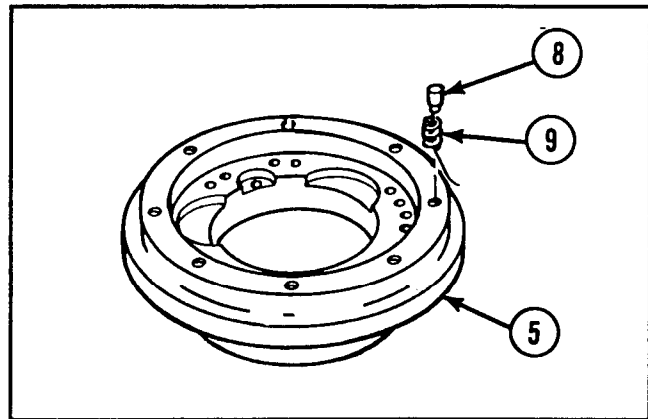

8 Unsolder and remove eight brushes (10) from outer contact set holder (4).

9 Remove eight compression springs (11) from outer contact set holder (4).

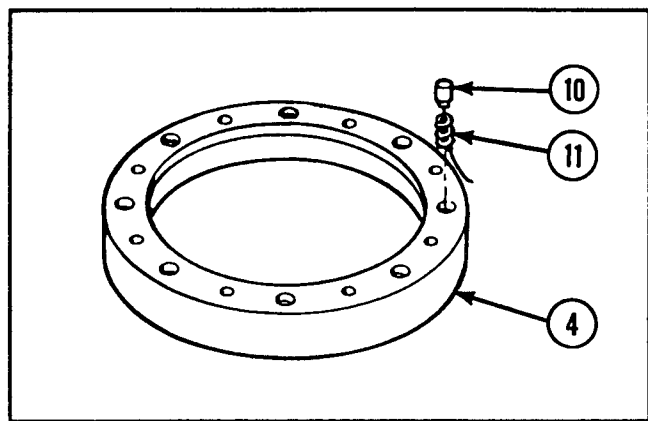

INSPECTION/REPAIR

1 Inspect for broken, damaged, or missing parts.

2 If holder housing, outer contact set holder, or inner contact set holder is broken, damaged, or missing, repair is by replacement of next higher assembly.

3 Repair is by replacement of authorized parts (TM 9-2350-238-24P-1) which do not meet inspection criteria.

REASSEMBLY

NOTE

Ensure brush wire passes through bottom of compression spring.

1 Install eight new brushes (1) in eight new compression springs (2).

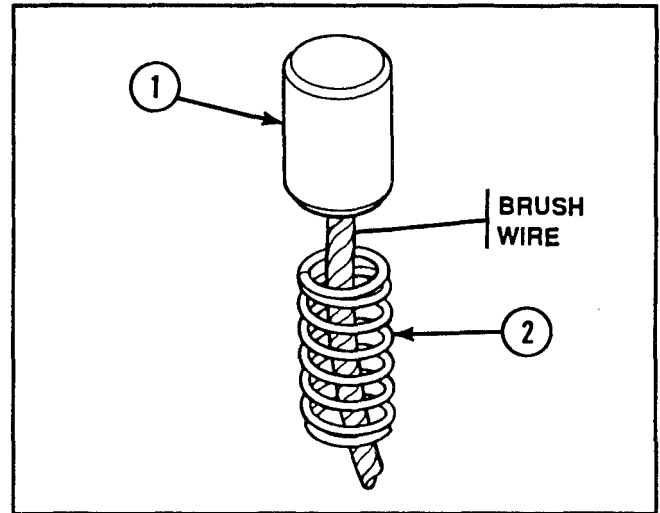

2 Install eight brushes (1) and eight compression springs (2) in outer contact set holder (3) with brush wire passing through hole in bottom of outer contact set holder.

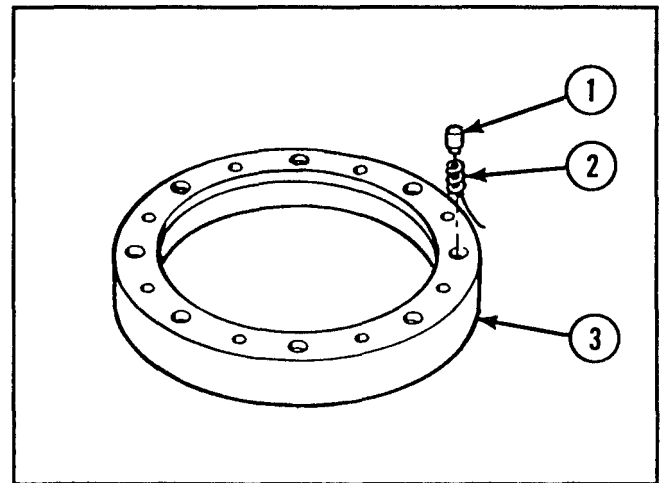

3 Press eight brushes (1) up and down in holes to ensure free movement.

4 Pull slack out of eight brush wires without compressing any of the eight compression springs (2).

5 Solder eight brush wires to outer contact set holder (3) per TB SIG-222.

6 Clip off excess wire. Ensure solder and wire do not rise above groove in outer contact set holder (3).

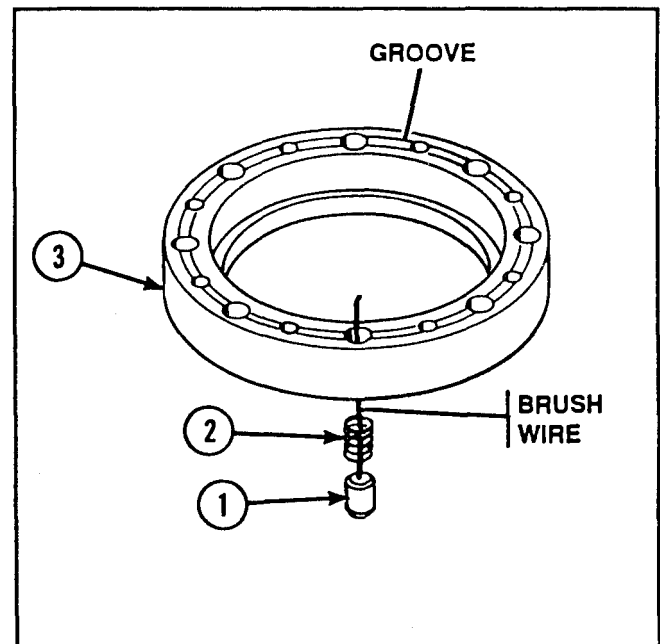

2-36. MAINTENANCE OF SLIP RING ELECTRICAL CONTACT SET ASSEMBLY (CONT).

REASSEMBLY (CONT)

NOTE

Ensure brush wire passes through bottom of compression spring.

- 7 Install eight new brushes (4) in eight new compression springs (5).

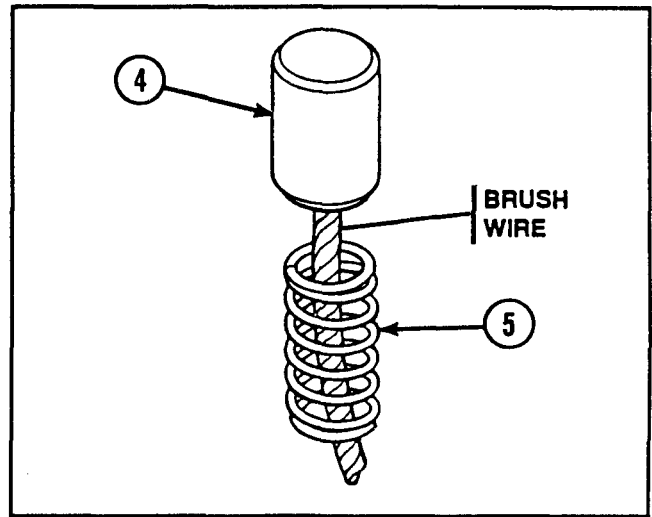

- 8 Install eight brushes (4) and eight compression springs (5) in inner contact set holder (6) with brush wire passing through hole in bottom of inner contact set holder.

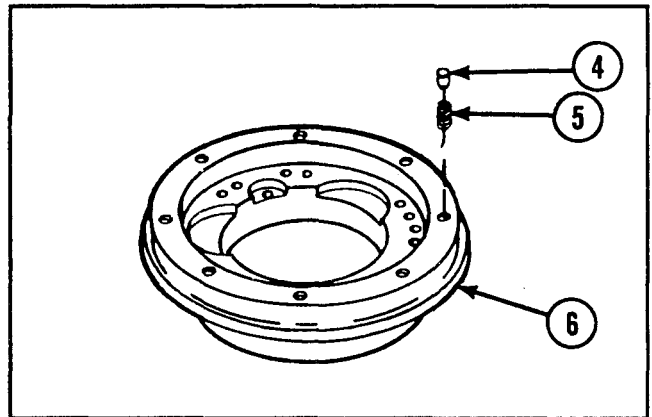

- 9 Press eight brushes (4) up and down in holes to ensure free movement.

- 10 Pull slack out of eight brush wires without compressing any of the eight compression springs (5).

- 11 Solder eight brush wires to inner contact set holder (6) per TB SIG-222.

- 12 Clip off excess wire. Ensure solder and wire do not rise above groove in inner contact set holder (6).

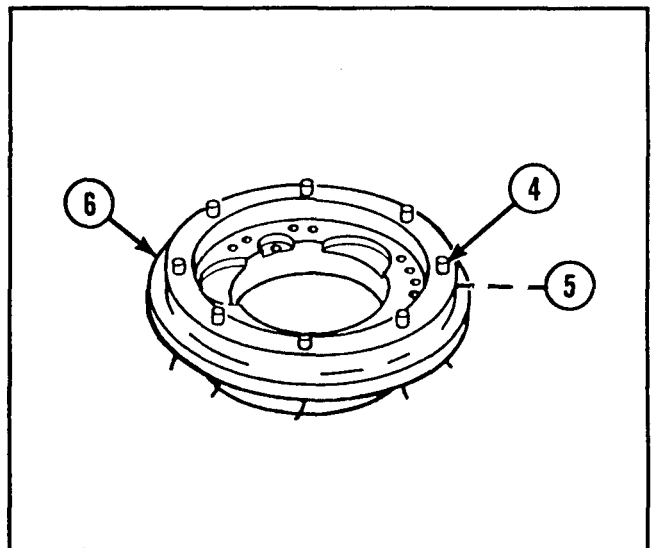

13 Install upper insulating ring (7) to outer contact set holder (3).

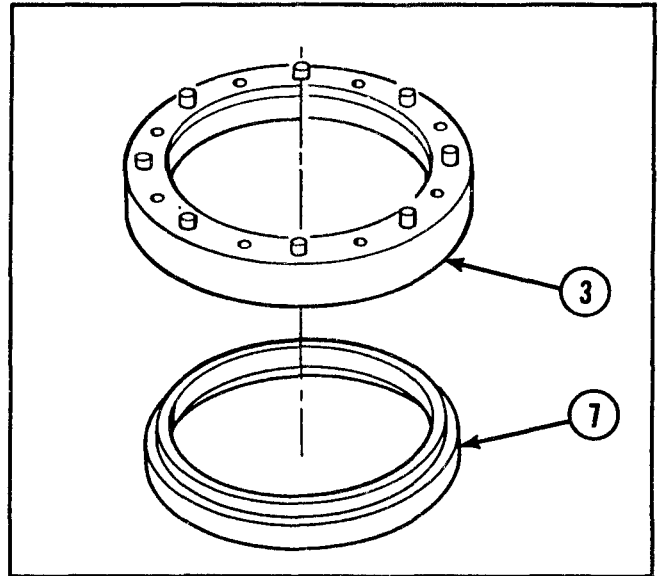

14 Install inner insulating ring (8) to inner contact set holder (6).

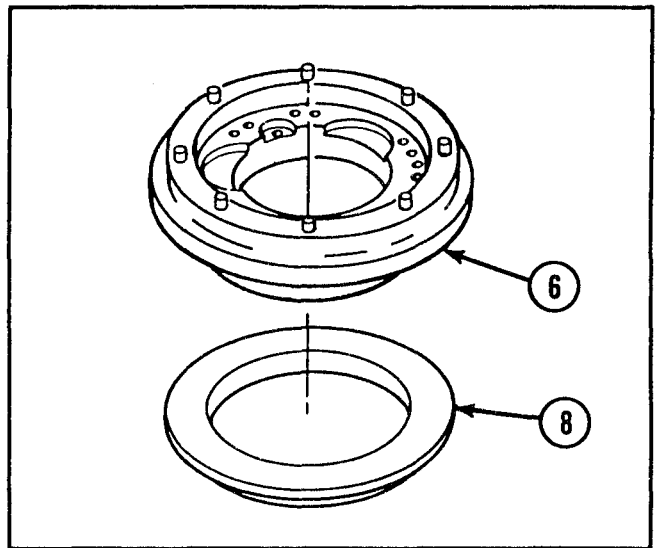

15 Install inner contact set holder (6) to holder housing (9). Align mounting holes.

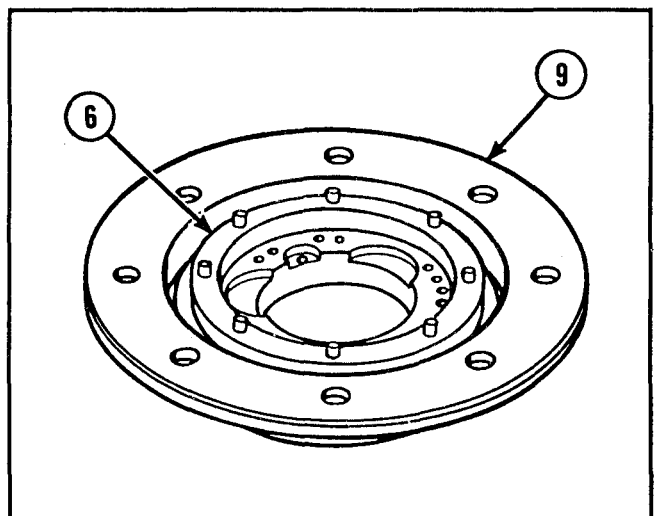

2-36. MAINTENANCE OF SLIP RING ELECTRICAL CONTACT SET ASSEMBLY (CONT).

REASSEMBLY (CONT)

- 16 Apply sealing compound to inner edge of holder housing (9) and outer edge of outer contact set holder (3).
- 17 Install outer contact set holder (3) in holder housing (9) over inner contact set holder (6).

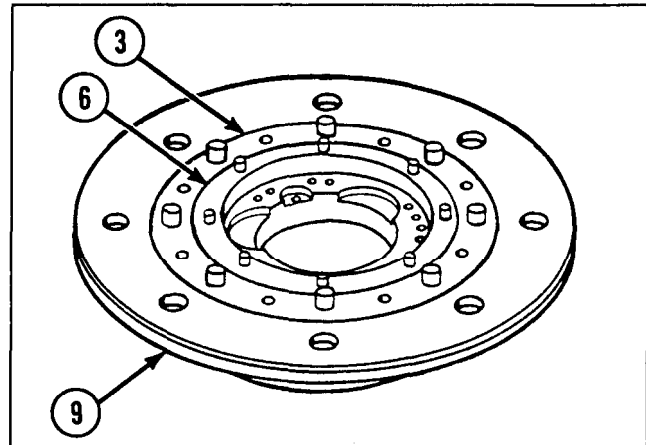

- 18 Install eight machine screws (10) to holder housing (9), and secure with new lockwire (11).

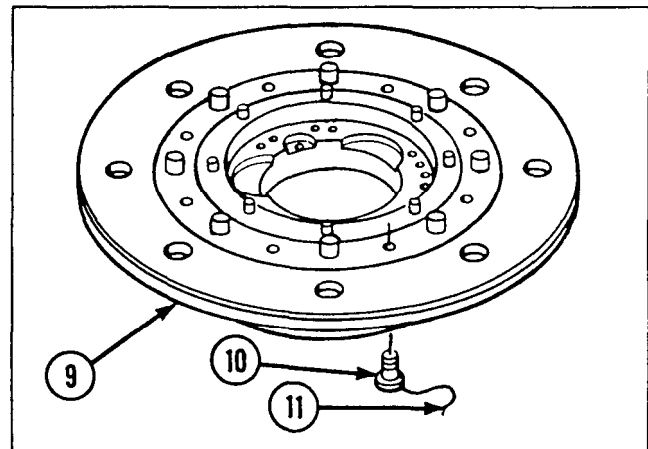

2-37. MAINTENANCE OF SLIP RING ELECTRICAL BRUSH CONNECTOR ASSEMBLY.

This task covers:		
a. <i>Disassembly</i>	b. <i>Inspection/Repair</i>	c. <i>Reassembly</i>
INITIAL SETUP		
<p>Tools and Special Tools</p> <p>Automotive maintenance and repair shop equipment: field maintenance, basic, less power (SC 4910-95-A31)</p> <p>Ž Plier wire twister</p> <ul style="list-style-type: none"> • Soldering gun 	<p>References</p> <p>TB SIG-222</p> <p>TM 9-2350-238-24P-1</p>	<p>Equipment Conditions</p> <p>2-73 Slip ring electrical brush connector assembly removed</p>
<p>Materials/Parts</p> <p>Lockwire (item 32, appx B)</p> <p>Solder (item 28, appx B)</p>		

DISASSEMBLY

NOTE

Slip ring connector assembly is part of a kit. If connector assembly must be replaced, order slip ring connector brush assembly parts kit.

- 1 Remove lockwire (1) and four socket head capscrews (2) from electrical receptacle connector (3) and snap ring spacer (4).

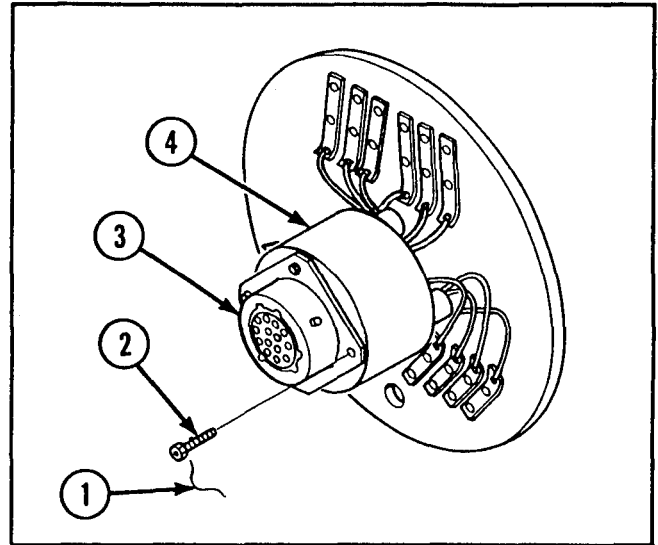

- 2 Remove lockwire (5) and three socket head capscrews (6) from terminal board assembly (7) and snap ring spacer (4).

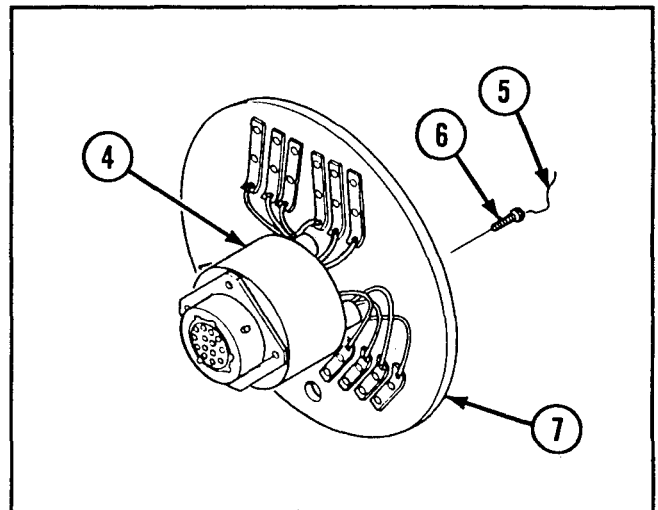

- 3 Remove electrical receptacle connector (3) and snap ring spacer (4) from terminal board assembly (7) far enough to expose electrical contacts.

- 4 Tag and unsolder 14 electrical wires (8) from terminal board assembly (7) and electrical receptacle connector (3).

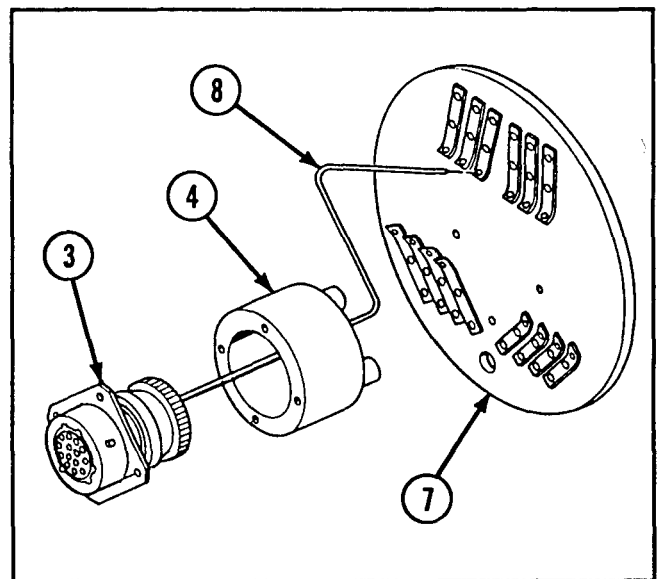

2-37. MAINTENANCE OF SLIP RING ELECTRICAL BRUSH CONNECTOR ASSEMBLY
(CONT).

INSPECTION/REPAIR

- 1 Inspect for broken, damaged, or missing parts.
- 2 Repair is by replacement of authorized parts (TM 9-2350-238-24P-1) which do not meet inspection criteria.

REASSEMBLY

- 1 Thread 14 electrical wires (1) through snap ring spacer (2).
- 2 Solder and untag 14 electrical wires (1) to electrical receptacle connector (3) and terminal board assembly (4) per TB SIG-222. Follow alphabetical sequence.
- 3 Install snap ring spacer (2) and three socket head capscrews (5) to terminal board assembly (4). Secure three socket head capscrews with new lockwire (6).

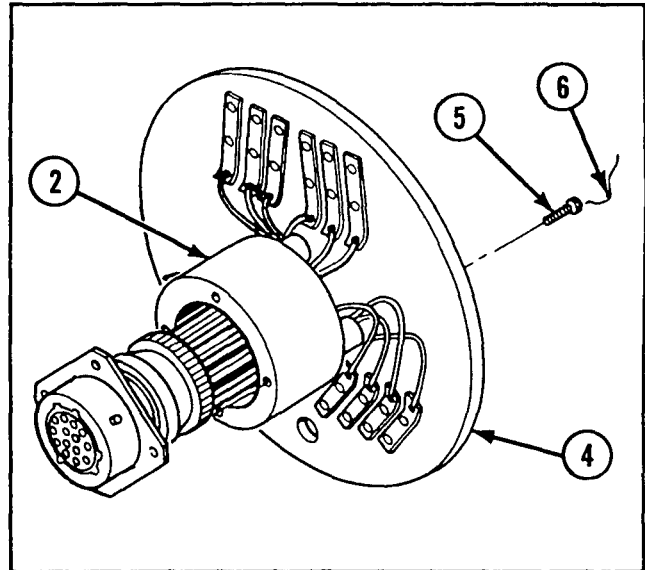
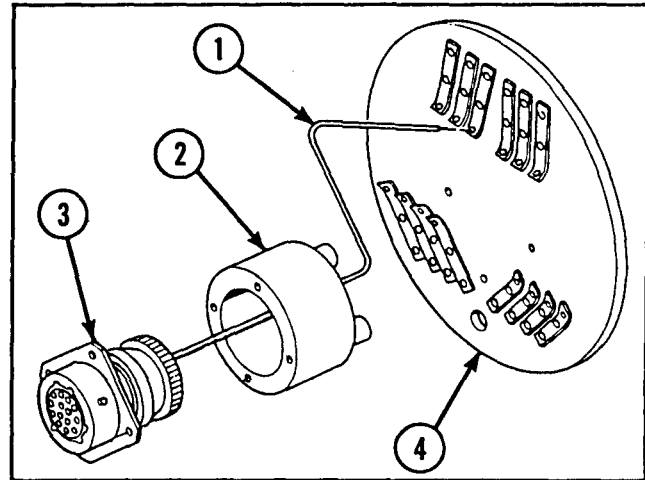

- 4 Install electrical receptacle connector (3) and four socket head capscrews (7) to snap ring spacer (2). Secure socket head capscrews with new lockwire (8).

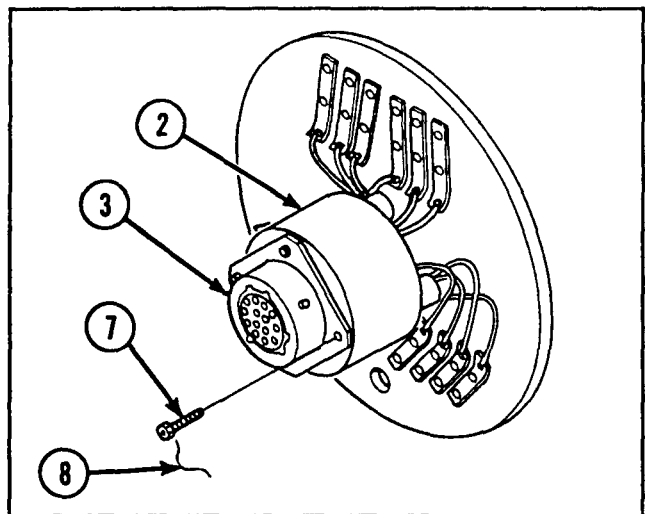

2-38. MAINTENANCE OF TRANSFER ASSEMBLY.

This task covers: a. *Removal* b. *Inspection/Repair* c. *Installation*

INITIAL SETUP

Tools and Special Tools

Automotive maintenance and repair shop equipment: field maintenance, basic, less power (SC 4910-95-A31)

- Torque wrench (0 to 150 ft-lb)

Hoist

Sling

Materials/Parts

Gasket

Self-locking bolt (16)

References

TM 9-2350-238-20-1

TM 9-2350-238-24P-1

TM 9-2520-234-35

Equipment Conditions

2-32 Engine removed

2-131 Power takeoff removed

Powerplant removed (TM 9-2350-238-20-1)

Oil drained from transmission (TM 9-2350-238-20-1)

R E M O V A L

- 1 Attach sling and hoist to housing.
- 2 Remove 16 self-locking bolts (1).
- 3 Remove four 1-1/2-in. bolts (2), four 6-in. bolts (3), two 5-1/4-in. bolts (4), and ten washers (5).
- 4 Remove engine coupling shaft (6).
- 5 Remove gasket (7) and transfer assembly (8).

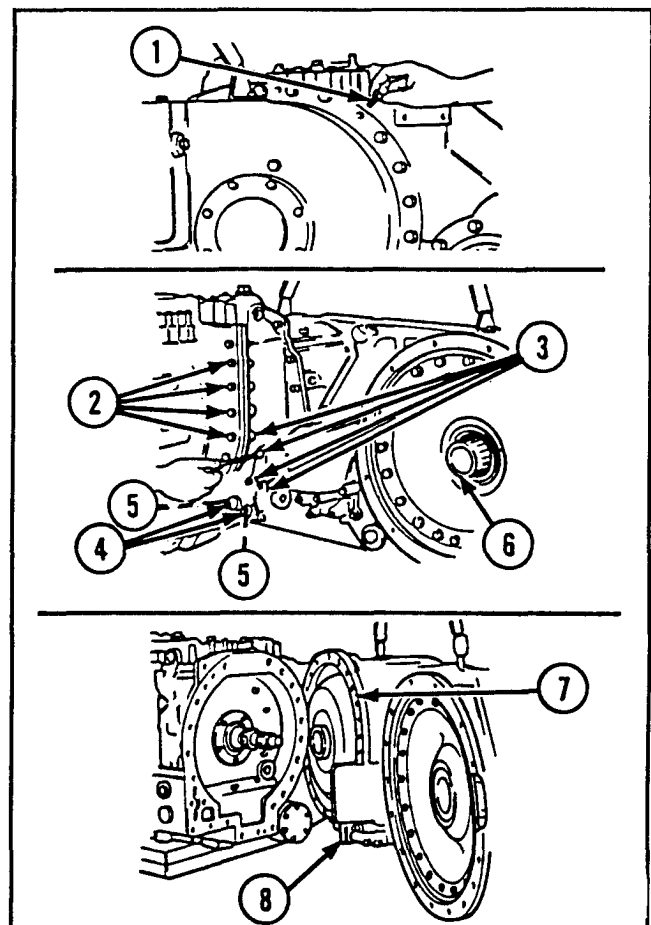

2-38. MAINTENANCE OF TRANSFER ASSEMBLY (CONT).

INSPECTION/REPAIR

- 1 Inspect for broken, damaged, or missing parts.
- 2 For complete repair of transfer assembly, refer to TM 9-2520-234-35.
- 3 For disposition of shipping and storage containers, notify depot maintenance.
- 4 Repair is by replacement of authorized parts (TM 9-2350-238-24P-1).

INSTALLATION

- 1 Install new gasket (1) and align transfer assembly (2) with transmission.
- 2 Install four 1-1/2-in. bolts (3), four 6-in. bolts (4), two 5-1/4-in. bolts (5), and ten washers (6). Torque bolts to 42.0 to 50.0 ft-lb (56.9 to 67.8 N-m).
- 3 Install 16 new self-locking bolts (7). Torque new self-locking bolts to 42.0 to 50.0 ft-lb (56.9 to 67.8 N-m).
- 4 Install engine coupling shaft (8).
- 5 Remove sling and hoist from housing.

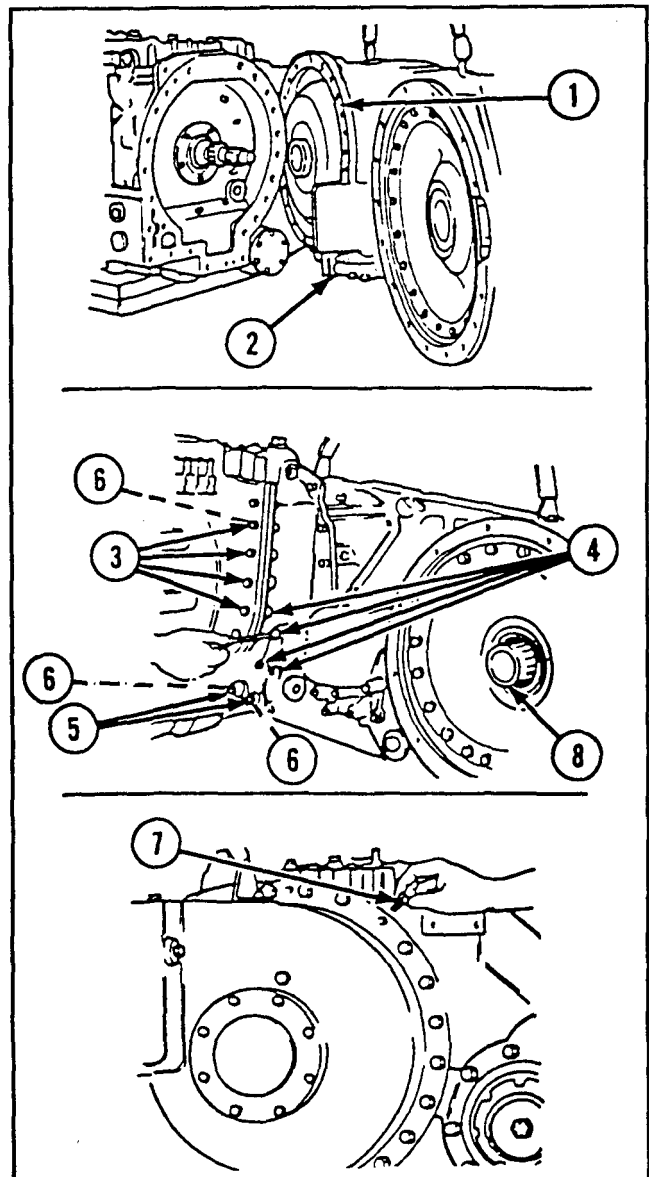

2-39. MAINTENANCE OF AUXILIARY DRIVE ASSEMBLY.

This task covers: a. *Disassembly* b. *Inspection/Repair* c. *Reassembly*

INITIAL SETUP

Tools and Special Tools

Automotive maintenance and repair shop equipment: field maintenance, basic, less power (SC 4910-95-A31)

- Micrometer
- Plier wire twister
- Torque wrench (0 to 175 ft.-lb)

Jacking screw (3) (item 23, appx E)

Spanner wrench (item 27, appx E)

References

TM 9-2350-238-10

TM 9-2350-238-20-1

TM 9-2350-238-24P-1

Equipment Conditions

Auxiliary drive assembly removed (TM 9-2350-238-20-1)

Materials/Parts

Antiseize compound (item 3, appx B)

Bearing gage (item 16, appx B)

Grease (item 17, appx B)

LockWire (item 34, appx B)

Preformed packing

Preformed packing

Shim

Shim (2)

White enamel (item 14, appx B)

DISASSEMBLY

- 1 Straighten tangs on key washer (1). Use spanner wrench to remove plain round nut (2) and key washer.
- 2 Grasp vehicular drive (3) and pull from clutch shouldered shaft (4).

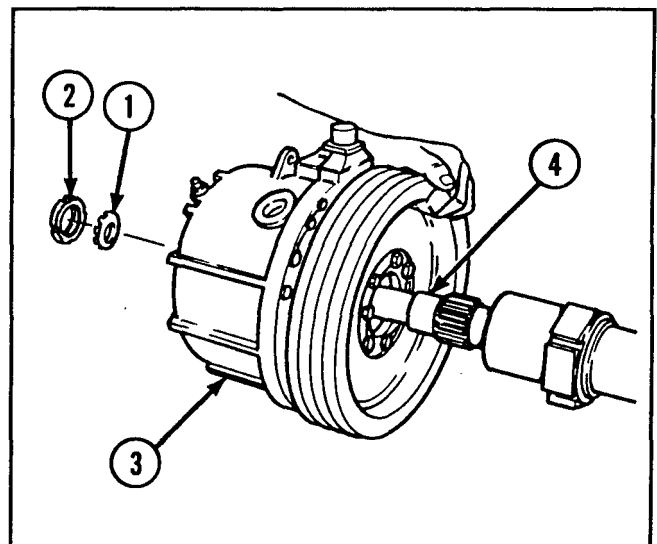

2-39. MAINTENANCE OF AUXILIARY DRIVE ASSEMBLY (CONT).

DISASSEMBLY (CONT)

3 Remove lockwire (5) and four hexagon head capscrews (6) securing clutch drive (7) to input drive (8).

4 Install three jacking screws in threaded holes to separate clutch drive (7) from input drive (8). Remove jacking screws.

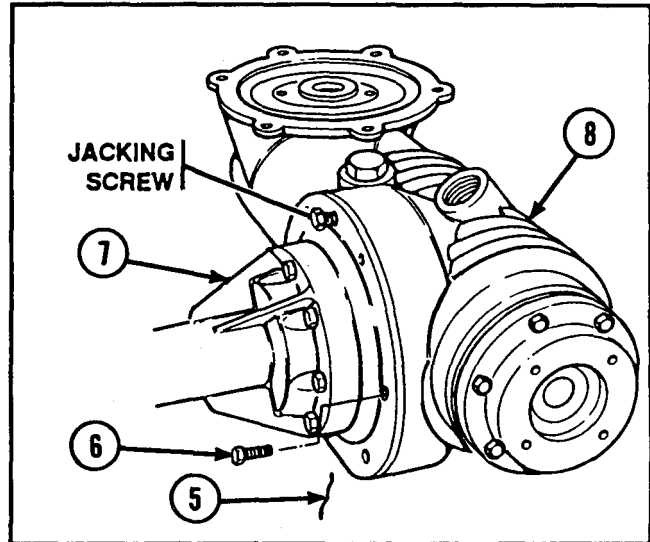

5 Remove preformed packing (9) and two shims (10) from clutch drive (7).

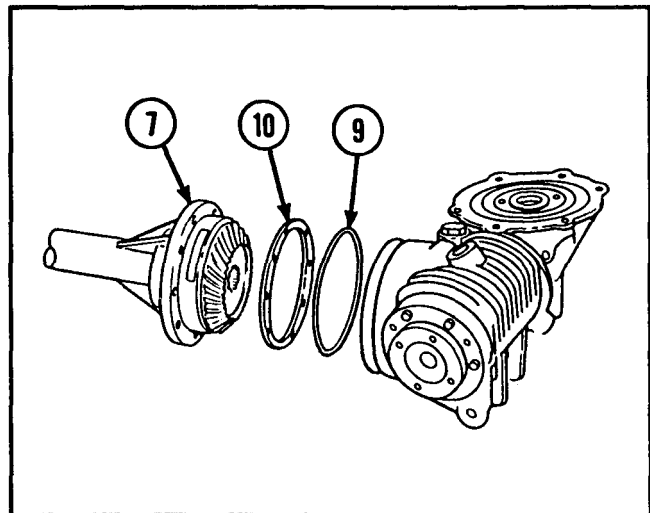

6 Remove lockwire (11) and eight hexagon head capscrews (12).

7 Separate generator drive (13) from input drive (8). Remove two shims (14). Remove preformed packing (15).

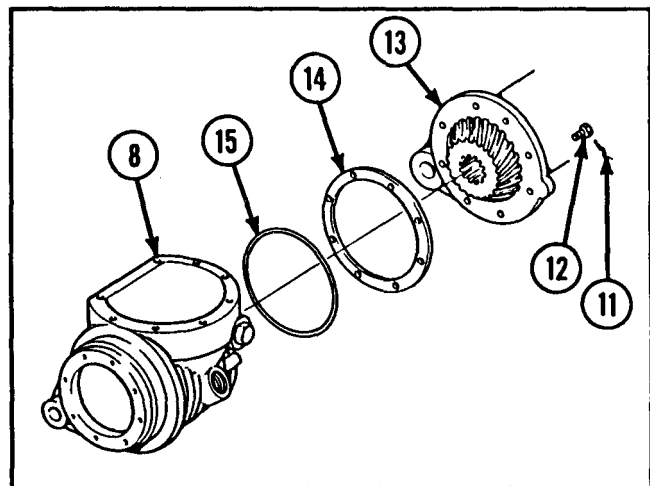

INSPECTION/REPAIR

- 1 Inspect for broken, damaged, or missing parts.
- 2 Vehicular drive is a repairable assembly. Refer to page 2-101.
- 3 Clutch drive is a repairable assembly. Refer to page 2-110.
- 4 Generator drive is a repairable assembly: Refer to page 2-116.
- 5 Input drive is a repairable assembly. Refer to page 2-131.
- 6 Repair is by replacement of authorized parts (TM 9-2350-238-24P-1).

REASSEMBLY

- 1 Install two new shims (1) on face of generator drive (2).
- 2 Install new preformed packing (3) in groove of input drive (4).
- 3 Install generator drive (2) on input drive (4) and secure with eight hexagon head capscrews (5). Secure hexagon head capscrews with new lockwire (6).
- 4 Remove input shaft mechanical housing from input drive mechanical housing (p 2-131).

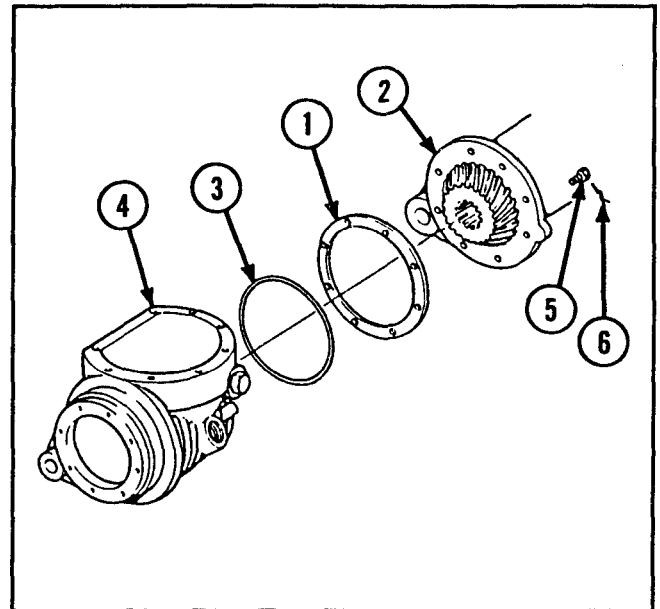

2-39. MAINTENANCE OF AUXILIARY DRIVE ASSEMBLY (CONT).

REASSEMBLY (CONT)

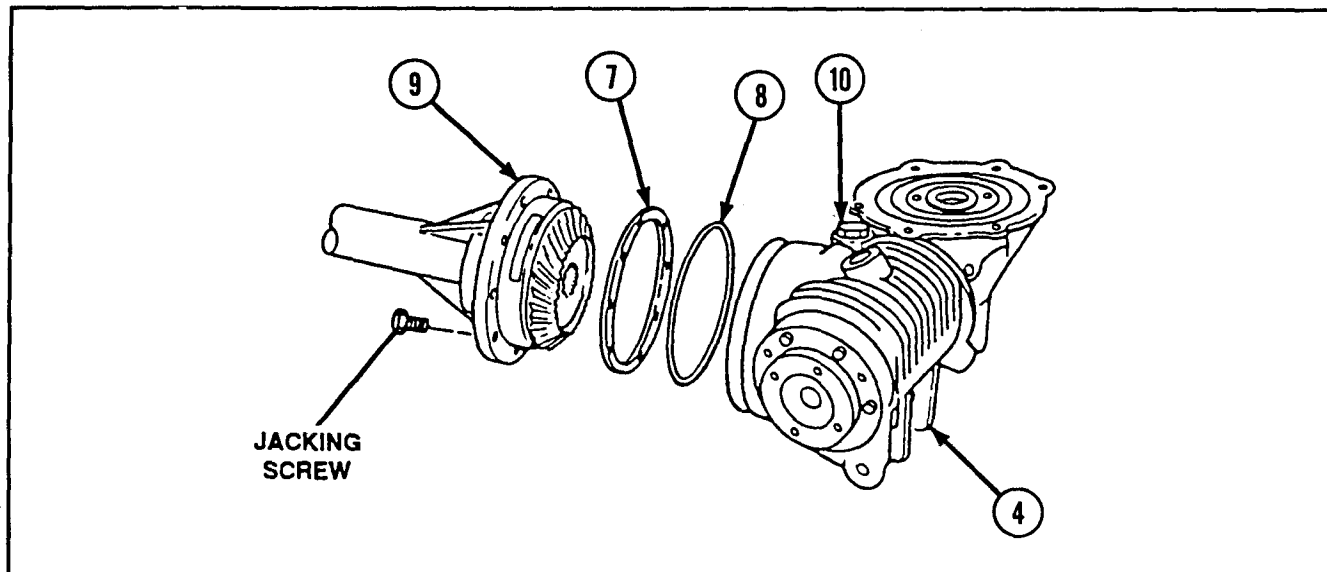

- 5 Install two new shims (7) and new preformed packing (8) on clutch drive (9).
- 6 Install clutch drive (9) into input drive (4) and secure with three evenly spaced jacking screws.
- 7 Remove plug (10). Insert bearing gage through hole and between large end of output gear teeth while rotating gears by hand. Reverse rotation and remove bearing gage after it has traveled through one tooth. Install plug.
- 8 Measure flattened portion of bearing gage to determine backlash measurement. Backlash should measure 0.005 to 0.006 in. (0.013 to 0.015 cm).
- 9 If backlash is not correct, remove clutch drive (9) and increase or decrease number of shims (7).

NOTE

Approximately 0.001 in. (0.003 cm) backlash change requires 0.0016 in. (0.0041 cm) shim change (one lamination).

- 10 Repeat steps 6 thru 9 until proper backlash is obtained.

11 Clean any remaining oil from output gear teeth and apply grease or white enamel on four or five teeth. Use input shaft opening in input drive for access.

12 Turn shaft counterclockwise and rotate output gears at least one complete revolution.

13 Remove three jacking screws and clutch drive (9).

14 Examine output gear matching gear teeth and determine gear tooth wear pattern. If backlash is correct (fig. 2-1), the gear tooth bearing contact area shall be equal in length and centered on tooth face within 10 percent of length and width. The contact area should be 0.3 to 0.7 in. (7.6 to 17.8 mm).

CAUTION

Contact areas extending to either end of the teeth are not acceptable.

15 Repeat steps 5 thru 13 if wear pattern is not correct (fig. 2-2 and 2-3). If wear pattern cannot be reached through proper shimming, repair generator drive (p 2-116).

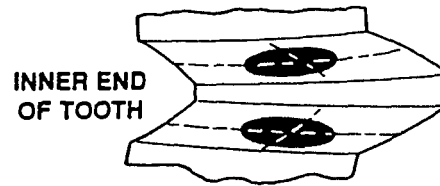

Figure 2-1. Correct Tooth Contact Pattern.

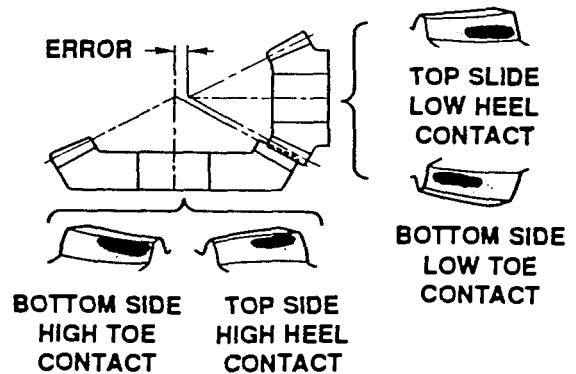

Figure 2-2. Backlash Too Large.

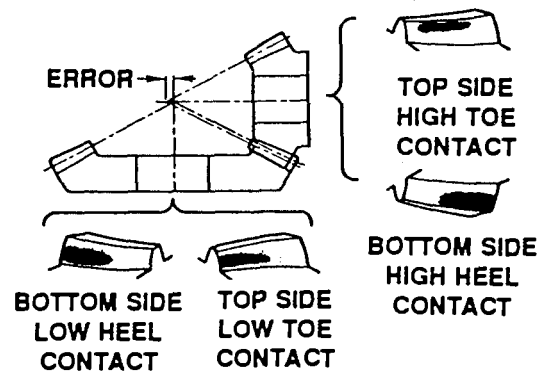
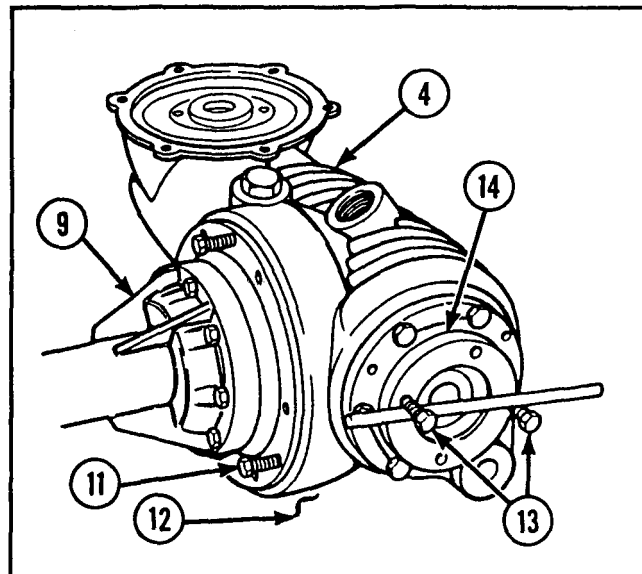

Figure 2-3. Backlash Too Small.

2-39. MAINTENANCE OF AUXILIARY DRIVE ASSEMBLY (CONT).

REASSEMBLY (CONT)

- 16 Secure clutch drive (9) to input drive (4) with four hexagon head capscrews (11) in bottom holes. Secure hexagon head capscrews with new lockwire (12).
- 17 Install input shaft mechanical housing in input drive mechanical housing (page 2-131).
- 18 Partially install two hexagon head capscrews (13) in output drive gear housing (14). Prevent clutch shouldered shaft from turning by placing a bar between capscrews.



- 19 Apply antiseize compound to splines and mating surfaces of clutch shouldered shaft (15), drive shaft housing (16), and inner bearing ring (17).
- 20 Install vehicular drive (18) on clutch shouldered shaft (15). Make sure splines mate properly.
- 21 Secure vehicular drive (18) to clutch shouldered shaft (15) with key washer (19) and plain round nut (20). Using spanner wrench, torque nut to 110 to 150 ft-lb (149 to 203 N-m). Bend tangs of key washer against plain round nut.
- 22 Lubricate auxiliary drive. Refer to TM 9-2350-238-10.

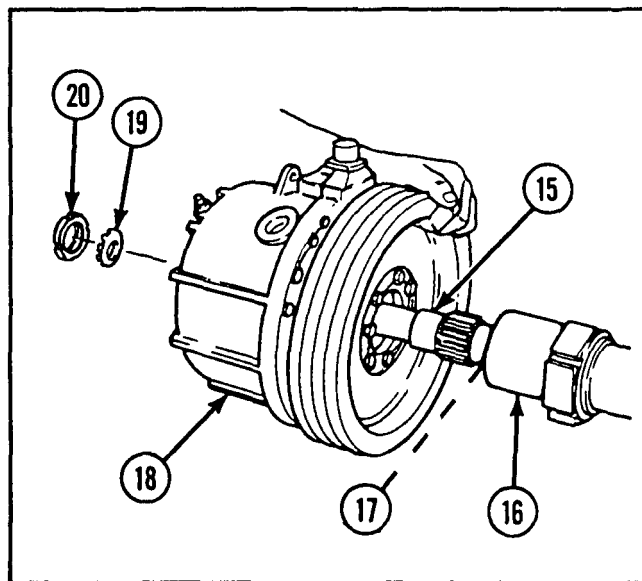

2-40. MAINTENANCE OF AUXILIARY DRIVE ASSEMBLY (VEHICULAR DRIVE).This task covers: a. *Disassembly* b. *Inspection/Repair* c. *Reassembly***INITIAL SETUP****Tools and Special Tools**

Automotive maintenance and repair shop equipment: field maintenance, basic, less power (SC 4910-95-A31)

- Arbor press
- Plier wire twister
- Soldering gun

Bearing replacer (item 11, appx E)

Clutch bearing replacer (item 17, appx E)

Jacking screw (2) (item 20, appx E)

Oil seal inserter (item 7, appx E)

Seal remover and replacer (item 10, appx E)

Materials/Parts

Grease (item 17, appx B)

Lockwire (item 32, appx B)

Lockwire (item 34, appx B)

Plain encased seal (2)

Sealing compound (item 26, appx B)

Self-locking nut

Silicone adhesive sealant (item 2, appx B)

Solder (item 28, appx B)

References

MIL-G-10924

TB SIG-222

TM 9-214

TM 9-2350-238-24P-1

Equipment Conditions

2-95 Vehicular drive removed

DISASSEMBLY

1 Remove self-locking nut (1), hexagon head capscrew (2), flat washer (3), and connecting link (4).

2 Remove two sleeve spacers (5) and non-metallic grommet (6) from connecting link (4).

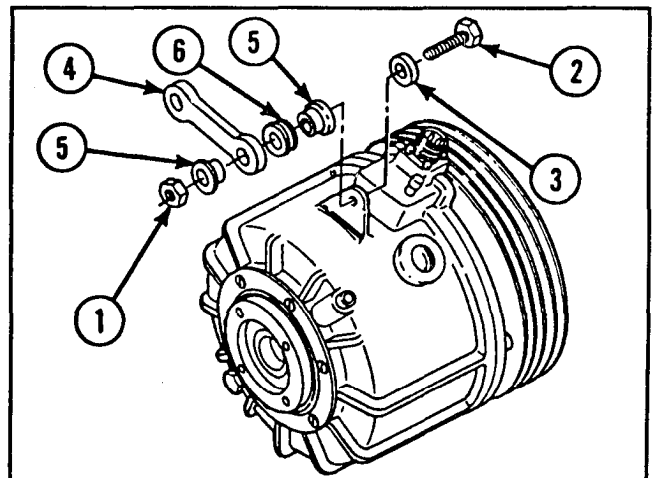

2-40. MAINTENANCE OF AUXILIARY DRIVE ASSEMBLY (VEHICULAR DRIVE) (CONT).

DISASSEMBLY (CONT)

3 Remove lockwire (7), eight hexagon head cap screws (8), and groove pulley (9) from mechanical clutch housing (10).

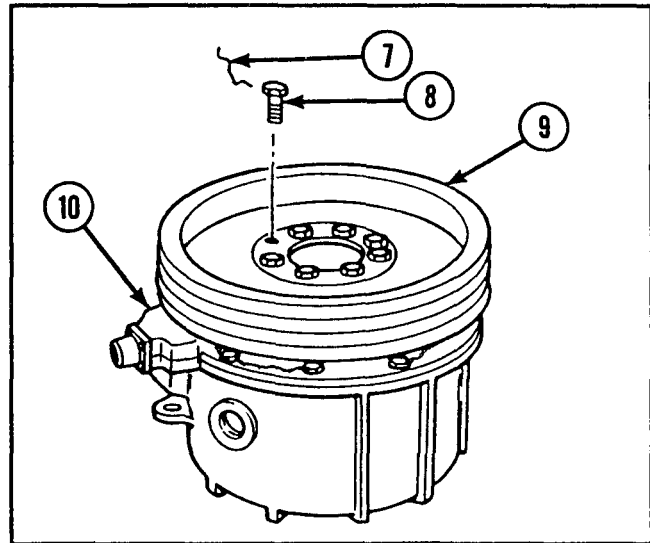

4 Remove lockwire (11) and four socket head cap screws (12). Loosen receptacle connector (13).

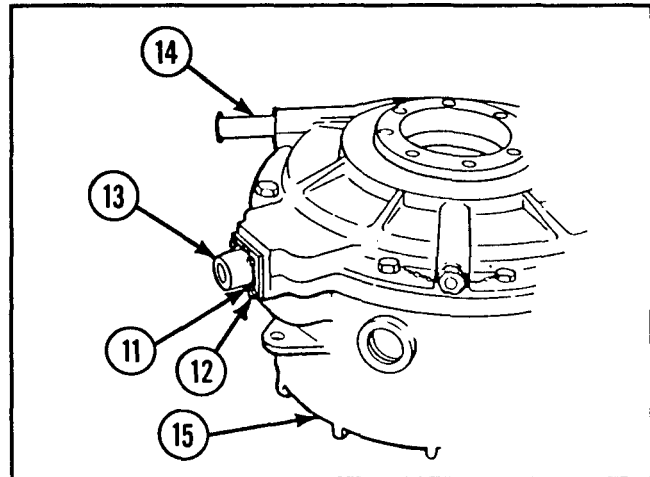

5 Remove gage rod clutch tube (14) from mechanical clutch housing (15).

6 Remove lubricant fitting (16).

7 Remove two pipe plugs (17).

8 Remove lockwire (18) and ten hexagon head cap screws (19) securing mechanical clutch housing (10). Use two jacking screws to loosen and remove mechanical clutch housing.

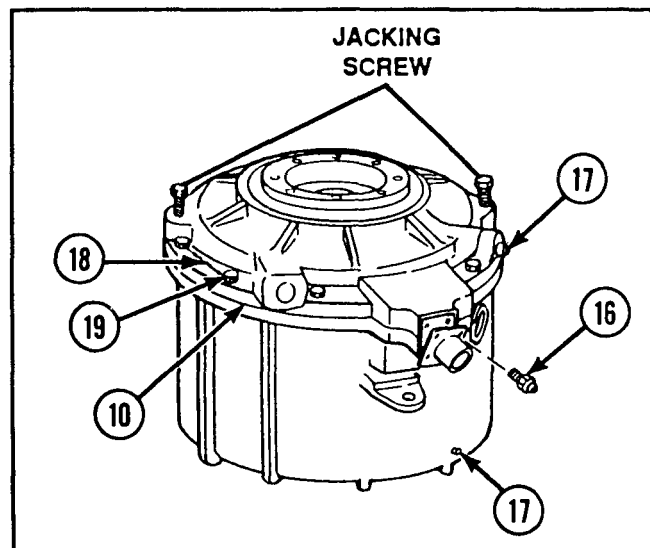

- 9 Remove top part of magnetic clutch (20) with electrical receptacle attached from bottom part of magnetic clutch (21).
- 10 Remove ring spacer (22) from bottom part of magnetic clutch (21).
- 11 Turn mechanical clutch housing (15) over. Using hammer and drift, lightly tap bottom part of magnetic clutch (21) free and remove.

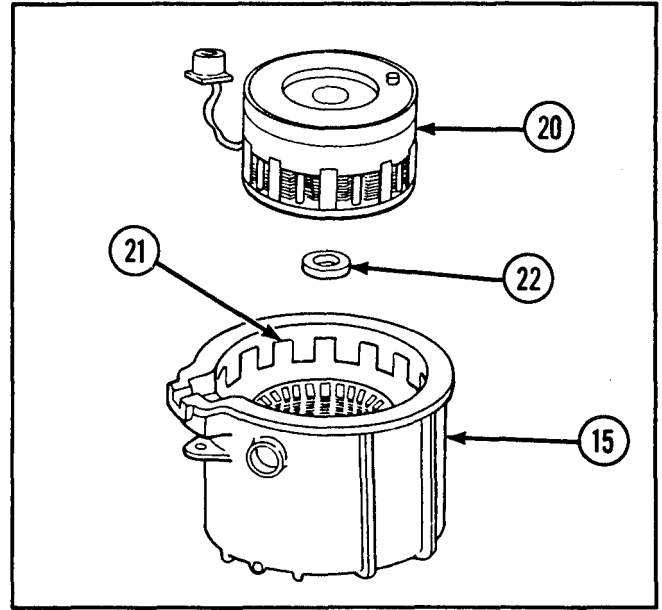

- 12 Using drift, tap free and remove annular ball bearing (23) and sleeve spacer (24) from bottom part of magnetic clutch (21).
- 13 Turn bottom part of magnetic clutch (21) over and remove annular ball bearing (25).

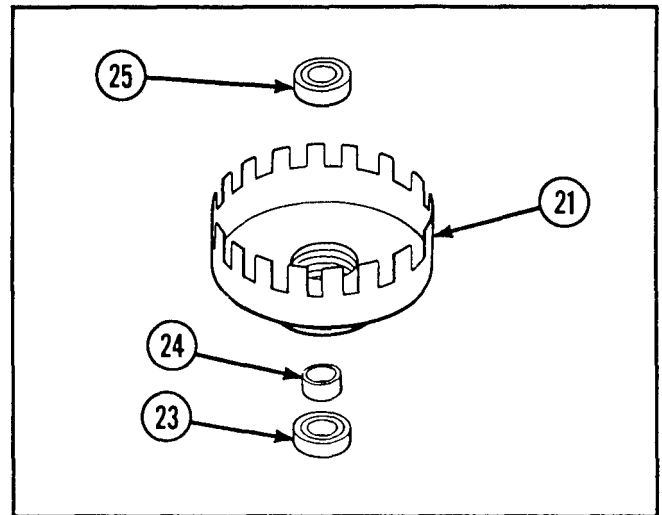

- 14 Remove six staked machine screws (26) and retaining plate (27) from mechanical clutch housing (15).

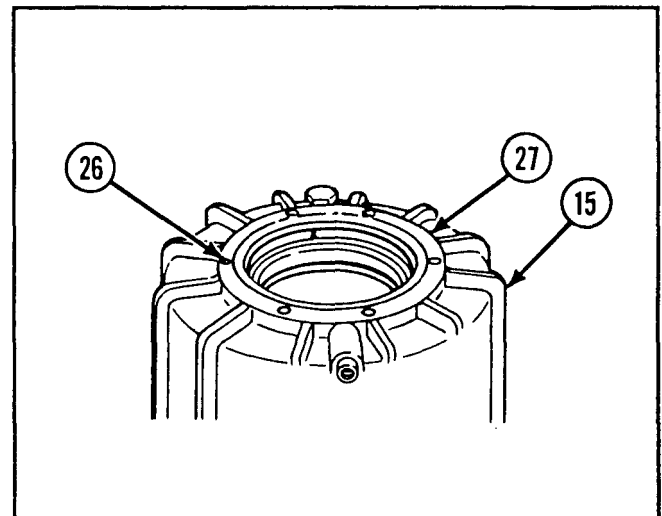

2-40. MAINTENANCE OF AUXILIARY DRIVE ASSEMBLY (VEHICULAR DRIVE) (CONT).

DISASSEMBLY (CONT)

15 Using seal remover and replacer, remove plain encased seal (28), retaining ring (29), annular ball bearing (30), and clutch bearing shield (31) from mechanical clutch housing (15).

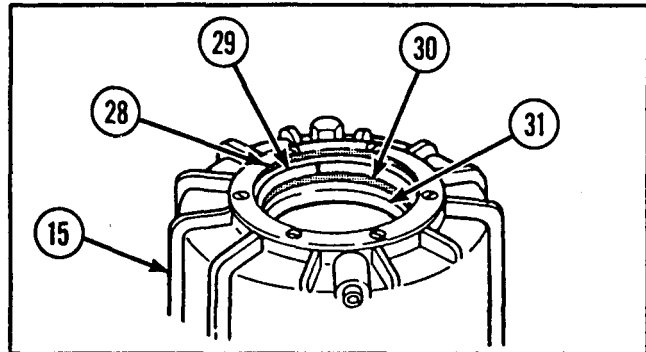

16 Remove fan drive body hub (32) from mechanical clutch housing (10).

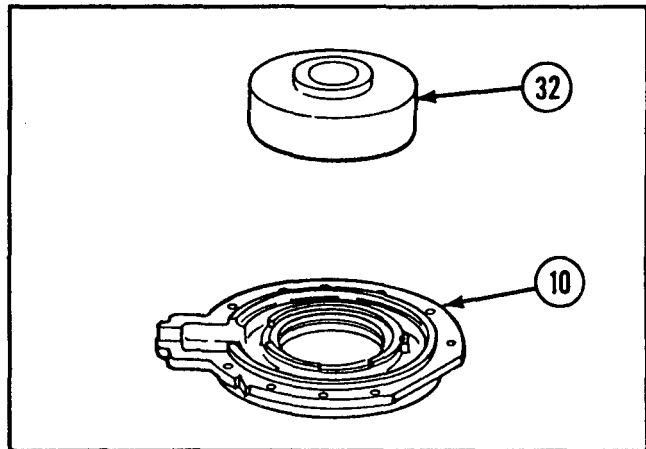

17 Remove six staked machine screws (33) and retaining plate (34) from mechanical clutch housing (10).

18 Using seal remover and replacer, remove plain encased seal (35), retaining ring (36), annular ball bearing (37), and clutch bearing shield (38) from mechanical clutch housing (10).

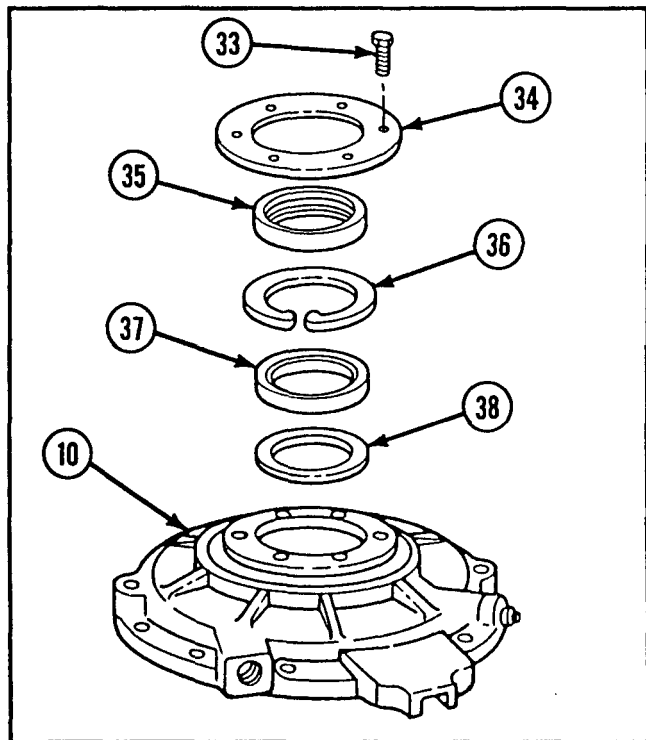

- 19 Unsolder electrical leads (39) from receptacle connector contact pins, and remove receptacle connector (13).

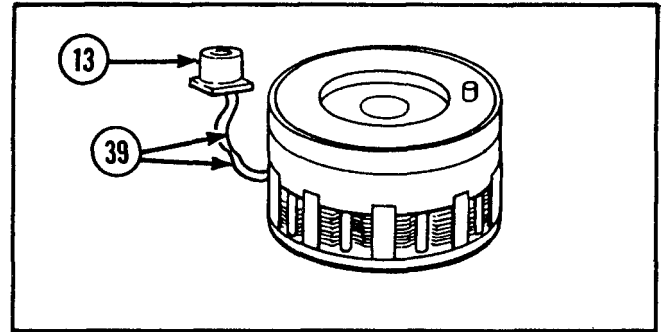

INSPECTION/REPAIR

- 1 Inspect for broken, damaged, or missing parts,
- 2 Inspect annular ball bearings. Refer to TM 9-214.
- 3 Inspect magnetic clutch for wear or warpage of clutch plates and signs of arcing or overheating. Spin rotor by hand and listen for

grinding noise. Apply 24 V dc to magnetic coil and check clutch operation. If damaged, refer to general maintenance, page 2-28.

- 4 Repair is by replacement of authorized parts (TM 9-2350-238-24P-1) which do not meet inspection criteria.

REASSEMBLY

- 1 Pack annular ball bearing (1) with grease. Install clutch bearing shield (2) and annular ball bearing into mechanical clutch housing (3), using clutch bearing replacer and press.
- 2 Install retaining ring (4).

CAUTION

An improperly installed plain encased seal will leak during operation.

- 3 Lightly lubricate mechanical clutch housing seal cavity with grease. Install new plain encased seal (5), using seal remover and replacer. Ensure lip of seal is toward inside of housing.
- 4 Install retaining plate (6) and secure with six machine screws (7). Stake each machine screw in place.

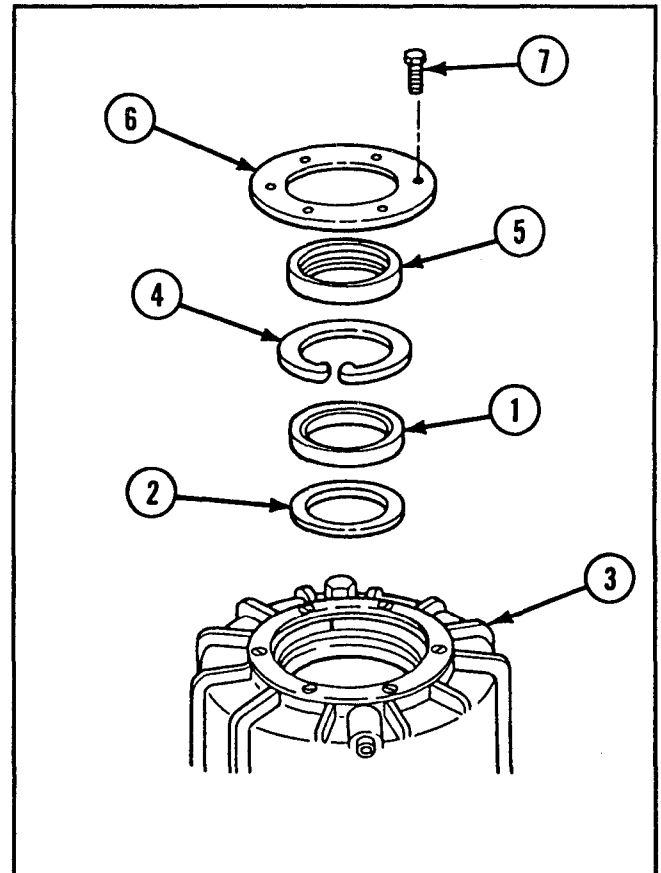

2-40. MAINTENANCE OF AUXILIARY DRIVE ASSEMBLY (VEHICULAR DRIVE) (CONT).

REASSEMBLY (CONT)

5 Pack annular ball bearing (8) with grease. Install clutch bearing shield (9) and annular ball bearing into mechanical clutch housing (10), using clutch bearing replacer and press.

6 Install retaining ring (11).

CAUTION

An improperly installed plain encased seal will leak during operation.

7 Lightly lubricate mechanical clutch housing seal cavity with grease. Install new plain encased seal (12), using oil seal inserter. Ensure lip of seal is toward inside of housing.

8 Install retaining plate (13) and secure with six machine screws (14). Stake each machine screw in place.

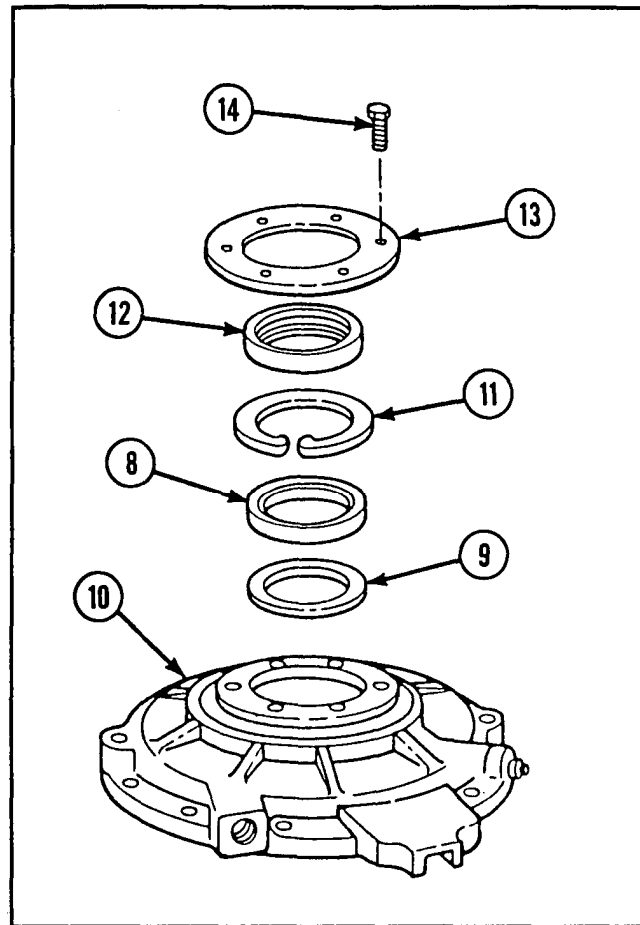

9 Pack annular ball bearing (15) and annular ball bearing (16) with grease. Place splined end of bottom part of magnetic clutch (17) down and install annular ball bearing (16) using bearing replacer and press.

10 Turn bottom part of magnetic clutch (17) over and install sleeve spacer (18). Pack space between sleeve spacer (18), annular ball bearing (16), and bottom part of magnetic clutch (17) with grease. Install annular ball bearing (15), using bearing replacer and press.

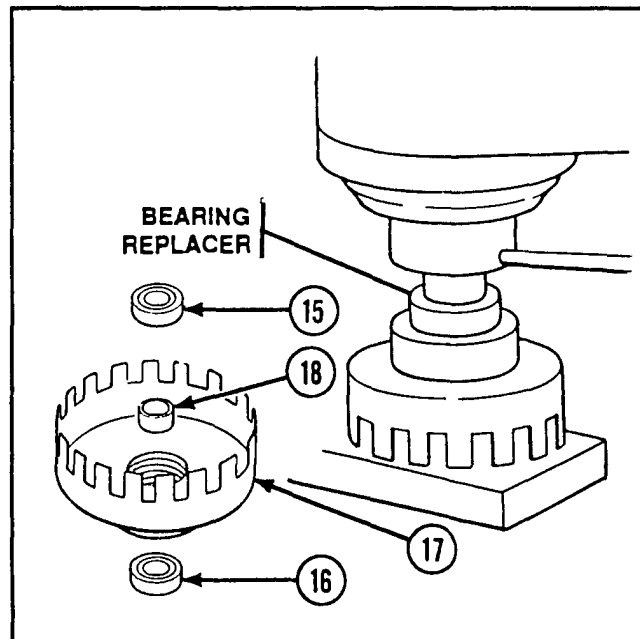

- 11 Solder electrical leads (19) to receptacle connector (20) contact pins. Refer to TB SIG-222.

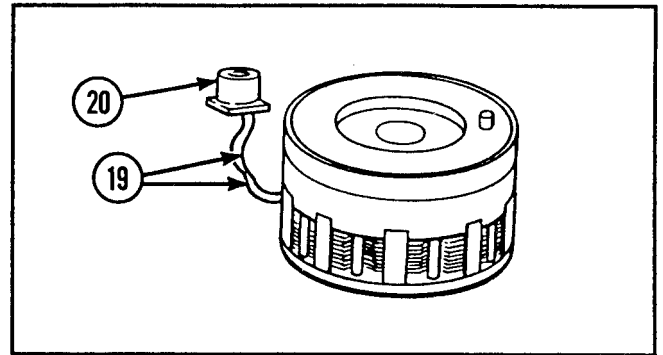

- 12 Install bottom part of magnetic clutch (17) into mechanical clutch housing (3). Ensure that lip of inner seal is worked up and over edge of magnetic clutch (17) and points inward evenly around clutch.

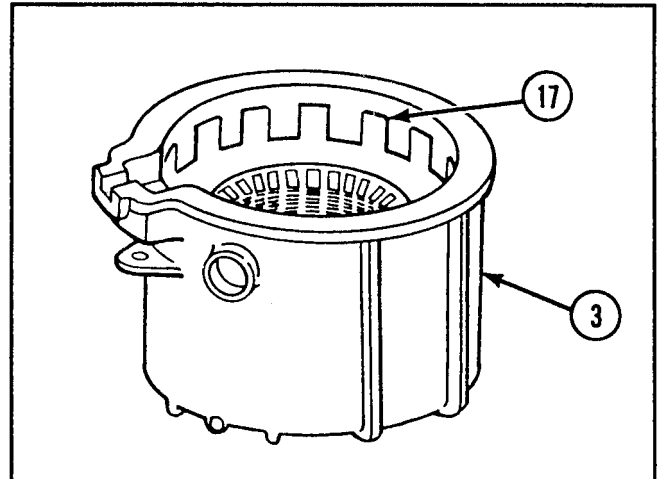

- 13 Place ring spacer (21) in bottom part of magnetic clutch (17) with external chamfer down.

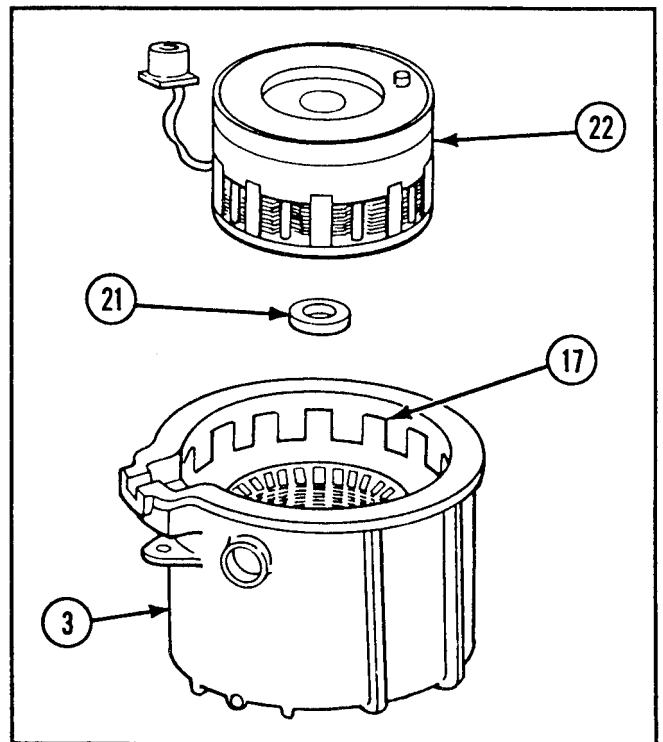

- 14 Position top part of magnetic clutch (22) directly over mechanical clutch housing (3). Carefully lower magnetic clutch (22) into mechanical clutch housing (3), rotating slightly to aid the alignment of magnetic clutch teeth with magnetic clutch plate grooves.

2-40. MAINTENANCE OF AUXILIARY DRIVE ASSEMBLY (VEHICULAR DRIVE) (CONT).

REASSEMBLY (CONT)

CAUTION

A nicked, scratched, or cut seal lip will leak during operation.

15 Install fan drive body hub (23) into mechanical clutch housing (10). Ensure lip of seal is worked up and over edge of magnetic clutch and points inward evenly around clutch.

16 Apply a coat of sealing compound or silicone adhesive sealant to mating surfaces of mechanical clutch housing (3) and mechanical clutch housing (10).

17 Install mechanical clutch housing (10) on mechanical clutch housing (3) by aligning guide pin on magnetic clutch with hole in mechanical clutch housing (10). Secure with ten hexagon head capscrews (24) and new lockwire (25) (item 34, appx B).

18 Secure receptacle connector (20) with four socket head capscrews (26) and new lockwire (27) (item 32, appx B).

19 Install two 5.0-psi (34.5-kPa) pressure relief grease fittings. Pack two new plain encased seals with grease. Refer to MIL-G-10924. Remove two pressure relief grease fittings and install two pipe plugs (28),

20 Install lubricant fitting (29).

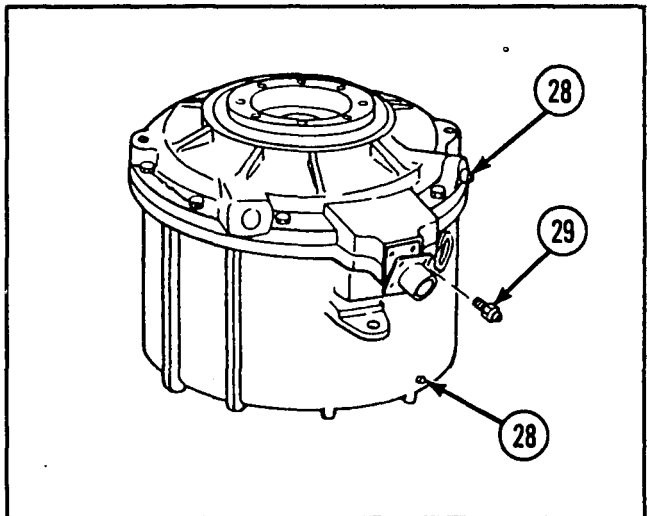
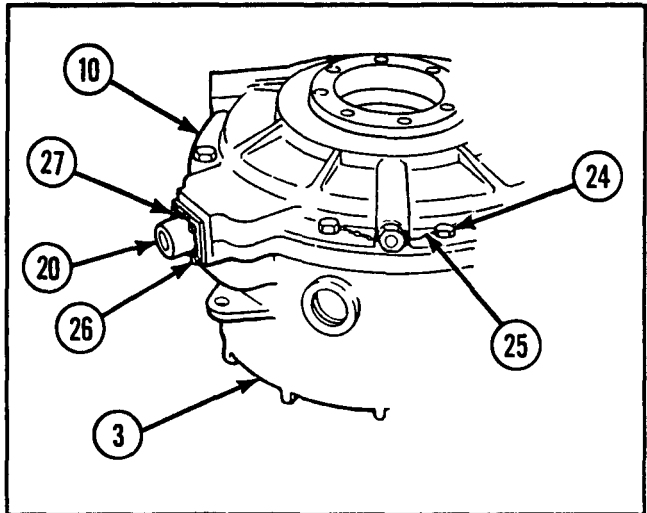
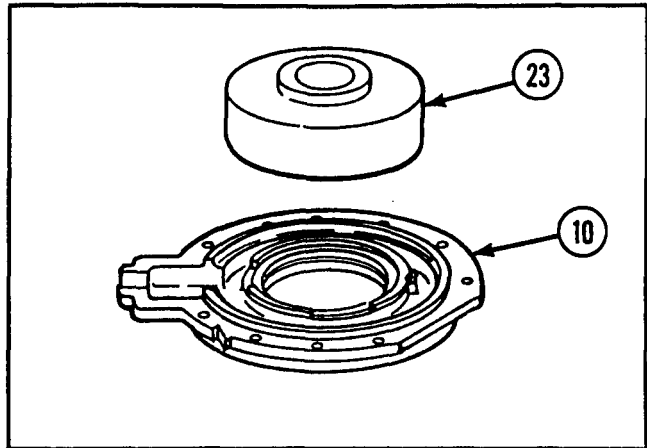

- 21 Install gage rod clutch tube (30) in mechanical clutch housing (3).
- 22 Install groove pulley (31) and secure using eight hexagon head capscrews (32). Secure capscrews with new lockwire (33) (item 34, appx B).

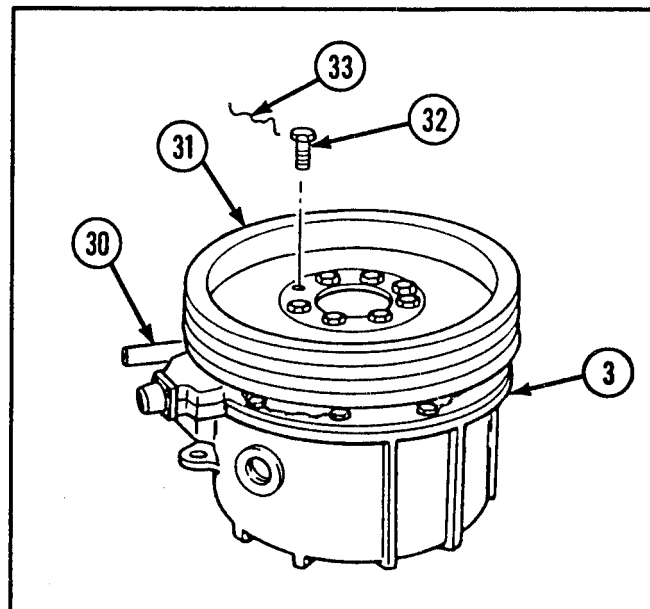

- 23 Install grommet (34) and two sleeve spacers (35) in connecting link (36).
- 24 Position connecting link (36) on mechanical clutch housing (3), and secure with flat washer (37), hexagon head capscrew (38), and new self-locking nut (39).

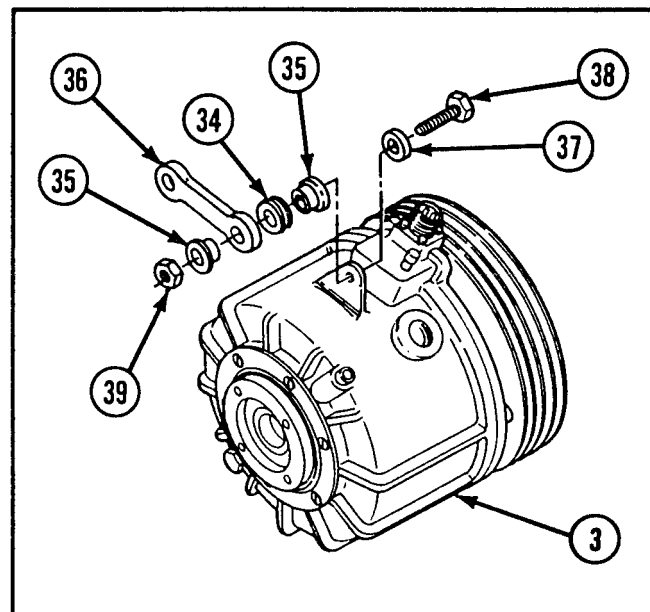

2-41. MAINTENANCE OF AUXILIARY DRIVE ASSEMBLY (CLUTCH DRIVE).

This task covers: a. *Disassembly* b. *Inspection/Repair* c. *Reassembly*

INITIAL SETUP

Tools and Special Tools

Automotive maintenance and repair shop equipment: field maintenance, basic, less power (SC 4910-95-A31)

- Mechanical gear puller kit
- Plier wire twister
- Puller
- Torque wrench (0 to 300 in.-lb)
- Vise

Bearing cup replacer (item 16, appx E)
 Bearing replacer (item 12, appx E)
 Face wrench socket (item 24, appx E)
 Gear replacer (item 18, appx E)
 Seal remover and replacer (item 10, appx E)
 Wood block

Materials/Parts

Gasket
 Grease (item 17, appx B)
 Lockwasher
 Lockwire (item 34, appx B)
 Plain encased seal (2)

References

TM 9-214
 TM 9-2350-238-24P-1

Equipment Conditions

2-95 Clutch drive removed

DISASSEMBLY

- 1 Remove retaining ring (1).
- 2 Remove lockwire (2) and eight hexagon head capscrews (3).
- 3 Pull output drive gear mechanical housing (4) with attached parts from drive shaft housing (5) and clutch shouldered shaft (6). Remove gasket (7).

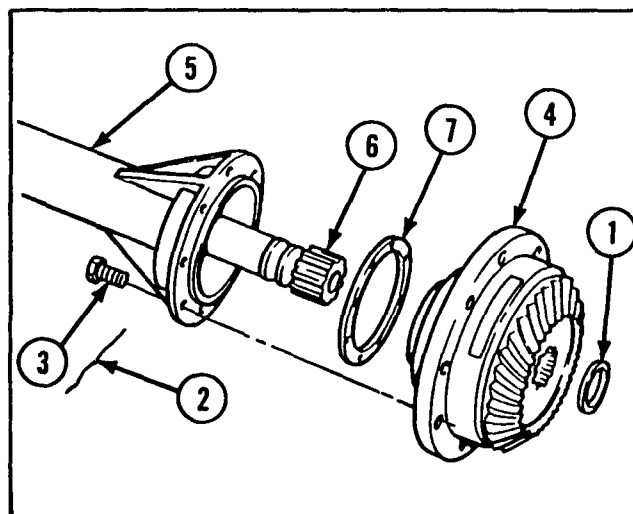

- 4 Pull clutch shouldered shaft (6) from forward end of drive shaft housing (5).
- 5 Remove socket head capscrew (8) and lockwasher (9).

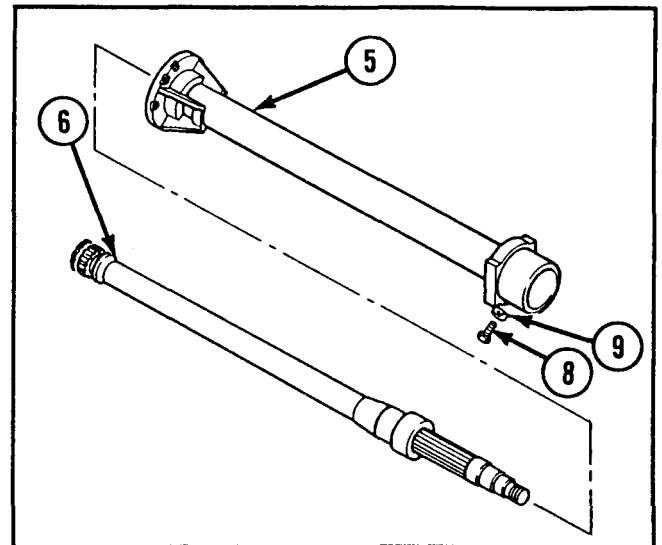

- 6 Place drive shaft housing (5) in vise. Using seal remover and replacer, remove two plain encased seals (10) and needle roller bearing (11) from drive shaft housing.

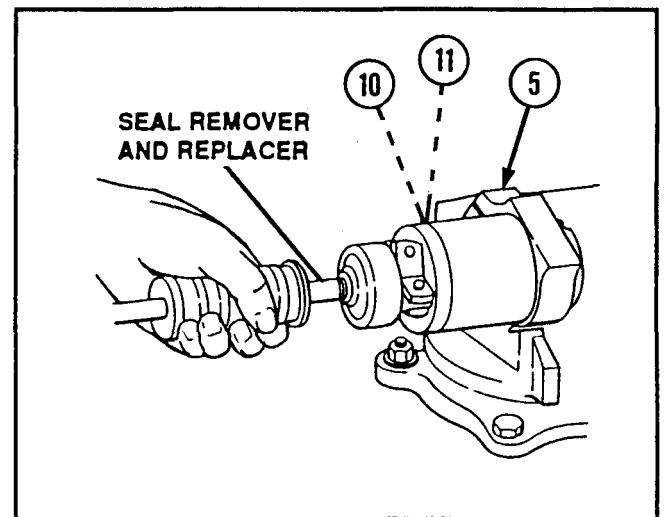

- 7 Using puller, remove inner bearing ring (12) from clutch shouldered shaft (6).

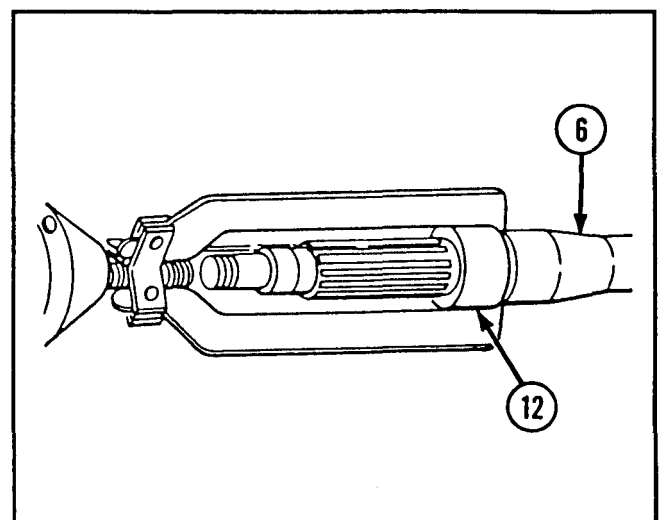

2-41. MAINTENANCE OF AUXILIARY DRIVE ASSEMBLY (CLUTCH DRIVE) (CONT).

DISASSEMBLY (CONT)

- 8 Straighten tangs on key washer (13).
Remove plain round nut (14).
- 9 Remove key washer (13), bearing retaining key washer (15), and tapered roller bearing (16) from output drive gear mechanical housing (4).
- 10 Remove output drive spiral gear (17) with cone-and-rollers (18) from output drive gear mechanical housing (4).
- 11 Using bearing puller, remove cone-and-rollers (18) from output drive spiral gear (17).
- 12 Using bearing puller, remove two tapered roller bearing cups (19 and 20) from output drive gear mechanical housing (4).

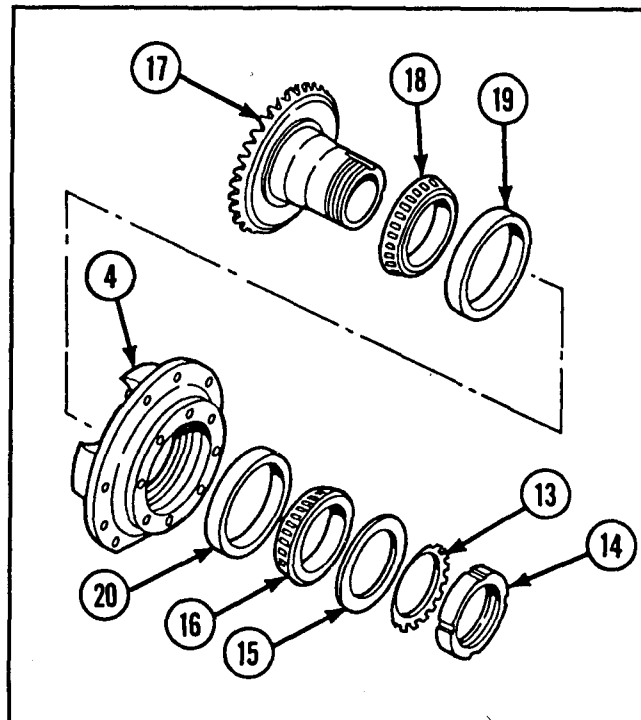

INSPECTION/REPAIR

- 1 Inspect for broken, damaged, or missing parts.
- 2 Inspect all bearings and inner bearing ring. Refer to TM 9-214.
- 3 If required, replace output drive bevel gear set as a matched pair. Refer to page 2-116.
- 4 Repair is by replacement of authorized parts (TM 9-2350-238-24P-1) which do not meet inspection criteria.

REASSEMBLY

- 1 Using bearing replacer, install cone-and-rollers (1) on output drive spiral gear (2).

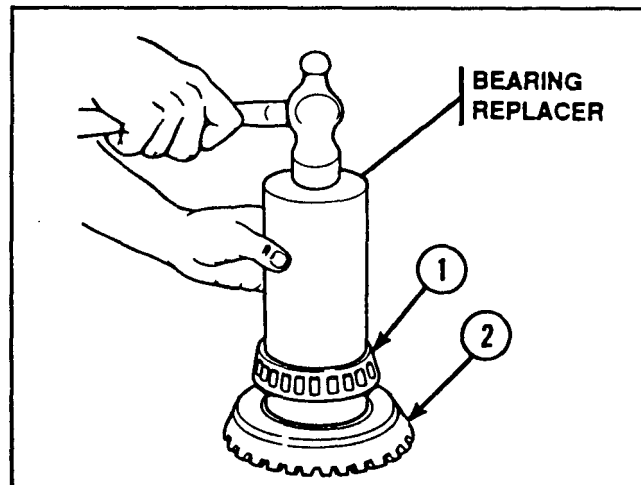

- 2 Using bearing cup replacer, install tapered roller bearing cup (3) in output drive gear mechanical housing (4).

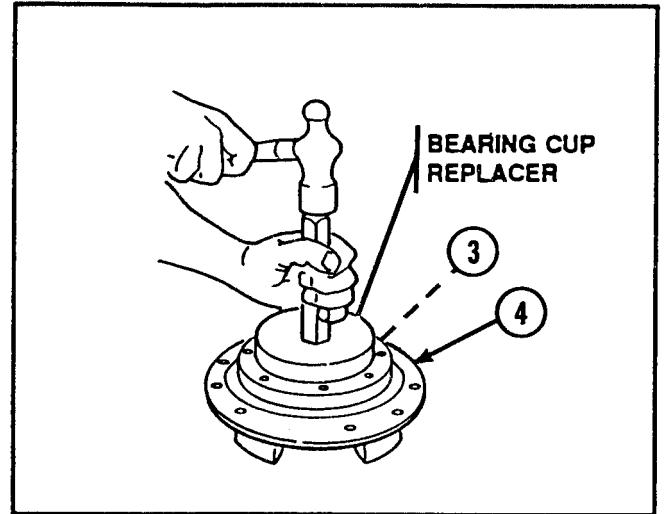

- 3 Using bearing cup replacer, install tapered roller bearing cup (5) in output drive gear mechanical housing (4).

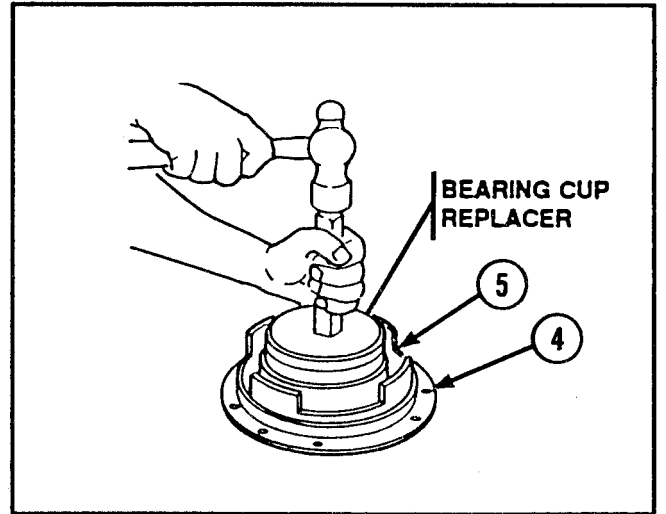

- 4 Install output drive spiral gear (2) in output drive gear mechanical housing (4).

- 5 Place gear end of output drive gear mechanical housing (4) on flat surface and install tapered roller bearing (6), bearing retaining key washer (7), key washer (8), and plain round nut (9) on output drive spiral gear (2).

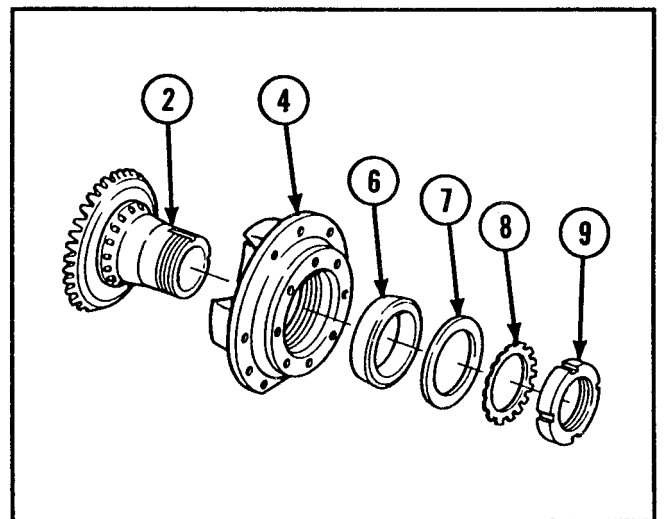

2-41. MAINTENANCE OF AUXILIARY DRIVE ASSEMBLY (CLUTCH DRIVE) (CONT).

REASSEMBLY (CONT)

- 6 Using face wrench socket and torque wrench, tighten plain round nut (9) to preload bearings until 15.0 to 25.0 in.-lb (1.7 to 2.8 N-m) is required to rotate output drive spiral gear (2) in output drive gear mechanical housing (4).
- 7 Bend tangs of key washer (8) into grooves of plain round nut (9).

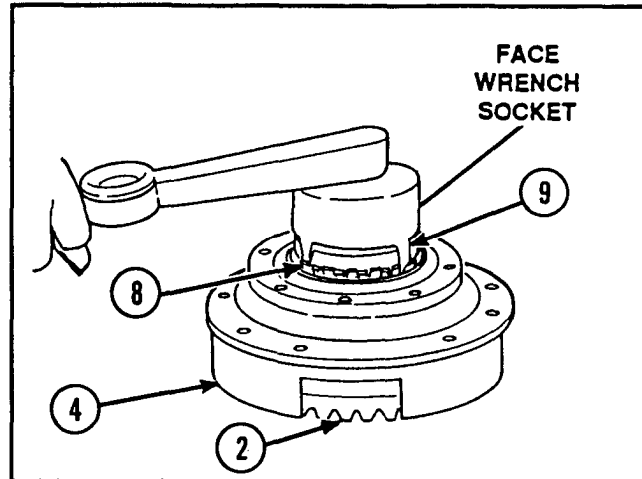

- 8 Lightly lubricate bearing surface with grease. Using gear replacer, install needle roller bearing (10) into drive shaft housing (11).

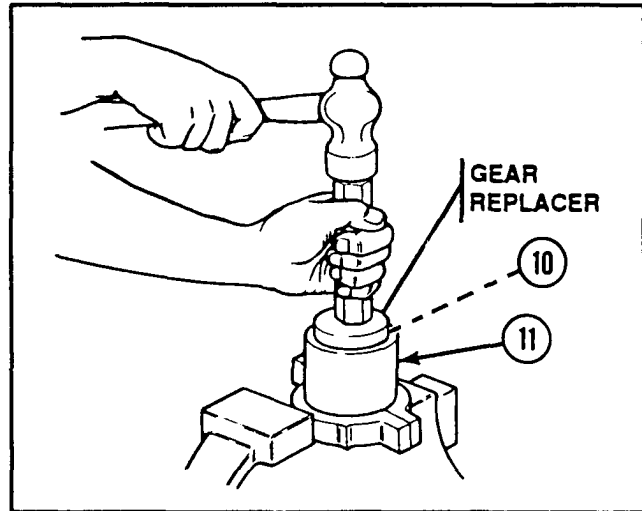

CAUTION

An improperly installed plain encased seal will leak during operation.

- 9 Using wood block, install two new plain encased seals (12) in drive shaft housing (11). Install new inner plain encased seal against needle roller bearing with open face of seal facing bearing. Install new outer plain encased seal with open face of seal facing out.
- 10 Pack seal openings with grease.

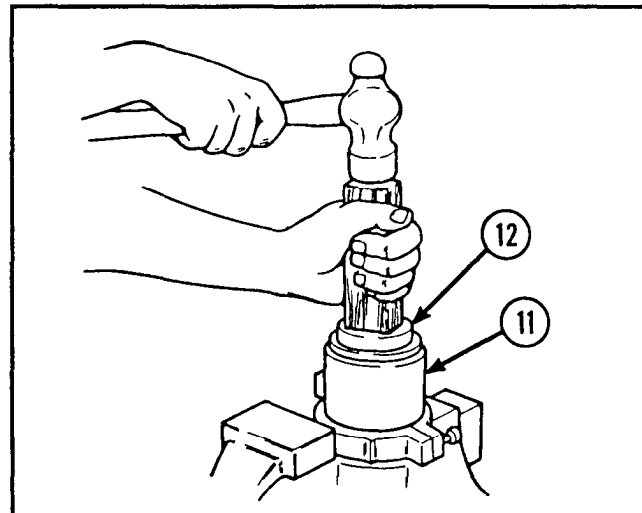

- 11 Using drift, install inner bearing ring (13) on clutch shouldered shaft (14).

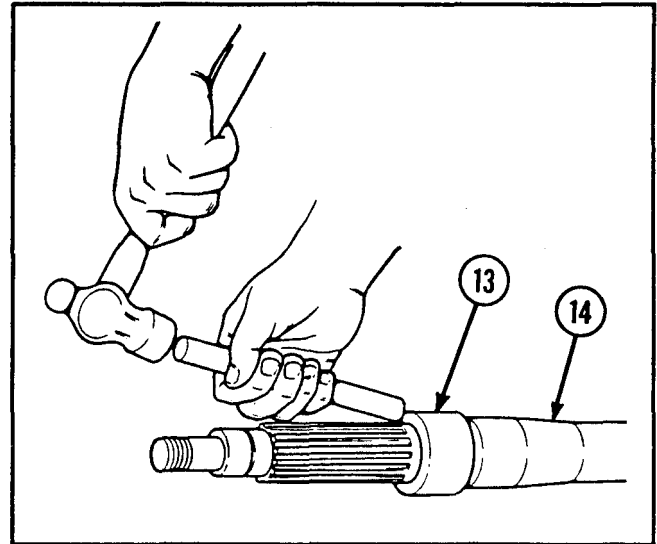

- 12 Install clutch shouldered shaft (14) into drive shaft housing (11). Ensure that splines do not damage needle roller bearing and that lip of inner seal is worked over edge of clutch shouldered shaft and points inward evenly.

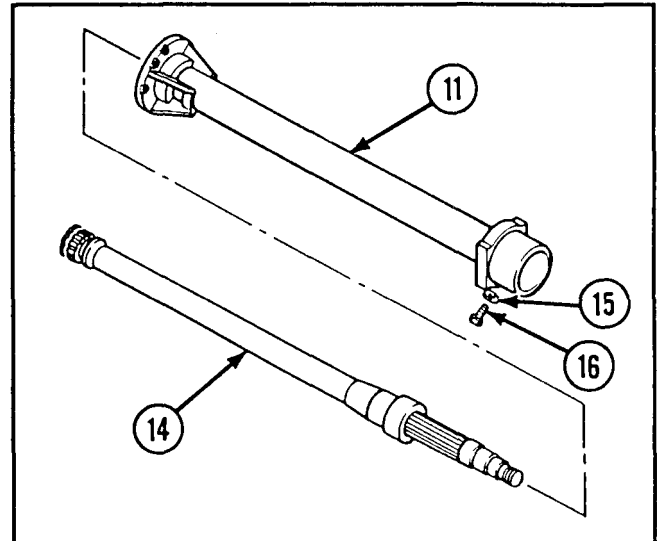

- 13 Install new lockwasher (15) and socket head capscrew (16) in drive shaft housing (11).

- 14 Install new gasket (17) on drive shaft housing (11).

- 15 Mate splines and insert clutch shouldered shaft (14) through output drive gear mechanical housing (4),

- 16 Seat output drive gear mechanical housing (4) on drive shaft housing (11) and gasket (17), and secure with eight hexagon head capscrews (18). Secure hexagon head capscrews with new lockwire (19).

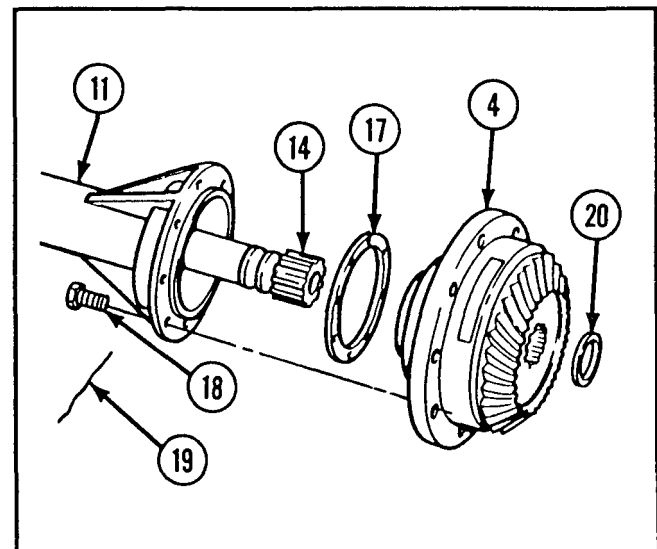

- 17 Install new retaining ring (20) on end of clutch shouldered shaft (14).

2-42. MAINTENANCE OF AUXILIARY DRIVE ASSEMBLY (GENERATOR DRIVE).

This task covers: a. *Disassembly* b. *Inspection/Repair* c. *Reassembly*

INITIAL SETUP

Tools and Special Tools

Automotive maintenance and repair shop equipment: field maintenance, basic, less power (SC 4910-95-A31)

- Arbor press
- Mechanical gear puller kit
- Plier wire twister
- Torque wrench (0 to 300 in.-lb)

- Bearing cone inserter (item 5, appx E)
- Bearing cup remover (item 9, appx E)
- Bearing cup replacer (item 14, appx E)
- Bearing cup replacer (item 16, appx E)
- Bearing replacer (item 12, appx E)
- Face wrench socket (item 24, appx E)
- Jacking screw (3) (item 20, appx E)
- Seal remover and replacer (item 10, appx E)

Materials/Parts

- Bearing gage (item 15, appx B)
- Lockwire (item 34, appx B)
- Lubricating oil (item 20, appx B)
- Plain encased seal
- Preformed packing
- Preformed packing (2)

Preformed packing

- Shim (2)
- Shim (4)
- White enamel (item 14, appx B)

References

- TM 9-214
- TM 9-2350-238-24P-1

Equipment Conditions

2-95 Generator drive removed

DISASSEMBLY

- 1 Remove lockwire (1), eight hexagon head capscrews (2), and gear set inspection access cover (3) from generator drive mechanical housing (4).
- 2 Remove preformed packing (5) from gear set inspection access cover (3).

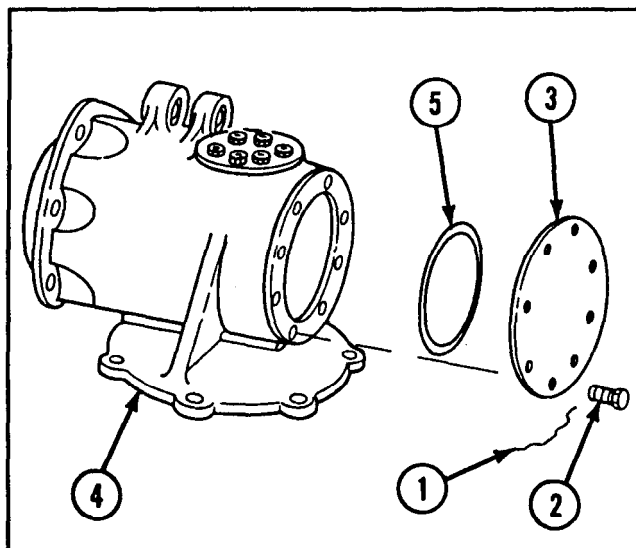

- 3 Remove lockwire (6) and six hexagon head capscrews (7) securing drive gear bearing housing (8) to generator drive mechanical housing (4).

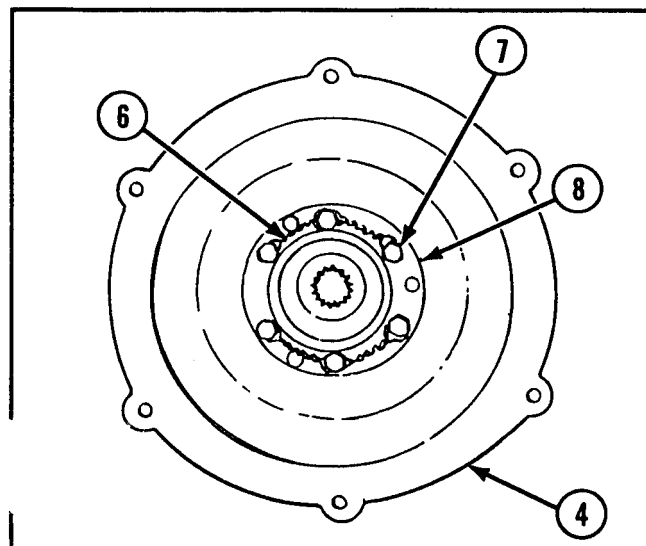

- 4 Using three jacking screws, remove drive gear bearing housing (8) from generator drive mechanical housing (4).

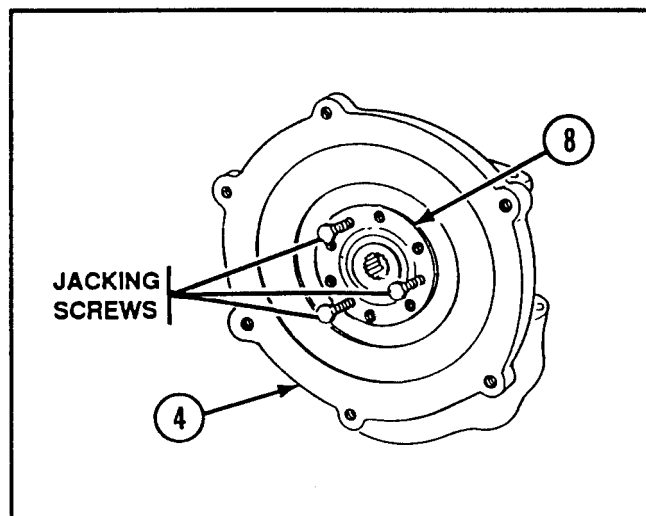

- 5 Remove two bearing carrier shims (9) and preformed packing (10) from drive gear bearing housing (8).

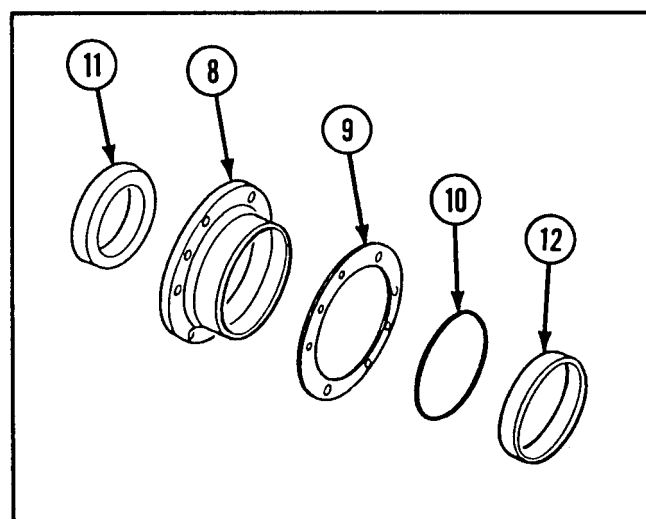

- 6 Using seal remover and replacer, remove plain encased seal (11) and tapered roller bearing cup (12) from drive gear bearing housing (8).

2-42. MAINTENANCE OF AUXILIARY DRIVE ASSEMBLY (GENERATOR DRIVE) (CONT).

DISASSEMBLY (CONT)

- 7 Remove lockwire (13), six hexagon head capscrews (14), and drive gearcase access cover (15) from generator drive mechanical housing (4).
- 8 Using three jacking screws, remove shaft bearing housing (16).
- 9 Remove two bearing carrier shims (17) and two preformed packings (18 and 19) from shaft bearing housing (16).
- 10 Using seal remover and replacer, remove tapered roller bearing cup (20) from shaft bearing housing (16).

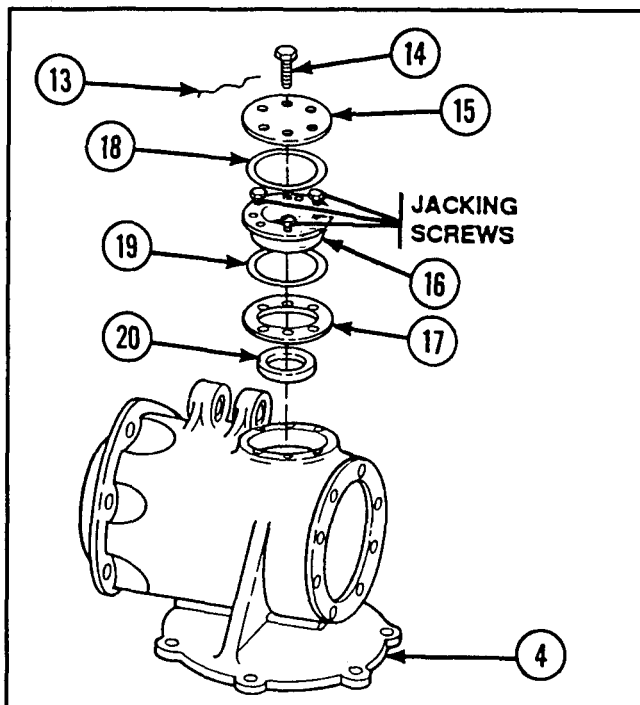

- 11 Remove gear set shouldered shaft (21) with attached tapered roller bearings (22) from generator drive mechanical housing (4).

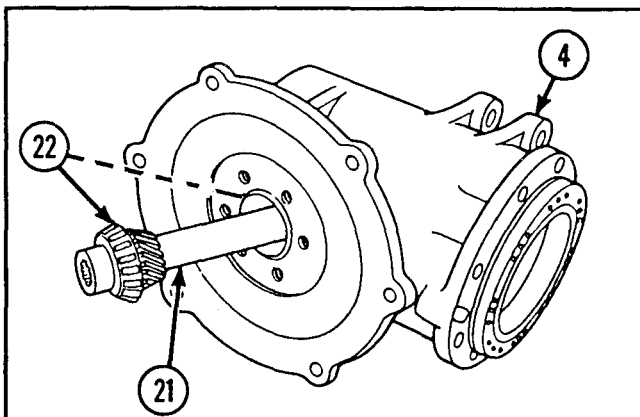

- 12 Using puller, remove two tapered roller bearings (22) from gear set shouldered shaft (21).

CAUTION

Do not remove bevel gear set spiral gear from gear set shouldered shaft unless gear or shaft is replaced. The bevel gear set spiral gear and bevel gear set spiral pinion gear are a matched set.

- 13 If required, remove bevel gear set spiral gear (23) from gear set shouldered shaft (21), using puller.

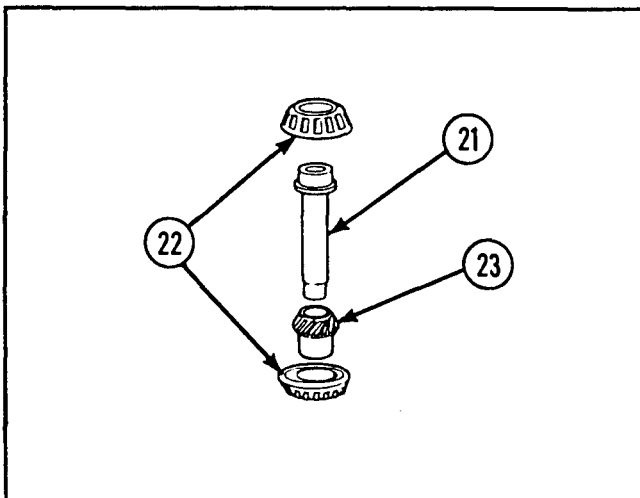

- 14 Remove lockwire (24) and six hexagon head capscrews (25) from bevel gear set spiral pinion gear (26).

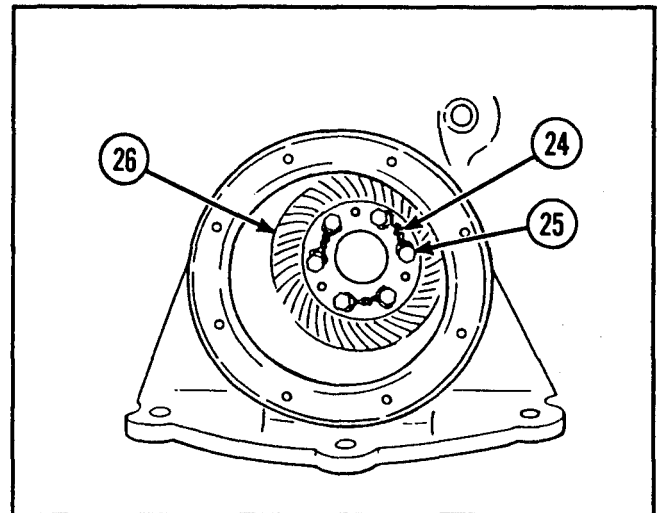

- 15 Using three jacking screws, remove bevel gear set spiral pinion gear (26) from mechanical generator drive housing (4).

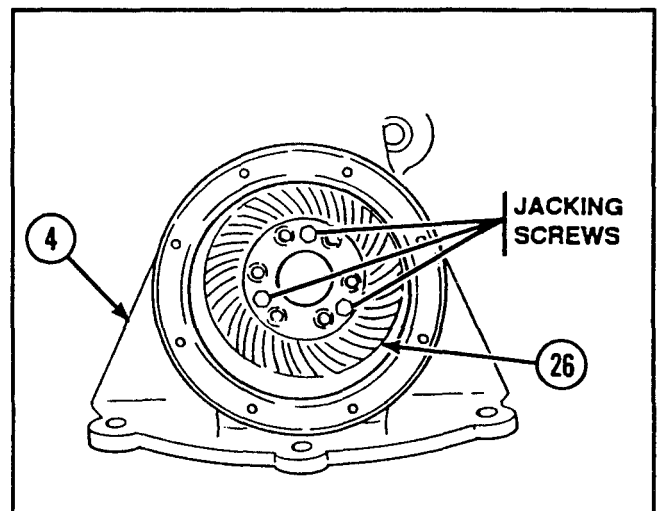

- 16 Remove machine key (27) and two drive gear to shaft shims (28) from bevel gear set spiral pinion gear (26).

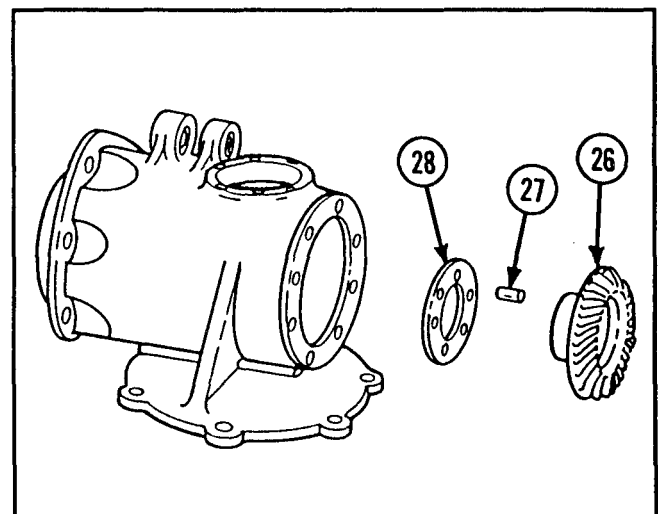

2-42. MAINTENANCE OF AUXILIARY DRIVE ASSEMBLY (GENERATOR DRIVE) (CONT).

DISASSEMBLY (CONT)

17 Straighten tangs on key washer (29).
Using face wrench socket, remove round plain nut (30).

18 Remove key washer (29), flat washer (31), and key washer (32) from output drive spiral pinion gear (33).

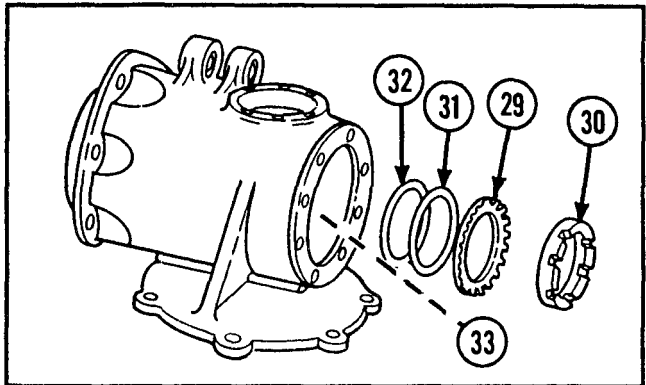

19 Press output drive spiral pinion gear (33) out of generator drive mechanical housing (4).

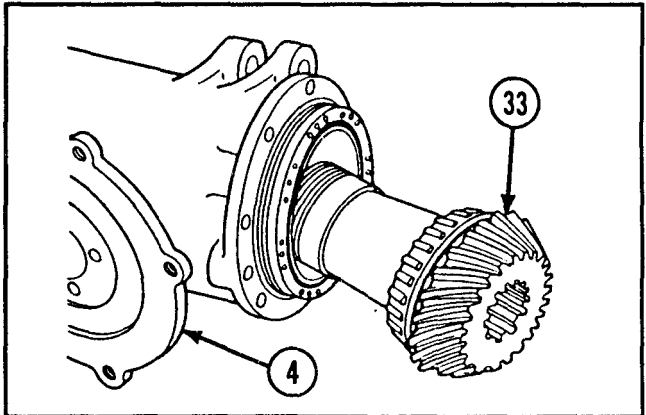

20 Using puller, remove cone and rollers (34) from output drive spiral pinion gear (33).

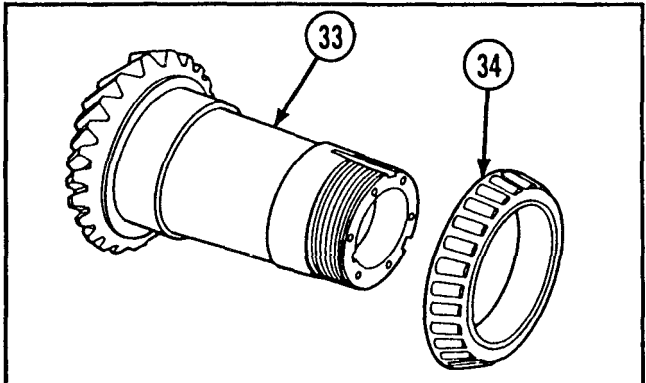

21 Using puller, remove tapered roller bearing (35) from generator drive mechanical housing (4).

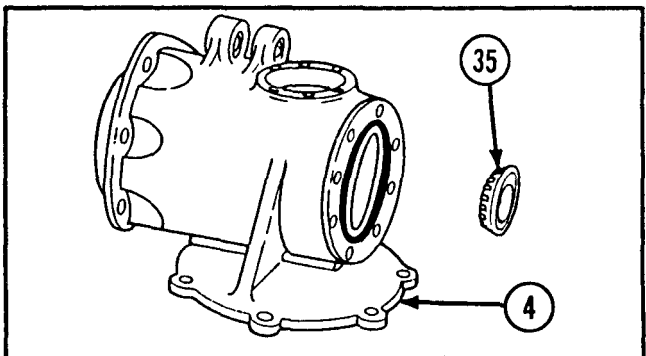

NOTE

Tapered roller bearing cup is supplied with tapered roller bearing. If tapered roller bearing cup is defective, replace tapered roller bearing.

- 22 Remove tapered roller bearing cup (36) and tapered roller cup (37) from generator drive mechanical housing (4).

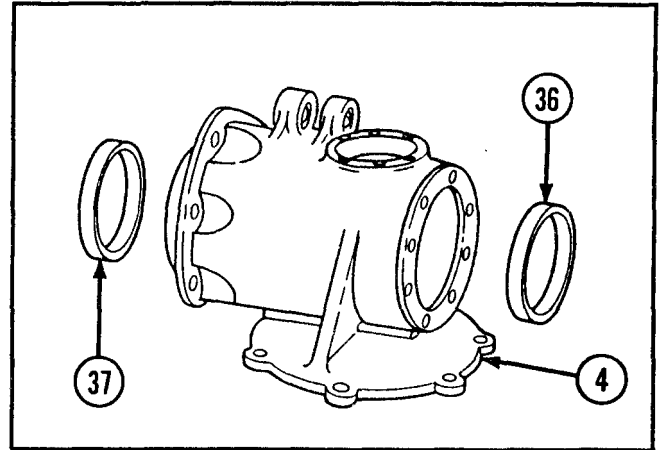

- 23 If damaged, remove two headless straight pins (38) from generator drive mechanical housing (4).

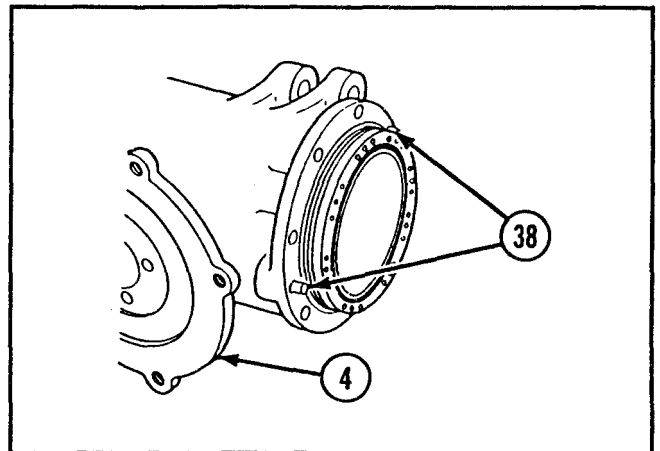

INSPECTION/REPAIR

- 1 Inspect for broken, damaged, or missing parts.
- 2 Inspect bearings. Refer to TM 9-214.
- 3 If required, replace gears as matched sets.

- 4 Repair is by replacement of authorized parts (TM 9-2350-238-24P-1) which do not meet inspection criteria.

REASSEMBLY

- 1 If removed, install two headless straight pins (1) to generator drive mechanical housing (2).

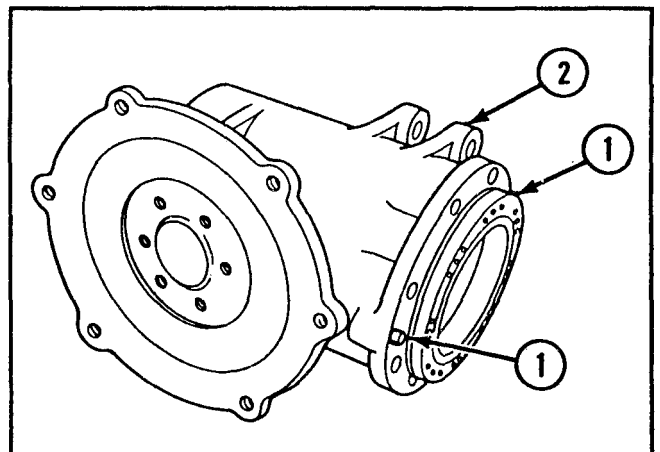

2-42. MAINTENANCE OF AUXILIARY DRIVE ASSEMBLY (GENERATOR DRIVE) (CONT).

REASSEMBLY (CONT)

- 2 Using bearing cup replacer (item 16, appx E), install tapered roller bearing cup (3) into generator drive mechanical housing (2).

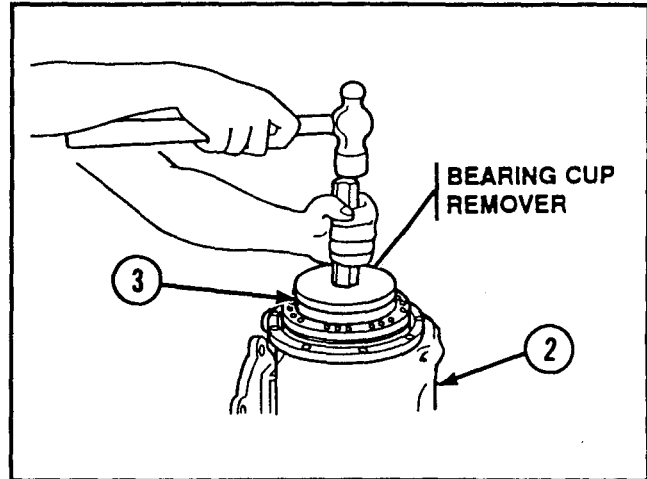

- 3 Using bearing cup remover, install tapered roller cup (4) into generator drive mechanical housing (2).

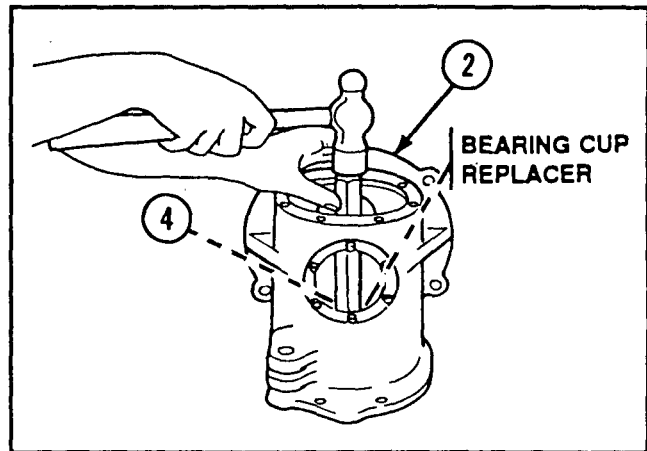

CAUTION

Output drive spiral pinion gear is one of a matched set. If replaced, refer to page 2-110 for replacement of matching parts.

- 4 Coat cone and rollers (5) with lubricating oil. Using bearing replacer, install cone and rollers onto output drive spiral pinion gear (6).

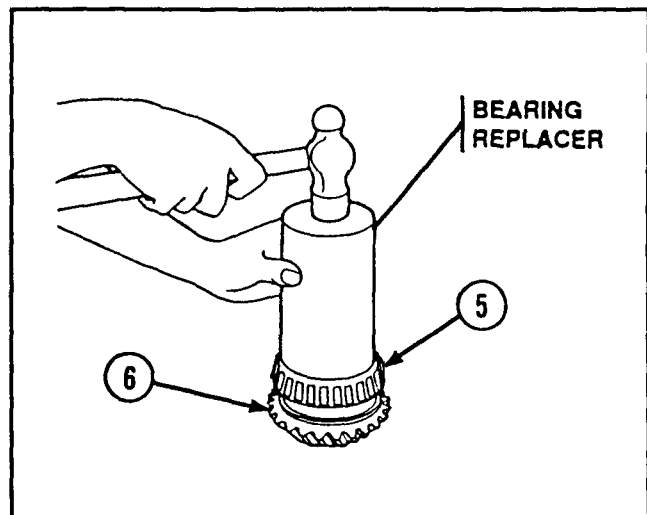

- 5 Install output drive spiral pinion gear (6) and attached cone and rollers (5) into generator drive mechanical housing (2). Ensure gear seats properly.

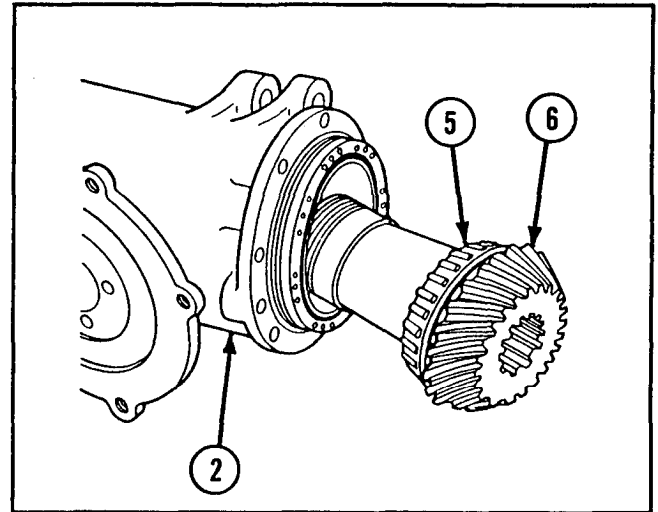

- 6 Coat tapered roller bearing (7) with lubricating oil and install bearing cone over end of output drive spiral pinion gear (6) in generator drive mechanical housing (2). Ensure bearing is completely seated in housing.

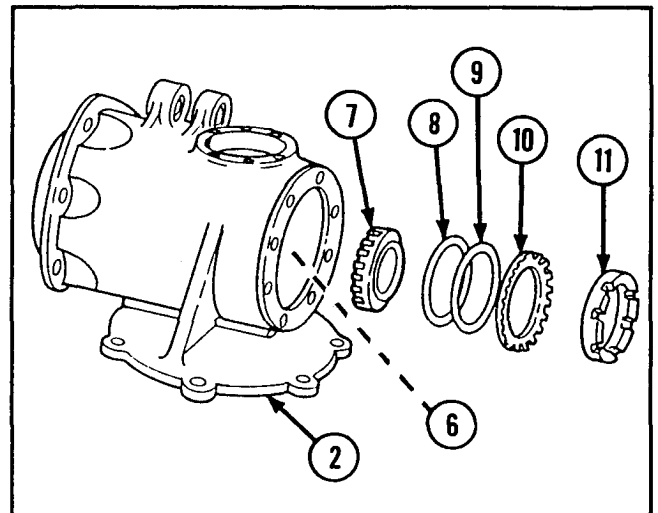

- 7 Hold output drive spiral pinion gear (6) in generator drive mechanical housing (2) and install key washer (8), flat washer (9), key washer (10), and round plain nut (11) on end of output drive spiral pinion gear.

- 8 Using face wrench socket, tighten round plain nut (11) until 15.0 to 25.0 in.-lb (1.7 to 2.8 N-m) is required to turn output drive spiral pinion gear within its bearings. After adjustment, bend tangs of key washer (10) into groove of round plain nut.

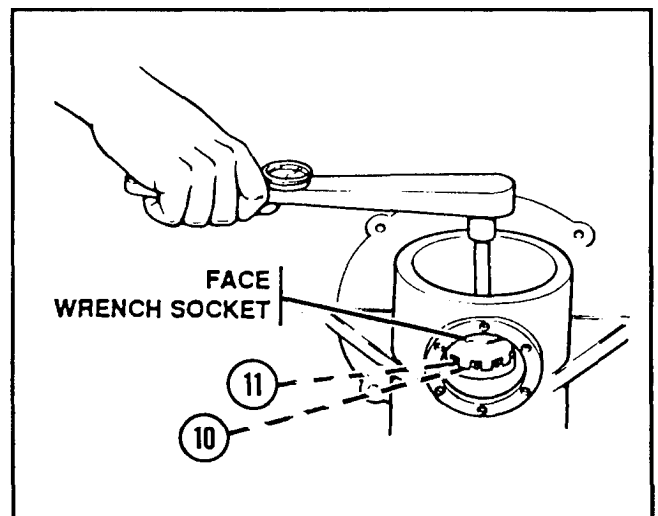

2-42. MAINTENANCE OF AUXILIARY DRIVE ASSEMBLY (GENERATOR DRIVE) (CONT).

REASSEMBLY (CONT)

CAUTION

If either bevel gear set spiral pinion gear or bevel gear set spiral gear is replaced, replace both gears as a matched set.

9 If removed, press bevel gear set spiral gear (12) onto gear set shouldered shaft (13) until seated. Do not disassemble after initial reassembly.

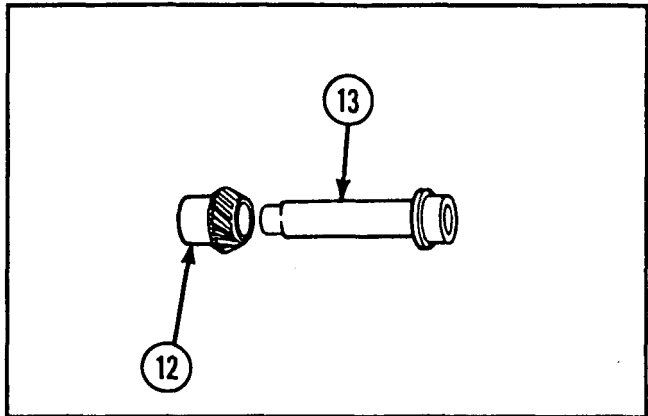

10 Using bearing cone inserter, install two tapered roller bearings (14) on gear set shouldered shaft (13).

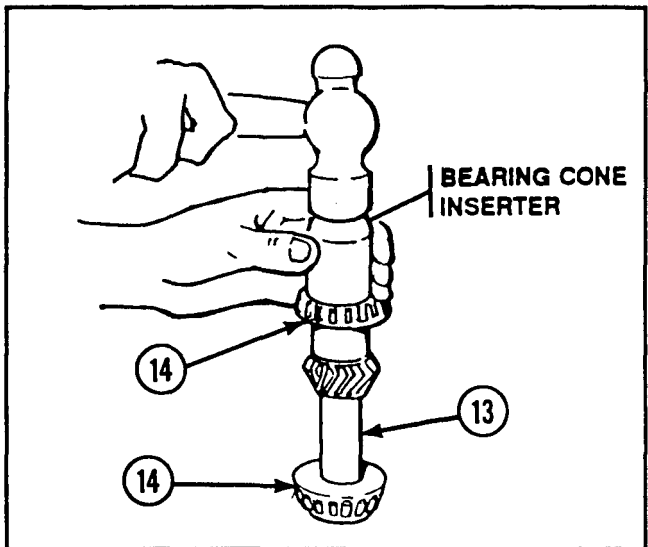

11 Using bearing cup replacer (item 14, appx E), install two tapered roller bearing cups (15) into shaft bearing housing (16) and drive gear bearing housing (17).

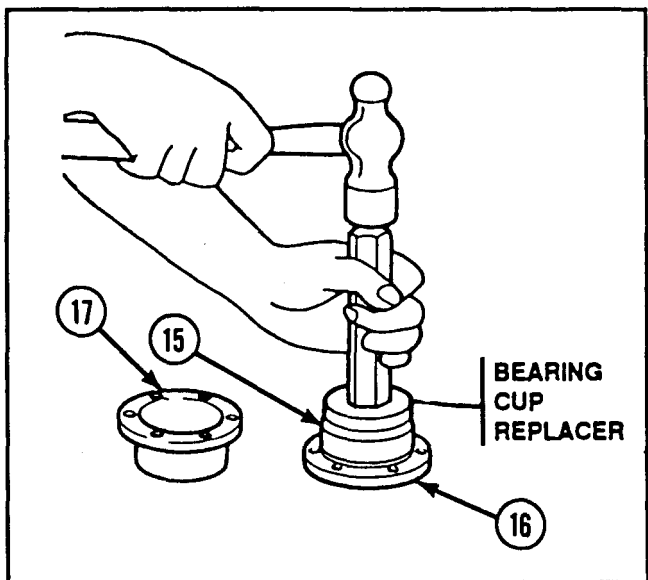

- 12 Install gear set shouldered shaft (13) with attached bearings into generator drive mechanical housing (2).

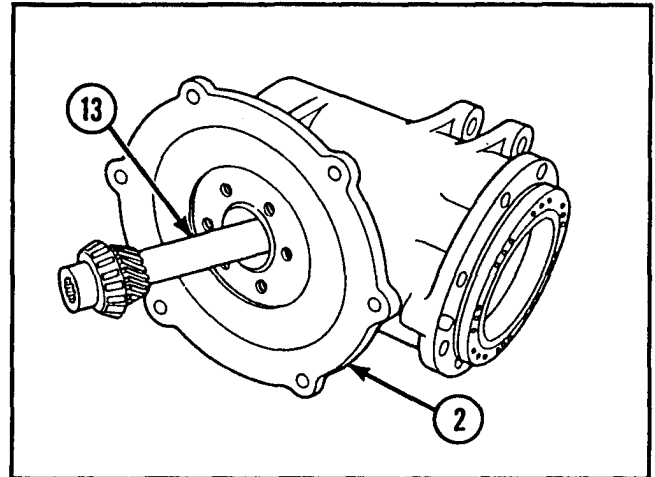

- 13 Install two new bearing carrier shims (18) on generator drive mechanical housing (2). Install shaft bearing housing (16) on generator drive mechanical housing. Ensure that bearing cup seats properly over tapered roller bearing.

- 14 Secure shaft bearing housing with three evenly-spaced hexagon head capscrews (19) tightened to ensure shaft bearing housing seats completely.

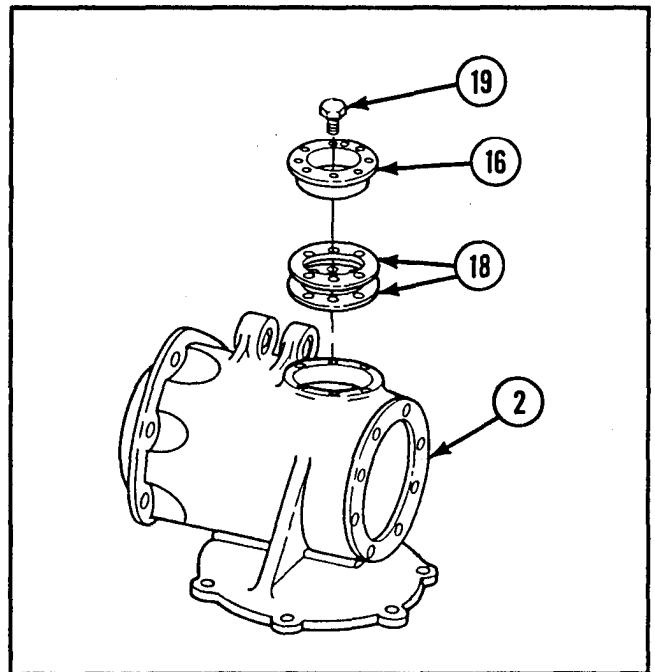

2-42. MAINTENANCE OF AUXILIARY DRIVE ASSEMBLY (GENERATOR DRIVE) (CONT).

REASSEMBLY (CONT)

- 15 Install two new bearing carrier shims (20) to generator drive mechanical housing (2). Install drive gear bearing housing (17) to generator drive mechanical housing. Ensure bearing cup seats properly over tapered roller bearing.

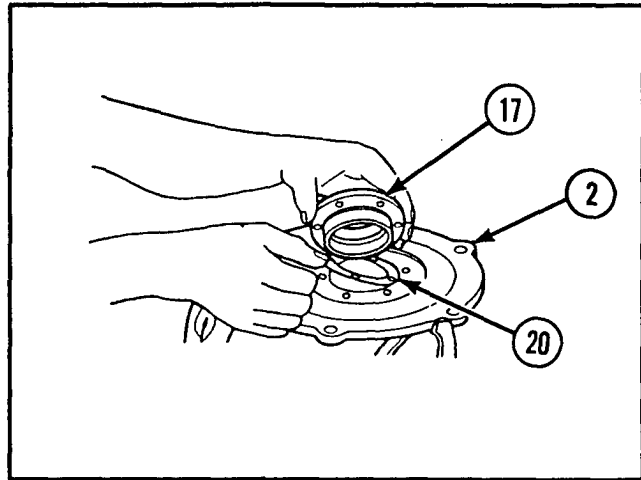

- 16 Secure drive gear bearing housing (17) with three evenly-spaced hexagon head capscrews (21) tightened to ensure drive gear bearing housing seats completely in generator drive mechanical housing (2).
- 17 Ensure that torque required to rotate gear set shouldered shaft (13) is 5.0 to 15.0 in.-lb (0.6 to 1.7 N-m). Remove shims from either bearing housing to reach required torque.
- 18 When torque is reached, remove one bearing housing, add 0.002 in. (0.005 cm) shim, and reinstall bearing housing.

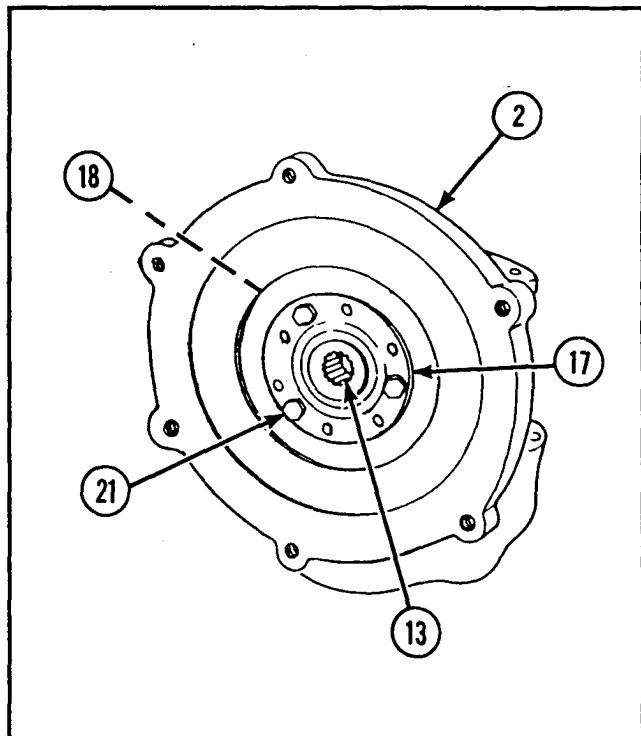

NOTE

Jacking screws may be required to remove drive gear bearing housing.

- 19 Remove three hexagon head capscrews (21), drive gear bearing housing (17), and bearing carrier shims (18). Mark bearing carrier shims for reinstallation.

- 20 Remove gear set shouldered shaft (13) from generator drive mechanical housing (2).

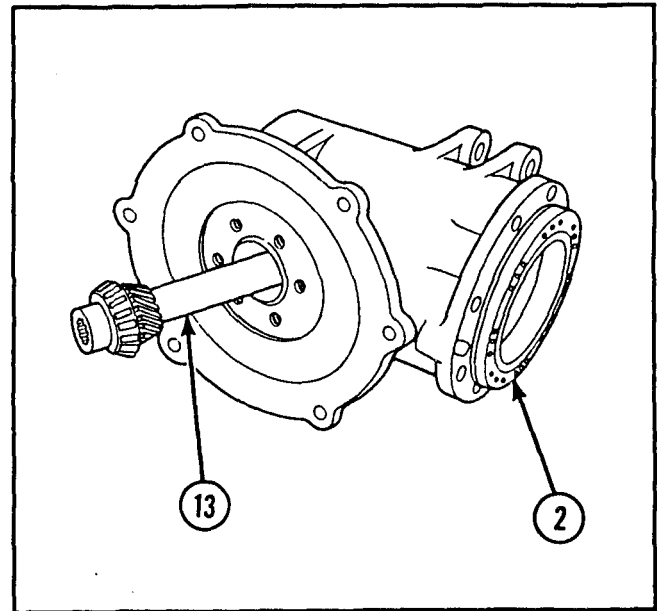

- 21 Install machine key (22) into output drive spiral pinion gear (6).
- 22 Install two new drive gear to shaft shims (23) on end of output drive spiral pinion gear (6).
- 23 Install bevel gear set spiral pinion gear (24) over shim and into end of output drive spiral pinion gear (6). Secure with six hexagon head capscrews (25). Secure capscrews with lockwire (26).

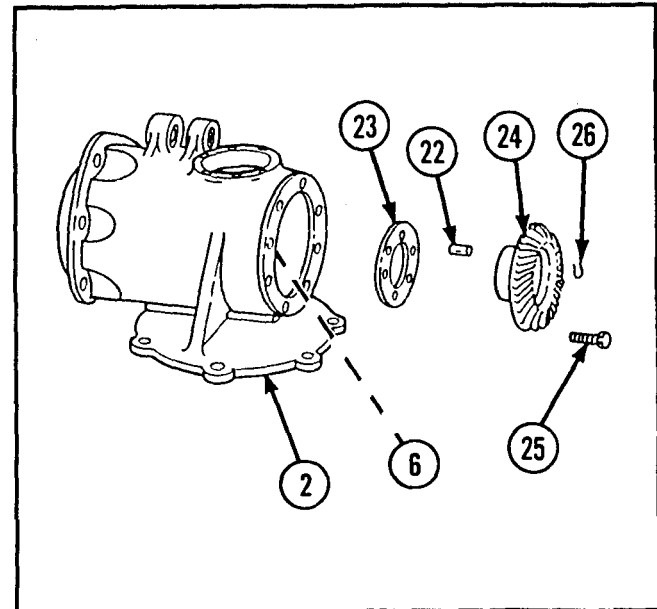

2-42. MAINTENANCE OF AUXILIARY DRIVE ASSEMBLY (GENERATOR DRIVE) (CONT).

REASSEMBLY (CONT)

24 Reinstall gear set shouldered shaft (13), bearing carrier shim (18), and drive gear bearing housing (17). Secure drive gear bearing housing with three hexagon head capscrews (21) tightened to ensure bearing housing seats completely in generator drive mechanical housing (2).

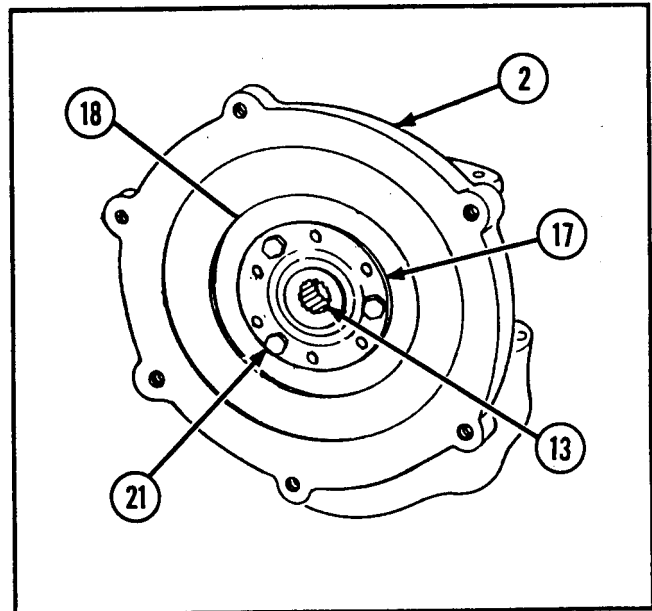

25 Insert bearing gage between bevel gear set spiral gear (12) and bevel gear set spiral pinion gear (23) teeth at large end of teeth to check gear backlash. Rotate gear set shouldered shaft (13) through one gear tooth and bearing gage. Reverse rotation and remove bearing gage.

26 Measure thickness of flattened portion of bearing gage to determine backlash. Backlash must be 0.002 to 0.003 in. (0.005 to 0.008 cm).

27 If backlash is not correct, transfer shims from one bearing housing to the other.

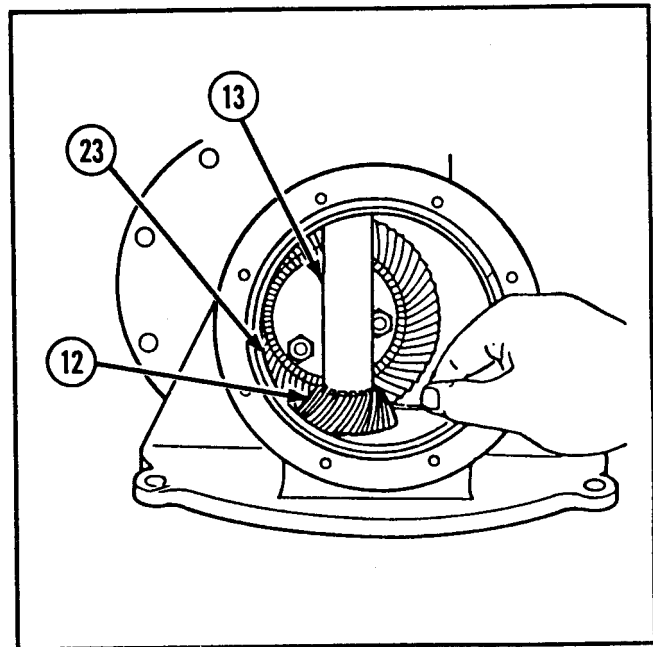

NOTE

To increase backlash, transfer shims from shaft bearing housing to drive gear bearing housing. To decrease backlash, transfer shims from drive gear bearing housing to shaft bearing housing. Each lamination of shim is 0.002 in. (0.005 cm) thick. About 0.001 in. (0.003 cm) change in backlash requires transfer of two shim laminations.

- 28 Apply white enamel to four or five teeth of bevel gear set spiral gear (12) and bevel gear set spiral pinion gear (23). Rotate gear set shouldered shaft (13). Examine wear pattern on gear teeth. Wear pattern should be about one half length and depth of tooth and centered on tooth face (p 2-97). Correct backlash (step 27) if wear pattern is not correct.

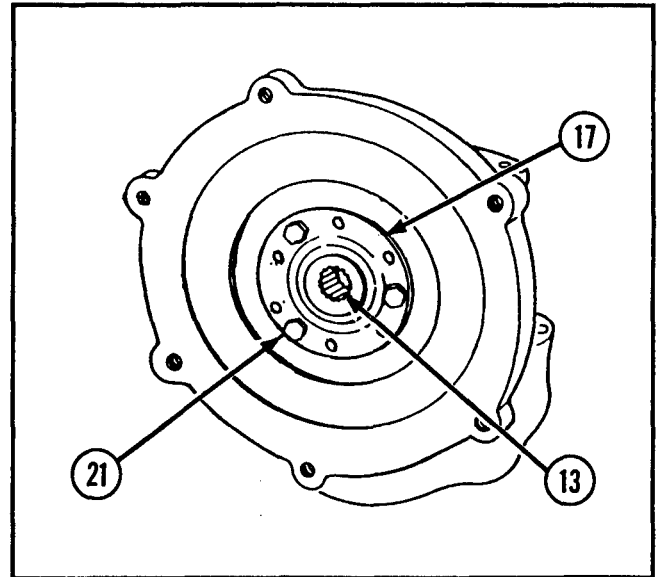

- 29 Remove three capscrews (21) and drive gear bearing housing (17). Using bearing cup replacer (item 14, appx E), install new plain encased seal (27) with open lip facing into drive gear bearing housing.

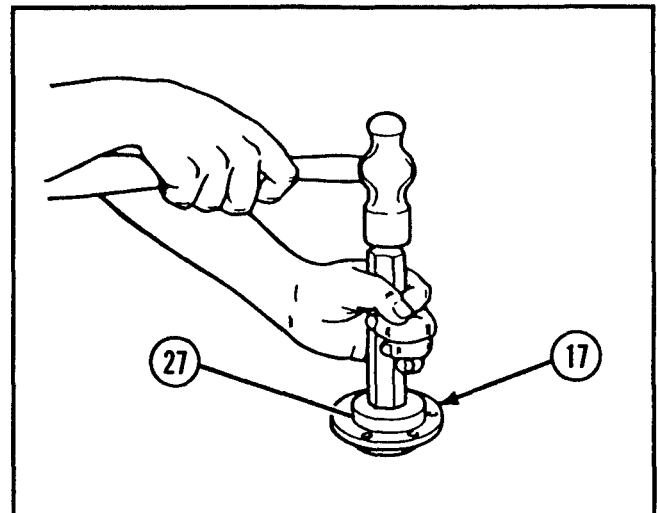

2-42. MAINTENANCE OF AUXILIARY DRIVE ASSEMBLY (GENERATOR DRIVE) (CONT).

REASSEMBLY (CONT)

30 Install new preformed packing (28) on drive gear bearing housing (17).

31 Ensure bearing carrier shim (18) is properly in place and install drive gear bearing housing (17) to generator drive mechanical housing (2). Secure drive gear bearing housing with six hexagon head capscrews (21). Secure capscrews with new lockwire (30).

32 Remove three hexagon head capscrews (19) and shaft bearing housing (16).

33 Install new preformed packing (31) onto shaft bearing housing (16).

34 Ensure bearing carrier shim (18) is properly in place and install shaft bearing housing (16) in generator drive mechanical housing (2). Install new preformed packing (32) in outer face of shaft bearing housing (16).

35 Install drive gearcase access cover (33). Secure drive gearcase access cover and shaft bearing housing (16) with six hexagon head capscrews (19). Secure six hexagon head capscrews with new lockwire (34).

36 Install new preformed packing (35) and gear set inspection access cover (36). Secure access cover with eight hexagon head capscrews (37). Secure hexagon head capscrews with new lockwire (38).

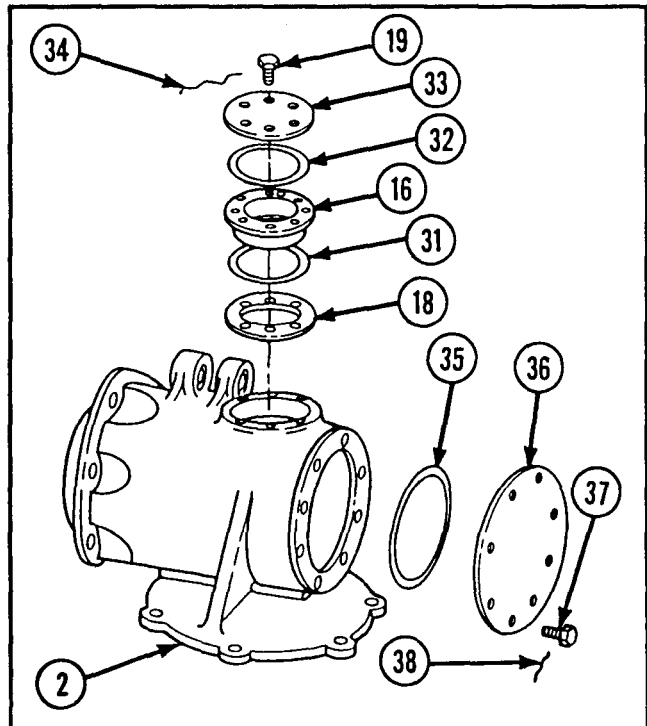
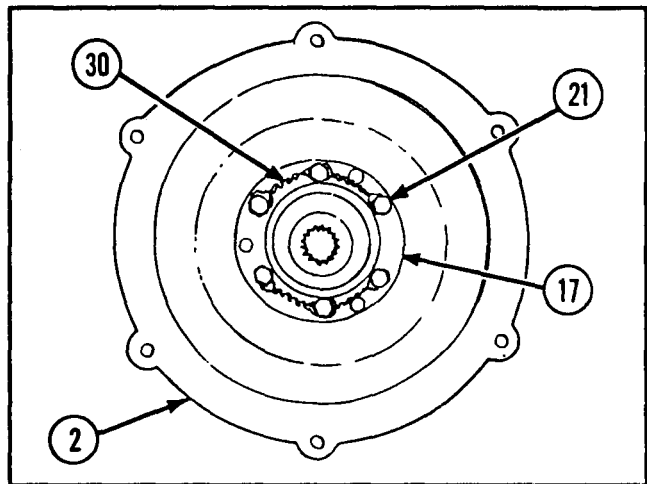
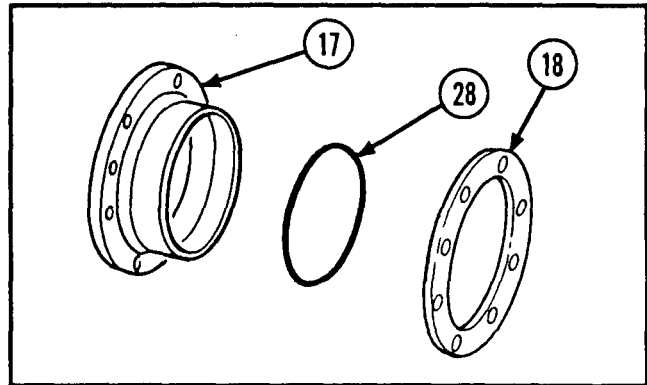

2-43. MAINTENANCE OF AUXILIARY DRIVE ASSEMBLY (INPUT DRIVE).

This task covers:		
a. <i>Disassembly</i>	b. <i>Inspection/Repair</i>	c. <i>Reassembly</i>
INITIAL SETUP		
<p><i>Tools and Special Tools</i></p> <p>Automotive maintenance and repair shop equipment: field maintenance, basic, less power (SC 4910-95-A31)</p> <ul style="list-style-type: none"> ● Mechanical gear puller kit ● Plier wire twister ● Press ● Retaining ring pliers <p>Bearing cup replacer (item 13, appx E) Bearing cup replacer (item 14, appx E)</p>		<p><i>References</i></p> <p>TM 9-214 TM 9-2350-238-24P-1</p> <p><i>Equipment Conditions</i></p> <p>2-95 Input drive removed</p>
<p><i>Materials/Parts</i></p> <p>Lockwire (item 34, appx B) Lubricating oil (item 20, appx B) Plain encased seal (2) Preformed packing Preformed packing</p>		

DISASSEMBLY

1 Remove lockwire (1) and six hexagon head capscrews (2) securing input shaft mechanical housing (3) to input drive mechanical housing (4).

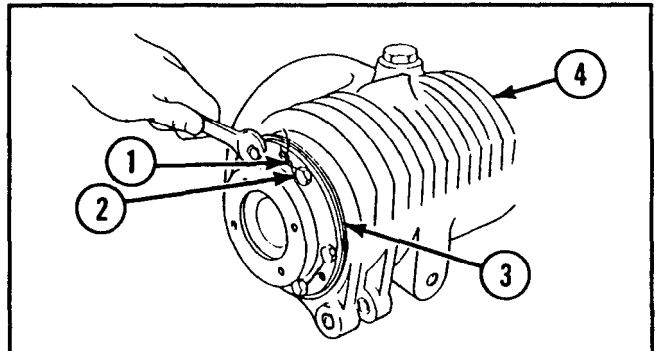

2 Using three of the six removed hexagon head capscrews (2) as jacking screws, loosen input shaft mechanical housing (3).

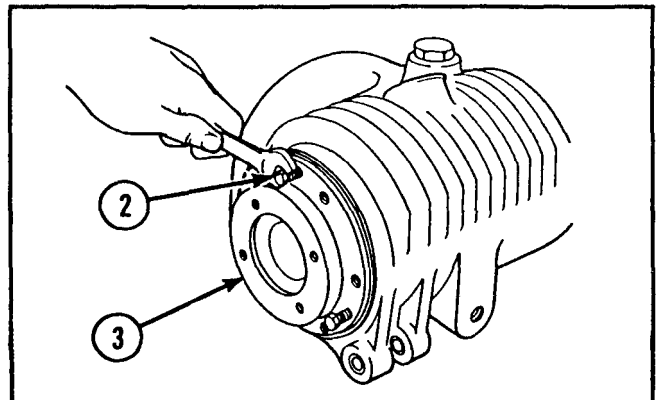

2-43. MAINTENANCE OF AUXILIARY DRIVE ASSEMBLY (INPUT DRIVE) (CONT).

DISASSEMBLY (CONT)

3 Pull input shaft mechanical housing (3) and input shouldered shaft (5) from input drive mechanical housing (4).

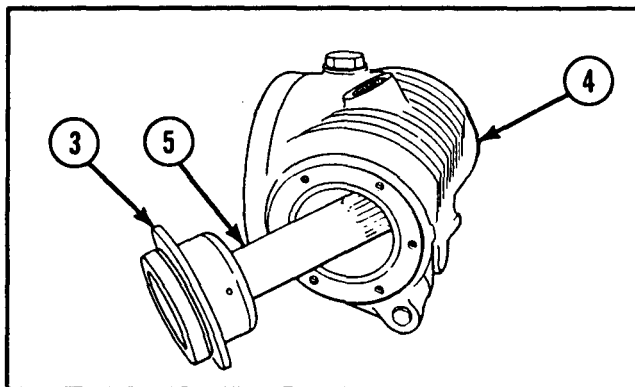

4 Remove machine plug (6) and preformed packing (7). Remove preformed packing from input drive mechanical housing (4).

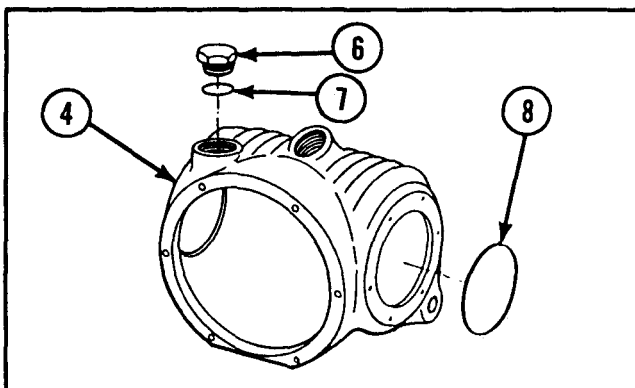

5 Using retaining ring pliers, remove retaining ring (9) from input shouldered shaft (5).

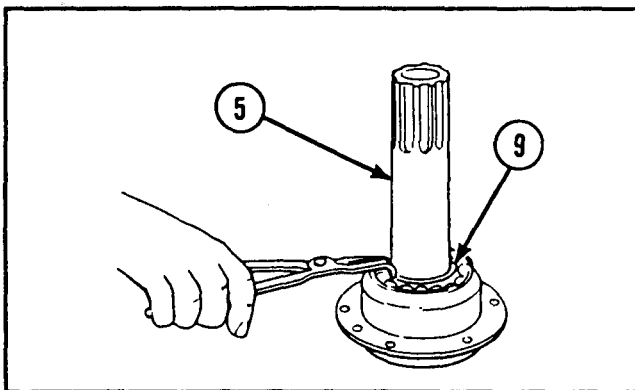

6 Using press, remove input shouldered shaft (5) from input shaft mechanical housing (3).

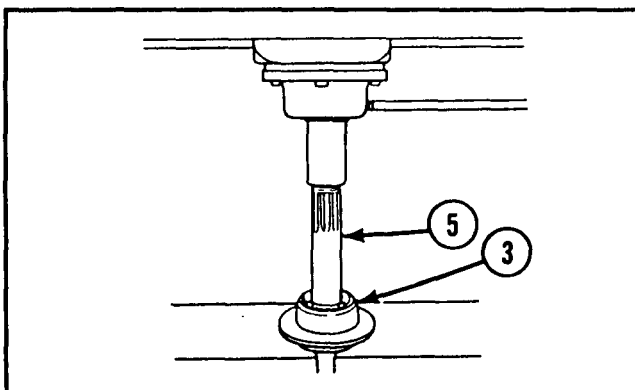

- 7 Using retaining ring pliers, remove retaining ring (10) from input shaft mechanical housing (3).

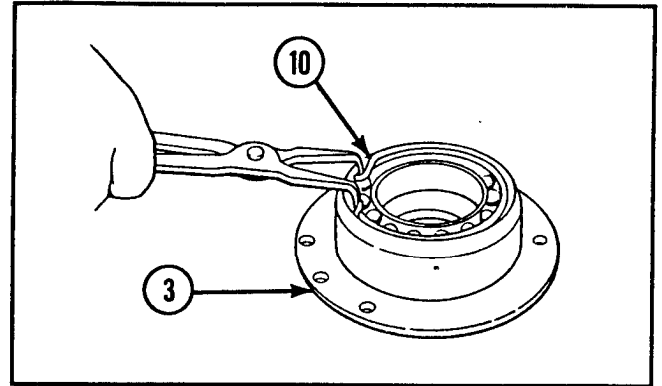

- 8 Pry two plain encased seals (11) from input shaft mechanical housing (3).
- 9 Using bearing puller, remove annular ball bearing (12) from input shaft bearing housing (3).

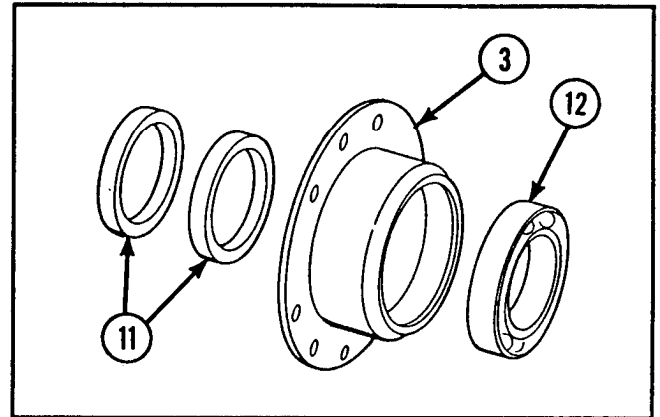

INSPECTION/REPAIR

- 1 inspect for broken, damaged, or missing parts.
- 2 inspect annular ball bearing per TM 9-214.
- 3 Repair is by replacement of authorized parts (TM 9-2350-238-24P-1) which do not meet inspection criteria.

REASSEMBLY

- 1 Lightly lubricate outer surface of annular ball bearing (1) with lubricating oil. Using bearing cup replacer (item 13, appx E), install annular ball bearing into input shaft mechanical housing (2).

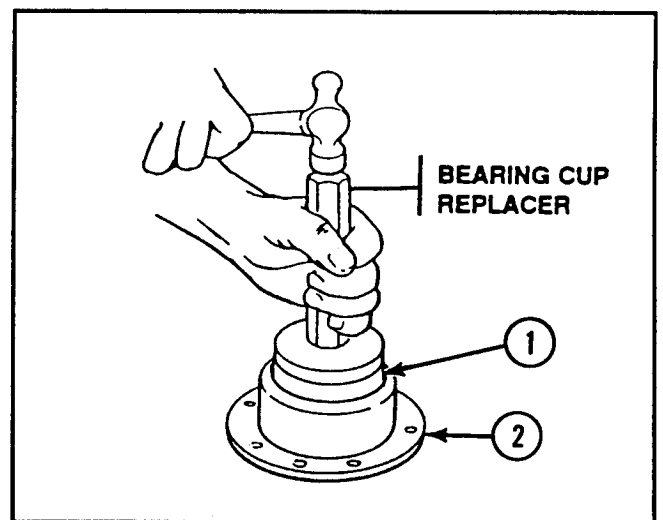

2-43. MAINTENANCE OF AUXILIARY DRIVE ASSEMBLY (INPUT DRIVE) (CONT).

REASSEMBLY (CONT)

- 2 Using retaining ring pliers, install retaining ring (3) in input shaft mechanical housing (2).

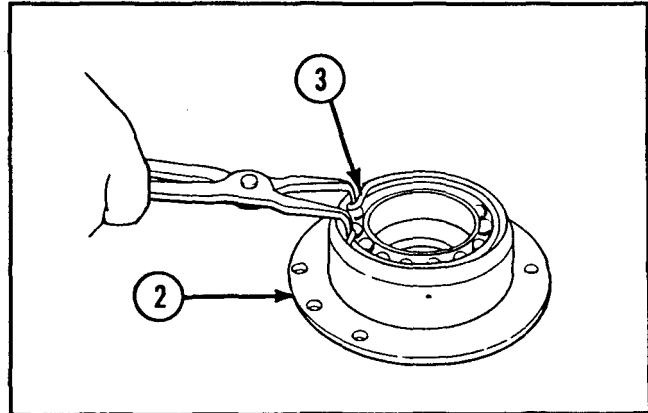

CAUTION

An improperly installed seal will leak during operation.

- 3 Using bearing cup replacer (item 14, appx E), install two new plain encased seals (4) to input shaft mechanical housing (2). Ensure lip of inner plain encased seal is toward annular ball bearing and lip of outer plain encased seal is toward outside of input shaft mechanical housing.

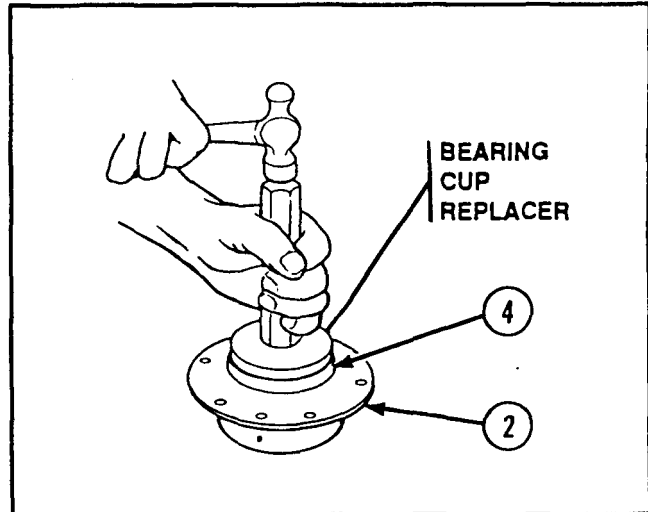

CAUTION

A nicked, scratched, or cut seal lip will leak during operation.

- 4 Install input shouldered shaft (5) through input shaft mechanical housing (2). Ensure lip of outer seal is over edge of input shouldered shaft and points outward. Using press, install input shouldered shaft into annular ball bearing (1) in input shaft mechanical housing.

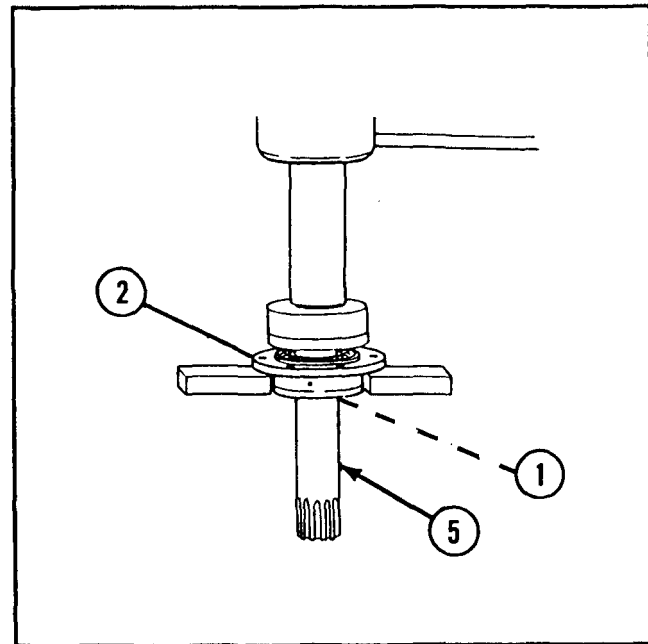

- 5 Using retaining ring pliers, install retaining ring (6) in input shouldered shaft (5) groove.

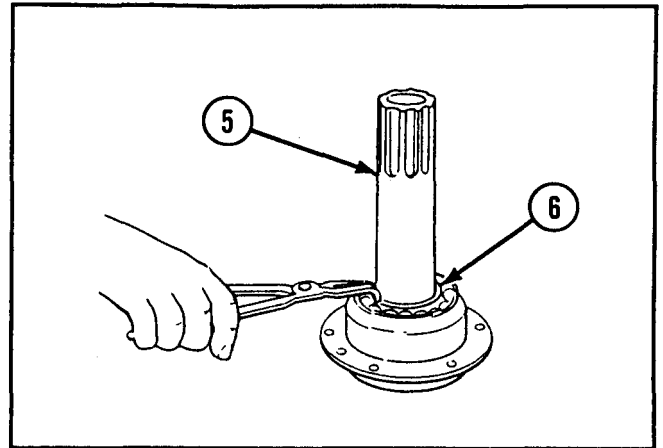

- 6 Install new preformed packing (7) and machine plug (8) in input drive mechanical housing (9).

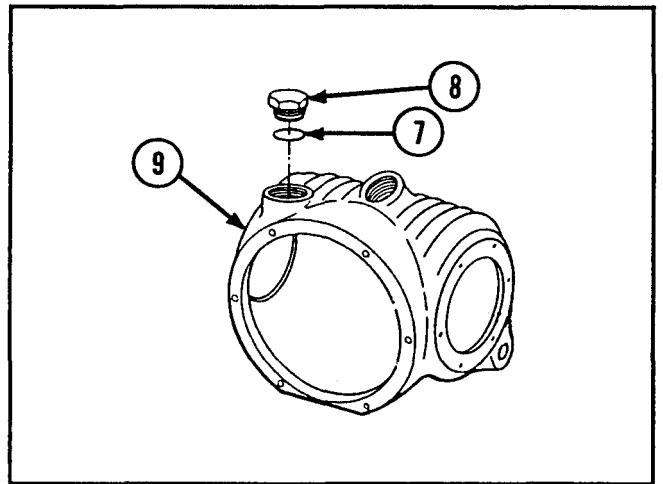

- 7 Install input shaft mechanical housing (2) with attached parts, new preformed packing (10), and six hexagon head capscrews (11) in input drive mechanical housing (9). Secure hexagon head capscrews with new lockwire (12).

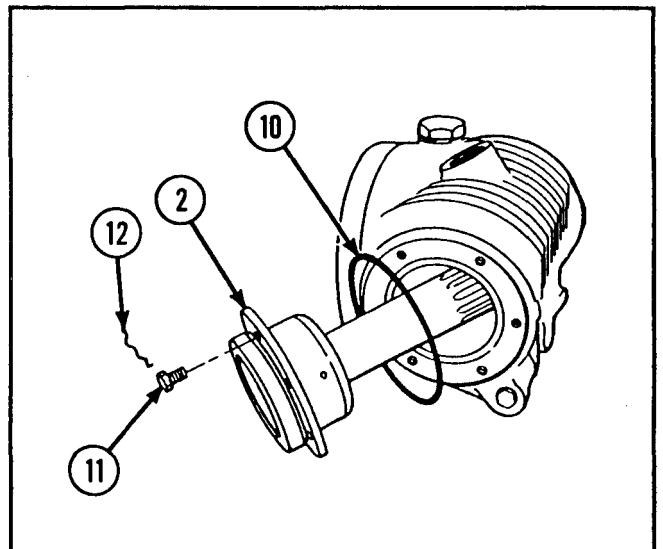

2-44. MAINTENANCE OF OIL FILLER NECK.

This task covers:	a. Disassembly	b. Inspection/Repair	c. Reassembly
-------------------	----------------	----------------------	---------------

INITIAL SETUP

Materials/Parts

- Lockwasher (6)
- Preformed packing
- Primer coating (item 22, appx B)
- White enamel (item 14, appx B)

References

- TM 9-2350-238-20-1
- TM 9-2350-238-24P-1

Equipment Conditions

- Oil filler neck removed (TM 9-2350-238-20-1)

DISASSEMBLY

- 1 Remove tube nipple (1), tube clinch sleeve (2), and tube coupling nut (3) from filler neck (4).
- 2 Remove six machine screws (5), six lockwashers (6), and gage rod cap assembly (7) with strainer element (8) from filler neck (4).
- 3 Remove preformed packing (9) and strainer element (8) from gage rod cap assembly (7).

INSPECTION/REPAIR

- 1 Inspect for broken, damaged, or missing parts.
- 2 If gage rod cap assembly is broken, damaged, or missing, repair is by replacement of next higher assembly.
- 3 Repair is by replacement of authorized parts (TM 9-2350-238-24P-1) which do not meet inspection criteria.

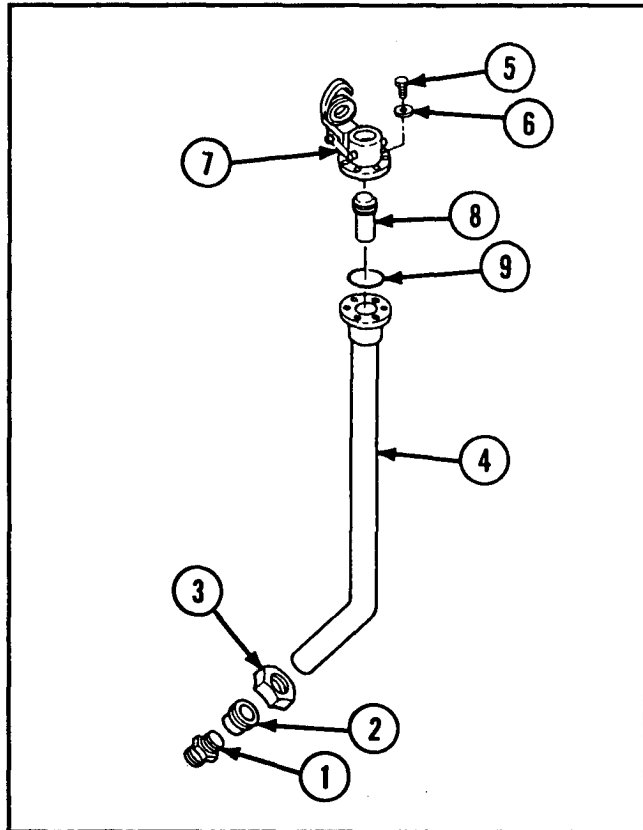

REASSEMBLY

- 1 Install strainer element (1) and new pre-formed packing (2) on gage rod cap assembly (3).
- 2 Install gage rod cap assembly (3), and secure with six new lockwashers (4) and six machine screws (5) on filler neck (6).
- 3 Install tube coupling nut (7), tube clinch sleeve (8), and tube nipple (9) on filler neck (6).
- 4 If necessary, touch up exterior surfaces with primer coating and white enamel.

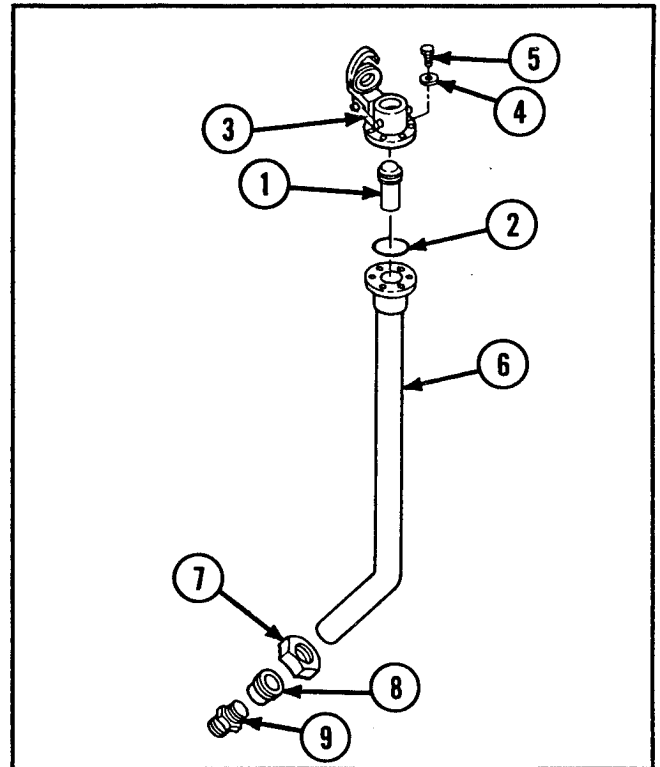

2-45. MAINTENANCE OF OIL DRAIN TUBE ASSEMBLY.

This task covers:	<i>a. Disassembly</i>	<i>b. Inspection/Repair</i>	<i>c. Reassembly</i>
INITIAL SETUP			
<i>Material/Parts</i>			
Locknut			
<i>References</i>			
TM 9-2350-238-20-1			
TM 9-2350-238-24P-1			
<i>Equipment Conditions</i>			
Oil drain tube assembly removed (TM 9-2350-238-20-1)			

2-45. MAINTENANCE OF OIL DRAIN TUBE ASSEMBLY (CONT).

DISASSEMBLY

- 1 Remove tube fitting locknut (1), tube elbow (2), tube clinch sleeve (3), and tube coupling nut (4) from metallic bent tube (5).
- 2 Remove tube cap (6), tube elbow (7), tube clinch sleeve (8), and tube coupling nut (9) from metallic bent tube (5).

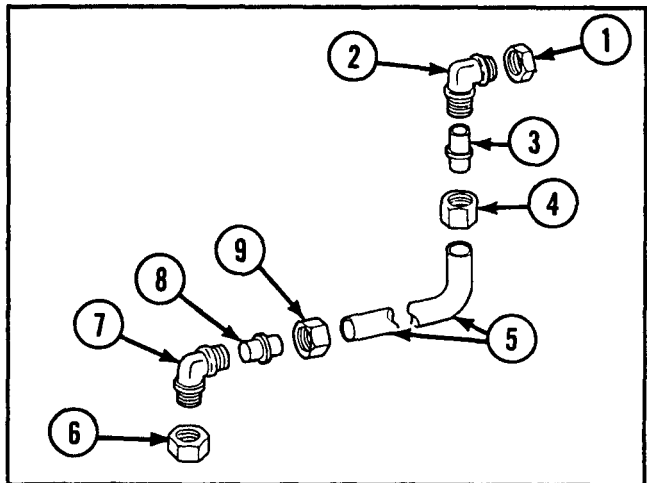

INSPECTION/REPAIR

- 1 Inspect for broken, damaged, or missing parts.
- 2 If metallic bent tube is broken, damaged, or missing, repair is by replacement of next higher assembly.
- 3 Repair is by replacement of authorized parts (TM 9-2350-238-24P-1) which do not meet inspection criteria.

REASSEMBLY

- 1 Install tube coupling nut (1), tube clinch sleeve (2), tube elbow (3), and tube cap (4) on metallic bent tube (5).
- 2 Install tube coupling nut (6), tube clinch sleeve (7), tube elbow (8), and new tube fitting locknut (9) on metallic bent tube (5).

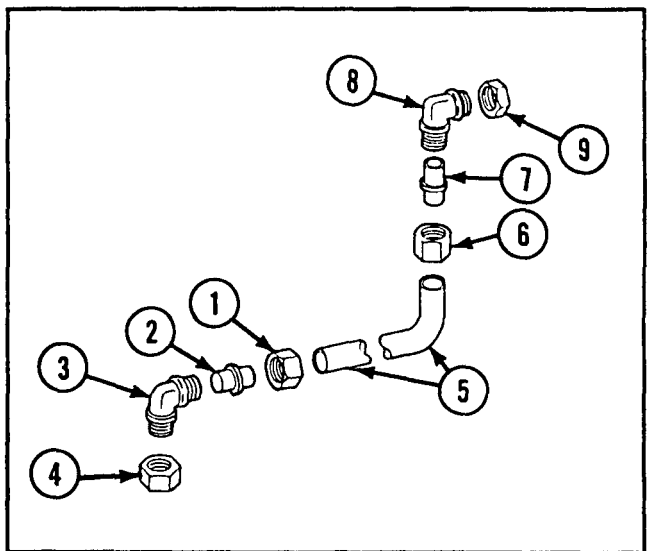

2-46. MAINTENANCE OF IMPACT WRENCH REGULATOR BALL VALVE.

This task covers:	a. <i>Disassembly</i>	b. <i>Inspection/Repair</i>	c. <i>Reassembly</i>
INITIAL SETUP			
<i>Tools and Special Tools</i>	<i>General Safety Instructions</i>		
Container	WARNING		
<i>Materials/Parts</i>	Wipe up any spilled hydraulic fluid to prevent injury to personnel.		
Lubricating oil (item 20, appx B)			
Pressure impact wrench regulator ball valve parts kit			
<i>References</i>			
TM 9-2350-238-20-1			
TM 9-2350-238-24P-1			
<i>Equipment Conditions</i>			
Impact wrench regulator ball valve and hydraulic lines and fittings removed (TM 9-2350-238-20-1)			

DISASSEMBLY

WARNING

Wipe up any spilled hydraulic fluid to prevent injury to personnel.

- 1 Using suitable container, drain oil from impact wrench regulator ball valve. Operate handle several times to drain remaining oil.

NOTE

Take care not to lose or damage parts not contained within pressure impact wrench regulator ball valve parts kit. If parts are lost or damaged, order a new impact wrench regulator ball valve.

- 2 Remove regulator valve knob (1) from handle assembly (2).

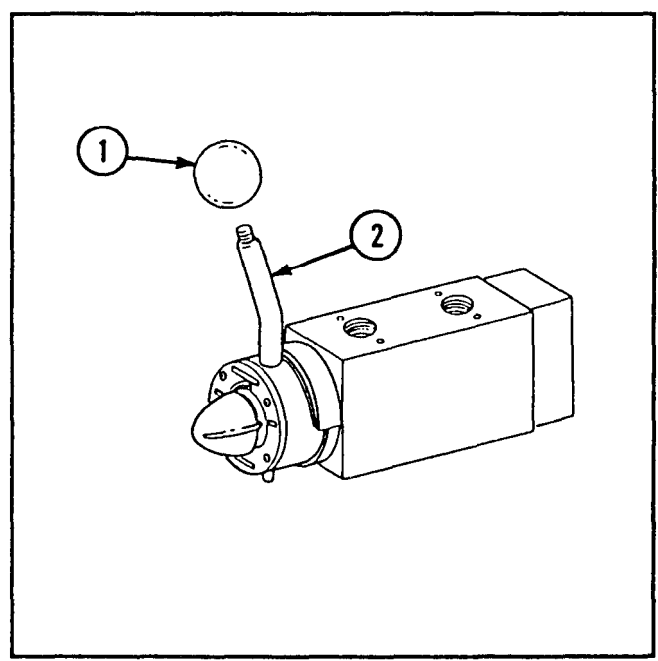

2-46. MAINTENANCE OF IMPACT WRENCHREGULATOR BALL VALVE (CONT).

DISASSEMBLY (CONT)

3 Unscrew cap (3) and remove nut (4), spring (5), and washer (6) from controller shaft (7).

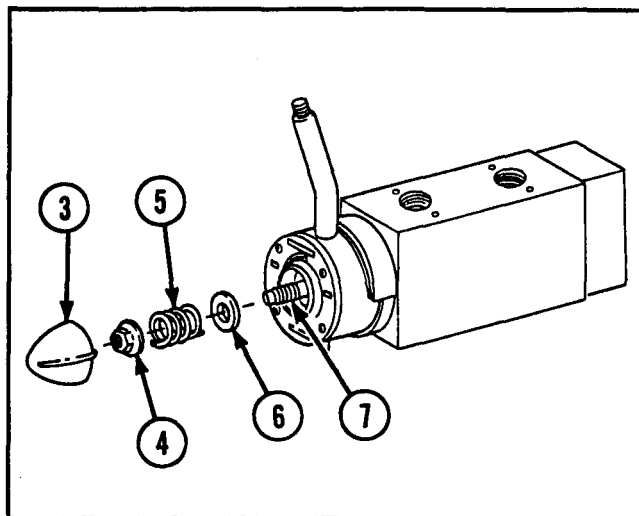

4 Remove assembly (2) from controller shaft (7).

Remove key (8) from controller shaft (7).

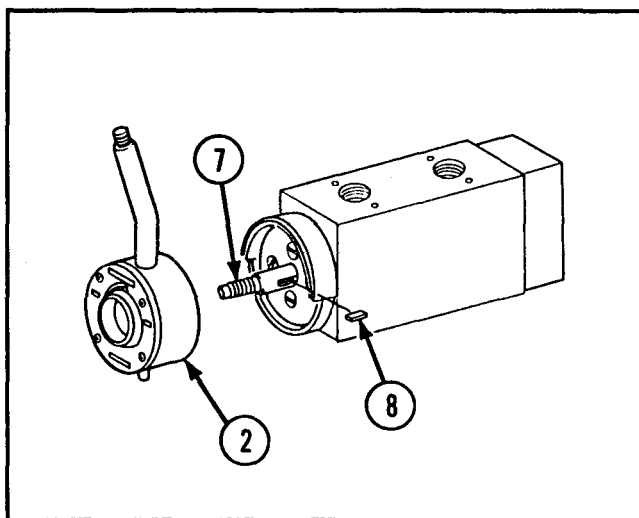

6 Remove four screws (9), disk (10), and cover (11) from block (12).

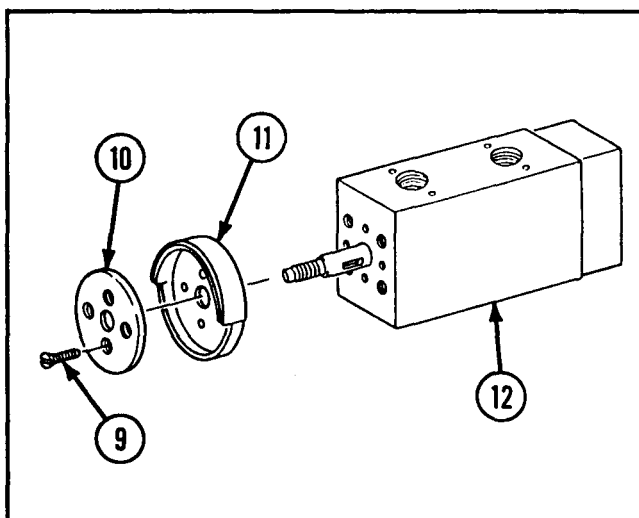

- 7 Remove four screws (13), end plate (14), and preformed packing (15) from block (12).

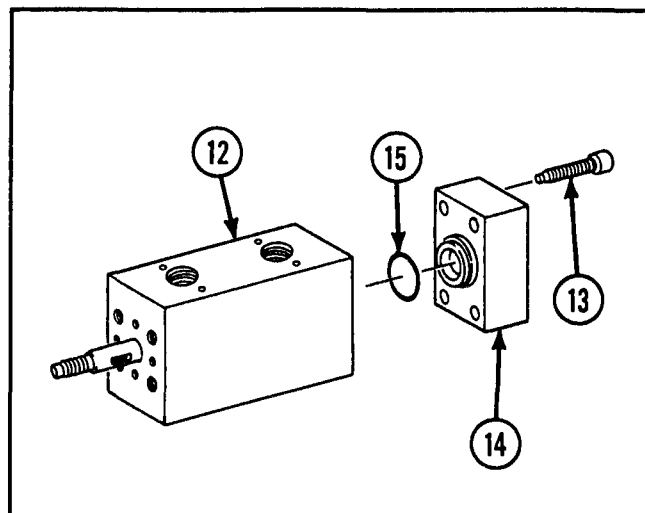

- 8 Push threaded end of controller shaft (7) into block (12).

- 9 Remove spring (16), piston (17), and sleeve (18) from block (12).

- 10 Remove two preformed packings (19) from sleeve (18).

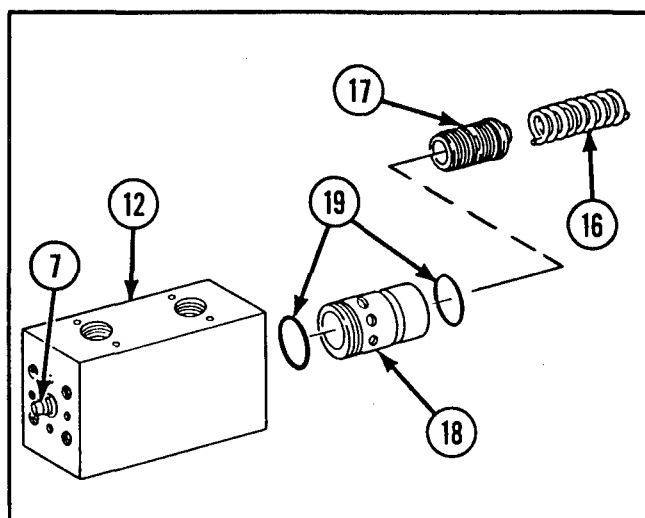

- 11 Remove controller shaft (7) and thrust bearing (20) from block (12).

- 12 Remove O-ring (21) from controller shaft (7).

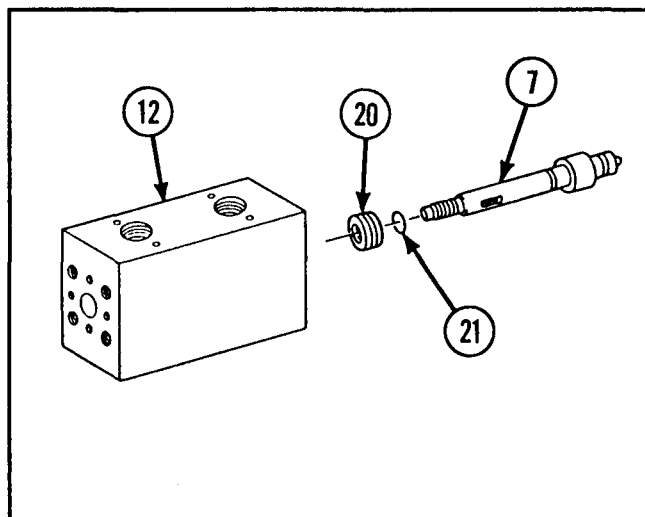

2-46. MAINTENANCE OF IMPACT WRENCH REGULATOR BALL VALVE (CONT).

DISASSEMBLY (CONT)

13 Remove bushing (22) from block (12).

14 Remove O-ring (23) from bushing (22).

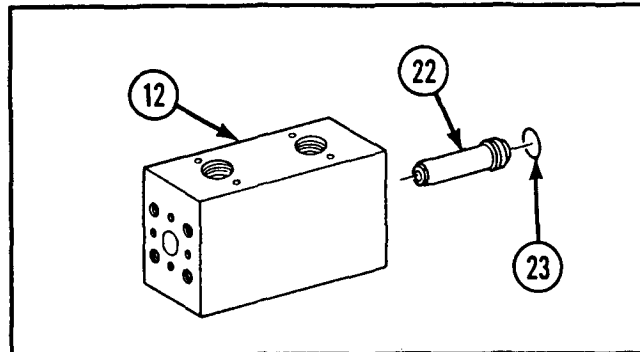

15 Remove plug (24) and O-ring (25) from block (12).

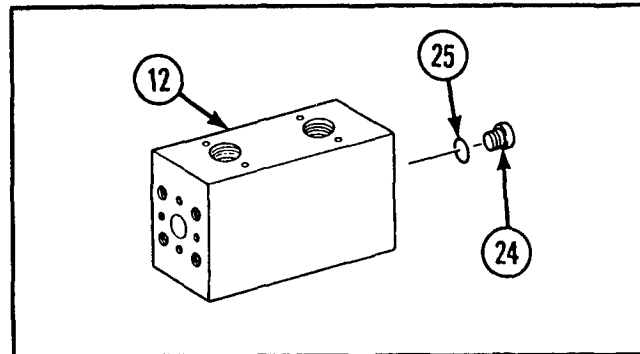

INSPECTION/REPAIR

- 1 Inspect for broken, damaged, or missing parts.
- 2 Inspect handle, disk, cover, and block for cracks and distortion.
- 3 Inspect piston, sleeve, and controller shaft for scoring.
- 4 Inspect ports for damage.
- 5 If any kit component is damaged, replace the entire pressure impact wrench regulator ball valve pads kit.

- 6 If any part that is not a component of the parts kit is broken, damaged, or missing, repair is by replacement of the next higher assembly.
- 7 Repair is by replacement of authorized parts (TM 9-2350-238-24P-1) which do not meet inspection criteria.

REASSEMBLY

- 1 Coat all preformed packings and O-rings with lubricating oil.
- 2 Install new O-ring (1) and plug (2) in block (3).

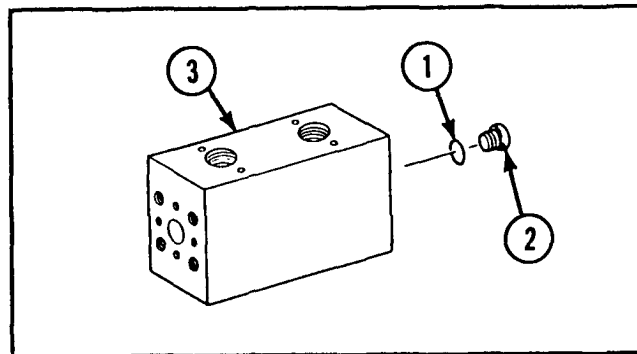

3 Install new O-ring (4) and thrust bearing (5) on controller shaft (6).

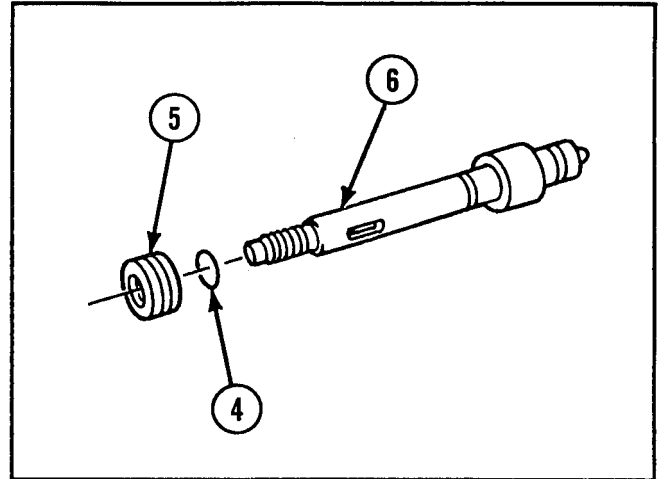

4 Install new O-ring (7) on bushing (8).

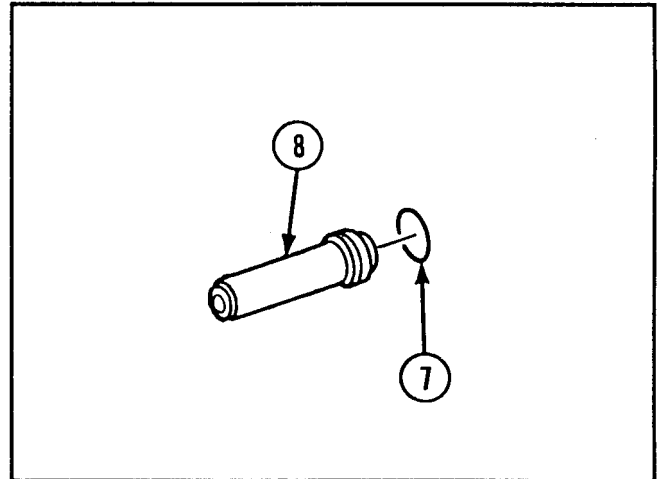

5 Install bushing (8) on controller shaft (6).

6 Install controller shaft (6) into block (3) until firmly seated.

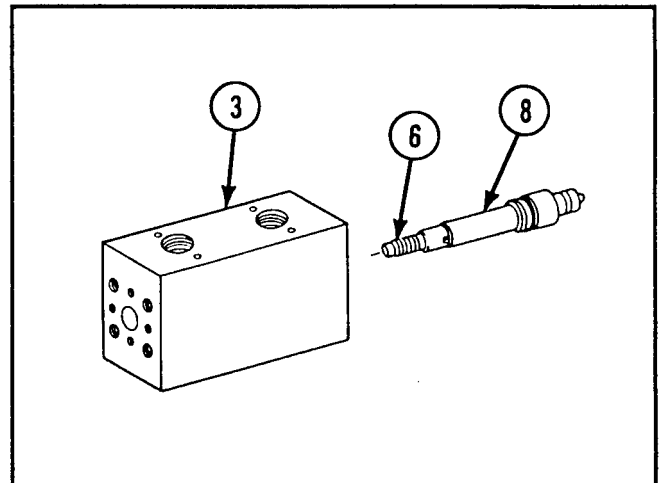

2-46. MAINTENANCE OF IMPACT WRENCH REGULATOR BALL VALVE (CONT).

REASSEMBLY (CONT)

CAUTION

A cut or nicked preformed packing will leak during operation.

7 Install two new preformed packings (9) on sleeve (10).

8 Install piston (11) in sleeve (10).

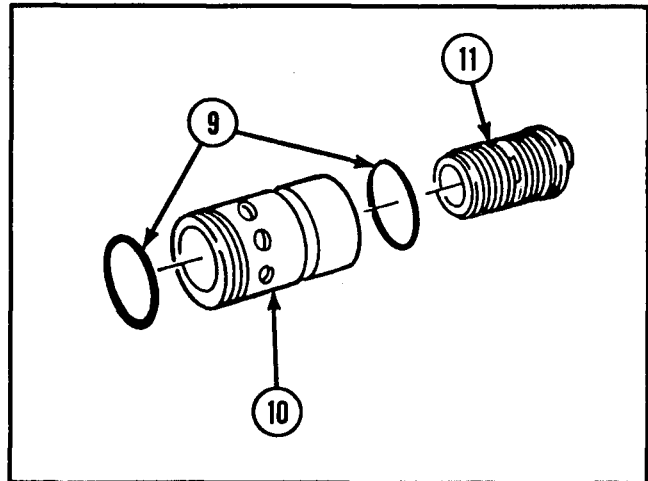

9 Install sleeve (10) in block (3) until firmly seated.

10 Install spring (12) in block (3).

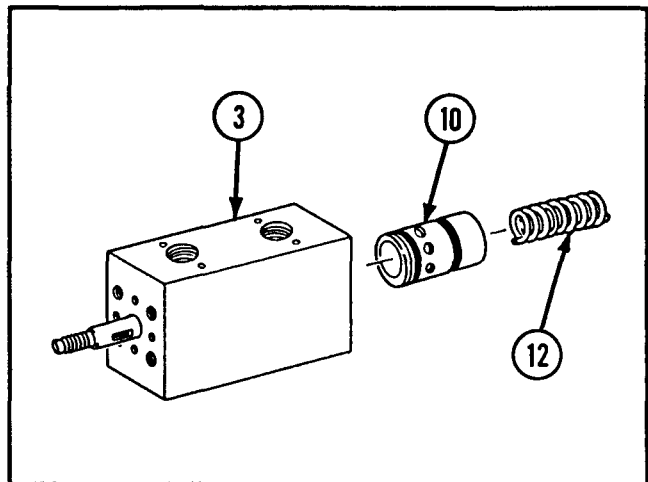

11 Install new preformed packing (13) in groove of end plate (14).

12 Install end plate (14) and four screws (15) on block (3).

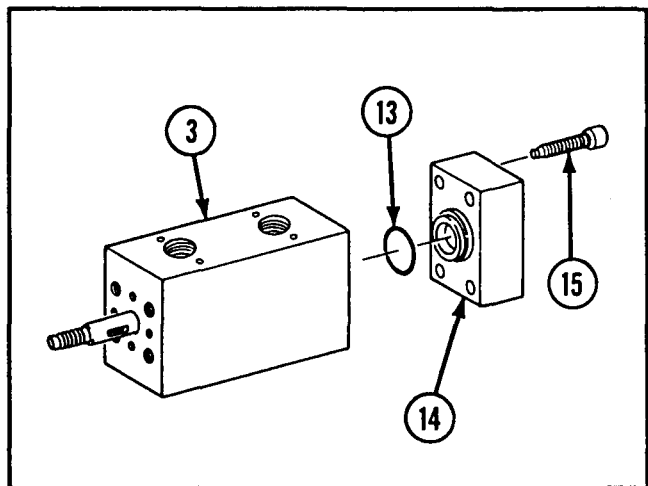

13 Install cover (16), disk (17), and four screws (18) on block (3).

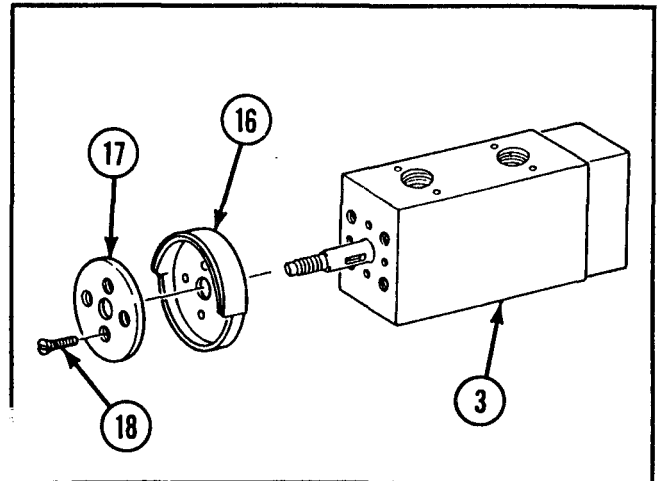

14 Install key (19) in controller shaft (6).

15 Align keyway in handle assembly (20) with key (19) and install handle controller shaft (6).

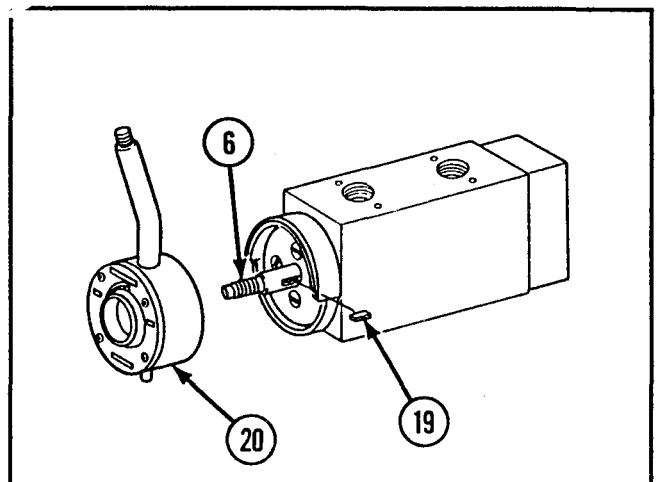

16 Install washer (21), spring (22), and nut (23) on controller shaft (6).

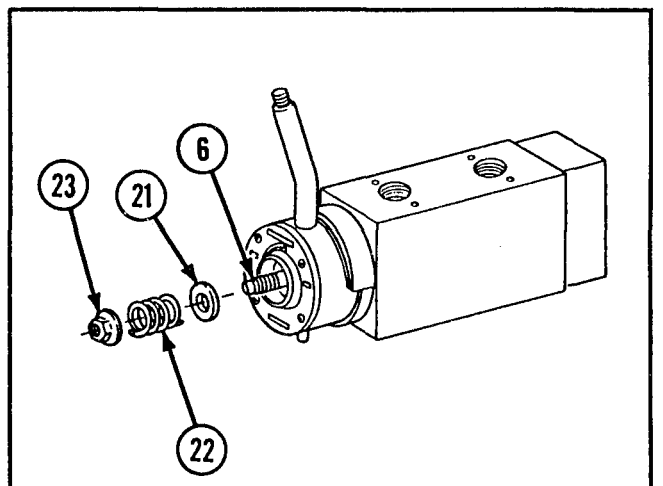

2-46. MAINTENANCE OF IMPACT WRENCH REGULATOR BALL VALVE (CONT).

REASSEMBLY (CONT)

- 17 Screw cap (24) on controller shaft (6).
- 18 Screw regulator valve knob (25) on handle assembly (20).

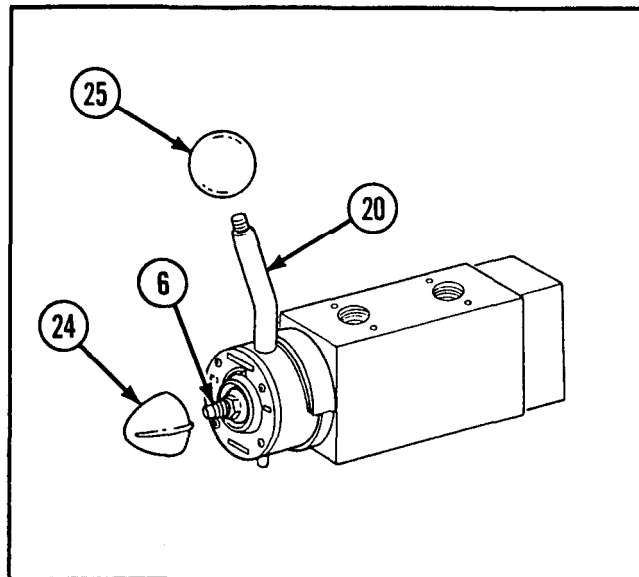

2-47. MAINTENANCE OF AUXILIARY DRIVE LINE BALL BEARING UNIT.

This task covers: a. *Disassembly* b. *Inspection/Repair* c. *Reassembly*

INITIAL SETUP

Tools and Special Tools

- Automotive maintenance and repair shop equipment field maintenance, basic, less power (SC 4910-95-A31)
 - Torque wrench (0 to 250 ft-lb)
- Face wrench socket (item 23, appx E)

Materials/Parts

- Grease (item 17, appx B)
- Lockwasher

References

- TM 9-214
- TM 9-2350-238-20-1
- TM 9-2350-238-24P-1

Equipment Conditions

- Auxiliary drive line ball bearing unit removed (TM 9-2350 -238-20-1)

DISASSEMBLY

- 1 Remove machine bolt (1), lockwasher (2), and companion flange (3).
- 2 Straighten tangs of key washer (4). Using face wrench socket, remove round plain nut (5).
- 3 Remove key washer (4) and pull pump input flange (6) from bearing unit housing (7).

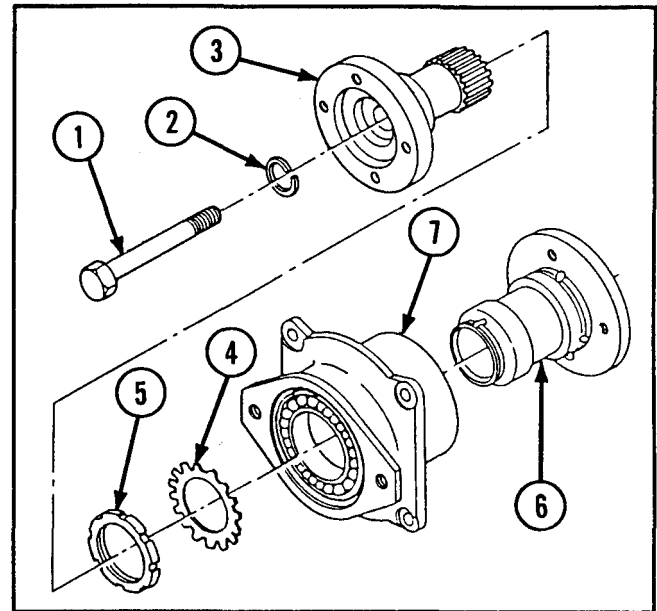

- 4 Using drift, drive output flange sleeve nut (8) from pump input flange (6).

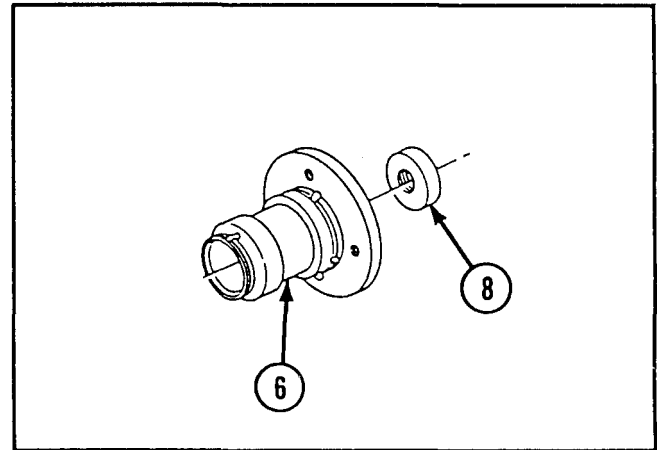

- 5 Insert drift into bearing unit housing (7) and remove annular ball bearing (9). Turn bearing unit housing over and remove annular ball bearing (10).
- 6 Remove spacer sleeve bushing (11) from bearing unit housing (7).

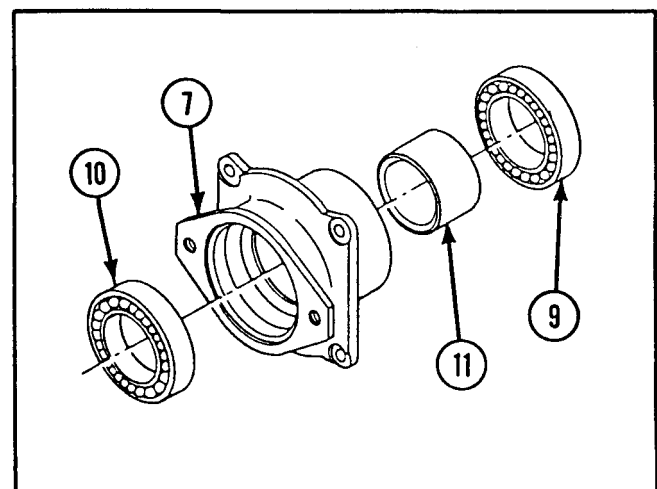

2-47. MAINTENANCE OF AUXILIARY DRIVE LINE BALL BEARING UNIT (CONT).

INSPECTION/REPAIR

- 1 Inspect for broken, damaged, or missing parts.
- 2 Inspect bearings per TM 9-214.
- 3 If output flange nut plate is damaged, repair is by replacement of next higher assembly.
- 4 Repair is by replacement of authorized parts (TM 9-2350-238-24P-1) which do not meet inspection criteria.

REASSEMBLY

- 1 Pack annular ball bearings (1 and 2) and bearing unit housing (3) cavity with grease.
- 2 Press annular ball bearing (1) into bearing unit housing (3) with seal facing out.
- 3 Install spacer sleeve bushing (4) into bearing unit housing (3).
- 4 Press annular ball bearing (2) into bearing unit housing (3) with seal facing out.

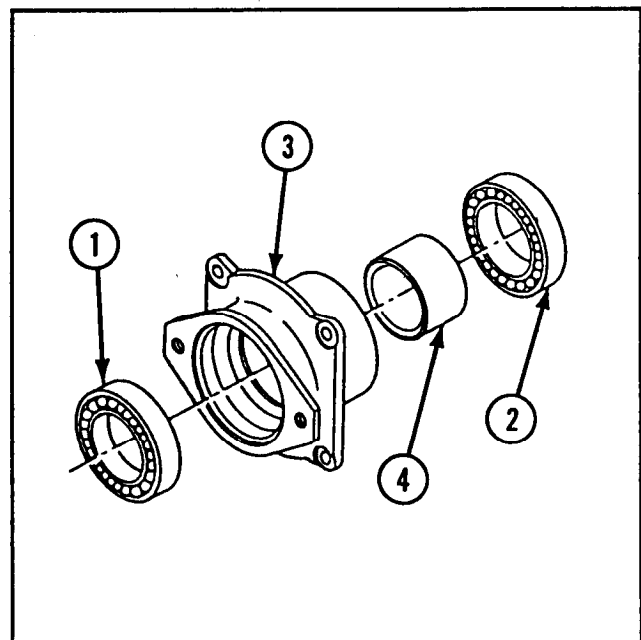

- 5 Apply a thin even coat of grease to pump input flange (5).
- 6 Install output flange sleeve nut (6) into pump input flange (5) and stake in eight places.

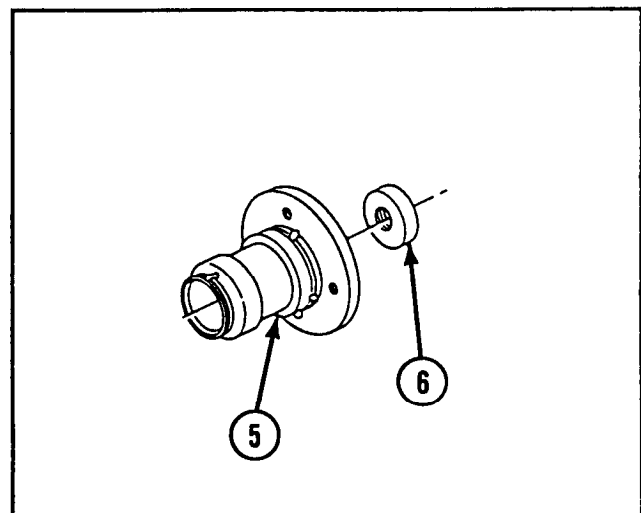

7 Install pump input flange (5) into bearing unit housing (3).

8 Install key washer (7) and round plain nut (8) on pump input flange (5). Tighten round plain nut with face wrench socket.

9 Bend tangs on key washer (7) into nut grooves,

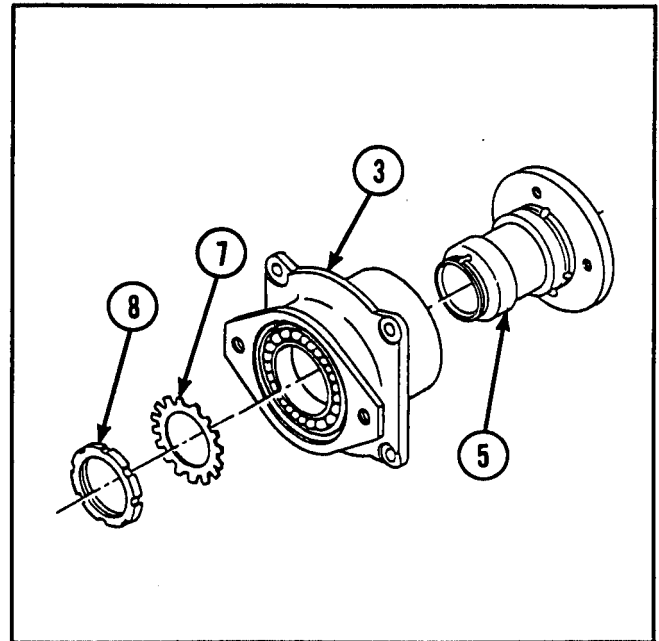

10 Install companion flange (9) in bearing unit housing (3).

11 Install new lockwasher (10) and machine bolt (11) into companion flange (9). Tighten machine bolt in output flange sleeve nut (6), and torque to 140 to 180 ft-lb (190 to 244 N-m).

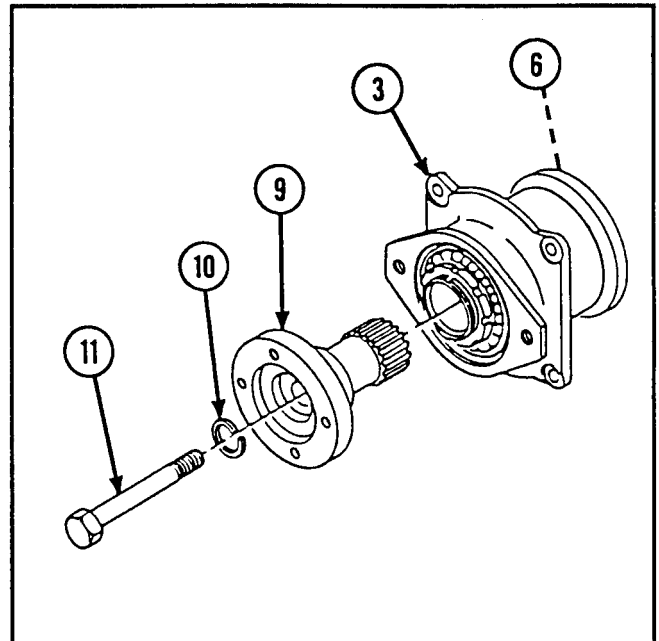

2-48. MAINTENANCE OF AIR CLEANER BLOWER ACCESS DOOR ASSEMBLY.

This task covers:	a. <i>Disassembly</i>	b. <i>Inspection/Repair</i>	c. <i>Reassembly</i>
INITIAL SETUP			
<i>Materials/Parts</i>			
Adhesive (item 1, appx B)			
Cleaning compound (item 5, appx B)			
Lockwasher (7)			
<i>References</i>			
TM 9-2350-238-20-1			
TM 9-2350-238-24P-1			
<i>Equipment Conditions</i>			
Air cleaner blower access door assembly removed (TM 9-2350-238-20-1)			

DISASSEMBLY

- 1 Remove three machine screws (1), three lockwashers (2), and door handle (3) from door (4).
- 2 Remove four machine screws (5), four lockwashers (6), four flat washers (7), and lock support (8) from door (4).
- 3 Remove two plate spacers (9) and flush latch (10) from lock support (8).
- 4 If damaged, remove nonmetallic seal (11) from door (4).

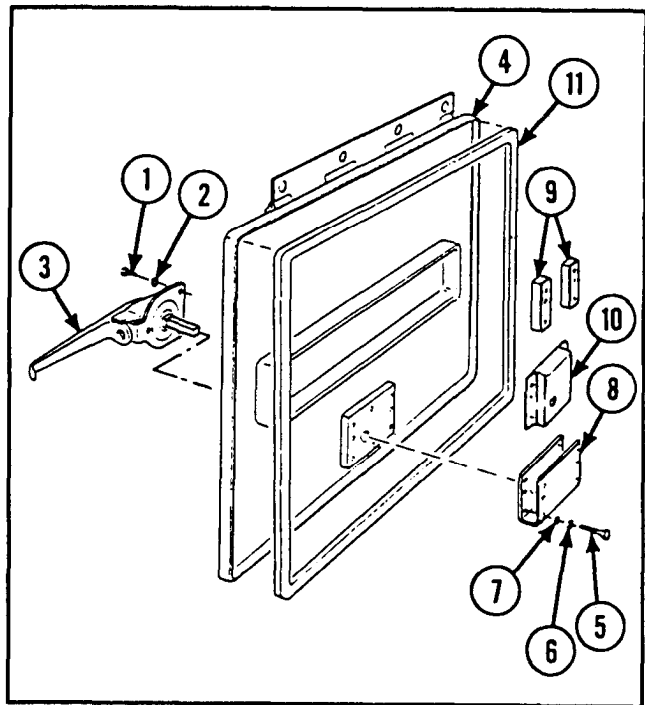

INSPECTION/REPAIR

- 1 Inspect for broken, damaged, or missing parts.
- 2 If door is broken, damaged, or missing, repair is by replacement of next higher assembly.
- 3 If door handle is broken, damaged, or missing, repair is by replacement of next higher assembly.
- 4 Repair is by replacement of authorized parts (TM 9-2350-238-24P-1) which do not meet inspection criteria,

REASSEMBLY

- 1 If nonmetallic seal (1) was removed, clean door (2) with cleaning compound. Coat new nonmetallic seal with adhesive and install new nonmetallic seal on door.
- 2 Install flush latch (3) and two plate spacers (4) in lock support (5).
- 3 Install lock support (5) on door (2), and secure with four flat washers (6), four new lockwashers (7), and four machine screws (8).
- 4 Install door handle (9) in door (2), and secure with three new lockwashers (10) and three machine screws (11).

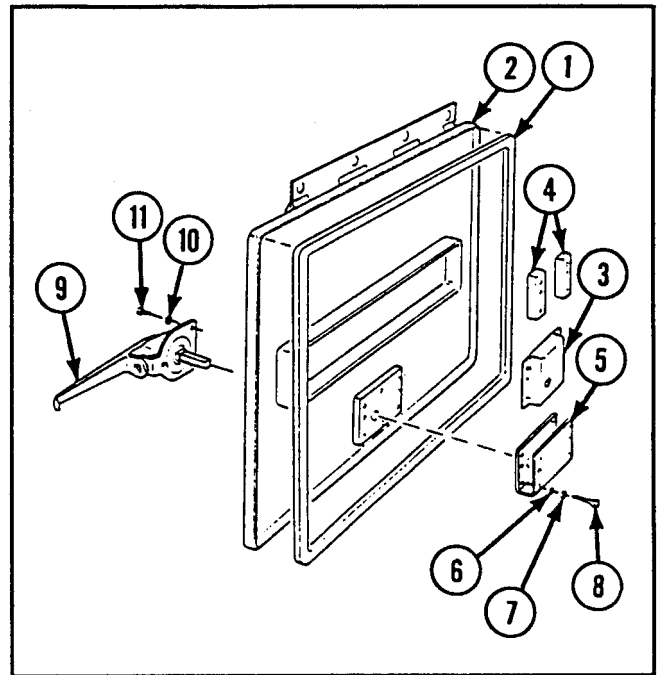

2-49. MAINTENANCE OF BATTERY ACCESS COVER.

This task covers: a. *Disassembly* b. *Inspection/Repair* c. *Reassembly*

INITIAL SETUP

Materials/Pads

- Adhesive (item 1, appx B)
- Cleaning compound (item 5, appx B)
- Handle spring pin (2)
- Lockwasher (8)
- Spring pin (2)
- Spring tension washer (2)

References

- TM 9-2350-238-20-1
- TM 9-2350-238-24P-1

Equipment Conditions

- Battery access cover removed (TM 9-2350-238-20-1)

2-49. MAINTENANCE OF BATTERY ACCESS COVER (CONT).

DISASSEMBLY

- 1 Remove two spring pins (1) and two flat washers (2) from two headed straight pins (3).
- 2 Remove two manual control handles (4) with two headed straight pins (3), two flat washers (5), and two spring tension washers (6) from door (7).
- 3 Remove two handle spring pins (8) and two manual control handles (4) from two headed straight pins (3).
- 4 Remove eight machine screws (9), eight lockwashers (10), and two rim latches (11) from door (7).
- 5 If damaged, remove access door seal (12) and rubber strip (13) from door (7).

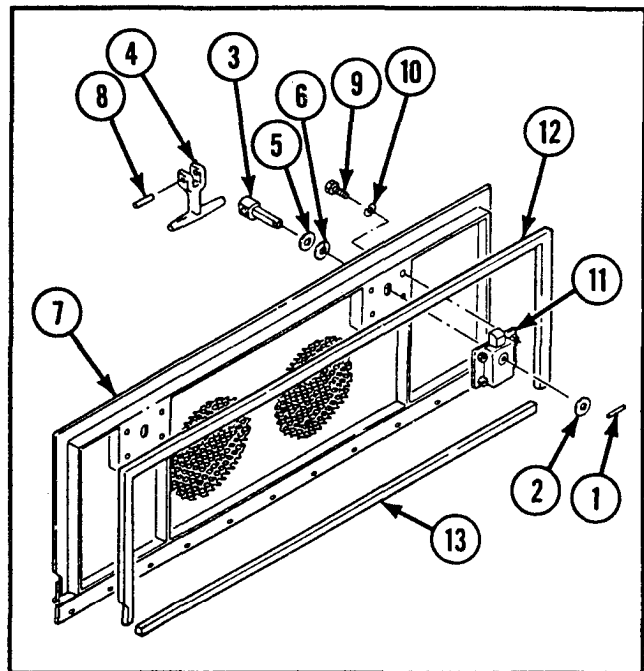

INSPECTION/REPAIR

- 1 Inspect for broken, damaged, or missing parts.
 - 2 Repair is by replacement of authorized parts (TM 9-2350-238-24P-1).
-
- 1 If access door seal (12) and rubber strip (13) were removed, clean door (7) with cleaning compound. Coat new access door seal (12) and new rubber strip (13) with adhesive, and install on door (7).
 - 2 Install two rim latches (11), eight new lockwashers (10), and eight machine screws (9) on door (7).
 - 3 Install two manual control handles (4) on two headed straight pins (3), and secure with two new handle spring pins (8).
 - 4 Install two new spring tension washers (6), two flat washers (5), and two headed straight pins (3) with two manual control handles (4) in door (7). Secure with two flat washers (2) and two new spring pins (1).

2-50. MAINTENANCE OF AIR CLEANER ACCESS DOOR.

This task covers: a. *Disassembly* b. *Inspection/Repair* c. *Reassembly*

INITIAL SETUP*Materials/Parts*

Adhesive (item 1, appx B)
 Cleaning compound (item 5, appx B)
 Lockwasher (4)
 Spring pin
 Spring pin
 Spring tension washer (2)

References

TM 9-2350-238-20-1
 TM 9-2350-238-24P-1

Equipment Conditions

Air cleaner access door removed (TM 9-2350-238-20-1)

DISASSEMBLY

- 1 Remove spring pin (1), flat washer (2), and spring tension washer (3) from headed straight pin (4).
- 2 Remove manual control handle (5) with headed straight pin (4), flat washer (6), and spring tension washer (7) from air cleaner door (8).
- 3 Remove spring pin (9) and manual control handle (5) from headed straight pin (4).
- 4 Remove four machine screws (10), four lockwashers (11), and rim latch (12) from air cleaner door (8).
- 5 If damaged, remove nonmetallic seal (13) from air cleaner door (8).

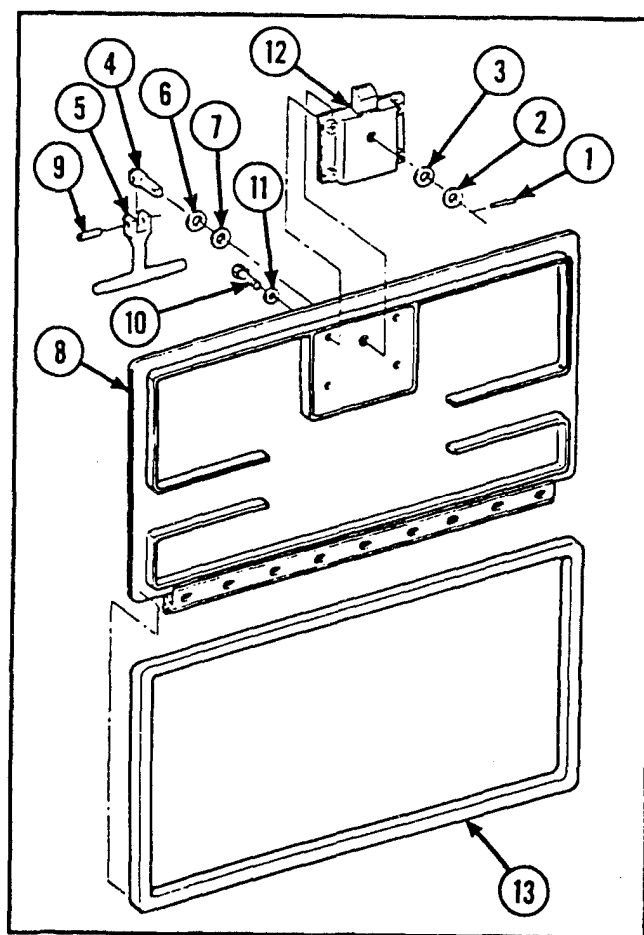

2-50. MAINTENANCE OF AIR CLEANER ACCESS DOOR (CONT).

INSPECTION/REPAIR

- 1 Inspect for broken, damaged, or missing parts.
- 2 If air cleaner door is broken, damaged, or missing, repair is by replacement of next higher assembly.
- 3 Repair is by replacement of authorized parts (TM 9-2350-238-24P-1) which do not meet inspection criteria.

REASSEMBLY

- 1 If nonmetallic seal (1) was removed, clean air cleaner door (2) with cleaning compound. Coat new nonmetallic seal (1) with adhesive, and install on air cleaner door (2).
- 2 Install rim latch (3) on air cleaner door (2), and secure with four new lockwashers (4) and four machine screws (5).
- 3 Install manual control handle (6) and new spring pin (7) on headed straight pin (8).
- 4 Install new spring tension washer (9), flat washer (10), and headed straight pin (8) with manual control handle (6) on air cleaner door (2).
- 5 Install new spring tension washer (11), flat washer (12), and new spring pin (13) on headed straight pin (8).

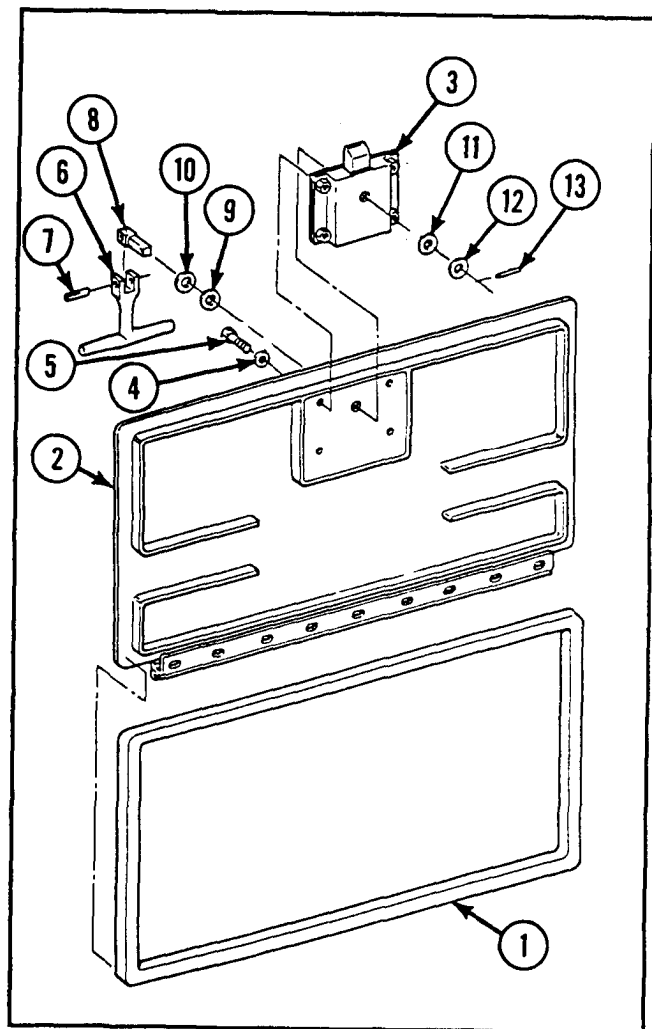

2-51. MAINTENANCE OF ENGINE FUEL FILTER ACCESS DOOR.

This task covers: a. *Disassembly* b. *Inspection/Repair* c. *Reassembly*

INITIAL SETUP*Materials/Parts*

Adhesive (item 1, appx B)
 Antiseize compound (item 3, appx B)
 Cotter pin
 Lockwasher (2)
 Spring tension washer

References

TM 9-2350-238-20-1
 TM 9-2350-238-24P-1

Equipment Conditions

Engine fuel filter access door removed (TM 9-2350-238-20-1)

DISASSEMBLY

- 1 Remove two hexagon head capscrews (1), two lockwashers (2), and retaining strap (3) from door plate (4).
- 2 Remove cotter pin (5) from driver's latch handle (6).
- 3 Remove slotted plain nut (7) and sleeve spacer (8) from driver's latch handle (6).
- 4 Remove driver's latch handle (6), spring tension washer (9), access door collar (10), torsion helical spring (11), driver's latch wheel (12), and flat washer (13) from door plate (4).
- 5 If damaged, remove cushioning pad (14) from door plate (4).

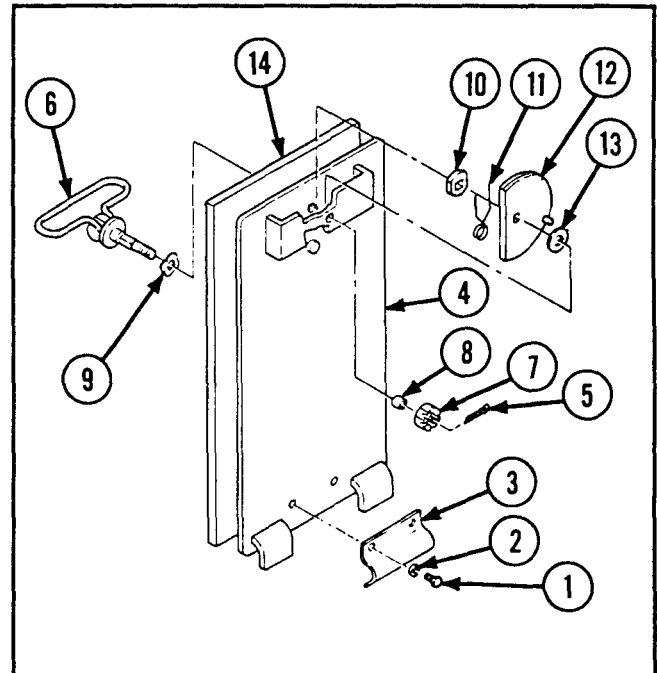

2-51. MAINTENANCE OF ENGINE FUEL FILTER ACCESS DOOR (CONT).

INSPECTION/REPAIR

- 1 Inspect for broken, damaged, or missing parts.
- 2 If door plate is broken, damaged, or missing, repair is by replacement of next higher assembly.
- 3 Repair is by replacement of authorized parts (TM 9-2350-238-24P-1) which do not meet inspection

REASSEMBLY

NOTE

Cushioning pad must be centered on plate within 0.03 in. (0.08 cm).

- 1 If removed, coat new cushioning pad (1) with adhesive and install on door plate (2).
- 2 Apply antiseize compound to mating surfaces of driver's latch handle (3), new spring tension washer (4), access door collar (5), torsion helical spring (6), driver's latch wheel (7), flat washer (8), and door plate (2).

NOTE

If necessary, toggle of driver's latch handle may be bent slightly to aid in installation.

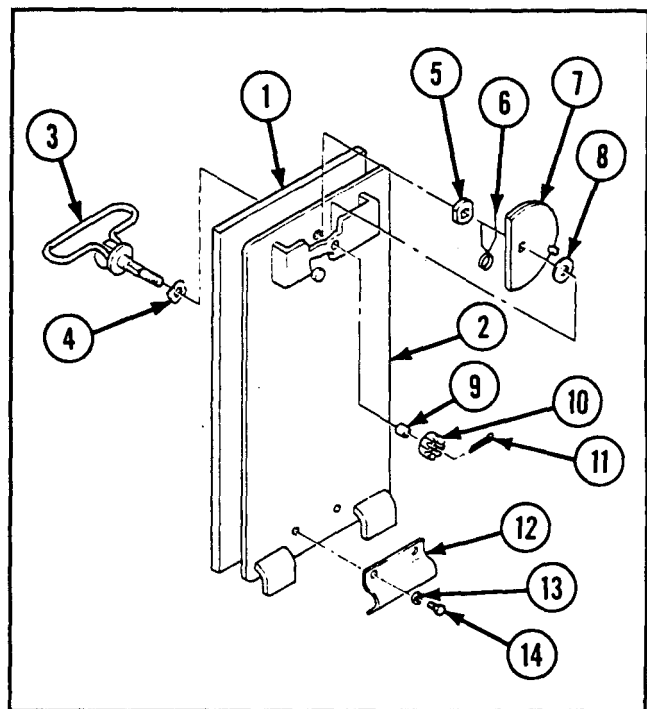

- 3 Install driver's latch handle (3), new spring tension washer (4), access door collar (5), torsion helical spring (6), driver's latch wheel (7), and flat washer (8) on door plate (2).
- 4 Install sleeve spacer (9) and slotted plain nut (10) on driver's latch handle (3).
- 5 Install new cotter pin (11) on driver's latch handle (3).
- 6 Install retaining strap (12), two new lockwashers (13), and two hexagon head capscrews (14) on door plate (2).

2-52. MAINTENANCE OF DRIVER'S HATCH COVER.

This task covers: a. *Disassembly* b. *Inspection/Repair* c. *Reassembly*

INITIAL SETUP*Tools and Special Tools*

Arc welder
 Automotive maintenance and repair shop
 equipment: field maintenance, basic,
 less power (SC 4910-95-A31)
 ● Torque wrench (0 to 150 ft-lb)
 Grinder

References

MIL-STD-1941
 TM 9-2350-238-24P-1

Equipment Conditions

Driver's hatch cover partially disassembled
 (TM 9-2350-238-20-1)

Materials/Parts

Adhesive (item 1, appx B)
 Electrode, 1/8-in.
 Electrode, 3/32-in.
 Soap (item 27, appx B)

DISASSEMBLY

- 1 Scribe vehicle hatch door (1) and hull (2) at three evenly spaced locations.
- 2 Raise vehicle hatch door (1) to vertical position.
- 3 If necessary, remove lubrication fitting (3) from cupola hinge torsion bar (4).
- 4 Remove cupola hinge torsion bar (4) from vehicle hatch door (1).
- 5 Remove vehicle hatch door (1) from hull (2).

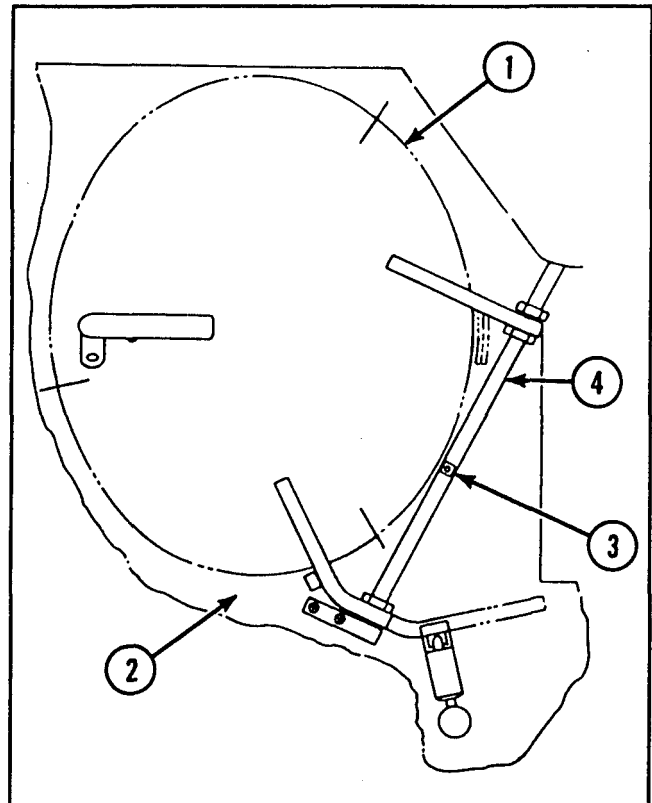

2-52. MAINTENANCE OF DRIVER'S HATCH COVER (CONT).

DISASSEMBLY (CONT)

NOTE

Cushioning pad can be reused if not damaged when removed from hatch cover. Pad is removed to protect it from burning when the new inner and outer arms are welded on.

- 6 Remove cushioning pad (5) from vehicle hatch door (1).
- 7 Remove outer arm (6) with strike (7) attached and inner arm (8) from vehicle hatch door (1) by grinding or cutting.

INSPECTION/REPAIR

- 1 Inspect for broken, damaged, or missing parts.
- 2 Clean cushioning pad with mild soap and water.
- 3 Repair is by replacement of authorized parts (TM 9-2350-304-24P-1).

REASSEMBLY

- 1 Grind excess weld material flush with vehicle hatch door (1).
- 2 Install new cushioning pad (2).
- 3 Position, align, and center vehicle hatch door (1) on hull (3).
- 4 Use a 30.0-lb (13.6-kg) weight to compress vehicle hatch door (1) evenly into cushioning pad (2).

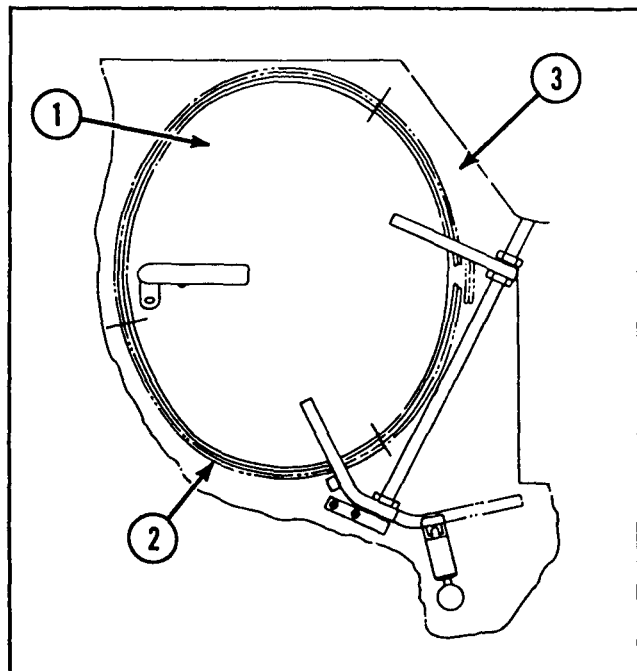
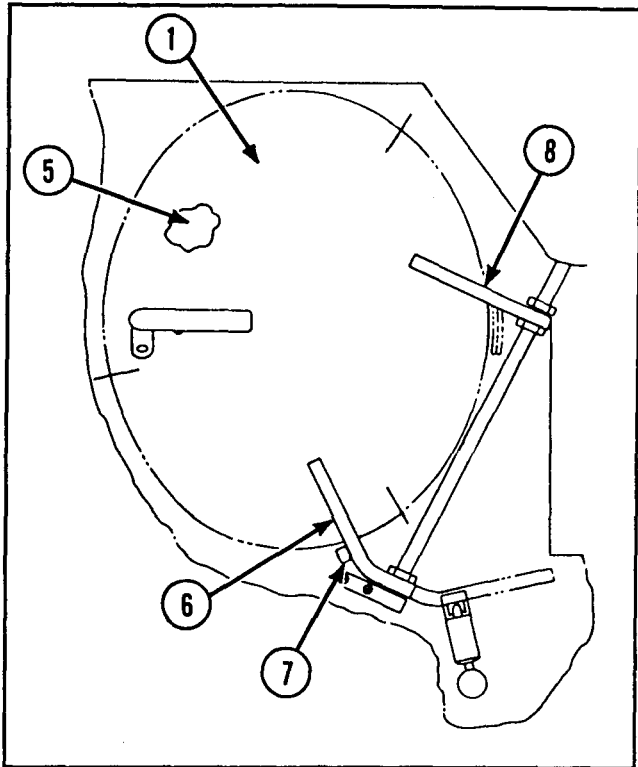

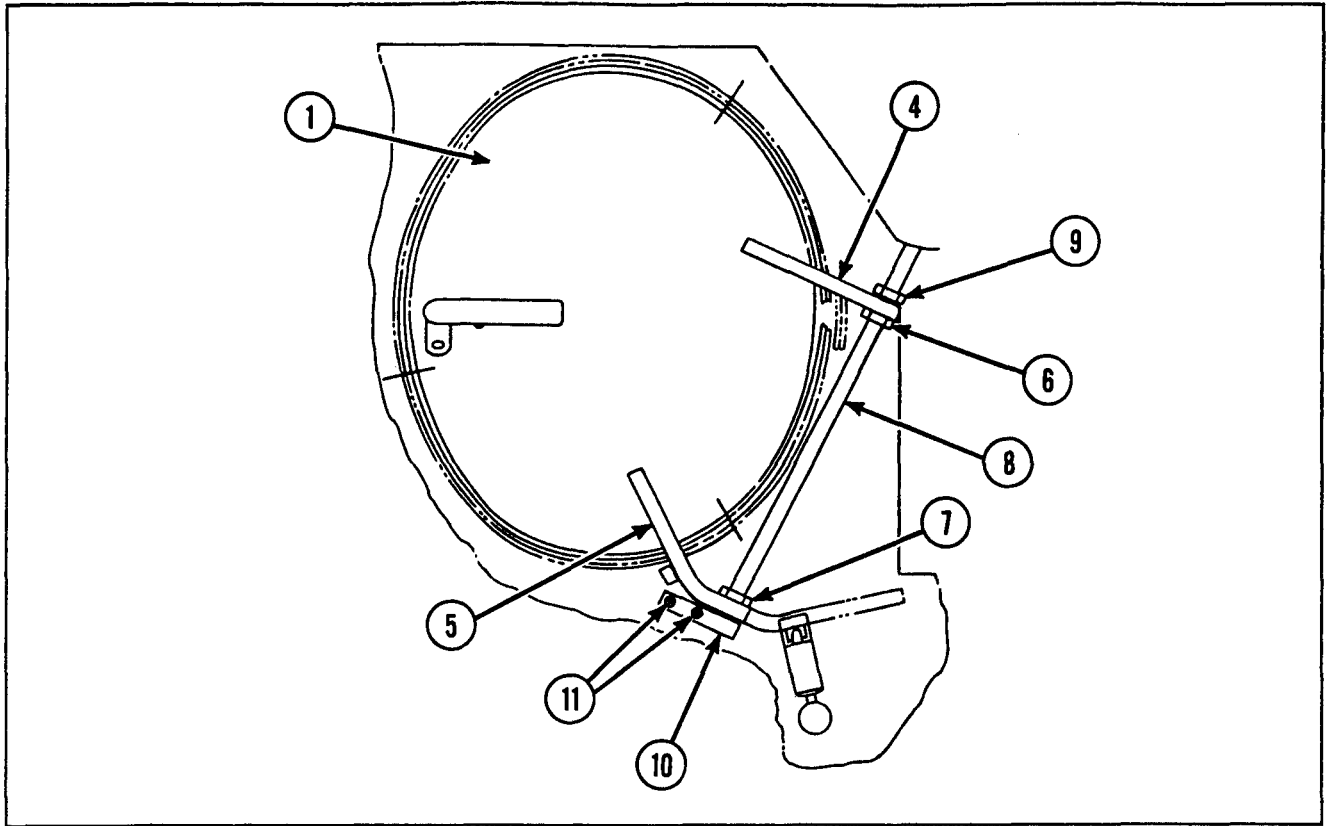

- 5 Position inner arm (4) and outer arm (5) on vehicle hatch door (1) and align them with two brackets (6 and 7).
- 6 Install cupola hinge torsion bar (8) through outer arm (5) and outer bracket (7), inner arm (4) and inner bracket (6), and hinge (9).
- 7 Install anchor (10) and two capscrews (11) on hull (3).
- 8 Center outer arm (5) between outer bracket (7) and anchor (10).
- 9 Center inner arm (4) between hinge (9) and inner bracket (6).

NOTE

Steps 10 thru 13 are written for outer arm, but also apply to inner arm.

- 10 Check clearance between outer arm (5) and vehicle hatch door (1).
- 11 If clearance between outer arm (5) and vehicle hatch door (1) exceeds 1/16 in. (0.16 cm), install not more than 1/4 in. (0.64 cm) of shims.
- 12 If necessary, cut enough shims to fit gap between outer arm (5) and vehicle hatch door (1).
- 13 Tack weld shims and/or outer arm (5) on vehicle hatch door (1).

2-52. MAINTENANCE OF DRIVER'S HATCH COVER (CONT).

REASSEMBLY (CONT)

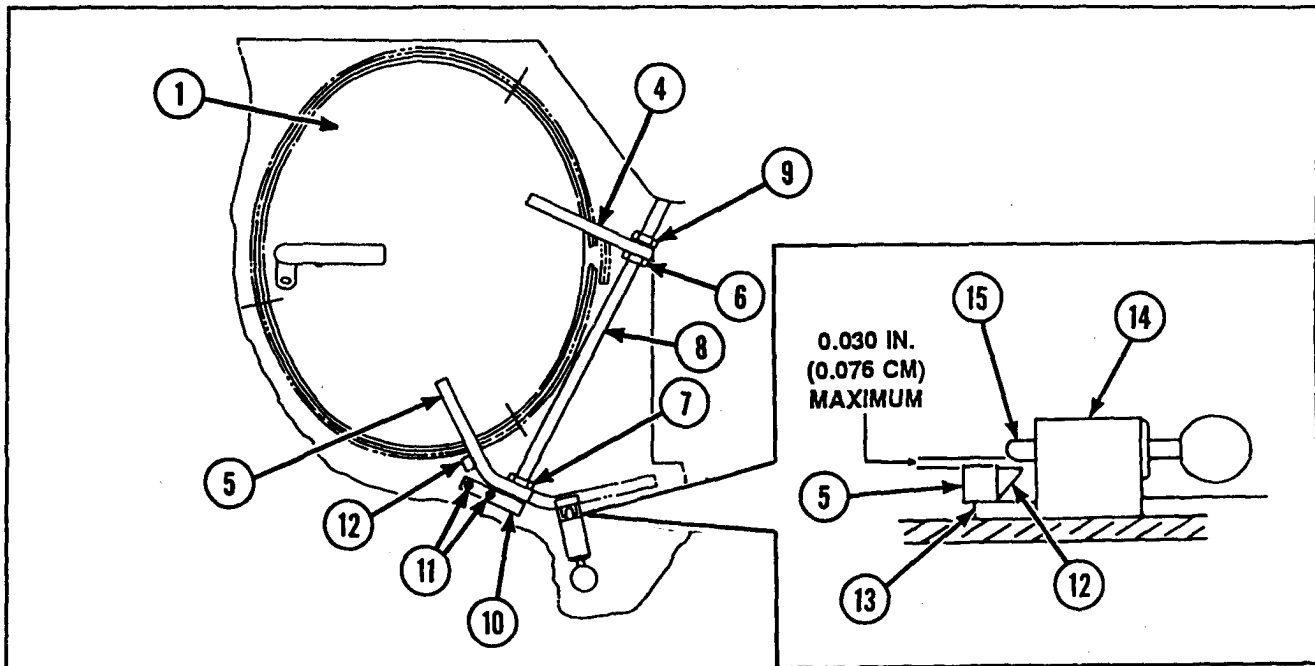

- 14 Remove weight from vehicle hatch door (1).
- 15 Remove two capscrews (11) from anchor (10).
- 16 Remove anchor (10) and cupola hinge torsion bar (8) from vehicle hatch door (1).
- 17 Remove vehicle hatch door (1) from vehicle.
- 18 Weld outer arm (5) and inner arm (4) to vehicle hatch door (1) per MIL-STD-1941, method 2.

CAUTION

Allow hatch cover to air cool slowly to prevent it from warping.

- 19 Install vehicle hatch door (1) in vertical position on two brackets (6 and 7) and hinge (9).
- 20 Install cupola hinge torsion bar (8) through outer arm (5) and outer bracket (7), inner arm (4) and inner bracket (6), and hinge (9).
- 21 Install anchor (10) and two capscrews (11) on hull (3).
- 22 Swing vehicle hatch door (1) from closed position to open position to check for binding.
- 23 If necessary, repeat steps 15 thru 22 to prevent vehicle hatch door (1) from binding.

NOTE

The latch pin should contact the strike in the middle.

- 24 Open vehicle hatch door (1) and position strike (12) on outer arm (5) and center on latch plate (13) to check clearances.
- 25 If necessary, grind down strike (12) to provide clearance between it and the latch block (14).
- 26 Position and clamp strike (12) on outer arm (5) so clearance between strike and latch pin (15) is less than 0.030 in. (0.076 cm).
- 27 Tack weld strike (12) to outer arm (5).
- 28 Recheck clearance between strike (12) and latch pin (15).
- 29 Open and latch vehicle hatch door (1) to confirm proper position and operation of strike (12).
- 30 Weld strike (12) on outer arm (5) per MIL-STD-1941. Allow to air cool.
- 31 Close vehicle hatch door (1). If necessary, grind strike (12) flush with outer arm (5).
- 32 Open and latch vehicle hatch door (1) to confirm proper position and operation of strike (12).
- 33 If necessary, grind down strike (12) to reduce clearance between it and latch pin (15) to less than 0.030 in. (0.076 cm).
- 34 Raise vehicle hatch door (1) to vertical position.
- 35 Remove two capscrews (11) from anchor (10).
- 36 Remove anchor (10) and cupola hinge torsion bar (8) from vehicle hatch door (1).
- 37 Remove vehicle hatch door (1) from hull (3).
- 38 Clean and paint rework areas per drawing 12369003.

2-52. MAINTENANCE OF DRIVER'S HATCH COVER (CONT).

REASSEMBLY (CONT)

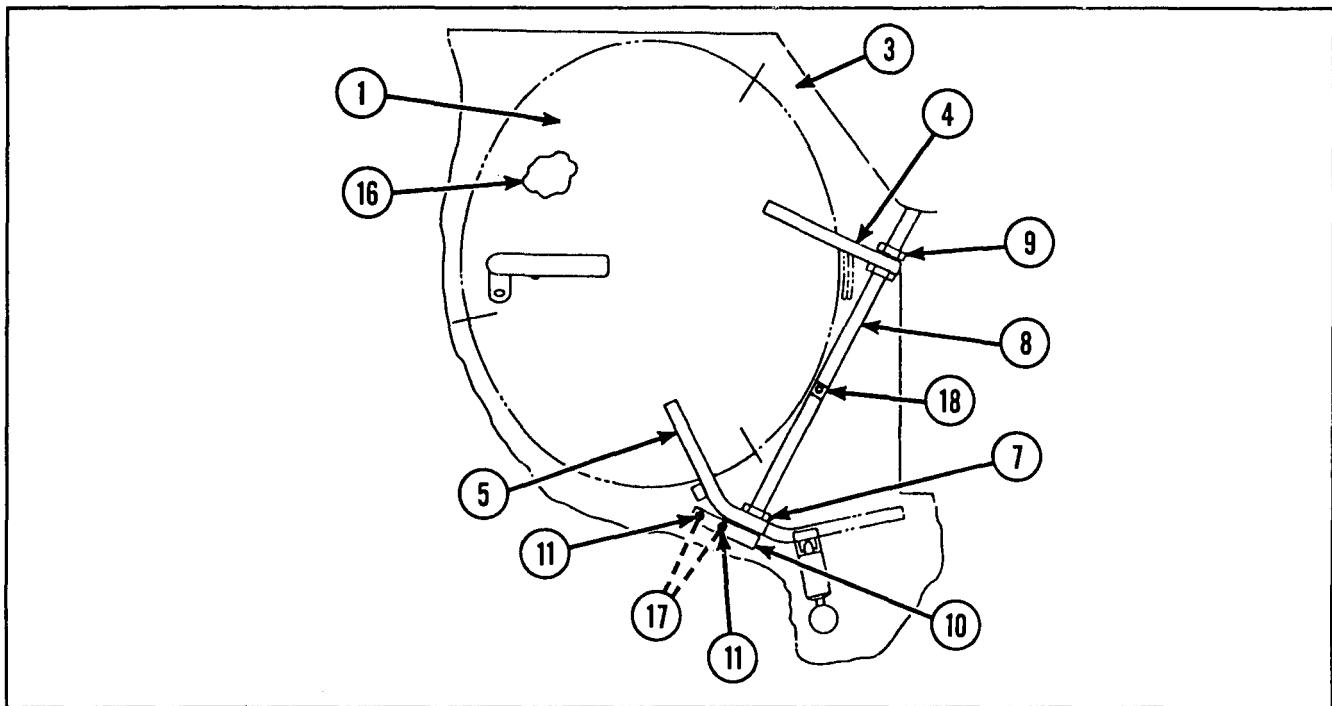

- 39 Coat mating surfaces of cushioning pad (16) and inside surface of vehicle hatch door (1) with adhesive.

NOTE

Notched area of cushioning pad goes around vehicle hatch door handle.

- 40 Install cushioning pad (16) on vehicle hatch door (1). Allow to air dry for one hour at a temperature greater than 65 °F (18 °C).
- 41 Install vehicle hatch door (1) in vertical position on two brackets (6 and 7) and hinge (9).
- 42 Install cupola hinge torsion bar (8) through outer arm (5) and outer bracket (7), inner arm (4) and inner bracket (6), and hinge (9).
- 43 Install anchor (10), two new lockwashers (17), and two cap screws (11) on hull (3).
- 44 Torque two cap screws (11) to 85 to 90 ft-lb (115 to 122 N-m) dry or 60 to 65 ft-lb (81 to 88 N-m) lubricated.
- 45 If removed, reinstall lubrication fitting (18) in cupola hinge torsion bar (8).

2-53. MAINTENANCE OF POWER TAKEOFF INSTALLATION.

This task covers: a. *Removal* b. *Inspection/Repair* c. *Installation*

INITIAL SETUP*Tools and Special Tools*

Automotive maintenance and repair shop equipment: field maintenance, basic, less power (SC 4910-95-A31)

- Soft-faced hammer

Hoist

Sling

Materials/Parts

Lockwasher (8)

Power takeoff gasket

References

TM 9-2350-238-20-1

TM 9-2350-238-24P-1

Equipment Conditions

Powerplant removed (TM 9-2350-238-20-1)

REMOVAL

- 1 Connect hoist and lifting straps to transmission power takeoff (1).
- 2 Remove eight hexagon head capscrews (2) and eight lockwashers (3) from transmission power takeoff (1).
- 3 Lift transmission power takeoff (1) from transfer case (4).
- 4 Remove power takeoff gasket (5) from transmission power takeoff (1).
- 5 Cover transfer case power takeoff opening.

INSPECTION/REPAIR

- 1 Inspect for broken, damaged, or missing parts.
- 2 Power takeoff unit is a repairable assembly. Notify general support maintenance.
- 3 Repair is by replacement of authorized parts (TM 9-2350-238-24P-1).

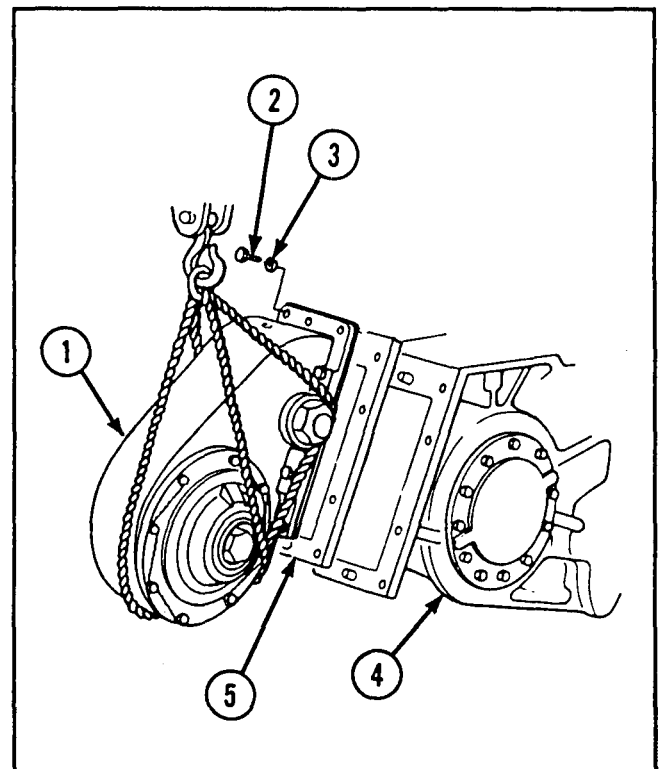

2-53. MAINTENANCE OF POWER TAKEOFF INSTALLATION (CONT).

INSTALLATION

1 Remove covering from transfer case power takeoff opening.

CAUTION

Failure to use power takeoff gasket may damage transmission power takeoff.

2 Install new power takeoff gasket (1) on transmission power takeoff (2).

3 Connect hoist and lifting straps to transmission power takeoff (2).

4 Align transmission power takeoff (2) with transfer case (3), and tap with soft-faced hammer to seat dowels.

5 Install eight new lockwashers (4) and eight hexagon head capscrews (5) on transfer case (3).

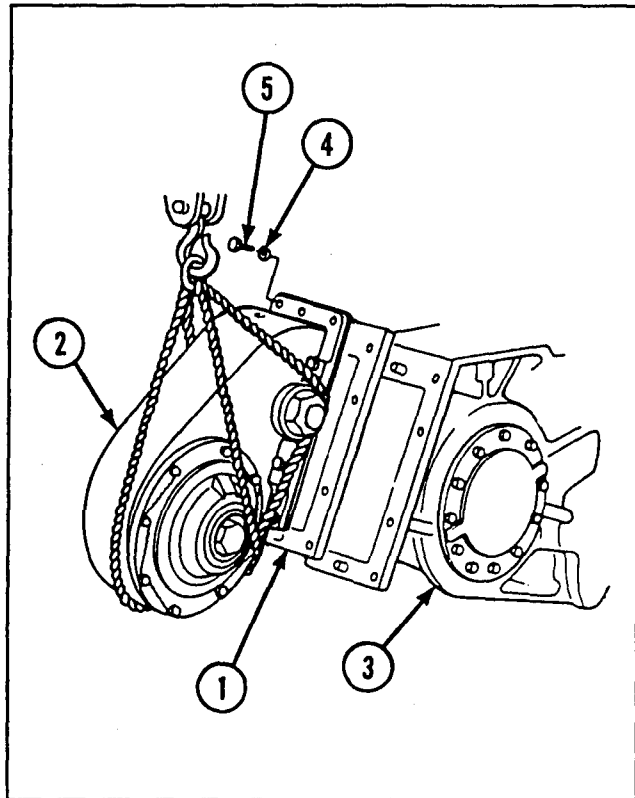

2-54. MAINTENANCE OF HYDRAULIC CYLINDER ASSEMBLY.

This task covers:	a. Disassembly	b. Inspection/Repair	c. Reassembly
INITIAL SETUP			
<p><i>Tools and Special Tools</i></p> <ul style="list-style-type: none"> Oil seal inserter (item 6, appx E) Spanner wrench (item 25, appx E) Spanner wrench (item 26, appx E) 		<p><i>Equipment Conditions</i></p> <p>Hydraulic cylinder assembly removed (TM 9-2350-238-20-1)</p>	
<p><i>Materials/Parts</i></p> <ul style="list-style-type: none"> Lubricating oil (item 20, appx B) Sealing compound (item 25, appx B) Spade cylinder parts kit 		<p><i>General Safety Instructions</i></p> <div style="border: 2px solid black; padding: 5px; text-align: center; width: fit-content; margin: 10px auto;">WARNING</div> <p>Wipe up any spilled hydraulic fluid to prevent injury to personnel.</p>	
<p><i>References</i></p> <ul style="list-style-type: none"> TM 9-2350-238-20-1 TM 9-2350-238-24P-1 			

DISASSEMBLY

WARNING

Wipe up any spilled hydraulic fluid to prevent injury to personnel.

- 1 Using spanner wrench (item 23, appx E), unscrew packing nut (1) from cylinder (2).

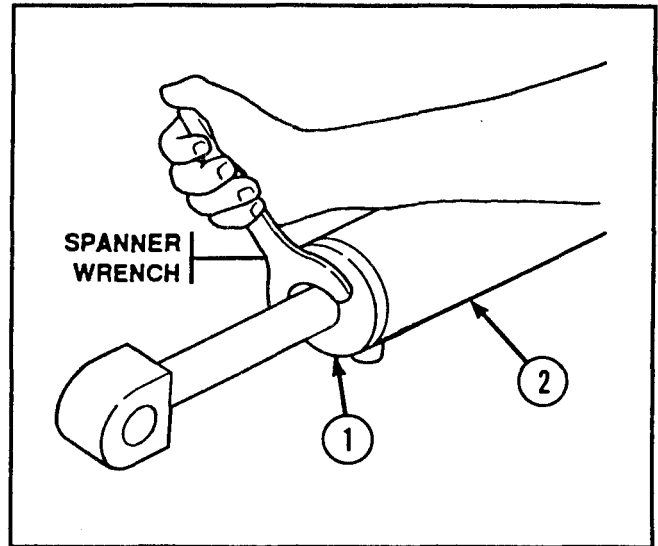

- 2 Pull piston rod (3) from cylinder (2).

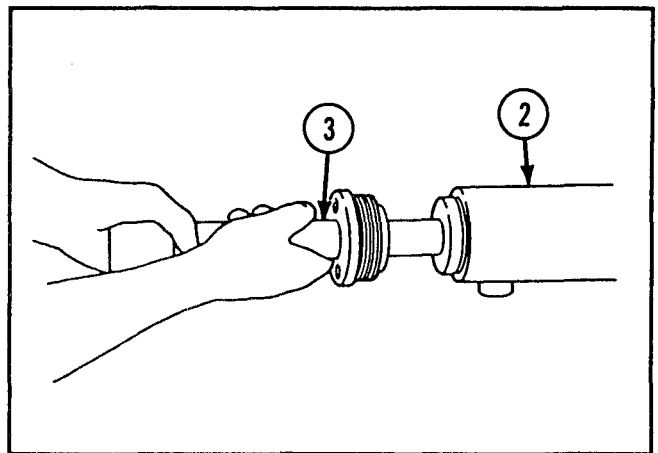

- 3 Remove preformed packing (4) from packing nut (1).

- 4 Remove two gasket retainers (5) and preformed packing (6) from piston (7).

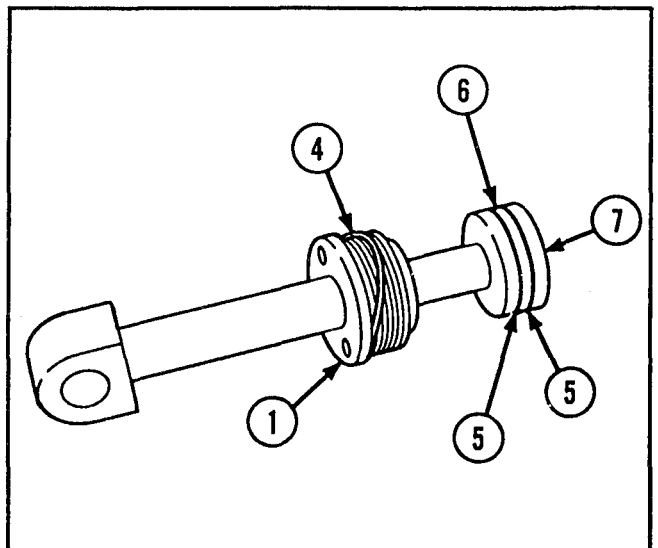

2-54. MAINTENANCE OF HYDRAULIC CYLINDER ASSEMBLY (CONT).

DISASSEMBLY (CONT)

CAUTION

Use care not to mar or scratch piston rod during removal of piston.

- 5 Hold piston rod (3) and remove piston (7) using spanner wrench (item 25, appx E).
- 6 Remove packing nut (1) and thread plug (8) from piston rod (3).

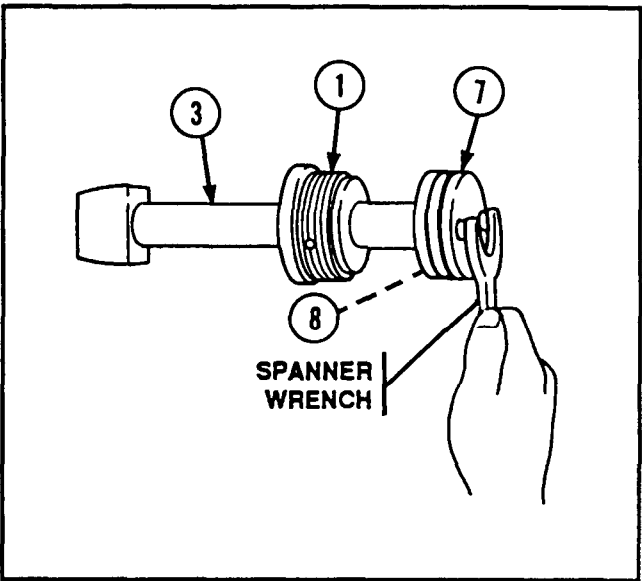

- 7 Remove plain seal (9) from packing nut (1).
- 8 Remove plain encased seal (10) and thread plug (11) from packing nut (1).

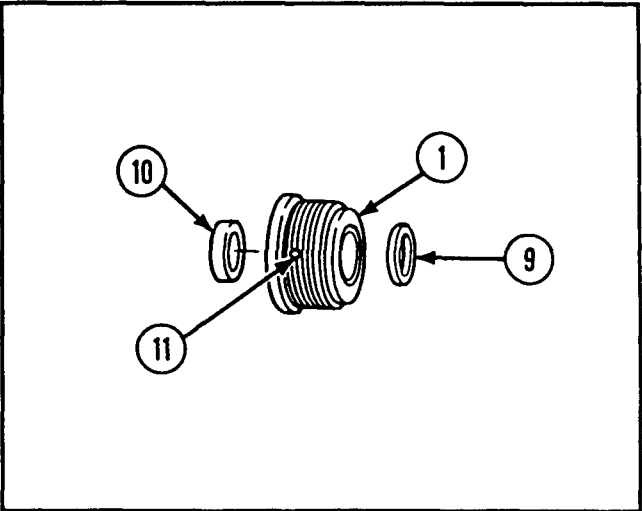

INSPECTION/REPAIR

- 1 Inspect for broken, damaged, or missing parts.
- 2 If piston is damaged, repair is by replacement of next higher assembly.
- 3 If piston rod is damaged, repair is by replacement of next higher assembly.
- 4 If cylinder is damaged, repair is by replacement of next higher assembly.
- 5 Replace all spade cylinder parts kit components.
- 6 Repair is by replacement of authorized parts (TM 9-2350-238-24P-1) which do not meet inspection criteria.

REASSEMBLY

- 1 Apply a coating of lubricating oil to seals and preformed packing.
- 2 Using oil seal inserter, install new plain encased seal (1) in packing nut (2).

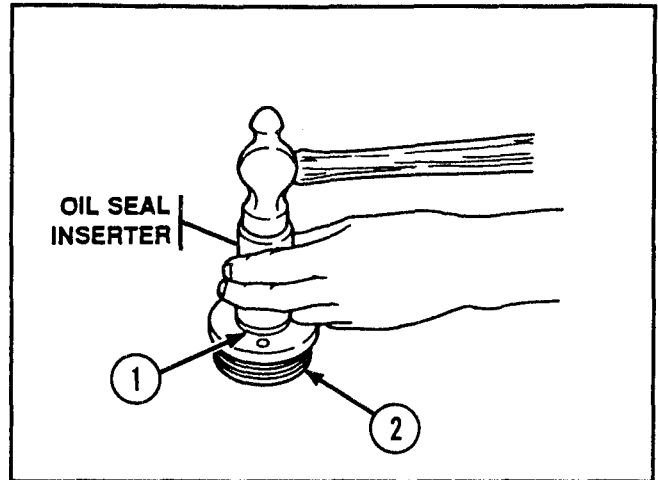

- 3 Install new thread plug (3) in packing nut (2).
- 4 Install new plain seal (4) in packing nut (2).
- 5 Install new preformed packing (5) on packing nut (2).

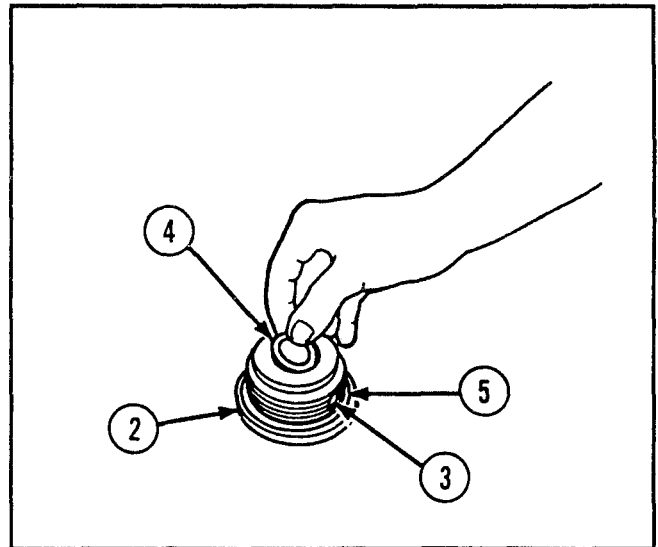

- 6 Install new preformed packing (6) and two new gasket retainers (7) on piston (8).

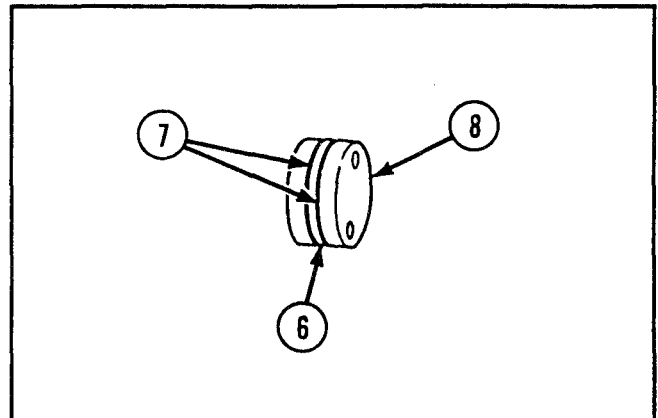

2-54. MAINTENANCE OF HYDRAULIC CYLINDER ASSEMBLY (CONT).

REASSEMBLY (CONT)

- 7 Install new thread plug (9) in piston rod (10).

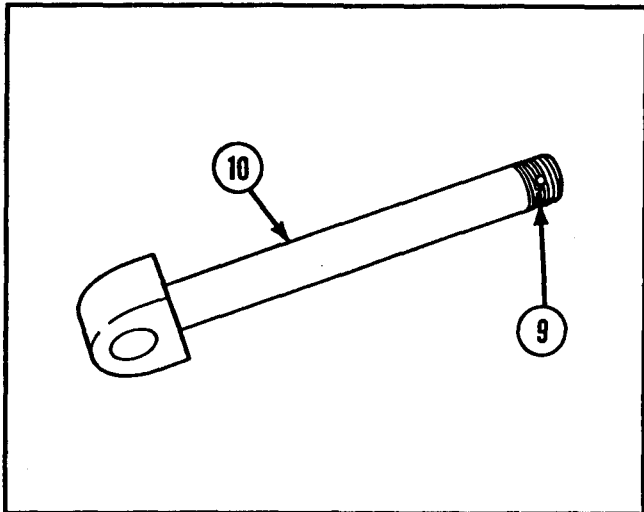

- 8 Apply seaing compound to packing nut (2) threads.
- 9 Install packing nut (2) on piston rod (10).

CAUTION

Use care not to mar or scratch piston rod during installation of piston.

- 10 Hold piston rod (10) and install piston (8) using spanner wrench (item 25, appx E).

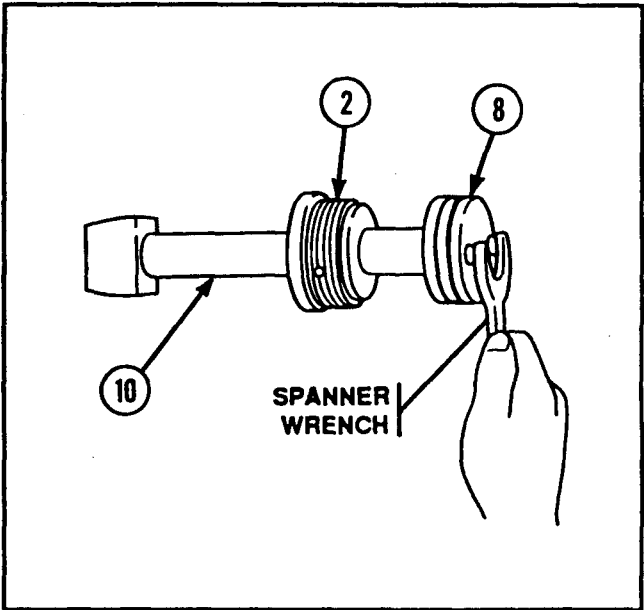

- 11 Install piston rod (10) in cylinder (11).

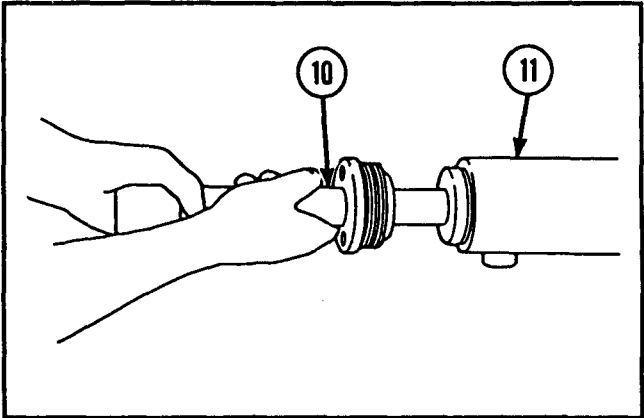

- 12 Using spanner wrench (item 26, appx E), tighten packing nut (2) in cylinder (11).

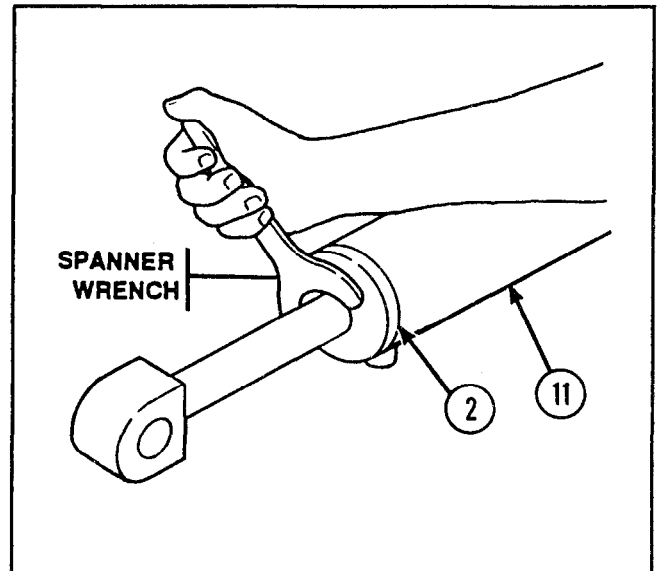

2 - 5 MAINTENANCE OF SPADE HYDRAULIC CONTROL VALVES, LINES, AND FITTINGS, AND DIRECT LINEAR VALVE.

This task covers:

- | | |
|-----------------------------|------------------------|
| a. <i>Removal</i> | d. <i>Reassembly</i> |
| b. <i>Disassembly</i> | e. <i>Installation</i> |
| c. <i>Inspection/Repair</i> | |

INITIAL SETUP

Materials/Parts

- Direct linear valve parts kit
- Lockwasher (2)
- Lubricating oil (item 20, appx B)

References

- TM 9-2350-238-20-1
- TM 9-2350-238-24P-1

General Safety Instructions

WARNING

Wipe up any spilled hydraulic fluid to prevent injury to personnel.

2-55. MAINTENANCE OF SPADE HYDRAULIC CONTROL VALVES, LINES, AND FITTINGS, AND DIRECT LINEAR VALVE (CONT).

REMOVAL

NOTE

For removal of hydraulic lines and fittings, refer to general maintenance, page 2-19.

- 1 Remove two hexagon head capscrews (1) and two lockwashers (2) from direct linear valve (3).
- 2 Remove direct linear valve (3) by disconnecting hydraulic lines and fittings.

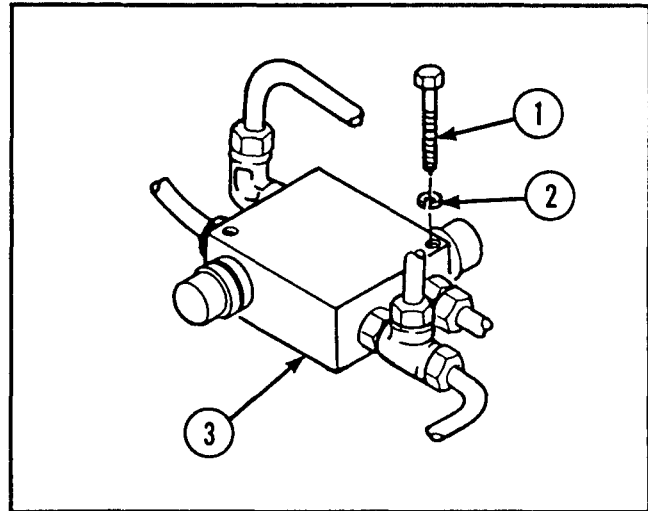

DISASSEMBLY

WARNING

Wipe up any spilled hydraulic fluid to prevent injury to personnel.

- 1 Remove two bonnets (1), two O-rings (2), and two backup rings (3) from direct linear valve body (4).

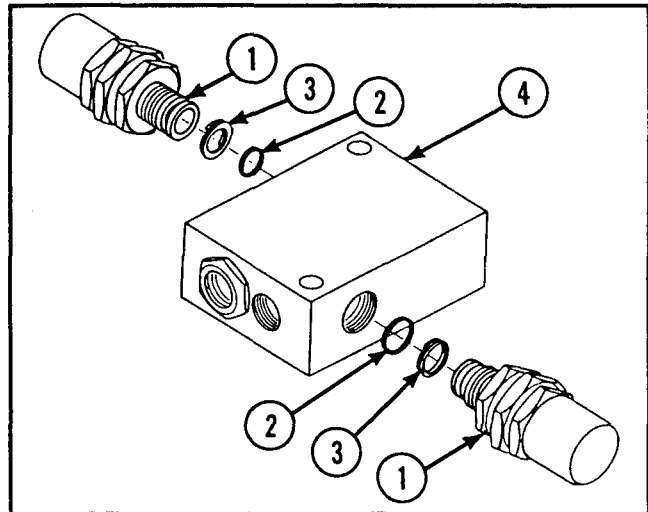

- 2 Remove two pistons (5), two O-rings (6), and two backup rings (7) from direct linear valve body (4).

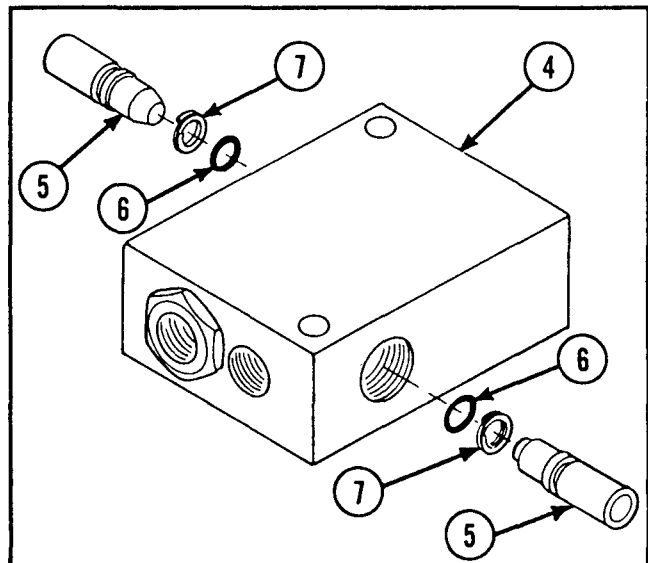

- 3 Remove two adapters (8), two O-rings (9), two backup rings (10), and two O-rings (11) from direct linear valve body (4).

NOTE

Adapter check balls are not authorized repair parts. Use care to ensure that they are not lost or damaged.

- 4 Remove two adapter check balls (12) from direct linear valve body (4).

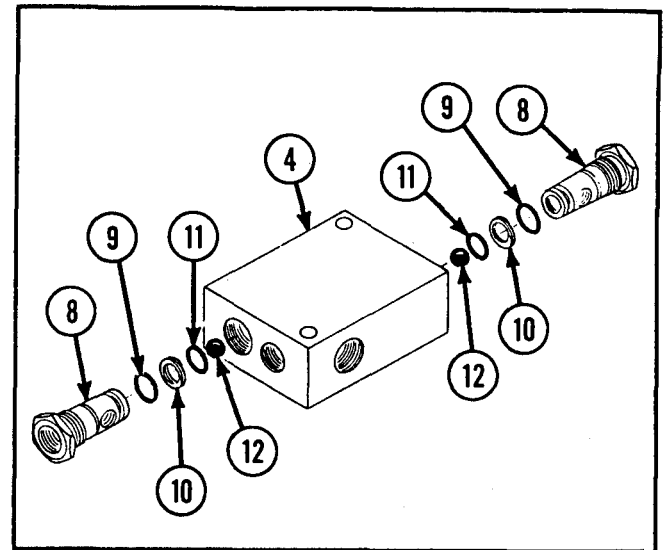

INSPECTION/REPAIR

- 1 Inspect for broken, damaged, or missing parts.
- 2 If bonnets, direct linear valve body, or adapters are broken, damaged, or missing, repair is by replacement of next higher assembly.
- 3 Replace all direct linear valve parts kit components.
- 4 Repair is by replacement of authorized parts (TM 9-2350-238-2P-1) which do not meet inspection criteria.

REASSEMBLY

CAUTION

A cut or nicked O-ring will leak during operation.

NOTE

Lubricate all O-rings with lubricating oil.

- 1 Install new O-ring (1), new backup ring (2), and new O-ring (3) on each of two adapters (4).
- 2 Install two adapter check balls (5) and two adapters (4) in direct linear valve body (6).

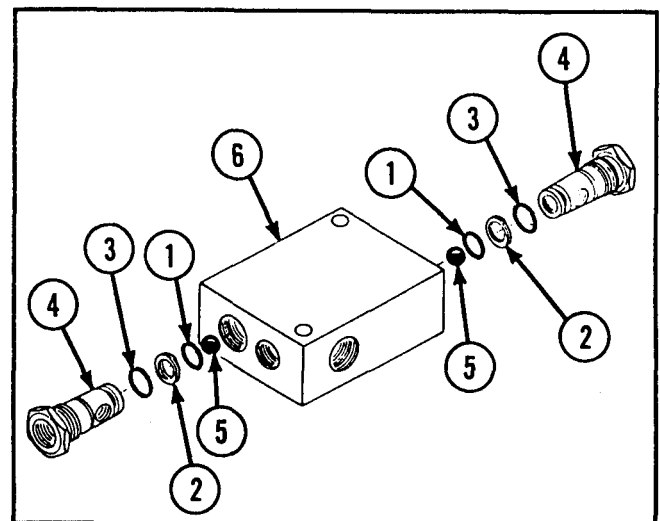

2-55. MAINTENANCE OF SPADE HYDRAULIC CONTROL VALVES, LINES, AND FITTINGS, AND DIRECT LINEAR VALVE (CONT).

REASSEMBLY (CONT)

- 3 Install new O-ring (7) and new backup ring (8) on each of two pistons (9).
- 4 Install two pistons (9) in direct linear valve body (6).

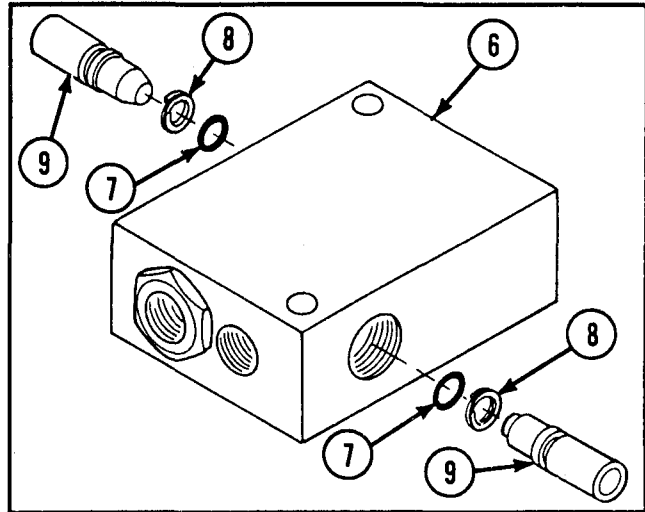

- 5 Install new O-ring (10) and new backup ring (11) on each of two bonnets (12).
- 6 Install two bonnets (12) to direct linear valve body (6).

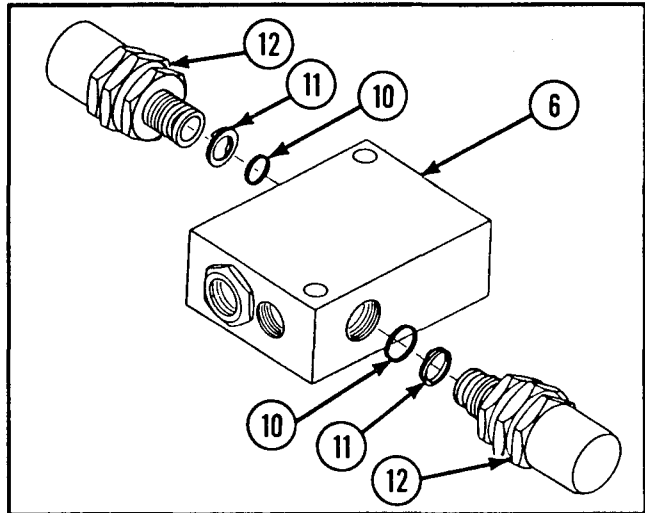

INSTALLATION

NOTE

For installation of hydraulic lines and fittings, refer to general maintenance, page 2-19.

- 1 Install direct linear valve (1) by connecting hydraulic lines and fittings.
- 2 Install two new lockwashers (2) and two hexagon head capscrews (3) to direct linear valve (1).

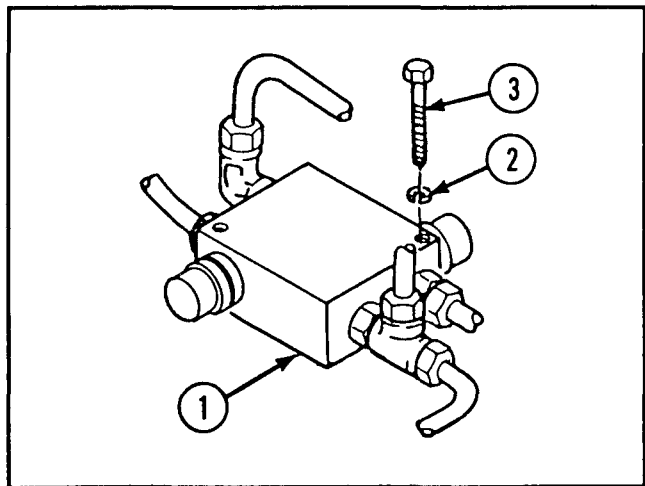

2-56. MAINTENANCE OF ENGINE BLOWER ASSEMBLY (HEATER INSTALLATION KIT).

This task covers:		a. <i>Disassembly</i>	b. <i>Inspection/Repair</i>	c. <i>Reassembly</i>
INITIAL SETUP				
Tools and Special Tools		References		
Automotive maintenance and repair shop equipment: field maintenance, basic, less power (SC 4910-95-A31)		TM 9-2350-238-20-1		
• Plier wire twister		TM 9-2350-238-24P-1		
		TM 9-2920-224-34&P		
Materials/Parts		Equipment Conditions		
Lockwasher (15)		Engine blower assembly removed (TM 9-2350-238-20-1)		
Lockwasher (2)				
Lockwire (item 32, appx B)				
Preformed packing				
Sealing compound (item 25, appx B)				

DISASSEMBLY

- 1 Remove five machine screws (1) and five lockwashers (2) from forward blower housing (3).
- 2 Remove ten machine screws (4) and ten lockwashers (5) from rear blower housing (6). Separate forward blower housing (3) from rear blower housing (6).

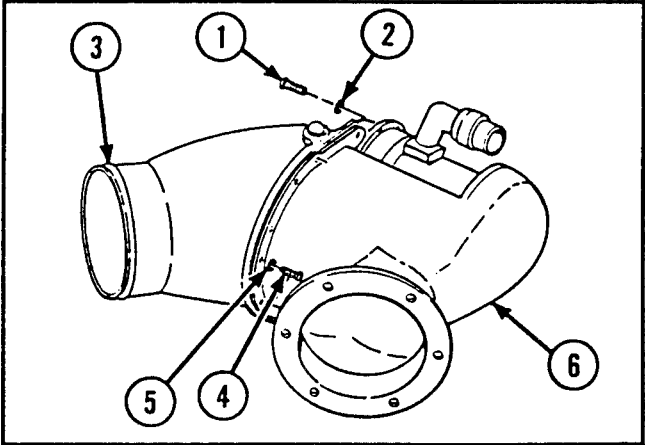

- 3 Remove lockwire (7), five capscrews (8), heater blower plate (9), and tube axial fan (10) from rear blower housing (6).

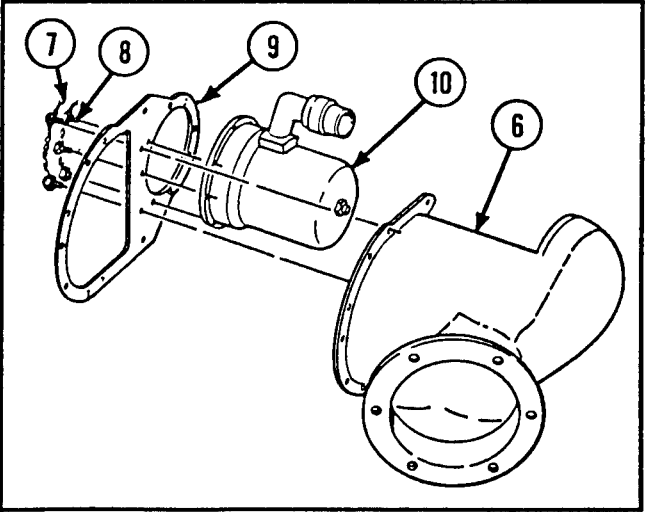

2-56. MAINTENANCE OF ENGINE BLOWER ASSEMBLY (HEATER INSTALLATION KIT)
(CONT).

DISASSEMBLY (CONT)

- 4 Remove expansion plug (11), lockwire (12), capscrew (13), and flat washer (14).
- 5 Pull solenoid shaft (15) from forward blower housing (3) and remove heater blower flap (16).

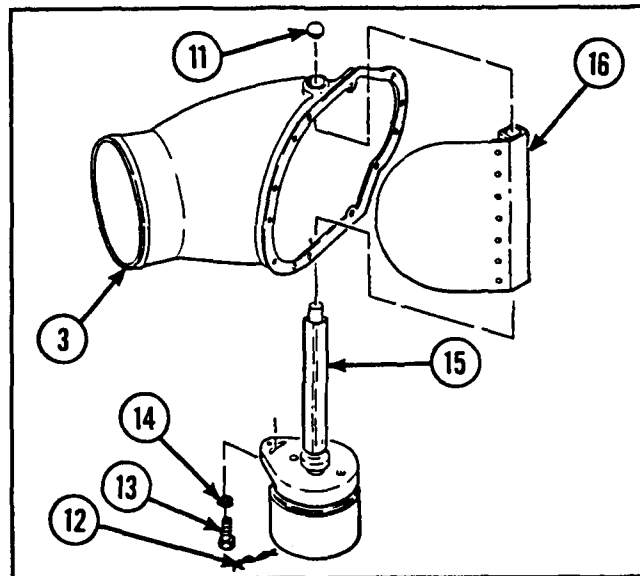

- 6 Remove two spring pins (17), solenoid shaft (15), flat washer (18), and preformed packing (19) from electrical solenoid (20).
- 7 Remove two hexagon plain nuts (21), two lockwashers (22), and blower assembly adapter (23) from electrical solenoid (20).

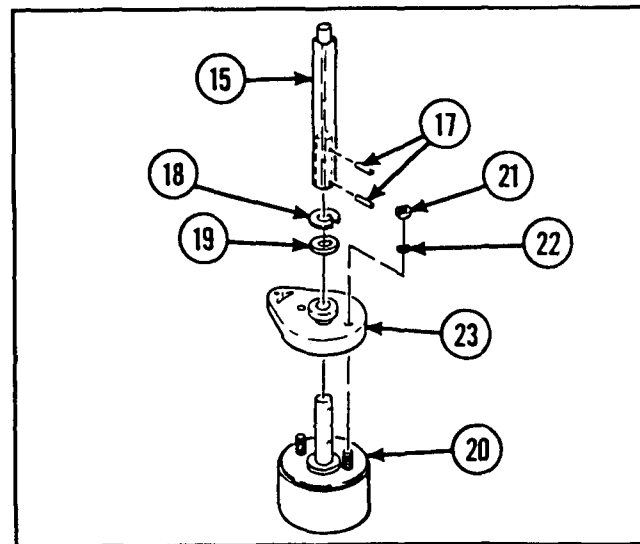

INSPECTION/REPAIR

- 1 Inspect for broken, damaged, or missing parts.
- 2 Tube axial fan is a repairable assembly. Refer to TM 9-2920-224-34&P.
- 3 Repair is by replacement of authorized parts (TM 9-2350-238-24P-1) which do not meet inspection criteria.

REASSEMBLY

- 1 Coat contact surface of electrical solenoid (1) with sealing compound and install blower assembly adapter (2), two new lockwashers (3), and two hexagon plain nuts (4) to electrical solenoid (1).
- 2 Install new preformed packing (5), flat washer (6), and solenoid shaft (7) on electrical solenoid (1). Secure with two spring pins (8).

NOTE

With heater blower flap fully open, adjust electrical solenoid to full neutral position.

- 3 Install heater blower flap (9) and solenoid shaft (7) in forward blower housing (10).
- 4 Install flat washer (11), capscrew (12), expansion plug (13), and new lockwire (14).

- 5 Install tube axial fan (15), blower heater plate (16), and five capscrews (17) to rear blower assembly (18). Secure with new lockwire (19).

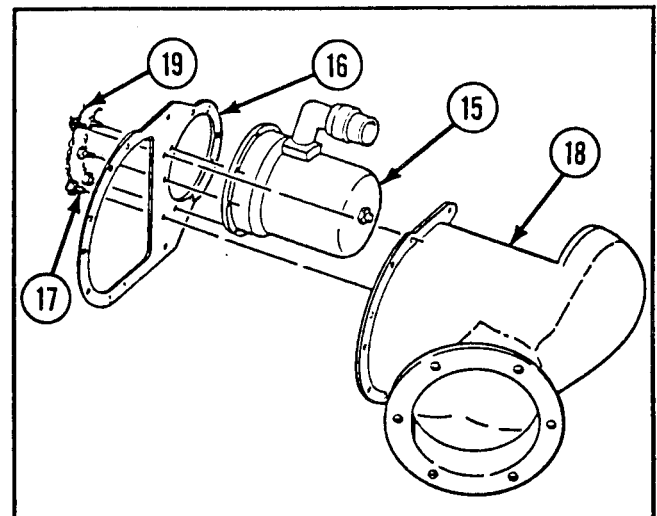
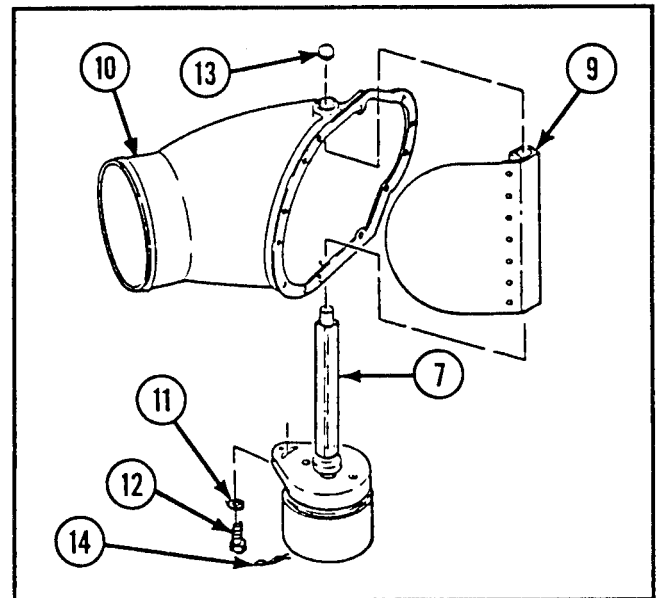
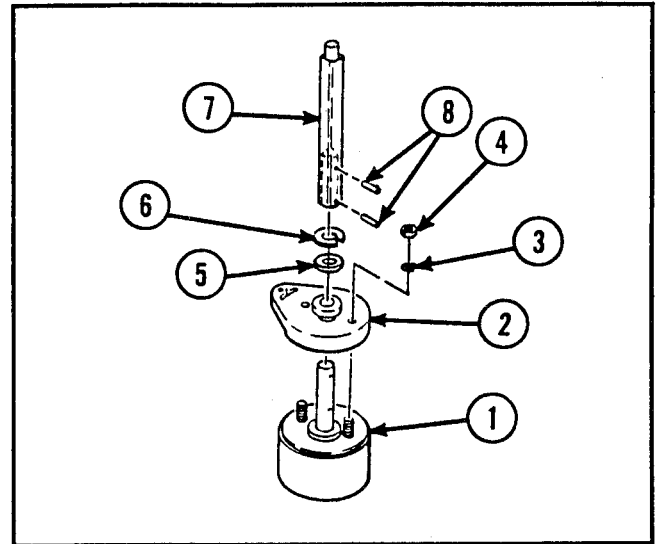

2-56. MAINTENANCE OF ENGINE BLOWER ASSEMBLY (HEATER INSTALLATION KIT)
(CONT).

REASSEMBLY (CONT)

NOTE

Coat forward blower housing and rear blower housing with sealing compound.

- 6 Align rear blower housing (18) with forward blower housing (10) and secure with ten new lockwashers (20) and ten machine screws (21).
- 7 Install five new lockwashers (22) and five machine screws (23).

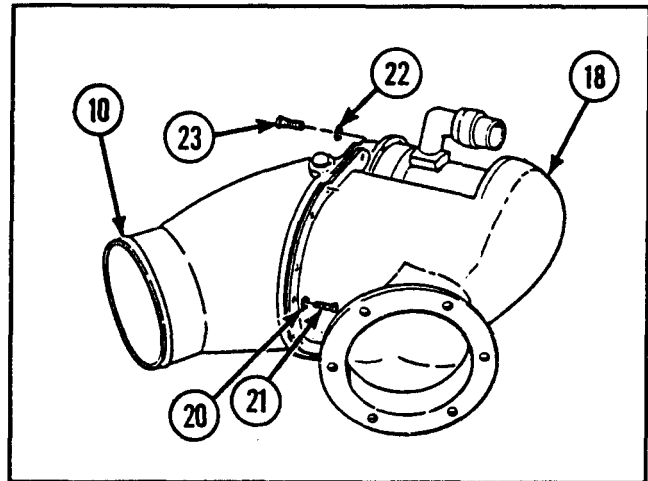

2-57. MAINTENANCE OF HEATER ELECTRICAL CONTROL BOX (HEATER INSTALLATION KIT).

This task covers:	a. <i>Disassembly</i>	b. <i>Inspection/Repair</i>	c. <i>Reassembly</i>
INITIAL SETUP			
<i>Materials/Parts</i>		<i>Equipment Conditions</i>	
Lockwasher (2)		Heater electrical control box removed	
Lockwasher (2)		(TM 9-2350-238-20-1)	
Varnish (item 31, appx B)			
<i>References</i>			
TM 9-2350-238-20-1			
TM 9-2350-238-24P-1			

DISASSEMBLY

NOTE

Procedures are written for driver's heater electrical control box, but also apply to coolant heater electrical control box and crew heater electrical control box.

- 1 Remove two threaded tapping screws (1), two assembled washer screws (2), panel (3) with attached parts, and two sheet spring nuts (4) from control case assembly (5).
- 2 Remove two hexagon plain nuts (6), two lockwashers (7), and two screws (8) from control case assembly (5).

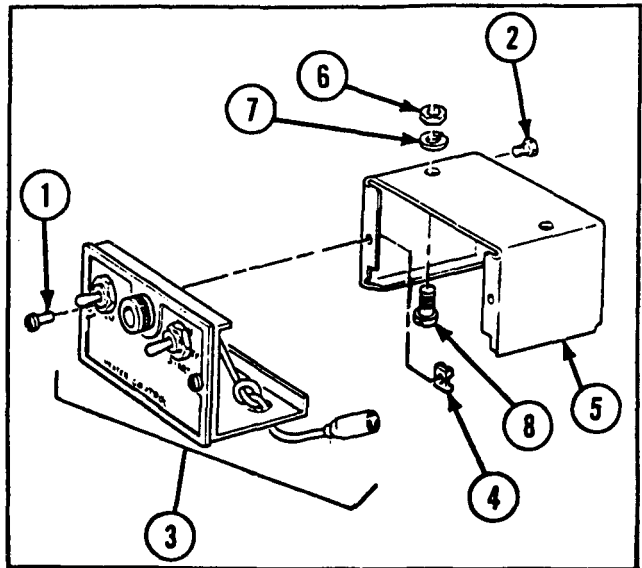

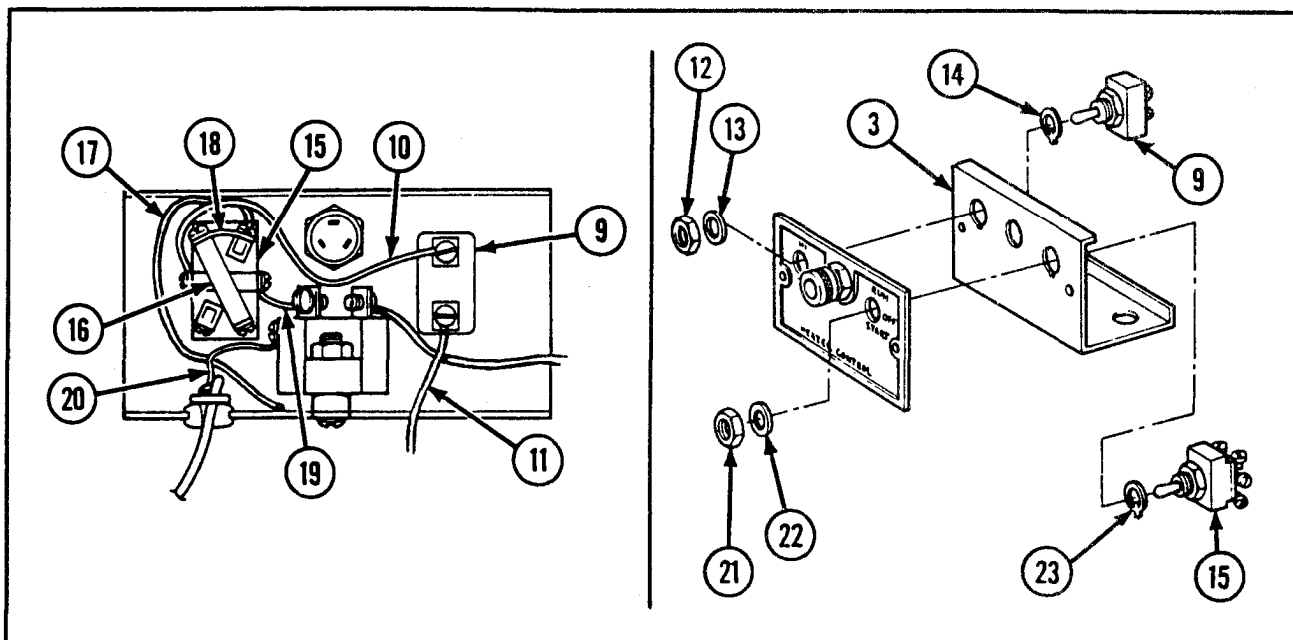

- 3 Remove screws at terminals 12 and 13 of HI/LO toggle switch (9), and disconnect two electrical leads (10 and 11).
- 4 Remove hexagon nut (12), lockwasher (13), HI/LO toggle switch (9), and key washer (14) from panel (3).
- 5 Remove screw from RUN/OFF/START toggle switch (15) terminals 21 and 18, and remove jumper assembly (16).
- 6 Remove screw from RUN/OFF/START toggle switch (15) terminal 14. Disconnect heater control switch electrical lead (17) and remove retaining plate (18) from RUN/OFF/START toggle switch.
- 7 Remove screw from RUN/OFF/START toggle switch (15) terminal 15 and disconnect lead (19).
- 8 Remove screw and disconnect lead (19) from RUN/OFF/START toggle switch (15) terminal 20.
- 9 Remove screw and disconnect three leads (20) from RUN/OFF/START toggle switch (15) terminal 19. Remove RUN/OFF/START toggle switch-to-HI/LO toggle switch lead (10) from panel (3).
- 10 Remove plain hexagon nut (21), lockwasher (22), RUN/OFF/START toggle switch (15), and key washer (23) from panel (3).

2-57. MAINTENANCE OF HEATER ELECTRICAL CONTROL BOX (HEATER INSTALLATION KIT) (CONT).

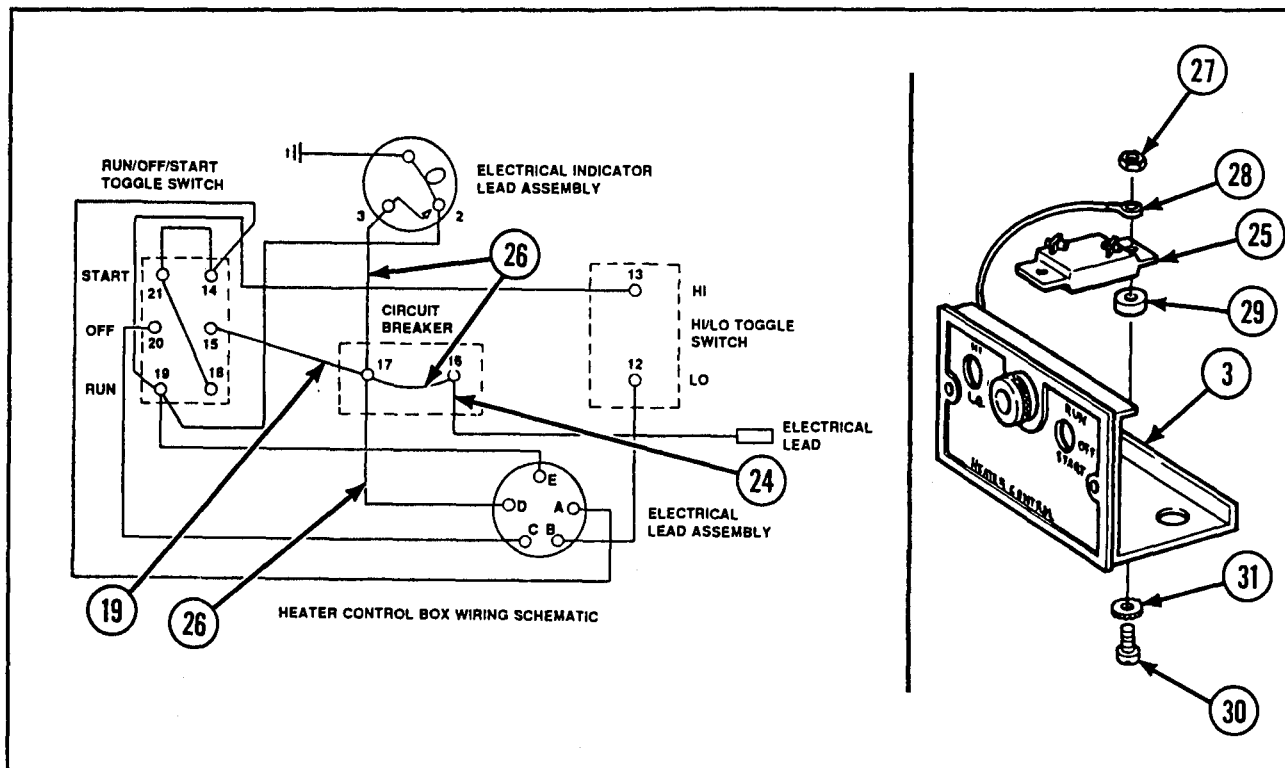

11 Remove screw and disconnect lead (24) from circuit breaker (25) terminal 16.

12 Remove screw and disconnect three leads (26) from circuit breaker (25) terminal 17. Remove lead (19) from panel (3).

13 Remove two nuts (27) and disconnect ground lead (28) from circuit breaker (25).

Remove circuit breaker (25), two spacers (29), two machine screws (30), and two lockwashers (31) from panel (3).

14 Remove circuit breaker (25) from panel (3).

15 Remove lens cap (32) and incandescent lamp (33) from electrical indicator lead assembly (34). Remove plain hexagon nut (35), lockwasher (36), indicator panel (37), and electrical indicator lead assembly (34) from panel (3).

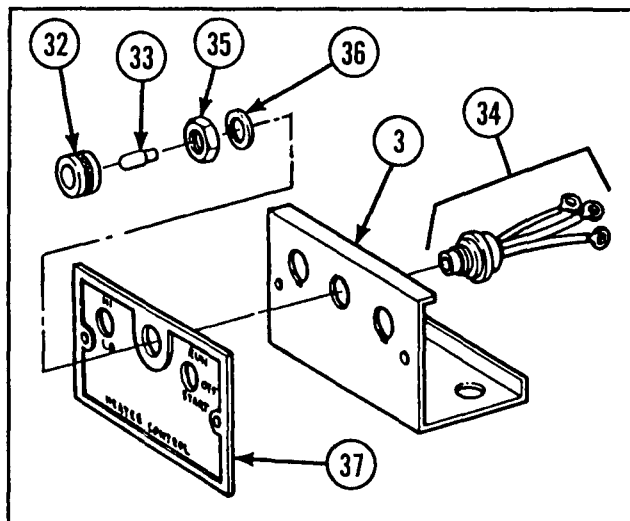

- 16 Remove four assembled washer screws (38), electrical lead assembly (39), and cable assembly mounting angle bracket (40) from panel (3).
- 17 Remove electrical lead (41) and nonmetallic grommet (42) from panel (3).

INSPECTION/REPAIR

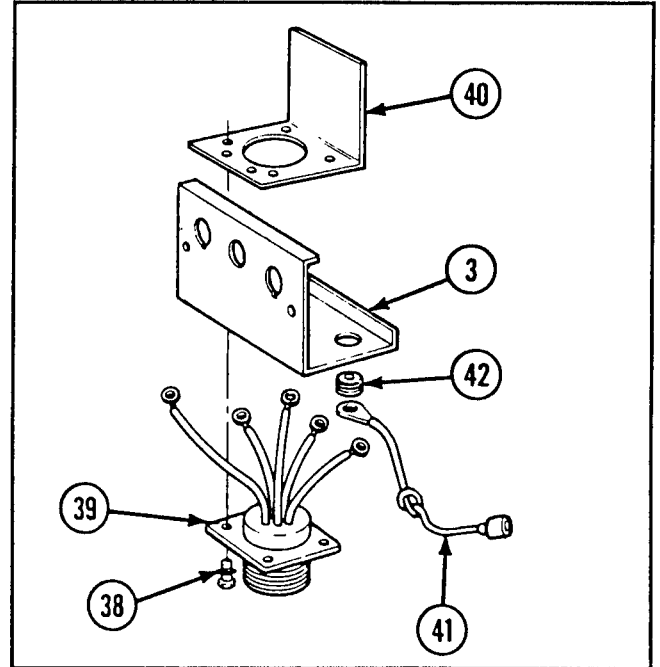

- 1 Inspect for broken, damaged, or missing parts.
- 2 For repair of electrical lead and shell connector, refer to general maintenance, page 2-21.
- 3 Repair is by replacement of authorized parts (TM 9-2350-238-24P-1) which do not meet inspection criteria.

REASSEMBLY

NOTE

Procedures are written for heater electrical control box, but also apply to coolant heater control box assembly and crew heater control box assembly.

- 1 Install cable assembly mounting angle bracket (1), electrical lead assembly (2), and four assembled washer screws (3) to panel (4).
- 2 Install electrical indicator lead assembly (5), indicator panel (6), lockwasher (7), and plain hexagon nut (8) to panel (4). Install incandescent lamp (9) and lens cap (10) to electrical indicator lead assembly.

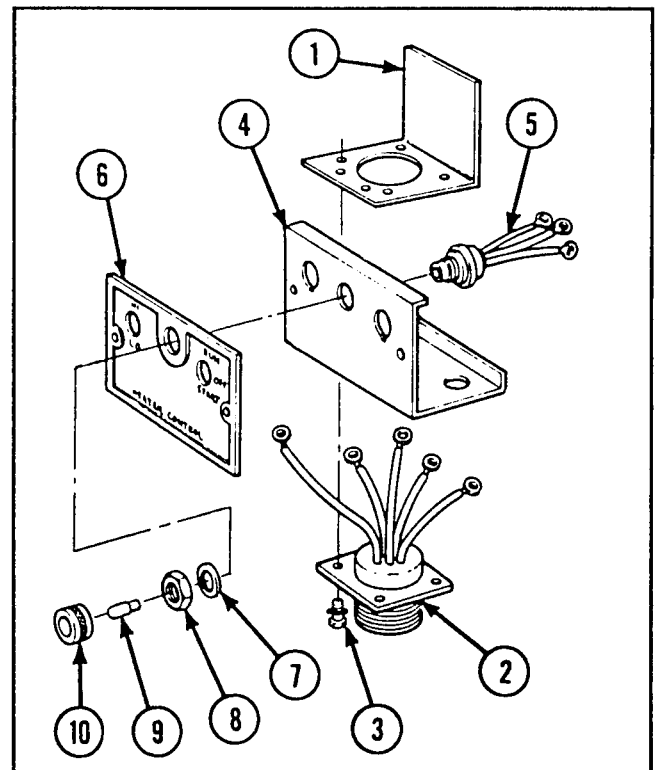

2-57. MAINTENANCE OF HEATER ELECTRICAL CONTROL BOX (HEATER INSTALLATION KIT) (CONT).

REASSEMBLY (CONT)

NOTE

Secure indicator ground lead to one of the circuit breaker mounting screws.

- 3 Install two new lockwashers (11), two machine screws (12), two spacers (13), circuit breaker (14), ground lead (15) from indicator lamp terminal 1, and two plain hexagon nuts (16).

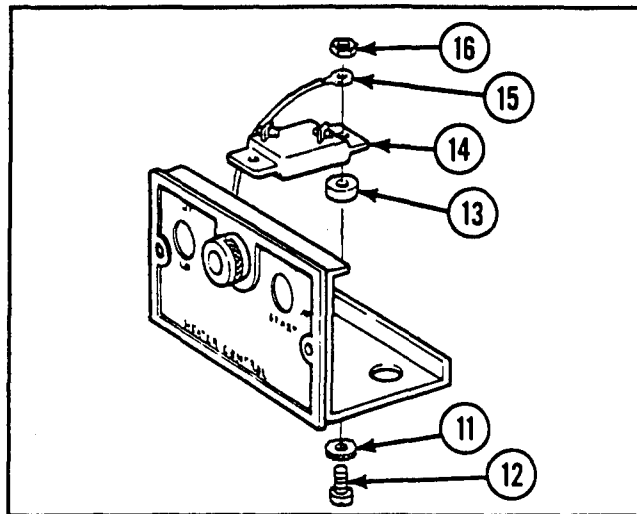

- 4 Install grommet (17) to panel (4). Install electrical lead (18) to circuit breaker terminal 16.

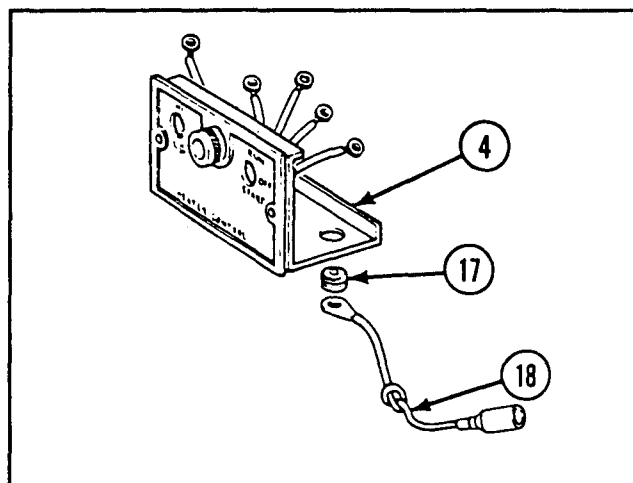

- 5 Install key washer (19), RUN/OFF/START toggle switch (20), lockwasher (21), and plain hexagon nut (22) to panel (4) with attached parts.

- 6 Install key washer (23), HI/LO toggle switch (24), lockwasher (25), and plain hexagon nut (26) to panel (4) with attached parts.

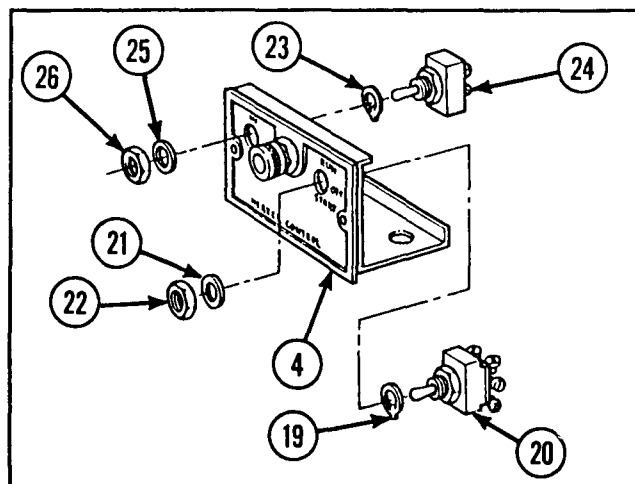

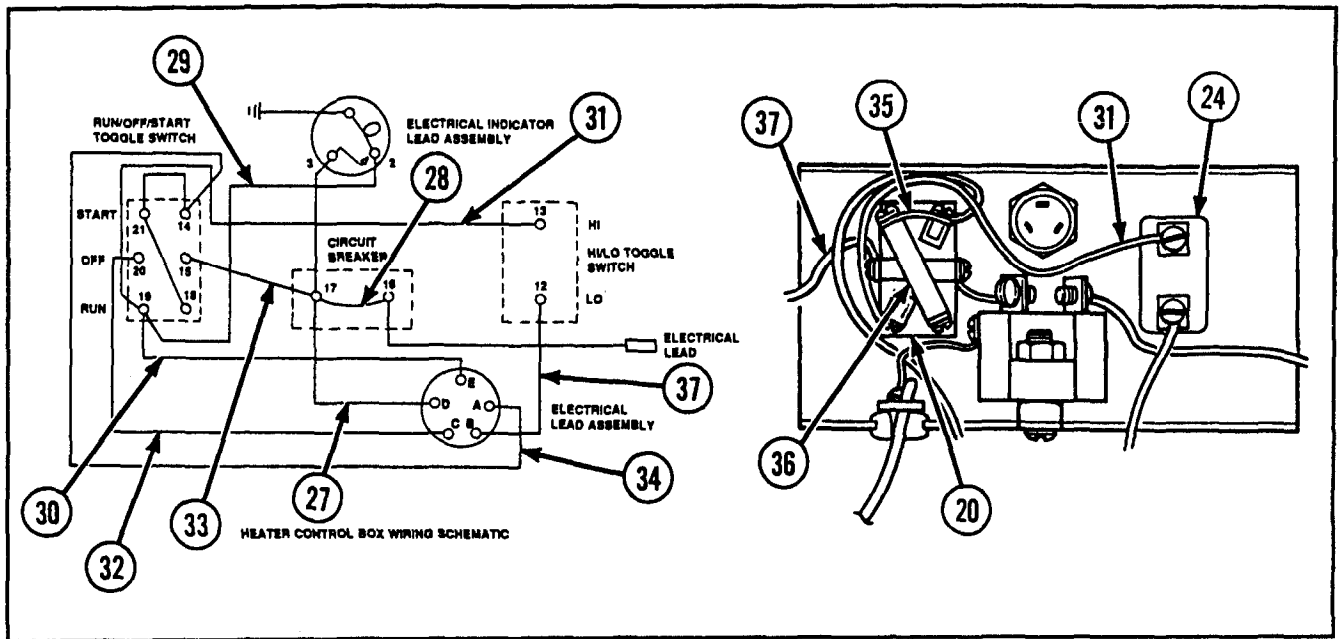

- 7 Connect lead from electrical indicator lead assembly terminal 3, lead (27) from electrical lead assembly pin D, and one end of lead (28) to circuit breaker terminal 17. Secure three leads with screw.
- 8 Connect lead (29) from indicator lamp terminal 2 to terminal 19 of RUN/OFF/START toggle switch (20).
- 9 Connect lead (30) from electrical lead assembly pin E to terminal 19 of RUN/OFF/START toggle switch (20).
- 10 Connect electrical lead (31) from HI/LO toggle switch (24) terminal 13 to RUN/OFF/START toggle switch terminal 20. Secure leads with screw.
- 11 Connect lead (32) from electrical lead assembly terminal C to RUN/OFF/START toggle switch (20) terminal 20. Secure to RUN/OFF/START toggle switch with screw.
- 12 Connect lead (33) from circuit breaker terminal 17 to RUN/OFF/START toggle switch (20) terminal 15. Secure to toggle switch with screw.
- 13 Install heater control switch electrical lead (34) from electrical lead assembly pin A, with retaining plate (35), and screw to RUN/OFF/START toggle switch (20) terminal 14.
- 14 Install retaining plate (35) and one end of jumper (36) to RUN/OFF/START toggle switch (20) terminal 21. Secure to toggle switch with screw.
- 15 Connect other end of jumper (36) to RUN/OFF/START toggle switch (20) terminal 18, and secure to toggle switch with screw.
- 16 Connect lead (37) from electrical lead assembly pin B to Hi/LO toggle switch (24) terminal 12. Secure lead to HI/LO toggle switch with screw.

2-57. MAINTENANCE OF HEATER ELECTRICAL CONTROL BOX (HEATER INSTALLATION KIT) (CONT).

REASSEMBLY (CONT)

- 17 Apply varnish or equivalent to all exposed metal where wires attach to screw terminals to protect against fungus growth and moisture.
- 18 Install two new lockwashers (38), two screws (39), and two plain hexagon nuts (40) into control case assembly (41). Install two sheet spring nuts (42), panel (4), two assembled washer screws (43), and two threaded tapping screws (44) to control case assembly (41).

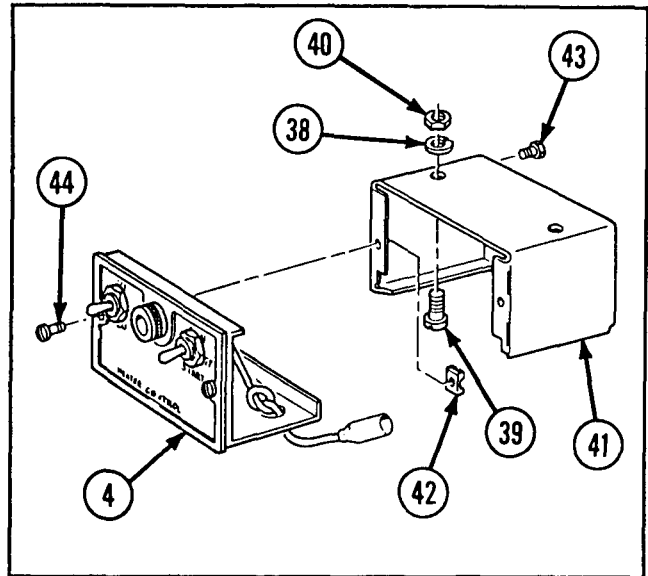

2-58. MAINTENANCE OF VEHICULAR WINDOW (DRIVER'S AND CRANE OPERATOR'S WINDSHIELD).

This task covers:	a. Disassembly	b. Inspection/Repair	c. Reassembly
INITIAL SETUP			
<i>Materials/Parts</i>			
Epoxy adhesive (item 1, appx B)			
Nonmetallic seal (figure C-3, appx C)			
Rubber section (figure C-4, appx C)			
Rubber strip (figure C-5, appx C)			
<i>References</i>			
TM 9-2350-238-20-1			
TM 9-2350-238-24P-1			
<i>Equipment Conditions</i>			
Vehicular window removed and partially disassembled (TM 9-2350-238-20-1)			

DISASSEMBLY

- 1 Remove rubber section (1).
- 2 Remove nonmetallic seal (2).
- 3 Remove rubber strip (3) and windshield (4) from frame (5).

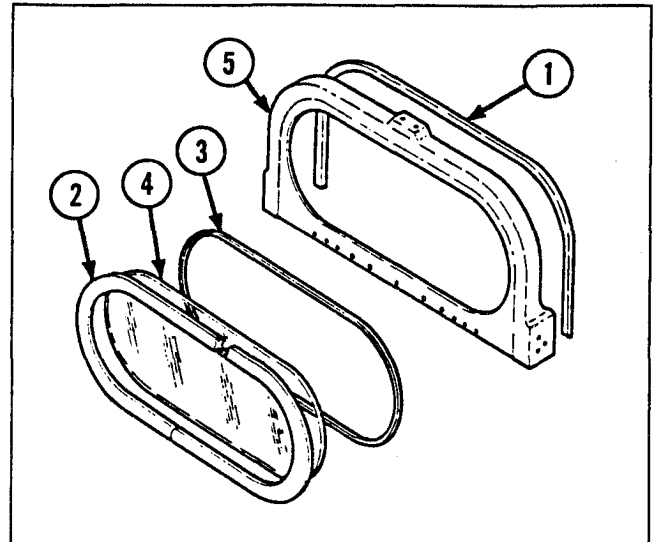

INSPECTION/REPAIR

- 1 Inspect for broken, damaged, or missing parts.
- 2 If frame is broken, damaged, or missing, repair is by replacement of next higher assembly.
- 3 Rubber section, rubber strip, and nonmetallic seal are manufactured items, refer to appendix C.
- 4 Repair is by replacement of authorized parts (TM 9-2350-238-24P-1) which do not meet inspection criteria.

REASSEMBLY

- 1 Install new rubber strip (3) and windshield (4) in frame (5).
- 2 Install new nonmetallic seal (2).
- 3 Apply epoxy adhesive to new rubber section (1), and install to frame (5).

2-59. MAINTENANCE OF VEHICULAR WINDOW AND CRANE WINDOW ASSEMBLY.

This task covers:	a. <i>Disassembly</i>	b. <i>Inspection/Repair</i>	c. <i>Reassembly</i>
INITIAL SETUP			
<i>Materials/Parts</i>		<i>Equipment Conditions</i>	
Epoxy adhesive (item 1, appx B)		Vehicular window or crane window assembly removed and partially disassembled (TM 9-2350-238-20-1)	
Rubber channel window-to-frame seal			
Self-locking nut (28)			
<i>References</i>			
TM 9-2350-238-20-1			
TM 9-2350-238-24P-1			

2-59. MAINTENANCE OF VEHICULAR WINDOW AND CRANE WINDOW ASSEMBLY
(CONT).

DISASSEMBLY

- 1 Remove 28 self-locking nuts (1), 56 flat washers (2), 28 machine screws (3), and right and left window panels (4 and 5).
- 2 Remove window-to-frame rubber channel seal (6) from frame (7).

INSPECTION/REPAIR

- 1 Inspect for broken, damaged, or missing parts.
- 2 Inspect window for chips, cracks, breaks, bubbles, and change of color.
- 3 If frame is broken, damaged, or missing, repair is by replacement of next higher assembly.
- 4 Repair is by replacement of authorized parts (TM 9-2350-238-24P-1) which do not meet inspection criteria.

REASSEMBLY

- 1 Apply adhesive to new window-to-frame rubber channel seal (6), and install seal in frame (7).
- 2 Install left and right window panels (5 and 4) in frame (7), and secure with 56 flat washers (2), 28 machine screws (3), and 28 new self-locking nuts (1).

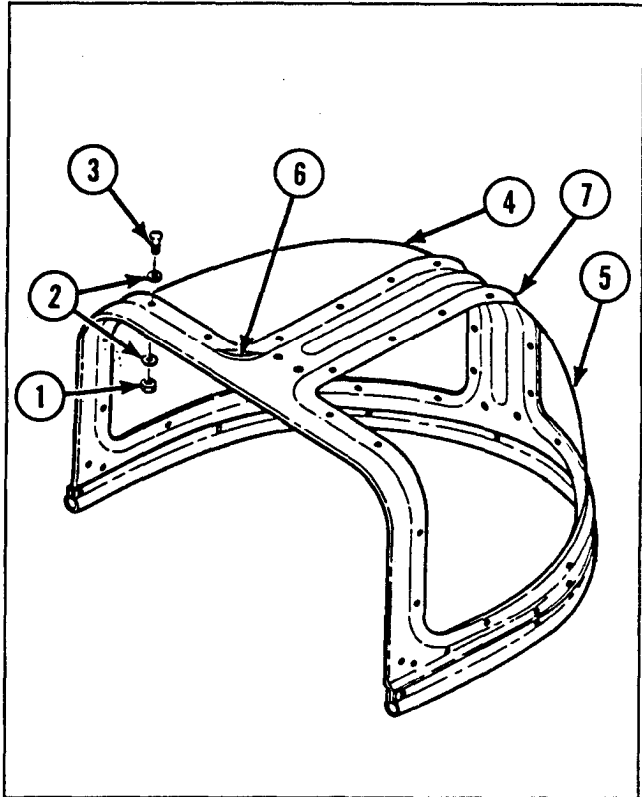

2-60. MAINTENANCE OF WINDSHIELD WIPER MOTOR ASSEMBLY (DRIVER'S WINDSHIELD ENCLOSURE KIT).

This task covers:	a. <i>Disassembly</i>	b. <i>Inspection/Repair</i>	c. <i>Reassembly</i>
INITIAL SETUP			
<i>Materials/Parts</i>			
Lockwasher (5)			
Lockwasher (7)			
Lockwasher (2)			
<i>References</i>			
TM 9-2350-238-20-1			
TM 9-2350-238-24P-1			
<i>Equipment Conditions</i>			
Windshield wiper motor assembly removed (TM 9-2350-238-20-1)			

DISASSEMBLY

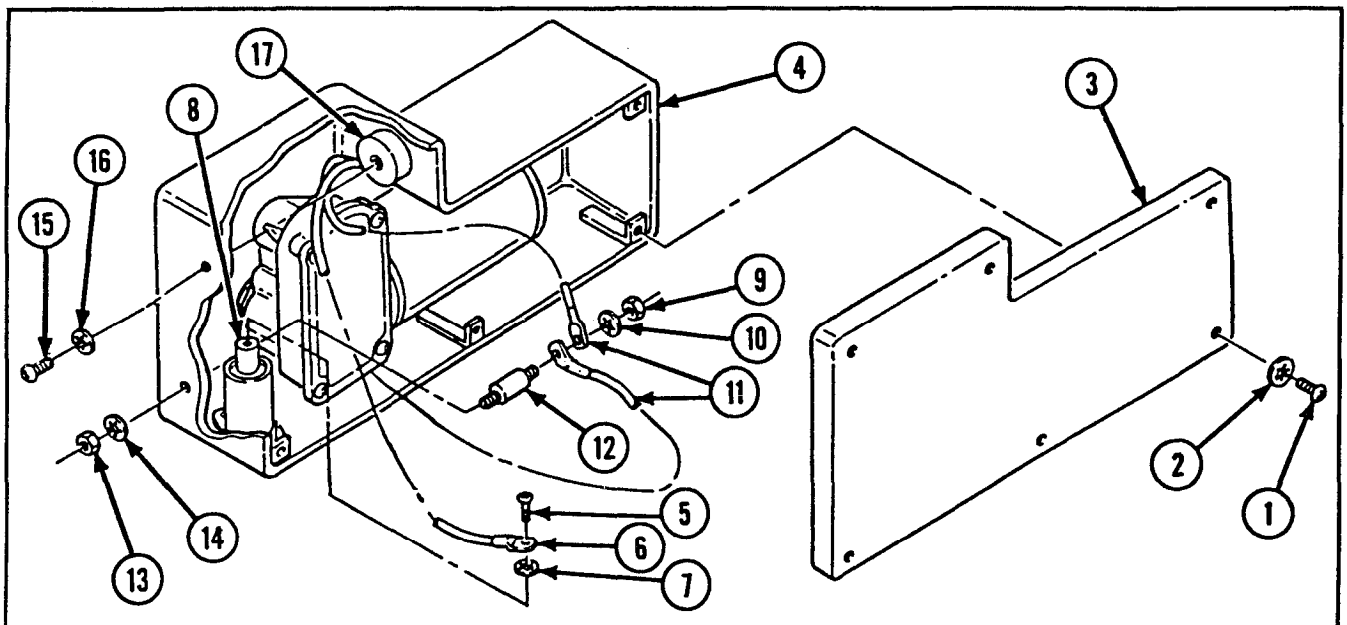

- 1 Remove six machine screws (1), six lockwashers (2), and cover (3) from shield assembly (4).
- 2 Remove machine screw (5), electrical lead (6), and lockwasher (7) from fixed capacitor (8).
- 3 Remove plain hexagon nut (9), lockwasher (10), two electrical leads (11), stand off insulator (12), plain hexagon nut (13), and lockwasher (14).
- 4 Remove machine screw (15), lockwasher (16), and induction motor coil (17).

2-60. MAINTENANCE OF WINDSHIELD WIPER MOTOR ASSEMBLY (DRIVER'S WINDSHIELD ENCLOSURE KIT) (CONT).

DISASSEMBLY (CONT)

- 5 Remove plain hexagon nut (18), lockwasher (19), machine screw (20), and capacitor (21).
- 6 Remove nut (22), plain hexagon nut (23), lockwasher (24), electrical lead (11) and windshield wiper motor (25) from shield assembly (4).
- 7 Remove two plain hexagon nuts (26), two lockwashers (27), two machine screws (28), and fixed capacitor (8).

INSPECTION/REPAIR

- 1 Inspect for broken, damaged, or missing parts.
- 2 Repair is by replacement of authorized parts (TM 9-2350-238-24P-1).

REASSEMBLY

- 1 Install fixed capacitor (1), two machine screws (2), two new lockwashers (3), and two plain hexagon nuts (4) in shield assembly (5).
- 2 Install windshield wiper motor (6).
- 3 Install electrical lead (7), new lockwasher (8), plain hexagon nut (9), and nut (10) to windshield wiper motor (6).
- 4 Install capacitor (11), machine screw (12), new lockwasher (13), and plain hexagon nut (14).

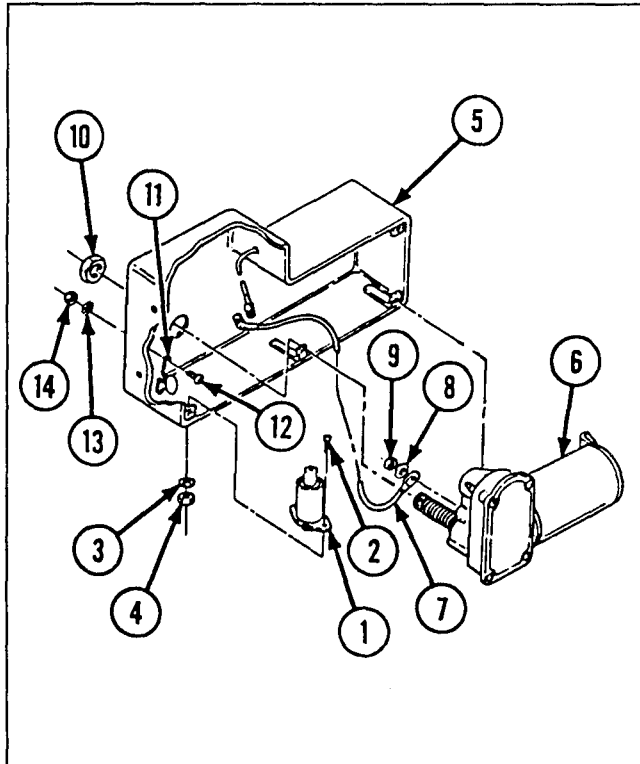
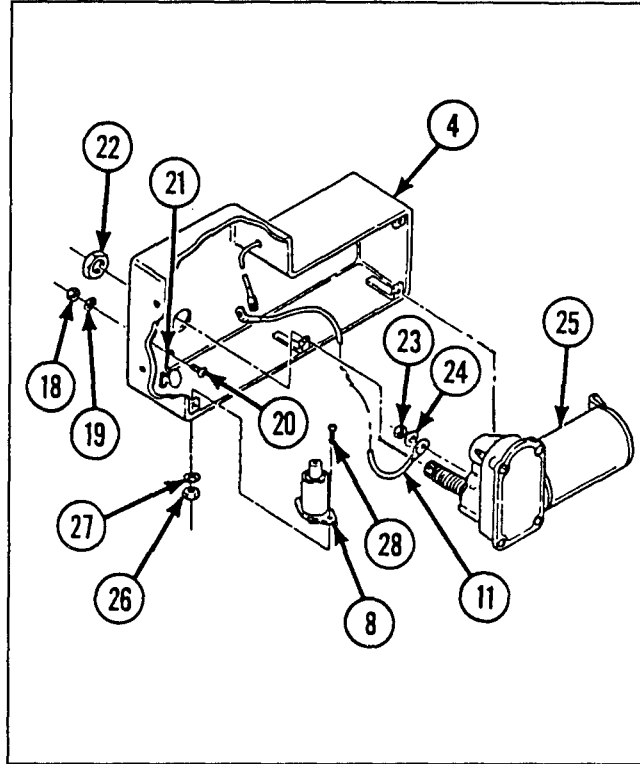

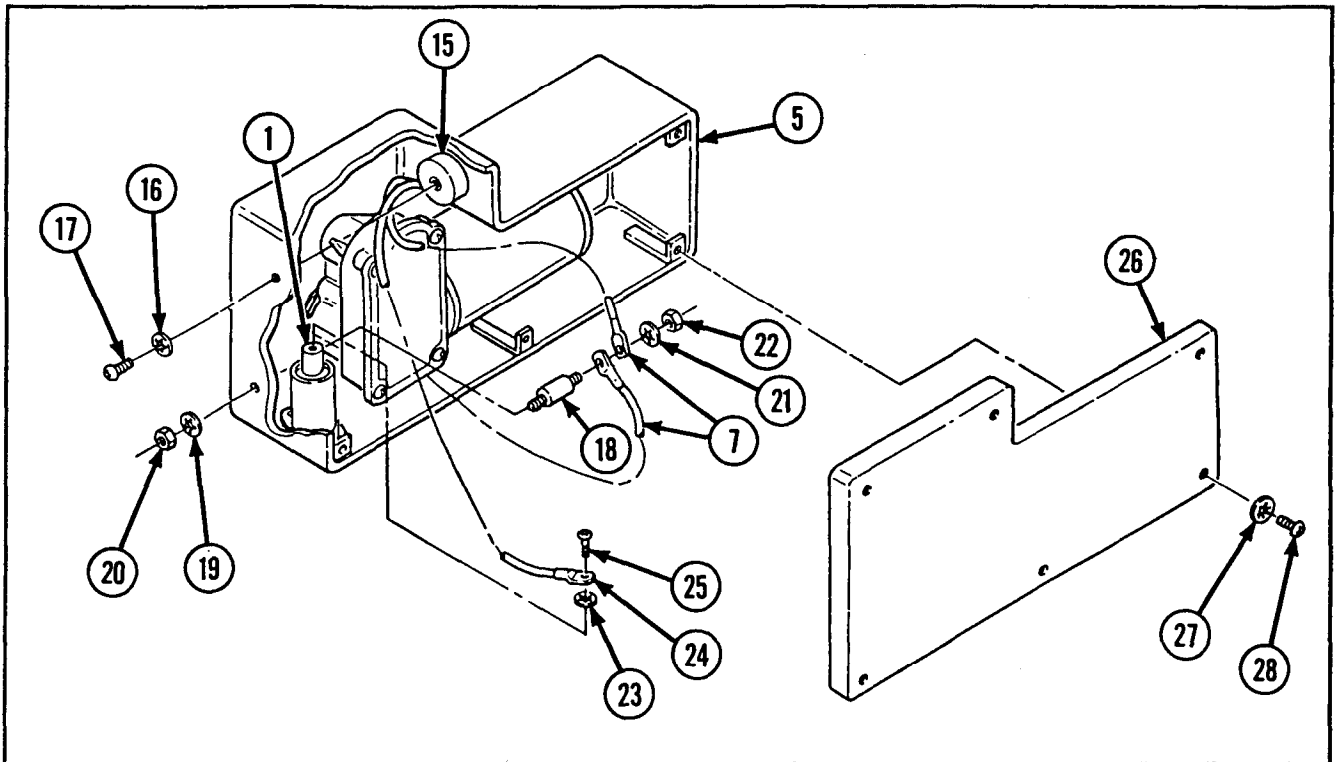

- 5 Install induction motor coil (15), new lockwasher (16), and machine screw (17).
- 6 Install standoff insulator (18), new lockwasher (19), and plain hexagon nut (20). Install two electrical leads (7), new lockwasher (21), and plain hexagon nut (22) on standoff insulator (18).
- 7 Install new lockwasher (23), electrical lead (24), and machine screw (25) to fixed capacitor (1).

2-61. MAINTENANCE OF AIR DEFLECTOR ASSEMBLY

This task covers:	a. <i>Disassembly</i>	b. <i>Inspection/Repair</i>	c. <i>Reassembly</i>
INITIAL SETUP			
<i>Materials/Parts</i>		<i>Equipment Conditions</i>	
Lockwasher (2)		Air deflector assembly removed (TM 9-2350-238-20-1)	
<i>References</i>			
TM 9-2350-238-20-1			
TM 9-2350-238-24P-1			

2-61. MAINTENANCE OF AIR DEFLECTOR ASSEMBLY (CONT).

DISASSEMBLY

- 1 Remove two machine screws (1), two lockwashers (2), and vent plate (3) from air ventilator (4).
- 2 Remove handle assembly (5), compression helical spring (6), and flat washer (7) from air ventilator (4).

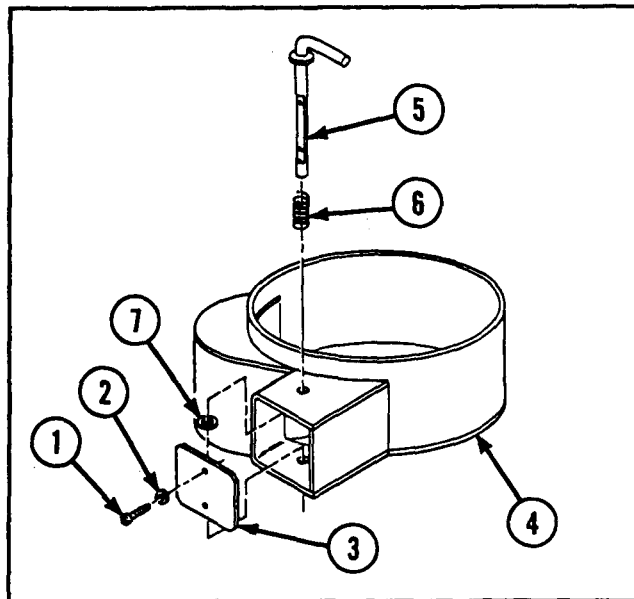

INSPECTION/REPAIR

- 1 Inspect for broken, damaged, or missing parts.
- 2 Repair is by replacement of authorized parts (TM 9-2350-238-24P-1).

REASSEMBLY

- 1 Install flat washer (1), compression helical spring (2), and handle assembly (3) in air ventilator (4).
- 2 Install vent plate (5), two new lockwashers (6), and two machine screws (7) in air ventilator (4).

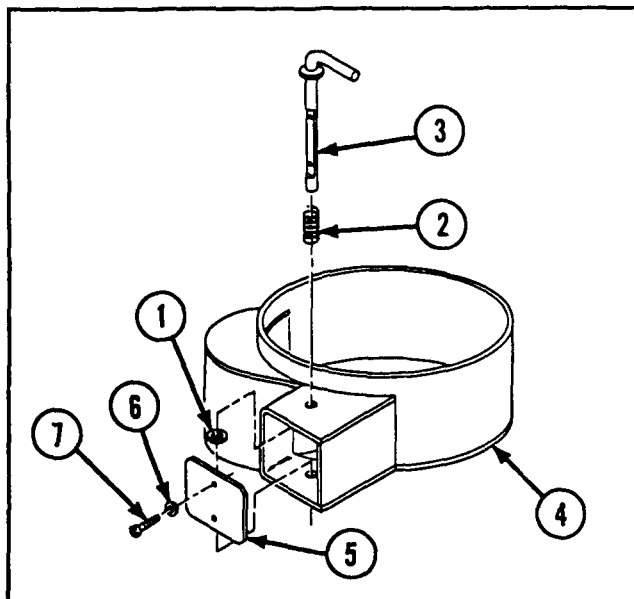

CHAPTER 3

GENERAL SUPPORT MAINTENANCE INSTRUCTIONS

CHAPTER INDEX

General	3-1
Maintenance of Double Rotary Pump	3-15
Maintenance of Pump and Slip Ring Assembly and Attaching Parts...	3-4
Maintenance of Slip Ring Assembly	3-12
Maintenance of Hydraulic Suspension Lockout Cylinder Assembly	3-33
Maintenance of Transmission Power Takeoff	3-45
Painting Procedures	3-1
Troubleshooting Information3-1

Section I. GENERAL SUPPORT GENERAL MAINTENANCE PROCEDURES

3-1. GENERAL. This section contains general repair methods and painting procedures. Special repair methods and cleaning procedures are provided, as required, in the individual maintenance instructions. For repair methods and cleaning procedures not found in this section, refer to page 2-2-29 of this manual.

3-2. PAINTING PROCEDURES.



Unusable CARC mixtures may be considered hazardous waste and may require disposal in accordance with Federal, state, DOD, and DA hazardous waste regulations. Consult the installation environmental office for proper disposal guidance. Mixed CARC has a flashpoint of approximately 38 °F (3 °C) due to the incorporation of solvents and is highly flammable.

Complete painting is authorized for and done by general support maintenance personnel or higher. CARC paint that has been opened must be used within 8 hours or it will deteriorate beyond use. Mix only what is needed for immediate use. instructions for materiel preparation, priming, and finish are given in TM 43-0139.

Section II. GENERAL SUPPORT TROUBLESHOOTING

3-3. TROUBLESHOOTING INFORMATION.

a. The symptom index can be used as a quick guide to troubleshooting. Common malfunctions are listed in alphabetical order under each major assembly, which appear in MAC order, with a page number reference to the troubleshooting table where a test or inspection and corrective action are provided.

3-3. TROUBLESHOOTING INFORMATION (CONT).

b. The general support troubleshooting table lists the malfunction, the test or inspection indicating the malfunction, and the necessary corrective action.

c. If the malfunction still exists after all listed general support maintenance corrections have been performed, notify depot maintenance.

d. This manual cannot list all malfunctions that may occur, nor all tests or inspections and corrective actions. If a malfunction is not listed or is not corrected by listed corrective actions, notify your supervisor.

GENERAL SUPPORT SYMPTOM INDEX

	Troubleshooting Procedure Page
HYDRAULIC SUSPENSION LOCKOUT CYLINDER ASSEMBLY	
Hydraulic suspension lockout cylinder assembly does not actuate	3-2
Hydraulic suspension lockout cylinder assembly does not lock	3-3
Hydraulic suspension lockout cylinder assembly does not unlock	3-4

Table 3-1. GENERAL SUPPORT TROUBLESHOOTING

MALFUNCTION
TEST OR INSPECTION
CORRECTIVE ACTION
HYDRAULIC SUSPENSION LOCKOUT CYLINDER ASSEMBLY
<p>1. HYDRAULIC SUSPENSION LOCKOUT CYLINDER ASSEMBLY DOES NOT ACTUATE.</p> <p style="margin-left: 40px;"><i>Step 1.</i> Check for low hydraulic pressure near pump and slip ring using pressure gage. Start engine and set HYD PUMP/PTO CLUTCH switch ON.</p> <ul style="list-style-type: none"> a. If pressure gage indicates about 450 psi, go to step 8. b. If pressure gage indicates less than 450 psi, go to step 2. Set HYD PUMP/PTO CLUTCH switch OFF. Stop engine. Remove pressure gage. <p style="margin-left: 40px;"><i>Step 2.</i> Check for open impact wrench manual shut-off valve.</p> <p style="margin-left: 80px;">If open, close impact wrench manual shut-off valve.</p> <p style="margin-left: 40px;"><i>Step 3.</i> Check for damaged or faulty impact wrench manual shut-off valve.</p> <p style="margin-left: 80px;">If damaged or faulty, replace impact wrench manual shut-off valve. Refer to TM 9-2350-238-20-1.</p>

Table 3-1. GENERAL SUPPORT TROUBLESHOOTING (CONT)

MALFUNCTION	TEST OR INSPECTION	CORRECTIVE ACTION
	<p>Step 4. Check for damaged or faulty impact wrench control check valve.</p>	<p>If damaged or faulty, replace impact wrench control check valve. Refer to TM 9-2350-238-20-1.</p>
	<p>Step 5. Check for damaged or faulty hull hydraulic relief valve.</p>	<p>If damaged or faulty, replace hull hydraulic relief valve. Refer to TM 9-2350-238-20-1.</p>
	<p>Step 6. Check for damaged or faulty hydraulic pump.</p>	<p>If damaged or faulty, replace hydraulic pump. Refer to page 3-4.</p>
	<p>Step 7. Check for damaged or faulty auxiliary drive.</p>	<p>If damaged or faulty, repair auxiliary drive. Refer to page 2-95.</p>
	<p>Step 8. Install pressure gage to lockout cylinder manifold test port. Start engine and set HYD PUMP/PTO CLUTCH switch N.</p>	<p>If pressure gage indicates a minimum of 450 psi, replace lockout pressure reducing valve. Refer to TM 9-2350-238-20-1. Set HYD PUMP/PTO CLUTCH switch OFF. Stop engine. Remove pressure gage.</p>
	<p>Step 9. Check for damaged or faulty lockout cylinder check valve.</p>	<p>If damaged or faulty, replace lockout cylinder check valve. Refer to TM 9-2350-238-20-1.</p>
<p>2. HYDRAULIC SUSPENSION LOCKOUT CYLINDER ASSEMBLY DOES NOT LOCK.</p>		
	<p>Step 1. Check for leaks and damaged or clogged tubes, hoses, and fittings.</p>	<p>a. Tighten all loose connections.</p> <p>b. Replace leaking or damaged components. Refer to TM 9-2350-238-20-1.</p>
	<p>Step 2. Check for leaking lockout cylinder(s).</p>	<p>Repair leaking lockout cylinder(s). Refer to page 3-33.</p>

3-3. TROUBLESHOOTING INFORMATION (CONT).

Table 3-1. GENERAL SUPPORT TROUBLESHOOTING (CONT)

MALFUNCTION
TEST OR INSPECTION
CORRECTIVE ACTION
<p>3. HYDRAULIC SUSPENSION LOCKOUT CYLINDER ASSEMBLY DOES NOT UNLOCK.</p> <p>Check for damaged or faulty lockout cylinder manifold check valve.</p> <p style="text-align: right;">If damaged or faulty, replace lockout cylinder manifold check valve. Refer to TM 9-2350-238-20-1.</p>

Section III. GENERAL SUPPORT MAINTENANCE PROCEDURES

3-4. MAINTENANCE OF PUMP AND SLIP RING ASSEMBLY AND ATTACHING PARTS.

This task covers:	<i>a. Removal</i>	<i>b. Inspection/Repair</i>	<i>c. Installation</i>
INITIAL SETUP			
<p><i>Tools and Special Tools</i></p> <p>Automotive maintenance and repair shop equipment: field maintenance, basic, less power (SC 4910-95-A31)</p> <ul style="list-style-type: none"> • Plier wire twister <p>Hoist Slings</p>		<p><i>Equipment Conditions</i></p> <p>Equipment stowage bin removed (TM 9-2350-238-20-1)</p> <p>Hydraulic reservoir drained (TM 9-2350-238-10)</p> <p>2-73 Wiring harnesses removed from slip ring assembly</p>	
<p><i>Materials/Parts</i></p> <p>Lockwasher Lockwire (item 34, appx B) Preformed packing (2) Preformed packing (4) Preformed packing</p>		<p><i>General Safety Instructions</i></p> <div style="border: 2px solid black; padding: 5px; text-align: center; width: fit-content; margin: 10px auto;">WARNING</div> <p>Wipe up any spilled hydraulic fluid to prevent injury to personnel.</p>	
<p><i>References</i></p> <p>TM 9-2350-238-10 TM 9-2350-238-20-1 TM 9-2350-238-20-2 TM 9-2350-238-24P-1</p>			

REMOVAL

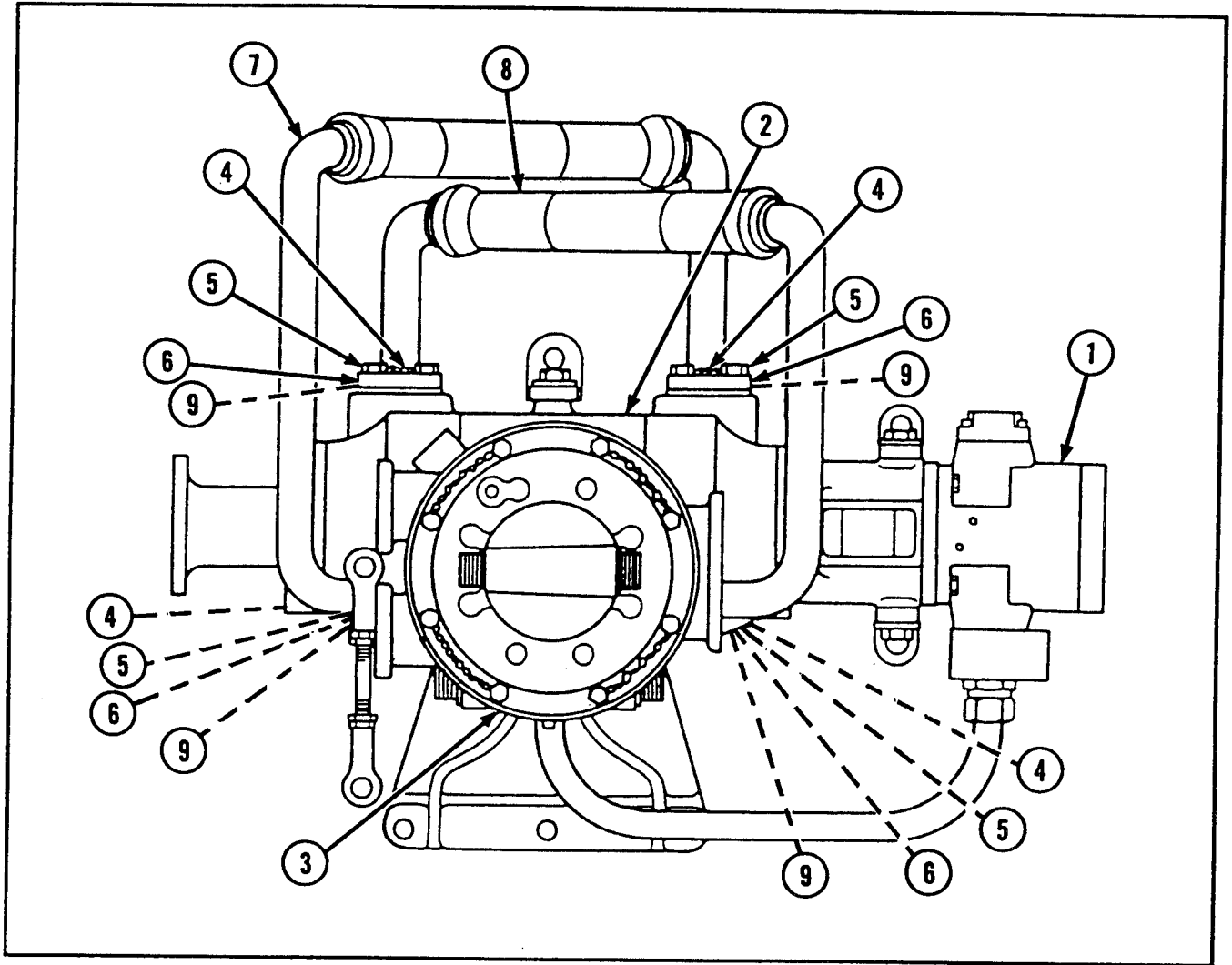
**WARNING**

Wipe up any spilled hydraulic fluid to prevent injury to personnel.

- 1 Disconnect all hydraulic lines and fittings from single rotary pump (1), double rotary pump (2), and slip ring assembly (3).
- 2 Remove lockwire (4), 16 hexagon head capscrews (5), and 8 split flange half-clamps (6).
- 3 Remove two nonmetallic hose assemblies (7 and 8) and four preformed packings (9) from slip ring assembly (3) and double rotary pump (2). Cover hose openings.

3-4. MAINTENANCE OF PUMP AND SLIP RING ASSEMBLY AND ATTACHING PARTS
(CONT).

REMOVAL (CONT)

- 4 Remove metal tube assembly (10), two tube nipples (11), and two preformed packings (12) from slip ring assembly (3) and single rotary pump (1). Cover tube openings.
- 5 Remove hexagon plain nut (13), lock-washer (14), hexagon head capscrew (15), and rod end plain bearing (16) from hull.

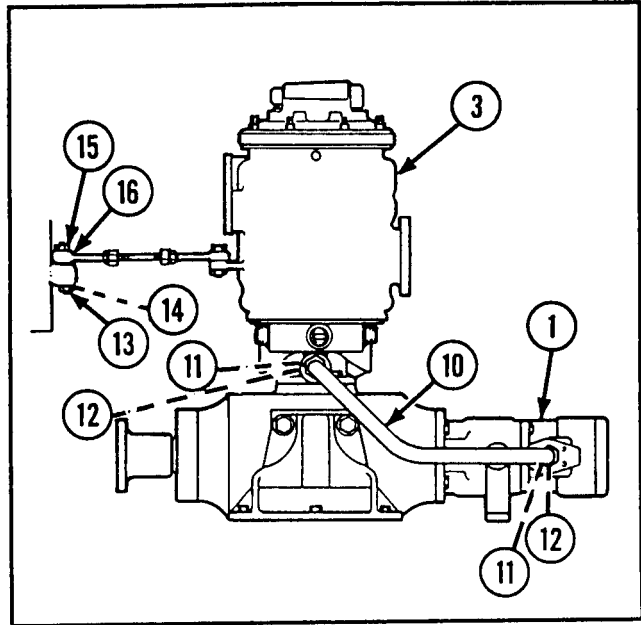

- 6 Remove four hexagon head capscrews (17) from slip ring assembly (3).
- 7 Remove slip ring assembly (3) and preformed packing (18) from double rotary pump (2).

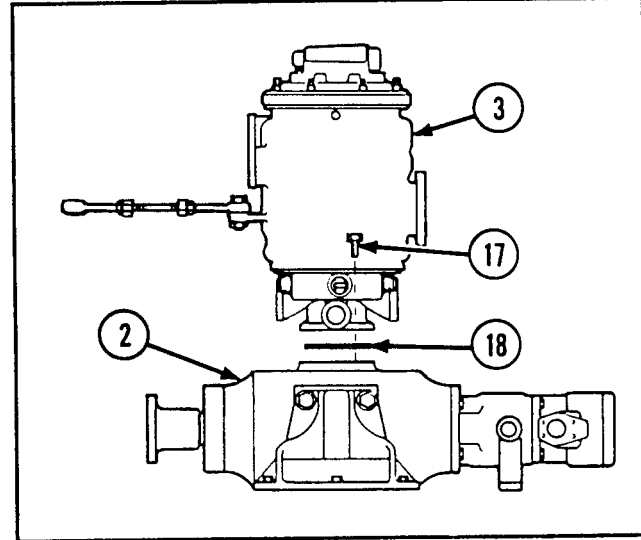

- 8 Disconnect pump to filter metal tube assembly (19) and lockout system hydraulic return line metal tube assembly (20) from double rotary pump (2). Cover tube openings.

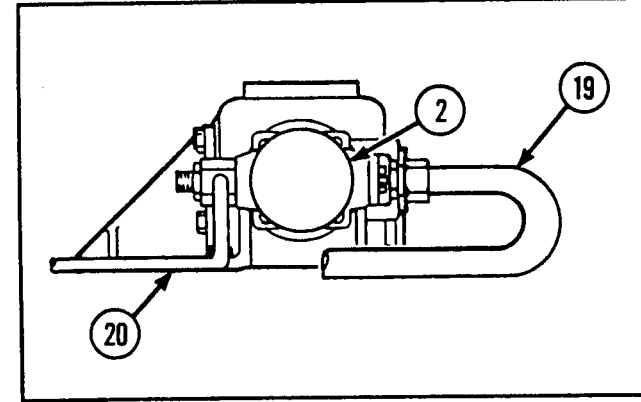

- 9 Remove lockwire (21) and four hexagon head capscrews (22) from pump drive flange (23).
- 10 Disconnect propeller shaft (24) from pump drive flange (23).

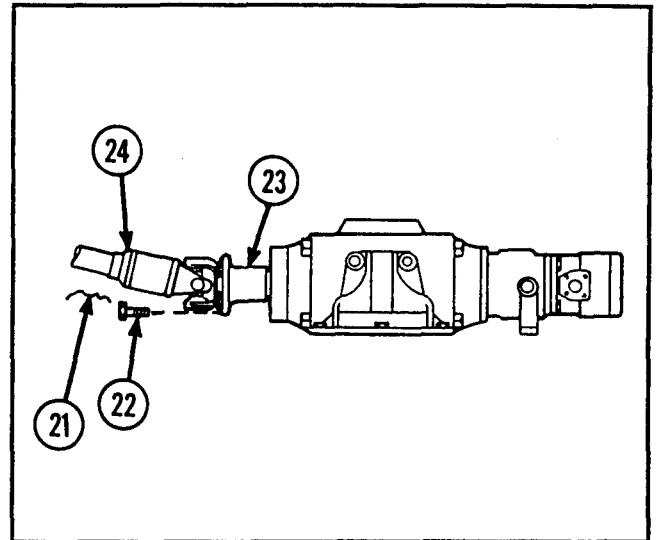

- 11 Remove lockwire (25), hexagon head capscrew (26), and flat washer (27) from hydraulic pump angle bracket (28) on double rotary pump (2).

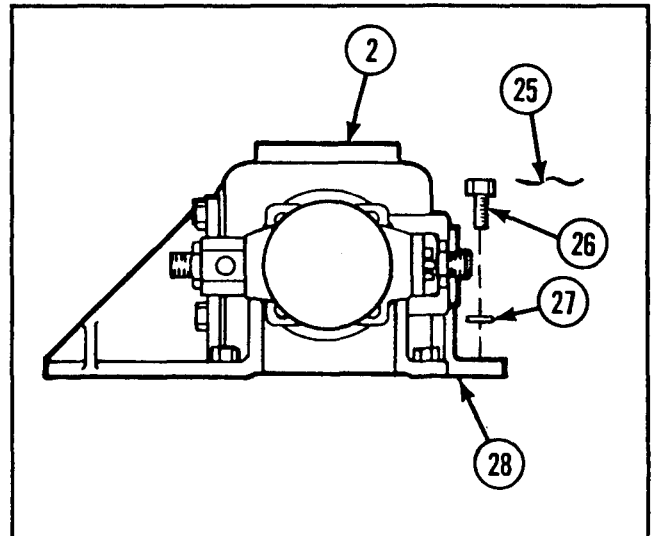

- 12 Remove lockwire (29), two hexagon head capscrews (30), and two flat washers (31) from pump and slip ring support (32) on double rotary pump (2).

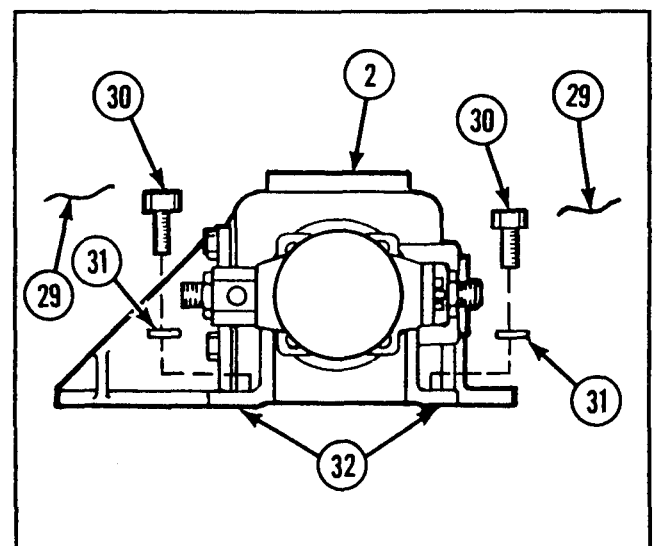

3-4. MAINTENANCE OF PUMP AND SLIP RING ASSEMBLY AND ATTACHING PARTS
(CONT).

REMOVAL (CONT)

- 13 Remove lockwire (33) and five hexagon head capscrews (34) from double pump base bracket (35) on double rotary pump (2).

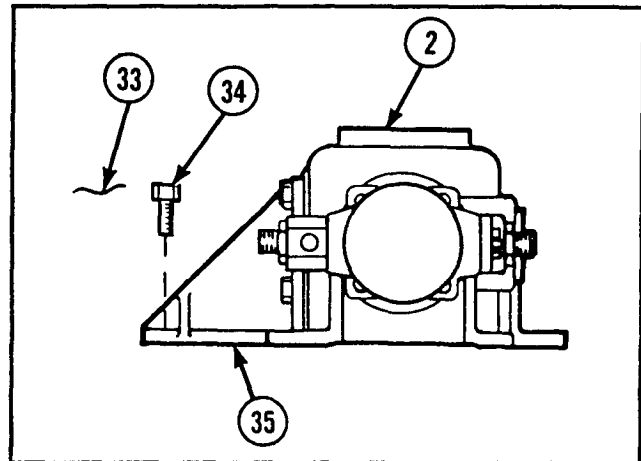

- 14 Attach sling to hull pump mount (36). Using sling and hoist, remove double rotary pump (2) with attached single rotary pump (1) through rear cab doors.

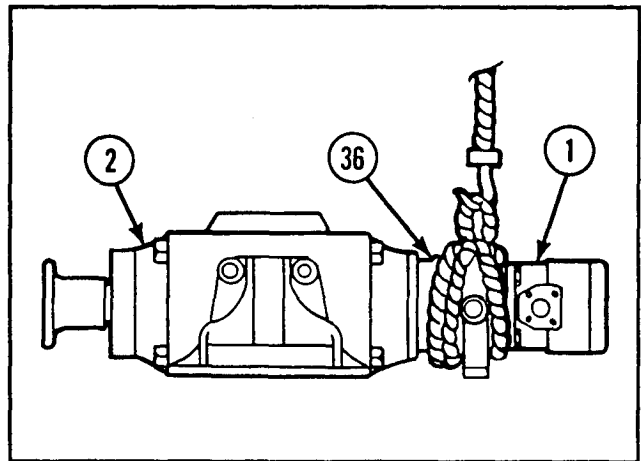

INSPECTION/REPAIR

- 1 Inspect for broken, damaged, or missing parts.
- 2 For further disassembly of slip ring assembly, refer to page 3-12.
- 3 For further disassembly of double rotary pump with attached single rotary pump, refer to page 3-15.
- 4 If double pump base bracket is damaged, repair is by replacement of next higher assembly.
- 5 Repair is by replacement of authorized parts (TM 9-2350-238-24P-1) which do not meet inspection criteria.

INSTALLATION

WARNING

Wipe up any spilled hydraulic fluid to prevent injury to personnel.

- 1 Attach sling to hull pump mount (1). Using sling and hoist, install double rotary pump (2) with attached single rotary pump (3) through rear cab doors.

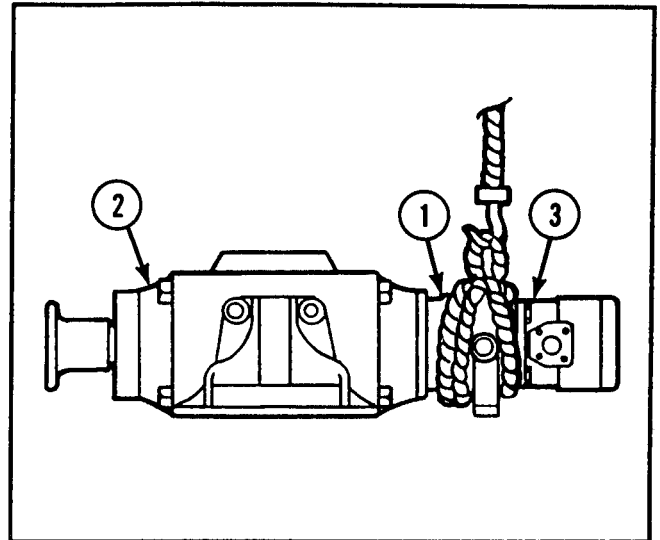

- 2 Install five hexagon head capscrews (4) and new lockwire (5) in double pump base bracket (6) on double rotary pump (2).

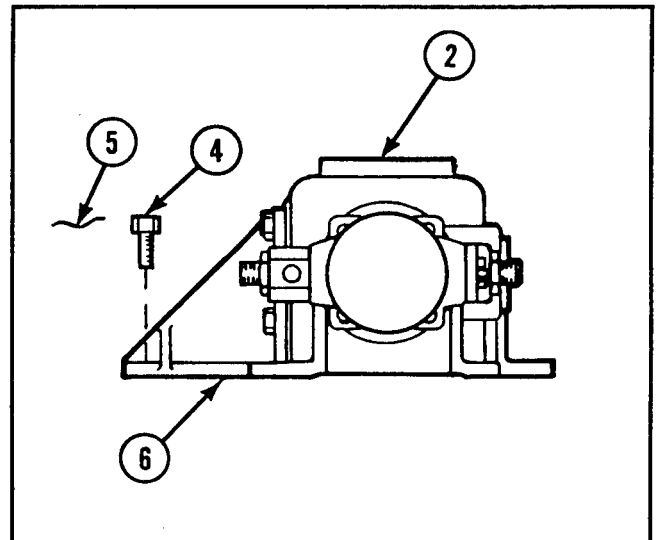

- 3 Install two flat washers (7), two hexagon head capscrews (8), and new lockwire (9) in pump and slip ring support (10) on double rotary pump (2).

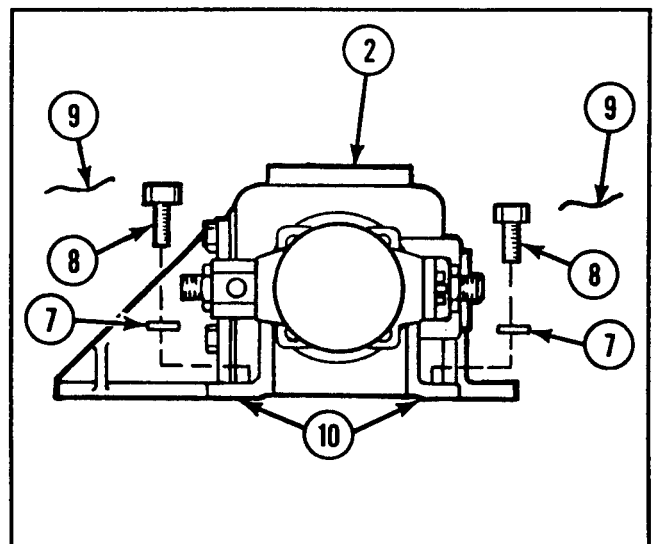

3-4. MAINTENANCE OF PUMP AND SLIP RING ASSEMBLY AND ATTACHING PARTS
(CONT).

INSTALLATION (CONT)

- 4 Install flat washer (11), hexagon head cap-screw (12), and new lockwire (13) in hydraulic pump angle bracket (14) on double rotary pump (2).

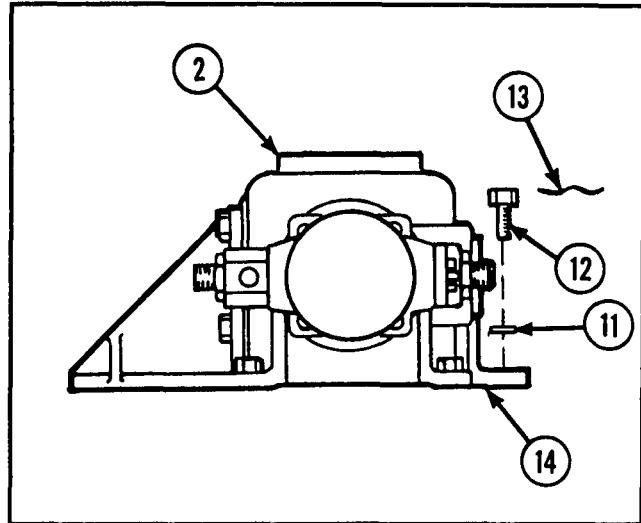

- 5 Install propeller shaft (15) to pump drive flange (16).
- 6 Install pump drive flange (16), four hexagon head capscrews (17), and new lockwire (18).

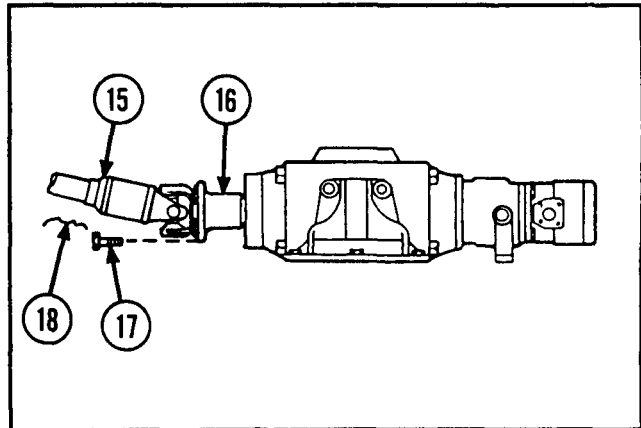

- 7 Uncover tube openings and connect lock-out system hydraulic return line metal tube assembly (19) and pump to filter metal tube assembly (20) to double rotary pump (2).

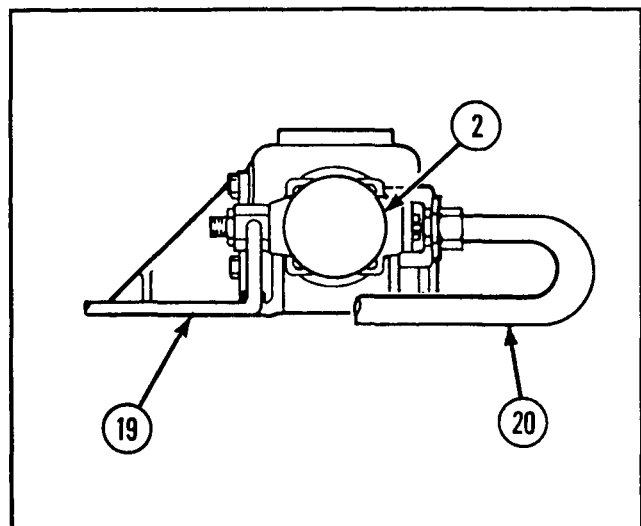

- 8 Install new preformed packing (21) and slip ring assembly (22) on double rotary pump (2).
- 9 Install four hexagon head capscrews (23) on slip ring assembly (22).

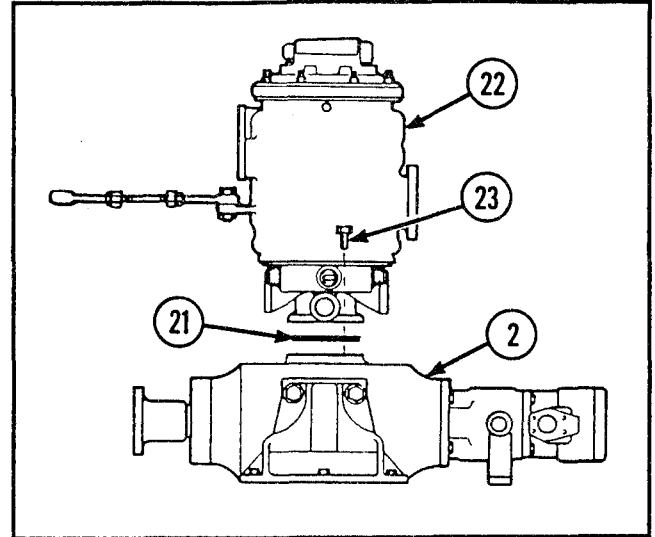

- 10 Install rod end plain bearing (24) on hull and secure with hexagon head capscrew (25), new lockwasher (26), and hexagon plain nut (27).
- 11 Uncover tube openings and install two new preformed packings (28), two tube nipples (29), and metal tube assembly (30) to slip ring assembly (22) and single rotary pump (3).

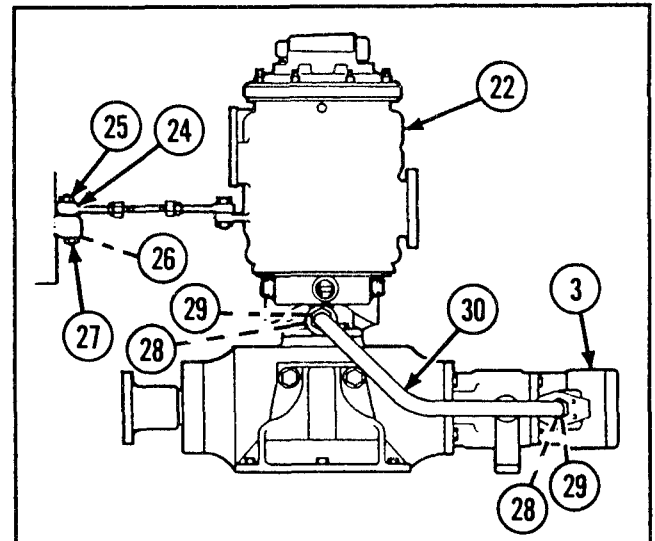

- 12 Uncover hose openings and install four new preformed packings (31) and two nonmetallic hose assemblies (32 and 33) to slip ring assembly (22) and double rotary pump (2).
- 13 Install 8 split flange half-clamps (34) and 16 hexagon head capscrews (35), and secure with new lockwire (36).
- 14 Connect all hydraulic lines and fittings to slip ring assembly (22).

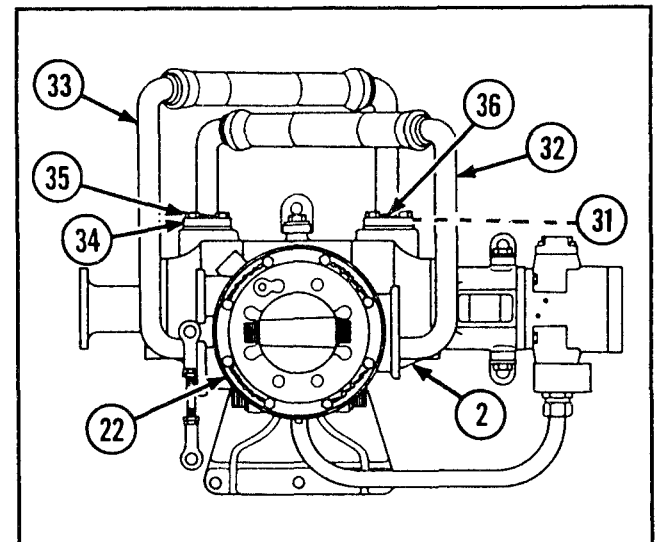

3-5. MAINTENANCE OF HYDRAULIC SLIP RING ASSEMBLY.

This task covers:	a. <i>Disassembly</i>	b. <i>Inspection/Repair</i>	c. <i>Reassembly</i>
INITIAL SETUP			
<i>Materials/Parts</i>	<i>General Safety Instructions</i>		
Hydraulic fluid (item 16, appx B)	<div style="border: 2px solid black; padding: 5px; display: inline-block; margin-bottom: 10px;">WARNING</div> <p>Wipe up any spilled hydraulic fluid to prevent injury to personnel.</p>		
Lockwasher			
Lubrication fitting			
Rubber seal (6)			
<i>References</i>			
TM 9-2350-238-24P-1			
<i>Equipment Conditions</i>			
3-4 Slip ring assembly removed from pump and slip ring assembly			
2-73 Slip ring electrical components removed			

DISASSEMBLY

WARNING

Wipe up any spilled hydraulic fluid to prevent injury to personnel.

- 1 Remove hexagon plain nut (1), lockwasher (2), hexagon head capscrew (3), and rod end plain bearing (4) from slip ring assembly (5).
- 2 Remove two rod end plain bearings (4) and two hexagon plain nuts (6) from rod end plain stud (7).
- 3 Remove hydraulic slip ring breather (8), pipe plug (9), and threaded machine plug (10) from slip ring assembly (5).
- 4 If damaged, remove lubrication fitting (11) from slip ring assembly (5).

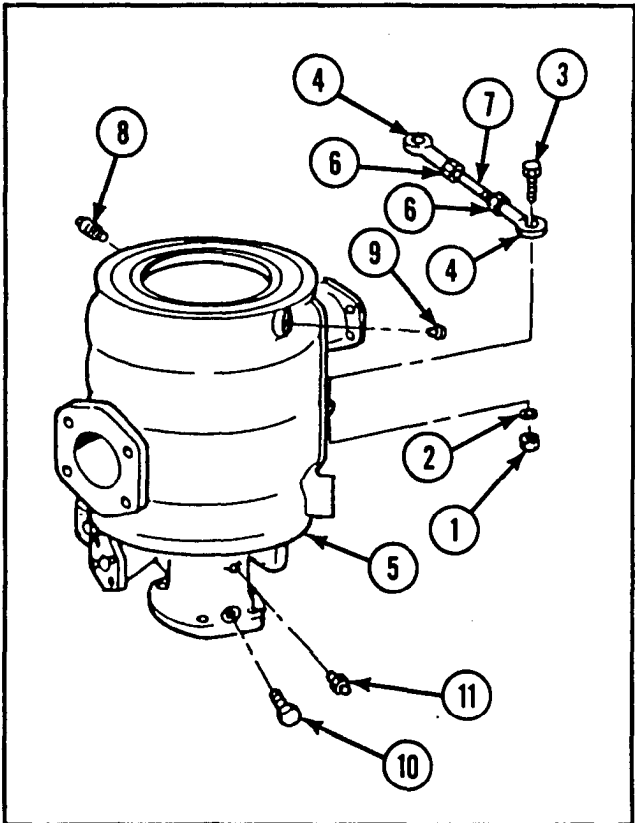

- 5 Remove post (12) from sleeve (13).
- 6 Remove six rubber seals (14) from post (12).

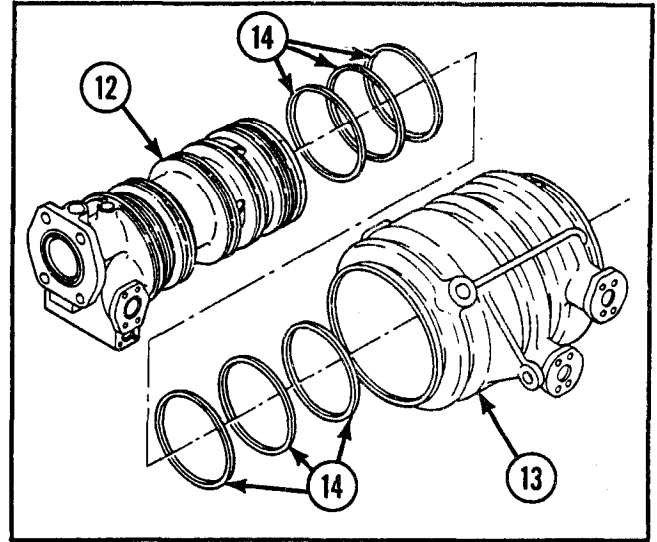

INSPECTION/REPAIR

- 1 Inspect for broken, damaged, or missing parts.
- 2 Inspect sleeve and post for damaged paint, refer to general maintenance, page 2-30.
- 3 If post is broken, damaged, or missing, repair is by replacement of next higher assembly. Return damaged post to depot for disposition.
- 4 If sleeve is broken, damaged, or missing, repair is by replacement of next higher assembly. Return damaged sleeve to depot for disposition.
- 5 Repair is by replacement of authorized parts (TM 9-2350-238-24P-1) which do not meet inspection criteria.

REASSEMBLY

- 1 Apply a coating of hydraulic fluid to six new rubber seals (1) and grooves in post (2).
- 2 Install six new rubber seals (1) on post (2).

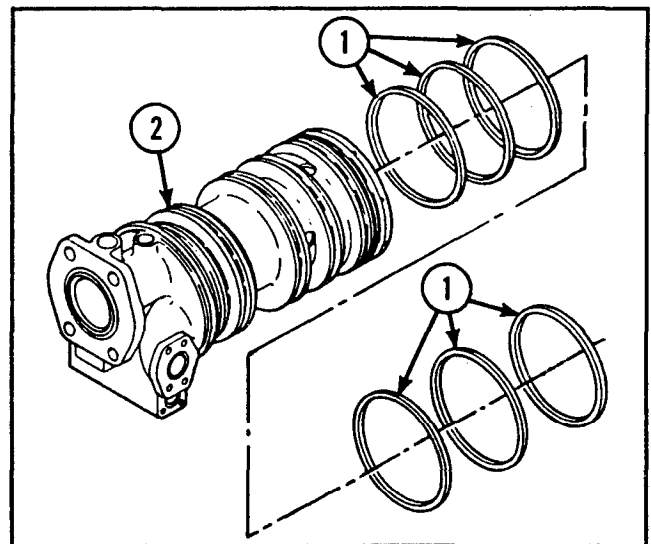

3-5. MAINTENANCE OF HYDRAULIC SLIP RING ASSEMBLY (CONT).

REASSEMBLY (CONT)

CAUTION

There is a close tolerance between post and sleeve. Use extreme care when installing post in sleeve so rubber seals will not be damaged. A cut or scratched seal will leak during operation.

- 3 Set sleeve (3) on a flat and smooth surface with cover end down.
- 4 Install post (2) in sleeve (3), open end first. Push slowly until post bottoms in sleeve.

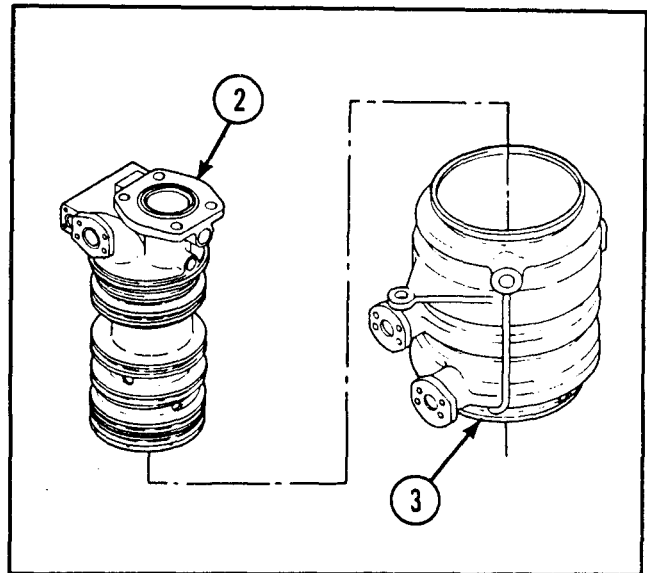

- 5 If removed, install new lubrication fitting (4) in slip ring assembly (5).
- 6 Install threaded machine plug (6), pipe plug (7), and hydraulic slip ring breather (8) in slip ring assembly (5).
- 7 Install two hexagon plain nuts (9) and two rod end plain bearings (10) on rod end plain stud (11).
- 8 Install rod end plain bearing (10), hexagon head capscrew (12), new lockwasher (13), and hexagon plain nut (14) on slip ring assembly (5).

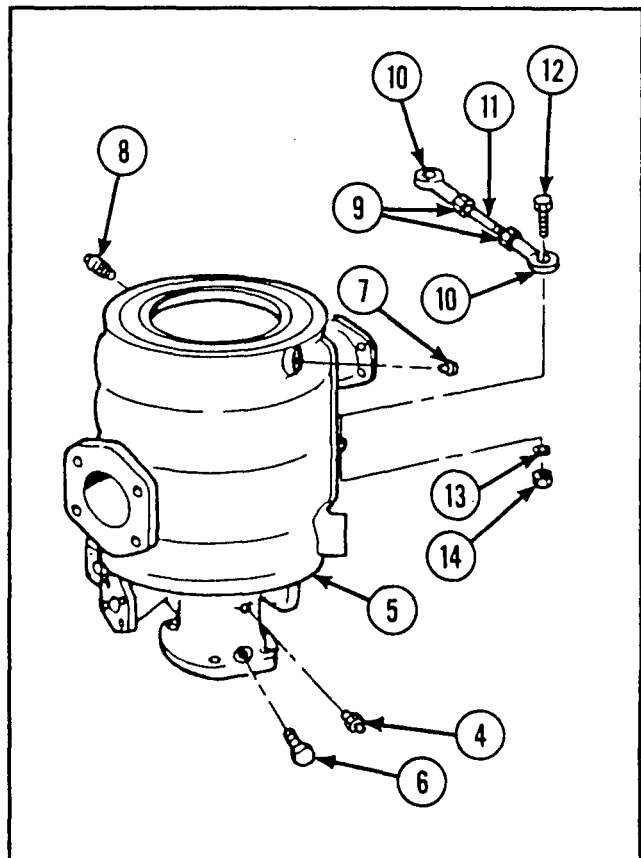

3-6. MAINTENANCE OF DOUBLE ROTARY PUMP.

This task covers:	a. <i>Disassembly</i>	b. <i>Inspection/Repair</i>	c. <i>Reassembly</i>
INITIAL SETUP			
<p><i>Tools and Special Tools</i></p> <p>Automotive maintenance and repair shop equipment: field maintenance, basic, less power (SC 4910-95-A31)</p> <ul style="list-style-type: none"> • Plier wire twister • Retaining ring pliers • Soft-faced hammer • Torque wrench (0 to 600 ft-lb) <p>Container Wood block</p> <p><i>Materials/Parts</i></p> <p>Double rotary pump parts kit Dowel pins (4) Hydraulic fluid (item 18, appx B) Lockwasher (8) Lockwire (item 34, appx B) Marking chalk (item 4, appx B) Preformed packing</p> <p><i>References</i></p> <p>TM 9-2350-238-24P-1</p>	<p><i>Equipment Conditions</i></p> <p style="text-align: center;">NOTE</p> <p>Single rotary pump can be removed without removing pump and slip ring assembly.</p> <p>3-4 Pump and slip ring assembly removed</p> <p><i>General Safety Instructions</i></p> <div style="border: 2px solid black; padding: 5px; text-align: center; width: fit-content; margin: 10px auto;">WARNING</div> <p>Wipe up any spilled hydraulic fluid to prevent injury to personnel.</p>		

DISASSEMBLY

NOTE

Single rotary hydraulic pump can be removed without removing pump and slip ring assembly from hull. Steps 1 thru 5 apply to removal of single rotary hydraulic pump from the hull pump mount.

- 1 Remove four socket head capscrews (1), single pump inlet manifold flange hydraulic adapter (2), and preformed packing (3) from single rotary hydraulic pump (4).

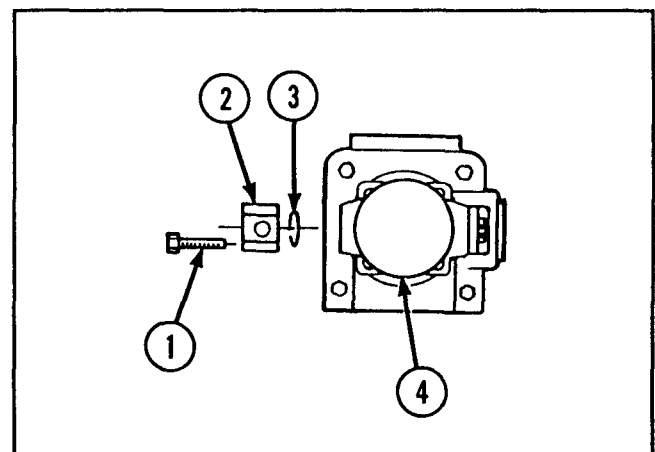

3-6. MAINTENANCE OF DOUBLE ROTARY PUMP (CONT).

DISASSEMBLY (CONT)

- 2 Rotate shaft of double rotary pump (5) until setscrews (6) are visible through hole in hull pump mount (7).
- 3 Using key wrench, loosen two setscrews (6) in single and double pump flexible hydraulic coupling (8).

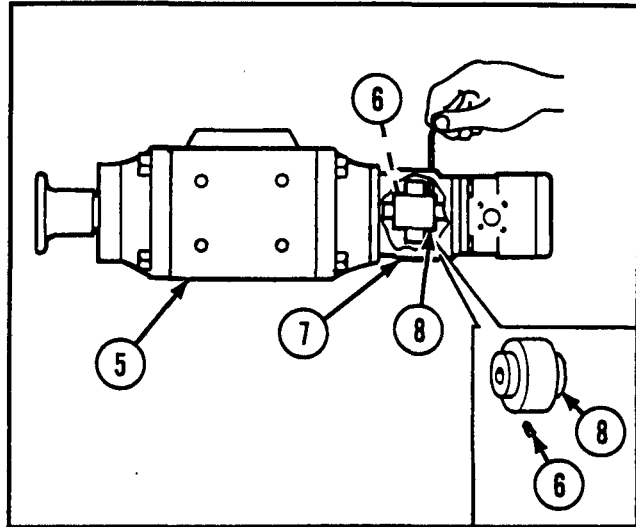

- 4 Remove lockwire (9) and four hexagon head capscrews (10) from single hydraulic rotary pump (4).
- 5 Remove single rotary hydraulic pump (4) from hull pump mount (7).

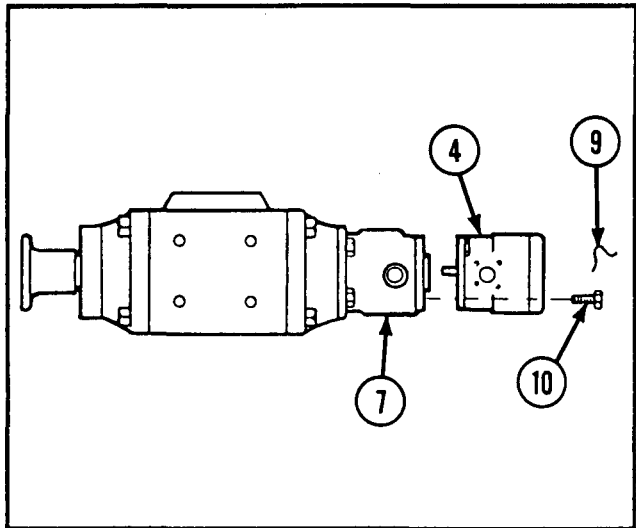

- 6 Remove lockwire (11), hexagon head capscrew (12), flat washer (13), and hydraulic pump angle bracket (14) from double rotary pump (5).
- 7 Remove lockwire (15), four hexagon head capscrews (16), and double pump base bracket (17) from double rotary pump (5).

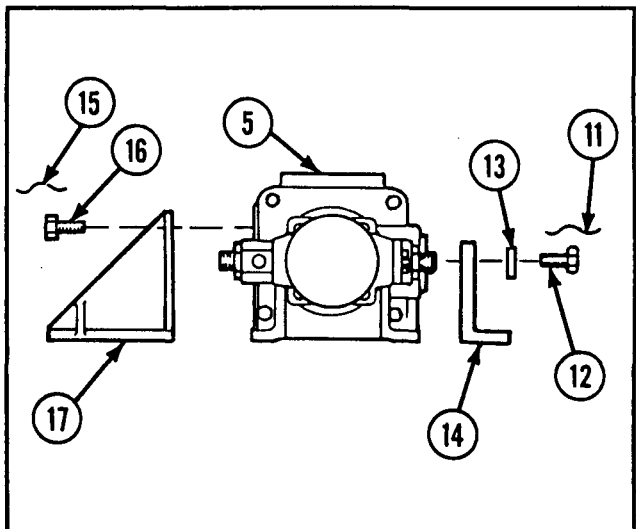

- 8 Remove lockwire (18), two hexagon head capscrews (19), two flat washers (20), and pump and slip ring support (21) from hull pump mount (7).

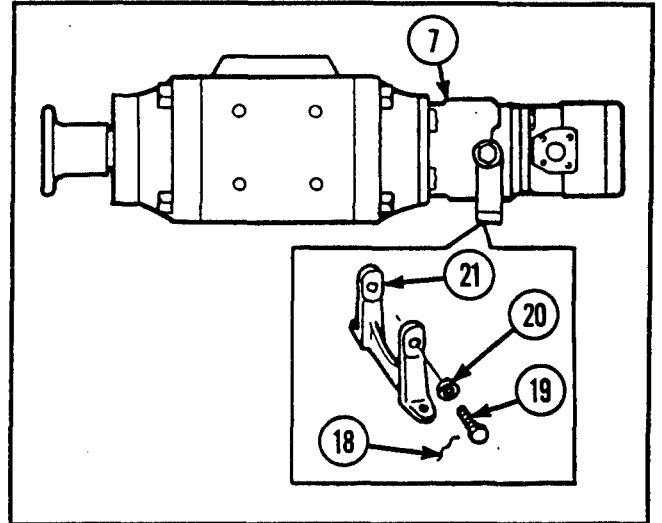

- 9 Remove lockwire (22) and four hexagon head capscrews (23) from hull pump mount (7).

- 10 Remove hull pump mount (7) from double rotary pump (5).

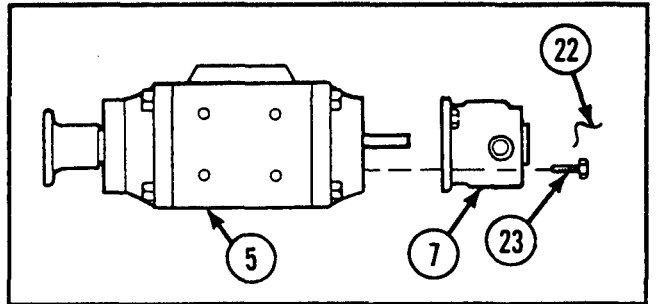

- 11 Remove hydraulic pump bushing (24) and single and double pump flexible hydraulic coupling (8) from hull pump mount (7).

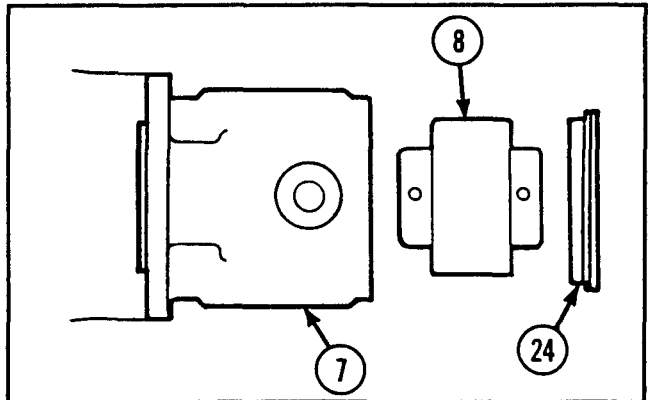

- 12 Using key wrench, loosen two setscrews (25) and remove pump drive flange (26) from double rotary pump (5).

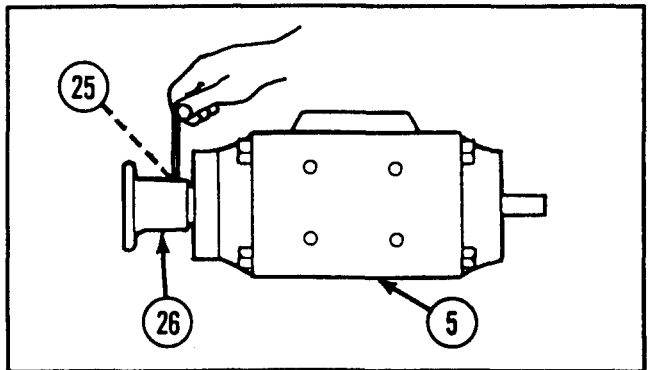

3-6. MAINTENANCE OF DOUBLE ROTARY PUMP (CONT).

DISASSEMBLY (CONT)

Wipe up any spilled hydraulic fluid to prevent injury to personnel.

Disassembly of hydraulic pumps must be performed in a clean, dry, dust-free area.

NOTE

There are two different manufacturers of the double rotary pump. They are interchangeable as an assembly, but differ internally for repair.

- 13 Using a suitable container, drain hydraulic fluid from pump. Rotate shaft slowly to drain remaining hydraulic fluid.

NOTE

- To ensure correct position at reassembly, etch match marks on double rotary pump housing and each cover using marking chalk.
- Steps 14 thru 31 apply to Parker-Hannifin or Hydreco double rotary pumps only.

- 14 Remove shaft key (27) from shaft (28).
- 15 Remove four ends-to-housing screws (29) and four ends-to-housing lockwashers (30) from pump rear cover (31).
- 16 Tap edge of pump rear cover (31) with soft-faced hammer to loosen cover.
- 17 Remove pump rear cover (31) from pump housing (32).

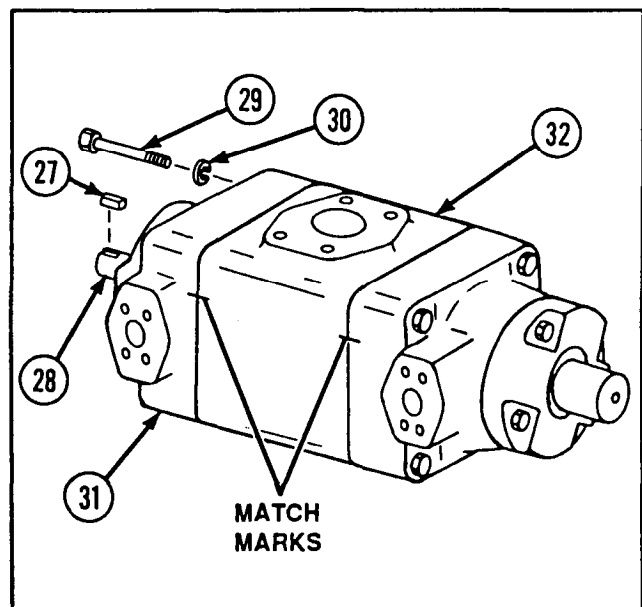

- 18 Remove ends-to-housing O-ring (33), shaft spacers O-ring (34), and shaft spacers backup ring (35) from pump rear cover (31).

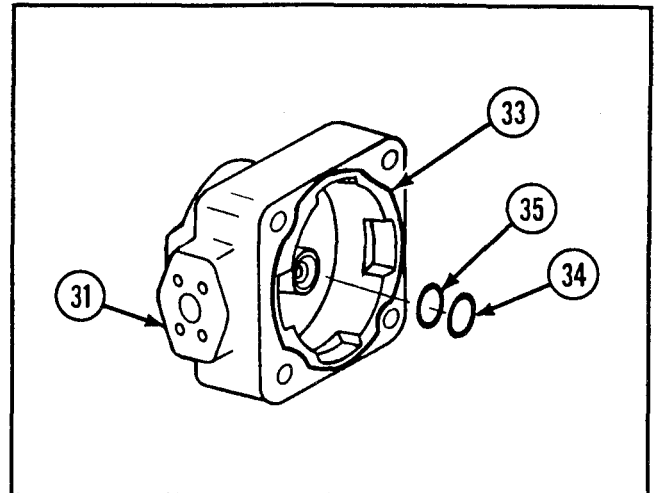

- 19 Using hammer and drift, remove shaft roller bearing (36) and small end shaft seal (37) from pump rear cover (31).

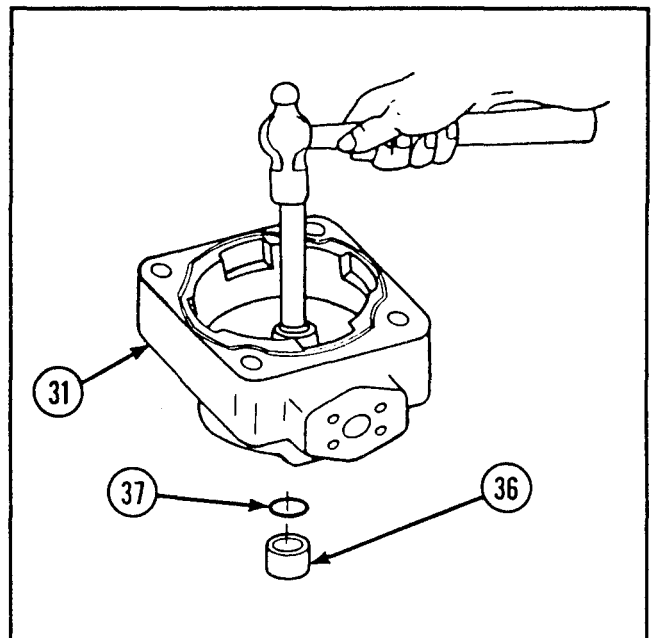

- 20 Remove pump rear cartridge (38) from shaft (28).
- 21 Remove cartridge-to-housing end O-ring (39) and cartridge-to-housing O-ring backup ring (40).

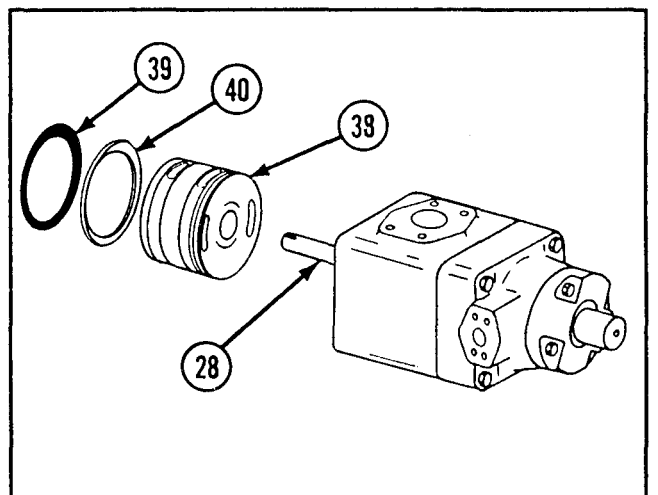

3-6. MAINTENANCE OF DOUBLE ROTARY PUMP (CONT).

DISASSEMBLY (CONT)

- 22** Remove two shaft spacers O-rings (41), two shaft spacers backup rings (42), and two spacers (43) from shaft (28).

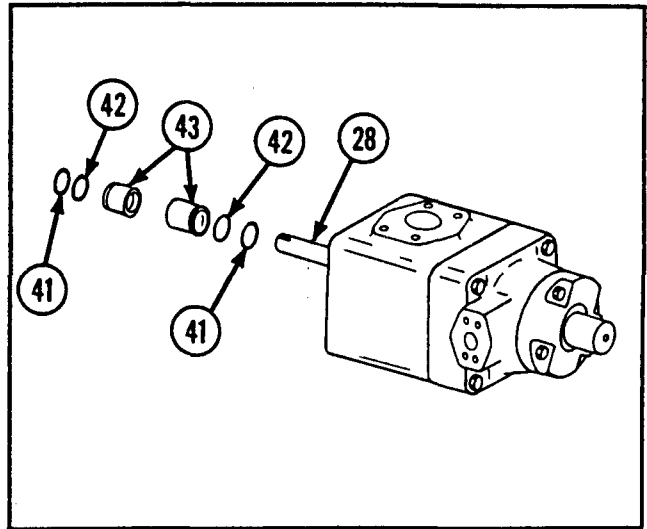

- 23** Remove four shaft capscrews (44) from end cap (45).
- 24** Remove shaft (28) and end cap (45) from pump housing (32).

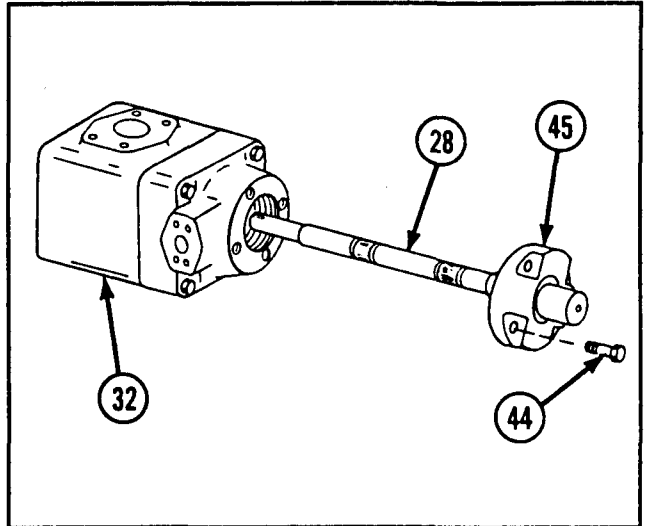

- 25** Remove four ends-to-housing screws (46) and four ends-to-housing lockwashers (47) from pump front cover (48).
- 26** Tap edge of pump front cover (48) with soft-faced hammer to loosen cover.
- 27** Remove pump front cover (48) from pump housing (32).

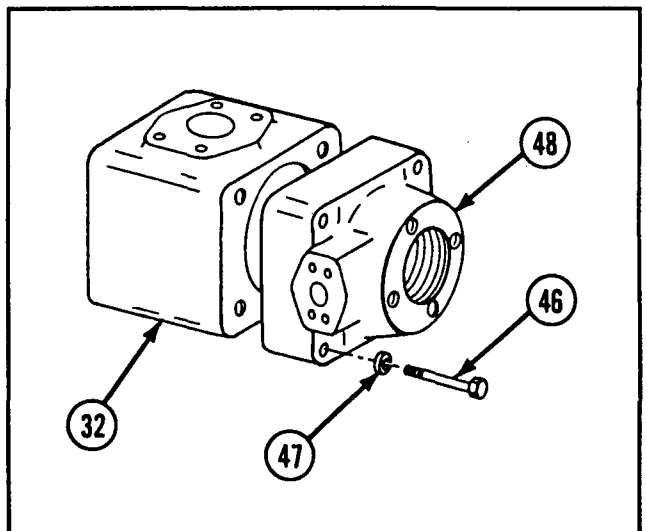

- 28 Remove shaft spacers O-ring (49) and shaft spacers backup ring (50) from pump front cover (48).
- 29 Remove ends-to-housing O-ring (51) and large end shaft seal (52) from pump front cover (48).

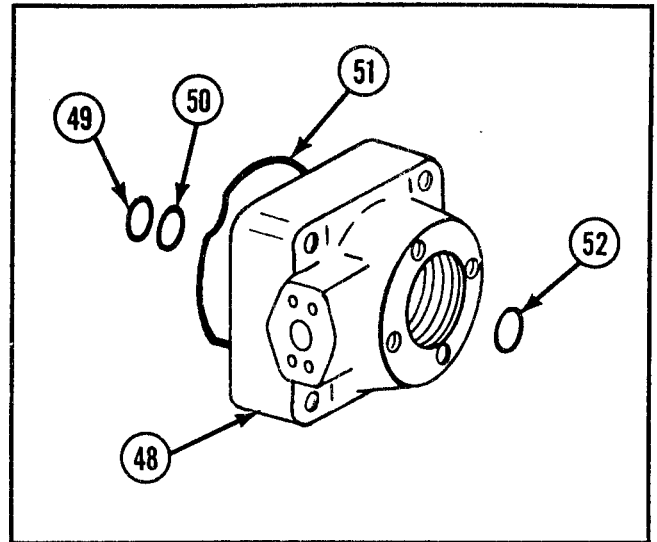

- 30 Remove pump front cartridge (53) from pump housing (32).
- 31 Remove cartridge-to-housing end O-ring (54) and cartridge-to-housing O-ring back-up ring (55) from pump front cartridge (53).

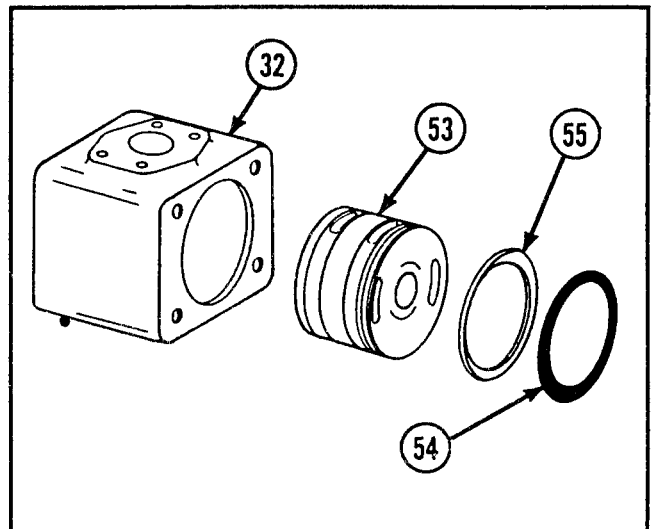

NOTE

Steps 32 thru 48 apply to Denison double rotary pumps only.

- 32 Remove four hexagon head capscrews (56) from output drive end cap (57).
- 33 Remove output drive end shaft key (58) from shaft (59).

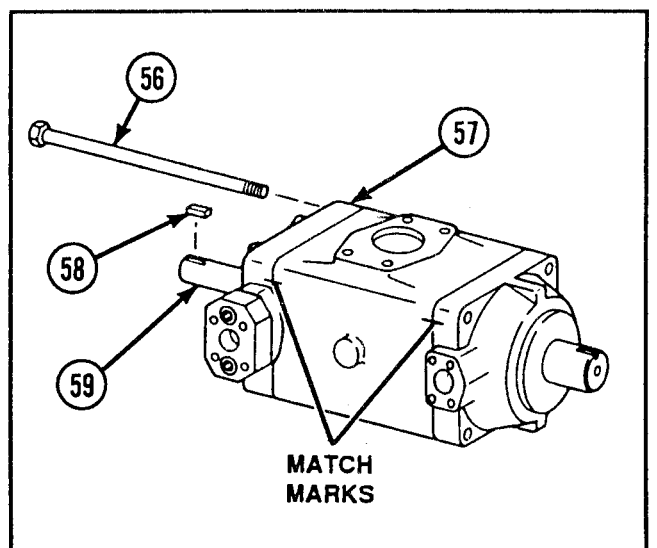

3-6. MAINTENANCE OF DOUBLE ROTARY PUMP (CONT).

DISASSEMBLY (CONT)

- 34 Tap edge of output drive end cap (57) with soft-faced hammer to loosen cap.

CAUTION

Ensure parts do not drop out of pump housing when removing output drive end cap.

- 35 Remove output drive end cap (57) from pump housing (60).

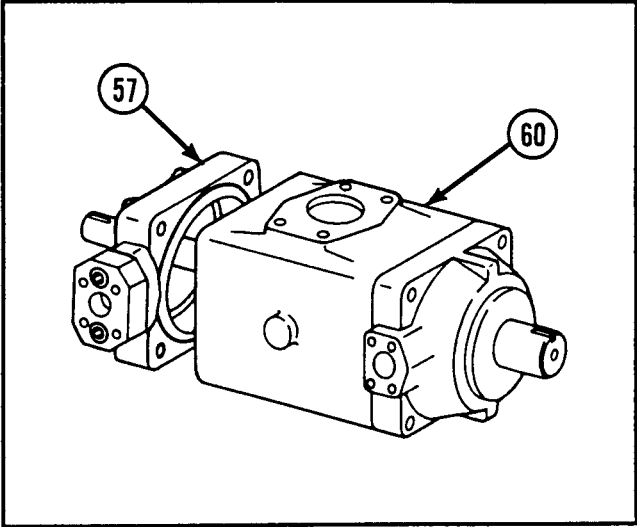

- 36 Remove two adapter plate capscrews (61), adapter plate (62), and adapter plate O-ring (63) from output drive end cap (57).

- 37 Remove output drive end shaft seal (64) and output drive end cap square section seal (65) from output drive end cap (57).

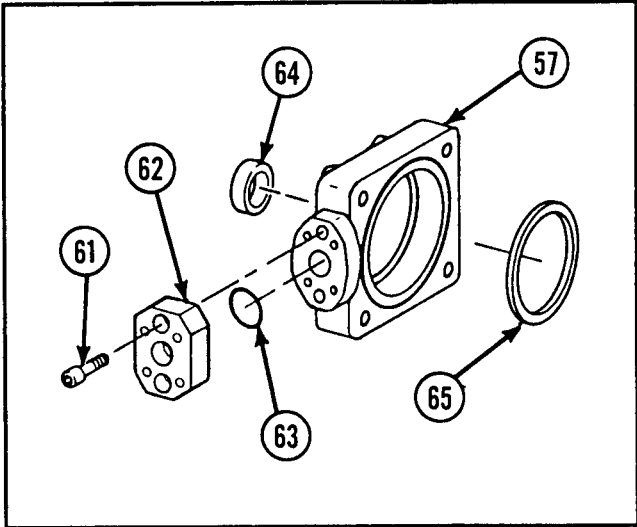

- 38 Remove pump rear port plate (66) from shaft (59).

- 39 Remove rear port plate inner square section seal (67) and rear port plate outer square section seal (68) from pump rear port plate (66).

- 40 If damaged, remove two dowel pins (69) from pump rear port plate (66).

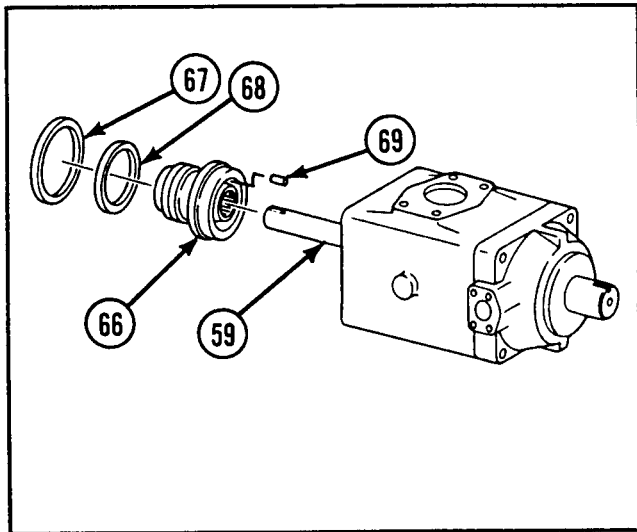

- 41 Remove pump front port plate (70) from shaft (59).
- 42 Remove front port plate outer square section seal (71) and front port plate inner square section seal (72) from pump front port plate (70).
- 43 If damaged, remove two dowel pins (73) from pump front port plate (70).

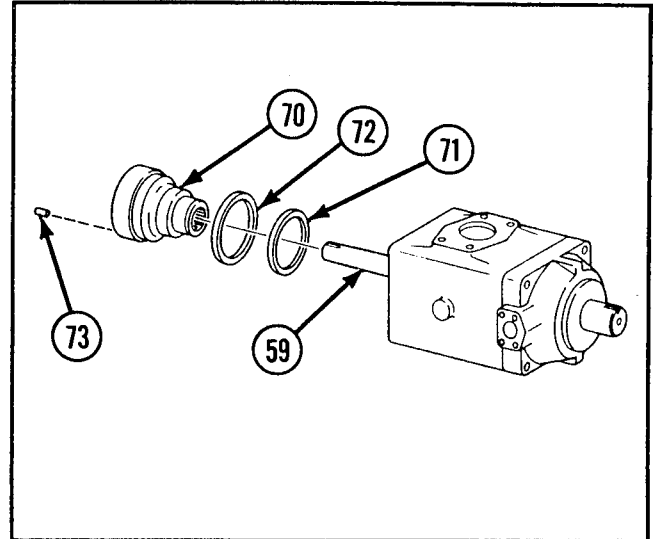

- 44 Remove input drive end wavy spring washer (74) and bearing-to-housing internal retaining ring (75) from pump housing (60).
- 45 Remove input drive end cap (76) with shaft (59) from pump housing (60).

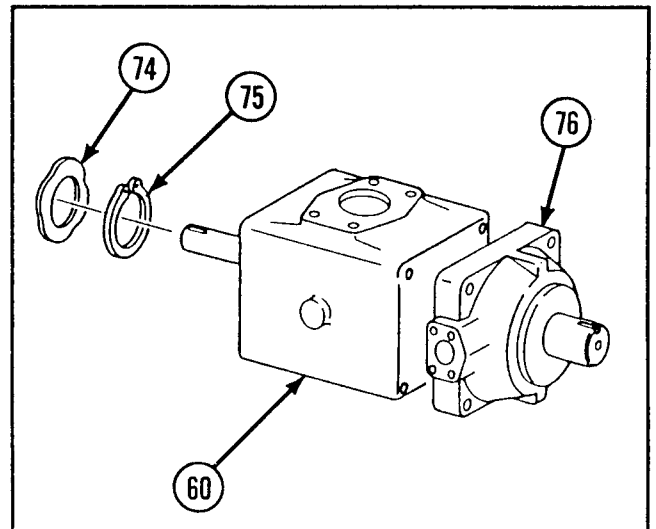

- 46 Remove input drive end shaft key (77) and shaft (59) from input drive end cap (76).

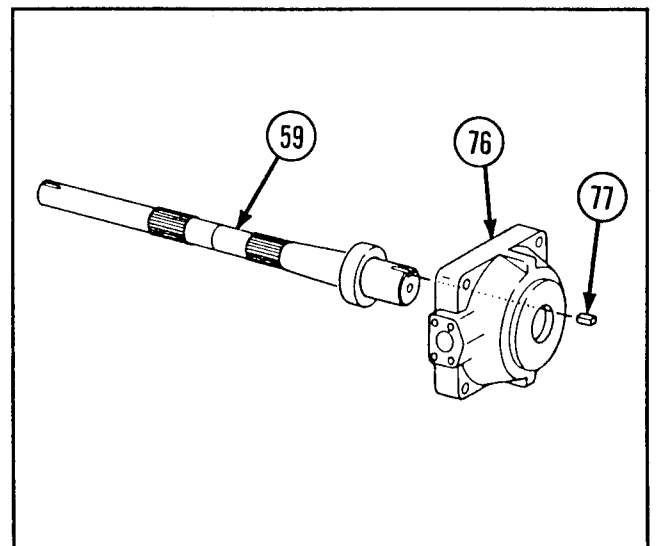

3-6. MAINTENANCE OF DOUBLE ROTARY PUMP (CONT).

DISASSEMBLY (CONT)

- 47 Remove input drive end cap square section seal (78) and input drive end dual lip shaft seal (79) from input drive end cap (76).

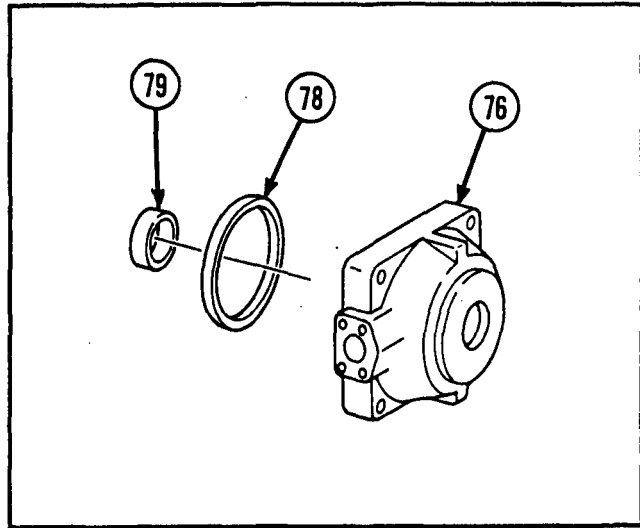

- 48 Remove bearing-to-shaft external retaining ring (80) and input drive end shaft bearing (81) from shaft (59).

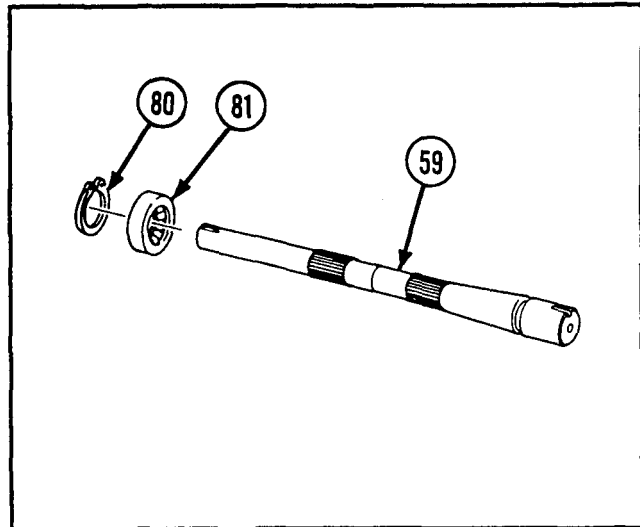

INSPECTION/REPAIR

- 1 Inspect for broken, damaged, or missing parts.
- 2 If any kit component is broken, damaged, or missing, replace entire double rotary pump parts kit.
- 3 Repair is by replacement of authorized parts (TM 9-2350-238-24P-1) which do not meet inspection criteria.

REASSEMBLY

WARNING

Wipe up any spilled hydraulic fluid to prevent injury to personnel.

NOTE

- Apply a light coat of hydraulic fluid to all packings, seals, and shaft to ease reassembly.
- Steps 1 thru 15 apply to Denison double rotary pumps only.

- 1 Install new input drive end shaft bearing (1) and bearing-to-shaft external retaining ring (2) to shaft (3).

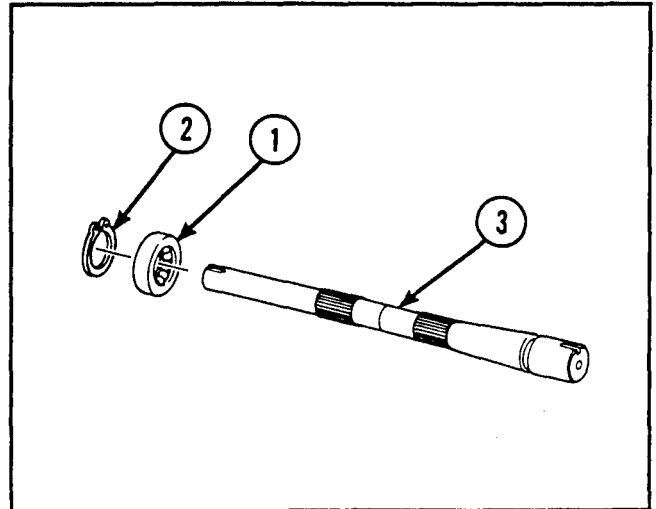

- 2 Install new input drive end cap square section seal (4) and new input drive end dual lip shaft seal (5) to input drive end cap (6).

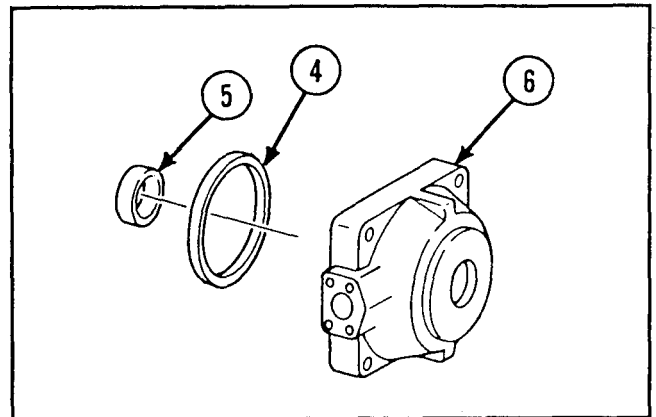

- NOTE**
Align match marks on input drive end cap and pump housing.

- 3 Install shaft (3), input drive end shaft key (7), and pump housing (8) to input drive end cap (6).
- 4 Install bearing-to-housing internal retaining ring (9) and input drive end wavy spring washer (10) to pump housing (8).

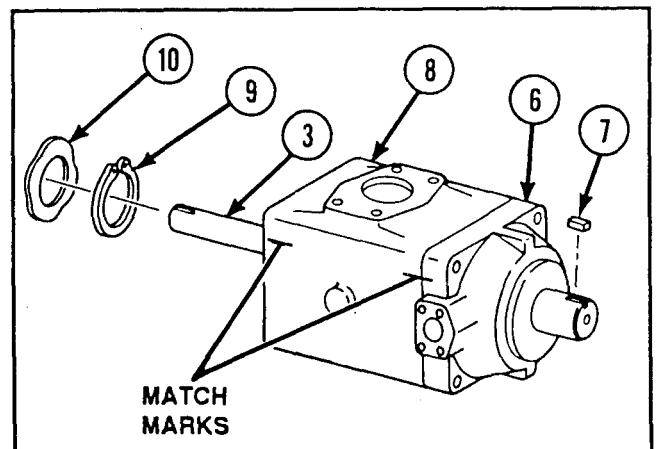

3-6. MAINTENANCE OF DOUBLE ROTARY PUMP (CONT).

REASSEMBLY (CONT)

- 5** If removed, install two new dowel pins (11) in pump front port plate (12).
- 6** Install new front port plate inner square section seal (13) and new front port plate outer square section seal (14) on pump front port plate (12).
- 7** Install pump front port plate (12) on splines of shaft (3).

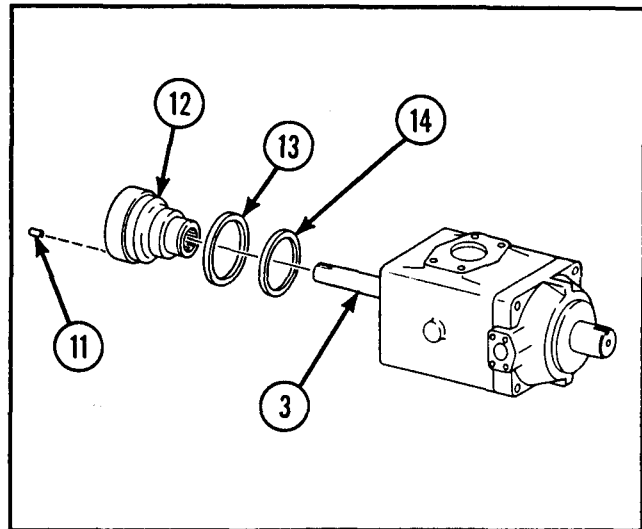

- 8** If removed, install two new dowel pins (15) in pump rear port plate (16).
- 9** Install new rear port plate outer square section seal (17) and new rear port plate inner square section seal (18) on pump rear port plate (16).
- 10** Install pump rear port plate (16) on splines of shaft (3).

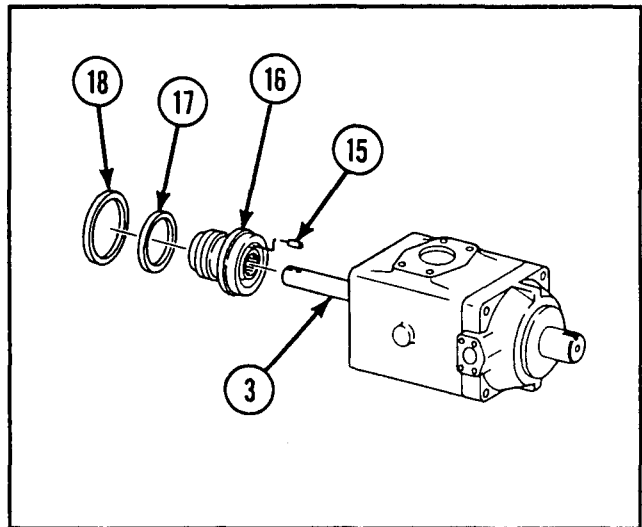

- 11** Install new output drive end shaft seal (19) and new output drive end cap square section seal (20) to output drive end rear cap (21).
- 12** Install new adapter plate O-ring (22), adapter plate (23), and two adapter plate capscrews (24) to output drive end cap (21).

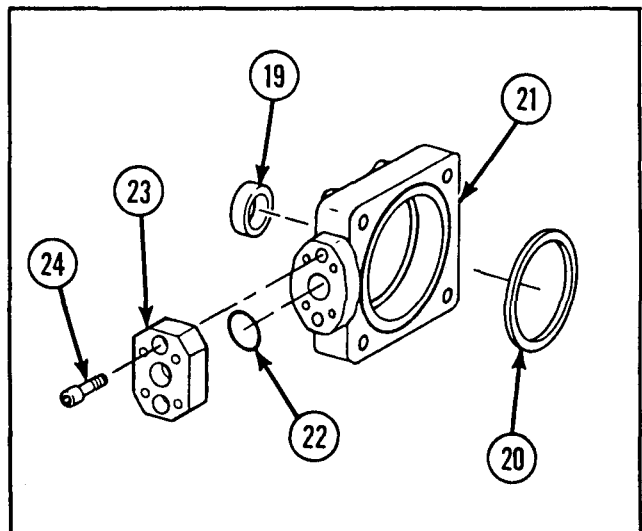

NOTE

Align match marks on output drive end cap and pump housing.

- 13 Install output drive end cap (21) to pump housing (8). Secure with four hexagon head capscrews (25).
- 14 Torque four hexagon head capscrews (25) to 250 ft-lb (339 N-m). Ensure shaft (3) can be turned without binding.
- 15 Install output drive end shaft key (26) on shaft (3).

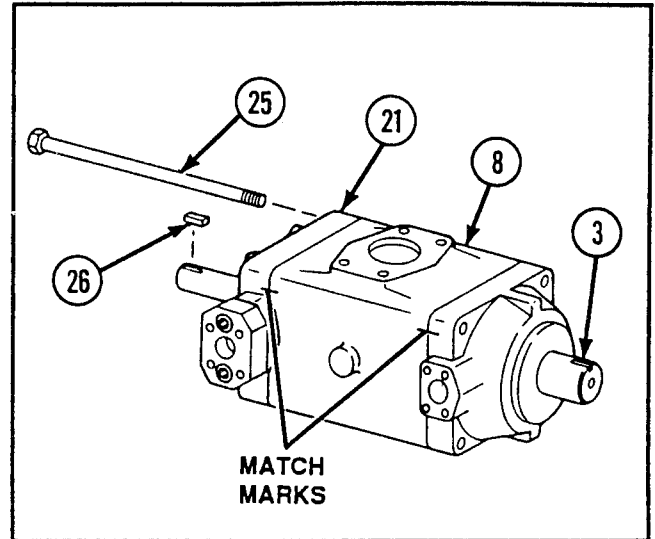

NOTE

Steps 16 thru 33 apply to Parker Hannifin or Hydreco double rotary pumps only.

- 16 Install new shaft spacers O-ring (27) and new shaft spacers backup ring (28) in pump front cover (29).
- 17 Install new large end shaft seal (30) and new ends-to-housing O-ring (31) in pump front cover (29).

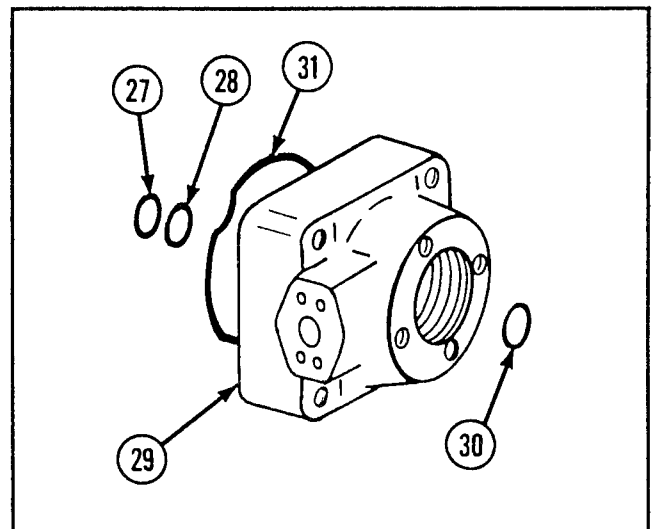

- 18 Install shaft (32) and end cap (33) to pump front cover (29).
- 19 Install four shaft capscrews (34) to end cap (33).

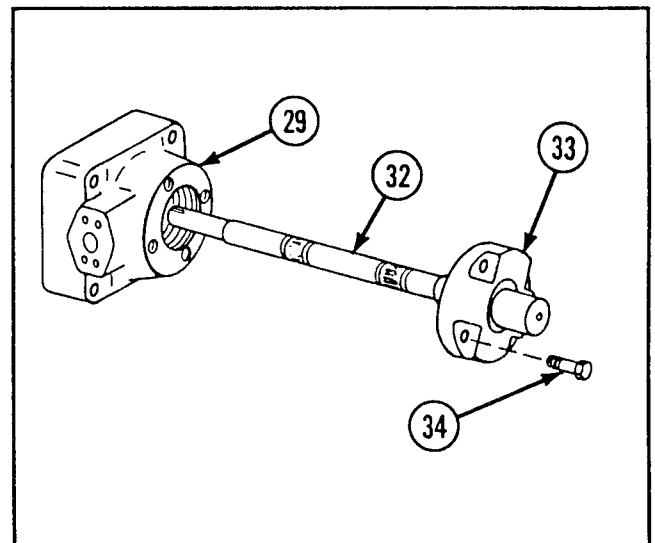

3-6. MAINTENANCE OF DOUBLE ROTARY PUMP (CONT).

REASSEMBLY (CONT)

- 20 Install new cartridge-to-housing end O-ring (35) and new cartridge-to-housing O-ring backup ring (36) to pump front cartridge (37).
- 21 Install pump front cartridge (37) on splines of shaft (32).

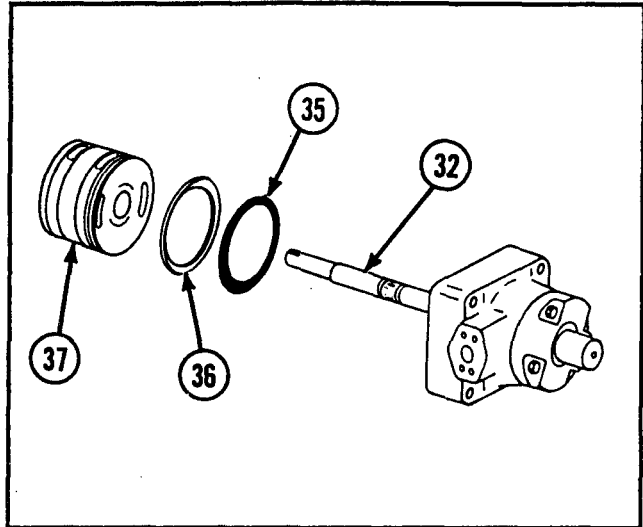

NOTE

Align match marks on pump front cover and pump housing.

- 22 Install pump front cover (29) to pump housing (38).
- 23 Install four new ends-to-housing lock-washers (39) and four ends-to-housing screws (40) to pump front cover (29).

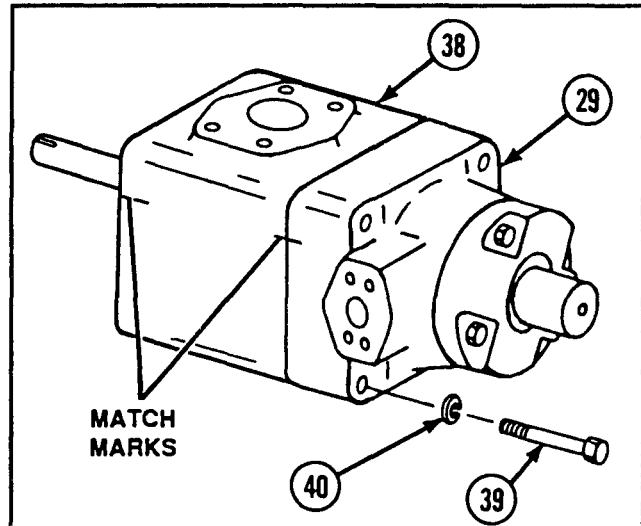

- 24 Install new shaft spacers backup ring (41) and new shaft spacers O-ring (42) to two spacers (43).
- 25 Install two spacers (43) on shaft (32).

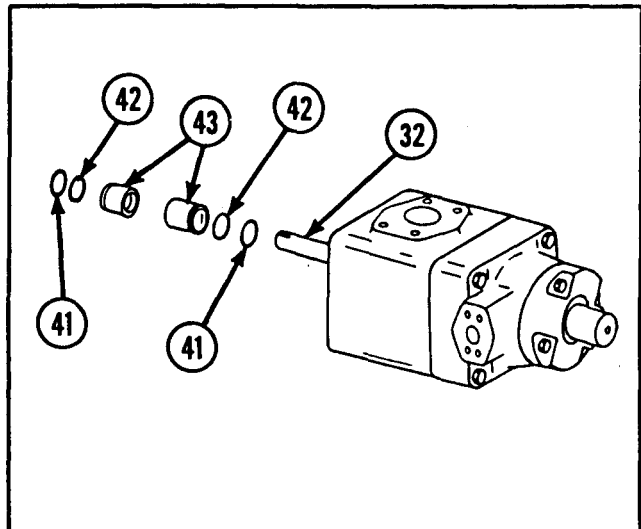

- 26 Install new cartridge-to-housing end O-ring (44) and new cartridge-to-housing O-ring backup ring (45) to pump rear cartridge (46).
- 27 Install pump rear cartridge (46) on splines of shaft (32).

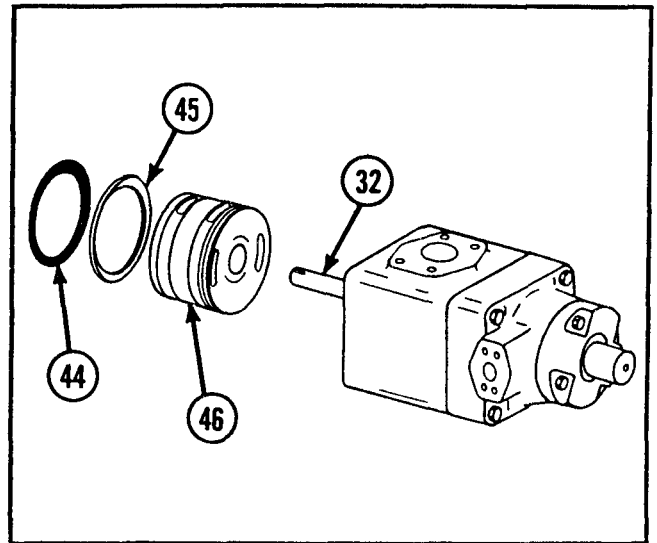

- 28 Install new ends-to-housing O-ring (47), new shaft spacers backup ring (48), and new shaft spacers O-ring (49) to pump rear cover (50).

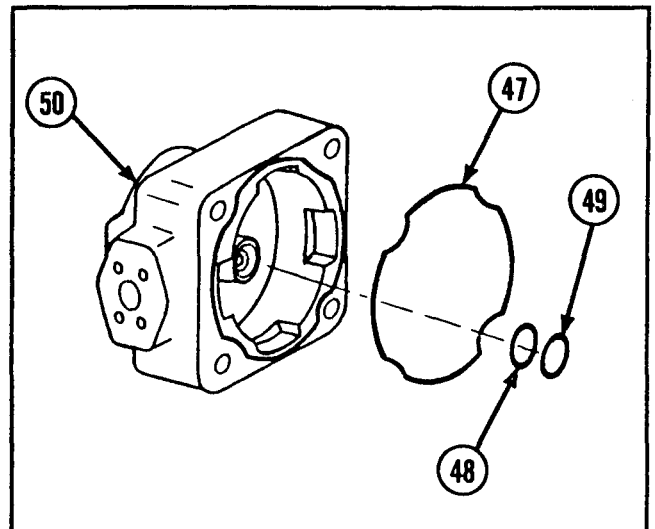

- 29 Using wood block and hammer, install new small end shaft seal (51) and new shaft roller bearing (52) in pump rear cover (50).

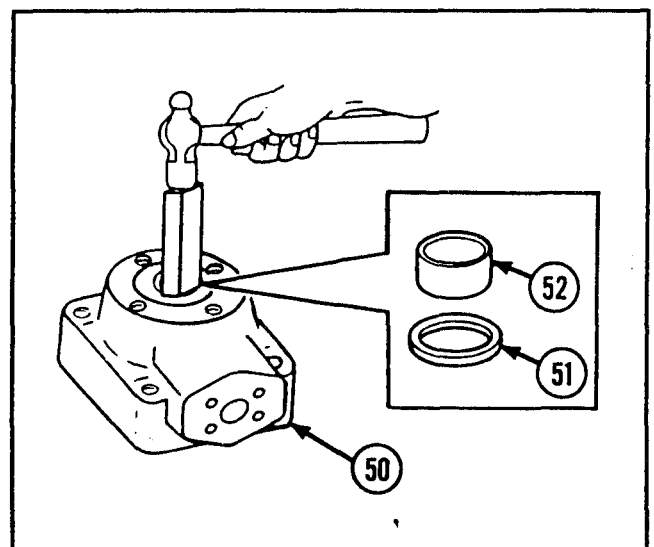

3-6. MAINTENANCE OF DOUBLE ROTARY PUMP (CONT).

REASSEMBLY (CONT)

NOTE

Align match marks on pump rear cover and pump housing.

- 30 Install pump rear cover (50) to pump housing (38).
- 31 Install four new ends-to-housing lockwashers (53) and four ends-to-housing screws (54) to pump rear cover (50).
- 32 Torque four ends-to-housing screws (39) in pump front cover and four ends-to-housing screws (54) in pump rear cover to 250 ft-lb (339 N-m). Ensure shaft (32) can be turned without binding.

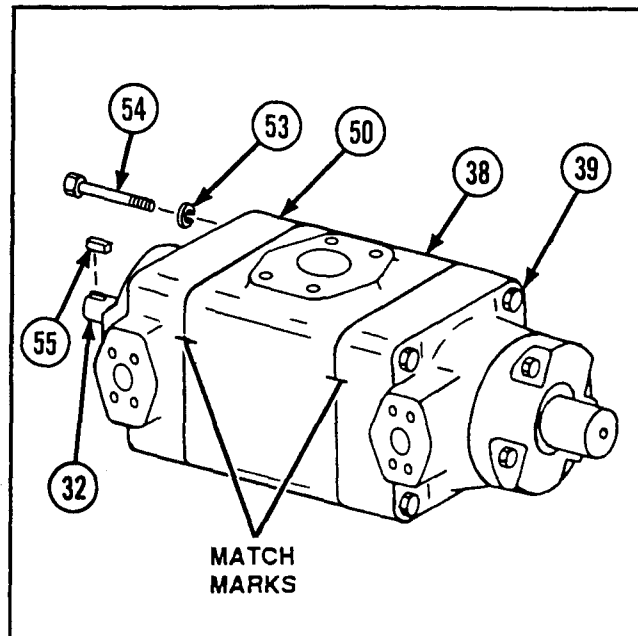

- 33 Install shaft key (55) to shaft (32).
- 34 Install pump drive flange (56) on double rotary pump (57).
- 35 Using key wrench, tighten two setscrews (58) in pump drive flange (56).

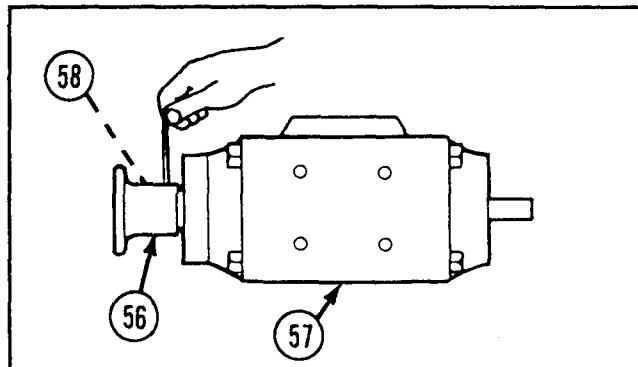

- 36 Install single and double pump flexible hydraulic coupling (59) and hydraulic pump bushing (60) to hull pump mount (61).

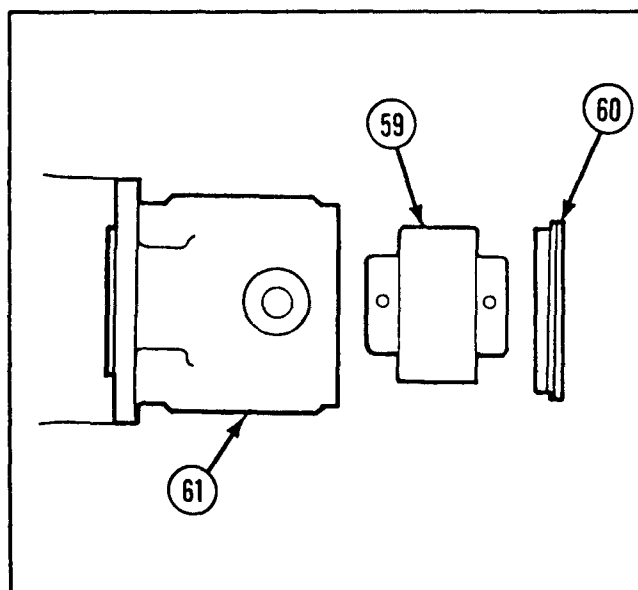

- 37** Install hull pump mount (61) to double rotary pump (57), and secure with four hexagon head capscrews (62) and new lockwire (63).

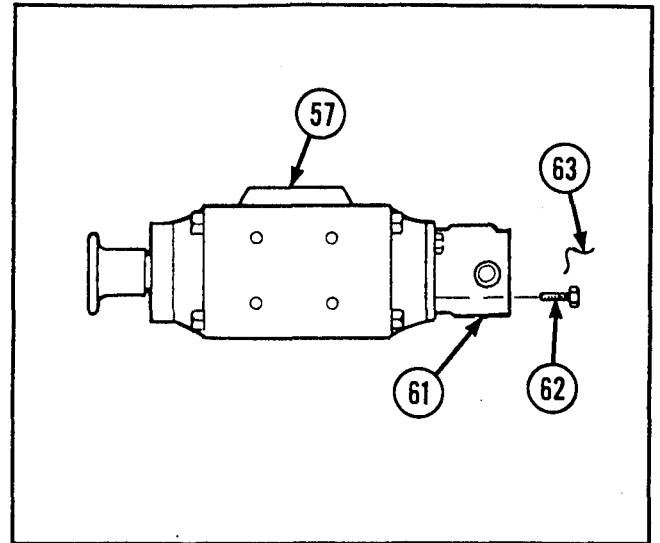

- 38** Install pump and slip ring support (64) to hull pump mount (61), and secure with two flat washers (65), two hexagon head capscrews (66), and new lockwire (67).

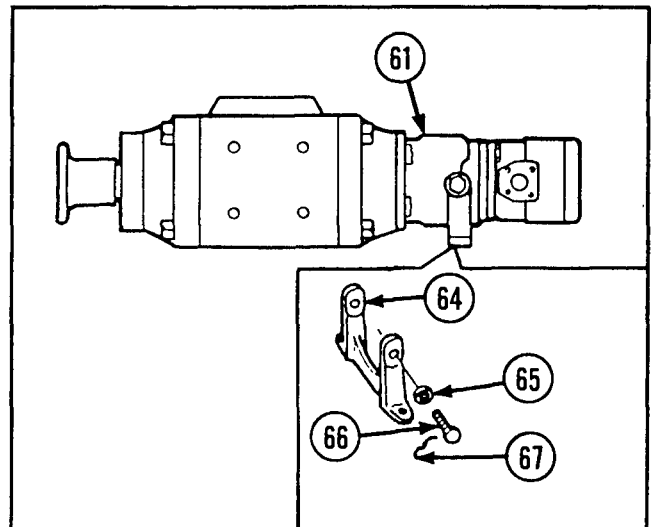

- 39** Install double pump base bracket (68) to double rotary pump (57), and secure with four hexagon head capscrews (69) and new lockwire (70).

- 40** Install hydraulic pump angle bracket (71) to double rotary pump (57), and secure with flat washer (72), hexagon head cap-screw (73), and new lockwire (74).

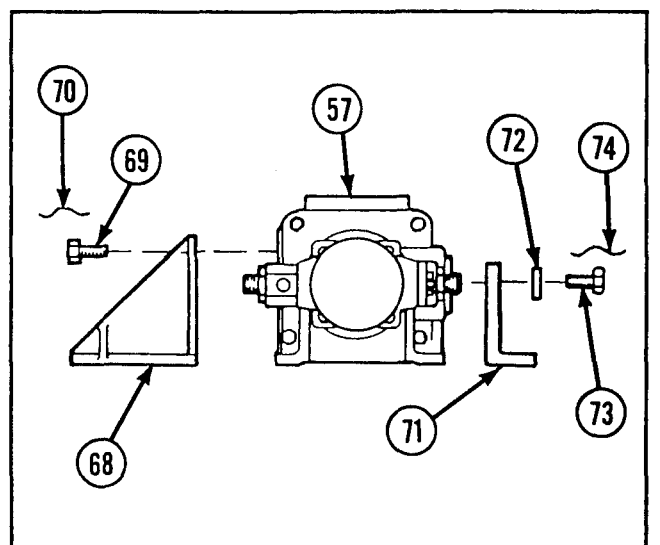

3-6. MAINTENANCE OF DOUBLE ROTARY PUMP (CONT).

REASSEMBLY (CONT)

NOTE

Steps 41 thru 44 apply to the installation of the single rotary hydraulic pump to the hull pump mount.

- 41 Install single rotary hydraulic pump (75) to hull pump mount (61), and secure with four hexagon head capscrews (76) and new lockwire (77).

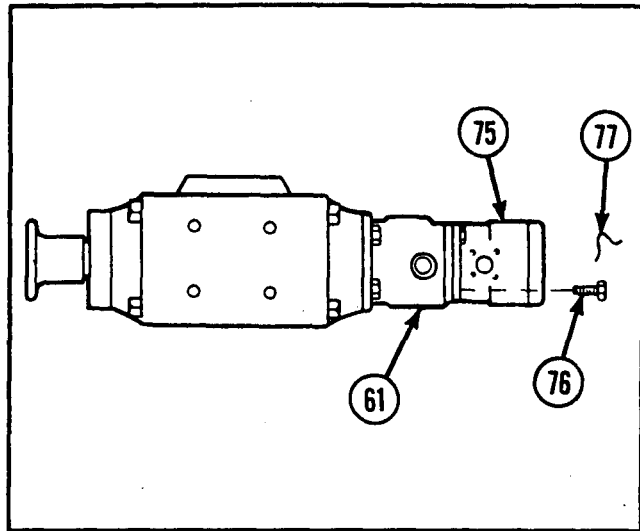

- 42 Rotate single and double pump flexible hydraulic coupling (59) until two setscrews (78) are visible through hole in hull pump mount (61).

- 43 Using key wrench, tighten two setscrews (78) in single and double pump flexible hydraulic coupling (59).

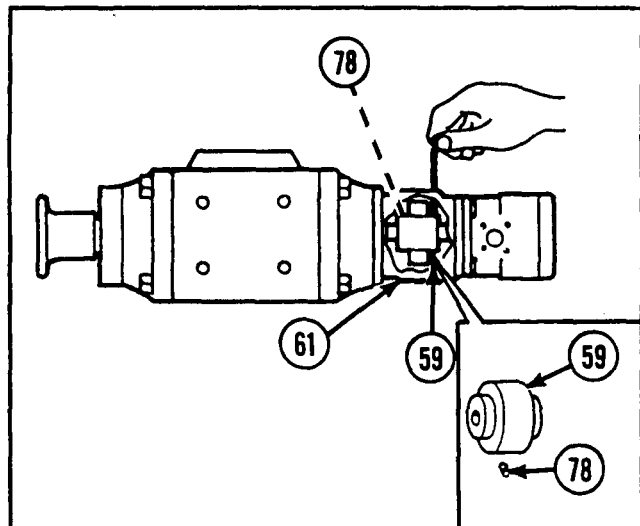

- 44 Install new preformed packing (79), single pump inlet manifold flange hydraulic adapter (80), and four socket head cap-screws (81) to single rotary hydraulic pump (75).

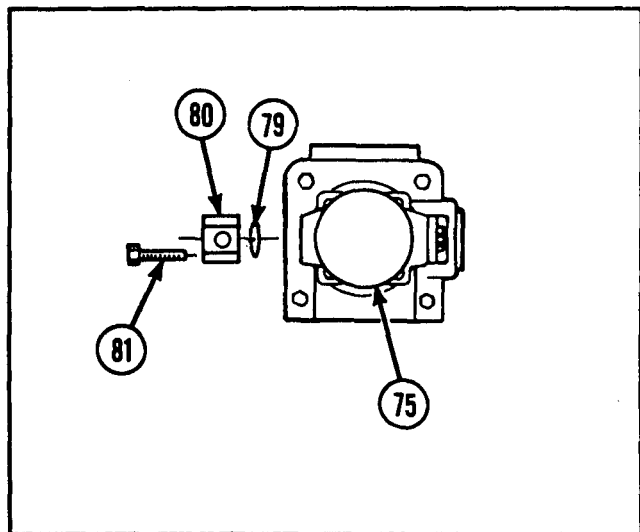

3-7. MAINTENANCE OF HYDRAULIC SUSPENSION LOCKOUT CYLINDER ASSEMBLY.

This task covers:	a. <i>Disassembly</i> b. <i>Inspection/Repair</i>	c. <i>Reassembly</i> d. <i>Test</i>
INITIAL SETUP		
<i>Tools and Special Tools</i>		
Automotive maintenance and repair shop equipment: field maintenance, basic, less power (SC 4910-95-A31)		
<ul style="list-style-type: none"> • Breaker bar, 3/4-in. drive • Plier wire twister • Press and block • Socket wrench • Torque wrench (0 to 150 ft-lb) • Torque wrench (0 to 600 ft-lb) • V-block 		
Bearing replacer (item 11, appx E)		
Lockout cylinder locknut spanner wrench (item 28, appx E)		
M3 hydraulic pump kit		
Manual control handle (item 4, appx E)		
Oil seal inserter (item 6, appx E)		
Wrench adapter (item 1, appx E)		
<i>Materials/Parts</i>		
Hydraulic fluid (item 18, appx B)		
Lockout cylinder parts kit		
Lockwasher (2)		
Preformed packing (2)		
Sealing compound (item 24, appx B)		
Self-aligning shell plain bearing (2)		
V-block stand		
<i>References</i>		
TM 9-214		
TM 9-237		
TM 9-2350-238-20-1		
TM 9-2350-238-24P-1		
<i>Equipment Conditions</i>		
Hydraulic suspension lockout cylinder assembly removed (TM 9-2350-238-20-1)		
<i>General Safety Instructions</i>		
WARNING		
<ul style="list-style-type: none"> • Wipe up any spilled hydraulic fluid to prevent injury to personnel. • Spring pressure exists behind eye. To avoid injury to personnel, use caution when removing eye. 		

DISASSEMBLY

WARNING

Wipe up any spilled hydraulic fluid to prevent injury to personnel.

- 1 Remove lockwire (1), two tube fitting plugs (2), and two preformed packings (3).
- 2 Drain hydraulic fluid from bleeder ports and control port in rod eye.

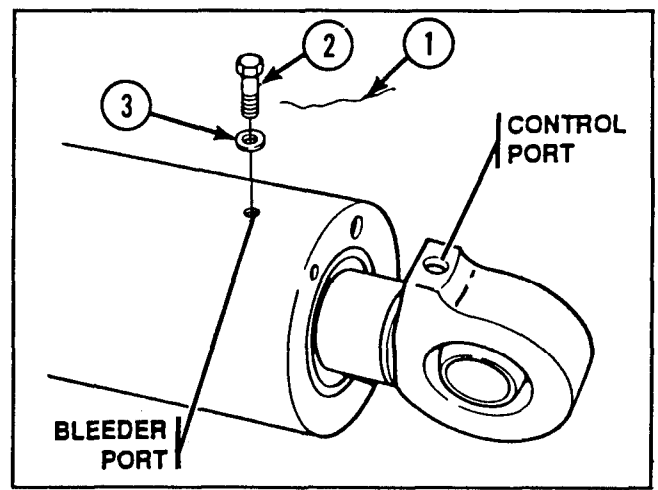

3-7. MAINTENANCE OF HYDRAULIC SUSPENSION LOCKOUT CYLINDER ASSEMBLY
(CONT).

DISASSEMBLY (CONT)

3 Remove internal wrench bolt (4), cylinder end wedge (5), internal wrench bolt (6), lockout cylinder key (7), and lockwasher (8).

4 Remove three internal wrench bolts (9).

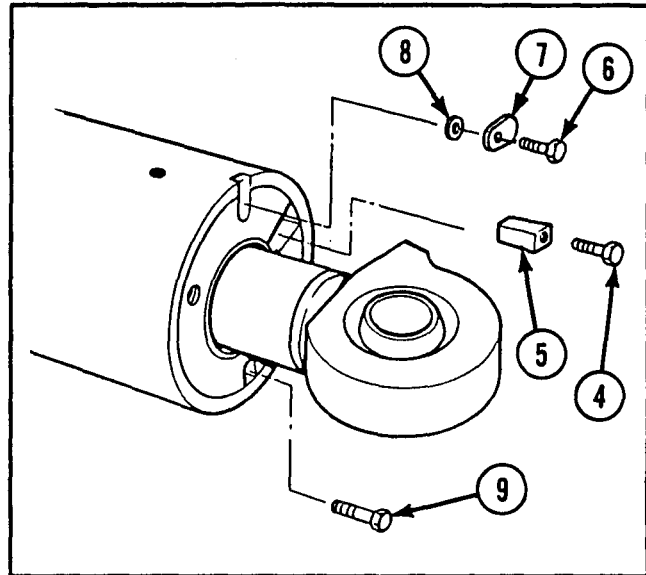

5 Using lockout cylinder locknut spanner wrench, loosen externally threaded ring (10) from actuating cylinder (11).

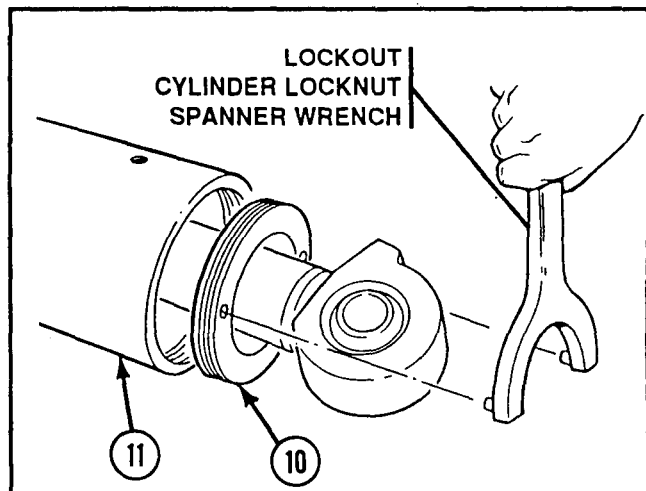

6 Remove cylinder rod (12) with eye (13), externally threaded ring (10), and cylinder head (14) from actuating cylinder (11).

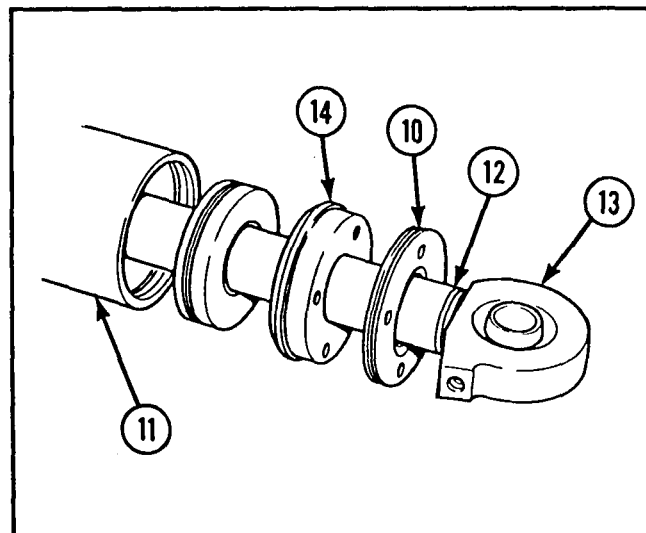

- 7 Remove lockwire (15) from six socket head capscrews (16).
- 8 Remove six socket head capscrews (16), two cylinder plate wedges (17), lockout cylinder key (18), lockwasher (19), and sleeve spacer (20).

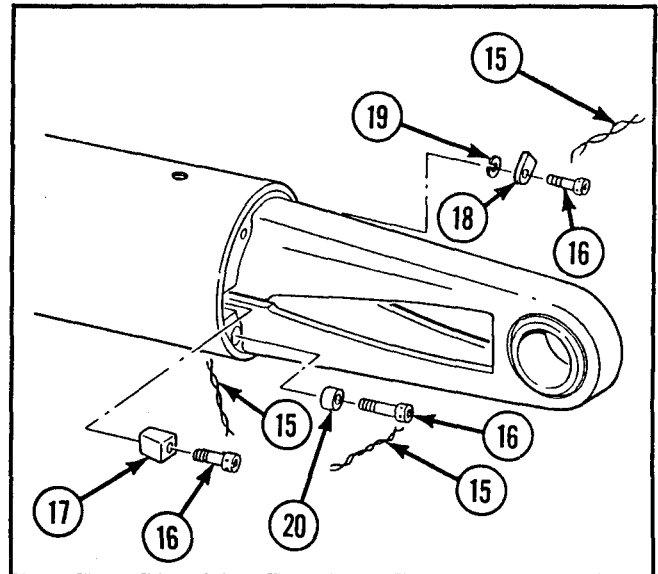

- 9 Remove adapter (21).
- 10 Remove cylinder head (22) from actuating cylinder (11).
- 11 Remove packing retainer (23), preformed packing (24), plain encased seal (25), and packing assembly (26).

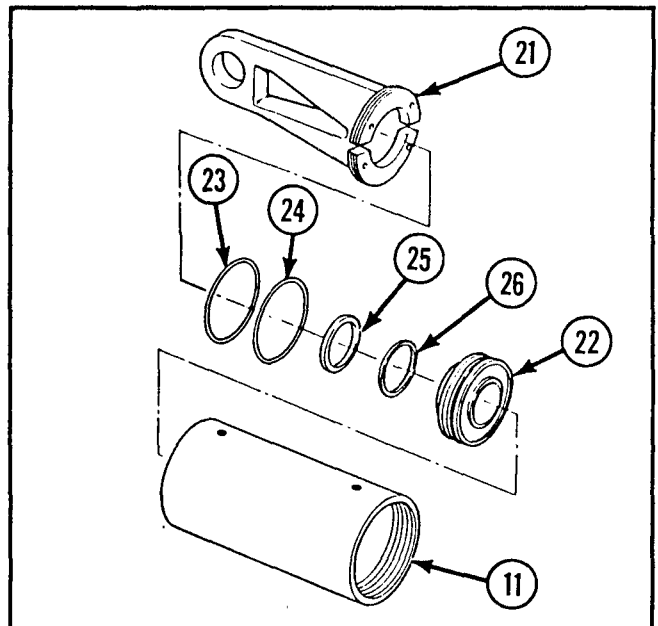

- 12 Using chisel, remove eye cylinder clip (27).

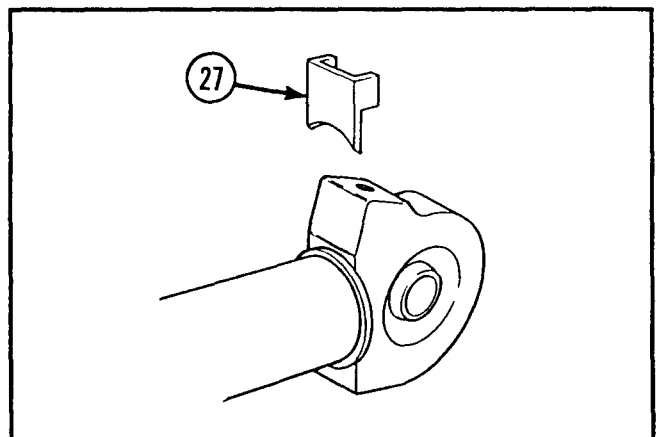

3-7. MAINTENANCE OF HYDRAULIC SUSPENSION LOCKOUT CYLINDER ASSEMBLY
(CONT).

DISASSEMBLY (CONT)

WARNING

Spring pressure exists behind eye.
To avoid injury to personnel, use caution when removing eye.

- 13 Using lockout cylinder locknut spanner wrench, wrench adapter, socket, and breaker bar, remove eye (13) from cylinder rod (12).

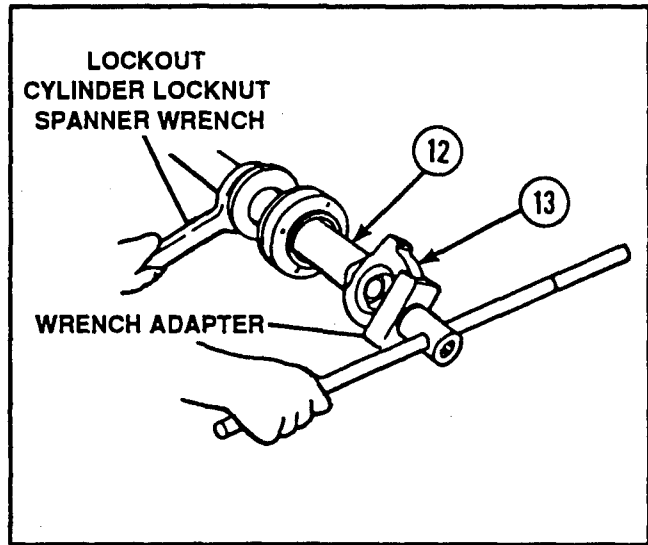

- 14 Remove sleeve spacer (28), externally threaded ring (10), cylinder head (14), and packing assembly (29) from cylinder rod (12).

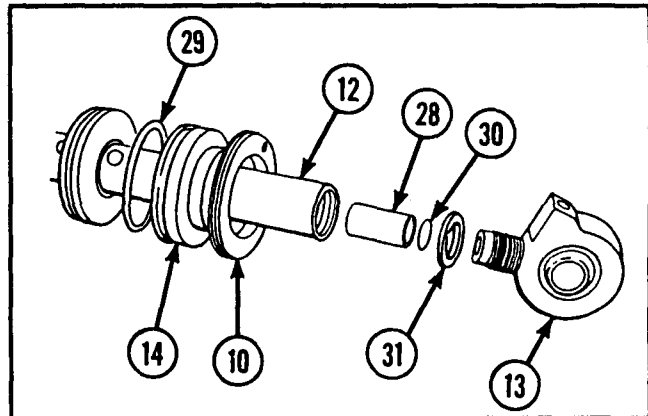

- 15 Remove preformed packing (30) and key washer (31) from eye (13).

- 16 Remove packing retainer (31), preformed packing (32), plain encased seal (33), and packing assembly (34) from cylinder head (14).

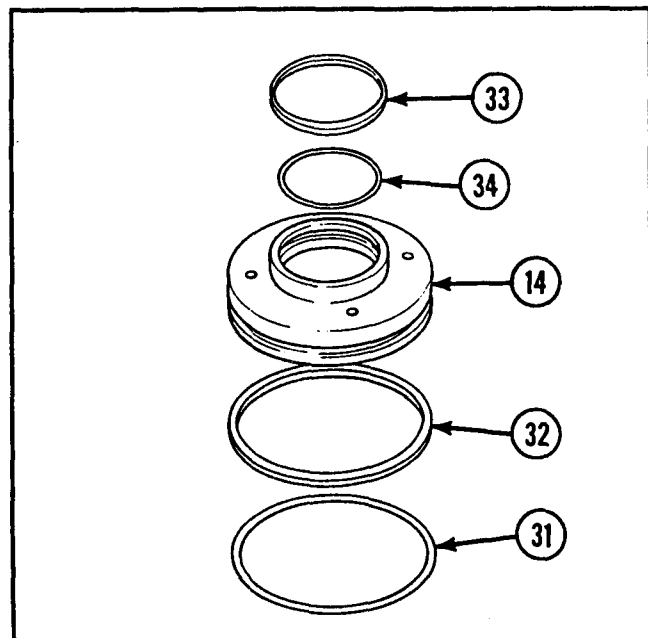

- 17 Remove retaining ring (35), piston vent (36), and piston spring washer (37) from cylinder rod (12).

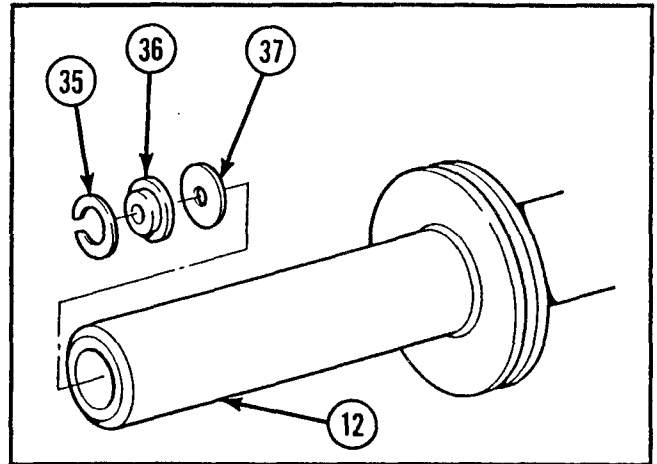

- 18 Pull shock absorber piston (38) and piston spring (39) through threaded end of cylinder rod (12). Remove four preformed packings (40).

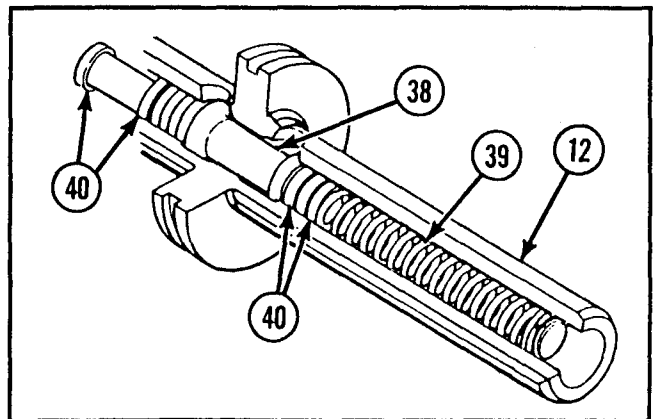

NOTE

Step 19 is illustrated for eye, but also applies to adapter.

- 19 Using press and block, force one self-aligning shell plain bearing (41) from eye (13) and one from adapter (21).

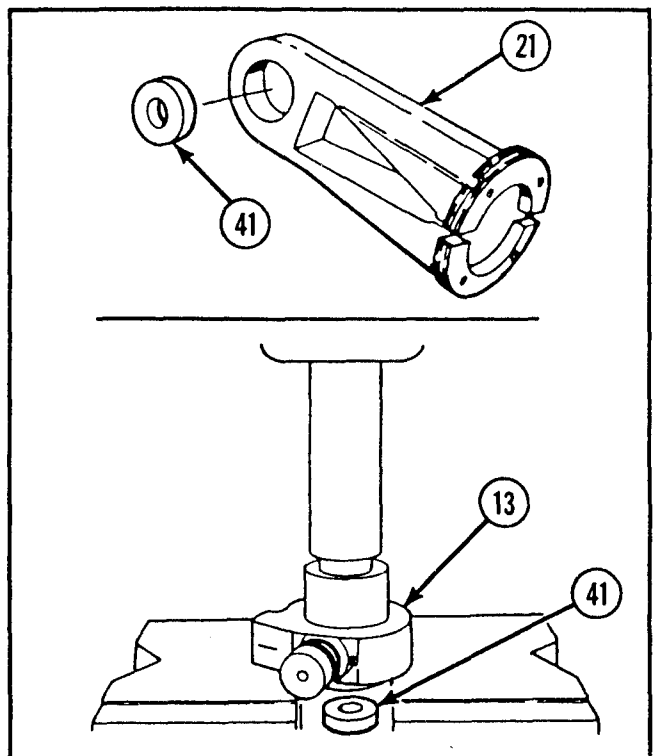

3-7. MAINTENANCE OF HYDRAULIC SUSPENSION LOCKOUT CYLINDER ASSEMBLY
(CONT).

INSPECTION/REPAIR

- 1 Inspect for broken, damaged, or missing parts.
- 2 Inspect bearings per TM 9-214.
- 3 If any kit component is damaged, replace entire lockout cylinder parts kit.
- 4 Repair is by replacement of authorized parts (TM 9-2350-238-24P-1) which do not meet inspection criteria.

REASSEMBLY

NOTE

Step 1 is illustrated for eye, but also applies to adapter.

- 1 Using press and bearing replacer, press one new self-aligning shell plain bearing (1) into eye (2) and one into adapter (3).
- 2 Using center punch, stake two self-aligning shell plain bearings (1) in four places on each side. Metal must extend to bearing race.
- 3 Place cylinder rod (4) on level, wooden V-block stand.
- 4 Slide new piston spring (5) through retaining ring end of cylinder rod (4) until it is past ring groove. Install new piston spring washer (6). Install new piston vent (7) with large end toward piston spring washer. Install new retaining ring (8).
- 5 Install four new preformed packings (9) in grooves on shock absorber piston (10).
- 6 Install shock absorber piston (10), small diameter first, into threaded end of cylinder rod (4).

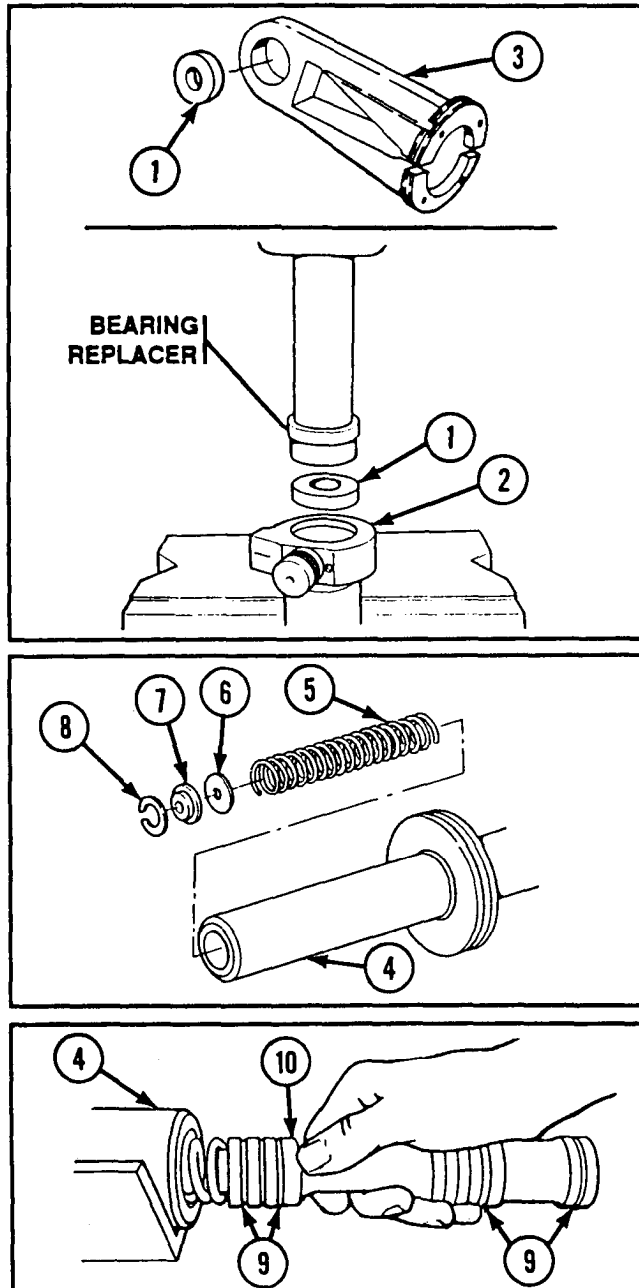

NOTE

Steps 7 thru 9 are written and illustrated for one cylinder head, but apply to both cylinder heads.

- 7 Install new packing assembly (11) in cylinder head (12).
- 8 Install new preformed packing (13) and new packing retainer (14) with concave side of packing retainer facing preformed packing.

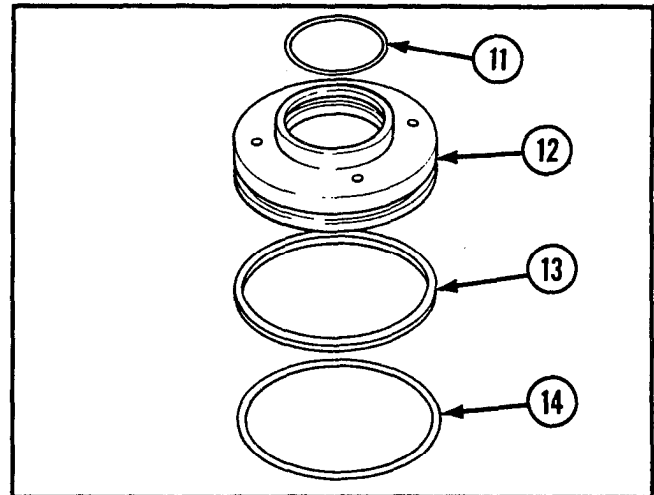

- 9 Using oil seal inserter and manual control handle, install new plain encased seal (15) in cylinder head (12) with lip facing out.

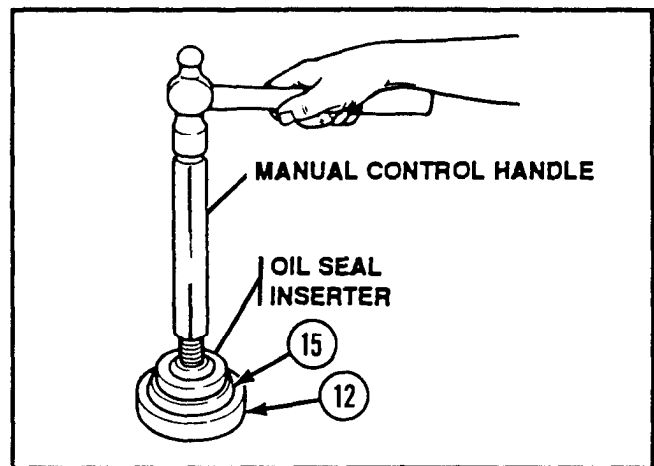

- 10 Install new packing assembly (16) and cylinder head (12) on eye end of cylinder rod (4) with threaded holes facing out.
- 11 Install externally threaded ring (17) on eye end of cylinder rod (4) with large diameter of four holes facing out.
- 12 Apply sealing compound to threaded area of eye (2).
- 13 Install sleeve spacer (18) into threaded end of cylinder rod (4).
- 14 Install new key washer (19) and new preformed packing (20) on eye (2).
- 15 Place end of eye (2) against sleeve spacer (18). Press against sleeve spacer to compress piston spring and engage eye threads.

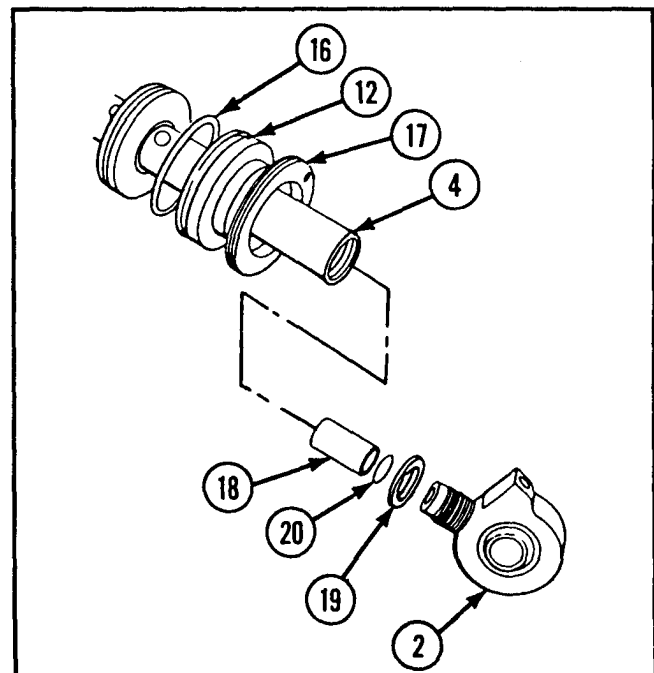

3-7. MAINTENANCE OF HYDRAULIC SUSPENSION LOCKOUT CYLINDER ASSEMBLY
(CONT).

REASSEMBLY (CONT)

NOTE

Align notch with tab in washer and shaft.

- 16 Using lockout cylinder locknut spanner wrench, wrench adapter, and torque wrench, secure eye (2) to cylinder rod (4). Torque to 300 to 400 ft-lb (407 to 542 N-m).

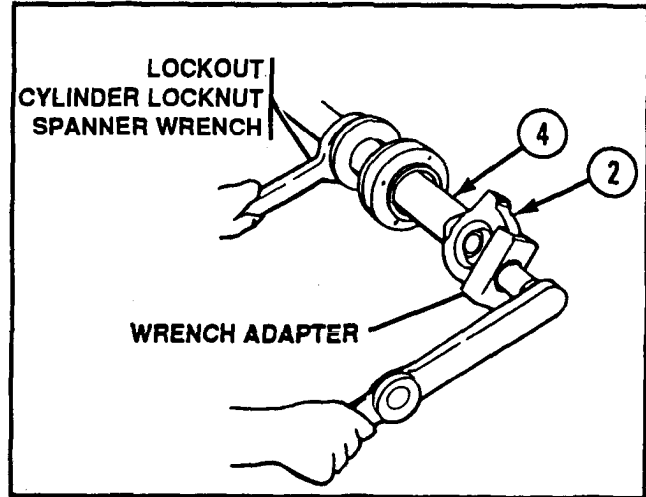

- 17 Insert cylinder head (21) into adapter end of actuating cylinder (22) so that threaded holes in cylinder head are facing out and are 45 degrees left and right of bleeder port centerline.

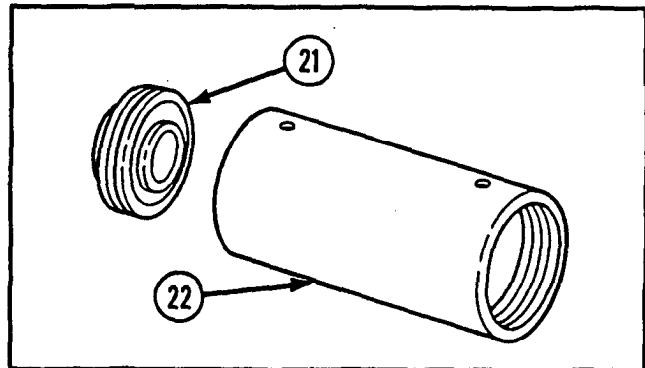

- 18 Insert assembled cylinder rod (4) into actuating cylinder (22). Ensure that cylinder rod is centered in actuating cylinder.
- 19 Work cylinder rod (4) through cylinder head (21).
- 20 Install two tube fitting plugs (23) without new preformed packings into actuating cylinder (22). Tighten tube fitting plugs finger tight.
- 21 Screw externally threaded ring (17) into actuating cylinder (22) until cylinder head (12) contacts tube fitting plug (23).
- 22 Back off externally threaded ring (17) until slots in externally threaded ring and cylinder head (12) are aligned. Do not exceed 180 degrees.

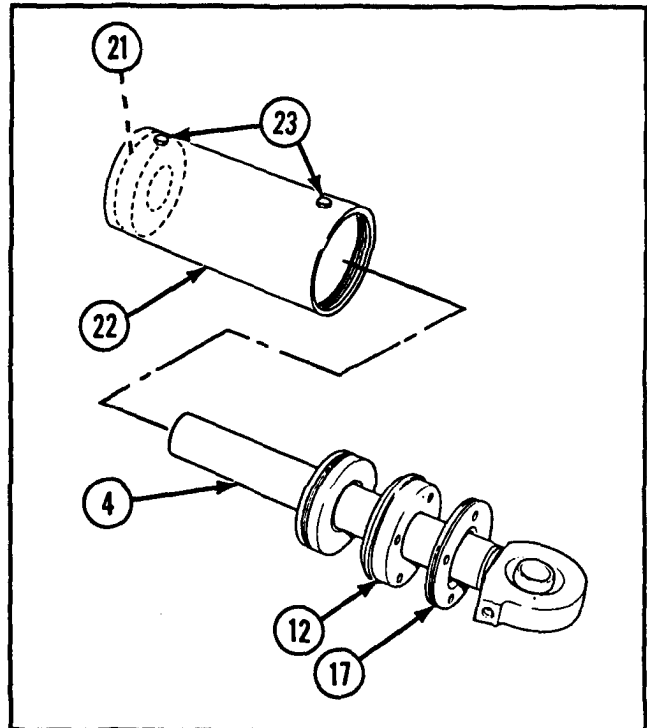

- 23 Apply sealing compound to three internal bolts (24), internal wrench bolt (25), and internal wrench bolt (26).

NOTE

Key prevents relative rotation between externally threaded ring and actuating cylinder.

- 24 Install new lockwasher (27), lockout cylinder key (28), and internal wrench bolt (25) in externally threaded ring (17).

- 25 Install cylinder end wedge (29), internal wrench bolt (26), and three internal wrench bolts (24). Do not tighten internal wrench bolts.

- 26 Spread externally threaded ring (17) by tightening internal wrench bolt (26) that secures cylinder end wedge (29) to cylinder head (12). Torque internal wrench bolt (26) to 5.2 to 6.2 ft-lb (7.1 to 8.4 N-m).

- 27 Torque internal wrench bolt (25) and three internal wrench bolts (24) to 5.2 to 6.2 ft-lb (7.1 to 8.4 N-m).

- 28 Apply sealing compound to threads of adapter (3).

- 29 Screw adapter (3) into actuating cylinder (22) until cylinder head (21) contacts tube fitting plug (23).

CAUTION

Backing off adapter more than 90 degrees will result in incorrect adjustment.

- 30 Back off adapter (3) until four screw holes are aligned with cylinder head holes.

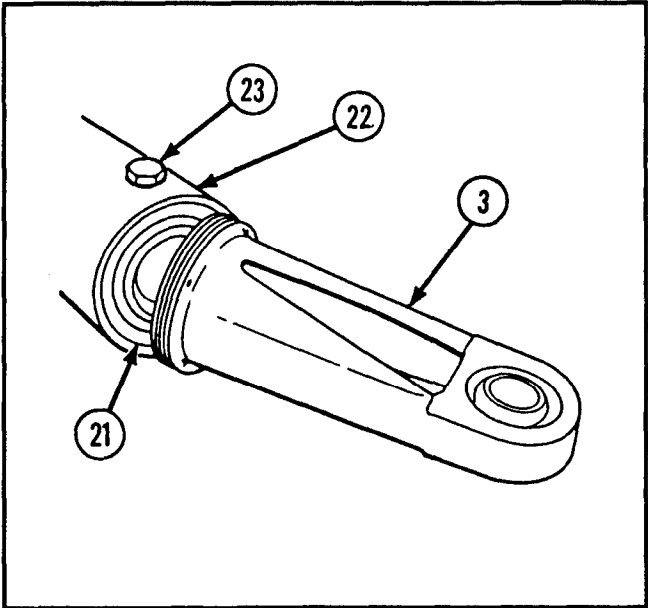
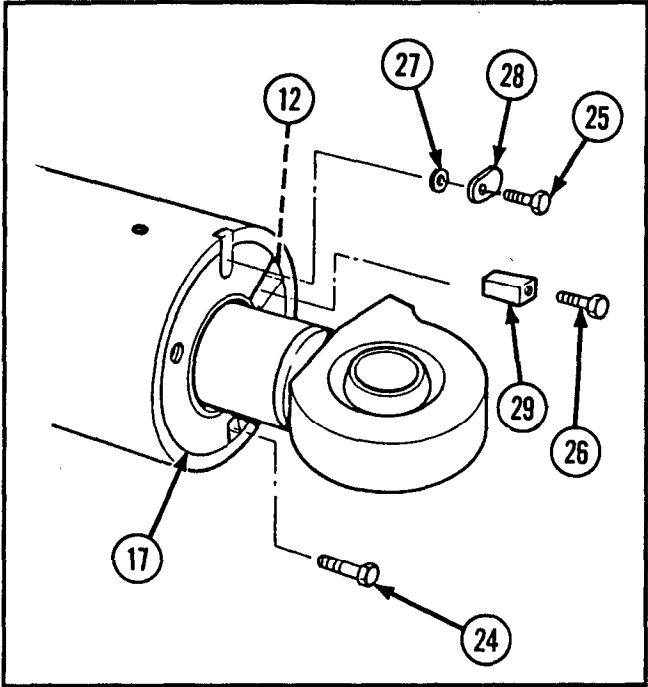

3-7. MAINTENANCE OF HYDRAULIC SUSPENSION LOCKOUT CYLINDER ASSEMBLY
(CONT).

REASSEMBLY (CONT)

- 31 Install sleeve spacer (30), new lockwasher (31), lockout cylinder key (32), and four socket head capscrews (33). Tighten socket head capscrews finger tight.
- 32 Install two cylinder plate wedges (34) and two socket head capscrews (35).
- 33 Spread adapter (3) into actuating cylinder (22) by torquing two socket head capscrews (35) to 5.2 to 6.2 ft-lb (7.1 to 8.4 N-m).
- 34 Torque four socket head capscrews (33) to 5.2 to 6.2 ft-lb (7.1 to 8.4 N-m).
- 35 Secure six socket head capscrews (33 and 35) with new lockwire (36).

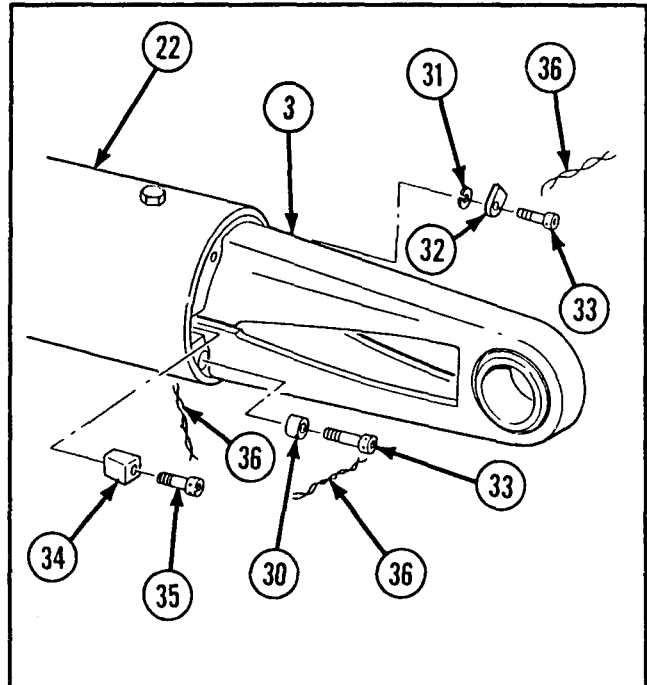

- 36 Insert new eye cylinder clip (37) into gap between eye (2) and key washer (19).

CAUTION

Protect cylinder rod from spatter of welding slag.

- 37 Weld eye cylinder clip (37) to key washer (19) per TM 9-237.

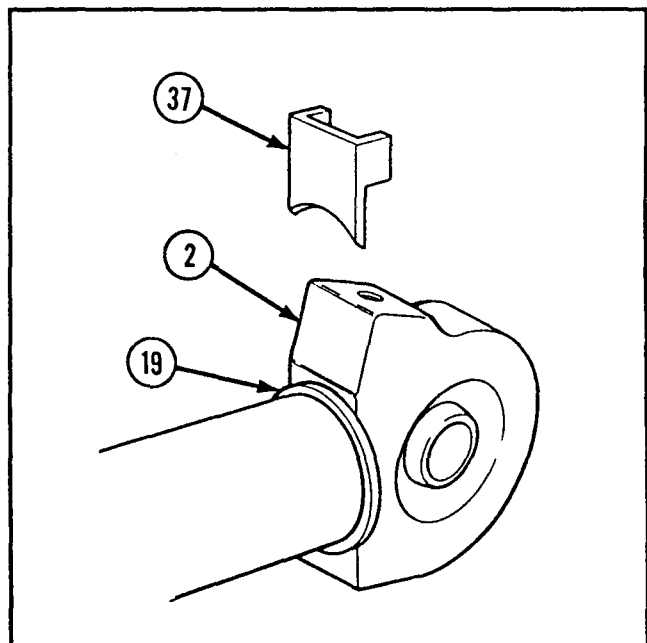

TEST

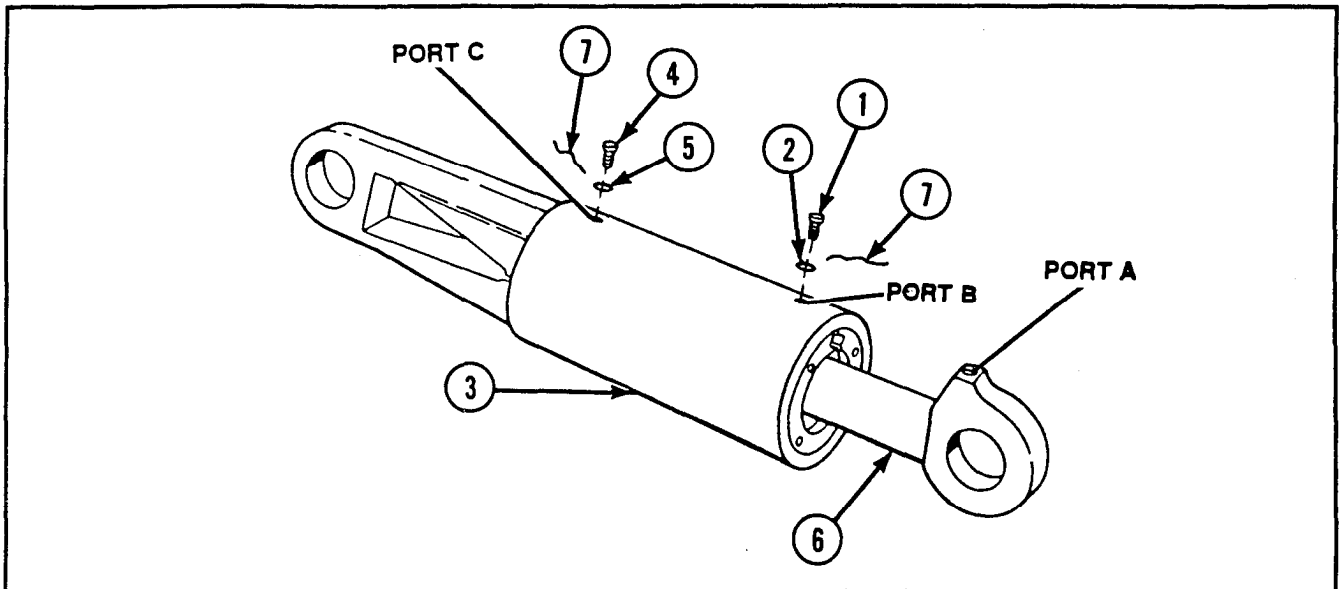

- 1 If necessary, remove plug from eye control port (port A).
- 2 If necessary, remove tube fitting plug (1) and preformed packing (2) from port B at eye end of actuating cylinder (3).
- 3 If necessary, remove tube fitting plug (4) and preformed packing (5) from port C at adapter end of actuating cylinder (3).
- 4 Retract cylinder rod (6) to minimum length. Place lockout cylinder assembly on bench with ports on top. Using M3 oil pump, fill cylinder with hydraulic fluid. Apply hydraulic fluid at 2 to 3 psi (14 to 21 kPa) through port A. Assist by filling through ports B and C. Fill slowly to make sure all air is removed from lockout cylinder assembly.
- 5 To test hydraulic fluid flow through shock absorber piston, apply 2 to 3 psi (14 to 21 kPa) hydraulic pressure at port A.

NOTE

Hydraulic fluid should flow freely from ports B and C.

- 6 To test shock absorber piston operation, install two new preformed packings (2 and 5) and two tube fitting plugs (1 and 4) in ports B and C.
- 7 Apply 150 psi (1034 kPa) hydraulic pressure at port A to compress piston spring.

NOTE

No leakage is allowed at port B, port C, or adapter end of cylinder. Relieve pressure.

- 8 Maintain pressure at port A, and remove two tube fitting plugs (1 and 4) and two preformed packings (2 and 5) from ports B and C.
- 9 To test cylinder head seals and rod seals, retract cylinder rod (6) to minimum length.

3-7. MAINTENANCE OF HYDRAULIC SUSPENSION LOCKOUT CYLINDER ASSEMBLY
(CONT).

TEST (CONT)

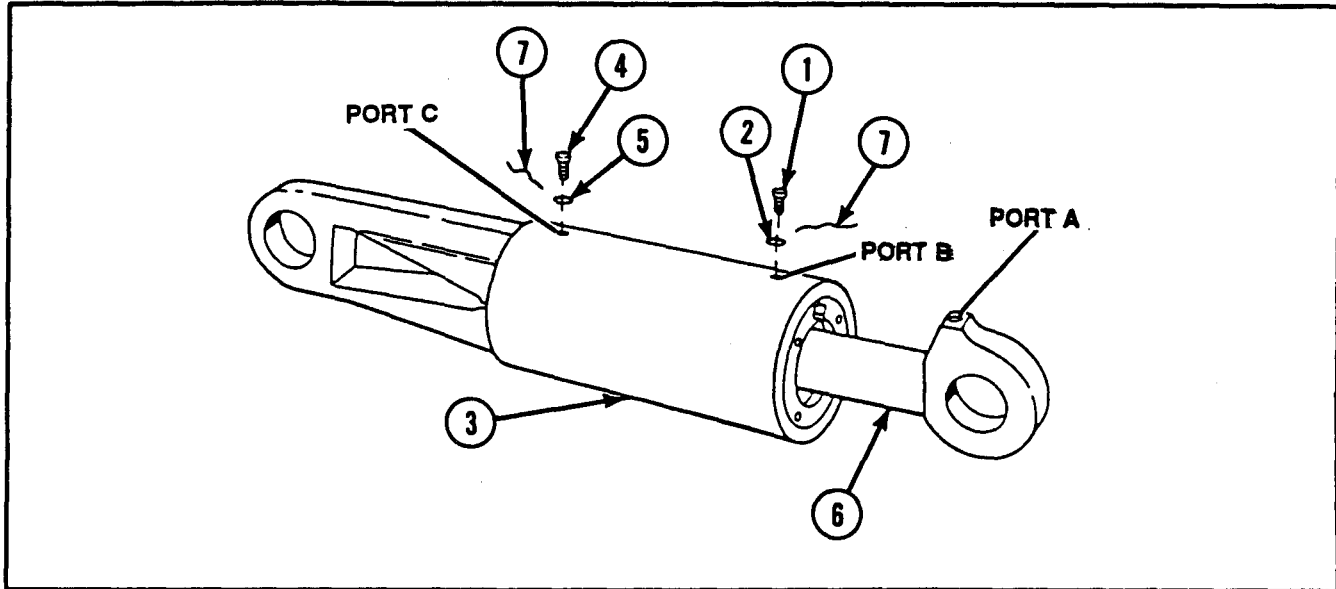

10 Install two new preformed packings (2 and 5) and tube fitting plugs (1 and 4) to ports B and C.

11 Apply 150 psi (1034 kPa) hydraulic pressure at port A to compress piston spring.

12 Maintain pressure at port A, and remove two tube fitting plugs (1 and 4) and two preformed packings (2 and 5) from ports B and C.

NOTE

No leakage is allowed at port C or around cylinder rod and cylinder head at eye end of cylinder.

13 Apply 3000 psi (20,685 kPa) hydraulic pressure at port B for 2 minutes.

14 Relieve pressure at ports A and B.

15 Install new preformed packing (5) and tube fitting plug (4) in port C and port A.

NOTE

No leakage or permanent distortion is allowed.

16 Apply 3000 psi (20,685 kPa) hydraulic pressure at port B for 5 minutes.

17 Remove tube fitting plug (4) and preformed packing (5) from port C. Install new preformed packings (2 and 5) on tube fitting plugs (1 and 4). Retract cylinder rod (6) to minimum length and install two tube fitting plugs.

18 Tighten two tube fitting plugs (1 and 4). Secure tube fitting plugs with new lockwire (7).

3-8. MAINTENANCE OF TRANSMISSION POWER TAKEOFF.

This task covers: a. *Disassembly* b. *Inspection/Repair* c. *Reassembly*

INITIAL SETUP*Tools and Special Tools*

Automotive maintenance and repair shop equipment: field maintenance, basic, less power (SC 4910-95-A31)

- Arbor press
- Mechanical gear puller kit
- Plier wire twister
- Retaining ring pliers
- Rubber hammer

Bearing cone replacer assembly (item 19, appx E)

Bearing cup replacer (item 15, appx E)

Bearing remover (item 8, appx E)

Bearing replacer (item 12, appx E)

Manual control handle (item 3, appx E)

Wood block

Materials/Parts

Lockwasher

Lockwasher

Lockwire (item 34, appx B)

Lubricating oil (item 20, appx B)

Plain encased seal (2)

Plain encased seal (2)

Preformed packing

Preformed packing

Preformed packing (2)

Primer coating (item 22, appx B)

Sealing compound (item 24, appx B)

Sealing compound (item 25, appx B)

White enamel (item 14, appx B)

References

TM 9-214

TM 9-2350-238-24P-1

Equipment Conditions

2-163 Transmission power takeoff removed

3-8. MAINTENANCE OF TRANSMISSION POWER TAKEOFF (CONT).

DISASSEMBLY

- 1 If damaged, remove pipe plug (1) from transmission power takeoff (2).
- 2 Remove hexagon plain nut (3), lockwasher (4), and idler gear pin shaft collar (5) from shoulder bolt (6).

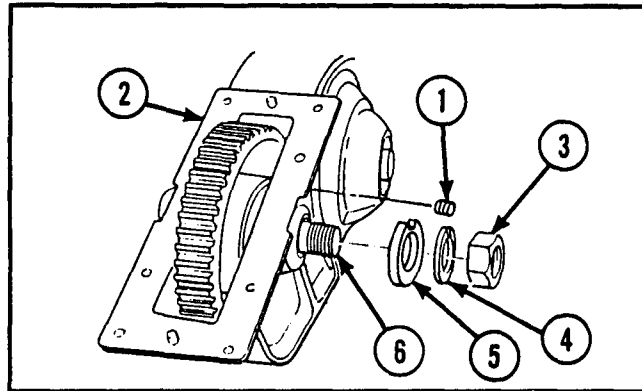

- 3 Using wood block, drive shoulder bolt (6) from spur gear (7) and gearcase (8).
- 4 Remove two preformed packings (9) from gearcase (8). Remove preformed packing (10) from shoulder bolt (6).

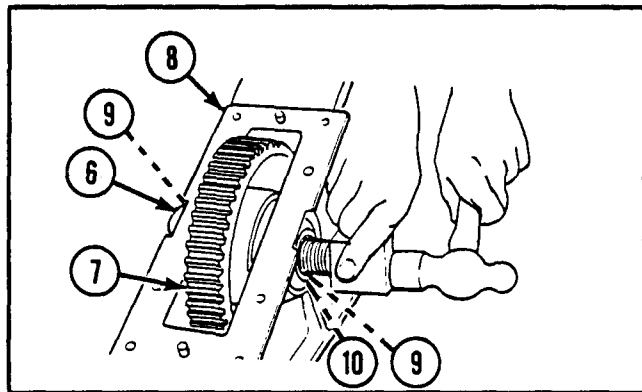

- 5 Lift spur gear (7) out of gearcase (8).

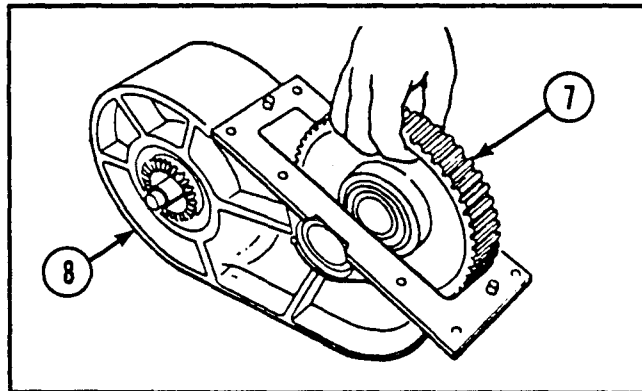

- 6 Remove two idler spur gear roller bearings (11) from each side of spur gear (7).

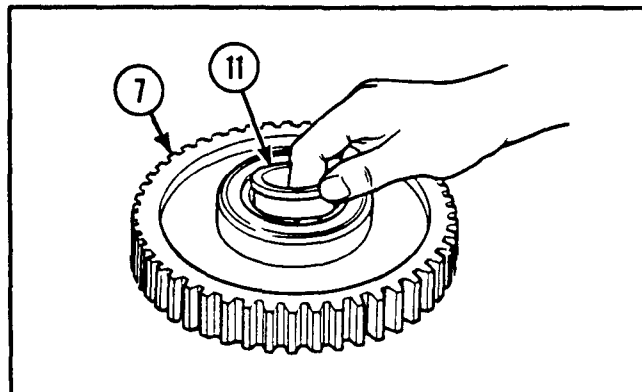

- 7 Remove idler gear bearing sleeve spacer (12) from spur gear (7).

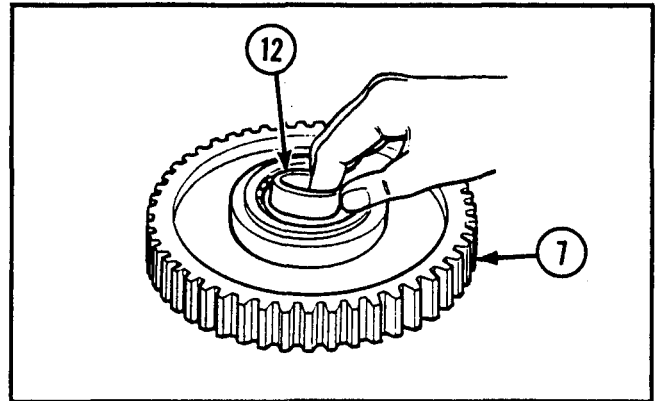

- 8 Using drift and press, remove idler spur gear roller bearing cones (13) from spur gear (7).

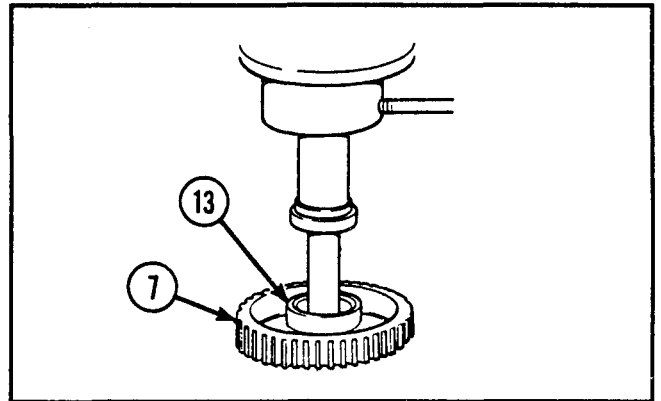

- 9 Remove external retaining ring (14) from externally relieved bolt (15).

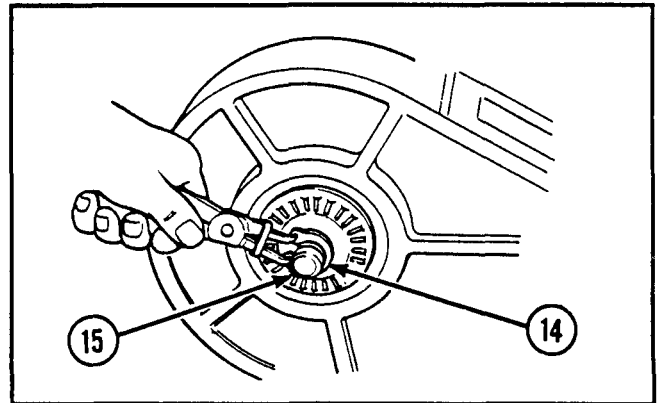

- 10 Pull externally relieved bolt (15) and lock-washer (16) from output gear cluster (17) and gearcase (8).

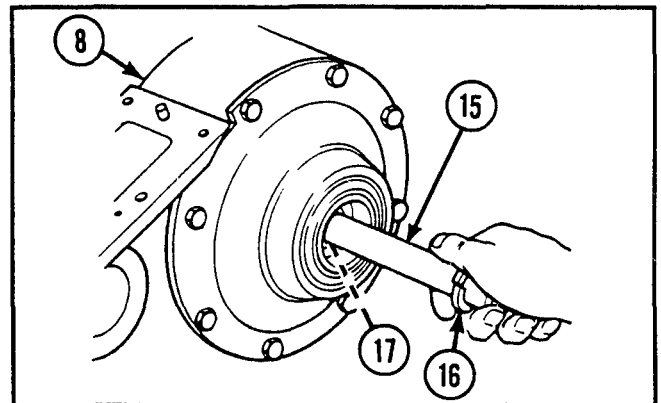

3-8. MAINTENANCE OF TRANSMISSION POWER TAKEOFF (CONT).

DISASSEMBLY (CONT)

- 11 Remove lockwire (18) and eight hexagon head capscrews (19) securing gearcase cover (20).

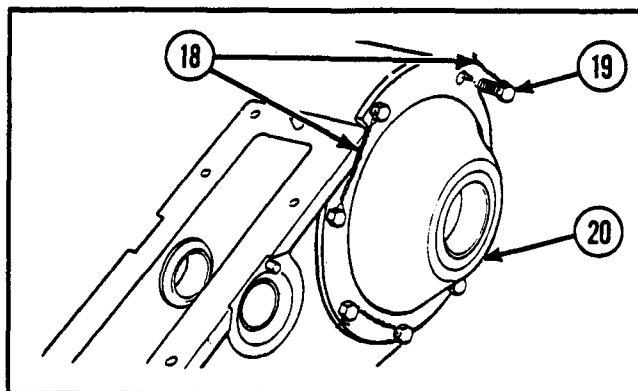

CAUTION

Do not damage mating surfaces of gearcase cover and gearcase.

- 12 Using rubber hammer, loosen gearcase cover (20). Pry carefully around edge and remove gearcase cover.

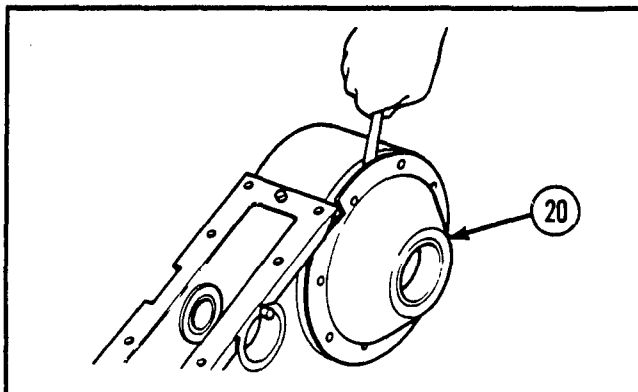

- 13 Remove preformed packing (21) from gearcase (8).

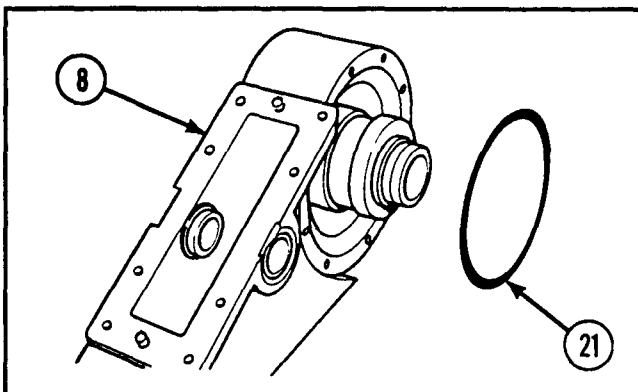

- 14 Remove two plain encased seals (22) from gearcase cover (20), using bearing cup replacer and manual control handle.

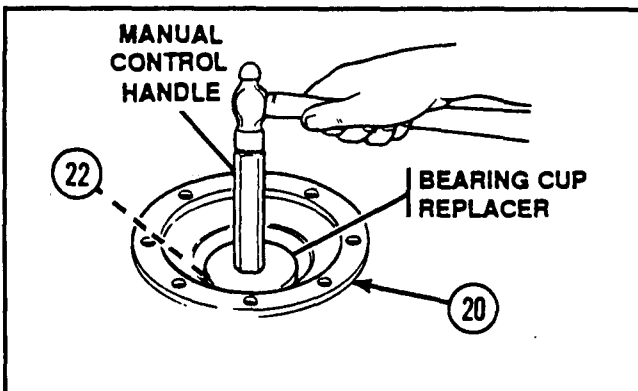

- 15 Using drift, tap output gear cluster (17) lightly to loosen two output gear annular ball bearings.

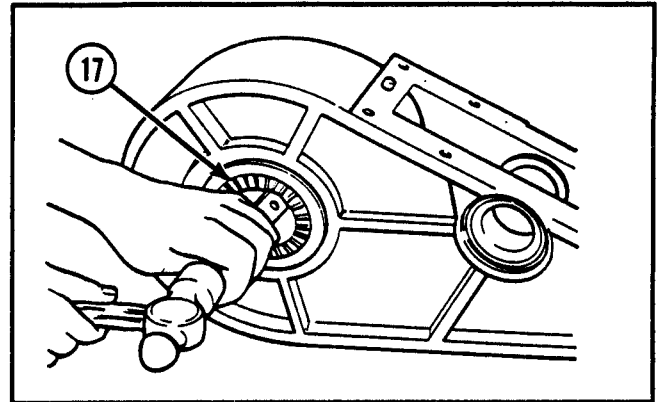

- 16 Remove output gear cluster (17) with two output gear annular ball bearings (23 and 24) from gearcase (8).

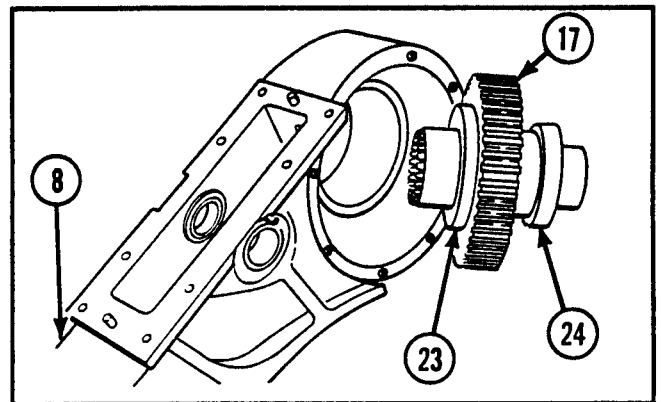

- 17 Using puller, remove two output gear annular ball bearings (23 and 24) from output gear cluster (17).

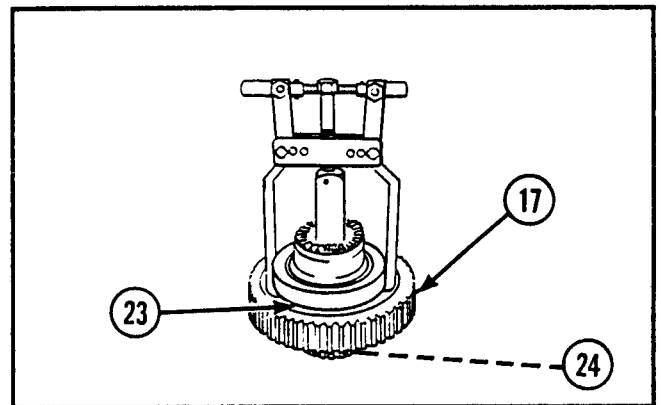

- 18 Remove two plain encased seals (25) from gearcase (8), using bearing cup replacer and manual control handle.

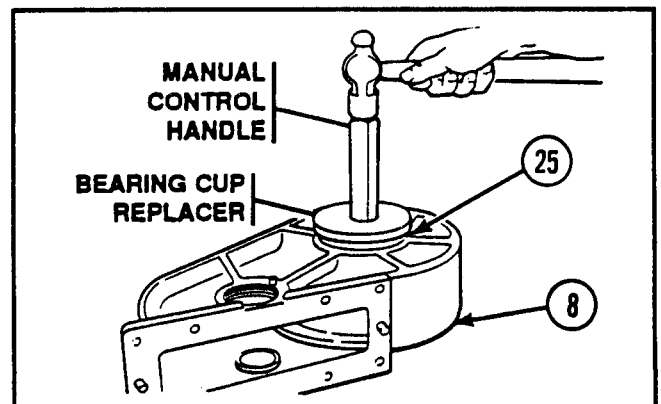

3-8. MAINTENANCE OF TRANSMISSION POWER TAKEOFF (CONT).

DISASSEMBLY (CONT)

- 19 If damaged, remove two headless straight pins (26) from gearcase (8).
- 20 If damaged, remove two headless straight pins (27) from gearcase (8).

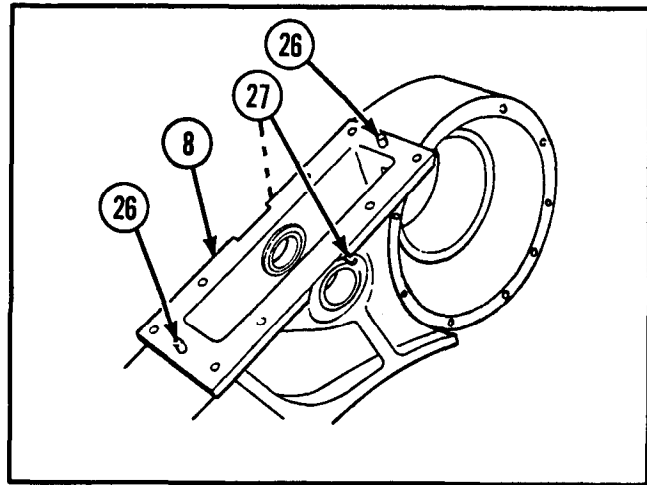

INSPECTION/REPAIR

- 1 Inspect for broken, damaged, or missing parts.
- 2 Inspect bearings per TM 9-214.
- 3 Inspect externally relieved bolt for damaged threads. Discard if threads are damaged.
- 4 If gearcase cover is broken, damaged, or missing, repair is by replacement of next higher assembly.
- 5 If gearcase is broken, damaged, or missing, repair is by replacement of next higher assembly.
- 6 Repair is by replacement of authorized parts (TM 9-2350-238-24P-1) which do not meet inspection criteria.

REASSEMBLY

- 1 If removed, install two headless straight pins (1) to gearcase (2).
- 2 If removed, install two headless straight pins (3) to gearcase (2).
- 3 Apply sealing compound (item 24, appx B) to outside diameter of two new plain encased seals (4).
- 4 Install two new plain encased seals (4) in gearcase (2) with seal lips back to back, using bearing cup replacer and manual control handle.

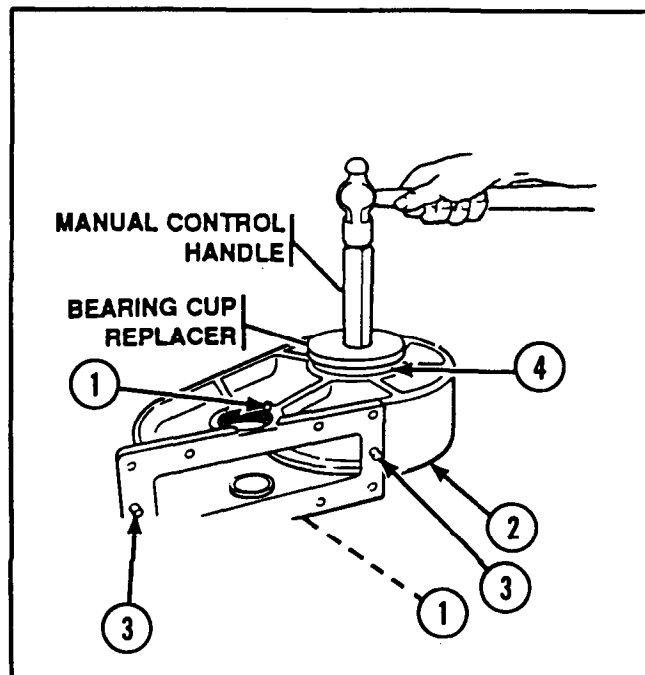

- 5 Using bearing cone replacer assembly and press, install output gear annular ball bearing (5) onto output gear cluster (6).
- 6 Using bearing replacer and press, install output gear annular ball bearing (7) onto output gear cluster (6).

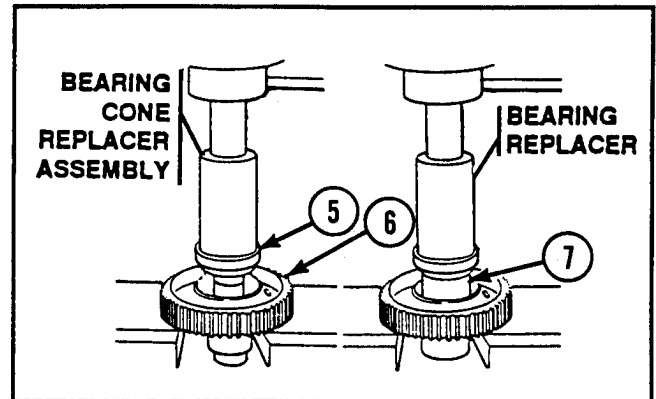

- 7 Lightly lubricate shafts of output gear cluster with lubricating oil. Install output gear cluster (6) in gearcase (2). Ensure wiper lip of inner seal is properly seated on gear with lip toward gear teeth. Using rubber hammer, tap output gear cluster into gearcase until ball bearing is seated.

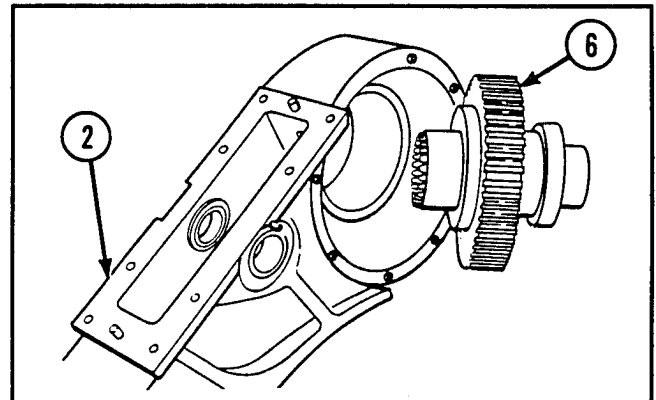

- 8 Apply sealing compound (item 24, appx B) to outside diameter of two new plain encased seals (8).
- 9 Install two plain encased seals (8) in gearcase cover (9) with seal lips back to back, using bearing cup replacer and manual control handle.

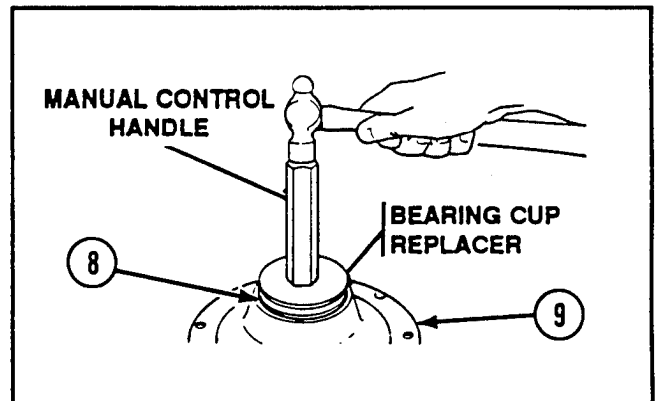

- 10 Install new preformed packing (10) in gearcase cover (9) opening.

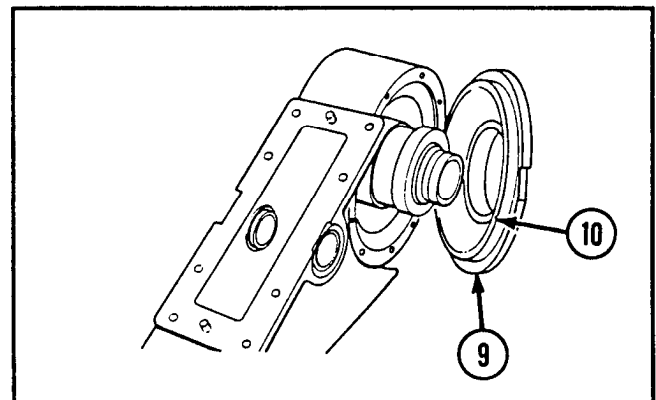

3-8. MAINTENANCE OF TRANSMISSION POWER TAKEOFF (CONT).

REASSEMBLY (CONT)

11 Lightly lubricate gear shaft with lubricating oil. Position gearcase cover (9) over installed output gear cluster (6). Ensure wiper lip of inner seal is properly seated on gear with lip toward gear teeth. Using drift, tap gearcase cover (9) onto gear until gearcase cover is seated over ball bearing.

12 Apply sealing compound (item 25, appx B) to threads of eight hexagon head cap-screws (10). Install eight hexagon head capscrews through gearcase cover (9) to gearcase (2).

13 Secure eight hexagon head capscrews (10) with new lockwire (11).

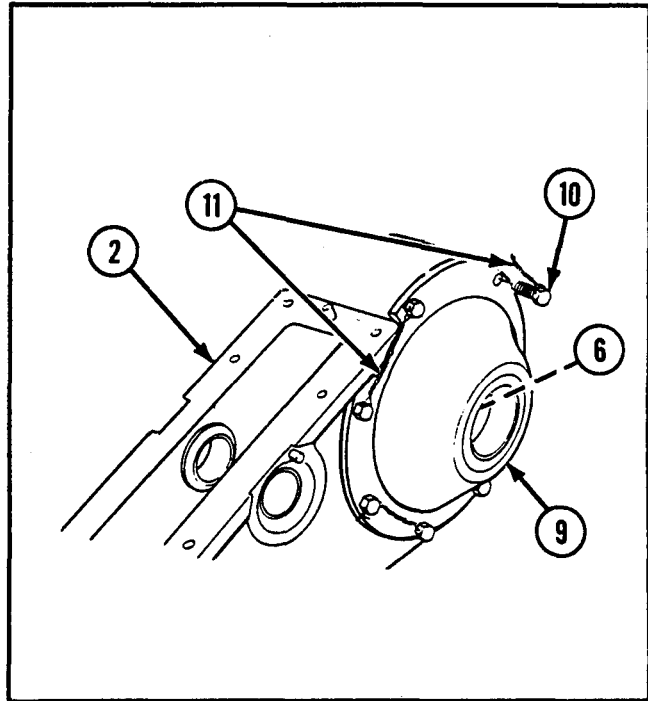

14 Install new lockwasher (12) and externally relieved bolt (13) through output gear cluster in gearcase (2).

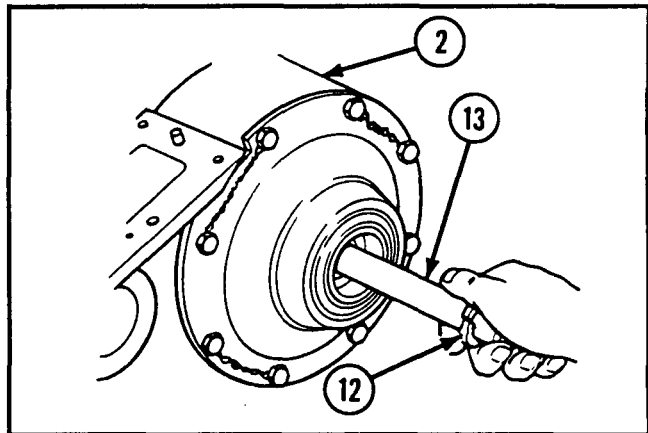

15 Install external retaining ring (14) to externally relieved bolt (13).

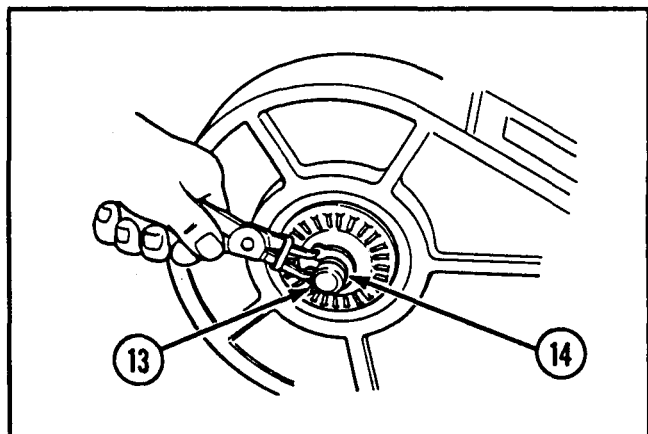

- 16 Install two idler spur gear roller bearing cones (15) on spur gear (16), using press, bearing remover and replacer, and manual control handle. Ensure idler spur gear roller bearing cones (15) are seated.

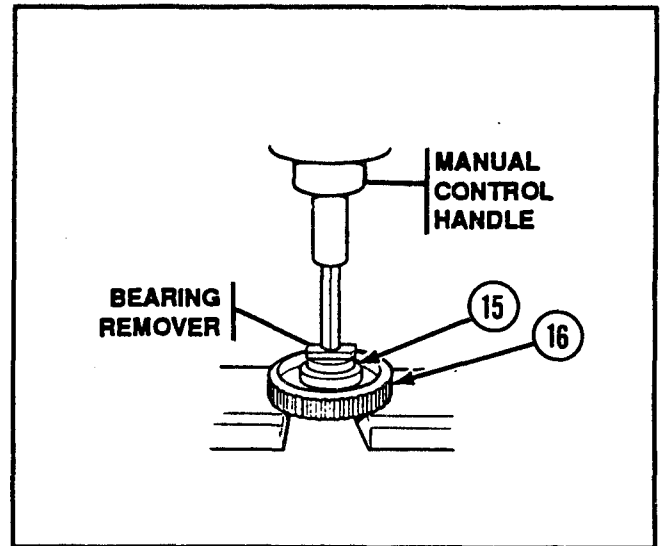

- 17 Install two idler spur gear roller bearings (17), with idler gear bearing sleeve spacer (18) between them, to spur gear (16).

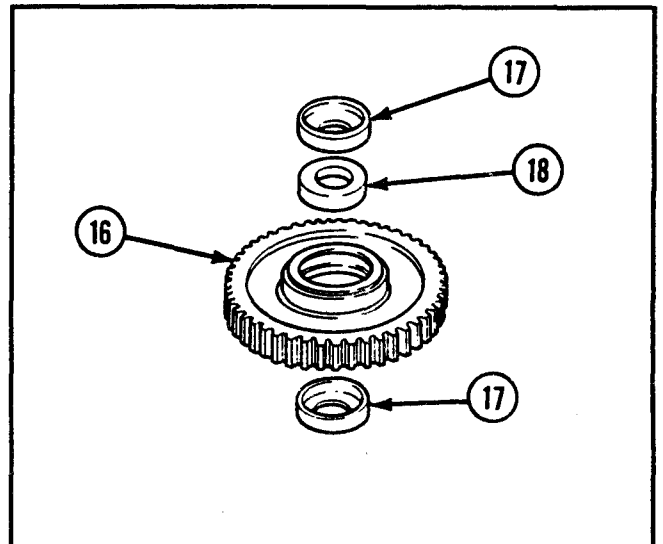

- 18 Install two new preformed packings (19) in gearcase (2).

- 19 Place spur gear (16) into gearcase (2).

- 20 Install shoulder bolt (20) to gearcase (2). If necessary, reach through gearcase and lift idler gear bearing sleeve spacer onto shoulder bolt. Align and start shoulder bolt through second bearing. Turn shoulder bolt so notch in head fits over headless straight pin. If necessary, tap shoulder bolt through gearcase, using rubber hammer.

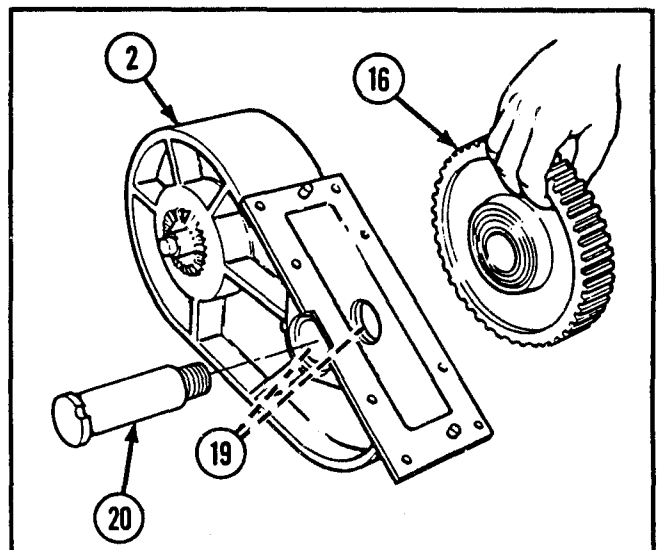

3-8. MAINTENANCE OF TRANSMISSION POWER TAKEOFF (CONT).

REASSEMBLY (CONT)

- 21** Install new preformed packing (21) into collar recess. Install idler gear pin shaft collar (22) over shoulder bolt (20) and align with headless straight pin. Secure shoulder bolt with new lockwasher (23) and hexagon plain nut (24).
- 22** If removed, install pipe plug (25) to transmission power takeoff (26).

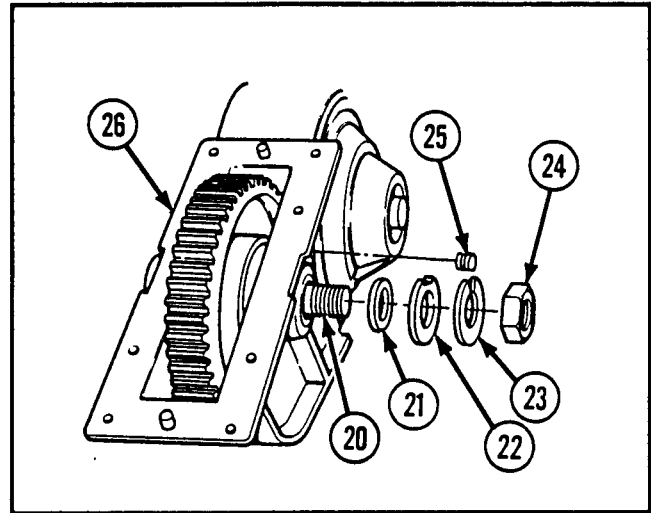

CAUTION

Do not paint areas specified in figure 3-1.

- 23** If necessary, prime using primer coating and paint using white enamel.

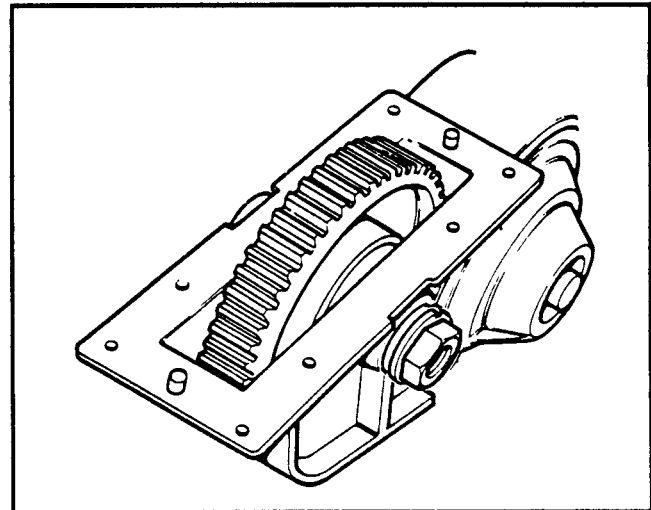

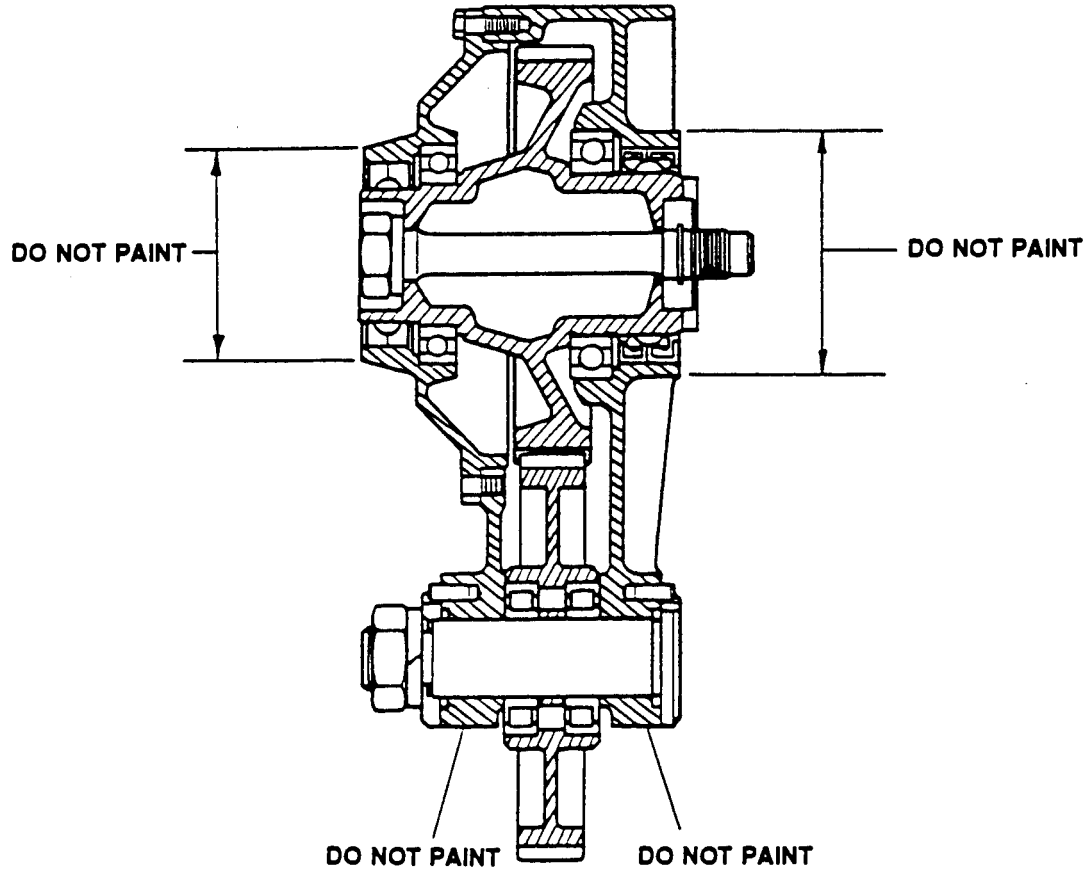

Figure 3-1. Painting Specifications for Transmission Power Takeoff.

Section IV. PREPARATION FOR STORAGE OR SHIPMENT

Refer to TM 9-2350-238-20-1 for details of preparation for storage or shipment.

APPENDIX A

REFERENCES

A-1. SCOPE

This appendix lists all forms, field manuals, technical bulletins, technical manuals, and miscellaneous publications referenced in this manual.

A-2. FORMS

DA Form 2028	Recommended Changes to Publications and Blank Forms
SF 368	Product Quality Deficiency Report

A-3. FIELD MANUALS

FM 21-11	First Aid for Soldiers
--------------------	------------------------

A-4. TECHNICAL BULLETINS

TB SIG-222	Solder and Soldering
----------------------	----------------------

A-5. TECHNICAL MANUALS

TM 9-214	Inspection, Care, and Maintenance of Antifriction Bearings
TM 9-237	Operator's Manual for Welding Theory and Application
TM 9-2350-238-10	Operator's Manual for Recovery Vehicle, Full Tracked: Light, Armored, M578
TM 9-2350-238-20-1	Unit Maintenance Manual for Hull and Related Components, Recovery Vehicle, Full Tracked: Light, Armored, M578
TM 9-2350-238-20-2	Unit Maintenance Manual for Armament and Turret Components, Recovery Vehicle, Full Tracked: Light, Armored, M578
TM 9-2350-238-24P-1	Unit, Direct Support, and General Support Repair Parts and Special Tools List for Recovery Vehicle, Full Tracked: Light, Armored, M578

A-5. TECHNICAL MANUALS (CONT)

- TM 9-2350-238-34-2 Direct and General Support Maintenance Manual for Armament and Turret Components, Recovery Vehicle, Full Tracked: Light, Armored, M578
- TM 9-2520-234-34P Direct Support and General Support Maintenance Repair Parts and Special Tools List (Including Depot Maintenance Repair Parts and Special Tools) for Power Train Assembly (8351100) (Allison Model XTG-411-2A) Composed of Transfer Assembly, Transmission Input (NSN 2520-00-894-9535), Transmission Assembly (NSN 2520-00-894-9533), Drive Assembly, Transmission Output Vehicle, Left (NSN 2520-00-894-9534), and Drive Assembly, Transmission Output Vehicle, Right (NSN 2520-00-894-9532)
- TM 9-2520-234-35 Field and Depot Maintenance Manual for Power Train Assembly (8351110) (Allison Model XTG-411-2A) Composed of: Transfer Assembly, Transmission Input (NSN 2520-00-894-9535); Transmission Assembly (2520-00-894-9533), Drive Assembly, Transmission Output Vehicle, Left (2520-00-894-9534), and Drive Assembly, Transmission Output Vehicle, Right (2520-00-894-9532)
- TM 9-2815-202-24 P Unit, Direct Support, and General Support Maintenance Repair Parts and Special Tools List for Engine, Diesel: Turbocharged, Fuel-Injected, Liquid-Cooled, "V" Type, 8 Cylinder, w/Container Assembly, Detroit Diesel-GMC Series 8V71 T, Model 7083-7398 (NSN 2815-00-762-4500 and 2815-00-936-7659), Model 7083-7395 (NSN 2815-01-043-7091 and 2815-01-043-7092), Model 7083-7399 (NSN 2815-00-134-4845), and Model 7083-7396 (NSN 2815-00-040-3120)
- TM 9-2815-202-34 Direct and General Support Maintenance for Engine, Diesel: Turbocharged, Fuel-Injected, Liquid-Cooled, "V" Type, 8 Cylinder, w/Container Assembly, Detroit Diesel-GMC Series 8V71T, Model 7083-7398 (NSN 2815-00-762-4500 and 2815-00-436-7654), Model 7083-7395 (NSN 2815-01-043-7091 and 2815-01-043-7092), Model 7083-7399 (NSN 2815-00-134-4845), and Model 7083-7396 (NSN 2815-00-040-3120)

TM 9-2920-224-34&P	Direct Support and General Support Maintenance Manual Including Repair Parts and Special tools List for Generator Assembly, Engine (300 amp) 8717421 (NSN 2920-00-795-6627), 10889713 (2920-00-830-6660), and 11642898 (2920-00-169-5715)
TM 9-6140-200-14	Lead-Acid Storage Batteries 12V 24V
TM 43-0139	Painting instructions for Field Use
TM 750-244-5-1	Procedures for Destruction of Equipment to Prevent Enemy Use
TM 750-244-6	Procedures for Destruction of Tank-Automotive Equipment to Prevent Enemy Use
TM 750-254	Cooling Systems: Tactical Vehicles

A-6. MISCELLANEOUS PUBLICATIONS

CTA 8-100	Army Medical Department Expendable/Durable Items
CTA 50-970	Expendable Items (Except Medical, Class V, Repair Parts, and Heraldic Items)
DA PAM 738-750	The Army Maintenance Management System (TAMMS)
SC 4910-95-A31	Automotive Maintenance and Repair Shop Equipment: Field Maintenance, Basic, Less Power

APPENDIX B

EXPENDABLE/DURABLE SUPPLIES AND MATERIALS LIST

Section I. INTRODUCTION

B-1. SCOPE. This appendix lists expendable/durable supplies and materials you will need to operate and maintain the M578 Recovery Vehicle. This listing is for informational purposes only and is not authority to requisition the listed items. These items are authorized to you by CTA 50-970, Expendable/Durable Items (Except Medical, Class V, Repair Parts, and Heraldic Items), or CTA 8-100, Army Medical Department Expendable/Durable Items.

B-2. EXPLANATION OF COLUMNS.

a. *Column (1) - Item Number.* This number is assigned to the entry in the listing and is referenced in the narrative instructions to identify the material (e.g., "cleaning compound (item 6, appx B)").

b. *Column (2) - Level.* This column identifies the lowest level of maintenance that requires the listed item.

O--Unit Maintenance
F--Direct Support Maintenance

c. *Column (3) - National Stock Number.* This is the National stock number assigned to the item; use it to request or requisition the item.

d. *Column (4) - Description.* Indicates the Federal item name and, if required, a description to identify the item. The last line for each item indicates the Contractor and Government Entity Code (CAGEC) in parentheses followed by the part number.

e. *Column (5) - Unit of Measure (U/M).* Indicates the measure used in performing the actual maintenance function. This measure is expressed by a two-character alphabetical abbreviation (e.g., ea, in., pr). If the unit of measure differs from the unit of issue, requisition the lowest unit of issue that will satisfy your requirements.

Section II. EXPENDABLE/DURABLE SUPPLIES AND MATERIALS LIST

(1) ITEM NUMBER	(2) LEVEL	(3) NATIONAL STOCK NUMBER	(4) DESCRIPTION	(5) U/M
1	O	8040-00-262-9026	ADHESIVE: rubber, type III (81348) MMM-A-1617 0.5-pint can	PT
2	F	8040-00-118-2695	ADHESIVE, SILICONE: RTV, type I (81349) MIL-A-46146 1-kit	TB
3	O	8030-00-597-5367	ANTISEIZE COMPOUND (81349) MIL-A-907 2.5-lb can	LB
4	O	7510-00-223-6701	CHALK, MARKING (81348) SS-C-255 1-gross (144)	EA
5	F	6850-00-597-9765	CLEANING COMPOUND: liquid form (solvent) (81348) O-C-1889 1-gal. container	GL
6	O	6850-00-559-2836	CLEANING COMPOUND: type I (81348) P-C-444 55-gal. drum	GL
7	O	5350-00-221-0872	CLOTH, ABRASIVE: 9 x 11 in. sheet (81348) P-C-458 50-sheet pg.	SH
8	O	8305-01-152-3587	CLOTH, BATISTE: lint-free (81349) MIL-C-40129 45-in. wide 1-yard	EA
9	O	8010-00-641-0426	COATING COMPOUND, NONSLIP: type II, color: OD (80244) MIL-W-5044 TY2 1-gal. container	GL
10	O	6850-00-281-1985	DRY CLEANING SOLVENT (58536) A-A-711 1-gal. container	GL

(1) ITEM NUMBER	(2) LEVEL	(3) NATIONAL STOCK NUMBER	(4) DESCRIPTION	(5) U/M
11	F	3439-00-165-4167	ELECTRODE, WELDING (36232) 1/8 in. 10 pound can	LB
12	F	3439-00-165-4165	ELECTRODE, WELDING (36232) 3/32 in. 10 pound can	LB
13	F	8010-01-229-9561	EPOXY COATING: enamel, olive drab (81349) (OD, Class opt) MIL-C-22750 1-gal. container	GL
14	F	8010-01-154-2334	EPOXY COATING KIT: enamel, white (81349) MIL-C-22750	KT
15	F	5210-00-640-6177	GAGE, BEARING (77220) PG-1	BX
16	F	5210-00-640-6178	GAGE, BEARING (77220) PR-1	BX
17	O	9150-00-065-0029 9150-00-190-0904 9150-00-190-0905	GREASE, AUTOMOTIVE AND ARTILLERY: (GAA) (81349) MIL-G-10924 2.25-oz tube 1.75-lb can 6.5-lb can	OZ LB LB
18	O	9150-00-935-9807 9150-00-935-9808	HYDRAULIC FLUID, PETROLEUM BASE: (OHT) (81349) MIL-H-6083 1-qt container 1-gal. container	QT GL
19	O	5350-00-193-7227	LAPPING AND GRINDING COMPOUND: abrasive grade (58536) A-A-1203 1-lb container	EA
20	O	9150-00-231-2356	LUBRICATING OIL: (OE/HDO) (81349) MIL-L-3150 5-gal. can	GL

Section II. EXPENDABLE/DURABLE SUPPLIES AND MATERIALS LIST (CONT)

(1) ITEM NUMBER	(2) LEVEL	(3) NATIONAL STOCK NUMBER	(4) DESCRIPTION	(5) U/M
21	O	5350-00-598-5537	PAPER, ABRASIVE (58536) A-A-1202 1-hd count	EA
22	F	8010-00-899-0931	PRIMER COATING (81348) TT-P-1757 1-qt container	QT
23	O	7920-00-205-1711	RAG, WIPING (81348) DDD-R-30 50-lb bale	LB
24	O	8030-00-081-2330 8030-00-900-4412	SEALING COMPOUND: blue, liquid, C or CV (81349) MIL-S-22473 50-cc bottle 250-cc bottle	CC CC
25	O	8030-00-291-1787	SEALING COMPOUND: type II, grade N (81349) MIL-S-45180 1-gal. container	GL
26	F	8030-00-123-6955	SEALING COMPOUND: RTV, silicone rubber (81349) MIL-S-23586	KT
27	F	8520-00-228-0598	SOAP, TOILET LIQUID (81348) P-S-624 1-gal. container	GL
28	F	3439-00-824-9856	SOLDER, TIN ALLOY (81348) QQ-S-571 16-oz. spool	OZ
29	O	7510-00-266-6712	TAPE, PRESSURE SENSITIVE (58536) A-A-883 60-yd roll	YD
30	O	8010-00-290-4079	THINNER, PAINT: type I TT-T-291 1-qt container	QT

(1) ITEM NUMBER	(2) LEVEL	(3) NATIONAL STOCK NUMBER	(4) DESCRIPTION	(5) U/M
31	O	8110-00-180-6343	VARNISH, OIL (81349) MIL-V-173	QT
32	F	9505-00-087-3956	WIRE, NONELECTRICAL (96906) MS20995F20 1-lb	LB
33	F	9505-00-684-4841	WIRE, NONELECTRICAL (96906) MS20995F32AR 1-lb	LB
34	F	9505-00-684-4843	WIRE, NONELECTRICAL (96906) MS20995F41 1-lb	LB

APPENDIX C

ILLUSTRATED LIST OF MANUFACTURED ITEMS

C-1. INTRODUCTION. This appendix includes complete instructions for making items authorized to be manufactured or fabricated at direct support and general support maintenance.

- a. A part number index in alphanumeric order is provided for cross-referencing the part number of the item to be manufactured to the figure which covers fabrication criteria.
- b. All bulk materials needed for manufacture of an item are listed by part number or specification number in a tabular list on the illustration,
- c. Figures C-6 and C-7 do not have part numbers.

C-2. MANUFACTURED ITEMS PART NUMBER INDEX.

Part Number	Figure Number
10900479-1	3
10946632AR	4
11643363-2	2
1711728-91AR	1
8328272AR	5

C-3. MANUFACTURED ITEMS ILLUSTRATIONS.

Fabricate sleeve from:
 NSN 5970-00-100-7261
 CAGEC 80244 PN 1711728-91AR

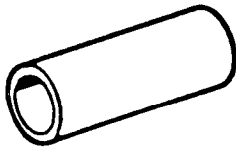

INSIDE DIA MIN	WALL THICK NOMINAL	FEDERAL STOCK NO.
.114	.020	17-I-1725-11
.129	.020	17-I-1725-41
.144	.020	17-I-1725-56
.162	.020	17-I-1725-76
.182	.020	17-I-1725-96
.204	.020	17-I-1726-11
.229	.020	17-I-1726-41
.258	.020	17-I-1726-76
.289	.020	17-I-1727-11

INSIDE DIA MIN	WALL THICK NOMINAL	FEDERAL STOCK NO.
.313	.020	17-I-1727-66
.330	.020	17-I-1728-11
.359	.025	17-I-1728-91
.375	.025	17-I-1728-131
.438	.025	17-I-1728-401
.500	.025	17-I-1728-501
.562	.030	17-I-1728-541
.625	.030	17-I-1728-651

Figure C-1. Insulation Sleeve.

C-3. MANUFACTURED ITEMS ILLUSTRATIONS (CONT).

NOTES:

1. RUBBER GRADE SA610 TO 620 A₁B₁C₁E₃F₂
OR
GRADE SB610 TO 620 A₁B₁C₁E₃F₂.
2. REINFORCEMENT: RUBBER HOSE SHALL BE REINFORCED WITH 2 PLY OF CLOTH, OSNABURG, COTTON, CLASS OPTIONAL, SPEC CCC-C-429.
3. CONSTRUCTION OF RUBBER HOSE SHALL CONSIST OF AN INNER SEAMLESS TUBE, INTERMEDIATE FABRIC REINFORCEMENT, AND AN OUTER TUBE WITH AN ELASTOMERIC MATERIAL IMPREGNATED FABRIC COVER.
4. APPLY PART NO. PER MIL-STD-130.

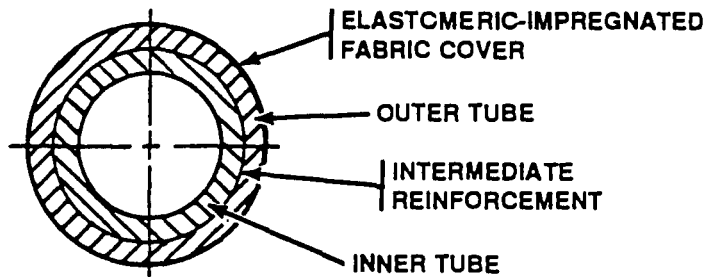

SECTION A-A
SCALE: 2/1

Fabricate hose from:

NSN 4720-01-101-8470
CAGEC 19207 PN 11643363-2

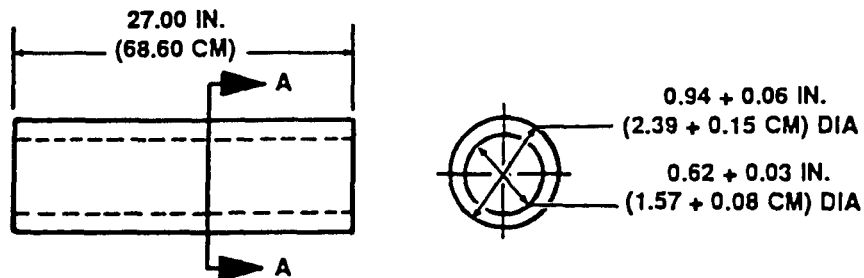

Figure C-2. Rubber Hose.

Fabricate nonmetallic seal from:

NSN 9390-00-839-4830
 CAGEC (19207) PN 10900479-1



Figure C-3. Nonmetallic Seal.

Fabricate rubber section from:

NSN 5330-00-947-5716
 CAGEC (19207) PN 10946632AR



Figure C-4. Rubber Section.

Fabricate rubber strip from:

NSN 9390-00-505-6594
 CAGEC (19207) PN 8328272AR



Figure C-5. Rubber Strip.

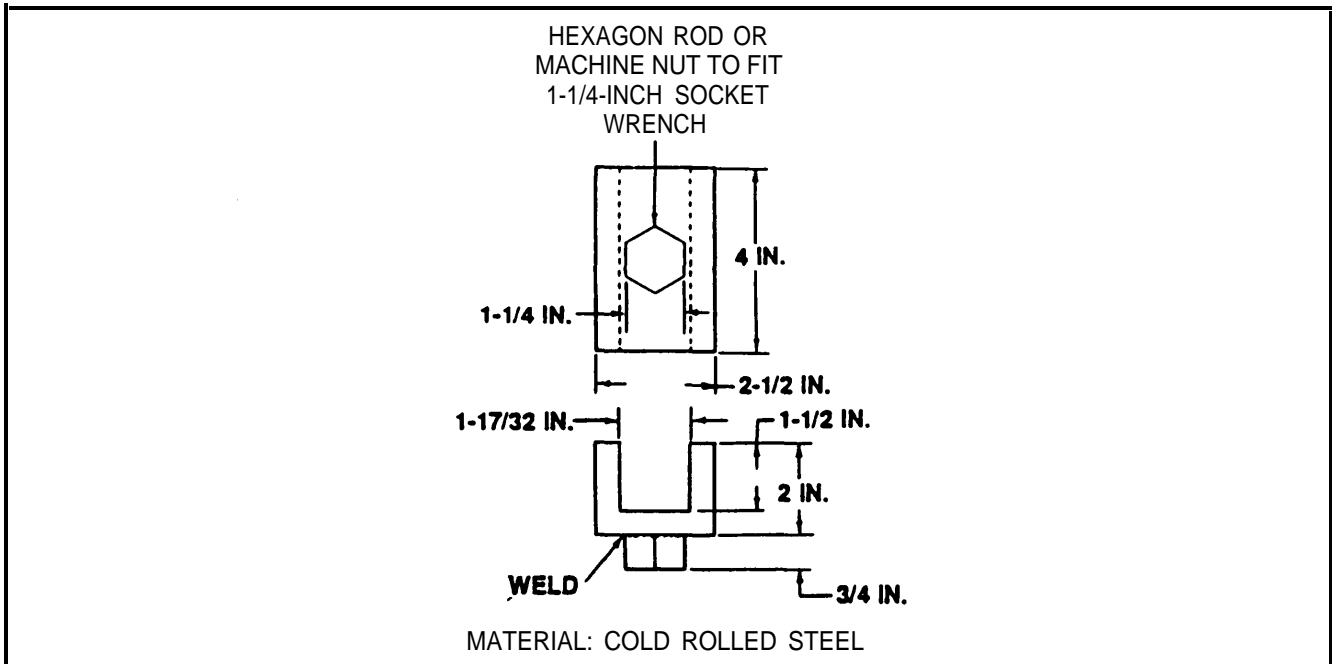

Figure C-6. Wrench Adapter.

C-3. MANUFACTURED ITEMS ILLUSTRATIONS (CONT).

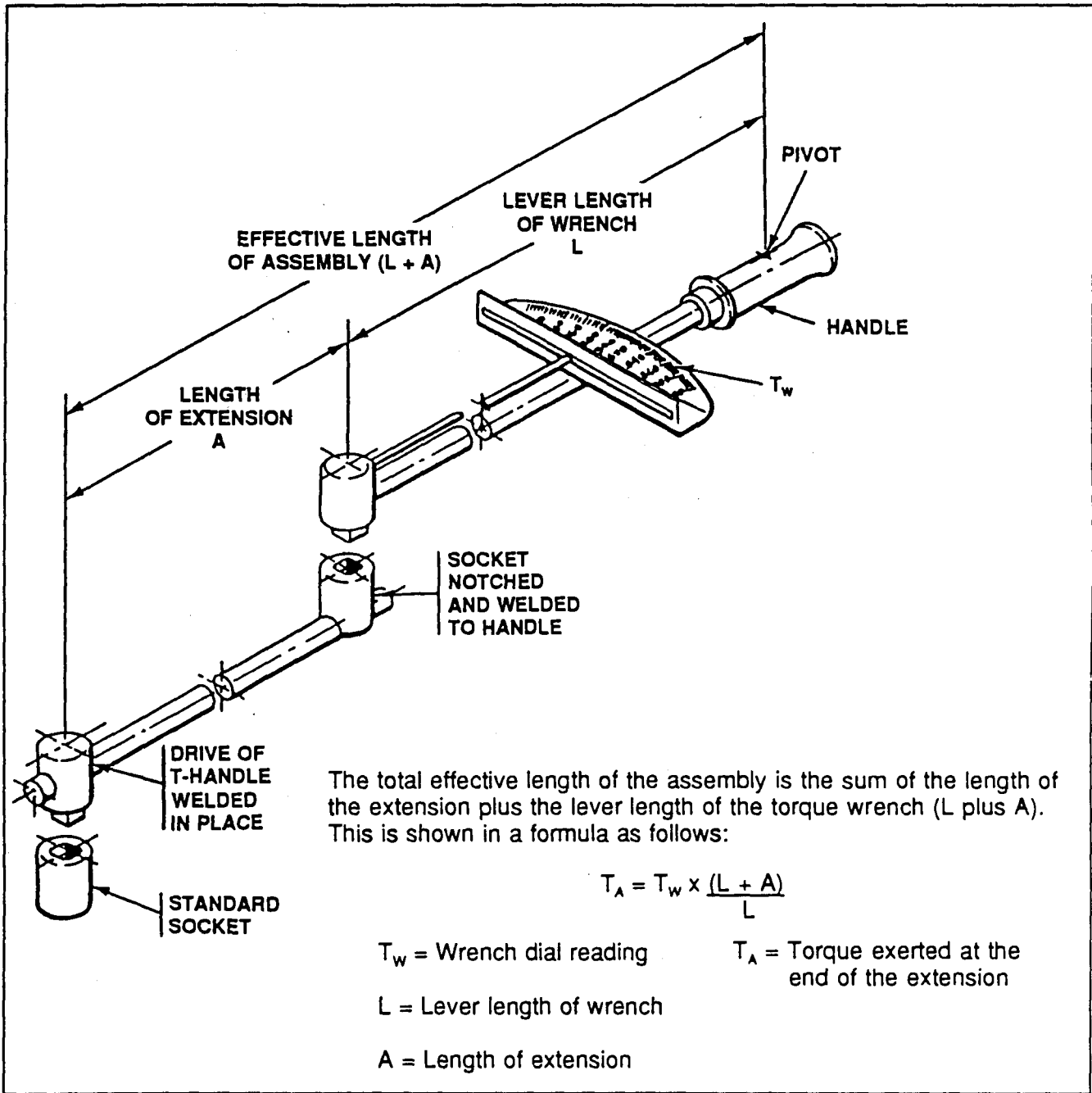

Figure C-7. Torque Wrench Extension.

APPENDIX D

TORQUE VALUES

D-1. Follow torque values given throughout this manual. When no torque value is given, follow the guide to prevent damaging parts.

D-2. The guide is based on using clean, dry threads.

TORQUE VALUE GUIDE

SCREW DIAMETER	TORQUE NO DASHES (SAE GRADE 2)	TORQUE 3 DASHES (SAE GRADE 5)	TORQUE 6 DASHES (SAE GRADE 8)	SOCKET SIZE
1/4 - 20 UNC	3 - 5 ft-lb (4 - 7 N-m)	6 - 8 ft-lb (8 - 11 N-m)	10 - 12 ft-lb (14 - 16 N-m)	7/16
1/4 - 28 UNF	4 - 6 ft-lb (5 - 8 N-m)	8 - 10 ft-lb (11 - 14 N-m)	9 - 14 ft-lb (12 - 19 N-m)	7/16
5/16 - 18 UNC	7 - 11 ft-lb (9 - 15 N-m)	13 - 17 ft-lb (18 - 23 N-m)	19 - 24 ft-lb (26 - 33 N-m)	1/2
5/16 - 24 UNF	7 - 11 ft-lb (9 - 15 N-m)	14 - 19 ft-lb (19 - 26 N-m)	23 - 28 ft-lb (31 - 38 N-m)	1/2
3/8 - 16 UNC	14 - 18 ft-lb (19 - 24 N-m)	26 - 31 ft-lb (35 - 42 N-m)	39 - 44 ft-lb (53 - 60 N-m)	9/16
3/8 - 24 UNF	15 - 19 ft-lb (20 - 26 N-m)	30 - 35 ft-lb (41 - 47 N-m)	46 - 51 ft-lb (62 - 69 N-m)	9/16
7/16 - 14 UNC	23 - 28 ft-lb (31 - 38 N-m)	44 - 49 ft-lb (60 - 66 N-m)	65 - 70 ft-lb (88 - 95 N-m)	5/8
7/16 - 20 UNF	23 - 28 ft-lb (31 - 38 N-m)	44 - 54 ft-lb (60 - 73 N-m)	69 - 79 ft-lb (94 - 107 N-m)	5/8
1/2 - 13 UNC	32 - 37 ft-lb (43 - 50 N-m)	65 - 75 ft-lb (88 - 102 N-m)	95 - 105 ft-lb (129 - 142 N-m)	3/4
1/2 - 20 UNF	34 - 41 ft-lb (46 - 56 N-m)	73 - 83 ft-lb (99 - 113 N-m)	113 - 123 ft-lb (153 - 167 N-m)	3/4
9/16 - 12 UNC	46 - 56 ft-lb (62 - 76 N-m)	100 - 110 ft-lb (136 - 149 N-m)	145 - 155 ft-lb (197 - 210 N-m)	13/16
9/16 - 18 UNF	47 - 57 ft-lb (64 - 77 N-m)	107 - 117 ft-lb (145 - 159 N-m)	165 - 175 ft-lb (224 - 237 N-m)	13/16
5/8 - 11 UNC	62 - 72 ft-lb (84 - 98 N-m)	140 - 150 ft-lb (190 - 203 N-m)	200 - 210 ft-lb (271 - 285 N-m)	15/16
5/8 - 18 UNF	67 - 77 ft-lb (91 - 104 N-m)	153 - 163 ft-lb (207 - 221 N-m)	235 - 245 ft-lb (319 - 332 N-m)	15/16

TORQUE VALUE GUIDE (CONT)

SCREW DIAMETER	TORQUE NO DASHES (SAE GRADE 2)	TORQUE 3 DASHES (SAE GRADE 5)	TORQUE 6 DASHES (SAE GRADE 8)	SOCKET SIZE
3/4 - 10 UNC	106 - 116 ft-lb (144 - 157 N-m)	260 - 270 ft-lb (353 - 366 N-m)	365 - 375 ft-lb (495 - 508 N-m)	1-1/4
3/4 - 16 UNF	115 - 125 ft-lb (156 - 169 N-m)	268 - 278 ft-lb (363 - 377 N-m)	417 - 427 ft-lb (565 - 579 N-m)	1-1/4
7/8 - 9 UNC	165 - 175 ft-lb (224 - 237 N-m)	385 - 395 ft-lb (522 - 536 N-m)	595 - 605 ft-lb (807 - 820 N-m)	1-5/16
7/8 - 14 UNF	178 - 188 ft-lb (241 - 255 N-m)	424 - 434 ft-lb (575 - 588 N-m)	663 - 673 ft-lb (899 - 912 N-m)	1-5/16
1 - 8 UNC	251 - 261 ft-lb (340 - 354 N-m)	580 - 590 ft-lb (786 - 800 N-m)	900 - 910 ft-lb (1220 - 1234 N-m)	1-1/2
1 - 14 UNF	255 - 265 ft-lb (346 - 359 N-m)	585 - 634 ft-lb (793 - 860 N-m)	943 - 993 ft-lb (1279 - 1346 N-m)	1-1/2
1-1/4 - 7 UNC	451 - 461 ft-lb (611 - 625 N-m)	1070 - 1120 ft-lb (1451 - 1518 N-m)	1767 - 1817 ft-lb (2396 - 2463 N-m)	1-7/8
1-1/4 - 12 UNF	488 - 498 ft-lb (662 - 675 N-m)	1211 - 1261 ft-lb (1642 - 1710 N-m)	1963 - 2013 ft-lb (2661 - 2729 N-m)	1-7/8
1-1/2 - 6 UNC	727 - 737 ft-lb (986 - 999 N-m)	1899 - 1949 ft-lb (2575 - 2642 N-m)	3111 - 3161 ft-lb (4218 - 4286 N-m)	2-1/4
1-1/2 - 12 UNF	816 - 826 ft-lb (1106 - 1120 N-m)	2144 - 2194 ft-lb (2907 - 2975 N-m)	3506 - 3556 ft-lb (4753 - 4821 N-m)	2-1/4

APPENDIX E

SPECIAL TOOLS AND EQUIPMENT





E-1. GENERAL. Repair parts, special tools, and support equipment are issued for maintaining the vehicle. Tools and equipment should not be used for purposes other than those prescribed. When not in use, they should be properly stowed.

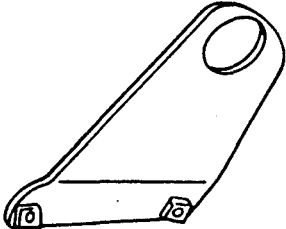

E-2. SPECIAL TOOLS, TMDE, AND SUPPORT EQUIPMENT. Special tools and equipment necessary to perform the maintenance described in this manual are listed for your information. Special tools and support equipment are listed in TM 9-2350-238-24P-1, which is the authority for requisitioning replacement.

E-3. REPAIR PARTS. Repair parts are issued for the replacement of parts that have become worn, broken, or otherwise unserviceable. Repair parts are listed in TM 9-2350-238-24P-1, which is the authority for requisitioning replacement.

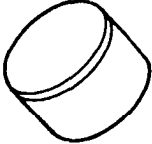

<p>ITEM 1</p>  <p>ADAPTER, WRENCH</p>	<p>No NSN (No PN)</p>	<p>For fabrication instructions, refer to fig. C-6, appx C. Used to remove cylinder eye from lockout cylinder (p 3-33).</p>
<p>ITEM 2</p>  <p>BRACKET, TRANSMISSION SLING MOUNTING</p>	<p>5340-00-977-5580 (8355697)</p>	<p>Used with lifting sling to lift transmission (p 2-32).</p>

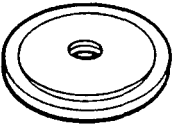

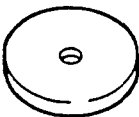
E-3. REPAIR PARTS (CONT).

<p>ITEM 3</p>  <p>HANDLE, MANUAL CONTROL</p>	<p>5340-00-316-9182 (7950864)</p>	<p>Used with bearing cup replacer to remove transmission power takeoff cover seals (p 3-45).</p>
<p>ITEM 4</p>  <p>HANDLE, MANUAL CONTROL</p>	<p>5340-00-708-3833 (7083883)</p>	<p>Used with oil seal replacers in lockout cylinder (p 3-33).</p>
<p>ITEM 5</p>  <p>INSERTER, BEARING CONE</p>	<p>5120-00-057-0302 (10934814)</p>	<p>Replace auxiliary drive shaft bearing cones (p 2-116).</p>
<p>ITEM 6</p>  <p>INSERTER, OIL SEAL</p>	<p>5120-00-733-8929 (10904174)</p>	<p>Replace lockout cylinder head seal (p 2-166 and 3-33). Used with handle 5120-00-708-3883.</p>

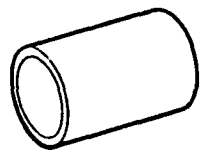
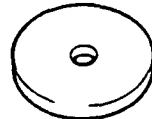
<p>ITEM 7</p>  <p>INSERTER, OIL SEAL</p>	<p>5120-00-733-8951 (10904181)</p>	<p>Replace seal in mechanical clutch housing (p 2-103). Used with handle 5120-00-708-3883.</p>
<p>ITEM 8</p>  <p>REMOVER, BEARING</p>	<p>5120-00-722-4063 (10902750)</p>	<p>Remove and replace transmission power takeoff idler gear bearings (p 3-45).</p>
<p>ITEM 9</p>  <p>REMOVER, BEARING CUP</p>	<p>5120-00-722-4067 (10902751)</p>	<p>Replace auxiliary drive gear housing outer bearing cap (p 2-116). Used with handle 5120-00-316-9182.</p>
<p>ITEM 10</p>  <p>REMOVER AND REPLACER, SEAL</p>	<p>5120-00-383-3672 (8375175)</p>	<p>Remove and replace plain encased seals and bearings in auxiliary drive assembly (p 2-101, 2-110, and 2-116). Used with handle 5120-00-316-9182.</p>

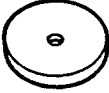
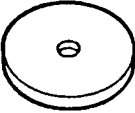

E-3. REPAIR PARTS (CONT).

<p>ITEM 11</p>  <p>REPLACER, BEARING</p>	<p>5120-00-733-8948 (10904179)</p>	<p>Replace auxiliary drive mechanical clutch housing inner bearing and lockout cylinder bearings (p 2-101 and 3-33).</p>
<p>ITEM 12</p>  <p>REPLACER, BEARING</p>	<p>5120-00-860-9579 (10908787)</p>	<p>Replace auxiliary drive gear inner bearing cones and transmission power takeoff output gear bearing (p 2-110, 2-116, and 3-45).</p>
<p>ITEM 13</p>  <p>REPLACER, BEARING CUP</p>	<p>5120-00-722-4071 (10902752)</p>	<p>Remove and replace auxiliary drive shaft carrier housing bearing and seals (p 2-131). Used with handle 5120-00-316-9182.</p>
<p>ITEM 14</p>  <p>REPLACER, BEARING CUP</p>	<p>5120-00-722-4083 (10902756)</p>	<p>Replace auxiliary drive shaft carrier bearing cups and outer carrier seal (p 2-116 and 2-131). Used with handle 5120-00-316-9182.</p>

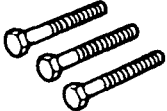
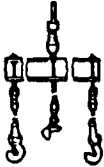
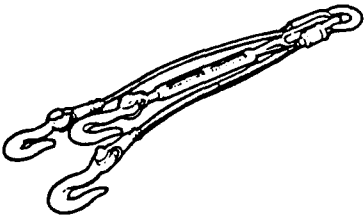

<p>ITEM 15</p>  <p>REPLACER, BEARING CUP</p>	<p>5120-00-722-4089 (10902757)</p>	<p>Replace transmission power takeoff cover seals (p 3-45). Used with handle 5120-00-316-9182.</p>
<p>ITEM 16</p>  <p>REPLACER, BEARING CUP</p>	<p>5120-00-722-4093 (10902758)</p>	<p>Replace auxiliary drive gear housing inner bearing cup and auxiliary drive gear case outer bearing cup (p 2-110 and 2-116). Used with handle 5120-00-316-9182.</p>
<p>ITEM 17</p>  <p>REPLACER, CLUTCH BEARING</p>	<p>5120-01-062-5606 (12253880)</p>	<p>Replace auxiliary drive vehicular housing bearings (p 2-101).</p>
<p>ITEM 18</p>  <p>REPLACER, GEAR</p>	<p>5210-00-098-6727 (8390373)</p>	<p>Replace auxiliary drive bearing unit flange bearings (p 2-110).</p>

E-3. REPAIR PARTS (CONT).

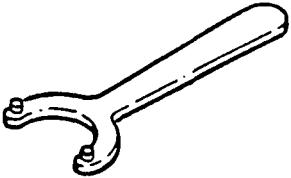
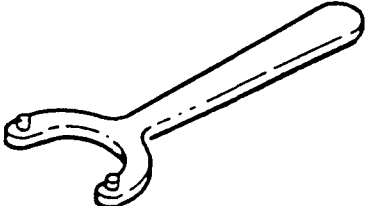
<p>ITEM 19</p>  <p>REPLACER ASSEMBLY, BEARING CONE</p>	<p>5120-00-343-0123 (8708070)</p>	<p>Replace transmission power takeoff output gear cover bearing (p 3-45).</p>
<p>ITEM 20</p>  <p>SCREW, JACKING</p>	<p>4910-00-722-3915 (10904195)</p>	<p>Used to separate clutch drive from input drive (p 2-95). Used to loosen and remove mechanical clutch end housing (p 2-101). Used to remove shaft bearing housing (p 2-116).</p>
<p>ITEM 21</p>  <p>SLING, ENGINE</p>	<p>4910-00-001-3993 (11643469)</p>	<p>Lift engine (p 2-32).</p>
<p>ITEM 22</p>  <p>SLING, TRANSMISSION</p>	<p>4910-00-473-7556 (7081593)</p>	<p>Lift transmission (p 2-32).</p>

<p>ITEM 23</p>  <p>SOCKET, FACE WRENCH</p>	<p>5120-00-860-9576 (10908791)</p>	<p>Turn auxiliary drive bearing unit bearing locknut (p 2-148).</p>
<p>ITEM 24</p>  <p>SOCKET, FACE WRENCH</p>	<p>5120-00-860-9575 (10908794)</p>	<p>Turn auxiliary drive gear bearing locknut (p 2-110 and 2-116).</p>
<p>ITEM 25</p>  <p>WRENCH, SPANNER</p>	<p>5120-00-264-3778 (426)</p>	<p>Remove spade cylinder piston from rod (p 2-164).</p>
<p>ITEM 26</p>  <p>WRENCH, SPANNER</p>	<p>5120-00-293-0245 (325291)</p>	<p>Remove packing nut from cylinder (p 2-164).</p>

E-3. REPAIR PARTS (CONT).

<p>ITEM 27</p>  <p>WRENCH, SPANNER</p>	<p>5120-01-310-1996 (10518265)</p>	<p>Turn vehicular drive retaining nut (p 2-95).</p>
<p>ITEM 28</p>  <p>WRENCH, SPANNER, LOCKOUT CYLINDER LOCKNUT</p>	<p>5120-00-733-8982 (10904219)</p>	<p>Hold lockout cylinder locknut (p 3-33).</p>

ALPHABETICAL INDEX

Subject **Page**

A

Air Cleaner Access Door, Maintenance of:

Disassembly	2-153
Inspection/Repair	2-154
Reassembly	2-154

Air Cleaner Blower Access Door Assembly, Maintenance of:

Disassembly	2-150
Inspection/Repair	2-150
Reassembly	2-151

Air Deflector Assembly, Maintenance of:

Disassembly	2-188
Inspection/Repair.	2-188
Reassembly	2-188

Air Separator Centrifugal Fan, Maintenance of:

Disassembly	2-45
Inspection/Repair	2-46
Reassembly	2-46

Auxiliary Drive Assembly, Maintenance of:

Disassembly	2-95
Inspection/Repair	2-97
Reassembly	2-97
Troubleshooting	2-14

Auxiliary Drive Assembly (Clutch Drive), Maintenance of:

Disassembly	2-110
Inspection/Repair	2-112
Reassembly	2-112

Auxiliary Drive Assembly (Generator Drive), Maintenance of:

Disassembly	2-116
Inspection/Repair	2-121
Reassembly	2-121
Troubleshooting	2-10

Auxiliary Drive Assembly (Input Drive), Maintenance of:

Disassembly	2-131
Inspection/Repair	2-133
Reassembly	2-133

ALPHABETICAL INDEX (CONT)

S u b j e c t **P a g e**

A (Cont)

Auxiliary Drive Assembly (Vehicular Drive), Maintenance of:

Disassembly	2-101
Inspection/Repair	2-105
Reassembly	2-105
Troubleshooting	2-12

Auxiliary Drive Line Ball Bearing Unit, Maintenance of:

Disassembly	2-147
Inspection/Repair	2-148
Reassembly	2-148

B

Battery Access Cover, Maintenance of:

Disassembly	2-152
Inspection/Repair	2-152
Reassembly	2-152

C

Cleaning	2-29
Clutch Drive (See Auxiliary Drive Assembly (Clutch Drive), Maintenance of:)	
Common Tools and Equipment	2-2
Corrosion Prevention and Control	1-3

D

Destruction of Army Materiel to Prevent Enemy Use	1-1
Double Rotary Pump, Maintenance of:	
Disassembly	3-15
Inspection/Repair	3-24
Reassembly	3-25
Driver's Hatch Cover, Maintenance of:	
Disassembly	2-157
Inspection/Repair	2-158
Reassembly	2-158

ALPHABETICAL INDEX (CONT)

S u b j e c t **P a g e**

D (Cont)

Driver's Instrument Panel Assembly (Gage and Indicator), Maintenance of:

Disassembly	2-74
Inspection/Repair	2-74
Reassembly	2-74

E

Engine and Related Parts, and Transmission Assembly, Maintenance of:

Inspection/Repair	2-36
Installation	2-37
Removal	2-32
Troubleshooting	2-4, 2-12

Engine Blower Assembly (Heater Installation Kit), Maintenance of:

Disassembly	2-173
Inspection/Repair	2-174
Reassembly	2-175

Engine Fuel Filter Access Door, Maintenance of:

Disassembly	2-155
Inspection/Repair	2-156
Reassembly	2-156

Equipment Characteristics, Capabilities, and Features 1-3

Equipment Data 1-4

Expendable/DurableSupplies and Materials List B-1

External Oil Lines and Fittings (Lower Engine) and Scavenger Reservoir, Maintenance of:

Inspection/Repair	2-42
Installation	2-42
Removal	2-41

F

Fabric Fuel Cell Filler Blocks (See Fabric Fuel Cell Installation and Fabric Fuel Cell Filler Blocks, Maintenance of:)

ALPHABETICAL INDEX (CONT)

Subject **Page**

F (Cont)

Fabric Fuel Cell Installation and Fabric Fuel Cell Filler Blocks, Maintenance of:

Cleaning	2-53
Fabric Fuel Cell Draining	2-47
Fabric Fuel Cell Test	2-66
Inspection/Repair	2-54
Installation	2-54
Removal	2-47

G

General	2-19,
	2-21,
	2-28,
	3-1

Generator Drive (See Auxiliary Drive Assembly (Generator Drive), Maintenance of:)

H

Heater Electrical Control Box (Heater Installation Kit),Maintenance of:)

Disassembly	2-176
Inspection/Repair	2-179
Reassembly	2-179

Hydraulic Cylinder Assembly, Maintenance of:

Disassembly	2-165
Inspection/Repair	2-166
Reassembly	2-167

Hydraulic Pressure Relief Valve (See Spade Hydraulic Control Valves, Lines, and Fittings and Hydraulic Pressure Relief Valve, Maintenance of:)

Hydraulic Slip Ring Assembly, Maintenance of:

Disassembly	3-12
Inspection/Repair	3-13
Reassembly	3-13

ALPHABETICAL INDEX (CONT)

Subject **Page**

H (Cont)

Hydraulic Suspension Lockout Cylinder Assembly, Maintenance of:

Disassembly	3-33
Inspection/Repair	3-38
Reassembly	3-38
Test	3-43
Troubleshooting	2-16, 3-2

I

Illustrated List of Manufactured items	C-1
--	-----

Impact Wrench Regulator Ball Valve, Maintenance of:

Disassembly	2-139
Inspection/Repair	2-142
Reassembly	2-142

Input Drive (See Auxiliary Drive Assembly (Input Drive), Maintenance of:)

L

Location and Description of Major Components	1-3
--	-----

Lockout Cylinder Assembly (See Hydraulic Suspension Lockout Cylinder Assembly, Maintenance of:)

Lubrication	2-30
-----------------------	------

M

Maintenance Forms, Records, and Reports	1-1
---	-----

N

Nonskid Areas	2-31
-------------------------	------

O

Official Nomenclature, Names, and Designations	1-2
--	-----

Oil Drain Tube Assembly, Maintenance of:

Disassembly	2-138
Inspection/Repair	2-138
Reassembly	2-138

ALPHABETICAL INDEX (CONT)

S u b j e c t	P a g e
O (Cont)	
Oil Filler Neck, Maintenance of:	
Disassembly	2-136
Inspection/Repair.	2-136
Reassembly	2-137
P	
Painting Instructions	2-30
Painting Procedures	3-1
Power Takeoff Installation, Maintenance of:	
Disassembly	2-164
Inspection/Repair	2-163
Reassembly	2-163
Troubleshooting	2-13
Preparation for Storage or Shipment	1-2
Pump and Slip Ring Assembly and Attaching Parts, Maintenance of:	
Inspection/Repair	3-8
Installation	3-9
R e m o v a l	3-5
Radiator Cooling Vaneaxial Fan	
Disassembly	2-68
Inspection/Repair	2-70
Reassembly	2-70
Troubleshooting	2-9
References	A-1
Repair Methods	2-28
Repair Parts	2-2
Replacing Cable Terminals and Shell Connectors	2-27
Reporting Equipment Improvement Recommendations (EIR)	1-2
Restenciling Vehicle Markings..	2-31

ALPHABETICAL INDEX (CONT)

Subject	Page
S	
Scavenger Reservoir (See External Oil Lines and Fittings (Lower Engine) and Scavenger Reservoir, Maintenance of:)	
Scope	1-1
Slip Ring Assembly (See Hydraulic Pump and Slip Ring Assembly and Attaching Parts, Maintenance of: and Hydraulic Slip Ring Assembly, Maintenance of:)	
Slip Ring Electrical Brush Connector Assembly, Maintenance of:	
Disassembly	2-91
Inspection/Repair	2-92
Reassembly	2-92
Slip Ring Electrical Contact Set Assembly, Maintenance of:	
Disassembly	2-84
Inspection/Repair	2-86
Reassembly	2-87
Slip Ring Cover (See Turret Slip Ring Cover, Maintenance of:)	
Slip Ring Disconnect to interior Disconnect Wiring Harness (See Slip Ring Electrical Components, Slip Ring Disconnect to interior Disconnect Wiring Harness, and Slip Ring to 24-Volt Feed Electrical Lead, Maintenance of:)	
Slip Ring Electrical Components, Slip Ring Disconnect to Interior Disconnect Wiring Harness, and Slip Ring to 24-Volt Feed Electrical Lead Assembly, Maintenance of:	
Inspection/Repair	2-76
Installation	2-76
Removal	2-73
Slip Ring to 24-Volt Feed Cable Assembly (See Slip Ring Electrical Components, Slip Ring Disconnect to Interior Disconnect Wiring Harness, and Slip Ring to 24-Volt Feed Electrical Lead, Maintenance of:)	
Spade Hydraulic Control Valves, Lines, and Fittings and Linear Valve, Maintenance of:	
Disassembly	2-170
Inspection/Repair	2-171
Installation	2-172
Reassembly	2-171
Removal	2-170
Special Tools and Equipment	E-1
Special Tools, TMDE, and Support Equipment	2-2

ALPHABETICAL INDEX (CONT)

Subject	Page
S (cont)	
Straight Adapter to Tube Fitting..	2-20
T	
Torque Values	2-29, D-1
Touchup and Recoating	2-31
Transfer Assembly, Maintenance of:	
Inspection/Repair	2-94
Installation	2-94
Removal	2-93
Transmission Assembly (See Engine and Related Parts, and Transmission Assembly, Maintenance of:)	
Transmission Power Takeoff, Maintenance of:	
Disassembly	3-46
Inspection/Repair	3-50
Reassembly	3-50
Troubleshooting Information	2-3, 3-1
Tube Elbow to Tube Fitting	2-19
Tube Nipple to Tube Fitting	2-20
Tube Reducer to Tube Fitting	2-20
Tube Tee to Tube Fitting	2-19
Turret Slip Ring Cover, Maintenance of:	
Disassembly	2-80
Inspection/Repair	2-82
Reassembly	2-82
Typical Female-Type Panel Mounting Receptacle Connector	2-21, 2-23
Typical Female-Type Plug Connector	2-25

ALPHABETICAL INDEX (CONT)

Subject **Page**

T (cont)

Typical Male-Type Panel Mounting Receptacle Connector 2-22,
2-24

Typical Male-Type Plug Connector 2-26

V

Vehicular Drive (See Auxiliary Drive Assembly (Vehicular Drive), Maintenance of:)

Vehicular Window and Crane Window Assembly, Maintenance of:

Disassembly 2-184

Inspection/Repair 2-184

Reassembly 2-184

Vehicular Window (Driver's and Crane Operator's Windshield), Maintenance of:

Disassembly 2-183

Inspection/Repair 2-183

Reassembly 2-183

W

Warnings a

Windshield Wiper Motor Assembly (Driver's Windshield Enclosure Kit), Maintenance of:

Disassembly 2-185

Inspection/Repair 2-186

Reassembly 2-186

By Order of the Secretary of the Army:

GORDON R. SULLIVAN
General, United States Army
Chief of Staff

Official:

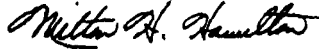

MILTON H. HAMILTON
Administrative Assistant to the
Secretary of the Army

0 6 6 2 0

Distribution: Distribute in accordance with DA Form 12-37-E Block 0931 requirements for
TM 9-2350-238-34-1



THEN . JOT DOWN THE DOPE ABOUT IT ON THIS FORM. CAREFULLY TEAR IT OUT, FOLD IT AND DROP IT IN THE MAIL.

SOMETHING WRONG WITH THIS PUBLICATION?

FROM (PRINT YOUR UNIT'S COMPLETE ADDRESS)

Your mailing address

DATE SENT

Date you filled out this form

PUBLICATION NUMBER

TM 9-2350-238-34-1

PUBLICATION DATE

31 March 1994

PUBLICATION TITLE DS and GS Maintenance

Manual for Hull and Related Components Recovery Vehicle, Full Tracked: Light, Armored, M578

BE EXACT PINPOINT WHERE IT IS

IN THIS SPACE TELL WHAT IS WRONG AND WHAT SHOULD BE DONE ABOUT IT:

PAGE NO.	PARA-GRAPH	FIGURE NO.	TABLE NO.
2-102	2-40		

CORRECT THE BOTTOM ILLUSTRATION BY CHANGING THE CALLOUT FOR THE MECHANICAL CLUTCH HOUSING FROM 11 TO 10 TO MATCH THE TEXT IN STEP 8.

SAMPLE

PRINTED NAME, GRADE OR TITLE, AND TELEPHONE NUMBER

Your name

SIGN HERE

Your signature

FILL IN YOUR
UNITS ADDRESS



DEPARTMENT OF THE ARMY

OFFICIAL BUSINESS

COMMANDER
U.S. ARMY TANK
AUTOMOTIVE COMMAND
ATTN: AMSTA-MB
WARREN, MI 48397-5000

TEAR ALONG PERFORATED LINE

METRIC CHART

THE METRIC SYSTEM AND EQUIVALENTS

LINEAR MEASURE

1 Centimeter = 10 Millimeters = 0.01 Meters = 0.3937 Inches
 1 Meter = 100 Centimeters = 1000 Millimeters = 39.37 Inches
 1 Kilometer = 1000 Meters = 0.621 Miles

WEIGHTS

1 Gram = 0.001 Kilograms = 1000 Milligrams = 0.035 Ounces
 1 Kilogram = 1000 Grams = 2.2 Lb
 1 Metric Ton = 1000 Kilograms = 1 Megagram = 1.1 Short Tons

LIQUID MEASURE

1 Milliliter = 0.001 Liters = 0.0338 Fluid Ounces
 1 Liter = 1000 Milliliters = 33.82 Fluid Ounces

SQUARE MEASURE

1 Sq Centimeter = 100 Sq Millimeters = 0.155 Sq Inches
 1 Sq Meter = 10,000 Sq Centimeters = 10.76 Sq Feet
 1 Sq Kilometer = 1,000,000 Sq Meters = 0.386 Sq Miles

CUBIC MEASURE

1 Cu Centimeter = 1000 Cu Millimeters = 0.06 Cu Inches
 1 Cu Meter = 1,000,000 Cu Centimeters = 35.31 Cu Feet

TEMPERATURE

$5/9 (^{\circ}\text{F} - 32) = ^{\circ}\text{C}$
 212° Fahrenheit is equivalent to 100° Celsius
 90° Fahrenheit is equivalent to 32.2° Celsius
 32° Fahrenheit is equivalent to 0° Celsius
 $9/5 \text{ C}^{\circ} + 32 = \text{F}^{\circ}$

APPROXIMATE CONVERSION FACTORS

TO CHANGE	TO	MULTIPLY BY
Inches	.Centimeters	2.540
Feet	.Meters	0.305
Yards	.Meters	0.914
Miles	.Kilometers	1.609
Square Inches	..Square Centimeters	6.451
Square Feet	..Square Meters	0.093
Square Yards	..Square Meters	0.836
Square Miles	..Square Kilometers	2.590
Acres	..Square Hectometers	0.405
Cubic Feet	..Cubic Meters	0.028
Cubic Yards	..Cubic Meters	0.765
Fluid Ounces	..Milliliters	29.573
Pints	..Liters	0.473
Quarts	..Liters	0.946
Gallons	..Liters	3.785
Ounces	..Grams	28.349
Pounds	..Kilograms	0.454
ShortTons	..Metric Tons	0.907
Pound Feet	..Newton-Meters	1.356
Pounds per Square Inch	..Kilopascals	6.895
Miles per Gallon	..Kilometers per Liter	0.425
Miles per Hour	..Kilometers per Hour	1.609

TO CHANGE	TO	MULTIPLY BY
Centimeters	..Inches	0.394
Meters	..Feet	3.280
Meters	..Yards	1.094
Kilometers	..Miles	0.621
Square Centimeters	..Square Inches	0.155
Square Meters	..Square Feet	10.764
Square Meter	..Square Yards	1.196
Square Kilometers	..Square Miles	0.386
Square Hectometers	..Acres	2.471
Cubic Meters	..Cubic Feet	35.315
Cubic Meters	..Cubic Yards	1.308
Milliliters	..Fluid Ounces	0.034
Liters	..Pints	2.113
Liters	..Quarts	1.057
Liters	..Gallons	0.264
Grams	..Ounces	0.035
Kilograms	..Pounds	2.205
Metric Tons	..Short Tons	1.102
Newton-Meters	..Pound-Feet	0.738
Kilopascals	..Pounds per Square inch	0.145
Kilometers per Liter	..Miles per Gallon	2.354
Kilometers per Hour	..Miles per Hour	0.621

