

**TECHNICAL MANUAL**

**DIRECT SUPPORT AND GENERAL SUPPORT MAINTENANCE MANUAL  
(INCLUDING DIRECT SUPPORT, AND GENERAL SUPPORT  
REPAIR PARTS LIST AND DEPOT MAINTENANCE ALLOWANCES)**

**FOR**

**ENGINE, DIESEL, WITH ACCESSORIES  
CUMMINS MODEL V8-300  
(2815-910-8217)**

**This copy is a reprint which includes current pages from Changes 1 and 2.**

---

**HEADQUARTERS, DEPARTMENT OF THE ARMY  
FEBRUARY 1972**

CHANGE }  
No. 2 }

HEADQUARTERS  
DEPARTMENT OF THE ARMY  
WASHINGTON, DC, 26 November 1976

**Direct Support and General Support Maintenance  
Manual (Including Direct Support, and General  
Support Repair Parts and Special Tools List**

**For**

**ENGINE, DIESEL, WITH ACCESSORIES  
CUMMINS MODEL V8-300  
(2815-00-910-8217)**

Current as of 6 April 1976

TM 9-2815-213-34, 2 February 1972, is changed as follows:

1. Remove old pages and insert new pages as indicated below. New or changed material is indicated by a vertical bar in the margin of the page. Added or revised illustrations are indicated by a vertical bar next to the identification number.

Remove pages

3-9 and 3-10  
3-31 and 3-32  
3-35 and 3-36  
3-61 and 3-62  
3-67 and 3-68  
B-7 through B-18  
B-21 through B-24  
B-43 and B-44  
B-61 and B-62  
B-67 through B-87

Insert pages

3-9 and 3-10  
3-31 and 3-32  
3-35 and 3-36  
3-61 and 3-62  
3-67 and 3-68  
B-7 through B-18  
B-21 through B-24  
B-43 and B-44  
B-61 and B-62  
B-77 through B-87

2. File this change sheet in front of the publication for reference purposes.

By Order of the Secretary of the Army:

Official:

PAUL T. SMITH  
*Major General, United States Army*  
*The Adjutant General*

BERNARD W. ROGERS  
*General, United States Army*  
*Chief of Staff*

Distribution:

To be distributed in accordance with DA Form 12-38, Direct/General Support TM requirements for 10-ton truck tractor, M123, M123AIC, M123C, M123E2 and Cargo Truck, M125.

CHANGE }  
No. 1 }

HEADQUARTERS  
DEPARTMENT OF THE ARMY  
WASHINGTON, DC, 23 July 1975

**Direct Support and General Support Maintenance Manual**

**(Including Direct Support, and General Support**

**Repair Parts and Special Tools List)**

**For**

**ENGINE, DIESEL, WITH ACCESSORIES**

**CUMMINS MODEL V8-300**

**(2815-00-910-8217)**

Current as of 7 April 1975

TM 9-2815-213-34, 2 February 1972, is changed as follows:

1. Remove old pages and insert new pages as indicated below. New or changed material in the maintenance portion is indicated by a vertical bar in the margin of the page. Added or revised illustrations are indicated by a vertical bar next to the identification number.

*Remove pages*

3-57 and 3-58  
3-61 and 3-62  
B-1 thru B-38  
B-59 and B-60  
None  
B-77 thru B-89

*Insert pages*

3-57 and 3-58  
3-61 and 3-62  
B-1 thru B-27  
B-59 and B-60  
B-62.1  
B-77 thru B-87

2. File this change sheet in front of the publication for reference purposes.

By Order of the Secretary of the Army:

Official:  
VERNE L. BOWERS  
*Major General, United States Army,  
The Adjutant General.*

FRED C. WEYAND  
*General, United States Army,  
Chief of Staff.*

Distribution:

To be distributed in accordance with DA Form 12-38, (qty rqr block No. 92). Direct and General Support maintenance requirements for Truck, Tractor, 10-Ton, 6x6 M123A/C and M123E2.

**DIRECT SUPPORT AND GENERAL SUPPORT  
 MAINTENANCE MANUAL  
 (INCLUDING DIRECT SUPPORT AND GENERAL SUPPORT  
 REPAIR PARTS LIST AND  
 DEPOT MAINTENANCE ALLOWANCES)**

FOR

**ENGINE, DIESEL, WITH ACCESSORIES  
 CUMMINS MODEL V8-300  
 (2815-910-8217)**

		Paragraph	Page
<b>CHAPTER</b>	<b>1. INTRODUCTION</b>		
Section	I. General.....	1-1	1-1
	II. Description and Data.....	1-4	1-1
<b>CHAPTER</b>	<b>2. MAINTENANCE INSTRUCTIONS</b>		
Section	I. Repair Parts, Special Tools and Equipment .....	2-1	2-1
	II. General Maintenance .....	2-4	2-1
	III. Removal of Engine Components .....	2-8	2-3
<b>CHAPTER</b>	<b>3. REPAIR INSTRUCTIONS</b>		
Section	I. General.....	3-1	3-1
	II. Repair of Cylinder Block.....	3-2	3-1
	III. Repair of Crankshaft .....	3-7	3-3
	IV. Repair of Connecting Rod and Piston Assembly .....	3-13	3-5
	V. Repair of Front Cover.....	3-19	3-8
	VI. Repair of Oil Pump Assembly .....	3-24	3-9
	VII. Repair of Camshaft .....	3-30	3-11
	VIII. Repair of Crankshaft Adapter.....	3-36	3-12
	IX. Repair of Flywheel Housing and Spacer Plate.....	3-40	3-12
	X. Repair of Oil Pan .....	3-46	1-3
	XI. Repair of Flywheel.....	3-52	3-13
	XII. Repair of Valve and Injector Tappets.....	3-58	3-14
	XIII. Repair of Cylinder Head .....	3-64	3-16
	XIV. Repair of Fuel Injectors .....	3-71	3-23
	XV. Repair of Rocker Arm Assembly and Push Rods .....	3-80	3-33
	XVI. Repair of Push Rod Cavity Covers.....	3-86	3-35
	XVII. Repair of Cylinder Head Covers.....	3-91	3-35
	XVIII. Repair of Air Compressor and Drive Assembly.....	3-96	3-36
	XIX. Repair of Fuel Pump and Fuel Lines.....	3-102	3-6
	XX. Repair of Water Crossover Pipe and Lifting Eyes.....	3-110	3-52
	XXI. Repair of Air Intake, Preheater Assembly and Intake Manifolds	3-114	3-52
	XXII. Repair of Water Pump Assembly .....	3-120	3-53
	XXIII. Repair of Fan Drive Pulley, Vibration Damper and Water Pump Pulley Assembly	3-125	3-2
	XXIV. Repair of Thermostat Assembly .....	3-131	3-54
	XXV. Repair of Fan, Fan Hub, and Bracket Assembly .....	3-137	3-56
	XXVI. Repair of Hydraulic Pump and Mounting Brackets .....	3-143	3-56
	XXVII. Repair of Alternator Assembly and Mounting Bracket .....	3-149	3-56
	XXVIII. Repair of Starter Assembly .....	3-155	3-56

\*This manual supersedes TM 9-2015-213-34, 13 April 1966 including all changes.

		Paragraph	Page
<b>CHAPTER</b>	<b>3. REPAIR INSTRUCTIONS--Continued</b>		
	XXIX. Repair of Oil Cooler.....	3-157	3-56
	XXX. Repair of Exhaust Manifolds .....	3-162	3-57
	XXXI. Engine Removal from Engine Rebuild Stand.....	3-162	3-57
	XXXII. Engine Test and Adjustment .....	3-167	3-57
	XXXIII. Repair and Rebuild Standards .....	3-174	3-62
<b>APPENDIX</b>	<b>A. REFERENCES</b>		
	<b>B. REPAIR PARTS AND SPECIAL TOOLS LIST</b>		
Section	I. Introduction.....		B-1
	II. Repair Parts List.....		B-4
Group	01 -ENGINE		
	0100 Engine Assembly.....		B-4
	0101 Block and Cylinder Head.....		B-5
	0102 Crankshaft .....		B-7
	0103 Flywheel Assembly.....		B-7
	0104 Piston and Connecting Rod.....		B-8
	0105 Valves and Camshaft .....		B-8
	0106 Engine Lubrication System.....		B-10
	0108 Manifolds .....		B-13
Group	03 -FUEL SYSTEM		
	0301 Fuel Injector.....		B-14
	0302 Fuel Pump .....		B-15
	0304 Air Cleaner .....		B-20
	0311 Starting Aids .....		B-20
Group	05 -COOLING SYSTEM		
	0503 Thermostat .....		B-21
	0504 Water Pump .....		B-22
	0505 Fan Assembly.....		B-22
Group	06 -ELECTRICAL SYSTEM		
	0601 Generator .....		B-22
Group	12 -BRAKES		
	1209 Air Compressor and Drive Mechanism .....		B-23
Group	14 -STEERING		
	1410 Hydraulic Pump Assembly .....		B-23
Group	33 -SPECIAL PURPOSE KITS		
	3301 Reusable Shipping Containers.....		B-24
Group	47 -GAGES		
	4701 Tachometer .....		B-24
Section	III. Special Tools List		
Group	26 -TOOLS AND TEST EQUIPMENT		
	2604 Special Tools.....		B-25
	2606 Test Equipment .....		B-27
Section	IV. Index-Federal Stock Number and Reference Number Cross-Reference to Figure and Item Number .....		Index-1

## LIST OF ILLUSTRATIONS

Number	Title	Page	Number	Title	Page
1-1.	Model V8-300 ..... Engine Assembly 3/4 Left Front View .....	1-2	3-12.	Piston Ring Gap Check .....	3-7
1-2.	Model V8-300 Engine Assembly 3/4 Right ... Rear View .....	1-3	3-13.	Rod Side Clearance Check .....	3-8
1-3.	Engine Assembly Rear Sectional View .....	1-6	3-14.	Crankshaft Oil Seal-Removal/Installation .....	3-9
2-1.	Exhaust Manifold-Removal/Installation .....	2-4	3-15.	Front Cover Bore Alinement Check .....	3-9
2-2.	Oil Cooler-Removal Installation .....	2-5	3-16.	Front Cover to Block Alinement Check .....	3-9
2-3.	Engine Rebuild Stand-Removal/ Installation .....	2-5	3-17.	Drive Gear Backlash Check .....	3-10
2-4.	Fan Hub and Bracket Assembly- Removal/Installation .....	2-5	3-18.	Camshaft End Play Check .....	3-11
2-5.	Thermostat Assembly-Removal/ Installation .....	2-6	3-19.	Crankshaft Gear Backlash Check .....	3-11
2-6.	Drive Pulleys and Vibration Damper- Removal/Installation .....	2-6	3-20.	Crankshaft Adapter Tightening Sequence .....	3-12
2-7.	Water Pump Assembly-Removal Installation .....	2-6	3-21.	Flywheel Housing Concentricity Check .....	3-13
2-8.	Air Intake Crossover and Preheater Assembly-Removal/Installation .....	2-7	3-22.	Flywheel Tightening Sequence .....	3-14
2-9.	Intake Manifold, Fuel Pump and Fuel Lines-Removal/Installation .....	2-7	3-23.	Flywheel Bearing Bore and Wobble Limits	3-14
2-10.	Water Crossover Pipe and Lifting Eye Removal/Installation .....	2-8	3-24.	Tappet Assembly Test .....	3-15
2-11.	Oil Dipstick Tube Assembly-Removal/ Installation .....	2-8	3-25.	Cylinder Head in Holding Fixture .....	3-16
2-12.	Cylinder Head Covers-Removal/ Installation .....	2-9	3-26.	Valve Assemblies-Removal/Installation .....	3-16
2-13.	Crankcase Breather Tube Removal/ Installation .....	2-9	3-27.	Injector Sleeves-Removal/Installation .....	3-16
2-14.	Push Rod Cavity Covers-Removal/ Installation .....	2-9	3-28.	Crosshead Guide-Removal/Installation .....	3-16
2-15.	Rocker Arms and Push Rods-Removal/ Installation .....	2-10	3-29.	Valve Seat Removal Sectional View .....	3-17
2-16.	Injector Clamps Removal/Installation .....	2-10	3-30.	Injector Sleeve Holder Installation .....	3-17
2-17.	Fuel Injector and Hold-Down Clamp .....	2-10	3-31.	Injector Tip Protrusion Measurement .....	3-17
2-18.	Valve Crossheads-Removal/Installation .....	2-11	3-32.	Valve Head and Collet Check .....	3-18
2-19.	Cylinder Head-Removal/Installation .....	2-11	3-33.	Crosshead Guide Check .....	3-18
2-20.	Valve and Injector Tappets-Removal/ Installation .....	2-11	3-34.	Valve Guide Check .....	3-18
2-21.	Flywheel-Removal/Installation .....	2-12	3-35.	Valve Spring Test .....	3-18
2-22.	Crankshaft Adapter-Removal/Installation .....	2-12	3-46.	Valve and Injector Counterbore Measurements .....	3-19
2-23.	Flywheel Housing-Removal/Installation .....	2-13	3-37.	Cylinder Head Regrooving .....	3-19
2-24.	Camshaft Gear, and Spacer Plate- Removal/Installation .....	2-13	3-38.	Valve Guide Installation .....	3-20
2-25.	Oil Pan-Removal/Installation .....	2-13	3-39.	Crosshead Guide Installation- .....	3-20
2-26.	Oil Pump Assembly-Removal/Installation .....	2-13	3-40.	Injector Sleeve Installation .....	3-20
2-27.	Front Cover-Removal/Installation .....	2-14	3-41.	Injector Sleeve Rolling-Upper Portion .....	3-21
2-28.	Connecting Rod and Piston Assembly- Removal/Installation .....	2-14	3-42.	Injector Sleeve Rolling-Lower Portion .....	3-21
2-29.	Crankshaft and Main Bearings-Removal/ Installation .....	2-14	3-43.	Injector Sleeve Seat Cutting .....	3-21
3-1.	Camshaft Bushing Removal .....	3-1	3-44.	Valve Seat Insert Counterbore .....	3-21
3-2.	Cylinder Sleeve Removal .....	3-1	3-45.	Intake Valve Port Swirl Plate Installation .....	3-22
3-3.	Main Bearing Bore Alinement Check .....	3-2	3-46.	Valve Seat Insert Peering .....	3-22
3-4.	Cylinder Sleeve Seals Installation .....	3-2	3-47.	Valve Seat Test.3 .....	3-22
3-5.	Crankshaft Dimensions .....	3-4	3-48.	Cylinder Head Tightening Sequence .....	3-23
3-6.	Crankshaft End Clearance Check .....	3-5	3-49.	Fuel Injector PT (Type C) .....	3-24
3-7.	Bearing Cap to Block Clearance Check .....	3-5	3-50.	Injector Cup-Removal/Installation .....	3-24
3-8.	Side Bolt Tightening Sequence .....	3-5	3-51.	Injector Link-Removal/Installation .....	3-24
3-9.	Piston and Ring Assembly .....	3-6	3-52.	Plunger Seat Pattern .....	3-24
3-10.	Connecting Rod Check .....	3-6	3-53.	Fuel Injector-Exploded View .....	3-26
3-11.	Ring Groove Wear Check .....	3-7	3-54.	Injector Check Ball Seating .....	3-26
			3-55.	Injector Body O-Ring Installation .....	3-26
			3-56.	Injector Body and Plunger Markings .....	3-27
			3-57.	Injector Cup Markings .....	3-27
			3-58.	Injector Plunger Seat Test .....	3-27
			3-59.	Injector Test Stand- .....	3-29
			3-60.	Alining Timing Wheel and Pointer .....	3-29
			3-61.	Hydraulic and Air Valves .....	3-29
			3-62.	Air Pressure Adjustment .....	3-30
			3-63.	Master Injector Installation- .....	3-30
			3-64.	Fuel Inlet Installation .....	3-30
			3-65.	Injector Mounted in Test Stand .....	3-30
			3-66.	Test Stand Air Pressure Connection .....	3-31
			3-67.	Load Cell Test .....	3-31
			3-68.	Ball Seat Resurfacing .....	3-32
			3-69.	Orifice Hole Burnishing Tool Installation .....	3-33
			3-70.	Orifice Plug Burnishing .....	3-33
			3-72.	Injector Push Rod Timing .....	3-33
			3-72.	Air Compressor Drive Gear Timing Mark .....	3-37

**LIST OF ILLUSTRATIONS-Continued**

<b>Number</b>	<b>Title</b>	<b>Page</b>	<b>Number</b>	<b>Title</b>	<b>Page</b>
3-73.	Fuel Pump PT (Type G) .....	3-38	3-108.	Gear Train-Points of Measurement .....	3-67
3-74.	Mounting Plate and Ball Joint Vise.....		3-109.	Oil Pressure Regulator and Oil Pump- Point of Measurement .....	3-39
	Installation.....	3-39	3-110.	Cylinder Head-Points of Measurement .....	3-69
3-75.	Governor Weights Assembly-Removal/ ..		3-111.	Tappets and Push Rod/Points of Measurement .....	3-69
	Installation.....	3-39	3-112.	Rocker Arms and Shaft-Points of Measurement .....	3-70
3-76.	Governor Shaft Oil Seals-Removal/ .....	3-39	3-113.	Water Pump-Points of Measurement .....	3-71
	Installation .....	3-39	3-114.	Assembly Data-Points of Measurement.....	3-72
3-77.	Tachometer Drive Assembly-Removal/...		B-1.	Engine and Container Assembly.....	B-39
	Installation.....	3-39	B-2.	Cylinder Block and Head Assembly .....	B-40
3-78.	Plunger Assembly-Removal/Assembly ...	3-40	B-3.	Crankshaft Main Bearing and Drive Pulley	B-41
3-79.	Fuel Pump Test Stand Equipment .....	3-42	B-4.	Flywheel Assembly.....	B-42
3-80.	Fuel Pump Test Stand .....	3-43	B-5.	Connecting Rod, Piston and Rings .....	B-43
3-81.	Mounting Pump on Test Stand .....	3-44	B-6.	Cylinder Head, Valves, Rocker Arms and Covers.....	B-44
3-82.	Engaging Stand Drive Shaft .....	3-45	B-7.	Front Cover and Camshaft.....	B-45
3-83.	Pump Preparation for Test and Calibration	3-46	B-8.	Engine Lubrication System (crankcase breather).....	B-46
3-84.	Fuel Pump Nameplate.....	3-46	B-9.	Engine Lubrication System (oil pan) .....	B-47
3-85.	Scribing Governor Barrel.....	3-47	B-10.	Engine Lubrication System (pump) .....	B-48
3-86.	Reaming Mainshaft Bushing .....	3-47	B-11.	Engine Lubrication System (oil cooler) .....	B-49
3-87.	Throttle Shaft O-ring Installation .....	3-47	B-12.	Manifold intake and Exhaust.....	B-50
3-88.	Throttle Assembly Installation .....	3-47	B-13.	Fuel Injector .....	B-51
3-89.	Thrust Washer-Drive Plunger Governor..		B-14.	Fuel Pump Assembly .....	B-52
	Clearance .....	3-48	B-15.	Fuel Pump Housing (exploded) .....	B-53
3-90.	Main Throttle Shaft Shim Check .....	3-49	B-16.	Fuel Pump Gear and Damper Assembly ...	B-54
3-91.	Weep Hole Leakage.....	3-49	B-17.	Fuel Shut-off and Solenoid Valve and Governor Spring Pack Assembly .....	B-55
3-92.	Governor Spring Shimming .....	3-50	B-18.	Governor Assembly (main shaft cover) .....	B-56
3-93.	Throttle Stop Screw Adjust.....	3-50	B-19.	Air Intake Components .....	B-57
3-94.	Idle Speed Setting .....	3-51	B-20.	Glow Plug and Heater Accessories .....	B-58
3-95.	Valve Timing Marks.....	3-58	B-21.	Thermostat and Crossover Tube .....	B-59
3-96.	Engine Firing Order.....	3-59	B-22.	Water Pump .....	B-60
3-97.	Crosshead Adjustments .....	3-59	B-23.	Fan, Hub, and Bracket .....	B-61
3-98.	Engine Blow-By Check .....	3-63	B-24.	Generator.....	B-62
3-99.	Manifold Fuel Pressure Check .....	3-63	B-25.	Air Compressor and Drive Mechanism .....	B-63
3-100.	Fuel Flow Rate Check .....	3-63	B-26.	Power Steering Pump .....	B-64
3-101.	Performance Curve .....	3-64	B-27.	Tachometer Drive .....	B-65
3-102.	Cylinder Block-Points of Measurement ...	3-65	B-28.	Special Tools.....	B-66 B-74
3-103.	Crankshaft and Bearings Points of.....		B-29.	Test Equipment.....	B-75 B-76
	Measurement .....	3-65			
3-104.	Connecting Rod-Points of Measurement	3-66			
3-105.	Piston-Points of Measurement .....	3-66			
3-106.	Cylinder Sleeve-Points of Measurement.	3-67			
3-107.	Camshaft and Bearings-Points of .....				
	Measurement .....	3-67			

**LIST OF CHARTS**

<b>Number</b>	<b>Title</b>	<b>Page</b>	<b>Number</b>	<b>Title</b>	<b>Page</b>
3-1.	Injection Timing.....	3-33	3-2.	Fuel Pump Troubleshooting.....	3-51



## CHAPTER 1 INTRODUCTION

---

### Section I. General

#### 1-1. Scope

a. This technical manual contains instruction for direct and general support maintenance of the Cummins Diesel Engine, Model V8-300, (fig. 1-1 and 1-2). It contains descriptions of, and procedures for, disassembly, inspection, repair, rebuild, and assembly of the engine.

b. Appendix A contains a list of current refer ences, including supply manuals, forms, technical manuals, and other available publications applicable to the engine.

c. Appendix B lists repair parts, special tools, and test equipment required for the performance of direct and general support maintenance of the engine.

#### 1-2. Forms and Records

Maintenance forms, records, and reports which are to be used by maintenance personnel at all maintenance levels are listed in and prescribed by TM 38-750.

#### 1-3. Reporting of Equipment Publication Improvement

The reporting of errors, omissions, and recommendations for improving this publication by the individual user is encouraged. Reports should be submitted on DA Form 2028, Recommended Changes to Publications, and forwarded direct to the Commanding General, U.S. Army Tank-Automotive Command Attention: ASMTA-4, Warren, MI 48090.

### Section II. Description and Data

#### 1-4. Description

##### a. General.

(1) In this manual the following terms will be used to identify the location for engine parts and assemblies:

(a) *Front*-fan end of engine.

(b) *Rear*-flywheel end of engine.

(c) *Right and Left*-are identified as viewed from the rear.

(2) The model V8-300 diesel engine is as eight cylinder, V-type, Valve-in-head, water cooled, compression-ignition engine, using the four stroke cycle principle of operation. The four strokes consist of intake, compression, power and exhaust. Intake and exhaust valves, and fuel injectors, are operated from a single camshaft. The intake stroke of the cycle brings filtered, heated air to the cylinders. The compression stroke compresses the air (17:1 compression ratio) to 500-600 p.s.i, and raises the cylinder temperature to approximately 1000 degrees Fahrenheit. During the top of the compression stroke and start of the power stroke, a metered charge of diesel fuel is injected into the cylinders. The high temperature within the cylinders ignites the diesel fuel resulting in the power stroke. The fourth stroke of the cycle exhausts the burned

gases from the cylinders. Proper engine operation depends upon the high compression of the intake air and the timed injection of the correct measure of diesel fuel into the cylinder.

b. *Engine Assembly*. The model V8-300 engine (fig. 1-1 and 1-2) is a diesel eight cylinder V-type, valve in head, water cooled, compression ignition engine. The engine is rated 300 horsepower at 3000 rpm and will operate on diesel fuel.

##### c. Engine Systems.

(1) *Fuel System*. The system consists of a filter, fuel pump with governor, fuel passages, and injectors (one for each cylinder). The system is designed so that the volume of liquid flow is proportionate to the fluid pressure, the time allowed to flow, and the size of the orifice fuel flows through. The pump draws fuel from the vehicle supply tank and delivers it to each injector. A governor controls the flow of fuel from the gear pump, as well as the idle and maximum engine speed.

(2) *Lubrication System*. All working parts of the engine are pressure lubricated. Oil is supplied by a dual-type gear driven lubricating pump located below the crankshaft and driven by the crankshaft gear. On completion of the lubrication cycle, oil is accumulated in the oil pan sump by gravity and is drawn from this sump by the oil

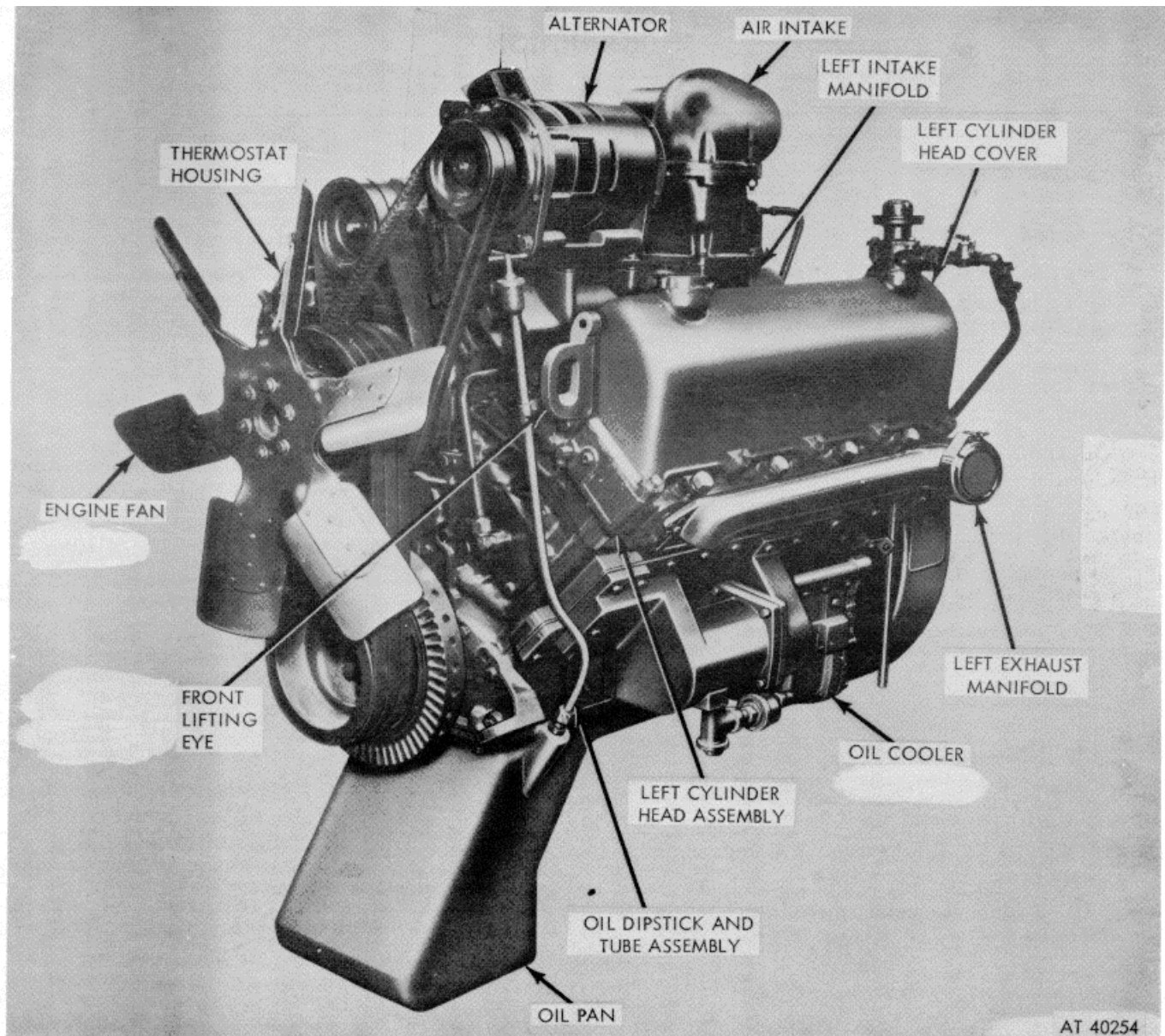

Figure 1-1. Model V8-300 engine assembly--3/4 left front view.

pump. Oil is delivered to all working parts of the engine through drillings in the block, cylinder head, crankshaft, and rocker levers. Lubricating oil is forced through the crankshaft to lubricate the main and connecting rod bearings. Lubricating oil pressure is controlled by a regulator which is an integral part of the oil pump assembly. The air compressor receives pressure lubrication from the engine oil supply. The oil flow cycle is as follows.

(a) Oil is drawn to oil pump through suction tube, in oil pan. It is then pumped through a passage in rear of block through right bank water header cover to front of the block.

(b) The oil flow crosses in front of block to left bank through oil filter and into cooler. From cooler, oil flows to left bank oil drilling at rear of engine. The oil pump by-pass dumps oil directly into pan.

(c) From left bank oil drilling, at rear of engine, oil flows to no. 4 cam bushing and no. 4 main bearing which in turn supplies no. 3 and 7 connecting rods.

(d) Right bank rocker arms are oiled intermittently through no. 5 cam bushing.

(e) From left bank oil drilling, oil flows to left bank tappets, to no. 2 and 3 cam bushings, and no. 2 and 3 main bearings. No. 3 main bear-

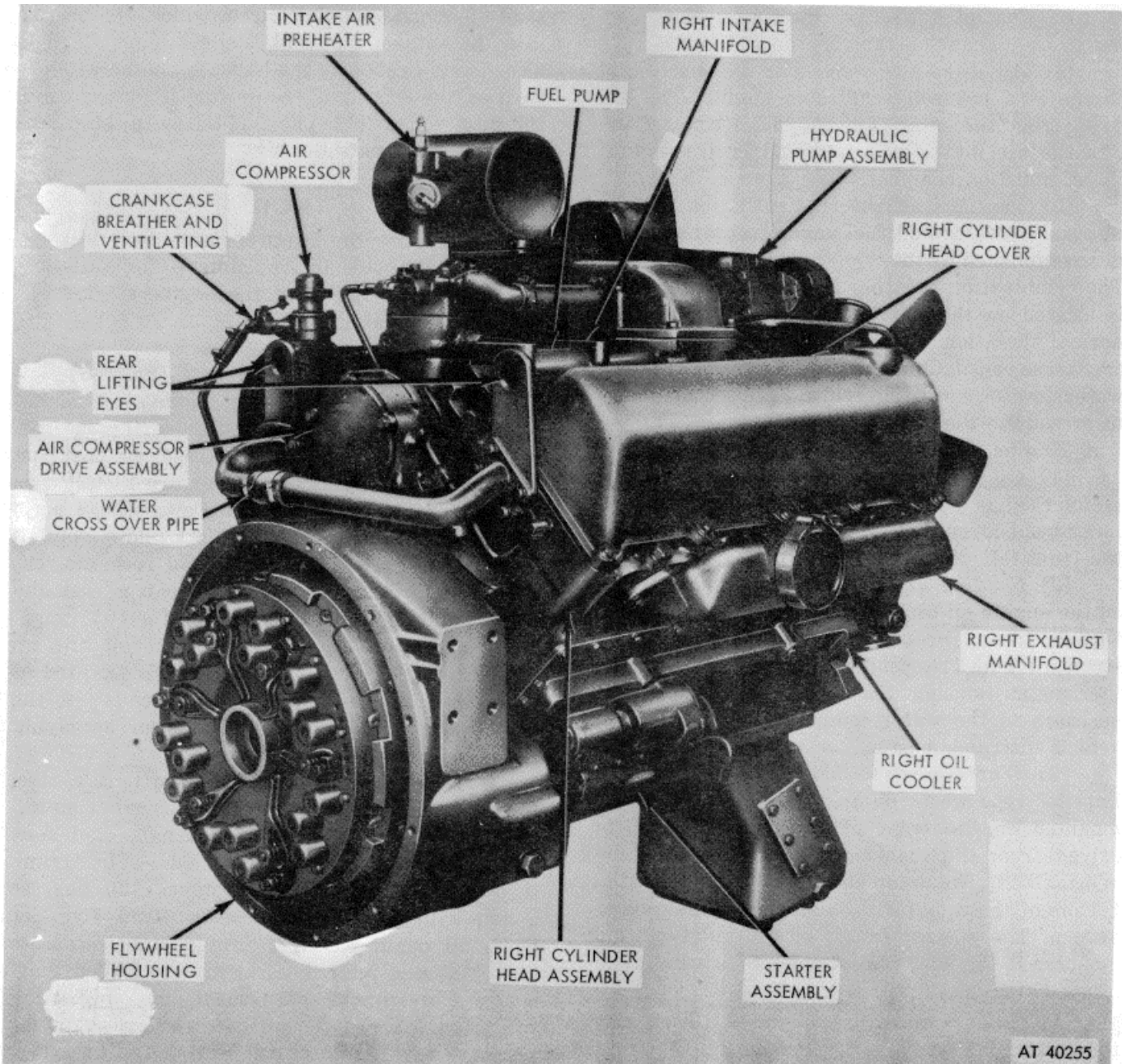

Figure 1-2. Model V8-300 engine assembly--3/4 right rear view.

ing supplies oil to no. 2 and 6 connecting rods.

(f) Oil flows through a crossover at front of block to supply no. 1 cam bushing and no. 1 main bearing. No. 1 main bearing supplies oil to no. 1 and no. 5 connecting rods.

(g) The left bank rocker arms are oiled intermittently through no. 1 cam bushing.

(h) Right bank tappets are oiled from drilling at rear of engine.

(i) Oil flows through a drilling in the air compressor gear case to the rear of the case, through a drilling in the compressor support

cover up to the bushing in support cover.

(3) *Cooling System.* The coolant is circulated by a centrifugal type water pump mounted on the front of the engine and is belt driven by the crankshaft pulley. The water circulates around the cylinder sleeves, through the cylinder heads, and around the injector sleeves. The injectors are seated in copper injector sleeves for quick dissipation of heat. Outlet castings at the front of the heads are connected to the thermostat housing. The thermostat maintains engine operating temperature between 173 degrees and 186

degrees. Coolant flows from the thermostat housing to the expansion tank in the radiator.

(4) *Air Intake System.* The V8-300 diesel engine is a naturally aspirated engine. The air flows from the air cleaner through connections into the air intake manifold and is drawn into the combustion chamber.

(5) *Ventilation System.* Ventilation for the removal of water and fuel vapor from the engine is accomplished by the crankcase breather system. The combination breather and pressurizing valve is located on the left hand valve cover. During normal operation with valve in the open position, crankcase ventilation is atmospheric. For the deep water fording operation, valve is closed manually to pressurize the engine crankcase.

d. *Engine External Components.*

(1) *Oil filler assembly and oil level gage.* The oil filler cap is mounted on top of the left hand cylinder head cover. The oil level gage is mounted on the front left of the engine oil pan.

(2) *Sending units.* A sending unit mounted on the engine oil cooler transmits engine oil pressure to the oil pressure gage on the vehicle instrument panel. A sending unit mounted to the thermostat housing transmits the coolant temperature to the water temperature gage on the vehicle instrument panel.

(3) *Water pump with pulley assembly.* The impeller type water pump with pulley assembly, mounted on the front of the cylinder head, is driven from the crankshaft pulley assembly by one fan belt. The pump circulates water from the bottom of the radiator through the engine cooling system. The coolant fan is of the pull-type and mounted to the idler pulley which is driven by the crankshaft pulley.

(4) *Water temperature thermostat.* The water thermostat is installed in a housing on the front of the right cylinder head. Water leaving this housing goes to the radiator expansion tank. The thermostat operates from 173 degrees to 186 degrees Fahrenheit. A thermostat by-pass line allows a limited circulation of coolant when the thermostat is closed.

(5) *Exhaust manifolds.* The exhaust manifolds installed on the right and left side of the engine, collect exhaust gases from the eight cylinders and route it to two exhaust pipe and muffler combinations located on each side of the vehicle.

(6) *Intake Manifold Heater.* To aid in starting the engine when the ambient temperature is 10 degrees Fahrenheit or below, an intake air preheater is used. The preheater equipment con-

sists of a hand-priming pump which pumps fuel into the intake manifold, a glow plug which is electrically heated by the battery, and a switch to turn on the glow plug while fuel is pumped into the intake manifold. The fuel burns in the intake manifold and heats the air.

**NOTE**

Refer to the, appropriate technical manuals listed in Appendix A for a detailed description of the engine starter and alternator.

e. *Engine Internal Components* (fig. 13).

(1) *Cylinder block with bearing cap assemblies.* The cylinder block with bearing cap assemblies which serve as a crankcase, is a cast iron alloy. Wet-type cylinder sleeves are installed in the cylinder block. Lubricating oil passage ways extend the full length of the block and supply oil to cylinder heads, crankshaft, and rocker levels.

(2) *Oil pan.* The engine oil pan is cast aluminum and contains a deep sump for 60% angularity operation. A scavenge intake oil line attached to the double acting oil pump (located at the flywheel end of the oil pan) extends into the front sump, providing an intake for supplying the necessary oil for lubrication.

(3) *Crankshaft.* The crankshaft, is a steel forging with four integrally forged counterweights, five main bearing journals, and four connecting rod bearing journals. The crank throws are forged in two planes 180 degrees apart, with two throws in each plane. Cylinder block oil drain passages provide lubrication to the crankcase main bearing. Holes drilled diagonally through the crankshaft and connecting rod bearing journals provide direct passages for pressure lubrication of connecting rod bearings. The crankshaft is statically and dynamically balanced.

(4) *Crankshaft bearings and crankshaft thrust bearings.* The five bearings supporting the crankshaft are steel-backed, copper-lead, insert type, split on the diameter so that each bearing half is interchangeable. A small tang at the joint positions the bearings in the cylinder block and bearing caps. Holes in the bearings are alined with the oil passages in the cylinder block. Grooves in the bearing surfaces aline with the drilled holes in the crankshaft bearing journals to provide a route for oil flow to connecting rod journals. Four crankshaft thrust half-rings (bearings) are mounted on both sides of the rear main

bearing cap to absorb crankshaft thrust loads. Dowel pins are used to position each dowel pin half-ring.

(5) *Crankshaft gear.* A crankshaft gear is keyed to the rear end of the crankshaft driving the gear train for the camshaft and air compressor.

(6) *Vibration damper.* A vibration damper is mounted to the forward end of the crankshaft to dampen crankshaft vibrations. The unit consists of a rubber damper hub and inertia member, both of which have alignment marks and are matched when assembled. The unit is further matched with alignment marks when installed on the crankshaft to aid in dynamic balance.

(7) *Connecting rod with piston pin bushing.* The connecting rod assemblies are two piece, I-beam, steel-forgings split at the crankshaft end. Two piston pin bushings are press fit into the rod at the piston end for the floating-type piston pin. The pin is held in the piston by two retaining rings.

(8) *Connecting rod bearings.* Connecting rod bearings are steel backed, copper-lead, insert type, split on the diameter. They are interchangeable and are installed without reaming, scraping, or use of shims.

(9) *Pistons.* Aluminum alloy pistons are "barrel ground", which provides a greater diameter at the thrust surface than at the piston pin bosses. Pistons have three piston rings (two compression and one oil). Compression rings are located in the bottom groove. All rings are located above the piston pin boss.

(10) *Camshaft.* A single camshaft positioned in the V-section of the cylinder block directly above the crankshaft, controls all valve and injector operations for both banks. It is supported by five camshaft bushings installed in the cylinder block. A camshaft thrust bearing is installed at the gear (rear) end of the camshaft to absorb thrust loads. Drilled oil passages in the cylinder block lubricate the five camshaft bearings. The camshaft gear is pressed and keyed to the rear of the camshaft and is meshed (marked "O") with the crankshaft gear. The camshaft is driven at one-half crankshaft speed. The camshaft gear is meshed with the fuel pump and air compressor drive gear at the upper rear portion of the engine. The camshaft has twenty-four cams, eight operate exhaust valves, eight operate intake valves, and eight operate fuel injectors.

(11) *Cylinder head.* Two cylinder heads (one each bank) are attached to the cylinder

block with 16 hold-down capscrews. Injectors and valves are mounted in the cylinder head. Rocker levers and bearing assemblies are located on top of each head on pedestals.

(12) *Valves, valve springs, valve rocker levers, bearings, and fuel injectors.*

(a) There are dual intake and exhaust valves for each cylinder. Sixteen valve rocker levers with bearing assemblies are mounted on the rocker lever shafts. A cross-head moves two valves in unison from pressure excited by the rocker lever. Right and left movement comes from a push tube connected to the cam followers. The cam followers ride on the lobe of the camshaft. The valves and their companion crossheads operate in replaceable guides. Valve springs are secured to valve stems by valve spring retainers and locks. Rocker lever shafts are supported by four rocker lever brackets mounted on the cylinder heads.

(b) Eight injector rocker levers and bearing assemblies are mounted on the rocker arm shaft along with the valve rocker assemblies. The injector is actuated by the same method used to actuate the valve.

(13) *Flywheel with Ring Gear Assembly.* The flywheel with ring gear assembly consists of a cast iron flywheel with a replaceable steel ring gear. The flywheel is attached to the rear of the crankshaft by means of a crankshaft adapter using eight capscrews. The ring gear meshes with the starter gear during the cranking operation.

(14) *Oil Pump Assembly.* The oil pump installed within the oil pan is of the positive placement gear type in mesh with a gear train. Oil is drawn from the oil pan sump through the oil pump inlet pipes (both suction and scavenger lines) to the pump inlet ports. Oil is pumped from the pressure pump under pressure through the discharge port into various drillings in the block, cylinder head, crankshaft, and rocker levers lubricating the engine. The scavenger evacuates oil from the rear of the oil pan and returns it to the main sump when the vehicle is operating on steep grades. Oil pressure is maintained by a regulator installed in the oil pressure pump.

#### **1-5. Tabulated Data**

Refer to TM 9-2320-206-20 for tabulated data pertaining to general characteristics and performance of the engine assembly.

##### *a. General.*

Manufacturer Cummins Engine Company, Inc.

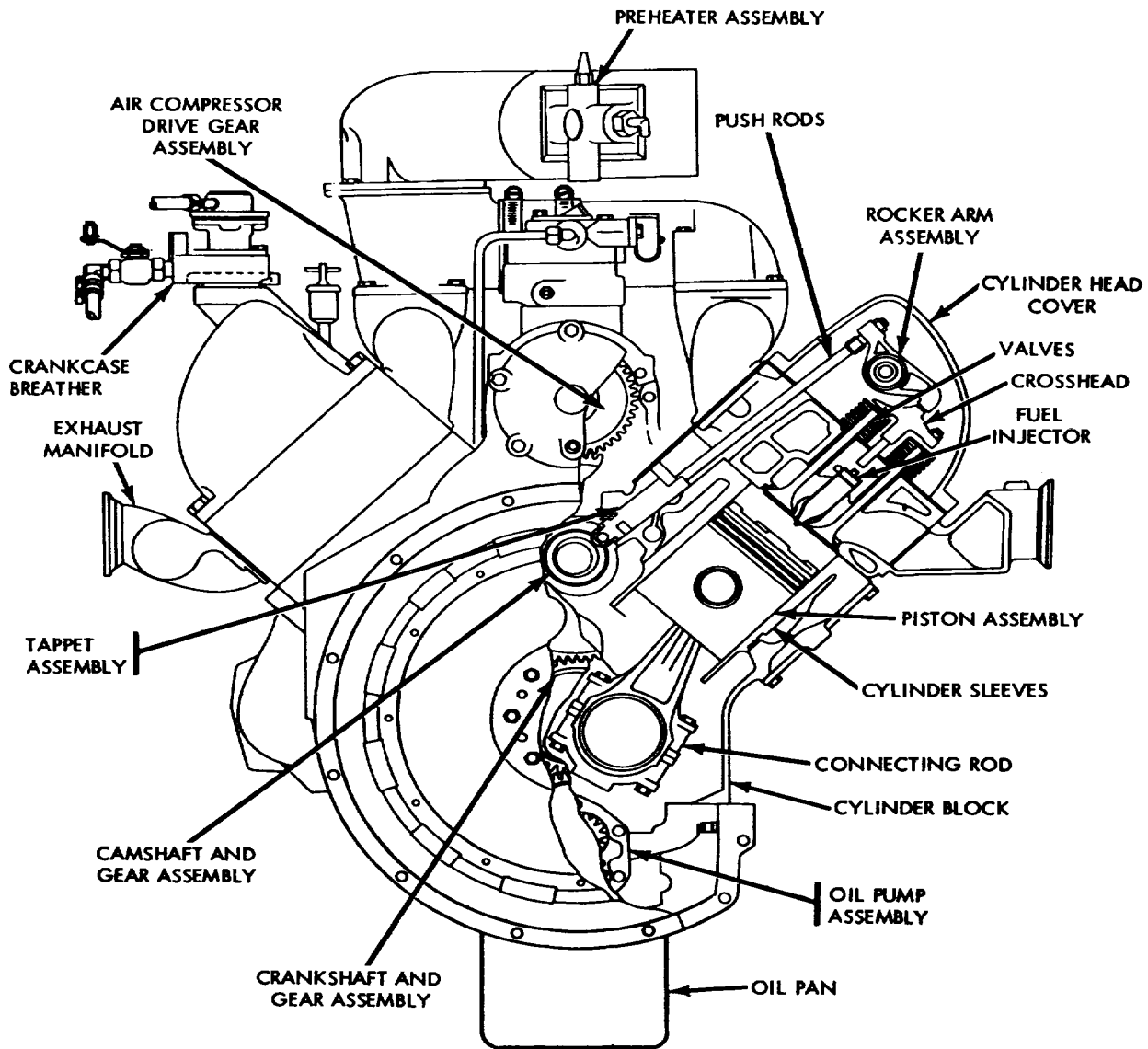

AT 40256

Figure 1-3. Engine assembly--rear sectional view.

Model.....	V8300	Number of rings per piston.....	3 (2 compression, 1 oil)
Ordinance number.....	10946107	Crankshaft type.....	counterweight
Type.....	Four cycle diesel valve-	Number of counterweight.....	4
.....	in-head V-type compression	Firing order.....	1-5-4-8-6-3-7-2
.....	ignition	Normal oil pressure.....	30 to 45 psi
Weight (dry).....	2,250 lb	Normal oil temperature:	
Number of cylinders.....	8	(degrees Fahrenheit).....	180 to 250
Type of cylinders.....	Wet type replaceable	Normal water temperature:	
.....	sleeve	(degrees Fahrenheit).....	165 to 195
Bore and stroke (inches) ..	5 1/2X4 1/8	b. Valves.	
Displacement.....	785 cu in	Number of valves:	
Maximum gross brake		Intake.....	16
horsepower.....	300 at 3000 rpm	Exhaust.....	16
Compression ratio.....	17:1	Type of valves.....	Poppet
Number of pistons.....	8		

Type of Guides ..... Removable  
Timing:  
Injector (discharge)..... No. 1 V-S on vibration  
Intake valve (closed) ..... damper timing mark  
Exhaust valve (closed) ..... matched to arrow on  
the engine block  
Valve lash adjustment (hot):  
Intake..... 0.014 inch  
Exhaust..... 0.027 inch  
*c. Oil Pump Assembly.*  
Manufacturer ..... Cummins Engine Com-  
pany, Inc.  
Type..... gear-type double lubrica-  
tion  
Driven by ..... crankshaft  
Capacity..... 25 gpm at 3000 rpm  
(approx.)

*d. Water Pump with Pulley Assembly.*  
Manufacturer ..... Cummins Engine Com-  
pany, Inc.  
Type ..... centrifugal w/split pulley  
Driven by ..... single belt  
Capacity ..... 80 gpm at 3000 rpm  
(approx.)  
*e. Crankcase Breather and Oil Filler  
Assemblies.*  
Manufacturer ..... Cummins Engine Com-  
pany, Inc.  
*f. Oil Filter Assembly (Full Flow).*  
Manufacturer ..... Cummins Engine Com-  
pany, Inc.  
Type ..... Replaceable element

## CHAPTER 2 MAINTENANCE INSTRUCTIONS

---

### Section I. Repair Parts, Special Tools, and Equipment

#### 2-1. Tools and Equipment

Tools, equipment, and repair parts authorized for the Cummins Model V8-300 diesel engine are listed in Appendix B.

#### 2-2. Special Tools and Equipment

Special tools and equipment required to perform

functions described in Chapter 3 are listed in Appendix B.

#### 2-3. Maintenance Repair Parts

Repair parts are listed in the repair parts and special tools listed in Appendix B.

### Section II. General Maintenance

#### 2-4. Scope

This section contains general maintenance instructions for cleaning, inspection, repair, and assembly of the engine. Instructions which apply only to specific subassemblies or components are provided in the subsequent sections in which those items are covered individually.

#### 2-5. Cleaning

*a. General.* The following procedures shall be applied in all maintenance work:

(1) Clean all parts before inspection, after repair, and before assembly.

(2) After cleaning, cover all parts or wrap them in a suitable covering as protection against dust and dirt.

*b. Castings*

(1) Clean the inner and outer surfaces of castings and all areas subject to oil and grease with a dry-cleaning solvent or mineral spirits paint thinner.

(2) Remove sludge and gum deposits from castings using stiff brush.

#### WARNING

Particles blown by compressed air are hazardous. Make certain the air stream is directed away from the user and any other persons in the area.

(3) Blow out all tapped holes with compressed air and dry castings, after cleaning with compressed air.

*c. Oil passages.* All oil passages must be clean and free of obstructions.

(1) Clean passages with wire or probes to break up any sludge or gum deposits.

(2) Wash passages by flushing with dry-cleaning solvent or mineral spirits paint thinner.

(3) Dry passages by blowing them out with dry, compressed air.

*d. Oil Seals, Electric Cables, and Flexible Hoses.* Clean seals, cables, and flexible hoses with soap and water.

#### CAUTION

Do not allow dry-cleaning solvent or mineral spirits paint thinner to be in contact with seals, cables, and flexible hoses. These cleaners cause leather, rubber, and synthetic materials to dry out, rot, and lose pliability, making them unserviceable.

*e. Ball Bearings.* Refer to TM 9-214 for information on care and maintenance of bearings.

#### 2-6. Inspection

*a. Castings.*

(1) Inspect all ferrous (cast iron, steel, etc.) castings for cracks with magna-flux equipment. Inspect all non-ferrous (aluminum) castings for cracks using a magnifying glass and a strong light. Carefully check areas adjacent to studs, pipe plugs and threaded inserts, also check sharp corners and fillets.

(2) Inspect machined surfaces of castings for nicks, burrs, or raised metal, and mark damaged areas for repair.

(3) Check all mating flanges on housings and supports with straight edge or surface plate for warpage. Inspect mating flanges for discoloration which may indicate persistent oil leakage.

(4) Inspect all pipe plug and cap screw tapped openings for damaged or stripped threads.



(5) Check all castings for conformance to applicable repair and rebuild standards in paragraph 3-174.

*b. Ball Bearings.* Refer to TM 9-214 for inspection of ball bearings. Check all bearings for conformance to the applicable repair and rebuild standards in paragraph 3-174.

*c. Studs.* Inspect all studs for stripped or damaged threads, bent or loose condition and for evidence of stretching.

*d. Gears.*

**NOTE**

There are no established wear limits on gear teeth. Good judgement is required to determine need for replacement.

(1) Inspect gears for cracks using magnaflux equipment. When magnaflux equipment is not available, use magnifying glass and strong light.

(2) Inspect all gear teeth for wear, sharp fins, burrs, and galled or pitted surfaces.

(3) Check all gears for conformance to applicable repair and rebuild standards.

*e. Bushings and Bushing-type Bearings.*

(1) Check all bushings and bushing-type bearings for secure fit in their respective casting or mating part and for evidence of heating which may be indicated by discoloration of bushing or bearing surface.

(2) Inspect bushings and bushing-type bearings for wear, burrs, nicks, or out-of-round condition.

(3) Check for dirt in lubricating holes or grooves of bushings or bushing-type bearings. Holes and grooves must be clean and free from damage to insure proper lubrication.

(4) Check all bushings and bushing-type bearings for conformance to applicable repair and rebuild standards in paragraph 3-174.

*f. Oil Seals.* Metal encased oil seals should be replaced unless inspection indicates the seal is not damaged.

(1) Inspect feather edge of oil seal for damage.

(2) Check seal for loss of pliability and resiliency.

*g. Core Hole Expansion Plugs.* Inspect core hole expansion plugs for evidence of leakage. Replace plugs if there is evidence of leaking or damage.

**2-7. Repair**

*a. Castings.*

(1) Replace all cracked castings.

(2) Replace all castings which do not conform to tolerances specific, repair and rebuild standards in paragraph 3-174

(3) Repair minor damage to machined surfaces with a fine mill file or crocus cloth dipped in dry-cleaning solvent or mineral spirits paint thinner. Replace all castings on which machined surfaces are burred or nicked to the point of impairing subsequent assembly or operation.

(4) Repair minor warpage of mounting flanges and gasket surfaces by working surface across a sheet of crocus cloth held tightly on a surface plate or similar flat surface. Replace castings having flanges which are warped to the point of impairing assembly or operation.

(5) Repair damaged pipe or cap screw threads in tapped holes with a tap, or repair threaded opening by installing a threaded insert.

**NOTE**

Pipe plug threads in castings must be in good condition to prevent oil and water leakage.

*b. Ball Bearings.*

(1) Replace all galled, pitted, or damaged ball bearings.

(2) Replace all ball bearings which do not conform to tolerances specified in the repair and rebuild standards in paragraph 3-174.

*c. Studs.* Replace all bent or loose studs, or studs showing evidence of stretching. Repair minor thread damage with a thread chaser. Replace all studs having stripped or several damaged threads. Remove and replace studs as outlined in (1) and (2) below.

**CAUTION**

Avoid damage to casting while using welding equipment. Refer to TM 9-237 for welding instructions.

(1) *Removal.* Using stud extractor, back studs out slowly to avoid heating and possible seizure. When studs are broken off too short to use stud extractor, drill stud and extract with a suitable remover. Short studs may also be removed by welding a piece of bar stock or a nut to stud and removing it with a wrench.

(2) *Replacement.* Only standard studs are supplied for replacement in steel or iron castings. Unless threads in castings are damaged beyond repair, use standard studs. If threaded openings are damaged and retapping will not clean up the threads, drill the tap opening in castings and install a suitable threaded insert.

**NOTE**

Special application studs have a nylok insert for sealing the threaded opening. The nylok insert end of the stud is inserted in the casting.

(3) *Oversize studs.* Only 0.003-inch oversize studs are furnished for field replacement of studs in aluminum castings. If a standard stud requires replacement, install a 0.003-inch oversize stud. For identification purposes, 0.003-inch oversize studs are dipped in red dye.

**NOTE**

Studs may have a coarse thread on one end and a fine thread on the other end. The coarse thread end must enter the aluminum casting. Studs having coarse threads on both ends are used in particular applications and normally the short threaded end is in the casting. Special application studs have a nylok insert for sealing threads of studs. The nylok insert end of stud is inserted in casting. Marking on coarse thread end of stud determines when stud is standard or oversize. All replacement studs have a special coating and must have a small amount of mica-base anti-seize compound applied on threads before the stud is installed in casting. Install replacement stud into opening slowly to prevent overheating.

*d. Gears.*

(1) Replace all cracked gears.

(2) Replace all gears which do not conform to tolerances specified in repair and rebuilt standards, paragraph 3-174.

(3) Replace gears having worn, pitted, or galled teeth. Remove sharp fins and burs from

gear teeth with a crocus cloth dipped in dry. cleaning solvent or mineral spirits paint thinner.

*e. Bushings and Bushing-type Bearings.* When bushings and bushing-type bearings are damaged or worn beyond the limits specified in paragraph 3-174, generally the mating parts with which they are used must also be replaced. Reference to (1) and (2) below will be made in the rebuild section for the particular part when replacement of bushings and bushing-type bearings is required.

(1) *Removal.* Remove bushings or bushing-type bearings by pressing out part with suitable arbor press or with the special tools provided.

(2) *Installation.* Clean repaired parts thoroughly before assembly or installation. Aline bushing or bushing-type bearing in casting or retaining cage and press into place with a suitable arbor press or with the special tools provided.

(3) *Reaming.* The bushing-type bearings in oil pump must be finish reamed after installation to size specified in repair and rebuild standards. All other bushing-type bearings are machined for proper clearance and do not need reaming.

*f. Oil Seals.* Oil seals must be replaced when thin feather edge is damaged or when seal material has become hard or brittle.

(1) *Removal.* Press or pry damaged oil seal from casting or housing, being careful not to damage bore in casting or housing.

(2) *Repair.* When oil seal bore in casting is burred or damaged to a point where an oil-tight seal is impossible, replace casting. Remove slight nicks, burs, and scratches from bore in casting with crocus cloth dipped in dry-cleaning solvent or mineral spirits paint thinner.

(3) *Installation.* Install new oil seal in bore of casting or adapter, using a suitable oil seal replacer tool.

**Section III. Removal of Engine Components**

**2-8. General**

*a. Removal and Installation.* The instructions for removal and installation of engine components have been arranged in the most logical order of removal for complete engine disassembly. Installation in general, shall be the reverse order of the removal instructions. To facilitate the removal, and later disassembly, assembly and installation procedures, the components are separated into categories, (i.e., external components, and internal components).

*b. External Components.* External components are defined as the basic units of the engine sys-

tems, (i.e., cooling, fuel, electrical, drive, intake, exhaust, hydraulic, and air, that are externally attached to the engine).

*c. Internal Components.* Internal components are defined as the units and assemblies within the engine block and oil pan, the cylinder heads and associated parts, and block.

**2-9. Engine Preparation**

**NOTE**

Check to insure that coolant and lube oil has been completely removed from engine.

a. Using a suitable hoisting device, (i.e., over-head chain fall, A frame hoist, or gooseneck hoist), attach lifting hooks to engine front and rear lifting eyes, (figs. 1-1 and 1-2) and raise engine.

b. Remove eight capscrews, spacers, and four lockplates, securing left bank exhaust manifold to head.  
c. Remove manifold and four manifold to block gaskets (fig. 21).

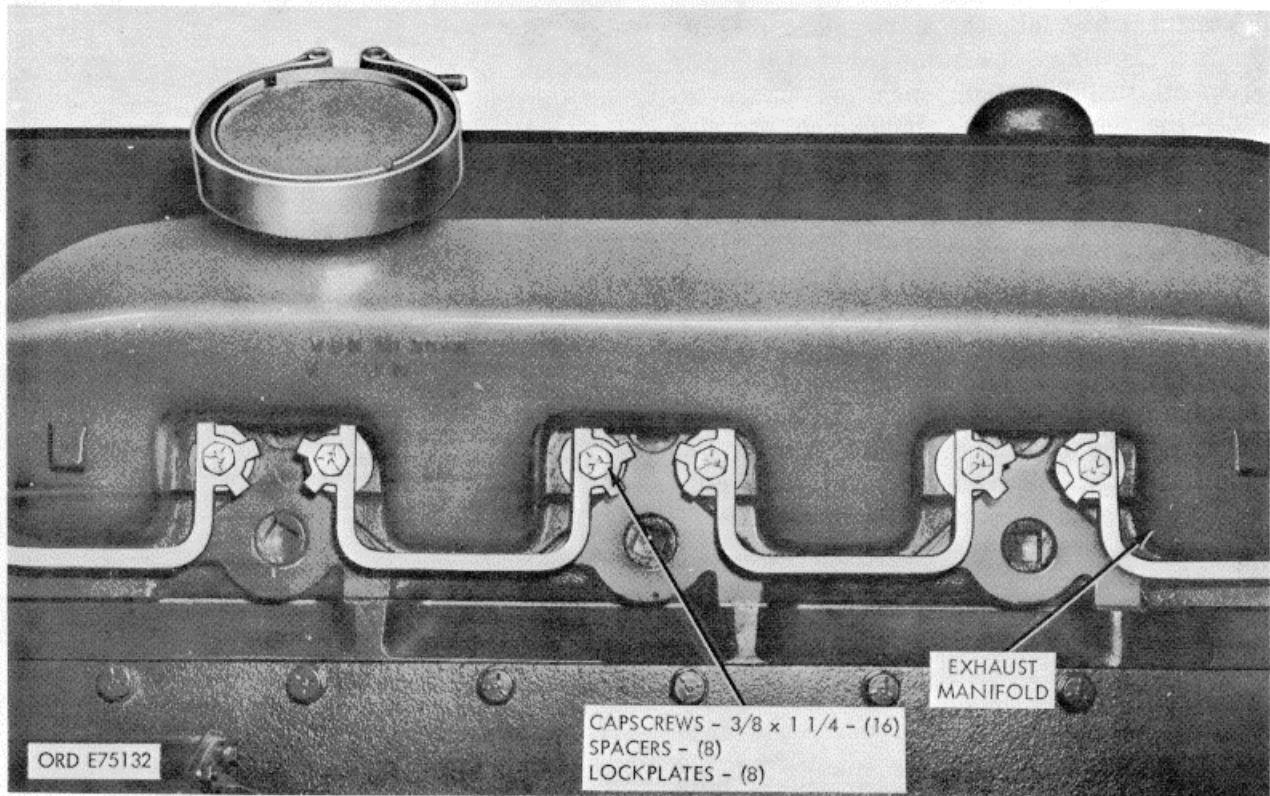

Figure 2-1. Exhaust manifold--removal/installation.

d. Remove 13 capscrews and lockwashers securing oil cooler to engine (fig. 2-2).

e. Remove oil cooler and four gaskets.

f. Remove 12 capscrews, lockwashers, and one gasket, securing cover plate to block and remove plate.

g. Install engine rebuild stand and adapter (26 and 27, fig. B-28) to engine block as shown in figure 2-3.

h. Remove hoisting equipment.

## 2-10. External Components

a. *Starter Assembly.* Remove three capscrews and lockwashers securing starter to flywheel housing, and remove starter.

b. *Exhaust Manifold-Right Bank.* Remove eight capscrews, spacers, four lockplates and four gaskets securing manifold to head.

c. *Alternator Assembly.*

(1) Disconnect electrical connector.

(2) Remove belt tension adjusting arm bolt.

(3) Remove two capscrews, and lockwashers securing alternator to mounting bracket and remove alternator.

(4) Remove four capscrews, lockwashers, and flat washers securing mounting bracket to intake manifold.

(5) Remove capscrew and lockwasher securing fan assembly mounting bracket to alternator mounting bracket.

(6) Remove capscrew, lockwasher and flat washer securing tension adjusting arm to block. Remove arm.

d. *Hydraulic Pump Assembly.*

### NOTE

If engine is received for repair without the power steering pump (hydraulic pump), bracket, pulley and drive belt, do not requisition these items for installation on the repaired engine. The rebuilt engine will be shipped to the using unit without the pump assembly.

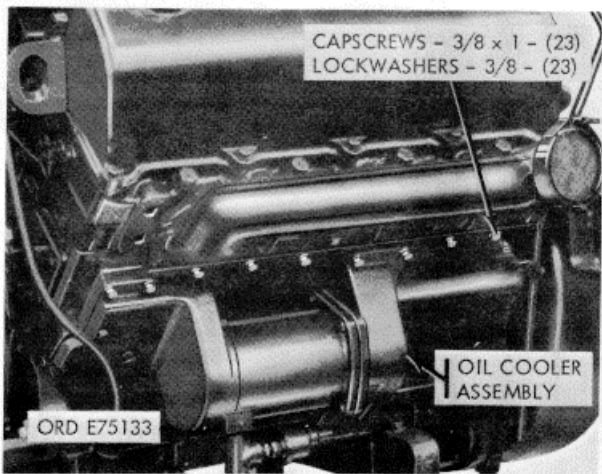
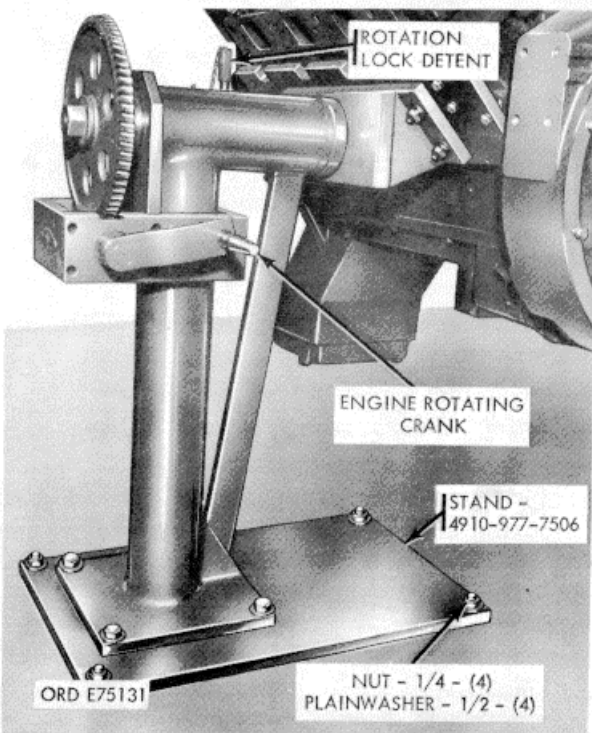

Figure 2-2. Oil cooler and cover plate--removal/installation.



NOTE: ENGINE STAND BOLTS MOUNTED IN CEMENT OR  
 Figure 2-3. Eligible rebuild stand--removal/installation.

- (1) Remove capscrew and lockwasher securing belt tension adjusting arm to pump bracket.
- (2) Remove two mounting bolts securing hydraulic pump and bracket assembly to main mounting bracket, and remove assembly.
- (3) Remove three capscrews, lockwashers, and flat washers securing bracket to engine block.
- (4) Remove capscrew and lockwasher se-

curing fan assembly mounting bracket to pump mounting bracket.

- (5) Remove pump assembly mounting bracket.
  - e. Fan, Fan Hub, and Bracket Assembly (fig. 2-4).

- (1) Loosen fan hub shaft and back-off adjusting screw to relieve belt tension.
- (2) Remove belts from crankshaft pulley.
- (3) Remove shaft locknut and washer.
- (4) Pull fan and hub assembly forward to remove from bracket. Remove washer from shaft.
- (5) Remove six capscrews and lockwashers securing bracket to engine block.
- (6) Remove two capscrews and lockwashers securing bracket to alternator and hydraulic pump brackets and remove bracket.

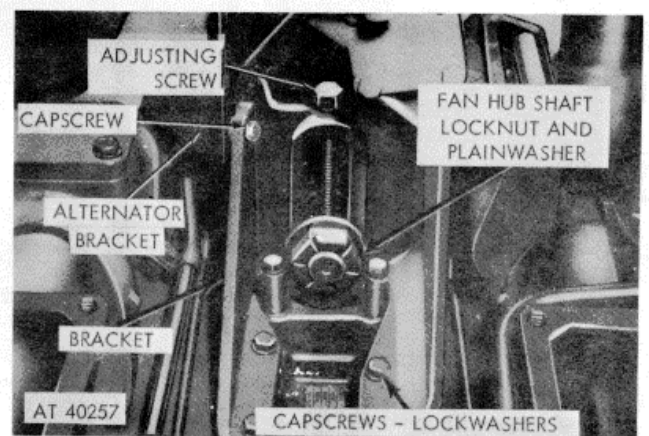

Figure 2-4. Fan hub and bracket assembly--removal/installation.

f. Thermostat Assembly (fig. 2-5).

- (1) Loosen clamp securing water pump hose to thermostat housing.
- (2) Remove four capscrews and lockwashers securing assembly to cylinder head.
- (3) Remove thermostat assembly and assembly to cylinder head gasket.

g. Fan Drive Pulley, Vibration Damper, and Water-Pump Drive Pulley (fig. 2-6).

- (1) Remove seven capscrews and lockwashers securing drive pulley and vibration damper to crankshaft.
- (2) Remove pulleys and vibration damper.

h. Water Pump Assembly (fig. 2-7).

- (1) Remove five capscrews and lockwashers securing water pump assembly to block.
- (2) Remove pump assembly by pulling straight forward so impeller clears block. Remove and discard gasket.

i. Air Intake and Preheater- Assembly (fig. 2-8).

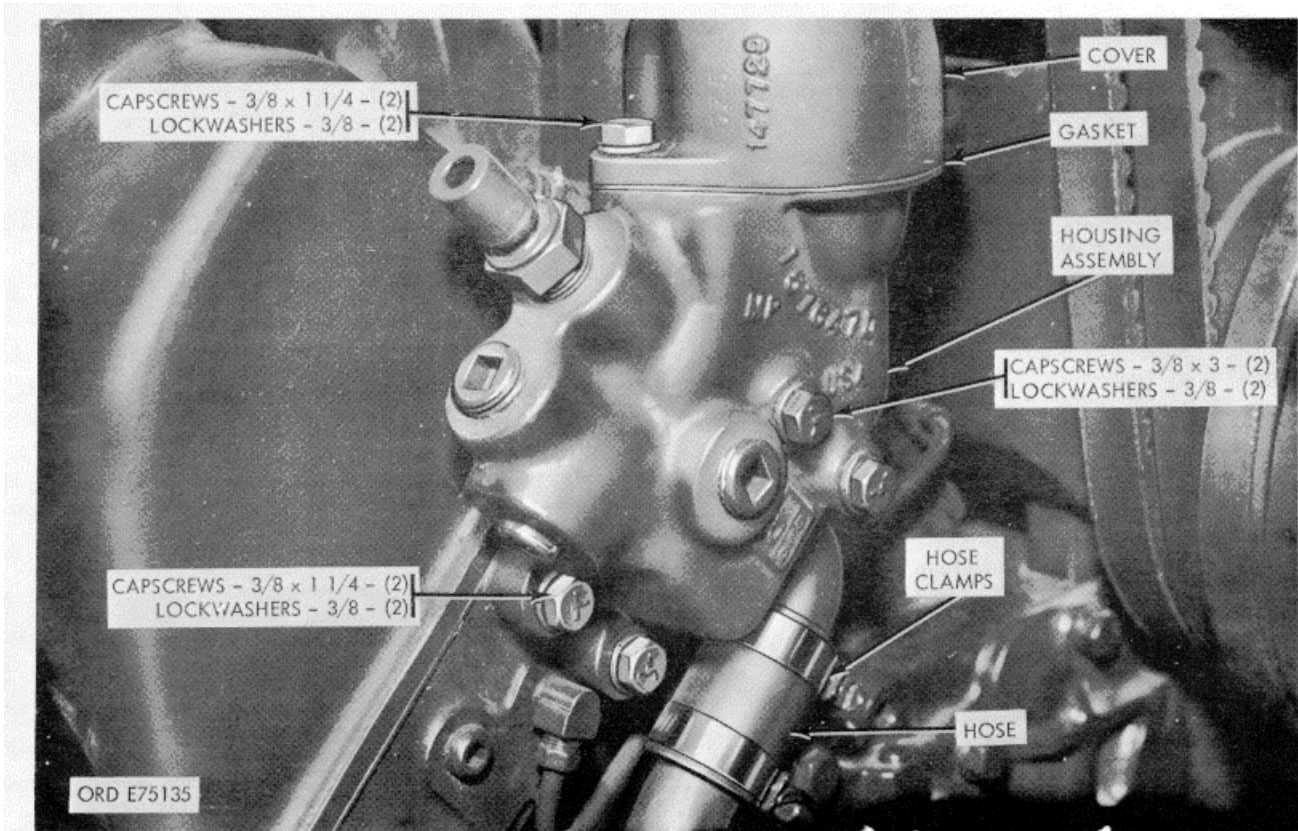

Figure 2-5. Thermostat assembly--removal/installation.

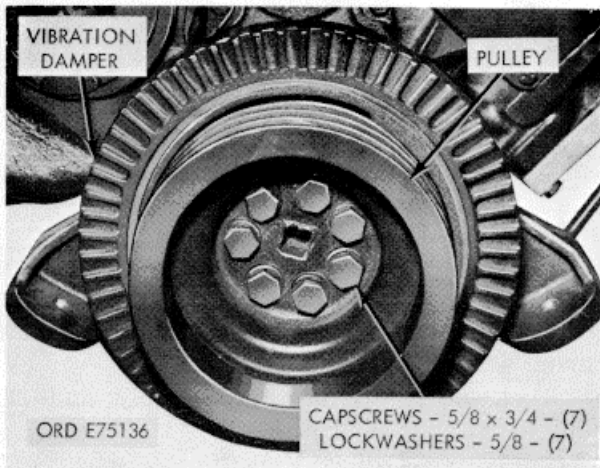

Figure 2-6. Drive pulleys and vibration damper--removal/installation.

(1) Loosen hose clamps on crossover to air compressor flexible hose connection.

(2) Remove eight capscrews, lockwashers, and flat washers securing crossover and preheater assembly to intake manifolds.

(3) Disconnect flexible hose at air compressor and remove crossover and preheater assembly from manifolds. Remove and discard two gaskets.

j. Intake Manifolds (fig. 2-9).

(1) Remove eight capscrews, lockwashers,

and flat washers securing each manifold to each cylinder head.

(2) Remove manifolds and gaskets.

k. Water Crossover Pipe and Lifting Eyes (fig. 2-10).

(1) Remove eight capscrews and lockwashers securing crossover and lifting eyes to cylinder heads.

(2) Remove crossover, lifting eyes, and two gaskets.

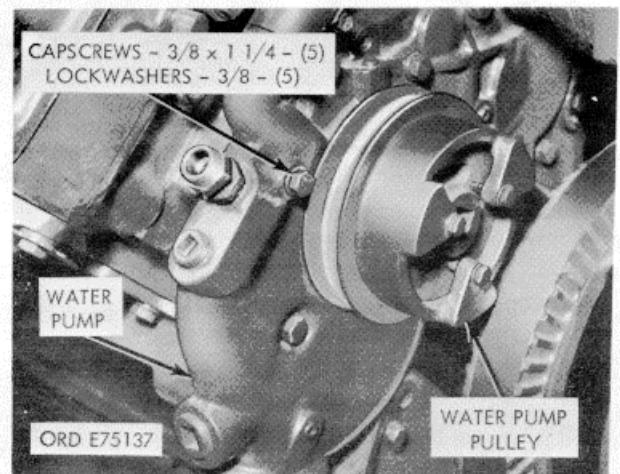

Figure 2-7. Water pump assembly--removal/installation.

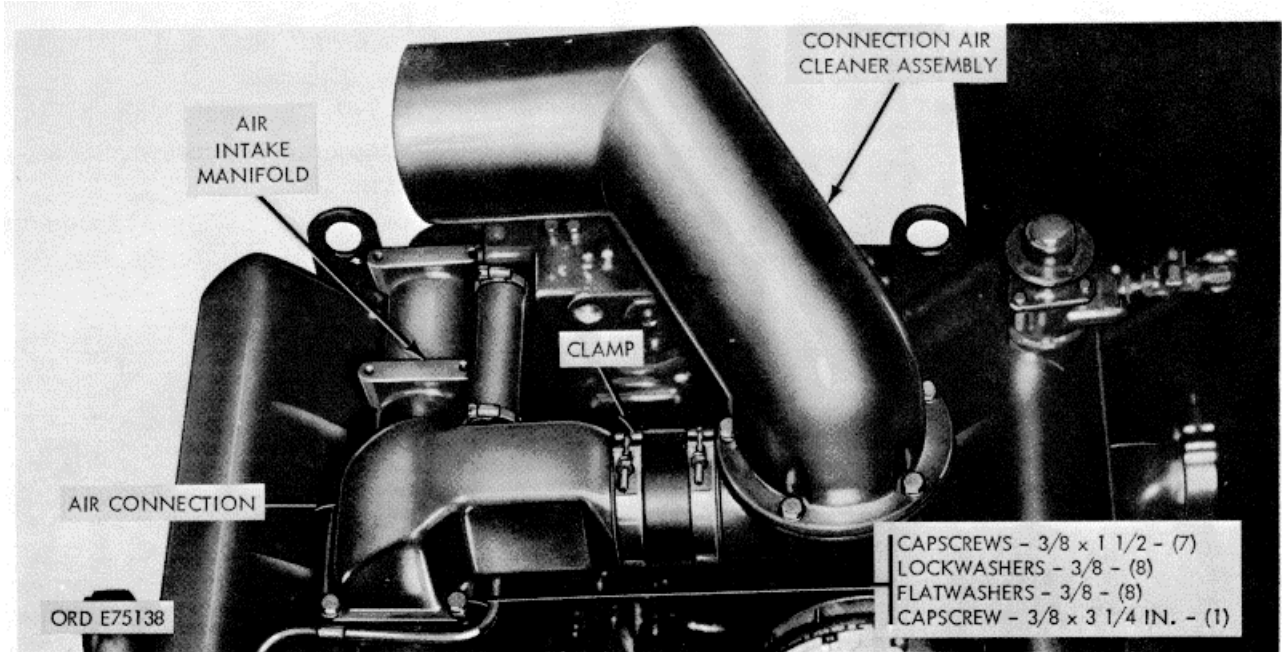

Figure 2-8. Air intake crossover and preheater assembly--removal/installation.

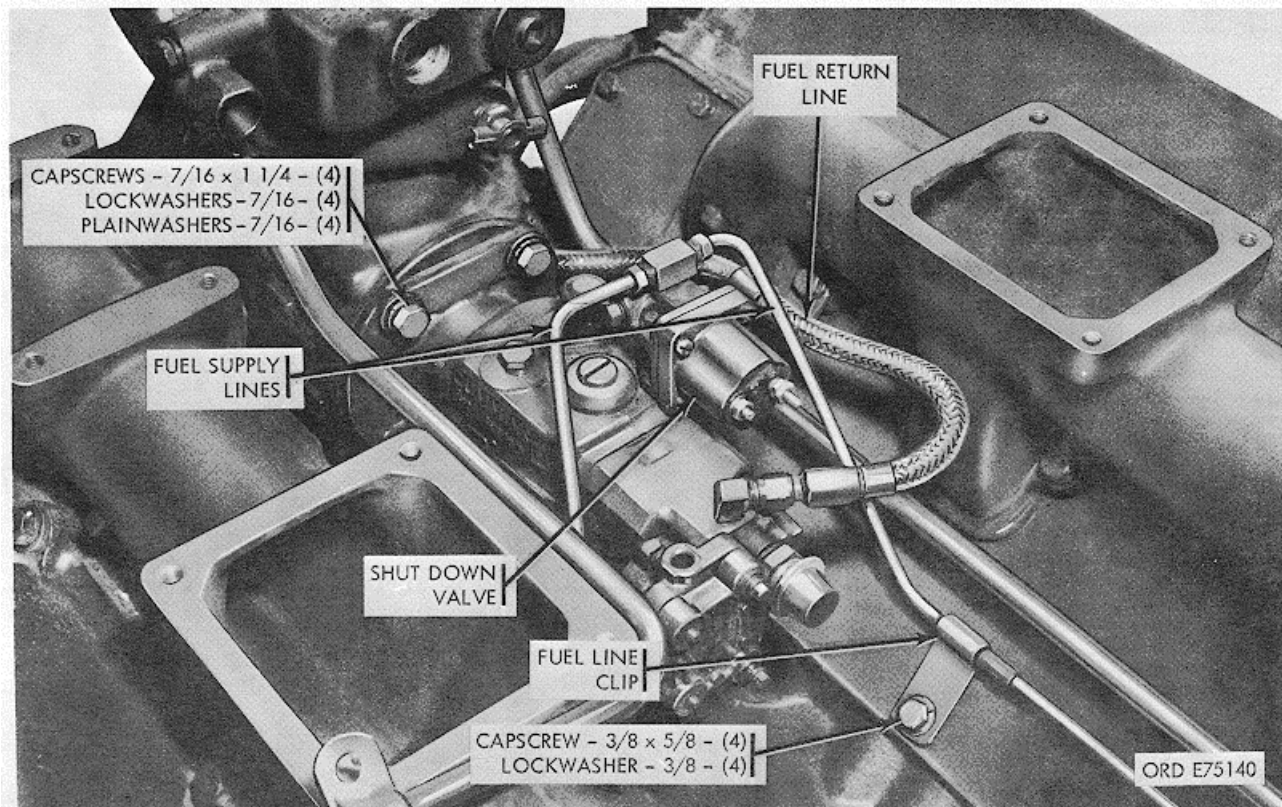

Figure 2-9. Intake manifolds fuel pump and fuel lines--removal/installation.

I. Fuel Pump and Fuel Lines (fig. 2 9).

- (1) Disconnect flexible fuel drain return line at fuel pump.
- (2) Disconnect two fuel supply lines at shutdown valve.

- (3) Disconnect fuel supply lines from cylinder heads (front end).
- (4) Loosen fuel supply line clips securing lines to push rod cavity covers, and remove lines.
- (5) Disconnect fuel drain crossover line at

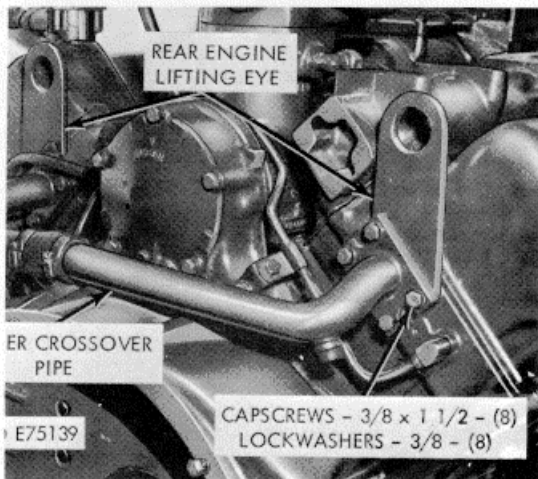

Figure 2-10. Water crossover pipe and engine lifting eyes--removal/installation.

rear end of each cylinder head and remove cross-over with flexible metallic drain return line attached.

(6) Loosen two capscrews, securing fuel pump support bracket (32, fig. B-18), to engine block.

(7) Remove four capscrews, lockwashers, and flat washers, securing fuel pump to air compressor housing and support bracket.

(8) Slide support bracket towards front, pull pump towards front and remove from compressor. Remove gasket.

(9) Remove two capscrews, lockwashers, and flat washers securing bracket to block and remove bracket.

#### NOTE

The fuel pump is driven through a freefloating coupling between the pump and compressor. Insure that coupling and plate are removed with pump.

*m. Air Compressor and Drive Assembly* (fig. 1-2).

(1) Disconnect coolant input and output lines at compressor.

(2) Disconnect air discharge line at compressor.

(3) Remove six capscrews (10, fig. B-25) and lockwashers (9, fig. B-25) securing rear support (8, fig. B-25) to flywheel housing.

(4) Remove support and gasket.

(5) Pull compressor and drive assembly toward front of engine, to disengage compressor

drive gear from camshaft gear, and remove compressor.

*n. Oil Dipstick Tube Assembly* (fig. 2-11).

(1) Remove capscrew and lockwasher securing tube clip to engine block.

(2) Disconnect tube at oil pan fitting and remove tube.

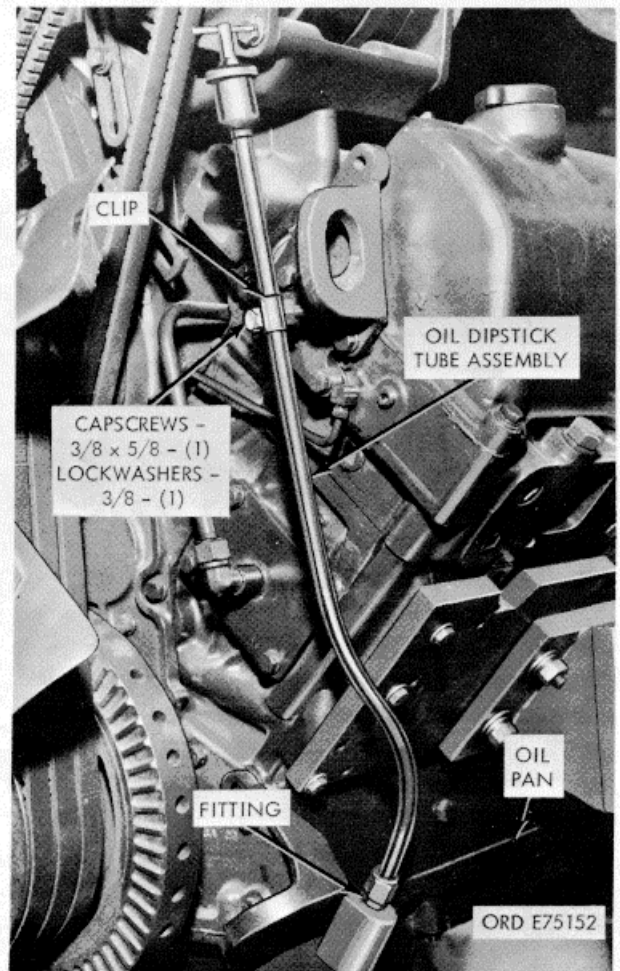

Figure 2-11. Oil dipstick tube assembly--removal/installation.

#### 2-11. Internal Components

*a. Cylinder Head Covers* (fig. 2-12).

(1) *Right Head Cover.*

(a) Remove ten capscrews, lockwashers, and plain washers securing cover to head.

(b) Remove cover and gasket.

(2) *Left Head Cover.*

(a) Loosen hose clamp securing breather tube to crankcase breather and pressurizing unit (fig. 2-13).

(b) Remove breather tube from unit.

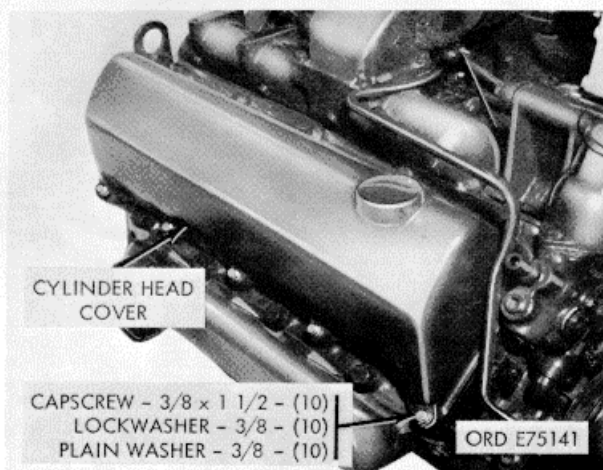

Figure 2-12. Cylinder head covers-removal/installation.

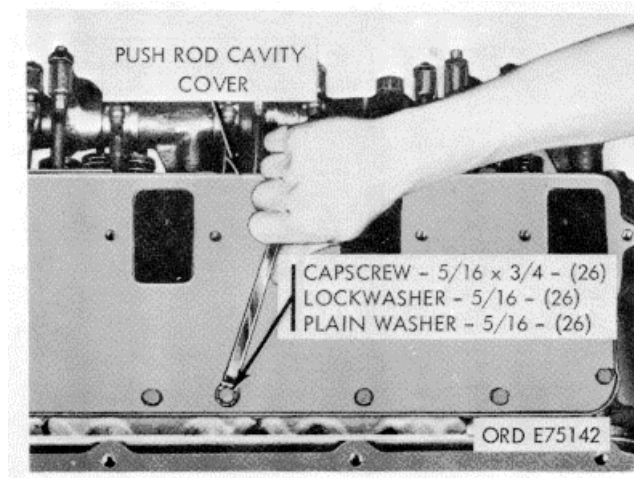

Figure 2-14. Push rod cavity covers-removal/installation.

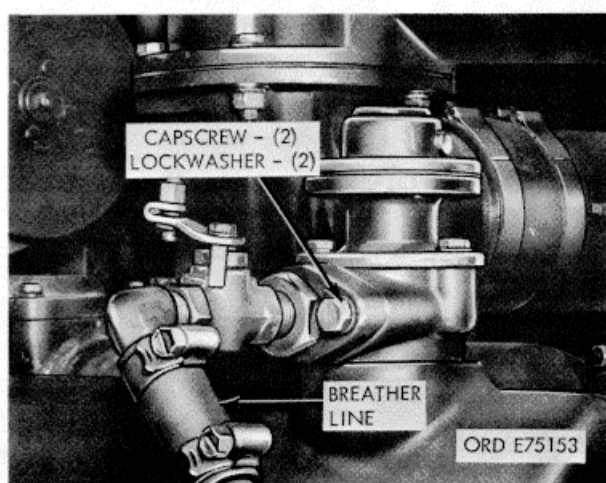

Figure 2-13. Crankcase breather tube-removal/installation.

(c) Remove ten capscrews, lockwashers, and flat washers securing cover to cylinder head.

(d) Remove cover, breather and pressurizing unit, and gasket.

*b. Push Rod Cavity Covers* (fig. 2-14).

(1) Remove 26 capscrews, lockwashers, and flat washers securing each cover to cylinder heads.

(2) Remove covers and gaskets.

*c. Rocker Arms and Push Rods* (fig. 2-15)

(1) Loosen all push rod adjusting screw locknuts and back-off adjusting screws.

(2) Secure rocker arms with rubber bands.

(3) Remove ten capscrews and flat washers securing each rocker arm to respective cylinder head.

(4) Remove rocker arms and brackets.

(5) Remove 24 push rods (16 valve and 8 injector) from tappets.

*d. Fuel Injectors* (fig. 2-16).

(1) Remove eight capscrews and flat washers and nylon inserts securing injector clamps to cylinder head.

(2) Remove clamps.

(3) Pull injectors from cylinder head (fig. 2-17).

*e. Valve Crossheads* (fig. 2-18). Remove sixteen crossheads by lifting each straight up from guides.

*f. Cylinder Heads* (fig. 2-19).

(1) Attach cylinder head lifting plate (45, fig. B-28).

(2) Attach lifting hook of chain fall, or other suitable lifting device, to lifting plate. Take-up slack in chain or cable.

(3) Remove 16 capscrews and flat washers (fig. 2-18) securing heads to block (eight cap screws per head).

(4) Using lifting device remove each cylinder head. Remove gaskets.

*g. Valve and Injector Tappets* (fig. 2-20).

(1) Remove 16 capscrews and lockwashers (eight per cylinder head) securing eight tappet guide plates to heads (four per head).

(2) Remove guide plates.

(3) Lift tappet assembly from block.

*h. Flywheel* (fig. 2-21).

(1) Cut lockwire on six capscrews securing flywheel to crankshaft adapter.

(2) Remove two opposing capscrews.

(3) Insert two 5/8 x 6-inch headless studs in



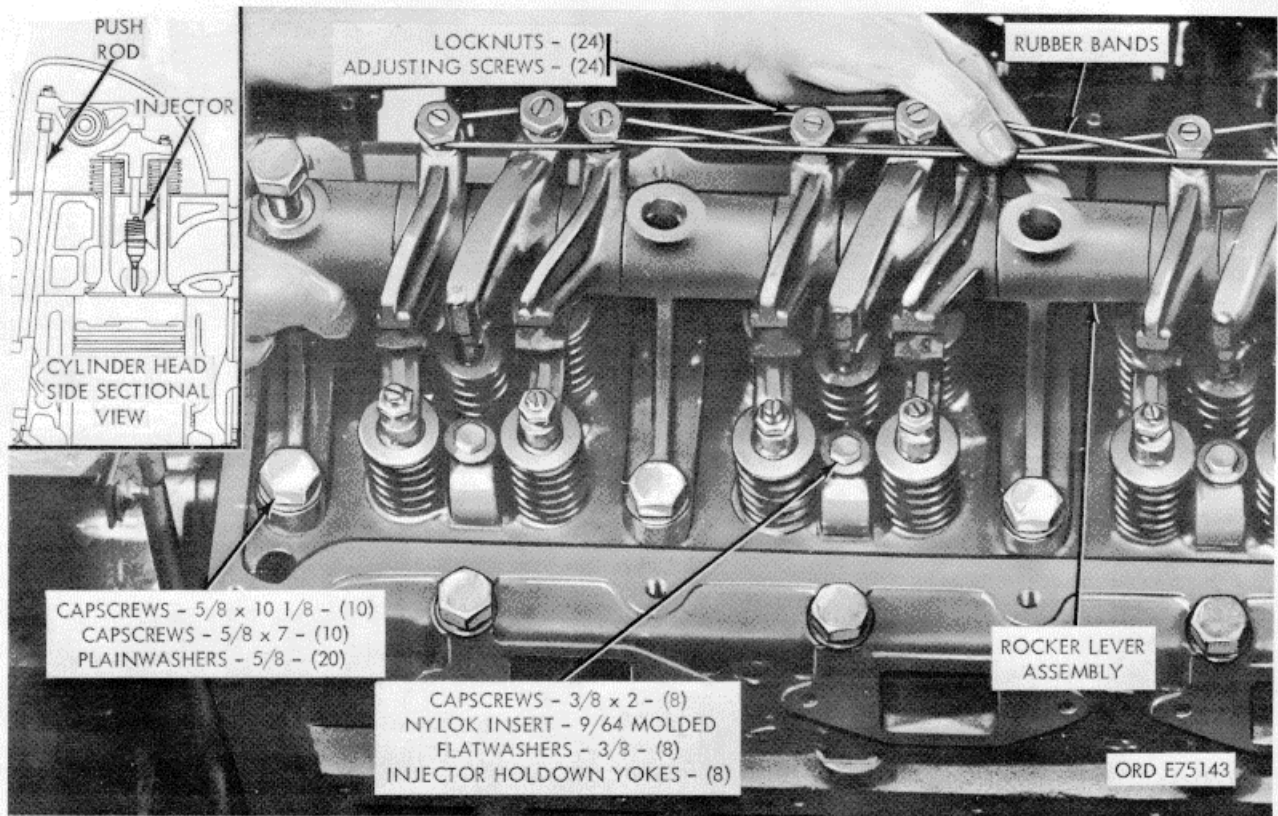

Figure 2-15. Rocker arms and push rods--removal/installation.

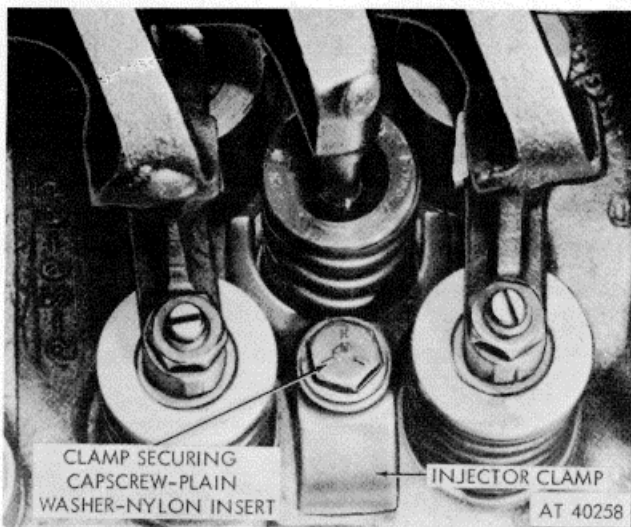

Figure 2-16. Injector clamps--removal/installation.

the holes and secure into the adapter. These shall serve as a support for removal of the flywheel.

(4) Remove two of the slotted head screws and install 1/2-13 x 2 1/2, inch capscrews.

(5) Remove the four remaining flywheel to adapter securing capscrews.

(6) Alternately turn-in the 1/2-inch cap

screws to pull flywheel from adapter onto the six-inch studs.

(7) Remove the flywheel by sliding over studs. Remove studs.

i. Crankshaft Adapter (fig. 2-22).

(1) Remove grease retainer cup from adapter base.

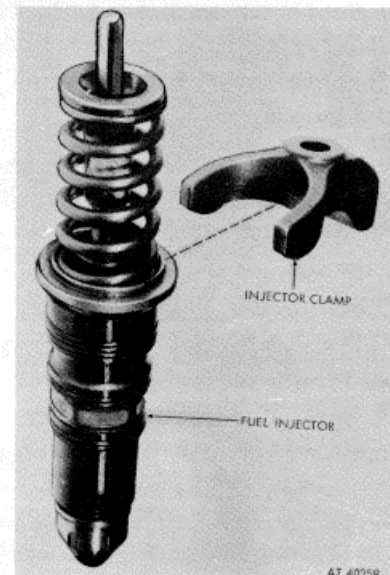

Figure 2-17. Fuel Injector and hold-down clamp.

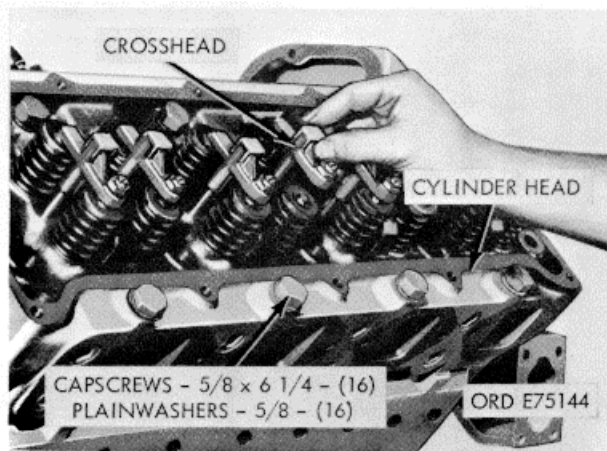

Figure 2-18. Valve crossheads - removal/installation.

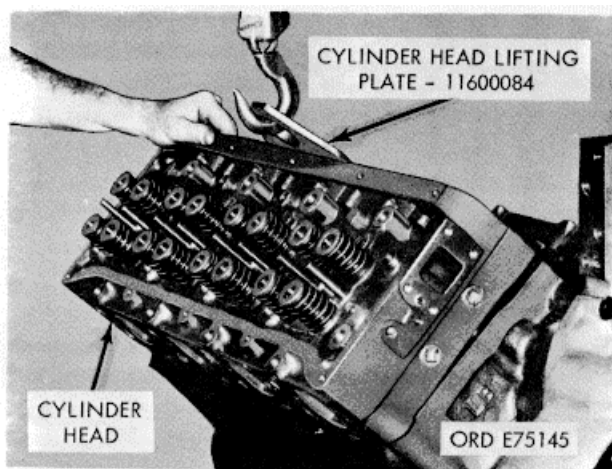

Figure 2-19. Cylinder heads - removal/installation.

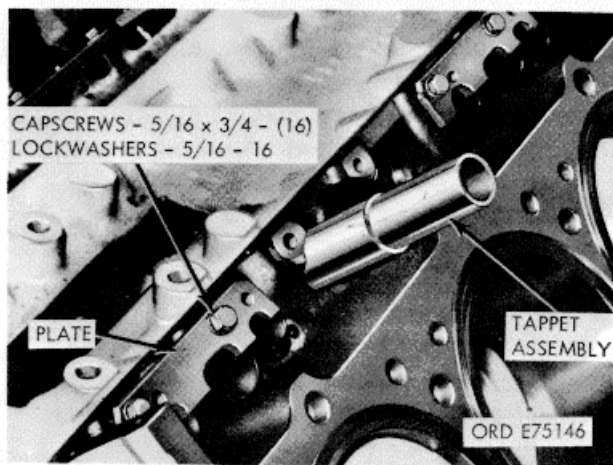

Figure 2-20. Valve and injector tappets - removal/installation.

(3) Remove adapter.

*J. Flywheel Housing* (fig. 2-23).

(1) Remove eight cap screws, lockwashers, and flat washers securing oil pan to flywheel housing.

(2) Remove seven cap screws and lockwashers securing flywheel housing to engine block.

(3) Using a rubber mallet, or brass head driver, free housing from block and remove housing and gasket.

*k. Camshaft, Gear, and Spacer Plate* (fig. 2-24).

(1) Straighten lockplate fingers on two cap screws securing camshaft thrust plate to engine block.

(2) Remove cap screws and discard lockplates.

(3) Remove camshaft and gear from block. Rotate camshaft gear slightly while pulling.

(4) Remove spacer plate and two plate to block gaskets.

*l. Oil Pan* (fig. 2-25).

(1) Remove six cap screws and lockwashers, on right side of pan, securing pan inspection plate (6, fig. B-9).

(2) Remove inspection plate and gasket.

(3) Reach inside oil pan and remove two cap screws and lockplates securing the oil pump by-pass tube (13, fig. B-9) and oil suction tube (20, fig. B-9), respectively, to the oil pan.

(4) Remove 12 cap screws, lockwashers, and flat washers securing oil pan to block.

(5) Remove pan and gasket.

*m. Oil Pump Assembly* (fig. 2-26).

(1) Remove cap screw, nut, lockplate, and clamps securing oil suction tube to block.

(2) Remove cap screw and lockplate securing oil by-pass tube to block.

(3) Remove four cap screws and lockplates securing oil pump to block.

(4) Remove pump and tubes from block.

*n. Front Cover* (fig. 2-27).

(1) Remove 12 cap screws and lockwashers securing cover to engine block.

(2) Remove cover and gasket. Pull straight out to avoid damaging the dowels.

*o. Connecting Rod and Piston Assembly* (fig. 2-28).

**NOTE**

The following instructions cover the removal of one connecting rod and piston assembly from engine block. Remove remaining seven rods and pistons in the same manner.

(2) Cut and remove lockwire on adapter to crankshaft securing screws and remove cap screws.

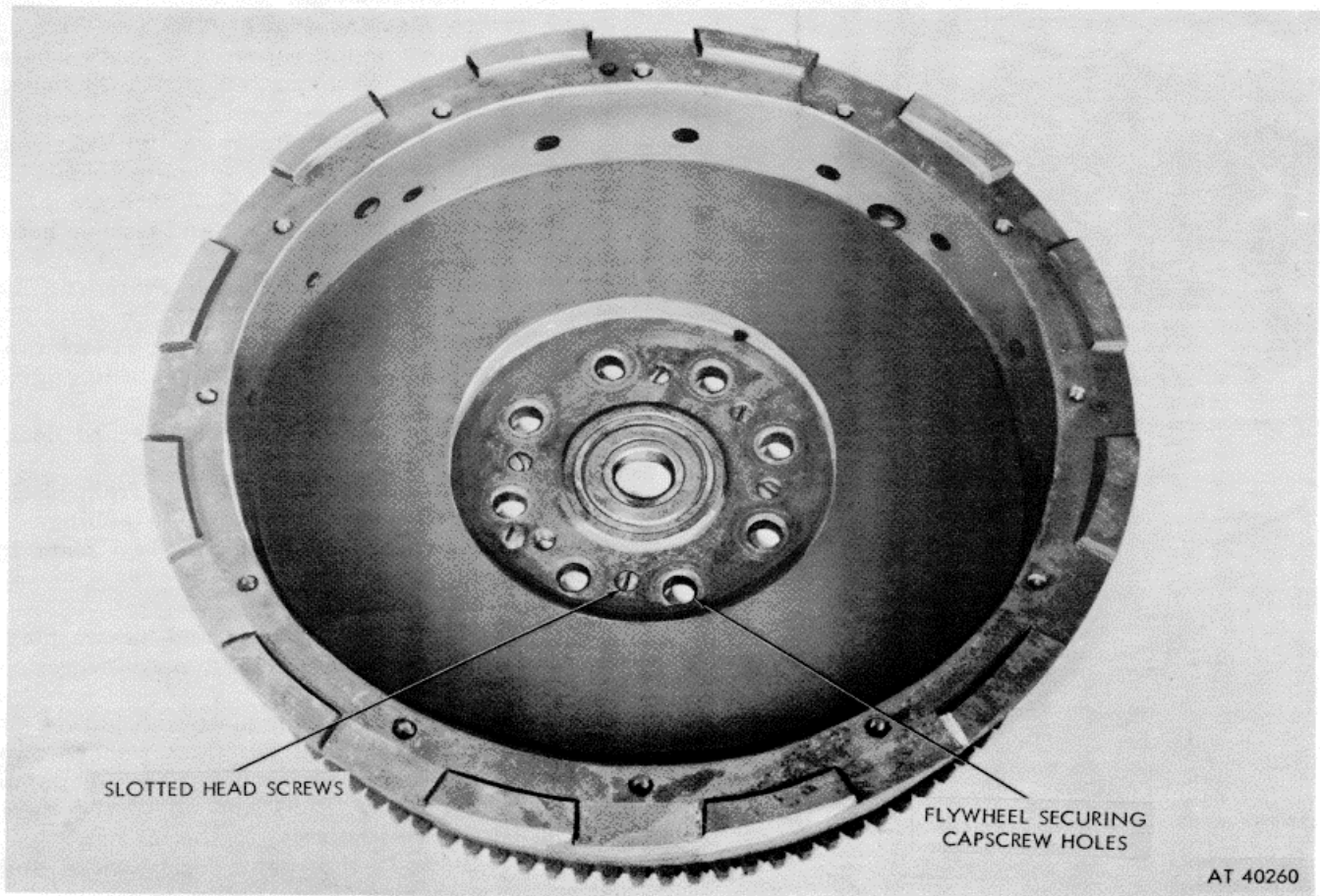

Figure 2-21. Flywheel-removal/installation.

- (1) Remove carbon and wear ridges at of cylinder to facilitate piston removal.
- (2) Straighten tangs of lockplates on two bolts and nuts securing rod to crankshaft.

- (3) Remove nuts and lockplates. Discard lockplates.
- (4) Using a rubber mallet or brass driver, tap rod bearing cap to free cap from crankshaft

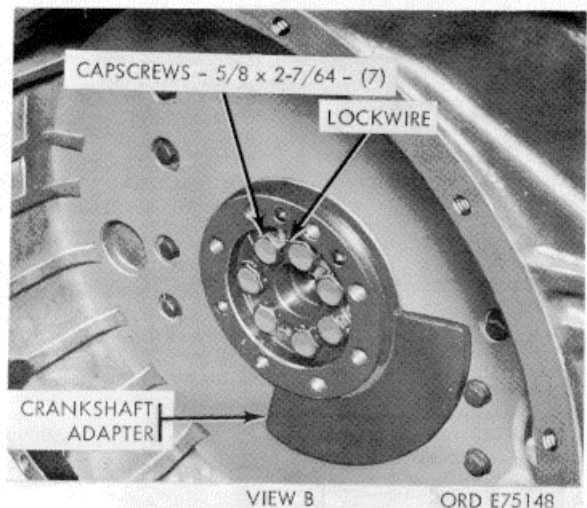
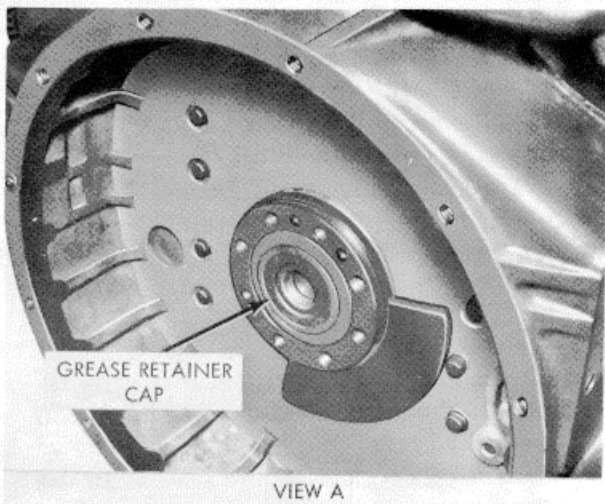

Figure 2-22. Crankshaft adapter-removal/installation.

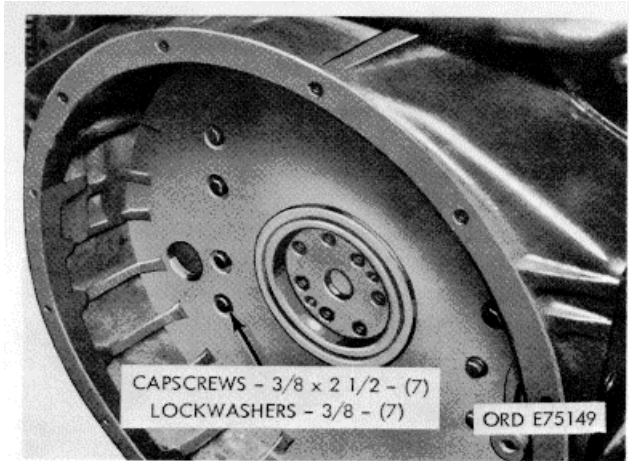

Figure 2-23. Flywheel housing - removal/installation.

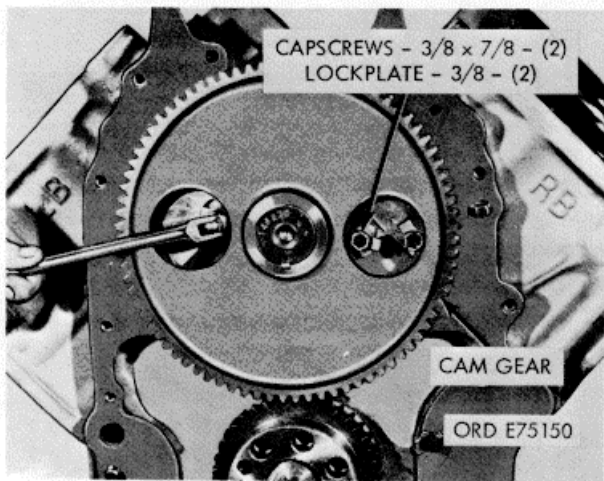

Figure 2-24. Camshaft, gear and spacer plate-removal/installation.

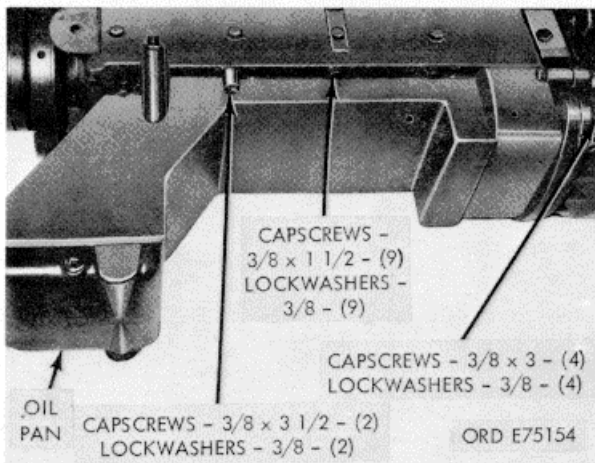

Figure 2-25. Oil pan-removal/installation.

- (5) Tape bearing half shell to cap as re. moved.
  - (6) Using a wooden stick, or hammer handle. push piston up out of cylinder.
  - (7) Tape upper bearing half shell to rod.
  - (8) Assemble cap on rod and tag to identify assembly with cylinder.
- p. Crankshaft and Main Bearings (fig. 2-29).
- (1) Remove 19 main bearing side locking bolts and plain washers.
  - (2) Remove 10 main bearing cap screws and, plain washers securing caps to block.
  - (3) Using a small pry bar, loosen and remove the bearing cap and bearing half shell. Mark half shells to identify with mating cap.
  - (4) Remove rear bearing thrust half rings.

**CAUTION**

Insure that lifter hooks are rubber covered or otherwise prepared to prevent metal-to-metal contact with shaft throws.

- (5) Using an overhead chain fall, or other suitable lifting device, attach a double hook lifter to two shaft throws and remove crankshaft from block.
- (6) Remove upper bearing half shells and tag on removal with mating bearing cap identification.
- (7) Remove rear bearing upper thrust halfrings.

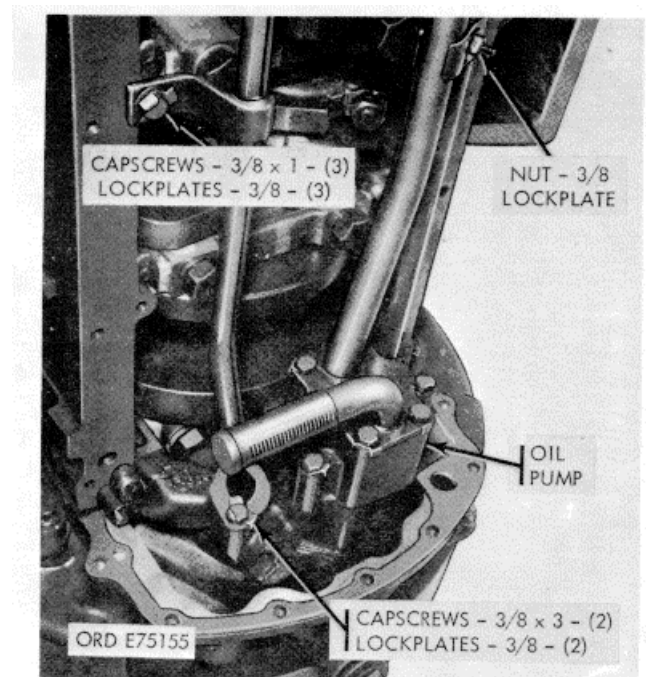

Figure 2-26. Oil pump assembly-removal/installation.

and remove cap and bearing half from crank shaft.

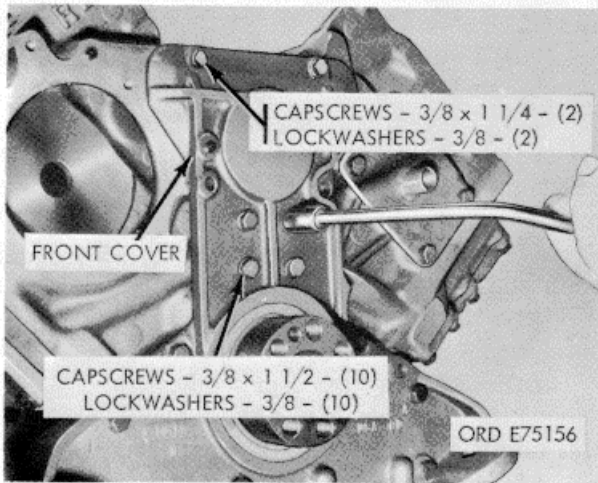

Figure 2-27. Front cover-removal/installation.

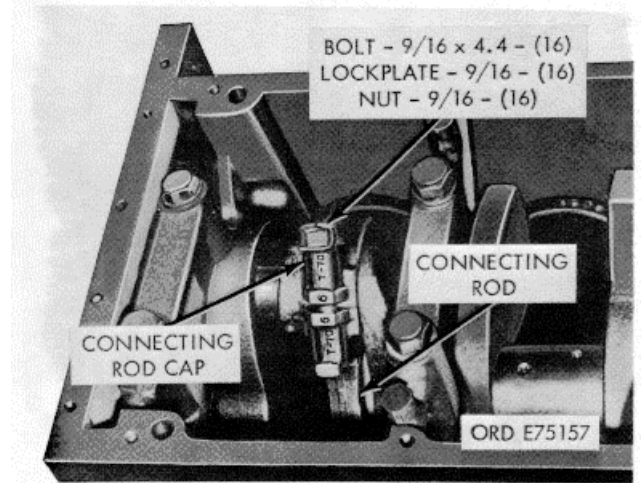

Figure 2-28. Connecting rod and piston assembly-removal/installation.

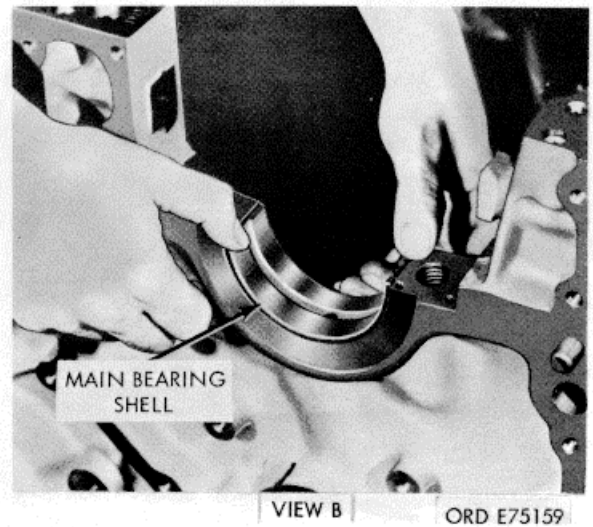
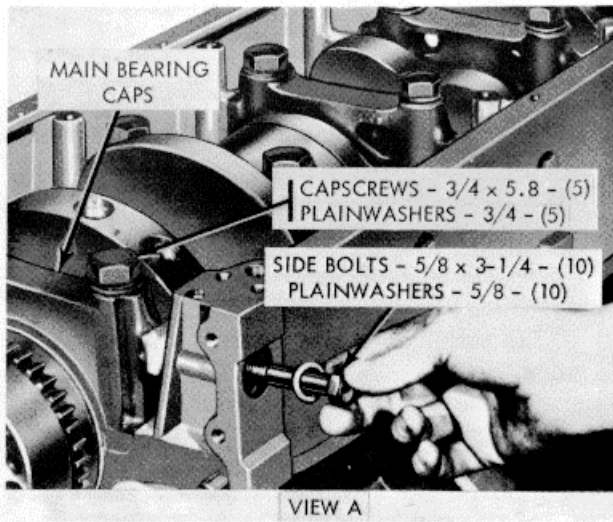

Figure 2-29. Crankshaft and main bearings-removal/installation.

## CHAPTER 3

### REPAIR INSTRUCTIONS

#### Section I. General

##### 3-1. Procedures

a. The repair instructions contained in chapter cover the disassembly, cleaning, inspection, repair, test, adjustment, and assembly components and component assemblies.

b. The procedures also provide for the installation of repaired components that permits a logical

order of engine reassembly.

c. The instructions covering cleaning, inspection, and repair are in addition to the general maintenance requirements of Chapter 2.

d. Standard parts kits used in repair are described in Appendix B.

#### Section II. Repair of Cylinder Block

##### 3-2. Disassembly

a. *Pipe Plugs*. Remove all pipe plugs from and water passages.

b. *Camshaft Bushings* (fig. 3-1).

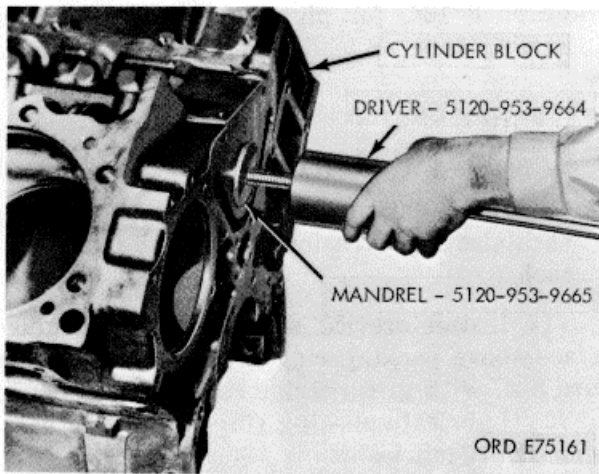

Figure 3-1. Camshaft bushing removal.

##### NOTE

Remove camshaft bushings only if inspection (para. 3-4) indicates need for replacement. Using camshaft driver and mandrel (7 and fig. B-28), remove and discard bushing(s).

Using camshaft driver and mandrel (7 and 8, fig. B-28), remove and discard bushing.

c. *Cylinder Sleeves* (fig. 3-2).

##### NOTE

Remove cylinder sleeves only if inspection (para. 3-4) indicates need of replacement.

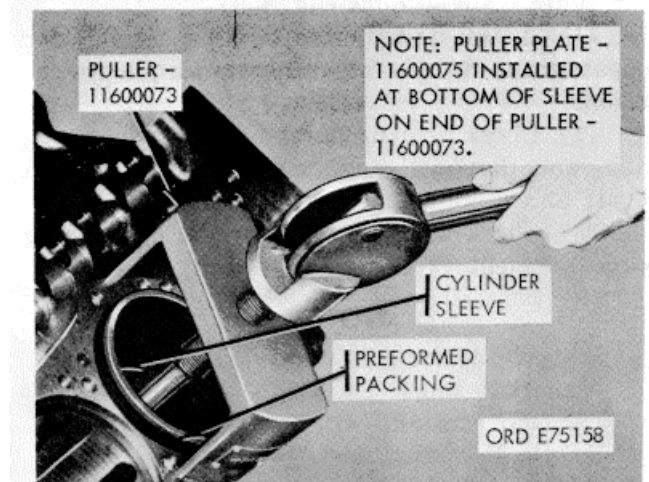

Figure 3-2. Cylinder sleeve removal

Using cylinder sleeve puller and plate (10 and 11, fig. B-28) remove and discard sleeve(s).

##### 3-3. Cleaning

Clean block in accordance with paragraph 2-5. Clean all water and oil passages with compressed air.

##### 3-4. Inspection

a. *Camshaft Bushings*.

(1) Visually inspect the five bushings in accordance with paragraph 2-6.

(2) Check the ID of the bushings against limits specified in repair and rebuild standards (para. 3-180). Replace any bushing worn beyond specified limits. Refer to paragraph 3-2.b. for bushing removal.

b. *Cylinder Sleeves*.

(1) Visually inspect each sleeve for cracks and scratches. Replace sleeve if cracks or heavy scratches are present.

(2) Check ID of the sleeve against limits specified in repair and rebuild standards (para 3-179). Measurements shall be made at middle, and skirt of sleeve. Replace any s worn beyond specified limits.

**NOTE**

Refer to paragraph 3-2.c. for sleeve removal. If any sleeve requires removal perform steps 3 and 4 below.

(3) Discard preformed packings and crevice seals.

(4) Using block gage (24, fig. B28) cylinder counterbore and bore against limits specified in repair and rebuild standards (13-175). Replace block if measurements are beyond specified limits.

*c. Main Bearing Bore* (fig. 33).

(1) Install and tighten bearing caps. Refer to paragraph 3-186, for cap screw torque specifications.

(2) Check bearing bores horizontally, vertically, and diagonally against limits specific repair and rebuild standards (para. 3-175).

(3) Check alignment of bore using bearing bore alignment checking bar (19, fig. B-28)

**NOTE**

Inspect bar for run-out and OD prior to use. Bar must be 3.7510-3.7506-inch OD and straight within 0.0005 in full length. Bar must pass through all bores and turn freely. Replace any cap that prevents free passage and turning.

*d. Tappet Bores.* Check valve and injector pet bores against limits specified in repair rebuild standards (para. 3-175).

*e. Block Mating Surfaces.* Check top machined surfaces of block with straight edge and feeler gage. If warped, distorted or uneven replace block.

*f. Expansion Plugs.* Inspect all expansion plugs for evidence of coolant leakage. Replace all plugs that are defective.

*g. Miscellaneous Parts.* Inspect main bearing cap screws, washers, and all pipe plugs. Check for damaged threads, nicks, burs, and other unserviceable conditions. Replace all unserviceable parts.

**3-5. Repair**

Repair of the cylinder block is limited to general procedures as outlined in paragraph 2-7. Any defect, or measurement outside the tolerances listed in paragraph 3-175, is cause for replacement of block.

**36. Assembly**

*a. Camshaft Bushings.* Refer to paragraph 3 2.b., and reverse the order of removal.

*b. Pipe Plugs.* Install all pipe plugs. Refer to paragraph 3-186, for plug torque specifications. Use sealing tape or lead solder to prevent leakage.

*c. Cylinder Sleeves.*

**NOTE**

Before installing sleeves insure that each sleeve protrusion is 0.004 to 0.006-inch.

(1) Install crevice seal ring on machined surface above packing ring grooves, as shown in figure 3-4, with green stripe color code showing.

(2) Lubricate packing rings with light coating of OE-10 lubricant.

(3) Roll each ring into grooves (fig. 3-4) and straighten using ring mold mark as a guide.

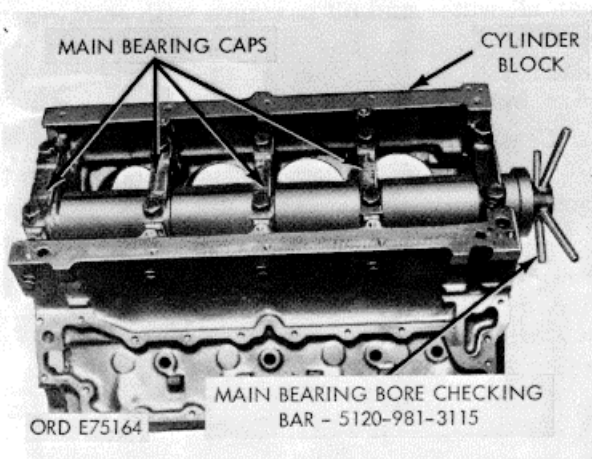

Figure 3-3. Main bearing bore alignment check

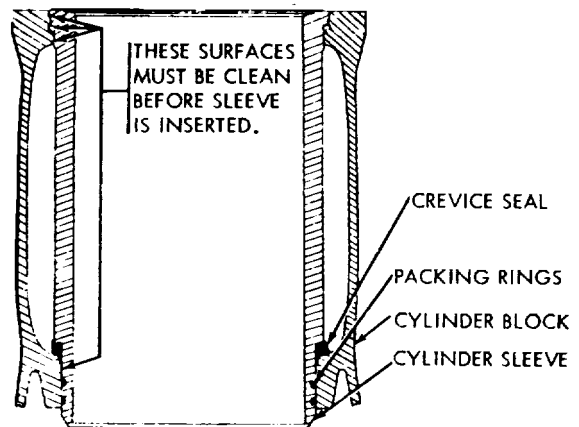

Figure 3-4. Cylinder sleeve sells installation

(4) Lubricate machined packing ring bore of block with light coat of OE-10 lubricant.

(5) Start sleeve into bore by hand.

(6) Use a sleeve driver (31, fig. B-28) place sleeve in block.

(7) Using a dial bore gage check sleeve against limits specified in repair and rebuild standards (para. 3-174). If specified limits are exceeded remove sleeve and check for possible

twisted seal rings, cocked crevice seal or sleeve to block contact which could cause distortion of sleeve. If no apparent cause is evident replace sleeve.

(8) Install sleeve and check sleeve protrusion using gage block (24, fig. B-28) to determine if protrusion is uniform.

### Section III.

#### 3-7. Disassembly

a. Attach a gear puller to shaft gear.

b. Using a heating torch heat gear hub 300 - 400 degrees Fahrenheit.

c. Apply 75 to 100 foot pounds torque on puller screw and remove gear and key.

d. Remove all pipe plugs.

#### 3-8. Cleaning

Clean crankshaft and gear in accordance with paragraph 2-5.

#### 3-9. Inspection

a. Visually inspect shaft journals for the following defects. Replace shaft if all or any defect is present:

(1) Deep nicks, grooves, scratches, evidence of galling or scuffing.

(2) Burned areas, if color is a very do blue.

(3) Heavy discoloration throughout shaft from over-all heating.

b. Measure all bearing surfaces with a micrometer (fig. 3-5). Check against wear limits specified in repair and rebuild standards (para 3-174).

c. Check shaft for out-of-round condition. Shaft must be reground or replaced if main bearings or journals are worn out-of-round more than 0.002.inch.

d. Visually inspect thrust flange at rear main bearing. If surface is scored or scratched, flange must be reground.

e. Measure flange wear (P, fig. 3-5).

#### NOTE

If flange wear does not exceed 0.003-inch at any one point, flange condition is acceptable. If wear is 0.003-inch or more, flange must be reground to restore flatness.

#### 3-10. Repair

a. *Regrinding Main Bearing and Rod Journal* If out-of-round or worn beyond repair and rebuild standards specified limits, (para. 3-175) main bearing and rod journals may be ground undersize.

#### NOTE

Undersize grinding shall be to a limit of 0.010-inch. If one bearing or journal requires grinding, all bearings or journals shall be ground to the same undersize dimension.

b. *Regrinding Rear Main Bearing Thrust Flange.* Flange shall be reground to restore flatness to accept either standard or oversize thrust rings.

#### NOTE

If total wear and regrinding does not exceed 0.005-inch, standard thrust rings may be used. Maximum regrinding for oversize rings shall not exceed 0.005-inch undersize.

c. *Minor Defects.* Minor defects on journal and bearing surfaces may be repaired by polishing with a crocus cloth dipped in dry-cleaning solvent or mineral spirits paint thinner.

d. *Repair Inspection.* Shaft must be inspected by the electro magna-flux method for fractures after refinishing. If any evidence of cracks are noted, replace shaft.

#### 3-11. Assembly

a. Install all pipe plugs using sealing tape or lead sealer to prevent leakage. Refer to para-graph 3-186, for pipe plug torque specifications.

b. Install key in shaft keyway.

c. Oil shaft with OE-10 lubricant.

#### CAUTION

When using heating torch keep flame away from direct contact with gear teeth.

d. Heat gear in oven, or with heating torch, to approximately 400 degrees Fahrenheit.

e. Using rubber mallet, or brass head driver, drive gear on shaft.



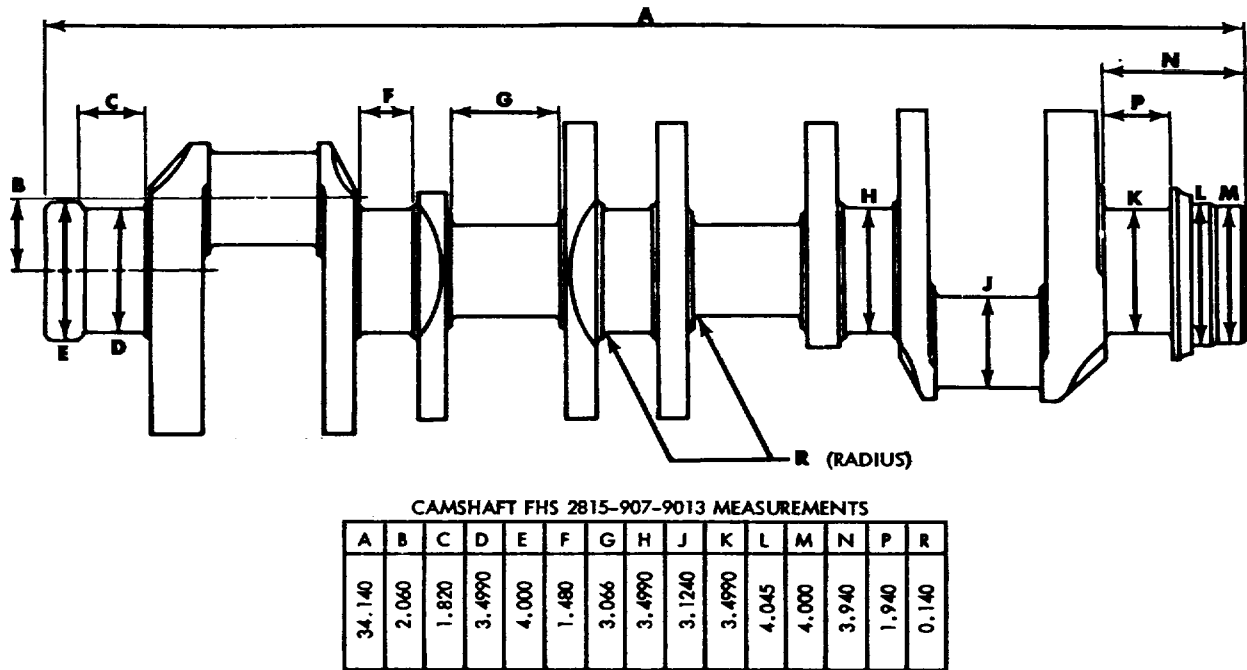

ORD E75167

Figure 3-5. Crankshaft dimensions.

### 3-12. Installation

- a. Lay upper main bearing shells in block engaging shell tang in recess. Refer to paragraph 2-II.p. (6) and (7).
- b. Coat shells with GAA.
- c. Install shaft in block. Refer to paragraph 2-11.p. (5) for installation instructions.
- d. Install upper thrust half-rings in rear main bearing with grooved side next to shaft flange.
- e. Coat lower bearing shells with GAA and snap into position in bearing caps.
- f. Install lower main bearing thrust half-rings over dowels in bearing cap.
- g. Install bearing caps over shaft.

**NOTE**

Main bearing caps are not interchangeable, insure that numbers stamped on caps correspond with numbers stamped on block.

- h. Lubricate threads of the bearing cap bolts with OE-10 lubricant.
- i. Install bolts and plain washers in each cap and engage threads by hand.
- j. Tighten bolts as follows:
  - (1) Alternately torque both bolts in each cap to 150-160 ft. lbs.

- (2) Alternately torque both bolts in each cap to 340-350 ft. lbs.
- (3) Fully loosen all bolts to relieve tension.
- (4) Alternately torque both bolts in each cap to 80-90 ft. lbs.
- (5) Alternately torque both bolts in each cap to 170-180 ft lbs.
- (6) Scribe each cap in line with a corner hex of each bolt head.
- (7) Advance each bolt 60 degrees alternately on each cap in 30 degree increments.

k. Check shaft clearance against limits specified in repair and rebuild standards (para. 3-176) as follows:

- (1) Using a suitable holder attach a dial indicator to rear of block (fig. 3-6) with gage plunger resting against flange face.
- (2) Using a pry bar move shaft to front of block.
- (3) Set gage to zero.
- (4) Move shaft to front of block and observe gage reading.

**NOTE**

If clearance, with a new shaft and thrust rings, is less than 0.005-inch loosen all bearing cap bolts and move shaft to front of block then to rear of block. Refer to paragraph 3-12.j., and

tighten cap bolts. Recheck end clearance. If the original shaft and thrust rings are installed and end clearance exceeds the wear limits the thrust rings must be replaced.

l. Check clearance between main bearing caps and block at side bolt contact area on each of cap; clearance must be 0.002-0.005-inch fig. 3-7).

m. Coat threads of bearing cap side bolts v OE-10 lubricant.

n. install bolts and flat washers engage threads by hand.

o. Refer to figure 3-8 for bolt tightening sequence. Torque each bolt to 70-75 foot-pounds 35-40 foot-pounds increments.

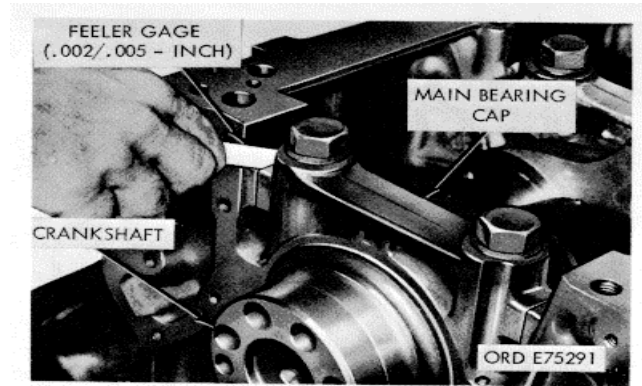

Figure 3-7. Bearing cap to block clearance check.

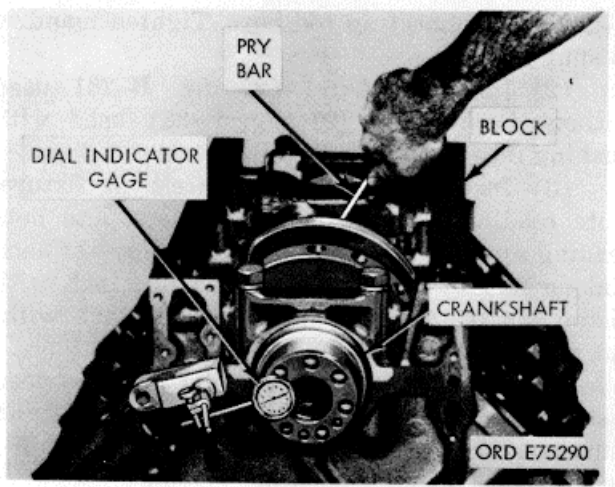

Figure 3-6. Crankshaft end clearance check.

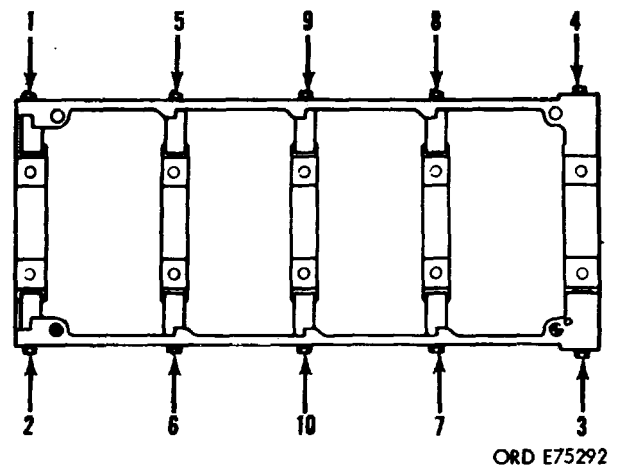

Figure 3-8. Side bolt tightening sequence.

#### Section IV. Repair of Connecting Rod and Piston Assembly

##### 3-13. Disassembly

- a. Remove piston pin snap rings.
- b. Heat pistons in hot water for several minutes to facilitate pin removal. Push pin from piston with thumb pressure.
- c. Using a suitable ring expander remove piston rings (fig. 3-9).

##### NOTE

Maintain each rod and piston assembly as a group. Do not mix with other assemblies.

##### 3-14. Cleaning

Refer to paragraph 25 for cleaning instructions.

##### 3-15. Inspection

- a. Inspect rod visually for nicks, notches gashes

; depressions with a 1/16-inch radius or less are not acceptable on the edge of the I beam section or on the periphery of the forging. Nicks, notches, or gashes 1/32-inch or less in depth may be removed by grinding and blending to the original contour within a minimum distance of 1/2 inch on either side of the defect.

b. Assemble cap to rod and tighten down bolt nuts to proper torque (para. 3-186).

c. Check crankpin bore with inside micrometers. The bore must be within limits shown in paragraph 3-177. Out-of-round limits should not exceed 0.00075 inch.

d. Using a dial bore gage, check crankpin bore for out-of-round condition. Out-of-round limits must not exceed 0.00075 inch.

e. Using inside micrometers, check piston pin bushing diameter. Piston pin bushing bore must

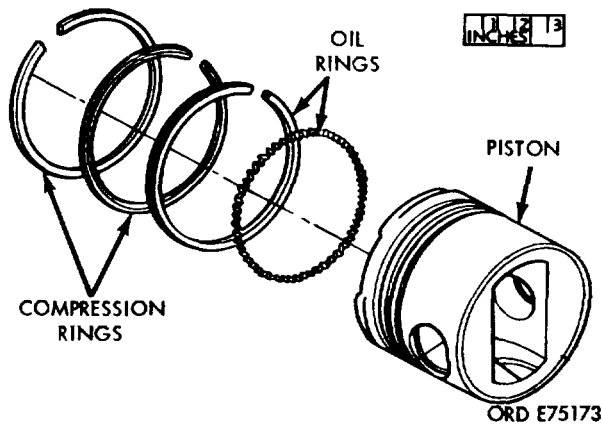

Figure 3-9. Piston and ring assembly.

not exceed wear limits shown in repair and build standards in paragraph 3-178. f. Check connecting rod piston pin and bearing bore alignment, rod twist, and rod centerline (fig. 3-10) in rod checking fixture (40, fig. B-28). Calibrate fixture, before checking rod, as foil (1) Select a new rod that has been checked for correct absolute length. (Production rods vary from 8.192/8.194 inches in length.)

(2) Assemble cap to rod and tighten nuts to proper torque (para. 3-186).

(3) Insert mandrel (22, fig. B-28) without bushing or (21, fig. B-28) used bushing into piston pin bushing bore.

(4) Insert mandrel (20, fig. B-28) crankpin bushing bore. Tighten mandrel in to snug fit.

(5) Position rod with mandrels installed into fixture (40, fig. B-28).

(6) Move dial holders so dial pins seat on piston pin bore mandrel. Turn dial indicator gages back to zero indication.

(7) Remove rod with mandrels installed from fixture, rotate rod 180 degrees and reinstall in fixture with connecting rod mandrel at top.

(8) Turn dial indicator adjusting screws until dial pins seat on connecting rod mandrels. Note reading of dial indicators. Divide reading in half and adjust each dial indicator gage accordingly.

(9) Remove mandrels from connecting bores.

g. Check rod alignment as follows:

**NOTE**

Measurements taken directly from dial indicator indicate comparative length and misalignment of bores.

(1) Install connecting rod mandrel (20,fig

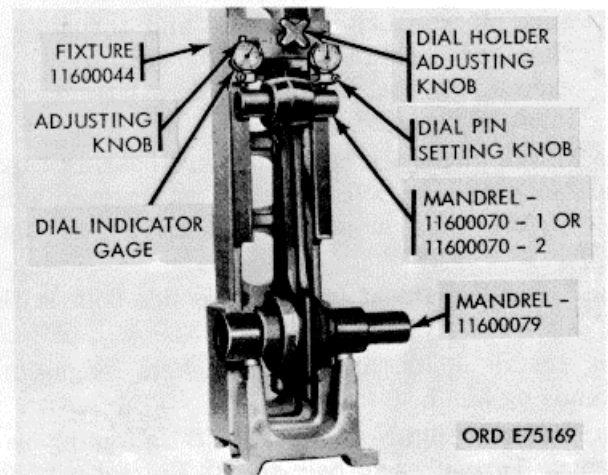

Figure 3-10. Connecting rod check.

B28) into connecting rod bore. Tighten mandrel to snug fit.

(2) Install mandrel (22, fig. B-28) used without bushing or (21, fig. B-28) used with bushing into piston pin bushing bore.

(3) Install rod with mandrels in fixture Note reading, rotate rod 180 degrees, and note reading again. Total cumulative readings of each dial on fixture must not exceed 0.004 inch with piston pin bushing installed or 0.008 inch without piston pin bushing installed.

h. Check rod twist with a feeler gage between piston pin mandrel and dial holding plate. Twist must not exceed 0.010-inch with bushing installed or 0.020-inch without bushing.

i. Check rod centerline as follows:

(1) Attach dial indicator gage to fixture (fig. 3-10) so that it will contact the milled surface of piston pin end of rod.

(2) Slide crankpin end of rod sideways to contact checking fixture on same side that dial indicator is mounted.

(3) Adjust indicator gage to zero reading. Turn Rod 180 degrees and repeat step (2) above. Dial indicator reading must not exceed 0.015 inch.

j. Check connecting rod bolts, bolt holes, and bolt pads as follows:

(1) Bolt head must rest squarely on milled surfaces of rod.

(2) With rod bolt in connecting rod and cap, measure bolt length without torque applied, then measure bolt length with it torqued to 105/115 ft lbs. If bolt length increases over 0.015 inch it must be discarded.

(3) Discard all bolts and nuts that have distorted threads.

(4) Check bolt hole diameter, if it exceeds 0.5643 inch, discard rod.

(5) Check bolt pad corner radius (0.25 0.2700 inch). If radius does not check to tolerance, machine to proper dimensions.

k. Inspect connecting rod bearing caps using ball point micrometer, dial indicator thickness gage, or Comparator. Refer to paragraph 3-177, for shell thickness and allowable wear.

l. Inspect pistons for scoring, burning, or damaged ring grooves and cracks inside piston struts. A badly scored piston must be replaced; a slightly scored piston may be cleaned and reused.

m. Inspect top of piston for burned spots indications of over-heating such as carbon formation on underside of the piston. Replace burned pistons.

n. Using ring groove wear gage (52, fig. 28) check groove wear as follows: (fig. 3-11)

(1) Insert ring groove wear gage (52, fig. B-28) into each of the top and second ring grooves.

(2) If shoulders of gage touch ring groove lands, piston must be discarded.

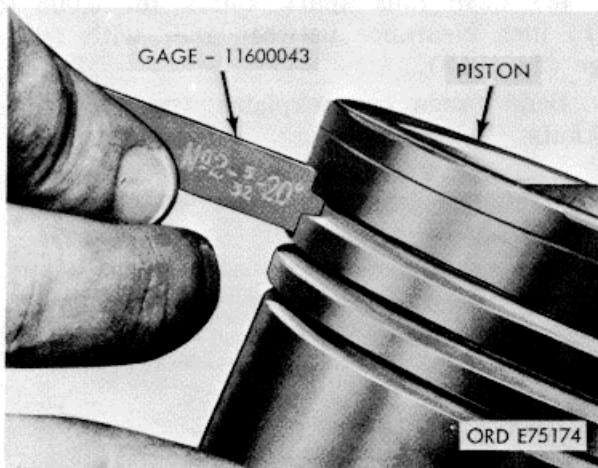

Figure 3-11. Ring groove wear check.

o. Check ring gap as follows:

(1) Insert each compression ring into worn portion of cylinder liner, seating it squarely using a piston head (fig. 3-12).

(2) Measure ring gap with feeler gage. The allowable ring gap is 0.013/0.0230: Rings exceeding this limit should be discarded.

(3) If necessary, file ring ends to obtain gap of 0.0130/0.0230 inch.

p. Measure piston skirt diameter with micrometer at right angle to piston pin bore. Refer to paragraph 3-178, for wear limits. If piston wear exceeds 0.004-inch discard piston.

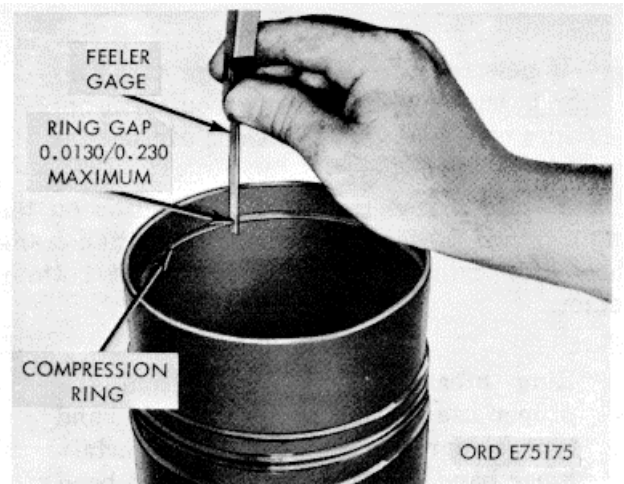

Figure 3-12. Piston ring gap check.

**NOTE**

Measurement should be taken at ambient air temperature of 70/90 degrees Fahrenheit.

q. Using inside micrometer, measure piston pin bore; discard piston if bore exceeds 2.005-inch.

**3-16. Repair**

Repair of the connecting rod and piston assembly is limited to general procedures as outlined in paragraph 2-7. Any defect, or measurement outside the tolerances listed in repair and rebuild standards (paras. 3-177, and 3-178) is cause for replacement. If piston pin bushings must be replaced use bushing driver (46, fig. B-28) for bushing removal and replacement. Check with plug gage (50, fig. B-28).

**3-17. Assembly**

Assemble rod to piston in reverse order of paragraph 3-13.

**NOTE**

When installing rings insure the word "Top" inscribed on the ring, is to the top of the piston.

**3-18. Installation**

a. Lubricate rod and piston assembly with OE- 10 lubricant.

b. Compress piston rings with suitable cylindrical ring compressor.

c. Remove connecting rod cap from bolts and make certain bolt heads are seated squarely on rod shoulder. These parts are not interchangeable (fig. 3-26).

**NOTE**

If new rods are used, be sure caps and rods have number stamped on them before caps are removed. Caps are not interchangeable.

d. Rotate engine to a vertical position on the engine stand. Rotate crankshaft to position crank throw for cylinder being assembled at bottom center.

**CAUTION**

Ring breakage will result from improper use of ring compressor. If band type compressor is used, make certain inner band does not slip down and bend piston.

e. With ring compressor in place, insert piston and rod assembly in the cylinder. Position numbered side of rod toward outside of block.

**CAUTION**

Pistons are marked to indicate which side is to be assembled to "Out" exhaust side.

f. Push piston assembly through ring compressor until rings seat in cylinder sleeve.

g. Moving to bottom of block, grasp piston and rod assembly by rod bolts and pull down to rod journal. Leave piston assembly a short distance from actual seating.

h. Coat rod bearing shell with GAA next to the crankshaft.

i. Roll rod bearing shell into rod. Shell locking tang must fit in milled recess.

j. Coat lower shell crankshaft bore with hit pressure grease, and seat in rod cap.

k. Position rod cap over bolts that numbered side of cap mates with numbered side of rod.

l. Lubricate bolt and nut threads and lock plates with clean OE-10 lubricating oil. Install lockplate and nuts to bolts, tighten nuts as outlined below.

(1) Tighten both nuts 55 to 66 foot-pounds torque.

(2) Tighten both nuts 105 to 115 foot pounds torque.

(3) Loosen both nuts completely to remove all tension.

(4) Tighten both nuts to 30 to 32 foot- pounds torque.

(5) Tighten both nuts to 60 to 65 foot-pounds torque.

(6) Advance both nuts to 60 degrees in 30 degrees increments.

m. Follow steps a through l above, install piston and rod assembly opposite one just installed. Secure rod to same crankshaft journal.

**NOTE**

Chamfered side of rod faces respective crankshaft cheeks and square sides face each other.

n. Check rod for freedom of movement and clearance.

(1) Use hand pressure to move rod side-ways. Tap lightly with soft hammer if necessary.

(2) If rod is not free, loosen cap and check for dirt or burrs. Secure cap as described above.

(3) Push rods apart. Check for 0.008 to 0.016 inch clearance between rods with feeler gage (fig. 3-13).

o. Bend tangs on lockplates (fig. 3-13), to locknuts.

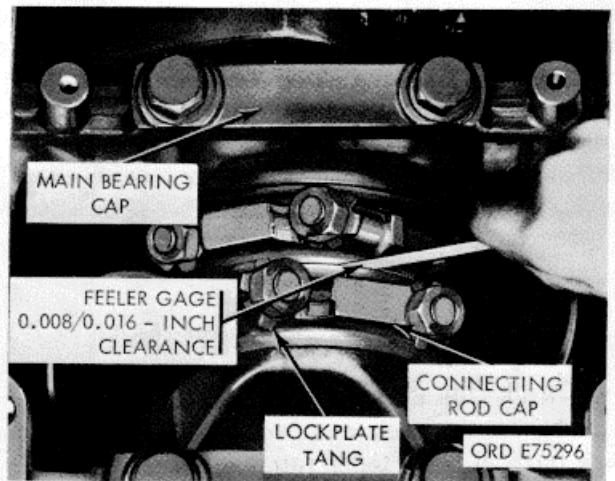

Figure 3-13. Rod side clearance check.

**Section V. Repair of Front Cover**

**3-19. Disassembly**

Using the front crankshaft oil seal driver (38, fig. B-28) and suitable arbor press remove oil seal as shown in figure 3-14.

**3-20. Cleaning**

Refer to paragraph 2-5 for cleaning instruction.

**3-21. Inspection**

Refer to paragraph 2-6 for inspection procedures.

**NOTE**

Dowel replacement is not authorized. If dowels are bent or damaged replace the cover.

**3-22. Repair**

No repair procedures beyond those specified paragraph 2-7 are authorized.

**3-23. Installation**

a. Position front cover with new gasket to block Secure snugly with lockwashers and capscrews.

b. Place dial indicator gage on crankshaft with dial pointer inside front cover bore. Rotate crankshaft and check total indicator reading. Run-out must not exceed 0.0025 inch (fig. 3-15).

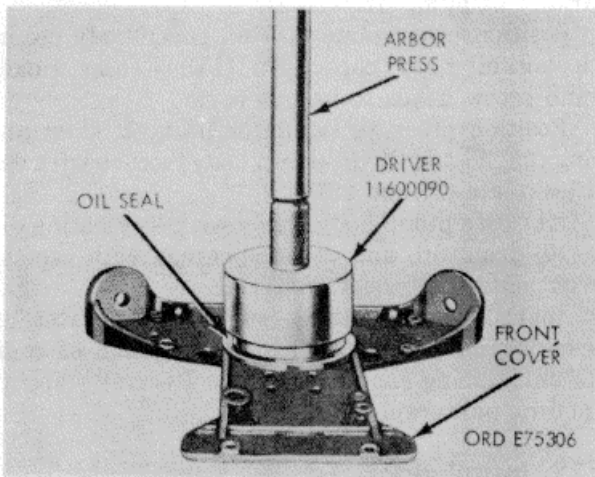

Figure 3-14. Crankshaft oil seal-removal/installation.

c. Check that the bottom of the front cover and cylinder block are level with a straight edge. There must be no variation (fig. 3-16).

d. Remove front cover and press in new oil seal (3-14).

(1) Position seal with open lip to inside.

(2) Use oil seal driver (38, fig. B-28) and arbox press for pressing operation.

e. Install cover and secure with lockwashers and capscrews. Tighten capscrews to 30 to 35 foot-pounds torque.

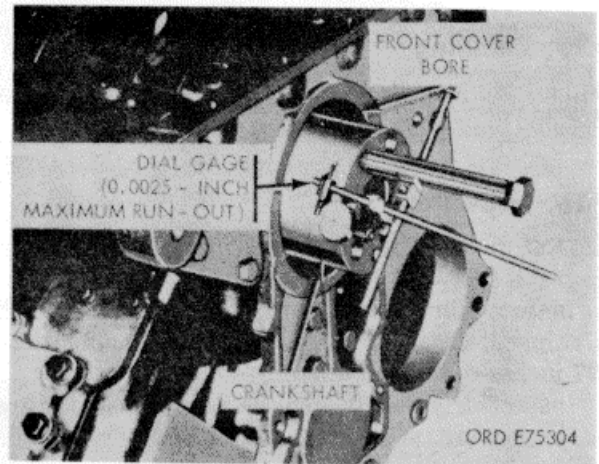

Figure 3-15. Front cover bore alinement check

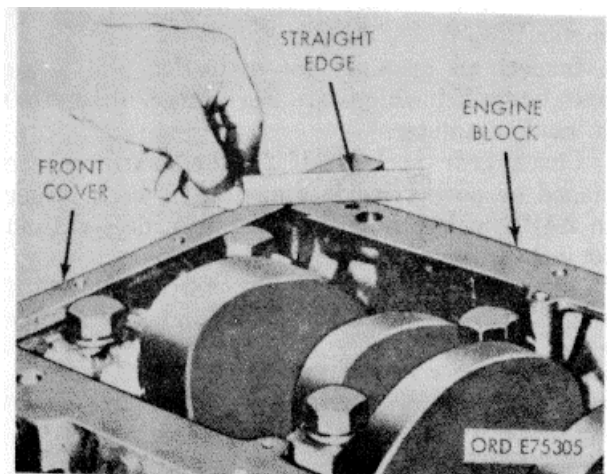

Figure 3-16. Front cover to block alinement check.

**Section VI. Repair of Oil Pump Assembly**

**3-24. Disassembly**

a. Remove two capscrews and lockplates (11 and fig. B-9) securing suction tube to pump.

b. Remove four capscrews and lockplates (11 19, fig. B-9) securing scavenger tube to pump Discard gasket (17).

c. Remove three capscrews and lockplates (11 and 12, fig. B-9) securing suction tube to pump. Discard gasket (21).

d. Remove four capscrews. (15, fig. B-10) securing cover plate (16) to pump cover (20). Remove plate

e. Remove four capscrews and lockplates (18 and 19, fig. B-10) securing pump cover to oil pump body (9). Tap cover with soft head hammer to remove from

dowels in pump body. Discard gasket (3).

f. Remove six capscrews and lockplates (32 and 33, fig. B-10) securing scavenger pump body (2) to oil pump body. Tap scavenger pump body to remove from dowels in oil pump body.

**NOTE**

Gears and shafts will be removed from the pumps only in inspection warrants.

g. Remove idler gear (31, fig. B-10) from shaft (30) in scavenger pump body.

h. Using a suitable puller; pull drive gear (17, fig. B-10) from cover.

i. Remove pressure regulator cap (28, fig. B-10) lockplate (27), spring (26), plunger (29) and shim (25) from bore.

### 3-25. Cleaning

Clean all components in accordance with instructions contained in paragraph 2-5

### 3-26. Inspection

a. Refer to general inspection procedures paragraph 2-6.

b. Inspect pump drive gear. Replace pump if teeth are chipped, cracked, scored or worn smaller than 2.397 inches outside diameter.

c. Inspect drive shaft, replace pump if shafts scored or worn smaller than 0.8740 inch outs diameter.

d. Inspect idler shafts, replace pump if shafts are scored or worn smaller than 0.8750 inch outside diameter.

e. Inspect all bushings for distortion and wear replace pump if bushings are worn larger than .8750' inch inside diameter.

f. Check gear pockets. If finished surfaces are damaged or pocket inside diameter is worn larger than 2.4105 inches or if depth is worn deeper than 1.252 inches, replace pump.

g. Inspect pressure regulator valve, replace if damaged. Check for burs or scratches on slide plunger.

### 3-27. Repair

No repair procedures beyond those specified in paragraph 2-7 are authorized.

### 3-28. Assembly

(fig. B-10)

a. Press idler shaft (30) into scavenger body (2) until shaft protrudes 1.935/1.965 inches from bottom surface to pocket.

b. Position idler gear (31) on scavenger idler shaft

c. Press lubricating oil pump driven gear (6) with drill oil hole on main shaft (7) until shaft protrudes 0.590/0.620 inch through gear. Insert shaft through pump body (9).

d. Press scavenger pump driven gear (6) on main shaft and maintain 0.002/0.004 inch clearance between gear and body.

e. Press lubricating oil pump drive gear (6) on drive shaft until drive end of shaft protrudes through gear 1.455/1.485 inches. Insert long end of shaft.

f. With convex (numbered) side of pump drive gear (17) up, press gear onto shaft until shaft protrudes

0.185/0.215 inch through drive gear.

g. With new gasket (3) over dowels in pump body, position scavenger body to lubricating oil pump body, engaging pump gears. Secure with lockplates and capscrews (32 and 33), lock capscrews in plate with lock tangs.

h. With new gasket (13) over dowels, position pump cover (20) to lubricating oil pump body, engaging pump gears; secure with lockplates and capscrews (18 and 19). Lock capscrews in place with lock tangs.

i. With dial indicator, check for 0.0035/0.0075 inch clearance of pump drive shaft.

j. Position cover plate (16) on cover body secure with socket head capscrews (15). Center punch around screw heads to lock in cover.

k. Position pressure regulator plunger, shim and spring (25, 26 and 29) in pump body, secure with cap and lockplate (27 and 28).

l. Lubricate pump body freely with lubricating oil, OE-10, drain oil, and cover openings with tape to prevent entry of foreign material.

m. Install tube assemblies (suction and aerator) on lubricating oil pump to permit installation of complete unit during engine assembly. Reverse steps a., b., and c., paragraph 3-24.

### 3-29. installation

a. Refer to paragraph 2-11m, and reverse removal procedures to install pump.

b. Check pump drive gear backlash as follows:

(1) Attach dial indicator to block, place indicator arm on gear teeth as shown in figure 3-19.

(2) Rotate gear by hand to advance position and set indicator at zero. Back gear to retard position and note indicator reading. Check indicator reading against specified limits in repair and rebuild standards (para. 3-181). If reading is outside limits specified pump gear train must be replaced.

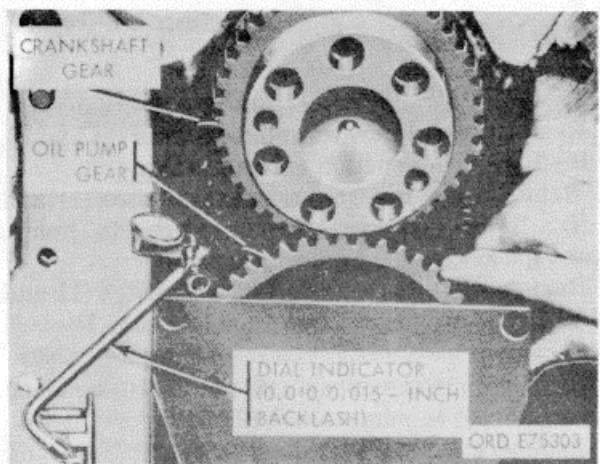

Figure 3-17. Drive gear backlash check.

**Section VII. Repair of Camshaft**

**3-30. Disassembly**

**NOTE**

Remove camshaft gear only if thrust plate or gear is chipped, cracked or visibly worn. If necessary to facilitate removal, heat gear to 400 degrees F.

- a. Place shaft in a suitable press between blocks and press off gear.
- b. Remove key and thrust plate. Discard key.

**3-31. Cleaning**

Clean camshaft and components in accordance with instructions contained in paragraph 2-5

**3-32. Inspection**

- a. Check shaft journals and injector lobes against specified limits in repair and rebuild standards paragraph 3-180. Replace shaft if any measurement is outside limits specified.
- b. Check thrust plate against specified limits in repair and rebuild standards, replace plate if limits are exceeded.
- c. Visibly inspect gear in accordance with general inspection procedures, paragraph 2-6
- d. Check gear diameter against specified limits in repair and rebuild standards paragraph 3-180. Replace gear if limits specified are exceeded

**3-33. Assembly**

- a. Install key in place, red tip to rear of camshaft.
- b. Coat camshaft thrust bearing with lubricating oil OE10 and place thrust bearing on camshaft.
- c. Coat gear hub area on camshaft with lubricating oil OE-10.
- d. Heat gear to 400 degrees Fahrenheit in oven or with heating torch and press gear onto shaft

**CAUTION**

When using heating torch, heat gear hub only. Do not direct flame at gear teeth.

**3-34. Repair**

Repair of camshaft and gear is limited to general procedures outlined in paragraph 2-7.

**3-35. Installation**

- a. Lubricate lobes and journals with high pressure grease.
- b. Install camshaft in the block (fig. 2-24).
- c. Index "0" mark on camshaft gear with "O" mark on crankshaft gear to insure correct timing.
- d. Secure camshaft thrust plate to block with lockplates and capscrews.

- e. Check camshaft and clearance as follows:
  - (1) With a suitable holder attach a dial indicator to the block, as shown in figure 3-18, with indicator arm resting on face of gear teeth.
  - (2) Push and pull on shaft several times.
  - (3) Push shaft in until shaft bottoms and set indicator to zero.
  - (4) Pull out oil shaft and note reading on indicator.
  - (5) Check reading against specified limits in repair and rebuild standards (para. 3-180). If end clearance is not within limits specified remove camshaft and replace thrust plate.
- f. Attach dial indicator as shown in figure 3-19 and measure gear backlash against limits specified in repair and rebuild standards (para. 3-180). If backlash is not within specified limits replace camshaft gear.

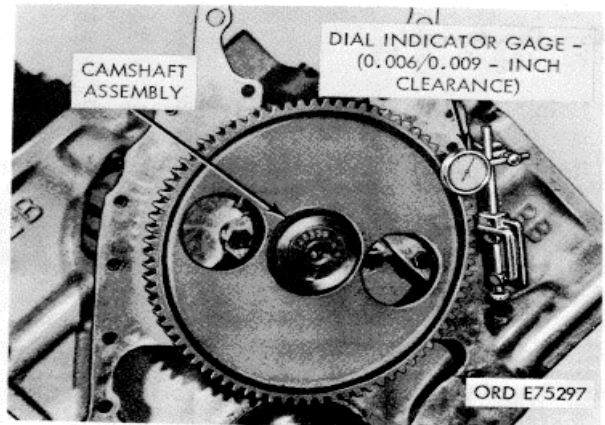

Figure 3-18. Camshaft end play check.

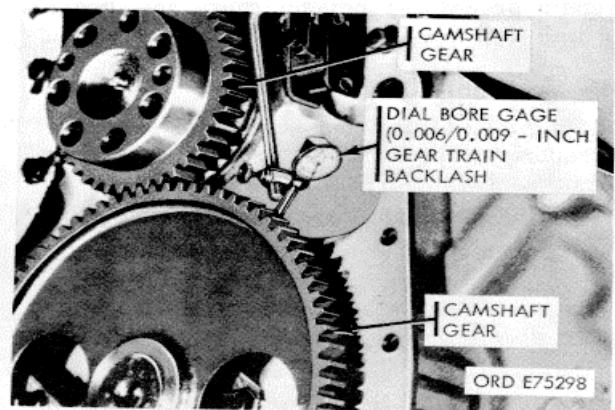

Figure 3-19. Crankshaft gear backlash check.



**Section VIII. Repair of Crankshaft Adapter**

**3-36. Cleaning**

Refer to paragraph 2-5 for cleaning instruction

**3-37. Inspection**

Inspect adapter in accordance with instruction in paragraph 2-6.

**3-38. Repair**

No repair procedures beyond those specified in paragraph 2-7 are authorized for this part.

**3-39. Installation**

- a. Refer to paragraph 2-11.i., and reverse procedures to install adapter.
- b. Tighten capscrews in the sequence as shown in figure 3-20.

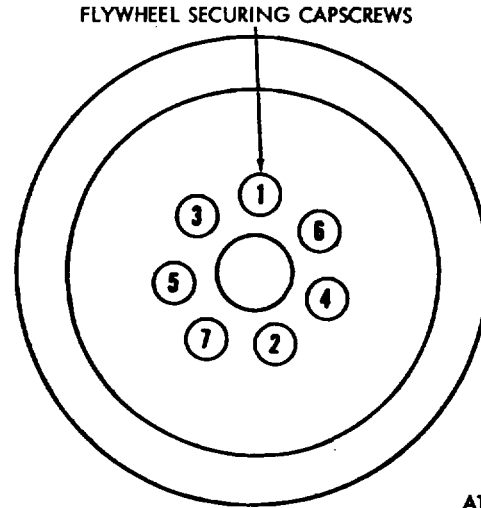

Figure 3-20. Crankshaft adapter tightening sequence

**Section IX. Repair of Flywheel Housing and Spacer Plate**

**3-40. Disassembly (fig. B4)**

- a. Using suitable arbor press remove oil seal (8).
- b. Remove pipe plugs (6 and 17).

**3-41. Cleaning**

Clean housing and spacer plate in accordance with instructions contained in paragraph 2-6

**3-42. Inspection**

Inspect housing and spacer plate in accordance with instructions in paragraph 2-6.

**3-43. Repair**

No repair procedures beyond those specified in paragraph 2-7 are authorized for these units.

**3-44. Assembly**

- a. Using a suitable arbor press, and with housing properly supported to prevent distortion install oil seal.
- b. Install pipe plugs.

**3-45. Installation (fig. B-4).**

- a. Install gasket (3) on block.
- b. Install spacer plate (2) and gasket (1).
- c. Install housing. Refer to paragraph 2-11 and snug tighten capscrews.

**NOTE**

If a replacement housing is to be installed replace dowels only if the housing will not line up within bore tolerance.

- d. Install dial gage and holder (34, fig. B-28) as shown in figure 3-21, and check crankshaft flange concentricity as follows:

- (1) Place chalk marks at position A, A', B, and B' as shown in (fig. 3-21).
- (2) Check reading at B and B'. Total runout is not to exceed 0.010 inch.
- (3) Check reading at A and A'. Total runout is not to exceed 0.010 inch.
- (4) If flywheel housing bore is not within limits, move as necessary to correct measurements.

**CAUTION**

Oil seal bore run-out must also remain within limit of 0.005-inch.

- e. If both bores cannot be brought within limits, the flywheel housing must be replaced.
- f. After measurements are brought within limits, tighten capscrews alternately and evenly; make final check after tightening. Tighten capscrews to 35 ft. lbs. torque.
- g. Check flywheel housing face as follows.
  - (1) Move dial gage-(fig. 3-21) and attachment to housing face.
  - (2) Using a pinch bar wedged between a main bearing cap and crankshaft throw, take up crankshaft end clearance.

(3) Turn crankshaft and check at points A, A', B, and B' housing face (fig. 3-21).

**NOTE**

Take up crankshaft end clearance in the same direction each time a measurement is taken.

(4) Total flywheel housing face run-out must not exceed 0.008 inch.

(5) If necessary, to correct housing face run-out, after the bore has been alined, remove housing and recheck mating surfaces. Then install housing on housing dowels and install capscrews. Tighten capscrews to 35 foot-pounds torque.

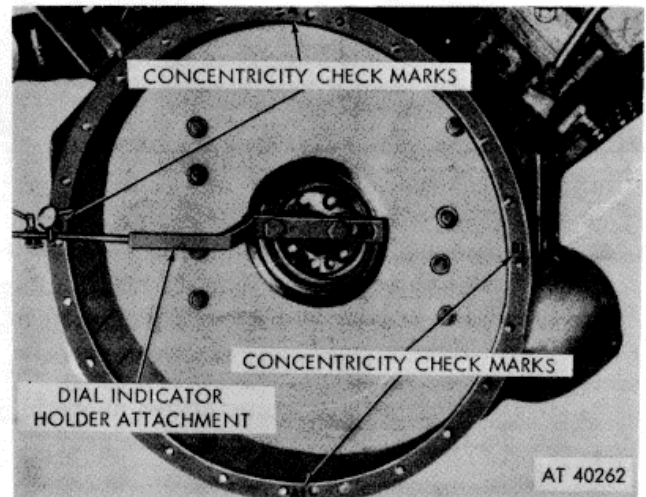

Figure 3-21. Flywheel housing concentricity check.

**Section X. Repair of Oil Pan**

**3-46. Disassembly**

Remove drain and pipe plugs.

**3-47. Cleaning**

Clean oil pan in accordance with instructions contained in paragraph 2-5.

**3-48. Inspection**

Inspect pan and plugs in accordance with instructions contained in paragraph 2-6.

**3-49. Repair**

- a. Repair damaged threaded holes by tapping. Refer to paragraph 2-7 for instructions.
- b. Repair small cracks by welding. Refer to paragraph 2-7 for welding instructions.

**CAUTION**

Do not weld finished surfaces.

**3-50. Assembly**

Install all pipe plugs and drain plugs.

**3-51. Installation (fig. B-9).**

- a. Shellac new single-piece gasket (9) to pan.
- b. Aline pan to block and install 12 capscrews, lockwashers, and flat washers (25, 3, and 24), finger tighten capscrews.
- c. Reach inside inspection opening on right side of pan and install two capscrews and lockwashers (10 and 11) securing suction and scavenger tubes (13 and 20) to sump.
- d. Shellac new single-piece gasket (7) to inspection plate (6).
- e. Install plate with six capscrews and lockwashers (5 and 3).
- f. Aline oil pan to flywheel housing and install two capscrews (12), lockwashers (3) and flat washers (24), finger tighten. Install six capscrews, lockwashers, and flat washers (16, 10, and 9).
- g. fig. B-4). Tighten all oil pan securing capscrews.

**Section XI. Repair of Flywheel**

**3-52. Disassembly**

Using blunt chisel and mallet drive the ring gear from the flywheel. Apply pressure, during removal, at various positions around ring gear to prevent distortion.

**3-53. Cleaning**

Clean flywheel and ring gear in accordance with instructions contained in paragraph 2-5.

**3-54. Inspection**

Inspect flywheel and ring gear in accordance with instructions contained in paragraph 2-6.

**3-55. Repair**

No repair procedures beyond those specified in paragraph 2-7 are authorized for flywheel or ring gear.

**3-56. Assembly**

Assemble flywheel and ring gear as follows: a. If an oven with a heat control is not available, heat gear with heating torch, (not a cutting torch) from inside diameter so heat travels outward towards the teeth.

b. Use a Tempilstick crayon or equivalent to determine amount of heat applied. Stroke gear with 600 degrees Fahrenheit crayon. At 600 degrees Fahrenheit the crayon will leave a liquid smear.

**CAUTION**

Overheating gear to temperatures above 600 degrees Fahrenheit will soften gear metal.

c. Place the ring gear on flywheel and quickly drive onto flywheel until gear is firmly seated.

**3-57. Installation**

a. Install two 5/8-18x6 inches long, guide headless studs in crankshaft flange.

b. Position flywheel over guide studs.

c. Insert eight flywheel capscrews, and tighten alternately to 50 to 60 foot-pounds torque in sequence shown in figure 3-22. Tighten flywheel capscrews to final torque of 200/205 foot-pounds.

d. Check flywheel bore and clutch face as follows:

(1) Attach indicator and check pilot bearing bore and drive ring pilot bore. Total run-out must not exceed 0.004 inch.

(2) Shift gage to indicate clutch mounting face.

(3) Chalk four marks equidistant on flywheel circumference (fig. 3-23).

(4) Turn crankshaft, taking up crankshaft end clearance as chalk marks aline with indicator Run-out must not exceed 0.005 inch.

(5) If run-out exceeds 0.005 inch, remove flywheel and clean flywheel and crankshaft mating surfaces.

(6) Again install flywheel and recheck bore and face.

**NOTE**

Crankshaft end clearance must be kept to rear limit while the above check is made.

(7) Tighten flywheel capscrews to a final 200 to 205 foot-pounds torque in 50 foot-pound increments in sequence shown in figure 3-22. Secure flywheel capscrews with locking wire.

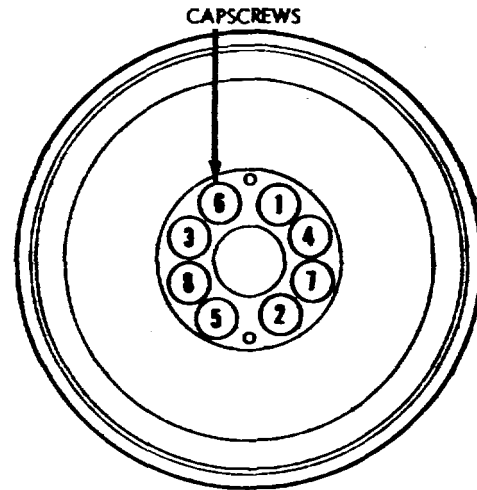

**NOTE: USE LOCKWIRE AS REQUIRED AT 40263**

Figure 3-22. Flywheel tightening sequence.  
**A-BORE .004 INCH (RUN OUT)**  
**B-CLUTCH MOUNTING FACE .005 INCH (WOBBLE)**

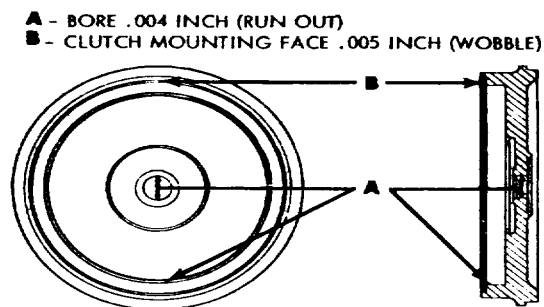

ORD E75309

**Section XII. Repair of Valve and Injector Tappets**

**3-58. Disassembly (fig. B-6).**

a. Remove and discard spring clips (31 and 35) from tappet body (25 and 33).

b. Place 0.006 inch shim between body side of roller (27 and 29) to prevent sprit back when removing roller. Press on end of pin

(26 and 32) that is not secured by lockwire to remove pin.  
 c. Discard pin and lockwire.  
 d. Press bearing sleeve (27) or injector roller (29) from injector tappet.

**3-59. Cleaning**

Clean tappets in accordance with instructions contained in paragraph 2-5.

**3-60. Inspection**

- a. Perform inspection in accordance with the instructions contained in paragraph 26.
- b. Check for scored, flaked, or chipped rollers on bearing sleeves. Discard damaged parts.

**NOTE**

If any of the above conditions exist, camshaft should be inspected very closely for damage.

- c. Measure tappet body outside diameter for wear. Measure roller and bearing sleeves od and id for wear. Discard if worn beyond limits contained in repair and rebuild standards paragraph 3-183.
- d. Check tappet sockets by "bluing" corresponding new push rod on ball end and rotating in tappet. A full seat should be indicated.
- e. Check body pin holes and inspect hole for burrs before reassembly.

**3-61. Repair**

No repair procedures beyond those specified in paragraph 2-7 are authorized for tappets.

**3-62. Assembly**

- a. Press new injector roller on bearing sleeve in tappet until securely seated.

**CAUTION**

Lubricating oil passage in pin must be aligned for proper lubrication.

- b. Insert 0.006 inch shim between side of roller or sleeve and tappet fork. Press pin through body and roller with lockwire in pin.

**362. Testing**

**NOTE**

Tests of either the injector or valve tappet assemblies require a surface plate, small V block with clamp (to hold tappet in position), and dial indicator calibrated in tenths of a thousandth inch attached to a surface plate (fig. 3-24).

- a. With a small wire, check indexing of pins and body lubricating oil passages.
- b. Check freeness of roller by rotating two or three turns. If "drag" is felt, the plating on the pin has probably picked up burrs during assembly or pin is not being held securely during assembly.
- c. Stand small V block on surface plate.
- d. Stand tappet assembly on surfacing plate with roller up. Secure tappet in V block with clamp.

- e. Using dial indicator gage (calibrated in tenths of a thousandth inch) check concentricity of rotating roller.

**CAUTION**

Injector and valve tappet dimensions are not alike. Use correct dimensions when checking wear.

**NOTE**

Roller eccentricity of the injector tappet cannot exceed 0.005 inch, the valve tapped cannot exceed 0.001 inch. Move indicator to a new location and recheck.

- f. Using same indicator check squareness of roller by sweeping indicator across diameter or end of roller, then sweeping the other end. Rotate tappet roller 180 degrees and check again at roller ends by sweeping across the diameter. Roller squareness must not exceed 0.001 inch in either injector or valve tappet assemblies. It is recommended to extend some downward pressure against the roller when gaging to assure firm contact.

**NOTE**

Assemblies that do not pass the inspections above must be disassembled, (perform inspection during disassembly to determine the cause for rejection) reassembled, and reinspected.

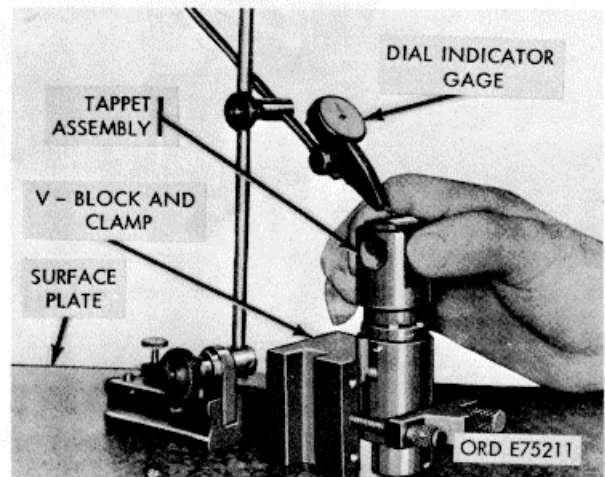

Figure 3-24. Tappet assembly test.

**3-63. Installation**

- a. Install new retainer spring on each tappet (31 and 35, fig. B-6).
- b. Install tappets in tappet bores of block, refer to paragraph 2-II.g. Injector tappets are larger

and are placed between valve tappets. Align tappet and lock in position with retainer plate. There

must be 0.010 inch clearance between tappet and plate when capscrew is tightened down.

**Section XIII. Repair of Cylinder Heads**

**3-64. Disassembly**

- a. Install head in holding fixture (25, fig. B-28 as shown in figure 3-25.
- b. Using valve spring compressor (44, fig. B-28) remove valve assemblies as shown in figure 3-26.
- c. Using injector sleeve puller (19, fig. B-28) remove injector sleeves as shown in figure 3-27.
- d. Using cross head guide puller (43, fig. B-28) remove crosshead guides as shown in figure 3-28.
- e. Remove all pipe plugs.

**3-45. Cleaning**

Clean cylinder heads and valve assemblies in accordance with instructions in paragraph 2

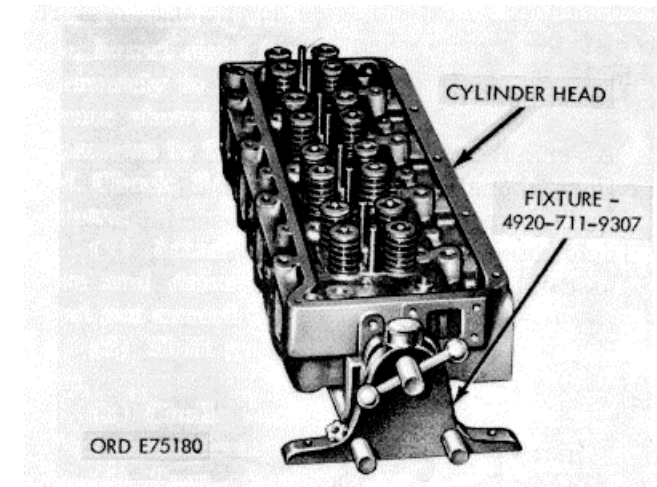

Figure 3-25. Cylinder head in fixture.

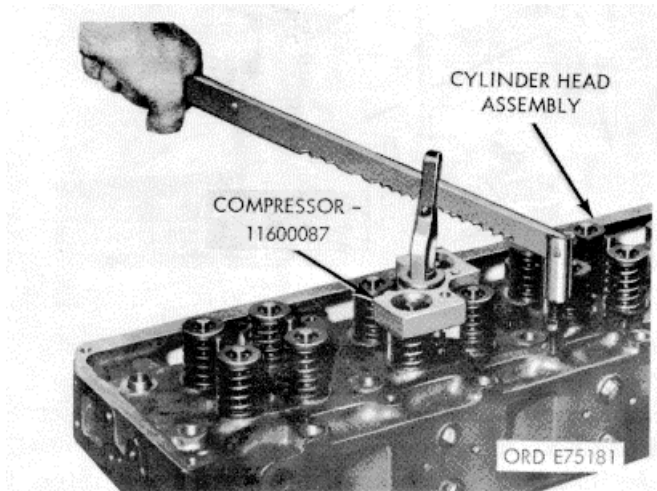

Figure 3-26. Valve assemblies-removal/installation.

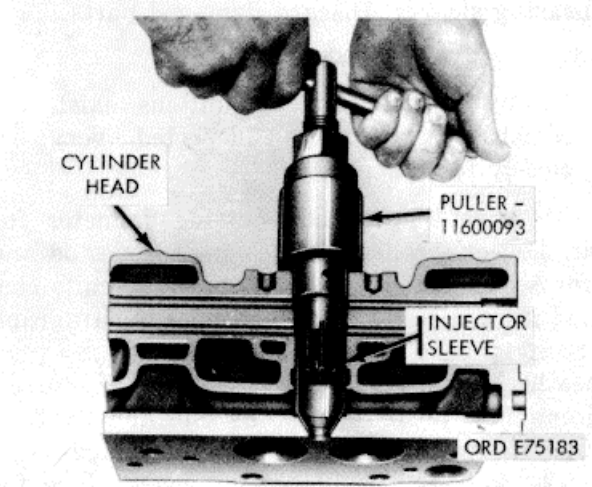

Figure 3-27. Injection sleeves-removal/installation.

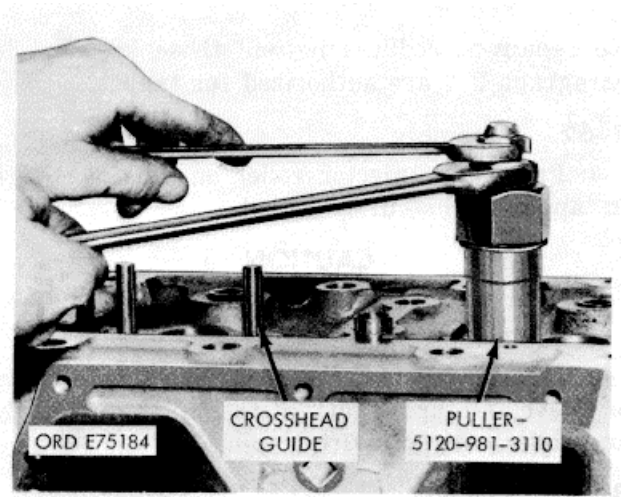

Figure 3-28. Crosshead guide-removal/installation.

**3-66. Inspection**

Refer to paragraph 2-6 for general inspection procedures.

a. *Cylinder Head Fuse Plugs* (fig. B-6). Cylinder heads are equipped with fuse plugs containing a metal alloy center that melts if the engine overheats. Examine all fuse plugs for evidence of overheating. Replace all defective plugs.

b. *Valve Seats* (fig. 3-29). Inspect for loose valve seats by tapping lightly on the cylinder head near the inserts. If valve seat is loose enough to bounce, or cannot be reground, mark for replacement. If valve seat area exceeds 0.125 inch at any point, replace head assembly.

c. *Injector Sleeves.*

- (1) Perform a water test as follows.

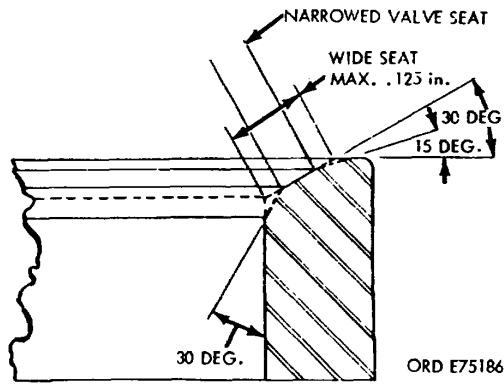

Figure 3-29. Valve seat-sectional view.

(a) Install injector sleeve holder (15, fig. B-28) on a scrap injector and cup assembly into each injector sleeve. Tighten sleeve holders to 10/12 foot-pounds torque or injector capscrews to 30/35 foot-pounds torque as shown in figure 3-30.

(b) Using water heated to 175/200 degrees Fahrenheit, test cylinder head for leaks at 35/85 pounds pressure.

(c) Check carefully around injector for any evidence of water leaks. Mark sleeves for replacement that evidence leakage. If cylinder head shows leakage, replace head.

(d) Open water outlet valve to check for free water circulation through cylinder head.

(2) Inspect injector sleeves for scratches on cup seat area and for continuous contact by using Prussian Blue. Mark sleeve that is scratched on does not show continuous seat contact, of at least 0.060 inch wide, for replacement.

(3) Check injector tip protrusion by installing injector assembly and torquing to 30/35 footpounds. If injector protrusion exceeds 0.125 inch mark sleeve for replacement (fig. 3-31).

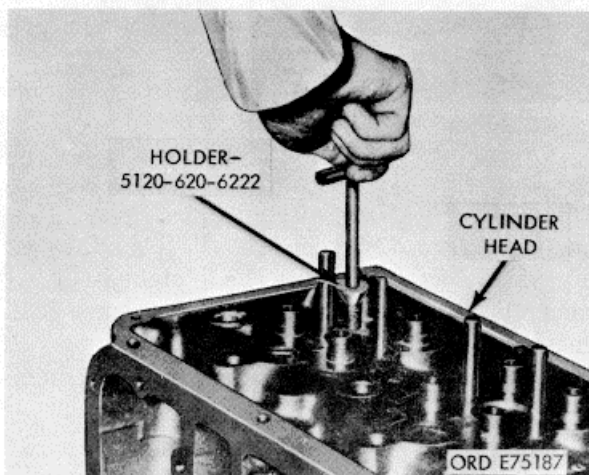

Figure 3-30. Injector sleeve holder installation.

**NOTE**

If nylok capscrew breakaway torque is less than 15 inch pounds, replace capscrews.

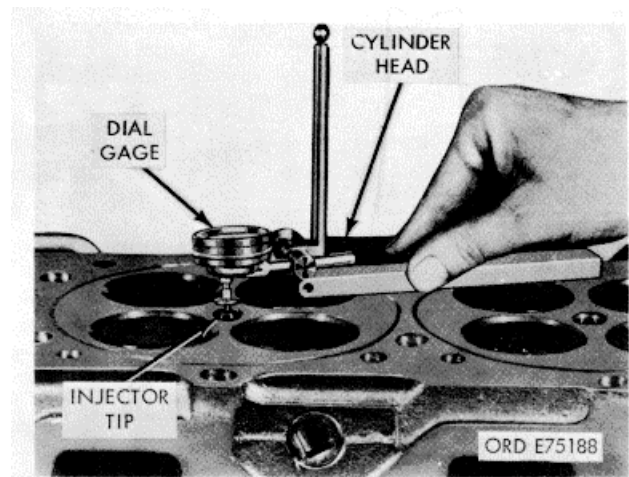

Figure 3-31. Injector tip protrusion measurement.

d. Valves.

(1) Inspect valve heads for pitted, cupped, cracked, or excessively worn condition. Check valve head rim thickness (fig. 3-32) and replace valve if less than 1/16 inch.

(2) Inspect valve stems for scored, cracked or excessively worn condition. If stems are worn beyond 0.4490 inch replace valve.

(3) Inspect collet recesses (fig. 3-32) for serviceability.

f. Crosshead Guides (fig. 3-33).

(1) Check crosshead guides with a square. They must be perpendicular at four right angles with the cylinder head.

(2) Measure outside diameter of crosshead guides using a micrometer. Guides must measure 0.4322 inch minimum. Discard if worn beyond that limit.

(3) Measure crosshead protrusion above block to 2.090/2.110 inches. Discard guides not within these tolerances.

g. Valve Guides (fig. 3-34).

(1) Adjust a small bore gage with a micrometer at 0.0002 inch above worn limit, and use as "No-Go" gage.

(2) Measure the hole at several points crosswise and endwise of the head.

(3) Mark valve guide for replacement if worn larger than 0.4545 inch inside diameter.

(4) Inspect sharp edge of guides for chips, cracks and burrs. If damaged, mark for replacement.

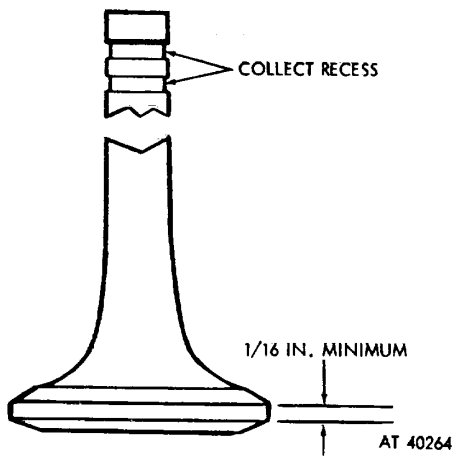

Figure 3-32. Valve head and collet check.

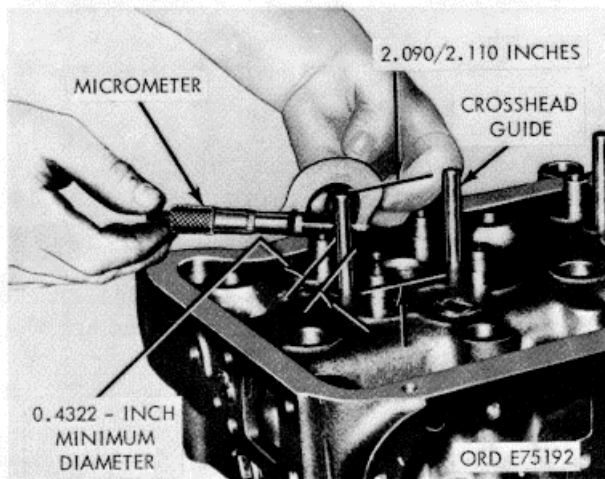

Figure 3-33. Crosshead guide cheek.

(5) Check valve guide protrusion to limit of 0.695/0.710 inch.

*h. Valve Springs* (fig. 3-35).

**NOTE**

Weak valve springs may cause flutter which results in excessive wear on both valve and seat. Valve flutter interferes with valve timing and may cause valve to strike the piston head. Weak springs may also cause valve warping, cracking and breaking.

(1) Using a spring tester capable of very accurate measurements of spring lengths and applied load, check springs against limits specified in repair and rebuild standards, paragraph 3-183.

**NOTE**

A 1/32 inch spacer may be used under valve spring when insert and valve have been refaced.

(2) Replace springs if load is less than indicated under "wear limits" at required compressed length.

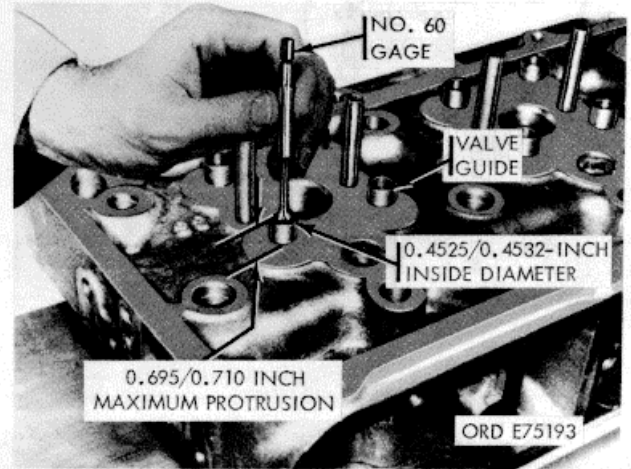

Figure 3-34. Valve guide check

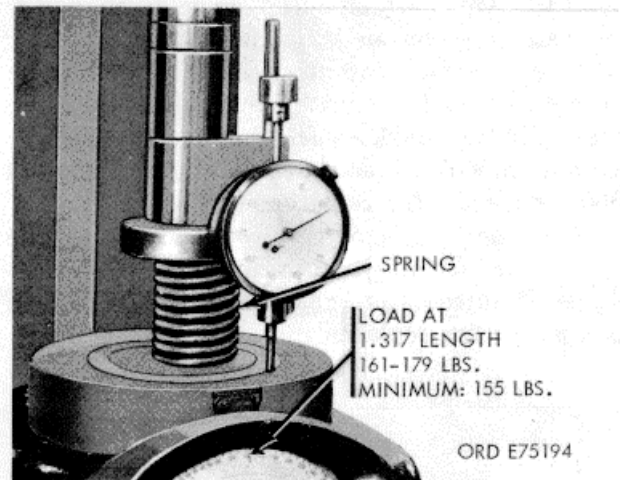

Figure 3-35. Valve spring test.

**3-67. Repair**

*a. Resurface Cylinder Head.* Resurface head only if it has been scratched, etched, or worn unevenly at point of contact with gasket sealing areas.

(1) Remove a maximum of 0.006 inch of material.

**NOTE**

The gasket surface should not deviate from a true plane *b*, more than 0.004-inch.

(2) Measure head height using micrometer or vernier calipers; dimensions must not exceed 4.4890/4.4990 inches.

(3) Restore counterbore and pocket depth at valves and shallow counterbore area around injector port (fig. 3-36) by grinding with a stone dressed to the indicated contours.

b. *Regroove Cylinder Head.* If cylinder head has been resurfaced, regroove with grooving tool (33, fig. B-28), as shown in figure 3-37.

(1) Select scrapped injector, preferably one with class "0" plunger bore and injector cup. Cut off cup to expose plunger bore, to keep cup seal area intact.

(2) Install injector in cylinder head and tighten 30/35 foot-pounds torque.

(3) Select correct tool spacer block, 0.940 inch thick. Assemble the regrooving tool, positioning largest pilot pin so it protrudes downward

in same direction as cutter; tighten assembly in place.

(4) Rotate cylinder head and install regrooving cutter in injector bore (fig. 347).

(5) Check position of stop in tool holder to make certain it will not contact water hole during regrooving operation.

(6) Adjust regrooving cutter so it protrudes 0.006/0.008 inch below stop. Rotate tool clockwise to cut grooves. Do not rotate counterclockwise.

**CAUTION**

Do not attempt to cut deeper than cutter groove depth or grooves will not form in head. Groove lands should be 0.010/0.015 inch wide and must not extended above head surface

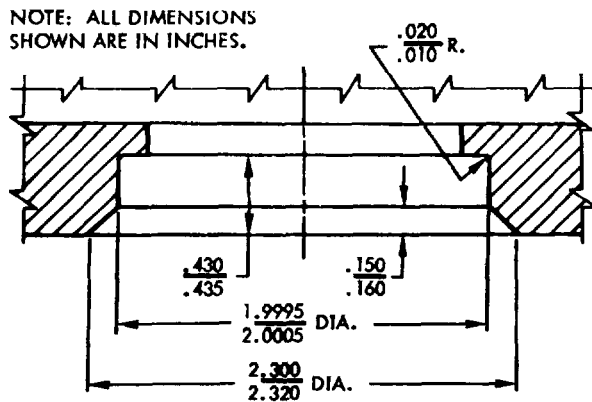

VIEW A. VALVE COUNTERBORE

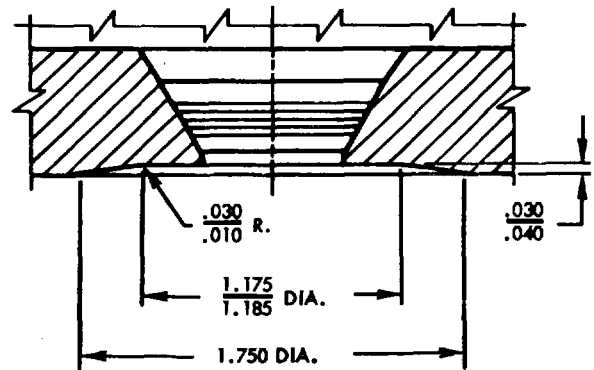

VIEW B. INJECTOR COUNTERBORE ORD E75195

Figure 3-36. Valve and injector counterbore dimensions.

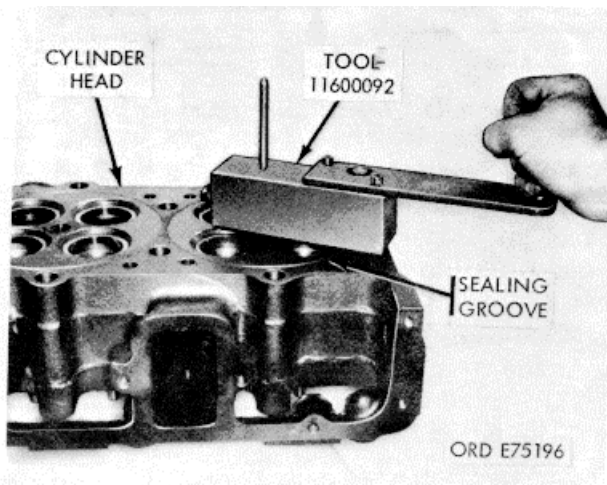

Figure 3-37. Cylinder head regrooving.

c. *Grind Valves.*

(1) Wet grind valve from horizontal to exactly 30 degree angle.

(2) Inspect rim thickness after grinding as shown in figure 332; if rim is less than 1/16 inch, valve is not suitable for use and must be replaced.

(3) Check valve in reamed guide and against newly ground valve seat face. Pencil mark valve face and drop into position and rotate 10 degrees. A good seat will be indicated if all pencil marks are broken. If pencil marks are not broken either valve seat or valve refacing tools have not been properly adjusted; final check should be made with vacuum tester.

**3-68. Assembly**

a. *Valve Guide.*



**CAUTION**

Insure that the 1/16 inch hole in valve guide is turned toward exhaust manifold and that the hole remains open after assembly.

(1) Install valve guides as shown in figure 338. Press in valve guide to 0.695/0.710 inch above head surface with valve guide driver (49, fig. B-28).

(2) Ream valve guide from bottom side of cylinder head using reamer, drill press and floating tool holder. Valve guide must have inside diameter of 0.4525/0.4532 inch after reaming.

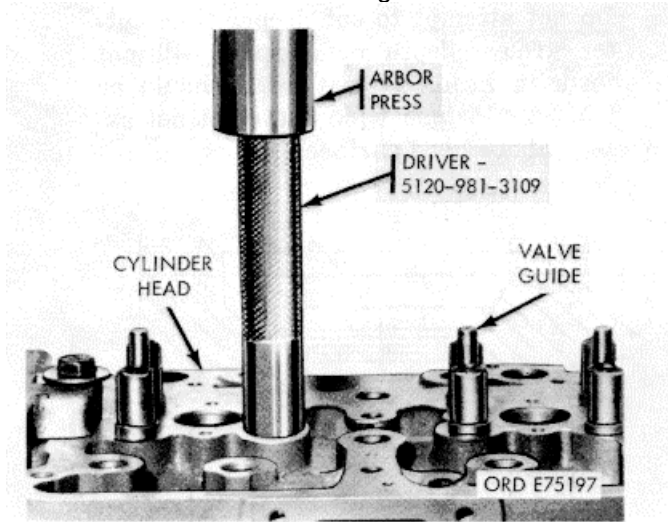

Figure 3-38. Valve guide installation

*b. Crosshead Guides.*

(1) Install crosshead guides as shown in figure 3-39. Press in crosshead guide to 2.090/2.110 inches above head surface with guide spacer (47, fig. B-28).

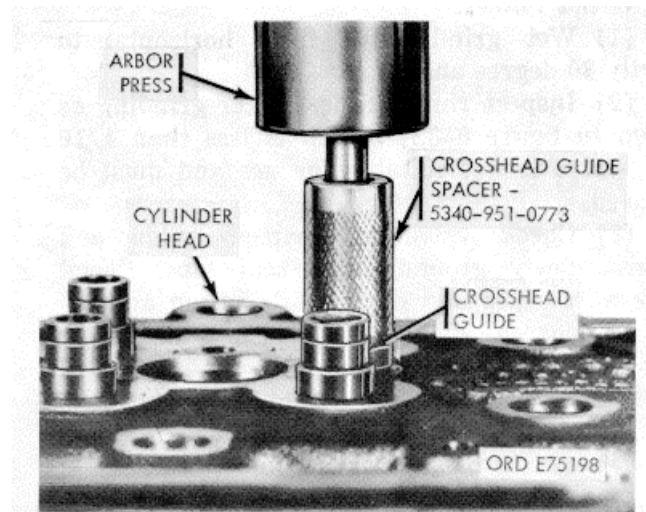

Figure 3-39. Crosshead guide installation.

(2) Ream crosshead guide bore to 15/82 inch if necessary after installation.

*c. Injector Sleeves.*

(1) Install injector sleeves using sleeve driver (14, fig. B-28) as shown in figure 3-40.

(2) Remove injector sleeve driver and install injector sleeve holder (fig. 3-30).

(3) Using sleeve expander (13, fig. B-28), roll upper portion of injector sleeve to 1.145/1.155 inches inside diameter as shown in figure 3-41.

**NOTE**

Set drill press at 250 rpm and 600 pounds pressure for 30 seconds; apply OE-10 oil during operation.

(4) Remove injector sleeve holder.

(5) Using sleeve roller (16, fig. B-28), roll lower portion of injector sleeve as shown in figure 3-48.

(6) Cut injector sleeve seat with sleeve cutter (17, fig. B-28) as shown in figure 343, to provide maximum allowable sleeve protrusion of 0.125 inch, 0.100/0.115 inch nominal.

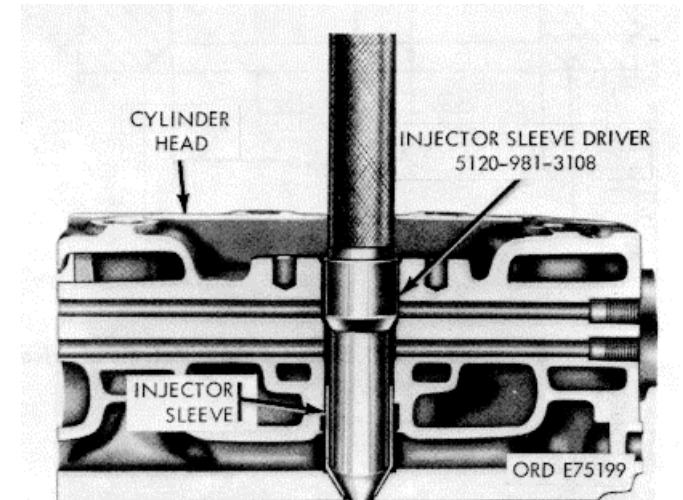

Figure 3-40. Injector sleeve installation.

*d. Valve Seat Inserts.*

(1) Recondition valve seat counterbore using tool kit, cutter, and valve guide (48, 51 and 41, fig. B-28) to proper size (A, fig. 3-36), as shown in figure 3-44.

(2) Install swirl plate in intake valve ports only as shown in figure 3-45.

(3) Install valve seat insert using valve seat insert tool kit and peen insert in cylinder head as shown in figure 3-46.

*e. Grind Valve Seats.*

(1) Select a suitable valve grinding machine

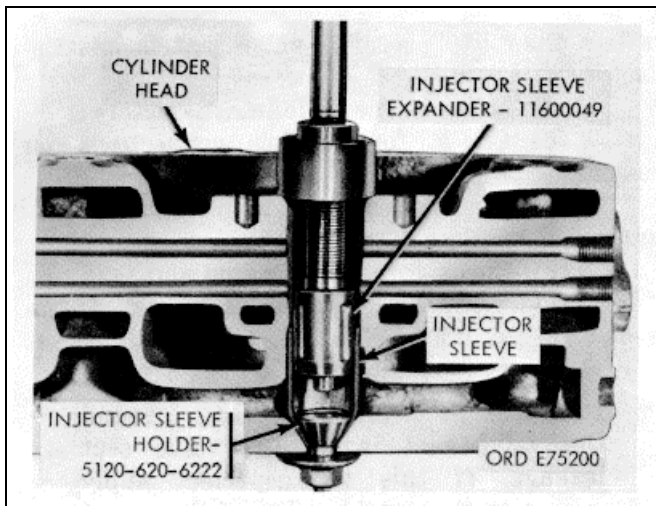

Figure 3-41. Injector sleeve rolling-upper portion.

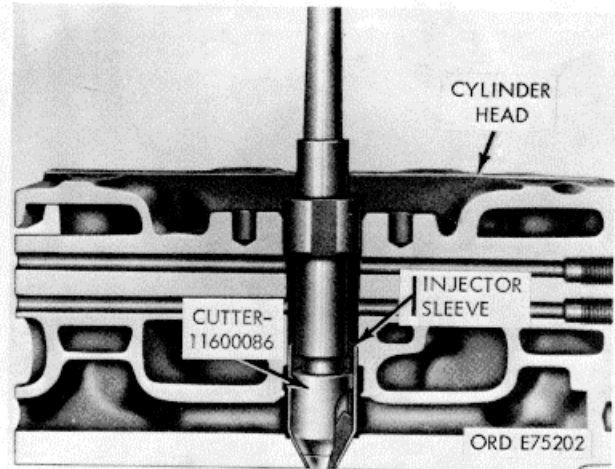

Figure 3-43. Injector sleeve seat cutting.

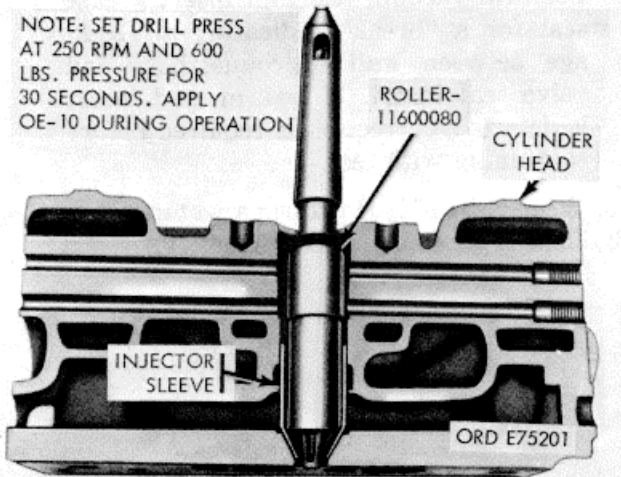

Figure 3-42. Injector sleeve rolling-lower portion

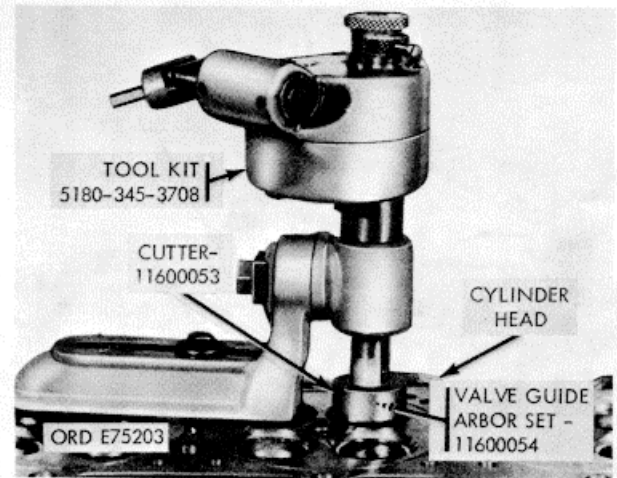

Figure 3-44. Valve seat insert counterbore.

and proper size mandrels to fit reamed valve guides. Dress grinding stone to 30 degrees from horizontal.

(2) Grind valve seats, holding motor as nearly vertical as possible.

(3) Check valve seat width which should be 1/16 to 1/4 inch.

(a) If ground seat is wider than 1/8 inch maximum stock can be removed from points "A" and "B" (fig. 3-29) with specially dressed valve seat grinder stones.

(b) Narrowing should not extend beyond chamfer on seat insert. Chamfer provides forpeen metal.

(4) Dress wheel for final finish and finish grind with light touches of stone against valve seat face.

(5) Check valve seat concentricity with valve seat indicator.

(a) Use valve guide as a center. Gage

must be a perfect fit on pilot mandrel.

(b) Run out should not exceed 0.002 inch total indicator reading.

f. Valve Assemblies. Reassemble valve assemblies in reverse order of disassembly (para. 3-64).

### 3-69. Tests

a. Valve Seating (fig. 3-47). Test valve seating for leaks with cylinder head gage (2, fig. B-29) as follows:

#### CAUTION

Never vacuum test cylinder head with injector installed. Installation of injectors could cause misalignment of valves in valve seat area and result in leakage during test.

(1) Select a vacuum cup of proper size for valve to be tested.

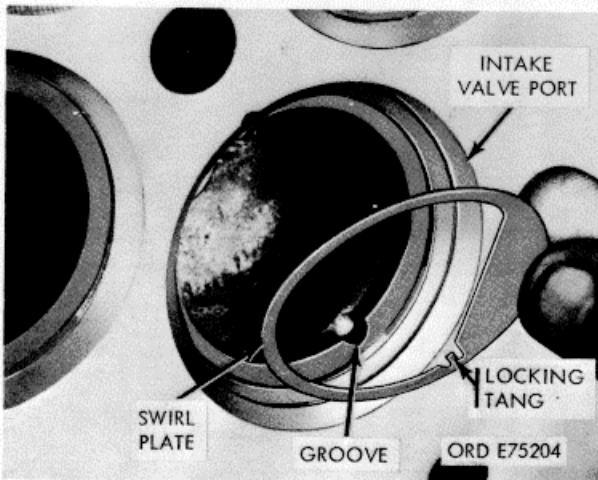

Figure 3-45. Intake valve port swirl plate-installation

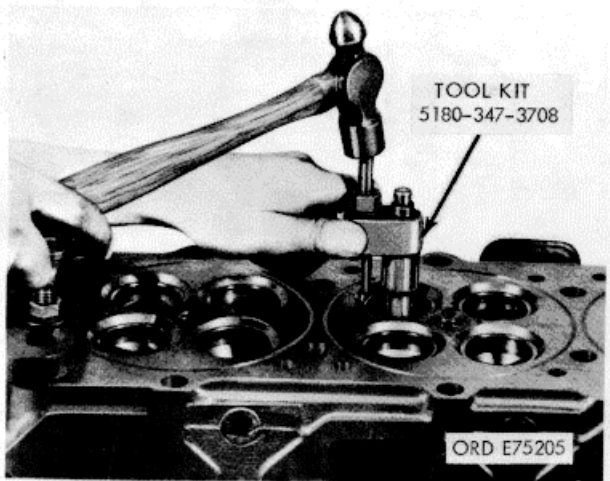

Figure 3-46. Valve seat insert peening.

(2) Valve and seats must be dry and clean. Place suction cup over valve head. O-Ring on cup should seat on flat surface of head surrounding valve. Grease area lightly with GAA for a better seal.

(3) Turn hand shut-off valve to open position. Hold push button down to operate vacuum pump.

(4) Operate vacuum pump until hand on vacuum gage stops climbing at 15/25 inches of mercury on the dial.

(5) Close shut-off valve; release push button to stop pump.

(6) Time vacuum pressure decrease on gage to test valve seat.

(a) "Start" timing as soon as hand reaches "15" inches of mercury on dial.

(b) "Stop" timing when hand reaches "12" inches of mercury on dial, if elapsed time

is less than "10" seconds valve seat is unsatisfactory. (7)

If valve seat seal is unsatisfactory:

(a) Check for leaking connections on tester.

(b) Operate tester with suction cup against clean glass plate.

(c) Check for dirt on valve and seat.

(8) If necessary regrind valve seat (para. 3-68.e.).

#### NOTE

It is possible to mistake leakage around the valve seat insert for valve seat leakage. If this is suspected, apply grease to the outside edge of the insert to make a grease seal.

Perform vacuum test and insert grease seal for a "break" indicating air leakage between wall of counterbore and valve seat insert. If leak around insert is detected, correction is required before continuing with test

b. *Head Assembly.* Perform a water test on the rebuilt head assembly (para. 366.c.).

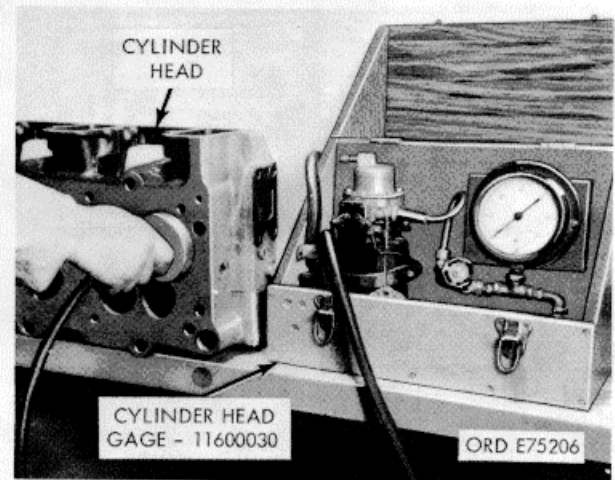

Figure 3-47. Valve seat test.

### 3-70. Installation

a. Make certain pipe plugs are installed and secure.

b. Clean mating surfaces of cylinder block and cylinder heads. Make certain cylinder walls are clean and well lubricated with OE-10 engine oil.

c. Place grommet retainers in water passages in block, small end up.

d. Lay gasket on flat surface. Press grommets in place by hand.

e. Install head gaskets over ring dowels so that

word "TOP" on gasket is visible. Be careful not to dislodge grommets as gasket is lowered over grommet retainers.

f. Using cylinder head lifting plate (45, fig. B-28) as shown in figure 2-19, capscrews, lift head with suitable hoist and lower into place over dowels.

g. Blow all liquid and dirt from cylinder head capscrew holes with compressed air.

### CAUTION

Keep rust preventative oil from internal engine parts to prevent corrosive damage.

h. Coat short cylinder head capscrews with

**\*TM 9-2815-213-34**

rust preventive lubricant and install. Tighten each in sequence shown in figure 3-48.

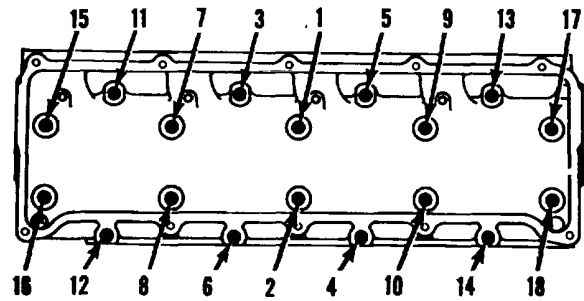

## Section XIV. Repair of Fuel Injectors

### 3-71. General

This section covers the disassembly, inspection, repair, assembly and testing of injectors (fig. 3-49). The injector is a simple mechanical unit which receives fuel from the fuel pump, under pressure, and injects it through fine injector cup spray holes into the combustion chamber. The description "PT Injectors" is only used to indicate that the injector is used with the PT fuel systems. The PT injectors are mounted in the cylinder head and are cylindrical in shape. The V8-300 engine uses of PT type C injector. It consists of two major assemblies: injector body and plunger; and the injector cup. The orifice descriptions below are given for functional maintenance purposes.

a. Adjustable Orifice Plug. The orifice plug used in the inlet drilling of the cylindrical injector adjusts delivery of fuel. Fuel delivery is adjusted by changing the orifice plug or by burnishing the plug in operating position. Some orifice plugs have a flange and require a gasket beneath the flange.

b. Drain Orifice. The drilled orifice in cup end of the injector is the drain drilling. This orifice is fixed in size and must not be altered in any way.

c. Metering Orifice. The orifice in cup end of the injector allows fuel to enter plunger bore and cup; do not alter in any manner.

### 3-72. Disassembly

(fig. 3-49).

a. Lift out injector plunger and spring. Tag mating parts.

### NOTE

Injector bodies and plungers are class fits, do not interchange.

b. Remove and discard O-Rings from injector body.

c. Disassemble clamp securing screen to injector body.

### NOTE

Do not remove adjustable orifice plug from inlet groove.

d. Place injector in injector cup wrench (30, fig. B-28) and install in injector holding fixture (29, fig. B-28) as shown in figure 3-50.

e. Remove injector cup; note size markings on injector body for future reference.

f. Remove ball retainer, ball, and gasket from top of injector body, discard gasket.

g. Place injector plunger in suitable holding device with spring retainer upward.

h. Pull link and retainer as an assembly.

i. Using a collet type hand tap holder, pull injector links (fig. 3-51).

### 3-73. Cleaning

Clean injector components in accordance with paragraph 2-5.

### 3-74. Inspection

Perform general inspection of components in accordance with wear limits in repair and rebuild standards (para. 3-183). Detailed inspection of injector components follow.

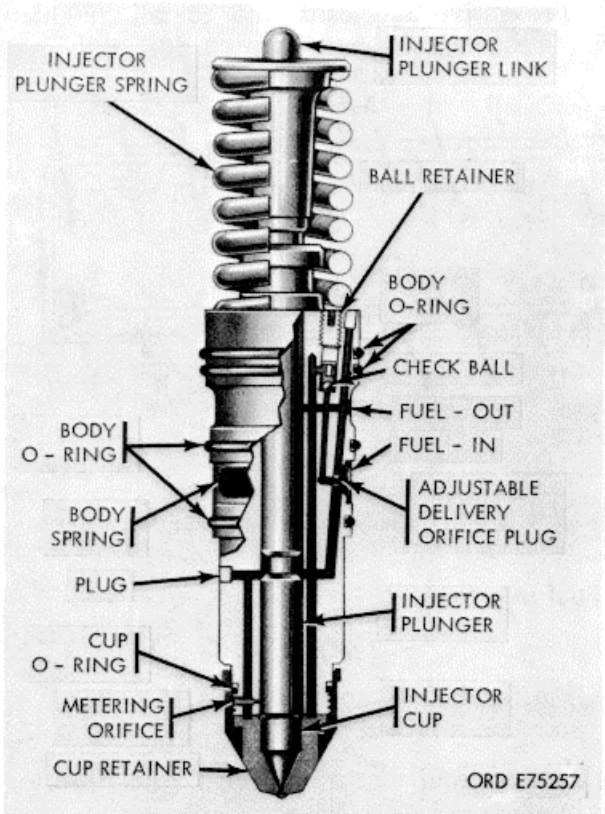

Figure 3-49. Fuel injector PT (type C)

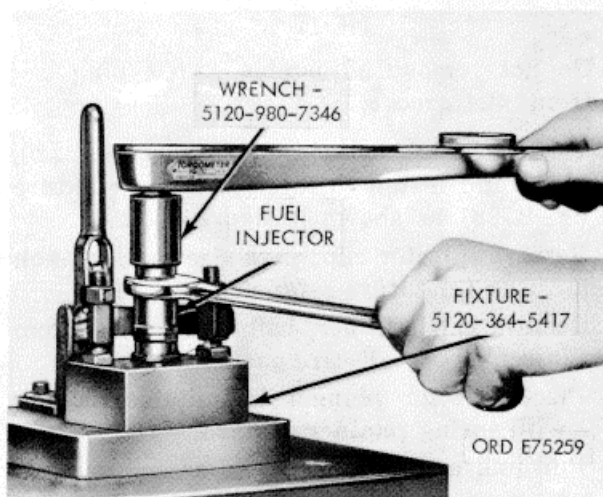

Figure 3-50. Injector cup-removal/installation.

**CAUTION**

Never alter size of injector spray holes.

a. *Injector Cup.* Inspect injector cup spray holes and tip with magnifying glass and compare with new cup. Discard cup if any of following conditions exist:

- (1) Interior/or exterior abrasive wear.
- (2) Corrosion damage and effect of excessive heat, usually resulting from high acid or

sulphur content in fuel or overload operating conditions.

(3) Enlarged or distorted spray holes, caused by cleaning with drills, wires, or other instruments.

(4) Plunger seat pattern covers less than 40 % continuous area around cup, cone or plunger bore (fig. 3-52).

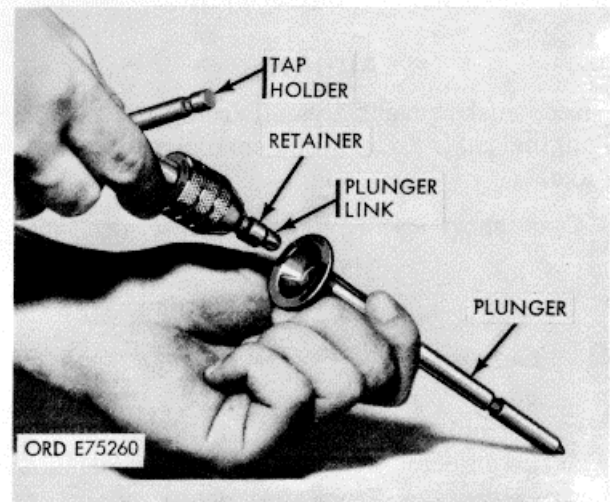

Figure 3-51. Injector Link-removal/installation.

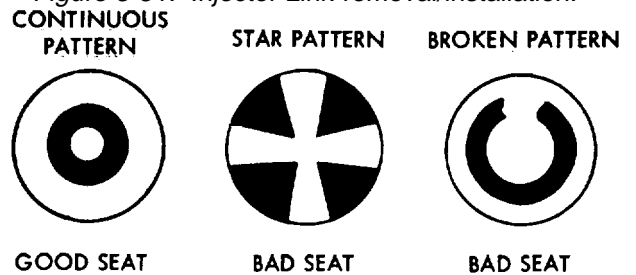

Figure 3-52. Plunger seat pattern.

b. *Injector Body.*

(1) Inspect injector body plunger bore for scoring, if scores are too deep, injector body should be replaced.

(2) Use strong magnifying glass to check for burrs, carbon, and distorted radii in orifices. When injector orifices are damaged, the injector will not function properly.

c. *Injector Plunger.*

(1) Check closely for metal seizure caused by scuffing or scoring.

(2) Spots or surface disruption at top of plunger or at mid-point, usually are normal results of rocker lever thrust action. Unless metal is displaced or wear is measureable at these points,

plunger may be reused. If worn excessively, place body and plunger.

(3) Narrow streaks running the length plunger usually are the result of varying thickness of penetrant treatment used to prevent rusting. Plunger is satisfactory for reuse unless surface distortion is evident.

d. Injector Spring.

(1) Check spring for excessive wear breaks.

(2) Test spring tension on spring tester that is capable of very accurate measurements of spring lengths and applied load by means of standards and dial indicator gage.

(3) If injector springs compress to dimensions at less than loads given in repair and rebuild standards, springs must be replaced.

**3-75. Repair** Repair of the injector assembly is limited to replacement of spare parts and general repair procedures in accordance with paragraph 2-7.

**3-76. Assembly**

(fig. 3-53).

a. Drop check ball into bore in top of injector body.

b. Using check ball seating tool (5, fig. B-28)

screw down against ball and tighten to 30-40 in-lb torque as shown in figure 3-54.

c. Install retainer plug, with a new gasket, and tighten to 30-40 inch pounds.

d. Lubricate new injector body O-ring with OE-30 oil.

e. Using O-ring tool (39, fig. B-28), slide O-ring onto injector body as shown in figure 3-55.

#### **NOTE**

If sealing surface of PT (type C) cup is slightly damaged, use lapping blocks and mixture of 600 grit lapping compound and OE-30 lubricant to smooth cup. Oscillate cup on block, applying light pressure. Clean thoroughly before installing.

f. Select plunger and body with same size markings (fig. 356), immerse injector plunger in clean injector test oil.

g. Install plunger in injector body from which it was removed and place injector in fixture (fig. 3-50).

#### **NOTE**

Oil injector cup and retainer with OE-30 oil before assembly.

h. Place new retaining ring on new plunger link and press link into place. Press retainer flush to 0.010 inch below bore surface.

i. Select cup of proper size (fig. 3-57) and install finger tight on injector body. Apply tension to align plunger in body, back off 1/2 turn, tighten with cup wrench (30, fig. B-28) to 55 foot-pounds as shown in figure 3-50.

#### **NOTE**

Spring tension in tool is controlled by spacers marked by the engine model which aligns plunger and cup when performing above operation.

#### **CAUTION**

If cup is replaced, always use identical replacement cup.

j. Check injector assembly plunger seating on test stand as described in paragraph 3-77.a.

k. Remove injector plunger from body. Lubricate plunger with test oil. Install injector spring and plunger in body. Check to see that it does not bind as it seats in cup.

l. Check cup spray pattern as described in test section. If spray pattern tools are not available, fill injector body two-thirds full of clean fuel. Insert plunger forcing fuel out cup spray holes to see that they are open and clean.

**3-77. Test and Calibration**

a. Injector Plunger Seat Test.

(1) Install injector assembly on test stand as shown in figure 3-58.

#### **NOTE**

Figure 3-56 illustrates the injector checking fixture currently in use in the Army supply system and is available through normal supply channels.

(2) Attach 80/90 p.s.i. air supply to test stand air coupling.

(3) Remove spring and plunger from the assembled injector and re-install plunger only in the injector body.

(4) Place injector in test set-up with cup seated in the counterbore below the air valve.

(5) Install cylindrical injectors with drain and outlet holes up.

(6) Position injector plunger with size mark centered between the injector inlet and drain openings. Fill opening with fuel oil and operate plunger several times to purge any air trapped in injector.

(7) Seat handle against injector plunger

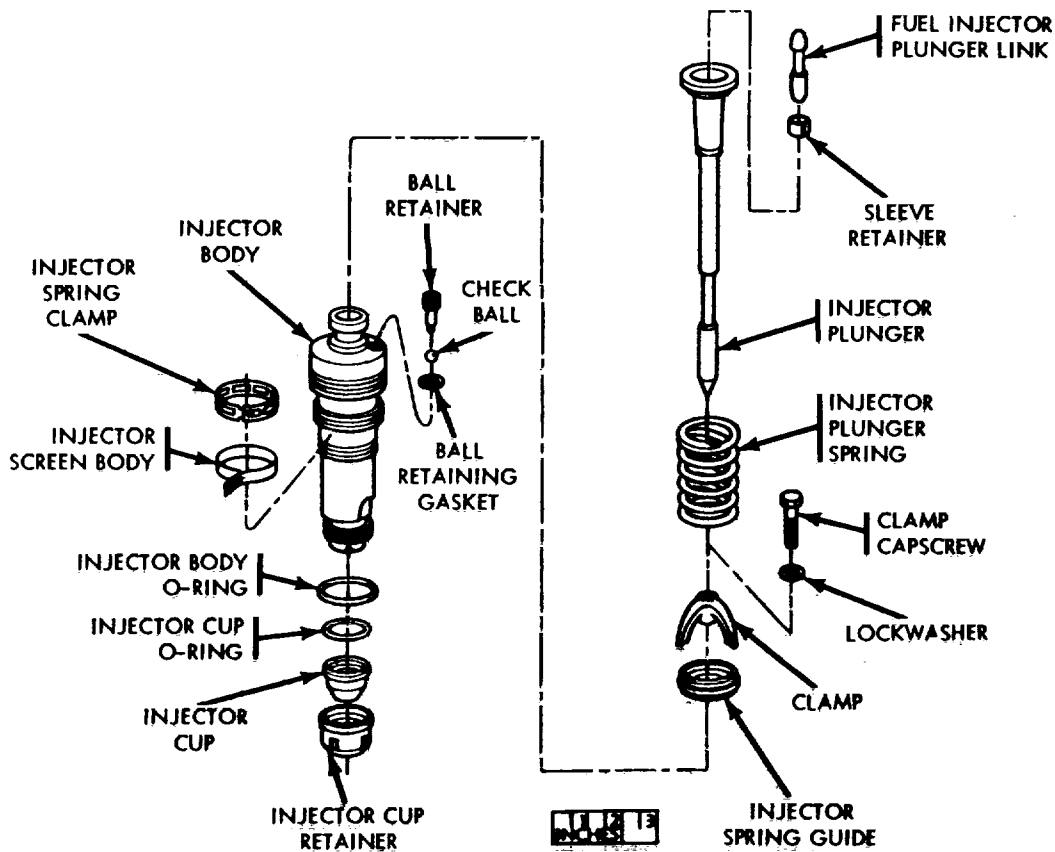

ORD E75258

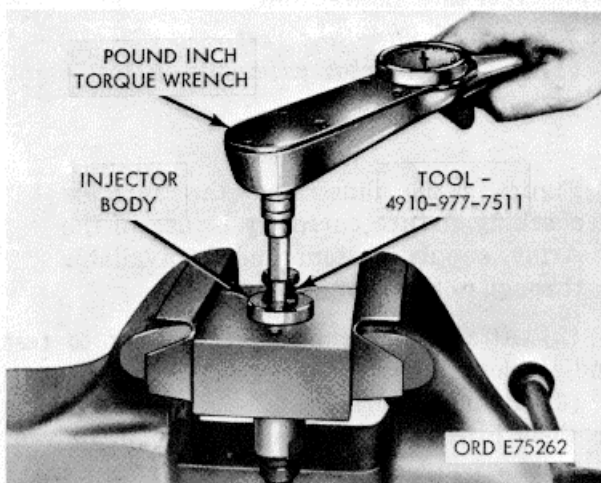

Figure 3-54. Injector check ball seating.

link and let weight control force against plunger Do not apply any additional force to handle during test.

(8) Turn on air pressure. Injector is acceptable if the duration of time before the first air bubble appears is more than ten seconds, and time between the observed air bubbles is not less than five seconds.

**CAUTION**

Before deciding the injector is leaking, be sure any air trapped in the fuel passage has been purged,

(9) If leakage exists, check for dirt or other foreign material, changing or reassembly of the cup will often correct leakage.

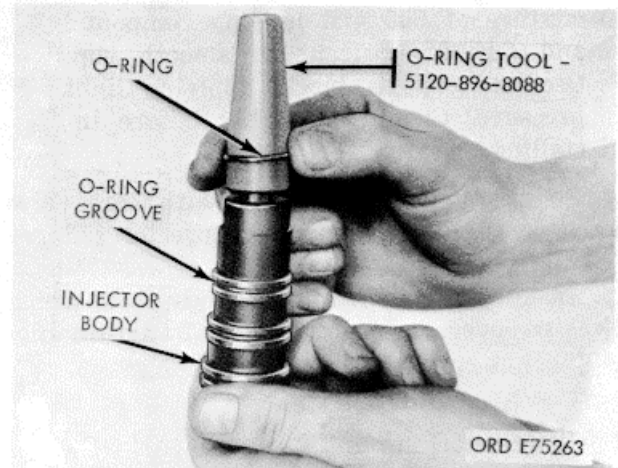

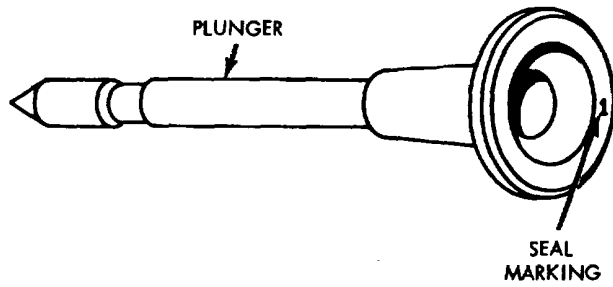

VIEW - A. PLUNGER

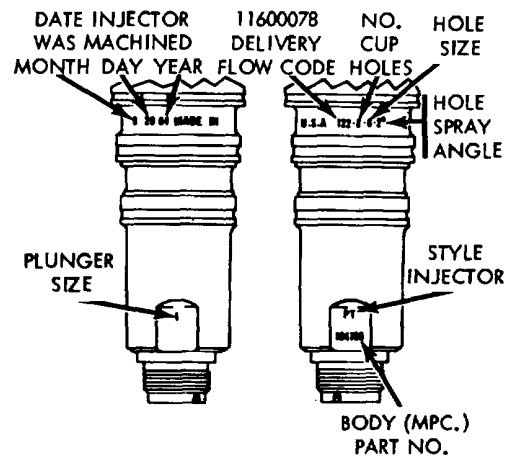

VIEW - B. BODY ORD E75264

Figure 3-56. Injector body and plunger markings.

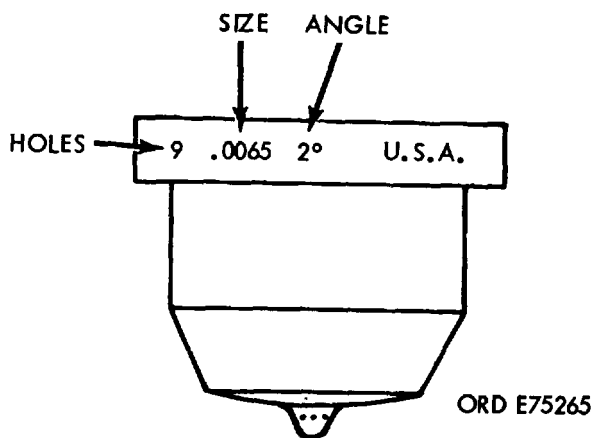

Figure 3-57. Injector cup marking.

10) If the cup seat is damaged in any way and injector does not pass cup-to-plunger seat test, plunger may be lapped into cup to obtain good seating. Use no greater than 300 grade lapping compound mixed with OE30 lubricating oil. Applying light pressure, oscillate plunger in cup back and forth for approximately one minute.

**CAUTION**

After lapping, both the cup and plunger must be thoroughly cleaned. Lapping compound will damage fuel system unless removed. The most effective cleaning process is the use of an ultrasonic cleaner, if available, and an after rinse in fuel oil.

(11) If injector is satisfactory, remove plunger. Re-install spring and plunger.  
 b. *Calibrating Injector Test Stand* (fig. 3-9). The injector test stand is used to test all injec-

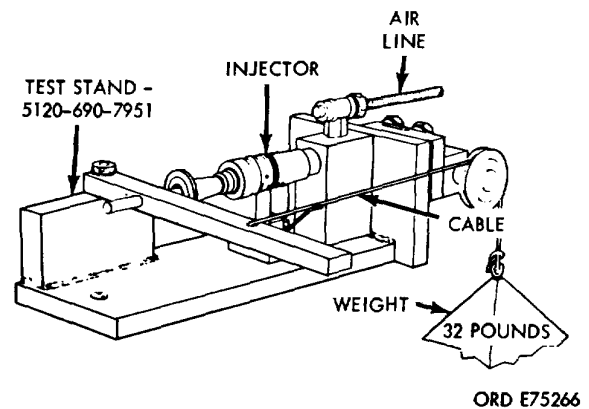

Figure 3-58. Injector plunger seat test.

tors. It flow tests the complete injector assembly by measuring fuel delivery. The injector is actuated under controlled conditions closely simulating actual operating conditions. The test stand counts injection strokes, supplying fuel at specified pressure, and measures the delivery in a glass graduate. The following preliminary steps and procedures are required prior to test stand operation.

**CAUTION**

Before operating the test stand make sure that the cam box is filled to the level of the sight glass with OES-30 oil.

**NOTE**

The test stand must be located near hot and cold water connections. Water temperature, controlled by a mixing valve, is used to maintain test fuel at an 80/100 degree Fahrenheit temperature range.



(1) Install factory calibrated master injector gage (36, fig. B-28), in test stand to adjusting other injectors for fuel delivery.

**CAUTION**

The master injector must never be tampered with.

(2) Fill hydraulic fluid reservoir.

(3) Test oil tank on stand must be kept at least ye full of diesel fuel.

(4) Aline timing mark (fig. 3-60) and close hydraulic valve and open the air valve (fig. 3-61). Place load cell tester (1, fig. B-29) in test stand and clamp in place by opening hydraulic valve (fig. 3-61).

**CAUTION**

Never operate test stand with load cell in position.

(5) Adjust air pressure by turning knurled button on air regulator until the load cell indicates within marked band on load cell gage (0 3-62). Lock knurled button in place with locknut. Note air gage pressure (gage at top hydraulic reservoir).

(6) Remove load test gage by opening ]draulic valve and returning air valve knob center position. With cylinder rod in down position, check to make sure hydraulic fluid shows hydraulic oil lever sight bulb.

(7) Open air valve. While cylinder rod is at the top of its travel, check to make sure there no air in hydraulic fluid sight glass.

(8) Make sure injector seat contains 0.0 inch restrictor orifice when calibrating test stand.

(9) Place injector adapter (fig. 3-63) o~master injector and engage locators in inject mounting holes. Make sure seat is retracted a timing marks are alined at timing wheel.

(10) Position test stand link (marked NV NH, H) over injector plunger link and place adapter and injector assembly in injector se tip back until link is below machine push rod. necessary adjust bracket so link is alined but r rubbing.

**NOTE**

Turn injector plunger so that class size marking on top of spring retainer is midway between inlet and drain connections.

(11) Open air valve (fig. 3-61) and as injector goes in clamped position make sure plunk link is properly alined and engaged in link gui

(12) Check air gage pressure at top of ]

draulic reservoir as originally established with load test cell. Close hydraulic valve (fig. 3-61) to lock injector in clamped position. Connect inlet and drain connectors (fig. 3-64) to injector.

(13) Start test stand motor and allow to run until fuel temperature reaches a minimum of 80 degrees.

(14) Adjust fuel pressure by turning pressure regulator knob until fuel pressure gage shows 120 psi. If this pressure can not be achieved, the trouble probably is due to a sticking air regulator, or to a worn gear pump. Pres. sure of 120 psi must be maintained at all times during calibration and testing.

(15) All counter wheels (fig. 3-60) must be set at zero (0) as a starting point.

(a) Shift silver-colored counter wheels to right, rotate as necessary then release them to indicate 1020 strokes. Rotate empty vial into position by turning vial knob.

(b) Clear counter by rotating with thumb screw until all white counter wheels show zero. (16) Engage counter and divert fuel to vial for measurement by pressing and releasing red flow start switch.

(17) Stir fuel with a rod to settle out foam. Check amount collected in vial at end of 1020 counter strokes.

(18) Look directly into vial at fuel level to avoid parallax. If this reading shows 129 cc which is 3 cc below correct injector master delivery specifications (132 cc @ 120 psi.), or an- other value, repeat test.

(19) Dump fuel from vial and repeat test at least twice to insure consistent results.

(20) If 3 cc low, it will be necessary to set counter up to approximately 1043 strokes or about 7 1/2 strokes for each cc. Roll counter back, all white counter wheels must show zero (0).

(21) Repeat tests and adjust counter as necessary to obtain 132 cc delivery at 120 psi. with fuel temperature at 80 degrees to 100 degrees Fahrenheit while master injector is in test stand. Check readings for three cycles to insure repeatability, at this point test stand is correctly calibrated.

(22) Remove master injector from test stand.

*c. Injector Spray Pattern Check.*

(1) Locate injector spray angle tester (6, fig. B-29) on or near injector test stand (fig. 3- 59) or other source of 50 p.s.i. constant fuel pressure, so that injector inlet connection of test stand will reach injector to be checked. Use injector test oil or diesel fuel to perform test.

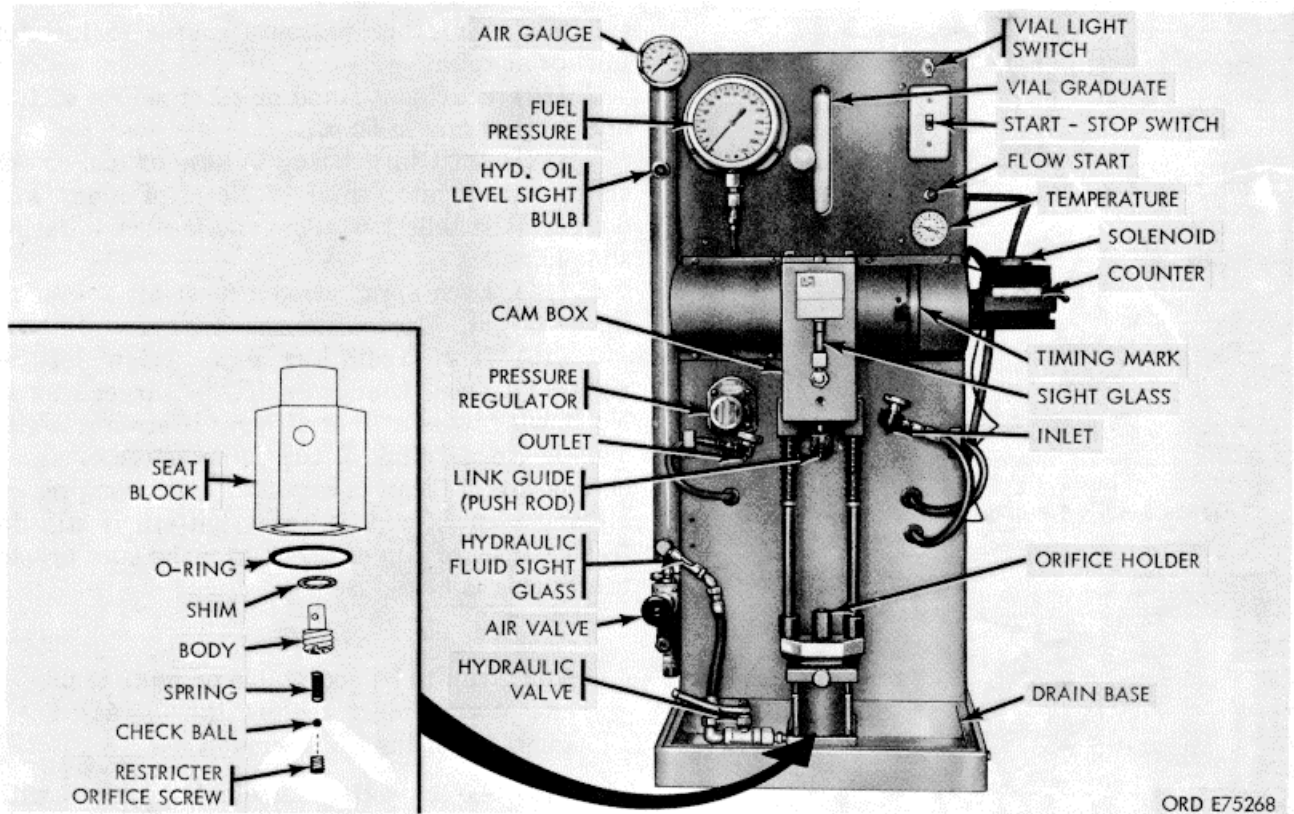
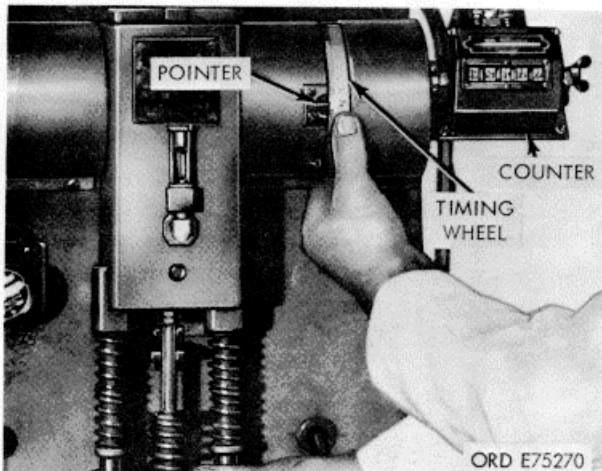

Figure 3-59. Injector test stand



(2) Attach drain hose to tester base and place loose end in test stand drain pan.

(3) Assemble 2 degree cup seat and space to seat bracket bore.

(4) Check cup markings as shown in figure 3-57, for number of spray holes and place 6 and 9 hole target ring in base.

(5) Insert injector in injector adapter (2' fig. B-28) as shown in (fig. 3-65).

(6) Remove plunger assembly and spring from injector.

(7) Select correct size plunger bore plug and rubber seal and install in injector plunger bore

(8) Install the solid knurled plug (fig. 65) in the injector drain opening.

(9) Place injector in spray angle tester seat (fig. 3-65) and adjust hold-down bracket to position required, then tighten thumb screw.

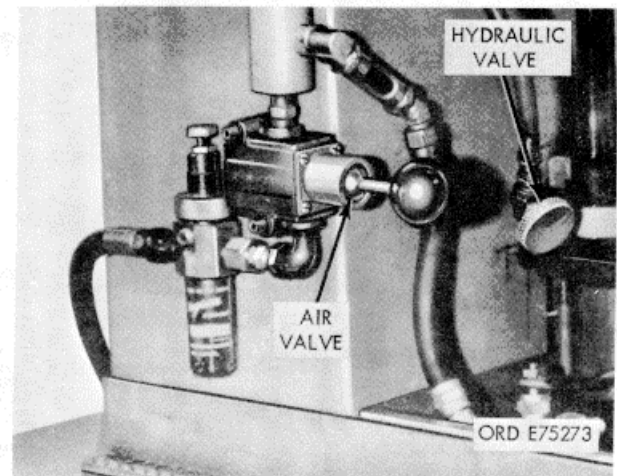

Figure 3-61. Hydraulic and air valves.

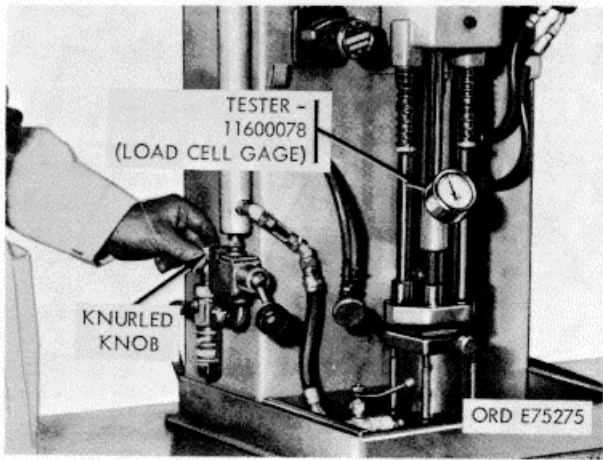

Figure 3-62. Air pressure adjustment.

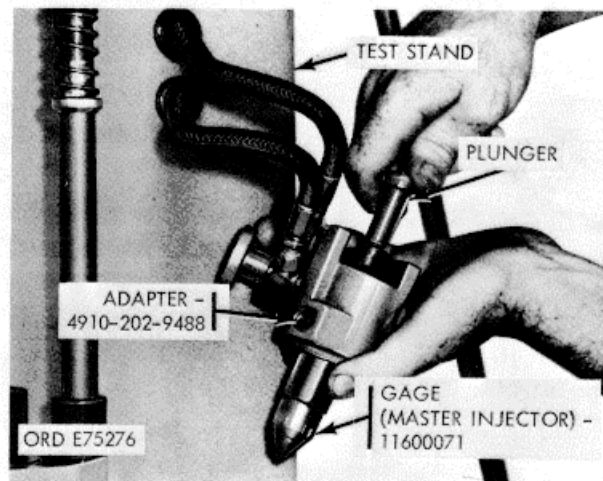

Figure 3-63. Master injector installation.

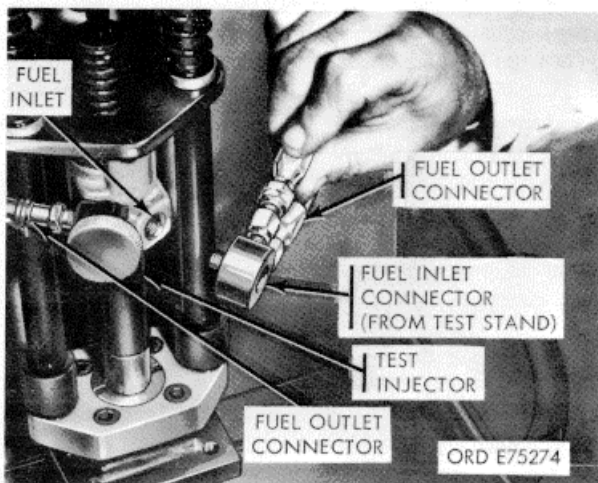

Figure 3-64. Fuel inlet installation

- (10) Tighten knurled knob to seal plunger bore.
- (11) Attach fuel inlet line from injector

test stand or other pressure source to injector inlet or adapter.

(12) Start test stand or other source of fuel and set pressure at 50 psi.

(13) Shift target ring in base of tool so one spray stream hits center of No. 1 or index window. This is tallest window and is next to target slide handle.

(14) Each spray stream must hit a window in the target.

(15) If a stream hits above, below, left, or right of a small window, shift the target ring so No. 1 window is at that stream. If stream is still outside No. 1 window, cup is defective or spray hole is dirty. Clean spray holes with compressed air and recheck cup. If spray pattern is still defective, discard cup or check to make sure proper target ring is being used.

**NOTE**

For a cup to be acceptable or more than one stream must require the increased tolerance of the No. 1 window.

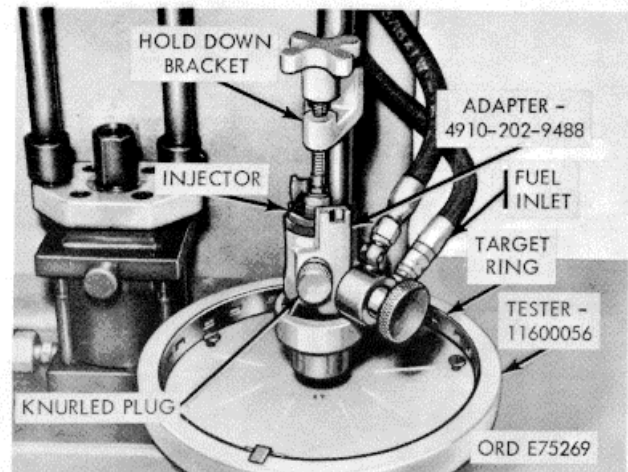

Figure 3-65. Injector mounted in test stand

(16) After testing, assemble plunger with spring in body and store in clean place until ready for flow test.

*d. Injector Flow Check.*

(1) The injector test stand must be located near hot and cold water connections. Water temperature, controlled by a mixing valve, is used to maintain test fuel at an 80/100 degree Fahrenheit temperature range.

(2) Fill test fuel tank  $\frac{a}{4}$  full of test fuel and maintain this level or higher during test. Test fuel capacity is approximately five gallons.

(3) Fill hydraulic fluid reservoir to half

level in sight bulb with clean type A auto transmission fluid. Be careful not to allow oil to standpipe in center of reservoir, figure 3-59.

(4) Fill cam box with 3 inches of OE lubricating oil. Refill with oil level drops to glass.

(5) Plug electrical connection into reel carrying necessary voltage to operate test stand

(6) Before clamping on injector in test stand must be timed by rotating timing wheel so mark and pointer are aligned as shown in figure

(7) Shop air pressure regulated by air regulator is used to apply balanced force on hydrl system, (fig. 3-66). Air gage at top of hydraulic I voir is used as a reference indicating that pre has not changed after being set using a load tei during test stand calibration.

(8) When air valve is opened, air travels ul in center of tube type hydraulic reservoir and 4 downward pressure against column of hydraulic (fig. 3-67), activating load cell tester.

(9) When both air valve and hydraulic valve3-61) are opened, hydraulic fluid is admitted piston in cylinder and lifts injector into clamped tion. Any leak in hydraulic clamping system directly affect injector loading and must not be per-mitted.

(10) In clamped position and with appropriate link in place, tension on injector is same as it operating engine. Use of improper link will clamp load and upset delivery valves.

(11) Fuel is delivered to injector through connector. Fuel pressure here is controlled a point by connecting line and pressure reg (3-64).

(12) The second connection with clear plastic line is injector outlet connection (fig. 3-64) which c drain fuel from injector back to tank.

(13) During test stand operation, operator a test cycle which diverts fuel to vial graduate so amount of fuel being injected can be measure

(14) Fuel is delivered to vial during a mea number of strokes as recorded by counter (fig. 3 e. Ball Valve Seating Check.

(1) Attach test stand inlet pressure line to connection injector adapter (23, fig. B-28) as s in (fig. 3-64).

(2) Hold injector plunger down against its seat in injector cup with injector in vertical position (fig.

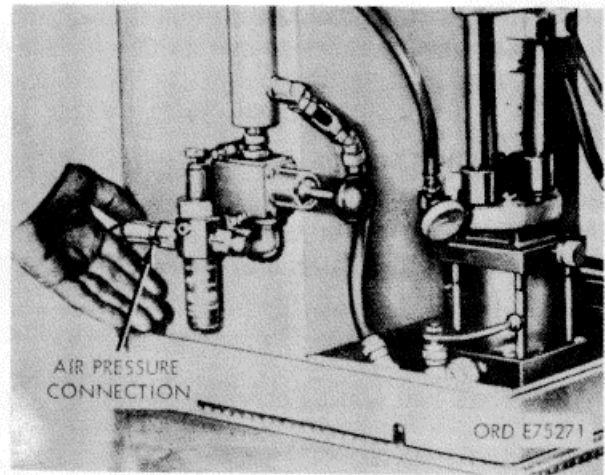

Figure 3-66. Test stand air pressure connection.

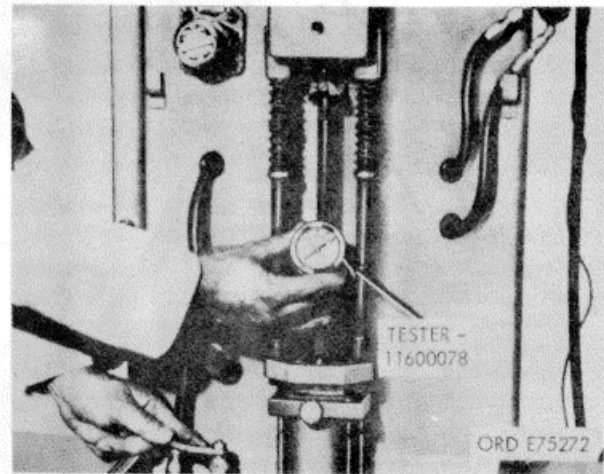

Figure 3-67. Load cell tester.

3-63), assembly may be hand held. Do not place in test stand holding device.

(3) Turn on test stand, and adjust pressure to 150 psi.

(4) Check orifice plug inlet opening of injector adapter (23, fig. B-28)ras shown in figure 3-62, for leakage past ball valve.

**NOTE**

Insure plunger is seated in cup.

(5) If leakage is observed, the ball must be reseated.

*f Seating the Ball Valve* (fig. 3-68).

(1) Remove retainer plug at top of injector body. Leave ball in place, but discard retainer gasket.

(2) Screw check ball seating tool (5, fig. B-28) as shown in figure 3-54, down against ball and tighten to 50 inch-pounds torque.

(3) Remove seating tool and install retainer with new gasket. Tighten retainer to 30-40 i pounds torque.

(4) Recheck injector for ball valve leakage (e above).

(5) If ball has not seated satisfactorily, it will be necessary to resurface ball seat using seating surface cutter (6, fig. B-28). Great care must be exercised in removing only enough material to reface a new seating surface and remove all metal cuttings.

(6) Re-install ball, new gasket, and retaining plug (f12) and fA3), above.

(7) Perform ball seating check (e above).

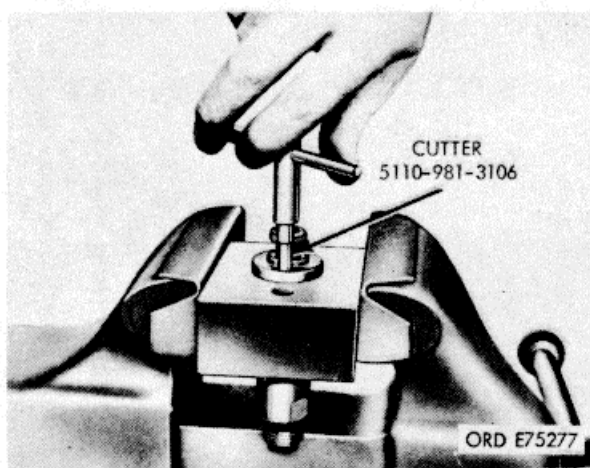

Figure 3-68. Ball seat resurfacing

#### g. Calibrating PT (Type C) Injectors.

(1) Remove injectors spring and plunk Lubricate injector adapter (23, fig. B-28) with h pressure lubricant so injector O-Rings will slide i adapter without damage to O-Rings.

(2) Install cap and rotate into its notched (fig. 3-63).

#### NOTE

The cap of the adapter contains a movable dowel screw so the fuel inlet can easily be centered in the sleeve hole after installing the cap.

(3) Seat injector in adapter so injector inlet aligns with adapter inlet after injector body is rotated into adapter. Cap pin must seat in slot in adapter. Check to be sure injector inlet is centered in sleeve inlet hole.

(4) Lock cap on injector and injector adapter (23, fig. B-28) with two socket head capscrews.

(5) Install spring and plunger in injector.

#### NOTE

Turn injector plunger so class size marking on top of spring retainer is midway between inlet and drain ports of injector.

(6) Assembly retainer plate over injector and injector adapter.

#### NOTE

The side of the retainer plate with two small pins locates against the injector adapter as it is installed in the test stand. All tests on the test stand are performed without a screen on the injector.

(7) PT injector delivery is adjusted during test by burnishing inlet orifice plug with orifice hole bur- nishing tool (9, fig. B-28). Install tool as shown in figure 3-69.

(8) Retract burnishing tool needle by pulling out small knob. With the needle retracted, tool may be left in connector during all test operations.

(9) Run injector through a test cycle (d above), check cc delivery. If delivery is lower than specifications, turn knob with indicator point until it is spaced <sup>1A</sup> inch from large knob (fig. 3-70).

(10) Slowly push small knob in until you feel needle enters orifice plug inside diameter, then turn knob counterclockwise to lock needle shaft to larger knob with indicator. Turn indicator knob in until you feel needle contact plug. Index indicator with mark for each two cc increased delivery (fig. 3-70).

(11) Back off adjusting screw and retract needle. Retest injector (para. d, above). If delivery is more than 116-117 cc. a new injector body must be install- | ed.

(12) Recheck injector delivery for specified 116-| 117 cc with new injector body.

### 3-78. Installation

- a. Inspect injector, it must be clean and the screen around inlet groove must have no gaps or holes.
- b. Check that copper sleeves in cylinder heads are clean, free of chips, and carbon particles.

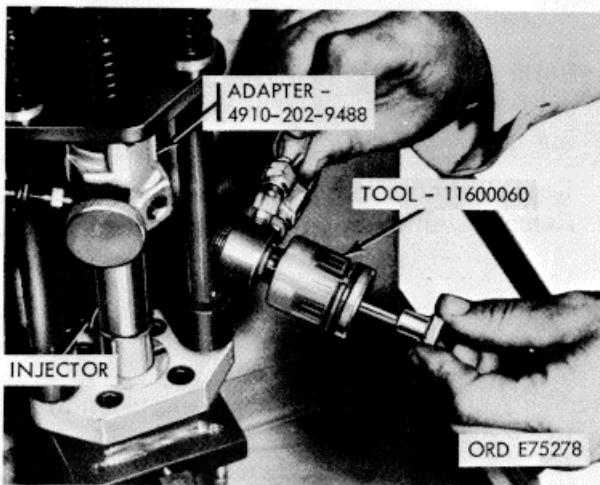

Figure 3-69. Orifice hole burnishing tool installation

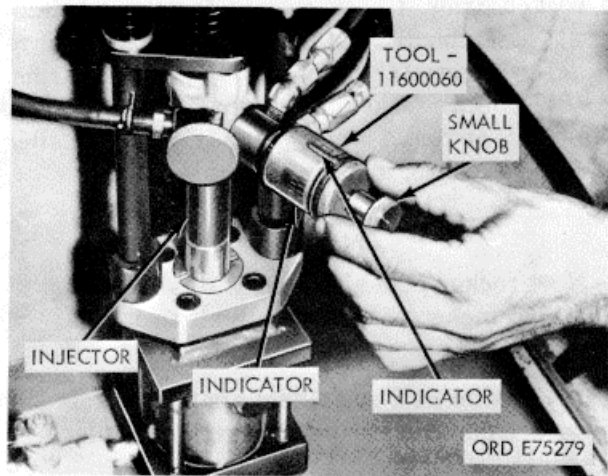

Figure 3-70. Orifice plug burnishing

- c. Lubricate O-Rings with GAA lubricant.
- d. Start injectors into bores with inlet toward camshaft. Guide them by hand until injectors are aligned in bores and not binding in any manner.
- e. A hard push on injector bodies with butt end of a hammer handle will seat injectors. A snap should be heard and felt as cups seat in copper sleeves.
- f. Install hold-down clamps, flatwashers, and capscrews. Tighten capscrews, 30 to 35 foot-pounds torque.

### 3-79. Injector Timing

#### NOTE

Woodruff key used to key camshaft gear to the camshaft provides one degree advanced timing and may be identified by a yellow-tip which is placed in a for-

ward position. Refer to Paragraph 3-43.

- a. Install injector push rod in no. 1 cylinder. Only no. 1 need be checked.
- b. Install injector timing fixture (12, fig. B-28) in injector bore as shown in figure 3-71. Indicator extension must rest in socket of injector push rod. Tighten tool in place with injector mounting capscrews.

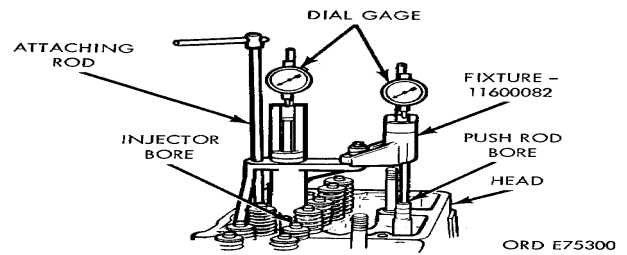

Figure 3-71. Injector push rod timing.

- c. Rotate engine counterclockwise to top center firing position. At point of maximum piston rise, set dial indicator above piston to zero.
- d. Rotate engine to 60 degrees ATDC; at this point, 60 degree mark on the moving plunger should be in line with groove on retainer.
- e. Set dial indicator for push rod travel to zero.
- f. Rotate engine in clockwise direction to approximately 60 degrees BTC of retainer. This is the same index mark indicated in d, above.
- g. Rotate engine in counterclockwise direction until dial indicator reading shows piston has traveled to location indicated at first check point under "Piston Travel" in chart 3-1 below. Read push rod travel on dial indicator and check reading against limits.

Chart 3-1. Injection Timing

Crank angle degrees	Piston travel inches	Push tube travel		
		normal	fast	slow
22.5 BTC	0.2032	0.0610	0.0575	0.0645
15.5 BTC	0.0816	0.0330	0.0307	0.0357
6.0 ETC	0.0143	0.0135	0.0115	0.0155

- h. Check push rod travel against piston travel

at each of remaining positions shown above (16 and 6.0 BTC). If push rod travel is greater or less than limits shown, timing is slow or fast respectively. A new camshaft key must be installed bring push rod travel within limits. Refer to paragraph 212.k. for removal of shaft, and pal graph 3-30 for disassembly.

**NOTE**

Before installing new key, make sure guide spring on tappet body is not holding tappet off camshaft lobe.

- i. Recheck limits as outlined in Chart 3-1.
- j. Remove timing fixture and injector push rod.

**Section XV. Repair of Rocker Arm Assembly and Push Rods**

**3-80. Disassembly**

(fig. B-6)

- a. Remove locating socket head screw (44) from mounting bracket (8). The rocker shaft locating socket head screws are located on rear left bank and front of right bank assemblies.
- b. Slide rocker arm shaft brackets and rock arms (47, 50, and 52) from the shaft (46).
- c. Remove rocker arm shaft plugs (45) from each end of each shaft.
- d. Remove adjusting screws (55) and locknut (54) from rocker arms.

**3.81. Cleaning**

Clean all parts in accordance with paragraph 2

**3-82. Inspection**

a. *Rocker Arm Assembly*

- (1) Perform general inspection of rocker arm assembly in accordance with paragraph 2-8
- (2) Gage rocker lever bushings with telescope gage and micrometer.
  - (a) Set telescopic gage 0.0002 inch above worn limit of 1.1905 inches for use as a plug gage.

**NOTE**

The inside diameter of a new rocker arm bushing is 1.1875/1.1895 inches and may wear to 1.1905 inches maximum.

- (b) Replace bushings worn beyond limits (para. d, below).
- (3) Check intake and exhaust rocker arm crosshead contact surface. If worn or damaged, replace with new rocker arm.
- (4) The ball end of rocker arm adjusting screws must be true spheres. Test with 1/4 inch radius gage and replace worn adjusting screw
- (5) Worn injector rocker arm sockets must be replaced. Wear is easily detected with fillet

gage or by observation of small protrusion at the bottom of socket.

(6) Check that all lubricating oil passages are open.

(7) Inspect thread condition on all screws and rocker arms. Check closely for thread damage at assembled position of locknut. Ensure that screws operate freely through rocker arms.

(8) Check rocker arm shaft for scoring, galling, out-of-round and wear. If worn smaller than 1.1845 inches, install new shaft.

**NOTE**

New rocker arm shaft measures 1.1856/1.1865 inches with a wear limit to 1.1845 inches,

(9) Examine rocker arm shaft brackets for cracks, breaks and stripped threads. Replace as necessary.

(10) Visually inspect arm side surfaces which mate with adjacent arms. If galled, grind surfaces to original smoothness.

b. *Push Rods.*

(1) Check ball end of all push rods for worn radii. A new allowance of 0.3150 inch. Check injector and valve push rod ball ends with 5/16 inch radius gage.

(2) Test sockets of push rods with ball end of a new rocker lever adjusting screw or with 1/4 inch fillet gage.

(3) Replace defective push rods. Extreme wear on either end of push rod will result in loss of lubricating oil pressure and may interfere with proper injector and valve adjustment.

**3-83. Repair**

Repair of the rocker arm assembly and push rods is limited to replacement of defective parts. Replace rocker arm bushing as follows:

- a. Press out worn bushing with mandrel and block set (4, fig. B-28).

- b. Blow out lubricating oil passages with compressed air.
- c. Install new bushings using mandrel and block set.

**3-84. Assembly**

- a. Dip rocker arm shaft plugs in lubricating oil, OE-10, to prevent galling. Insert plugs in shaft with an appropriate mandrel. Refer to paragraph 3-'80.

**NOTE**

Shafts are plugged at both ends. Do not install plug in shaft without a mandrel.

- b. Install rocker arm adjusting screws and nuts.
- c. Install sockets in injector rocker arms.
- d. Coat rocker arm shaft with OE-10 lubricating oil.
- e. Position rocker arm shaft bracket with locating screw hole on rocker shaft. Aline shaft and bracket locating holes and secure with allen head locating screw.
- f Slide valve rocker arm, injector arm, and valve rocker arm onto rocker arm shaft.
- g. Slide rocker arm shaft bracket onto shaft and repeat Step 6 until all arms are in place.
- h. Slide the last bracket into position.

**NOTE**

For ease of handling tie rocker arm assembly together with heavy rubber bands or cord (fig. 2-15). Keep that end of assembly which is opposite the locating screw up, to prevent parts from sliding off.

**3-85. Installation**

- a. Install push rods in tappets.

**NOTE**

Injector push rod is the largest and fits between the exhaust and intake push rods. If new rod is used, make sure it has same part number as the one removed.

- b. Position rocker arm assembly to cylinder head and engage push rod adjusting screws in push rod sockets.

**CAUTION**

Rocker arm adjusting screws must be loose to permit tightening the cylinder head hold down capscrews.

- c. Repeat procedures in paragraph 3-70g and h, for capscrews through rocker arm brackets.
- d. With feeler gage, check for clearance between all rocker arms and rocker arm brackets.

**Section XVI. Repair of Push Rod Cavity Covers**

**3-86. Disassembly**

There are no disassembly procedures required.

**3-87. Cleaning**

Clean covers in accordance with the requirement paragraph 2-5.

**3-88. inspection**

Inspect in accordance with paragraph 2-6.

**3-89. Repair**

Repair is limited to replacement of defective parts and general repair procedures in accordance with paragraph 2-7.

**3-90. Installation**

- a Check for installation of pipe plugs in the block.
- b. Position cover with new gasket to block (fig. 2-14). Secure with flatwashers and capscrews.

**Section XVII. Repair of Cylinder Head Covers**

**3-91. Disassembly**

There are no disassembly procedures required.

**3-92. Cleaning**

Clean covers in accordance with paragraph 2-5.

**3-93. inspection**

Inspect cover in accordance with paragraph 2-6.

**3-94. Repair**

Repair is limited to replacement of defective covers and general repair procedures in accordance with paragraph 2-7. Refer to TM 9-2320-206-20 for repair of breather tube assembly.

**3-95. Installation**

Refer to paragraph 2-11a, and reverse procedures.



### Section XVIII. Repair of Air Compressor and Drive Assembly

#### 3-96. Disassembly

- a. Remove drive gear and woodruff from shaft
- b. If inspection indicates need, remove sleeve bushing from air compressor rear support.

#### 3-97. Cleaning

Clean air compressor and drive assembly in accordance with paragraph 2-5.

#### 3-98. Inspection

- a. Inspect oil flow passage in air compressor rear support to insure unrestricted passage.
- b. Inspect air compressor rear support sleeve bushing for wear, restricted oil groove, and alinement of oil ports in support. Replace bushing if excessive wear is evident.
- c. Inspect drive gear against specified limits in repair and rebuild standards paragraph 3-136. Replace gear if outside limits specified.
- d. Inspect air compressor in accordance with paragraph 2-6.

#### 3-99. Repair

Repair of air compressor and drive assembly is limited to replacement of spared parts or units

#### 3-100. Assembly

- a. Install drive gear on drive shaft.
- b. Press sleeve bushing into air compressor rear support.

#### CAUTION

Be sure that oil ports in sleeve bushing are alined with corresponding oil ports in rear support.

#### 3-101. Installation

- a. Slide air compressor and drive assembly with new gasket, into engagement of drive gear with camshaft gear.

#### CAUTION

Be sure that "O" index mark on drive gear tooth (fig. 3-72) is alined between the two punched-marked teeth on camshaft gear.

- b. Secure assembly snug tight only with three capscrews as shown in figure 8-78.
- c. Attach a dial indicator to flywheel housing as shown in figure 3-70.
- d. Advance drive gear as far as possible and set dial indicator to zero.
- e. Retard drive gear and note indicator reading.

#### NOTE

Indicator reading should be within 0.006-0.009 inch. If reading is outside these limits, gear train must be replaced.

- f. Remove capscrews and lockwashers (step b.).
- g. Install rear support on drive shaft and position to housing securing support with five capscrews and lockwashers.

### Section XIX. Repair of Fuel Pump and fuel Lines

#### 3-102. Disassembly

#### NOTE

Perform the requirements of paragraph 3-104 a through d before disassembling the pump. If the pump operation is in accordance with the specified requirement of these paragraphs, proceed to paragraph 3-107 (fuel pump test and calibration Disassembly of the pump will not be necessary).

- a. *Disassembly Into Sub-assemblies.* Mount fuel pump (fig. 3-73) to fuel pump mounting plate and ball joint vise (1 and 2, fig. 28) as shown in figure 3-74.

- (1) *Fuel shut-off solenoid valve assembly* B-17).

- (a) Remove two capscrews, lockwashers, and flat washers (3, 4, and 5) securing valve to pump.
- (b) Remove valve (1). Discard O-Ring (17).
- (c) Remove four screws and lockwashers (14 and 15) securing coil assembly (13) to pump housing (6).
- (d) Remove shield (12), O-Rings (8 and 11), spring (10), and valve (9).
- (e) Remove knob (18) on manual override shaft (7) and remove shaft.
- (f) Remove outlet connection (2) and pipe plug (16).
- (2) *Fuel pump damper assembly* (fig. B-16).
- (a) Remove two capscrews, lockwashers, and flat washer (23, 24, and 25) securing damper assembly to pump gear assembly.

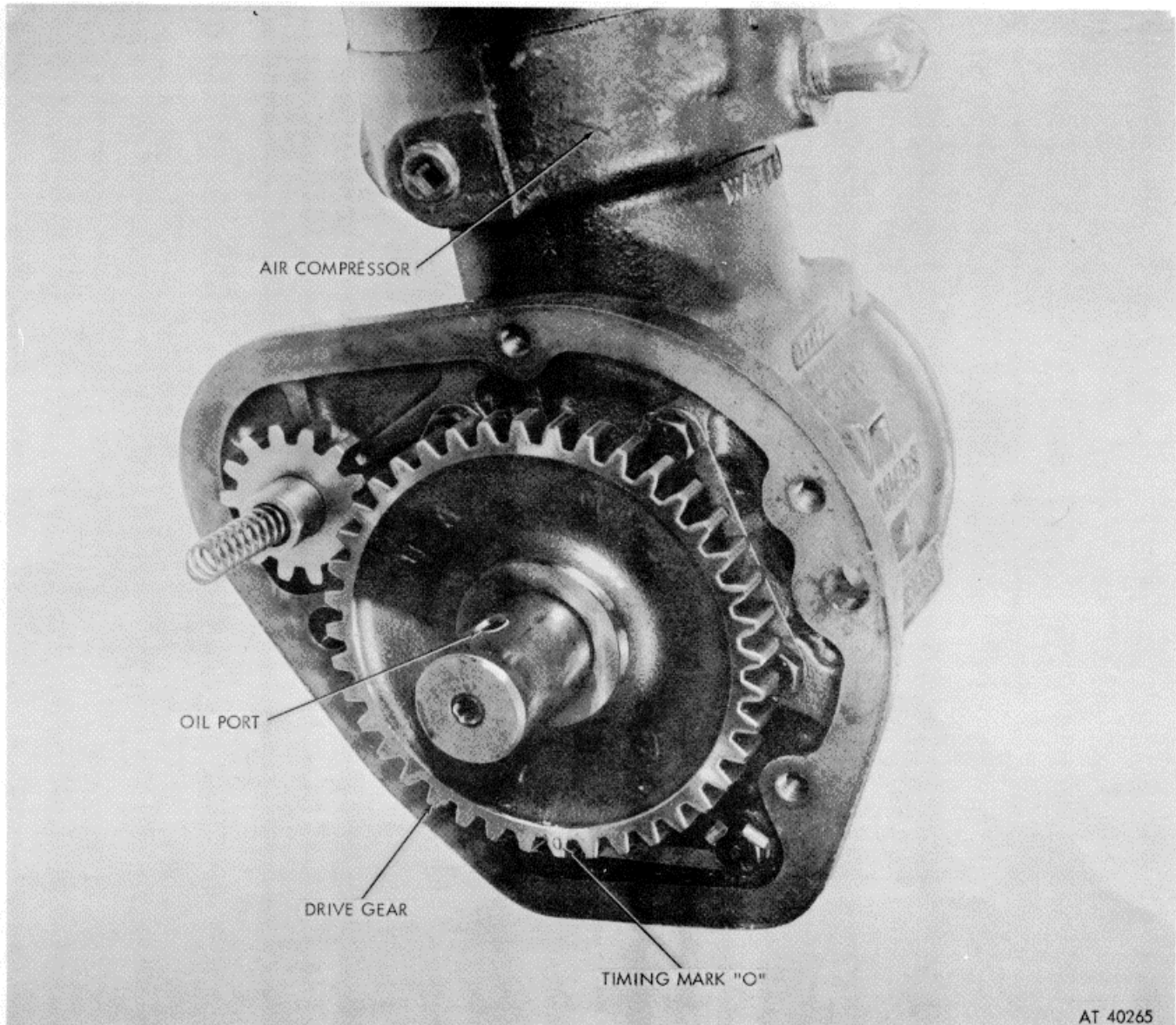

Figure 3-72. Air compressor drive gear timing mark.

(b) Remove plate (16), packing (17), nylon washer (18), diaphragm (19), O-ring (20), body (21), and seal ring (22).

(3) *Mainshaft Cover and Governor Assembly* (fig. B-18).

(a) Remove six capscrews, lockwashers, and plain washers (33, 34, and 35) securing main shaft cover and governor assembly to pump housing.

(b) Using fuel pump governor weights puller (28, fig. B-28), remove governor weights assembly (19) from cover as shown in figure 3-75.

(c) Remove retaining ring (30) from governor weight carrier shaft (27).

(d) Remove sleeve bushing (29) and drive shaft gear (28).

(e) Remove weight pivot pins (24) and hollow pin shafts (25), supporting governor weights (26), and thrust washers (20).

(f) Remove weights, washers, compression spring (21), flat shimming washers (22), and weight assist plunger (23).

(g) Remove capscrew (7), lockwasher (8), flat washer (9), and hub (10) securing drive assembly to cover.

**NOTE**

The hub is keyed to the shaft by key (18).  
 (h) Remove tachometer drive gear (16),

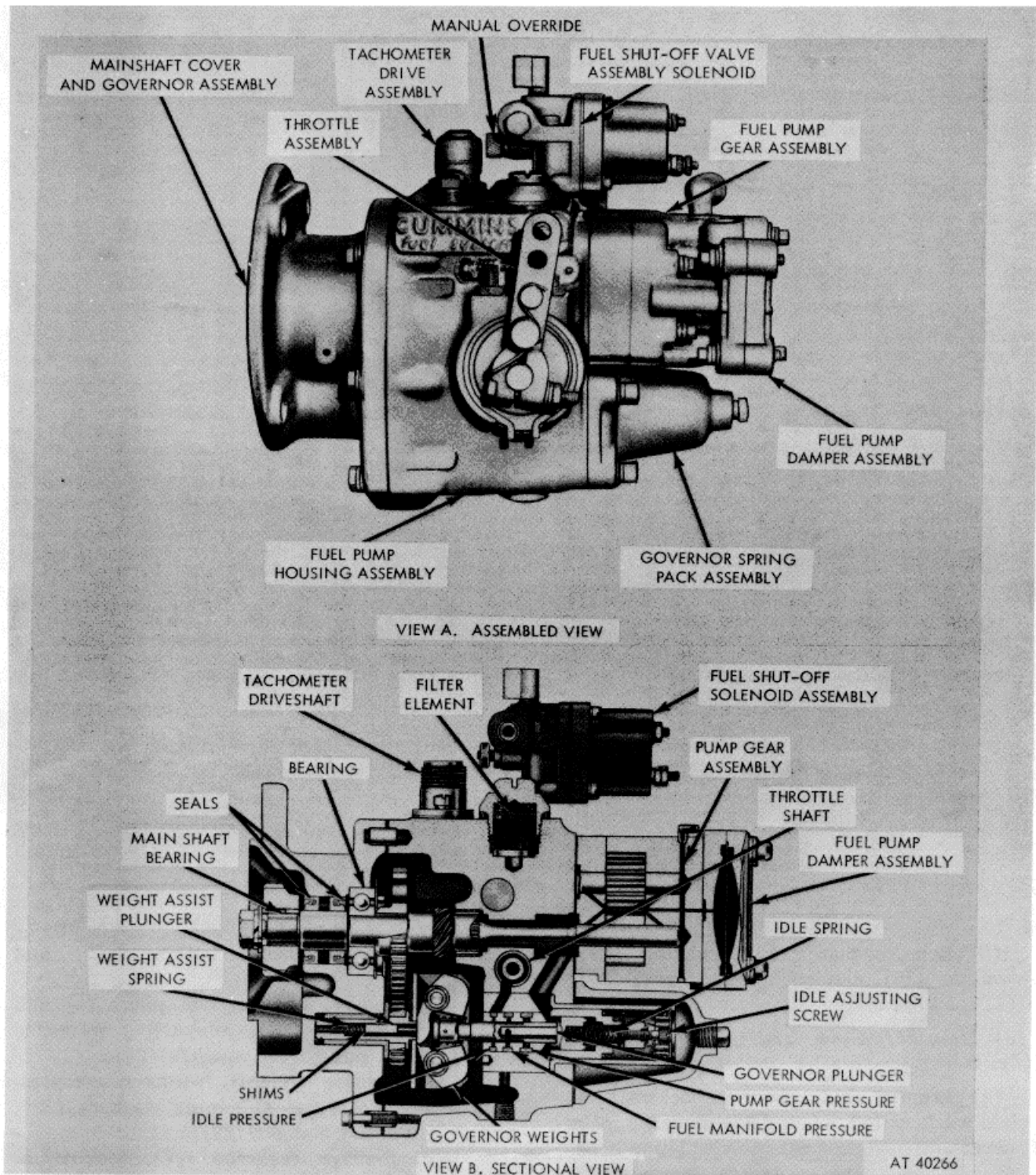

Figure 3-73. Fuel Pump PT (type G).

pump drive gear (15), bearing ring (14), and drive shaft ball bearing (13), from drive shaft

(i) Using oil seal tool (35, fig. B-28), re(12).

move two oil seals (11) from cover as shown in figure 3-76.

(4) Fuel Pump Gear Assembly (fig. B-16).

(a) Remove four capscrews (10, 13, and

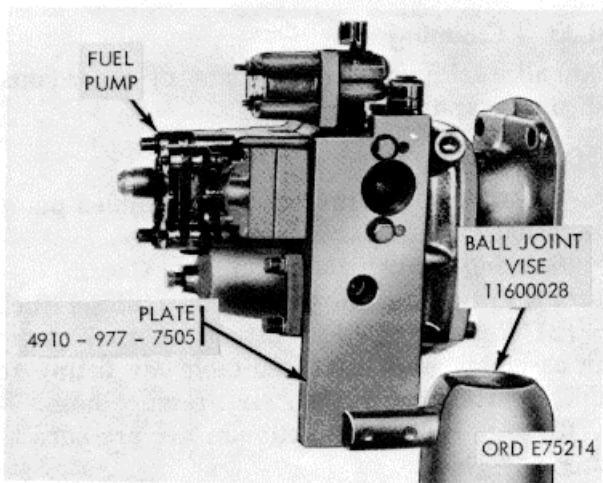

Figure 3-74. Mounting plate and ball joint vise installation.

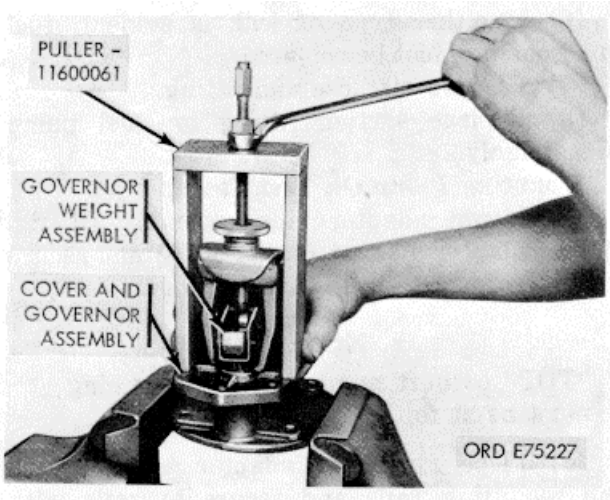

Figure 3-75. Governor weight assembly removal/installation.

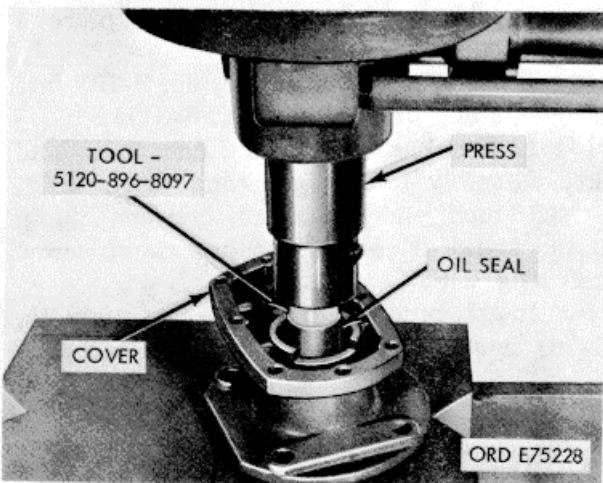

Figure 3-76. Governor shaft oil seals-removal/installation

(14) and lockwashers (9) securing gear assembly (1) to pump housing. Remove gasket (2).

(b) Separate cover (15) and housing from two dowels (4) to release two shafts (6 and 7) two gears (5). Discard gasket (8).

(c) Remove ring dowels (3) from housing.

(d) Remove inlet adapter (12) and ball check valve elbow (11) from cover.

(5) *Governor Spring Pack Assembly* (fig. B-17).

(a) Cut seal wire (33) and remove cap-screw seal (34).

(b) Remove two capscrews (32), two capscrews (36), four lockwashers (31) and four flat washers (30) securing assembly to pump housing. Discard gasket (28).

(c) Remove spring pack assembly from housing barrel.

(d) Remove snap ring (27) from guide and clip assembly (22).

(e) Remove spring retainer (26), high speed spring shims (25), and high speed spring (24).

(f) Remove idle adjusting screw (23), adjusting screw washer (21), idle speed spring (20), and plunger (19).

(g) Remove pipe plug (35) from cover.

(6) *Tachometer Drive Assembly* (fig. B-27).

(a) Remove two slotted-head screws (3) securing tachometer cable drive adapter (1) and cap (2) to pump housing.

(b) Remove adapter, cap, gasket (2), and shaft seal (5). Discard gasket.

(c) Using a brass drift, as shown in figure 3-77, drive the assembled shaft (6), bearing

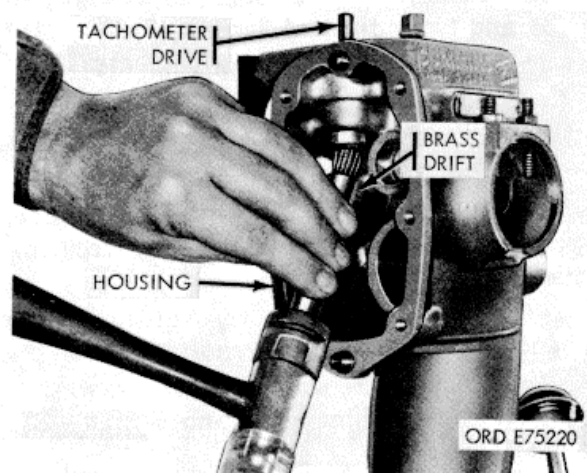

Figure 3-77. Tachometer drive assembly-removal/installation.

sleeve (7), and gear (8) from housing.

(d) Press the gear from shaft and remove bearing sleeve.

b. *Fuel Pump Housing Assembly* (fig. B-15).

(1) *Filter Assembly*.

(a) Remove filter cap (3), sealing ring (2), filter spring (4), and filter element (5).

(b) Discard sealing ring.

(2) *Governor Plunger Assembly*.

(a) Remove plunger assembly from housing as shown in figure 3-78.

(b) Remove spring pack housing (31).

(c) Remove pin (36) securing drive governor plunger (16) to plunger spacer (37) and shaft (35).

(d) Remove compression spring (33), shims (34), and thrust washer (38).

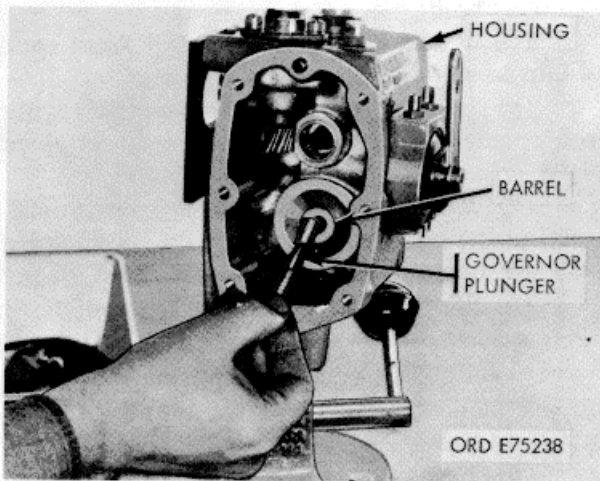

Figure 3-78. Plunger assembly-removal/installation.

(3) *Throttle Assembly*.

(a) Remove two throttle adjusting jam nuts (6) and two adjusting screws (7).

(b) Remove throttle snap ring (17).

(c) Cut seal wire (24) and remove throttle cover seal (23).

(d) Pull throttle assembly from housing

(e) Remove nut (22), lockwasher (21), flat washer (20), and capscrew (19) securing throttle lever (18) to shaft.

(f) Remove shaft cover (16), spacer (15), and stop pin (14) from shaft (13).

(g) Remove setscrew (8), lockwasher (9), plunger (10), shim (11), and O-Ring (12) from shaft.

(4) Remove pipe plug (27), clip (28), fuel body plug (43), O-Ring (42), and pipe plug (1) from pump housing.

### 3-103. Cleaning

Clean all fuel pump components in accordance with paragraph 2-5.

### 3-104. Inspection

a. Visual. Visually inspect the assembled pump in accordance with paragraph 2-6.

b. Housing Porosity and Leakage Check.

(1) Fill fuel pump with clean diesel fuel.

(2) Remove suction fitting at fuel pump gear assembly and install suitable air fitting to facilitate attaching 20 psi. air pressure hose.

(3) Apply 20 psi maximum air pressure to fitting.

(4) Pour fuel oil over pump and examine for leaks indicated by air bubbles.

(5) Wipe pump dry and check for seepage of fuel oil from inside pump.

(6) If either type of leak is evident, fuel pump housing must be replaced.

(7) Remove air hose and fitting.

(8) Replace suction fitting on fuel pump gear assembly.

c. Mounting Pump On Test Stand.

(1) Mount adapter ring assembly (2, fig. 3-79) to adapter bracket (1, fig. 3-79) and secure with four capscrews and plain washers.

#### NOTE

"TOP" or part number on adapter ring must be at top.

(2) Place ring and adapter assembly on stand mounting rails and secure to rails with clamp bar (fig. 3-80). Finger tighten clamp bar only.

(3) Mount pump on adapter ring and bracket assembly and secure with four capscrews and flat washers (fig. 3-81).

(4) Place coupling insert (3, fig. 3-79) into coupling in stand drive shaft (fig. 3-81).

(5) Loosen bar clamp and slide pump and bracket assembly to engage stand drive shaft. Allow 1.16-inch end clearance between pump drive and stand drive. Tighten bar clamp screw securely (fig. 3-82).

(6) Install pump inlet adapter assembly (5, fig. 3-79) in pump inlet port as shown in figure 3-82.

(7) Connect 1/2-inch ID flexible hose (11, fig. 3-79) from stand suction control valve (fig. 3-82) to flare connector of inlet adapter assembly on pump.

(8) Connect 1/4-inch clear flexible hose (7, fig. 3-79) from stand supercharger inlet con-

necter (fig. 3-83), to 1/4-inch flare connector on pump inlet adapter assembly.

**NOTE**

If during operation of the stand oil is sucked into vacuum gage no. 1 (fig. 3-80) it will be necessary to use a supplementary vacuum gage (vacuum gage no. 2, fig. 3-80). Disconnect hose from stand supercharger inlet connector (fig. 3-83) to pump inlet adapter. Connect flexible hose from supplementary vacuum gage no. 2 to pump inlet adapter (5, fig. 3-79).

(9) Install pump discharge fitting assembly (4, fig. 3-79) in pump fuel shutoff solenoid valve (fig. 3-83).

(10) Install flexible hose (10, fig. 3-79) from stand "PRESSURE GAGE" outlet to pump discharge fitting (fig. 3-83).

(11) Install flexible hose (9, fig. 3-79) from stand "FUEL INPUT" connection to pump discharge fitting (fig. 3-83)

(12) Install 1/2-inch ID flexible hose (8, fig. 3-79) from stand "FUEL OUTLET" connector to stand "FUEL RETURN" connector (fig. 3-83).

(13) Install flexible hose (6, fig. 3-79) to no. 1 accumulator can (fig. 3-38), from stand "LEAK TEST" connector.

(14) Turn on fuel heat switch (fig. 3-80), observe that temperature on "FUEL TEMPERATURE" gage is between 80 to 100 degrees for testing.

*d. Gear Pump Test.*

**CAUTION**

Never operate fuel pump until check valve has been checked for restrictions.

(1) Set stand motor switch (fig. 3-80) to "FORWARD." This corresponds to code designation on pump name plate. "L" for left-hand (fig. 3-84), as viewed from rear of pump.

(2) Open stand "BYPASS VALVE," "SUCTION VALVE" and "FLOW CONTROL VALVE." Back seat all other valves to prevent leakage (fig. 3-80).

(3) Open pump solenoid manual override knob (fig. 3-73) by turning fully clockwise.

(4) Install throttle spring (fig. 3-82) to hold throttle in wide open position.

(5) Set stand 4-way valve to "ROTAMETER" position (fig. 3-80).

(6) Set stand power switch to "ON" position.

(7) Turn range crank to "LOW RANGE" (fig. 3-80).

(8) Start stand and pump operation by depressing start switch. Depress and release switch until pump operation is between 400-450 rpm as observed on stand "TACHOMETER" (fig. 3-80).

**NOTE**

Check rotameter for presence of air in fuel flow. If air bubbles are present, work pump throttle from full open to idle, several times, to relieve any entrapped air in pump.

(9) Turn on "AUX MOTOR" switch for one minute, to eliminate any air entrapped in test stand (fig. 3-80).

(10) Adjust "FUEL REGULATOR" to a maximum of 20 psi as observed on "FUEL PRESSURE" gage (fig. 3-80).

(11) Shut-off "AUX MOTOR" switch.

**NOTE**

If air bubbling persists check all lines for leakage. If no leaks are uncovered, or, if fuel pump fails to pick-up fluid the pump must be disassembled and repaired or replaced. Proceed with the following steps only if pump is operating satisfactorily.

(12) Increase pump speed to 2100 rpm.

(13) Set pump throttle to wide open position.

(14) Set "SUCTION VALVE," "BYPASS VALVE" and "FLOW CONTROL" to fully open position.

**NOTE**

Indicated flow on the rotameter should be not less than 850 pounds per hour (pph).

*e. Inspection of Sub-Assemblies.*

(1) *Fuel Shut-Off Solenoid Valve Assembly.*

(a) Visually inspect shut-off valve and valve seat for wear and corrosion. Valve seat must be 0.015 inch minimum width.

(b) Check oil assembly with ohm-meter. Replace coil if resistance is below 30 +3 ohms.

(2) *Fuel Pump Damper Assembly.* Inspect body, plate, and diaphragm for excessive wear.

(3) *Mainshaft Cover and Governor Assembly.*

(a) Perform general inspection in accordance with paragraph 2-6.

(b) Place one leg of depth gage base of pedestal across the carrier walls and measure down to the front cover gasket surface (no

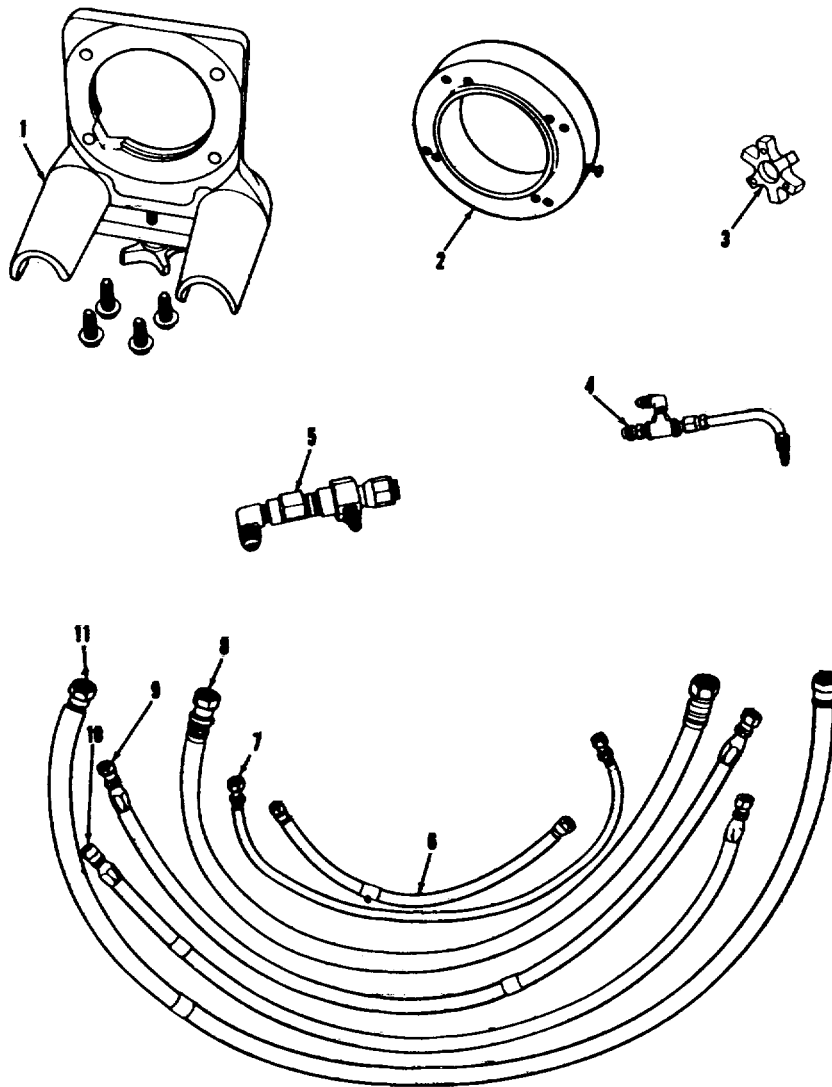

- |  |                                     |
|--|-------------------------------------|
| 1 Adapter bracket (11020392)             | 7 Fuel manifold hose (11020361-10)  |
| 2 Adapter ring assembly (11020532)       | 8 Fuel suction hose (110203613)     |
| 3 Coupling insert (110200539)            | 9 Fuel input hose (11020361-11)     |
| 4 Discharge fitting assembly (11020540)  | 10 Fuel pressure hose (11020361-14) |
| 5 Leakage accumulator hose (11020361-10) | 11 Fuel return hose (11020361-12)   |
| 6 Leakage accumulator hose (11020361-10) |                                     |

Figure 3-79. Fuel pump test stand equipment.

Gasket). Move depth gage to opposite side of carrier and again measure to front cover gasket surface directly across cover from previous measurement (do not turn carrier or cover). Average these two measurements. This procedure is necessary to determine uneven carrier wall heights.

(c) Position depth gage across carrier directly over weight assist plunger. Measure

down to plunger.

(b) Subtract second measurement from average determined under (b) above. The result is the weight assist protrusion. If weight assist protrusion is below specifications, (0.840/0.860), add shims on reassembly. If weight assist protrusion is above specifications, remove shims or grind exposed end of weight assist plunger.

(4) Pump Gear Assembly.

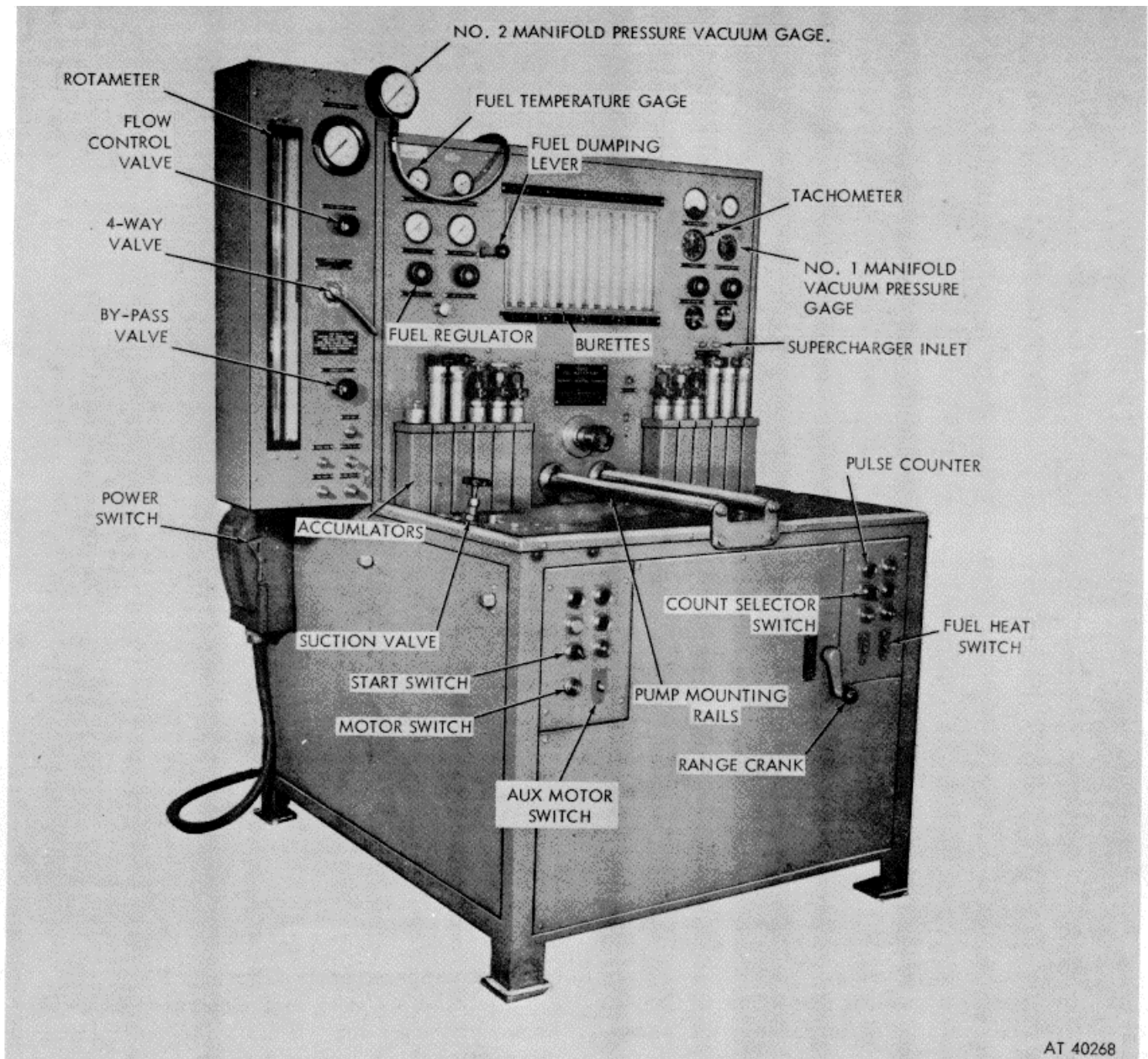

Figure 3-80. Fuel pump test stand.

(a) Perform general inspection in accordance with paragraph 2-6.

(b) Check pump shafts for wear or scoring. Discard shaft if damaged. Replace shaft if worn smaller than 0.4998/0.5001 inch.

(c) Check gear width. New gears are 0.7483/0.7486 inch wide. If gears are scored or worn, gear must be replaced.

(d) Check gear body and cover for scoring or wear. Replace parts if required. New gear pocket depth should be 0.7479/0.7483 inch. Shaft bore in cover and body should be 0.5013/0.5016

inch I.D. Replace pump if parts are defective.

**NOTE**

If shaft bore is scored 1/3 of circumference or more in cover or body, replace shaft. If scored less than 1/3 clean shaft.

(5) *Governor Spring Pack Assembly*. Perform general inspection in accordance with paragraph 2-6.

(6) *Tachometer Drive Assembly*. Perform general inspection in accordance with paragraph 2-8.



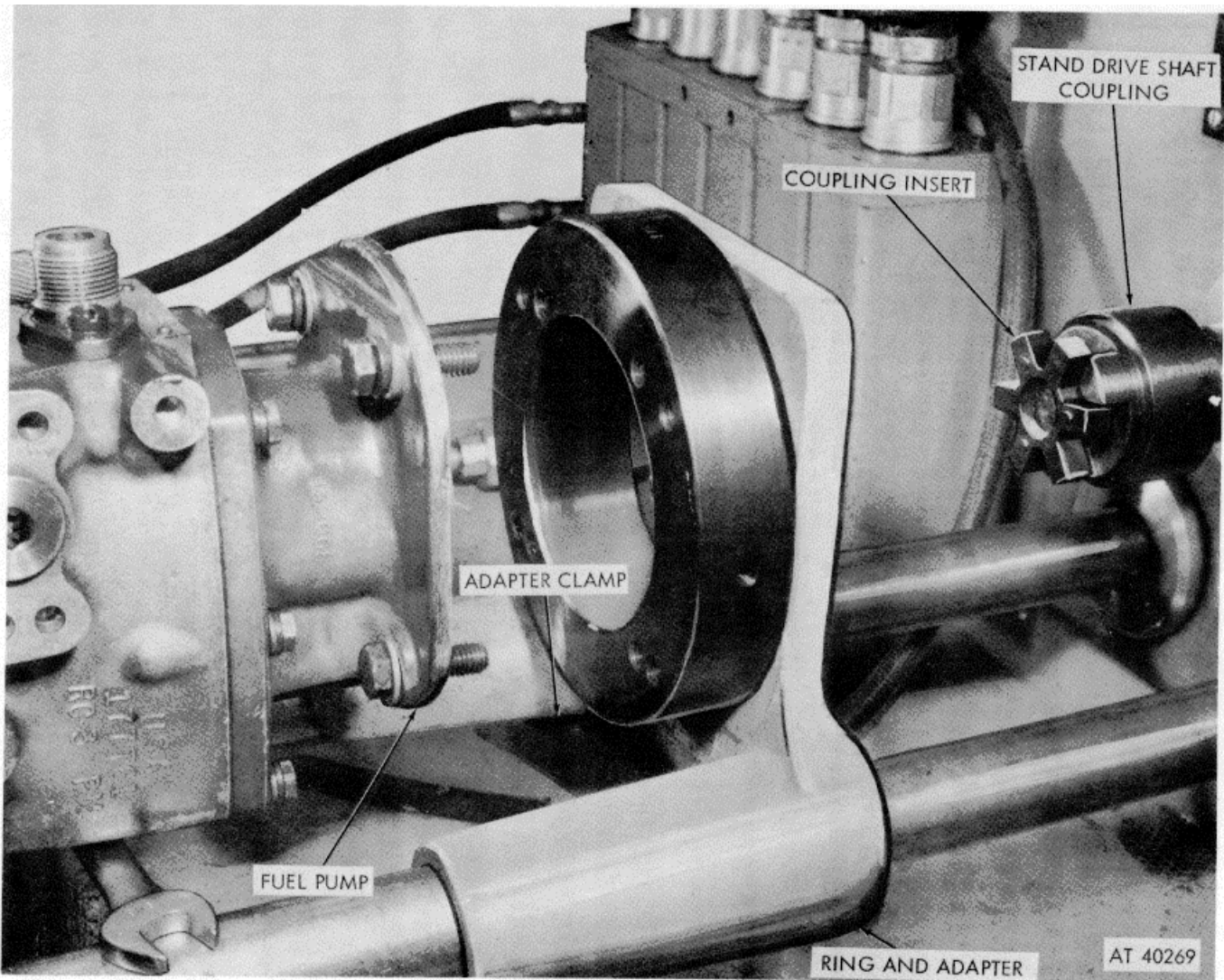

Figure 3-81. Pump mounted on test stand.

(7) *Fuel Pump Housing.*

(a) Perform general inspection of housing and components in accordance with paragraph 2-6.

(b) Check front main shaft bushing for evidence of seizure or burns.

(c) Using an inside micrometer measure inside diameter of bushing. If worn beyond 0.7525-inch replace bushing.

3-105. Repair

a. *Fuel Shut-Off Solenoid Valve Assembly.* Repair of the valve assembly is limited to general maintenance repair procedures, paragraph 2-7, and replacement of defective spared parts (appendix B).

b. *Fuel Pump Damper Assembly.* Repair of the damper assembly is limited to general maintenance procedures (para. 2-7), and replacement

of defective spared parts (appendix B).

c. *Mainshaft Cover and Governor Assembly.* Repair of the assembly is limited to general maintenance repair procedures (para. 2-7), and replacement of spared parts (appendix B).

d. *Pump Gear Assembly.* Repair of the gear assembly is limited to general maintenance repair procedures (para. 2-7), and replacement of spared parts (appendix B).

e. *Governor Spring Pack Assembly.*

(1) Replace governor if worn beyond limits specified in serviceability standards. Replace with plunger and lap to fit with No. 80 fine grit lapping compound. Remove all lapping compound from parts.

**NOTE**

PTG Governor Plungers are color coded. Red represents size 0 (standard) and

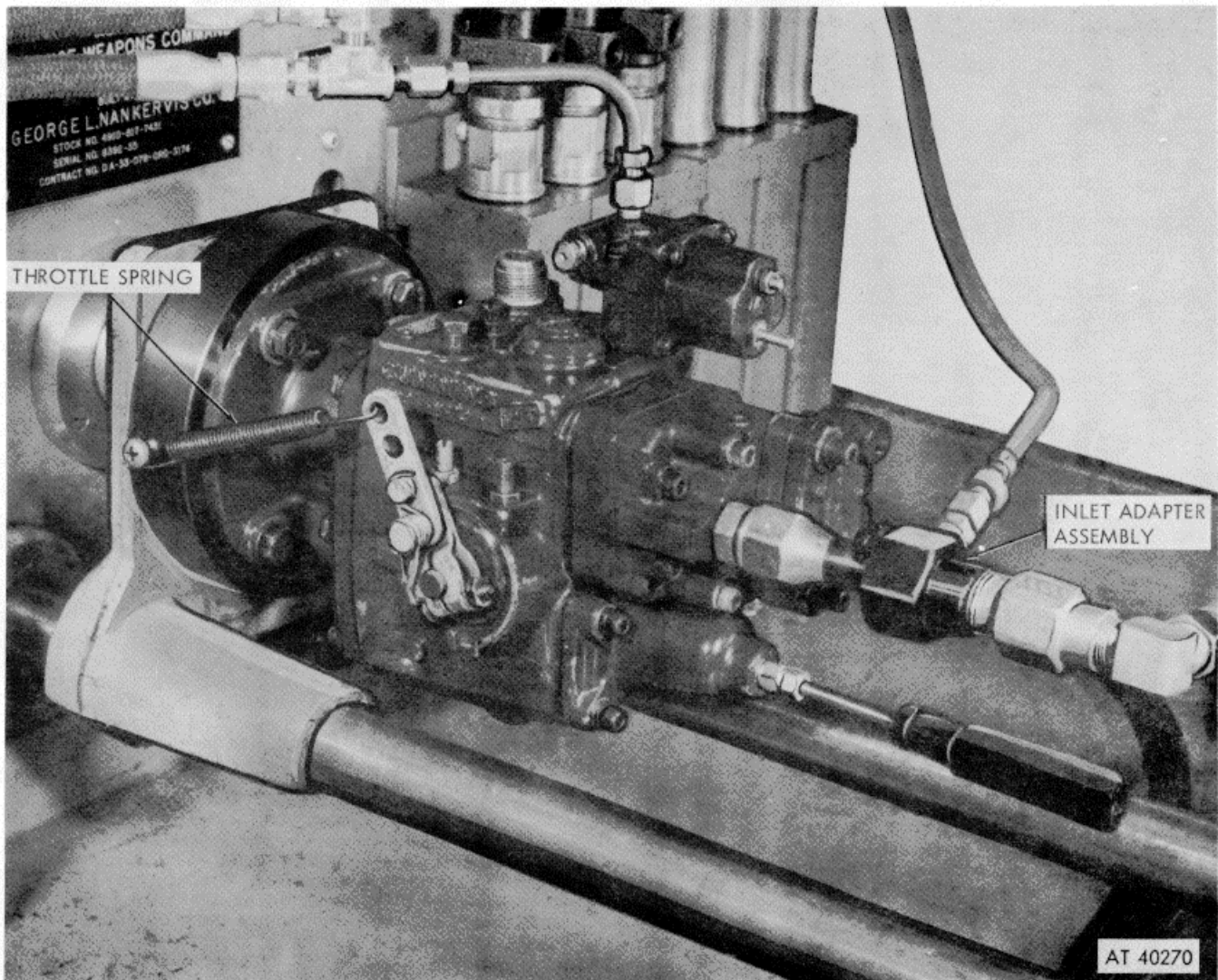

Figure 3-82. Pump to stand drive shaft engagement.

Blue represents size 1 (oversize). Standard size diameter is 0.37460-0.37468 and oversize diameter is 0.37470-0.37478.

(2) If governor barrel is worn too large for the oversize plunger, replace barrel by heating housing in boiling water 112 to 2 minutes, and press out worn governor barrel.

#### CAUTION

Remove spring dowel which secures barrel in fuel pump, before attempting to remove governor barrel. To pull spring dowel, insert wire hook into hole provided in dowel and remove.

(3) Check barrel bore in housing to determine whether standard size barrel (fig. B-17)

can be used. Minimum 0.001 inch interference fit is required.

(4) To locate a new governor barrel in the housing, scribe a center line on barrel and housing, lining up the fuel passages to prevent fuel flow restriction (fig. 3-85).

(5) Heat housing in oven to 300 degrees Fahrenheit.

(6) Cool barrel in dry ice or by another suitable method.

(7) Coat new governor barrel with high pressure lubricant.

(8) Place governor barrel in housing bore lining up scribe marks, then press barrel into housing with arbor press.

(9) Select new governor plunger and fit it in barrel. If plunger enters try larger size plunger. If the larger size plunger fits loosely in bore, replace barrel and plunger.

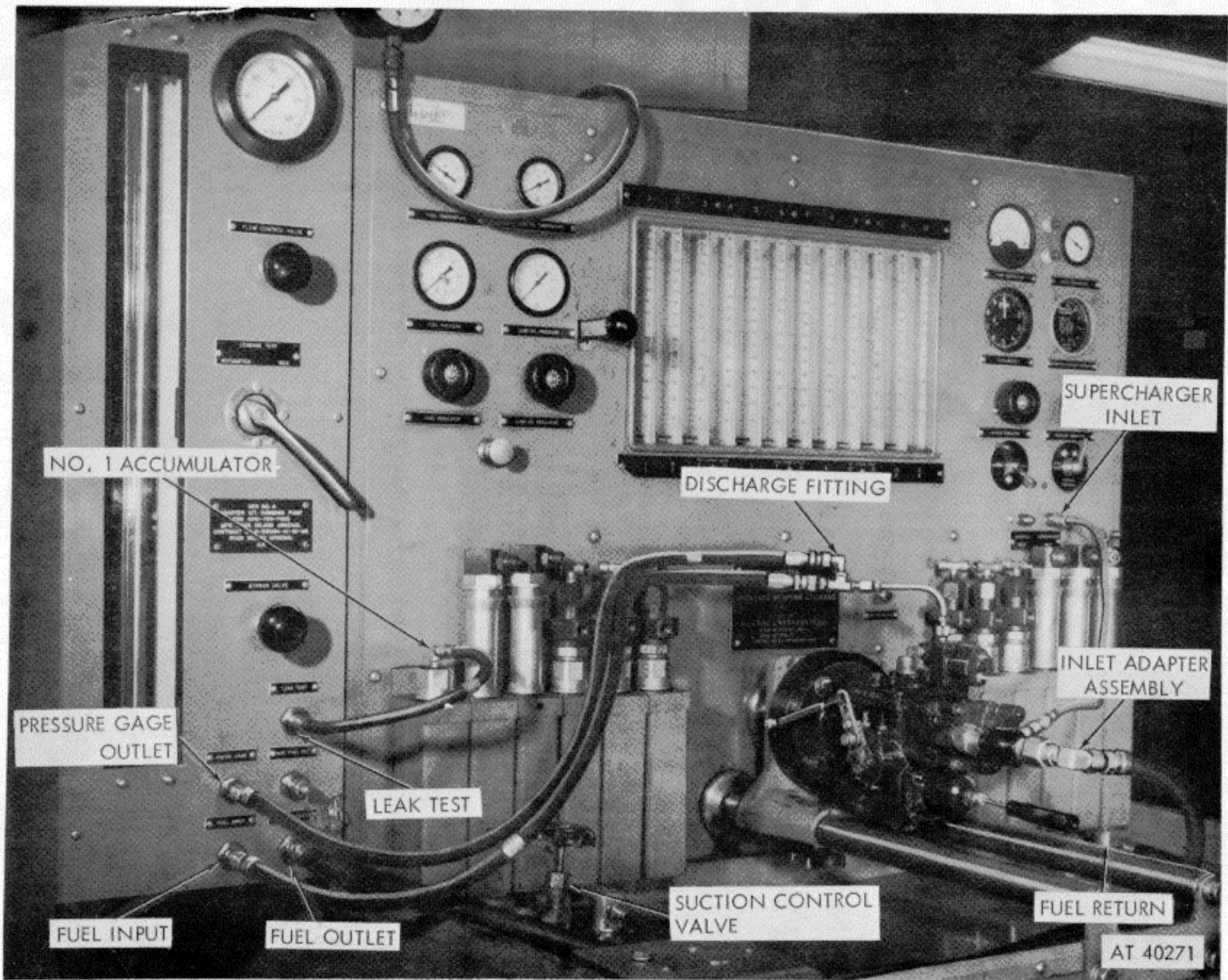
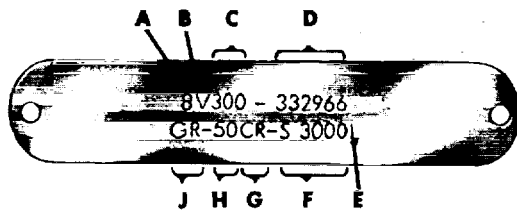

Figure 3-83. Pump preparation for test and calibration.



- A - NUMBER OF ENGINE CYLINDERS
  - B - ENGINE TYPE
  - C - ENGINE HORSEPOWER
  - D - FUEL PUMP SERIAL NUMBER
  - E - DIRECTION OF ROTATION AS VIEWED FROM FRONT (L - LEFT)
  - F - SPEED AT RPM
  - G - ENGINE MODEL CODE
  - H - CALIBRATION RELEASE CODE
  - J - INDICATES GOVERNOR REGULATED
- ORD E75248

(10) Brush plunger lightly with crocus cloth to remove any lubricant.

(11) If lapping is necessary, see paragraph e(1), above.

(12) Install spring dowel into bottom of barrel, with slot of pin to front of housing.

*f. Tachometer Drive Assembly.* Repair of tachometer drive assembly is limited to general maintenance repair procedures (para. 2-7) and replacement of spared parts (appendix B).

*g. Fuel Pump Housing.*

(1) Perform general maintenance repair procedures (para. 2-7) and replace defective spared parts (appendix B).

**NOTE**

If replacement of front main shaft bushing (fig. B-18) is necessary perform steps (2) through (5).

(2) Drive out worn bushing using a gouge chisel and mallet.

(3) Apply thin coat of high pressure lubricant and press bushing flush into housing bore using arbor press.

(4) Attach fuel pump fixture (42, fig. B-28) as shown in figure 3-86.

(5) Line ream bushing to 0.7495/0.7505 inch.

### 3-106. Assembly of Sub-Assemblies and pump

#### a. Pump Housing.

(1) Install all pipe plugs, dowels, and clips using new O-Rings as required.

(2) Assemble throttle assembly in reverse order of disassembly (para. 3-102.b. (3)), installing new O Ring with O-Ring assembly tool (37, fig. B-28) as shown in figure 3-87.

(3) Install throttle assembly as shown in figure 3-88.

(4) Install compression spring and assemble

governor plunger. Assembled in reverse order of (para. 3-102.b. (2)).

(5) Insure clearance between thrust washer and drive plunger governor as shown in figure 3-89.

(6) Install governor plunger assembly as shown in figure 3-78.

(7) Install new filter assembly. Assemble in reverse order of disassembly (para. 3102, b. (1)).

b. *Tachometer Drive Assembly.* Assemble in reverse order of disassembly (para. 3-102.a. (7)).

c. *Governor Spring Pack Assembly.* Assemble in reverse order of disassembly (para. 3-102.a. (6)).

d. *Fuel Pump Gear.* Assemble in reverse order of disassembly (para. 3-102.a. (5)) insuring that notches in housing and cover correspond.

e. *Mainshaft Cover and Governor Assembly.*

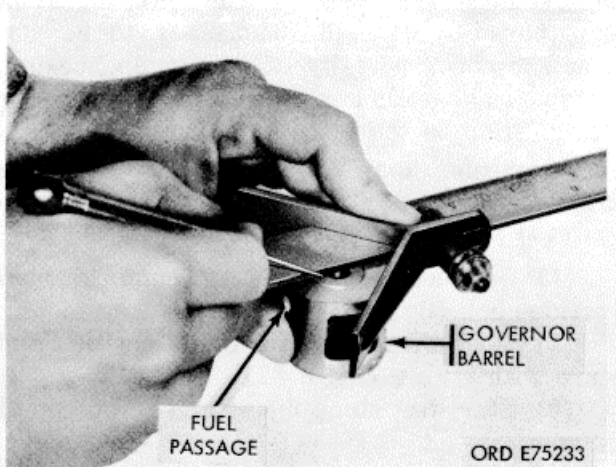

Figure 3-85. Scribing governor barrel.

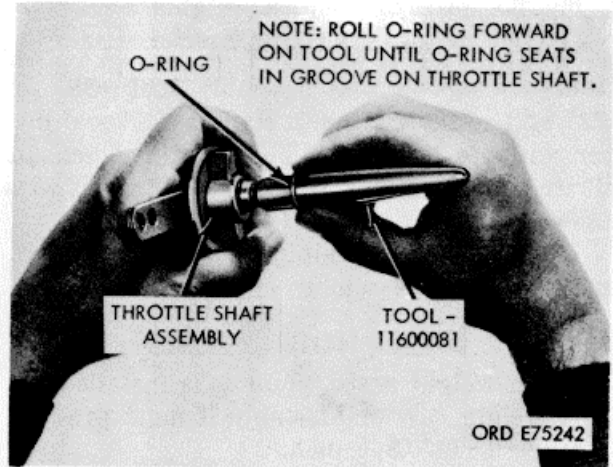

Figure 3-87. Throttle shaft O-ring installation.

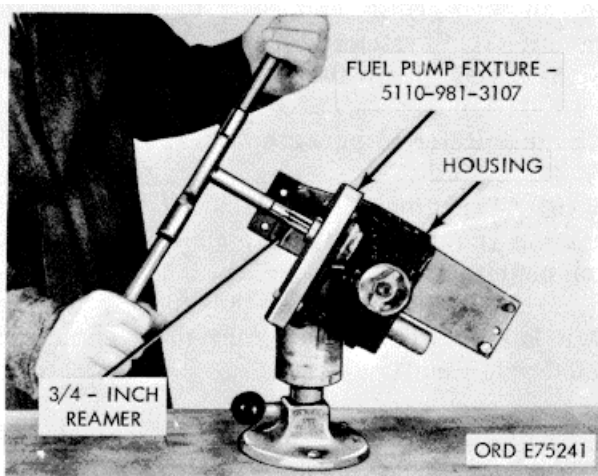

Figure 3-86. Reaming mainshaft bushing.

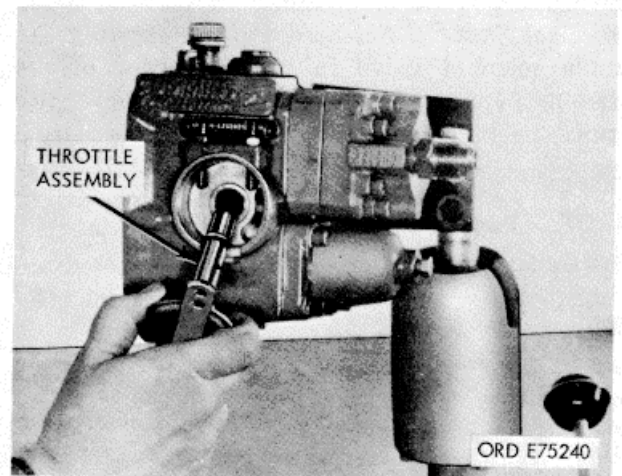

Figure 3-88. Throttle assembly installation.

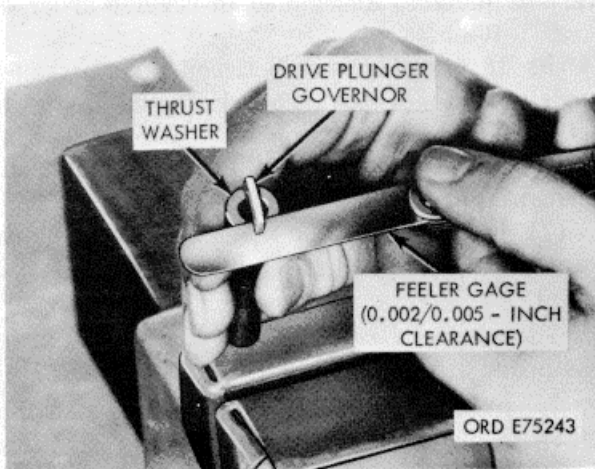

Figure 3-89. Thrust washer-drive plunger governor clearance.

**CAUTION**

When installing governor weight assembly, do not press against weights. Press against center of weights carrier shaft.

(1) Using oil seal assembly tool (35, fig. B-28) and suitable press, install first oil seal into cover with lip toward inside of cover. Then, install second oil seal into reverse side of cover with lip toward inside of cover (fig. 3-76).

(2) Assemble remaining components in reverse order of disassembly (para. 3-102.a. (3)).

**NOTE**

When weight assist plunger is installed in weight carrier assembly it must protrude 0.840/0.860 inch.

*f. Fuel Pump Damper Assembly.* Assemble damper assembly in reverse order of disassembly (para 3-102.a. (2)).

*g. Fuel Shut-Off Solenoid Valve Assembly.* Assemble solenoid valve in reverse order of disassembly (para. 3-102.a. (1)). Use new preformed packing, O-Ring, and gaskets for assembly.

**3-107. Fuel Pump Test and Calibration**

*a. General.* PT type G fuel pump is tested and calibrated on the fuel pump test stand (fig. 3-80).

*b. Fuel Pump Test and Calibration Data.*

Engine model .....	V8 300
Pump code .....	50CR3000
HP C rpm (sea level) .....	300 @ 3000
Fuel rate-lb hr min/max .....	119/124
Engine fuel pressure min/max.....	215 235
Flow meter-lb hr @ rpm.....	560 @ 3000

Governor-cutoff rpm .....	3020 3040
Set-p.s.i. @ max rpm .....	40 @ 3250
Throttle leakage--cc .....	35
Idle speed-p.s.i. @ rpm.....	22 @ 600
Manifold pressure p.s.i. @ rpm.....	227 @ 3000
Check point 1 p.s.i. @ rpm.....	165/173 @ 200
Check point 2 p.s.i. @ rpm.....	117/125 @ 2000
Weight assist p.s.i. @ rpm .....	46/54 800
Weight assist setting .....	890/910
Gear pump size .....	3/4
Idle plunger code No .....	40
Torque spring-part No .....	142698
Torque spring-color code .....	WHITE-BROWN
Torque spring--hims .....	NONE
Governor spring-part No .....	147292
Governor spring--color code .....	BROWN
Governor weight-part No.....	107261
Injector-part No .....	BM97421
Injector-flow code .....	117
Piston-part No .....	172580
Camshaft-part No .....	155500

*c. Test Fuel.* Fill fuel pump test stand with authorized fuel.

*d. Precalibration Tests.* The precalibration tests (para. 3104.b., 3-104.d.) are to be performed to check porosity of fuel pump housing, excessive leakage, or low gear pump output, prior to calibration on the fuel pump test stand.

*e. Mounting Pump For Calibration.* Refer to paragraph 3-104.c., for procedures.

*f. Fuel Pump Run-In.*

(1) Completely open the fuel pump manual override knob (fig. 3-73).

(2) Open throttle to maximum position and secure with spring (fig. 3-82).

(3) Start test stand motor and run pump at 500 rpm.

(4) If pump is newly rebuilt or has been disassembled and reassembled, run at slightly overrated speed of 3000 rpm for 5 minutes to flush, allow bearings and seals to seat, and to purge air from system.

(5) Check pump fuel flow in the flow meter for air. If air is present, correct the leak before continuing. Refer to paragraph 3-104.d. (8) and (9).

(6) Check main throttle shaft for proper shimming (fig. 3-90) to insure main throttle port is completely open.

(7) Periodically check the fuel to insure that it is 80 to 100 degrees Fahrenheit and clean of all foreign matter.

**NOTE**

If visual inspection or run-in check indicate internal problems perform inspection of the disassembled pump.

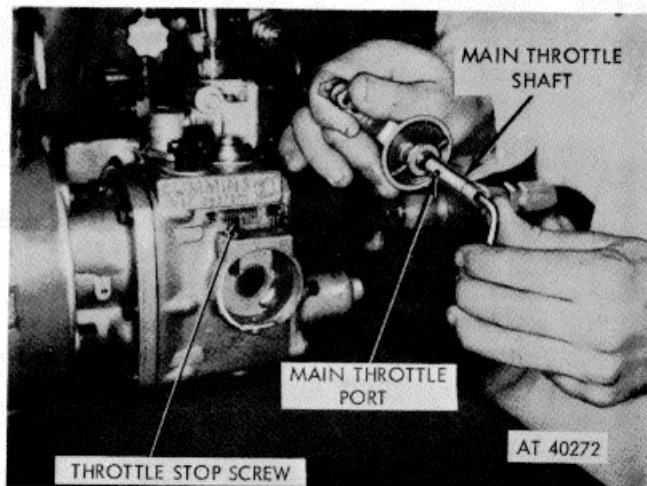

Figure 3-90. Main throttle shaft shim check.

g. Calibration Procedure (Flow Meter Method:

**CAUTION**

Test stand motor switch is marked "REVERSE" and "FORWARD." For all testing of this pump the stand switch must be set to the "FORWARD" position. This corresponds to the rotation requirements of "L" on the pump name-plate (fig. 3-84). Refer to paragraph 3-104.d. (1).

(1) Check Pump Seals.

(a) With test stand operating at 5C rpm (throttle wide open) close control valve in fuel pump suction line till vacuum gage reads 1 inches vacuum. The fuel flow control or need valve should be open during this check.

(b) Put a small amount of Lubriplate ( light cup grease over the vent or "weep" hole main shaft seal bore of fuel pump front cover (fig. 3-91).

(c) If the lubricant is sucked into the ho at the 15-inch vacuum setting, it is an indicate that the seal will not permit proper fuel pun performance and should be replaced.

(d) Perform the above check on the throttle shaft to check the shaft O-Ring. App lubricant at the throttle.

(e) Remove tachometer cap and fill the tachometer seal bore with test fuel from the stand. If the fuel is drawn into the pump, r place the seal.

**NOTE**

During the above checks observe the flow meter for the presence of air bubbles. Air bubbles are an indication of air leakage into the system. Check the

line connections between tank and pump for tightness. Check for proper mating of gear pump to pump housing. Insure that fuel supply tank is full.

(2) Adjust Vacuum.

(a) Open test stand flow control valve completely.

(b) Increase pump speed to 100 rpm below engine rated speed of 3000 rpm.

(c) Adjust control valve in fuel pump suction line to obtain 8 on vacuum gage (fig. 3-80).

(3) Set Pump Flow.

(a) Set pump speed to 3000 rpm.

(b) Close flow control valve (fig. 3-80) until flow meter registers 540 p.p.h.

(c) There must be no air bubbles visible in the flow meter.

**NOTE**

Disregard change in vacuum meter readings.

(4) Set Ground Speed.

(a) With throttle wide open, increase pump speed to point where fuel pressure just begins to decrease (peak point). This should occur at speed of 3020 to 3040 rpm. Check speed twice as fuel pump tachometer drive is turning at /2 engine speed.

(b) If peak point speed is lower than specified, add shims (fig. 3-92) between governor spring and retainer. To reduce speed, remove shims. Each 0.001 inch shim thickness will change speed approximately 2 rpm.

(5) Set Throttle Leakage.

(a) Insure that flow-meter reading is 540

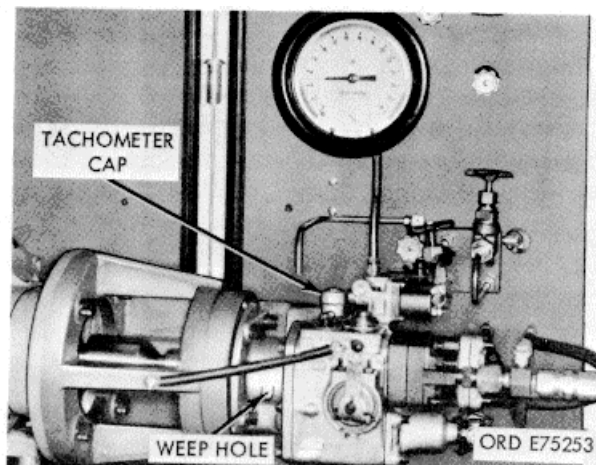

Figure 3-91. Weep hole leakage.

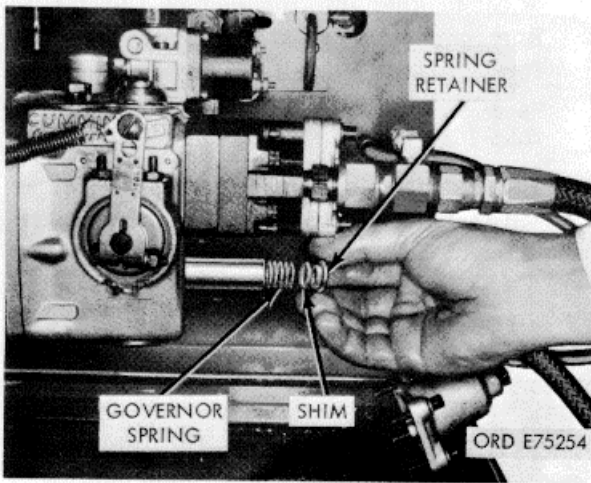

Figure 3-92. Governor spring shimming.

p.p.h. with throttle fully open (3000 RPM).

(b) Reduce speed to 500 rpm.

(c) Set 4-way valve to "LEAKA TEST" position.

(d) Turn count selector switch to 1000 pulse position (fig. 3-80).

**NOTE**

Fuel delivery should be 35cc-plus or minus 5-cc for a one minute period. The test stand has a maximum count of 1000 strokes, therefore, at 3000 RPM each cycle will be of one-third minute duration, and the fuel delivery will also be one-third the above cc valves. (e) Pull out fuel dumping lever (3-80).

(f) Remove throttle spring and manually operate throttle.

(g) Depress pulse counter button to No. 1 burette (fig. 3-80) and push in fuel dumping lever.

**NOTE**

Burette will overflow before cycle is completed, therefore, it is important to push-in fuel dumping lever and return throttle to idle position when burette is filled.

(h) Increase speed to 3000 rpm and h

(i) Pull out fuel dumping lever and press counter button to start count.

**NOTE**

At completion of count cycle the fuel delivery in No. 1 burette should be 10 to 13.5 cc. If not to specification adjust throttle stop screw (fig. 3-93) until fuel delivery is to specification and lock

setting.

(6) Set Idle Speed.

(a) Set throttle shaft to idle position.

(b) Set 4-way valve to "IDLE" position.

(c) Set speed to 600 rpm.

**NOTE**

Reading on pressure gage should be 22 p.s.i. If pressure is low, adjust idle adjusting screw using idle adjusting tool (32, fig. B-28) as shown in figure 3-94. (Remove pipe plug to insert tool). To lower pressure, back-out screw. If pressure is low, and screw bottoms on guide, washers will have to be added to the spring end of the screw.

(d) Each time pipe plug is removed to adjust idle screw, run pump until purged of air.

(7) Check Point Flow Tests.

(a) Set 4-way valve to "ROTAMETER" position.

(b) Set throttle to full open position.

(c) Operate pump at 2500 rpm and adjust flow to 445 p.p.h. Pressure gage should read 165-173 p.s.i.

(d) Reduce speed to 2000 rpm and adjust flow to 335 p.p.h. Pressure gage should read 117-125 p.s.i.

(e) Reduce speed to 800 rpm and adjust

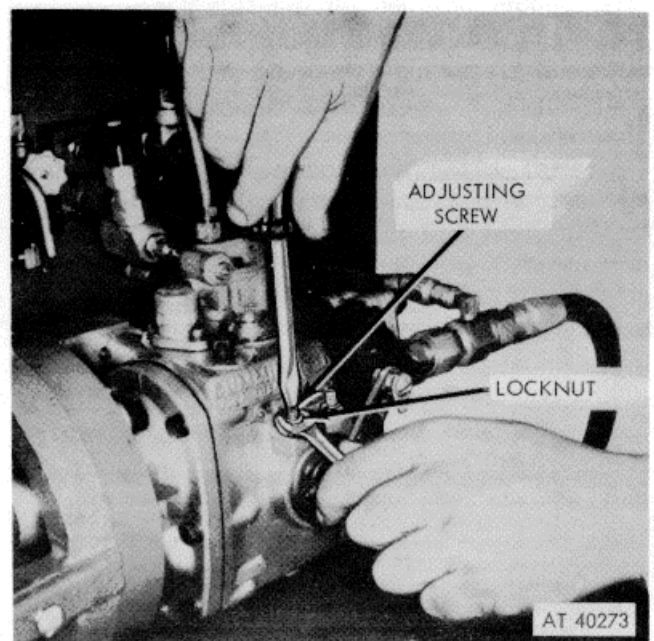

Figure 3-93. Throttle stop screw adjust.

properly seat 'or that correct spring is installed.

(g) If pressure is low add shims below the governor weight assist plunger (fig. 3-92) in the governor weight carrier.

(h) If pressure is high, remove shims.

**NOTE**

If shims are added or removed recheck pump calibration.

(i) Reduce Speed to 500 rpm and press "STOP" button.

(j) Close pump solenoid valve by turning manual override knob fully counterclockwise.

**3-108. Fuel Pump Troubleshooting with Test Stand**

Chart 3-2 lists the malfunctions, probable causes, and corrective actions applicable to the PT (type G) fuel pump that can be determined and corrected with the use of the fuel pump test stand (fig. 3-80).

**3-1 09. Installation**

Refer to paragraph 210.1., and reverse procedures for the installation of the fuel pump and fuel lines.

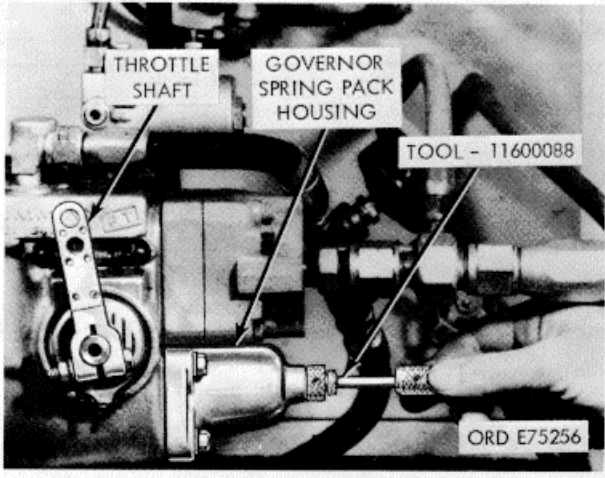

Figure 3-94. Idle speed setting.

flow to 140 p.p.h. Pressure gage should read 46-45 p.s.i.

**NOTE**

If check point tests are out of tolerance perform the following steps.

(f) Check torque spring to insure that spring is

**Chart 3-2. Troubleshooting Fuel Pump**

Malfunction	Probable cause	Corrective action
	<b>FUEL PUMP ASSEMBLY</b>	
1. Pump gear will not pick up necessary fuel at 450 rpm.	a. Openings not sealed correctly.	a. Seal all openings and use new gaskets where
	b. Suction connection is not tight or is damaged-	b. Tighten suction connection or re-is damaged
c. Idle plunger dirty.	c. Check the face of the idler plunger.	
2. Air bubbles and fuel are passing through the flowmeter cover	a. Front seat leakage.	a. Install new seals in the cover after first removing the pump from the stand and then remove the front
	<b>NOTE</b>	
	This can be located by covering the "weep hole" in front cover with high pressure grease which stops air leak.	
	b. Suction connection is not tight or the fitting is damaged.	b. Tighten suction connection and replace damaged parts.
	c. Shutoff valve leaking air. Leakage is either past shut-off override shaft O-Ring or past main housing O-Rings	c. Replace O-Rings to resume satisfactory operation.
3. Governor cannot be adjusted	a. Governor spring incorrect due correctly at breaking point.	a. Replace worn spring. either to wear or incorrect spring.
	b. Incorrect selection of shims positioned between governor spring and retainer	b. If speed is lower than specified add shims. Conversely to reduce speed remove shims.
	<b>NOTE</b>	
	Each 0.001 inch shim will change speed 2 rpm.	

**NOTE**  
"Governor cutoff rpm" on the V8300 engine fuel pump is- 3020 to 3040 rpm--



**Chart 4.-Troublsshooting Fuel Pump Continued**

Malfunction	Probable cause	Corrective action
<b>FUEL PUMP ASSEMBLY</b>		
<p>4. The 40 p.s.i. checkpoint cannot be obtained within specified maximum speed limits</p> <p style="text-align: center;">NOTE</p> <p>"Governor setting 3020 to 3040 rpm" is 40 psi manifold pressure is specified.</p>	<p>a. Governor plunger has wrong chamfer or has a worn chamfer.</p> <p>b. Governor barrel and plunger in correct Aft.</p> <p>c. Governor torque spring incorrect.</p> <p>d. Governor weight incorrect or weight assist setting incorrect.</p>	<p>a. Replace plunger with correct chafer</p> <p>b. Refit governor barrel to accept a plunger two classes larger.</p> <p>c. Install correct spring.</p> <p>d. Install correct weights Make weight assist setting 0.890/0.910-inch and 46 to 54 psi e 800 rpm for V8-300 engine pump.</p>
<p>5. Throttle leakage is above specified.</p> <p style="text-align: center;">NOTE</p> <p>The permissible throttle leakage is 3cc.</p>	<p>a. Throttle shaft scored or incorrect fit in throttle sleeve.</p> <p>b. Governor plunger incorrect fit in governor barrel.</p>	<p>a. Install new throttle shaft (standard or oversize) and lap to fit.</p> <p>b. Install new governor plunger (standard or oversize) and lap to fit.</p>
<p>6. Incorrect fuel manifold pressure.</p> <p style="text-align: center;">NOTE</p> <p>Fuel manifold pressure should be 227 psi @ 3000 rpm.</p>	<p>a. Incorrect idle plunger (button) or surface finish is rough.</p> <p>b. Gear pump fails to pump 850 pounds of fuel per hour at 2100 rpm.</p> <p>c. Wrong throttle restriction.</p>	<p>a. Install new idle plunger.</p> <p>b. Install new gear pump.</p>
<p>7. Incorrect check point pressure.</p> <p style="text-align: center;">NOTE</p> <p>Checkpoint pressure should be 165 to 170 p.s.i. at 2500 rpm.</p>	<p>a. Idle plunger rough or has void &amp;</p> <p>b. 800 rpm checkpoint.</p> <p>c. Incorrect torque or governor spring.</p>	<p>a. Polish surface with oilstone or replace with like or serviceable part.</p> <p>b. Check 800 rpm checkpoint under malfunction No. 8 to be sure it is within specifications before proceeding.</p> <p>c. Remove front cover and check for proper torque or governor spring.</p>
<p>8. 800 rpm checkpoint out of specification.</p> <p style="text-align: center;">NOTE</p> <p>The desired checkpoint pressure at 800 rpm is 46 to 54.</p>	<p>a. Checkpoint pressure is too low.</p> <p>b. Checkpoint pressure is too high.</p>	<p>a. If weight assist protrusion is within specification (0.890 to 0.910 inch) one or more shims may be added to the assembly to obtain the desired pressure.</p> <p>b. Remove weight assist shims required to decrease pressure.</p>

**Section XX. Repair of Water Crossover Pipe and Lifting Eyes**

**3-110. Cleaning**

Clean components in accordance with paragraph 2-5.

**3-111. Inspection**

Refer to paragraph 26 for inspection procedure

**3-112. Repair**

Refer to paragraph 2-7 for general repair procedures.

**3-113. Installation**

- a. Position (rear) engine lifting eye, water

connection and new gaskets to right bank cylinder head (fig. 210). Secure with lockwashers and cap screws.

- b. Position water connection with new gasket to left bank cylinder head. Secure with lockwashers and cap screws.

- c. Install new water hose and clamps on water crossover pipe.

- d. Position crossover pipe to connections. Place hose in position and secure with hose clamps.

**Section XXI. Repair of Air Intake Preheater Assembly and Intake Manifolds**

**3-114. Disassembly**

(fig. B-20).

- a. Remove hoses from assembly.
- b. Remove preheater adapter (2) from cleaner assembly connection.

- c. Remove nozzle (6) and key washer (5) from adapter.

- d. Remove glow plug from air cleaner assembly connection.

### 3-115. Cleaning

Refer to paragraph 2-5 for general cleaning procedures. Clean adapter and nozzle with carburetor cleaner or equivalent. Insure that nozzle screen and spray holes are open.

### 3-116. Inspection

Refer to paragraph 2-6 for general inspect procedures. Check glow plug operation with a vdc source of power.

### 3-117. Repair

Refer to paragraph 27 for general repair procedures. Replace all defective parts.

### 3-118. Assembly

Refer to paragraph 3114 and reverse procedures.

### 3-119. Installation

Refer to paragraph 2-10.i., and 2-10.j., and reverse removal procedures.

## Section XXII. Repair of Water Pump Assembly

### 3-120. Disassembly

(fig. B-22).

a. Remove large snap ring from pump housing by reaching through the access ports in the drive pulley, with a pair of snap ring pliers.

b. Using a suitable puller, pull the impeller (18) from the drive shaft.

c. Press on impeller end of shaft to remove assembly from pump body. Press out bear (11).

d. Remove carbon face seal (15) from pump body.

e. Press shaft through drive pulley (3) and large bearing (8). Lift off spacer (9).

f. Remove snap ring (10) from groove shaft.

### 3-121. Cleaning

Clean all components in accordance with instructions contained in paragraph 2-7.

### 3-122. Inspection

Perform general inspection of all component accordance with instructions contained in paragraph 2-7. Specific inspection procedures follow.

a. Inspect water pump bearings. Replace those with rough or worn races.

b. Inspect water pump impeller. Replace impeller assembly if cracked or corroded to extent that it will interfere with circulation.

c. Replace impeller assembly if the minimum 0.001 inch press-fit between shaft and impeller exceeded. Measure impeller bore and shaft side diameter to project this minimum allowance

d. Inspect water pump mounting parts damage. Replace as necessary.

e. Examine carbon seal carefully to make sure it is not cracked or chipped. Replace if necessary

f. Inspect silicone oil seal. Replace if damaged

g. Inspect ceramic seal seat that is bonded to the impeller counterbore (vane side) for damage and excessive wear. Replace if seal is damaged.

### 3-123. Assembly

a. Lubricate shaft outside diameter and bearings inside diameter with multipurpose industrial grease.

#### CAUTION

Do not use lead base sealer.

b. Pack bearings with GAA.

#### NOTE

One piece sealed bearing must be installed on the shaft and pressed in the body with BLACK shield to the pulley end of the shaft.

c. Install snap ring in groove of shaft. Press inner bearing on shaft with shielded side out to ward impeller end of shaft until inner race seats against snap ring.

d. Position shaft and bearing in bore of pump body. Slide spacer over shaft seating on shoulder of shaft.

e. Fill cavity of bore 1 to % full of GAA.

f. Place large bearing over shaft and into bore of housing with shielded side out. Press bearing into its seat in the housing bore.

g. Install large snap ring in bore of pump body to secure bearings in place.

h. Support shaft on impeller end and press on pulley fixed sheave until sheave hub is tight against bearing inner race. Attach adjustable sheave to complete the pulley installation.

i. Turn water pump body assembly over and press in a new carbon face seal using a suitable mandrel and pressing arbor.

**NOTE**

Driving flange of seal case must seat properly on edge of bore in pump body.  
j. Support pump on pulley end of shaft.  
Pr on impeller and maintain 0.010/0.020 inch

clearance between impeller vanes and pump body.

**3-124. Installation**

Position water pump and new gasket to cylinder block and secure with five cap screws and lock washers.

**Section XXIII. Repair of Fan Drive Pulley, Vibration Damper, and Water Pump Pulley Assembly**

**3-125. Disassembly**

Using a soft hammer or brass driver, remove vibration damper from water pump drive pulley hub.

**3-126. Cleaning**

Refer to paragraph 2-5 for cleaning procedure

**3-127. Inspection**

Refer to paragraph 26 for inspection procedure

**3-128. Repair**

Repair of the assembly is limited to the procedures of paragraph 27.

**3-129. Assembly**

Press vibration damper onto water pump pulley hub. Insure that cap screw holes are aligned.

**3-130. Installation**

a. Loosen adjustable sheave on water pump and set crankshaft-to-pump drive belt in pulley.

b. Set water pump drive belt on drive pulley. c. Position pulley and damper assembly on crankshaft flange.

d. Position three sheave fan drive pulley to vibration damper and secure to crankshaft with seven cap screws and lockwashers.

e. Tighten water pump pulley adjustable sheave to obtain required belt tension.

**Section XXIV. Repair of Thermostat Assembly**

**3-131. Disassembly**

(fig. B-21).

a. Remove two cap screws (16) lockwasher and flat washer (15) securing thermostat cover (14) to housing (7).

b. Remove thermostat (12) and gasket (13) c. Remove pipe plugs (10) and temperature transmitter (11).

d. Loosen hose clamp and remove hose.

(3) Compare thermostat operation with temperature indicated on thermometer.

c. The high range thermostats installed on the V8-300 engine start to open at 173 degrees Fahrenheit and are fully open at 186 degrees Fahrenheit.

d. Discard thermostats not operating in correct range. Replace with same range thermostat.

e. Inspect thermostat for physical damage. If damaged, replace thermostat.

**3-132. Cleaning**

Refer to paragraph 2-5 for cleaning procedure:

**3-133. Inspection**

a. Perform general inspection in accordance with paragraph 26.

b. Check thermostat as follows:

(1) Immerse thermostat and thermometer in water.

**NOTE**

Season thermostat by operating thermostat for a period of 45 minutes at 200 degrees Fahrenheit.

(2) Cool water to the initial operating temperature, 173 degrees Fahrenheit of the thermostat.

**3-134. Repair**

Refer to paragraph 2-7 for general repair procedures.

**3-135. Assembly**

Refer to paragraph 3-131 and reverse procedures.

**3-136. Installation**

a. Position thermostat housing with new gasket to cylinder head and secure with four cap-screws and lockwashers.

b. Position hose on water pump and tighten hose clamps.

## Section XXV. Repair of Fan, Fan Hub, and Bracket Assembly

### 3-137. Disassembly

(fig. B23).

- a. Remove six cap screws (1) and lockwashers (2) securing fan (3) fan spacer (4) pilot spacer (6) to seven sheave pulley (11).
- b. Pull cotter pin and remove nut (7) washer (8) from shaft (13).
- c. Press shaft from pulley.
- d. Remove bearings (9) and oil seal (12).
- e. Using suitable puller remove bearing outer races (10).

### 3-138. Cleaning

Clean all components in accordance with procedures in paragraph 2-5.

### 3-139. Inspection

- a. Inspect bearing cone and rollers, and tape roller bearing cup (rear). Replace if damaged, rough or worn.
- b. Inspect threads for stripped or crossed threads. Replace all damaged parts.
- c. Inspect fan hub nut, idler seal, and idler fan hub shaft for damage or wear. Replace if damaged or worn.
- d. Perform general inspection in accordance with paragraph 2-6.

### 3-140. Repair

Repair of the assembly is limited to the instructions in paragraph 2-7.

### 3-141. Assembly

#### CAUTION

Align shaft in bearing before pressing. Use only enough pressure to slide bearing over the shaft.

- a. Using suitable arbor press install outer races of tapered bearings into fan hub housing with cupped area up. Outer races must be against shoulders provided in housing.
- b. Pack bearing cones of both bearings with GAA.

c. Install pipe plugs in housing. Seal plugs with sealing tape or sealer to prevent leaks.

d. Install rear bearing inner race with largest inside diameter into rear of fan hub and press new oil seal into housing flush with bore.

e. Install shaft through oil seal and bearing inner race. Seat with light tapping of a soft hammer or press.

f. Fill cavity between bearings ½ to ¾ full of GAA.

g. Install front bearing, clamp washer, and retaining nut.

h. Slowly rotate housing around spindle and at the same time tighten retaining nut until a small "drag" is felt during rotation of housing.

#### CAUTION

Hub must be rotated while nut is being tightened. Failure to rotate hub will result in excessive end play.

i. Tap fan hub assembly lightly with a soft hammer to relieve clearances. Check shaft end clearance. It must be 0.001/0.007 inch and the hub must rotate freely. Loosen or tighten nut and repeat step h above, if required. Lock retaining nut with cotter pin.

j. Apply GAA to outer bearing. Assemble new gasket, spacer, and fan to pulley assembly with lockwashers and cap screws.

### 3-142. Installation

a. Install fan assembly bracket on block (fig. 24) and secure with six cap screws and lock-washers.

b. Position flatwasher on shaft and insert shaft in bracket. Secure with flatwasher and lock nut.

c. Install adjusting bolt in bracket and through shaft.

d. Set hydraulic pump drive belt on inner sheave, and two alternator drive belts on next two sheaves.

e. Install three drive belts from crankshaft drive pulley to three outer sheaves of fan drive pulley.

## Section XXVI. Repair of Hydraulic Pump and Mounting Bracket

#### NOTE

If engine is received for repair without the power steering pump (hydraulic pump), bracket, pulley and drive belt, do not requisition these items for installation on the repaired engine. The repaired or rebuilt engine will be shipped

to the using unit without the pump assembly.

### 3-143. Disassembly

(fig. B-26).

a. Remove swivel elbow (7) and nipple (6).

b. Remove adapter (10) bushing (9) and elbow (8).

c. Remove locknut (2) securing pulley to shaft and remove pulley and woodruff key (3).

d. Remove two cap screws (14) lockwasher (12) and flat spacer washers (15) securing pump (5) to mounting bracket (4).

**3-144. Cleaning**

Clean all components in accordance with procedures in paragraph 2-5.

**3-145. Inspection**

Perform general inspection in accordance with paragraph 2-6.

**3-146. Repair**

Repair of the pump and brackets is limited to the instructions contained in paragraph 2-7.

**3-147. Assembly**

Refer to paragraph 3-143 and reverse procedures to assemble the pump.

Insure that flat spacer washers are placed between pump body and mounting bracket.

**3-148. Installation**

a. Install pump and bracket assembly mounting bracket on block and secure with three cap screws, lockwashers and plain washers.

b. Install pump and bracket assembly on engine mounting bracket and secure with two cap screws, lockwashers, and plain washers.

c. Install pump drive belt on pulley.

d. Install tension adjusting strap on engine block with cap screw, lockwasher and plain washer. Finger tighten.

e. Secure tension adjusting strap to pump mounting bracket with cap screw, lockwasher, and plain washer.

f. Adjust pump to obtain proper belt tension and tighten tension strap to block securing cap-screw.

**NOTE**

**Section XXVII. Repair of Alternator Assembly and Mounting Bracket.**

**3-149. Disassembly**

(fig. B-24)

a. Remove locknut from shaft and remove two sheave pulley and key.

b. Remove cap screw and lockwasher securing adjusting arm to alternator end plate.

**3-150. Cleaning**

Clean all components in accordance with procedures in paragraph 2-5.

**3-151. Inspection**

Perform general inspection in accordance with the requirements of paragraph 2-6.

**3-152. Repair**

Repair of the alternator and bracket is limited to the instructions of paragraph 2-7. The alternator shall be replaced if noisy or voltage cannot be maintained between 27-29 volts.

**3-153. Assembly**

Refer to paragraph 3-149 and reverse disassembly procedures.

**3-154. Installation**

Refer to paragraph 2-10.c., and reverse removal procedures.

**Section XXVIII. Repair of Starter Assembly**

**3-155. Inspection and Repair**

Refer to TM 9-2920-242-34 for inspection and repair procedures, and repair parts listing.

**3-156. Installation**

Refer to paragraph 2-10.a., and reverse removal procedures.

**Section XXIX. Repair of Oil Cooler**

(14) and filter element (15).

**3-157. Disassembly**

(fig. B-11)

a. Remove transmitter (16) and bushing (17) from pipe tee (18).

b. Remove pipe plug (5) and (10).

c. Remove five cap screws (23) and lockwasher (7) securing cover (12) to housing (22).

d. Remove gasket (13) O-Rings (24) retainer

**3-158. Cleaning**

a. *Oil Side.*

**CAUTION**

Perform the following operation in a well ventilated area to avoid toxic effect of chemicals being used.

(1) Immerse the filter element in carbon tetrachloride to trichloethylene, or other approved cleaning solvent.

(2) Using a rubber suction cup force solvent around and through the tubes until clean.

**NOTE**

If all passages are badly clogged, circulate an oakite or alkaline solution through the tubes.

(3) After cleaning flush thoroughly with hot water.

*b. Water Side.*

(1) Plug oil inlet and outlet.

(2) Immerse oil cooler in solution of one part muriatic acid, nine parts water, one pound oxalic acid, and 0.01 gallon of pyridene to each five gallons of acid.

(3) Remove core when foaming and bubbling stops. This usually takes 30 to 60 seconds.

(4) Immerse unit in a 5 percent solution sodium carbonate. Remove when bubbling stops and pressure flush with clean warm water.

(5) Clean' inside of case thoroughly will steam or solvent.

**3-159. Inspection**

a. Perform general inspection in accordant with

**Section XXX. REPAIR OF EXHAUST MANIFOLDS**

**3-162. Cleaning**

Clean manifolds in accordance with instructions in paragraph 2-5.

**3-163. Inspection**

Inspect manifolds in accordance with instructions in

paragraph 2-6.

b. Assembly oil cooler. Plug oil outlet and attach 70/100 p.s.i. air line to oil inlet.

c. Immerse unit in water and apply air pressure. The slightest leak will be indicated by the appearance of air bubbles.

d. Assemble front and rear heads to cooler.

e. Plug either inlet or outlet connection and check for leaks as described in steps (1) and (2) above.

**3-160. Repair**

a. Header leaks may occur where tubes protrude through header plate or where header is soldered. The header may become cracked in service due to excessive pressure. Resolder tubes to header as necessary.

**CAUTION**

Do not burn tubes or header material with torch flame.

b. Perform general repairs in accordance with paragraph 2-7.

**3-161. Assembly**

Assemble cooler in reverse order of disassembly (para 3-157), and perform a leak test.

**CAUTION**

Insure element is assembled so "O" marks are aligned on case and element.

paragraph 2-6.

**3-164. Installation** (right bank)

Secure manifold to head with eight cap screws, spacers, four lockplates, and four gaskets.

**Section XXXI. ENGINE REMOVAL FROM REBUILD STAND**

**3-165. General**

Attach lifting hooks to hoist to front and rear engine lifting eyes (fig. 1-1 and 1-2), and takes slack in chain.

**3-166. Rebuild Stand Removal**

a. Remove cap screws and lockwasher securing engine stand and adapter plate to engine block.

b. Remove stand and adapter from engine. c. Install gasket and left side cover plate to block securing

with 12 cap screws and lockwashers.

d. Install oil cooler and four gaskets securing with 13 cap screws and lockwashers to block and cover plate.

e. Install left bank manifold and four gaskets to cylinder head securing with eight cap screws, spacers, and four lockplates.

**Section XXXII. ENGINE TEST AND ADJUSTMENT**

**3-167. Adjustment**

a. Injectors, Crossheads, and Valves.

(1) Injector plungers, crossheads and valve must be adjusted before starting engine first time at cold setting and-again during engine test after

reaching operating temperature.

(2) Always adjust injectors before crossheads and valves.

(3) Valve timing marks are located on the vibration damper at the front of the engine (95).

### CAUTION

Check that index marks on outer ring and hub of vibration damper are in line. If not, replace vibration damper.

(4) To align the timing marks, rotate the engine manually in a counterclockwise rotation (left-hand as viewed from flywheel low towards the fan) until one of the sets of marks <sup>47</sup> is in line with the "A" arrow head on the front cover. <sup>vs.</sup> In this position, both intake and exhaust valves will be closed for one of the cylinders indicated. Make adjustments on cylinder.

(5) Adjust injector plunger, then crossheads and valves of each cylinder as explained in succeeding paragraphs. Turn crankshaft clockwise to the next VS mark corresponding to the order of the engine which is 1-5-4-8-6-3-7-2 figure 3-96 for complete sequence of adjustments.

(6) After injectors, crossheads and valves are adjusted for this cylinder, rotate crankshaft in direction of rotation (right-hand) to the next VS mark corresponding to the order of the engine and repeat the adjustment procedures.

### NOTE

Two complete revolutions (720 degrees) of the crankshaft are needed to set all injector plungers, crossheads and valves. Injectors, crossheads and valves can be adjusted for only one cylinder at any one VS setting.

#### b. Injector Plungers.

(1) Turn adjusting screw down until plunger just contacts cup, then advance an additional degree to squeeze oil from cup.

(2) Loosen adjusting screw one turn.

(3) With a torque wrench calibrated in pounds and a screwdriver adapter, tighten adjusting screw for a cold setting (70 degrees Fahrenheit) at 50 inch-pounds torque. Setting 140 degrees Fahrenheit 50 inch-pounds.

#### c. Valve Crossheads.

(1) Loosen valve crosshead adjusting locknut and back off screw one turn.

(2) Use light finger pressure at "A" to crosshead in contact with valve stem at point "B" (fig 3-97).

(3) Turn adjusting screw down until it contacts its mating valve stem at point "C" (fig. 3-97).

(4) Advance adjusting screw slightly, then loosen. Retighten adjusting screw until valve contact is made.

(5) Tighten 7/16 inch high locknut 60 to 70 foot-pounds torque.

(6) Check clearance between crosshead and valve spring retainer with a wire gage. There must be a minimum of 0.025 inch clearance at this point.

#### d. Valve Clearance.

### NOTE

The same engine position used in setting the injectors is used for setting the intake and exhaust valves.

(1) Loosen the locknut and back-off the adjusting screw. Insert feeler gage between rocker lever and top of crosshead; turn screw down until lever just touches the gage. Lock adjusting screw in position with locknut.

(2) Always make final valve adjustment after injectors and crossheads are adjusted and with the engine at operating temperature (140 degrees Fahrenheit). Valve clearances are as follows: Intake Valves: 0.016 inch at 70 degrees Fahrenheit, 0.014 inch at 140 degrees Fahrenheit. Exhaust Valves: 0.029 inch at 70 degrees Fahrenheit, 0.027 inch at 140 degrees Fahrenheit.

(3) Position valve covers on heads with new gaskets. Secure with flatwashers, lockwashers, and cap screws.

### 3-168. Starting and Testing

Engine break-in and testing are accomplished together. Break-in on a new or rebuilt engine is

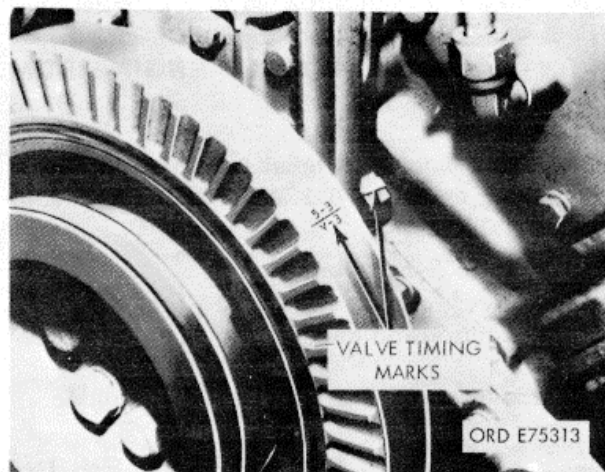

Figure 3-95. Valve timing marks.

engine horsepower (288 H.P.) ] capacity is insufficient, testing procedure must be modified to prevent damage to the dynamometer

a. Using proper lifting device, place engine on dynamometer test stand.

b. Position engine on the front engine support and preselected risers for the rear engine supports; secure engine mounting pads to engine support risers with bolts, lockwashers and nuts. Remove lifting device.

c. Position dynamometer driveshaft flange to engine flywheel. Use proper flywheel adapter flange to match flywheel cap screw holes.

d. Check for proper alignment.

(1) If direct or flexible drive coupled, place a dial gage holding fixture on face of flywheel housing and dial gage on adapter flange hub; bar engine over to obtain measurement. Relocate flange hub on flywheel as needed and retighten cap screws. Flywheel adapter flange must be concentric to flywheel and flywheel housing within 0.005 inch total run-out. When using a direct coupled dynamometer, a reading must be taken from face of flywheel housing to outer edge of dynamometer drive flange. It must not exceed 0.005 inch total run-out when barring dynamometer one complete revolution.

(2) If universal drive coupled, flywheel and dynamometer drive flanges must be concentric within 0.005 inch run-out; reading to be taken as above. Install engine so that centerline of engine crankshaft and centerline of dynamometer drive shaft are, by design, out of plane either horizontally or vertically from 1/4 inch minimum to 1/2 inch maximum. True alignment will cause universal bearing failure. Secure flywheel to drive flange with lockwashers and cap screws.

e. Connect water supply and return hose to the water cooling arrangement.

f. Attach fuel pump return line, if used.

g. Attach fuel supply line to fuel pump suction connection.

h. Connect electrical connections to starting motor if motor is used for starting. If another means of starting is used make necessary connections.

i. Connect throttle linkage and all instruments which are included on the control panel of the particular dynamometer being used.

j. Connect exhaust piping to engine exhaust manifold.

k. Connect air intake piping to air intake manifold. Use a standard air cleaner approved for the V8300 engine.

l. Connect a full flow lubricating oil filter to remove any entrapped dirt or grit.

m. Install a Blow-By Checking Tool (3, fig. B-28) to the crankcase breather with adapter.

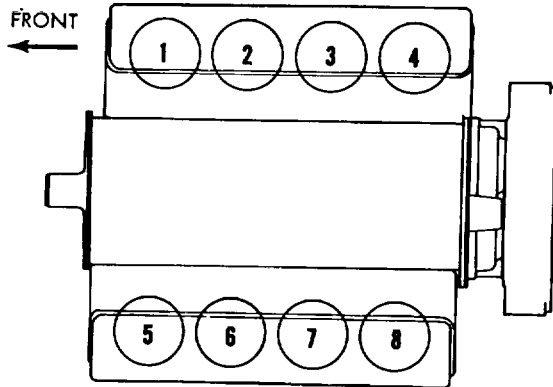

FIRING ORDER: 1 - 5 - 4 - 8 - 6 - 3 - 7 - 2

ORD E75314

Figure 3-96. Engine firing order.

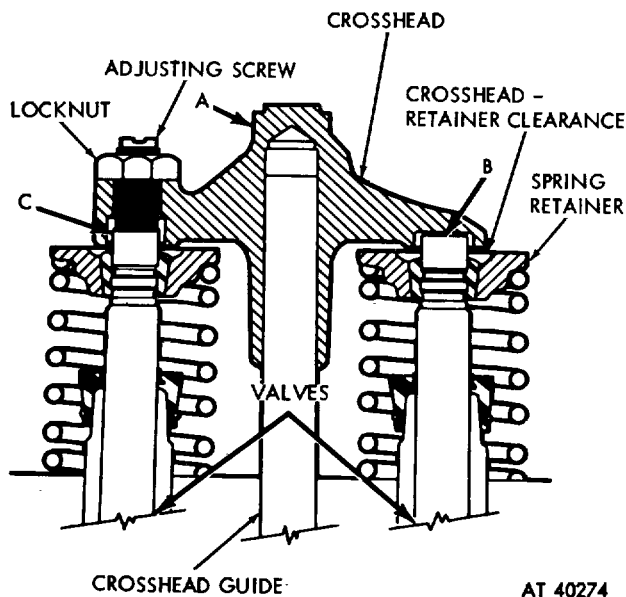

AT 40274

Figure 3-97. Crosshead adjustment.

essential because it provides an operating period during which coving parts acquire their finish and mating surfaces reach a full seat. Engine testing helps detect possible assembly errors as the need for adjustments as engine "breaks-in" as well as establishing a period for final adjustments for best engine performance. A dynamometer provides the simplest and most accurate tool for testing and breaking in an engine. (Follow the instructions in sequence below for pre starting checks, dynameter mounting, engine starting, testing, adjustments and break-in.

### 3-169. Dynamometer Test

Check the capacity of the dynamometer. The stand must be capable of testing at 96 percent c maximum



Also, connect a manometer to the Blow-By Tool measure the amount of blow-by gases escaping past the piston rings.

**NOTE**

This is essential to indicate seating of rings and to ascertain if and when additional run-in time is necessary.

**3-170. Preparation For Starting**

As an assist in priming the fuel and lubricating oil systems it is recommended that all filter: removed and serviced with their respective

- a. Prime fuel pump before starting engine the first time. Remove plug next to tachometer drive and fill with clean diesel fuel.
- b. Check Fuel Tanks. There must be an adequate supply of good grade, clean diesel fuel the tanks.
- c. Close all drain cocks and open vent cocks, on air compressor and vent (pipe plugs) water crossover tubes to insure circulation.
- d. Fill engine with required coolants until it flows from vent cocks and vents; close all vents and fill the system.
- e. Fill oil pan to "L" (low) mark on dipstick.
- f. Connect a hand or motor driven priming pump line from a source of clean OES-20 It lubricating oil to Oil Cooler (Left Bank) "INL OUTLET" connections, fill oil pan to "H" position of the dipstick.
- g. Prime until a 30 psi minimum pressure obtained.
- h. Crank engine for at least 15 seconds while maintaining external oil pressure at a minimum of 15 psi.
- i. Allow engine to fire and operate 5 to seconds.
- j. Remove external oil supply and replace full flow oil filter system as used on the vehicle.
- k. Fill crankcase with oil to "H" (high) n on dipstick. Grades used, OES-10, OES-2( OES-30, will depend on ambient temperature. special oil is required for break-in period. change in oil viscosity or type is needed for or newly rebuilt engines.

**CAUTION**

Service engine oil after a few minutes of operation to compensate for oil absorbed into filter- elements and leakage.

- l. Check Oil Level. Add oil if necessary to reach the "H" level on the dipstick. Never operate engine below "L" mark or above "H" mark.

**3-171. Starting Engine**

- a. Position the throttle at idle speed.
- b. Disengage the drive unit.
- c. Electrical shut-down valve operates (opens) automatically.

**NOTE**

A manual override knob provided on the forward end of the electric shut-down valve allows the valve to be opened in case of electric power failure. To operate "open" by turning fully clockwise.

- d. Press starter button or turn switch-key to "start" position.
- e. Warm-up engine.
- f. Check all tubing, hoses, lines, fittings and plugs for leaks. Correct as necessary.
- g. Open cooling water supply valves to heat exchanger. Introduce water to absorption unit per manufacturers instructions.

**3-172. Test Procedure**

**NOTE**

Dynamometer manufacturers provide a figure known as a "brake constant" with each dynamometer. This simplifies computing brake horsepower, since only engine rpm and the scale reading in pounds need be found.

- a. Horsepower Ratings.
  - (1) The maximum horsepower rating 300 at 3000 rpm is established for engines on number 1 curve in figure 101 in automotive or intermittent-duty applications at sea level, 60 degrees Fahrenheit intake air temperature and 29.92 inches Hg. (Mercury barometric pressure).
  - (2) Where necessary an engine may be derated because of high altitude-operation or for the sake of fuel economy, the derating may be done by reducing governed rpm or maximum fuel rate in the proportion desired.
  - (3) Naturally-aspirated engines must be derated 3 percent for each 1000 feet altitude above sea level, and 1 percent for each 10 degrees Fahrenheit ambient temperature rise above 60 degrees Fahrenheit.
  - (4) New or rebuilt engines during dynamometer test are not required to deliver more than 96 percent of maximum horsepower at power checks. The additional 4 percent will be achieved after a few hours operation.
- b. Break-In-Run. Start engine and idle at approximately 800 rpm no-load for 5 to 10 minutes.

Check oil pressure and water circulation: look leaks.

(1) Apply dynamometer load to develop horsepower at speed (rpm) indicated below.

Maximum Rated HP @ RPM-300 @ 3000

Maximum Fuel Rate lbs./hr.-120

Maximum Crankcase Pressure-5

Valve and Injector Settings (130 degrees/150 degrees Fahrenheit)

Injector, Inch-Pounds-50

Valves: Intake-14, Exhaust-27

First ½h Hour HP @ RPM-75 @ 2000

Second ½ Hour HP @ RPM-125 @ 2500

Third ½ Hour HP @ RPM-150 @ 2700

Fourth ½ Hour HP @ RPM--250 @ 3000

Fifth ½'i Hour HP @ RPM-275 @ 3000

Power check 5 min. maximum 96 percent Rated Power-288 @ 3000

(2) Check crankcase blow-by (paragraph below). If not excessive, reduce run-in time by one-half.

(3) If blow-by is too high, run engine for time period shown under item (1) above.

(4) At first period only: Run the engine until temperature reaches 140 degrees Fahrenheit. Add to bring level up to "H" mark on dipstick.

(5) At second period only: Reset valves and injectors. Set engine governed speed and fuel rate.

(6) At third and thereafter: if blow-by is excessive, reduce load to preceding phase and run 30 minutes; then return to original sequence and continue planned program.

*c. Blow-By Check.*

(1) Install right bank rocker housing. Install sealed type oil dipstick.

(2) Install left bank rocker housing. Install sealed type oil dipstick.

(3) Attach a manometer to the hose coupling the checking too (fig 3-98), and fill the tube w water to the "0" mark at the middle of scale.

(4) Manometer readings must be taken frequently during the break-in test to note any blow-by crease. If there is any increase, engine speed must be decreased for a few minutes and then brought back to original setting.

(5) During each 5 minute power check, keep a constant check on the manometer. If the pressure rises, more run-in is required. Maximum pressure limits for engine running, at governed speed a operating at 96 percent to 100 percent of rated horsepower are listed in paragraph b (1), above.

(6) Observe variation in rate of blow-by during initial engine run. If the crankcase pressure, or blow-by is greater at the end of the testing period than maximum values listed, the engine should be operated at 96-100 percent rated load and rpm for minutes. If the blow-by is not increasing, although it may be above 5 inches of water (maximum crankcase pressure), there is

generally no reason for concern. As the rings and cylinder liner combination wear in, the blow should come down below 5 inches of water. If blow-by does not decrease after 30 minutes, continue to operate for up to 50 hours. If blow-by is not below 5 inches of water within 50 hours of operation, the engine must be considered unacceptable.

*d. Power Check.*

(1) Run engine at rated speed for 5 minutes. It should indicate 96 percent of rated power at standard fuel rate (120 pounds per hour). Check crankcase blow-by.

(2) If crankcase blow-by exceeds value shown (5 inches of water), reduce engine speed and load to preceding level. Run engine 30 to 45 minutes.

(3) Repeat procedures described above until engine develops 96 percent power (288 horsepower) at standard fuel rate (120 pounds per hour) within permissible crankcase blow-by limit (5 inches of water).

**CAUTION**

Do not exceed 5 minute power check limitation.

(4) During power check, check lubricating oil as follows:

(a) Oil pressure at idle speed, 10 to 30 p.s.i. @ 225 degrees Fahrenheit, at maximum speed, 60 p.s.i., maximum. Lubricating oil pressure should remain at or near a constant figure at constant engine speed and load, after normal operating temperatures have reached.

**NOTE**

Abnormally high oil pressures may indicate restricted lubricating oil lines. Low pressures indicate an insufficient oil supply or increased oil clearance which may be due to bearing wear.

(b) Under full load conditions, oil pressure may drop to 30 p.s.i. and oil temperature may reach 250 degrees Fahrenheit to 265 degrees Fahrenheit for a short period. This is not cause for alarm.

**CAUTION**

Any sudden increase in oil temperature which is not caused by loading increases in a warning of possible mechanical failure and should be investigated at once.

(c) After the first 5 to 10 minutes operation the engine should be shut down and engine oil added to compensate for engine oil absorbed by filters.

Thereafter, check oil level of the engine, with the dipstick every two (2) hours during run-in test. Maintain oil level at "H" mark on the dipstick.

(5) Check engine coolant as follows:

(a) After engine is started, add coolant as required to completely fill cooling system and replace entrapped air.

(b) The ideal water temperature is 175 degrees Fahrenheit for best engine performance. It should not exceed 190 degrees Fahrenheit during operation.

(c) Do not turn off engine immediately after load operation. Heat stored in the iron masses will boil cooling water in the jackets if air and water circulation cease while engine is still hot. Allow engine to idle for a few minutes before shutting down.

(6) Check fuel pressures as follows.

(a) Check fuel manifold pressure with fuel system pressure gage (4, fig. B-29) as shown figure 3-99. Accelerate from idle to full throttle a record maximum pressure recorded on gage; it should be 202 to 218 pounds.

(b) Check fuel rate with fuel flow rate check gage (2, fig. B-24) as shown in figure 3-100.1 gage's flow tank is placed between the engine and the fuel supply tank. Fuel return line(s) and the fuel pump suction line are then attached to the circulating tank.

#### NOTE

As the engine burns fuel, the float valve allows make-up fuel to flow into the cir-

culating tank from the fuel supply tank. This make-up fuel passes through the flowmeter and is the fuel rate of the engine registered in pounds per hour. Fuel rate is 120 pounds per hour.

(c) Accelerate engine from idle to full throttle and check manifold pressure with Pressure Gage. It should be 202 to 218 pounds.

(d) Refer to Section XIX Fuel Pump for fuel pump governor adjustments.

(e) Inspect all fuel lines and connections for leaks and security of mounting.

(f) Inspect lubricating oil connections for leaks. Check oil cooler for security of mounting and inlet/outlet connections for leaks.

(g) After run-in has been completed, load applications should be minimal for the first 50 hours of operation. This gives new parts a chance to "wear-in" without undue stress and strain.

#### 3-173. Performance Curve

Figure 3-101 is an engine performance curve. Solid lines represent maximum ratings at 500 feet altitude 29.38 inches mercury and 85 degrees Fahrenheit ambient air temperature. The dotted lines indicate standard sea level conditions. These curves indicate engine performance with fuel system, water pump, lubricating oil pump and air cleaner. It does not include battery charging generator, compressor, fan and optional equipment.

### Section XXXIII. REPAIR AND REBUILD STANDARDS

#### 3-174. General

The repair and rebuild standards give maximum minimum, and key clearances of new or rebuilt parts. Wear limits are given, which indicate the point which a part or parts may be worn, in order to receive maximum service before replacement. Normally, parts which have not been worn beyond the dimensions shown in "Wear Limits" column will be

proved for further service. An asterisk in the "Wear Limits" column indicates that the part or parts should be replaced when worn beyond the limits given in the "New Dimensions" column. All dimensions are given in inches.

#### 3-175. Cylinder Block

(para 3-4)

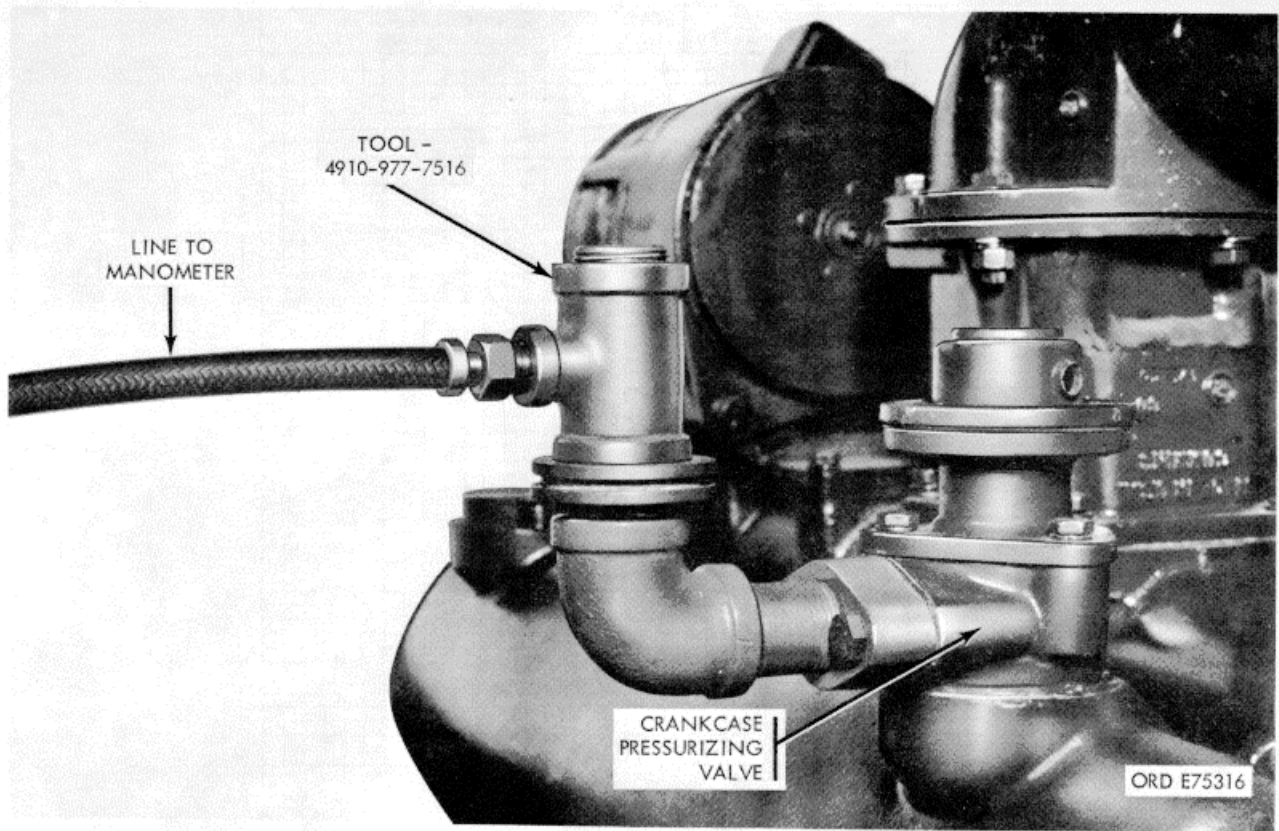

Figure 3-98. Engine blow-by check.

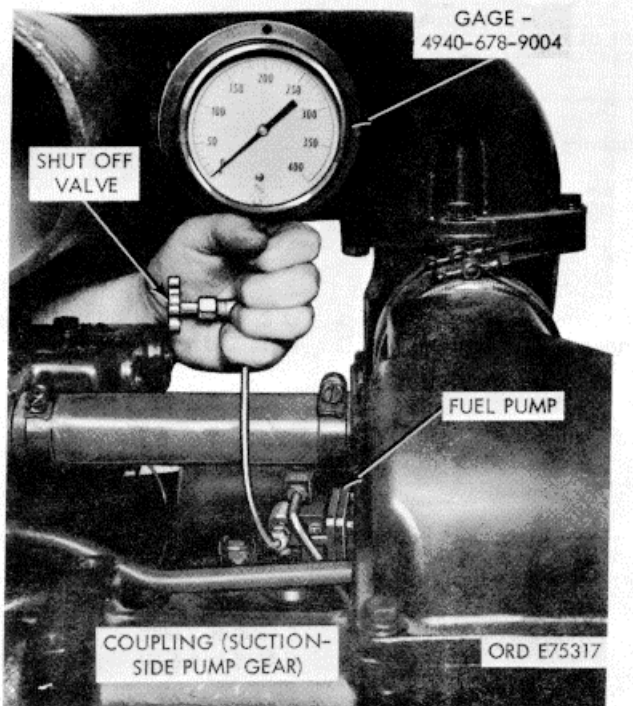

Figure 3-99. Manifold fuel pressure check.

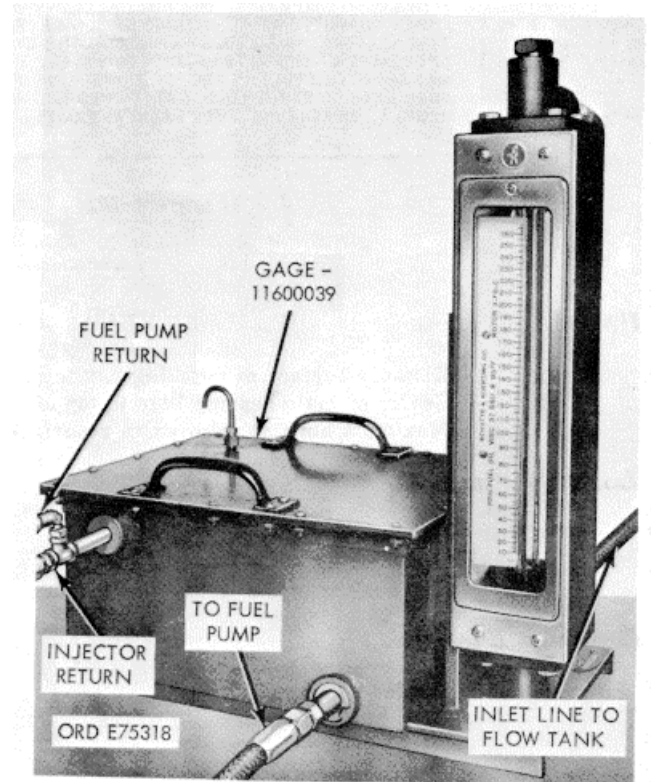
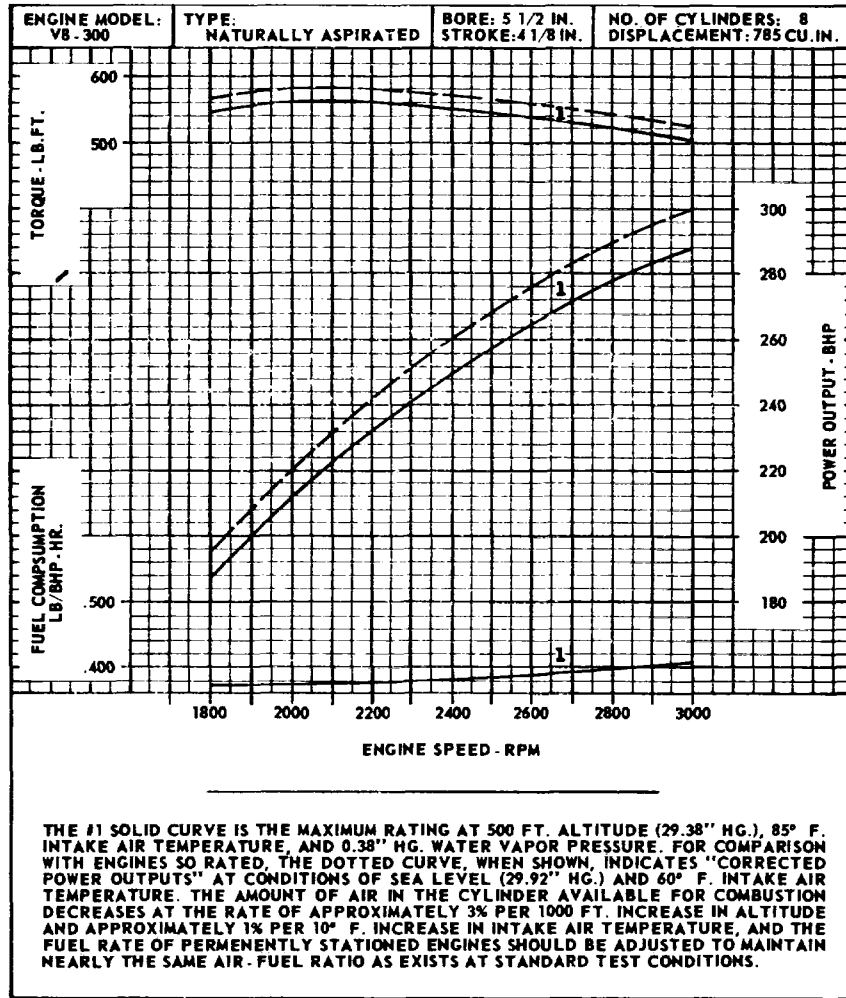

Figure 3-100. Fuel flow rate check.



ORD E75319

Figure 3-101. Performance curve.

Fig. No.	Ref. Letter	Point of Measurement	New Dimensions (inches)	Wear Limits (inches)
<b>a. Height</b>				
3-102.	a	Distance surface of checking bar to top of cylinder block.....	1.2710/11.2765	11.2655
	b	Center of main bearing bore to top of cylinder block .....	3.1480/13.1540	13.1420
		Maximum amount removed in resurfacing.....		.006
<b>b. Liner Counterbore.</b>				
3-102	c	Inside diameter.....	.4990 to 6.5010	6.6016
	d	Depth 0.....	.3500 to 0.3520	*
		Depth after repair .....		.4130
<b>c. Camshaft Bushing.</b>				
3-102.	e	Inside diameter.....	.4990 to 2.5005	2.5020
		Bore inside diameter .....	.6245 to 2.6255	
<b>d. Main Bearing Bore.</b>				
3-102.	f	Inside diameter.....	.7520 to 3.7530	3.75.5
		Alignment-Check with checking bar 5120-981-3115		

Fig. No.	Ref. Letter	Point of Measurement	New Dimensions (inches)	Wear Limits (inches)
<b>e. Tappet Bore Inside Diameter</b>				
g		Valve .....	1.1000 to 1.1010	1.1025
g		Injector .....	1.4000 to 1.4010	1.4025
		Out-of-round .....		0.0015

**3-176. Crankshaft**  
(para. 3-9)

**a. Crankshaft Journals.**

3-103.	a	Diameter of main bearing journals .....	3.4990 to 3.5000	3A.4965
	b	Rod journal diameter .....	3.1240 to 3.1253	3.1215
	c	Rear main (thrust) width .....	1.9400 to 1.9420	1.9440

**b. Crankshaft End Clearance.**

3-6		Flywheel end of assembled crankshaft .....	0.005 to 0.015	0.0220
-----	--	--	----------------	--------

**c. Crankshaft Bearings.**

3-103.	d	Main bearing shell thickness .....	0.1245 to 0.12525	0.1230
	e	Thrust bearing thickness .....	0.1510 to 0.1530	0.1490
	f	Crankshaft adapter outside diameter .....	4.749 to 4.751	4.717

**3-177. Connecting Rod**  
(para. 8-19)

**a. Measurements.**

3-104.	a	Length center to center .....	8.1920 to 8.1940	
	b	Inside diameter of connecting rod bore .....	3.3160 to 3.3165	
3-104	c	Inside diameter of connecting rod bore (piston pin end-in rod) .....	1.9995 to 2.0005	
	d	Inside diameter of piston pin bushing .....	1.7510 to 1.7515	1.7525

**b. Bearing Shell.**

3-104.	e	Shell thickness .....	0.0942 to 0.0947	0.0929
		Journal clearance .....	0.0015 to 0.0045	0.0070

**c. Bore Misalignment. Check on Fixture (Refer to fig. 3-10).**

		Bend with bushing installed .....	0.0040
		Twist with bushing installed .....	0.0100

**3-178. Piston**  
(para. 3-15)

**a. Measurements.**

3-105.	a	Outside diameter of piston skirt (at 70sF.) .....	5.4870 to .4880	5.4830
	b	Piston pin bore inside diameter .....	1.7485 to 1.7489	1.7500
	c	Piston pin outside diameter .....	1.7488 to 1.7490	1.7478

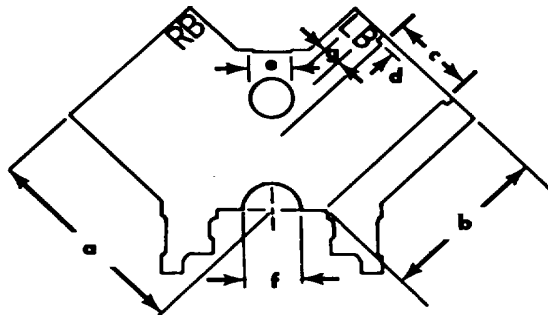

ORD E75326

Figure 3-102. Cylinder block-points of measurement.

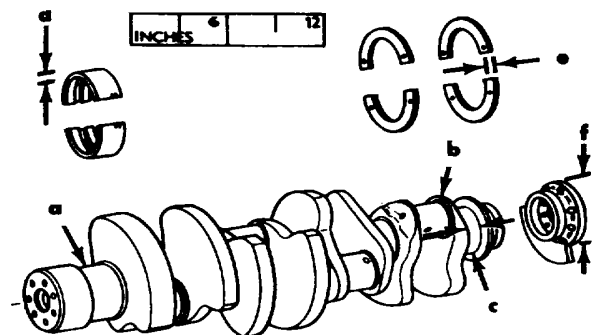

ORD E75327

Figure 3-103. Crankshaft and bearings-points of measurement.

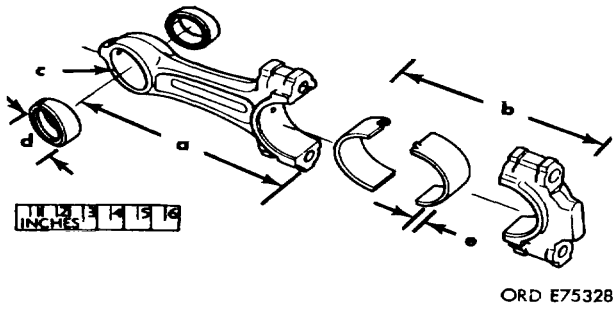

Figure 3-104. Connecting rod-points of measurement

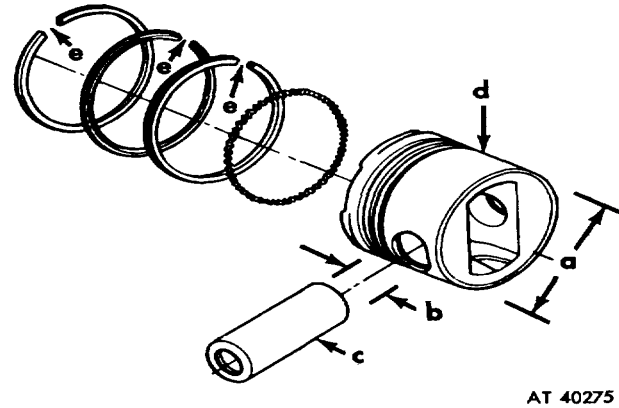
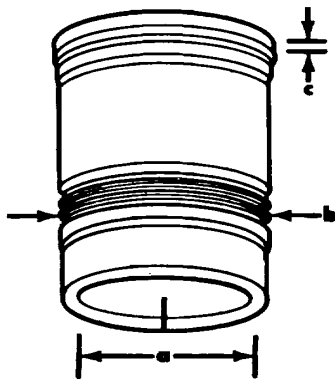
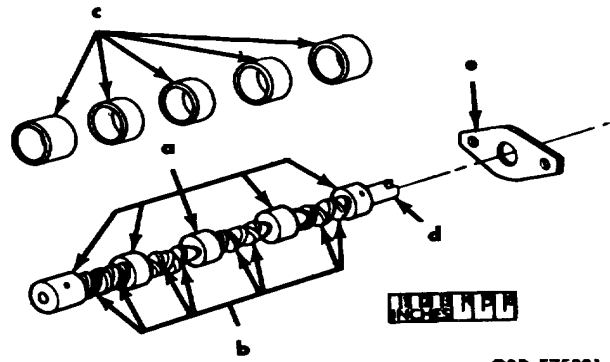

Figure 3-105. Piston-points of measurement.

Fig. No.	Ref. Letter	Point of Measurement	New Dimensions (inches)	Wear Limits (inches)
<b>b. Ring</b>				
3-105	d	Piston ring-to-groove clearance (use gage 1600043) new ring flush with piston wall .....	0.002	0.006
	e	Piston ring gap clearance (In new liners) .....		
		Top compression ring. Part Number (15434-129260) .....	0.017 to 0.027	
		Level compression ring. Part Number (15434168680) .....	0.013 to 0.023	
		Oil ring. Part Number (15434-172550) .....	0.015 to 0.027	
<b>3-179. Cylinder Sleeve</b> (para. 3-2.b.)				
3-106.	a	Cylinder sleeve inside diameter .....	5.4995 to 5010	5.5050
	a	Cylinder sleeve out-of-round: Packing ring area .....		0.0015
		Above piston pin area .....		0.003
	b	Cylinder sleeve outside diameter: Packing ring hands .....	5.9930 to 5.9970	5.9900
		Top flange (press fit area) .....	6.5015 to 6.5035	6.5015
	c	Cylinder sleeve flange: Thickness .....	0.3550 to 0.3560	0.355
		Protrusion above block .....	0.0040 to 0.0060	0.0040
		Cylinder sleeve to block packing ring bore clearance .....	0.0020 to 0.0080	
<b>3-180. Camshaft and Bearings</b> (para 832)				
<b>a. Camshaft.</b>				
3-107.	a	Outside diameter of journals .....	2.4960 to 2.4970	2.4940
	b	Injector(s) lobe total lift .....	0.1680to0.1720	0.1670
<b>b. Camshaft Bearings.</b>				
3-107.	c	Inside diameter of camshaft bushing .....	2.4990 to 2.5005	2.5020
	d	End play of camshaft .....	0.0070 to 0.0110	0.0150
	e	Engine camshaft thrust plate (thickness) .....	0.124 to 0.126	*
* Replace thrust plate when end play exceeds 0.0150.				
<b>3-181. Gear Train</b>				
<b>a Crankshaft Gear (para. 3-9).</b>				
3-108.	a	Inside diameter of gear .....	4.040 to 4.041	*
	b	Outside diameter of crankshaft .....	4.045 to 4.046	*
	ab	Gear-to-crankshaft clearance .....	PRESS FIT	



ORD E75330



ORD E75331

Figure 3-106. Cylinder sleeve-points of measurement. Figure 3-107. Camshaft and bearings points of measurement.

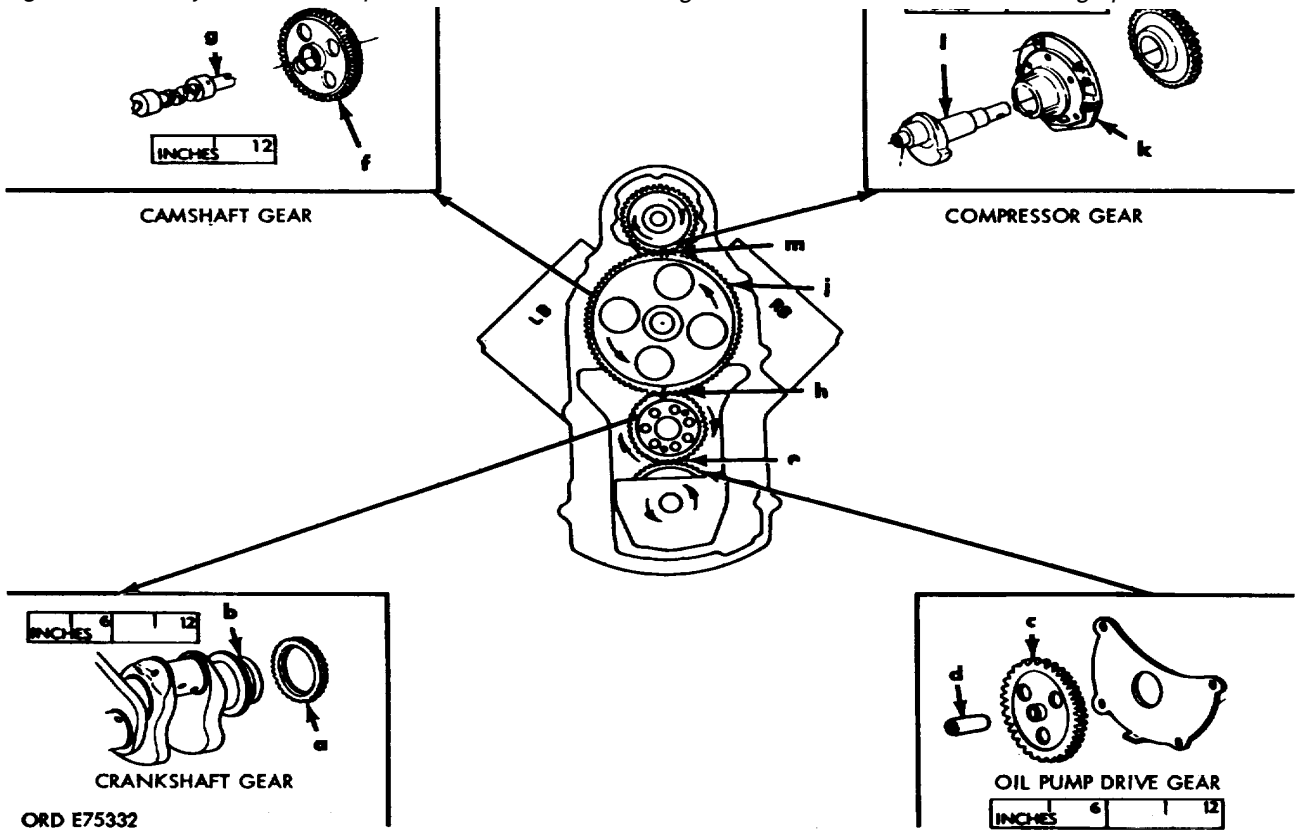

3-108.	c	Inside diameter of gear .....	0.8730 to 0.8735	*
	d	Outside diameter of driveshaft .....	0.8745 to 0.8750	*
3-108.	d	Gear to shaft clearance.....	PRESS FIT	
	e	Oil pump drive gear	0.010 to 0.015	0.015

Figure 3-108. Gear train-points of measurement.



Fig. No.	Ref. Letter	Point of Measurement	New Dimensions (inches)	Wear Limits (inches)
<b>c. Camshaft Gear (para 3-32).</b>				
3-108.	f	Inside diameter of gear .....	1.7980 to 1.7985	*
	g	Outside diameter of shaft.....	1.7985 to 1.7990	
	g	Gear to shaft clearance.....	PRESS FIT	
	h	Camshaft to crankshaft backlash.....	0.006 to 0.009	0.009
	j	Camshaft and clearance.....	0.007 to 0.001	0.011
<b>d. Air Compressor Drive Gear (para 3-9),</b>				
3-108.	k	Inside diameter of gear .....	1.2885 to 1.2890	*
	l	Outside diameter of shaft.....	1.2890 to 1.2895	
		Gear to shaft clearance.....	PRESS FIT	
	m	Gear to camshaft gear backlash .....	0.006 to 0.009	0.009

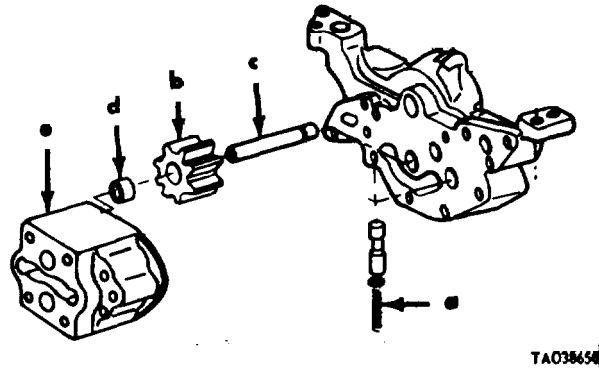

Figure 3-109. Oil pressure regulator and oil pump-points of measurement.

**a Valve Spring Measurements.**

3-109.	a	Free spring length (approx.).....	3.410	*
	a	Compressed length (at valve opening) (Force 45 lbs.).....	2.125	
	a	Compressed length (at max. valve opening) (Force of 35 lbs.)....	71.438	

**b. Oil Pump**

3-109	b	Pump gear(s) outside diameter.....	2.399 to 2.400	2397
	c	Shifts (3) outside diameter .....	0.8745 to 0.8750	0.8740
	d	Bushings (4) inside diameter .....	0.8770 to 0.8775	0.8785
	e	Gear pockets (2) inside diameter.....	2.4070 to 2.4090	2.4105
		Gear pockets (2) inside depth.....	12490 to 12510	1.252

**3-183. cylinder Head**

(para 3-66)

**a. Valves, Guides and Valve Seats.**

3-110.	a	Outside diameter of valve stem .....	0.4500 to 0.4512	0.4490
	b	Inside diameter of valve guide .....	0.4525 to 0.4532	0.4545
	c	Valve guide protrusion.....	695 to 0.710	*
	d	Intake valve seat insert thickness.....	0.2580 to 0.2200	*
	e	Exhaust valve seat insert thickness.....	0.02180 to 0.820	*
3-110.	f	Swirl plate thickness (intake) .....	0.0200 to 0.0210	*
	c	Head counterbore inside diameter 0 (std) .....	1.995 to 2.0005	*
	ad/ae	Angle of seating face-valve and insert seat.....	30 Degrees	*
	c	Valve seat width.....		0.1250
	g	Valve springs.(5340-082-0126) .....		0.0780
		Free length.....		2.090
		Load Length: Valve open-1.317.....	161 to 179 lbs.	155 lbs.
		Number of coils.....	6'..	

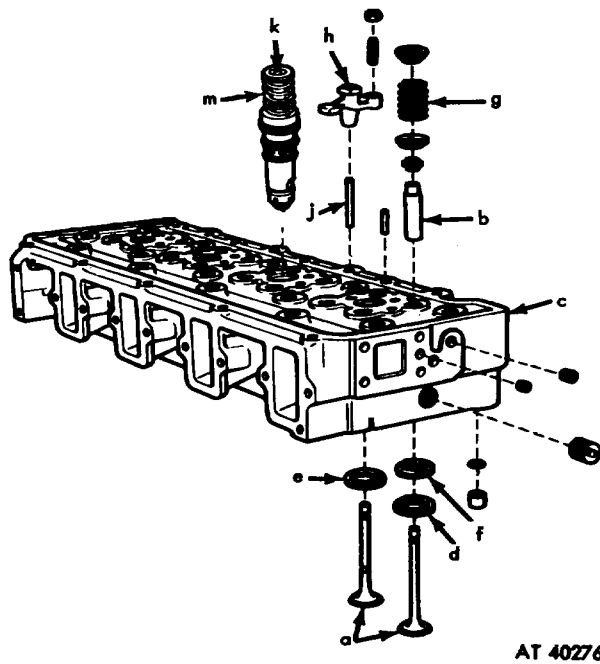

Figure 3-110. Cylinder Head-Points of measurement.

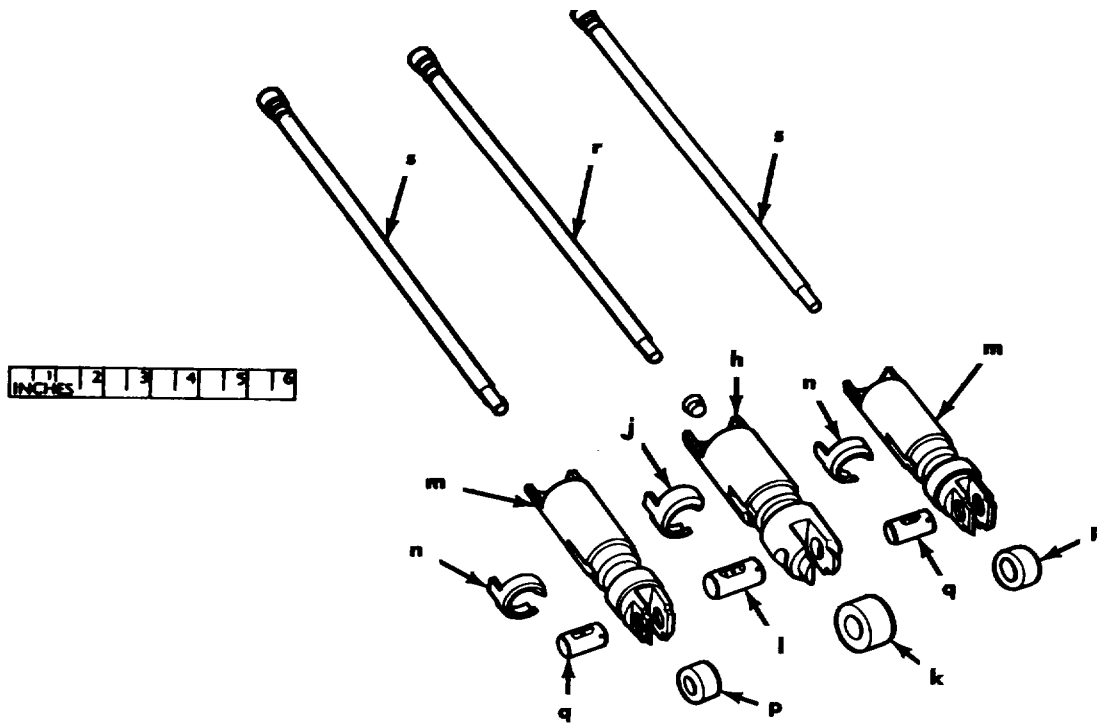

Figure 3-111. Tappets and push rods-points of measurement.

**b. Tappets and Push Rods.**

**(1) Injector tappet.**

3-111.	h	Body outside diameter .....	1.3980 to 1.3900	1.3965
	J	Guide spring outside diameter .....	1.456	
	k	Roller outside diameter .....	1.1690 to 1.1710	1.1670
	k	Roller inside diameter .....	0.6280 to 0.6290	0.6300
	l	Roller pin outside diameter .....	0.6246 to 0.6250	0.6235

**(2) Valve tappet.**

3-111.	m	Body outside diameter .....	1.0980to 1.0990	1.0965
	n	Guide spring outside diameter .....	1.148	
3-111.	p	Roller outside diameter .....	0.9290 to 0.9310	0.9270
	p	Roller inside diameter .....	0.5030 to 0.5040	0.5050
	q	Roller pin outside diameter .....	0.4995 to 0.5000	0.4985

**(3) Injector Push Rod.**

3-111.	r	Ball end radius .....	0.3110 to 0.3125	0.3200
	r	Socket end radius .....	0.2188 to 0.2203	0.2165

**(4) Valve Push Rod.**

3-111.	s	Ball end radius .....	0.3110 to 0.3125	0.3150
	s	Socket end radius .....	0.1875 to 0.1890	0.1850

**c. Rocker Lever and Shaft (para. 3-82).**

3-112.	t	Lever bushing-inside diameter .....	1.875 to 1.1895	1.1905
	u	Shaft-outside diameter .....	1.1855 to 1.1865	1.1845
		Adjusting screw ball end radius:		
	v	Injector .....	0.4350 to 0.4370	*
	w	Valve .....	0.3725 to 0.3745	*
	x	Rocker lever(s) and rocker lever brackets .....	Clearance	*

**d. Cylinder Head (para. 3-66).**

3-110	c	Cylinder head height .....	4.4950 to 4.5050	*
	y	Injector tip protrusion .....	0.1000 to 0.1150	0.1250

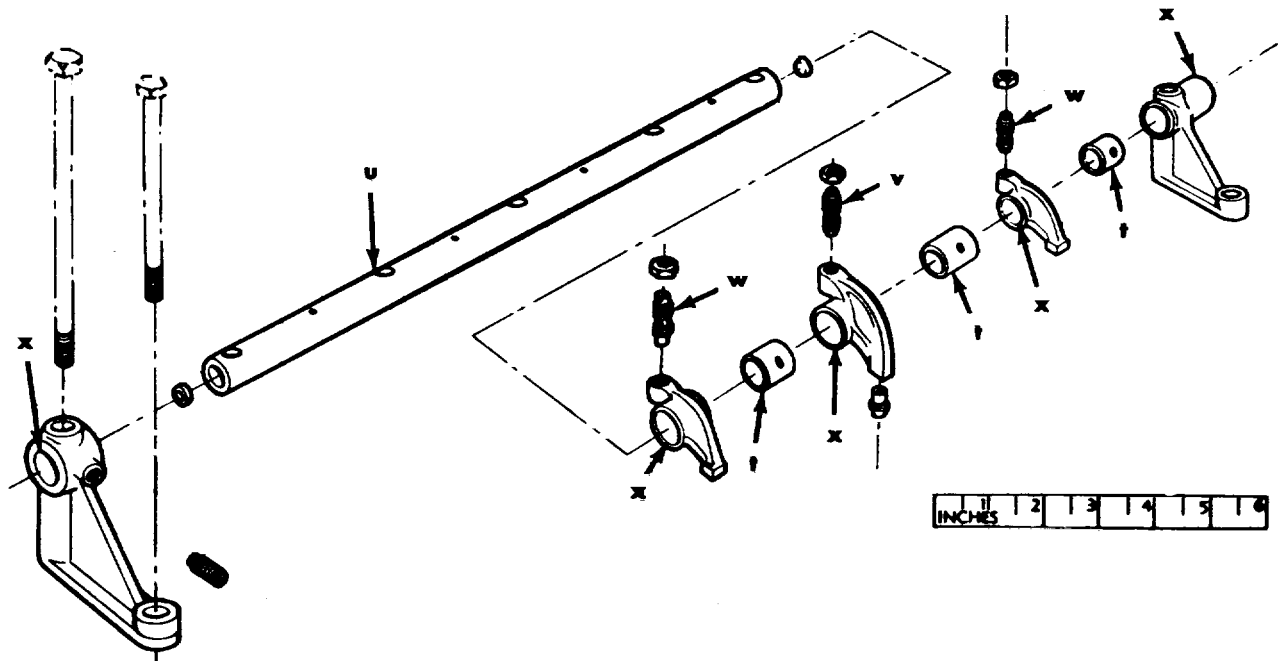

Figure 3-112. Rocker arms and shaft-points of measurement.

Fig. No.	Ref. Letter	Point of Measurement	New Dimensions (inches)	Wear Limits (inches)
3-110.	c	Injector sleeve-upper inside diameter .....	1.140 to 1.150	*
	c	Guide-outside diameter .....	0.4332 to 0.4335	0.4322
	y	Protrusion above the head.....	2.0900 to 2.1100	*
	c	Inside diameter .....	0.4340 to 0.4360	0.4400
<b>e. Injector Plunger Spring Data (para. 3-74).</b>				
3-110.	z	Free length.....	2.4500 to 2.4900	*
		Load at:		
		2.139 inches.....	87.6 to 95.6 lbs.	*
		1.975 inches.....	13 to 147 lbs.	*
	z	Injector cup torque-ft. lbs. ....	50 to 55	
z	Orifice plug torque-ft. lbs. ....	6 to 8		

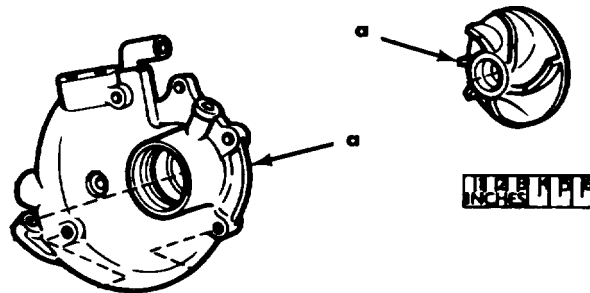

Figure 3-113. Water pump-points of measurement.

3-113.	a	Impeller to body clearance.....	0.0100 to 1.0200	*
<b>3-185. Assembly Data</b>				
3-114.	a	Front cover Crankshaft to seal bore .....	0.0050	
3-114.	b	Flywheel and Housing Housing bore run-out.....	0.010	*
		Housing face run-out .....	0.008	*
3-114.		Flywheel pilot bearing .....		*
	c	Bore run-out.....	004	*
	c	Clutch face run-out .....	005	*

**3-186. Torque Specifications**

**CAUTION**

Bolts threaded into aluminum may require reduction in torque of 30 percent or more, unless inserts are used.

Fig.	Item	Nut or bolt size	Lb-ft. torque
<b>. Cylinder Block Group.</b>			
2-29	*Main bearing stude nuts or cap screws .....	3/4x 5.8in.	170 to 180 +
3-8	Main bearing side bolts .....	5/8x31/4in.	70 to 75
2-28	*Connecting rod nuts.....	9/16x4.4in.	60 to 65+
2-6	Vibration damper mounting cap screws.....	5/5x3y4 in.	190 to 200
	Crankshaft pipe plugs .....	1/8 in.	5
	Engine block-pipe plugs .....	1/8 in.	5 to 10
	Engine block-pipe plugs .....	1/2 in.	45 to 55

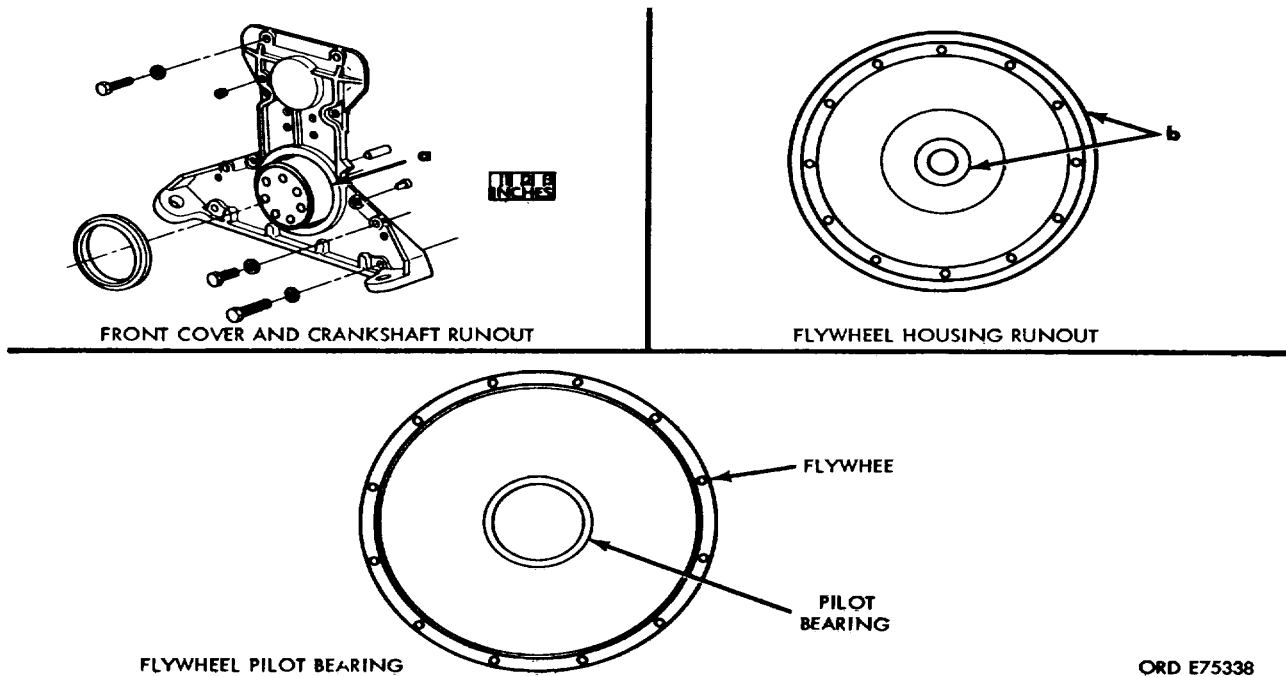

Figure 3-114. Assembly data-points of measurement (run-out).

Fig.	Item	Nut or bolt size	Lb.-ft. torque
2-27	Front cover-cap screws.....	2/8x1 to1 1/2 in.	30 to 35
+ equals template method of tightening cap screws.			
<b>Cylinder Head Group.</b>			
3-46	Cylinder head cap screws.....	5/8x6 1/4 in.	175 to 185
2-15	Cylinder head cap screws.....	5/8x7in.	175 to 186
2-16	Cylinder head cap screws.....	5/8x10 1/8 in.	175 to 18
2-18	Valve crosshead nuts.....	7/16 n.	60 to 70
2-9	Fuel fittings.....		11 to 18
<b>c. Rock Lever. Cam Follower and Tappet Group.</b>			
2-12	Cylinder head cover cap screw.....	3/8x1 1/2in.	30 to 35
2-15	Valve injector adjusting screw jam nut.....	5/16x 3/4 in.	18 to 20
<b>d. PT Fuel Pump Group</b>			
B-18	Front cover cap screws.....	3/8x3 1/2 in.	**90 to 96
B-17	Spring pack cap screw.....	1/4x1.28 in,	**90 to 96
B-16	Gear pump cap screws.....	1/4x1.78 in.	7 to 9
	Gear pump cap screws.....	1/4x2.5 in.	7 to 9
B16	Gear pump cap screw.....	1/4x3.5 in.	7 to 9
W16	Fuel pump damper cap screws.....	1/4x1 1/4 in.	7 to 9
W17	Electric shut-down valve capscrewa.....	.#10-24	**15 to 20
*These cap screws or nuts are tightened by template method.			
**Inch-pounds.			
<b>e. Injector and Connections Group.</b>			
3-49	Cups.....		55
3-48	Orifice plug.....		*8 to 10
2-15	Mounting cap screws (9/64 nylon insert).....	3/8x2.in,	30 to 35
<b>f. Lubrication System Group.</b>			
2-25	Oil pan cap screw (108707).....	3/8X1./2	28 to35
2-2	Oil cooler plate cap screw.....	3/8x1 in.	29 to 31

Fig.	Item	Nut or bolt size	Lb-ft. torque
B-9	Oil pan drain plug .....	1 in. dia.	60 to 70
B-10	Oil pump cover cap screws .....	3/8x7/8in.	29 to 31
<b>g. Cooling System Group.</b>			
2-4	Fan hub marsden nut.....	1 ¼ in. dia.	400 to 500
2-7	Water pump pulley adjustable cap screws.....	1/4x1 ¼ in.	8 to 10
2-10	Water header cover plates.....	3/8x1 in.	29 to 31
<b>h. Intake and Exhaust System Group.</b>			
2-1	Exhaust manifold.....	3/8x1 1/4 in.	29 to 31
2-8	Intake manifold.....	3/8x 1 1/4 in.	29 to 31
B-12	Preheater nozzle .....		15 to 20
B-19	Air inlet adapter cap screws .....	5/16x1 ¾ in.	17
<b>i. Air Compressor Group.</b>			
2-10	Air compressor support cap screws.....	3/8x1 ¼ in.	29 to 31
	Air compressor mounting cap screws .....	3/8x3¼. in.	29 to 31
<b>j. Engine Mounting and Adaption Group.</b>			
3-22	Flywheel cap screws (140567).....	5/8x1.5 in.	200 to 205
2-22	Crankshaft adapter (140566) .....	5/8x 27/64 in.	200 to 205
2-28	Flywheel/gear housing cap screws .....	3/8x2 1/2 in.	28 to 86

**NOTE**

Always use the specific specifications of the manufacturer listed above when assembling the engine and its components. The torque values given are based on the use of clean, dry threads. Reduce torque 10 percent when threads are lubricated with engine oil. Reduce by 20 percent if new plated bolts are used.

**APPENDIX A  
REFERENCES**

**1. Publication Indexes**

Index of Army Motion Pictures, and related audio-visual aids.....	DA Pam 10.-1
Military Publications:	
Index of Administrative Publications.....	DA Pam 310-1
Index of Blank Forms .....	DA Pam .10-2
Military Publications: Index of Supply Catalogs and Supply Manuals (excluding Types 7, 8 and 9) .....	DA Pam 310-6
Military Publications Index of Technical Manuals, Technical Bulletins, Supply Manuals Types 7, 8 and 9, Supply Bulletins and Lubrication Orders .....	DA Pam 3104
Index of Doctrinal Training and Organizational Publications .....	DA Pam 31.3
Military Publications U.S. Army Equipment Index of Modification Work Orders.....	DA Pam 310-7

**2. Supply Catalogs**

The following Department of the Army Supply Catalogs pertain to this materiel:

Tool Kit, Auto Fuel and Electrical System Repair (4910-24-0655).....	SC 491-9-CL-A50
Tool Kit, Automotive Maintenance:	
Organizational (2nd Echelon), Set 2, Common (5180-754-0650).....	SC 4910-95-CLA72
Tool Kit, Automotive Maintenance:	
Organizational (2nd Echelon), Set 2, Supplemental (4940-754-0743).....	SC 4940-9.-CIA08
Tool Kit, Organizational Maintenance, Set No. 1, Common (5180-754-0654).....	SC 4910-95-CLA74

**3. Forms**

- a. Refer to DA Pamphlet 310-2 for listing of blank forms required for support of this materiel.
- b. TM 38-750 contains instructions on use of applicable forms.

**4. Other Publications**

a. Vehicle (Operation, Maintenance and Overhaul).	
Truck Tractor 10-ton, 6 x 6, M123, M123C and M123A1C and Truck, Cargo M125 .	TM 9-2320-206-10
Truck Tractor 10-ton, 6 x 6, M123, M123C and M123A1C and Truck, Cargo M125	TM 9-2320-206-20
Organizational Maintenance Repair Parts and Special Tools for Truck, Tractor, 10-ton, 6 x 6, M123, M123C and M123A1C and Truck, Cargo M125 ..	TM 9-2320-206-20P
Direct Support and General Support Maintenance (including repair parts) for Truck Tractor, 10-ton, 6 x 6, M123, M123C, and M123A1C and Truck, Cargo M125.....	TM 9-2320-206-34
b. Accessory Maintenance.	
Direct Support, General Support and Depot Maintenance Manuals (including repair parts.) Generator Assembly (2920-737-4750) (Electric Autolight Model GHA-4802UT) .....	TM 9-2920-209-35
Engine Electrical Generator:	
Delco-Remy (2920-735-5736).....	TM 9-2920-2145
Engine Electrical Alternator:	
Leece-Neville.....	TM 9-2920-22535P
Engine Electrical Starter:	
Leece-Neville (2920-267-9987).....	M 9-2920-24335
c. Miscellaneous (Maintenance and Overhaul).	
Authorized Abbreviations and Brevity Symbols .....	AR 310-50
Maintenance Assistance and Instruction Team Program.....	AR 750-51
Dictionary of United States Army Terms .....	AR 310-25
Inspection, Care, and Maintenance of Antifriction Bearings.....	TM 9-214
Military Symbols .....	FM 21-30
Ordnance Corps Equipment Data Sheets.....	TM 9500

Ordnance Engines:

Run-in and Test Procedures .....	TB 9-2800-20050
Organization, Policies, and Responsibilities for Maintenance Operations .....	AR 750
Preservation, Packaging, and Packing of Military Supplies and Equipment .....	TM 38-230-1
Preservation, Packaging, Packing and Marking of Item of Supply.....	AR 700-15
Principles of Automotive Vehicles .....	TM 9-8000
Protection of Ordnance General Supplies in Open Storage.....	TB ORD 379
Publications for Packaging Army General Supplies .....	SB 764
Report of Packaging and Handling Deficiencies .....	AR 7008
The Army Maintenance Management System .....	TM 38750
Use and Care of Handtools and Measuring Tools .....	TM 9-24
Welding; Theory and Application.....	TM 9-287



## APPENDIX B

## REPAIR PARTS AND SPECIAL TOOLS LIST

## Section I.

**B-1. Scope**

This appendix lists the repair parts and specific tools required for the performance of direct support and general support maintenance of the V8-300 diesel engine.

**B-2. General.**

This Repair Parts and Special Tools List divided into the following sections:

*a. Section II. Repair Parts List.* A list of repair parts authorized for use in the performance maintenance. The list also includes parts which must be removed for replacement of the authorized parts. Parts lists are composed functional groups in ascending numeric, sequence, with the parts in each group listed figure and item number sequence. Bulk material are listed in NSN sequence.

*b. Section III. Special Tools, Test and Support Equipment.* A list of special tools, test and support equipment authorized for the performance of maintenance at the direct support and general support levels.

*c. Section IV. National Stock Number and Part Number Index.* A list, in ascending numerical sequence, of all National stock numbers appearing in the listings, followed by a list in alphanumeric sequence, of all part number appearing in the listings. National stock number, and part numbers are cross-referenced to each illustration figure and item number appearance. This index is followed by a cross-reference list reference designations to figure and item number: when applicable.

**B-3. Explanation of Columns.**

The following provides an explanation of columns found in the tabular listings: a. Illustration. This column is divided follows:

(1) *Figure Number.* Indicates the figure number of the illustration in which the item shown.

(2) *Item Number.* The number used identify each item called out in the illustration

*b. Source, Maintenance, and Recoverability Codes (SMR).*

(1) *Source Code.* Source codes are assigned to support items to indicate the manner of acquiring support items for maintenance, repair, or overhaul of end items. Source codes are entered in the first and second positions of the Uniform SMR Code format as follows:

**Code****Definition**

PA ..... Item procured and stocked for anticipated or known usage.

PB ..... Item procured and stocked for insurance purpose because essentially dictates that a minimum quantity be available in the supply systems.

PC ..... Item procured and stocked and which otherwise would be coded PA except that it is deteriorate in nature.

PD ..... Support item, excluding support equipment, procured for initial issue or outfitting and stocked only for subsequent or additional initial issues or outfittings. Not subject to automatic replenishment.

PE ..... Support equipment procured and stocked for initial issue or outfitting to specified maintenance repair activities.

PF ..... Support equipment which will not be stocked but which will be centrally procured on demand.

PG ..... Item procured and stocked to provide for sustained support for the life of the equipment. It is applied to item peculiar to the equipment which, because of probable discontinuance or shutdown of production facilities, would prove uneconomical to reproduce at a later time.

KD ..... An item of a depot overhaul/repair kit and not purchased separately. Depot kit defined as a kit that provides items required at the time of overhaul or repair.

KF ..... An item of a maintenance kit and not purchased separately. Maintenance kit defined as a kit that provides an item that can be replaced at organizational or intermediate levels of maintenance.

KB ..... Item included in both a depot overhaul/repair kit and a maintenance kit.

MO .... Item to be manufactured or fabricated at organizational level.

MF ..... Item to be manufactured or fabricated at the direct support maintenance level.

MH ..... Item to be manufactured or fabricated at the general support maintenance level.

MD ..... Item to be manufactured or fabricated at the depot maintenance level.

AO Item to be assembled at organizational level.

AF ..... Item to be assembled at direct support maintenance level.

AH ..... Item to be assembled at general support maintenance level.

**CodeDefinition**

AD.... Item to be assembled at depot maintenance level  
 XA.... Item is not procured or stocked because requirements for the item will result in replacement of the next higher assembly.  
 XB.... Item is not procured or stocked. If not available through salvage, requisition.  
 XD.... A support item that is not stocked. required, item will be procured through normal supply channels.

**NOTE**

Cannibalization or salvage may be used as a source of supply for any items source coded above except those coded XA, XD, and aircraft support items as restricted by AR 700-42.

(2) *Maintenance Code.* Maintenance cc are assigned to indicate the levels of maintenance authorized to USE and REPAIR support items The maintenance codes are entered in the t and fourth positions of the Uniform SMR C format as follows:

(a) The maintenance code entered in third position will indicate the lowest maintenance level authorized to remove, replace, use the support item. The maintenance c entered in the third position will indicate on the following levels of maintenance:

Code	Application/Explanation
C.....	Crew or operator maintenance performed within organizational maintenance.
O.....	Support item is removed, replaced, used a organizational level.
I.....	Support item is removed, replaced, used by the direct support element of integrated support maintenance.
F.....	Support item is removed, replaced, used a direct support level.
H.....	Support item is removed, replaced, used a general support level.
D.....	Support items that are removed, replaced, us depot, mobile depot, specialized repair activity only.

**NOTE**

Codes "I" and "F" will be considered the same by direct support units.

(b) The maintenance code entered in fourth position indicates whether the item is t repaired and identifies the lowest maintenance level with the capability to perform comp repair (i.e., all authorized maintenance functions). This position will contain one of following maintenance codes:

Code	Application/Explanation
O.....	The lowest maintenance level capable of complete repair of the support item is the organizational level.
F.....	The lowest maintenance level capable of con repair of the support item is the direct support level.
H.....	The lowest maintenance level capable of complete repair of the support item is the general

support level.

D..... The lowest maintenance level capable of complete repair of the support item is the depot level, performed by depot, mobile depot or specialized repair activity.  
 L..... Repair restricted to designated specialized repair activity.  
 Z..... Nonreparable. No repair is authorized.  
 B..... No repair is authorized. The item may be reconditioned by adjusting, lubricating, etc., at the user level. No parts or special tools are procured for the maintenance of this item.

(3) *Recoverability Code.* Recoverability codes are assigned to support items to indicate the disposition action on unserviceable items. The recoverability code is entered in the fifth position of the Uniform SMR Code format as follows:

**Recoverability Codes Definition**

Z.....	Nonreparable item. When unserviceable, condemn and dispose at the level indicate in position 3.
O.....	Reparable item. When uneconomically repairable, condemn and dispose at organizational level.
F.....	Reparable item. When uneconomically repairable, condemn and dispose at the direct support level.
H.....	Reparable item. When uneconomically repairable, condemn and dispose at the general support level.
D.....	Reparable item. When beyond lower level repair capability, return to depot. Condemnation and disposal not authorized below depot level.
L.....	Reparable item. Repair, condemnation, and disposal not authorized below depot/specialized repair activity level.
A.....	Item requires special handling or condemnation procedures because of specific reasons (i.e., precious metal content, high dollar value, critical material or hazardous material). Refer to appropriate manuals/directives for specific instructions.

c. *National Stock Number.* Indicates the National stock number assigned to the item and will be used for requisitioning purposes.

d. *Part Number.* Indicates the primary number used by the manufacturer (individual, company, firm, corporation, or Government activity), which controls the design and characteristics of the item by means of its engineering drawings, specifications standards, and inspection requirements, to identify an item or range of items.

**NOTE**

When a stock numbered item is requisitioned, the repair part received may have a different part number than the part being replaced.

e. *Federal Supply Code for Manufacturer (FSCM).* The FSCM is a 5-digit numeric code

listed in SB 708-42 which is used to identify the manufacturer, distributor, or Government agency, etc.

*f. Description.* Indicates the Federal item name and, if required, a minimum description to identify the item. Items that are included in kits and sets are listed below the name of the kit or set with the quantity of each item in the kit or set indicated in the quantity incorporated in unit column. When the part to be used differs between serial numbers of the same model, the effective serial numbers are shown as the last line of the description. In the Special Tools List, the initial basis of issue (BOI) appears as the last line in the entry for each special tool, TMDE, and support equipment. When density of equipments supported exceeds density spread indicated in the basis of issue, the total authorization is increase accordingly.

*g. Unit of Measure (U/M).* Indicates the standard of the basic quantity of the listed item as used in performing the actual maintenance function. This measure is expressed by a two character alphabetical abbreviation (e.g., ea., in pr, etc.). When the unit of measure differs from the unit of issue, the lowest unit of issue that will satisfy the required units of measure will be requisitioned.

*h. Quantity Incorporated in Unit.* Indicate the quantity of the item used in the breakout shown on the illustration figure, which prepared for a functional group, subfunctions group, or an assembly. A "V" appearing in this column in lieu of a quantity indicates that no specific quantity is applicable, (e.g., shims spacers, etc.).

#### **B-4. Special Information**

*a.* Repair parts kits and gasket sets appear a the last entries in the repair parts listing for the figure in which its parts are listed as repair parts

*b.* The following publications pertain to the M123A1C and M123E2 10-ton trucks which us the V8-300 diesel engine:

#### **Publication and short title**

LO 9-2320-206-12, Truck, Tractor, 10-Ton, 6x6  
 TM 9-2320-206-ESC, Truck, Tractor, 10-Ton, 6x6  
 TM 9-2320-206-20, Truck, Tractor, 10-Ton, 6x6  
 TM 9-2320-206-20P, Truck, Tractor, 10-Ton, 6x6

#### **B-5. How To Locate Repair Parts**

*a. When National Stock Number or Part Number is Unknown:*

(1) *First.* Using the table of contents, determine the functional subgroup within which the repair part belongs. This is necessary since illustrations are prepared for functional subgroups and listings are divided into the same groups.

(2) *Second.* Find the illustration covering the functional subgroups to which the repair part belongs.

(3) *Third.* Identify the repair part on the illustration and note the illustration figure and item number of the repair part.

(4) *Fourth.* Using the Repair Parts Listing, find the figure and item number noted on the illustration.

*b. When National Stock Number or Part Number is Known.*

(1) *First.* Using the Index of National Stock Numbers and Part Numbers, find the pertinent National stock number or part number. This index is in ascending NSN sequence followed by a list of part numbers in ascending alphameric sequence, cross-referenced to the illustration figure number and item number.

(2) *Second.* After finding the figure and item number, locate the figure and item number in the repair parts list.

#### **B-6. Reporting of Errors.**

You can improve this manual by recommending improvements using DA Form 2028 (Recommended Changes to Publications and Blank Forms) and mailing the form direct to Commander, US Army Tank-Automotive Command, ATTN: AMSTA-MTP, Warren, MI 48090. A reply will be furnished direct to you.

SECTION II

(1) ILLUSTRATION		(2)	(3)	(4)	(5)	(6) DESCRIPTION	(7)	(8)
(a) FIG NO.	(b) ITEM NO.	SMR CODE	NATIONAL STOCK NUMBER	PART NUMBER	FSCM	USABLE ON CODE	U/M	QTY INC IN UNIT
						GROUP 01-ENGINE 0100-ENGINE ASSEMBLY		
B-1	1	PAFDL	2815-00-910-8218	5703466	19207	ENGINE, DIESEL, WITH ..... CONTAINER: Truck Tractor	EA	1
						<b>NOTE</b> See group 3301 for engine container repair parts		
B-1	2	PAFDL	2815-00-910-8217	10946107-1	19207	ENGINE, DIESEL: Cummins Model..... V8-300	EA	1
B-1	3	PAOZZ	2815-00-226-8089	154643	15434	BRACKET, LIFTING: engine rear .....	EA	2
B-1	4	XBOXX		154528	15434	BRACKET, LIFTING: front, left .....	EA	1
B-1	5	PAOZZ	5310-00-637-9541	MS35338-46	96906	WASHER, LOCK: engine lifting .....	EA	8
B-1	6	PAOZZ	5305-00-269-3214	MS90725-64	96906	SCREW, CAP, HEXAGON HEAD:..... engine lifting bracket	EA	8
B-1	-	PAFZZ	2815-00-910-8219	BM 95886	15434	PARTS KIT, ENGINE OVER- .....	EA	1
B-1	-					HAUL: V8-300 diesel engine		
B-2	19					GASKET .....	EA	1
B-4	1					GASKET .....	EA	1
B-4	3					GASKET .....	EA	1
B-4	8					SEAL .....	EA	1
B-7	18					SEAL .....	EA	1
B-9	7					GASKET .....	EA	1
B-9	9					GASKET .....	EA	1
B-9	7					GASKET .....	EA	1
B-9	21					GASKET .....	EA	1
B-10	3					GASKET .....	EA	1
B-10	13					GASKET .....	EA	1
B-10	27					GASKET .....	EA	1
B-11	1					GASKET .....	EA	1
B-11	2					GASKET .....	EA	1
B-11	13					GASKET .....	EA	1
B-11	24					PACKING .....	EA	2
B-11	25					GASKET .....	EA	1
B-11	26					GASKET .....	EA	1
B-11	27					GASKET .....	EA	1
B-11	28					GASKET .....	EA	1
B-20	7					SPACER.....	EA	4
B-21	7					GASKET .....	EA	1
B-22	5					SEAL .....	EA	1
B-22	23					GASKET .....	EA	1
B-23	6					GASKET .....	EA	1
B-23	12					SEAL .....	EA	1
B-25	2					GASKET .....	EA	1
B-25	7					GASKET .....	EA	1
B-24.1	-					GASKET.....	EA	1
B-25-	-					PACKING .....	EA	1
B-25-	-					PACKING .....	EA	1
B-25-	-					GASKET .....	EA	1
B-25-	-					PACKING .....	EA	1
B-2	-	PAFZZ	5330-00-918-0606	BM 96854	15434	GASKET SET: cylinder head .....	EA	1
B-2	7					GROMMET .....	EA	17
B-2	8					GASKET .....	EA	2
B-2	9					RETAINER.....	EA	17
B-2	28					PACKING, PREFORMED .....	EA	4
B-6	7					GASKET .....	EA	2
B-8	3					GASKET .....	EA	1
B-12	9					GASKET .....	EA	2

(1) ILLUSTRATION		(2)	(3)	(4)	(5)	(6) DESCRIPTION	(7)	(8)
(a) FIG NO.	(b) ITEM NO.	SMR CODE	NATIONAL STOCK NUMBER	PART NUMBER	FSCM	USABLE ON CODE	U/M	QTY INC IN UNIT
B-12	10					0100-ENGINE ASSEMBLY-Cont		
B-12	12					GASKET .....	EA	2
B-12	17					GASKET .....	EA	2
B-12	19					LOCKPLATE.....	EA	8
B-13	13					GASKET .....	EA	8
B-19	11					PACKING, PREFORMED .....	EA	32
B-20	6					GASKET .....	EA	1
B-21	15					GASKET .....	EA	1
B-2	1	PAFH	2815-00-913-1743	BM 176119	15434	0101-BLOCK AND CYLINDER HEAD CYLINDER HEAD, DIESEL .....	EA	2
B-2	2	PAFZZ	5310-00-081-8500	127316	15434	ENGINE: includes guides, springs and inserts		
B-2	3	PAFZZ	5306-00-082-0660	151348	15434	WASHER: cylinder head (36), side .....	EA	46
B-2	4	PAFZZ	5306-00-970-8923	151350	15434	locking cap screw (10)		
B-2	5	PAFZZ	5306-00-082-0661	151349	15434	SCREW, CAP, HEXAGON HEAD:.....	EA	16
B-2	6	PAHZZ	2815-00-085-7442	147056	15434	cylinder head		
B-2	7	PAFZZ	5330-00-866-5079	132705	15434	SCREW, CAP, HEXAGON HEAD:.....	EA	10
B-2	8	PAFZZ	2815-00-972-5388	149973	15434	cylinder head		
B-2	9	PAFZZ	2815-00-712-8496	131168	15434	BOLT, EXTERNALLY RELIEVED:.....	EA	10
B-2	10	XAHZZ		161991	15434	cylinder head		
B-2	11	XBHZZ		S 136	15434	SLEEVE, INJECTOR: cylinder head .....	EA	8
B-2	12	XAHZZ		161992	15434	GROMMET: cylinder head gasket.....	EA	17
B-2	13	PAHZZ	5306-00-062-3995	148001	15434	part of kit P/N BM 96854		
B-2	14	PAHZZ	5310-00-595-6612	MS20002-12	96906	GASKET: cylinder head part of kit.....	EA	2
B-2	15	PAHZZ	2815-00-454-7806	167825	15434	part of kit P/N BM 96854		
B-2	16	PAHZZ	5305-00-269-3211	MS90725-60	96906	RETAINER: cylinder head grommet.....	EA	17
B-2	17	PAHZZ	5310-00-637-9641	MS35338-46	96906	part of kit P/N BM 96854		
B-2	18	PAHZZ	5310-00-562-6563	S 602	15434	CAP, MAIN BEARING: inter- .....	EA	3
B-2	19	PAHZZ	2815-00-084-7784	151781	15434	mediate		
B-2	20	PAFZZ	4730-00-018-9566	189566	21450	SCREW, CAP: main bearing side .....	EA	10
B-2	21	PAHDL	2815-00-454-5058	BM 94173	15434	locking		
B-2	22	PAFZZ	4730-00-801-8186	S 915A	15434	CAP, MAIN BEARING: front .....	EA	1
B-2	23	PAHZZ	5330-00-913-3949	168035	15434	BOLT, SHOULDER: main bearing .....	EA	10
B-2	24	PAHZZ	5330-00-082-0454	122929	15434	caps		
B-2	25	PAHZZ	2815-00-994-4418	155172	15434	WASHER, FLAT: main bearing caps .....	EA	10
B-2	26	PAHZZ	2815-00-903-6633	158630	15434	COVER: water header: cylinder block .....	EA	1
B-2	27	PAFZZ	5365-00-086-8293	100973	15434	SCREW, CAP, HEXAGON HEAD:.....	EA	4
B-2	28	PAFZZ	5330-00-582-7484	MS90121-116	96906	water header cover		
						WASHER, LOCK: water header .....	EA	4
						cover		
						WASHER: water header cover.....	EA	4
						GASKET: water head, cylinder block .....	EA	1
						part of kit P/N BM 95886		
						PLUG, PIPE: cylinder block .....	EA	1
						BLOCK, CYLINDER: diesel engine,.....	EA	1
						V8-300		
						PLUG, PIPE: cylinder block .....	EA	2
						PACKING, CYLINDER LINER: .....	EA	8
						bottom		
						PACKING, CYLINDER LINER: .....	EA	8
						center		
						PACKING, CYLINDER LINER: .....	EA	8
						upper		
						CYLINDER SLEEVE: cast iron, .....	EA	8
						6.175 in. O.D., 5.520 in. bore dia., 8.250 in. overall length		
						DOWEL: cylinder head to block .....	EA	1
						PACKING, PREFORMED: cylinder .....	EA	4
						head to block part of kit P/N BM 96854		
					<b>B-5</b>			

(1) ILLUSTRATION		(2)	(3)	(4)	(5)	(6) DESCRIPTION	(7)	(8)
(a) FIG NO.	(b) ITEM NO.	SMR CODE	NATIONAL STOCK NUMBER	PART NUMBER	FSCM	USABLE ON CODE	U/M	QTY INC IN UNIT
B-2	29	XAHZZ		148000	15434	0101-BLOCK AND CYLINDER HEAD-Cont		
B-2	30	PAHZZ	5315-00-632-9388	5329388	19207	CAP, MAIN BEARING: rear .....	EA	1
B-2	31	PAHZZ	5315-00-082-1901	128765	15434	DOWEL: main bearing cap, front .....	EA	1
						DOWEL: main bearing cap, .....	EA	3
						intermediate		
B-2	32	PAHZZ	5315-00-081-8509	128766	15434	DOWEL: main bearing cap, rear .....	EA	1
B-3	1	PAOZZ	5305-00-905-0831	64487J	15434	0102-CRANKSHAFT SCREW, CAP, HEXAGON HEAD:.....	EA	7
						vibration damper		
B-3	2	PAOZZ	5310-00-820-6653	MS35338-50	96906	WASHER, LOCK: vibration damper .....	EA	7
						mounting		
B-3	3	PAOZZ	3020-00-905-4427	164349	15434	PULLEY, GROOVE: fan drive .....	EA	1
B-3	4	PAOZZ	2815-00-909-5956	BM 92141	15434	DAMPER, VIBRATION .....	EA	1
B-3	5	PAOZZ	2815-00-924-4491	163821	15434	PULLEY: water pump drive.....	EA	1
B-3	6	PAHHH	2815-00-907-9013	158370	15434	CRANKSHAFT, ENGINE .....	EA	1
B-3	7	PAHZZ	3120-00-994-4419	146590	15434	BEARING, FRONT, UPPER: .....	EA	1
						HALF: crankshaft (standard) Part of set P/N BM 71630		
B-3	7	KFHZZ		146591	15434	BEARING, FRONT, UPPER .....	EA	1
						HALF: crankshaft (undersize) Part of		
						set P/N BM 72531		
B-3	8	PAHZZ	3120-00-994-4421	146690	15434	BEARING, INTERMEDIATE, .....	EA	3
						UPPER HALF: crankshaft		
						(standard) Part of set P/N BM 71630		
B-3	8	KFHZZ		140091	15434	BEARING, INTERMEDIATE, .....	EA	3
						UPPER HALF: crankshaft		
						(undersize) Part of set P/N BM 71531		
B-3	9	PAHZZ	2815-00-085-7470	150100	15434	RING, THRUST: crankshaft Part of.....	EA	4
						sets P/N BM 71630 and P/N BM		
						71531		
B-3	10	PAHZZ	5315-00-081-8509	128766	15434	DOWEL: upper half, crankshaft .....	EA	4
B-3	11	PAHZZ	3120-00-994-4423	146610	15434	BEARING, REAR, UPPER HALF:.....	EA	1
						Crankshaft (standard) Part of set		
						P/N BM 71630		
B-3	11	KFHZZ		140141	15434	BEARING, REAR, UPPER HALF:.....	EA	1
						crankshaft (undersize) Part of set		
						P/N BM 71531		
B-3	12	PAHZZ	4730-00-018-9566	189566	21450	PLUG, PIPE: crankshaft .....	EA	1
B-3	13	PAHZZ	5315-00-062-4395	144131	15434	KEY, WOODRUFF: crankshaft gear .....	EA	1
B-3	14	PAHZZ	2815-00-453-9077	161701	15434	CUP: crankshaft grease retaining .....	EA	1
B-3	15	PAHZZ	5306-00-081-8507	140566	15434	BOLT, EXTERNALLY RELIEVED:.....	EA	7
						flywheel adapter to crankshaft		
B-3	16	PAHZZ	2815-00-297-0068	158759	15434	ADAPTER: flywheel .....	EA	1
B-3	17	PAHZZ	5315-00-082-1901	128765	15434	DOWEL: lower half crankshaft thrust .....	EA	4
						ring		
B-3	18	PAHZZ	2815-00-085-7457	154166	15434	SHIELD, OIL: gear housing.....	EA	1
B-3	19	PAHZZ	2815-00-842-5330	154167	15434	SLINGER, OIL: crankshaft .....	EA	1
B-3	20	PAHZZ	3020-00-082-1899	150138	15434	GEAR, CRANKSHAFT: engine.....	EA	1
B-3	21	PAHZZ	3120-00-994-4424	140100	15434	BEARING, REAR, LOWER HALF:.....	EA	1
						crankshaft (standard) Part of set P/N		
						P/N BM 71630		
B-3	21	KFHZZ		14661	15434	BEARING, REAR, LOWER HALF:.....	EA	1
						crankshaft (undersize) Part of set		
						P/N BM 71531		
B-3	22	PAHZZ	3120-00-994-4422	140090	15434	BEARING, INTERMEDIATE, .....	EA	3
						LOWER HALF: crankshaft		
						(standard) Part of set P/N BM 17630		
B-3	22	KFHZZ		146601	15434	BEARING, INTERMEDIATE, .....	EA	3
						LOWER HALF: crankshaft		
						(undersize) Part of set-P/N BM 71531		
					<b>B-6</b>			

(1) ILLUSTRATION		(2)	(3)	(4)	(5)	(6) DESCRIPTION	(7)	(8)
(a) FIG NO.	(b) ITEM NO.	SMR CODE	NATIONAL STOCK NUMBER	PART NUMBER	FSCM	USABLE ON CODE	U/M	QTY INC IN UNIT
B-3	23	PAHZZ	3120-00-994-4420	140080	15434	0102-CRANKSHAFT-Continued BEARING, FRONT, LOWER HALF: .....	EA	1
B-3	23	KFHZZ		140081	15434	crankshaft (standard) part of set P/N BM 17630 BEARING, FRONT, LOWER HALF: .....	EA	1
B-3	-	PAHZZ	2815-00-085-7444	BM71630	15434	crankshaft (undersize part of set P/N BM 71531 BEARING SET, CRANKSHAFT:.....	EA	1
B-3	7					standard BEARING HALF .....	EA	1
B-3	8					BEARING HALF .....	EA	3
B-3	9					RING, THRUST .....	EA	4
B-3	11					BEARING HALF .....	EA	1
B-3	21					BEARING HALF .....	EA	1
B-3	22					BEARING HALF .....	EA	3
B-3	23					BEARING HALF .....	EA	1
B-3	-	PAHZZ	2815-00-903-1334	BM 71531	15434	BEARING SET, CRANKSHAFT:..... 0.010 undersize BEARING HALF .....	EA	1
B-3	7					BEARING HALF .....	EA	3
B-3	8					RING, THRUST .....	EA	4
B-3	9					BEARING HALF .....	EA	1
B-3	11					BEARING HALF .....	EA	1
B-3	21					BEARING HALF .....	EA	3
B-3	22					BEARING HALF .....	EA	1
B-3	23					BEARING HALF .....	EA	1
B-4	1	PAFZZ	2815-00-084-7783	151780	15434	0103-FLYWHEEL ASSEMBLY GASKET: cylinder block part of kit.....	EA	1
B-4	2	PAFZZ	2815-00-297-0619	151035	15434	P/N BM 95886 PLATE, SPACER: block to flywheel.....	EA	1
B-4	3	PAFZZ	5330-00-980-9604	151100	15434	housing GASKET: flywheel housing to plate .....	EA	1
B-4	4	PAFZZ	2815-00-104-3637	69562	15434	part of kit P/N BM 95886 DOWEL, MASTER: flywheel housing.....	EA	1
B-4	5	PAFZZ	2815-00-815-0530	102957	15434	to block TOWEL, DIAMOND: flywheel hous-.....	EA	1
B-4	6	PAOZZ	4730-00-018-9566	189566	21450	ing to block LUG, PIPE: top flywheel housing .....	EA	1
B-4	7	XBFZZ		174437	15434	HOUSING: flywheel .....	EA	1
B-4	8	KFFZZ		186908	15434	SEAL, OIL: crankshaft to flywheel.....	EA	1
B-4	9	PAFZZ	5310-00-562-6553	S 602	15434	part of kit P/N BM 95886 WASHER, FLAT: flywheel housing to .....	EA	18
B-4	10	PAFZZ	5310-00-637-9541	MS35338-46	96906	block WASHER, LOCK: flywheel housing to .....	EA	18
B-4	11	PAFZZ	5305-00-177-5552	S 126	15434	block SCREW, CAP, HEXAGON HEAD:.....	EA	9
B-4	12	PAFZZ	2815-00-907-8979	BM 78683	15434	flywheel housing to block FLYWHEEL ASSEMBLY WITH .....	EA	1
B-4	13	PAFZZ	3020-00-528-5053	4797	15434	RING GEAR GEAR, RING,: flywheel.....	EA	1
B-4	14	PAFZZ	5306-00-335-4755	8333620	19207	BOLT: flywheel to crankshaft .....	EA	6
B-4	15	PAFZZ	5305-00-269-3220	MS90725-70	96906	SCREW, CAP, HEXAGON HEAD.....	EA	3
B-4	16	PAFZZ	5305-00-269-3215	MS90725-65	96906	flywheel housing to block SCREW, CAP, HEXAGON HEAD:.....	EA	6
B-4	17	PAOZZ	4730-00-289-4770	S 995	15434	flywheel housing LUG, PIPE: flywheel housing drain .....	EA	2
B-4	18	PAFZZ	5305-00-269-3210	MS90725-59	96906	SCREW, CAP, HEXAGON HEAD:.....	EA	8
B-4	19	PAFZZ	2815-00-353-9395	68908	15434	plate to block LOCKPLATE: plate to block.....	EA	8
					<b>B-7</b>			

(1) ILLUSTRATION		(2)	(3)	(4)	(5)	(6) DESCRIPTION	(7)	(8)
(a) FIG NO.	(b) ITEM NO.	SMR CODE	NATIONAL STOCK NUMBER	PART NUMBER	FSCM	USABLE ON CODE	U/M	QTY INC IN UNIT
B-5	1	KFHZZ		129260	15434	0104-PISTON AND CONNECTING ROD RING, PISTON: upper part of set.....	EA	8
B-5	2	KFHZZ		168680	15434	P/N BM 92350 RING, PISTON: lower Part of set.....	EA	8
B-5	3	KFHZZ		12550	15434	P/N BM 92350 RING AND SPACER, PISTON: Part .....	EA	8
B-5	4	PAHZZ	2815-00-907-8952	BM 93100	154341	set of P/N BM 92350 PISTON SET: with pin and snap rings .....	EA	8
B-5	5	KFHZZ		172580	15434	PISTON: diesel engine .....	EA	8
B-5	6	PAHZZ	5305-00-062-4373	155267	15434	RING, RETAINING: piston pin .....	EA	16
B-5	7	PAHZZ	2815-00-082-0462	140120	15434	PIN, PISTON .....	EA	8
B-5	8	PAHZZ	3120-00-994-4432	126600	15434	BEARING: piston pin .....	EA	16
B-5	6	PAHZZ	2815-00-909-2491	156304	15434	BOLT connecting rod .....	EA	16
B-5	10	PAHZZ	2815-00-907-8950	BM 79166	15434	CONNECTING ROD, PISTON: with- out bearing .....	EA	8
B-5	10	XDHZZ		BM 97339	15434	CONNECTING ROD:.....	EA	8
B-5	11	PAHZZ	2815-00-062-9566	139950	15434	LOCKPLATE: connecting rod bolt.....	EA	16
B-5	12	PAHZZ	5310-00-062-6632	139438	15434	NUT, HEXAGON: connecting rod.....	EA	16
B-5	13	PAHZZ	3120-00-913-9746	156310	15434	bolt BEARING: connecting rod Part of set .....	EA	16
B-5	13	KFHZZ		156311	15434	P/N BM 96100 BEARING: connecting rod Part of set .....	EA	16
B-5	-	PAHZZ	2815-00-911-7612	BM 92350	15434	P/N BM 97590 RING SET, PISTON: standard .....	EA	1
B-5	1					RING, PISTON .....	EA	8
B-5	2					RING, PISTON .....	EA	8
B-5	3					RING AND SPACE, PISTON .....	EA	8
B-5	-	PAHZZ	3120-00-908-7320	BM 96100	15434	BEARING SET, CONNECTING ROD .....	EA	1
B-5	13					standard BEARING .....	EA	16
B-5	-	PAHZZ	3120-00-910-8220	BM 97590	15434	BEARING SET, CONNECTING ROD .....	EA	1
B-5	13					0.010 in. undersize BEARING .....	EA	16
B-6	1	PAFZZ	5310-00-562-6553	S 602	15434	0105-VALVES AND CAMSHAFT WASHER, FLAT: cylinder head cover.....	EA	20
B-6	2	PAFZZ	5310-00-637-9541	MS35338-46	96906	WASHER LOCK: cylinder head cover.....	EA	20
B-6	3	PAFZZ	5305-00-269-3214	MS90725-64	96906	SCREW, CAP, HEXAGON HEAD:.....	EA	20
B-6	4	XBFZZ		156144	15434	cylinder head cover COVER, CYLINDER HEAD: right .....	EA	1
B-6	5	XBFZZ		BM 97370	15434	bank COVER, CYLINDER HEAD: left.....	EA	1
B-6	6	PAOZZ	2815-00-362-1548	S 2902	15434	bank CAP, FIILER: cylinder head cover.....	EA	1
B-6	7	PAFZZ	5330-00-994-4409	151299	15434	GASKET: cylinder head cover Part of .....	EA	2
B-6	8	PAFZZ	2815-00-085-3952	138935	15434	set P/N BM 96854 BRACKET: rocker lever shaft.....	EA	8
B-6	9	PAFZZ	2815-00-994-4434	127554	15434	LOCK, VALVE SPRING RETAINING:.....	EA	64
B-6	10	PAFZZ	2815-00-085-7469	139896	15434	half-collet, intake and exhaust valve GUIDE, VALVE SPRING: exhaust .....	EA	32
B-6	11	PAFZZ	5360-00-082-0126	128235	15434	and intake valve SPRING, HELICAL, COMPRESSION:.....	EA	32
B-6	12	PAFZZ	2815-00-905-4453	163361	15434	intake and exhaust valve RETAINER, VALVE COMPRESSION.....	EA	32
B-6	13	PAFZZ	5330-00-994-4435	156641	15434	SPRING: intake and exhaust valve SEAL: intake valve.....	EA	16

**B-8**



(1) ILLUSTRATION		(2)	(3)	(4)	(5)	(6) DESCRIPTION	(7)	(8)
(a) FIG NO.	(b) ITEM NO.	SMR CODE	NATIONAL STOCK NUMBER	PART NUMBER	FSCM	USABLE ON CODE	U/M	QTY INC IN UNIT
B-6	14	PAFZZ	2815-00-981-3160	138937	15434	0105-VALVES AND CAMSHAFT -Continued GUIDE, VALVE STEM: intake and..... exhaust valve	EA	32
B-6	15	PAFZZ	5315-00-907-0712	161837	15434	PIN, SPRING DOWEL, SPLIT .....	EA	10
B-6	16	PAFZZ	4730-00-018-9566	189566	21450	PLUG, PIPE: cylinder head.....	EA	1
B-6	17	PAFZZ	5340-00-721-5329	70459	15434	PLUG, FUSE: cylinder head .....	EA	1
B-6	18	PAFZZ	4730-00-289-4770	S 995	15434	PLUG, PIPE: cylinder head.....	EA	1
B-6	19	PAFZZ	2815-00-085-7441	146064	15434	PLATE, SWIRL: intake valve .....	EA	16
B-6	20	PAFZZ	2815-00-085-7452	146120	15434	SEAT, VALVE: intake .....	EA	16
B-6	21	PAFZZ	2815-00-994-4438	138886	15434	VALVE, POPPET: engine intake.....	EA	16
B-6	22	PAFZZ	2815-00-939-8084	171085	15434	PLATE, GUIDE: tappets .....	EA	8
B-6	23	PAFZZ	5310-00-407-9566	MS35338-45	96906	WASHER, LOCK: tappet guide.....	EA	16
B-6	24	PAFZZ	5306-00-225-8497	MS90725-32	96906	SCREW, CAP, HEXAGON HEAD:..... tappet guide plate	EA	16
B-6	25	PAFZZ	2815-00-939-8924	BM 94150	15434	TAPPET, POPPET VALVE: intake .....	EA	16
B-6	26	PAFZZ	2815-00-783-9751	108187	15434	and exhaust PIN, STRAIGHT, HEADLESS: intake .....	EA	16
B-6	27	PAFZZ	3120-00-984-1851	152082	15434	and exhaust tappet BEARING, SLEEVE: intake and exhaust6 .....	EA	16
B-6	28	PAFZZ	2815-00-909-2485	168327	15434	PIN, ROLLER, CAM FOLLOWER:.....	EA	16
B-6	29	PAFZZ	3120-00-973-2972	154571	15434	intake and exhaust tappet BEARING SLEEVE: injector tappet.....	EA	8
B-6	30	PAFZZ	2815-00-045-9875	114223	15434	PIN, INJECTOR: tappet roller .....	EA	8
B-6	31	PAFZZ	2815-00-045-9877	156438	15434	CLIP, SPRING: intake and exhaust tappet.....	EA	16
B-6	32	PAFZZ	5315-00-783-9730	108186	15434	PIN, STRAIGHT, HEADLESS:..... injector tappet	EA	8
B-6	33	PAFZZ	2815-00-907-8954	BM 94151	15434	TAPPET, INJECTOR .....	EA	8
B-6	34	PAFZZ	2815-00-505-5119	107738	15434	SOCKET, CAM FOLLOWER: injector tappet .....	EA	8
B-6	35	PAFZZ	2815-00-045-9876	156439	15434	CLIP, SPRING: injector tappet.....	EA	8
B-6	36	PAFZZ	2815-00-944-4437	138887	15434	VALVE, POPPET: engine exhaust.....	EA	16
B-6	37	PAFZZ	2815-00-085-7434	127930	15434	SEAT, VALVE: exhaust .....	EA	16
B-6	38	PAFZZ	2815-00-085-7450	138948	15434	GUIDE, CROSSHEAD: exhaust.....	EA	16
B-6	39	PAFZZ	2815-00-085-7451	144896	15434	CROSSHEAD, VALVE: intake .....	EA	8
B-6	39	PAFZZ	2815-00-085-7438	144897	15434	CROSSHEAD, VALVE: exhaust .....	EA	8
B-6	40	PAFZZ	5305-00-062-4378	147389	15434	SETScrew: crosshead adjusting .....	EA	16
B-6	41	PAFZZ	5310-00-275-3435	S 273	15434	NUT, PLAIN, HEXAGON: crosshead .....	EA	16
B-6	42	PAFZZ	2990-00-970-8930	153615	15434	adjusting setscrew ROD, PUSH: injector tappet (early).....	EA	8
B-6	42	PAFZZ	2815-00-148-7469	169352	15434	ROD, PUSH: injector tappet (late).....	EA	8
B-6	43	PAFZZ	2815-00-994-4444	153614	15434	ROD, PUSH: intake and exhaust valve .....	EA	16
B-6	43	PAFZZ	2815-00-159-8678	169351	15434	(early) ROD, PUSH: intake and exhaust .....	EA	16
B-6	44	PAFZZ	5305-00-297-4022	168319	15434	valve (late) SETScrew: rocker shaft locating.....	EA	2
B-6	45	PAFZZ	5340-00-470-6173	161825	15434	PLUG, PIPE: rocker shaft .....	EA	4
B-6	46	PAFZZ	2815-00-916-1879	BM 71425	15434	SHAFT, ROCKER ARM: left and .....	EA	2
B-6	47	PAFZZ	2815-00-912-4609	BM 96832	15434	right bank ROCKER ARM: exhaust valve .....	EA	8
B-6	48	PAFZZ	3120-00-082-0240	141875	15434	BUSHING, SLEEVE, ROCKER ARM:..... intake and exhaust valve	EA	16
B-6	49	PAFZZ	2815-00-085-3944	152173	15434	SOCKET, INJECTOR: rocker arm .....	EA	8
B-6	50	PAFZZ	2815-00-912-4611	BM 96828	15434	ROCKER ARM: injector tappet .....	EA	8
B-6	51	PAFZZ	3120-00-082-0241	146975	15434	BUSHING, SLEEVE: injector rocker .....	EA	8
B-6	52	XBFZZ		BM 96830	15434	arm ROCKER ARM: intake poppet valve .....	EA	8
B-6	53	PAFZZ	2815-00-085-3954	143021	15434	BRACKET, END: rocker lever shaft .....	EA	2

(1) ILLUSTRATION		(2)	(3)	(4)	(5)	(6) DESCRIPTION	(7)	(8)
(a) FIG NO.	(b) ITEM NO.	SMR CODE	NATIONAL STOCK NUMBER	PART NUMBER	FSCM	USABLE ON CODE	U/M	QTY INC IN UNIT
B-6	54	PAFZZ	5310-00-062-4407	101499	15434	0105-VALVES AND CAMSHAFT -Cont NUT, PLAIN, HEXAGON: rocker.....	EA	16
B-6	55	PAFZZ	5305-00-947-3437	168306	15434	arm adjusting SCREW, ADJUSTING: valve rotor.....	EA	16
B-6	56	PAFZZ	2815-00-994-4443	142992	15434	tappet SCREW, ADJUSTING: injector.....	EA	8
B-7	1	PAFZZ	5305-00-269-3213	MS90725-62	96906	SCREW, CAP, HEXAGON HEAD:.....	EA	2
B-7	2	PAFZZ	5310-00-637-9541	M535338-46	96906	front cover retaining WASHER, LOCK: front cover retain-.....	EA	14
B-7	3	PAFZZ	4730-00-018-9566	189566	21450	ing PLUG, PIPE.....	EA	1
B-7	4	PAFZZ	5330-00-815-0895	158551	15434	COVER, FRONT: engine cylinder .....	EA	1
B-7	5	PAFZZ	2815-00-772-5352	70645	15434	block DOWEL, MASTER: front cover to .....	EA	1
B-7	6	KFFZZ		186907	15434	cylinder block GASKET: front cover Part of kit .....	EA	1
B-7	7	PAHZZ	2815-00-085-7476	155500	15434	P/N BM 95886 CAMSHAFT, DIESEL ENGINE .....	EA	1
B-7	8	PAHZZ	3120-00-086-7743	148210	15434	BEARING, SLEEVE, CAMSHAFT: .....	EA	3
B-7	9	PAHZZ	5315-00-987-5340	139114	15434	intermediate, numbers 2, 3 and 4 Part P/N BM 96104	EA	1
B-7	10	PAHZZ	2815-00-353-9395	68908	15434	KEY, WOODRUFF: camshaft .....	EA	2
B-7	11	PAHZZ	5305-00-269-3210	MS90725-59	96906	LOCKPLATE: thrust plate retaining.....	EA	2
B-7	12	PAHZZ	3020-00-088-1702	150129	15434	SCREW, CAP, HEXAGON HEAD:.....	EA	2
B-7	13	PAHZZ	2815-00-909-2481	169747	15434	thrust plate retaining GEAR, SPUR: camshaft accessory .....	EA	1
B-7	14	PAHZZ	3120-00-082-0447	147160	15434	drive PLATE, THRUST: engine camshaft .....	EA	1
B-7	15	PAFZZ	2815-00-719-4598	68568	15434	BEARING, SLEEVE, CAMSHAFT: .....	EA	2
B-7	16	PAFZZ	5305-00-269-3214	MS90725-64	96906	front and rear Part of set P/N BM 96104	EA	1
B-7	17	PAFZZ	5305-00-269-3211	MS90725-60	96906	DOWEL, DIAMOND: front cover to .....	EA	10
B-7	18	PAFZZ	2815-00-999-5354	158556	15434	cylinder block SCREW, CAP, HEXAGON HEAD:.....	EA	2
B-7	8	PAHZZ	3120-00-939-7137	BM 96104	15434	front cover retaining SCREW, CAP, HEXAGON HEAD: EA .....	EA	1
B-7	14					SEAL, OIL: front cover Part of kit .....	EA	3
B-7						P/N BM 95886 BEARING SET, SLEEVE: camshaft .....	EA	1
B-7						BEARING .....	EA	2
B-7						BEARING .....	EA	2
B-8	1	PAOZZ	2815-00-909-2451	162761	15434	0106-ENGINE LUBRICATION SYSTEM VALVE, BREATHER, PRESSURIZ- .....	EA	1
B-8	2	PAOZZ	5330-00-821-9164	122135	15434	ING, DEEP WATER FORDING, ASSEMBLY GASKET: breather .....	EA	1
B-8	3	XBOZZ		S 915	15434	Part of set P/N BM 96854 NIPPLE, PIPE: breather valve .....	EA	1
B-8	4	PAOZZ	2815-00-909-2479	175505	15434	VALVE,BREATHER, CRANKCASE .....	EA	1
B-8	5	PAOZZ	4730-00-081-4203	134325	15434	ELBOW, PIPE: valve to hose.....	EA	1
B-8	6	PAOZZ	4730-00-277-5822	43828A	15434	CLAMP, HOSE: breather valve.....	EA	2
B-8	7	XBOZZ		69974	15434	HOSE: breather valve .....	EA	1
B-8	8	XBOZZ		176105	15434	TUBE: hose to elbow .....	EA	1
B-8	9	PAOZZ	5340-00-839-0653	68425	15434	CLAMP, TUBE.....	EA	1
B-8	10	PAOZZ	5310-00-637-9541	MS35338-46	96906	WASHER, LOCK: tube clamp .....	EA	1
					<b>B-10</b>			

(1) ILLUSTRATION		(2)	(3)	(4)	(5)	(6) DESCRIPTION	(7)	(8)
(a) FIG NO.	(b) ITEM NO.	SMR CODE	NATIONAL STOCK NUMBER	PART NUMBER	FSCM	USABLE ON CODE	U/M	QTY INC IN UNIT
B-8	11	XBOZZ		S 181B	15434	0106-ENGINE LUBRICATION SYSTEM-Cont SCREW, CAP, HEXAGON HEAD:..... tube clamp	EA	1
B-8	12	XBOZZ		68190	15434	SUPPORT, ANGLE .....	EA	1
B-8	13	PAOZZ	5310-00-562-6558	S 626	15434	WASHER: support, angle .....	EA	1
B-8	14	PAOZZ	5305-00-269-3215	MS90725-65	96906	SCREW, CAP, HEXAGON HEAD:..... support, angle	EA	1
B-9	1	PAOZZ	6680-00-919-2892	175802	15434	GAGE, DIPSTICK .....	EA	1
B-9	2	PAOZZ	5310-00-521-8595	S 223	15434	NUT, PLAIN, HEXAGON: dipstick..... tube clamp	EA	1
B-9	3	PAOZZ	5310-00-637-9541	MS35338-46	96906	WASHER, LOCK: oil pan .....	EA	21
B-9	4	XBOZZ		164724	15434	BRACKET: tube support, dipstick .....	EA	1
B-9	5	PAFZZ	5305-00-269-3213	MS90725-62	96906	SCREW, CAP, HEXAGON HEAD:..... inspection plate	EA	6
B-9	6	XBFZZ		175220	15434	COVER, OIL PAN: inspection plate .....	EA	1
B-9	7	PAFZZ	5330-00-910-4439	175221	15434	GASKET: inspection cover, oil pan .....	EA	1
B-9	8	PAFZZ	2815-00-909-2477	175219	15434	Part of kit P/N BM 95886 PAN, OIL, DIESEL ENGINE: front .....	EA	1
B-9	9	PAFZZ	5330-00-994-4404	151101	15434	sump GASKET: oil pan Part of kit P/N .....	EA	1
B-9	10	PAFZZ	5305-00-269-3211	MS90725-60	96906	BM 95886 SCREW, CAP, HEXAGON HEAD:..... pump tubes	EA	5
B-9	11	PAFZZ	2815-00-353-9395	68908	15434	LOCKPLATE, CAPSCREW: oil pan .....	EA	12
B-9	12	PAFZZ	5305-00-269-3220	MS90725-70	96906	SCREW, CAP, HEXAGON HEAD:..... pump tubes	EA	13
B-9	13	XBFZZ		BM 97374	15434	TUBE, BY-PASS: oil pump .....	EA	1
B-9	14	PAFZZ	4730-00-801-8186	S 915A	15434	PLUG, PIPE: aerator tube .....	EA	1
B-9	15	XBFZZ		175229	15434	CLAMP, TUBE: pump tubes .....	EA	2
B-9	16	XBFZZ		BM 97375	15434	TUBE, SCAVENGER AND AERA-.....	EA	1
B-9	17	PAFZZ	5330-00-909-2478	160640	15434	TOR: oil pump to fan GASKET, ASBESTOS AND RUB- .....	EA	1
B-9	18	XBFZZ		67224	15434	BER: scavenger oil pump cover Part of kit P/N BM 95886	EA	1
B-9	19	PAFZZ	5305-00-269-3210	MS90725-59	96906	SPACER: gear cover .....	EA	4
B-9	20	XBFZZ		BM 97373	15434	SCREW, CAP, HEXAGON HEAD:..... scavenger tube	EA	1
B-9	21	PAFZZ	5330-00-903-9525	156467	15434	TUBE, SUCTION: oil pump .....	EA	1
B-9	22	PAFZZ	5810-00-846-1056	S 224	15434	GASKET, ASBESTOS AND RUB- .....	EA	1
B-9	23	PAFZZ	5305-00-269-3214	MS90725-64	96906	BER: oil tube suction flange Part of kit P/N BM 95886	EA	12
B-9	24	PAFZZ	5310-00-562-6553	S 602	15434	NUT, PLAIN: tube clamp .....	EA	20
B-9	25	PAOZZ	4730-00-492-6040	163759	15434	SCREW, CAP, HEXA- .....	EA	1
B-9	26	XBOZZ		175801	15434	GON HEAD: oil pan .....	EA	1
B-9	27	XBOZZ		S 117	15434	WASHER, FLAT: oil pan .....	EA	1
B-9	28	PAOZZ	2940-00-417-5800	65798	15434	ADAPTER STRAIGHT: dipstick tube .....	EA	1
B-10	1	PAFZZ	2815-00-907-8955	BM 94676	15434	TUBE, DIPSTICK: oil pan .....	EA	1
B-10	2	XAHZZ		161042	15434	SCREW, CAP: clamp, dipstick tube .....	EA	1
B-10	3	PAHZZ	5330-00-401-5108	163013	15434	CLAMP, TUBE: dipstick .....	EA	1
B-10	4	PAHZZ	5315-00-475-2576	70760	15434	PUMP, OIL, DOUBLE, ASSEMBLY .....	EA	1
B-10	5	PAHZZ	3120-00-132-0286	69514	15434	BODY, SCAVENGER PUMP GAS- .....	EA	1
						KET: scavenger pump Part of kit .....	EA	1
						P/N BM 95886		
						DOWEL: scavenger and lubrication .....	EA	2
						pump body		
						BUSHING, DRIVESHAFT: scaven-..... ger and lubricating pump	EA	3
					<b>B-11</b>			

(1) ILLUSTRATION		(2)	(3)	(4)	(5)	(6) DESCRIPTION	(7)	(8)
(a) FIG NO.	(b) ITEM NO.	SMR CODE	NATIONAL STOCK NUMBER	PART NUMBER	FSCM	USABLE ON CODE	U/M	QTY INC IN UNIT
B-10	6	PAHZZ	3020-00-682-7710	43863	15434	0106-ENGINE LUBRICATION SYSTEM-Cont		
B-10	7	PAHZZ	3040-00-459-7158	162685	15434	GEAR: lubricating pump.....	EA	2
						DRIVE SHAFT, SCAVENGER.....	EA	1
B-10	8	PAHZZ	5305-00-269-3214	MS90725-64	96906	PUMP SCREW, CAP, HEXAGON HEAD: .....	EA	2
						lubricating body		
B-10	9	XAHZZ		160538	15434	BODY, LUBRICATING PUMP.....	EA	1
B-10	10	PAHZZ	3120-00-870-9520	69236	15434	DOWEL .....	EA	2
B-10	11	PAHZZ	3120-00-566-0480	68365	15434	BUSHING: lubricating pump.....	EA	2
B-10	12	PAHZZ	2815-00-086-8384	143405	15434	SHAFT, DRIVE: lubricating pump .....	EA	1
B-10	13	PAHZZ	2815-00-084-7800	143694	15434	GASKET: lubricating pump Part of.....	EA	1
						kit P/N BM 95886		
B-10	14	PAHZZ	2815-00-190-8888	146933	15434	PLATE, LOCK: capscrew, cover.....	EA	4
B-10	15	XBHZZ		114463	15434	SCREW, CAP: gear and pump cover .....	EA	4
B-10	16	XAHZZ		157952	15434	PLATE: lubricating pump and gear .....	EA	1
						cover		
B-10	17	PAHZZ	3020-00-082-0461	149151	15434	GEAR DRIVE: oil pump.....	EA	1
						pump cover		
B-10	18	PAHZZ	5305-00-269-3210	MS90725-59	96906	SCREW, CAP, HEXAGON HEAD: .....	EA	4
B-10	19	XBHZZ		158168	15434	LOCKPLATE: capscrew, pump cover.....	EA	2
B-10	20	XAHZZ		162592	15434	COVER, LUBRICATING PUMP .....	EA	1
B-10	21	PAHZZ	3020-00-460-6429	131275	15434	GEAR, DRIVE: lubricating pump.....	EA	1
B-10	22	PAHZZ	2940-00-459-6558	175282	15434	LOCKPLATE: capscrew .....	EA	4
B-10	23	PAHZZ	5305-00-269-3213	MS90725-62	96906	SCREW, CAP, HEXAGON HEAD .....	EA	1
						lubricating pump		
B-10	24	PAHZZ	5305-00-269-3215	MS90725-65	96906	SCREW, CAP, HEXAGON HEAD .....	EA	1
						lubricating pump		
B-10	25	PAHZZ	5365-00-907-9008	68251	15434	SHIM, PRESSURE REGULATOR: .....	EA	1
						oil pump spacer		
B-10	26	PAHZZ	5360-00-664-5343	68274	15434	SPRING, OIL PUMP BYPASS: .....	EA	1
						pressure regulator		
B-10	27	PAHZZ	2815-00-907-9012	156083	15434	GASKET: lockplate pressure regu-.....	EA	1
						lator Part of kit P/N BM 95886		
B-10	28	XBHZZ		162653	15434	CAP: pressure regulator.....	EA	1
B-10	29	PAHZZ	2815-00-791-1453	127558	15434	PLUNGER, REGULATOR: lubricat-.....	EA	1
						ing pump		
B-10	30	PAHZZ	2815-00-973-0481	149718	15434	SHAFT, IDLER: lubricating oil pump.....	EA	1
B-10	31	XBHZZ		162607	15434	GEAR: lubricating pump.....	EA	1
B-10	32	PAHZZ	2815-00-353-9395	68908	15434	LOCKPLATE: capscrew, scavenger .....	EA	6
						pump		
B-10	33	PAHZZ	5305-00-269-3217	MS90725-67	90906	SCREW, CAP, HEXAGON HEAD: .....	EA	6
						scavenger pump		
B-11	1	KFHZZ		173298	15434	GASKET: plate to block, left bank.....	EA	1
						Part of kit P/N BM 95886		
B-11	2	KFHZZ		173299	15434	GASKET: water header cover, right.....	EA	1
						bank part of kit P/N BM 95886		
B-11	3	XBHZZ		173297	15434	COVER, WATER HEADER: right bank .....	EA	1
B-11	4	PAOZZ	4730-00-142-1851	AMC61S41-141PC2	80064	PLUG, PIPE: right bank cover.....	EA	1
					<b>B-12</b>			

(1) ILLUSTRATION		(2)	(3)	(4)	(5)	(6) DESCRIPTION	(7)	(8)
(a) FIG NO.	(b) ITEM NO.	SMR CODE	NATIONAL STOCK NUMBER	PART NUMBER	FSCM	USABLE ON CODE	U/M	QTY INC IN UNIT
B-11	5	PAOZZ	4730-00-289-4770	S 995	15434	0106-ENGINE LUBRICATION SYSTEM-Continued PLUG, PIPE: left bank cover (2), oil cooler (2)	EA	4
B-11	6	PAHZZ	5305-00-269-3211	MS90725-60	96906	SCREW, CAP, HEXAGON HEAD: left bank (12), right bank (18)	EA	30
B-11	7	PAHZZ	5310-00-637-9541	MS35338-46	96906	WASHER, LOCK: left bank Plate (12), right bank cover (22), oil cooler (19)	EA	53
B-11	8	PAHZZ	5305-00-735-8098	S 174B	15434	SCREW, CAP, HEXAGON HEAD: right bank cover	EA	4
B-11	9	PAOZZ	4730-00-042-6318	444697	19207	PLUG, PIPE: right bank cover	EA	1
B-11	10	PAOZZ	4730-00-801-8186	S 915A	15434	PLUG, PIPE: oil cooler cover	EA	3
B-11	11	PAOZZ	4730-00-018-9566	189566	21450	PLUG, PIPE: oil cooler cover	EA	1
B-11	12	XBOZZ		173286	15434	COVER, OIL COOLER: housing	EA	1
B-11	13	PAOZZ	5330-00-401-5107	173288	15434	GASKET: cooler cover to housing Part of kit P/N BM 95886	EA	1
B-11	14	PAOZZ	2930-00-437-0567	142616	15434	RETAINER: oil cooler element	EA	1
B-11	15	PAOZZ	2940-00-470-6701	173287	15434	ELEMENT, OIL COOLER	EA	1
B-11	16	PAOZZ	6620-00-993-5546	MS24539-1	96906	TRANSMITTER, OIL PRESSURE: oil cooler	EA	1
B-11	17	XBOZZ		181374	15434	BUSHING, OIL TRANSMITTER: oil cooler	EA	1
B-11	18	XBOZZ		181373	15434	TEE, PIPE, OIL TRANSMITTER: oil cooler	EA	1
B-11	19	PAOZZ	5305-00-269-3216	MS35295-66	96906	SCREW, CAP, HEXAGON HEAD: cooler mounting	EA	4
B-11	20	PAOZZ	5305-00-269-3217	MS90725-67	96906	SCREW, CAP, HEXAGON HEAD: cooler mounting	EA	5
B-11	21	PAOZZ	5305-00-269-3214	MS90725-64	96906	SCREW, CAP, HEXAGON HEAD: cooler mounting	EA	4
B-11	22	XBOZZ		173296	15434	HOUSING, OIL COOLER	EA	1
B-11	23	PAOZZ	5305-00-269-3213	MS90725-62	96906	SCREW, CAP, HEXAGON HEAD	EA	6
B-11	24	PAOZZ	2815-00-813-7765	158295	15434	PACKING, PREFORMED: oil cooler Part of kit P/N BM 95886	EA	2
B-11	25	KFOZZ		183831	15434	GASKET: cooler cover, left bank plate Part of kit P/N BM 95886	EA	1
B-11	26	PAOZZ	5330-00-401-5105	183832	15434	GASKET: cooler cover, left bank plate Part of kit P/N BM 95886	EA	1
B-11	27	PAOZZ	5330-00-401-5106	173291	15434	GASKET: cooler cover, left bank plate Part of kit P/N BM 95886	EA	1
B-11	28	PAOZZ	5330-00-401-2004	173289	15434	GASKET: cooler housing, left bank plate Part of kit P/N BM 95886	EA	1
B-11	29	XBHZZ		173292	06840	PLATE, WATER HEADER: left bank	EA	1
B-11	30	PAHZZ	4710-00-927-9304	180099	29510	BAFFLE, WATER: left bank	EA	1
B-11	31	XBHZZ		182008	62983	SCREW, MACHINE: water baffle	EA	2
B-12	1	PAOZZ	4730-00-226-8444	102408	15434	0108-MANIFOLDS COUPLING: exhaust manifold	EA	2
B-12	2	PAOZZ	2815-00-907-8972	157618	15434	MANIFOLD, EXHAUST: left bank	EA	1
B-12	3	PAOZZ	4730-00-142-1851	AMC61S41- 141PC2	80064	PLUG, PIPE: right bank exhaust	EA	1
B-12	4	PAOZZ	2815-00-909-2486	166598	15434	MANIFOLD, EXHAUST: right bank	EA	1
B-12	5	PAOZZ	5305-00-269-3214	MS90725-64	96906	SCREW, CAP, HEXAGON HEAD: intake manifold	EA	16
B-12	6	PAOZZ	5310-00-637-9.541	MS35338-46	96906	WASHER, LOCK: intake manifold	EA	16
B-12	7	PAOZZ	5310-00-562-6553	S 602	15434	WASHER, PLAIN: intake manifold	EA	16
B-12	8	PAOZZ	2815-00-909-2476	156497	15434	MANIFOLD, INTAKE: left and right bank	EA	2
					<b>B-13</b>			

(1) ILLUSTRATION		(2)	(3)	(4)	(5)	(6) DESCRIPTION	(7)	(8)
(a) FIG NO.	(b) ITEM NO.	SMR CODE	NATIONAL STOCK NUMBER	PART NUMBER	FSCM	USABLE ON CODE	U/M	QTY INC IN UNIT
B-12	9	PAOZZ	5330-00-909-2489	156348	15434	0108-MANIFOLDS-Contigued GASKET: intake manifold Part of set .....	EA	2
B-12	10	PAOZZ	5330-00-994-4410	151707	15434	P/N BM 96854 GASKET: intake manifold to block .....	EA	2
B-12	11	PAOZZ	2815-00-084-7796	154226	15434	Part of set P/N BM 96854 COVER, PUSH TUBE: right and left .....	EA	2
B-12	12	PAOZZ	5330-00-994-4411	154396	15434	bank GASKET: Push tube cover Part of .....	EA	2
B-12	13	PAOZZ	5310-00-562-6558	S 626	15434	P/N BM 96854 WASHER, FLAT: tube cover to block .....	EA	16
B-12	14	PAOZZ	5310-00-407-9566	MS35338-45	96906	WASHER, LOCK: tube cover to block.....	EA	26
B-12	15	PAOZZ	5306-00-225-8497	MS90725-32	96906	SCREW, CAP HEXAGON HEAD:.....	EA	26
B-12	16	PAOZZ	5305-00-269-3213	MS90725-62	96906	tube cover to block SCREW, CAP, HEXAGON HEAD:.....	EA	16
B-12	17	PAOZZ	2815-00-974-9872	139247	15434	exhaust manifold LOCKPLATE: exhaust manifolds Part.....	EA	8
B-12	18	PAOZZ	5310-00-134-4169	63842	15434	of set P/N BM 96854 WASHER, PLAIN: exhaust manifolds .....	EA	16
B-12	19	PAOZZ	5330-00-993-5101	139677	15434	GASKET: exhaust manifolds.....	EA	8
						<b>GROUP 03-FUEL SYSTEM</b>		
						<b>0301-FUEL INJECTOR</b>		
B-13	1	PAFZZ	2910-00-920-7557	BM 97421	15434	INJECTOR ASSEMBLY: cylinder.....	EA	8
B-13	2	XAFZZ		163947	15434	RETAINER,INJECTOR: body .....	EA	8
B-13	3	PAFZZ	2910-00-920-7556	BM 93636	15434	CUP, INJECTOR: body.....	EA	8
B-13	4	PAFZZ	5330-00-695-3295	70776	15434	PACKING, PREFORMED: injector.....	EA	8
B-13	5	PAFZZ	5330-00-993-5100	101754	15434	cup PACKING, PREFORMED: injector.....	EA	32
B-13	6	PAFZZ	2910-00-085-7465	136749	15434	body Part of set P/N BM 96854 SCREEN, INJECTOR: Plunger body .....	EA	8
B-13	7	PAFZZ	2910-00-085-7465	136042	15434	CLAMP, INJECTOR SPRING: plunger .....	EA	8
B-13	8	PAFZZ	5340-00-459-9937	148524	15434	body SEAT, SPRING: injector plunger.....	EA	8
B-13	9	PAFZZ	5360-00-086-7710	128040	15434	injector plunger SPRING, HELICALCOMPRESSION:.....	EA	8
B-13	10	PAFZZ	2910-00-912-9104	148504	15434	RETAINER, SLEEVE: injector .....	EA	8
B-13	11	PAFZZ	2910-00-912-4554	170948	15434	plunger LINK, FUEL INJECTOR PLUNGER .....	EA	8
B-13	12	PAFZZ	2910-00-908-7307	BM 91011	15434	INJECTOR BODY AND PLUNGER .....	EA	8
B-13	13	PAFZZ	3120-00-062-9559	147558	15434	ASSEMBLY: cylinder head RETAINER, BALL: fuel injector.....	EA	8
B-13	14	PAFZZ	5330-00-959-1563	147559	15434	GASKET: fuel injector .....	EA	8
B-13	15	PAFZZ	3110-00-100-6149	MS19059-47	96906	BEARING, BALL: fuel injector .....	EA	8
B-13	16	PAFZZ	5305-00-062-2230	131430	15434	SCREW, CAP, HEXAGON HEAD:.....	EA	8
B-13	17	PAFZZ	5310-00-637-9541	MS35338-46	96906	injector pump WASHER, LOCK: injector clamp .....	EA	8
B-13	18	PAFZZ	2910-00-970-1277	128002	15434	CLAMP, INJECTOR: plunger and body.....	EA	8
					<b>B-14</b>			

(1) ILLUSTRATION		(2)	(3)	(4)	(5)	(6) DESCRIPTION	(7)	(8)
(a) FIG NO.	(b) ITEM NO.	SMR CODE	NATIONAL STOCK NUMBER	PART NUMBER	FSCM	USABLE ON CODE	U/M	QTY INC IN UNIT
B-14	1	PAFHH	2910-00-920-7554	BM 97400 AR50828	15434 15434	0302-FUEL PUMP PUMP ASSEMBLY, FUEL: with pump .....	EA	1
B-15	1	PAHZZ	4730-00-042-8988	428988	19207	gear, pump damper, governor and main shaft cover, governor spring assemblies	EA	1
B-15	2	PAHZZ	3805-00-961-9470	154088	15434	PLUG, PIPE: top fuel pump housing .....	EA	1
B-15	3	PAHZZ	2910-00-507-3271	157088	15434	RING, SEALING: fuel filter cap .....	EA	1
B-15	4	PAHZZ	5360-00-597-4570	70700	15434	Part of set P/N BM 68356	EA	1
B-15	5	PAHZZ	2910-00-790-8736	146483	15434	CAP, FILTER ELEMENT: fuel pump .....	EA	1
B-15	6	PAHZZ	5310-00-971-7989	MS35691-5	96906	SPRING: fuel filter holddown.....	EA	1
B-15	7	PAHZZ	2910-00-774-4246	109915	15434	FILTER ELEMENT, FLUID: fuel.....	EA	1
B-15	8	PAHZZ	5305-00-062-4373	142149	15434	pump	EA	2
B-15	9	PAHZZ	5310-00-045-3299	MS35338-42	90906	NUT, PLAIN, HEXAGON: jam throt- tle adjusting	EA	2
B-15	10	PAHZZ	5315-00-973-0414	149040	15434	SCREW, SLOTTED, HEADLESS: .....	EA	2
B-15	11	PAHZZ	5310-00-984-0273	142179	15434	throttle adjusting	EA	1
B-15	12	PAHZZ	5330-00-081-9289	100478	15434	SETSCREW, throttle shaft .....	EA	1
B-15	13	PAHZZ	2910-00-085-7439	149030	15434	WASHER, LOCK: throttle shaft.....	EA	1
B-15	13	PAHZZ	2910-00-914-7319	149031	15434	PLUNGER, FUEL PUMP: throttle .....	EA	1
B-15	14	PAHZZ	5315-00-253-3408	148976	15434	shaft	EA	1
B-15	15	PAHZZ	5310-00-858-3509	148916	15434	SPACER: throttle adjusting shim .....	EA	1
B-15	16	PAHZZ	2990-00-858-3526	148977	15434	PACKING, PREFORMED: throttle .....	EA	1
B-15	17	PAHZZ	5340-00-786-0102	S 16206	15434	shaft part of set P/N BM 68356	EA	1
B-15	18	XBHZZ		173708	15434	SHAFT, THROTTLE: standard size .....	EA	1
B-15	19	PAHZZ	5305-00-493-3959	S 159B	15434	SHAFT, THROTTLE: oversize .....	EA	1
B-15	20	PAHZZ	5310-00-141-1795	AN960-416	88044	PIN: throttle stop .....	EA	1
B-15	21	PAHZZ	5310-00-562-6552	S 600	15434	SPACER: throttle shaft .....	EA	1
B-15	22	PAHZZ	5310-00-971-7989	MS35691-5	96906	COVER: throttle shaft .....	EA	1
B-15	23	PAHZZ	2910-00-065-5544	124019	15434	RING, SNAP, RETAINING: throttle .....	EA	1
B-15	24	PAHZZ	5340-00-464-7064	124020	15434	shaft	EA	1
B-15	25	PAHZZ	5305-00-253-5612	MS21318-15	96906	LEVER AND LOCK, THROTTLE: .....	EA	1
B-15	26	PAHZZ	9905-00-733-7622	105375	15434	fuel Pump	EA	1
B-15	27	PAHZZ	4730-00-716-6580	68606	15434	SCREW, CAP, HEXAGON HEAD:.....	EA	1
B-15	28	PAHZZ	2910-00-400-5178	163733	15434	throttle shaft lever retaining	EA	1
B-15	29	PAHZZ	2910-00-759-1299	BM 76338	15434	WASHER, FLAT: throttle lever .....	EA	1
B-15	30	PAHZZ	5315-00-844-0140	118227	15434	WASHER, LOCK: throttle lever.....	EA	1
B-15	31	PAHZZ	2910-00-829-5603	140618	15434	NUT, PLAIN, HEXAGON: throttle.....	EA	1
B-15	32	PAHZZ	2910-00-910-9637	BM 75508	15434	adjusting	EA	1
B-15	33	PAHZZ	5360-00-905-0042	142698	15434	SEAL: throttle shaft cover .....	EA	2
B-15	34	PAHZZ	5365-00-507-3224	101841	15434	WIRE, SEAL: throttle shaft cover .....	EA	1
B-15	34	PAHZZ	5365-00-507-3225	101842	15434	SCREW, DRIVE: identification plate .....	EA	2
						PLATE, IDENTIFICATION: fuel pump.....	EA	1
						PLUG, PIPE: fuel pump .....	EA	1
						CLIP: governor barrel.....	EA	1
						HOUSING ASSEMBLY .....	EA	1
						PIN, HOLLOW: fuel pump housing .....	EA	1
						HOUSING, SPRING PACK: fuel pump .....	EA	1
						BARREL ASSEMBLY, GOVERNOR:.....	EA	1
						fuel pump	EA	1
						SPRING, HELICAL, COMPRESSION:.....	EA	1
						mechanical governor torque control	EA	V
						SHIM: mechanical governor torque .....	EA	V
						control plunger	EA	V
						SHIM: mechanical governor torque.....	EA	V
						control plunger	EA	V

**B-15**

(1) ILLUSTRATION		(2)	(3)	(4)	(5)	(6) DESCRIPTION	(7)	(8)
(a) FIG NO.	(b) ITEM NO.	SMR CODE	NATIONAL STOCK NUMBER	PART NUMBER	FSCM	USABLE ON CODE	U/M	QTY INC IN UNIT
B-15	34	PAHZZ	5365-00-543-3744	101843	15434	0302-FUEL PUMP-Continued SHIM: mechanical governor torque.....	EA	V
B-15	35	PAHZZ	2910-00-907-8961	169660	15434	control plunger PLUNGER, FUEL INJECTOR: stan-.....	EA	1
B-15	35	PAHZZ	2910-00-907-8960	169661	15434	dard size PLUNGER, FUEL INJECTOR: oversize.....	EA	1
B-15	36	PAHZZ	5315-00-907-0711	137372	15434	PIN, SPRING, GOVERNOR: plunger.....	EA	1
B-15	37	PAHZZ	2910-00-829-5604	144302	15434	SPACER: governor plunger .....	EA	1
B-15	38	PAHZZ	3120-00-764-7090	138905	15434	WASHER, THRUST: fuel pump gov-.....	EA	1
B-15	39	PAHZZ	2990-00-772-1778	70690	15434	ernor plunger PLUNGER, GOVERNOR: drive .....	EA	1
B-15	40	PAHZZ	3120-00-810-6032	100193	15434	BEARING, SLEEVE: tachometer .....	EA	1
B-15	41	PAHZZ	5315-00-369-2588	68549	15434	drive gear PIN, STRAIGHT, HEADLESS: fuel .....	EA	1
B-15	42	PAHZZ	5330-00-582-7484	MS9021-116	96906	pump housing to mainshaft PACKING, PREFORMED: Plug to .....	EA	1
B-15	43	PAHZZ	5365-00-988-3668	139473	15434	fuel pump housing part of set P/N BM 68356 PLUG: fuel pump housing .....	EA	1
B-16	1	PAHZZ	2910-00-924-3912	AR 50101	15434	PUMP ASSEMBLY: gear fuel supply .....	EA	1
B-16	2	PAHZZ	5330-00-838-9975	177764	15434	GASKET: gear pump to fuel pump.....	EA	1
B-16	3	PAHZZ	3120-00-719-5719	101468	15434	part of set P/N BM 68356 PIN, HOLLOW: gear pump cover .....	EA	1
B-16	4	PAHZZ	5315-00-014-1244	64816A	15434	PIN, STRAIGHT, HEADLESS: gear .....	EA	1
B-16	5	PAHZZ	3020-00-702-3882	119363	15434	pump cover to housing GEAR: fuel supply gear pump.....	EA	2
B-16	6	PAHZZ	2910-00-933-3012	175864	15434	SHAFT, DRIVE: fuel supply gear .....	EA	1
B-16	7	PAHZZ	2910-00-567-4354	100215	15434	pump SHAFT, DRIVE: fuel supply gear .....	EA	1
B-16	8	PAHZZ	5330-00-567-3463	110855	15434	pump GASKET: gear pump cover to hous-.....	EA	1
B-16	9	PAHZZ	5310-00-484-1718	181466	15434	ing Part of set P/N BM 68356 WASHER, LOCK: gear pump .....	EA	12
B-16	10	PAHZZ	5305-00-509-8106	171546	15434	SCREW, CAP, HEXAGON HEAD:.....	EA	2
B-16	11	PAHZZ	4820-00-130-4820	175836	15434	gear pump cover to housing VALVE, ELBOW BALL CHECK: .....	EA	1
B-16	12	PAHZZ	4730-00-506-4880	70777	15434	gear pump housing ADAPTER: fuel inlet hose .....	EA	1
B-16	13	PAHZZ	5305-00-423-7693	171548	15434	SCREW, CAP, HEXAGON HEAD:.....	EA	6
B-16	14	XBHZZ		171550	15434	gear pump cover to housing SCREW, CAP, HEXAGON HEAD:.....	EA	4
B-16	15	XBHZZ		AR50100	15434	gear pump housing COVER, HOUSING: gear pump.....	EA	1
B-16	16	PAHZZ	2910-00-829-5617	153338	15434	PLATE: damper .....	EA	1
B-16	17	PAHZZ	5330-00-809-2667	100099	15434	PACKING, PREFORMED: Part of set .....	EA	1
B-16	18	PAHZZ	5365-00-965-0870	160514	15434	P/N BM 68356 WASHER, NONMETALLIC: Part of .....	EA	1
B-16	19	PAHZZ	2910-00-951-3536	139834	15434	set P/N BM 68356 DISK, SOLID, PLAIN: fuel pump .....	EA	1
					<b>B-16</b>	damper		



(1) ILLUSTRATION		(2)	(3)	(4)	(5)	(6) DESCRIPTION	(7)	(8)
(a) FIG NO.	(b) ITEM NO.	SMR CODE	NATIONAL STOCK NUMBER	PART NUMBER	FSCM	USABLE ON CODE	U/M	QTY INC IN UNIT
B-16	20	PAHZZ	5330-00-809-3276	139988	15434	0302-FUEL PUMP-Continued PACKING, PREFORMED: fuel damp- er body to diaphragm Part of set P/N BM 68356	EA	1
B-16	21	XBHZZ		153336	15434	HOUSING, FUEL PUMP	EA	1
B-16	22	PAHZZ	5330-00-080-0483	151900	15434	WASHER, NONMETALLIC Part of set P/N BM 68356	EA	1
B-16	23	PAHZZ	5305-00-267-8977	MS90726-10	96906	SCREW, CAP, HEXAGON HEAD: fuel damper	EA	2
B-16	24	XBHZZ		24582	78570	WASHER, LOCK: fuel damper assem- bly	EA	2
B-16	25	PAHZZ	5310-00-141-1795	AN 960-416	88044	WASHER, FLAT: fuel damper assem- bly	EA	2
B-17	1	PAHZZ	4810-00-512-3534	BM 69979	15434	VALVE, SOLENOID: 24 volt, single terminal	EA	1
B-17	2	PAHZZ	4730-00-278-4592	7089727	19207	ADAPTER, OUTLET: fuel shut-off valve	EA	1
B-17	3	PAHZZ	5305-00-509-8106	171546	15434	SCREW, CAP, HEXAGON HEAD: shutoff valve to fuel pump housing	EA	2
B-17	4	XBHZZ		24582	78570	WASHER, LOCK: shut-off valve to fuel pump housing	EA	2
B-17	5	PAHZZ	5310-00-262-2986	67684	15434	WASHER, FLAT: shut-off valve to fuel pump housing	EA	2
B-17	6	XBHZZ		129826	15434	HOUSING, SHUT-OFF VALVE	EA	1
B-17	7	PAHZZ	2910-00-084-7813	143679	15434	SHAFT, MANUAL OVERRIDE: fuel shut-off valve	EA	1
B-17	8	PAHZZ	5330-00-816-8148	114791	15434	PACKING, PREFORMED: fuel shut-off valve part of set P/N BM 68356	EA	1
B-17	9	PAHZZ	2910-00-085-3939	129827	15434	DIAPHRAGM: shut-off valve	EA	1
B-17	10	PAHZZ	5310-00-082-1888	129768	15434	WASHER, SPRING TENSION: fuel shut-off valve	EA	1
B-17	11	PAHZZ	5330-00-081-9299	129888	15434	PACKING, PREFORMED: fuel shut-off valve Part of set P/N BM 68356	EA	1
B-17	12	PAHZZ	2910-00-084-7787	129839	15434	COVER, ACCESS: solenoid coil assembly	EA	1
B-17	13	PAHZZ	2910-00-085-7436	134074	15434	SOLENOID COIL ASSEMBLY: fuel shut-off valve	EA	1
B-17	14	XBHZZ		S 607	15434	WASHER, LOCK: solenoid coil as- sembly to housing	EA	4
B-17	15	PAHZZ	5305-00-858-0037	S 1214	15434	SCREW, MACHINE: solenoid coil assembly to housing	EA	4
B-17	16	PAHZZ	4730-00-011-3175	70295	15434	PLUG, PIPE: fuel shut-off valve	EA	1
B-17	17	PAHZZ	5330-00-951-3538	154087	15434	PACKING, PREFORMED: solenoid coil assembly sealing Part of set P/N BM 68356	EA	1
B-17	18	PAHZZ	5355-00-082-1189	129838	15434	KNOB, MANUAL OVERRIDE: fuel shut-off valve	EA	1
B-17	19	PAHZZ	2815-00-907-8964	137370	15434	PLUNGER, IDLER SPRING: gover- nor spring Pack	EA	1
B-17	20	PAHZZ	5360-00-082-0124	144195	15434	SPRING, HELICAL, COMPRESSION: governor spring pack	EA	1
B-17	21	PAHZZ	5310-00-507-3259	70715	15434	WASHER, FLAT: governor adjusting screw	EA	1
					<b>B-17</b>			

(1) ILLUSTRATION		(2)	(3)	(4)	(5)	(6) DESCRIPTION	(7)	(8)
(a) FIG NO.	(b) ITEM NO.	SMR CODE	NATIONAL STOCK NUMBER	PART NUMBER	FSCM	USABLE ON CODE	U/M	QTY INC IN UNIT
						0302-FUEL PUMP-Continued		
B-17	22	PAHZZ	2910-00-132-0769	BM 70797	15434	GUIDE AND CLIP ASSEMBLY: gov- ernor spring pack	EA	1
B-17	23	PAHZZ	5305-00-506-5722	70716	15434	SCREW, IDLE ADJUSTING: gover- nor spring pack	EA	1
B-17	24	PAHZZ	5360-00-902-8478	147292	15434	SPRING, HELICAL, COMPRESSION: governor spring pack	EA	1
B-17	25	PAHZZ	5365-00-507-3260	70717	15434	SHIM: high speed spring adjusting	EA	V
B-17	25	PAHZZ	5365-00-507-3261	70717A	15434	SHIM: high speed spring adjusting	EA	V
B-17	25	PAHZZ	5365-00-507-3262	70717B	15434	SHIM: high speed spring adjusting	EA	V
B-17	26	PAHZZ	5340-00-898-1497	70713	15434	RETAINER, SPRING: spring pack	EA	1
B-17	27	PAHZZ	5365-00-598-1070	MS16627-93	96906	RING, RETAINING: governor spring pack	EA	1
B-17	28	PAHZZ	5330-00-562-1176	70706	15434	GASKET: spring pack cover to fuel pump	EA	1
B-17	29	PAHZZ	2910-00-858-3522	44678	15434	COVER, SPRING PACK: fuel pump assembly	EA	1
B-17	30	PAHZZ	5310-00-141-1795	AN960-416	88044	WASHER, FLAT: spring pack cover	EA	4
B-17	31	PAHZZ	5310-00-484-1718	181466	15434	WASHER, LOCK: spring pack cover	EA	4
B-17	32	XBHZZ		171552	15434	SCREW, CAP, HEXAGON HEAD: spring pack cover	EA	2
B-17	33	PAHZZ	5340-00-464-7064	124020	15434	WIRE, SEAL: spring packing seal	EA	1
B-17	34	PAHZZ	2910-00-065-5544	124019	15434	SEAL, SPRING PACK	EA	2
B-17	35	PAHZZ	4730-00-369-7824	177999	15434	PLUG, PIPE: spring pack	EA	1
B-17	36	PAHZZ	5305-00-267-8977	MS90726-10	96906	SCREW, CAP, HEXAGON HEAD: spring pack cover	EA	2
B-18	1	PAHZZ	2910-00-369-8240	BM 91679	15434	GOVERNOR AND COVER ASSEM- BLY: fuel pump	EA	1
B-18	2	PAFZZ	5330-00-779-2534	103005	15434	GASKET: mainshaft governor hous- ing to air compressor Part of kit P/N BM 95886	EA	1
B-18	3	PAHZZ	5310-00-562-6557	S 622	15434	WASHER, FLAT: mainshaft hous- ing to air compressor	EA	4
B-18	4	PAHZZ	5310-00-209-0965	MS35338-47	96906	WASHER, LOCK: mainshaft hous- ing to air compressor	EA	4
B-18	5	PAHZZ	5305-00-045-1988	MS90725-87	96906	SCREW CAP, HEXAGON HEAD: mainshaft housing to air compressor	EA	4
B-18	6	PAFZZ	3010-00-507-8347	109859	15434	INSERT, FLEXIBLE NYLON: mainshaft drive coupling	EA	1
B-18	7	PAHZZ	5806-00-019-4227	69793	15434	SCREW, CAP, HEXAGON HEAD: mainshaft drive coupling	EA	3
B-18	8	PAHZZ	5310-00-637-9541	MS35338-46	96906	WASHER, LOCK: mainshaft drive coupling	EA	3
B-18	9	PAHZZ	5310-00-562-6553	S 602	15434	WASHER, FLAT: mainshaft drive coupling	EA	3
B-18	10	PAHZZ	2910-00-695-3285	101918	15434	DRIVER, MAINSHAFT, HALF- HUB: mainshaft to air compressor counterweight driver	EA	1
B-18	11	PAHZZ	5330-00-507-8346	7451	80201	SEAL, OIL, drive shaft Part of set P/N BM 68356	EA	2
B-18	12	PAHZZ	2910-00-773-9369	100192	15434	MAINSHAFT, FUEL PUMP DRIVE	EA	1
B-18	13	PAHZZ	3110-00-144-8499	S 1650	15434	BEARING, BALL, ANNULAR: fuel pump drive mainshaft	EA	1
					<b>B-18</b>			

(1) ILLUSTRATION		(2)	(3)	(4)	(5)	(6) DESCRIPTION	(7)	(8)
(a) FIG NO.	(b) ITEM NO.	SMR CODE	NATIONAL STOCK NUMBER	PART NUMBER	FSCM	USABLE ON CODE	U/M	QTY INC IN UNIT
B-18	14	PAHZZ	2990-00-772-1778	70690	15434	0302-FUEL PUMP-Cont	EA	1
B-18	15	PAHZZ	3020-00-562-1173	103036	15434	RING, RETAINING: ..... mainshaft ball bearing	EA	1
B-18	16	PAHZZ	3040-00-788-2762	100205	15434	GEAR, DRIVE: fuel pump ..... mainshaft	EA	1
B-18	17	PAHZZ	5330-00-506-4866	100764	15434	GEAR, DRIVE: tachometer ..... GASKET: mainshaft housing ..... to fuel pump housing Part of set P/N BM 68356	EA EA	1 1
B-18	18	PAHZZ	5315-00-695-3292	MS20066-116	96906	KEY: governor drive gear.....	EA	1
B-18	19	PAHZZ	2910-00-920-7555	BM 97398	15434	WEIGHT ASSEM-..... BLY, GOVERNOR: fuel control	EA	1
B-18	20	PAHZZ	3120-00-603-2691	157594	15434	WASHER, THRUST: ..... governor counterweights	EA	2
B-18	21	PAHZZ	5360-00-081-8487	143847	15434	SPRING, HELICAL, ..... COMPRESSION: governor weight assist	EA	1
B-18	22	XBHZZ		144179	15434	WASHER, FLAT: ..... governor weight assist shim	EA	1
B-18	23	PAHZZ	5315-00-082-0448	144178	15434	PLUNGER: governor..... weight assist	EA	1
B-18	24	PAHZZ	5315-00-805-1674	70693	15434	PIN, SHOULDER, ..... HEADLESS: governor counterweight Pivot	EA	2
B-18	25	PAHZZ	5315-00-550-7895	108882	15434	PIN, HOLLOW: ..... governor counterweight retaining	EA	2
B-18	26	PAHZZ	2990-00-792-1571	107261	15434	COUNTERWEIGHT: ..... fuel supply governor	EA	2
B-18	27	PAHZZ	2990-00-735-8564	116000	15434	CARRIER, GOVER-..... NOR COUNTER WEIGHTS	EA	1
B-18	28	PAHZZ	3020-00-701-1112	113244	15434	GEAR, GOVERNOR..... DRIVE SHAFT	EA	1
B-18	29	PAHZZ	3120-00-904-9595	163994	15434	BUSHING, SLEEVE:..... governor drive shaft gear	EA	1
B-18	30	XBHZZ		5103-50	15434	RING, RETAINING: ..... governor sleeve bushing	EA	1
B-18	31	PAHZZ	5305-00-269-3210	MS90725-59	96906	SCREW, CAP, HEXAGON HEAD:..... fuel pump bracket to block	EA	2
B-18	32	XBHZZ		164597	15434	BRACKET, SUPPORT, FUEL..... PUMP	EA	1
B-18	33	PAFZZ	5305-00-071-2241	MS90725-10	96906	SCREW, CAP, HEXAGON HEAD:..... mainshaft governor housing to fuel pump	EA	6
B-18	34	PAFZZ	5310-00-562-6552	S 600	15434	WASHER, LOCK: mainshaft..... governor housing to fuel pump	EA	6
B-18	35	PAFZZ	5310-00-141-1795	AN960-416	88044	WASHER, FLAT: mainshaft..... governor housing to fuel pump	EA	6
B-18		PAHZZ	5330-00-888-4988	BM 68356	15434	GASKET SET, FUEL PUMP: diesel..... engine	EA	1
B-15	2					RING, SEALING .....	EA	1
B-15	12					PACKING, PREFORMED .....	EA	1
B-15	42					PACKING, PREFORMED .....	EA	1
B-16	2					GASKET .....	EA	1
B-16	8					GASKET .....	EA	1
B-16	17					PACKING, PREFORMED .....	EA	1
					<b>B-19</b>			

(1) ILLUSTRATION		(2)	(3)	(4)	(5)	(6) DESCRIPTION	(7)	(8)
(a) FIG NO.	(b) ITEM NO.	SMR CODE	NATIONAL STOCK NUMBER	PART NUMBER	FSCM	USABLE ON CODE	U/M	QTY INC IN UNIT
B-16	18					0302-FUEL PUMP-Cont		
B-16	20					WASHER, NONMETALLIC.....	EA	1
B-16	22					PACKING, PREFORMED.....	EA	1
B-17	8					WASHER, NONMETALLIC.....	EA	1
B-17	11					PACKING, PREFORMED.....	EA	1
B-17	17					PACKING.....	EA	1
B-17	32					PACKING, PREFORMED.....	EA	1
B-18	11					GASKET.....	EA	1
B-18	17					SEAL.....	EA	1
B-27	4					GASKET.....	EA	1
B-27	5					GASKET.....	EA	1
0302	-	PAHZZ	5330-00-580-5327	8060396	19207	PACKING WITH RETAINER.....	EA	1
0302	-	PAHZZ	5330-00-664-1055	70415	15434	PACKING, PREFORMED.....	EA	1
B-19	1	PAOZZ	5305-00-269-3214	MS90725-64	96906	0304-AIR CLEANER SCREW, CAP, HEXAGON HEAD:.....	EA	7
B-19	2	XBOZZ		159085	56232	right bank air intake CONNECTION, AIR INTAKE: right.....	EA	1
B-19	3	PAOZZ	5310-00-562-6553	S 602	15434	bank WASHER, FLAT: air intake.....	EA	13
B-19	4	PAOZZ	5310-00-637-9541	MS35338-46	96906	WASHER, LOCK: air intake.....	EA	13
B-19	5	PAOZZ	5305-00-269-3221	MS90725-71	96906	SCREW, CAP, HEXAGON HEAD:.....	EA	1
B-19	6	PAOZZ	4730-00-877-6298	43828	15434	right bank air intake CLAMP, HOSE: air intake.....	EA	2
B-19	7	PAOZZ	4720-00-458-8079	155790	15434	HOSE, NONMETALLIC: air intake.....	EA	1
B-19	8	XBOZZ		175285	15434	CONNECTION, AIR CLEANER.....	EA	1
B-19	9	PAOZZ	5305-00-735-8098	S 163D	15434	ASSEMBLY: air intake SCREW, CAP, HEXAGON HEAD:.....	EA	1
B-19	10	PAOZZ	5305-00-269-3213	MS90725-62	96906	air cleaner assembly SCREW, CAP, HEXAGON HEAD:.....	EA	4
B-19	11	PAOZZ	5330-00-903-7701	156659	15434	air cleaner assembly GASKET: air cleaner assembly part.....	EA	1
B-19	12	XBOZZ		175284	15434	of set P/N BM 96854 CONNECTION, AIR INTAKE.....	EA	1
B-19	13	PAOZZ	5310-00-621-8595	S 223	15434	NUT: air intake assembly.....	EA	1
B-19	14	PAOZZ	4730-00-289-0212	125740	15434	CLAMP, HOSE: intake manifold.....	EA	2
B-19	15	PAOZZ	4720-00-731-8248	69996	15434	connection HOSE, INTAKE: manifold.....	EA	1
B-19	16	PAOZZ	4730-00-716-6580	68606	15434	connection PLUG, PIPE: right intake manifold.....	EA	1
B-20	1	PAOZZ	4730-00-019-4242	68139	15434	0311-STARTING AIDS ELBOW, PIPE: pre-heater adapter.....	EA	1
B-20	2	PAOZZ	4730-00-803-9527	125880	15434	ADAPTER: pre-heater adapter.....	EA	1
B-20	3	PAOZZ	5330-00-970-3461	68061-A	15434	SEAL, PREFORMED: pre-heater adapter.....	EA	1
B-20	4	PAOZZ	5315-00-758-0366	43468	15434	PIN, TYPE 4 groove: pre-heater.....	EA	1
B-20	5	PAOZZ	5310-00-393-6475	68178-1	15434	WASHER, KEY: pre-heater nozzle.....	EA	1
B-20	6	PAOZZ	2815-00-506-5720	69215	15434	NOZZLE: pre-heater.....	EA	1
B-20	7	PAOZZ	5365-00-197-9327	67946	15434	SPACER, RING: pre-heater Part of.....	EA	1
B-20	8	PAOZZ	2920-00-506-5719	68812	15434	kit P/N BM 95886 PLUG, GLOW: pre-heater.....	EA	1
B-20	9	PAOZZ	5310-00-682-5944	118273	15434	WASHER, FLAT: glow plug.....	EA	1
B-20	10	PAOZZ	4730-00-716-6580	68606	15434	PLUG, PIPE: air heater.....	EA	1
					<b>B-20</b>			

(1) ILLUSTRATION		(2)	(3)	(4)	(5)	(6) DESCRIPTION	(7)	(8)
(a) FIG NO.	(b) ITEM NO.	SMR CODE	NATIONAL STOCK NUMBER	PART NUMBER	FSCM	USABLE ON CODE	U/M	QTY INC IN UNIT
B-21	1	XBOZZ		BM 94658	15434	GROUP 05-COOLING SYSTEM 0503-THERMOSTAT CONNECTION, WATER CROSS- .....	EA	1
B-21	2	PAOZZ	4730-00-877-6298	43828	15434	OVER: right bank CLAMP, HOSE .....	EA	2
B-21	3	PAOZZ	3805-00-607-7652	69969	15434	HOSE, WATER CONNECTION, .....	EA	1
B-21	4	XBOZZ		181355	15434	CROSSOVER PIPE CONNECTION, WATER: left bank .....	EA	1
B-21	5	PAOZZ	5310-00-637-9541	MS35338-46	96906	WASHER, LOCK .....	EA	14
B-21	6	PAOZZ	5305-00-269-3214	MS90725-64	96906	SCREW, CAP, HEXAGON HEAD: .....	EA	8
B-21	7	PAOZZ	5330-00-255-0331	9221	15434	GASKET: water connection Part of .....	EA	2
B-21	8	PAOZZ	5330-00-918-9646	140514	15434	kit P/N BM 95886 GASKET: thermostat housing Part of .....	EA	1
B-21	9	XBOZZ		157647	15434	set P/N BM 96854 HOUSING, THERMOSTAT .....	EA	1
B-21	10	PAOZZ	5305-00-269-3213	MS90725-62	96906	SCREW, CAP, HEXAGON HEAD: .....	EA	2
B-21	11	PAOZZ	5305-00-269-3220	MS90725-70	96906	thermostat housing SCREW, CAP, HEXAGON HEAD: .....	EA	2
B-21	12	PAOZZ	4730-00-801-8186	S 915A	15434	thermostat housing PLUG, PIPE: thermostat housing .....	EA	2
B-21	13	PAOZZ	6685-00-814-5271	MS24537-1	96906	TRANSMITTER, TEMPERATURE: .....	EA	1
B-21	14	PAOZZ	6620-00-062-4404	VD-103118-173	19207	thermostat THERMOSTAT .....	EA	1
B-21	15	PAOZZ	5330-00-086-8294	140329	15434	GASKET: thermostat housing cover .....	EA	1
B-21	16	XBOZZ		147729	15434	Part of set P/N BM 96854 COVER, THERMOSTAT HOUSING .....	EA	1
B-21	17	PAOZZ	5310-00-562-6553	S 602	15434	WASHER, FLAT: thermostat .....	EA	2
B-21	18	PAOZZ	5305-00-269-3211	MS90725-68	96906	SCREW, CAP, HEXAGON HEAD: .....	EA	2
B-22	1	XBOZZ		187609	15434	thermostat housing SCREW, CAP, HEXAGON HEAD: .....	EA	3
B-22	2	PAOZZ	5310-00-562-6552	S 600	15434	half fixed Pulley WASHER, PULLEY: half fixed pulley .....	EA	3
B-22	3	PAOZZ	2930-00-907-8963	175209	15434	PULLEY, HALF FIXED, WATER .....	EA	1
B-22	4	PAOZZ	2930-00-907-8962	175208	15434	PUMP: front PULLEY, HALF ADJUSTABLE, .....	EA	1
B-22	5	PAOFF	2930-00-908-7311	BM 940607	15434	WATER PUMP: back PUMP ASSEMBLY, WATER .....	EA	1
B-22	6	PAFZZ	2930-00-914-0992	163785	15434	SEAL: water pump Part of kit P/N .....	EA	1
B-22	7	XBFZZ		70183	76680	BM 95886 RETAINER, BEARING: water pump .....	EA	1
B-22	8	PAFZZ	3110-00-829-2049	69866	15434	BEARING, BALL, ANNULAR: water .....	EA	1
B-22	9	PAFZZ	3120-00-810-7040	154639	15434	pump WASHER, THRUST: water pump .....	EA	1
B-22	10	XBFZZ		S 16237	15434	RING, SNAP: shouldered shaft .....	EA	1
B-22	11	PAFZZ	3110-00-082-1877	154577	15434	BEARING, BALL, ANNULAR: .....	EA	1
B-22	12	PAFZZ	2930-00-903-7696	159329	15434	water pump SHAFT, SHOULDERED: water pump .....	EA	1
B-22	13	PAFZZ	4730-00-289-4770	S 995	15434	PLUG, PIPE: water pump .....	EA	1
B-22	14	XAFZZ		175206	15434	BODY, WATER PUMP .....	EA	1
B-22	15	PAFZZ	4320-00-994-4408	144306	15434	SEAL ASSEMBLY, PLAIN: water .....	EA	1
B-22	16	PAFZZ	5970-00-086-7709	13509	15434	pump SEAT, CERAMIC: water pump .....	EA	1
B-22	17	XAFZZ		143913	15434	ADHESIVE BANDING .....	EA	1
					<b>B-21</b>			

(1) ILLUSTRATION		(2)	(3)	(4)	(5)	(6)	(7)	(8)
(a) FIG NO.	(b) ITEM NO.	SMR CODE	NATIONAL STOCK NUMBER	PART NUMBER	FSCM	DESCRIPTION  USABLE ON CODE	U/M	QTY INC IN UNIT
B-22	18	PAFZZ	2930-00-908-7315	BM 76114	15434	0504-WATER PUMP-Continued	EA	1
B-22	19	PAOZZ	5310-00-637-9541	MS35338-46	96906	IMPELLER ASSEMBLY: water pump.....	EA	5
B-22	20	PAOZZ	5305-00-269-3213	MS90725-62	96906	WASHER, LOCK: water Pump body.....	EA	1
B-22	21	PAOZZ	4730-00-801-8186	S 915A	15434	SCREW, CAP, HEXAGON HEAD:.....	EA	1
B-22	22	PAOZZ	2930-00-085-7421	154358	15434	water pump body PLUG, PIPE: water pump body.....	EA	1
B-22		PAOZZ	3030-00-722-2095	69976	15434	GASKET: water pump to block Part of kit P/N BM 95886	EA	1
B-23	1	PAOZZ	5305-00-269-3217	MS90725-67	96906	BELTS, MATCHED SET: water pump.....	EA	1
B-23	2	PAOZZ	5310-00-637-9541	MIS35338-46	96906	0505-FAN ASSEMBLY	EA	6
B-23	3	PAOZZ	2930-00-904-9585	113608	15434	SCREW, CAP, HEXAGON HEAD:.....	EA	6
B-23	4	XBFZZ		152237	15434	fan to Pulley	EA	1
B-23	5	PAFZZ	5330-00-973-0040	143108	15434	WASHER, LOCK: fan to pulley .....	EA	1
B-23	6	PAFZZ	5310-00-062-9556	146650	15434	IMPELLER, FAN AXIAL.....	EA	1
B-23	7	PAFZZ	5310-00-062-9557	146651	15434	SPACER, PILOT: fan idler pulley .....	EA	1
B-23	8	PAFZZ	3110-00-100-3161	99045-53	15434	GASKET: fan pilot spacer Part of kit P/N BM 95886	EA	1
B-23	9	PAFZZ	3110-00-198-2170	15245	60038	NUT: idler shaft.....	EA	1
B-23	10	XBFZZ		175203	15434	WASHER, FLAT, KEY: clamp washer .....	EA	1
B-23	11	PAFZZ	5330-00-551-4007	106276	15434	CONE AND ROLLERS, TAPERED.....	EA	2
B-23	12	PAFZZ	2930-00-914-6042	175204	15434	ROLLER BEARING: front and rear	EA	2
B-23	13	XBFZZ		175205	15434	CUP, TAPERED ROLLER BEAR:.....	EA	2
B-23	14	XBFZZ		173061	15434	idler pulley front and rear	EA	1
B-23	15	PAFZZ	5306-00-912-9105	9948	15434	PULLEY, FAN, HUB .....	EA	1
B-23	16	PAFZZ	5305--00-426-3023	S 131C	15434	SEAL, OIL: fan hub Part of kit P/N BM 95886	EA	1
B-23	17	PAFZZ	5310-00-209-0965	MS35338-47	96906	SHAFT, IDLER: fan hub.....	EA	1
B-23	18	PAFZZ	5310-00-753-4099	67532	15434	WASHER: idler shaft .....	EA	2
B-23	19	PAOZZ	3030-00 -918-9644	BM 96103	15434	BRACKET, FAN.....	EA	1
B-24	1	PAOZZ	3030-00-918-0605	BM 96101	15434	BOLT, MACHINE .....	EA	1
B-24	2	XBOZZ		60136	35510	SCREW, CAP, HEXAGON HEAD:.....	EA	6
B-24	3	PAOZZ	5310-00-920-0831	22082	35510	fan bracket	EA	6
B-24	4	PAOZZ	3020-00-905-4420	173058	15434	WASHER, LOCK: fan bracket.....	EA	1
B-24	5	PAOZZ	5305-00-269-3210	MS90725-59	96906	NUT, SELF-LOCKING: idler shaft.....	EA	1
B-24	6	PAOZZ	5310-00-637-9541	MS35338-46	96906	SCREW, CAP, HEXAGON HEAD:.....	EA	2
B-24	7	PAOZZ	5310-00-562-6553	S 602	15434	adjusting link	EA	8
B-24	8	PAOZZ	2920-00-933-2563	121037	15434	WASHER, FLAT: adjusting link.....	EA	8
B-24	9	PAOFF	2920-00-909-2483	10929868	19207	WASHER, FLAT: adjusting link.....	EA	1
B-24	10	PAOZZ	5305-00-269-3214	MS90725-64	96906	LINK, ADJUSTING: generator.....	EA	1
B-24	11	XBOZZ		170629	15434	GENERATOR: model 3002AA, Leece- Neville, 28 volts	EA	1
					<b>B-22</b>	SCREW, CAP, HEXAGON HEAD:.....	EA	6
						generator mounting	EA	1
						BRACKET, GENERATOR .....	EA	1

(1) ILLUSTRATION		(2)	(3)	(4)	(5)	(6) DESCRIPTION	(7)	(8)
(a) FIG NO.	(b) ITEM NO.	SMR CODE	NATIONAL STOCK NUMBER	PART NUMBER	FSCM	USABLE ON CODE	U/M	QTY INC IN UNIT
B24.1	1	PAOFF	2920-00-785-0833	MS53011-1	96906	0603-STARTING MOTOR CRANKING MOTOR ASSEMBLY:.....	EA	1
B24.1	2	PAOZZ	2920-00-807-2408	1119849	19207	Leece-Neville RELAY SOLENOID: starter assem- .....	EA	1
B24.1	3	PAOZZ	5330-00-909-2490	114123	15434	GASKET: starter mounting .....	EA	1
B24.1	4	PAOZZ	5305-00-911-1862	153581	15434	SCREW, CAP, HEXAGON HEAD:.....	EA	3
B24.1	-	PAOZZ	5330-00-199-5886	119116	15434	starter mounting WASHER, SELF-SEALING: starter .....	EA	3
B-25	1	PAFHH	2530-00-919-6460	BB 75284	15434	GROUP 12-BRAKES 1209-AIR COMPRESSOR AND DRIVE MECHANISM COMPRESSION, AIR .....	EA	1
B-25	2	PAFZZ	2910-00-084-7785	139845	15434	GASKET: compressor flange to fly- .....	EA	1
B-25	3	PAFZZ	3805-00-445-0607	130081	15434	wheel Part of kit P/N BM 95886 WASHER, THRUST: accessory drive .....	EA	1
B-25	4	PAFZZ	3020-00-903-9535	150139	15434	spur gear GEAR, SPUR: accessory drive .....	EA	1
B-25	5	PAFZZ	3120-00-445-0606	130080	15434	WASHER, THRUST: accessory drive .....	EA	1
B-25	6	PAFZZ	2910-00-062-9564	144800	15434	to compressor support cover BUSHING, SLEEVE: compressor sup- .....	EA	1
B-25	7	PAFZZ	5330-00-445-0609	117077	15434	port cover GASKET: support cover Part of kit.....	EA	1
B-25	8	XBOFF		139915	15434	P/N BM 95886 COVER, COMPRESSOR SUPPORT .....	EA	1
B-25	9	PAFZZ	5310-00-637-9541	MS35338-46	96906	WASHER, LOCK: support cover.....	EA	6
B-25	10	PAFZZ	5305-00-269-3221	MS90727-71	96906	SCREW, CAP, HEXAGON HEAD:.....	EA	6
B-25	-	PAHZZ	3805-00-441-0145	128086	15434	support cover PACKING, PREFORMED: compressor.....	EA	1
B-25	-	PAHZZ	5330-00-821-9162	128087	15434	exhaust PACKING, PREFORMED: compressor.....	EA	1
B-25	-	PAHZZ	5330-00-822-3954	127950	15434	unloader GASKET: compressor air connection.....	EA	1
B-25	-	PAHZZ	5330-00-905-2679	128085	15434	PACKING, PREFORMED: compressor.....	EA	1
B-26	1	PAOZZ	3030-00-288-1338	MS51069-44	96906	GROUP 14-STEERING 1410-HYDRAULIC PUMP ASSEMBLY BELT, PUMP DRIVE.....	EA	1
B-26	2	XBOZZ		10945942	19207	NUT, PUMP PULLEY .....	EA	1
B-26	3	PAOZZ	3020-00-138-8081	11649251	19207	PULLEY, PUMP, GROOVED.....	EA	1
B-26	4	XBOZZ		11659874	19207	BRACKET, PUMP MOUNTING .....	EA	1
B-26	5	PAOZZ	2530-00-768-7663	11602730	19207	PUMP, HYDRAULIC.....	EA	1
B-26	6	XBOZZ		AN816-16-12E	88044	NIPPLE, PUMP INLET.....	EA	1
B-26	7	PAOZZ	4730-00-363-7007	11649253	19207	ELBOW, PUMP INLET .....	EA	1
B-26	8	PAOZZ	4730-00-231-3908	AN915-6	88044	ELBOW, PUMP OUTLET .....	EA	1
B-26	9	XBOZZ		144042	21450	BUSHING, PIPE: inlet.....	EA	1
B-26	10	PAOZZ	4730-00-927-7272	MS39158-9	96906	ADAPTER, PUMP: outlet .....	EA	1
B-26	11	PAOZZ	5305-00-269-2804	MS90726-61	96906	SCREW, CAP, HEXAGON HEAD:.....	EA	2
B-26	12	PAOZZ	5310-00-637-9541	MS35338-46	96906	pump WASHER, LOCK: Pump .....	EA	3
B-26	13	PAOZZ	5310-00-809-4085	MS27183-16	96906	WASHER, FLAT: mounting bracket .....	EA	2
					<b>B-23</b>			

(1) ILLUSTRATION		(2)	(3)	(4)	(5)	(6) DESCRIPTION	(7)	(8)
(a) FIG NO.	(b) ITEM NO.	SMR CODE	NATIONAL STOCK NUMBER	PART NUMBER	FSCM	USABLE ON CODE	U/M	QTY INC IN UNIT
B-26	14	PAOZZ	5305-00-269-2800	MS90726-57	96906	1410-HYDRAULIC PUMP ASSEMBLY-Continued		
B-26	15	PAOZZ	5310-00-080-6004	MS27183-14	96906	SCREW, CAP, HEXAGON HEAD:.....	EA	1
B-26	-	PAOZZ	5315-00-616-5525	MS35756-9	96906	mounting bracket	EA	1
						WASHER, FLAT: mounting bracket .....	EA	1
						KEY: Pump shaft .....	EA	1
						GROUP 33-SPECIAL PURPOSE KITS		
						3301-REUSABLE SHIPPING CONTAINERS		
B-1	7	PAFDL	8145-00-912-4617	10944664	19207	CONTAINER, SHIPPING AND STOR- .....	EA	1
B-1	8	XAFDL		10924731	19207	AGE: V8-300 diesel engine	EA	1
B-1	9	PAFZZ	6685-00-906-0156	83565883	19207	CONTAINER, UPPER: shipping .....	EA	1
B-1	10	PAFZZ	4820-00-620-8128	8876456	19207	INDICATOR: humidity .....	EA	1
B-1	11	PAFZZ	4820-00-242-4064	8876442	19207	VALVE ASSEMBLY: air relief .....	EA	1
						VALVE, TANK ASSEMBLY: air .....	EA	1
						filling		
B-1	12	PAFZZ	5310-00-763-8920	MS51967-20	96906	NUT, HEXAGON: shipping con-.....	EA	42
						tainer		
B-1	13	PAFZZ	5310-00-232-8194	MS35338-50	96906	WASHER, LOCK: shipping con- .....	EA	42
						tainer		
B-1	14	XBFZZ		10926305	19207	PACKING, PREFORMED: shipping .....	EA	1
						container		
B-1	15	PAFZZ	5305-00-724-5911	MS90725-163	96906	SCREW, CAP, HEXAGON HEAD:.....	EA	42
						shipping container		
B-1	16	XAFDL		10924730	19207	CONTAINER, LOWER: shipping .....	EA	1
						GROUP 47-GAGES (NON-ELECTRICAL)		
						4701-TACHOMETER		
B-27	1	PAOZZ	4730-00-908-6335	155445	15434	ADAPTER, CABLE DRIVE: tacho-.....	EA	1
						meter		
B-27	2	PAOZZ	5340-00-377-3070	9052-1	15434	CAP,TACHOMETER: adapter.....	EA	1
B-27	3	PAFZZ	5305-00-622-9483	MS35265-81	96906	SCREW, SLOTTED HEAD: tacho- .....	EA	2
						meter housing		
B-27	4	PAOZZ	5330-00-591-8519	70732	15434	GASKET: tachometer, housing Part.....	EA	1
						of set P/N BM 68856		
B-27	5	PAOZZ	5330-00-641-1149	70809	15434	SEAL, TACHOMETER: drive shaft .....	EA	1
						Part of set P/N BM 68356		
B-27	6	PAHZZ	2910-00-905-0038	174421	15434	SHAFT, SHOULDERED: tachometer.....	EA	1
						drive		
B-27	7	PAHZZ	3120-00-507-3264	70723	15434	BUSHING, SLEEVE: tachometer .....	EA	1
B-27	8	PAHZZ	3020-00-790-3417	70720	15434	GEAR, HELICAL: tachometer drive .....	EA	1
						follower		
					<b>B-24</b>			



Section III. SPECIAL TOOLS, TEST AND SUPPORT EQUIPMENT

(1) ILLUSTRATION		(2)	(3)	(4)	(5)	(6) DESCRIPTION	(7)	(8)
(a) FIG NO.	(b) ITEM NO.	SMR CODE	NATIONAL STOCK NUMBER	PART NUMBER	FSCM	USABLE ON CODE	U/M	QTY INC IN UNIT
						GROUP 26-TOOLS AND TEST EQUIPMENT		
B-28	1	PAHZZ	4910-00-977-7605	11600040	19207	2604-SPECIAL TOOLS PLATE, MOUNTING, FUEL .....	EA	1
B-28	2	PAHZZ	4910-00-999-1506	11600028	19207	PUMP: used with vise BOI: 1 auth for 1-20 equip	EA	1
B-28	3	PAHZZ	4910-00-977-7516	11600037	19207	VISE, BALL JOINT: holding, fuel .....	EA	1
B-28	4	PAHZZ	3460-00-999-1210	11600069	19207	pump BOI: 1 auth for 1-20 equip BLOW-BY CHECKING TOOL: .....	EA	1
B-28	5	PAFZZ	4910-00-977-7511	11600066	19207	crankcase pressure BOI: 1 auth for 1-20 equip MANDREL, ROD LOCATING: used .....	EA	1
B-28	6	PAFZZ	5110-00-981-3106	ST 955	15434	with fixture P/N ST 561 BOI: 1 auth for 1-20 Equip	EA	1
B-28	7	PAHZZ	5120-00-963-9665	11600077	19207	BALL, SEATING TOOL .....	EA	1
B-28	8	PAHZZ	5120-00-953-9664	11600076	19207	INJECTOR BOI: 1 auth for 1-20 equip	EA	1
B-28	9	PAFZZ	4910-00-999-1503	11600060	19207	CUTTER, BALL SEAT: injector .....	EA	1
B-28	10	PAHZZ	5120-00-999-1262	11600073	19207	body BOI: 1 auth for 1-20 equip MANDREL: used with driver P/N .....	EA	1
B-28	11	PAHZZ	5120-00-999-1263	11600075	19207	11600076 BOI: 1 auth for 1-20 Equip DRIVER: install/remove camshaft .....	EA	1
B-28	12	PAFZZ	4910-00-999-1269	11600082	19207	bushings BOI: 1 auth for 1-20 equip BURNISHER, ADJUSTABLE: .....	EA	1
B-28	13	PAFZZ	5130-00-999-1268	11600049	19207	burnish injector orifice BOI: 1 auth for 1-20 equip	EA	1
B-28	14	PAFZZ	5120-00-981-3108	11600050	19207	PULLER, MECHANICAL: remove .....	EA	1
B-28	15	PAFZZ	5120-00-620-6222	ST 384	15434	cylinder sleeve BOI: 1 auth for 1-20 equip	EA	1
B-28	16	PAFZZ	4910-00-977-7529	ST 772	16434	PLATE, PULLER: used with puller .....	EA	1
B-28	17	PAFZZ	4910-00-981-3105	11600086	19207	P/N 11600073 BOI: 1 auth for 1-20 equip	EA	1
B-28	18	PAHZZ	5120-00-981-3115	11600063	19207	FIXTURE, TIMING: injector BOI: 1 .....	EA	1
B-28	19	PAFZZ	5120-00-977-7528	11600093	19207	auth for 1-20 Equip EXPANDER, SLEEVE: seal injector .....	EA	1
B-28	20	PAHZZ	3460-00-999-1259	11600079	19207	sleeve BOI: 1 auth for 1-20 equip DRIVER: install injector sleeve BOI: .....	EA	1
B-28	21	PAHZZ	3460-00-999-1257	11600070-1	19207	1 auth for 1-20 equip HOLDING TOOL, INJECTOR BOI: .....	EA	1
B-28	22	PAHZZ	3460-00-999-1258	11600070-2	19207	1 auth for 1-20 equip ROLLING TOOL, INJECTOR .....	EA	1
						SLEEVE BOI: 1 auth for 1-20 equip CUTTER, INJECTOR SLEEVE .....	EA	1
						BOI: 1 auth for 1-20 equip BAR, CHECKING: main bearing .....	EA	1
						bore alinement BOI: 1 auth for 1-20 equip	EA	1
						PULLER, MECHANICAL: injector .....	EA	1
						sleeve BOI: 1 auth for 1-20 equip MANDREL, CRANK PIN: used with .....	EA	1
						fixture P/N ST 561 BOI: 1 auth for 1-20 equip	EA	1
						MANDREL, ROD LOCATING: used .....	EA	1
						with fixture P/N ST 561 BOI: 1 auth for 1-20 equip	EA	1
						MANDREL, ROD LOCATING: used .....	EA	1
						with fixture P/N ST 561 BOI: 1 auth for 1-20 equip	EA	1
					<b>B-25</b>			

(1) ILLUSTRATION		(2)	(3)	(4)	(5)	(6) DESCRIPTION	(7)	(8)
(a) FIG NO.	(b) ITEM NO.	SMR CODE	NATIONAL STOCK NUMBER	PART NUMBER	FSCM	USABLE ON CODE	U/M	QTY INC IN UNIT
B-28	23	PAFZZ	4910-00-202-9488	11600068	19207	2604-SPECIAL TOOLS-Cont ADAPTER, INJECTOR: used with .....	EA	1
B-28	24	PAFZZ	5210-00-690-7949	11600041	19207	test stand P/N J8686-Model B BOI: 1 auth for 1-20 equip	EA	1
B-28	25	PAHZZ	4920-00-711-9307	11600047	19207	GAGE, PROTRUSION: to check .....	EA	1
B-28	26	PAFZZ	4910-00-977-7510	11600046	19207	cylinder sleeve protrusion BOI: 1 auth for 1-20 equip	EA	1
B-28	27	PAFZZ	4910-00-977-7506	11600042	19207	FIXTURE, CYLINDER HEAD BOI:.....	EA	1
B-28	28	PAHZZ	5120-00-999-1504	11600061	19207	1 auth for 1-20 equip	EA	1
B-28	29	PAFZZ	5120-00-364-5417	11600045	19207	PLATE, ADAPTER: used with.....	EA	1
B-28	30	PAFZZ	5120-00-980-7346	11600051	19207	engine stand P/N 11600042 BOI: 1 auth for 1-20 equip	EA	1
B-28	31	PAHZZ	5120-00-999-1206	11600048	19207	STAND, MAINTENANCE: to .....	EA	1
B-28	32	PAHZZ	5120-00-999-1497	11600088	19207	mount engine for rebuild BOI: 1 auth for 1-20 equip	EA	1
B-28	33	PAHZZ	4910-00-999-1499	11600092	19207	PULLER, MECHANICAL: remove.....	EA	1
B-28	34	PAHZZ	4910-00-499-5428	ST 112	15434	fuel pump BOI: 1 auth for 1-20 equip	EA	1
B-28	35	PAHZZ	5120-00-896-8097	11600031	19207	FIXTURE ASSEMBLY, .....	EA	1
B-28	36	PAFZZ	4910-00-999-1500	11600071	19207	INJECTOR: holding injector BOI: 1 auth for 1-20 equip	EA	1
B-28	37	PAHZZ	5120-00-999-1505	11600081	19207	WRENCH, CUP: remove and install .....	EA	1
B-28	38	PAHZZ	5120-00-999-1267	11600090	19207	injector cup BOI: 1 auth for 1-20 equip	EA	1
B-28	39	PAFZZ	5120-00-896-8088	11600033	19207	DRIVER, LINER: install cylinder.....	EA	1
B-28	40	PAHZZ	4910-00-977-7507	ST 561	15434	sleeve BOI: 1 auth for 1-20 equip	EA	1
B-28	41	PAHZZ	4910-00-346-3708	11600027	19207	TOOL, IDLE ADJUSTING BOI: 1 .....	EA	1
B-28	42	PAHZZ	5110-00-981-3107	ST 490	15434	auth for 1-20 equip	EA	1
B-28	43	PAHZZ	5120-00-981-3110	11600065	19207	TOOL, CYLINDER HEAD: to .....	EA	1
B-28	44	PAHZZ	5120-00-999-1207	11600087	19207	groove cylinder head BOI: 1 auth for 1-20 equip	EA	1
B-28	45	PAFZZ	4910-00-977-7489	11600084	19207	ATTACHMENT, INDICATOR:.....	EA	1
					<b>B-26</b>	cylinder block attachment BOI: 1 auth for 1-20 equip	EA	1
						FRONT SEAL ASSEMBLY TOOL:.....	EA	1
						install pump cover oil seal BOI: 1 auth for 1-20 equip	EA	1
						MASTER INJECTOR: calibrate test .....	EA	1
						stand BOI: 1 auth for 1-20 equip	EA	1
						INSTALLING TOOL, TUBE: install.....	EA	1
						O-ring on throttle shaft BOI: 1 auth for 1-20 equip	EA	1
						REPLACER: remove and install.....	EA	1
						front crankshaft oil seal BOI: 1 auth for 1-20 equip	EA	1
						O-RING ASSEMBLY TOOL: install .....	EA	1
						injector cup O-ring BOI: 1 auth for 1- 20 equip	EA	1
						FIXTURE, CONNECTING ROD:.....	EA	1
						rod holder BOI: 1 auth for 1-20 equip	EA	1
						INSERT KIT, VALVE SEAT BOI: 1 .....	EA	1
						auth for 1-20 equip	EA	1
						REAMER, FIXTURE: fuel pump.....	EA	1
						main shaft bushing BOI: 1 auth for 1-20 equip	EA	1
						PULLER, CROSSHEAD GUIDE .....	EA	1
						BOI: 1 auth for 1-20 equip	EA	1
						COMPRESSOR, VALVE SPRING .....	EA	1
						BOI: 1 auth for 1-20 equip	EA	1
						FIXTURE, LIFTING HEAD: .....	EA	1
						cylinder head removal BOI: 1 auth for 1-20 equip	EA	1

(1) ILLUSTRATION		(2)	(3)	(4)	(5)	(6) DESCRIPTION	(7)	(8)
(a) FIG NO.	(b) ITEM NO.	SMR CODE	NATIONAL STOCK NUMBER	PART NUMBER	FSCM	USABLE ON CODE	U/M	QTY INC IN UNIT
B-28	46	PAHZZ	4910-00-977-7519	11600085	19207	2604-SPECIAL TOOLS-Cont BLOCK AND MANDREL: rod.....	EA	1
B-28	47	PAHZZ	5340-00-951-0773	ST 712	15434	bushing removal BOI: 1 auth for 1-20 equip SPACER, SLEEVE: set crosshead .....	EA	1
B-28	48	PAHZZ	3460-00-999-1173	11600054	19207	guide height BOI: 1 auth for 1-20 equip MANDREL SET, VALVE GUIDE:.....	EA	1
B-28	49	PAHZZ	5120-00-981-3109	11600057	19207	used with kit P/N 11600027 BOI: 1 auth for 1-20 equip DRIVER, VALVE GUIDE: install .....	EA	1
B-28	50	PAHZZ	5220-00-981-7010	11600065	19207	valve guides BOI: 1 auth for 1-20 equip GAGE, PLUG: measure piston pin.....	EA	1
B-28	51	PAHZZ	5133-00-999-1208	11600053	19207	bushing size BOI: 1 auth for 1-20 equip CUTTER SET, COUNTERBORE:.....	EA	1
B-28	52	PAHZZ	5210-00-999-1209	11600043	19207	used with kit P/N 11600027 BOI: 1 auth for 1-20 equip GAGE: groove wear: piston ring.....	EA	1
B-29	1	PAHZZ	4910-00-999-1502	11600078	19207	groove BOI: 1 auth for 1-20 equip  2606-TEST EQUIPMENT LOAD INDICATOR ASSEMBLY: .....	EA	1
B-29	2	PAHZZ	4910-00-999-1496	11600039	19207	used with test stand P/N J8686- Model B BOI: 1 auth for 1-20 equip TESTER, FUEL FLOW BOI: 1 auth .....	EA	1
B-29	3	PAHZZ	6685-00-78-9004	ST 435	15434	for 1-20 equip GAGE, PRESSURE, DIAL .....	EA	1
B-29	4	PAHZZ	4910-00-898-0645	ST 417	15434	INDICATING BOI: 1 auth for 1-20 equip TESTER, VALVE SEATING BOI: 1 .....	EA	1
B-29	5	PAFDL	4910-00-202-9465	J8686-MODEL B	33287	auth for 1-20 equip STAND, INJECTOR TEST BOI: 1.....	EA	1
B-29	6	PAFZZ	4910-00-999-1501	1600056	19207	auth for 1-20 equip TESTER, INJECTOR CUP: used.....	EA	1
B-29	7	PAHDL	4910-00-817-7431	1020200	19204	with test stand P/N J8686-Model B BOI: 1 auth for 1-20 equip STAND, FUEL PUMP TEST BOI: 1 .....	EA	1
B-29	8	PAHDL	4910-00-763-7495	1020519	19204	auth for 1-20 equip TEST PANEL: used with test stand.....	EA	1
						P/N 11020200 BOI: 1 auth for 1-20 equip		

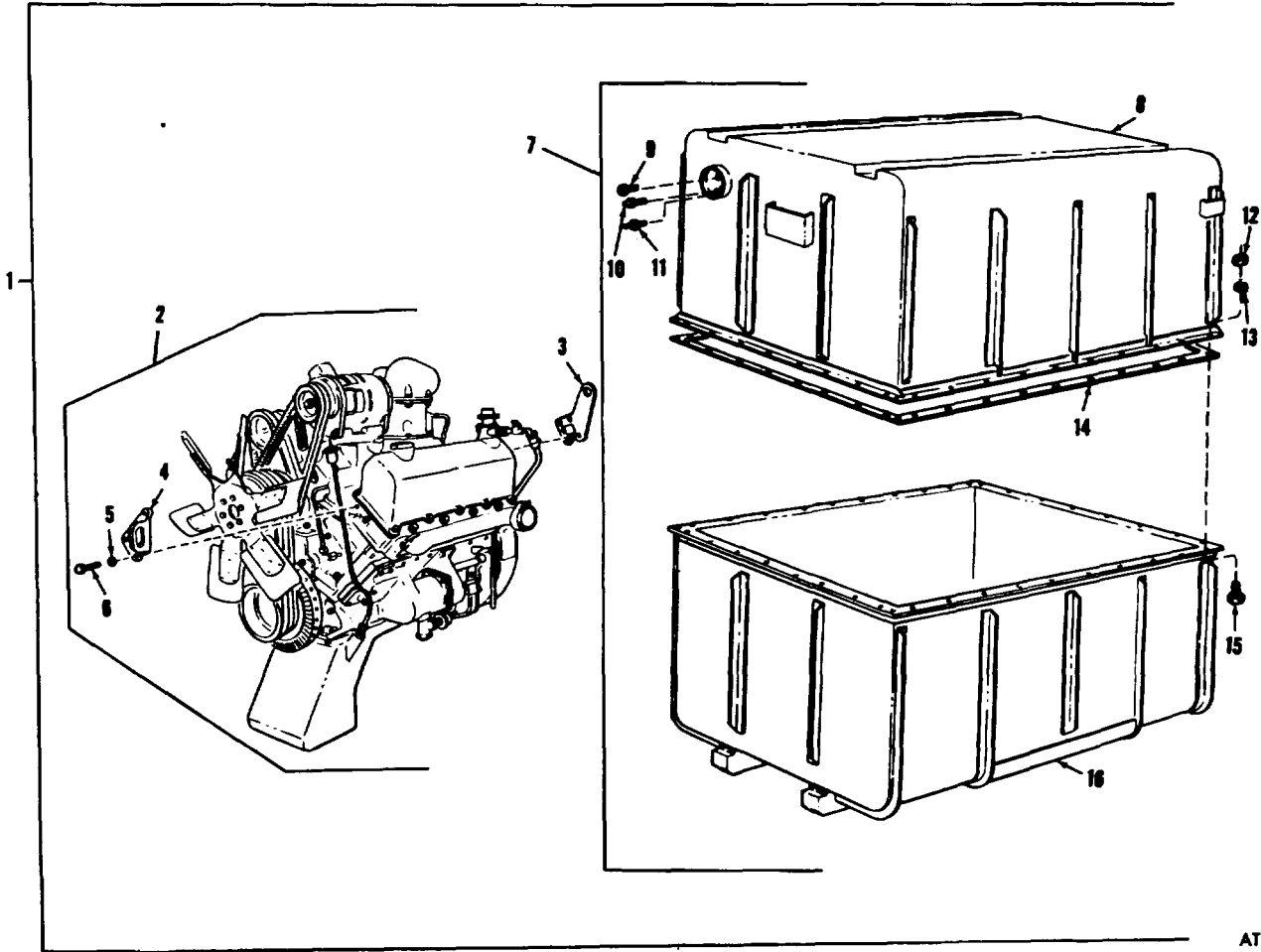

AT 40277

Figure B-1. Engine and container assembly.

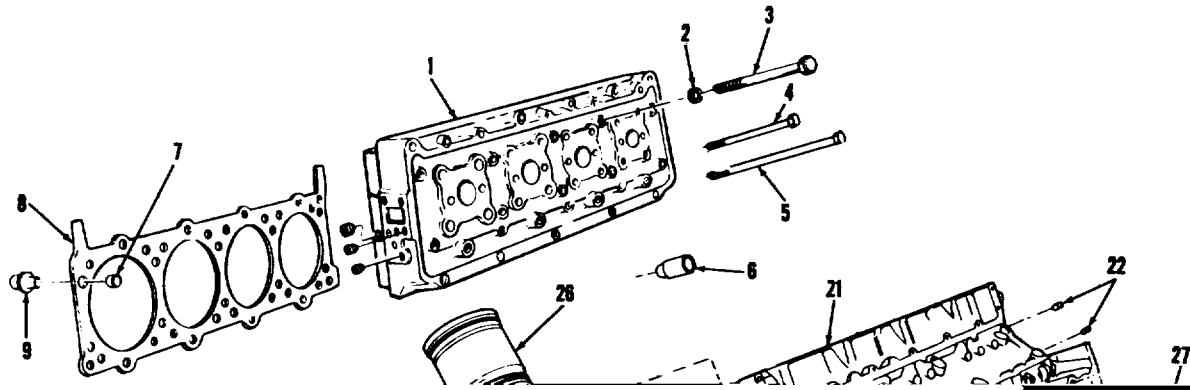

Figure B-2. Cylinder block and head assembly.

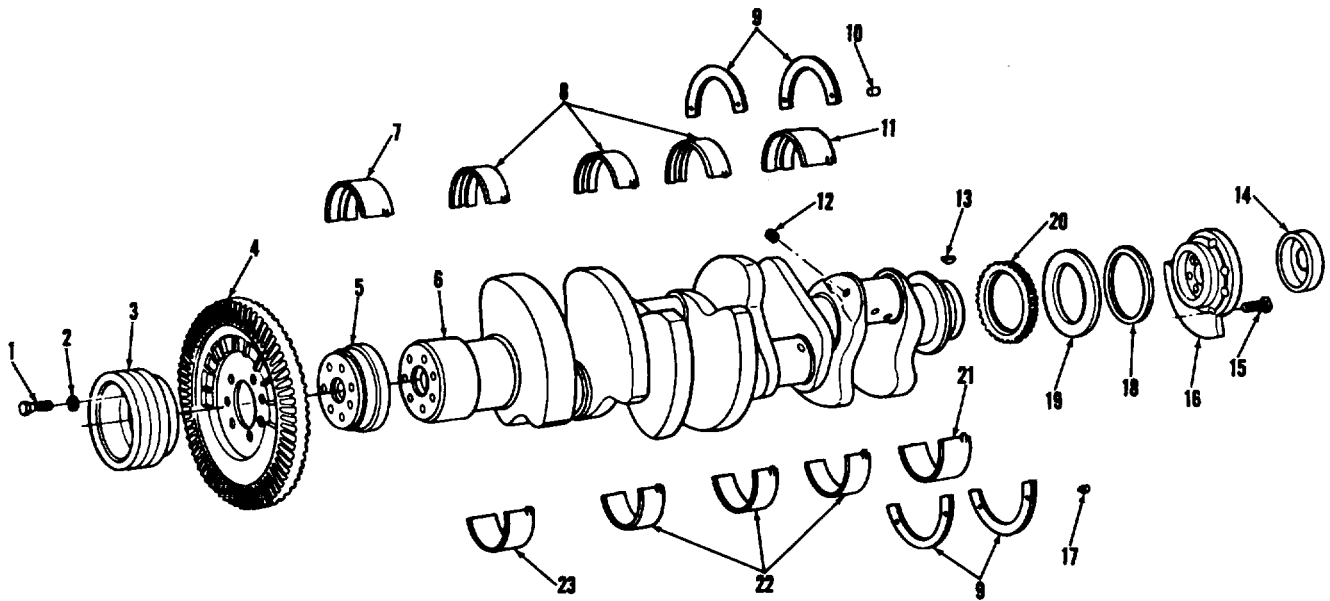
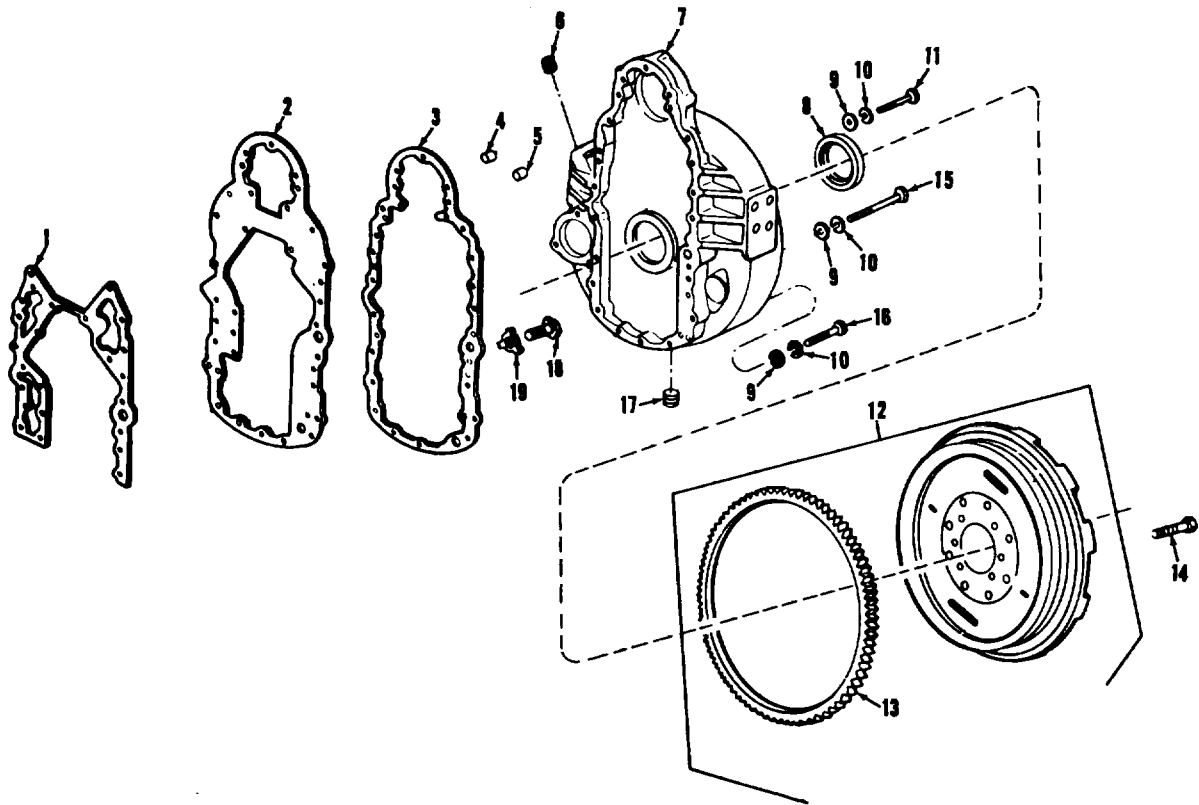

Figure B-3. Crankshaft main bearing and drive pulley.



AT 40280

Figure B-4. Flywheel assembly.

B-42

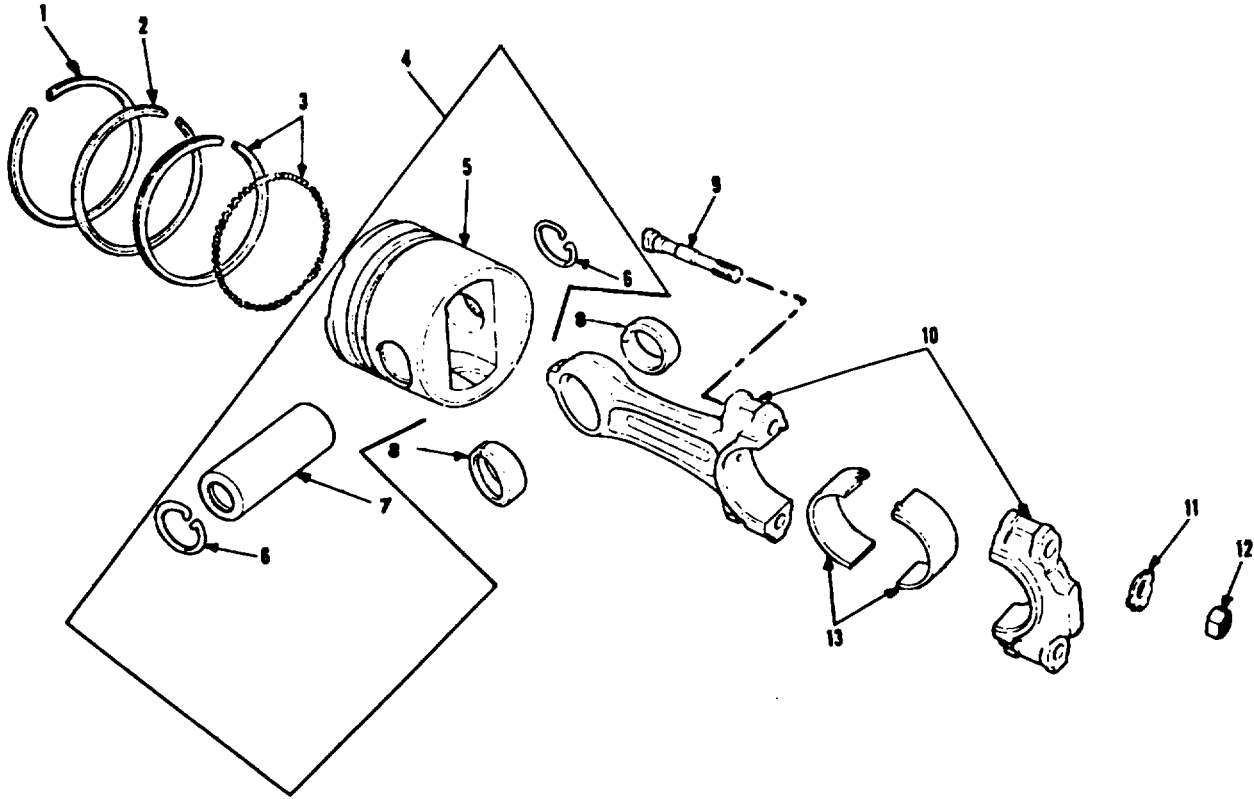

AT 40281

Figure B-5. Connecting rod, piston and rings.



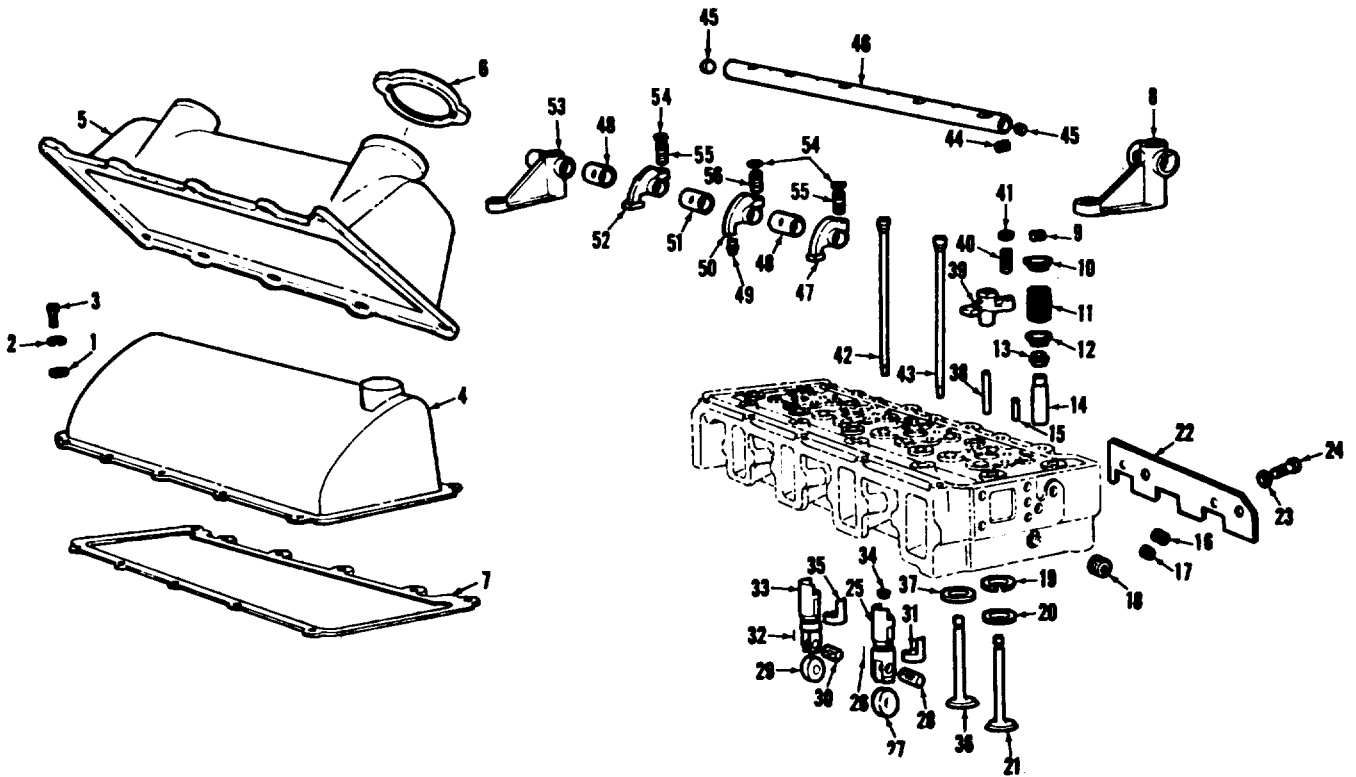

AT 40282

Figure B-6. Cylinder head, valves, rocker arms, and covers.

B-44

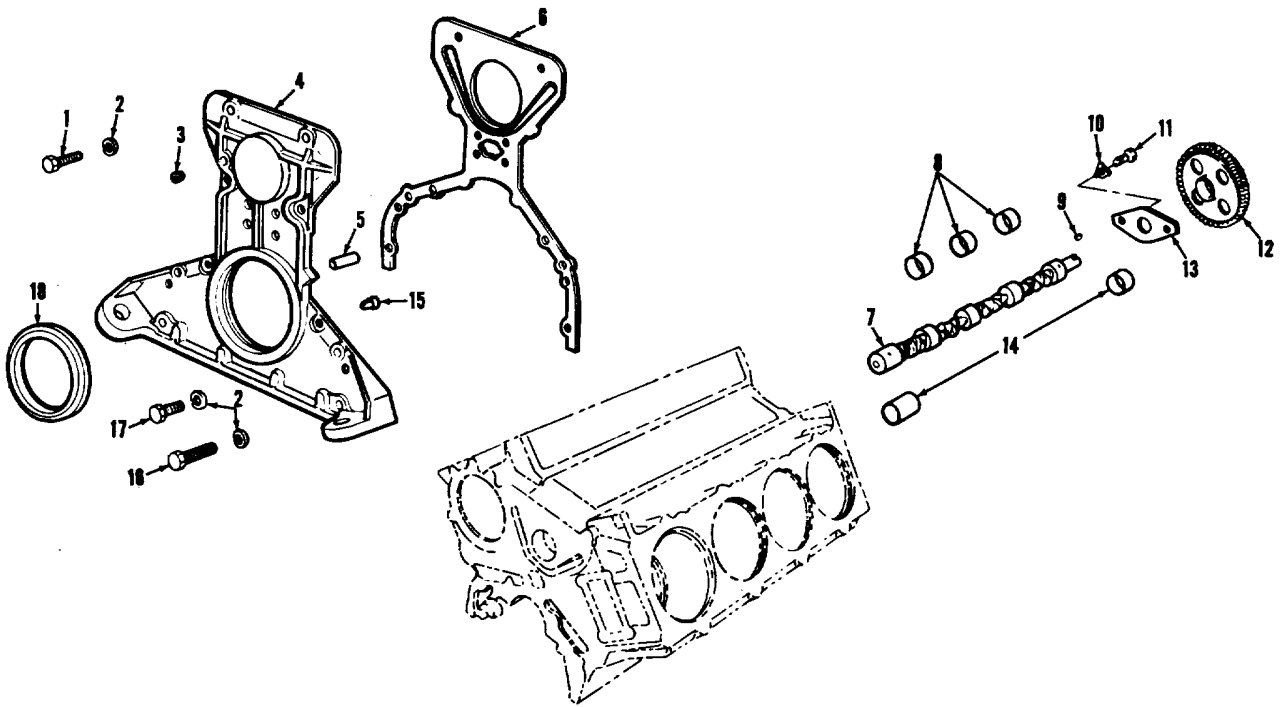

AT 40283

Figure B-7. Front cover and camshaft.

B-45

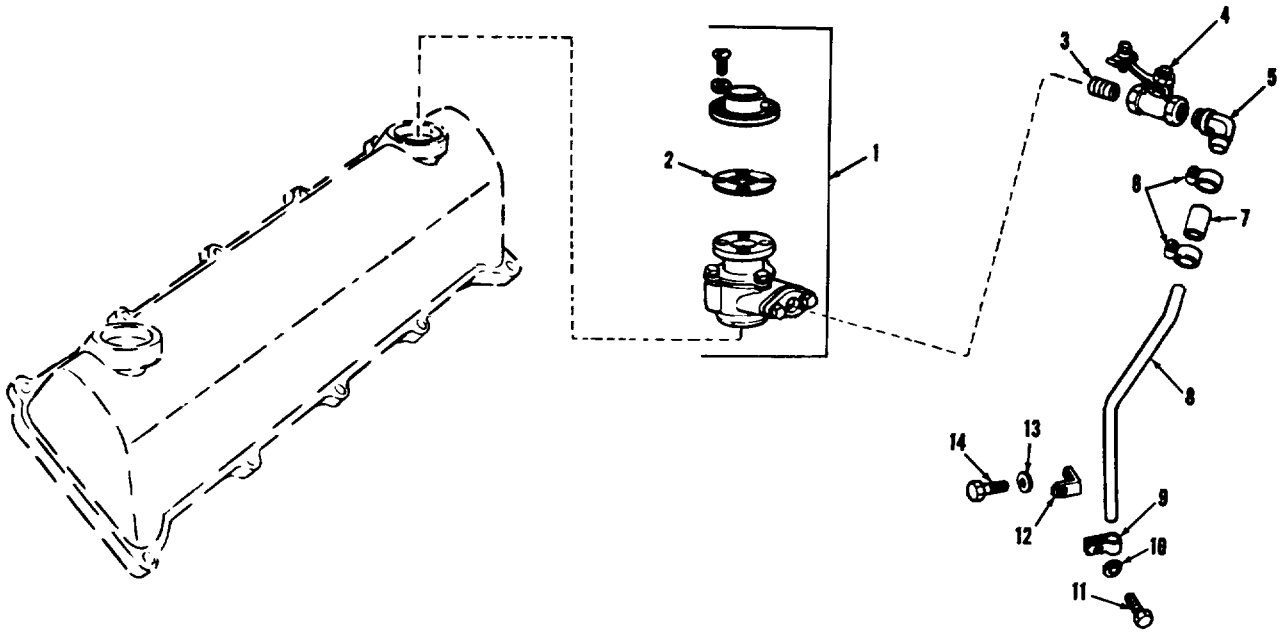

AT 40284

Figure B-8. Engine lubrication system (crankcase breather).

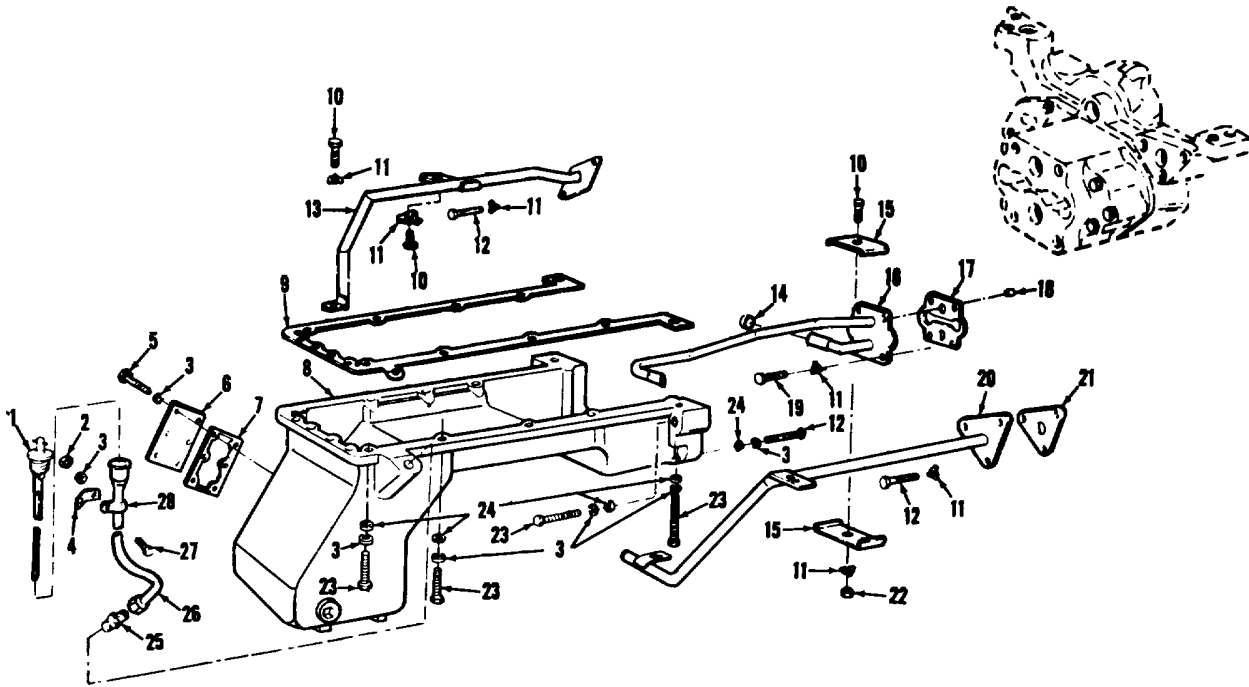

AT 40285

Figure B-9. Engine lubrication system (oil pan).

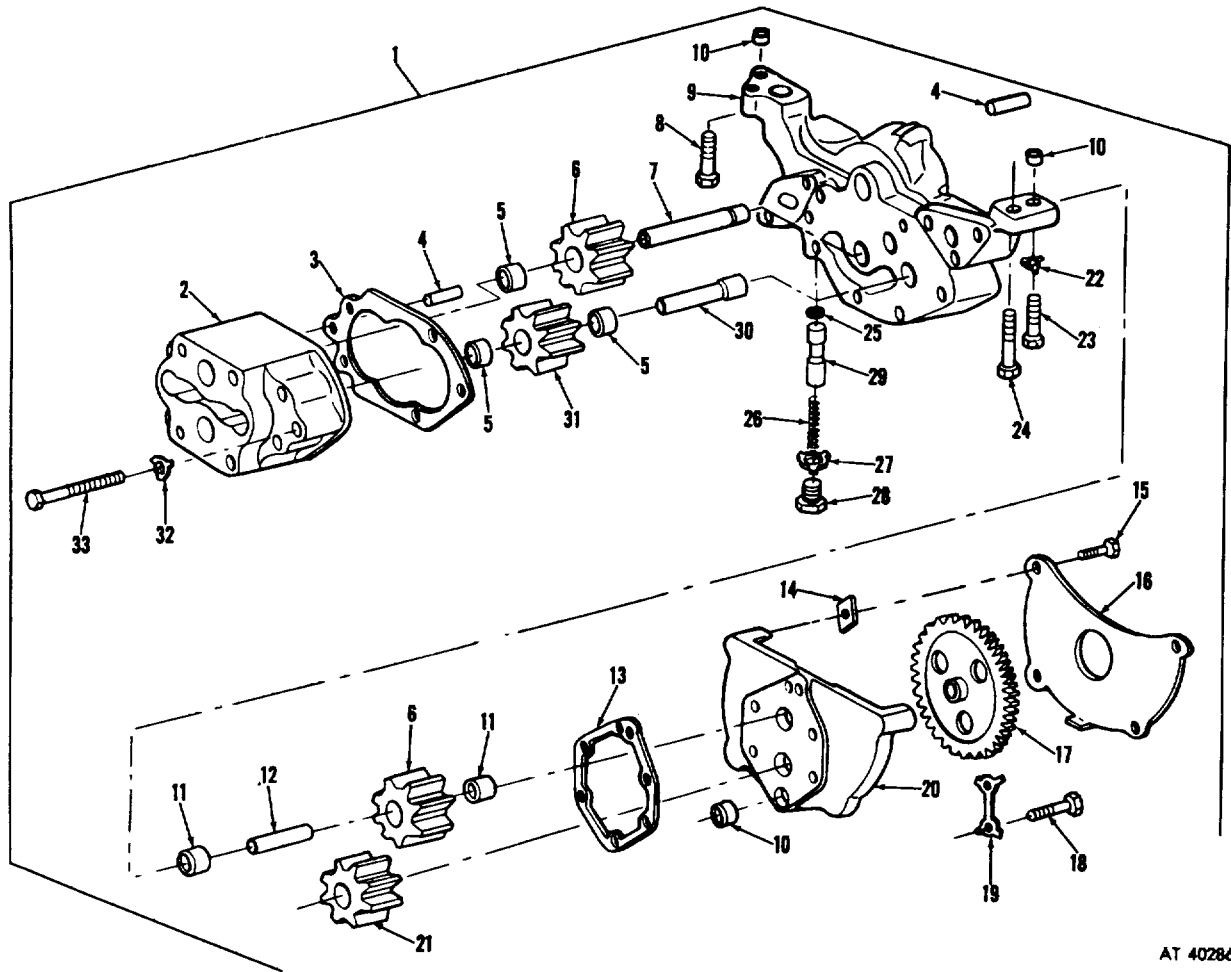

AT 40286

Figure B-10. Engine lubrication system (pump).

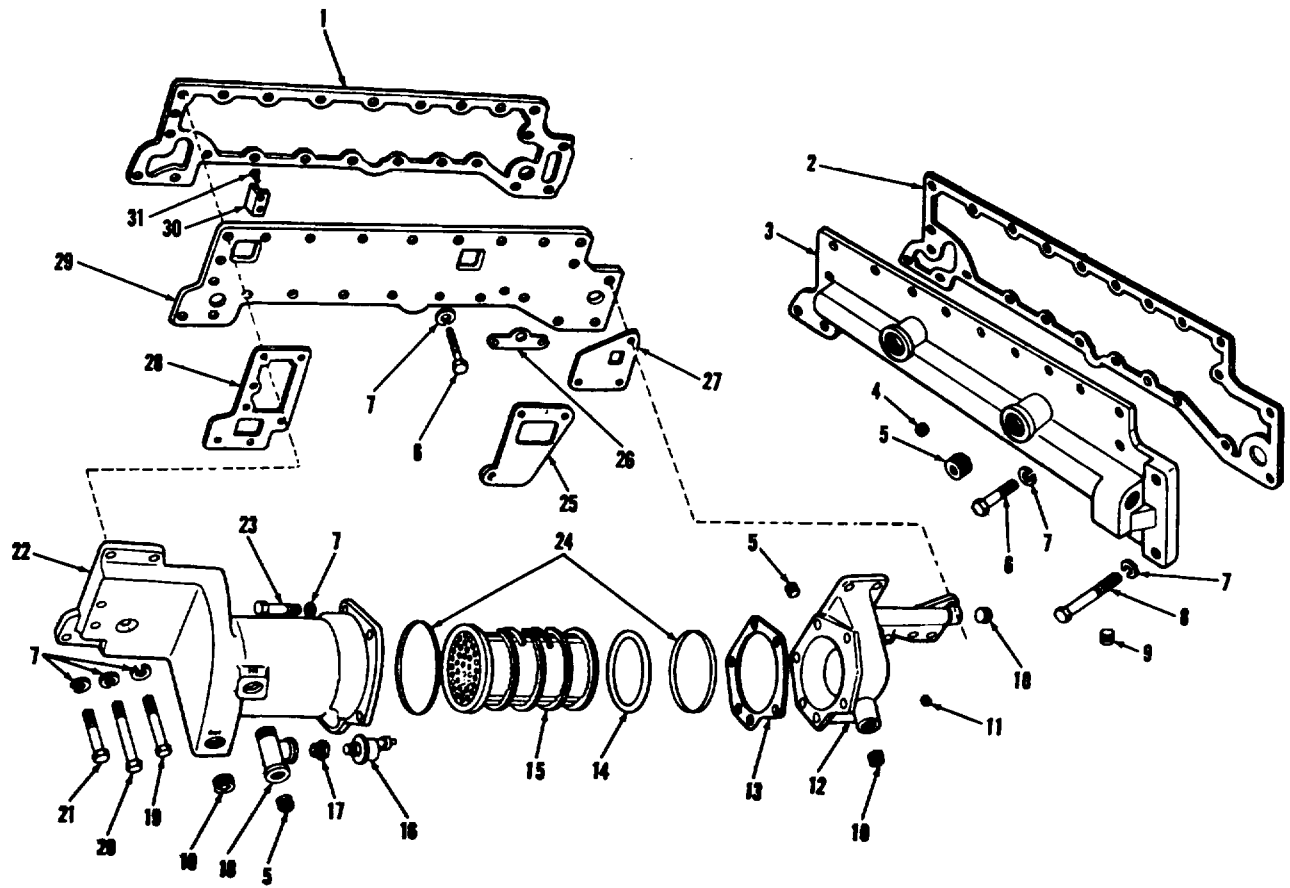

AT 40287

Figure B-11. Engine lubrication system (oil cooler).

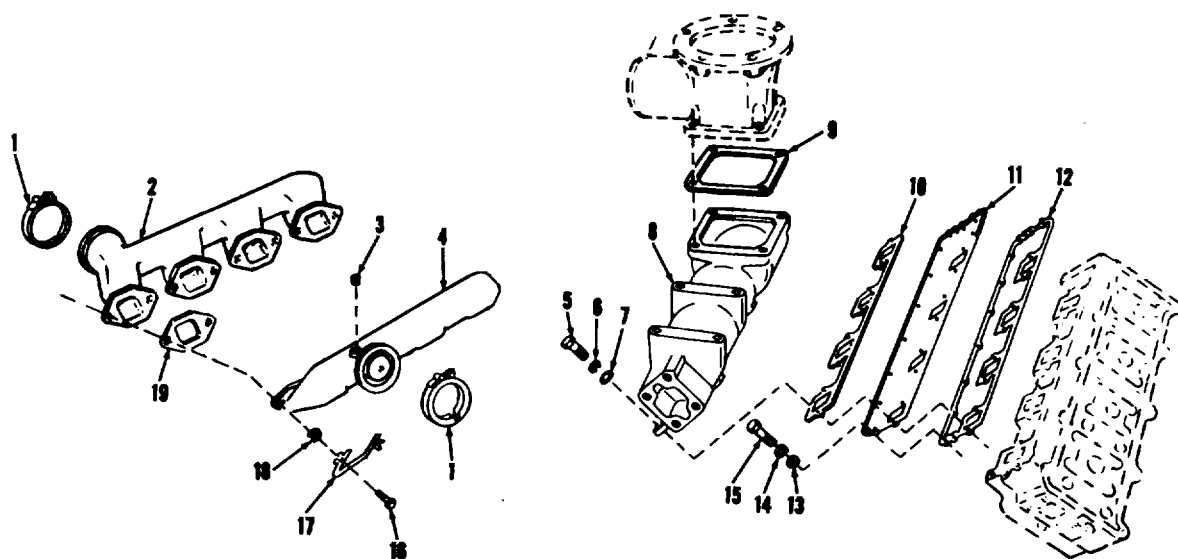
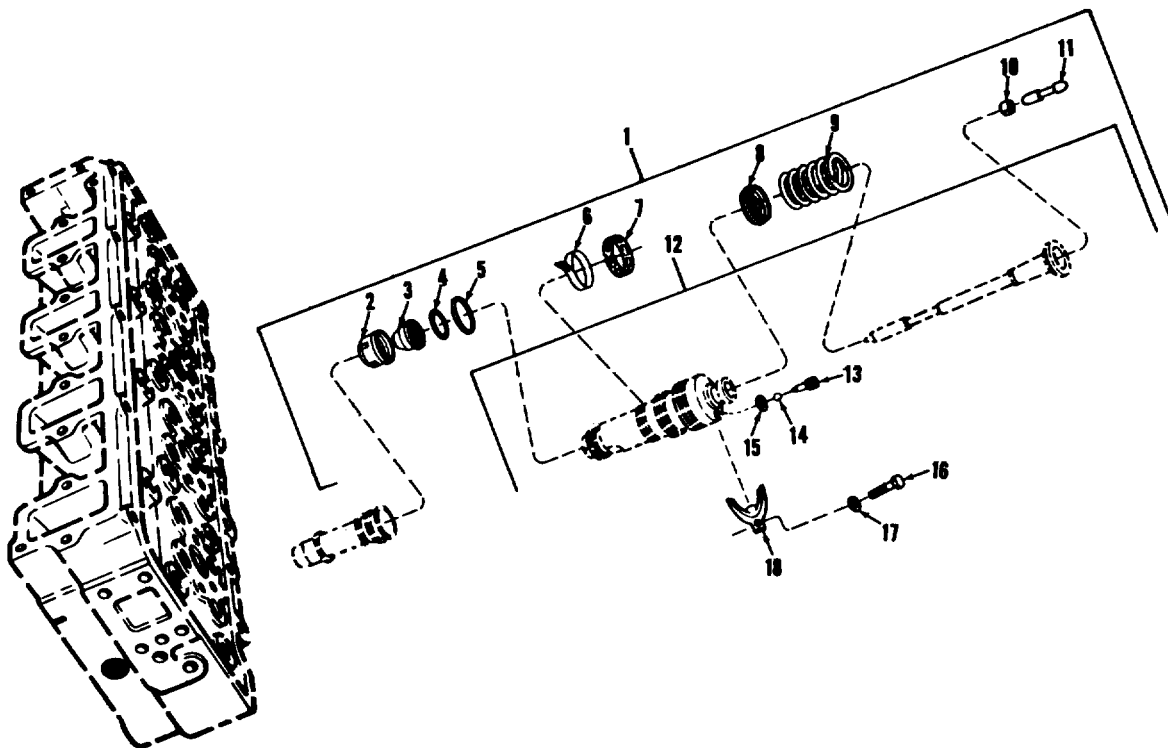

Figure B-12. Manifold-intake and exhaust.

AT 40288



AT 40289

Figure B-13. Fuel injector.



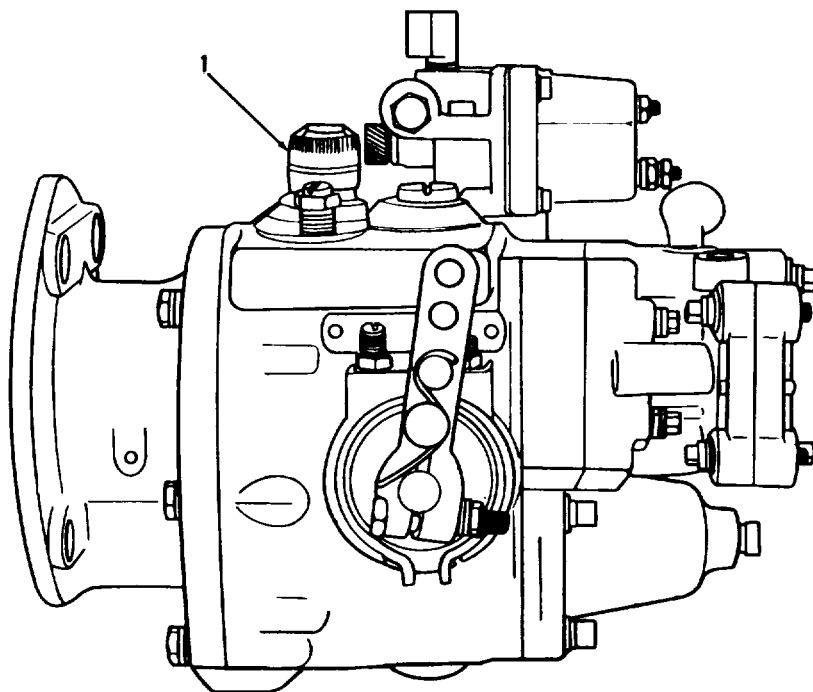

AT 40290

*Figure B-14. Fuel pump assembly.*

**B-52**

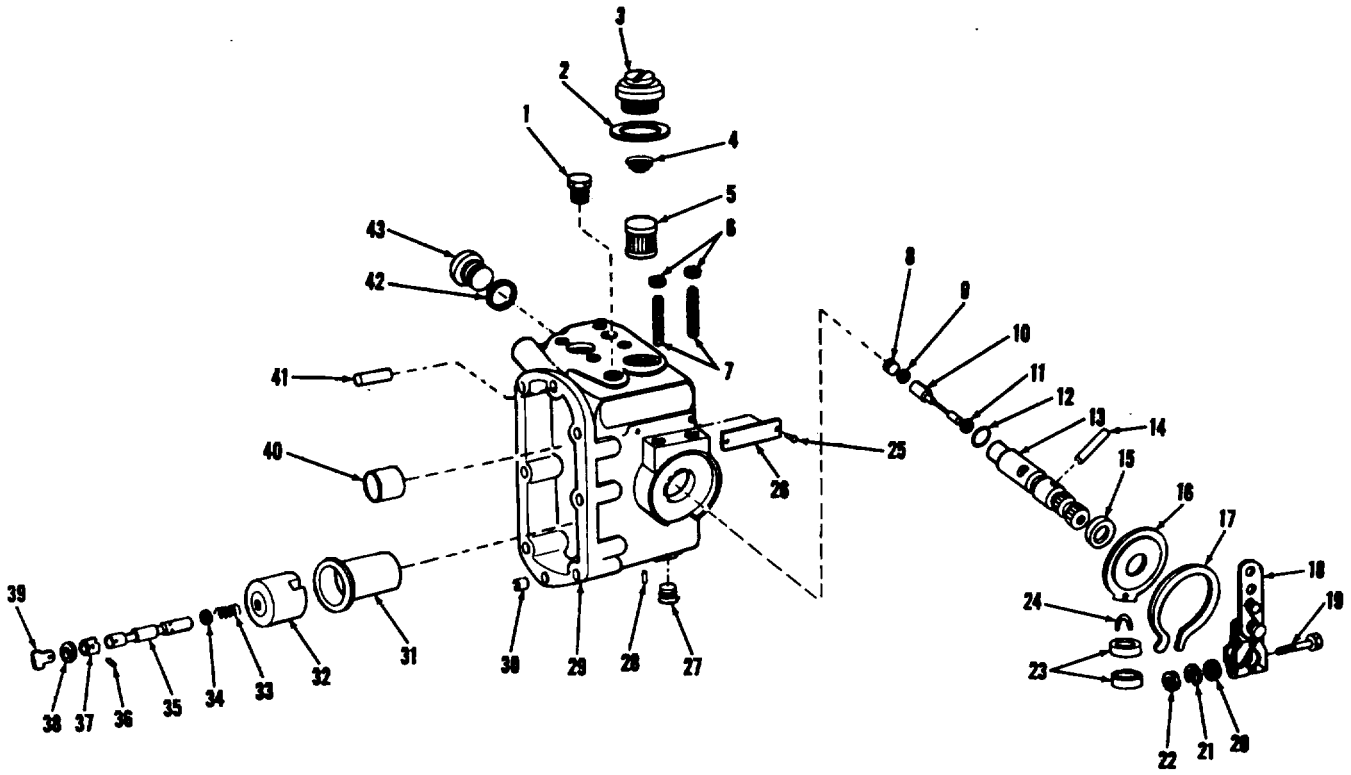

AT 40291

Figure B-15. Fuel pump housing (exploded view).

B-53

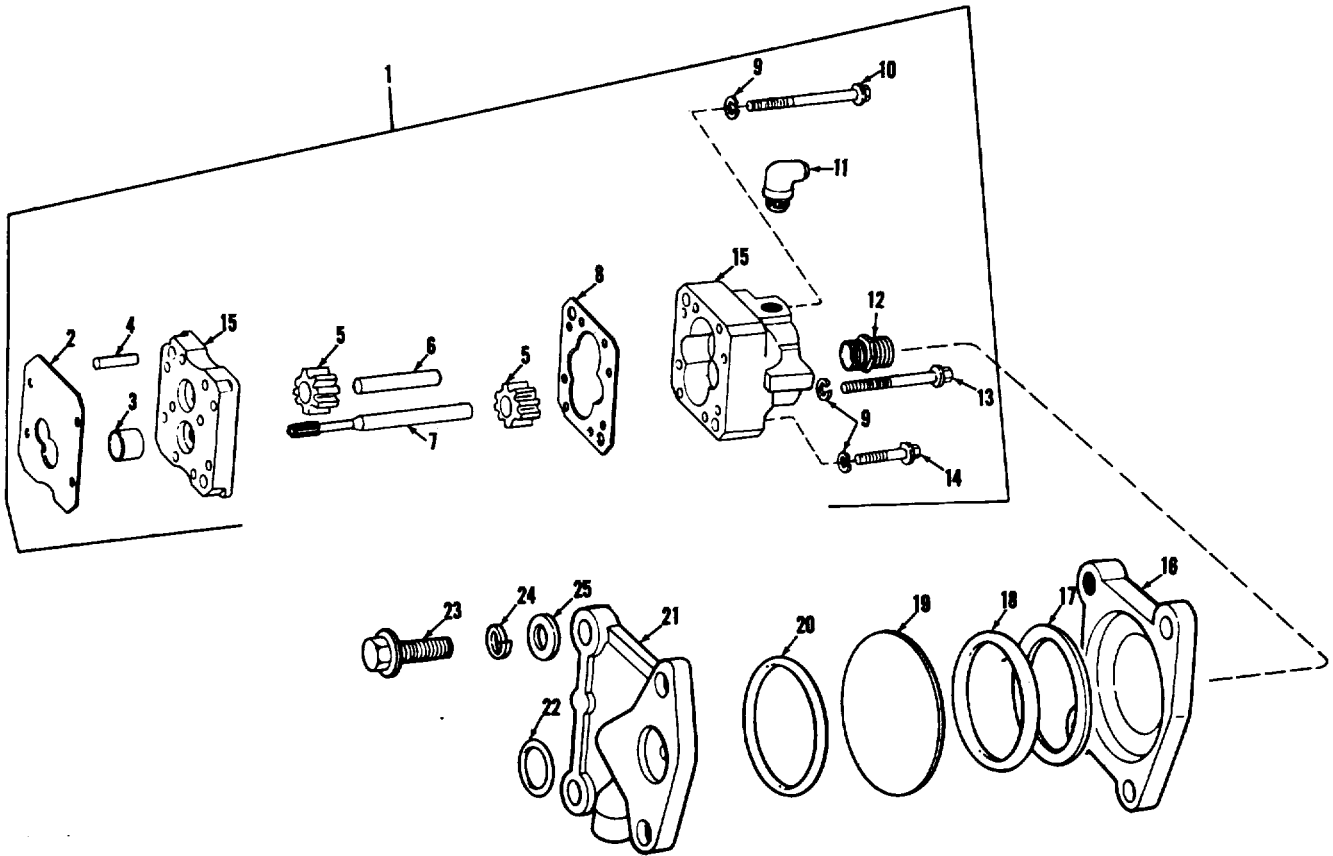

AT 40292

Figure B-16. Fuel pump gear and damper assembly.

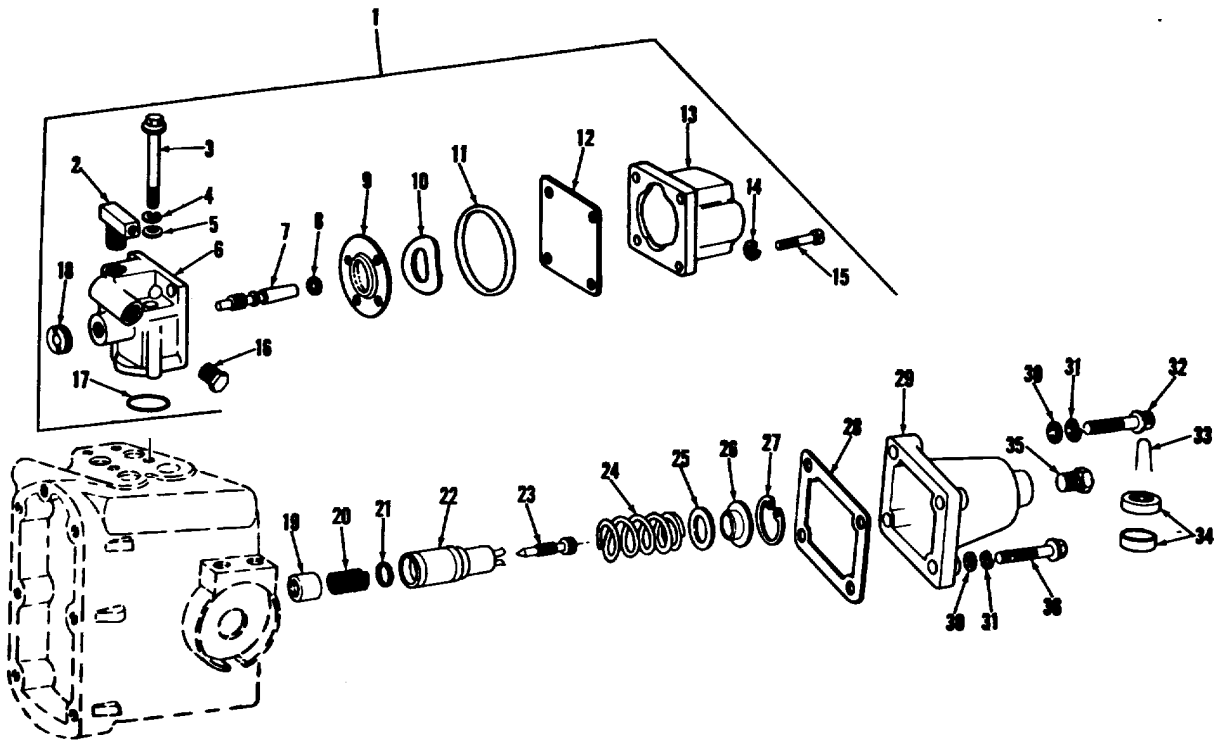

AT 40293

Figure B-17. Fuel shutoff solenoid valve and governor spring pack.

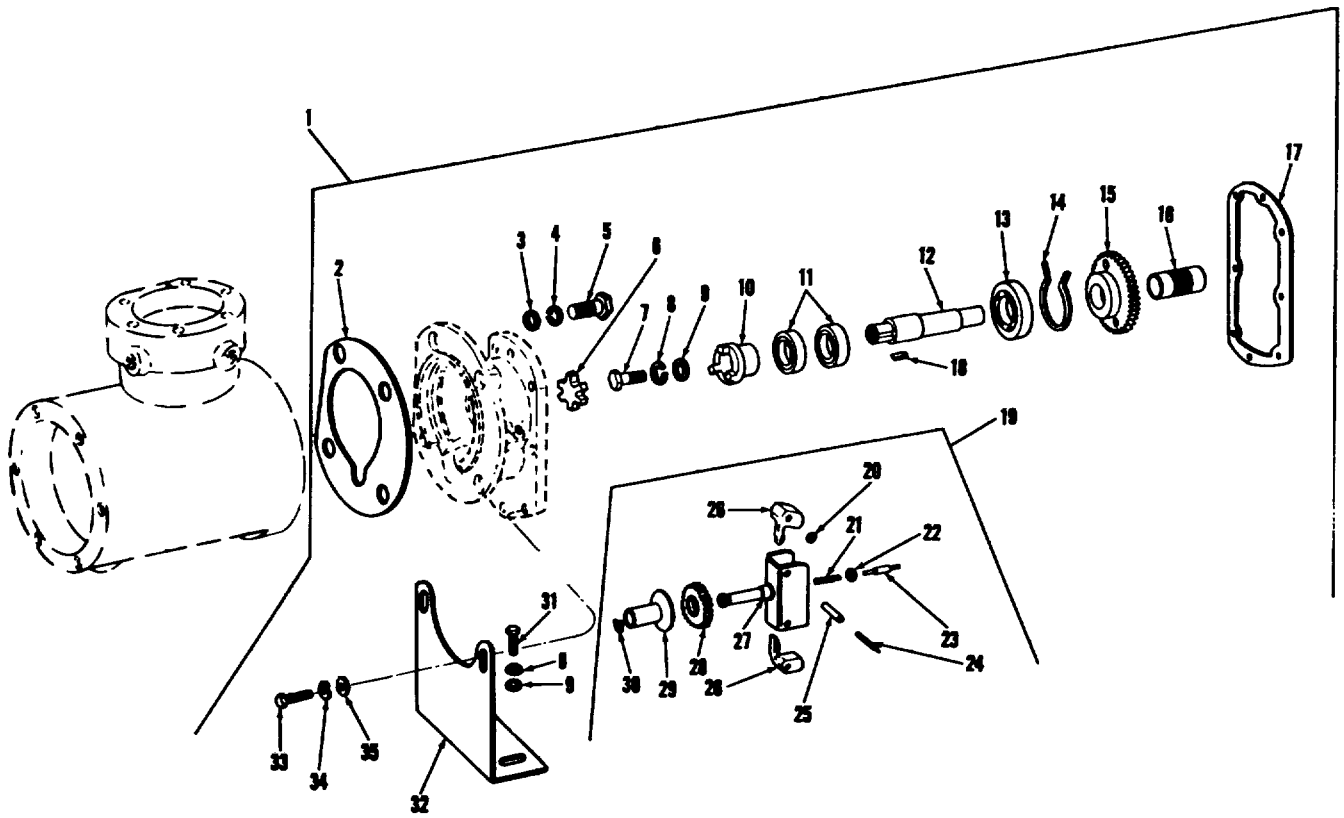

AT 40294

Figure B-18. Governor assembly (main shaft cover).

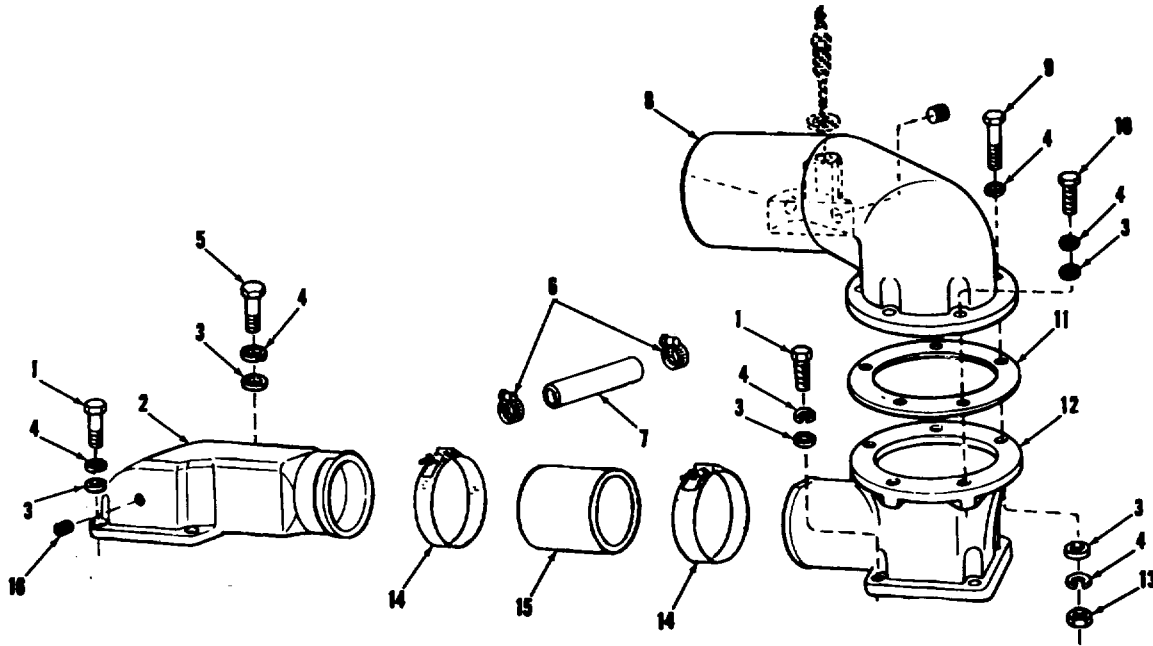

AT 40295

Figure B-19. Air intake components.

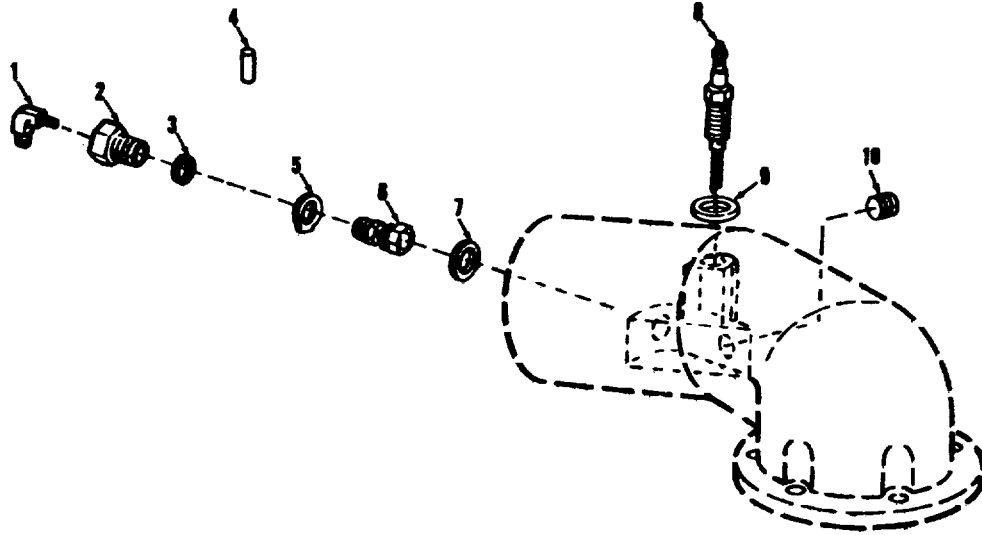

AT 40296

Figure B-20. Glow plug and heater accessories.

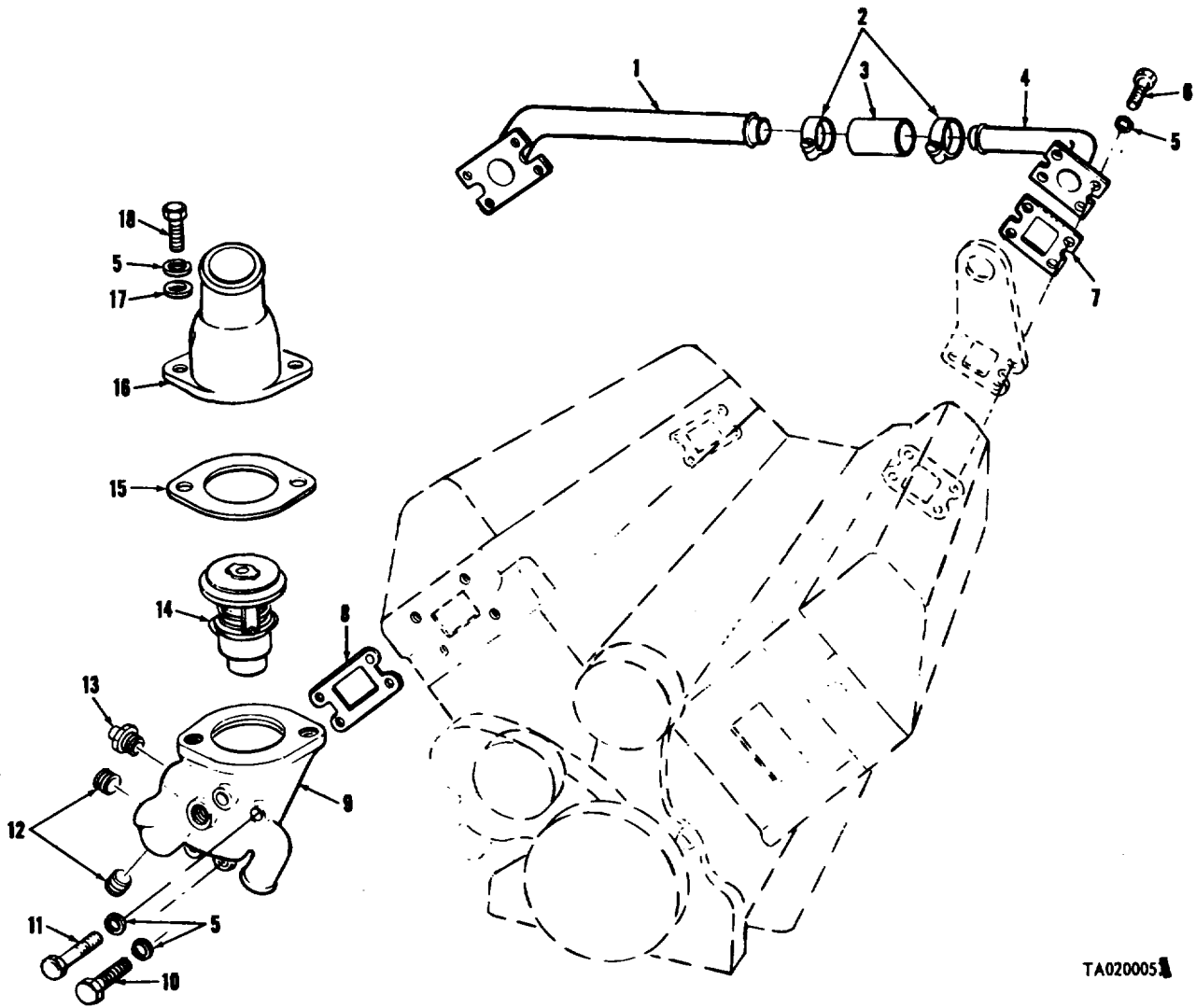

TA020005

Figure B-21. Thermostat and crossover tube.



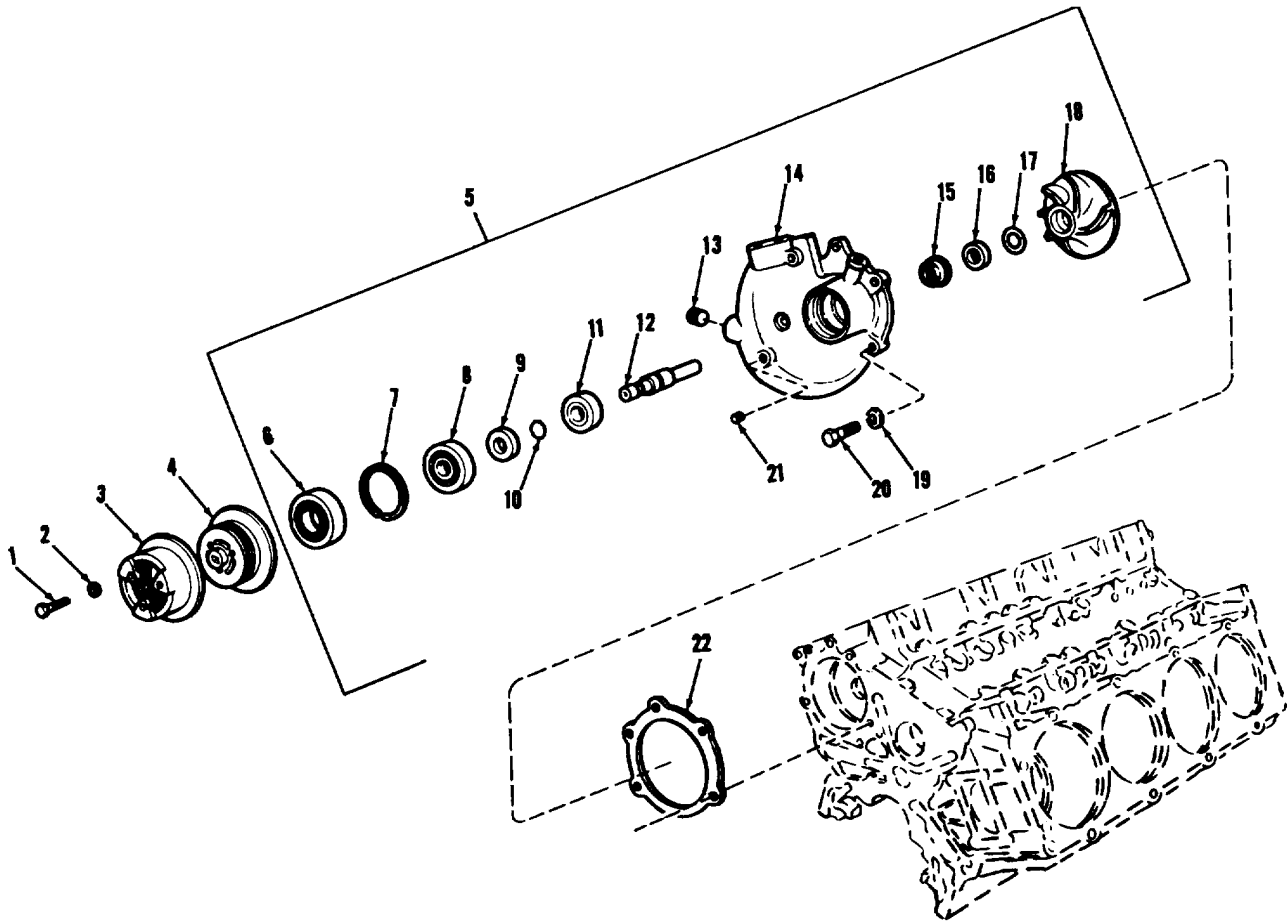

AT 40298

Figure B-22. Water pump.

B-60

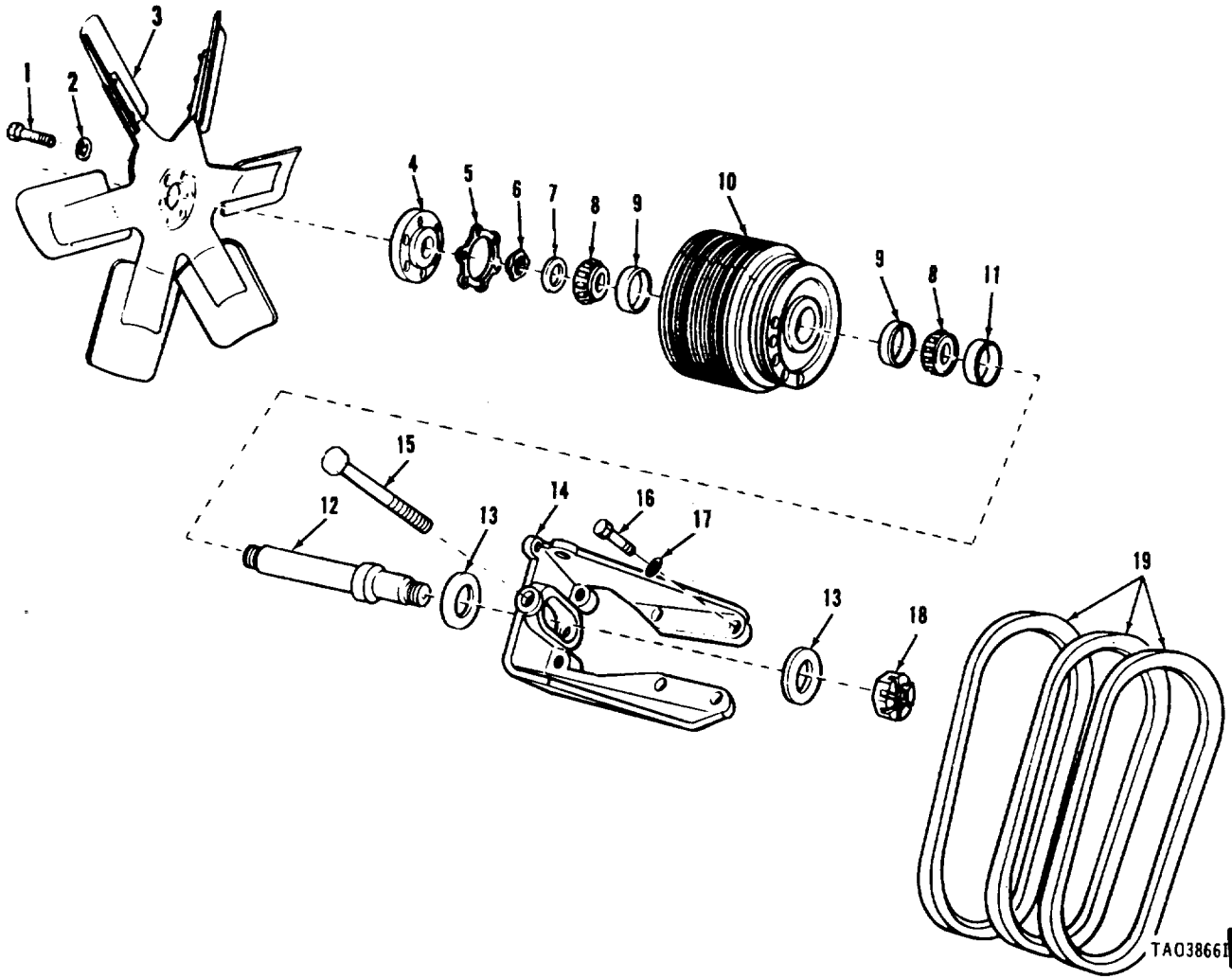
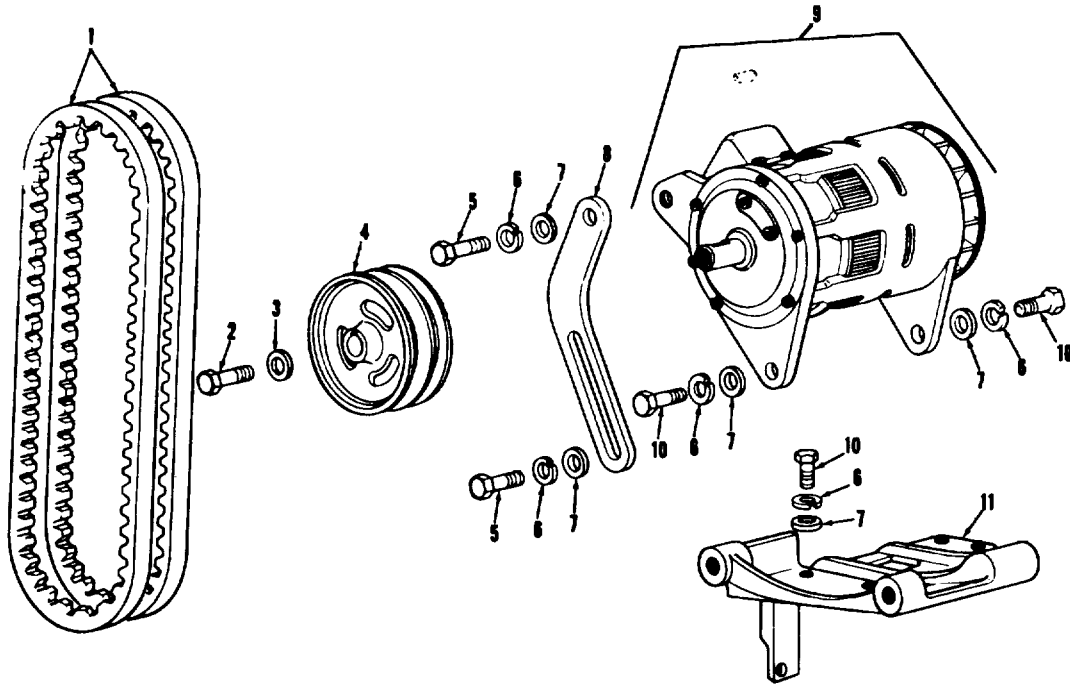

Figure B-23. Fan, hub, and bracket.



AT 40300

Figure B-24. Generator.

B-62

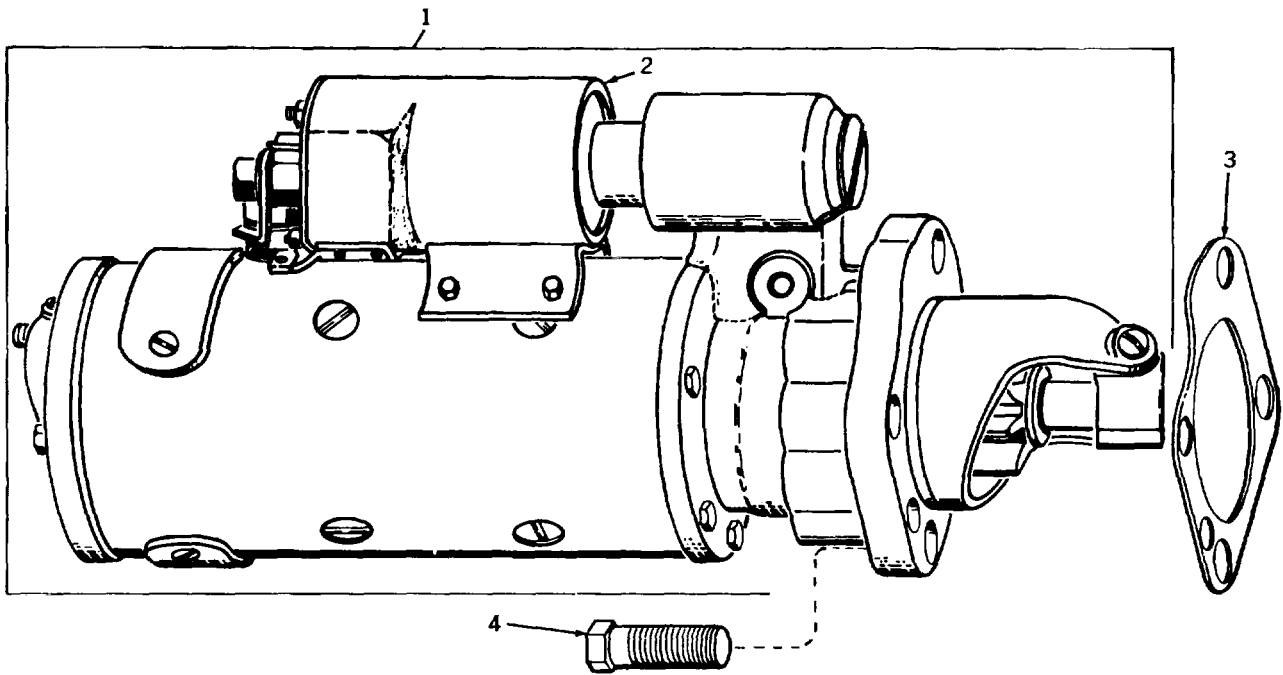

ORD E73341

Figure B-24.1. Starter assembly-diesel engine.

B-62.1

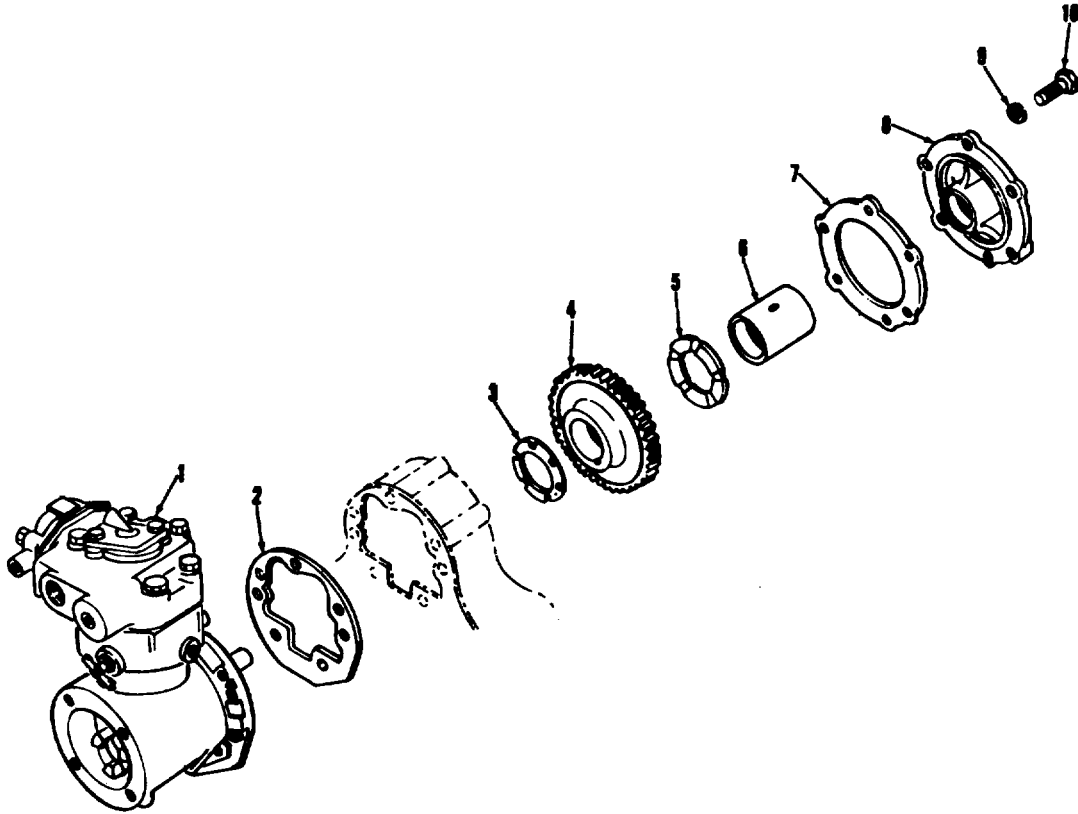

AT 40301

Figure B-25. Air compressor and drive mechanism.

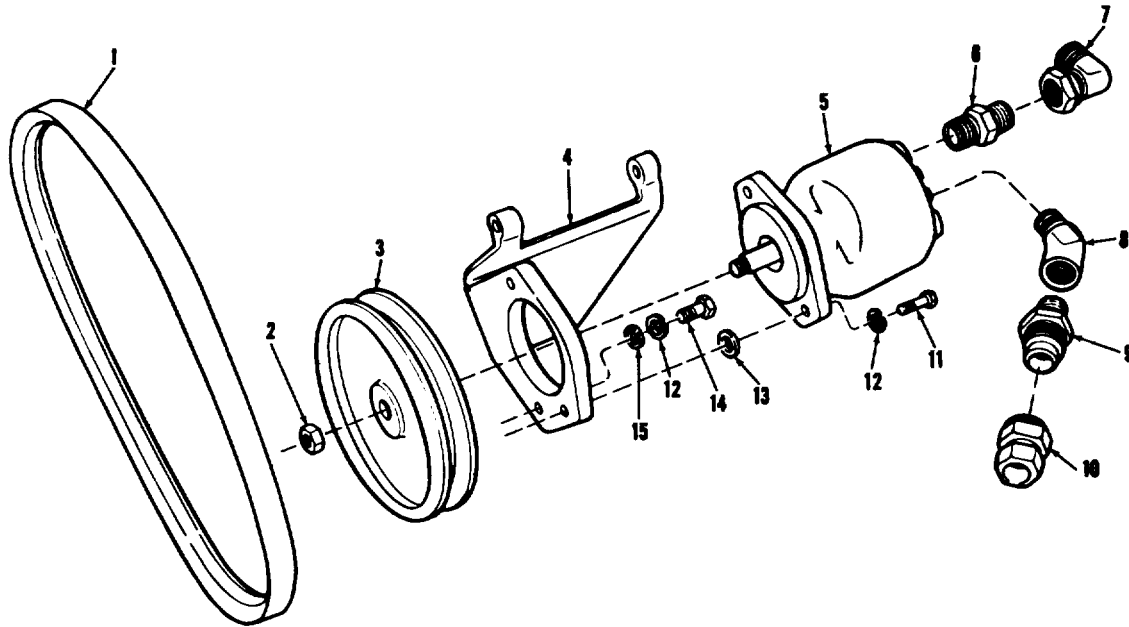

AT 40302

Figure B-26. Power steering pump.

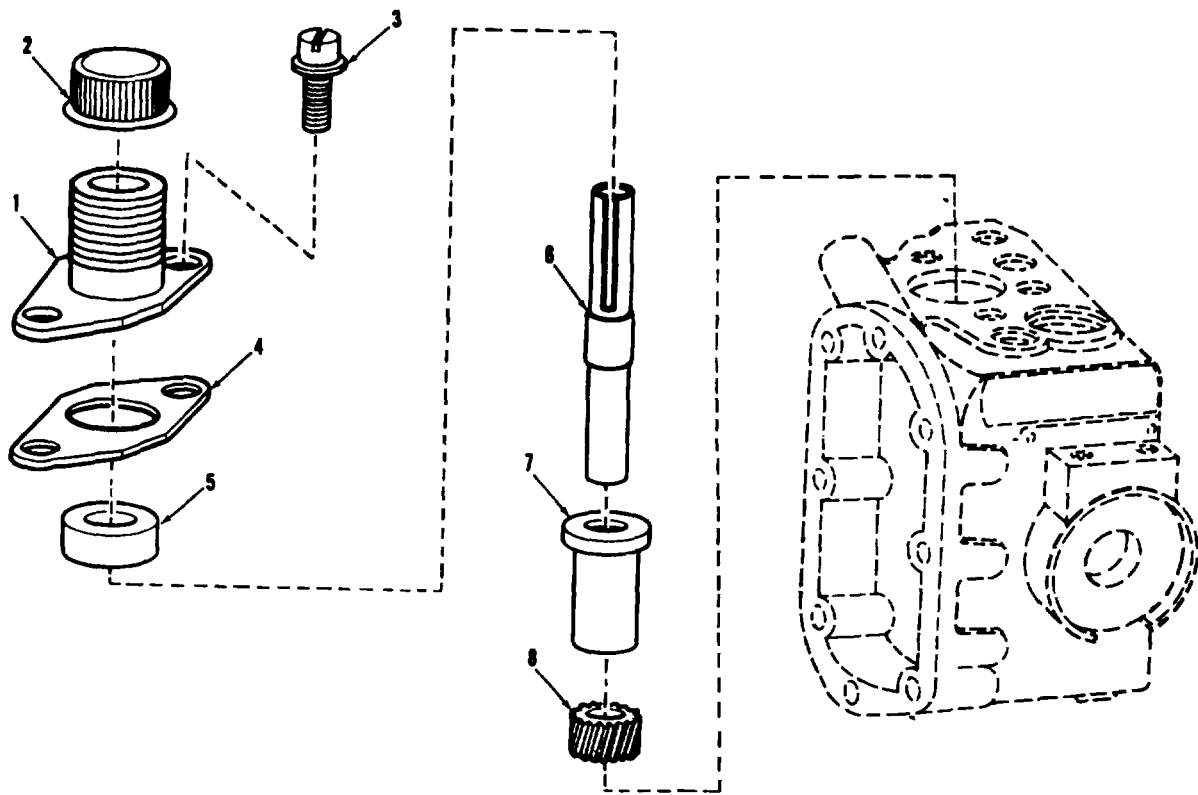

AT 40303

Figure B-27. Tachometer drive (fuel pump).

B-65

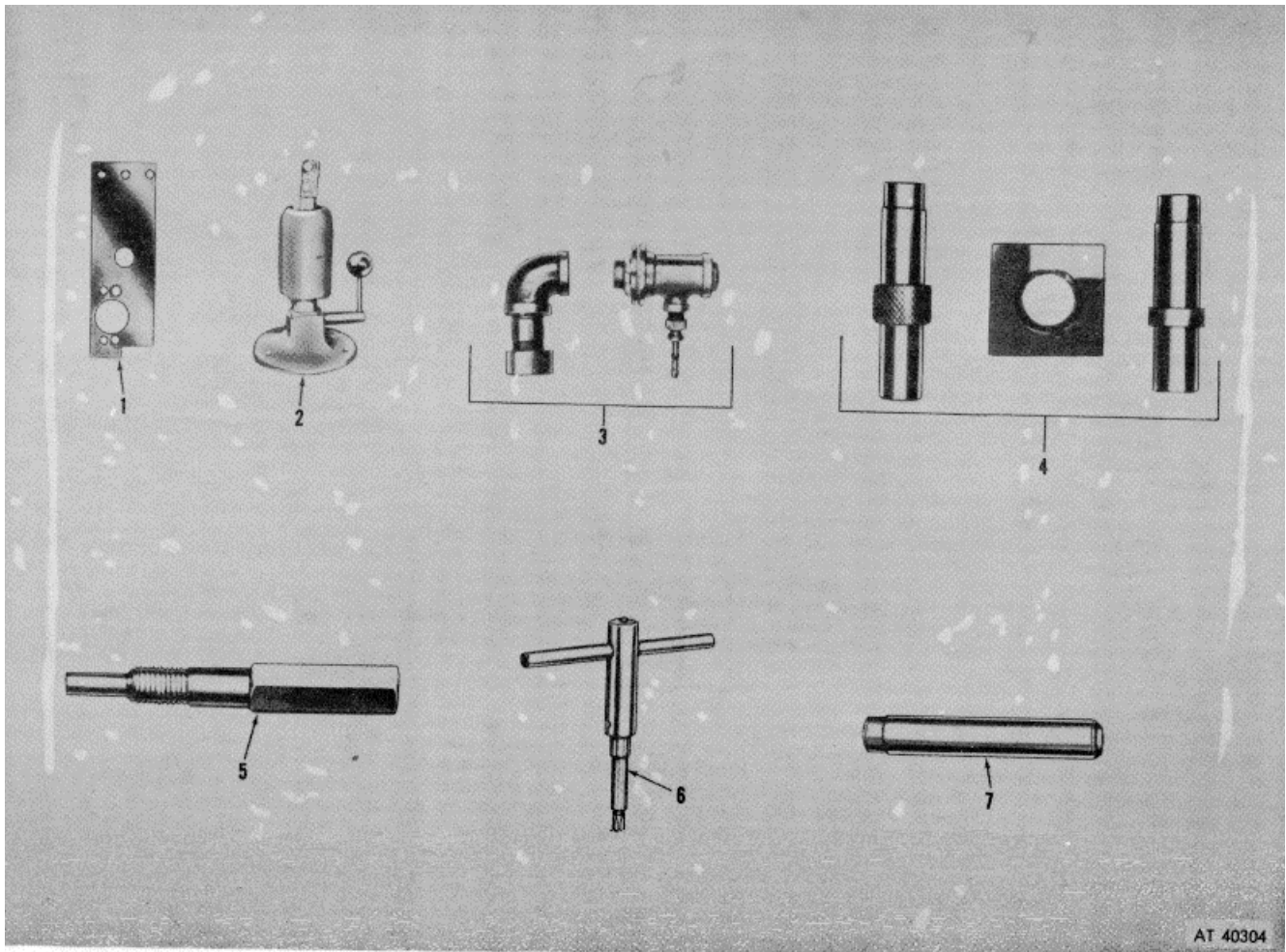

AT 40304

Figure B-28. Special tools. (Sheet 1 of 9)

B-66



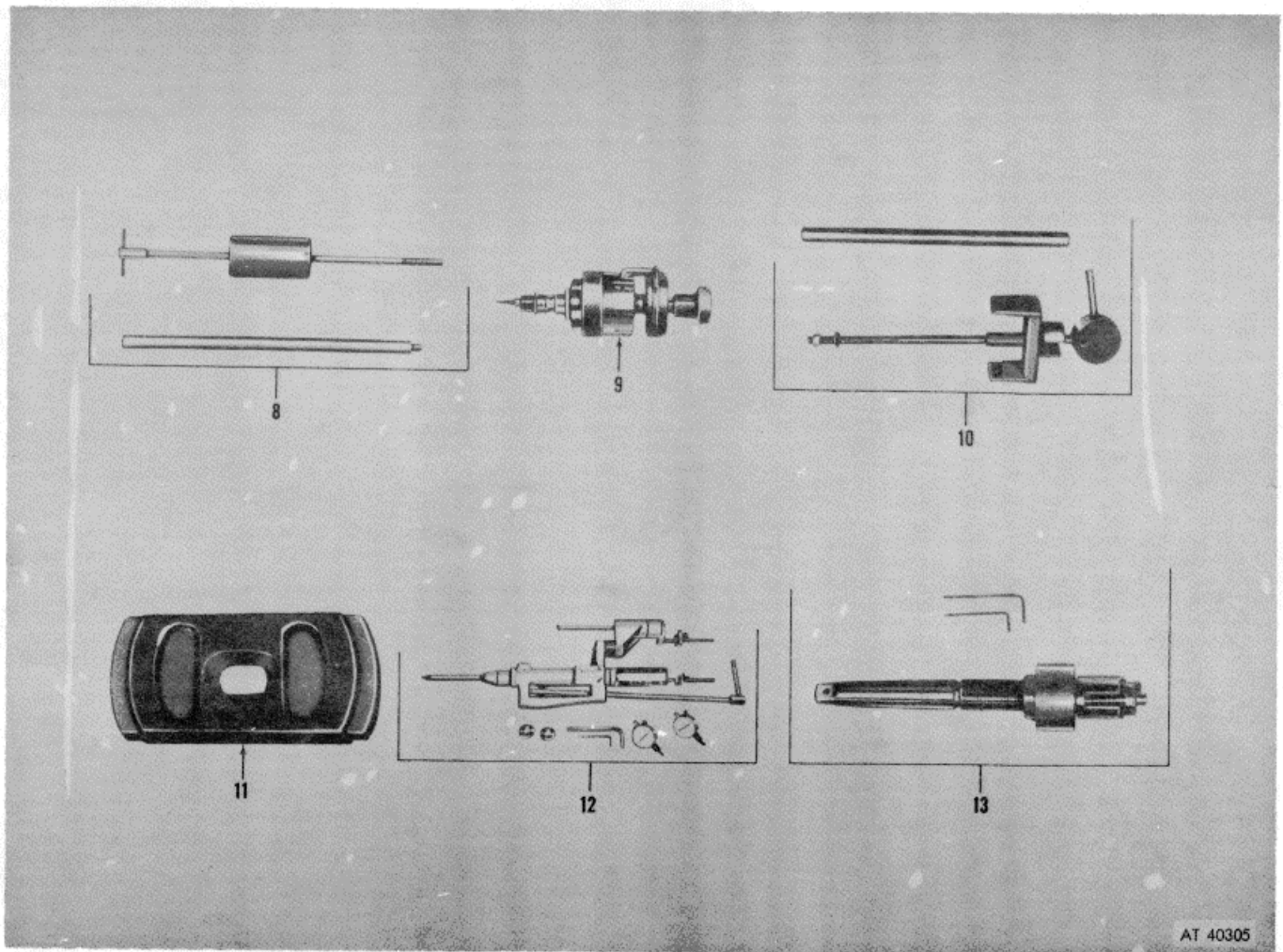

Figure B-28. Special tools. (Sheet 2 of 9)

B-67

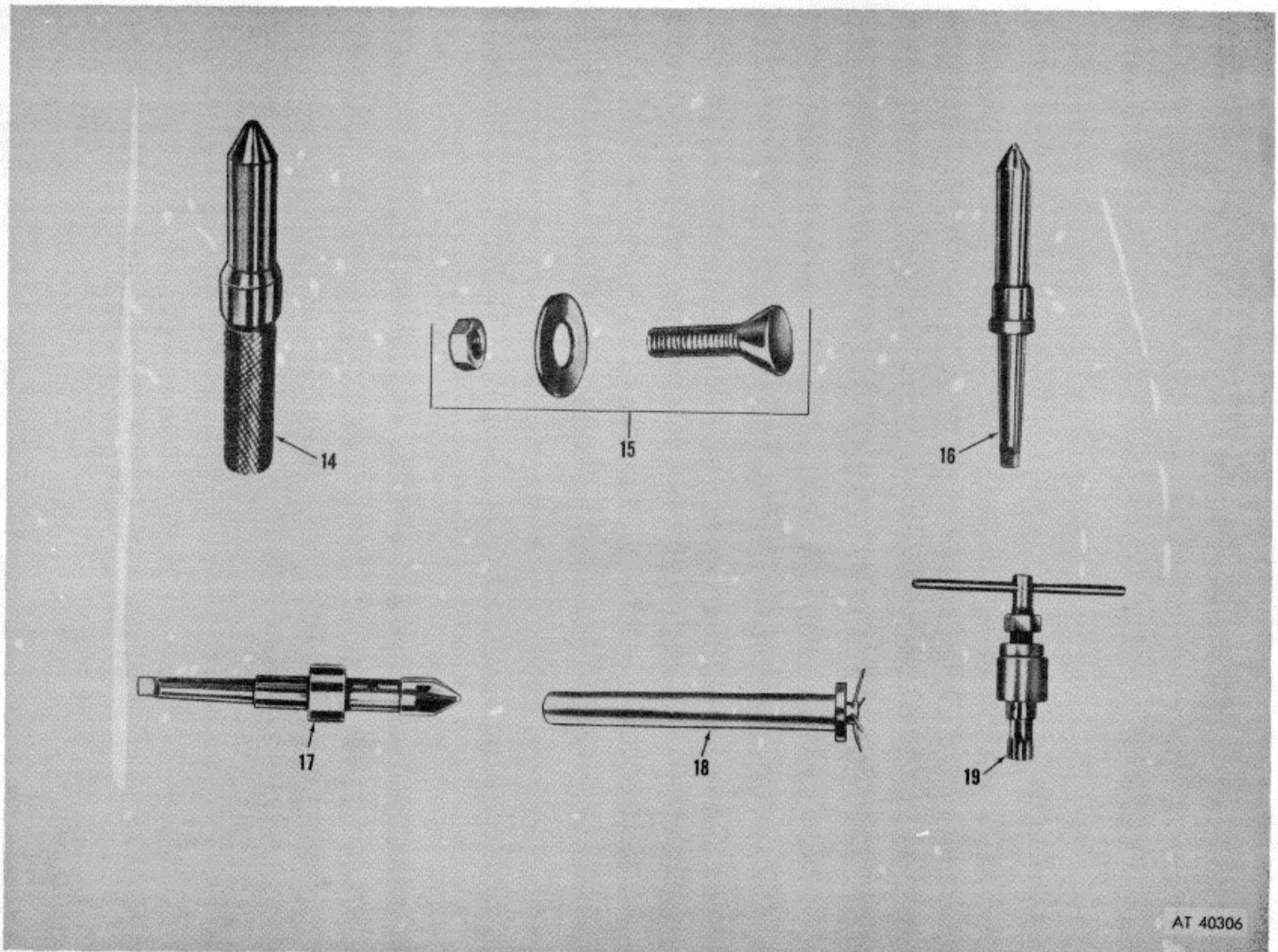

Figure B-28. Special tools. (Sheet 3 of 9)

B-68

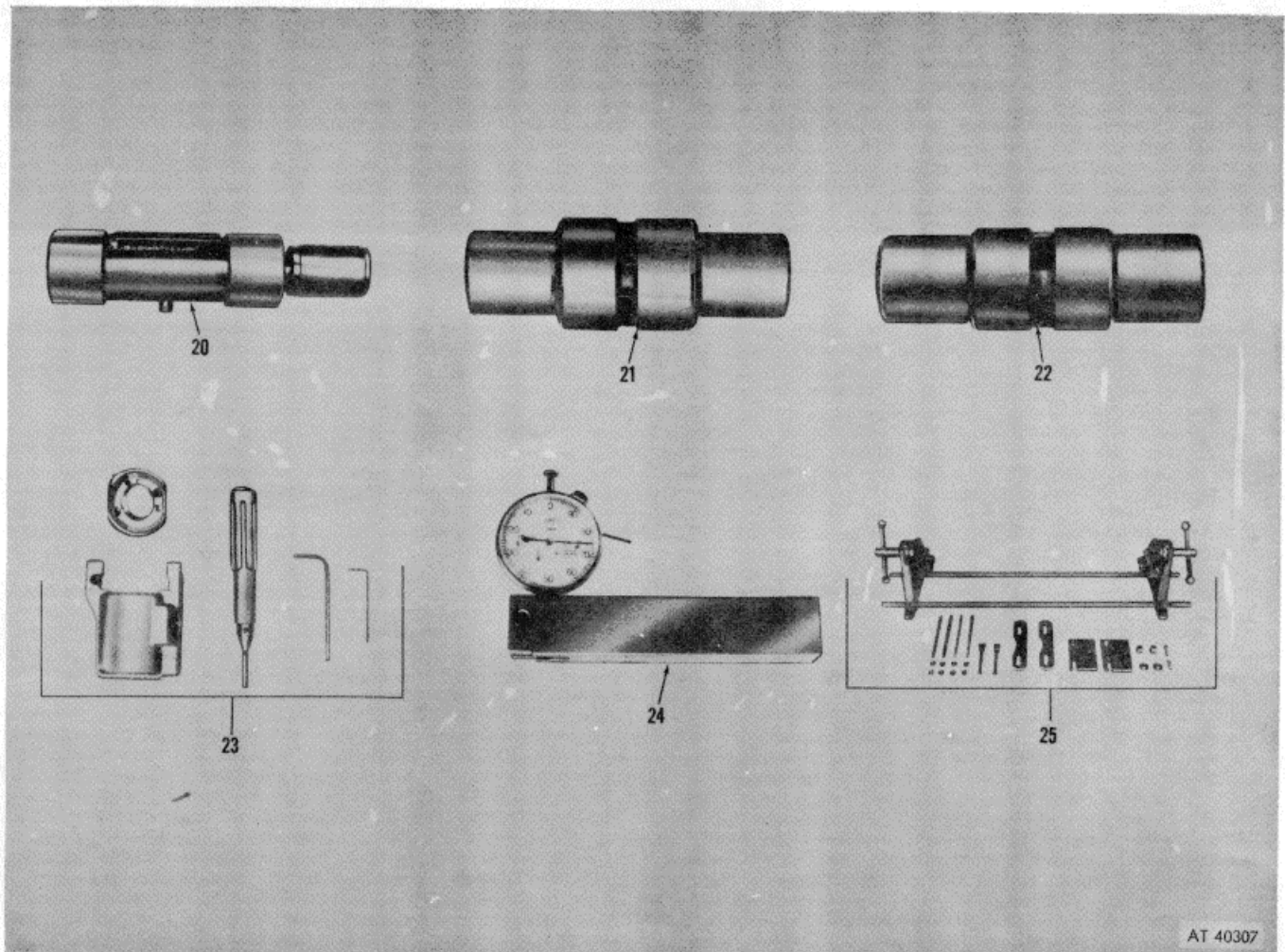

Figure B-28. Special tools. (Sheet 4 of 9)

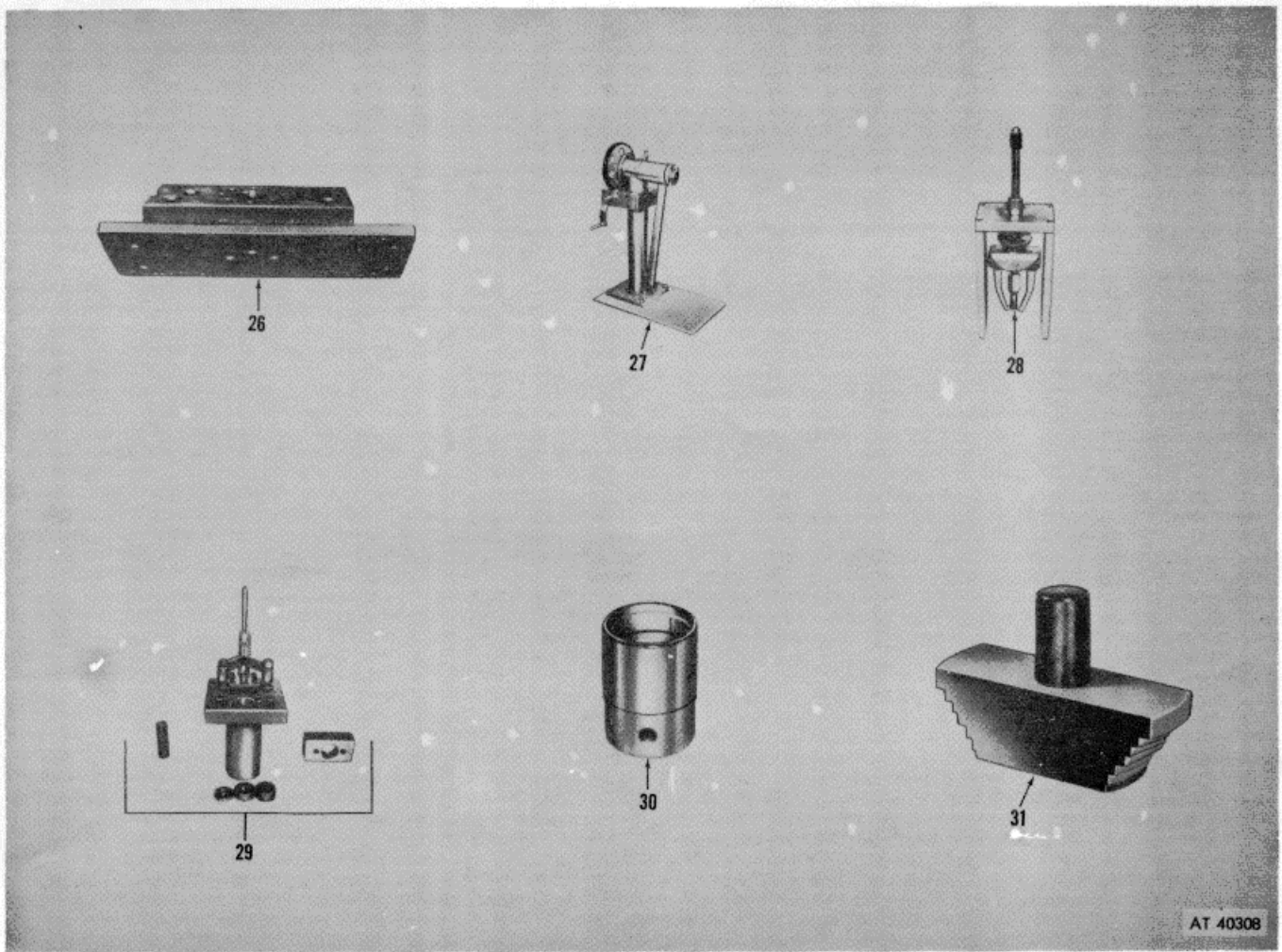

Figure B-28. Special tools. (Sheet 5 of 9)

B-70

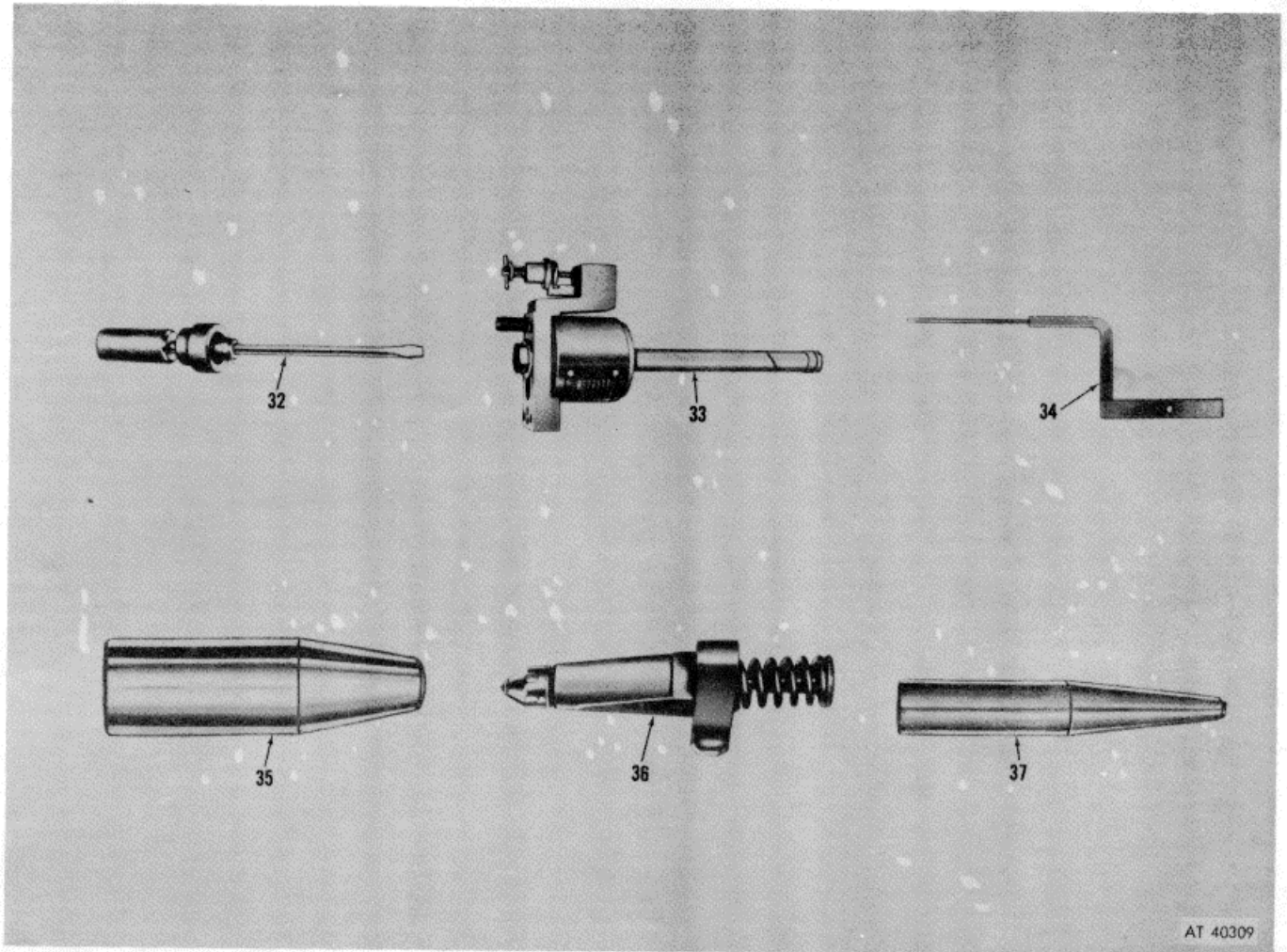

Figure B-28. Special tools. (Sheet 6 of 9)

B-71

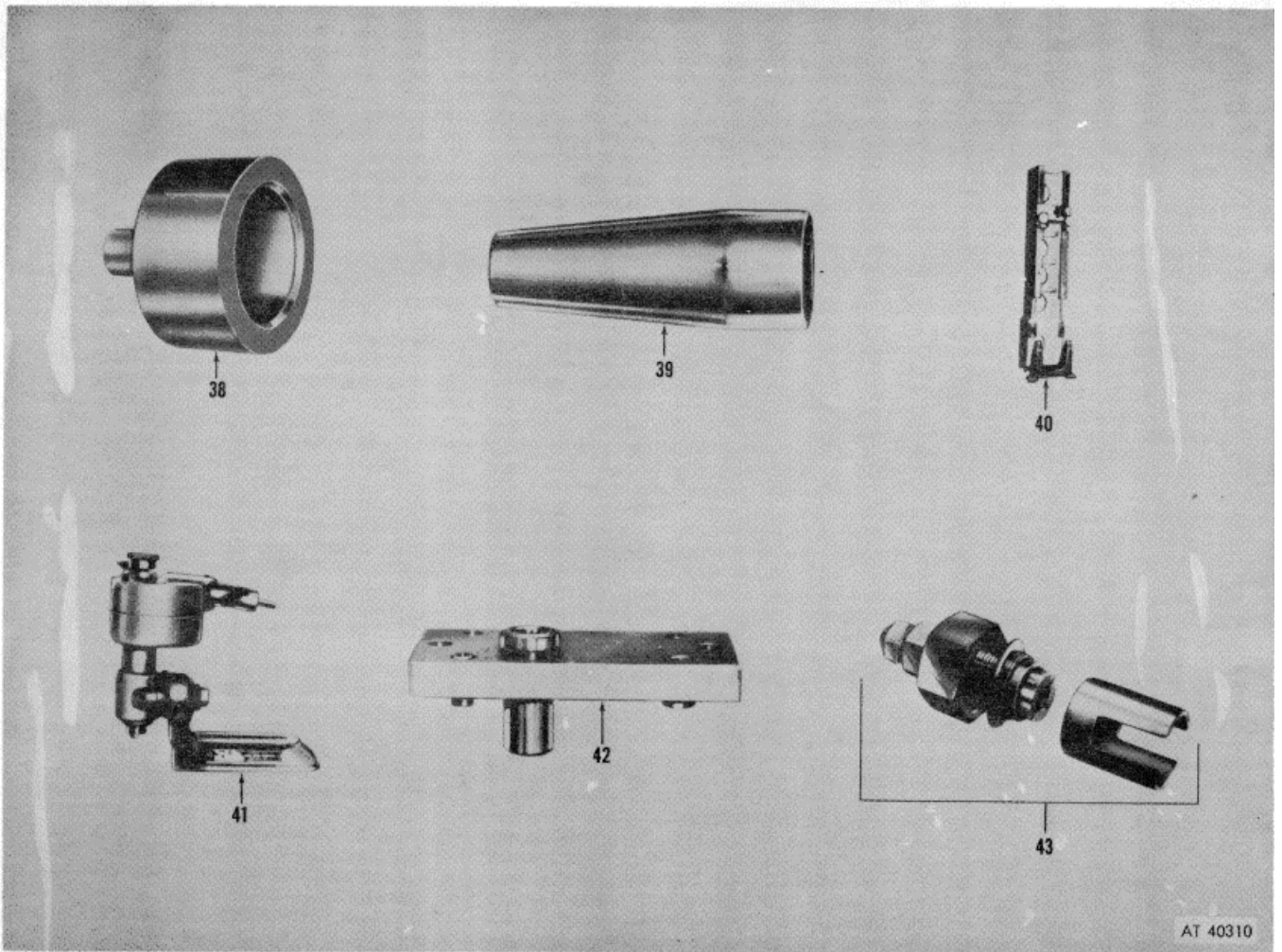

Figure B-28. Special tools. (Sheet 7 of 9)

B-72

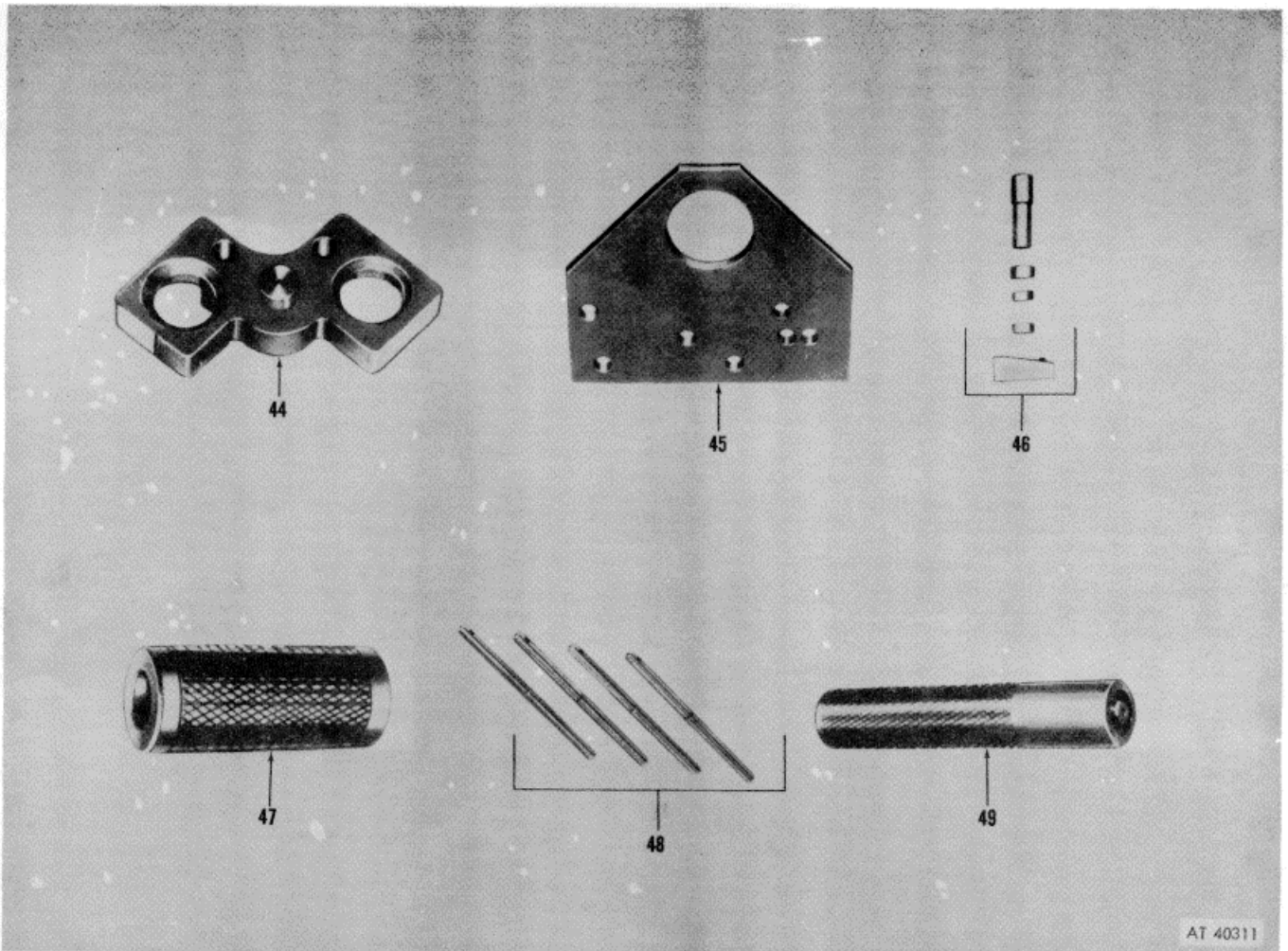

Figure B-28. Special tools. (Sheet 8 of 9)

B-73

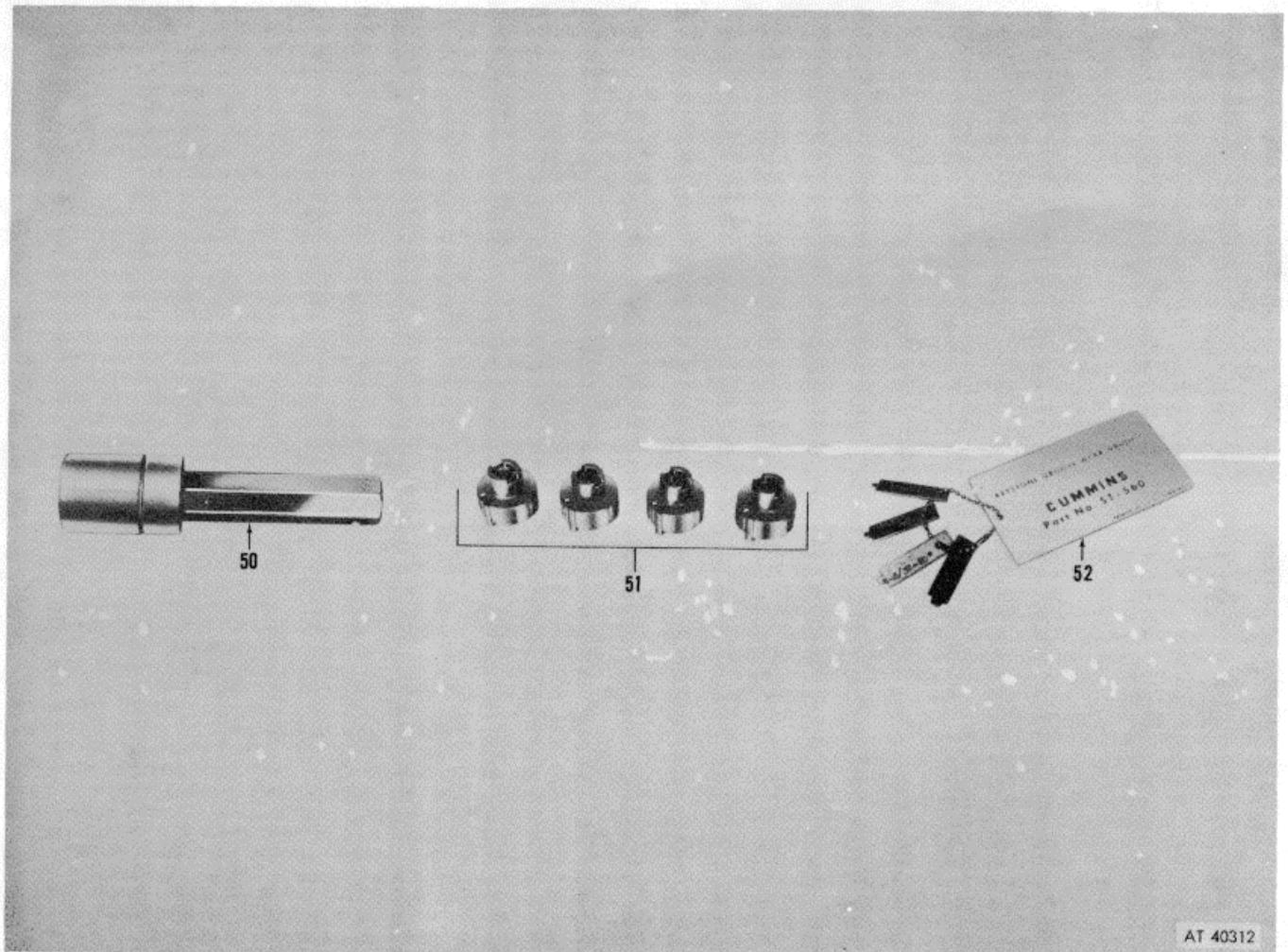

Figure B-28. Special tools. (Sheet 9 of 9)

B-74



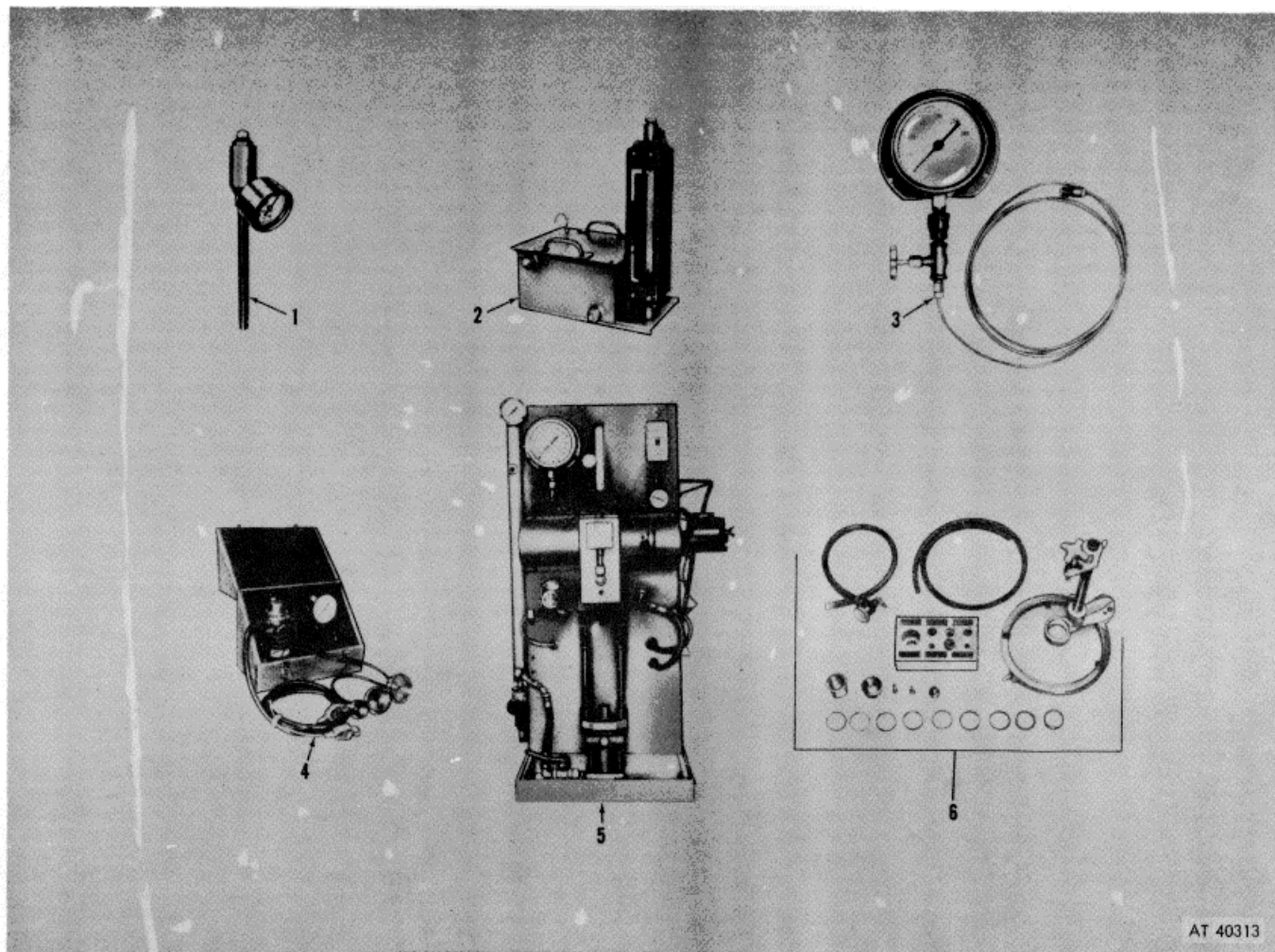

Figure B-29. Test equipment. (Sheet 1 of 2)

B-75

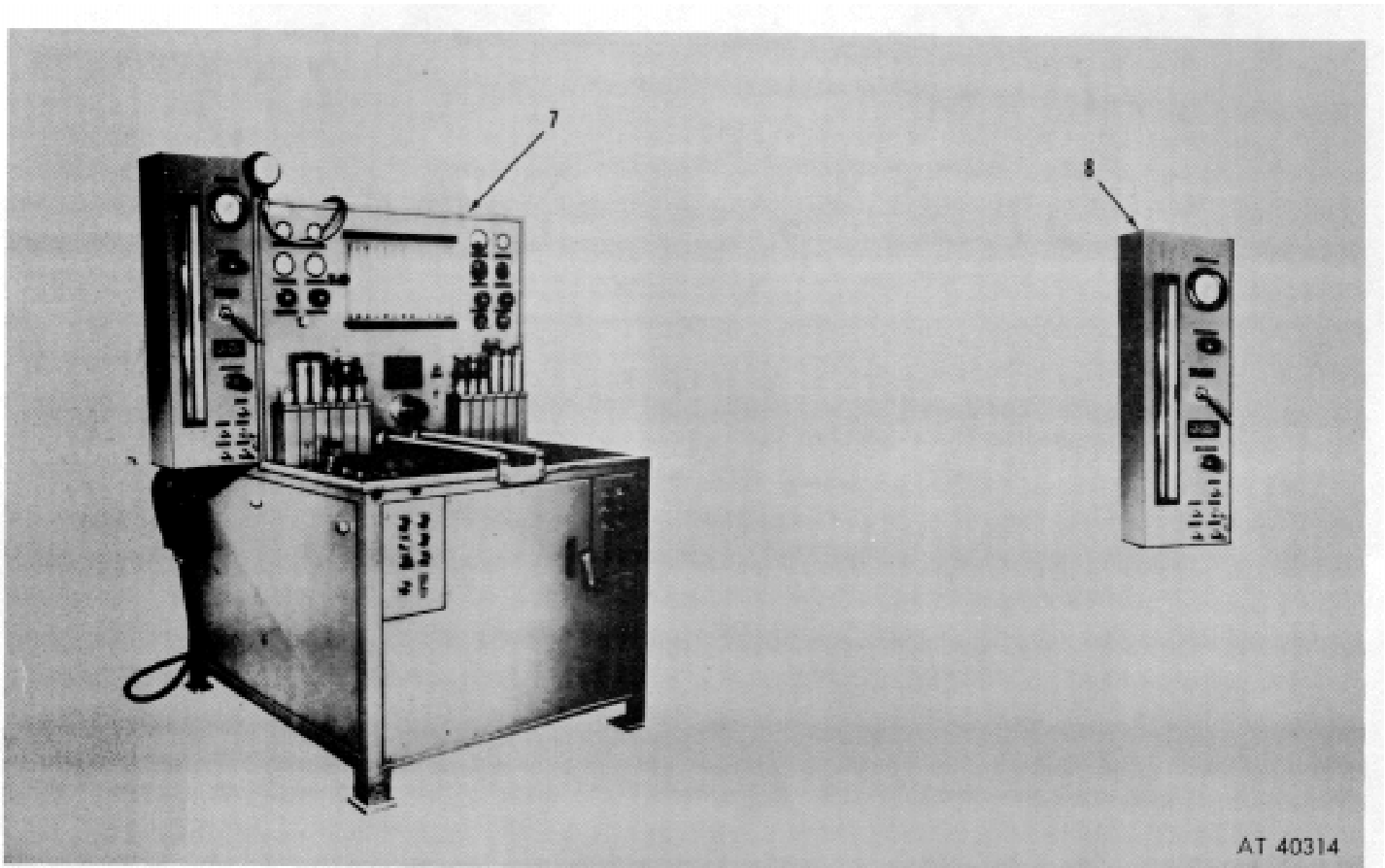

Figure B-29. Test equipment. (Sheet 2 of 2)

B-76

**SECTION IV**  
**INDEX-NATIONAL STOCK NUMBER AND REFERENCE NUMBER**  
**CROSS-REFERENCE TO FIGURE AND ITEM NUMBER**  
**NATIONAL STOCK NUMBER CROSS-REFERENCE TO FIGURE AND ITEM NUMBER**

<b>NATIONAL STOCK NUMBER</b>	<b>FIGURE NUMBER</b>	<b>ITEM NUMBER</b>	<b>NATIONAL STOCK NUMBER</b>	<b>FIGURE NUMBER</b>	<b>ITEM NUMBER</b>
2530-00-768-7663	B-26	5	2815-00-907-8954	B-6	33
2530-00-919-6460	B-25	1	2815-00-907-8955	B-10	1
2815-00-045-9875	B-6	30	2815-00-907-8964	B-17	19
2815-00-045-9876	B-6	35	2815-00-907-8972	B-12	2
2815-00-045-9877	B-6	31	2815-00-907-8979	B-4	12
2815-00-062-9566	B-5	11	2815-00-907-9012	B-10	27
2815-00-082-0462	B-5	8	2815-00-907-9013	B-3	6
2815-00-084-7783	B-4	1	2815-00-909-2451	B-8	1
2815-00-084-7784	B-2	19	2815-00-909-2476	B-12	8
2815-00-084-7796	B-12	11	2815-00-909-2479	B-8	4
2815-00-084-7800	B-10	13	2815-00-909-2481	B-7	13
2815-00-085-3944	B-6	49	2815-00-909-2485	B-6	28
2815-00-085-3952	B-6	8	2815-00-909-2486	B-12	4
2815-00-085-3954	B-6	53	2815-00-909-2491	B-5	9
2815-00-085-7434	B-6	37	2815-00-909-5956	B-3	4
2815-00-085-7438	B-6	39	2815-00-910-8217	B-1	2
2815-00-085-7441	B-6	19	2815-00-910-8218	B-1	1
2815-00-085-7442	B-2	6	2815-00-910-8219	B-1	-
2815-00-085-7444	B-3	-	2815-00-911-7612	B-5	-
2815-00-085-7450	B-6	38	2815-00-912-4609	B-6	47
2815-00-085-7451	B-6	39	2815-00-912-4611	B-6	50
2815-00-085-7452	B-6	20	2815-00-913-1743	B-2	1
2815-00-085-7457	B-3	18	2815-00-916-1879	B-6	46
2815-00-085-7469	B-6	10	2815-00-924-4491	B-3	5
2815-00-085-7470	B-3	9	2815-00-939-8084	B-6	22
2815-00-085-7476	B-7	7	2815-00-939-8924	B-6	25
2815-00-086-8384	B-10	12	2815-00-972-5388	B-2	8
2815-00-104-3637	B-4	4	2815-00-973-0481	B-10	30
2815-00-148-7469	B-6	42	2815-00-974-9872	B-12	17
2815-00-159-8678	B-6	43	2815-00-981-3160	B-6	14
2815-00-190-8888	B-10	14	2815-00-994-4418	B-2	25
2815-00-226-8089	B-1	3	2815-00-994-4434	B-6	9
2815-00-297-0068	B-3	16	2815-00-994-4437	B-6	36
2815-00-297-0619	B-4	2	2815-00-994-4438	B-6	21
2815-00-353-9395	B-4	19	2815-00-994-4443	B-6	56
	B-7	10	2815-00-994-4444	B-6	43
	B-10	32	2815-00-999-5354	B-7	18
2815-00-362-1548	B-6	6	2910-00-062-9564	B-25	6
2815-00-453-9077	B-3	14	2910-00-065-5544	B-15	23
2815-00-454-5058	B-2	21		B-17	34
2815-00-454-7806	B-2	15	2910-00-084-7785	B-25	2
2815-00-505-5119	B-6	34	2910-00-084-7787	B-17	12
2815-00-506-5720	B-20	6	2910-00-084-7813	B-17	7
2815-00-712-8495	B-2	9	2910-00-085-3939	B-17	9
2815-00-719-4598	B-7	15	2910-00-085-7436	B-17	13
2815-00-772-5352	B-7	5	2910-00-085-7439	B-15	13
2815-00-783-9751	B-6	26	2910-00-085-7461	B-13	7
2815-00-791-1453	B-10	29	2910-00-085-7465	B-13	6
2815-00-813-7765	B-11	24	2910-00-132-0769	B-17	22
2815-00-815-0530	B-4	5	2910-00-369-8240	B-18	1
2815-00-842-5330	B-3	19	2910-00-400-5178	B-15	28
2815-00-903-1334	B-3	-	2910-00-507-3271	B-15	3
2815-00-903-6633	B-2	26	2910-00-567-4354	B-16	7
2815-00-905-4453	B-6	12	2910-00-695-3285	B-18	10
2815-00-907-8950	B-5	10	2910-00-759-1299	B-15	29
2815-00-907-8952	B-5	4	2910-00-773-9369	B-18	12

## NATIONAL STOCK NUMBER CROSS-REFERENCE TO FIGURE AND ITEM NUMBER

NATIONAL STOCK NUMBER	FIGURE NUMBER	ITEM NUMBER	NATIONAL STOCK NUMBER	FIGURE NUMBER	ITEM NUMBER
2910-00-774-4246	B-15	7	3030-00-918-9644	B-23	191
2910-00-790-8736	B-15	5	3040-00-459-7158	B-10	7
2910-00-829-5603	B-15	31	3040-00-788-2762	B-18	16
2910-00-829-5604	B-15	37	3110-00-082-1877	B-22	11
2910-00-829-5617	B-16	6	3110-00-100-3161	B-23	81
2910-00-858-3522	B-17	29	3110-00-100-6149	B-13	15
2910-00-905-0038	B-27	6	3110-00-144-8499	B-18	13
2910-00-907-8960	B-15	35	3110-00-198-2170	B-23	91
2910-00-907-8961	B-15	35	3110-00-829-2049	B-22	8
2910-00-908-7307	B-13	12	3120-00-062-9559	B-13	13
2910-00-910-9637	B-15	32	3120-00-082-0240	B-6	48
2910-00-912-4554	B-13	11	3120-00-082-0241	B-6	51
2910-00-912-9104	B-13	10	3120-00-082-0447	B-7	14
2910-00-914-7319	B-15	13	3120-00-086-7743	B-7	8
2910-00-920-7554	B-14	1	3120-00-132-0286	B-10	5
2910-00-920-7555	B-18	19	3120-00-445-0606	B-25	5
2910-00-920-7556	B-13	3	3120-00-507-3264	B-27	7
2910-00-920-7557	B-13	1	3120-00-566-0480	B-10	11
2910-00-924-3912	B-16	1	3120-00-603-2691	B-18	20
2910-00-933-3012	B-16	6	3120-00-719-5719	B-16	31
2910-00-951-3536	B-16	19	3120-00-764-7090	B-15	38
2910-00-970-1277	B-13	18	3120-00-810-6032	B-15	40
2920-00-506-5719	B-20	8	3120-00-810-7040	B-22	9
2920-00-807-2408	B-24.1	2	3120-00-870-9520	B-10	10
2920-00-909-2483	B-24	9	3120-00-904-9595	B-18	29
12920-00-785-0833	B-24.1	1	3120-00-908-7320	B-5	-
2920-00-933-2563	B-24	8	3120-00-910-8220	B-5	
2930-00-085-7421	B-22	22	3120-00-913-9746	B-5	13
2930-00-437-0567	B-1	14	3120-00-939-7137	B-7	
2930-00-903-7696	B-22	12	3120-00-973-2972	B-6	29
2930-00-904-9585	B-23	3	3120-00-984-1851	B-6	27
2930-00-907-8962	B-22	4	3120-00-994-4419	B-3	7
2930-00-907-8963	B-22	3	3120-00-994-4420	B-3	23
2930-00-908-7311	B-22	5	3120-00-994-4421	B-3	8
2930-00-908-7315	B-22	18	3120-00-994-4422	B-3	22
2930-00-914-0992	B-22	6	3120-00-994-4423	B-3	11
1 2930-00-914-6042	B-23	12	3120-00-994-4424	B-3	21
2940-00-417-5800	B-9	28	3120-00-994-4432	B-5	7
2940-00-459-6558	B-10	22	3460-00-999-1173	B-28	48
2940-00-470-6701	B-11	15	3460-00-999-1257	B-28	21
2990-00-735-8564	B-18	27	3460-00-999-1258	B-28	22
	B-18	14	3805-00-441-0145	B-25	
2990-00-792-1571	B-18	26	3805-00-445-0607	B-25	3
2990-00-858-3526	B-15	16	3805-00-607-7652	B-21	3
2920-00-970-8930	B-6	42	3805-00-961-9470	B-15	2
3010-00-507-8347	B-18	6	4320-00-994-4408	B-22	15
3020-00-082-0461	B-10	17	4710-00-927-9304	B-11	30
3020-00-082-1899	B-3	20	4200-00-458-8079	B-19	
3020-00-088-1702	B-7	12	4720-00-731-8248	B-19	5
3020-00-138-8081	B-26	3	4730-00-011-3175	B-17	16
3020-00-460-6429	B-10	21	4730-00-018-9566	B-2	20
3020-00-528-5053	B-4	13		B-3	12
3020-00-562-1173	B-18	15		B-4	6
3020-00-682-7710	B-10	6		B-6	16
3020-00-701-1112	B-18	28		B-7	3
3020-00-702-3882	B-16	5		B-11	11
3020-00-790-3417	B-27	8	4730-00-019-4842	B-20	1
3020-00-903-9535	B-25	4	4730-00-042-6318	B-11	9
3020-00-905-4427	B-243	3	4730-00-041-4203	B-8	1
3020-00-905-4420	B-24	4	4730-00-081-4203	B-15	5
3030-00-288-1338	B-26	1	4730-00-042-1851	B-11	4
3030-00-722-2095	B-22	-		B-12	3
3030-00-918-0605	B-24	1	4730-00-226-8444	B-12	1
			4731-00-231-3908	B-26	8
			4780-00-277-5822	B-8	6

## NATIONAL STOCK NUMBER CROSS-REFERENCE TO FIGURE AND ITEM NUMBER

NATIONAL STOCK NUMBER	FIGURE NUMBER	ITEM NUMBER	NATIONAL STOCK NUMBER	FIGURE NUMBER	ITEM NUMBER
4730-00-278-4592	B-17	2	5120-00-981-3109	B-28	49
4730-00-287-0464	B-26	6	5120-00-981-3110	B-28	43
4730-00-289-0212	B-19	14	5120-00-981-3115	B-28	18
	B-6	18	5120-00-999-1207	B-28	44
4730-00-289-4770	B-4	17	5120-00-999-1206	B-28	31
	B-11	5	5120-00-999-1262	B-28	10
	B-22	13	5120-00-999-1263	B-28	11
4730-00-363-7007	B-26	7	5120-00-999-1267	B-28	38
4730-00-369-7824	B-7	35	5120-00-999-1497	B-28	32
4730-00-492-6040	B-9	25	5120-00-999-1504	B-28	28
4730-00-506-4880	B-16	12	5120-00-999-1505	B-28	37
	B-19	16	5120-00-999-1209	B-28	52
4730-00-716-6580	B-15	27	5120-00-690-7949	B-28	24
	B-20	10	5130-00-999-1268	B-28	13
	B-11	10	5220-00-981-7010	B-28	50
4730-00-801-8186	B-2	22	5133-00-999-1208	B-28	51
	B-21	12	5305-00-045-1988	B-18	5
	B-22	21	5305-00-062-2230	B-13	16
4730-00-803-9527	B-20	2	5305-00-062-4373	B-5	6
	B-21	2	5305-00-071-2241	B-18	33
	B-19	6		B-15	8
4730-00-877-6298	B-27	1	5305-00-177-5552	B-4	11
4730-00-908-6335	B-26	10	5305-00-253-5612	B-15	25
4730-00-927-7272	B-17	1	5305-00-267-8977	B-16	23
4810-00-512-3534	B-16	11		B-17	36
4820-00-130-4820	B-1	11	5305-00-269-2800	B-26	14
4820-00-242-4064	B-1	10	5305-00-269-2804	B-26	11
4820-00-620-8123	B-29	5	5305-00-269-3210	B-4	18
4910-00-202-9465	B-28	23		B-7	11
4910-00-202-9488	B-28	41		B-10	18
4910-00-345-3708	B-28	34		B-18	31
4910-00-499-5428	B-29	8		B-24	5
4910-00-763-7495	B-29	7	5305-00-269-3211	B-2	16
4910-00-817-7431	B-29	4		B-7	17
4910-00-898-0645	B-28	45		B-11	6
4910-00-977-7489	B-28	1		B-21	18
4910-00-977-7505	B-28	9	5305-00-269-3213	B-7	1
4910-00-977-7506	B-28	40		B-10	23
4910-00-977-7507	B-28	26		B-11	23
4910-00-977-7510	B-28	5		B-12	16
4910-00-977-7511	B-28	3		B-19	10
4910-00-977-7516	B-28	46		B-21	10
4910-00-977-7519	B-28	16		B-22	20
4910-00-977-7529	B-28	17	5305-00-269-3214	B-1	6
4910-00-981-3105	B-28	12		B-6	3
4910-00-999-1269	B-29	2		B-7	16
4910-00-999-1496	B-28	33		B-10	8
4910-00-999-1499	B-28	36		B-11	21
4910-00-999-1500	B-29	6		B-12	5
4910-00-999-1501	B-29	1		B-19	1
4910-00-999-1502	B-28	9		B-21	6
4910-00-999-1503	B-28	2		B-24	10
4910-00-999-1506	B-28	25	5305-00-269-3215	B-4	16
4920-00-711-9307	B-28	6		B-8	14
5110-00-981-3106	B-28	42	5305-00-269-3215	B-10	24
5110-00-981-3107	B-28	29	5305-00-269-3216	B-11	19
5120-00-364-5417	B-28	15	5305-00-269-3217	B-10	33
5120-00-620-6222	B-28	39		B-11	20
5120-00-896-8088	B-28	35		B-23	1
5120-00-896-8097	B-28	8	5305-00-269-3220	B-4	15
5120-00-953-9664	B-28	7		B-21	11
5120-00-953-9665	B-28	19	5305-00-269-3221	B-19	5
5120-00-977-7528	B-28	30		B-25	10
5120-00-980-7346	B-28	14			
5120-00-981-3108	B-28				

## NATIONAL STOCK NUMBER CROSS-REFERENCE TO FIGURE AND ITEM NUMBER

NATIONAL STOCK NUMBER	FIGURE NUMBER	ITEM NUMBER	NATIONAL STOCK NUMBER	FIGURE NUMBER	ITEM NUMBER
5305-00-297-4022	B-6	44	5310-00-595-6612	B-2	14
5305-00-423-7693	B-16	13	5310-00-637-9541	B-1	5
5305-00-426-3023	B-23	17		B-2	17
5305-00-493-3959	B-15	19		B-4	10
5305-00-506-5722	B-17	23		B-6	12
	B-17	3		B-11	7
5305-00-509-8106	B-16	10		B-7	2
5305-00-622-9483	B-27	3		B-12	6
5305-00-724-5911	B-1	15		B-13	17
	B-19	9		B-19	4
5305-00-735-8098	B-11	8		B-18	8
5305-00-858-0037	B-17	15		B-21	5
5305-00-905-0831	B-3	1		B-22	19
5305-00-911-1862	B-24.1	4		B-23	2
5305-00-947-3437	B-6	55		B-24	6
5306-00-019-4227	B-18	7		B-25	9
5306-00-062-3995	B-2	13		B-26	12
5306-00-081-8507	B-3	15	5310-00-682-5944	B-20	9
5306-00-082-0660	B-2	3	5310-00-753-4099	B-23	18
5306-00-082-0661	B-2	5	5310-00-763-8920	B-1	12
	B-12	15	5310-00-858-3509	B-15	15
5306-00-225-8497	B-6	24	5310-00-809-4085	B-26	13
5306-00-335-4755	B-4	14	5310-00-920-0831	B-24	3
15306-00-426-3023	B-23	16	5310-00-971-7989	B-15	6
5306-00-912-9105	B-23	15		B-15	22
5306-00-970-8923	B-2	4	5310-00-984-0273	B-15	11
5310-00-045-3299	B-15	9	5330-00-080-0483	B-16	22
5310-00-062-4407	B-6	54	5330-00-081-9289	B-15	12
5310-00-062-6632	B-5	12	5330-00-081-9299	B-17	11
5310-00-062-9556	B-23	6	5330-00-082-0454	B-2	24
5310-00-062-9557	B-23	7	5330-00-086-8294	B-21	15
5310-00-080-6004	B-26	15	5330-00-199-5886	B-24.1	-
5310-00-081-8500	B-2	2	5330-00-255-0331	B-21	7
5310-00-082-1888	B-17	10	5330-00-401-2004	B-11	28
5310-00-134-4169	B-12	18	5330-00-401-5105	B-11	26
	B-10	25	5330-00-401-5107	B-11	13
5310-00-141-1795	B-15	20	5330-00-401-5106	B-11	27
	B-17	30	5330-00-401-5108	B-10	3
	B-18	35	5330-00-445-0609	B-26	7
	B-23	17	5330-00-507-8346	B-18	ill
5310-00-209-0965	B-18	4	5330-00-506-4866	B-18	17
5310-00-232-8194	B-1	13	5330-00-551-4007	B-23	11
5310-00-262-2986	B-17	5	5330-00-562-1176	B-17	28
5310-00-275-3435	B-6	41	5330-00-567-3463	B-16	8
5310-00-393-6475	B-20	5	5330-00-580-5327	GP 0302	-
	B-12	14		B-15	42
5310-00-407-9566	B-6	23	5330-00-582-7484	B-2	28
	B-17	31	5330-00-641-1149	B-27	5
5310-00-484-1718	B-16	9	5330-00-591-8519	B-27	4
5310-00-507-3259	B-17	21	5330-00-664-1055	GP0302	-
5310-00-521-8595	B-19	13	5330-00-695-3295	B-13	4
	B-18	34	5330-00-809-2667	B-16	17
5310-00-562-6552	B-15	21	5330-00-779-2534	B-18	2
	B-22	2	5330-00-809-3276	B-16	20
	B-4	9	5330-00-816-8148	B-17	8
5310-00-562-6553	B-2	18	5330-00-815-0895	B-7	4
	B-6	1	5330-00-821-9162	B-25	-
	B-12	7	5330-00-821-9164	B-8	2
	B-18	9	5330-00-822-3954	B-25	-
	B-19	3	5330-00-838-9975	B-16	2
	B-21	17	5330-00-866-5079	B-2	7
	B-24	7	5330-00-888-4988	B-18	-
5310-00-562-6557	B-18	3	5330-00-903-7701	B-19	11
5310-00-562-6558	B-8	13	5330-00-905-2679	B-25	-
5310-00-562-6558	B-12	13	5330-00-909-2490	B-24.1	31

## NATIONAL STOCK NUMBER CROSS-REFERENCE TO FIGURE AND ITEM NUMBER

NATIONAL STOCK NUMBER	FIGURE NUMBER	ITEM NUMBER	NATIONAL STOCK NUMBER	FIGURE NUMBER	ITEM NUMBER
5330-00-909-2489	B-12	9	5360-00-082-0126	B-6	11
5330-00-913-3949	B-2	23	5360-00-086-7710	B-13	9
5330-00-918-0606	B-2	-	5360-00-664-5343	B-10	26
5330-00-918-9646	B-21	8	5360-00-902-8478	B-17	24
5330-00-961-3638	B-17	17	5360-00-905-0042	B-15	33
5330-00-959-1563	B-13	14	5365-00-086-8293	B-2	27
5330-00-970-3461	B-20	3	5365-00-197-9327	B-20	7
5330-00-973-0040	B-23	5	5365-00-507-3224	B-15	34
5330-00-980-9604	B-4	3	5365-00-507-3225	B-15	34
5330-00-993-5100	B-13	5	5365-00-507-3260	B-17	25
5330-00-993-5101	B-12	19	5365-00-507-3261	B-17	25
5330-00-994-4409	B-6	7	5365-00-507-3262	B-17	25
5330-00-994-4410	B-12	10	5365-00-543-3744	B-15	34
5330-00-994-4411	B-12	12	5365-00-598-1070	B-17	27
5330-00-944-4435	B-6	13	5365-00-907-9008	B-10	25
5340-00-459-9937	B-13	8	5365-00-965-0870	B-16	18
5340-00-464-7064	B-15	24	5365-00-988-3668	B-15	43
	B-17	33	5970-00-086-7709	B-22	16.
5340-00-470-6173	B-6	45	6620-00-062-4404	B-21	14
5340-00-721-5329	B-6	17	6620-00-993-5546	B-11	16
5340-00-786-0102	B-15	17	6685-00-678-9004	B-29	3
5340-00-898-1497	B-17	26	6685-00-814-5271	B-21	13
5340-00-951-0773	B-28	47	6685-00-906-0156	B-1	9
5355-00-082-1189	B-17	18	8145-00-912-4617	B-1	7
5360-00-081-8487	B-18	21	9905-00-733-7622	B-15	26
5360-00-082-0124	B-17	20			

## Reference Number Cross- Reference to Figure and Item Number

Part Number	FSCM	Fig. No.	Item No.	Part Number	FSCM	Fig. No.	Item No.
AN818-16-12B	88044	B-26	6	S 600	15434	B-22	2
AN915-6	88044	B-26	8			B-15	21
AN960-416	88044	B-15	20			B-18	34
		B-16	25			B-22	2
		B-17	30	5602	15434	B-2	18
		B-18	35			B-4	9
AR500100	15434	B-16	15			B-6	1
AR50101	15434	B-16	1			B-12	7
1 AR50828	15434	B-14	1			B-12	9
BM68356	15434	B-18				B-19	3
BM69979	15434	B-17	1			B-21	17
BM70797	15434	B-17	27			B-24	7
BM71425	15434	B-6	46	S-607	15434	B-17	14
BM71531	15434	B-3	-	S 622	15434	B-18	3
BM71630	15434	B-3		S 626	15434	B-5	13
BM75294	15434	B-25	1			B-12	13
BM75508	15434	B-15	32	S 915	15434	B-5	3
BM70114	15434	B-22	18	S 915A	15434	B-2	22
BM76119	15434	B-2	1			B11	10
BM76338	15434	B-15	29			B-21	12
BM78683	15434	B-4	12			B-22	1
BM79166	15434	B-S	10	S 995	15434	B-4	17
BM91011	15434	B-13	12			B-6	18
BM91679	15434	B-18	1			B-11	5
BM92141	15434	B-3	4			B-22	13
BM92350	15434	B-S	-	ST 112	15434	B-28	34
BM93100	15434	B-S	4	ST 384	15434	B-28	15
BM93636	15434	B-13	3	ST 417	15434	B-29	4
BM940607	15434	B-22	5	ST 435	15434	B-29	3
BM94150	15434	B-6	25	ST 490	15434	B-28	42
BM94151	15434	B-6	33	ST 561	15434	B-28	40
BM94173	15434	B-2	21	ST 712	15434	B-28	47
BM94658	15434	B-21	1	ST 772	15434	B-28	16
BM94676	15434	B-10	1	ST 955	15434	B-28	6
BM95886	15434	B-1	-	MS16627-93	96906	B-17	27
BM96100	15434	B-2	-	MS19059-47	96906	B-13	15
BM96101	15434	B-24	1	MS20002-12	96906	B-2	14
1 BM96103	15434	B-23	19	MS20066-16	96906	B-18	18
BM96104	15434	B-7	-	MS21318-15	96906	B-15	25
BM96M25	15434	B-6	50	MS24537-i	96906	B-21	13
BM96830	15434	B-6	52	MS24539-1	96906	B-11	16
BM96832	15434	B-6	47	MS27183-14	96906	B-26	15
BM96854	15434	B-2	-	MS27183-16	96906	B-26	13
1BM97339	15434	B-S	10	MS35265-81	96906	B-27	3
BM97370	15434	B-6	S	MS35295-66	96906	B-11	19
BM97398	15434	B-18	19	MS35338-42	96906	B-15	9
BM97400	15434	B-14	1	MS35335-45	96906	B-6	23
BM97421	15434	B-13	1			B-12	14
BM97590	15434	B-S	-	MS35338-46	96906	B-1	5
JS686-MODEL B	33287	B-29	5			B-2	17
S117	15434	B-9	27			B-4	10
S1212	15434	B-17	15			B-6	2
S126	15434	B-4	11			B-7	2
S131C	15434	B-23	16			B-S	10
S136	15434	B-2	11			B-1	7
S159B	15434	B-15	19			B-12	6
S16206	15434	B-15	17			B-3	17
S16237	15434	B-22	10			B-S8	8
S163D	15434	B-19	9			B-19	4
S1650	15434	B-18	13			B-21	5
S174B	15434	B-11	8			B-22	19
S18SB	15434	B-8	11				
S223	15434	B-19	13				



## Reference Number Cross- Reference to Figure and Item Number

Part Number	FSCM	Fig. No.	Item No.	Part Number	FSCM	Fig. No.	Item No.
		B-23	2	100193	15434	B-15	40
		B-24	6	100205	15434	B-18	16
		B-25	9	100215	15434	B-16	7
		B-26	12	100478	15434	B-15	12
		B-23	17	100973	15434	B-2	27
MS35338-47	96906	B-18	4	100764	15434	B-18	17
		B-3	2	101499	15434	B-6	54
MS35338-50	96906	B-1	13	101468	15434	B-16	3
		B-15	22	101841	15434	B-15	3
MS35691-5	96906	B-15	6	101754	15434	B-13	5
MS35756-9	96906	B-26	-	101842	15434	B-15	34
MS39158-9	96906	B-26	10	101843	15434	B-15	34
MS51069-44	96906	B-26	1	101918	15434	B-18	10
MS51967-20	96906	B-1	12	102408	15434	B-12	1
IMS53011-1	96906	B-24.1	1	102957	15434	B-4	5
		B-15	42	103036	15434	B-18	15
MS9021-116	96906	B-2	28	103005	15434	B-18	2
MS90725-10	96906	B-18	33	105375	15434	B-15	26
		B-12	15	107261	15434	B-18	26
MS90725-32	96906	B-6	24	106276	15434	B-23	118
		B-7	11	108186	15434	B-6	32
		B-10	18	108187	15434	B-6	26
MS90725-59	96906	B-4	18	107738	15434	B-6	34
		B-18	31	108882	15434	B-18	25
		B-24	5	10924730	19207	B-1	16
		B-7	17	10926305	19207	B-1	14
		B-11	6	10929868	19207	B-24	9
MS90725-60	96906	B-2	16	10924731	19207	B-1	8
		B-10	23	10945942	19207	B-26	2
		B-11	23	10946107-1	19207	B-107-1	2
MS90725-62	96906	B-7	1	10944664	19207	B-1	7
		B-12	16	109859	15434	B-18	
		B-19	10	109915	15434	B-15	7
		B-21	10	11020200	19207	B-29	7
		B-22	20	11020519	19207	B-29	8
		B-6	3	119849	19207	B-24.1	2
		B-7	16	113244	15434	B-18	28
MS90725-64	96906	B-1	6	110855	15434	B-16	8
		B-10	8	113608	15434	B-23	
		B-11	21	114123	15434	B-24.1	3
		B-12	5	114223	15434	B-6	30
		B-19	1	114463	15434	B-10	15
		B-21	6	114791	15434	B-17	8
		B-24	10	116000	15434	B-18	27
		B-8	14	11600028	19207	B-28	2
		B-10	24	11600031	19207	B-28	35
MS90725-65	96906	B-4	16	11600027	19207	B-28	41
		B-11	20	11600037	19207	B-28	3
		B-23	1	11600039	19207	B-29	2
MS90725-67	96906	B-10	33	11600033	19207	B-28	39
MS90725-68	96906	B-21	18	11600040	19207	B-28	1
		B-21	11	11600042	19207	B-28	27
MS90725-70	96906	B-4		1511600041	19207	B-28	24
		B-25	10	11600045	19207	B-28	2
MS90725-71	96906	B-19	5	11600043	19207	B-28	52
MS90725-87	96906	B-18	5	11600046	19207	B-28	26
MS90725-163	96906	B-1	15	11600047	19207	B-28	25
		B-17	37	11600049	19207	B-28	13
MS90726-10	96906	B-16	23	11600048	19207	B-28	31
MS90726-57	96906	B-26	14	11600050	19207	B-28	14
MS90726-91	96906	B-26	11			B-28	51
VD-103118-173	19207	B-21	14	11600051	19207	B-28	30
100099	15434	B-16	17				
100192	15434	B-18	12				

## Reference Number Cross- Reference to Figure and Item Number

Part Number	FSCM	Fig. No.	Item No.	Part Number	FSCM	Fig. No.	Item No.
11600054	19207	B-28	48	129826	15434	B-17	6
11600065	19207	B-28	43	129827	15434	B-17	9
11600056	19207	B-29	6	129838	15434	B-17	18
11600057	19207	B-28	49	129839	15434	B-17	12
11600059	19207	B-28	4	129888	15434	B-17	11
11600060	19207	B-28	9	130080	15434	B-25	6
11600061	19207	B-28	28	180081	15434	B-25	8
11600063	19207	B-28	18	131168	15434	B-2	Y
11600065	19207	B-28	60	1312765	15434	B-10	21
11600066	19207	B-28	6	131430	15434	B-1S	16
11600068	19207	B-28	23	132705	15434	B-2	7
11600070-1	19207	B-28	21	134074	15434	B-17	17
11600070-2	19207	B-28	22	134326	15434	B-8	6
11600071	19207	B-28	86	136079	15434	B-22	16
11600073	19207	B-28	10	136042	15434	B-15	7
11600075	19207	B-28	11	136749	15434	B-19	6
11600076	19207	B-28	8	137870	15434	B-17	19
11600077	19207	B-28	7	137372	15434	B-15	86
11600078	19207	B-29	1	138886	15434	B-6	21
11600079	19207	B-28	20	138887	15434	B-6	86
11600081	19207	B-28	87	138905	15434	B-1s	88
11600082	19207	B-28	12	138935	15434	B-6	8
11600084	19207	B-28	45	138937	15434	B-6	14
11600085	19207	B-28	46	138948	16434	B-6	38
11600086	19207	B-28	17	139114	15434	B-7	9
11600087	19207	B-28	44	139247	15434	B-12	17
11600088	19207	B-28	72	139438	15434	B-5	12
11600090	19207	B-28	38	139473	15434	B-15	43
11600092	19207	B-28	33	139677	15434	B-12	19
11600093	19207	B-28	19	139834	15434	B-16	19
11602730	19207	B-26	5	139845	15434	B-25	2
11649251	19207	B-26	3	139896	15434	B-6	10
11649253	19207	B-26	7	139915	15434	B-25	8
11659874	19207	B-26	4	139950	15434	B-5	11
117077	15434	B-25	7	139988	15434	B-16	20
118227	15434	B-15	30	140080	15434	B-3	23
118273	15434	B-20	9	140081	15434	B-3	23
119116	15434	B-24.1	-	140090	15434	B-3	22
119363	15434	B-16	5	140091	15434	B-3	8
121037	15434	B-24	8	140100	15434	B-3	21
122135	15434	B-8	2	140120	15434	B-5	8
122929	15434	B-2	24	140141	15434	B-3	11
		B-17	34	140514	15434	B-21	8
124019	15434	B-15	29	140629	15434	B-21	15
124020	15434	B-17	33	140618	15434	B-15	31
125740	15434	B-19	14	141875	15434	B-6	48
125880	15434	B-20	2	142149	15434	B-15	8
126600	15434	B-5	7	142179	15434	B-15	11
127316	15434	B-2	2	142616	15434	B-11	14
127554	15434	B-6	9	142698	15434	B-15	33
127558	15434	B-10	29	142992	15434	B-6	56
127930	15434	B-6	37	143021	15434	B-6	51
127950	15434	B-25	-	143108	15434	B-23	51
128002	15434	B-13	18	143405	15434	B-10	12
128040	15434	B-13	9	143679	15434	B-17	7
128085	15434	B-25	-	143694	15434	B-10	13
128086	15434	B-25	-	14838417	15434	B-18	21
128087	15434	B-25	-	143913	15434	B-22	17
128235	15434	B-6	11	144042	21450	B-26	9
		B-3	17	144178	15434	B-18	23
128765	15434	B-2	31	144131	15434	B-3	13
128766	15434	B-2	32	144179	15434	B-18	22
		B-3	10				
129768	15434	B-17	10				

## Reference Number Cross- Reference to Figure and Item Number

Part Number	FSCM	Fig. No.	Item No.	Part Number	FSCM	Fig. No.	Item No.
144195	15484	B-17	20	153615	15484	B-6	4
144S02	15484	B-IS	87	154087	15484	B-17	17
144S06	15434	B-22	15	154088	15484	B-15	2
144800	15484	B-25	6	154166	15484	B-5	18
144896	15484	B-6	39	154167	15484	B-25	19
144807	15484	B-6	59	154227	15484	B-12	11
146064	15484	B-6	19	154858	15484	B-22	22
146120	15484	B-6	20	15436	15484	B-12	12
146488	15484	B-15	5	154542	15484	B-i	4
146500	15484	B-8	7	154716	15484	B-6	29
146591	15484	B-2	7	165445	15484	B-22	11
146601	15484	B-3	22	154689	15484	B-22	9
146610	15484	B-11	1	154643	15484	B-1	8
146611	15484	B-9	21	156172	1544	B-2	25
14660	15484	B-25	6	155267	15484	B-1	6
1146651	15484	B-8	7	155445	15484	B-27	1
146690	15484	B-6	8	155500	15434	B-7	7
146983	15484	B-10	14	155790	15484	B-19	7
146975	15484	B-6	51	156088	15484	B-0	27
147066	15484	B-2	6	156144	15484	B-6	4
147160	15484	B-7	14	156304	15484	B-S	9
147292	15484	B-17	24	156810	15484	B-S	1i
147889	15484	B-6	40	156811	15434	B-S	1i
147558	15484	B-18	18	156348	15484	B-12	9
147559	15484	B-15	14	156438	15484	B-6	81
147729	15434	B-21	16	156439	15484	B-6	55
148000	1544	B-2	29	156497	15484	B-12	8
148001	1544	B-2	18	156641	15484	B-6	19
148210	15484	B-7	8	156659	15484	B-19	11
148295	15484	B-11	24	157088	15484	B-15	3
148504	15484	B-18	10	157504	15484	B-18	20
148524	15434	B-18	8	157618	15484	B-12	2
148916	15484	B-15	15	157647	15434	B-21	9
148976	15484	B-1S	14	157952	15484	B-10	16
148977	15434	B-S	16	158168	15484	B-10	19
149030	15484	B-1S	18	158370	15484	B-S	6
149081	15434	B-1S	18	158551	15484	B-7	4
149040	15484	B-1S	10	158556	15484	B-7	18
149151	15484	B-10	17	158680	15484	B-2	26
14918	15484	B-1	30	so 15 9	15484	B-s	16
149978	15484	B-2	8	159085	15484	B-19	2
150100	15484	B-8	9	159829	15484	B-22	12
150129	15484	B-5	12	160514	15484	B-16	18
150188	15484	B-3	20	160588	15484	B-10	9
150139	15484	B-25	4	161042	15484	B-10	2
151035	15484	B-4	2	161701	15484	B-S	14
151100	15484	B-4	S	161825	15484	B-6	45
151299	15434	B-6	7	161837	15484	B-6	15
151848	15434	B-2	8	161991	15434	B-2	10
151349	15484	B-2	5	161992	15484	B-2	12
151350	15484	B-2	4	162592	15434	B-10	20
151707	15434	B-12	10	162607	15434	B-10	31
151780	15484	B-4	1	162663	15434	B-10	28
151781	15434	B-2	19	162685	15484	B-10	7
151900	15484	B-16	22	162761	15434	B-B	1
152082	15434	B-6	27	168013	15434	B-10	3
152173	15484	B-6	49	168061	15484	B-6	1
152237	15484	B-23	4	163733	15434	B-15	28
115245	60038	B-23	9	163785	15484	B-22	6
158336	15484	B-16	21	168821	15484	B-S	5
153338	15484	B-16	16	163947	15484	B-13	2
153581	15484	B-24.1	4	163994	15484	B-18	29
153614	15434	B-6	43	164349	15484	B-3	3

## Reference Number Cross- Reference to Figure and Item Number

Part Number	FSCM	Fig. No.	Item No.	Part Number	FSCM	Fig. No.	Item No.
167825	15434	B-2	15			B-3	12
168035	15434	B-2	23			B-4	6
168306	15434	B-6	55			B-6	16
168319	15434	B-6	44			B-7	3
168680	15434	B-5	2			B-11	11
169327	15434	B-6	28	22082	33510	B-24	3
169351	15434	B-6	43	24582	78570	B-16	24
169352	15434	B-6	42			B-17	4
169660	15434	B-15	35	428988	19207	B-15	1
169661	15434	B-15	35	43468	15434	B-20	4
169747	15434	B-7	13	43828	15434	B-19	6
170629	15434	B-24	11			B-21	2
170948	15434	B-13	11	43828A	15434	B-8	6
111085	15434	B-6	25	43863	15434	B-10	6
		B-17	3	44678	15434	B-17	29
171546	15434	B-16	10	444697	19207	B-11	
171548	15434	B-16	13	4797	15434	B-4	13
171550	15434	B-16	14	5103-50	15434	B-18	3
171552	15434	B-17	32	5329388	19207	B-2	30
172550	15434	B-5	3	5703466	19207	B-1	
173058	15434	B-24	4	60136	35510	B-24	2
1173061	15434	B-23	14	63842	15434	B-12	18
173286	15434	B-II	12	64487J	15434	B-3	1
173287	15434	B-II	15	64816A	15434	B-16	
173288	15434	B-II	13	65798	15434	B-9	28
173289	15434	B-II	28	67532	15434	B-23	18
173291	15434	B-II	27	67684	15434	B-17	5
173292	06840	B-11	29	67946	15434	B-20	7
173296	06840	B-II	22	68061-A	15434	B-20	3
173297	15434	B-II	3	68139	15434	B-20	1
173298	15434	B-II	1	68178-1	15434	B-20	5
173299	15434	B-II	2	68190	15434	B-8	12
173708	15434	B-15	18	68251	15434	B-10	25
174421	15434	B-27	6	68274	15434	B-10	26
174437	15434	B-4	7	68365	15434	B-10	11
175203	15434	B-23	10	68425	15434	B-8	9
175204	15434	B-23	12	68549	15434	B-15	41
175205	15434	B-23	13	68568	15434	B-7	15
175206	15434	B-22	14	68606	15434	B-15	27
175208	15434	B-22	4			B-19	16
175209	15434	B-22	3			B-20	10
175282	15434	B-10	22	68812	15434	B-20	8
175284	15434	B-19	12	68908	15434	B-4	19
175285	15434	B-19	8			B-7	10
175505	15434	B-9	26			B-15	27
175801	15434	B-9	26	69215	15434	B-20	7
175836	15434	B-16	11	69236	15434	B-10	10
176105	15434	B-8	8	69514	15434	B-10	5
177764	15434	B-16	2	69562	15434	B-4	4
177999	16434	B-17	35	69793	15434	B-18	7
180099	29510	B-11	30	69866	15434	B-22	8
181355	15434	B-21	4	69969	15434	B-21	3
181373	15434	B-10	18	69974	15434	B-8	7
181374	15434	B-11	17	69976	15434	B-22	
		B-17	31	70183	76680	B-22	7
181466	15434	B-16	9	69996	15434	B-19	15
182006	62983	B-11	31	70295	15434	B-17	16
183831	15434	B-11	25	70415	15434	GP 0302	-
183832	15434	B-11	26				
186907	15434	B-7		6			
186908	15434	B-4		8			

## Reference Number Cross- Reference to Figure and Item Number

Part Number	FSCM	Fig. No.	Item No.	Part Number	FSCM	Fig. No.	Item No.
70459	15434	B-6	17	70760	15434	B-10	4
70645	15434	B-7	5	70776	15434	B-13	4
		B-18	14	70809	15434	B-27	5
70690	15434	B-15	39	70777	15434	B-16	12
70693	15434	B-18	24	7089727	19207	B-17	2
70700	15434	B-15	4	7451	80201	B-18	11
7075	15434	B-17	28	8060396	19207	GP 0302	-
lvil3	15434	B-17	28	8333620	19207	B-G	14
70715	15434	B-17	21	8355883	19207	B-1	9
70716	15434	B-17	23	8376442	19207	B-1	11
70717	15434	B-17	25	8376456	19207	B-1	10
70717A	15434	B-17	25	9052-1	15434	B-27	2
70717B	15434	B-17	25	9221	15434	B-21	7
70720	15434	B-27	8	99045-53	15434	B-23	8
70723	15434	B-27	7	9948	15434	B-23	15
70732	15434	B-27	4				

B-87

INDEX

Paragraph	Page	Paragraph	Page
<b>A</b>			
Adapter, crankshaft:		Fuel pump mainshaft cover and governor assembly .....	3-106c 3-47
Cleaning .....	3-36 3-12	Fuel pump shut-off solenoid valve assembly.....	3-106g 3-48
Inspection.....	3-37 3-12	Fuel pump tachometer assembly ....	3-106b 3-47
Installation.....	3-39 3-12	Hydraulic pump and bracket assembly.....	3-147 3-56
Repair .....	3-38 3-12	Oil cooler .....	3-161 3-57
Removal .....	2-11i 2-10	Oil pan .....	3-50 3.13
Adjustment:		Oil pump assembly .....	3-28 3-10
Crossheads, valve .....	3-167 3-57	Rocker arm assembly .....	3-84 3-35
Fuel manifold pressure .....	3-172d(6) 3-62	Starter .....	3-155 3-56
Injectors, engine test .....	3-167 3-57	Tappets, valve and injector.....	3-62 3-15
Vacuum fuel pump .....	3-107g(2) 349	Thermostat assembly .....	3-135 3-54
Valve clearance, engine test.....	3-167 357	Water crossover pipe assembly ....	3-113c 3-52
Air compressor and drive assembly:		Water pump .....	3-123 3-53
Assembly .....	3-100 336	Assembly data, repair and rebuild standards.....	3-185 3-71
Cleaning .....	3-97 336	<b>B</b>	
Disassembly.....	3-96 336	Ball Bearings:	
Inspection.....	3-98 336	Cleaning.....	2-5e 2-1
Installation.....	3-101 3-36	Inspection .....	2-6b 2-2
Removal.....	2-10m 2-8	Repair .....	2-7b 2-2
Repair .....	3-99 3-36	Ball valve, injector:	
Air intake preheater assembly:		Seating	
Assembly .....	3-118 3-53	Seating check .....	3-77e 3-31
Cleaning.....	3-115 3-53	Bearing bore, main .....	33-2
Description .....	1-4c(4) 1-4	Bearing caps, main.....	14e(1) 1-4
Disassembly.....	3-114 352	Bearings, bushing type	
Inspection.....	3-116 3-3	Inspection .....	2-6 2-2
Installation.....	3-119 353	Repair .....	2-7e 2-3
Removal.....	2-10i 2-5	Bearings, connecting rod .....	2-7 211
Repair .....	3-152 3-53	Bearings, crankshaft thrust.....	2-11p 2-13
Alternator:		Bearings, main:	
Assembly .....	3-153 3-56	Cleaning.....	3-8 3-3
Cleaning.....	3-150 3-56	Installation .....	3-12 3-4
Inspection .....	3-149 3-56	Removal.....	3-56 213
Installation.....	3-154 3-56	Repair .....	3-10 3-3
Removal.....	2-10c 2-4	Bearings, rocker arm .....	3-82 3-34
Repair .....	3-152 3-56	Blow-by check .....	3-172c 3-61
Assembly:		Break-in run, engine .....	3-172b 3-60
Air compressor and drive assembly .....	3-100 3-36	Breather, crankcase .....	3-33 3-11
Air intake preheater assembly .....	3-118 3-53	Assembly .....	3-91 3-35
Alternator .....	3-153 3-56	Cleaning.....	3-92 3-35
Camshaft .....	3-33 3-11	Inspection .....	3-93 3-35
Connecting rod and piston assembly.....	3-17 3-7	Removal.....	2-11a(2) 2-8
Crankshaft.....	3-11 11	Repair .....	3-194 3-36
Cylinder block .....	3-6 3-2	Bushing, piston pin:	
Cylinder head.....	3-68 3-19	Boring .....	3-16 3-7
Cylinder head cover .....	2-11 2-8	Inspection .....	3-15 3-5
Fan drive pulley, vibration damper assembly.....	3-129 3-54	Bushings and bushing-type bearings, inspection .....	2-6e 2-2
Fan, and fan hub assembly .....	3-141 3-55	Bushings, camshaft:	
Flywheel .....	3-56 3-14	Inspection. ....	3-4a 3-1
Flywheel housing .....	3-44 3-12	Installation .....	3-6 3-2
Fuel injectors.....	3-76 3-25	Removal.....	3-2b 3-1
Fuel pump damper assembly.....	3-106f 3-48	Repair and rebuild standards.....	3-180 3-66
Fuel pump gear assembly.....	3-106d 3-47	<b>C</b>	
Fuel pump governor spring and assembly.....	3-106c 3-47	Calibration	
Fuel pump housing .....	3-106a 3-47	Fuel pump procedure.....	3-107 3-48

INDEX-Continued

	Paragraph	Page		Paragraph	Page
Injectors .....	3-77	3-32	Oil pan .....	3-47	3-13
Mounting fuel pump for .....	3-104c	3-40	Oil passages .....	2-5C	2-1
Castings			Oil pump assembly .....	3-25	3-10
Cleaning.....	2-5b	21	Oil seals .....	2-5d	2-1
Inspection.....	2-6a	2-1	Rocker arm assembly .....	3-81	3-34
Repair .....	2-7a	2-2	Starter .....	3-155	3-56
Camshaft:			Tappets, valve and injector .....	3-59	3-14
Assembly .....	3-3	3-11	Thermostat assembly.....	3-132	3-54
Cleaning .....	3-31	3-11	Water crossover pipe assembly .....	3-110	3-52
Disassembly .....	3-30	3-11	Water pump .....	3-11	3-53
Inspection.....	3-32	3-11	Clearance adjustment, valve .....	3-167	3-57
Installation.....	3-35	3-11	Clearance check:		
Removal.....	2-11k	2-11	Crankshaft end .....	3-12k	3-4
Repair .....	3-34	3-11	Main bearing caps.....	3-121	3-5
Repair and rebuild standards .....	3-180	3-66	Compressor, air:		
Camshaft bushings:			Assembly .....	3-100	3-36
Inspection .....	3-4a	3-1	Cleaning .....	3-97	3-36
Installation .....	3-6a	3-2	Disassembly .....	3-96	3-36
Removal .....	3-2b	3-1	Inspection .....	3-98	3-36
Repair and rebuild standards .....	3-175	3-62	Installation .....	3-101	3-36
Charts:			Removal.....	2-10m	2-8
Injection timing (chart3-1) .....	3-79	3-33	Repair .....	3-99	3-36
Troubleshooting, fuel pump (chart 3-2) .....	3-108	3-51	Repair and rebuild standards .....	3-181	3-36
Cleaning:			Connecting rods:		
Air compressor and drive assembly .....	3-97	3-36	Assembly .....	3-17	3-7
Air intake and preheater assembly .....	3-115	3-53	Cleaning .....	3-14	3-5
Alternator .....	3-150	3-56	Description .....	1-4e(7)	1-5
Camshaft .....	3-31	3-51	Disassembly.....	3-13	3-5
Castings .....	2-5b	2-1	Inspection.....	3-15	3-5
Connecting rod and piston assembly.....	3-14	3-6	Installation, rod and piston .....	3-18	3-7
Cylinder block .....	3-3	3-1	Removal.....	2-11o	2-11
Crankshaft .....	3-8	3	Repair .....	3-16	3-7
Cylinder head.....	3-65	16	Repair and rebuild standards .....	3-177	3-65
Cylinder head cover .....	3-92	3-353	Cooler, oil (see oil cooler)		
Electrical cable .....	2-5d	2-1	Cooling system:		
Fan drive pulley, vibration damper.....	3-126	3-54	Description .....	1-4c(3)	1-3
Fan, fan hub and bracket assembly .....	3-138	3-55	Torque specifications .....	3-186g	3-73
Flexible hoses .....	2-5d	2-1	Cover and governor assembly, mainshaft (see mainshaft cover and governor assembly)		
Flywheel.....	3-53	3-13	Cover, front (see front cover)		
Flywheel housing .....	3-41	3-12	Covers, cylinder head (see cylinder head covers)		
Front cover.....	3-20	3-8	Covers, push rod cavity (see push rod cavity covers)		
Fuel injectors.....	3-73	3-23	Crankcase breather:		
Fuel pump damper assembly.....	3-103	3-40	Assembly .....	3-91	3-35
Fuel pump gear assembly.....	3-103	3-40	Cleaning .....	3-92	3-35
Fuel pump governor spring pack assembly.....	3-103	3-40	Inspection.....	3-99	3-65
Fuel pump housing .....	3-103	3-40	Removal .....	2-11a(2)	2-8
Fuel pump mainshaft cover and governor assembly .....	3-103	3-40	Repair .....	3-94	3-35
Fuel pump shutoff solenoid valve assembly .....	3-103	3-40	Crankshaft:		
Fuel pump tachometer assembly ....	3-103	3-40	Assembly .....	3-3	
General .....	2-5a	2-1	Bearings, description .....	1-4e(4)	1-4
Hydraulic pump and bracket assembly.....	3-144	3-56	Cleaning .....	3-3	3-3
Oil cooler.....	3-158	3-56	Description .....	1-4e(3)	1-4
			Disassembly.....	3-167	3-3
			Inspection .....	3-9	1-4
			Installation .....	3-12	3-4
			Removal.....	2-11p	2-13
			Repair .....	3-10	3-3
			Repair and rebuild standards .....	3-176	3-65

INDEX-Continued

Paragraph	Page	Paragraph	Page
Crankshaft adapter:		Valves .....	1-5b 1-6
Cleaning .....	3-36 3-12	Water pump w/pulley .....	1-5d 1-7
Inspection .....	3-37 3-12	Description, engine .....	1-4 1-1
Installation .....	3-39 3-12	Dipstick assembly .....	2-10n 2-8
Removal .....	2-11i 2-10	Disassembly:	
Repair .....	3-38 3-12	Air compressor and	
Crossheads, valve:		drive assembly .....	3-96 3-36
Adjustment .....	3-167 3-57	Air intake and preheater	
Inspection .....	3-82 3-34	assembly .....	3-114 3-52
Installation .....	3-85 3-35	Alternator assembly .....	3-149 3-56
Removal .....	2-11e 2-9	Camshaft .....	3-30
Crossover, water and lifting eyes:		Connecting rod and piston	
Assembly .....	3-113c 3-52	assembly .....	3-13 3-5
Cleaning .....	3-110 3-52	Crankshaft .....	3-7 3-3
Inspection .....	3-111 3-52	Cylinder heads .....	3-64 3-16
Installation .....	3-113 3-52	Cylinder head cover .....	3-91 3-35
Removal .....	2-10k 2-6	Fan drive pulley, vibration	
Repair .....	3-112 3-52	damper assembly .....	3-125 3-54
Cylinder block:		Fan and fan hub	
Assembly .....	3-6 3-2	assembly .....	3-137 3-55
Cleaning .....	3-3 3-1	Flywheel .....	3-52 3-13
Description .....	1-4e(1) 1-4	Fuel injectors .....	3-72 3-23
Disassembly .....	3-2 3-1	Fuel pump damper assembly .....	3-102a(2) 3-36
Inspection .....	3-4 3-1	Fuel pump gear assembly .....	3-102a(4) 3-38
Repair .....	3-5 3-2	Fuel pump governor spring	
Repair and rebuild standards .....	3-175 3-62	pack assembly .....	3-102a(5) 3-39
Cylinder heads:		Fuel pump housing .....	3-102b 3-40
Assembly .....	3-68 3-19	Fuel pump shutoff solenoid	
Cleaning .....	3-65 3-16	valve assembly .....	3-102a(1) 3-36
Description .....	1-4e(11) 1-5	Fuel pump tachometer	
Disassembly .....	3-64 3-16	assembly .....	3-102a(6) 3-39
Inspection .....	3-66 3-16	Hydraulic pump and bracket	
Installation .....	3-70 3-22	assembly .....	3-143 3-55
Regroove .....	3-67b 3-19	Oil cooler .....	3-157 3-56
Removal .....	2-11f 2-9	Oil pan .....	3-46 3-13
Repair .....	3-67 3-18	Oil pump .....	3-24 3-9
Repair and rebuild standards .....	3-183 3-68	Rocker arm assembly .....	3-80 3-34
Resurface .....	3-67a 3-18	Starter .....	3-155 3-56
Tests .....	3-69 3-21	Tappets, valve and injector .....	3-58 3-14
Cylinder head covers .....	2-11a 2-8	Thermostat assembly .....	3-131 3-54
Cylinder head fuse plugs (see fuse plugs)		Water pump .....	3-120 3-53
Cylinder sleeves:		Drive cover, air compressor	
Assembly .....	3-6c 3-2	(see air compressor)	
Cleaning .....	3-3 3-1	Dynamometer test .....	3-169 3-59
Disassembly .....	3-2c 3-1	<b>E</b>	
Inspection .....	3-4b 3-1	Electrical cables, cleaning .....	2-5d 2-1
Installation .....	3-6c 3-2	Engine assembly .....	1-4b 1-1
Removal .....	3-2c 3-1	Engine external components, description	
Repair .....	3-5 3-2	Exhaust manifolds .....	1-4d(5) 1-4
Repair and rebuild standards .....	3-179 3-66	Intake manifold heater .....	1-4d(6) 1-4
<b>D</b>		Oil filler assembly .....	1-4d(1) 1-4
Damper assembly, fuel pump (see fuel		Sending units .....	1-4d(2) 1-4
pump damper assembly)		Water pump with pulley .....	1-4d(3) 1-4
Damper, vibration (see vibration damper)		Water temperature thermostat .....	1-4d(4) 1-4
Data:		Engine internal components, description	
Engine .....	1-5 1-5	Camshaft .....	1-4e(10) 1-5
Fuel pump test and calibration .....	3-107 3-48	Connecting rod bearings .....	1-43(8) 1-5
General .....	1-5a 1-5	Connecting rod with piston pin	
Oil filter .....	1-5f 1-7	bushings .....	1-4e(7) 1-5
Oil Pump .....	1-5c 1-7	Crankshaft .....	1-4e(3) 1-4



INDEX-Continued

Paragraph	Page	Paragraph	Page
Crankshaft bearings and thrust bearings .....	1-4e(4)	14	
Crankshaft gear .....	1-4e(5)	1-5	
Cylinder block with bearing cap assemblies .....	1-4e(1)	14	
Flywheel with ring gear assembly .....	1-4e(13)	1-5	
Cylinder heads .....	1-4e(11)	1-5	
Flywheel with ring gear assembly .....	1-4e(13)	1-5	
Oil pan .....	1-4e(2)	14	
Oil pump assembly .....	1-4e(14)	1-5	
Pistons .....	1-4e (9)	1-5	
Valves, valve springs, valve rocker arms, bearings and fuel injectors .....	1-4e(12)	1-5	
Vibration damper.....	1-4e(6)	1-5	
Engine preparation .....	2-5	2-3	
Engine rebuild stand:			
Engine mounting .....	2-7	2-3	
General, engine removal.....	3-165	3-57	
Stand removal .....	3-166	3-57	
Engine systems .....	1-4c	1-1	
Engine test:			
Adjust crossheads.....	3-167	3-57	
Adjust injectors.....	3-167	3-57	
Adjust valve clearance .....	3-167	3-57	
Blow-by check .....	3-172c	3-61	
Break-in run .....	3-172b	3-60	
Dynamometer test .....	3-169	3-59	
Filling cooling system.....	3-170d	3-60	
Horsepower rating .....	3-172a	360	
Performance curve .....	3-173	3-62	
Preparation for starting .....	3170	3-60	
Power check .....	3-172d	361	
Priming lubrication system .....	3-170e	3-60\	
Starting engine .....	3-171	3-60	
Test procedure .....	3-172	3-60	
Errors, reporting of			
Exhaust manifold:			
Cleaning .....	3-162	3-57	
Description .....	14d(5)	1-4	
Inspection .....	3-163	357	
Installation.....	3-164	3-57	
Removal.....	2-10b	2-4	
Exhaust system torque specifications .....	3-186h	3-73	
Expansion plugs, inspection .....	2-6f	2-2	
<b>F</b>			
Fan, fan hub, and bracket assembly:			
Assembly .....	3-141	3-55	
Cleaning.....	3-138	3-55	
Disassembly .....	3-137	3-55	
Inspection .....	3-139	3-55	
Installation .....	3-142	3-55	
Removal .....	2-10e	2-5	
Repair .....	3-140	3-55	
Fan drive pulley, vibration damper:			
Assembly .....	3-129	3-54	
Cleaning.....	3-126	3-54	
Disassembly.....	3-125	3-54	
Inspection .....	3-127	3-54	
Installation .....	3-130	3-54	
Removal .....	2-10g	2-5	
Repair .....	3-128	3-54	
Flow, checking injector .....	3-77d	3-30	
Flow, fuel pump, setting .....	3-107g(3)	3-49	
Flowmeter method, fuel pump calibration .....	3-107	3-49	
Flywheel:			
Assembly .....	3-5	3-14	
Cleaning.....	3-1	3-13	
Description .....	14e(13)	1-5	
Disassembly .....	3-52	3-13	
Inspection .....	3-54	3-13	
Installation .....	3-57	314	
Removal .....	2-11h	2-9	
Repair .....	3-55	3-13	
Repair and rebuild standards, assembly data.....	3-185	3-71	
Flywheel, crankshaft adapter installation.....	3-9	3-12	
Flywheel housing:			
Assembly .....	3-44	3-12	
Cleaning .....	3-41	3-12	
Disassembly .....	3-40	3-12	
Inspection .....	3-42	3-12	
Installation .....	3-45	3-12	
Removal.....	2-11j	12-1	
Repair .....	3-43	3-12	
Repair and rebuild standards.....	3-185	3-71	
Forms, Records and reports:			
Forms and records .....	1-2	1-1	
Reporting of errors .....	1-3	1-1	
Front cover:			
Assembly .....	3-23d	3-9	
Cleaning.....	3-20	3-8	
Disassembly .....	3-19	3-8	
Inspection .....	3-21	3-8	
Installation .....	3-23	3-9	
Removal.....	3-10	2-11	
Repair .....	3-22	3-9	
Repair and rebuild standards.....	3-185	3-71	
Fuel injectors:			
Adjustable orifice plug .....	3-71a	3-23	
Assembly .....	3-76	3-25	
Ball valve seating check .....	3-77e	3-31	
Calibration.....	3-77g	3-32	
Cleaning .....	3-73	3-23	
Disassembly .....	3-72	3-23	
Drain orifice .....	3-71b	3-23	
Flow checking .....	3-77d	3-25	
General .....	3-75	3-25	
Inspection .....	3-74	3-23	
Installation .....	3-78	3-23	
Metering orifice .....	3-71c	3-23	
Plunger seat testing- .....	3-77a	3-25	
Removal .....	2-11h	2-9	
Repair .....	3-75	3-25	
Seating ball valve - .....	3-77f	3-31	
Spray pattern check.....	3-77c	3-28	
Testing and calibration.....	3-77	3-25	
Test stand calibrating.....	3-77b	3-29	
Timing .....	3-79	3-33	

INDEX-Continued

	Paragraph	Page		Paragraph	Page
Fuel lines:			Fuel pump tachometer:		
Cleaning .....	3-103	3-40	Assembly .....	3-106	3-47
Inspection .....	3-104	340	Cleaning .....	3-103	3-40
Installation .....	3-109	3-51	Disassembly .....	3-102a(6)	3-39
Removal .....	2-11k	2-11	Inspection .....	3-104e(6)	3-43
Fuel pump:			Repair .....	3-105f	3-46
Assembly .....	3-106	347	Fuel system, description .....	1-4c(1)	1-1
Calibration .....	3-107	3-48	Fuse plugs, cylinder head, inspection .....	366.a	3-16
Calibration, flowmeter method of ..	3-107g	3-49	<b>G</b>		
Checkout pressure .....	3-1079(7)	3-50	Gears, inspection, general .....	2-6d	2-2
Cleaning .....	3-10	3-340	Gears, repair, general .....	2-7d	2-3
Disassembly .....	3-102	3-36	Gear train, repair and rebuild standards:		
Governor speed, setting ..	3-107(4)	3-49	Air compressor drive gear .....	3-181d	3-68
Idle speed, setting .....	3-107g(6)	350	Camshaft gear .....	3-181c	368
Inspection .....	3-104	3-40	Crankshaft gear .....	3-181	36
Installation .....	3-109		Oil pump drive gear .....	3-181b	87
Pump flow, setting .....	3-107g(3)	349	Governor spring pack assembly (see		
Removal .....	3-10		fuel pump)		
Run-in .....	3107	348	Ground valves, cylinder head .....	3-67c	3-19
Seals, checking .....	3-107g(1)	3-49	Guides, crosshead (see Crosshead guides)		
Tests .....	3-107d	3-48	Guides, valve (see Valve guides)		
Test stand mounting .....	3-104c	3-40	<b>H</b>		
Throttle linkage setting .....	3-107g (5)	3-49	Head, cylinder (see Cylinder heads)		
Troubleshooting (chart 3-2) .....	3-108	3-49	Heater, intake manifold (see Intake		
Vacuum adjust .....	3-107a(2)	3-49	manifold heater)		
Fuel pump damper assembly:			Hoses, flexible, cleaning .....	2-5d	2-1
Assembly .....	3-106f	3-48	Horsepower rating, engine test .....	3-172a	3-60
Cleaning .....	3-103	3-40	Housing, flywheel (see Flywheel housing)		
Disassembly .....	3-102a(2)	3-36	Housing, fuel pump (see Fuel pump housing)		
Inspection .....	3-104e (2)	3-41	Hydraulic pump:		
Repair .....	3-105b	3-44	Assembly .....	4-14	3-56
Fuel pump gear assembly:			Cleaning .....	3-144	3-56
Assembly .....	3-106d	3-47	Disassembly .....	3-143	3-55
Cleaning .....	3-103	3-40	Inspection .....	3-145	3-56
Disassembly .....	102a(4)	3-38	Installation .....	3-148	3-56
Inspection .....	3-102a(4)	3-38	Removal .....	2-10d	2-4
Repair .....	3-105	3-44	Repair .....	3-146	3-6
Fuel pump governor spring pack assembly:			<b>I</b>		
Assembly .....	3-47		Idle speed, fuel pump, setting .....	3-107g(6)	3-50
Cleaning .....	3-103	340	Injector, fuel (see Fuel injector)		
Disassembly .....	102a(5)	3-39	Inspection, general maintenance .....	2-6	2-1
Inspection .....	3-104e(5)	3-43	Inspection of:		
Repair .....	3-105e	3-44	Air compressor and drive		
Fuel pump housing:			assembly .....	3-98	3-36
Assembly .....	3-106a	3-47	Air intake preheater assembly .....	3-116	353
Cleaning .....	3-103	3-40	Alternator .....	3-151	3-56
Disassembly .....	3102b	340	Ball bearings .....	2-6	2
Inspection .....	3-104(7)	3-44	Bushings and bushing type		
Repair .....	3-105g	3-46	bearings .....	2-6e	2-2
Fuel pump mainshaft cover and			Black mating surfaces .....	3-4e	3-4
governor assembly:			Camshaft .....	3-83-	3-11
Assembly .....	3-106c	3-47	Castings .....	2-6a	2-1
Cleaning .....	3-103	3-40	Connecting rod and piston		
Disassembly .....	3-102a(3)	3-37	assembly .....	3-15	3-5
Inspection .....	3-104e(3)	3G41	Core hole expansion plugs .....	2-6f	2-2
Repair .....	3-105c	3-44-	Crankshaft .....	3-9	33
Fuel pump shut-off solenoid valve assembly:			Cylinder block .....	3-4	3-1
Assembly .....	3-106g	3-48	Cylinder heads .....	3-66	3-16
Cleaning .....	3-103	3-40	Cylinder head covers .....	3-93	3-35
Disassembly .....	3-102a(1)	3-36			
Inspection .....	3-104e(1)	3-41			
Repair .....	3-105a	3-44			

INDEX -Continued

Paragraph	Page	Paragraph	Page
Cylinder sleeve .....	3-4b	3-1	
Cylinder sleeve counterbore .....	3-4b(4)	3-2	
Expansion plugs .....	2-6f	2-2	
Exhaust manifold .....	3-163	3-57	
Fan drive pulley, vibration damper assembly .....	3-127	3-54	
Fan and fan hub assembly .....	3-139	3-55	
Flywheel .....	3-54	3-13	
Flywheel housing .....	3-42	3-12	
Front cover .....	3-21	3-8	
Fuel injectors .....	3-74	3-23	
Fuel pump assembly .....	3-104	3-40	
Fuel pump damper assembly .....	3-104e(2)	3-41	
Fuel pump gear assembly .....	3-104e(4)	3-42	
Fuel pump governor spring pack assembly .....	3-104e(5)	3-43	
Fuel pump housing .....	3-104e(7)	3-44	
Fuel pump mainshaft cover and governor assembly .....	3-104e(3)	3-41	
Fuel pump .....	3-104	3-40	
Fuel pump solenoid valve assembly .....	3-104e(1)	3-41	
Fuel pump tachometer assembly .....	104e (6)	3-43	
Fuse plugs, cylinder head .....	6a	3-16	
Gears .....	2-6d	2-2	
Hydraulic pump assembly .....	3-145	3-56	
Injector body .....	3-74b	3-24	
Injector cap .....	3-74a	3-24	
Injector plunger .....	3-74c	3-24	
Injector sleeves .....	3-66	3-16	
Injector spring .....	3-74d	3-26	
Intake manifold .....	3-116	3-53	
Main bearing bore .....	3-4c	3-2	
Main bearing caps .....	3-4c	3-2	
Oil pan .....	3-48	3-13	
Oil pump .....	3-26	3-10	
Oil seals .....	3-26f	2-2	
Pistons .....	3-151	3-56	
Push rods .....	3-82b	3-34	
Rocker arm assembly .....	3-82	3-34	
Starter .....	3-155	3-56	
Studs .....	2-6c	2-2	
Tappet bores .....	3-4d	3-2	
Tappets .....	3-60	3-15	
Valves .....	3-66d	3-172	
Valve guides .....	3-66g	3-17	
Valve springs .....	3-66h	3-182	
Vibration damper .....	3-127	3-154	
Water crossover pipe .....	3-111	3-52	
Water pump assembly .....	12		
Installation of:			
Air compressor and drive assembly .....	3-101	3-36	
Air intake preheater assembly .....	3-119	3-53	
Alternator and bracket assembly .....	3-39	3-12	
Connecting rod and piston assembly .....	3-18	3-7	
Crankshaft .....	3-12	3-4	
Crankshaft adapter .....	3-39	3-12	
Cylinder heads .....	3-70	3-22	
Cylinder head covers .....	3-94	3-35	
Exhaust manifold .....	3-164	3-57	
Fan drive pulley and vibration damper assembly .....	3-130	3-54	
Fan, fan hub, and bracket assembly .....	3-136	3-55	
Flywheel .....	3-57	3-14	
Flywheel housing and spacer plate .....	3-45	3-12	
Front cover .....	23	3-9	
Fuel injectors .....	3-78	3-32	
Fuel pump .....	3-109	3-51	
Hydraulic pump assembly and bracket .....	3-148	3-56	
Intake manifold .....	3-119	3-5	
Main bearings .....	3-4		
Oil cooler .....	3-166d	3-5	
Oil pan .....	3-31	3-13	
Oil pump .....	3-29	3-10	
Push rods .....	3-85a	3-85	
Rocker arm assembly .....	3-8Sb	3-35	
Starter .....	3-156	3-56	
Tappets .....	3-63	3-16	
Water crossover pipe and lifting eyes .....	3-113	3-62	
Water pump assembly .....	3-124	3-54	
Intake manifolds:			
Cleaning .....	3-115	3-63	
Description .....	1-4d(6)	1-4	
Inspection .....	3-116	363	
Installation .....	3-119	3-53	
Removal .....	6		
Repair .....	3-117	3-53	
Intake system torque specifications .....	3-186h	3-73	
<b>L</b>			
Leakage test, fuel pump .....	3-104b	3-40	
Lifting eyes, rear:			
Inspection .....	3-111	3-62	
Installation .....	3113	362	
Removal .....	2-10lk	2-6	
Location, engine components .....	1-4a	1-1	
Lubrication system, description .....	1-4e(2)	14	
Lubrication system priming, engine test .....	3-170e	340	
<b>M</b>			
Main bearing:			
Cleaning .....	3-3	3-1	
Inspection .....	3-4c	3-2	
Installation .....	3-4	2-4	
Removal .....	2-11p	2-13	
Main bearing bore, inspection .....	3-4c	3-2	
Main, bearing caps, inspection .....	3-4c	3-21	
Maintenance repair parts .....	2-3	2-1	
Manifold pressure, fuel pump adjust .....	3-107g(6)	3-50	
Mating surface, block inspection .....	3-4e	3-2	
Mounting engine on engine stand .....	2-9	2-3	
<b>O</b>			
Oil cooler:			
Assembly .....	3-161	3-57	
Cleaning .....	3-158	3-56	

INDEX-Continued

	Paragraph	Page		Paragraph	Page
Disassembly.....	3-157	3-56	Porosity and leakage test, fuel pump .....	3-104b	3-40
Inspection.....	3-159	3-57	Preheater:		
Installation.....	3-166d	3-57	Assembly .....	3-8	3-53
Removal.....	2-9d	2-4	Cleaning.....	3-15	3-53
Repair .....	3-160	3-57	Disassembly .....	3-114	3-52
Oil dipstick tube assembly, removal .	2-10n	2-8	Inspection .....	3-116	3-53
Oil filler assembly:			Pressure, fuel pump, manifold		
Data .....	1-e	1-7	adjust .....	3107g(6)	3-50
Description .....	1-4d(1)	1-4	Pressure, check point, fuel pump		
Oil filter assembly, data .....	1-5f	1-7	compare.....	3-107g	3-49
Oil pan:			Pressure check, fuel pump, weight		
Assembly .....	3-50	3-13	assist .....	3-107g(7)	3-50
Cleaning.....	3-47	3-13	Priming engine lubrication system,		
Description .....	1-4e(2)	1-4	engine test .....	3-107e	84
Disassembly.....	46	3-13	Procedure, engine test .....	3-172	360
Inspection.....	3-48	313	Procedure, repair instructions .....	3-1	3-1
Installation.....	3-51	3-13	Pump, fuel- (see fuel pump)		
Removal.....	22-1e	2-9	Pump, hydraulic (see hydraulic pump)		
Repair .....	3-9	3-13	Pump, oil (see oil pump)		
Oil passages, cleaning .....	2-5c	2-1	Pump, water (see water pump)		
Oil pressure regulator and oil pump,			Push rod:		
repair and rebuild standards:			Inspection .....	3-82b	334
Oil pump.....	3-182	368	Installation .....	3-85a	3-35
Valve spring measurement .....	3-182a	3-68	Removal.....	2-11c	2-9
Oil pump:			Repair .....	3-83	3-34
Assembly .....	3-28	3-10	Push rod cavity covers:		
Cleaning.....	3-25	3-10	Inspection .....	3-93	3-35
Data .....	1-5c	1-7	Installation .....	3-95	3-35
Description .....	1-4e(14)	1-5	Removal.....	2-11b	2-9
Disassembly.....	3-24	3-9	Repair .....	3-94	3-35
Inspection.....	2-6	3-10			
Installation.....	3-29	3-10	<b>R</b>		
Removal.....	2-11m	2-11	Rating horsepower, engine test.....	3-172a	3-60
Repair .....	3-27	3-10	Regrinding crankshaft .....	3-10a	3-3
Oil seals:			Regroove cylinder head:.....	3-67b	3-19
Cleaning.....	2-5d	2-1	Removal of:		
Inspection.....	2-6f	2-2	Air compressor and drive		
Replacement.....	2-7f	2-3	assembly.....	2-10m	2-8
Operational theory .....	1-4a (2)	1-1	Air intake preheater assembly .....	2-10i	2-5
<b>P</b>			Alternator and bracket assembly ....	2-10c	2-4
Parts, special tools, and equipment:			Camshaft, gear and spacer plate....	2-11k	2-11
Maintenance repair parts .....	2-3	2-1	Connecting rod and piston		
Special tools and equipment .....	2-2	2-1	assembly.....	2-11o	2-11
Tools and equipment .....	2-1	2-1	Crankshaft .....	2-11p	2-13
Pipe plugs, cylinder block:			Crankshaft adapter .....	2-11i	210
Inspection.....	3-2a	3-1	Cylinder heads.....	2-11f	2-9
Installation.....	33-6b	3-2	Cylinder head covers .....	2-11a	2-8
Removal.....	3-2a	3-1	Engine Components, general .....	2-8	2-3
Torque specifications .....	3-186a	371	Engine from rebuild stand.....	3-166	3-57
Pistons:			Exhaust manifolds .....	2-9b	2-4
Cleaning.....	3-14	3-55	External components .....	2-8c	2-3
Description .....	1-4e(9)	1-5	Fan drive pulley and vibration		
Disassembly.....	3-13	3-5	damper assembly .....	2-10g	2-5
Inspection.....	3-15	3-5	Fan, fan hub, and bracket		
Installation.....	3-18	3-7	assembly.....	2-10e	2-5
Removal.....	2-11o	2-11	Flywheel.....	2-11h	2-9
Repair and rebuild standards .....	3-178	3-65	Flywheel housing .....	2-11j	2-11
Piston pin bushing:			Front cover.....	2-11n	2-11
Boring.....	3-16	3-7	Fuel injectors .	2-11d	2-9
Replacing .....	3-16	3-7	Fuel pump.....	2-10l	2-7
Plunger seat, injector, test .....	3-77a	3-25	Hydraulic pump assembly and		
			bracket.....	2-10d	2-4

INDEX-Continued

Paragraph	Page	Paragraph	Page
Intake manifolds .....	2-10j	2-6	
Internal components .....	2-8c	2-3	
Main bearings .....	2l 2-lp	2-13	
Oil cooler .....	2-9d	2-4	
Oil dipstick tube assembly .....	2-10n	2-8	
Oil pan .....	2-111	2-11	
Oil pump - .....	2-11m	2-11	
Push rod cavity covers .....	11b	2-9	
Push rods .....	2-lc	2-	
Rocker arm assembly .....	2-lc	2-9	
Starter .....	10a	2-4	
Tappets .....	211g	2-9	
Thermostat assembly- .....	2-10	2-5	
Water crossover pipe assembly .....	2-lOk	2-6	
Water pump assembly .....	2-10h	2-5	
Repair, general maintenance .....	2-7	2-2	
Repair of:			
Air compressor and drive assembly .....	3-33	3-36	
Air intake preheater assembly .....	3-117	3-53	
Alternator and bracket assembly .....	2-10c	3-24	
Camshaft .....	3-324	3-11	
Connecting rod and piston assembly .....	3-16	3-16	
Crankshaft .....	3-10	3-10	
Crankshaft, adapter .....	3-39	3-12	
Cylinder block .....	3-5	3-2	
Cylinder block .....	3-5	3-2	
Cylinder head covers .....	3-94	3-5	
Cylinder heads .....	3-67	3-18	
Fan drive pulley and vibration damper assembly .....	3-128	354	
Fan, fan hub, and bracket assembly .....	3-140	3-55	
Flywheel .....	3-55	3-13	
Flywheel housing and spacer plate .....	3-43	3-12	
Front cover .....	3-22	3-9	
Fuel injectors .....	3-75	3-25	
Fuel pump (see fuel pump)			
Hydraulic pump assembly and bracket .....	3-146	3-56	
Intake manifolds .....	3-117	3-53	
Oil cooler .....	3-160	3-57	
Oil pan .....	3-49	3-13	
Oil pump .....	3-27	3-10	
Push rod cavity covers .....	3-89	3-35	
Push rods .....	3-83	3-34	
Rocker arm assembly .....	3-83	3-34	
Starter .....	3-155	3-56	
Tappets .....	3-61	3-15	
Thermostat assembly pipe .....	3-134	3-54	
Water crossover pipe assembly .....	3-112	3-52	
Water pump assembly .....	3-124	3-54	
Repair and rebuild standards:			
Assembly data .....	3-185	3-71	
Camshaft and bearings .....	3-180	3-66	
Connecting rod .....	3-177	3-65	
Crankshaft and bearings .....	3-176	3-65	
Cylinder block .....	3-175	3-62	
Cylinder head .....	3-183a	3-68	
Cylinder sleeve .....	3-179	3-66	
Gear train .....	3-181	3-66	
General .....	3-174	3-62	
Oil pressure regulator and pump .....	3-182	3-68	
Piston .....	3-178	3-65	
Rocker arm and shaft .....	3-183c	3-70	
Tappets and push rods .....	3-183b	3-70	
Torque specifications .....	3-186	3-71	
Water pump .....	3-184	3-71	
Reporting of errors .....	1-3	1-1	
Resurface cylinder head .....	3-67a	3-18	
Ring gap, piston, inspection .....	3-15	3-5	
Ring gear (see Flywheel)			
Rocker arm assembly:			
Assembly .....	3-84	3-3	
Cleaning .....	3-81	344	
Description .....	1-4e(12)	1-5	
Disassembly .....	3-80	3-34	
Inspection .....	3-82	3-34	
Installation .....	3-85	3-35	
Removal .....	3-11e	2-9	
Repair .....	3-83	334	
Repair and rebuild standards .....	3-183	3-68	
Rods connecting (see Connecting rods)			
Rods, push (see Push rods)			
Run-in, fuel pump .....	3-107	3-48	
<b>S</b>			
Scope, general maintenance .....	2-4	2-1	
Seals, fuel pump, check .....	3-107g	49	
Seals, oil:			
Cleaning .....	2-5d	2-1	
Inspection .....	2-6f	2-2	
Repair .....	2-7f	2-3	
Seating check, injector ball valve .....	3-77e	3-31	
Seating, injector ball valve .....	3-77f	3-31	
Seating, valve .....	3-69	3-21	
Seats, valve (see Valve seats)			
Sending units .....	1-4d(2)	14	
Set idle speed, fuel pump .....	3-107g(6)	3-50	
Setting, fuel pump flow .....	3-107g(3)	3-49	
Setting, fuel pump governed speed .....	3-107g(4)	3-49	
Setting fuel pump throttle linkage .....	3-107g(5)	3-49	
Scope .....	1-1	1-1	
Shut-off, solenoid, fuel (see Fuel pump shut-off solenoid valve)			
Skirt diameter, piston .....	3-15	3-5	
Special, tools, and equipment .....	2-2	2-1	
Speed, setting fuel pump idle .....	3-107g(6)	3-50	
Starter:			
Cleaning .....	3-155	3-56	
Inspection .....	3-155	3-56	
Installation .....	3-156	3-56	
Removal .....	2-10a	2-4	
Repair .....	3-155	3-6	
Studs:			
Inspection .....	2-6c	2-2	
Oversize .....	2-7c(3)	2-3	
Removal .....	2-7c(1)	2-2	
Replacement .....	27c(2)	2-2	

INDEX-Continued

Paragraph	Page	Paragraph	Page
<b>T</b>			
Tabulated data .....	1-5	1-5	
Tachometer drive assembly:			
Assembly .....	3-106b	3-47	
Cleaning .....	3-103	3-40	
Inspection .....	3-104e(6)	3-40	
Disassembly .....	3-102a(6)	3-39	
Repair .....	3-105f	3-46	
Tappets:			
Assembly .....	3-62	3-15	
Cleaning .....	3-59	3-14	
Disassembly .....	3-58	3-14	
Inspection .....	3-60	3-15	
Installation .....	3-63	3-15	
Removal .....	2-11g	2-9	
Repair .....	3-61	3-15	
Testing .....	3-62	3-15	
Tappet bores, inspection .....	3-4d	3-2	
Tests:			
Ball valve seating, injector .....	3-77f	3-31	
Engine (see Engine test)			
Fuel injectors .....	3-77	3-25	
Fuel pump .....	3-107d	3-48	
Fuel shut-off solenoid valve .....	3-104e(1)	3-41	
Gear assembly test, fuel pump .....	3-107d	3-41	
Head assembly .....	3-69b	3-22	
Housing porosity fuel pump .....	3-104b	3-41	
Injector flow .....	3-77	3-3	
Injector plunger seat .....	3-77	3-30	
Injector sprat pattern .....	3-77	3-25	
Leakage, fuel pump .....	3-104d	3-41	
Oil cooler .....	3-159	3-57	
Pre-calibration, fuel pump .....	3-107d	3-48	
Tappets .....	3-62	3-15	
Thermostat .....	3-133	3-54	
Valve seating .....	3-69	3-21	
Test fuel, fuel pump .....	3-107c	3-48	
Test procedure, engine .....	3-172	3-60	
Test stand, injector, calibrating .....	3-77b	3-27	
Thermostat:			
Assembly .....	3-135	3-54	
Cleaning .....	3-132	3-54	
Disassembly .....	3-131	3-54	
Inspection .....	3-133	3-54	
Installation .....	3-136	3-54	
Removal .....	2-10f	2-5	
Thrust flange, crankshaft regrinding .....	3-9b	3-3	
Throttle linkage, fuel pump, set .....	3-107g	3-49	
Timing injection .....	3-79	3-33	
Tools and equipment .....	2-1	2-1	
Torque specifications:			
Air compressor group .....	3-186i	3-73	
Cooling system group .....	3-186g	3-73	
Cylinder block group .....	3-186g	3-71	
Cylinder head group .....	3-186	3-72	
Engine mounting group .....	3-186j	3-73	
Injector and connections group .....	3-186e	3-72	
Intake and exhaust system group .....	3-186h	3-73	
Lubrication system group .....	3-186f	3-72	
PT fuel pump group .....	3-186d	3-72	
Rocker arm, cam follower, and tappet group .....	3-186d	3-72	
Troubleshooting: fuel pump (chart 3-2) .....	3-108	3-51	
<b>V</b>			
Vacuum adjust fuel pump .....	3-107g(2)	3-49	
Valve Crossheads .....	2-11e	2-9	
Valve guides .....	1-4e(12)	1-5	
Valves:			
Clearance adjustment .....	3-167	3-57	
Data .....	1-5b	1-6	
Description .....	1-4e(12)	1-5	
Grinding .....	3-67c	3-19	
Inspection .....	3-66d	3-17	
Valve seats:			
Assembly .....	3-68d	3-20	
Inspection .....	3-68b	3-16	
Grinding .....	3-68	3-20	
Valve springs:			
Description .....	1-4e(12)	1-5	
Inspection .....	3-66	3-15	
Ventilation system .....	1-4c(5)	1-4	
Vibration damper:			
Assembly .....	3-129	3-54	
Cleaning .....	3-126	3-54	
Description .....	1-4e(6)	1-5	
Disassembly .....	3-125	3-54	
Inspection .....	3-127	3-54	
Installation .....	3-130	3-54	
Removal .....	2-10g	2-5	
Repair .....	3-128	3-54	
<b>W</b>			
Water crossover pipe:			
Cleaning .....	3-110	3-52	
Inspection .....	3-111	3-52	
Installation .....	3-113	3-52	
Removal .....	2-10k	2-6	
Repair .....	3-112	3-52	
Water Pump:			
Assembly .....	3-123	3-53	
Cleaning .....	3-121	3-53	
Data .....	1-5d	1-7	
Description .....	1-4d(3)	1-4	
Disassembly .....	3-120	3-53	
Inspection .....	3-122	3-53	
Installation .....	3-124	3-54	
Removal .....	2-10h	2-5	
Repair and rebuild standards .....	3-184	3-71	
Weight assist pressure check .....	3-107g(7)	3-50	

By Order of the Secretary of the Army:

W. C. WESTMORELAND,  
*General, United States Army,*  
*Chief of Staff.*

Official:

VERNE L. BOWERS,  
*Major General, United States Army,*  
*The Adjutant General.*

Distribution:

To be distributed in accordance with DA Form 12-38, Direct and General Support Maintenance requirements for Truck, Tractor, 10 Ton, 6X6 Model M123A1C and M123E2.

☆US GOVERNMENT PRINTING OFFICE: 1992 0-311-831 (60111)

RECOMMENDED CHANGES TO EQUIPMENT TECHNICAL PUBLICATIONS

**SOMETHING WRONG WITH THIS PUBLICATION?**



THEN... JOT DOWN THE DOPE ABOUT IT ON THIS FORM, CAREFULLY TEAR IT OUT, FOLD IT AND DROP IT IN THE MAIL!

FROM: (PRINT YOUR UNIT'S COMPLETE ADDRESS)

DATE SENT

PUBLICATION NUMBER

TM 11-5825-270-10

PUBLICATION DATE

23 Jul 81

PUBLICATION TITLE

Radio Frequency R-2176/FRN

BE EXACT... PIN-POINT WHERE IT IS

PAGE NO	PARA-GRAPH	FIGURE NO	TABLE NO
---------	------------	-----------	----------

IN THIS SPACE TELL WHAT IS WRONG AND WHAT SHOULD BE DONE ABOUT IT:

TEAR ALONG PERFORATED LINE

PRINTED NAME, GRADE OR TITLE, AND TELEPHONE NUMBER

SIGN HERE:

DA FORM 2028-2  
JUL 79

PREVIOUS EDITIONS ARE OBSOLETE.

P.S.—IF YOUR OUTFIT WANTS TO KNOW ABOUT YOUR RECOMMENDATION MAKE A CARBON COPY OF THIS AND GIVE IT TO YOUR HEADQUARTERS.