

# ROUTINE

*MWO effective date is 22 Jun 2005 and completion date is 15 December 2008*

MWO 5-2350-262-35-1

## MODIFICATION WORK ORDER

---

### MODIFICATION OF ARMORED COMBAT EARTHMOVER (ACE), M9

(NSN 2350-00-808-7100) (EIC ASA)

### SYSTEM IMPROVEMENT PLAN (SIP) PHASE 4 BLOCK MODIFICATION

---

HEADQUARTERS, DEPARTMENT OF THE ARMY, WASHINGTON, D.C.

22 June 2005

#### REPORTING ERRORS AND RECOMMENDING IMPROVEMENTS

You can help improve this MWO. If you find any mistakes or if you know of a way to improve the procedures, please let us know. Mail your DA Form 2028, (Recommended Changes to Equipment Technical Publications), through the Internet, on the Army Electronic Product Support (AEPS) website. The Internet address is <http://aeeps.ria.army.mil>. If you need a password, scroll down and click on "ACCESS REQUEST FORM." The DA Form 2028 is located in the ONLINE FORMS PROCESSING section of the AEPS. Fill out the form and click on SUBMIT. Using this form on the AEPS will enable us to respond quicker to your comments and better manage the DA Form 2028 program. You may also mail, fax, or email your letter or DA Form 2028 direct to: AMSTA-LC-CI/TECH PUBS, TACOM-RI, 1 Rock Island Arsenal, Rock Island, IL 61299-7630. The email address is [TACOM-TECH-PUBS@ria.army.mil](mailto:TACOM-TECH-PUBS@ria.army.mil). The fax number is DSN 793-0726 or Commercial (309) 782-0726.

**DISTRIBUTION STATEMENT A.** Approved for public release; distribution is unlimited.

Modification Work Order  
for  
Armored Combat Earthmover (ACE), M9

SYSTEM IMPROVEMENT PLAN (SIP) PHASE 4 BLOCK MODIFICATION

**TABLE OF CONTENTS**

		Page
<b>CHAPTER 1</b>	<b>INTRODUCTION .....</b>	<b>1-1</b>
<b>CHAPTER 2</b>	<b>POWER PACKAGE REMOVAL/REPLACEMENT IMPROVEMENTS</b>	<b>2-1</b>
Section I	MWO Parts List.....	2-1
Section II	Tools Required .....	2-2
Section III	Hardware Installation Guide .....	2-2
Section IV	Modification Procedures .....	2-4
<b>CHAPTER 3</b>	<b>INSTALLATION OF NEW CONFIGURATION FIXED DRY POWDER FIRE EXTINGUISHER SYSTEM AND MODIFICATION OF NEW PRODUCTION FIXED DRY POWDER FIRE EXTINGUISHER SYSTEM.....</b>	<b>3-1</b>
Section I	MWO Parts List.....	3-1
Section II	Tools Required .....	3-2
Section III	Removal Procedures and Right Side Bottle Holder Shield Modification for Halon (Old Production).....	3-2
Section IV	Removal Procedures for Dry Powder (New Production Vehicle..... Serial Numbers 574 through 625).....	3-3
Section V	Nozzle Installation Procedures for Left Side (All Vehicles).....	3-3
Section VI	Nozzle Installation Procedures for Right Side (All Vehicles) .....	3-5
Section VII	Installation Procedures for Dry Powder (all Vehicles).....	3-7

DISTRIBUTION STATEMENT A.      Approved for public release; distribution is unlimited.

## CHAPTER 1 INTRODUCTION

### 1-1 PURPOSE

The purpose of this Modification Work Order is to improve the performance capabilities of the M9 ACE through vehicle modification and improved hardware.

### 1-2 PRIORITY

This modification is classified ROUTINE.

### 1-3 END ITEM TO BE MODIFIED

Nomenclature	NSN	Part Number	CAGEC	Model Number	Serial Number
Armored Combat Earthmover (ACE), M9	2350-00-808-7100	TA13211E8600	97403	M9 ACE	All

### 1-4 COMPONENTS TO BE MODIFIED

Not applicable.

### 1-5 PARTS TO BE MODIFIED

See applicable chapter.

### 1-6 APPLICATION

- a. Time compliance schedule: MWO effective date is 22 June 2005 and completion date is 15 December 2008.
- b. The lowest level of maintenance authorized to apply this MWO: Direct Support (DS).
- c. Work Force/Skills and hour requirements for application of this MWO to a single unit, end item, or system are as follows:

#### REQUIREMENTS

WORK FORCE/SKILLS	MAN-HOURS
Construction Equipment Repair (62B10)	
1. Power Package Quick Disconnect Installation	52
2. Dry Powder Fire Extinguisher Bottle Installation	5

Total man-hours required for a single application of this MWO is 57 hours

- d. MWOs to be applied prior to or concurrently with the application of this MWO: Not applicable.

- e. Additional information deemed necessary to assist in the application of this MWO:

**PUBLICATIONS:**

AR 750-10  
MIL-PRF-63002H(TM)

TM 750-245-4  
DA Pam 738-750

DA Pam 738-751  
TB 43-0209

**1-7 TECHNICAL PUBLICATIONS AFFECTED/CHANGED**

**PUBLICATIONS:**

TM 5-2350-262-20-1, dated January 1997, with Change 3, dated March 2000  
TM 5-2350-262-20-2, dated January 1997, with Change 3, dated March 2000  
TM 5-2350-262-24P, dated March 2000  
TM 5-2350-262-34, dated January 1997, with Change 2, dated March 2000

**1-8 MWO KITS/PARTS AND THEIR DISPOSITION**

- a. See applicable chapter for parts.
- b. Return removed (no longer required) parts to Unit for disposition.

**1-9 SPECIAL TOOLS; TOOL KITS; JIGS; TEST, MEASUREMENT, AND DIAGNOSTIC EQUIPMENT (TMDE); AND FIXTURES REQUIRED**

See applicable chapter for tools/kits.

**1-10 MODIFICATION PROCEDURES**

See applicable chapter for modification procedures.

**1-11 CALIBRATION REQUIREMENTS**

Not applicable.

**1-12 WEIGHT AND BALANCE DATA**

Weight and balance are not significantly affected.

**1-13 QUALITY ASSURANCE REQUIREMENTS**

- a. General. Quality assurance will be accomplished in accordance with TM 750-245-4.
- b. Physical Inspection. Check components that are removed or installed during the modification for stability of mounting.
- c. Functional Inspection. Start vehicle and insure that vehicle is operating properly, in accordance with TM 5-2350-262-10.

**1-14 RECORDING AND REPORTING OF THE MODIFICATION**

- a. Records and Reports. The organization responsible for MWO application will report application information as follows:

(1) Reporting will be accomplished by electronic means. MWO application information can be input directly in the Modification Management Information System (MMIS) over the Internet. Entry into the MMIS system is password protected. New users can register on-line at <https://mmis.army.mil>. Passwords are normally approved and issued within 48 hours. If you do not have access to the internet you may send an Excel Spreadsheet with the below information to: [lfilary@tacom.army.mil](mailto:lfilary@tacom.army.mil).

(2) Submission will be comprised of the nine (9) data elements listed in the Table below. Elements 1, 2, 8 & 9 are given for this MWO (as shown). The person reporting the MWO data will acquire the remaining elements 3, 4, 5, 6, 7 and input all nine into MMIS.

<u>DATA ELEMENT</u>	<u>INPUT DATA</u>
1. Materiel Change Number (MCN)	1-01-05-0004
2. MWO Number	MWO 5-2350-262-35-1
3. Unit Identifier Code	
4. NSN of the End Item	
5. Serial Number	
6. USA Registration Number	
7. Date of Application	
8. Hours Required for Application	
9. Software Version	N/A

- b. Records and Reports. Record the modification in accordance with AR 750-10, DA Pam 738-750, and DA Pam 738-751.
- c. Marking Equipment. Stamp "MWO 35-1" on border of existing vehicle data plate 13214E2452.

**1-15 MATERIEL CHANGE (MC) NUMBER**

This Modification Work Order is authorized by MC number 1-01-05-0004.

**1-16 MODIFICATION IDENTIFICATION**

See applicable chapters.

## CHAPTER 2

### POWER PACKAGE REMOVAL/REPLACEMENT IMPROVEMENTS

**SUBJECT:** Installation and modification of hardware to improve power package removal and replacement

**DATE:** 22 June 2005

**DESCRIPTION:** Nine quick-disconnects are installed at various locations. Hose from rear steer unit to rear engine mount is removed and replaced with a shorter hose. An elbow is replaced and two new elbows are added. A hydraulic tube, hull bracket, and hose are removed and discarded and replaced with a new hose and elbow. An identical quick-disconnect is reversed to reduce possibility of incorrectly reconnecting lines. Rear engine mounting bolt is removed and discarded and replaced with a guide pin. Bracket and retaining strap between left front of transfer case power package mount and right side of hydraulic manifold are removed and discarded, and replaced by new bracket. Bracket on hull bottom plate under transfer case is removed and discarded.

**TM REFERENCES:** The technical manual references in this procedure are: TM 5-2350-262-34, dated January 1997, with Change 2, dated March 2000 and TM 5-2350-262-24P, dated March 2000.

## SECTION I. MWO PARTS LIST

**Table 2-1. MWO Parts List**

Part No.	CAGE	NSN	Description	Qty
12352677-13	19207	4720-01-059-2540	Hose Assembly	1
12491608	19207	4720-01-513-1393	Hose Assembly	1
12481029	19207	5340-01-502-6319	Bracket, Hose	1
02022502	63323	4730-01-499-9897	Elbow, Tube 35 Degree	1
H2-62-T6	97111	4730-01-494-8226	Quick Disconnect, Coupler	1
H2-63-T6	97111	4730-01-245-7605	Quick Disconnect, Nipple	1
H3-62-T8	97111	4730-01-393-5269	Quick Disconnect, Coupler	4
H3-63-T8	97111	4730-01-243-3539	Quick Disconnect, Nipple	4
H4-62-T10	97111	4730-01-491-9958	Quick Disconnect, Coupler	1
H4-63-T10	97111	4730-01-243-3540	Quick Disconnect, Nipple	1
H8-62-T16	97111	4730-01-491-9949	Quick Disconnect, Coupler	1
H8-63-T16	97111	4730-01-245-7604	Quick Disconnect, Nipple	1
H12-62-T24	97111	4730-01-491-9941	Quick Disconnect, Coupler	2
H12-63-T24	97111	4730-01-491-9912	Quick Disconnect, Nipple	2
6402-06-06-O	5E240	4730-01-494-8218	Adapter	1
2266-8-8S	01276	4730-01-196-4871	Adapter	4
2266-10-10S	01276	4730-01-250-1793	Adapter	1
2266-16-16S	01276	4730-01-241-4650	Adapter	1
6402-24-24-O	5E240	4730-01-491-9650	Adapter	2
202702-6-6S	01276	4730-00-491-9576	Adapter	1
202702-8-8S	01276	4730-01-156-4835	Adapter	4
202702-10-10S	01276	4730-00-906-0721	Adapter	1
202702-16-16S	01276	4730-00-930-5392	Adapter	1
202702-24-24S	01276	4730-01-492-2209	Adapter	2
B1821BH038C100N	80204	5305-00-068-0510	Screw	1
MS21333-128	96906	5340-00-702-2848	Clamp, Loop	2
MS27183-14	96906	5310-00-080-6004	Washer, Flat	1

**Table 2-1. MWO Parts List - Continued**

Part No.	CAGE	NSN	Description	Qty
MS35338-46	96906	5310-00-637-9541	Washer, Lock	1
MS51967-8	96906	5310-00-732-0558	Nut, Plain, Hex	1
12355438	19207	5315-01-229-9007	Guide Pin	1
MS51521B6Z	96906	4730-01-223-0529	Elbow, Tube 90 Degree	1
MS51521B24	96906	4730-00-409-8797	Elbow, Tube 90 Degree	1

## SECTION II. TOOLS REQUIRED

### 2-1 COMMON TOOLS REQUIRED

- a. Tool Kit, General Mechanics: Automotive, NSN 5180-00-177-7033
- b. Shop Equipment, Automotive Maintenance and Repair: Field Maintenance, Basic, Less Power, NSN 4910-00-754-0705
- c. Shop Equipment, Automotive Maintenance and Repair: Field Maintenance, Supplemental No.1, Less Power, NSN 4910-00-754-0706
- d. Lifting device must have a weight capacity greater than 6000 lb (2724 kg).

### 2-2 SPECIAL TOOLS REQUIRED

Reference TM 5-2350-262-34, Power Package Replacement, INITIAL SETUP for power package removal and installation procedures.

## SECTION III. HARDWARE INSTALLATION GUIDE

**Table 2-2. Hardware Installation Guide**

Figure/Table	Part Number	NSN	Description	Remarks
Figure 2-1	MS51525A8-10Z	4730-01-074-0907	Adapter	Quick-disconnects are identical (Figures 4 and 48, TM 5-2350-262-24P).
Air compressor and fuel return lines	H4-62SL-T10	4730-01-243-3538	QD, Coupler	
	H4-63-T10	4730-01-243-3540	QD, Nipple	
	MS51525A8-10Z	4730-01-074-0907	Adapter	
Figure 2-2	2266-16-16S	4730-01-241-4650	Adapter	Hose 12352677-13 is 42 inches long and replaces hose 12352677-7.
Lower rear engine bracket, top fitting	H8-62-T16	4730-01-491-9949	QD, Coupler	
	H8-63-T16	4730-01-245-7604	QD, Nipple	
	202702-16-16S	4730-00-930-5392	Adapter	
	12352677-13	4720-01-059-2540	Hose Assembly	

Table 2-2. Hardware Installation Guide - Continued

Figure/Table	Part Number	NSN	Description	Remarks
Figure 2-2	6402-24-24-0	4730-01-491-9650	Adapter	Elbow, Tube 35 Degree replaces Elbow, Tube 45 Degree MS51509A24.
Lower rear engine bracket, middle fitting	H12-62-T24	4730-01-491-9941	QD, Coupler	
	H12-63-T24	4730-01-491-9912	QD, Nipple	
	202702-24-24S	4730-01-492-2209	Adapter	
	02022502	4730-01-499-9897	Elbow, Tube 35 Degree	
Figure 2-2	6402-24-24-0	4730-01-491-9650	Adapter	Hose Assembly 12491608 replaces hose 13214E2551 and tube 12325766. Brackets 13214E2553 and 13214E2554 with attaching hardware are removed and discarded.
Lower rear engine bracket, bottom fitting	H12-62-T24	4730-01-491-9941	QD, Coupler	
	H12-63-T24	4730-01-491-9912	QD, Nipple	
	202702-24-24S	4730-01-492-2209	Adapter	
	12491608	4720-01-513-1393	Hose Assembly	
	MS51521B24	4730-00-409-8797	Elbow, Tube 90 Degree	
Figure 2-2	12355438	5315-01-229-9007	Guide Pin	Center mounting bolt B1821BH075C350L is removed and discarded.
Rear engine lower mounting bracket 13214E2669				
Figure 2-3	6402-06-06-O	4730-01-494-8218	Adapter	
Compensating pump between hose and elbow	H2-62-T6	4730-01-494-8226	QD, Coupler	
	H2-63-T6	4730-01-245-7605	QD, Nipple	
	202702-6-6S	4730-00-491-9576	Adapter	
	MS51521B6Z	4730-01-223-0529	Elbow, Tube 90 Degree	
Figure 2-4, 2-5	12481029	5340-01-502-6319	Bracket, Hose	Retaining straps 13214E1987, 13214E2833, and bracket 13214E2832 with attaching hardware are removed and discarded.
Lower left front engine transfer case and hull bottom under transfer case	B1821BH038C100N	5305-00-068-0510	Screw	
	MS21333-128	5340-00-702-2848	Clamp, Loop	
	MS27183-14	5310-00-080-6004	Washer, Flat	
	MS35338-46	5310-00-637-9541	Washer, Lock	
	MS51967-8	5310-00-732-0558	Nut, Plain, Hex	
	12335107	2510-01-193-7179	Transfer Case Lifting Eye	
Figure 2-5	2266-8-8S	4730-01-196-4871	Adapter	
Left side of right side high pressure filter	H3-62-T8	4730-01-393-5269	QD, Coupler	
	H3-63-T8	4730-01-243-3539	QD, Nipple	
	202702-8-8S	4730-01-156-4835	Adapter	
Figure 2-5	2266-8-8S	4730-01-196-4871	Adapter	
Left side of left side high pressure filter	H3-62-T8	4730-01-393-5269	QD, Coupler	
	H3-63-T8	4730-01-243-3539	QD, Nipple	
	202702-8-8S	4730-01-156-4835	Adapter	



**Table 2-2. Hardware Installation Guide - Continued**

Figure/Table	Part Number	NSN	Description	Remarks
Figure 2-6	2266-8-8S	4730-01-196-4871	Adapter	
Bottom of main hydraulic accumulator	H3-62-T8	4730-01-393-5269	QD, Coupler	
	H3-63-T8	4730-01-243-3539	QD, Nipple	
	202702-8-8S	4730-01-156-4835	Adapter	
Figure 2-7	2266-10-10S	4730-01-250-1793	Adapter	
Ejector cylinder	H4-62-T10	4730-01-491-9958	QD, Coupler	
	H4-63-T10	4730-01-243-3540	QD, Nipple	
	202702-10-10S	4730-00-906-0721	Adapter	
Figure 2-7	2266-8-8S	4730-01-196-4871	Adapter	
Ejector cylinder	H3-62-T8	4730-01-393-5269	QD, Coupler	
	H3-63-T8	4730-01-243-3539	QD, Nipple	
	202702-8-8S	4730-01-156-4835	Adapter	

## SECTION IV. MODIFICATION PROCEDURES

### NOTE

Pay attention to all Notes, Cautions, and Warnings per TM 5-2350-262-34, Power Package Replacement.

This procedure requires the power package to be completely disconnected from the vehicle and removed by following the steps below.

### WARNING

High pressure is present in the M9 hydraulic system. Do not disconnect any hydraulic system component unless hydraulic system pressure has been relieved. Failure to comply may result in severe injury or death.

- a. Perform INITIAL SETUP for power package removal and installation procedures per TM 5-2350-262-34, Power Package Replacement.

### WARNING

Air system contains high pressure. Do not disconnect any air system hose, tube, or fitting unless air pressure has been relieved. Failure to comply may result in severe injury to personnel.

### NOTE

Step b below applies to Figure 2-1.

- b. Remove and reinstall quick-disconnect (2) on air compressor line with male coupling to air compressor (1). Verify quick-disconnect (3) on fuel return line has male coupling to fuel tank.

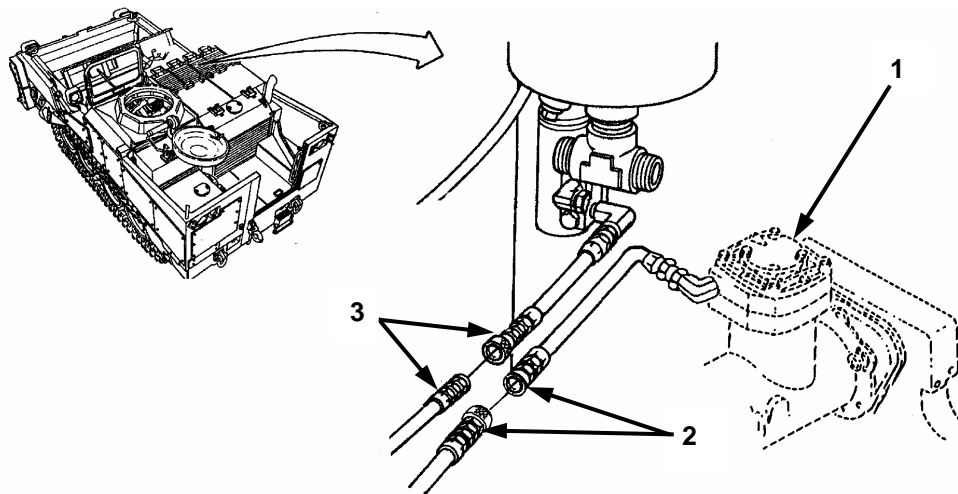

**Figure 2-1. Quick-Disconnect Reinstall at Air Compressor**

- c. Remove power package per TM 5-2350-262-34, Power Package Replacement–Removal.

**NOTE**

Recommend applying Chapter 3 at this time while power package is removed.

Steps d through p below apply to Figure 2-2.

- d. On top fitting (3) of bracket (21), remove and discard hose (1) from rear of steer unit (2).
- e. Install quick-disconnect (10) at top fitting (3) and to new hose (20) with male coupling to bracket side (21).

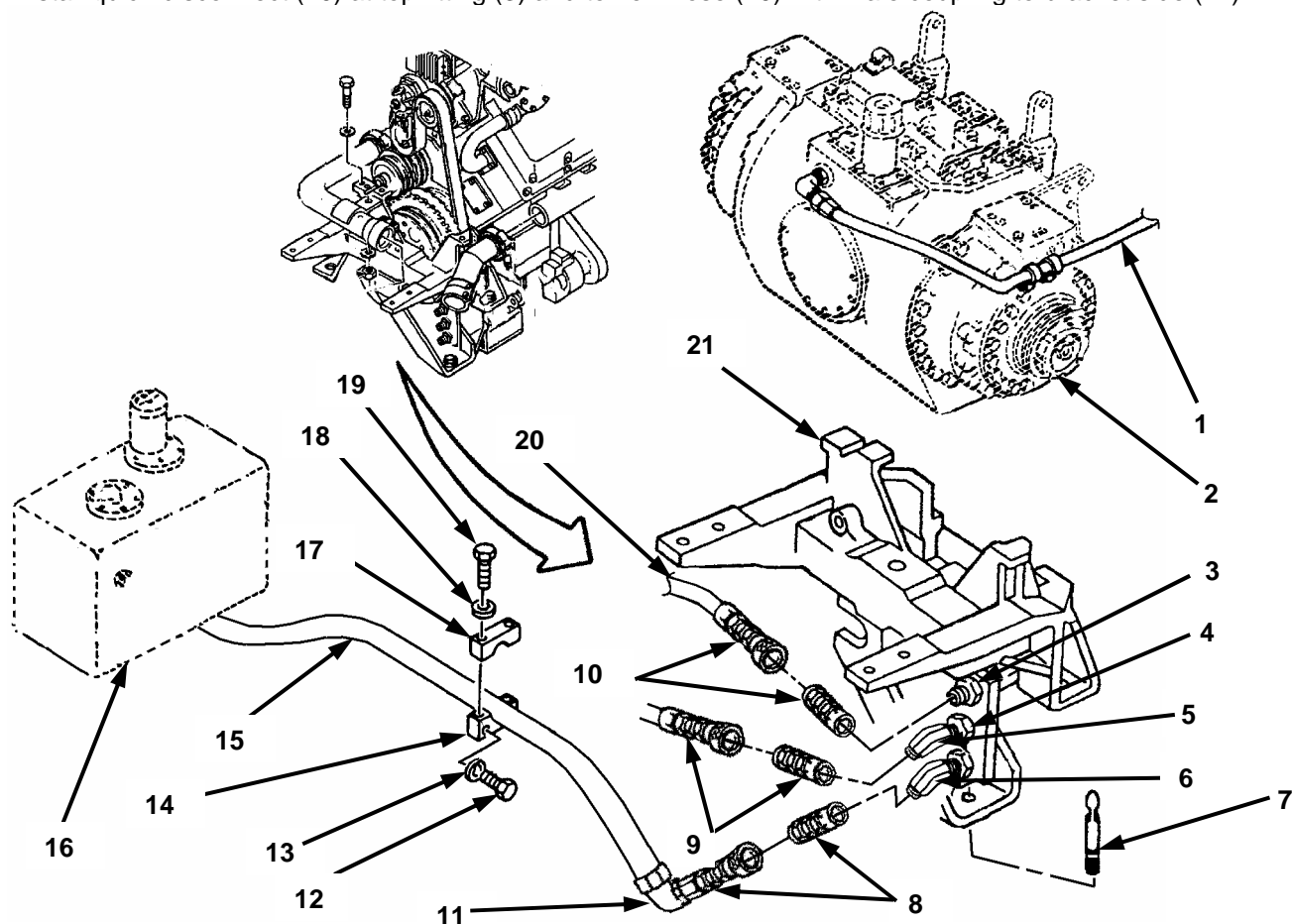

**Figure 2-2. Quick-Disconnects and Guide Pin at Lower Rear Engine Bulkhead**

## MWO 5-2350-262-35-1

- f. On middle fitting (4) of bracket (21), remove and discard 45° elbow MS51509A24 and install 35° elbow (5), facing down, on bracket.
- g. Install quick-disconnect (9) at middle fitting (4) on bracket (21) with male coupling to bracket side.
- h. Remove and discard two bolts (19), washers (18), and bracket (17) from bracket (14) on hull bottom plate.
- i. Remove and discard hose 13214E2551 and tube 12325766 from bottom fitting (6) of bracket (21) and hydraulic tank (16) bottom.
- j. Remove and discard bracket (14) from hull bottom plate, using method (1) or (2):
  - (1) Remove and discard two bolts (12), washers (13), and bracket (14) from hull bottom plate.

### **WARNING**

When cutting and grinding CARC painted equipment, ensure proper ventilation and that personnel wear appropriate protective equipment. Dust from grinding CARC paint is to be treated and disposed of as hazardous waste. Failure to comply may result in injury or death.

- (2) Using suitable aluminum cutting tool, cut and discard welded bracket (14) from hull.
  - (a) Grind raw area smooth on hull bottom plate using a suitable aluminum grinding tool.
  - (b) Clean, prime, and paint raw area using suitable CARC primer and finish paint per TB 43-0209.
- k. Install quick-disconnect (8) at bottom fitting (6) on bracket (21) with male coupling to bracket side.
- l. Install new 90° elbow (11) on one end of new hose (15).
- m. Install female quick-disconnect half (8) to 90° elbow (11).
- n. Route hose (15) on hull bottom in front of steer unit (2) and install hose end on bottom of hydraulic tank (16).
- o. Install guide pin (7) at lower rear engine mounting point.
- p. Install power package per TM 5-2350-262-34, Power Package Replacement–Installation, with following changes:

**NOTE**

Steps (1) through (4) below apply to Figure 2-3.

- (1) While performing TASK F per TM 5-2350-262-34, Power Package Replacement–Installation, adjust 90° elbow (2) on compensating pump to face up and angle towards transfer case.

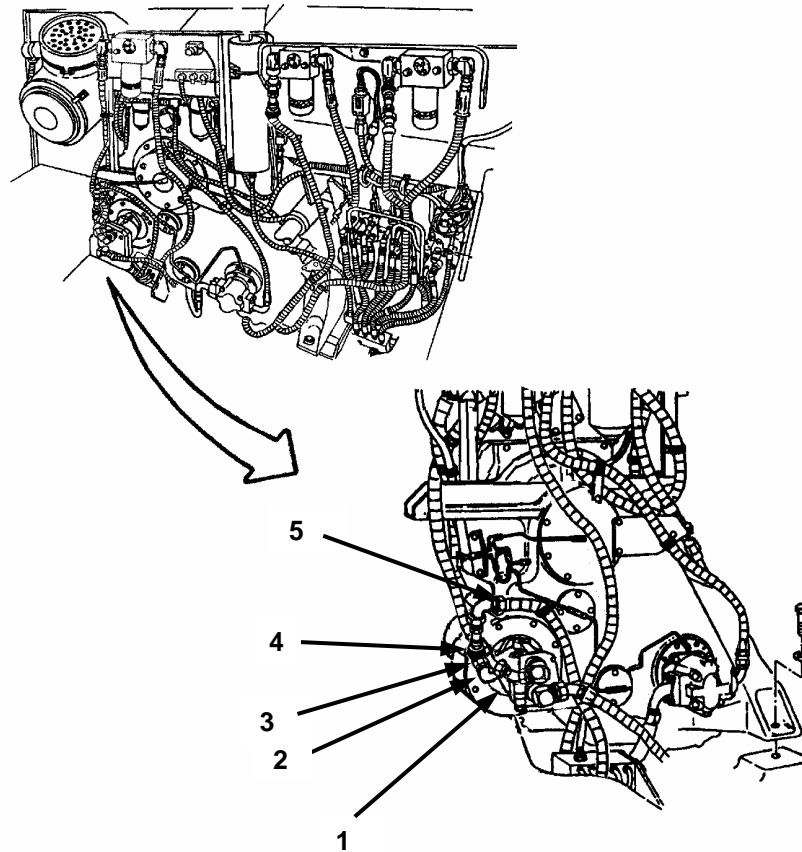

**Figure 2-3. Compensating Pump between Hose and Elbow**

- (2) Install quick-disconnect (3) on compensating pump at elbow (2) with male coupling to compensating pump.
- (3) Install new 90° elbow (4) to female half quick-disconnect coupling (3).
- (4) Reroute hose (5) up through front tubes on manifold, next to compensating pump, and above compensating pump to 90° elbow (4).

**NOTE**

Steps (5) (a), (b), and (c) below apply to Figure 2-4.

- (5) While performing TASK J and K per TM 5-2350-262-34, Power Package Replacement–Installation, perform the following steps:
- (a) Remove and discard cap screw (9), retaining strap (8), flat washer (6), and nut (5) from bracket (1).
- (b) Remove and discard two cap screws (7), flat washers (4), nuts (3), and bracket (1) from plate (2).
- (c) Remove and discard two machine bolts (10), retaining strap (13), flat washers (11), and nuts (12) from hull bottom plate.

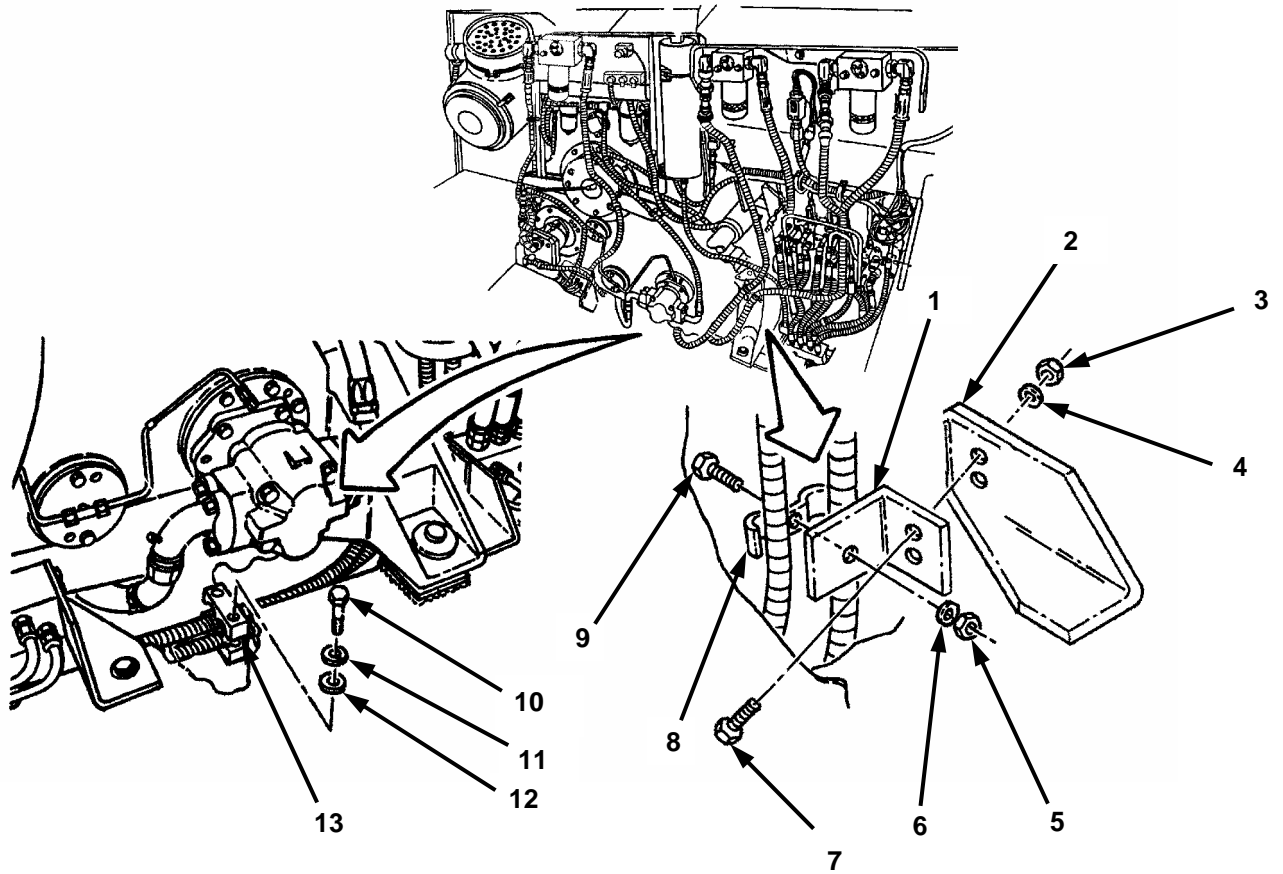
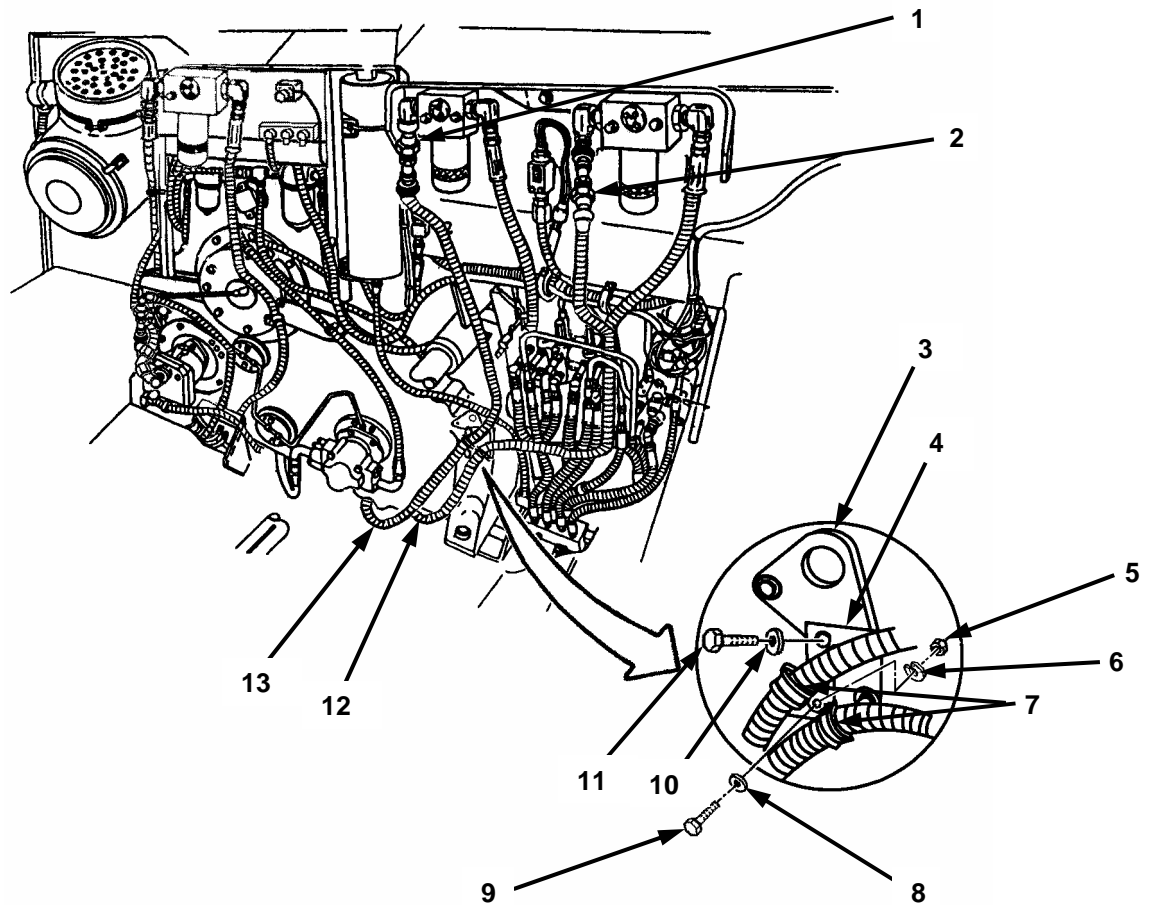

Figure 2-4. Hull Bottom Plate

**NOTE**

Steps (6) through (10) below apply to Figure 2-5.

- (6) Reroute hoses (12 and 13) in front of engine transfer case, between scavenger pump and transfer case motor mount.



**Figure 2-5. High Pressure Filters**

- (7) Install new bracket (4) to lifting eye (3) at bottom two bolt locations with existing two bolts (11) and washers (10).
- (8) Secure hoses (12 and 13) with clamps (7) to front of bracket (4) with screw (9), flat washer (8), lock washer (6), and nut (5).
- (9) Install quick-disconnect (1) at power package side high pressure filter with male coupling to high pressure filter.
- (10) Install quick-disconnect (2) at driver's compartment side high pressure filter with female coupling to high pressure filter.

**NOTE**

Step (11) below applies to Figure 2-6.

- (11) While performing FOLLOW-ON TASKS per TM 5-2350-262-34, Power Package Replacement–Installation, install quick-disconnect (2) at bottom of main hydraulic accumulator (1) with male coupling to main hydraulic accumulator.

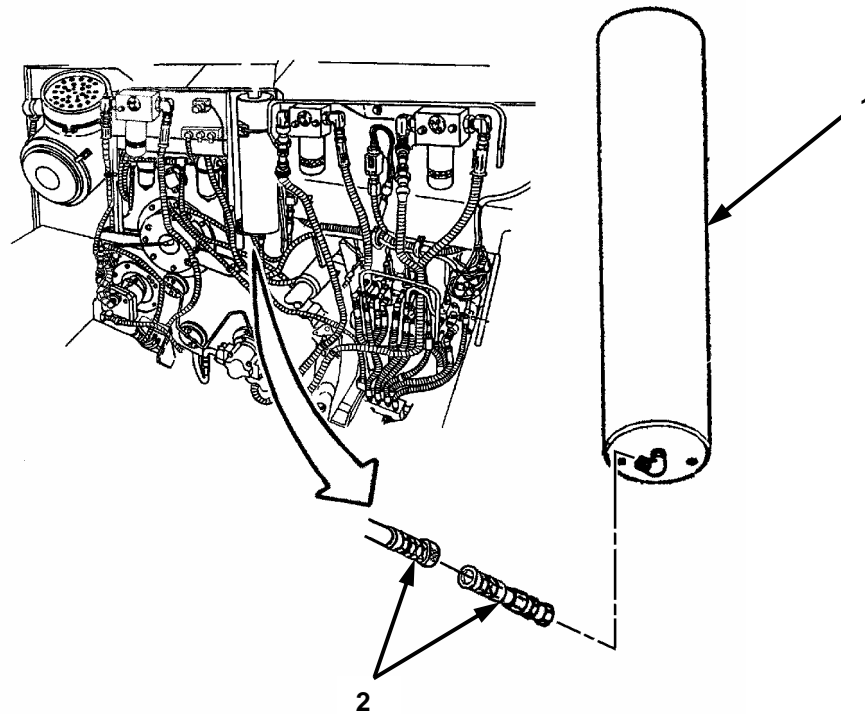
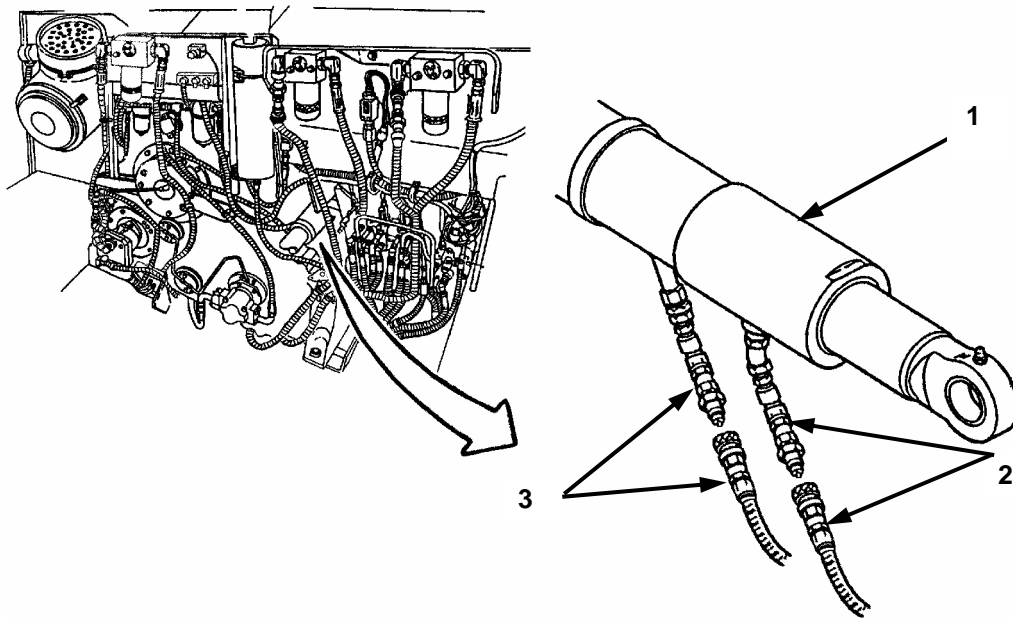

**Figure 2-6. Main Hydraulic Accumulator**

**NOTE**

Step (12) below applies to Figure 2-7.

- (12) While performing FOLLOW-ON TASKS per TM 5-2350-262-34, Power Package Replacement–Installation, install two quick-disconnects (2 and 3) at ejector cylinder (1) with male couplings to ejector cylinder.



**Figure 2-7. Ejector Cylinder**

**NOTE**

If ejector assembly is hitting the high pressure filter hose (1), refer to [M9 ACE News 'n' Views](#), June 2003, Volume 26 from within the Army Knowledge Online website, for recommended 45° elbow installation procedures.



## CHAPTER 3

# INSTALLATION OF NEW CONFIGURATION FIXED DRY POWDER FIRE EXTINGUISHER SYSTEM AND MODIFICATION OF NEW PRODUCTION FIXED DRY POWDER FIRE EXTINGUISHER SYSTEM

**SUBJECT:** Installation of new configuration fixed dry powder fire extinguisher system and modification of existing new production fixed dry powder fire extinguisher system.

**DATE:** 22 June 2005

**DESCRIPTION:** Remove and replace existing fixed halon fire extinguisher system with new configuration fixed dry powder fire extinguisher system. Remove and replace existing (new production vehicle serial numbers 574 through 625) fixed dry powder fire extinguisher system with new configuration fixed dry powder fire extinguisher system.

**TM REFERENCES:** The technical manual references in this procedure are: TM 5-2350-262-20-1, dated January 1997, with Change 3, dated March 2000; TM 5-2350-262-20-2, dated January 1997, with Change 3, dated March 2000; and TM 5-2350-262-24P, dated March 2000.

## SECTION I. MWO PARTS LIST

**Table 3-1. MWO Parts List**

Part Number	CAGE	NSN	Description	Qty
10199	54905	4730-01-473-2745	Adapter, Bottle	2
10250	54905	4310-01-472-5238	Nozzle, Discharge	4
10780	54905	5340-01-472-6330	Bracket, Nozzle	4
14607	54905	4210-01-472-8469	Fire Bottle	2
15048	54905	4210-01-472-5233	Actuator Assembly	2
K9190606-4-4-4C-30	5S586	4720-01-473-4348	Sheath	2
ST1587	14242	5340-01-497-5565	Strap, T-Bolt	4
ST1588	14242	5340-01-497-5549	Strap, Trunnion	4
12355423	19207	5340-01-254-6556	Cover, Access	1*
12357165	19207	5340-01-254-4385	Gasket	1
12476191-1	19207	4720-01-500-8723	Hose, Assembly, 17 inch	1
12476191-2	19207	4720-01-500-8728	Hose, Assembly, 20 inch	1
12476191-3	19207	4720-01-500-8730	Hose, Assembly, 28 inch	2
12476192	19207	5340-01-500-8635	Actuator, Cover	2
12476249	19207	5340-01-500-8656	Base, Plate	2
12481025	19207	2590-01-491-4468	Cable, Assembly	2
B1821BH025C050N	80204	5305-00-071-2506	Screw	8
B1821BH025C063N	80204	5305-00-068-7837	Screw, Cap	4
B1821BH025C075N	80204	5305-00-068-0508	Screw	10
B1821BH031C100N	80204	5306-00-226-4827	Screw	8
MS20392-3C43	96906	5315-00-811-9106	Pin, Straight, Headless	8
MS24665-132	96906	5315-00-839-2325	Pin, Cotter	8
MS25082-10	96906	5310-00-721-8000	Nut, Plain	2
MS27151-28	96906	5310-00-985-0782	Nut, Stamped	2
MS27183-10	96906	5310-00-809-4058	Washer, Flat	4
MS27183-49	96906	5310-01-333-1883	Washer	16
MS35338-139	80205	5310-00-933-8121	Washer, Lock	8
MS51513A12	96906	5310-00-466-7496	Tee	2

Table 3-1. MWO Parts List - Continued

Part Number	CAGE	NSN	Description	Qty
M45913/1-5CG5Z	81349	5310-01-495-9634	Nut, Self Locking	8
4FBTX-SS	30780	4730-00-842-1766	Adapter	2
2102-8-8	30780	4730-00-289-2357	Elbow, Pipe, 90 Degree	2
8-8 140339	81343	4730-00-541-0793	Elbow, Pipe, 45 Degree	3
5227606	19207	4730-00-350-4437	Reducer, Tube	2
7968260	19207	4210-00-796-8260	Handle, Fire Extinguisher	2*
F-2738-A01-3-1-24	81348	5340-01-469-7199	Seal, Antipilferage	2

\* If in serviceable condition, reuse these parts.

## SECTION II. TOOLS REQUIRED

Tool Kit, General Mechanics: Automotive, NSN 5180-00-177-7033

## SECTION III. REMOVAL PROCEDURES AND RIGHT SIDE BOTTLE HOLDER SHIELD MODIFICATION FOR HALON (OLD PRODUCTION)

### NOTE

Pay attention to all Notes, Cautions, and Warnings per TM 5-2350-262-20-1, Fixed Halon Fire Extinguisher Tubes, Hose, and Fittings Replacement (Old Production) and TM 5-2350-262-20-2, Muffler Shields Replacement.

### CAUTION

Before removing the halon bottle, ensure control valve remains in reset position to avoid triggering fire extinguisher. Failure to comply may result in damage to equipment or injury to personnel. Regardless of indication on pressure gauge i.e., safeguards must be in place even if pressure gauge reads "0.0 psig".

- a. Remove halon fire extinguisher tubes, hoses, and fittings per TM 5-2350-262-20-1.
- b. Remove halon fire extinguisher control valve, cable guides, and cable per TM 5-2350-262-20-1 and TM 5-2350-262-20-2.
- c. Remove halon extinguisher, canisters, and clamps per TM 5-2350-262-20-1.

### WARNING

When cutting and grinding CARC painted equipment, ensure proper ventilation and that personnel wear appropriate protective equipment. Dust from grinding CARC paint is to be treated and disposed of as hazardous waste. Failure to comply may result in injury or death.

### NOTE

Steps d through f below apply to Figure 3-1.

- d. Using suitable aluminum cutting tool, cut right side fire extinguisher bottle holder shield from holder, leaving 1.5 inches on each side (Figure 3-1).
- e. Using suitable aluminum grinder, smooth new edges and surfaces.

- f. Clean, prime, and paint raw area with suitable CARC prime and finish paint per TB 43-0209.

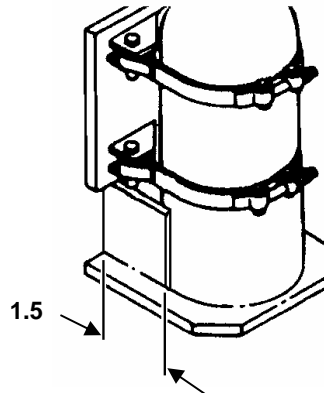

Figure 3-1. Fire Extinguisher Bottle Holder Shield

## SECTION IV. REMOVAL PROCEDURES FOR DRY POWDER (NEW PRODUCTION VEHICLE SERIAL NUMBERS 574 THROUGH 625)

### NOTE

Pay attention to all Notes, Cautions, and Warnings per TM 5-2350-262-20-1, Fixed Dry Powder Fire Extinguisher Hoses and Fittings Replacement (New Production) and TM 5-2350-262-20-2, Muffler Shields Replacement.

- a. Remove dry powder fire extinguisher hoses and fittings per TM 5-2350-262-20-1. Remove and discard four nozzle brackets, nozzles, elbows, and hoses.
- b. Remove dry powder fire extinguisher control valve and cable per TM 5-2350-262-20-1 and TM 5-2350-262-20-2.
- c. Remove dry powder fire extinguisher cylinder and clamps per TM 5-2350-262-20-1.
- d. If in like-new condition, re-use dry powder bottles Part Number 14607. Bottles date-stamped five years or older must be static tested by qualified service facility before reuse is authorized.

## SECTION V. NOZZLE INSTALLATION PROCEDURES FOR LEFT SIDE (ALL VEHICLES)

### NOTE

Steps a through f below apply to Figure 3-2.

- a. Using suitable machinist's ruler, measure, mark, and center punch, for drilling and tapping four holes for two brackets (10780) on left side (Figure 3-2).
- b. Drill 4 x .25 x 20-UNC-2B holes .375 inch deep only and bottom end tap holes, ensuring maximum thread depth of .375 inch.
- c. Install two brackets (Figure 3-2) with four washers (MS27183-49) and screws (B1821BH025C050N).
- d. Install one 90° elbow (2102-8-8) and nozzle (10250) at LOCATION D (Figure 3-2). Using suitable machinist's protractor and straight edge, direct 90° elbow towards engine with 25° angle down from horizontal.

- e. Install two 45° elbows (8-8 140339) and one nozzle (10250) at LOCATION E (Figure 3-2).
- f. Direct forward 45° elbow at LOCATION E (Figure 3-2) towards vehicle front with 45° angle down. Direct rear 45° elbow at Location E (Figure 3-2) towards vehicle rear with 45° angle up.

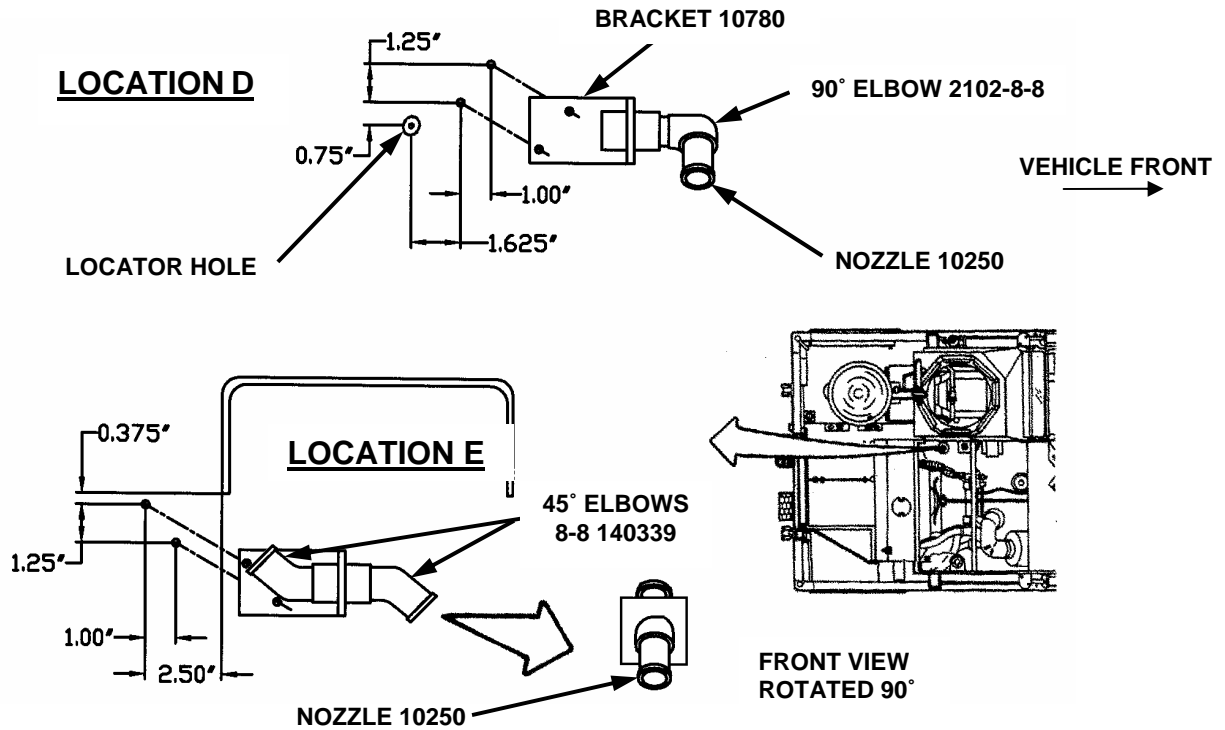

**Figure 3-2. Left Side Nozzle Bracket Installation**

**NOTE**

Locator hole for Location D (Figure 3-2 above) is hole for fire extinguisher system cable into driver's compartment.

Steps g through h below apply to Figure 3-3 below.

- g. Inside operator compartment, wire rope free play measurement should not exceed two inches (changed from four inches to two inches).
- h. Refer to Figure 3-3 below to verify placement of hoses and elbows.

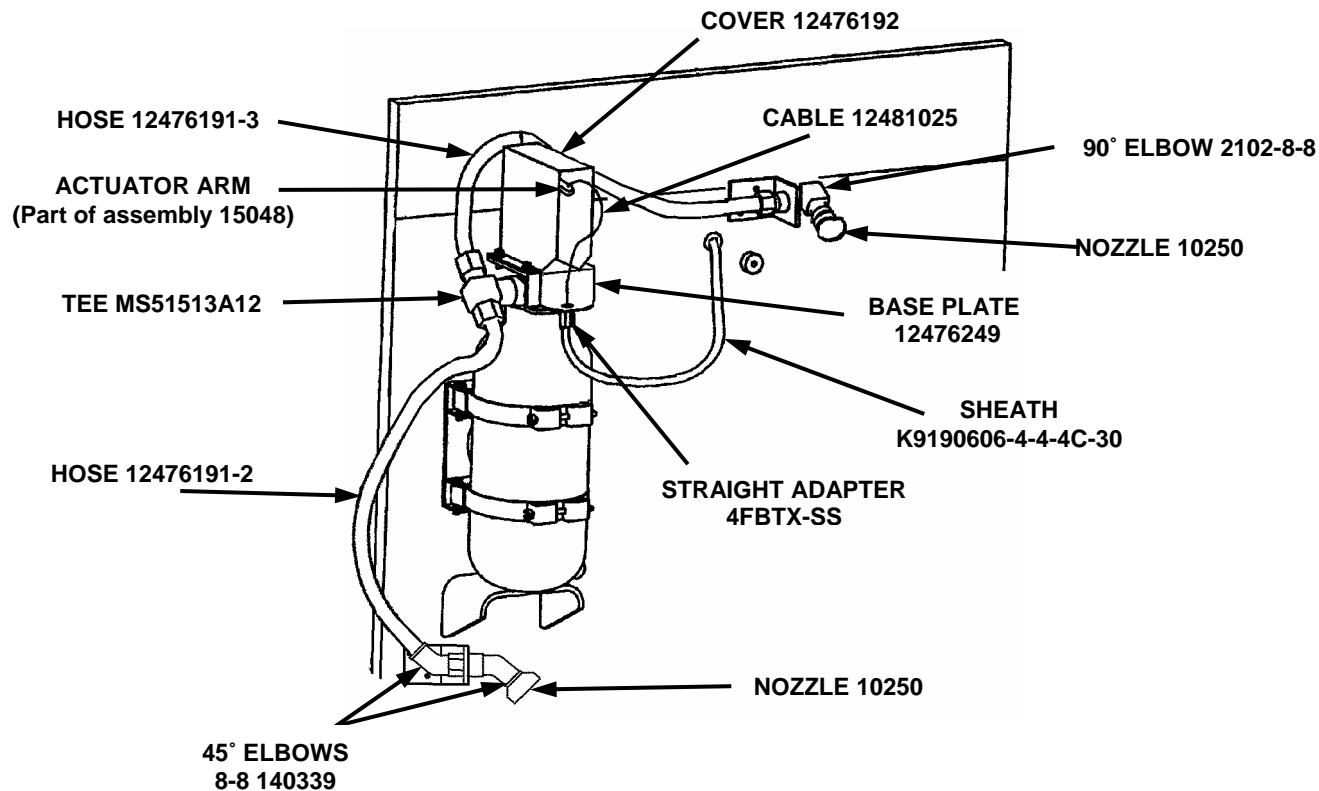

Figure 3-3. Left Side Installation

## SECTION VI. NOZZLE INSTALLATION PROCEDURES FOR RIGHT SIDE (ALL VEHICLES)

### NOTE

Steps a through e below apply to Figure 3-4.

- a. Using suitable machinist's ruler, measure, mark, and center punch, for drilling and tapping four holes for two brackets (10780) on right side (Figure 3-4).
- b. Drill 4 x .25 x 20-UNC-2B holes .375 inch deep only and bottom end tap holes, ensuring maximum thread depth of .375 inch.
- c. Install two brackets (Figure 3-4) with four washers (MS27183-49) and screws (B1821BH025C050N).
- d. Install 90° elbow (2102-8-8) and nozzle (10250) at LOCATION F (Figure 3-4). Using suitable machinist's protractor and straight edge, direct 90° elbow towards engine at 10° down from horizontal.
- e. Install 45° elbow (8-8 140339) and nozzle at (10250) LOCATION G (Figure 3-4). Direct 45° elbow directly towards left side of vehicle.

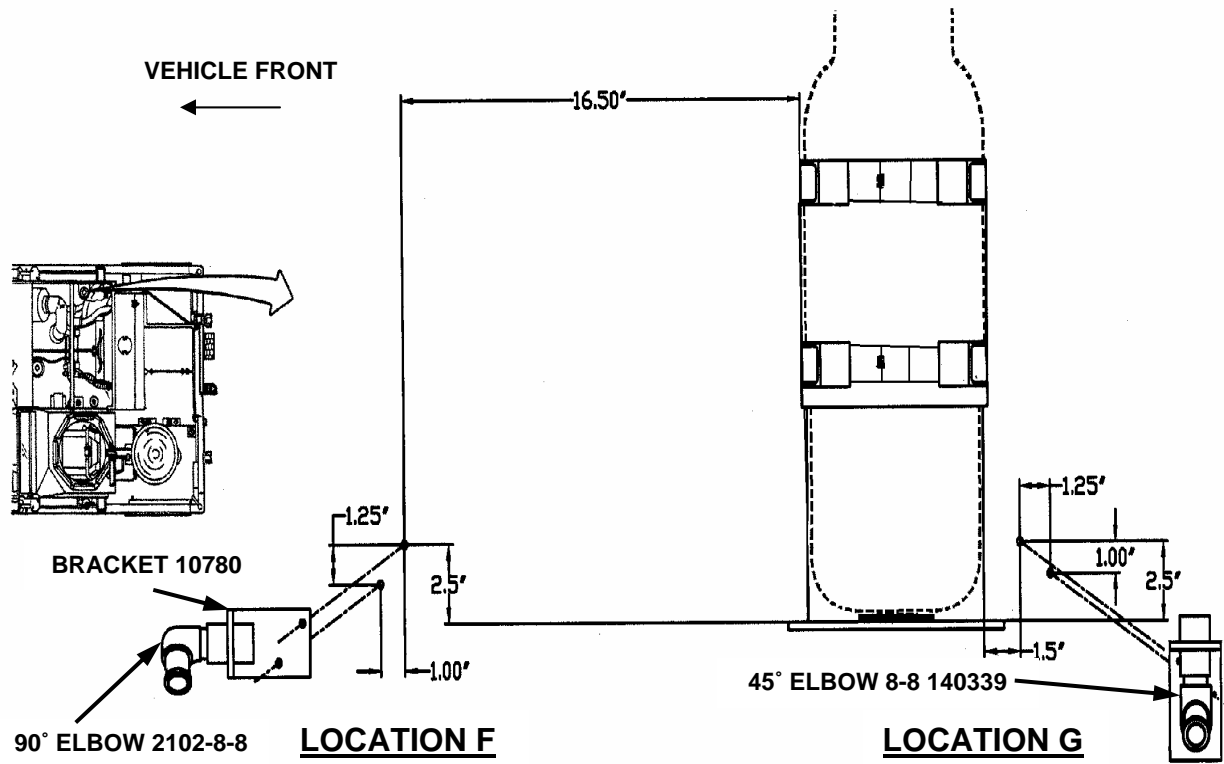

Figure 3-4. Right Side Nozzle Bracket Installation

**NOTE**

Steps f through g below apply to Figure 3-5.

- f. Outside on right side of vehicle, wire rope free play measurement should not exceed two inches (changed from four inches to two inches).
- g. Refer to Figure 3-5 below to verify placement of hoses and elbows.

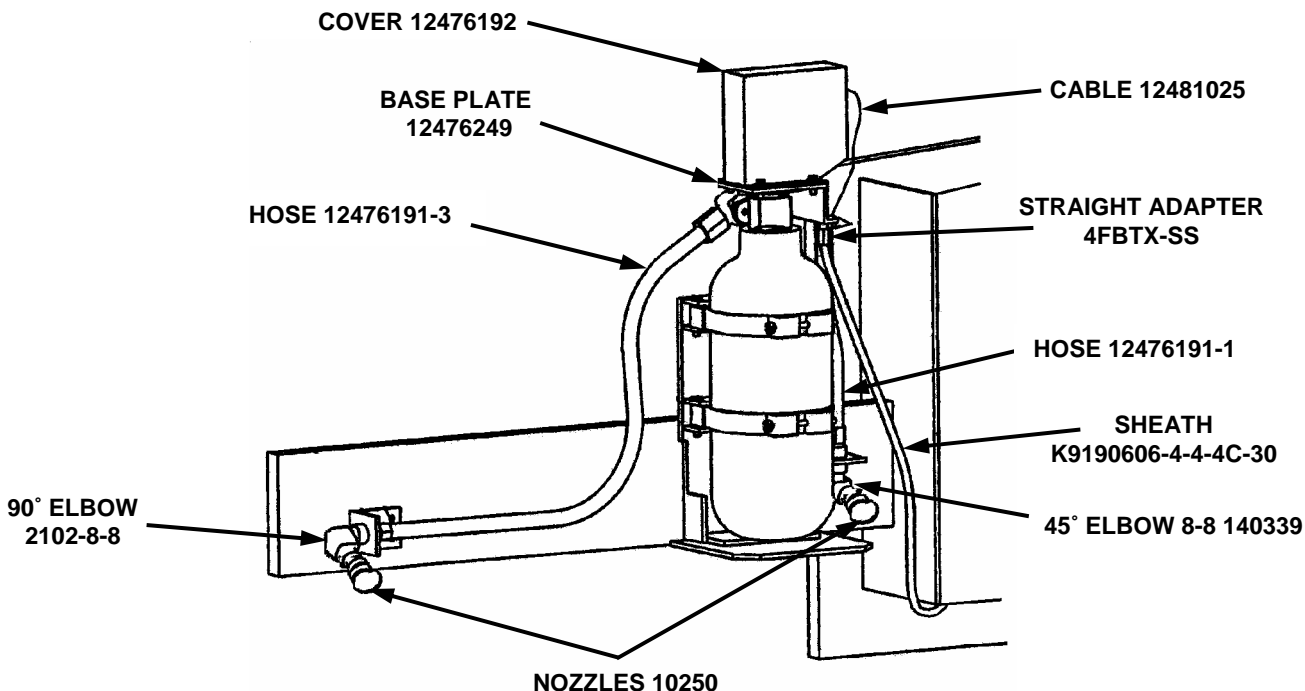

Figure 3-5. Right Side Installation

## SECTION VII. INSTALLATION PROCEDURES FOR DRY POWDER (ALL VEHICLES)

- a. Install dry powder fire extinguisher hoses and fittings per TM 5-2350-262-20-1.
- b. Install dry powder fire extinguisher control valve and cable per TM 5-2350-262-20-1 and TM 5-2350-262-20-2. Use new straight adapter, actuator cover, actuator assemblies, base plate, cable, and sheath identified in Figures 3-3 and 3-5 above. Ensure actuator assemblies 15048 are replaced with new ones supplied.
- c. Ensure cable is installed up through actuator arm and over arm, then down through base plate, seating cable ball end in bottom of actuator arm.
- d. If in serviceable condition, reuse access cover 12355423 and fire extinguisher handles 7968260.
- e. Install dry powder fire extinguisher cylinder and clamps per TM 5-2350-262-20-1.

By Order of the Secretary of the Army:

PETER J. SCHOOMAKER  
*General, United States Army*  
*Chief of Staff*

Official:



SANDRA R. RILEY

*Administrative Assistant to the*  
*Secretary of the Army*

0515401

DISTRIBUTION: To be distributed in accordance with the Initial Distribution Number (IDN) 256841, requirements for MWO 5-2350-262-35-1.