

TECHNICAL MANUAL

**ORGANIZATIONAL
MAINTENANCE**

**TRUCK TRACTOR, LINE HAUL,
50,000 GVWR, 6 x 4, M915A1**

(NSN 2320-01-125-2640)

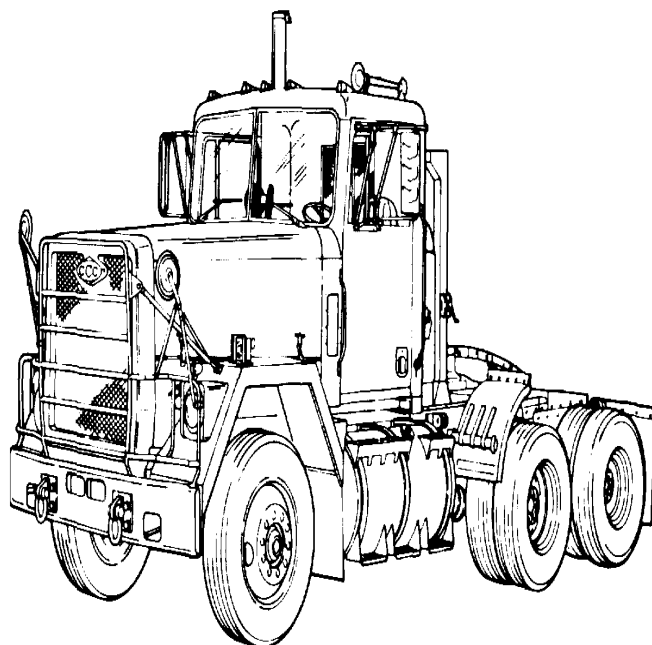

DECEMBER 1983

**HEADQUARTERS,
DEPARTMENT OF THE ARMY**

**HOW TO USE THIS MANUAL
PAGE xiii**

**GENERAL INFORMATION
PAGE 1-1**

**EQUIPMENT DESCRIPTION
AND DATA
PAGE 1-2**

**PRINCIPLES OF OPERATION
PAGE 1-14**

**PREVENTIVE MAINTENANCE
CHECKS AND SERVICES (PMCS)
PAGE 2-3**

**TROUBLESHOOTING
PAGE 2-29**

**STE/ICE TROUBLESHOOTING
PAGE 2-329**

**GENERAL MAINTENANCE
INSTRUCTIONS
PAGE 3-2**

**ENGINE
PAGE 3-13**

**FUEL SYSTEM
PAGE 3-94**

**EXHAUST SYSTEM
PAGE 3-212**

**COOLING SYSTEM
PAGE 3-246**

DECEMBER 1983

his manual may include copyrighted technical data of one or more of the following subcontractors of AM General Corporation:

1981	Alinabal, Division of MPB Corporation
1981	Anchorlock, Division of Lear Siegler, Inc.
1980	Argo Instruments, Inc.
1981	Bendix Corporation
1982	Bostrom, Division of UOP, Inc.
1976	The Budd Company
1982	Cole-Hersee Company
1982	Cummins Engine Company, Inc.
1980	Delco-Remy, Division of General Motors Corporation
1982	Detroit Diesel Allison, Division of General Motors Corporation
1981	Eaton Corporation, Axle Division
1981	Firestone Steel Products Company, Division of Firestone Tire and Rubber Company
1980	Goodyear Tire and Rubber Company
1981	Grote Manufacturing Company
1980	Gunite, Division of Kelsey-Hayes Co.
1981	Holland Hitch Company
1980	Hupp, Moble Products Division
1981	Leece-Neville, Sheller Globe Division
1982	McCord Heat Transfer, Division of Ex-Cell-O Corporation
1979	Nelson Muffler, Division of Nelson Industries, Inc.
1982	Owatonna Tool Company
1979	Phillips Temco, Inc., Division of J.B. Carter
1982	Rockwell International
1978	Snap-On Tool Company

AM General has written permission from any and all such subcontractors holding copyrights to grant the United States Government a royalty free, nonexclusive and irrevocable license throughout the world for Governmental purposes to publish, translate, reproduce, deliver, perform, dispose of, and to authorize others so to do, all technical data now or hereafter covered by copyright. Any use other than that authorized above must be made with the express permission of AM General or the subcontractor whose copyrighted material is being used. This notice must be reproduced on all copies or portions thereof.

TM 9-2320-283-20-1
C1

HEADQUARTERS
DEPARTMENT OF THE ARMY
Washington D.C , 20 April 1993

Change

No. 1

TECHNICAL MANUAL
ORGANIZATIONAL MAINTENANCE
TRUCK TRACTOR, LINE HAUL,
50,000 GVWR, 6X4, M915A1
(NSN 2320-01-125-2640)

TM 9-2320-283-20-1, 8 December 1983, is changed as follows:

1. Remove old pages and insert new pages as indicated below.
2. The Preventive Maintenance Checks and Services have been completely replaced; no change bars or pointing hands will appear on pages 2-3 through 2-28.12.

<i>Remove Pages</i>	<i>Insert Pages</i>
2-3 thru 2-28	2-3 thru 2-28.12

3. File this change sheet in the front of the publication for information purposes.

By Order of the Secretary of the Army:

GORDON R. SULLIVAN
General, United States Army
Chief of Staff

Official:

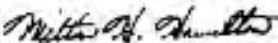
MILTON H. HAMILTON
Administrative Assistant to the
Secretary of the Army
4047

Distribution:

To be distributed in accordance with DA Form 12-38-E, Block 0322, requirements for TM 9-2320-283-20-1.

Approved for public release; distribution is unlimited.

WARNING**CARBON MONOXIDE (EXHAUST GAS) CAN KILL YOU**

Carbon monoxide is without color or smell, but it can kill you. Breathing air with carbon monoxide produces symptoms of headache, dizziness, loss of muscular control, a sleepy feeling, and coma. Brain damage or death can result from heavy exposure. Carbon monoxide occurs in the exhaust fumes of fuel burning heaters and internal combustion engines. Carbon monoxide can become dangerously concentrated under conditions of no air movement. Precautions must be followed to insure crew safety when the personnel heater, main engine, or auxiliary engine of any vehicle is operated for any purpose.

1. DO NOT operate personnel heater or engine of vehicle in a closed place, unless the place has a lot of moving air.
2. DO NOT idle engine for long periods without ventilator blower operating.
3. DO NOT drive any vehicle with inspection plates, cover plates, or engine compartment doors removed, unless necessary for maintenance purposes.
4. BE ALERT at all times during vehicle operation for exhaust odors and exposure symptoms. If either is present, IMMEDIATELY VENTILATE personnel compartments. If symptoms persist, remove affected crew to fresh air; keep warm; DO NOT PERMIT PHYSICAL EXERCISE; if necessary, give artificial respiration.

FOR ARTIFICIAL RESPIRATION, REFER TO FM2111.

5. BE AWARE: the field protective mask for chemical biological radiological (CBR) protection will not protect you from carbon monoxide poisoning.

THE BEST DEFENSE AGAINST CARBON MONOXIDE POISONING IS GOOD VENTILATION.

WARNING

Whenever hood is raised, insert the S-shaped safety hook through the two matching holes in the prop channels to prevent the hood from falling accidentally.

WARNING

Let radiator cool before removing cap. Remove radiator cap in two steps. First, place a thick cloth over the cap and slowly rotate cap counterclockwise to its first stop; pause, and let pressure escape from cooling system. Then rotate cap further counterclockwise until you can remove it. Failure to follow this procedure can result in serious burns.

WARNING

Do not smoke, have open flames, or make sparks around the batteries, especially if the caps are off. Battery gases can explode and cause injury.

WARNING

Particles blown by compressed air are hazardous. Always direct air stream away from the user and other persons in the area. User must wear a safety eyeshield when using compressed air in cleaning.

WARNING

Improper cleaning methods and use of unauthorized cleaning solvents could injure personnel and damage equipment. See TM 9-247 for proper cleaning methods and authorized solvents.

WARNING

Compressed air used for cleaning purposes will not exceed 30 psi. Use only with effective chip guarding and personnel protective equipment (goggles/shield, gloves, etc.).

WARNING

Ether is highly explosive. Dispose of ether cylinders properly. Be alert for the strong odor of spilled ether. Guard against flame or sparks in work area when servicing ether cylinder.

WARNING

During normal operation, the exhaust pipes and muffler can become very hot. Be careful not to touch these components with your bare hands. Do not allow your body to come in contact with the hot pipes or muffler. Exhaust system components may be hot enough to cause serious burns.

WARNING

Cooling system components become hot during operation. To avoid personal injury, do not service cooling system components until cooling system has cooled down.

WARNING

Always remove negative battery ground cables first and install them last to avoid sparks that can cause an explosion. Failure to follow this precaution may result in serious injury to you and other personnel.

WARNING

Transmission oil is hot. Use care when draining transmission oil to prevent personal injury.

WARNING

Never work on air system components without first draining air pressure. Failure to follow this precaution can result in serious injury.

d

ORGANIZATIONAL MAINTENANCE MANUAL

TRUCK TRACTOR, LINE HAUL,
50,000 GVWR, 6 X 4, M915A1

REPORTING ERRORS AND RECOMMENDING IMPROVEMENTS

You can help improve this manual. If you find any mistakes or if you know of a way to improve the procedures, please let us know. Mail your letter, DA Form 2028 (Recommended Changes to Publications and Blank Forms), or DA Form 20282 located in the back of this manual directly to Commander, U.S. Army Tank Automotive Command, ATTN:DRSTAMB, Warren, MI 48090. A reply will be furnished to you.

VOLUME 1 OF 3

	Page
HOW TO USE THIS MANUAL	xiii
CHAPTER 1 INTRODUCTION	1-1
1-1. Overview	1-1
Section I GENERAL INFORMATION	1-1
1-2. Scope	1-1
1-3. Maintenance Forms, Records, and Reports	1-1
1-4. Destruction of Army Materiel to Prevent Enemy Use	1-1
1-5. Preparation for Storage or Shipment	1-1
1-6. Reporting Equipment Improvement Recommendations (EIR)	1-2
1-7. Warranty Information	1-2
Section II EQUIPMENT DESCRIPTION AND DATA	1-2
1-8.. Equipment Characteristics, Capabilities, and Features	1-2
1-9. Location and Description of Major Components	1-3
1-10. Equipment Data	1-8

		Page
Section III	PRINCIPLES OF OPERATION	1-14
	1-11. Engine.....	1-15
	1-12. Fuel System.....	1-18
	1-13. Exhaust System.....	1-27
	1-14. Cooling System.....	1-28
	1-15. Electrical System	1-31
	1-16. Transmission	1-58
	1-17. Front Axle and Suspension	1-62
	1-18. Rear Tandem Axles.....	1-63
	1-19. Compressed Air System.....	1-66
	1-20. Brake System	1-68
	1-21. Auxiliary Air-Powered Systems.....	1-82
	1-22. Steering System	1-86
	1-23. Cab Heating and Ventilating System.....	1-88
	1-24. Winterization Kit.....	1-92
CHAPTER 2	SERVICE AND TROUBLESHOOTING INSTRUCTIONS	2-1
	2-1. Overview.....	2-1
Section I	REPAIR PARTS; SPECIAL TOOLS; TESTS, MEASUREMENT AND DIAGNOSTIC EQUIPMENT (TMDE); AND SUPPORT EQUIPMENT	2-1
	2-2. Common Tools and Equipment	2-1
	2-3. Special Tools, TMDE, and Support Equipment.....	2-1
	2-4. Repair Parts.....	2-1
Section II	SERVICE UPON RECEIPT	2-2
	2-5. Checking Unpacked Equipment	2-2
	2-6. Deprocessing Unpacked Equipment	2-2
Section III	PREVENTIVE MAINTENANCE CHECKS AND SERVICES (PMCS)	2-3
	2-7. General.....	2-3
	2-8. Organizational Preventive Maintenance Checks and Services.....	2-4
Section IV	(TROUBLESHOOTING)	2-29
	2-9. General.....	2-29
	2-10. Troubleshooting Symptom Index.....	2-31
	2-11. Troubleshooting Procedures	2-36
Section V	STE/ICE TROUBLESHOOTING	2-329
	2-12. General.....	2-329
	2-13. How to Use the STE/ICE Test Index	2-329
	2-14. Vehicle Test Meter Troubleshooting.....	2-329
	2-15. STE/ICE VTM Set-Up Procedure Test Number GO1.....	2-331
	2-16. STE/ICE Description and Operation.....	2-331
	2-17. CI Engine GO-Chain Index.....	2-344
	2-18. CI Engine NO-GO Chain Index	2-344
	2-19. Vehicle Testing Troubleshooting Procedures.....	2-345
	2-20. STE/ICE GO Chain Tests.....	2-347
	2-21. STE/ICE NO-GO Chain Tests	2-369

CHAPTER 3.	ORGANIZATIONAL MAINTENANCE	3-1
	3-1. Overview	3-1
Section I	GENERAL MAINTENANCE INSTRUCTIONS	3-2
	3-2. General	3-2
	3-3. Task Summary	3-2
	3-4. Cleaning	3-3
	3-5. Inspection	3-5
	3-6. Repair	3-6
	3-7. Assembly	3-8
	3-8. Operational Checks	3-9
	3-9. Torque Limits	3-10
Section II	ENGINE	3-13
	3-10 General	3-13
	3-11. Task Summary	3-13
	3-12. Engine Oil Service	3-16
	3-13. Rocker Cover and Gasket Replacement	3-22
	3-14. Rocker Cover Filler Cap Replacement	3-28
	3-15. Breather Tubes and Hoses Replacement	3-32
	3-16. Oil Level Dipstick Replacement	3-40
	3-17. Oil Level Dipstick Tube Brace and Clamp Replacement	3-44
	3-18. Air Compressor Cooling Tubes Replacement	3-50
	3-19. Air Compressor Intake Tube Replacement	3-56
	3-20. Water Crossover Tube and Connections Replacement	3-62
	3-21. Water Transfer Tube and Bracket Replacement	3-72
	3-22. Engine Lifting Bracket Replacement	3-78
	3-23. Engine Dataplate Replacement	3-84
	3-24. Fan Brace, Bracket, and Spacers Replacement	3-88
Section III	FUEL SYSTEM	3-94
	3-25 General	3-94
	3-26 Task Summary	3-94
	3-27. Fuel Filter Screen Replacement	3-98
	3-28. Engine Fuel Lines and Fittings Replacement	3-102
	3-29. Air Cleaner Assembly Replacement	3-114
	3-30. Air Cleaner Filter Element Replacement	3-122
	3-31. Turbocharger Air Crossover Connection Replacement	3-130
	3-32. Air Cleaner Tube Replacement	3-136
	3-33. Solenoid Valve Replacement	3-142
	3-34. Fuel Tank Replacement	3-150
	3-35. Fuel Heater Replacement	3-158
	3-36. Fuel Hoses and Fittings Replacement	3-166
	3-37. Water Separator Fuel Filter Replacement	3-174
	3-38. Ether Cylinder Replacement	3-178
	3-39. Ether Quick Start Thermostat Replacement	3-182
	3-40. Ether Quick Start Kit Replacement	3-186
	3-41. Accelerator Pedal and Linkage Replacement	3-194
	3-42. Fuel Control Lever Replacement	3-206

Section IV	EXHAUST SYSTEM	3-212
	3-43. General	3-212
	3-44. Task Summary	3-212
	3-45. Muffler and Heat Shield Replacement	3-214
	3-46. Exhaust Stack Pipe Replacement	3-222
	3-47. Exhaust Flex Pipe Replacement	3-228
	3-48. Turbocharger Outlet Pipe Replacement	3-234
	3-49. Muffler Inlet Pipe Replacement	3-240

Section V	COOLING SYSTEM	3-246
	3-50. General	3-246
	3-51. Task Summary	3-246
	3-52. Cooling System Service	3-250
	3-53. Radiator Replacement	3-260
	3-54. Radiator Support Rods Replacement	3-272
	3-55. Transmission and Steering System Cooler Replacement	3-278
	3-56. Upper Fan Shroud Replacement	3-286
	3-57. Lower Fan Shroud Replacement	3-292
	3-58. Lines, Fittings, and Hoses Replacement	3-296
	3-59. Thermostat and Thermostat Housing Replacement	3-314
	3-60. Water Manifolds Replacement	3-324
	3-61. Water Shut-off Valves and Lines Replacement	3-338
	3-62. Water Filter and Bracket Replacement	3-346
	3-63. Water Pump Drive Belt Replacement	3-352
	3-64. Water Pump Replacement	3-356
	3-65. Fan and Fan Clutch Replacement	3-364
	3-66. Fan Clutch Air Valve Replacement	3-372
	3-67. Fan Clutch Drive Belts Replacement	3-378

VOLUME 2 OF 3

Section VI	ELECTRICAL SYSTEM	3-384
	3-68. General	3-384
	3-69. Task Summary	3-384
	3-70. Alternator and Bracket Replacement	3-396
	3-71. Alternator Drive Belts Replacement	3-406
	3-72. Starter Motor and Solenoid Replacement	3-412
	3-73. Left-Hand Instrument Panel Gage Replacement	3-420
	3-74. Ignition Switch Replacement	3-426
	3-75. Pushbutton Starter Switch Replacement	3-430
	3-76. Ether Start Switch Replacement	3-436
	3-77. Pushbutton Clearance Lamp Switch Replacement	3-440
	3-78. Headlamp Switch Replacement	3-446
	3-79. Blackout Toggle Switch Replacement	3-452
	3-80. Turn Signal Switch Replacement	3-458
	3-81. Heater Fan Switch Replacement	3-468
	3-82. Headlamp Dimmer Switch Replacement	3-474

Section VI	ELECTRICAL SYSTEM (Continued)	Page
	3-83. Cigar Lighter Replacement.....	3-478
	3-84. Low Air Pressure Lamp Replacement.....	3-482
	3-85. Ether Lamp and Clearance Lamp Replacement	3-486
	3-86. Wiper Lamp and Washer Lamp Replacement	3-490
	3-87. Warning and Indicator Lamps Replacement	3-496
	3-88. Three Position Engine Retarder Switch Replacement	3-504
	3-89. Engine Retarder Foot Switch Replacement	3-510
	3-90. Fuel Pump Engine Retarder Switch Replacement	3-516
	3-91. Headlamp Assembly Replacement	3-524
	3-92. Turn Signal and Marker Lamp Replacement.....	3-532
	3-93. Cab Clearance Lamp Assembly Replacement.....	3-540
	3-94. Blackout Marker Lamp Assembly Replacement.....	3-546
	3-95. Blackout Headlamp Assembly Replacement	3-554
	3-96. Stoplamp-Taillamp Assembly Replacement.....	3-562
	3-97. Blackout Taillamp Assembly Replacement	3-572
	3-98. Dome Lamp and Switch Replacement	3-582
	3-99. Map Lamp and Switch Replacement.....	3-588
	3-100. Hot Engine Temperature Switch Replacement	3-592
	3-101. Water Temperature Sending Unit Replacement	3-598
	3-102. Oil Pressure Sending Unit Replacement.....	3-602
	3-103. Transmission Temperature Sending Unit Replacement	3-606
	3-104. Low Oil Pressure Sending Unit Replacement	3-610
	3-105. Fuel Level Sending Unit Replacement	3-614
	3-106. Neutral Safety Switch and Reverse Switch Replacement	3-618
	3-107. Differential Lock Pressure Switch Replacement	3-626
	3-108. Park Brake Pressure Switch Replacement	3-634
	3-109. Low Air Pressure Switch Replacement	3-640
	3-110. Low Air Pressure Buzzer Replacement.....	3-644
	3-111. Turn Signal Flasher Replacement.....	3-648
	3-112. Instrument Panel Relays Replacement	3-652
	3-113. Instrument Panel 24 Volt Relay Replacement.....	3-656
	3-114. Manual Reset Circuit Breaker and Mounting Bracket Replacement	3-660
	3-115. Starter Relay Replacement.....	3-666
	3-116. Starting Circuit Diode Replacement	3-670
	3-117. Horn Replacement.....	3-674
	3-118. Horn Button Replacement	3-678
	3-119. Battery Charging.....	3-684
	3-120. Battery Power Disconnect and Connect Procedure	3-694
	3-121. Battery Replacement	3-702
	3-122. Battery Box Replacement.....	3-708
	3-123. Battery Box Latch Replacement.....	3-712
	3-124. Battery Cable Replacement.....	3-716
	3-125. Slave Start Receptacle Replacement.....	3-736
	3-126. Wiring Harness Replacement.....	3-740
	3-127. Wiring Harness Repair	3-742

Section VI	ELECTRICAL SYSTEM (Continued).	
	3-128. Ground Strap and Cables Replacement.....	3-766
	3-129. Blackout Marker Lamp and Headlamp Cable Replacement	3-772
	3-130. Trailer Receptacle Bracket Replacement.....	3-778
	3-131. STE/ICE Connector Bracket Replacement	3-784
	3-132. Utility Outlet Receptacle Replacement.....	3-788
Section VII	TRANSMISSION	3-792
	3-133. General	3-792
	3-134. Task Summary	3-792
	3-135. Transmission Servicing	3-794
	3-136. Oil Level Gage and Tube Replacement	3-806
	3-137. Shifter Control Replacement	3-812
	3-138. Shifter Control Cable Replacement.....	3-820
	3-139. Shifter Control Mounting Bracket Replacement	3-832
	3-140. Modulator Control Replacement.....	3-838
	3-141. Lines and Fittings Replacement	3-846
Section VIII	PROPELLER SHAFTS AND UNIVERSAL JOINTS	3-856
	3-142. General	3-856
	3-143. Task Summary	3-856
	3-144. Primary Propeller Shaft and Universal Joints Replacement.....	3-858
	3-145. Interaxle Propeller Shaft and Universal Joints Replacement.....	3-868
Section IX	FRONT AXLE	3-876
	3-146. General	3-876
	3-147. Task Summary	3-876
	3-148. Steering Arm Replacement	3-878
	3-149. Steering Knuckle Assembly Replacement.....	3-882
	3-150. Tie Rod Arm Replacement	3-892
Section X	REAR AXLE	3-896
	3-151. General	3-896
	3-152. Task Summary	3-896
	3-153. Rear Axle Oil Service.....	3-898
	3-154. Rear Axle Shaft Replacement	3-904
Section XI	BRAKE SYSTEM	3-908
	3-155. General	3-908
	3-156. Task Summary	3-908
	3-157. Slack Adjuster Replacement	3-916
	3-158. Brake Assembly Replacement	3-922
	3-159. Brake Shoe Replacement.....	3-928
	3-160. Camshaft and Camshaft Bracket Replacement	3-934
	3-161. Spider and Anchor Pin Replacement	3-940
	3-162. Dust Shield Replacement.....	3-944
	3-163. Air Lines and Fittings Replacement.....	3-948

Section XI

BRAKE SYSTEM (Continued).

Page

3-164	Front Axle and Rear-Rear Axle Brake Chamber Replacement	3-950
3-165	Front Axle and Rear-Rear Axle Brake Chamber Repair	3-956
3-166	Forward-Rear Axle Brake Chamber Replacement	3-962
3-167	Front External Air Couplings Replacement	3-968
3-168	Supply Reservoir Replacement	3-976
3-169	Primary Reservoir Replacement.....	3-984
3-170	Secondary Reservoir Replacement.....	3-990
3-171	Park Brake Valve Replacement.....	3-996
3-172	Park Brake Valve Repair	3-1002
3-173	Trailer Hand Brake Valve Replacement	3-1010
3-174	Brake Treadle Valve Replacement.....	3-1020
3-175	Trailer Supply Valve Replacement	3-1030
3-176	Trailer Supply Valve Repair.....	3-1036
3-177	Relay Valve Replacement	3-1044
3-178	Forward-Rear Axle Quick Release Valve Replacement	3-1052
3-179	Rear-Rear Axle Quick Release Valve Replacement	3-1058
3-180	Mountable Tee Replacement	3-1064
3-181	Front Axle Ratio Valve Replacement.....	3-1072
3-182	Double Check and Quick Release Valve Replacement	3-1078
3-183	Double Check and Stoplamp Valve Replacement.....	3-1084
3-184	Firewall Double Check Valve Replacement	3-1092
3-185	Secondary Reservoir Double Check Valve Replacement	3-1098
3-186	Supply Reservoir Safety Valve Replacement.....	3-1104
3-187	Secondary Reservoir Check Valve Replacement.....	3-1108
3-188	Primary and Secondary Reservoir Draincock Replacement	3-1112
3-189	Primary Reservoir Check Valve Replacement	3-1116
3-190	Supply Reservoir Drain Valve Replacement.....	3-1120
3-191	Supply Reservoir Single Check Valve Replacement.....	3-1124
3-192	Tractor Protection Valve Replacement.....	3-1130
3-193	Brake Pedal Double Check Valve Replacement	3-1138
3-194	Fifth Wheel Toggle Valve Replacement	3-1144
3-195	Differential Toggle Valve Replacement	3-1152
3-196	Trailer Couplings, Brackets, and Hose Replacement	3-1160
3-197	Hose Tender Replacement.....	3-1168
3-198	Air Dryer Replacement	3-1172
3-199	Air Dryer Repair	3-1180
3-200	Air Dryer Dehydrate Cartridge Replacement.....	3-1194

Section XII	WHEELS	3-1203
	3-201 General.....	3-1203
	3-202 Task Summary	3-1203
	3-203 Front Wheel Alinement	3-1206
	3-204 Front Drum Replacement	3-1210
	3-205 Front Hub, Bearings, and Seals Replacement	3-1214
	3-206 Rear Brake Drum Replacement	3-1222
	3-207 Rear Hub, Bearings, and Seals Replacement.....	3-1226
	3-208 Tire Replacement	3-1238
Section XIII	STEERING SYSTEM	3-1245
	3-209 General.....	3-1245
	3-210 Task Summary	3-1245
	3-211 Steering System Service	3-1248
	3-212 Steering System Testing	3-1254
	3-213 Steering Wheel Replacement.....	3-1264
	3-214 Upper Steering Column Replacement and Repair	3-1270
	3-215 Lower Steering Column Replacement and Repair	3-1282
	3-216 Vertical Link Replacement.....	3-1292
	3-217 Steering Arm Replacement	3-1298
	3-218 Tie Rod and Ball Joints Replacement	3-1304
	3-219 Steering Pump and Reservoir Replacement	3-1310
	3-220 Power Steering Lines and Fittings Replacement.....	3-1318
Section XIV	FRAME AND TOWING ATTACHMENTS	3-1329
	3-221 General.....	3-1329
	3-222 Task Summary	3-1329
	3-223 Secondary Reservoir Support Replacement	3-1334
	3-224 Muffler Inlet Pipe Support Replacement.....	3-1338
	3-225 Supply Reservoir Mounting Brackets Replacement	3-1344
	3-226 Step Replacement	3-1350
	3-227 Air Dryer Mounting Bracket Replacement	3-1358
	3-228 Tiedown Bracket Replacement.....	3-1362
	3-229 Vehicle Lifting Bracket Replacement.....	3-1366
	3-230 Clevis Pin Replacement	3-1372
	3-231 Transmission Oil Filter Mounting Bracket Replacement	3-1376
	3-232 Forward-Rear Axle Stop Replacement.....	3-1380
	3-233 Blackout Taillamp Mounting Bracket Replacement.....	3-1384
	3-234 Taillamp Bracket Replacement	3-1388
	3-235 Rear Tow Eye Bracket, Shackle, and Pin Replacement	3-1392
	3-236 Brush Guard Replacement.....	3-1398
	3-237 Bumper, Towing Eyes, and Vehicle Class Sign Replacement	3-1404
	3-238 Tow Pintle Replacement.....	3-1412
	3-239 Service Deck Replacement	3-1420
	3-240 Spare Tire Carrier Replacement.....	3-1426

Section XIV

FRAME AND TOWING ATTACHMENTS (Continued)

3-241 Spare Tire Winch Cable Replacement 3-1432
 3-242 Spare Tire Winch Replacement and Repair 3-1438
 3-243 Spare Tire Winch Pillar Replacement 3-1446
 3-244 Fifth Wheel Adjustment 3-1452
 3-245 Fifth Wheel Replacement 3-1458
 3-246 Fifth Wheel Ramp Replacement 3-1466

Section XV

SPRINGS, SHOCK ABSORBERS, AND TORQUE RODS

3-247 General 3-1470
 3-248 Task Summary 3-1470
 3-249 Front Spring Pin Screws and Fittings
 Replacement 3-1472
 3-250 Shock Absorber Replacement 3-1478
 3-251 Torque Rods Replacement 3-1484

Section XVI

CAB AND BODY

3-252 General 3-1492
 3-253 Task Summary 3-1492
 3-254 Right-Hand Instrument Cluster Panel Assembly
 Replacement 3-1498
 3-255 Left-Hand Instrument Cluster Panel Assembly
 Replacement 3-1504
 3-256 Instrument Panel Center Panel Assembly
 Replacement 3-1510
 3-257 Glove Compartment Door Assembly Replacement 3-1516
 3-258 Instrument Panel Assembly Replacement 3-1522
 3-259 Inside Assist Handle Replacement 3-1528
 3-260 Center Floor Pan Access Cover Replacement 3-1532
 3-261 Ventilator Replacement 3-1536
 3-262 Padlock Bracket Replacement 3-1540
 3-263 Outside Rear Handle Replacement 3-1544
 3-264 Outside Front Handle Replacement 3-1548
 3-265 Door Plate Replacement 3-1552
 3-266 Door Frame Seal Replacement 3-1556
 3-267 Insulator Replacement 3-1560
 3-268 Grille Replacement 3-1566
 3-269 Hood Replacement 3-1576
 3-270 Hood Panel and Component Replacement 3-1584
 3-271 Front Fender Replacement 3-1600
 3-272 Quarter Fender Replacement 3-1612
 3-273 Splash Shield Replacement 3-1618
 3-274 Rear Mud Flap and Bracket Replacement 3-1622
 3-275 Cab Headliner Panel Replacement 3-1626
 3-276 Cab Trim Panel Replacement 3-1630
 3-277 Insulation Replacement 3-1634
 3-278 Sun Visor Replacement 3-1638
 3-279 Floor Mat Replacement 3-1642
 3-280 Driver's Seat Replacement 3-1646
 3-281 Driver's Seat Riser Replacement 3-1650

Section XVI	CAB AND BODY (Continued)	
	3-282 Seat Belt Replacement.....	3-1654
	3-283 Companion Seat Replacement.....	3-1660
	3-284 Companion Seat Riser, Fire Extinguisher Brackets, and Toolbox Replacement	3-1664
Section XVII	ACCESSORY ITEMS	3-1672
	3-285 General.....	3-1672
	3-286 Task Summary	3-1672
	3-287 Door Mirror Replacement	3-1676
	3-288 Spotter Mirror Replacement	3-1682
	3-289 Air Horn and Control Valve Replacement.....	3-1688
	3-290 Windshield Washer Replacement	3-1694
	3-291 Windshield Washer Control Valve Replacement	3-1700
	3-292 Windshield Wiper Control Replacement	3-1704
	3-293 Windshield Wiper Blade Assembly Replacement	3-1710
	3-294 Windshield Wiper Assembly Replacement	3-1714
	3-295 Windshield Wiper Motor Replacement.....	3-1720
	3-296 Heater Air Hose Replacement.....	3-1726
	3-297 Heater Valve, Hoses, Tubes, and Clamps Replacement	3-1730
	3-298 Heater Assembly Replacement and Repair	3-1736
	3-299 Heater Blower Assembly Replacement and Repair	3-1746
	3-300 Heater Control Panel Replacement.....	3-1754
	3-301 Heater Control Panel Repair.....	3-1760
	3-302 Air Diffuser Assembly Replacement.....	3-1766
	3-303 Defroster Fan Replacement	3-1772
	3-304 Defroster Fan Repair	3-1776
	3-305 Data and Instruction Plates Replacement	3-1782
	3-306 Winterization Kit (Refer to TB 9-2320-283-14)	
Section XVIII	GAGES (NON-ELECTRICAL)	3-1786
	3-307 General.....	3-1786
	3-308 Task Summary	3-1786
	3-309 Tachograph Replacement	3-1788
	3-310 Speedometer Shaft Replacement	3-1798
	3-311 Speedometer Drive Sleeve Adapter Replacement.....	3-1802
	3-312 Speedometer Driven Gear Replacement	3-1806
	3-313 Tachometer Shaft Replacement.....	3-1810
	3-314 Pressure Gage Replacement	3-1816
	3-315 Air Cleaner Restriction Gage and Bracket Replacement	3-1822
	3-316 Air Cleaner Restriction Gage Tube Replacement	3-1828
Section XIX	STE/ICE COMPONENTS	3-1832
	3-317 General.....	3-1832
	3-318 Task Summary	3-1832
	3-319 Pulse Tachometer Replacement	3-1834
	3-320 Pressure Transducer Replacement.....	3-1838

		Page
APPENDIX A	REFERENCES	A-i
	A-1 Publication Indexes.....	A-i
	A-2 Forms	A-i
	A-3 Other Publications	A-i
APPENDIX B	MAINTENANCE ALLOCATION CHART	B-1
Section I	INTRODUCTION	B-1
	B-1 General.....	B-1
	B-2 Maintenance Functions	B-1
	B-3 Explanation of Columns in the MAC,	
Section II	B-2	
	B-4 Explanation of Columns in Tool and Test	
	Equipment Requirements, Section III	B-4
Section II	MAINTENANCE ALLOCATION CHART	B-5
Section III	TOOL AND TEST EQUIPMENT REQUIREMENTS	B-24
APPENDIX C	EXPENDABLE SUPPLIES AND MATERIALS LIST	C-1
Section I	INTRODUCTION	C-1
	C-1 Scope.....	C-
	C-2 Explanation of Columns.....	C-1
Section II	EXPENDABLE SUPPLIES AND MATERIALS LIST	C-2
APPENDIX D	SCHEMATIC DIAGRAMS	D-1
Section I	INTRODUCTION	D-1
	D-1 Scope.....	D-1
	D-2 Electrical System Diagrams.....	D-1
	D-3 Compressed Air System Diagrams	D-1
APPENDIX E	ILLUSTRATED LIST OF MANUFACTURED ITEMS	E-1
Section I	INTRODUCTION	E-1
	E-1 General.....	E-1
	E-2 Manufactured Item Part Number Index	E-1
Section II	ILLUSTRATED MANUFACTURING INSTRUCTIONS	E-2
GLOSSARY	Glossary-1
Section I	LIST OF ABBREVIATIONS	Glossary-1
Section II	DEFINITION OF UNUSUAL TERMS	Glossary-1
ALPHABETICAL INDEX		Index-1

HOW TO USE THIS MANUAL

As a maintenance technician, you are responsible for maintaining the equipment covered in this manual. The best way to do this is with the aid of your maintenance manual. Below is a sample problem.

PROBLEM: Vehicle operator reports that the engine cranks but fails to start.

1. Turn to the cover of your manual.

On the righthand side you will find a listing for "TROUBLESHOOTING." Along with the listing is a page number and a black marker. Follow either the page number reference or the black marker to the first page in the troubleshooting section.

2. What is the quickest way to find the solution to the problem?

Turn to paragraph 2-10.

This is the "TROUBLESHOOTING SYMPTOM INDEX." Follow the numerical listing "ENGINE" until you see item 2, "Engine cranks but fails to start." Now go to the page listed directly to the right of the malfunction.

3. What caused the problem?

Turn to paragraph 2-11.

These are the "TROUBLESHOOTING PROCEDURES." Locate the symptom "Engine cranks but fails to start." Here you will find the most likely causes of the problem. After following each step in the order listed and finding the problem, let's say, "The fuel solenoid valve is defective," go to the referenced paragraph.

4. How do you fix the problem?

Turn to paragraph 3-33.

This is the maintenance procedure for the fuel solenoid valve. It is arranged step-by-step so everything you need to know to maintain the fuel solenoid valve is covered. Now you are ready to correct the problem.

Your maintenance manual is easy to use. You eliminate mistakes and are always made aware of the warnings and cautions you need to know for personnel and equipment safety.

The M915A1 Truck Tractor and equipment are non-metric and do not require any metric tools. Therefore, metric units are not supplied in this manual. Furthermore, for the sake of clarity, tactical instructions will also remain non-metric.

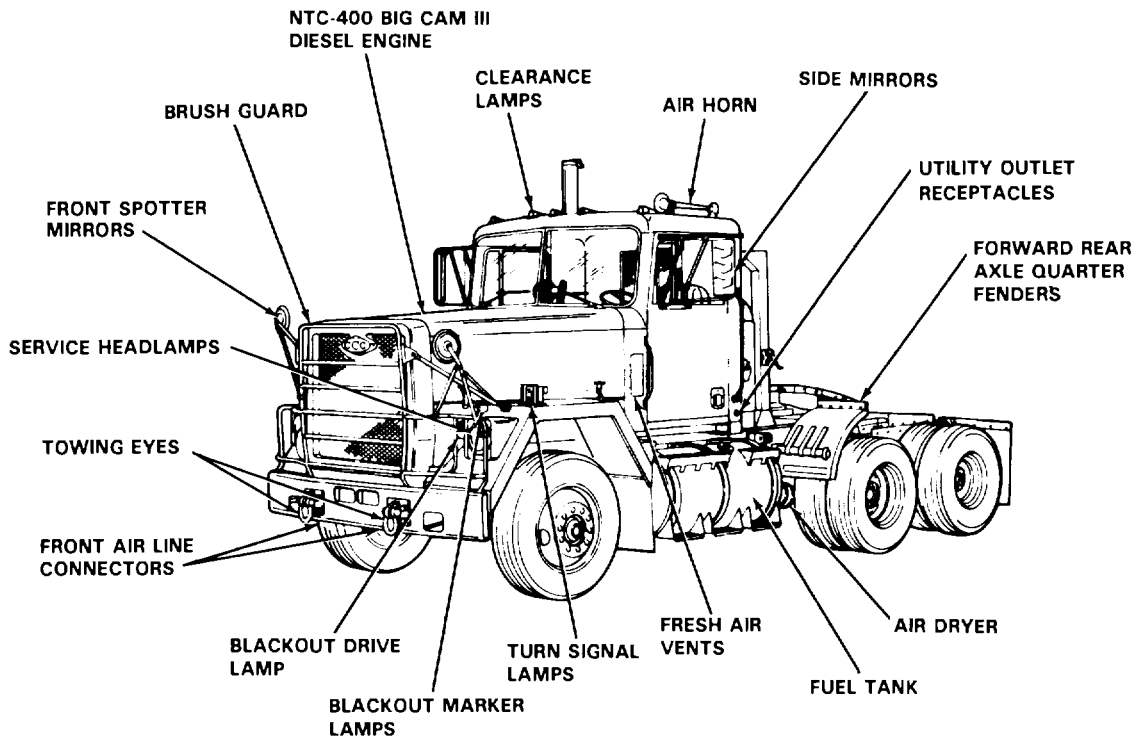

M915A1 - LEFT FRONT 3/4 VIEW.

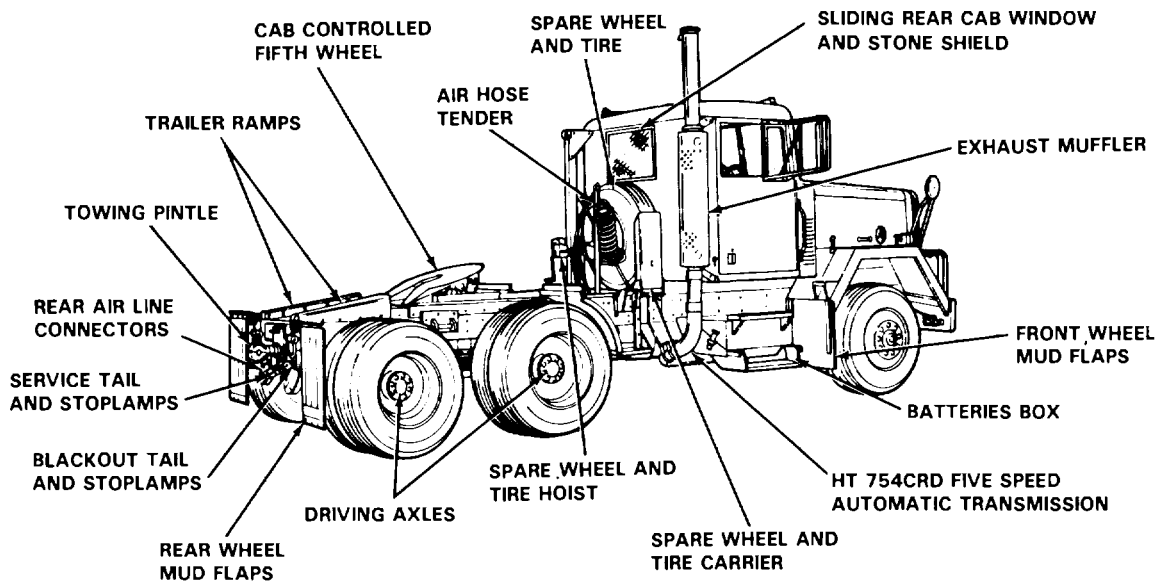

M915A1- RIGHT REAR 3/4 VIEW.

CHAPTER 1

1-1. SECTION I. OVERVIEW

This chapter provides the following information:

- a. Forms and record data required for maintenance.
- b. Physical descriptions and data of major components
- c. Functional explanations of components maintained at the organizational level.

1-2. SCOPE

Type of Manual: Organizational maintenance.

Model Number and Equipment Name: M915A1, Truck Tractor, Line Haul, 50,000 GVWR, 6 x 4.

Purpose of Equipment: Used with the M-872 Trailer for on-road, line hauling of loads up to a gross vehicle weight rating of 50,000 lbs (30,000 lbs on fifth wheel).

1-3. MAINTENANCE FORMS, RECORDS, AND REPORTS.

Department of the Army forms and procedures used for equipment maintenance will be those prescribed by TM 38-750, The Army Maintenance Management System.

1-4. DESTRUCTION OF ARMY MATERIEL TO PREVENT ENEMY USE

Requirements and procedures for destruction of Army materiel to prevent enemy use are given in TM 750-244-6.

1-5. PREPARATION FOR STORAGE OR SHIPMENT.

Storage information is given in TM 740-90-1, Administrative Storage.

SECTION II. GENERAL INFORMATION.

1-6. REPORTING EQUIPMENT IMPROVEMENT RECOMMENDATIONS (EIR).

If your M915A1 Truck Tractor needs improvement, let us know. Send us an EIR. You, the user, are the only one who can tell us what you don't like about your equipment. Let us know why you don't like the design. Put it on an SF368 (Quality Deficiency Report). Mail it to us at: Commander, U.S. Army Tank Automotive Command, ATTN: DRSTAM, Warren, Michigan 48090. We'll send you a reply.

1-7. WARRANTY INFORMATION.

Warranty information can be found in TB9-2300-295-15/20 (M915A1 Warranty Bulletin).

1-8. SECTION II. EQUIPMENT CHARACTERISTICS, CAPABILITIES, AND FEATURES

The characteristics and capabilities of the M915A1 Truck Tractor are given in paragraphs 19 and 110. Two of the more important features that allow for ease of maintenance are:

- a. Commercial-type replacement parts for entire vehicle available through national network of dealers and vendors.
- b. Commercial operating components that require no special maintenance procedures and a minimum of special tools:
 - (1) Six-cylinder, in-line, four-stroke, four-cycle, turbocharged diesel engine.
 - (2) Five speed automatic transmission.
 - (3) Rear tandem axles.

EQUIPMENT DESCRIPTION AND DATA.

1-9. LOCATION AND DESCRIPTION OF MAJOR COMPONENTS.

a. Exterior Components.

The illustration below identifies the major exterior components located on the M915A1 vehicle. For more information, see the Operator's Manual. TM 9-2320-283-10.

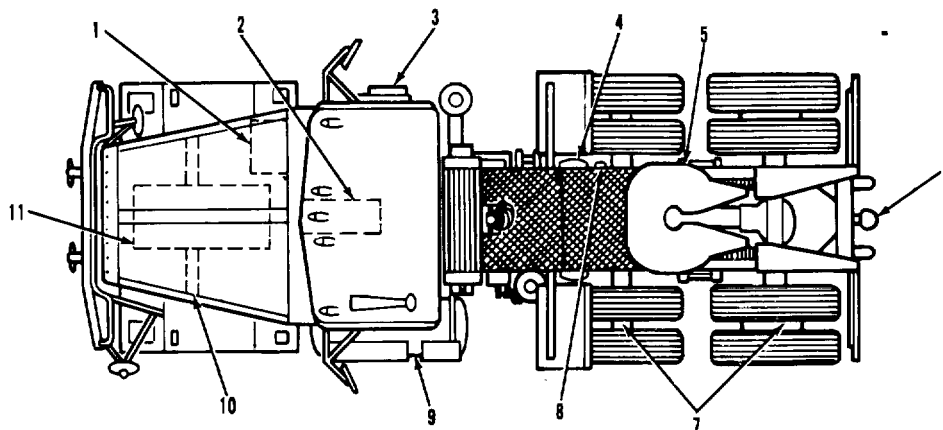

1. AIR CLEANER. Heavy duty, tri-phase, dry type with automatic dust unloader.
2. TRANSMISSION. Automatic with five forward speeds and one reverse speed.
3. BATTERIES. Four, heavy duty, 12-volt, maintenance free, connected in series-parallel.
4. AIR BRAKE CHAMBER. Standard diaphragm, S-cam type.
5. FIFTH WHEEL. Slide mounted with air operated release.
6. TOWING PINTLE. Swivel type with a 49,000 lb maximum gross trailer weight capacity.
7. REAR TANDEM AXLES. Single reduction type.
8. REAR AXLE DIFFERENTIAL LOCKOUT. Air operated.
9. FUEL TANK. Aluminum with shallow dished heads and half baffle construction.
10. FRONT AXLE. Non-driving, steering type with I-beam construction.
11. ENGINE. In-line, six-cylinder, four stroke, four cycle, turbocharged diesel.

TA 236751

EQUIPMENT DESCRIPTION AND DATA.

1-9. LOCATION AND DESCRIPTION OF MAJOR COMPONENTS (Continued).

b. Interior Components.

The illustration below identifies the major interior components located on the M915A1 vehicle. For more information, see the Operator's Manual, TM 9-2320-283-10.

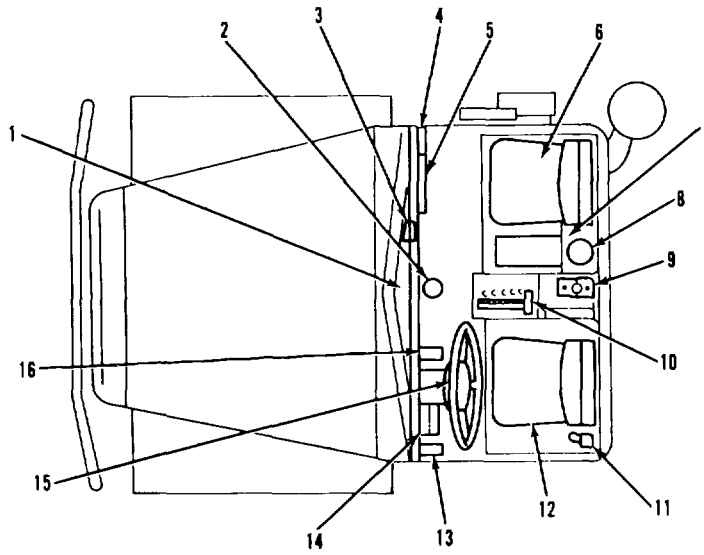

TA 236752

EQUIPMENT DESCRIPTION AND DATA.

1-9. LOCATION AND DESCRIPTION OF MAJOR COMPONENTS (Continued).

b. Interior Components (Continued).

1. INSTRUMENT PANEL. Hinged type; used to house instrument gages and lamps.
2. WINDSHIELD WASHER RESERVOIR. Air pressure type.
3. DIFFERENTIAL LOCKOUT CONTROL. Three-way, two-position toggle valve.
4. VENTILATOR. Two-way hingeless type.
5. HEATER. Hot water type with two blower wheels.
6. COMPANION SEAT. Fully adjustable, shock mounted, bracket style.
7. TOOL BOX. Located under companion seat with two hinged doors for easy access.
8. FIRE EXTINGUISHER. Located behind tool box. Hand portable, stored pressure type.
9. FIFTH WHEEL RELEASE CONTROL. Three-way, two-position toggle valve.
10. TRANSMISSION SHIFTER CONTROL. Mounted to cab floor with cable type control.
11. AIR HORN VALVE. Mounted on cab roof above driver's door with chain type control.
12. DRIVER'S SEAT. Fully adjustable, suspension type.
13. ENGINE RETARDER FOOT PEDAL. Mounted on cab floor with electric switch control.
14. BRAKE PEDAL AND VALVE. Mounted on cab floor with dual type air control.
15. STEERING WHEEL. Fixed position, molded plastic type with steel reinforced sleeve.
16. ACCELERATOR PEDAL. Mounted on floor with linkage type control.

EQUIPMENT DESCRIPTION AND DATA.

1-9. LOCATION AND DESCRIPTION OF MAJOR COMPONENTS (Continued).

c. Engine Components.

The Cummins NTC400 Engine is used on all M915A1 vehicles. It is an inline, six cylinder, four stroke, four cycle, turbocharged diesel engine. The engine is a common production diesel truck engine, without special operating or maintenance requirements. This subparagraph provides you with illustrations that identify engine components serviced at the organizational level.

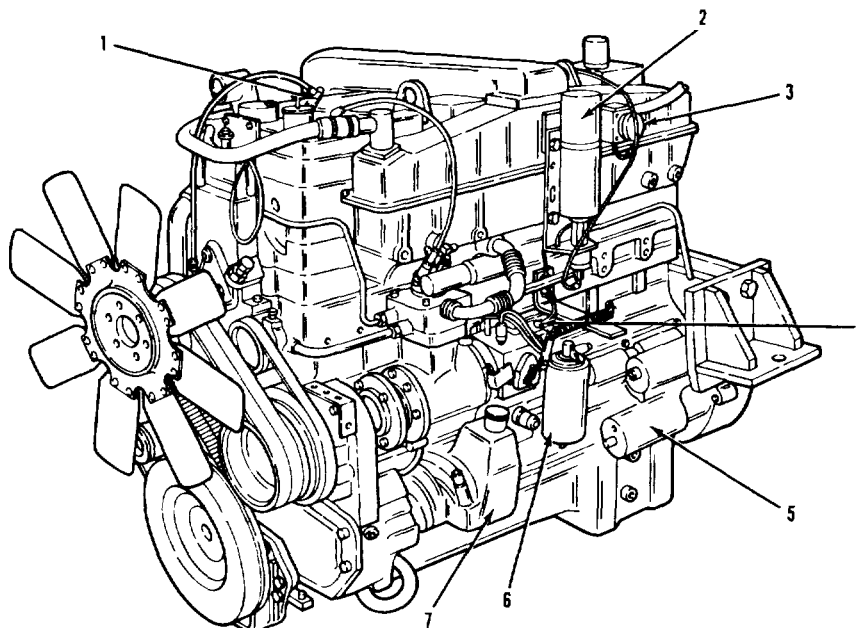

1. FAN CLUTCH AIR VALVE. Mechanically actuated, air control type.
2. ETHER QUICK START KIT. Electrically actuated with replaceable 18-oz ether container.
3. STE/ICE CONNECTOR. Standard circular type with bayonet coupling.
4. FUEL SOLENOID SHUTOFF VALVE. Electrically actuated, coil type.
5. STARTER MOTOR AND SOLENOID. 24-volt, heavy duty, water resistant type with an electric shift engagement, over-running clutch drive.
6. FUEL FILTER/WATER SEPARATOR. Spin-on type element with water draincock.
7. POWER STEERING PUMP AND RESERVOIR. Heavy duty, roll vane type with built in flow control and relief valve.

TA 236753

EQUIPMENT DESCRIPTION AND DATA.

1-9. LOCATION AND DESCRIPTION OF MAJOR COMPONENTS (Continued).

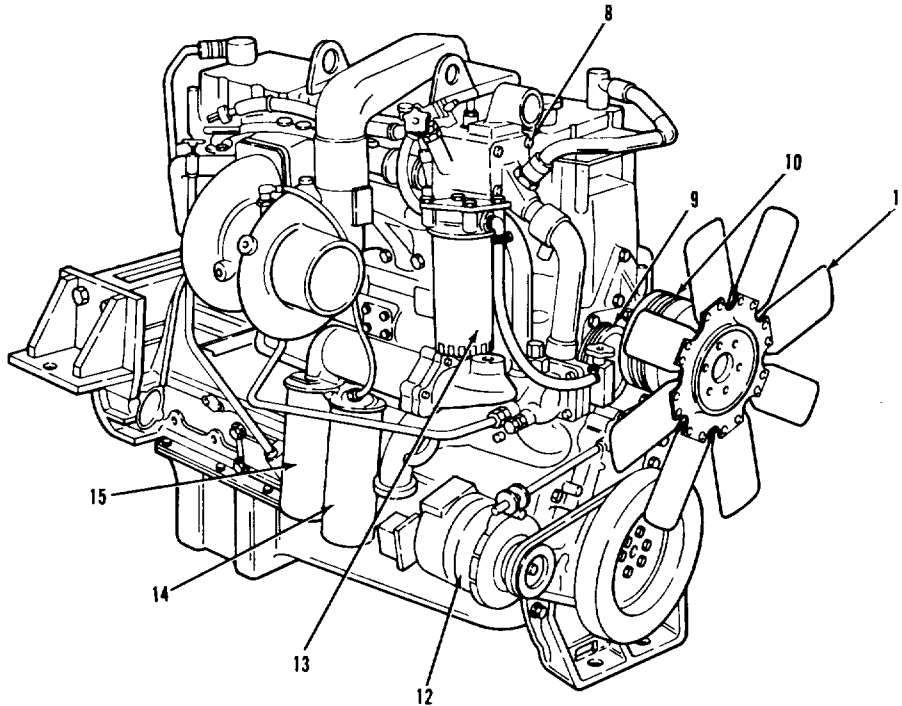
c. Engine Components (Continued).

- 8. THERMOSTAT. Located in cast housing. 180 degree blocking type.
- 9. WATER PUMP. Belt driven, eccentric type.
- 10. FAN CLUTCH. Pneumatically operated, thermostatically controlled.
- 11. FAN. 8-blade, clockwise rotating type.
- 12. ALTERNATOR. 14-volt, self load limiting type with a fully adjustable, built in, solid state voltage regulator.
- 13. WATER FILTER. Spin-on type element with chemical protection and positive filtration.
- 14. OIL FILTER. Full-flow, spin-on type element.
- 15. OIL FILTER. By-pass, spin-on type element.

TA 236754

EQUIPMENT DESCRIPTION AND DATA.

1-10. EQUIPMENT DATA.

The following table contains equipment data for components and subassemblies that have maintenance authorized at the organizational level. For additional equipment data concerning the M915A1, refer to TM 9-2320-283-10.

OVERALL CHARACTERISTICS

National Stock Number	2320-01-125-2640
Gross Vehicle Weight Rating.....	50,000 lbs
Curb Weight (empty)	19,720 lbs
Gross Vehicle Weight (28,400 lbs 5th wheel load)	48,120 lbs
Gross Axle Weight Rating:	
Front Axle.....	13,000
Rear Tandem Axles	40,000 lbs
Axle Loads (empty):	
Front Axle.....	9,730 lbs
Rear Tandem Axles	9,100 lbs
Axle Loads (28,400 lbs 5th wheel load):	
Front Axle.....	11,580 lbs
Rear Tandem Axles	36,540 lbs
Gross Combination Weight Rating	105,000 lbs
Towed Load (M872 Trailer-28,400 lbs on king pin).....	54,000 lbs
Gross Combination Weight	103,230 lbs

DIMENSIONAL DATA

Overall Length (Chassis).....	262.00 in.
Overall Width:	
Including Mirrors	124.00 in.
Mirrors Folded.....	96.00 in.
Overall Height:	
To Top of Exhaust Stack	142.00 in.
To Top of Air Horn	115.50 in.
Cab to Rear Tandem Axle Centerline	86.00 in.
Bumper to Back of Cab	119.00 in.
Bumper to Front Axle	38.00 in.
Rear Tandem Axle Centerline to End of Frame	53.50 in.
Wheel Base	167.00 in.
Tandem Axle Spacing	52.00 in.
Fifth Wheel Centerline to Rear Tandem Axle Centerline	0 to 8 in.

EQUIPMENT DESCRIPTION AND DATA.

1-10. EQUIPMENT DATA (Continued).

DIMENSIONAL DATA (Continued)

Tread Width:		
Front	78.40 in.
Rear	72.00 in.
Dual Tire Spacing 13.25 in.		
Overall Length with M872 Trailer	55.00 ft
Angle of Approach	38*
Minimum Turning Diameter (curb to curb)	53.50 ft
Minimum Ground Clearance (under rear walking beam; empty)	10.40 in.
Fording Depth (maximum; hardbottom)	20 in.

PERFORMANCE

Maximum Speed Forward (at 2,100 rpm-5th gear)	58 mph
Speed on 3.9% Grade	25 mph
Maximum Grade	19.9
Maximum Drawbar Pull (at 0.7 coefficient)	20,541 lbs
Maximum Side Slope (with adequate tractive surface)	10%

Make	Cummins
Model	NTC-400 Big Cam III
Type	4-Stroke, In-line Diesel
Displacement	855 CID
Compression Ratio	14.0:1
Maximum Horsepower (at 2,100 rpm)	400
Maximum Torque (at 1,300 rpm)	1,250 lb-ft
Lube Capacity	44 qts
Governed Speed	2,100 rpm
Retarder (integral with engine):		
Make	Jacobs
Model	30E Series

EQUIPMENT DESCRIPTION AND DATA.

1-10. EQUIPMENT DATA (Continued).

ELECTRICAL SYSTEM

Type 12-volt Basic/24-volt Starting

Batteries:

 Make Delco Remy

 Model 1200 Series

 TypeMaintenance Free

 Quantity and Potential Four, 12-volt

Starting Motor:

 Make Leece-Neville

 Model 7406 MA Series

 Type24-volt

Alternator:

 Make Leece-Neville

 Model 2500 JB/TR Series

 Model 2500 JB/TR Series

 Type 12-volt With Integral Voltage
Regulator and Transformer-Rectifier for 24-volt dc; 85/15-amp

TRANSMISSION

Make Detroit Diesel Allison

Model HT 754 CRD

Type 5-speed, Fully Automatic

Torque Converter TC 498, Lockup type

Shifter Remote Control Cable

Oil Capacity 8 gal.

FRONT AXLE

Make Eaton

Model EFA 13F3

Type Reverse Elliot/Forged I-Beam

Rated Capacity 13,000 lbs

Maximum Steering Angle 40*

EQUIPMENT DESCRIPTION AND DATA.

1-10 EQUIPMENT DATA (Continued).

REAR TANDEM AXLE

Make Eaton
 Model (forward/rear) DS 401P
 Ratio 4.33:1
 Rated Capacity (Tandem) 40,000 lbs
 Forward Rear:
 Type Controlled Traction Biasing
 Oil Capacity 40 pts
 Rear Rear:
 Type Differential
 Oil Capacity 36 pts
 Lubrication Pressure
 Interaxle Differential Lockup Air Controlled

BRAKES

Service:
 Make Eaton
 Model (front/rear) 541/541 L.W.
 Type Air Drum "S" Cam
 Diameter x Width (front/rear) 15-1/2 x 5 in./16-1/2 x 7 in.
 Parking:
 Make Anchorlock
 Model 3030
 Type Spring Brake Actuator
 Location Forward-Rear Tandem Axle

WHEELS

Make Firestone
 Model 27404
 Size 22.50 x 8.25 in.
 Number of Studs/Bolt Circle 10/11.25 in.
 Stud Size (diameter) 1.125 in.
 Rated Capacity 7,000.00 lbs

EQUIPMENT DESCRIPTION AND DATA.

1-10. EQUIPMENT DATA (Continued).

TIRES

Make	Goodyear
Type	Radial Ply/On Road	
Size	11.00 x 22.50 in.
Load	Range/Ply Rating G/14
Rated Capacity (single/dual)	6040 lbs/5300 lbs
Air Pressure (maximum cold):		
Front	105 psi
Rear	95 psi

STEERING

Gear:		
Make	Ross
Model	HFB-64
Type	Integral Gear
Ratio	20.4:1
Wheel:		
Make	Sheller Globe
Diameter	20 in.
Pump:		
Make	Eaton
Model	B165R
Type	Positive Displacement Roll Vane; Gear Driven
Flow Rates	3.25 GPM at 600 RPM and 1200 psi; 4.3-5.0 GPM at 3000 RPM and 50 psi

SUSPENSION

Front:		
Type	Asymmetrical Leaf; Pin and Shackle
Rate	1,861 lbs/in.
Static Deflection	2.73 in.

EQUIPMENT DESCRIPTION AND DATA.

1-10. EQUIPMENT DATA (Continued).

SUSPENSION (Continued)

Rear:

Make Hendrickson
 Model RTE380
 Type Walking Beam;
 Rated Capacity 40,000 lbs
 Static Deflection 97 in.

FIFTH WHEEL

Make Holland
 Model FW2536
 Type Sliding; Cab Con-
 trolled Air Lock
 Rated Capacity:
 Drawbar Pull 150,000 lbs
 Vertical Load 40,000 lbs
 King Pin Size 2.0 in.
 Pitch (fore/aft) 150/10
 Travel 12 in.

PINTLE

Make Holland
 Model No 760
 Rated Capacity 25 ton

SECTION III. PRINCIPLES OF OPERATIONS

these components relate to each other. The explanations are divided into the following paragraphs:

1-11. ENGINE

- a Engine Oil System Components and Piping
- b Engine Oil Monitoring System
- c Engine Retarder Brake Controls
- b Rear Tandem Axle

1-12. FUEL SYSTEM

- a Fuel Delivery
- b Accelerator Pedal and Linkage.
- c Air Intake
- d Ether Quick-Start System.

1-13. EXHAUST SYSTEM

1-14. COOLING SYSTEM

- a Cooling System Components and Piping
- b Coolant Temperature Monitoring System

1-15. ELECTRICAL SYSTEM

- a Starting System
- b Batteries and Power Generating System.
- c Service Lighting System
- d Blackout Lighting System.
- e Relays, Circuit Breakers, and Diode
- f Electric Horn.
- g Wiring

1-16. TRANSMISSION

1-17. FRONT AXLE AND SUSPENSION

1-18. REAR TANDEM AXLES

- a Rear Tandem Axle Components. Differential Lockout.

1-19. COMPRESSED AIR SYSTEM

1-20. BRAKE SYSTEM

- a Air Brake System Arrangement.
- b Brake System Components.
- c Brake System Switches and Lamps.

1-21. AUXILIARY AIR-POWERED SYSTEMS

- a Windshield Wipers and Washers.
- b Air Horn.
- c Fan Clutch Controls.

1-22. STEERING SYSTEM

1-23. CAB HEATING AND VENTILATING SYSTEM

1-24. WINTERIZATION KIT

PRINCIPLES OF OPERATION.**1-11. ENGINE.****a. Engine Oil System Components and Piping.**

BREATHER TUBE. Allows fumes from hot oil to escape.

OIL FILLER. Located in front rocker arm cover. Used for replenishing oil supply.

OIL PUMP. Circulates oil through engine to provide cooling and lubrication.

OIL COOLER. Coolant circulates through internal tubes of cooler and carries away heat from engine oil.

PRIMARY OIL FILTER. Throwaway filter removes dirt and foreign particles from oil.

BYPASS OIL FILTER. Throwaway filter provides filtration when primary filter is clogged or damaged.

DRAIN PLUG. Located in bottom of engine oil pan. Used to drain oil from engine.

OIL RETURN LINE. Carries return oil from turbocharger to engine block.

OIL LEVEL DIPSTICK. Engine oil level indicator.

OIL SUPPLY LINE. Carries oil under pressure to cool and lubricate turbocharger

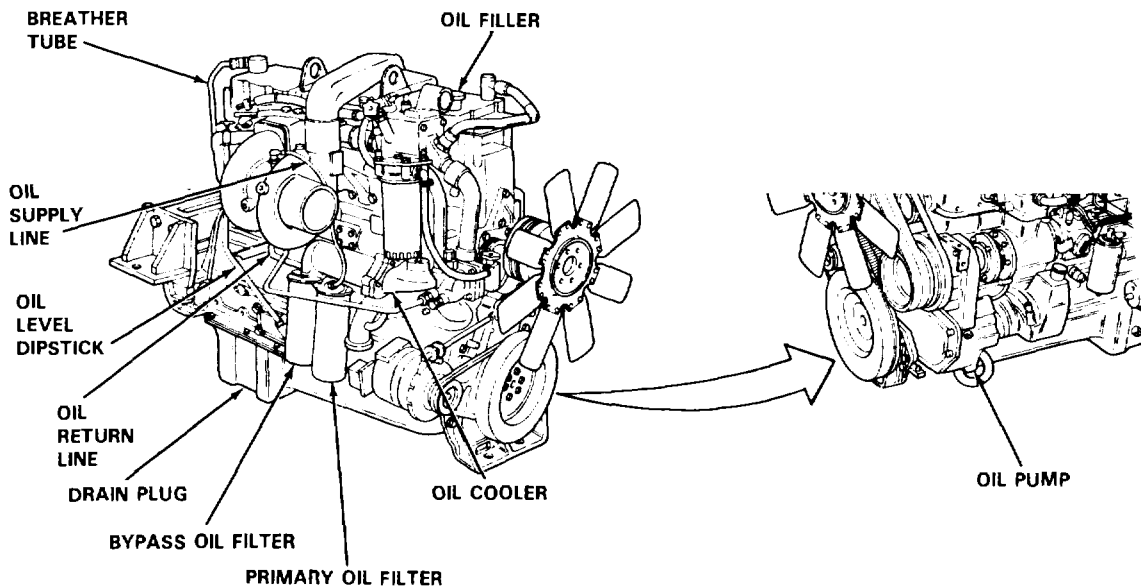

TA 236755

PRINCIPLES OF OPERATION.

1-11. ENGINE (Continued).

b. Engine Oil Monitoring System.

BATTERY PACK. Consists of four, 12-volt, maintenance free batteries. Two batteries are wired in parallel in each set. Each set is connected in series for 24-volt output. Battery pack is used for both 12-volt and 24-volt output.

IGNITION SWITCH. Supplies 24-volt power to relay (RY-9), which in turn provides 12-volt power to electrical system, including oil pressure gage and warning lamp circuits.

RELAY (RY-9). Energized by 24-volt power from ignition switch. When energized, RY-9 supplies 12-volt power to circuit breaker (CB-2).

CIRCUIT BREAKER (CB-2). Protects electrical components of oil system by opening circuit when load exceeds 20 amperes. May be manually reset by pressing CB-2 button in.

OIL PRESSURE GAGE. Activated by electrical signal from oil pressure sending unit. Indicates engine oil pressure.

OIL PRESSURE SENDING UNIT. Provides electrical signal to oil pressure gage to indicate engine oil pressure.

OIL WARNING LAMP. Indicator lamp is activated by 12-volt power from pressure switch when engine oil pressure drops below 5 psi.

PRESSURE SWITCH. Closes to supply 12-volt power to oil warning lamp when oil pressure drops below 5 psi

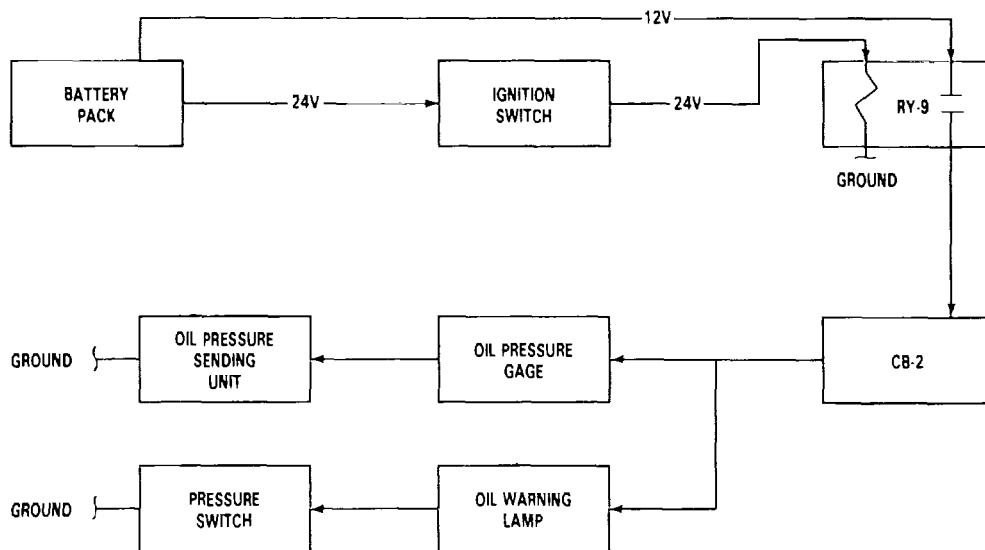

TA 236756

PRINCIPLES OF OPERATION.

1-11. ENGINE (Continued).

c. Engine Retarder Brake Controls.

BATTERY PACK. Consists of four, 12-volt, maintenance free batteries. Two batteries are wired in parallel in each set. Each set is connected in series for 24-volt output. Battery pack is used for both 12-volt and 24-volt output.

IGNITION SWITCH. Supplies 24-volt power to relay (RY-9), which in turn provides 12-volt power to electrical system, including engine retarder brake circuit.

RELAY (RY-9). Energized by 24-volt power from ignition switch. When energized, RY-9 supplies 12-volt power to circuit breaker (CB-2).

CIRCUIT BREAKER (CB-2). Protects electrical components of engine retarder brake circuit by opening when load exceeds 20 amperes. May be manually reset by pressing CB-2 button in.

FOOT SWITCH. Allows driver to activate engine brake circuit with left foot. When depressed, switch supplies 12-volt power through CB-2, throttle switch, and engine retarder switch, to energize selected solenoid valve(s).

THROTTLE SWITCH. Switch is open when accelerator pedal is pressed down to prevent activation of engine retarder brake. Activating arm on fuel pump lever closes switch when accelerator is disengaged.

ENGINE RETARDER SWITCH. Three-position switch allows driver to select engine braking for two cylinders (LOW), four cylinders (MED), or six cylinders (HIGH). Depressing pedal actuated foot switch completes 12-volt power circuit to energize one, two, or three solenoids.

SOLENOID VALVES. Operate engine braking mechanism when activated.

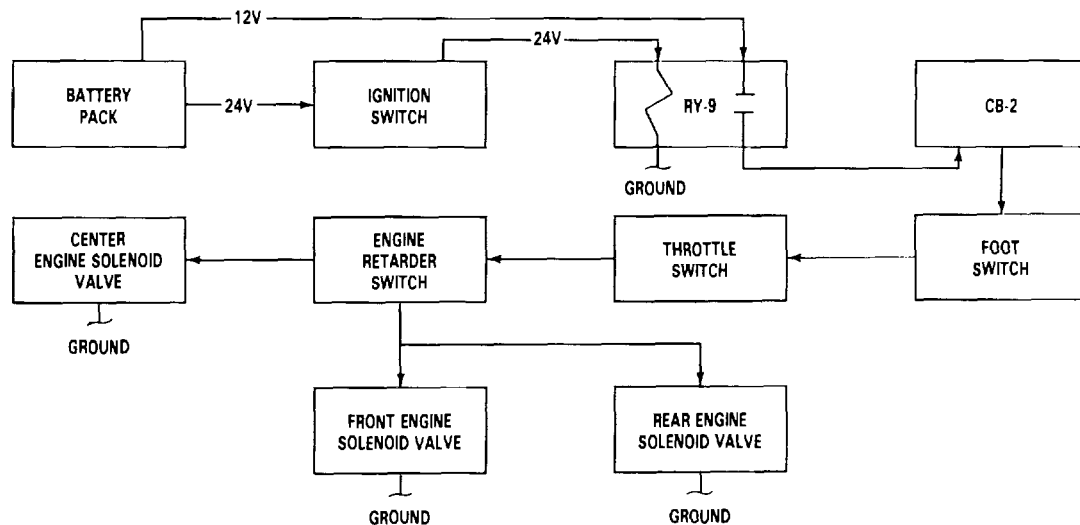

TA 2366757

PRINCIPLES OF OPERATION.**1-12. FUEL SYSTEM.****a. Fuel Delivery.**

BATTERY PACK. Consists of four, 12-volt, maintenance free batteries. Two batteries are wired in parallel in each set. Each set is connected in series for 24-volt output. Battery pack is used for both 12-volt and 24-volt output.

IGNITION SWITCH. Supplies 24-volt power to relay (RY-9), which in turn provides 12-volt power to electrical system, including fuel system circuit.

SOLENOID SHUTOFF VALVE. Normally closed, shutting off fuel supply to engine. Open when ignition switch is ON.

RELAY (RY-9). Energized by 24-volt power from ignition switch. When energized, RY-9 supplies 12-volt power to circuit breaker (CB-2).

CIRCUIT BREAKER (CB-2). Protects electrical components of fuel system by opening circuit when load exceeds 20 amperes. May be manually reset by pressing CB-2 button.

FUEL GAGE. Actuated by electrical signal from fuel sending unit which shows level of fuel in tank.

FUEL LEVEL SENDING UNIT. Provides electrical signal to fuel gage for indicating fuel quantity in tank.

FUEL TANK. 118 gallon capacity (100 gallon draw).

FILTER AND WATER SEPARATOR. Throwaway filter removes impurities and water from fuel. Petcock at bottom allows operator to drain off water filtered from fuel.

FUEL PUMP. Gear driven by air compressor. Built-in governor meters fuel through screen filter, solenoid shutoff valve, and into injectors. Excess fuel from pump is returned to tank. A tachometer drive is located on the fuel pump housing.

PRINCIPLES OF OPERATION.

1-12. FUEL SYSTEM (Continued).

a. Fuel Delivery (Continued).

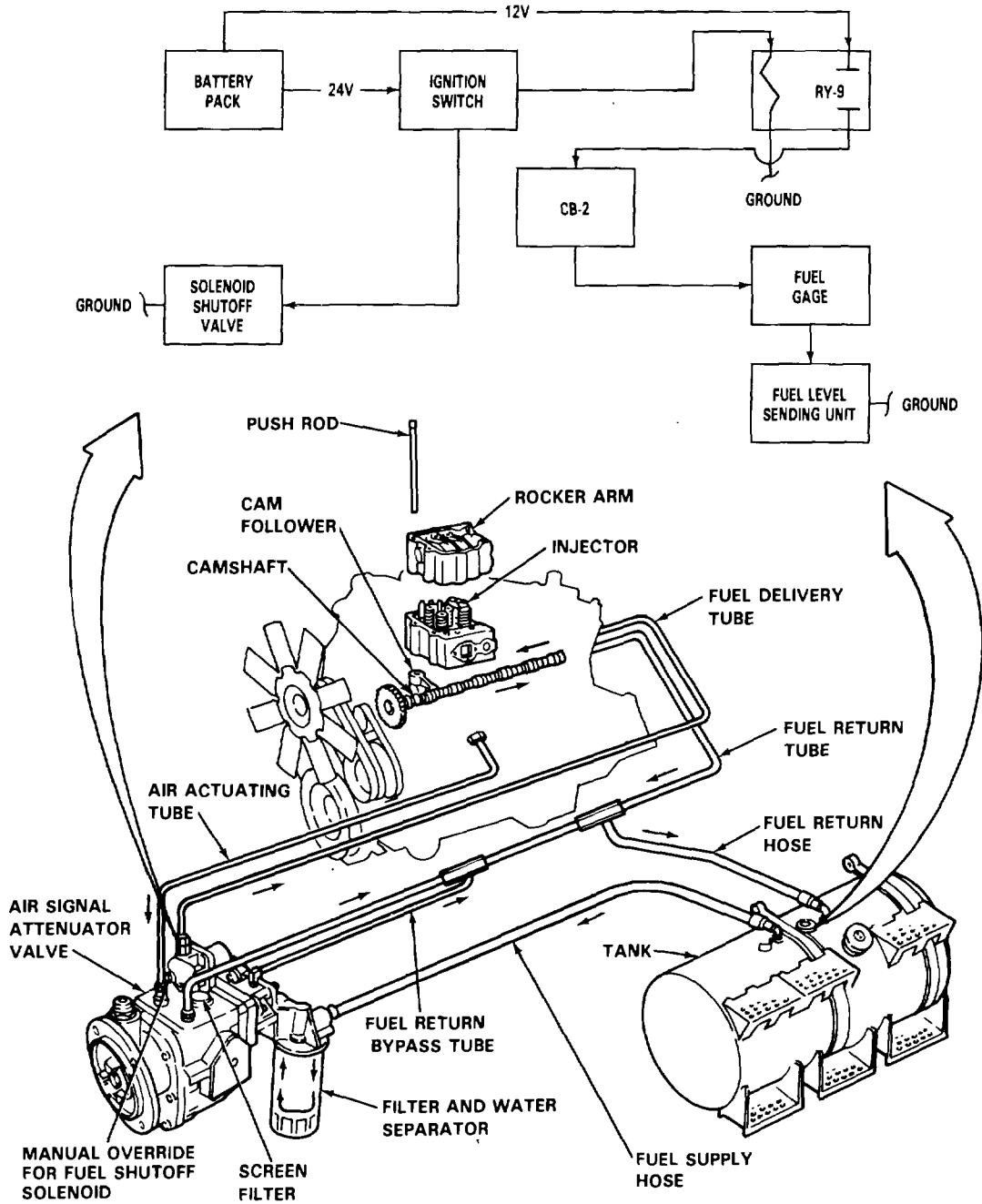

TA 236758

PRINCIPLES OF OPERATION.**1-12. FUEL SYSTEM (Continued).****a. Fuel Delivery (Continued).**

AIR ACTUATING TUBE. Carries pressurized air from intake manifold to air signal attenuator valve.

AIR SIGNAL ATTENUATOR VALVE. Modifies fuel flow helping to eliminate noise and exhaust smoke. Operated by pressurized air from manifold.

SCREEN FILTER. Located in fuel pump. Provides additional filtration for fuel prior to entering engine.

MANUAL OVERRIDE FOR FUEL SHUTOFF SOLENOID. Normally closed, can be screwed open to allow operation of engine when solenoid is not working.

CAM FOLLOWER. Mechanical lever transmits cam lobe movement from camshaft to push rod.

CAMSHAFT. Determines valve and injector timing.

FUEL RETURN BYPASS TUBE. Carries excess fuel from fuel pump to fuel tank.

FUEL SUPPLY HOSE. Carries fuel from fuel tank to fuel pump.

ROCKER ARM. Transmits directional movement from push rod to injector.

PUSH ROD. Transmits motion from cam follower to rocker arm.

INJECTOR. Cam timed to meter and inject proper amount of fuel into each

FUEL DELIVERY TUBE. Carries fuel under pressure from fuel pump to fuel injectors.

FUEL RETURN TUBE. Carries excess fuel from injectors back to tank.

PRINCIPLES OF OPERATION.

1-12. FUEL SYSTEM (Continued).

a. Fuel Delivery (Continued).

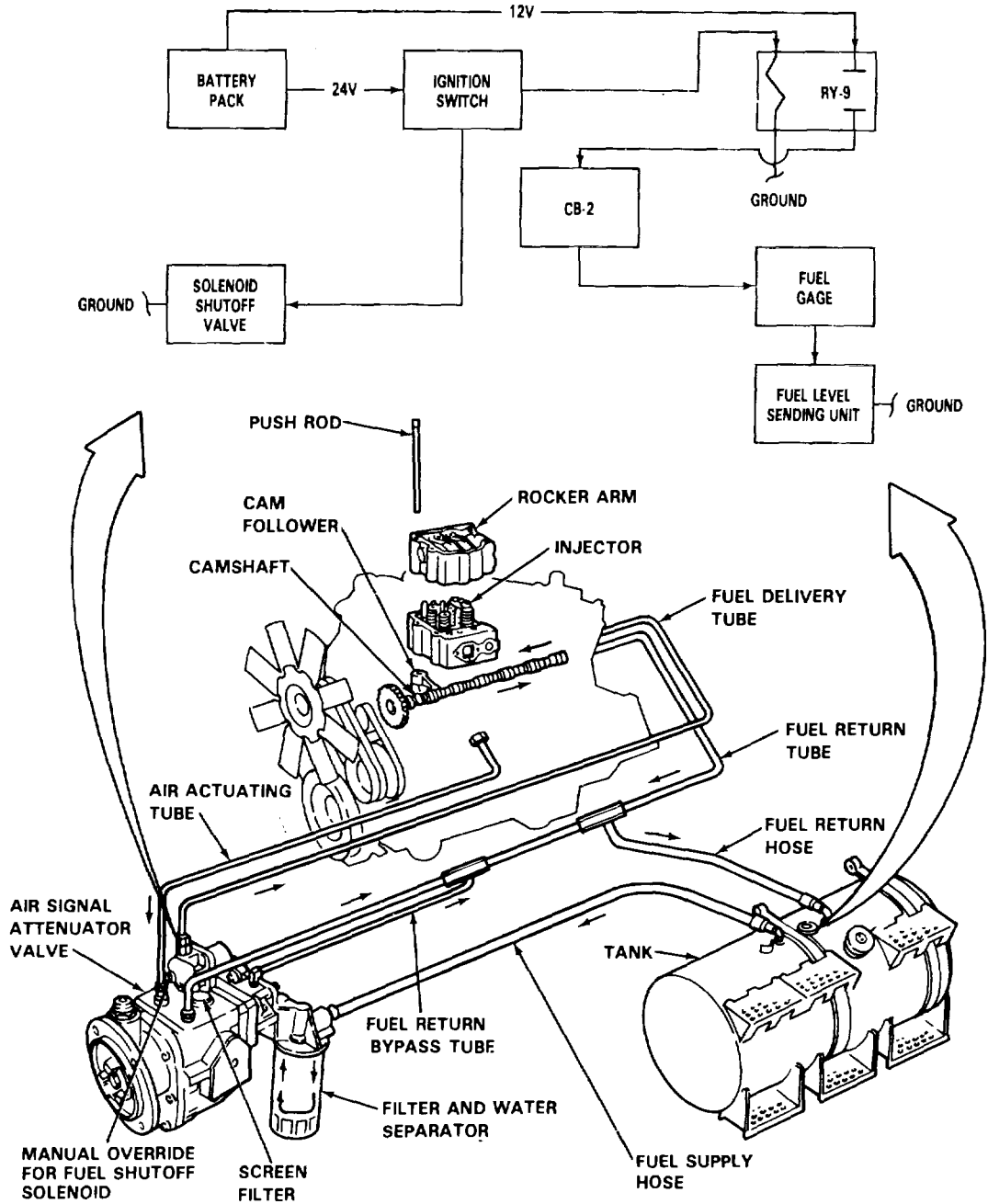

TA 236759

PRINCIPLES OF OPERATION.

1-12. FUEL SYSTEM (Continued).**b. Accelerator Pedal and Linkage.**

ACCELERATOR PEDAL. Connected by mechanical linkage to pivot lever under cab.

PIVOT LEVER. Mechanical linkage that connects accelerator pedal to accelerator rod.

ACCELERATOR ROD. Connects accelerator pedal to fuel control lever on fuel pump.

FUEL CONTROL LEVER. Controls flow of fuel through fuel pump, thus setting engine speed.

FUEL CONTROL RETURN SPRING. Returns fuel control lever to normal position when accelerator pedal is not engaged.

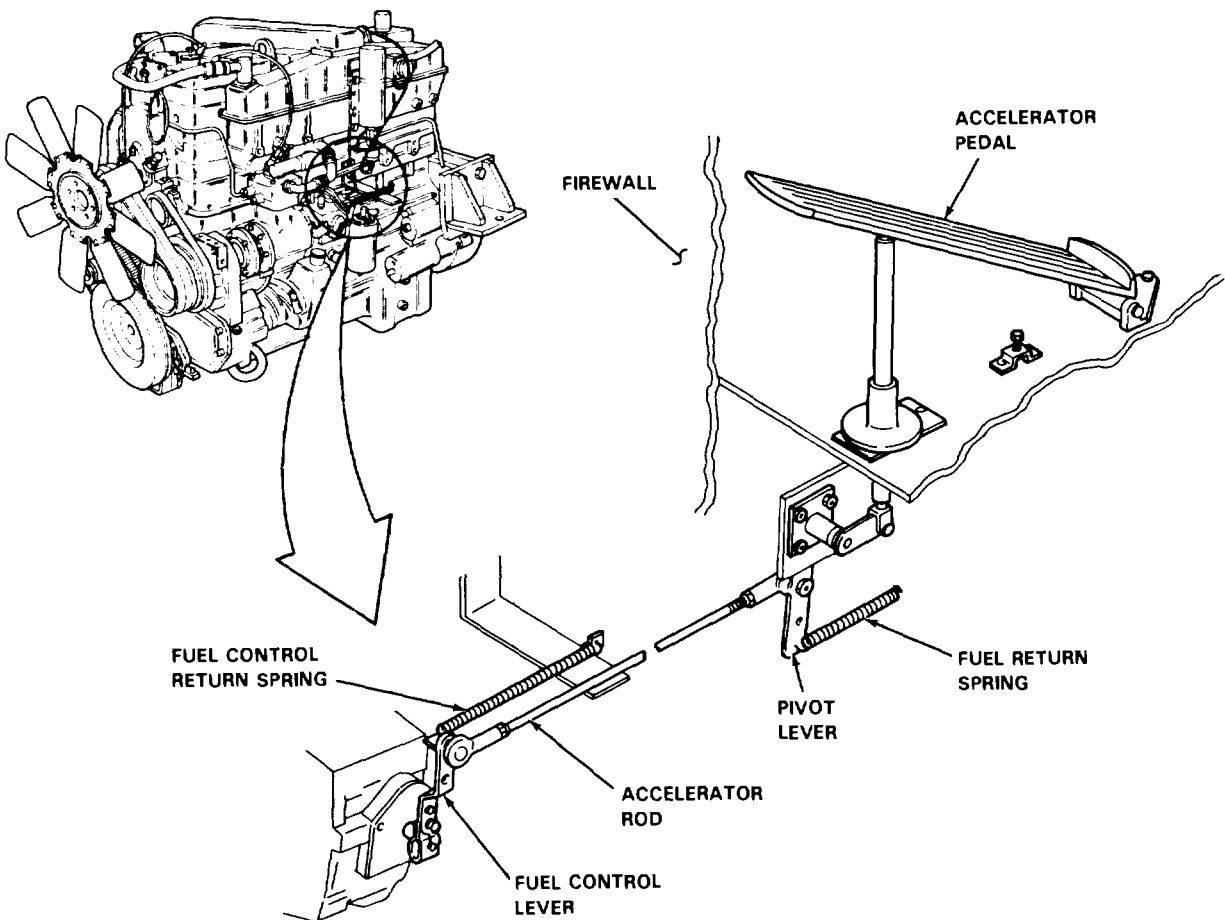

TA 236760

PRINCIPLES OF OPERATION.**1-12. FUEL SYSTEM (Continued).****c. Air Intake.**

AIR RESTRICTION INDICATOR. Mounted on instrument panel. Signal changes from green to red in indicator housing when air cleaner needs servicing. A tube connects indicator to air cleaner outlet. When air flow through cleaner is restricted, the red signal becomes visible. Factory set to signal at a specific filter restriction. Resetting is accomplished by pushing a button on top of the indicator.

CROSSOVER TUBE. Directs compressed air from turbocharger, through after cooler, to intake manifold.

AFTERCOOLER. Cools air entering intake manifold from turbocharger. Water flow from engine cooling system absorbs heat. (See illustration of cooling system in paragraph 1-14a).

ENGINE INTAKE MANIFOLD. Directs compressed air charge to each cylinder after it has been cooled by aftercooler.

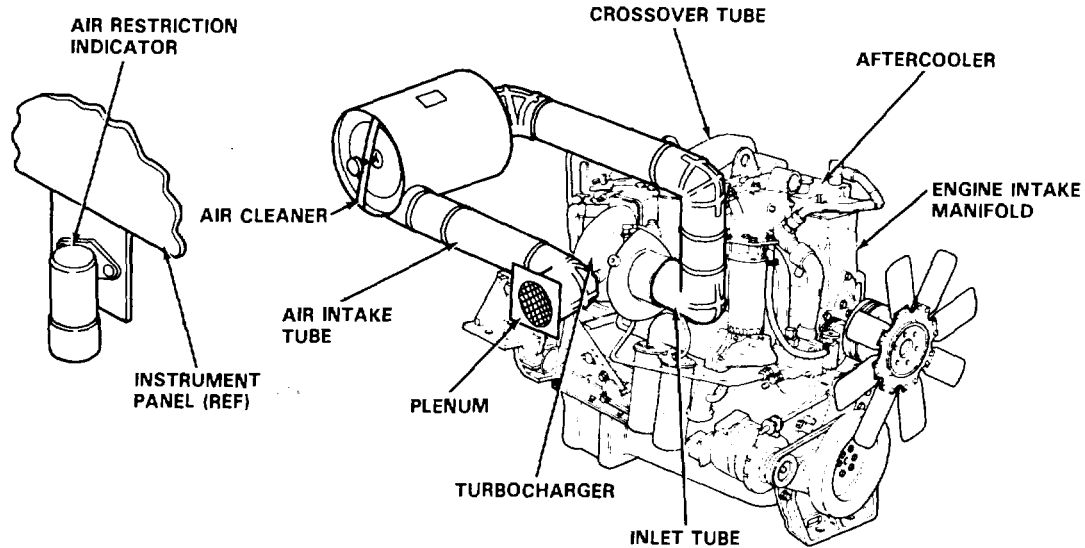

PRINCIPLES OF OPERATION.**1-12. FUEL SYSTEM (Continued).****c. Air Intake (Continued).**

INLET TUBE. Directs air from air cleaner to turbocharger.

TURBOCHARGER. Driven by exhaust gases. Compresses air into intake manifold to increase engine power.

PLENUM. Directs outside air into air intake tube.

AIR INTAKE TUBE. Draws outside air through grille mounted plenum and into air cleaner.

AIR CLEANER. Mounted on fire wall. Removes impurities from air entering turbocharger. Has replaceable, dry, two-stage element.

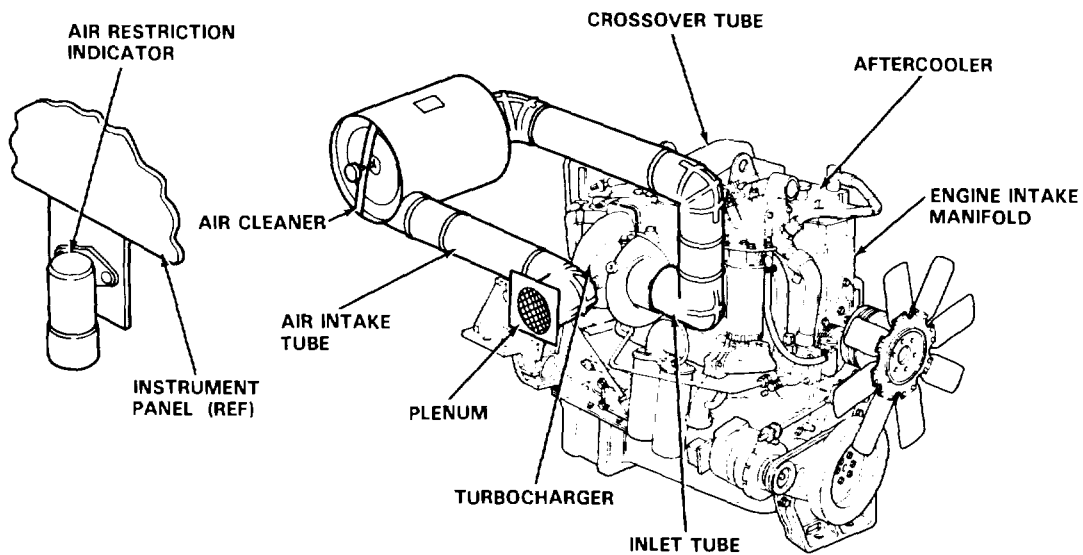

TA 236762

PRINCIPLES OF OPERATION.

1-12. FUEL SYSTEM (Continued).

d. Ether Quick-Start System.

BATTERY PACK. Consists of four, 12-volt, maintenance free batteries. Two batteries are wired in parallel in each set. Each set is connected in series for 24-volt output. Battery pack is used for both 12-volt and 24-volt output.

IGNITION SWITCH. Supplies 24-volt power to relay (RY-9), which in turn provides 12-volt power to electrical system, including ether quick-start system circuit.

RELAY (RY-9). Energized by 24-volt power from ignition switch. When energized, RY-9 supplies 12-volt power to circuit breaker (CB-3).

CIRCUIT BREAKER (CB-3). Protects electrical components and wiring of quick-start system by opening circuit when load exceeds 20 amperes. May be manually reset by pressing CB-3 button in.

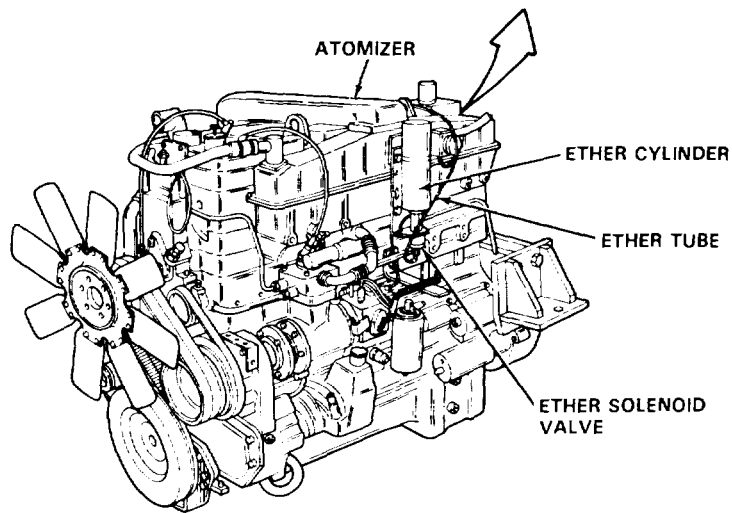
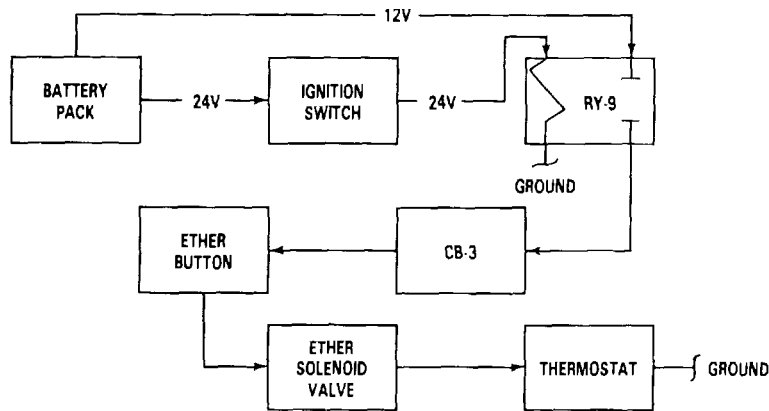

TA 236763

PRINCIPLES OF OPERATION.

1-12. FUEL SYSTEM (Continued).

d. Ether Quick-Start System (Continued).

ETHER SOLENOID VALVE. Controls release of ether from cylinder. When solenoid is energized, ether flows to atomizer.

THERMOSTAT. Opens when coolant temperature is above 50°F to prevent ether solenoid valve from activating.

ETHER CYLINDER. Replaceable 18-oz ether container.

ETHER TUBE. Carries ether from solenoid valve to atomizer.

ATOMIZER. Sprays fine ether mist into engine air intake manifold.

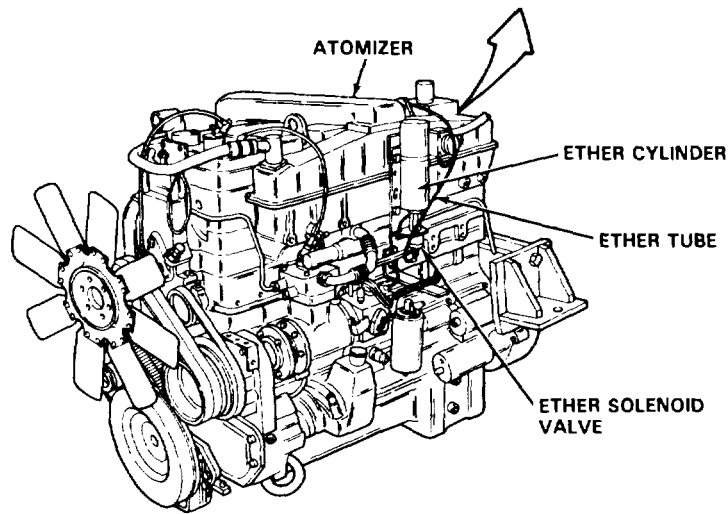
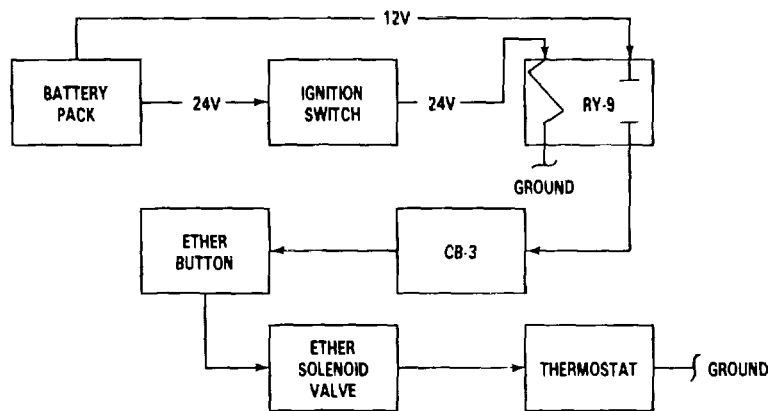

TA 23674

PRINCIPLES OF OPERATION.**1-13. EXHAUST SYSTEM.**

EXHAUST STACK CAP. Prevents entry of rain and dirt into exhaust pipes when engine is not in use.

EXHAUST MANIFOLD. Bolted to exhaust ports on cylinder heads. Collects exhaust from ports and directs it to turbocharger.

TURBOCHARGER. See illustration and description in paragraph 1-12c.

TURBOCHARGER OUTLET PIPE. Carries hot exhaust away from turbocharger.

FLEX PIPE(S). Connects turbocharger outlet pipe, muffler inlet pipe, and muffler. Pipes are flexible to allow for vibrations and expansion in system.

MUFFLER INLET PIPE. Carries exhaust from turbocharger outlet pipe to muffler.

MUFFLER. Directs exhaust through baffles to deaden noise.

EXHAUST STACK. Directs exhaust from muffler.

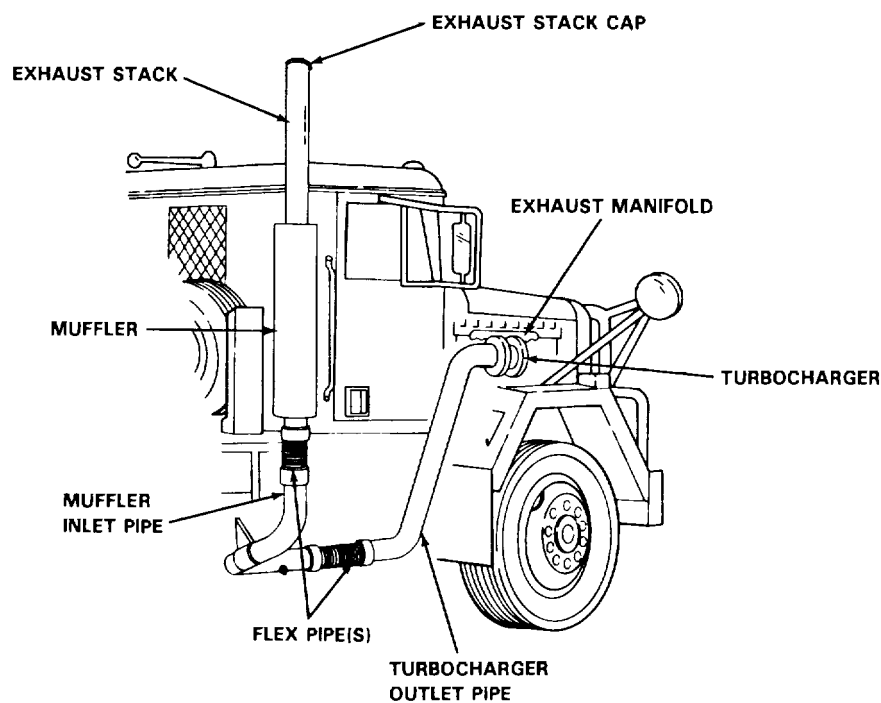

TA 236765

PRINCIPLES OF OPERATION.**1-14. COOLING SYSTEM.****a. Cooling System Components and Piping.**

RADIATOR CAP. Closes off filler opening and keeps system under pressure up to a maximum of 10 psi.

RADIATOR. Coolant is circulated through a series of fins and baffles so that outside air flow can dissipate heat.

WATER FILTER. Removes dirt and foreign particles from coolant.

WATER SHUT-OFF VALVE(S). Can be closed to allow replacement of water filter without having to drain cooling system.

OIL COOLER. Engine oil circulates through internal tubes of cooler, and coolant carries away heat.

THERMOSTAT. Shuts off coolant flow to radiator until temperature reaches 180°F. Coolant is then directed through radiator inlet hose to the radiator.

FAN CLUTCH ACTUATOR. When coolant temperature rises above 190°F, actuator directs compressed air into fan clutch, causing fan to engage.

WATER MANIFOLD. Collects coolant from cylinder head and directs it to thermostat housing.

FAN. Draws air through radiator to control coolant temperature.

FAN CLUTCH. Air pressure from actuator engages fan when coolant temperature rises above 190°F.

AFTERCOOLER. Coolant flowing through core cools hot air entering intake manifold port from turbocharger.

WATER CROSSOVER TUBE. Carries coolant under pressure from block to after-cooler.

COMPRESSOR COOLING WATER TUBE "A." Carries coolant from water pump to air compressor.

COMPRESSOR COOLING WATER TUBE "B." Carries coolant from air compressor to thermostat housing.

ACCESSORY DRIVE. Powers the fan and water pump.

THERMOSTAT DEAERATION (AIR REMOVAL) LINE. Escape route for air trapped in radiator or thermostat housing.

PRINCIPLES OF OPERATION.

1-14. COOLING SYSTEM (Continued).

a. Cooling System Components and Piping (Continued).

RADIATOR INLET HOSE. Channels hot coolant into radiator when thermostat is open.

WATER PUMP BYPASS HOSE. Allows air bubbles from coolant to escape from water

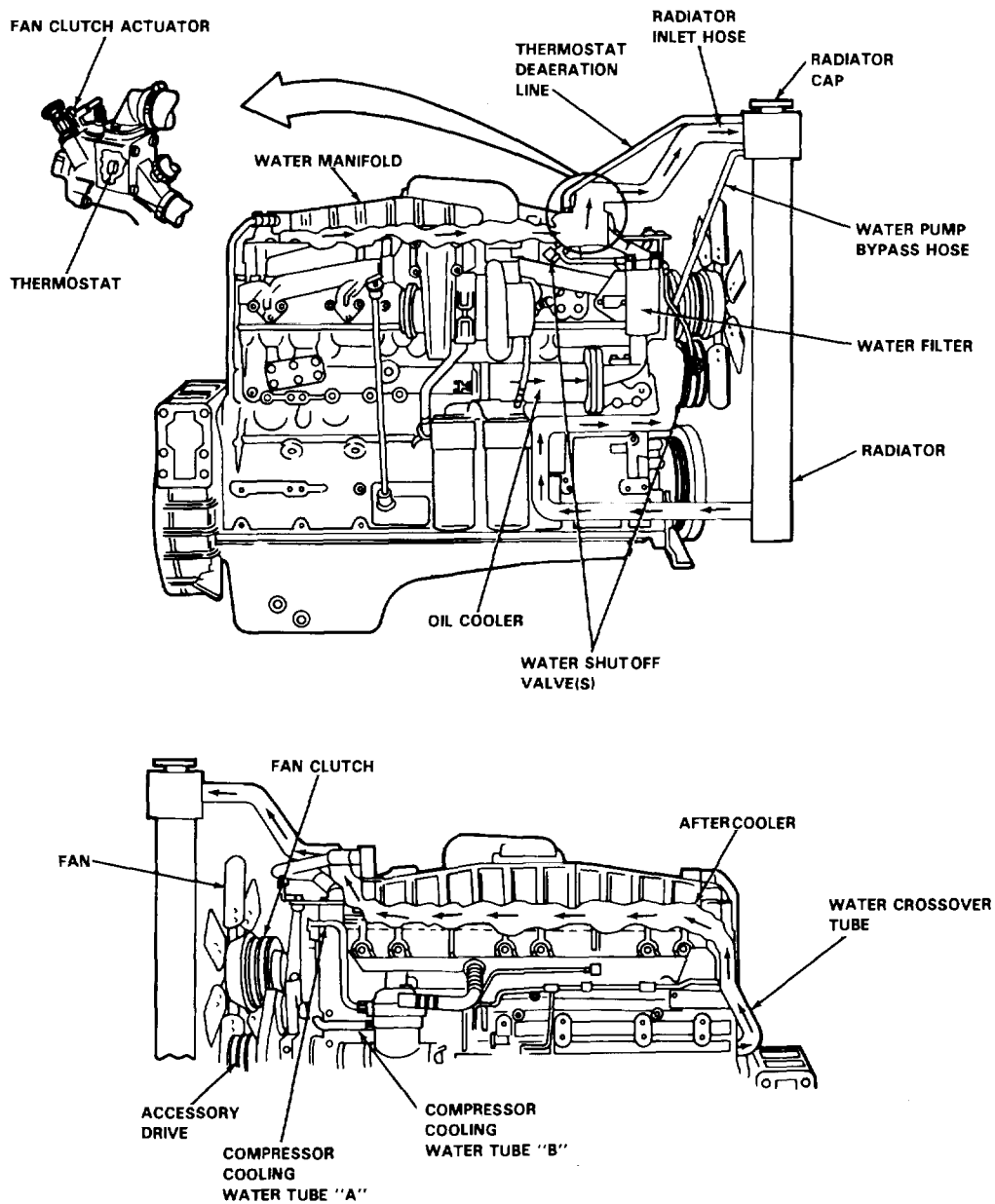

TA 236766

PRINCIPLES OF OPERATION.

1-14. COOLING SYSTEM (Continued).

b. Coolant Temperature Monitoring System.

BATTERY PACK. Consists of four, 12-volt, maintenance free batteries. Two batteries are wired in parallel in each set. Each set is connected in series for 24-volt output. Battery pack is used for both 12-volt and 24-volt output.

IGNITION SWITCH. Supplies 24-volts to relay (RY-9), which in turn provides 12-volt power to electrical system, including coolant temperature monitoring system.

RELAY (RY-9). Energized by 24-volts from ignition switch. When energized, RY-9 supplies 12-volt power to circuit breaker (CB-2).

CIRCUIT BREAKER (CB-2). Protects electrical components and wiring of coolant system by opening circuit when load exceeds 20 amperes. May be manually reset by pressing CB-2 button in.

WATER TEMPERATURE GAGE. Shows coolant temperature when actuated by electrical signal from water temperature sending unit.

WATER TEMPERATURE SWITCH. Normally open switch is closed to activate indicator lamp when coolant temperature exceeds 2250F.

ENGINE COOLANT TEMPERATURE WARNING LAMP. Activated by 12-volt power from water temperature switch when engine temperature exceeds 225°F.

WATER TEMPERATURE SENDING UNIT. Provides electrical signal to temperature gage.

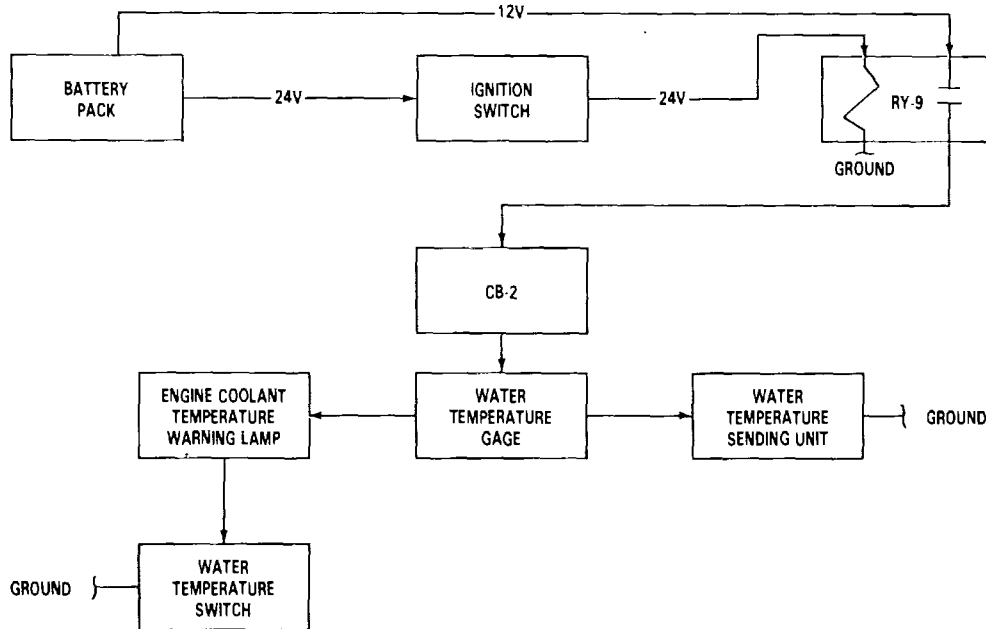

TA 236767

PRINCIPLES OF OPERATION.

1-15. ELECTRICAL SYSTEM.

a. Starting System.

BATTERY PACK. Consists of four, 12-volt, maintenance free batteries. Two batteries are wired in parallel in each set. Each set is connected in series for 24-volt output. Battery pack is used for both 12-volt and 24-volt output.

STARTER MOTOR. When energized, motor engages with ring gear on flex plate (flywheel) to start engine.

STARTER MOTOR SOLENOID. 24-volt power is applied to starter solenoid when starter relay is energized. Solenoid closes and supplies 24-volt power, which energizes starter motor.

STARTER RELAY. With ignition switch in ON position, transmission shift control lever in neutral, and ENGINE START button depressed, relay energizes and closes starter solenoid circuit.

IGNITION SWITCH. Supplies 24-volt power to relay (RY-9), which in turn provides 12-volt power to electrical system, including engine starting system circuit.

SOLENOID SHUTOFF VALVE. Normally closed. When the ignition switch is turned to ON position, valve opens allowing fuel to pass to injectors. (Refer to paragraph 1-12 for description of fuel system).

NEUTRAL SAFETY SWITCH. Normally open. Prevents starting circuit from being activated when transmission shift control lever is in any position other than neutral.

ENGINE START BUTTON. Activates starting circuit by energizing the starter relay.

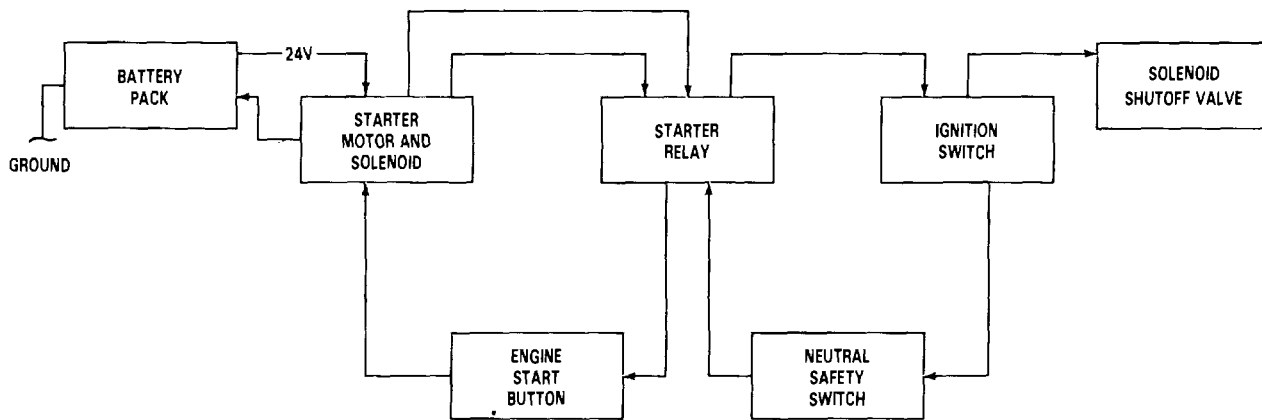

TA 236768

PRINCIPLES OF OPERATION.

1-15. ELECTRICAL SYSTEM (Continued).

b. Batteries and Power Generating System.

The batteries and power generating system provide 12-volt and 24-volt power to the electrical system.

BATTERY PACK. Consists of four, 12-volt, maintenance free batteries. Two batteries are wired in parallel in each set. Each set is connected in series for 24-volt output. Battery pack is used for both 12-volt and 24-volt output.

AC GENERATOR (ALTERNATOR). Generates voltage for recharging battery pack. Has external 24-volt transformer-rectifier.

IGNITION SWITCH. Supplies 24-volt power to relay (RY-9), which in turn provides 12-volt power to electrical system, including batteries and power generating system circuits.

RELAY (RY-9). Energized by 24-volt power from ignition switch. When energized, RY-9 supplies 12-volt power to circuit breaker (CB-2).

CIRCUIT BREAKER (CB-2). Protects electrical components of voltmeter circuit by opening when load exceeds 20 amperes. May be manually reset by pressing CB-2 button in.

VOLTMETER. 10-16 gage indicates voltage provided by battery pack and alternator.

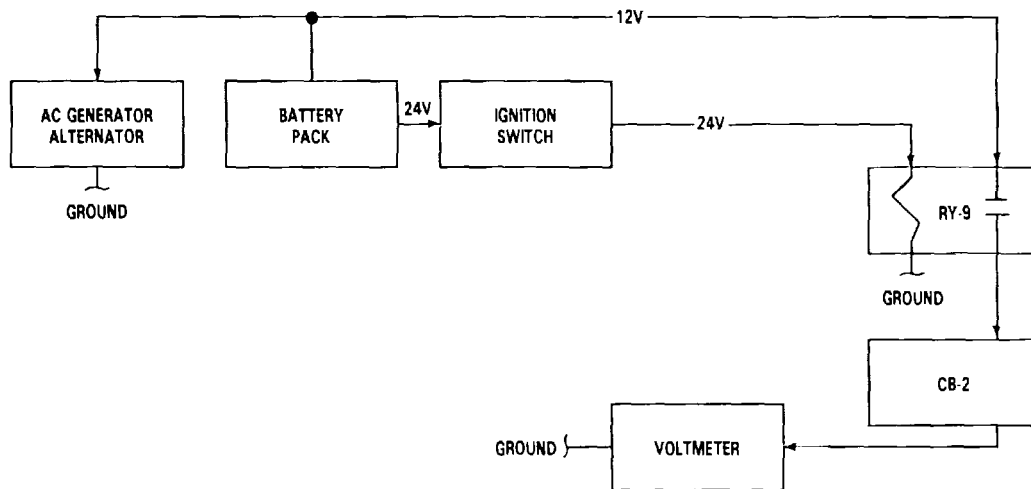

TA 236769

PRINCIPLES OF OPERATION.**1-15. ELECTRICAL SYSTEM (Continued).****c. Service Lighting System.**

The service lighting system provides illumination required while operating the vehicle. This system consists of the following subsystems:

- (1) Headlamps and Taillamps.
- (2) Marker and Clearance Lamps.
- (3) Turn Signals and Hazard Warning Lamps.
- (4) Backup Lamps.
- (5) Instruments, Gages, Dome Lamp, and Map Lamps.
- (6) Stoplamps. (Refer to Brake System Switches and Lamps, para 1-20c).

Individual circuit descriptions (except for stoplamps) can be found in this subparagraph. A complete electrical schematic diagram and wiring harness diagrams can be found in Appendix D (TM 9-2320-283-20-3).

PRINCIPLES OF OPERATION.**1-15. ELECTRICAL SYSTEM (Continued).****c. Service Lighting System (Continued).****(1) Headlamps and Taillamps.**

When headlamp switch is in ON position and blackout toggle switch is in NORMAL position, battery power is supplied to illuminate headlamps, tail- lamps, and trailer taillamps. The trailer taillamps are powered through cab and chassis connectors.

HIGH BEAM LAMP. When power is supplied to each high beam filament in the headlamps, the high beam indicator is illuminated by the same circuit.

BATTERY PACK. Consists of four, 12-volt, maintenance free batteries. Two batteries are wired in parallel in each set. Each set is connected in series for 24-volt output. Battery pack is used for both 12-volt and 24-volt output.

CIRCUIT BREAKER (CB-9). Protects 24-volt blackout stop, marker, and tail lamp circuits for trailers used with the M915A1.

HEADLAMP SWITCH. Has one OFF position and two ON positions. In either ON position, 12-volt battery power illuminates taillamps. Only when pulled fully ON will headlamps illuminate.

DIMMER SWITCH. Two-position, floor-mounted switch. Switch is always closed in one of two positions to energize either low beam or high beam headlamp filament.

BLACKOUT TOGGLE SWITCH. Two-position safety switch for NORMAL and BLACKOUT modes of operation. To select mode, switch is pulled out and placed to either position. Set to NORMAL position, 12-volt power from headlamp switch passes through blackout toggle switch contacts to energize tail- lamps, headlamps (through dimmer switch), and coil of relay. Set to

BLACKOUT position 12-volt power is removed from regular service lamps and electrical horn while 12-volt power from headlamp switch is supplied through blackout toggle switch to blackout taillamp, marker lamps, and headlamps.

HEADLAMPS. 12-volt, dual filament, sealed beams.

TAILLAMPS. Each assembly contains two bulbs: a double-element bulb is used for taillamp, turn signal lamp, and stoplamp; and a separate bulb is used for the backup lamp. The taillamp circuit is energized through the blackout toggle switch when headlamp switch is in either ON position.

RELAY (RY-6). When normally open contacts are closed, relay provides 24-volt power to trailer taillamps.

PRINCIPLES OF OPERATION.

1-15. ELECTRICAL SYSTEM (Continued).

c. Service Lighting System (Continued).

(1) Headlamps and Taillamps (Continued).

24-VOLT TRAILER CONNECTORS. Cab and chassis mounted 12-pin connectors. Provide 24-volt output to trailers with 24-volt electrical system.

12-VOLT TRAILER CONNECTOR. Cab mounted 7-pin connector. Provides 12-volt output to trailers with 12-volt electrical system.

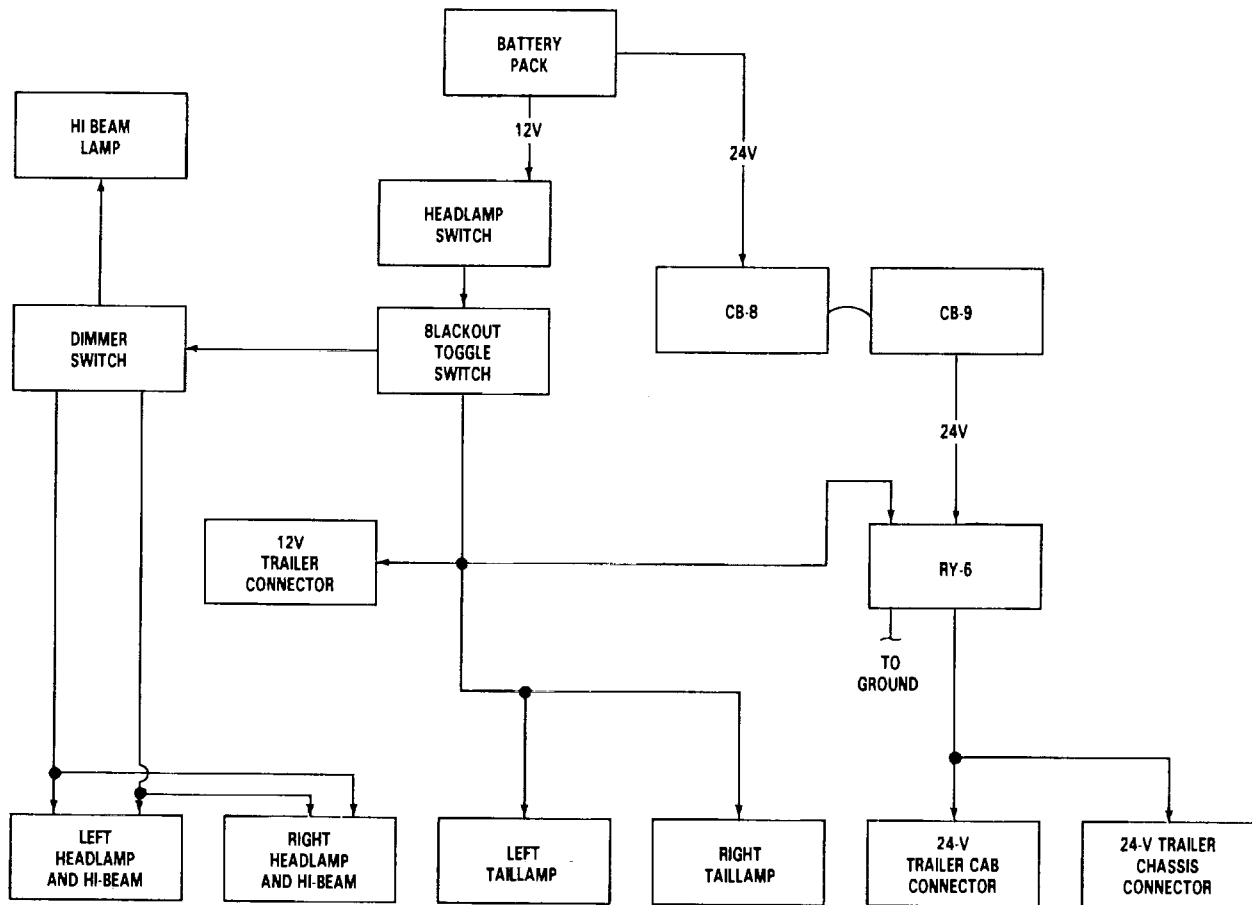

TA 236770

PRINCIPLES OF OPERATION.**1-15. ELECTRICAL SYSTEM (Continued).****c. Service Lighting System (Continued).****(2) Marker and Clearance Lamps.**

When headlamp switch is in either ON position and blackout toggle switch is in NORMAL position, 12-volt power is supplied to illuminate clearance lamps, front marker lamps, and trailer marker lamps. Trailer marker lamps receive power through connectors mounted on cab and chassis.

BATTERY PACK. Consists of four, 12-volt, maintenance free batteries. Two batteries are wired in parallel in each set. Each set is connected in series for 24-volt output. Battery pack is used for both 12-volt and 24-volt output.

CIRCUIT BREAKER (CB-7). Protects 12-volt marker and clearance lamp switch circuit. May be manually reset by pushing button in.

HEADLAMP SWITCH. Has one OFF position and two ON positions. Supplies 12-volt power in either ON position, to clearance lamps, marker lamps, and 12-volt tractor connector when blackout toggle switch is in NORMAL position.

BLACKOUT TOGGLE SWITCH. With toggle switch is set to NORMAL position and headlamp switch is set to ON position, 12-volt power is supplied to marker lamps, clearance lamps, and 12-volt tractor connector.

12-VOLT TRAILER CONNECTOR. Seven-pin connector, containing 12-volt circuit for trailer clearance and marker lamps.

CLEARANCE LAMP SWITCH. Provides capability of flashing clearance lamps on cab and 12-volts supplied to the tractor connector, when switch is depressed and released. 12-volt power is supplied to switch when headlamp switch is in ON position and blackout toggle switch is in NORMAL position.

CLEARANCE LAMPS. Each unit has a replaceable single-element bulb that illuminates when headlamp switch is in either ON position and blackout toggle is in NORMAL position. The clearance lamps will flash when clearance lamp switch is depressed and released.

MARKER LAMP ASSEMBLY. Each assembly has two bulbs that illuminate whenever headlamp switch is in ON position and blackout toggle switch is in NORMAL position. One bulb is used as a marker lamp, and the other is for turn signals.

RELAY (RY-6). Normally open contacts are closed by 12-volt power when blackout toggle switch is in NORMAL position and headlamp switch is in ON position. When contacts of relay close, 24 volts from circuit breaker CB-9 is supplied to tractor chassis connector.

PRINCIPLES OF OPERATION.

1-15. ELECTRICAL SYSTEM (Continued).

c. Service Lighting System (Continued).

(2) Marker and Clearance Lamps (Continued).

CIRCUIT BREAKER (CB-9). Protects electrical components for 24-volt tractor receptacle circuits by opening when load exceeds 20 amperes. May be manually reset by pressing CB-9 button in.

24-VOLT TRAILER CONNECTOR. Chassis mounted 12-pin connector, containing 24-volt power for 24-volt trailer marker lamp circuits.

24-VOLT TRAILER CONNECTOR. Cab mounted 12-pin connector provides 24-volt power for towed vehicles marker lamp circuits.

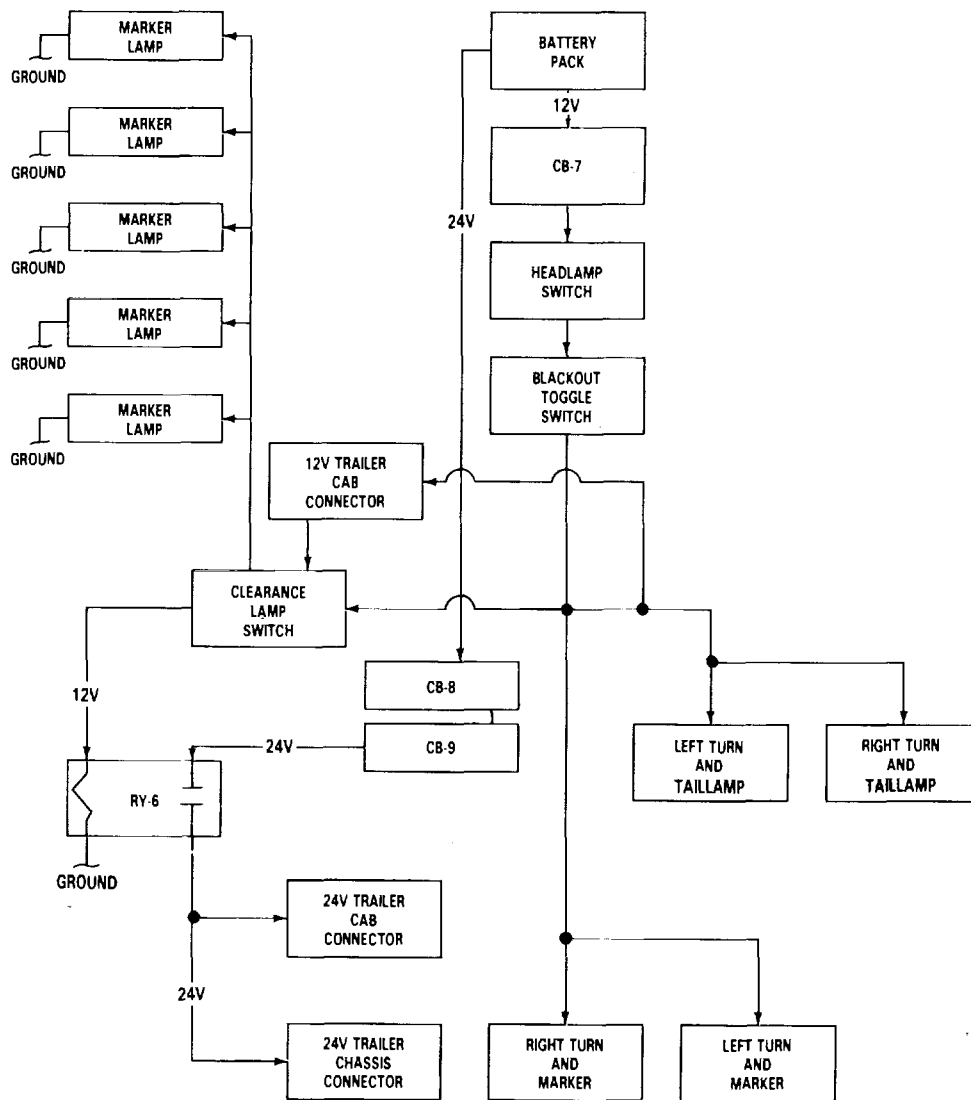

TA 236771

PRINCIPLES OF OPERATION.**1-15. ELECTRICAL SYSTEM (Continued).****c. Service Lighting System (Continued).****(3) Turn Signal and Hazard Warning Lamps.**

When the blackout toggle switch is in NORMAL position, battery power is applied to the turn signal switch to illuminate right or left front turn signals and rear turn signals as well as trailer turn signals through tractor-mounted connector. Also, the turn signal switch contains a hazard warning switch that allows the operator to flash all lamps in the turn signal system simultaneously.

BATTERY PACK. Consists of four, 12-volt, maintenance free batteries. Two batteries are wired in parallel in each set. Each set is connected in series for 24-volt output. Battery pack is used for both 12-volt and 24-volt output.

CIRCUIT BREAKER (CB-5). Protects electrical components of flasher, turn signal switch, and hazard warning switch circuits by opening when load exceeds 20 amperes. May be manually reset by pressing CB-5 button in. **CIRCUIT BREAKER (CB-8).** Protects electrical components of 24-volt relay and circuits by opening when load exceeds 20 amperes. May be manually reset by pressing CB-8 button in.

BLACKOUT TOGGLE SWITCH. Two-position switch for normal and blackout modes of operation. When set to NORMAL position, 12-volt power from circuit breaker (CB-5) passes through switch contacts to turn signal switch, flasher unit, and hazard warning switch.

FLASHER UNIT. Receives 12-volt power from blackout toggle switch in NORMAL position and supplies this power alternately on and off to turn signal control or hazard warning switch when either one is engaged.

TURN SIGNAL SWITCH. When engaged, it receives 12-volt power from flasher unit. (The flasher unit receives 12-volt power through blackout toggle switch and circuit breaker CB-5). Power is then supplied to:

- (a) Front left or right turn signals.
- (b) Rear left or right turn signals.
- (c) 12-volt trailer connector.
- (d) Relays RY-2 and RY-3 (to supply power to both tractor mounted 24-volt connectors for trailer turn signals).

PRINCIPLES OF OPERATION.

1-15. ELECTRICAL SYSTEM (Continued).

c. Service Lighting System (Continued).

(3) Turn Signal and Hazard Warning Lamps (Continued).

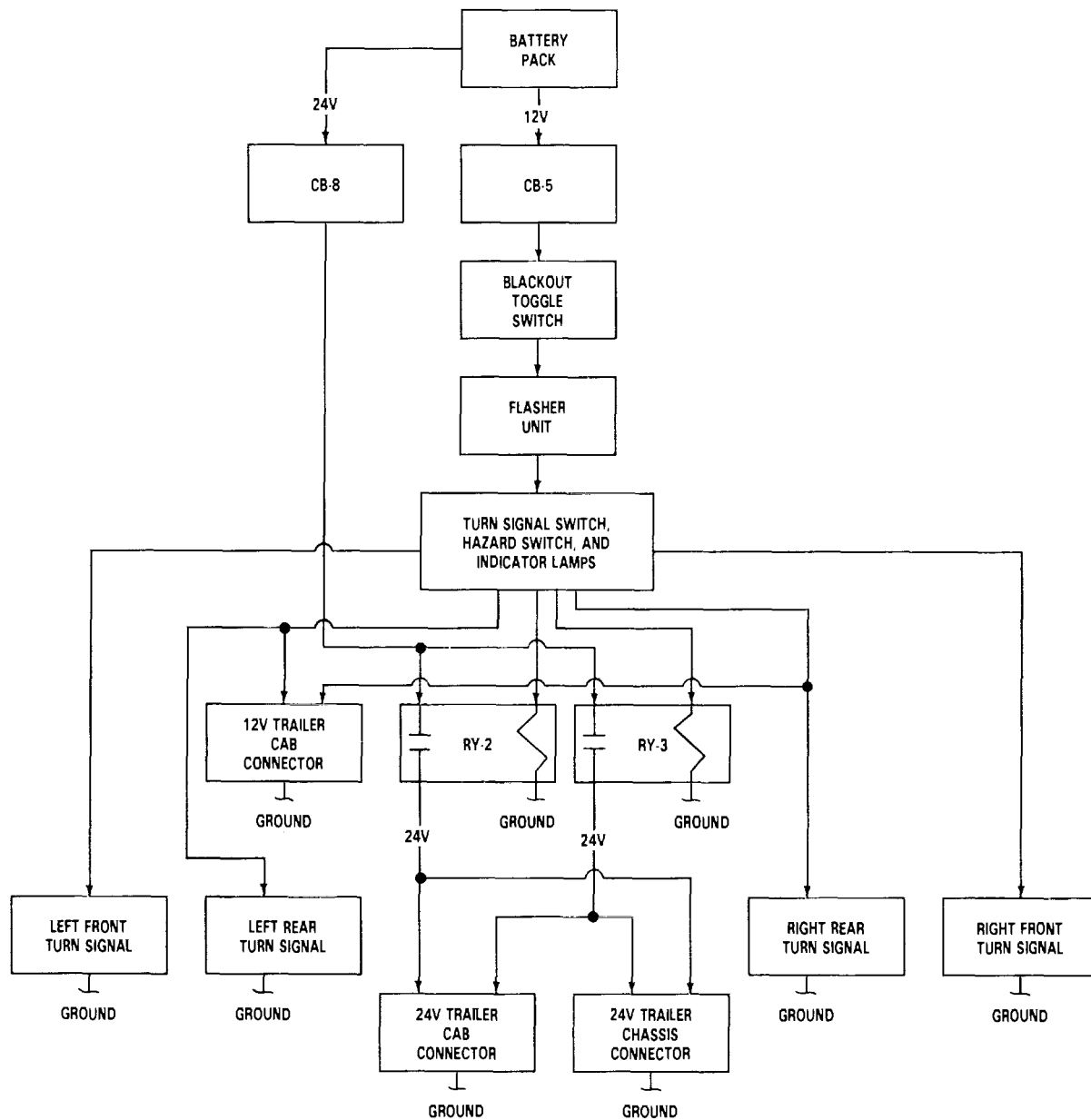

TA 236772

PRINCIPLES OF OPERATION.**1-15. ELECTRICAL SYSTEM (Continued).**c. Service Lighting System (Continued).(3) Turn Signal and Hazard Warning Lamps (Continued).

INDICATOR LAMPS. Three bulbs to indicate left turn (green), right turn (green), or hazard (red). Bulbs are energized, by selection, with 12-volt power from flasher unit.

HAZARD WARNING SWITCH. When engaged, it receives 12-volt power from blackout toggle switch through flasher and energizes all lights in the turn signal circuits at the same time.

RELAY (RY-2). Normally open contacts are closed by 12-volt power from left turn signal switch or hazard warning switch. When relay is energized, 24-volt power is supplied to tractor mounted connector for trailer left turn signals.

RELAY (RY-3). Normally open contacts are closed by 12-volt power from right turn signal switch or hazard warning switch. When relay is energized, 24-volt power is supplied to tractor mounted connector for trailer right turn signals.

12-VOLT TRAILER CONNECTOR. Cab mounted seven-pin connector provides 12-volt power to the trailer turn signal lamps.

24-VOLT TRAILER CONNECTOR. Chassis mounted 12-pin connector provides 24-volt power to the trailer turn signal lamps.

24-VOLT TRAILER CONNECTOR. Cab mounted 12-pin connector provides 24-volt power to vehicles.

REAR TAILLAMPS. Each assembly contains two bulbs; the taillamp turn signal and stoplamp circuits use the same bulb. When either the turn signal switch or hazard warning switch are on, the turn signal and stoplamp filaments flash. When the turn signal control is activated, only the bulb on the side selected flashes. If the brakes are engaged at the same time that the hazard warning switch is on, both bulbs flash. When the brakes are engaged and the turn signal control is activated, one bulb will flash and the other bulbs will remain on constantly.

MARKER AND TURN SIGNAL LAMP ASSEMBLY. Each assembly has a replaceable single filament bulb that flashes when turn signal switch or hazard warning signal is on.

PRINCIPLES OF OPERATION.

1-15. ELECTRICAL SYSTEM (Continued).

c. Service Lighting System (Continued).

(3) Turn Signal and Hazard Warning Lamps (Continued).

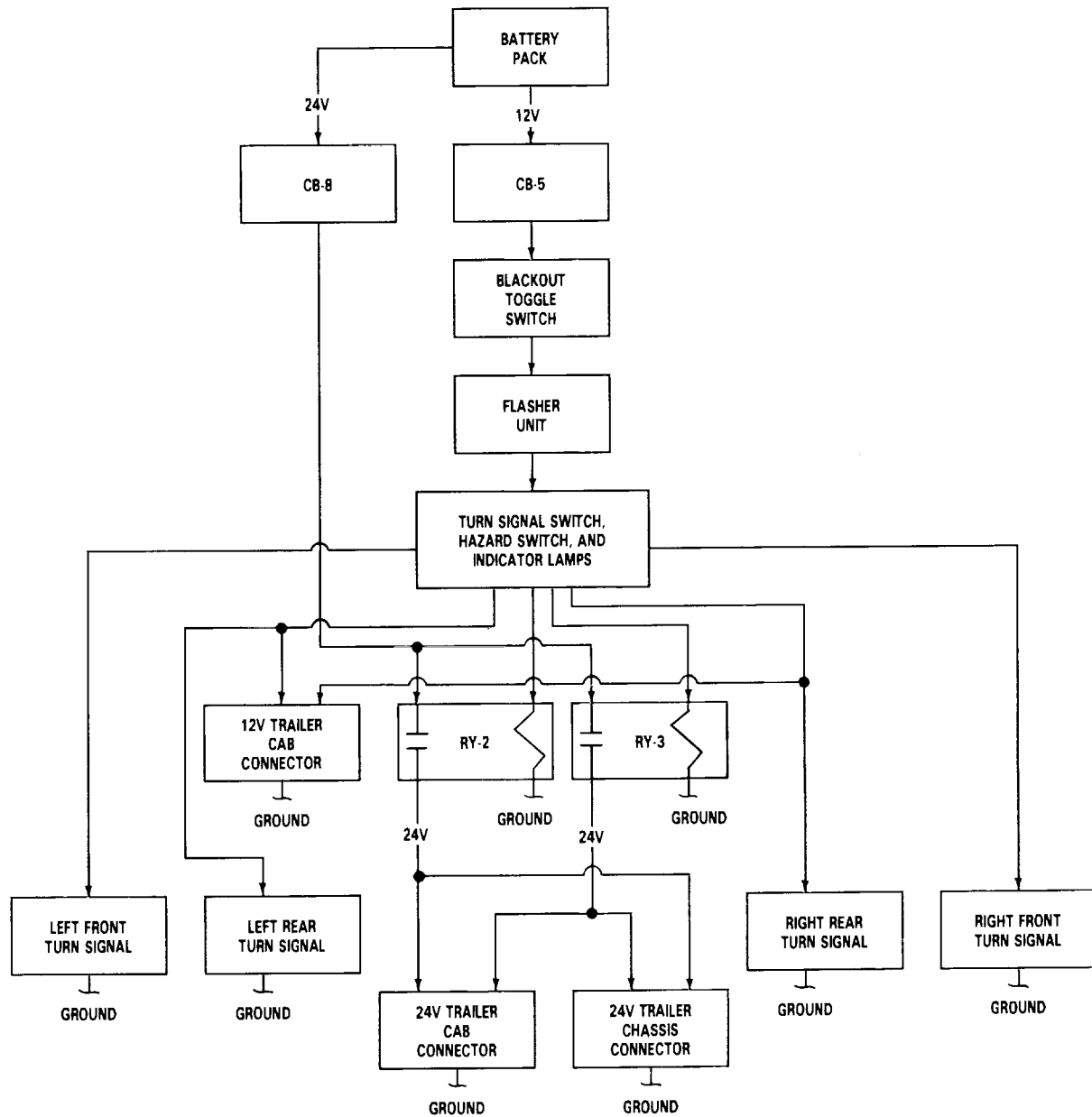

TA 236773

PRINCIPLES OF OPERATION.**1-15. ELECTRICAL SYSTEM (Continued).**c. Service Lighting System (Continued).(4) Backup Lamps.

When the operator places the transmission shift lever in REVERSE position (R), the reverse switch closes. When blackout toggle switch is in NORMAL position and ignition switch is in ON position, the circuit is energized to illuminate backup bulb in each taillamp assembly.

BATTERY PACK. Consists of four, 12-volt, maintenance free batteries. Two batteries are wired in parallel in each set. Each set is connected in series for 24-volt output. Battery pack is used for both 12-volt and 24-volt output.

IGNITION SWITCH. Supplies 24-volt to relay (RY-9), which in turn provides 12-volt power to electrical system, including backup lamp circuit.

RELAY (RY-9). Energized by 24-volts from ignition switch. When energized, RY-9 supplies 12-volt power to circuit breaker (CB-3).

CIRCUIT BREAKER (CB-3). Protects electrical components of backup switch circuit by opening when load exceeds 20 amperes. May be manually reset by pressing CB-3 button in.

REVERSE SWITCH. Normally open contacts. When closed, it receives 12-volt battery power through circuit breaker CB-3 and supplies power through normally closed contacts of relay RY-7 to energize backup lamps in taillamp assemblies.

RELAY (RY-7). Normally closed contacts are opened by 12-volt power when blackout toggle switch is placed to BLACKOUT position. This prevents the backup lamps from coming on whenever the blackout toggle switch is in BLACKOUT mode.

TAILLAMP (BACKUP LAMP). Each assembly contains two bulbs: a taillamp, turn signal, and stoplamp bulb that contains two filaments; and a backup bulb that contains one filament. When the backup switch closes, the backup lamp illuminates.

CIRCUIT BREAKER (CB-5). Protects electrical components of relay RY-7 circuits by opening when load exceeds 20 amperes. May be manually reset by pressing CB-5 button in.

PRINCIPLES OF OPERATION.

1-15. ELECTRICAL SYSTEM (Continued).

c. Service Lighting System (Continued).

(4) Backup Lamps.

BLACKOUT TOGGLE SWITCH. Two-position switch for NORMAL and BLACKOUT modes of operation. In this circuit, the switch is used to prevent operation of the backup lamp. In BLACKOUT position, 12-volt power from circuit breaker CB-5 passes through toggle switch and energizes coil of relay RY-7, thus

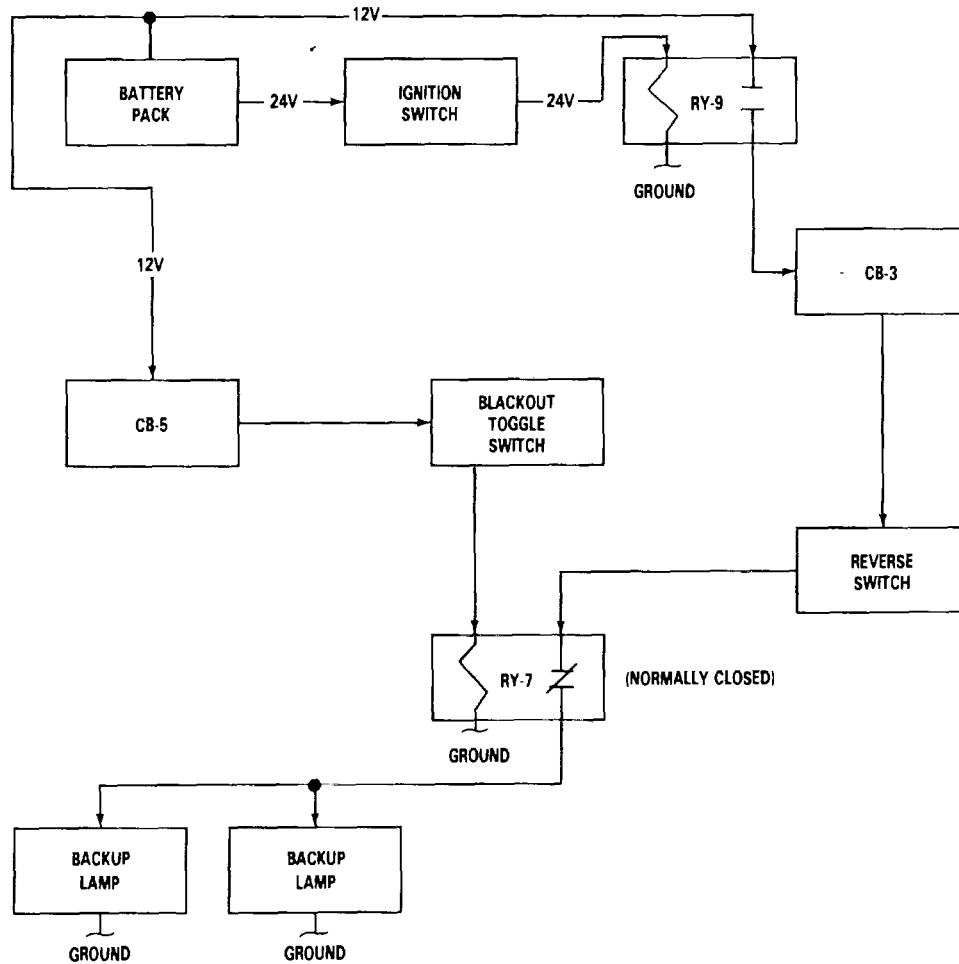

TA 236774

PRINCIPLES OF OPERATION.**1-15. ELECTRICAL SYSTEM (Continued).**c. Service Lighting System (Continued).(5) Instruments, Gages, Dome Lamp, and Map Lamps.

Instrument gages operate when ignition switch is in ON position. Instrument lamps illuminate when headlamp switch is pulled to ON position. Dome lamp and map lamps illuminate whenever dome or map lamp switches are on and blackout toggle switch is in NORMAL position.

BATTERY PACK. Consists of four, 12-volt, maintenance free batteries. Two batteries are wired in parallel in each set. Each set is connected in series for 24-volt output. Battery pack is used for both 12-volt and 24-volt output.

IGNITION SWITCH. Supplies 24-volt power to relay (RY-9), which in turn provides 12-volt power to electrical system, including instrument gage, dome lamp, and map lamp circuits.

RELAY (RY-9). Energized by 24-volt power from ignition switch. When energized, RY-9 supplies 12-volt power to circuit breaker (CB-2).

CIRCUIT BREAKER (CB-2). Protects electrical components of instrument gage circuit by opening when load exceeds 20 amperes. May be manually reset by pressing CB-2 button in.

WATER TEMPERATURE GAGE. Changes in water temperature cause sending unit to increase and decrease resistance in circuit. As resistance changes, voltage at gage is changed, operating gage.

FUEL LEVEL GAGE. Changes in fuel level cause sending unit to increase and decrease resistance in circuit, as resistance changes, voltage at gage is changed, operating gage.

VOLTMETER. In series with 12-volt system. Shows voltage in system when ignition switch is in either ACCESSORY or IGNITION (ON) position.

TRANSMISSION OIL TEMPERATURE GAGE. Changes in transmission temperature cause sending unit to increase and decrease resistance in circuit. As resistance changes, voltage at gage is changed, operating gage.

ENGINE OIL PRESSURE GAGE. Changes in engine oil pressure cause sending unit to increase and decrease resistance in circuit as resistance changes, voltage at gage is changed, operating gage.

CIRCUIT BREAKER (CB-5). Protects 12-volt electric horn and turn signal flasher circuits.

PRINCIPLES OF OPERATION.

1-15. ELECTRICAL SYSTEM (Continued).

c. Service Lighting System (Continued).

(5) Instruments, Gages, Dome Lamp, and Map Lamps.

CIRCUIT BREAKER (CB-1). Protects electrical components of dome and map lamps circuit by opening when load exceeds 20 amperes. May be manually reset by pressing CB-1 button in.

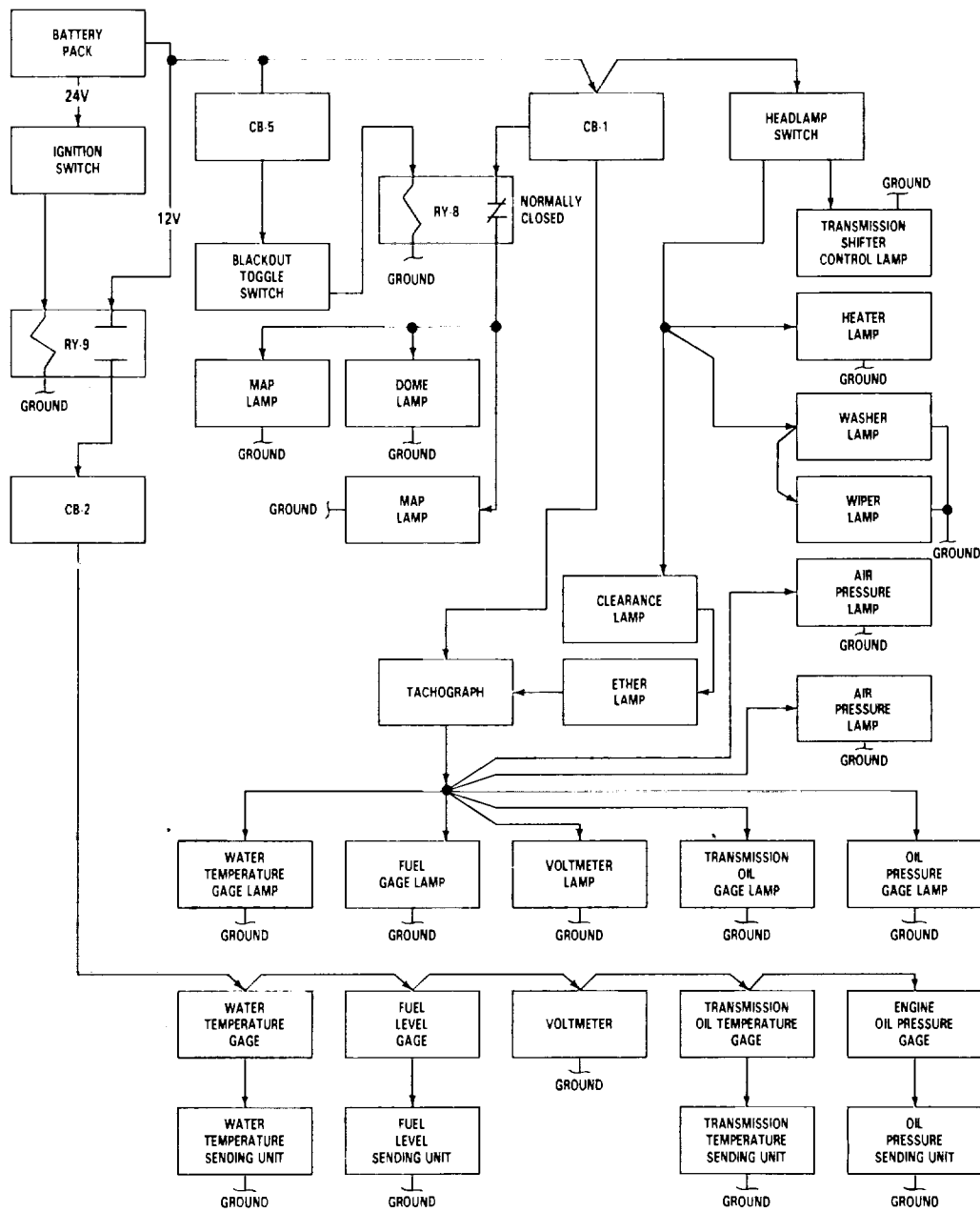

TA 236775

PRINCIPLES OF OPERATION.**1-15. ELECTRICAL SYSTEM (Continued).**c. Service Lighting System (Continued).(5) Instruments, Gages, Dome Lamp, and Map Lamps.

RELAY (RY-8). Normally closed contacts are opened by 12-volt power when blackout toggle switch is placed in BLACKOUT position. This prevents the dome and map lamps from coming on whenever the blackout toggle switch is in the BLACKOUT mode.

BLACKOUT TOGGLE SWITCH. Two-position switch for NORMAL and BLACKOUT modes of operation. In this circuit, the switch is used to prevent operation of the dome and map lamps. In BLACKOUT position, 12-volt power from circuit breaker CB-1 passes through the switch and energizes coil of relay RY-8, thus preventing dome and map lamps from possibly coming on.

DOMELAMP AND MAP LAMPS SWITCH ASSEMBLY. When the dome lamp or map lamps switch is in ON position and the blackout toggle switch is in NORMAL position, the lamp is energized by 12-volt power through relay (RY-8) and circuit breaker (CB-1).

HEADLAMP SWITCH. Has one OFF position and two ON positions. In either ON position, 12-volt power passes through the switch to energize the following lamps in this circuit:

- (a) Instrument lamps on left-hand instrument cluster.
- (b) Clearance, ether switch, and tachograph illumination lamps on center cluster.
- (c) Switch and functional indicators on right-hand instrument cluster.
- (d) Illumination lamps on heater panel.
- (e) Illumination lamps on shifter control tower.

The headlamp switch has a variable rheostat that allows the operator to adjust the brightness of all lamps in this circuit by turning the switch knob.

TACHOGRAPH. Receives 12-volt power from headlamp switch for illumination.

WINDSHIELD WIPER AND WASHER LAMPS. Receives 12-volt power from headlamp switch for illumination.

HEATER PANEL LAMPS. When headlamp switch is in either ON position, lamps are energized by 12-volt power and illuminate heater control panel.

TRANSMISSION SHIFTER CONTROL LAMP. When headlamp switch is in either ON position, lamp is energized by 12-volt battery power and illuminates transmission shifter control.

PRINCIPLES OF OPERATION.

1-15. ELECTRICAL SYSTEM (Continued).

c. Service Lighting System (Continued).

(5) Instruments, Gages, Dome Lamp, and Map Lamps.

GAGE LAMPS. Receive 12-volt power when headlamp switch is on. Illuminates

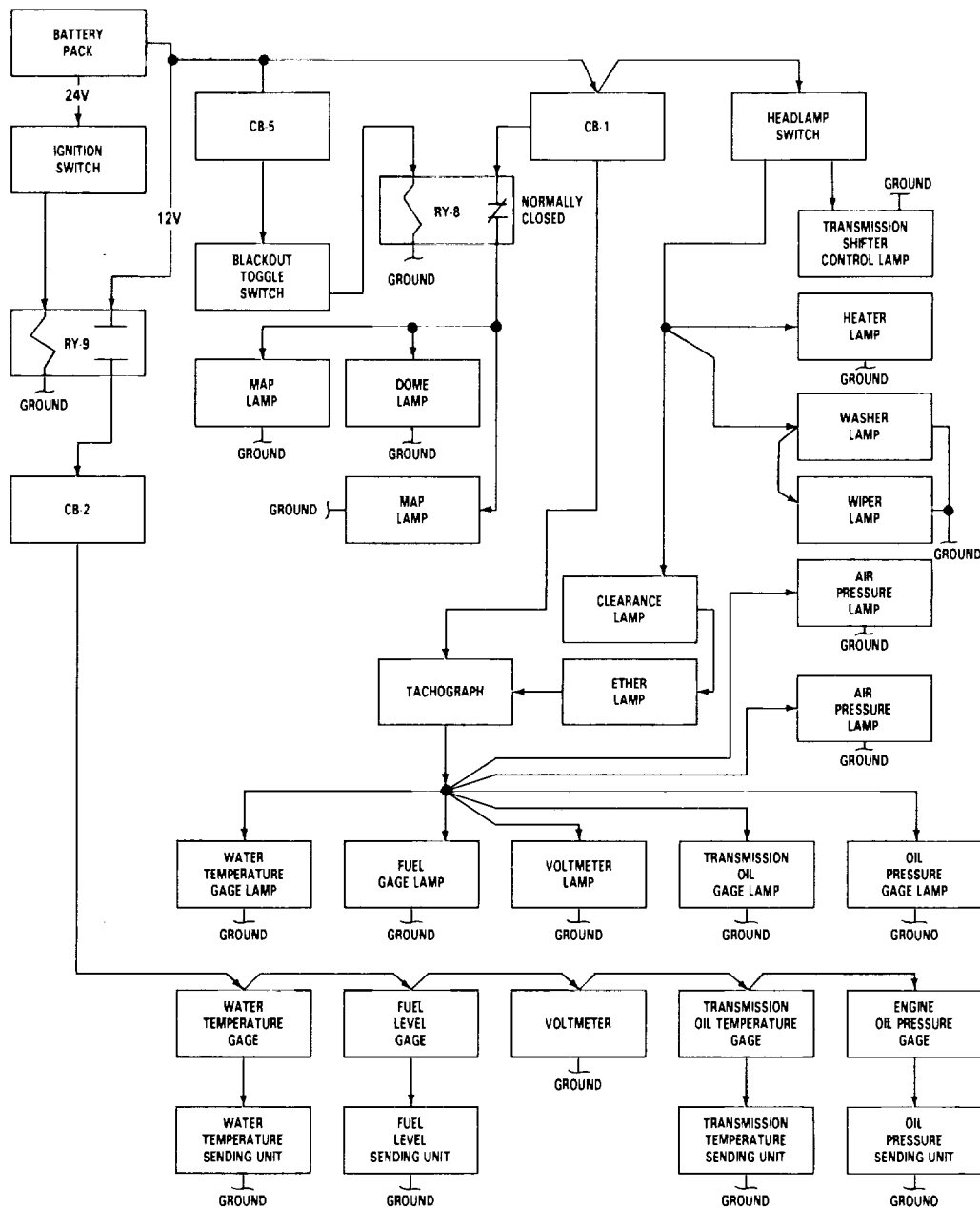

TA 236776

PRINCIPLES OF OPERATION.**1-15. ELECTRICAL SYSTEM (Continued).**d. Blackout Lighting System.

The blackout lighting system prevents operation of the horn and all service lighting, except instrument lamps. The system provides the following intensity lighting for operation:

- (1) One blackout drive headlamp.
- (2) Two front blackout marker lamps.
- (3) Two taillamps and stoplamps.
- (4) Trailer taillamps, stoplamps, and marker lamps at cab and chassis mounted 12-pin trailer connector.

BATTERY PACK. Consists of four, 12-volt, maintenance free batteries. Two batteries are wired in parallel in each set. Each set is connected in series for 24-volt output. Battery pack is used for both 12-volt and 24-volt output.

IGNITION SWITCH. Supplies 24-volt power to relay (RY-9), which in turn provides 12-volt power to electrical system, including blackout lighting system.

BLACKOUT TOGGLE SWITCH. Two-position switch for NORMAL and BLACKOUT modes of operation. With this switch in BLACKOUT position, 12-volt battery power is available from headlamp switch to energize: blackout headlamp, blackout marker lamps, taillamps, and relays RY-4 and RY-5.

BLACKOUT HEADLAMP. Consists of a single, replaceable sealed beam unit. With headlamp switch in ON position, the blackout headlamp is energized by 12-volt battery power.

BLACKOUT MARKER LAMPS. Each consists of a replaceable bulb that is energized by 12-volt battery power when the headlamp switch is in either ON position.

RELAY (RY-4). Normally open contacts are closed by 12-volt power when blackout toggle switch is in BLACKOUT position. When relay is energized, 24-volt power is supplied from circuit breaker CB-9 through 24-volt trailer connector.

RELAY (RY-5). Normally open contacts are closed by 12-volt power when blackout toggle switch is in BLACKOUT position. When relay is energized, 24-volt power is supplied from circuit breaker CB-8 through 24-volt trailer connector for blackout taillamps.

CIRCUIT BREAKER (CB-1). Protects electrical components of stop switch circuit by opening when load exceeds 20 amperes. May be manually reset by pressing CB-1 button in.

PRINCIPLES OF OPERATION.

1-15. ELECTRICAL SYSTEM (Continued).

d. Blackout Lighting System (Continued).

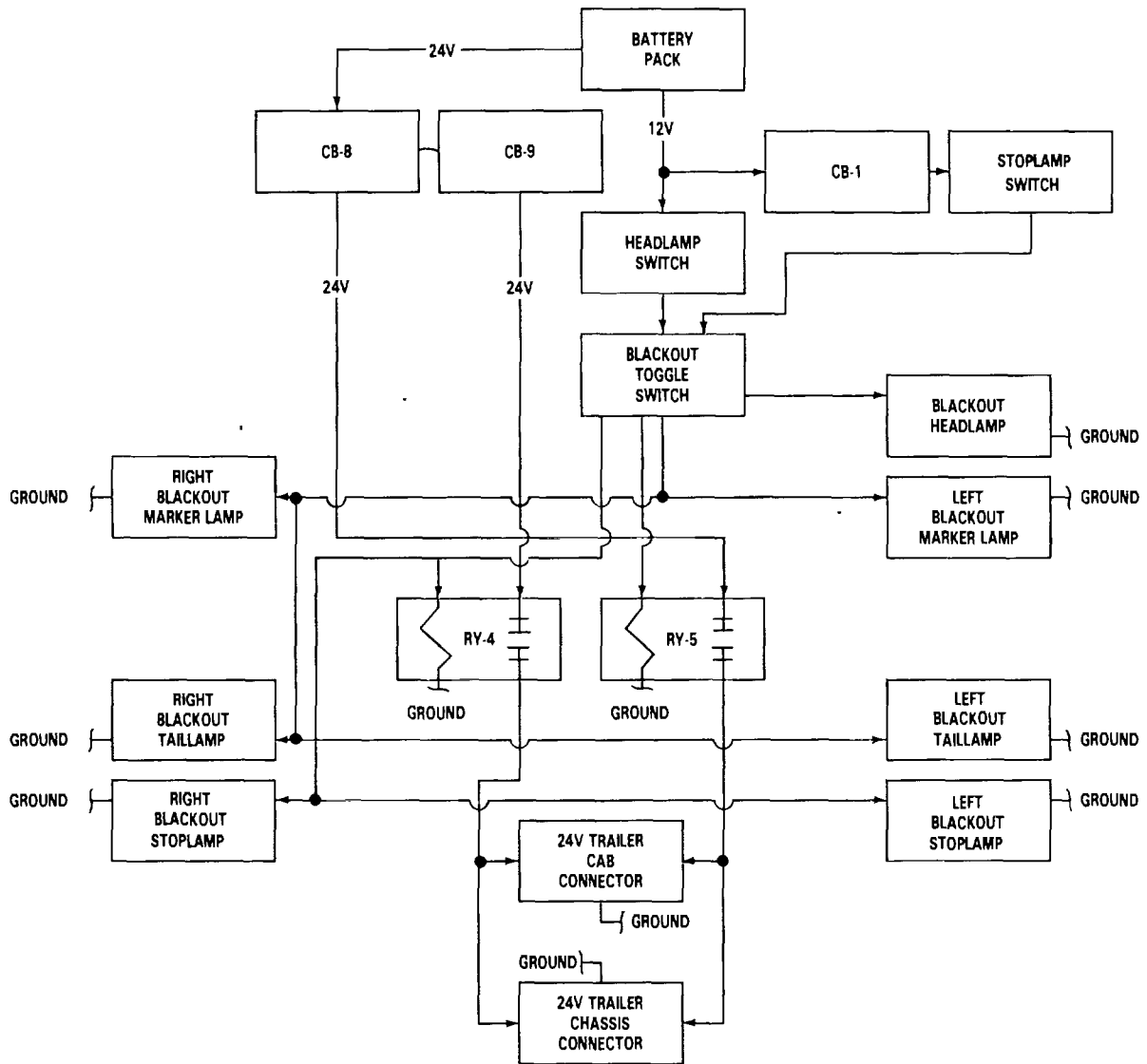

TA 236777

PRINCIPLES OF OPERATION.**1-15. ELECTRICAL SYSTEM (Continued).**d. Blackout Lighting System (Continued).

CIRCUIT BREAKER (CB-8). Protects electrical components of 24-volt blackout taillamp relay circuit by opening when load exceeds 20 amperes. May be manually reset by pressing CB-8 button in.

HEADLAMP SWITCH. Has one OFF position and two ON positions. Supplies 12-volt power to the blackout toggle switch.

CIRCUIT BREAKER (CB-9). Protects electrical components of 24-volt blackout stoplamp relay circuit by opening when load exceeds 20 amperes. May be manually reset by pressing CB-9 button in.

24-VOLT TRAILER CONNECTOR. Cab mounted 12-pin connector to provide 24-volt power to trailers for blackout taillamps and stoplamps.

REAR BLACKOUT LAMPS. Contains bulbs for blackout taillamps and stoplamps. Black out taillamp is energized when the blackout toggle switch is in BLACKOUT position and the headlamp switch is in either ON position. Stoplamps are energized when the stoplamp switch is actuated.

24-VOLT TRAILER CONNECTOR. Chassis mounted 12-pin connector to provide 24-volt power to trailer blackout taillamps and stoplamps.

STOP LAMP SWITCH. Part of the brake system. Shown and described in paragraph 1-20b. In this circuit, the switch receives 12-volt power from circuit breaker CB-1. When the brakes are engaged, switch closes and supplies 12-volt power through the blackout toggle switch to energize relay RY-4. With this relay closed, 24-volt power is supplied through circuit breaker CB-9 to the 24-volt tractor mounted trailer connector.

PRINCIPLES OF OPERATION.

1-15. ELECTRICAL SYSTEM (Continued).

d. Blackout Lighting System (Continued).

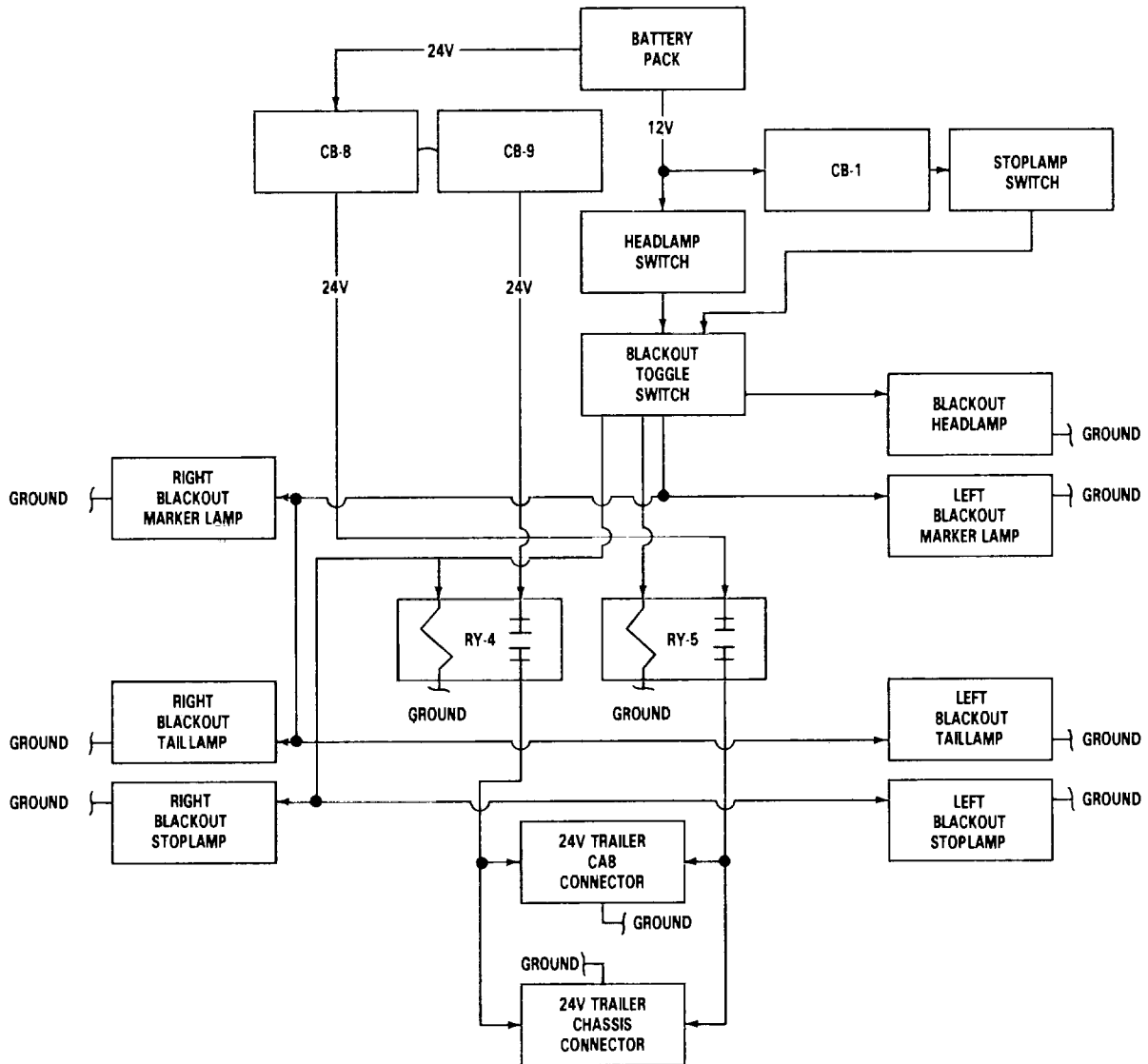

TA 236778

PRINCIPLES OF OPERATION.**1-15. ELECTRICAL SYSTEM (Continued).**e. Relays, Circuit Breakers, and Diode.

RELAY (RY-1). When normally open contacts are closed, relay provides 12-volt power to electric horn.

RELAY (RY-2). When normally open contacts are closed, relay provides 24-volt power to trailer left turn signal lamp.

RELAY (RY-3). When normally open contacts are closed, relay provides 24-volt power to trailer right turn signal lamp.

RELAY (RY-4). When normally open contacts are closed, relay provides 24-volt power to trailer blackout stoplamp.

RELAY (RY-5). When normally open contacts are closed, relay provides 24-volt power to trailer blackout taillamps.

RELAY (RY-6). When normally open contacts are closed, relay provides 24-volt power to trailer marker and taillamps.

RELAY (RY-7). When normally closed contacts are opened, relay disconnects 12-volt power from tractor backup lamps.

RELAY (RY-8). When normally closed contacts are opened, relay disconnects 12-volt power from dome lamp and map lamps.

RELAY (RY-9). When normally open contacts are closed, relay provides 12-volt power to heater motor, backup lamp, defroster fans, ether quick-start kit, engine brake retarder, air dryer, low air switch, park brake switch, differential lockout switch, instrument gages, and indicator lamps.

PRINCIPLES OF OPERATION.

1-15. ELECTRICAL SYSTEM (Continued).

e. Relays, Circuit Breakers, and Diode.

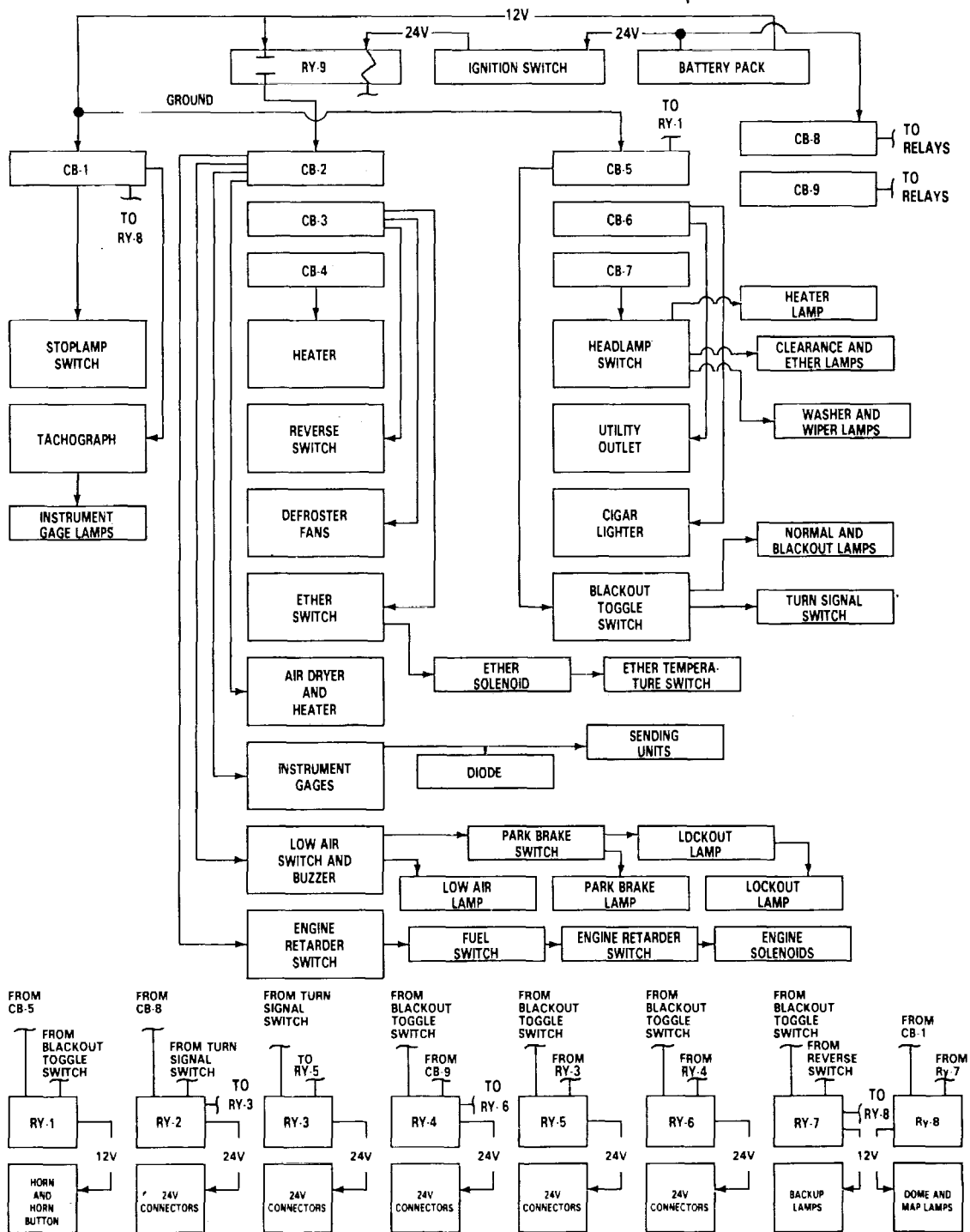

TA 236779

PRINCIPLES OF OPERATION.**1-15. ELECTRICAL SYSTEM (Continued).**e. Relays, Circuit Breakers, and Diode.

ENGINE TEMPERATURE DIODE. Provides a circuit to illuminate engine temperature indicator when engine is cranking. Prevents engagement of starter by feedback voltage when water temperature switch closes.

CIRCUIT BREAKER (CB-9). Protects 24-volt blackout stoplamp, marker, and taillamp circuits for trailers used with the M915A1.

CIRCUIT BREAKER (CB-8). Protects 24-volt left and right turn signals and blackout taillamp circuits for trailers used with the M915A1.

CIRCUIT BREAKER (CB-7). Protects 12-volt headlamp and operational lamp switch circuit.

CIRCUIT BREAKER (CB-6). Protects 12-volt cigar lighter circuit and 12-volt utility outlets.

CIRCUIT BREAKER (CB-5). Protects 12-volt electric horn and turn signal flasher circuits.

CIRCUIT BREAKER (CB-4). Protects 12-volt heater fan motor circuit.

CIRCUIT BREAKER (CB-3). Protects 12-volt backup lamps, ether start, and defroster fan circuits.

CIRCUIT BREAKER (CB-2). Protects 12-volt engine retarder brake, moisture ejection valve heater, air dryer heater, instrument gages, low air, park brake, and differential lockout circuits.

CIRCUIT BREAKER (CB-1). Protects 12-volt stoplamp, blackout toggle switch, turn signal, dome lamp, map lamps, and instrument lighting circuits.

PRINCIPLES OF OPERATION.

1-15. ELECTRICAL SYSTEM (Continued).

e. Relays, Circuit Breakers, and Diode.

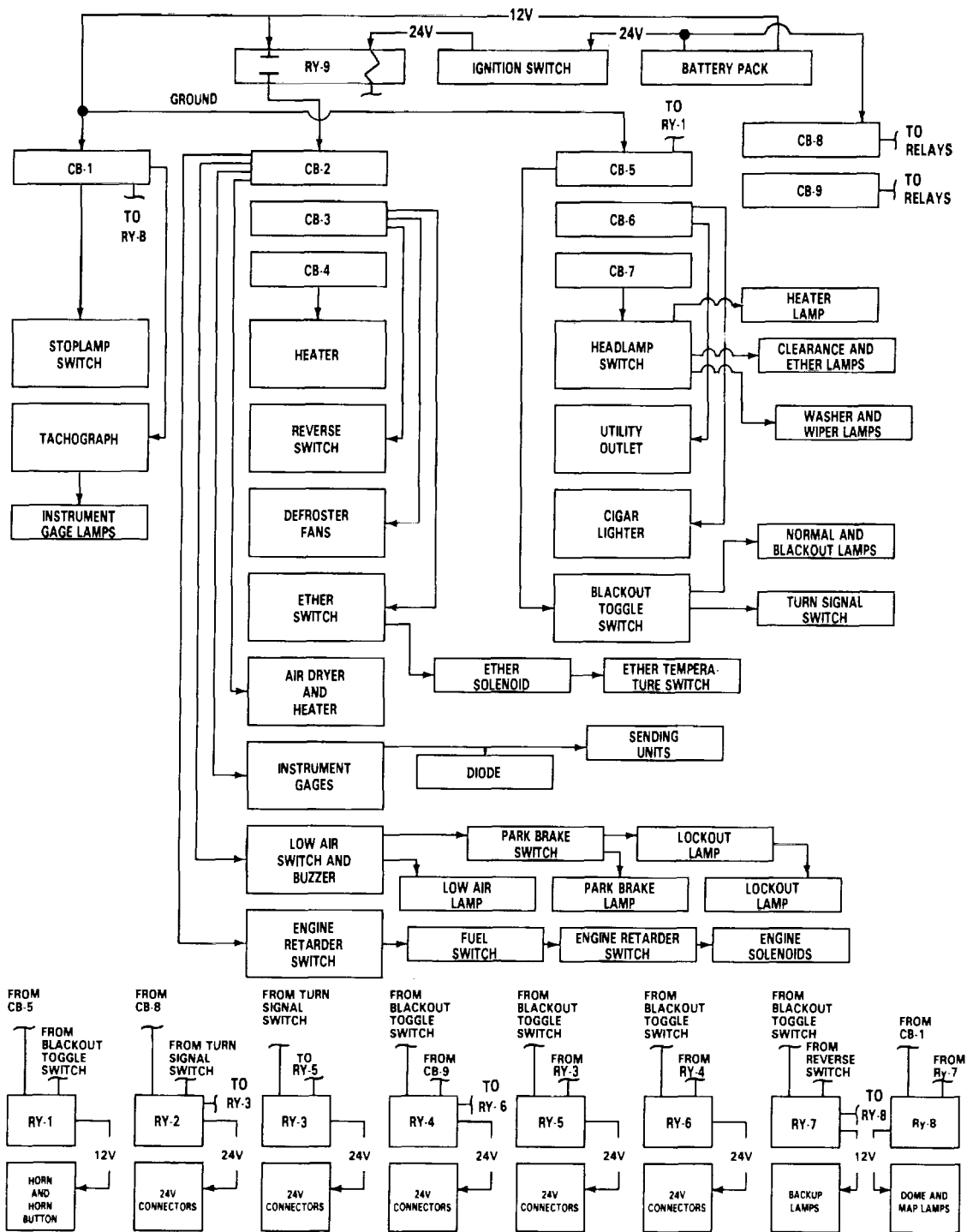

TA 236780

PRINCIPLES OF OPERATION.**1-15. ELECTRICAL SYSTEM (Continued).**f. Electric Horn.

BATTERY PACK. Consists of four, 12-volt, maintenance free batteries. Two batteries are wired in parallel in each set. Each set is connected in series for 24-volt output. Battery pack is used for both 12-volt and 24-volt output.

CIRCUIT BREAKER (CB-5). Protects electrical components of horn circuit by opening when load exceeds 20 amperes. May be manually reset by pressing CB-5 button in.

BLACKOUT TOGGLE SWITCH. Two-position switch for NORMAL and BLACKOUT modes of operation. With switch set to NORMAL and horn button depressed, 12-volt power from circuit breaker passes through switch contacts to relay.

HORN BUTTON. Pushing this button activates horn circuit and energizes horn.

RELAY (RY-1). Normally open contacts are closed by 12-volt power from blackout toggle switch when horn button is depressed. With relay deenergized, 12 volts are supplied from a second lead from circuit breaker, through contacts of relay to horn.

ELECTRIC HORN. The horn is energized by 12-volt power when horn button is

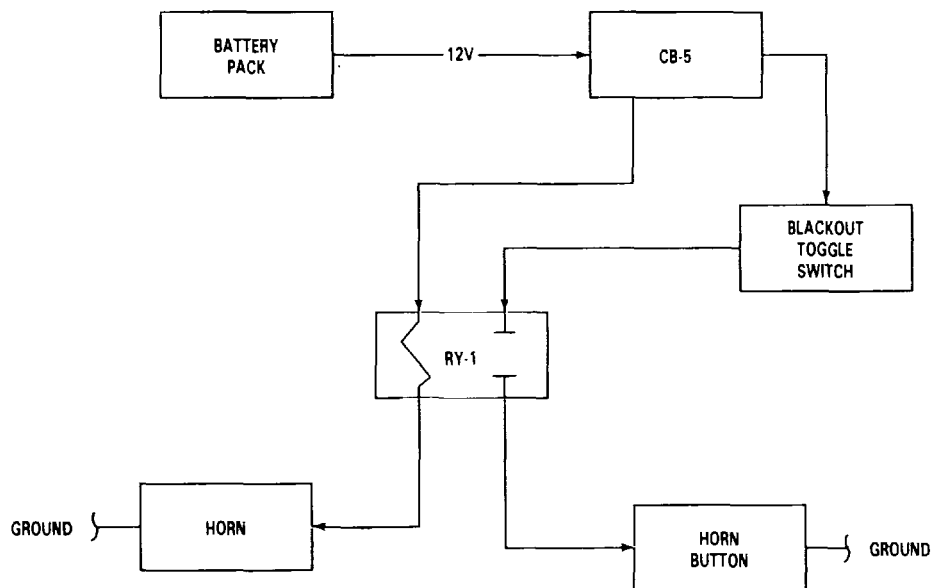

TA 236781

PRINCIPLES OF OPERATION.**1-15. ELECTRICAL SYSTEM (Continued).**g. Wiring.

The electrical wiring on the M915A1 vehicle is contained in braided or loomed harness assemblies. The wires are permanently hot-stamped with individual circuit numbers. The circuit numbers appear two inches from each termination end. Refer to Appendix D (TM 9-2320-283-20-3) for wiring harness drawings and wiring diagram for circuit numbers and terminations.

PRINCIPLES OF OPERATION.**1-16. TRANSMISSION.**

BATTERY PACK. Consists of four, 12-volt, maintenance free batteries. Two batteries are wired in parallel in each set. Each set is connected in series for 24-volt output. Battery pack is used for both 12-volt and 24-volt output.

IGNITION SWITCH. Supplies 24-volt power to relay (RY-9), which in turn provides 12-volt power to electrical system, including transmission.

RELAY (RY-9). Energized by 24-volt power from ignition switch. When energized, RY-9 supplies 12-volt power to circuit breaker (CB-2).

CIRCUIT BREAKER (CB-2). Protects electrical components of transmission oil temperature circuit when load exceeds 20 amperes. May be manually reset by pressing CB-2 button in.

TRANSMISSION OIL TEMPERATURE GAGE. Signal from sending unit actuates pointer gage, showing transmission oil temperature.

TACHOGRAPH. Receives signals from speedometer and tachometer cables and shows MPH, RPM, and miles driven. Also, records this data on 7-day disk pack. (Refer to para 3-309 for more information on tachograph disk pack).

TRANSMISSION OIL TEMPERATURE SENDING UNIT. Provides electrical signal to temperature gage for indicating transmission oil temperature.

PRINCIPLES OF OPERATION.

1-16. TRANSMISSION (Continued).

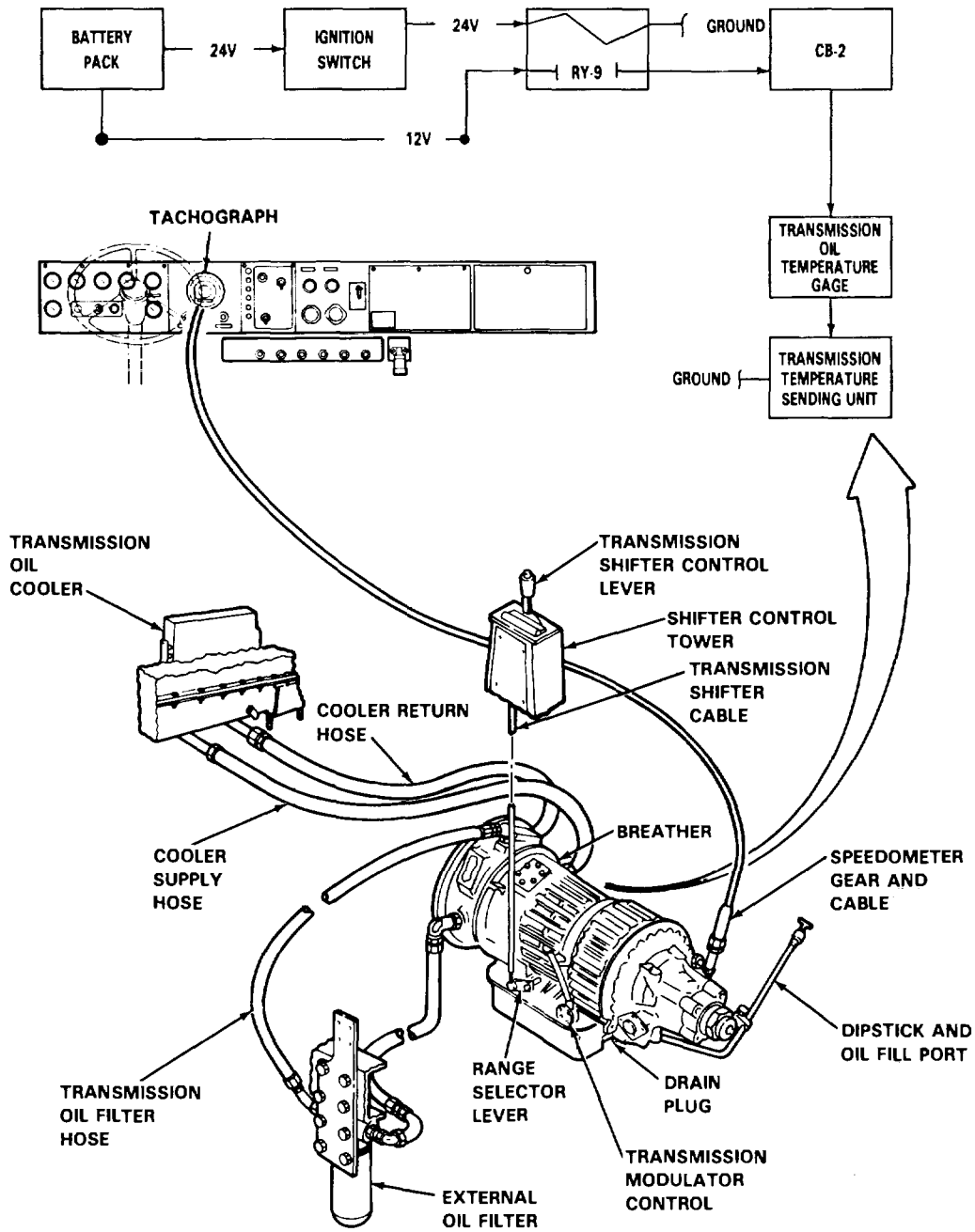

TA 236782

PRINCIPLES OF OPERATION.**1-16. TRANSMISSION (Continued).**

SPEEDOMETER GEAR AND CABLE. Provides engine speed input to tachograph.

DIPSTICK AND OIL FILL PORT. Used to inspect and replenish oil supply.

TRANSMISSION MODULATOR CONTROL. Receives mechanical signal from throttle lever and fuel pump. This signal determines transmission gear range setting.

DRAIN PLUG. Provides access for draining oil. Has magnetic base to attract foreign particles in oil, an early warning of unusual wear of internal parts.

TRANSMISSION SHIFT CONTROL LEVER. Receives mechanical signal from shifter cable and internally sets transmission gear range.

TRANSMISSION TO OIL FILTER HOSE(S). Carry oil between transmission and external oil filter.

EXTERNAL OIL FILTER. Spin-on type element used to remove dirt and foreign particles from transmission oil.

COOLER SUPPLY HOSE. Carries hot oil from transmission to cooler.

COOLER RETURN HOSE. Carries cooled oil from cooler back to transmission.

TRANSMISSION OIL COOLER. Receives hot oil from the transmission through the supply hose, circulates the oil through air cooled fins, and sends cooled oil back to transmission through return hose.

TRANSMISSION SHIFTER CONTROL LEVER. Allows operator to select desired transmission gear range. (Refer to TM 9-2320-283-10).

TRANSMISSION SHIFTER CONTROL TOWER. Floor mounted. Used to house transmission range shifter control.

TRANSMISSION SHIFTER CABLE. Mechanically transmits signal from transmission shifter control tower to transmission range selector lever.

BREATHER. Prevents air pressure build-up in case.

PRINCIPLES OF OPERATION.

1-16. TRANSMISSION (Continued).

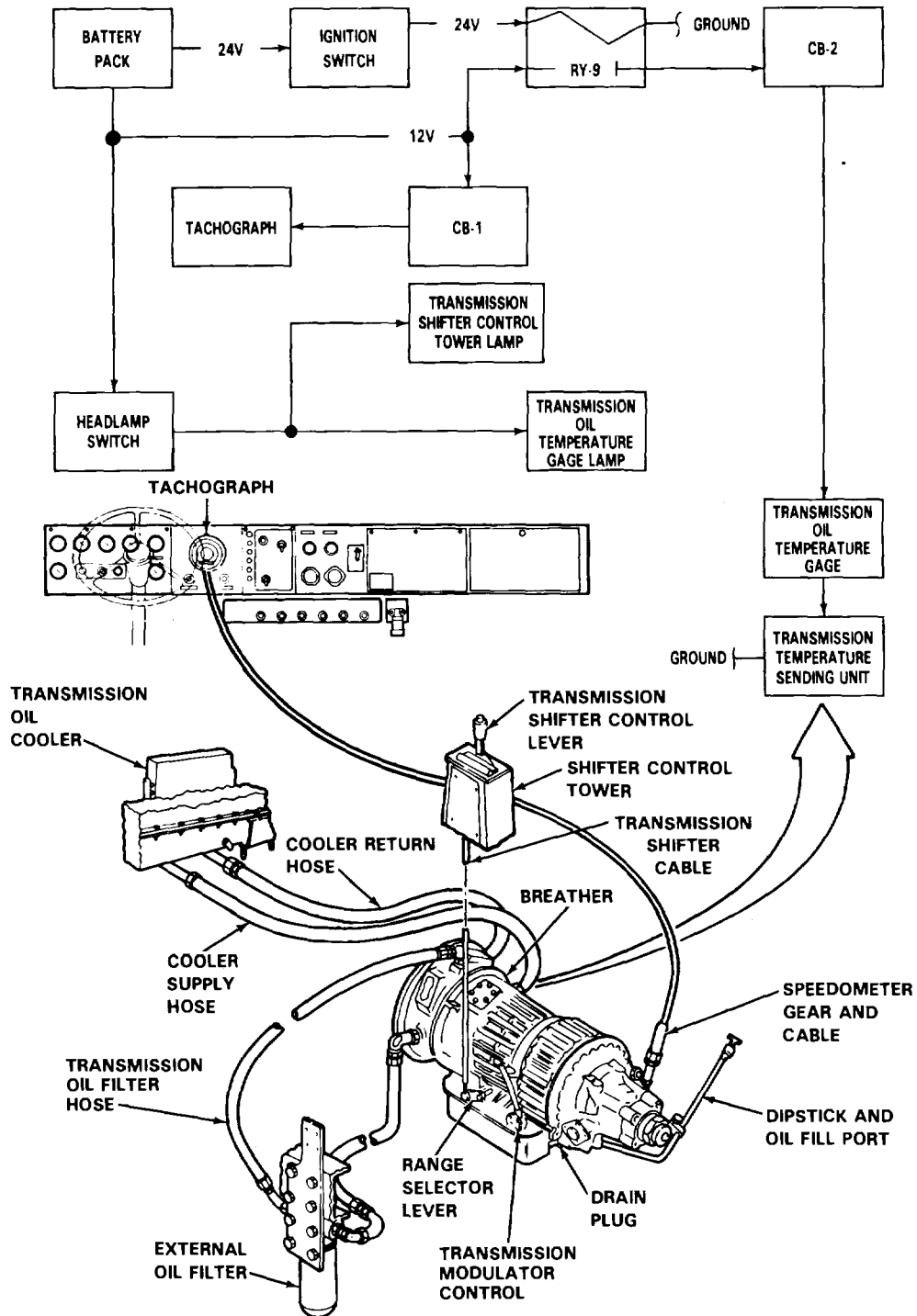

TA 236783

PRINCIPLES OF OPERATION.**1-17. FRONT AXLE AND SUSPENSION.**

LEAF SPRINGS. Absorb and minimize amount of road shock transmitted to vehicle frame.

SHACKLE. Swinging support that permits leaf spring to vary in length as it is deflected.

BRAKE AIR CHAMBER. Pressure is supplied to chambers from air system to mechanically actuate brake mechanism. (Refer to brake system, para 1-20c).

KNUCKLE AND KINGPIN ASSEMBLY. Moveable joint between the wheel and axle I-beam.

DRUM. Houses wheel brakes. Serves as mount for front wheels.

STEERING ARM. Connects to power steering drag link. (Refer to para 1-22).

TIE ROD ASSEMBLY. Connects left and right knuckles for synchronized movement of both wheels.

SHOCK ABSORBERS. Supplement spring and stabilize spring fluctuations caused

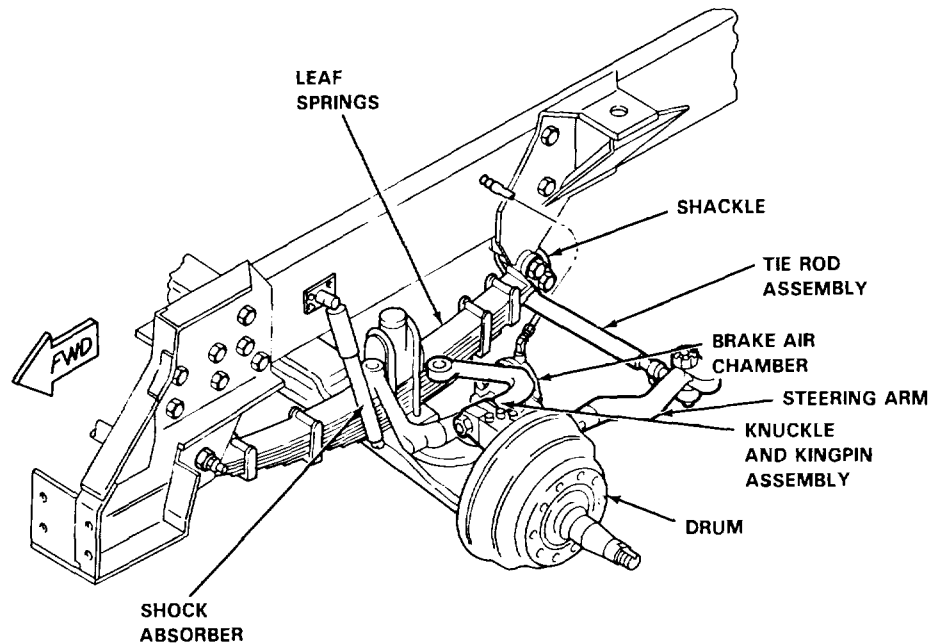

TA 236784

PRINCIPLES OF OPERATION.

1-18. REAR TANDEM AXLES.

a. Rear Tandem Axle Components.

HUB AND DRUM ASSEMBLY. Serves as mount for rear wheels. Houses brake shoe assemblies which can be mechanically forced against it to slow or stop vehicle.

FILLER PLUG. Used to inspect oil level and replenish oil supply.

AXLE SHAFT. Located inside axle housing. Transmits power from differential gear assembly to hub assembly.

INTERAXLE PROPELLER SHAFT. Transmits power to rear-rear axle.

BREATHER. Allows fumes from hot oil to escape.

PINION YOKE. Connects to propeller shaft from transmission.

MAGNETIC STRAINER. Keeps lubrication system clean. Magnet traps small particles and screen blocks out large particles of foreign material.

DIFFERENTIAL LOCKOUT CHAMBER Air actuated by lockout switch located in cab interior. (Refer to para 1-18b for description).

DRAIN PLUG. Allows draining oil at service intervals.

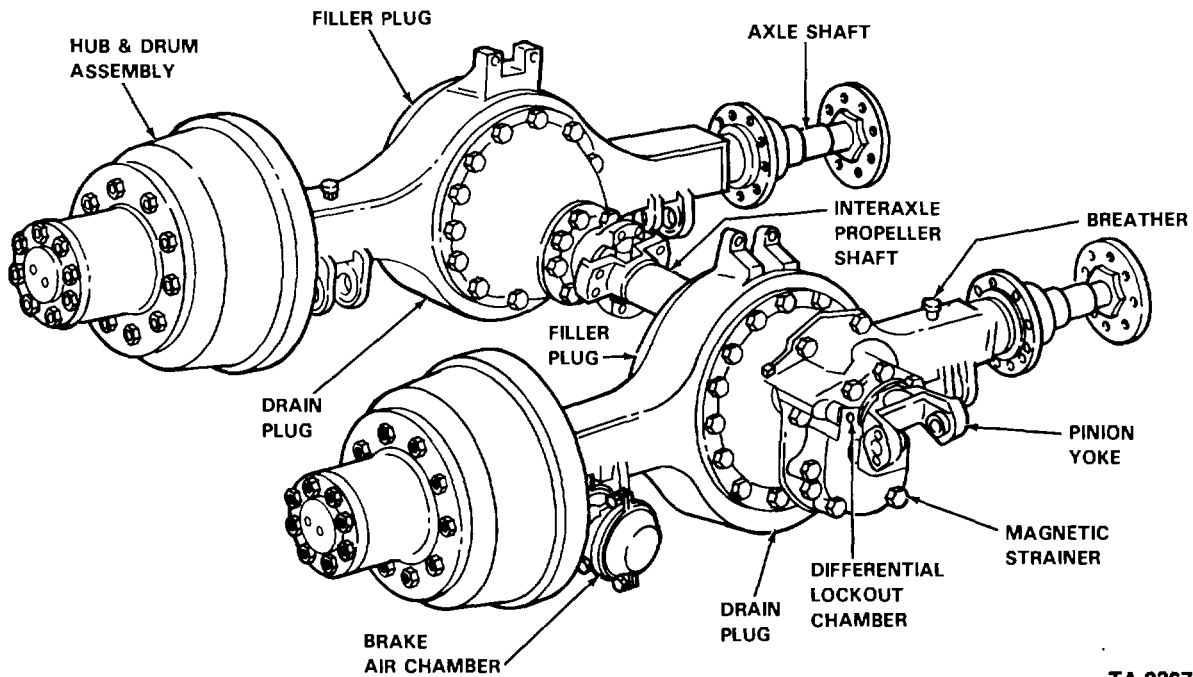

TA 236785

PRINCIPLES OF OPERATION.**1-18. REAR TANDEM AXLES (Continued).****b. Rear Tandem Axle Differential Lockout.**

Activating the differential lockout control locks the interaxle differential, thereby connecting the transmission and both front and rear tandem axles solidly together.

The forward-rear tandem axle is equipped with a NO-SPINE differential which automatically locks, eliminating differential action independent of manual control. At least three wheels on the rear tandem must turn when the interaxle differential lock is engaged.

BATTERY PACK. Consists of four, 12-volt, maintenance free batteries. Two batteries are wired in parallel in each set. Each set is connected in series for 24-volt output. Battery pack is used for both 12-volt and 24-volt output.

IGNITION SWITCH. Supplies 24-volt power to relay (RY-9), which in turn provides 12-volt power to electrical system, including differential lockout indicator circuit.

RELAY (RY-9). Energized by 24-volt power from ignition switch. When energized, RY-9 supplies 12-volt power to circuit breaker (CB-2).

LOCKOUT INDICATOR. Illuminates when lockout switch is closed.

CIRCUIT BREAKER (CB-2). Protects electrical components of differential lockout circuit by opening when load exceeds 20 amperes. May be manually reset by pressing CB-2 button in.

AIR MANIFOLD. Routes air from reservoir to control valve.

LOCKOUT CHAMBER. When air pressure is applied, chamber mechanically locks rear axle differential in place so that drive is applied to both rear axles. Without air pressure, differential applies drive to axle that offers least resistance.

CONTROL VALVE. When engaged, air pressure is applied to lockout rear differential action.

LOCKOUT SWITCH. Normally open. Closed by 60 psi air pressure to activate lockout indicator circuit.

PRINCIPLES OF OPERATION.

1-18. REAR TANDEM AXLES (Continued).

b. Rear Tandem Axle Differential Lockout.

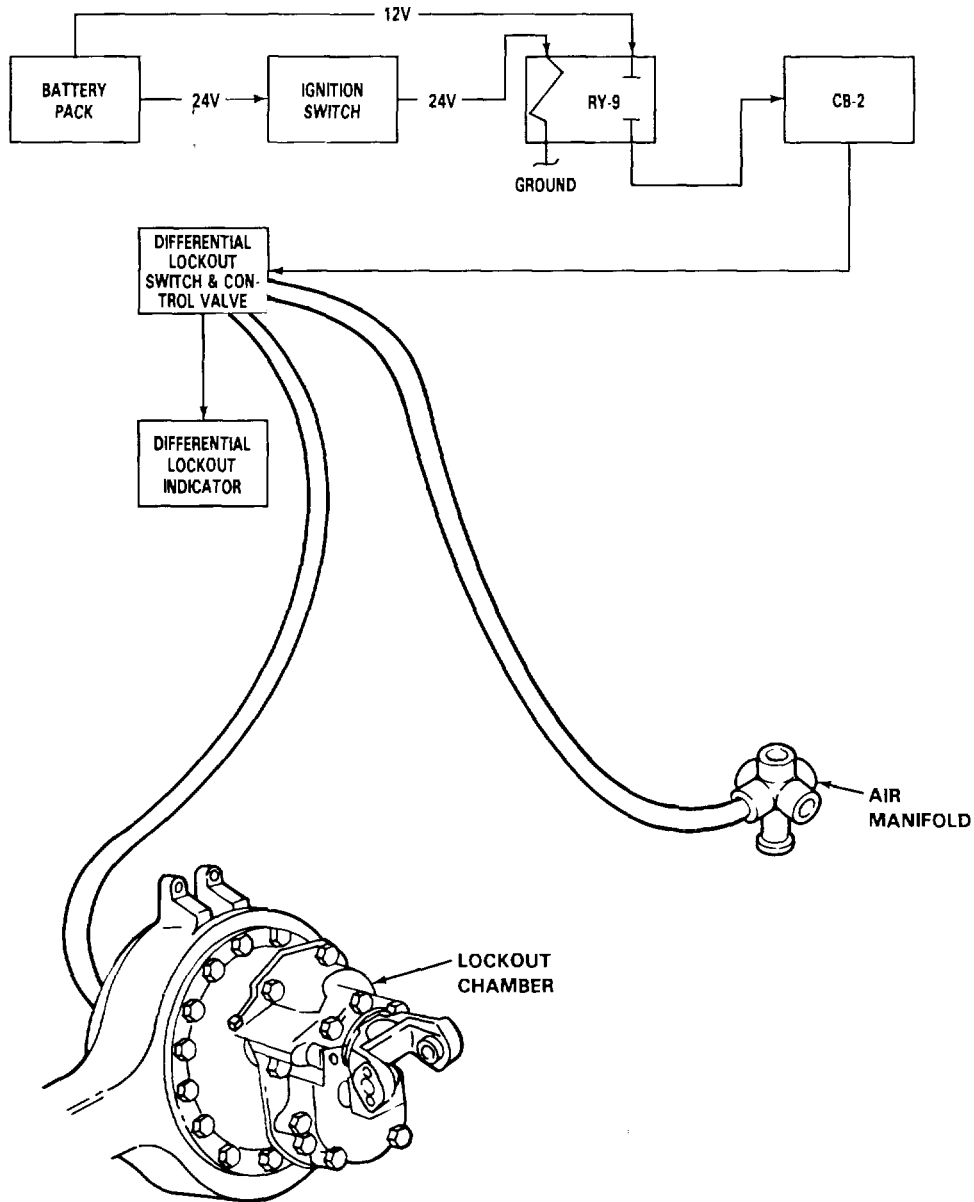

TA 236786

PRINCIPLES OF OPERATION.**1-19. COMPRESSED AIR SYSTEM.**

This paragraph provides information on components of the compressed air system. For information on the brake system, refer to paragraph 1-20. For information on the auxiliary air-powered systems, refer to paragraph 1-21. For a complete air system diagram, refer to Appendix D (TM 9-2320-283-20-3).

ACCESSORY DRIVE. Driven by camshaft gear. Provides power to operate air compressor.

AIR COMPRESSOR. Draws air from air aftercooler, compresses it, and directs it to the air dryer.

AIR COMPRESSOR GOVERNOR. Opens unloading valve to prevent further air compression when air pressure reaches 125 psi. Closes unloading valve to begin air compression when air pressure falls below 100 psi.

CHECK VALVE(S). One way valve(s) prevent air from flowing out of primary or secondary reservoirs back to supply reservoir.

PRIMARY RESERVOIR. Receives compressed air from supply reservoir and stores it for use in brake system. (Refer to para 1-20).

DRAINCOCK(S). Used to drain compressed air and moisture from primary, secondary, and supply reservoirs.

QUICK DISCONNECT COUPLER. Used in conjunction with tire inflation air hose and chuck.

AUTOMATIC DRAIN VALVE. Automatically ejects moisture and contaminants from supply tank. Each time brake is applied, a pressure drop occurs in the supply tank, causing drain valve to open momentarily.

AIR DRYER. Collects and removes moisture and contaminants before air reaches supply reservoir. Provides "dry air" for air brake system.

SUPPLY RESERVOIR. Receives compressed air from air dryer and supplies it to primary and secondary reservoirs.

SAFETY VALVE. Vents air when pressure in supply tank rises above 150 psi.

SINGLE CHECK VALVE. One-way check valve prevents air from flowing out of supply reservoir back to air compressor.

DOUBLE CHECK VALVE. One-way check valve prevents air from flowing out of primary reservoir or air manifold back to secondary reservoir.

SECONDARY RESERVOIR. Receives compressed air from supply reservoir and supplies it to auxiliary air-powered systems and brake system.

PRINCIPLES OF OPERATION.

1-19. COMPRESSED AIR SYSTEM (Continued).

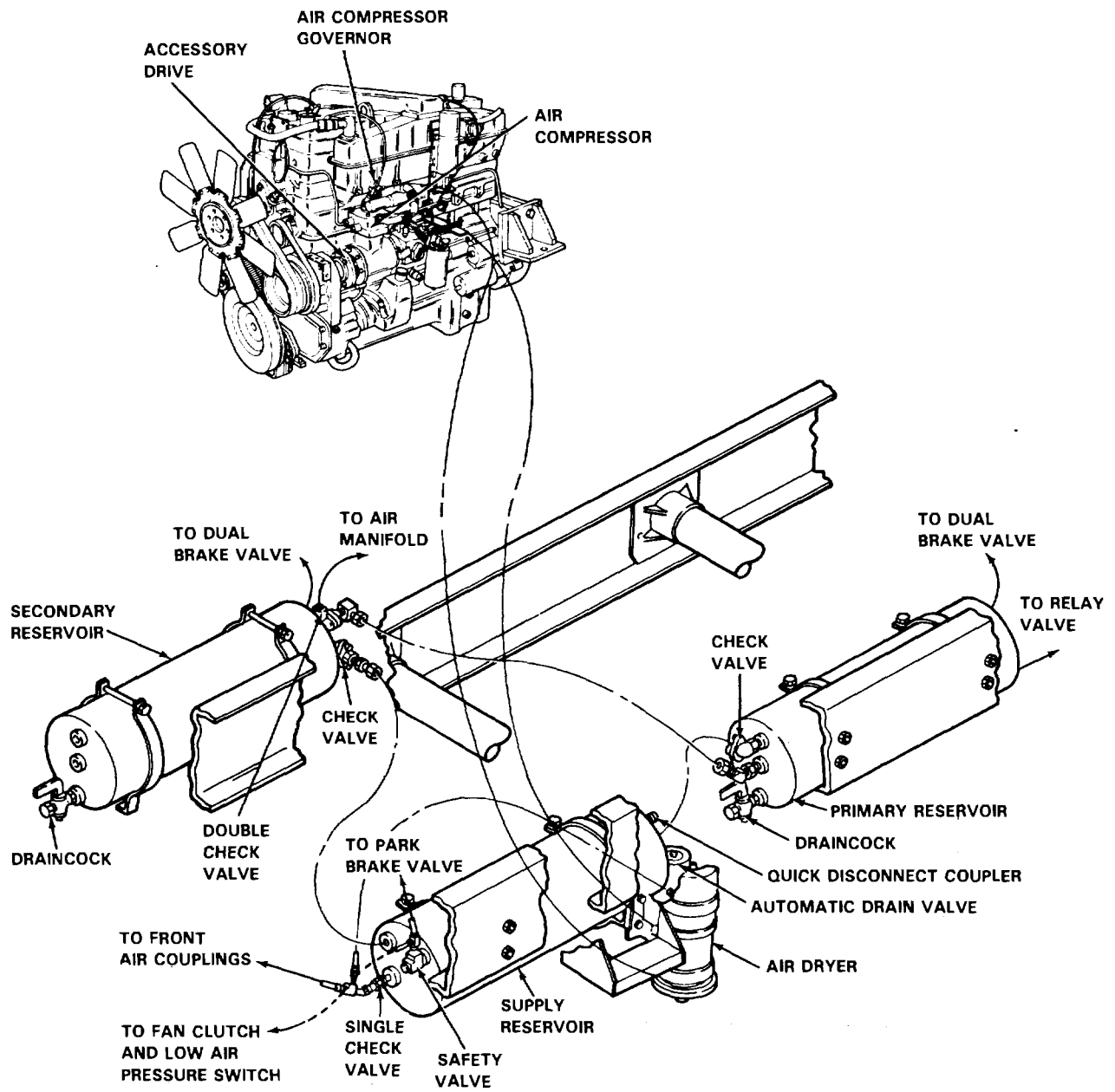

TA 236787

PRINCIPLES OF OPERATION.

1-20. BRAKE SYSTEM.

a. Air Brake System Arrangement.

NOTE

The components shown below are described in paragraphs 1-19 and 1-20.

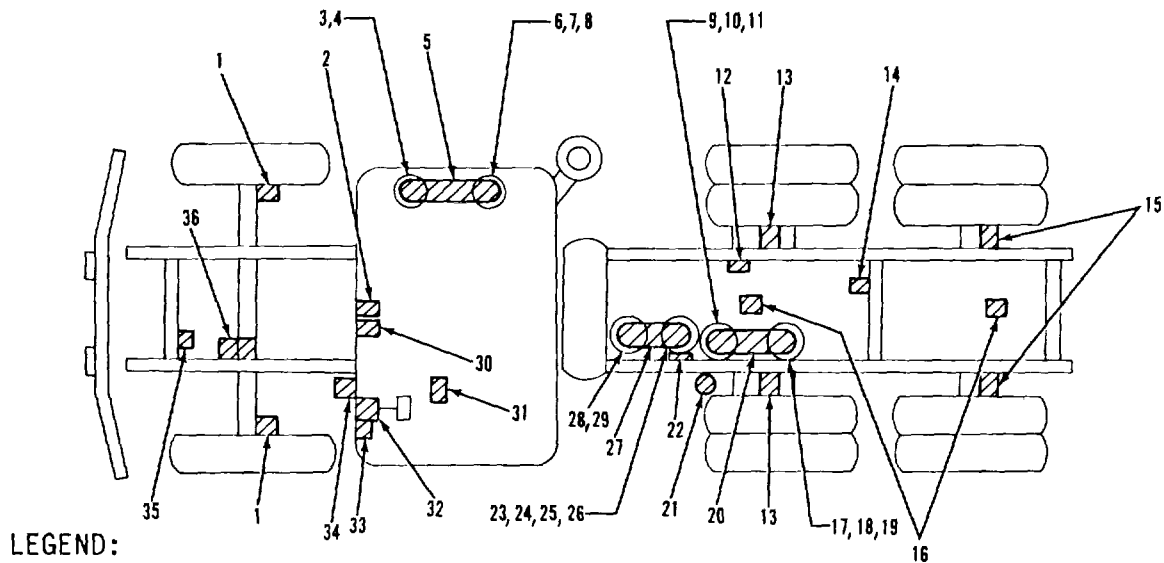

- | | |
|---|--|
| <p>1. FRONT AXLE BRAKE CHAMBER (2) (para 1-20b)</p> <p>2. PARKING BRAKE VALVE (para 1-20b)</p> <p>3. DRAINCOCK (para 1-19)</p> <p>4. PLUG (2)</p> <p>5. SECONDARY RESERVOIR (para 1-19)</p> <p>6. DOUBLE CHECK VALVE (para 1-19)</p> <p>7. 90° CHECK VALVE (para 1-19)</p> <p>8. 90° ELBOW</p> <p>9. DRAINCOCK (para 1-19)</p> <p>10. 45° ELBOW</p> <p>11. 45° CHECK VALVE (para 1-19)</p> <p>12. DOUBLE CHECK AND QUICK RELEASE VALVE (para 1-20b)</p> <p>13. FORWARD-REAR AXLE BRAKE CHAMBER (2) (para 1-20b)</p> <p>14. RELAY VALVE (para 1-20b)</p> <p>15. REAR-REAR AXLE AIR BRAKE CHAMBER (2) (para 1-20b)</p> <p>16. QUICK RELEASE VALVE (2) (para 1-20b)</p> <p>17. ADAPTER</p> | <p>18. 90° ELBOW</p> <p>19. PLUG</p> <p>20. PRIMARY RESERVOIR (para 1-19)</p> <p>21. AIR DRYER (para 1-19)</p> <p>22. TRACTOR PROTECTION VALVE (para 1-20b)</p> <p>23. AUTOMATIC DRAIN VALVE (para 1-19)</p> <p>24. 90° ELBOW</p> <p>25. QUICK RELEASE COUPLER (para 1-19)</p> <p>26. SAFETY VALVE (para 1-19)</p> <p>27. SUPPLY RESERVOIR (para 1-19)</p> <p>28. 90° ELBOW (2)</p> <p>29. CHECK VALVE (para 1-19)</p> <p>30. TRAILER SUPPLY VALVE (para 1-19)</p> <p>31. TRAILER HAND CONTROL BRAKE VALVE (para 1-20b)</p> <p>32. BRAKE TREADLE VALVE (para 1-20b)</p> <p>33. DOUBLE CHECK VALVE (para 1-20b)</p> <p>34. DOUBLE CHECK AND STOPLAMP VALVE (para 1-20b)</p> <p>35. FRONT AXLE RATIO VALVE (para 1-20b)</p> <p>36. AIR COMPRESSOR/GOVERNOR (para 1-19)</p> |
|---|--|

TA 236788

PRINCIPLES OF OPERATION.**1-20. BRAKE SYSTEM (Continued).****b. Brake System Components.**

This subparagraph describes and illustrates the following components:

- (1) S-Type Cam Brake
- (2) Slack Adjuster
- (3) Front Axle Air Brake Chamber
- (4) Forward-Rear Axle Brake Chamber
- (5) Rear-Rear Axle Brake Chamber
- (6) Brake Treadle Valve
- (7) Parking Brake Valve
- (8) Trailer Hand Control Brake Valve
- (9) Trailer Supply Valve
- (10) Front Axle Ratio Valve
- (11) Double Check and Stoplamp Valve
- (12) Double Check Valve
- (13) Tractor Protection Valve
- (14) Double Check and Quick Release Valve
- (15) Quick Release Valve
- (16) Relay Valve

PRINCIPLES OF OPERATION.

1-20. BRAKE SYSTEM (Continued).

b. Brake System Components (Continued).

(1) S-Type Cam Brakes.

Used on all axles. Brake shoes are forced against brake drum when cam is rotated by slack adjuster arm.

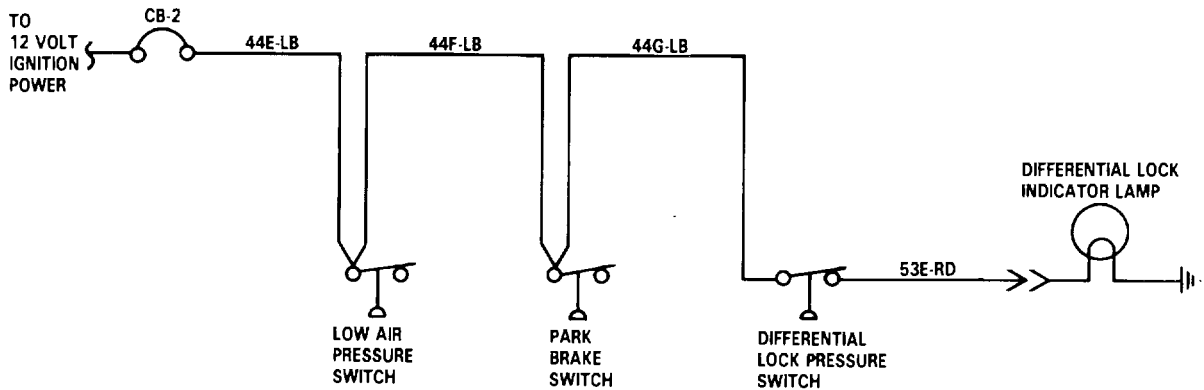

(2) Slack Adjuster.

Converts linear force of brake chamber push rod into a torque which turns brake camshaft and applies brakes.

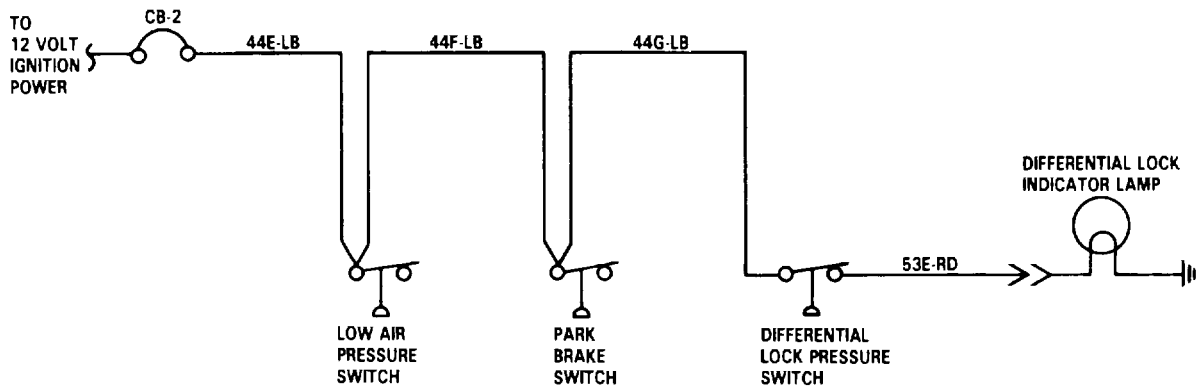

TA 236789

PRINCIPLES OF OPERATION.

1-20. BRAKE SYSTEM (Continued).

b. Brake System Components (Continued).

(3) Front-Axle Air Brake Chamber.

Receives compressed air from ratio valve to mechanically rotate slack adjuster.

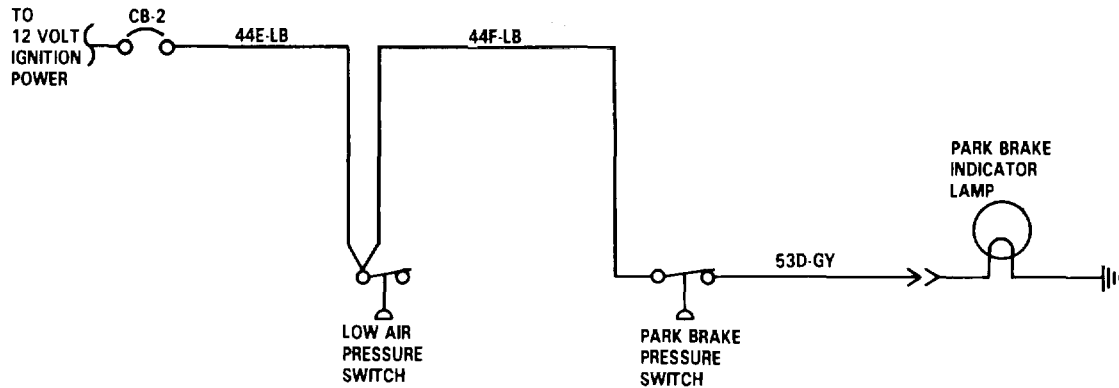

(4) Forward-Rear Axle Brake Chamber.

Receives compressed air from double check and quick release valve to mechanically rotate slack adjuster. Spring loaded chamber rotates slack adjuster (and applies brakes) when air pressure drops due to one of the following:

- (a) Compressed air system failure.
- (b) Application of park brakes.
- (c) Air system draining.

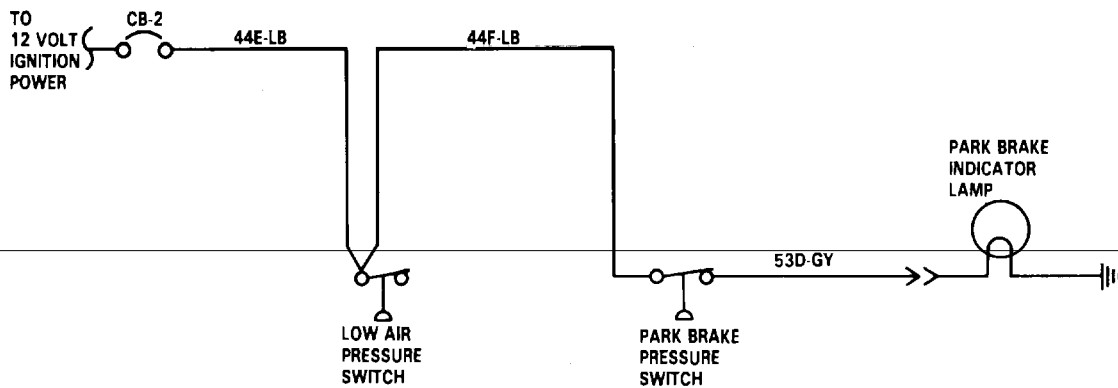

PRINCIPLES OF OPERATION.

1-20. BRAKE SYSTEM (Continued).

b. Brake System Components (Continued).

(5) Rear-Rear Axle Brake Chamber.

Receives compressed air from quick release valve to mechanically rotate slack adjuster.

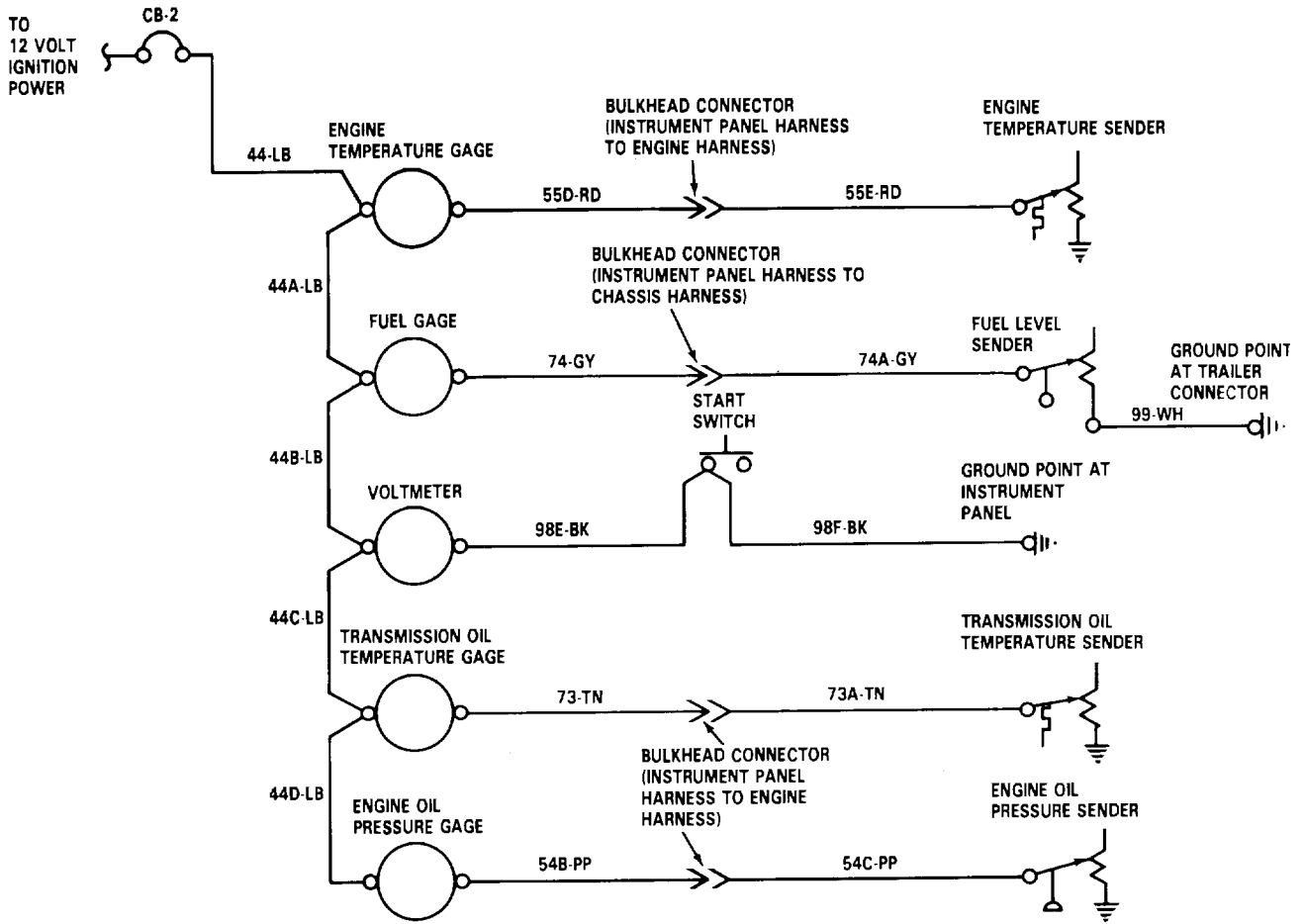

(6) Brake Treadle Valve.

Supplies air to front and rear service brakes at the same time when brake pedal is pushed

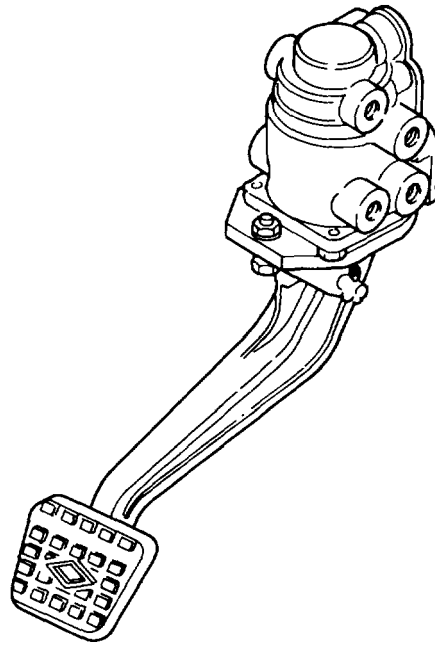

TA 236791

PRINCIPLES OF OPERATION.**1-20. BRAKE SYSTEM (Continued).****b. Brake System Components (Continued).****(7) Parking Brake Valve.**

Normally supplies air pressure holding spring brakes in compressed position. When knob is pulled out, air pressure is exhausted, allowing spring brakes to apply.

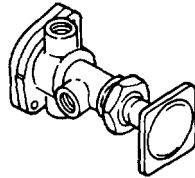
**(8) Trailer Hand Control Brake Valve.**

Applies trailer brakes only. Opens connections between air supply reservoir and trailer service brake lines as handle is turned clockwise.

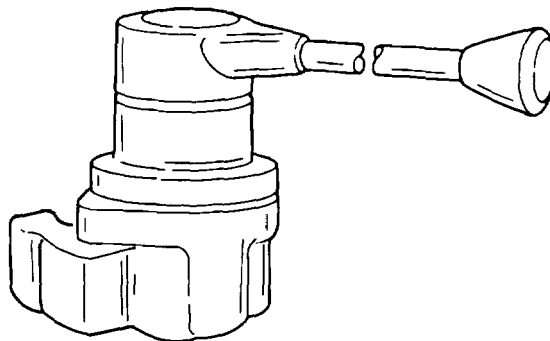

TA 236792

PRINCIPLES OF OPERATION.**1-20. BRAKE SYSTEM (Continued).****b. Brake System Components (Continued).****(9) Trailer Supply Valve.**

In applied position, supplies air pressure to trailer service and emergency air lines.

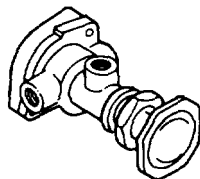
**(10) Front Axle Ratio Valve.**

Directs air pressure from a single incoming line to brakes on both ends of the front axle. Limits brake application pressure to actuators during normal service braking.

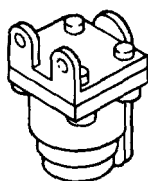

TA 236793

PRINCIPLES OF OPERATION.**1-20. BRAKE SYSTEM (Continued).****b. Brake System Components (Continued).****(11) Double Check and Stoplamp Valve.**

Directs air flow from two ports of brake treadle valve into a single outlet line leading to the tractor protection valve. Does not allow air pressure to flow back into brake treadle valve. Stoplamps are switched on when this valve is actuated.

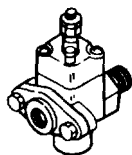
**(12) Double Check Valve.**

Directs air flow from brake treadle valve and front gladhands into tractor protection valve. Does not allow air pressure to flow back into brake treadle valve or front gladhands.

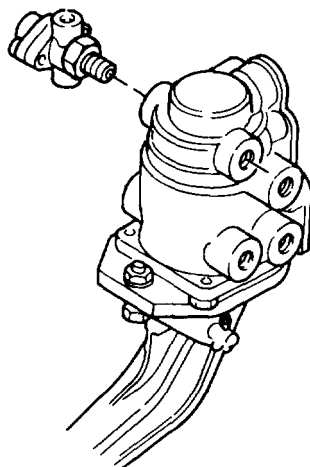

TA 236794

PRINCIPLES OF OPERATION.**1-20. BRAKE SYSTEM (Continued).****b. Brake System Components (Continued).****(13) Tractor Protection Valve.**

Directs air pressure from brake treadle valve or trailer supply valve to rear gladhands and couplings

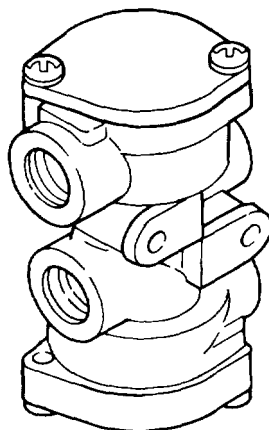
**(14) Double Check and Quick Release Valve.**

Primarily functions as an exhaust valve for the spring chamber of the forward-rear axle brake valve. Also prevents service and emergency brake application from occurring at the same time.

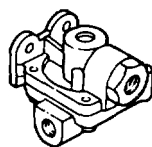

TA 236795

PRINCIPLES OF OPERATION.**1-20. BRAKE SYSTEM (Continued).****b. Brake System Components (Continued).****(15) Quick Release Valve.**

Speeds up exhaust of air from rear-axle brake chambers when operator releases brakes.

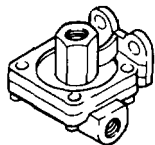
**(16) Relay Valve.**

Applies rear brakes faster and more firmly than if they were actuated directly by air pressure in control lines from cab brake valves.

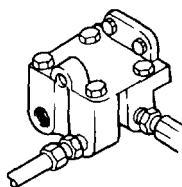

TA 236796

PRINCIPLES OF OPERATION.**1-20. BRAKE SYSTEM (Continued).****c. Brake System Switches and Lamps.**

BATTERY PACK. Consists of four, 12-volt, maintenance free batteries. Two batteries are wired in parallel in each set. Each set is connected in series for 24-volt output. Battery pack is used for both 12-volt and 24-volt output.

IGNITION SWITCH. Supplies 24-volt to relay (RY-9), which in turn provides 12-volt power to electrical system, including brake system switch and indicator circuits.

RELAY (RY-9). Energized by 24-volt power from ignition switch. When energized, RY-9 supplies 12-volt power to circuit breaker (CB-2).

CIRCUIT BREAKER (CB-1). Protects electrical components of stoplamp circuit by opening when load exceeds 20 amperes. May be manually reset by pressing CB-1 button in.

CIRCUIT BREAKER (CB-2). Protects electrical components of stoplamp circuit by opening when load exceeds 20 amperes. May be manually reset by pressing CB-2 button in.

CIRCUIT BREAKER (CB-8). Protects electrical components of 24-volt trailer brake system relay circuit by opening when load exceeds 20 amperes. May be manually reset by pressing CB-8 button in.

CIRCUIT BREAKER (CB-9). Protects electrical components of 24-volt trailer brake system relay circuit by opening when load exceeds 20 amperes. May be manually reset by pressing CB-9 button in.

PARK BRAKE LAMP. Illuminates when park brakes are applied. Receives 12-volt power through circuit breaker CB-2 when parking brake switch is closed.

PARK BRAKE SWITCH. Normally open, air actuated switch, located on parking brake. Closes to energize park brake lamp when parking brakes are actuated.

STOPLAMP SWITCH. Normally open air actuated switch. Closes when brakes are actuated. Receives 12-volt power from circuit breaker CB-1 and supplies this power to blackout toggle switch.

BLACKOUT TOGGLE SWITCH. Two-position switch for NORMAL and BLACKOUT modes of operation. 12-volt power is received from closed stoplamp switch and circuit breaker CB-1. With switch set to NORMAL position, 12-volt power is supplied through turn signal switch to tractor taillamps-stoplamps. Also, 12-volt power is supplied to 12-volt trailer connector. With switch set to BLACKOUT position, 12-volt power is supplied to blackout stoplamps.

PRINCIPLES OF OPERATION.

1-20. BRAKE SYSTEM (Continued).

c. Brake System Switches and Lamps (Continued).

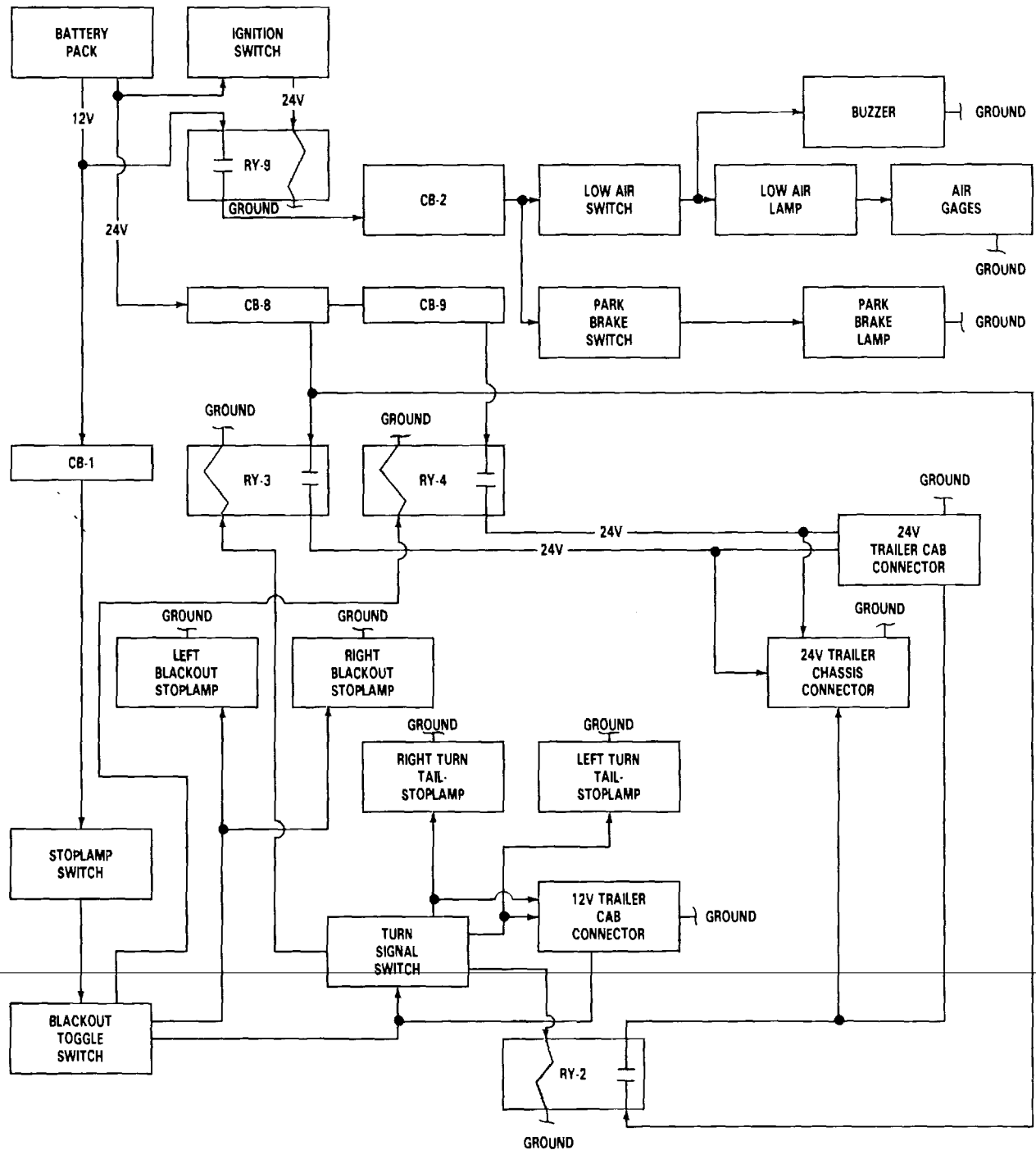

TA 236797

PRINCIPLES OF OPERATION.**1-20. BRAKE SYSTEM (Continued).****c. Brake System Switches and Lamps (Continued).**

TAILLAMPS-STOPLAMPS. Each assembly contains two bulbs: a single-filament bulb for the backup lamp; and a two-filament bulb for the taillamp, turn signal lamp, and stoplamp. Receive 12-volt power through circuit breaker CB-1, closed stoplamp switch, closed contacts of blackout toggle switch, and turn signal switch.

12-VOLT TRAILER CONNECTOR. When stoplamp switch is closed and blackout toggle switch is in NORMAL position, 12-volt power is supplied to tractor mounted connector for trailer stoplamps.

REAR AIR PRESSURE GAGE. Direct pressure gage indicates air pressure in rear service reservoir.

LOW AIR PRESSURE WARNING

INDICATOR (12-volt). Circuit normally held open by air pressure. Closes to activate control panel indicator when pressure drops below 70 psi.

FRONT AIR PRESSURE GAGE. Direct pressure gage. Indicates air pressure in front service reservoir.

24-VOLT TRAILER CONNECTOR. Cab mounted 12-pin connector to provide 24-volt power to trailers.

24-VOLT TRAILER CONNECTOR. Chassis mounted 12-pin connector to provide 24-volt power to trailer stoplamps.

RELAY (RY-2). When normally open contacts are closed, relay provides 24-volt power to trailer left turn signal lamp.

RELAY (RY-3). When normally open contacts are closed, relay provides 24-volt power to trailer right turn signal lamp.

RELAY (RY-4). When normally open contacts are closed, relay provides 24-volt power to trailer blackout stoplamp.

TURN SIGNAL CONTROL. Receives 12-volt power from blackout toggle switch and distributes 12-volt power to right and left taillamps-stoplamps, 12-volt trailer connector, and relay (RY-3).

PRINCIPLES OF OPERATION.

1-20. BRAKE SYSTEM (Continued).

c. Brake System Switches and Lamps (Continued).

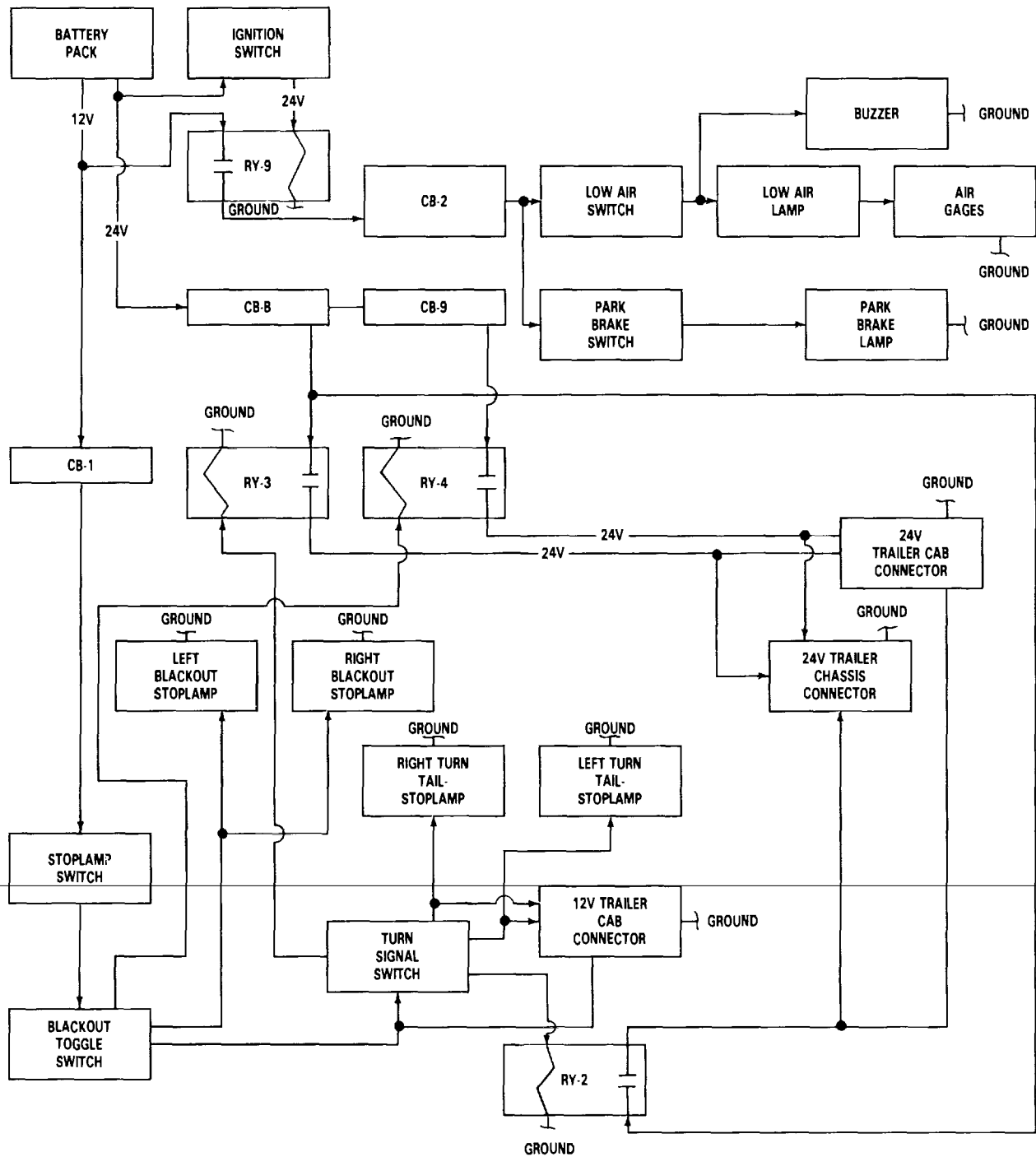

TA 236798

PRINCIPLES OF OPERATION.**1-21. AUXILIARY AIR-POWERED SYSTEMS.****a. Windshield Wipers and Washers.**

WIPER CONTROL VALVE. In OFF position, valve directs air from supply line to park line. When pulled out, it diverts air to wiper line. By turning clockwise (LOW) or counterclockwise (HIGH), desired speed is selected. To park wipers, turn valve to center position and push in.

WASHER CONTROL VALVE. When button is pushed, air flows from manifold to reservoir.

WIPER SUPPLY LINE. Carries air for wiper system from manifold to control knob.

WASHER AIR SUPPLY LINE. Carries air from manifold to control button.

COMPRESSED AIR SUPPLY MANIFOLD. Supplies compressed air to washer and wiper through supply lines.

WIPER ARM. Connects wiper blade to linkage. Moved by motor.

WIPER BLADE. Actuated by wiper arm to clear windshield of water.

RESERVOIR FILLER CAP. Filter underneath cap prevents dirt from entering system. Cap closes firmly to maintain pressure in system.

WASHER FLUID RESERVOIR. Holds supply of washer fluid.

RESERVOIR AIR LINE. Carries pressurized air from button to reservoir when pressure forces fluid into washer hose.

PARK AIR LINE. When knob is pushed into PARK position, air flows through park line to motor, causing wiper blades to move down to REST position.

WIPER AIR LINE. When knob is in WIPE position, air flows through wiper line to motor, starting wiper blades in motion.

WIPER MOTOR. Air-powered motor turns wipers back and forth when air comes from wiper line, or moves them down windshield to PARK position when air comes through park line.

WIPER LINKAGE. Linkage from motor actuates two wiper arms.

PRINCIPLES OF OPERATION.

1-21. AUXILIARY AIR-POWERED SYSTEMS.

a. Windshield Wipers and Washers Continued

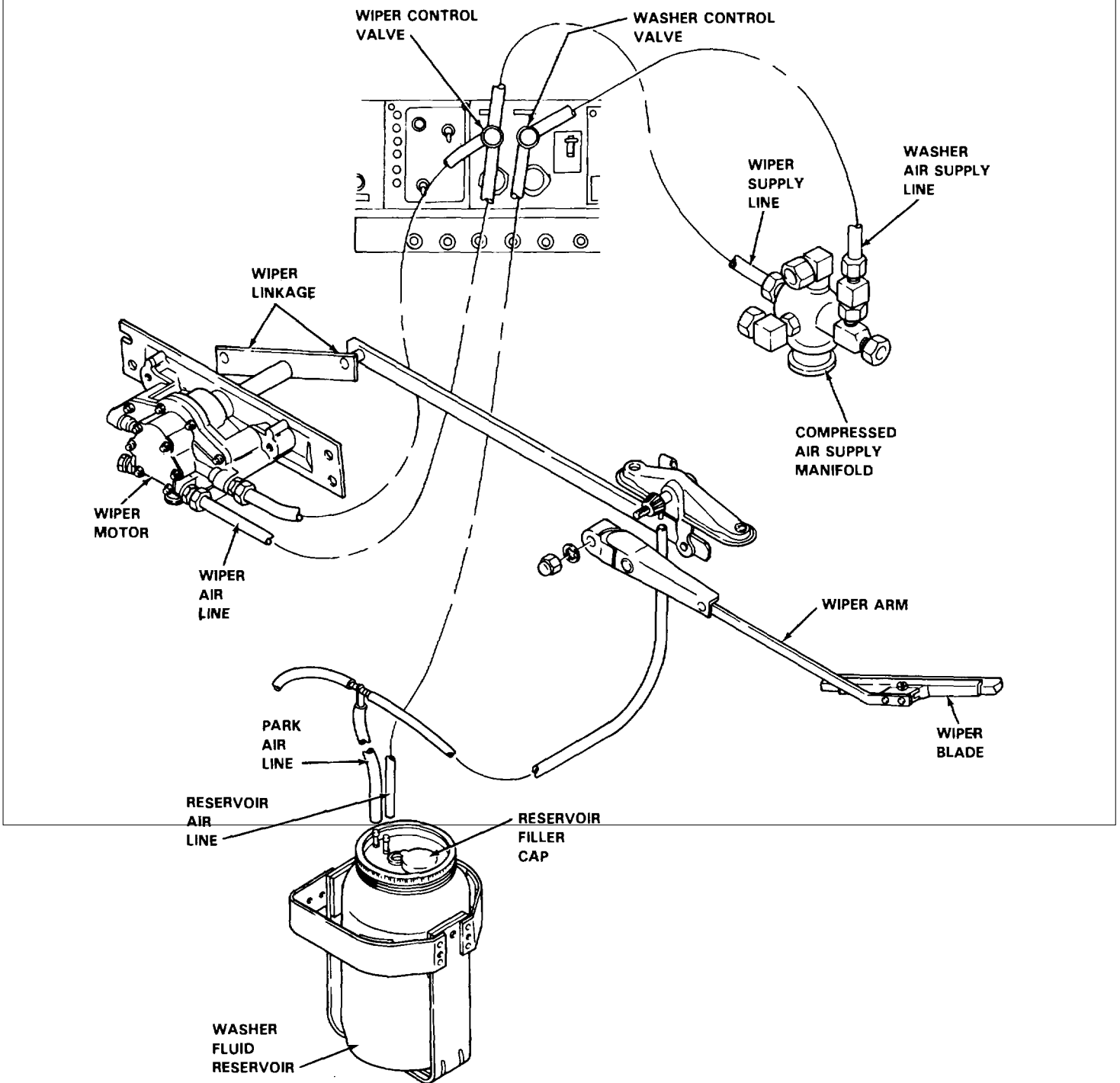

PRINCIPLES OF OPERATION.**1-21. AUXILIARY AIR-POWERED SYSTEMS.****b. Air Horn**

AIR HORN. Air-powered signaling device.

LEVER. Actuates control valve when pulling chain in cab downward.

CONTROL VALVE. Allows compressed air to flow to horn when lever is pulled downward.

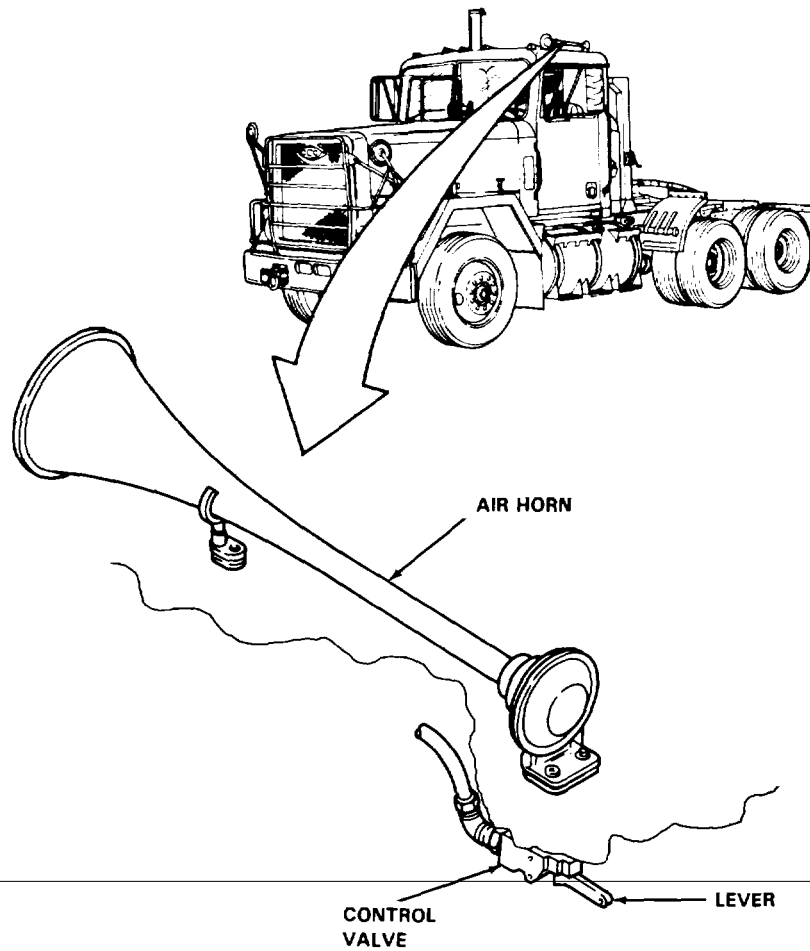

TA 236800

PRINCIPLES OF OPERATION.**1-21. AUXILIARY AIR-POWERED SYSTEMS.****c. Fan Clutch Controls**

FAN CLUTCH. When actuator opens, compressed air from primary reservoir engages clutch to actuate fan.

FAN CLUTCH ACTUATOR. Opens air connection between primary reservoir and fan clutch when coolant temperature rises above 190°F.

PRIMARY RESERVOIR. Supplies air pressure to engage clutch and rotate fan when actuator opens air connection.

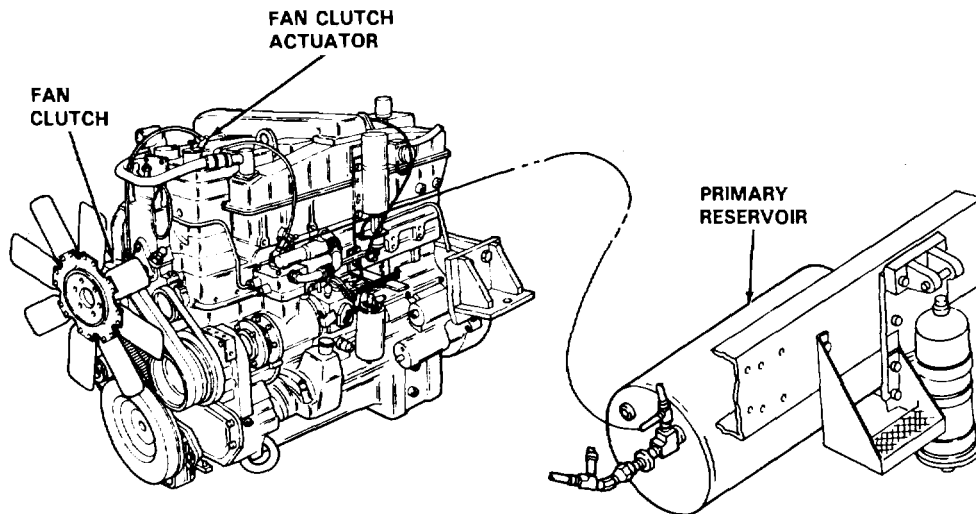

TA 236801

PRINCIPLES OF OPERATION.**1-22. STEERING SYSTEM.**

POWER STEERING COOLER. Cools power steering fluid by means of a finned unit on vehicle grille, exposed to outside air. After the fluid is cooled, it is returned to the power steering system.

STEERING COOLER RETURN LINE. Carries hydraulic fluid from power steering cooler back to reservoir.

STEERING GEAR SUPPLY LINE. Carries hydraulic fluid under pressure from pump to steering gear.

HYDRAULIC PUMP AND RESERVOIR. Pump supplies hydraulic pressure to power steering system. Reservoir provides a supply of oil to assure complete filling of hydraulic system.

STEERING WHEEL. Provides rotational torque to steering shaft, actuating steering system.

STEERING COLUMNS. Transmit torque from steering wheel to steering gear.

UNIVERSAL JOINTS. Change angle of torque from steering wheel and applies it to input shaft of power steering gear.

TIE ROD ASSEMBLY. Connects steering arms so that wheels turn together.

STEERING ARM. Transmits forward and backward movement from drag link to knuckle assembly.

DRAG LINK. Transfers motion of pitman arm to steering arm and tie rod.

PITMAN ARM. Transfers steering torque (boosted by power steering gear) to drag link.

POWER STEERING GEAR. Hydraulically multiplies input torque from steering column and transmits it to pitman arm.

STEERING COOLER SUPPLY LINE. Carries hydraulic fluid from steering gear to power steering cooler.

TA 236802

PRINCIPLES OF OPERATION.

1-22. STEERING SYSTEM.

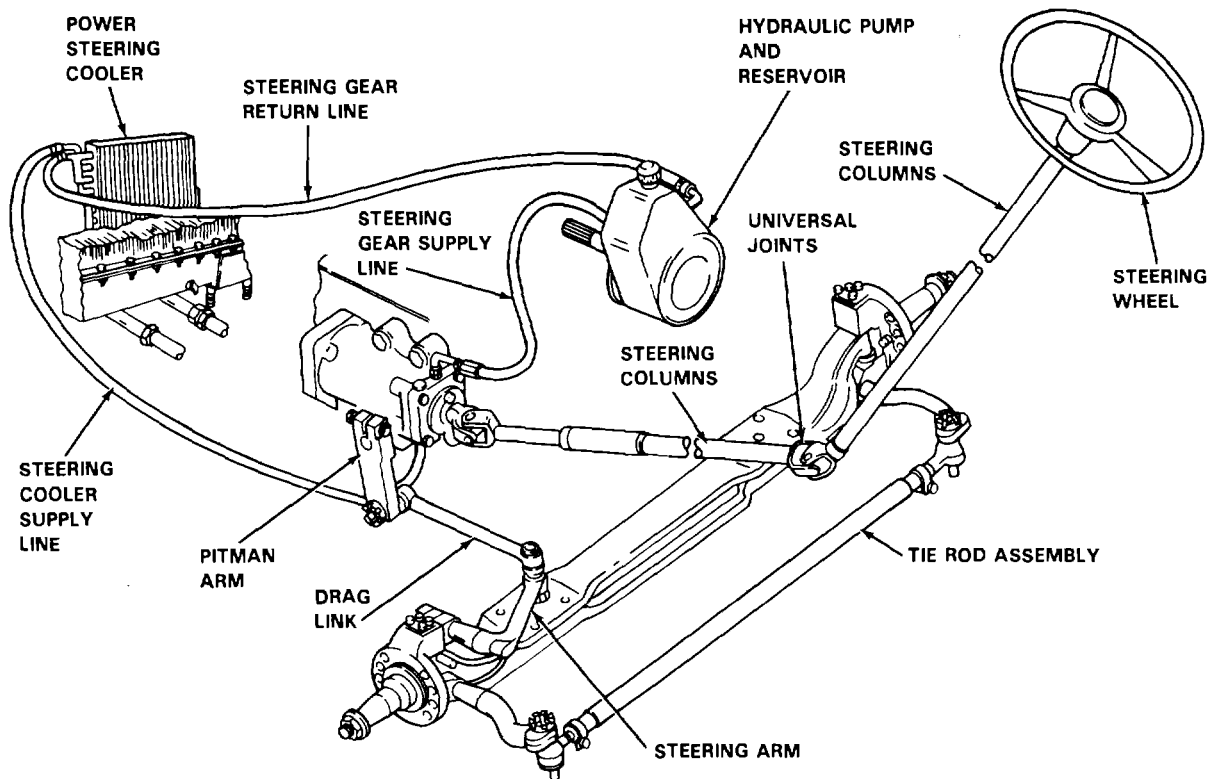

TA 236802

PRINCIPLES OF OPERATION.**1-23. CAB HEATING AND VENTILATING SYSTEM.**

BATTERY PACK. Consists of four, 12-volt, maintenance free batteries. Two batteries are wired in parallel in each set. Each set is connected in series for 24-volt output. Battery pack is used for both 12-volt and 24-volt output.

IGNITION SWITCH. Supplies 24-volt power to relay (RY-9), which in turn provides 12-volt power to electrical system, including cab heating controls.

RELAY (RY-9). Energized by 24-volt power from ignition switch. When energized, RY-9 supplies 12-volt power to circuit breaker (CB-4).

CIRCUIT BREAKER (CB-4). Protects electrical components of heater fan switch by opening when load exceeds 20 amperes. May be manually reset by pressing CB-4 button in.

FAN SWITCH. Four-position switch with three ON positions. Supplies 12-volt power from circuit breaker (CB-4) to motor. Current flow increases as switch is moved from LOW to MEDIUM to HIGH.

HEADLAMP SWITCH. Supplies 12-volt power to heater lamp when switched to ON position.

HEATER LAMP. Illuminates heater fan control.

HEATER CONTROL. Allows driver to heat cab. Connected by cable to water control valve.

DRIVER HEAT CONTROL. Allows driver to open or close heat vent for driver side of cab. Connected by cable to heat control lever.

PASSENGER HEAT CONTROL. Allows passenger to open or close heat vent for passenger side of cab. Connected by cable to vent control lever.

FRESH VENT CONTROL. Allows driver to control fresh air vent on passenger side. Connected by cable to vent control lever.

RECIRCULATION VENT CONTROL. Allows driver to recirculate cab air through heater. Connected by cable to recirculation control lever.

HEATER SHUTOFF VALVE. Supplies coolant to control valve. Manual shutoff handle allows complete cutoff of coolant flow to heater.

HEATER SUPPLY HOSE. Carries coolant from front water manifold, through control valve, to heater.

PRINCIPLES OF OPERATION.

1-23. CAB HEATING AND VENTILATING SYSTEM (Continued)

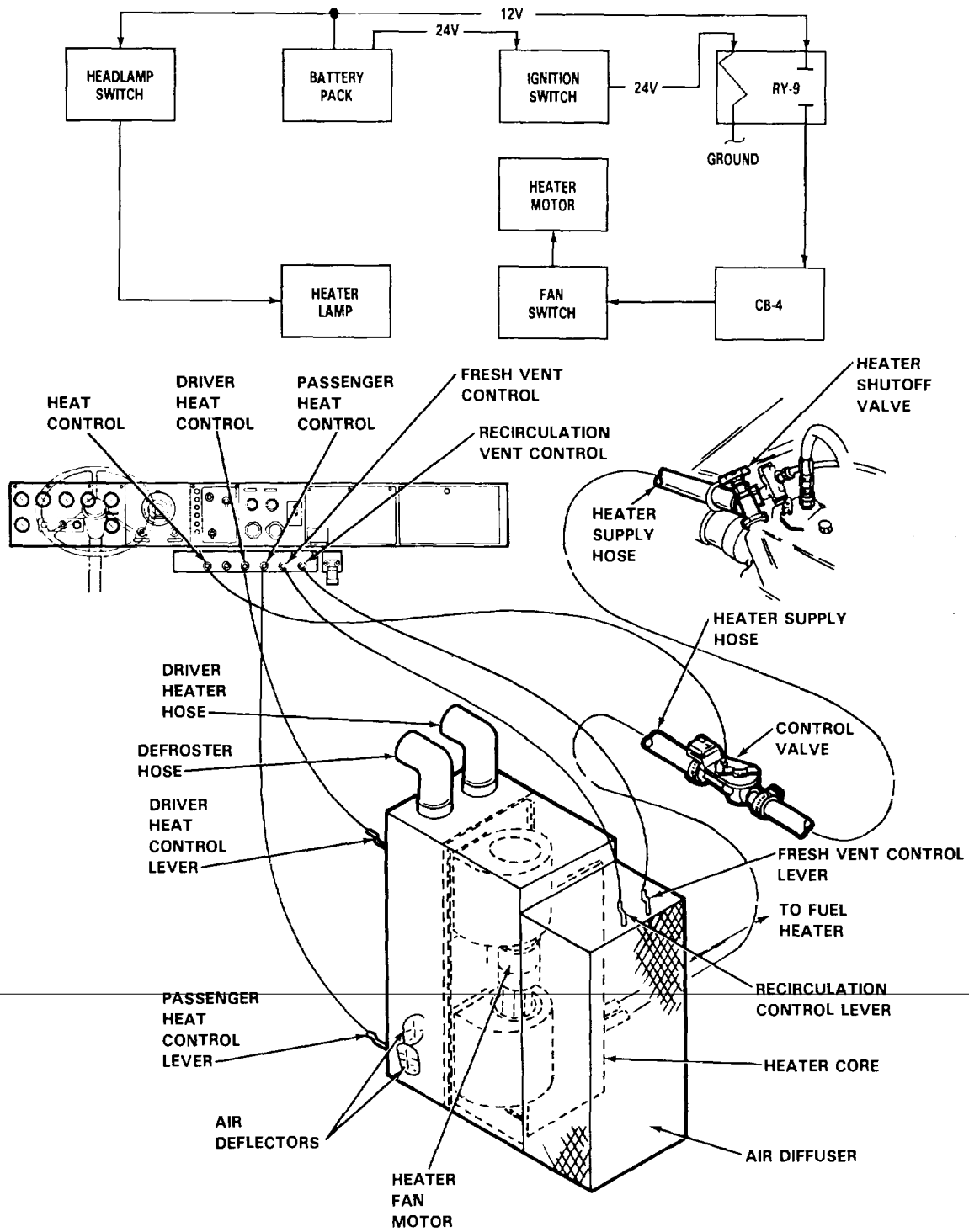

PRINCIPLES OF OPERATION.**1-23. CAB HEATING AND VENTILATING SYSTEM (Continued)**

DEFROSTER HOSE. Supplies heat for defrosting front windshield.

DRIVER HEAT HOSE. Supplies heat to driver's side of cab compartment.

RECIRCULATION CONTROL LEVER. Actuates shutter inside heater. Connected by cable to recirculation vent control knob.

FRESH VENT CONTROL LEVER. Actuates shutters at fresh air vent. Connected by cable to fresh vent control knob.

AIR DIFFUSER. Contains baffles that direct flow of air to heater or cab compartment.

HEATER CORE. Circulates hot water through tubing and transfers heat to air coming from air diffuser.

HEATER FAN MOTOR. Drives two fans for distributing heat and air. Actuated by fan switch.

AIR DEFLECTOR(S). Supply heat to lower area of cab compartment.

PASSENGER HEAT CONTROL LEVER. Actuates flap at heat vent for passenger.

Connected by cable to passenger pull knob.

DRIVER HEAT CONTROL LEVER. Actuates flap at heat vent for driver. Connected by cable to driver pull knob.

CONTROL VALVE. Controls heater temperature by regulating flow of hot water to heater core. Cable from heater knob in cab opens valve as knob is pulled.

Valve is spring loaded to close as knob is pushed in. Some water passes through this valve even when it is fully closed.

PRINCIPLES OF OPERATION.

1-23. CAB HEATING AND VENTILATING SYSTEM (Continued)

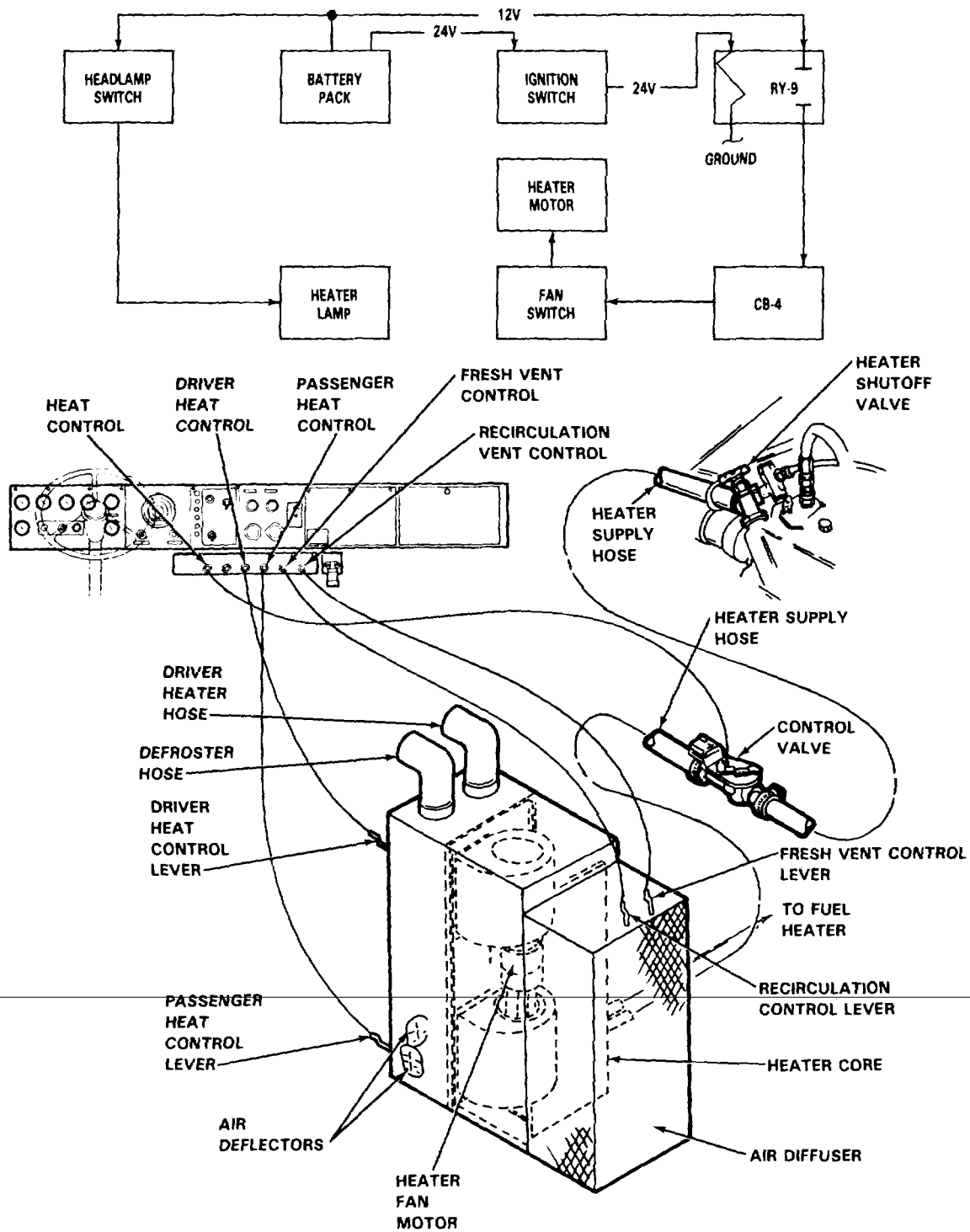

TA 236804

PRINCIPLES OF OPERATION.

1-24. WINTERIZATION KIT.

Refer to TB-9-2320-283-14 for winterization kit information.

CHAPTER 2
SERVICE AND TROUBLESHOOTING INSTRUCTIONS

2-1. OVERVIEW.

This chapter provides information on common tools, special tools, and troubleshooting instructions. The information is divided into the following sections:

- Section I. Repair Parts; Special Tools; Test, Measurement, and Diagnostic Equipment (TMDE); and Support Equipment.
- Section II. Service Upon Receipt.
- Section III. Preventive Maintenance Checks and Services (PMCS).
- Section IV. Troubleshooting.
- Section V. STE/ICE Troubleshooting.

SECTION I. REPAIR PARTS; SPECIAL TOOLS; MEASUREMENT, AND DIAGNOSTIC EQUIPMENT (TMDE); AND SUPPORT EQUIPMENT

2-2. COMMON TOOLS AND EQUIPMENT.

Refer to the Modified Table of Organization and Equipment (MTOE) for authorized common tools and equipment applicable to your unit.

2-3. SPECIAL TOOLS, TMDE, AND SUPPORT EQUIPMENT.

Special tools and support equipment are listed and illustrated in TM 92320-283-20P. Information pertaining to types of maintenance, maintenance levels, and work times for M915A1 components, subsystems, and systems are listed in the maintenance allocation chart (MAC). The MAC is located in Appendix B (TM 9-2320-283-20-3).

2-4. REPAIR PARTS.

Repair parts are listed and illustrated in TM 9-2320-283-20P.

SECTION II. SERVICE UPON RECEIPT

2-5. CHECKING UNPACKED EQUIPMENT.

a. Inspect the equipment for damage incurred during shipment. If the equipment has been damaged, report the damage on DD Form 6, Packaging Improvement Report.

b. Check the equipment against the packing slip to see if the shipment is complete. Report all discrepancies in accordance with the instructions of TM 38-750.

2-6. DEPROCESSING UNPACKED EQUIPMENT.

LOCATION/ITEM	ACTION	REMARKS
1. Protective wrappings.	Remove.	
2. All instrument panel switches.	Set to OFF, if necessary.	Refer to TM 9-2320-283-10 for locations.
3. Battery cables.	Connect to batteries.	Refer to paragraph 3-120.
4. Entire vehicle.	<ul style="list-style-type: none"> a. Inventory basic issue items. b. Perform operator's preventive maintenance checks and service. c. Perform organizational preventive maintenance checks and services. d. Lubricate as needed. 	<ul style="list-style-type: none"> Refer to TM 9-2320-283-10. Refer to TM 9-2320-283-10. Refer to paragraph 3-8. Refer to LO 9-2320-283-12.

SECTION III. PREVENTIVE MAINTENANCE CHECKS AND SERVICES (PMCS)

2-7. PREVENTIVE MAINTENANCE CHECKS AND SERVICES (PMCS) INTRODUCTION. This section contains Unit PMCS requirements for the M915A1 vehicle. The PMCS tables contain checks and services necessary to ensure the vehicle is ready for operation. Using the PMCS tables, perform maintenance at the specified intervals. Preventive Maintenance Checks and Services in TM 9-2320-283-10 must be completed before doing Unit preventive maintenance.

2-8. MAINTENANCE FORMS AND RECORDS. Every mission begins and ends with paperwork. There is not much of it, but it must be kept up. The filled out forms and records have several uses. They are a record of the services, repairs, and modifications made on the vehicle; they are reports to unit maintenance and to the Commander; and they serve as a checklist to find out what is wrong with the vehicle after its last use, and whether those faults have been fixed. For information needed on forms and records, see DA PAM 738-750.

2-9. GENERAL MAINTENANCE PROCEDURES.

WARNING

Adhesives, solvents, and sealing compounds can burn easily, can give off harmful vapors, and are harmful to skin and clothing. To avoid injury or death, keep away from fire and use in well-ventilated area. If adhesive, solvents, or sealing compound get on skin or clothing, wash immediately with soap and water.

a. **CLEANLINESS.** Dirt, grease, oil and debris only get in the way and may cover up a serious problem. Use dry cleaning solvent on metal surfaces and soapy water on rubber.

b. **BOLTS, NUTS, AND SCREWS.** Check bolts, nuts, and screws for obvious looseness, missing, bent, or broken condition and tighten or replace as necessary. They cannot all be checked with a tool, of course, but look for chipped paint, bare metal, or rust around bolt heads.

c. **WELDS.** Look for loose or chipped paint, rust, or gaps where parts are welded together. If a bad weld is found, have it repaired.

d. **ELECTRIC WIRES AND CONNECTORS.** Look for cracked or broken insulation, bare wires, and loose or broken connectors. Tighten loose connectors and make sure the wires are in good shape.

e. **HYDRAULIC LINES AND FITTINGS.** Look for wear, damage, leaks, and make sure clamps and fittings are tight. Wet spots show leaks, of course, but a stain around a fitting or connector may indicate a leak. If a connector or fitting is loose, tighten it. If something is broken or worn out, repair or replace per applicable procedure.

2-10. FLUID LEAKAGE. It is necessary to know how fluid leakage affects the status of fuel, oil, coolant, and the hydraulic systems. The following are definitions of types/classes of leakage necessary to know in order to determine the status of the vehicle.

2-3 Change 1

CAUTION

Equipment operation is allowable with minor leakages (Class I or II). Of course, consideration must be given to the fluid capacity in the item/system being checked/inspected. When in doubt, notify the supervisor. When operating with Class I or II leaks, continue to check fluid levels as required in the PMCS. Class III leaks should be repaired per applicable procedure.

- a. Class I. Seepage or fluid as indicated by wetness or discoloration not great enough to form drops.
- b. Class II. Leakage of fluid great enough to form drops but not enough to cause drops to drip from item being checked/inspected.
- c. Class III. Leakage of fluid great enough to form drops that fall from the item being checked/inspected.

2-10. PREVENTIVE MAINTENANCE CHECKS AND SERVICES (PMCS) TABLES.

- a. Do the (S) PREVENTIVE MAINTENANCE once every six months and/or every 3,000 miles (4,827 KM) whichever comes first.
- b. Do the (A) PREVENTIVE MAINTENANCE once each year and/or every 6,000 miles (9,654 KM) whichever comes first.
- c. Do the (B) PREVENTIVE MAINTENANCE once each year and/or every 12,000 miles (19,308 KM) whichever comes first.
- d. Always do the PREVENTIVE MAINTENANCE in the same order until it gets to be a habit. Once practiced, it will be easy to spot anything wrong in a hurry.
- e. If something does not work, troubleshoot with instructions in Chapter 2.
- f. If anything looks wrong and is not fixed, write a DA Form 2404.
- g. When doing preventive maintenance, take along the tools and supplies needed to make all the checks. Always take a clean cloth or two.

Table 2-1. Unit Level Preventive Maintenance Checks and Services M915A1

Item No.	Interval	Item to Check/ Service	Procedure	Not Fully Mission Capable If:
1	Semi-Annual	Pre-Service Checks	<p><u>PRIOR TO ROAD TEST</u> Ensure Operator/Crew has performed -10 PMCS listed in TM 9-2320-283-10.</p> <p>ROAD TEST Maintenance personnel will be with vehicle operator to assist in performing -10 PMCS checks and verify pre-service checks.</p> <p>NOTE The following will be performed during the road test. These inspections must be performed before any -20 level PMCS regardless of interval.</p> <p>For road test, vehicle will be driven at least five miles over different ground to give enough time to detect any malfunctions.</p> <p>a. Notice if starter engages smoothly and turns the engine at normal cranking speed.</p> <p>b. Listen for unusual engine noise at idle, at operating speeds, and under acceleration. Be alert for excessive vibration and the smell of oil, fuel and exhaust.</p>	<p>a. Starter in-operative or makes excessive grinding sound.</p> <p>b. Engine knocks, rattles or smokes excessively.</p>
			<p>2-5 Change 1</p>	

Table 2-1. Unit Level Preventive Maintenance Checks And Services M915A1

Item No.	Interval	Item to Be Inspected	Procedure	Not Mission Capable If:
1	Semi-Annual	Pre-Service Checks	<p>c. Check for transmission response to shifting and for smoothness of operation in all speed ranges. Be alert Continued for unusual noises and difficulty in shifting in any speed range.</p> <p>d. Check for transfer response to shifting and for smoothness of operation in all gear ranges. Be alert for unusual noises and difficulty in shifting in any gear range.</p> <p>e. Test for response to accelerator feed. Observe for sticking pedal.</p> <p>f. With vehicle speed approximately 5 mph (8 kph) turn steering wheel to left, then right, to detect steering backlash, shimmy or if freeplay is more than 1-1/2 inches (38 mm) in either direction. Vehicle should respond instantly. With vehicle moving on straight, level terrain, lightly hold steering wheel to check for pull and wandering.</p> <p>g. Apply brake pedal with steady force. Vehicle should slow down and stop without pulling to one side or jerking. Release brake pedal. The brakes should release immediately and without difficulty.</p> <p>h. Observe vehicle response to road shocks, side sway or continuous bouncing indicates a malfunction.</p>	<p>c. Transmission shifts improperly, does not shift or makes excessive noises.</p> <p>d. Transfer jumps out of gear or makes excessive noises.</p> <p>e. Pedal sticking or binding.</p> <p>f. Steering binds, grabs, wanders or freeplay is more than 1-1/2 inch (38 mm) in either direction.</p> <p>g. Brakes chatter, pull to one side or inoperative. Brakes will not release.</p> <p>h. Handling is unstable.</p>
			2-6 Change 1	

Table 2-1. Unit Level Preventive Maintenance Checks and Services M915A1

Item No.	Interval	Item to be Inspected	Procedures:	Not Mission Capable If:
1	Semi-Annual	Pre-Service Checks Continued	<p style="text-align: center;"><u>AFTER ROAD TEST</u></p> <p>a. Make sure the vehicle has been cleaned of mud, gravel, etc, from the underbody, outside and crew compartment area.</p> <p style="text-align: center;"><u>CAUTION</u></p> <p>Do not hold steering wheel at full left or right position for longer than 10 seconds. Oil overheating and pump damage can result.</p> <p>b. With vehicle stopped, turn steering wheel to extreme left, then to the extreme right to check for hard steering.</p> <p>c. Check engine operation at all speeds. Ensure that engine does not go over engine governed speed - 600-2100 rpm.</p>	<p>b. Hard steering is evident.</p> <p>c. Engine governed speed - no load is below 600 rpm or exceeds 2100 rpm.</p>

Change 1 2-7

Table 2-1. Unit Level Preventive Maintenance Checks And Services M915A1

Item No.	Interval	Item to be Inspected	Procedures:	Not Mission Capable If:
2	Semi-Annual	Brake System	<p style="text-align: center;"><u>WARNING</u></p> <p>Brake drums can get very hot during vehicle operation. Place hand near drum to check for excessive heat but do not touch.</p> <p>Carefully check and compare each brake drum for overheating which can indicate a dragging brake. Cool brake drums could mean improper adjustment, defective, or inoperative brakes.</p>	Brake drums are overheated or excessively cool.
3	Semi-Annual	Body	Inspect loose rivets, cracks, loose or missing bolts and general damage.	Any body damage that would hinder vehicle operation.
4	Semi-Annual	Vehicle Exterior	<p>Inspect the following for completeness, security and operation:</p> <ul style="list-style-type: none"> a. Glass b. Hinges c. Panels d. Data, Caution and Warning Plates e. Leaks f. Tow Pintle 	e. Any Class III leak.
5	Semi-Annual	Fuel System	<ul style="list-style-type: none"> a. Inspect fuel filter/water separator assembly for dents and cracks that could cause leaks. b. Replace filter element every 3, 000 miles (4, 827 km) or semi-annually, whichever occurs first. 	<ul style="list-style-type: none"> a. Any Class III leak. b. Fuel filter clogged.

Table 2-1. Unit Level Preventive Maintenance Checks and Services M915A1

Item No.	Interval	Item to be Inspected	Procedures:	Not Mission Capable If:
5	Semi-Annual	Fuel System Continued	<p style="text-align: center;"><u>WARNING</u></p> <p>Adhesives, solvents, and sealing compounds can burn easily, can give off harmful vapors, and are harmful to skin and clothing. To avoid injury or death, keep away from fire and use in well-ventilated area. If adhesive, solvents, or sealing compound get on skin or clothing, wash immediately with soap and water.</p> <p>c. Clean screen by soaking in a carbon dissolving agent, followed by flushing in a sonic cleaner unit, or clean the screen in fuel oil and dry with compressed air. Visually inspect screen for holes or embedded metal particles in mesh.</p> <p>d. Purge and clean fuel tank (TB 43-0212), if required.</p> <p>e. Inspect fuel injection pump, nozzle lines, and fittings for leaks and damage. Any nozzle loose or damaged.</p> <p>f. Inspect all fuel lines for loose connections, splits, cracks, and kinks that could leak.</p>	<p>c. Screen is worn or damaged.</p> <p>e. Rubber cap missing or torn on return line.</p> <p>f. Any Class III leak.</p>
6	Semi-Annual	After-cooler	Check aftercooler for leaks and loose hardware.	Class III leaks or loose hardware.

Table 2-1. Unit Level Preventive Maintenance Checks And Services M915A1

Item No.	Interval	Item to be Inspected	Procedures:	Not Mission Capable If:
7	Semi-Annual	Engine Accessory Drive	Check for missing, broken, cracked and frayed drivebelts, dry rot, excessive fraying and cracks.	Any drivebelt is missing or broken. Belt fiber has more than one crack (1/8 Belt inch in depth or 50% of belt thickness) or has frays more than 2 inches long.
8	Semi-Annual	Water Pump	<p>a. Inspect the pulley for alignment (paragraph 3-63).</p> <p>b. Check the belt for proper tension (1/2 to 3/4 inch, 1.2 to 1.9 cm) deflection when you press down firmly.</p> <p>c. Inspect the water pump for leaks and fan shrouds to see if they are securely mounted.</p>	
9	Semi-Annual	Thermostat Housing and Front, Center, and Rear Water Manifolds	Inspect thermostat housing and water manifold for leaks.	

Table 2-1. Unit Level Preventive Maintenance Checks and Services M915A1

Item No.	Interval	Item to be Inspected	Procedures:	Not Mission Capable If:
10	Semi-Annual	Alternator Wiring and Engine Mount	a. Check for loose wiring connections or worn insulation. b. Inspect for cracked or loose engine mounts.	a. Loose connections or worn insulation. b. Cracked or loose engine mounts.
11	Semi-Annual	Radiator and Hoses	a. Check core for leaks, clogging, and bent fins. b. Check hoses for leaks and deterioration from oil and solvents. c. Test coolant (TB 750-651). d. If required, drain radiator and block. Flush and refill cooling system with proper antifreeze/water mixture (paragraph 3-52).	
12	Semi-Annual	Cooling System	<p style="text-align: center;"><u>WARNING</u></p> <p>If vehicle has been operating, use extreme care to avoid being burned when removing cooling system radiator cap. Use heavy rags or gloves to protect hands. Turn radiator cap only one-half turn counterclockwise and allow pressure to be relieved before fully removing cap.</p> <p style="text-align: center;"><u>NOTE</u></p> <p>Coolant level is correct when sight glass is full (TM 9-2320-273-10).</p>	

Table 2-1. Unit Level Preventive Maintenance Checks And Services M915A1

Item No.	Interval	Item to be Inspected	Procedures:	Not Mission Capable If:
12	Semi-Annual	Cooling System	<p>Use MIL-A-46153 in temperatures above 0°F (180C) and MIL-A-11755 in temperatures below 0°F (-18° Continued C) .</p> <p>a. Check coolant condition. Test coolant to see if draining is necessary (TB 750-651). is required.</p> <p>b. Check all hoses for looseness, splits, wear, and cracks that would cause leaks.</p> <p>c. Inspect hose clamps for wear and serviceability. serviceable.</p> <p style="text-align: center;">CAUTION</p> <p>Apply lubricant sparingly to the fan clutch fitting. Excessive use of lubricant may cause grease to enter in the fan pulley grooves causing slippage of the fan belts.</p> <p style="text-align: center;">NOTE</p> <p>Fan clutch should be lubricated every 6, 000 miles or 6 months, whichever occurs first.</p>	<p>a. Coolant condition/testing shows draining</p> <p>b. Class III leakage evident. Hoses are loose or have splits or cracks.</p> <p>c. Hose clamps are worn or un-</p>
13	Semi-Annual	Fan Clutch	Lubricate fan clutch with GAA.	

Table 2-1. Unit Level Preventive Maintenance Checks and Services M915A1

Item No.	Interval	Item to be Inspected	Procedures:	Not Mission Capable If:
14	Semi-Annual	Engine Crankcase	<p style="text-align: center;">NOTE COLD TEMPERATURE OPERATION</p> <p>For operation of equipment in expected continuous temperatures below 0° F (-18° C), remove lubricants prescribed in the key for temperatures above 0° F (-18° C). Re-lubricate with lubrication specified in the key for temperatures 0° F to -50° F (-18° C to -460 C).</p> <p style="text-align: center;">NOTE</p> <p>If AOAP laboratory is not available, drain and refill engine crankcase with OE/HDO every 6, 000 miles (9, 654 km) or semi-annually, whichever comes first.</p> <p>a. Drain and refill crankcase with OE/HDO. b. Replace engine oil filter and bypass oil filter. leak. c. Check all oil lines and hoses for cracks and wear that could cause leaks. d. Check oil filter housing, and oil pan drain plug for looseness. Make sure oil pan bolts are tight.</p>	<p>"Do not operate" received from AOAP lab.</p> <p>b. Oil filter has Class III</p> <p>c. Cracks, frays, leaks, and wear are evident.</p> <p>d. Drain plugs and oil pan bolts are loose.</p>

Table 2-1. Unit Level Preventive Maintenance Checks And Services M915A1

Item No.	Interval	Item to be Inspected	Procedures:	Not Mission Capable If:
15	Semi-Annual	Rocker Cover Gaskets	Check rocker cover gasket for oil leaks. If necessary, tighten bolts and/or replace gaskets (paragraph 3-13).	
16	Semi-Annual	Oil Cooler and Lines	Check oil cooler for leaks, loose hardware, and damaged fittings.	
17	Semi-Annual Pump and	Power Steering leaks.	<p>a. Inspect power steering pump for leaks, cracks, and damage.</p> <p>b. Check steering stops for proper adjustment (paragraph 3-217.1).</p> <p>c. Check steering gear poppet valve for proper adjustment (paragraph 3-217.2).</p> <p>d. Change filter when fluid is contaminated.</p>	<p>a. Cracks, damage or Class III</p> <p>b. Steering stops out of adjustment.</p> <p>c. Steering gear poppet valve is out of</p> <p>d. Fluid is contaminated.</p>

Change 1 2-14

Table 2-1. Unit Level Preventive Maintenance Checks and Services M915A1

Item No.	Interval	Item to be Inspected	Procedures:	Not Mission Capable If:
18	Semi-Annual	Air Cleaner	a. Check that air cleaner housing and turbocharger inlet and outlet hoses are secure. b. Check filter elements for contamination. Clean or replace as necessary.	b. Filter is contaminated.
19	Semi-Annual	Cab, Engine, and Front Rear Light Wiring Harness	Check all wiring harnesses for frays, splits, missing insulation or poor connections. Replace as necessary. <p style="text-align: center;"><u>WARNING</u></p> Do not smoke, have open flames, or make sparks around the batteries, especially if the caps are off. Battery gasses can explode and cause injury. <p style="text-align: center;"><u>NOTE</u></p> Refer to TM 9-6140-200-14 for more specific details on battery maintenance.	Insulation missing. Frays, splits, poor connections evident.
20	Semi-Annual	Battery Electrical System	a. Inspect battery box for corrosion and debris. b. Clean slave receptacle and coat with corrosion preventive compound. c. Check and record specific gravity of each cell. specific gravity. d. Inspect battery cables for frays, splits, and looseness. or loose.	a. Corrosion that has made holes in metal battery box. b. Terminals corroded. c. If cell is below 1.225 d. Cables frayed, split,

Table 2-1. Unit Level Preventive Maintenance Checks And Services M915A1

Item No.	Interval	Item to be Inspected	Procedures:	Not Mission Capable If:
21	Semi-Annual	Tires	<p style="text-align: center;"><u>CAUTION</u></p> <p>Do not mix radial and bias tires on the same vehicle. Make sure tires are cold when you check pressure.</p> <p>a. Inspect tires for unusual wear, penetrating objects, and improper matching.</p> <p>b. Make sure all wheel lugnuts are installed and tightened to correct torque value 450 lb-ft (610 N.m).</p>	<p>a. Tires improperly match.</p> <p>b. Any missing lugnut and/or improperly torqued.</p>
22	Semi-Annual	Wheel Alignment	<p>Check toe-in and adjust as necessary. Toe-in should be 1/32 inch plus or minus 1/32 inch for both wheels (paragraph 3-202).</p>	<p>Toe-in cannot be adjusted.</p>
23	Semi-Annual	Steering Gear Mounting Bolts	<p>Check steering gear for loose or missing mounting bolts.</p>	<p>Loose or missing bolts.</p>

Table 2-1. Unit Level Preventive Maintenance Checks and Services M915A1

Item No.	Interval	Item to be Inspected	Procedures:	Not Mission Capable If:
24	Semi-Annual	Exhaust System	<p style="text-align: center;"><u>WARNING</u></p> <p>The exhaust pipe and muffler can become very hot during vehicle operation. Be careful not to touch these parts with bare hands, or allow body to come in contact with pipe or muffler. Exhaust system parts can become hot enough to cause serious burns.</p> <p>a. Inspect exhaust manifold, exhaust pipes, muffler, and tailpipe for corrosion, carbon deposits which may indicate leaks.</p> <p>b. Inspect for damaged pipes, loose clamps and leaking gaskets or seals.</p> <p>c. Inspect raincap to make sure it operates freely. freely, does not close when engine is off, or missing.</p>	<p>a. Evidence of corrosion or carbon deposits evident.</p> <p>b. Pipes damaged, clamps loose, gaskets or seals leaking.</p> <p>c. Raincap does not operate</p>

Table 2-1. Unit Level Preventive Maintenance Checks And Services M915A1

Item No.	Interval	Item to be Inspected	Procedures:	Not Mission Capable If:
25	Semi-Annual	Drive Line Universal Joint, Slip Yokes Splines	<p style="text-align: center;">NOTE</p> <p>The pressurized grease gun should be held on the fittings until new grease appears. This will assure that all the contaminated grease has been forced out.</p> <p>a. Lubricate drive line universal joint with GAA and check for looseness or side play.</p> <p>b. Lubricate slip yokes and spline with GAA and check for looseness or side play.</p> <div style="text-align: center;">  </div>	<p>a. Fitting will not purge old lubricant out of component, loose or side play.</p> <p>b. Fitting will not purge old lubricant out of component, loose or side play.</p>

Table 2-1. Unit Level Preventive Maintenance Checks and Services M915A1

Item No.	Interval	Item to be Inspected	Procedures:	Not Mission Capable If:
26	Semi-Annual	Univer- sal Joints and Pro- peller Shafts	Inspect for loose bearings, dam- aged seals, and damaged lube fittings. Tighten bolts if nec- essary (paragraph 3-144 and 3-145).	Fitting will not purge old lubricant out of component.
27	Semi-Annual	Front and Rear Slack Adjust- ers	<p style="text-align: center;">NOTE</p> Pressure gun should be held on fittings until new grease ap- pears. This will assure that all the old contaminated grease has been forced out. Lubricate front and rear slack adjusters with GAA.	Fitting will not purge old lubricant out of component.
28	Semi-Annual	Forward Rear Axle and Rear Axle	<p style="text-align: center;">NOTE COLD TEMPERATURE OPERATION</p> For operating of equipment in expected continuous tempera- tures below 0°F (-18°C), remove lubricants prescribed in the key for temperatures above 0°F (-18° C). Re-lubricate with lubri- cants specified in the key for temperatures 0° F to -500F (-18°C to -46°C). <p style="text-align: center;">NOTE</p> Pressure gun should be held on fittings until new grease ap- pears. This will assure that all the old contaminated grease has been forced out.	Fitting will not purge old lubricant out of component.

Table 2-1. Unit Level Preventive Maintenance Checks And Services M915A1

Item No.	Interval	Item to be Inspected	Procedures:	Not Mission Capable If:
28	Semi-Annual	Forward Axle and Rear Axle Continued	<p>a. After the first initial 1,000 miles of operation, drain the differentials while the assembly is still warm from operation. Inspect the magnetic drain plug for signs of excessive metal particle buildup.</p> <p>b. Clean the magnetic drain plug and magnetic fill plugs and replace when lubricant has stopped draining.</p> <p style="text-align: center;">NOTE</p> <p>Axles must not be flushed with any solvent such as kerosene.</p> <p>c. Check and refill both axle differentials with GO as required. Maintain lube level with bottom of filler hole.</p>	<p>a. Excessive metal particle buildup.</p>
29	Semi-Annual	Rear Axle Spring and Walking Beam	<p>a. Lubricate Axle Spring and Walking Beam with GAA.</p> <p style="text-align: center;">NOTE</p> <p>Adhesives, solvents, and sealing compounds can burn easily, can give off harmful vapors, and are harmful to skin and clothing. To avoid injury or death, keep away from fire and use in well-ventilated area. If adhesive, solvents or sealing compound get on skin or clothing, wash immediately with soap and water.</p>	<p>a. Fitting will not purge old lubricant out and of component.</p>

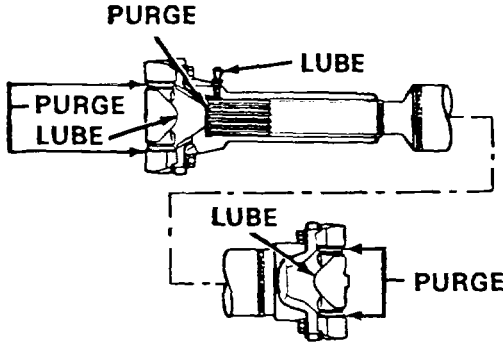
Table 2-1. Unit Level Preventive Maintenance Checks and Services M915A1

Item No.	Interval	Item to be Inspected	Procedures:	Not Mission Capable If:
29	Semi-Annual	Rear Axle Spring and Walking Beam Continued	Axle Housing Vent Plug b. Remove vent plug from axle housing. Wash vent plug in solvent and allow to air dry. cleaned. c. Coat threads with pipe thread sealing compound and install axle housing breather.	b. Axle vent plug missing or cannot be
30	Semi-Annual	Front Axles Drag Link	<p style="text-align: center;">NOTE COLD TEMPERATURE OPERATION</p> <p>For operating of equipment in expected continuous temperatures below 0°F (-18° C), remove lubricants prescribed in the key for temperatures above 0° F (-18° C). Re-lubricate with lubricants specified in the key for temperatures 0° F to -50° F (-18° C to -46° C).</p> <p style="text-align: center;">NOTE</p> <p>Pressure gun should be held on fittings until new grease appears. This will assure that all the old contaminated grease has been forced out.</p> <p>Lubricate drag link with GAA.</p>	Fitting will not purge old lubricant out of component.

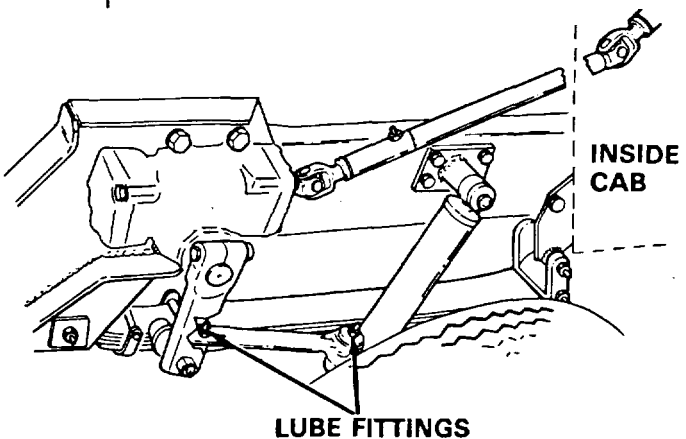

Table 2-1. Unit Level Preventive Maintenance Checks And Services M915A1

Item No.	Interval	Item to be Inspected	Procedures:	Not Mission Capable If:
30	Semi-Annual	Front Axles Continued (Steering Shaft Universals)	Inspect steering shaft for looseness and lubricate with GAA.	Fitting will not purge old lubricant out of component.
31	Semi-Annual	Tie Rod	<p style="text-align: center;">NOTE</p> Pressure gun should be held on fittings until new grease appears. This will assure that all the old contaminated grease has been forced out. Lubricate tie rod ends with GAA.	Fitting will not purge old lubricant out of component, loose or side play.
32	Semi-Annual	Front Wheel Knuckle	<p style="text-align: center;">NOTE</p> Pressure gun should be held on fittings until new grease appears. This will assure that all the old contaminated grease has been forced out.	

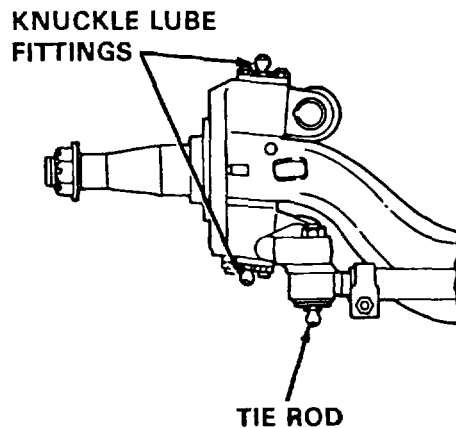

Table 2-1. Unit Level Preventive Maintenance Checks and Services M915A1

Item No.	Interval	Item to be Inspected	Procedures:	Not Mission Capable If:
33	Semi-Annual	Hydraulic Steering Lines	<p>Follow routing of all hydraulic steering lines, hoses, and tubes to inspect for loose fitting, rubbing, chaffing, cracks, bends, breaks, and leaks. Tighten if loose and replace hoses that are damaged.</p> <p style="text-align: center;">WARNING</p> <p>Do not start engine or move vehicle when anyone is under vehicle. Severe injury or death could result.</p>	Class III leaks evident.
34	Semi-Annual	Frame and Cross-	<p>a. Inspect frame side rails for cracks, breaks, bends, wear deterioration and missing and members loose fasteners.</p> <p>b. Inspect crossmembers for cracks, breaks, bends, wear deterioration and missing and loose fasteners.</p>	<p>a. Cracks, bends, or breaks in frame. Any loose or missing</p> <p>b. Cracks, bends, or breaks in members. Any loose or missing fasteners.</p>

Table 2-1. Unit Level Preventive Maintenance Checks And Services M915A1

Item No.	Interval	Item to be Inspected	Procedures:	Not Mission Capable If:
35	Semi-Annual	5th Wheel Assemblies	Check air cylinder, connecting lines, and fittings for leaks and damage.	
36	Semi-Annual	Air Dryer	a. Inspect connecting lines and fittings for leaks and damage. b. Replace air dryer dehydrator cartridge (paragraph 3-200).	
37	Semi-Annual	Air Brake System	a. Inspect air reservoirs air valves, air chambers, connecting lines and fittings for damage or leaks. b. Inspect trailer brake hose and coupling for leaks or damage.	
38	Semi-Annual	Parking Brake	Inspect spring brake control valve, lines and double air brake chambers for leaks and damaged fittings.	Air leaks or damaged fittings.

Change 1 2-24

Table 2-1. Unit Level Preventive Maintenance Checks and Services M915A1

Item No.	Interval	Item to be Inspected	Procedures:	Not Mission Capable If:
39	Semi-Annual	Brake Pedal	Lubricate brake pedal with OE/HDO. 	Fitting will not purge old lubricant or component.
40	Semi-Annual	Accelerator Pedal and Linkage	Lubricate accelerator pedal and linkage with OE/HDO. 	Fitting will not purge old lubricant out of component.
41	Semi-Annual	Air Brake Hoses	a. Check all outer casings of brake hoses for chafing, cracking, crimping or abrading through the first ply of fabric. Replace hose if there is any evidence of leakage or bulges (paragraph 3-163).	

Table 2-1. Unit Level Preventive Maintenance Checks And Services M915A1

Item No.	Interval	Item to be Inspected	Procedures:	Not Mission Capable If:
			<p style="text-align: center;">FINAL ROAD TEST</p> <p>After all services and inspections have been completed, take vehicle on a short road test to make sure all corrections have been accomplished. Correct any defects or malfunctions that occur during this test.</p> <p>During road test:</p> <ol style="list-style-type: none"> 1. Listen for any noises. 2. Check steering operation. 3. Check operation of brakes. 4. Check transmission operation; all ranges. 5. Check engine retarder (JACOBS ENGINE BRAKE) operation (TM 9-2320-283-10). 6. Note any loss of power or rough running engine. 7. Check drive line lockup system operation(TM 9-2320-283-10). 	

Change 1 2-26

Table 2-1. Unit Level Preventive Maintenance Checks and Services M915A1

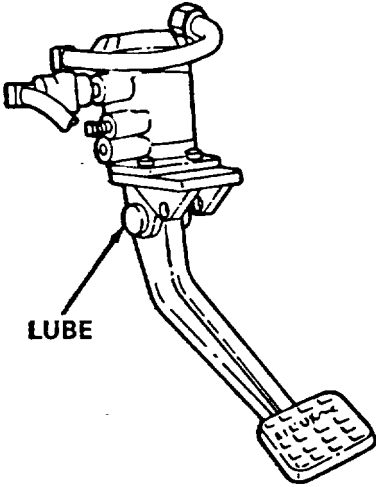
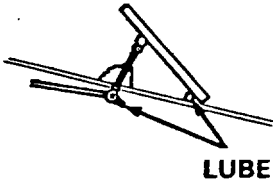
Item No.	Interval	Item to be Inspected	Procedures:	Not Mission Capable If:
42	Annual	Head-lights	Check headlight adjustment. Adjust headlights (paragraph 3-91.1).	
43	Annual	Starter	<p>a. Remove starter.</p> <p>b. Remove three socket head screws and add three to five drops of OE/HDO to each reservoir.</p> <div data-bbox="548 716 1060 1115" style="text-align: center;">  <p>SOCKET HEAD SCREWS</p> </div> <p style="text-align: center;"><u>WARNING</u></p> <p>Adhesives, solvents, and sealing compounds can burn easily, can give off harmful vapors, and are harmful to skin and clothing. To avoid injury or death, keep away from fire and use in well-ventilated area. If adhesive, solvents, or sealing compound get on skin or clothing, wash immediately with soap and water.</p> <p>c. Clean drive and drive spline and apply a thin coat of grease (GAA).</p>	

Table 2-1. Unit Level Preventive Maintenance Checks And Services M915A1

Item No.	Interval	Item to be Inspected	Procedures:	Not Mission Capable If:
44	Annual	Tires	<p style="text-align: center;">NOTE</p> <p>Rotate tires (refer to TM 9-2610-200-14, paragraph 2-9).</p> <p style="text-align: center;">WARNING</p> <ul style="list-style-type: none"> * Changing tire pressure or wheel alinement, out of the recommended specifications, may adversely affect the vehicle's handling characteristics. Loss of vehicle control may result in serious injury or death and damage to equipment. * Never mix radial tires and bias ply tires on the same axle. If radial tires are used in combination with bias ply tires on a vehicle, the radial tires must be placed on the rear axle only. Failure to do this may cause damage to equipment or injury to personnel. <p style="text-align: center;">NOTE</p> <p>Vehicle must be up on jack stands for the following checks.</p> <p>a. Inspect tires for uneven wear and balance.</p>	<p>a. Tires exhibit excessive or uneven wear or balance.</p>

Table 2-1. Unit Level Preventive Maintenance Checks and Services M915A1

Item No.	Interval	Item to be Inspected	Procedures:	Not Mission Capable If:
44	Annual	Tires Continued	<p>b. Tighten wheel lug nuts to 90-110 lb-ft (122-149 N-m) in tightening sequence shown.</p> <p style="text-align: center;">TIGHTENING SEQUENCE</p>  <p style="text-align: center;">NOTE If vehicle is new, and has been driven less than 3, 000 miles (4, 800 km), it is not necessary to aline wheels unless abnormal handling is reported.</p> <p>c. Check alinement of front and rear wheels (see TM 9-2320-280-20-1, paragraph(s) 8-7 and 8-8).</p>	<p>b. Any broken studs, loose or missing lug nuts.</p> <p>c. Front or rear wheel are out of alinement.</p>

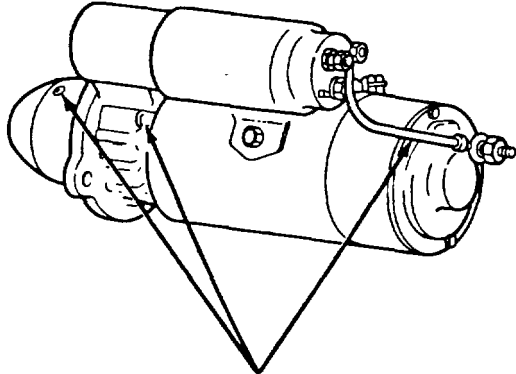
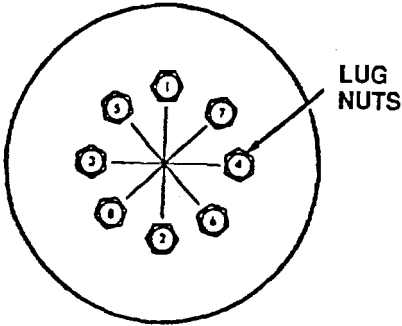
Change 1 2-28.1

Table 2-1. Unit Level Preventive Maintenance Checks And Services M915A1

Item No.	Interval	Item to be Inspected	Procedures:	Not Mission Capable If:
45	Annual	Front Wheel Bearings	<p style="text-align: center;">NOTE</p> <p>Do not remove wheels from hubs. Use truck wheel lift to remove wheels and hub as an assembly.</p> <p style="text-align: center;">NOTE</p> <p>See paragraph 3-205 for bearing removal and installation.</p> <p>a. Remove, clean and repack with GAA front wheel bearings.</p> <p>b. Check wheel bearings for looseness, damage or wear (paragraph 3-205).</p> <p>c. Clean hub and brake shoe assemblies with brake cleaning solvent. Replace brake shoes if necessary (paragraph 3-159).</p> <p style="text-align: center;">NOTE</p> <p>If hub has one gouge or grooves, turn hub into Direct Support for resurfacing.</p> <p>d. Check brake drums for obvious grooves and uneven wear.</p>	<p>b. Loose, damaged or worn.</p> <p>d. Deep grooves or uneven wear is evident.</p>
46	Annual	Rear Axles	<p>a. Inspect each input and output shaft seal for damage and leaks.</p> <p style="text-align: center;">NOTE</p> <p>Do not remove wheels from hubs. Use truck wheel lift to remove wheels and hub as an assembly.</p> <p>b. Remove, clean, and check wheel bearings for damage or wear (paragraph 3-205).</p>	<p>a. Class III leaks.</p> <p>b. Loose, damaged or worn.</p>

Table 2-1. Unit Level Preventive Maintenance Checks and Services M915A1

Item No.	Interval	Item to be Inspected	Procedures:	Not Mission Capable If:
46	Annual	Rear Axles	<p>c. Clean hub and brake shoe assemblies. Replace brake shoes if necessary (paragraph Continued 3-159).</p> <p style="text-align: center;">NOTE</p> <p>If hub has one gouge or grooves, turn hub into Direct Support for resurfacing.</p> <p>d. Check brake drums for obvious grooves and uneven wear. is evident.</p>	d. Deep grooves or uneven wear
47	Annual	Forward Rear Axle Lube Pump and Magnetic Strainer	<p style="text-align: center;">NOTE</p> <p>The magnetic strainer should be checked and cleaned the first 1, 000 miles of operation. After that, check and clean the magnetic strainer every 24, 000 miles or 12 months, whichever occurs first.</p> <p style="text-align: center;">NOTE</p> <p>Adhesives, solvents, and sealing compounds can burn easily, can give off harmful vapors, and are harmful to skin and clothing. To avoid injury or death, keep away from fire and use in well-ventilated area. If adhesive, solvents, or sealing compound get on skin or clothing, wash immediately with soap and water.</p> <p>a. Check and clean the magnetic strainer, remove the strainer from the power divider cover and inspect for wear material.</p> <p>b. Wash the magnetic strainer in solvent; blow dry with compressed air to remove oil and metal particles. Reinstall.</p>	

Table 2-1. Unit Level Preventive Maintenance Checks And Services M915A1

Item No.	Interval	Item to be Inspected	Procedures:	Not Mission Capable If:
48	Annual	Springs and Shocks	<p>a. Check spring leaves for cracks and breaks.</p> <p>b. Check spring clips, saddles, saddle caps, spring hangers for presence, looseness, cracks, and visible damage.</p> <p>c. Check for missing or broken retaining hardware, bolts or parts of suspension system.</p> <p>d. Check all shock absorbers. Look for oil leaks and damage.</p> <p>e. Check rubber bushings for cracks, damage, and looseness.</p> <p>f. Lubricate front axle spring with GAA.</p>	<p>a. Cracks or breaks evident.</p> <p>b. Missing, loose, cracks, or visible damage evident.</p> <p>c. Any retaining hardware parts, bolts or parts are missing or broken.</p> <p>d. Class III oil leaks or damage is present.</p> <p>e. Rubber bushings are cracked, damaged or loose.</p>

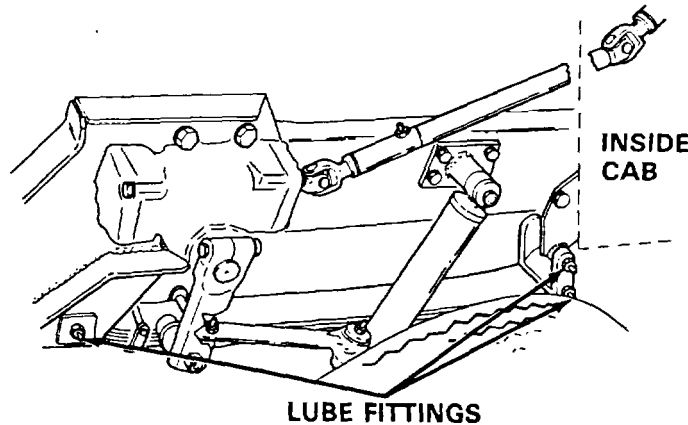

Change 2-28.4

Table 2-1. Unit Level Preventive Maintenance Checks and Services M915A1

Item No.	Interval	Item to be Inspected	Procedures:	Not Mission Capable If:
49	Annual	Transmission	<p>a. Check transmission for leaks and damage to connecting lines and fittings (paragraph 3-141).</p> <p>b. Change the transmission oil and external transmission oil filter after the initial 3, 000 miles or 3 months, whichever occurs first. Thereafter, the oil and external filter should be changed every 24, 000 miles or 12 months, whichever comes first.</p> <p style="text-align: center;">NOTE</p> <p>The automatic transmission should be at operating temperature when the transmission oil is drained. This will ensure quicker and better drainage.</p> <p>c. Replace the external transmission oil filter and fill the transmission through the dipstick opening with 7.8 gallons.</p> <p>d. Remove and clean the transmission breather.</p>	<p>a. Class III leaks or damage is present.</p>

Change 1 2-28.5

Table 2-1. Unit Level Preventive Maintenance Checks And Services M915A1

Item No.	Interval	Item to be Inspected	Procedures:	Not Mission Capable If:
			<p style="text-align: center;">FINAL ROAD TEST</p> <p>After all services and inspections have been completed, take vehicle on a short road test to make sure all corrections have been accomplished. Correct any defects or malfunctions that occur during this test.</p> <p>During road test:</p> <ol style="list-style-type: none"> 1. Listen for any noises. 2. Check steering operation. 3. Check operation of brakes. 4. Check transmission operation; all ranges. 5. Check engine retarder (JACOBS ENGINE BRAKE) operation (TM 9-2320-283-10). 6. Note any loss of power or rough running engine. 7. Check differential lockup system operation(TM 9-2320-283-10). 	

Change 1 2-28.6

Table 2-1. Unit Level Preventive Maintenance Checks and Services M915A1

Item No.	Interval	Item to be Inspected	Procedures:	Not Mission Capable If:
50	Biennially	Front Wheel Knuckle	<p style="text-align: center;">NOTE</p> <p>Pressure gun should be held on fittings until new grease appears. This will assure that all the old contaminated grease has been forced out. Lubricate wheel knuckle with GAA.</p>	Fittings will not purge old lubricant out of component.
51	Biennially	Forward Rear and Rear Axles	<p style="text-align: center;">NOTE</p> <p>Drain and fill the forward-rear axle and rear-rear axle lubrication, including axle hubs, every 24, 000 miles or 24 months, whichever comes first.</p> <p style="text-align: center;">CAUTION</p> <p>Prior to filling the forward-rear axle, remove the filler plug at the top of the differential carrier near the power divider cover and add two pints of gear lube. Reinstall fill plug. Add the remaining 38 pints to the forward-rear axle differential housing.</p>	

Change 1 2-28.7

Table 2-1. Unit Level Preventive Maintenance Checks And Services M915A1

Item No.	Interval	Item to be Inspected	Procedures:	Not Mission Capable If:
51	Biennially	Forward Rear and Rear Axles Continued	Drain and refill axle differentials with GO.	Differentials have not been drained within specified interval.

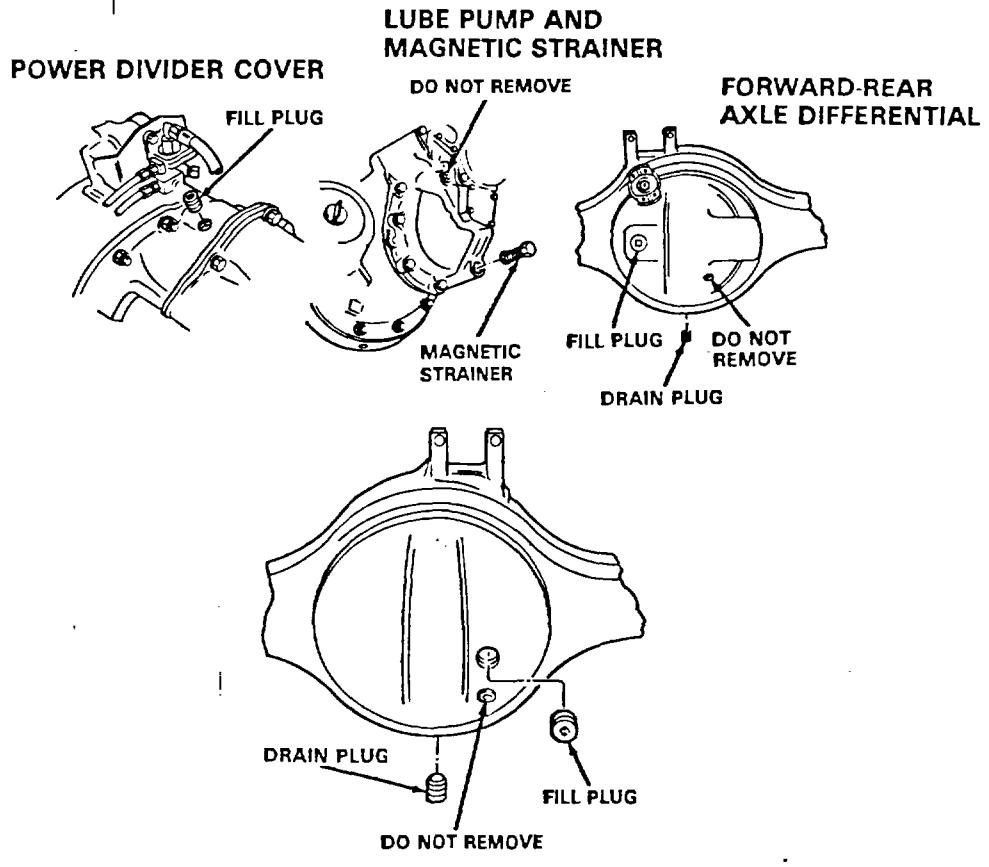

Table 2-1. Unit Level Preventive Maintenance Checks and Services M915A1

Item No.	Interval	Item To Be Inspected	Procedures	Not Mission Capable If:
52	Biennially	Forward Rear and Rear-Rear Axle Hub Bearings	<p style="text-align: center;">CAUTION</p> <p>If maintenance or new hub bearings are required in either the forward-rear axle or rear-rear axle, it will be necessary to tilt each side of the rear axles to assure that adequate gear lube is supplied to the individual hub bearings after installation.</p> <p>a. Fill forward-rear axle and rear-rear axle with proper gear lube and replace filler plugs.</p> <p>b. Raise left side of rear axle approximately 4 inches above the ground. Maintain this position for two minutes to allow gear lube to flow into hub bearings at the opposite or right side.</p> <div style="display: flex; align-items: center;"> <div style="margin-right: 10px;"> <p>RAISE TO 4" ABOVE GROUND LEVEL FOR TWO MINUTES. REPEAT FOR OTHER SIDE.</p> </div>  </div> <p style="text-align: center;">Change 1 2-28.9</p>	

Table 2-1. Unit Level Preventive Maintenance Checks and Services M915A1

Item No.	Interval	Item To Be Inspected	Procedures	Not Mission Capable If:
52	Biennially	Forward Rear and Rear-Rear Axle Hub Bearings	<p>c. Repeat this procedure for the opposite or right side.</p> <p>d. With vehicle level again, add additional gear lube through the differential cover filler hole. The forward-rear axle and the rear-rear axle should require two pints each.</p>	
53	Biennially	Internal Transmission Oil Filter	<p>Transmission internal oil filter should be changed every 24,000 miles or 24 months, whichever occurs first.</p> <p style="text-align: center;">Change 1 2-28.10</p>	

M915A1 TRUCK
PMCS PARTS LIST

<u>ITEM NO</u>	<u>PART NUMBER</u>	<u>STOCK NUMBER</u>	<u>NOMENCLATURE</u>	<u>QTY</u>	<u>REMARKS</u>
SEMI-ANNUAL (6,000 MILES)					
1	299670	2940-01-019-4513	ENG-FF-OIL-FTR	1	
2	3304232	2940-01-145-9455	ENG-BP-OIL-FTR	1	
3	250C127	2940-01-065-8396	INT-AIR-FTR	1	DON'T REUSE
4	286718	2940-01-081-1391	DESSICANT-PACK	1	
ANNUAL (12,000 MILES)					
1	299670	2940-01-019-4513	ENG-FF-OIL-FTR	1	
2	3304232	2940-01-145-9455	ENG-BP-OIL-FTR	1	
3	250C127	2940-01-065-8396	INT-AIR-FTR	1	DON'T REUSE
4	286718	2940-01-081-1391	DESSICANT-PACK	1	
5	FS1212	2910-01-146-1099	PRI-FUEL-FILT	1	
6	WF2071	4330-00-274-4712	ENG-WTR-FILTER	1	
7	25010643	2520-01-132-4842	TRANS-EXT-FTR	1	
8	250C128	2940-01-066-1237	EXT-AIR-FTR	1	CLEAN 5X ONLY
BIENNIAL (24,000 MILES)					
1	299670	2940-01-019-4513	ENG-FF-OIL-FTR	1	
2	3304232	2940-01-145-9455	ENG-BP-OIL-FTR	1	
3	250C127	2940-01-065-8396	INT-AIR-FTR	1	DON'T REUSE
4	286718	2940-01-081-1391	DESSICANT-PACK	1	
5	FS1212	2910-01-146-1099	PRI-FUEL-FILT	1	
6	WF2071	4330-00-274-4712	ENG-WTR-FILTER	1	
7	25010643	2520-01-132-4842	TRANS-EXT-FTR	1	
8	250C128	2940-01-066-1237	EXT-AIR-FTR	1	CLEAN 5X ONLY
9	23013625	2520-01-096-1739	TRANS-INT-FTR	1	
10	ERS-27549-PL	2530-01-198-4500	P/S PMP FILTER	1	
11	380-8036	5330-01-177-9673	SEAL, WHL BRNG	2	M915A1 FRONT AX
12	330-3009	5330-01-071-8179	HUB GASKET	2	M915A1 FRONT AX
13	47697	5330-01-117-1014	SEAL, WHL BRNG	4	M915A1 TANDEM

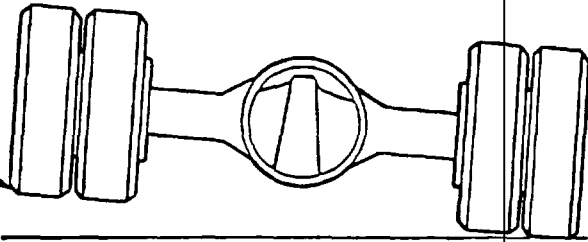
Change 1 2-28.11

LUBRICATION TABLE

LUBRICANTS (SEE NOTE 24)	REFILL CAPACITY (APR.)	EXPECTED TEMPERATURES		
		Above +32°F	+40°F to -10°F	0°F to 65 °F
OE/HDO - OIL ENGINE	11.5 GAL WITH BOTH FILTERS	OE/HDO 30	OE/HDO 10	OEA
OE/HDO AND OEA (ARCTIC GRADE) TRANSMISSION	22 QUARTS	OE/HDO 10	OE/HDO 10	OEA
GO LUBRICANT, MULTIPURPOSE TRANSFER CASE	5 QUARTS	GO 80/90	GO 80/90	GO 75
GO LUBRICANT, MULTIPURPOSE DIFFERENTIALS	SEE NOTE 7A	GO 85/140	GO 80/90 (40°F LIMIT)	GO 75
GO LUBRICANT, MULTIPURPOSE WINCH DRUM	5 QUARTS	GO 80/90	GO 80/90	GO 75
OE.HDO-OIL AND OEA (ARCTIC GRADE) WINCH RESERVOIR	42 GALLONS OE/HDO 10	OE/HDO 10	OEA	
DEXRON	2 QUARTS			
GAA - GREASE AUTOMOTIVE & ARTILLERY	AS REQUIRED	ALL TEMPERATURES		
CW11-LUBR, CHAIN EXPOSED GEAR AND WIRE ROPE	AS REQUIRED			
		INTERVALS D - DAILY (OPERATOR) S - SEMIANNUALLY (6 MONTHS) A -ANNUALLY 1 -1,000 MILES 2 - 2,000 MILES 10 - 10,000 MILES 24 - 24,000 MILES 50 - 50,000 MILES 100 - 100,000 MILES FOR ARCTIC OPERATION REFER TO FM 9-207		

U S GOVERNMENT PRINTING OFFICE 1993 -746 .017/80157

CHANGE 1 2-28.12

2-9. SECTION IV.

- a. This section provides procedures to troubleshoot vehicle systems, assemblies, and components for which repairs are authorized at the organizational maintenance level.
- b. In many cases, you will be given connector pin designations and harness connections to help make your troubleshooting easier. In Appendix D (TM 9-2320-283-20-3) you will find information that will help you identify connector pins and harness locations that are not yet familiar to you.
- c. For your convenience, the appropriate STE/ICE GO and NO-GO chain tests will be referenced next to the corresponding malfunction in the troubleshooting symptom index. The procedures for these tests can be found in section V of this chapter. In the event that STE/ICE equipment is not available (or where it is not applicable), use this section as a troubleshooting substitute.
- d. The troubleshooting procedures in this section cannot give all the answers or correct all vehicle malfunctions encountered. However, these procedures are organized as step-by-step studies that direct tests and inspections toward the source of a problem and successful correction.
- e. Don't begin troubleshooting with the first malfunction you find. Search for other visible malfunctions. From other malfunctions you may be able to find a common problem area in which to concentrate your efforts.
- f. Check all tags, service request forms, and vehicle log book for repair history. This may also help lead you to the source of a problem.
- g. Always check the easiest and most obvious things first. For example, check the appropriate circuit breaker and relay for an electrical problem, before troubleshooting the entire circuit. This simple rule saves time and trouble.
- h. Before correcting a problem, diagnose the cause of the problem. Do not allow the same failure to occur again.

WARNING

Operation of a deadlined vehicle without preliminary inspection could cause further damage to a disabled component and possible injury to personnel.

TROUBLESHOOTING

2-9. GENERAL (Continued).

NOTE

• The following list of circuit colors and abbreviations are used in the troubleshooting schematics found in paragraph 2-11.

White	WH	Yellow	YL	Light Blue	LB	Tan	TN
Red	RD	Light Green	LG	Dark Blue	DB	Brown	BR
Pink	PK	Dark Green	DG	Purple	PP	Gray	GY
Orange	OR					Black	BK

• The following symbols shown below are used throughout the troubleshooting procedures. They are listed here as reference only. Additional symbols are used in specific procedures and labeled as required.

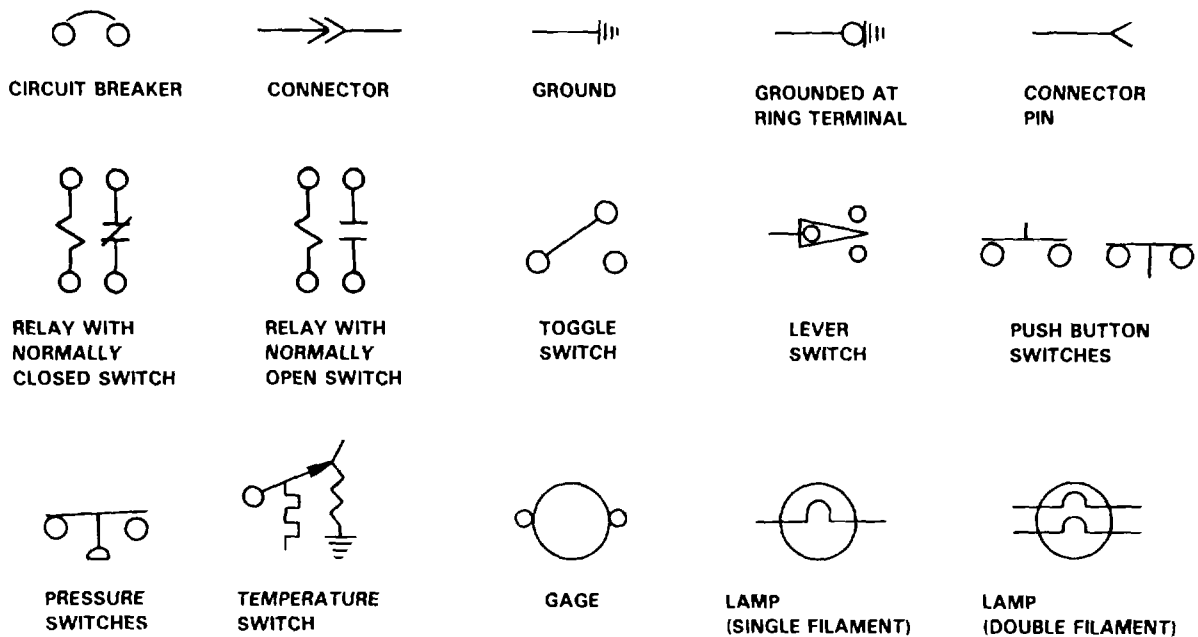

i. In the following troubleshooting procedures you will be asked to test for certain voltage measurements. The word nominal will follow a voltage measurement where an exact voltage reading is not important. In these cases a close voltage reading will be considered normal. For example, 10.5 volts dc would be acceptable if measuring for 12-volts dc nominal. However, 10.5 volts dc would not be acceptable if only measuring for 12-volts dc. Remember, a nominal measurement means an approximate measurement.

TROUBLESHOOTING.

2-10. TROUBLESHOOTING SYMPTOM INDEX.		
MALFUNCTION NO	MALFUNCTION	TROUBLESHOOTING PROCEDURE PAGE
ENGINE		
1	Engine Fails to Crank (STE/ICE Tests GO1-GO2-NG20)	2-36
2	Engine Cranks, but Fails to Start (STE/ICE Tests GO1-GO2-NG30-NG80)	2-36
3	Engine Will Not Idle (STE/ICE Tests GO1-G67)	2-37
4	Engine Overheats (Temperature Exceeds 210°F) (STE/ICE Tests GO1-GO3-G05-NG31)	2-37
5	Intermittent Loss of Power (STE/ICE Tests GO1-G06-G08)	2-38
6	Sudden Loss of Power (STE/ICE Tests GO1-GO6-GO8-NG90)	2-39
7	Gradual Loss of Power (STE/ICE Tests GO1-GO6-GO8-NG90)	2-39
8	Low or No Engine Oil Pressure (STE/ICE Tests GO1-G03-NG05-NG31)	2-40
9	Excessive Exhaust Smoke During Acceleration (STE/ICE Tests GO1-NG90)	2-40
10	Excessive Exhaust Smoke Throughout Speed Range (STE/ICE Tests GO1-NG90)	2-41
11	Engine Stops (STE/ICE Tests GO1-G07-NG36)	2-41
12	High Oil Use (STE/ICE Tests GO1-G08)	2-41
13	Slow Deceleration (Engine "Floats") (STE/ICE Tests GO1-NG90)	2-42
14	High Fuel Use (STE/ICE Tests GO1-GO6-NG90-NG130)	2-42
15	Exhaust Fumes in Cab	2-42
COOLING SYSTEM		
16	No Cab Heat	2-43
ELECTRICAL SYSTEM		
17	Ether Solenoid Fails to Operate When Ether Start Switch is Pushed.....	2-44
18	All Electrical Systems are Weak (STE/ICE Tests GO1-G04)	2-49
19	Starter Operates Slowly (STE/ICE Tests GO1-GO2-NG30-NG130)	2-50
20	Starter Fails to Operate (STE/ICE Tests GO1-G04-NG20-NG80-NG81)	2-51
21	Batteries Do Not Hold a Charge (Electrical System Shorted) (STE/ICE Tests GO1-NG81)	2-60

TROUBLESHOOTING.

2-10. TROUBLESHOOTING SYMPTOM INDEX.

MALFUNCTION NO	MALFUNCTION	TROUBLESHOOTING PROCEDURE PAGE
ELECTRICAL SYSTEM		
22	Starter Motor is Noisy and Engagement is Erratic (STE/ICE Tests GO1-G02-G04-NG20-NG80).....	2-62
23	Retarder Not Working in One or Two Selector Positions	2-62
24	No Retarding Action.....	2-66
25	Batteries are Being Undercharged or Overcharged (STE/ICE Tests GO1-G04-NG50-NG80-NG81)	2-70
26	Hot Engine Indicator Not Working (STE/ICE Tests GO1-NG31)	2-71
27	Low Engine Oil Indicator Not Working (STE/ICE Tests GO1-NG05-NG31).....	2-76
28	Low Air Pressure Indicator and/or Buzzer Not Working	2-80
29	Differential Lock Lamp Not Working	2-84
30	Park Brake Lamp Not Working	2-87
31	Instrument Panel Gages Not Working	2-90
32	Tachograph Clock Not Working	2-98
33	No Power at 12-volt Circuit Breakers CB-2, CB-3, and/or CB-4.....	2-100
34	No Power at 12-volt Circuit Breakers CB-1, CB-5, CB-6, and/or CB-7.....	2-110
35	No Power at 24-volt Circuit Breakers CB-8 and/or CB-9.....	2-120
36	Shift Tower Lamp Not Working.....	2-124
37	Ether Lamp and/or Clearance Lamp Not Working	2-125
38	Washer Lamp and/or Wiper Lamp Not Working	2-128
39	Heater Lamp Not Working	2-130
40	Instrument Panel Gage Lamp or Lamps Not Working	2-131
41	Both Headlamps Blink On and Off.....	2-134
42	One Headlamp Not Working.....	2-138
43	Both Headlamps Not Working in either High or Low Beam Position	2-140
44	Headlamp Switch Not Working.....	2-142
45	Dimmer Switch Indicator Lamp Not Working.....	2-143
46	Both Front Marker Lamps Not Working (Front Turn Signal Lamps OK).....	2-144
47	One Front Marker Lamp Not Working (Front Turn Signal Lamp OK)	2-146
48	One or More Cab Clearance and Marker Lamps Not Working	2-150
49	All Cab Clearance and Marker Lamps Not Working	2-154
50	One Taillamp Not Working	2-156
51	Both Taillamps Not Working	2-157
52	One Front Turn Signal Lamp Not Working	2-160

TROUBLESHOOTING.

2-10. TROUBLESHOOTING SYMPTOM INDEX.

MALFUNCTION NO	MALFUNCTION	TROUBLESHOOTING PROCEDURE PAGE
ELECTRICAL SYSTEM (Continued)		
53	Both Front and Rear Turn Signal Lamps Not Working	2-164
54	One Rear Turn Signal Lamp Not Working	2-168
55	Both Rear Turn Signal Lamps Not Working	2-169
56	Both Stoplamps Not Working	2-170
57	One Stoplamp Not Working	2-174
58	Both Reverse Lamps Not Working	2-178
59	One Reverse Lamp Not Working	2-182
60	Blackout Headlamp Not Working	2-184
61	Both Blackout Marker Lamps Not Working	2-188
62	One Blackout Marker Lamp Not Working	2-188
63	Both Blackout Stoplamps Not Working	2-192
64	One Blackout Stoplamp Not Working	2-198
65	Both Blackout Taillamps Not Working	2-200
66	One Blackout Taillamp Not Working	2-201
67	All Blackout Lamps Not Working	2-203
68	Both 12-volt Trailer Stoplamps Not Working	2-204
69	One 12-volt Trailer Stoplamp Not Working	2-204
70	Both 12-volt Trailer Turn Signal Lamps Not Working	2-206
71	One 12-volt Trailer Turn Signal Lamp Not Working	2-206
72	Both 12-volt Trailer Taillamps Not Working	2-208
73	One Trailer Taillamp Not Working	2-209
74	All 12-volt Trailer Clearance and Marker Lamps Not Working	2-209
75	Both 24-volt Trailer Stoplamps Not Working	2-212
76	One 24-volt Trailer Stoplamp Not Working	2-218
77	Both 24-volt Trailer Turn Signal Lamps Not Working	2-228
78	One 24-volt Trailer Turn Signal Lamp Not Working	2-230
79	Both 24-volt Trailer Taillamps Not Working	2-232
80	Both 24-volt Trailer Blackout Stoplamps Not Working	2-242
81	24-volt Trailer Blackout Taillamps Not Working	2-252
82	Electrical Horn Not Working	2-266
83	Personnel Heater Fan Motor Not Working	2-272
84	Dome Lamp Not Working	2-274
85	Both Map Lamps Not Working	2-278
86	One Map Lamp Not Working	2-278
87	Map Lamps Light, but are Dim	2-280
88	Cigar Lighter Receptacle Not Working	2-282
89	Left Side Utility Outlet Receptacle Not Working	2-283
90	Both Utility Outlet Receptacles Not Working	2-284

TROUBLESHOOTING.

2-10. TROUBLESHOOTING SYMPTOM INDEX.

MALFUNCTION NO	MALFUNCTION	TROUBLESHOOTING PROCEDURE PAGE
TRANSMISSION		
91	Transmission Shifts at too High a Speed.....	2-292
92	Transmission Shifts at too Low a Speed	2-292
93	Transmission Overheating in all Ranges	2-292
94	No Response to Shift Lever Movement	2-292
95	Rough Shifting	2-293
96	Transmission Oil Dirty, Foamy, and/or Milky	2-293
97	Loss of Power	2-294
98	Clutch Slippage in all Forward Gears	2-294
99	Vehicle Moves in Neutral	2-294
100	Oil Thrown from Filler Tube	2-294
PROPELLER SHAFTS AND UNIVERSAL JOINTS		
101	Excessive Shaft Noise or Vibration.....	2-295
102	Excessive Backlash	2-296
103	Continuous Axle or Wheel Noise	2-296
104	Lubricant Leaking	2-297
105	Excessive or Uneven Tire Wear	2-297
REAR AXLE		
106	Rear Axle Assembly Not Tracking Properly.....	2-298
BRAKE SYSTEM		
107	Air Pressure Low.....	2-298
108	Air Pressure High.....	2-300
109	Park Brakes Will Not Release	2-302
110	Trailer Brakes Will Not Release.....	2-302
111	Service Brakes Will Not Release (One Wheel Only)	2-304
112	Service Brakes Will Not Apply	2-304
113	No Service Brakes on Trailer Only	2-306
114	Trailer Hand Control Will Not Apply Trailer	
	Service Brakes.....	2-306

TROUBLESHOOTING.

2-10. TROUBLESHOOTING SYMPTOM INDEX.

MALFUNCTION NO	MALFUNCTION	TROUBLESHOOTING PROCEDURE PAGE
BRAKE SYSTEM (Continued)		
115	Park Brakes Will Not Apply	2-308
116	Service Brakes are Weak or Slow Working (All Wheels)	2-308
117	Front Service Brakes are Weak or Slow Working	2-308
118	Rear Service Brakes are Uneven or Erratic.....	2-310
119	Service Brakes are Uneven or Erratic on One or More Wheels.....	2-310
120	Brakes Overheat.....	2-312
121	Stop lamps Do Not Operate (Brakes Normal)	2-314
122	Pressure Gage(s) Not Indicating or Not Accurate (Brakes Normal).....	2-314
123	Air Horn Not Working.....	2-316
124	Windshield Wipers Not Working	2-316
125	Interaxle Differential Lockout Not Working	2-316
WHEELS		
126	Tires Wearing Unevenly	2-318
127	Noisy or Bumping Sounds While Traveling on Road.....	2-318
STEERING SYSTEM		
128	Front Tires Wearing Unevenly	2-320
129	Vehicle Does Not Fully Steer from Stop to Stop.....	2-321
130	Front End Wanders	2-321
131	Front End Shimmies	2-323
132	Vehicle Oversteers	2-324
133	Hard Steering in One Direction.....	2-325
134	Hard Steering in Both Directions.....	2-325
135	Lost Motion or Excessive Play in Steering Wheel	2-326
FRAME AND TOWING ATTACHMENTS		
136	Towing Pintle Does Not Pivot or Latch, or Jaw is Stuck	2-326
137	Excessive Jerking of Towed Trailer	2-327
138	Excessive Noise or Popping Sounds from Fifth Wheel when Turning.....	2-327

TROUBLESHOOTING.

2-10. TROUBLESHOOTING SYMPTOM INDEX.

MALFUNCTION

TEST OR INSPECTION

CORRECTIVE ACTION

ENGINE

1. ENGINE FAILS TO CRANK.

Check electrical system.

- a. Troubleshoot starting system. (Refer to malfunction 20).
- b. Notify direct support maintenance.

2. ENGINE CRANKS BUT FAILS TO START.

Step 1. Check for leaking or broken fuel lines.

Tighten connections, or replace fuel lines (para 3-28 or 3-36).

Step 2. Check fuel specifications for cold weather operation.
(Refer to TM 9-2320-283-10).

Replace fuel, if necessary.

Step 3. Turn ignition switch on and off, while assistant listens for clicking sounds at fuel solenoid valve.

Replace or repair fuel solenoid valve (para 3-33).

Step 4. Check for dirt and water in fuel.

Replace water separator fuel filter, and clean fuel filter screen (para 3-27 and 3-37).

Step 5. Check exhaust system for damage or blockage.

- a. Replace damaged portion of exhaust system (para 3-45 thru 3-49).
- b. Clear blockage from exhaust system.

TROUBLESHOOTING.

2-10. TROUBLESHOOTING SYMPTOM INDEX.

MALFUNCTION

TEST OR INSPECTION

CORRECTIVE ACTION

2. ENGINE CRANKS BUT FAILS TO START (Continued).

- Step 6. Check for air intake restriction.
 - a. Clean or replace air cleaner filter element (para 3-30).
 - b. Clean or replace air cleaner tube (para 3-32).
- Step 7. Check electrical system.
Troubleshoot starting system. (Refer to malfunction 19).
- Step 8. Notify direct support maintenance.

3. ENGINE WILL NOT IDLE.

- Step 1. Check for loose or broken fuel supply lines.
Tighten connections, or replace fuel supply lines (para 3-28 or 3-36).
- Step 2. Check for dirt and water in fuel.
Replace water separator fuel filter, and clean fuel filter screen (para 3-27 and 3-37).
- Step 3. Notify direct support maintenance.

4. ENGINE OVERHEATS (TEMPERATURE EXCEEDS 210°F).

- Step 1. Check for loose or broken fan clutch drive belts.
Adjust or replace belts (para 3-67).
- Step 2. Check for defective water temperature gage.
Refer to malfunction 31, steps 1 and 8.

TROUBLESHOOTING.**2-10. TROUBLESHOOTING SYMPTOM INDEX.****MALFUNCTION****TEST OR INSPECTION****CORRECTIVE ACTION****4. ENGINE OVERHEATS (TEMPERATURE EXCEEDS 210°F) (Continued).**

- | | |
|--------|---|
| Step 3 | Check water temperature sending unit.
Refer to malfunction 31, step 8. |
| Step 4 | With engine running and radiator cap removed, check for proper coolant flow. <ul style="list-style-type: none"> a Replace thermostat (para 3-59). b Replace water pump (para 3-64). |
| Step 5 | With engine running and radiator cap installed, check for signs of leaks and collapsed radiator hoses. <ul style="list-style-type: none"> a Replace hose, if necessary (para 3-58). b Replace radiator, if leaking (para 3-53). |
| Step 6 | Check fan clutch operation. <ul style="list-style-type: none"> a Check air valve tubes for cracks. Replace if necessary (para 3-163). b Replace air valve (para 3-66). c Replace fan clutch (para 3-65). |
| Step 7 | Notify direct support maintenance. |

5. INTERMITTENT LOSS OF POWER.

- | | |
|--------|--|
| Step 1 | Check for leaking fuel lines.
Tighten connections, or replace fuel lines (para 3-28 or 3-36). |
| Step 2 | Check fuel tank vent plug for blockage.
Remove and clean fuel tank air vent (para 3-34). |

TROUBLESHOOTING.

2-10. TROUBLESHOOTING SYMPTOM INDEX.

MALFUNCTION

TEST OR INSPECTION

CORRECTIVE ACTION

5. INTERMITTENT LOSS OF POWER.

Step 3 Check for dirt and water in fuel.
 Replace water separator fuel filter, and clean fuel filter screen (para 3-27 and 3-37).

6. SUDDEN LOSS OF POWER.

Step 1 Check fuel level in tank.
 Add fuel, if necessary (Refer to TM 9-2320-283-10).
 Step 2 Check fuel tank vent plug for blockage.
 Remove and clean fuel tank vent plug (para 3-34).
 Step 3 Refer to malfunction 2, steps 1 thru 7.

7. GRADUAL LOSS OF POWER.

Step 1 Check for leaking fuel lines.
 Tighten connections, or replace fuel lines (para 3-28 or 3-36).
 Step 2 Check for air intake restriction.
 Remove blockage from air intake.
 Step 3 Check for loose accelerator linkage.
 Adjust and replace parts (para 3-41).
 Step 4 Check fuel specifications for cold weather operation.
 (Refer to TM 9-2320-283-10).
 Replace fuel, if necessary.

TROUBLESHOOTING.

2-10. TROUBLESHOOTING SYMPTOM INDEX.

MALFUNCTION

TEST OR INSPECTION

CORRECTIVE ACTION

7 GRADUAL LOSS OF POWER (Continued).

Step 5 Check for dirt and water in fuel.
 Replace water separator fuel filter, and clean fuel filter screen (para 3-27 and 3-37).

8 LOW OR NO ENGINE OIL PRESSURE.

Step 1 Check for defective engine oil pressure gage.
 Refer to malfunction 31, steps 1 and 12.
 Step 2 Check for defective engine oil pressure sending unit.
 Refer to malfunction 31, step 12.
 Step 3 Notify direct support maintenance.

9 EXCESSIVE EXHAUST SMOKE DURING ACCELERATION.

Step 1 Check for black or gray exhaust smoke.
 a Clear blockage from air intake.
 b Clean air cleaner element.
 c Repair air crossover leaks or replace turbocharger air crossover connection (para 3-31).
 d Notify direct support maintenance.
 Step 2 Check for blue exhaust smoke If exhaust is blue, check maintenance log for excessive oil usage.
 Notify direct support maintenance.

TROUBLESHOOTING.

2-10. TROUBLESHOOTING SYMPTOM INDEX.

MALFUNCTION

TEST OR INSPECTION

CORRECTIVE ACTION

9 EXCESSIVE EXHAUST SMOKE DURING ACCELERATION (Continued).

Step 3 Check for white exhaust smoke (normal in cold weather) If exhaust is white, check radiator coolant for signs of oil. Notify direct support maintenance.

10 EXCESSIVE EXHAUST SMOKE THROUGHOUT SPEED RANGE.

Step 1 If exhaust smoke is black, check fuel specification for correct fuel type.
 Replace fuel, if necessary (Refer to TM 9-2320-283-10).
 Step 2 Refer to malfunction 9, steps 1 thru 3.

11 ENGINE STOPS.

Step 1 Check fuel level in tank.
 Add fuel, if necessary (Refer to TM 9-2320-283-10).
 Step 2 Check fuel tank vent plug for blockage.
 Remove and clean fuel tank vent plug (para 3-34).
 Step 3 Refer to malfunction 2, steps 1 thru 7.
 Step 4 Notify direct support maintenance.

12 HIGH OIL USE.

Step 1 Check for overfilling.
 a Check oil level.
 b Make sure proper oil level gage (dipstick) is being used by matching it against known correct configuration.

TROUBLESHOOTING.

2-10. TROUBLESHOOTING SYMPTOM INDEX.

MALFUNCTION

TEST OR INSPECTION

CORRECTIVE ACTION

12 HIGH OIL USE (Continued).

- Step 2 Check that proper grade oil is used for climate.
Replace oil, if necessary (Refer to LO 9-2320-283-12).
- Step 3 Check for loose or broken oil lines.
 - a Tighten connections, or replace oil lines.
 - b Notify direct support maintenance.

13 SLOW DECELERATION (ENGINE "FLOATS").

- Check for air leaks in fuel pump supply lines.
Tighten connections, or replace fuel lines (para 3-28 or 3-36).

14 HIGH FUEL USE.

- Check for leaking and broken fuel lines.
Tighten connections, or replace fuel lines (para 3-28 or 3-36).

15 EXHAUST FUMES IN CAB.

- Check for loose or defective manifold, or leaks in turbocharger outlet or muffler inlet pipes.
 - a Replace pipes as required (para 3-48 and 3-49).
 - b If manifold or turbocharger is defective, notify direct support maintenance.

TROUBLESHOOTING.

2-10. TROUBLESHOOTING SYMPTOM INDEX.

MALFUNCTION

TEST OR INSPECTION

CORRECTIVE ACTION

COOLING SYSTEM

16 NO CAB HEAT.

- | | |
|--------|--|
| Step 1 | Check heater and heater air hoses for leaks or blockage. |
| | a Adjust cables, if necessary (para 3-301). |
| | b Replace heater air hoses (para 3-296). |
| | c Replace or repair heater (para 3-298). |
| Step 2 | Check for closed water control valve. |
| | a Open valve. |
| | b Bleed heater (para 3-52). |
| Step 3 | With engine running and radiator cap removed, check for proper coolant flow and level. |
| | a Replace thermostat (para 3-59). |
| | b Replace water pump (para 3-64). |
| | c Replace radiator (para 3-53). |
| Step 4 | Check fan clutch operation. |
| | a Check fan clutch air valve tubes for cracks. Replace, if necessary (para 3-163). |
| | b Replace fan clutch air valve (para 3-66). |
| | c Replace fan clutch (para 3-65). |

TROUBLESHOOTING.

2-10. TROUBLESHOOTING SYMPTOM INDEX.

MALFUNCTION

TEST OR INSPECTION

CORRECTIVE ACTION

ELECTRICAL SYSTEM

17 ETHER SOLENOID FAILS TO OPERATE WHEN ETHER START SWITCH IS PUSHED.

1 Remove circuit breaker bracket far enough to access circuit breaker CB-3 (para 3-114), and go to step 2.

NOTE

Ignition switch must be in ON position and battery power connected when doing the following checks.

2 Check for voltage at circuit 51-LG terminal of circuit breaker CB-3

12-volts dc nominal

Install circuit breaker bracket (para 3-114), and go to step 3

Reset circuit breaker CB-3 and/or troubleshoot CB-3 circuit. (Refer to malfunction 33).

3 Check for voltage at circuit 51-LG terminal of ether start switch

12-volts dc nominal

Go to step 4

Repair circuit 51-LG (para 3-127).

NOTE

Ether start switch must be pushed and held when doing the following checks.

4 Disconnect circuit 51B-DG from solenoid valve, and go to step 5.

5 Have assistant operate ether start switch while checking for voltage at circuit 51A-DG terminal of ether start switch.

12-volts dc nominal

Go to step 6

Replace switch (para 3-76). Connect circuit 51B-DG to solenoid.

TROUBLESHOOTING.

2-11. TROUBLESHOOTING PROCEDURES (Continued).

MALFUNCTION	INSTRUCTION	INDICATION	YES	NO
-------------	-------------	------------	-----	----

17. ETHER SOLENOID FAILS TO OPERATE WHEN ETHER START SWITCH IS PUSHED
(Continued).

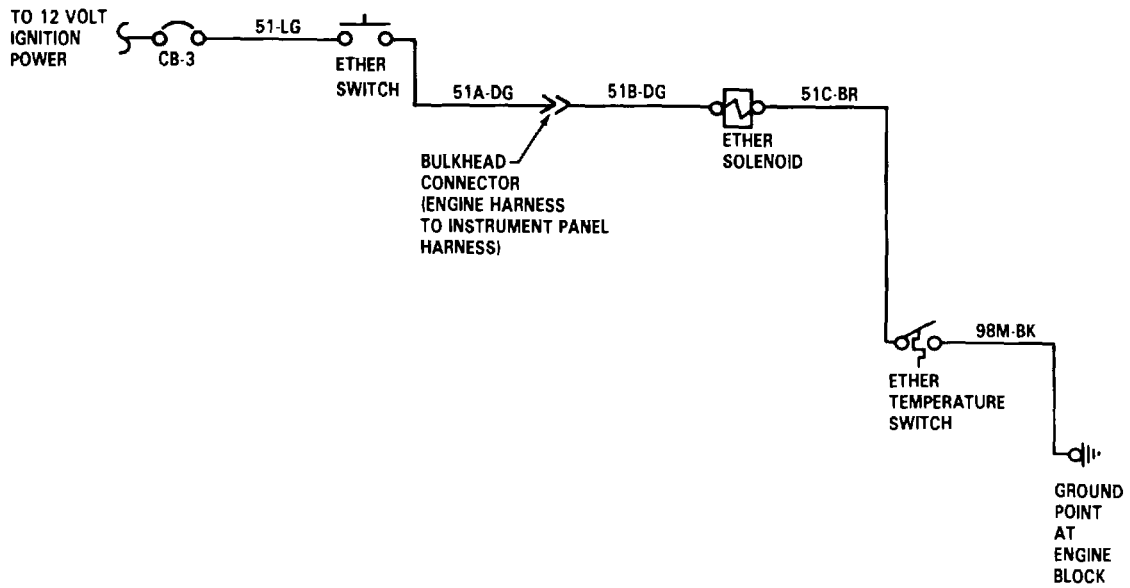

TROUBLESHOOTING.

2-11. TROUBLESHOOTING PROCEDURES (Continued).

MALFUNCTION	INSTRUCTION	INDICATION	YES	NO
<p>17 ETHER SOLENOID FAILS TO OPERATE WHEN ETHER START SWITCH IS PUSHED (Continued).</p>				
<p>6 Disconnect circuit 51A-DG from 51B-DG at connector, and go to step 7.</p>				
<p>7 Check for voltage at circuit 51A-DG (pin 6 of connector)</p>	<p>12-volts dc nominal</p>	<p>Connect circuit 51A-DG to 51B-DG, and go to step 8.</p>		<p>Repair circuit 51A-DG (para 3-127).</p>
<p>8 Have assistant operate ether start switch while checking for voltage at circuit 51B-DG of solenoid valve.</p>	<p>12-volts dc nominal</p>	<p>Go to step 9</p>		<p>Repair circuit 51B-DG (para 3-127).</p>
<p>NOTE</p>				
<p>-With positive lead on circuit 51B-DG (or other suitable 12-volt source), check ground with negative lead when doing the following checks.</p>				
<p>-Engine coolant must be below 70°F.</p>				
<p>9 Check for voltage at circuit 98M-BK of engine block.</p>	<p>12-volts dc nominal</p>	<p>Go to step 10</p>		<p>Tighten and/or clean connection. Connect circuit 51B-DG to solenoid valve.</p>
<p>10 Check for voltage at circuit 98M-BK of thermostat</p>	<p>12-volts dc nominal</p>	<p>Go to step 11</p>		<p>Repair wire 98M-BK (para 3-127). Connect circuit 51B-DG to solenoid valve.</p>

TROUBLESHOOTING.

2-11. TROUBLESHOOTING PROCEDURES (Continued).

MALFUNCTION	INSTRUCTION	INDICATION	YES	NO
-------------	-------------	------------	-----	----

17. ETHER SOLENOID FAILS TO OPERATE WHEN ETHER START SWITCH IS PUSHED
(Continued).

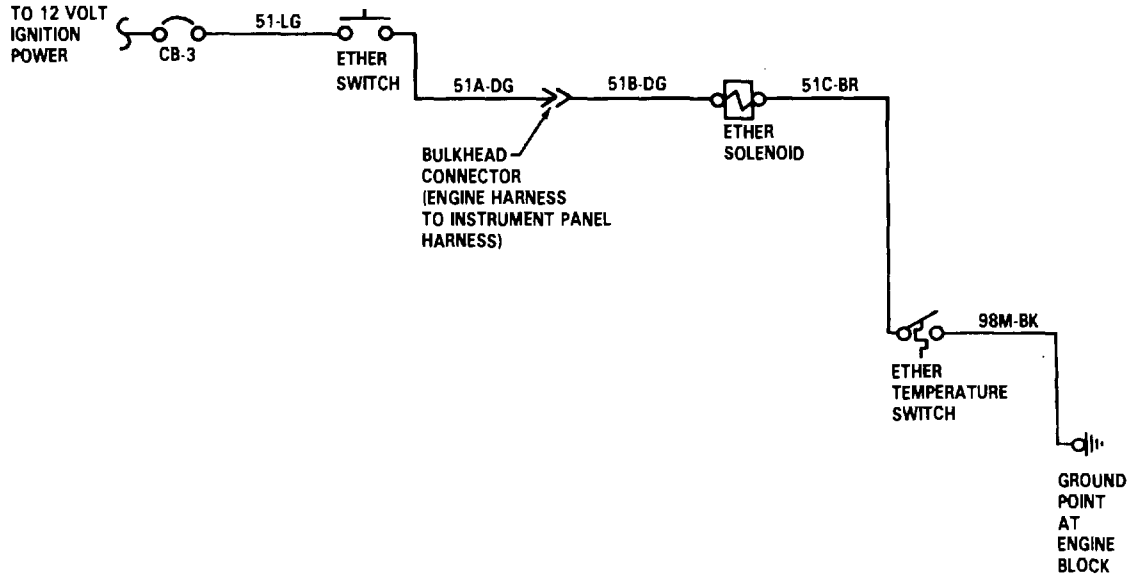

TROUBLESHOOTING.

2-11. TROUBLESHOOTING PROCEDURES (Continued).

MALFUNCTION	INSTRUCTION	INDICATION	YES	NO
<p>17. ETHER SOLENOID FAILS TO OPERATE WHEN ETHER START SWITCH IS PUSHED (Continued).</p>				
11.	Check for voltage at circuit 51C-BR terminal of thermostat.	12-volts dc nominal.	Go to step 12.	Replace thermostat (para 3-39). Connect circuit 51B-DG to solenoid valve.
12.	Check for voltage at circuit 51C-BR terminal of solenoid valve.	12-volts dc nominal.	Go to step 13.	Repair wire 51C-BR (para 3-127). Connect circuit 51B-DG to solenoid valve.
<p>WARNING Ether burns easily. Avoid open flames to prevent personal injury to you and other personnel.</p>				
13.	Remove ether supply tube from engine (para 3-40), and go to step 14.			
14.	Connect circuit 51B-DG to solenoid valve, and go to step 15.			
15.	Have assistant press and hold ether start switch while watching for shot of ether from atomizer.	Ether sprays from end of supply line.	Ether system OK. Install ether supply tube (para 3-40).	Replace atomizer, clean supply tube, or replace solenoid valve (para 3-40).

TROUBLESHOOTING.

2-11. TROUBLESHOOTING PROCEDURES (Continued).

MALFUNCTION	INSTRUCTION	INDICATION	YES	NO
-------------	-------------	------------	-----	----

17 ETHER SOLENOID FAILS TO OPERATE WHEN ETHER START SWITCH IS PUSHED (Continued).

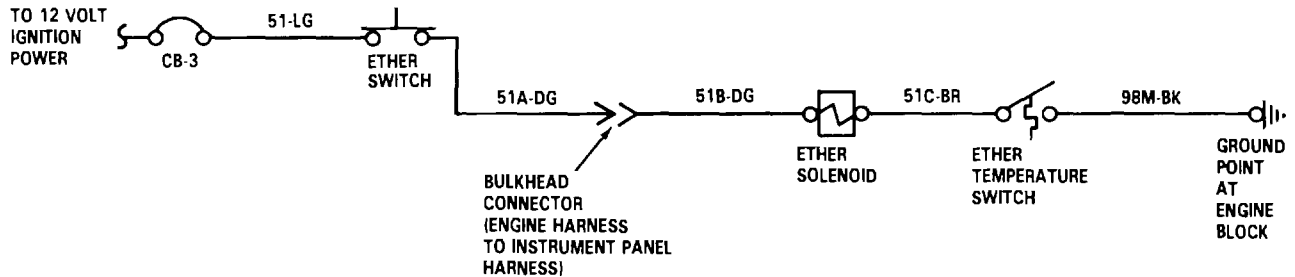

18 ALL ELECTRICAL SYSTEMS ARE WEAK.

1	Inspect battery Terminals	a	Loose	Tighten terminals.	Go to step b.
		b	Corroded or dirty	Clean terminals.	Go to step 2.
2	Inspect battery Case		Cracked or broken	Replace battery (para 3-121).	Go to step 3.
3	Inspect cables		Frayed or broken	Replace battery cable(s) (para 3-124).	Go to step 4.

NOTE

One defective battery in a series-parallel connection will bring down charge of other batteries.

4	Check battery test indicators	a	Green	Test battery (malf 19, step 2).	Go to step b.
		b	Dark	Charge battery (para 3-119).	Go to step c.
		c	Yellow	Replace battery (para 3-121)	Refer to malfunction 25.

TA 236828

TROUBLESHOOTING.

2-11. TROUBLESHOOTING PROCEDURES (Continued).

MALFUNCTION	INSTRUCTION	INDICATION	YES	NO
-------------	-------------	------------	-----	----

19 STARTER OPERATES SLOWLY.

- | | | | | |
|---|--|---------------------|------------------------------------|--------------------------|
| 1 | Check battery test indicator. | a Green | Go to step 2. | |
| | | b Dark | Charge battery (para 3-119). | |
| | | c Yellow | Replace battery (para 3-121). | |
| 2 | Test batteries under load: | | | |
| | a Connect a multimeter to positive and negative battery posts. | | | |
| | b Have an assistant crank engine for 10 seconds. | | | |
| | c Observe meter | 18-volts dc nominal | Notify direct support maintenance. | Refer to malfunction 18. |

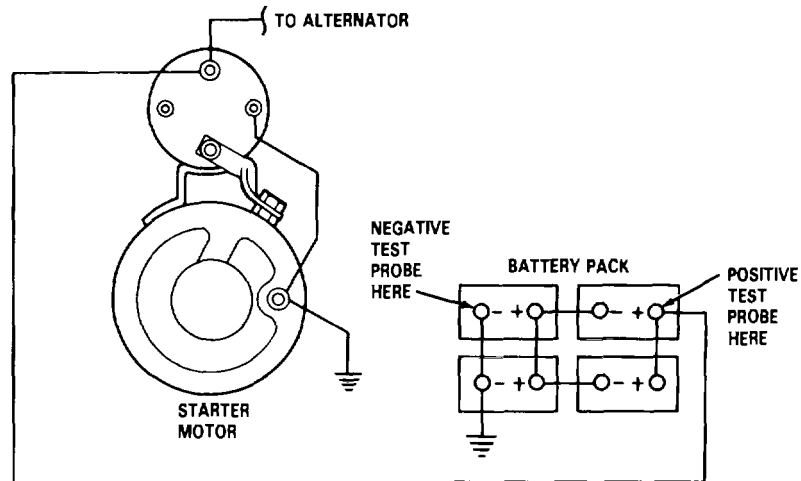

TROUBLESHOOTING.

2-11. TROUBLESHOOTING PROCEDURES (Continued).

MALFUNCTION	INSTRUCTION	INDICATION	YES	NO
-------------	-------------	------------	-----	----

20 STARTER FAILS TO OPERATE.

NOTE

Ignition switch must be in ON position and transmission shift control must be in neutral position when doing the following checks.

- | | | | | |
|---|--|---------------------|--------------|---|
| 1 | Check for voltage at starter solenoid main battery cable connection. | 24-volts dc nominal | Go to step 2 | Refer to malfunction 18. |
| 2 | Check for voltage at circuit 46C-YL terminal of starter relay. | 24-volts dc nominal | Go to step 3 | Repair circuit 46B-YL and/or 46C-YL (para 3-127). |

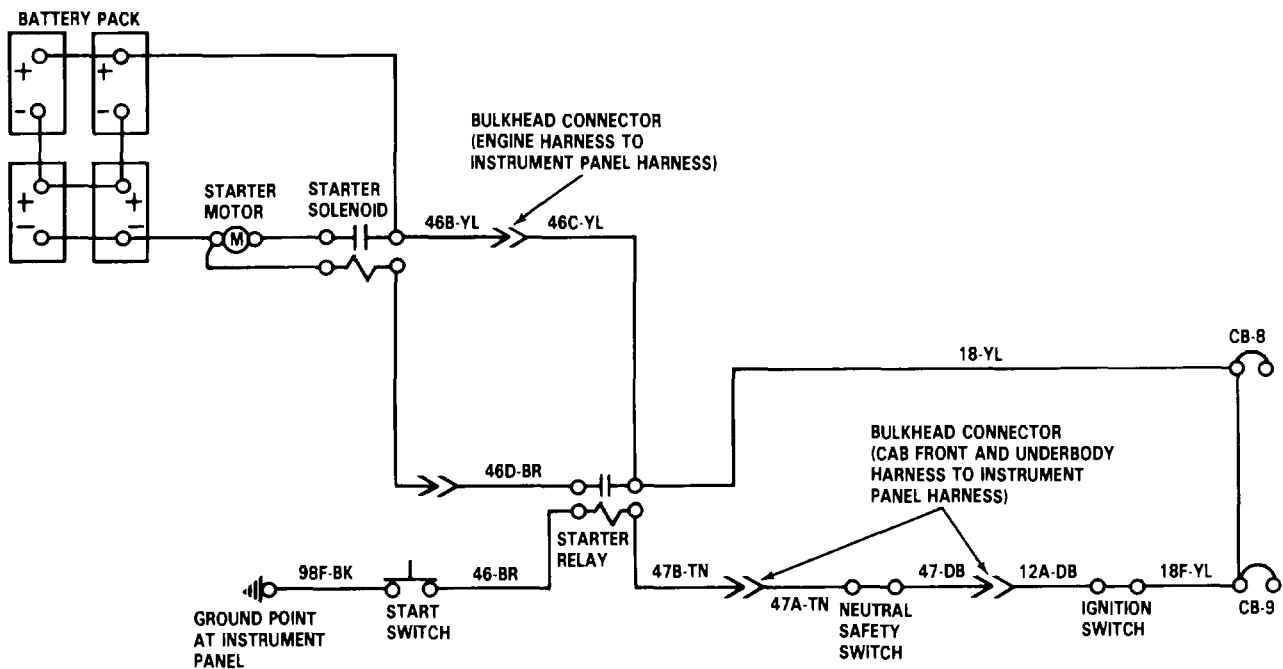

TROUBLESHOOTING.

2-11. TROUBLESHOOTING PROCEDURES (Continued).

MALFUNCTION	INSTRUCTION	INDICATION	YES	NO
20 STARTER FAILS TO OPERATE (Continued).				
3	Remove circuit breaker bracket far enough to access circuit breaker CB-8 (para 3-114), and go to step 4.			
4	Check for voltage at circuit 18-YL terminal of circuit breaker CB-8	24-volts dc nominal	Go to step 5	Repair circuit 18-YL (para 3-127). Install circuit breaker bracket (para 3-114).
5	Check for voltage at circuit 18F-YL terminal of ignition switch	24-volts dc nominal	Install circuit breaker bracket (para 3-114), and go to step 6	Repair circuit 18F-YL and/or clean and tighten connections at circuit breakers CB-8 and CB-9. Install circuit breaker bracket (para 3-114). Replace switch (para 3-74).
6	Check for voltage at circuit 12A-DB terminal of ignition switch.	24-volts dc nominal	Go to step 7	
7	Check for voltage at circuit 47-DB terminal of neutral safety switch	24-volts dc nominal	Go to step 8	Repair circuit 47-DB and/or 12A-DB (para 3-127).

TROUBLESHOOTING.

2-11. TROUBLESHOOTING PROCEDURES (Continued).

MALFUNCTION	INSTRUCTION	INDICATION	YES	NO
-------------	-------------	------------	-----	----

20. STARTER FAILS TO OPERATE (Continued).

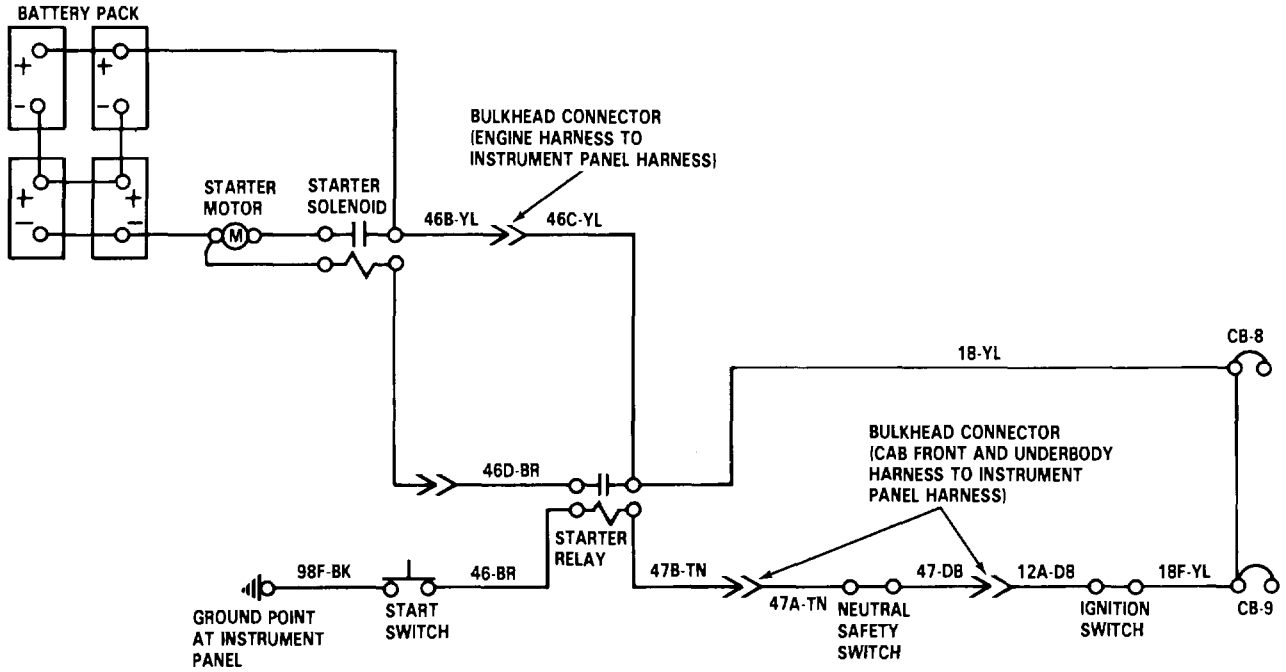

TROUBLESHOOTING.

2-11. TROUBLESHOOTING PROCEDURES (Continued).

MALFUNCTION	INSTRUCTION	INDICATION	YES	NO
20 STARTER FAILS TO OPERATE (Continued).				
8	Check for voltage at circuit 47A-TN terminal of neutral safety switch.	24-volts dc nominal	Go to step 9	Replace neutral safety switch (para 3-106).
9	Check for voltage at circuit 47B-TN terminal of starter relay	24-volts dc nominal	Go to step 10	Repair circuit 47B-TN and/or 47A-TN (para 3-127).
NOTE				
With positive lead on circuit 47B-TN, check ground with negative lead when doing the following checks.				
10	Check for voltage at circuit 98F-BK ground point of instrument panel.	24-volts dc nominal	Go to step 11	Tighten and/or clean connection.
11	Check for voltage at circuit 98F-BK terminal- of start switch	24-volts dc nominal	Go to step 12	Repair circuit 98F-BK (para 3-127).

TROUBLESHOOTING.

2-11. TROUBLESHOOTING PROCEDURES (Continued).

MALFUNCTION	INSTRUCTION	INDICATION	YES	NO
-------------	-------------	------------	-----	----

20. STARTER FAILS TO OPERATE (Continued).

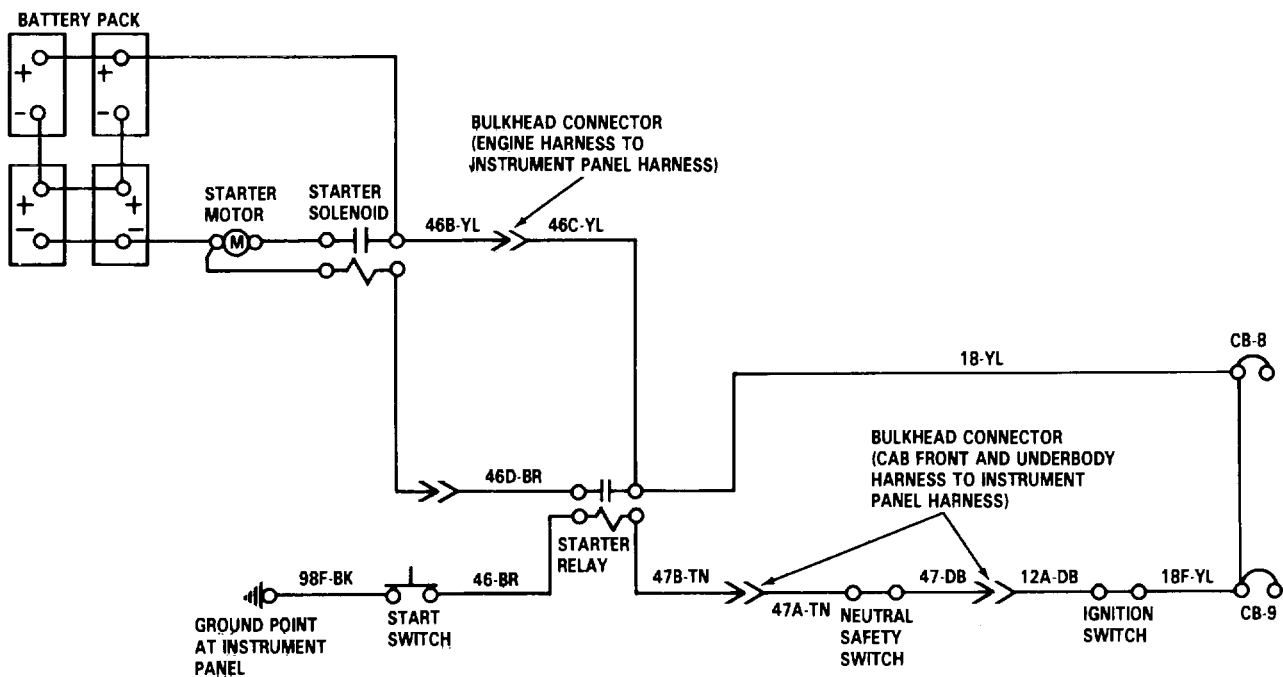

TROUBLESHOOTING.

2-11. TROUBLESHOOTING PROCEDURES (Continued).				
MALFUNCTION	INSTRUCTION	INDICATION	YES	NO
20. STARTER FAILS TO OPERATE (Continued).				
NOTE				
The start switch must be pushed and held when doing steps 12 thru 18.				
12	Check for voltage at circuit 46-BR terminal of start switch.	24-volts dc nominal	Go to step 13 (para 3-75).	Replace switch
13	Check for voltage at circuit 46-BR terminal of starter relay	24-volts dc nominal 3-127).	Go to step 14 46-BR (para	Repair circuit
14	Release and depress start switch (clicking sound).	Starter relay should operate (clicking sound).	Go to step 15 relay (para	Replace starter
NOTE				
With negative lead on a good chassis or body ground, use positive lead when doing the following checks.				
15	Check for voltage at circuit 46D-BR terminal of starter relay	24-volts dc nominal	Go to step 16	Replace starter relay (para 3-115).
16	Check for voltage at circuit 46E-BR terminal of starter motor solenoid	24-volts dc nominal	Go to step 17	Repair circuits 46E-BR and/or 46D-BR (para 3-127).

TROUBLESHOOTING.

2-11. TROUBLESHOOTING PROCEDURES (Continued).

MALFUNCTION	INSTRUCTION	INDICATION	YES	NO
-------------	-------------	------------	-----	----

20. STARTER FAILS TO OPERATE (Continued).

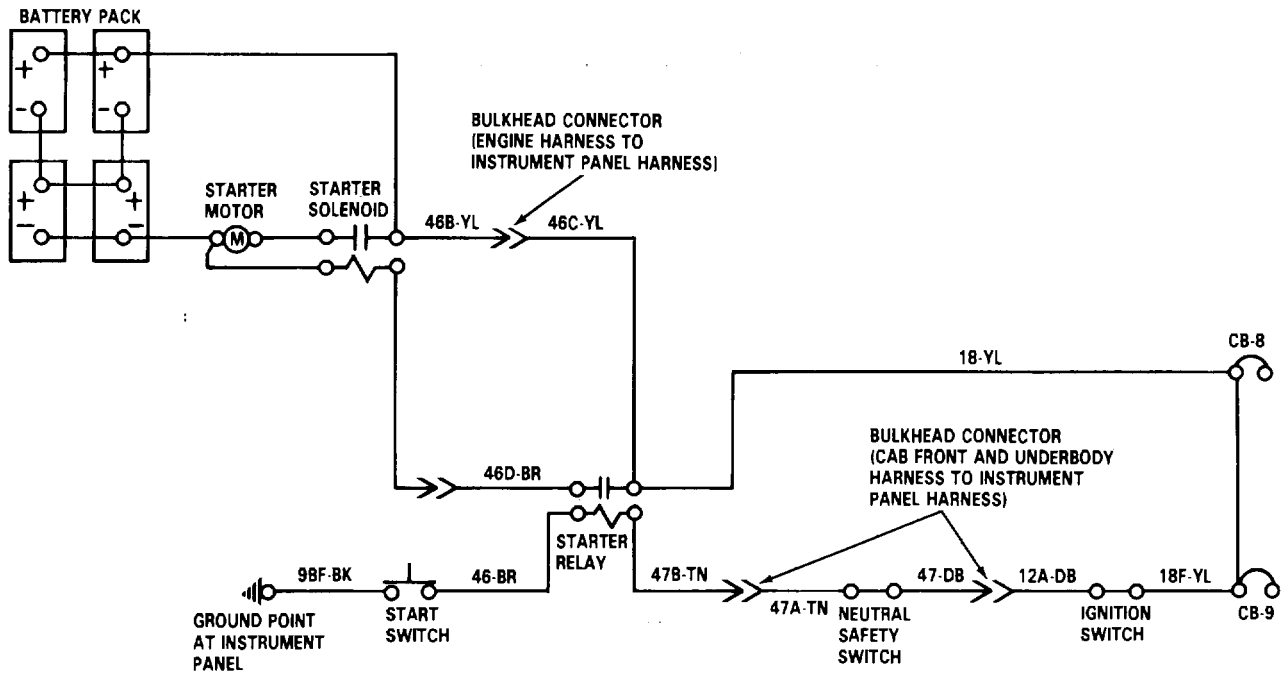

TROUBLESHOOTING.

2-11. TROUBLESHOOTING PROCEDURES (Continued).				
MALFUNCTION	INSTRUCTION	INDICATION	YES	NO
20. STARTER FAILS TO OPERATE (Continued).				
NOTE				
With positive lead on circuit 46E-BR, check ground with negative leads when doing the following checks.				
17	Check for voltage at starter motor main battery ground connection.	24-volts dc nominal	Go to step 18	Refer to malfunction 18.
18	Check for voltage at starter motor solenoid ground connection	24-volts dc nominal	Go to step 19	Repair, clean, or tighten ground cable noid ground terminal and starter motor ground stud.
19	Release and depress start switch	Starter cranks	Starting system OK	Replace starter motor (para

TROUBLESHOOTING.

2-11. TROUBLESHOOTING PROCEDURES (Continued).

MALFUNCTION	INSTRUCTION	INDICATION	YES	NO
-------------	-------------	------------	-----	----

20. STARTER FAILS TO OPERATE (Continued).

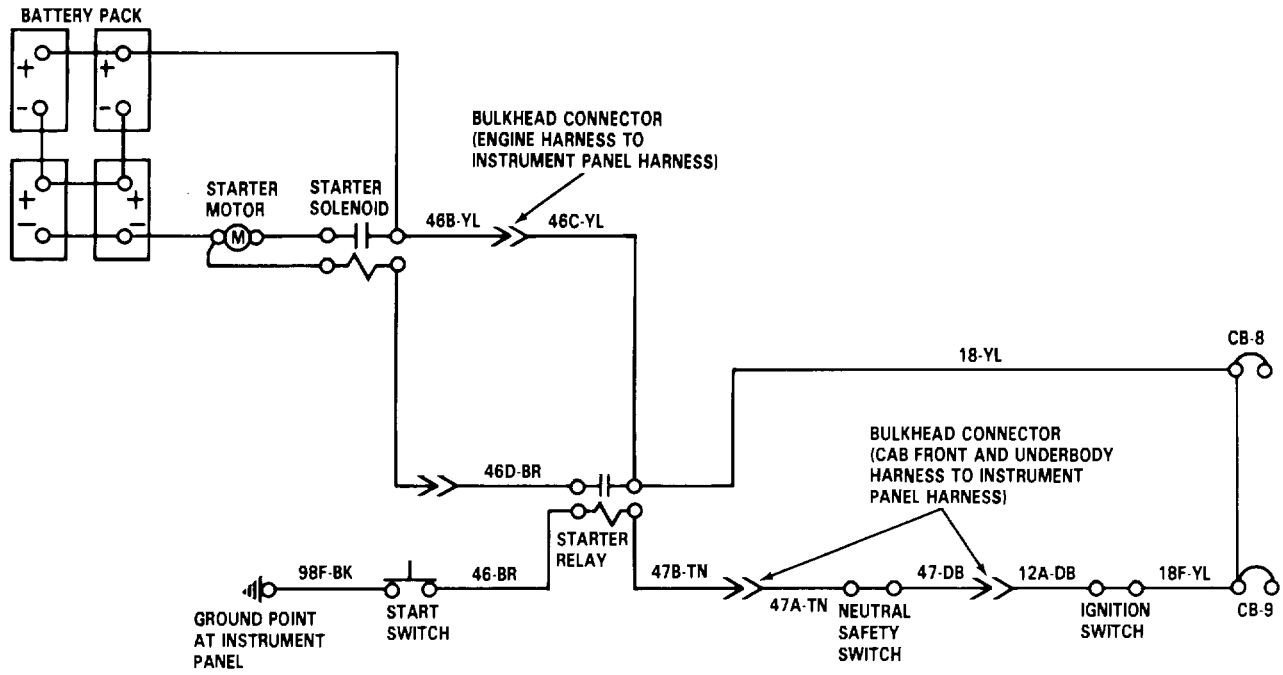

TROUBLESHOOTING.

2-11. TROUBLESHOOTING PROCEDURES (Continued).				
MALFUNCTION	INSTRUCTION	INDICATION	YES	NO
21. BATTERIES DO NOT HOLD A CHARGE (ELECTRICAL SYSTEM SHORTED).				
	Check for shorts to ground:			
a	Disconnect battery ground cable at battery (para 3-120).			
b	Set multimeter to 50 volts dc.			
c	Turn all electrical systems off (Refer to TM 9-2320-283-10).			
d	Unplug tachometer clock at back of tachograph (para 3-309).			
e	Connect positive meter lead to removed ground cable and negative meter lead to battery negative terminal.			
f	Observe meter	Any voltage indication	Go to step g	Test batteries. (Refer to malfunction 18, step 4).

TROUBLESHOOTING.

2-11. TROUBLESHOOTING PROCEDURES (Continued).

MALFUNCTION	INSTRUCTION	INDICATION	YES	NO
-------------	-------------	------------	-----	----

21. BATTERIES DO NOT HOLD A CHARGE (ELECTRICAL SYSTEM SHORTED) (Continued).

Check for shorts to ground
(continued):

g	Remove each relay, one at a time, until meter drops to 0 volts	0 voltage indication	Check for defective circuit, and repair (Refer to para 3-127 and Appendix D) If OK, go to step h.	Go to step i.
h	Remove electrical components in faulty circuit, one at a time, until meter drops below 0 volts.	0 voltage indication	Replace defective components.	Go to step k.
i	Remove one wire at a time from circuit breakers CB-1 thru CB-9, until meter drops to 0 volts	0 voltage indication	Check for defective circuit, and repair (Refer to para 3-127 and Appendix D) If OK, go to step j.	Go to step j.
j	Remove electrical components in faulty circuit, one at a time, until meter drops to 0 volts.	0 voltage indication	Replace defective components.	Go to step k.
k	Install tachograph clock connector (para 3-309), and go to step 1.			
l	Remove meter, and connect battery ground cable (para 3-120).			

TROUBLESHOOTING.

2-11. TROUBLESHOOTING PROCEDURES (Continued).

MALFUNCTION	INSTRUCTION	INDICATION	YES	NO
-------------	-------------	------------	-----	----

22. STARTER MOTOR IS NOISY AND ENGAGEMENT IS ERRATIC.

Replace starter motor (para 3-72).

23. RETARDER NOT WORKING IN ONE OR TWO SELECTOR POSITIONS.

NOTE

*Ignition switch must be in ON position, engine retarder foot switch must be pressed, and throttle must be in idle position when doing the following checks.

*Do steps 1 thru 4 if low range is not working.

· Do step 1 and steps 5 thru 7 if medium range is not working.

*Do step 8 if high range is not working.

· Do step 1 and steps 5 thru 7 if medium and high range are not working.

1	Check for voltage at circuit 52F-GY terminal of engine retarder switch	12 volts dc nominal	Go to step 2	Reset circuit breaker CB-2 and/or troubleshoot CB-2 circuit (Refer to malfunction 33).
2	Set engine retarder switch to LOW range. (Refer to TM 9-2320-283-10) Go to step 3.			
3	Check for voltage at circuit 52G-LG terminal of engine retarder switch.	12 volts dc nominal	Go to step 3	Replace switch (para 3-88).

TROUBLESHOOTING.

2-11. TROUBLESHOOTING PROCEDURES (Continued).

MALFUNCTION	INSTRUCTION	INDICATION	YES	NO
-------------	-------------	------------	-----	----

23. RETARDER NOT WORKING IN ONE OR TWO SELECTOR POSITIONS (Continued).

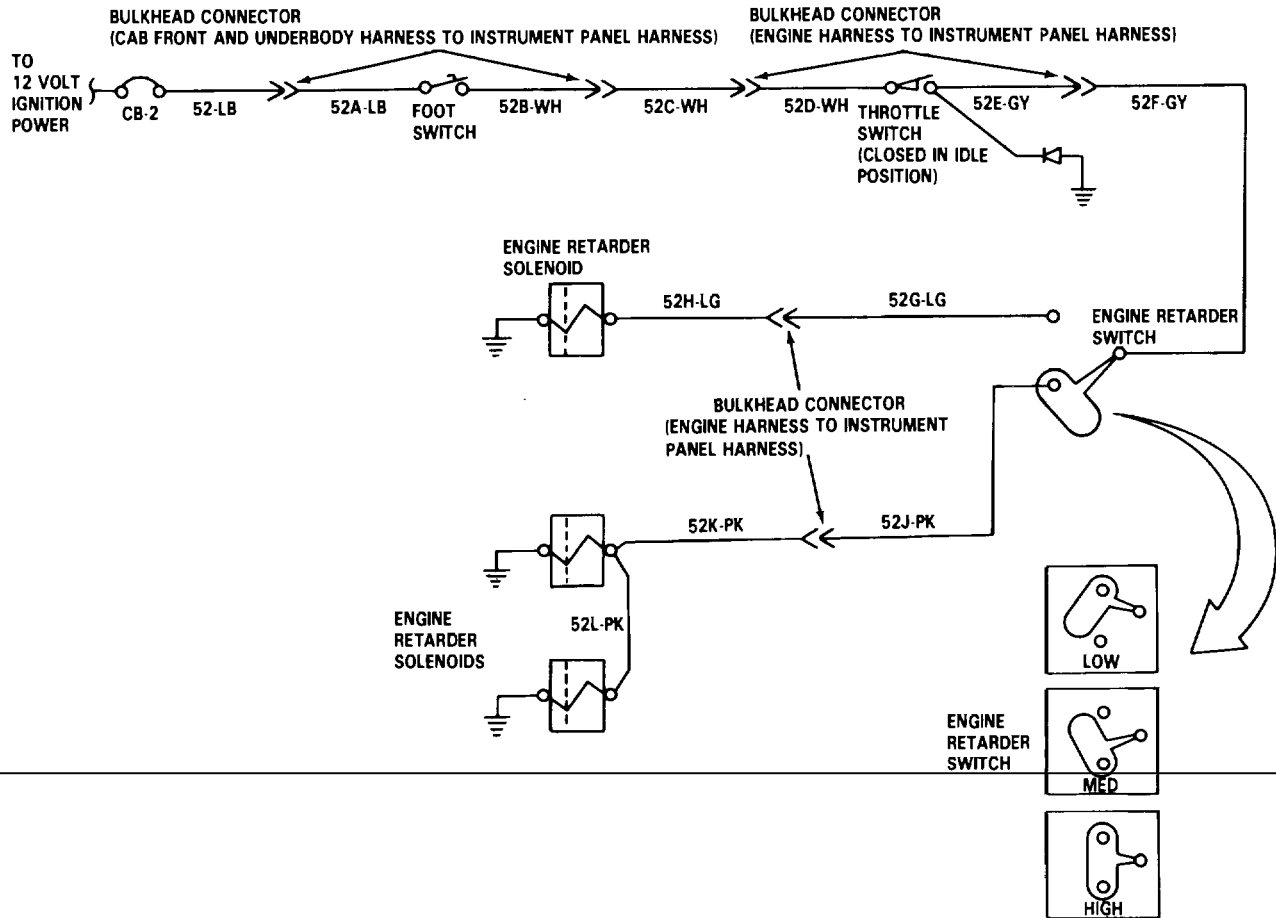

TROUBLESHOOTING.

2-11. TROUBLESHOOTING PROCEDURES (Continued).				
MALFUNCTION	INSTRUCTION	INDICATION	YES	NO
23. RETARDER NOT WORKING IN ONE OR TWO SELECTOR POSITIONS (Continued).				
4	Check for voltage at circuit 52H-LG terminal of engine retarder solenoid	12 volts dc nominal	Notify direct support maintenance	Repair circuit 52H-LG and/or 52G-LG (para 3-127).
5	Set engine retarder switch to MED range. (Refer to TM 9-2320-283-10) Go to step 6.			
6	Check for voltage at circuit 52J-PK terminal of engine retarder switch.	12 volts dc nominal	Go to step 8	Replace switch (para 3-88).
7	Check for voltage at circuit 52K-PK terminal of engine retarder solenoid	12 volts dc nominal	Notify direct support maintenance	Repair circuit 52K-PK and/or 52J-PK (para 3-127).
8	Check for voltage at circuit 52K-PK terminal of engine retarder switch.	12 volts dc nominal	Notify direct support maintenance	Repair circuit 52K-PK (para 3-127).

TROUBLESHOOTING.

2-11. TROUBLESHOOTING PROCEDURES (Continued).

MALFUNCTION	INSTRUCTION	INDICATION	YES	NO
-------------	-------------	------------	-----	----

23. RETARDER NOT WORKING IN ONE OR TWO SELECTOR POSITIONS (Continued).

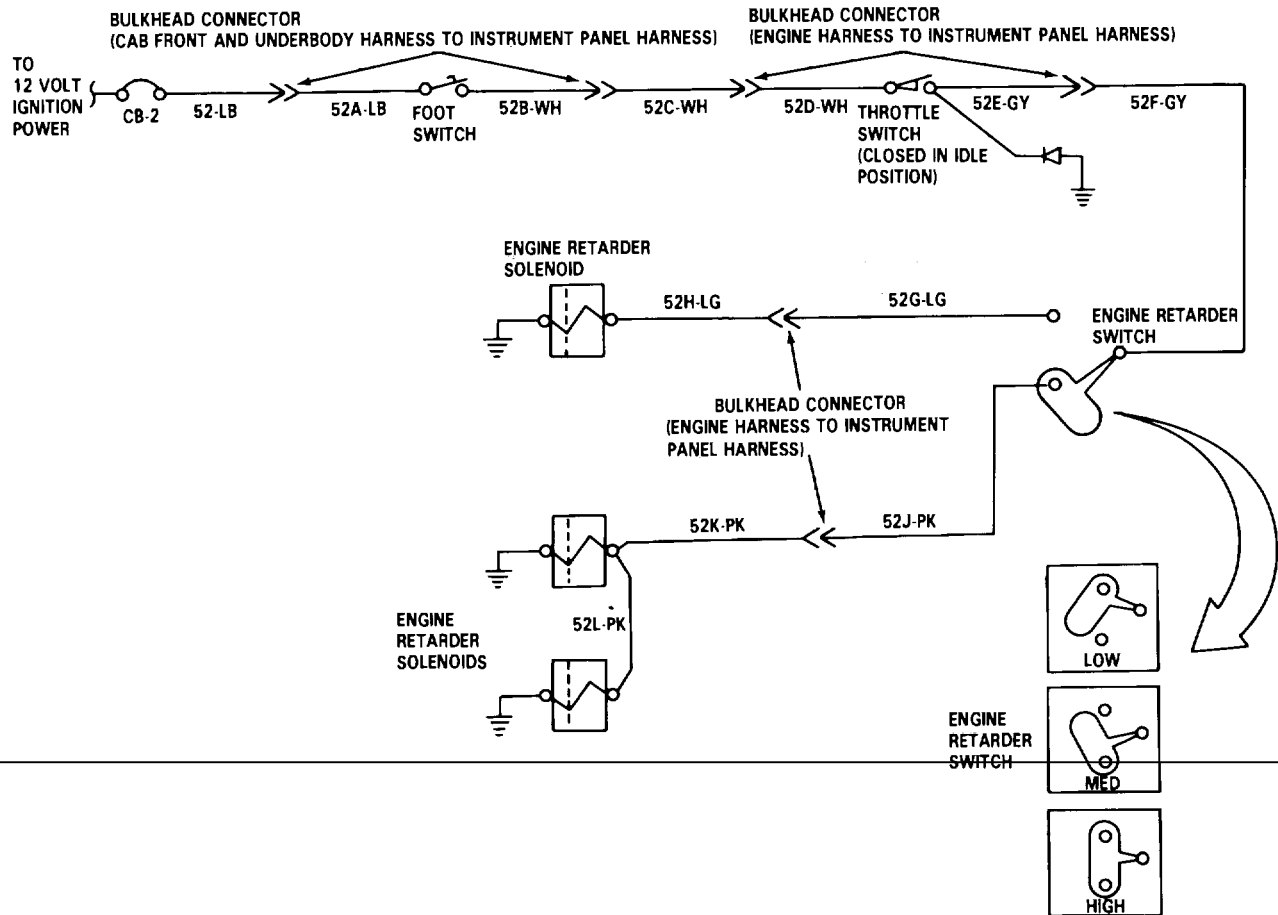

TROUBLESHOOTING.

2-11. TROUBLESHOOTING PROCEDURES (Continued).

MALFUNCTION	INSTRUCTION	INDICATION	YES	NO
24. NO RETARDING ACTION.				
1.	Remove circuit breaker bracket far enough to access circuit breaker CB-2 (para 3-114), and go to step 2.			
NOTE				
Ignition switch must be in ON position, battery power connected, and engine retarder foot switch pressed with throttle in idle position when doing the following checks.				
2	Check for voltage at circuit 52-LB terminal of circuit breaker CB-2 to step 3	12 volts dc nominal	Install circuit breaker bracket (para 3-114), and go circuit	Reset circuit breaker CB-2 and/or troubleshoot CB-2 (Refer to malfunction 33).
3	Check for voltage at circuit 52A-LB terminal of foot switch	12 volts dc nominal	Go to step 4	Repair circuit 52A-LB and/or
4	Check for voltage at circuit 52B-WH terminal of foot switch.	12 volts dc nominal	Go to step 5	52-LB (para Replace foot switch (para 3-89).
5	Disconnect circuit 52B-WH from 52C-WH at connector, and go to step 6.			
6	Check for voltage at circuit 52B-WH (pin M of connector)	12 volts dc nominal	Connect circuits 52B-WH to 52C-WH, and go to step 7.	Repair circuit 52B-WH (para 3-127).

TROUBLESHOOTING.

2-11. TROUBLESHOOTING PROCEDURES (Continued).

MALFUNCTION	INSTRUCTION	INDICATION	YES	NO
-------------	-------------	------------	-----	----

24. NO RETARDING ACTION (Continued).

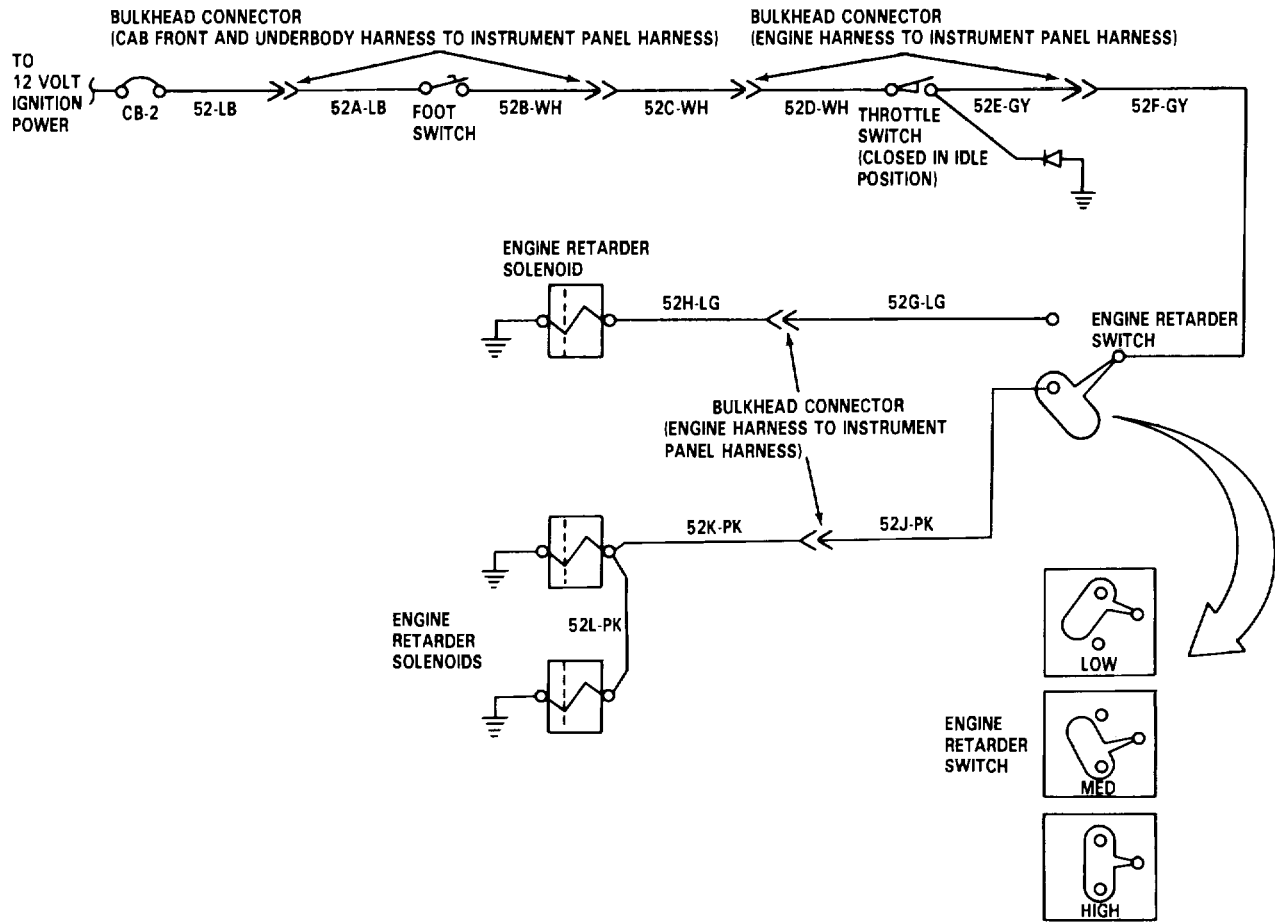

TROUBLESHOOTING.

2-11. TROUBLESHOOTING PROCEDURES (Continued).

MALFUNCTION	INSTRUCTION	INDICATION	YES	NO
24. NO RETARDING ACTION (Continued).				
7	Disconnect circuit 52C-WH from 52D-WH at connector, and go to step 8.			
8	Check for voltage at circuit 52C-WH (pin 13 of connector)	12 volts dc nominal	Connect circuit 52C-WH to 52D-WH, and go to step 9.	Repair circuit 52C-WH (para 3-127).
9	Check for voltage at circuit 52D-WH terminal of throttle switch.	12-volts dc nominal	Go to step 10	Repair circuit 52D-WH (para 3-127).
10	Check for voltage at circuit 52E-GY terminal of engine retarder switch.	12-volts dc nominal	Go to step 11	Repair throttle switch (para 3-90).
11	Check for voltage at circuit 52F-GY terminal of engine retarder switch	12 volts dc nominal	Go to step 12	Replace circuit 52F-GY and/or 52E-GY (para 3-127).
12	Set engine retarder switch to HIGH range. (Refer to TM 9-2320-283-10) Go to step 13.			
13	Check for voltage at circuit 52G-LG terminal of engine retarder switch.	12 volts dc nominal	Notify direct support maintenance	Replace engine retarder switch (para 3-89).

TROUBLESHOOTING.

2-11. TROUBLESHOOTING PROCEDURES (Continued).

MALFUNCTION	INSTRUCTION	INDICATION	YES	NO
-------------	-------------	------------	-----	----

24. NO RETARDING ACTION (Continued).

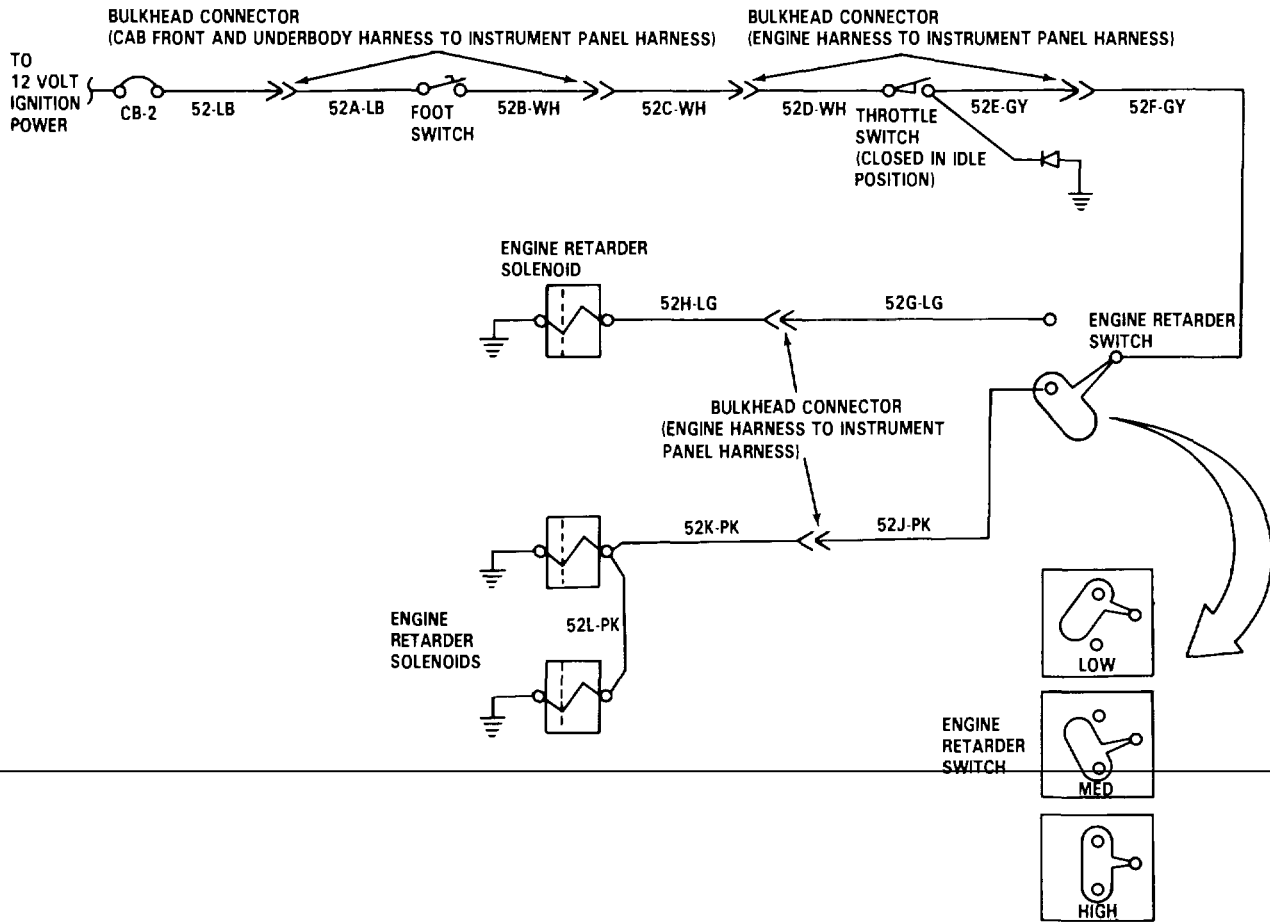

TROUBLESHOOTING.

2-11. TROUBLESHOOTING PROCEDURES (Continued).

MALFUNCTION	INSTRUCTION	INDICATION	YES	NO
-------------	-------------	------------	-----	----

25. BATTERIES ARE BEING UNDERCHARGED OR OVERCHARGED.

1	Check condition of batteries (Refer to malfunction 18).			
2	Check alternator drive belts for proper tension	a Loose b Damaged	Tighten belts (para 3-71). Replace belts (para 3-71).	Go to step b. Go to step 3.
3	Check all charging circuit wiring and connections	a Loose b Defective	Clean and tighten connections. Repair or replace wiring (para 3-127 or 3-126).	Go to step b. Go to step 4.
4	Notify to direct support maintenance.			

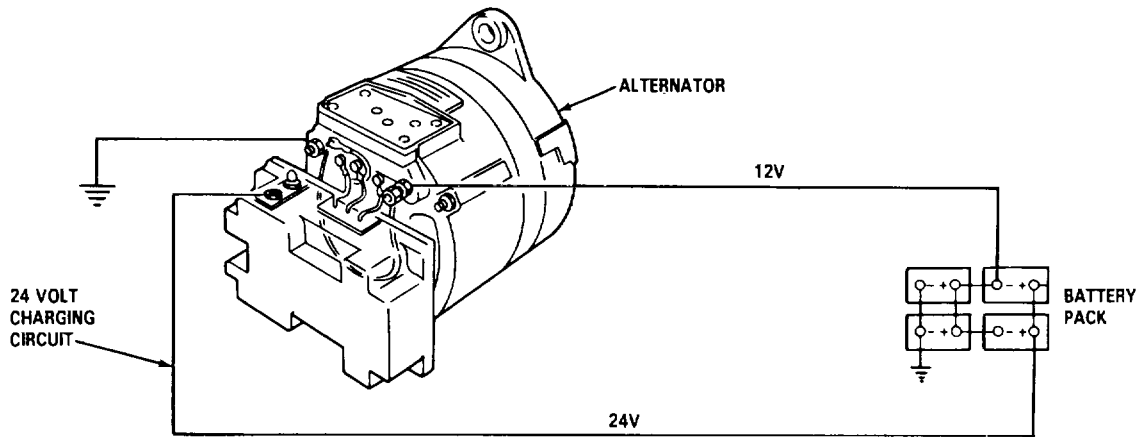

TROUBLESHOOTING.

2-11. TROUBLESHOOTING PROCEDURES (Continued).

MALFUNCTION	INSTRUCTION	INDICATION	YES	NO
-------------	-------------	------------	-----	----

26. HOT ENGINE INDICATOR NOT WORKING.

1. Remove circuit breaker bracket far enough to access circuit breaker CB-2 (para 3-114), and go to step 2.

NOTE

Ignition switch must be in ON position and battery power connected when doing the following checks.

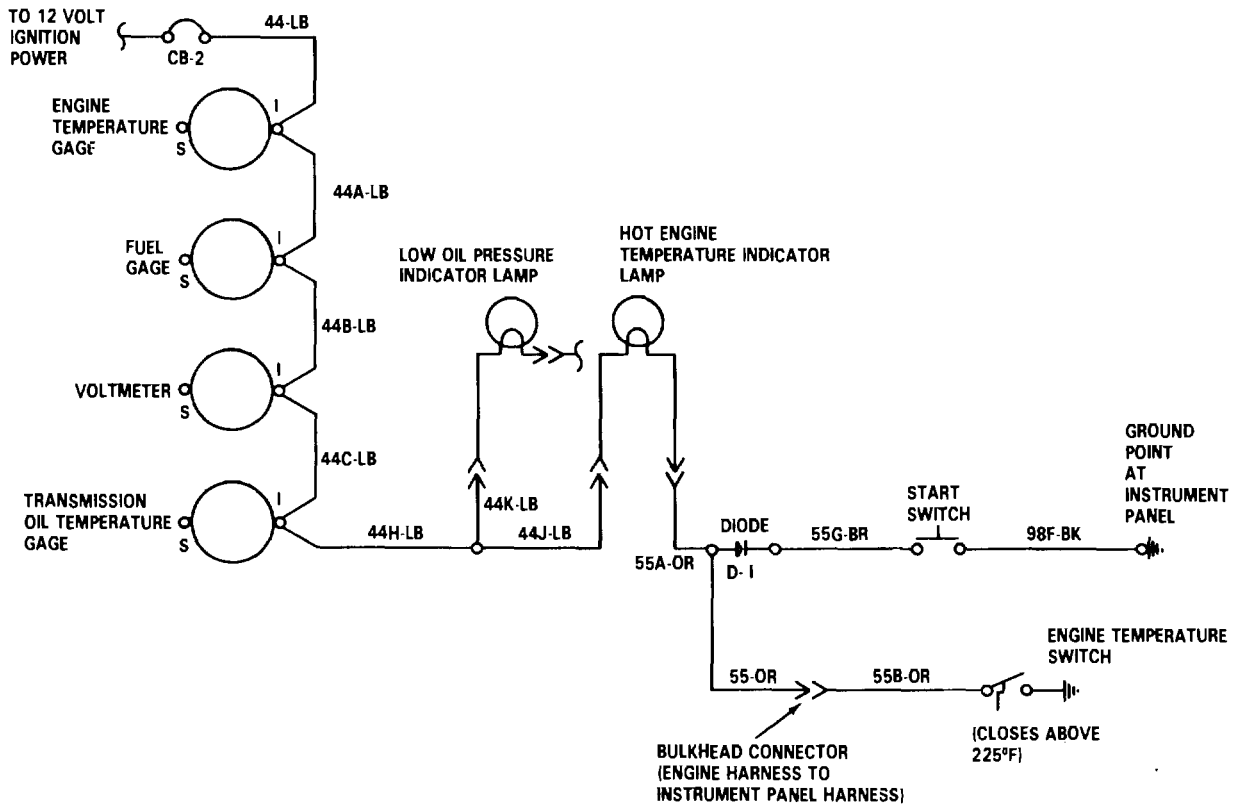

TROUBLESHOOTING.

2-11. TROUBLESHOOTING PROCEDURES (Continued).				
MALFUNCTION	INSTRUCTION	INDICATION	YES	NO
26. HOT ENGINE INDICATOR NOT WORKING (Continued).				
2	Check for voltage at circuit 44-LB terminal of circuit breaker CB-2 3-114), and go	12-volts dc nominal	Install circuit breaker bracket (para	Troubleshoot CB-2 circuit. (Refer to malfunction 33). to step 3.
3	Check for voltage at circuit 44-LB terminal of engine temperature gage.	12 volts dc nominal	Go to step 4	Repair circuit 44-LB (para 3-127).
4	Check for voltage at circuit 44A-LB terminal of fuel gage	12 volts dc nominal	Go to step 5	Repair circuit 44A-LB (para 3-127).
5	Check for voltage at circuit 44B-LB terminal -of voltmeter	12 volts dc nominal	Go to step 6	Repair circuit 44B-LB (para 3-127).
6	Check for voltage at circuit 44C-LB terminal of transmission oil temperature gage.	12 volts dc nominal	Go to step 7	Repair circuit 44C-LB (para 3-127).
7	Check for voltage at circuit 44J-LB terminal of hot engine indicator lamp socket	12 volts dc nominal	Go to step 8	Repair circuits 44H-LB and/or 44J-LB (para 3-127)
NOTE				
With positive lead on circuit 44J-LB (or other suitable 12-volt source), check ground with negative lead when doing the following checks.				
8	Check for voltage at circuit 98F-BK ground point of instrument panel.	12-volts dc nominal	Go to step 9	Tighten and/or clean connection.

TROUBLESHOOTING.

2-11. TROUBLESHOOTING PROCEDURES (Continued).

MALFUNCTION	INSTRUCTION	INDICATION	YES	NO
-------------	-------------	------------	-----	----

26. HOT ENGINE INDICATOR NOT WORKING (Continued).

9	Check for voltage at circuit 98F-BK terminal of start switch	12-volts dc nominal	Go to step 10	Repair circuit 98F-BK (para 3-127).
---	--	---------------------	---------------	-------------------------------------

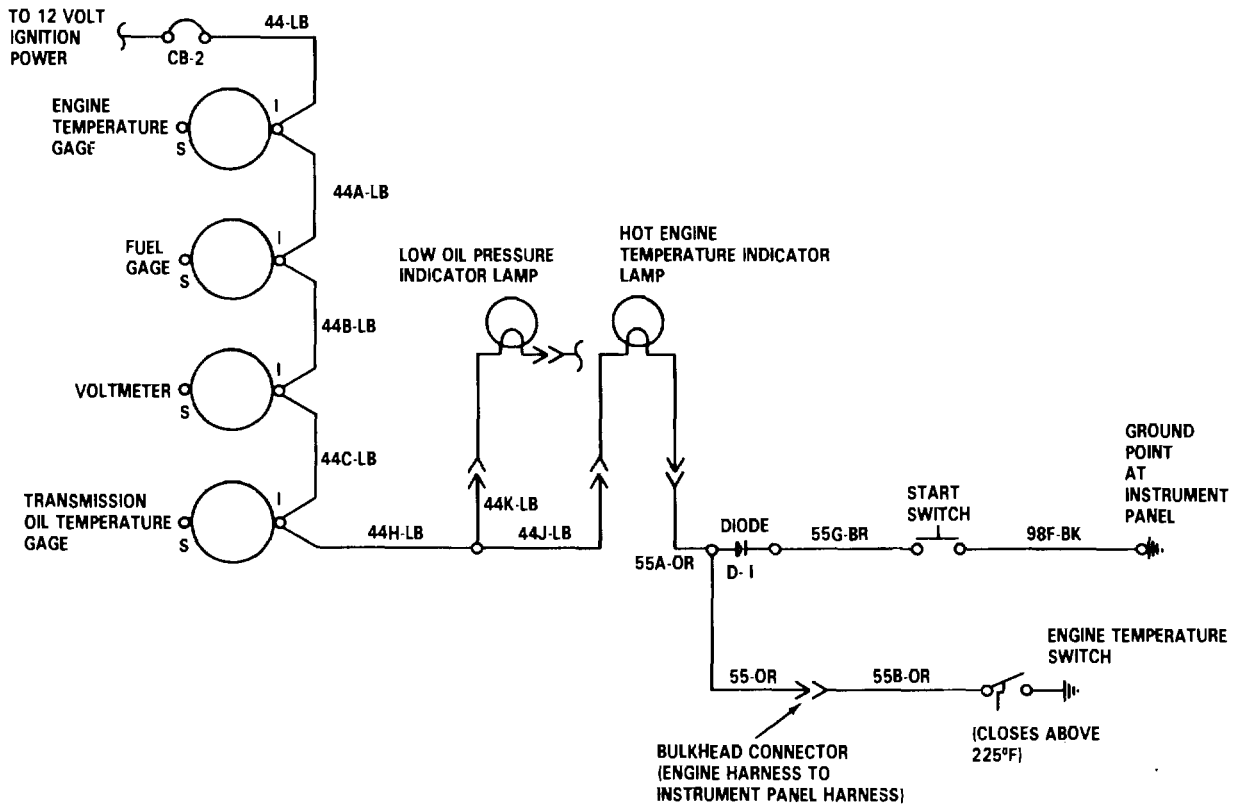

TROUBLESHOOTING.

2-11. TROUBLESHOOTING PROCEDURES (Continued).				
MALFUNCTION	INSTRUCTION	INDICATION	YES	NO
26. HOT ENGINE INDICATOR NOT WORKING (Continued).				
10	To prevent starter motor from operating, disconnect circuit 46E-BR from starter solenoid.			
NOTE				
The start switch must be pushed and held when doing steps 11 thru 14.				
11	Check for voltage at circuit 55C-BR terminal of start switch.	12-volts dc nominal	Go to step 11	Replace switch (para 3-75).
12	Check for voltage at circuit 55C-BR terminal of diode D-1	12-volts dc nominal	Go to step 12	Repair circuit 55C-BR (para 3-127).
13	Check for voltage at circuit 55A-OR terminal of diode D-1.	12-volts dc nominal	Go to step 13	Replace diode (para 3-116).
14	Check for voltage at circuit 55A-OR terminal of hot engine indicator lamp socket.	12-volts dc nominal	Go to step 14	Repair circuit 55A-OR (para 3-127).
15	Release and depress start switch, hot engine indicator lamp should light.	Lamp lights	Go to step 15	Replace bulb (para 3-87).
16	Remove circuit 55B-OR from engine temperature switch, and ground it to engine block	Hot engine indicator lamp lights	Replace engine temperature switch (para 3-100), and go to step 17	Repair circuits 55B-OR and/or 55-OR (para 3-127), +and go to step 17

TROUBLESHOOTING.

2-11. TROUBLESHOOTING PROCEDURES (Continued).

MALFUNCTION	INSTRUCTION	INDICATION	YES	NO
-------------	-------------	------------	-----	----

26. HOT ENGINE INDICATOR NOT WORKING (Continued).

17 Reconnect circuit
46E-BR to starter
solenoid.

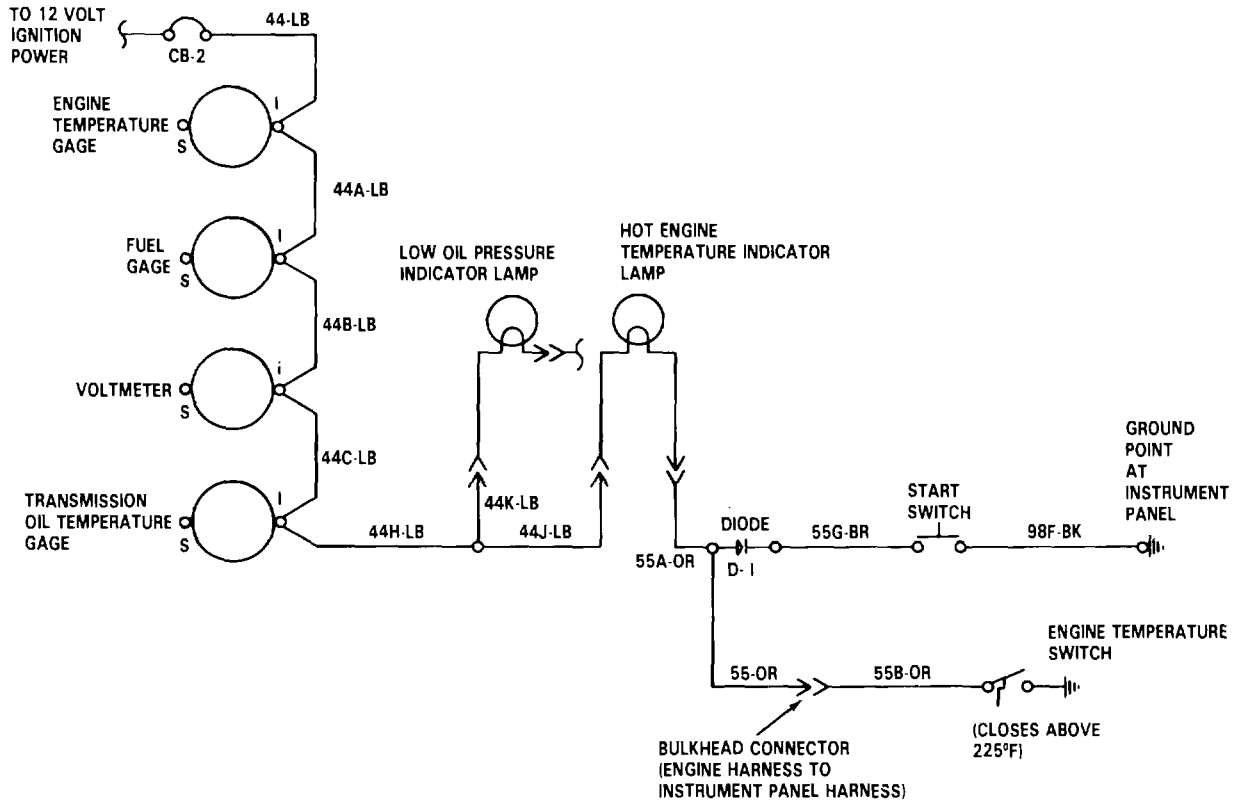

TROUBLESHOOTING.

2-11. TROUBLESHOOTING PROCEDURES (Continued).

MALFUNCTION	INSTRUCTION	INDICATION	YES	NO
-------------	-------------	------------	-----	----

27. LOW ENGINE OIL INDICATOR NOT WORKING.

1 Remove circuit breaker bracket far enough to access circuit breaker CB-2 (para 3-114), and go to step 2

NOTE

Ignition switch must be in ON position and battery power connected when doing the following checks.

2	Check for voltage at circuit 44-LB terminal of circuit breaker CB-2	12-volts dc nominal	Install circuit breaker bracket (para 3-114) and go to step 3	Reset circuit breaker CB-2 and/or troubleshoot CB-2 circuit (Refer to malfunction 33).
3	Check for voltage at circuit 44-LB terminal of engine temperature gage.	12-volts dc nominal	Go to step 4	Repair circuit 44-LB (para 3-127).
4	Check for voltage at circuit 44A-LB terminal of fuel gage	12-volts dc nominal	Go to step 5	Repair circuit 44A-LB (para 3-127).
5	Check for voltage at circuit 44B-LB terminal of voltmeter	12-volts dc nominal	Go to step 6	Repair circuit 44B-LB (para 3-127).
6	Check for voltage at circuit 44C-LB terminal of transmission oil temperature gage.	12-volts dc nominal	Go to step 7	Repair circuit 44C-LB (para 3-127).
7	Check for voltage at circuit 44K-LB terminal of low oil pressure indicator lamp socket.	12-volts dc nominal	Go to step 8	Repair circuit 44K-LB and/or 44H-LB (para 3-127).

TROUBLESHOOTING.

2-11. TROUBLESHOOTING PROCEDURES (Continued).

MALFUNCTION	INSTRUCTION	INDICATION	YES	NO
-------------	-------------	------------	-----	----

27. LOW ENGINE OIL INDICATOR NOT WORKING (Continued).

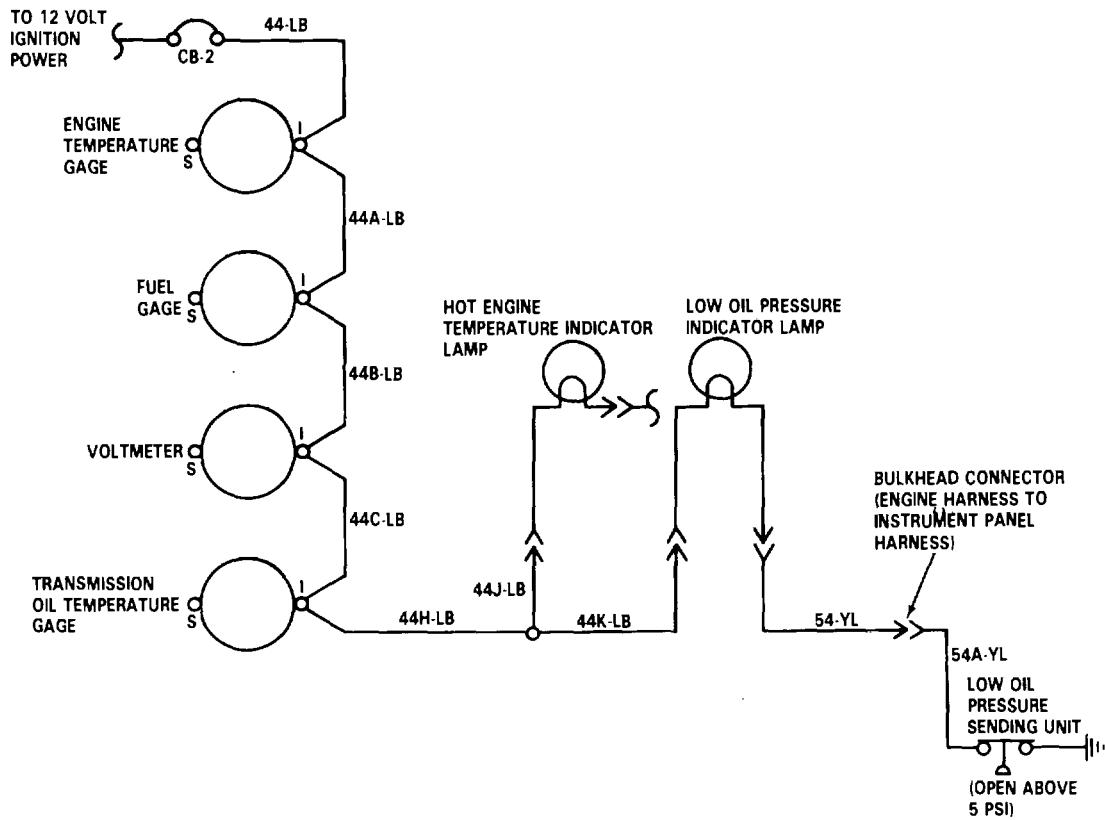

TROUBLESHOOTING.

2-11. TROUBLESHOOTING PROCEDURES (Continued).				
MALFUNCTION	INSTRUCTION	INDICATION	YES	NO
27. LOW ENGINE OIL INDICATOR NOT WORKING (Continued).				
NOTE				
With positive lead on circuit 44K-LB, check ground with negative lead.				
*The following checks should be made with the engine shut off.				
8	Check for voltage at circuit 54A-YL terminal of oil pressure sending unit.	12-volts dc nominal	Go to step 9	Replace switch (para 3-104).
9	Check for voltage at circuit 54-YL terminal of low oil pressure indicator lamp socket.	12-volts dc nominal	Replace bulb (para 3-87), and go to step 10	Repair circuits 54-YL and/or 54A-YL (para 3-127).
10	Start engine and monitor oil pressure gage	15-45 psi	Go to step 11	Stop engine. Replace oil pressure gage (para 3-73).
11	Start engine	Indicator lamp turns off	Low oil pressure indicator lamp circuit OK Go to step 12.	Replace low oil pressure sending unit (para 3-104).
12	With engine running oil pressure indicator should remain off	Indicator lamp lights irrationally	Replace low oil pressure sending unit (para 3- 104).	Low oil pressure indicator lamp system OK.

TROUBLESHOOTING.

2-11. TROUBLESHOOTING PROCEDURES (Continued).

MALFUNCTION	INSTRUCTION	INDICATION	YES	NO
-------------	-------------	------------	-----	----

27. LOW ENGINE OIL INDICATOR NOT WORKING (Continued).

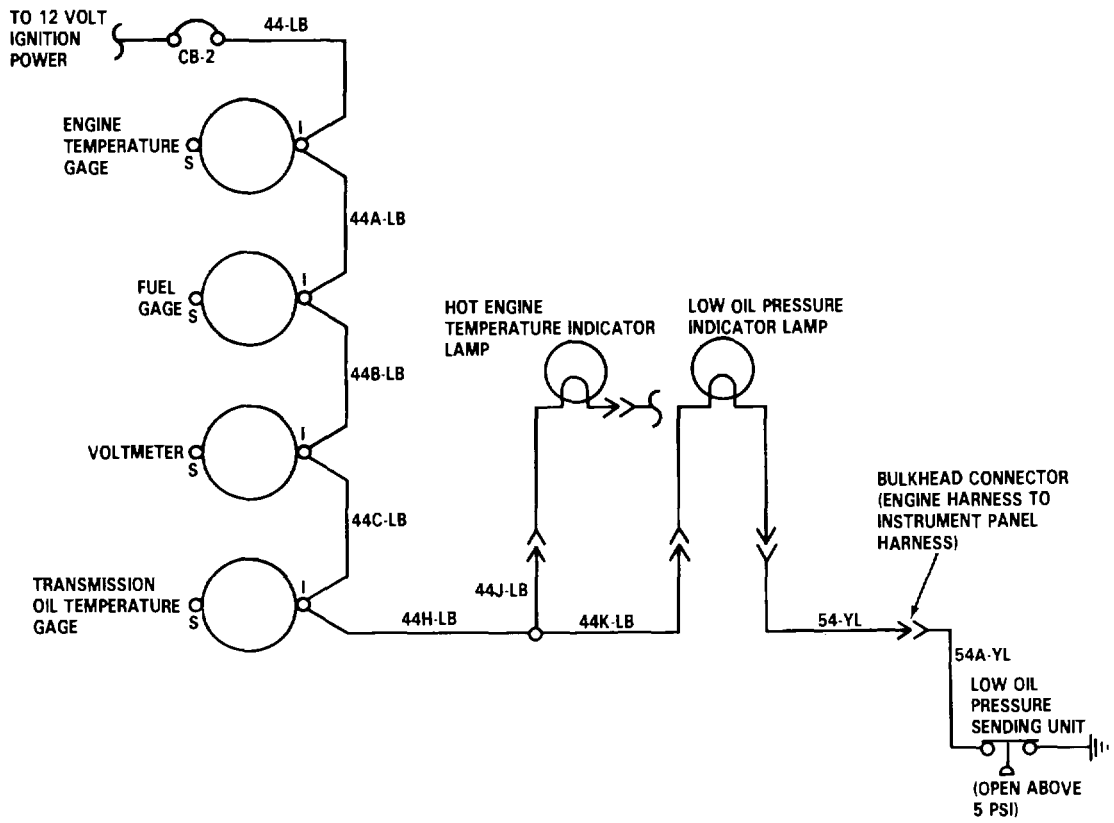

TROUBLESHOOTING.

2-11. TROUBLESHOOTING PROCEDURES (Continued).

MALFUNCTION	INSTRUCTION	INDICATION	YES	NO
-------------	-------------	------------	-----	----

28. LOW AIR PRESSURE INDICATOR AND/OR BUZZER NOT WORKING.

1. Remove circuit breaker bracket far enough to access circuit breaker CB-2 (para 3-114), and go to step 2.

NOTE

Ignition switch must be in ON position and battery power connected when doing the following checks.

- | | | | | |
|---|--|---------------------|--------------|--|
| 2 | Check for voltage at circuit 44E-LB terminal of circuit breaker CB-2 | 12-volts dc nominal | Go to step 3 | Reset circuit breaker CB-2 and/or troubleshoot CB-2 circuit (Refer to malfunction 33). |
|---|--|---------------------|--------------|--|

- | | | | | |
|---|--|---------------------|--------------|-------------------------------------|
| 3 | Check for voltage at circuit 44E-LB terminal of low air pressure switch. | 12-volts dc nominal | Go to step 4 | Repair circuit 44E-LB (para 3-127). |
|---|--|---------------------|--------------|-------------------------------------|

NOTE

When doing the following checks, make sure vehicle system air pressure is below 60 psi.

- | | | | | |
|---|--|---------------------|--------------|------------------------------|
| 4 | Check for voltage at circuit 53A-DB terminal of low air pressure switch. | 12-volts dc nominal | Go to step 5 | Replace switch (para 3-109). |
|---|--|---------------------|--------------|------------------------------|

NOTE

If buzzer is operating properly, but indicator lamp will not light, proceed to step 8. Otherwise, begin with step 5.

TROUBLESHOOTING.

2-11. TROUBLESHOOTING PROCEDURES (Continued).

MALFUNCTION	INSTRUCTION	INDICATION	YES	NO
-------------	-------------	------------	-----	----

28. LOW AIR PRESSURE INDICATOR AND/OR BUZZER NOT WORKING (Continued).

5	Check for voltage at circuit 53A-DB terminal of buzzer	12-volts dc nominal	Go to step 6 3-127).	Repair circuit 53A-DB (para
---	--	---------------------	-------------------------	-----------------------------

NOTE

With positive lead on circuit 53A-DB, check for ground with negative lead when doing the following checks.

6	Check for voltage at circuit 99E-BK ground point of instrument panel	12-volts dc nominal	Go to step 7	Clean and/or tighten ground point connection.
---	--	---------------------	--------------	---

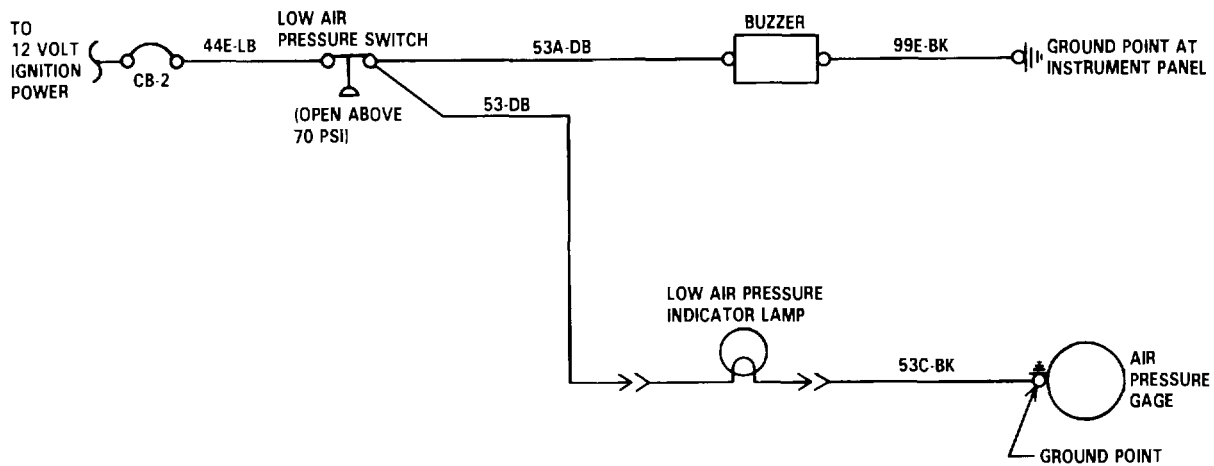

TROUBLESHOOTING.

2-11. TROUBLESHOOTING PROCEDURES (Continued).

MALFUNCTION	INSTRUCTION	INDICATION	YES	NO
-------------	-------------	------------	-----	----

28. LOW AIR PRESSURE INDICATOR AND/OR BUZZER NOT WORKING (Continued).

7	Check for voltage at circuit 99E-BK terminal of buzzer	12-volts dc nominal	Replace buzzer (para 3-110), and go to step 8.	Repair circuit 99E-BK (para 3-127).
---	--	---------------------	--	-------------------------------------

NOTE

With negative lead connected to a good ground, use positive lead to check for voltage.

8	Check for voltage at circuit 53-DB terminal of low air pressure indicator lamp socket.	12-volts dc nominal	Go to step 9	Repair circuit 53-DB (para 3-127).
---	--	---------------------	--------------	------------------------------------

NOTE

With positive lead on circuit 53-DB, check for ground with negative lead.

9	Check for voltage at circuit 53C-BK ground point of air pressure gage	12-volts dc nominal point connection.	Go to step 10 tighten ground	Clean and/or
---	---	---------------------------------------	------------------------------	--------------

10	Check for voltage at circuit 53C-BK terminal of low air pressure indicator lamp socket.	12-volts dc nominal	Replace bulb (para 3-84)	Repair circuit 53C-BK (para 3-127).
----	---	---------------------	--------------------------	-------------------------------------

TROUBLESHOOTING.

2-11. TROUBLESHOOTING PROCEDURES (Continued).

MALFUNCTION	INSTRUCTION	INDICATION	YES	NO
-------------	-------------	------------	-----	----

28. LOW AIR PRESSURE INDICATOR AND/OR BUZZER NOT WORKING (Continued).

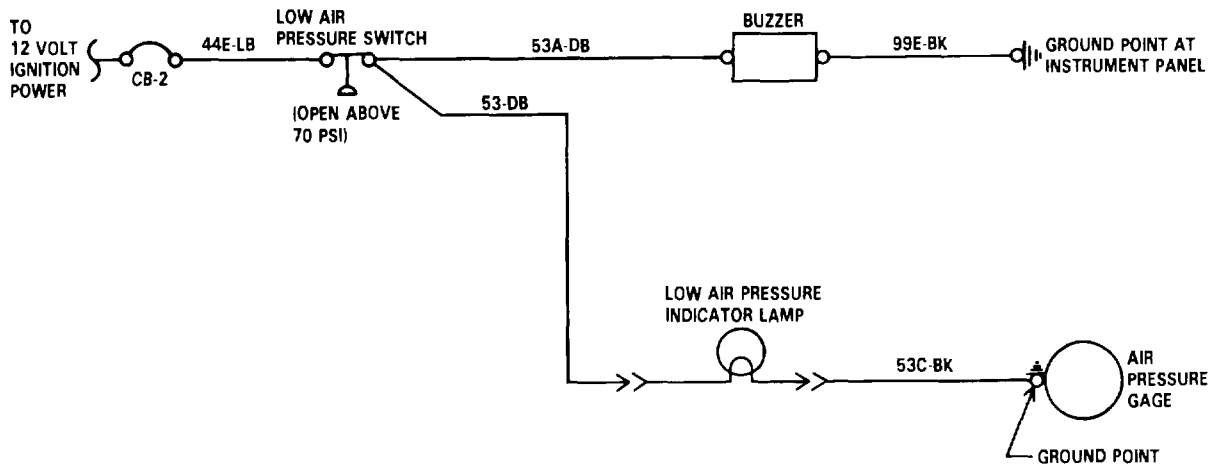

TROUBLESHOOTING.

2-11. TROUBLESHOOTING PROCEDURES (Continued).

MALFUNCTION	INSTRUCTION	INDICATION	YES	NO
-------------	-------------	------------	-----	----

29. DIFFERENTIAL LOCK LAMP NOT WORKING.

- 1 Remove circuit breaker bracket far enough to access circuit breaker CB-2 (para 3-114), and go to step 2.

NOTE

Ignition switch must be in ON position and battery power connected when doing the following checks.

2	Check for voltage at circuit 44E-LB terminal of circuit breaker CB-2	12-volts dc nominal	Install circuit breaker bracket (para 3-114), and go to step 2	Reset circuit breaker CB-2 and/or troubleshoot CB-2 circuit (Refer to malfunction 33).
3	Check for voltage at circuit 44E-LB terminal of low air pressure switch.	12-volts dc nominal	Go to step 4	Repair circuit 44E-LB (para 3-127).
4	Check for voltage at circuit 44F-LB terminal of park brake pressure switch.	12-volts dc nominal	Go to step 5	Repair circuit 44F-LB (para 3-127).
5	Check for voltage at circuit 44G-LB terminal of differential lock pressure switch.	12-volts dc nominal	Go to step 6	Repair circuit 44G-LB (para 3-127).

NOTE

.Lock pressure switch must be in LOCK position when doing the following checks.
 .With negative lead connected to a good ground, use positive lead to check for voltage.

TROUBLESHOOTING.

2-11. TROUBLESHOOTING PROCEDURES (Continued).

MALFUNCTION	INSTRUCTION	INDICATION	YES	NO
29. DIFFERENTIAL LOCK LAMP NOT WORKING (Continued).				
6.	Check for voltage at circuit 53E-RD terminal of differential lock pressure switch.	12-volts dc nominal.	Go to step 7. (para 3-107).	Replace switch
7.	Check for voltage at circuit 53E-RD terminal differential lock indicator lamp.	12-volts dc nominal.	Go to step 8. 53E-RD (para 3-127).	Repair circuit

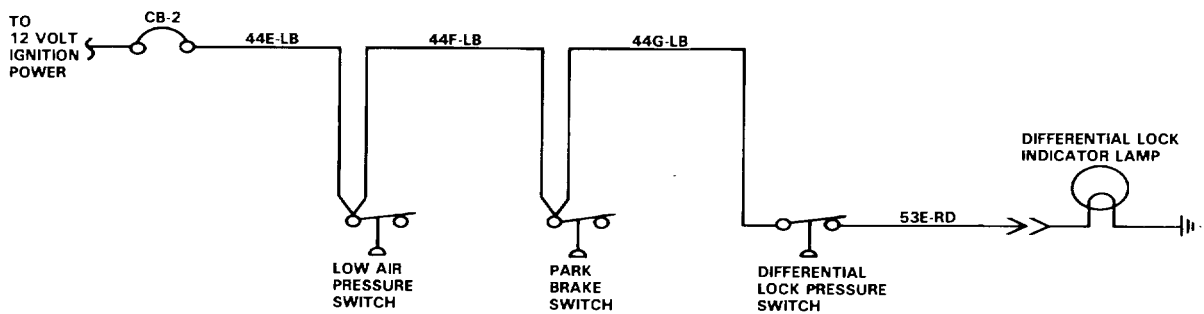

TA 236847

TROUBLESHOOTING.

2-11. TROUBLESHOOTING PROCEDURES (Continued).

MALFUNCTION	INSTRUCTION	INDICATION	YES	NO
-------------	-------------	------------	-----	----

29. DIFFERENTIAL LOCK LAMP NOT WORKING (Continued).

NOTE

With positive lead on circuit 53E-RD, check ground with negative lead when doing the following checks.

- | | | | | |
|----|---|----------------------|---------------------------|---|
| 8. | Check for voltage at differential lock indicator lamp ground point. | 12-volts dc nominal. | Replace bulb (para 3-87). | Clean and/or tighten ground point connection. |
|----|---|----------------------|---------------------------|---|

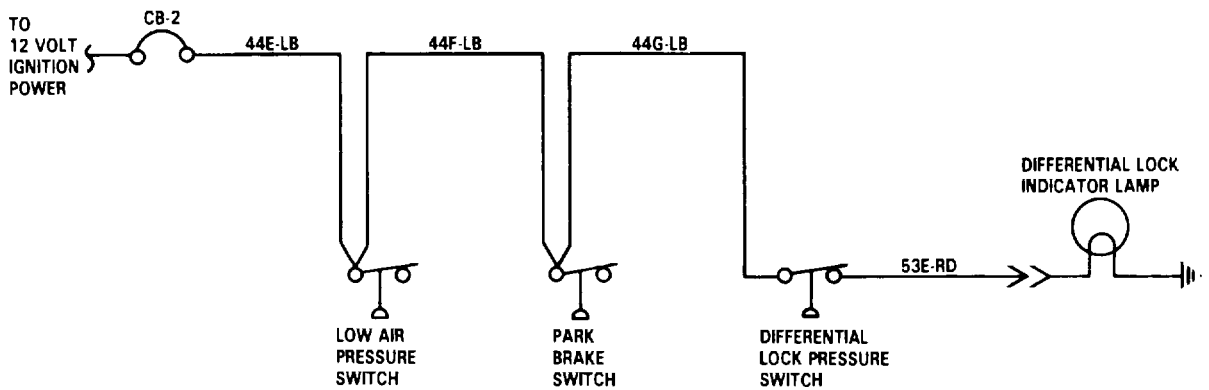

TA 236848

TROUBLESHOOTING.

2-11. TROUBLESHOOTING PROCEDURES (Continued).

MALFUNCTION	INSTRUCTION	INDICATION	YES	NO
30. PARK BRAKE LAMP NOT WORKING.	<ol style="list-style-type: none"> Remove circuit breaker bracket far enough to access circuit breaker bracket CB-2 (para 3-114), and go to step 2. 			
NOTE				
Ignition switch must be in ON position and battery power connected when doing the following checks.				
<ol style="list-style-type: none"> Check for voltage at circuit 44E-LB terminal of circuit breaker CB-2. 		12-volts dc nominal.	Install circuit breaker bracket (para 3-114), and go to step 3.	Reset circuit breaker CB-2 and/or troubleshoot CB-2 circuit. (Refer to malfunction 33).
<ol style="list-style-type: none"> Check for voltage at circuit 44E-LB terminal of low air 		12-volts dc nominal.	Go to step 4.	Repair circuit 44E-LB (para 3-127).

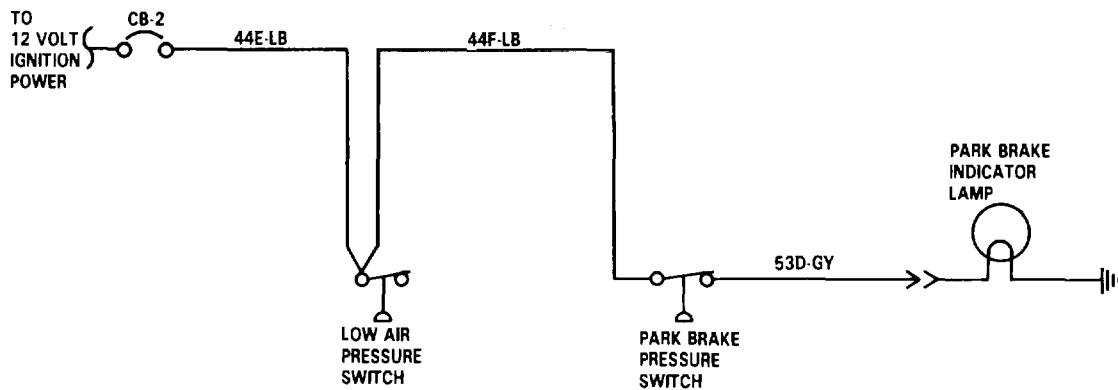

TA 236849

TROUBLESHOOTING.

2-11. TROUBLESHOOTING PROCEDURES (Continued).				
MALFUNCTION	INSTRUCTION	INDICATION	YES	NO
30. PARK BRAKE LAMP NOT WORKING (Continued).				
4.	Check for voltage at circuit 44F-LB terminal of park brake pressure switch.	12-volts dc nominal.	Go to step 5.	Repair circuit 44F-LB (para 3-127).
NOTE				
<ul style="list-style-type: none"> • Park brake control must be pulled when doing the following checks. • With negative lead connected to a good ground, use positive lead to check for voltage. 				
5.	Check for voltage at circuit 53D-GY terminal of park brake pressure switch.	12-volts dc nominal.	Go to step 6.	Replace switch (para 3-108).
6.	Check for voltage at circuit 53D-GY terminal of park brake indicator lamp.	12-volts dc nominal.	Go to step 7.	Replace circuit 53D-GY (para 3-127).
NOTE				
With positive lead on circuit 53D-GY, check ground with negative lead when doing the following checks.				
7.	Check for voltage at park brake indicator lamp.	12-volts dc nominal.	Replace bulb (para 3-87).	Clean and/or tighten connection.

TROUBLESHOOTING.

2-11. TROUBLESHOOTING PROCEDURES (Continued).

MALFUNCTION	INSTRUCTION	INDICATION	YES	NO
-------------	-------------	------------	-----	----

30. PARK BRAKE LAMP NOT WORKING (Continued).

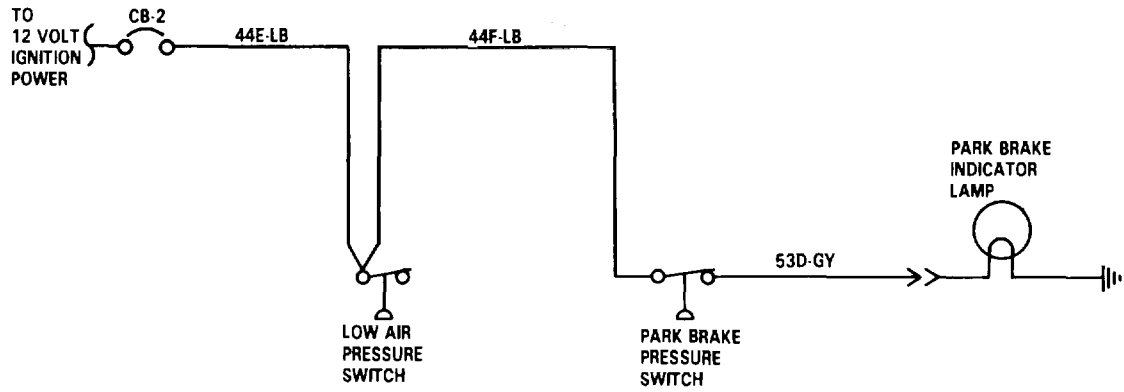

TA 236850

TROUBLESHOOTING.

2-11. TROUBLESHOOTING PROCEDURES (Continued).

MALFUNCTION	INSTRUCTION	INDICATION	YES	NO
31. INSTRUMENT PANEL GAGES NOT WORKING.				
1.	Remove circuit breaker bracket far enough to access circuit breaker CB-2 (para 3-114), and go the step 2.			
NOTE				
Ignition switch must be in ON position and battery power connected when doing the following checks				
2.	Check for voltage at circuit 44-LB terminal of circuit breaker CB-2.	12-volts dc nominal.	Install circuit breaker bracket (para 3-114), and go to step 3.	Reset circuit breaker CB-2 and/or troubleshoot CB-2 circuit. (Refer to malfunction 33).
3.	Check for voltage at circuit 44-LB terminal of water temperature gage.	12-volts dc nominal.	Go to step 4.	
4.	Check for voltage at circuit 44A-LB terminal of fuel gage.	12-volts dc nominal.	Go to step 5.	
5.	Check for voltage at circuit 44B-LB terminal of voltmeter.	12-volts dc nominal.	Go to step 6.	
6.	Check for voltage at circuit 44C-LB terminal of transmission oil temperature gage.	12-volts dc nominal.	Go to step 7.	
7.	Check for voltage at circuit 44D-LB terminal of engine oil pressure gage.	12-volts dc nominal.	Go to step 8.	
2-90				

TROUBLESHOOTING.

2-11. TROUBLESHOOTING PROCEDURES (Continued).

MALFUNCTION	INSTRUCTION	INDICATION	YES	NO
-------------	-------------	------------	-----	----

31. INSTRUMENT PANEL GAGES NOT WORKING (Continued).

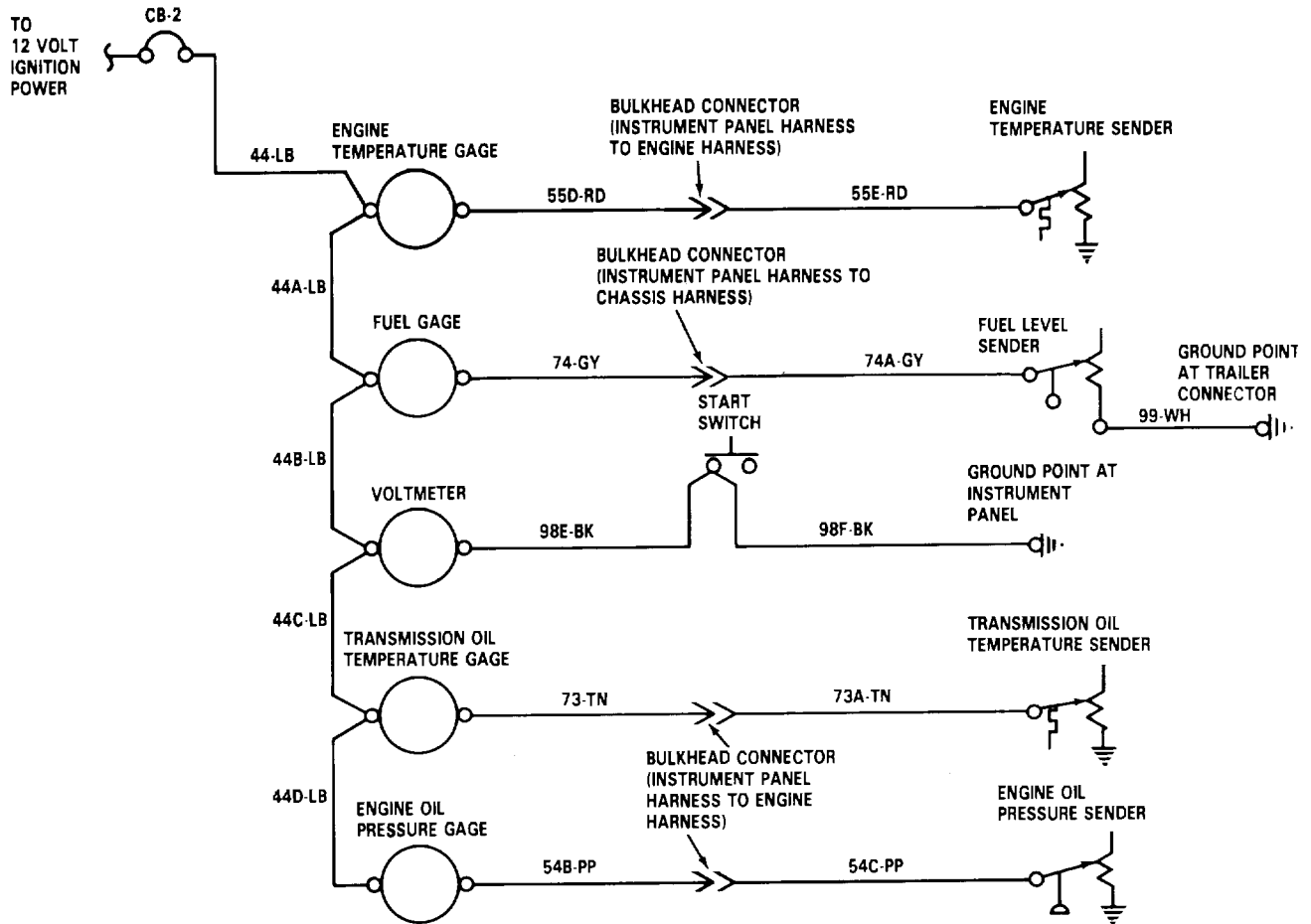

TA 236851

TROUBLESHOOTING.

2-11. TROUBLESHOOTING PROCEDURES (Continued).

MALFUNCTION	INSTRUCTION	INDICATION	YES	NO
<p>31. INSTRUMENT PANEL GAGES NOT WORKING (Continued).</p>				
<p>NOTE</p>				
<ul style="list-style-type: none"> • Determine which gage is not working by visual inspection, then go to the proper step as listed below. • If water temperature gage is not working, do step 8. • If fuel gage is not working, do step 9. • If voltmeter is not working, do step 10. • If transmission oil temperature gage is not working, do step 11. • If engine oil pressure gage is not working, do step 12. 				
8.	<p>Check water temperature gage:</p>			
a.	<p>With a jumper wire, momentarily ground circuit 55D-RD terminal of water temperature gage.</p>	<p>Gage operates.</p>	<p>Go to step b.</p>	<p>Replace gage (para 3-73).</p>
b.	<p>With a jumper wire momentarily ground circuit 55E-RD terminal of water temperature sending unit.</p>	<p>Gage operates.</p>	<p>Replace sending unit (para 3-101).</p>	<p>Repair circuit 55D-RD and/or 55D-RD (para 3-127).</p>

TROUBLESHOOTING.

2-11. TROUBLESHOOTING PROCEDURES (Continued).

MALFUNCTION	INSTRUCTION	INDICATION	YES	NO
-------------	-------------	------------	-----	----

31. INSTRUMENT PANEL GAGES NOT WORKING (Continued).

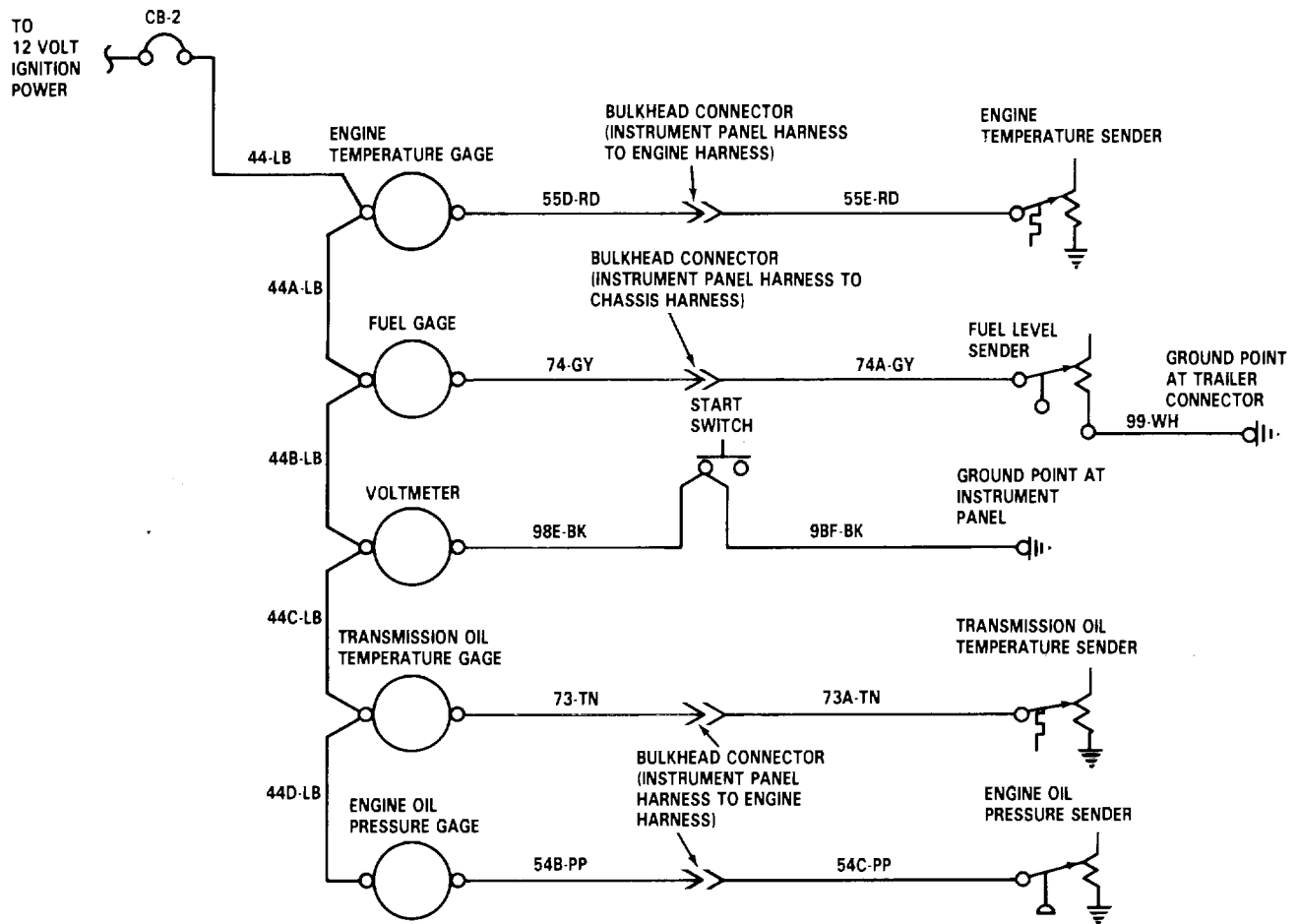

TA 236852

TROUBLESHOOTING.

2-11. TROUBLESHOOTING PROCEDURES (Continued).

MALFUNCTION	INSTRUCTION	INDICATION	YES	NO
31. INSTRUMENT PANEL GAGES NOT WORKING (Continued).				
9.	Check fuel gage:			
a.	With a jumper wire, momentarily ground circuit 74-GY terminal of fuel gage.	Gage operates.	Go to step b.	Replace gage (para 3-73).
b.	With a jumper wire, momentarily ground circuit 74A-GY terminal of fuel level sending unit.	Gage operates.	Replace sending unit (para 3-105).	Repair circuit 74-GY and/or 74A-GY (para 3-127).
10.	Check voltmeter:			
a.	With a jumper wire, momentarily ground circuit 98E-BK terminal of voltmeter.	Gage operates.	Go to step b.	Replace gage (para 3-73).
b.	With a jumper wire, momentarily ground circuit 98E-BK terminal of start switch.	Gage operates.	Go to step c.	Repair circuit 98E-BK (para 3-127).
c.	With a jumper wire, momentarily ground circuit 98F-BK at instrument panel ground point.	Gage operates.	Tighten and/or clean circuit 98F-BK connection to instrument	Repair circuit 98F-BK (para 3-127).

TROUBLESHOOTING.

2-11. TROUBLESHOOTING PROCEDURES (Continued).

MALFUNCTION	INSTRUCTION	INDICATION	YES	NO
-------------	-------------	------------	-----	----

31. INSTRUMENT PANEL GAGES NOT WORKING (Continued).

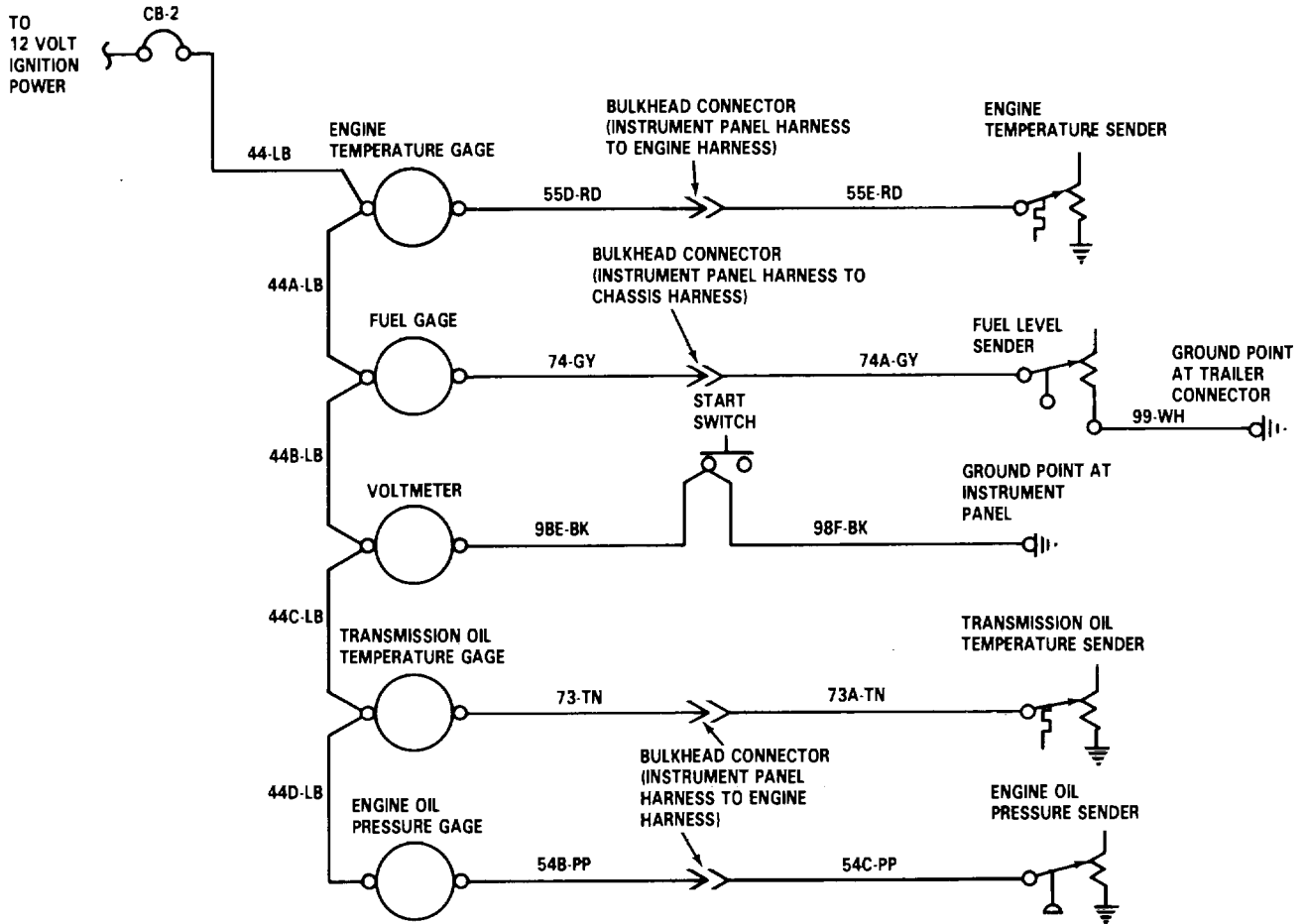

TA 236853

TROUBLESHOOTING.

2-11. TROUBLESHOOTING PROCEDURES (Continued).

MALFUNCTION	INSTRUCTION	INDICATION	YES	NO
31. INSTRUMENT PANEL GAGES NOT WORKING (Continued).				
11. Check transmission oil temperature gage:				
a.	With a jumper wire, momentarily ground circuit 73-TN terminal of transmission oil temperature gage.	Gage oper-ates. Go to step b.		Replace gage (para 3-73).
b.	With a jumper wire, momentarily ground circuit 73A-TN terminal of transmission temperature sending unit.	Gage oper-ates.	Replace sending unit (para 3-103).	Repair circuits 73-TN and/or 73A-TN (para 3-127).
12. Check engine oil pressure gage:				
a.	With a jumper wire, momentarily ground circuit 54B-PP terminal of engine oil pressure gage.	Gage oper-ates. Go to step b.		Replace gage (para 3-73).
b.	With a jumper wire, momentarily ground circuit 54C-PP terminal of oil pressure sending unit.	Gage oper-ates.	Replace sending unit (para 3-102).	Repair circuits 54B-PP and/or 54C-PP (para 3-127).

TROUBLESHOOTING.

2-11. TROUBLESHOOTING PROCEDURES (Continued).

MALFUNCTION	INSTRUCTION	INDICATION	YES	NO
-------------	-------------	------------	-----	----

31. INSTRUMENT PANEL GAGES NOT WORKING (Continued).

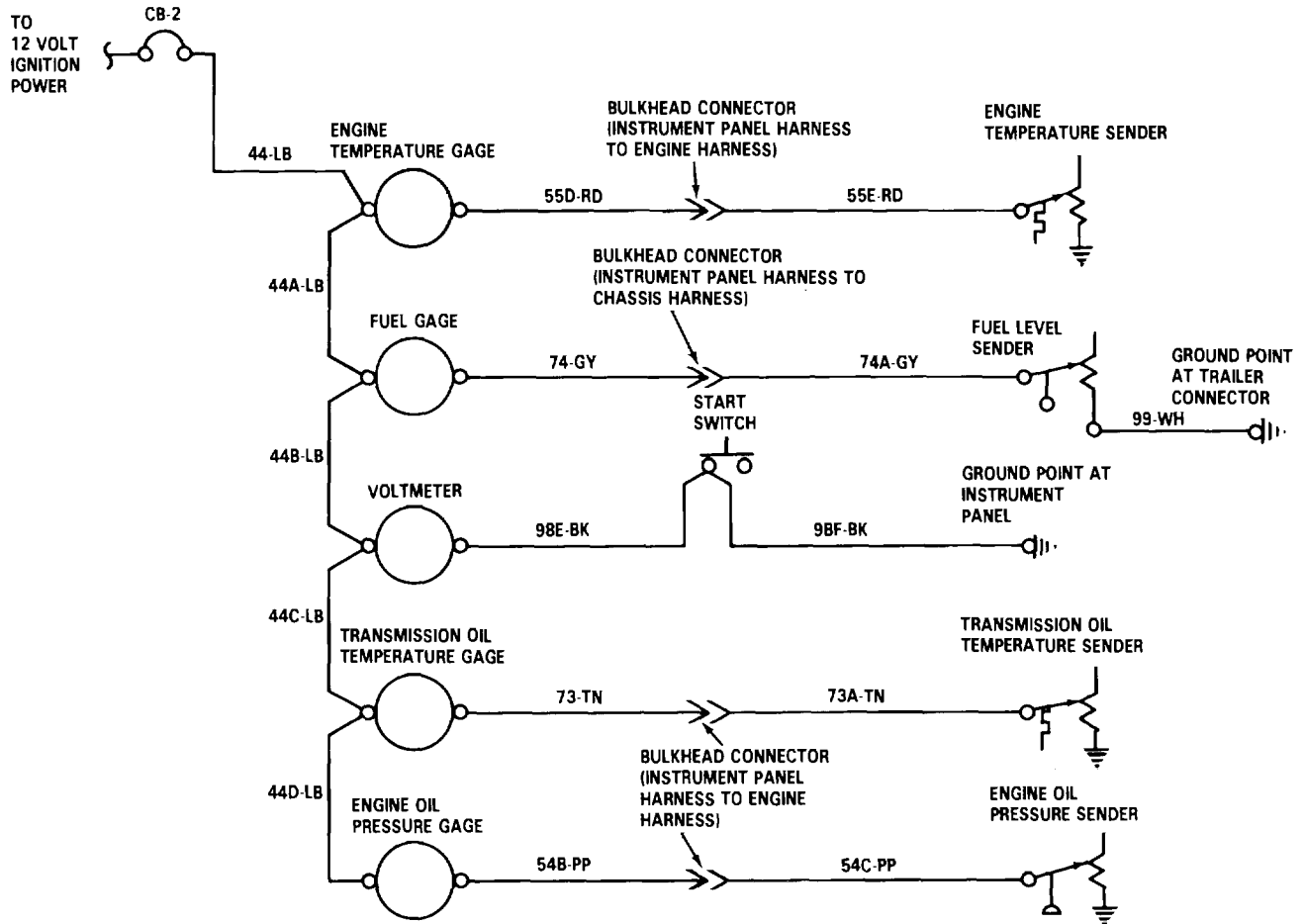

TA 236854

TROUBLESHOOTING.

2-11. TROUBLESHOOTING PROCEDURES (Continued).

MALFUNCTION	INSTRUCTION	INDICATION	YES	NO
32. TACHOGRAPH CLOCK NOT WORKING.				
1.	Remove circuit breaker bracket far enough to access circuit breaker CB-2 (para 3-114), and go to step 2.			
2.	Check for voltage at circuit 59-OR terminal of circuit breaker CB-1.	12-volts dc nominal.	Install circuit breaker bracket (para 3-114), and go to step 3.	Reset circuit breaker CB-1 and/or troubleshoot CB-1 circuit. (Refer to malfunction 34).
3.	Check for voltage at circuit 59-OR terminal of tachograph clock.	12-volts dc nominal.	Go to step 4.	Repair circuit 59-OR (para 3-127).
NOTE				
With positive lead on circuit 59-OR, check ground with negative lead when doing the following checks.				
4.	Check for voltage at circuit 99S-BK ground point of instrument panel.	12-volts dc nominal.	Go to step 5.	Clean and tighten ground point connection.
5.	Check for voltage at circuit 99S-BK terminal of tachograph clock.	12-volts dc nominal.	Replace tachograph (para 3-309).	Repair circuit 99S-BK (para 3-127).
2-98				

TROUBLESHOOTING.

2-11. TROUBLESHOOTING PROCEDURES (Continued).

MALFUNCTION	INSTRUCTION	INDICATION	YES	NO
-------------	-------------	------------	-----	----

32. TACHOGRAPH CLOCK NOT WORKING (Continued).

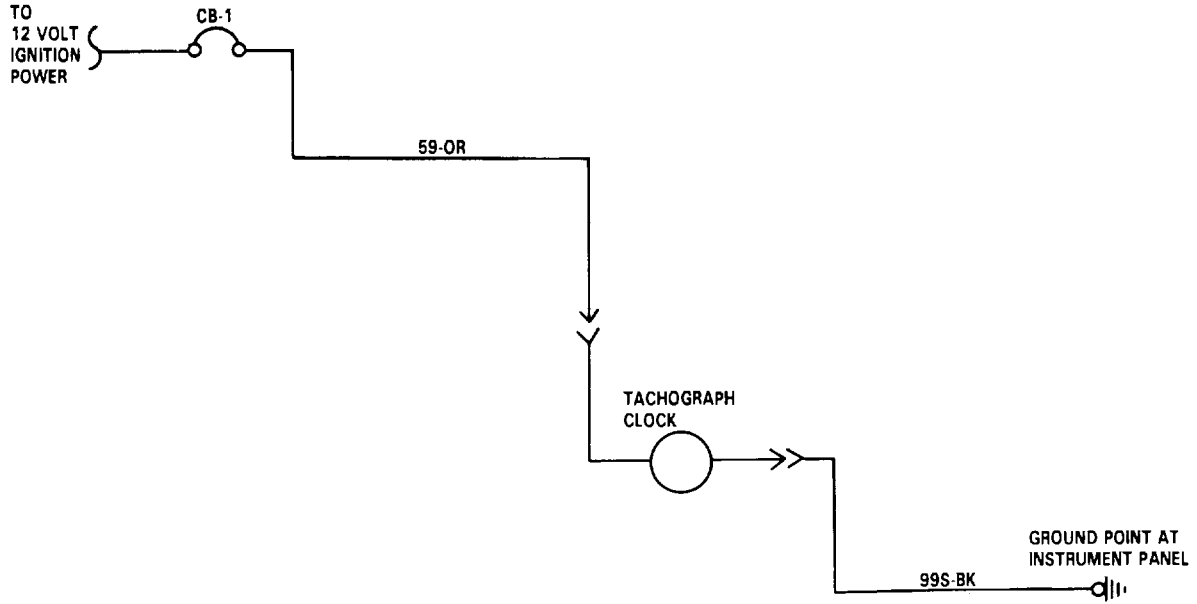

TA 236855

TROUBLESHOOTING.

2-11. TROUBLESHOOTING PROCEDURES (Continued).

MALFUNCTION	INSTRUCTION	INDICATION	YES	NO
33.	NO POWER AT 12-VOLT CIRCUIT BREAKERS CB-2, CB-3, AND/OR CB-4.			
1.	Check for voltage to circuit breakers CB-8 and CB-9. (Refer to malfunction 35). Leave circuit breaker bracket removed for access in later steps.	24-volts dc nominal.	Go to step 3.	Repair circuit 18F-YL (para 3-127).
NOTE				
Ignition switch must be in ON position when doing the following check.				
3.	Check for voltage at circuit 12B-DB terminal of ignition switch. (para 3-114).	24-volts dc nominal.	Go to step 4. (para 3-74). Install circuit	Replace switch
4.	Check for voltage at circuit 12B-DB terminal of relay RY-9.	24-volts dc nominal.	Go to step 5.	Repair circuit 12B-DB (para 3-127). Install bracket (para 3-114).
NOTE				
With positive lead on circuit 12B-DG, check ground with negative lead when doing the following checks.				

TROUBLESHOOTING.

2-11. TROUBLESHOOTING PROCEDURES (Continued).

MALFUNCTION	INSTRUCTION	INDICATION	YES	NO
33.	NO POWER AT 12-VOLT CIRCUIT BREAKERS CB-2, CB-3, AND/OR CB-4 (Continued).			
5.	Check for voltage at ground point.	24-volts dc nominal.	Go to step 6.	Clean and tighten ground connection. Install circuit breaker bracket (para 3-114).
6.	Check for voltage at circuit 99D-BK terminal of relay RY-9.	24-volts dc nominal.	Go to step 7.	Repair circuit 99D-BK and/or 99E-BK (para 3-127). Install circuit breaker bracket (para 3-114).

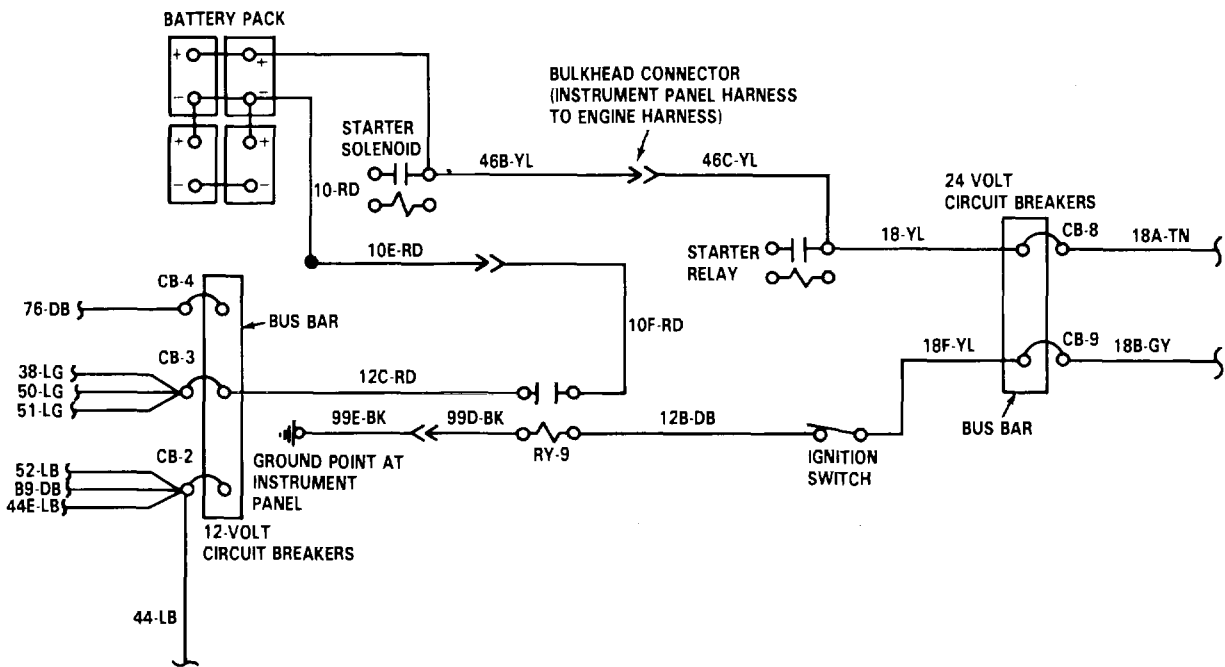

TA 236856

TROUBLESHOOTING.

2-11. TROUBLESHOOTING PROCEDURES (Continued).

MALFUNCTION	INSTRUCTION	INDICATION	YES	NO
33. NO POWER AT 12-VOLT CIRCUIT BREAKERS CB-2, CB-3, AND/OR CB-4 (Continued).				
7.	Check for voltage at circuit 10-RD terminal of battery.	12-volts dc nominal. Go to step 8.		Refer to malfunction 18.
8.	Check for voltage at circuit 10F-RD of relay RY-9.	12-volts dc nominal. Go to step 9.		Repair circuit 10F-RD, 1bE-RD, and/or 10-RD (para 3-127). Install circuit breaker bracket (para 3-114).
NOTE				
Ignition switch must be in ON position when doing the following checks.				
9.	Check for voltage at circuit 12C-RD terminal of relay RY-9.	12-volts dc nominal. Go to step 10.		Replace relay RY-9 (para 3-115). Install circuit breaker bracket (para 3-114).
10.	Check for voltage at circuit 12C-RD terminal of circuit breaker CB-3. bracket (para 3-114).	12-volts dc nominal. Go to step 11.		Repair circuit 12C-RD (para 3-127). Install circuit breaker
11.	Check for voltage at circuit 38-LG terminal of circuit breaker CB-3.	12-volts dc nominal.	Circuit breaker CB-3 is OK. Go to step 14.	Go to step 12.

TROUBLESHOOTING.

2-11. TROUBLESHOOTING PROCEDURES (Continued).

MALFUNCTION	INSTRUCTION	INDICATION	YES	NO
33.	NO POWER AT 12-VOLT CIRCUIT BREAKERS CB-2, CB-3, AND/OR CB-4 (Continued).			

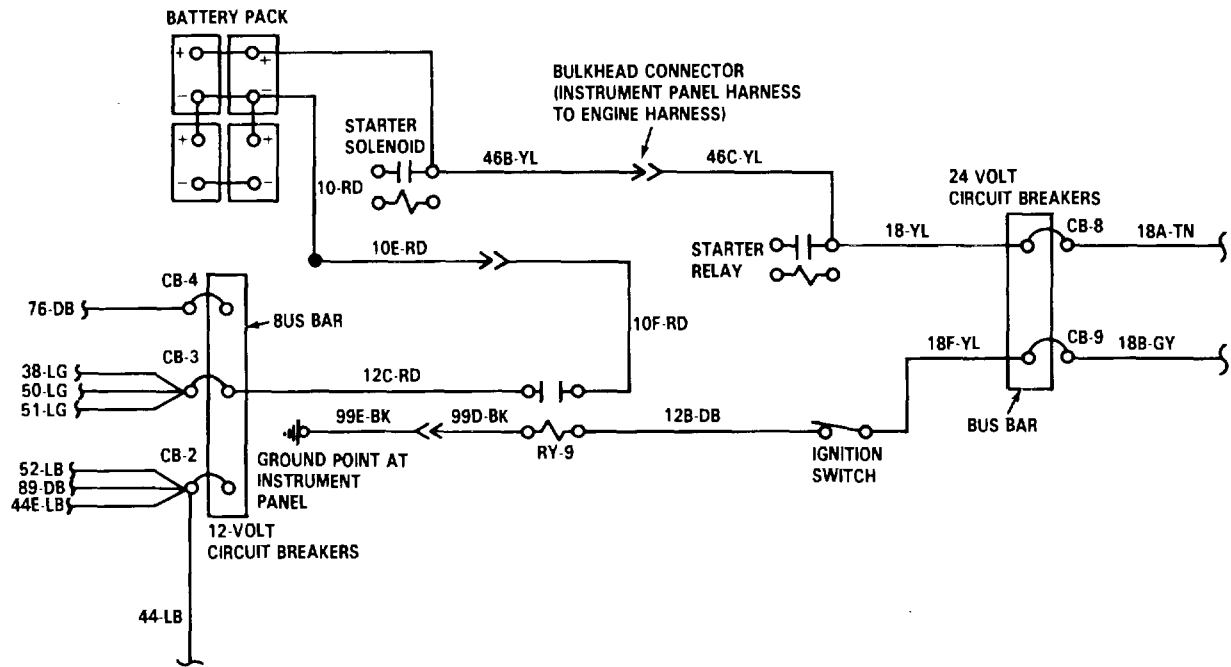

TA 236857

TROUBLESHOOTING.

2-11. TROUBLESHOOTING PROCEDURES (Continued).

MALFUNCTION	INSTRUCTION	INDICATION	YES	NO
33. NO POWER AT 12-VOLT CIRCUIT BREAKERS CB-2, CB-3, AND/OR CB-4 (Continued).				
12.	Remove circuits 38-LG, 50-LG, and 31-LG from circuit breaker CB-3, and reset breaker. Check for voltage at circuit breaker terminal.	12-volts dc nominal.	Go to step 13.	Replace circuit breaker CB-3 (para 3-114).
13.	Reconnect circuit 38-LG, 50-LG, and 51-LG to circuit breaker CB-3. Check for voltage at terminal.	12-volts dc nominal.	Circuit breaker CB-2 is OK. Go to step 14.	If circuit breaker trips, circuit 38-LG, 50-LG, or 51-LG is shorted to ground. Refer to wiring diagram (Appendix D, figure FO-9) and malfunction of faulty system. Install circuit breaker bracket (para 3-114).
14.	Check for voltage at bus bar terminal of circuit breaker CB-4.	12-volts dc nominal.	Go to step 15.	Clean and tighten bus bar connections at circuit breakers CB-2, CB-3, and CB-4. Install circuit breaker bracket (para 3-114).

TROUBLESHOOTING.

2-11. TROUBLESHOOTING PROCEDURES (Continued).

MALFUNCTION	INSTRUCTION	INDICATION	YES	NO
-------------	-------------	------------	-----	----

33. NO POWER AT 12-VOLT CIRCUIT BREAKERS CB-2, CB-3, AND/OR CB-4 (Continued).-

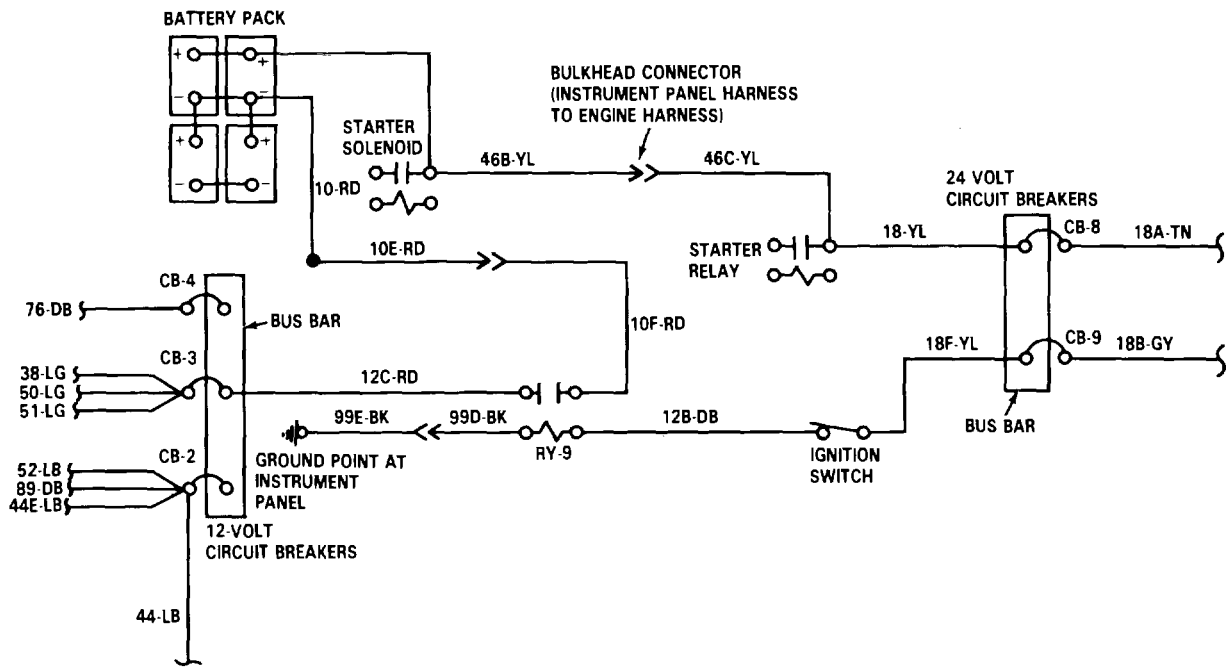

TA 236858

TROUBLESHOOTING.

2-11. TROUBLESHOOTING PROCEDURES (Continued).

MALFUNCTION	INSTRUCTION	INDICATION	YES	NO
33. NO POWER AT 12-VOLT CIRCUIT BREAKERS CB-2, CB-3, AND/OR CB-4 (Continued).				
15.	Check for voltage at circuit 75-DB terminal of circuit breaker CB-4.	12-volts dc nominal.	Circuit breaker CB-4 is OK. Go to step 18.	Go to step 16.
16.	Remove circuit 76-DB from circuit breaker CB-4, and reset breaker. Check for voltage at circuit breaker terminal.	12-volts dc nominal.	Go to step 17.	Replace circuit breaker CB-4 (para 3-114).
17.	Reconnect circuit 76-DB to circuit breaker CB-4. Check for voltage at terminal.	12-volts dc nominal.	Circuit breaker CB-4 is OK, Go to step 18.	If circuit breaker trips, circuit 76-DB is shorted to ground. Refer to wiring diagram (Appendix D, figure FO-9) and malfunction of inoperative system. Install circuit breaker bracket (para 3-114).
18.	Check for voltage at bus bar terminal of circuit breaker CB-2.	12-volts dc nominal.	Go to step 19.	Clean and tighten bus bar connections at circuit breakers CB-2, CB-3, and CB-4.

TROUBLESHOOTING.

2-11. TROUBLESHOOTING PROCEDURES (Continued).

MALFUNCTION	INSTRUCTION	INDICATION	YES	NO
33.	NO POWER AT 12-VOLT CIRCUIT BREAKERS CB-2, CB-3, AND/OR CB-4 (Continued).			

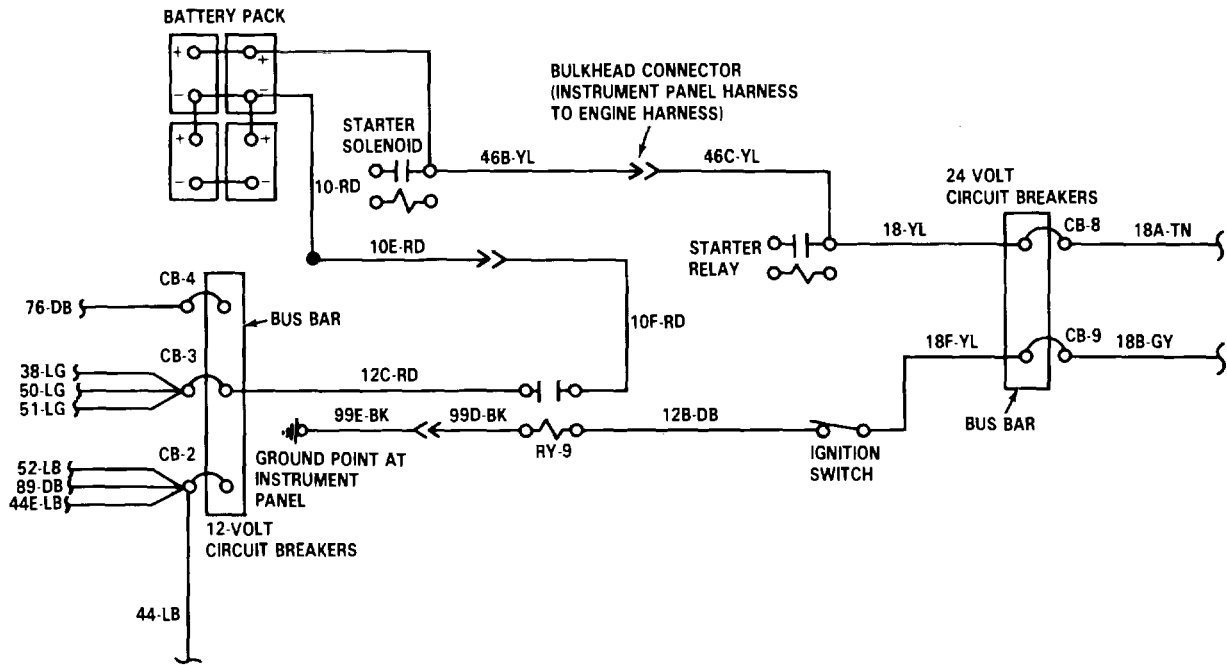

TA 236860

TROUBLESHOOTING.

2-11. TROUBLESHOOTING PROCEDURES (Continued).				
MALFUNCTION	INSTRUCTION	INDICATION	YES	NO
33.	NO POWER AT 12-VOLT CIRCUIT BREAKERS CB-2, CB-3, AND/OR CB-4 (Continued).			
19.	Check for voltage at circuit 52-LB terminal of circuit breaker CB-2.	12-volts dc nominal.	Circuit breaker CB-2 is OK.	Go to step 20.
20.	Remove circuit 52-LB, 89-DB, 44E-LB, and 44-LB from circuit breaker CB-2, and reset breaker. Check for voltage at circuit breaker terminal.	12-volts dc nominal.	Go to step 21.	Replace circuit breaker CB-2 (para 3-114).
21.	Reconnect circuits 52-LB, 89-DB, 44E-LB, and 44-LB. Check for voltage at terminal.	12-volts dc nominal.	Circuit breaker CB-2 is OK.	If circuit breaker trips, circuit 52-DB, 89-DB, 44D-LB, or 44-LB is shorted to ground. Refer to wiring diagram (Appendix D, figure FO-9) and malfunction of inoperative system. Install circuit breaker bracket (para 3-114).

TROUBLESHOOTING.

2-11. TROUBLESHOOTING PROCEDURES (Continued).

MALFUNCTION	INSTRUCTION	INDICATION	YES	NO
-------------	-------------	------------	-----	----

33. NO POWER AT 12-VOLT CIRCUIT BREAKERS CB-2, CB-3, AND/OR CB-4 (Continued).

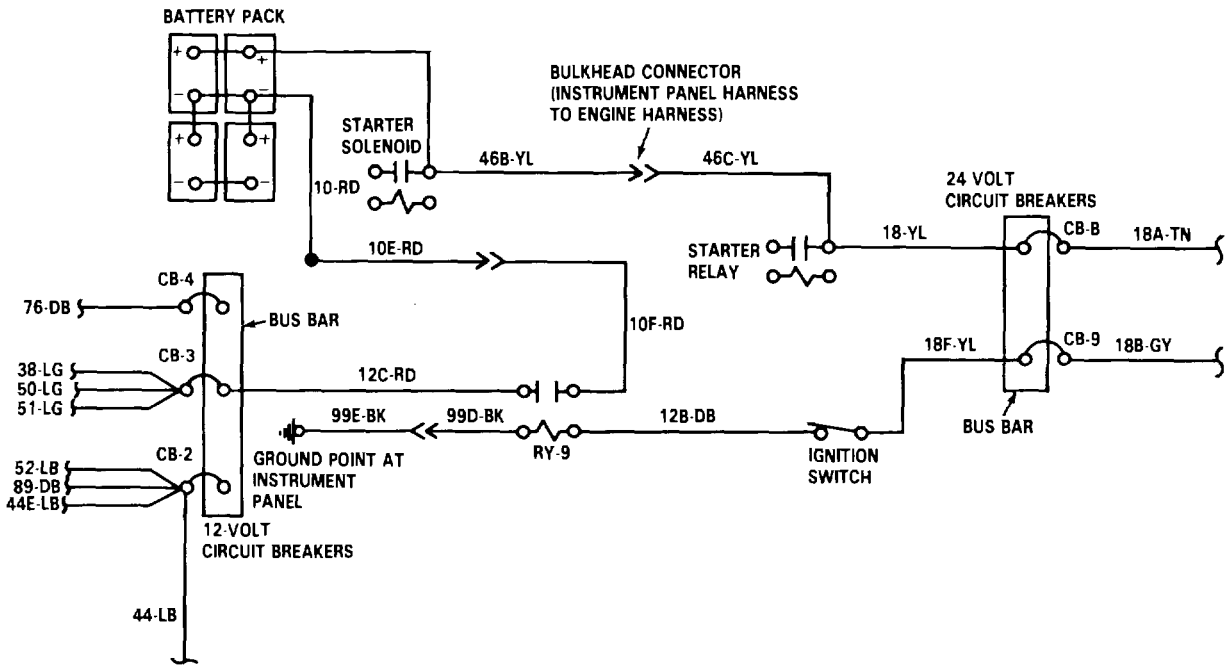

TA 236861

TROUBLESHOOTING.

2-11. TROUBLESHOOTING PROCEDURES (Continued).

MALFUNCTION	INSTRUCTION	INDICATION	YES	NO
<p>34. NO POWER AT 12-VOLT CIRCUIT BREAKERS CB-1, CB-5, CB-6, AND/OR CB-7.</p>				
1.	Check for voltage at circuit 10-RD terminal of battery.	12-volts dc nominal.	Go to step 2.	Refer to malfunction 18.
2.	Remove circuit breaker bracket far enough to access circuit breaker CB-1 (para 3-114), and go to step 3.			
3.	Check for voltage at circuit 10C-PK terminal of circuit breaker CB-1.	12-volts dc nominal. Go to step 4.		Repair circuits 10-RD, IOB-PK, and/or 10C-PK (para 3-127). Install circuit breaker bracket (para 3-114).
4.	Check for voltage at circuit 25-OR terminal of circuit breaker CB-1.	12-volts dc nominal.	Circuit breaker CB-1 is OK. Go to step 7.	Go to step 5.
5.	Remove circuits 59-OR, 25-OR, and 15D-OR from circuit breaker CB-1, and reset breaker. Check for voltage at circuit breaker terminal.	12-volts dc nominal.	Go to step 6.	Replace circuit breaker CB-1 (para 3-114).

TROUBLESHOOTING.

2-11. TROUBLESHOOTING PROCEDURES (Continued).

MALFUNCTION	INSTRUCTION	INDICATION	YES	NO
-------------	-------------	------------	-----	----

34.	NO POWER AT 12-VOLT CIRCUIT BREAKERS CB-1, CB-5, CB-6, AND/OR CB-7 (Continued).			
-----	---	--	--	--

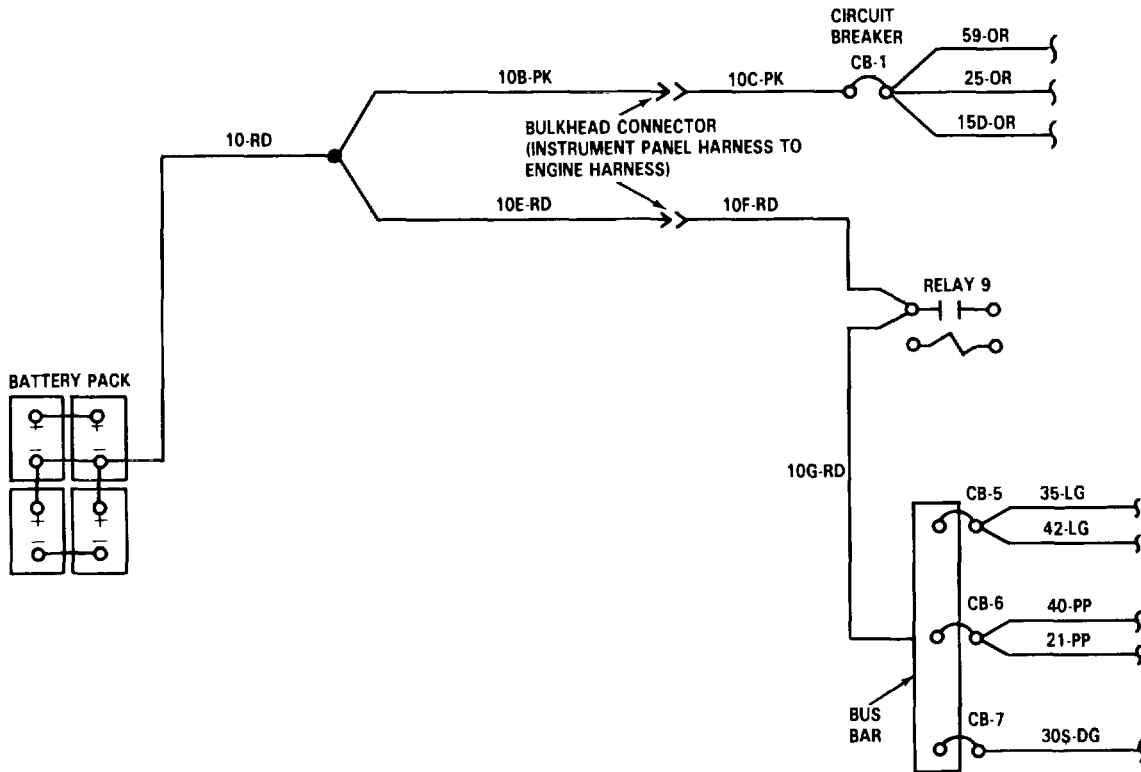

TA 236862

TROUBLESHOOTING.

2-11. TROUBLESHOOTING PROCEDURES (Continued).

MALFUNCTION	INSTRUCTION	INDICATION	YES	NO
34. NO POWER AT 12-VOLT CIRCUIT BREAKERS CB-1, CB-5, CB-6, AND/OR CB-7 (Continued).				
6.	Reconnect circuits 59-OR, 25-OR, and 15D-OR to circuit breaker CB-1. Check for voltage at terminal.	12-volts dc nominal.	Circuit breaker CB-1 is OK. Go to step 7.	If circuit breaker trips, circuit 59-OR, 25-OR, or 15D-OR is shorted to ground. Refer to wiring diagram (Appendix D, figure FO-8) and malfunction of faulty system. Install circuit breaker bracket (para 3-114).
7.	Check for voltage at circuit 10F-RD terminal of ignition relay RY-9. circuit breaker bracket (para 3-114).	12-volts dc nominal.	Go to step 8.	Repair circuits 10-RD and/or 10F-RD (para 3-127). Install

TROUBLESHOOTING.

2-11. TROUBLESHOOTING PROCEDURES (Continued).

MALFUNCTION	INSTRUCTION	INDICATION	YES	NO
-------------	-------------	------------	-----	----

34. NO POWER AT 12-VOLT CIRCUIT BREAKERS CB-1, CB-5, CB-6, AND/OR CB-7 (Continued).

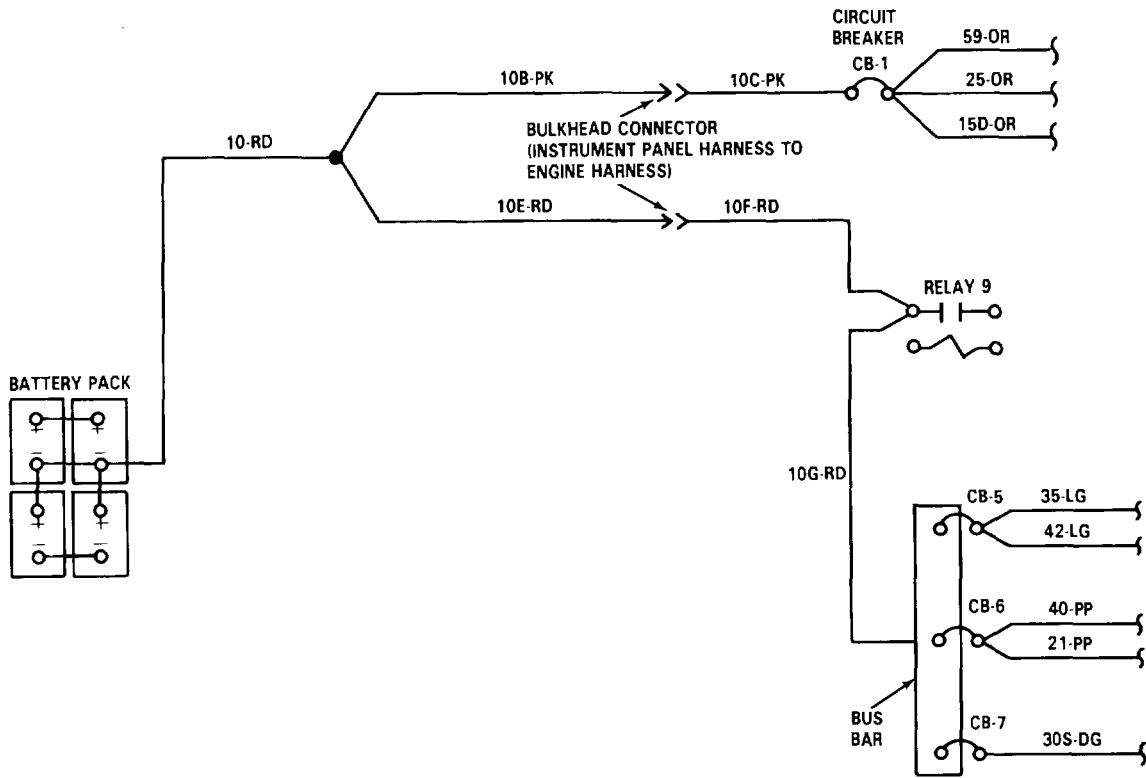

TA 236863

TROUBLESHOOTING.

2-11. TROUBLESHOOTING PROCEDURES (Continued).

MALFUNCTION	INSTRUCTION	INDICATION	YES	NO
34.	NO POWER AT 12-VOLT CIRCUIT BREAKERS CB-1, CB-5, CB-6, AND/OR CB-7 (Continued).			
8.	Check for voltage at circuit 100G-RD terminal of circuit breaker CB-6. panel (para 3-114).	12-volts dc nominal.	Go to step 9.	Repair circuit 10G-RD (para 3-127). Install circuit breaker
9.	Check for voltage at circuit 40-PP terminal of circuit breaker CB-6.	12-volts dc nominal.	Circuit breaker CB-6 is OK. Go to step 12.	Go to step 10.
10.	Remove circuits 40-PP and 21-PP from circuit breaker CB-6 and, reset breaker. Check for voltage at circuit breaker terminal.	12-volts dc nominal.	Go to step 11.	Replace circuit breaker CB-6 (para 3-114).
11.	Reconnect circuits 40-PP and 21-PP to circuit breaker CB-6. Check for voltage at terminal.	12-volts dc nominal.	Circuit breaker CB-6 is OK. Go to step 12.	If breaker trips, circuit 40-PP or 21-PP is shorted to ground. Refer to wiring diagram (Appendix D, figure FO-8) and malfunction of faulty system. Install circuit breaker bracket (para 3-114).

TROUBLESHOOTING.

2-11. TROUBLESHOOTING PROCEDURES (Continued).

MALFUNCTION	INSTRUCTION	INDICATION	YES	NO
-------------	-------------	------------	-----	----

34. NO POWER AT 12-VOLT CIRCUIT BREAKERS CB-1, CB-5, CB-6, AND/OR CB-7 (Continued).

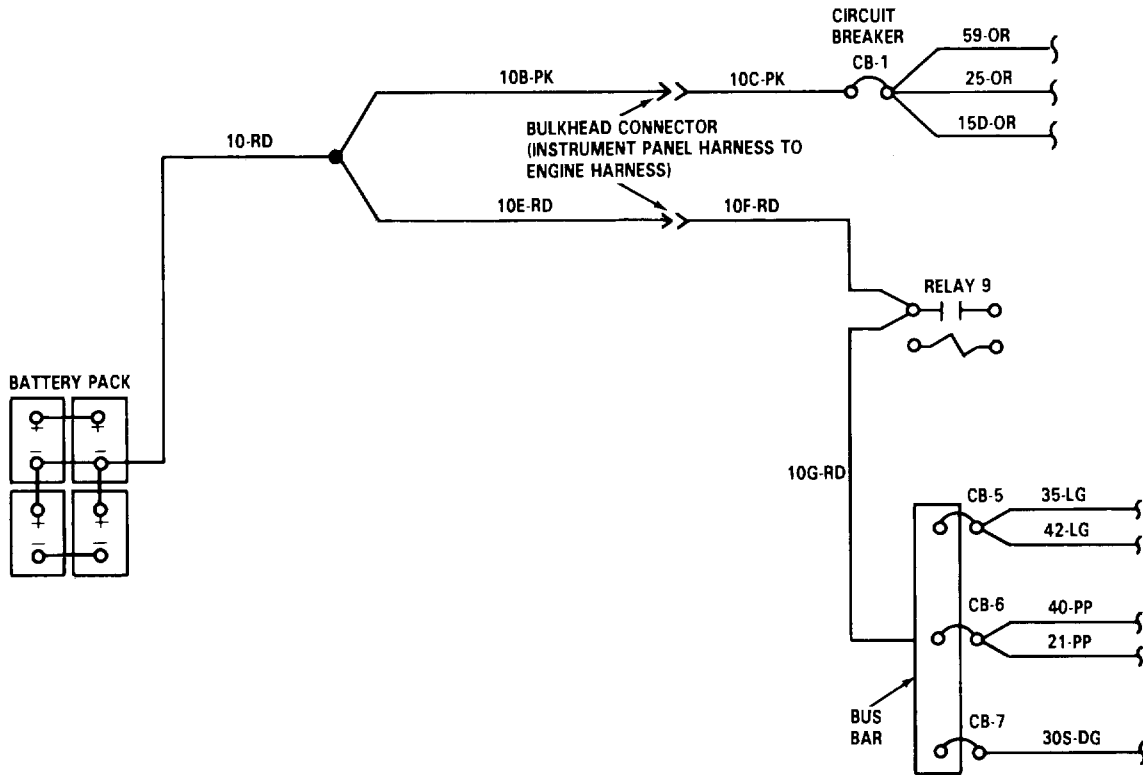

TA 236863

TROUBLESHOOTING.

2-11. TROUBLESHOOTING PROCEDURES (Continued).

MALFUNCTION	INSTRUCTION	INDICATION	YES	NO
34. NO POWER AT 12-VOLT CIRCUIT BREAKERS CB-1, CB-5, CB-6, AND/OR CB-7 (Continued).				
12.	Check for voltage at bus bar terminal of circuit breaker CB-5.	12-volts dc nominal.	Go to step 13.	Clean and tighten bus bar connections at circuit breakers CB-5, CB-6, and CB-7. Install circuit breaker bracket (para 3-114).
13.	Check for voltage at circuit 35-LG terminal of circuit breaker CB-5.	12-volts dc nominal.	Circuit breaker CB-5 is OK. Go to step 16.	Go to step 14.
14.	Remove circuits 35-LG and 42-LG from circuit breaker CB-5, and reset breaker. Check for voltage at circuit breaker terminal.	12-volts dc nominal.	Go to step 15.	Replace circuit breaker CB-5 (para 3-114).
15.	Reconnect circuits 35-LG and 42-LG to circuit breaker CB-5. Check for voltage at terminal.	12-volts dc nominal.	Circuit breaker CB-5 is OK. Go to step 16.	If circuit breaker trips, circuit 35-LG or 42-LG is shorted to ground. Refer to wiring diagram (Appendix D, figure FO-8) and malfunction of faulty system. Install circuit breaker bracket (para 3-114).

TROUBLESHOOTING.

2-11. TROUBLESHOOTING PROCEDURES (Continued).

MALFUNCTION	INSTRUCTION	INDICATION	YES	NO
-------------	-------------	------------	-----	----

34. NO POWER AT 12-VOLT CIRCUIT BREAKERS CB-1, CB-5, CB-6, AND/OR CB-7 (Continued).

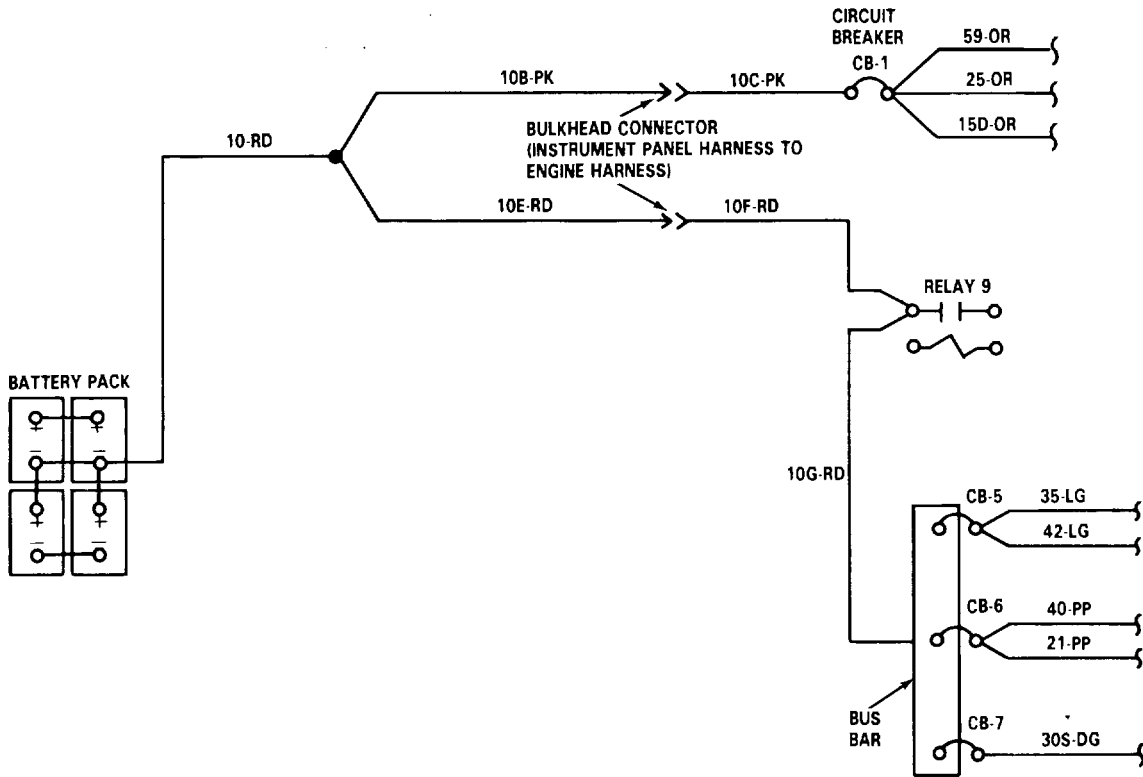

TA 236864

TROUBLESHOOTING.

2-11. TROUBLESHOOTING PROCEDURES (Continued).				
MALFUNCTION	INSTRUCTION	INDICATION	YES	NO
34. NO POWER AT 12-VOLT CIRCUIT BREAKERS CB-1, CB-5, CB-6, AND/OR CB-7 (Continued).				
16.	Check for voltage at bus bar terminal of circuit breaker CB-7.	12-volts dc nominal.	Go to step 17.	Clean and tighten bus bar connections at circuit breakers CB-5, CB-6, and CB-7. Install circuit breaker bracket (para 3-114). Go to step 18.
17.	Check for voltage at circuit 30S-DG terminal of circuit breaker CB-7.	12-volts dc nominal.	Circuit breaker CB-7 is OK.	Go to step 18.
18.	Remove circuit 30S-DG from circuit breaker CB-7, and reset breaker. Check for voltage at circuit breaker terminal.	12-volts dc nominal.	Go to step 19.	Replace circuit breaker CB-7 (para 3-114).
19.	Reconnect circuit 30S-DG to circuit breaker CB-7. Check for voltage at terminal.	12-volts dc nominal.	Circuit breaker CB-7 is OK.	If circuit breaker trips, circuit 30S-DG is shorted to ground. Refer to wiring diagram (Appendix D, figure FO-8) and malfunction of faulty system. Install circuit breaker bracket (para 3-114).

TROUBLESHOOTING.

2-11. TROUBLESHOOTING PROCEDURES (Continued).

MALFUNCTION	INSTRUCTION	INDICATION	YES	NO
-------------	-------------	------------	-----	----

34. NO POWER AT 12-VOLT CIRCUIT BREAKERS CB-1, CB-5, CB-6, AND/OR CB-7 (Continued).

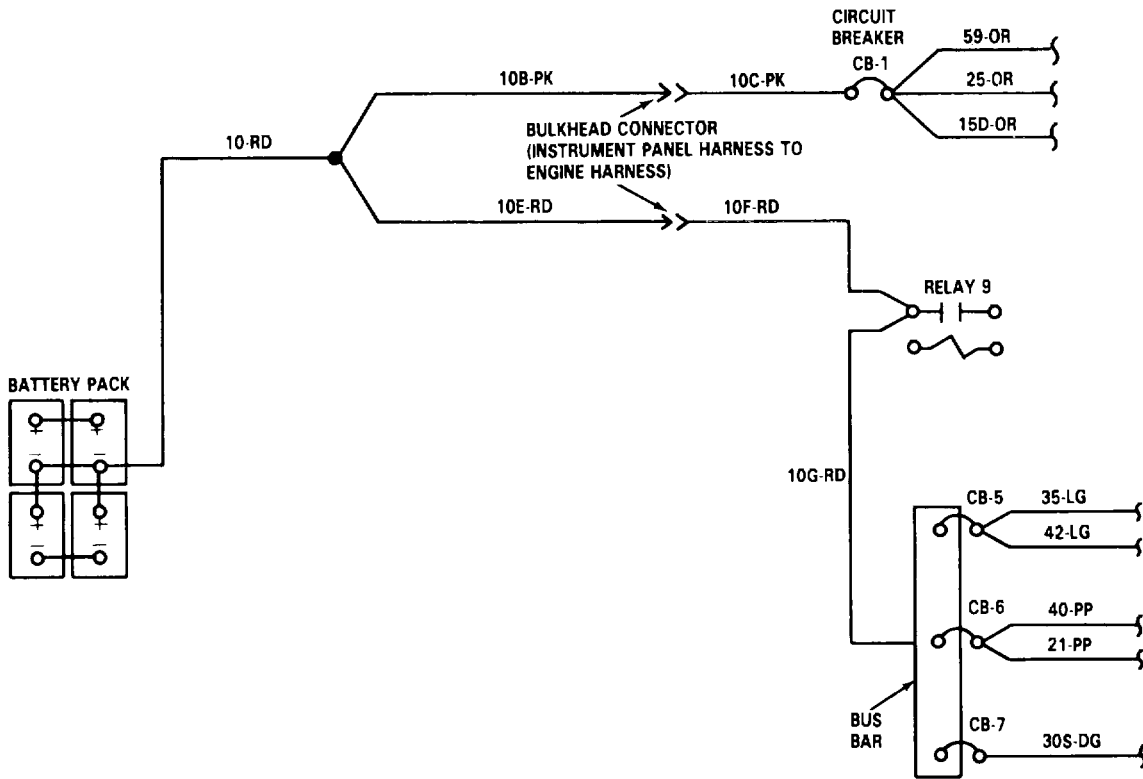

TA 236865

TROUBLESHOOTING.

2-11. TROUBLESHOOTING PROCEDURES (Continued).

MALFUNCTION	INSTRUCTION	INDICATION	YES	NO
35. NO POWER AT 24-VOLT CIRCUIT BREAKERS CB-8 AND/OR CB-9.				
1.	Check for voltage at starter solenoid main battery cable connection.	24-volts dc nominal.	Go to step 2.	Refer to malfunction 18.
2.	Check for voltage at circuit 46C-YL terminal of starter relay.	24-volts dc nominal.	Go to step 3.	Repair circuit 46B-YL and/or 46C-YL (para
3.	Remove circuit breaker bracket far enough to access circuit breaker CB-8 (para 3-114), and go to step 4.			
4.	Check for voltage at circuit 18-YL terminal of circuit breaker CB-8.	24-volts dc nominal.	Go to step 5.	Repair circuit 18-YL (para 3-127). Install circuit breaker bracket (para 3-114). Go to step 6.
5.	Check for voltage at circuit 18A-TN terminal of circuit breaker CB-8.	24-volts dc nominal.	Circuit breaker CB-8 is OK. Go to step 8.	
6.	Remove circuit 18A-TN from circuit breaker CB-8, and reset breaker. Check for voltage at circuit breaker terminal.	24-volts dc nominal.	Go to step 7.	Replace circuit breaker CB-8 (para 3-114).

TROUBLESHOOTING.

2-11. TROUBLESHOOTING PROCEDURES (Continued).

MALFUNCTION	INSTRUCTION	INDICATION	YES	NO
-------------	-------------	------------	-----	----

35. NO POWER AT 24-VOLT CIRCUIT BREAKERS CB-8 AND/OR CB-9 (Continued).

- | | | | | |
|--|--|---------------------------------------|---------------------------------------|--|
| <p>7. Reconnect circuit 18A-TN to circuit breaker CB-8. for voltage at terminal.</p> | | <p>24-volts dc nominal.
Check</p> | <p>Circuit breaker CB-8 is OK. Go</p> | <p>If circuit breaker trips, to step 8. circuit 18A-TN is shorted to ground. Refer to wiring diagram (Appendix D, figure FO-8) and malfunction of faulty system. Install circuit breaker panel (para 3-114).</p> |
|--|--|---------------------------------------|---------------------------------------|--|

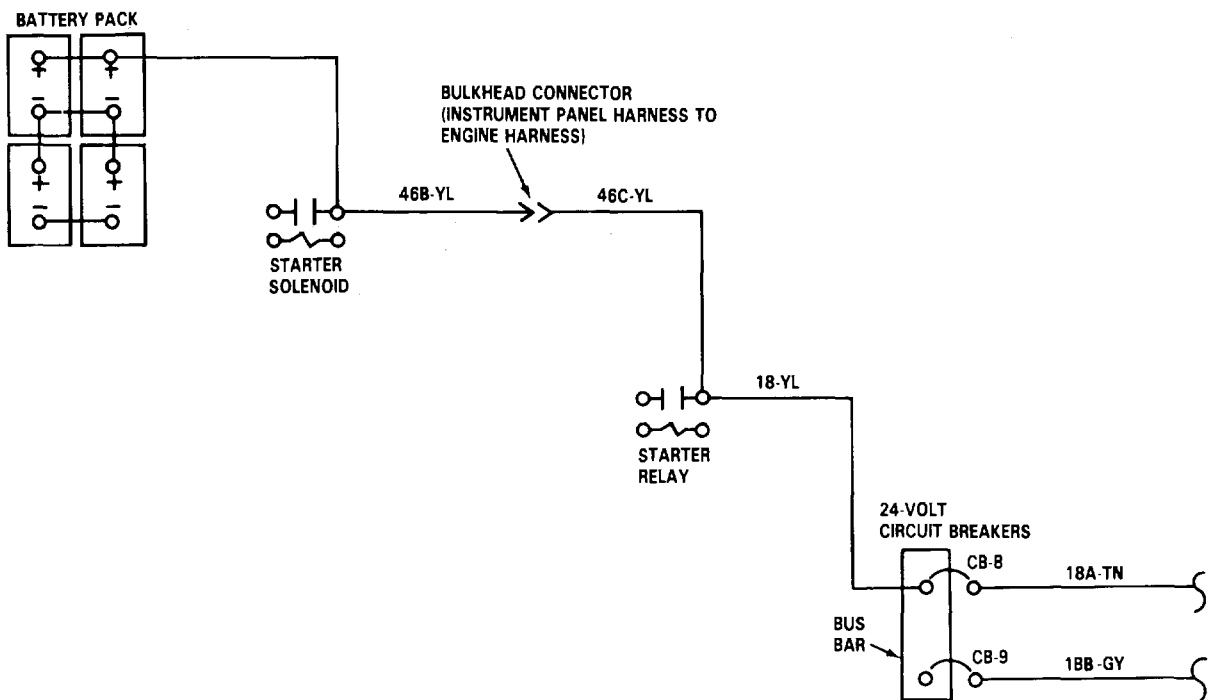

TA 236866

TROUBLESHOOTING.

2-11. TROUBLESHOOTING PROCEDURES (Continued).

MALFUNCTION	INSTRUCTION	INDICATION	YES	NO
35. NO POWER AT 24-VOLT CIRCUIT BREAKERS CB-8 AND/OR CB-9 (Continued).				
8.	Check for voltage at bus bar terminal of circuit breaker CB-9.	24-volts dc nominal.	Go to step 9.	Clean and tighten bus bar connections at circuit breakers CB-8 and CB-9. Install circuit breaker bracket (para 3-114).
9.	Check for voltage at circuit 18B-GY terminal of circuit breaker CB-9.	24-volts dc nominal.	Circuit breaker CB-9 is OK.	Go to step 10.
10.	Remove circuit 18B-GY from circuit breaker CB-9, and reset breaker. Check for voltage at circuit breaker terminal.	24-volts dc nominal.	Go to step 11.	Replace circuit breaker CB-9 (para 3-114).
11.	Reconnect circuit 18B-GY to circuit breaker CB-9. Check for voltage at terminal.	24-volts dc nominal.	Circuit breaker CB-9 is OK.	If circuit breaker trips, circuit 18B-GY is shorted to ground. Refer to wiring diagram (Appendix D, figure FO-8) and malfunction of faulty system. Install circuit breaker bracket (para 3-114).

TROUBLESHOOTING.

2-11. TROUBLESHOOTING PROCEDURES (Continued).

MALFUNCTION	INSTRUCTION	INDICATION	YES	NO
-------------	-------------	------------	-----	----

35. NO POWER AT 24-VOLT CIRCUIT BREAKERS CB-8 AND/OR CB-9 (Continued).

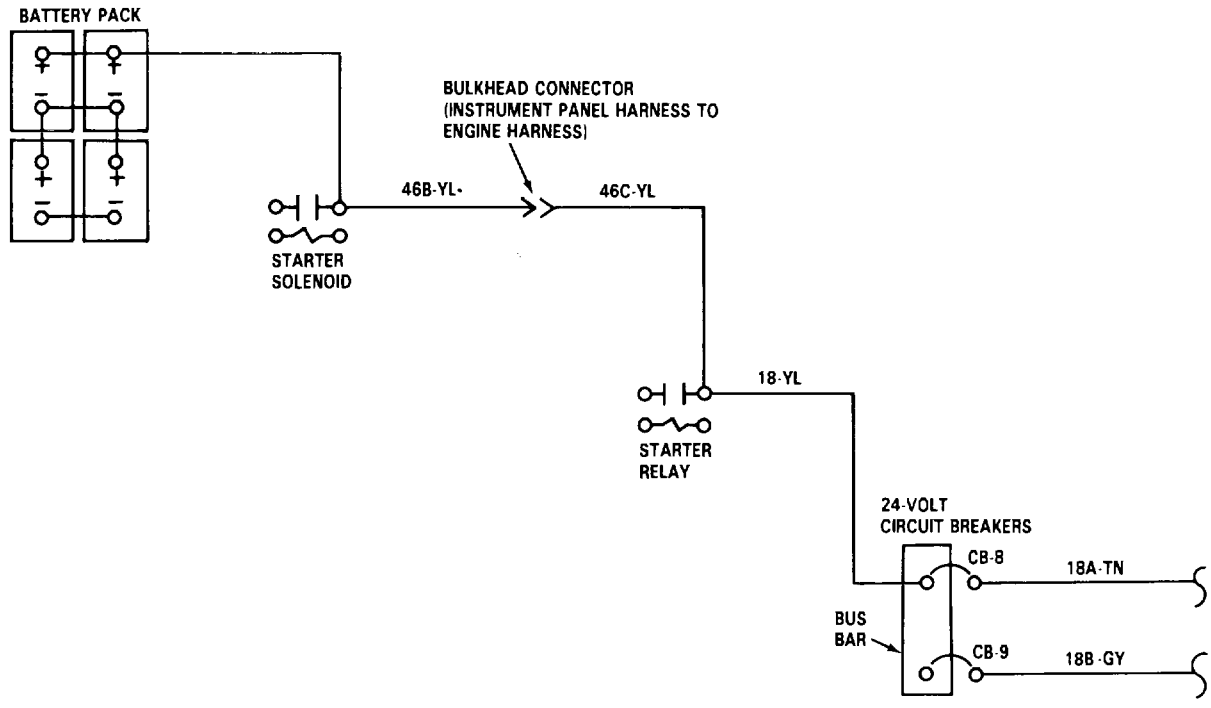

TA 236867

TROUBLESHOOTING.

2-11. TROUBLESHOOTING PROCEDURES (Continued).

MALFUNCTION	INSTRUCTION	INDICATION	YES	NO
36. SHIFT TOWER LAMP NOT WORKING.				
NOTE				
Headlamp rheostat switch must be rotated fully clockwise when doing the following checks.				
1.	Check for voltage at circuit 29S-BR terminal of headlamp switch.	12-volts dc nominal.	Go to step 2.	Refer to malfunction 44.
2.	Disconnect circuit 29S-BR from 29T-BR at connector. Check for voltage at circuit 29S-BR (pin k of connector).	12-volts dc nominal.	Connect circuit 29S-BR to 29T-BR, and go to step 3.	Repair circuit 29S-BR (para 3-127). Connect circuit 29S-BR to 29T-BR.
3.	Check for voltage at circuit 29S-BR terminal of shift tower lamp.	12-volts dc nominal.	Go to step 4.	Repair circuit 29T-BR (para 3-127).
4.	Remove bulb from shift tower lamp (para 3-87). Check for voltage at lamp socket.	12-volts dc nominal.	Replace bulb (para 3-87).	Clean socket and install bulb (para 3-87).

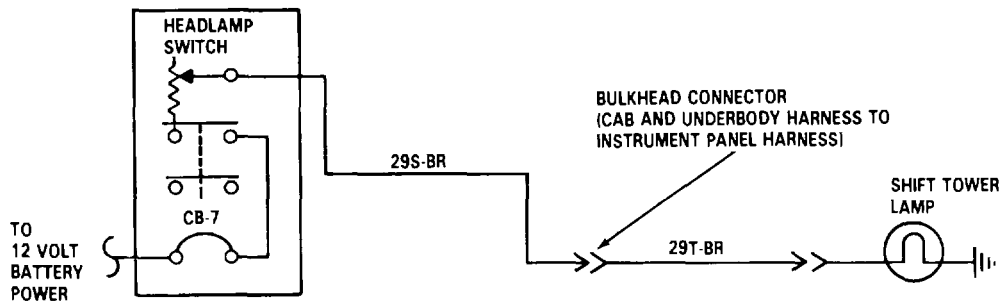

TA 236868

TROUBLESHOOTING.

2-11. TROUBLESHOOTING PROCEDURES (Continued).

MALFUNCTION	INSTRUCTION	INDICATION	YES	NO
-------------	-------------	------------	-----	----

37. ETHER LAMP AND/OR CLEARANCE LAMP NOT WORKING.

NOTE

- Headlamp rheostat switch must be rotated fully clockwise when doing the following checks.
- Do steps 1 thru 6 only if clearance lamp is not working or if both lamps are not working.
- Do steps 3 thru 5 and step 7 only if ether lamp is not working.

1.	Check for voltage at circuit 29-BR terminal Of headlamp switch.	12-volts dc nominal.	Go to step 2.	Refer to malfunction 44.
----	---	----------------------	---------------	--------------------------

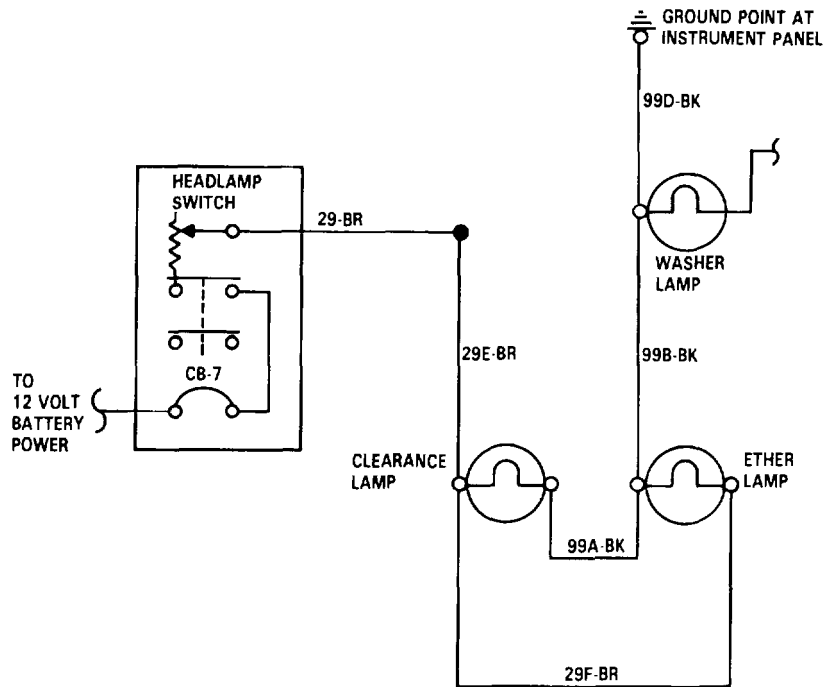

TA 236869

TROUBLESHOOTING.

2-11. TROUBLESHOOTING PROCEDURES (Continued).				
MALFUNCTION	INSTRUCTION	INDICATION	YES	NO
37. ETHER LAMP AND/OR CLEARANCE LAMP NOT WORKING (Continued).				
2.	Check for voltage at circuit 29E-BR terminal of clearance lamp.	12-volts dc nominal.	Go to step 3.	Repair circuit 29E-OR and/or 29-BR
NOTE				
With positive lead on circuit 29E-BR, check ground with negative lead when doing the following checks.				
3.	Check for voltage at ground point of circuit 99D-BK.	12-volts dc nominal.	Go to step 4.	Clean and/or tighten ground con-
4.	Check for voltage at circuit 99D-BK terminal of washer lamp.	12-volts dc nominal.	Go to step 5.	Repair circuit 99D-BK (para 3-127).
5.	Check for voltage at circuit 99B-BK terminal of ether lamp.	12-volts dc nominal.	Go to step 6.	Repair circuit 99B-BK (para 3-127).
6.	Check for voltage at circuit 99A-BK terminal of clearance lamp.	12-volts dc nominal.	Replace bulb (para 3-85).	Repair circuit 99A-BK (para 3-127).
7.	Check for voltage at circuit 29F-BR terminal of ether lamp.	12-volts dc nominal.	Replace bulb (para 3-85).	Repair circuit 29F-BR (para 3-127).
2-126				

TROUBLESHOOTING.

2-11. TROUBLESHOOTING PROCEDURES (Continued).

MALFUNCTION	INSTRUCTION	INDICATION	YES	NO
-------------	-------------	------------	-----	----

37. ETHER LAMP AND/OR CLEARANCE LAMP NOT WORKING (Continued).

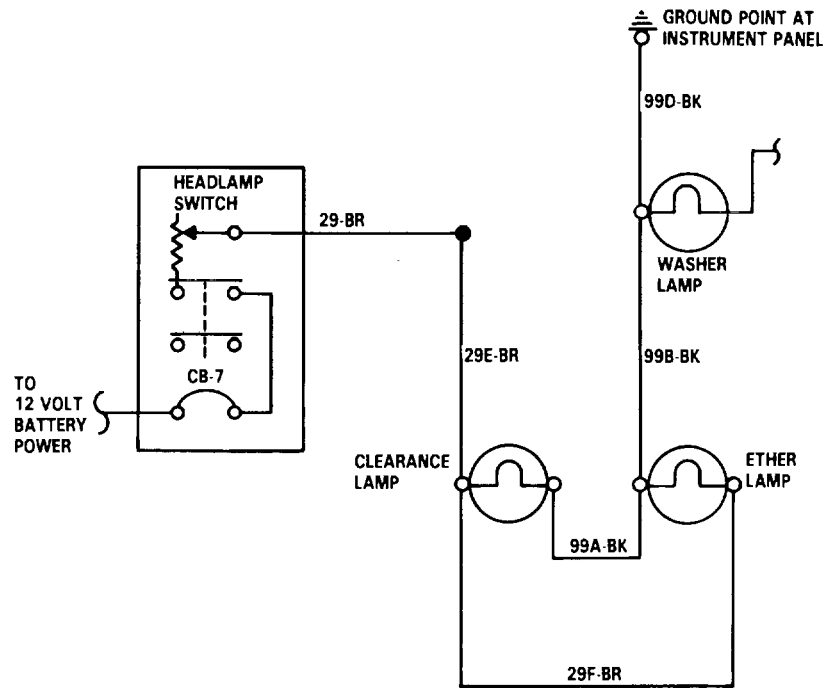

TA 236870

TROUBLESHOOTING.

2-11. TROUBLESHOOTING PROCEDURES (Continued).

MALFUNCTION	INSTRUCTION	INDICATION	YES	NO
<p>38. WASHER LAMP AND/OR WIPER LAMP NOT WORKING.</p>				
<p>NOTE</p>				
<ul style="list-style-type: none"> • Headlamp rheostat switch must be rotated fully clockwise when doing the following check. • Do steps 1 thru 5 only if wiper lamp is not working or if both lamps are not working. • Do steps 3, 4, and 6 only if washer lamp is not working. 				
1.	Check for voltage at circuit 29-BR terminal of headlamp switch.	12-volts dc nominal.	Go to step 2.	Refer to malfunction 44.
2.	Check for voltage at circuit 29-BR terminal of wiper lamp.	12-volts dc nominal.	Go to step 3.	Repair circuit 29-BR (para 3-127).
<p>NOTE</p>				
<p>With positive lead on circuit 29-BR, check ground with negative lead when doing the following checks.</p>				
3.	Check for voltage at ground point of circuit 99D-BK.	12-volts dc nominal.	Go to step 4.	Clean and/or tighten ground point connec-
4.	Check for voltage at circuit 99D-BK terminal of washer lamp.	12-volts dc nominal.	Go to step 5 or 6.	Repair circuit 99D-BK (para 3-127).
<p>2-128</p>				

TROUBLESHOOTING.

2-11. TROUBLESHOOTING PROCEDURES (Continued).

MALFUNCTION	INSTRUCTION	INDICATION	YES	NO
-------------	-------------	------------	-----	----

38. WASHER LAMP AND/OR WIPER LAMP NOT WORKING (Continued).

5.	Check for voltage at circuit 99C-BK terminal of wiper lamp.	12-volts dc nominal.	Replace bulb (para 3-86).	Repair circuit 99C-BK (para 3-127).
6.	Check for voltage at circuit 29C-BR terminal of washer lamp.	12-volts dc nominal.	Replace bulb (para 3-86).	Repair circuit 29C-BR (para 3-127).

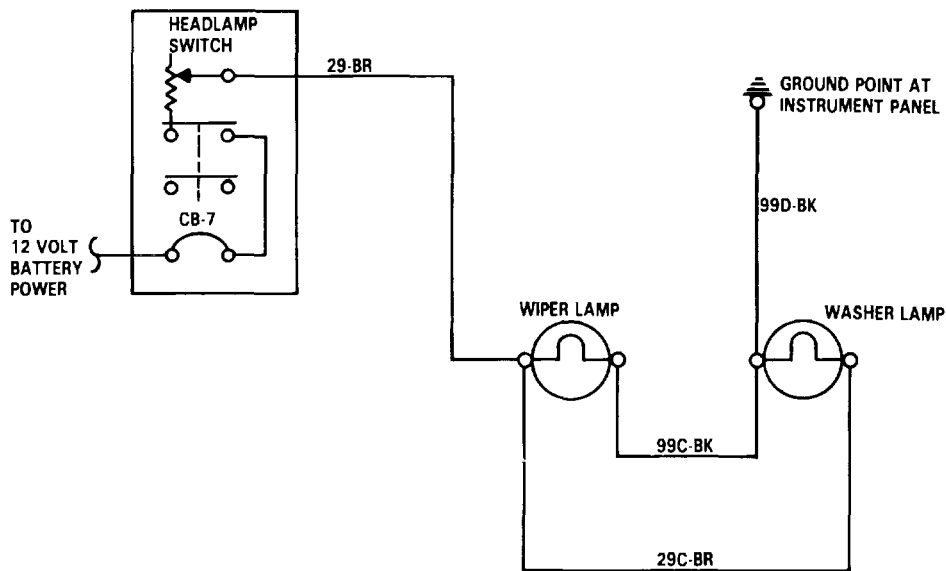

TA 236871

TROUBLESHOOTING.

2-11. TROUBLESHOOTING PROCEDURES (Continued).

MALFUNCTION	INSTRUCTION	INDICATION	YES	NO
39. HEATER LAMP NOT WORKING.				
NOTE				
Headlamp rheostat switch must be rotated fully clockwise when doing the following checks.				
1	Check for voltage at circuit 29-BR terminal of headlamp switch.	12-volts dc nominal	Go to step 2 function 44.	Refer to mal-
2	Check for voltage at circuit 29-BR terminal of heater lamp connector.	12-volts dc nominal 3-127).	Go to step 3 29-BR (para	Repair circuit
3	Remove bulb from heater lamp socket (para 3-87), and go to step 4.			
4	Check for voltage at socket	12-volts dc nominal	Replace bulb (para 3-87)	Clean socket and install bulb (para 3-87).

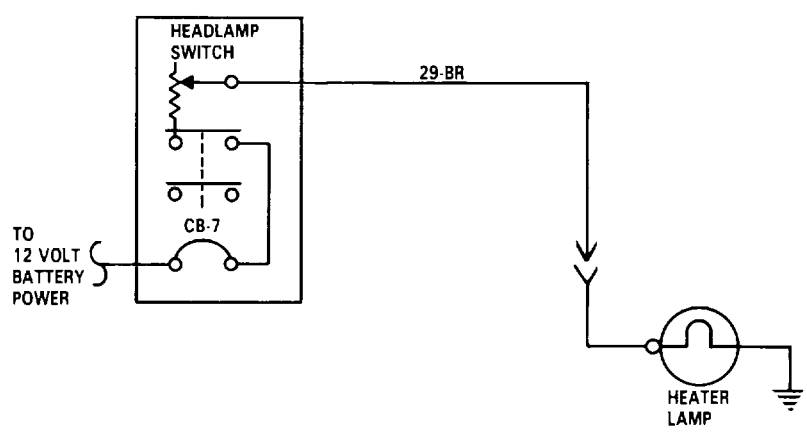

TA 236872

TROUBLESHOOTING.

2-11. TROUBLESHOOTING PROCEDURES (Continued).

MALFUNCTION	INSTRUCTION	INDICATION	YES	NO
-------------	-------------	------------	-----	----

40. INSTRUMENT PANEL GAGE LAMP OR LAMPS NOT WORKING.

NOTE

- Headlamp rheostat switch must be rotated fully clockwise and pulled out to ON position when doing the following checks.
- Do steps 1 thru 5 only if all lamps are not working.
- Do steps 6 thru 8 only if one lamp is not working. Faulty fuel lamp is shown in this procedure.

1.	Check for voltage at circuit 29-BR terminal Of headlamp switch.	12-volts dc nominal.	Go to step 2.	Refer to mal- function 44.
----	---	----------------------	---------------	----------------------------

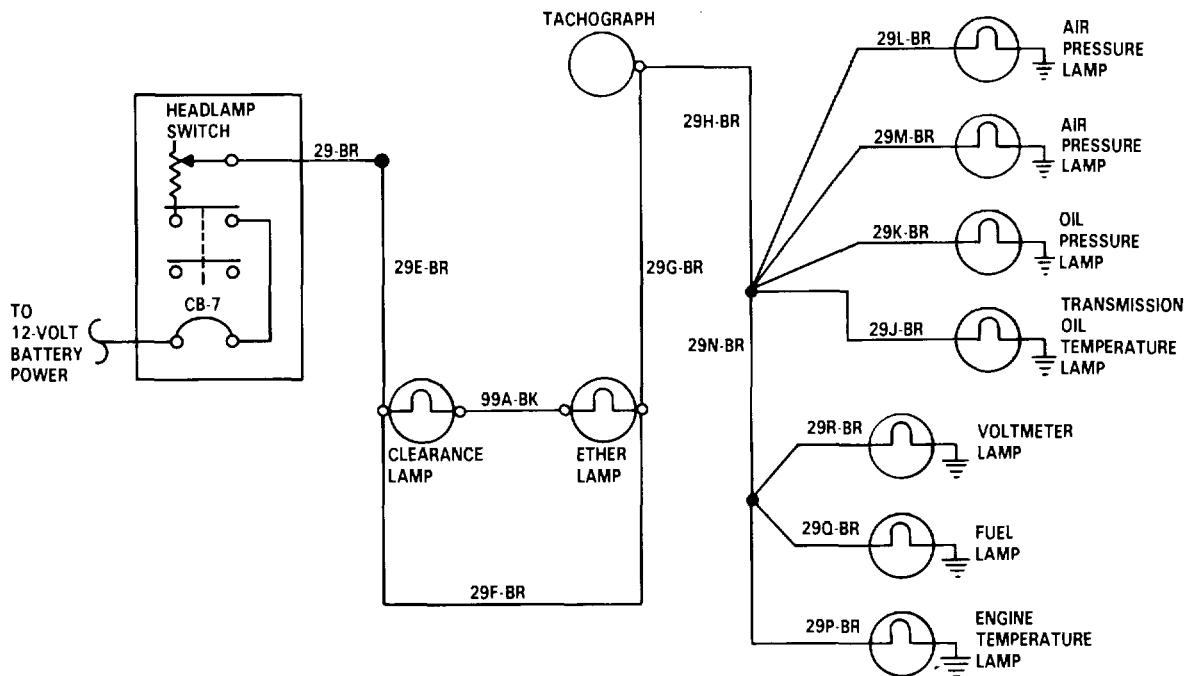

TA 236873

TROUBLESHOOTING.

2-11. TROUBLESHOOTING PROCEDURES (Continued).

MALFUNCTION	INSTRUCTION	INDICATION	YES	NO
40. INSTRUMENT PANEL GAGE LAMP OR LAMPS NOT WORKING (Continued).				
2	Check for voltage at circuit 29E-BR terminal of clearance lamp	12-volts dc nominal 29-BR (para	Go to step 3 29E-BR and/or	Repair circuit
3	Check for voltage at circuit 29F-BR terminal of ether lamp	12-volts dc nominal 3-127).	Go to step 4 29F-BR (para	Repair circuit
4	Check for voltage at circuit 29G-BR terminal of tachograph	12-volts dc nominal 3-127).	Go to step 5 29G-BR (para	Repair circuit
5	Check for voltage at circuit 29K-BR terminal of oil pressure lamp	12-volts dc nominal circuit OK	Instrument panel lamp 3-127).	Repair circuit 29H-BR (para
6	Check for voltage at circuit 29Q-BR terminal of fuel gage	12-volts dc nominal 29N-BR	Go to step 7 29Q-BR and/or (para	Repair circuit
7	Remove bulb from socket (para 3-73), and go to step 8.			
8	Check for voltage at circuit 29Q-BR socket of fuel lamp	12-volts dc nominal tion.	Replace bulb (para 3-73)	Clean lamp socket connec-

TROUBLESHOOTING.

2-11. TROUBLESHOOTING PROCEDURES (Continued).

MALFUNCTION	INSTRUCTION	INDICATION	YES	NO
-------------	-------------	------------	-----	----

40. INSTRUMENT PANEL LAMP OR LAMPS NOT WORKING (Continued).

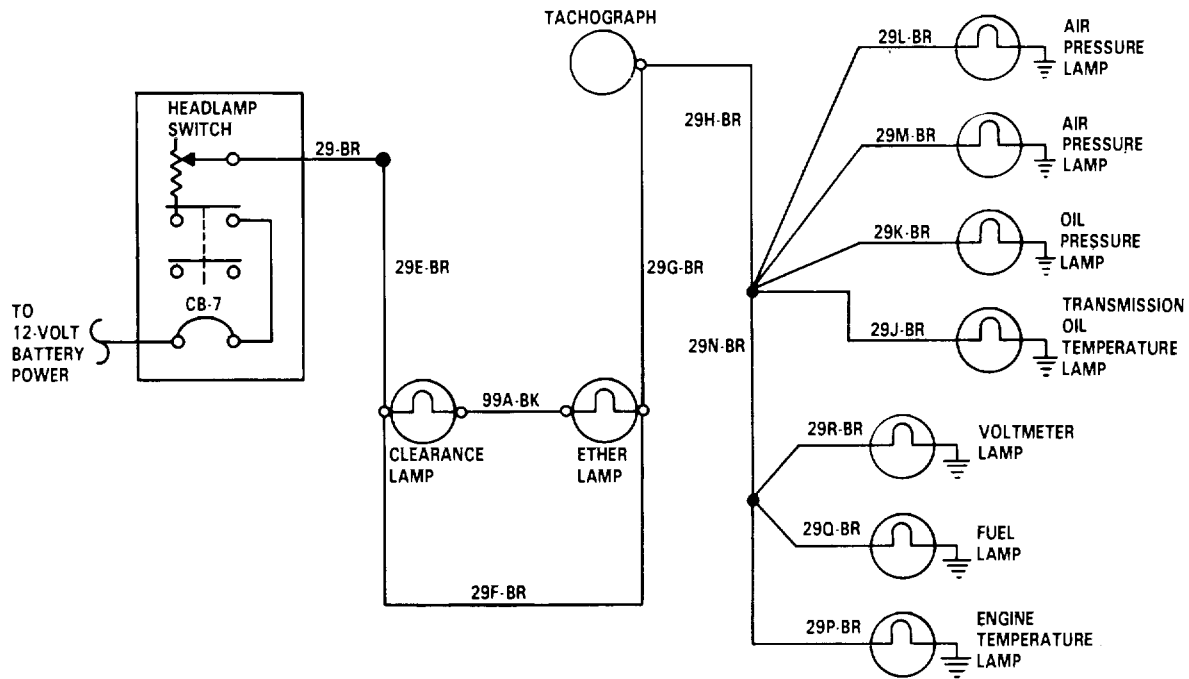

TA 236874

TROUBLESHOOTING.

2-11. TROUBLESHOOTING PROCEDURES (Continued).

MALFUNCTION	INSTRUCTION	INDICATION	YES	NO
41.	BOTH HEADLAMPS BLINK ON AND OFF.			
NOTE				
Blackout toggle switch must be set to NORMAL position and headlamp switch in ON position when doing steps 1 and 2.				
1.	Set dimmer switch to low beam position.	Lamp blinks on and off.	Go to step 3.	Go to step 2.
2.	Set dimmer switch to high beam position.	Lamp blinks on and off.	Go to step 13.	Headlamp OK.
3.	Set blackout toggle switch to BLACKOUT position.	Blackout headlamp blinks on and off.	Go to step 4.	Repair circuit 26-GY (para 3-127) and/or refer to malfunction 44.
4.	Set blackout toggle switch to NORMAL position. Check circuit 26A-DB terminal of blackout toggle switch.	Loose.	Tighten connection,	Go to step 5.
5.	Turn off headlamp switch, and go to step			
6.	Check circuit 26A-DB to circuit 26B-DB for continuity.	Infinity.	Repair circuit 26A-DB (para 3-127).	Go to step 7.
7.	Check circuit 26B-DB to dimmer switch for continuity.	Infinity.	Repair circuit 26B-DB (para 3-127).	Go to step 8.

TROUBLESHOOTING.

2-11. TROUBLESHOOTING PROCEDURES (Continued).

MALFUNCTION	INSTRUCTION	INDICATION	YES	NO
41.	BOTH HEADLAMPS BLINK ON AND OFF (Continued).			
8.	Turn on headlamp switch, and go to step 9.			
9.	Check circuit 26B-DB terminal of dimmer switch.	Loose.	Tighten connection.	Go to step 10.

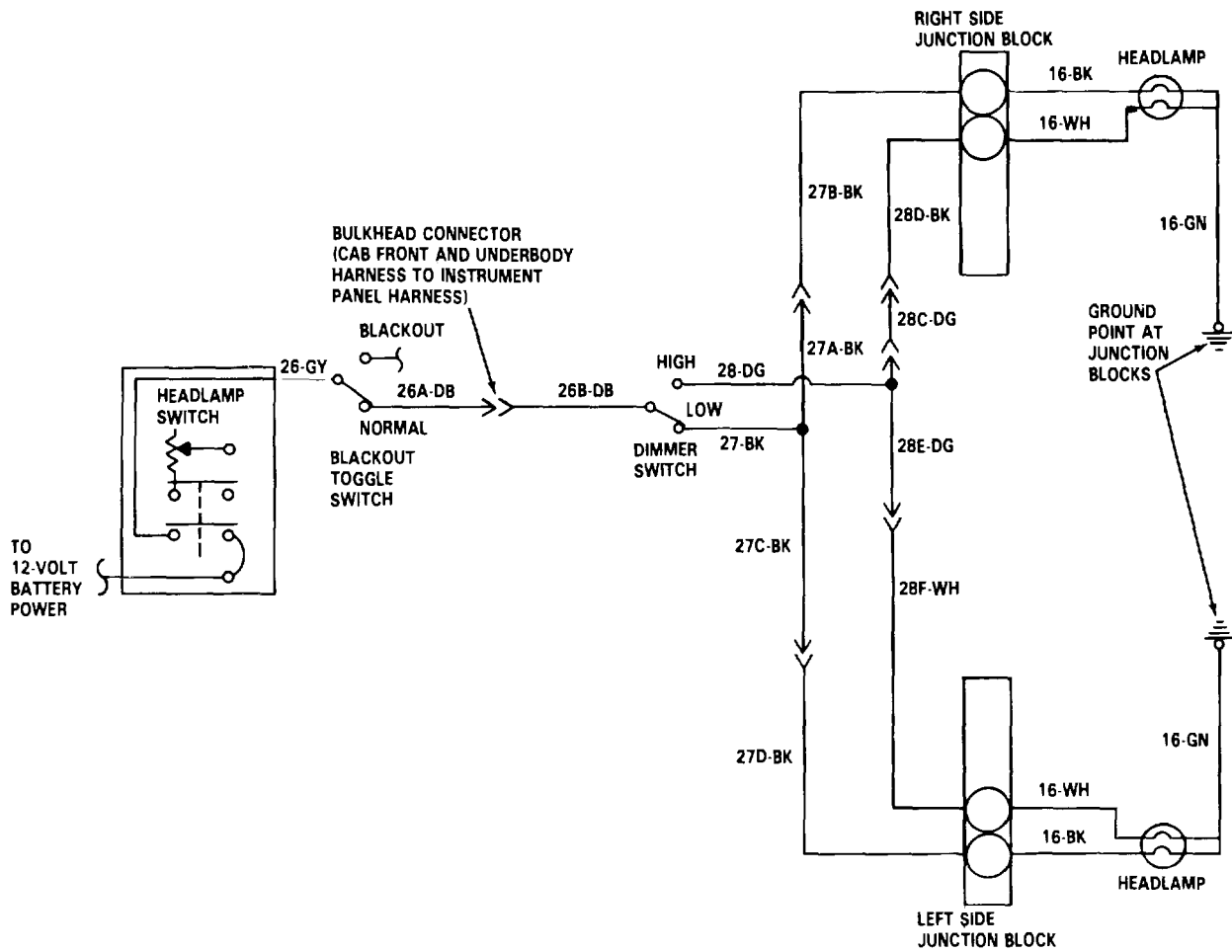

TA 236875

TROUBLESHOOTING.

2-11. TROUBLESHOOTING PROCEDURES (Continued).

MALFUNCTION	INSTRUCTION	INDICATION	YES	NO
41. BOTH HEADLAMPS BLINK ON AND OFF (Continued).				
10.	Check circuit 27-BK terminal of dimmer switch.	Loose.	Tighten connection.	Go to step 11.
11.	Turn off headlamp switch, and go to step 12.			
12.	Check circuit 27-BK for continuity.	Infinity.	Repair circuit 27-BK (para 3-127).	Low beam headlamp circuit OK.
13.	Set blackout toggle switch to BLACKOUT position.	Blackout headlamp blinks on and off	Repair circuit 26-GY (para 3-127).	Go to step 14.
14.	Set blackout toggle switch to NORMAL position. Check circuit 26A-DB terminal of operation switch. 15. Turn off headlamp switch, and go to step 16.	Loose.	Tighten connection.	Go to step 15.
16.	Check circuit 26A-DB to circuit 26B-DB for continuity.	Infinity.	Repair circuit 26A-DB (para 3-127).	Go to step 17.
17.	Check circuit 26B-DB to dimmer switch for continuity.	Infinity.	Repair circuit 26B-DB (para 3-127).	Go to step 18.
18.	Turn on headlamp switch, and go to step 19.		Go to step 20.	
19.	Check circuit 26B-DB terminal of dimmer switch.	Loose.	Tighten connections.	Go to step 20.

TROUBLESHOOTING.

2-11. TROUBLESHOOTING PROCEDURES (Continued).

MALFUNCTION	INSTRUCTION	INDICATION	YES	NO
41. BOTH HEADLAMPS BLINK ON AND OFF (Continued).				
20.	Check circuit 28-DG terminal of dimmer switch.	Loose connection.	Tighten	Go to step 21.
21.	Turn off headlamp switch, and go to step 22.			
22.	Check circuit 28-DG for continuity.	Infinity. 28C-DG (para	Repair circuit lamp circuit	High beam headlamp circuit

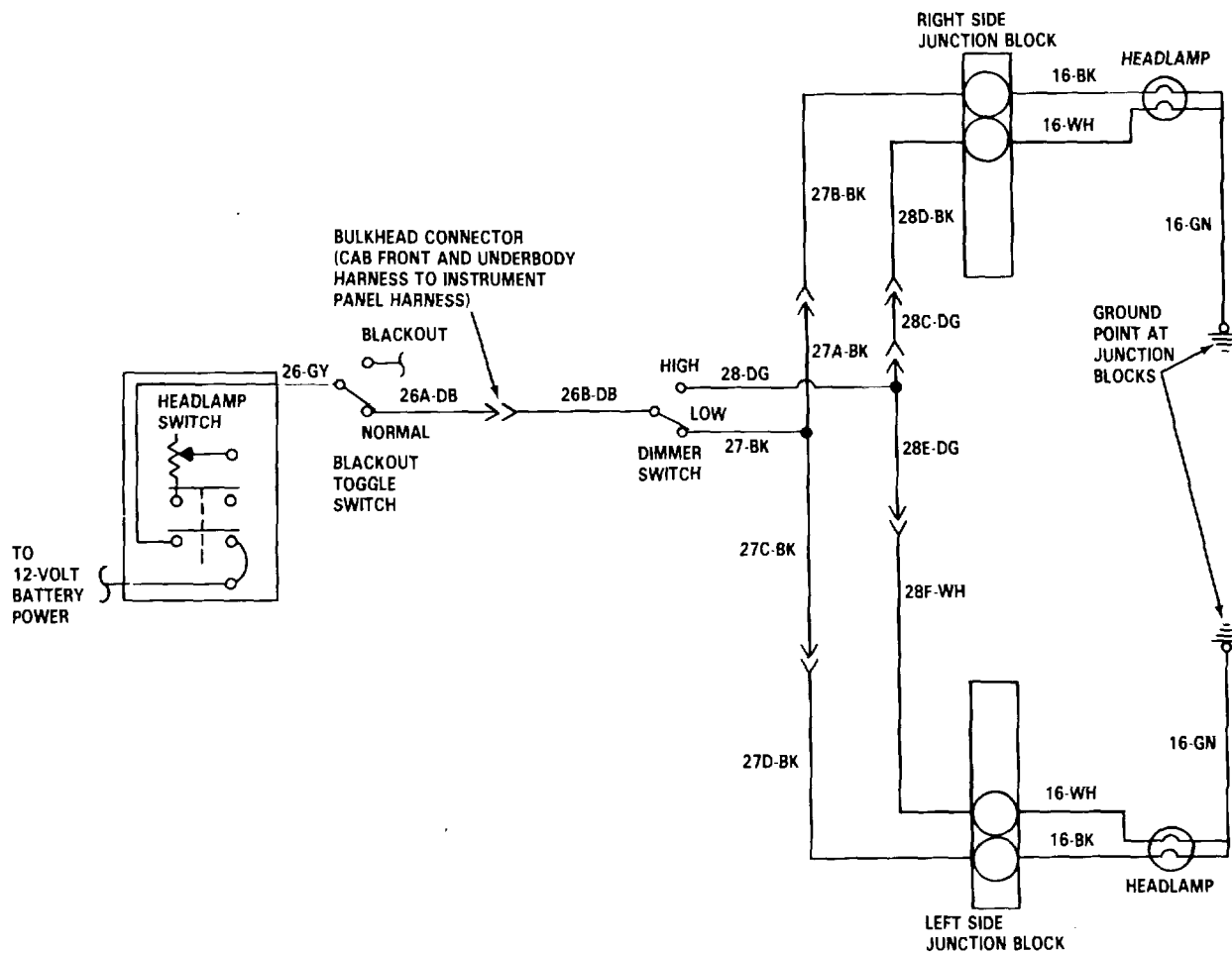

TA 236876

TROUBLESHOOTING.

2-11. TROUBLESHOOTING PROCEDURES (Continued).

MALFUNCTION	INSTRUCTION	INDICATION	YES	NO
-------------	-------------	------------	-----	----

42. ONE HEADLAMP NOT WORKING.

NOTE

- Blackout toggle switch must be set to NORMAL position and headlamp switch in ON position when doing the following checks.
- Faulty right-side headlamp is shown in this procedure. Apply similar troubleshooting technique for left- side headlamp.

1.	Set dimmer switch to low beam position. (para 3-91).	Headlamp works.	Replace headlamp	Go to step 2.
2.	Set dimmer switch to high beam position. (para 3-91).	Headlamp works.	Replace headlamp	Go to step 3.
3.	Remove right-side headlamp assembly far enough to expose junction block (para 3-91), and go to step 4.			
4.	With dimmer switch set on high beam, check for voltage at circuit 16-WH terminal of headlamp connector. side headlamp assembly (para 3-91).	12-volts dc nominal.	Go to step 5.	Repair circuit 28D-BK, 28C-DG, and/or 16-WH (para 3-127). Install right-

NOTE

With positive lead on circuit 16-WH, check ground using negative lead when doing the following checks.

TROUBLESHOOTING.

2-11. TROUBLESHOOTING PROCEDURES (Continued).

MALFUNCTION	INSTRUCTION	INDICATION	YES	NO
-------------	-------------	------------	-----	----

42. ONE HEADLAMP NOT WORKING (Continued).

5.	Check for voltage of circuit 16-GN ground point at junction block.	12-volts dc nominal.	Go to step 6. tighten connection.	Clean and/or
----	--	----------------------	-----------------------------------	--------------

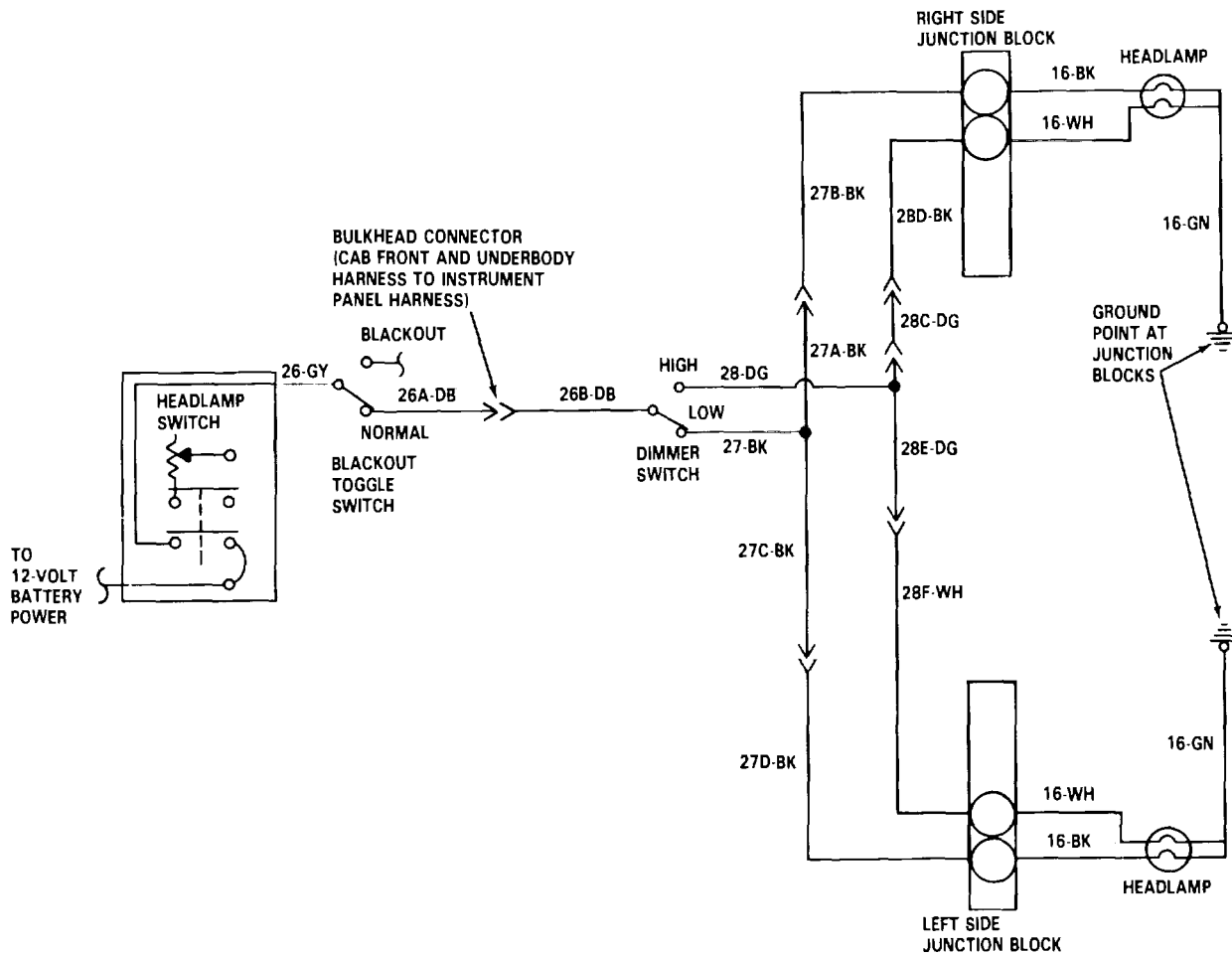

TA 236877

TROUBLESHOOTING.

2-11. TROUBLESHOOTING PROCEDURES (Continued).

MALFUNCTION	INSTRUCTION	INDICATION	YES	NO
-------------	-------------	------------	-----	----

42. ONE HEADLAMP NOT WORKING (Continued).

- | | | | | |
|----|--|----------------------|-------------------------------|------------------------------------|
| 6. | Check for voltage at circuit 16-GN terminal of headlamp connector. | 12-volts dc nominal. | Replace headlamp (para 3-91). | Repair circuit 16-GN (para 3-127). |
|----|--|----------------------|-------------------------------|------------------------------------|

43. BOTH HEADLAMPS NOT WORKING IN EITHER HIGH OR LOW BEAM POSITION.

NOTE

Headlamp switch must be set to ON position when doing the following checks.

- | | | | | |
|----|--|---------------------------|------------------------------------|---|
| 1. | Set blackout toggle switch to BLACKOUT position. | Blackout headlamp lights. | Go to step 4. | Go to step 2. |
| 2. | Check for voltage at circuit 26-GY terminal of headlamp switch. | 12 volts dc nominal. | Go to step 3. | Refer to malfunction 44. |
| 3. | Check for voltage at circuit 26-GY terminal of blackout toggle switch. | 12-volts dc nominal. | Go to step 4. | Repair circuit 26-GY (para 3-127). |
| 4. | Set blackout toggle switch to NORMAL position. Check for voltage at circuit 26A-DB terminal of blackout toggle switch. | 12-volts dc nominal. | Go to step 5. | Replace blackout toggle switch (para 3-79). |
| 5. | Check for voltage at circuit 26B-DB terminal of dimmer switch. | 12-volts dc nominal. | Replace dimmer switch (para 3-82). | Repair circuit 26B-DB (para 3-127). |

TROUBLESHOOTING.

2-11. TROUBLESHOOTING PROCEDURES (Continued).

MALFUNCTION	INSTRUCTION	INDICATION	YES	NO
-------------	-------------	------------	-----	----

43. BOTH HEADLAMPS NOT WORKING IN EITHER HIGH OR LOW BEAM POSITION (Continued).

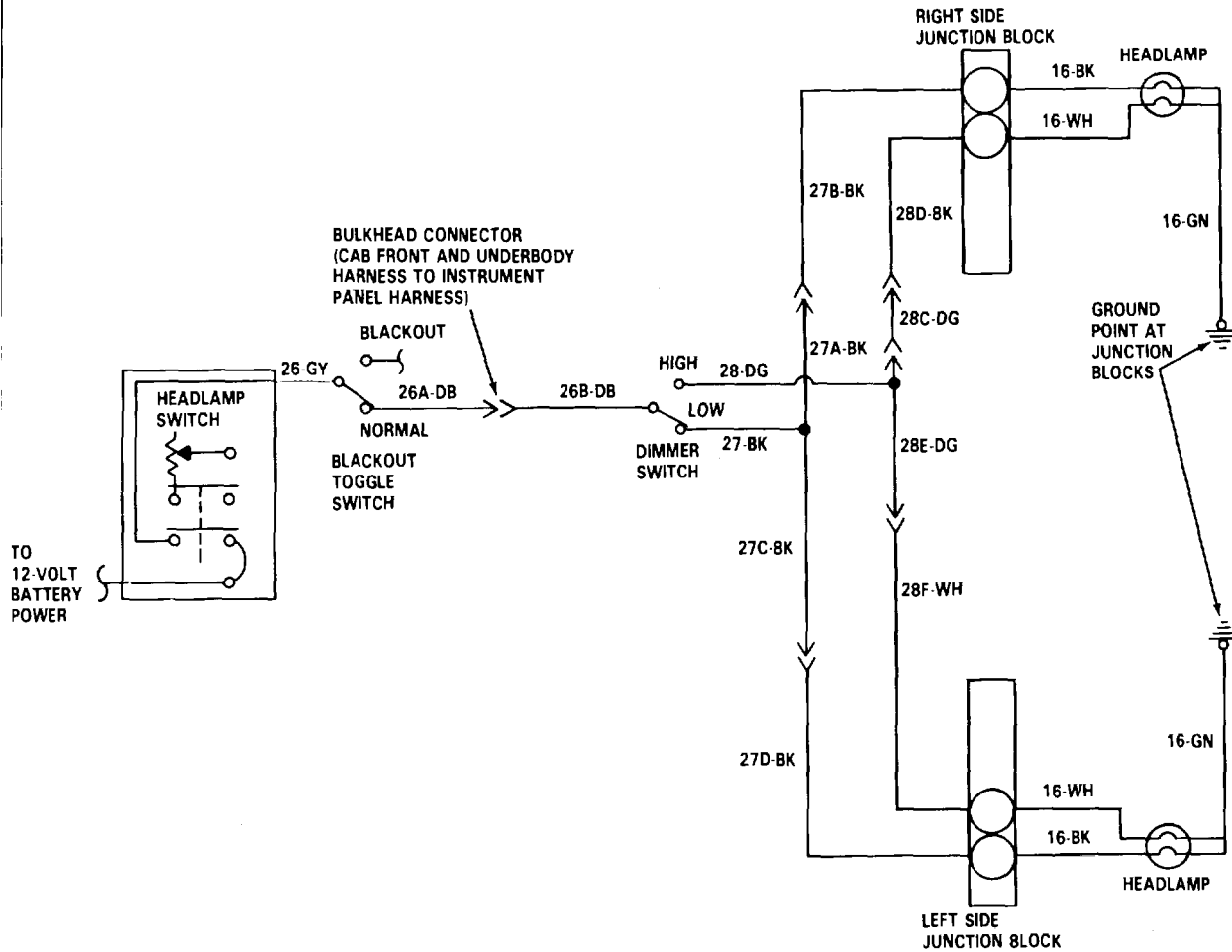

TA 236878

TROUBLESHOOTING.

2-11. TROUBLESHOOTING PROCEDURES (Continued).

MALFUNCTION	INSTRUCTION	INDICATION	YES	NO
44. HEADLAMP SWITCH NOT WORKING.				
1	Check for voltage at circuit 10-RD terminal of battery.	12-volts dc nominal	Go to step 2 function 18.	Refer to mal-
2	Disconnect circuit O1B-RD from 10OC-RD at engine harness connector, and go to step 3.			
3	Check for voltage at circuit 10B-RD 10C-RD, and go to step 4	12-volts dc nominal 10-RD (para 3-127).	Connect circuit 10B-RD to	Repair circuit 10B-RD and/or
4	Check for voltage at circuit 10C-RD terminal of circuit breaker CB-1.	12-volts dc nominal 3-127).	Go to step 5 IOC-PK (para	Repair circuit
5	Check for voltage at circuit 10D-PK terminal of headlamp switch	12-volts dc nominal (para 3-78)	Replace head-lamp switch 3-127).	Repair circuit 10D-PK (para

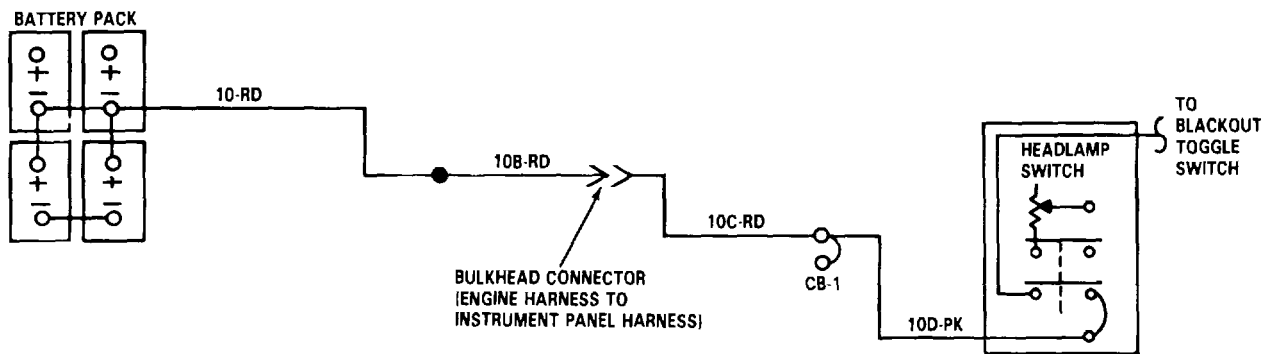

TA 236879

2-11. TROUBLESHOOTING PROCEDURES (Continued).

MALFUNCTION	INSTRUCTION	INDICATION	YES	NO
-------------	-------------	------------	-----	----

45. DIMMER SWITCH INDICATOR LAMP NOT WORKING

NOTE

Blackout toggle switch must be set to NORMAL position, headlamp switch must be set to ON position, and dimmer switch must be set on high beam when doing the following checks.

- | | | | | |
|----|---|----------------------|---------------------------------------|---|
| 1. | Disconnect circuit 28A-DG from 28B-DG at connector, and go to step 2. | | | |
| 2. | Check for voltage at circuit 28A-DG (pin G of connector). go to step 3. | 12-volts dc nominal. | Connect circuit 28A-DG to 28B-DG, and | Repair circuit 28A-DG (para 3-127). |
| 3. | Remove bulb from lamp socket (para 3-87), and go to step 4. | | | |
| 4. | Check for voltage at circuit 28B-DG terminal of socket. (para 3-127). | 12-volts dc nominal. | Replace bulb (para 3-87). | Clean socket and/or repair circuit 28B-DG |

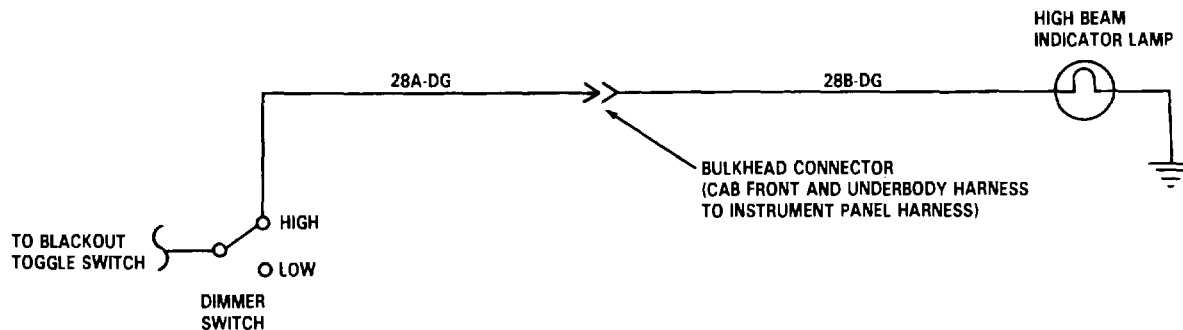

TA 236880

TROUBLESHOOTING.

2-11. TROUBLESHOOTING PROCEDURES (Continued).

MALFUNCTION	INSTRUCTION	INDICATION	YES	NO
46.	BOTH FRONT MARKER LAMPS NOT WORKING (FRONT TURN SIGNAL LAMPS OK).			
NOTE				
Blackout toggle switch must be set to NORMAL position and headlamp switch must be set to ON position when doing the following checks.				
1.	Check for voltage at circuit 30-OR terminal of headlamp switch.	12-volts dc nominal.	Go to step 2.	Refer to malfunction 44.
2.	Check for voltage at circuit 30-OR terminal of blackout toggle switch.	12-volts dc nominal.	Go to step 3.	Repair circuit 30-OR (para 3-127).
3.	Check for voltage at circuit 30R-BR of blackout toggle switch.	12-volts dc nominal.	Go to step 4.	Replace blackout toggle switch (para
4.	Disconnect circuit 30A-BR from 30B-BR of connector, and go to step 6.			
5.	Check for voltage at circuit 30A-BR (pin B of connector).	12-volts dc nominal.	Connect circuit 30A-BR to 30B-BR, and go to step 6.	Repair circuit 30A-BR and/or 30R-BR (para 3-127).

TROUBLESHOOTING.

2-11. TROUBLESHOOTING PROCEDURES (Continued).

MALFUNCTION	INSTRUCTION	INDICATION	YES	NO
46.	BOTH FRONT MARKER LAMPS NOT WORKING (FRONT TURN SIGNAL LAMPS OK) (Continued).			
6.	Disconnect circuit 30E-BR from 30F-BR of connector, and go to step 7.			
7.	Check for voltage at circuit 30E-BR (pin B of connector).	12-volts dc nominal.	Connect circuit 30E-BR to 30F-BR. Marker lamp circuit OK.	Repair circuit 30B-BR (para 3-127). Connect circuits 30E-BR and 30F-BR.

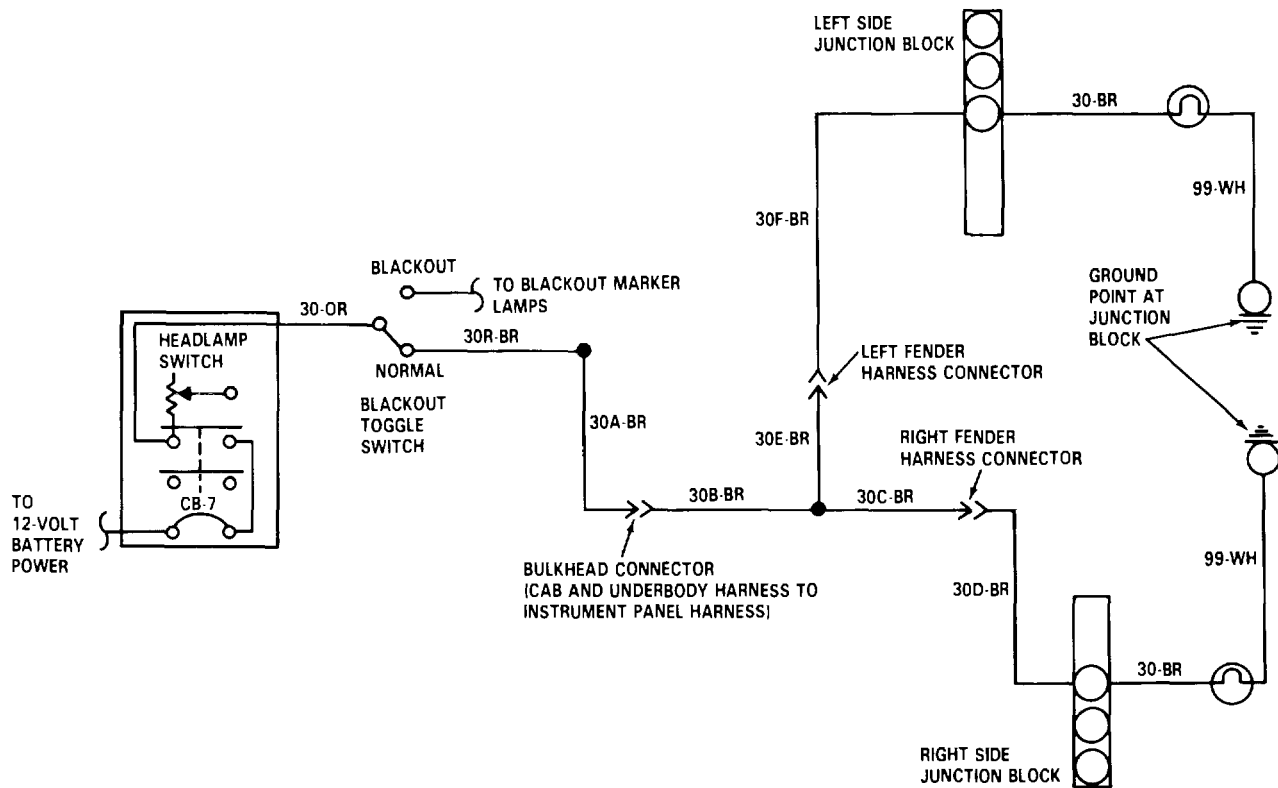

TA 236881

TROUBLESHOOTING.

2-11. TROUBLESHOOTING PROCEDURES (Continued).

MALFUNCTION	INSTRUCTION	INDICATION	YES	NO
47.	ONE FRONT MARKER LAMP NOT WORKING (FRONT TURN SIGNAL LAMP OK).			
NOTE				
<ul style="list-style-type: none"> • Set blackout toggle switch to NORMAL position and headlamp switch to ON position when doing the following checks. • Faulty right marker lamp is shown in this procedure. Apply similar troubleshooting technique for left marker lamp. 				
1.	Disconnect circuit 30C-BR from 30D-BR at connector, and go to step 2.			
2.	Check for voltage at 30C-BR terminal of connector. and go to step 3.	12-volts dc nominal.	Connect circuit 30C-BR to 30D-BR,	Repair circuit 30C-BR (para 3-127).
3.	Remove headlamp assembly (para 3-91), and go to step 4.			
4.	Check for voltage at circuit 30D-BR of junction block.	12-volts dc nominal.	Go to step 5.	Repair circuit 30D-BR (para 3-127). Install headlamp assembly (para 3-91).
5.	Remove marker lamp bulb (para 3-92), and go to step 6.			

TROUBLESHOOTING.

2-11. TROUBLESHOOTING PROCEDURES (Continued).

MALFUNCTION	INSTRUCTION	INDICATION	YES	NO
-------------	-------------	------------	-----	----

47. ONE FRONT MARKER LAMP NOT WORKING (FRONT TURN SIGNAL LAMP OK) (Continued).

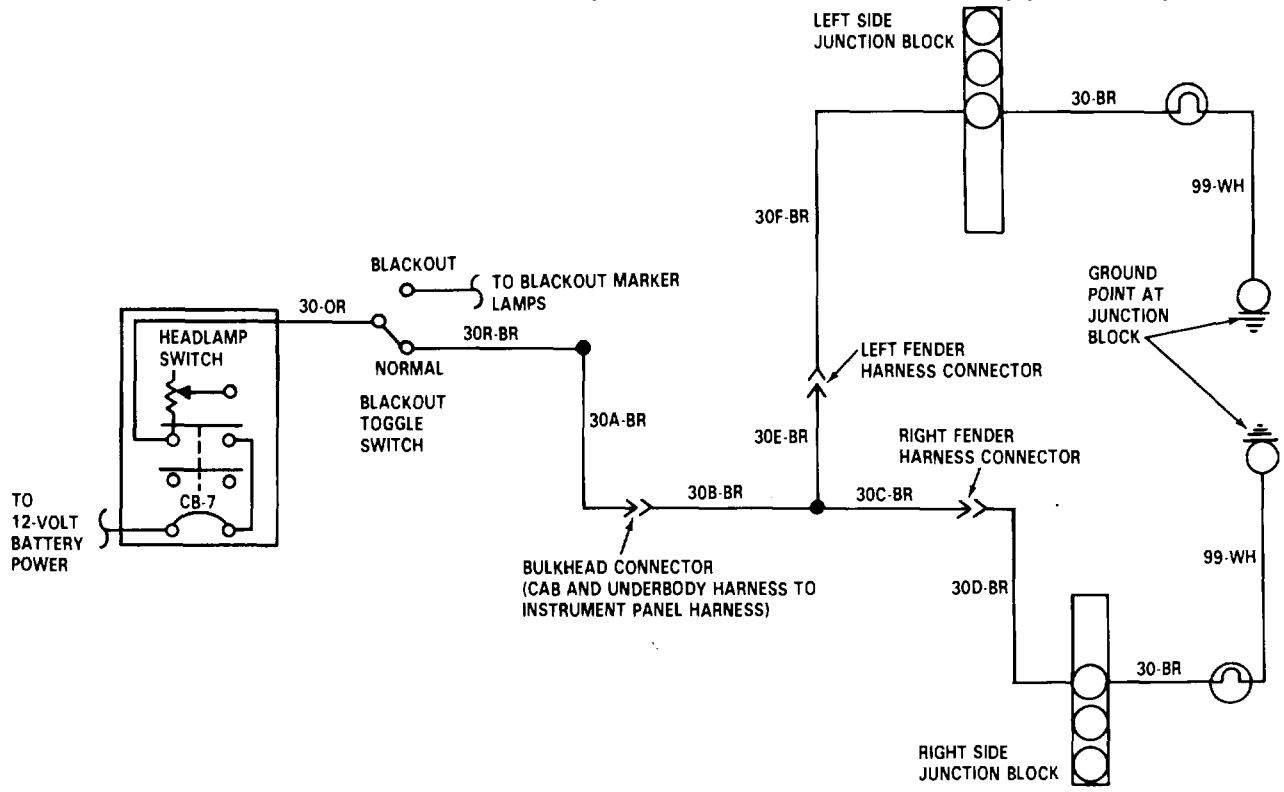

TA 236882

TROUBLESHOOTING.

2-11. TROUBLESHOOTING PROCEDURES (Continued).

MALFUNCTION	INSTRUCTION	INDICATION	YES	NO
47. ONE FRONT MARKER LAMP NOT WORKING (FRONT TURN SIGNAL LAMP OK) (Continued).				
NOTE				
With positive lead connected to circuit 30-BR, check ground with negative lead when doing the following checks.				
6.	Check for voltage at circuit 30-BR terminal of lamp socket.	12-volts dc nominal.	Install bulb (para 3-92), and go to step 7.	Repair circuit 30-BR (para 3-127). Install bulb (para 3-92). Install headlamp assembly (para 3-91).
7.	Check for voltage at circuit 99-WH terminal of ground point at junction block.	12-volts dc nominal. Go to step 8.		Install headlamp assembly (para 3-91).
8.	Check for voltage at circuit 99-WH terminal of lamp socket.	12-volts dc nominal.	Replace bulb (para 3-92). Install headlamp assembly (para 3-91). Marker lamp circuit OK.	Repair circuit 99-WH (para 3-127). Replace bulb (para 3-92). Install headlamp assembly (para 3-91).

TROUBLESHOOTING.

2-11. TROUBLESHOOTING PROCEDURES (Continued).

MALFUNCTION	INSTRUCTION	INDICATION	YES	NO
-------------	-------------	------------	-----	----

47. ONE FRONT MARKER LAMP NOT WORKING (FRONT TURN SIGNAL LAMP OK) (Continued).

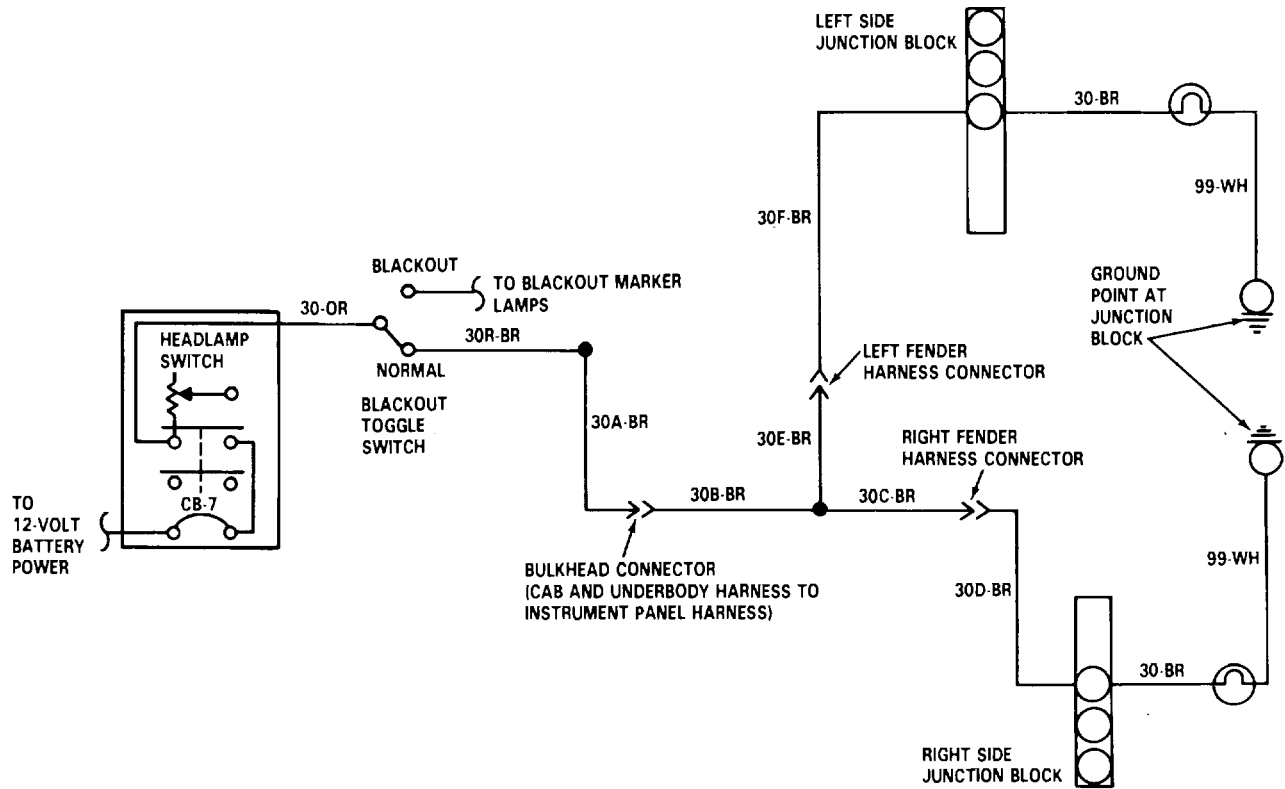

TA 236883

TROUBLESHOOTING.

2-11. TROUBLESHOOTING PROCEDURES (Continued).

MALFUNCTION	INSTRUCTION	INDICATION	YES	NO
48.	ONE OR MORE CAB CLEARANCE AND MARKER LAMPS NOT WORKING.			
NOTE				
<ul style="list-style-type: none"> • If all cab clearance and marker lamps do not work, go to malfunction 49. • Blackout toggle switch must be set to NORMAL position and headlamp switch in ON position when doing the following checks. • It is assumed here that lamp at circuit 31D-BR and 31E-BR is working. Apply similar troubleshooting technique for other lamp combinations. 				
1.	Remove bulb at circuit 31E-BR (para 3-93), and go to step 2.			
2.	Check for voltage at circuit 31E-BR terminal of lamp socket.	12-volts dc nominal.	Replace bulb (para 3-93), and go to step 3.	Repair circuit 31E-BR (para 3-127). Install bulb (para 3-93), and go to step 3.
3.	Remove bulb at circuit 31A-BR (para 3-93), and go to step 4.			
4.	Check for voltage at circuit 31A-BR terminal of socket.	12-volts dc nominal.	Replace bulb (para 3-95), and go to step 5.	Repair circuit 31A-BR (para 3-127). Install bulb (para 3-93), and go to step 5.

TROUBLESHOOTING.

2-11. TROUBLESHOOTING PROCEDURES (Continued).

MALFUNCTION	INSTRUCTION	INDICATION	YES	NO
-------------	-------------	------------	-----	----

48. ONE OR MORE CAB CLEARANCE AND MARKER LAMPS NOT WORKING (Continued).

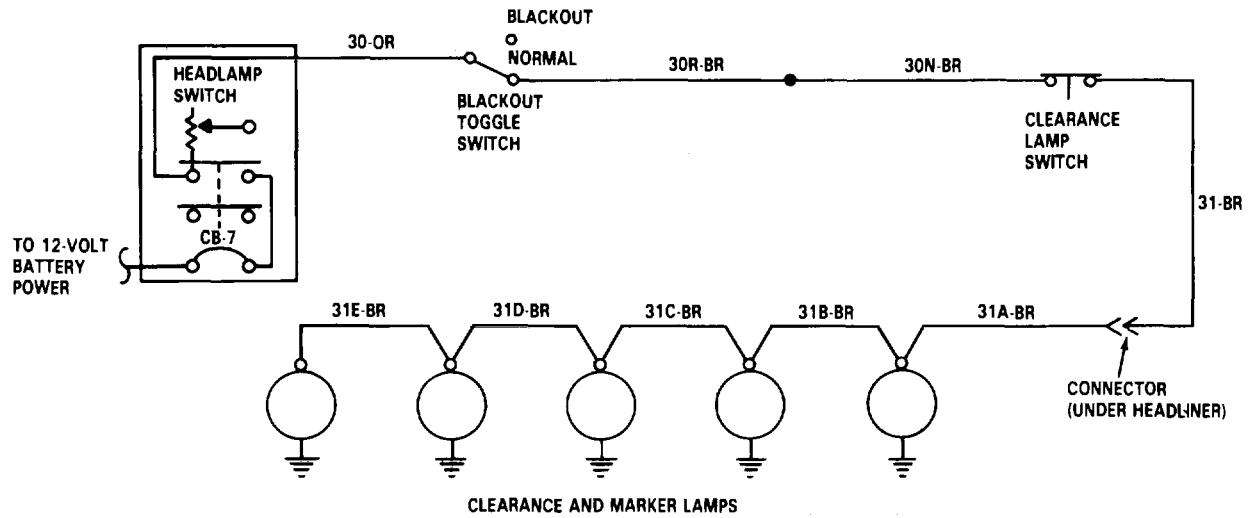

TA 236884

TROUBLESHOOTING.

2-11. TROUBLESHOOTING PROCEDURES (Continued).

MALFUNCTION	INSTRUCTION	INDICATION	YES	NO
48.	ONE OR MORE CAB CLEARANCE AND MARKER LAMPS NOT WORKING (Continued).			
5.	Remove bulb at circuit 31B-BR and 31C-BR (para 3-93), and go to step 6.	12-volts dc nominal.	Replace bulb (para 3-93), and go to step 7.	Repair circuit 31B-BR (para 3-127). Install bulb (para 3-93), and go to step 7.
6.	Check for voltage at circuit 31B-BR terminal of socket.	12-volts dc nominal.	Replace bulb (para 3-93), and go to step 7.	Repair circuit 31B-BR (para 3-127). Install bulb (para 3-93), and go to step 7.
7.	Remove bulb at circuit 31C-BR and 31D-BR (para 3-93), and go to step 8.	12-volts dc nominal.	Replace bulb (para 3-93).	Repair circuit 31C-BR (para 3-127). Install bulb (para 3-93).
8.	Check for voltage at circuit 31C-BR terminal of socket.	12-volts dc nominal.	Replace bulb (para 3-93).	Repair circuit 31C-BR (para 3-127). Install bulb (para 3-93).

TROUBLESHOOTING.

2-11. TROUBLESHOOTING PROCEDURES (Continued).

MALFUNCTION	INSTRUCTION	INDICATION	YES	NO
-------------	-------------	------------	-----	----

48. ONE OR MORE CAB CLEARANCE AND MARKER LAMPS NOT WORKING (Continued).

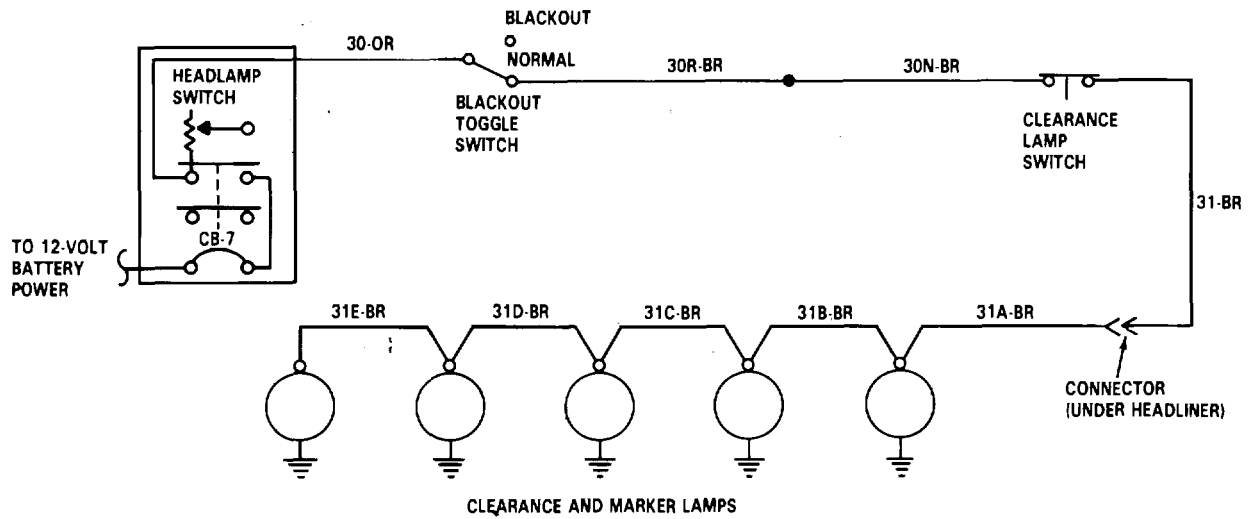

TA 236885

TROUBLESHOOTING.**2-11. TROUBLESHOOTING PROCEDURES (Continued).**

MALFUNCTION	INSTRUCTION	INDICATION	YES	NO
49.	ALL CAB CLEARANCE AND MARKER LAMPS NOT WORKING.			
	NOTE			
	Blackout toggle switch must be set to NORMAL position and headlamp switch in ON position when doing the following checks.			
1.	Check for voltage at circuit 30-OR terminal of headlamp switch.	12-volts dc nominal.	Go to step 2.	Refer to malfunction 44.
2.	Check for voltage at circuit 30-OR terminal of blackout toggle switch.	12-volts dc nominal.	Go to step 3.	Repair circuit 30-OR (para 3-127).
3.	Check for voltage at circuit 30R-BR terminal of blackout toggle switch.	12-volts dc nominal.	Go to step 4.	Replace blackout toggle switch (para 3-79).
4.	Check for voltage at circuit 30N-BR terminal of clearance lamp switch.	12-volts dc nominal.	Go to step 5.	Repair circuit 30N-BR and/or 30R-BR (para 3-127).
5.	Check for voltage at circuit 31-BR terminal of clearance lamp switch.	12-volts dc nominal.	Go to step 6.	Replace clearance lamp switch (para 3-93).
6.	Remove four to six screws at upper left corner of cab headliner to access connector, and go to step 7.			

TROUBLESHOOTING.

2-11. TROUBLESHOOTING PROCEDURES (Continued).

MALFUNCTION	INSTRUCTION	INDICATION	YES	NO
-------------	-------------	------------	-----	----

49. ALL CAB CLEARANCE AND MARKER LAMPS NOT WORKING (Continued).

7.	Disconnect circuit 31-BR from 31A-BR at connector, and go to step 8.			
8.	Check for voltage at circuit 31-BR terminal of connector.	12-volts dc nominal.	Connect circuit 31-BR and 31A-BR, and go to step 9.	Repair circuit 31-BR (para 3-127). Install headliner (para 3-275).
9.	Check for voltage at circuit 31A-BR terminal of lamp.	12-volts dc nominal.	Cab clearance and marker lamp circuit OK. Go to malfunction 48.	Repair circuit 31A-BR (para 3-127). Install headliner (para 3-275).

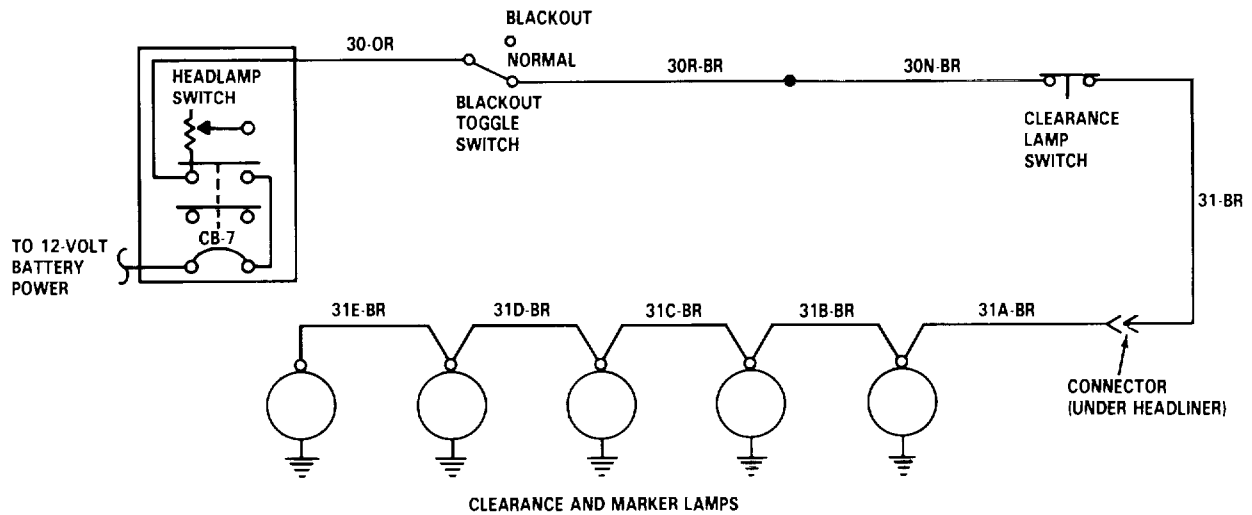

TA 236886

TROUBLESHOOTING.

2-11. TROUBLESHOOTING PROCEDURES (Continued).

MALFUNCTION	INSTRUCTION	INDICATION	YES	NO
50.	ONE TAILLAMP NOT WORKING.			
	NOTE			
	<ul style="list-style-type: none"> • Blackout toggle switch must be set to NORMAL position and headlamp switch in ON position when doing the following checks. • Faulty left taillamp is shown in this procedure. Apply similar troubleshooting technique for right taillamp. 			
	1.	Remove bulb (para 3-96), and go to step 2.		
2.	Check for voltage at lamp socket.	12-volts dc nominal.	Replace bulb (para 3-96).	Go to step 3.
3.	Check for voltage at circuit 30M-BR terminal of taillamp assembly.	12-volts dc nominal.	Clean connection at socket or replace taillamp (para 3-96).	Repair circuit 30M-BR (para 3-127). Install taillamp bulb (para 3-96).
2-156				

TROUBLESHOOTING.

2-11. TROUBLESHOOTING PROCEDURES (Continued).

MALFUNCTION	INSTRUCTION	INDICATION	YES	NO
-------------	-------------	------------	-----	----

51. BOTH TAILLAMPS NOT WORKING.

NOTE

Blackout toggle switch must be set to NORMAL position and headlamp switch in ON position when doing the following checks.

1.	Check for voltage at circuit 30-OR terminal of headlamp switch.	12-volts dc nominal.	Go to step 2.	Refer to malfunction 44.
2.	Check for voltage at circuit 30-OR terminal of blackout toggle	12-volts dc nominal.	Go to step 3.	Repair circuit 30-OR (para 3-127).

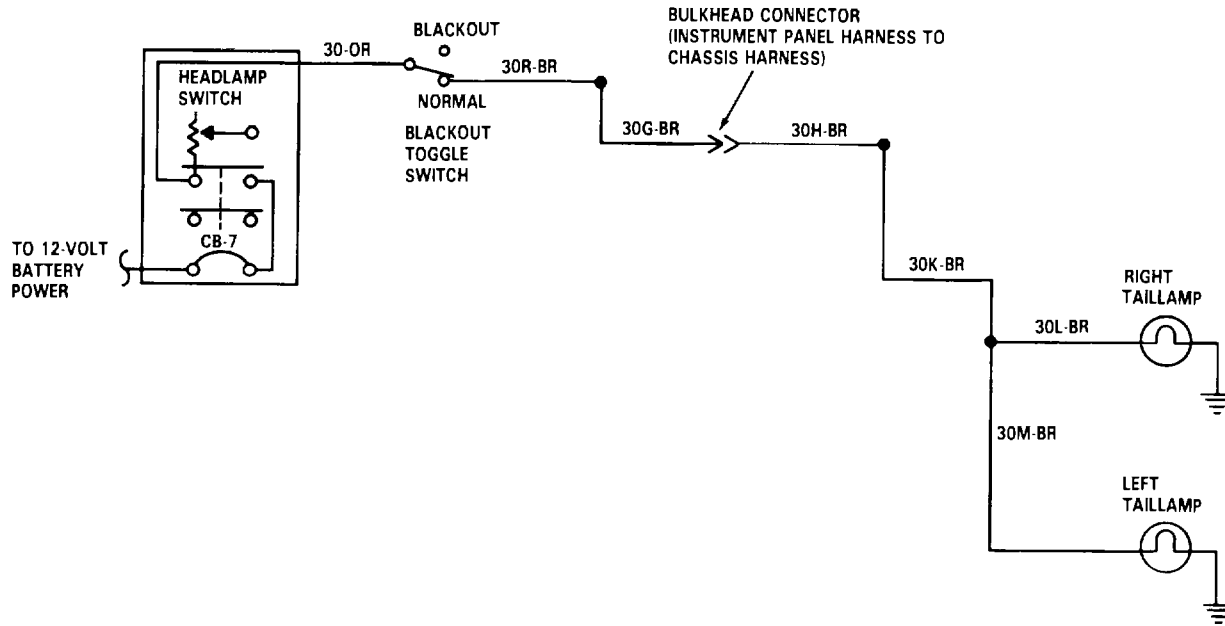

TA 236887

TROUBLESHOOTING.**2-11. TROUBLESHOOTING PROCEDURES (Continued).**

MALFUNCTION	INSTRUCTION	INDICATION	YES	NO
51. BOTH TAILLAMPS NOT WORKING (Continued).				
3.	Check for voltage at circuit 30R-BR terminal of blackout toggle switch.	12-volts dc nominal.	Go to step 4.	Replace black-out toggle switch (para 3-79).
4.	Disconnect 30G-GR from 30H-BR, and go to step 5.			
5.	Check for voltage at circuit 30G-BR terminal of connector.	12-volts dc nominal.	Connect circuit 30G-BR to 30H-BR, and go to step 6.	Repair circuit 30G-BR and/or 30R-BR (para 3-127).
6.	Check for voltage at circuit 30L-BR terminal of right taillamp. 3-96), and go to step 7.	12-volts dc nominal.	Clean socket and replace bulb (para	Go to step 7.
7.	Check for voltage at circuit 30M-BR terminal of left taillamp.	12-volts dc nominal.	Clean socket and replace bulb (para 3-96).	Repair circuit 30H-BR and/or 30K-BR (para 3-127).
2-158				

TROUBLESHOOTING.

2-11. TROUBLESHOOTING PROCEDURES (Continued).

MALFUNCTION	INSTRUCTION	INDICATION	YES	NO
-------------	-------------	------------	-----	----

51. BOTH TAILLAMPS NOT WORKING (Continued).

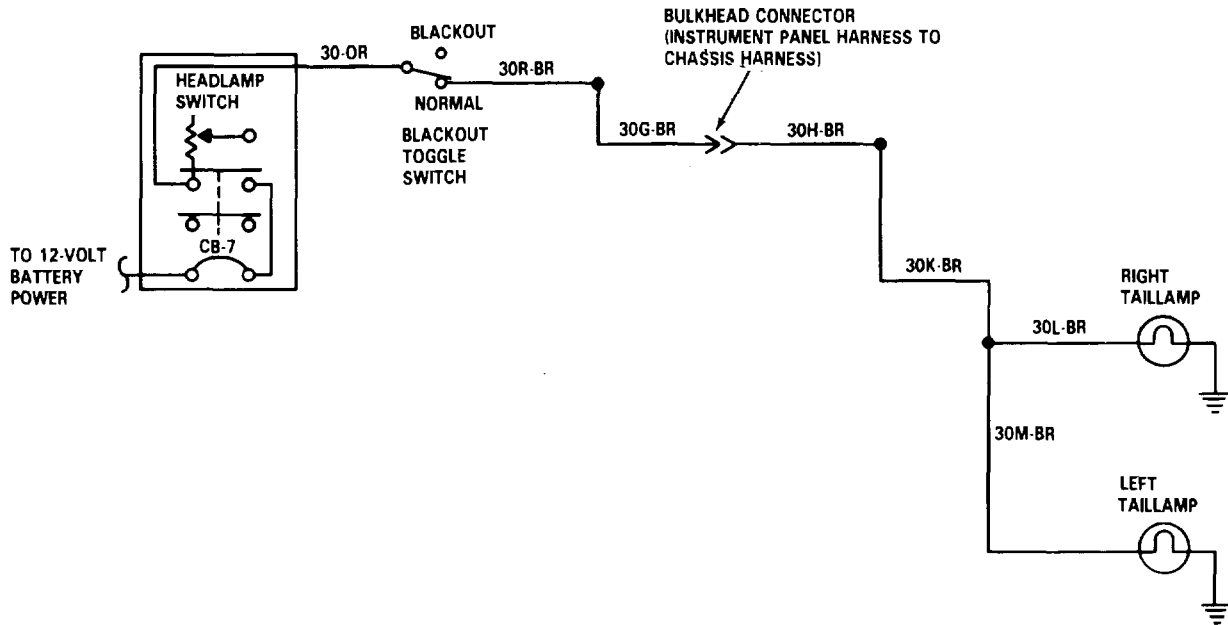

TA 236888

TROUBLESHOOTING.

2-11. TROUBLESHOOTING PROCEDURES (Continued).

MALFUNCTION	INSTRUCTION	INDICATION	YES	NO
52. ONE FRONT TURN SIGNAL LAMP NOT WORKING.				
NOTE				
<ul style="list-style-type: none"> • Blackout toggle switch must be set to NORMAL position and turn signal switch set for right turn. • Faulty right front turn signal lamp is shown in this procedure. Apply similar troubleshooting technique for left front turn signal. 				
1.	Disconnect circuit 36-PK from 36A-PK at connector, and go to step 2.			
2.	Check for voltage at circuit 36-PK terminal of connector.	12-volts dc nominal.	Connect 36-PK to 36A-PK, and go to step 3.	Repair circuit 36-PK (para 3-127).
3.	Disconnect circuit 36B-PK from circuit 36A-PK at connector, and go to step 4.			
4.	Check for voltage at circuit 36A-PK terminal of connector. to step 5.	12-volts dc nominal.	Connect circuit 36A-PK to 36B-PK, and go	Repair circuit 36A-PK (para 3-127).
5.	Remove headlamp assembly far enough to access junction block (para 3-91), and go to step 6.			
6.	Check for voltage at circuit 36B-PK terminal of junction block.	12-volts dc nominal.	Go to step 7.	Repair circuit 36B-PK (para 3-127). Install headlamp assembly (para 3-91).

TROUBLESHOOTING.

2-11. TROUBLESHOOTING PROCEDURES (Continued).

MALFUNCTION	INSTRUCTION	INDICATION	YES	NO
-------------	-------------	------------	-----	----

52. ONE FRONT TURN SIGNAL LAMP NOT WORKING (Continued).

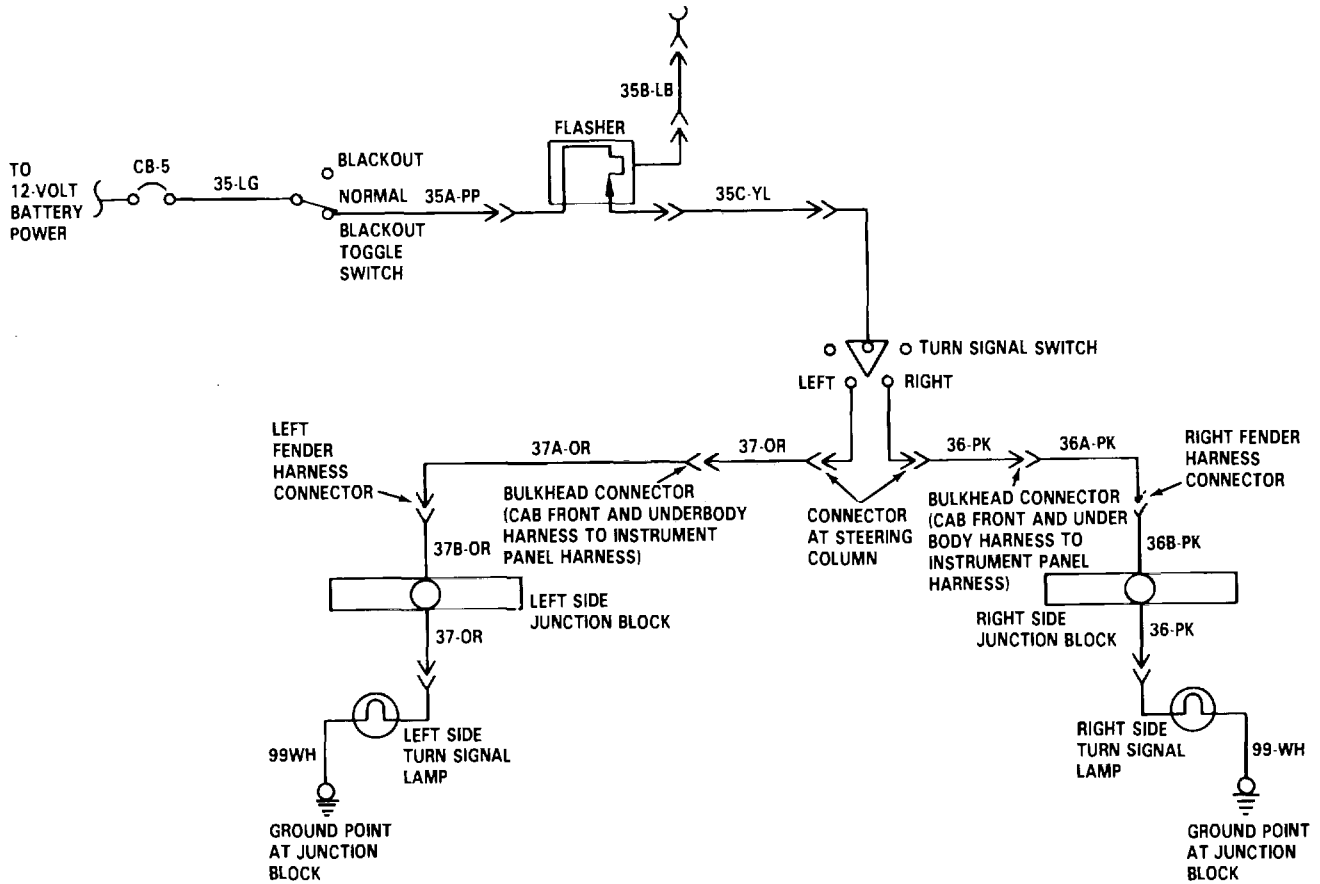

TA 236889

TROUBLESHOOTING.

2-11. TROUBLESHOOTING PROCEDURES (Continued).

MALFUNCTION	INSTRUCTION	INDICATION	YES	NO
52. ONE FRONT TURN SIGNAL LAMP NOT WORKING (Continued).				
7.	Remove bulb from socket, and go to step 8.			
8.	Check for voltage at turn signal lamp socket.	12-volts dc nominal.	Go to step 9.	Repair circuit 36-PK (para 3-127). Install headlamp assembly (para 3-91). Install turn signal bulb (para 3-92).
NOTE				
With positive lead at socket, check ground with negative lead when doing the following checks.				
9.	Check for voltage at circuit 99-WH ground point of junction block.	12-volts dc nominal.	Go to step 10.	Clean and tighten ground point connection. Install assembly (para 3-78). Install turn signal bulb (para 3-92).
10.	Check for voltage at circuit 99-WH terminal of lamp socket.	12-volts dc nominal.	Replace bulb (para 3-92). Install headlamp assembly (para 3-91).	Repair circuit 99-WH (para 3-127). Install headlamp assembly (para 3-91). Install turn signal bulb (para 3-92).

TROUBLESHOOTING.

2-11. TROUBLESHOOTING PROCEDURES (Continued).

MALFUNCTION	INSTRUCTION	INDICATION	YES	NO
-------------	-------------	------------	-----	----

52. ONE FRONT TURN SIGNAL LAMP NOT WORKING (Continued).

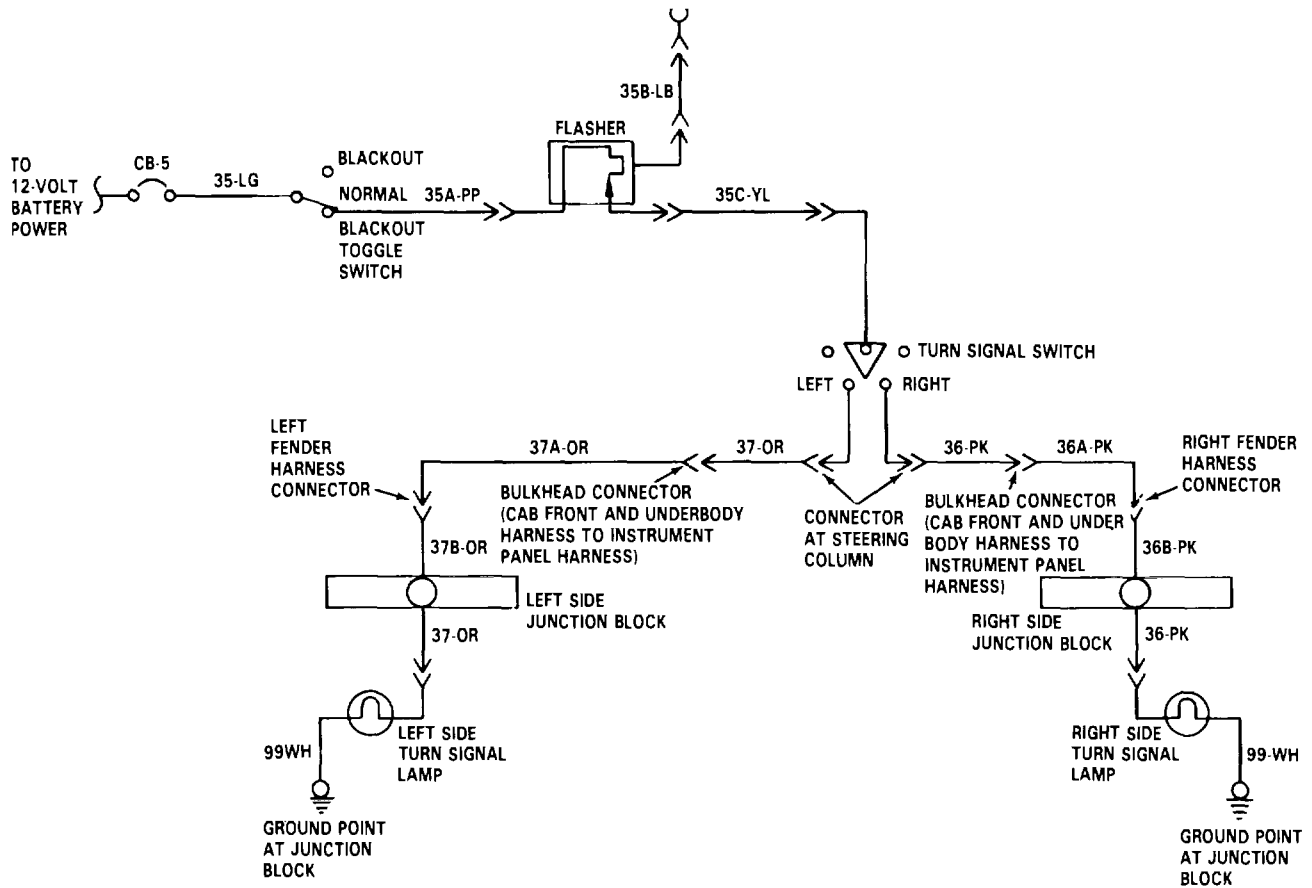

TA 236890

TROUBLESHOOTING.

2-11. TROUBLESHOOTING PROCEDURES (Continued).

MALFUNCTION	INSTRUCTION	INDICATION	YES	NO
53. BOTH FRONT AND REAR TURN SIGNAL LAMPS NOT WORKING.				
NOTE				
<p>Blackout toggle switch must be set to NORMAL position and turn signal switch set to hazard position.</p>				
1.	<p>Remove circuit breaker bracket far enough to access circuit breaker CB-5 (para 3-114), and go to step 2.</p>			
2.	<p>Check for voltage at circuit 35-LG terminal of circuit breaker CB-5.</p>	<p>12-volts dc nominal.</p>	<p>Install circuit breaker bracket (para 3-114), and go to step 3.</p>	<p>Reset circuit breaker and/or troubleshoot CB-5 circuit. (refer to malfunction 34).</p>
3.	<p>Check for voltage at circuit 35-LG terminal of blackout toggle switch.</p>	<p>12-volts dc nominal.</p>	<p>Go to step 4.</p>	<p>Replace circuit 35-LG (para 3-127).</p>
4.	<p>Check for voltage at circuit 35A-PP terminal of blackout toggle switch.</p>	<p>12-volts dc nominal.</p>	<p>Go to step 5.</p>	<p>Replace blackout toggle switch (para 3-79).</p>
5.	<p>Disconnect circuit 35A-PP from flasher, and go to step 6.</p>			

TROUBLESHOOTING.

2-11. TROUBLESHOOTING PROCEDURES (Continued).

MALFUNCTION	INSTRUCTION	INDICATION	YES	NO
-------------	-------------	------------	-----	----

53. BOTH FRONT AND REAR TURN SIGNAL LAMPS NOT WORKING (Continued).

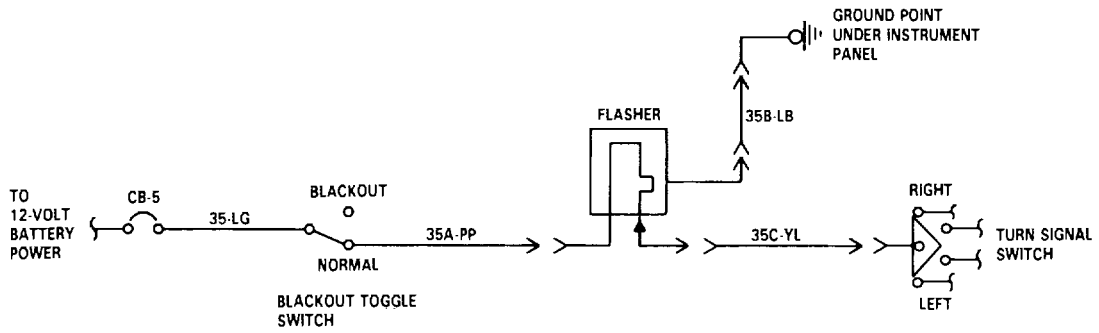

TA 236891

TROUBLESHOOTING.

2-11. TROUBLESHOOTING PROCEDURES (Continued).

MALFUNCTION	INSTRUCTION	INDICATION	YES	NO
53. BOTH FRONT AND REAR TURN SIGNAL LAMPS NOT WORKING (Continued).				
6.	Check for voltage at circuit 35A-PP terminal of connector.	12-volts dc nominal.	Go to step 7.	Repair circuit 35A-PP (para connect circuit 35A-PP to flasher).
7.	Connect jumper wire from flasher terminal (X) to connector circuit 35A-PP, and go to step 8.			
8.	Check for voltage at flasher terminal (L).	12-volts dc nominal.	Connect circuit 35A-PP to flasher, and go to step 9.	Replace flasher (para 3-111).
9.	Disconnect circuit 35C-YL from turn signal switch, and go to step 10.			
10.	Check for voltage at circuit 35C-YL terminal of connector.	12-volts dc nominal.	Replace turn signal switch (para 3-80).	Repair circuit 35C-YL (para 3-127).

TROUBLESHOOTING.

2-11. TROUBLESHOOTING PROCEDURES (Continued).

MALFUNCTION	INSTRUCTION	INDICATION	YES	NO
-------------	-------------	------------	-----	----

53. BOTH FRONT AND REAR TURN SIGNAL LAMPS NOT WORKING (Continued).

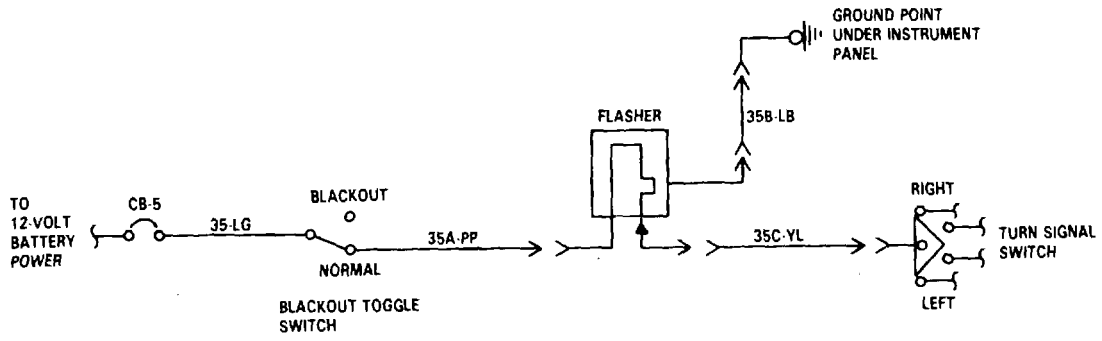

TA 236892

TROUBLESHOOTING.

2-11. TROUBLESHOOTING PROCEDURES (Continued).

MALFUNCTION	INSTRUCTION	INDICATION	YES	NO
<p>54. ONE REAR TURN SIGNAL LAMP NOT WORKING.</p>				
<p>NOTE</p>				
<ul style="list-style-type: none"> • Blackout toggle switch must be set to NORMAL position and turn signal switch set for right turn. • Faulty right rear turn signal lamp is not shown in this procedure. Apply similar troubleshooting technique for left rear turn signal lamp. 				
1.	Disconnect circuit 36C-DG from turn signal switch, and go to step 2.			
2.	Connect jumper from circuit 35C-YL to yellow circuit of turn signal switch connector, and go to step 3.			
3.	Check for voltage at green circuit of turn signal switch connector.	12-volts dc nominal.	Connect circuit 35C-YL to turn signal switch connector and, go to step 2.	Replace turn signal switch (para 3-80).
4.	Disconnect circuit 36C-DG from 36D-DG at connector, and go to step 5.			
5.	Check for voltage at circuit 36C-DG terminal of connector.	12-volts dc nominal.	Connect circuit 36C-DG to 36D-DG and, go to step 6.	Repair circuit 36C-DG (para 3-127), and connect circuit 36C-DG to 36D-DG.

TROUBLESHOOTING.

2-11. TROUBLESHOOTING PROCEDURES (Continued).

MALFUNCTION	INSTRUCTION	INDICATION	YES	NO
54. ONE REAR TURN SIGNAL LAMP NOT WORKING (Continued).	6. Remove lens at tail-lamp assembly (para 3-96), and go to step 7.			
	7. Check for voltage at circuit 36F-DG (top terminal inside taillamp assembly).	12-volts dc nominal.	Replace bulb (para 3-96) and/or clean socket connection.	Repair circuits 36F-DG and/or 36D-DG (para 3-127).

55. BOTH REAR TURN SIGNAL LAMPS NOT WORKING.

Check turn signal switch circuit.
(Refer to malfunction 53)

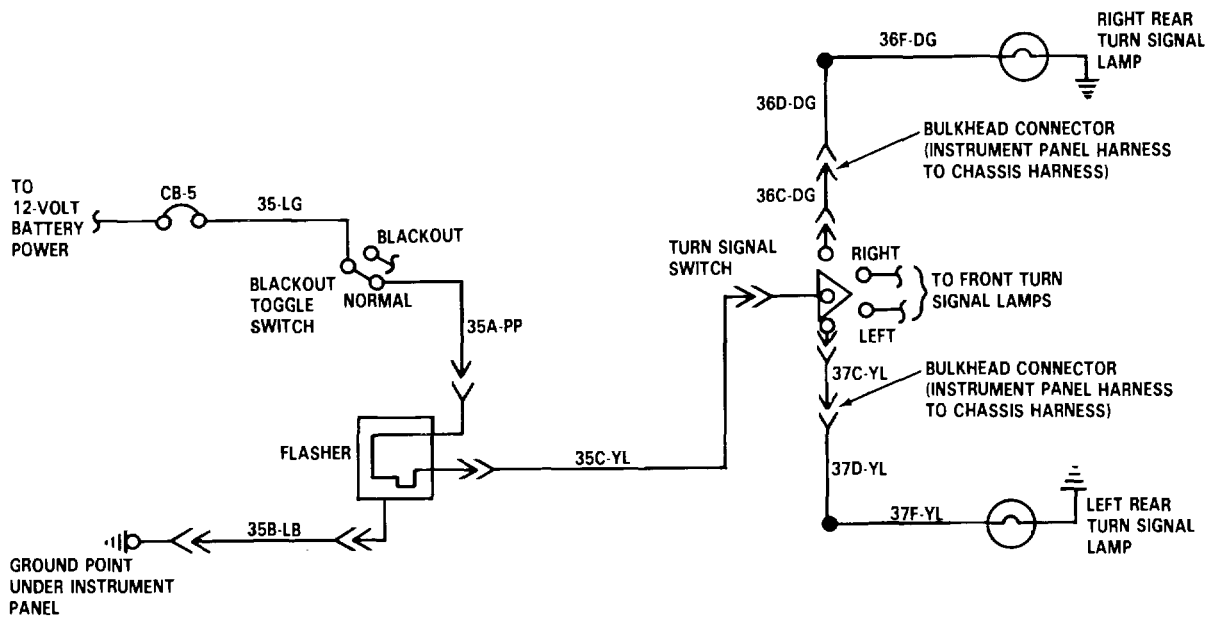

TA 236893

TROUBLESHOOTING.**2-11. TROUBLESHOOTING PROCEDURES (Continued).**

MALFUNCTION	INSTRUCTION	INDICATION	YES	NO
56. BOTH STOPLAMPS NOT WORKING.				
	1. Remove circuit breaker bracket far enough to access circuit breaker CB-1 (para 3-114), and go to step 2.			
	2. Check for voltage at circuit 25-OR terminal of circuit breaker CB-1.	12-volts dc nominal.	Install circuit breaker bracket (para 3-114), and go to step 3.	Reset circuit breaker CB-1 and/or troubleshoot CB-1 circuit. (Refer to malfunction 34).
	3. Disconnect circuit 25-OR from 25A-OR at connector, and go to step 4.			
	4. Check for voltage at circuit 25-OR terminal of connector.	12-volts dc nominal.	Connect circuit 25-OR to 25A-OR, and go to step 5.	Repair circuit 25-OR (para 3-127).
	5. Connect jumper wire from circuit 25-OR to 25A-OR, and go to step 6.			
	6. Check for voltage at circuit 25A-OR terminal of stoplamp switch.	12-volts dc nominal.	Go to step 7.	Repair circuit 25A-OR (para 3-127).
2-170				

TROUBLESHOOTING.

2-11. TROUBLESHOOTING PROCEDURES (Continued).

MALFUNCTION	INSTRUCTION	INDICATION	YES	NO
-------------	-------------	------------	-----	----

56. BOTH STOPLAMPS NOT WORKING (Continued).

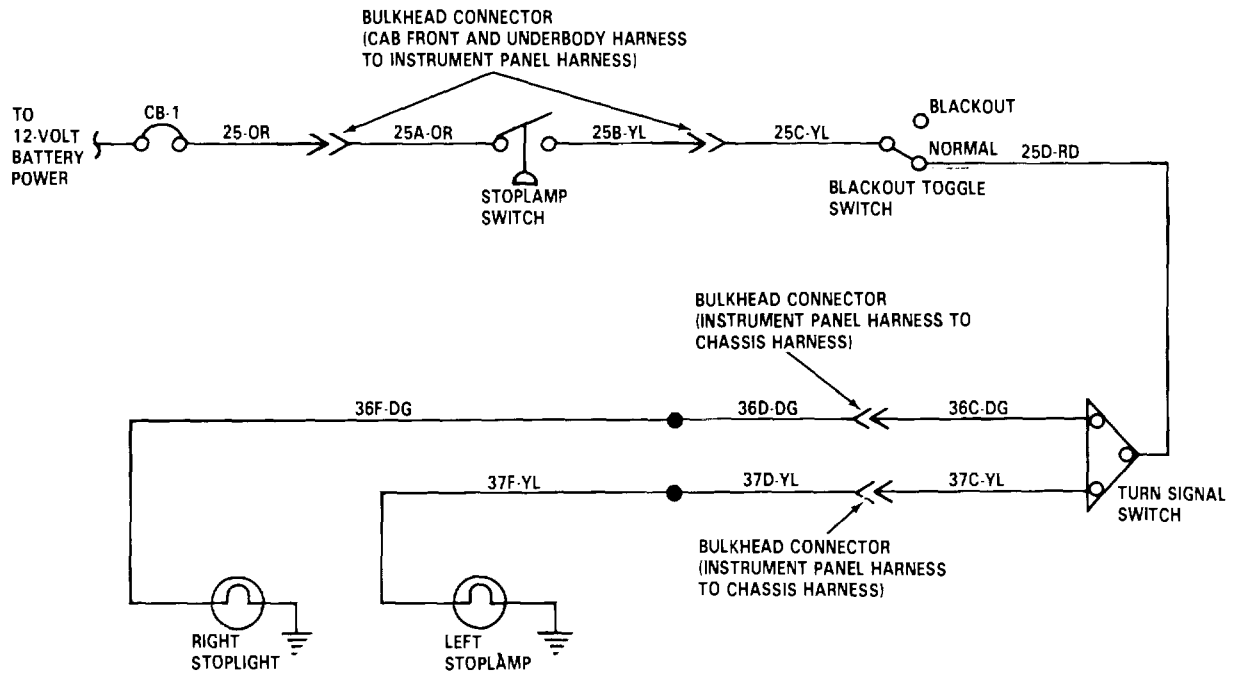

TA 236894

TROUBLESHOOTING.**2-11. TROUBLESHOOTING PROCEDURES (Continued).**

MALFUNCTION	INSTRUCTION	INDICATION	YES	NO
56. BOTH STOPLAMPS NOT WORKING (Continued).	NOTE			
	Blackout toggle switch must be set to NORMAL position, air system pressurized to 105 psi, and brake pedal depressed by assistant when doing the following checks.			
7.	Check for voltage at circuit 25B-YL terminal of stoplamp switch.	12-volts dc nominal.	Go to step 8.	Replace stoplamp switch (para 3-183).
8.	Check for voltage at circuit 25B-YL terminal of connector. and go to step 9.	12-volts dc nominal.	Connect circuit 25B-LY to 25C-LY,	Repair circuit 25B-YL (para 3-127).
9.	Check for voltage at circuit 25C-YL terminal of blackout toggle switch.	12-volts dc nominal.	Go to step 10.	Repair circuit 25C-YL (para 3-127).
10.	Check for voltage at circuit 25D-RD terminal of blackout toggle switch.	12-volts dc nominal.	Go to step 11.	Replace blackout toggle switch (para 3-79).

TROUBLESHOOTING.

2-11. TROUBLESHOOTING PROCEDURES (Continued).

MALFUNCTION	INSTRUCTION	INDICATION	YES	NO
-------------	-------------	------------	-----	----

56. BOTH STOPLAMPS NOT WORKING (Continued).

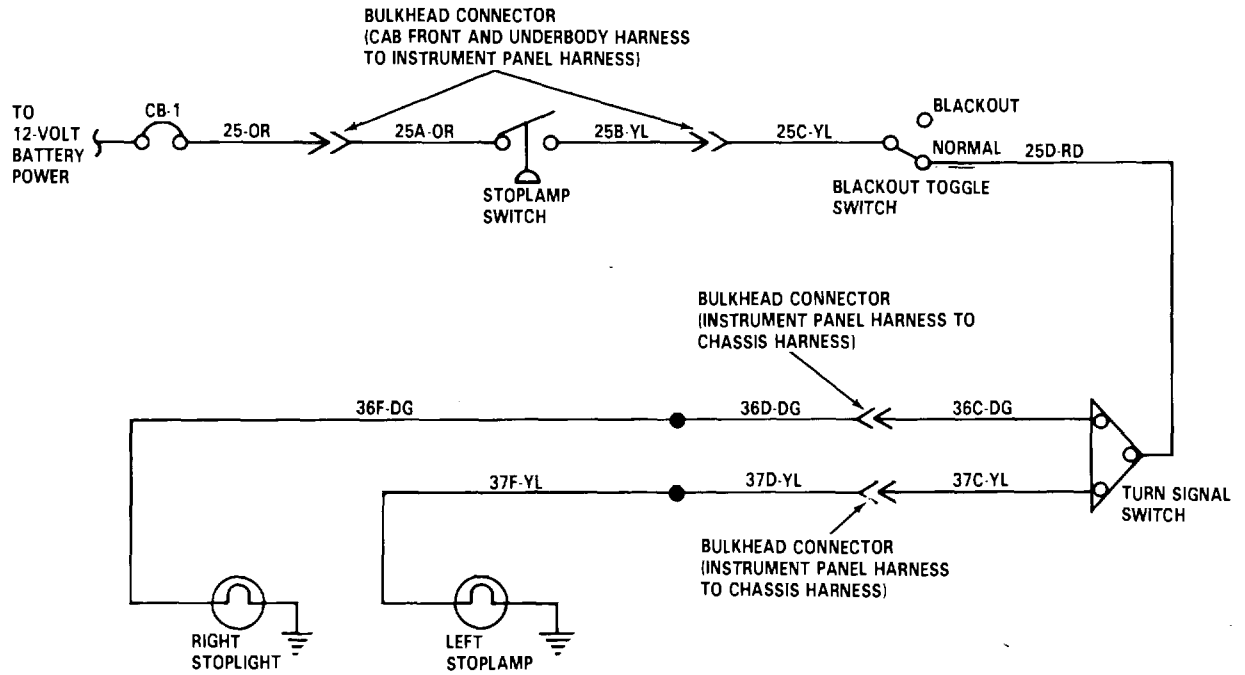

TA 236895

TROUBLESHOOTING.

2-11. TROUBLESHOOTING PROCEDURES (Continued).

MALFUNCTION	INSTRUCTION	INDICATION	YES	NO
56. BOTH STOPLAMPS NOT WORKING (Continued).				
11.	Disconnect turn signal switch connector, and go to step 12.			
12.	Check for voltage at circuit 25D-RD of connector.	12-volts dc nominal.	Go to step 13.	Repair circuit 25D-RD (para 3-127).
13.	Connect jumper across circuit 25D-RD to grey-black circuit, and go to step 14.			
14.	Check for voltage at either circuit 36C-DG or 37C-YL terminal of connector.	12-volts dc nominal.	Connect circuit 36C-DG and 37C-YL to circuit 25D-RD. Replace both stoplamp bulbs (para 3-96) and/or clean socket connections.	Replace turn signal switch (para 3-80).
57. ONE STOPLAMP NOT WORKING.				
NOTE				
<ul style="list-style-type: none"> • Blackout toggle switch must be set to NORMAL position, air system pressurized to 105 psi, and brake pedal depressed by assistant when doing the following checks. • Faulty right stoplamp is shown in this procedure. Apply similar troubleshooting technique for left stoplamp. 				

2-11. TROUBLESHOOTING PROCEDURES (Continued).

MALFUNCTION	INSTRUCTION	INDICATION	YES	NO
-------------	-------------	------------	-----	----

57 ONE STOPLAMP NOT WORKING (Continued).

- | | | | | |
|---|---|---------------------|---|---|
| 1 | Disconnect turn signal switch connector, and go to step 2. | | | |
| 2 | Connect jumper across circuit 25D-RD to gray-black circuit, and go to step 3. | | | |
| 3 | Check for voltage at circuit 36C-DG terminal of connector | 12-volts dc nominal | Connect circuit 36C-DG to 25D-RD, and go to step 4. | Replace turn signal switch (para 3-80). |

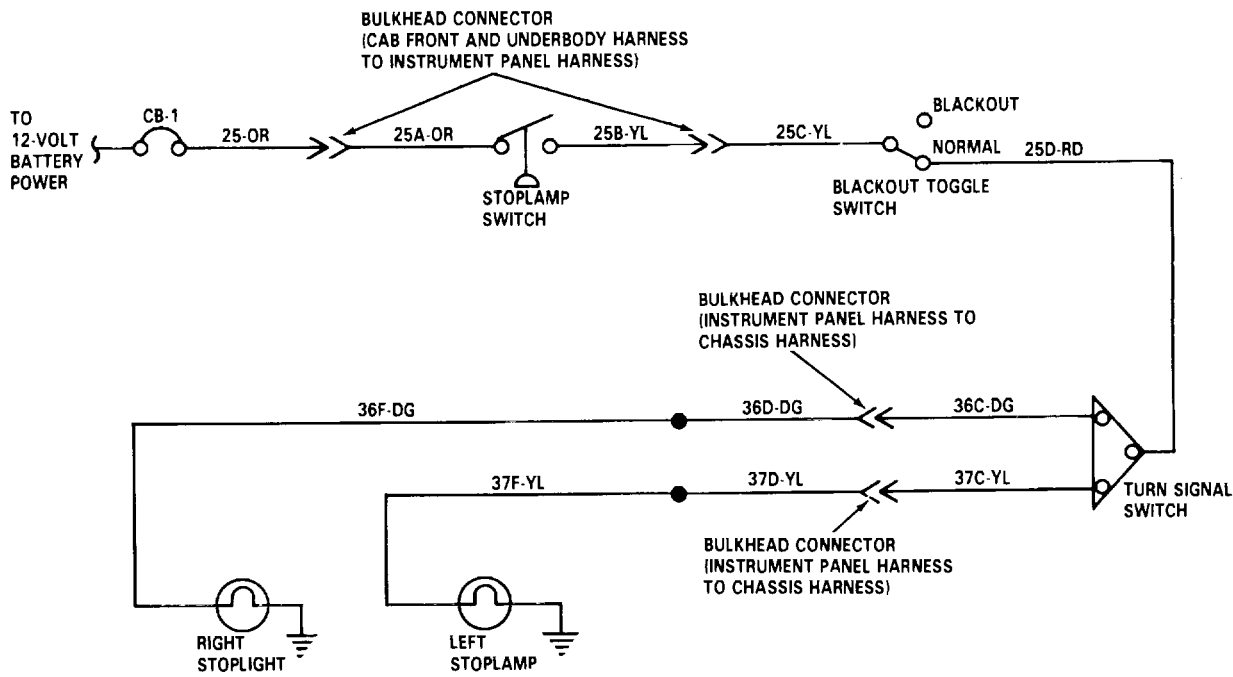

2-11. TROUBLESHOOTING PROCEDURES (Continued).

MALFUNCTION	INSTRUCTION	INDICATION	YES	NO
57 ONE STOPLAMP NOT WORKING (Continued).				
4	Disconnect circuit 36D-DG from 36C-DG at connector, and go to step 5.			
5	Check for voltage at circuit 36C-DG terminal of connector	12-volts dc nominal	Connect circuit 36D-DG to 36C-DG, and go to step 6.	Repair circuit 36C-DG (para 3-127).
6	Remove terminal cover at taillamp assembly (para 3-96), and go to step 7.			
7	Check for voltage at circuit 36F-DG terminal of taillamp assembly	12-volts dc nominal	Install cover (para 3-96), and go to step 8.	Repair circuit 36F-DG and/or 36D-DG (para 3-127).
NOTE				
With positive lead on circuit 36F-DG, check ground with negative lead when doing the following checks.				
8	Remove lens at taillamp assembly (para 3-96), and go to step 9.			
9	Check for voltage at lamp socket	12-volts dc nominal taillamp	Replace bulb Install lens of socket assembly (para 3-96)	Clean connections at Install lens of taillamp assembly (para 3-96).

2-11. TROUBLESHOOTING PROCEDURES (Continued).

MALFUNCTION	INSTRUCTION	INDICATION	YES	NO
-------------	-------------	------------	-----	----

57. ONE STOPLAMP NOT WORKING (Continued).

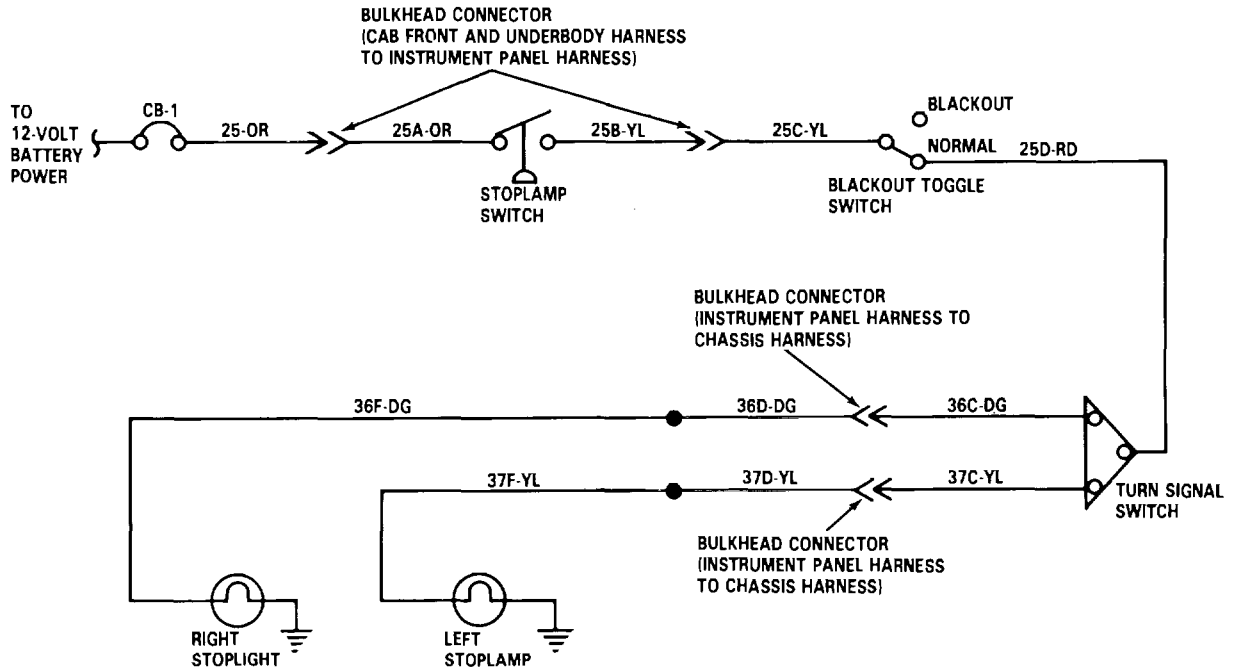

2-11. TROUBLESHOOTING PROCEDURES (Continued).

MALFUNCTION	INSTRUCTION	INDICATION	YES	NO
58 BOTH REVERSE LAMPS NOT WORKING.	1 Remove circuit breaker bracket far enough to access circuit breaker CB-3 (para 3-114), and go to step 2	NOTE		
	Ignition switch must be on, battery power connected, transmission shift control lever in reverse (R), and blackout toggle switch in NORMAL position when doing the following checks.			
2 Check for voltage at circuit 38-LG terminal of circuit breaker CB-3	12-volts dc nominal	Go to step 3		Reset circuit breaker CB-3 and/or trouble-shoot CB-3 circuit. (Refer to malfunction 33).
3 Disconnect circuit 38-LG from 38A-LG at connector, and go to step 4.				
4 Check for voltage at circuit 38-LG terminal of connector	12-volts dc nominal	Go to step 5		Repair circuit 38-LG (para 3-127). Install circuit breaker bracket (para 3-114).
5 Connect jumper wire from circuit 38-LG to 38A-LG, and go to step 6.				
6 Access reverse switch, and disconnect circuit 38A-LG from switch (para 3-106).				

2-11. TROUBLESHOOTING PROCEDURES (Continued).

MALFUNCTION	INSTRUCTION	INDICATION	YES	NO
58. BOTH REVERSE LAMPS NOT WORKING (Continued).				
7. Check for voltage at circuit 38A-LG terminal of reverse switch.	12-volts dc nominal.	Go to step 8.	Repair circuit	38A-LG (para 3-127). Install circuit breaker bracket (para 3-114).
8. Connect jumper wire from circuit 38A-LG to reverse switch, and go to step 9.				
9. Check for voltage at circuit 38B-OR terminal of reverse switch.	12-volts dc nominal.		Connect circuit 38A-LG and 38B-LG to reverse switch, and go to step 10.	Replace reverse switch (para 3-106). Install circuit breaker bracket (para 3-114).

2-11. TROUBLESHOOTING PROCEDURES (Continued).

MALFUNCTION	INSTRUCTION	INDICATION	YES	NO
58 BOTH REVERSE LAMPS NOT WORKING (Continued).				
10	Check for voltage at circuit 38B-OR terminal of connector	12-volts dc nominal circuit 38B-OR	Remove jumper wire, install 3-127 to 38C-OR, and go to step 11	Repair circuit 38B-OR (para 3-114). Install circuit breaker bracket (para 3-114).
11	Remove relay RY-7 (para 3-112), and go to step 12.			
12	Check for voltage at circuit 38C-BR terminal of relay RY-7	12-volts dc nominal 3-112), and go	Install relay RY-7 (para 3-127) to step 13	Repair circuit 38C-OR (para 3-114). Install relay RY-7 (para 3-112). Install circuit breaker bracket (para 3-114). Replace relay RY-7 (para 3-112) Install
13	Move blackout toggle switch from NORMAL to BLACKOUT and back to NORMAL position	Clicking sound at 'relay RY-7 and go to step	Install circuit breaker bracket (para 3-114), circuit breaker 14	bracket (para 3-114).
14	Disconnect circuit 38E-OR from 38D-OR at connector, and go to step 15.			
15	Check for voltage at circuit 38D-OR terminal of connector	12-volts dc nominal	Go to step 16	Repair circuit 38D-OR (para 3-127).
16	Remove taillamp cover (para 3-96), and go to step 17.			
17	Check for voltage at circuit 38G-OR terminal of lamp	12-volts dc nominal	Reverse lamp circuit OK	Repair circuit 38E-OR (para 3-127).

2-11. TROUBLESHOOTING PROCEDURES (Continued).

MALFUNCTION	INSTRUCTION	INDICATION	YES	NO
-------------	-------------	------------	-----	----

58. BOTH REVERSE LAMPS NOT WORKING (Continued).

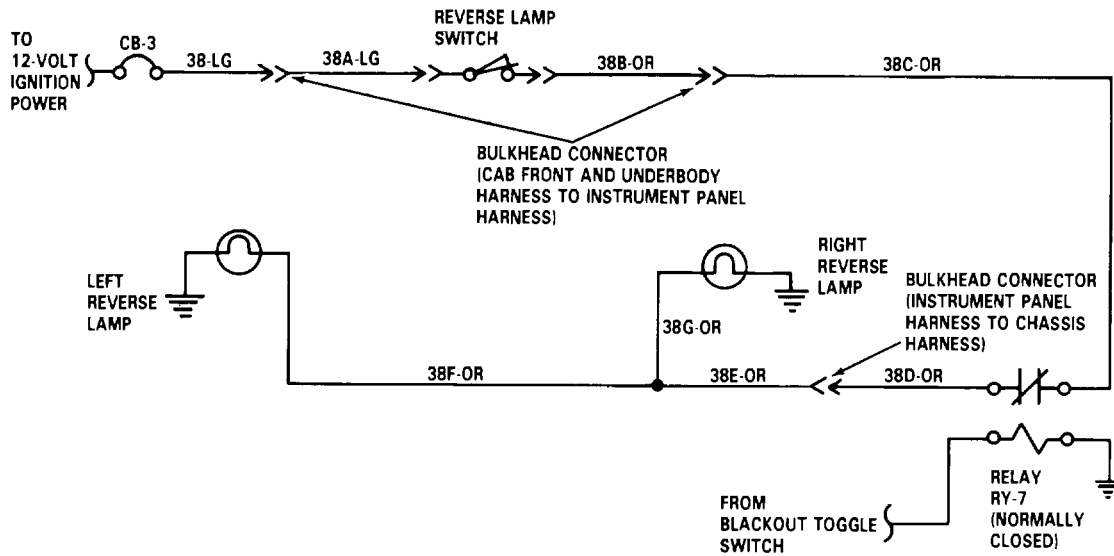

2-11. TROUBLESHOOTING PROCEDURES (Continued).

MALFUNCTION	INSTRUCTION	INDICATION	YES	NO
59. ONE REVERSE LAMP NOT WORKING.				
NOTE				
<ul style="list-style-type: none"> •Ignition switch must be on, transmission shift control lever in reverse (R), and blackout toggle switch in NORMAL position when doing the following checks. •Faulty right reverse lamp is shown in this procedure. Apply similar troubleshooting technique for left reverse lamp. 				
1. Remove taillamp cover (para 3-96), and go to step 2.				
2. Check for voltage at circuit 38G-OR terminal of taillamp.	12-volts dc nominal.	Install tail-lamp cover (para 3-96), and go to step 3.		Repair circuit 38G-OR (para 3-127). Install taillamp cover (para 3-96).
NOTE				
With positive lead on circuit 38G-OR, check ground with negative lead when doing the following checks. 3. Remove lens and bulb from taillamp assembly (para 3-96), and go to step 4.				
4. Check for voltage at socket ground of taillamp assembly.	12-volts dc nominal.	Replace bulb (para 3-96).		Clean socket connection, and install bulb (para 3-96).

2-11. TROUBLESHOOTING PROCEDURES (Continued).

MALFUNCTION	INSTRUCTION	INDICATION	YES	NO
-------------	-------------	------------	-----	----

59. ONE REVERSE LAMP NOT WORKING (Continued).

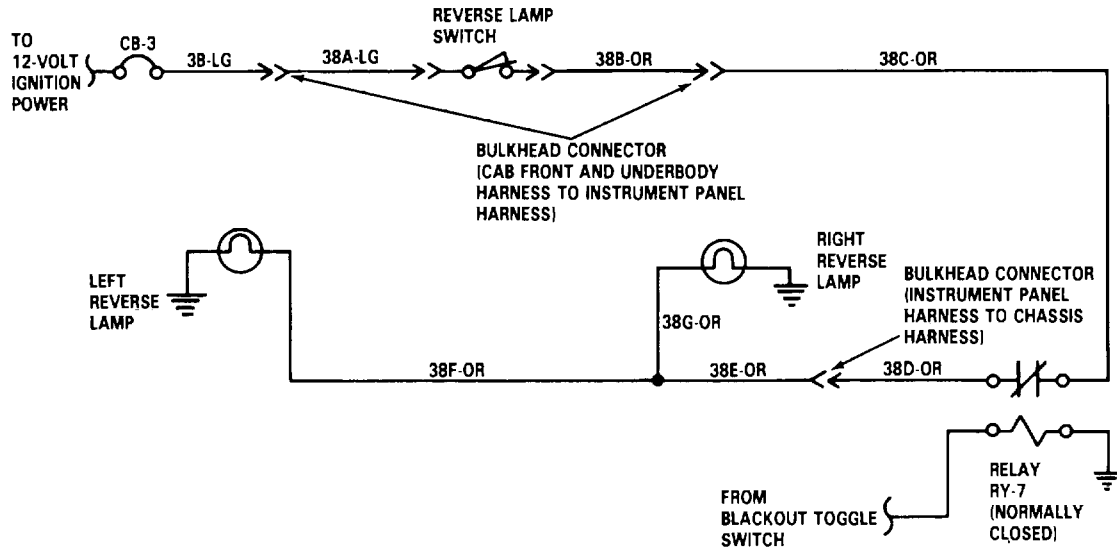

2-11. TROUBLESHOOTING PROCEDURES (Continued).

MALFUNCTION	INSTRUCTION	INDICATION	YES	NO
60. BLACKOUT HEADLAMP NOT WORKING.				
NOTE				
Headlamp switch must be in ON position and blackout toggle switch set to BLACKOUT position when doing the following checks.				
1	Check for voltage at circuit 26-GY terminal of headlamp switch.	12-volts dc nominal	Go to step 2	Refer to malfunction 44.
2	Check for voltage at circuit 26-GY terminal of blackout toggle switch.	12-volts dc nominal	Go to step 3	Repair circuit 26-GY (para 3-127).
3	Check for voltage at circuit 19-LB terminal of blackout toggle switch.	12-volts dc nominal	Go to step 4	Replace blackout toggle switch (para 3-79).
4	Disconnect circuit 19-LB from 19A-LB at connector, and go to step 5.			
5	Check for voltage at circuit 19-LB (pin E of connector)	12-volts dc nominal	Connect circuit 19-LB to 19A-LB, and go to step 6.	Repair circuit 19-LB (para 3-127).
6	Disconnect circuit 19A-LB from 19B-LB at connector, and go to step 7.			
7	Check for voltage at circuit 19A-LB terminal of connector	12-volts dc nominal	Connect circuit 19A-LB to 19B-LB, and go to step 8.	Repair circuit 19A-LB (para 3-127).

2-11. TROUBLESHOOTING PROCEDURES (Continued).

MALFUNCTION	INSTRUCTION	INDICATION	YES	NO
-------------	-------------	------------	-----	----

60. BLACKOUT HEADLAMP NOT WORKING (Continued).

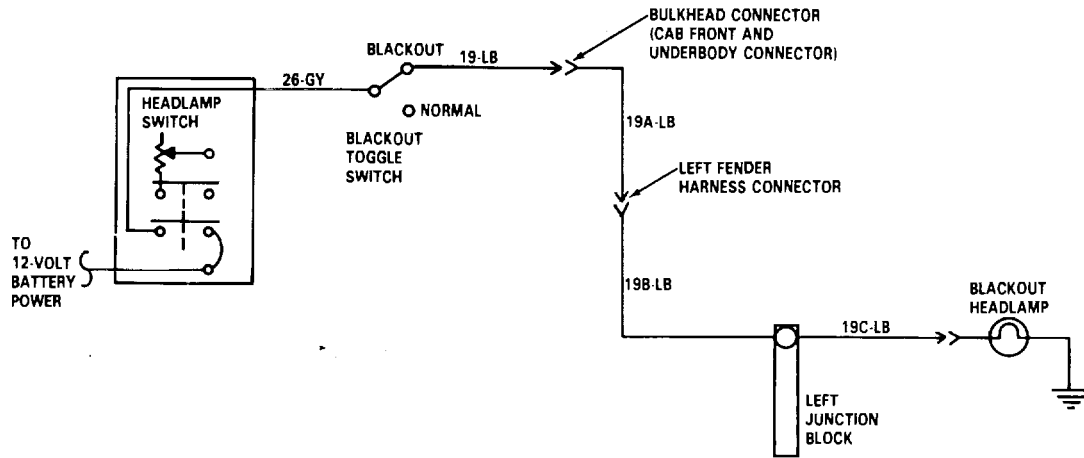

2-11. TROUBLESHOOTING PROCEDURES (Continued).

MALFUNCTION	INSTRUCTION	INDICATION	YES	NO
60. BLACKOUT HEADLAMP NOT WORKING (Continued).				
8. Access junction block by removing headlamp assembly (para 3-91), and go to step 9.				
9. Check for voltage at circuit 19B-LB of junction block.	12-volts dc nominal.		Install head-lamp assembly (para 3-91), and go to step 10.	Repair circuit 19B-LB (para 3-127).
10. Disconnect circuit 19C-LB from blackout headlamp, and go to step 11.				
11. Check for voltage at circuit 19C-LB of connector.	12-volts dc nominal.	Go to step 12. Repair circuit		19C-LB (para 3-127).
NOTE				
With positive lead on circuit 19C-LB, check ground with negative lead when doing the following checks.				
12. Remove lens and bulb from blackout headlamp (para 3-95), and go to step 13.				
13. Check for voltage and socket ground.	12-volts dc nominal.		Replace bulb (para 3-95).	Clean socket connection. Install bulb and lens to blackout head-lamp (para 3-95).

2-11. TROUBLESHOOTING PROCEDURES (Continued).

MALFUNCTION	INSTRUCTION	INDICATION	YES	NO
-------------	-------------	------------	-----	----

60. BLACKOUT HEADLAMP NOT WORKING (Continued).

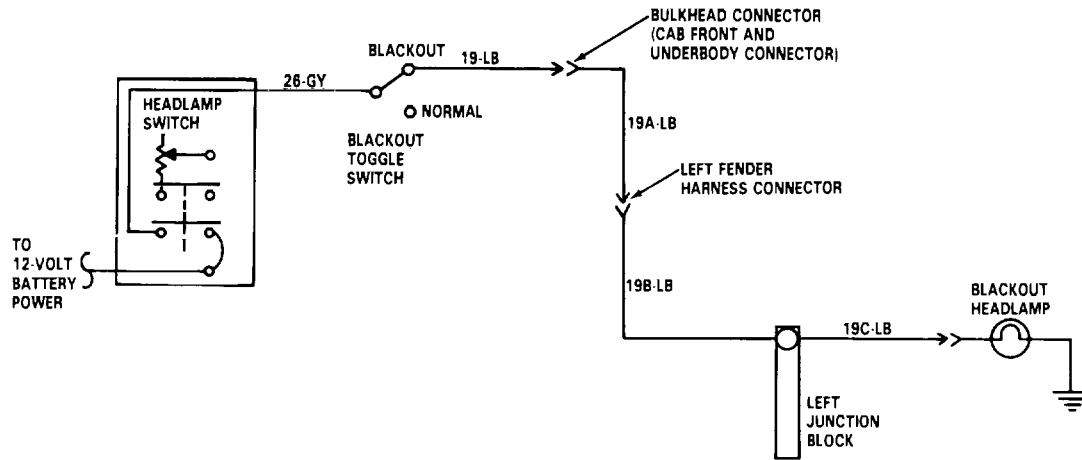

2-11. TROUBLESHOOTING PROCEDURES (Continued).

MALFUNCTION	INSTRUCTION	INDICATION	YES	NO
61. BOTH BLACKOUT MARKER LAMPS NOT WORKING.				
NOTE				
Headlamp switch must be in ON position and blackout toggle switch set to BLACKOUT position when doing the following checks.				
1 Check for voltage at circuit 30-OR terminal of headlamp switch.	12-volts dc nominal	Go to step 2		Refer to malfunction 44.
2 Check for voltage at circuit 30-OR terminal of blackout toggle	12-volts dc nominal	Go to step 3		Repair circuit 30-OR (para 3-127). switch.
3 Check for voltage at circuit 23Z-TN terminal of blackout toggle switch	12-volts dc nominal	Go to step 4		Replace blackout toggle switch (para 3-79).
4 Disconnect circuit 23-TN from 23A-TN at connector, and go to step 5.				
5 Check for voltage at circuit 23-TN terminal of connector	12-volts dc nominal	Repair circuit 23A-TN (para 3-127)		Repair circuit 23-TN and/or 23Z-TN (para 3-127)
62 ONE BLACKOUT MARKER LAMP NOT WORKING.				
NOTE				
-Headlamp switch must be in ON position and blackout toggle switch set to BLACKOUT position when doing the following checks.				

2-11. TROUBLESHOOTING PROCEDURES (Continued).

MALFUNCTION	INSTRUCTION	INDICATION	YES	NO
-------------	-------------	------------	-----	----

62. ONE BLACKOUT MARKER LAMP NOT WORKING (Continued).

•Faulty right blackout marker lamp is shown in this procedure. Apply similar troubleshooting technique for left blackout marker lamp.

- 1 Disconnect circuit 23B-TN from 23C-TN at connector, and go to step 2.
- 2 Check for voltage at circuit 23B-TN terminal of connector

12-volts dc nominal

Connect circuit 23B-TN to 23C-TN, and go To step 3.

Repair circuit 23B-TN (para 3-127).

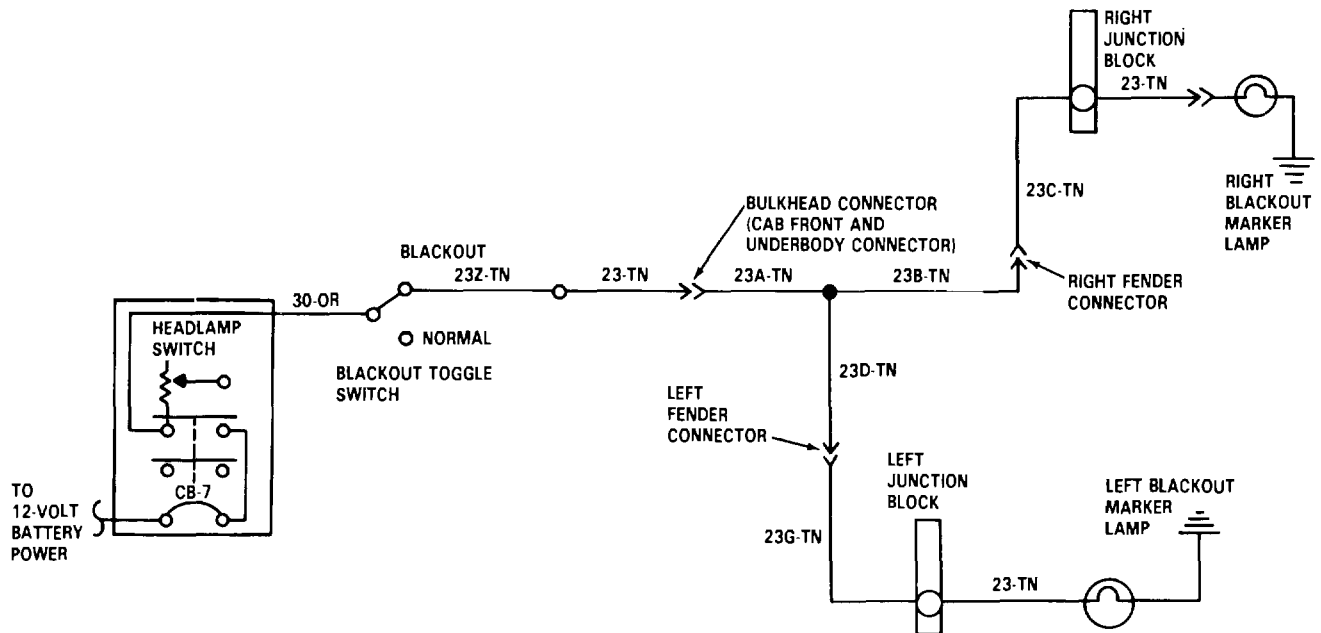

2-11. TROUBLESHOOTING PROCEDURES (Continued).

MALFUNCTION	INSTRUCTION	INDICATION	YES	NO
-------------	-------------	------------	-----	----

62. ONE BLACKOUT MARKER LAMP NOT WORKING (Continued).

3 Remove right headlamp assembly (para 3-91), and go to step 4.

4	Check for voltage at circuit 23C-TN of junction block	12-volts dc nominal	Install headlamp assembly (para 3-91), and go to step 3	Repair circuit 23C-TN (para 3-127). Install headlamp assembly (para 3-91).
---	---	---------------------	---	--

5 Disconnect circuit 23-TN from right marker lamp, and go to step 6.

6	Check for voltage at circuit 23-TN terminal of connector	12-volts dc nominal	Go to step 7 23-TN (para 3-127).	Repair circuit
---	--	---------------------	----------------------------------	----------------

NOTE

With positive lead on circuit 23-TN, check ground with negative lead when doing the following checks.

7 Remove bulb from right marker lamp (para 3-94).

8	Check for voltage at socket ground	12-volts dc nominal	Replace bulb (para 3-94), and install lens (para 3-94)	Clean socket connection, and install bulb (para 3-94).
---	------------------------------------	---------------------	--	--

2-11. TROUBLESHOOTING PROCEDURES (Continued).

MALFUNCTION	INSTRUCTION	INDICATION	YES	NO
-------------	-------------	------------	-----	----

62. ONE BLACKOUT MARKER LAMP NOT WORKING (Continued).

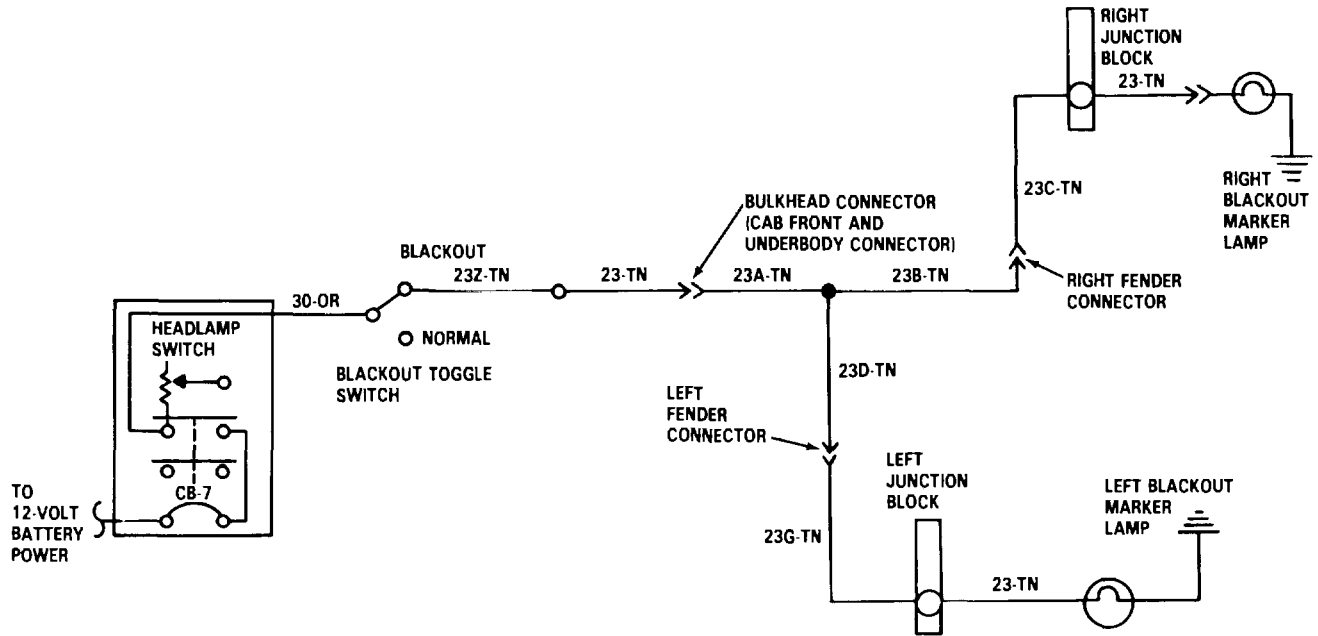

2-11. TROUBLESHOOTING PROCEDURES (Continued).

MALFUNCTION	INSTRUCTION	INDICATION	YES	NO
63 BOTH BLACKOUT STOPLAMPS NOT WORKING.	1 Remove circuit breaker bracket far enough to access circuit breaker CB-1 (para 3-114), and go to step 2.			
	2 Check for voltage at circuit 25-OR terminal of circuit breaker CB-1	12-volts dc nominal	Go to step 3	Reset circuit breaker CB-1 and/or troubleshoot CB-1 circuit. (Refer to malfunction 33).
	3 Disconnect circuit 25-OR from 25A-OR at connector, and go to step 4.			
	4 Check for voltage at circuit 25-OR terminal of connector	12-volts dc nominal	Go to step 5	Repair circuit 25-OR (para 3-127). Install circuit breaker bracket (para 3-114).
	5 Connect jumper wire between 25-OR and 25A-OR, and go to step 6.			
	6 Check for voltage at circuit 25A-OR terminal of stoplamp switch	12-volts dc nominal	Go to step 7	Repair circuit 25A-OR (para 3-127). Remove jumper and connect circuit 25-OR to 25A-OR. Install circuit breaker bracket (para 3-114).

2-11. TROUBLESHOOTING PROCEDURES (Continued).

MALFUNCTION	INSTRUCTION	INDICATION	YES	NO
-------------	-------------	------------	-----	----

63. BOTH BLACKOUT STOPLAMPS NOT WORKING (Continued).

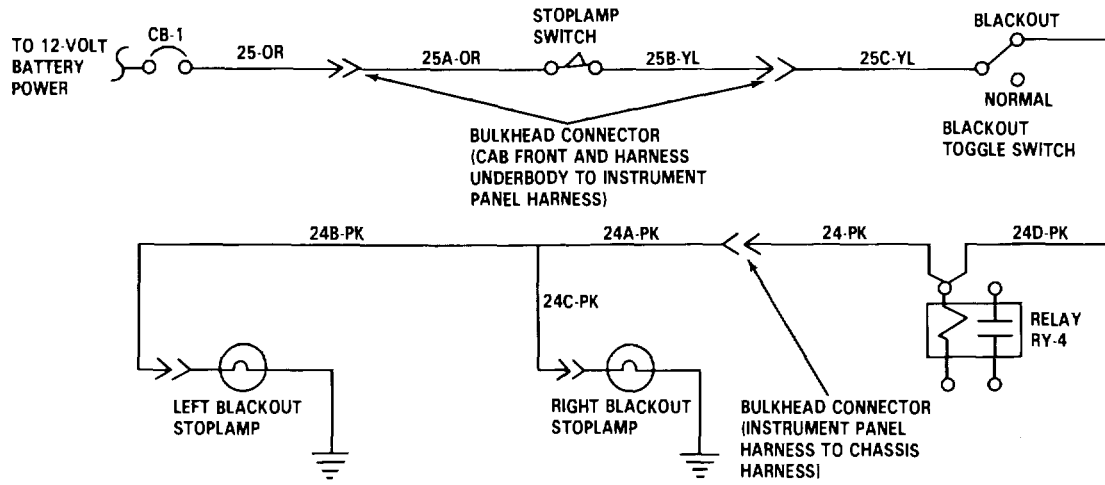

2-11. TROUBLESHOOTING PROCEDURES (Continued).

MALFUNCTION	INSTRUCTION	INDICATION	YES	NO
63 BOTH BLACKOUT STOPLAMPS NOT WORKING (Continued).				
NOTE				
Blackout toggle switch must be set to BLACKOUT position, air system pressurized to 105 psi, and brake pedal depressed by assistant when doing the following checks.				
7	Check for voltage at circuit 25B-YL terminal of stoplamp switch	12-volts dc nominal	Go to step 8	Replace stop-lamp switch (Para 3-97). Install circuit breaker bracket (para 3-114).
8	Check for voltage at circuit 25B-YL terminal of connector	12-volts dc nominal circuit 25B-YL	Remove jumper wire. Connect 3-127 to 25C-YL, and go to step 9	Repair circuit 25B-YL (para 3-114). Install circuit breaker bracket (para 3-114).
9	Check for voltage at circuit 25C-YL terminal of blackout toggle switch.	12-volts dc nominal	Go to step 10	Repair circuit 25C-YL (para 3-127). Install circuit breaker bracket (para 3-114).

2-11. TROUBLESHOOTING PROCEDURES (Continued).

MALFUNCTION	INSTRUCTION	INDICATION	YES	NO
-------------	-------------	------------	-----	----

63. BOTH BLACKOUT STOPLAMPS NOT WORKING (Continued).

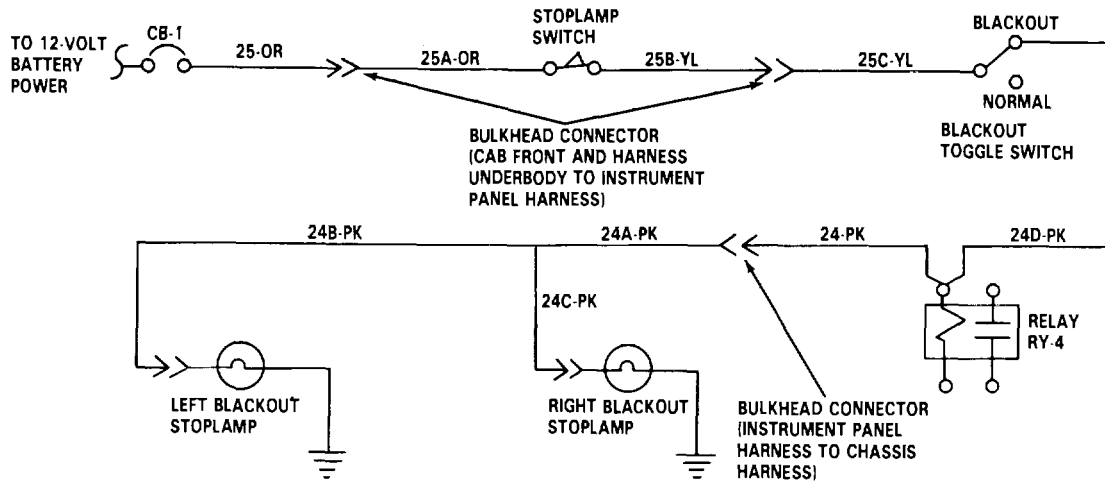

2-11. TROUBLESHOOTING PROCEDURES (Continued).

MALFUNCTION	INSTRUCTION	INDICATION	YES	NO
63. BOTH BLACKOUT STOPLAMPS NOT WORKING (Continued).				
10. Check for voltage at circuit 24D-PK terminal of blackout toggle switch.	12-volts dc nominal.	Go to step 11.		Replace black-out toggle switch (para 3-79). Install circuit breaker bracket (para 3-114).
11. Remove relay RY-4 (para 3-112), and go to step 12.				
12. Check for voltage at circuit 24D-PK terminal of relay RY-4.	12-volts dc nominal.	Install relay RY-4 (para 3-112). Install circuit breaker bracket (para 3-114).		Repair circuit 24D-PK (para 3-127). Install relay RY-4 (para 3-112). Install circuit breaker bracket (para 3-114).
13. Disconnect circuit 24-PK from 24A-PK at connector, and go to step 14.				
14. Check for voltage at circuit 24-PK (pin N of connector).	12-volts dc nominal.	Repair circuit 24A-PK (para 3-127).		Repair circuit 24-PK (para 3-127).

2-11. TROUBLESHOOTING PROCEDURES (Continued).

MALFUNCTION	INSTRUCTION	INDICATION	YES	NO
-------------	-------------	------------	-----	----

63. BOTH BLACKOUT STOPLAMPS NOT WORKING (Continued).

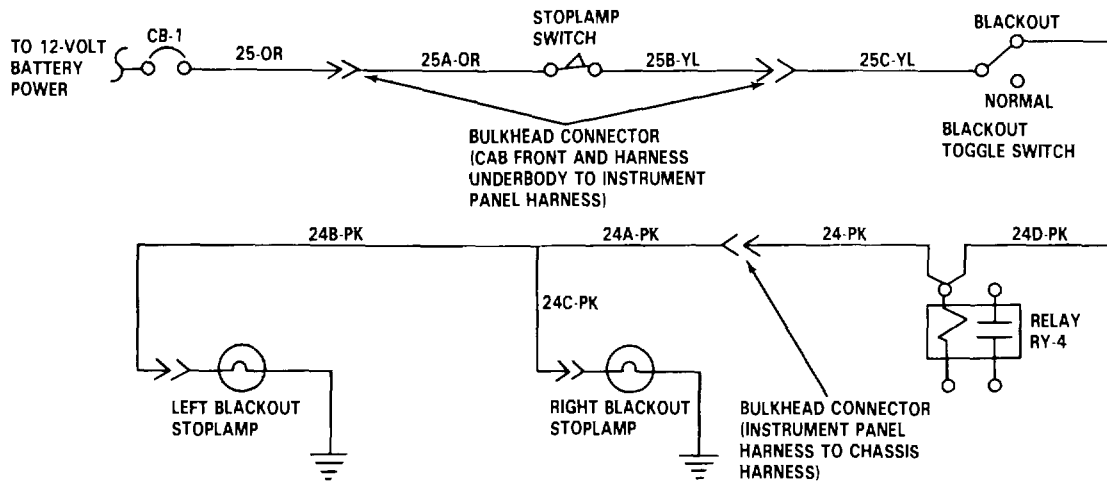

2-11. TROUBLESHOOTING PROCEDURES (Continued).

MALFUNCTION	INSTRUCTION	INDICATION	YES	NO
64. ONE BLACKOUT STOPLAMP NOT WORKING.				
NOTE				
<ul style="list-style-type: none"> •Blackout toggle switch must be set to BLACKOUT position, air system pressurized to 105 psi, and brake pedal depressed by assistant when doing the following checks. •Faulty right blackout stoplamp is shown in this procedure. Apply similar troubleshooting technique for left blackout stoplamp. 				
1. Disconnect circuit 24C-PK from right blackout stoplamp, and go to step 2.				
2. Check for voltage at circuit 24C-PK terminal of connector lamp and, go to step 3.	12-volts dc nominal blackout stop-	Connect circuit 24C-PK to 3-127).		Repair circuit 24C-PK (para
NOTE				
With positive lead on circuit 24C-PK, check ground with negative lead when doing the following checks.				
3. Remove door from blackout stoplamp (para 3-97), and go step 4.				
4. Check for voltage at socket of stoplamp assembly	12-volts dc nominal	Replace bulb (para 3-97)		Clean socket connection, and install door to blackout stoplamp (para 3-97).

2-11. TROUBLESHOOTING PROCEDURES (Continued).

MALFUNCTION	INSTRUCTION	INDICATION	YES	NO
-------------	-------------	------------	-----	----

64. ONE BLACKOUT STOPLAMP NOT WORKING (Continued).

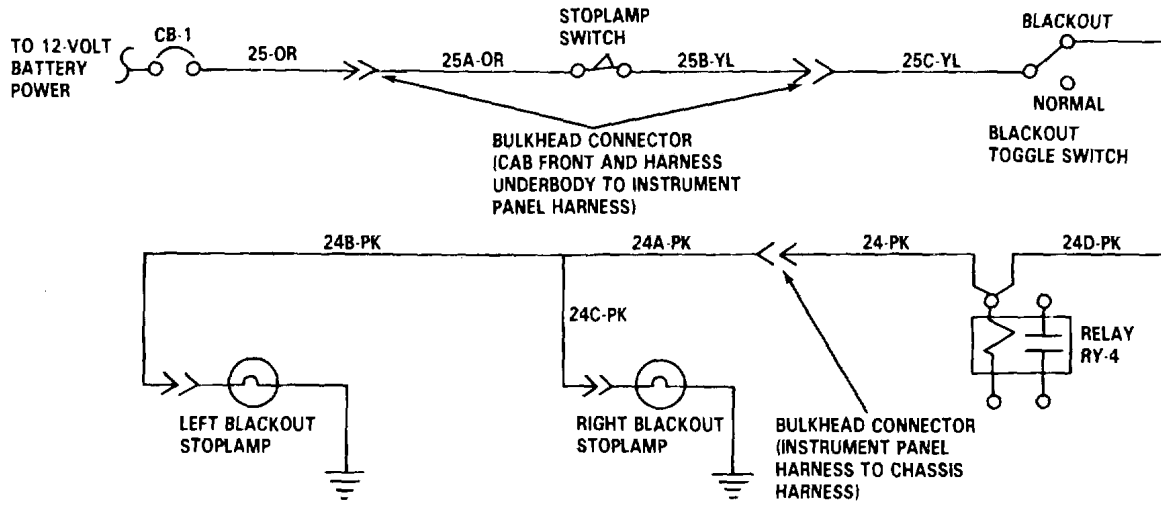

2-11. TROUBLESHOOTING PROCEDURES (Continued).

MALFUNCTION	INSTRUCTION	INDICATION	YES	NO
65. BOTH BLACKOUT TAILLAMPS NOT WORKING.				
NOTE				
Headlamp switch must be in ON position and blackout toggle switch in BLACKOUT position when doing the following checks.				
1. Check for voltage at circuit 30-OR terminal of headlamp switch.	12-volts dc nominal.	Go to step 2.	Refer to malfunction 44.	
2. Check for voltage at circuit 30-OR terminal of blackout toggle switch.	12-volts dc nominal.	Go to step 3.	Repair circuit 30-OR (para 3-127).	
3. Check for voltage at circuit 23Z-TN terminal of blackout toggle switch.	12-volts dc nominal.	Go to step 4.	Replace blackout toggle switch (para 3-79).	
4. Disconnect 23L-TN from 23S-TN at connector and, go to step 5.				
5. Check for voltage at circuit 23L-TN terminal of connector.	12-volts dc nominal.	Repair circuit 23S-TN (para 3-127).	Repair circuit 23L-TN and/or 23S-TN (para	

2-11. TROUBLESHOOTING PROCEDURES (Continued).

MALFUNCTION	INSTRUCTION	INDICATION	YES	NO
-------------	-------------	------------	-----	----

66. ONE BLACKOUT TAILLAMP NOT WORKING.

NOTE

- Headlamp switch must be in ON position and blackout toggle switch in BLACKOUT position when doing the following checks.

- Faulty right blackout taillamp is shown in this procedure. Apply similar troubleshooting technique for left blackout taillamp.

- | | | | |
|---|-----------------------------|----------------------|---|
| <ol style="list-style-type: none"> 1. Disconnect circuit 23W-TN from right blackout taillamp, and go to step 2. 2. Check for voltage at circuit 23W-TN terminal of connector. | <p>12-volts dc nominal.</p> | <p>Go to step 3.</p> | <p>Repair circuit 23W-TN (para 3-127).3</p> |
|---|-----------------------------|----------------------|---|

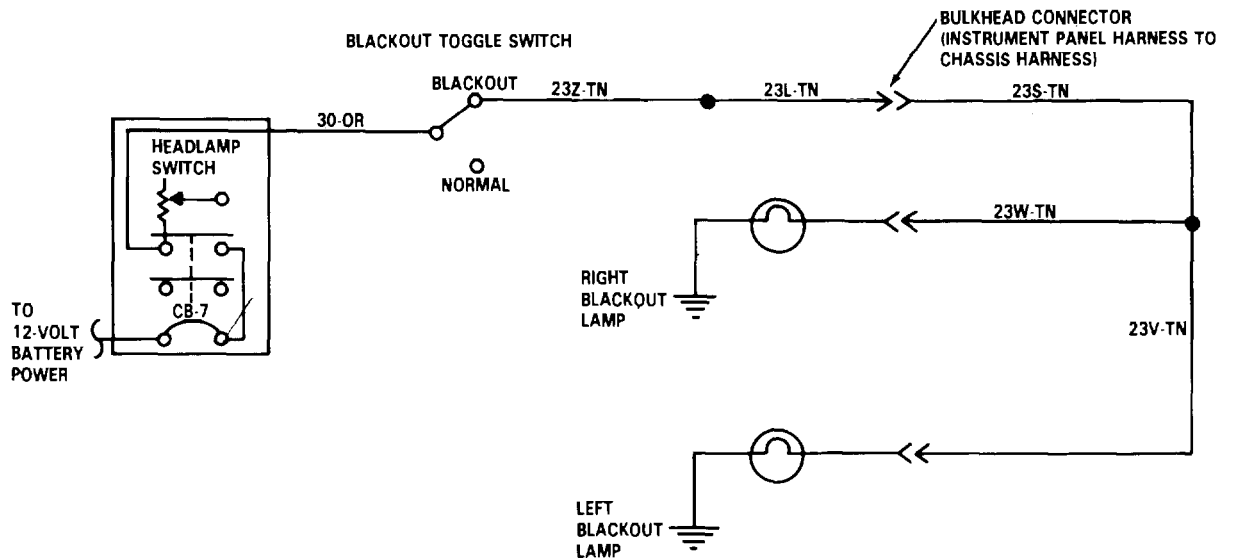

2-11. TROUBLESHOOTING PROCEDURES (Continued).

MALFUNCTION	INSTRUCTION	INDICATION	YES	NO
-------------	-------------	------------	-----	----

66. ONE BLACKOUT TAILLAMP NOT WORKING (Continued).

NOTE

With positive lead on circuit 23W-TN, check ground with negative lead when doing the following checks.

3. Remove bulb from blackout taillamp (para 3-97), and go to step 4.
4. Check for ground at socket of blackout taillamp.

12-volts dc nominal.

Replace bulb (para 3-97).

Clean socket connector, and install bulb

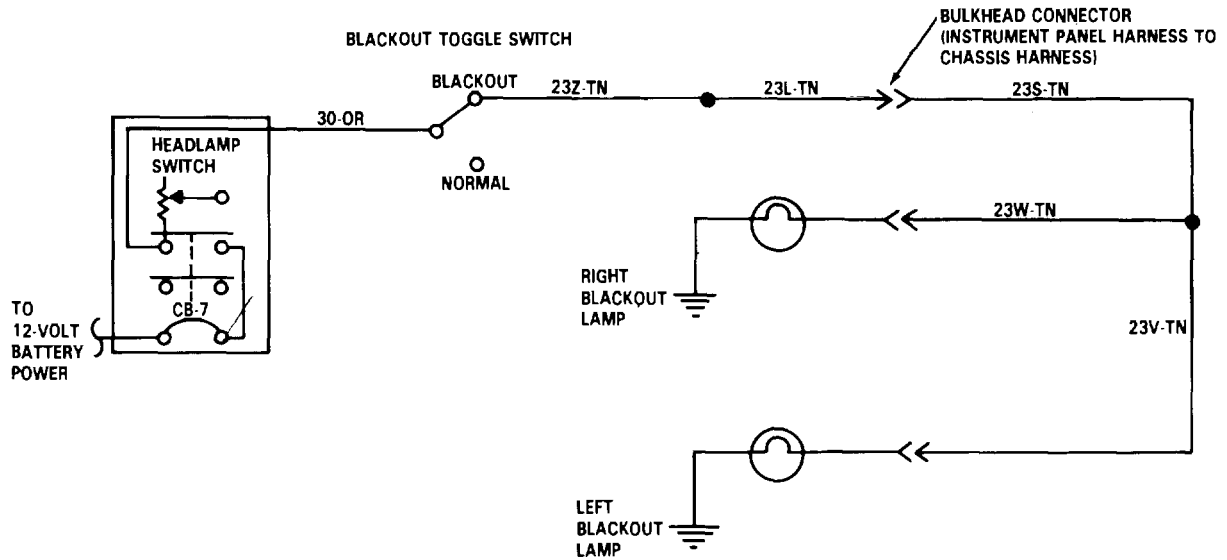

2-11. TROUBLESHOOTING PROCEDURES (Continued).

MALFUNCTION	INSTRUCTION	INDICATION	YES	NO				
<p>67. ALL BLACKOUT LAMPS NOT WORKING.</p> <p style="text-align: center;">NOTE</p> <ul style="list-style-type: none"> •-Headlamp switch must be in ON position and blackout toggle switch in BLACKOUT position when doing the following checks. •It is assumed here that NORMAL lighting system is OK. <table border="0" style="width: 100%;"> <tr> <td data-bbox="186 619 511 682">Check BLACKOUT lighting system.</td> <td data-bbox="592 619 738 682">Blackout lamps light.</td> <td data-bbox="925 619 1112 682">Blackout lighting system OK.</td> <td data-bbox="1201 619 1388 745">Replace blackout toggle switch (para 3-79).</td> </tr> </table>					Check BLACKOUT lighting system.	Blackout lamps light.	Blackout lighting system OK.	Replace blackout toggle switch (para 3-79).
Check BLACKOUT lighting system.	Blackout lamps light.	Blackout lighting system OK.	Replace blackout toggle switch (para 3-79).					

2-11. TROUBLESHOOTING PROCEDURES (Continued).

MALFUNCTION	INSTRUCTION	INDICATION	YES	NO
-------------	-------------	------------	-----	----

68. BOTH 12-VOLT TRAILER STOPLAMPS NOT WORKING.

NOTE

Blackout toggle switch must be set to NORMAL position, air system pressurized to 105 psi, and brake pedal depressed by assistant when doing the following checks.

1. Disconnect 12-volt trailer connector, and go to step 2.
2. Check for voltage at circuit 36E-DG and 37E-YL (pins 3 and 5 of connector).

12-volts dc nominal.

Recheck trailer stoplamp circuit.

Refer to Malfunction 56.

69. ONE 12-VOLT TRAILER STOPLAMP NOT WORKING.

NOTE

- Blackout toggle switch must be set to NORMAL position, air system pressurized to 105 psi, and brake pedal depressed by assistant when doing the following checks.

- It is assumed here that chassis stoplamp circuit is OK. Faulty right trailer stoplamp is shown in this procedure. Apply similar troubleshooting technique for left trailer stoplamp.

TROUBLESHOOTING.

2-11. TROUBLESHOOTING PROCEDURES (Continued).

MALFUNCTION	INSTRUCTION	INDICATION	YES	NO
-------------	-------------	------------	-----	----

69. ONE 12-VOLT TRAILER STOPLAMP NOT WORKING (Continued).

- | | | | | |
|----|--|----------------------|---------------------------------------|-------------------------------------|
| 1. | Disconnect 12-volt trailer connector, and go to step 2. | | | |
| 2. | Check for voltage at circuit 36E-DG (pin 5 of connector). repair as necessary. | 12-volts dc nominal. | Recheck trailer stoplamp circuit, and | Repair circuit 36E-DG (para 3-127). |

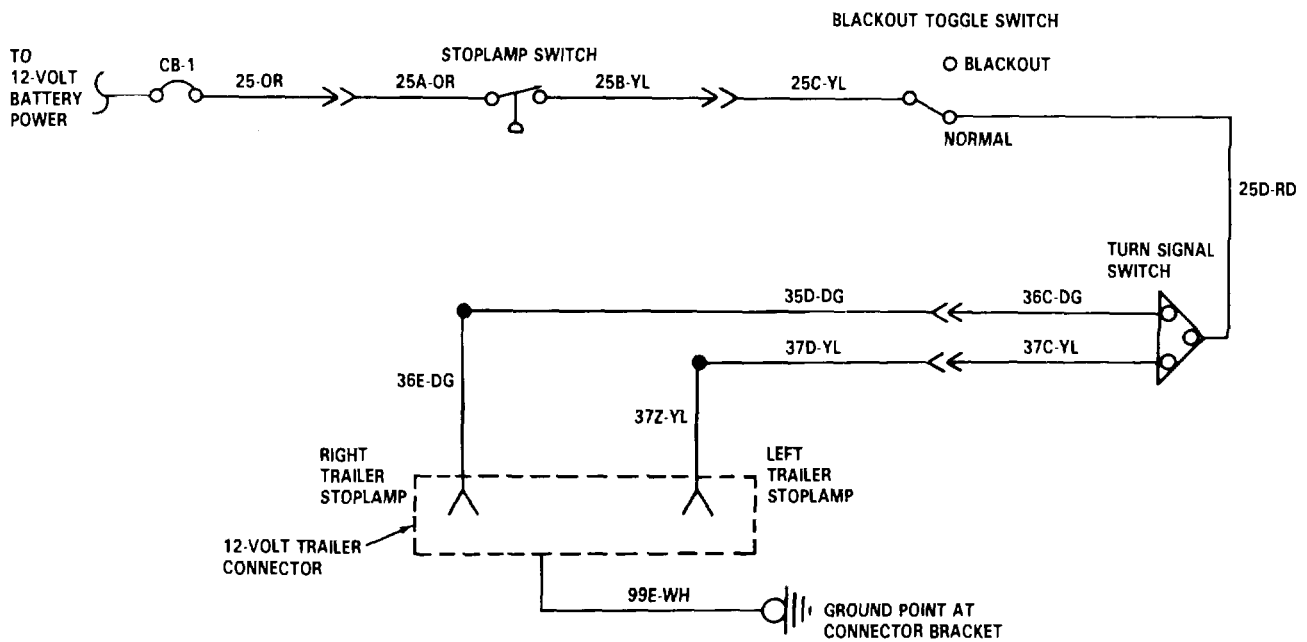

TA 236911

TROUBLESHOOTING.

2-11. TROUBLESHOOTING PROCEDURES (Continued).

MALFUNCTION	INSTRUCTION	INDICATION	YES	NO
-------------	-------------	------------	-----	----

70. BOTH 12-VOLT TRAILER TURN SIGNAL LAMPS NOT WORKING.

NOTE

Blackout toggle switch must be set to NORMAL position and turn signal switch set to hazard position when doing the following checks.

1.	Disconnect 12-volt trailer connector, and go to step 2.			
2.	Check for voltage at circuit 36E-DG and 37E-YL (pins 3 and 5 of connector).	12-volts dc nominal.	Recheck trailer turn signal lamp circuit.	Refer to malfunction 53.

71. ONE 12-VOLT TRAILER TURN SIGNAL LAMP NOT WORKING.

NOTE

- Blackout toggle switch must be set to NORMAL position and turn signal switch set for right turn when doing the following checks.
- It is assumed here that chassis turn signal lamp circuit is OK. Faulty right-side trailer turn signal lamp is shown in this procedure. Apply same troubleshooting technique for left-side trailer turn signal lamp.

1.	Disconnect 12-volt trailer connector, and go to step 2.			
2.	Check for voltage at circuit 36E-DG (pin 5 of connector). circuit.	12-volts dc nominal.	Recheck trailer right turn signal lamp	Repair circuit 36E-DG (para 3-127).

TROUBLESHOOTING.

2-11. TROUBLESHOOTING PROCEDURES (Continued).

MALFUNCTION	INSTRUCTION	INDICATION	YES	NO
-------------	-------------	------------	-----	----

71. ONE 12-VOLT TRAILER TURN SIGNAL LAMP NOT WORKING (Continued).

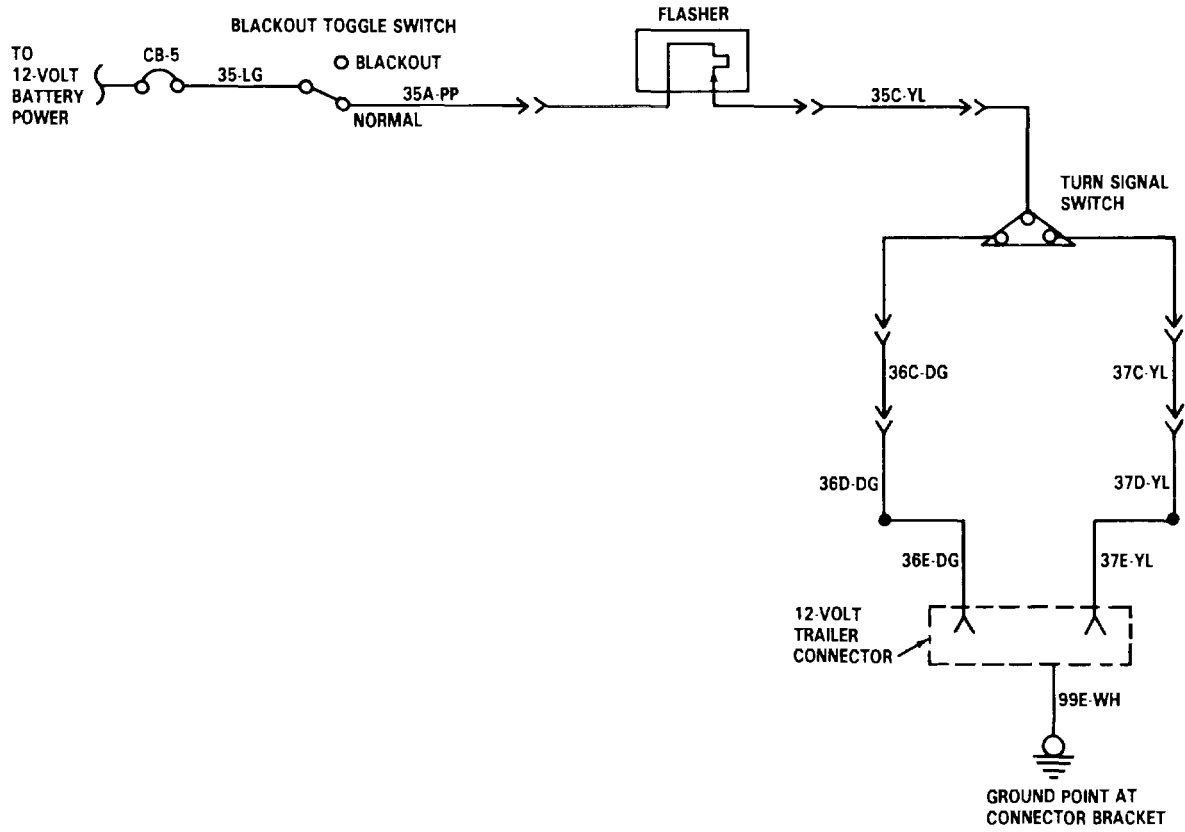

TROUBLESHOOTING.

2-11. TROUBLESHOOTING PROCEDURES (Continued).

MALFUNCTION	INSTRUCTION	INDICATION	YES	NO
-------------	-------------	------------	-----	----

72. BOTH 12-VOLT TRAILER TAILLAMPS NOT WORKING.

NOTE

Headlamp switch must be in ON position and blackout toggle switch set to NORMAL position when doing the following checks.

- | | | | |
|---|-----------------------------|--|--|
| <ol style="list-style-type: none"> 1. Disconnect 12-volts trailer connector, and go to step 2. 2. Check for voltage at circuit 30J-BR (pin 2 of connector). | <p>12-volts dc nominal.</p> | <p>Recheck trailer taillamp circuit.</p> | <p>Repair circuit 30J-BR (para 3-127).</p> |
|---|-----------------------------|--|--|

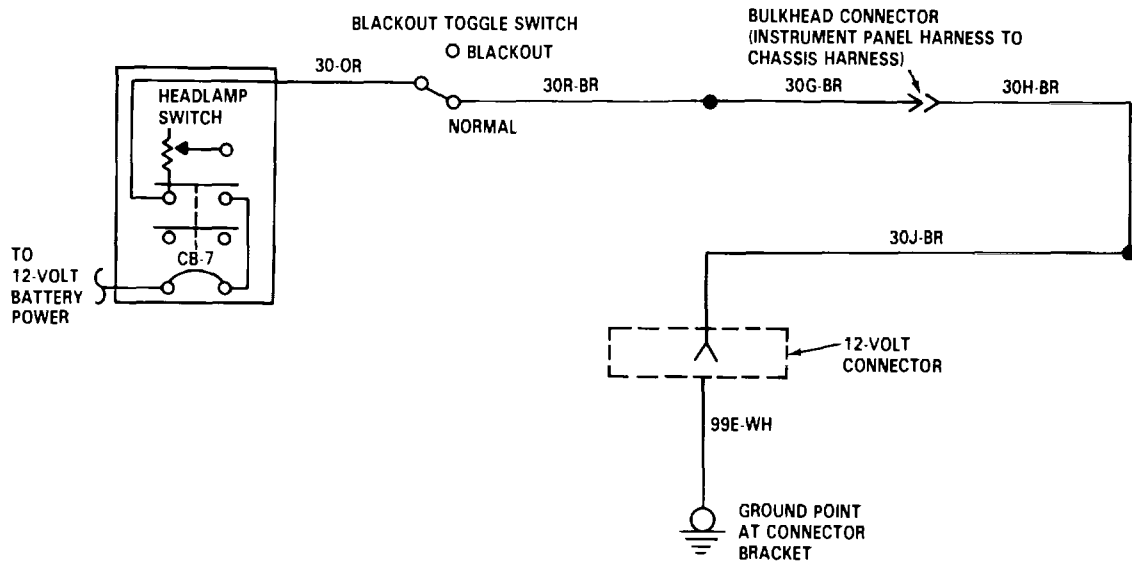

TA 236913

TROUBLESHOOTING.

2-11. TROUBLESHOOTING PROCEDURES (Continued).

MALFUNCTION	INSTRUCTION	INDICATION	YES	NO
-------------	-------------	------------	-----	----

73. ONE TRAILER TAILLAMP NOT WORKING.

NOTE

Headlamp switch must be in ON position and blackout toggle switch set to NORMAL position when doing the following checks.

Check trailer taillamp circuit for defects.

74. ALL 12-VOLT TRAILER CLEARANCE AND MARKER LAMPS NOT WORKING.

NOTE

- Headlamp switch must be in ON position and blackout toggle switch set to NORMAL position when doing the following checks.
- It is assumed here that chassis clearance and marker lamps are OK.

1. Disconnect circuit 31B-BK from 31C-BK at connector, and go to step 2.

TROUBLESHOOTING.

2-11. TROUBLESHOOTING PROCEDURES (Continued).

MALFUNCTION	INSTRUCTION	INDICATION	YES	NO
74. ALL 12-VOLT TRAILER CLEARANCE AND MARKER LAMPS NOT WORKING (Continued).				
2.	Check for voltage at circuit 31B-BK (pin A of connector). to step 3.	12-volts dc nominal.	Connect circuit 31B-BK to 31C-BK, and go	Repair circuit 31B-BK (para 3-127).
3.	Disconnect 12-volt trailer connector, and go to step 4.			
4.	Check for voltage at circuit 31C-BK (pin 2 of connector). circuit.	12-volts dc nominal.	Recheck trailer clearance and marker lamp	Repair circuit 31C-B (para 3-127).

TROUBLESHOOTING.

2-11. TROUBLESHOOTING PROCEDURES (Continued).

MALFUNCTION	INSTRUCTION	INDICATION	YES	NO
-------------	-------------	------------	-----	----

74. ALL 12-VOLT TRAILER CLEARANCE AND MARKER LAMPS NOT WORKING (Continued).

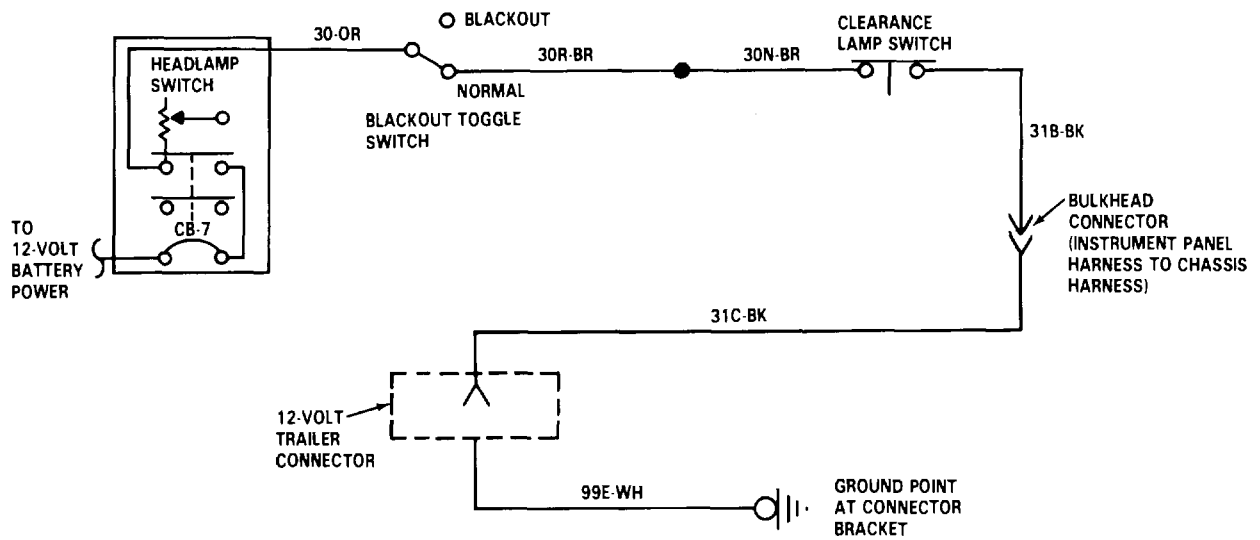

TA 236914

TROUBLESHOOTING.

2-11. TROUBLESHOOTING PROCEDURES (Continued).

MALFUNCTION	INSTRUCTION	INDICATION	YES	NO
75. BOTH 24-VOLT TRAILER STOPLAMPS NOT WORKING.				
<p>NOTE</p> <ul style="list-style-type: none"> • Blackout toggle switch must be set to NORMAL position, air system pressurized to 105 psi, and brake pedal depressed by assistant when doing the following checks. • It is assumed here that chassis stop-lamps are OK. Apply same trouble-shooting technique for either cab or chassis connector. 				
1. Disconnect turn signal switch connector, and go to step 2.				
2. Connect jumper wire between circuit 25D-RD and gray-black wire terminal of turn signal switch, and go to step 3.				
3. Check for voltage at either circuit 36G-DG or 37G-YL of turn signal switch connector.		12-volts dc nominal.	Go to step 4.	Replace turn signal switch (para 3-80).

TROUBLESHOOTING.

2-11. TROUBLESHOOTING PROCEDURES (Continued).

MALFUNCTION	INSTRUCTION	INDICATION	YES	NO
-------------	-------------	------------	-----	----

75. BOTH 24-VOLT TRAILER STOPLAMPS NOT WORKING (Continued).

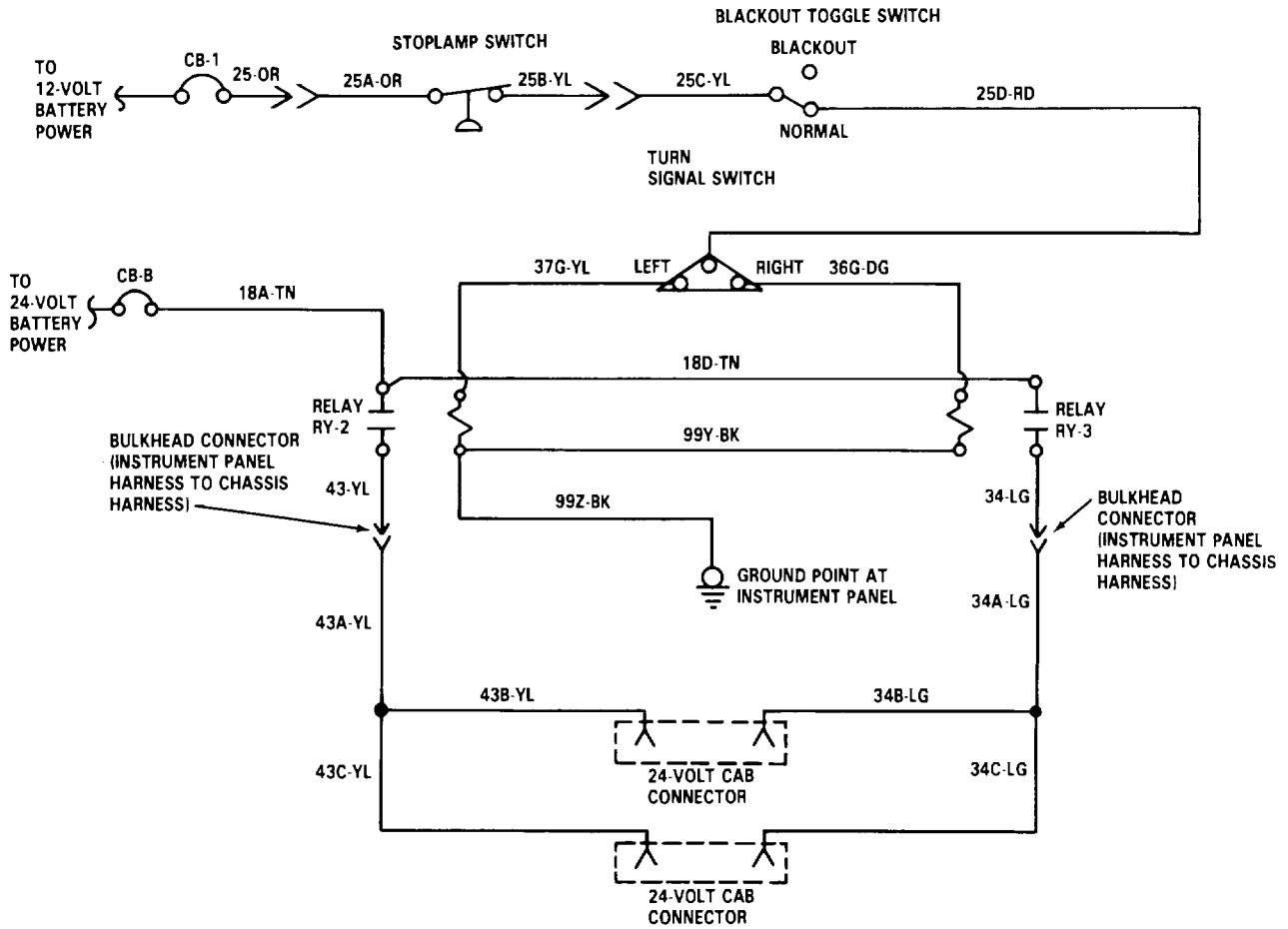

TA 236915

TROUBLESHOOTING.

2-11. TROUBLESHOOTING PROCEDURES (Continued).

MALFUNCTION	INSTRUCTION	INDICATION	YES	NO
75. BOTH 24-VOLT TRAILER STOPLAMPS NOT WORKING (Continued).				
NOTE				
With positive lead on circuit 36G-DG, check ground with negative lead for steps 4 thru 8.				
4.	Remove circuit breaker bracket far enough to access relay RY-3 and relay connector (para 3-114), and go to step 5.			
5.	Remove relay RY-3 (para 3-112), and go to step 6.			
6.	Check for voltage at circuit 99Z-BK ground point. Install relay RY-3, relay connector, and circuit breaker bracket (para 3-112 and	12-volts dc nominal.	Go to step 7. tighten ground connection.	Clean and

TROUBLESHOOTING.

2-11. TROUBLESHOOTING PROCEDURES (Continued).

MALFUNCTION	INSTRUCTION	INDICATION	YES	NO
-------------	-------------	------------	-----	----

75. BOTH 24-VOLT TRAILER STOPLAMPS NOT WORKING (Continued).

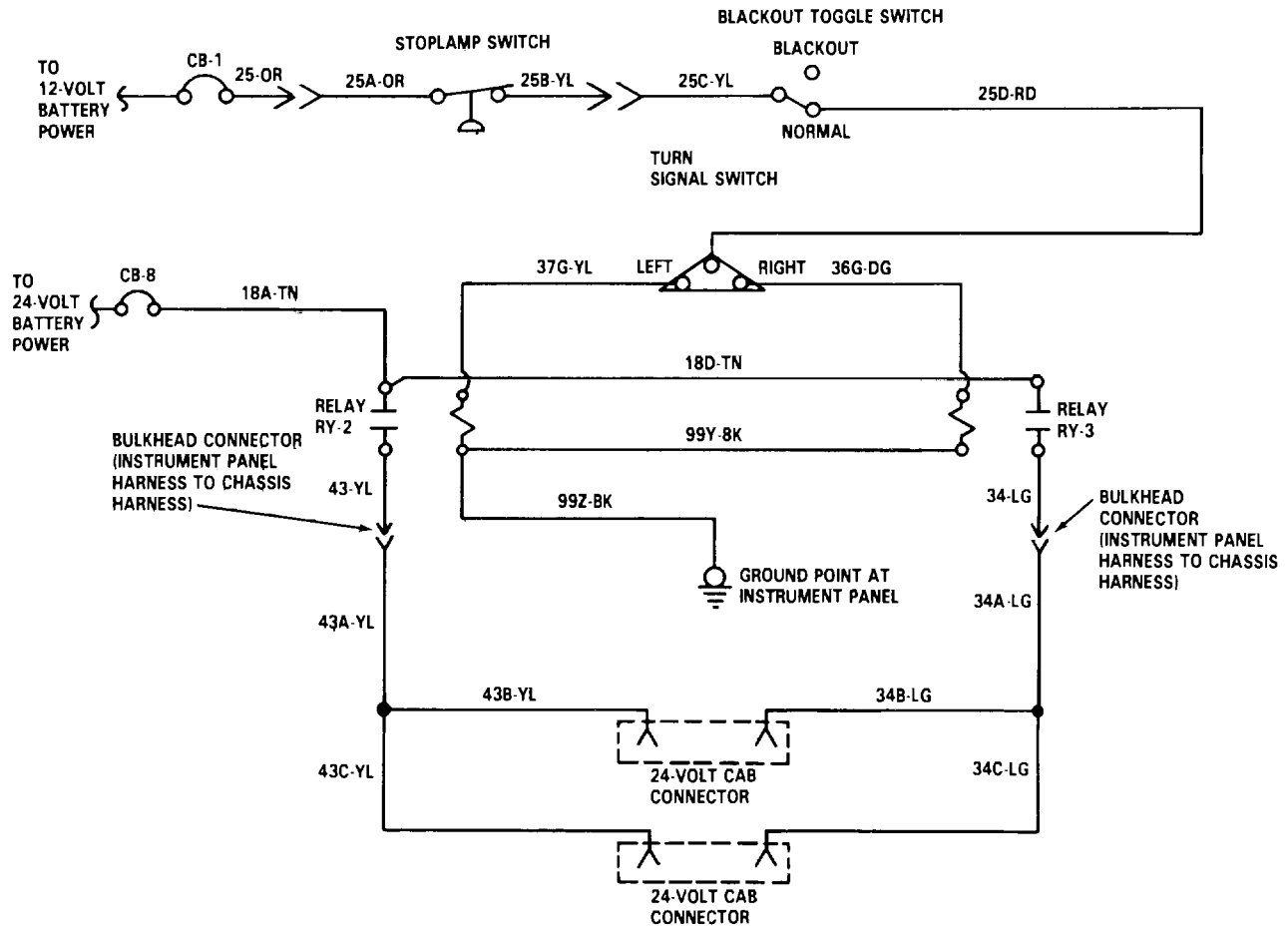

TA 236916

TROUBLESHOOTING.

2-11. TROUBLESHOOTING PROCEDURES (Continued).

MALFUNCTION	INSTRUCTION	INDICATION	YES	NO
75. BOTH 24-VOLT TRAILER STOPLAMPS NOT WORKING (Continued).				
	7. Remove relay RY-2 (para 3-112), and go to step 8.			
	8. Check for voltage at circuit 99Z-BK terminal of relay RY-2.	12-volts dc nominal.	Go to step 9.	Repair circuit 99Z-BK (para 3-127). Install relays RY-2 and RY-3, relay connector, and circuit breaker bracket (para 3-112 and 3-114).
	9. Check for voltage at circuit 18A-TN terminal of circuit breaker CB-8.	24-volts dc nominal.	Go to step 10.	Reset circuit Breaker CB-8 and/or trouble Shoot CB-8 circuit. (Refer to malfunction 35).
	10. Check for voltage at circuit 18A-TN terminal of relay connector.	24-volts dc nominal.	Install relays Ry-2 and RY-3, relay connector, and circuit breaker bracket (para 3-112 and 3-114). Recheck trailer circuit.	Repair circuit 18A-TN (para 3-127). Install relays RY-2 and RY-3, relay connector, and circuit breaker bracket (para 3-112 and 3-114).

TROUBLESHOOTING.

2-11. TROUBLESHOOTING PROCEDURES (Continued).

MALFUNCTION	INSTRUCTION	INDICATION	YES	NO
-------------	-------------	------------	-----	----

75. BOTH 24-VOLT TRAILER STOPLAMPS NOT WORKING (Continued).

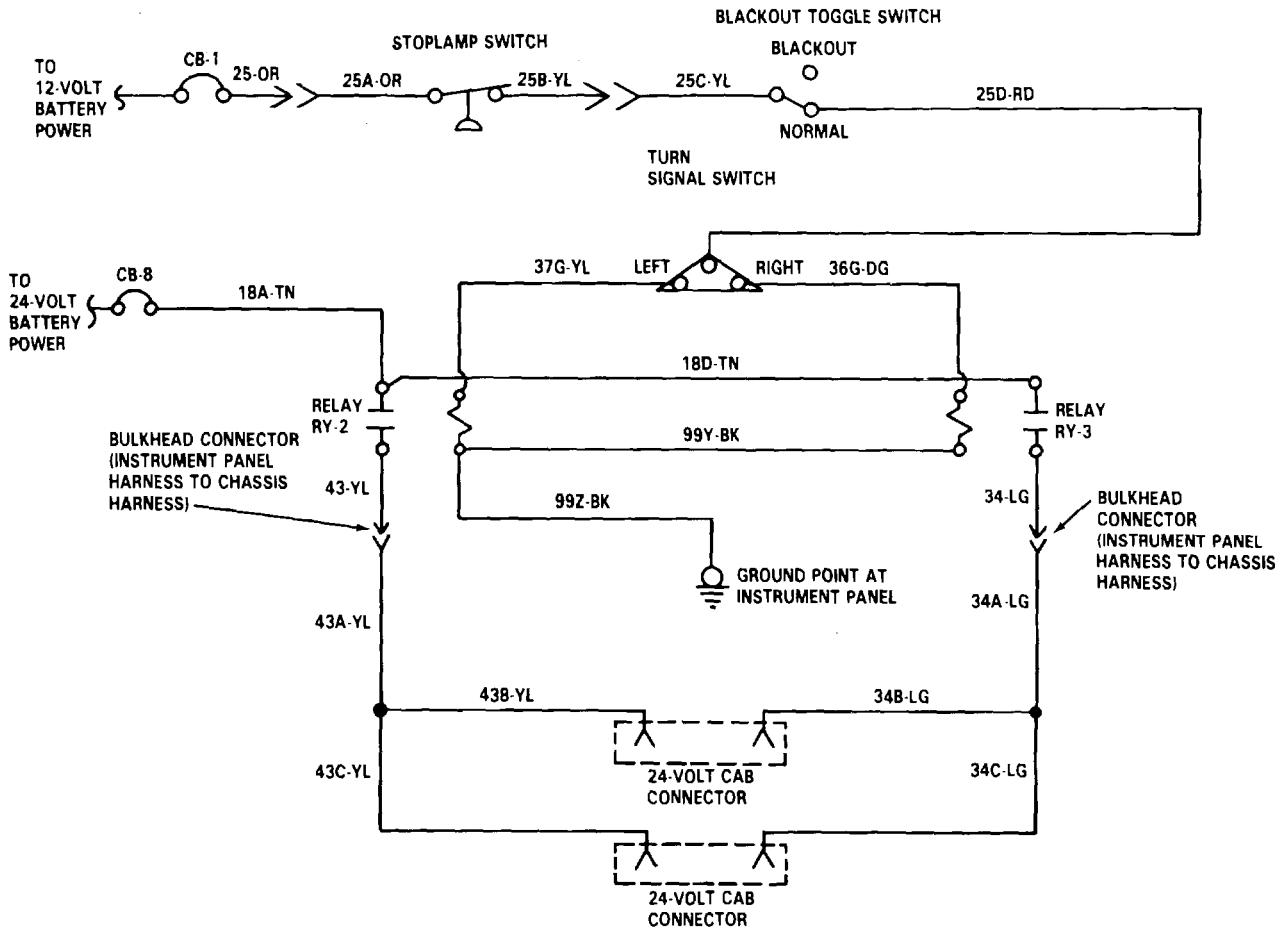

TA 236917

TROUBLESHOOTING.

2-11. TROUBLESHOOTING PROCEDURES (Continued).

MALFUNCTION	INSTRUCTION	INDICATION	YES	NO
-------------	-------------	------------	-----	----

76. ONE 24-VOLT TRAILER STOPLAMP NOT WORKING.

NOTE

- Blackout toggle switch must be set to NORMAL position, air system pressurized to 105 psi, and brake pedal depressed by assistant when doing the following checks.
- It is assumed here that chassis stop-lamp circuit is OK. Faulty right trailer stoplamp is shown in this procedure. Apply similar trouble-shooting technique for left trailer stoplamp.
- Do steps 1 thru 20 when troubleshooting 24-volt cab connector.
- Do steps 1 thru 19 and steps 21 and 22 when troubleshooting 24-volt chassis connector.

1.	Disconnect turn signal switch connector and, go to step 2.			
2.	Connect jumper wire between circuit 25D-RD and grey/black circuit, and go to step 3.			
3.	Check for voltage at circuit 36G-DG terminal of turn signal switch.	12-volts dc nominal.	Connect turn signal connector, and go to step 4.	Replace turn signal switch (para 3-80).

TROUBLESHOOTING.

2-11. TROUBLESHOOTING PROCEDURES (Continued).

MALFUNCTION	INSTRUCTION	INDICATION	YES	NO
-------------	-------------	------------	-----	----

76. ONE 24-VOLT TRAILER STOPLAMP NOT WORKING (Continued).

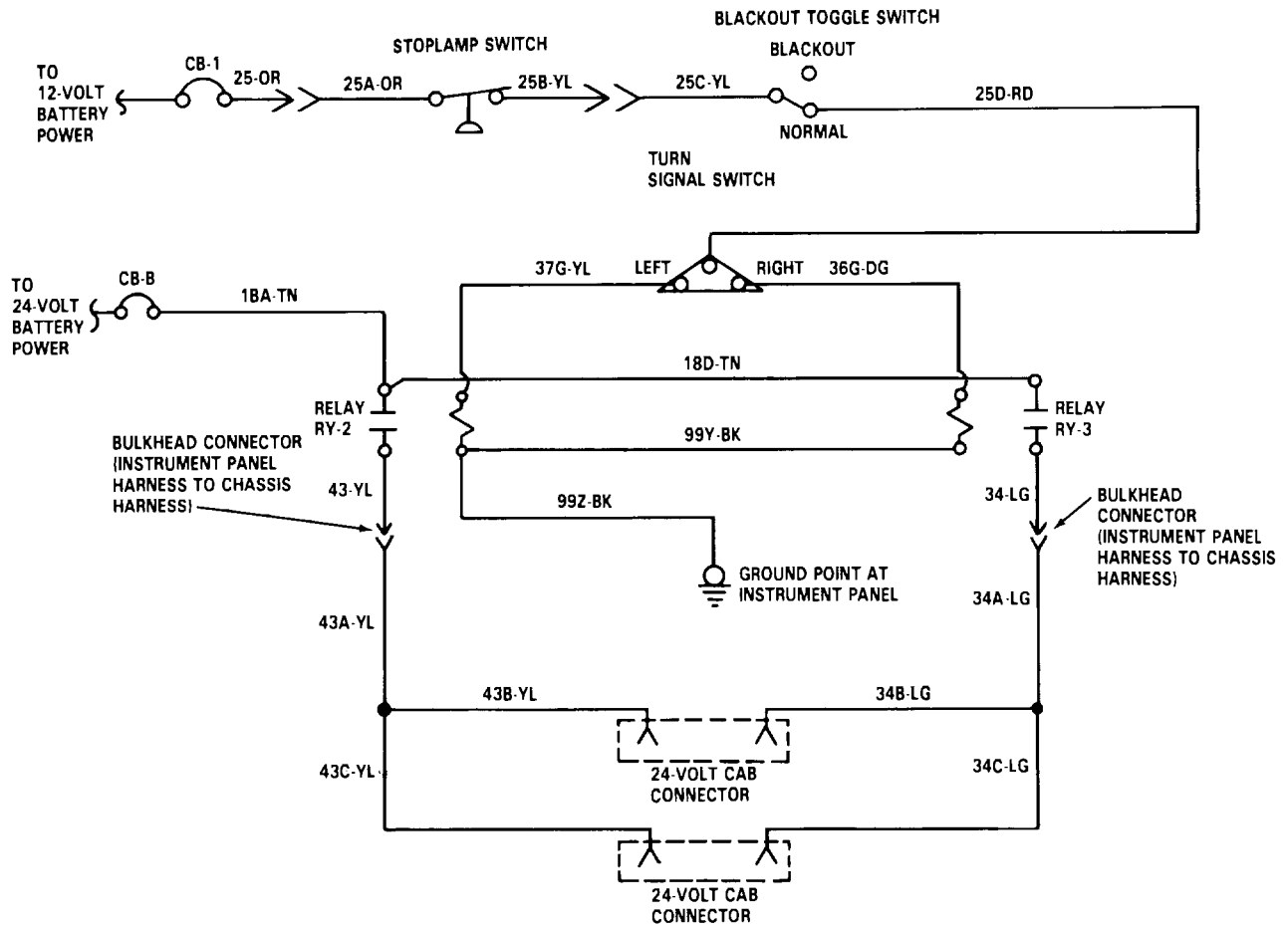

TA 236918

TROUBLESHOOTING.

2-11. TROUBLESHOOTING PROCEDURES (Continued).

MALFUNCTION	INSTRUCTION	INDICATION	YES	NO
76. ONE 24-VOLT TRAILER STOPLAMP NOT WORKING (Continued).				
	4. Remove circuit breaker bracket far enough to access relay RY-3 and relay connector (para 3-114), and go to step 5.			
	5. Remove relay RY-3 (para 3-112), and go to step 6.			
	6. Check for voltage at circuit 36G-DG terminal of relay RY-3.	12-volts dc nominal.	Go to step 7.	Repair circuit 36G-DG (para 3-127). Install relay connector, and circuit breaker bracket (para 3-112 and 3-114).
<p>NOTE</p> <p>With positive lead on circuit 36G-DG, check ground with negative lead for steps 7 thru 10.</p>				
	7. Check for voltage at circuit 99Z-BK ground point.	12-volts dc nominal.	Go to step 8.	Clean and tighten ground connection. Install relay RY-3, relay connector, and circuit breaker bracket (para 3-112 and 3-114).

TROUBLESHOOTING.

2-11. TROUBLESHOOTING PROCEDURES (Continued).

MALFUNCTION	INSTRUCTION	INDICATION	YES	NO
-------------	-------------	------------	-----	----

76. ONE 24-VOLT TRAILER STOPLAMP NOT WORKING (Continued).

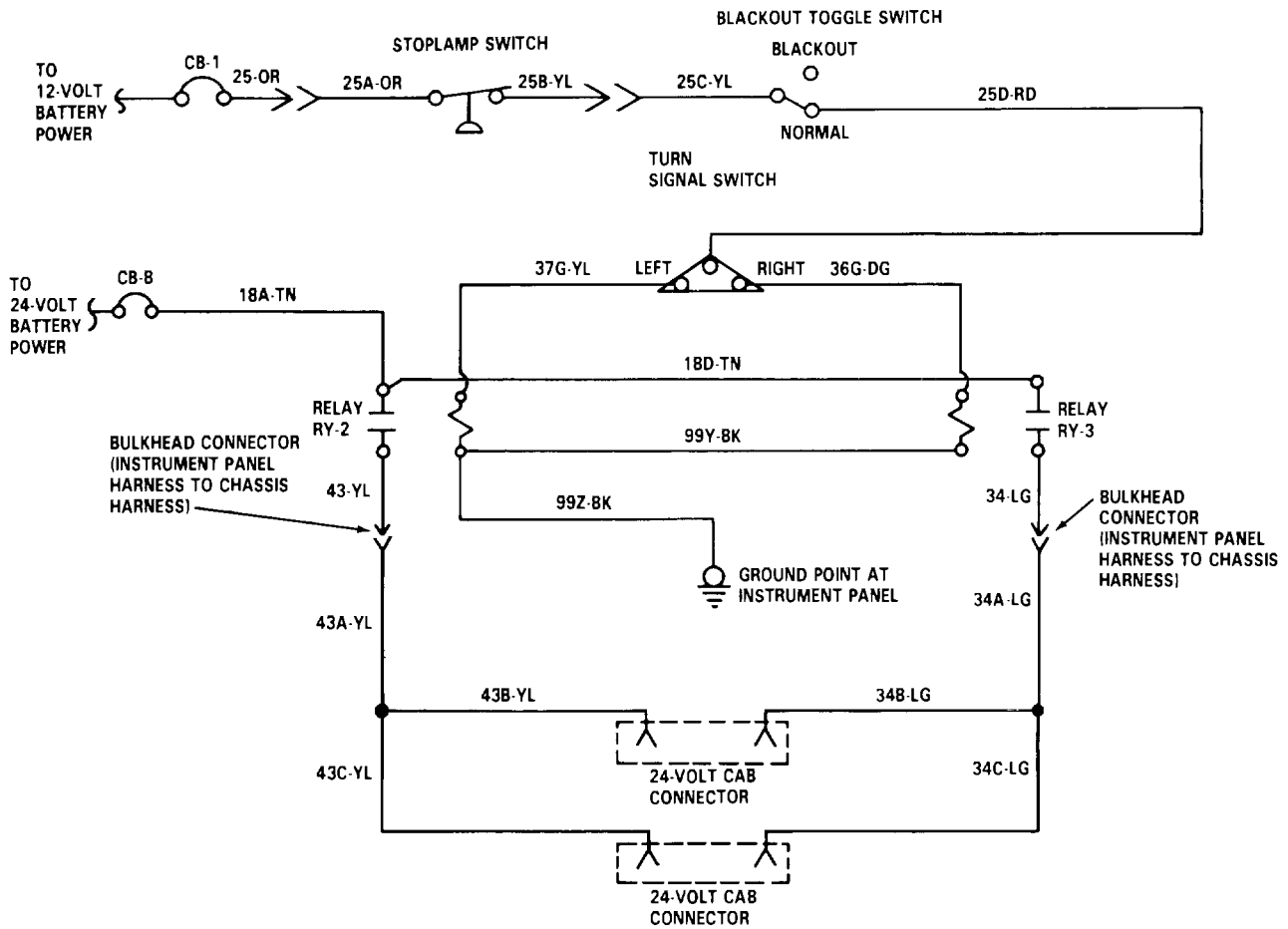

TA 236919

TROUBLESHOOTING.

2-11. TROUBLESHOOTING PROCEDURES (Continued).

MALFUNCTION	INSTRUCTION	INDICATION	YES	NO
76. ONE 24-VOLT TRAILER STOPLAMP NOT WORKING (Continued).				
8	Remove relay RY-2 (para 3-112), and go to step 9.			
9	Check for voltage at circuit 99Z-BK terminal of relay connector	12-volts dc nominal 3-127)	Go to step 10	Repair circuit 99Z-BK (para 3-112 and 3-114). Install relays RY-2 and RY-3, relay connector, and circuit breaker bracket (para 3-112 and 3-114).
10	Check for voltage at circuit 99Y-BK terminal of relay connector	12-volts dc nominal	Go to step 11	Repair circuit 99Y-BK (para 3-127) Install relays RY-2 and RY-3, relay connector, and circuit breaker bracket (para 3-112 and 3-114).
11	Check for voltage at circuit 18A-TN terminal of circuit breaker CB-8	24-volts dc nominal	Go to step 12	Reset circuit breaker CB-8 and/or troubleshoot CB-8 circuit (Refer to malfunction 35).

TROUBLESHOOTING.

MALFUNCTION	INSTRUCTION	INDICATION	YES	NO
-------------	-------------	------------	-----	----

76. ONE 24-VOLT TRAILER STOPLAMP NOT WORKING (Continued).

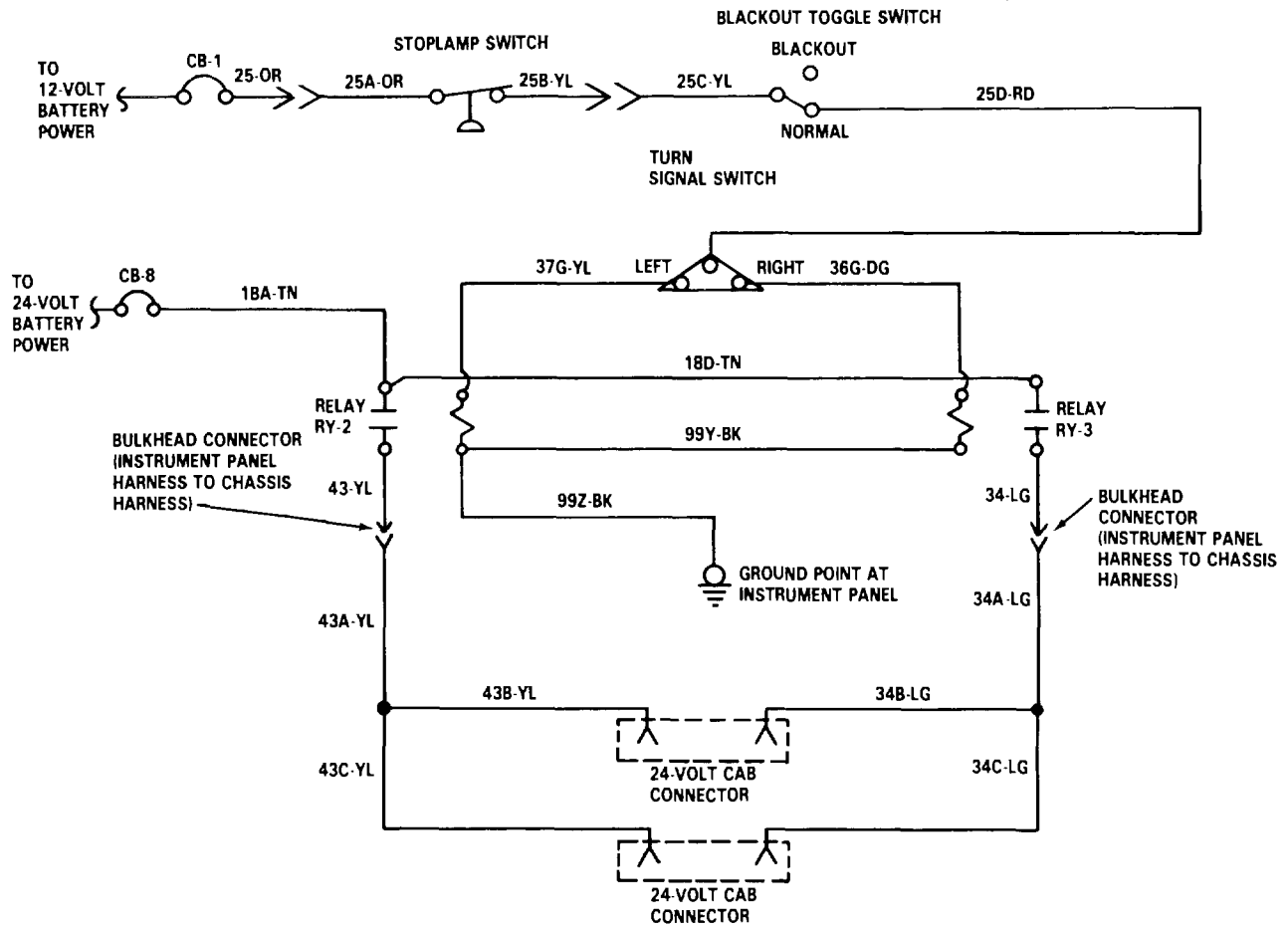

TA 236920

TROUBLESHOOTING.

2-11. TROUBLESHOOTING PROCEDURES (Continued).

MALFUNCTION	INSTRUCTION	INDICATION	YES	NO
76. ONE 24-VOLT TRAILER STOPLAMP NOT WORKING (Continued).				
12.	Remove relay RY-2 (para 3-112), and go to step 13.			
13.	Check for voltage at circuit 18A-TN terminal of relay RY-2.	24-volts dc nominal.	Go to step 14.	Repair circuit 18A-TN (para 3-127).
14.	Check for voltage at circuit 18D-TN terminal of relay RY-3.	24-volts dc nominal.	Go to step 15.	Repair circuit 18D-TN (para 3-127). Install relay RY-3 and relay connector (para 3-112 and 3-114).
15.	Install relay RY-3 (para 3-112), and go to step 16.			
16.	Move blackout toggle switch from NORMAL to BLACKOUT and back to NORMAL position.	Listen for clicking sound at RY-3.	Install relay RY-3, relay connector, and circuit breaker bracket (para 3-112 and 3-114), and go to step 17.	Replace relay RY-3. Install relay connector and circuit breaker bracket (para 3-112 and 3-114).
17.	Disconnect circuit 34-LG from 34A-LG, and go to step 18.			

TROUBLESHOOTING.

2-11. TROUBLESHOOTING PROCEDURES (Continued).

MALFUNCTION	INSTRUCTION	INDICATION	YES	NO
-------------	-------------	------------	-----	----

76. ONE 24-VOLT TRAILER STOPLAMP NOT WORKING (Continued).

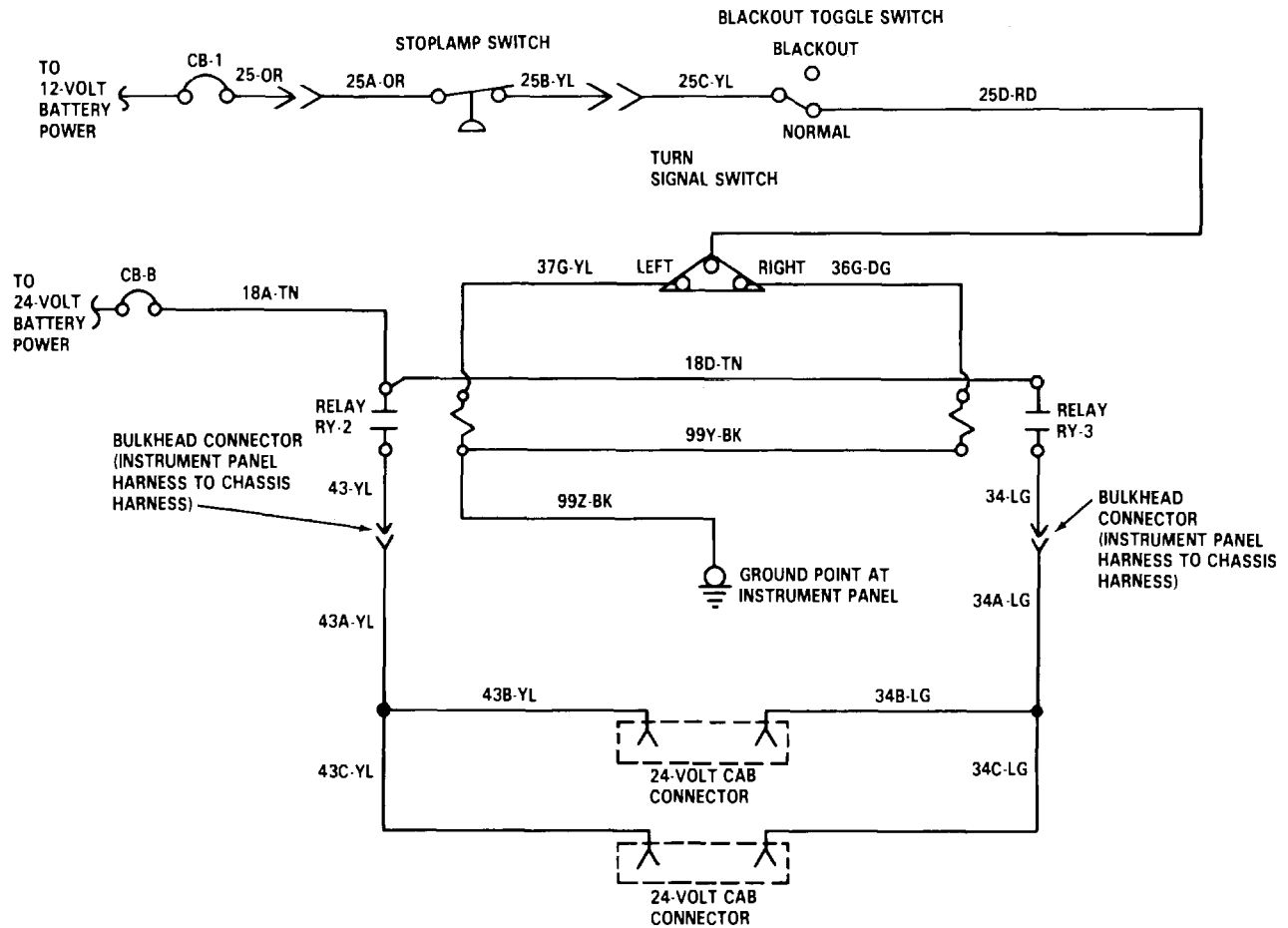

TA 236921

TROUBLESHOOTING.

2-11. TROUBLESHOOTING PROCEDURES (Continued).

MALFUNCTION	INSTRUCTION	INDICATION	YES	NO
76. ONE 24-VOLT TRAILER STOPLAMP NOT WORKING (Continued).				
18.	Check for voltage at circuit 34-LG terminal of connector.	24-volt dc nominal.	Connect circuit 34-LG to 34A-LG, and go to step 19.	Repair circuit 34-LG (para 3-127).
19.	Remove trailer 24-volt cab connector, and go to step 20.			
20.	Check for voltage at 34B-LG terminal of connector.	24-volts dc nominal.	Recheck trailer circuit.	Repair circuit 34B-LG and/or 34A-LG (para
21.	Remove trailer 24-volt chassis connector, and go to step 22.			
22.	Check for voltage at 34C-LG terminal of connector.	24-volts dc nominal.	Recheck trailer circuit.	Repair circuit 34C-LG and/or 34A-LG (para 3-127).

TROUBLESHOOTING.

2-11. TROUBLESHOOTING PROCEDURES (Continued).

MALFUNCTION	INSTRUCTION	INDICATION	YES	NO
-------------	-------------	------------	-----	----

76. ONE 24-VOLT TRAILER STOPLAMP NOT WORKING (Continued).

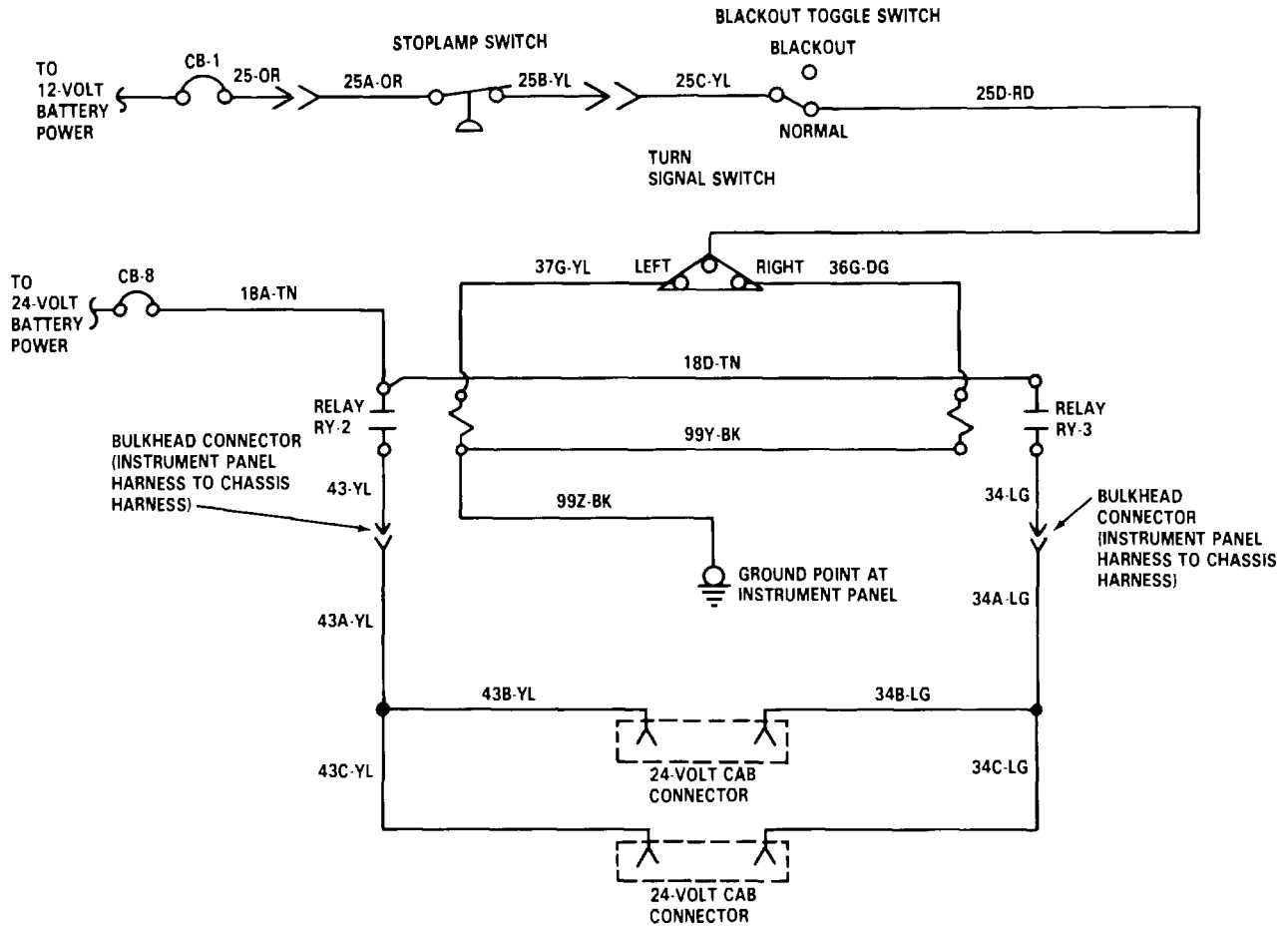

TA 236922

TROUBLESHOOTING.

2-11. TROUBLESHOOTING PROCEDURES (Continued).

MALFUNCTION	INSTRUCTION	INDICATION	YES	NO
-------------	-------------	------------	-----	----

77. BOTH 24-VOLT TRAILER TURN SIGNAL LAMPS NOT WORKING.

NOTE

- Blackout toggle switch must be set to NORMAL position and turn signal switch HAZARD control set to on position when doing the following checks.
- It is assumed here that chassis turn signal lamps are OK. Apply same troubleshooting technique for either cab or chassis connector.

1.	Disconnect turn signal switch connector, and go to step 2.			
2.	Connect jumper wire between circuit 35C-YL and yellow wire at turn signal connector, and go to step 3.			
3.	Check for voltage at circuit 37G-YL or 36G-DG of turn signal switch connector.	12-volts dc nominal.	Remove jumper wire, connect turn signal switch connector, and go to step 4.	Replace turn signal switch (para 3-80).
4.	Go to malfunction 75, step 4.			

TROUBLESHOOTING.

2-11. TROUBLESHOOTING PROCEDURES (Continued).

MALFUNCTION	INSTRUCTION	INDICATION	YES	NO
-------------	-------------	------------	-----	----

77. BOTH 24-VOLT TRAILER TURN SIGNAL LAMPS NOT WORKING (Continued).

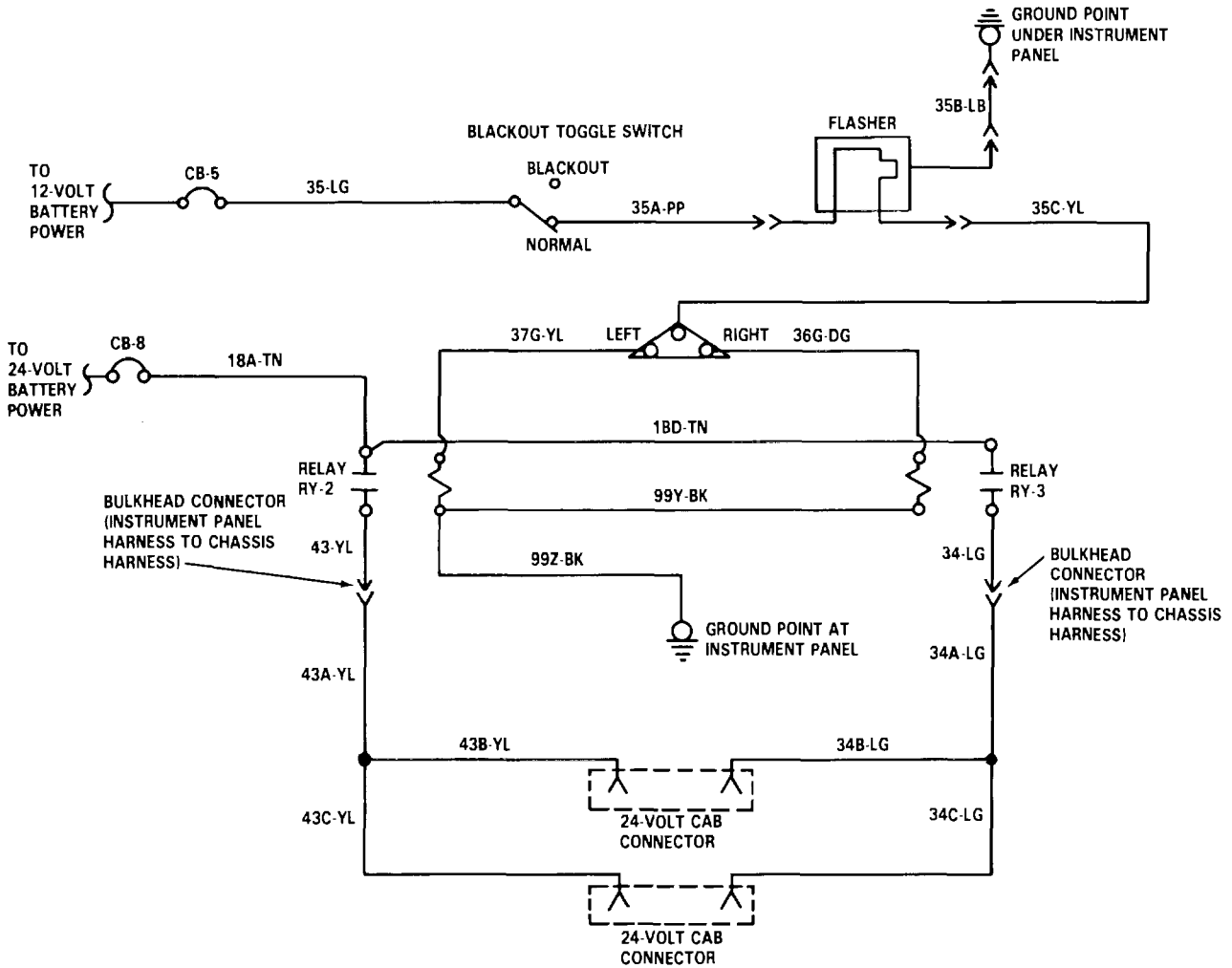

TA 236923

TROUBLESHOOTING.

2-11. TROUBLESHOOTING PROCEDURES (Continued).

MALFUNCTION	INSTRUCTION	INDICATION	YES	NO
-------------	-------------	------------	-----	----

78. ONE 24-VOLT TRAILER TURN SIGNAL LAMP NOT WORKING.

NOTE

- Blackout toggle switch must be set to NORMAL position and turn signal switch set for right turn when doing the following check.
- It is assumed here that chassis turn signal lamps are OK. Faulty right trailer turn signal lamp is shown in this procedure. Apply similar troubleshooting technique for left trailer turn signal switch lamp.

1.	Disconnect turn signal switch connector, and go to step 2.			
2.	Connect jumper wire between circuit 35C-YL and yellow wire at turn signal connector, and go to step 3.			
3.	Check for voltage at circuit 37G-YL or 36G-DG of turn signal switch connector.	12-volts dc nominal.	Remove jumper wire, connect turn signal switch connector, and go to step 4.	Replace turn signal switch (para 3-80).
4.	Go to malfunction 76, step 4.			

TROUBLESHOOTING.

2-11. TROUBLESHOOTING PROCEDURES (Continued).

MALFUNCTION	INSTRUCTION	INDICATION	YES	NO
-------------	-------------	------------	-----	----

78. ONE 24-VOLT TRAILER TURN SIGNAL LAMP NOT WORKING (Continued).

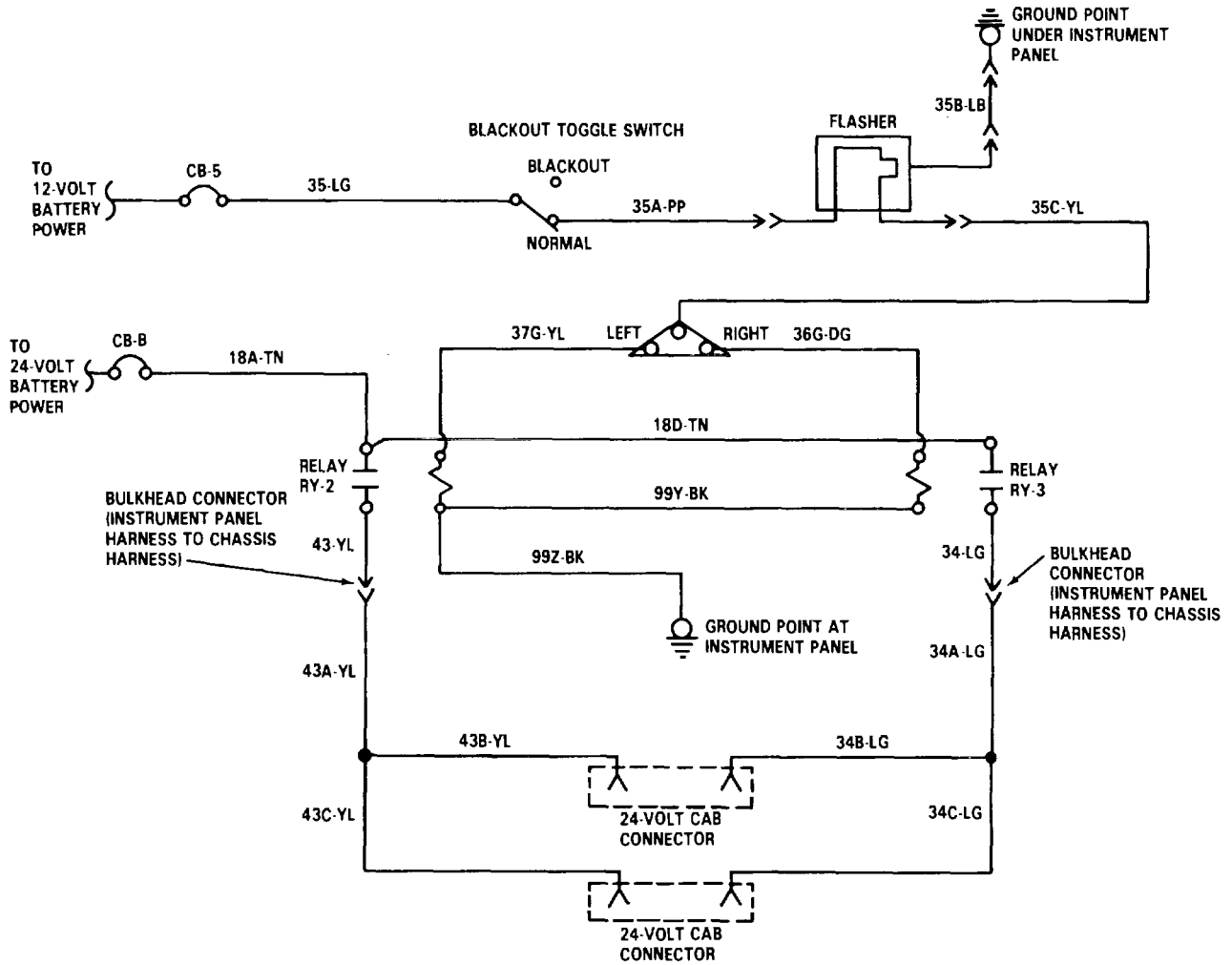

TA 236924

TROUBLESHOOTING.

2-11. TROUBLESHOOTING PROCEDURES (Continued).

MALFUNCTION	INSTRUCTION	INDICATION	YES	NO
-------------	-------------	------------	-----	----

79. BOTH 24-VOLT TRAILER TAILLAMPS NOT WORKING.

NOTE

- Headlamp switch must be in ON position and blackout toggle switch must be set to NORMAL position when doing the following check.
- It is assumed here that chassis tail lamps are OK.
- Do steps 1 thru 22 when troubleshooting 24-volt cab connector.
- Do steps 1 thru 20 and steps 23 and 24 when troubleshooting 24-volt chassis connector.

1.	Check for voltage at circuit 30N-BR terminal of clearance lamp switch.	12-volts dc nominal.	Go to step 2.	Repair circuit 30N-BR (para 3-127).
2.	Remove circuit breaker bracket far enough to access relay RY-6 and relay connector (para 3-114), and go to step 3.			
3.	Remove RY-6 (para 3-112), and go to step 4.			
4.	Check for voltage at circuit 30P-BR terminal of relay RY-6.	12-volts dc nominal.	Go to step 5.	Repair circuit 30P-BR (para 3-127). Install relay RY-6, relay connector, and circuit breaker bracket (para 3-112 and 3-114).

TROUBLESHOOTING.

2-11. TROUBLESHOOTING PROCEDURES (Continued).

MALFUNCTION	INSTRUCTION	INDICATION	YES	NO
-------------	-------------	------------	-----	----

79. BOTH 24-VOLT TRAILER TAILLAMPS NOT WORKING (Continued).

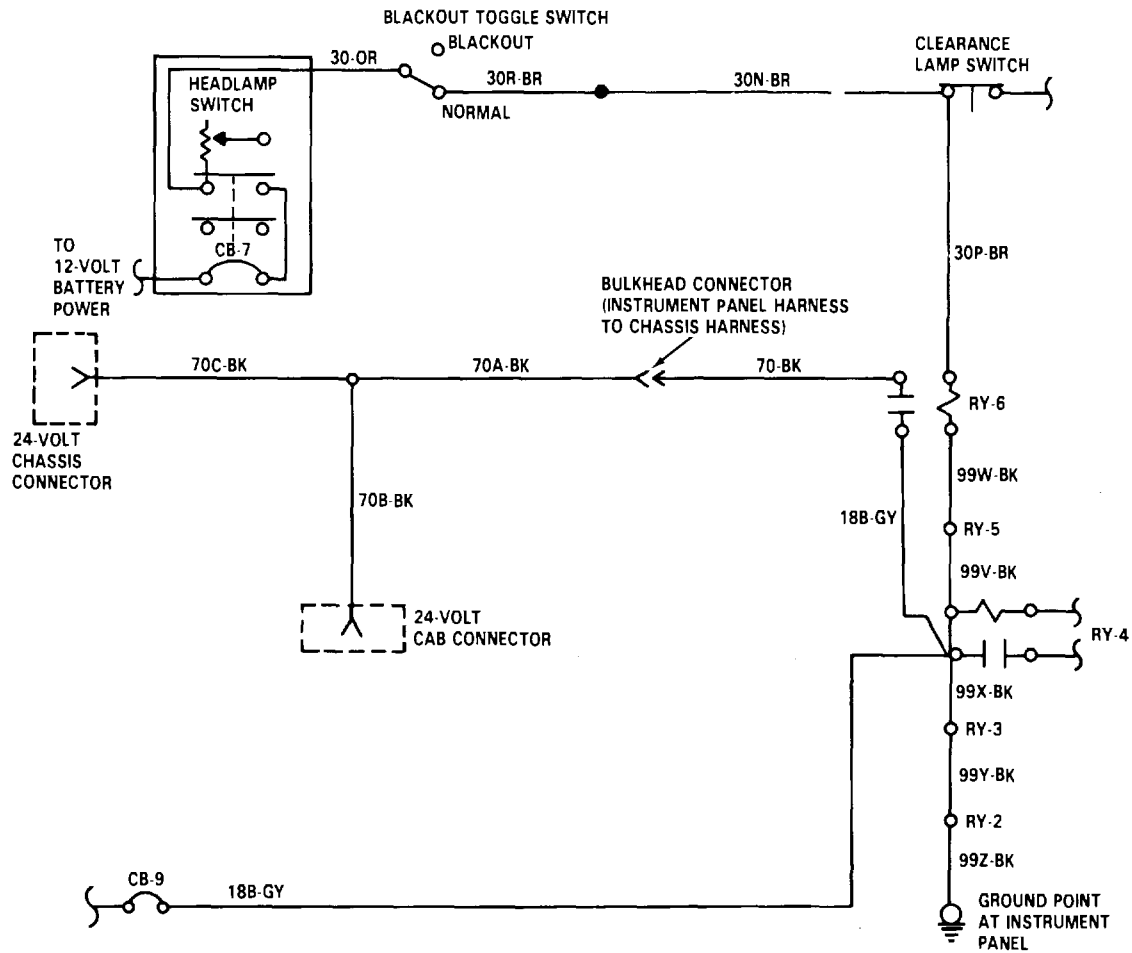

TA 236925

TROUBLESHOOTING.

2-11. TROUBLESHOOTING PROCEDURES (Continued).

MALFUNCTION	INSTRUCTION	INDICATION	YES	NO
-------------	-------------	------------	-----	----

79. BOTH 24-VOLT TRAILER TAILLAMPS NOT WORKING (Continued).

NOTE

With positive lead on circuit 30P-BR, check ground with negative lead for step 5 thru 13.

5.	Check for voltage at circuit 99Z-BK ground point.	12-volts dc nominal.	Go to step 6.	Clean and tighten ground connection. Install relay RY-6, relay connector, and circuit breaker bracket (para 3-112 and 3-114).
6.	Remove relay RY-2 (para 3-112), and go to step 7.			
7.	Check for voltage at circuit 99Z-BK terminal of relay RY-2.	12-volts dc nominal.	Install relay RY-2, and go to step 8.	Repair circuit 99Z-BK (para 3-127). Install relays RY-3 and RY-6, relay connector, and circuit breaker bracket (para 3-112 and 3-114).

TROUBLESHOOTING.

2-11. TROUBLESHOOTING PROCEDURES (Continued).

MALFUNCTION	INSTRUCTION	INDICATION	YES	NO
-------------	-------------	------------	-----	----

79. BOTH 24-VOLT TRAILER TAILLAMPS NOT WORKING (Continued).

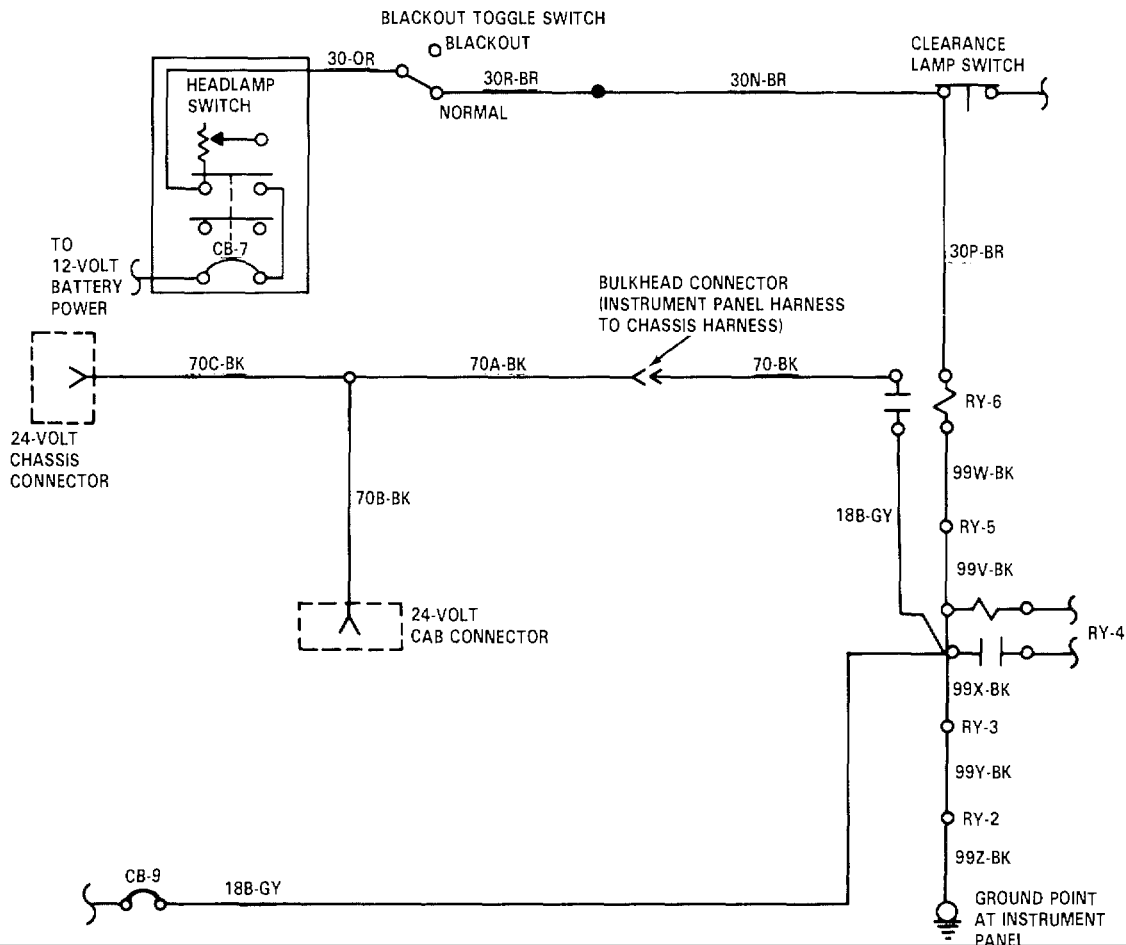

TROUBLESHOOTING.

2-11. TROUBLESHOOTING PROCEDURES (Continued).

MALFUNCTION	INSTRUCTION	INDICATION	YES	NO
79. BOTH 24-VOLT TRAILER TAILLAMPS NOT WORKING (Continued).				
8	Remove relay RY-3 (para 3-112), and go to step 9.			
9	Check for voltage at circuit 99Y-BK terminal of relay RY-3	12-volts dc nominal	Install relay RY-3 (para 3-112), and go to step 10	Repair circuit 99Y-BK (para 3-127) Install relays RY-6 RY-3, relay connector, and circuit breaker bracket (para 3-112 and 3-114).
and				
10	Remove relay RY-4 (para 3-112), and go to step 11.			
11	Check for voltage at circuit 99X-BK terminal of relay RY-4	12-volts dc nominal	Go to step 12	Repair circuit 99X-BK (para 3-127) Install RY-6, relay connector, and circuit breaker bracket (para 3-112 and 3-114).

TROUBLESHOOTING.

2-11. TROUBLESHOOTING PROCEDURES (Continued).

MALFUNCTION	INSTRUCTION	INDICATION	YES	NO
-------------	-------------	------------	-----	----

79. BOTH 24-VOLT TRAILER TAILLAMPS NOT WORKING (Continued).

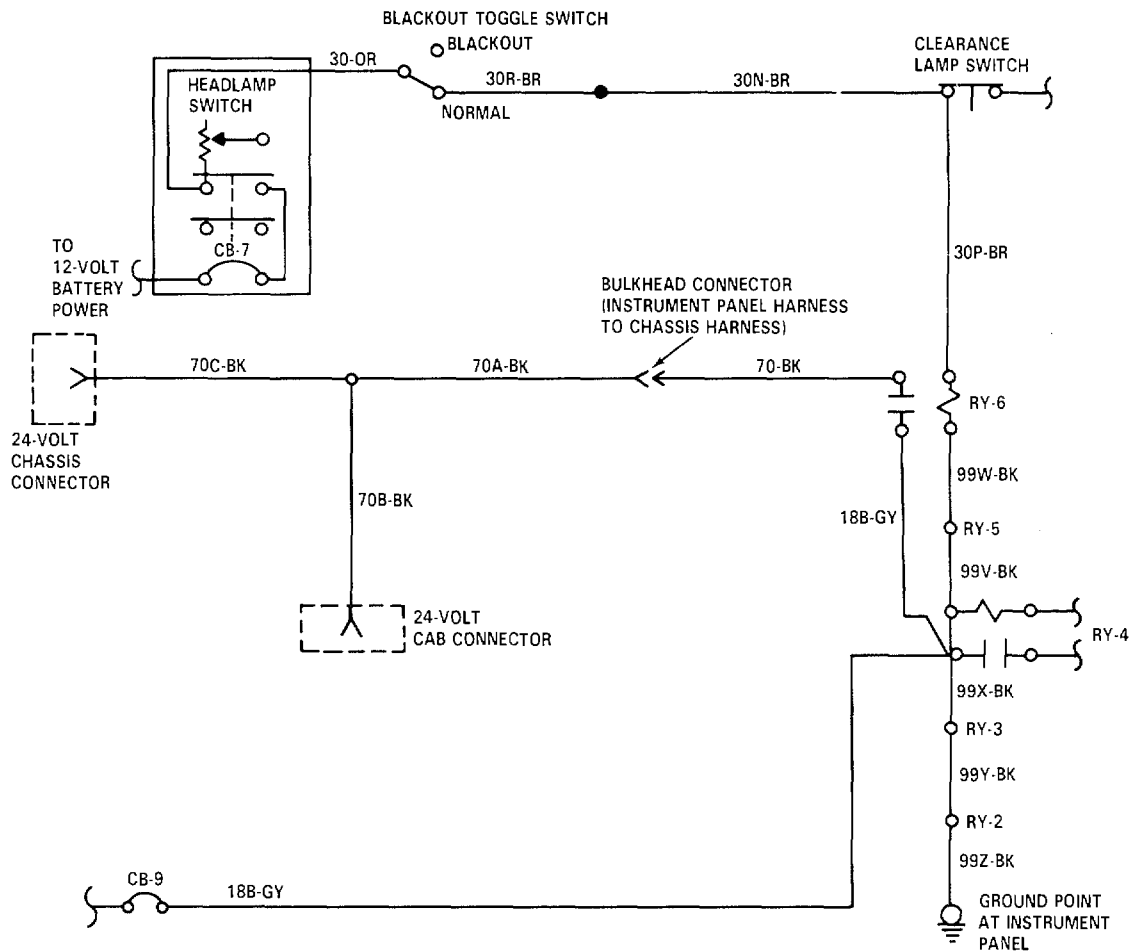

TROUBLESHOOTING.

2-11. TROUBLESHOOTING PROCEDURES (Continued).

MALFUNCTION	INSTRUCTION	INDICATION	YES	NO
79. BOTH 24-VOLT TRAILER TAILLAMPS NOT WORKING (Continued).				
12	Remove relay RY-5 (para 3-112), and go to step 13.			
13	Check for voltage at circuit 99W-BK terminal of relay RY-5	12-volts dc nominal	Install relay RY-5 (para 3-112), and go to step 14	Repair circuit 99W-BK (para 3-127) Install relay RY-6 and RY-5, relay connector, and circuit breaker bracket (para 3-112 and 3-114).
14	Check for voltage at circuit 18B-GY terminal of circuit breaker CB-9	24-volts dc nominal	Go to step 15	Reset circuit breaker CB-9 and/or troubleshoot CB-9 circuit (Refer to malfunction 35).
15	Check for voltage at circuit 18B-GY terminal of relay RY-4	24-volts dc nominal	Install relay RY-4 (para 3-112), and go to step 16.	Repair circuit 18B-GY (para 3-127).
16	Check for voltage at circuit 18C-GY terminal of relay RY-6	24-volts dc nominal	Go to step 17	Repair circuit 18C-GY (para 3-127).

TROUBLESHOOTING.

2-11. TROUBLESHOOTING PROCEDURES (Continued).

MALFUNCTION	INSTRUCTION	INDICATION	YES	NO
-------------	-------------	------------	-----	----

79. BOTH 24-VOLT TRAILER TAILLAMPS NOT WORKING (Continued).

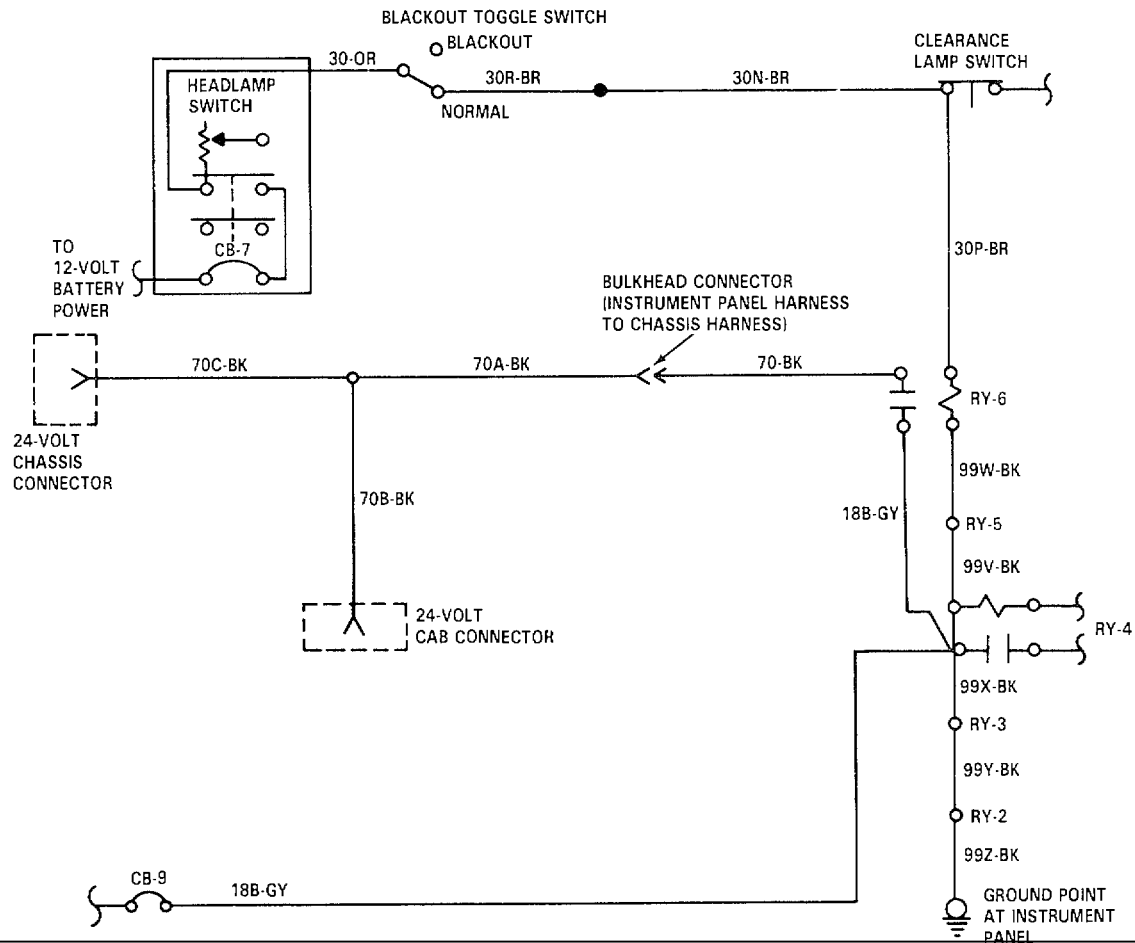

TROUBLESHOOTING.

2-11. TROUBLESHOOTING PROCEDURES (Continued).

MALFUNCTION	INSTRUCTION	INDICATION	YES	NO
79. BOTH 24-VOLT TRAILER TAILLAMPS NOT WORKING (Continued).				
17	Install relay RY-6, and go to step 18.			
18	Set blackout toggle switch from NORMAL to BLACKOUT then back to NORMAL position	Listen for relay RY-6	Install relay clicking sound at circuit breaker bracket (para 3-112 and 114), and go to step 19	Replace relay RY-6, relay connector, and connector and circuit breaker bracket (para 3-112 and 3-114).
19	Disconnect circuit 70A-BK from 70-BK at connector, and go to step 20.			
20	Check for voltage at circuit 70-BK (pin K of connector)	24-volts dc nominal	Connect circuit 70A-BK to 70-BK, and go to step 21 or 22.	Repair circuit 70-BK (para 3-127).
21	Disconnect 24-volt cab connector, and go to step 22.			
22	Check for voltage at circuit 70B-BK (pin E of connector)	24-volts dc nominal	Recheck trailer taillamp circuit	Repair circuit 70A-BK and/or 70B-BK (para 3-127)
23	Disconnect 24-volt chassis connector, and go to step 24.			
24	Check for voltage at circuit 70C-BK (pin E of connector)	24-volts dc nominal	Recheck trailer taillamp circuit	Repair circuit 70A-BK and/or 70C-BK (para 3-127)

TROUBLESHOOTING.

2-11. TROUBLESHOOTING PROCEDURES (Continued).

MALFUNCTION	INSTRUCTION	INDICATION	YES	NO
-------------	-------------	------------	-----	----

79. BOTH 24-VOLT TRAILER TAILLAMPS NOT WORKING (Continued).

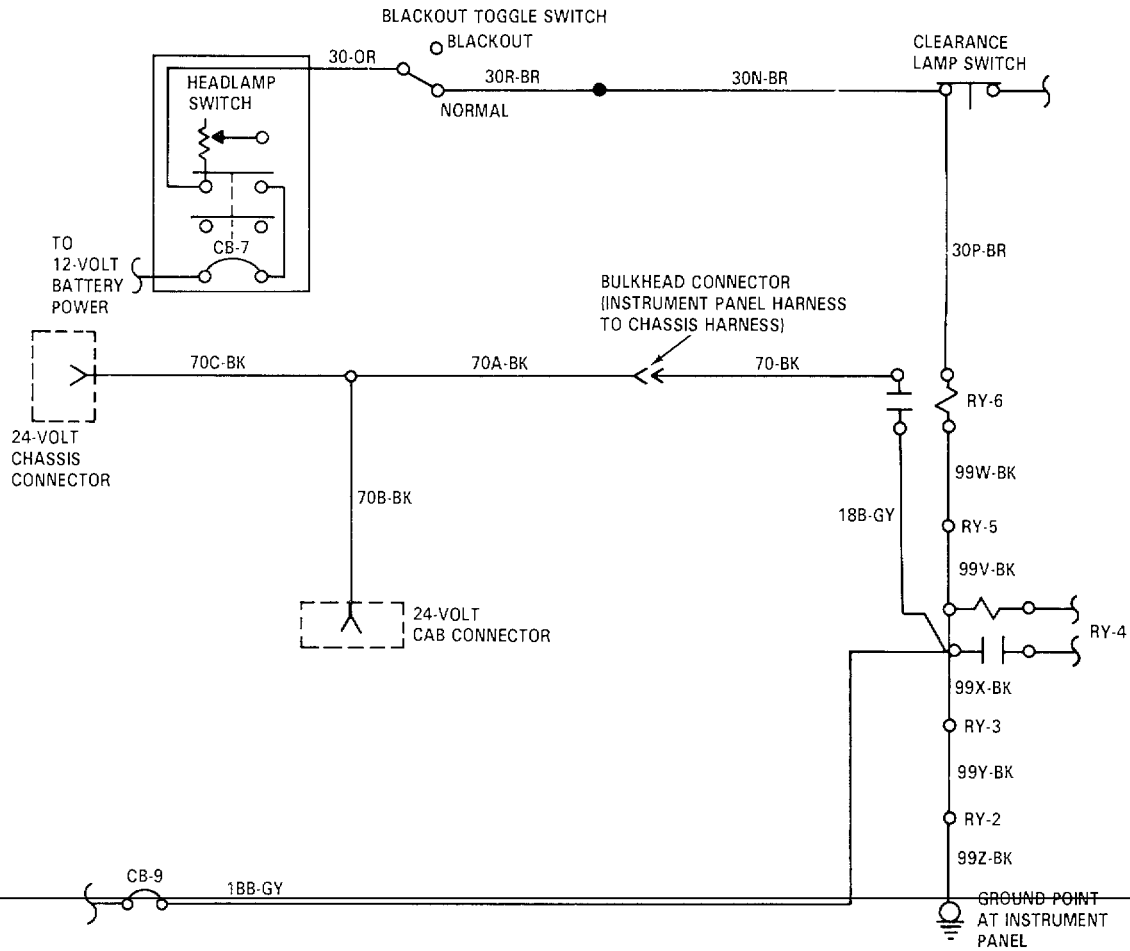

TROUBLESHOOTING.

2-11. TROUBLESHOOTING PROCEDURES (Continued).

MALFUNCTION	INSTRUCTION	INDICATION	YES	NO
-------------	-------------	------------	-----	----

80. BOTH 24-VOLT TRAILER BLACKOUT STOPLAMPS NOT WORKING.

NOTE

-Blackout toggle switch must be set to BLACKOUT position, air system pressurized to 105 psi, and brake pedal depressed by assistant when doing the following check.

-It is assumed here that chassis stop- lamp circuit is OK.

-Do steps 1 thru 17 when troubleshoot- ing 24-volt cab connector.

-Do steps 1 thru 15 and steps 18 and 19 when troubleshooting 24-volt chassis connector.

1	Check for voltage at 12-volts dc circuit 24D-PK terminal of blackout toggle switch	Go to step 2 nominal	Replace black-out toggle switch (para 3-79).
2	Remove circuit breaker bracket far enough to access relay RY-4 and relay connector (para 3-114), and go to step 3.		
3	Remove relay RY-4 (para 3-112), and go to step 4.		

TROUBLESHOOTING.

2-11. TROUBLESHOOTING PROCEDURES (Continued).

MALFUNCTION	INSTRUCTION	INDICATION	YES	NO
-------------	-------------	------------	-----	----

80. BOTH 24-VOLT TRAILER BLACKOUT STOPLAMPS NOT WORKING (Continued).

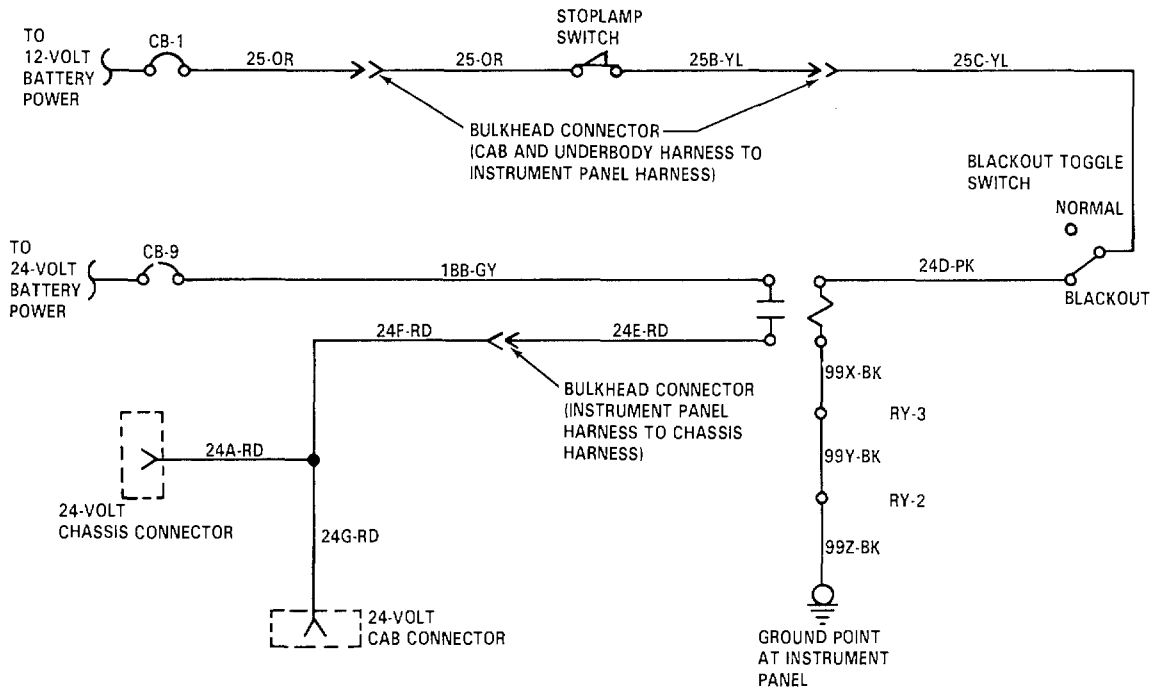

TROUBLESHOOTING.

2-11. TROUBLESHOOTING PROCEDURES (Continued).

MALFUNCTION	INSTRUCTION	INDICATION	YES	NO
-------------	-------------	------------	-----	----

80. BOTH 24-VOLT TRAILER BLACKOUT STOPLAMPS NOT WORKING (Continued).

(para 4	Check for voltage at 12-volts dc circuit 24D-PK terminal of relay connector		Go to step 5 nominal	Repair circuit 924D-PK 3-127) Install relay RY-4, relay connector, and circuit breaker bracket (para 3-112 and 3-114).
------------	---	--	----------------------	--

NOTE

With positive lead on circuit 24D-PK, check ground with negative lead for steps 5 thru 10.

ground 5	Check for voltage at 12-volts dc circuit 99Z-BK ground point		Go to step 6 nominal	Clean and tighten point connection Install relay RY-4, relay connector, and circuit breaker bracket (para 3-112 and 3-114).
-------------	--	--	----------------------	---

TROUBLESHOOTING.

2-11. TROUBLESHOOTING PROCEDURES (Continued).

MALFUNCTION	INSTRUCTION	INDICATION	YES	NO
-------------	-------------	------------	-----	----

80. BOTH 24-VOLT TRAILER BLACKOUT STOPLAMPS NOT WORKING (Continued).

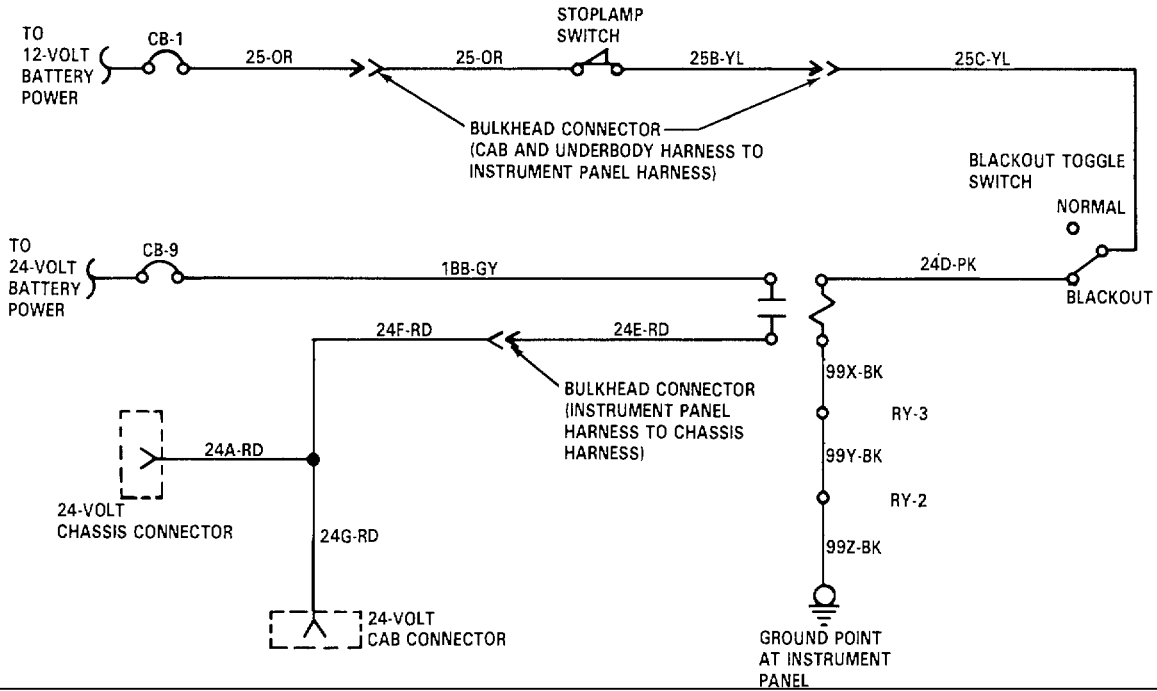

TROUBLESHOOTING.

2-11. TROUBLESHOOTING PROCEDURES (Continued).

MALFUNCTION	INSTRUCTION	INDICATION	YES	NO
-------------	-------------	------------	-----	----

80. BOTH 24-VOLT TRAILER BLACKOUT STOPLAMPS NOT WORKING (Continued).

6	Remove relay RY-2 (para 3-112), and go to step 7.			
7	Check for voltage at circuit 99Z-BK terminal of relay connector	12-volts dc nominal	Install relay RY-2 (para 3-112), and to step 8	Repair circuit 99Z-BK (para 3-127) Install relays RY-2
and				connector, and circuit breaker bracket (para 3-112 and 3-114).
8	Remove relay RY-3 (para 3-112), and go to step 9.			
9	Check for voltage at circuit 99Y-BK terminal of relay connector	12-volts dc nominal	Install relay RY-3 (para 3-112), and go to step 10	Repair circuit 99Y-BK (para 3-127) Install relays RY-3
and				RY-4, relay connector, and circuit breaker bracket (para 3-112 and 3-114).

TROUBLESHOOTING.

2-11. TROUBLESHOOTING PROCEDURES (Continued).

MALFUNCTION	INSTRUCTION	INDICATION	YES	NO
-------------	-------------	------------	-----	----

80. BOTH 24-VOLT TRAILER BLACKOUT STOPLAMPS NOT WORKING (Continued).

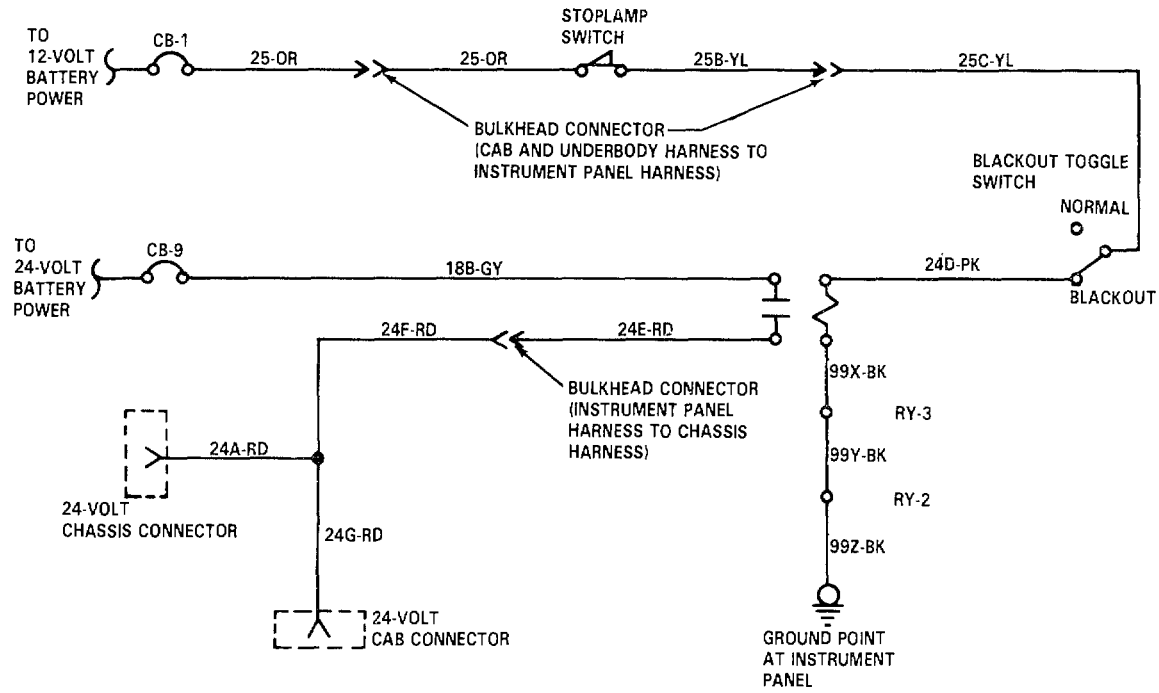

TROUBLESHOOTING.

2-11. TROUBLESHOOTING PROCEDURES (Continued).				
MALFUNCTION	INSTRUCTION	INDICATION	YES	NO
80. BOTH 24-VOLT TRAILER BLACKOUT STOPLAMPS NOT WORKING (Continued).				
10	Check for voltage at circuit 99X-BK terminal of relay connector	12-volts dc nominal	Go to step 11	Repair circuit 99X-BK (para 3-127) Install relay RY-4, relay connector, and circuit breaker bracket (para 3-112 and 3-114).
11	Check for voltage at circuit 18B-GY terminal of circuit breaker CB-g	24-volts dc nominal	Go to step 12	Reset circuit breaker CB-9 and/or troubleshoot (Refer shoot CB-9 to malfunction 35).
12	Check for voltage at circuit 18B-GY terminal of relay RY-4	24-volts dc nominal step 13	Install relay RY-4, and go to 3-127)	Repair circuit 18B-GY (para Install relay connector, and circuit breaker bracket (para 3-112 and 3-114).

TROUBLESHOOTING.

2-11. TROUBLESHOOTING PROCEDURES (Continued).

MALFUNCTION	INSTRUCTION	INDICATION	YES	NO
-------------	-------------	------------	-----	----

80. BOTH 24-VOLT TRAILER BLACKOUT STOPLAMPS NOT WORKING (Continued).

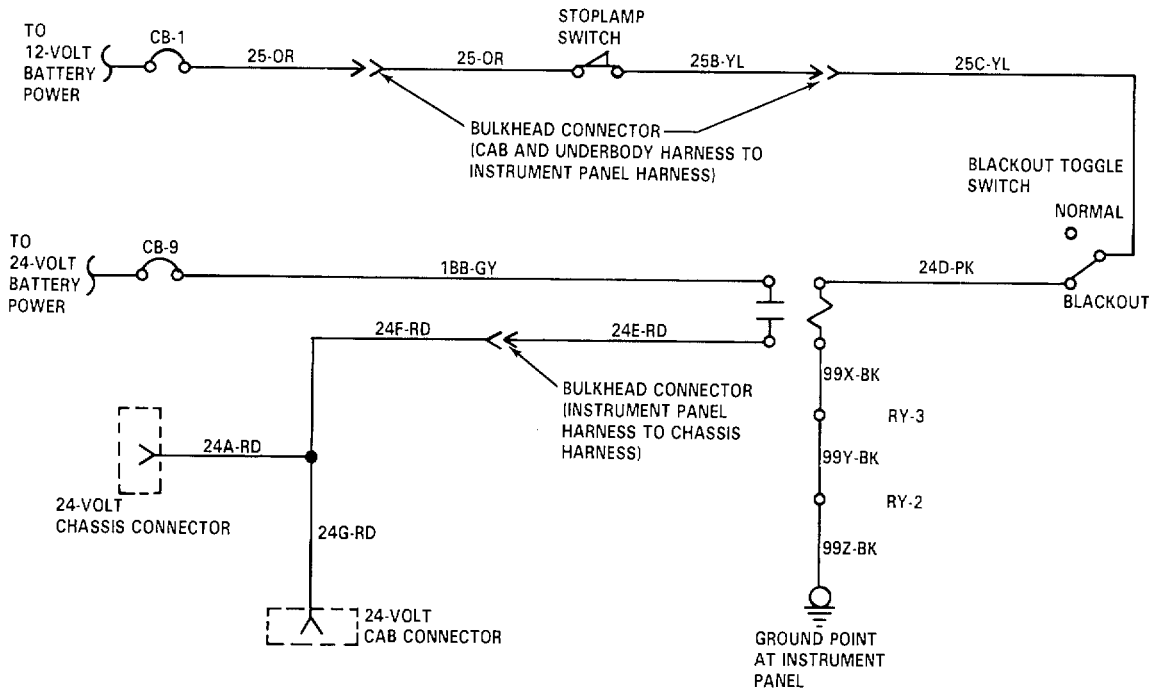

TROUBLESHOOTING.

2-11. TROUBLESHOOTING PROCEDURES (Continued).

MALFUNCTION	INSTRUCTION	INDICATION	YES	NO
80. BOTH 24-VOLT TRAILER BLACKOUT STOPLAMPS NOT WORKING (Continued).				
13	Move blackout toggle		Listen for	Install relay
	Replace relay			
	RY-4	switch from BLACKOUT	clicking	connector and
	Install	to NORMAL and back to	sounds at	circuit breaker
	relay connector	BLACKOUT position relay RY-4	bracket (para	and circuit
			3-112 and	breaker
			3-114), and go	(para 3-112
			to step 14	3-114).
14	Disconnect circuit			
	24F-RD from 24E-RD at			
	connector, and go to			
	step 15.			
15	Check for voltage at 24-volts dc		Connect circuit	Repair circuit
	circuit 24E-RD (pin H		nominal	24F-RD to
	24E-RD (para		24E-RD, and	3-127).
	of connector)		go to step 16.	
16	Disconnect 24-volt cab			
	connector, and go to			
	step 17.			
17	Check for voltage at 24-volts dc		Recheck 24-volt	Repair circuit
	circuit 24G-RD (pin F		nominal	trailer black-
	24G-RD and/or		out stoplamp	24F-RD (para
	of connector)		circuit	3-127).
18	Disconnect 24-volt			
	chassis connector,			
	and go to step 19.			

TROUBLESHOOTING.

2-11. TROUBLESHOOTING PROCEDURES (Continued).

MALFUNCTION	INSTRUCTION	INDICATION	YES	NO
80. BOTH 24-VOLT TRAILER BLACKOUT STOPLAMPS NOT WORKING (Continued).				
19	Check for voltage at 24-volt dc circuit 24H-RD (pin F nominal of connector)		Recheck 24-volt trailer black-out stoplamp circuit	Repair circuit 24H-RD and/or 24F-RD (para 3-127).

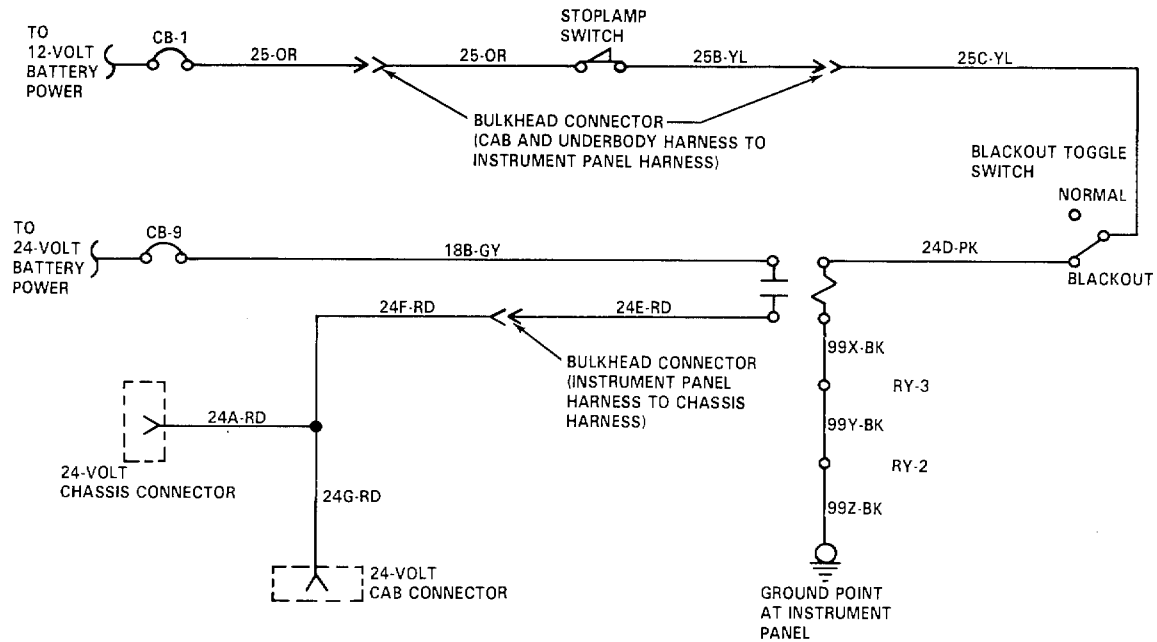

TROUBLESHOOTING.

2-11. TROUBLESHOOTING PROCEDURES (Continued).

MALFUNCTION	INSTRUCTION	INDICATION	YES	NO
-------------	-------------	------------	-----	----

81. 24-VOLT TRAILER BLACKOUT TAILLAMPS NOT WORKING.

NOTE

.Headlamp switch must be in ON position and blackout toggle switch set to BLACKOUT position when doing the following checks.

-It is assumed here that chassis tail-lamp circuit is OK.

-Do steps 1 thru 23 when troubleshooting 24-volt cab connector.

-Do steps 1 thru 21 and steps 24 and 25 when troubleshooting 24-volt chassis connector.

1	Check for voltage at 12-volts dc circuit 23Z-TN blackout toggle switch	Go to step 2 nominal	Replace blackout toggle switch (para 3-79)
---	--	----------------------	--

2	Remove circuit breaker bracket far enough to access relay RY-5 and relay connector (para 3-114), and go to step 3.
---	--

3	Remove relay RY-5 (para 3-112), and go to step 4.
---	---

TROUBLESHOOTING.

2-11. TROUBLESHOOTING PROCEDURES (Continued).

MALFUNCTION	INSTRUCTION	INDICATION	YES	NO
-------------	-------------	------------	-----	----

81. 24-VOLT TRAILER BLACKOUT TAILLAMPS NOT WORKING (Continued).

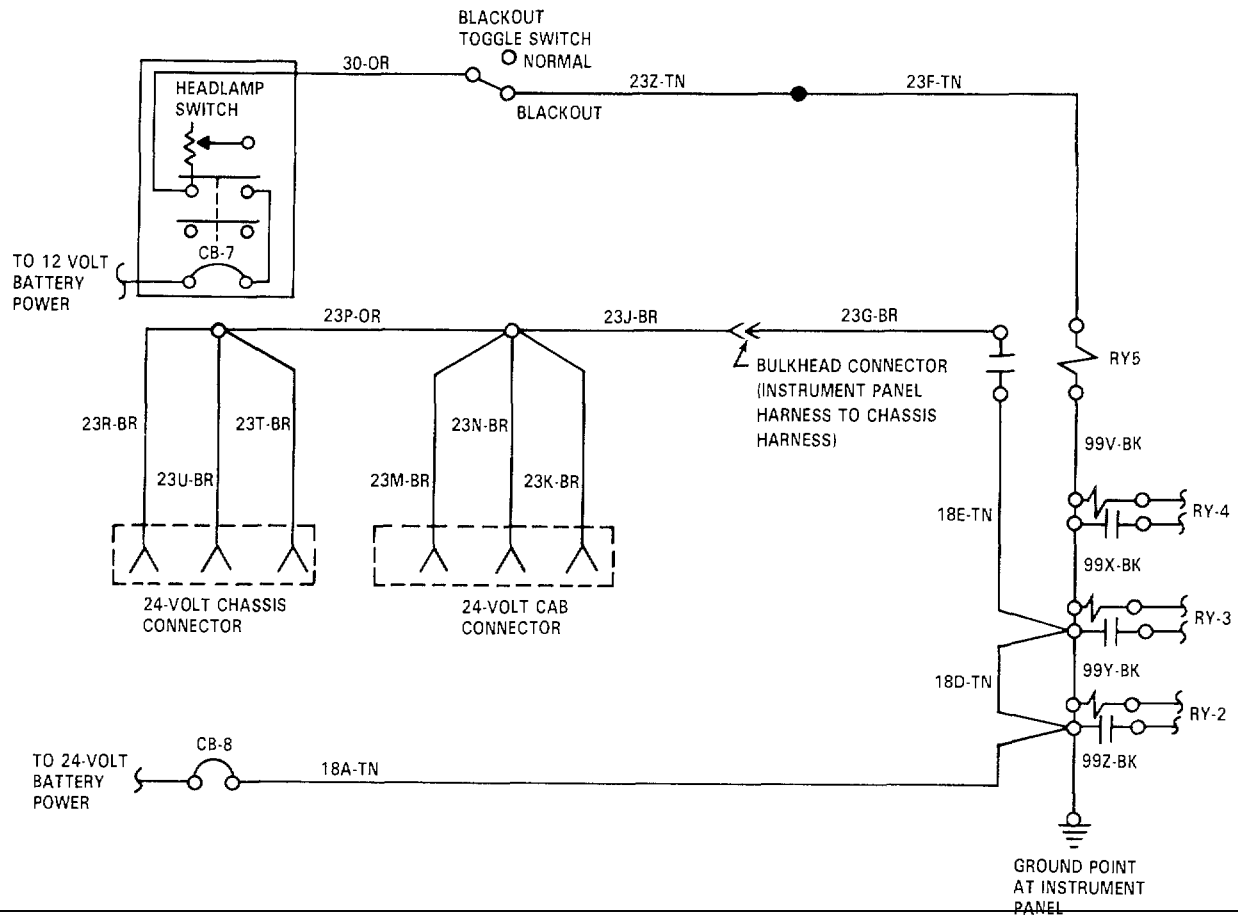

TROUBLESHOOTING.

2-11. TROUBLESHOOTING PROCEDURES (Continued).

MALFUNCTION	INSTRUCTION	INDICATION	YES	NO
81. 24-VOLT TRAILER BLACKOUT TAILLAMPS NOT WORKING (Continued).				
4 and/or	Check for voltage at 12-volts dc circuit 23F-TN terminal of relay RY-5		Go to step 5 nominal	Repair circuit 23F-TN 23Z-TN (para relay RY-5, relay connector, and circuit breaker bracket (para 3-112 and 3-114).
NOTE				
With positive lead on circuit 23F-TN, check ground with negative lead for steps 5 thru 12.				
5 ground	Check for voltage at 12-volts dc circuit 99Z-BK ground point		Go to step 6 nominal	Clean and tighten connection. Install relay RY-5, relay connector, and circuit breaker bracket (para 3-112 and 3-114).

TROUBLESHOOTING.

2-11. TROUBLESHOOTING PROCEDURES (Continued).

MALFUNCTION	INSTRUCTION	INDICATION	YES	NO
-------------	-------------	------------	-----	----

81. 24-VOLT TRAILER BLACKOUT TAILLAMPS NOT WORKING (Continued).

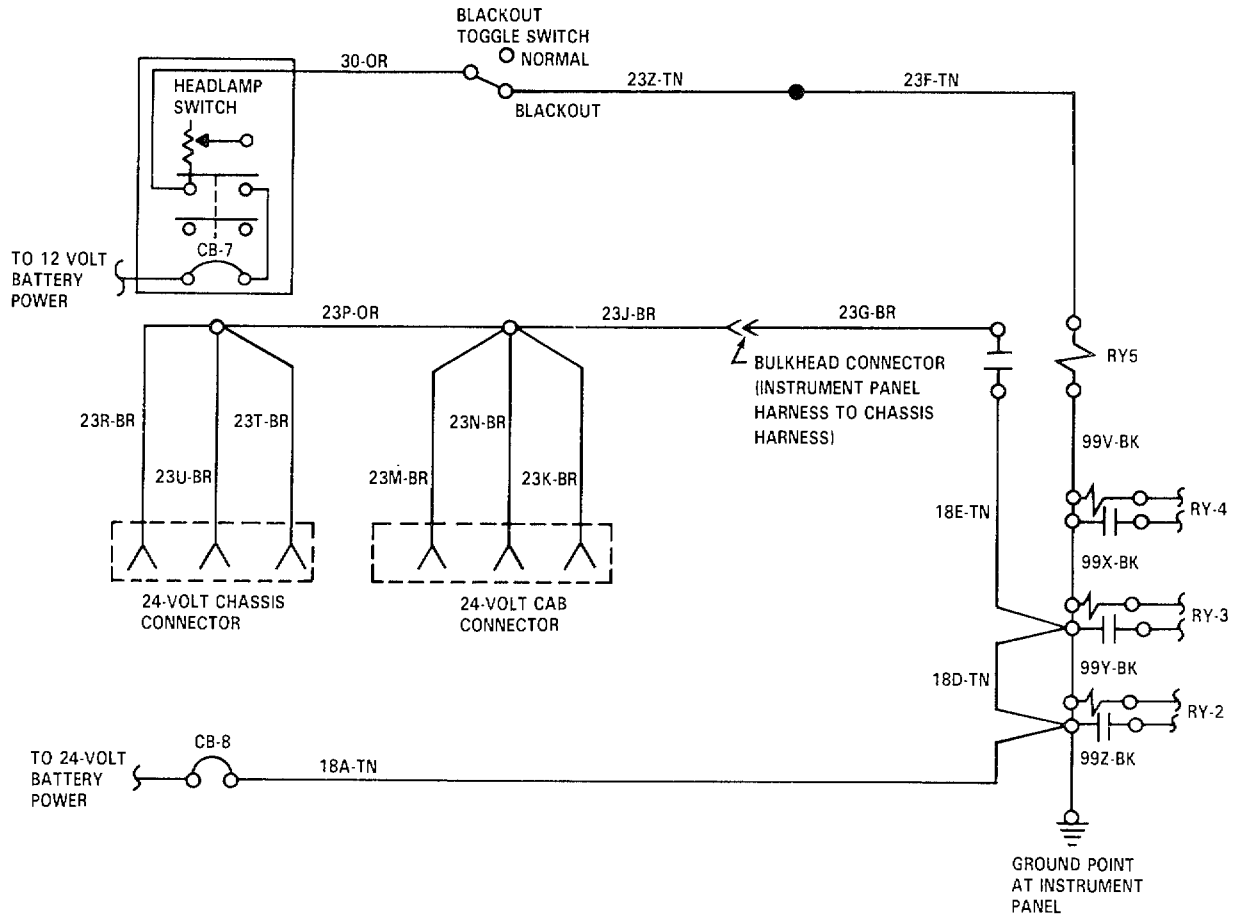

TROUBLESHOOTING.

2-11. TROUBLESHOOTING PROCEDURES (Continued).

MALFUNCTION	INSTRUCTION	INDICATION	YES	NO
-------------	-------------	------------	-----	----

81. 24-VOLT TRAILER BLACKOUT TAILLAMPS NOT WORKING (Continued).

6	Remove relay RY-2 (para 3-112), and go to step 7.			
7	Check for voltage at 12-volts dc circuit 99Z-BK terminal of relay connector		Install relay nominal 3-112), and go to step 8	Repair circuit RY-2 (para 3-127) Install relays RY-2
8	Remove relay RY-3 (para 3-112), and go to step 9.			RY-5, relay connector, and circuit breaker bracket (para 3-112 and 3-114).
9	Check for voltage at 12-volts dc circuit 99Y-BK terminal of relay connector		Install relay nominal 3-112), and go to step 10	Repair circuit RY-3 (para 3-127) Install relays RY-3
and				RY-5, relay connector, and circuit breaker bracket (para 3-112 and 3-114).

TROUBLESHOOTING.

2-11. TROUBLESHOOTING PROCEDURES (Continued).

MALFUNCTION	INSTRUCTION	INDICATION	YES	NO
-------------	-------------	------------	-----	----

81. 24-VOLT TRAILER BLACKOUT TAILLAMPS NOT WORKING (Continued).

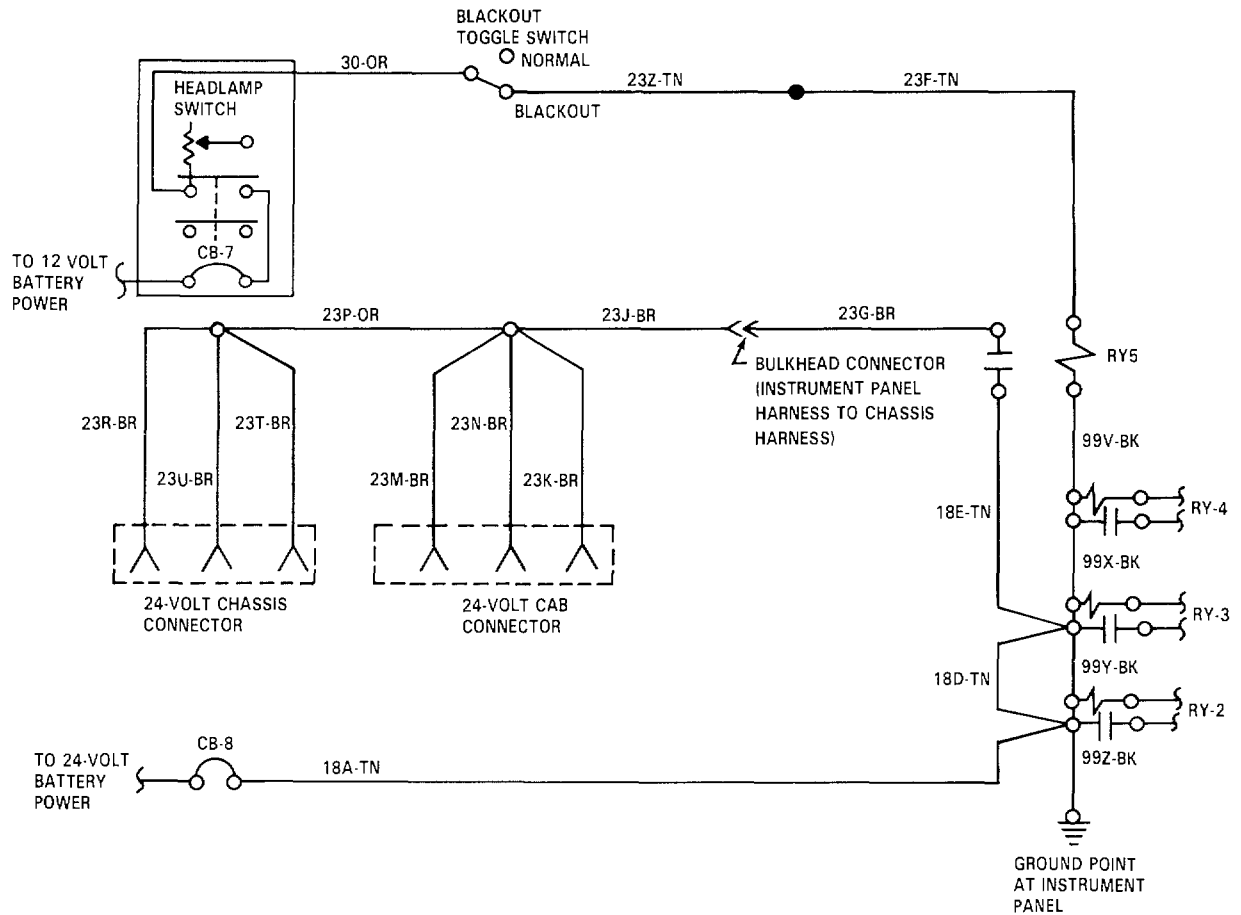

TROUBLESHOOTING.

2-11. TROUBLESHOOTING PROCEDURES (Continued).

MALFUNCTION	INSTRUCTION	INDICATION	YES	NO
81. 24-VOLT TRAILER BLACKOUT TAILLAMPS NOT WORKING (Continued).				
10	Remove relay RY-4 (para 3-112), and go to step 11.			
11	Check for voltage at circuit 99X-BK of relay connector	12-volts dc nominal	Install relay RY-4 (para 3-112), and go to step 12	Repair circuit 99X-BK (para 3-127) Install relays RY-4
and				
12	Check for voltage at circuit 99V-BK terminal of relay connector	12-volts dc nominal	Go to step 13	RY-5, relay connector, and circuit breaker bracket (para 3-112 and 3-114). Repair circuit 99V-BK (para 3-127) Install relay RY-5, relay connector, and circuit breaker bracket (para 3-112 and 3-114).
13	Check for voltage at circuit 18A-TN of circuit breaker CB-8	24-volts dc nominal	Go to step 14	Reset circuit breaker CB-8 and/or troubleshoot CB-2 circuit (Refer to malfunction 35).

TROUBLESHOOTING.

2-11. TROUBLESHOOTING PROCEDURES (Continued).

MALFUNCTION	INSTRUCTION	INDICATION	YES	NO
-------------	-------------	------------	-----	----

81. 24-VOLT TRAILER BLACKOUT TAILLAMPS NOT WORKING (Continued).

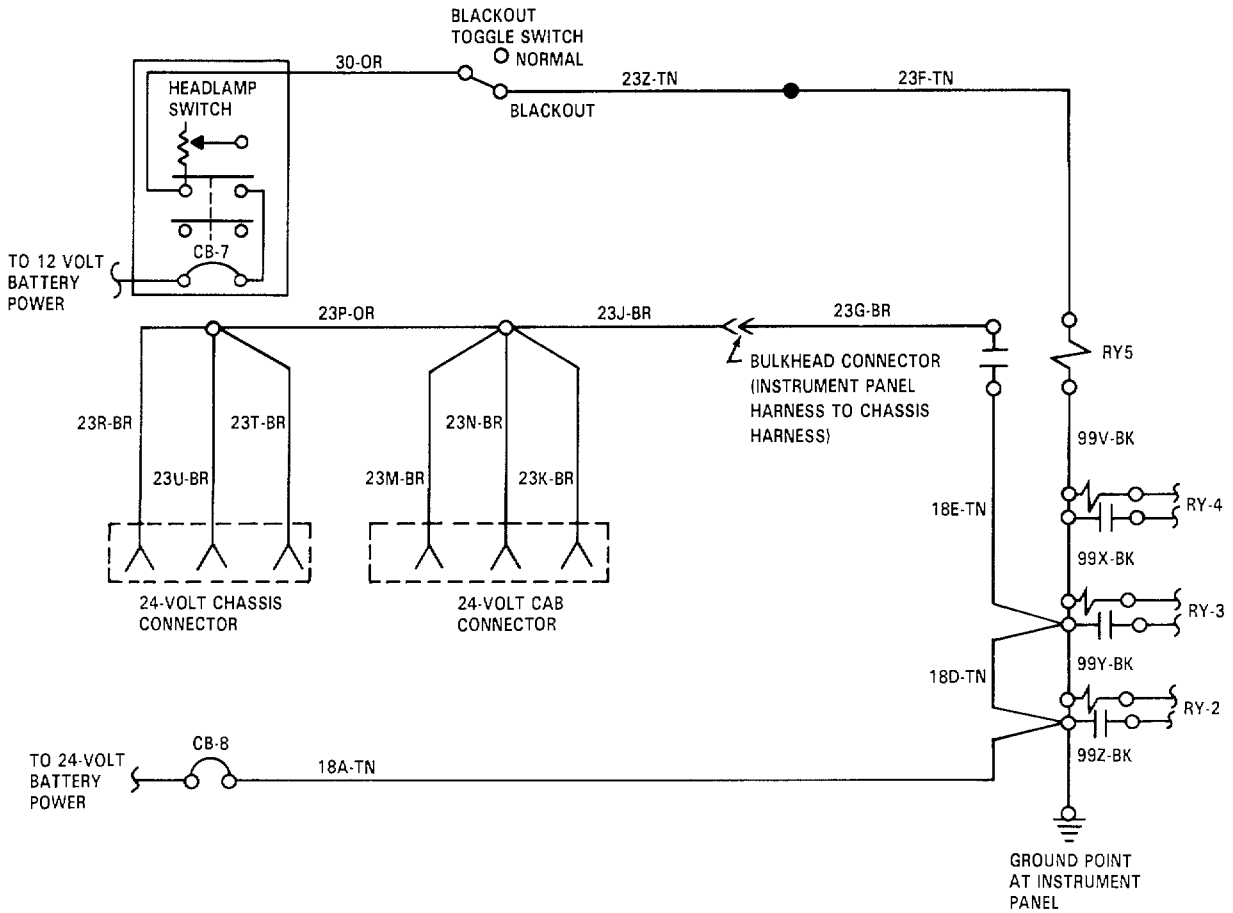

TROUBLESHOOTING.

2-11. TROUBLESHOOTING PROCEDURES (Continued).

MALFUNCTION	INSTRUCTION	INDICATION	YES	NO
-------------	-------------	------------	-----	----

81. 24-VOLT TRAILER BLACKOUT TAILLAMPS NOT WORKING (Continued).

14	Remove relay RY-2 (para 3-112), and go to step 15.			
15	Check for voltage at circuit 18A-TN terminal of relay connector	24-volts dc nominal	Install relay RY-2 (para 3-112), and go to step 16	Repair circuit 18A-TN (para 3-127) Install relays RY-2
16	Remove relay RY-3 (para 3-112), and go to step 17.			connector, and circuit breaker bracket (para 3-112 and 3-114).
17	Check for voltage at circuit 18D-TN terminal of relay connector	24-volts dc nominal	Install relay RY-3 (para 3-112), and go to step 18	Repair circuit 18D-TN (para 3-127) Install relays RY-3

and

and

connector, and circuit breaker bracket (para 3-112 and 3-114).

TROUBLESHOOTING.

2-11. TROUBLESHOOTING PROCEDURES (Continued).

MALFUNCTION	INSTRUCTION	INDICATION	YES	NO
-------------	-------------	------------	-----	----

81. 24-VOLT TRAILER BLACKOUT TAILLAMPS NOT WORKING (Continued).

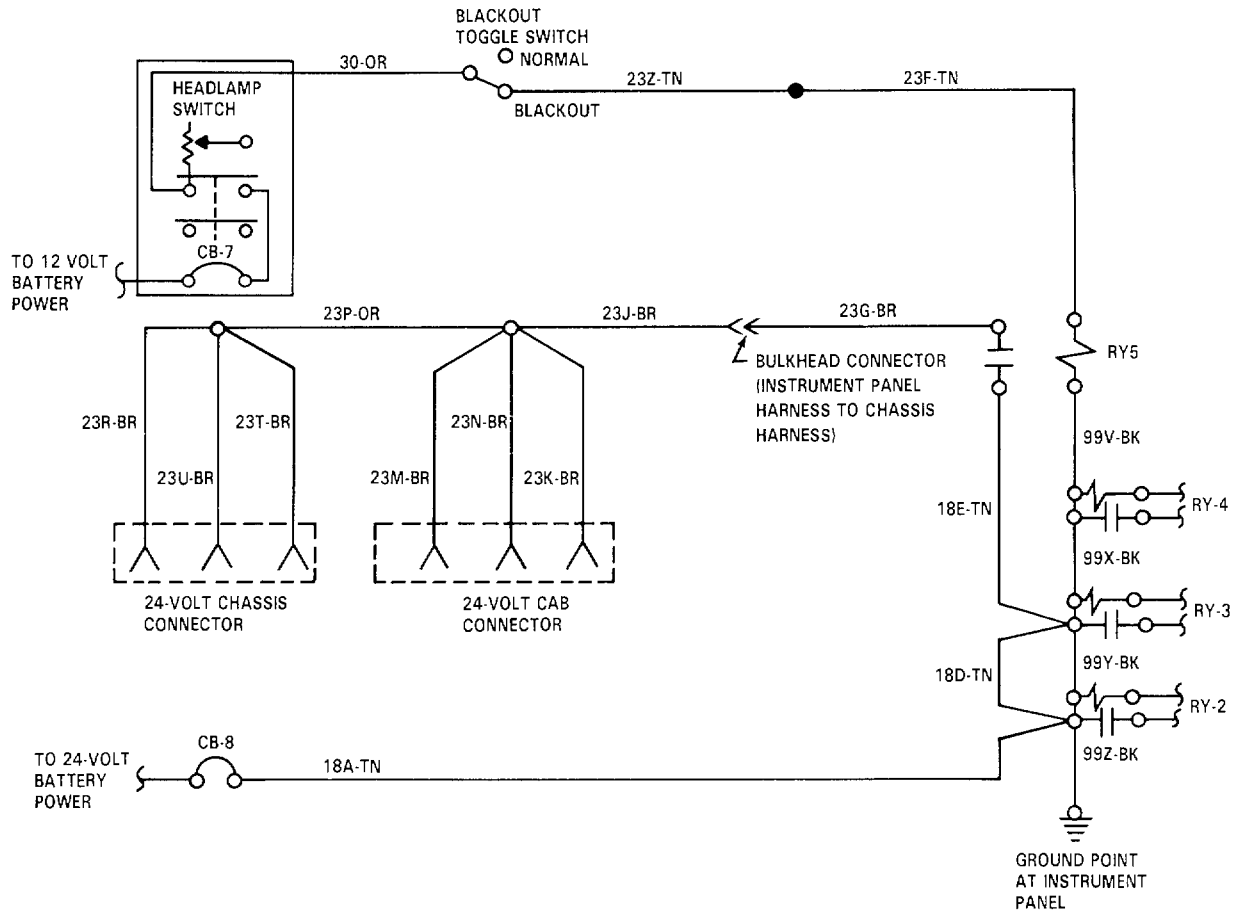

TROUBLESHOOTING.

2-11. TROUBLESHOOTING PROCEDURES (Continued).				
MALFUNCTION	INSTRUCTION	INDICATION	YES	NO
81. 24-VGLT TRAILER BLACKOUT TAILLAMPS NOT WORKING (Continued).				
18	Check for voltage at circuit 18E-TN of circuit breaker CB-8	24-volts dc nominal	Install RY-5 (para 3-112), and go to step 19	Repair circuit 18E-TN (para 3-127) Install RY-5, relay connector, and circuit breaker bracket (para 3-112 and 3-114).
19	Move blackout toggle switch from BLACKOUT to NORMAL and back to BLACKOUT position	relay RY-5	Listen for clicking sounds at bracket (para 3-112 and 3-114), and go to step 20	Install relay connector and circuit breaker (para 3-112 and 3-114).
19	Replace relay RY-5 relay connector	Install relay RY-5		
20	Disconnect circuit 23G-BR from 23J-BR at connector, and go to step 21.			
21	Check for voltage at circuit 23G-BR (pin J of connector)	24-volts dc nominal	Connect circuit 23G-BR to 23J-BR, and go to step 22.	Repair circuit 23G-BR (para 3-127).

TROUBLESHOOTING.

2-11. TROUBLESHOOTING PROCEDURES (Continued).

MALFUNCTION	INSTRUCTION	INDICATION	YES	NO
-------------	-------------	------------	-----	----

81. 24-VOLT TRAILER BLACKOUT TAILLAMPS NOT WORKING (Continued).

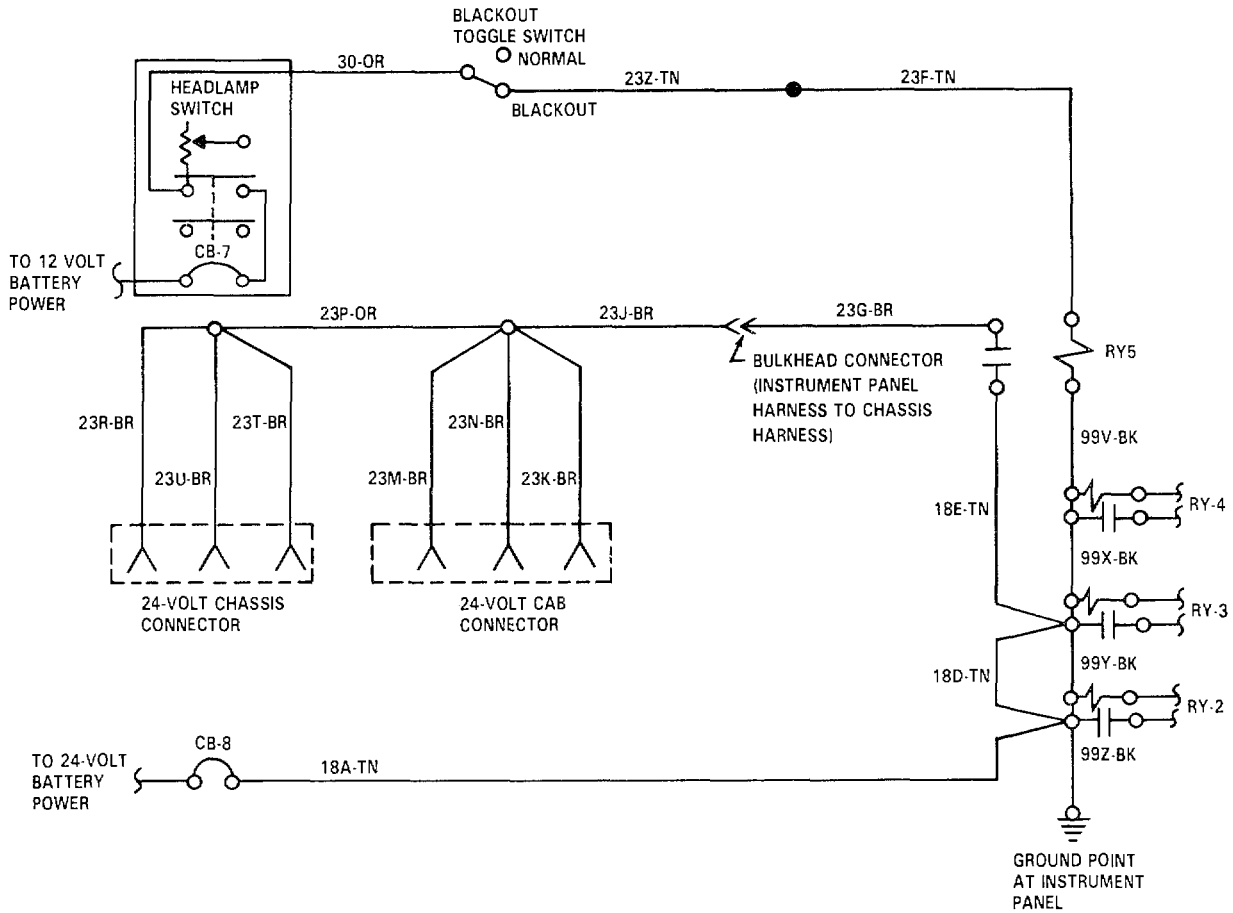

TROUBLESHOOTING.

2-11. TROUBLESHOOTING PROCEDURES (Continued).

MALFUNCTION	INSTRUCTION	INDICATION	YES	NO
81. 24-VOLT TRAILER BLACKOUT TAILLAMPS NOT WORKING (Continued).				
22	Disconnect 24-volt cab connector, and go to step 23.			
23	Check for voltage at 24-volts dc circuit 23N-BR (pin H of connector)		Recheck trailer nominal cuit	Repair circuit taillamp cir- 3-127).
24	Disconnect 24-volt chassis connector, and go to step 25.			
25	Check for voltage at 24-volts dc circuit 23U-BR (pin Anominal of connector)		Recheck trailer taillamp cir- cuit	Repair circuit 23P-BR and/or 23J-BR (para

2-11. TROUBLESHOOTING PROCEDURES (Continued).

MALFUNCTION	INSTRUCTION	INDICATION	YES	NO
-------------	-------------	------------	-----	----

81. 24-VOLT TRAILER BLACKOUT TAILLAMPS NOT WORKING (Continued).

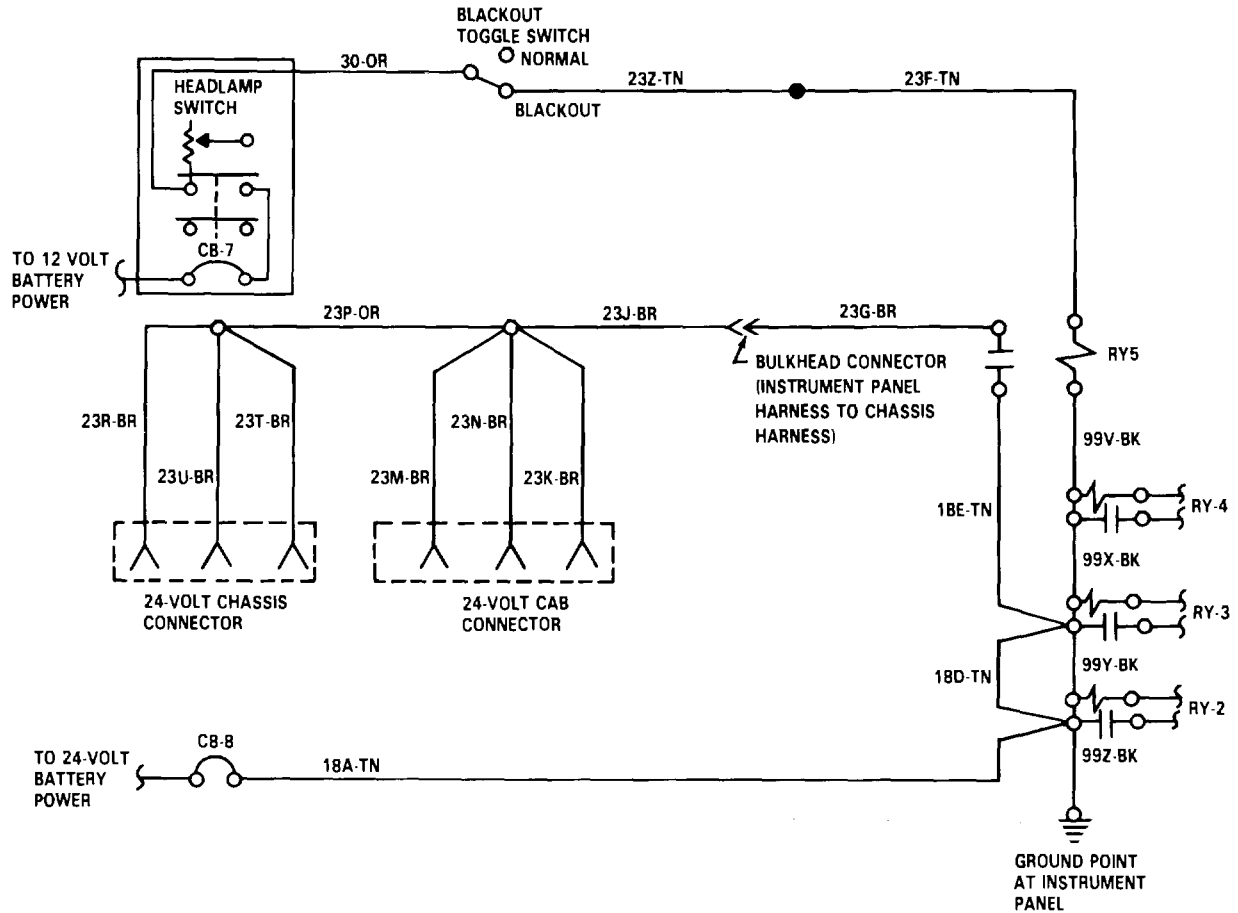

TOUBLESHOOTING.

2-11. TROUBLESHOOTING PROCEDURES (Continued).

MALFUNCTION	INSTRUCTION	INDICATION	YES	NO
82.	ELECTRICAL HORN NOT WORKING.	NOTE		
	Blackout toggle switch must be set to NORMAL position when doing the following checks.			
1.	Remove circuit breaker bracket far enough to access circuit breaker CB-5 (para 3-114), and go to step 2.			
2.	Check for voltage at circuit 35-LG or 42-LG terminal of circuit breaker CB-5.	12-volts dc nominal.	Go to step 3.	Reset circuit breaker CB-5 and/or troubleshoot CB-5 circuit. (Refer to malfunction 34).
3.	Check for voltage at circuit 35-LG terminal of blackout toggle switch.	12-volts dc nominal.	Go to step 4.	Repair circuit 35-LG (para 3-127). Install circuit breaker bracket (para 3-114).
4.	Remove relay RY-1 (para 3-112), and go to step 5.			

TROUBLESHOOTING.

2-11. TROUBLESHOOTING PROCEDURES (Continued).

MALFUNCTION	INSTRUCTION	INDICATION	YES	NO
-------------	-------------	------------	-----	----

82. ELECTRICAL HORN NOT WORKING (Continued).

5. Check for voltage at circuit 41B-PP terminal of relay connector.		12-volts dc nominal.	Go to step 6.	Repair circuit 41B-PP and/or 35A-PP (Para 3-127). Install relay RY-4 and circuit breaker bracket (para 3-112 and 3-114).
---	--	----------------------	---------------	--

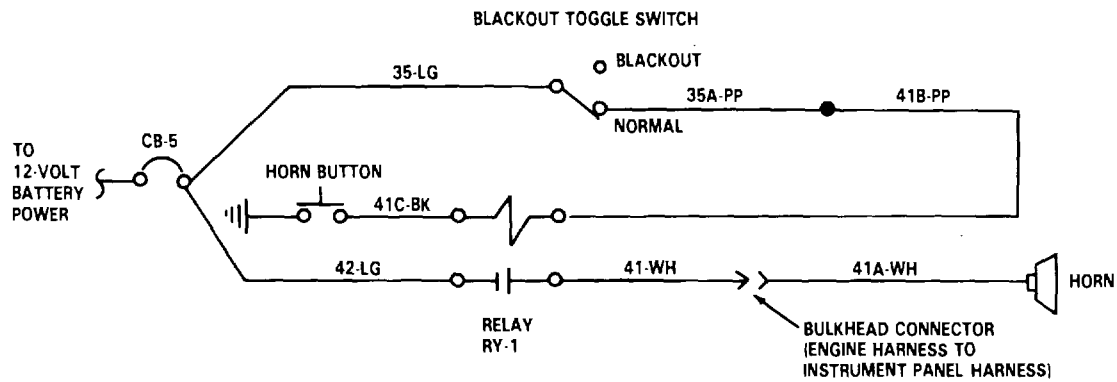

TA 236942

TROUBLESHOOTING.

2-11. TROUBLESHOOTING PROCEDURES (Continued).

MALFUNCTION	INSTRUCTION	INDICATION	YES	NO
-------------	-------------	------------	-----	----

82. ELECTRICAL HORN NOT WORKING (Continued).

NOTE

With positive lead on circuit 41B-PP (or other suitable hot lead), check ground with negative lead for steps 6 thru 9.

6. Remove horn button (para 3-118), and go to step 7.

7. Check for voltage at horn button plate.

12-volts dc nominal.

Go to step 8.

Clean horn button plate. button (para 3-118). Install relay RY-1 and circuit breaker bracket (para 3-112 and 3-114).

8. Check for voltage at circuit 41C-BK terminal at horn button.

12-volts dc nominal.

Install horn button (para 3-118), and go to step 9.

Clean horn button contact cups. Install relay RY-1 and circuit breaker bracket (para 3-112 and 3-114).

NOTE

Assistant must press and hold horn button when doing the following checks.

TROUBLESHOOTING.

2-11. TROUBLESHOOTING PROCEDURES (Continued).

MALFUNCTION	INSTRUCTION	INDICATION	YES	NO
-------------	-------------	------------	-----	----

82. ELECTRICAL HORN NOT WORKING (Continued).

9.	Check for ground at circuit 41C-BK terminal of relay connector.	12-volts dc nominal.	Go to step 10.	Repair circuit 41C-BK (para 3-127). Install circuit breaker bracket (para 3-112 and 3-114).
----	---	----------------------	----------------	---

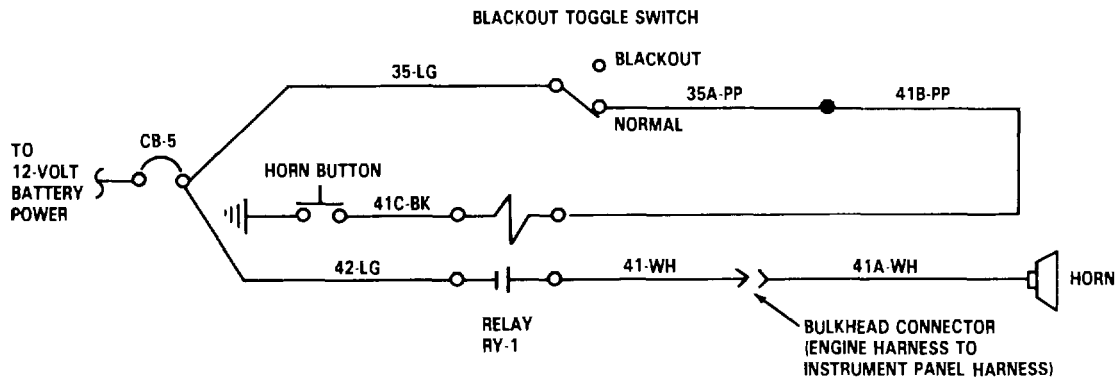

TA 236943

TROUBLESHOOTING.

2-11. TROUBLESHOOTING PROCEDURES (Continued).

MALFUNCTION	INSTRUCTION	INDICATION	YES	NO
82.	ELECTRICAL HORN NOT WORKING (Continued).			
10.	Install relay RY-1 (para 3-112), and go to step 11.			
11.	Disconnect horn (para 3-117), and go to step 12.			
12.	Move blackout toggle switch from NORMAL to BLACKOUT and back to NORMAL position.	Listen for clicking sound at relay RY-1.	Install circuit breaker bracket (para 3-114), and go to step 13.	Replace relay RY-1. Install circuit breaker bracket (para 3-112 and 3-114). Connect horn (para 3-117).
13.	Disconnect circuit 41-WH from 41A-WH at connector, and go to step 14.			
14.	Check for voltage at circuit 41-WH (pin 17 of connector).	12-volts dc nominal.	Connect engine harness connector, and go to step 15.	Repair circuit 41-WH (para 3-127). Connect horn (para 3-117).
15.	Check for voltage at circuit 41A-WH terminal of horn.	12-volts dc nominal.	Replace horn (para 3-117).	Repair circuit 41A-WH (para 3-127).
2-270				

TROUBLESHOOTING.

2-11. TROUBLESHOOTING PROCEDURES (Continued).

MALFUNCTION	INSTRUCTION	INDICATION	YES	NO
-------------	-------------	------------	-----	----

82. ELECTRICAL HORN NOT WORKING (Continued).

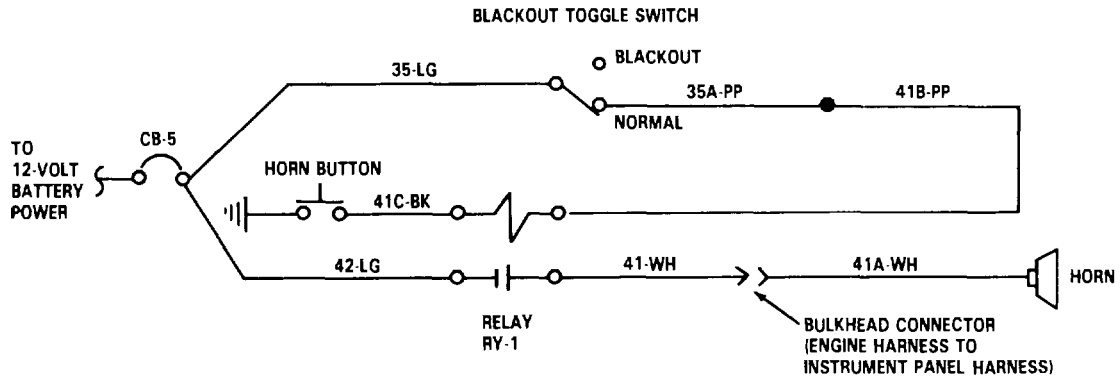

TA 236944

TROUBLESHOOTING.

~~2-11. TROUBLESHOOTING PROCEDURES (Continued).~~

MALFUNCTION	INSTRUCTION	INDICATION	YES	NO
-------------	-------------	------------	-----	----

83. PERSONNEL HEATER FAN MOTOR NOT WORKING.

NOTE

- Make sure ignition switch is in ON position and heater fan switch is set at speed being tested when doing the following checks.
- If any speed is working, begin with step 3.

1. Remove circuit breaker bracket far enough to access circuit breaker CB-4 (para 3-114), and go to step 2.

2. Check for voltage at circuit 76-DB terminal of circuit breaker CB-4.

12-volts dc nominal.
and go to step

Install circuit breaker panel (para 3-114), shoot CB-4 circuit.

Reset circuit breaker CB-4 and/or troubleshoot. (Refer to malfunction 33).

3. Check for voltage at circuit 76-DB terminal of heater fan switch.

12-volts dc nominal.

Go to step 4.

Repair circuit 76-DB (para 3-127).

4. Check for voltage at LOW, MED, and HIGH terminals of heater fan switch.

12-volts dc nominal.

Replace personnel heater motor (para 3-299).

Replace heater fan switch (para 3-81).

2-272

TROUBLESHOOTING.

2-11. TROUBLESHOOTING PROCEDURES (Continued).

MALFUNCTION	INSTRUCTION	INDICATION	YES	NO
-------------	-------------	------------	-----	----

83. PERSONNEL HEATER FAN MOTOR NOT WORKING (Continued).

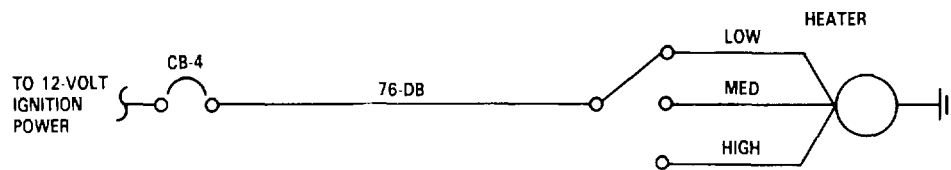

TA 236945

2-273

TROUBLESHOOTING.

2-11. TROUBLESHOOTING PROCEDURES (Continued).

MALFUNCTION	INSTRUCTION	INDICATION	YES	NO
84.	DOME LAMP NOT WORKING.			
<p>NOTE Blackout toggle switch must be set to NORMAL position and dome lamp switch set to ON position when doing the following checks.</p>				
1.	Turn on map lamps.	Both light	Go to step 2	Go to step 4.
2.	Remove dome lamp bulb (para 3-98), and go to step 3.			
3.	Check for voltage at circuit 15B-YL terminal of dome lamp.	12-volt dc nominal.	Replace bulb (para 3-98). 3-127).	Repair circuit 15B-YL (para
4.	Remove circuit breaker bracket far enough to access circuit breaker CB-1 (para 3-114), and go to step 5.			
5.	Check for voltage at circuit 15D-OR terminal of circuit breaker CB-1.	12-volts dc nominal.	Go to step 6.	Reset circuit breaker CB-1 and/or trouble-shoot CB-1 to malfunction 34).

TROUBLESHOOTING.

2-11. TROUBLESHOOTING PROCEDURES (Continued).

MALFUNCTION	INSTRUCTION	INDICATION	YES	NO
-------------	-------------	------------	-----	----

84. DOME LAMP NOT WORKING (Continued).

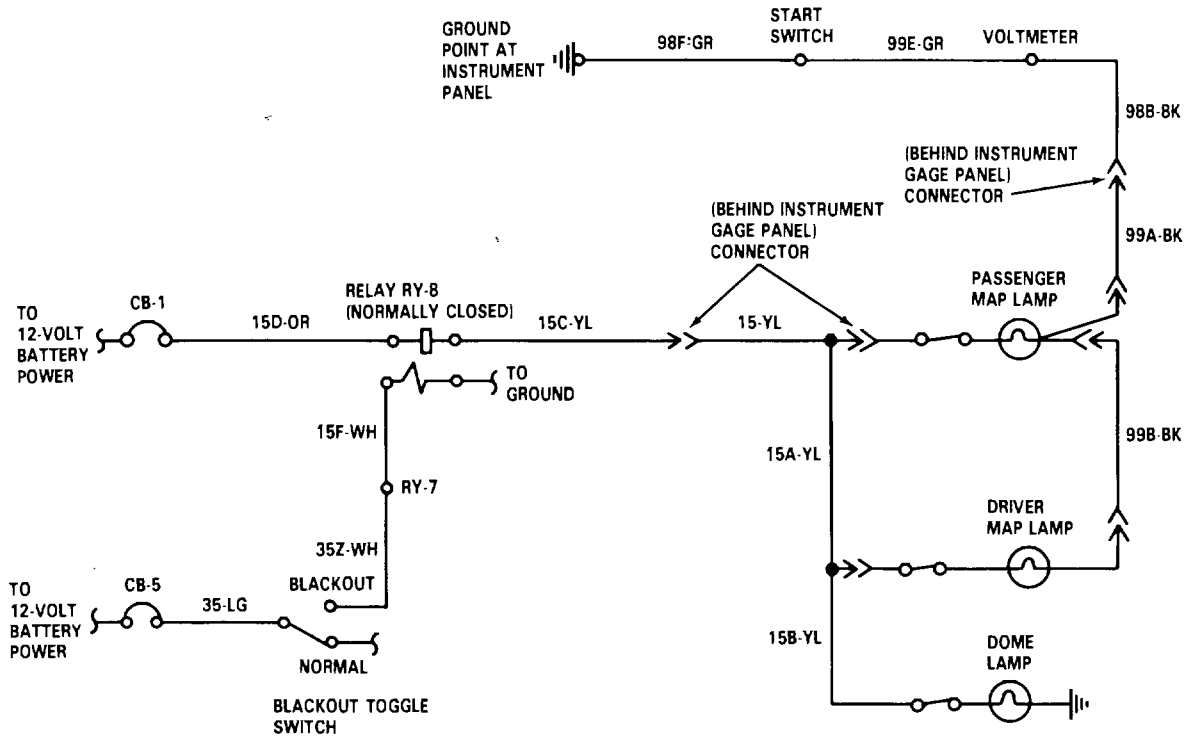

TA 236946

TROUBLESHOOTING.

2-11. TROUBLESHOOTING PROCEDURES (Continued).

MALFUNCTION	INSTRUCTION	INDICATION	YES	NO
84.	DOME LAMP NOT WORKING (Continued).			
	6. Remove relay RY-8 (para 3-112), and go to step 7.			
	7. Check for voltage at circuit 15D-OR terminal of relay connector.	12-volts dc nominal.	Go to step 8.	Repair circuit 15D-OR (para 3-127). Install relay RY-8 and circuit breaker bracket (para 3-112 and 3-114).
	8. Connect jumper wire between circuit 15D-OR and pin 30 on relay RY-8, and go to step 9.			
	9. Check for voltage at pin 87A of relay RY-8.	12-volts dc nominal.	Install relay RY-8 and circuit breaker bracket (para 3-112 and 3-114), and go to step 10.	Replace relay RY,8 (para 3-112). Install circuit breaker bracket (para 3-114).
	10. Disconnect circuit 15C-YL from 15-YL at connector, and go to step 11.			
	11. Check for voltage at circuit 15G-YL terminal of connector.	12-volts dc nominal.	Repair circuit 15-YL (para 3-127).	Repair circuit 15C-YL (para 3-127).

TROUBLESHOOTING.

2-11. TROUBLESHOOTING PROCEDURES (Continued).

MALFUNCTION	INSTRUCTION	INDICATION	YES	NO
-------------	-------------	------------	-----	----

84. DOME LAMP NOT WORKING (Continued).

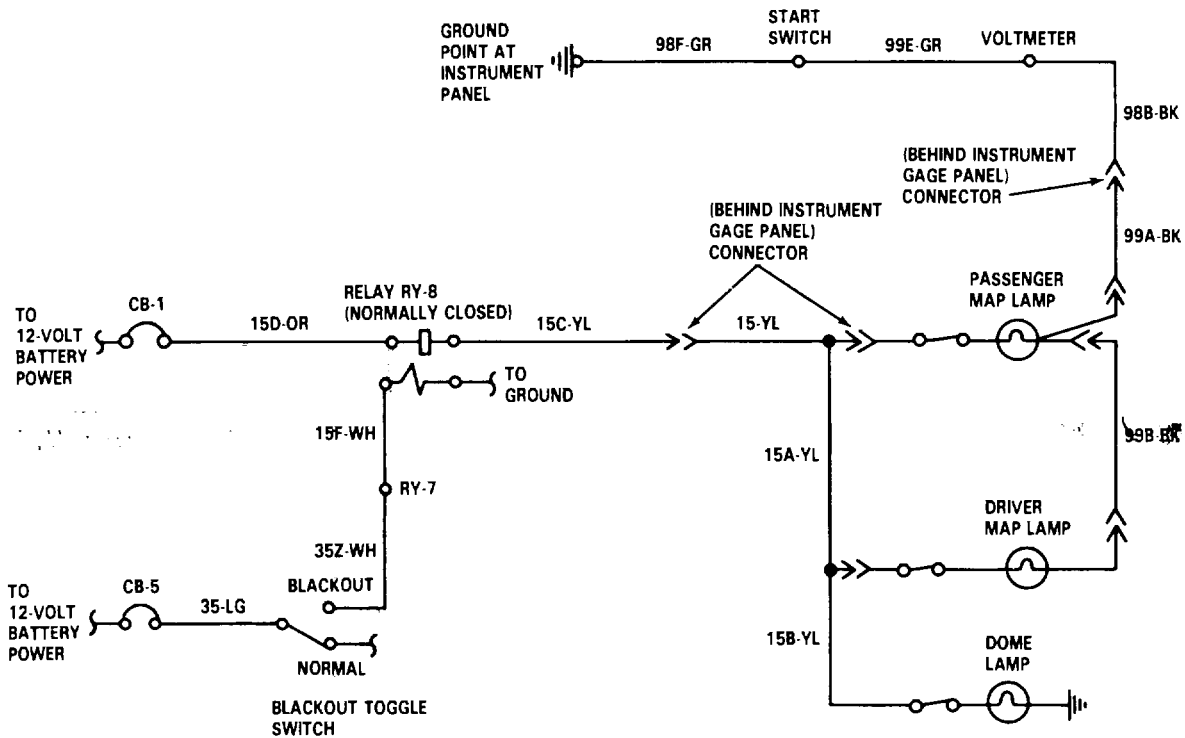

TA 236947

TROUBLESHOOTING.

2-11. TROUBLESHOOTING PROCEDURES (Continued).

MALFUNCTION	INSTRUCTION	INDICATION	YES	NO
-------------	-------------	------------	-----	----

85. BOTH MAP LAMPS NOT WORKING.

NOTE

Blackout toggle switch must be set to NORMAL position and map lamp switch set to ON position when doing the following checks.

Refer to malfunction 84, step 3.

86. ONE MAP LAMP NOT WORKING.

NOTE

- Blackout toggle switch must be set to NORMAL position and map lamp switch set to ON position when doing the following checks.
- Faulty driver's map lamp is shown in this procedure. Apply similar troubleshooting technique for passenger's map lamp.

1. Remove driver's map lamp (para 3-99).

2. Check for voltage at circuit 15A-YL terminal of connector.

12-volts dc nominal.

Replace bulb (para 3-99).

Repair circuit 15A-YL (para 3-127).

TROUBLESHOOTING.

2-11. TROUBLESHOOTING PROCEDURES (Continued).

MALFUNCTION	INSTRUCTION	INDICATION	YES	NO
-------------	-------------	------------	-----	----

86. ONE MAP LAMP NOT WORKING (Continued).

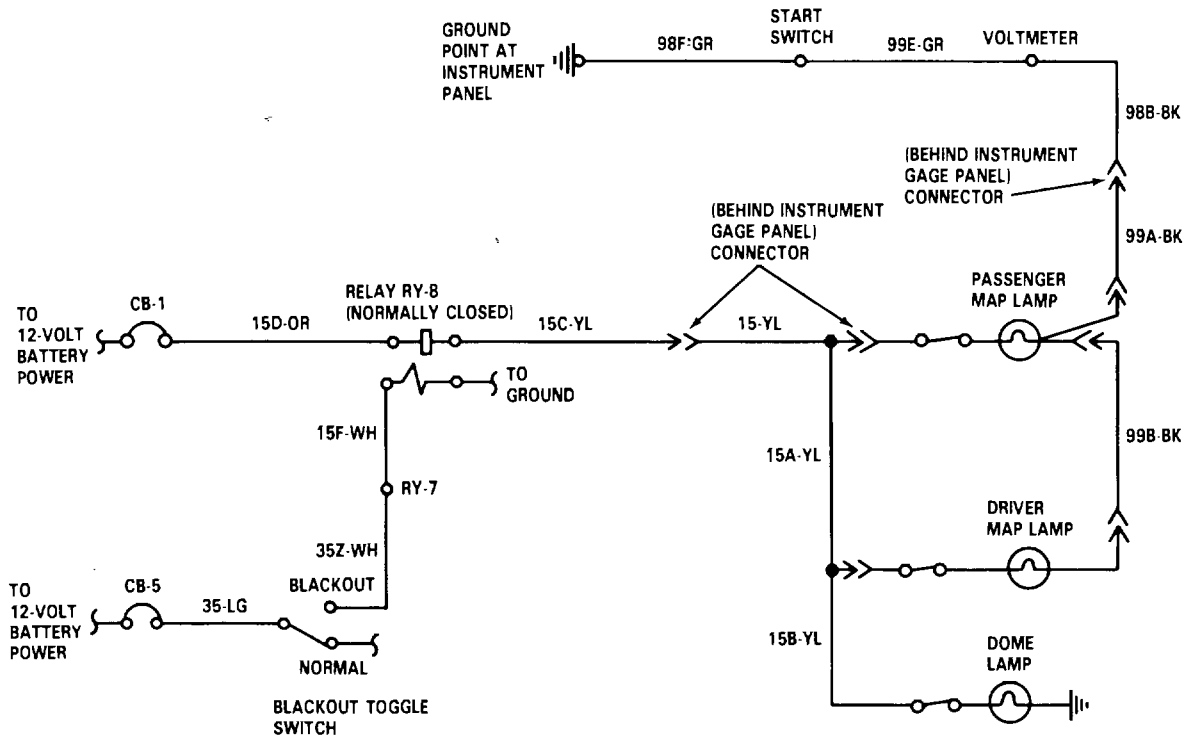

TA 236948

TROUBLESHOOTING.

2-11. TROUBLESHOOTING PROCEDURES (Continued).

MALFUNCTION	INSTRUCTION	INDICATION	YES	NO
87. MAP LAMPS LIGHT, BUT ARE DIM.	<p style="text-align: center;">NOTE</p> <ul style="list-style-type: none"> • Blackout toggle switch must be set to NORMAL position and map lamp switch set to ON position when doing the following checks. • With positive lead at known hot circuit, check ground with negative lead when doing the following checks. 			
1. Check for voltage at circuit 98F-BK ground point of instrument panel.		12-volts dc nominal.	Go to step 2.	Clean and tighten ground point connection.
2. Check for voltage at circuit 98F-BK terminal of start switch.		12-volts dc nominal.	Go to step 3.	Repair circuit 98F-BK (para 3-127).
3. Check for voltage at circuit 99E-BK terminal of voltmeter.		12-volts dc nominal.	Go to step 4.	Repair circuit 99E-BK (para 3-127).
4. Disconnect circuit 98B-BK from 99A-BK at connector, and go to step 5.				
5. Check for voltage at circuit 98B-BK terminal of connector. to step 6.		12-volts dc nominal. 99A-BK, and go	Connect circuit 98B-BK to 3-127).	Repair circuit 98B-BK (para
6. Remove passenger's map lamp (para 3-99).				

TROUBLESHOOTING.

2-11. TROUBLESHOOTING PROCEDURES (Continued).

MALFUNCTION	INSTRUCTION	INDICATION	YES	NO
-------------	-------------	------------	-----	----

87. MAP LAMPS LIGHT, BUT ARE DIM (Continued).

7. Check for voltage at circuit 99A-BK terminal of connector.		12-volts dc nominal.	Replace passenger's map lamp (para 3-99).	Repair circuit 99A-BK (para 3-127). Install lamp (para 3-99).
---	--	----------------------	---	---

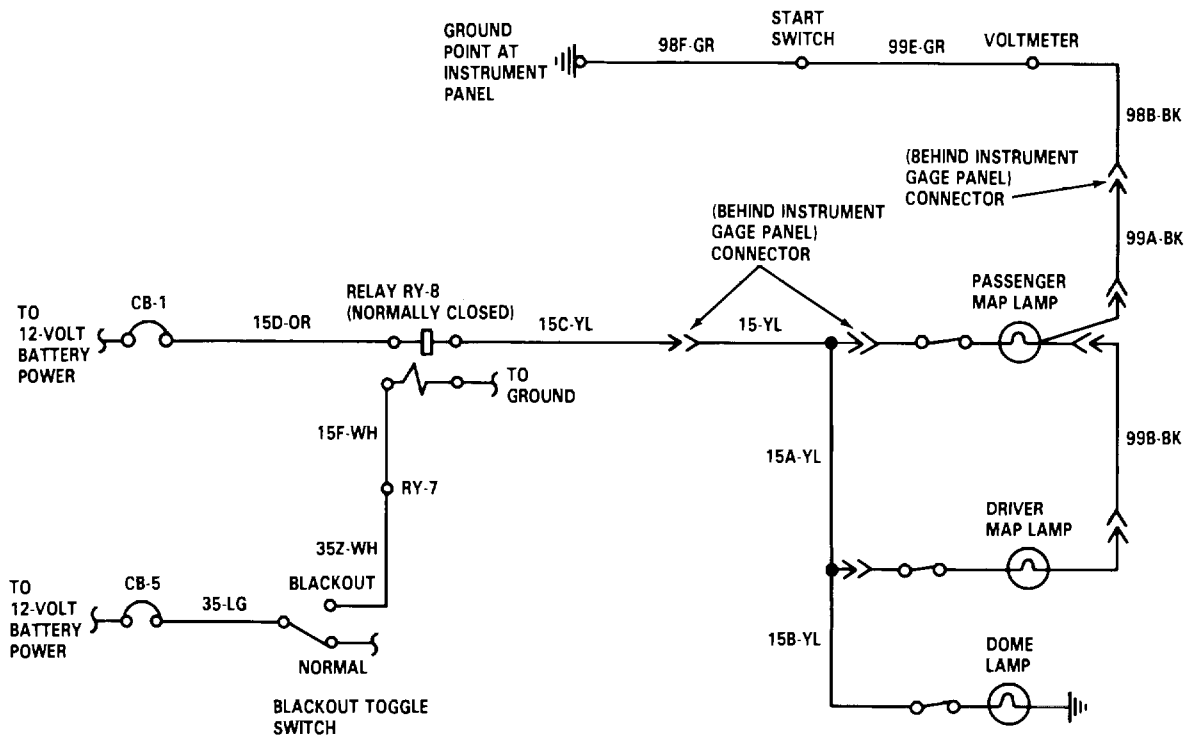

TA 236949

TROUBLESHOOTING.

2-11. TROUBLESHOOTING PROCEDURES (Continued).

MALFUNCTION	INSTRUCTION	INDICATION	YES	NO
88.	CIGAR LIGHTER RECEPTACLE NOT WORKING.			
1.	Remove circuit breaker bracket far enough to access circuit breaker CB-6 (para 3-114), and go to step 2.			
2.	Check for voltage at circuit 40-PP terminal of circuit breaker CB-6.	12-volts dc nominal.	Install circuit breaker bracket (para 3-114), and go to step 2.	Reset circuit breaker CB-6 and/or trouble-shoot CB-6 circuit. (Refer to malfunction 34).
3.	Disconnect circuit 40-PP from lighter receptacle, and go to step 4.			
4.	Check for voltage at circuit 40-PP terminal of connector.	12-volts dc nominal. 3-83).	Replace cigar lighter (para 3-127).	Repair circuit 40-PP (para

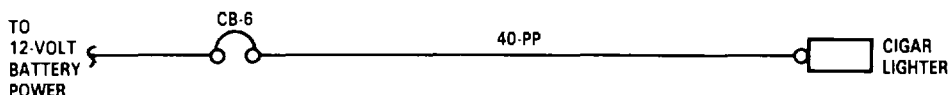

TA 236950

TROUBLESHOOTING.

2-11. TROUBLESHOOTING PROCEDURES (Continued).

MALFUNCTION	INSTRUCTION	INDICATION	YES	NO
-------------	-------------	------------	-----	----

89. LEFT SIDE UTILITY OUTLET RECEPTACLE NOT WORKING.

NOTE

It is assumed here that right side utility outlet receptacle is OK.

1. Remove trim panel far enough to access utility outlet receptacle (para 3-276), and go to step 2.

2. Check for voltage at circuit 21B-PP terminal of utility outlet receptacle. (para 3-276).

12-volts dc nominal.

Go to step 3.

Repair circuit 21B-PP (para 3-127). Install trim panel

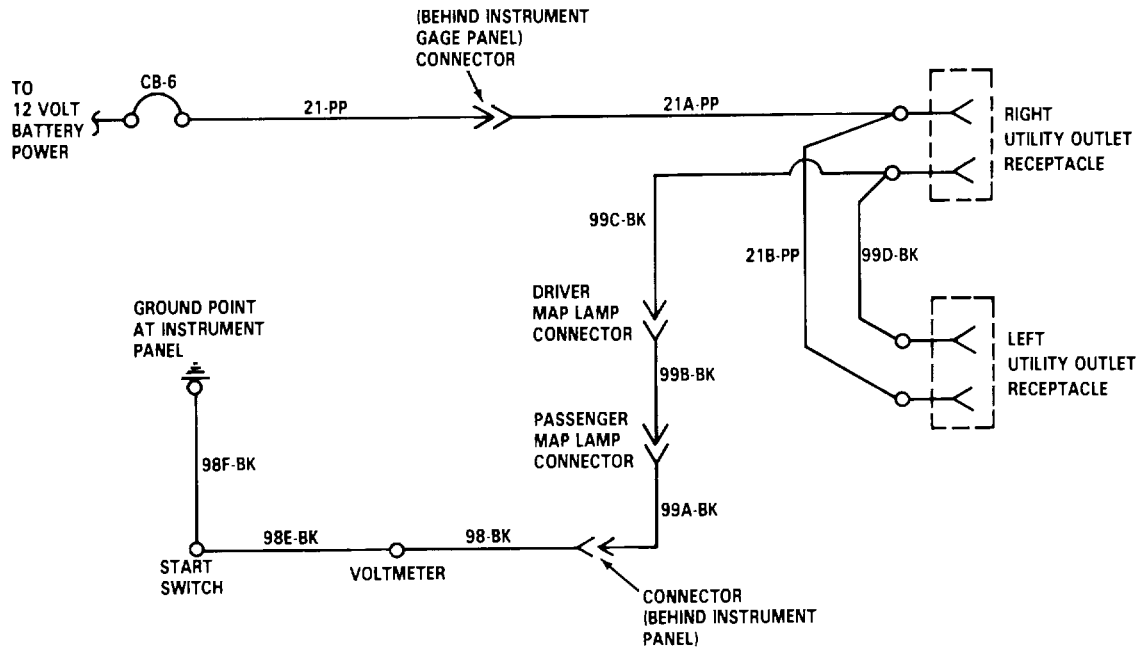

TROUBLESHOOTING.

2-11. TROUBLESHOOTING PROCEDURES (Continued).

MALFUNCTION	INSTRUCTION	INDICATION	YES	NO
-------------	-------------	------------	-----	----

NOTE

With positive lead on circuit 21BPP, check ground with negative lead when doing the following checks.

- | | | | | |
|---|--|-------------------------------------|---|--|
| 3. | Check for ground at circuit 99D-BK terminal of utility outlet receptacle. | 12-volts dc nominal. (para 3-132). | Replace work-lamp receptacle 3-127). | Repair circuit 99D-BK (para |
| 90. BOTH UTILITY OUTLET RECEPTACLES NOT WORKING. | | | | |
| 1. | Remove circuit breaker bracket far enough to access circuit breaker CB-6 (para 3-114), and go to step 2. | | | |
| 2. | Check for voltage at circuit 21-PP terminal of circuit breaker CB-6. | 12-volts dc nominal. | Install circuit breaker bracket (para 3-114), and go to step 3. | Reset circuit breaker CB-6 and/or trouble-shoot CB-6 circuit. (Refer to malfunction 34). |
| 3. | Disconnect circuit 21-PP from 21A-PP (located behind instrument gages), and go to step 4. | | | |
| 4. | Check for voltage at circuit 21-PP terminal of connector. to step 5. | 12-volts dc nominal. 21A-PP, and go | Connect circuit 21-PP to 3-127). | Repair circuit 21-PP (para |

TROUBLESHOOTING.

2-11. TROUBLESHOOTING PROCEDURES (Continued).

MALFUNCTION	INSTRUCTION	INDICATION	YES	NO
-------------	-------------	------------	-----	----

90. BOTH UTILITY OUTLET RECEPTACLES NOT WORKING (Continued).

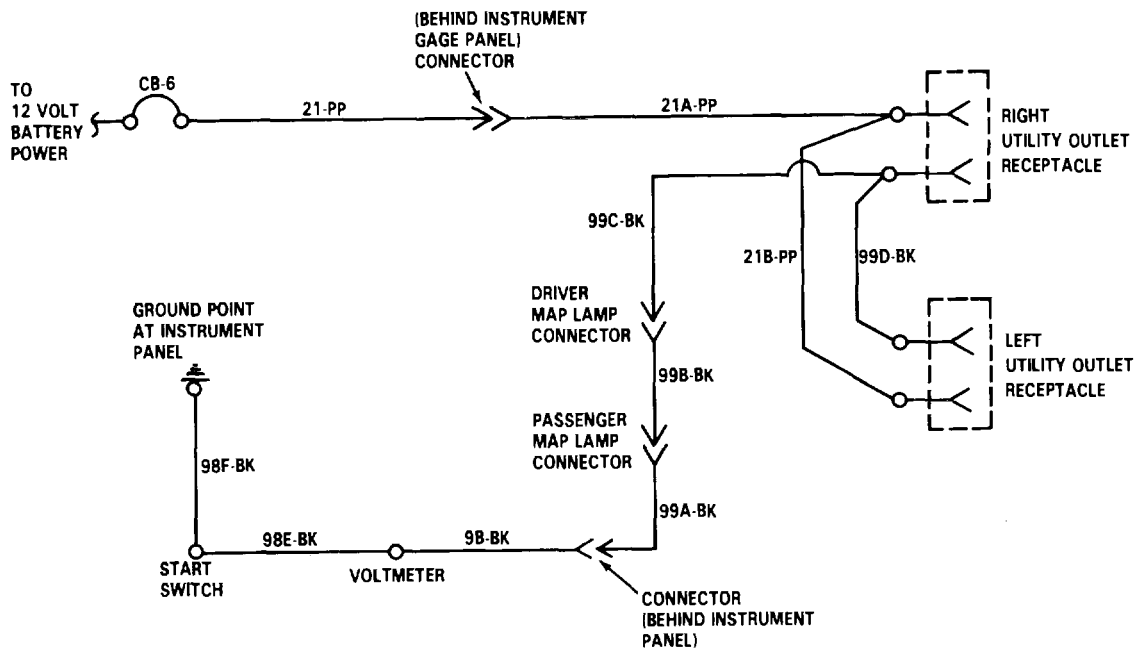

TA 236952

TROUBLESHOOTING.

2-11. TROUBLESHOOTING PROCEDURES (Continued).

MALFUNCTION	INSTRUCTION	INDICATION	YES	NO
-------------	-------------	------------	-----	----

90. BOTH UTILITY OUTLET RECEPTACLES NOT WORKING (Continued).

5. Remove right side trim panel far enough to access utility outlet receptacle (para 3-276), and go to step 6.

6. Check for voltage at circuit 21A-PP terminal of utility outlet receptacle.

12-volts dc nominal.

Go to step 7. 21A-PP (para 3-127). Install trim panel

Repair circuit

NOTE

With positive lead on circuit 21APP (or suitable 12volt power lead), check ground with negative lead when doing the following checks.

7. Check for voltage at circuit 98F-BK ground point of instrument panel.

12-volts dc nominal.

Go to step 8.

Clean and tighten ground point connections. Install trim panel (para 3-276).

2-286

TROUBLESHOOTING.

2-11. TROUBLESHOOTING PROCEDURES (Continued).

MALFUNCTION	INSTRUCTION	INDICATION	YES	NO
-------------	-------------	------------	-----	----

90. BOTH UTILITY OUTLET RECEPTACLES NOT WORKING (Continued).

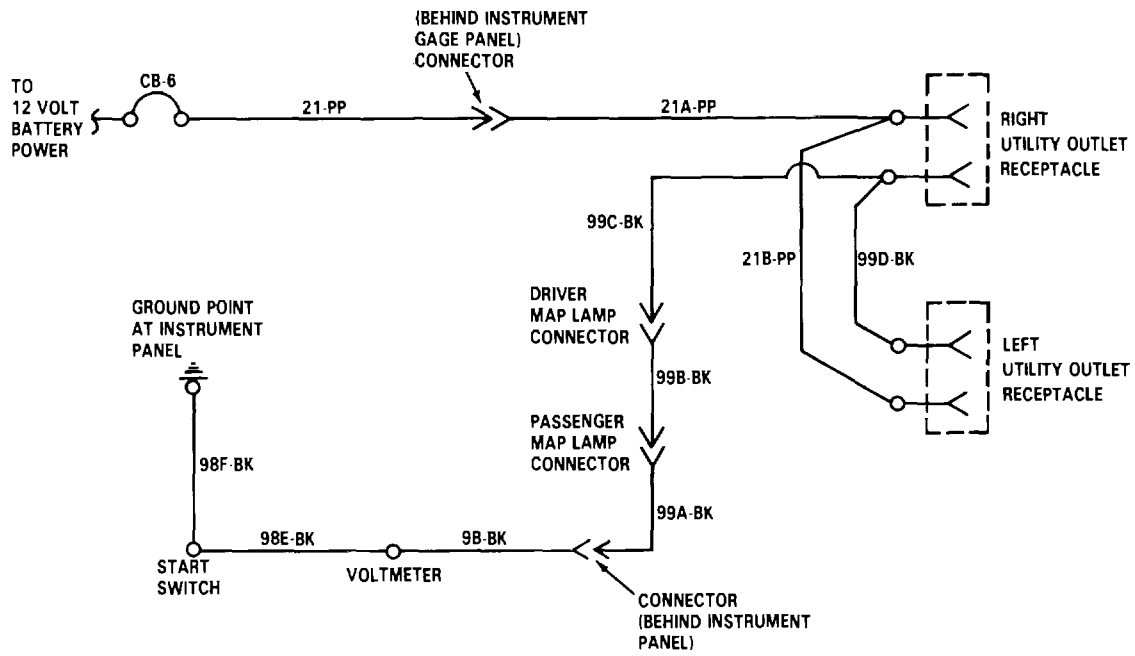

TA 236953

TROUBLESHOOTING.

2-11. TROUBLESHOOTING PROCEDURES (Continued).

MALFUNCTION	INSTRUCTION	INDICATION	YES	NO
90. BOTH UTILITY OUTLET RECEPTACLES NOT WORKING (Continued).				
8.	Check for ground at circuit 98F-BK terminal of start switch	12-volts dc nominal.	Go to step 9.	Repair circuit 98F-BK (para 3-127). Install trim panel (para 3-276).
9.	Check for ground at circuit 98E-BK terminal of voltmeter.	12-volts dc nominal.	Go to step 10.	Repair circuit 98E-BK (para 3-127). Install trim panel (para 3-276).
10.	Disconnect circuit 98-BK from 98A-BK at connector (located behind instrument gages), and go to step 12.			
11.	Check for ground at circuit 98-BK terminal of connector.	12-volts dc nominal.	Connect circuit 98-BK to 99A-BK, and go to step 12.	Repair circuit 98-BK (para 3-127). Connect circuit 98-BK to 99A-BK, and install trim panel (para 3-276).

TROUBLESHOOTING.

2-11. TROUBLESHOOTING PROCEDURES (Continued).

MALFUNCTION	INSTRUCTION	INDICATION	YES	NO
-------------	-------------	------------	-----	----

90. BOTH UTILITY OUTLET RECEPTACLES NOT WORKING (Continued).

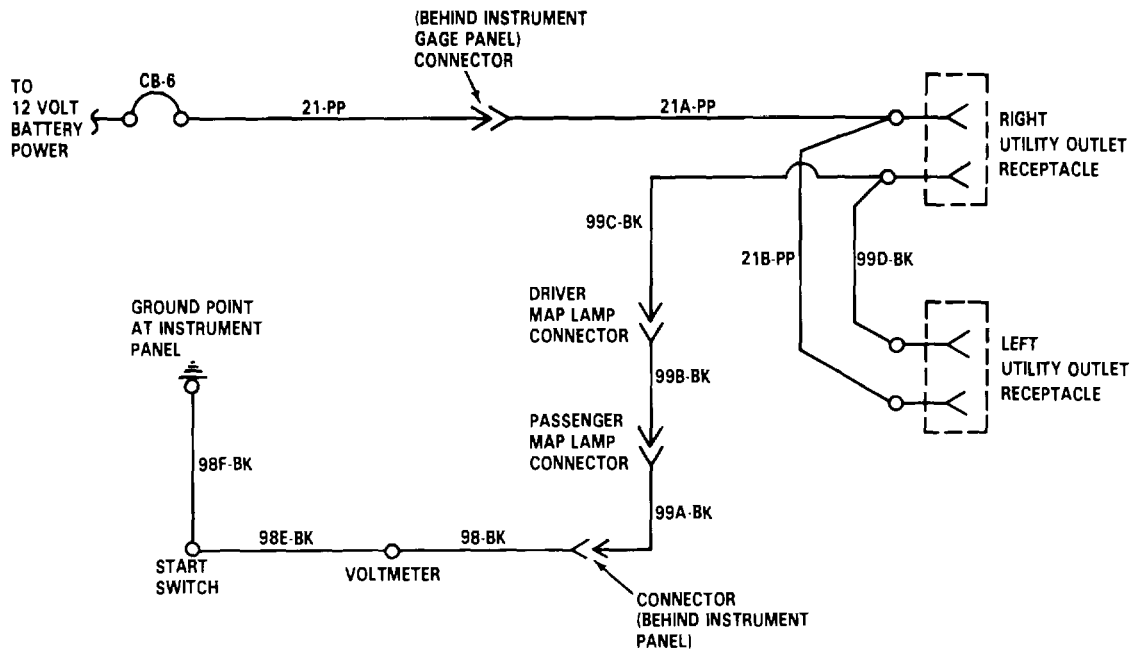

TA 236954

TROUBLESHOOTING.

2-11. TROUBLESHOOTING PROCEDURES (Continued).

MALFUNCTION	INSTRUCTION	INDICATION	YES	NO
90.	BOTH UTILITY OUTLET RECEPTACLES NOT WORKING (Continued).			
	12. Remove passenger's map lamp (para 3-99), and go to step 13.			
	13. Check for ground at circuit 99A-BK terminal of connector.	12-volts dc nominal.	Install driver's map lamp (para 3-99), and go to step 14.	Repair circuit 99A-BK (para 3-127). Install passenger's map lamp (para 3-99). Install trim panel (para 3-276).
	14. Remove driver's map lamp (para 3-99), and go to step 15.			
	15. Check for ground at circuit 99B-BK terminal of connector. and go to step driver's map	12-volts dc nominal.	Install passenger's map lamp (para 3-99),	Repair circuit 99B-BK (para 3-127). Install 3-99). Install trim panel (para 3-276).
	16. lamp (para circuit 99C-BK terminal of utility outlet receptacle. (para 3-276).	12-volts dc nominal.	Utility outlet receptacle circuit OK.	Repair circuit 99C-BK (para 3-127). Install trim panel

TROUBLESHOOTING.

2-11. TROUBLESHOOTING PROCEDURES (Continued).

MALFUNCTION	INSTRUCTION	INDICATION	YES	NO
-------------	-------------	------------	-----	----

90. BOTH UTILITY OUTLET RECEPTACLES NOT WORKING (Continued).

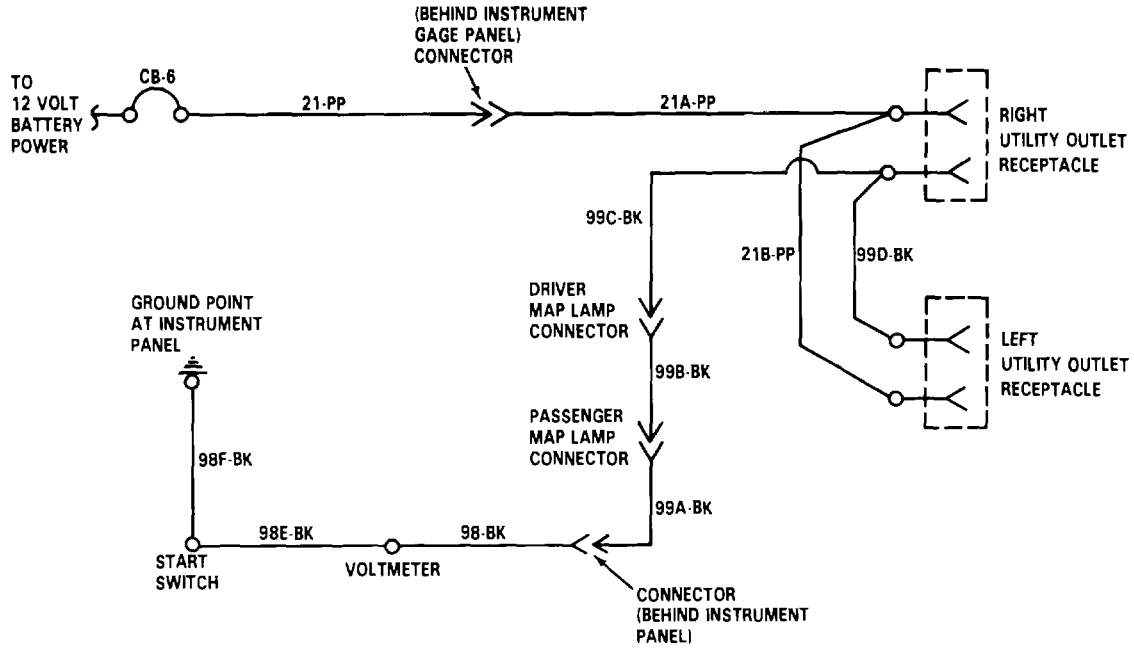

TA 236955

TROUBLESHOOTING.

2-11. TROUBLESHOOTING PROCEDURES (Continued)

MALFUNCTION

TEST OR INSPECTION

CORRECTIVE ACTION

TRANSMISSION

91. TRANSMISSION SHIFTS AT TOO HIGH A SPEED.

Step 1. Check adjustment of modulator linkage.

Adjust modulator linkage (para 3-140).

Step 2. Notify direct support maintenance.

92. TRANSMISSION SHIFTS AT TOO LOW A SPEED.

Step 1. Check adjustment of modulator linkage.

Adjust modulator linkage (para 3-140).

Step 2. Notify direct support maintenance.

93. TRANSMISSION OVERHEATING IN ALL RANGES.

Step 1. Check oil level.

- a. Oil level low; add oil (para 3-135).
- b. Oil level high; drain oil to proper level (para 3-135).

Step 2. Notify direct support maintenance.

94. NO RESPONSE TO SHIFT LEVER MOVEMENT.

Step 1. Check oil level.

Oil level low; add oil (para 3-135).

Step 2. Check for disconnected or damaged shifter control cable.

- a. Connect or replace shifter control cable (para 3-138).
- b. Notify direct support maintenance.

TROUBLESHOOTING.

2-11. TROUBLESHOOTING PROCEDURES (Continued)**MALFUNCTION****TEST OR INSPECTION****CORRECTIVE ACTION**

95. ROUGH SHIFTING.

Step 1. Check shifter control cable adjustment.

Adjust shifter control cable (para 3-138).

Step 2. Check modulator control adjustment.

Adjust modulator control (para 3-140).

Step 3. Check shifter control.

a. Replace shifter control (para 3-137).

b. Notify direct support maintenance.

96. TRANSMISSION OIL DIRTY, FOAMY, AND/OR MILKY.

NOTE

- Dirt and grit in transmission oil indicates oil needs changing.
- Foaminess indicates contamination of oil by air.
- Milkeness indicates contamination of oil by coolant.

Step 1. Inspect oil for dirt and grit.

a. Service transmission (para 3-135).

b. Tighten all fittings (para 3-141).

c. Notify direct support maintenance.

Step 2. Inspect for excessive foaminess.

a. Oil low; add oil (para 3-135).

b. Replace transmission oil filter (para 3-135).

c. Notify direct support maintenance.

TROUBLESHOOTING.**2-11. TROUBLESHOOTING PROCEDURES (Continued)****MALFUNCTION****TEST OR INSPECTION****CORRECTIVE ACTION**

96. TRANSMISSION OIL DIRTY, FOAMY, AND/OR MILKY (Continued).

Step 3. Inspect for milkiness in oil.

Notify direct support maintenance.

97. LOSS OF POWER.

Check oil level.

- a. Oil level low; add oil (para 3-135).
- b. Notify direct support maintenance.

98. CLUTCH SLIPPAGE IN ALL FORWARD GEARS.

Check oil level.

- a. Oil level low; add oil (para 3-135).
- b. Notify direct support maintenance.

99. VEHICLE MOVES IN NEUTRAL.

Check shifter control cable adjustment.

- a. Adjust shifter control cable (para 3-138).
- b. Notify direct support maintenance.

100. OIL THROWN FROM FILLER TUBE.

Step 1. Check fit of oil level gage (dipstick) in filler tube.

- a. Secure oil level gage.
- b. Replace oil level gage, if necessary (para 3-136).

Step 2. Check for worn gasket at oil level gage.

Replace oil level gage (para 3-136).

TROUBLESHOOTING.

2-11. TROUBLESHOOTING PROCEDURES (Continued).

MALFUNCTION	TEST OR INSPECTION	CORRECTIVE ACTION
-------------	--------------------	-------------------

100. OIL THROWN FROM FILLER TUBE (Continued).

Step 3. Check part number on oil level gage against part number shown in TM 9-2320-283-20P.

Replace oil level gage (para 3-136).

Step 4. Check for high oil level.

Drain oil to proper level (para 3-135).

Step 5. Check for clogged breather.

Clean breather.

PROPELLER SHAFTS AND UNIVERSAL JOINTS

101. EXCESSIVE SHAFT NOISE OR VIBRATION.

Step 1. Check torque of yoke nuts at universal joints.

Torque nuts to 300 lb-ft.

Step 2. Check torque of capscrews.

Torque capscrews to 100-110 lb-ft.

Step 3. Inspect propeller shafts and universal joints for evidence of damage or excessive wear.

Replace worn or damaged components (para 3-144 or 3-145).

Step 4. Check universal joints for adequate lubrication.

Lubricate. (Refer to LO 9-2320-283-12).

Step 5. Check for proper shaft alinement (propeller shafts are properly phased when cross and bearing in yokes at each end of shaft are in same place).

Disassemble and aline as necessary (para 3-144 or 3-145).

TROUBLESHOOTING.**2-11. TROUBLESHOOTING PROCEDURES (Continued).****MALFUNCTION****TEST OR INSPECTION****CORRECTIVE ACTION****101. EXCESSIVE SHAFT NOISE OR VIBRATION (Continued).****NOTE**

Look for arrow marks on propeller shaft and slip yoke. Arrows will point toward each other. If marks are not visible, punch mark in each member insuring reassembly in same relative position.

Step 6. Remove propeller shaft from vehicle (para 3-144 or 3-145). Check freedom of motion of splines by moving shaft from fully retracted to fully extended. If excessive force is required to retract or extend shaft, or it does not reach full travel, separate shaft halves and balance weight, and inspect splines for wear, damage, and lubrication.

Replace shaft assembly, if required (para 3-144 or 3-145).

102. EXCESSIVE BACKLASH.

Step 1. Check all universal joints.

Lubricate and replace as necessary (para 3-144 or 3-145).

Step 2. Check drive axle capscrews on universal joints for tightness.

Torque to 100-110 lb-ft (para 3-144 or 3-145). If problem continues, notify direct support maintenance.

103. CONTINUOUS AXLE OR WHEEL NOISE.

Step 1. Check lube level in axle housing.

Fill axle housing to proper level. (Refer to LO 9-2320-283-12).

Step 2. Check lube pump cover (forward rear axle) for visible damage.

Notify direct support maintenance.

TROUBLESHOOTING.

2-11. TROUBLESHOOTING PROCEDURES (Continued).

MALFUNCTION

TEST OR INSPECTION

CORRECTIVE ACTION

103. CONTINUOUS AXLE OR WHEEL NOISE (Continued).

Step 3. Check that brake shoes are not dragging. Check for overheating of brake drum. Using jack, raise wheel until it is clear of ground. Use tanker bar to pry up under wheel to check for loose bearings. Any movement of wheels indicates loose bearings. With brakes released, spin wheels to check for tight bearings. Wheel should spin freely and smoothly. Remove hub and drum to check condition of bearings (para 3-205).

- a. Adjust dragging brakes (para 3-157).
- b. Replace bearings, if necessary (para 3-205).

Step 4. Visually inspect tires.

Inflate tires to proper pressure or replace, if necessary. (Refer to TM 9-2320-283-10).

Step 5. Check wheel balance.

Notify direct support maintenance.

104. LUBRICANT LEAKING.

Step 1. Check all cover plate bolts for tightness.

Tighten bolts or notify direct support maintenance.

Step 2. Check vent breathers in forward-rear and rear-rear axles.

Clean or replace as necessary (para 3-153).

105. EXCESSIVE OR UNEVEN TIRE WEAR.

Step 1. Check front axle wheel alignment.

Align front wheels (para 3-203).

Step 2. Check brake adjustment.

Adjust brake, if required (para 3-157).

TROUBLESHOOTING.

2-11. TROUBLESHOOTING PROCEDURES (Continued).

MALFUNCTION	TEST OR INSPECTION	CORRECTIVE ACTION
-------------	--------------------	-------------------

105. EXCESSIVE OR UNEVEN TIRE WEAR (Continued).

Step 3. Check cold tire pressure.

Inflate to proper pressure. (Refer to TM 9-2320-283-10).

REAR AXLE

106. REAR AXLE ASSEMBLY NOT TRACKING PROPERLY.

Step 1. Check fifth wheel for secure mounting (this step applies only if a trailer is attached).

Tighten and torque (para 3-245).

Step 2. Check torque rods for looseness and damage.

Notify direct support maintenance.

Step 3. Check for dragging brakes by jacking vehicle and rotating wheels by hand.

Adjust or replace (para 3-157 or 3-159).

Step 4. Check wheel bearing adjustment using a pry bar. No movement is allowable. Check for damage and proper lubrication.

Adjust, lubricate, or replace (para 3-207).

Step 5. Check hubs and drums for damage.

Replace (para 3-207).

BRAKE SYSTEM

107. AIR PRESSURE LOW.

Step 1. Check for air exhausting through open or damaged air reservoir drain valves.

- a. Close primary or secondary air reservoir draincock.
- b. Replace drain valve or primary reservoir (para 3-169 or 3-188).

TROUBLESHOOTING.

2-11. TROUBLESHOOTING PROCEDURES (Continued).

MALFUNCTION	TEST OR INSPECTION	CORRECTIVE ACTION
-------------	--------------------	-------------------

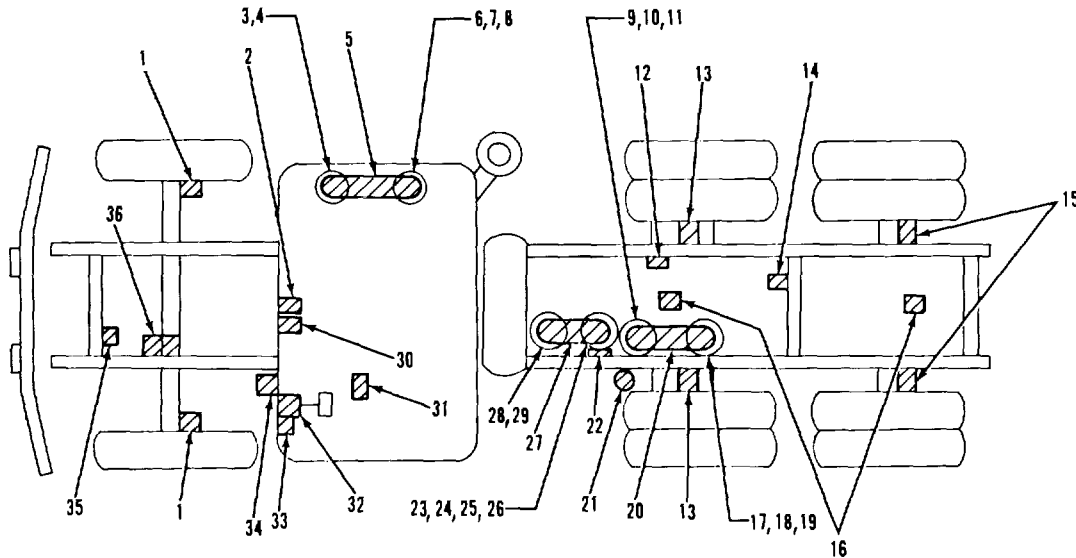

LEGEND:

- | | |
|--|--------------------------------------|
| 1. FRONT AXLE BRAKE CHAMBER (2) | 19. PLUG |
| 2. PARKING BRAKE VALVE | 20. PRIMARY RESERVOIR |
| 3. DRAINCOCK | 21. AIR DRYER |
| 4. PLUG (2) | 22. TRACTOR PROTECTION VALVE |
| 5. SECONDARY RESERVOIR | 23. AUTOMATIC DRAIN VALVE |
| 6. DOUBLE CHECK VALVE | 24. 90° ELBOW |
| 7. 90° CHECK VALVE | 25. QUICK RELEASE COUPLER |
| 8. 90° ELBOW | 26. SAFETY VALVE |
| 9. DRAINCOCK | 27. SUPPLY RESERVOIR |
| 10. 45° ELBOW | 28. 90° ELBOW (2) |
| 11. 45° CHECK VALVE | 29. CHECK VALVE |
| 12. DOUBLE CHECK AND QUICK RELEASE VALVE | 30. TRAILER SUPPLY VALVE |
| 13. FORWARD-REAR AXLE BRAKE CHAMBER (2) | 31. TRAILER HAND CONTROL BRAKE VALVE |
| 14. RELAY VALVE | 32. BRAKE TREADLE VALVE |
| 15. REAR-REAR AXLE AIR BRAKE CHAMBER (2) | 33. DOUBLE CHECK VALVE |
| 16. QUICK RELEASE VALVE (2) | 34. DOUBLE CHECK AND STOPLAMP VALVE |
| 17. ADAPTER | 35. FRONT AXLE RATIO VALVE |
| 18. 90° ELBOW | 36. AIR COMPRESSOR/GOVERNOR |

TA 236956

TROUBLESHOOTING.

2-11. TROUBLESHOOTING PROCEDURES (Continued).

MALFUNCTION

TEST OR INSPECTION

CORRECTIVE ACTION

107. AIR PRESSURE LOW (Continued).

Step 2. Check for loose air connections between the compressor, governor, and air reservoirs.

Tighten any loose air connections and replace damaged components, air lines, and connectors (para 3-163).

Step 3. Check air governor by noting on air gages when air compressor shuts off and starts up again. Air compressor should shut off no higher than 125 psi and start when air pressure drops 25 psi after shut off.

Notify direct support maintenance if air compressor does not operate within the pressure specifications above.

Step 4. With the engine not running, loosen the compressor output line at compressor and listen for escaping air.

- a. If air escapes continuously, replace the check valve in that line at the supply reservoir (para 3-191).
- b. If the check valve is OK, notify direct support maintenance.

Step 5. Check air line connections for tightness and air lines for cracks or breaks.

Tighten or replace connections and lines as necessary (para 3-163).

108. AIR PRESSURE HIGH.

Step 1. Check for inoperative pressure safety relief valve on the supply reservoir.

If reservoir exceeds 150 psi, replace safety release valve (para 3-186).

Step 2. Refer to malfunction 107, step 3.

TROUBLESHOOTING.

2-11. TROUBLESHOOTING PROCEDURES (Continued).

MALFUNCTION	TEST OR INSPECTION	CORRECTIVE ACTION
-------------	--------------------	-------------------

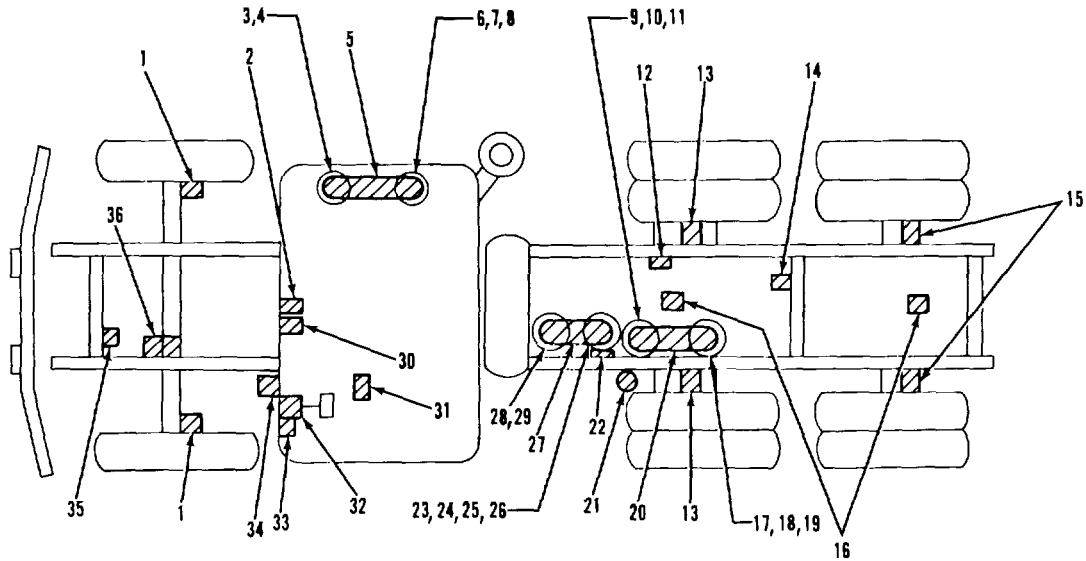

LEGEND:

- | | |
|--|--------------------------------------|
| 1. FRONT AXLE BRAKE CHAMBER (2) | 19. PLUG |
| 2. PARKING BRAKE VALVE | 20. PRIMARY RESERVOIR |
| 3. DRAINCOCK | 21. AIR DRYER |
| 4. PLUG (2) | 22. TRACTOR PROTECTION VALVE |
| 5. SECONDARY RESERVOIR | 23. AUTOMATIC DRAIN VALVE |
| 6. DOUBLE CHECK VALVE | 24. 90° ELBOW |
| 7. 90° CHECK VALVE | 25. QUICK RELEASE COUPLER |
| 8. 90° ELBOW | 26. SAFETY VALVE |
| 9. DRAINCOCK | 27. SUPPLY RESERVOIR |
| 10. 45° ELBOW | 28. 90° ELBOW (2) |
| 11. 45° CHECK VALVE | 29. CHECK VALVE |
| 12. DOUBLE CHECK AND QUICK RELEASE VA | 30. TRAILER SUPPLY VALVE |
| 13. FORWARD-REAR AXLE BRAKE CHAMBER (; | 31. TRAILER HAND CONTROL BRAKE VALVE |
| 14. RELAY VALVE | 32. BRAKE TREADLE VALVE |
| 15. REAR-REAR AXLE AIR BRAKE CHAMBER | 33. DOUBLE CHECK VALVE |
| 16. QUICK RELEASE VALVE (2) | 34. DOUBLE CHECK AND STOPLAMP VALVE |
| 17. ADAPTER | 35. FRONT AXLE RATIO VALVE |
| 18. 90° ELBOW | 36. AIR COMPRESSOR/GOVERNOR |

TA 236957

TROUBLESHOOTING.

2-11. TROUBLESHOOTING PROCEDURES (Continued).

MALFUNCTION

TEST OR INSPECTION

CORRECTIVE ACTION

109. PARK BRAKES WILL NOT RELEASE.

Step 1. Check reservoir pressure gage and verify that LOW PRESSURE warning lamp is out.

Refer to malfunction 107.

Step 2. Verify PARK BRAKE manual valve is closed.

Close valve. Replace valve if it will not close (para 3-171).

Step 3. Check air lines for leakage or damage. Use a soap solution to check for leakage at connections (watch for bubbles).

Replace damaged lines and tighten loose connections (para 3-163).

Step 4. Check the air line between forward-rear and rear-rear axle quick release valves for damage or leaks using a soap solution.

a. Replace line if damaged, and tighten connections (para 3-163).

b. Replace the park brake valve (para 3-171).

110. TRAILER BRAKES WILL NOT RELEASE.

Step 1. Check vehicle air hoses for proper connections. Close trailer supply valve and disconnect hoses.

Reconnect hoses and open supply valve.

Step 2. Check trailer for air leaks or defective brakes.

Troubleshoot trailer.

TROUBLESHOOTING.

2-11. TROUBLESHOOTING PROCEDURES (Continued).

MALFUNCTION	TEST OR INSPECTION	CORRECTIVE ACTION
-------------	--------------------	-------------------

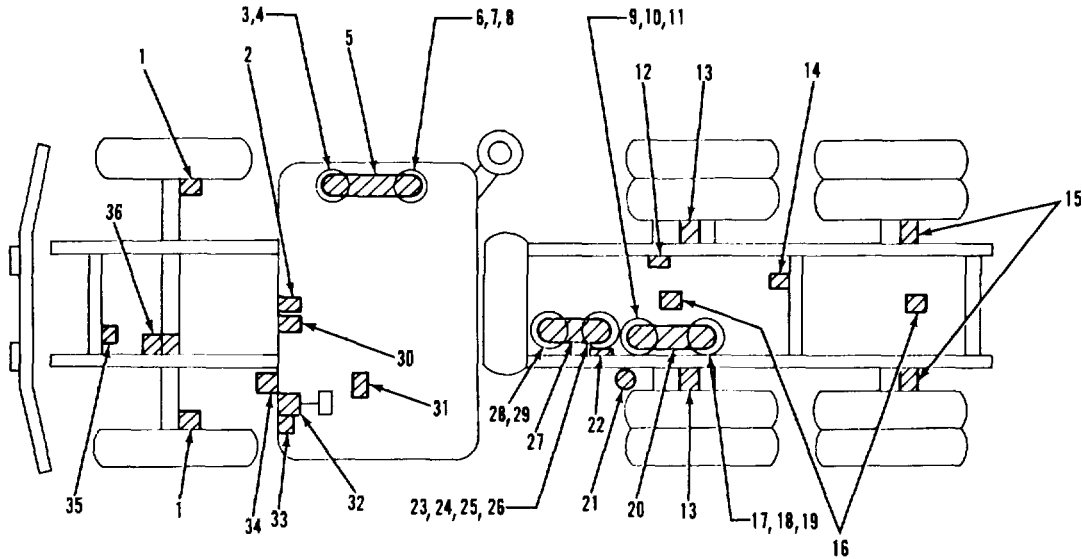

LEGEND:

- | | |
|---------------------------------------|--------------------------------------|
| 1. FRONT AXLE BRAKE CHAMBER (2) | 19. PLUG |
| 2. PARKING BRAKE VALVE | 20. PRIMARY RESERVOIR |
| 3. DRAINCOCK | 21. AIR DRYER |
| 4. PLUG (2) | 22. TRACTOR PROTECTION VALVE |
| 5. SECONDARY RESERVOIR | 23. AUTOMATIC DRAIN VALVE |
| 6. DOUBLE CHECK VALVE | 24. 90° ELBOW |
| 7. 90° CHECK VALVE | 25. QUICK RELEASE COUPLER |
| 8. 90° ELBOW | 26. SAFETY VALVE |
| 9. DRAINCOCK | 27. SUPPLY RESERVOIR |
| 10. 45° ELBOW | 28. 90° ELBOW (2) |
| 11. 45° CHECK VALVE | 29. CHECK VALVE |
| 12. DOUBLE CHECK AND QUICK RELEASE VP | 30. TRAILER SUPPLY VALVE |
| 13. FORWARD-REAR AXLE BRAKE CHAMBER (| 31. TRAILER HAND CONTROL BRAKE VALVE |
| 14. RELAY VALVE | 32. BRAKE TREADLE VALVE |
| 15. REAR-REAR AXLE AIR BRAKE CHAMBER | 33. DOUBLE CHECK VALVE |
| 16. QUICK RELEASE VALVE (2) | 34. DOUBLE CHECK AND STOPLAMP VALVE |
| 17. ADAPTER | 35. FRONT AXLE RATIO VALVE |
| 18. 90° ELBOW | 36. AIR COMPRESSOR/GOVERNOR |

TA236958

TROUBLESHOOTING.

2-11. TROUBLESHOOTING PROCEDURES (Continued).

MALFUNCTION

TEST OR INSPECTION

CORRECTIVE ACTION

111. SERVICE BRAKES WILL NOT RELEASE (ONE WHEEL ONLY).

Troubleshoot brakes.

Refer to brake malfunctions 109 and 110.

112. SERVICE BRAKES WILL NOT APPLY.

Step 1. Check pressure gages in cab.

Operate engine to build up proper pressure. (Refer to TM 9-2320-283-10).

Step 2. Check position of parking brake and trailer supply valves.

Position correctly. (Refer to TM 9-2320-283-10).

Step 3. Check intervehicle connections.

Connect air hoses correctly and open trailer supply valve.

Step 4. Check for leakage at dual brake treadle valve using a soap solution.

Tighten connections or replace defective brake treadle valve (para 3-174).

Step 5. Check brakes for proper adjustment and worn linings.

a. Adjust brakes (para 3-157).

b. Replace brakes shoes (para 3-159).

TROUBLESHOOTING.

2-11. TROUBLESHOOTING PROCEDURES (Continued).

MALFUNCTION	TEST OR INSPECTION	CORRECTIVE ACTION
-------------	--------------------	-------------------

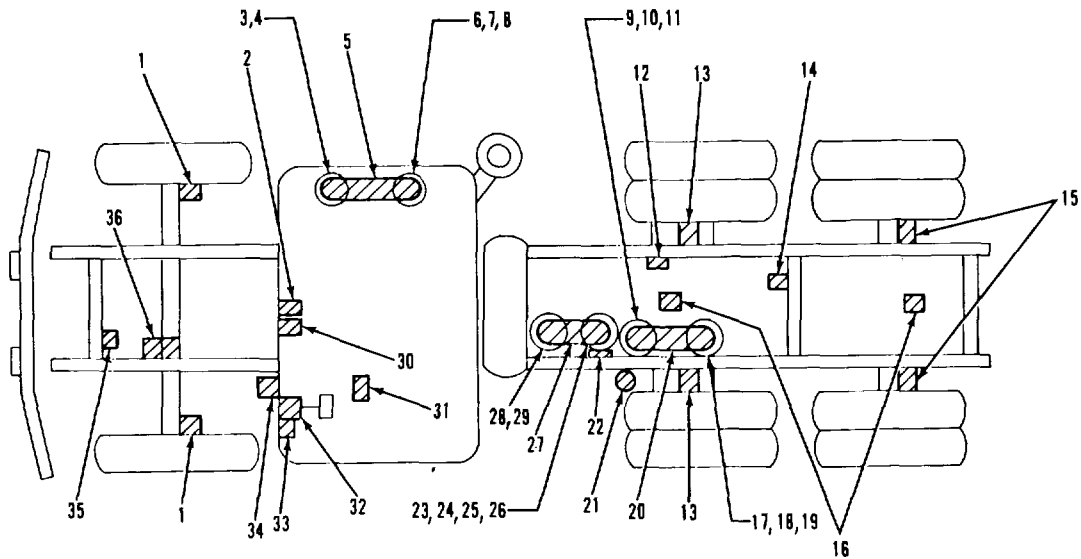

LEGEND:

- | | |
|---------------------------------------|--------------------------------------|
| 1. FRONT AXLE BRAKE CHAMBER (2) | 19. PLUG |
| 2. PARKING BRAKE VALVE | 20. PRIMARY RESERVOIR |
| 3. DRAINCOCK | 21. AIR DRYER |
| 4. PLUG (2) | 22. TRACTOR PROTECTION VALVE |
| 5. SECONDARY RESERVOIR | 23. AUTOMATIC DRAIN VALVE |
| 6. DOUBLE CHECK VALVE | 24. 90° ELBOW |
| 7. 90° CHECK VALVE | 25. QUICK RELEASE COUPLER |
| 8. 90° ELBOW | 26. SAFETY VALVE |
| 9. DRAINCOCK | 27. SUPPLY RESERVOIR |
| 10. 45° ELBOW | 28. 90° ELBOW (2) |
| 11. 45° CHECK VALVE | 29. CHECK VALVE |
| 12. DOUBLE CHECK AND QUICK RELEASE VW | 30. TRAILER SUPPLY VALVE |
| 13. FORWARD-REAR AXLE BRAKE CHAMBER (| 31. TRAILER HAND CONTROL BRAKE VALVE |
| 14. RELAY VALVE | 32. BRAKE TREADLE VALVE |
| 15. REAR-REAR AXLE AIR BRAKE CHAMBER | 33. DOUBLE CHECK VALVE |
| 16. QUICK RELEASE VALVE (2) | 34. DOUBLE CHECK AND STOPLAMP VALVE |
| 17. ADAPTER | 35. FRONT AXLE RATIO VALVE |
| 18. 90° ELBOW | 36. AIR COMPRESSOR/GOVERNOR |

TA 236959

TROUBLESHOOTING.

2-11. TROUBLESHOOTING PROCEDURES (Continued).	
MALFUNCTION	TEST OR INSPECTION CORRECTIVE ACTION
113. NO SERVICE BRAKES ON TRAILER ONLY.	<p>Step 1. Check service air hose connection and position of trailer supply valve. Reconnect hose properly and open trailer supply valve.</p> <p>Step 2. Check trailer supply valve for damage or leakage using a soap solution. Replace defective valve (para 3-175).</p> <p>Step 3. Check double check valve(s) for damage or leakage using a soap solution. Replace defective valve(s) (para 3-182, 3-183, 3-185, and 3-193).</p>
114. TRAILER HAND CONTROL WILL NOT APPLY TRAILER SERVICE BRAKES.	<p>Step 1. Check air lines between trailer hand control and double check valve for leakage using a soap solution. Repair leaks.</p> <p>Step 2. Check tractor protection valve for damage or leaks using a soap solution. Tighten connections or replace valve (para 3-192).</p> <p>Step 3. Check double check valve for damage or leaks using a soap solution. Tighten connections or replace valve (para 3-183).</p>

TROUBLESHOOTING.

2-11. TROUBLESHOOTING PROCEDURES (Continued).

MALFUNCTION	TEST OR INSPECTION	CORRECTIVE ACTION
-------------	--------------------	-------------------

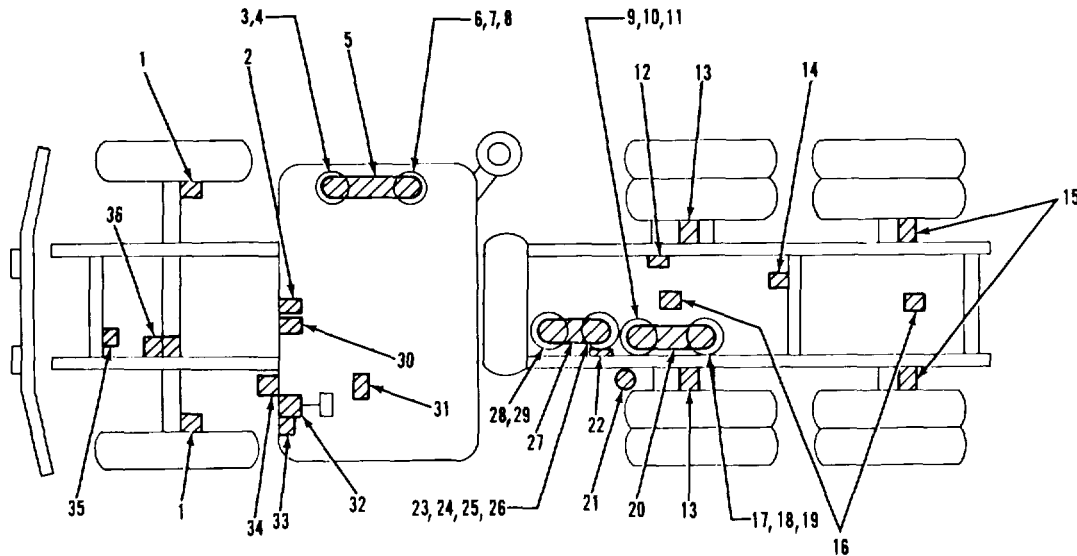

LEGEND:

- | | |
|--------------------------------------|--------------------------------------|
| 1. FRONT AXLE BRAKE CHAMBER (2) | 19. PLUG |
| 2. PARKING BRAKE VALVE | 20. PRIMARY RESERVOIR |
| 3. DRAINCOCK | 21. AIR DRYER |
| 4. PLUG (2) | 22. TRACTOR PROTECTION VALVE |
| 5. SECONDARY RESERVOIR | 23. AUTOMATIC DRAIN VALVE |
| 6. DOUBLE CHECK VALVE | 24. 90° ELBOW |
| 7. 900 CHECK VALVE | 25. QUICK RELEASE COUPLER |
| 8. 90° ELBOW | 26. SAFETY VALVE |
| 9. DRAINCOCK | 27. SUPPLY RESERVOIR |
| 10. 45° ELBOW | 28. 90° ELBOW (2) |
| 11. 45° CHECK VALVE | 29. CHECK VALVE |
| 12. DOUBLE CHECK AND QUICK RELEASE V | 30. TRAILER SUPPLY VALVE |
| 13. FORWARD-REAR AXLE BRAKE CHAMBER | 31. TRAILER HAND CONTROL BRAKE VALVE |
| 14. RELAY VALVE | 32. BRAKE TREADLE VALVE |
| 15. REAR-REAR AXLE AIR BRAKE CHAMBER | 33. DOUBLE CHECK VALVE |
| 16. QUICK RELEASE VALVE (2) | 34. DOUBLE CHECK AND STOPLAMP VALVE |
| 17. ADAPTER | 35. FRONT AXLE RATIO VALVE |
| 18. 90° ELBOW | 36. AIR COMPRESSOR/GOVERNOR |

TA 236960

TROUBLESHOOTING.

2-11. TROUBLESHOOTING PROCEDURES (Continued).		
MALFUNCTION	TEST OR INSPECTION	CORRECTIVE ACTION
115. PARK BRAKES WILL NOT APPLY.	Step 1. Inspect vent on park brake valve for damage or clogging.	Clean vent or replace valve (para 3-171).
	Step 2. Check air brake chambers for proper position of caging bolt.	Uncage bolt. (Refer to TM 9-2320-283-10).
116. SERVICE BRAKES ARE WEAK OR SLOW WORKING (ALL WHEELS).	Step 1. Check for low reservoir pressure. Pressure should not be below 70 lbs. (Buzzer sounds at pressure below 70 lbs).	See malfunction 106.
	Step 2. Check service air lines for damage and leakage using a soap solution.	Tighten loose connections and replace damaged lines.
	Step 3. Check brake linings and adjustment.	Replace brake shoes and/or adjust as necessary (para 3-157 and 3-159).
117. FRONT SERVICE BRAKES ARE WEAK OR SLOW WORKING.	Step 1. Check air lines between brake pedal valve and front brake chambers for damage and leakage using a soap solution.	Tighten loose connections and replace damaged lines.
	Step 2. Check the ratio valve for damage and leakage using a soap solution.	Replace defective ratio valve (para 3-181).

TROUBLESHOOTING.

2-11. TROUBLESHOOTING PROCEDURES (Continued).

MALFUNCTION	TEST OR INSPECTION	CORRECTIVE ACTION
-------------	--------------------	-------------------

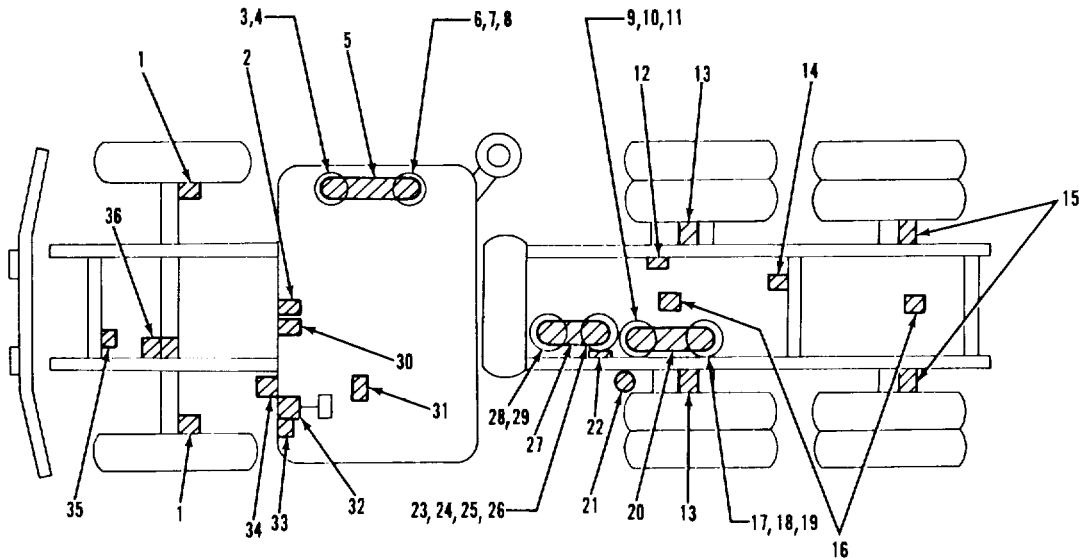

LEGEND:

- | | |
|---------------------------------------|--------------------------------------|
| 1. FRONT AXLE BRAKE CHAMBER (2) | 19. PLUG |
| 2. PARKING BRAKE VALVE | 20. PRIMARY RESERVOIR |
| 3. DRAINCOCK | 21. AIR DRYER |
| 4. PLUG (2) | 22. TRACTOR PROTECTION VALVE |
| 5. SECONDARY RESERVOIR | 23. AUTOMATIC DRAIN VALVE |
| 6. DOUBLE CHECK VALVE | 24. 90° ELBOW |
| 7. 90° CHECK VALVE | 25. QUICK RELEASE COUPLER |
| 8. 90° ELBOW | 26. SAFETY VALVE |
| 9. DRAINCOCK | 27. SUPPLY RESERVOIR |
| 10. 45° ELBOW | 28. 90° ELBOW (2) |
| 11. 45° CHECK VALVE | 29. CHECK VALVE |
| 12. DOUBLE CHECK AND QUICK RELEASE V/ | 30. TRAILER SUPPLY VALVE |
| 13. FORWARD-REAR AXLE BRAKE CHAMBER | 31. TRAILER HAND CONTROL BRAKE VALVE |
| 14. RELAY VALVE | 32. BRAKE TREADLE VALVE |
| 15. REAR-REAR AXLE AIR BRAKE CHAMBER | 33. DOUBLE CHECK VALVE |
| 16. QUICK RELEASE VALVE (2) | 34. DOUBLE CHECK AND STOPLAMP VALVE |
| 17. ADAPTER | 35. FRONT AXLE RATIO VALVE |
| 18. 90° ELBOW | 36. AIR COMPRESSOR/GOVERNOR |

TA 236961

TROUBLESHOOTING.

2-11. TROUBLESHOOTING PROCEDURES (Continued).		
MALFUNCTION	TEST OR INSPECTION	CORRECTIVE ACTION
<p>117. FRONT SERVICE BRAKES ARE WEAK OR SLOW WORKING (Continued).</p> <p>Step 3. Check brake pedal valve for damage and leakage using a soap solution.</p> <p style="padding-left: 40px;">Replace defective valve (para 3-174).</p> <p>Step 4. Check front brakes for worn linings (shoes) and proper adjustments.</p> <p style="padding-left: 40px;">Adjust brakes and replace linings, if necessary (para 3-157 or 3-159).</p>		
<p>118. REAR SERVICE BRAKES ARE UNEVEN OR ERRATIC.</p> <p>Step 1. Check for leakage in air lines between service brake relay valve and wheel air chambers using a soap solution.</p> <p>Step 2. Check for air leakage between air reservoir and rear service brake relay valve.</p> <p style="padding-left: 40px;">Tighten loose connections or replace damaged lines.</p> <p>Step 3. Leak test rear brake part of the brake treadle valve.</p> <p style="padding-left: 40px;">Tighten loose connections or replace brake treadle valve (para 3-174)</p> <p>Step 4. Check brake shoes for proper adjustment.</p> <p style="padding-left: 40px;">Adjust brake shoes (para 3-157).</p>		
<p>119. SERVICE BRAKES ARE UNEVEN OR ERRATIC ON ONE OR MORE WHEELS.</p> <p>Step 1. Have an assistant press and hold brake pedal down and perform leakage test on air lines at affected wheels using a soap solution.</p>		

TROUBLESHOOTING.

2-11. TROUBLESHOOTING PROCEDURES (Continued).

MALFUNCTION	TEST OR INSPECTION	CORRECTIVE ACTION
-------------	--------------------	-------------------

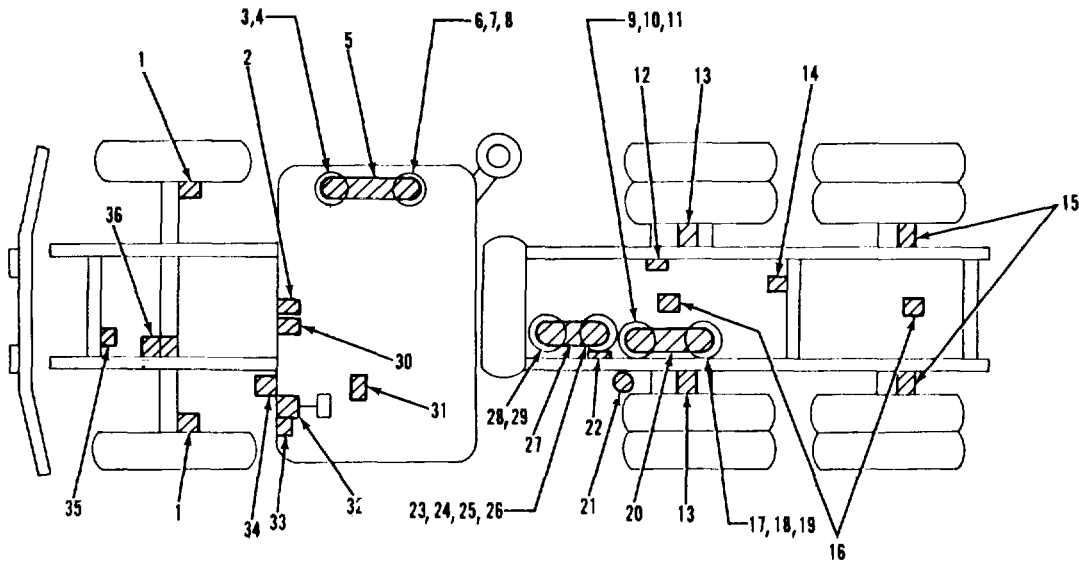

LEGEND:

- | | |
|---|--------------------------------------|
| 1. FRONT AXLE BRAKE CHAMBER (2) | 19. PLUG |
| 2. PARKING BRAKE VALVE | 20. PRIMARY RESERVOIR |
| 3. DRAINCOCK | 21. AIR DRYER |
| 4. PLUG (2) | 22. TRACTOR PROTECTION VALVE |
| 5. SECONDARY RESERVOIR | 23. AUTOMATIC DRAIN VALVE |
| 6. DOUBLE CHECK VALVE | 24. 90° ELBOW |
| 7. 90° CHECK VALVE | 25. QUICK RELEASE COUPLER |
| 8. 90° ELBOW | 26. SAFETY VALVE |
| 9. DRAINCOCK | 27. SUPPLY RESERVOIR |
| 10. 45° ELBOW | 28. 90° ELBOW (2) |
| 11. 45° CHECK VALVE | 29. CHECK VALVE |
| 12. DOUBLE CHECK AND QUICK RELEASE VAL | 30. TRAILER SUPPLY VALVE |
| 13. FORWARD-REAR AXLE BRAKE CHAMBER (2) | 31. TRAILER HAND CONTROL BRAKE VALVE |
| 14. RELAY VALVE | 32. BRAKE TREADLE VALVE |
| 15. REAR-REAR AXLE AIR BRAKE CHAMBER (| 33. DOUBLE CHECK VALVE |
| 16. QUICK RELEASE VALVE (2) | 34. DOUBLE CHECK AND STOPLAMP VALVE |
| 17. ADAPTER | 35. FRONT AXLE RATIO VALVE |
| 18. 90° ELBOW | 36. AIR COMPRESSOR/GOVERNOR |

TA 236962

TROUBLESHOOTING.**2-11. TROUBLESHOOTING PROCEDURES (Continued).****MALFUNCTION****TEST OR INSPECTION****CORRECTIVE ACTION****119. SERVICE BRAKES ARE UNEVEN OR ERRATIC ON ONE OR MORE WHEELS (Continued).**

Step 2. Loosen line fitting at affected wheel air chamber and have an assistant lightly depress brake pedal. Listen for air exhausting from line. No air indicates a clogged line.

Replace damaged or clogged line.

Step 3. Check brake adjustment (para 3-157).

Step 4. Press brake pedal down and listen for air leakage around wheel air chamber clamp.

Tighten clamp or replace brake chamber (para 3-165 for front brakes, para 3-165 or 3-166 for rear brakes).

Step 5. Remove drum to inspect (para 3-204 or 3-206).

a. Clean, repair, or replace defective brake components (para 3-158 thru 3-162).

b. Check brake shoes (linings) for grease, glazing, and proper installation (para 3-159).

120. BRAKES OVERHEAT.

Step 1. Check for low reservoir pressure.

If below 70 psi, see malfunction 107 (forward-rear axle only).

Step 2. Check for damaged or leaking front ratio valve or rear relay valves.

Tighten loose connections or replace defective valve (para 3-181 or 3-177, as applicable).

TROUBLESHOOTING.

2-11. TROUBLESHOOTING PROCEDURES (Continued).

MALFUNCTION

TEST OR INSPECTION

CORRECTIVE ACTION

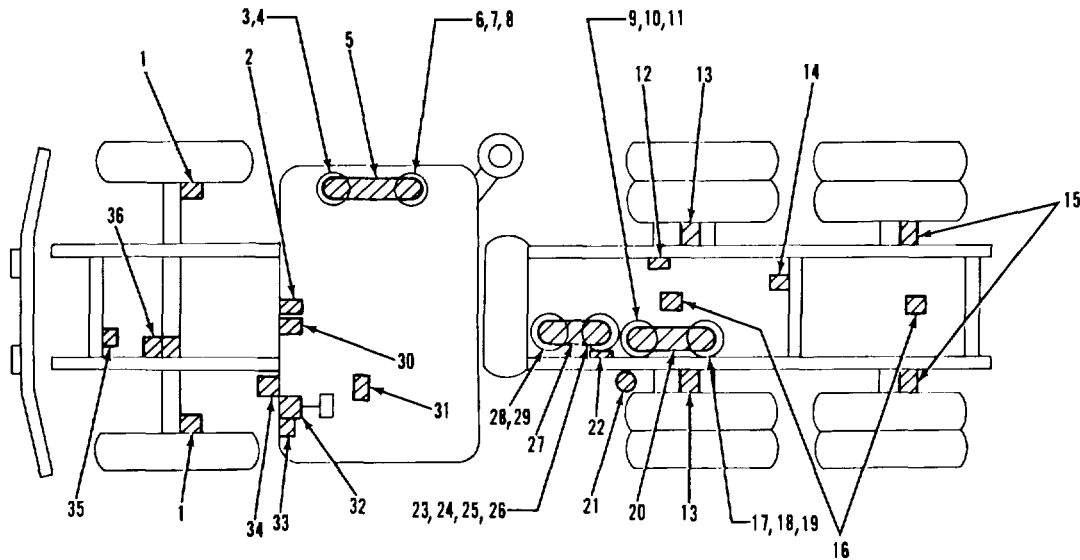

LEGEND:

- | | |
|---|--|
| <ul style="list-style-type: none"> 1. FRONT AXLE BRAKE CHAMBER (2) 2. PARKING BRAKE VALVE 3. DRAINCOCK 4. PLUG (2) 5. SECONDARY RESERVOIR 6. DOUBLE CHECK VALVE 7. 90° CHECK VALVE 8. 90° ELBOW 9. DRAINCOCK 10. 45° ELBOW 11. 45° CHECK VALVE 12. DOUBLE CHECK AND QUICK RELEASE VAL 13. FORWARD-REAR AXLE BRAKE CHAMBER (2) 14. RELAY VALVE 15. REAR-REAR AXLE AIR BRAKE CHAMBER (; 16. QUICK RELEASE VALVE (2) 17. ADAPTER 18. 90° ELBOW | <ul style="list-style-type: none"> 19. PLUG 20. PRIMARY RESERVOIR 21. AIR DRYER 22. TRACTOR PROTECTION VALVE 23. AUTOMATIC DRAIN VALVE 24. 90° ELBOW 25. QUICK RELEASE COUPLER 26. SAFETY VALVE 27. SUPPLY RESERVOIR 28. 90° ELBOW (2) 29. CHECK VALVE 30. TRAILER SUPPLY VALVE 31. TRAILER HAND CONTROL BRAKE VALVE 32. BRAKE TREADLE VALVE 33. DOUBLE CHECK VALVE 34. DOUBLE CHECK AND STOPLAMP VALVE 35. FRONT AXLE RATIO VALVE 36. AIR COMPRESSOR/GOVERNOR |
|---|--|

TA 236963

TROUBLESHOOTING.

2-11. TROUBLESHOOTING PROCEDURES (Continued).

MALFUNCTION

TEST OR INSPECTION

CORRECTIVE ACTION

120. BRAKES OVERHEAT (Continued).

Step 3. Check for dragging brakes.

Adjust brakes (para 3-157).

Step 4. Remove drum (para 3-204 thru 3-206), and inspect brake assembly. Apply brakes lightly and observe shoe movement for smooth operation.

Clean, repair, or replace defective components (para 3-158 thru 3-162).

Step 5. Inspect wheel bearings for damage and proper lubrication.

Adjust, lube, or replace bearings (para 3-204 thru 3-207, as applicable).

121. STOPLAMPS DO NOT OPERATE (BRAKES NORMAL).

Check for defective wiring or electrical connectors.

Refer to malfunction 56.

122. PRESSURE GAGE(S) NOT INDICATING OR NOT ACCURATE (BRAKES NORMAL).

Step 1. Disconnect affected air line(s) at gage(s), and press brake pedal. If no air exhausts, the line is clogged or broken.

Replace defective line or gage (para 3-163).

TROUBLESHOOTING.

2-11. TROUBLESHOOTING PROCEDURES (Continued).

MALFUNCTION	TEST OR INSPECTION	CORRECTIVE ACTION
-------------	--------------------	-------------------

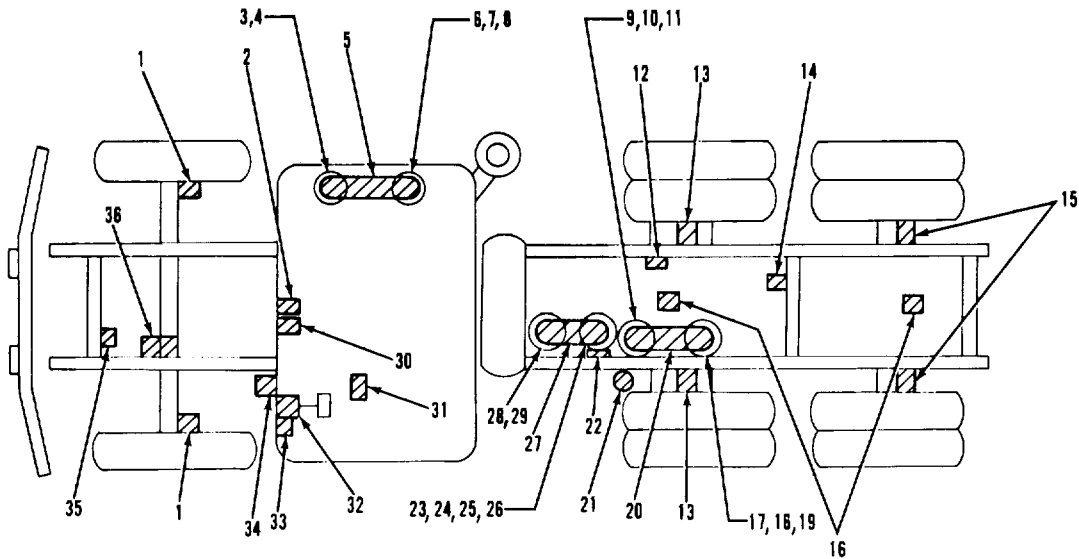

LEGEND:

- | | |
|--------------------------------------|--------------------------------------|
| 1. FRONT AXLE BRAKE CHAMBER (2) | 19. PLUG |
| 2. PARKING BRAKE VALVE | 20. PRIMARY RESERVOIR |
| 3. DRAINCOCK | 21. AIR DRYER |
| 4. PLUG (2) | 22. TRACTOR PROTECTION VALVE |
| 5. SECONDARY RESERVOIR | 23. AUTOMATIC DRAIN VALVE |
| 6. DOUBLE CHECK VALVE | 24. 90° ELBOW |
| 7. 90° CHECK VALVE | 25. QUICK RELEASE COUPLER |
| 8. 90° ELBOW | 26. SAFETY VALVE |
| 9. DRAINCOCK | 27. SUPPLY RESERVOIR |
| 10. 45° ELBOW | 28. 90° ELBOW (2) |
| 11. 45° CHECK VALVE | 29. CHECK VALVE |
| 12. DOUBLE CHECK AND QUICK RELEASE V | 30. TRAILER SUPPLY VALVE |
| 13. FORWARD-REAR AXLE BRAKE CHAMBER | 31. TRAILER HAND CONTROL BRAKE VALVE |
| 14. RELAY VALVE | 32. BRAKE TREADLE VALVE |
| 15. REAR-REAR AXLE AIR BRAKE CHAMBER | 33. DOUBLE CHECK VALVE |
| 16. QUICK RELEASE VALVE (2) | 34. DOUBLE CHECK AND STOPLAMP VALVE |
| 17. ADAPTER | 35. FRONT AXLE RATIO VALVE |
| 18. 90° ELBOW | 36. AIR COMPRESSOR/GOVERNOR |

TA 236964

TROUBLESHOOTING.**2-11. TROUBLESHOOTING PROCEDURES (Continued).**

MALFUNCTION

TEST OR INSPECTION

CORRECTIVE ACTION

123. AIR HORN NOT WORKING.

Step 1. Check air gage for low pressure reading.

If air pressure is below 20 psi, operate engine until air pressure is back to 125 psi. See malfunction 107.

Step 2. Inspect air lines for damage or clogging.

- a. Replace damaged or clogged lines (para 3-163).
- b. Replace defective manually operated horn valve (para 3-289).

124. WINDSHIELD WIPERS NOT WORKING.

Step 1. Check for air leakage in lines to wiper control valve using a soap solution.

Tighten loose connections and replace damaged lines (para 3-163).

Step 2. Check to see if wiper mechanical linkage is binding or broken.

Replace defective linkage (para 3-294).

Step 3. Loosen air lines at wiper motor and turn control to RUN position. Air should exhaust from line.

- a. If no air exhausts, replace control valve (para 3-192).
- b. If air exhausts, replace motor (para 3-295).

125. INTERAXLE DIFFERENTIAL LOCKOUT NOT WORKING.

Step 1. Check air system pressure.

Charge air system to 105 psi.

TROUBLESHOOTING.

2-11. TROUBLESHOOTING PROCEDURES (Continued).

MALFUNCTION	TEST OR INSPECTION	CORRECTIVE ACTION
-------------	--------------------	-------------------

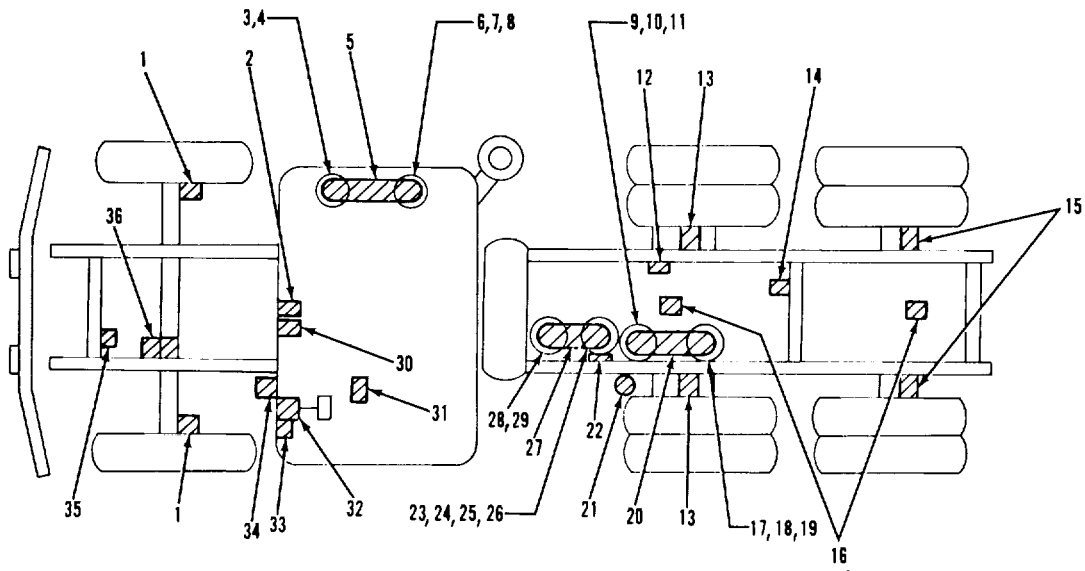

LEGEND:

- | | |
|--|--|
| <ul style="list-style-type: none"> 1. FRONT AXLE BRAKE CHAMBER (2) 2. PARKING BRAKE VALVE 3. DRAINCOCK 4. PLUG (2) 5. SECONDARY RESERVOIR 6. DOUBLE CHECK VALVE 7. 90° CHECK VALVE 8. 90° ELBOW 9. DRAINCOCK 10. 45° ELBOW 11. 45° CHECK VALVE 12. DOUBLE CHECK AND QUICK RELEASE VAL 13. FORWARD-REAR AXLE BRAKE CHAMBER (2) 14. RELAY VALVE 15. REAR-REAR AXLE AIR BRAKE CHAMBER (16. QUICK RELEASE VALVE (2) 17. ADAPTER 18. 90° ELBOW | <ul style="list-style-type: none"> 19. PLUG 20. PRIMARY RESERVOIR 21. AIR DRYER 22. TRACTOR PROTECTION VALVE 23. AUTOMATIC DRAIN VALVE 24. 90° ELBOW 25. QUICK RELEASE COUPLER 26. SAFETY VALVE 27. SUPPLY RESERVOIR 28. 90° ELBOW (2) 29. CHECK VALVE 30. TRAILER SUPPLY VALVE 31. TRAILER HAND CONTROL BRAKE VALVE 32. BRAKE TREADLE VALVE 33. DOUBLE CHECK VALVE 34. DOUBLE CHECK AND STOPLAMP VALVE 35. FRONT AXLE RATIO VALVE 36. AIR COMPRESSOR/GOVERNOR |
|--|--|

TA 236965

TROUBLESHOOTING.

2-11. TROUBLESHOOTING PROCEDURES (Continued).

MALFUNCTION

TEST OR INSPECTION

CORRECTIVE ACTION

125. INTERAXLE DIFFERENTIAL LOCKOUT NOT WORKING (Continued).

Step 2. Disconnect air lines at rear axle; then engage lockout control valve on instrument panel. Check for air pressure at rear axle. No air indicates clogged lines or defective lockout control valve.

- a. Replace clogged lines (para 3-163).
- b. Replace defective control valve (para 3-195).
- c. If air controls are working normally, notify direct support maintenance.

WHEELS

126. TIRES WEARING UNEVENLY.

Step 1. Refer to malfunction 105.

Step 2. Check wheel bearings for adjustment, lubrication, and damage.

Adjust bearings (para 3-204 or 3-207).

127. NOISY OR BUMPING SOUND WHILE TRAVELING ON ROAD.

Step 1. Check lug wheel stud capnuts for proper torque.

Torque lug nuts to 350 lb-ft.

Step 2. Inspect U-bolts for tightness.

Torque U-bolts to 125-165 lb-ft.

Step 3. Inspect spring shackle pins for looseness using a pry bar. No noticeable movement is allowable.

Refer to direct support maintenance.

TROUBLESHOOTING.

2-11. TROUBLESHOOTING PROCEDURES (Continued).

MALFUNCTION	TEST OR INSPECTION	CORRECTIVE ACTION
-------------	--------------------	-------------------

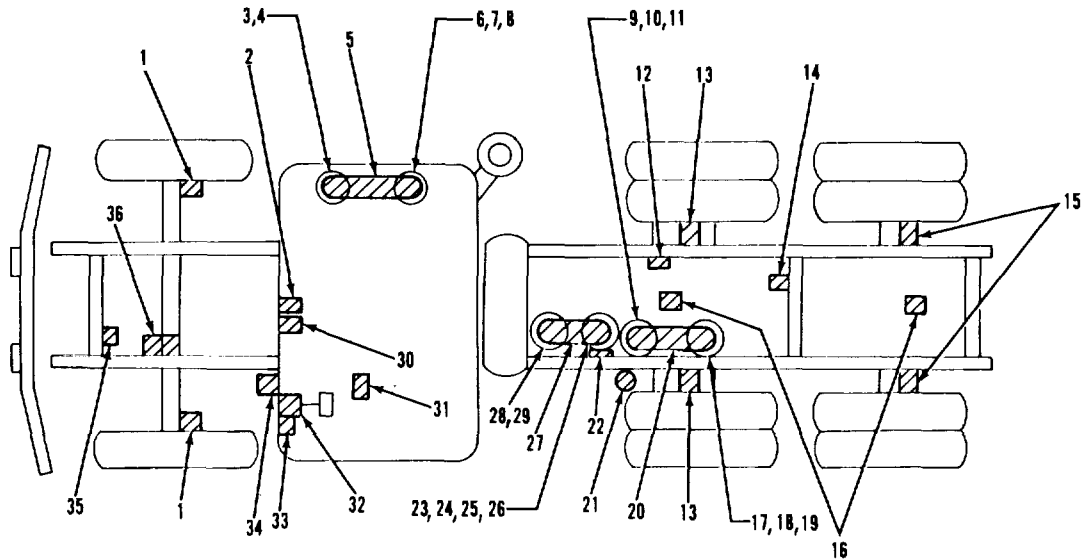

LEGEND:

- | | |
|---|--------------------------------------|
| 1. FRONT AXLE BRAKE CHAMBER (2) | 19. PLUG |
| 2. PARKING BRAKE VALVE | 20. PRIMARY RESERVOIR |
| 3. DRAINCOCK | 21. AIR DRYER |
| 4. PLUG (2) | 22. TRACTOR PROTECTION VALVE |
| 5. SECONDARY RESERVOIR | 23. AUTOMATIC DRAIN VALVE |
| 6. DOUBLE CHECK VALVE | 24. 90° ELBOW |
| 7. 90° CHECK VALVE | 25. QUICK RELEASE COUPLER |
| 8. 90° ELBOW | 26. SAFETY VALVE |
| 9. DRAINCOCK | 27. SUPPLY RESERVOIR |
| 10. 45° ELBOW | 28. 90° ELBOW (2) |
| 11. 45° CHECK VALVE | 29. CHECK VALVE |
| 12. DOUBLE CHECK AND QUICK RELEASE VAL | 30. TRAILER SUPPLY VALVE |
| 13. FORWARD-REAR AXLE BRAKE CHAMBER (2) | 31. TRAILER HAND CONTROL BRAKE VALVE |
| 14. RELAY VALVE | 32. BRAKE TREADLE VALVE |
| 15. REAR-REAR AXLE AIR BRAKE CHAMBER | 33. DOUBLE CHECK VALVE |
| 16. QUICK RELEASE VALVE (2) | 34. DOUBLE CHECK AND STOPLAMP VALVE |
| 17. ADAPTER | 35. FRONT AXLE RATIO VALVE |
| 18. 90° ELBOW | 36. AIR COMPRESSOR/GOVERNOR |

TA 236966

TROUBLESHOOTING.

2-11. TROUBLESHOOTING PROCEDURES (Continued).

MALFUNCTION

TEST OR INSPECTION

CORRECTIVE ACTION

127. NOISY OR BUMPING SOUND WHILE TRAVELING ON ROAD (Continued).

Step 4. Check wheel bearings for vertical looseness using a pry bar beneath tire. Check for proper lubrication and damage.

Adjust, lubricate, or replace bearing (para 3-204 or 3-207).

Step 5. Inspect rear axle shaft for damage by jacking up both wheels. Turn wheel while listening for a rumbling or grinding sound at the axle. Repeat on other wheel.

Replace axle shaft (para 3-154).

STEERING SYSTEM

128. FRONT TIRES WEARING UNEVENLY.

Step 1. Inspect U-bolts for tightness.

Torque U-bolts to 125-165 lb-ft.

Step 2. Inspect spring shackle pins for looseness using a pry bar. No noticeable movement is allowable.

Refer to direct support maintenance.

Step 3. Check wheel bearings for vertical looseness using a pry bar beneath the tire. Check for proper lubrication and damage.

Adjust, lubricate, or replace bearing (para 3-204 or 3-207, as applicable).

Step 4. Check for proper toe-in (1/32-inch \pm 1/32-inch).

Adjust toe-in (para 3-203).

Step 5. Check brakes for proper adjustment.

Adjust brakes (para 3-157).

TROUBLESHOOTING.

2-11. TROUBLESHOOTING PROCEDURES (Continued).

MALFUNCTION

TEST OR INSPECTION

CORRECTIVE ACTION

129. VEHICLE DOES NOT FULLY STEER FROM STOP TO STOP.

Step 1. Check all steering linkage for proper lubrication.

Lubricate. (Refer to LO 9-2320-283-12).

Step 2. Check steering arm for damage.

Replace steering arm (para 3-217).

Step 3. Check vertical link for damage or looseness. No play is allowable.

Replace vertical link (para 3-216).

Step 4. Check the tie rod for damage or loose end. No play is allowable.

Replace tie rod end, if loose (para 3-218).

Step 5. Check steering gear mounting bolts for tightness.

Notify direct support maintenance.

130. FRONT END WANDERS.

Step 1. Check tire pressure.

Bring tires to proper pressure. (Refer to TM 9-2320-283-10).

Step 2. Check for insufficient front end lubrication.

Lubricate. (Refer to LO 9-2320-283-12).

Step 3. Check for loose wheel stud capnuts.

Torque nuts to 475 lb-ft.

TROUBLESHOOTING.

2-11. TROUBLESHOOTING PROCEDURES (Continued).

MALFUNCTION

TEST OR INSPECTION

CORRECTIVE ACTION

130. FRONT END WANDERS (Continued).

Step 4. Check for insufficient fifth wheel lubrication (only if trailer is attached).

Lubricate. (Refer to LO 9-2320-283-12).

Step 5. Check for loose spring U-bolts.

Torque nuts on U-bolts to 125-165 lb-ft.

Step 6. Check wheel bearings for play using a pry bar.

Adjust or replace bearing (para 3-205).

Step 7. Inspect tie rod for damaged and loose ends. No play is allowable.

Replace tie rod end, if loose (para 3-218).

Step 8. Inspect vertical link for damage.

Replace vertical link (para 3-216).

Step 9. Check propeller shafts and universal joints for wear and damage. Wear is indicated by any movement between shaft and joint in any direction.

Replace (para 3-144 or 3-145).

Step 10. Check spring pins for wear using a pry bar. No noticeable movement is allowed.

Notify direct support maintenance.

Step 11. Check steering gear for looseness.

Notify direct support maintenance.

TROUBLESHOOTING.

2-11. TROUBLESHOOTING PROCEDURES (Continued).

MALFUNCTION

TEST OR INSPECTION

CORRECTIVE ACTION

131. FRONT END SHIMMIES.

Step 1. Check for badly worn or unevenly worn tires.

Replace tires (para 3-208).

Step 2. Check for improperly mounted tire or wheel.

Replace tire (para 3-208).

Step 3. Check wheel bearings for play using a pry bar.

Adjust or replace bearing (para 3-205 or 3-207).

Step 4. Check all steering linkage for proper lubrication. (Refer to LO 9-2320-283-12).

Step 5. Inspect tie rod for damaged and loose ends. No play is allowable.

Replace tie rod end, if loose or damaged (para 3-218).

Step 6. Inspect vertical link for damage.

Replace vertical link (para 3-216).

Step 7. Check wheel and brake drums for proper balance.

Balance or replace wheel or brake drums (para 3-204 or 3-206).

Step 8. Check for proper toe-in (1/32-inch \pm 1/32-inch).

Adjust toe-in (para 3-203).

Step 9. Check for air in hydraulic system.

Start engine. Turn steering wheel right then left several times until shimmy is eliminated. Shut down engine. Check fluid level and add to full mark. (Refer to LO 9-2320-283-12).

TROUBLESHOOTING.

2-11. TROUBLESHOOTING PROCEDURES (Continued).

MALFUNCTION

TEST OR INSPECTION

CORRECTIVE ACTION

132. VEHICLE OVERSTEERS.

Step 1. Check fifth wheel lubrication.

Lubricate. (Refer to LO 9-2320-283-12).

Step 2. Check all steering linkage for proper lubrication.

(Refer to LO 9-2320-283-12).

Step 3. Inspect tie rod for damaged and loose ends. No end play is allowable.

Replace tie rod end, if loose or damaged (para 3-218).

Step 4. Inspect vertical link for damage.

Replace vertical link (para 3-216).

Step 5. Check upper and lower steering column for binding.

Repair or replace (para 3-214 or 3-215, as applicable).

Step 6. Check steering gear for looseness.

Notify direct support maintenance.

Step 7. Check rear axle mounts for looseness.

Notify direct support maintenance.

TROUBLESHOOTING.**2-11. TROUBLESHOOTING PROCEDURES (Continued).**

MALFUNCTION

TEST OR INSPECTION

CORRECTIVE ACTION

133. HARD STEERING IN ONE DIRECTION.

Step 1. Check tire pressure.

Inflate tires to proper pressure. (Refer to TM 9-2320-283-10).

Step 2. Inspect vehicle for overload.

Reduce load.

Step 3. Check hydraulic system pressure (para 3-212).

a. Replace pump (para 3-219).

b. Notify direct support maintenance.

134. HARD STEERING IN BOTH DIRECTIONS.

Step 1. Refer to malfunction 133, steps 1 and 2.

Step 2. Check hydraulic fluid level.

Add fluid as necessary (Refer to LO 9-2320-283-12).

Step 3. Check for low pump pressure and flow (para 3-212).

a. Replace pump (para 3-219).

b. Notify direct Support maintenance.

Step 4. Check for restrictions in return line.

Replace (para 3-220).

Step 5. Check for oversized tires. (Refer to TM 9-2320-283-10).

Replace tires (para 3-208).

TROUBLESHOOTING.

2-11. TROUBLESHOOTING PROCEDURES (Continued).

MALFUNCTION

TEST OR INSPECTION

CORRECTIVE ACTION

135. LOST MOTION OR EXCESSIVE PLAY IN STEERING WHEEL.

- Step 1. Check for loose steering wheel.
Repair or replace steering wheel (para 3-213).
- Step 2. Check for loose steering gear on frame.
Notify direct support maintenance.
- Step 3. Check for loose steering arm on steering gear.
Notify direct support maintenance.
- Step 4. Inspect tie rod for damaged and loose ends. No play is allowable. ii
Replace tie rod end, if loose or damaged (para 3-218).
- Step 5. Inspect vertical link for damage.
Replace vertical link (para 3-216).
- Step 6. Check upper and lower steering column for binding.
Repair or replace (para 3-214 or 3-215, as applicable).

FRAME AND TOWING ATTACHMENTS

136. TOWING PINTLE DOES NOT PIVOT OR LATCH, OR JAW IS STUCK.

- Step 1. Check for proper lubrication.
Lubricate. (Refer to LO 9-2320-283-12).
- Step 2. Check lock for damage.
Replace pintle hook (para 3-238).

TROUBLESHOOTING.

2-11. TROUBLESHOOTING PROCEDURES (Continued).	
MALFUNCTION	TEST OR INSPECTION CORRECTIVE ACTION
137. EXCESSIVE JERKING OF TOWED TRAILER.	<p>Step 1. Check for proper lubrication of fifth wheel.</p> <p>Lubricate. (Refer to LO 9-2320-283-12).</p> <p>Step 2. Check bolts and brackets on fifth wheel for tightness.</p> <p>Tighten and torque (para 3-245).</p> <p>Step 3. Inspect coupler jaw and locks for damage.</p> <p>Replace fifth wheel (para 3-245).</p>
138. EXCESSIVE NOISE OR POPPING SOUNDS FROM FIFTH WHEEL WHEN TURNING.	<p>Step 1. Check for proper lubrication of fifth wheel. Lubricate. (Refer to LO 9-2320-283-12).</p> <p>Step 2. Check all mounting bolts on fifth wheel for tightness. Tighten and torque (para 3-245).</p> <p>Step 3. Inspect locks for damage. Replace fifth wheel (para 3-245).</p>
2-327/(2-328 blank)	

SECTION V. STE/ICE TROUBLESHOOTING**2-12. GENERAL.**

a. This SECTION is applicable only if STE/ICE (Simplified Test Equipment for Internal Combustion Engines) is available. This SECTION contains information and tests which may be used with STE/ICE to locate malfunctions which develop in the M915A1 truck. The tests can be used during troubleshooting, PMCS, or prior to replacing parts to help isolate malfunctions, anticipate failures, and to make sure that proper repairs have been made.

b. STE/ICE is used primarily with the M915A1 truck's electrical system. Tests can also be performed on certain mechanical systems. These tests cannot cover all possible troubles which may occur. If a particular malfunction is not covered, refer to paragraph 2-10, Troubleshooting Symptom Index, to locate the conventional troubleshooting procedure for the malfunction observed. To obtain the maximum number of observed symptoms of the malfunction, question the truck's operator.

2-13. HOW TO USE THE STE/ICE TEST INDEX.

The Troubleshooting Symptom Index (para 2-10) contains a list of various troubles which may occur during operation or inspection of the M915A1 truck and which can be diagnosed with conventional test equipment. If STE/ICE equipment can also be used to determine the cause of the trouble, a STE/ICE GO or NO-GO chain Test Index number will immediately follow the listed malfunction. When one of the STE/ICE Test Index Numbers appears, go to either paragraph 2-17 or 2-18 and do the test called for.

STE/ICE tests cannot be done for all the malfunctions listed in the Troubleshooting System Index. Not all STE/ICE diagnostic tests, where the primary fault is unknown, relate to the observed malfunctions listed in paragraph 2-10. Refer to Test Index paragraphs 2-17 and 2-18 for additional tests which can only be performed with STE/ICE equipment.

2-14. VEHICLE TEST METER TROUBLESHOOTING.

a. The Vehicle Test Meter (VTM) is the heart of the STE/ICE system. VTM Troubleshooting Procedures are found in paragraphs 2-19 and 2-20. Additional VTM troubleshooting can be found in TM 9-4910-571-12&P.

STE/ICE TROUBLESHOOTING.

2-14. VEHICLE TEST METER TROUBLESHOOTING (Continued).

b. The STE/ICE VTM operator may follow either of two test procedures when using STE/ICE as follows:

(1) Diagnostic Test Procedures.

The GO/NO-GO diagnostic test procedures are used for troubleshooting malfunctioning vehicles where the primary fault is unknown. In the GO logic chain, the satisfactory result (yes) from each test leads to a GO to the next test. If the truck fails the test in the GO chain, the unsatisfactory result leads to a corrective action, higher level of maintenance, or to the NO-GO chain. The NO-GO logic chain contains procedures to determine the cause of failure and is arranged in steps detailing fault isolation and corrective action. When using a GO or NO-GO diagnostic procedure, the VTM operator must start at the beginning of the logic chain because the limits and steps for each test depend on previous steps.

(2) General Purpose Test Procedures.

The general purpose test procedures are used for making individual measurements when primary fault diagnosis has been done through the use of a troubleshooting table and verification of a malfunctioning part or system is desirable before parts replacement. Refer to this test procedure method when performing one specific STE/ICE test or when you do not want to follow the diagnostic GO/NO-GO logic chains. All VTM general purpose test procedures applicable to the M915A1 truck are found in TM 9-4910-571-12&P. General purpose test procedures may also be done using the M915A1 Truck Test Card found at the back of this TM.

c. The GO chain index, paragraph 2-17, contains a list of GO test numbers and titles. Refer to this paragraph for locating a specific GO chain test.

d. The NO-GO chain index, paragraph 2-18, contains a list of NO-GO test numbers and titles. Refer to this paragraph for locating a specific NO-GO chain test.

e. The M915A1 Truck Test Cards are found at the back of this TM. Use the sheet for reference purposes when doing general purpose test procedures. As you become more experienced you can rely solely on the Test Cards for doing GO/NO-GO chain and general purpose test procedures.

STE/ICE TROUBLESHOOTING.

2-15. STE/ICE VTM SET-UP PROCEDURE TEST NUMBER GO1.

The STE/ICE VTM set-up and internal checks must be done before performing any truck tests. Do test number GO1 to checkout the proper function of the VTM and associated cables.

2-16. STE/ICE DESCRIPTION AND OPERATION.

a. General. The following describes the operation of the Simplified Test Equipment/Internal Combustion Engines (STE/ICE) system and contains detailed operating procedures.

STE/ICE is used to test the serviceability of M915A1 trucks and to perform primary fault detection and isolation. After the MOS has identified a faulty part or subsystem, he/she is referred to a paragraph number for replacement or repair procedures for individual parts.

b. Description and Operation. STE/ICE is a testing system that performs tests and measurements on internal combustion engines. STE/ICE measures standard voltage, current, resistance, pressure, temperature, and speed (RPM). Special tests, such as compression unbalance test and starter system evaluations, are performed by STE/ICE. Standard equipment functions including vacuum pressure gage, compression gage, low-current tester, and multimeter are features of the STE/ICE set.

STE/ICE is portable and operates on either 12 or 24-volt truck batteries or equivalent power source. The STE/ICE system consists of a Vehicle Test Meter (VTM), a Transducer Kit (TK), four electrical cables, a transit case, and technical publications.

c. Personnel Required. One mechanic is required to perform most tests. An additional mechanic is required to perform certain specific tests.

d. Vehicle Test Meter.

(1) General. The VTM provides a method for the MOS to test M915A1 truck electrical and mechanical components. Readings are either pass/fail indications or digital displays in units familiar to the mechanic (psi, rpm, volts, ohms, amps, etc.). The Diagnostic Connector Assembly (DCA) is mounted on a bracket attached to the left hand (driver's side) of the engine block, and provides accessibility to the most frequently needed test points. The use of the VTM through the DCA is referred to as DCA mode. The VTM interfaces with the vehicle directly with transducers installed on the vehicle in the DCA mode. The use of the VTM through the TK is referred to as TK mode. The VTM interfaces with the vehicle with transducers from the transducer kit (TK). The DCA and the TK can be used at the same time. This may be necessary when the diagnostic connector assembly has a missing transducer, such as when doing the oil pressure test. If a transducer is missing, a no sensor indication (E002) is displayed when a measurement is made. If this happens, the TK mode can be

STE/ICE TROUBLESHOOTING.

2-16. STE/ICE DESCRIPTION AND OPERATION (Continued).

used to make the measurement. The use of the VTM through the DCA and TK is referred to as the combined mode. Additional tests can be done that involve manually probing and/or connecting transducers to appropriate test points. Operating power for the VTM is drawn from the M915A1 truck batteries or some equivalent source. Power is routed to the VTM through the DCA connected to the batteries. The STE/ICE general purpose testing capabilities that may be applied to the M915A1 truck are 0-1000 psig pressure, 0 to 45-volts dc, and 0-40k ohms resistance. The following control functions can be performed in conjunction with the special test: interleave (displays rpm with next test), display maximum value, display minimum value, and display peak-to-peak value.

(2) Controls and Indicators. The controls and readout display on the VTM are illustrated. The following paragraphs describe how the controls are used and how the display functions.

(a) Power Switch (PUSH ON/PULL OFF). The power switch controls DC power to the VTM. The VTM can operate from a 12 volt or 24 volt battery system. When the power switch is pushed in (PUSH ON), the VTM power is on. To shut the VTM off, pull out the power switch (PULL OFF). The power switch contains a 4-ampere circuit breaker. The power switch will pop out automatically if something is wrong which causes the VTM to use more power than it should. If the switch pops out, check your hookup carefully and try again before returning the VTM to Direct Support Maintenance.

(b) TEST SELECT Switches. The TEST SELECT switches are used to select the actual test to be performed. There are ten positions on each switch numbered 0 through 9. The number dialed into these switches is read by the VTM when you press the test button. Changing the TEST SELECT switch position has no effect until the TEST button is pushed.

(c) TEST Button. Depressing and releasing the TEST button causes the test measurement to begin. Observe the measured value on the readout display. The reading will be in units normally used for the particular truck measurement. These units are listed on the VTM's flip cards, in the GO/NO-GO test pages, and on the Vehicle Test Card Sheets in the back of this TM. The TEST button must be pressed and immediately released. Depressing and holding the TEST button down initiates an offset test. Offset tests are described in paragraphs 2-20 and 2-21, and in TM 9-4910-571-12&P.

(d) Readout Display. The readout display will show different types of readouts during testing up to a maximum of 4-characters (for example .8.8.8.8). The types of readouts are described in detail in paragraph 2-16, d., (3) "Readouts", with a summary following:

STE/ICE TROUBLESHOOTING.

2-16. STE/ICE DESCRIPTION AND OPERATION (Continued).

1. Status Readout. This type of readout keeps the mechanic informed of what is happening such as power applied, failed test, etc.
2. Numerical Readout. This type of readout is the measured value in units of the measurement being made. If you are measuring on the 0-45 dc range, the number 24 on the display indicates 24-volts.
3. Error Readout. This type of readout indicates that the wrong test number was selected, the transducer is not connected, or the VTM is faulty.

(e) Flip Cards. The flip cards list the 2-digit test number system for selecting the various tests. The cards also summarize the test and operating instructions contained herein.

(f) Power/DCA Connector J1. Connector J1 connects the VTM to either the M915A1 truck diagnostic connector using the DCA cable or the truck batteries using the power cable. Operating power and signals from installed transducers are supplied to the VTM through the DCA cable.

(g) Transducer Cable Connectors J2 and J3. Connector J2 or J3 connects the VTM to any transducer in the transducer kit. Operating power is supplied to the transducer, and signals from the transducers are supplied to the VTM through the cable. Connectors J2 and J3 are identical and can be interchanged with each other or used in combination.

(h) Test Probe Cable Connector J4. Connector J4 connects test leads to the VTM when doing manual or general purpose voltage and resistance tests.

- (3) Readouts. The following paragraphs describe the different types of readout that can occur during testing.
 - (a) Status Readout. A status readout keeps the mechanic informed of what is happening. For example, .8.8.8.8 is displayed each time the power switch is pushed on. It means that power is applied and that all elements of the display are operative. It changes to ---- 1-1/2 seconds later, indicating that the VTM

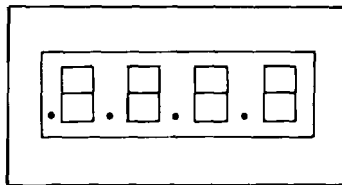

TA 236967

STE/ICE TROUBLESHOOTING.

2-16. STE/ICE DESCRIPTION AND OPERATION (Continued).

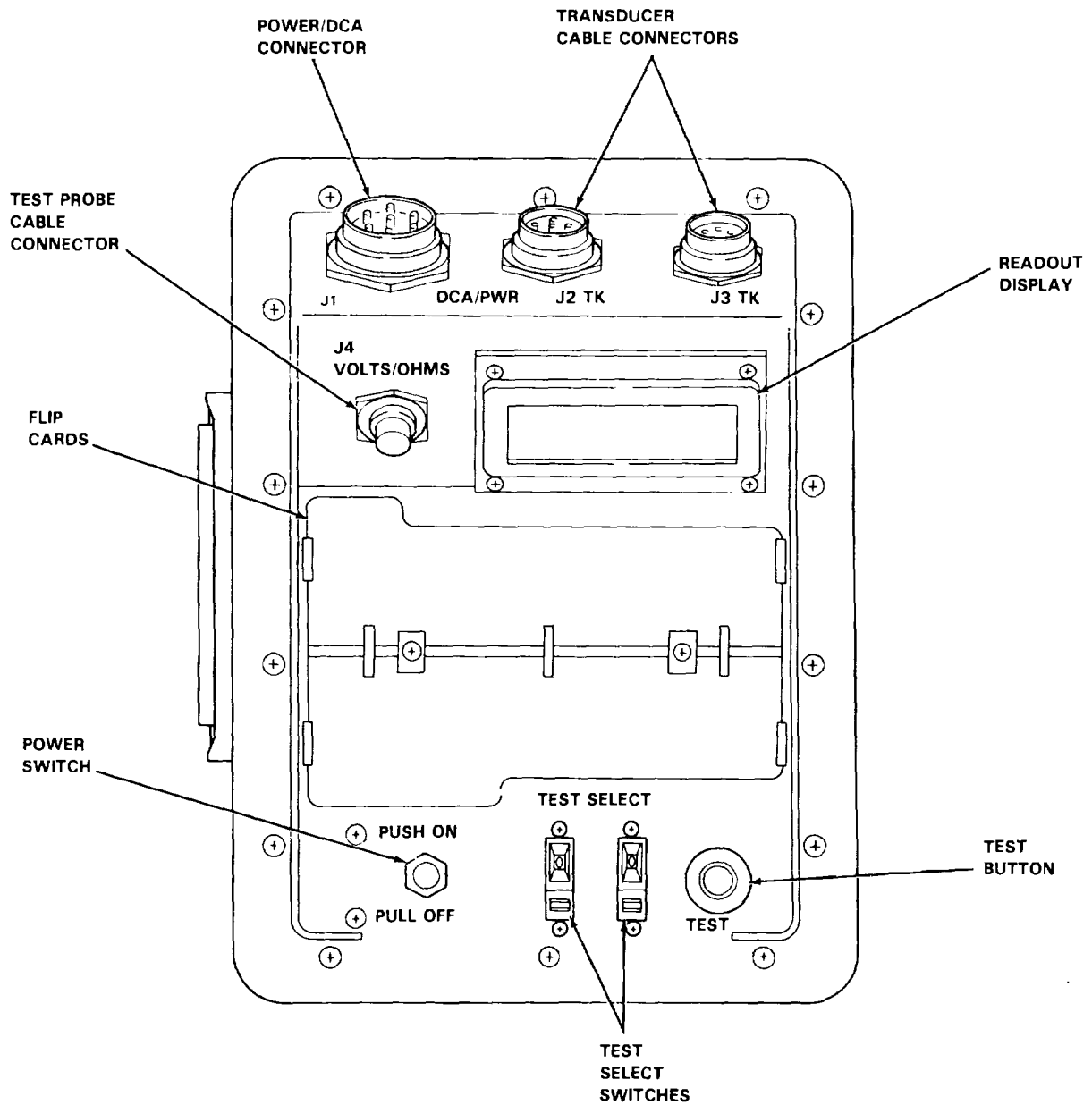

TA 236968

VTM Controls and Readout Display.

STE/ICE TROUBLESHOOTING.

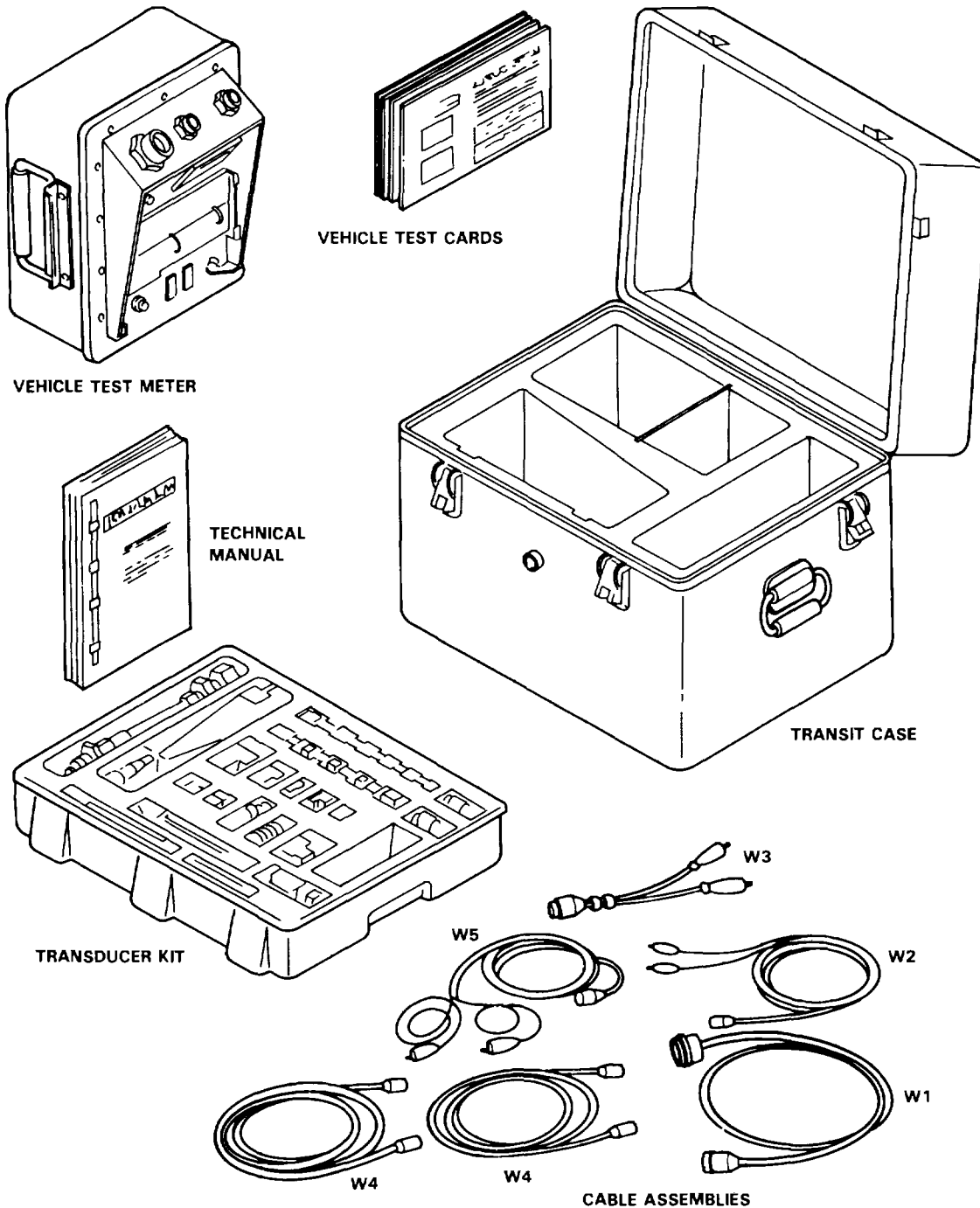

TA 236969

Simplified Test Equipment Internal Combustion Engine (STE/ICE) System.

STE/ICE TROUBLESHOOTING.

2-16. STE/ICE DESCRIPTION AND OPERATION (Continued).

(b) Prompting Message. A prompting message is any action message to the mechanic. It is a signal for you to do something such as crank the engine. For example, UEH tells you to enter the vehicle type identification number into the VTM. After the operator action is performed, the test will automatically continue. Prompting messages are listed on page 2-338.



(c) Numerical Readout. A numerical readout is the measured value in units of the measurement being made. For example, if you are measuring 0-45 VDC, 12.7 is volts dc. If you are measuring 0-25 psig pressure, 12.7 is psig. The units for each test are listed on the flip card. The numbers displayed in the VTM are always sensitive unless there is a minus shown to make them negative.



(d) Error Readout. E001 is a representative error readout. There are 17 different error readouts. All error readouts start with E. An error readout is a warning that you forgot to connect the transducer, selected a wrong test number, failed to start the engine, etc. All of the error messages mean you must correct the problem before continuing testing. If the error message does



(e) Confidence Error Readouts. EUU4 is a representative error readout resulting from the detection of a faulty VTM during confidence test. For detailed information concerning confidence error readouts, refer to TM 9-4910-571-12&P.

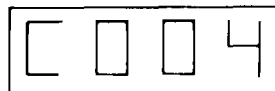

STE/ICE TROUBLESHOOTING.

2-16. STE/ICE DESCRIPTION AND OPERATION (Continued).

STATUS READOUTS

VTM Readout

Interpretation

.8.8.8.8 A readout of .8.8.8.8 appears for 1 to 2 seconds each time the power is applied to the VTM. It means that there is power to the VTM, and that all elements of the readout display are operative.

A readout of ---- indicates the following:

- (1) After power turn on, it signifies that the VTM is ready for testing.
- (2) During a compression unbalance test, it signifies testing is in progress.

.9.9.9.9 A readout of .9.9.9.9 indicates that the VTM is reading a test value beyond the range of its measurement capability. Either (1) the wrong test number is selected for the parameter being measured, or (2) there is a fault in the truck.

PASS A PASS or FAIL readout is the result of a test that checks the condition of a component being measured. A PASS/FAIL readout means just that the component either passes the test or fails the test.
 FAIL

STE/ICE TROUBLESHOOTING.

2-16. STE/ICE DESCRIPTION AND OPERATION (Continued).

PROMPTING MESSAGES	
VTM Readout	Interpretation
UEH	Signal to mechanic to enter vehicle type identification number (VID) on the TEST SELECT switches. Vehicle ID number, when available, is found under TEST DATA on the flip card, and on the vehicle test card sheet.
CYL	Signal to mechanic to enter number of cylinders on the TEST select switches.
GO	Signal to mechanic to crank engine in compression unbalance or first peak tests.
CIP	Signal to operator to apply full throttle in a CI power test.
OFF	Signal to mechanic to stop cranking in compression unbalance test or to release the accelerator in the CI power test.
CAL	Signal to the mechanic to release the TEST button during an offset test.
66	Numbers are used for prompting messages in two tests. In confidence test 66 signals the mechanic to dial in 99 and wait for readout display of PASS. In CI power test 12, the first number to appear on the VTM is the signal to release the accelerator.

ERROR READOUT	
VTM Readout	Interpretation
E000	Occurs if you request the VTM for information it does not have. For example, if you request the vehicle ID and it has not been entered.
E001	Occurs in either the DCA or TK mode of operation. It indicates that a non-existent test number has been dialed into the TEST SELECT switches.

STE/ICE TROUBLESHOOTING.

2-16. STE/ICE DESCRIPTION AND OPERATION (Continued).

ERROR READOUT (Continued)	
VTM Readout	Interpretation
E002	Indicates that the required transducer is not connected or installed.
E003	Indicates that a test number has been dialed which does not apply to the vehicle under test. It can only occur in the DCA mode.
E004	Indicates that a vehicle identification number or number of cylinders information has not been entered.
E005	Indicates that the transducer offset test was not performed.
E007	Indicates conflict between the vehicle identification number (VID) dialed in and the number of cylinders dialed in. It may occur in response to either VID entry or number of cylinders entry.
E008	Indicates the VTM is not receiving the required voltage signal for the test selected. This error code is related only to starter and compression balance tests.
E009 test.	Indicates that the engine was not running at the start of the test.
E010	A wrong vehicle number was dialed into the VTM.
E011	Indicates that the throttle control was operated incorrectly during power test taking; too much time to either accelerate or decelerate.
E013	Indicates bad data was taken for the test in progress. Repeat the test one (1) time.
E014	Indicates that a wrong number of cylinders was dialed into the VTM.
E018	Indicates that an engine RPM or AC frequency test was terminated automatically to protect the VTM. Termination is only after several minutes of no-signal operation. Most likely, the VTM was left on the truck and the engine stalled.

STE/ICE TROUBLESHOOTING.

2-16. STE/ICE DESCRIPTION AND OPERATION (Continued).

e. Cable Assemblies.

(1) General. The cable assemblies are shown below and are referred to by the cable number and by a name which describes how the cable is used. If necessary, the two transducer cables (W4) can be joined with the adapter

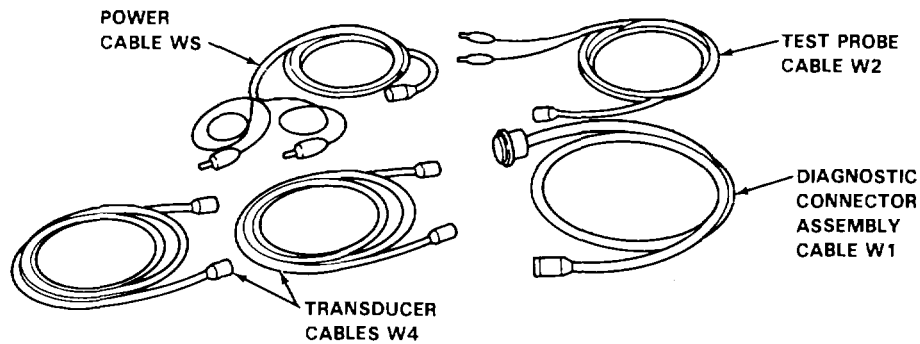

(2) Installation. When cables are connected, a large key on the cable connector mates with a keyway on the transducer connector or the VTM connector for proper installation. If you experience any difficulty during testing and

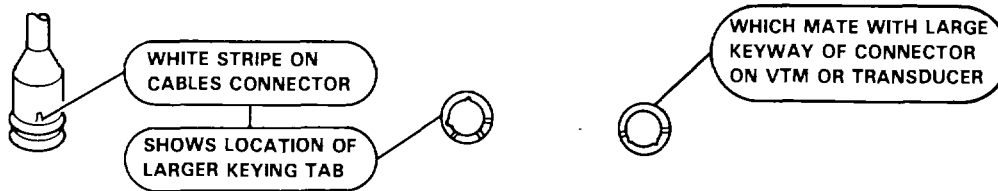

f. Transducer Kit.

(1) General. The transducer kit contains a pulse tachometer transducer, a pressure, and a vacuum transducer plus the necessary adapters (bushings, plugs, tees, etc.). Also included in the kit is a current probe for measuring current and a test probe cable for measuring voltage and resistance.

All fittings do not have part number markings. The legend will help to identify the items.

Before installing any transducer kit item on the truck, be sure to clean the mounting surfaces. This is particularly important if you are going to open fuel lines or tap into manifolds. Dirt particles entering the engine can cause damage to both the engine and the transducer kit item.

STE/ICE TROUBLESHOOTING.

2-16. STE/ICE DESCRIPTION AND OPERATION (Continued).

The transducers should be kept clean, free of dirt and grease, and handled with reasonable care.

NOTE

Transducers for measuring engine RPM (pulse tachometer) and fuel pressure are permanently installed on the M915A1 truck. The following material is for reference only or when trouble-shooting a faulty transducer.

(2) Pressure Transducers. The pressure transducers have a small breather hole on the side of the housing which should be kept unplugged. Do not use high pressure.

(3) Pulse Tachometer. Make sure that the slotted hole in the engine tachometer drive shaft is clear and not hard packed before installing the pulse tachometer.

(4) Threaded Adapters. Observe threaded fittings carefully to avoid engaging straight threads with pipe threads.

Each measurement device (transducer) in the transducer kit has its own identification resistor. The VTM uses this identification resistor to check that the correct transducer is connected for the measurement being made. If the correct transducer is not connected, error code E002 will be displayed.

STE/ICE TROUBLESHOOTING.

2-16. STE/ICE DESCRIPTION AND OPERATION (Continued).

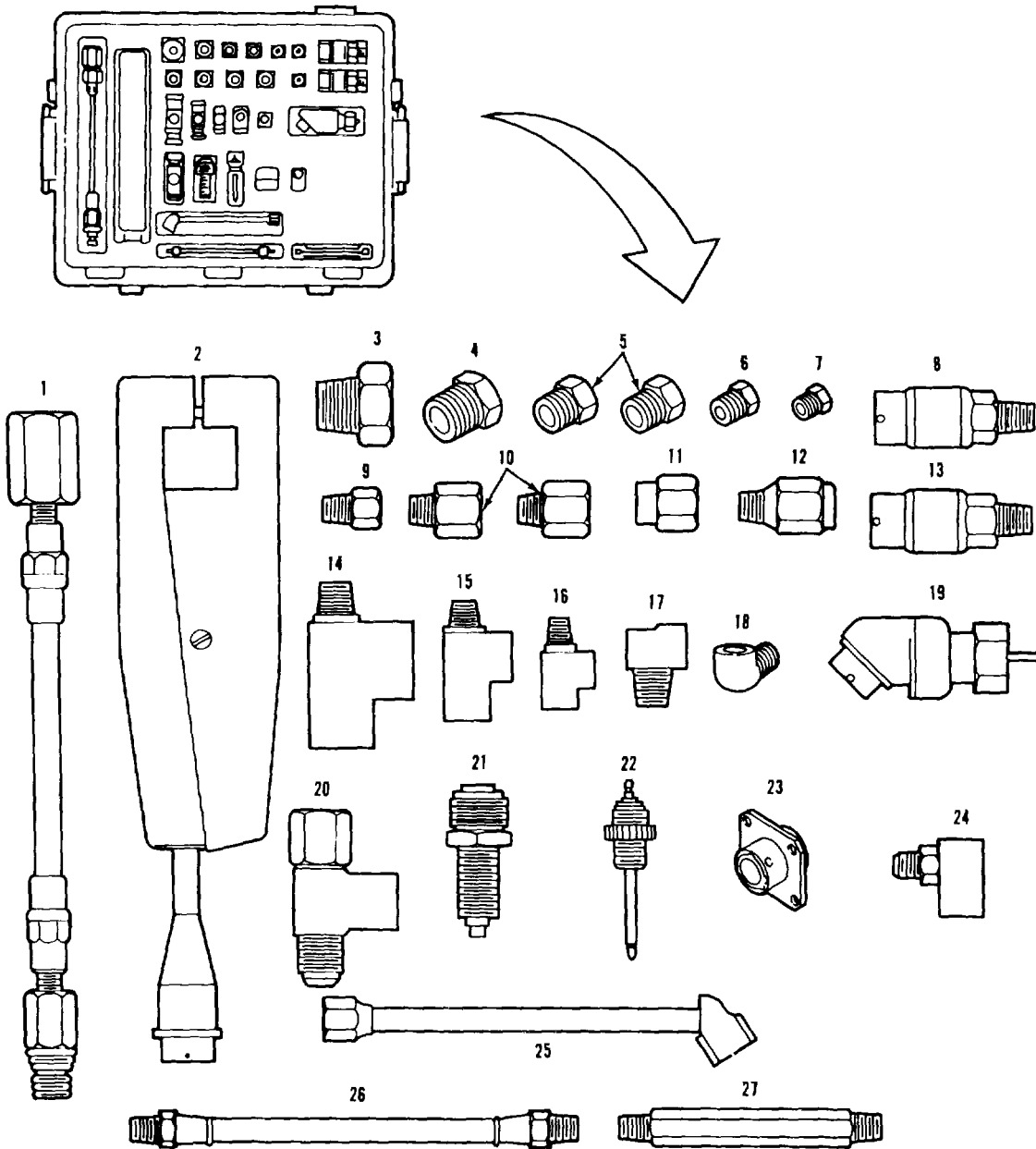

Transducer Kit.

STE/ICE TROUBLESHOOTING.

2-16. STE/ICE DESCRIPTION AND OPERATION (Continued).

TRANSDUCER KIT COMPONENTS				
ITEM NO	TK NO.	PART NUMBER	QTY	ITEMS
1	10	11669227	1	Hose & fitting assembly (spark plug
2	11	112258878	1	Current probe
3	12	12258853-1	1	Pipe thread reducer, 3/4 MPT to 1/4 FPT
4	13	12258853-3	1	Pipe thread reducer, 1/2 MPT to 1/4 FPT
5	14	12258853-2	2	Pipe thread reducer, 3/8 MPT to 1/4 FPT
6	15	444620	1	Hex head plug, 1/4 MPT
7	16	5327970	1	Hex head plug, 1/8 MPT
8	17	12258876	1	Pressure transducer, 0-1000 psi
10	20	3204X2	2	Adapter, 1/8 MPT to 1/4 FPT
11	19	3304X2	1	Coupling reducer, 1/8 FPT to 1/4 FPT
9	21	12258881	1	Snubber
12	18	234X5	1	Male connector, 5/16 tube to 1/4 MPT
13	22	12258877	1	Pressure transducer, -30 in. Hg to 25 psig
14	23	444152	1	Street tee, 1/2 pipe thread
15	24	3750X4	1	Street tee, 1/4 pipe thread
16	25	547002	1	Street tee, 1/8 pipe thread
17	26	12258879-2	1	Street elbow, 1/4 pipe thread
18	27	12258879-1	1	Street elbow, 1/8 pipe thread
19	34	12258875	1	Pulse tachometer
20	32	12258880	1	Fuel line adapter
21	31	MS53099-2	1	Tachometer drive adapter
23	29	MS3119E14-19	1	Adapter (connector-to-connector)
22	30	7540877	1	Ignition adapter
24	28	12258762	1	Tee, inverted flare
25	33	8840543	1	Air chuck
26	35	11669236	1	Hose assembly, 1/8 MPT
27	36	12258852	1	Pipe nipple, 1/8 MPT

STE/ICE TROUBLESHOOTING.

2-17. CI ENGINE GO CHAIN INDEX.

GO TEST NUMBER	MODE	TEST TITLE	PAGE NUMBER
G01	DCA	VTM Connections and Checkout	2-347
G02	TK	First Peak Test - Starter Current	2-352
G03	TK	Engine Start - Lubrication Check	2-354
G04	DCA	Charging Circuit and Battery Voltage Test	2-357
G05	DCA	Engine Warmup/Coolant Check/Oil Pressure Test	2-361
G06	DCA	Governor Check/Power Test	2-363
G07	DCA	Idle Speed/Governor Check	2-365
G08	DCA	Compression Unbalance Test	2-366

2-18. CI ENGINE NO-GO CHAIN INDEX.

NO-GO TEST NUMBER	MODE	TEST TITLE	PAGE NUMBER
NG05	TK	Low Oil Pressure Check	2-368
NG20	DCA	No Crank - No Start	2-370
NG30	DCA	Engine Crank - No Start	2-371
NG31	DCA	Gage Test	2-375
NG50	DCA	Charging Circuit Tests	2-377
NG80	DCA-TK	Starter Circuit Tests	2-378
NG81	DCA	Battery Tests	2-383
NG90	DCA	Governor/Power Test Fault Isolation	2-388
NG130	DCA	Engine Tightness Test	2-393

STE/ICE TROUBLESHOOTING.

2-19. VEHICLE TESTING TROUBLESHOOTING PROCEDURES.

a. General. To troubleshoot an M915A1 truck problem, the mechanic can use the STE/ICE (vehicle test meter and transducers) and the truck test cards found in the back of this TM.

b. Data Entry Tests. For information regarding Data Entry, Cylinder Entry, Vehicle ID Entry, and Data Display Tests, refer to TM 9-4910-571-12&P.

c. Offset Tests. The STE/ICE VTM performs a test by setting the TEST SELECT switches to the test number and pressing the TEST button. For some tests, an offset is required before the test itself can be performed. This is done by selecting the number of the desired test and holding the TEST button down for several seconds.

The offset test nulls out characteristic differences in the VTM, test leads, and transducers. It zeros the meter. Once the offset is performed, the VTM automatically corrects for the offset before displaying measured values. The displayed offset value should be checked against limits on the vehicle test card sheet. If the displayed value is outside these limits, either the transducer or the test cable is faulty and must be replaced. This is another form of self-test. The offset is performed when each transducer is connected. All tests requiring offset are identified by a (*) on the flip cards and by OFFSET LIMITS on the vehicle test card sheet. The offset test is performed with the test probe cable or transducer connected to the VTM. Care should be taken to see that no stimulus is applied to the transducer. Test probe cable leads should be shorted together. To perform an offset test, dial the test number into the TEST SELECT switches. Press and hold the TEST button until the prompting message CAL appears on the display. In a few seconds after release of the TEST button, a number will appear. This is the measured offset value associated with the test probe cable or transducer and cable.

d. Control Tests. These tests are used to change (or control) the way a vehicle test is displayed or the way it is run. There are four (4) control tests:

- 01 Interleave (alternates back and forth to display RPM with next test).
- 02 Display minimum value for next test.
- 03 Display maximum value for next test.
- 04 Display peak-to-peak value for next test.

Control tests 01, 02, 03, and 04 specify the action to be taken by the next test only. A subsequent test will reset the control.

(1) Interleave (Test 01). This test alternately measures engine speed and a second parameter such as fuel pressure or alternator voltage. To initiate interleave, dial 01 into the TEST SELECT switches and press and release the TEST button. The prompting message PASS will signal the mechanic to dial in the second test number and again press and release the TEST button.

STE/ICE TROUBLESHOOTING.

2-19. VEHICLE TESTING TROUBLESHOOTING PROCEDURES (Continued).

(2) Minimum Value (Test 02). This test displays the minimum value measured during a test. To initiate a minimum value display, dial 02 into the TEST SELECT switches and press and release the TEST button. The prompting message PASS will signal the mechanic to dial the desired test number and again press and release the TEST button. The minimum value is displayed and updated whenever a lower minimum value is measured. Entering 02 and the test number again will reset the process and a new minimum value will be displayed.

(3) Maximum Value (Test 03). This test displays the maximum value measured during a test. To initiate a maximum value display, dial 03 into the TEST SELECT switches and press and release the TEST button. The maximum value is displayed and updated whenever a higher maximum value is measured. Entering 03 and the test number again will reset the process and a new maximum value will be displayed.

(4) Peak-to Peak Value (Test 04). This test displays the peak-to-peak value of alternator/generator output volts (82), 45 volts DC (89), 1500 amps DC (90), and battery volts (67). To start a peak-to-peak measurement, dial 04 into the TEST SELECT switches and press the test button. The prompting message PASS will signal the operator to dial in one of the four numbers (82, 89, 90, or 67) and again press the TEST button.

STE/ICE TROUBLESHOOTING.

2-20. STE/ICE GO CHAIN TESTS.

a. Table 2-9 contains the STE/ICE GO-Chain tests necessary to troubleshoot the M915A1 truck.

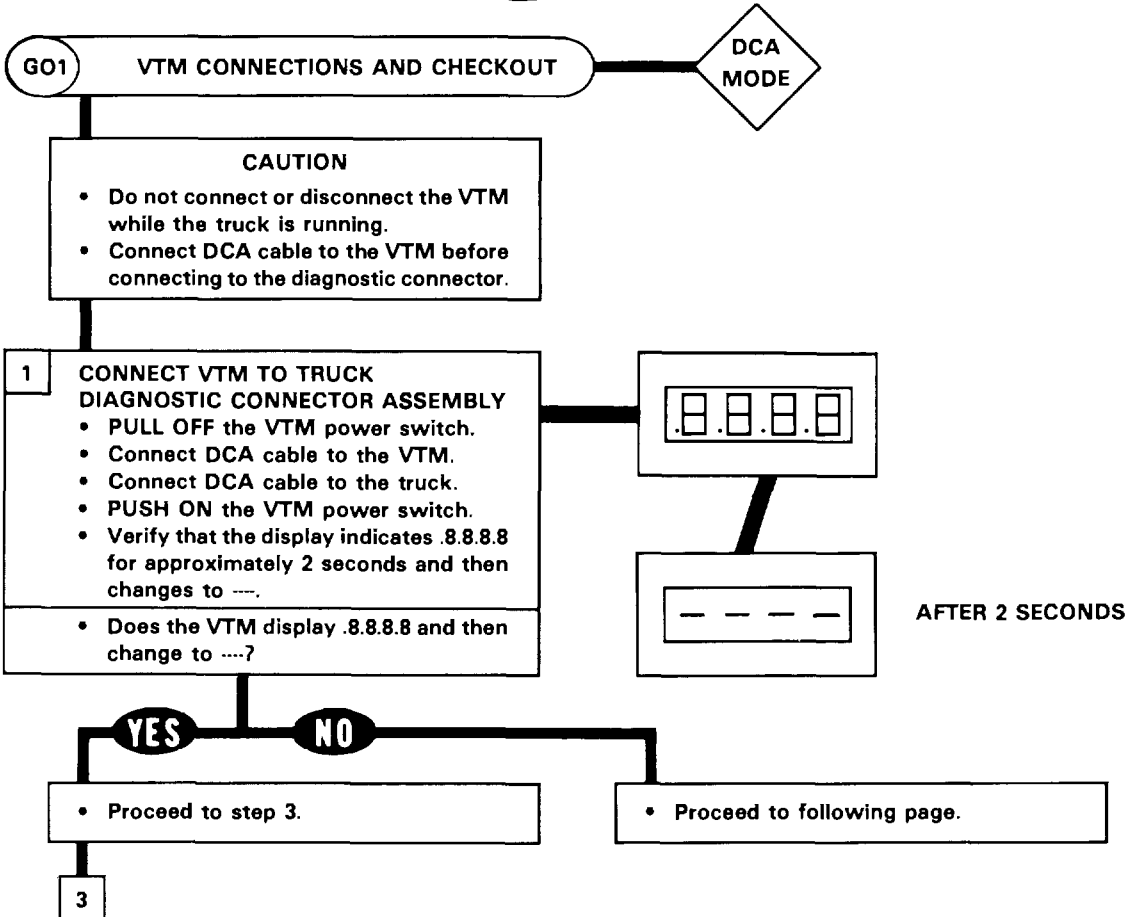
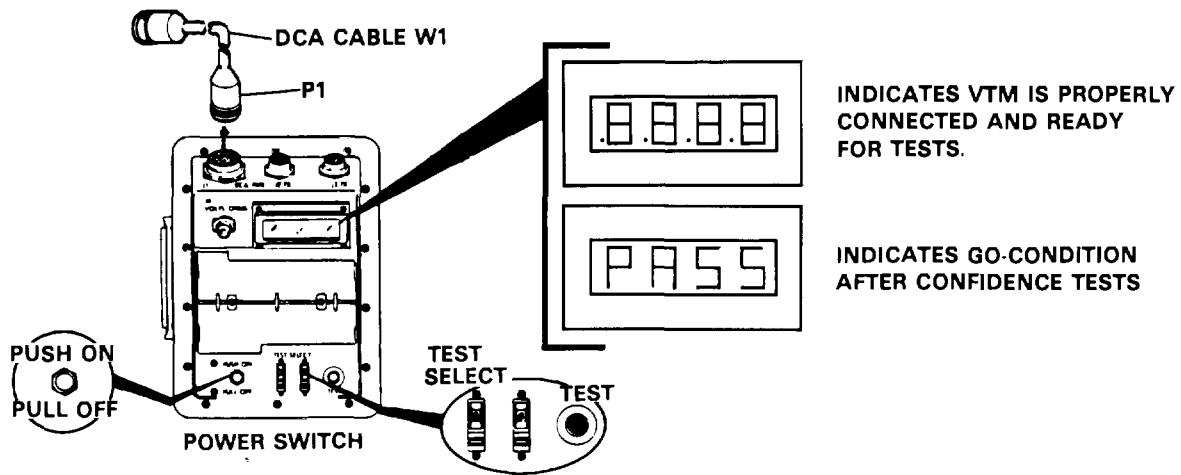

TA 236973
TA 236973

STE/ICE TROUBLESHOOTING.

2-20. STE/ICE GO CHAIN TESTS (Continued).

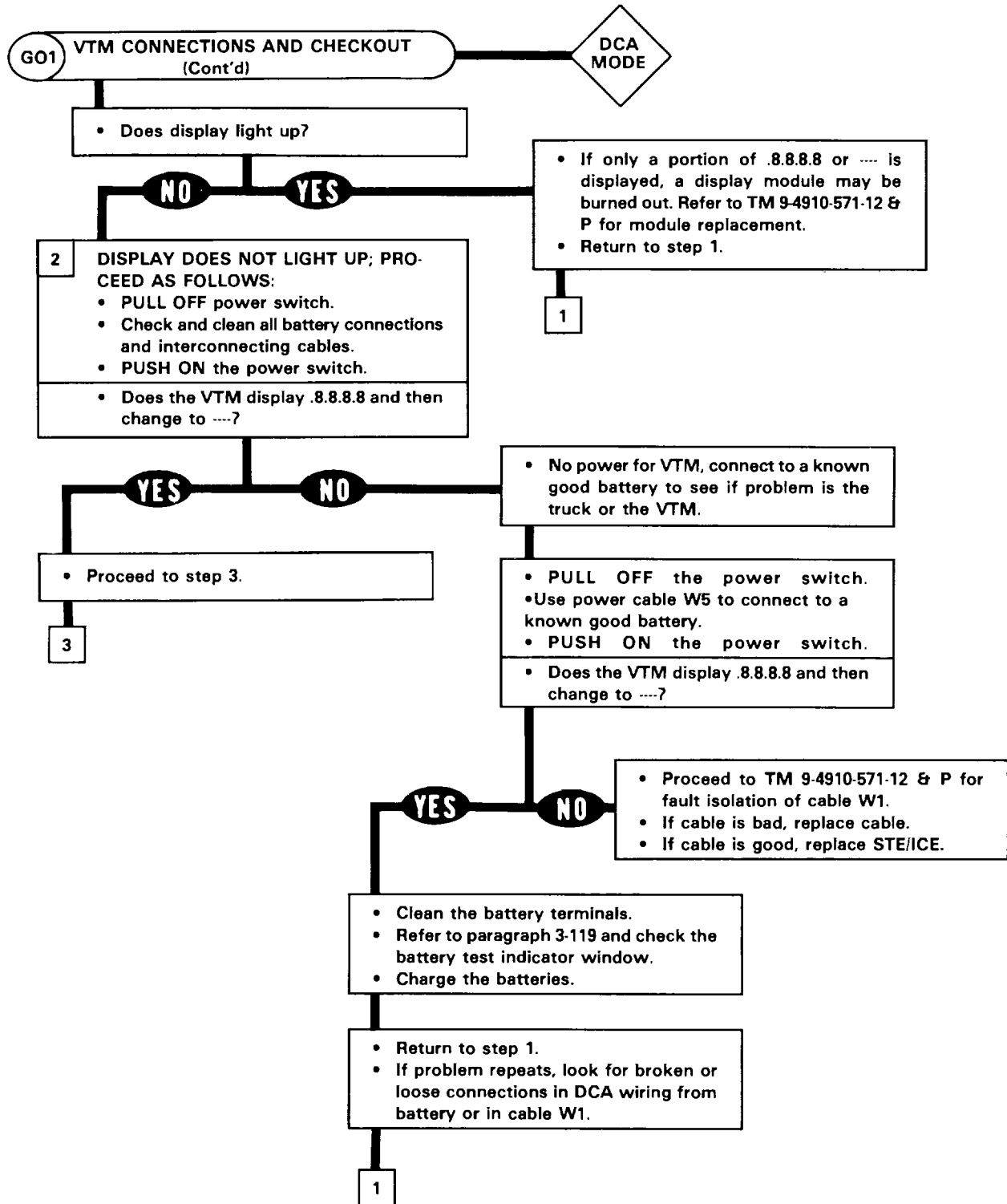

STE/ICE TROUBLESHOOTING.

2-20. STE/ICE GO CHAIN TESTS (Continued).

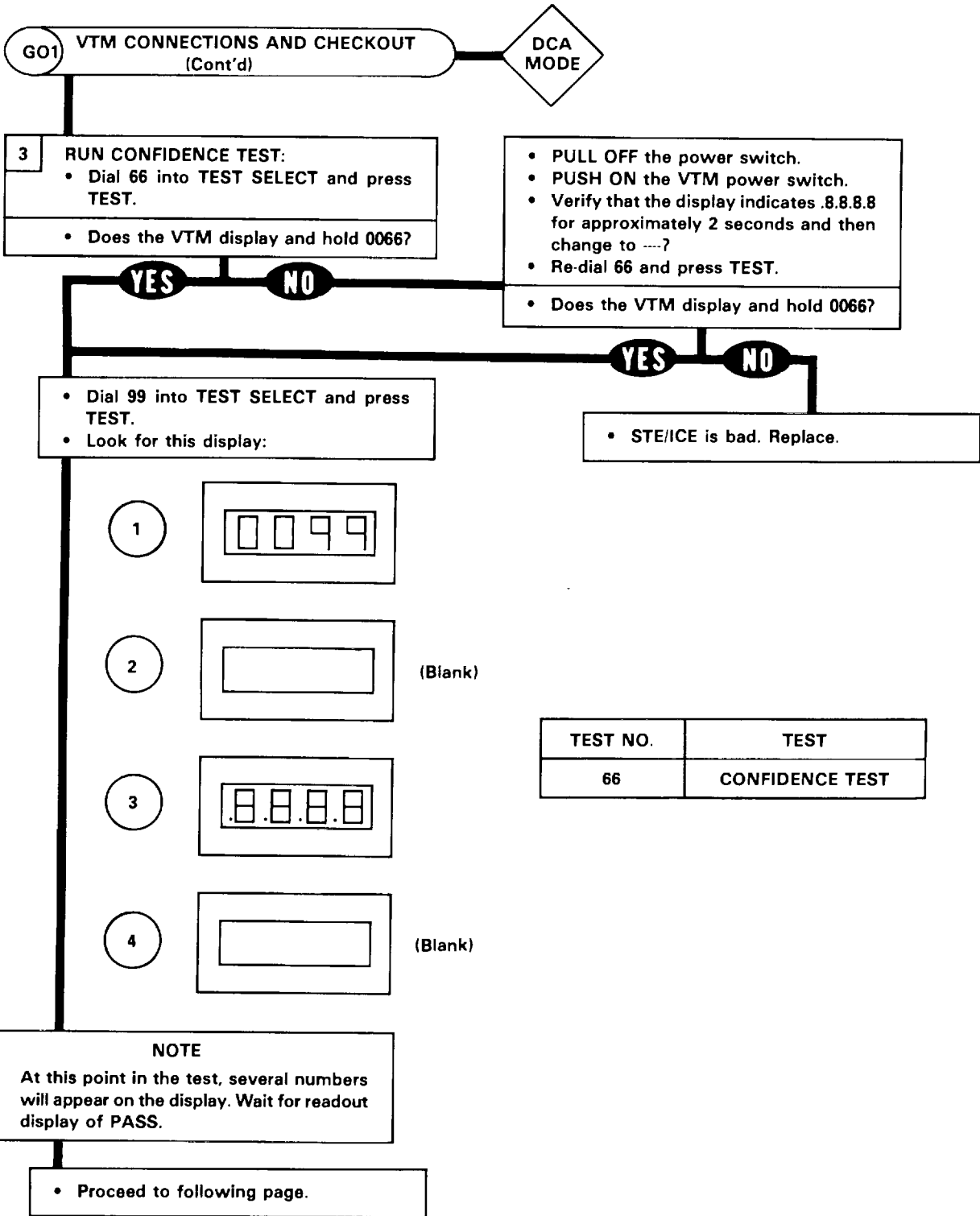

TA 236974

STE/ICE TROUBLESHOOTING.

2-20. STE/ICE GO CHAIN TESTS (Continued).

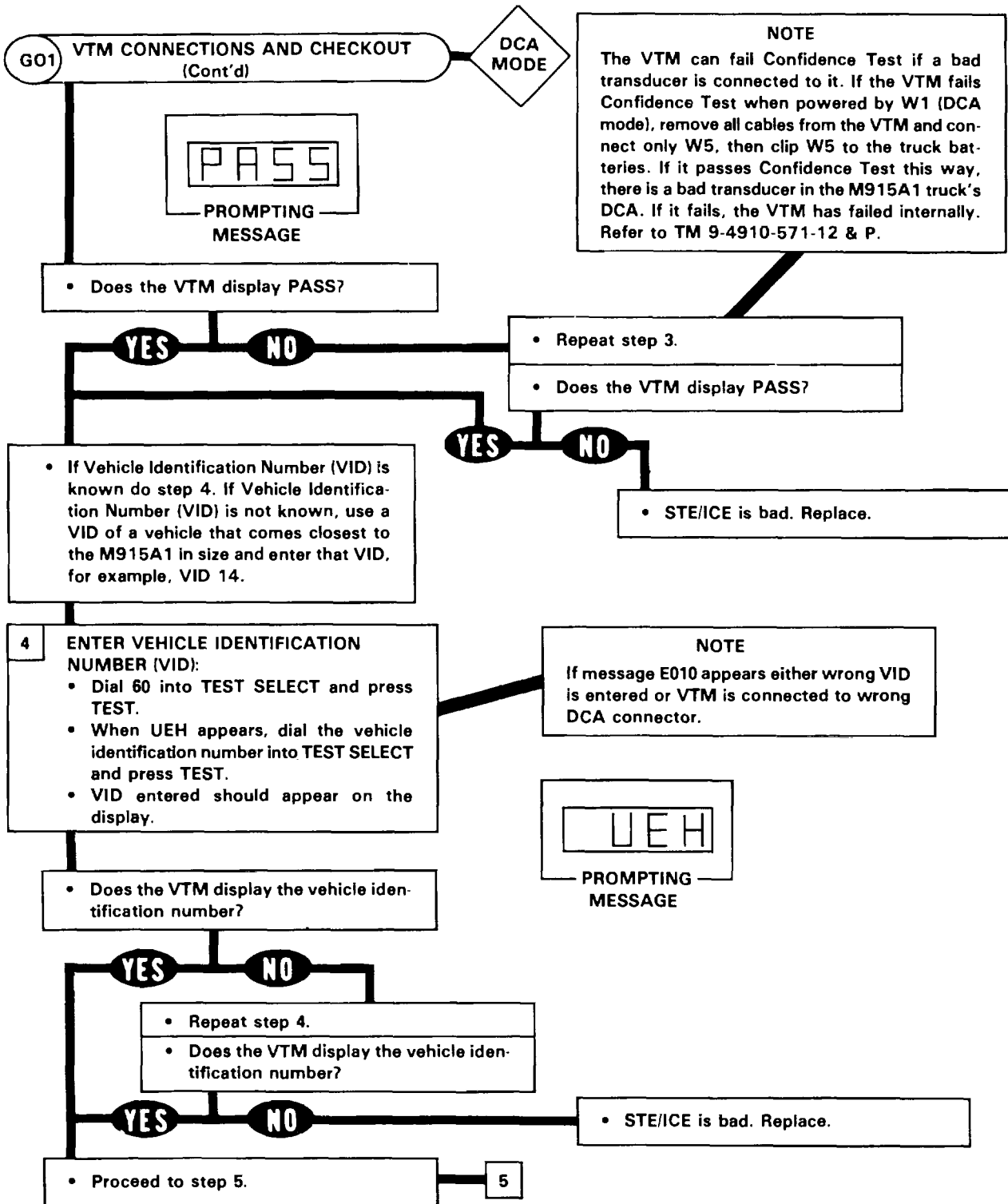

TA 236975

STE/ICE TROUBLESHOOTING.

2-20. STE/ICE GO CHAIN TESTS (Continued).

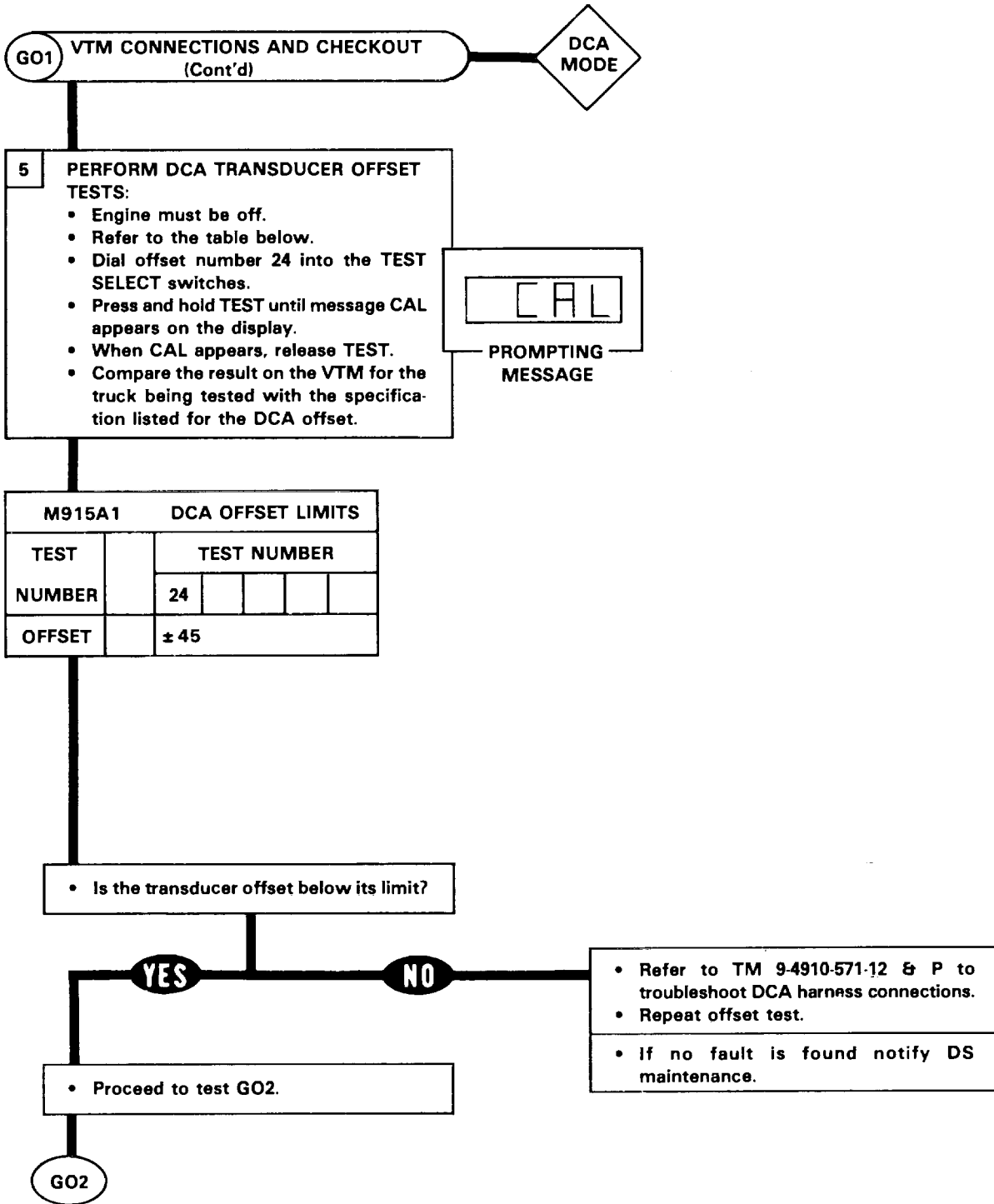

TA 236976

STE/ICE TROUBLESHOOTING.

2-20. STE/ICE GO CHAIN TESTS (Continued).

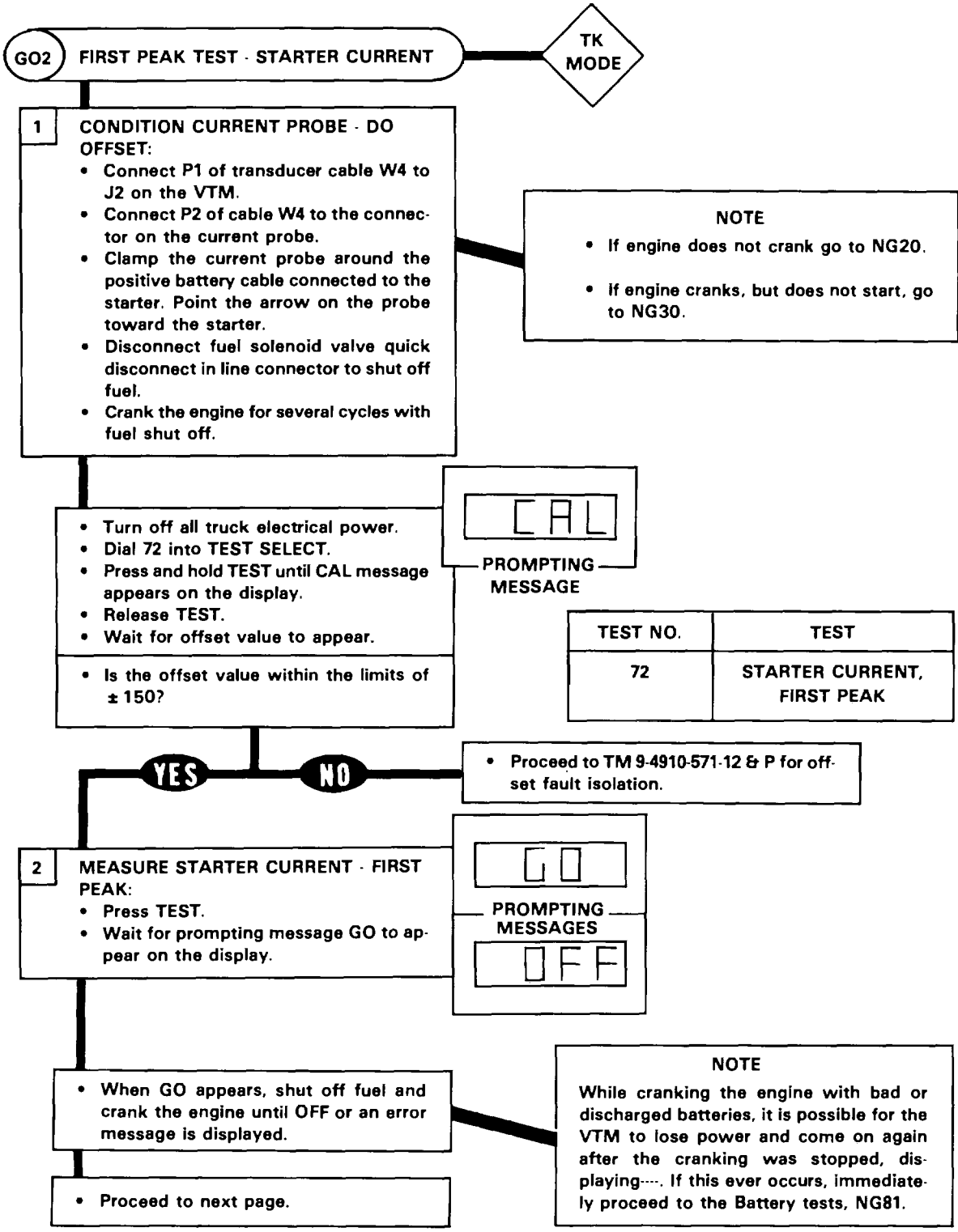

TA 236977

2-20. STE/ICE GO CHAIN TESTS (Continued).

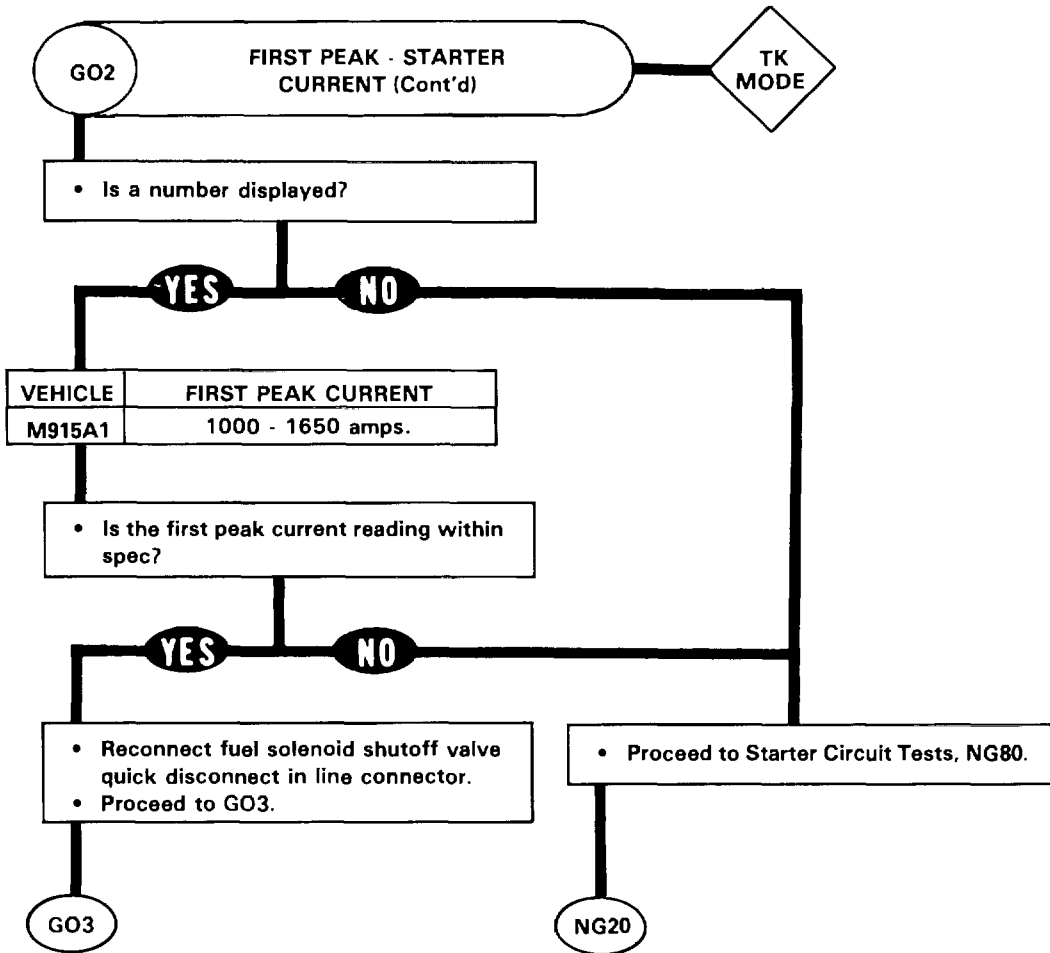

STE/ICE TROUBLESHOOTING.

2-20. STE/ICE GO CHAIN TESTS (Continued).

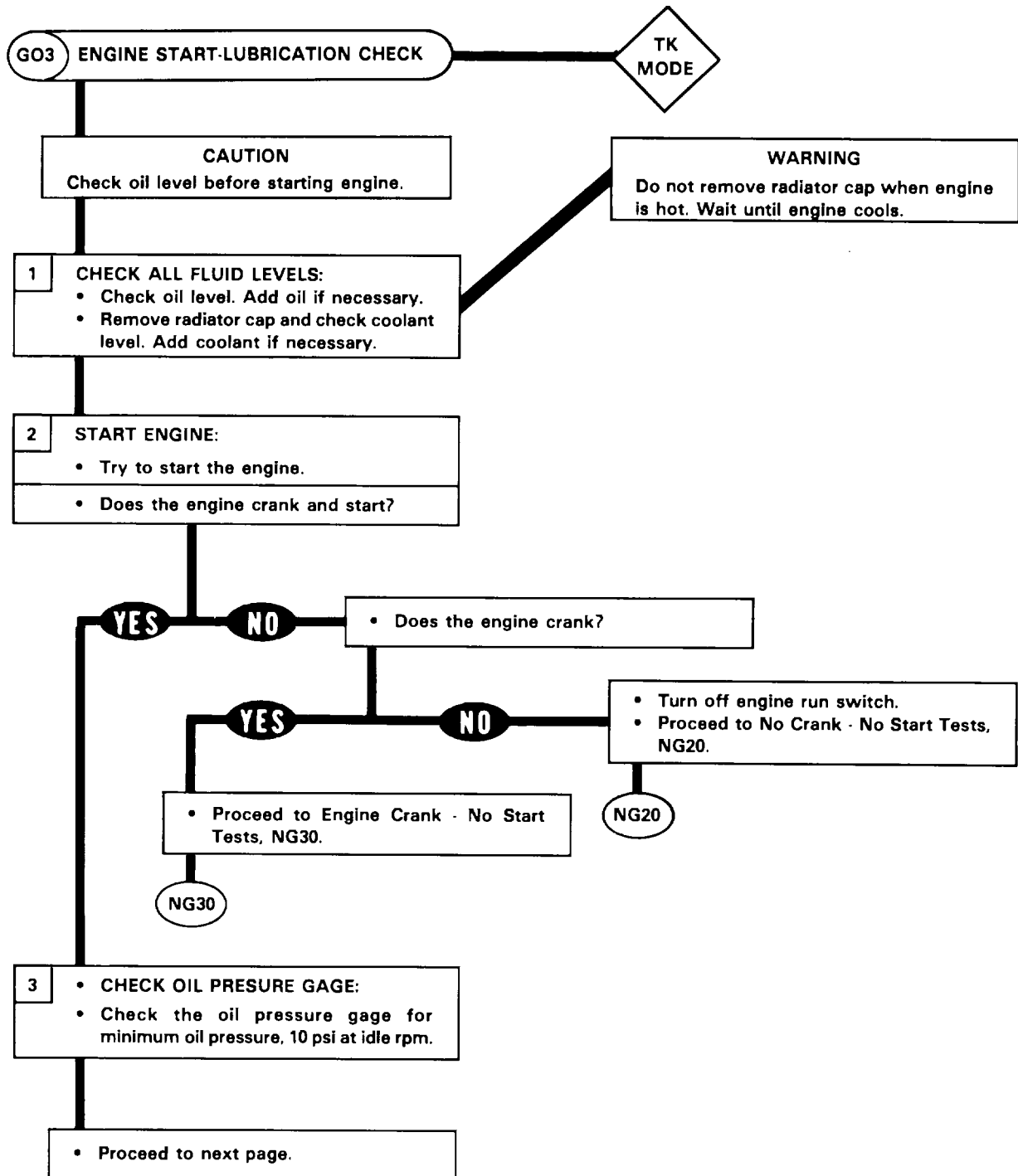

STE/ICE TROUBLESHOOTING.

2-20. STE/ICE GO CHAIN TESTS (Continued).

Table 2-9. STE/ICE GO-Chain Test (Cont'd)

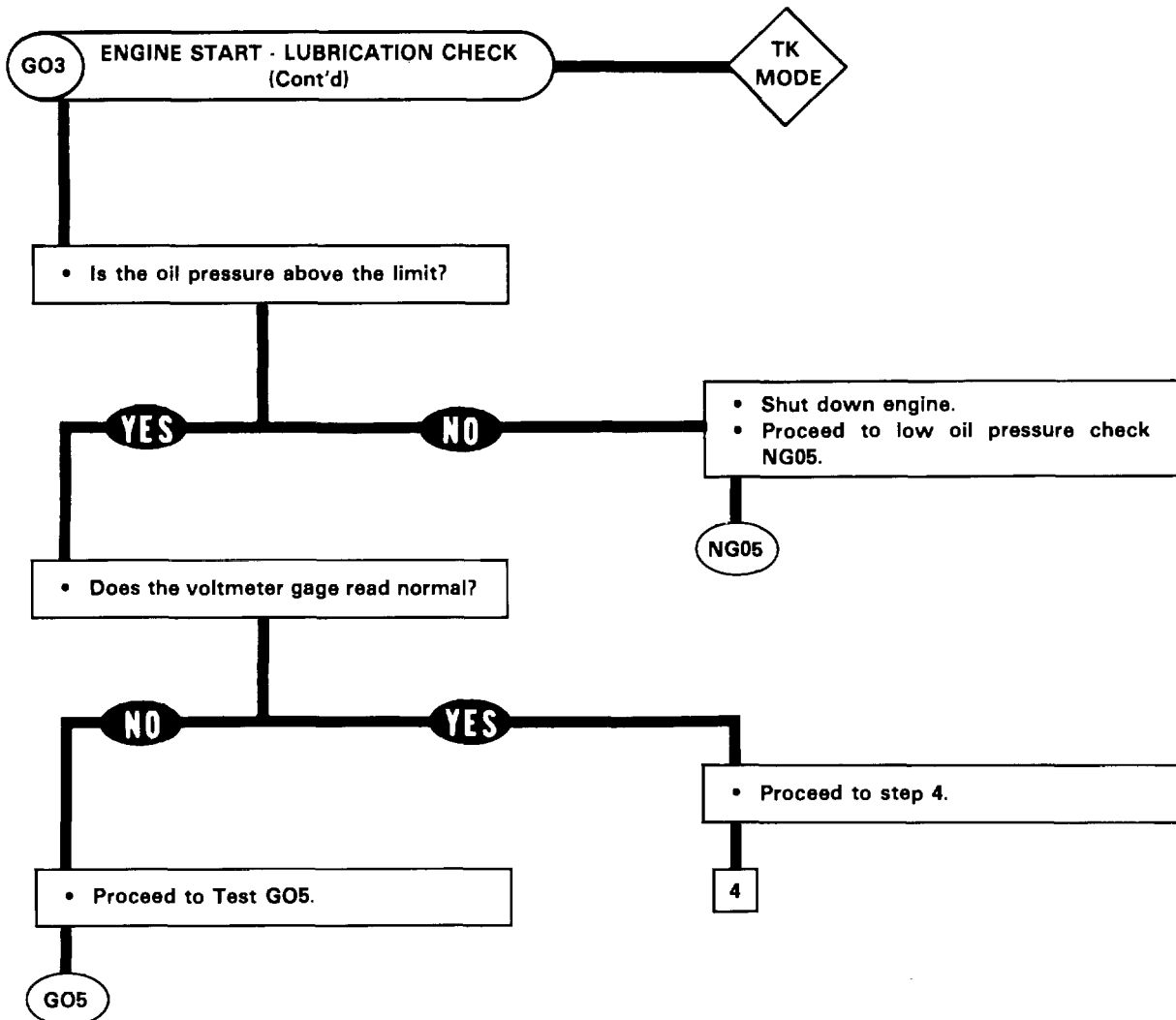

STE/ICE TROUBLESHOOTING.

2-20. STE/ICE GO CHAIN TESTS (Continued).

Table 2-9. STE/ICE GO-Chain Test (Cont'd)

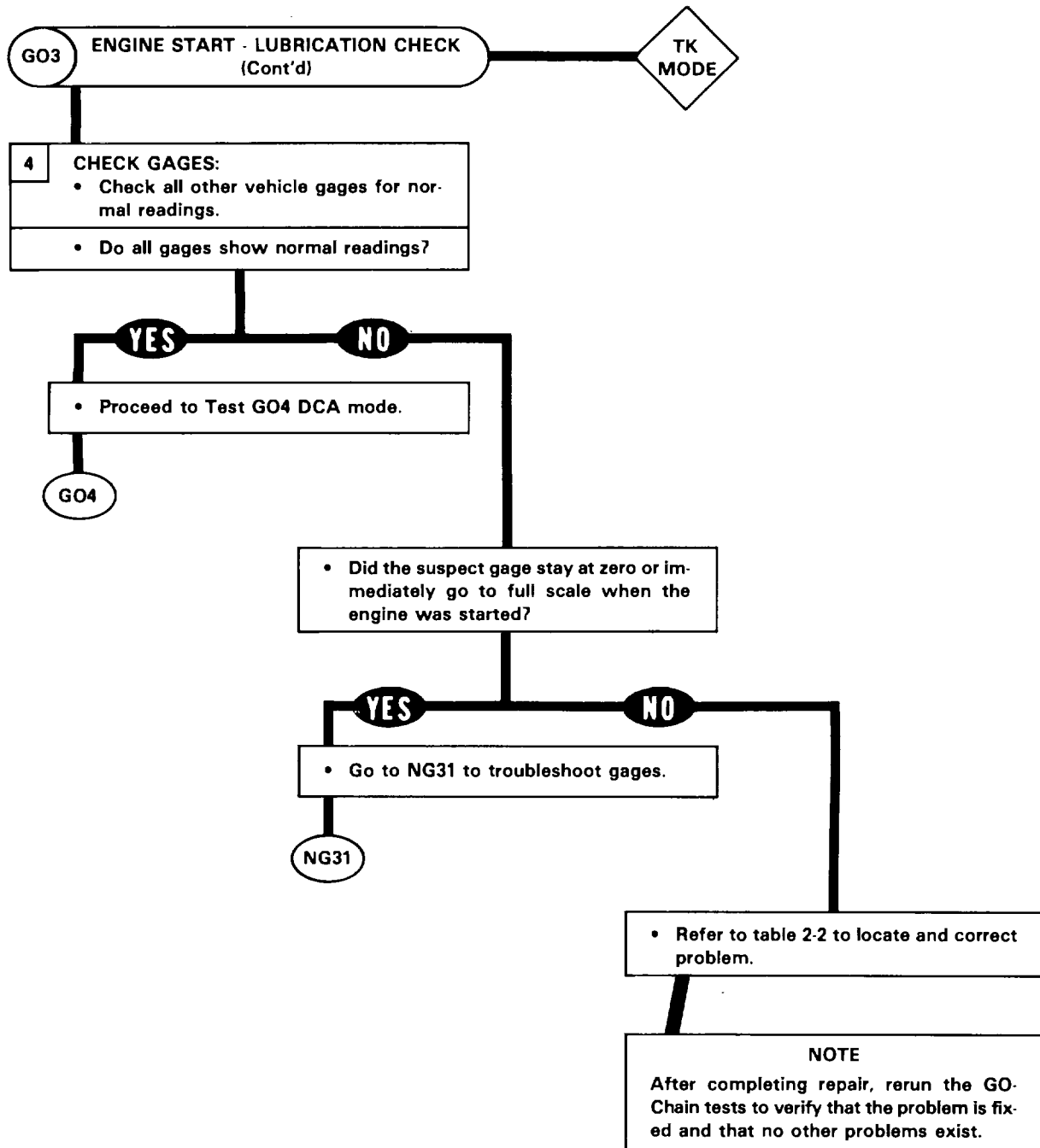

STE/ICE TROUBLESHOOTING.

2-20. STE/ICE GO CHAIN TESTS (Continued).

Table 2-9. STE/ICE GO-Chain Test (Cont'd)

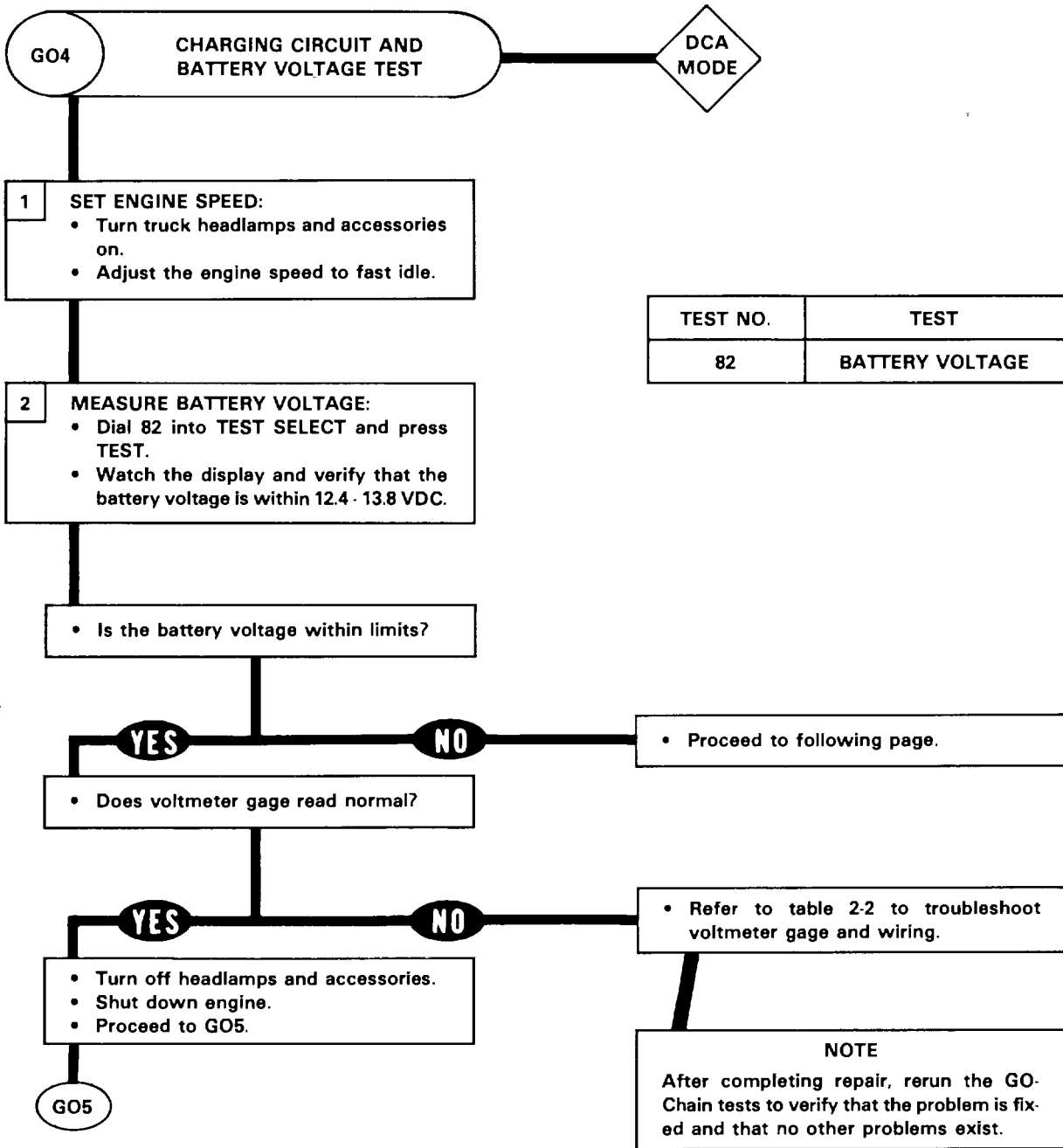

STE/ICE TROUBLESHOOTING.

2-20. STE/ICE GO CHAIN TESTS (Continued).

Table 2-9. STE/ICE GO-Chain Test (Cont'd)

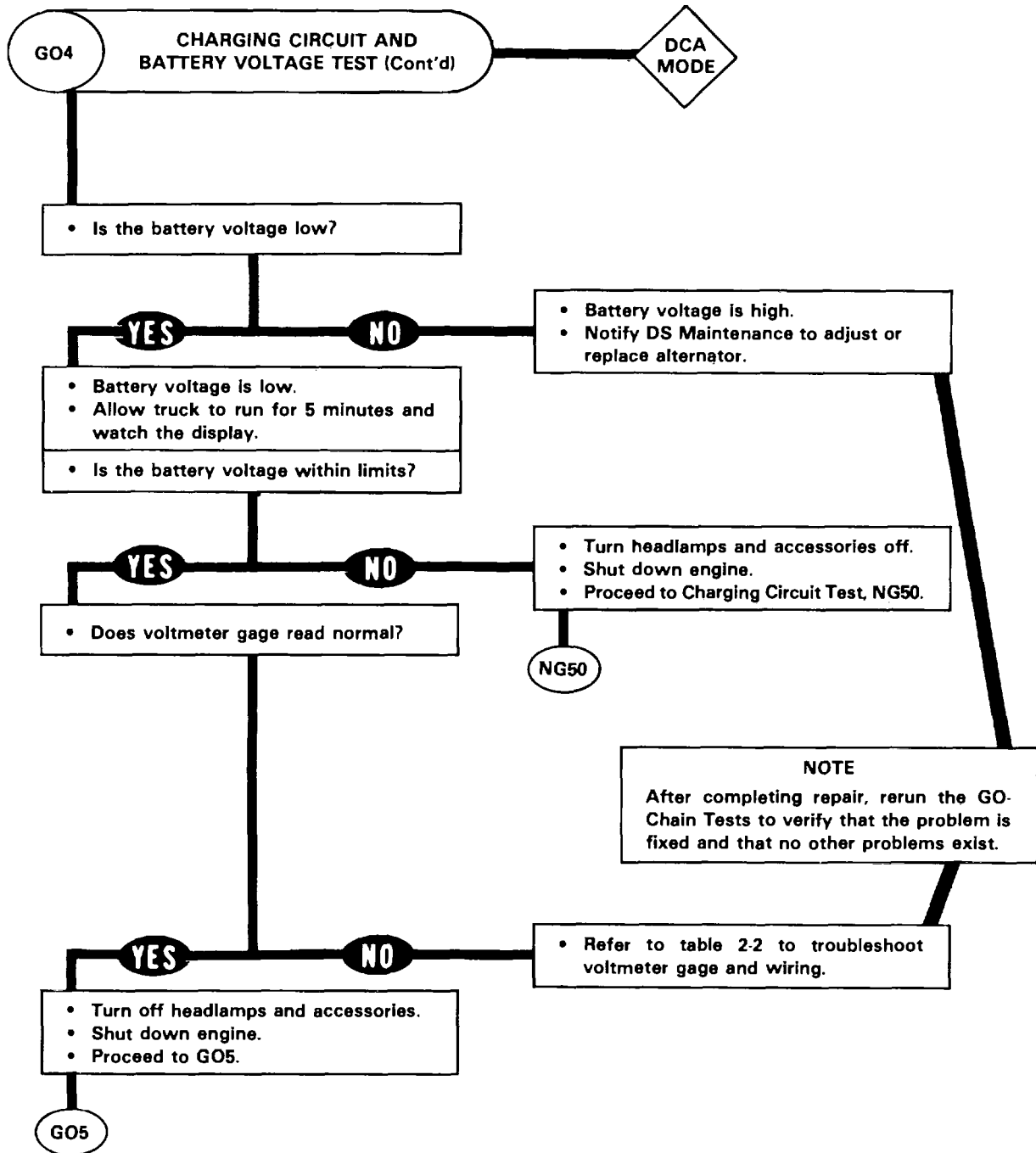

STE/ICE TROUBLESHOOTING.

2-20. STE/ICE GO CHAIN TESTS (Continued).

Table 2-9. STE/ICE GO-Chain Test (Cont'd)

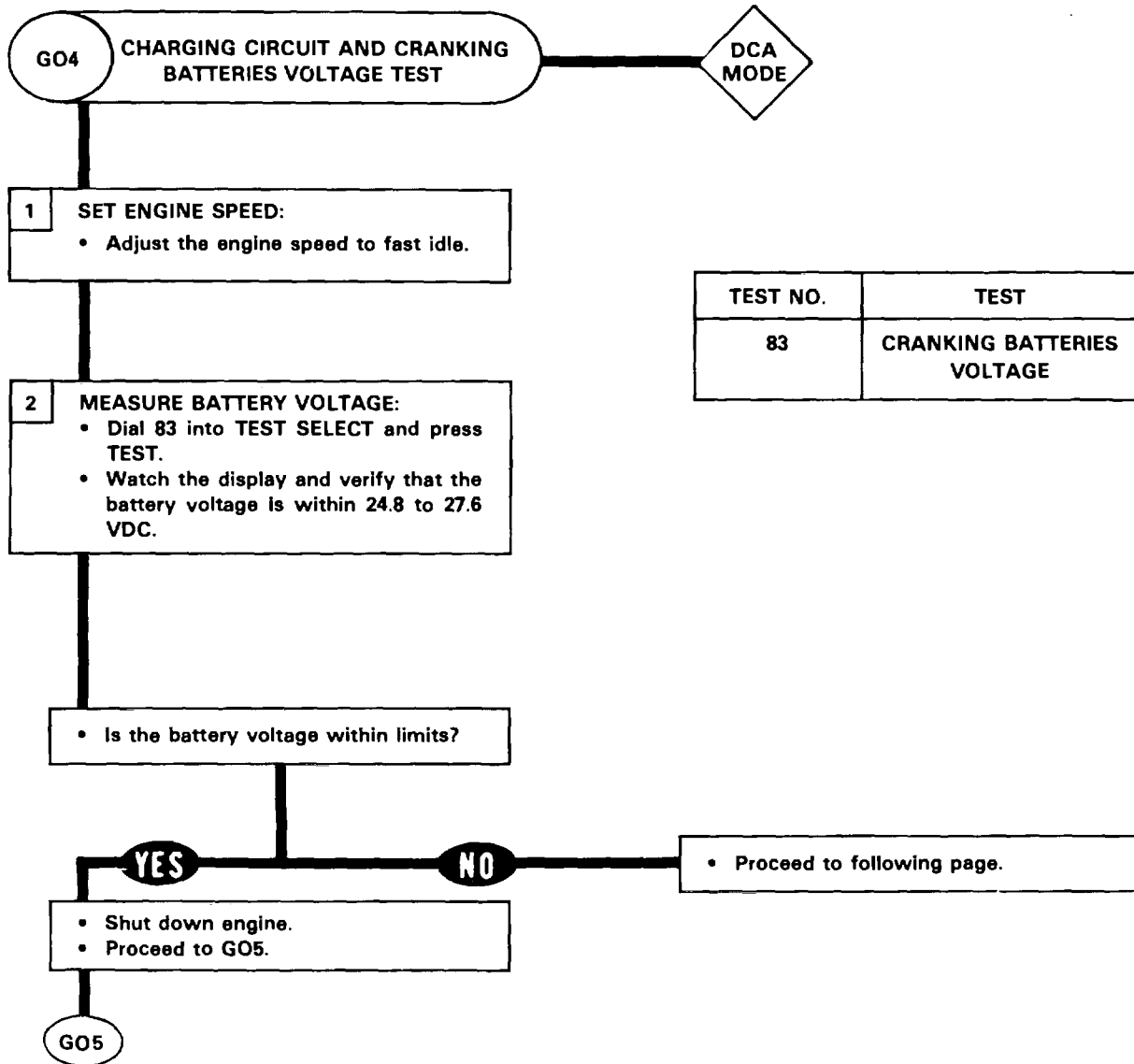

STE/ICE TROUBLESHOOTING.

2-20. STE/ICE GO CHAIN TESTS (Continued).

Table 2-9. STE/ICE GO-Chain Test (Cont'd)

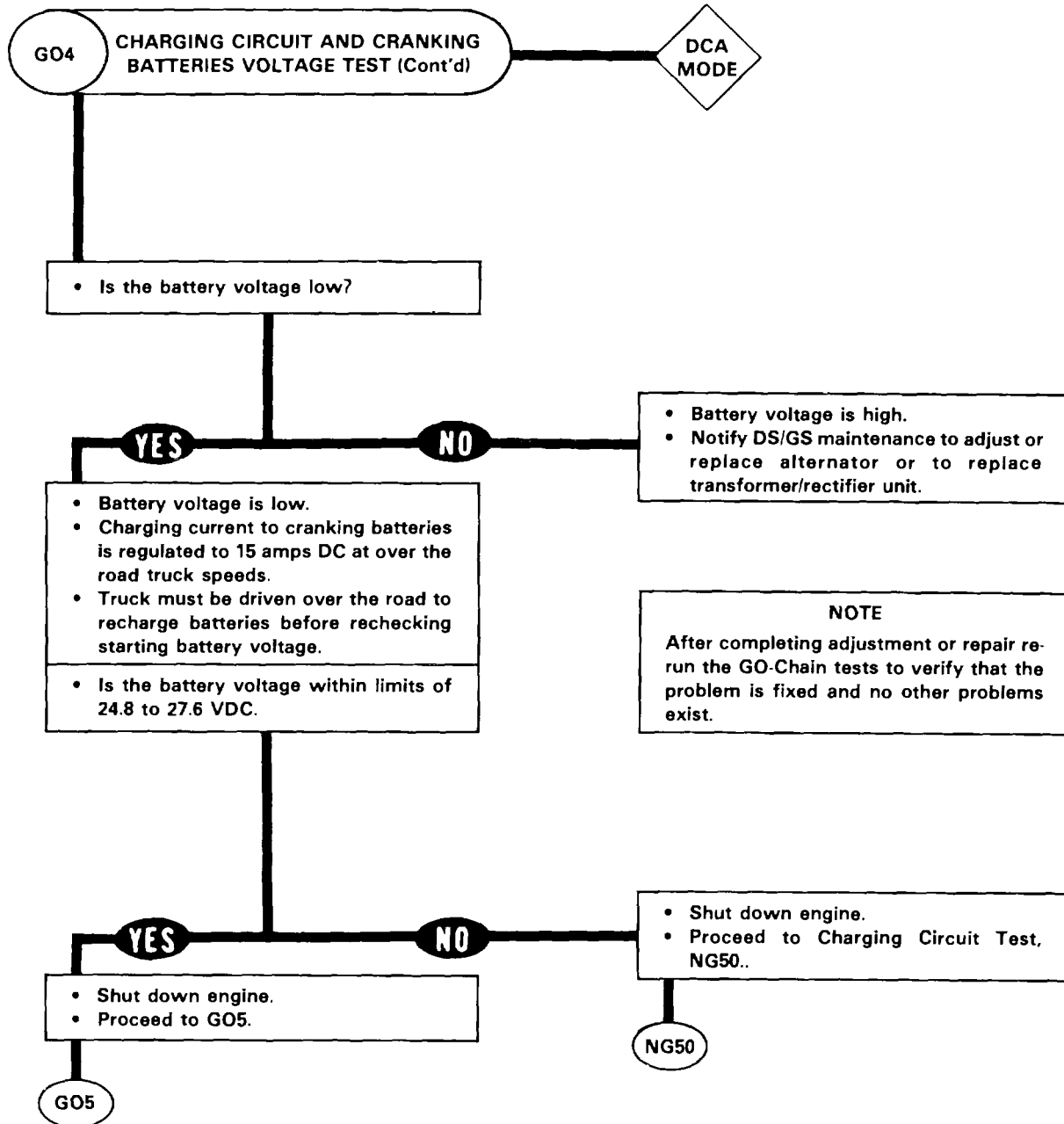

STE/ICE TROUBLESHOOTING.

2-20. STE/ICE GO CHAIN TESTS (Continued).

Table 2-9. STE/ICE GO-Chain Test (Cont'd)

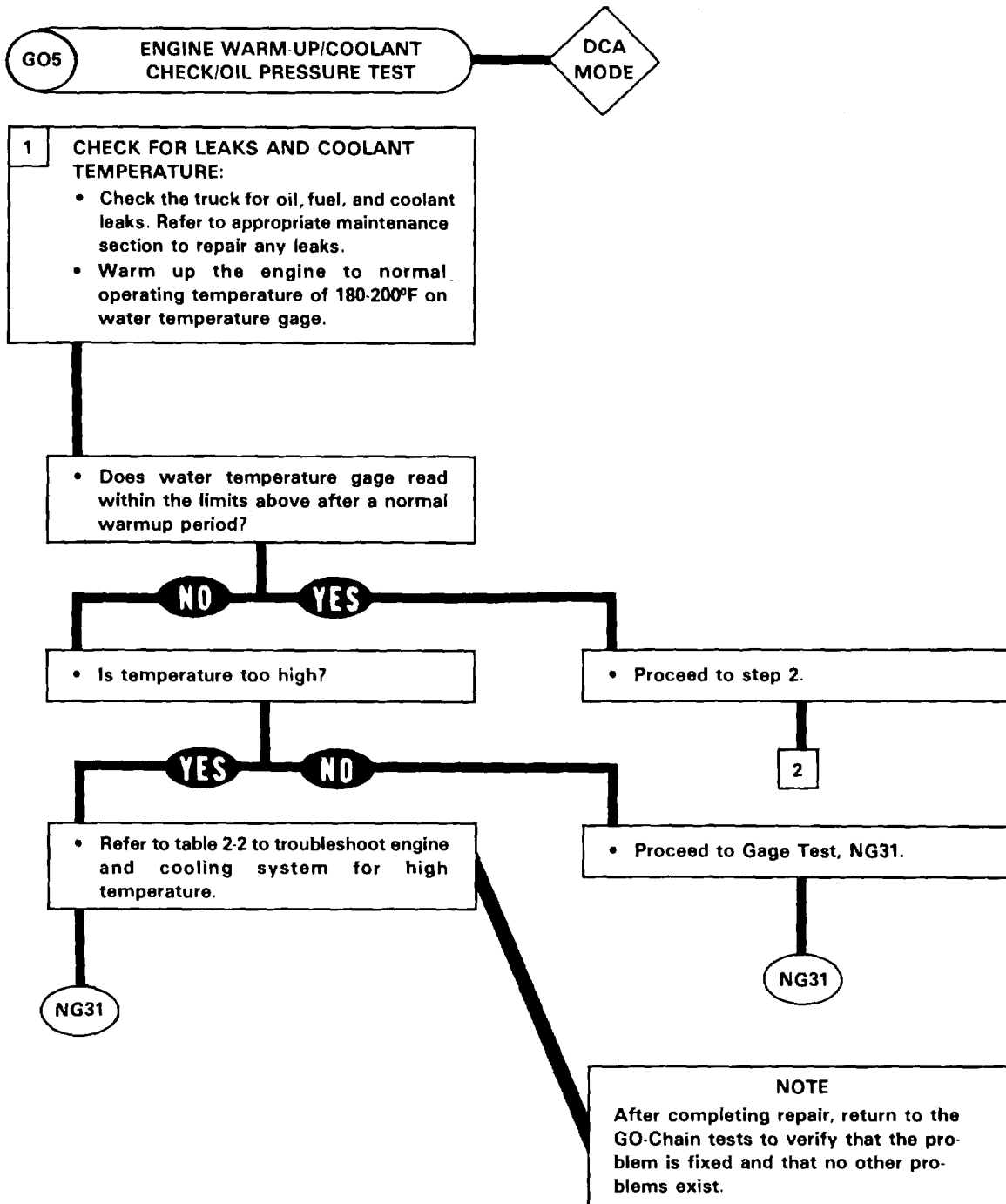

STE/ICE TROUBLESHOOTING.

2-20. STE/ICE GO CHAIN TESTS (Continued).

Table 2-9. STE/ICE GO-Chain Test (Cont'd)

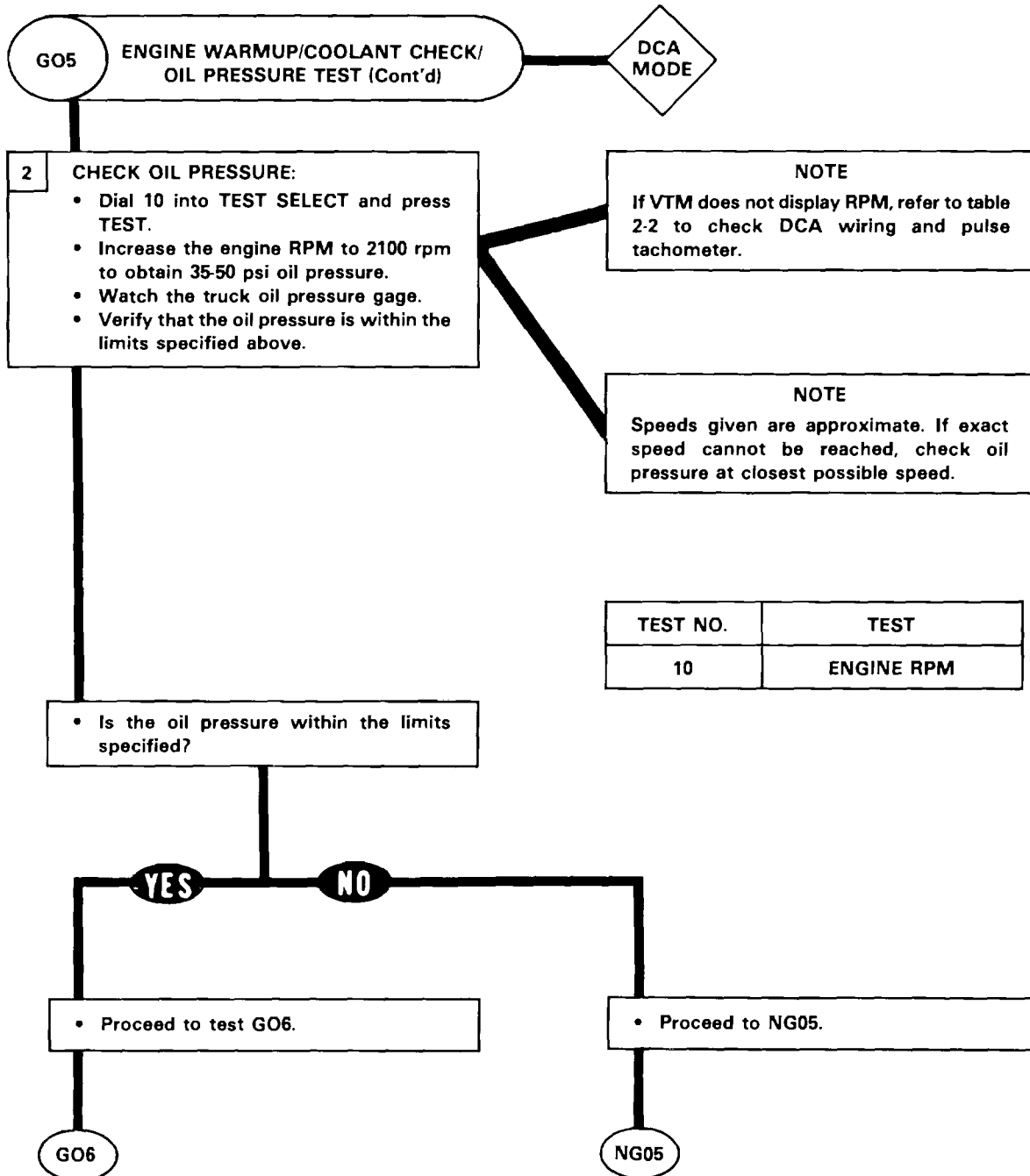

TEST NO.	TEST
10	ENGINE RPM

STE/ICE TROUBLESHOOTING.

2-20. STE/ICE GO CHAIN TESTS (Continued).

Table 2-9. STE/ICE GO-Chain Test (Cont'd)

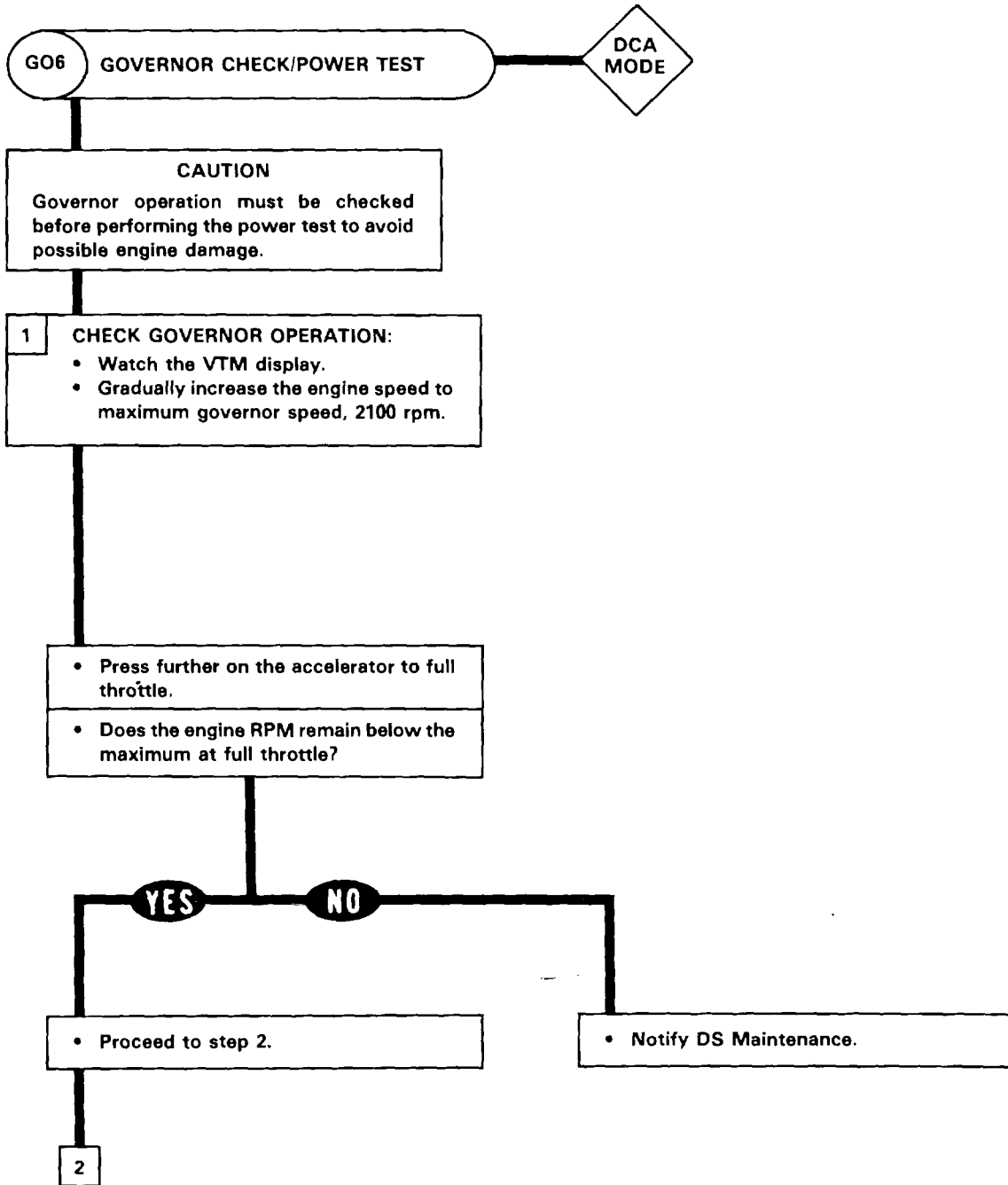

STE/ICE TROUBLESHOOTING.

2-20. STE/ICE GO CHAIN TESTS (Continued).

Table 2-9. STE/ICE GO-Chain Test (Cont'd)

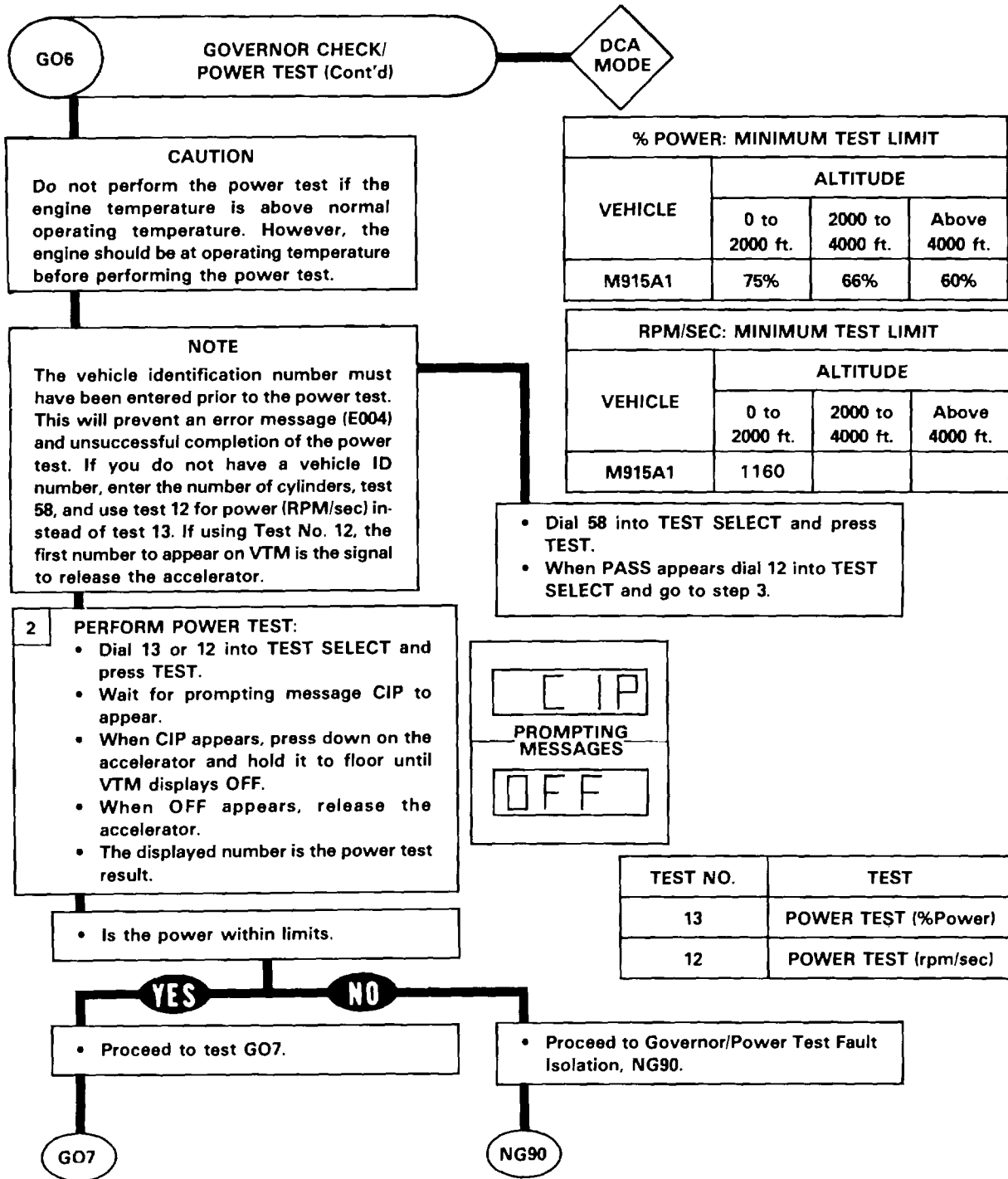

STE/ICE TROUBLESHOOTING.

2-20. STE/ICE GO CHAIN TESTS (Continued).

Table 2-9. STE/ICE GO-Chain Test (Cont'd)

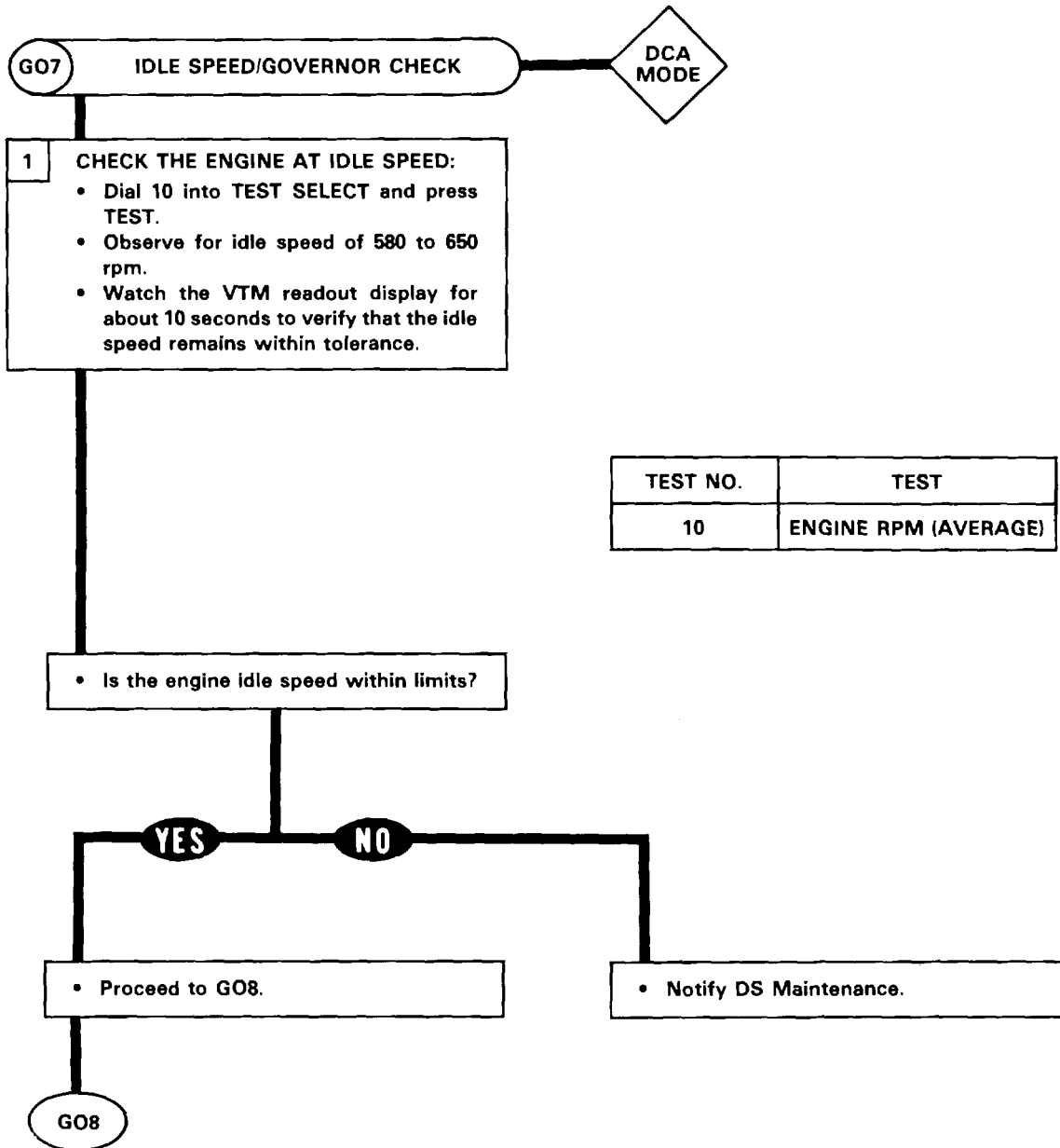

TEST NO.	TEST
10	ENGINE RPM (AVERAGE)

STE/ICE TROUBLESHOOTING.

2-20. STE/ICE GO CHAIN TESTS (Continued).

Table 2-9. STE/ICE GO-Chain Test (Cont'd)

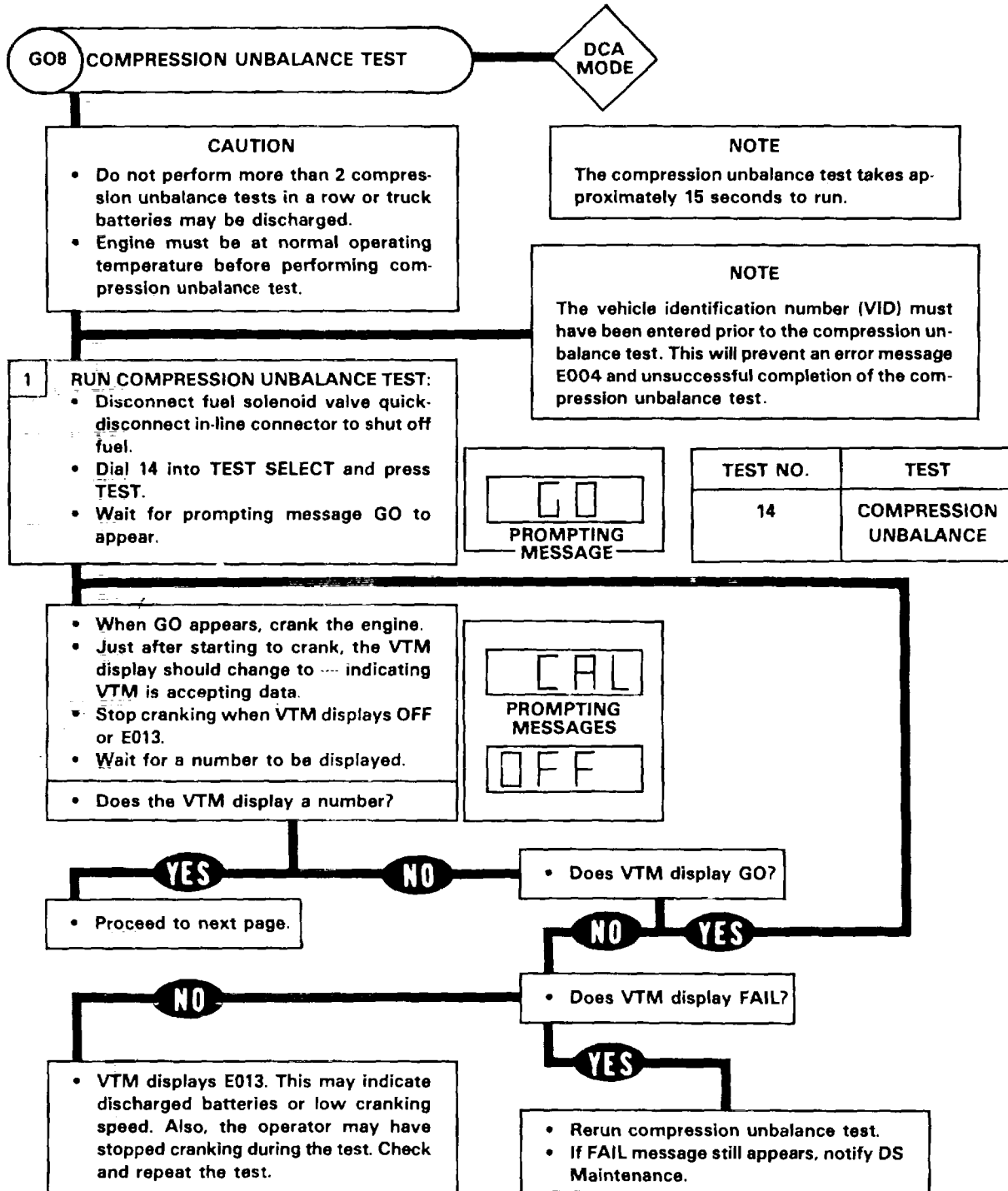

STE/ICE TROUBLESHOOTING.

2-20. STE/ICE GO CHAIN TESTS (Continued).

Table 2-9. STE/ICE GO-Chain Test (Cont'd)

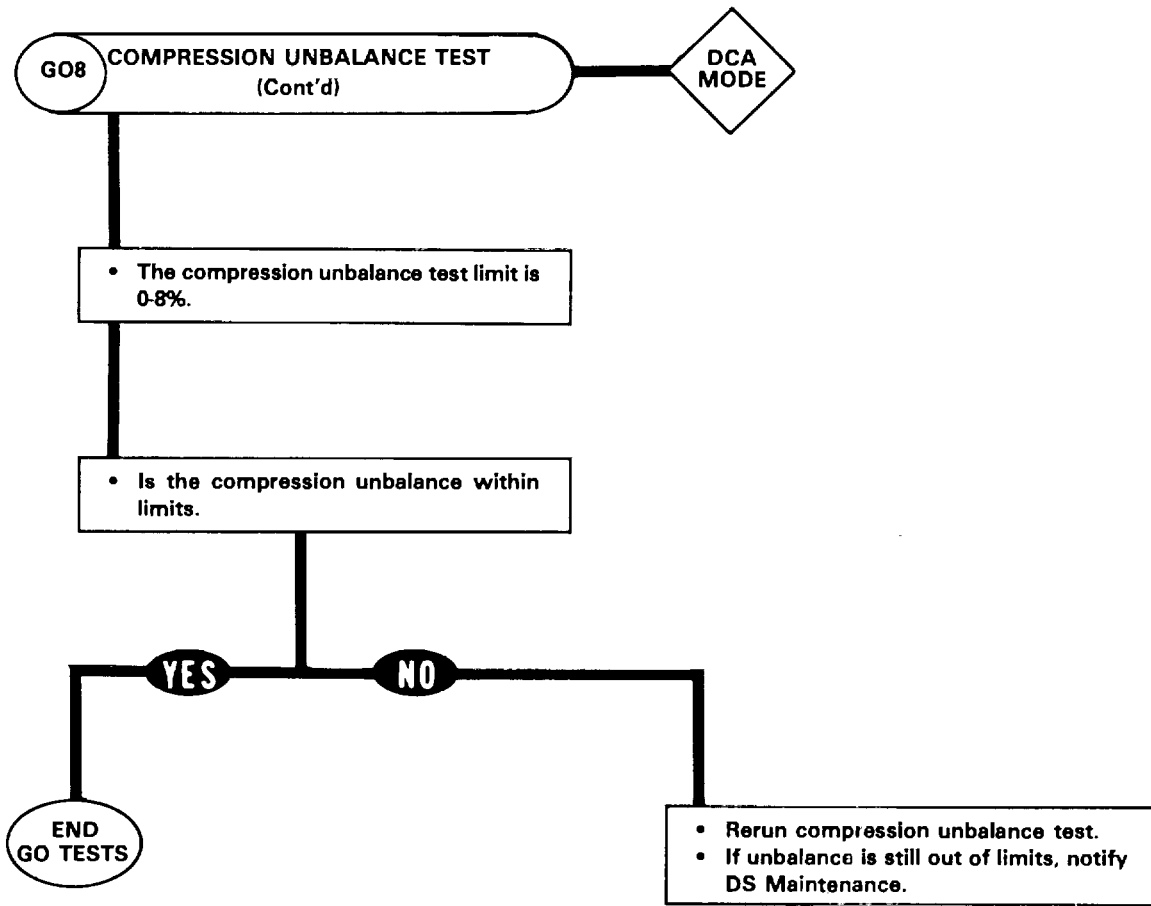

STE/ICE TROUBLESHOOTING.

2-20. STE/ICE GO CHAIN TESTS (Continued).

Table 2-10. STE/ICE NO GO-Chain Test (Cont'd)

b. Table 2-10 contains the STE/ICE NO-GO Chain Tests necessary to troubleshoot the M915A1 truck.

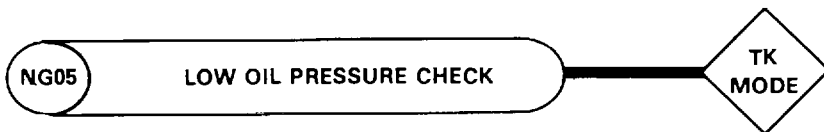
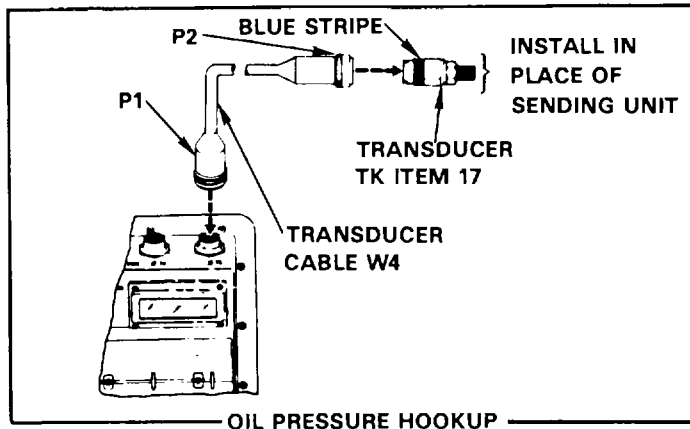

- 1 **INSTALL TRANSDUCER - DO OFFSET:**
- Stop truck engine.
 - Remove oil pressure sending unit.
 - Install pressure transducer TK item 17 (blue stripe) with suitable adapter in place of sending unit on engine.
 - Connect P1 of the transducer cable W4 to J1 or J2 on the VTM.
 - Connect P2 of the transducer cable to the connector on the pressure transducer.

TEST NO.	TEST
01	INTERLEAVE
50	0-1000 PSIG PRESSURE

- Dial 50 into TEST SELECT.
 - Press and hold TEST until CAL message appears on display.
 - Release TEST.
 - Wait for offset value to appear on the display.
- Is the offset value within the limits -150 to +150?

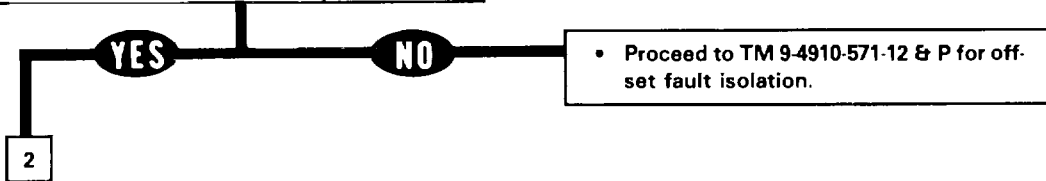

TA 236980

STE/ICE TROUBLESHOOTING.

2-21. STE/ICE GO CHAIN TESTS.

Table 2-10. STE/ICE NO-GO-Chain Test (Cont'd)

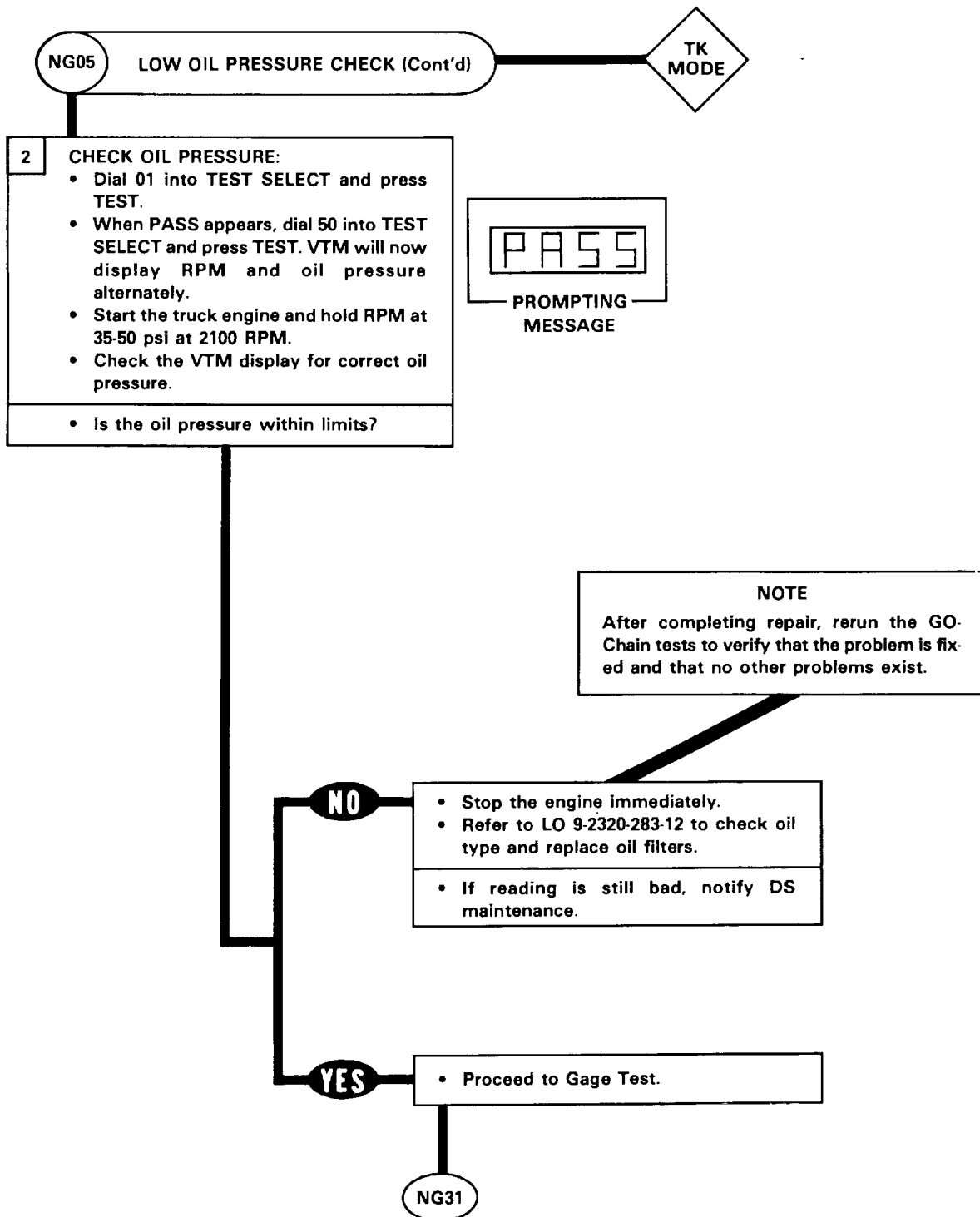

TA 236981

STE/ICE TROUBLESHOOTING.

2-21. STE/ICE GO CHAIN TESTS (Continued).

Table 2-10. STE/ICE NO-GO-Chain Test (Cont'd)

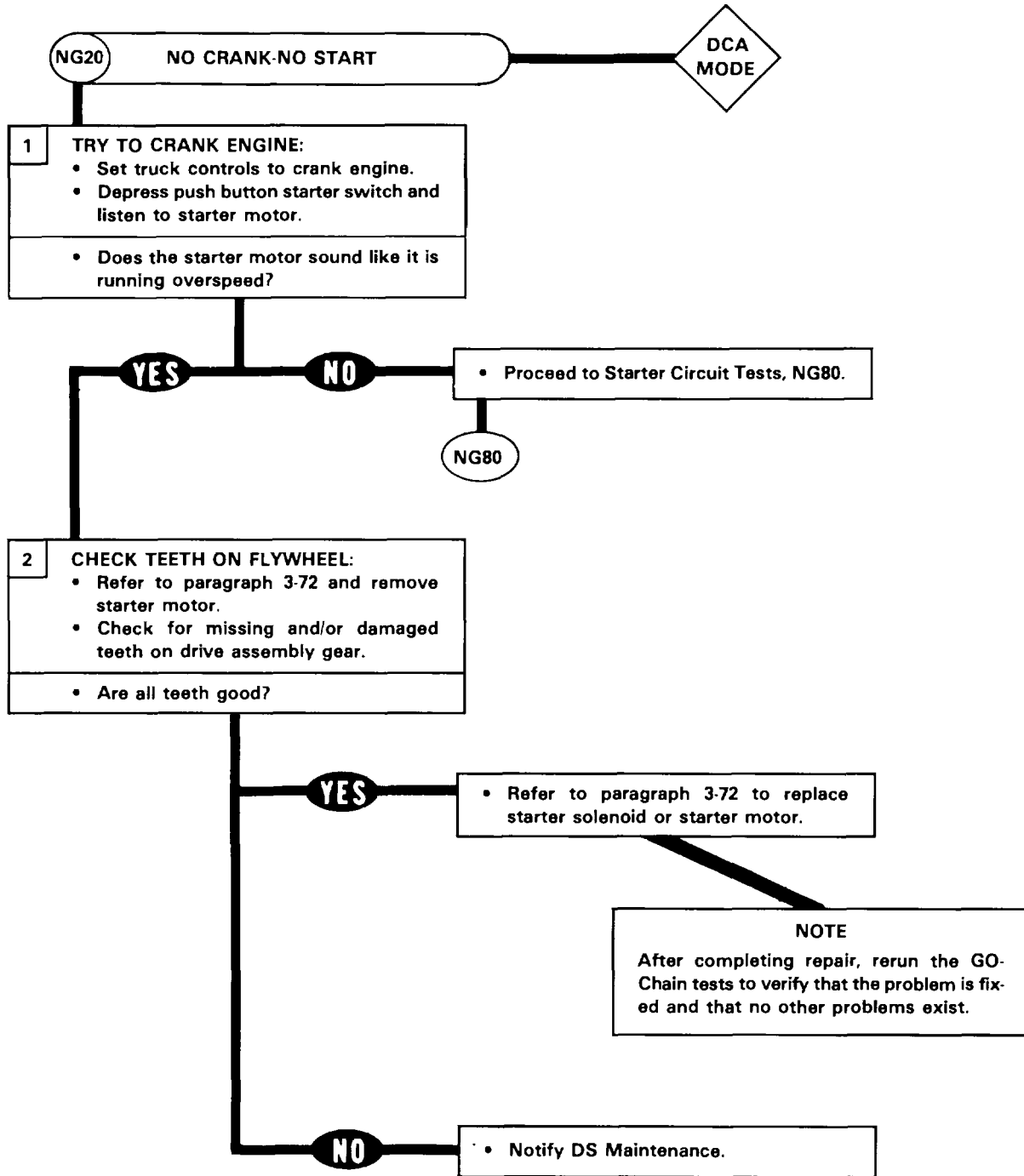

STE/ICE TROUBLESHOOTING.

2-21. STE/ICE GO CHAIN TESTS (Continued).

Table 2-10. STE/ICE NO-GO-Chain Test (Cont'd)

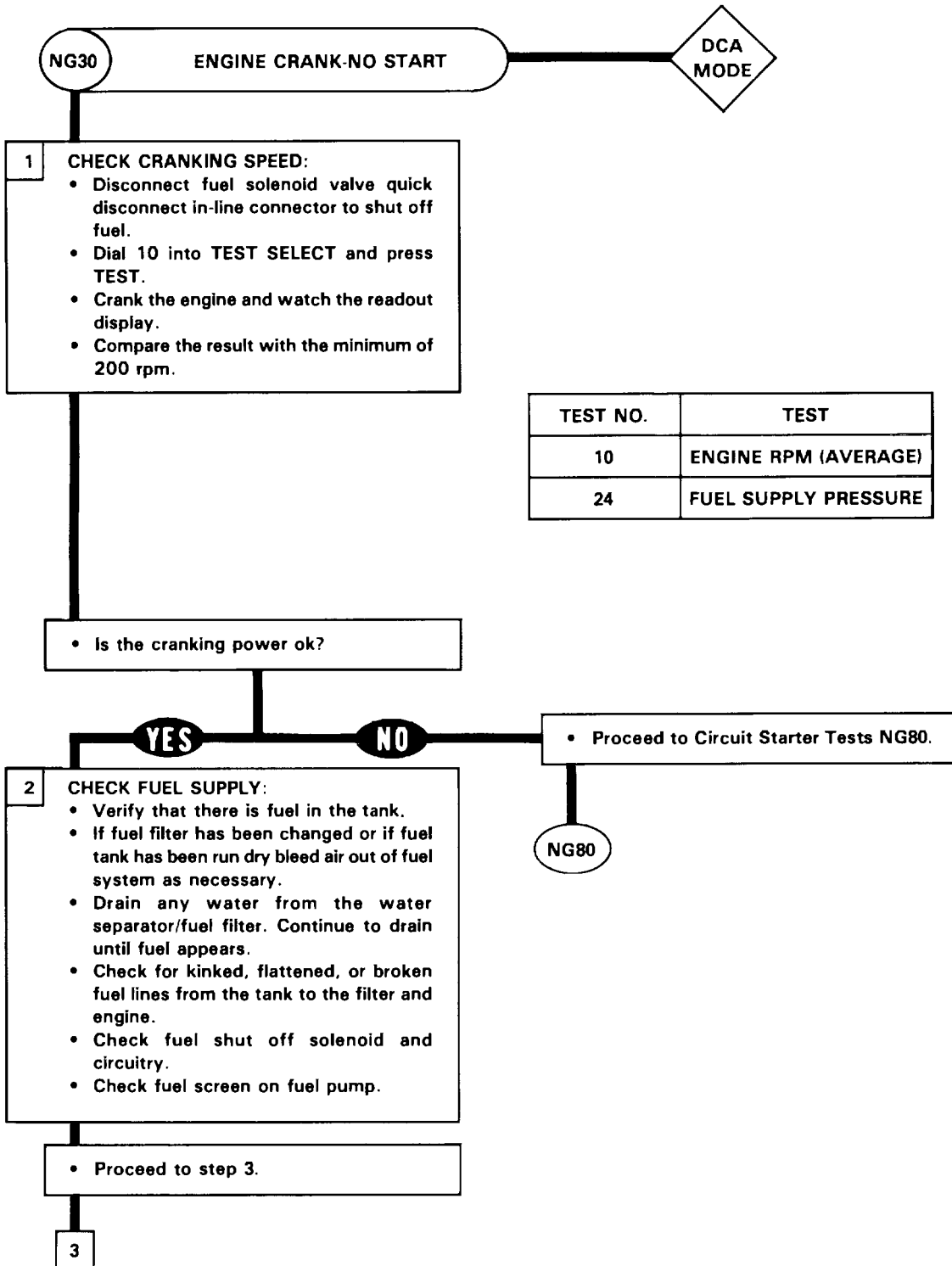

TEST NO.	TEST
10	ENGINE RPM (AVERAGE)
24	FUEL SUPPLY PRESSURE

STE/ICE TROUBLESHOOTING.

2-21. STE/ICE GO CHAIN TESTS (Continued).

Table 2-10. STE/ICE NO-GO-Chain Test (Cont'd)

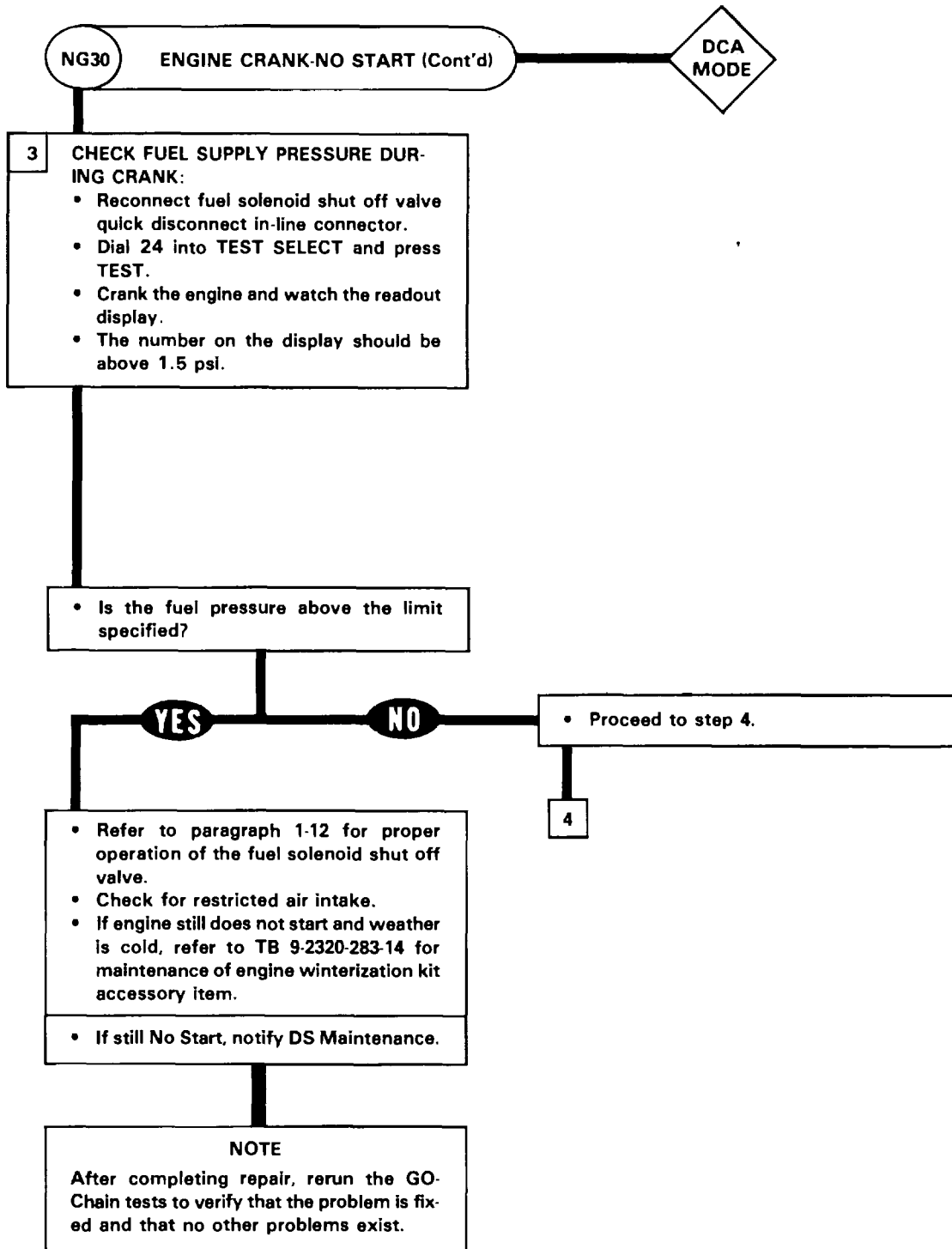

STE/ICE TROUBLESHOOTING.

2-21. STE/ICE GO CHAIN TESTS (Continued).

Table 2-10. STE/ICE NO-GO-Chain Test (Cont'd)

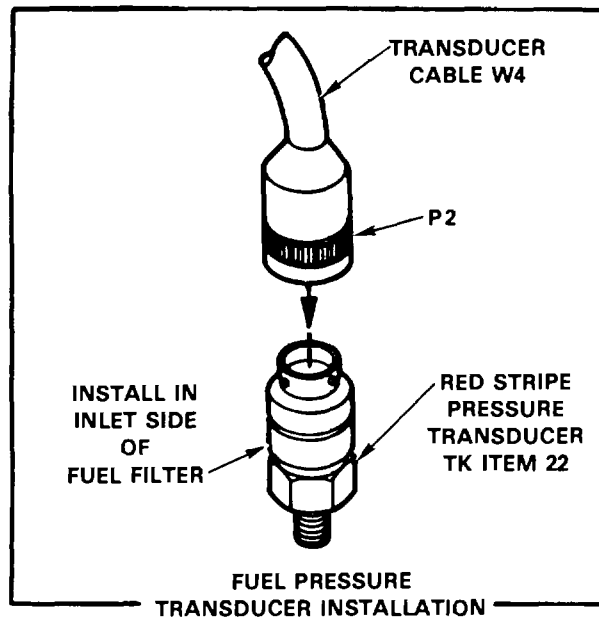

CAUTION
Before opening the fuel line, make sure that the area around the fuel line is clean.

- 4** **INSTALL TRANSDUCER:**
- Using suitable adapter install pressure transducer (red stripe) in the inlet side of the fuel filter.
 - Connect P1 of transducer cable W4 to J2 on the VTM.
 - Connect P2 of the transducer cable to the connector on the transducer.

• Proceed to next page.

STE/ICE TROUBLESHOOTING.

2-21. STE/ICE GO CHAIN TESTS (Continued).

Table 2-10. STE/ICE NO-GO-Chain Test (Cont'd)

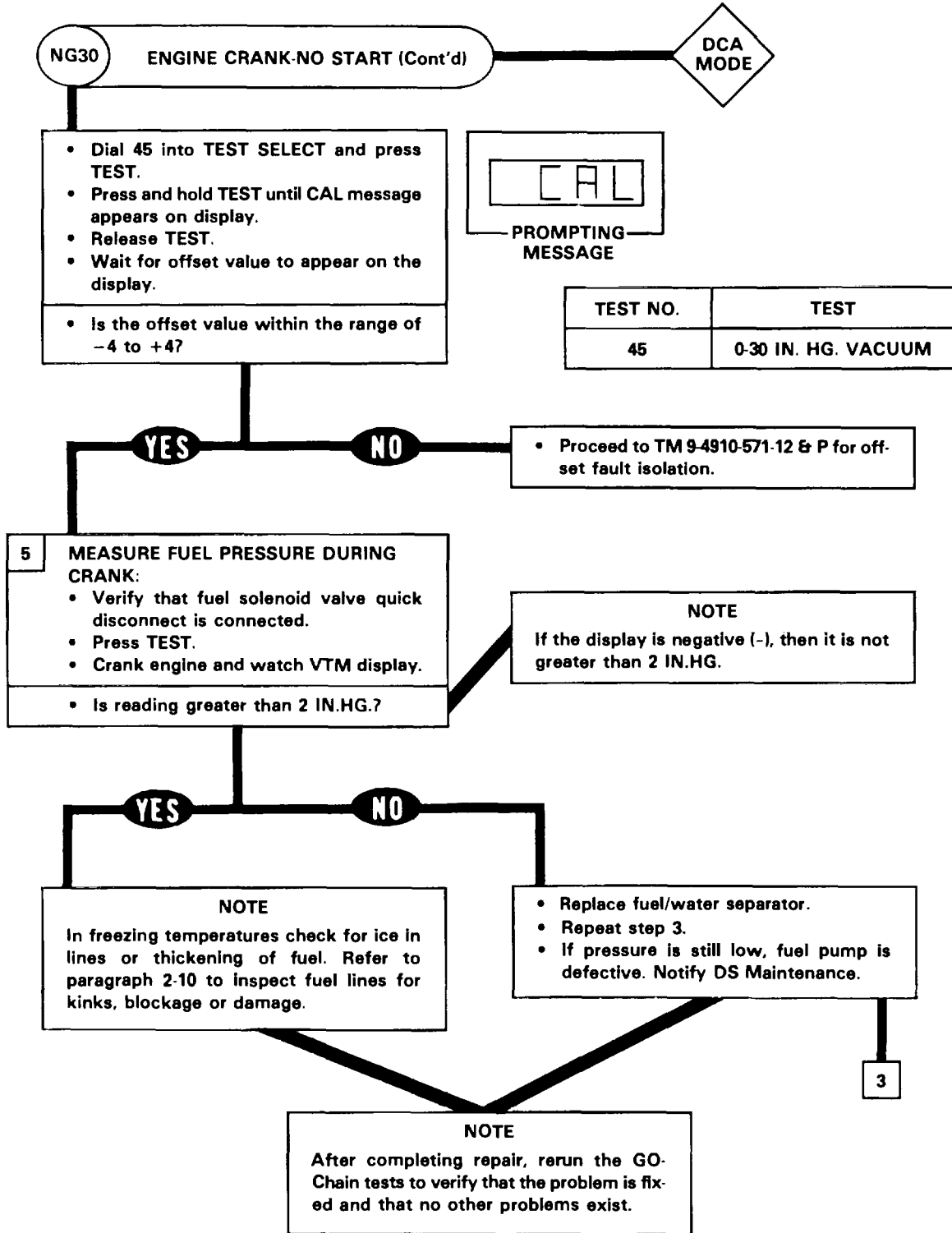

STE/ICE TROUBLESHOOTING.

2-21. STE/ICE GO CHAIN TESTS (Continued).

Table 2-10. STE/ICE NO-GO-Chain Test (Cont'd)

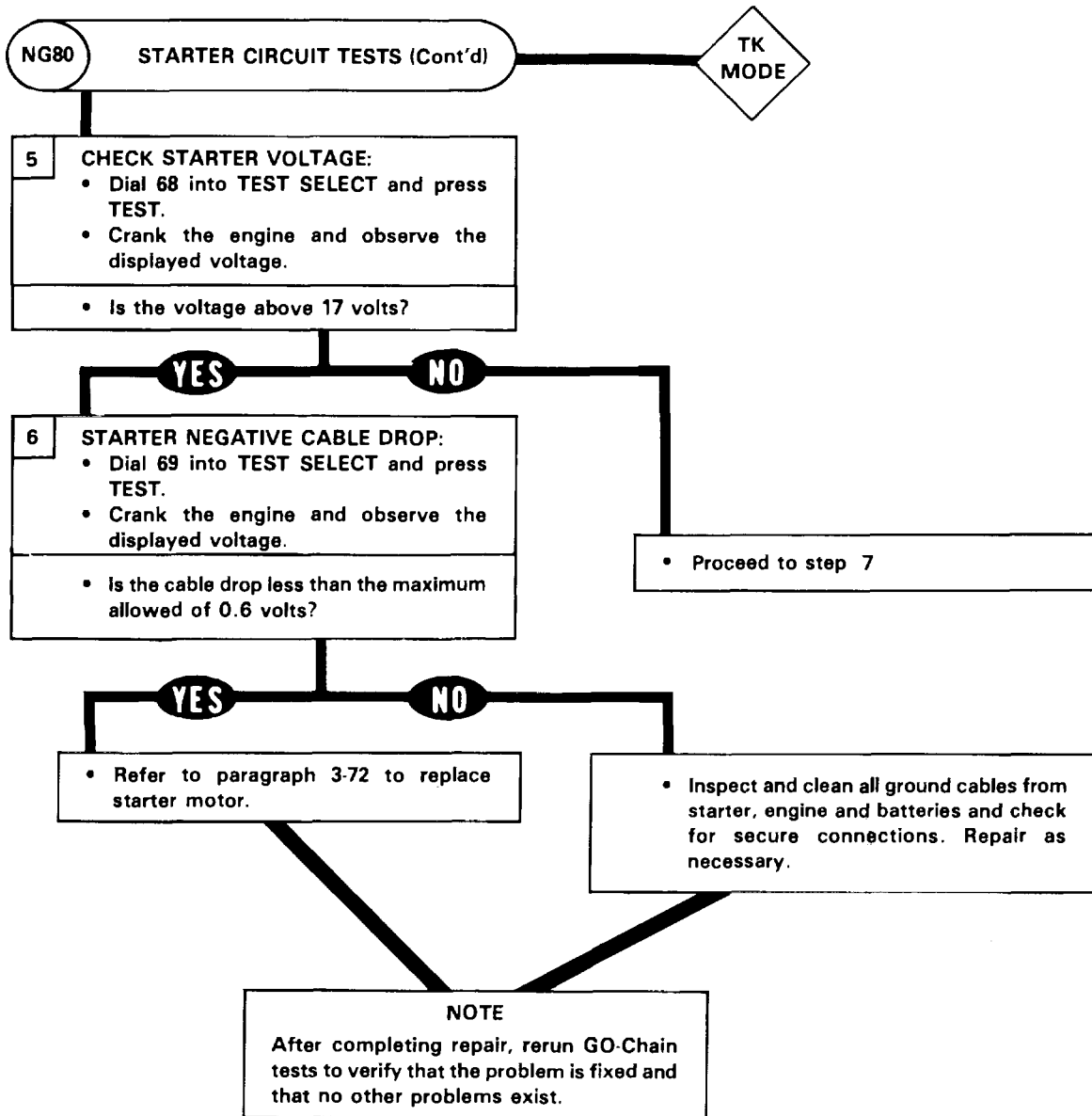

STE/ICE TROUBLESHOOTING.

2-21. STE/ICE GO CHAIN TESTS (Continued).

Table 2-10. STE/ICE NO-GO-Chain Test (Cont'd)

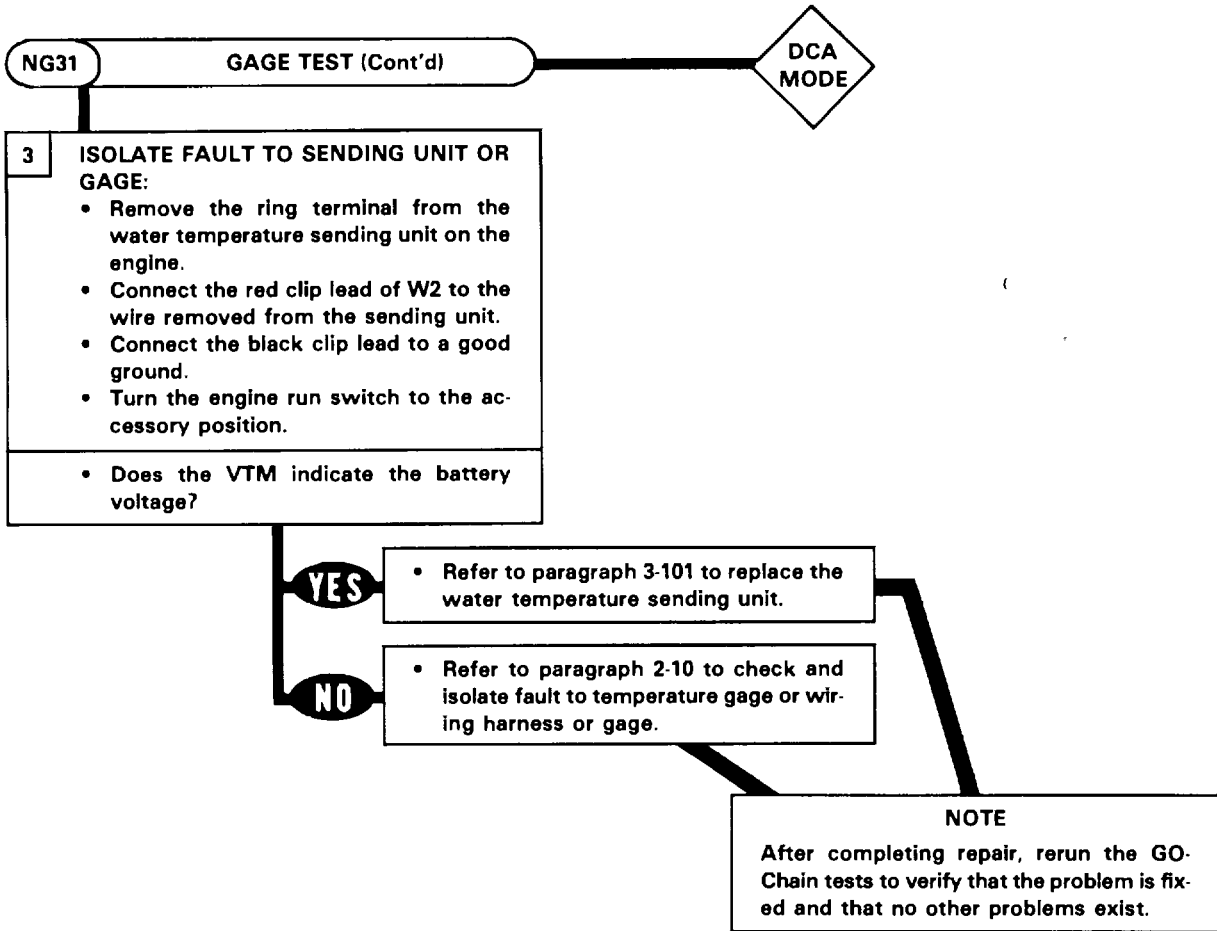
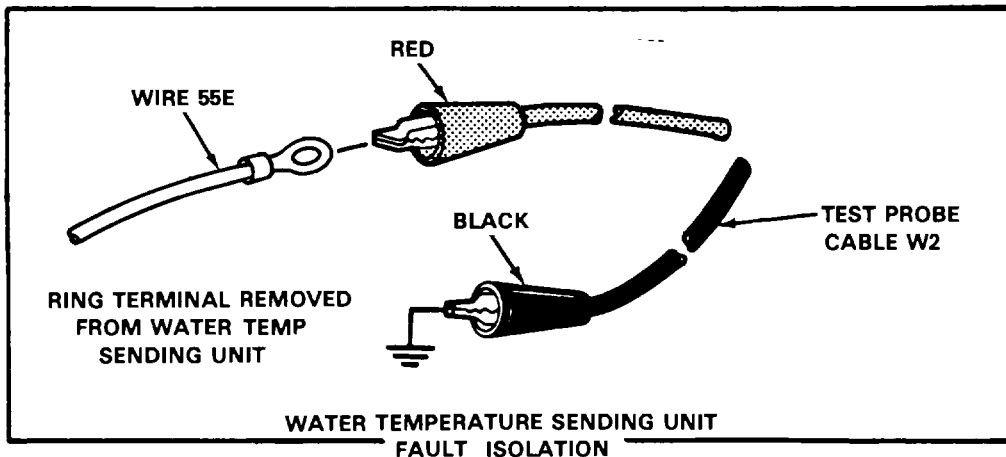

TA 236985

STE/ICE TROUBLESHOOTING.

2-21. STE/ICE GO CHAIN TESTS (Continued).

Table 2-10. STE/ICE NO-GO-Chain Test (Cont'd)

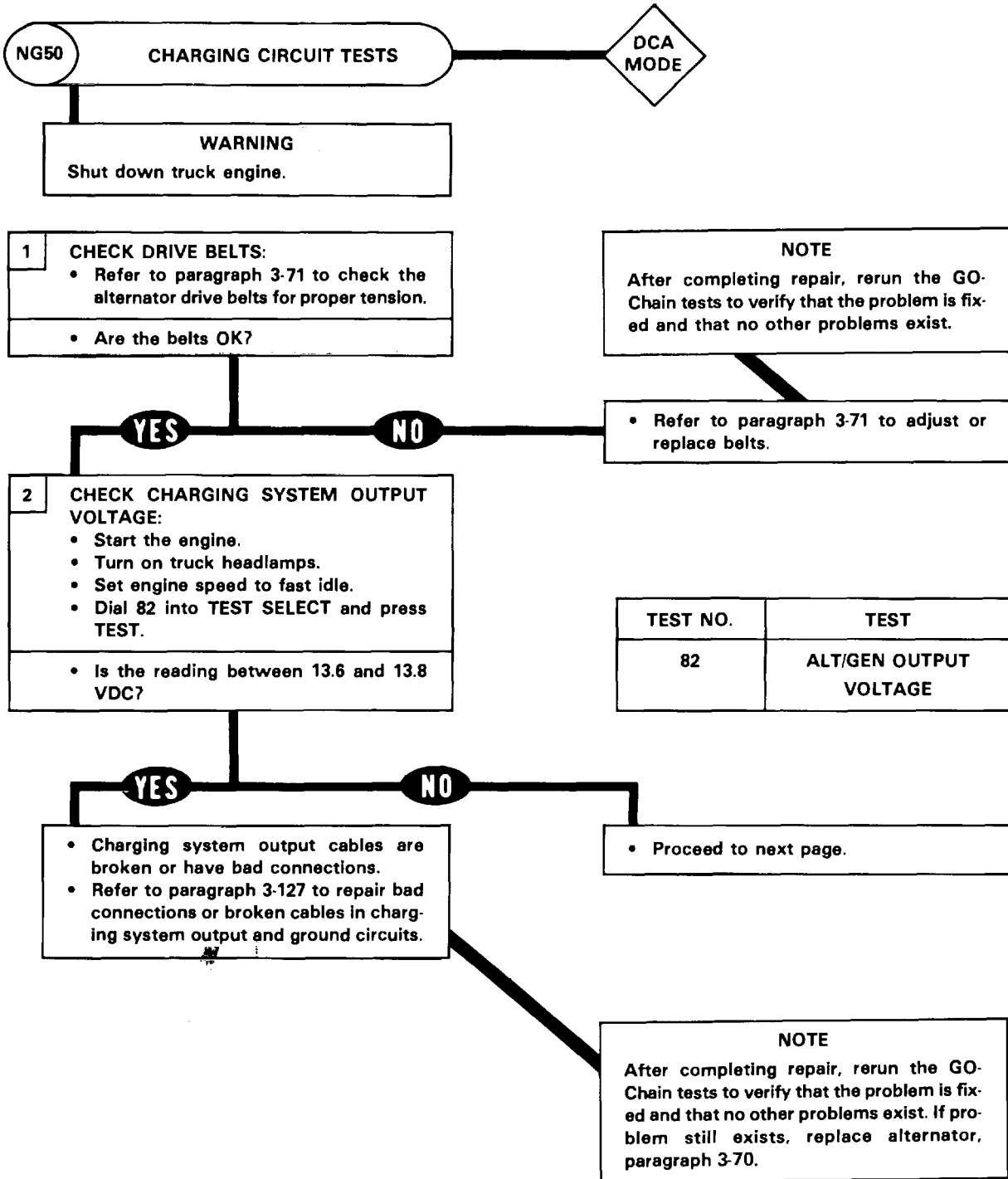

STE/ICE TROUBLESHOOTING.

2-21. STE/ICE GO CHAIN TESTS (Continued).

Table 2-10. STE/ICE NO-GO-Chain Test (Cont'd)

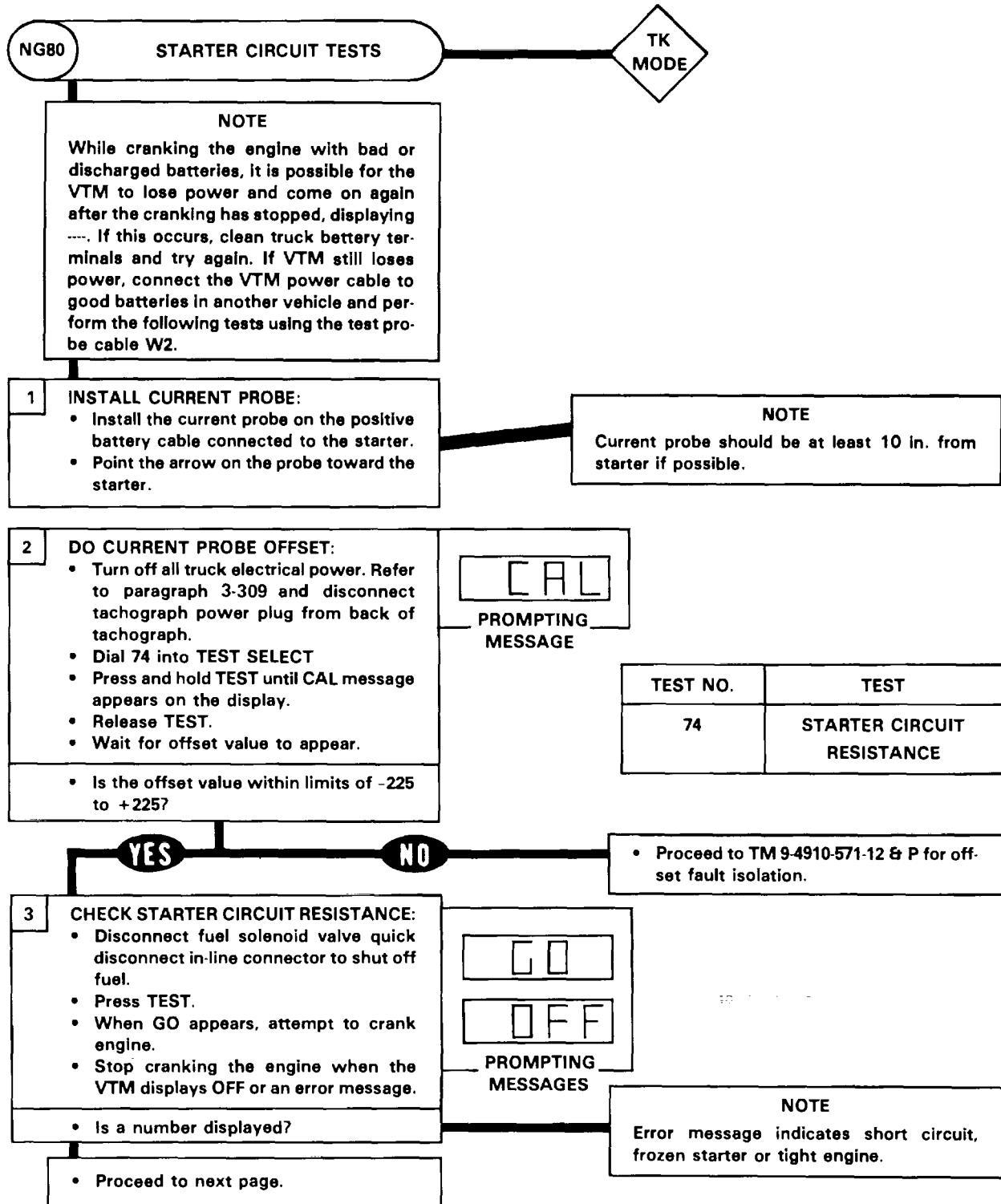

TA 236986

STE/ICE TROUBLESHOOTING.

2-21. STE/ICE GO CHAIN TESTS (Continued).

Table 2-10. STE/ICE NO-GO-Chain Test (Cont'd)

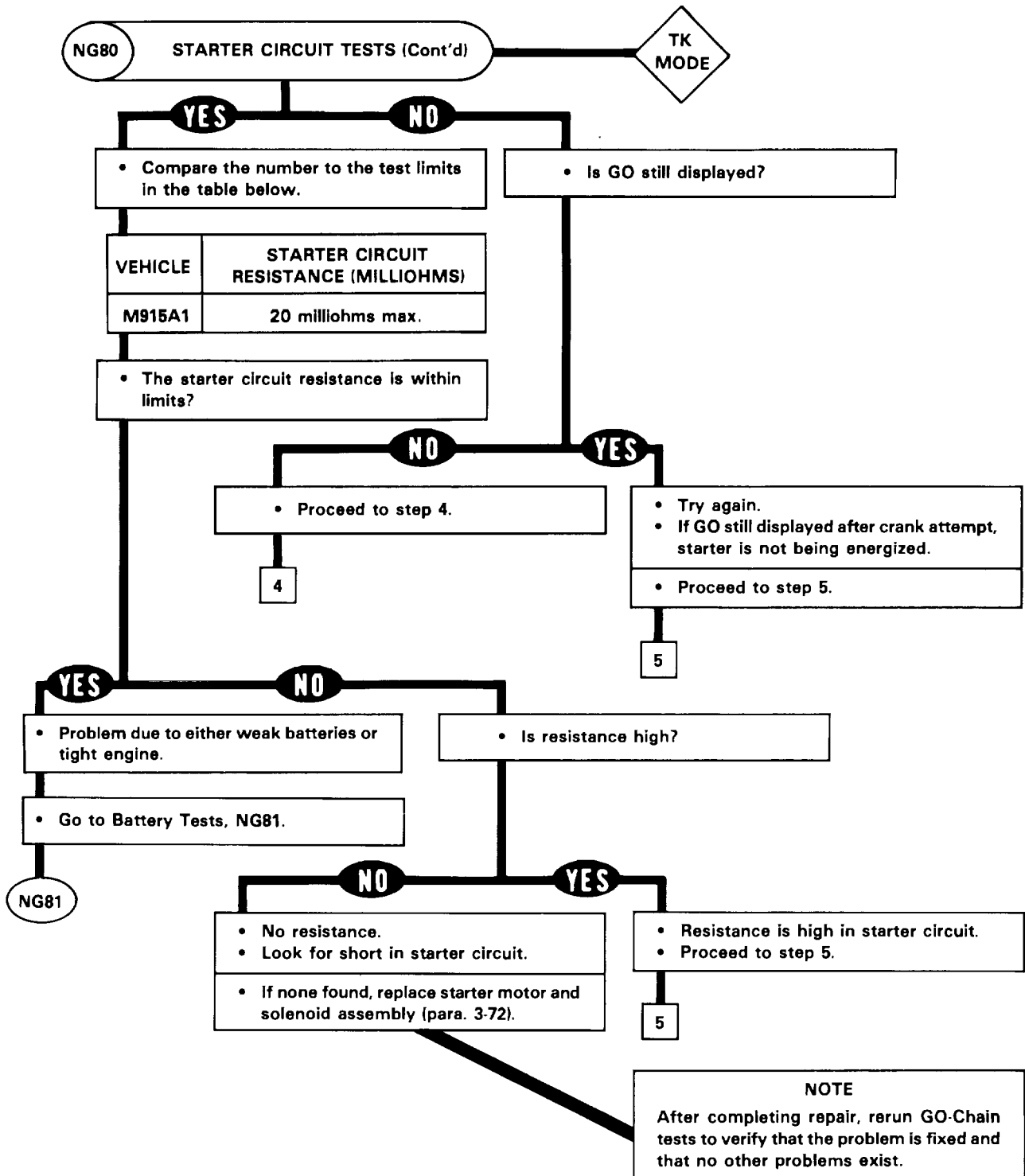

STE/ICE TROUBLESHOOTING.

2-21. STE/ICE GO CHAIN TESTS (Continued).

Table 2-10. STE/ICE NO-GO-Chain Test (Cont'd)

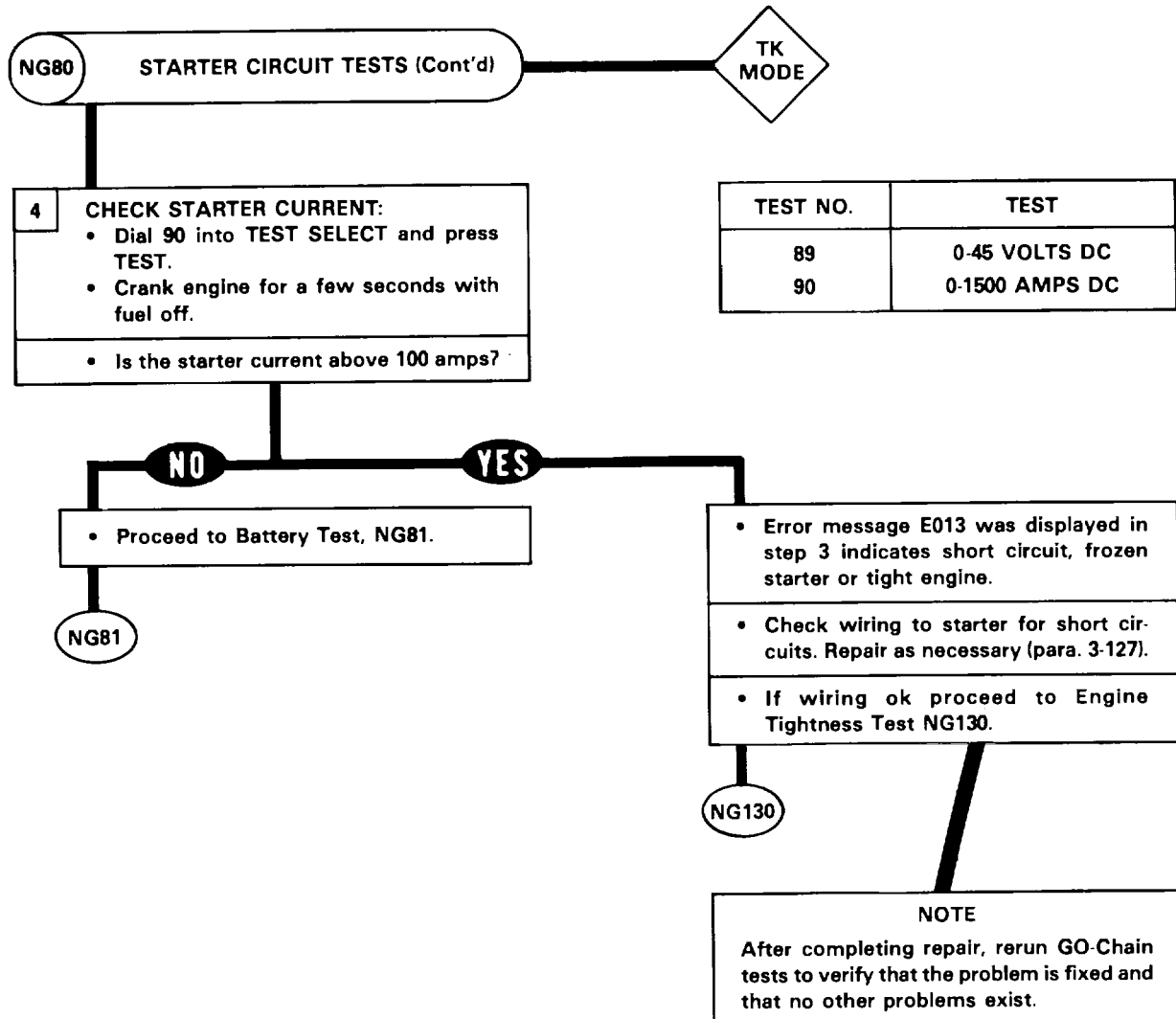

2-21. STE/ICE GO CHAIN TESTS (Continued).

Table 2-10. STE/ICE NO-GO-Chain Test (Cont'd)

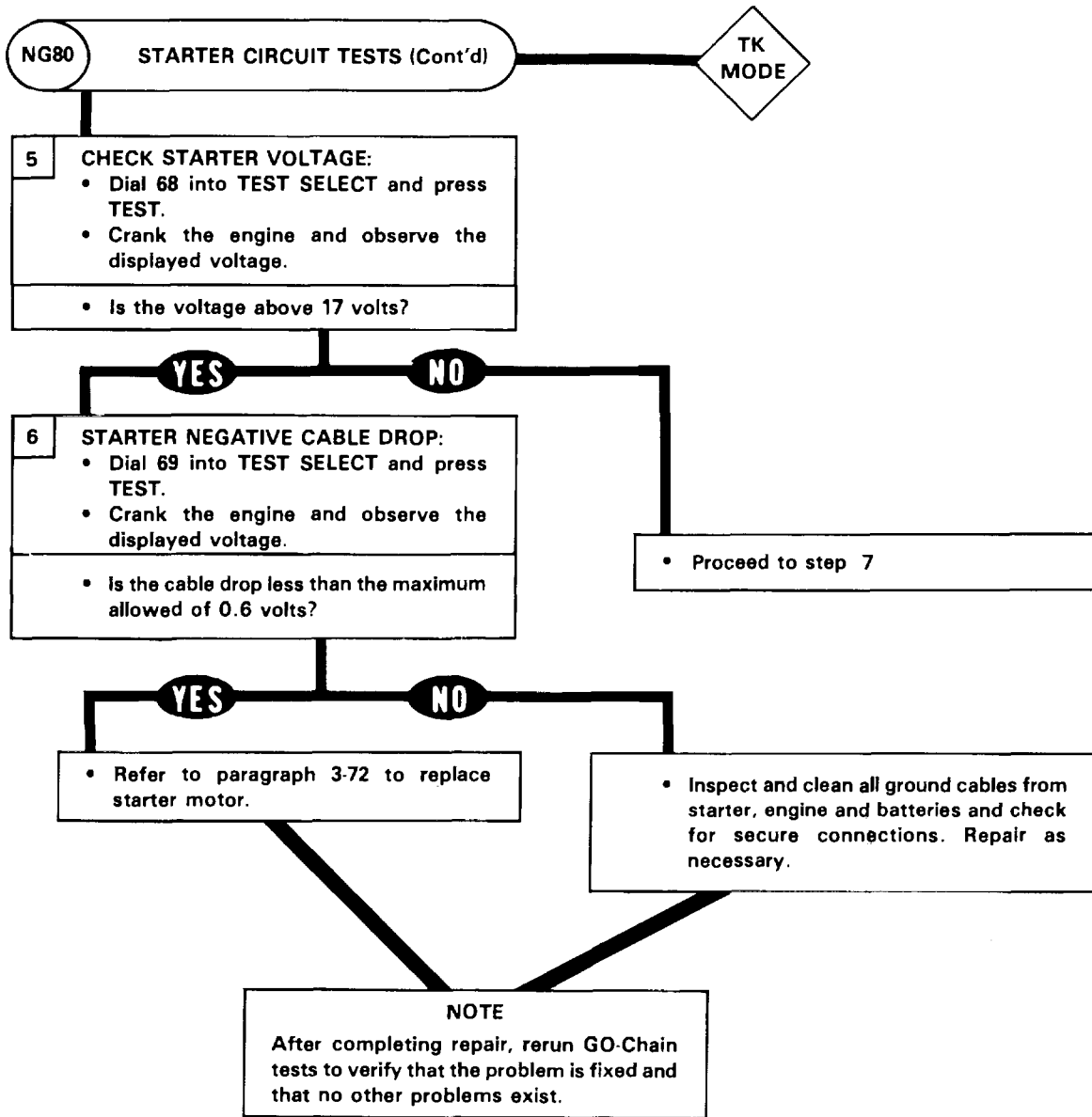

STE/ICE TROUBLESHOOTING.

2-21. STE/ICE GO CHAIN TESTS (Continued).

Table 2-10. STE/ICE NO-GO-Chain Test (Cont'd)

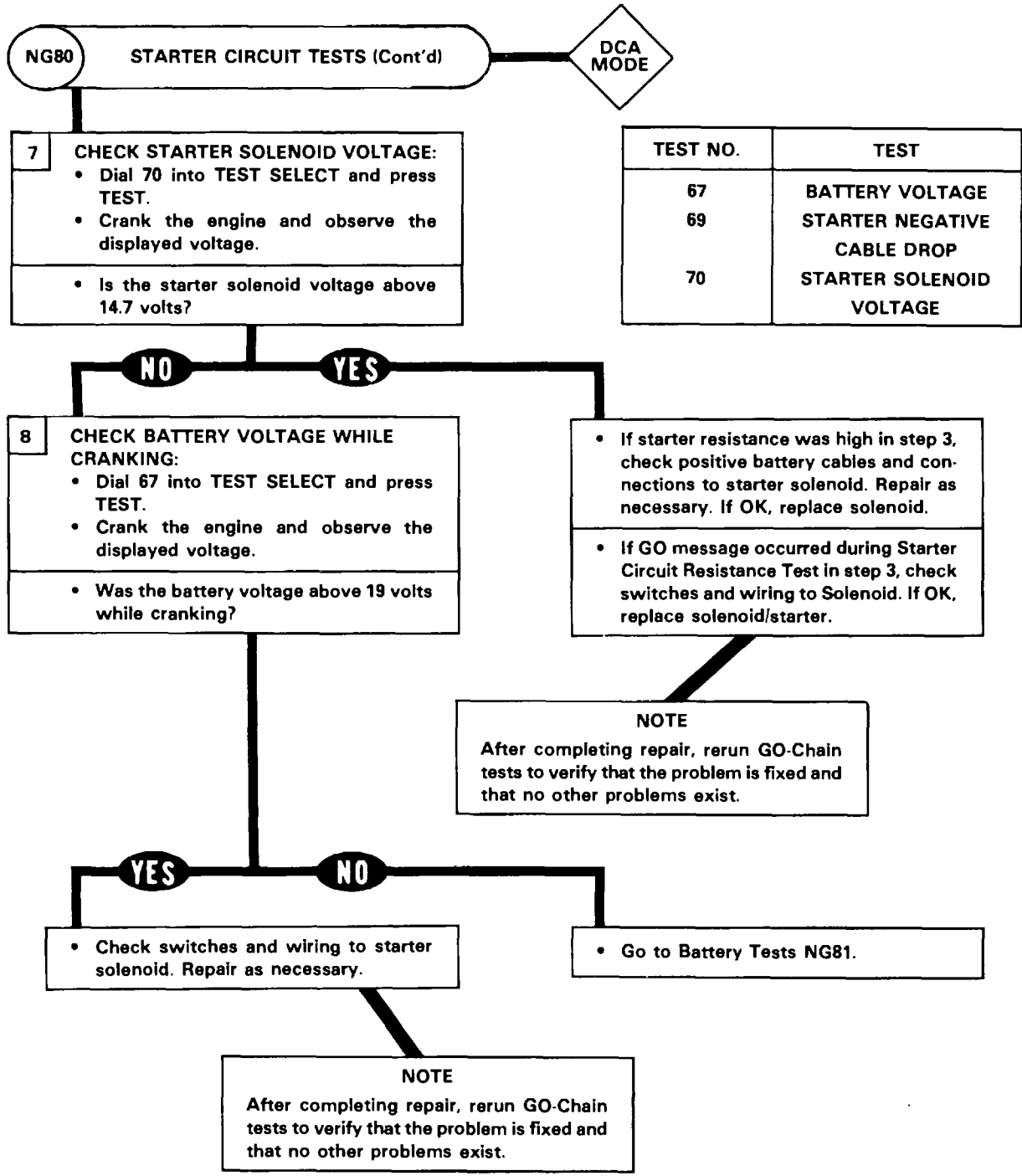

STE/ICE TROUBLESHOOTING.

2-21. STE/ICE GO CHAIN TESTS (Continued).

Table 2-10. STE/ICE NO-GO-Chain Test (Cont'd)

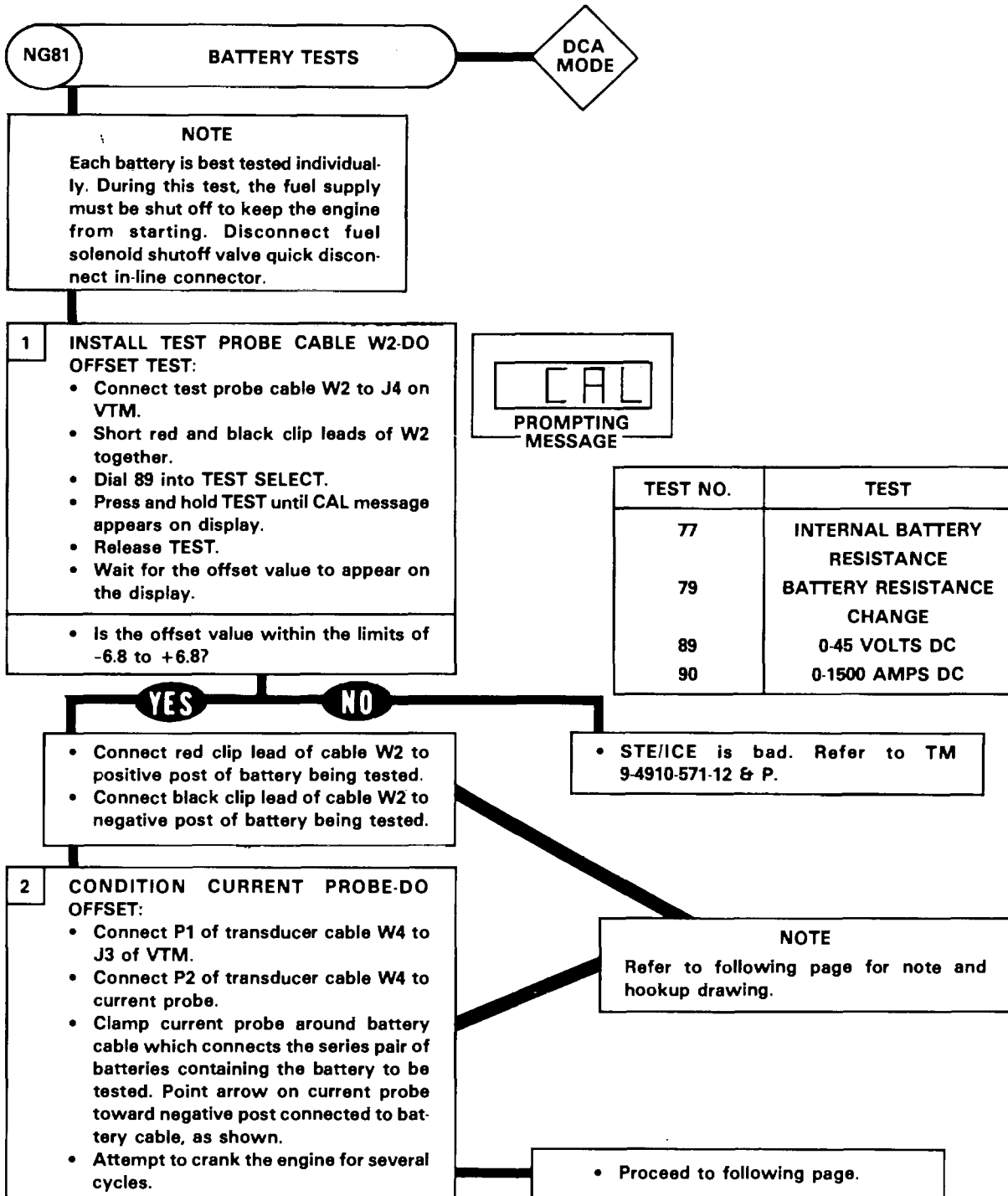

TA 236987

STE/ICE TROUBLESHOOTING.

2-21. STE/ICE GO CHAIN TESTS (Continued).

Table 2-10. STE/ICE NO-GO-Chain Test (Cont'd)

NOTE

TEST PROCEDURE FOR COMMERCIAL MAINTENANCE-FREE BATTERIES

1. Test each battery of a series pair, then proceed to batteries of next series pair.
2. To find the series pairs of batteries, find pairs for which the negative terminal of one battery is connected by a cable to the positive terminal of another battery. This makes the two batteries a series pair. For example in the figure below, batteries A and B are a series pair, and batteries C and D are also a series pair.
3. To test battery C or D. clamp current probe around cable connecting battery C and battery D. Point arrow on current probe in the direction of the negative post connected to the cable.
4. The test probe cable W2 is first connected to battery C for testing battery C.
5. The test probe cable W2 is then connected to battery D for testing battery D. (Current probe in same place as for testing battery C.)
6. To test battery A or B, clamp current probe around cable connecting battery A and battery B. Point arrow on current probe in the direction of the negative post connected to the cable.
7. The test probe cable W2 is then connected to battery B for testing battery B.

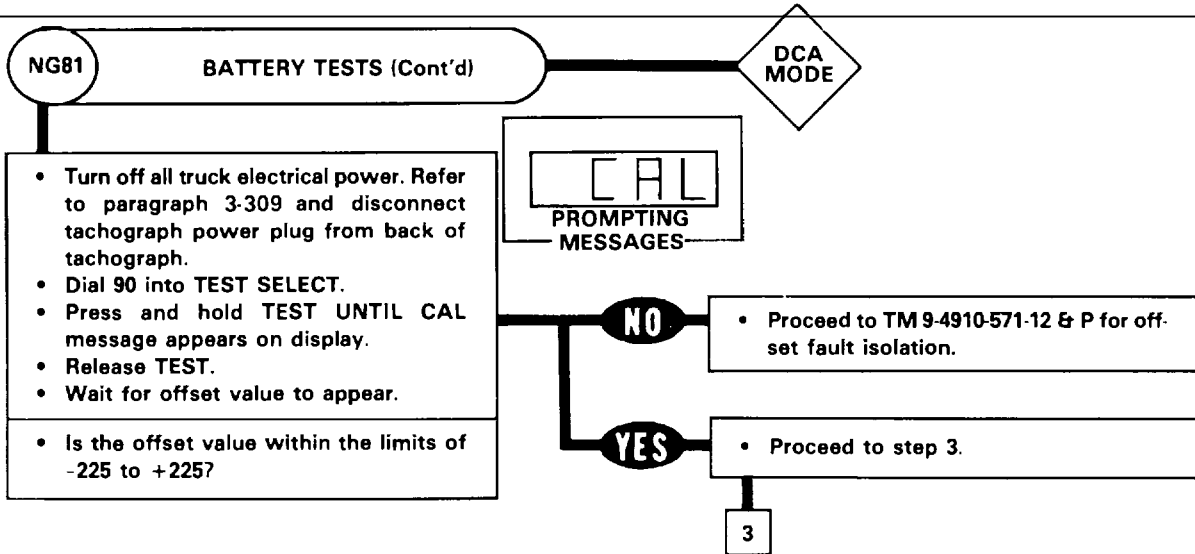
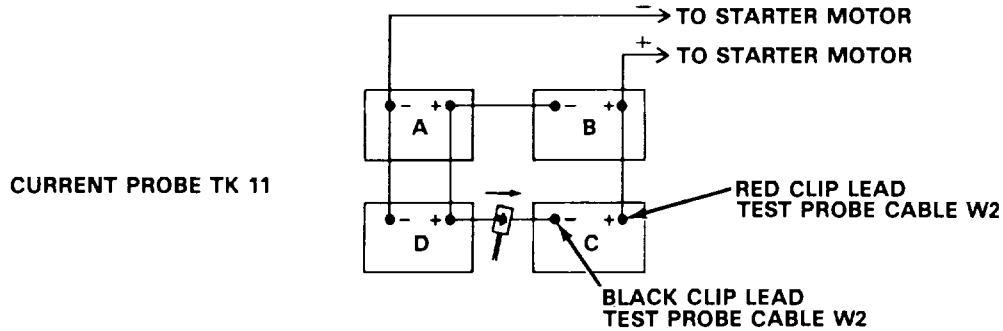

STE/ICE TROUBLESHOOTING.

2-21. STE/ICE NO-GO CHAIN TESTS (Continued).

Table 2-10. STE/ICE NO-GO Chain Tests (Cont'd)

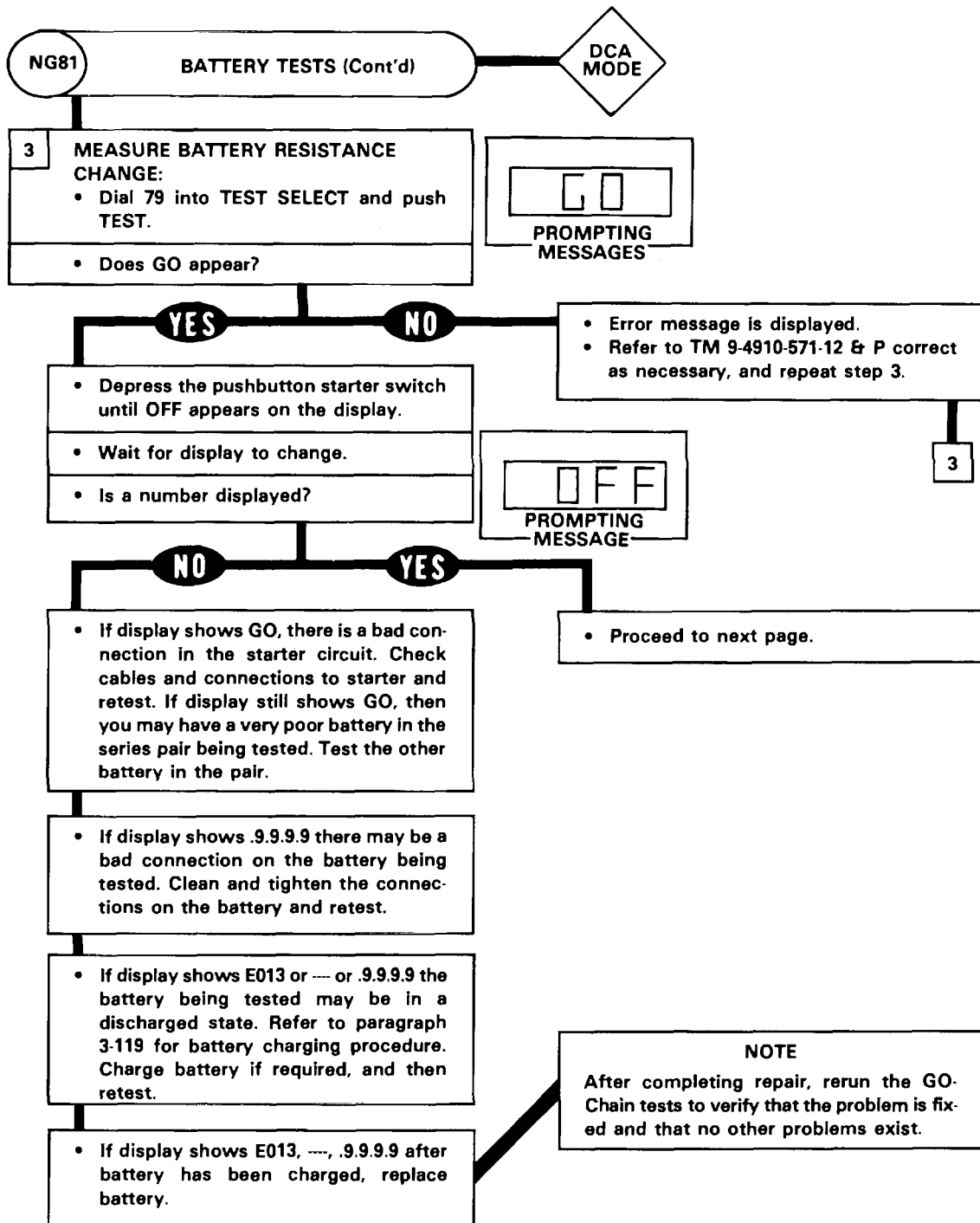

STE/ICE TROUBLESHOOTING.

2-21. STE/ICE NO-GO CHAIN TESTS (Continued).

Table 2-10. STE/ICE NO-GO Chain Tests (Cont'd)

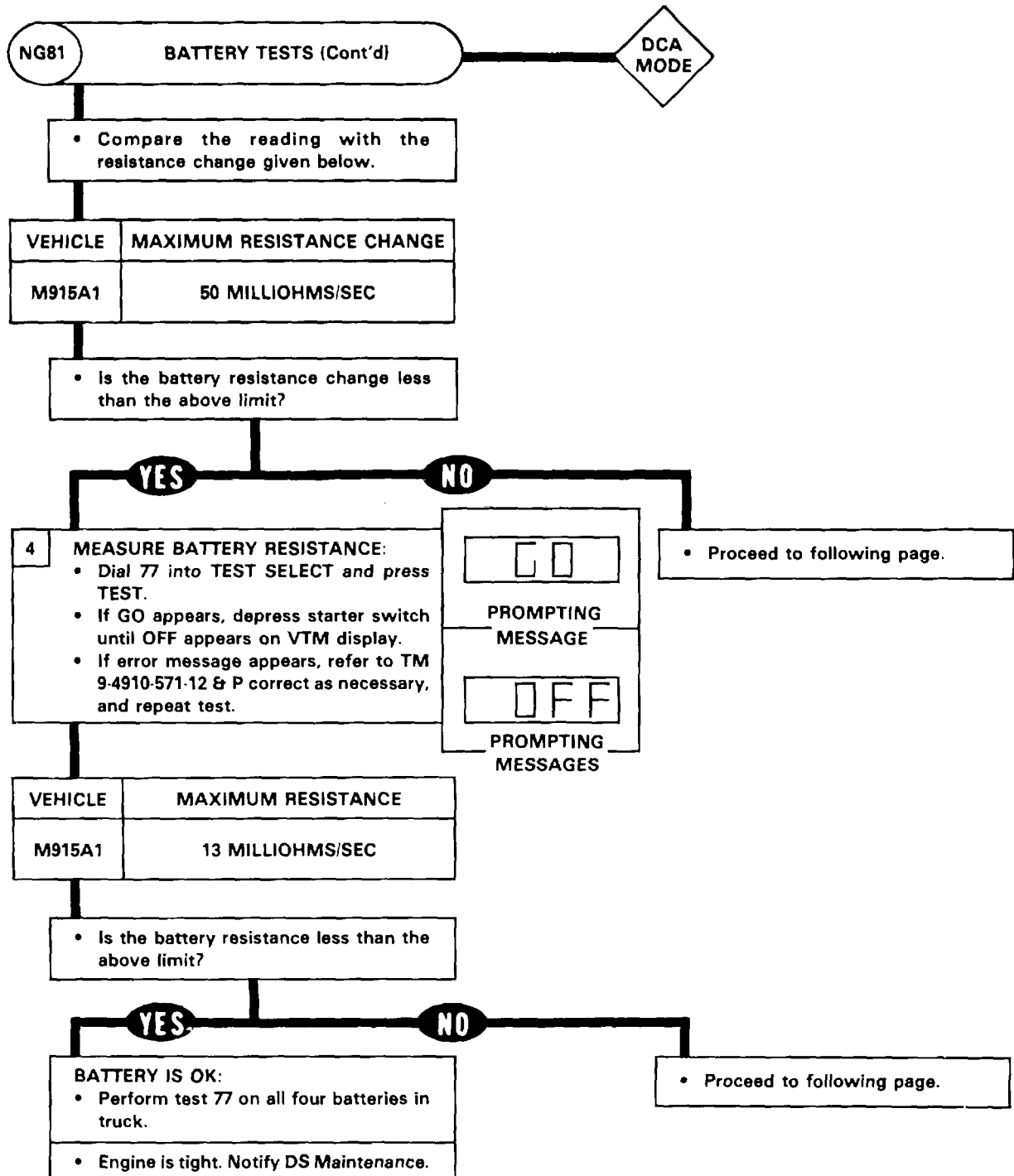

STE/ICE TROUBLESHOOTING.

2-21. STE/ICE NO-GO CHAIN TESTS (Continued).

Table 2-10. STE/ICE NO-GO Chain Tests (Cont'd)

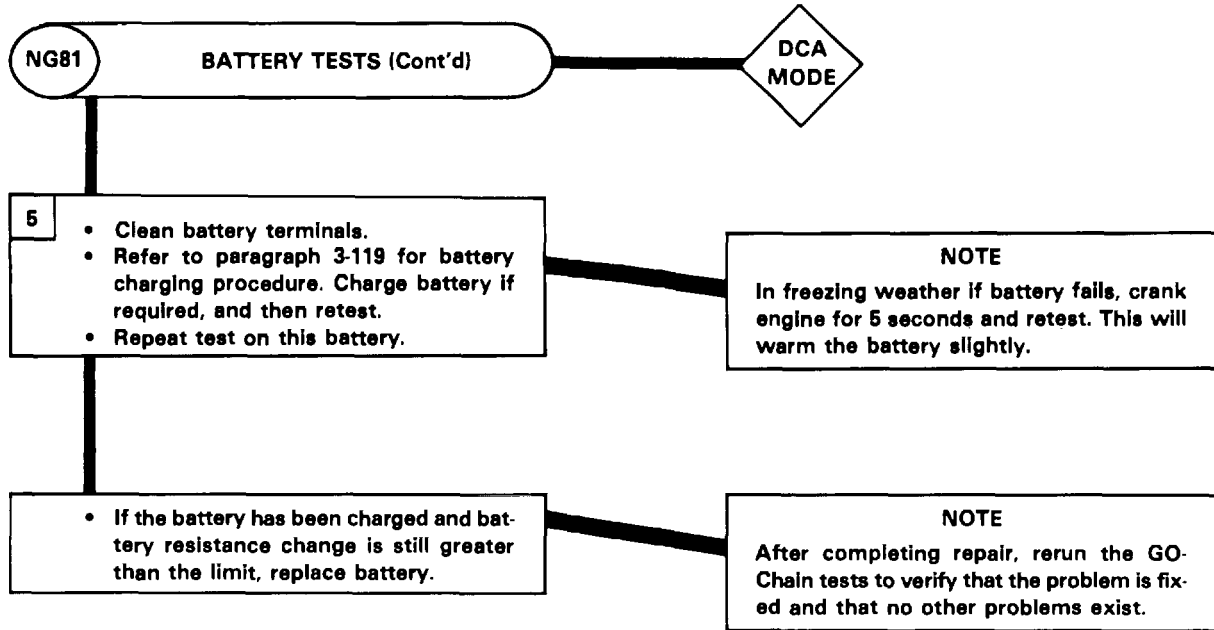

STE/ICE TROUBLESHOOTING.

2-21. STE/ICE NO-GO CHAIN TESTS (Continued).

Table 2-10. STE/ICE NO-GO Chain Tests (Cont'd)

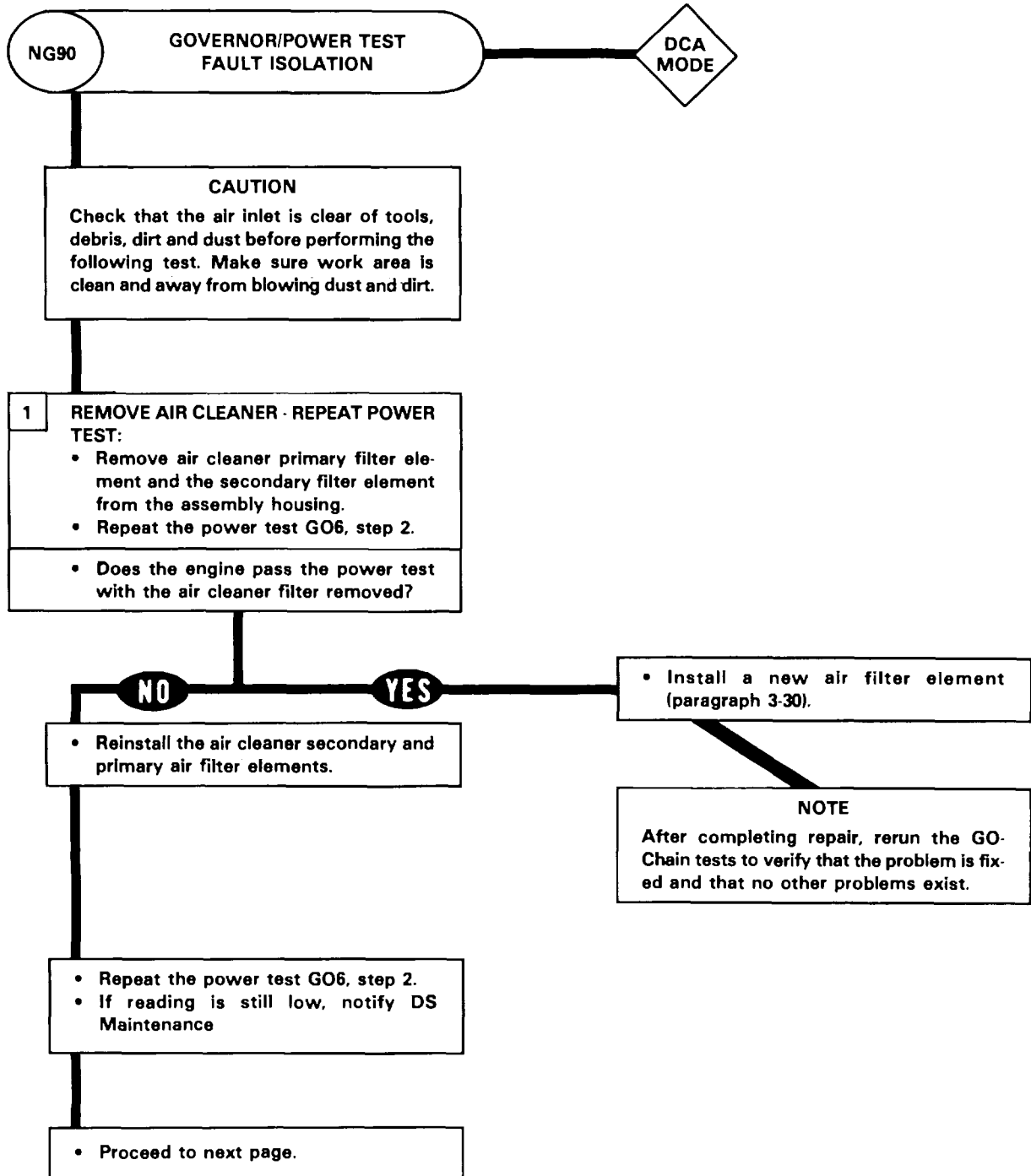

STE/ICE TROUBLESHOOTING.

2-21. STE/ICE NO-GO CHAIN TESTS (Continued).

Table 2-10. STE/ICE NO-GO Chain Tests (Cont'd)

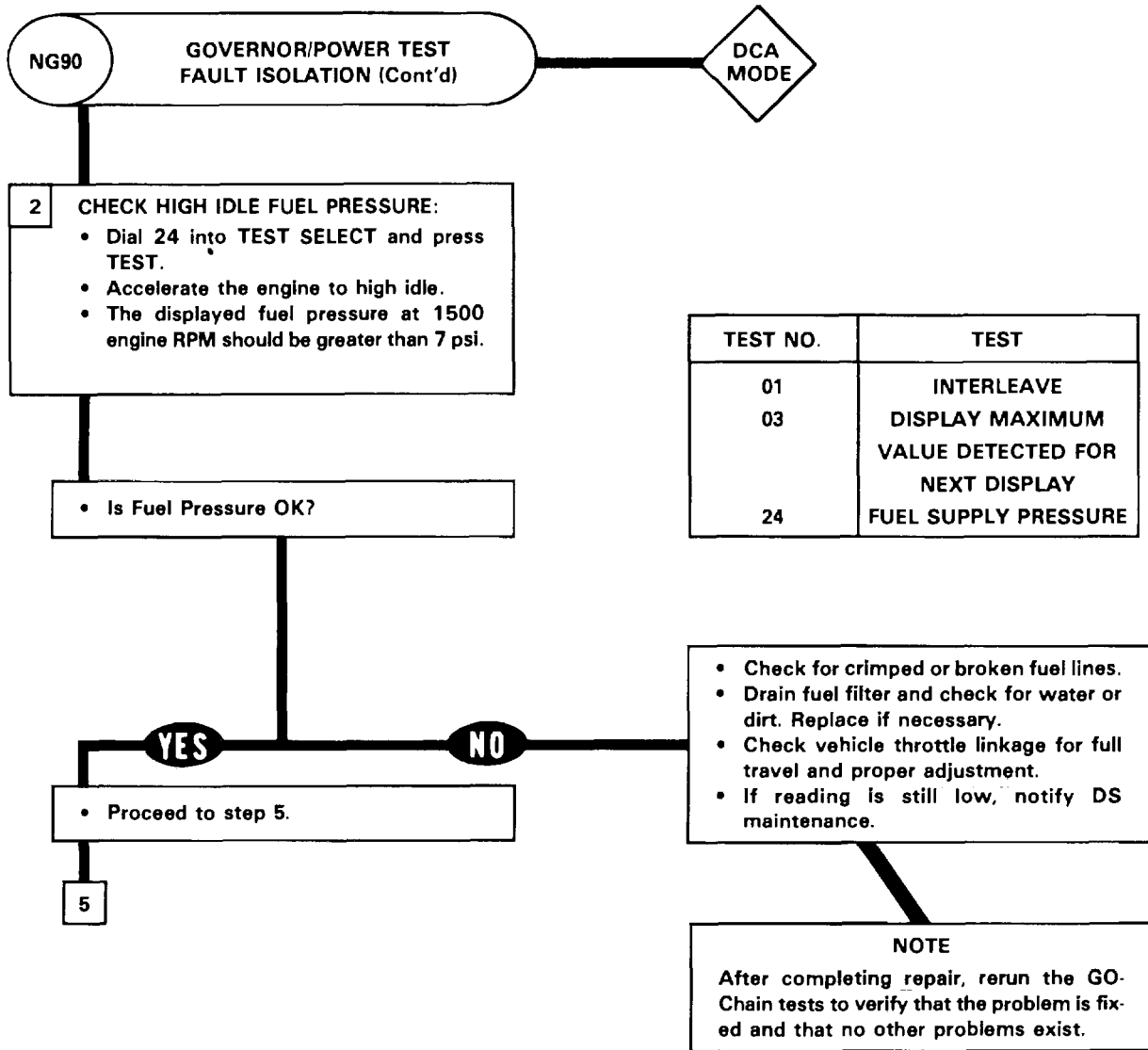

TEST NO.	TEST
01	INTERLEAVE DISPLAY MAXIMUM VALUE DETECTED FOR NEXT DISPLAY FUEL SUPPLY PRESSURE
03	
24	

STE/ICE TROUBLESHOOTING.

2-21. STE/ICE NO-GO CHAIN TESTS (Continued).

Table 2-10. STE/ICE NO-GO Chain Tests (Cont'd)

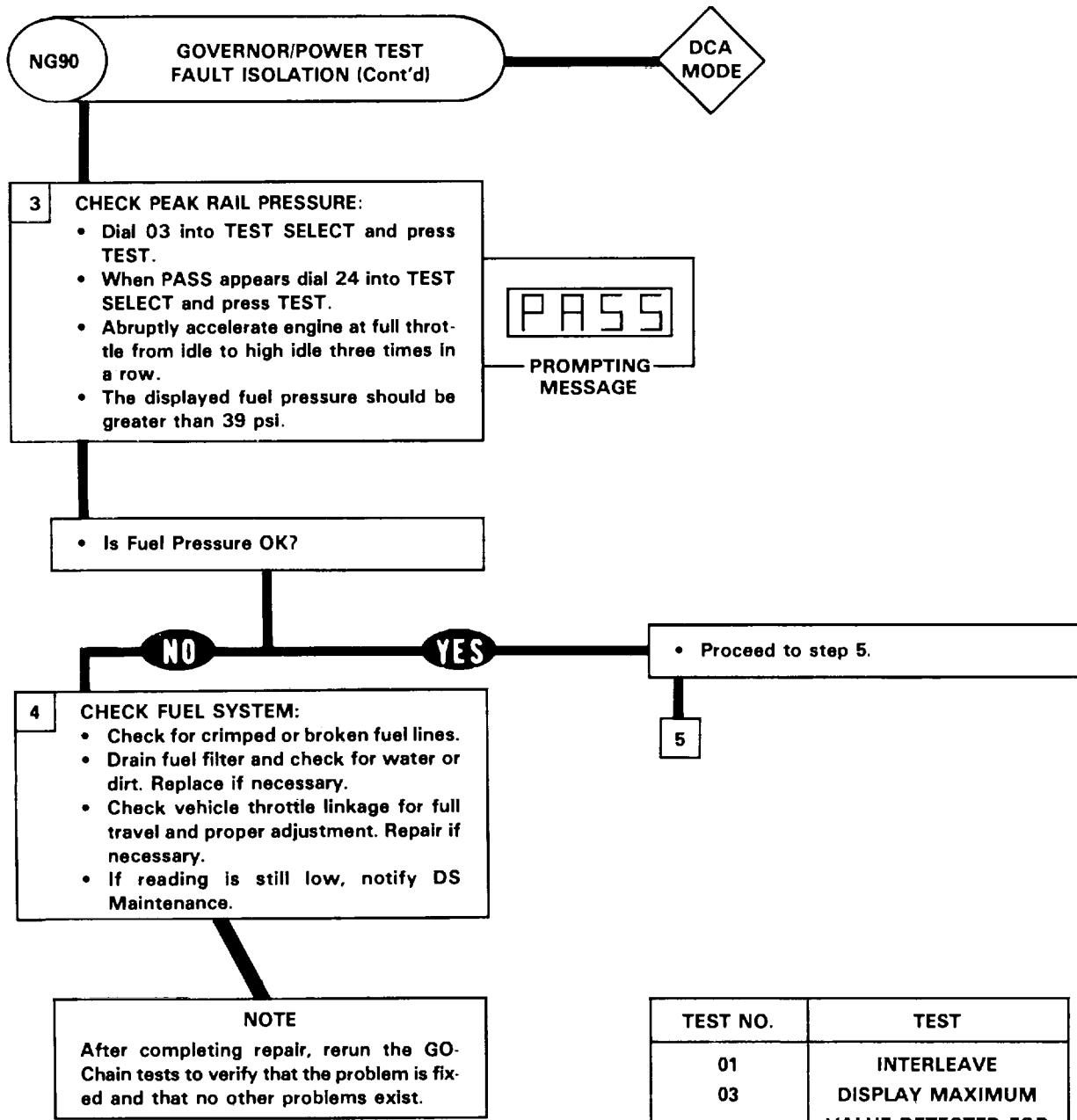

TEST NO.	TEST
01	INTERLEAVE
03	DISPLAY MAXIMUM VALUE DETECTED FOR NEXT TEST
24	FUEL SUPPLY PRESSURE

STE/ICE TROUBLESHOOTING.

2-21. STE/ICE NO-GO CHAIN TESTS (Continued).

Table 2-10. STE/ICE NO-GO Chain Tests (Cont'd)

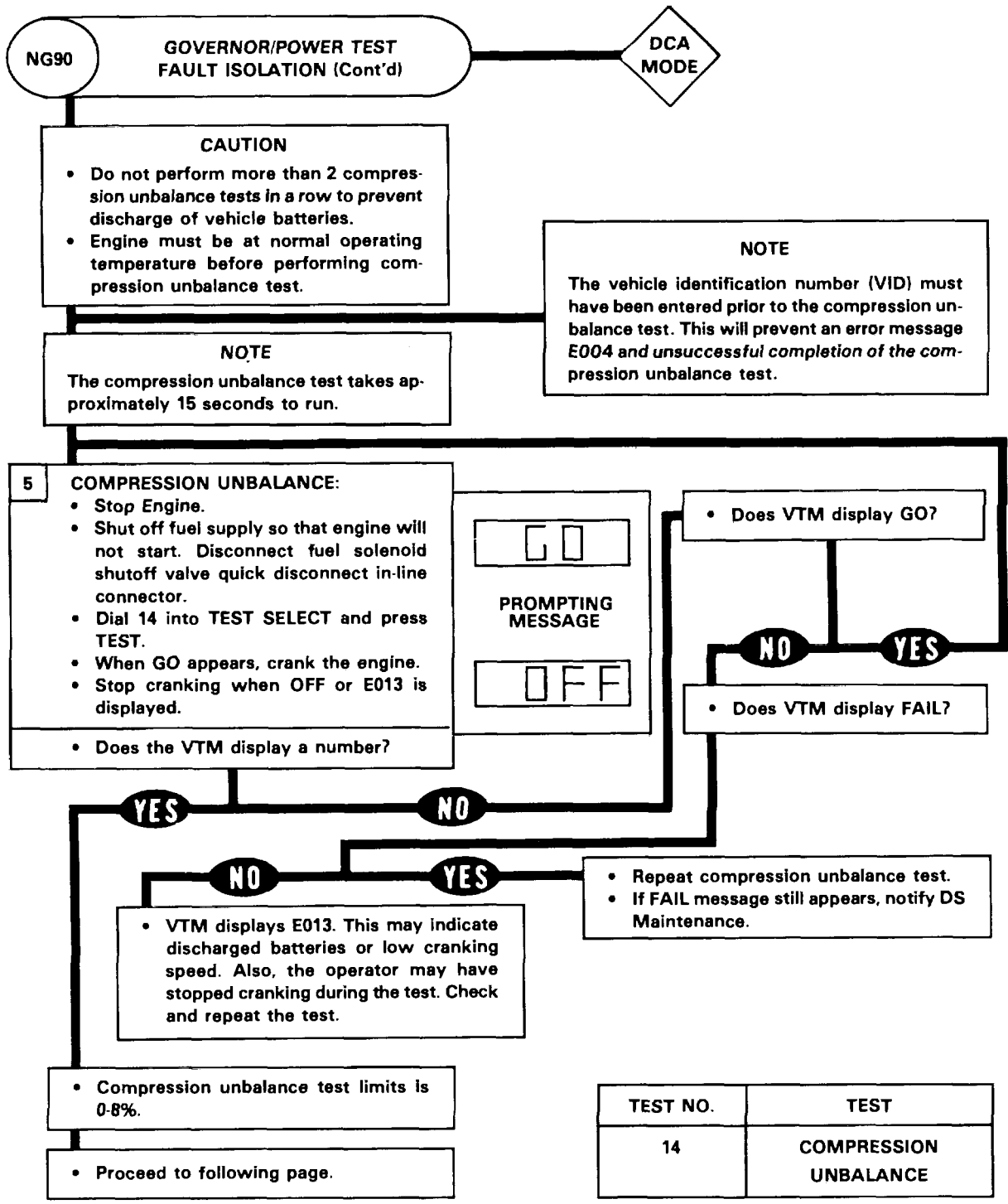

STE/ICE TROUBLESHOOTING.

2-21. STE/ICE NO-GO CHAIN TESTS (Continued).

Table 2-10. STE/ICE NO-GO Chain Tests (Cont'd)

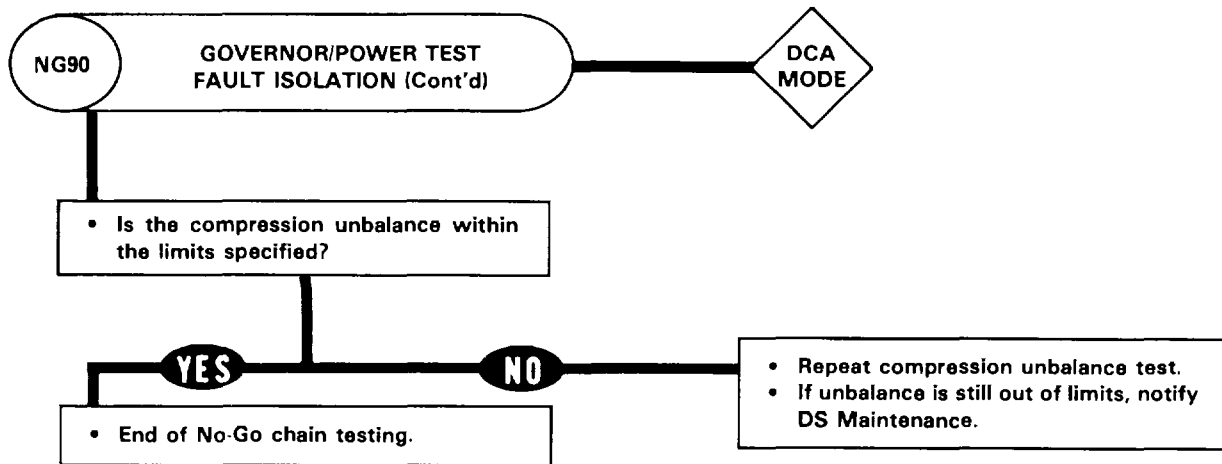

STE/ICE TROUBLESHOOTING.

2-21. STE/ICE NO-GO CHAIN TESTS (Continued).

Table 2-10. STE/ICE NO-GO Chain Tests (Cont'd)

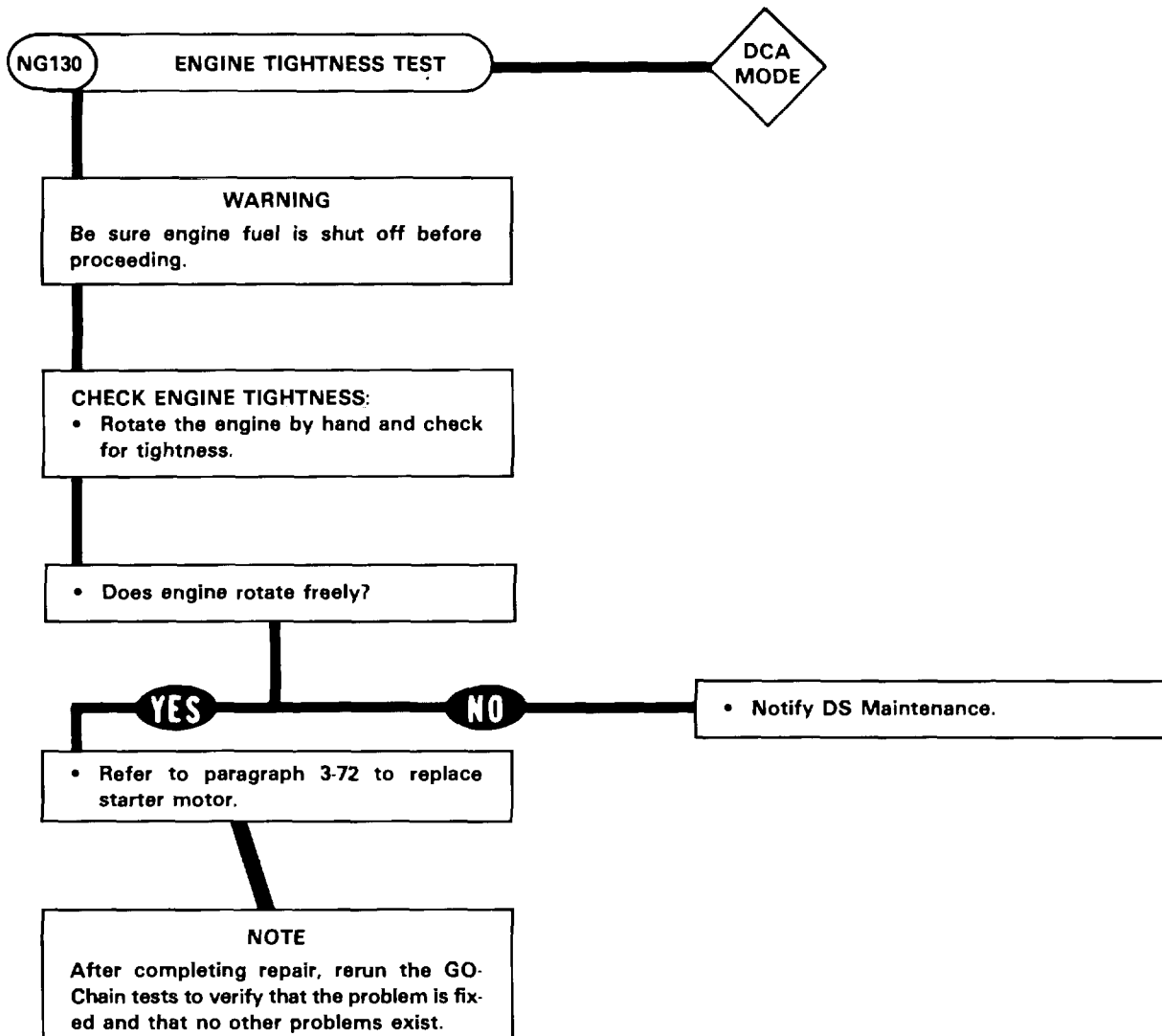

CHAPTER 3

3-1. OVERVIEW.

a. This chapter provides information on cleaning, inspection, testing, adjustment, replacement, and repair of components. Torque limits are provided in paragraph 3-9.

b. This information is divided into the following Sections:

Section I.	General Maintenance Instructions
Section II.	Engine
Section III.	Fuel System
Section IV.	Exhaust System
Section V.	Cooling System
Section VI.	Electrical System
Section VII.	Transmission
Section VIII.	Propeller Shafts and Universal Joints
Section IX.	Front Axle
Section X.	Rear Axle
Section XI.	Brake System
Section XII.	Wheels
Section XIII.	Steering System
Section XIV.	Frame and Towing Attachments
Section XV.	Springs, Shock Absorbers, and Torque Rods
Section XVI.	Cab and Body
Section XVII.	Accessory Items
Section XVIII.	Gages (Non-Electrical)
Section XIX.	STE/ICE Components

3-2. SECTION I. GENERAL.

a. This section provides general instructions for:

- (1) Cleaning, inspection, repair, and assembly of vehicle component parts.
- (2) Operational checks after performing maintenance.

b. Publications which provide additional information on general shop practice techniques, preservation, welding, sheet metal work, etc. are listed in appendix A of this manual. To find a particular general service instruction, use the task summary below.

3-3. TASK SUMMARY.		
TASK PARA.	PROCEDURE	PAGE NO.
3-4.	Cleaning <ol style="list-style-type: none"> a. General Instructions b. The Importance of Cleaning c. External Engine Cleaning d. Disassembled Parts Cleaning e. Castings f. Oil Passages g. Oil Seals, Electrical, Cables, and Flexible Hoses h. Ball-Roller Bearings 	3-3
3-5.	Inspection <ol style="list-style-type: none"> a. General Instructions b. Castings c. Ball-Roller Bearings d. Studs, Bolts, and Capscrews e. Gears f. Bushings and Bushing Type Bearings g. Oil Seals 	3-5
3-6.	Repair <ol style="list-style-type: none"> a. General Instructions b. Castings c. Ball-Roller Bearings d. Studs e. Gears f. Bushings and Bushing Type Bearings g. Oil Seals 	3-6
3-7.	Assembly <ol style="list-style-type: none"> a. General b. Precautionary Rules c. Using Thread Sealing Tape 	3-8
3-8.	Operational Checks <ol style="list-style-type: none"> a. General b. Operational Checks 	3-9
3-9.	Torque Limits	3-10

GENERAL MAINTENANCE INSTRUCTIONS.**3-4. CLEANING.**

a. General Instructions. Cleaning procedures will be the same for the majority of parts and components which makeup the vehicle and vehicle subassemblies. General cleaning procedures are detailed in "b" through "h" below.

b. The Importance of Cleaning. Great care and effort are required in all cleaning operations. The presence of dirt and foreign material is a constant threat to satisfactory vehicle operation and maintenance. The following will apply to all cleaning operations:

- (1) Clean all parts before inspection, after repair, and before assembly.
- (2) Hands must be kept free of any accumulation of grease which can collect dust and grit.
- (3) After cleaning, all parts must be covered or wrapped in plastic or paper to protect them from dust and/or dirt.

WARNING

Particles blown by compressed air are hazardous. Always direct air stream away from the user and other persons in the area. User must wear a safety eyeshield when using compressed air in cleaning.

c. External Engine Cleaning. All electrical equipment and other parts that could be damaged by steam cleaning or moisture must be removed, and all openings covered before cleaning. Dry with compressed air.

d. Disassembled Parts Cleaning. Place all disassembled parts in suitable wire baskets for cleaning.

- (1) Dry and cover all cleaned parts.
- (2) Place on or in "racks" and hold for inspection or repair.
- (3) All parts subject to rusting must be lightly oiled and wrapped.
- (4) Keep all related parts and components together. Do not mix parts.

WARNING

Improper cleaning methods and use of unauthorized cleaning solvents will injure personnel and damage equipment. See TM 9-247 for correct information.

GENERAL MAINTENANCE INSTRUCTIONS.**3-4. CLEANING (Continued).**e. Castings.

- (1) Clean inner and outer surfaces of castings and all areas subject to grease and oil with cleaning solvents. (Refer to TM 9-247).
- (2) Use a stiff brush to remove sludge and gum deposits.

WARNING

Particles blown by compressed air are hazardous. Always direct air stream away from the user and other persons in the area. User must wear safety eyeshield when using compressed air in cleaning.

- (3) Use compressed air to blow out all tapped holes and to dry castings after cleaning.

f. Oil Passages. Particular attention must be given to all oil passages in castings and machined parts. All oil passages must be clean and free of any obstructions.

- (1) Clean passages with wire probes to break up any sludge or gum deposits.
- (2) Wash passages by flushing with solvents. (Refer to TM 9-247).
- (3) Dry passages with compressed air.

CAUTION

Do not allow drycleaning solvents to come in contact with seals, cables, or flexible hoses. These cleaners cause leather, rubber, and synthetic materials to dry out, rot, and lose pliability, making them unserviceable.

g. Oil Seals, Electrical Cables, and Flexible Hoses. Clean with soap and water.

h. Ball-Roller Bearings.

- (1) Bearings require special cleaning. After removing surface oil and gum deposits, place bearing in hot oil (140°F) to loosen congealed oil and grease. Wipe bearings dry (do not use compressed air). After cleaning, coat bearings with oil, wrap in paper, and hold for inspection.
- (2) Refer to TM 9-214 for information on and care of bearings.

GENERAL MAINTENANCE INSTRUCTIONS.**3-5. INSPECTION.**

a. General Instructions. The procedures for inspection will be the same for many of the parts and components which makeup the vehicle and vehicle subassemblies. The general procedures are detailed in "b" through "g" below. Use specified inspection equipment for inspection where cracks and other damage cannot be spotted visually. Exercise extreme care in all phases of inspection.

b. Castings.

- (1) Inspect all ferrous and non-ferrous castings for cracks using a magnifying glass and strong light.
- (2) Refer to MIL-I-6866 (Inspection Process, Penetrant Methods) and MIL-I-6868 (Inspection Process, Magnetic Particles).
- (3) Closely check areas around studs, pipe plugs, threaded inserts, and sharp corners. Replace all cracked castings.
- (4) Inspect machined surfaces for nicks, hurrs, or raised metal. Mark damaged areas for repair or replacement.
- (5) Inspect all pipe plugs, pipe plug openings, capscrews, and capscrew openings for damaged or stripped threads.
- (6) Check all gasket mating surfaces for warpage with a straightedge or surface plate. Inspect mating flanges for discolorations which may indicate persistent oil leakage.
- (7) Check all castings for conformance to applicable repair standards.

c. Ball-Roller Bearings. Refer to TM 9-214 for inspection of bearings. Check all bearings for conformance to applicable repair standards.

d. Studs, Bolts and Capscrews. Replace if bent, loose, stretched, or if threads are damaged.

e. Gears.

NOTE

There are no established wear limits on gear teeth. Good judgment is required to determine if gears require replacement.

- (1) Inspect all gears for cracks, using a magnifying glass and strong light. No cracks are allowed.

GENERAL MAINTENANCE INSTRUCTIONS.**3-5. INSPECTION (Continued). I**

- (2) Inspect gear teeth for wear, sharp fins, burrs, and galled or pitted surfaces.
- (3) Check keyway slots for wear and/or damage.
 - f. Bushings and Bushing Type Bearings.
 - (1) Check all bushings and bushing type bearings for secure fit, evidence of heating, wear, burrs, nicks, and out-of-round conditions.
 - (2) Check for dirt in lubrication holes or grooves. Holes and grooves must be clean and free from damage.
 - g. Oil Seals. Oil seals are mandatory replacement items.

3-6. REPAIR.

a. General Instructions. Repair of most parts and components is limited to procedures outlined in applicable maintenance instructions and the following general procedures detailed in "b" through "h" below.

CAUTION

Repaired items must be thoroughly cleaned to remove metal chips and abrasives to prevent them from entering working parts of vehicle.

b. Castings.

- (1) All cracked castings will be replaced.
 - (2) Only minor repairs to machined surfaces, flanges, and gasket mating surfaces are permitted. Remove minor nicks, burrs, and/or scratches with:
 - (a) Fine mill file.
 - (b) Crocus cloth dipped in cleaning solvent.
 - (c) Lapping across a surface plate.
 - (3) Remachining of machined surfaces to repair damage, warpage, or uneven surfaces is not permitted.
 - (4) Repair damaged threaded holes with a thread tap. Repair oversize holes with threaded inserts.
- c. Ball-Roller Bearings. Refer to TM 9-214.

GENERAL MAINTENANCE INSTRUCTIONS.**3-6. REPAIR (Continued).**

d. Studs. Repair minor thread damage with a thread chaser. Replace all bent, stretched, stripped, or damaged studs as outlined below:

- (1) Remove with a stud remover. Back studs out slowly to avoid heat buildup and seizure which can cause studs to break off.
- (2) If a stud is broken off too short to use a stud remover, use an extractor or the "welding method" to remove.

CAUTION

Refer to TM 9-237 (Welding Instructions) to avoid damage to castings if "welding method" is used.

- (3) A broken stud can be removed by welding bar stock or a nut to stud and removing with wrench.

NOTE

Standard studs may have a coarse thread on one end and a fine thread on the other end. The coarse thread end is installed in the aluminum casting. Studs having coarse threads on both ends are used in some applications. The shorter threaded end goes into the casting. Refer to TM 9-2320-283-20P for correct part numbers.

- (4) All replacement studs have special coating and must have a small amount of anti-seize compound (MIL-A-13881) applied on threads before stud is installed. Install replacement studs slowly to prevent heat build-up and snapping off.

e. Gears.

- (1) Remove gears using suitable pullers.
- (2) Use the same methods described in paragraph 3-6 b (2) to remove minor nicks, burrs, or scratches on gear teeth.

f. Bushings and Bushing Type Bearings. When bushings and bushing type bearings seize to a shaft and spin in the bore, the associated parts must also be replaced.

GENERAL MAINTENANCE INSTRUCTIONS.**3-6. REPAIR (Continued).**

g. Oil Seals.

- (1) Remove oil seals by pressing or prying out, being careful not to damage casting or adapter bore.
- (2) Always install new seal in bore using proper seal replacing tool.

3-7. ASSEMBLY.

a. General. Extreme care must be exercised in all component assembly operations to ensure satisfactory vehicle performance. Precautionary rules for assembly are outlined below. Step-by-step procedures for assembly of various components are covered in the paragraph relating to the specific component.

b. Precautionary Rules.

- (1) Cleanliness is essential in all component assembly operations. Dirt and dust, even in minute quantities, are abrasive. Parts must be cleaned as specified, and kept clean. Wrap or cover parts and components when assembly procedures are not immediately completed.
- (2) Coat all bearings and contact surfaces with operating oil (axle oil for axle parts, transmission oil for transmission parts, etc.) to ensure lubrication of parts during initial operation after repair.
- (3) Use new gaskets and preformed packings during assembly of all components.

c. Using Thread Sealing Tape. Certain fittings have a thin strip of thread sealing tape applied to the pipe threads before installation. This is done to provide a better seal and also to permit easier removal of fitting. Fittings requiring a thread sealing tape are identified in the particular assembly procedure calling for the installation of such fittings. The method of wrapping fittings with thread sealing tape is as follows:

- (1) Be sure the fitting is thoroughly clean and dry before applying the thread sealing tape. All dirt, grease, oil, and scale must be removed.
- (2) Start the tape one or two threads from the small or leading edge of the fitting, joining the tape together with an overlap of approximately 1/8-inch.
- (3) Wrap the tape tightly in the same direction as you would turn a nut. Press the tape into the minor diameter of threads without cutting or ripping the tape.
- (4) Torque the fittings to their specified torque. Do not use power tools.



GENERAL MAINTENANCE INSTRUCTIONS.**3-8. OPERATIONAL CHECKS.**

a. General. After any maintenance action, always check your work. Be sure vehicle or applicable vehicle system is fully operational and safe before returning equipment to operator. General operational checks are listed below. Specific operational checks are covered in the paragraph relating to the component or system, where necessary.

b. Operational Checks.

- (1) Operate applicable vehicle systems in accordance with TM 9-2320283-10.
- (2) Start and run engine. Be sure all gages read normal.
- (3) Visually check all fluid connections (tubes, hoses, and fittings) that were loosened, for leakage. Eliminate all leakage by tightening or replacing parts.
- (4) Check all air connections (tubes, hoses, and fittings), that were loosened, for leakage by applying soap solution. Eliminate all leakage by tightening or replacing parts.
- (5) Road test vehicle. Be sure all gages read normal. Listen for unusual noises. Be sure vehicle may be operated safely (e.g. steering, brakes, etc.) and that performance is satisfactory.
- (6) Check for "tripped" circuit breakers. Look for smoke that may indicate an electrical short.

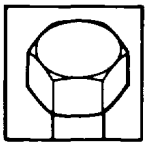
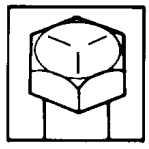
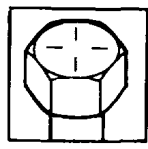
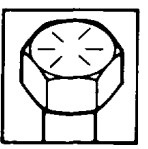
GENERAL MAINTENANCE INSTRUCTIONS.

3-9. TORQUE LIMITS.				
USAGE	MUCH USED	MUCH USED	USED AT TIMES	USED AT TIMES
CAPSCREW DIAMETER AND MINIMUM TENSILE STRENGTH (PSI)	To 1/2-69,000 To 3/4-64,000 To 1-55,000	To 3/4-120,000 To 1-115,000	To 5/8-140,000 To 3/4-133,000	150,000
QUALITY OF MATERIAL	INDETERMINATE	MINIMUM COMMERCIAL	MEDIUM COMMERCIAL	BEST COMMERCIAL
SAE GRADE NUMBER	1 or 2	5	6 or 7	8
CAPSCREW HEAD MARKINGS: Manufacturer's marks may vary. These are all SAE Grade 5:				
				
CAPSCREW BODY SIZE (Inches)-(Thread)	TORQUE (lb-ft)	TORQUE (lb-ft)	TORQUE (lb-ft)	TORQUE (lb-ft)
1/4 - 20	5	8	10	12
- 28	6	10	14	
5/16 - 18	11	17	19	24
- 24	13	19	27	
3/8 - 16	18	31	34	44
- 24	20	35	49	
7/16 - 14	28	49	55	70
- 20	30	55	78	
1/2 - 13	39	75	85	105
- 20	41	85	120	
9/16 - 12	51	110	120	155
- 18	55	120	170	
5/8 - 11	83	150	167	210
- 18	95	170	240	
3/4 - 10	105	270	280	375
- 16	115	295	420	
7/8 - 9	160	395	440	605
- 14	175	435	675	
1 - 8	235	590	660	910
- 14	250	660	990	

TA 236993

GENERAL MAINTENANCE INSTRUCTIONS.**3-9. TORQUE LIMITS (Continued).**

1. Always use the torque values listed above when specific specifications are not available.

NOTE

Do not use above values in place of those specified in this manual; special attention should be observed in case of SAE Grade 6, 7, and 8 capscrew.

2. The above is based on use of clean and dry threads.
3. Reduce torque by 10% when oil is used as a lubricant.
4. Reduce torque by 20% if new plated capscrews are used.

CAUTION

Capscrews threaded into aluminum may require reductions in torque of 30% or more, unless inserts are used.

SECTION II. ENGINE

3-10. GENERAL.

This section provides procedures authorized at the organizational maintenance level to replace engine components. To find a specific procedure contained in this section, see the task summary below.

3-11. TASK SUMMARY.

INITIAL SETUP

APPLICABLE CONFIGURATIONS

All.

TEST EQUIPMENT

None.

SPECIAL TOOLS

Wrench, oil and fuel filter, spin-on
(15434) 3375049.

MATERIALS/PARTS (P/N)

Tape, thread sealing
Item 32, Appendix C.
Container(s), 40 quart capacity.
Element, oil filter, spin-on
(15434) 299670.
Element, oil filter, spin-on
(15434) 3304232.
Gasket, rocker cover
(15434) 3016453.
Grommet (4)
(15434) S-1003-S.

PERSONNEL REQUIRED

One (MOS-63S).

REFERENCES (TM)

TM 9-2320-283-10.
LO 9-2320-283-12.
TM 9-2320-283-20P.

TROUBLESHOOTING REFERENCES

Paragraph 2-11.

EQUIPMENT CONDITION

PARAGRAPH

(Refer to specific paragraph for this information).

CONDITION DESCRIPTION

Gasket
(15434) 157911.
Hose, connection (2)
(15434) 155789.
Screw, nameplate (5)
(15434) S-2286.
Gasket, water inlet connection
(15434) 3032348.
Gasket, water outlet
(15434) 215045.

SPECIAL ENVIRONMENTAL CONDITIONS

None.

GENERAL SAFETY INSTRUCTIONS

Engine off.
Transmission in neutral.
Park brake set.

ENGINE.

3-11. TASK SUMMARY (Continued).			
LIST OF TASKS			
TASK NO.	TASK	TASK REF	TROUBLESHOOTING REF NO. (PARA)
1	Engine Oil Service a. Draining Oil. b. Oil Filter Element Replacement.	3-12 3-12a 3-12b	2-11
2	Rocker Cover and Gasket Replacement a. Removal. b. Cleaning and Inspection. c. Installation.	3-13 3-13a 3-13b 3-13c	2-11
3	Rocker Cover Filler Cap Replacement a. Removal. b. Cleaning and Inspection. c. Installation.	3-14 3-14a 3-14b 3-14c	
4	Breather Tubes and Hoses Replacement a. Removal. b. Cleaning and Inspection. c. Installation.	3-15 3-15a 3-15b 3-15c	2-11
5	Oil Level Dipstick Replacement a. Removal. b. Cleaning and Inspection. c. Installation.	3-16 3-16a 3-16b 3-16c	2-11
6	Oil Level Dipstick Tube Brace and Clamp Replacement a. Removal. b. Cleaning and Inspection. c. Installation.	3-17 3-17a 3-17b 3-17c	
7	Air Compressor Cooling Tubes Replacement a. Removal. b. Cleaning and Inspection. c. Installation.	3-18 3-18a 3-18b 3-18c	2-11

ENGINE.

3-11. TASK SUMMARY (Continued).			
LIST OF TASKS			
TASK NO.	TASK	TASK REF	TROUBLESHOOTING REF NO. (PARA)
8	Air Compressor Intake Tube Replacement a. Removal. b. Cleaning and Inspection. c. Installation.	3-19 3-19a 3-19b 3-19c	2-11
9	Water Crossover Tube and Connections Replacement a. Removal. b. Cleaning and Inspection. c. Installation.	3-20 3-20a 3-20b 3-20c	2-11
10	Water Transfer Tube and Bracket Replacement a. Removal. b. Cleaning and Inspection. c. Installation.	3-21 3-21a 3-21b 3-21c	2-11
11	Engine Lifting Bracket Replacement a. Removal. b. Cleaning and Inspection. c. Installation.	3-22 3-22a 3-22b 3-22c	
12	Engine Dataplate Replacement a. Removal. b. Installation.	3-23 3-23a 3-23b	2-11
13	Fan Brace, Bracket, and Spacers Replacement a. Brace and Spacers Removal. b. Bracket Removal. c. Cleaning and Inspection. d. Bracket Installation. e. Brace and Spacers Installation.	3-24 3-24a 3-24b 3-24c 3-24d 3-24e	

ENGINE.

3-12. ENGINE OIL SERVICE.

THIS TASK COVERS

- a. Draining Oil.
- b. Oil Filter Element Replacement.

INITIAL SETUP

APPLICABLE CONFIGURATIONS

All.

EQUIPMENT CONDITION
PARAGRAPH

None.

CONDITION DESCRIPTION

None.

TEST EQUIPMENT

None.

SPECIAL TOOLS

Wrench, oil and fuel filter, spin-on
(15434) 3375049.

MATERIALS/PARTS (P/N)

Element, oil filter, spin-on
(15434) 299670.
Element, oil filter, spin-on
(15434) 3304232.
Container(s), 40 quart capacity.

PERSONNEL REQUIRED

One (MOS-63S).
One (MOS-64C).

SPECIAL ENVIRONMENTAL CONDITIONS

None.

REFERENCES (TM)

TM 9-2320-283-10.
LO 9-2320-283-12.
TM 9-2320-283-20P.

GENERAL SAFETY INSTRUCTIONS

Engine off.
Transmission in neutral.
Park brake set.

TROUBLESHOOTING REFERENCES

Paragraph 2-11.

ENGINE.

3-12. ENGINE OIL SERVICE (Continued).

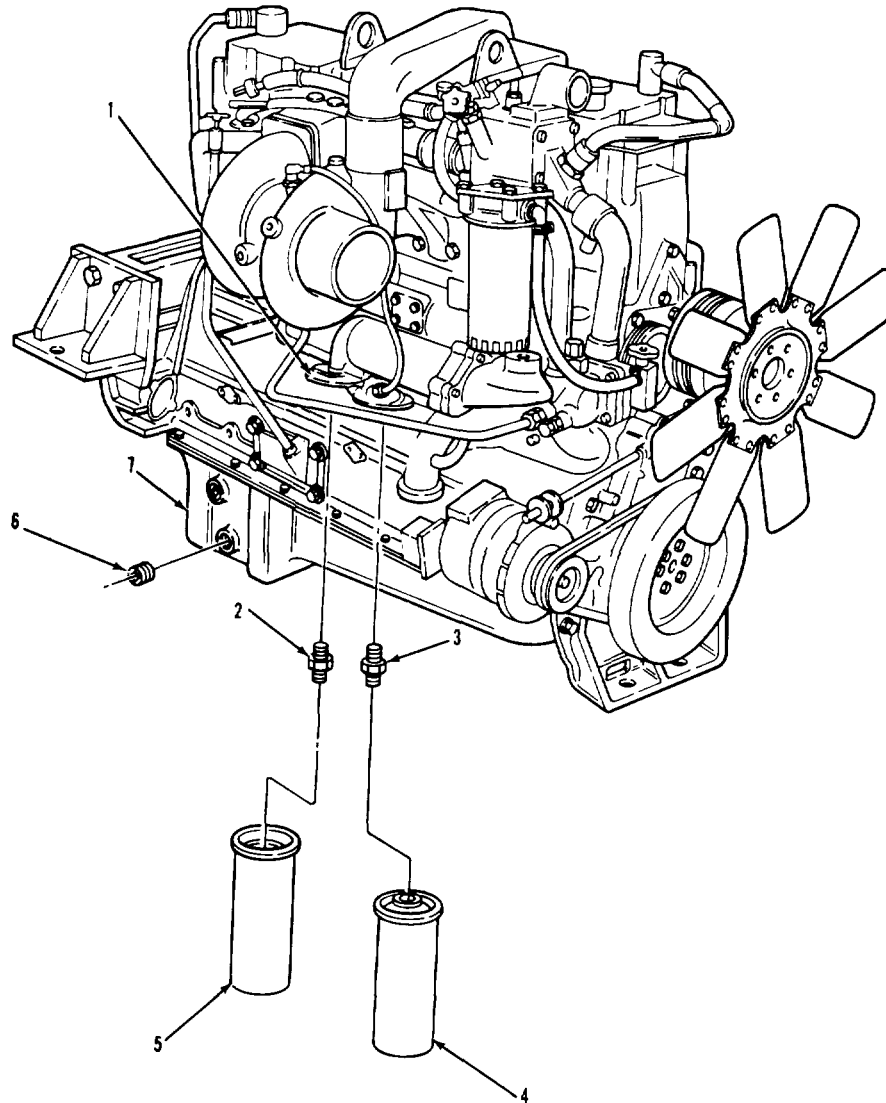

LEGEND:

- | | |
|---|---|
| <ul style="list-style-type: none"> 1. OIL COOLER ASSEMBLY 2. HEAD FILTER ADAPTER 3. FILTER HEAD ADAPTER 4. OIL FILTER SPIN-ON ELEMENT (FULL-FLOW) | <ul style="list-style-type: none"> 5. OIL FILTER SPIN-ON ELEMENT (BYPASS) 6. OIL DRAIN PLUG 7. DRAIN PLUG WASHER 8. ENGINE OIL PAN ASSEMBLY |
|---|---|

TA 236994

ENGINE.

3-12. ENGINE OIL SERVICE (Continued).

LOCATION/ITEM	ACTION	REMARKS
A. DRAINING OIL.		
NOTE		
<ul style="list-style-type: none"> • Have suitable container(s) ready to catch oil. • Engine should be warm. 		
1. Drain plug (6) and washer (7).	<ul style="list-style-type: none"> a. Remove from item (8). b. Inspect for metal chips. c. Install in item (8). 	Allow all oil to drain out. If chips are found notify DS/GS maintenance.
B. OIL FILTER ELEMENT REPLACEMENT.		
NOTE		
Have a suitable container ready to catch any spilled oil.		
2. Element (4) and element (5).	Remove from item (1) using spin-on filter wrench.	Discard item (4) and item (5).
3. Adapter (3) and adapter (2).	<ul style="list-style-type: none"> a. Clean and inspect. and 3-5. b. Remove from item (1). c. Install in item (1). 	Refer to paragraphs 3-4 Only remove if damaged.

ENGINE.

3-12. ENGINE OIL SERVICE (Continued).

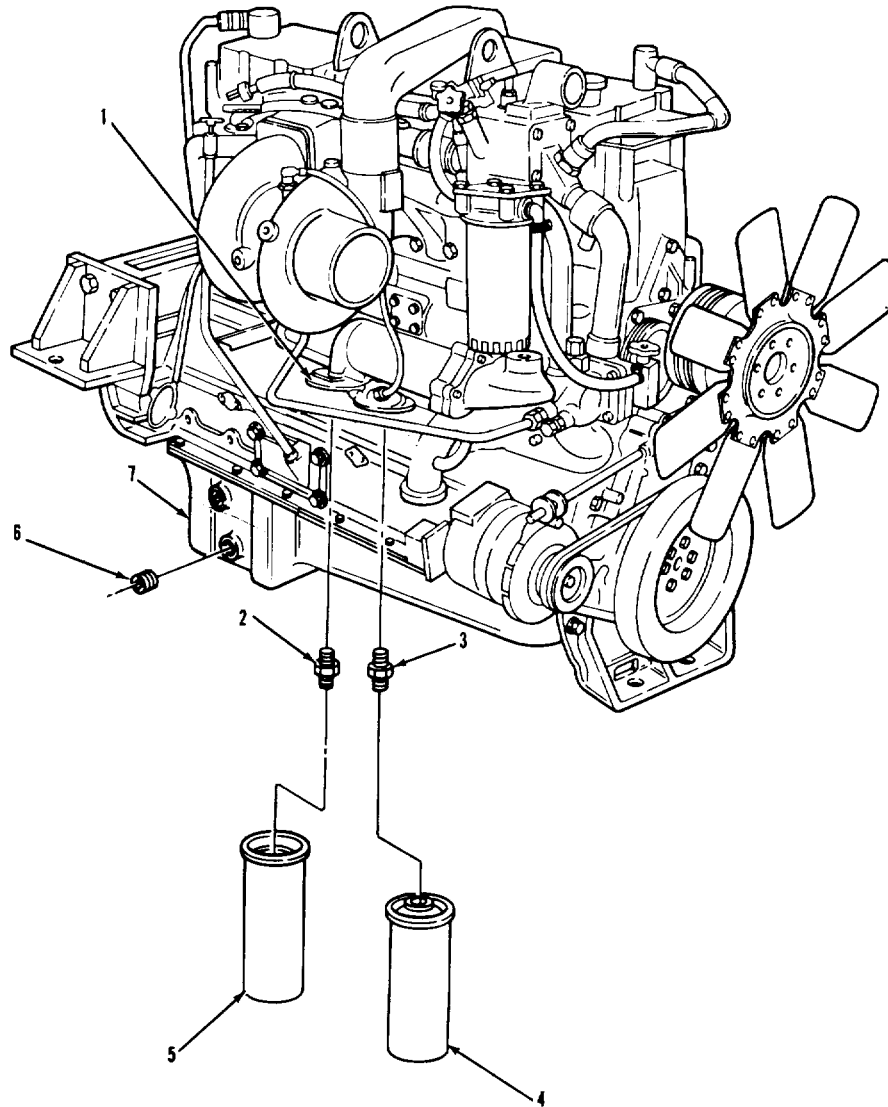

LEGEND:

- | | |
|---|---|
| <ul style="list-style-type: none"> 1. OIL COOLER ASSEMBLY 2. HEAD FILTER ADAPTER 3. FILTER HEAD ADAPTER 4. OIL FILTER SPIN-ON ELEMENT (FULL-FLOW) | <ul style="list-style-type: none"> 5. OIL FILTER SPIN-ON ELEMENT (BYPASS) 6. OIL DRAIN PLUG 7. DRAIN PLUG WASHER 8. ENGINE OIL PAN ASSEMBLY |
|---|---|

TA 236995

ENGINE.

3-12. ENGINE OIL SERVICE (Continued).

LOCATION/ITEM	ACTION	REMARKS
B. OIL FILTER ELEMENT REPLACEMENT (Continued).		
NOTE		
Look at illustration to be sure elements are installed in correct location. The full-flow element has seven holes around the threaded hole for the adapter. The bypass element has only two holes in this area.		
4. New element (4) and new element (5).	<ul style="list-style-type: none"> a. Fill with proper oil and put oil on gaskets. b. Screw on item (2) and item (3) until gaskets touch item (1). c. Using spin-on filter wrench, tighten item (4) and item (5) one turn after gaskets contact item (1). 	Refer to LO 9-2320-283-12.
5. Engine oil pan (8).	Fill with proper oil based on temperature range.	Refer to LO 9-2320-283-12.
6. Engine.	<ul style="list-style-type: none"> a. Start up and check for leaks; retighten as necessary. b. Shut down and check dipstick for correct oil level. 	Refer to TM 9-2320-283-10.
NOTE		
Follow-on maintenance action required: None.		

ENGINE.

3-12. ENGINE OIL SERVICE (Continued).

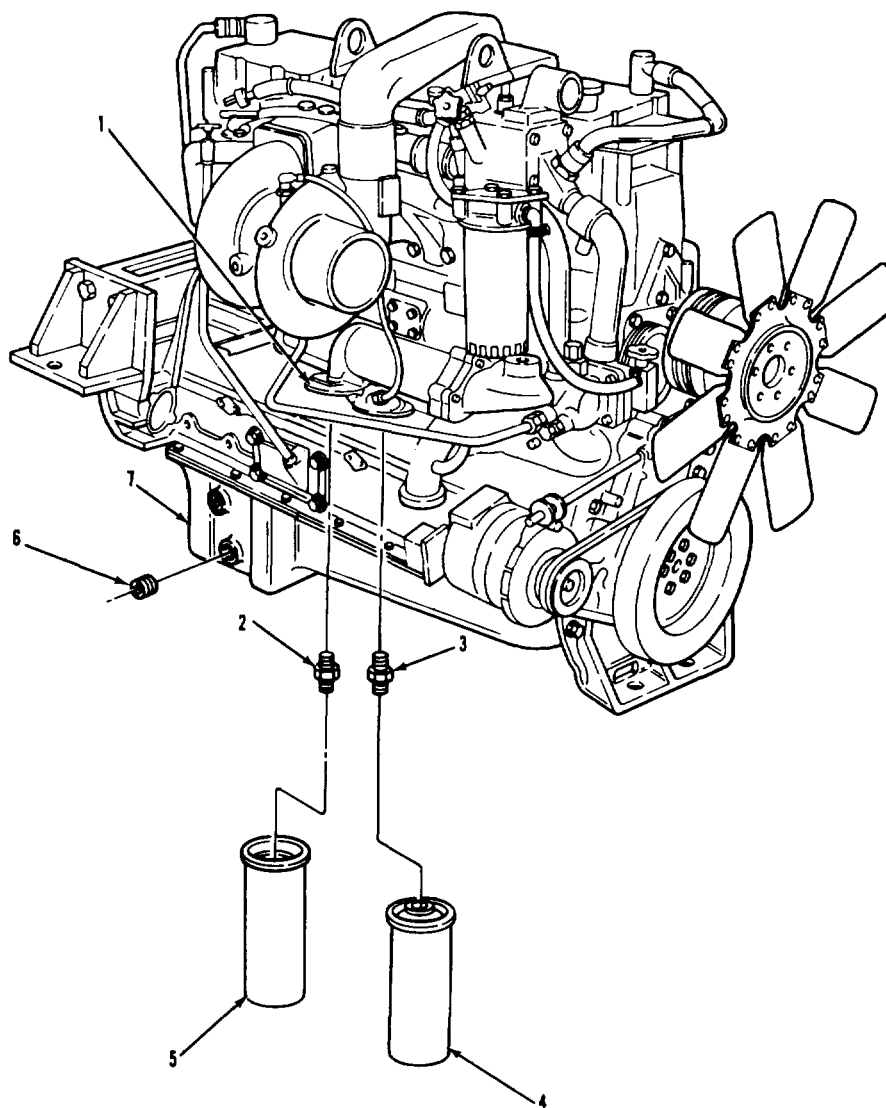

LEGEND:

- | | |
|---|--|
| 1. OIL COOLER ASSEMBLY | 5. OIL FILTER SPIN-ON ELEMENT (BYPASS) |
| 2. HEAD FILTER ADAPTER | 6. OIL DRAIN PLUG |
| 3. FILTER HEAD ADAPTER | 7. DRAIN PLUG WASHER |
| 4. OIL FILTER SPIN-ON ELEMENT (FULL-FLOW) | 8. ENGINE OIL PAN ASSEMBLY |

ENGINE.

3-13. ROCKER COVER AND GASKET REPLACEMENT

THIS TASK COVERS

- a. Removal.
- b. Cleaning and Inspection.
- c. Installation.

INITIAL SETUP

<u>APPLICABLE CONFIGURATIONS</u>	<u>EQUIPMENT CONDITION PARAGRAPH</u>	<u>CONDITION DESCRIPTIONS</u>
All	Front cover and gasket:	
<u>TEST EQUIPMENT</u> None	3-14 Center cover and gasket:	Rocker cover filler cap removed.
<u>SPECIAL TOOLS</u> None.	3-31.	Turbocharger air crossover connection removed.
<u>MATERIALS/PARTS (P/N)</u> Gasket, rocker cover (15434) 3016453.	Rear cover and gasket: None.	 None.
<u>PERSONNEL REQUIRED</u> One (MOS-63S).	<u>SPECIAL ENVIRONMENT CONDITIONS</u> None.	
<u>REFERENCES (TM)</u> TM 9-2320-283-20P.	<u>GENERAL SAFETY INSTRUCTIONS</u> Engine off. Transmission in neutral. Park brake set.	
<u>TROUBLESHOOTING REFERENCES</u> Paragraph 2-11.		

ENGINE.

3-13. ROCKER COVER AND GASKET REPLACEMENT (Continued).

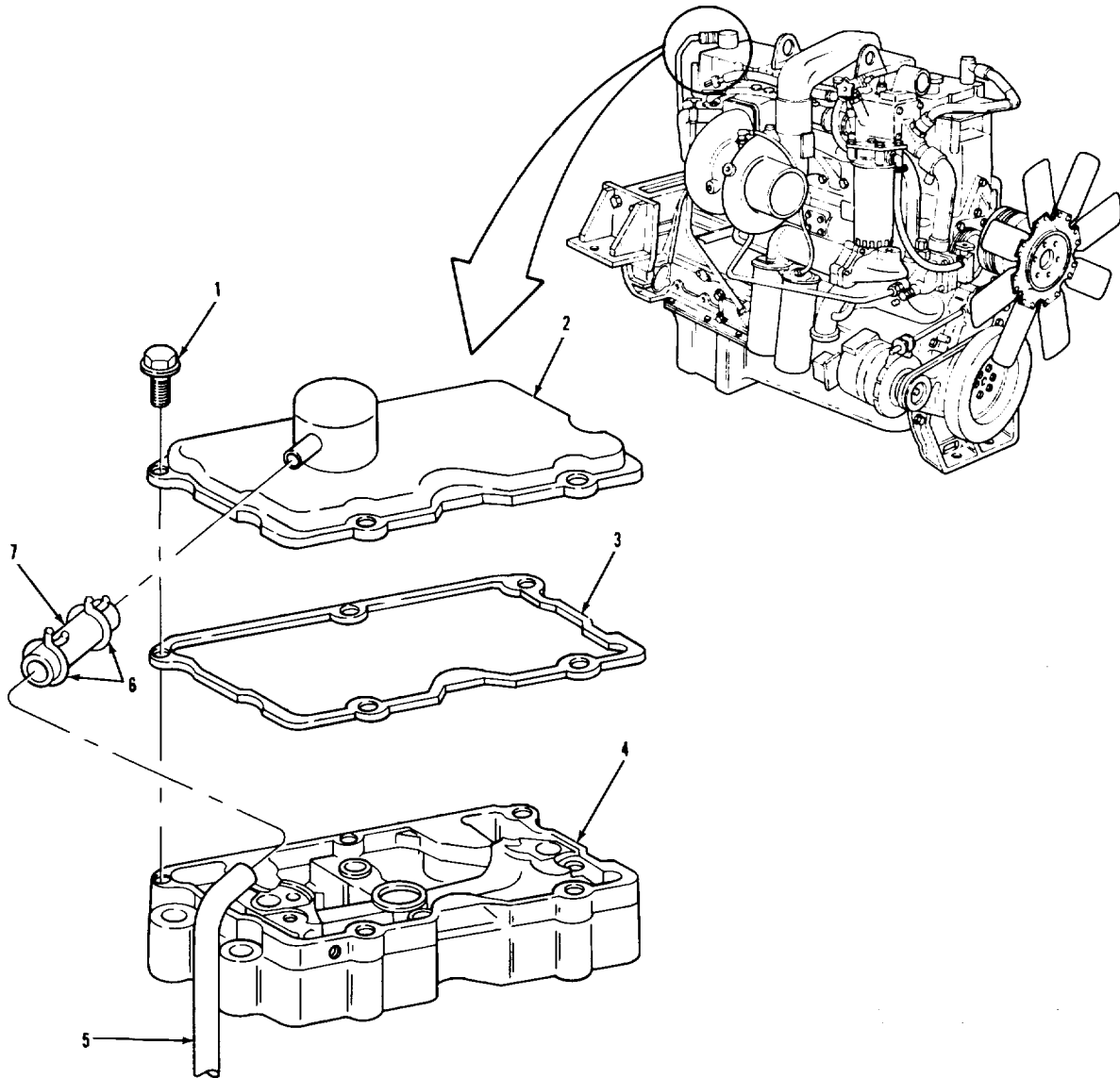

LEGEND:

- | | | | |
|----|--------------------------|----|----------------|
| 1. | CAPTIVE WASHER SCREW (5) | 5. | BREATHER TUBE |
| 2. | REAR ROCKER COVER | 6. | HOSE CLAMP (2) |
| 3. | ROCKER COVER GASKET | 7. | BREATHER HOSE |
| 4. | ENGINE BRAKE RETARDER | | |

ENGINE.

3-13. ROCKER COVER AND GASKET REPLACEMENT (Continued).

LOCATION/ITEM	ACTION	REMARKS
NOTE		
Replacement is similar for any of the three rocker covers. Rear cover replacement is shown here.		
A. REMOVAL.		
1. Hose (7) and two clamps (6).	Remove from item (2) and item (5).	
2. Five screws (1).	Remove from item (2).	
3. Cover (2) and gasket (3).	Remove from item (4).	Discard item (3).
B. CLEANING AND INSPECTION.		
4. All parts.	Clean and inspect.	a. Refer to paragraphs 3-4 and 3-5. b. Be sure all of old gasket is scraped off.
C. INSTALLATION.		
5. Cover (2) and new gasket (3).	Put on item (4).	
6. Five screws (1).	Secure item (2) and item (3) to item (4).	
7. Hose (7) and two clamps (6).	Install on item (5) and item (2).	

ENGINE.

3-13. ROCKER COVER AND GASKET REPLACEMENT (Continued).

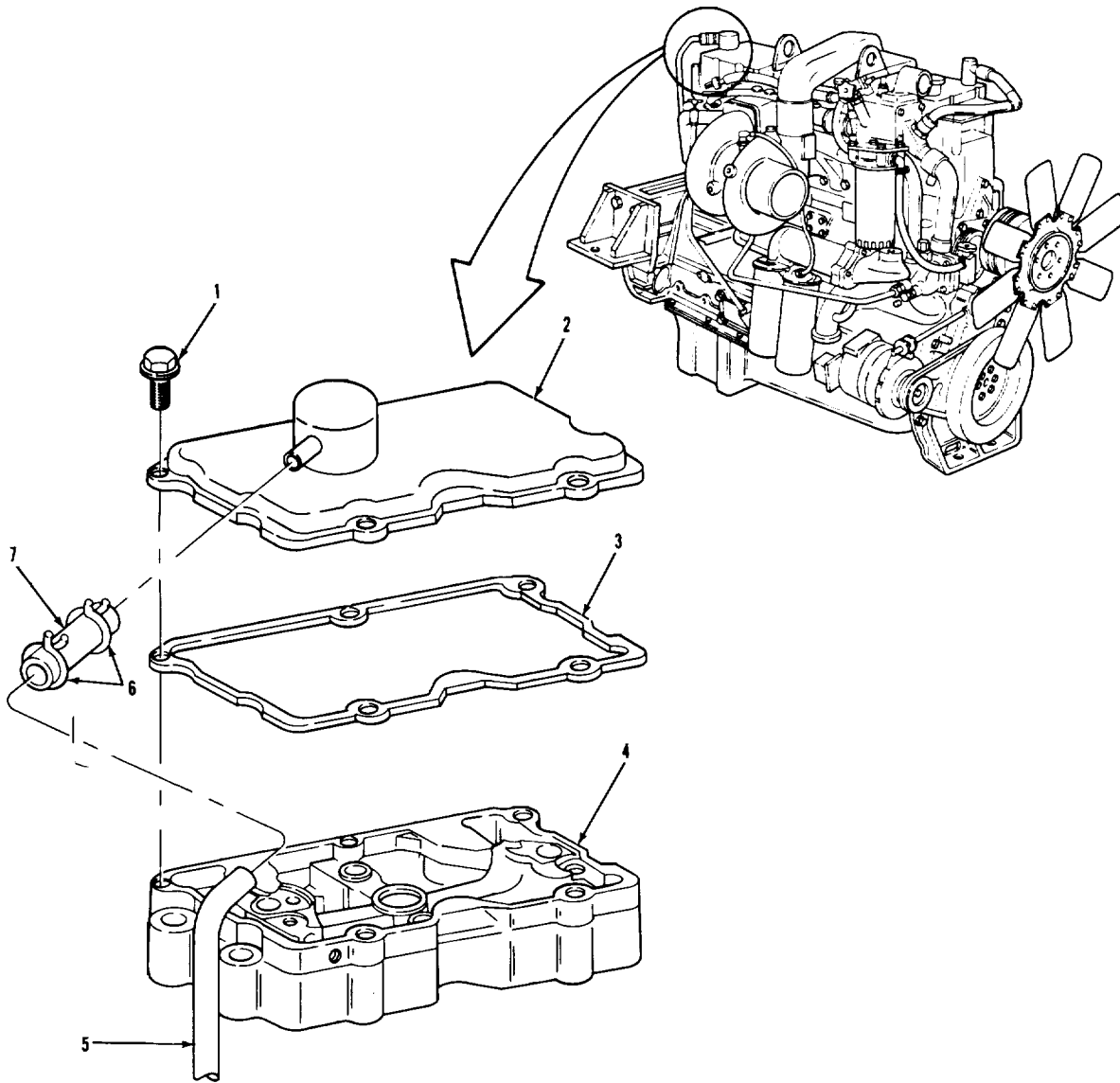

LEGEND:

- | | | | |
|----|--------------------------|----|----------------|
| 1. | CAPTIVE WASHER SCREW (5) | 5. | BREATHER TUBE |
| 2. | REAR ROCKER COVER | 6. | HOSE CLAMP (2) |
| 3. | ROCKER COVER GASKET | 7. | BREATHER HOSE |
| 4. | ENGINE BRAKE RETARDER | | |

ENGINE.

3-13. ROCKER COVER AND GASKET REPLACEMENT (Continued).

LOCATION/ITEM

ACTION

REMARKS

C. INSTALLATION (Continued).

NOTE

Follow-on maintenance action required:

Front cover and gasket:

Install rocker cover filler cap
(para 3-14).

Center cover and gasket:

Install turbocharger air cross-
over connection (para 3-31).

Rear cover and gasket:

None.

ENGINE.

3-13. ROCKER COVER AND GASKET REPLACEMENT (Continued).

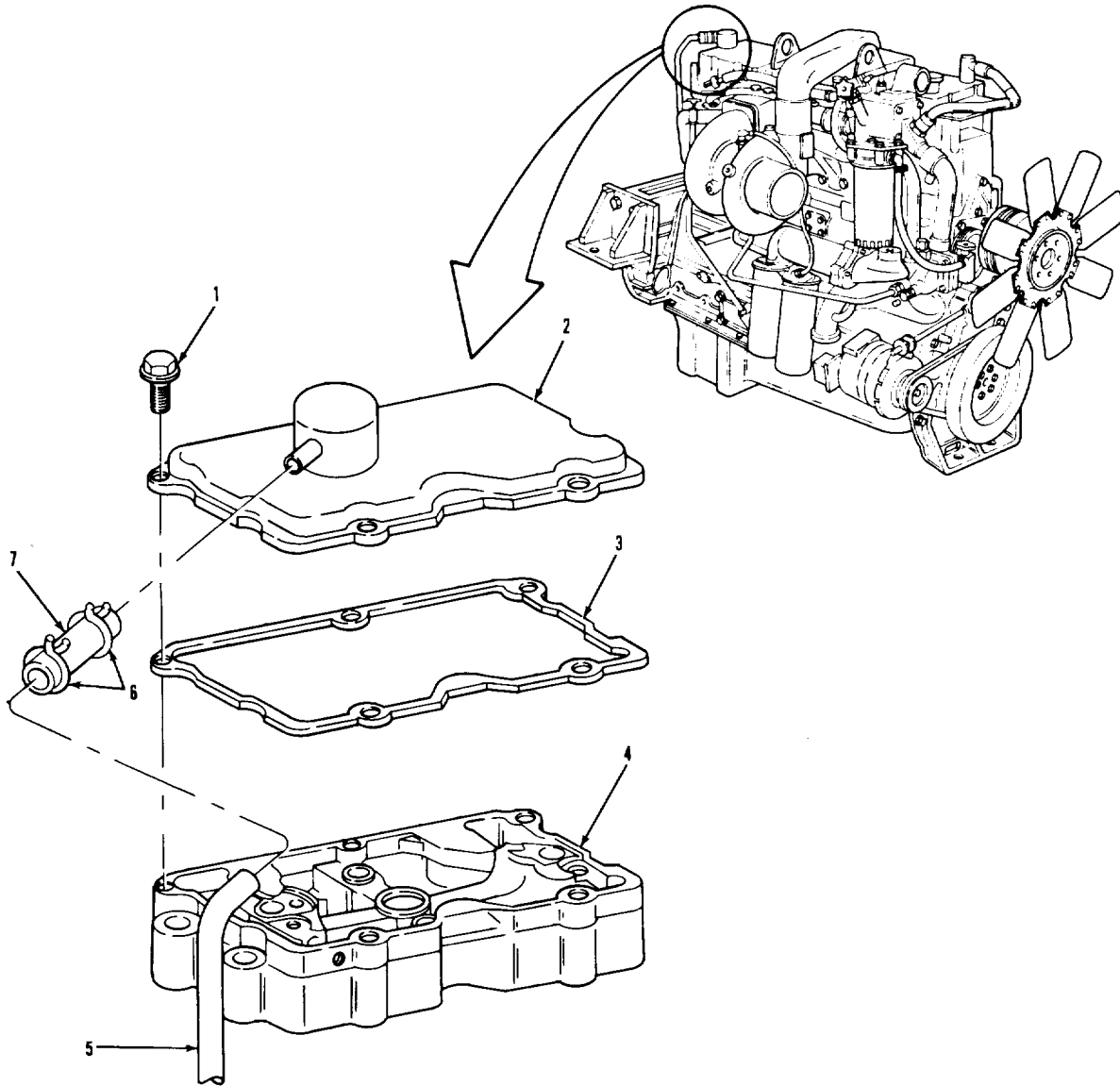

LEGEND:

- | | | | |
|----|--------------------------|----|----------------|
| 1. | CAPTIVE WASHER SCREW (5) | 5. | BREATHER TUBE |
| 2. | REAR ROCKER COVER | 6. | HOSE CLAMP (2) |
| 3. | ROCKER COVER GASKET | 7. | BREATHER HOSE |
| 4. | ENGINE BRAKE RETARDER | | |

ENGINE.

3-14. ROCKER COVER FILLER CAP REPLACEMENT.

THIS TASK COVERS

- a. Removal.
- b. Cleaning and Inspection.
- c. Installation.

INITIAL SETUP

APPLICABLE CONFIGURATIONS

All.

EQUIPMENT CONDITION

PARAGRAPH

None.

CONDITION DESCRIPTION

None.

TEST EQUIPMENT

None.

SPECIAL TOOLS

None.

MATERIALS/PARTS (P/N)

None.

PERSONNEL REQUIRED

One (MOS-63S).

SPECIAL ENVIRONMENTAL CONDITIONS

None.

REFERENCES (TM)

None.

GENERAL SAFETY INSTRUCTIONS

Engine off.
Transmission in neutral.
Park brake set.

TROUBLESHOOTING REFERENCES

None.

ENGINE.

3-14. ROCKER COVER FILLER CAP REPLACEMENT (Continued).

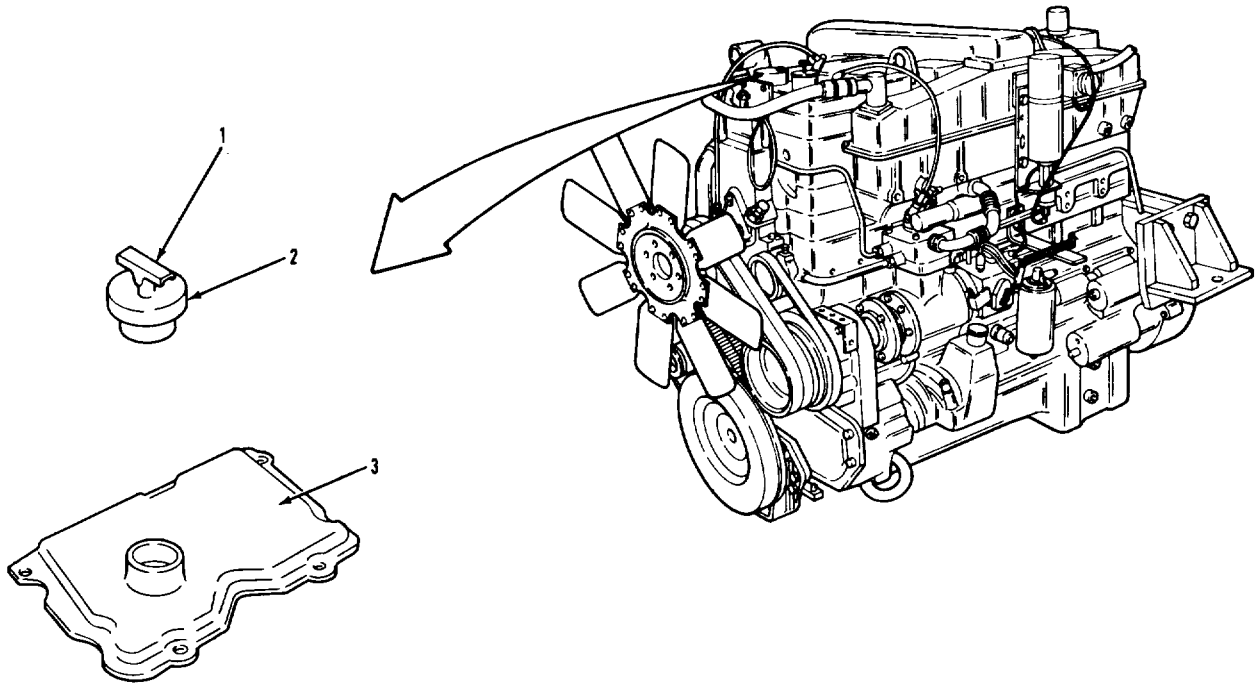

LEGEND:

- 1. LOCK SCREW
- 2. FILLER CAP
- 3. FRONT ROCKER COVER

ENGINE.

3-14. ROCKER COVER FILLER CAP REPLACEMENT (Continued).

LOCATION/ITEM	ACTION	REMARKS
A. REMOVAL.		
1. Lock screw (1).	Loosen.	
2. Cap (2).	Remove from item (4).	
B. CLEANING AND INSPECTION.		
3. All parts.	Clean and inspect.	Refer to paragraphs 3-4 and 3-5.
C. INSTALLATION.		
4. Cap (2).	Place in item (4).	
5. Lock screw (1).	Tighten.	Finger tight only.
<p>NOTE Follow-on maintenance action required: None.</p>		

ENGINE.

3-14. ROCKER COVER FILLER CAP REPLACEMENT (Continued).

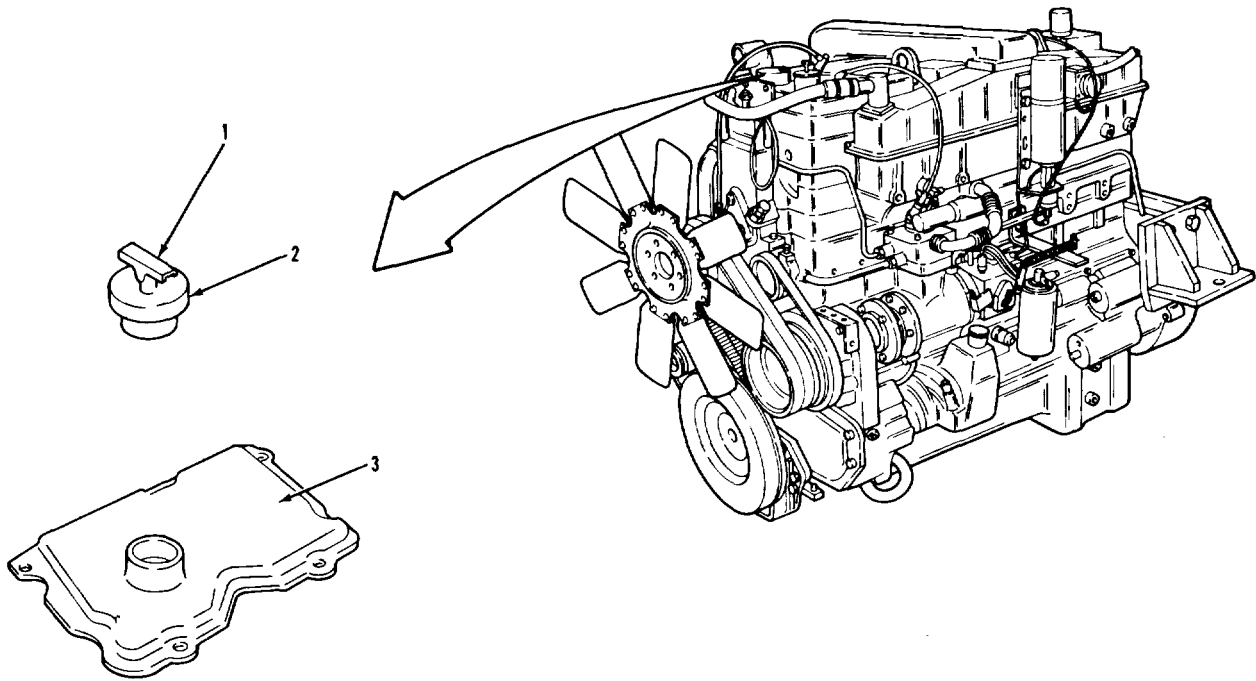

LEGEND:

- 1. LOCK SCREW
- 2. FILLER CAP
- 3. FRONT ROCKER COVER

ENGINE.

3-15. BREATHER TUBES AND HOSES REPLACEMENT.

THIS TASK COVERS

- a. Removal.
- b. Cleaning and Inspection.
- c. Installation.

INITIAL SETUP

APPLICABLE CONFIGURATIONS

All.

EQUIPMENT CONDITION

PARAGRAPH

None.

CONDITION DESCRIPTION

None.

TEST EQUIPMENT

None.

SPECIAL TOOLS

None.

MATERIALS/PARTS (P/N)

None.

PERSONNEL REQUIRED

One (MOS-63S).

SPECIAL ENVIRONMENTAL CONDITIONS

None.

REFERENCES (TM)

None.

GENERAL SAFETY INSTRUCTIONS

Engine off.
Transmission in neutral.
Park brake set.

TROUBLESHOOTING REFERENCES

Paragraph 2-11.

ENGINE.

3-15. BREATHER TUBES AND HOSES REPLACEMENT (Continued).

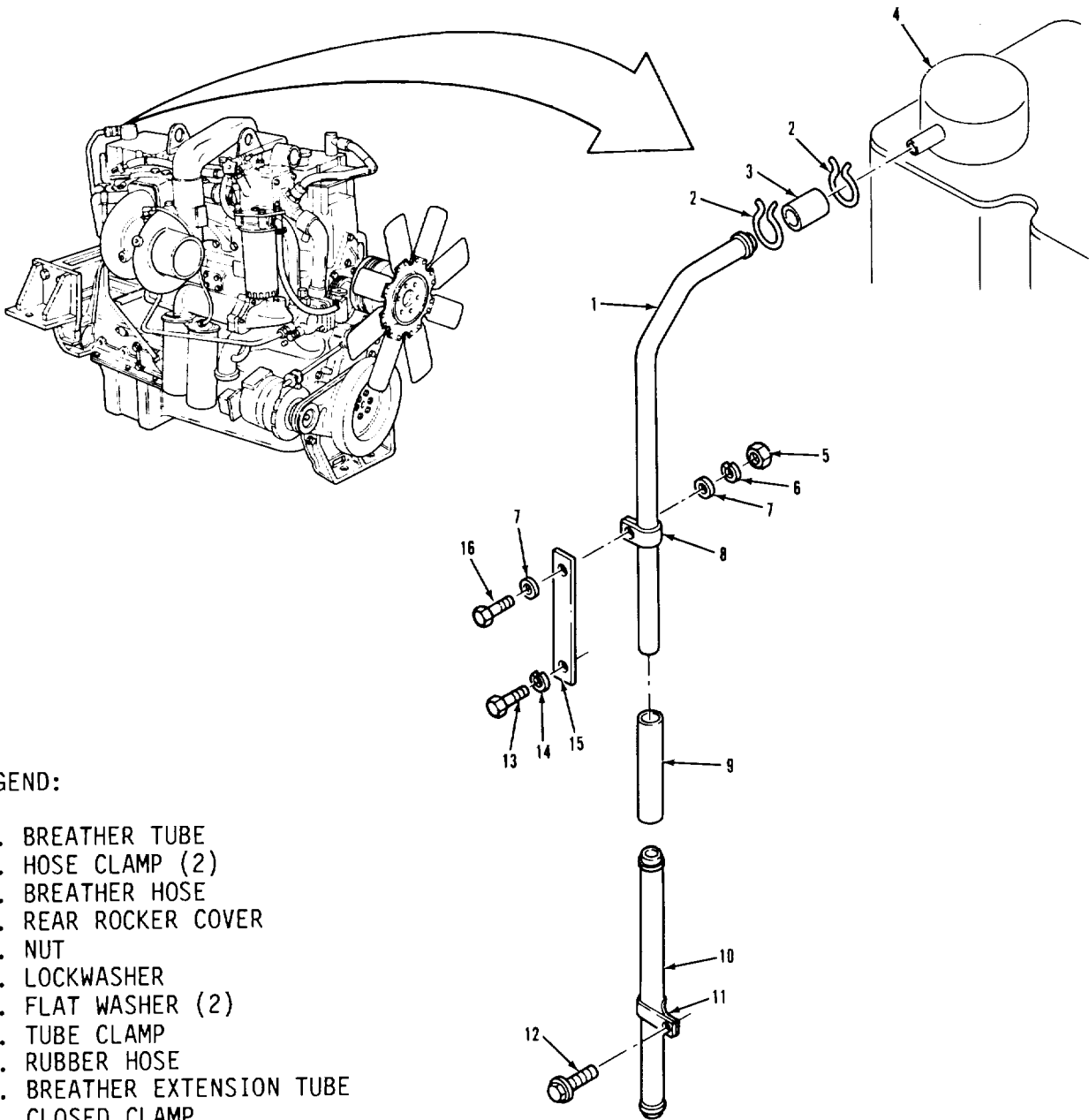

LEGEND:

- 1. BREATHER TUBE
- 2. HOSE CLAMP (2)
- 3. BREATHER HOSE
- 4. REAR ROCKER COVER
- 5. NUT
- 6. LOCKWASHER
- 7. FLAT WASHER (2)
- 8. TUBE CLAMP
- 9. RUBBER HOSE
- 10. BREATHER EXTENSION TUBE
- 11. CLOSED CLAMP
- 12. SELF-TAPPING SCREW
- 13. SCREW
- 14. LOCKWASHER
- 15. CROSSOVER BRACE
- 16. SCREW

ENGINE.

3-15. BREATHER TUBES AND HOSES REPLACEMENT (Continued).

LOCATION/ITEM	ACTION	REMARKS
A. REMOVAL.		
1. Two clamps (2).	Squeeze and slide from item (3) to item (1).	
2. Hose (3).	Pull from item (4).	
3. Screw (13) and lockwasher (14).	Remove from item (15).	
4. Screw (12).	Remove from item (11).	
5. Tube (1), hose (3), tube (10), and hose (9).	Remove.	Access from under vehicle.
6. Screw (16), two washers (7), lockwasher (6), and nut (5).	Remove from item (15) and item (8).	
7. Hose (3).	Remove from item (1).	
8. Hose (9).	Remove from item (1) and item (10).	
9. Clamp (11), clamp (8), and two clamps (2).	Remove from item (1) and item (10).	

ENGINE.

3-15. BREATHER TUBES AND HOSES REPLACEMENT (Continued).

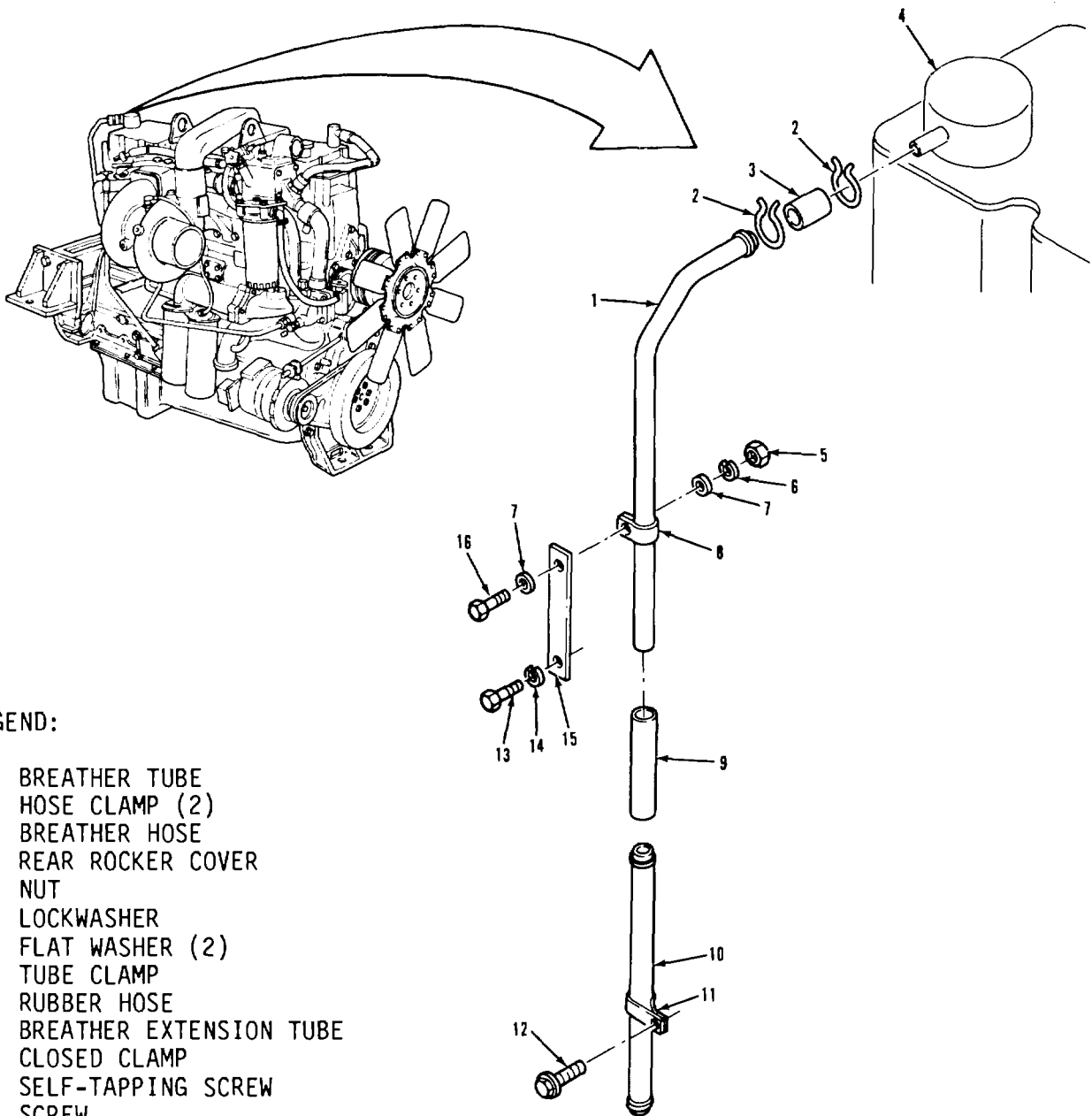

LEGEND:

- 1. BREATHER TUBE
- 2. HOSE CLAMP (2)
- 3. BREATHER HOSE
- 4. REAR ROCKER COVER
- 5. NUT
- 6. LOCKWASHER
- 7. FLAT WASHER (2)
- 8. TUBE CLAMP
- 9. RUBBER HOSE
- 10. BREATHER EXTENSION TUBE
- 11. CLOSED CLAMP
- 12. SELF-TAPPING SCREW
- 13. SCREW
- 14. LOCKWASHER
- 15. CROSSOVER BRACE
- 16. SCREW

TA 237903

ENGINE.

3-15. BREATHER TUBES AND HOSES REPLACEMENT (Continued).

LOCATION/ITEM	ACTION	REMARKS
B. CLEANING AND INSPECTION.		
10. All parts.	Clean and inspect.	Refer to paragraphs 3-4 and 3-5.
C. INSTALLATION.		
11. Clamp (11), clamp (8), and two clamps (2).	Put on item (1) and item (10).	
12. Hose (9).	Install on item (1) and item (10).	
13. Hose (3).	Install on item (1).	
14. Screw (16), two washers (7), lockwasher (6), and nut (5).	Install item (15) on item (8).	Do not tighten.
15. Hose (3), tube (1), hose (9), and tube (10).	Put in place on engine.	
16. Hose (3).	Install on item (4).	
17. Two clamps (2). (4) and item (1).	Secure item (3) to item	

ENGINE.

3-15. BREATHER TUBES AND HOSES REPLACEMENT (Continued).

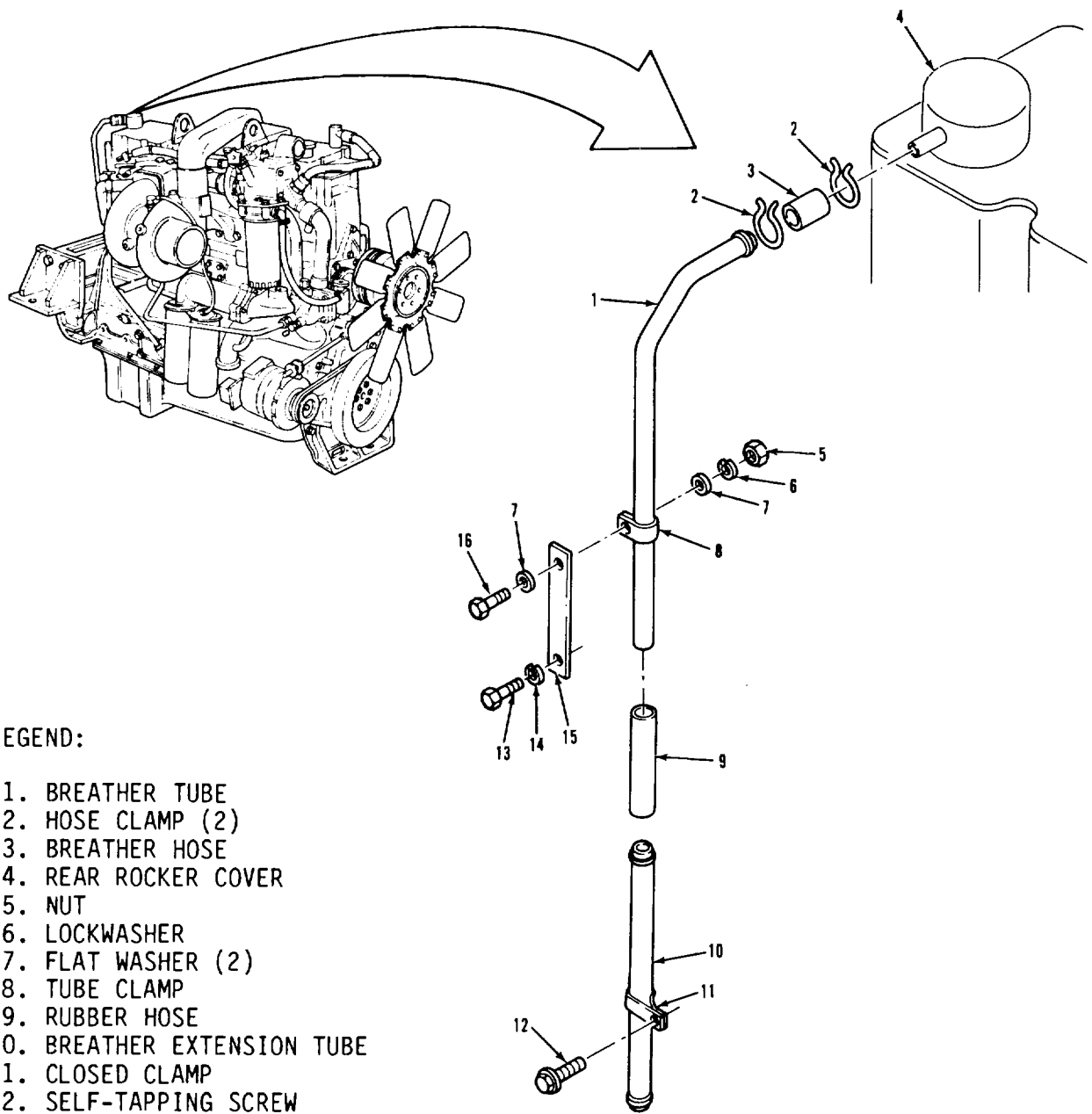

LEGEND:

- 1. BREATHER TUBE
- 2. HOSE CLAMP (2)
- 3. BREATHER HOSE
- 4. REAR ROCKER COVER
- 5. NUT
- 6. LOCKWASHER
- 7. FLAT WASHER (2)
- 8. TUBE CLAMP
- 9. RUBBER HOSE
- 10. BREATHER EXTENSION TUBE
- 11. CLOSED CLAMP
- 12. SELF-TAPPING SCREW
- 13. SCREW
- 14. LOCKWASHER
- 15. CROSSOVER BRACE
- 16. SCREW

ENGINE.

3-15. BREATHER TUBES AND HOSES REPLACEMENT (Continued).

LOCATION/ITEM	ACTION	REMARKS
---------------	--------	---------

C. INSTALLATION (Continued).

18. Screw (13) and lockwasher (14).	Secure item (15) to engine.	
-------------------------------------	-----------------------------	--

19. Screw (16) and nut (5).	Tighten.	
-----------------------------	----------	--

20. Screw (12).	Secure item (11) to engine.	
-----------------	-----------------------------	--

NOTE

Follow-on maintenance action required:
None.

ENGINE.

3-15. BREATHER TUBES AND HOSES REPLACEMENT (Continued).

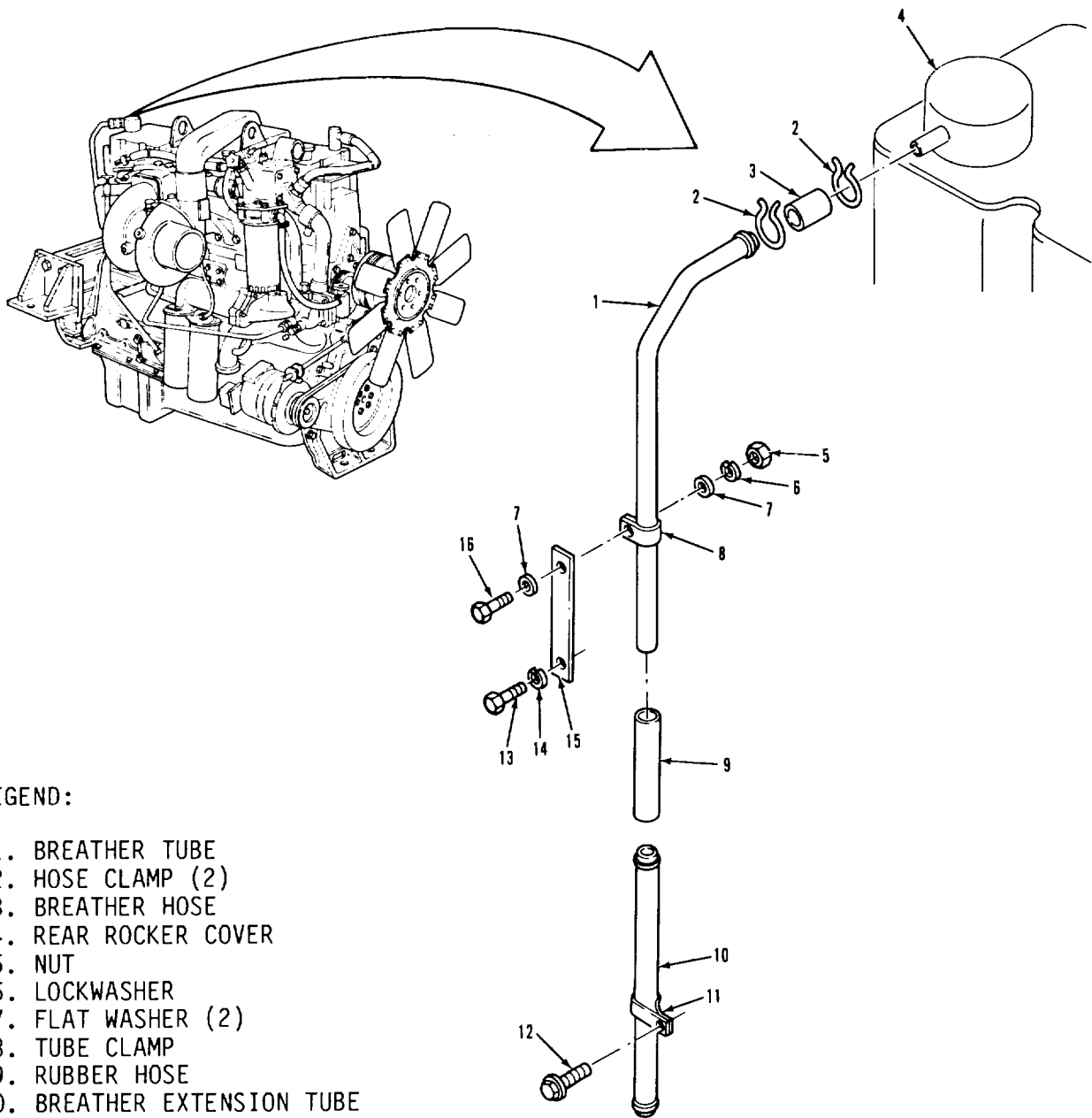

LEGEND:

- 1. BREATHER TUBE
- 2. HOSE CLAMP (2)
- 3. BREATHER HOSE
- 4. REAR ROCKER COVER
- 5. NUT
- 6. LOCKWASHER
- 7. FLAT WASHER (2)
- 8. TUBE CLAMP
- 9. RUBBER HOSE
- 10. BREATHER EXTENSION TUBE
- 11. CLOSED CLAMP
- 12. SELF-TAPPING SCREW
- 13. SCREW
- 14. LOCKWASHER
- 15. CROSSOVER BRACE
- 16. SCREW

ENGINE.

3-16. OIL LEVEL DIPSTICK REPLACEMENT.

THIS TASK COVERS

- a. Removal.
- b. Cleaning and Inspection.
- c. Installation.

INITIAL SETUP

APPLICABLE CONFIGURATIONS

All.

EQUIPMENT CONDITION

PARAGRAPH

None.

CONDITION DESCRIPTION

None.

TEST EQUIPMENT

None.

SPECIAL TOOLS

None.

MATERIALS/PARTS (P/N)

None.

PERSONNEL REQUIRED

One (MOS-63S).

SPECIAL ENVIRONMENTAL CONDITIONS

None.

REFERENCES (TM)

None.

Transmission in neutral.

Park brake set.

GENERAL SAFETY INSTRUCTIONS

Engine off.

TROUBLESHOOTING REFERENCES

Paragraph 2-11.

ENGINE.

3-16. OIL LEVEL DIPSTICK REPLACEMENT (Continued).

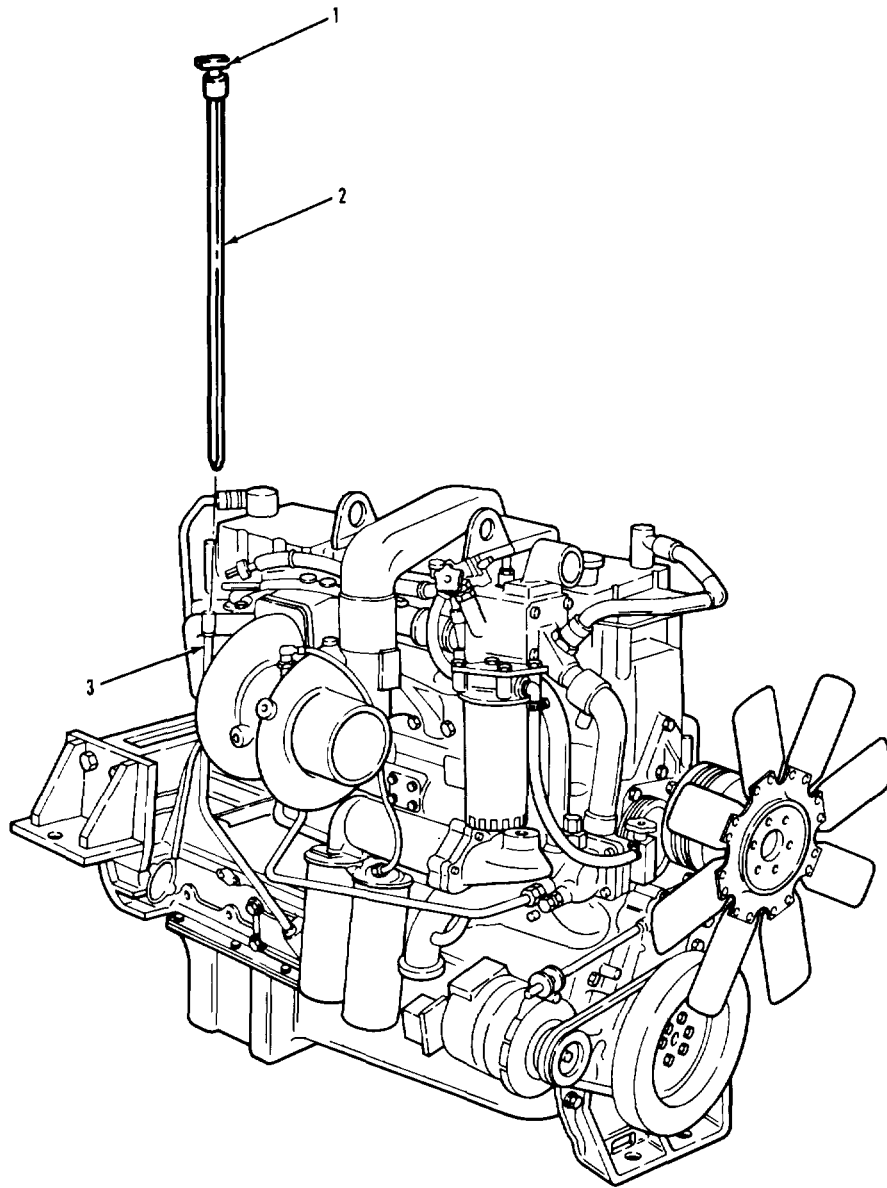

LEGEND:

- 1. LOCK SCREW
- 2. OIL LEVEL DIPSTICK
- 3. OIL LEVEL DIPSTICK TUBE

ENGINE.

3-16. OIL LEVEL DIPSTICK REPLACEMENT (Continued).

LOCATION/ITEM	ACTION	REMARKS
A. REMOVAL.		
1. Lock screw (1).	Loosen.	
2. Dipstick (2).	Remove from item (3).	
B. CLEANING AND INSPECTION.		
3. Dipstick (2). and 3-5.	Clean and inspect.	Refer to paragraphs 3-4
C. INSTALLATION.		
4. Dipstick (2).	Install in item (3).	
5. Lock screw (1).	Tighten.	Finger tight only.
<p>NOTE Follow-on maintenance action required: None.</p>		

ENGINE.

3-16. OIL LEVEL DIPSTICK REPLACEMENT (Continued).

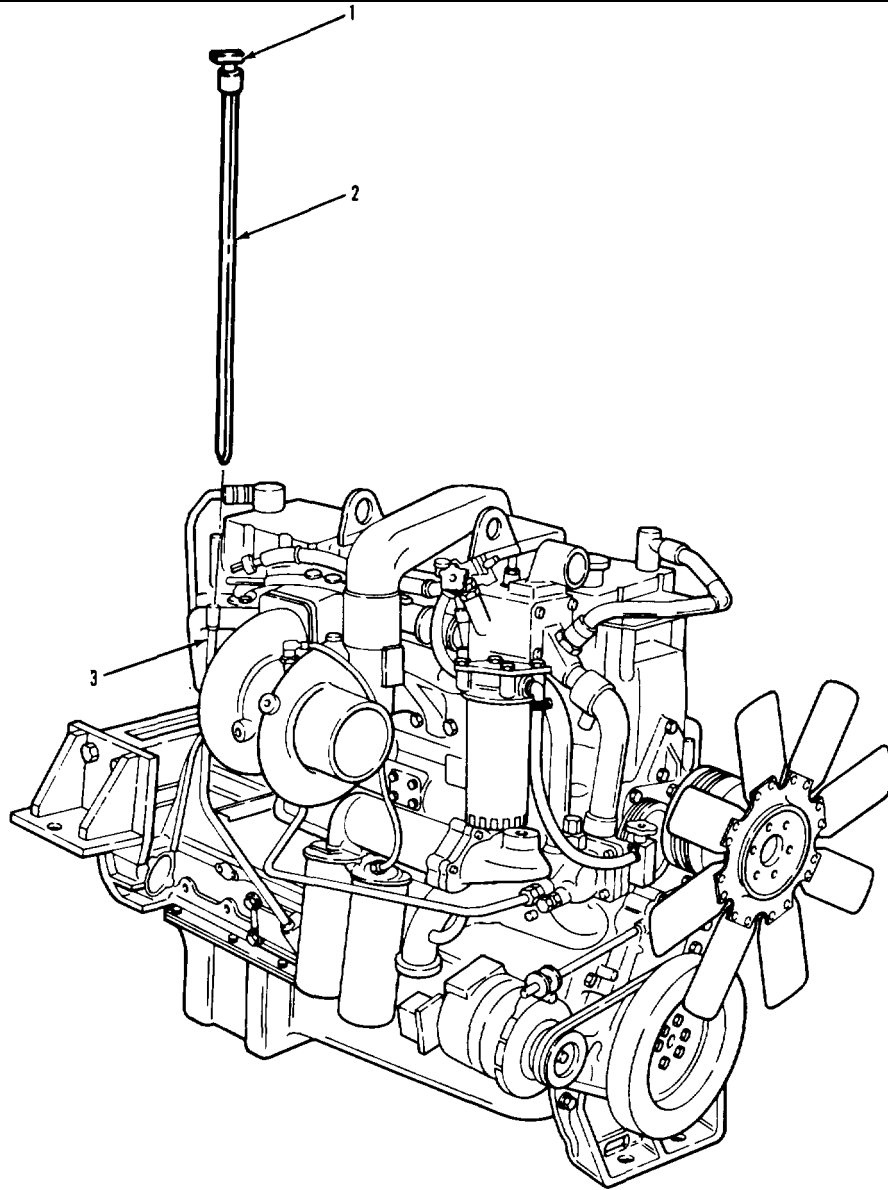

LEGEND:

- 1. LOCK SCREW
- 2. OIL LEVEL DIPSTICK
- 3. OIL LEVEL DIPSTICK TUBE

ENGINE.

3-17. OIL LEVEL DIPSTICK TUBE BRACE AND CLAMP REPLACEMENT.

THIS TASK COVERS

- a. Removal.
- b. Cleaning and Inspection.
- c. Installation.

INITIAL SETUP

APPLICABLE CONFIGURATIONS

All.

EQUIPMENT CONDITION

PARAGRAPH

None.

CONDITION DESCRIPTION

None.

TEST EQUIPMENT

None.

SPECIAL TOOLS

None.

MATERIALS/PARTS (P/N)

None.

PERSONNEL REQUIRED

One (MOS-63S5).

SPECIAL ENVIRONMENTAL CONDITIONS

None.

REFERENCES (TM)

None.

Transmission in neutral.

Park brake set.

GENERAL SAFETY INSTRUCTIONS

Engine off.

TROUBLESHOOTING REFERENCES

None.

ENGINE.

3-17. OIL LEVEL DIPSTICK TUBE BRACE AND CLAMP REPLACEMENT (Continued).

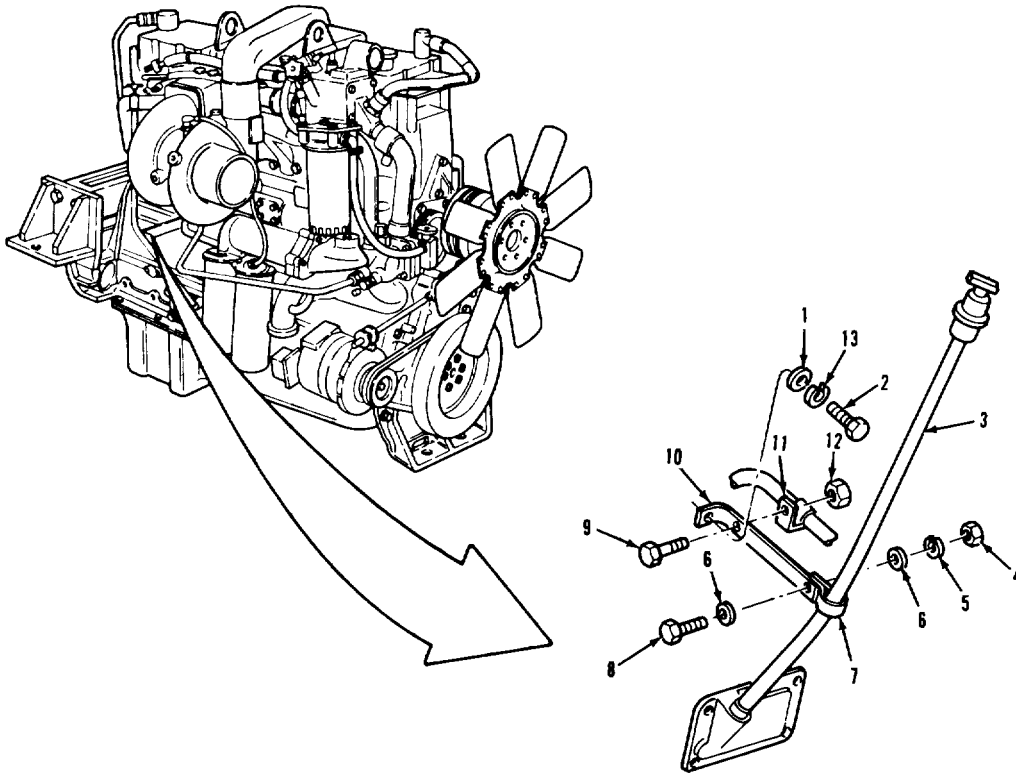

LEGEND:

- | | |
|----------------------------|---------------------------------|
| 1. WASHER | 8. SCREW |
| 2. SCREW | 9. SCREW |
| 3. OIL LEVEL DIPSTICK TUBE | 10. TUBE BRACE |
| 4. NUT | 11. COOLANT RETURN HOSE BRACKET |
| 5. LOCKWASHER | 12. NUT |
| 6. FLAT WASHER (2) | 13. LOCKWASHER |
| 7. CLAMP | |
| 7. CLAMP | |

ENGINE.

3-17. OIL LEVEL DIPSTICK TUBE BRACE AND CLAMP REPLACEMENT (Continued).

LOCATION/ITEM	ACTION	REMARKS
A. REMOVAL.		
1. Screw (8), two washers (6), lock-washer (5), and nut (4).	Remove from item (10) and item (7).	
2. Clamp (7).	Remove from item (3).	
3. Screw (9) and nut (12).	Remove from item (10) and item (11).	
4. Screw (2), lock-washer (13), and washer (1).	Remove from item (10).	
B. CLEANING AND INSPECTION.		
5. All parts and 3-5.	Clean and inspect.	Refer to paragraphs 3-4
C. INSTALLATION.		
6. Screw (2), lock-washer (13), and washer (1).	Secure item (10) to engine.	
7. Screw (9) and nut (12).	Secure item (11) to item (10).	

ENGINE.

3-17. OIL LEVEL DIPSTICK TUBE BRACE AND CLAMP REPLACEMENT (Continued).

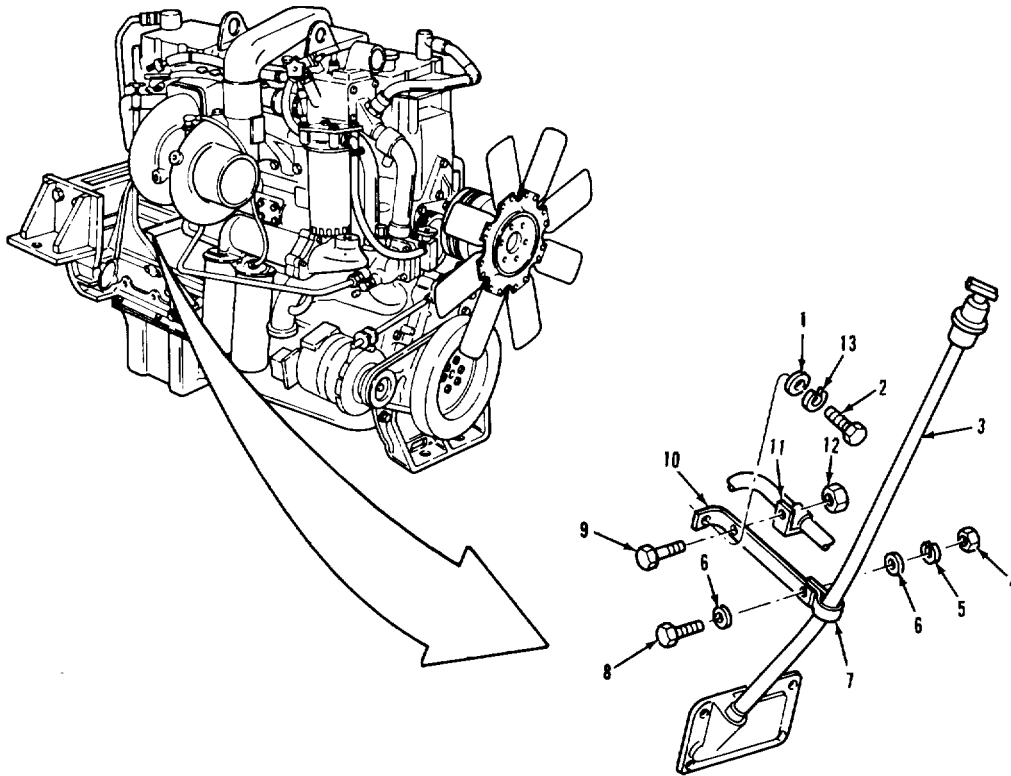

LEGEND:

- | | |
|----------------------------|---------------------------------|
| 1. WASHER | 8. SCREW |
| 2. SCREW | 9. SCREW |
| 3. OIL LEVEL DIPSTICK TUBE | 10. TUBE BRACE |
| 4. NUT | 11. COOLANT RETURN HOSE BRACKET |
| 5. LOCKWASHER | 12. NUT |
| 6. FLAT WASHER (2) | 13. LOCKWASHER |
| 7. CLAMP | |

ENGINE.

3-17. OIL LEVEL DIPSTICK TUBE BRACE AND CLAMP REPLACEMENT (Continued).

LOCATION/ITEM	ACTION	REMARKS
C. INSTALLATION (Continued).		
8. Clamp (7).	Install on item (3).	
9. Screw (8), two washers (6), lock-washer (5), and nut (4).	Secure item (7) to item (10).	
<p>NOTE Follow-on maintenance action required: None.</p>		

ENGINE.

3-17. OIL LEVEL DIPSTICK TUBE BRACE AND CLAMP REPLACEMENT (Continued).

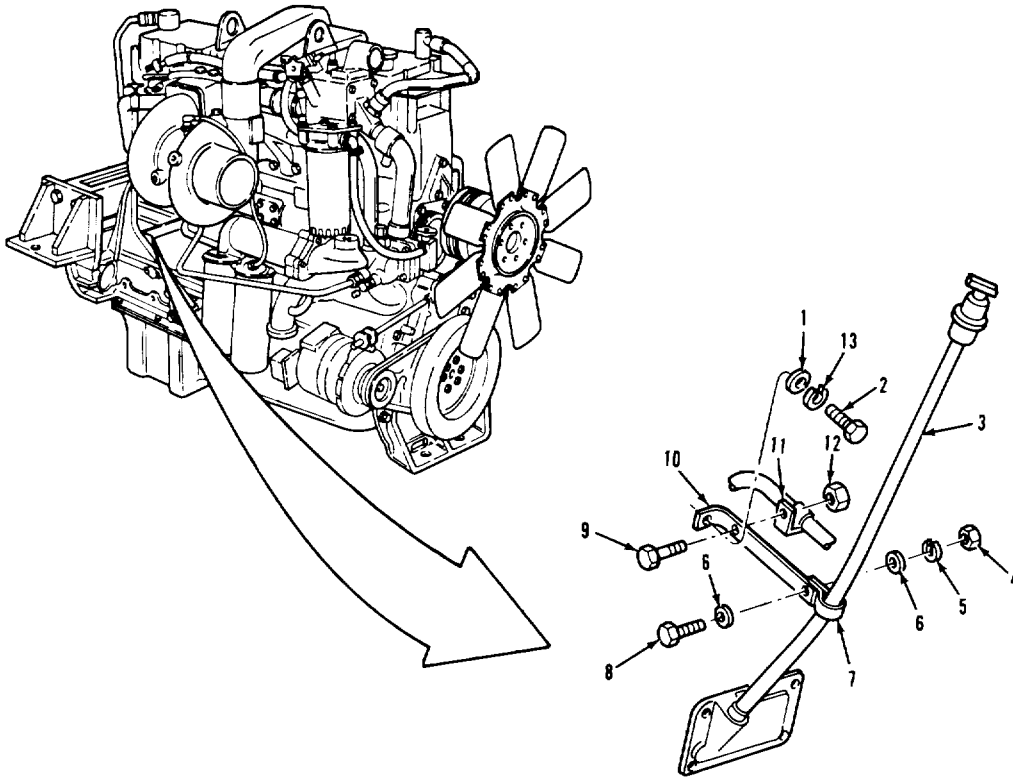

LEGEND:

- | | |
|----------------------------|---------------------------------|
| 1. WASHER | 8. SCREW |
| 2. SCREW | 9. SCREW |
| 3. OIL LEVEL DIPSTICK TUBE | 10. TUBE BRACE |
| 4. NUT | 11. COOLANT RETURN HOSE BRACKET |
| 5. LOCKWASHER | 12. NUT |
| 6. FLAT WASHER (2) | 13. LOCKWASHER |
| 7. CLAMP | |

ENGINE.

3-18. AIR COMPRESSOR COOLING TUBES REPLACEMENT.

THIS TASK COVERS

- a. Removal.
- b. Cleaning and Inspection.
- c. Installation.

INITIAL SETUP

APPLICABLE CONFIGURATIONS

All.

EQUIPMENT CONDITION

PARAGRAPH

3-52.

CONDITION DESCRIPTION

Coolant drained.

TEST EQUIPMENT

None.

SPECIAL TOOLS

None.

MATERIALS/PARTS (P/N)

Tape, thread sealing
 Item 32, Appendix C.
 Grommet (4)
 (15434) S-1003-A.

PERSONNEL REQUIRED

One (MOS-63S).

SPECIAL ENVIRONMENTAL CONDITIONS

None.

REFERENCES (TM)

TM 9-2320-283-10.
 TM 9-2320-283-20P.
 Park brake set.

GENERAL SAFETY INSTRUCTIONS

Engine off.
 Transmission in neutral.

TROUBLESHOOTING REFERENCES

Paragraph 2-11.

ENGINE.

3-18. AIR COMPRESSOR COOLING TUBES REPLACEMENT (Continued).

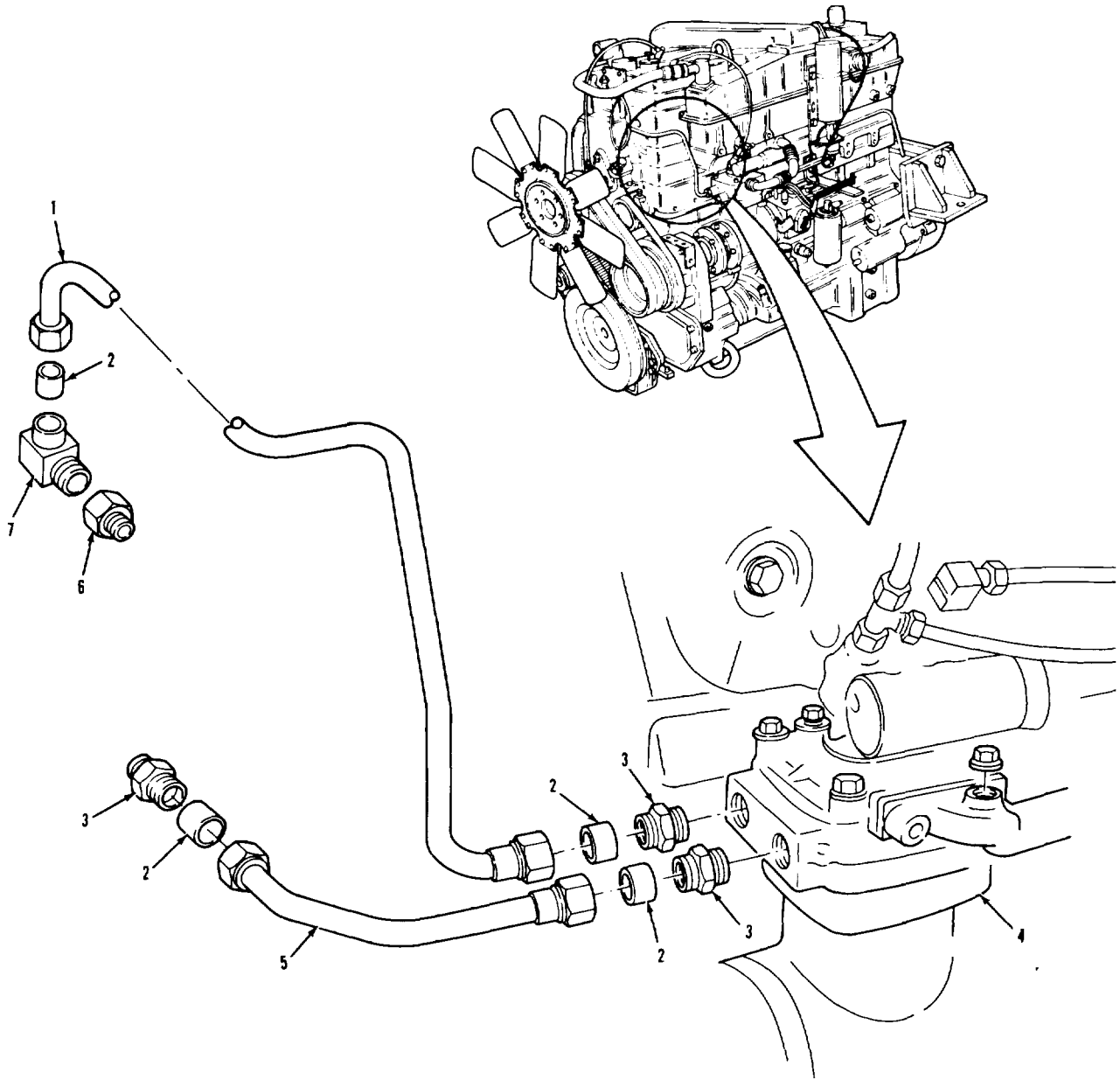

- 1. COMPRESSOR COOLING WATER TUBE
- 2. GROMMET (4)
- 3. NIPPLE (3)
- 4. AIR COMPRESSOR

- 5. COMPRESSOR COOLING WATER TUBE
- 6. PLAIN STRAIGHT ADAPTER
- 7. MALE ELBOW ADAPTER

TA 237011

ENGINE.

3-18. AIR COMPRESSOR COOLING TUBES REPLACEMENT (Continued).

LOCATION/ITEM	ACTION	REMARKS
NOTE		
	*	To replace adapter (7) and adapter (6), refer to paragraph 3-58 (Water Bypass Tube Replacement).
	*	It may be necessary to loosen idler pulley for clearance.(Refer to para 3-63).
A. REMOVAL.		
1. Tube (5) and two grommets (2).	Remove from two items (3).	Discard two items (2).
2. Tube (1) and two grommets (2).	Remove from item (3) and item (7).	Discard two items (2).
3. Three nipples (3).	Remove from item (4) and engine.	
B. CLEANING AND INSPECTION.		
4. All parts.	Clean and inspect.	Refer to paragraph 3-4
C. INSTALLATION.		
5. Three nipples (3).	Install in item (4) and engine.	Put thread sealing tape on pipe threads.
6. Tube (1) and two new grommets (2).	Install on item (7) and item (3).	
7. Tube (5) and two new grommets (2).	Install on two items (3).	

ENGINE.

3-18. AIR COMPRESSOR COOLING TUBES REPLACEMENT (Continued).

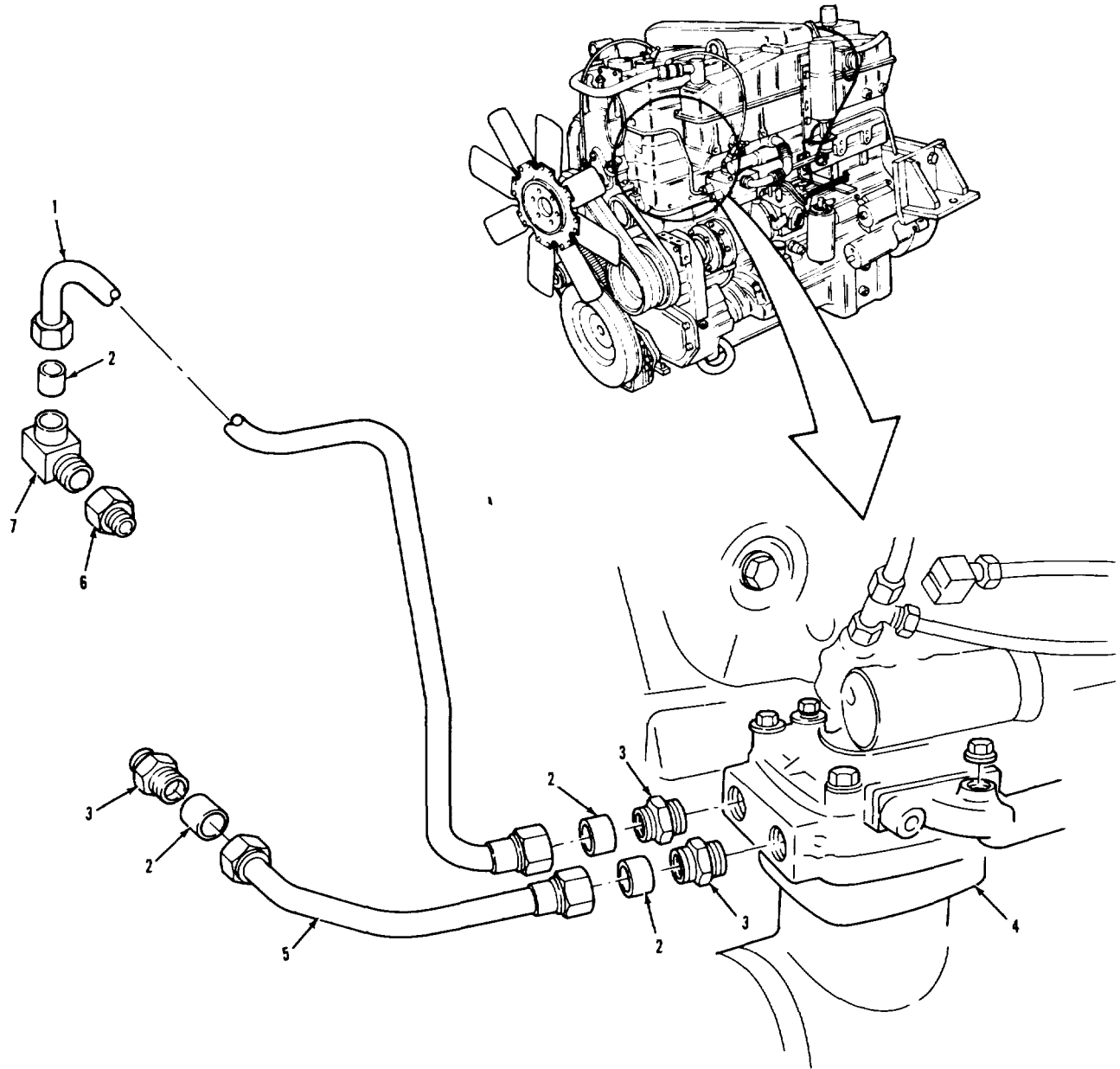

- 1. COMPRESSOR COOLING WATER TUBE
- 2. GROMMET (4)
- 3. NIPPLE (3)
- 4. AIR COMPRESSOR

- 5. COMPRESSOR COOLING WATER TUBE
- 6. PLAIN STRAIGHT ADAPTER
- 7. MALE ELBOW ADAPTER

TA 237012

ENGINE.

3-18. AIR COMPRESSOR COOLING TUBES REPLACEMENT (Continued).

LOCATION/ITEM	ACTION	REMARKS
C. INSTALLATION (Continued).	NOTE	Follow-on maintenance action required Fill cooling system (TM 9-2320-283-10).

ENGINE.

3-18. AIR COMPRESSOR COOLING TUBES REPLACEMENT (Continued).

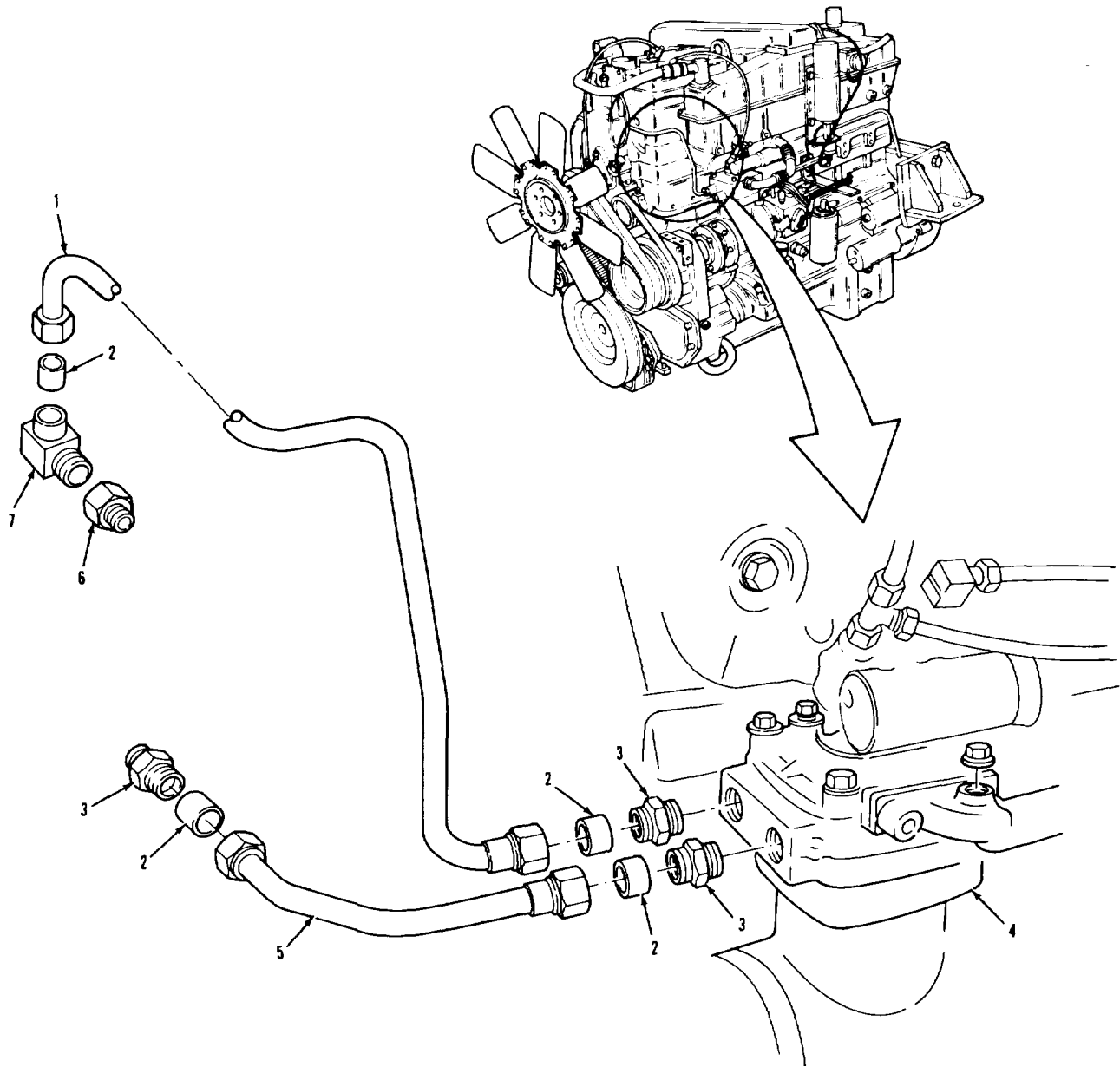

LEGEND:

- 1. COMPRESSOR COOLING WATER TUBE
- 2. GROMMET (4)
- 3. NIPPLE (3)
- 4. AIR COMPRESSOR

- 5. COMPRESSOR COOLING WATER TUBE
- 6. PLAIN STRAIGHT ADAPTER
- 7. MALE ELBOW ADAPTER

TA 237013

ENGINE.

3-19. AIR COMPRESSOR INTAKE TUBE REPLACEMENT.

THIS TASK COVERS

- a. Removal.
- b. Cleaning and Inspection.
- c. Installation.

INITIAL SETUP

<p><u>APPLICABLE CONFIGURATIONS</u> ALI.</p>	<p><u>EQUIPMENT CONDITION PARAGRAPH</u> None.</p>	<p><u>CONDITION DESCRIPTION</u> None.</p>
<p><u>TEST EQUIPMENT</u> None.</p>		
<p><u>SPECIAL TOOLS</u> None.</p>		
<p><u>MATERIALS/PARTS (P/N)</u> Tape, thread sealing Item 32, Appendix C. Gasket (15434) 157911.</p>		
<p><u>PERSONNEL REQUIRED</u> One (MOS-63S).</p>	<p><u>SPECIAL ENVIRONMENTAL CONDITIONS</u> None.</p>	
<p><u>REFERENCES (TM)</u> TM 9-2320-283-20P.</p>	<p><u>GENERAL SAFETY INSTRUCTIONS</u> Engine off. Transmission in neutral. Park brake set.</p>	
<p><u>TROUBLESHOOTING REFERENCES</u> Paragraph 2-11.</p>		

ENGINE.

3-19. AIR COMPRESSOR INTAKE TUBE REPLACEMENT.

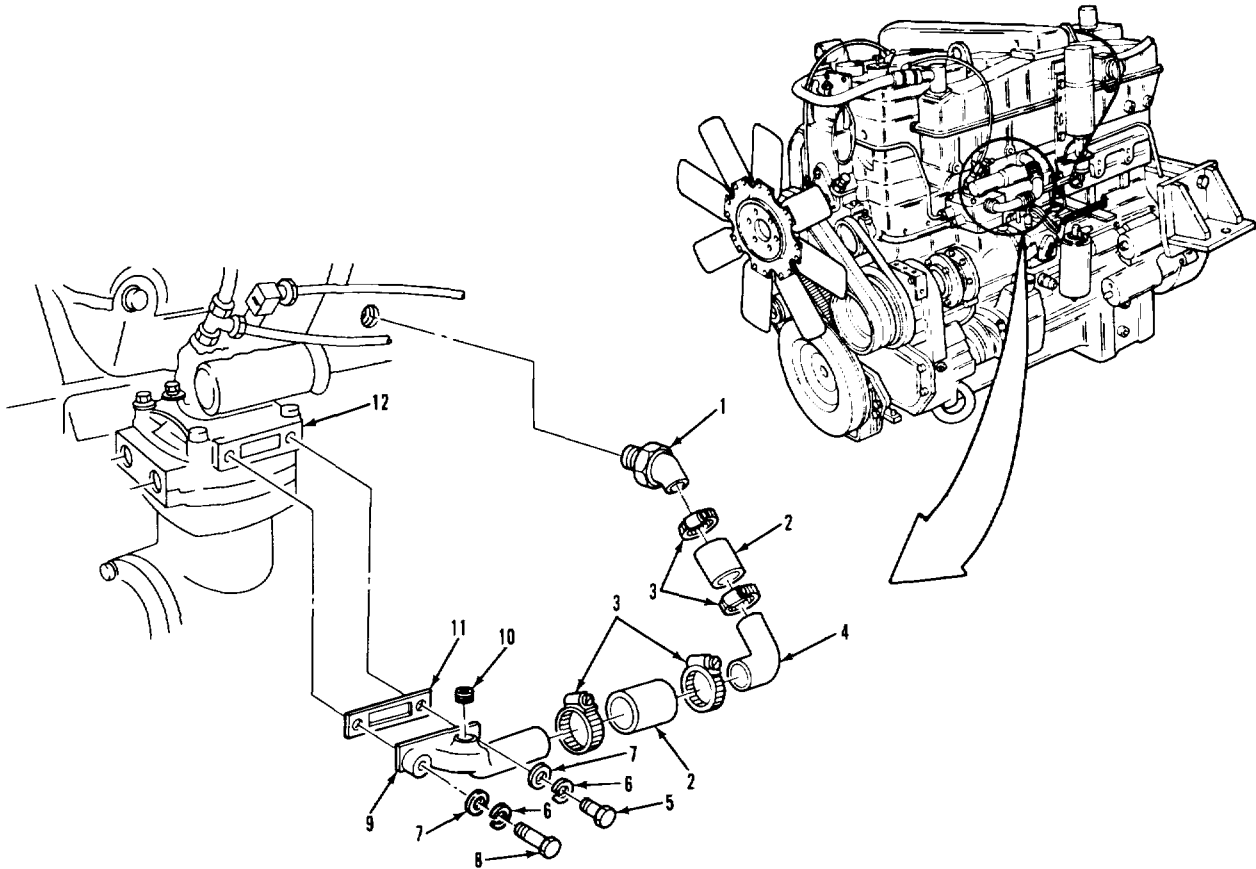

LEGEND:

- | | |
|-------------------------|------------------------------------|
| 1. AIR INTAKE CONNECTOR | 7. PLAIN WASHER (2) |
| 2. AIR INTAKE HOSE (2) | 8. SCREW |
| 3. HOSE CLAMP (4) | 9. AIR COMPRESSOR INTAKE CONNECTOR |
| 4. AIR INTAKE TUBE | 10. PIPE PLUG |
| 5. SCREW | 11. GASKET |
| 6. LOCKWASHER (2) | 12. AIR COMPRESSOR |

TA 237014

ENGINE.

3-19. AIR COMPRESSOR INTAKE TUBE REPLACEMENT (Continued).

LOCATION/ITEM	ACTION	REMARKS
A. REMOVAL.		
1. Four clamps (3).	Loosen.	
2. Plug (10).	Remove from item (9).	
3. Screw (5), screw (8), two lock-washers (6), and two washers (7).	Remove from item (9).	
4. Connector (9) and gasket (11).	Remove from item (12) and item (2).	Discard item (11).
5. Hose (2) and two clamps (3).	Remove from item (4).	
6. Tube (4).	Remove from item (2).	
7. Hose (2) and two clamps (3).	Remove from item (1).	
8. Connector (1).Remove from engine.		
B. CLEANING AND INSPECTION.		
9. All parts. and 3-5.	Clean and inspect.	Refer to paragraphs 3-4
C. INSTALLATION.		
10. Connector (1).	Install in engine.	Put thread sealing tape

ENGINE.

3-19. AIR COMPRESSOR INTAKE TUBE REPLACEMENT (Continued).

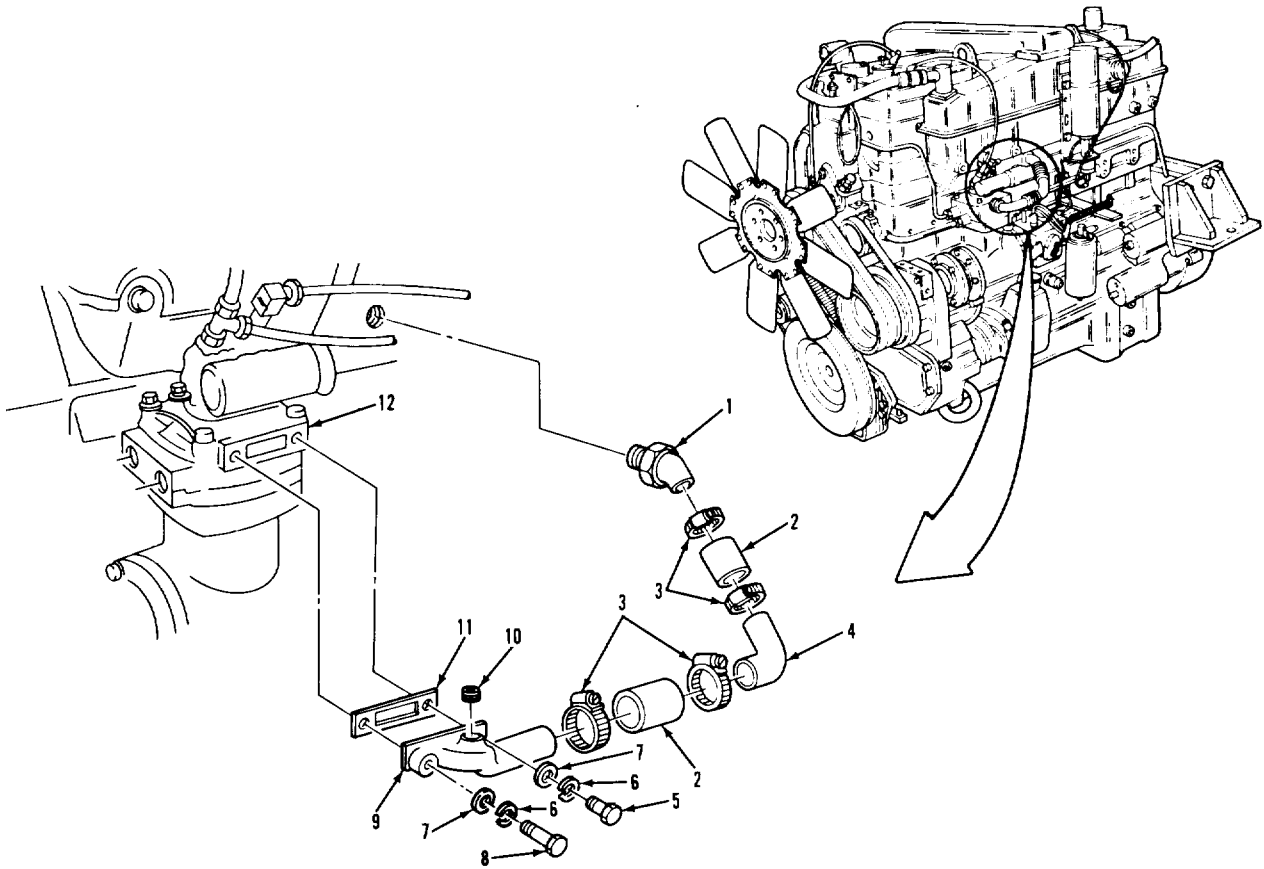

LEGEND:

- | | |
|-------------------------|------------------------------------|
| 1. AIR INTAKE CONNECTOR | 7. PLAIN WASHER (2) |
| 2. AIR INTAKE HOSE (2) | 8. SCREW |
| 3. HOSE CLAMP (4) | 9. AIR COMPRESSOR INTAKE CONNECTOR |
| 4. AIR INTAKE TUBE | 10. PIPE PLUG |
| 5. SCREW | 11. GASKET |
| 6. LOCKWASHER (2) | 12. AIR COMPRESSOR TA23715 |

TA 237015

ENGINE.

3-19. AIR COMPRESSOR INTAKE TUBE REPLACEMENT (Continued).

LOCATION/ITEM	ACTION	REMARKS
C. INSTALLATION (Continued).		
11. Hose (2) and two clamps (3).	Install on item (1).	Do not tighten clamps (3).
12. Tube (4).	Install in item (2).	
13. Hose (2) and two clamps (3).	Install on item (4).Do not tighten.	
14. Connector (9) and new gasket (11).	Install in item (2) and on item (12).	
15. Screw (5), screw (8), two lock-washers (6), and two washers (7).	Secure item (9) and item (11) to item (12).	
16. Plug (10).	Install in item (9).	Put thread sealing tape on threads.
17. Four clamps (3).Tighten.		
NOTE		
		Follow-on maintenance action required:
		None.

ENGINE.

3-19. AIR COMPRESSOR INTAKE TUBE REPLACEMENT (Continued).

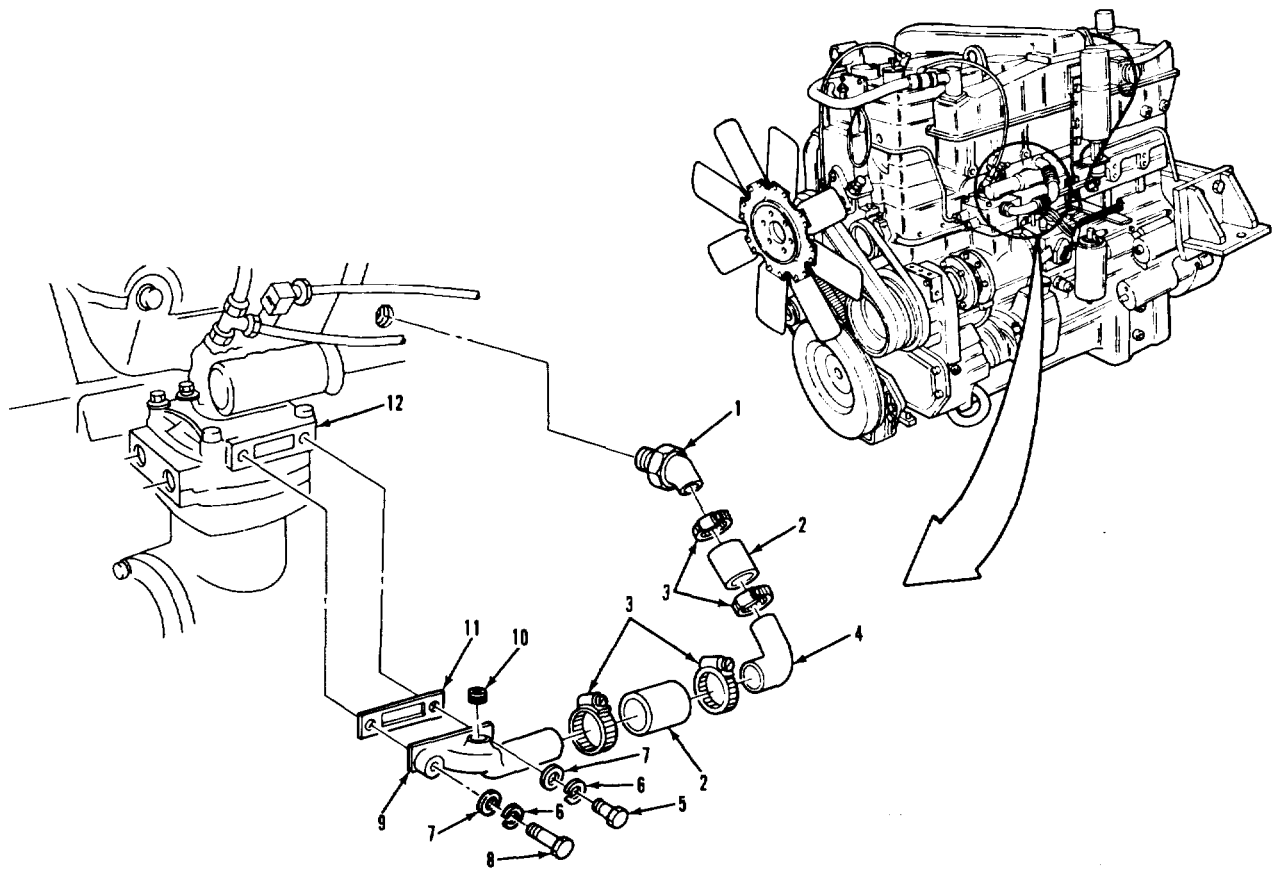

LEGEND:

- | | |
|-------------------------|------------------------------------|
| 1. AIR INTAKE CONNECTOR | 7. PLAIN WASHER (2) |
| 2. AIR INTAKE HOSE (2) | 8. SCREW |
| 3. HOSE CLAMP (4) | 9. AIR COMPRESSOR INTAKE CONNECTOR |
| 4. AIR INTAKE TUBE | 10. PIPE PLUG |
| 5. SCREW | 11. GASKET |
| 6. LOCKWASHER (2) | 12. AIR COMPRESSOR |

TA237016

ENGINE.

3-20. WATER CROSSOVER TUBE AND CONNECTIONS REPLACEMENT.

THIS TASK COVERS

- a. Removal.
- b. Cleaning and Inspection.
- c. Installation.

INITIAL SETUP

<u>APPLICABLE CONFIGURATIONS</u>	<u>EQUIPMENT CONDITION PARAGRAPH</u>	<u>CONDITION DESCRIPTION</u>
All.	3-52.	Coolant drained.
	TM 9-2320-283-10.	Air system drained.
<u>TEST EQUIPMENT</u>		
None.	3-29.	Air cleaner assembly removed.
<u>SPECIAL TOOLS</u>		
None.		
<u>MATERIALS/PARTS (P/N)</u>		
Tape, thread sealing Item 32, Appendix C. Hose, connection (2) (15434) 155789. Gasket, water inlet connection (15434) 3032348. Gasket, water outlet (15434) 215045.		
<u>PERSONNEL REQUIRED</u>	<u>SPECIAL ENVIRONMENTAL CONDITIONS</u>	
Two (MOS-63S).	None.	
<u>REFERENCES (TM)</u>	<u>GENERAL SAFETY INSTRUCTIONS</u>	
TM 9-2320-283-10. TM 9-2320-283-20P.	Engine off. Transmission in neutral. Park brake set.	
<u>TROUBLESHOOTING REFERENCES</u>		
Paragraph 2-11.		

ENGINE.

3-20. WATER CROSSOVER TUBE AND CONNECTIONS REPLACEMENT (Continued).

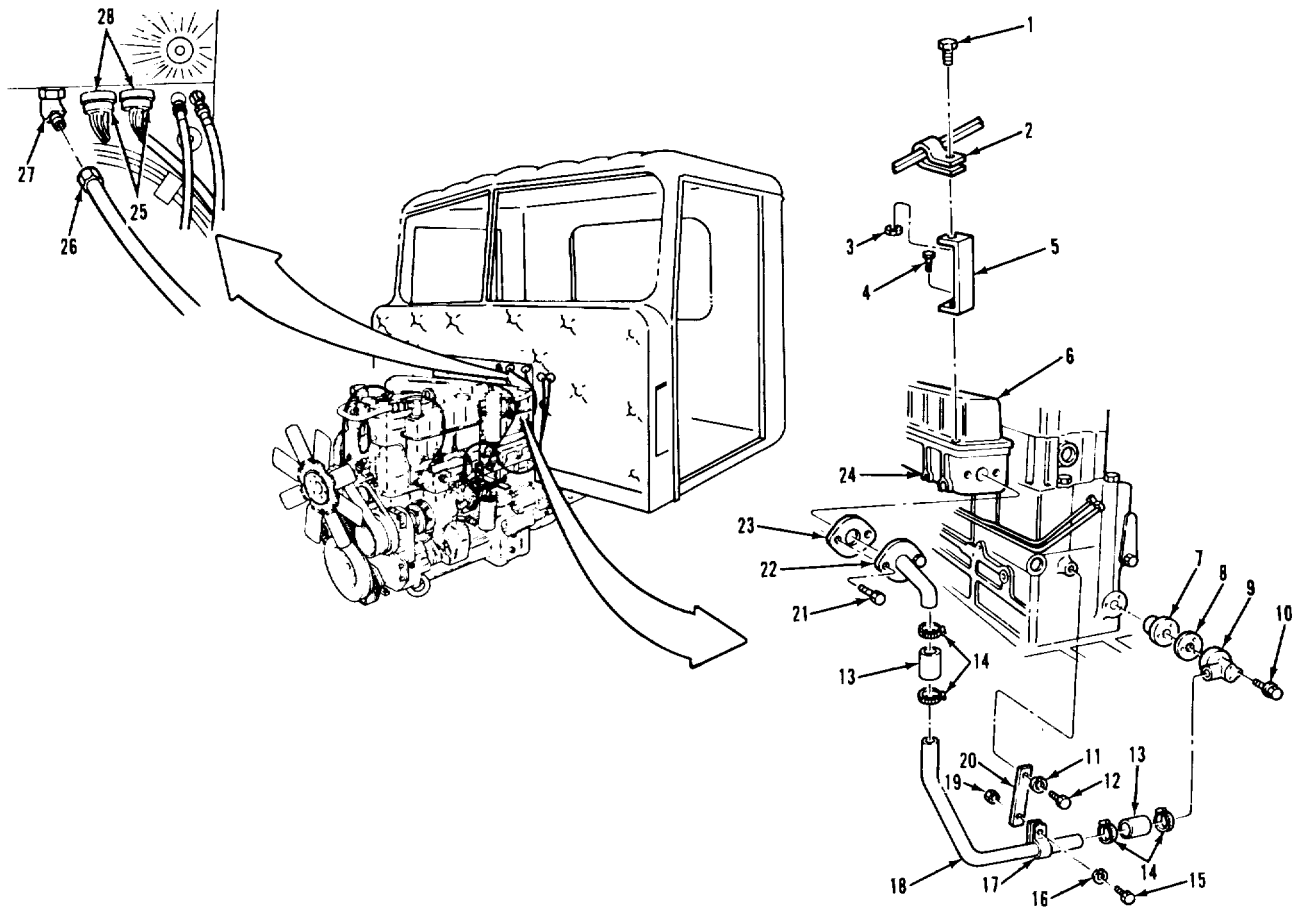

LEGEND:

- | | | |
|-----------------------------------|-----------------------------------|-----------------------------------|
| 1. SCREW | 11. LOCKWASHER | 22. WATER INLET CONNECTION |
| 2. LOOP CLAMP | 12. SCREW | 23. WATER INLET CONNECTION GASKET |
| 3. NUT | 13. CONNECTION HOSE (2) | 24. INTAKE MANIFOLD |
| 4. SCREW WITH CAPTIVE WASHER | 14. HOSE CLAMP (4) | 25. ELECTRICAL CONNECTOR (2) |
| 5. BRACKET | 15. SCREW | 26. AIR TUBE |
| 6. AFTERCOOLER COVER | 16. LOCKWASHER | |
| 7. WATER OUTLET ADAPTER | 17. HOSE CLAMP | |
| 8. WATER OUTLET GASKETTUBE | 18. WATER CROSSOVER | |
| 9. WATER OUTLET CONNECTION | 19. NUT | |
| 10. SCREW WITH CAPTIVE WASHER (3) | 20. CROSSOVER BRACE | 28. ELECTRICAL RECEPTACLE (2) |
| | 21. SCREW WITH CAPTIVE WASHER (2) | |

TA237017

ENGINE.

3-20. WATER CROSSOVER TUBE AND CONNECTIONS REPLACEMENT (Continued).

LOCATION/ITEM	ACTION	REMARKS
A. REMOVAL.		
1. Two connectors (25).	Disconnect from two items (28).	
2. Tube (26).	Disconnect from item (27).	
3. Screw (1) and nut (3).	Remove from item (2) and item (5).	
4. Screw (4). item (6).	Remove from item (5) and item (6).	
5. Screw (12) and washer (11).	Remove from item (20).	
6. Four clamps (14).	Loosen.	
7. Tube (18) and two hoses (13).	Remove from item (22) and item (9).	
8. Screw (15), lock-washers (16), and nut (19).	Remove from item (17) and item (20).	
9. Clamp (17) and two hoses (13).	Remove from item (18).	Discard two items (13).
10. Three screws (10).	Remove from item (9).	
11. Connection (9) and gasket (8).	Remove from item (7).	Discard item (8).
3-64		

ENGINE.

3-20. WATER CROSSOVER TUBE AND CONNECTIONS REPLACEMENT (Continued).

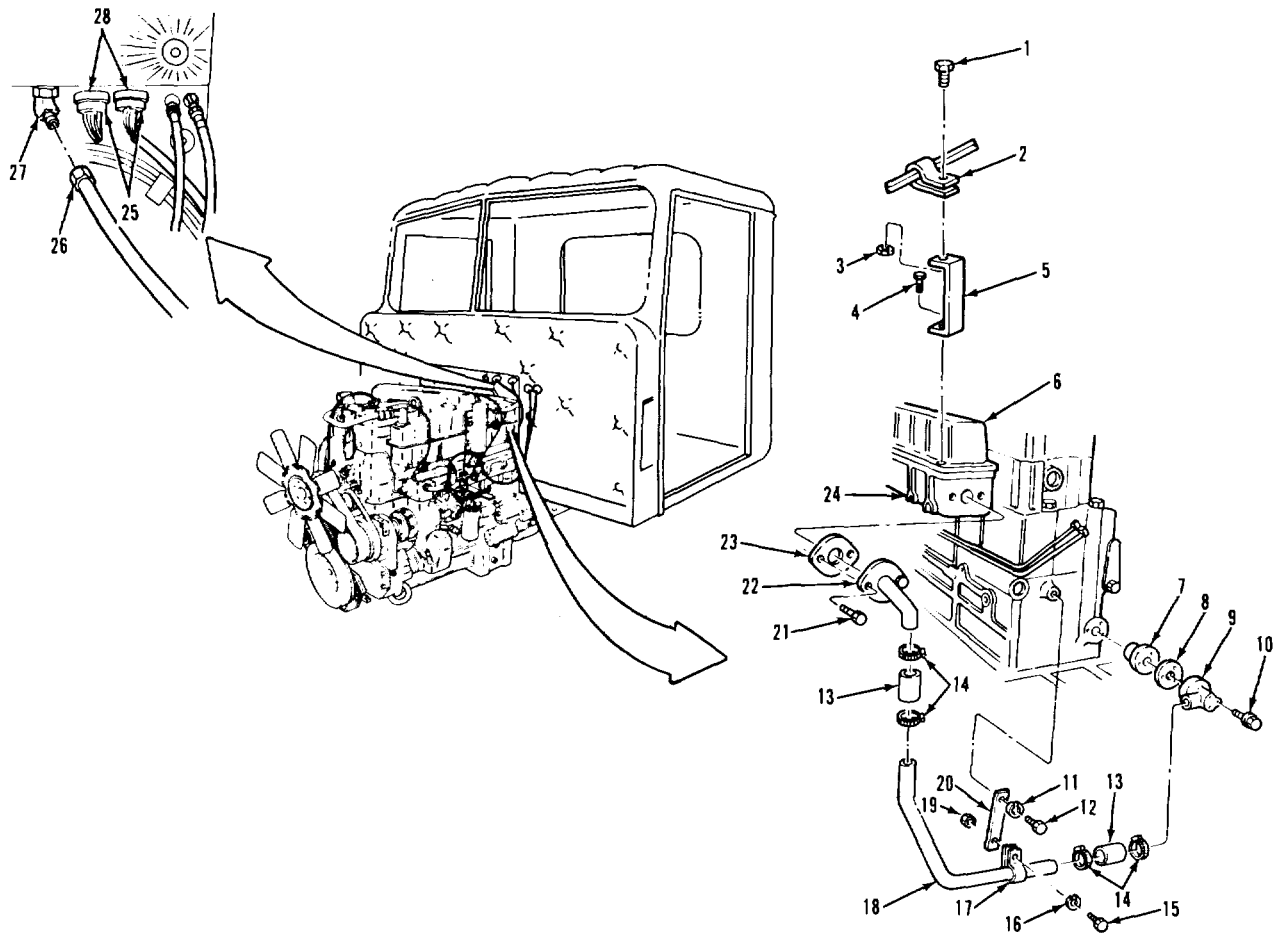

LEGEND:

- | | | |
|-----------------------------------|-----------------------------------|-----------------------------------|
| 1. SCREW | 11. LOCKWASHER | 22. WATER INLET CONNECTION |
| 2. LOOP CLAMP | 12. SCREW | 23. WATER INLET CONNECTION GASKET |
| 3. NUT | 13. CONNECTION HOSE (2) | 24. INTAKE MANIFOLD |
| 4. SCREW WITH CAPTIVE WASHER | 14. HOSE CLAMP (4) | 25. ELECTRICAL CONNECTOR (2) |
| 5. BRACKET | 15. SCREW | 26. AIR TUBE |
| 6. AFTERCOOLER COVER | 16. LOCKWASHER | 27. ELBOW |
| 7. WATER OUTLET ADAPTER | 17. HOSE CLAMP | 28. ELECTRICAL RECEPTACLE (2) |
| 8. WATER OUTLET GASKET | 18. WATER CROSSOVER TUBE | |
| 9. WATER OUTLET CONNECTION | 19. NUT | |
| 10. SCREW WITH CAPTIVE WASHER (3) | 20. CROSSOVER BRACE | |
| | 21. SCREW WITH CAPTIVE WASHER (2) | |

TA 237018

ENGINE.

3-20. WATER CROSSOVER TUBE AND CONNECTIONS REPLACEMENT (Continued).

LOCATION/ITEM	ACTION	REMARKS
A. REMOVAL (Continued).		
12. Adapter (7).	Remove from engine block.	
13. Two screws (21).	Remove from item (22).	
14. Connection (22) and gasket (23).	Remove from item (24).	Discard item (23).
B. CLEANING AND INSPECTION		
15. All parts.	Clean and inspect.	Refer to paragraphs 3-4 and 3-5.
C. INSTALLATION.		
16. Connection (22) and new gasket (23).	Put in place on item (24).	
17. Two screws (21).	Secure item (22) to item (24).	
18. Adapter (7).	Install in engine block.	Put thread sealing tape on threads.
19. Connection (9) and new gasket (8).	Put in place on item (7).	
20. Two screws (10).	Secure item (9) to item (7).	
3-66		

ENGINE.

3-20. WATER CROSSOVER TUBE AND CONNECTIONS REPLACEMENT (Continued).

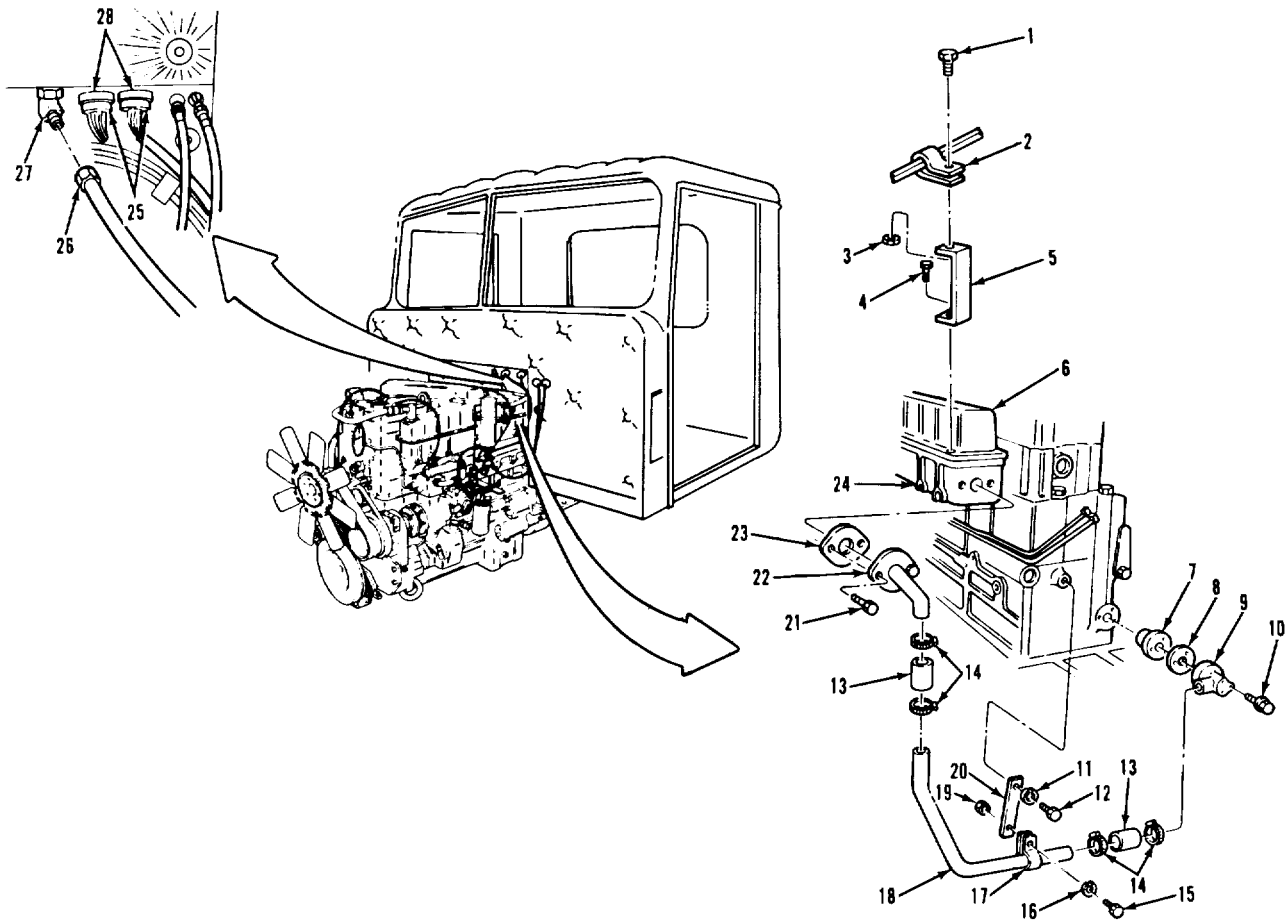

LEGEND:

- | | | |
|-----------------------------------|-----------------------------------|-----------------------------------|
| 1. SCREW | 11. LOCKWASHER | 22. WATER INLET CONNECTION |
| 2. LOOP CLAMP | 12. SCREW | 23. WATER INLET CONNECTION GASKET |
| 3. NUT | 13. CONNECTION HOSE (2) | 24. INTAKE MANIFOLD |
| 4. SCREW WITH CAPTIVE WASHER | 14. HOSE CLAMP (4) | 25. ELECTRICAL CONNECTOR (2) |
| 5. BRACKET | 15. SCREW | 26. AIR TUBE |
| 6. AFTERCOOLER COVER | 16. LOCKWASHER | 27. ELBOW |
| 7. WATER OUTLET ADAPTER | 17. HOSE CLAMP | 28. ELECTRICAL RECEPTACLE (2) |
| 8. WATER OUTLET GASKET | 18. WATER CROSSOVER TUBE | |
| 9. WATER OUTLET CONNECTION | 19. NUT | |
| 10. SCREW WITH CAPTIVE WASHER (3) | 20. CROSSOVER BRACE | |
| | 21. SCREW WITH CAPTIVE WASHER (2) | |

TA 237019

ENGINE.

3-20. WATER CROSSOVER TUBE AND CONNECTIONS REPLACEMENT (Continued).

LOCATION/ITEM	ACTION	REMARKS
C. INSTALLATION (Continued).		
21. Clamp (17) and two new hoses (13).	Install on item (18).	
22. Screw (15), lock-washer (16), and nut (19).	Install item (20) on item (17).	Do not tighten.
23. Two clamps (14).	Secure two items (13) to item (18).	
24. Two clamps (14).	Slip over two items (13).	
25. Two hoses (13).	Install on item (22) and item (9).	
26. Screw (12) and washer (11).	Secure item (20) to engine block.	
27. Screw (15), lock-washer (16), and nut (19).	Tighten.	
28. Two clamps (14).	Tighten.	
29. Screw (4).	Secure item (5) to item (6).	
30. Screw (1) and nut (3).	Secure item (2) to item (5).	

ENGINE.

3-20. WATER CROSSOVER TUBE AND CONNECTIONS REPLACEMENT (Continued).

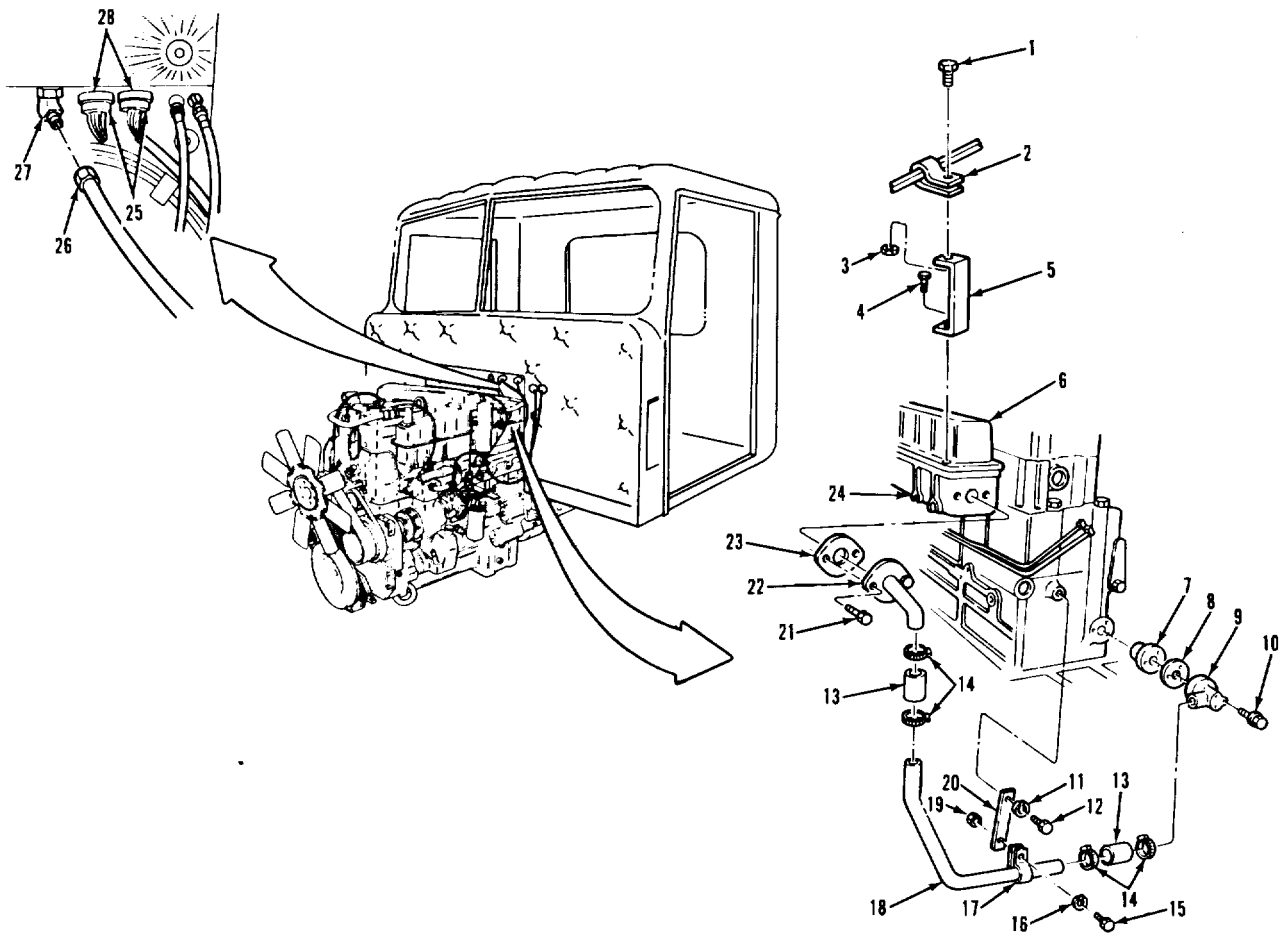

LEGEND:

- | | | |
|-----------------------------------|-----------------------------------|-----------------------------------|
| 1. SCREW | 11. LOCKWASHER | 22. WATER INLET CONNECTION |
| 2. LOOP CLAMP | 12. SCREW | 23. WATER INLET CONNECTION GASKET |
| 3. NUT | 13. CONNECTION HOSE (2) | 24. INTAKE MANIFOLD |
| 4. SCREW WITH CAPTIVE WASHER | 14. HOSE CLAMP (4) | 25. ELECTRICAL CONNECTOR (2) |
| 5. BRACKET | 15. SCREW | 26. AIR TUBE |
| 6. AFTERCOOLER COVER | 16. LOCKWASHER | 27. ELBOW |
| 7. WATER OUTLET ADAPTER | 17. HOSE CLAMP | 28. ELECTRICAL RECEPTACLE (2) |
| 8. WATER OUTLET GASKET | 18. WATER CROSSOVER TUBE | |
| 9. WATER OUTLET CONNECTION | 19. NUT | |
| 10. SCREW WITH CAPTIVE WASHER (3) | 20. CROSSOVER BRACE | |
| | 21. SCREW WITH CAPTIVE WASHER (2) | |

TA 237020

ENGINE.

3-20. WATER CROSSOVER TUBE AND CONNECTIONS REPLACEMENT (Continued).

LOCATION/ITEM	ACTION	REMARKS
C. INSTALLATION (Continued).		
31. Tube (26).	Connect to item (27).	
32. Two connectors (25).	Connect to two items (28).	
NOTE		
		Follow-on maintenance action required:
		Install air cleaner assembly (para 3-39).
		Fill cooling system (TM 9-2320-283-10).

ENGINE.

3-20. WATER CROSSOVER TUBE AND CONNECTIONS REPLACEMENT (Continued).

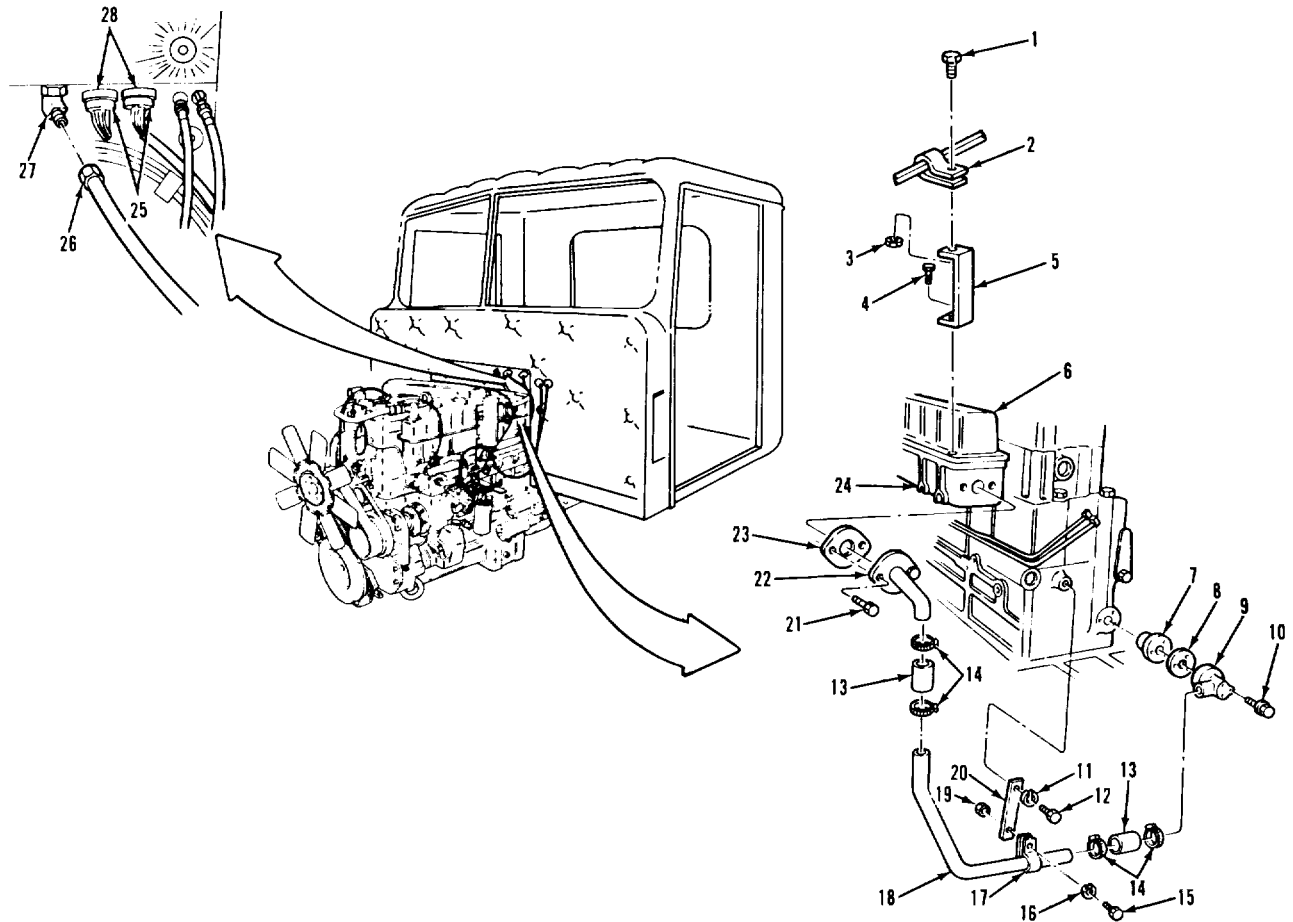

LEGEND:

- | | | |
|-----------------------------------|-----------------------------------|-----------------------------------|
| 1. SCREW | 11. LOCKWASHER | 22. WATER INLET CONNECTION |
| 2. LOOP CLAMP | 12. SCREW | 23. WATER INLET CONNECTION GASKET |
| 3. NUT | 13. CONNECTION HOSE (2) | 24. INTAKE MANIFOLD |
| 4. SCREW WITH CAPTIVE WASHER | 14. HOSE CLAMP (4) | 25. ELECTRICAL CONNECTOR (2) |
| 5. BRACKET | 15. SCREW | 26. AIR TUBE |
| 6. AFTERCOOLER COVER | 16. LOCKWASHER | 27. ELBOW |
| 7. WATER OUTLET ADAPTER | 17. HOSE CLAMP | 28. ELECTRICAL RECEPTACLE (2) |
| 8. WATER OUTLET GASKET | 18. WATER CROSSOVER TUBE | |
| 9. WATER OUTLET CONNECTION | 19. NUT | |
| 10. SCREW WITH CAPTIVE WASHER (3) | 20. CROSSOVER BRACE | |
| | 21. SCREW WITH CAPTIVE WASHER (2) | |

TA 237021

ENGINE.

3-21. WATER TRANSFER TUBE AND BRACKET REPLACEMENT.

THIS TASK COVERS

- a. Removal.
- b. Cleaning and Inspection.
- c. Installation.

INITIAL SETUP

<p><u>APPLICABLE CONFIGURATIONS</u> All.</p>	<p><u>EQUIPMENT CONDITION PARAGRAPH</u> 3-52.</p>	<p><u>CONDITION DESCRIPTION</u> Cooling system drained.</p>
<p><u>TEST EQUIPMENT</u> None.</p>		
<p><u>SPECIAL TOOLS</u> None.</p>		
<p><u>MATERIALS/PARTS (P/N)</u> None.</p>		
<p><u>PERSONNEL REQUIRED</u> One (MOS-63S).</p>	<p><u>SPECIAL ENVIRONMENTAL CONDITIONS</u> None.</p>	
<p><u>REFERENCES (TM)</u> TM 9-2320-283-10.</p>	<p><u>GENERAL SAFETY INSTRUCTIONS</u> Engine off. Transmission in neutral. Park brake set.</p>	
<p><u>TROUBLESHOOTING REFERENCES</u> Paragraph 2-11.</p>		

ENGINE.

3-21. WATER TRANSFER TUBE AND BRACKET REPLACEMENT (Continued).

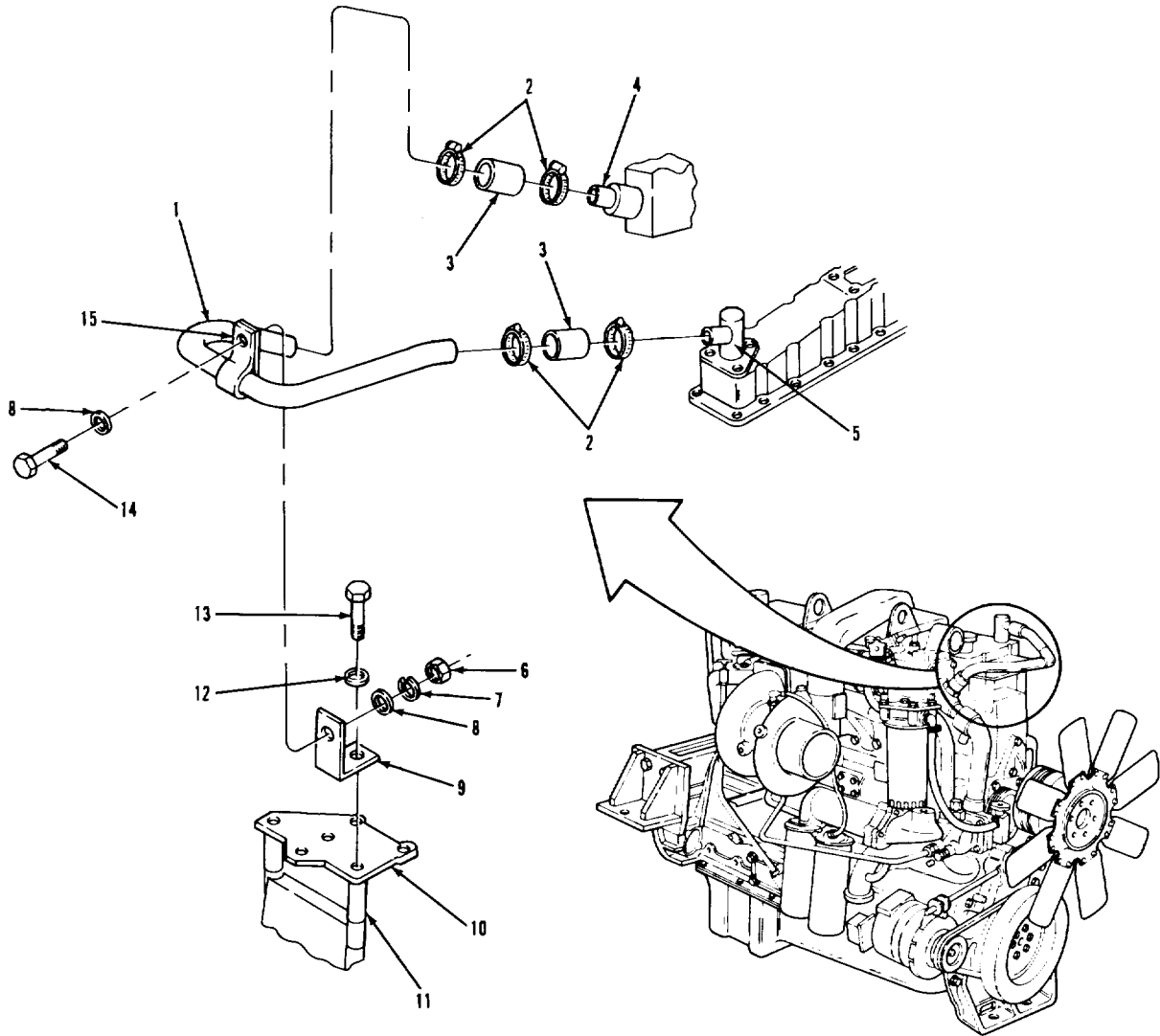

- 1. WATER TRANSFER TUBE
- 2. HOSE CLAMPS (4)
- 3. CONNECTION HOSE (2)
- 4. THERMOSTAT HOUSING HOSE NIPPLE
- 5. CONNECTION WATER OUTLET
- 6. HEXAGON NUT
- 7. LOCKWASHER
- 8. PLAIN WASHER (2)

- 9. TUBE SUPPORT BRACKET
- 10. FAN BRACE
- 11. LONG SPACER
- 12. PLAIN WASHER
- 13. SCREW
- 14. HEXAGON CAPSCREW
- 15. HOSE CLAMP

TA 237022

ENGINE.

3-21. WATER TRANSFER TUBE AND BRACKET REPLACEMENT (Continued).

LOCATION/ITEM	ACTION	REMARKS
A. REMOVAL.		
1. Screw (14), two washers (8), lock-washer (7), and nut (6).	Remove from item (15) and item (9).	
2. Clamp (15).	Remove from item (1).	
3. Four clamps (2).	Loosen.	
4. Tube (1), two hoses (3), and four clamps (2).	Remove from item (4) and item (5).	Cut off and discard any cable tie straps from item (1).
5. Screw (13) and washer (12).	Remove from item (9).	Item (11) may fall out.
B. CLEANING AND INSPECTION		
6. All parts.	Clean and inspect.	Refer to paragraphs 3-4 and 3-5.
C. INSTALLATION.		
7. Bracket (9).	Place in position on item (10).	

ENGINE.

3-21. WATER TRANSFER TUBE AND BRACKET REPLACEMENT (Continued).

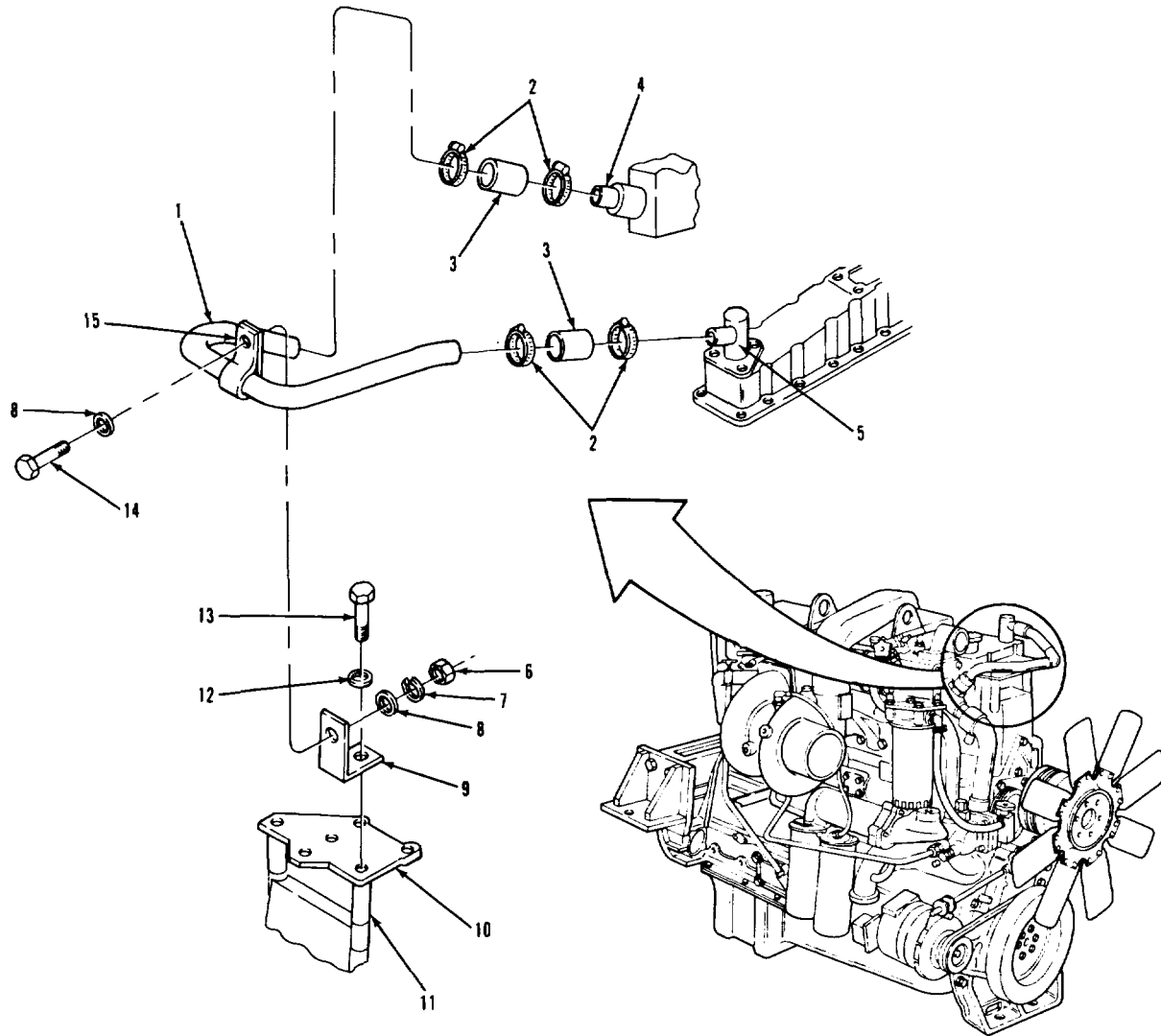

- | | |
|-----------------------------------|-------------------------|
| 1. WATER TRANSFER TUBE | 9. TUBE SUPPORT BRACKET |
| 2. HOSE CLAMPS (4) | 10. FAN BRACE |
| 3. CONNECTION HOSE (2) | 11. LONG SPACER |
| 4. THERMOSTAT HOUSING HOSE NIPPLE | 12. PLAIN WASHER |
| 5. CONNECTION WATER OUTLET | 13. SCREW |
| 6. HEXAGON NUT | 14. HEXAGON CAPSCREW |
| 7. LOCKWASHER | 15. HOSE CLAMP |
| 8. PLAIN WASHER (2) | |

TA 237023

ENGINE.

3-21. WATER TRANSFER TUBE AND BRACKET REPLACEMENT (Continued).

LOCATION/ITEM	ACTION	REMARKS
C. INSTALLATION (Continued).		
8. Screw (13) and washer (12).	Secure item (9), item (10), and item (11).	Torque to 44-49 lb-ft.
9. Tube (1), two hoses (3), and four clamps (2).	Install on item (4) and item (5).	a. Do not tighten clamps (2). b. Install new cable tie straps to replace any that were removed in step 4.
10. Clamp (15).	Install on item (1).	
11. Screw (14), two washers (8), lockwasher (7), and nut (6).	Secure item (15) to item (9).	
12. Four clamps (2).	Tighten.	
NOTE		
Follow-on maintenance action required: Add coolant, and check for leaks and proper operation (TM 9-2320-283-10).		

ENGINE.

3-21. WATER TRANSFER TUBE AND BRACKET REPLACEMENT (Continued).

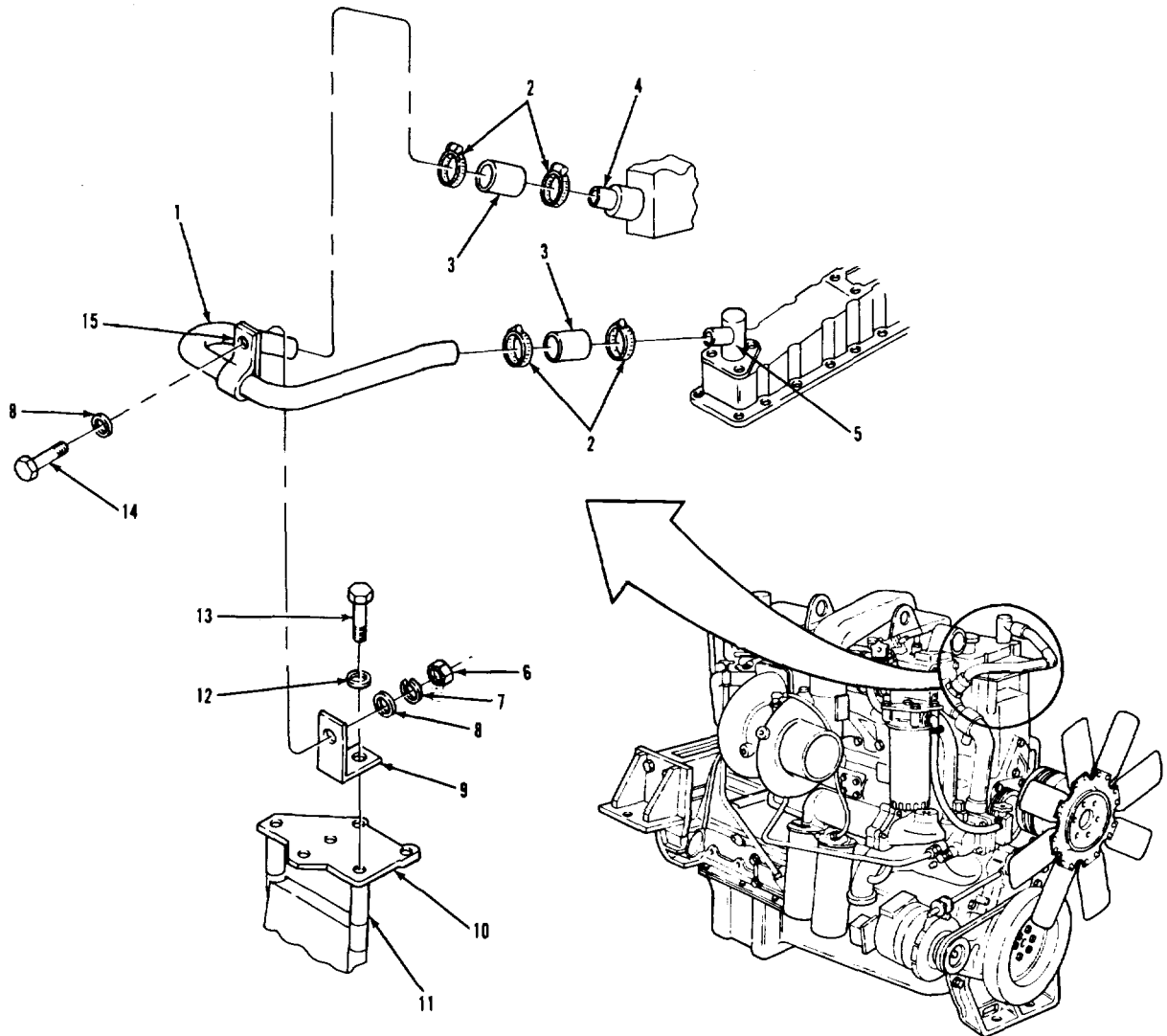

- | | |
|-----------------------------------|-------------------------|
| 1. WATER TRANSFER TUBE | 9. TUBE SUPPORT BRACKET |
| 2. HOSE CLAMPS (4) | 10. FAN BRACE |
| 3. CONNECTION HOSE (2) | 11. LONG SPACER |
| 4. THERMOSTAT HOUSING HOSE NIPPLE | 12. PLAIN WASHER |
| 5. CONNECTION WATER OUTLET | 13. SCREW |
| 6. HEXAGON NUT | 14. HEXAGON CAPSCREW |
| 7. LOCKWASHER | 15. HOSE CLAMP |
| 8. PLAIN WASHER (2) | |

TA 237024

ENGINE.

3-22. ENGINE LIFTING BRACKET REPLACEMENT.

THIS TASK COVERS

- a. Removal.
- b. Cleaning and Inspection.
- c. Installation.

INITIAL SETUP

<p><u>APPLICABLE CONFIGURATIONS</u> All.</p>	<p><u>EQUIPMENT CONDITION PARAGRAPH</u> None.</p>	<p><u>CONDITION DESCRIPTION</u> None.</p>
<p><u>TEST EQUIPMENT</u> None.</p>		
<p><u>SPECIAL TOOLS</u> None.</p>		
<p><u>MATERIALS/PARTS (P/N)</u> None.</p>		
<p><u>PERSONNEL REQUIRED</u> One (MOS-63S).</p>	<p><u>SPECIAL ENVIRONMENTAL CONDITIONS</u> None.</p>	
<p><u>REFERENCES (TM)</u> None.</p>	<p><u>GENERAL SAFETY INSTRUCTIONS</u> Engine off. Transmission in neutral. Park brake set.</p>	
<p><u>TROUBLESHOOTING REFERENCES</u> None.</p>		

ENGINE.

3-22. ENGINE LIFTING BRACKET REPLACEMENT (Continued).

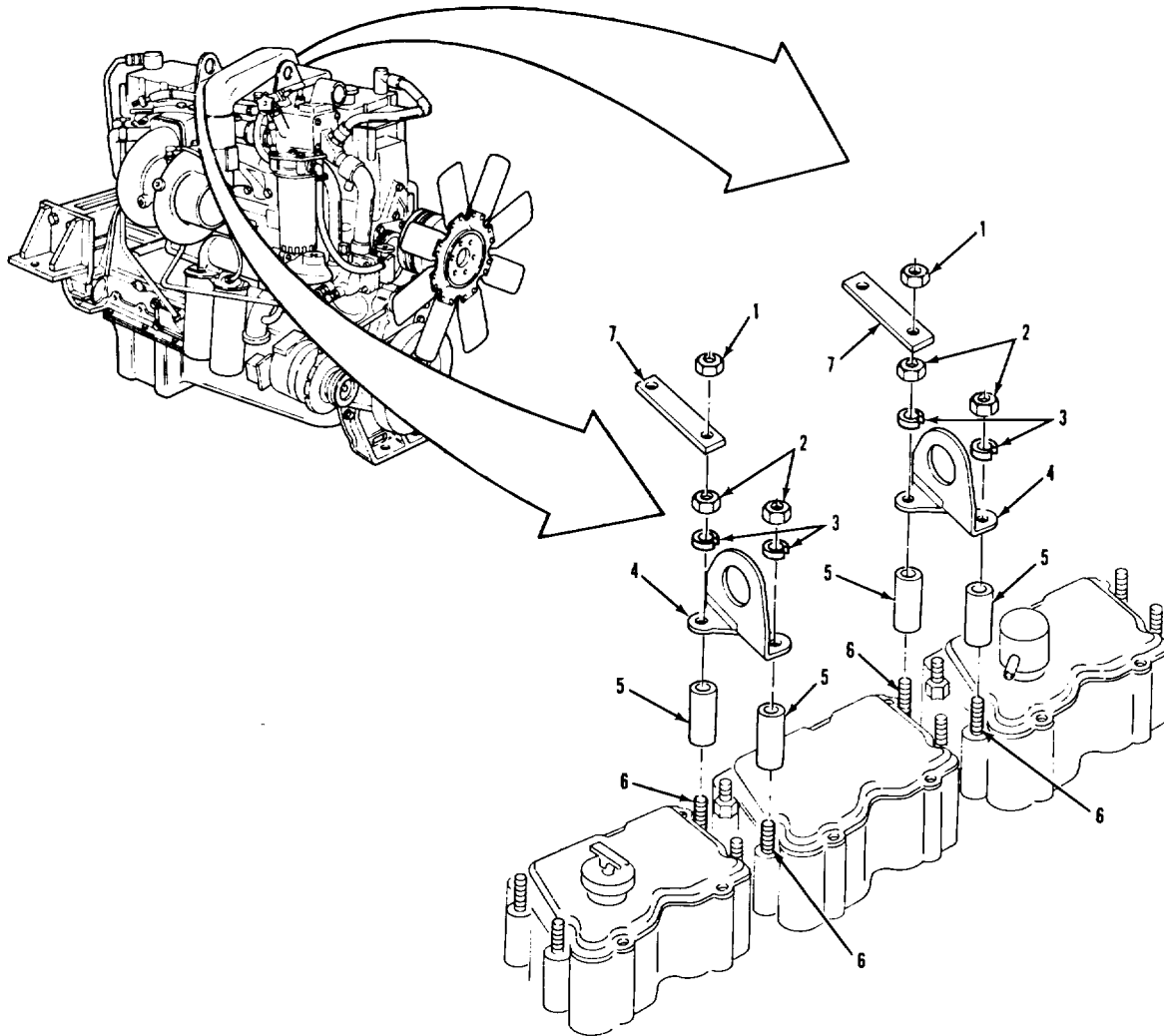

LEGEND:

- | | |
|-------------------------------|------------------------------------|
| 1. HEX NUT (2) | 5. SHORT SPACER (4) |
| 2. HEXAGON FLANGE NUT (4) | 6. STUD (4) |
| 3. LOCKWASHER (4) | 7. HEATER TUBE SUPPORT BRACKET (2) |
| 4. ENGINE LIFTING BRACKET (2) | |

TA237025

ENGINE.

3-22. ENGINE LIFTING BRACKET REPLACEMENT (Continued).

LOCATION/ITEM	ACTION	REMARKS
A. REMOVAL.		
1. Two nuts (1).	Remove from two items (6) and two items (7).	
2. Two brackets (7).	Remove from two items (6).	
3. Four nuts (2), lockwashers (3), two brackets (4), and spacers (5).	Remove from four items (6).	
B. CLEANING AND INSPECTION		
4. All parts.	a. Clean.	Refer to paragraph 3-4.
NOTE		
		If studs (6) are found to be defective, refer to DS/GS maintenance.
	b. Inspect.	Refer to paragraph 3-5.
D. INSTALLATION.		
5. Four spacers (5) and two brackets (4).	Install on four items (6).	
6. Four nuts (2) and lockwashers (3).	Secure two items (4).	Torque to 60 lb-ft.

ENGINE.

3-22. ENGINE LIFTING BRACKET REPLACEMENT (Continued).

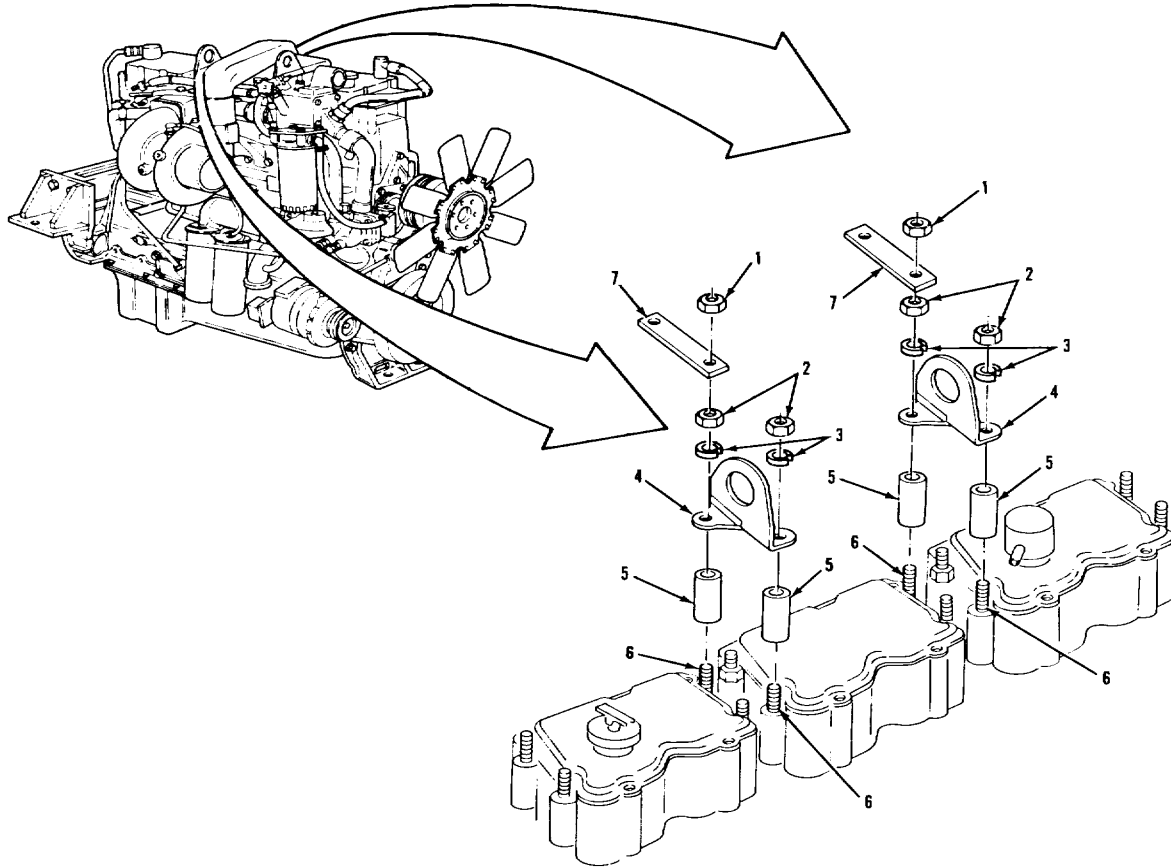

LEGEND

- | | |
|---------------------------|------------------------------------|
| 1. HEX NUT (2) | 5. SHORT SPACER (4) |
| 2. HEXAGON FLANGE NUT (4) | 6. STUD (4) |
| 3. LOCKWASHER (4) | 7. HEATER TUBE SUPPORT BRACKET (2) |
| 4. ENGINE LIFTING BRACKET | |

TA237026

ENGINE.

3-22. ENGINE LIFTING BRACKET REPLACEMENT (Continued).

LOCATION/ITEM	ACTION	REMARKS
C. INSTALLATION (Continued).		
7. Two brackets (7).	Position on two items (6).	
8. Two nuts (1).	Secure two items (7).	
<p>NOTE Follow-on maintenance action required: None.</p>		
<p>3-82</p>		

ENGINE.

3-22. ENGINE LIFTING BRACKET REPLACEMENT (Continued).

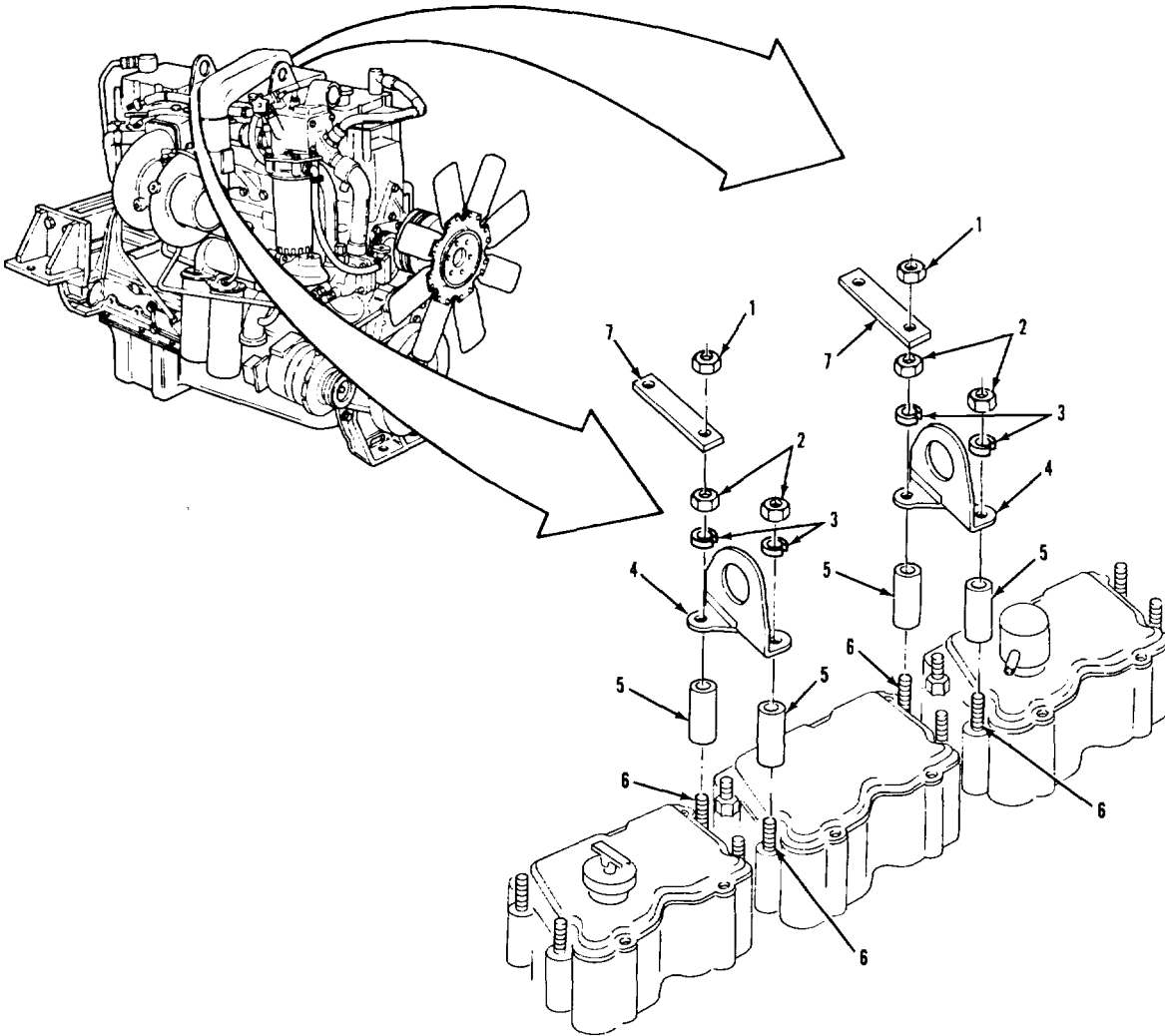

LEGEND:

- | | | | |
|----|----------------------------|----|---------------------------------|
| 1. | HEX NUT (2) | 5. | SHORT SPACER (4) |
| 2. | HEXAGON FLANGE NUT (4) | 6. | STUD (4) |
| 3. | LOCKWASHER (4) | 7. | HEATER TUBE SUPPORT BRACKET (2) |
| 4. | ENGINE LIFTING BRACKET (2) | | |

TA237027

ENGINE.

3-23. ENGINE DATAPLATE REPLACEMENT.

THIS TASK COVERS

- a. Removal.
- b. Installation.

INITIAL SETUP

APPLICABLE CONFIGURATIONS

All.

EQUIPMENT CONDITION
PARAGRAPH

None.

CONDITION DESCRIPTION

None.

TEST EQUIPMENT

None.

SPECIAL TOOLS

None.

MATERIALS/PARTS (P/N)

Screw, nameplate (5)
(15434) S-2286.

PERSONNEL REQUIRED

One (MOS-63S .

SPECIAL ENVIRONMENTAL CONDITIONS

None.

REFERENCES (TM)

TM 9-2320-283-20P.

GENERAL SAFETY INSTRUCTIONS

Engine off.
Transmission in neutral.
Park brake set.

TROUBLESHOOTING REFERENCES

Paragraph 2-11.

ENGINE.

3-23. ENGINE DATAPLATE REPLACEMENT (Continued).

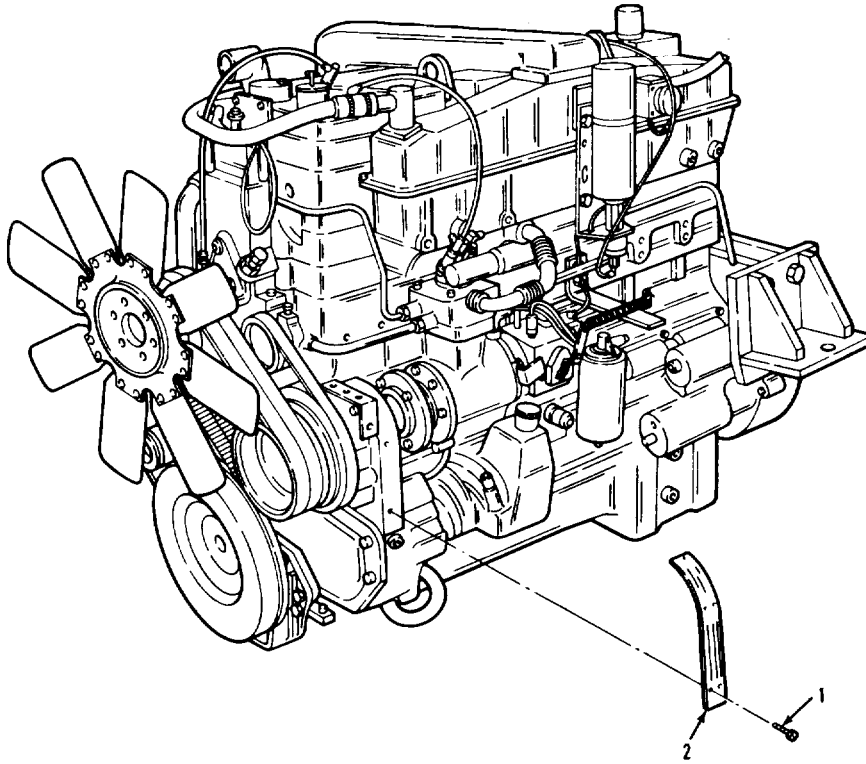

LEGEND:

- 1. NAMEPLATE SCREW (5)
- 2. DATAPLATE

TA 237028

ENGINE.

3-23. ENGINE DATAPLATE REPLACEMENT (Continued).

LOCATION/ITEM	ACTION	REMARKS
A. REMOVAL		
1. Five screws (1).	Pry from item (2).	Discard five items (1).
2. Dataplate (2).	Remove from engine.	
B. INSTALLATION		
3. Dataplate (2).	Put in place on engine.	
4 screws (1).	Secure item (2) in engine	Use a hammer.

NOTE

Follow-on maintenance action required: None.

ENGINE.

3-23. ENGINE DATAPLATE REPLACEMENT (Continued).

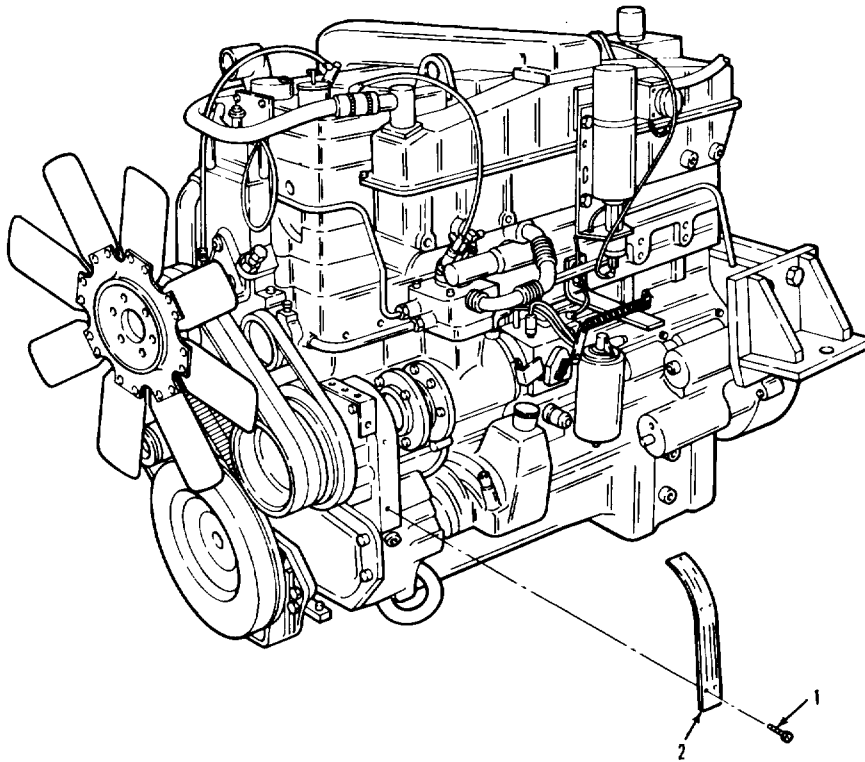

LEGEND:

- 1. NAMEPLATE SCREW (5)
- 2. DATAPLATE

TA 237029

ENGINE.

3-24. FAN BRACE, BRACKET, AND SPACERS REPLACEMENT.

THIS TASK COVERS

- | | |
|-------------------------------|------------------------------------|
| a. Brace and Spacers Removal. | d. Bracket Installation. |
| b. Bracket Removal. | e. Brace and Spacers Installation. |
| c. Cleaning and Inspection. | |

INITIAL SETUP

<u>APPLICABLE CONFIGURATIONS</u>	<u>EQUIPMENT CONDITION PARAGRAPH</u>	<u>CONDITION DESCRIPTION</u>
All.	None.	None.
<u>TEST EQUIPMENT</u>		
None.		
<u>SPECIAL TOOLS</u>		
None.		
<u>MATERIALS/PARTS (P/N)</u>		
None.		
<u>PERSONNEL REQUIRED</u>	<u>SPECIAL ENVIRONMENTAL CONDITIONS</u>	
One (MOS-63S).	None.	
<u>REFERENCES (TM)</u>	<u>GENERAL SAFETY INSTRUCTIONS</u>	
None.	Engine off. Transmission in neutral. Park brake set.	
<u>TROUBLESHOOTING REFERENCES</u>		
None.		

ENGINE.

3-24. FAN BRACE, BRACKET, AND SPACERS REPLACEMENT (Continued).

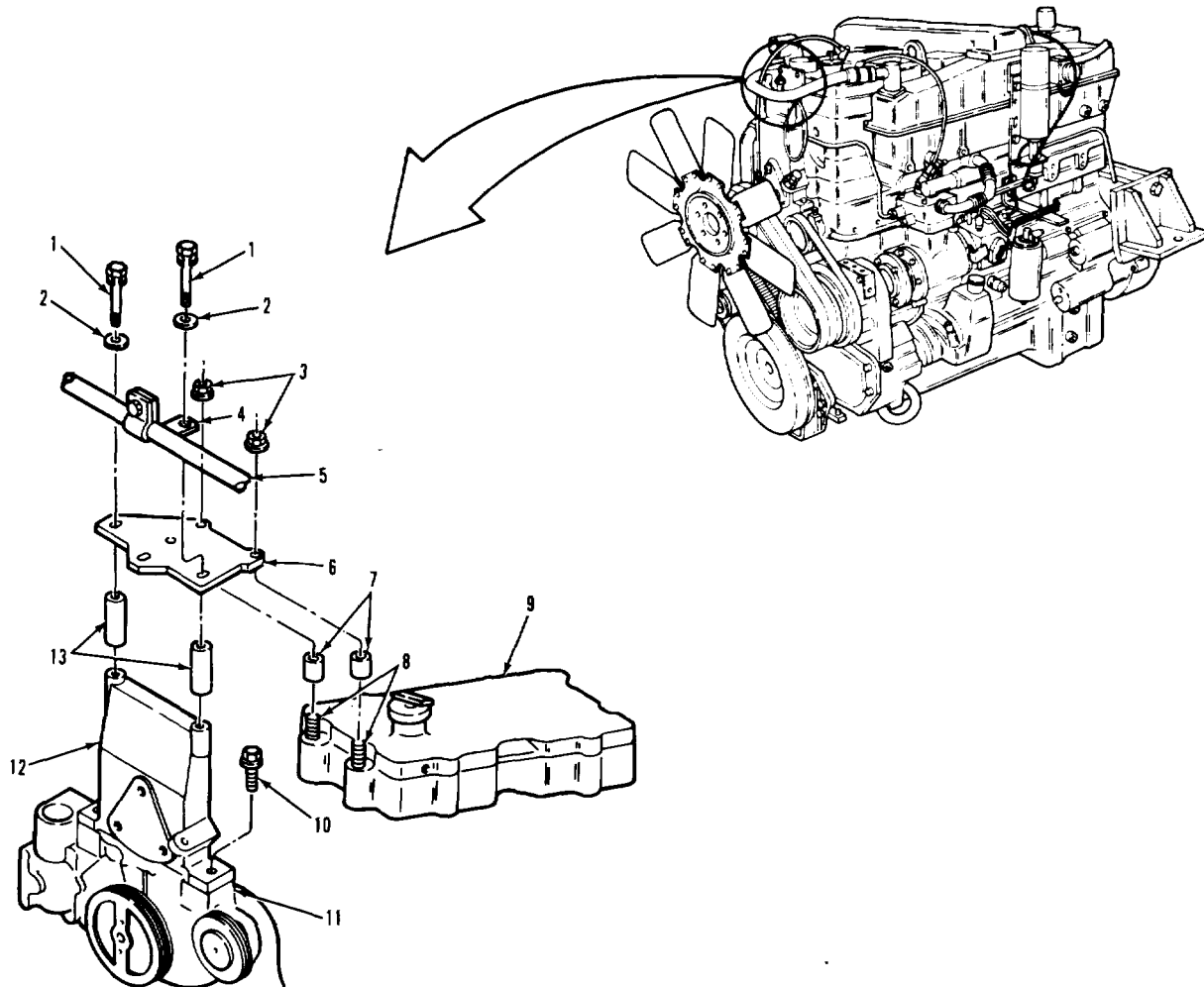

- | | |
|---------------------------|-----------------------------------|
| 1. SCREW (2) | 8. STUD (2) |
| 2. PLAIN WASHER (2) | 9. FRONT ROCKER COVER |
| 3. HEXAGON FLANGE NUT (2) | 10. SCREW WITH CAPTIVE WASHER (2) |
| 4. TUBE SUPPORT BRACKET | 11. WATER PUMP |
| 5. WATER TRANSFER TUBE | 12. FAN BRACKET |
| 6. FAN BRACE | 13. LONG SPACER (2) |
| 7. SHORT SPACER (2) | |

TA 2370

ENGINE.

3-24. FAN BRACE, BRACKET, AND SPACERS REPLACEMENT (Continued).

LOCATION/ITEM	ACTION	REMARKS
A. BRACE AND SPACERS REMOVAL		
<p>NOTE It may be necessary to loosen rocker cover for clearance. (Refer to para 3-24).</p>		
1. Two screws (1), washers (2), and spacers (13).	Remove from item (4), item (6), and item (12).	Remove left side first so that item (5) can be moved out of the way.
2. Two nuts (3), brace (6), and two spacers (7).	Remove from two items (8).	
B. BRACKET REMOVAL.		
3. Fan and fan clutch.	Remove.	Refer to paragraph 3-65.
4. Two screws (10).	Remove from item (12).	
5. Bracket (12).	Remove from item (11).	
C. CLEANING AND INSPECTION.		
6. All parts and 3-5.	Clean and inspect.	Refer to paragraphs 3-4
D. BRACKET INSTALLATION. I		
7. Bracket (12).	Put in place on item (11).	

ENGINE.

3-24. FAN BRACE, BRACKET, AND SPACERS REPLACEMENT (Continued).

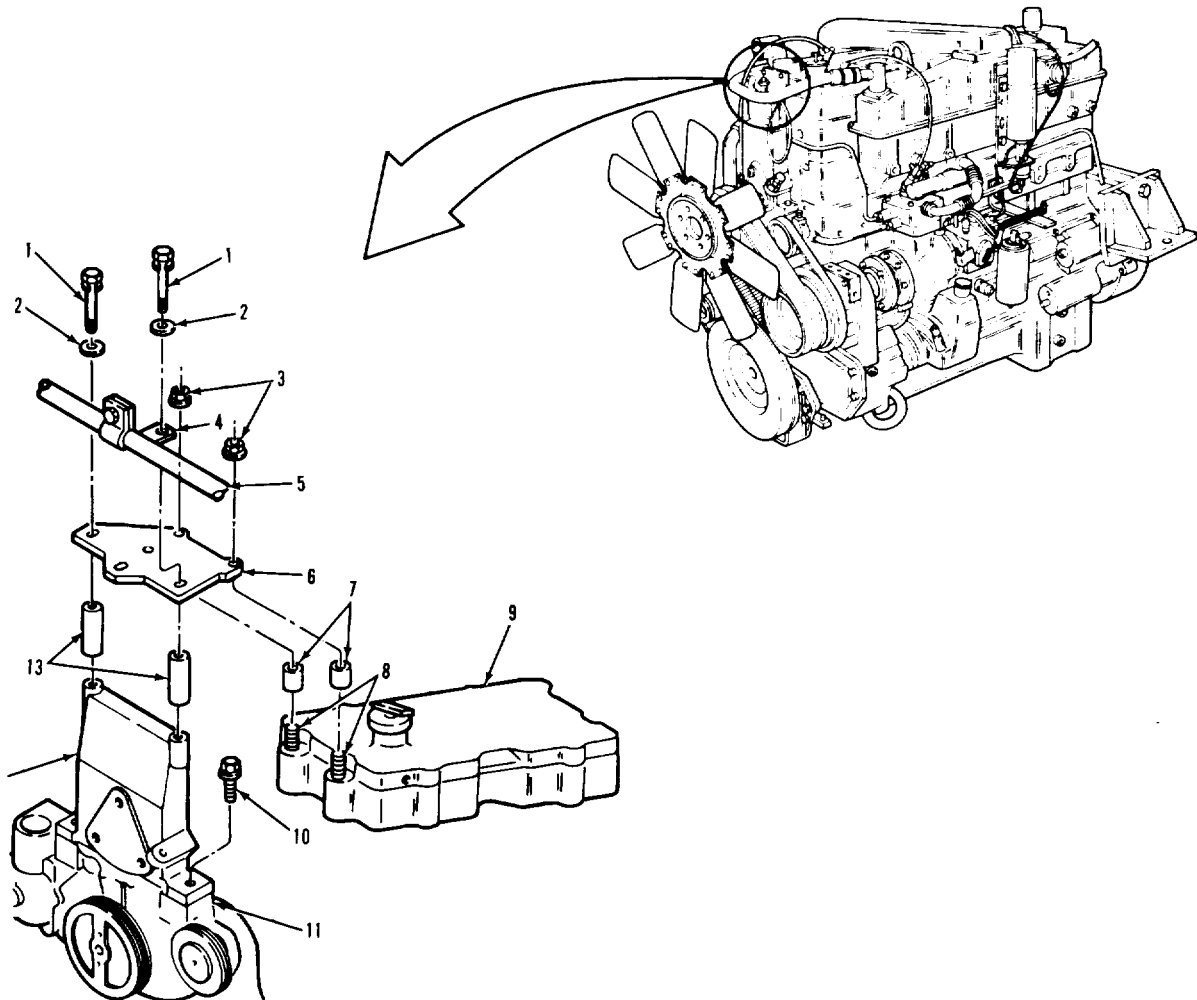

- | | |
|---------------------------|-----------------------------------|
| 1. SCREW (2) | 8. STUD (2) |
| 2. PLAIN WASHER (2) | 9. FRONT ROCKER COVER |
| 3. HEXAGON FLANGE NUT (2) | 10. SCREW WITH CAPTIVE WASHER (2) |
| 4. TUBE SUPPORT BRACKET | 11. WATER PUMP |
| 5. WATER TRANSFER TUBE | 12. FAN BRACKET |
| 6. FAN BRACE | 13. LONG SPACER (2) |
| 7. SHORT SPACER (2) | |

TA237031

ENGINE.

3-24. FAN BRACE, BRACKET, AND SPACERS REPLACEMENT (Continued).

LOCATION/ITEM	ACTION	REMARKS
D. BRACKET INSTALLATION (Continued)		
8. Two screws (10).	Secure item (12) to item (11).	
9. Fan and fan clutch.	Install	Refer to paragraph 3-65.
E. BRACE AND SPACERS INSTALLATION		
10. Two spacers (7) And brace (6).	Place on two items (8).	
11. Two screws (1), washers (2), and spacers (13).	Secure item (6) and item (4) to item (12).	Torque to 49 lb-ft.
12. Two nuts (3).	Secure item (6) and two items (7) to item (9).	Torque to 60 lb-ft.

NOTE

Follow-on maintenance action required: None.

ENGINE.

3-24. FAN BRACE, BRACKET, AND SPACERS REPLACEMENT (Continued).

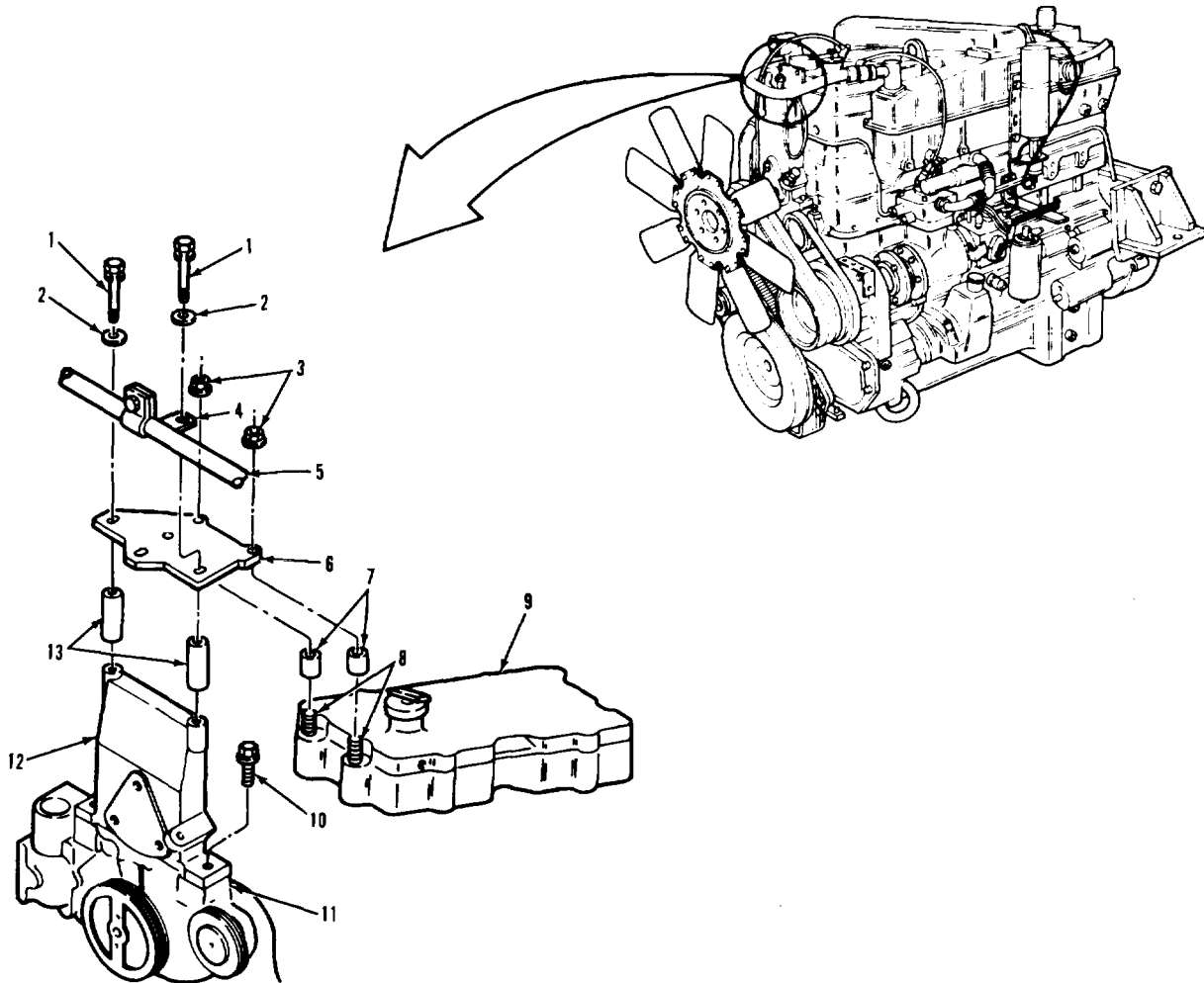

LEGEND:

- | | |
|---------------------------|-----------------------------------|
| 1. SCREW (2) | 8. STUD (2) |
| 2. PLAIN WASHER (2) | 9. FRONT ROCKER COVER |
| 3. HEXAGON FLANGE NUT (2) | 10. SCREW WITH CAPTIVE WASHER (2) |
| 4. TUBE SUPPORT BRACKET | 11. WATER PUMP |
| 5. WATER TRANSFER TUBE | 12. FAN BRACKET |
| 6. FAN BRACE | 13. LONG SPACER (2) |
| 7. SHORT SPACER (2) | |

TA237032

SECTION III. FUEL SYSTEM

3-25. GENERAL

This section provides procedures authorized at the organizational maintenance level to replace fuel system components. To find a specific procedure contained in this section, see the task summary below.

3-26. TASK SUMMARY.

INITIAL SETUP

<u>APPLICABLE CONFIGURATIONS</u>	<u>EQUIPMENT CONDITION PARAGRAPH</u>	<u>CONDITION DESCRIPTION</u>
All.	(Refer to specific paragraph for this information).	
<u>TEST EQUIPMENT</u>		
None.		
<u>SPECIAL TOOLS</u>		
None.		
<u>MATERIALS/PARTS (P/N)</u>		
Solvent, drycleaning, SD-2 Item 29, Appendix C.		Ring, cap seal (15434) 154088.
Tape, thread sealing Item 32, Appendix C.		Gasket, crossover mounting (15434) 216487.
Rags, wiping Item 22, Appendix C.		Seal, rectangular ring (15434) 154087.
Solution, soap Item 28, Appendix C.		Seal, rectangular ring (15434) 129888.
Adhesive, liquid, rubber, Type II Item 1, Appendix C.		Filter, fuel, water separator (33457) FS1212.
Containers for draining fuel (AR).		Seal, ring (15434) 255622.
Oil, fuel: diesel (match oil in vehicle) Item 12, 13, or 14, Appendix C.		Gasket, cylinder (06991) 111025.
Grease, automotive and artillery Item 7, Appendix C.		Pin, cotter (2) (24617) 103362.
<u>PERSONNEL REQUIRED</u>	<u>SPECIAL ENVIRONMENTAL CONDITIONS</u>	
Three (MOS-63S).	Darkened area for element inspection.	
	Work area clean and away from blowing dirt and dust.	

FUEL SYSTEM.

3-26. TASK SUMMARY (Continued).

INITIAL SETUP (Continued)

REFERENCES (TM)

TM 9-2320-283-10.
TM 9-2320-283-20P.

GENERAL SAFETY INSTRUCTIONS

Engine off.
Transmission in neutral.
Park brake set.
Guard against flame or sparks in work area.

TROUBLESHOOTING REFERENCES

Paragraph 2-11.

LIST OF TASKS

TASK NO.	TASK	TASK REF	TROUBLESHOOTING REF NO. (PARA)
1	Fuel Filter Screen Replacement	3-27	2-11
	a. Removal.	3-27a	
	b. Cleaning and Inspection.	3-27b	
	c. Installation.	3-27c	
2	Engine Fuel Lines and Fittings Replacement	3-28	2-11
	a. Actuating Line Removal.	3-28a	
	b. Air Actuating Line Installation	3-28b	
	c. Fuel Pump Return Line Removal.	3-28c	
	d. Fuel Pump Return Line Installation.	3-28d	
	e. Manifold Fuel Return Line Removal.	3-28e	
	f. Manifold Fuel Return Line Installation.	3-28f	
	g. Fuel Delivery Line Removal.	3-28g	
	h. Fuel Delivery Line Installation.	3-28h	
3	Air Cleaner Assembly Replacement	3-29	2-11
	a. Removal.	3-29a	
	b. Cleaning and Inspection.	3-29b	
	c. Installation.	3-29c	

FUEL SYSTEM.

3-26. TASK SUMMARY (Continued).

LIST OF TASKS

TASK NO.	TASK	TASK REF	TROUBLESHOOTING REF NO. (PARA)
4	Air Cleaner Filter Element Replacement	3-30	2-11
	a. Removal.	3-30a	
	b. Cleaning.	3-30b	
	c. Inspection.	3-30c	
	d. Installation.	3-30d	
5	Turbocharger Air Crossover Connection Replacement	3-31	2-11
	a. Removal.	3-31a	
	b. Cleaning and Inspection.	3-31b	
	c. Installation.	3-31c	
6	Air Cleaner Tube Replacement	3-32	2-11
	a. Removal.	3-32a	
	b. Cleaning and Inspection.	3-32b	
	c. Installation.	3-32c	
7	Solenoid Valve Replacement	3-33	2-11
	a. Removal.	3-33a	
	b. Disassembly.	3-33b	
	c. Cleaning and Inspection.	3-33c	
	d. Assembly.	3-33d	
	e. Installation.	3-33e	
	f. Operational Check.	3-33f	
8	Fuel Tank Replacement	3-34	2-11
	a. Removal.	3-34a	
	b. Cleaning and Inspection.	3-34b	
	c. Installation.	3-34c	
9	Fuel Heater Replacement	3-35	2-11
	a. Removal.	3-35a	
	b. Cleaning and Inspection.	3-35b	
	c. Installation.	3-35c	

FUEL SYSTEM.

3-26. TASK SUMMARY (Continued).			
LIST OF TASKS			
TASK NO.	TASK	TASK REF	TROUBLESHOOTING REF NO. (PARA)
10	Fuel Hoses and Fittings Replacement	3-36	2-11
	a. Fuel Supply Hose Removal.	3-36a	
	b. Fuel Supply Hose Installation.	3-36b	
	c. Fuel Supply to Engine Hose Removal.	3-36c	
	d. Fuel Supply to Engine Hose Installation.	3-36d	
	e. Fuel Return Hose Removal.	3-36e	
	f. Fuel Return Hose Installation.	3-36f	
11	Water Separator Fuel Filter Replacement	3-37	2-11
	a. Removal.	3-37a	
	b. Installation.	3-37b	
12	Ether Cylinder Replacement	3-38	2-11
	a. Removal.	3-38a	
	b. Installation.	3-38b	
13	Ether Quick Start Thermostat Replacement	3-39	2-11
	a. Removal.	3-39a	
	b. Cleaning and Inspection.	3-39b	
	c. Installation.	3-39c	
14	Ether Quick Start Kit Replacement	3-40	2-11
	a. Removal.	3-40a	
	b. Cleaning and Inspection.	3-40b	
	c. Installation.	3-40c	
15	Accelerator Pedal and Linkage Replacement	3-41	2-11
	a. Removal.	3-41a	
	b. Cleaning and Inspection.	3-41b	
	c. Installation.	3-41c	
16	Fuel Control Lever Replacement	3-42	2-11
	a. Removal.	3-42a	
	b. Cleaning and Inspection.	3-42b	
	c. Installation.	3-42c	

FUEL SYSTEM.

3-27. FUEL FILTER SCREEN REPLACEMENT.

THIS TASK COVERS

- a. Removal.
- b. Cleaning and Inspection.
- c. Installation.

INITIAL SETUP

<p><u>APPLICABLE CONFIGURATIONS</u> All.</p>	<p><u>EQUIPMENT CONDITION PARAGRAPH</u> 3-314.</p>	<p><u>CONDITION DESCRIPTION</u> Pressure transducer</p>
<p><u>TEST EQUIPMENT</u> None.</p>		
<p><u>SPECIAL TOOLS</u> None.</p>		
<p><u>MATERIALS/PARTS (P/N)</u> Solvent, drycleaning, SD-2 Item 29, Appendix C. Ring, cap seal (15434) 154088.</p>		
<p><u>PERSONNEL REQUIRED</u> One (MOS-63S).</p>	<p><u>SPECIAL ENVIRONMENTAL CONDITIONS</u> None.</p>	
<p><u>REFERENCES (TM)</u> TM 9-2320-283-20P.</p>	<p><u>GENERAL SAFETY INSTRUCTIONS</u> Engine off. Transmission in neutral. Park brake set.</p>	
<p><u>TROUBLESHOOTING REFERENCES</u> Paragraph 2-11.</p>		

FUEL SYSTEM.

3-27. FUEL FILTER SCREEN REPLACEMENT (Continued).

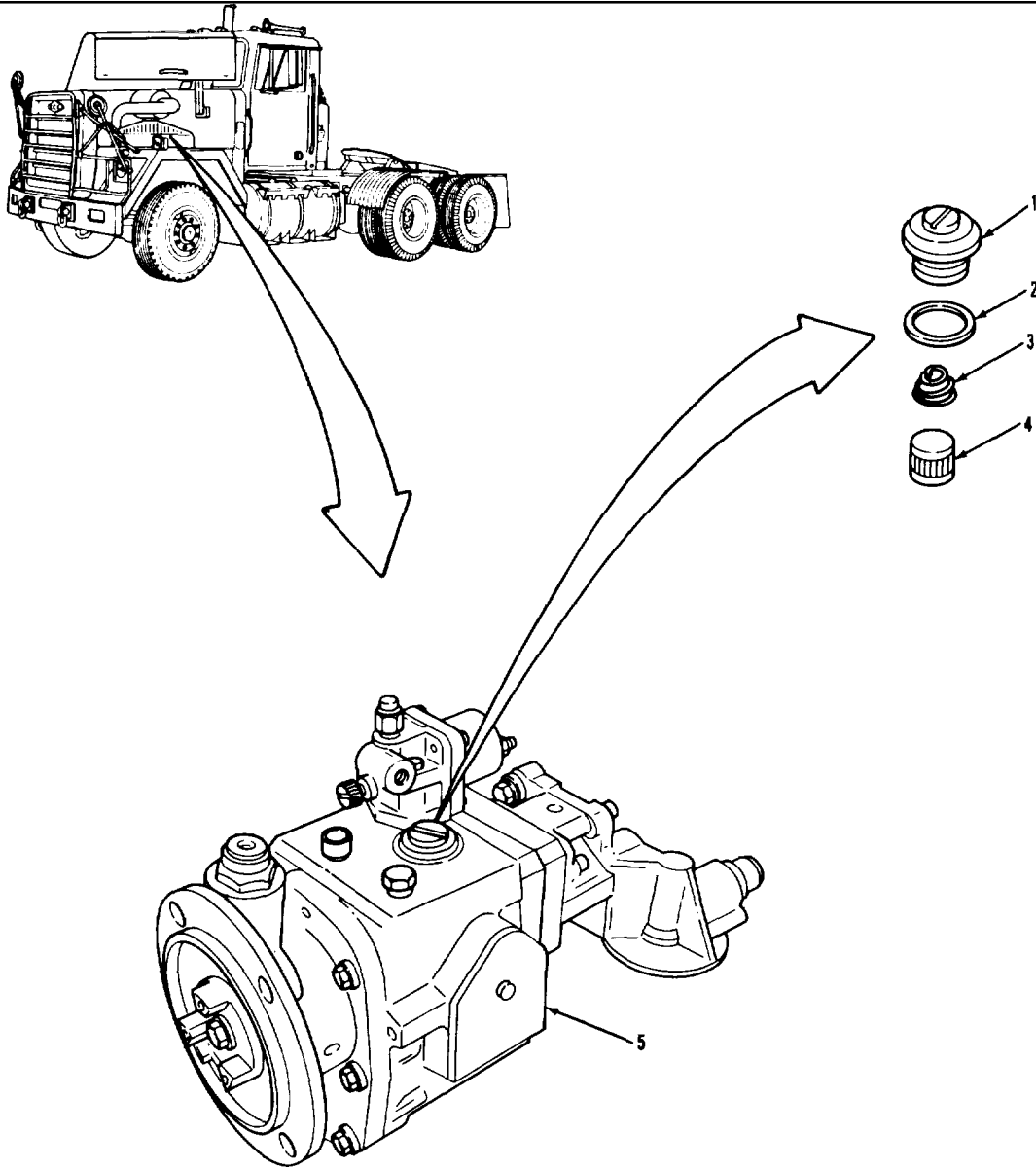

- 1. FILTER SCREEN CAP
- 2. SEAL CAP RING
- 3. FILTER SPRING

- 4. FUEL FILTER SCREEN
- 5. FUEL PUMP HOUSING

FUEL SYSTEM.

3-27. FUEL FILTER SCREEN REPLACEMENT (Continued).

LOCATION/ITEM	ACTION	REMARKS
A. REMOVAL.		
1. Cap (1).	Unscrew from item (5).	
2. Ring (2).	a. Remove from item (1).	
	b. Discard item (2).	
3. Spring (3) and screen (4).	Remove from item (5).	
B. LEANING AND INSPECTION		
4. All parts.	a. Clean with solvent.	Refer to paragraph 3-4.
	b. Inspect.	Refer to paragraph 3-5.
C. INSTALLATION.		
5. Screen (4) and spring (3).	Set in item (5).	Opening in item (4) must face item (5) when installed.
6. New ring (2).	Put on item (1).	
7. Cap (1). tighten, until fully seated.	Screw in item (5) and	
<p>NOTE Follow-on maintenance action required: Install pressure transducer (para 3-314).</p>		

FUEL SYSTEM.

3-27. FUEL FILTER SCREEN REPLACEMENT (Continued).

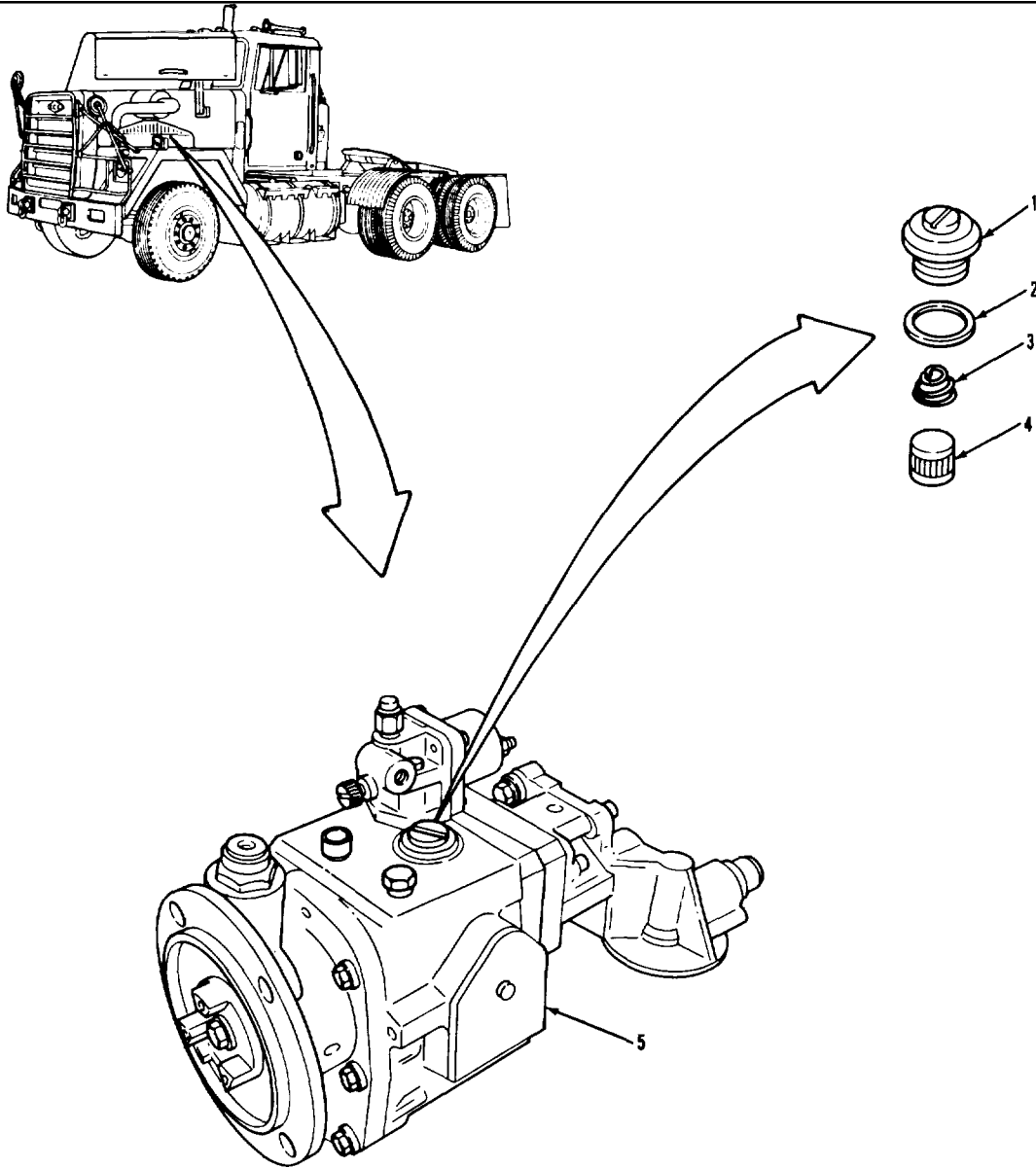

- 1. FILTER SCREEN CAP
- 2. SEAL CAP RING
- 3. FILTER SPRING

- 4. FUEL FILTER SCREEN
- 5. FUEL PUMP HOUSING

FUEL SYSTEM.

3-28. ENGINE FUEL LINES AND FITTINGS REPLACEMENT.

THIS TASK COVERS

- | | |
|--|--|
| a. Air Actuating Line Removal. | f. Manifold Fuel Return Line Installation. |
| b. Air Actuating Line Installation. | g. Fuel Delivery Line Removal. |
| c. Fuel Pump Return Line Removal. | h. Fuel Delivery Line Installation. |
| d. Fuel Pump Return Line Installation. | |
| e. Manifold Fuel Return Line Removal. | |

INITIAL SETUP

<u>APPLICABLE CONFIGURATIONS</u> All.	<u>EQUIPMENT CONDITION PARAGRAPH</u> None.	<u>CONDITION DESCRIPTION</u> None.
<u>TEST EQUIPMENT</u> None.		
<u>SPECIAL TOOLS</u> None.		
<u>MATERIALS/PARTS (P/N)</u> Tape, thread sea ing Item 32, Appendix C.		
<u>PERSONNEL REQUIRED</u> One (MOS-63S).	<u>SPECIAL ENVIRONMENTAL CONDITIONS</u> None.	
<u>REFERENCES (TM)</u> None.	<u>GENERAL SAFETY INSTRUCTIONS</u> Engine off. Transmission in neutral. Park brake set.	
<u>TROUBLESHOOTING REFERENCES</u> Paragraph 2-11.		

FUEL SYSTEM.

3-28. ENGINE FUEL LINES AND FITTINGS REPLACEMENTS (Continued).

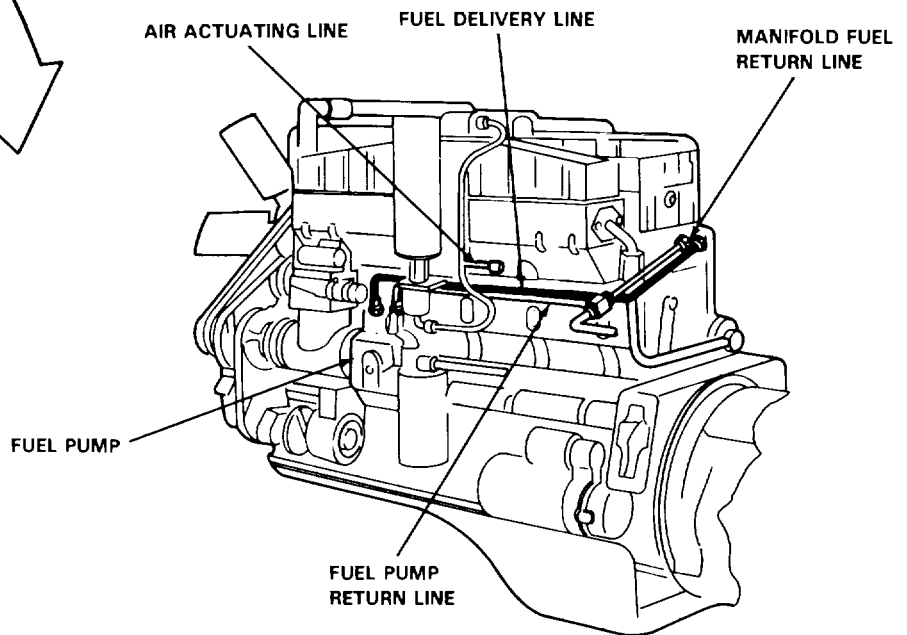
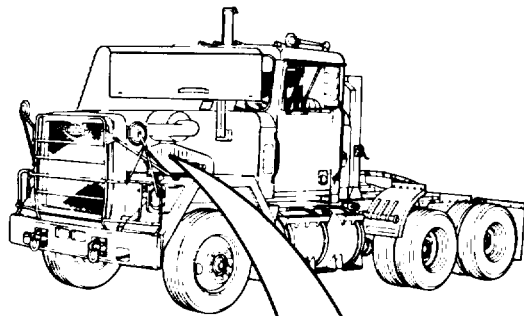

FUEL SYSTEM.

3-28. ENGINE FUEL LINES AND FITTINGS REPLACEMENTS (Continued).

LOCATION/ITEM	ACTION	REMARKS
A. AIR ACTUATING LINE REMOVAL		
1. Screw (4), lockwasher (5), washer (6), and spacer (8).	Remove from item (7) and item (9).	
2. Tube (27). item (29).	Remove from item (25) and item (29).	
3. Screw (10), lockwasher (2), washer (3), and nut (1).	Remove from item (12) and item (9).	
4. Clamp (12).	Remove from item (27).	
5. T-Fitting (29).	Remove from engine.	
6. Fitting (25).	Remove from item (22).	
B. AIR ACTUATING LINE INSTALLATION.		
7. Fitting (25).	Install in item (22).	Put thread sealing tape
8. T-Fitting (29).	Install in engine.	a. Put thread sealing tape on pipe threads. b. Point towards front of vehicle.
9. Clamp (12).	Put on item (27).	
10. Screw (10), lockwasher (2), washer (3), and nut (1).	Install item (12) on item (9).	Do not tighten.

FUEL SYSTEM.

3-28. ENGINE FUEL LINES AND FITTINGS REPLACEMENTS (Continued).

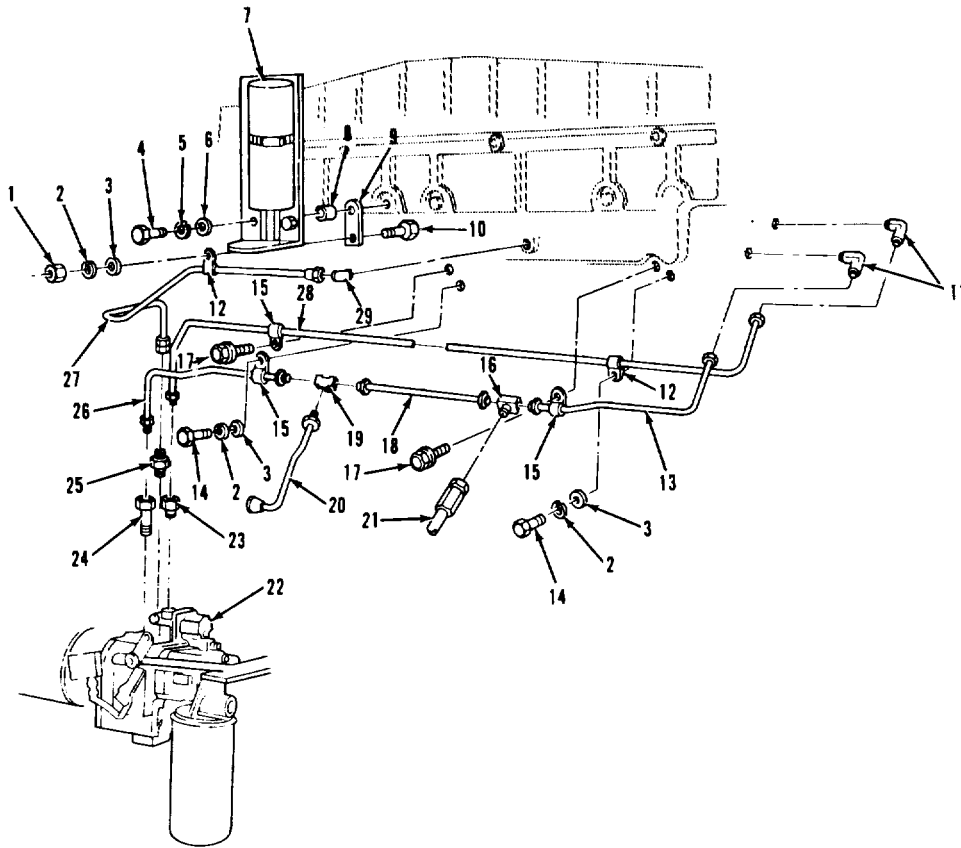

- | | | |
|--------------------------|-----------------------------------|-------------------------------------|
| 1. HEX NUT | 12. TUBE CLAMP (2) | 21. FUEL RETURN HOSE |
| 2. LOCKWASHER (3) | 13. FUEL TUBE | 22. FUEL PUMP |
| 3. WASHER (3) | 14. SCREW (2) | 23. FUEL FITTING |
| 4. SCREW | 15. TUBE CLAMP (3) | 24. ASA VALVE |
| 5. LOCKWASHER | 16. MALE BRANCH TEE | 25. FUEL FITTING |
| 6. WASHER | 17. SCREW WITH CAPTIVE WASHER (2) | 26. FUEL TUBE |
| 7. ETHER QUICK START KIT | 18. FUEL TUBE | 27. FUEL TUBE |
| 8. SPACER | 19. FEMALE UNION TEE | 28. FUEL TUBE |
| 9. SUPPORT BRACKET | 20. FUEL TUBE | 29. T-FITTING WITH ADAPTER AND PLUG |
| 10. SCREW | | |
| 11. ELBOW (2) | | |

TA 237026

FUEL SYSTEM.

3-28. ENGINE FUEL LINES AND FITTINGS REPLACEMENTS (Continued).

LOCATION/ITEM	ACTION	REMARKS
B. AIR ACTUATING LINE INSTALLATION (Continued).		
11. Tube (27), clamp (12), and bracket (9).	a. Put in place in item (29) and item (25). b. Line up item (9) with hole in engine. c. Remove.	Hold item (12) in place on item (27) or mark location.
12. Screw (10) and nut (1).	Tighten.	
13. Tube (27). item (29).	Install on item (25) and	
14. Screw (4), lock-washer (5), washer (6), and spacer (8).	Install in item (7) and item (9).	
C. FUEL PUMP RETURN LINE REMOVAL		
15. Screw (14), lock-washer (2), and washer (3).	Remove from item (15).	
16. Tube (26). item (19).	Remove from item (24) and	
17. Valve (24).	Remove from item (22).	
18. Tube (20). item (22).	Remove from item (19) and	
19. Tube (18). item (16).	Remove from item (19) and	
20. Hose (21).	Remove from item (16).	
21. Tee (16).	Remove from item (13).	
3-106		

FUEL SYSTEM.

3-28. ENGINE FUEL LINES AND FITTINGS REPLACEMENTS (Continued).

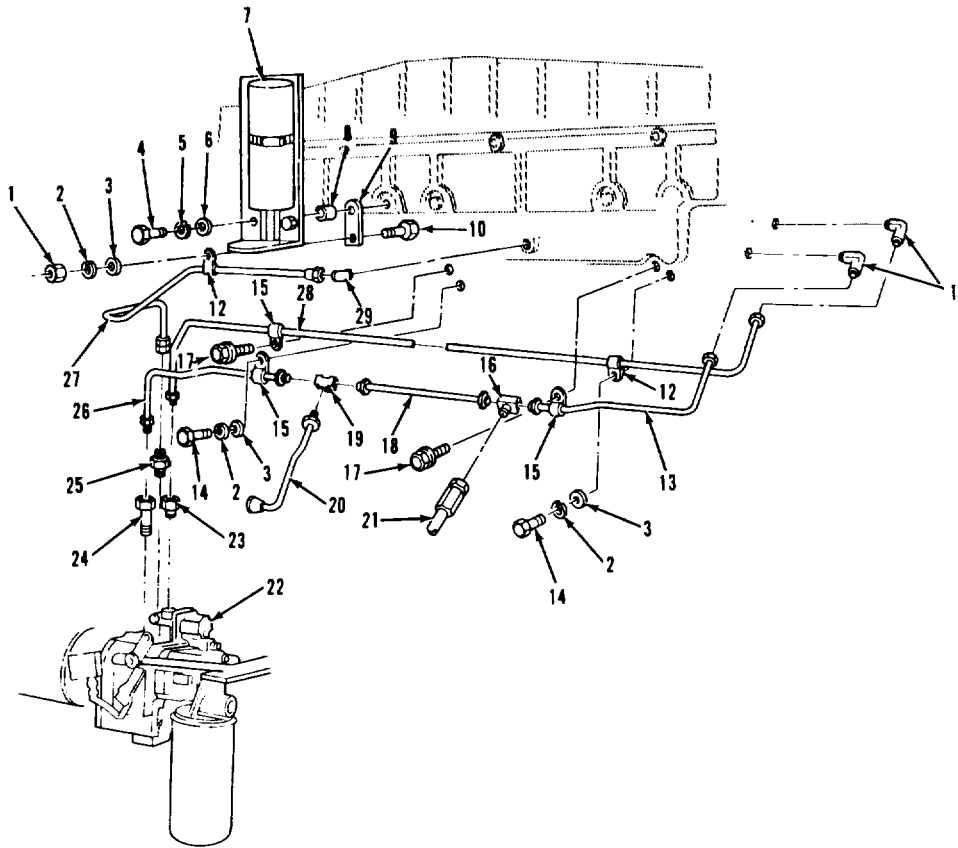

- | | | |
|--------------------------|-----------------------------------|-------------------------------------|
| 1. HEX NUT | 12. TUBE CLAMP (2) | 21. FUEL RETURN HOSE |
| 2. LOCKWASHER (3) | 13. FUEL TUBE | 22. FUEL PUMP |
| 3. WASHER (3) | 14. SCREW (2) | 23. FUEL FITTING |
| 4. SCREW | 15. TUBE CLAMP (3) | 24. ASA VALVE |
| 5. LOCKWASHER | 16. MALE BRANCH TEE | 25. FUEL FITTING |
| 6. WASHER | 17. SCREW WITH CAPTIVE WASHER (2) | 26. FUEL TUBE |
| 7. ETHER QUICK START KIT | 18. FUEL TUBE | 27. FUEL TUBE |
| 8. SPACER | 19. FEMALE UNION TEE | 28. FUEL TUBE |
| 9. SUPPORT BRACKET | 20. FUEL TUBE | 29. T-FITTING WITH ADAPTER AND PLUG |
| 10. SCREW | | |
| 11. ELBOW (2) | | |

FUEL SYSTEM.

3-28. ENGINE FUEL LINES AND FITTINGS REPLACEMENTS (Continued).

LOCATION/ITEM	ACTION	REMARKS
D. FUEL PUMP RETURN LINE INSTALLATION		
22. Tee (16).	Install on item (13).	
23. Hose (21).	Install on item (16).	
24. Tube (18).	Install on item (16).	
25. Tee (19).	Install on item (18).	Do not tighten.
26. Tube (20).	Install on item (22) and item (19).	
27. Tube (18).	Tighten in item (19).	
28. Clamp (15).	Put on item (26).	
29. Valve (24).	Install in item (22). on pipe threads.	Put thread sealing tape
30. Tube (26).-	Install in item (24) and item (19).	
31. Screw (14), lock-washer (2), and washer (3).	Secure item (15) to engine.	
E. MANIFOLD FUEL RETURN LINE REMOVAL		
32. Air cleaner assembly.	Remove.	Refer to paragraph 3-29.
33. Screw (17).	Remove from item (15).	
34. Tube (13).	Remove from item (16) and item (11).	
35. Clamp (15).	Remove from item (13)	
36. Elbow (11).	Remove from engine	Note position for installation.

FUEL SYSTEM.

3-28. ENGINE FUEL LINES AND FITTINGS REPLACEMENTS (Continued).

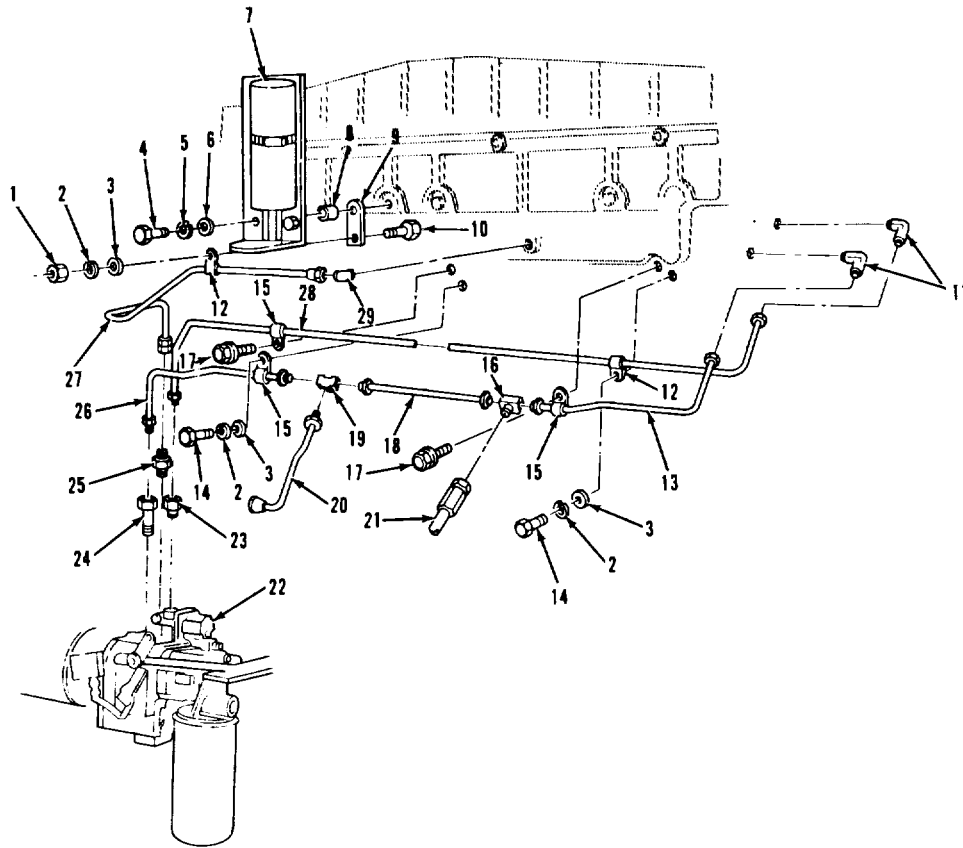

- | | | |
|--------------------------|-----------------------------------|-------------------------------------|
| 1. HEX NUT | 12. TUBE CLAMP (2) | 21. FUEL RETURN HOSE |
| 2. LOCKWASHER (3) | 13. FUEL TUBE | 22. FUEL PUMP |
| 3. WASHER (3) | 14. SCREW (2) | 23. FUEL FITTING |
| 4. SCREW | 15. TUBE CLAMP (3) | 24. ASA VALVE |
| 5. LOCKWASHER | 16. MALE BRANCH TEE | 25. FUEL FITTING |
| 6. WASHER | 17. SCREW WITH CAPTIVE WASHER (2) | 26. FUEL TUBE |
| 7. ETHER QUICK START KIT | 18. FUEL TUBE | 27. FUEL TUBE |
| 8. SPACER | 19. FEMALE UNION TEE | 28. FUEL TUBE |
| 9. SUPPORT BRACKET | 20. FUEL TUBE | 29. T-FITTING WITH ADAPTER AND PLUG |
| 10. SCREW | | |
| 11. ELBOW (2) | | |

FUEL SYSTEM.

3-28. ENGINE FUEL LINES AND FITTINGS REPLACEMENTS (Continued).

LOCATION/ITEM	ACTION	REMARKS
F. MANIFOLD FUEL RETURN LINE INSTALLATION.		
37. Elbow (11). on pipe threads.	Install in engine.	Put thread sealing tape
38. Clamp (15). 39 Tube (13). item (16).	Put on item (13). Install in item (11) and item (16).	
40. Screw (17). 41. Air cleaner assembly.	Secure item (15) to engine. Install.	Refer to paragraph 3-29.
G. FUEL DELIVERY LINE REMOVAL.		
42. Fuel pump return line.	Remove.	Refer to subparagraph C.
43. Manifold fuel return line.	Remove.	Refer to subparagraph E.
44. Screw (14), lock- washer (2), and washer (3).	Remove from item (12).	
45. Screw (17). 46. Tube (28). item (11).	Remove from item (15). Remove from item (23) and item (11).	
47. Clamp (12) and clamp (15).	Remove from item (28).	
48. Elbow (11). for installation.	Remove from engine.	Note position of elbow
49. Fitting (23).	Remove from item (22).	
3-110		

FUEL SYSTEM.

3-28. ENGINE FUEL LINES AND FITTINGS REPLACEMENTS (Continued).

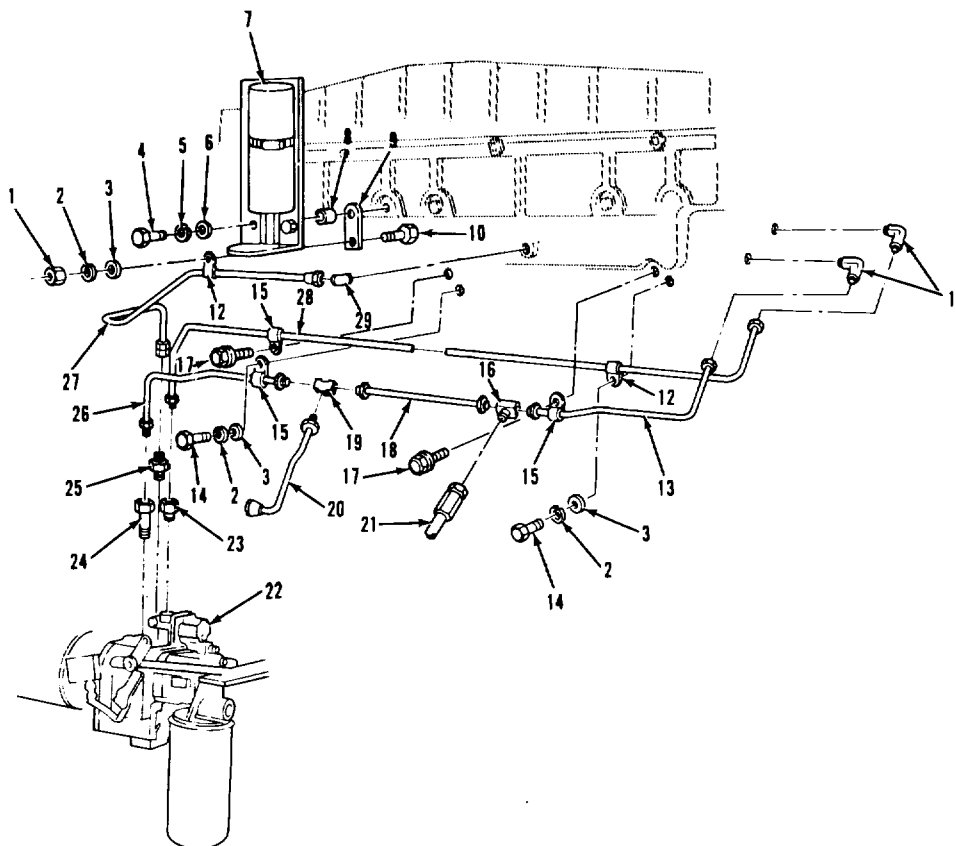

LEGEND

- | | | | | | |
|----|-----------------------|----|-------------------------------|----|---------------------------------|
| 1 | HEX NUT | 12 | TUBE CLAMP (2) | 21 | FUEL RETURN HOSE |
| 2 | LOCKWASHER (3) | 13 | FUEL TUBE | 22 | FUEL PUMP |
| 3 | WASHER (3) | 14 | SCREW (2) | 23 | FUEL FITTING |
| 4 | SCREW | 15 | TUBE CLAMP (3) | 24 | ASA VALVE |
| 5 | LOCKWASHER | 16 | MALE BRANCH TEE | 25 | FUEL FITTING |
| 6 | WASHER | 17 | SCREW WITH CAPTIVE WASHER (2) | 26 | FUEL TUBE |
| 7 | ETHER QUICK START KIT | 18 | FUEL TUBE | 27 | FUEL TUBE |
| 8 | SPACER | 19 | FEMALE UNION TEE | 28 | FUEL TUBE |
| 9 | SUPPORT BRACKET | 20 | FUEL TUBE | 29 | T-FITTING WITH ADAPTER AND PLUG |
| 10 | SCREW | | | | |
| 11 | ELBOW (2) | | | | |

TA 237039

FUEL SYSTEM.

3-28. ENGINE FUEL LINES AND FITTINGS REPLACEMENTS (Continued).

LOCATION/ITEM	ACTION	REMARKS
H. FUEL DELIVERY LINE INSTALLATION.		
50 Fitting (23)	Install in item (22)	Put thread sealing tape on pipe threads.
51 Elbow (11)	Install in engine	Put thread sealing tape on pipe threads.
52 Clamp (12) and clamp (15).	Put on item (28).	
53 Tube (28)	Install on item (11) and item (23).	
54 Screw (17)	Secure item (15) to engine.	
55 Screw (14), lock-washer (2), and washer (3).	Secure item (12) to engine.	
56 Manifold return line.	Install	Refer to subparagraph F.
57 Fuel pump return line.	Install	Refer to subparagraph D.
<p>NOTE Follow-on maintenance action required. None.</p>		

FUEL SYSTEM.

3-28. ENGINE FUEL LINES AND FITTINGS REPLACEMENTS (Continued).

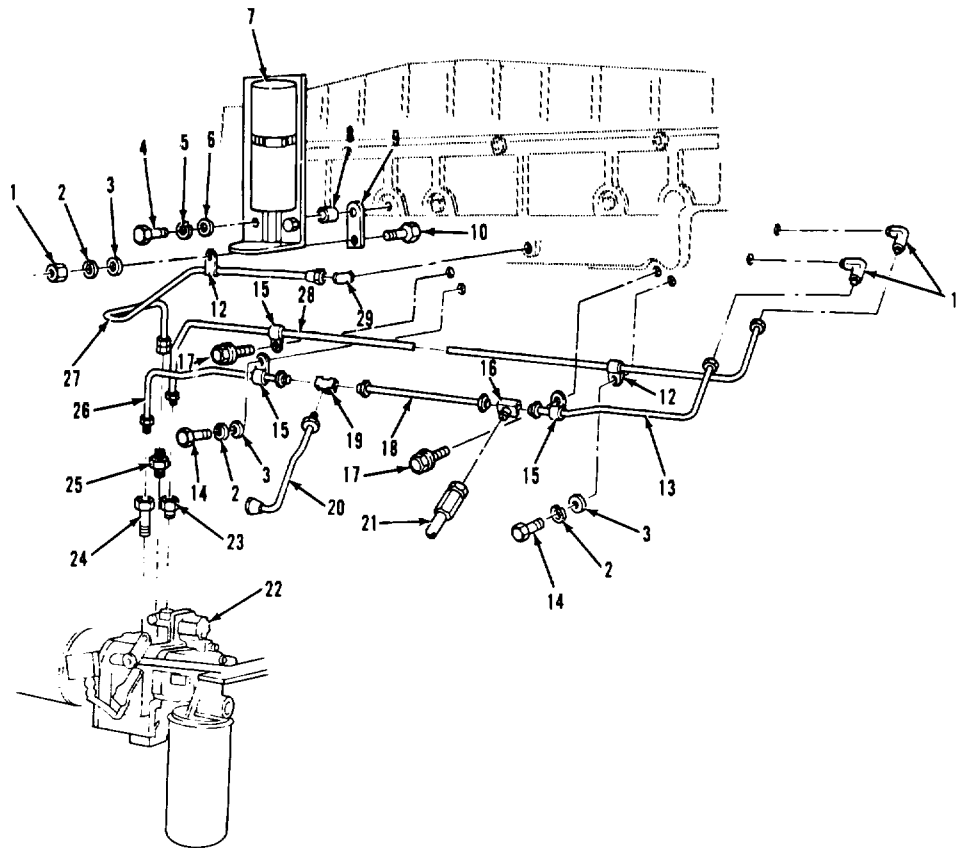

LEGEND

- | | | |
|-------------------------|----------------------------------|------------------------------------|
| 1 HEX NUT | 12 TUBE CLAMP (2) | 21 FUEL RETURN HOSE |
| 2 LOCKWASHER (3) | 13 FUEL TUBE | 22 FUEL PUMP |
| 3 WASHER (3) | 14 SCREW (2) | 23 FUEL FITTING |
| 4 SCREW | 15 TUBE CLAMP (3) | 24 ASA VALVE |
| 5 LOCKWASHER | 16 MALE BRANCH TEE | 25 FUEL FITTING |
| 6 WASHER | 17 SCREW WITH CAPTIVE WASHER (2) | 26 FUEL TUBE |
| 7 ETHER QUICK START KIT | 18 FUEL TUBE | 27 FUEL TUBE |
| 8 SPACER | 19 FEMALE UNION TEE | 28 FUEL TUBE |
| 9 SUPPORT BRACKET | 20 FUEL TUBE | 29 T-FITTING WITH ADAPTER AND PLUG |
| 10 SCREW | | |
| 11. ELBOW (2) | | |

TA 237040

FUEL SYSTEM.

3-29. AIR CLEANER ASSEMBLY REPLACEMENT.

THIS TASK COVERS

- a. Removal.
- b. Cleaning and Inspection.
- c. Installation.

INITIAL SETUP

<p><u>APPLICABLE CONFIGURATIONS</u> All.</p>	<p><u>EQUIPMENT CONDITION PARAGRAPH</u> None.</p>	<p><u>CONDITION DESCRIPTION</u> None.</p>
<p><u>TEST EQUIPMENT</u> None.</p>		
<p><u>SPECIAL TOOLS</u> None.</p>		
<p><u>MATERIALS/PARTS (P/N)</u> Rags, wiping Item 22, Appendix C. Solvent, dry cleaning, SD-2 Item 29, Appendix C.</p>		
<p><u>PERSONNEL REQUIRED</u> One (MOS-63S).</p>	<p><u>SPECIAL ENVIRONMENTAL CONDITIONS</u> None.</p>	
<p><u>REFERENCES (TM)</u> None.</p>	<p><u>GENERAL SAFETY INSTRUCTIONS</u> Engine off. Transmission in neutral. Park brake set.</p>	
<p><u>TROUBLESHOOTING REFERENCES</u> Paragraph 2-11.</p>		

FUEL SYSTEM.

3-29. AIR CLEANER ASSEMBLY REPLACEMENT (Continued).

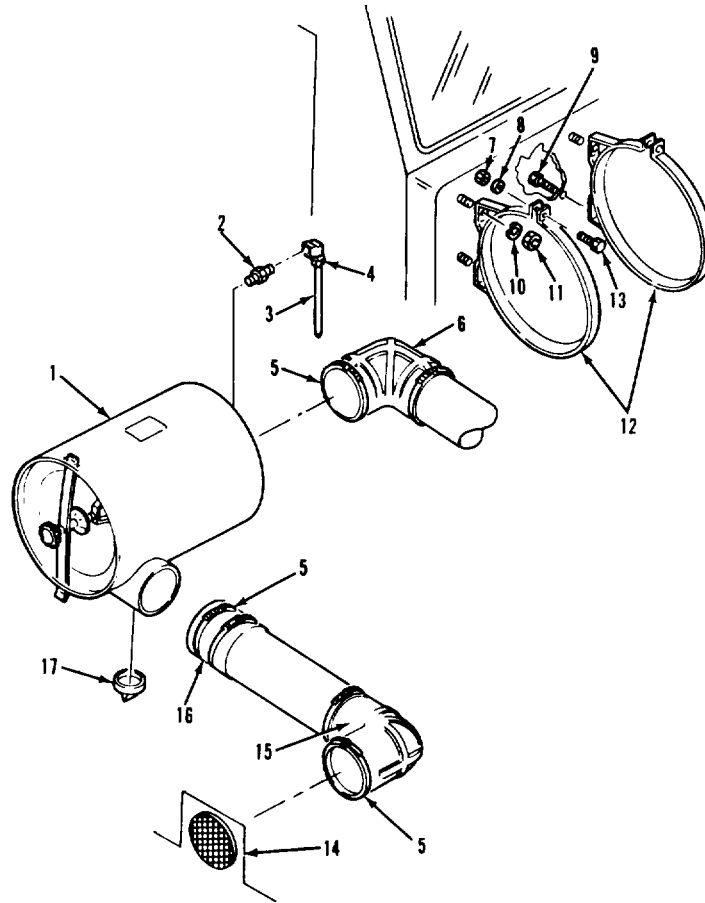

LEGEND:

- | | |
|------------------------------|----------------------------------|
| 1 AIR CLEANER ASSEMBLY | 10 LOCKWASHER (4) |
| 2 NIPPLE AND FILTER ASSEMBLY | 11 HEX NUT (4) |
| 3 TUBE | 12 BRACKET (2) |
| 4 ELBOW | 13 SCREW (2) |
| 5 AIR INTAKE TUBE CLAMP (3) | 14 HOOD SEAL RIGHT-HAND RETAINER |
| 6 90° AIR TUBE ELBOW | 15 900 AIR INTAKE ELBOW |
| 7 HEX NUT (2) | 16 SPECIAL 220 ELBOW |
| 8 LOCKWASHER (2) | 17 DUST AND MOISTURE BOOT |
| 9. SCREW | |

TA 237041

FUEL SYSTEM.

3-29. AIR CLEANER ASEMBLY REPLACEMENT (Continued).

LOCATION/ITEM	ACTION	REMARKS
A. REMOVAL.		
1. Three clamps (5).	Loosen.	
2. Elbow (6).	Pull from item (1).	
3. Tube (3).	Remove from item (4).	
4. Elbow (15).	Pull from item (14).	
5. Elbow (16).	Pull from item (1).	
6. Two screws (13), lockwashers (8), and nuts (7).	Remove from two items (12).	
7. Air cleaner assembly (1).	Remove from two items (12).	
8. Elbow (4).	Remove from item (2).	
9. Nipple and filter assembly (2).	Remove from item (1).	
10. Boot (17).	Remove from item (1).	
11. Screw (9), four nuts (11), and lockwashers (10).	Remove from two items (12).	
12. Two brackets (12).	Remove from firewall.	
B. CLEANING AND INSPECTION.		
13. Air cleaner assem- bly (1) and boot (17).	Wipe clean with damp rag.	

FUEL SYSTEM.

3-29. AIR CLEANER ASSEMBLY REPLACEMENT (Continued).

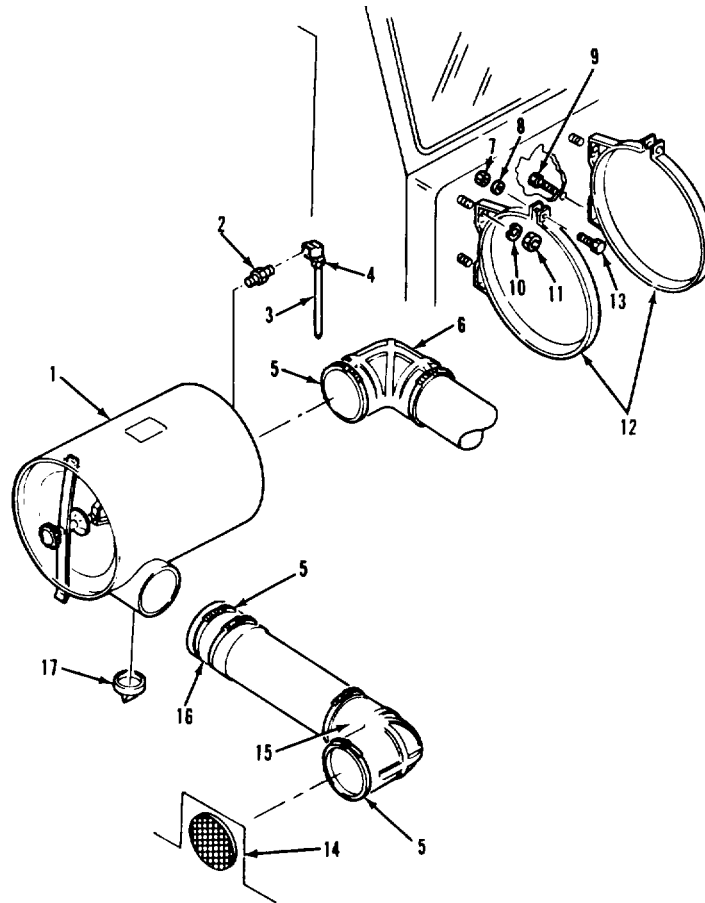

LEGEND:

- | | |
|------------------------------|----------------------------------|
| 1 AIR CLEANER ASSEMBLY | 10 LOCKWASHER (4) |
| 2 NIPPLE AND FILTER ASSEMBLY | 11 HEX NUT (4) |
| 3 TUBE | 12 BRACKET (2) |
| 4 ELBOW | 13 SCREW (2) |
| 5 AIR INTAKE TUBE CLAMP (3) | 14 HOOD SEAL RIGHT-HAND RETAINER |
| 6 90° AIR TUBE ELBOW | 15 90° AIR INTAKE ELBOW |
| 7 HEX NUT (2) | 16 SPECIAL 220 ELBOW |
| 8 LOCKWASHER (2) | 17 DUST AND MOISTURE BOOT |
| 9. SCREW | |

TA 237042

FUEL SYSTEM.**3-28. ENGINE FUEL LINES AND FITTINGS REPLACEMENTS (Continued).**

LOCATION/ITEM	ACTION	REMARKS
B. CLEANING AND INSPECTION (Continued).		
14 Two brackets (12), elbow (4), and nipple and filter assembly (2).	Clean with solvent and rags	Refer to paragraph 3-4.
15 All parts	Inspect	Refer to paragraph 3-5.
C. INSTALLATION.		
16 Boot (17)	Install on item (1).	
17 Nipple and filter assembly (2).	Install in item (1).	
18 Elbow (4)	Install on item (2).	
19 Two brackets (12).	Put in position on firewall.	
20 Screw (9), four nuts (11), and four lockwashers (10).	Secure two items (12).	
21 Air cleaner assembly (1).	Put in two items (12).	
22 Two screws (13), lockwasher (8), and nuts (7).	Install in two items (12)	Do not tighten.
23 Elbow (16)	Push on item (1).	
24 Elbow (15)	Push on item (14).	

FUEL SYSTEM.

3-29. AIR CLEANER ASSEMBLY REPLACEMENT (Continued).

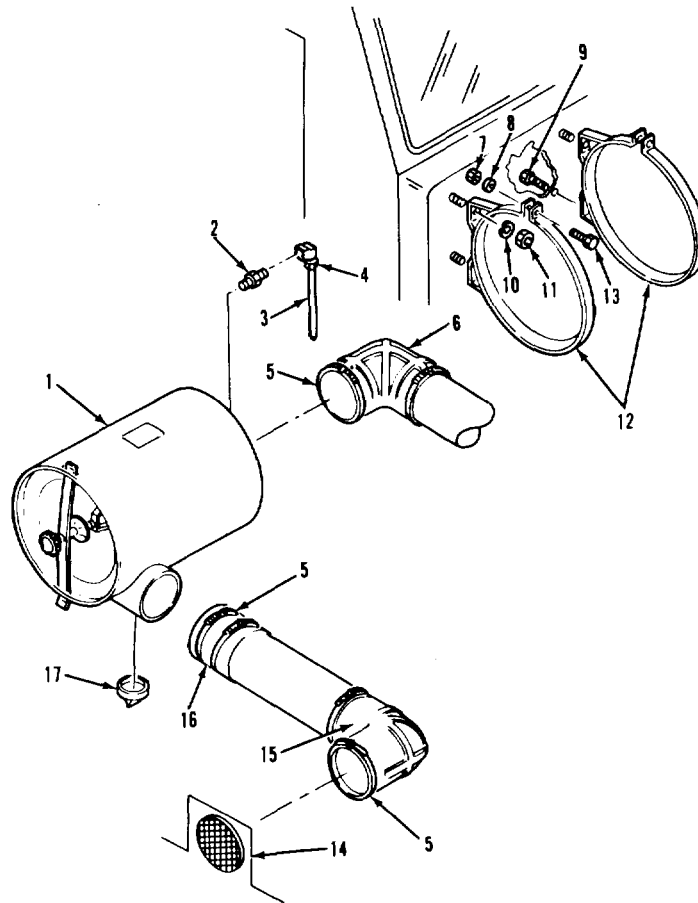

LEGEND

- | | |
|------------------------------|----------------------------------|
| 1 AIR CLEANER ASSEMBLY | 10 LOCKWASHER (4) |
| 2 NIPPLE AND FILTER ASSEMBLY | 11 HEX NUT (4) |
| 3 TUBE | 12 BRACKET (2) |
| 4 ELBOW | 13 SCREW (2) |
| 5 AIR INTAKE TUBE CLAMP (3) | 14 HOOD SEAL RIGHT-HAND RETAINER |
| 6 900 AIR TUBE ELBOW | 15 900 AIR INTAKE ELBOW |
| 7 HEX NUT (2) | 16 SPECIAL 220 ELBOW |
| 8 LOCKWASHER (2) | 17 DUST AND MOISTURE BOOT |
| 9 SCREW | |

TA 237043

FUEL SYSTEM.

3-28. ENGINE FUEL LINES AND FITTINGS REPLACEMENTS (Continued).

LOCATION/ITEM	ACTION	REMARKS
C. INSTALLATION (Continued).		
25 Tube (3) 26 Elbow (6) 27 Three clamps (5) 28 Two screws (13), lockwashers (8), and nuts (7).	Install on item (4). Push on item (1). Tighten. Tighten.	
NOTE		
Follow-on maintenance action required:		
None.		

FUEL SYSTEM.

3-29. AIR CLEANER ASSEMBLY REPLACEMENT (Continued).

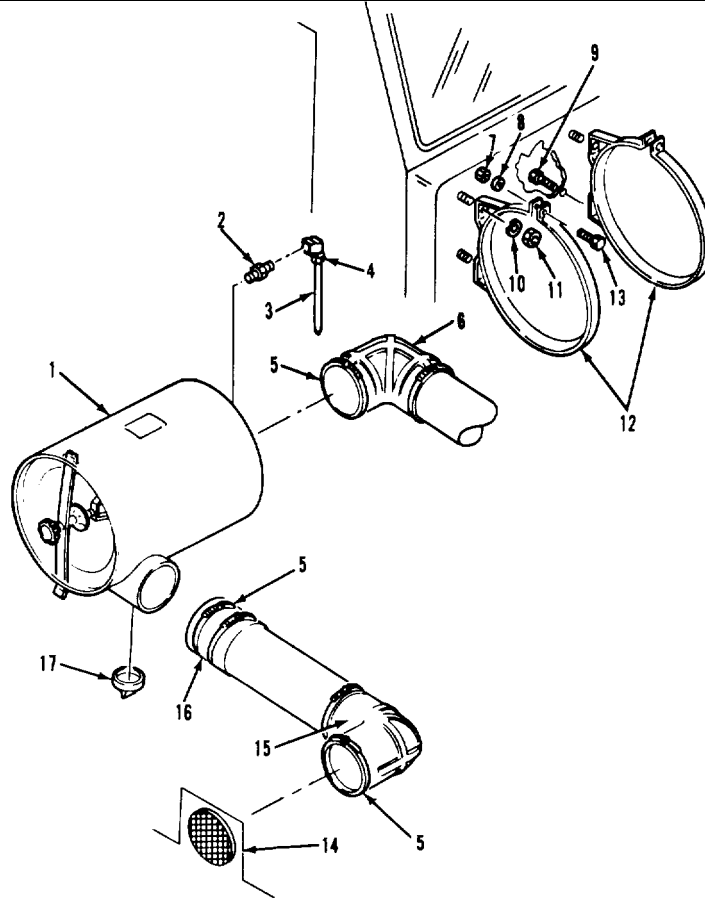

LEGEND

- | | |
|------------------------------|----------------------------------|
| 1 AIR CLEANER ASSEMBLY | 10 LOCKWASHER (4) |
| 2 NIPPLE AND FILTER ASSEMBLY | 11 HEX NUT (4) |
| 3 TUBE | 12 BRACKET (2) |
| 4 ELBOW | 13 SCREW (2) |
| 5 AIR INTAKE TUBE CLAMP (3) | 14 HOOD SEAL RIGHT-HAND RETAINER |
| 6 900 AIR TUBE ELBOW | 15 900 AIR INTAKE ELBOW |
| 7 HEX NUT (2) | 16 SPECIAL 22° ELBOW |
| 8 LOCKWASHER (2) | 17 DUST AND MOISTURE BOOT |
| 9 SCREW | |

FUEL SYSTEM.

3-30. AIR CLEANER ASSEMBLY REPLACEMENT.

THIS TASK COVERS

- a. Removal.
- b. Cleaning and Inspection.
- c. Installation.

INITIAL SETUP

<p><u>APPLICABLE CONFIGURATIONS</u> All.</p>	<p><u>EQUIPMENT CONDITION PARAGRAPH</u> None.</p>	<p><u>CONDITION DESCRIPTION</u> None.</p>
<p><u>TEST EQUIPMENT</u> None.</p>		
<p><u>SPECIAL TOOLS</u> None.</p>		
<p><u>MATERIALS/PARTS (P/N)</u> Rags, wiping Item 22, Appendix C. Solution, soap Item 28, Appendix C.</p>		
<p><u>PERSONNEL REQUIRED</u> One (MOS-63SJ).</p>	<p><u>SPECIAL ENVIRONMENTAL CONDITIONS</u> Darkened area for element inspection.</p>	
<p><u>REFERENCES (TM)</u> None.</p>	<p><u>GENERAL SAFETY INSTRUCTIONS</u> Engine off. Transmission in neutral. Park brake set.</p>	
<p><u>TROUBLESHOOTING REFERENCES</u> Paragraph 2-11.</p>		

FUEL SYSTEM.

3-30. AIR CLEANER FILTER ELEMENT REPLACEMENT (Continued).

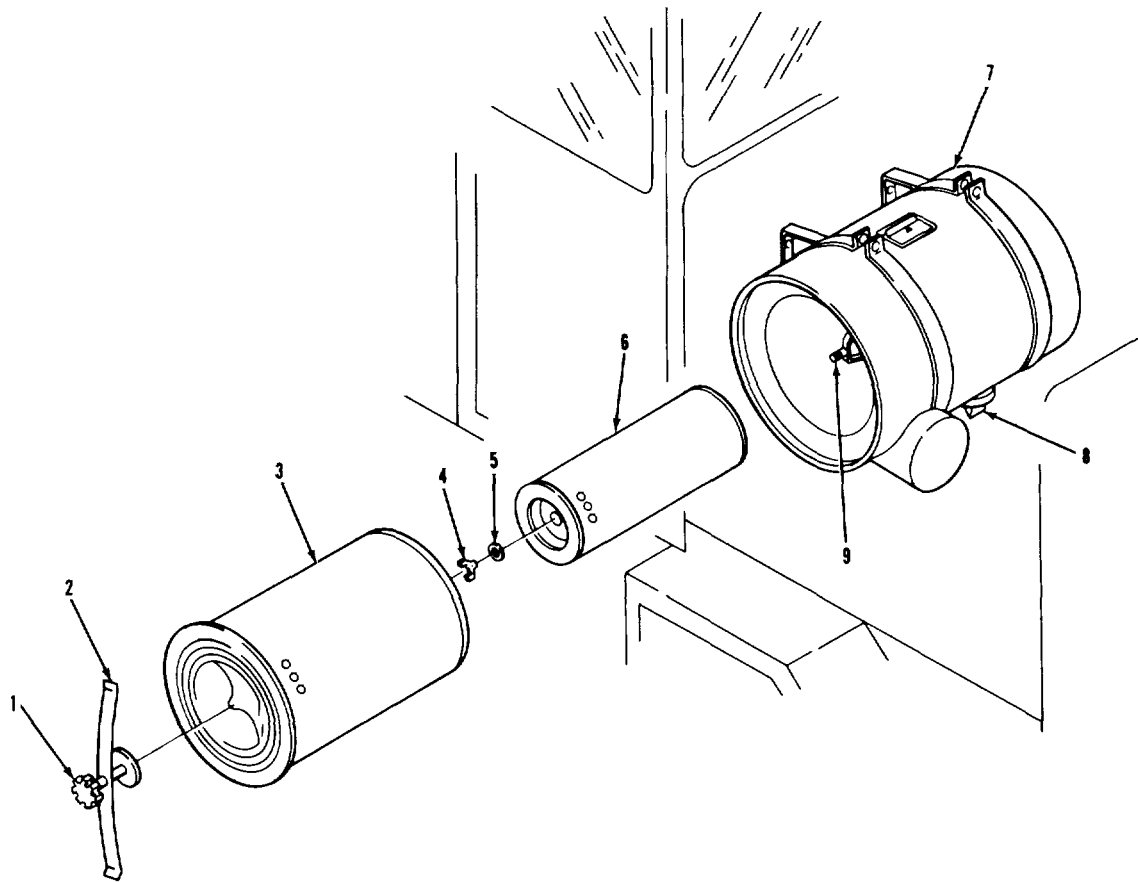

LEGEND:

- | | | | |
|---|-----------------------|---|--------------------------|
| 1 | HANDLE | 6 | SECONDARY FILTER ELEMENT |
| 2 | RETAINER BAR ASSEMBLY | 7 | CANISTER |
| 3 | FILTER ELEMENT | 8 | DUST AND MOISTURE BOOT |
| 4 | WINGNUT | 9 | THREADED ROD |
| 5 | WASHER | | |

TA 237045

FUEL SYSTEM.

3-28. ENGINE FUEL LINES AND FITTINGS REPLACEMENTS (Continued).

LOCATION/ITEM	ACTION	REMARKS
A. REMOVAL.		
1 Handle (1)	Loosen.	
2 Retainer bar assembly (2).	Remove from item (7).	
3 Element (3)	Remove from item (7).	
NOTE		
Do not clean secondary filter element. Do not remove unless to replace with a new element. This should be done after the outside element has been cleaned five times.		
4 Wingnut (4) and washer (5).	Remove from rod (9).	
5 Element (6)	Remove from rod (9)	Rubber seal may stick making removal difficult Work back and forth to free.
B. CLEANING.		
WARNING		
Do not use more than 30 psi of compressed air for cleaning purposes. Use protective equipment (goggles/- shield, gloves, etc.) to prevent injury.		

FUEL SYSTEM.

3-30. AIR CLEANER FILTER ELEMENT REPLACEMENT (Continued).

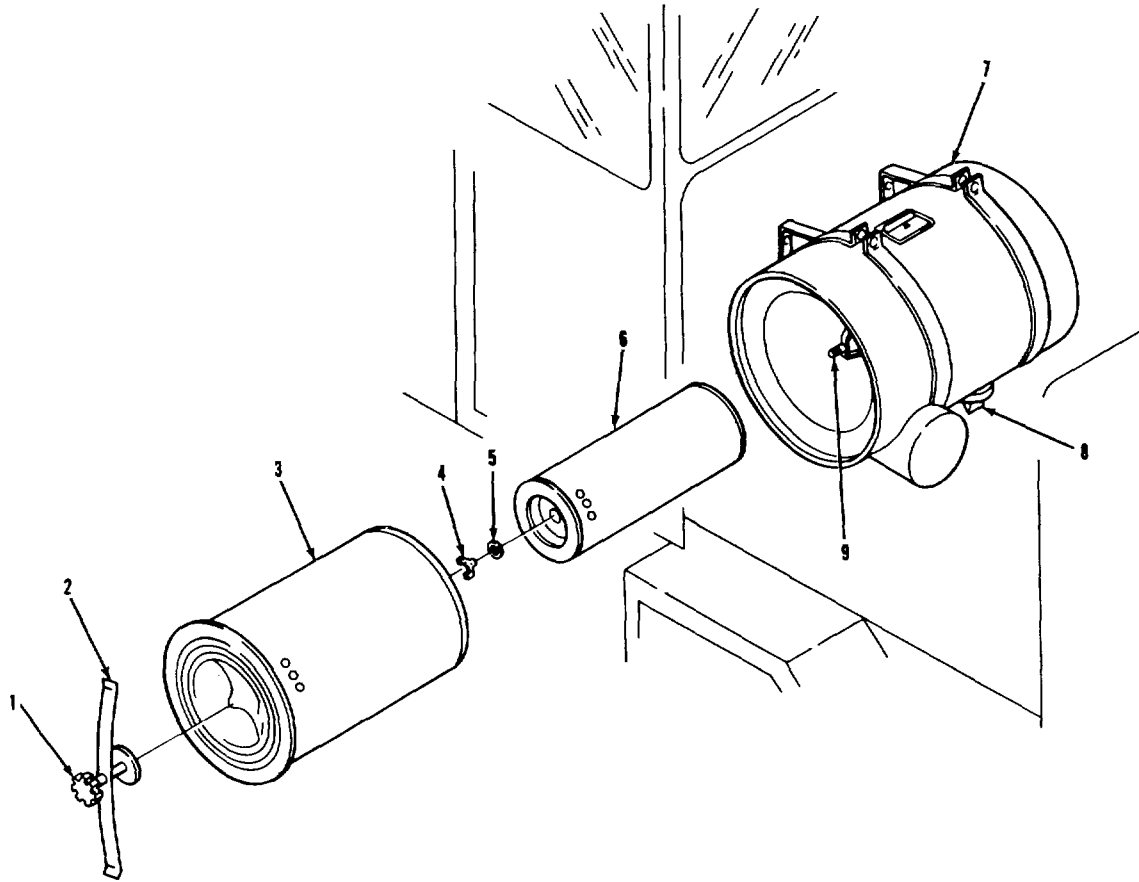

LEGEND:

- | | | | |
|---|-----------------------|---|--------------------------|
| 1 | HANDLE | 6 | SECONDARY FILTER ELEMENT |
| 2 | RETAINER BAR ASSEMBLY | 7 | CANISTER |
| 3 | FILTER ELEMENT | 8 | DUST AND MOISTURE BOOT |
| 4 | WINGNUT | 9 | THREADED ROD |
| 5 | WASHER | | |

TA 237046

FUEL SYSTEM.

3-30. AIR CLEANER FILTER ELEMENT REPLACEMENT (Continued).

LOCATION/ITEM	ACTION	REMARKS
B. CLEANING (Continued).		
6 Element (3)	a Tap to shake dust loose. b Blow out dust with compressed air. c Wash with soap solution and water, rinse with clean water, and allow to air dry.	Skip this step if item (3) seems clean after steps a and b.
7 Boot (8)	a Remove from item (7). b Wipe inside clean with a damp rag.	
8 Canister (7)	c Install on item (7). Wipe inside clean with a damp rag.	
C. INSPECTION.		
9 All parts 10 Element (3)	Inspect Shine light inside element Watch outside for light shining through leaks.	Refer to paragraph 3-5. If item (3) is damaged, replace.
D. INSTALLATION.		
11 Element (6)	Place in item (7).	
12 Wingnut (4) and washer (5).	Secure item (6).	

FUEL SYSTEM.

3-30. AIR CLEANER FILTER ELEMENT REPLACEMENT (Continued).

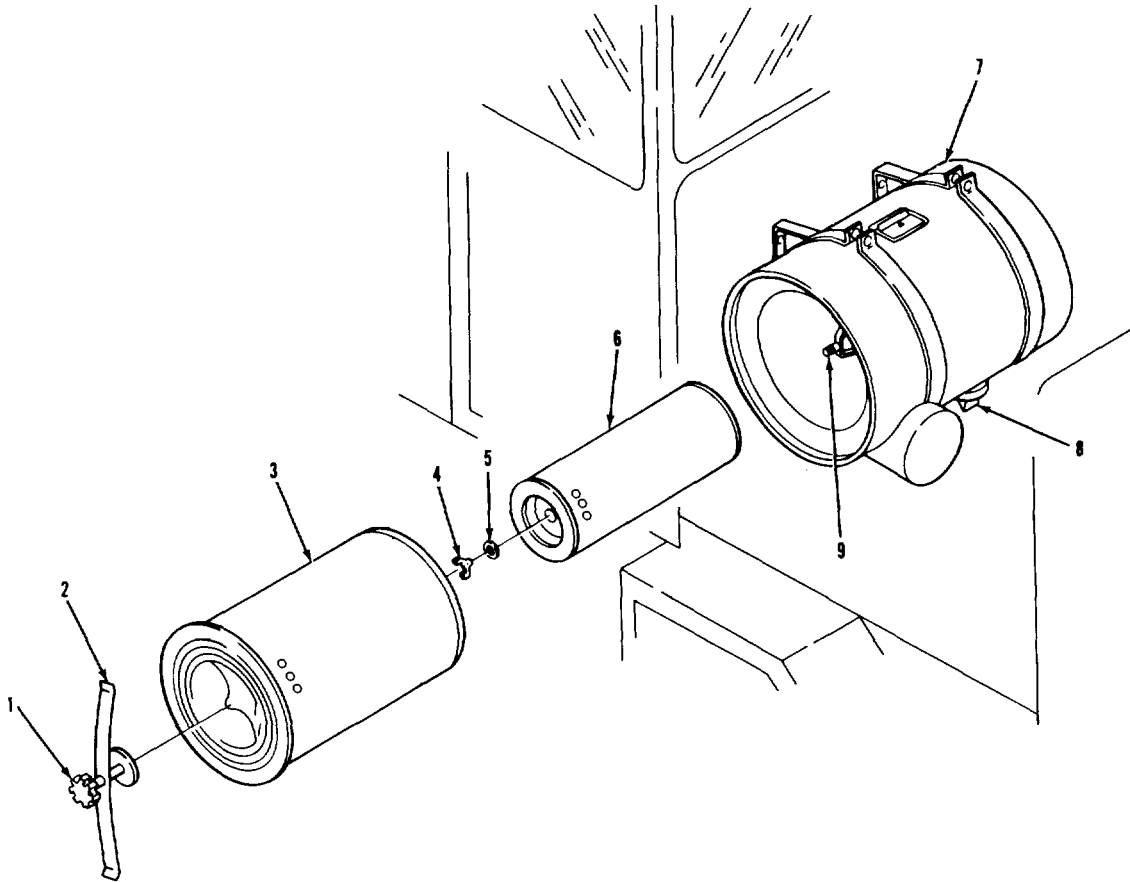

LEGEND:

- | | |
|-------------------------|----------------------------|
| 1 HANDLE | 6 SECONDARY FILTER ELEMENT |
| 2 RETAINER BAR ASSEMBLY | 7 CANISTER |
| 3 FILTER ELEMENT | 8 DUST AND MOISTURE BOOT |
| 4 WINGNUT | 9 THREADED ROD |
| 5 WASHER | |

TA 237047

FUEL SYSTEM.

3-30. AIR CLEANER FILER ELEMEN REPLACEMENT (Continued).

LOCATION/ITEM	ACTION	REMARKS
D. INSTALLATION (Continued).		
13 Element (3)	Place in item (7).	
14 Retainer bar assembly (2).	Put in slots in item (7).	
15 Handle (1)	Tighten.	
NOTE		
Follow-on maintenance action required:		
None.		

FUEL SYSTEM.

3-30. AIR CLEANER FILTER ELEMENT REPLACEMENT (Continued).

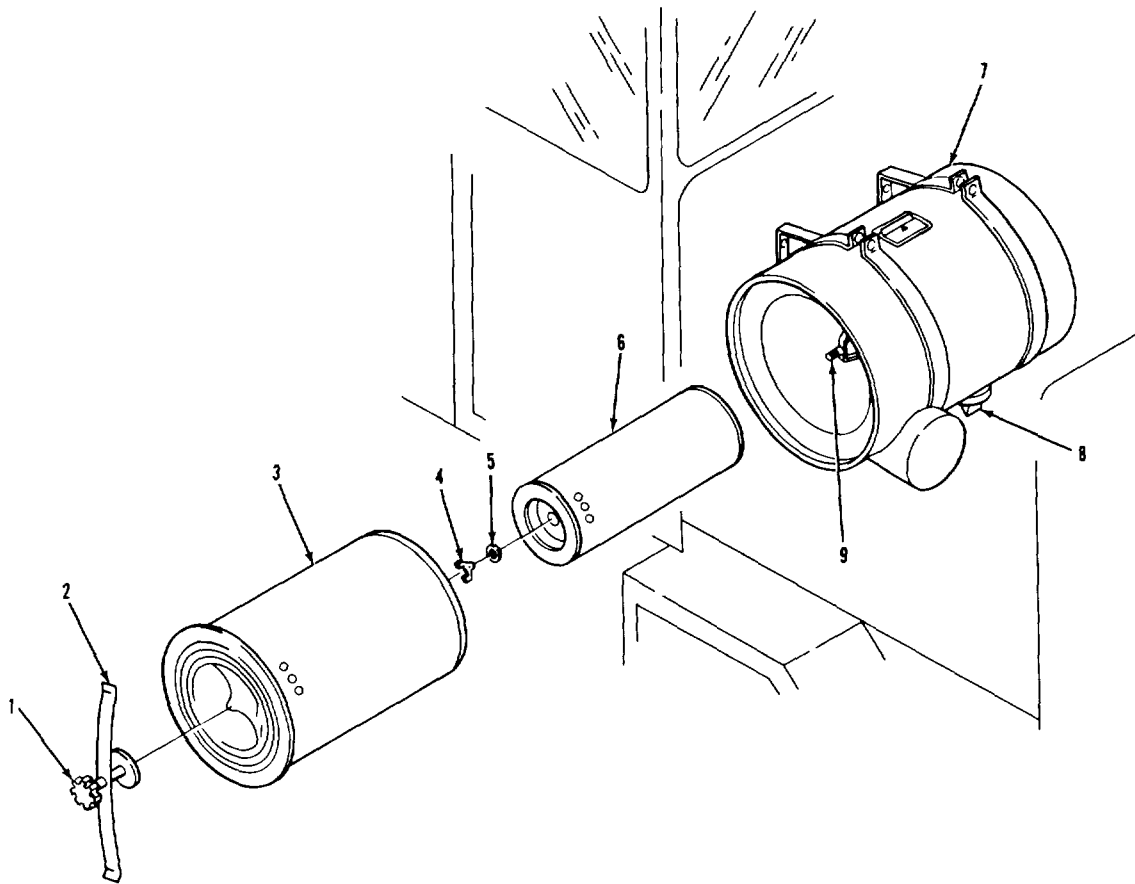

LEGEND:

- | | | | |
|---|-----------------------|---|--------------------------|
| 1 | HANDLE | 6 | SECONDARY FILTER ELEMENT |
| 2 | RETAINER BAR ASSEMBLY | 7 | CANISTER |
| 3 | FILTER ELEMENT | 8 | DUST AND MOISTURE BOOT |
| 4 | WINGNUT | 9 | THREADED ROD |
| 5 | WASHER | | |

TA 237048

FUEL SYSTEM.

3-31. TURBOCHARGER AIR CROSSOVER CONNECTION REPLACEMENT.

THIS TASK COVERS

- a. Removal.
- b. Cleaning and Inspection.
- c. Installation.

INITIAL SETUP

<p><u>APPLICABLE CONFIGURATIONS</u> All.</p> <p><u>TEST EQUIPMENT</u> None.</p> <p><u>SPECIAL TOOLS</u> None.</p> <p><u>MATERIALS/PARTS (P/N)</u> Solvent, dry cleaning, SD-2 Item 29, Appendix C. Rags, wiping Item 22, Appendix C. Tape, thread sealing Item 32, Appendix C. Gasket, crossover mounting (15434) 216487.</p> <p><u>PERSONNEL REQUIRED</u> One (MOS-63S).</p> <p><u>REFERENCES (TM)</u> TM 9-2320-283-20P.</p> <p><u>TROUBLESHOOTING REFERENCES</u> Paragraph 2-11.</p>	<p><u>EQUIPMENT CONDITION PARAGRAPH</u> None.</p> <p><u>SPECIAL ENVIRONMENTAL CONDITIONS</u> Work area clean and away from blowing dirt and dust.</p> <p><u>GENERAL SAFETY INSTRUCTIONS</u> Engine off. Transmission in neutral. Park brake set.</p>	<p><u>CONDITION DESCRIPTION</u> None.</p>
---	--	---

FUEL SYSTEM.

3-31. TURBOCHARGER AIR CROSSOVER CONNECTION REPLACEMENT (Continued).

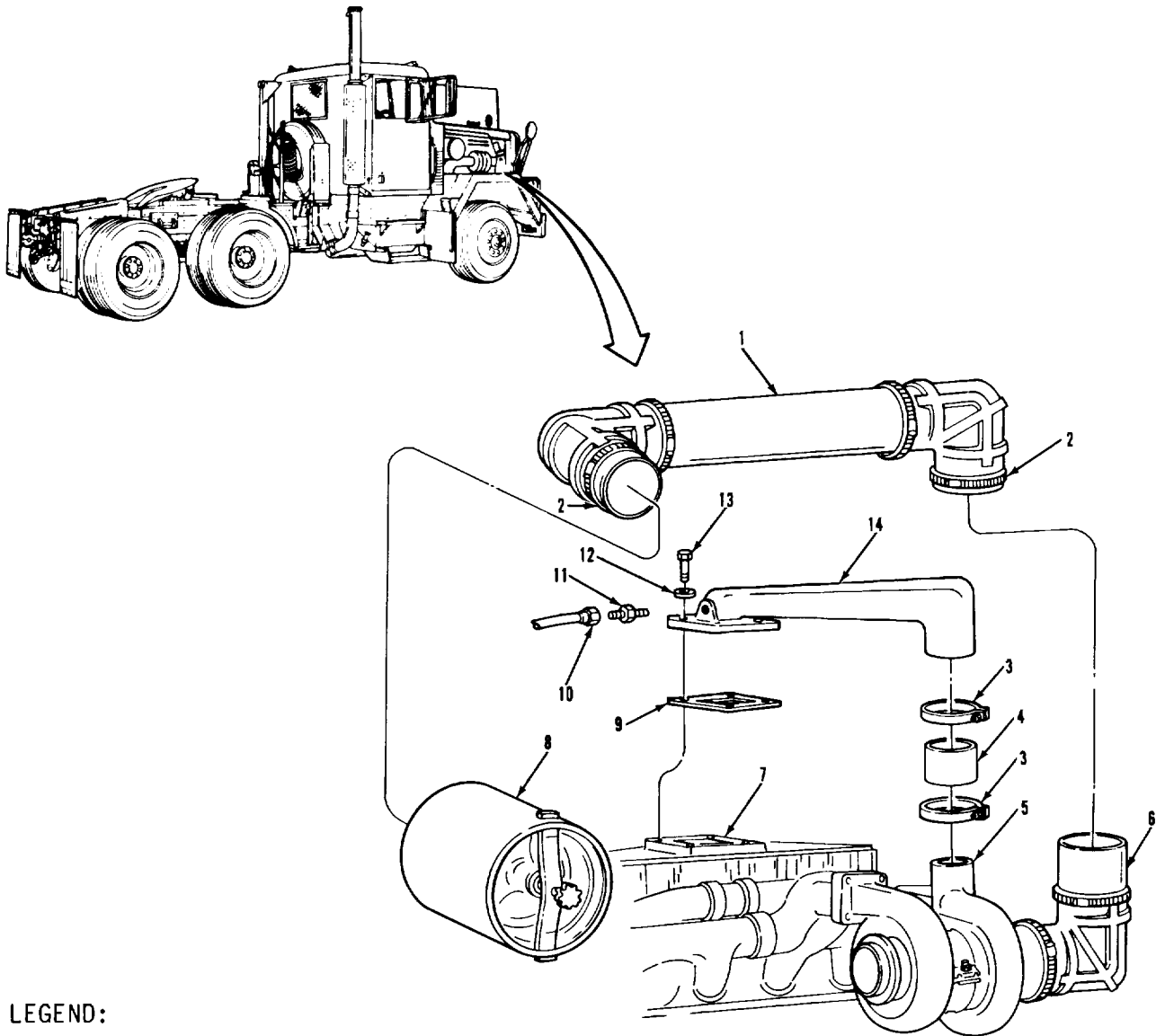

LEGEND:

LEGEND

- | | |
|---------------------------|-----------------------------|
| 1 ELBOW AND TUBE ASSEMBLY | 8 AIR CLEANER ASSEMBLY |
| 2 CLAMP (2) | 9 CROSSOVER MOUNTING GASKET |
| 3 HOSE CLAMP (2) | 10 NYLON TUBE |
| 4 HOSE | 11 ATOMIZER |
| 5 TURBOCHARGER | 12 PLAIN WASHER (4) |
| 6 LOWER AIR CLEANER TUBE | 13 SCREW (4) |
| 7 AFTERCOOLER COVER | 14 AIR CROSSOVER CONNECTION |

TA237049

FUEL SYSTEM.

3-31. TURBOCHARGER AIR CROSSOVER CONNECTION REPLACEMENT (Continued).

LOCATION/ITEM	ACTION	REMARKS
<p>CAUTION</p> <p>Dirt in the air passages can severely damage the turbocharger and engine. Be sure your work area is clean. Clean parts before installation. Cover openings to keep out dust while you are working.</p>		
A. REMOVAL		
1 Two clamps (2)	Loosen.	
2 Elbow and tube assembly (1)	Remove from item (8) and item (6).	
3 Two clamps (3)	Loosen.	
4 Tube (10)	Remove from item (11).	
5 Four screws (13) and washers (12).	Remove from item (14).	
6 Connection (14), gasket (9), hose (4), and two clamps (3).	Remove from item (5) and item (7).	Discard gasket.
7 Atomizer (11)	Remove from item (14).	
B. CLEANING AND INSPECTION.		
8 All parts	a Clean with solvent and rags	<p>a Refer to paragraph 3-4.</p> <p>b Be sure all old gasket is cleaned from item (14) and item (7).</p>

FUEL SYSTEM.

3-31. TURBOCHARGER ATR CROSSOVER CONNECTION REPLACEMENT (Continued).

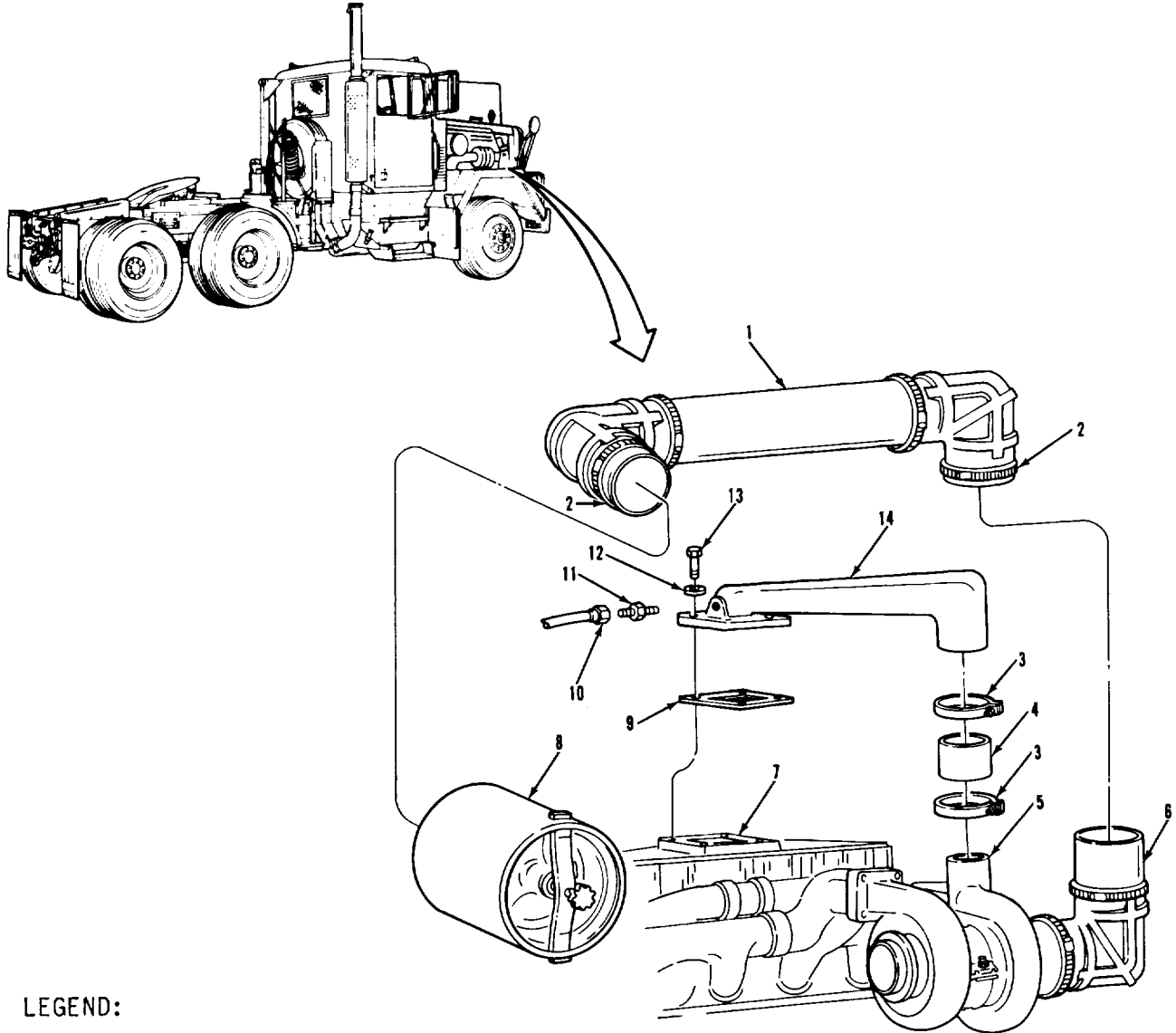

LEGEND:

- | | |
|---------------------------|-----------------------------|
| 1 ELBOW AND TUBE ASSEMBLY | 8 AIR CLEANER ASSEMBLY |
| 2 CLAMP (2) | 9 CROSSOVER MOUNTING GASKET |
| 3 HOSE CLAMP (2) | 10 NYLON TUBE |
| 4 HOSE | 11 ATOMIZER |
| 5 TURBOCHARGER | 12 PLAIN WASHER (4) |
| 7 AFTERCOOLER COVER | 14 AIR CROSSOVER CONNECTION |

FUEL SYSTEM.

3-31. TURBOCHARGER AIR CROSSOVER CONNECTION REPLACEMENT (Continued).

LOCATION/ITEM	ACTION	REMARKS
B. CLEANING AND INSPECTION (Continued).		
8 All parts (continued).	b Inspect	Refer to paragraph 3-5.
C. INSTALLATION.		
9 Atomizer (11)	Install in item (14)	Put thread sealing tape on threads.
10 Hose (4) and two clamps (3).	Put on item (5).	
11 Connection (14) and new gasket (9).	Put in place on item (7) and in item (4).	
12 Four screws (13) and washers (12)	Secure item (14) to item (7).	
13 Two clamps (3)	Tighten.	
14 Tube (10)	Install on item (11).	
15 Elbow and tube assembly (1)	Put on item (6) and item (8).	
16 Two clamps (2)	Tighten.	
<p>NOTE Follow-on maintenance action required: None.</p>		

FUEL SYSTEM.

3-31. TURBOCHARGER AIR CROSSOVER CONNECTION REPLACEMENT (Continued).

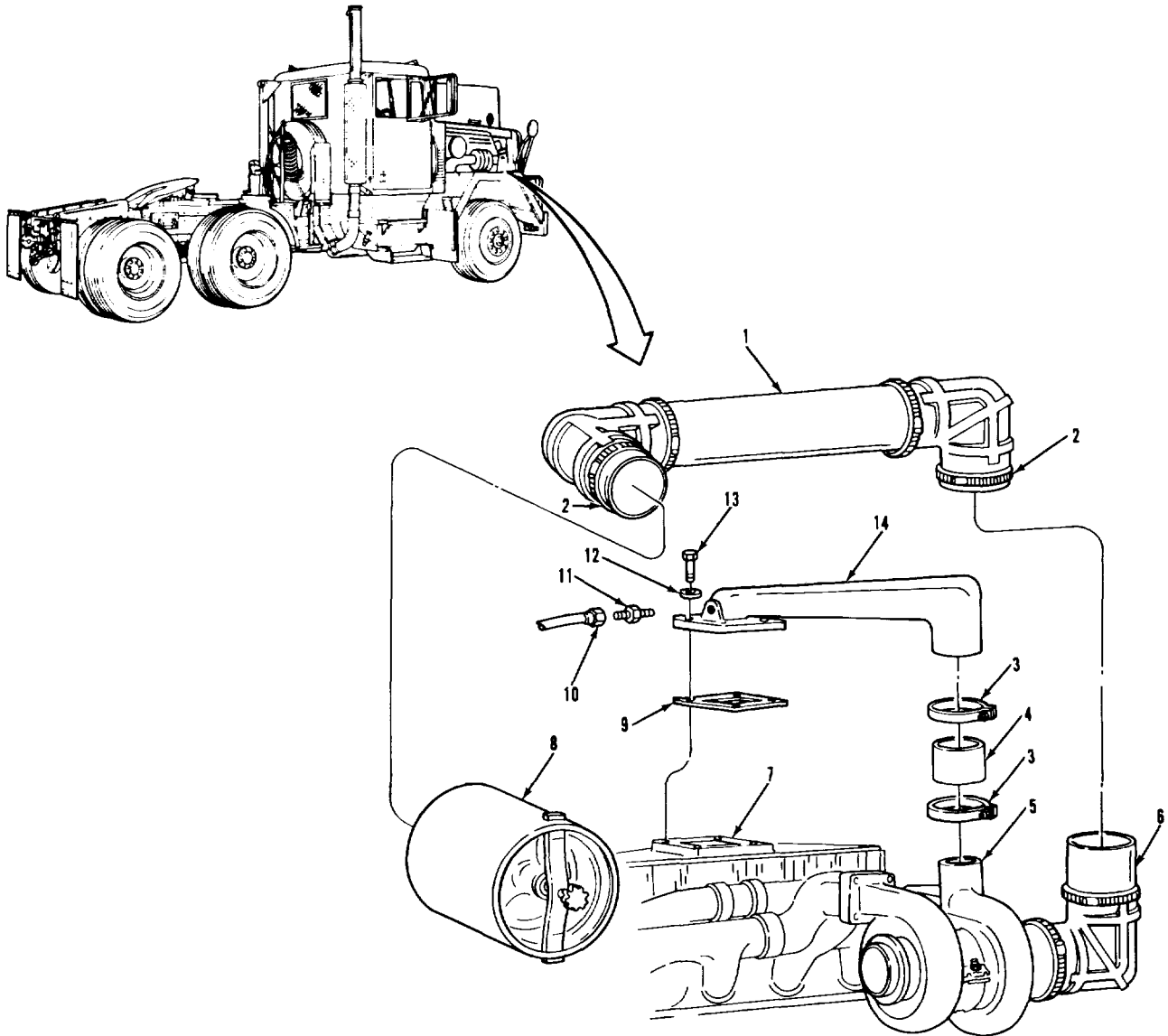

- | | | | |
|---|-------------------------|----|---------------------------|
| 1 | ELBOW AND TUBE ASSEMBLY | 8 | AIR CLEANER ASSEMBLY |
| 2 | CLAMP (2) | 9 | CROSSOVER MOUNTING GASKET |
| 3 | HOSE CLAMP (2) | 10 | NYLON TUBE |
| 4 | HOSE | 11 | ATOMIZER |
| 5 | TURBOCHARGER | 12 | PLAIN WASHER (4) |
| 6 | LOWER AIR CLEANER TUBE | 13 | SCREW (4) |
| 7 | AFTERCOOLER COVER | 14 | AIR CROSSOVER CONNECTION |

TA 237051

FUEL SYSTEM.

3-32. AIR CLEANER TUBE REPLACEMENT.

THIS TASK COVERS

- a. Removal.
- b. Cleaning and Inspection.
- c. Installation.

INITIAL SETUP

<p><u>APPLICABLE CONFIGURATIONS</u> All.</p> <p><u>TEST EQUIPMENT</u> None.</p> <p><u>SPECIAL TOOLS</u> None.</p> <p><u>MATERIALS/PARTS (P/N)</u> Rags, wiping Item 22, Appendix C.</p> <p><u>PERSONNEL REQUIRED</u> One (MOS-63SR).</p> <p><u>REFERENCES (TM)</u> None.</p> <p><u>TROUBLESHOOTING REFERENCES</u> Paragraph 2-11.</p>	<p><u>EQUIPMENT CONDITION PARAGRAPH</u> None.</p> <p><u>SPECIAL ENVIRONMENTAL CONDITIONS</u> Work area clean and away from blowing dirt and dust.</p> <p><u>GENERAL SAFETY INSTRUCTIONS</u> Engine off. Transmission in neutral. Park brake set.</p>	<p><u>CONDITION DESCRIPTION</u> None.</p>
---	--	---

FUEL SYSTEM.

3-32. AIR CLEANER TUBE REPLACEMENT (Continued).

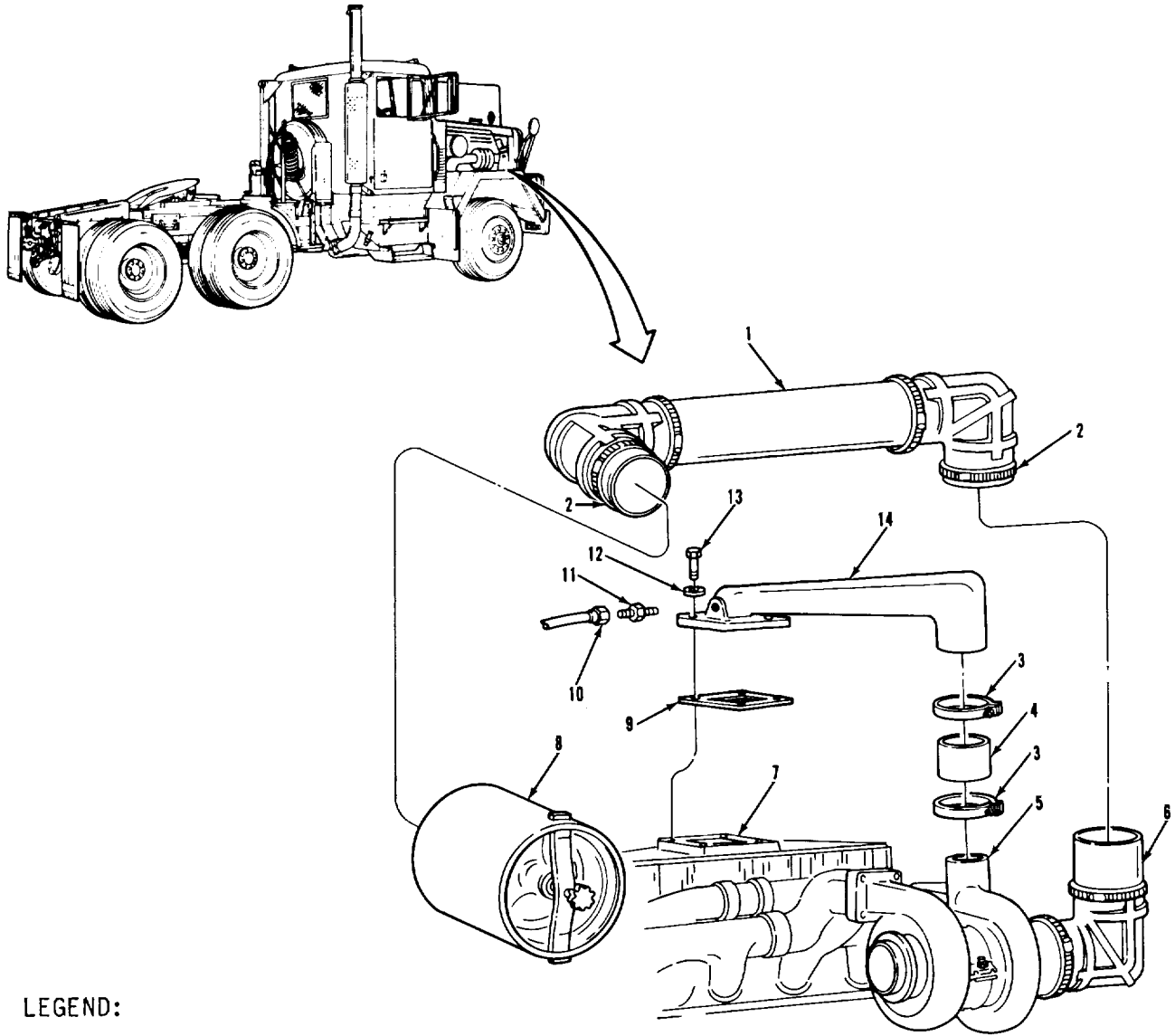

LEGEND:

- 1 90° AIR INTAKE ELBOW (3)
- 2 AIR INIAKE TUBE LAMP (1U)
- 3 UPPER AIR CLEANER TUBE
- 4 LOWER AIR CLEANER TUBE
- 5 90" AIR INTAKE ELBOW
- 6 HOOD SEAL RIGHT HAND RETAINER
- 7 TURBOCHARGER
- 8 AIR CLEANER INLET TUBE
- 9 SPECIAL 220 ELBOW
- 10 AIR CLEANER ASSEMBLY

TA 237052

FUEL SYSTEM.

3-32. AIR CLEANER TUBE REPLACEMENT (Continued).

LOCATION/ITEM	ACTION	REMARKS
<p>CAUTION</p> <p>Dirt in the air passages can severely damage the turbocharger and engine. Be sure your work area is clean. Clean parts before installation. Cover openings to keep out dust while you are working.</p>		
<p>A. REMOVAL</p>		
<p>1 Ten clamps (2)</p> <p>2 Three elbows (1), elbow (5), elbow (9), tube (3), tube (4), tube (8), and ten clamps (2).</p>	<p>Loosen.</p> <p>Remove from item (6), item (7), and item (10).</p>	
<p>B. CLEANING AND INSPECTION.</p>		
<p>3 All parts</p>	<p>a Wipe clean with damp rag</p> <p>b Inspect</p>	<p>Refer to paragraph 3-4.</p> <p>Refer to paragraph 3-5.</p>
<p>C. INSTALLATION.</p>		
<p>4, Three elbows (1), elbow (5), elbow (9), tube (3), tube (4), tube (8), and ten clamps (2).</p>	<p>Install between item (10), item (7), and item (6).</p>	

FUEL SYSTEM.

3-32. AIR INTAKE TUBE REPLACEMENT (Continued).

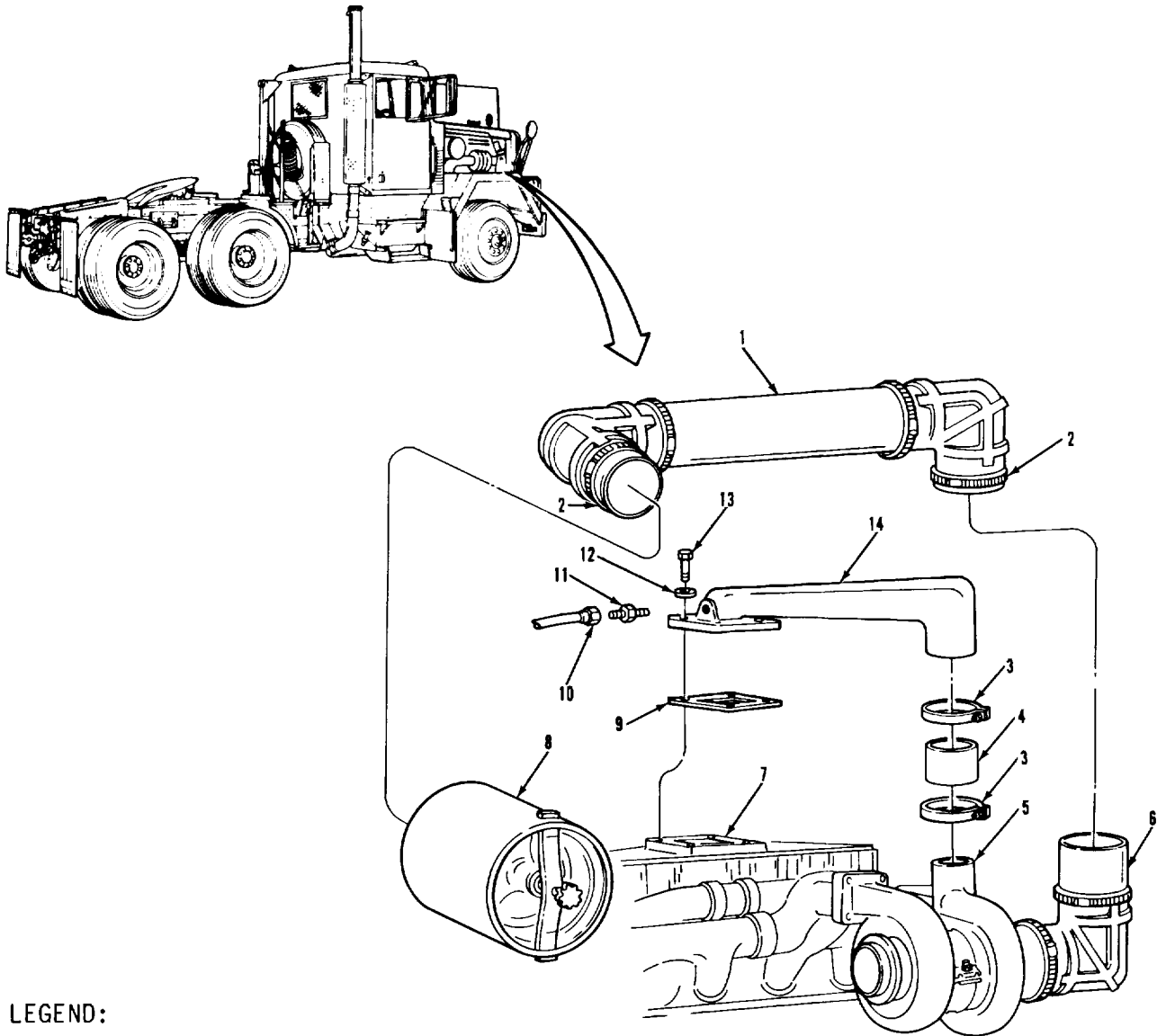

LEGEND:

- 1 900 AIR INTAKE ELBOW (3)
- 2 AIR INTAKE TUBE CLAMP (10)
- 3 UPPER AIR CLEANER TUBE
- 4 LOWER AIR CLEANER TUBE
- 5 900 AIR INTAKE ELBOW
- 6 HOOD SEAL RIGHT HAND
RETAINER
- 7 TURBOCHARGER
- 8 AIR CLEANER INLET TUBE
- 9 SPECIAL 220 ELBOW
- 10 AIR CLEANER ASSEMBLY

TA237053

FUEL SYSTEM.

3-28. ENGINE FUEL LINES AND FITTINGS REPLACEMENTS (Continued).

LOCATION/ITEM	ACTION	REMARKS
C. INSTALLATION (Continued)		
5	Ten clamps (2)	Tighten.
<p style="text-align: center;">NOTE</p> <p style="text-align: center;">Follow-on maintenance action required: None.</p>		

FUEL SYSTEM.

3-32. AIR CLEANER TUBE REPLACEMENT (Continued).

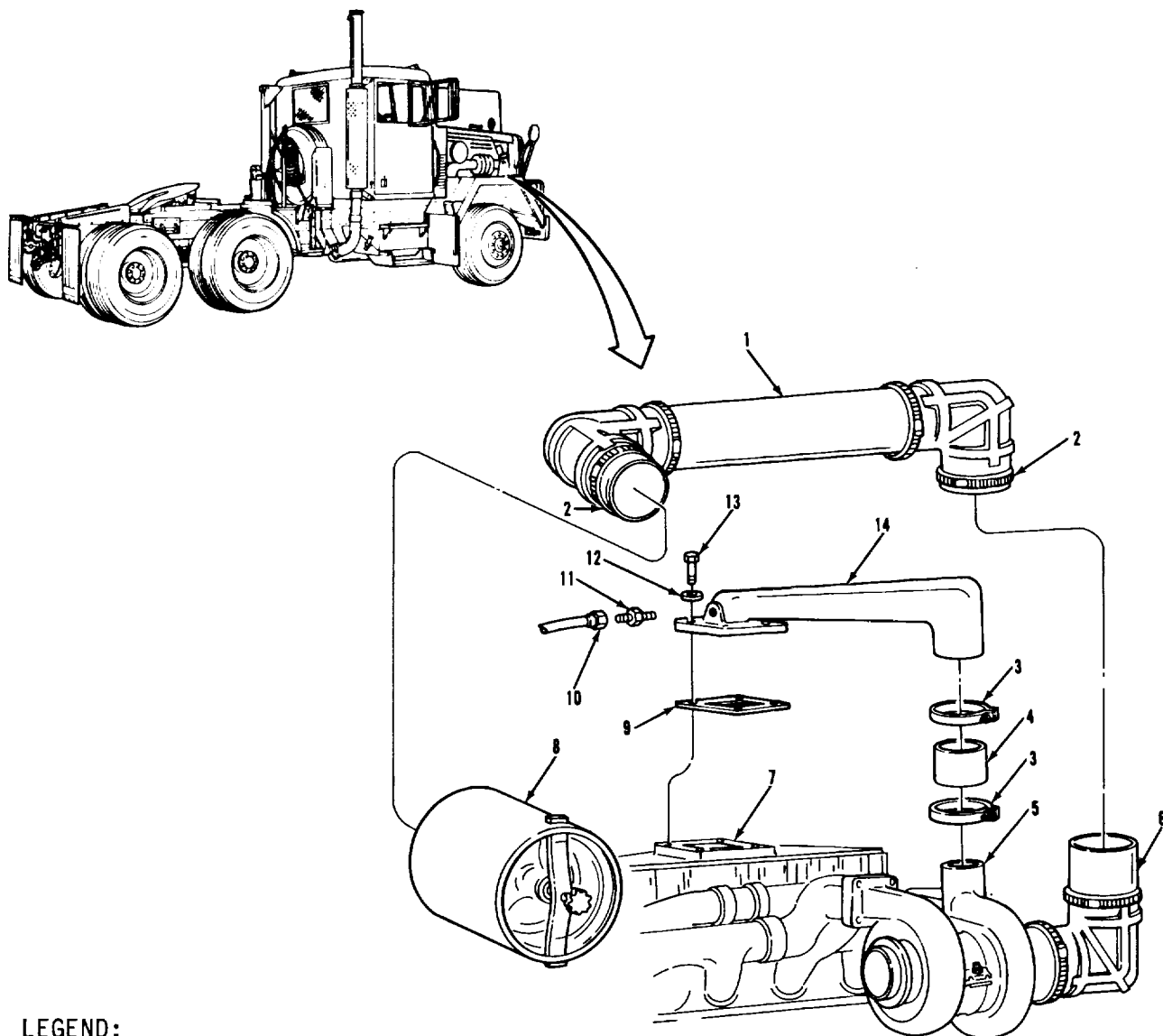

LEGEND:

- 1. 90° AIR INTAKE ELBOW (3)
- 2. AIR INTAKE TUBE CLAMP (10)
- 3. UPPER AIR CLEANER TUBE
- 4. LOWER AIR CLEANER TUBE
- 5. 90° AIR INTAKE ELBOW
- 6. HOOD SEAL RIGHT HAND
RETAINER
- 7. TURBOCHARGER
- 8. AIR CLEANER INLET TUBE
- 9. SPECIAL 22° ELBOW
- 10. AIR CLEANER ASSEMBLY

TA 237054

FUEL SYSTEM.

3-33. SOLENOID VALVE REPLACEMENT.

THIS TASK COVERS

- | | |
|-----------------------------|----------------------|
| a. Removal. | d. Assembly |
| b. Disassembly. | e. Installation. |
| c. Cleaning and Inspection. | f. Operational Check |

INITIAL SETUP

<u>APPLICABLE CONFIGURATIONS</u> All.	<u>EQUIPMENT CONDITION PARAGRAPH</u> 3-314.	<u>CONDITION DESCRIPTION</u> Pressure transducer removed.
--	--	--

TEST EQUIPMENT
None.

SPECIAL TOOLS
None.

MATERIALS/PARTS (P/N)
Rags, wiping
Item 32, Appendix C.
Solvent, drycleaning, SD-2
Item 29, Appendix C.
Seal, rectangular ring
(15434) 154087.
Seal, rectangular ring
(15434) 129888.

PERSONNEL REQUIRED
One (MOS-63S).

SPECIAL ENVIRONMENTAL CONDITIONS
None.

REFERENCES (TM)
TM 9-2320-283-20P.
TM 9-2320-283-10.
Park brake set.

GENERAL SAFETY INSTRUCTIONS
Engine off.
Transmission in neutral.

TROUBLESHOOTING REFERENCES
Paragraph 2-11.

FUEL SYSTEM.

3-33. SOLENOID VALVE REPLACEMENT (Continued).

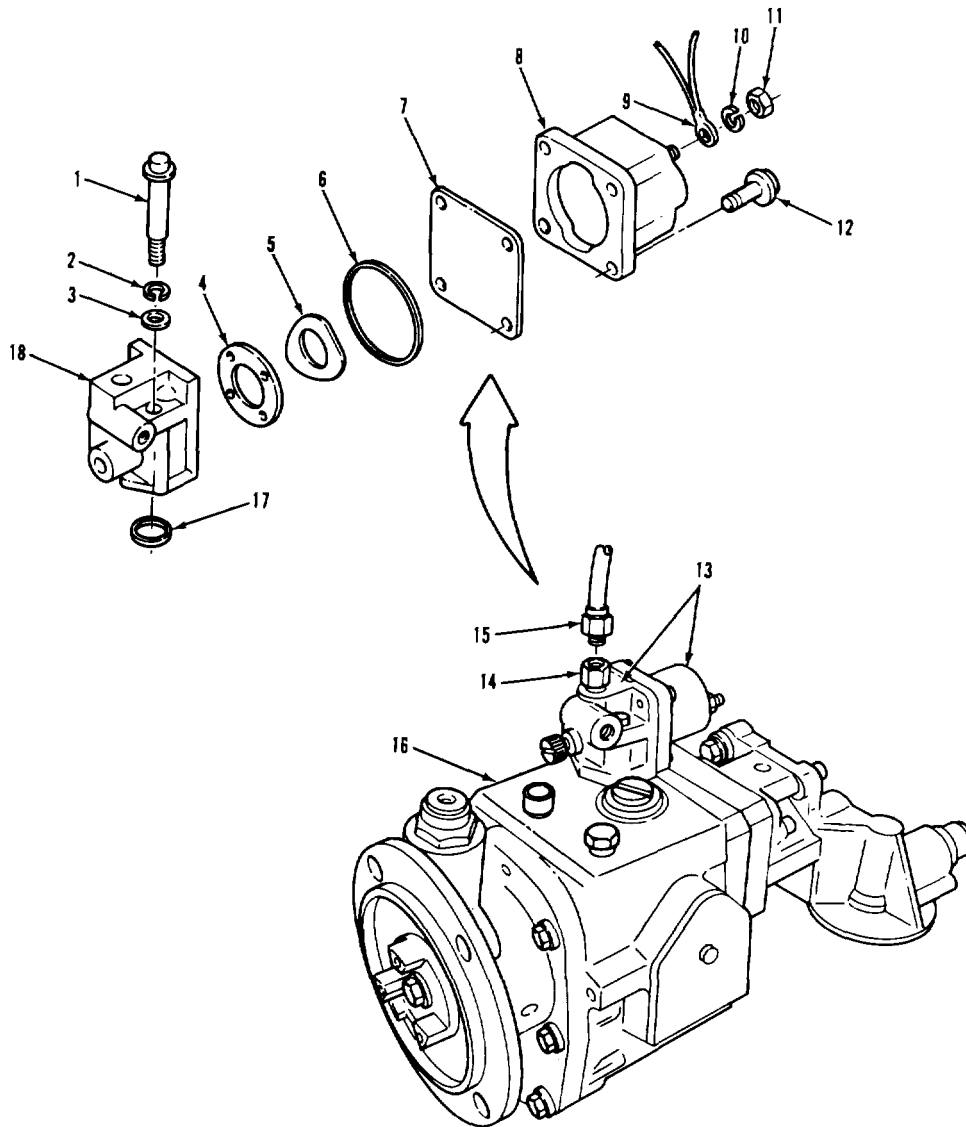

LEGEND:

- | | |
|-----------------------------|---------------------------------|
| 1. SOCKET HEAD CAPSCREW (2) | 10. LOCKWASHER |
| 2. LOCKWASHER (2) | 11. NUT |
| 3. PLAIN WASHER (2) | 12. SOLENOID MOUNTING SCREW (4) |
| 4. VALVE DISK | 13. SOLENOID VALVE |
| 5. SHUTOFF VALVE SPRING | 14. FUEL FITTING |
| 6. RECTANGULAR RING SEAL | 15. FUEL TUBE |
| 7. SHUTOFF VALVE SHIELD | 16. FUEL PUMP ASSEMBLY |
| 8. ELECTRICAL SOLENOID | 17. RECTANGULAR RING SEAL |
| 9. WIRE | 18. VALVE BODY |

TA 237055

FUEL SYSTEM.

3-33. SOLENOID VALVE REPLACEMENT (Continued).

LOCATION/ITEM	ACTION	REMARKS
A. REMOVAL.		
1. Nut (11), lock-washer (10), and wire (9).	Remove from item (8).	
2. Tube (15).	Remove from item (14).	
3. Two screws (1), lockwashers (2), and washers (3).	Remove from item (13).	
4. Valve (13) and seal (17).	a. Remove from item (16). b. Discard item (17).	
5. Fitting (14).Remove from item (13).		
B. DISASSEMBLY.		
6. Four screws (12).	Remove from item (8).	Scribe alinement marks on items (8) and (9) before disassembly.
7. Solenoid (8), shield (7), spring (5), disk (4), and seal (6).	a. Remove from item (18). b. Discard item (6).	
C. CLEANING AND INSPECTION.		
8. Solenoid (8).	Wipe with clean dry rag.	
9. All parts (except solenoid (8)).	Clean with solvent and a stiff brush.	Refer to paragraph 3-4.
10. All parts.	Inspect.	Refer to paragraph 3-5.

FUEL SYSTEM.

3-33. SOLENOID VALVE REPLACEMENT (Continued).

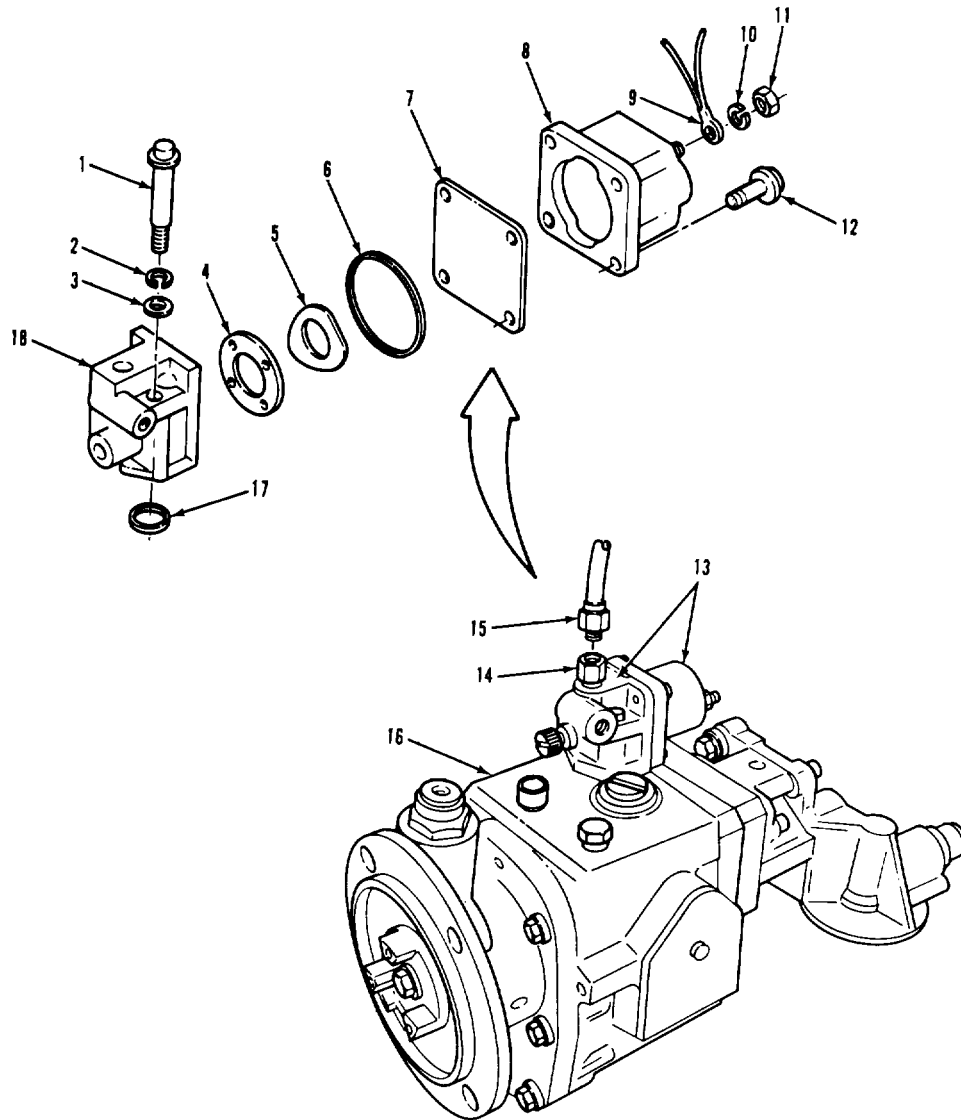

LEGEND:

- | | |
|-----------------------------|---------------------------------|
| 1. SOCKET HEAD CAPSCREW (2) | 10. LOCKWASHER |
| 2. LOCKWASHER (2) | 11. NUT |
| 3. PLAIN WASHER (2) | 12. SOLENOID MOUNTING SCREW (4) |
| 4. VALVE DISK | 13. SOLENOID VALVE |
| 5. SHUTOFF VALVE SPRING | 14. FUEL FITTING |
| 6. RECTANGULAR RING SEAL | 15. FUEL TUBE |
| 7. SHUTOFF VALVE SHIELD | 16. FUEL PUMP ASSEMBLY |
| 8. ELECTRICAL SOLENOID | 17. RECTANGULAR RING SEAL |
| 9. WIRE | 18. VALVE BODY |

TA 237056

FUEL SYSTEM.

3-33. SOLENOID VALVE REPLACEMENT (Continued).

LOCATION/ITEM	ACTION	REMARKS
D. ASSEMBLY.		
11. Disk (4).	Put in item (18).	Rubber side of item (4) faces in.
12. Spring (5).	Put on item (4).	
13. New seal (6).	Put in item (18).	
14. Shield (7).	Put on item (8).	
15. Solenoid (8) and shield (7).	Put on item (18).	
16. Four screws (12).	Secure item (8) to item (18).	Insure that scribe marks are alined.
E. INSTALLATION.		
17. Fitting (14).	Install in item (13).	
18. New seal (17).	Put in item (13).	
19. Valve (13).	Position on item (16).	
20. Two screws (1), lockwashers (2), and washers (3).	Secure item (13) to item (17).	
21. Tube (15).	Install in item (14).	
22. Wire (9), lockwashers (10), and nut (11).	Install on item (8).	Install on longer stud.

FUEL SYSTEM.

3-33. SOLENOID VALVE REPLACEMENT (Continued).

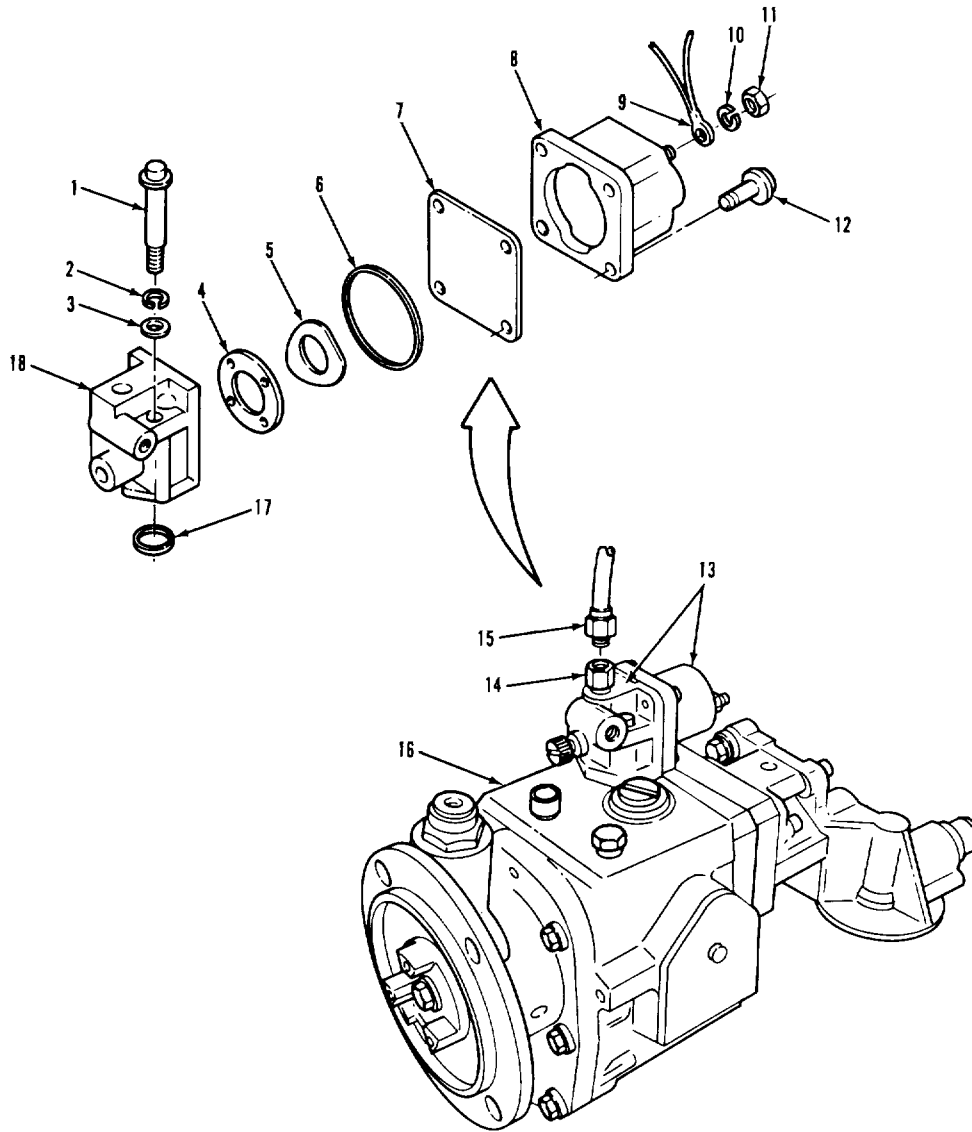

LEGEND:

- | | |
|-----------------------------|---------------------------------|
| 1. SOCKET HEAD CAPSCREW (2) | 10. LOCKWASHER |
| 2. LOCKWASHER (2) | 11. NUT |
| 3. PLAIN WASHER (2) | 12. SOLENOID MOUNTING SCREW (4) |
| 4. VALVE DISK | 13. SOLENOID VALVE |
| 5. SHUTOFF VALVE SPRING | 14. FUEL FITTING |
| 6. RECTANGULAR RING SEAL | 15. FUEL TUBE |
| 7. SHUTOFF VALVE SHIELD | 16. FUEL PUMP ASSEMBLY |
| 8. ELECTRICAL SOLENOID | 17. RECTANGULAR RING SEAL |
| 9. WIRE | 18. VALVE BODY |

TA 237057

FUEL SYSTEM.

3-33. SOLENOID VALVE REPLACEMENT (Continued).

LOCATION/ITEM	ACTION	REMARKS
F. OPERATIONAL CHECK.		
23. Pressure transducer.	Install.	Refer to paragraph 3-314.
24. Engine run switch.	Turn ON and OFF several times.283-10.	a. Refer to TM 9-2320- b. Assistant turns switch.
25. Solenoid valve (13).	Listen for "click" when run switch is turned ON or OFF.	
26. Engine.	Start up.	a. Refer to TM 9-2320-283-10. b. Engine will not start if solenoid is not working.
27. Solenoid valve (13).	Check for leaks.	
28. Engine.	Shut down.	Refer to TM 9-2320-283-10.
NOTE		
Follow-on maintenance action required:		
None.		

FUEL SYSTEM.

3-33. SOLENOID VALVE REPLACEMENT (Continued).

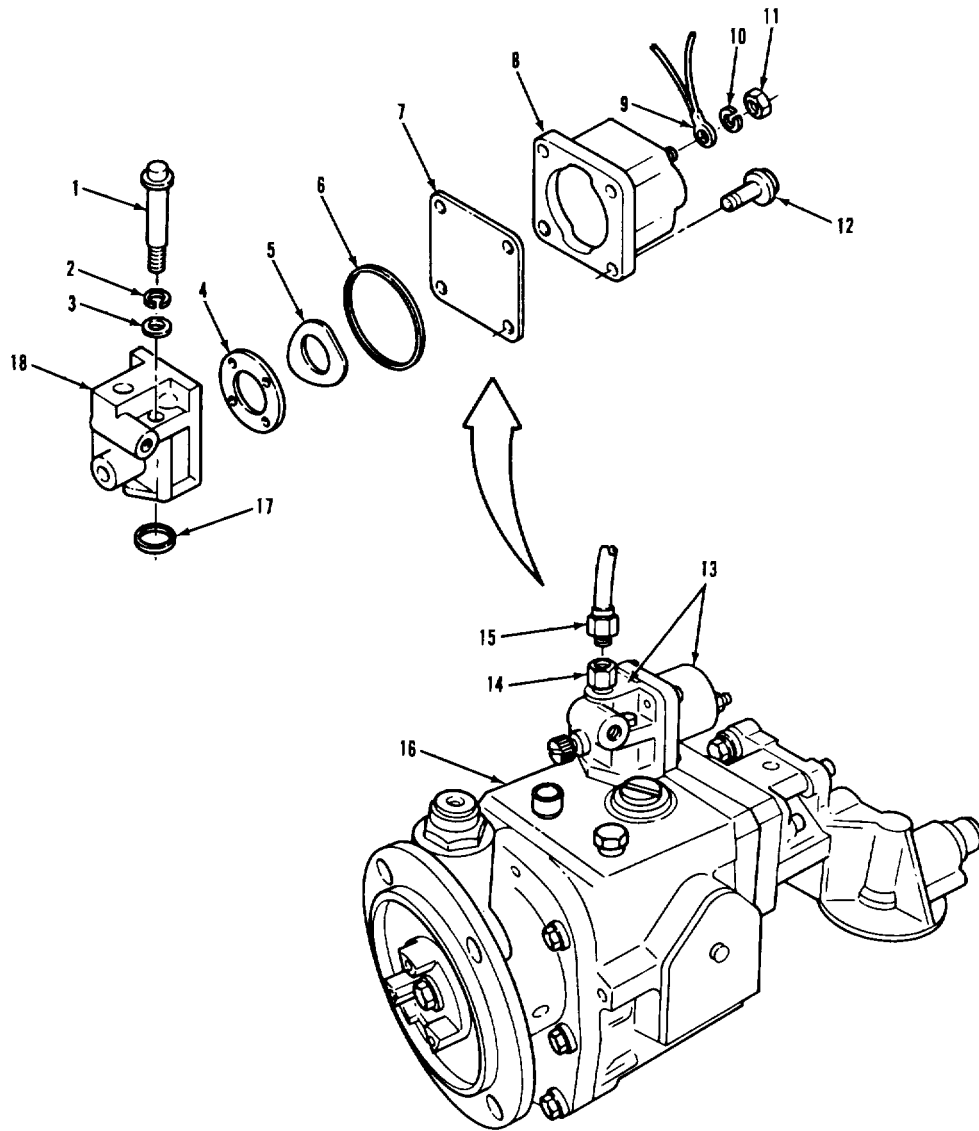

LEGEND:

- | | |
|-----------------------------|---------------------------------|
| 1. SOCKET HEAD CAPSCREW (2) | 10. LOCKWASHER |
| 2. LOCKWASHER (2) | 11. NUT |
| 3. PLAIN WASHER (2) | 12. SOLENOID MOUNTING SCREW (4) |
| 4. VALVE DISK | 13. SOLENOID VALVE |
| 5. SHUTOFF VALVE SPRING | 14. FUEL FITTING |
| 6. RECTANGULAR RING SEAL | 15. FUEL TUBE |
| 7. SHUTOFF VALVE SHIELD | 16. FUEL PUMP ASSEMBLY |
| 8. ELECTRICAL SOLENOID | 17. RECTANGULAR RING SEAL |
| 9. WIRE | 18. VALVE BODY |

TA 237058

FUEL SYSTEM.

3-34. FUEL TANK REPLACEMENT.

THIS TASK COVERS

- a. Removal.
- b. Cleaning and Inspection.
- c. Installation.

INITIAL SETUP

APPLICABLE CONFIGURATIONS

All.

EQUIPMENT CONDITION
PARAGRAPH

3-105.

CONDITION DESCRIPTION

Fuel level sending unit removed.

TEST EQUIPMENT

None.

SPECIAL TOOLS

None.

MATERIALS/PARTS (P/N)

Rags, wiping
 Item 22, Appendix C.
 Solvent, drycleaning, SD-2
 Item 29, Appendix C.
 Tape, thread sealing
 Item 32, Appendix C.
 Adhesive, liquid, rubber, Type II
 Item 1, Appendix C.
 Container for draining fuel (AR).

PERSONNEL REQUIRED

Two (MOS-63S).

SPECIAL ENVIRONMENTAL CONDITIONS

None.

REFERENCES (TM)

TM 9-2320-283-10.

GENERAL SAFETY INSTRUCTIONS

Engine off.
 Transmission in neutral.
 Park brake set.

TROUBLESHOOTING REFERENCES

None.

FUEL SYSTEM.

3-34. FUEL TANK REPLACEMENT (Continued).

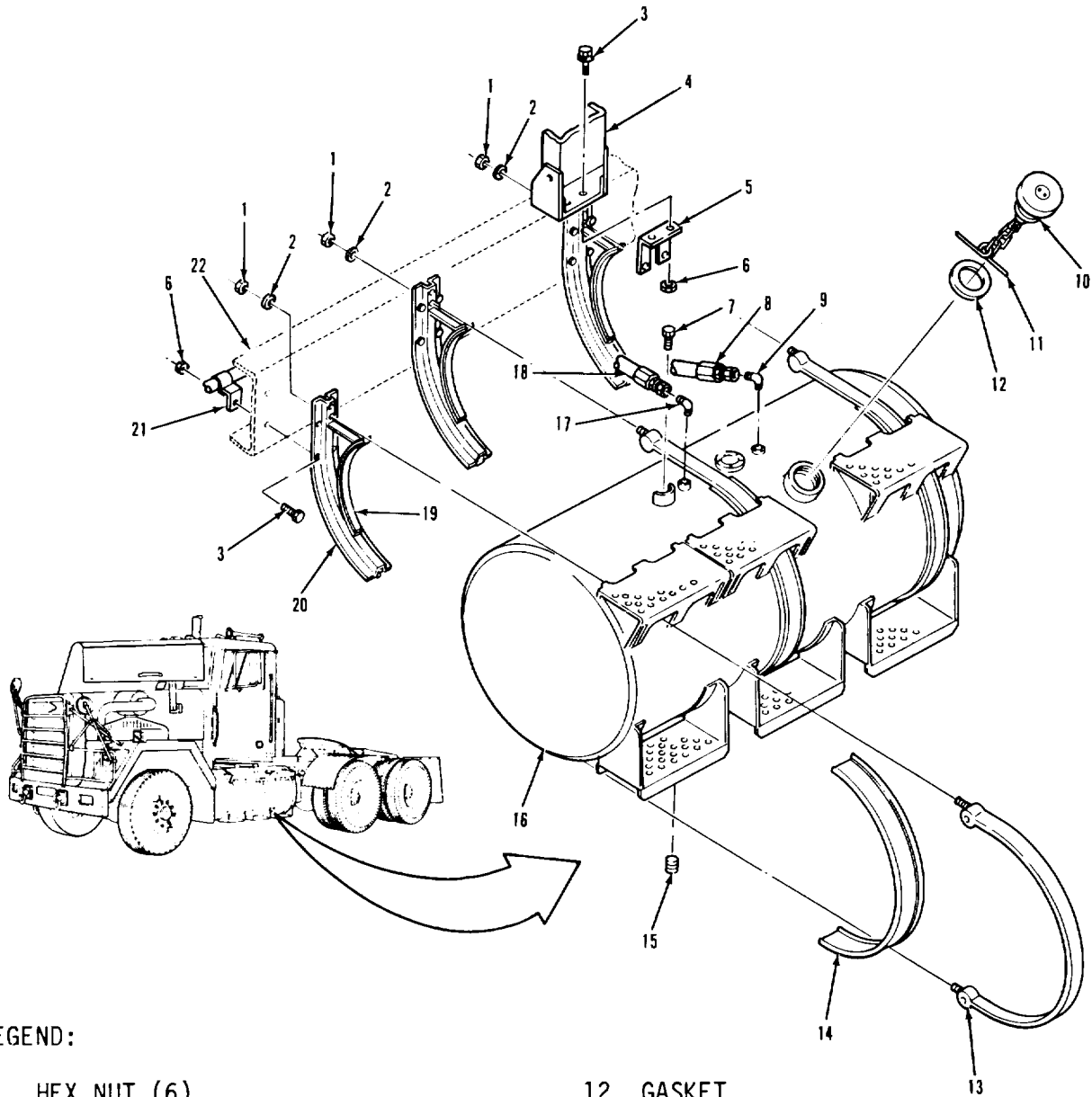

LEGEND:

- | | |
|----------------------------------|-------------------------------------|
| 1. HEX NUT (6) | 12. GASKET |
| 2. WASHER (6) | 13. FUEL TANK STRAP ASSEMBLY (3) |
| 3. HEX FLANGED SCREW (14) | 14. FUEL TANK STRAP INSULATOR (3) |
| 4. SPARE TIRE CARRIER ASSEMBLY | 15. DRAIN PLUG |
| 5. TIRE CARRIER MOUNTING BRACKET | 16. FUEL TANK ASSEMBLY |
| 6. HEX FLANGED NUT (14) | 17. ELBOW |
| 7. VENT PLUG | 18. FUEL SUPPLY HOSE |
| 8. FUEL RETURN HOSE | 19. FUEL TANK BRACKET INSULATOR (3) |
| 9. ELBOW | 20. FUEL TANK MOUNTING BRACKET (3) |
| 10. CAP ASSEMBLY | 21. TUBE SUPPORT (3) |
| 11. BAR | 22. FRAME |

TA 237059

FUEL SYSTEM.

3-34. FUEL TANK REPLACEMENT (Continued).

LOCATION/ITEM	ACTION	REMARKS
<div style="border: 1px solid black; padding: 2px; display: inline-block;">A. REMOVAL.</div>		
NOTE		
Have suitable container ready to catch fuel.		
1. Plug (15).	a. Remove from item (16).	
	b. Drain fuel into suitable container.	
2. Hose (8) and hose (18).	Remove from item (9) and item (17).	
3. Elbow (9) and elbow (17).	Remove from item (16).	
<u>WARNING</u>		
Be sure tank is supported so it cannot fall.		
4. Six nuts (1) and lockwashers (2).	Remove from three items (13).	
5. Three straps (13).	Remove from item (16).	
6. Tank assembly (16).	Lower to ground.	
7. Three insulators (14).	Remove from three items (13).	
8. Vent (7).	Remove from item (16).	

FUEL SYSTEM.

3-34. FUEL TANK REPLACEMENT (Continued).

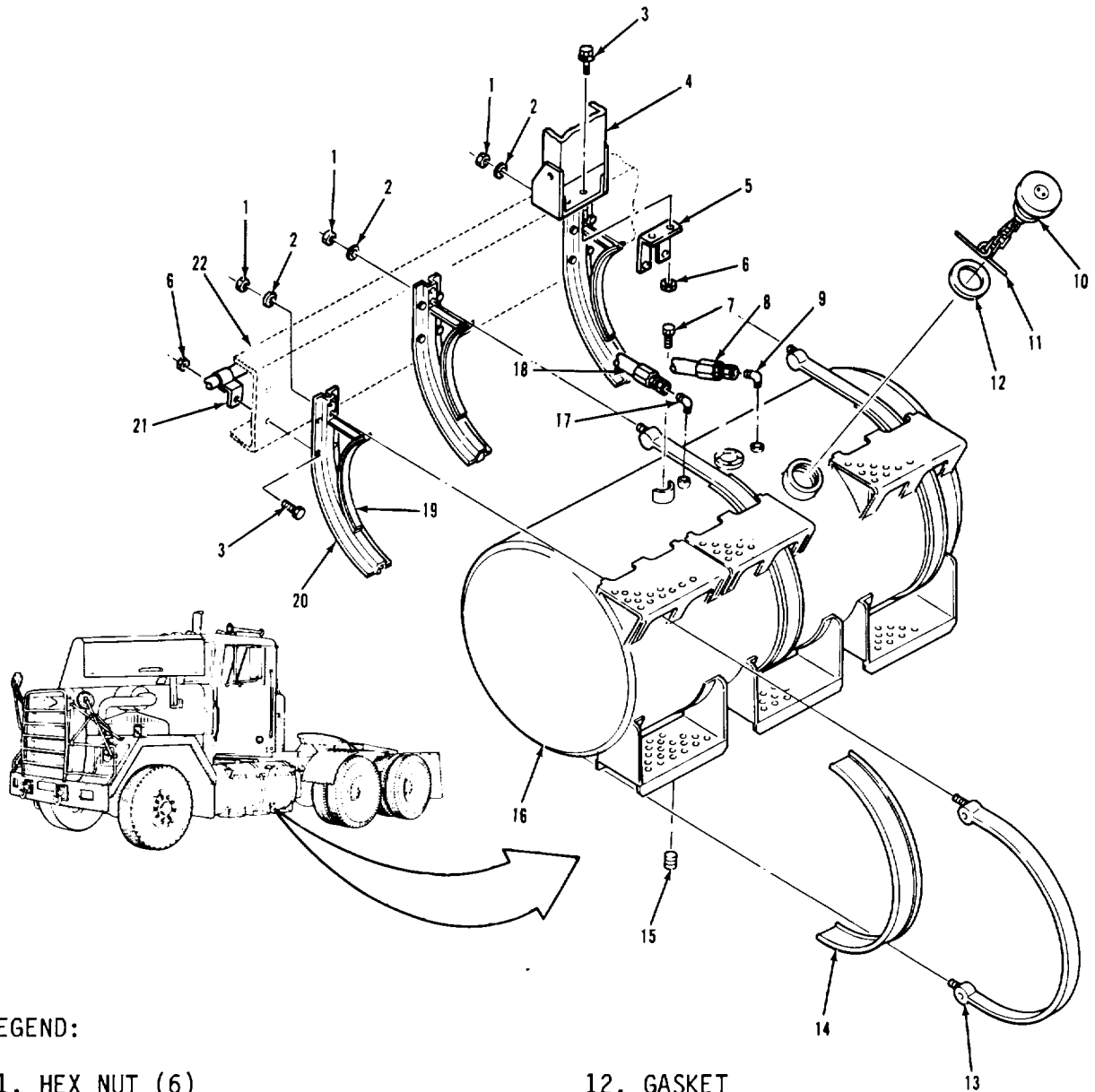

LEGEND:

- | | |
|----------------------------------|-------------------------------------|
| 1. HEX NUT (6) | 12. GASKET |
| 2. WASHER (6) | 13. FUEL TANK STRAP ASSEMBLY (3) |
| 3. HEX FLANGED SCREW (14) | 14. FUEL TANK STRAP INSULATOR (3) |
| 4. SPARE TIRE CARRIER ASSEMBLY | 15. DRAIN PLUG |
| 5. TIRE CARRIER MOUNTING BRACKET | 16. FUEL TANK ASSEMBLY |
| 6. HEX FLANGED NUT (14) | 17. ELBOW |
| 7. VENT PLUG | 18. FUEL SUPPLY HOSE |
| 8. FUEL RETURN HOSE | 19. FUEL TANK BRACKET INSULATOR (3) |
| 9. ELBOW | 20. FUEL TANK MOUNTING BRACKET (3) |
| 10. CAP ASSEMBLY | 21. TUBE SUPPORT (3) |
| 11. BAR | 22. FRAME |

TA 237060

FUEL SYSTEM.

3-34. FUEL TANK REPLACEMENT (Continued).

LOCATION/ITEM	ACTION	REMARKS
A. REMOVAL (Continued).		
9. Cap assembly (10).	Remove from item (16).	Use long round nose pliers to remove item (11) from screen of item (16).
10. Gasket (12).	Remove from item (10).	
11. Two screws (3) and nuts (6).	Remove from item (4) and item (5).	
12. Twelve screws (3) and nuts (6).	Unscrew and remove three items (20), item (5), and three items (21) from item (22).	
13. Three insulators (19).	Remove from three items (20).	
B. CLEANING AND INSPECTION.		
14. All parts except insulators (14) and (19).	Clean with solvent and rags.	Refer to paragraph 3-4.
15. All parts.	Inspect.	Refer to paragraph 3-5.
C. INSTALLATION.		
16. Twelve screws (3) and nuts (6).	Secure three items (20), item (5), and three items (21) to item (22).	
17. Two screws (3) and nuts (6).	Secure item (5) to item (4).	
18. Three insulators (19).	Install on three items (20) with adhesive.	
19. Gasket (12).	Put on item (10).	

FUEL SYSTEM.

3-34. FUEL TANK REPLACEMENT (Continued).

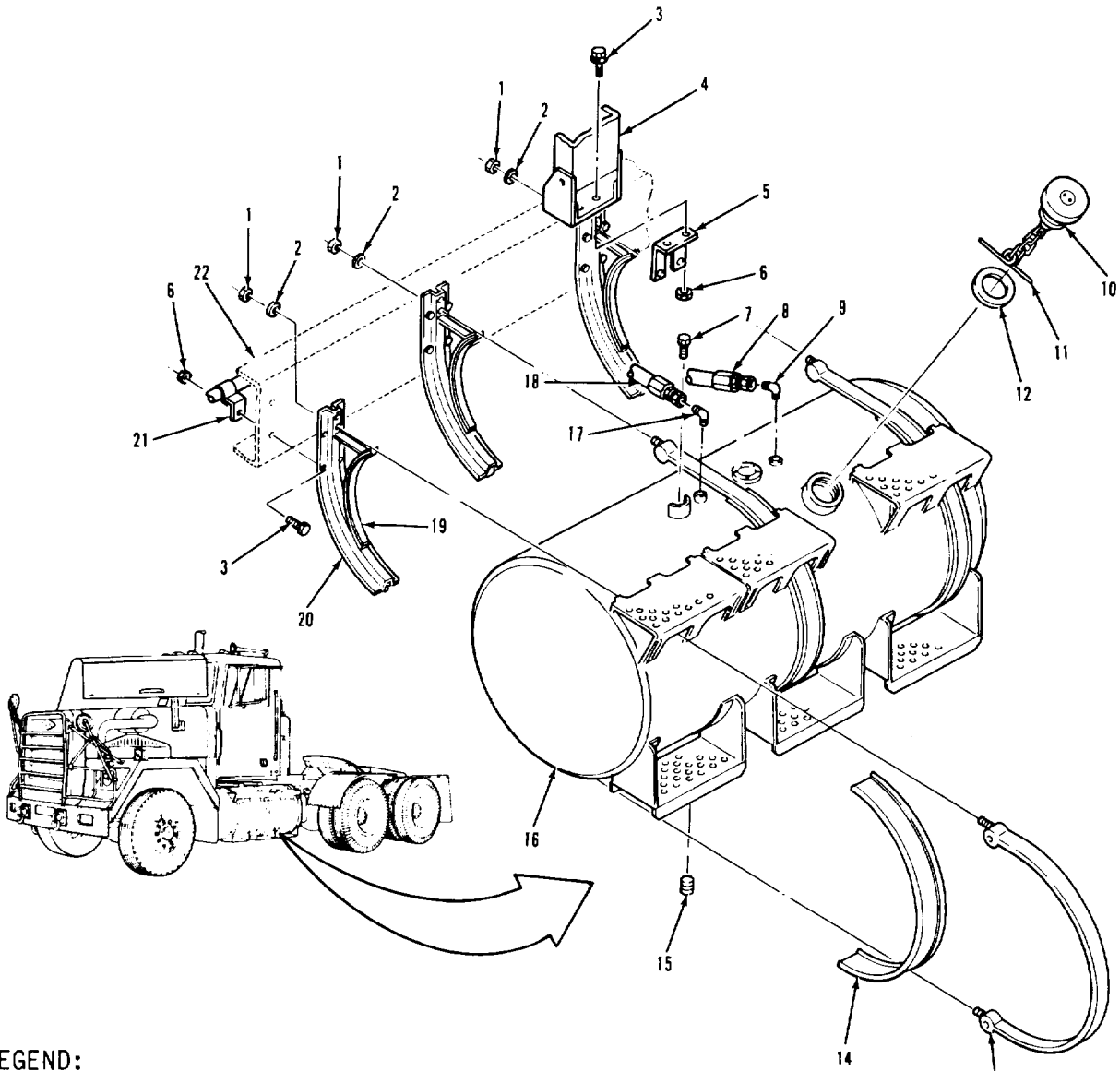

LEGEND:

- | | |
|----------------------------------|-------------------------------------|
| 1. HEX NUT (6) | 12. GASKET |
| 2. WASHER (6) | 13. FUEL TANK STRAP ASSEMBLY (3) |
| 3. HEX FLANGED SCREW (14) | 14. FUEL TANK STRAP INSULATOR (3) |
| 4. SPARE TIRE CARRIER ASSEMBLY | 15. DRAIN PLUG |
| 5. TIRE CARRIER MOUNTING BRACKET | 16. FUEL TANK ASSEMBLY |
| 6. HEX FLANGED NUT (14) | 17. ELBOW |
| 7. VENT PLUG | 18. FUEL SUPPLY HOSE |
| 8. FUEL RETURN HOSE | 19. FUEL TANK BRACKET INSULATOR (3) |
| 9. ELBOW | 20. FUEL TANK MOUNTING BRACKET (3) |
| 10. CAP ASSEMBLY | 21. TUBE SUPPORT (3) |
| 11. BAR | 22. FRAME |

TA 237061

FUEL SYSTEM.

3-34. FUEL TANK REPLACEMENT (Continued).		
LOCATION/ITEM	ACTION	REMARKS
C INSTALLATION (Continued).		
20. Cap assembly (10).	Install in item (16).	Use long round nose pliers to install item (11) in screen of item (16).
21. Vent (7).	Install in item (16).	
22. Three insulators (14).	Install on three items (13).	
23. Tank assembly (16).	Install on three items (20). (16) are level with ground.	Be sure steps on item
24. Three straps (13). into three items (20).	Install around item (16) and	
25. Six nuts (1) and lockwashers (2).	Secure three items (13) to three items (20).	
26. Elbow (9) and elbow (17).	Install in item (16).	a. Put thread sealing tape on pipe threads. b. Point item (9) and item (17) toward frame.
27. Hose (8) and hose (18).	Install on item (9) and item (17).	
28. Plug (15).	Install in item (16).	
NOTE		
Follow-on maintenance action required:		
Install fuel level sending unit (para 3-105).		
Fill fuel tank with proper diesel fuel (TM 9-2320-283-10).		
Start engine, check for leaks, retighten connections as necessary, shut down engine (TM 9-2320-283-10).		

FUEL SYSTEM.

3-34. FUEL TANK REPLACEMENT (Continued).

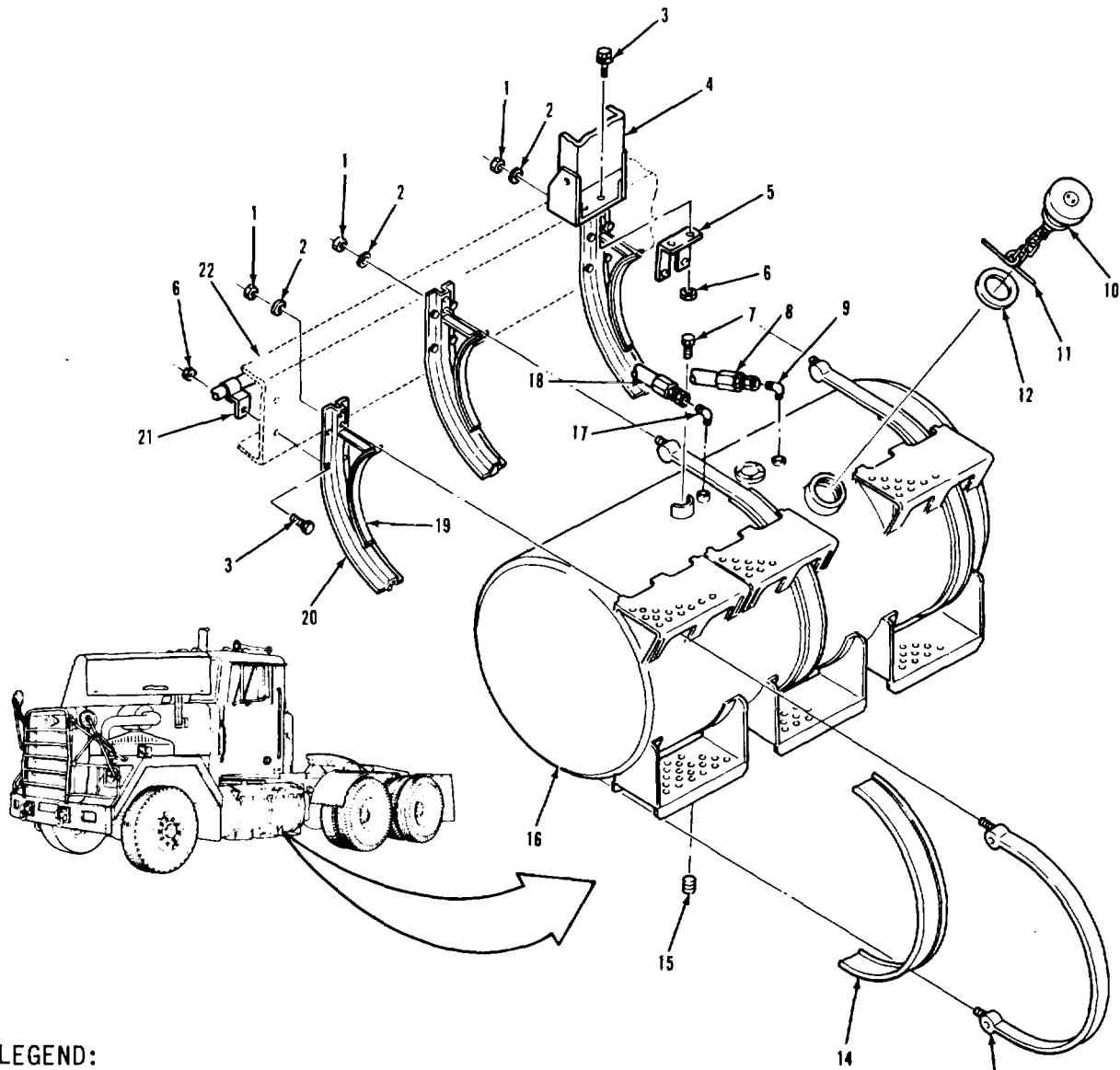

LEGEND:

- | | |
|----------------------------------|-------------------------------------|
| 1. HEX NUT (6) | 12. GASKET |
| 2. WASHER (6) | 13. FUEL TANK STRAP ASSEMBLY (3) |
| 3. HEX FLANGED SCREW (14) | 14. FUEL TANK STRAP INSULATOR (3) |
| 4. SPARE TIRE CARRIER ASSEMBLY | 15. DRAIN PLUG |
| 5. TIRE CARRIER MOUNTING BRACKET | 16. FUEL TANK ASSEMBLY |
| 6. HEX FLANGED NUT (14) | 17. ELBOW |
| 7. VENT PLUG | 18. FUEL SUPPLY HOSE |
| 8. FUEL RETURN HOSE | 19. FUEL TANK BRACKET INSULATOR (3) |
| 9. ELBOW | 20. FUEL TANK MOUNTING BRACKET (3) |
| 10. CAP ASSEMBLY | 21. TUBE SUPPORT (3) |
| 11. BAR | 22. FRAME |

TA 237062

FUEL SYSTEM.

3-35. FUEL HEATER REPLACEMENT.

THIS TASK COVERS

- a. Removal.
- b. Cleaning and Inspection.
- c. Installation.

INITIAL SETUP

<p><u>APPLICABLE CONFIGURATIONS</u> All.</p>	<p><u>EQUIPMENT CONDITION PARAGRAPH</u> 3-52.</p>	<p><u>CONDITION DESCRIPTION</u> Radiator drained.</p>
<p><u>TEST EQUIPMENT</u> None.</p>		
<p><u>SPECIAL TOOLS</u> None.</p>		
<p><u>MATERIALS/PARTS (P/N)</u> Rags, wiping Item 22, Appendix C. Solvent, drycleaning, SD-2 Item 29, Appendix C. Tape, thread sealing Item 32, Appendix C.</p>		
<p><u>PERSONNEL REQUIRED</u> One (MOS-63S .</p>	<p><u>SPECIAL ENVIRONMENTAL CONDITIONS</u> None.</p>	
<p><u>REFERENCES (TM)</u> None.</p>	<p><u>GENERAL SAFETY INSTRUCTIONS</u> Engine off. Transmission in neutral. Park brake set.</p>	
<p><u>TROUBLESHOOTING REFERENCES</u> Paragraph 2-11.</p>		

FUEL SYSTEM.

3-35. FUEL HEATER REPLACEMENT (Continued).

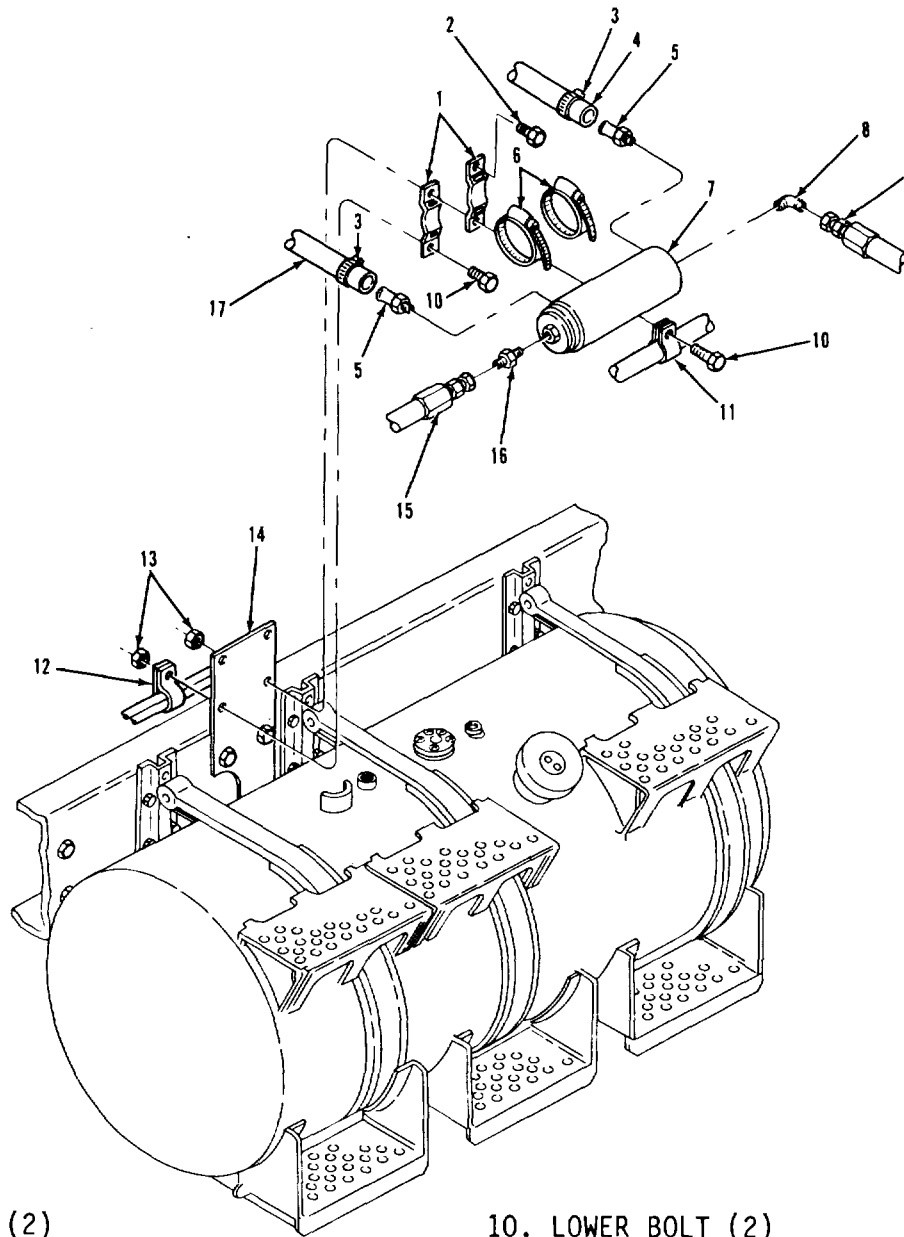

LEGEND:

- | | |
|--------------------------------|---------------------------------|
| 1. BRACKET (2) | 10. LOWER BOLT (2) |
| 2. UPPER BOLT (2) | 11. CLAMP |
| 3. HOSE CLAMP (2) | 12. CLAMP |
| 4. FUEL HEATER TO ENGINE HOSE | 13. NUT (4) |
| 5. FUEL HEATER HOSE NIPPLE (2) | 14. OIL FILTER MOUNTING BRACKET |
| 6. CLAMP (2) | 15. FUEL SUPPLY TO ENGINE HOSE |
| 7. FUEL HEATER | 16. CONNECTOR |
| 8. ELBOW | 17. HEATER TO FUEL HEATER HOSE |
| 9. FUEL SUPPLY HOSE | |

TA 237063

FUEL SYSTEM.

3-35. FUEL HEATER REPLACEMENT (Continued).

LOCATION/ITEM	ACTION	REMARKS
A. REMOVAL.		
NOTE		
For the next two steps have suitable plugs available.		
1. Hose (9).	Remove from item (8).	Hold up and plug end to prevent fuel spillage.
2. Hose (15).	Remove from item (16).	Hold up and plug end to prevent fuel spillage.
3. Two clamps (6).	Open all the way.	
4. Two clamps (3).	Loosen.	
5. Hose (4) and hose (17).	Pull from two items (5).	Have a drain pan ready to catch any spillage.
6. Heater (7).	Remove from two items (6).	Handle carefully to prevent excess coolant and fuel spillage.
7. Two nipples (5), connector (16), and elbow (8).	Remove from item (7).	
8. Two screws (10), two screws (2), and four nuts (13).	Remove from two items (1), item (11), and item (12).	
9. Two brackets (1).	Remove from item (14).	
10. Two clamps (6).	Remove from two items (1).	
B. CLEANING AND INSPECTION.		
11. All parts.	Clean with solvent and rags.	Refer to paragraph 3-4.
3-160		

FUEL SYSTEM.

3-35. FUEL HEATER REPLACEMENT (Continued).

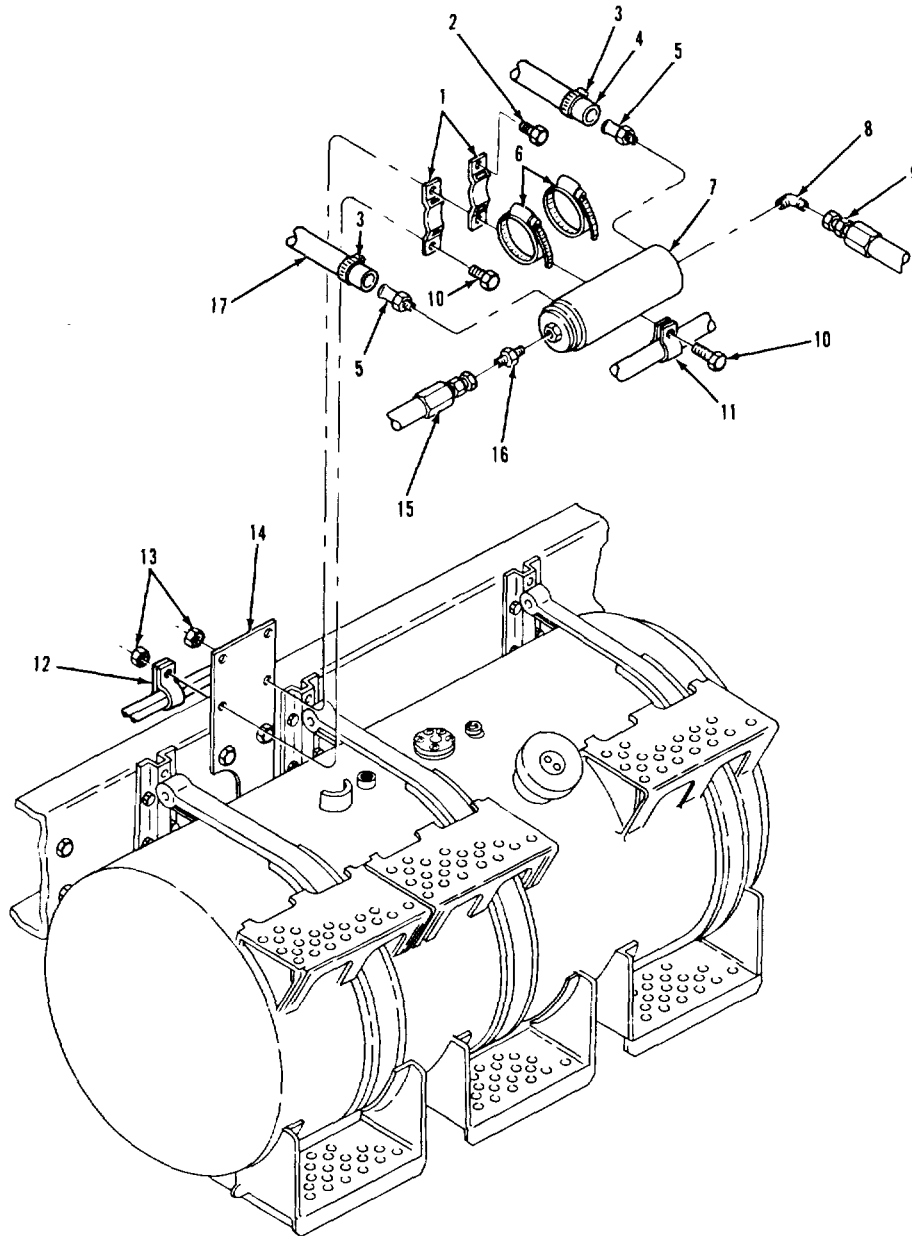

LEGEND:

- | | |
|--------------------------------|---------------------------------|
| 1. BRACKET (2) | 10. LOWER BOLT (2) |
| 2. UPPER BOLT (2) | 11. CLAMP |
| 3. HOSE CLAMP (2) | 12. CLAMP |
| 4. FUEL HEATER TO ENGINE HOSE | 13. NUT (4) |
| 5. FUEL HEATER HOSE NIPPLE (2) | 14. OIL FILTER MOUNTING BRACKET |
| 6. CLAMP (2) | 15. FUEL SUPPLY TO ENGINE HOSE |
| 7. FUEL HEATER | 16. CONNECTOR |
| 8. ELBOW | 17. HEATER TO FUEL HEATER HOSE |
| 9. FUEL SUPPLY HOSE | |

TA 237064

FUEL SYSTEM.

3-35. FUEL HEATER REPLACEMENT (Continued).

LOCATION/ITEM	ACTION	REMARKS
B. CLEANING AND INSPECTION (Continued).		
12. Heater (7).	Flush out with clean running water.	a. Only run water through ports on side of item (7). b. If water comes out of ends of item (7), replace item (7).
13. All parts.	Inspect.	Refer to paragraph 3-5.
C. INSTALLATION.		
14. Two clamps (6).	Put through two items (1).	
15. Two brackets (1).	Place on item (14).	
16. Two screws (10), two screws (2), and four nuts (13).	Secure two items (1), item (11), and item (12) to item (14).	Longer screws go on bottom.
17. Two nipples (5), connector (16), and elbow (8).	Install in item (7).	a. Put thread sealing tape on pipe threads. b. Point item (8) away from two items (5).
18. Two clamps (3).	Slip over item (4) and item (17).	
19. Heater (7).	Place in two items (6).	
20. Hose (4) and hose (17).	Push on two items (5).	
21. Two clamps (3).	Tighten.	
22. Two clamps (6).	Tighten around item (7).	

FUEL SYSTEM.

3-35. FUEL HEATER REPLACEMENT (Continued).

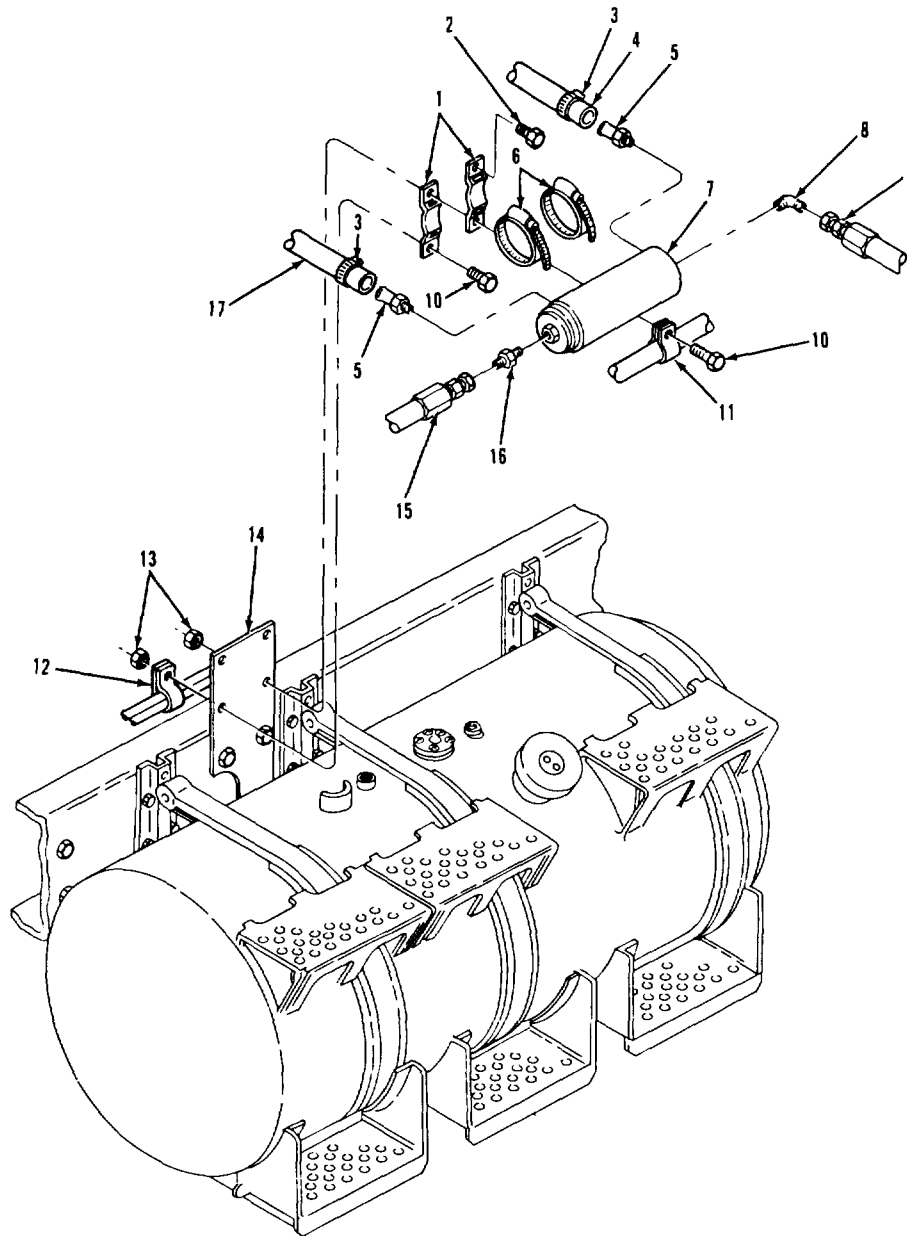

LEGEND:

- | | |
|--------------------------------|---------------------------------|
| 1. BRACKET (2) | 10. LOWER BOLT (2) |
| 2. UPPER BOLT (2) | 11. CLAMP |
| 3. HOSE CLAMP (2) | 12. CLAMP |
| 4. FUEL HEATER TO ENGINE HOSE | 13. NUT (4) |
| 5. FUEL HEATER HOSE NIPPLE (2) | 14. OIL FILTER MOUNTING BRACKET |
| 6. CLAMP (2) | 15. FUEL SUPPLY TO ENGINE HOSE |
| 7. FUEL HEATER | 16. CONNECTOR |
| 8. ELBOW | 17. HEATER TO FUEL HEATER HOSE |
| 9. FUEL SUPPLY HOSE | |

TA 237065

FUEL SYSTEM.

3-35. FUEL HEATER REPLACEMENT (Continued).

LOCATION/ITEM	ACTION	REMARKS
C. INSTALLATION (Continued).		
23. Hose (15).	Unplug and install on item (16).	
24. Hose (9).	Unplug and install on item (8).	
NOTE		
Follow-on maintenance action required:		
Service cooling system (para 3-52).		

FUEL SYSTEM.

3-35. FUEL HEATER REPLACEMENT (Continued).

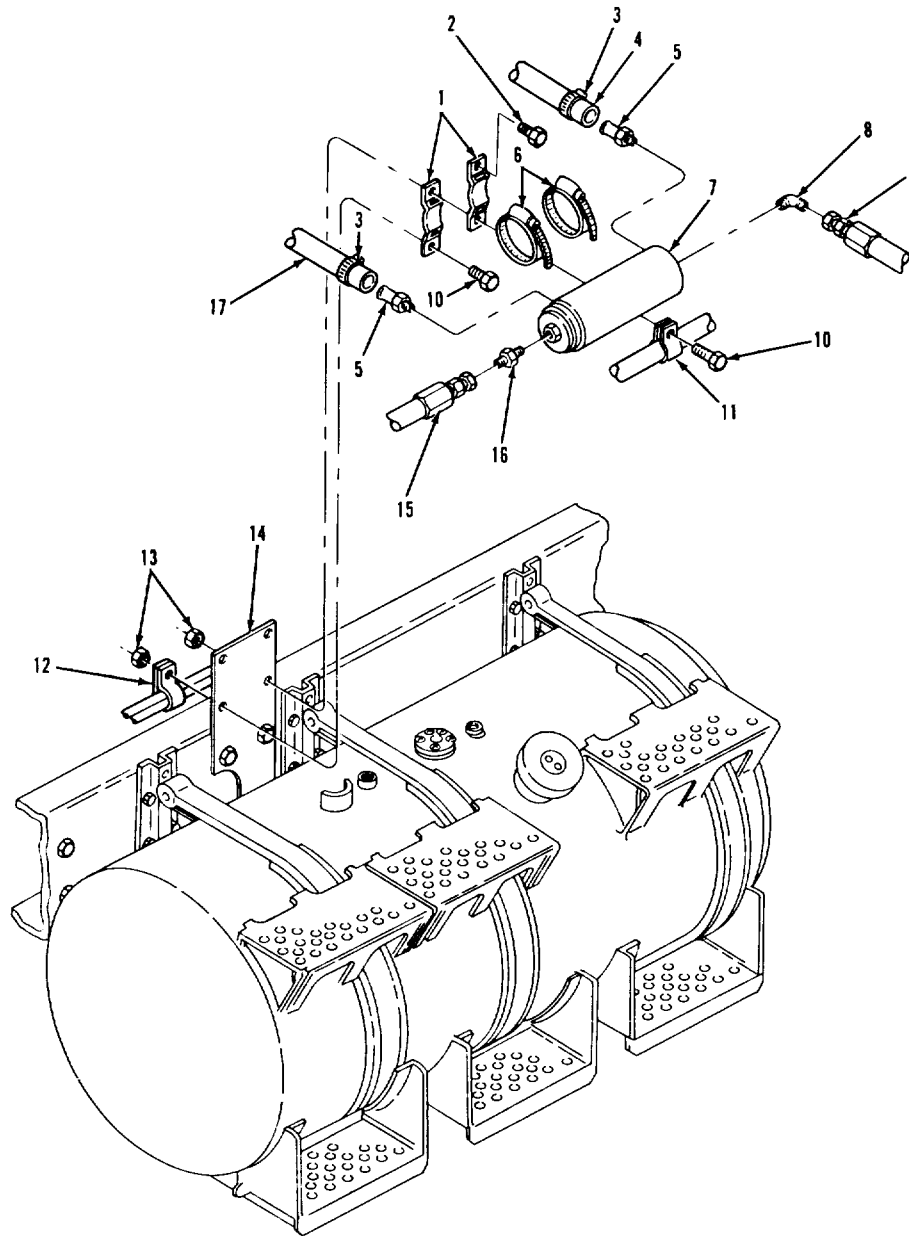

LEGEND:

- | | |
|--------------------------------|---------------------------------|
| 1. BRACKET (2) | 10. LOWER BOLT (2) |
| 2. UPPER BOLT (2) | 11. CLAMP |
| 3. HOSE CLAMP (2) | 12. CLAMP |
| 4. FUEL HEATER TO ENGINE HOSE | 13. NUT (4) |
| 5. FUEL HEATER HOSE NIPPLE (2) | 14. OIL FILTER MOUNTING BRACKET |
| 6. CLAMP (2) | 15. FUEL SUPPLY TO ENGINE HOSE |
| 7. FUEL HEATER | 16. CONNECTOR |
| 8. ELBOW | 17. HEATER TO FUEL HEATER HOSE |
| 9. FUEL SUPPLY HOSE | |

TA 237066

FUEL SYSTEM.

3-36. FUEL HOSES AND FITTINGS REPLACEMENT.

THIS TASK COVERS

- | | |
|--|---|
| a. Fuel Supply Hose Removal. | d. Fuel Supply to Engine Hose Installation. |
| b. Fuel Supply Hose Installation. | e. Fuel Return Hose Removal. |
| c. Fuel Supply to Engine Hose Removal. | f. Fuel Return Hose Installation. |

INITIAL SETUP

<u>APPLICABLE CONFIGURATIONS</u> All.	<u>EQUIPMENT CONDITION PARAGRAPH</u> None.	<u>CONDITION DESCRIPTION</u> None.
<u>TEST EQUIPMENT</u> None.		
<u>SPECIAL TOOLS</u> None.		
<u>MATERIALS/PARTS (P/N)</u> Tape, thread sealing Item 32, Appendix C.		
<u>PERSONNEL REQUIRED</u> One (MOS-63S).	<u>SPECIAL ENVIRONMENTAL CONDITIONS</u> None.	
<u>REFERENCES (TM)</u> None.	<u>GENERAL SAFETY INSTRUCTIONS</u> Engine off. Transmission in neutral. Park brake set.	
<u>TROUBLESHOOTING REFERENCES</u> Paragraph 2-11.		

FUEL SYSTEM.

3-36. FUEL HOSES AND FITTINGS REPLACEMENT (Continued).

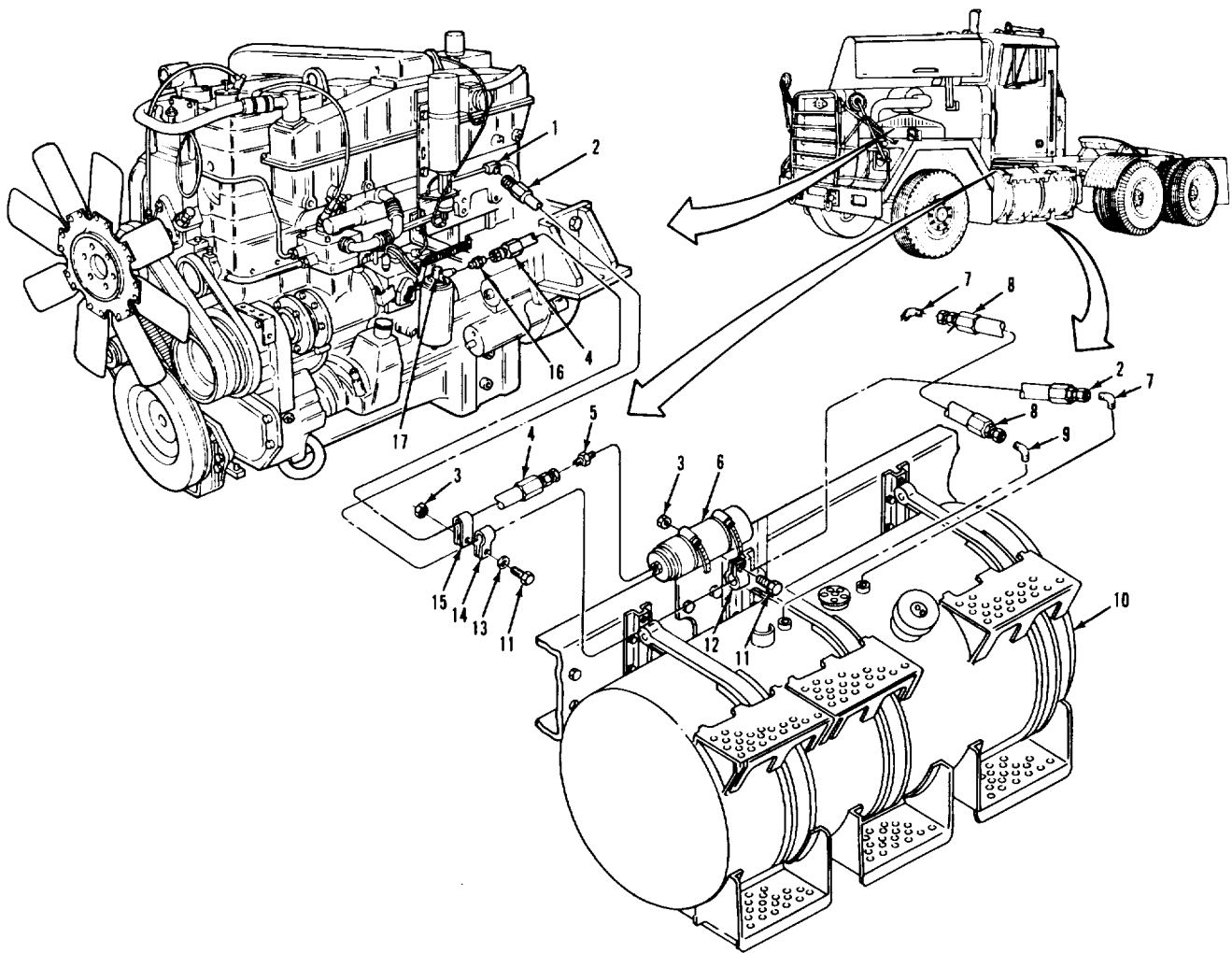

LEGEND:

- | | |
|-------------------------------|---------------------------|
| 1. MALE BRANCH TEE | 10. FUEL TANK |
| 2. FUEL RETURN HOSE | 11. SCREW (2) |
| 3. NUT (2) | 12. CLAMP |
| 4. FUEL SUPPLY TO ENGINE HOSE | 13. WASHER |
| 5. CONNECTOR | 14. FUEL RETURN HOSE CLIP |
| 6. FUEL HEATER ASSEMBLY | 15. FUEL SUPPLY HOSE CLIP |
| 7. ELBOW (2) | 16. FUEL INLET NIPPLE |
| 8. FUEL SUPPLY HOSE | 17. FUEL FILTER HEAD |
| 9. ELBOW | |

TA 237067

FUEL SYSTEM.

3-36. FUEL HOSES AND FITTINGS REPLACEMENT (Continued).

LOCATION/ITEM	ACTION	REMARKS
A. FUEL SUPPLY HOSE REMOVAL.		
1. Hose (8).	Remove from item (7) and item (9).	
2. Elbow (7).	Remove from item (6).	
3. Elbow (9).	Remove from item (10).	
B. FUEL SUPPLY HOSE INSTALLATION.		
4. Elbow (9).	Install in item (10).	a. Put thread sealing tape on pipe threads. b. Point towards frame.
5. Elbow (7).	Install on item (6).	a. Put thread sealing tape on pipe threads. b. Point to left side of vehicle.
6. Hose (8).	Install on item (7) and item (9).	
C. FUEL SUPPLY TO ENGINE HOSE REMOVAL.		
7. Hose (4).	Remove from item (5).	
8. Connector (5).	Remove from item (6).	
9. Screw (11), washer (13), and nut (3).	Remove from item (14) and item (15).	
10. Hose (4).	Remove from item (16).	
11. Nipple (16).	Remove from item (17).	
12. Clip (15).	Remove from item (4).	

FUEL SYSTEM.

3-36. FUEL HOSES AND FITTINGS REPLACEMENT (Continued).

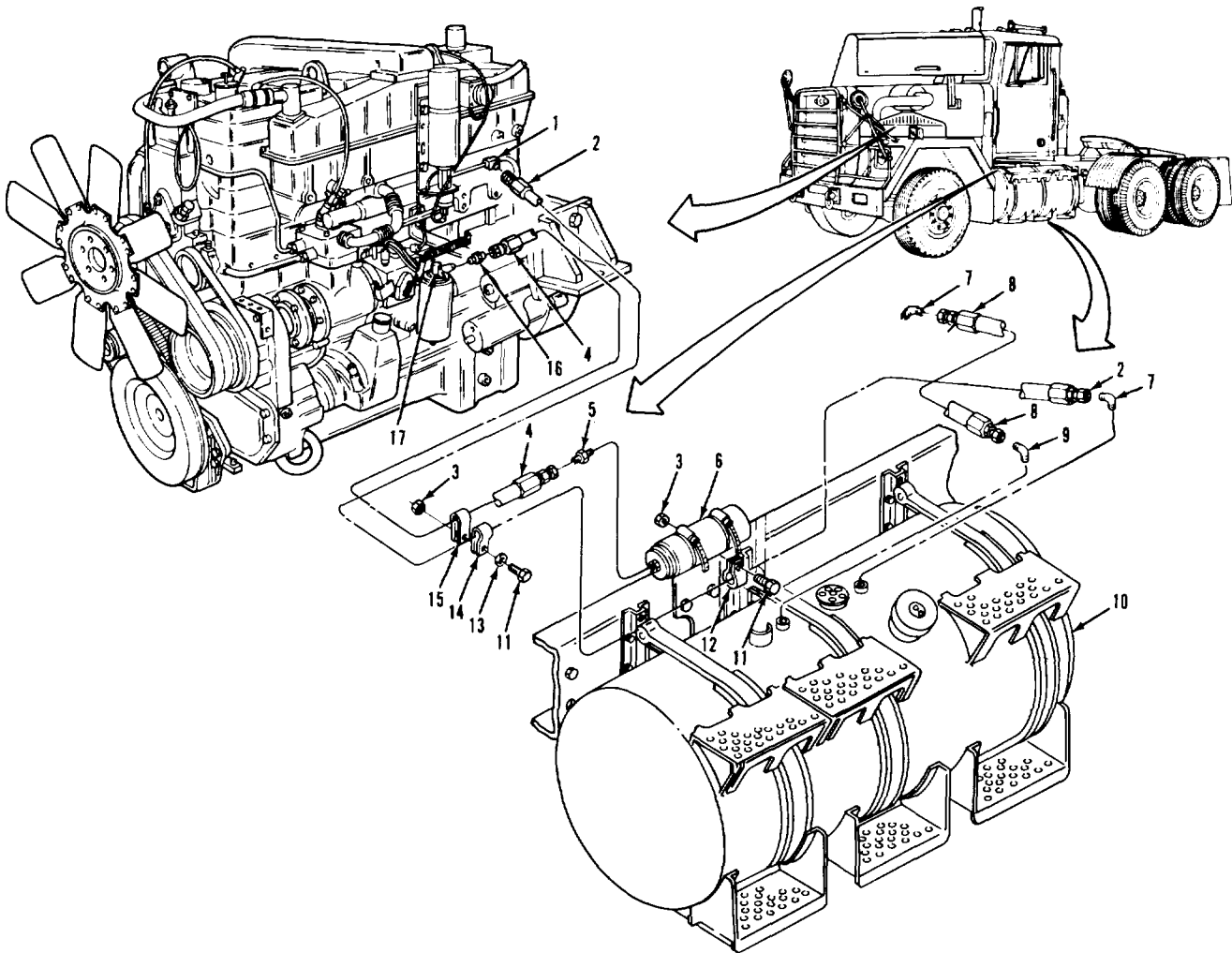

LEGEND:

- | | |
|-------------------------------|---------------------------|
| 1. MALE BRANCH TEE | 10. FUEL TANK |
| 2. FUEL RETURN HOSE | 11. SCREW (2) |
| 3. NUT (2) | 12. CLAMP |
| 4. FUEL SUPPLY TO ENGINE HOSE | 13. WASHER |
| 5. CONNECTOR | 14. FUEL RETURN HOSE CLIP |
| 6. FUEL HEATER ASSEMBLY | 15. FUEL SUPPLY HOSE CLIP |
| 7. ELBOW (2) | 16. FUEL INLET NIPPLE |
| 8. FUEL SUPPLY HOSE | 17. FUEL FILTER HEAD |
| 9. ELBOW | |

TA 237068

FUEL SYSTEM.

3-36. FUEL HOSES AND FITTINGS REPLACEMENT (Continued).

LOCATION/ITEM	ACTION	REMARKS
D. FUEL SUPPLY TO ENGINE HOSE INSTALLATION.		
13. Nipple (16).	Install in item (17).	Put thread sealing tape on pipe threads.
14. Hose (4).	Install on item (16).	
15. Clip (15).	Put on item (4).	
16. Screw (11), washer (13), and nut (3).	Secure item (14) and item (15) to frame.	
17. Connector (5).	Install in item (6).	Put thread sealing tape on pipe threads.
18. Hose (4).	Install on item (5).	
E. FUEL RETURN HOSE REMOVAL.		
19. Screw (11) and nut (3).	Remove from item (12).	
20. Hose (2).	Remove from item (7).	
21. Elbow (7).	Remove from item (10).	
22. Screw (11), washer (13), and nut (3).	Remove from item (14) and item (15).	
23. Hose (2).	Remove from item (1).	
24. Clip (14) and clamp (12).	Remove from item (2).	

FUEL SYSTEM

3-36. FUEL HOSES AND FITTINGS REPLACEMENT (Continued).

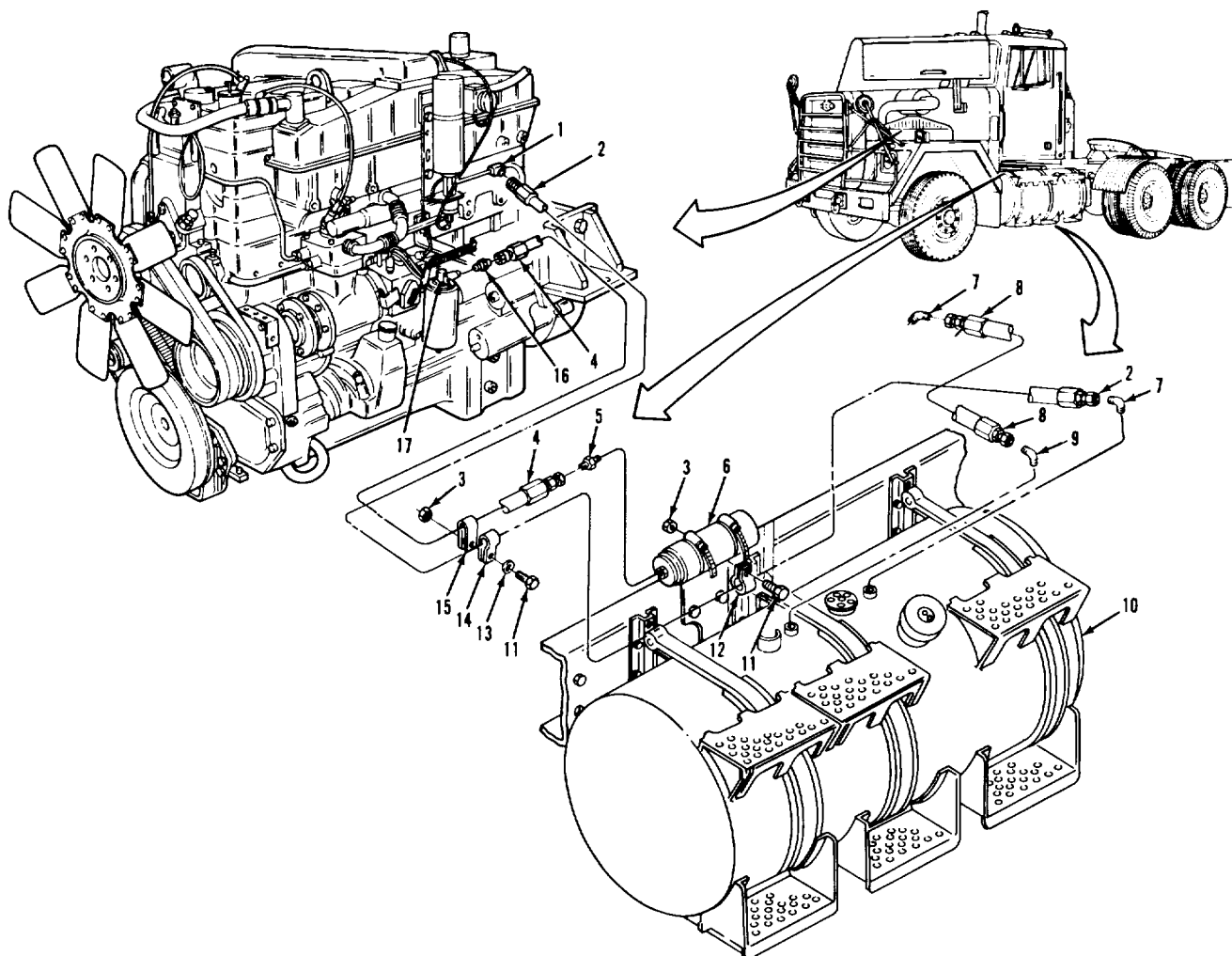

LEGEND:

- | | |
|-------------------------------|---------------------------|
| 1. MALE BRANCH TEE | 10. FUEL TANK |
| 2. FUEL RETURN HOSE | 11. SCREW (2) |
| 3. NUT (2) | 12. CLAMP |
| 4. FUEL SUPPLY TO ENGINE HOSE | 13. WASHER |
| 5. CONNECTOR | 14. FUEL RETURN HOSE CLIP |
| 6. FUEL HEATER ASSEMBLY | 15. FUEL SUPPLY HOSE CLIP |
| 7. ELBOW (2) | 16. FUEL INLET NIPPLE |
| 8. FUEL SUPPLY HOSE | 17. FUEL FILTER HEAD |
| 9. ELBOW | |

FUEL SYSTEM

3-36. FUEL HOSES AND FITTINGS REPLACEMENT (Continued).

LOCATION/ITEM	ACTION	REMARKS
F. FUEL RETURN HOSE INSTALLATION.		
25. Hose (2).	Install on item (1).	
26. Clip (14).	Put on item (2).	
27. Screw (11), washer (13), and nut (3).	Secure item (14) and item (15) to frame.	
28. Elbow (7).	Install in item (10).	a. Put thread sealing tape on pipe threads. Point toward frame.
29. Hose (2).	b. Install on item (7).	
30. Clamp (12).	Put on item (2).	
31. Screw (11) and nut (3).	Secure item (12).	
<p>NOTE Follow-on maintenance action required: None.</p>		

FUEL SYSTEM

3-36. FUEL HOSES AND FITTINGS REPLACEMENT (Continued).

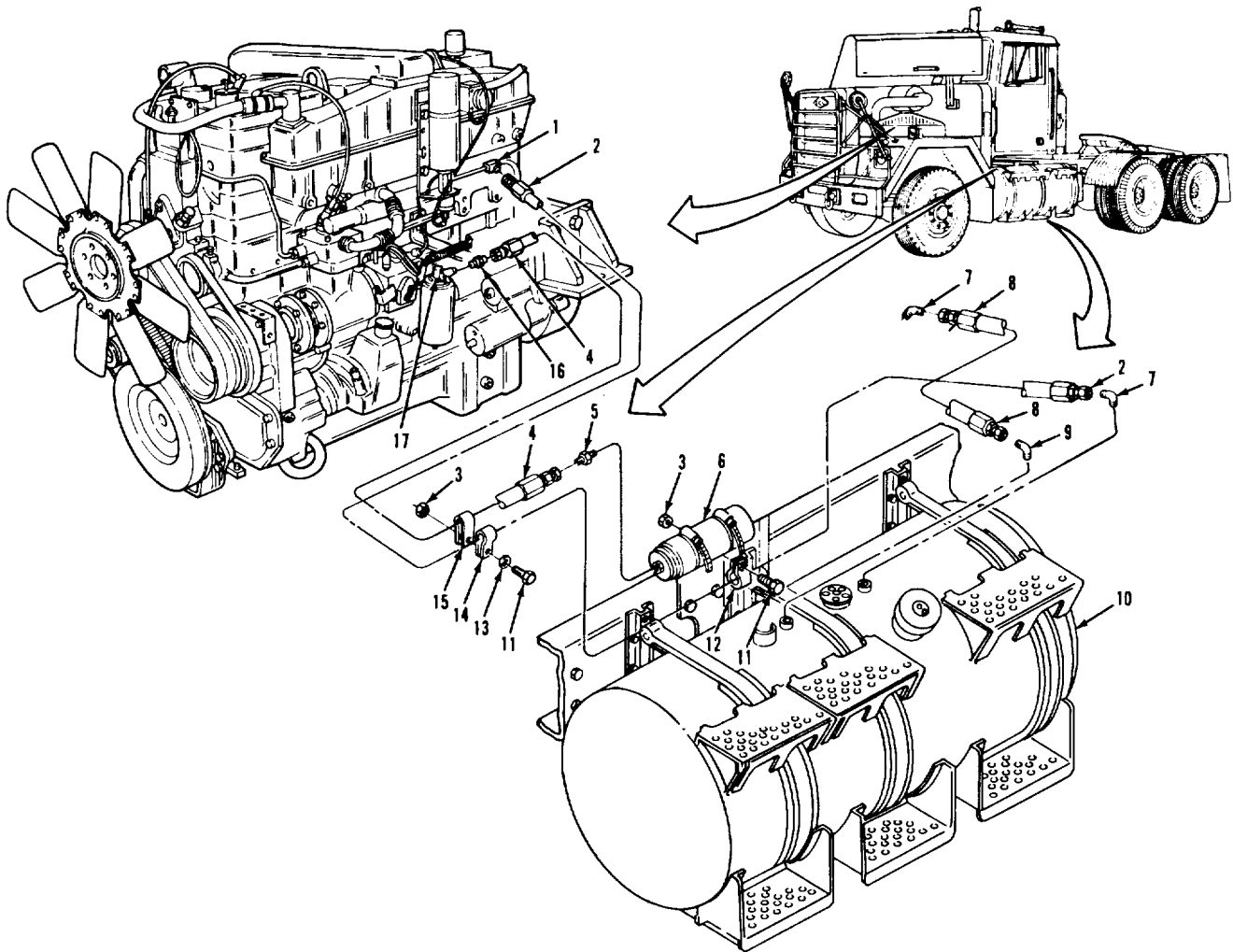

LEGEND:

- | | |
|-------------------------------|---------------------------|
| 1. MALE BRANCH TEE | 10. FUEL TANK |
| 2. FUEL RETURN HOSE | 11. SCREW (2) |
| 3. NUT (2) | 12. CLAMP |
| 4. FUEL SUPPLY TO ENGINE HOSE | 13. WASHER |
| 5. CONNECTOR | 14. FUEL RETURN HOSE CLIP |
| 6. FUEL HEATER ASSEMBLY | 15. FUEL SUPPLY HOSE CLIP |
| 7. ELBOW (2) | 16. FUEL INLET NIPPLE |
| 8. FUEL SUPPLY HOSE | 17. FUEL FILTER HEAD |
| 9. ELBOW | |

FUEL SYSTEM

3-37. WATER SEPARATOR FUEL FILTER REPLACEMENT.

THIS TASK COVERS

- a. Removal.
- b. Cleaning and Inspection.

INITIAL SETUP

EQUIPMENT CONDITION

APPLICABLE CONFIGURATIONS

All.

PARAGRAPH

None.

CONDITION DESCRIPTION

None.

TEST EQUIPMENT

None.

SPECIAL TOOLS

None.

MATERIALS/PARTS (P/N)

Filter, fuel, water separator
(33457) FS1212.

Seal, ring

(15434) 255622.

Oil, fuel: diesel (match oil in vehicle)

Item 12, 13, or 14, Appendix C.

PERSONNEL REQUIRED

One (MOS-63S).

SPECIAL ENVIRONMENTAL CONDITIONS

None.

REFERENCES (TM)

IM 9-2320-2 3-10.

TM 9-2320-283-20P.

Park brake set.

GENERAL SAFETY INSTRUCTIONS

Engine off.

Transmission in neutral.

TROUBLESHOOTING REFERENCES

Paragraph 2-11.

FUEL SYSTEM

3-37. WATER SEPARATOR FUEL FILTER REPLACEMENT (Continued).

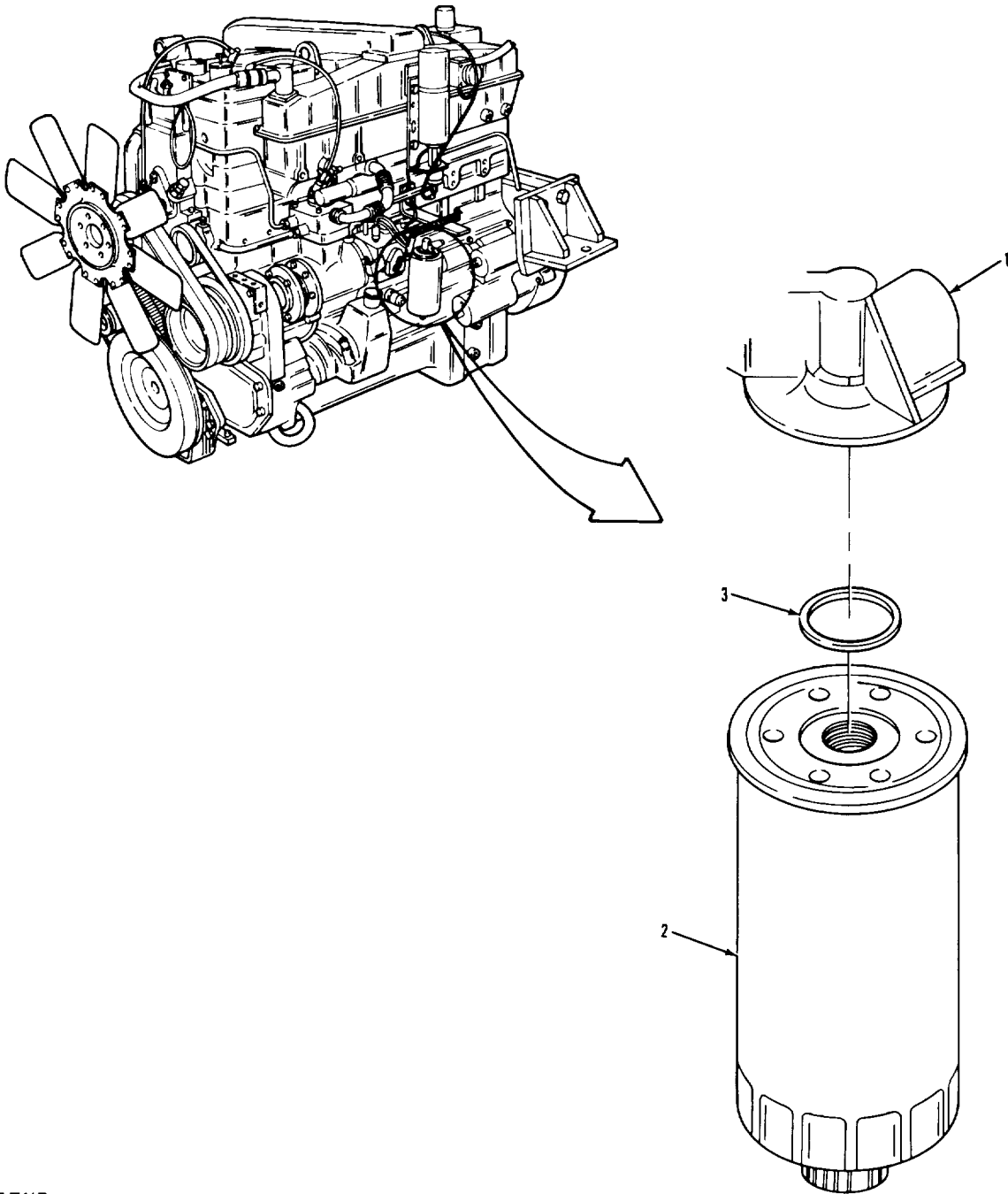

LEGEND:

- 1. FUEL FILTER HEAD
- 2. WATER SEPARATOR FUEL FILTER
- 3. RING SEAL

FUEL SYSTEM

3-37. WATER SEPARATOR FUEL FILTER REPLACEMENT (Continued).

LOCATION/ITEM	ACTION	REMARKS
A. REMOVAL.		
1. Filter (2) and seal (3).	Unscrew and remove from item (1). b.	a. Empty fuel into a suitable container for disposal. Discard item (2) and item (3).
B. INSTALLATION.		
2. New filter (2). of item (2) is closed.	Fill with clean fuel.	Be sure drain on bottom
3. Filter (2) and new seal (3).	Screw on item (1) by hand until snug.	Do not tighten with wrench.
4. Filter (2). leaks.	Start engine and check for TM 9-2320-283-10.	Refer to
<p>NOTE Follow-on maintenance action required: None.</p>		

FUEL SYSTEM

3-37. WATER SEPARATOR FUEL FILTER REPLACEMENT (Continued).

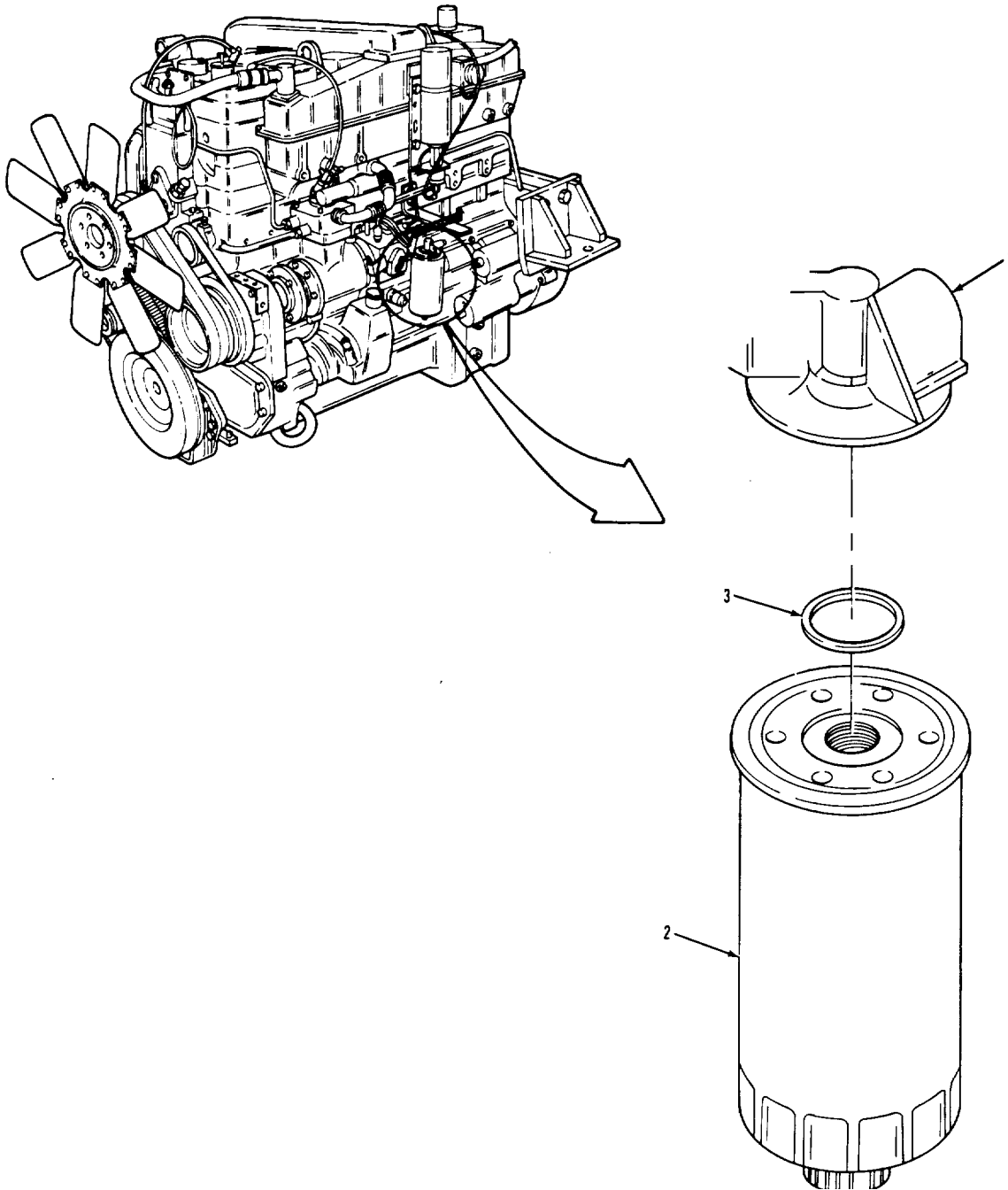

LEGEND:

- 1. FUEL FILTER HEAD
- 2. WATER SEPARATOR FUEL FILTER
- 3. RING SEAL

FUEL SYSTEM

3-38. ETHER CYLINDER REPLACEMENT.

THIS TASK COVERS

- a. Removal.
- b. Cleaning and Inspection.

INITIAL SETUP

APPLICABLE CONFIGURATIONS

All.

EQUIPMENT CONDITION

PARAGRAPH

None.

CONDITION DESCRIPTION

None.

TEST EQUIPMENT

None.

SPECIAL TOOLS

None.

MATERIALS/PARTS (P/N)

Gasket, cylinder
(06991) 111025.

PERSONNEL REQUIRED

One (MOS-63S).

SPECIAL ENVIRONMENTAL CONDITIONS

None.

REFERENCES (TM)

TM 9-2320-283-20P.

GENERAL SAFETY INSTRUCTIONS

Engine off.
Transmission in neutral.
Park brake set.
Guard against flame or sparks in
work area.

TROUBLESHOOTING REFERENCES

Paragraph 2-11.

FUEL SYSTEM

3-38. ETHER CYLINDER REPLACEMENT (Continued).

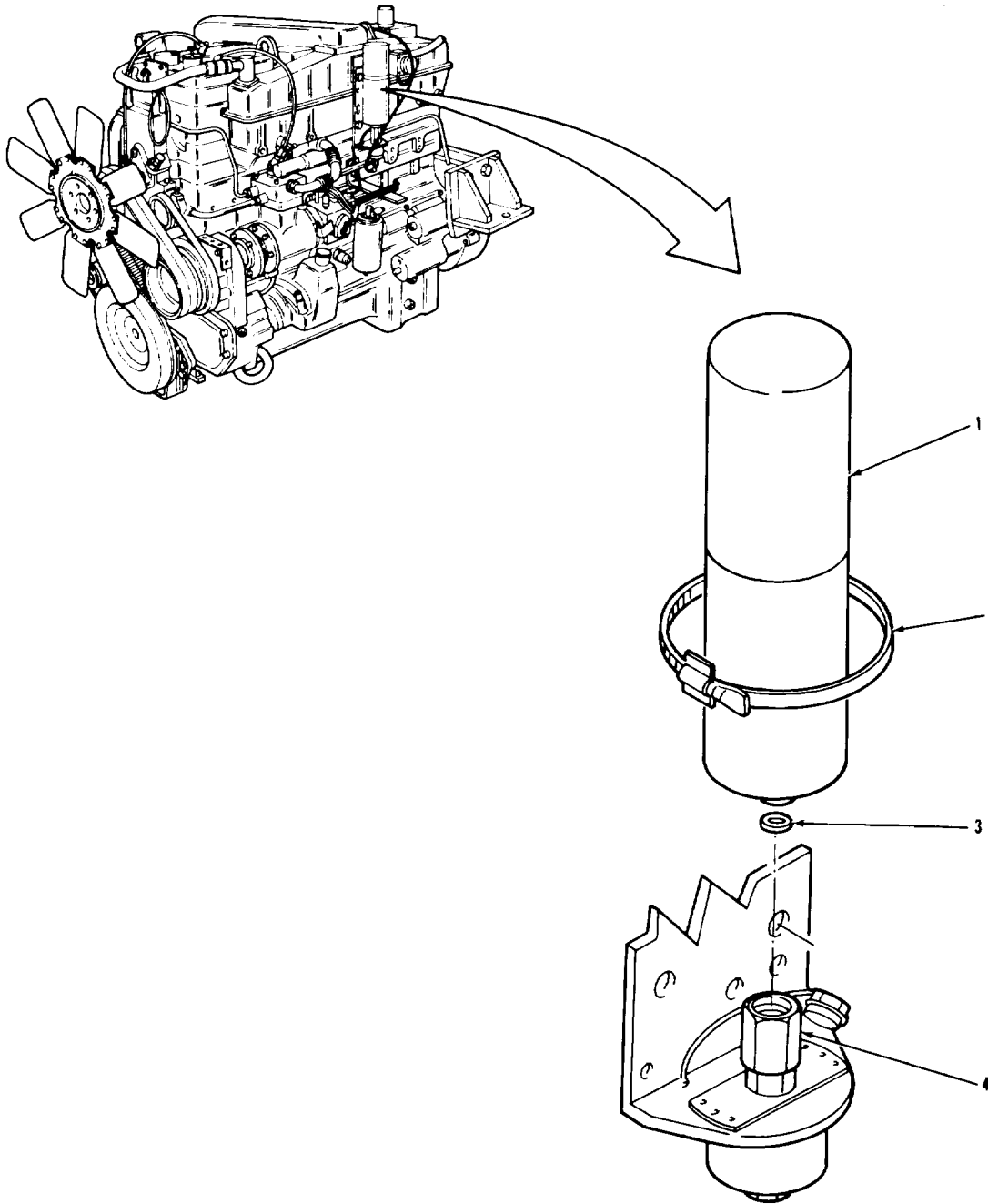

LEGEND:

- 2. CYLINDER CLAMP
- 3. CYLINDER GASKET
- 4. VALVE AND BRACKET ASSEMBLY

FUEL SYSTEM

3-38. ETHER CYLINDER REPLACEMENT (Continued).

LOCATION/ITEM	ACTION	REMARKS
<p><u>WARNING</u> Ether is highly explosive. Dispose of cylinder properly. Be alert for the strong odor of spilled ether. Guard against flame or sparks in work area.</p>		
<p>A. REMOVAL.</p>		
<p>1. Clamp (2).</p>	<p>Loosen.</p>	
<p>2. Cylinder (1) and gasket (3).</p>	<p>Unscrew and remove from item (4).</p>	<p>Discard item (3).</p>
<p>B. INSTALLATION.</p>		
<p><u>NOTE</u> Check opening of cylinder and valve for dirt or lint before installation.</p>		
<p>3. Cylinder (1) and new gasket (3).</p>	<p>Install in item (4).</p>	
<p>4. Clamp (2).</p>	<p>Tighten.</p>	
<p><u>NOTE</u> Follow-on maintenance action required: None.</p>		

FUEL SYSTEM

3-38. ETHER CYLINDER REPLACEMENT (Continued).

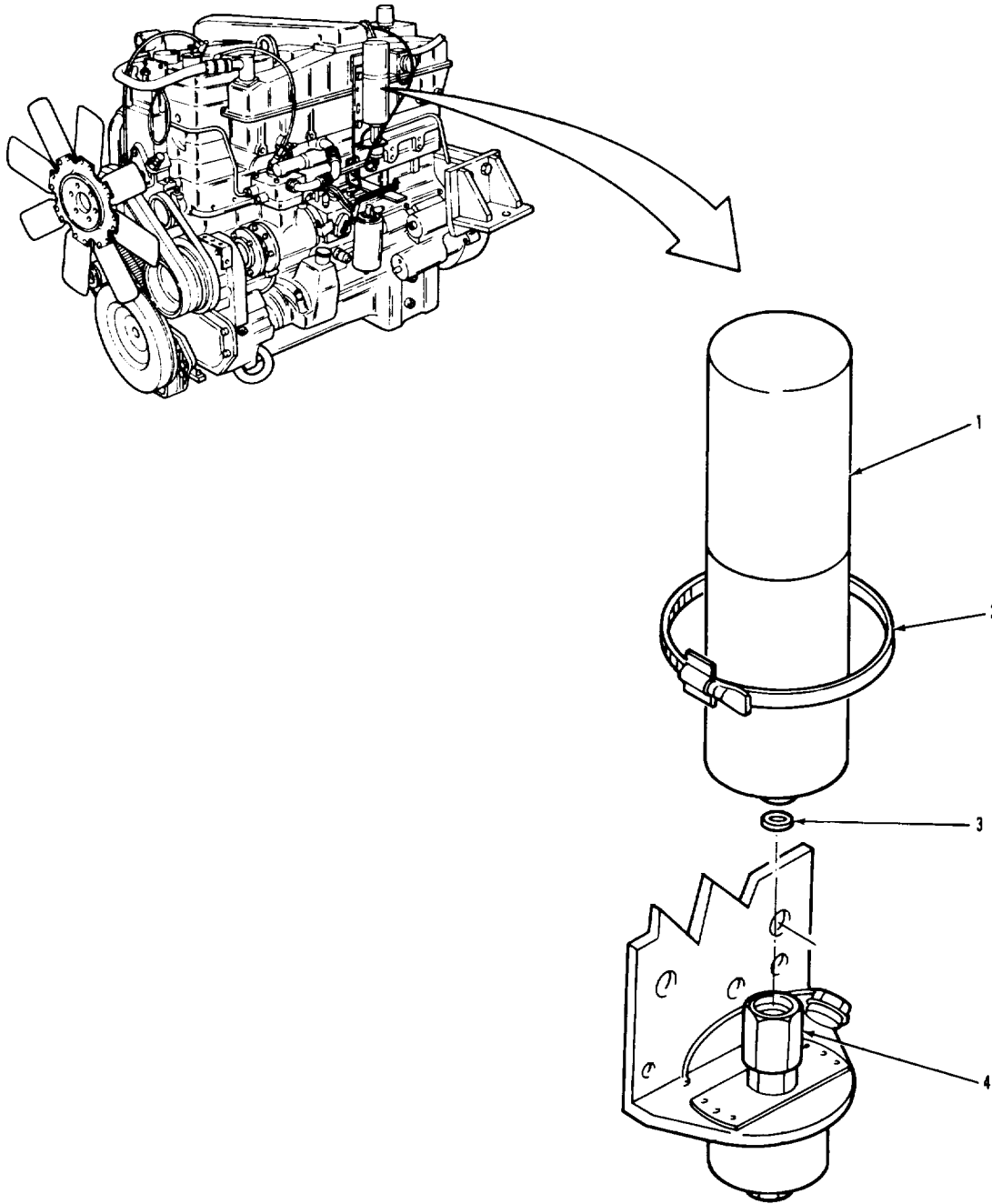

LEGEND:

- 1. ETHER CYLINDER
- 2. CYLINDER CLAMP
- 3. CYLINDER GASKET
- 4. VALVE AND BRACKET ASSEMBLY

FUEL SYSTEM

3-39. ETHER QUICK START THERMOSTAT REPLACEMENT.

THIS TASK COVERS

- a. Removal.
- b. Cleaning and Inspection.
- c. Installation.

INITIAL SETUP

APPLICABLE CONFIGURATIONS

All.

EQUIPMENT CONDITION

PARAGRAPH

3-52.

CONDITION DESCRIPTION

Radiator drained.

TEST EQUIPMENT

None.

SPECIAL TOOLS

None.

MATERIALS/PARTS (P/N)

Tape, thread sealing
Item 32, Appendix C.

PERSONNEL REQUIRED

One (MOS-63S).

SPECIAL ENVIRONMENTAL CONDITIONS

None.

REFERENCES (TM)

None.

GENERAL SAFETY INSTRUCTIONS

Engine off.
Transmission in neutral.
Park brake set.

TROUBLESHOOTING REFERENCES

Paragraph 2-11.

FUEL SYSTEM

3-39. ETHER QUICK START THERMOSTAT REPLACEMENT (Continued).

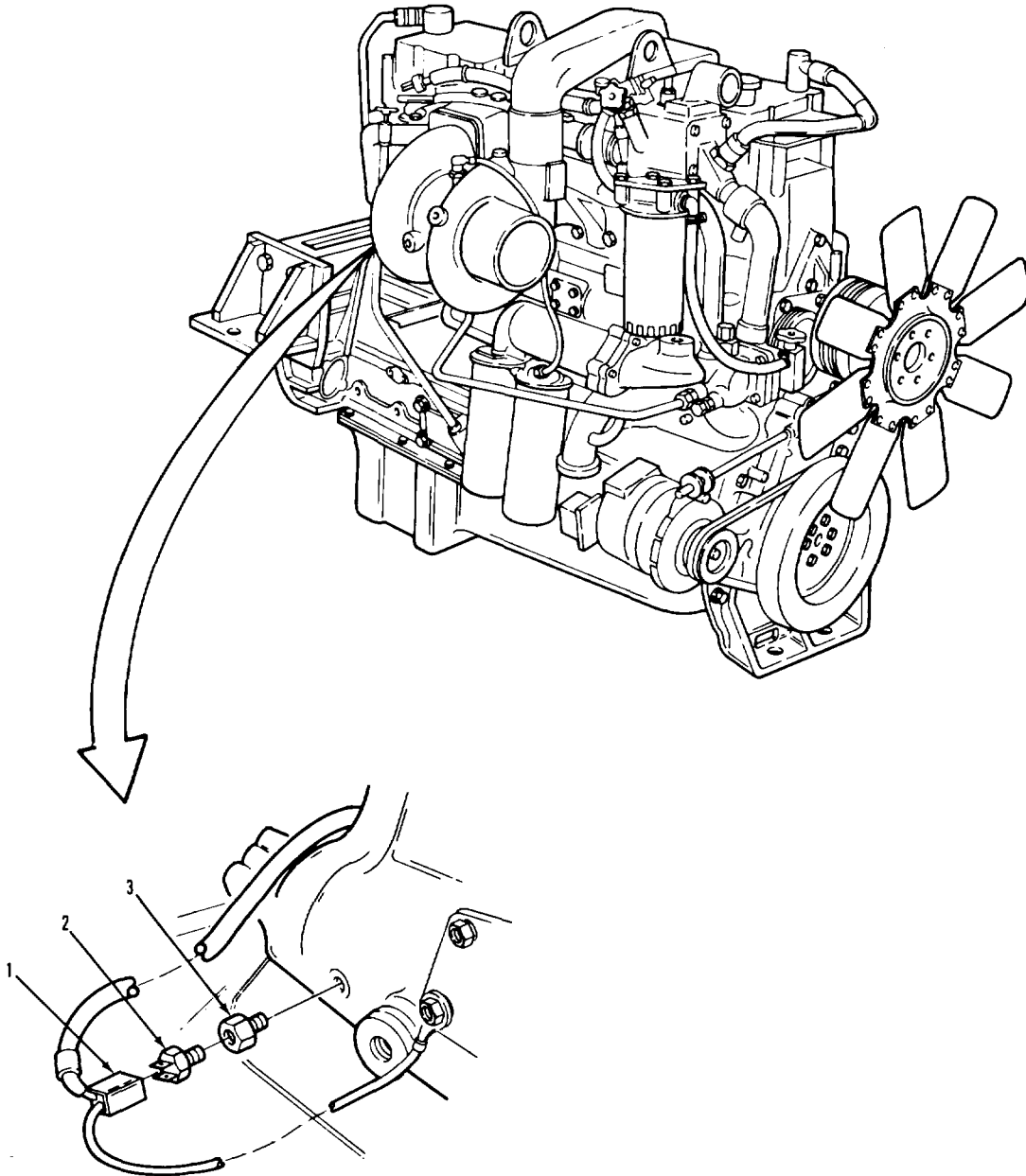

LEGEND:

- 1. ELECTRICAL CONNECTOR
- 2. THERMOSTAT
- 3. REDUCER

FUEL SYSTEM

3-39. ETHER QUICK START THERMOSTAT REPLACEMENT (Continued).

LOCATION/ITEM	ACTION	REMARKS
A. REMOVAL.		
1. Connector (1).	Pull from item (2).	
2. Thermostat (2).	Remove from item (3).	
3. Reducer (3).	Remove from engine.	
B. CLEANING AND INSPECTION.		
4. All parts.	Clean and inspect. and 3-5.	Refer to paragraphs 3-4
C. INSTALLATION.		
5. Reducer (3).	Install in engine. on threads.	Put thread sealing tape
6. Thermostat (2).	Install in item (3). on threads.	Put thread sealing tape
7. Connector (1).	Push on item (2).	
NOTE		
Follow-on maintenance action required: Service cooling system (para 3-52).		

FUEL SYSTEM

3-39. ETHER QUICK START THERMOSTAT REPLACEMENT (Continued).

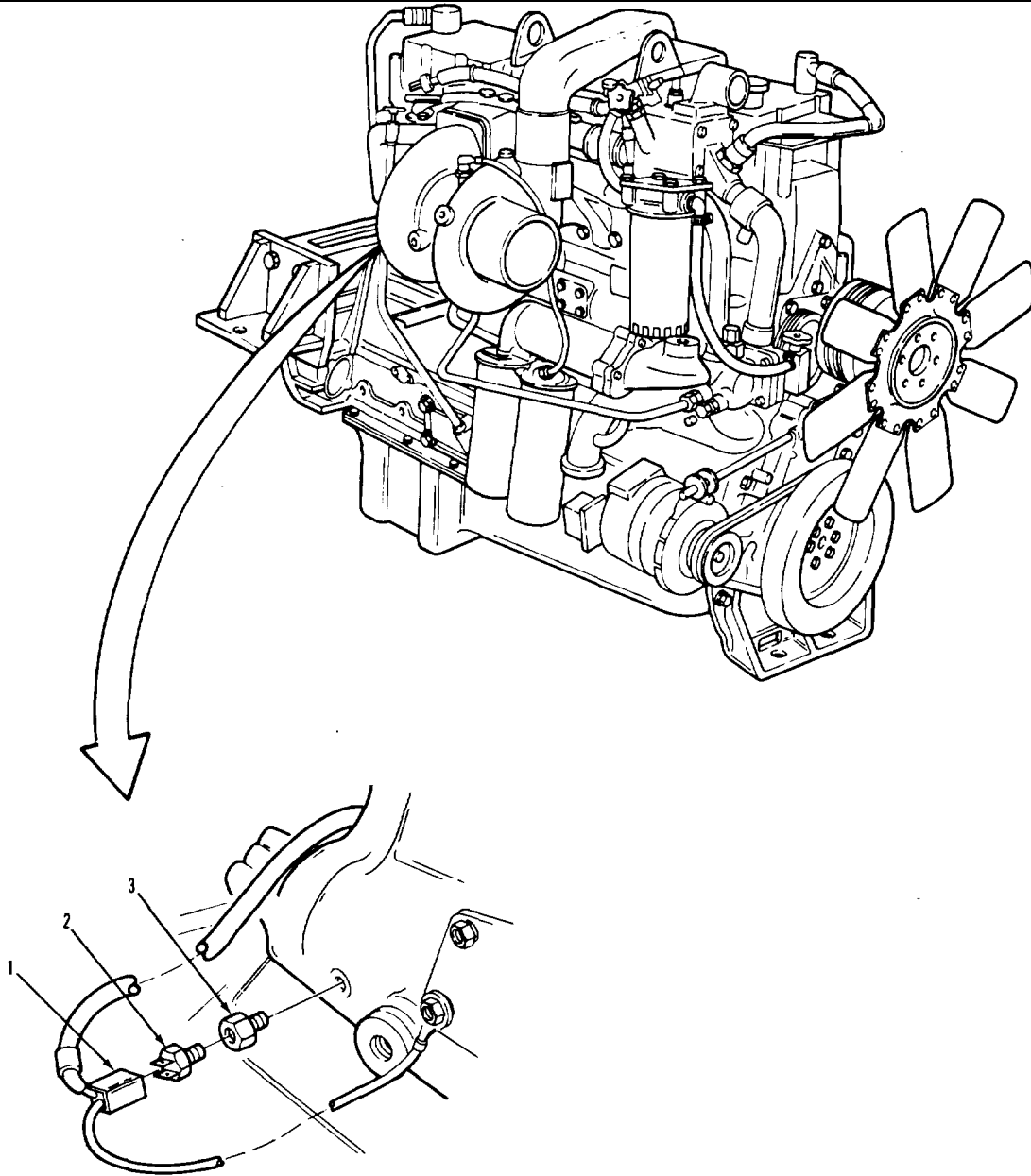

LEGEND:

- 1. ELECTRICAL CONNECTOR
- 2. THERMOSTAT
- 3. REDUCER

FUEL SYSTEM

3-40. ETHER QUICK START KIT REPLACEMENT.

THIS TASK COVERS

- a. Removal.
- b. Cleaning and Inspection.
- c. Installation.

INITIAL SETUP

APPLICABLE CONFIGURATIONS

All.

EQUIPMENT CONDITION

PARAGRAPH

3-38.

CONDITION DESCRIPTION

Ether cylinder removed.

TEST EQUIPMENT

None.

SPECIAL TOOLS

None.

MATERIALS/PARTS (P/N)

Rags, wiping
 Item 22, Appendix C.
 Solvent, drycleaning, SD-2
 Item 29, Appendix C.
 Tape, thread sealing
 Item 32, Appendix C.

PERSONNEL REQUIRED

One (MOS-63S).

SPECIAL ENVIRONMENTAL CONDITIONS

None.

REFERENCES (TM)

None.
 Transmission in neutral.
 Park brake set.

GENERAL SAFETY INSTRUCTIONS

Engine off.

TROUBLESHOOTING REFERENCES

Paragraph 2-11.

FUEL SYSTEM

3-40. ETHER QUICK START KIT REPLACEMENT (Continued).

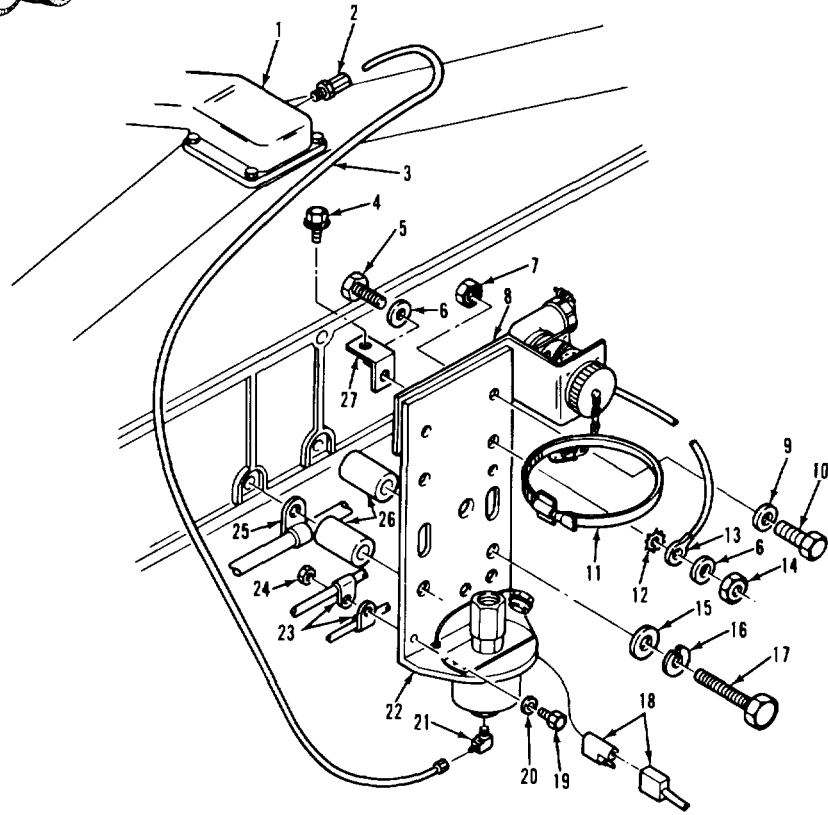
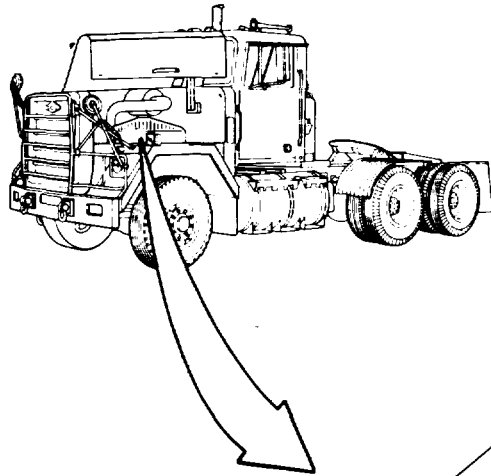

LEGEND:

- | | | |
|--------------------------------------|--------------------|--------------------------------|
| 1. TURBOCHARGER CROSSOVER CONNECTION | 9. WASHER (2) | 19. SCREW |
| 2. ATOMIZER | 10. SCREW (2) | 20. WASHER |
| 3. NYLON TUBE | 11. CYLINDER CLAMP | 21. ELBOW |
| 4. SCREW WITH CAPTIVE WASHER | 12. WASHER | 22. VALVE AND BRACKET ASSEMBLY |
| 5. SCREW | 13. WIRE | 23. CLAMP (2) |
| 6. WASHER (2) | 14. NUT | 24. NUT |
| 7. NUT (2) | 15. WASHER (2) | 25. SUPPORT BRACKET |
| 8. STE/ICE CONNECTOR BRACKET | 16. LOCKWASHER (2) | 26. MOUNTING SPACER (2) |
| | 17. SCREW (2) | 27. TUBE CLIP |
| | 18. PLUG (2) | |

FUEL SYSTEM

3-40. ETHER QUICK START KIT REPLACEMENT (Continued).

LOCATION/ITEM	ACTION	REMARKS
A. REMOVAL.		
1. Two plugs (18).	Disconnect.	
2. Tube (3).	Remove from item (2) and item (21).	
3. Atomizer (2).	Remove from item (1).	
4. Two screws (10), washers (9), and nuts (7).	Remove from item (22) and item (8).	
5. Screw (4).	Remove from item (27).	
6. Two screws (17), lockwashers (16), washers (15), and spacers (26).	Remove from item (22) and item (25).	
7. Screw (19), water (20), and nut (24).	Remove from item (22) and two items (23).	
8. Screw (5), two washers (6), washer (12), wire (13), and nut (14).	Remove from item (22) and item (27).	
9. Clamp (11).	Remove from item (22).	
10. Elbow (21).	Remove from item (22).	
B. CLEANING AND INSPECTION.		
11. All parts.	a. Clean with solvent and rags. b. Inspect.	Refer to paragraph 3-4. Refer to paragraph 3-5.
<div style="border: 1px solid black; height: 20px; width: 100%;"></div>		

FUEL SYSTEM

3-40. ETHER QUICK START KIT REPLACEMENT (Continued).

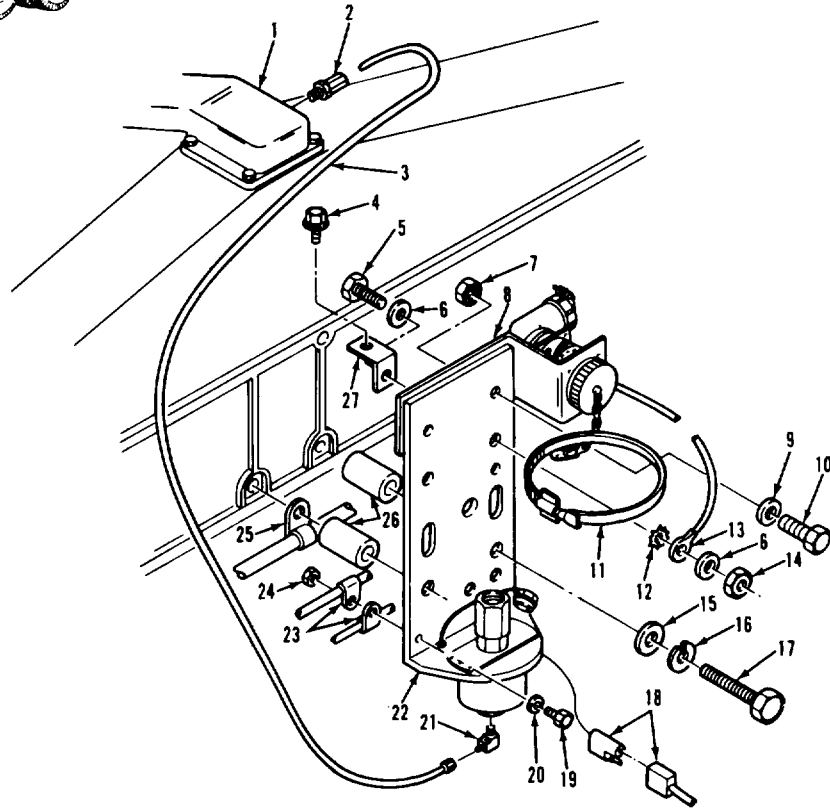
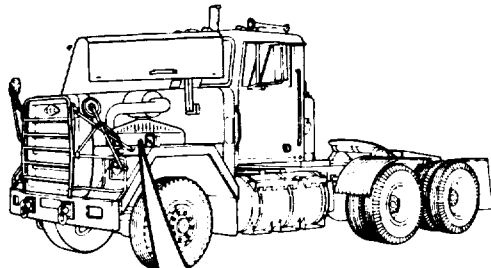

LEGEND:

- | | | |
|--------------------------------------|--------------------|--------------------------------|
| 1. TURBOCHARGER CROSSOVER CONNECTION | 9. WASHER (2) | 19. SCREW |
| 2. ATOMIZER | 10. SCREW (2) | 20. WASHER |
| 3. NYLON TUBE | 11. CYLINDER CLAMP | 21. ELBOW |
| 4. SCREW WITH CAPTIVE WASHER | 12. WASHER | 22. VALVE AND BRACKET ASSEMBLY |
| 5. SCREW | 13. WIRE | 23. CLAMP (2) |
| 6. WASHER (2) | 14. NUT | 24. NUT |
| 7. NUT (2) | 15. WASHER (2) | 25. SUPPORT BRACKET |
| 8. STE/ICE CONNECTOR BRACKET | 16. LOCKWASHER (2) | 26. MOUNTING SPACER (2) |
| | 17. SCREW (2) | 27. TUBE CLIP |
| | 18. PLUG (2) | |

FUEL SYSTEM

3-40. ETHER QUICK START KIT REPLACEMENT (Continued).

LOCATION/ITEM	ACTION	REMARKS
C. INSTALLATION.		
12. Elbow (21).	Install in item (22). b.	a. Put thread sealing tape on threads Point towards front of vehicle.
13. Screw (5), two washers (6), washer (12), wire (13), and nut (14).	Install in item (22) and item (27).	Do not tighten.
14. Screw (4).	Install in item (27) and engine.	
15. Screw (19), washer (20), and nut (24).	Install in item (22) and two items (23).	
16. Two screws (17), lockwashers (16), washers (15), and spacers (26).	Install in item (22) and item (25).	
17. Screw (5) and nut (14).	Tighten.	
18. Clamp (11).	Install in item (22).	
19. Two screws (10), washers (9), and nuts (7).	Install in item (22) and item (8).	
20. Atomizer (2).	Install in item (1). on threads.	Put thread sealing tape
21. Tube (3). item (21).	Install on item (2) and	

FUEL SYSTEM

3-40. ETHER QUICK START KIT REPLACEMENT (Continued).

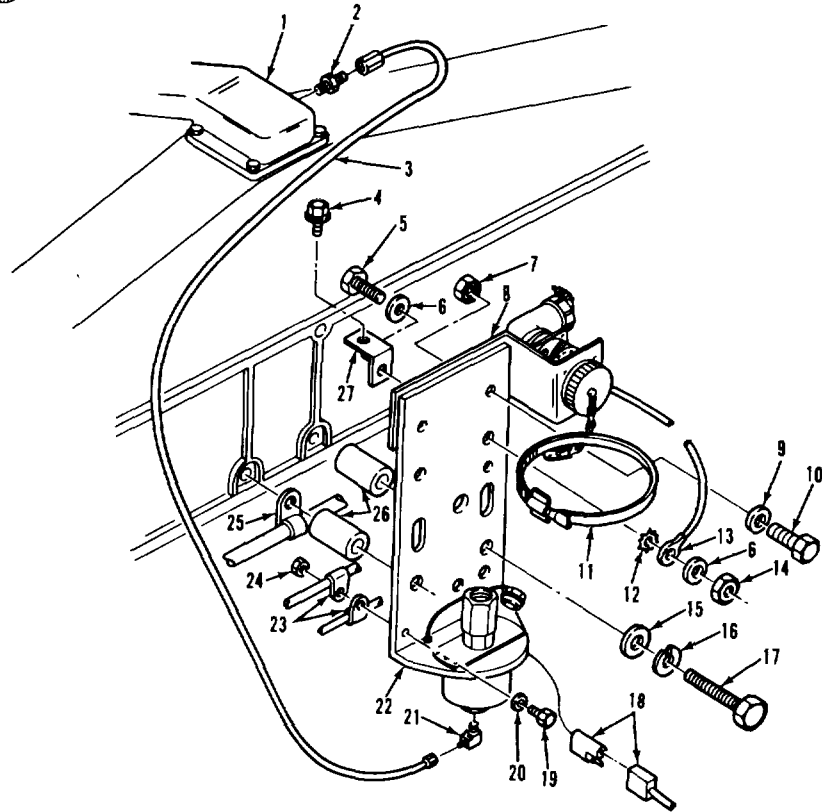
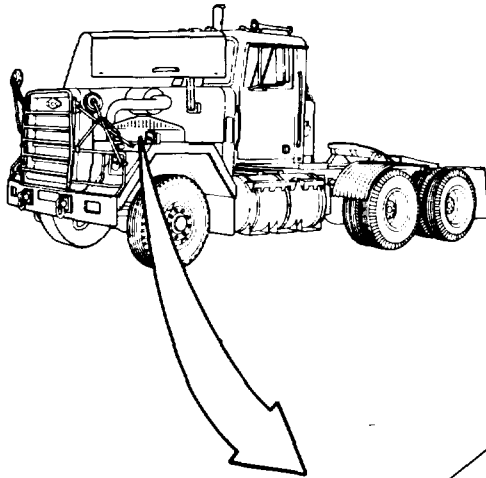

LEGEND:

- | | | |
|--------------------------------------|--------------------|--------------------------------|
| 1. TURBOCHARGER CROSSOVER CONNECTION | 9. WASHER | 19. SCREW |
| 2. ATOMIZER | 10. SCREW (Z) | 20. WASHER |
| 3. NYLON TUBE | 11. CYLINDER CLAMP | 21. ELBOW |
| 4. SCREW WITH CAPTIVE WASHER | 12. WASHER | 22. VALVE AND BRACKET ASSEMBLY |
| 5. SCREW | 13. WIRE | 23. CLAMP (2) |
| 6. WASHER (2) | 14. NUT | 24. NUT |
| 7. NUT (2) | 15. WASHER (2) | 25. SUPPORT BRACKET |
| 8. STE/ICE CONNECTOR BRACKET | 16. LOCKWASHER (2) | 26. MOUNTING SPACER (2) |
| | 17. SCREW (2) | 27. TUBE CLIP |
| | | |

FUEL SYSTEM

3-40. ETHER QUICK START KIT REPLACEMENT (Continued).

LOCATION/ITEM	ACTION	REMARKS
---------------	--------	---------

C. INSTALLATION (Continued).

22. Two plugs (18). Connect.

NOTE

Follow-on maintenance action required:
Install ether cylinder (para 3-38).

FUEL SYSTEM

3-40. ETHER QUICK START KIT REPLACEMENT (Continued)

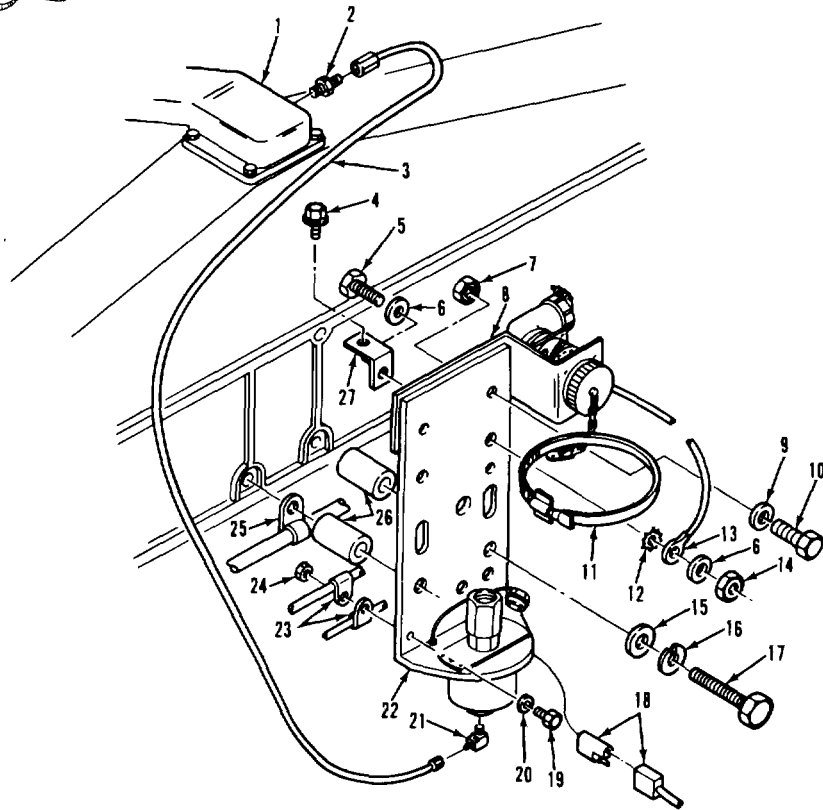
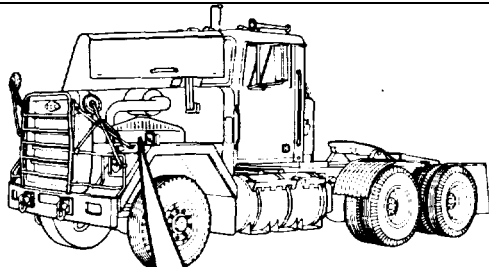

LEGEND:

- 1. TURBOCHARGER CROSSOVER CONNECTION
- 2. ATOMIZER
- 3. NYLON TUBE
- 4. SCREW WITH CAPTIVE WASHER
- 5. SCREW
- 6. WASHER (2)
- 7. NUT (2)
- 8. STE/ICE CONNECTOR

- 9. WASHER (2)
- 10. SCREW (2)
- 11. CYLINDER CLAMP
- 12. WASHER
- 13. WIRE
- 14. NUT
- 15. WASHER (2)
- 16. LOCKWASHER (2)
- 17. SCREW (2)
- 18. PLUG (2)

- 19. SCREW
- 20. WASHER
- 21. ELBOW
- 22. VALVE AND BRACKET ASSEMBLY
- 23. CLAMP (2)
- 24. NUT
- 25. SUPPORT BRACKET
- 26. MOUNTING SPACER (2)
- 27. TUBE CLIP

FUEL SYSTEM

3-41. ACCELERATOR PEDAL AND LINKAGE REPLACEMENT.

THIS TASK COVERS

- a. Removal.
- b. Cleaning and Inspection.
- c. Installation.

INITIAL SETUP

APPLICABLE CONFIGURATIONS

All.

EQUIPMENT CONDITION

PARAGRAPH

None.

CONDITION DESCRIPTION

None.

TEST EQUIPMENT

None.

SPECIAL TOOLS

None.

MATERIALS/PARTS (P/N)

Rags, wiping

Item 22, Appendix C.

Solvent, drycleaning, SD-2

Item 29, Appendix C.

Pin, cotter (2)

(24617) 103362.

Grease, automotive and artillery

Item 7, Appendix C.

PERSONNEL REQUIRED

Two (MOS-63Sj).

SPECIAL ENVIRONMENTAL CONDITIONS

None.

REFERENCES (TM)

TM 9-2320-283-20P.

Transmission in neutral.

Park brake set.

GENERAL SAFETY INSTRUCTIONS

Engine off.

TROUBLESHOOTING REFERENCES

None.

FUEL SYSTEM

3-41. ACCELERATOR PEDAL AND LINKAGE REPLACEMENT (Continued).

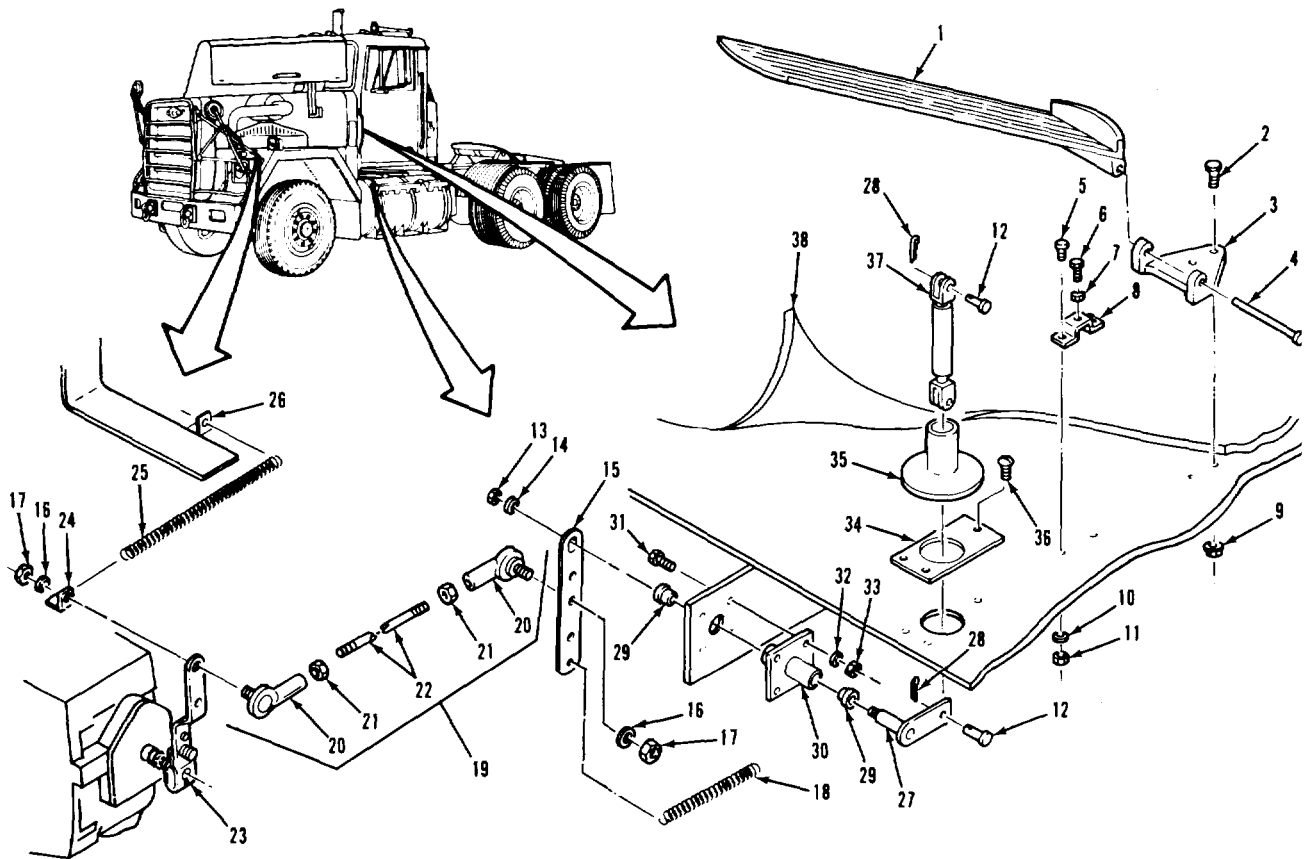

LEGEND:

- | | | |
|------------------------|---------------------------------|--------------------------------|
| 1. ACCELERATOR PEDAL | 15. ACCELERATOR BELLCRANK LEVER | 26. MODULATOR BRACKET ASSEMBLY |
| 2. OVAL HEAD SCREW (2) | 16. WASHER (2) | 27. LEVER AND PIVOT ASSEMBLY |
| 3. PEDAL BRACKET | 17. HEX NUT (2) | 28. COTTER PIN (2) |
| 4. STRAIGHT PIN | 18. LEVER RETURN SPRING | 29. FLANGED BEARING (2) |
| 5. PAN HEAD SCREW (2) | 19. ACCELERATOR LINK ASSEMBLY | 30. BELLCRANK BRACKET |
| 6. HEX HEAD SCREW | 20. BALL JOINT (2) | 31. SCREW (4) |
| 7. HEX NUT | 21. JAM NUT (2) | 32. PLAIN WASHER (4) |
| 8. PEDAL STOP BRACKET | 22. LINK | 33. PT NUT (4) |
| 9. NUT (2) | 23. FUEL CONTROL LEVER | 34. SEAL RETAINER |
| 10. LOCKWASHER (2) | 24. SPRING CLIP | 35. ACCELERATOR SEAL |
| 11. HEX NUT (2) | 25. ACCELERATOR RETURN SPRING | 36. SELF-TAPPING SCREW (3) |
| 12. CLEVIS PIN (2) | | 37. ROD ASSEMBLY |
| 13. PT NUT | | 38. FLOOR MAT |
| 14. WASHER | | |

TA 237081

FUEL SYSTEM

3-41. ACCELERATOR PEDAL AND LINKAGE REPLACEMENT (Continued).

LOCATION/ITEM	ACTION	REMARKS
A. REMOVAL.		
1. Pin (28) inside cab.	Remove from item (12)	Discard item (28).
2. Pin (12)	Remove from item (37) and item (1).	
3. Pin (4)	Drive from item (3) and item (1).	
4. Pedal (1)	Remove.	
5. Mat (38)	Pull back, out of way.	
6. Two screws (2) and nuts (9).	Remove from item (3).	
7. Bracket (3)	Remove.	
8. Two screws (5), lockwashers (10), and nuts (11).	Remove from item (8).	
9. Bracket (8)	Remove.	
10. Screw (6) and nut (7).	Remove from item (8).	
11. Three screws (36)	Remove from item (34).	
12. Retainer (34) and seal (35).	Remove.	
13. Pin (28)	Remove from item (12)	Discard item (28).
14. Pin (12)	Remove from item (37) and item (27).	
15. Rod (37)	Remove.	

FUEL SYSTEM

3-41. ACCELERATOR PEDAL AND LINKAGE REPLACEMENT (Continued).

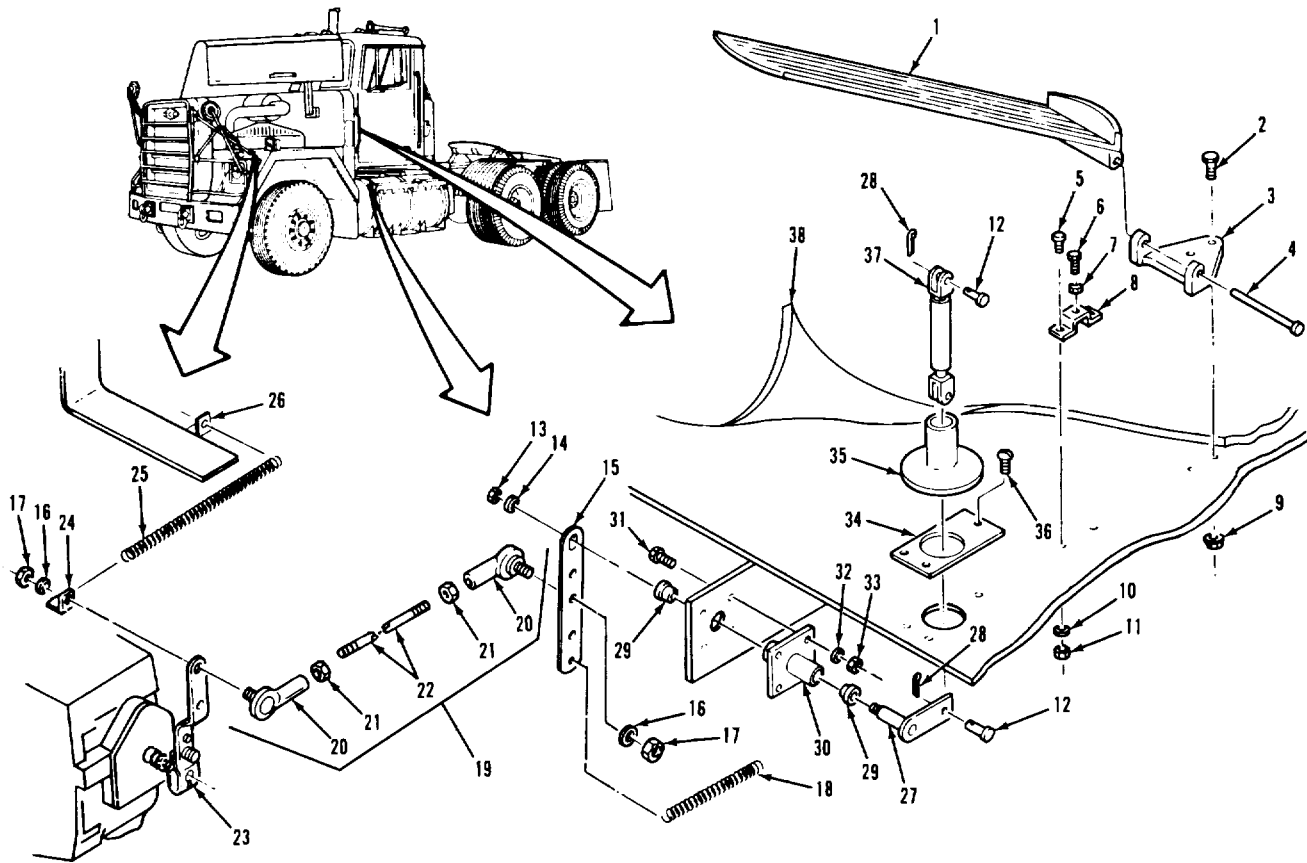

LEGEND:

- | | | |
|------------------------|---------------------------------|--------------------------------|
| 1. ACCELERATOR PEDAL | 15. ACCELERATOR BELLCRANK LEVER | 26. MODULATOR BRACKET ASSEMBLY |
| 2. OVAL HEAD SCREW (2) | 16. WASHER (2) | 27. LEVER AND PIVOT ASSEMBLY |
| 3. PEDAL BRACKET | 17. HEX NUT (2) | 28. COTTER PIN (2) |
| 4. STRAIGHT PIN | 18. LEVER RETURN SPRING | 29. FLANGED BEARING (2) |
| 5. PAN HEAD SCREW (2) | 19. ACCELERATOR LINK | 30. BELLCRANK BRACKET |
| 6. HEX HEAD SCREW | 20. BALL JOINT (2) | 31. SCREW (4) |
| 7. HEX NUT | 21. JAM NUT (2) | 32. PLAIN WASHER (4) |
| 8. PEDAL STOP BRACKET | 22. LINK | 33. PT NUT (4) |
| 9. NUT (2) | 23. FUEL CONTROL LEVER | 34. SEAL RETAINER |
| 10. LOCKWASHER (2) | 24. SPRING CLIP | 35. ACCELERATOR SEAL |
| 11. HEX NUT (2) | 25. ACCELERATOR RETURN SPRING | 36. SELF-TAPPING SCREW (3) |
| 12. CLEVIS PIN (2) | | 37. ROD ASSEMBLY |
| 13. PT NUT | | 38. FLOOR MAT237082 |
| 14. WASHER | | |

FUEL SYSTEM

3-41. ACCELERATOR PEDAL AND LINKAGE REPLACEMENT (Continued).

LOCATION/ITEM	ACTION	REMARKS
A. REMOVAL (Continued).		
16. Spring (18).	Unhook and remove from item (15) and bottom of cab.	
17. Nut (13), washer (14), and lever (15).	Remove from item (27).	
18. Lever and pivot assembly (27) and two bearings (29).	Remove from item (30).	
19. Spring (25).	Unhook and remove from item (24) and item (26).	
20. Nut (17), washer (16), and clip (24).	Remove from item (23).	
21. Link assembly (19) and lever (15).	Remove.	
22. Nut (17), washer (16), and lever (15).	Remove from item (20).	
23. Two nuts (21). 24. Two ball joints (20) and nuts (21).	Loosen from two items (20). Two ball joints	Remove from item (22).
25. Four screws (31), washers (32), and nuts (33).	Remove from item (30). mechanic.	Assistant helps
26. Bracket (30).	Remove.	

FUEL SYSTEM

3-41. ACCELERATOR PEDAL AND LINKAGE REPLACEMENT (Continued).

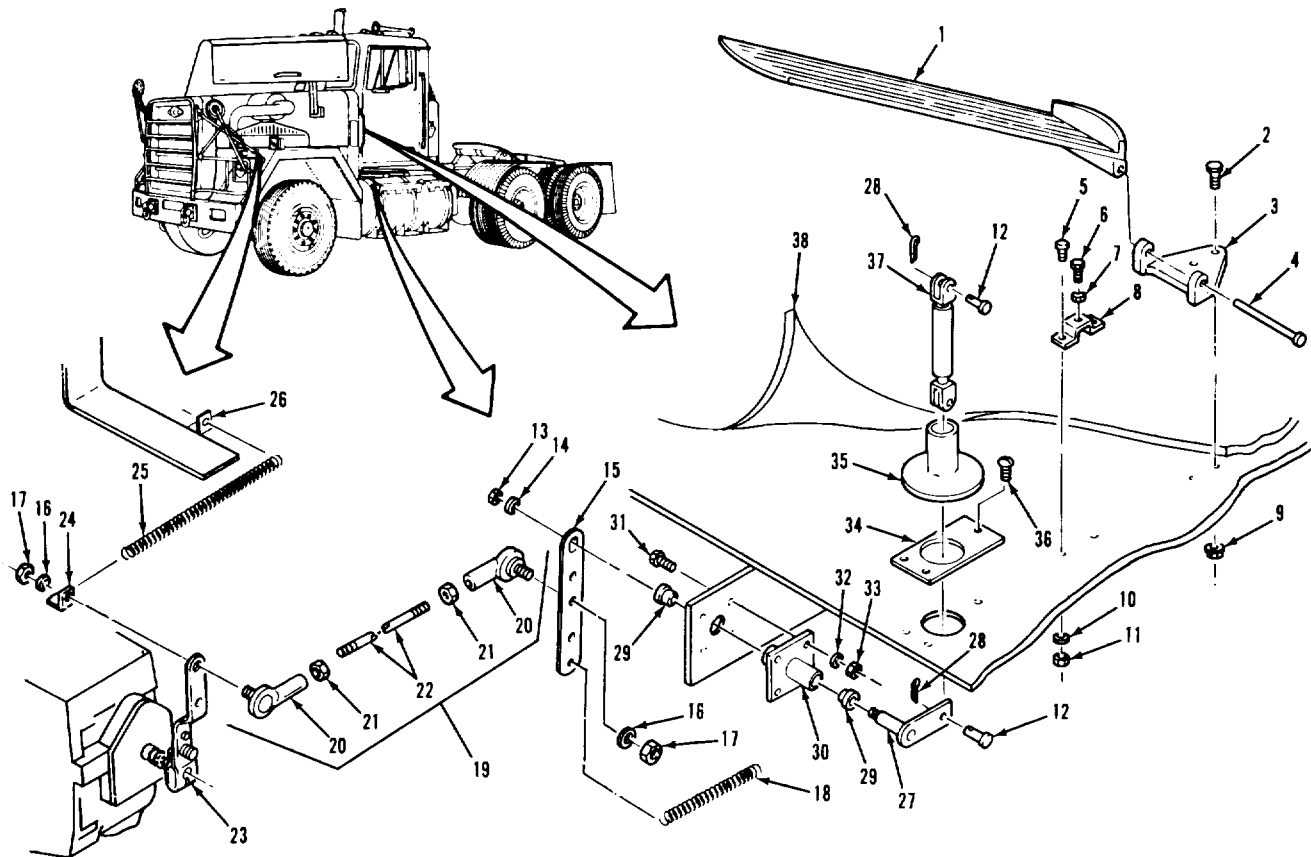

LEGEND:

- | | | |
|------------------------|---------------------------------|--------------------------------|
| 1. ACCELERATOR PEDAL | 15. ACCELERATOR BELLCRANK LEVER | 26. MODULATOR BRACKET ASSEMBLY |
| 2. OVAL HEAD SCREW (2) | 16. WASHER (2) | 27. LEVER AND PIVOT ASSEMBLY |
| 3. PEDAL BRACKET | 17. HEX NUT (2) | 28. COTTER PIN (2) |
| 4. STRAIGHT PIN | 18. LEVER RETURN SPRING | 29. FLANGED BEARING (2) |
| 5. PAN HEAD SCREW (2) | 19. ACCELERATOR LINK ASSEMBLY | 30. BELLCRANK BRACKET |
| 6. HEX HEAD SCREW | 20. BALL JOINT (2) | 31. SCREW (4) |
| 7. HEX NUT | 21. JAM NUT (2) | 32. PLAIN WASHER (4) |
| 8. PEDAL STOP BRACKET | 22. LINK | 33. PT NUT (4) |
| 9. NUT (2) | 23. FUEL CONTROL LEVER | 34. SEAL RETAINER |
| 10. LOCKWASHER (2) | 24. SPRING CLIP | 35. ACCELERATOR SEAL |
| 11. HEX NUT (2) | 25. ACCELERATOR RETURN SPRING | 36. SELF-TAPPING SCREW (3) |
| 12. CLEVIS PIN (2) | | 37. ROD ASSEMBLY |
| 13. PT NUT | | 38. FLOOR MAT |
| 14. WASHER | | |

FUEL SYSTEM

3-41. ACCELERATOR PEDAL AND LINKAGE REPLACEMENT (Continued).

LOCATION/ITEM	ACTION	REMARKS
B. CLEANING AND INSPECTION.		
27. All parts except seal (35).	Clean with solvent and rags	Refer to paragraph 3-4.
28. Seal (35)	Wipe clean with damp rag.	
29. All parts	Inspect	Refer to paragraph 3-5.
C. INSTALLATION.		
30. Bracket (30)	Put in place under cab.	
31. Four screws (31), washers (32), and nuts (33).	Secure item (30) mechanic.	Assistant helps
32. Nut (21) and ball joint (20)	a. Screw on item (22) as far as possible. b. Secure item (20) with item (21).	
33. Lever (15)	Put on item (20).	
34. Nut (17) and washer (16)	Secure item (15) to item (20).	
35. Lever and pivot assembly (27) and two bearings (29).	Put in item (30) (23).	Put grease on two items
36. Lever (15)	Put on item (27).	
37. Washer (14) and nut (13)	Secure item (15) to item (27).	
38. Rod (37) and pin (12).	Install in item (27).	
39. New pin (28)	Install in item (12).	

FUEL SYSTEM.

3-41. ACCELERATOR PEDAL AND LINKAGE REPLACEMENT (Continued).

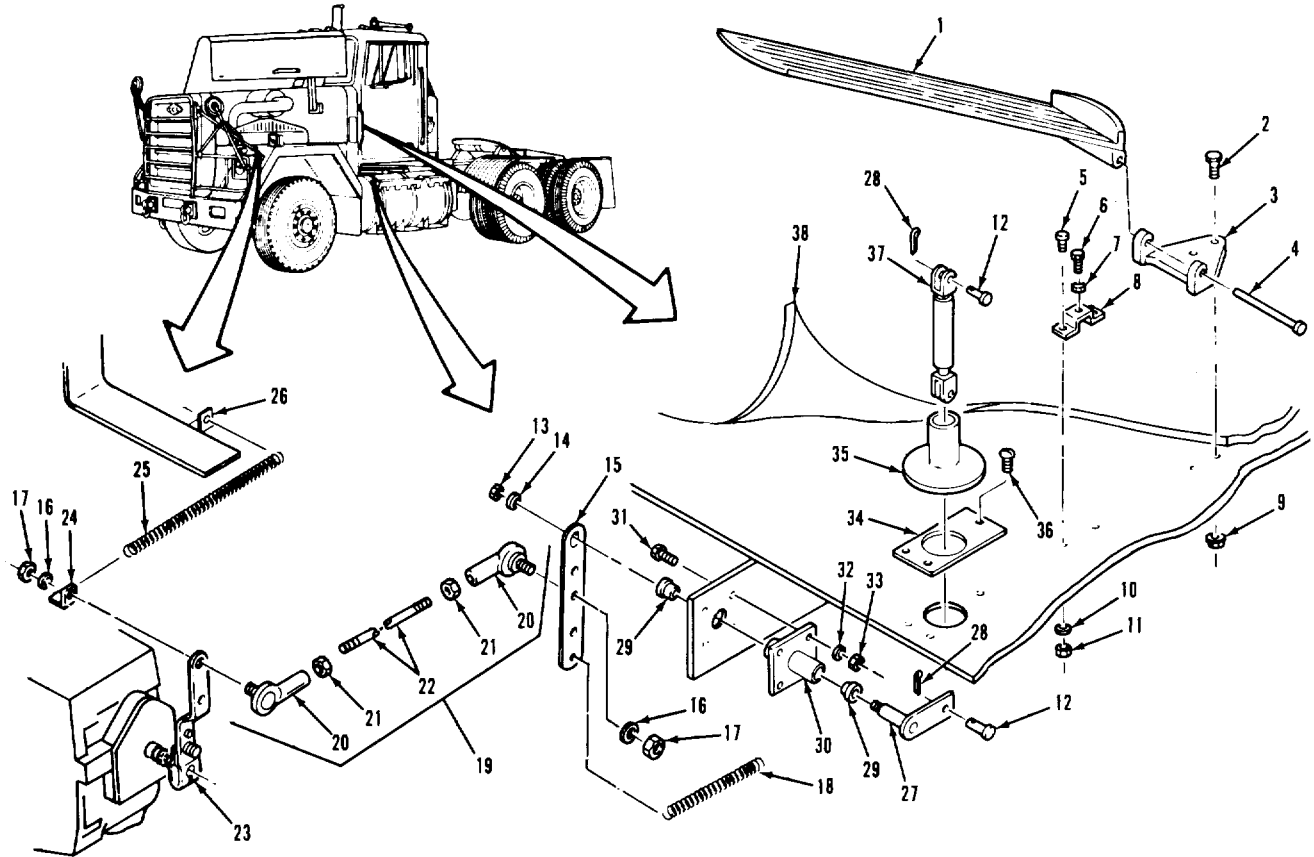

LEGEND:

- | | | |
|------------------------|---------------------------------|--------------------------------|
| 1. ACCELERATOR PEDAL | 15. ACCELERATOR BELLCRANK LEVER | 26. MODULATOR BRACKET ASSEMBLY |
| 2. OVAL HEAD SCREW (2) | 16. WASHER (2) | 27. LEVER AND PIVOT ASSEMBLY |
| 3. PEDAL BRACKET | 17. HEX NUT (2) | 28. COTTER PIN (2) |
| 4. STRAIGHT PIN | 18. LEVER RETURN SPRING | 29. FLANGED BEARING (2) |
| 5. PAN HEAD SCREW (2) | 19. ACCELERATOR LINK ASSEMBLY | 30. BELLCRANK BRACKET |
| 6. HEX HEAD SCREW | 20. BALL JOINT (2) | 31. SCREW (4) |
| 7. HEX NUT | 21. JAM NUT (2) | 32. PLAIN WASHER (4) |
| 8. PEDAL STOP BRACKET | 22. LINK | 33. PT NUT (4) |
| 9. NUT (2) | 23. FUEL CONTROL LEVER | 34. SEAL RETAINER |
| 10. LOCKWASHER (2) | 24. SPRING CLIP | 35. ACCELERATOR SEAL |
| 11. HEX NUT (2) | 25. ACCELERATOR RETURN SPRING | 36. SELF-TAPPING SCREW (3) |
| 12. CLEVIS PIN (2) | | 37. ROD ASSEMBLY |
| 13. PT NUT | | 38. FLOOR MAT |
| 14. WASHER | | |

TA 237084

FUEL SYSTEM.

3-41. ACCELERATOR PEDAL AND LINKAGE REPLACEMENT (Continued).

LOCATION/ITEM	ACTION	REMARKS
C. INSTALLATION (Continued).		
40. Spring (18).	Hook to item (15) and to bottom of cab.	
41. Seal (35) and	Slide over item (37). retainer (34).	
42. Three screws (36).	Secure item (34) and item (35) to cab floor.	
43. Screw (6) and nut (7).	Screw in bracket (8) as far as it will go.	Do not tighten item (7).
44. Two screws (5), washers (10), and nuts (11).	Secure item (8) to cab floor.	
45. Two screws (2) and nuts (9).	Secure item (3) to cab floor.	
46. Mat (38).	Put back in place.	
47. Pedal (1).	Put in bracket (3).	
48. Pin (4).	Drive in item (3) and item (1).	
49. Pin (12).	Put in item (37) and item (1).	
50. New pin (28).	Install in item (12).	
51. Lever (23).	Push toward rear of vehicle as far as it will go.	
52. Nut (21) and ball joint (20).	Screw on item (22) until aligned with hole in item (23).	Do not pull on item (22).
53. Nut (17), washer (16), and clip (24).	Secure item (20) to item (23).	

FUEL SYSTEM.

3-41. ACCELERATOR PEDAL AND LINKAGE REPLACEMENT (Continued).

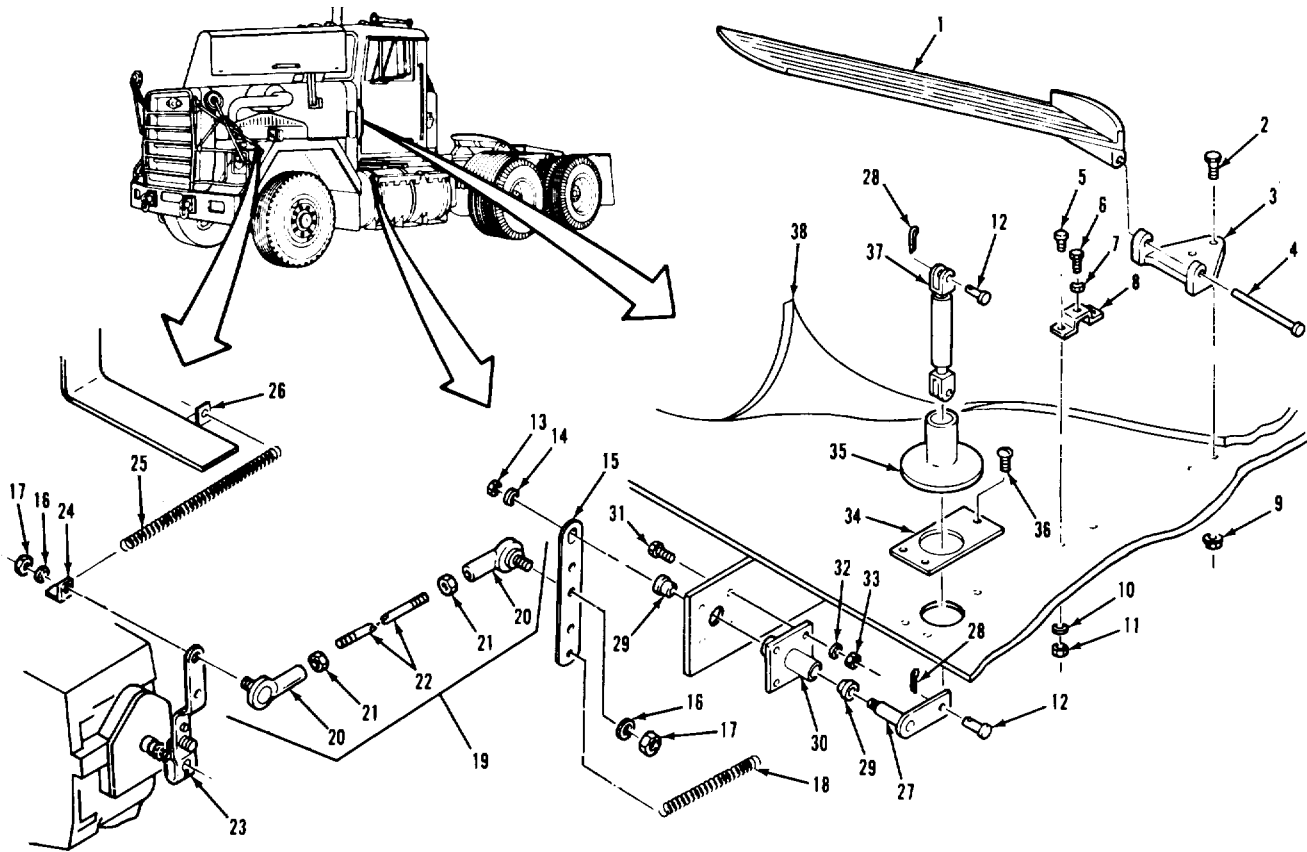

LEGEND:

- | | | |
|------------------------|---------------------------------|--------------------------------|
| 1. ACCELERATOR PEDAL | 15. ACCELERATOR BELLCRANK LEVER | 26. MODULATOR BRACKET ASSEMBLY |
| 2. OVAL HEAD SCREW (2) | 16. WASHER (2) | 27. LEVER AND PIVOT ASSEMBLY |
| 3. PEDAL BRACKET | 17. HEX NUT (2) | 28. COTTER PIN (2) |
| 4. STRAIGHT PIN | 18. LEVER RETURN SPRING | 29. FLANGED BEARING (2) |
| 5. PAN HEAD SCREW (2) | 19. ACCELERATOR LINK ASSEMBLY | 30. BELLCRANK BRACKET |
| 6. HEX HEAD SCREW | 20. BALL JOINT (2) | 31. SCREW (4) |
| 7. HEX NUT | 21. JAM NUT (2) | 32. PLAIN WASHER (4) |
| 8. PEDAL STOP BRACKET | 22. LINK | 33. PT NUT (4) |
| 9. NUT (2) | 23. FUEL CONTROL LEVER | 34. SEAL RETAINER |
| 10. LOCKWASHER (2) | 24. SPRING CLIP | 35. ACCELERATOR SEAL |
| 11. HEX NUT (2) | 25. ACCELERATOR RETURN SPRING | 36. SELF-TAPPING SCREW (3) |
| 12. CLEVIS PIN (2) | | 37. ROD ASSEMBLY |
| 13. PT NUT | | 38. FLOOR MAT |
| 14. WASHER | | |

TA 237085

FUEL SYSTEM.

3-41. ACCELERATOR PEDAL AND LINKAGE REPLACEMENT (Continued).

LOCATION/ITEM	ACTION	REMARKS
C. INSTALLATION (Continued).		
54. Nut (21).	Tight against item (20).	
55. Spring (25).	Hook to item (24) and item (26).	
56. Lever (23).	Push toward front of vehicle as far as it will go without bending.	Hold in this position while assistant does step 57.
57. Screw (6).	Unscrew until it is against item (1).	
58. Nut (7).	Secure against item (8).	
NOTE		
Follow-on maintenance action required: None.		

FUEL SYSTEM.

3-41. ACCELERATOR PEDAL AND LINKAGE REPLACEMENT (Continued).

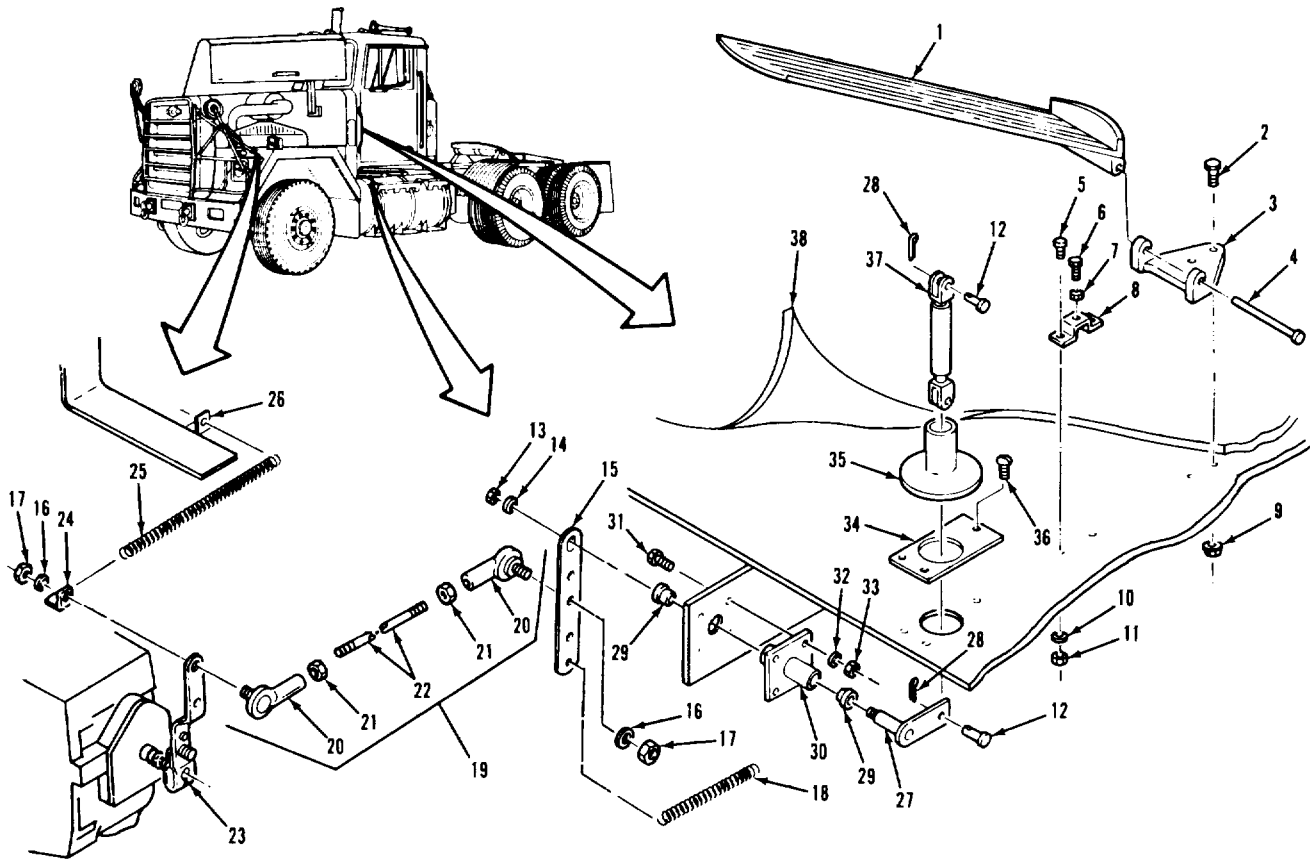

LEGEND:

- | | | |
|------------------------|---------------------------------|--------------------------------|
| 1. ACCELERATOR PEDAL | 15. ACCELERATOR BELLCRANK LEVER | 26. MODULATOR BRACKET ASSEMBLY |
| 2. OVAL HEAD SCREW (2) | 16. WASHER (2) | 27. LEVER AND PIVOT ASSEMBLY |
| 3. PEDAL BRACKET | 17. HEX NUT (2) | 28. COTTER PIN (2) |
| 4. STRAIGHT PIN | 18. LEVER RETURN SPRING | 29. FLANGED BEARING (2) |
| 5. PAN HEAD SCREW (2) | 19. ACCELERATOR LINK ASSEMBLY | 30. BELLCRANK BRACKET |
| 6. HEX HEAD SCREW | 20. BALL JOINT (2) | 31. SCREW (4) |
| 7. HEX NUT | 21. JAM NUT (2) | 32. PLAIN WASHER (4) |
| 8. PEDAL STOP BRACKET | 22. LINK | 33. PT NUT (4) |
| 9. NUT (2) | 23. FUEL CONTROL LEVER | 34. SEAL RETAINER |
| 10. LOCKWASHER (2) | 24. SPRING CLIP | 35. ACCELERATOR SEAL |
| 11. HEX NUT (2) | 25. ACCELERATOR RETURN SPRING | 36. SELF-TAPPING SCREW (3) |
| 12. CLEVIS PIN (2) | | 37. ROD ASSEMBLY |
| 13. PT NUT | | 38. FLOOR MAT |
| 14. WASHER | | |

TA 237086

FUEL SYSTEM.

3-42. FUEL CONTROL LEVER REPLACEMENT.

THIS TASK COVERS

- a. Removal.
- b. Cleaning and Inspection.
- c. Installation.

INITIAL SETUP

<p><u>APPLICABLE CONFIGURATIONS</u> All.</p>	<p><u>EQUIPMENT CONDITION PARAGRAPH</u> None.</p>	<p><u>CONDITION DESCRIPTION</u> None.</p>
<p><u>TEST EQUIPMENT</u> None.</p>		
<p><u>SPECIAL TOOLS</u> None.</p>		
<p><u>MATERIALS/PARTS (P/N)</u> Rags, wiping Item 22, Appendix C. Solvent, drycleaning, SD-2 Item 29, Appendix C.</p>		
<p><u>PERSONNEL REQUIRED</u> One (MOS-63S).</p>	<p><u>SPECIAL ENVIRONMENTAL CONDITIONS</u> None.</p>	
<p><u>REFERENCES (TM)</u> None.</p>	<p><u>GENERAL SAFETY INSTRUCTIONS</u> Engine off. Transmission in neutral. Park brake set.</p>	
<p><u>TROUBLESHOOTING REFERENCES</u> Paragraph 2-11.</p>		

FUEL SYSTEM.

3-42. FUEL CONTROL LEVER REPLACEMENT (Continued).

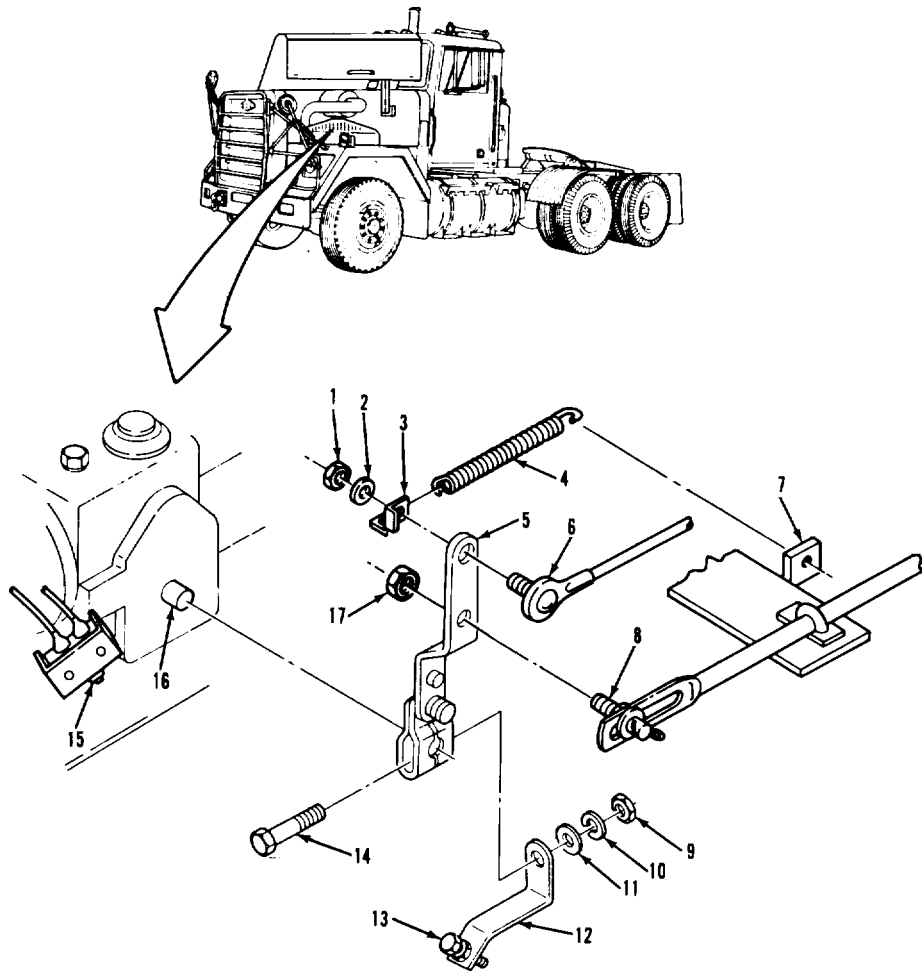

LEGEND:

- | | |
|-------------------------------|------------------------------|
| 1. HEX NUT | 10. LOCKWASHER |
| 2. LOCKWASHER | 11. PLAIN WASHER |
| 3. SPRING CLIP | 12. LIMIT SWITCH PIVOT LEVER |
| 4. ACCELERATOR RETURN SPRING | 13. SCREW |
| 5. FUEL CONTROL LEVER | 14. SCREW |
| 6. ACCELERATOR LINK ASSEMBLY | 15. SWITCH |
| 7. MODULATOR BRACKET ASSEMBLY | 16. THROTTLE SHAFT |
| 8. LINK PIN | 17. LOCKNUT |
| 9. JAM NUT | |

TA 237087

FUEL SYSTEM.

3-42. FUEL CONTROL LEVER REPLACEMENT (Continued).

LOCATION/ITEM	ACTION	REMARKS
A. REMOVAL.		
1. Spring (4). item (7).	Unhook from item (3) and	
2. Nut (1), lock-washer (2), and clip (3).	Remove from item (6).	
3. Link assembly (6).	Remove from item (5).	
4. Nut (17).	Remove from item (8).	
5. Pin (8).	Remove from item (5).	
6. Nut (9), lock-washer (10), washer (11), lever (12), and and screw (14).	Remove from item (5).	
7. Lever (5).	Remove from item (16).	
B. CLEANING AND INSPECTION.		
8. All parts.	a. Clean with solvent and rags. b. Inspect.	Refer to paragraph 3-4. Refer to paragraph 3-5.
C. INSTALLATION.		
9. Shaft (16).	Turn clockwise as far as it will go.	
10. Lever (5).	Put on item (16) so item (6) will go in hole.	Do not pull on item (6).

FUEL SYSTEM.

3-42. FUEL CONTROL LEVER REPLACEMENT (Continued).

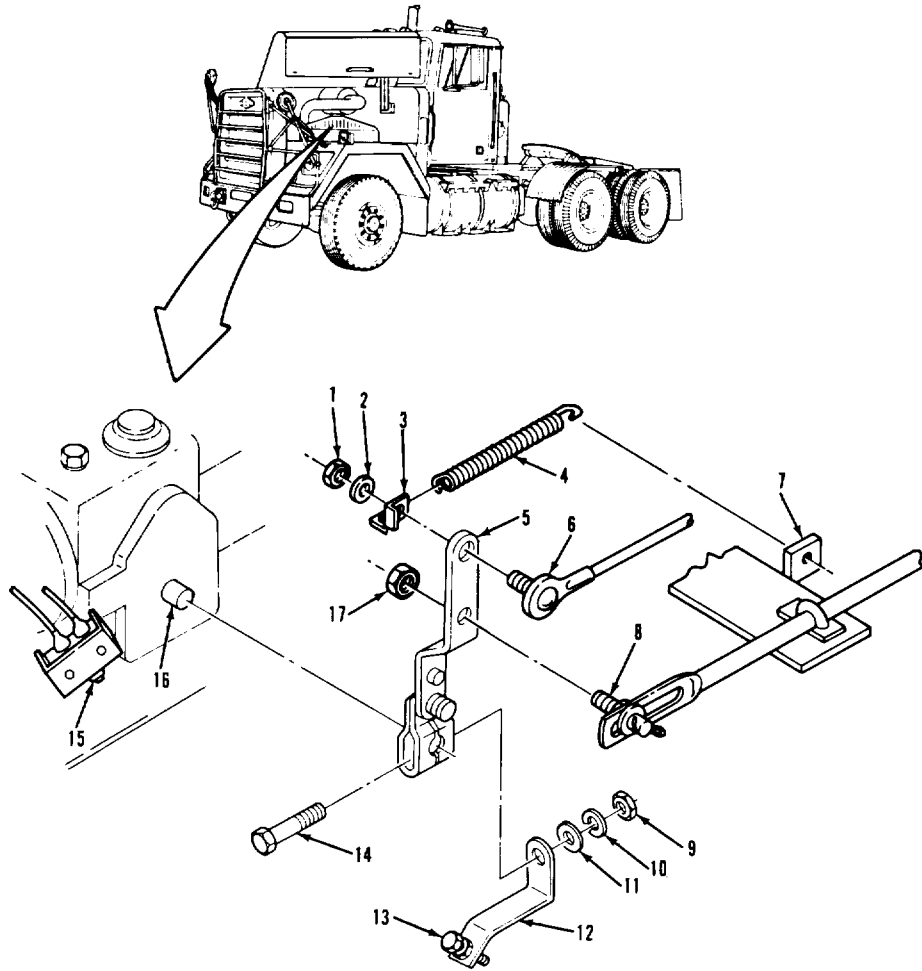

LEGEND:

- | | |
|-------------------------------|------------------------------|
| 1. HEX NUT | 10. LOCKWASHER |
| 2. LOCKWASHER | 11. PLAIN WASHER |
| 3. SPRING CLIP | 12. LIMIT SWITCH PIVOT LEVER |
| 4. ACCELERATOR RETURN SPRING | 13. SCREW |
| 5. FUEL CONTROL LEVER | 14. SCREW |
| 6. ACCELERATOR LINK ASSEMBLY | 15. SWITCH |
| 7. MODULATOR BRACKET ASSEMBLY | 16. THROTTLE SHAFT |
| 8. LINK PIN | 17. LOCKNUT |
| 9. JAM NUT | |

TA 237088

FUEL SYSTEM.

3-42. FUEL CONTROL LEVER REPLACEMENT (Continued).

LOCATION/ITEM	ACTION	REMARKS
C. INSTALLATION (Continued).		
11. Screw (14), lever (12), washer (11), lockwasher (10), and nut (9).	Secure item (5) to item (16).	When item (16) is turned clockwise as far as it will go, item (13) should just depress item (15) until it "clicks". Turn item (13) as needed.
12. Pin (8).	Put in item (5).	
13. Nut (17).	Secure item (8) to item (5).	
14. Link assembly (6).	Put in item (5).	
15. Clip (3), lock-washer (2), and nut (1).	Secure item (6) to item (5).	
16. Spring (4).	Hook to item (3) and item (7).	
NOTE		
Follow-on maintenance action required: None.		

FUEL SYSTEM.

3-42. FUEL CONTROL LEVER REPLACEMENT (Continued).

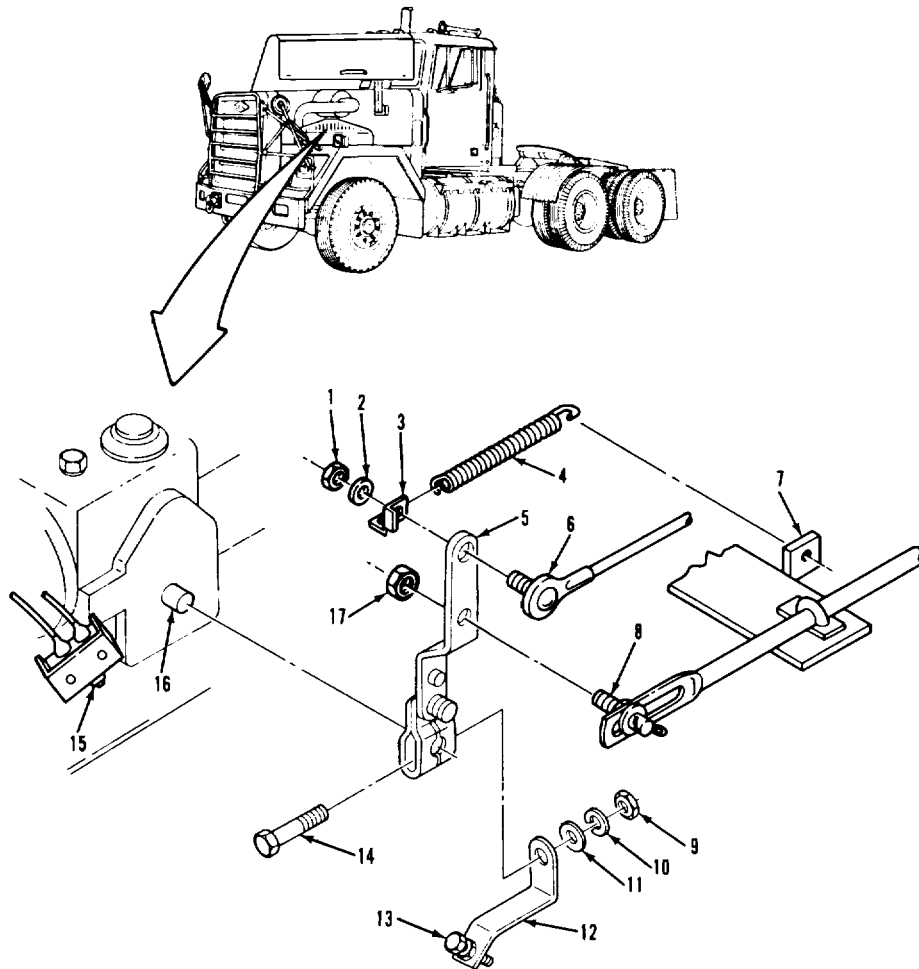

LEGEND:

- | | |
|-------------------------------|------------------------------|
| 1. HEX NUT | 10. LOCKWASHER |
| 2. LOCKWASHER | 11. PLAIN WASHER |
| 3. SPRING CLIP | 12. LIMIT SWITCH PIVOT LEVER |
| 4. ACCELERATOR RETURN SPRING | 13. SCREW |
| 5. FUEL CONTROL LEVER | 14. SCREW |
| 6. ACCELERATOR LINK ASSEMBLY | 15. SWITCH |
| 7. MODULATOR BRACKET ASSEMBLY | 16. THROTTLE SHAFT |
| 8. LINK PIN | 17. LOCKNU |
| 9. JAM NUT | |

SECTION IV. EXHAUST SYSTEM

3-43. GENERAL.

This section provides procedures authorized at the organizational maintenance level to replace exhaust system components. To find a specific procedure contained in this section, see the task summary below.

3-44. TASK SUMMARY.

INITIAL SETUP

APPLICABLE CONFIGURATIONS

All.

EQUIPMENT CONDITION

PARAGRAPH

(Refer to specific paragraph for this information).

CONDITION DESCRIPTION

TEST EQUIPMENT

None.

SPECIAL TOOLS

None.

MATERIALS/PARTS (P/N)

Rags, wiping

Item 22, Appendix C.

Solvent, drycleaning, SD-2

Item 29, Appendix C.

Coupling, reducer

(34623) 5932836.

Coupling (3)

(34623) 5932837.

PERSONNEL REQUIRED

Two (MOS-63S).

SPECIAL ENVIRONMENTAL CONDITIONS

None.

REFERENCES (TM)

TM 9-2320-283-20P.

GENERAL SAFETY INSTRUCTIONS

Engine off.

Transmission in neutral.

Park brake set.

TROUBLESHOOTING REFERENCES

Paragraph 2-11.

Wait until exhaust components are cool.

EXHAUST SYSTEM.

3-44. TASK SUMMARY (Continued).			
LIST OF TASKS			
TASK NO.	TASK	TASK REF	TROUBLESHOOTING REF NO. (PARA)
1	Muffler and Heat Shield Replacement a. Removal. b. Cleaning and Inspection. c. Installation.	3-45 3-45a 3-45b 3-45c	2-11
2	Exhaust Stack Pipe Replacement a. Removal. b. Cleaning and Inspection. c. Installation.	3-46 3-46a 3-46b 3-46c	2-11
3	Exhaust Flex Pipe Replacement a. Removal. b. Cleaning and Inspection. c. Installation.	3-47 3-47a 3-47b 3-47c	2-11
4	Turbocharger Outlet Pipe Replacement a. Removal. b. Cleaning and Inspection. c. Installation.	3-48 3-48a 3-48b 3-48c	2-11
5	Muffler Inlet Pipe Replacement a. Removal. b. Cleaning and Inspection. c. Installation.	3-49 3-49a 3-49b 3-49c	2-11

EXHAUST SYSTEM.

3-45. MUFFLER AND HEAT SHIELD REPLACEMENT.

THIS TASK COVERS

- a. Removal.
- b. Cleaning and Inspection.
- c. Installation.

INITIAL SETUP

<p><u>APPLICABLE CONFIGURATIONS</u> All.</p>	<p><u>EQUIPMENT CONDITION PARAGRAPH</u> 3-46.</p>	<p><u>CONDITION DESCRIPTION</u> Exhaust stack pipe removed.</p>
<p><u>TEST EQUIPMENT</u> None.</p>		
<p><u>SPECIAL TOOLS</u> None.</p>		
<p><u>MATERIALS/PARTS (P/N)</u> Coupling, reducer (34623) 5932836.</p>		
<p><u>PERSONNEL REQUIRED</u> Two (MOS-63S).</p>	<p><u>SPECIAL ENVIRONMENTAL CONDITIONS</u> None.</p>	
<p><u>REFERENCES (TM)</u> TM 9-2320-283-20P.</p>	<p><u>GENERAL SAFETY INSTRUCTIONS</u> Engine off. Transmission in neutral. Park brake set. Wait until exhaust components are cool.</p>	
<p><u>TROUBLESHOOTING REFERENCES</u> Paragraph 2-11.</p>		

EXHAUST SYSTEM.

3-45. MUFFLER AND HEAT SHIELD REPLACEMENT (Continued).

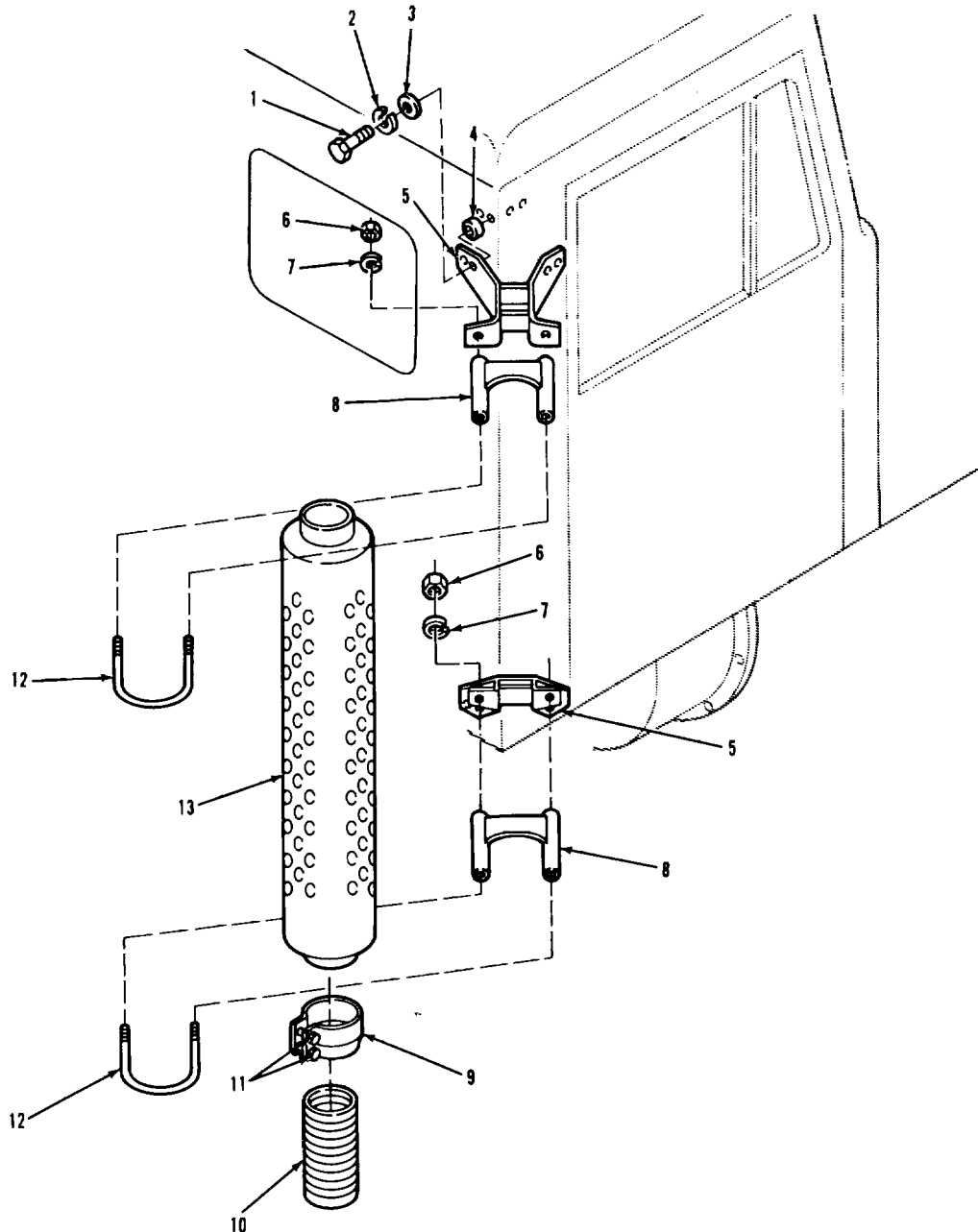

LEGEND:

- | | |
|--|--------------------------------------|
| 1. HEX HEAD SCREW (8) | 8. CLAMP (2) |
| 2. LOCKWASHER (8) | 9. REDUCER COUPLING |
| 3. WASHER (8) | 10. EXHAUST FLEX PIPE |
| 4. INSULATOR (8) | 11. COUPLING SCREW (2) |
| 5. MUFFLER MOUNTING BRACKET ASSEMBLY (2) | 12. U-BOLT (2) |
| 6. NUT (4) | 13. MUFFLER AND HEAT SHIELD ASSEMBLY |
| 7. LOCKWASHER (4) | |

TA 237090

EXHAUST SYSTEM.

3-45. MUFFLER AND HEAT SHIELD REPLACEMENT (Continued).

LOCATION/ITEM	ACTION	REMARKS
<u>WARNING</u>		
During normal operation, the exhaust pipes and muffler can become very hot. Be careful not to touch these components with your bare hands. Do not allow your body to come in contact with the hot pipes or muffler. Exhaust system components may be hot enough to cause serious burns.		
A. REMOVAL.		
1. Two screws (11).	Loosen.	
2. Coupling (9).	Slide down over item (10).	
3. Four nuts (6), four lockwashers (7), two U-bolts (12), and two clamps (8).	Remove from item (13) and two items (5).	Assistant holds item (13).
4. Muffler and heat shield assembly (13).	Lift from item (10). removal.	Assistant aids in
5. Eight screws (1), lockwashers (2), washers (3), and two brackets (5).	Remove.	
6. Eight insulators (4) .	Press from two items (5).	
7. Coupling (9).	a. Lift from item (10).	
	b. Discard item (9).	

EXHAUST SYSTEM.

3-45. MUFFLER AND HEAT SHIELD REPLACEMENT (Continued).

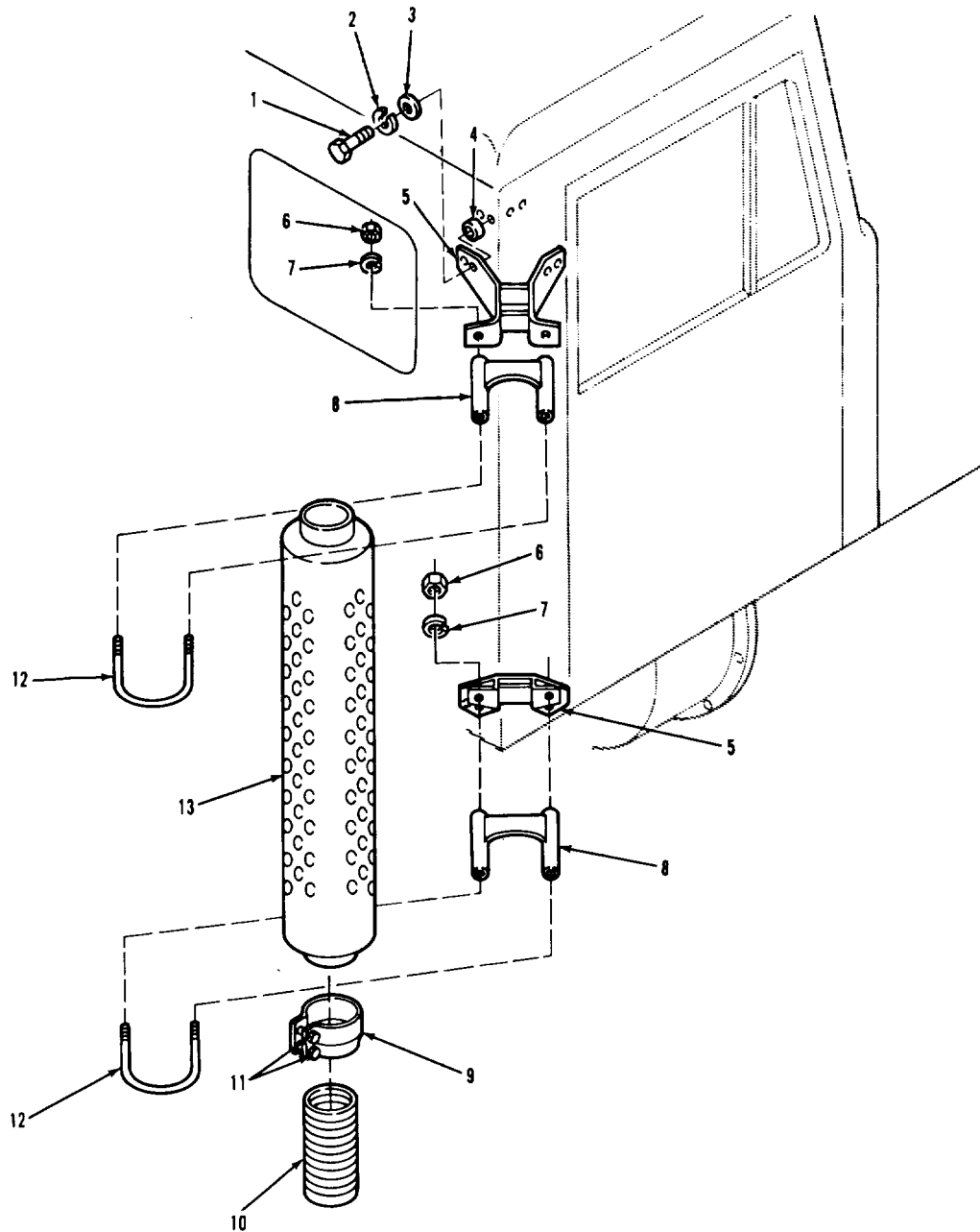

LEGEND:

- | | |
|--|--------------------------------------|
| 1. HEX HEAD SCREW (8) | 8. CLAMP (2) |
| 2. LOCKWASHER (8) | 9. REDUCER COUPLING |
| 3. WASHER (8) | 10. EXHAUST FLEX PIPE |
| 4. INSULATOR (8) | 11. COUPLING SCREW (2) |
| 5. MUFFLER MOUNTING BRACKET ASSEMBLY (2) | 12. U-BOLT (2) |
| 6. NUT (4) | 13. MUFFLER AND HEAT SHIELD ASSEMBLY |
| 7. LOCKWASHER (4) | |

TA 237091

EXHAUST SYSTEM.

3-45. MUFFLER AND HEAT SHIELD REPLACEMENT (Continued).

LOCATION/ITEM	ACTION	REMARKS
B. CLEANING AND INSPECTION.		
8. All parts.	a. Clean.	Refer to paragraph 3-4.
	b. Inspect for burrs, cracks, holes, or dents.	Refer to paragraph 3-5.
C. INSTALLATION.		
9. Eight insulators (4).	a. Lubricate with grease. b. Press into two items (5).	
10. Two brackets (5).	a. Position on cab. b. Secure with eight items (1), items (2), and items (3).	
11. Two clamps (8), two U-bolts (12), four lockwashers (7), and four nuts (6).	Install in two items (5).	Do not tighten four items (6).
12. New coupling (9).	Slide over item (10).	
13. Muffler and heat shield assembly (13).	Slide in two items (8) and two items (12).	a. Position item (13) so heat shield faces door and step. b. Assistant holds item (13) in place until it is secure.
14. Coupling (9).	Position over item (10) and item (13).	

EXHAUST SYSTEM.

3-45. MUFFLER AND HEAT SHIELD REPLACEMENT (Continued).

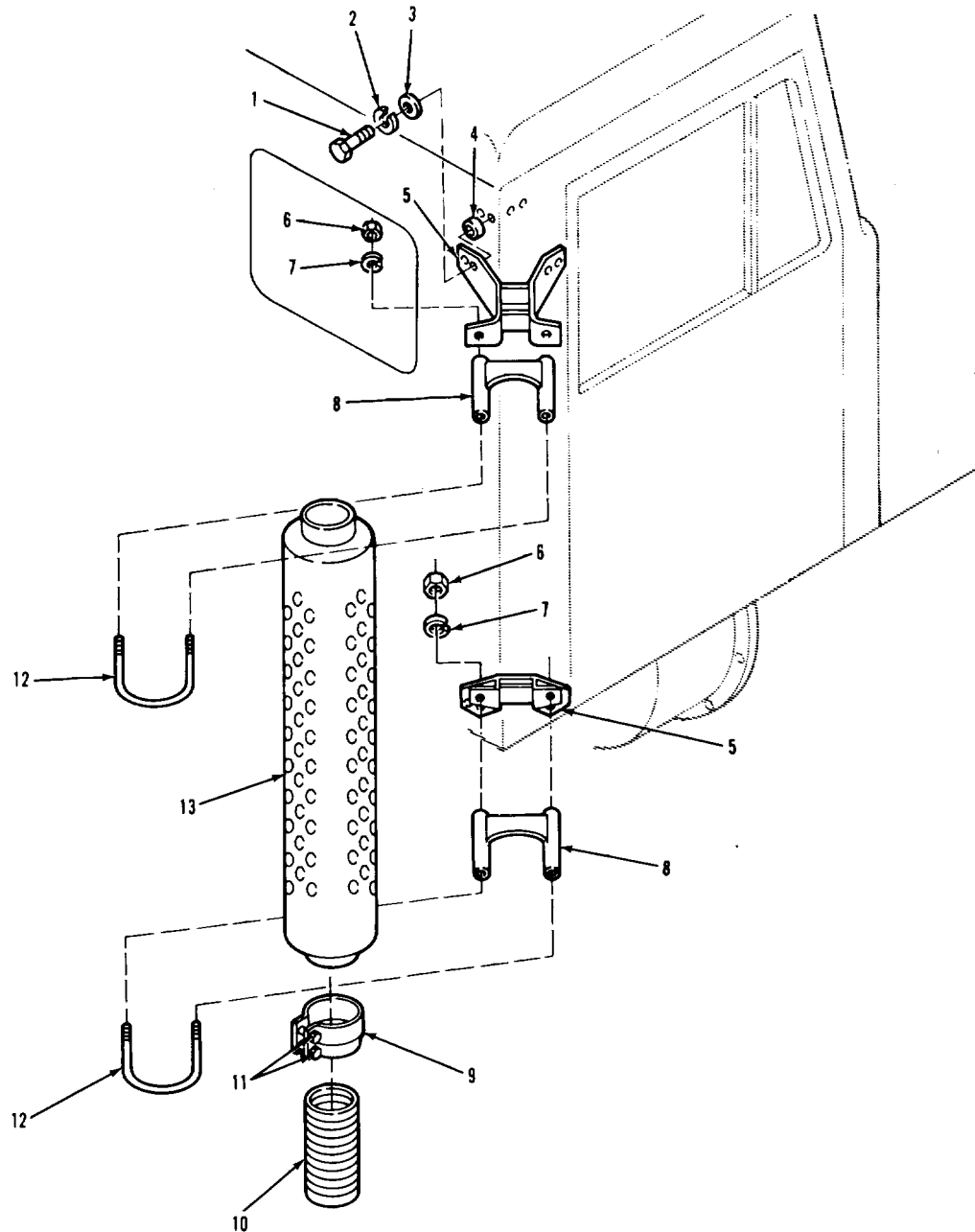

LEGEND:

- | | |
|--|--------------------------------------|
| 1. HEX HEAD SCREW (8) | 8. CLAMP (2) |
| 2. LOCKWASHER (8) | 9. REDUCER COUPLING |
| 3. WASHER (8) | 10. EXHAUST FLEX PIPE |
| 4. INSULATOR (8) | 11. COUPLING SCREW (2) |
| 5. MUFFLER MOUNTING BRACKET ASSEMBLY (2) | 12. U-BOLT (2) |
| 6. NUT (4) | 13. MUFFLER AND HEAT SHIELD ASSEMBLY |
| 7. LOCKWASHER (4) | |

TA 237092

EXHAUST SYSTEM.

3-45. MUFFLER AND HEAT SHIELD REPLACEMENT (Continued).

LOCATION/ITEM	ACTION	REMARKS
C. INSTALLATION (Continued).		
15. Two screws (9).	Tighten to 31-42 lb-ft.	
16. Four nuts (6).	Tighten.	
NOTE		
Follow-on maintenance action required:		
Install exhaust stack pipe (para 3-46).		

EXHAUST SYSTEM.

3-45. MUFFLER AND HEAT SHIELD REPLACEMENT (Continued).

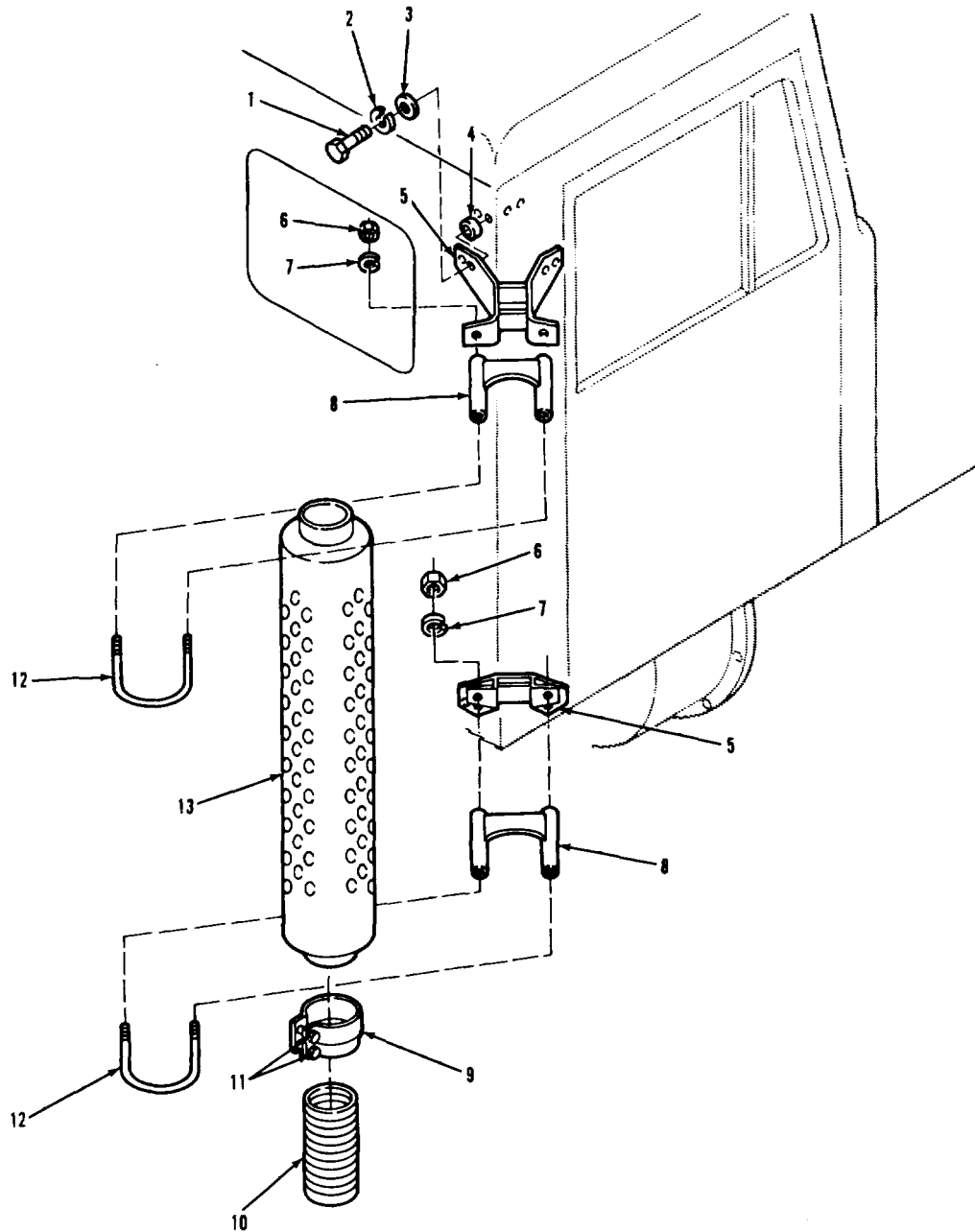

LEGEND:

- | | |
|--|--------------------------------------|
| 1. HEX HEAD SCREW (8) | 8. CLAMP (2) |
| 2. LOCKWASHER (8) | 9. REDUCER COUPLING |
| 3. WASHER (8) | 10. EXHAUST FLEX PIPE |
| 4. INSULATOR (8) | 11. COUPLING SCREW (2) |
| 5. MUFFLER MOUNTING BRACKET ASSEMBLY (2) | 12. U-BOLT (2) |
| 6. NUT (4) | 13. MUFFLER AND HEAT SHIELD ASSEMBLY |
| 7. LOCKWASHER (4) | |

TA 237093

EXHAUST SYSTEM.

3-46. EXHAUST STACK PIPE REPLACEMENT.

THIS TASK COVERS

- a. Removal.
- b. Cleaning and Inspection.
- c. Installation.

INITIAL SETUP

<p><u>APPLICABLE CONFIGURATIONS</u> All.</p>	<p><u>EQUIPMENT CONDITION PARAGRAPH</u> None.</p>	<p><u>CONDITION DESCRIPTION</u> None.</p>
<p><u>TEST EQUIPMENT</u> None.</p>		
<p><u>SPECIAL TOOLS</u> None.</p>		
<p><u>MATERIALS/PARTS (P/N)</u> Rags, wiping Item 22, Appendix C. Solvent, drycleaning, SD-2 Item 29, Appendix C.</p>		
<p><u>PERSONNEL REQUIRED</u> One (MOS-63S).</p>	<p><u>SPECIAL ENVIRONMENTAL CONDITIONS</u> None.</p>	
<p><u>REFERENCES (TM)</u> None.</p>	<p><u>GENERAL SAFETY INSTRUCTIONS</u> Engine off. Transmission in neutral. Park brake set. Wait until exhaust components are cool.</p>	
<p><u>TROUBLESHOOTING REFERENCES</u> Paragraph 2-11.</p>		

EXHAUST SYSTEM.

3-46. EXHAUST STACK PIPE REPLACEMENT (Continued).

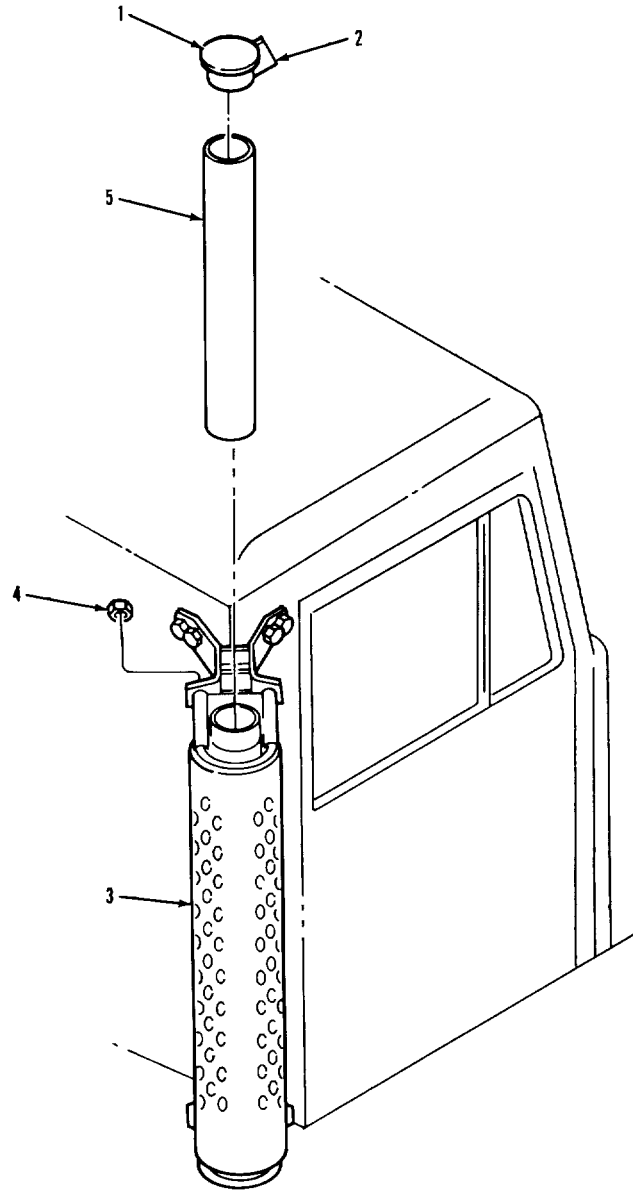

LEGEND:

- | | |
|-------------------------------------|-----------------------|
| 1. EXHAUST STACK CAP ASSEMBLY | 4. CLAMP NUT (2) |
| 2. EXHAUST STACK CAP ASSEMBLY NUT | 5. EXHAUST STACK PIPE |
| 3. MUFFLER AND HEAT SHIELD ASSEMBLY | |

TA 237094

EXHAUST SYSTEM.

3-46. EXHAUST STACK PIPE REPLACEMENT (Continued).

LOCATION/ITEM	ACTION	REMARKS
<u>WARNING</u>		
During normal operation, the exhaust pipes and muffler can become very hot. Be careful not to touch these components with your bare hands. Do not allow your body to come in contact with the hot pipes or muffler. Exhaust system components may be hot enough to cause serious burns.		
A. REMOVAL.		
1. Two nuts (4).	Loosen.	
2. Pipe (5).	Lift up out of item (3).	
3. Nut (2).	Loosen.	
4. Cap assembly (1).	Remove from item (5).	
B. CLEANING AND INSPECTION.		
5. All parts.	a. Clean with solvent and rags.	Refer to paragraph 3-4.
	b. Inspect for burrs, cracks, or distortions.	Refer to paragraph 3-5.
6. Cap assembly (1).	Check for free movement.	
C. INSTALLATION.		
7. Cap assembly (1).	Put on item (5).	
8. Nut (2).	Tighten.	

EXHAUST SYSTEM.

3-46. EXHAUST STACK PIPE REPLACEMENT (Continued).

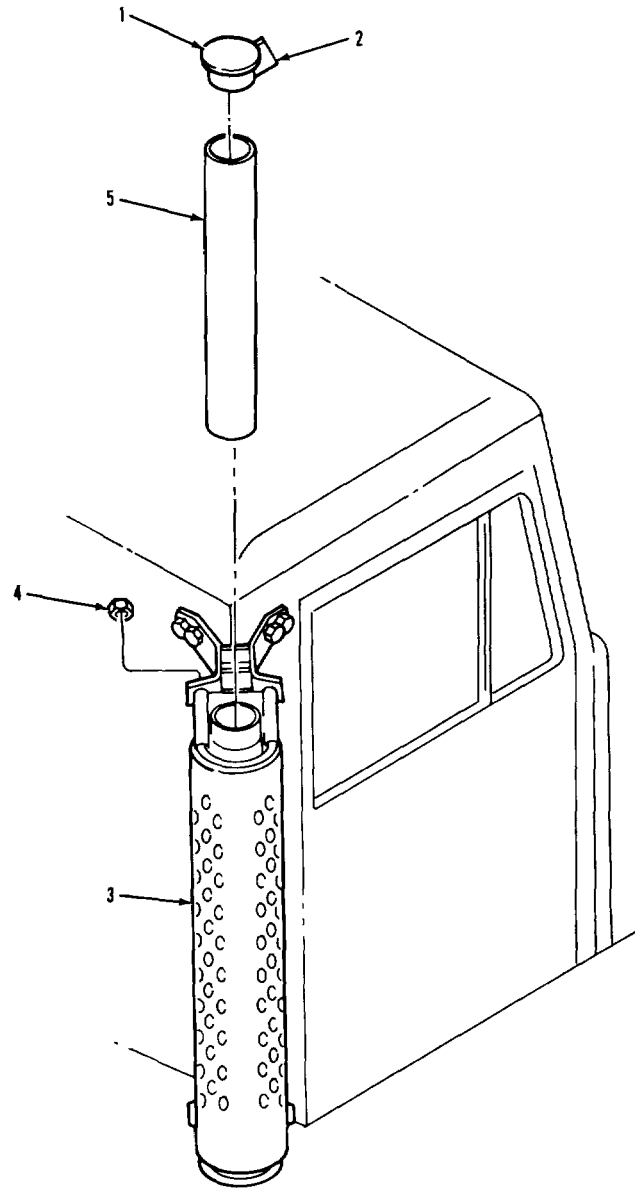

LEGEND:

- | | |
|-------------------------------------|-----------------------|
| 1. EXHAUST STACK CAP ASSEMBLY | 4. CLAMP NUT (2) |
| 2. EXHAUST STACK CAP ASSEMBLY NUT | 5. EXHAUST STACK PIPE |
| 3. MUFFLER AND HEAT SHIELD ASSEMBLY | |

TA 237095

EXHAUST SYSTEM.

3-46. EXHAUST STACK PIPE REPLACEMENT (Continued).

LOCATION/ITEM	ACTION	REMARKS
C. INSTALLATION (Continued).		
9. Pipe (5).	Put in item (3).	
10. Two nuts (4).	Tighten.	
NOTE		
Follow-on maintenance action required:		
None.		

EXHAUST SYSTEM.

3-46. EXHAUST STACK PIPE REPLACEMENT (Continued).

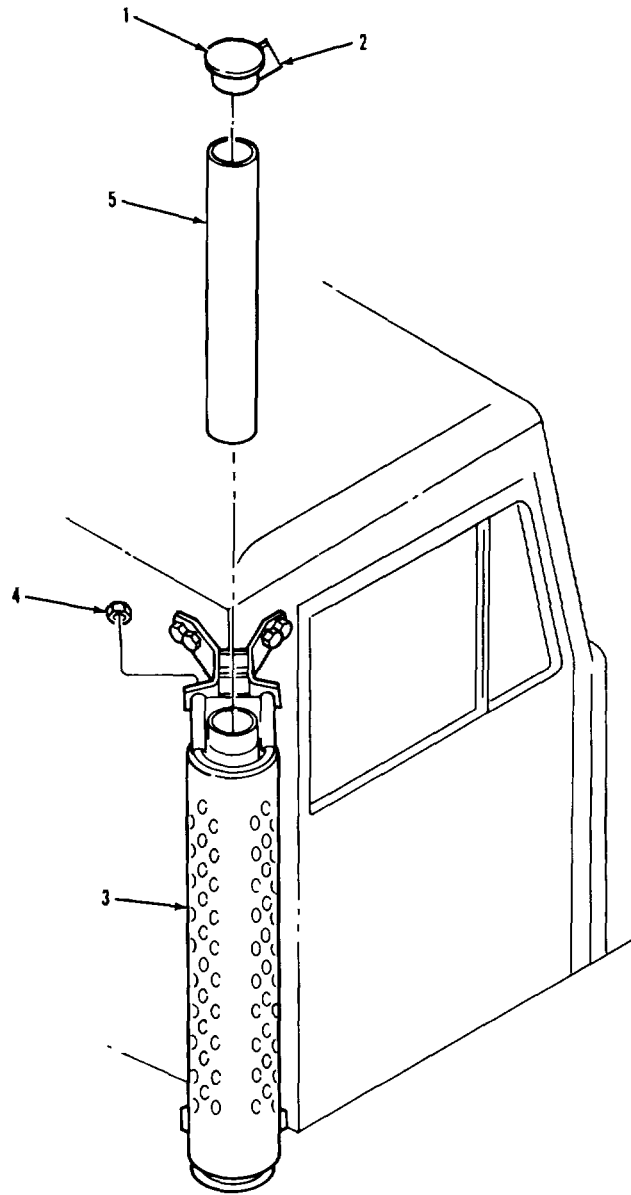

LEGEND:

- | | |
|-------------------------------------|-----------------------|
| 1. EXHAUST STACK CAP ASSEMBLY | 4. CLAMP NUT (2) |
| 2. EXHAUST STACK CAP ASSEMBLY NUT | 5. EXHAUST STACK PIPE |
| 3. MUFFLER AND HEAT SHIELD ASSEMBLY | |

TA 237096

EXHAUST SYSTEM.

3-47. EXHAUST FLEX PIPE REPLACEMENT.

THIS TASK COVERS

- a. Removal.
- b. Cleaning and Inspection.
- c. Installation.

INITIAL SETUP

APPLICABLE CONFIGURATIONS

All.

EQUIPMENT CONDITION

PARAGRAPH

None.

CONDITION DESCRIPTION

None.

TEST EQUIPMENT

None.

SPECIAL TOOLS

None.

MATERIALS/PARTS (P/N)

Coupling
(34623) 5932837.
Coupling, reducer
(34623) 5932836.

PERSONNEL REQUIRED

One (MOS-63S).

SPECIAL ENVIRONMENTAL CONDITIONS

None.

REFERENCES (TM)

TM 9-2320-283-20P.

GENERAL SAFETY INSTRUCTIONS

Engine off.
Transmission in neutral.
Park brake set.
Wait until exhaust components are cool.

TROUBLESHOOTING REFERENCES

Paragraph 2-11.

EXHAUST SYSTEM.

3-47. EXHAUST FLEX PIPE REPLACEMENT (Continued).

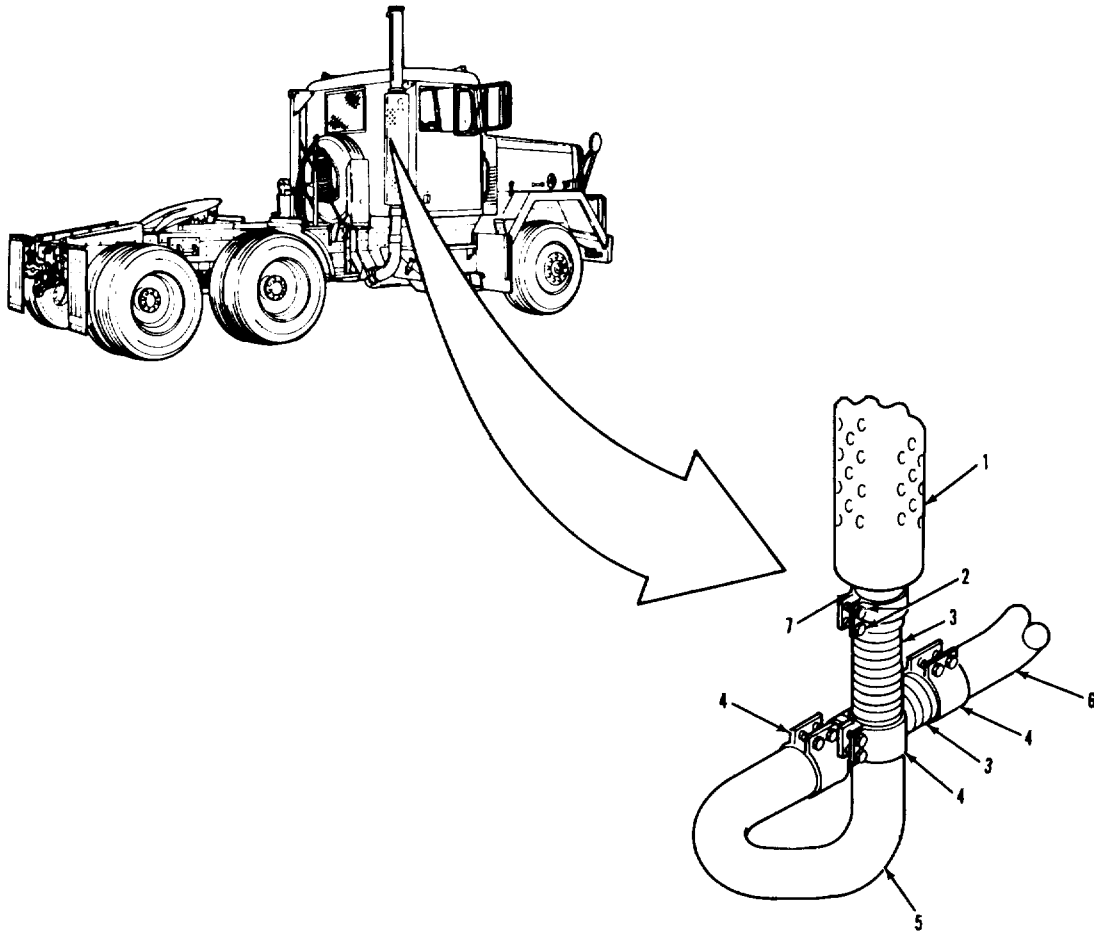

LEGEND:

- | | |
|-------------------------------------|-----------------------|
| 1. MUFFLER AND HEAT SHIELD ASSEMBLY | 5. MUFFLER INLET PIPE |
| 2. COUPLING SCREW (8) | 6. TURBO OUTLET PIPE |
| 3. EXHAUST FLEX PIPE (2) | 7. REDUCER COUPLING |
| 4. COUPLING (3) | |

TA 237097

EXHAUST SYSTEM.

3-47. EXHAUST FLEX PIPE REPLACEMENT (Continued).

LOCATION/ITEM	ACTION	REMARKS
<u>WARNING</u>		
During normal operation, the exhaust pipes and muffler can become very hot. Be careful not to touch these components with your bare hands. Do not allow your body to come in contact with the hot pipes or muffler. Exhaust system components may be hot enough to cause serious burns.		
A. REMOVAL.		
1. Eight screws (2).	Loosen.	
2. Coupling (7) and three couplings (4).	Slide over two items (3).	
3. Two pipes (3).	Remove.	
4. Coupling (7) and three couplings (4).	Remove from two items (3). three items (4).	Discard item (7) and
B. CLEANING AND INSPECTION.		
5. All parts.	a. Clean.	Refer to paragraph 3-4.
	b. Inspect.	Refer to paragraph 3-5.
C. INSTALLATION.		
6. New coupling (7), and three new couplings (4).	Slide over two items (3).	

EXHAUST SYSTEM.

3-47. EXHAUST FLEX PIPE REPLACEMENT (Continued).

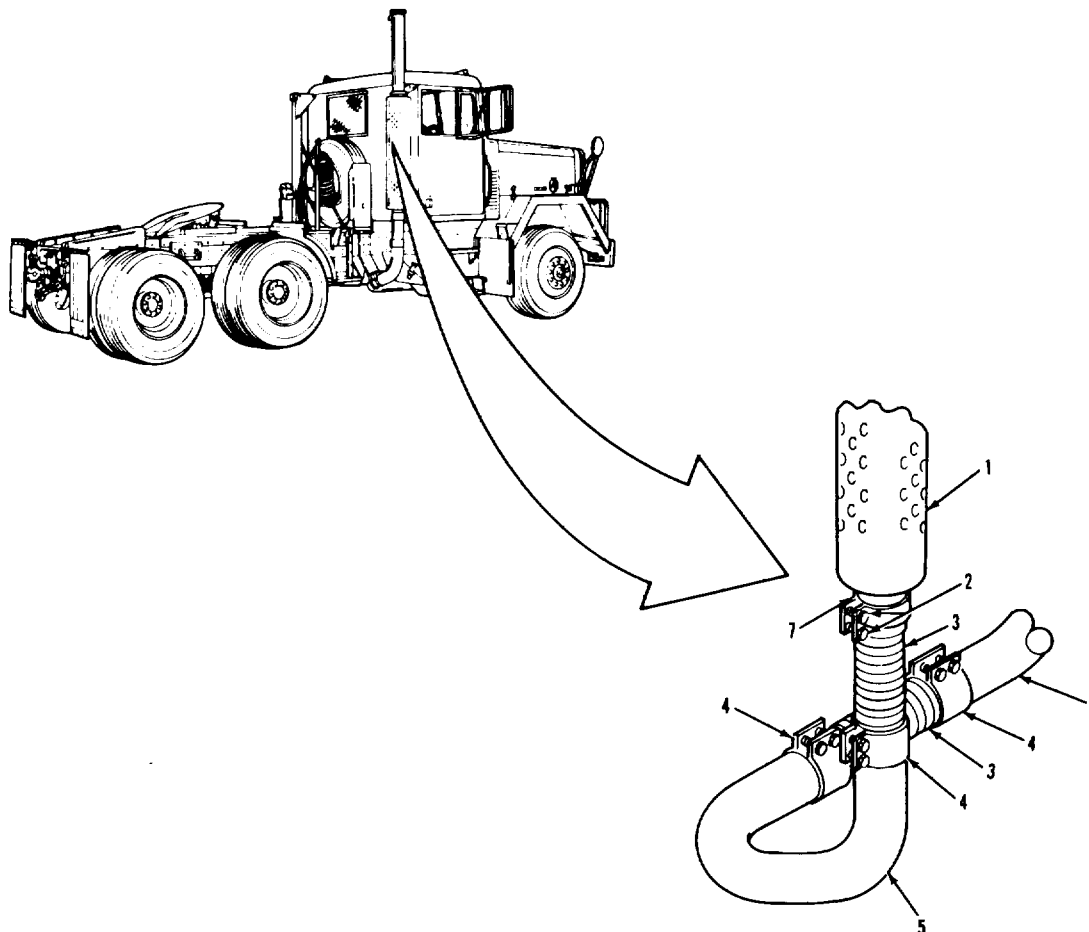

LEGEND:

- 1. MUFFLER AND HEAT SHIELD ASSEMBLY
- 2. COUPLING SCREW (8)
- 3. EXHAUST FLEX PIPE (2)
- 4. COUPLING (3)

- 5. MUFFLER INLET PIPE
- 6. TURBO OUTLET PIPE
- 7. REDUCER COUPLING

TA 237098

EXHAUST SYSTEM.

3-47. EXHAUST FLEX PIPE REPLACEMENT (Continued).

LOCATION/ITEM	ACTION	REMARKS
C. INSTALLATION (Continued).		
7. Two pipes (3). item (5), and item (6).	Put in place between item (1),	
8. Coupling (7) and three couplings (4).	Slide in position to secure two items (3).	
9. Eight screws (2).	Torque to 31-42 lb-ft.	

NOTE

Follow-on maintenance action required:
None.

EXHAUST SYSTEM.

3-47. EXHAUST FLEX PIPE REPLACEMENT (Continued).

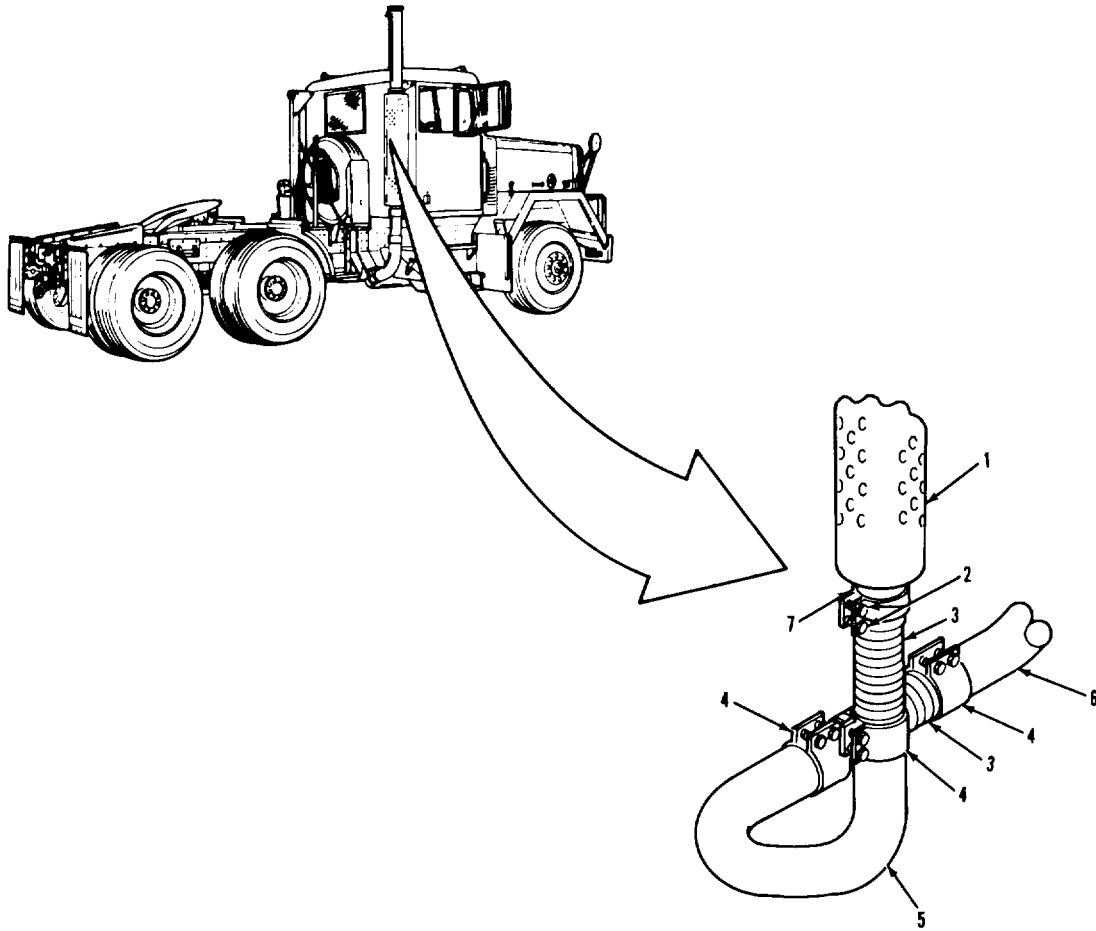

LEGEND:

- 1. MUFFLER AND HEAT SHIELD ASSEMBLY
- 2. COUPLING SCREW (8)
- 3. EXHAUST FLEX PIPE (2)
- 4. COUPLING (3)

- 5. MUFFLER INLET PIPE
- 6. TURBO OUTLET PIPE
- 7. REDUCER COUPLING

EXHAUST SYSTEM.

3-48. TURBOCHARGER OUTLET PIPE REPLACEMENT.

THIS TASK COVERS

- a. Removal.
- b. Cleaning and Inspection.
- c. Installation.

INITIAL SETUP

EQUIPMENT CONDITION

APPLICABLE CONFIGURATIONS

All.

PARAGRAPH

TM 9-2320-283-10.

CONDITION DESCRIPTION

Right front of vehicle raised on safety stands.

TEST EQUIPMENT

None.

SPECIAL TOOLS

None.

MATERIALS/PARTS (P/N)

Rags, wiping
 Item 22, Appendix C.
 Solvent, drycleaning, SD-2
 Item 29, Appendix C.
 Coupling, reducer
 (34623) 5932837.

PERSONNEL REQUIRED

Two (MOS-63S).

SPECIAL ENVIRONMENTAL CONDITIONS

None.

REFERENCES (TM)

TM 9-2320-283-10.
 TM 9-2320-283-20P.

GENERAL SAFETY INSTRUCTIONS

Engine off.
 Transmission in neutral.
 Park brake set.
 Wait until exhaust components are cool.

TROUBLESHOOTING REFERENCES

Paragraph 2-11.

EXHAUST SYSTEM.

3-48. TURBOCHARGER OUTLET PIPE REPLACEMENT (Continued).

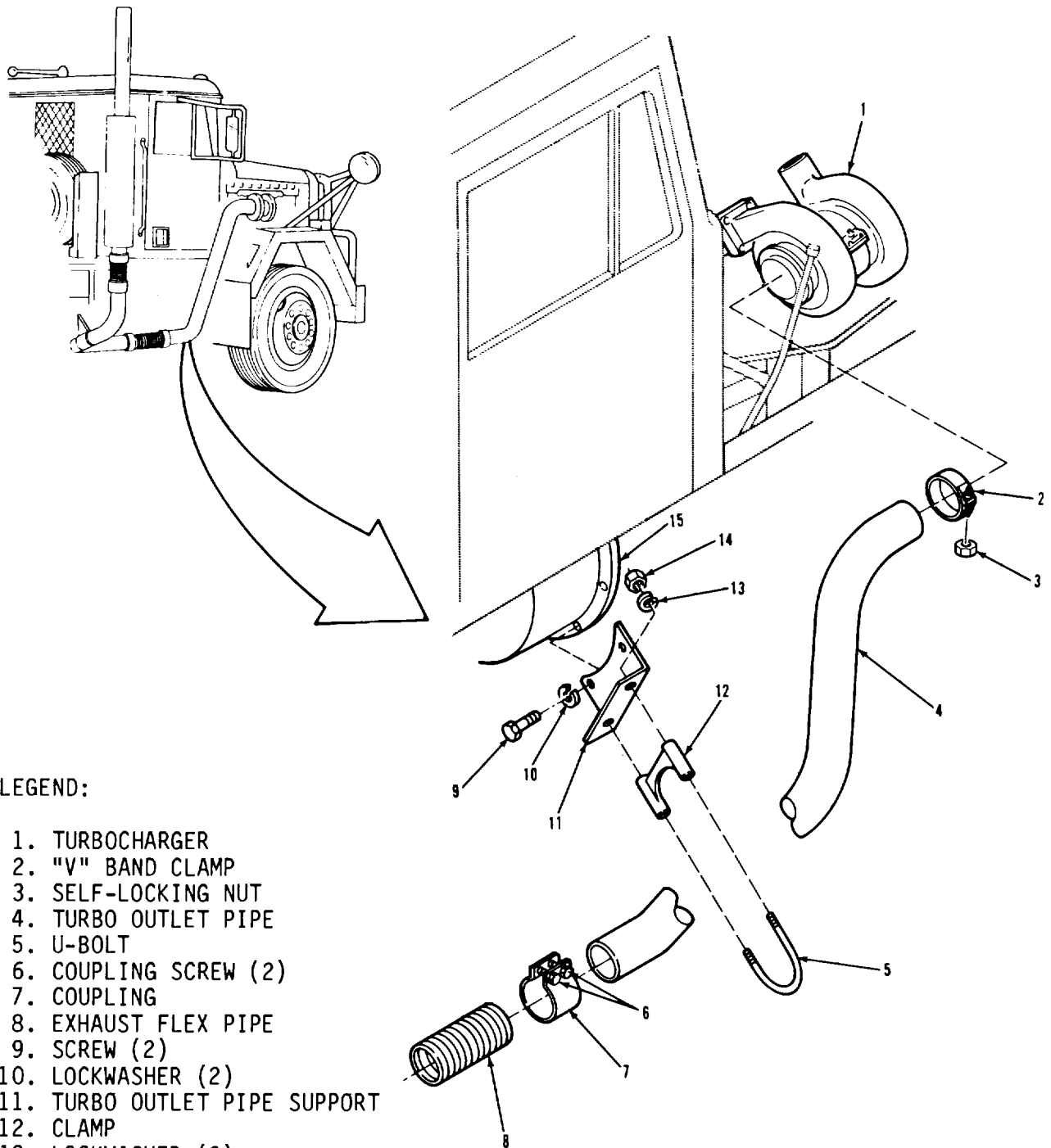

LEGEND:

- 1. TURBOCHARGER
- 2. "V" BAND CLAMP
- 3. SELF-LOCKING NUT
- 4. TURBO OUTLET PIPE
- 5. U-BOLT
- 6. COUPLING SCREW (2)
- 7. COUPLING
- 8. EXHAUST FLEX PIPE
- 9. SCREW (2)
- 10. LOCKWASHER (2)
- 11. TURBO OUTLET PIPE SUPPORT
- 12. CLAMP
- 13. LOCKWASHER (2)
- 14. NUT (2)
- 15. TRANSMISSION

TA 237100
TA 237100

EXHAUST SYSTEM.

3-47. EXHAUST FLEX PIPE REPLACEMENT (Continued).

LOCATION/ITEM	ACTION	REMARKS
<u>WARNING</u>		
During normal operation, the exhaust pipes and muffler can become very hot. Be careful not to touch these components with your bare hands. Do not allow your body to come in contact with the hot pipes or muffler. Exhaust system components may be hot enough to cause serious burns.		
A. REMOVAL		
1. Nut (3). 2. Clamp (2). 3. Two screws (7). 4. Coupling (6). 5. Two nuts (14), two lockwashers (13), clamp (12), and U-bolt (5).	Remove from item (2). Slide on item (4). Loosen item (7). Slide on item (8). Remove from item (4) and item (11).	
6. Pipe (3). item (1).	Remove from item (8) and	Discard item (7).
7. Two screws (9) and lockwashers (10).	Remove from item (11).	
8. Support (11).	Remove from item (15).	
B. CLEANING AND INSPECTION.		
9. All parts.	Clean with solvent and rags.	Refer to paragraph 3-4.
10. All parts.	Inspect.	Refer to paragraph 3-5.
3-236		

EXHAUST SYSTEM.

3-48. TURBOCHARGER OUTLET PIPE REPLACEMENT (Continued).

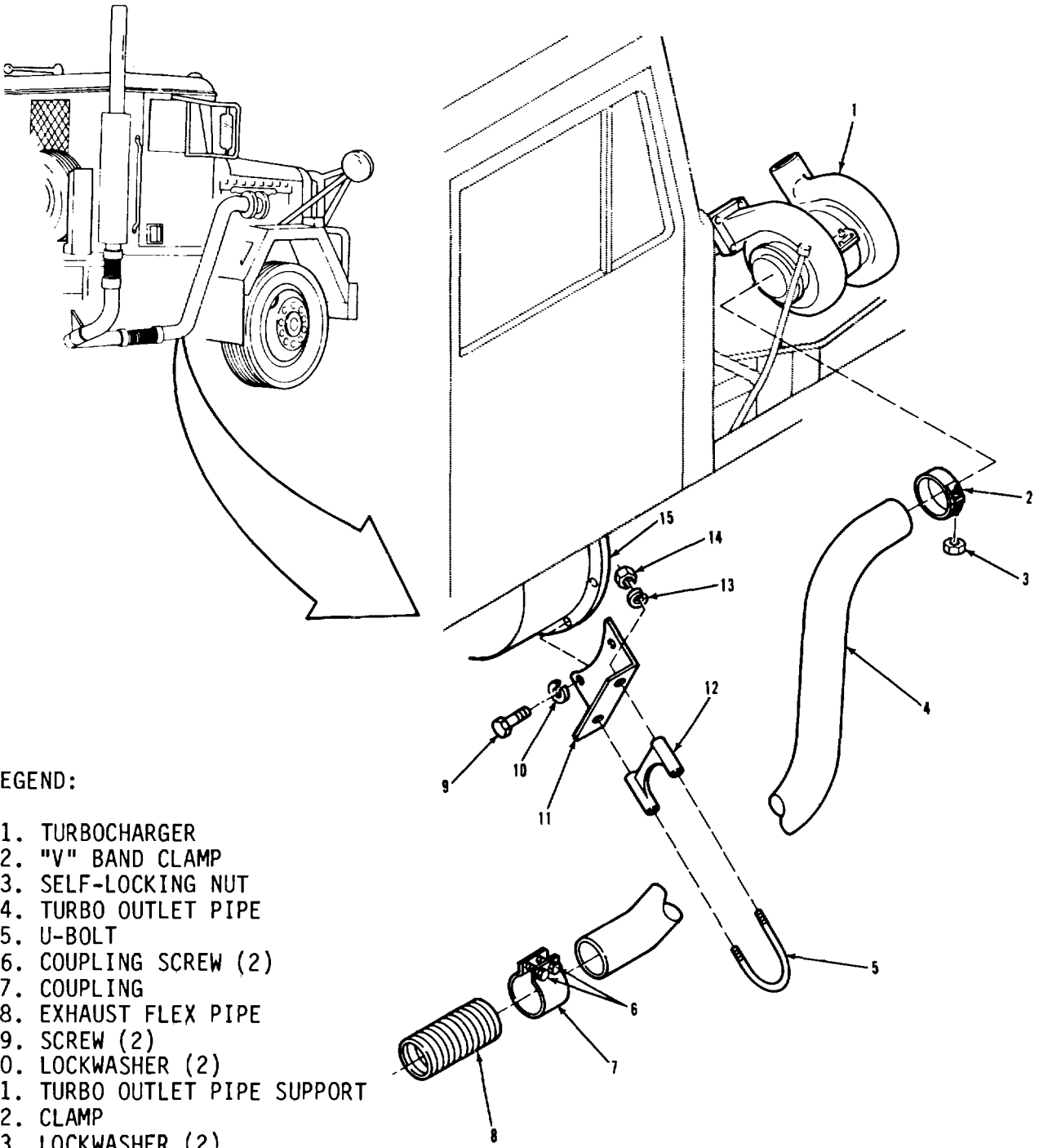

LEGEND:

- 1. TURBOCHARGER
- 2. "V" BAND CLAMP
- 3. SELF-LOCKING NUT
- 4. TURBO OUTLET PIPE
- 5. U-BOLT
- 6. COUPLING SCREW (2)
- 7. COUPLING
- 8. EXHAUST FLEX PIPE
- 9. SCREW (2)
- 10. LOCKWASHER (2)
- 11. TURBO OUTLET PIPE SUPPORT
- 12. CLAMP
- 13. LOCKWASHER (2)
- 14. NUT (2)
- 15. TRANSMISSION

TA 237101

TA 237101

EXHAUST SYSTEM.

3-48. TURBOCHARGER OUTLET PEPE REPLACEMENT (Continued).

LOCATION/ITEM	ACTION	REMARKS
C. INSTALLATION. I		
11. Support (11).	Put in place on item (15).	
12. Two screws (8) and lockwashers (10).	Secure item (11) to item (15).	
13. Clamp (12), U-bolt (5), two lockwashers (13), and two nuts (14).	Install on item (11).	Do not tighten.
14. New coupling (7).	Slip over item (8).	
15. Clamp (2).	Slip over item (1).	
16. Pipe (3).	a. Put in position through item (5) and item (12). b. Line up with item (1).	
17. Clamp (2) and nut (3).	Secure item (4) to item (1).	
18. Coupling (7).	Position over item (4) and item (8).	
19. Two screws (6).	Torque to 31-42 lb-ft.	
20. Two nuts (14).	Tighten.	

NOTE

Follow-on maintenance action required:

None.

EXHAUST SYSTEM.

3-48. TURBOCHARGER OUTLET PIPE REPLACEMENT (Continued).

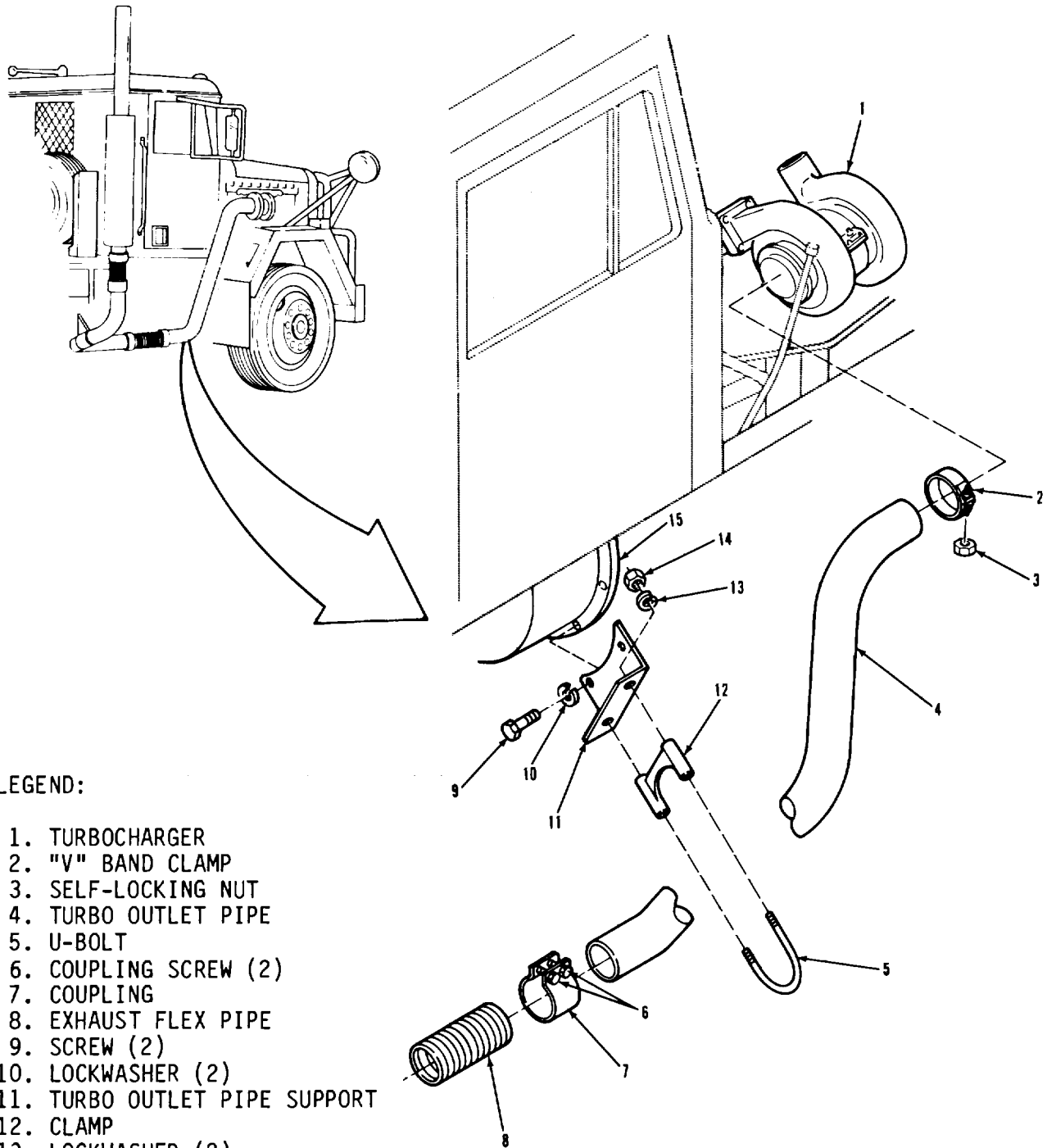

LEGEND:

- 1. TURBOCHARGER
- 2. "V" BAND CLAMP
- 3. SELF-LOCKING NUT
- 4. TURBO OUTLET PIPE
- 5. U-BOLT
- 6. COUPLING SCREW (2)
- 7. COUPLING
- 8. EXHAUST FLEX PIPE
- 9. SCREW (2)
- 10. LOCKWASHER (2)
- 11. TURBO OUTLET PIPE SUPPORT
- 12. CLAMP
- 13. LOCKWASHER (2)
- 14. NUT (2)
- 15. TRANSMISSION

TA 237102

TA 237102

EXHAUST SYSTEM.

3-49. MUFFLER INLET PIPE REPLACEMENT.

THIS TASK COVERS

- a. Removal.
- b. Cleaning and Inspection.
- c. Installation.

INITIAL SETUP

APPLICABLE CONFIGURATIONS

All.

PARAGRAPH

None.

EQUIPMENT CONDITION
CONDITION DESCRIPTION

None.

TEST EQUIPMENT

None.

SPECIAL TOOLS

None.

MATERIALS/PARTS (P/N)

Rags, wiping
 Item 22, Appendix C.
 Solvent, dry cleaning, SD-2
 Item 29, Appendix C.
 Coupling
 (34623) 5932837.

PERSONNEL REQUIRED

One (MOS-63S).

SPECIAL ENVIRONMENTAL CONDITIONS

None.

REFERENCES (TM)

TM 9-2320-283-2OP.

GENERAL SAFETY INSTRUCTIONS

Engine off.
 Transmission in neutral.
 Park brake set.
 Wait until exhaust components are cool.

TROUBLESHOOTING REFERENCES

Paragraph 2-11.

EXHAUST SYSTEM.

3-49. MUFFLER INLET PIPE REPLACEMENT (Continued).

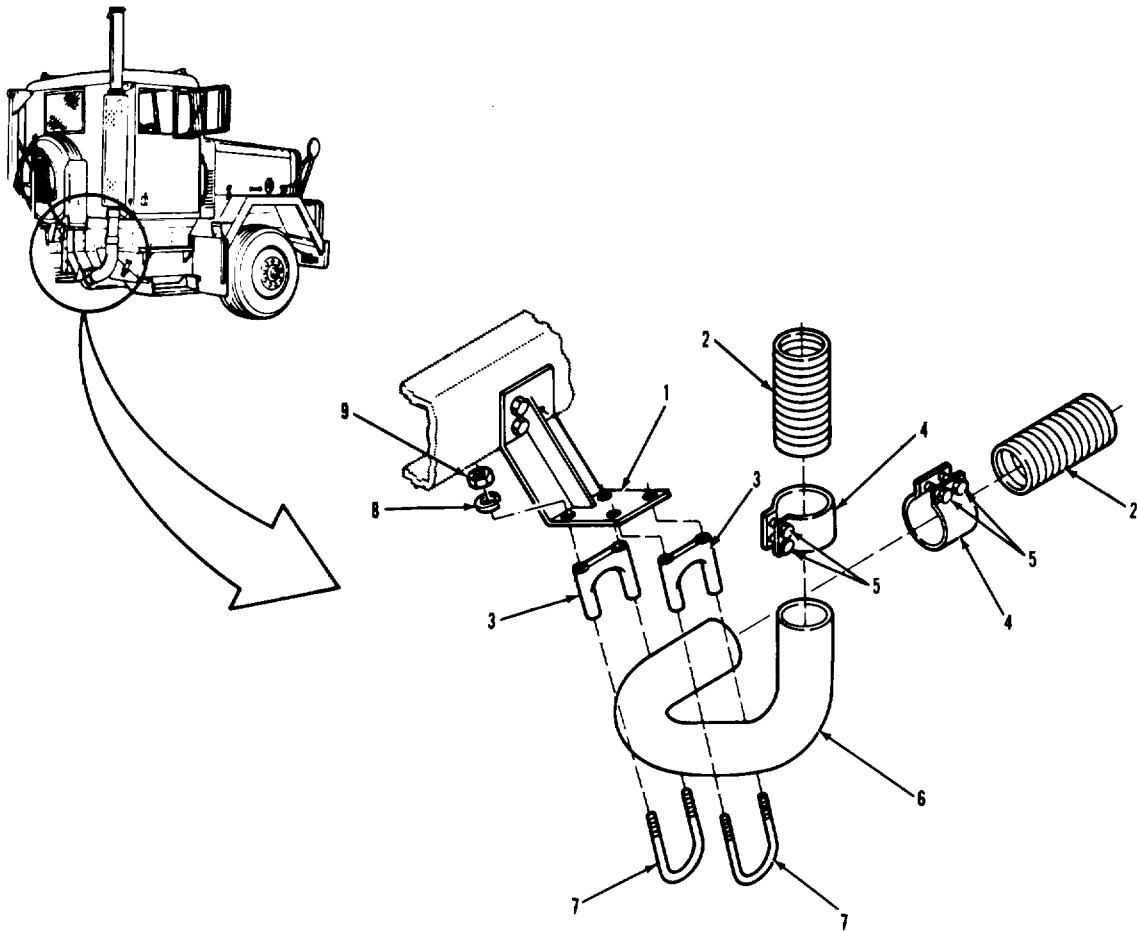

TA237103

LEGEND:

- | | |
|--|-----------------------|
| 1. MUFFLER INLET PIPE SUPPORT ASSEMBLY | 6. MUFFLER INLET PIPE |
| 2. EXHAUST FLEX PIPE (2) | 7. U-BOLT (2) |
| 3. CLAMP (2) | 8. LOCKWASHER (4) |
| 4. COUPLING (2) | 9. NUT (4) |
| 5. COUPLING SCREW (4) | |

EXHAUST SYSTEM.

3-49. MUFFLER INLET PIPE REPLACEMENT (Continued).

LOCATION/ITEM	ACTION	REMARKS
---------------	--------	---------

WARNING

During normal operation, the exhaust pipes and muffler can become very hot. Be careful not to touch these components with your bare hands. Do not allow your body to come in contact with the hot pipes or muffler. Exhaust system components may be hot enough to cause serious burns.

A. REMOVAL.

- | | | | |
|----|---|------------------------------------|------------------------|
| 1. | Four nuts (9), four lockwashers (8), two clamps (3), and two U-bolts (7). | Remove from item (6) and item (1). | |
| 2. | Four screws (5). | Loosen two items (4). | |
| 3. | Two couplings (4). | Slide on item (6). | |
| 4. | Pipe (6) and two couplings (4). | Remove from two items (2). | Discard two items (4). |

B. CLEANING AND INSPECTION.

- | | | | |
|----|---------------------|---------------------------|-------------------------|
| 5. | All parts.
rags. | a. Clean with solvent and | Refer to paragraph 3-4. |
| | | b. Inspect. | Refer to paragraph 3-5. |

EXHAUST SYSTEM.

3-49. MUFFLER INLET PIPE REPLACEMENT (Continued).

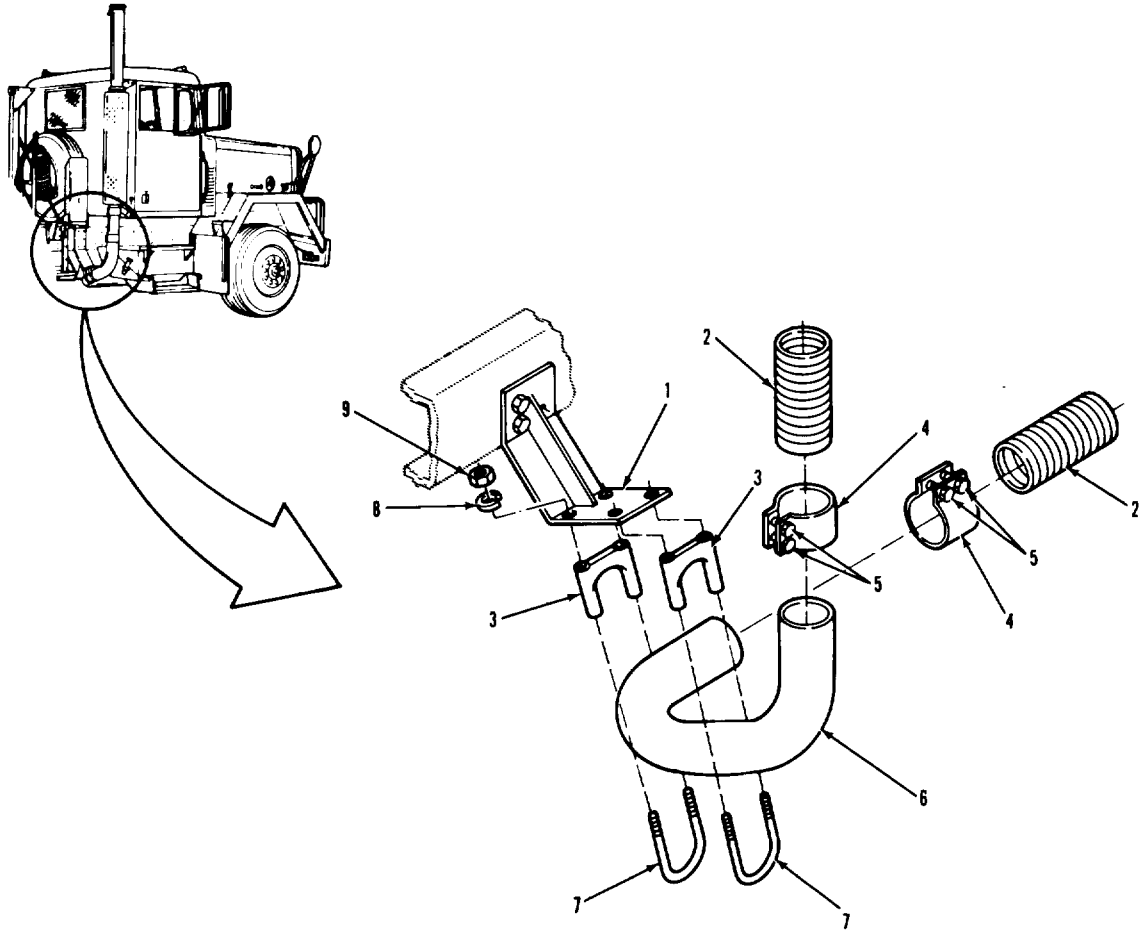

LEGEND:

- | | |
|--|-----------------------|
| 1. MUFFLER INLET PIPE SUPPORT ASSEMBLY | 6. MUFFLER INLET PIPE |
| 2. EXHAUST FLEX PIPE (2) | 7. U-BOLT (2) |
| 3. CLAMP (2) | 8. LOCKWASHER (4) |
| 4. COUPLING (2) | 9. NUT (4) |
| 5. COUPLING SCREW (4) | |

TA 237104

EXHAUST SYSTEM.

3-49. MUFFLER INLET PIPE REPLACEMENT (Continued).		
LOCATION/ITEM	ACTION	REMARKS
C. INSTALLATION.		
6. Two new couplings (4).	Slide on item (6).	
7. Pipe (6). two items (2).	Put in position between	
8. Two clamps (3), two U-bolts (7), four lockwashers (8), and four nuts (9).	Install on item (1) and item (6).	Do not tighten two items (9).
9. Two couplings (4). and item (6).	Position on two items (2)	
10. Four screws (3).	Torque to 31-42 lb-ft.	
11. Two nuts (9).	Tighten.	
NOTE		
Follow-on maintenance action required:		
None.		

EXHAUST SYSTEM.

3-49. MUFFLER INLET PIPE REPLACEMENT (Continued).

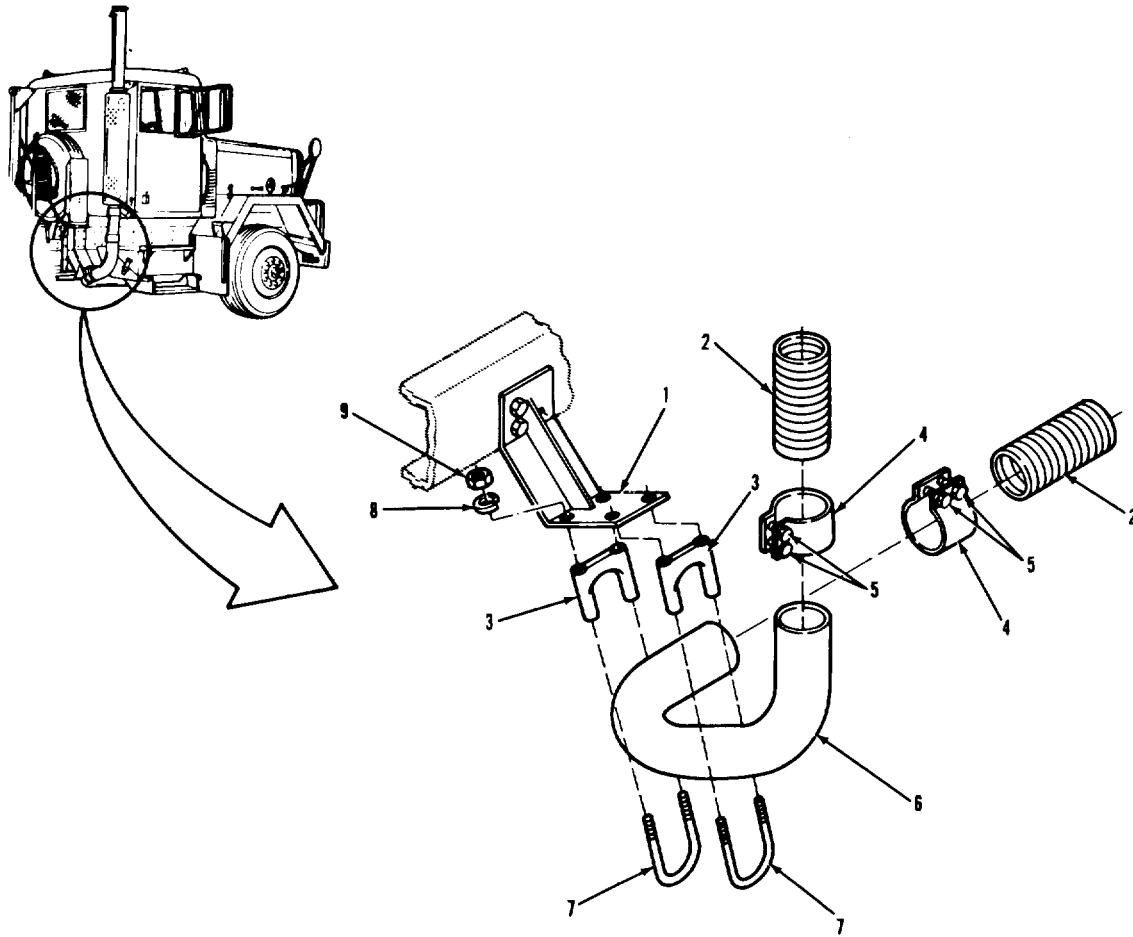

LEGEND:

- | | |
|--|-----------------------|
| 1. MUFFLER INLET PIPE SUPPORT ASSEMBLY | 6. MUFFLER INLET PIPE |
| 2. EXHAUST FLEX PIPE (2) | 7. U-BOLT (2) |
| 3. CLAMP (2) | 8. LOCKWASHER (4) |
| 4. COUPLING (2) | 9. NUT (4) |
| 5. COUPLING SCREW (4) | |

SECTION V. COOLING SYSTEM

3-50. GENERAL.

This section provides procedures authorized at the organizational maintenance level to service and replace cooling system components. To find a specific procedure contained in this section, see the task summary below.

3-51. TASK SUMMARY.

INITIAL SETUP	
<u>APPLICABLE CONFIGURATIONS</u>	<u>EQUIPMENT CONDITION</u>
All.	<u>PARAGRAPH</u> <u>CONDITION DESCRIPTION</u> (Refer to specific paragraph for this information).
<u>TEST EQUIPMENT</u>	
None.	
<u>SPECIAL TOOLS</u>	
Seal mandrel (15434) ST-1225.	
<u>MATERIALS/PARTS (P/N)</u>	
Tape, thread sealing Item 32, Appendix C.	Gasket, water connection (15434) 3024960.
Antifreeze Item 2 or 3, Appendix C.	Gasket, thermostat housing (15434) 208128.
Oil, lubricating: OE/HDO-30 Item 16, Appendix C.	Seal, housing (15434) 186780.
Grease, automotive and artillery Item 7, Appendix C.	Gasket, water outlet connection (15434) 3019158.
Insulator (2) (76005) CBA 24-500.	Ring, sealing (6) (15434) 3024709.
O-ring (15434) 43463-A.	O-ring, coupling (4) (15434) 70624.
O-ring (2) (15434) 212161.	Gasket, water pump (15434) 3002385.
<u>PERSONNEL REQUIRED</u>	<u>SPECIAL ENVIRONMENTAL CONDITIONS</u>
Two (MOS-63S).	Vehicle parked on level ground.

COOLING SYSTEM.

3-51. TASK SUMMARY (Continued).

<u>INITIAL SETUP (Continued)</u>	
<u>REFERENCES (TM)</u> TM 9-2320-283-10. TM 9-2320-283-20P. TM 750-254.	<u>GENERAL SAFETY INSTRUCTIONS</u> Engine off. Transmission in neutral. Park brake set. Wait until cooling system components are cool. Wear eye protection.
<u>TROUBLESHOOTING REFERENCES</u> Paragraph 2-11.	Wait until transmission and steering fluids are cool.

LIST OF TASKS			
TASK NO.	TASK	TASK REF	TROUBLESHOOTING REF NO. (PARA)
1	Cooling System Service	3-52	2-11
	a. Draining.	3-52a	
	b. Cleaning and Flushing.	3-52b	
	c. Inspection of Draincocks.	3-52c	
	d. Sight Glass Replacement.	3-52d	
	e. Filling.	3-52d	
	f. Operational Checks.	3-52e	
2	Radiator Replacement	3-53	2-11
	a. Removal.	3-53a	
	b. Cleaning and Inspection.	3-53b	
	c. Installation.	3-53c	
3	Radiator Support Rods Replacement	3-54	
	a. Removal.	3-54a	
	b. Cleaning and Inspection.	3-54b	
	c. Installation.	3-54c	
4	Transmission and Steering System Cooler Replacement	3-55	2-11
	a. Removal.	3-55a	
	b. Cleaning and Inspection.	3-55b	
	c. Installation.	3-55c	

COOLING SYSTEM.

3-51. TASK SUMMARY (Continued).			
LIST OF TASKS			
TASK NO.	TASK	TASK REF	TROUBLESHOOTING REF NO. (PARA)
5	Upper Fan Shroud Replacement	3-56	
	a. Removal.	3-56a	
	b. Cleaning and Inspection.	3-56b	
6	Lower Fan Shroud Replacement	3-57	
	a. Removal.	3-57a	
	b. Cleaning and Inspection.	3-57b	
7	Lines, Fittings, and Hoses Replacement	3-58	2-11
	a. Inspection.	3-58a	
	b. Deaeration Line Replacement.	3-58b	
	c. Radiator Inlet Hose Replacement.	3-58c	
	d. Water Pump Bypass Hose Replacement.	3-58d	
	e. Overflow Tube Replacement.	3-58e	
	f. Radiator Outlet Hoses and Tube Replacement.	3-58f	
	g. Water Bypass Tube Replacement.	3-58g	
	h. Water Transfer Tube Replacement.	3-58h	
	i. Water Pump to Radiator Connection Replacement.	3-58i	
	8	Thermostat and Thermostat Housing Replacement	3-59
a. Removal.		3-59a	
b. Disassembly.		3-59b	
b. Cleaning and Inspection.		3-59c	
d. Testing.		3-59d	
e. Assembly.		3-59e	
9	Water Manifolds Replacement	3-60	2-11
	a. Removal.	3-60a	
	b. Cleaning and Inspection.	3-60b	
	c. Installation.	3-60c	

COOLING SYSTEM.

3-51. TASK SUMMARY (Continued).			
LIST OF TASKS			
TASK NO.	TASK	TASK REF	TROUBLESHOOTING REF NO. (PARA)
10	Water Shutoff Valves and Lines Replacement	3-61	2-11
	a. Removal.	3-61a	
	b. Cleaning and Inspection.	3-61b	
	c. Installation.	3-61c	
11	Water Filter and Bracket Replacement	3-62	2-11
	a. Removal.	3-62a	
	b. Cleaning and Inspection.	3-62b	
	c. Installation.	3-62c	
12	Water Pump Drive Belt Replacement	3-63	2-11
	a. Removal.	3-63a	
	b. Installation.	3-63b	
	c. Adjustment.	3-63c	
13	Water Pump Replacement	3-64	2-11
	a. Removal.	3-64a	
	b. Cleaning and Inspection.	3-64b	
	c. Installation.	3-64c	
14	Fan and Fan Clutch Replacement	3-65	2-11
	a. Removal.	3-65a	
	b. Cleaning and Inspection.	3-65b	
	c. Installation.	3-65c	
	d. Operational Check.	3-65d	
15	Fan Clutch Air Valve Replacement	3-66	
	a. Removal.	3-66a	
	b. Cleaning and Inspection.	3-66b	
	c. Installation.	3-66c	
	d. Operational Check.	3-66d	
16	Fan Clutch Drive Belts Replacement	3-67	2-11
	a. Removal.	3-67a	
	b. Installation.	3-67b	
	c. Adjustment.	3-67c	

COOLING SYSTEM.

3-52. COOLING SYSTEM SERVICE.

THIS TASK COVERS

- a. Draining.
- b. Cleaning and Flushing.
- c. Inspection of Draincocks.
- d. Sight Glass Replacement.
- e. Filling.
- f. Operational Checks.

INITIAL SETUP

APPLICABLE CONFIGURATIONS

All.

EQUIPMENT CONDITION

PARAGRAPH

None.

CONDITION DESCRIPTION

None.

TEST EQUIPMENT

None.

SPECIAL TOOLS

None.

MATERIALS/PARTS IP/N)

Tape, thread sea ing
Item 32, Appendix C.
Antifreeze
Item 2 or 3, Appendix C.
O-ring (subparagraph d only)
(23705) 241-04.

PERSONNEL REQUIRED

One (MOS-63SR).

SPECIAL ENVIRONMENTAL CONDITIONS

Vehicle parked on level ground.

REFERENCES (TM)

IM 9-2320-283-10.
TM 750-254.
Park brake set.
Wait until cooling system

GENERAL SAFETY INSTRUCTIONS

Engine off.
Transmission in neutral.

TROUBLESHOOTING REFERENCES

Paragraph 2-11.

components are cool.
Wear eye protection.

COOLING SYSTEM.

3-52. COOLING SYSTEM SERVICE (Continued).

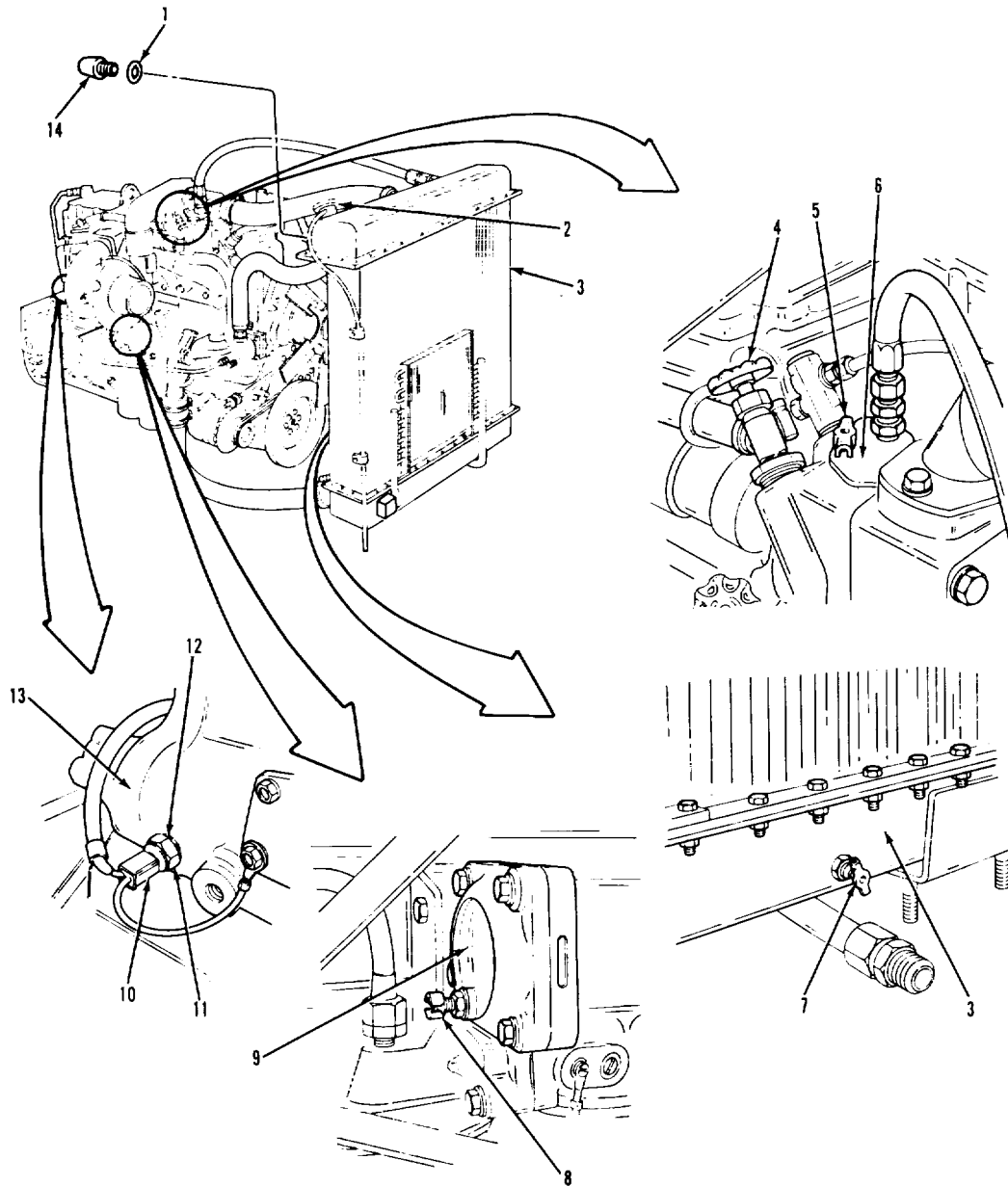

TA 237106

- | | |
|-----------------------------------|----------------------------------|
| 1. O-RING | 8. OIL COOLER DRAINCOCK |
| 2. RADIATOR CAP | 9. OIL COOLER |
| 3. RADIATOR ASSEMBLY | 10. THERMOSTAT PLUG |
| 4. HEATER SHUTOFF VALVE | 11. ETHER QUICK START THERMOSTAT |
| 5. FRONT WATER MANIFOLD DRAINCOCK | 12. REDUCER |
| 6. FRONT WATER MANIFOLD | 13. ENGINE BLOCK |
| 7. RADIATOR DRAINCOCK | 14. SIGHT GLASS |

COOLING SYSTEM.

3-52. COOLING SYSTEM SERVICE (Continued).

LOCATION/ITEM	ACTION	REMARKS
A. DRAINING.	WARNING	

Let radiator cool before removing cap. Be sure to follow step 1 when removing cap. Failure to do so could result in serious burns and other injury to personnel.

1.	Cap (2).	<ul style="list-style-type: none"> a. Cover with a thick cloth and turn counterclockwise to first stop. b. Allow pressure to escape from cooling system. c. When all pressure has escaped, remove from item (3). 	
2.	Valve (4).	Open by turning counterclockwise as far as possible.	
3.	Draincock (7).	<ul style="list-style-type: none"> a. Place a suitable container underneath. b. Open and let coolant drain out. 	
4.	Draincock (5).	Open when level of coolant goes below item (6) when five gallons of coolant have drained from item (3).	Level of coolant is below level of item (6)
5.	Draincock (8).	<ul style="list-style-type: none"> a. Place a suitable container underneath. b. Open and let coolant drain out. c. When coolant stops draining, close. 	

COOLING SYSTEM.

3-52. COOLING SYSTEM SERVICE (Continued).

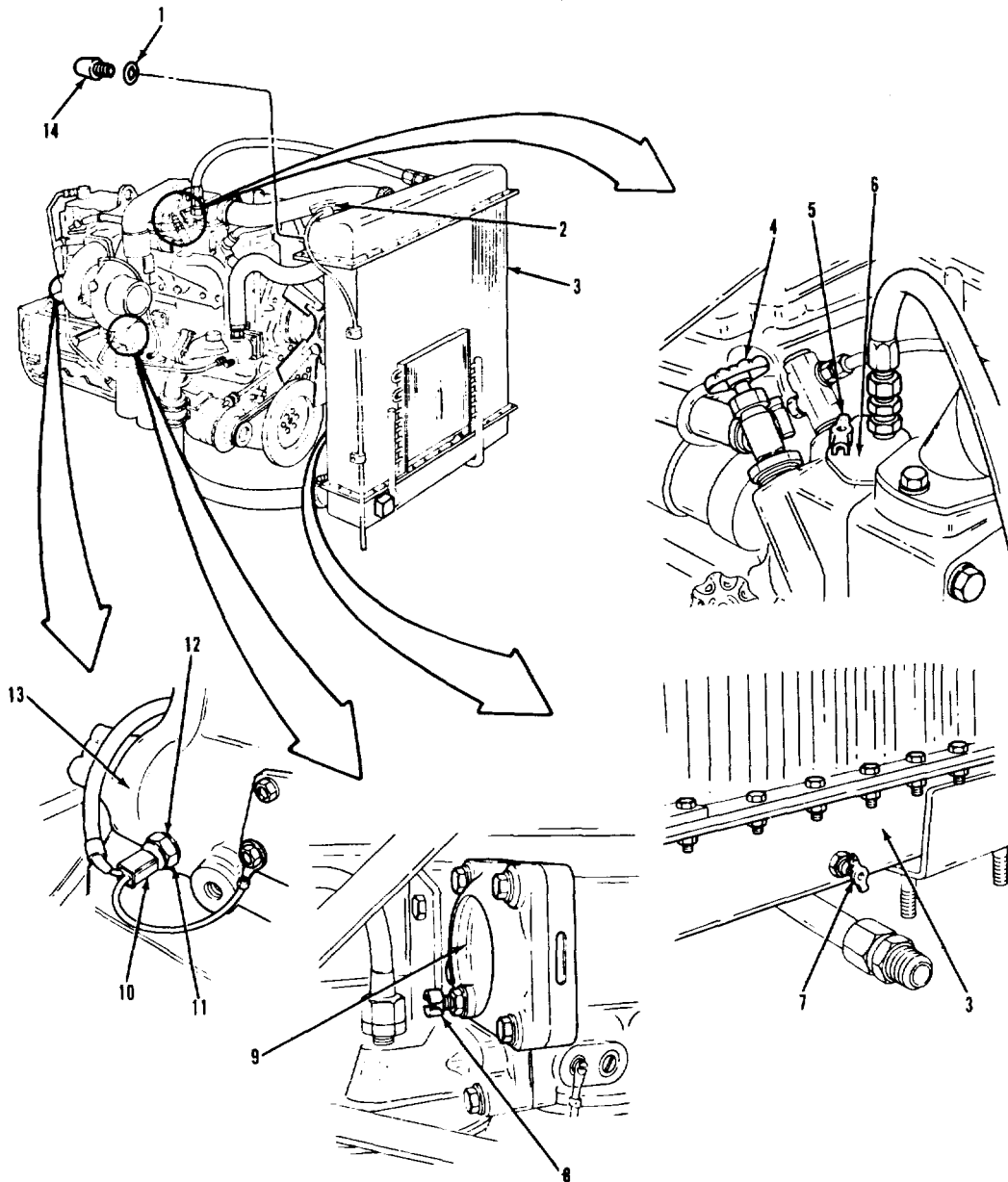

- | | |
|-----------------------------------|----------------------------------|
| 1. O-RING | 8. OIL COOLER DRAINCOCK |
| 2. RADIATOR CAP | 9. OIL COOLER |
| 3. RADIATOR ASSEMBLY | 10. THERMOSTAT PLUG |
| 4. HEATER SHUTOFF VALVE | 11. ETHER QUICK START THERMOSTAT |
| 5. FRONT WATER MANIFOLD DRAINCOCK | 12. REDUCER |
| 6. FRONT WATER MANIFOLD | 13. ENGINE BLOCK |
| 7. RADIATOR DRAINCOCK | 14. SIGHT GLASS |

COOLING SYSTEM.

3-52. COOLING SYSTEM SERVICE (Continued).

LOCATION/ITEM	ACTION	REMARKS
A. DRAINING (Continued).		
6. Plug (10).	Remove from item (11).	
7. Thermostat (11). underneath.	a. Place a suitable container b. Remove from item (12) and let coolant drain out. c. When coolant stops draining, wrap threads with thread sealing tape, and reinstall into item (12).	Do not remove item (12) from item (13).
8. Heater control valve.	Open, and let coolant drain out of heating system.	Refer to TM 9-2320-283-10.

B. CLEANING AND FLUSHING.

NOTE

If it is necessary to clean and flush the cooling system, refer to TM 750- 254 (Cooling Systems: Tactical Vehicles).

C. INSPECTION OF DRAINCOCKS.

9. Three draincocks (5), (7), and (8).	a. Remove from items (6), (3), and (9).	
	b. Clean and inspect.	Refer to paragraphs 3-4 and 3-5.
	c. Wrap threads with thread sealing tape.	Refer to paragraph 3-7.
	d. Install into items (6), (3), and (9), and close.	

COOLING SYSTEM.

3-52. COOLING SYSTEM SERVICE (Continued).

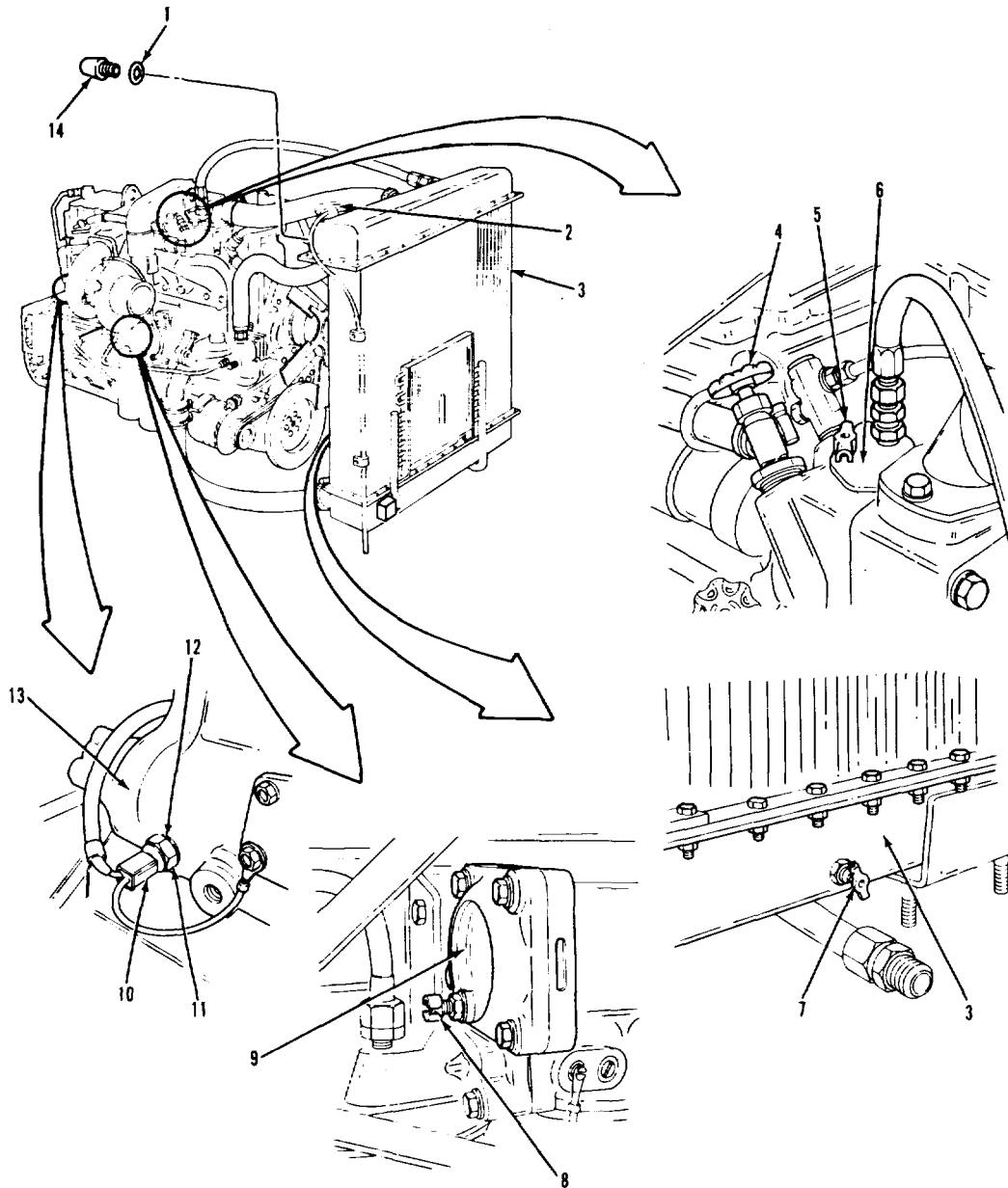

TA 7108

- | | |
|-----------------------------------|----------------------------------|
| 1. O-RING | 8. OIL COOLER DRAINCOCK |
| 2. RADIATOR CAP | 9. OIL COOLER |
| 3. RADIATOR ASSEMBLY | 10. THERMOSTAT PLUG |
| 4. HEATER SHUTOFF VALVE | 11. ETHER QUICK START THERMOSTAT |
| 5. FRONT WATER MANIFOLD DRAINCOCK | 12. REDUCER |
| 6. FRONT WATER MANIFOLD | 13. ENGINE BLOCK |
| 7. RADIATOR DRAINCOCK | 14. SIGHT GLASS |

COOLING SYSTEM.

3-52. COOLING SYSTEM SERVICE (Continued).		
LOCATION/ITEM	ACTION	REMARKS
D. SIGHT GLASS REPLACEMENT.		
10. Sight glass (14).	Unscrew from item (3).	
11. O-ring (1).	Remove from item (14).	Discard item (1).
12. Sight glass (14). and 3-5.	Clean and inspect.	Refer to paragraphs 3-4
13. New O-ring (1).	Install on item (14).	
14. Sight glass (14).	Install in item (3).	
E. FILLING.		
15. Draincock (5).	Open.	
16. Radiator (3). flows out of item (5).	Add coolant until it over-	Refer to TM 750-254 (Cooling Systems: Tac- tical Vehicles) for proper antifreeze mix- ture. Never use more than a 60 percent anti- freeze solution. Use arctic antifreeze for subzero temperatures.
17. Draincock (5).	Close.	
18. Radiator (3).	Add coolant until item (1) is filled.	
F. OPERATIONAL CHECKS.		
19. Engine.	Start.	
20. Cooling system.	Check for leaks.	Refer to TM 9-2320-283- 10. Make sure heater control valve is open.

COOLING SYSTEM.

3-52. COOLING SYSTEM SERVICE (Continued).

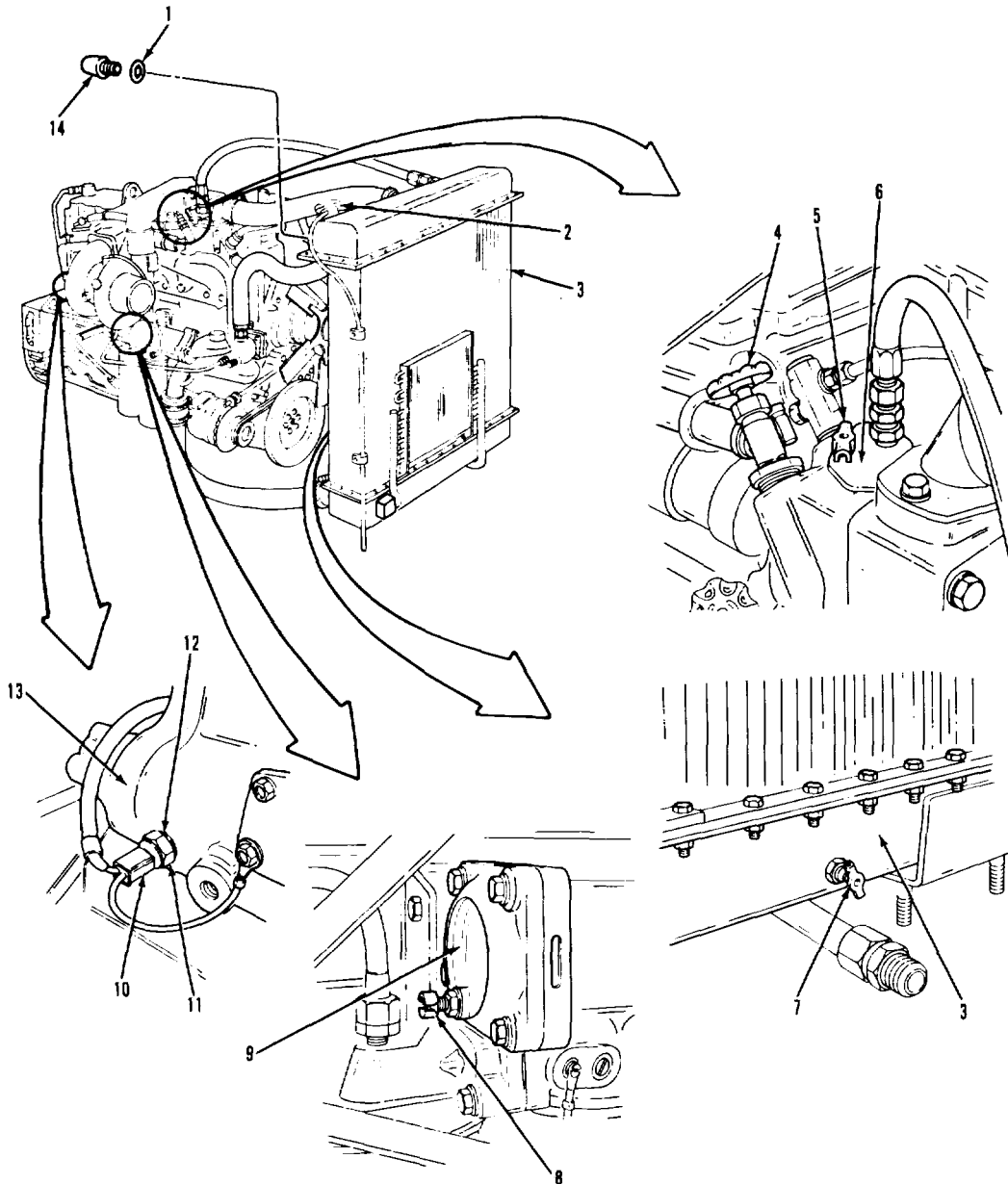

TA 237109

- | | |
|-----------------------------------|----------------------------------|
| 1. O-RING | 8. OIL COOLER DRAINCOCK |
| 2. RADIATOR CAP | 9. OIL COOLER |
| 3. RADIATOR ASSEMBLY | 10. THERMOSTAT PLUG |
| 4. HEATER SHUTOFF VALVE | 11. ETHER QUICK START THERMOSTAT |
| 5. FRONT WATER MANIFOLD DRAINCOCK | 12. REDUCER |
| 6. FRONT WATER MANIFOLD | 13. ENGINE BLOCK |
| 7. RADIATOR DRAINCOCK | 14. SIGHT GLASS |

COOLING SYSTEM.

3-52. COOLING SYSTEM SERVICE (Continued).			
LOCATION/ITEM	ACTION		REMARKS
F. OPERATIONAL CHECKS (Continued).			
21.	Radiator (3). to top of item (14).	Make sure coolant level is needed.	Add more coolant, if
22.	Cap (2).	Install on item (3).	
23.	Engine.	Shutdown.	Refer to TM 9-2320-283- 10.
NOTE			
Follow-on maintenance action required:			
None.			

COOLING SYSTEM.

3-52. COOLING SYSTEM SERVICE (Continued).

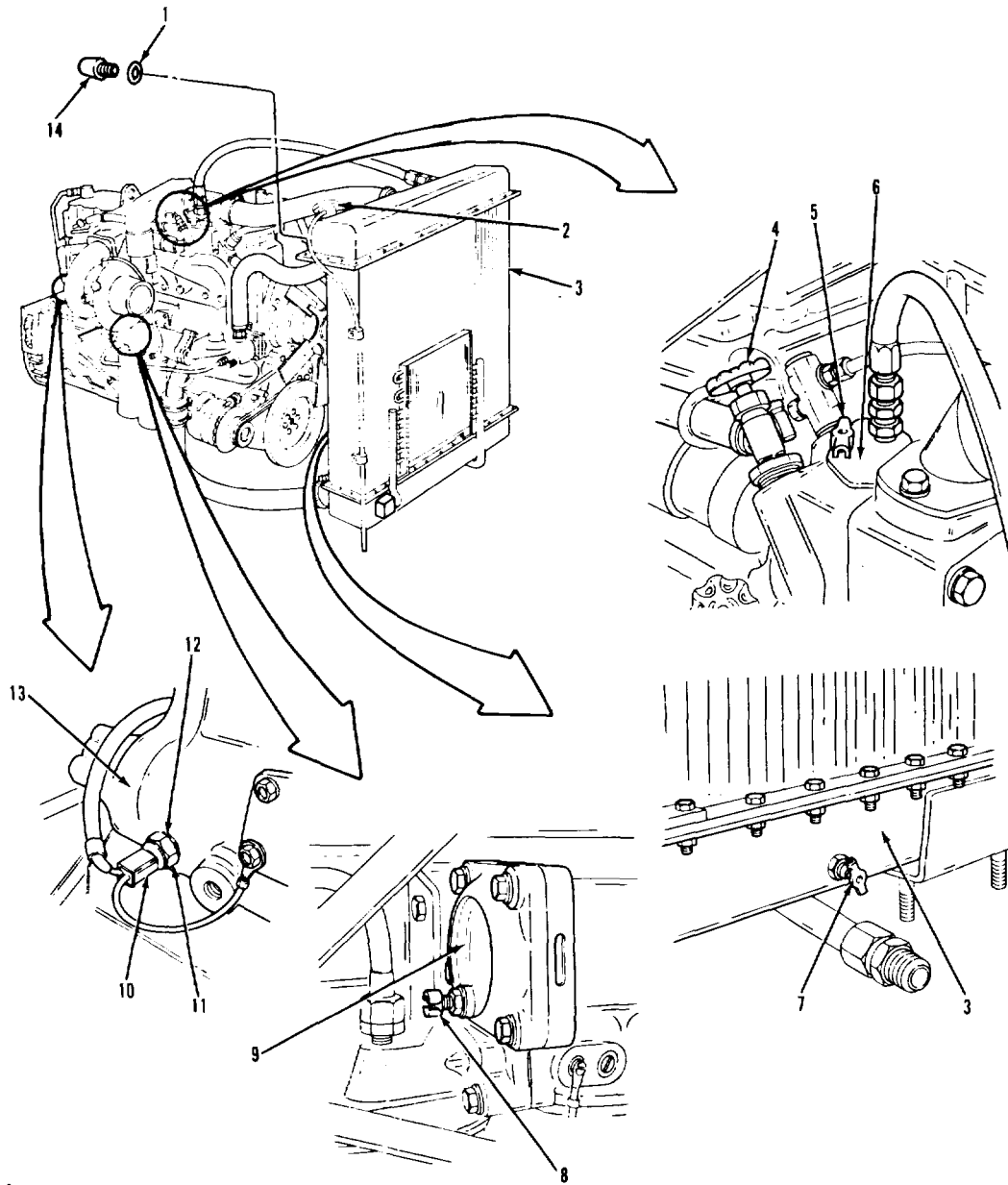

LEGEND:

- | | |
|-----------------------------------|----------------------------------|
| 1. O-RING | 8. OIL COOLER DRAINCOCK |
| 2. RADIATOR CAP | 9. OIL COOLER |
| 3. RADIATOR ASSEMBLY | 10. THERMOSTAT PLUG |
| 4. HEATER SHUTOFF VALVE | 11. ETHER QUICK START THERMOSTAT |
| 5. FRONT WATER MANIFOLD DRAINCOCK | 12. REDUCER |
| 6. FRONT WATER MANIFOLD | 13. ENGINE BLOCK |
| 7. RADIATOR DRAINCOCK | 14. SIGHT GLASS |

TA 237110

TA 237110

COOLING SYSTEM.

3-53. RADIATOR REPLACEMENT.

THIS TASK COVERS

- a. Removal.
- b. Cleaning and Inspection.
- c. Installation.

INITIAL SETUP

APPLICABLE CONFIGURATIONS

<u>APPLICABLE CONFIGURATIONS</u>	<u>EQUIPMENT CONDITION PARAGRAPH</u>	<u>CONDITION DESCRIPTION</u>
All.	3-52.	Coolant drained.
None.	3-269.	Hood removed.
	3-236.	Brush guard removed.
	3-268.	Grill removed.

SPECIAL TOOLS

None.

MATERIALS/PARTS I P/N)

Tape, thread sealing
 Item 32, Appendix C.
 Insulator (2)
 (76005) CBA 24-500.

PERSONNEL REQUIRED

One (MOS-63S).

SPECIAL ENVIRONMENTAL CONDITIONS

None.

REFERENCES (TM)

TM 9-2320-283-10.
 TM 9-2320-283-20P.

GENERAL SAFETY INSTRUCTIONS

Engine off.
 Transmission in neutral.
 Park brake set.
 Wait until cooling system components are cool.

TROUBLESHOOTING REFERENCES

Paragraph 2-11.

COOLING SYSTEM.

3-53. RADIATOR REPLACEMENT (Continued).

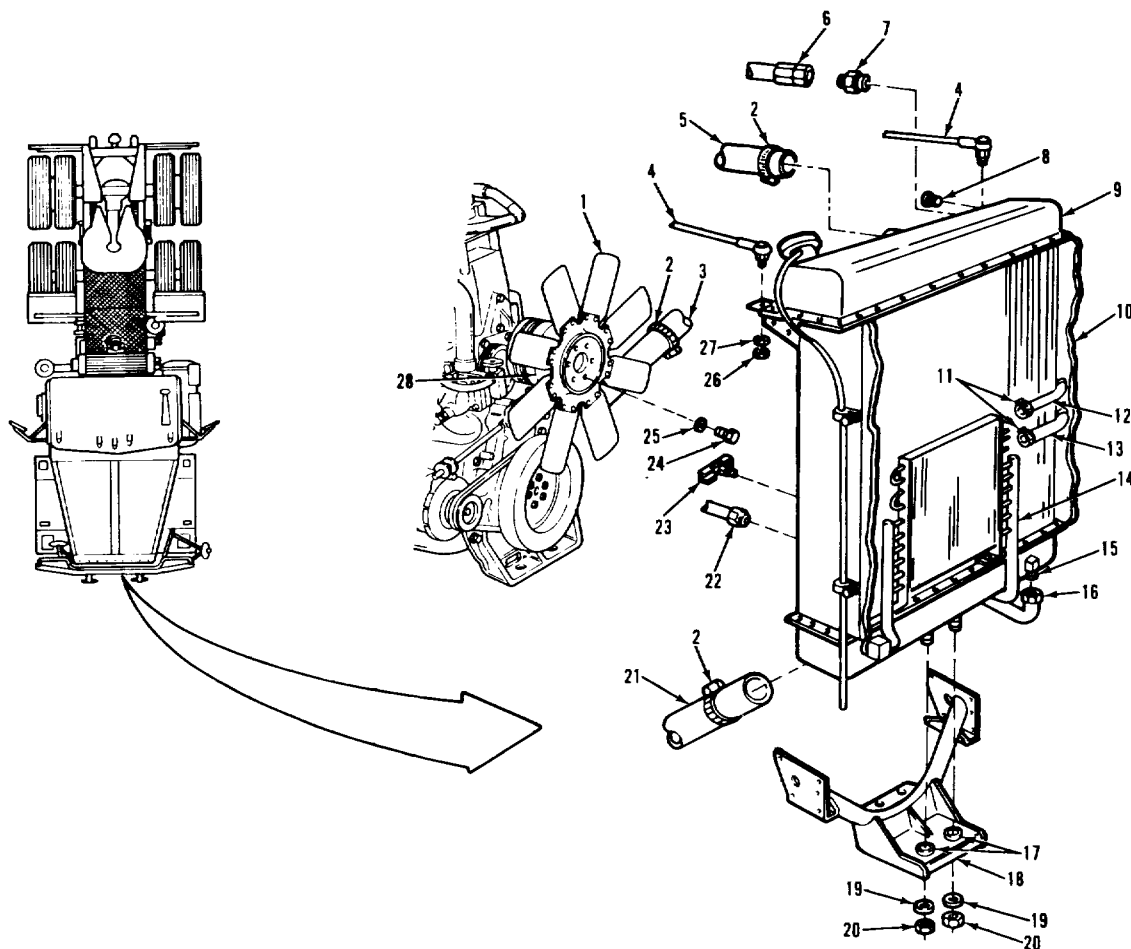

LEGEND:

- | | |
|---|---|
| <ul style="list-style-type: none"> 1. FAN ASSEMBLY 2. RADIATOR HOSE CLAMP (3) 3. WATER PUMP BYPASS HOSE 4. RADIATOR SUPPORT ROD (2) 5. RADIATOR INLET HOSE 6. DEAERATION LINE HOSE ASSEMBLY 7. REDUCER 8. PIPE PLUG 9. RADIATOR ASSEMBLY 10. RADIATOR GRILLE SUPPORT BRACKET 11. HOSE CLAMP (2) 12. COOLER TO GEAR HOSE 13. COOLER TO PUMP HOSE 14. OIL COOLER ASSEMBLY | <ul style="list-style-type: none"> 15. 90 DEGREE ELBOW 16. COOLER SUPPLY HOSE ASSEMBLY 17. INSULATOR (2) 18. FRONT CROSSMEMBER ASSEMBLY 19. HARDENED WASHER (2) 20. HEXAGON HEAD NUT (2) 21. RADIATOR OUTLET HOSE 22. COOLER RETURN HOSE ASSEMBLY 23. DRAINCOCK 24. HEXAGON HEAD SCREW (6) 25. LOCKWASHER (6) 26. HEXAGON HEAD NUT (2) 27. LOCKWASHER (2) 28. FAN CLUTCH ASSEMBLY |
|---|---|

TA237111

COOLING SYSTEM

3-53. RADIATOR REPLACEMENT (Continued)

LOCATION/ITEM	ACTION	REMARKS
A. REMOVAL		
1. Hose (12), hose (13), and two clamps (11).	a. Loosen screws on two items (11). b. Pull items (12) and (13) off of item (14). c. Remove item (11) from items (12) and (13). d. Pull items (12) and (13) out of item (10).	Have suitable container ready to catch oil
2. Hoses (16) and hose (22).	Remove from items (14) and (15).	Have suitable container ready to catch oil.
3. Hose (6).	Remove from item (7).	
4. Hose (3), hose (5), hose (21), (2).	a. Loosen screws on three items (2). b. Pull items (3), (5), and (21) off of item (9).	Have suitable container ready to catch coolant from item (21). Leave items (2) on items (3), (5), and (21).
5. Radiator (9). lifting device. bracket.	Support with suitable radiator support rod	Use side bolt holes in
6. Two nuts (26), lockwashers (27), and rods (4).	Remove from item (9).	
7. Two nuts (20) and washers (19).	Remove from studs of item (9).	

COOLING SYSTEM.

3-53. RADIATOR REPLACEMENT (Continued).

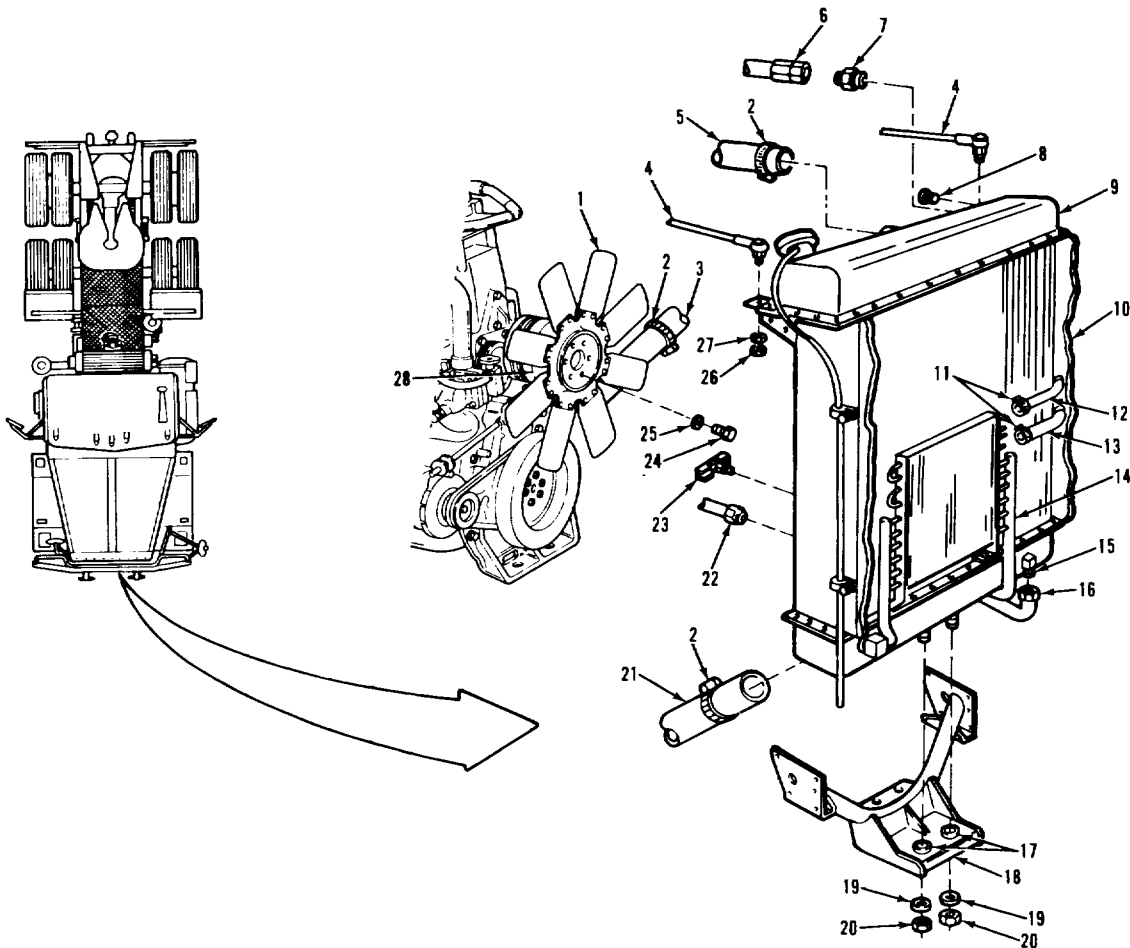

LEGEND:

- | | |
|---|---|
| <ul style="list-style-type: none"> 1. FAN ASSEMBLY 2. RADIATOR HOSE CLAMP (3) 3. WATER PUMP BYPASS HOSE 4. RADIATOR SUPPORT ROD (2) 5. RADIATOR INLET HOSE 6. DEAERATION LINE HOSE ASSEMBLY 7. REDUCER 8. PIPE PLUG 9. RADIATOR ASSEMBLY 10. RADIATOR GRILLE SUPPORT BRACKET 11. HOSE CLAMP (2) 12. COOLER TO GEAR HOSE 13. COOLER TO PUMP HOSE 14. OIL COOLER ASSEMBLY | <ul style="list-style-type: none"> 15. 90 DEGREE ELBOW 16. COOLER SUPPLY HOSE ASSEMBLY 17. INSULATOR (2) 18. FRONT CROSSMEMBER ASSEMBLY 19. HARDENED WASHER (2) 20. HEXAGON HEAD NUT (2) 21. RADIATOR OUTLET HOSE 22. COOLER RETURN HOSE ASSEMBLY 23. DRAINCOCK 24. HEXAGON HEAD SCREW (6) 25. LOCKWASHER (6) 26. HEXAGON HEAD NUT (2) 27. LOCKWASHER (2) 28. FAN CLUTCH ASSEMBLY |
|---|---|

TA237112

COOLING SYSTEM

3-53. RADIATOR REPLACEMENT (Continued)

LOCATION/ITEM	ACTION	REMARKS
A. REMOVAL (Continued).		
8. Radiator (9). forward so that item (1) can be removed.	Using lifting device, tilt	
9. Six screws (24) and lock- washers (25).	Remove from items (1) and (28).	
10. Fan (1).	Remove from item (28).	
11. Radiator (9) and two insulators (17).	Using lifting device, lift off of item (18).	Discard two items (17).
NOTE		
If radiator was removed for access only, skip steps 12 thru 24.		
12. Upper shroud.	Remove.	Refer to paragraph 3-56.
13. Lower shroud.	Remove.	Refer to paragraph 3-57.
14. Overflow tube.	Remove.	Refer to paragraph 3-58.
15. Transmission and steering system cooler.	Remove.	Refer to paragraph 3-55. Reinstall mounting hard- ware into item (9), and note location.
16. Two radiator grille support brackets.	Remove.	Refer to paragraph 3-268.

COOLING SYSTEM.

3-53. RADIATOR REPLACEMENT (Continued).

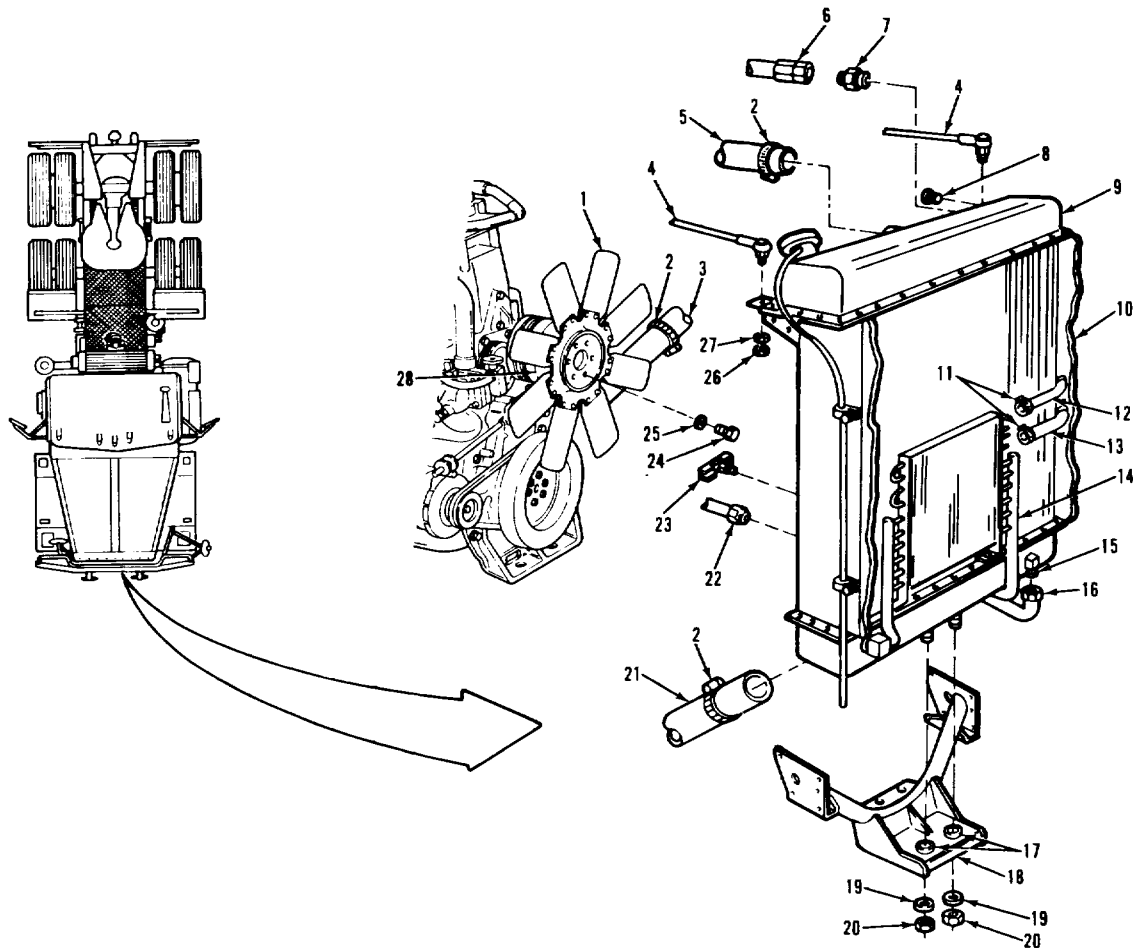

LEGEND:

- | | |
|---|---|
| <ul style="list-style-type: none"> 1. FAN ASSEMBLY 2. RADIATOR HOSE CLAMP (3) 3. WATER PUMP BYPASS HOSE 4. RADIATOR SUPPORT ROD (2) 5. RADIATOR INLET HOSE 6. DEAERATION LINE HOSE ASSEMBLY 7. REDUCER 8. PIPE PLUG 9. RADIATOR ASSEMBLY 10. RADIATOR GRILLE SUPPORT BRACKET 11. HOSE CLAMP (2) 12. COOLER TO GEAR HOSE 13. COOLER TO PUMP HOSE 14. OIL COOLER ASSEMBLY | <ul style="list-style-type: none"> 15. 90 DEGREE ELBOW 16. COOLER SUPPLY HOSE ASSEMBLY 17. INSULATOR (2) 18. FRONT CROSSMEMBER ASSEMBLY 19. HARDENED WASHER (2) 20. HEXAGON HEAD NUT (2) 21. RADIATOR OUTLET HOSE 22. COOLER RETURN HOSE ASSEMBLY 23. DRAINCOCK 24. HEXAGON HEAD SCREW (6) 25. LOCKWASHER (6) 26. HEXAGON HEAD NUT (2) 27. LOCKWASHER (2) 28. FAN CLUTCH ASSEMBLY |
|---|---|

TA237113

COOLING SYSTEM

3-53. RADIATOR REPLACEMENT (Continued)

LOCATION/ITEM	ACTION	REMARKS
A. REMOVAL (Continued).		
17. Draincock (23), reducer (7), and plug (8).	Remove from item (9).	
B. CLEANING AND INSPECTION		
18. All parts	Clean and inspect.	Refer to paragraphs 3-4 and 3-5. If item (9) is damaged, refer to DS/GS maintenance.
C. INSTALLATION		
19. Draincock (23), reducer (7), and plug (8).	a. Wrap with thread sealing tape. b. Install into item (9).	Refer to paragraph 3-7.
20. Two radiator grille support brackets.	Install. 3-268.	Refer to paragraph
21. Transmission and steering system cooler	Install.	Refer to paragraph 3-55. Make sure cooler is installed in same location as it was removed.
22. Overflow tube.	Install.	Refer to paragraph 3-58.
23. Lower shroud.	Install.	Refer to paragraph 3-57.
24. Upper shroud.	Install.	Refer to paragraph 3-56.
3-266		

COOLING SYSTEM.

3-53. RADIATOR REPLACEMENT (Continued).

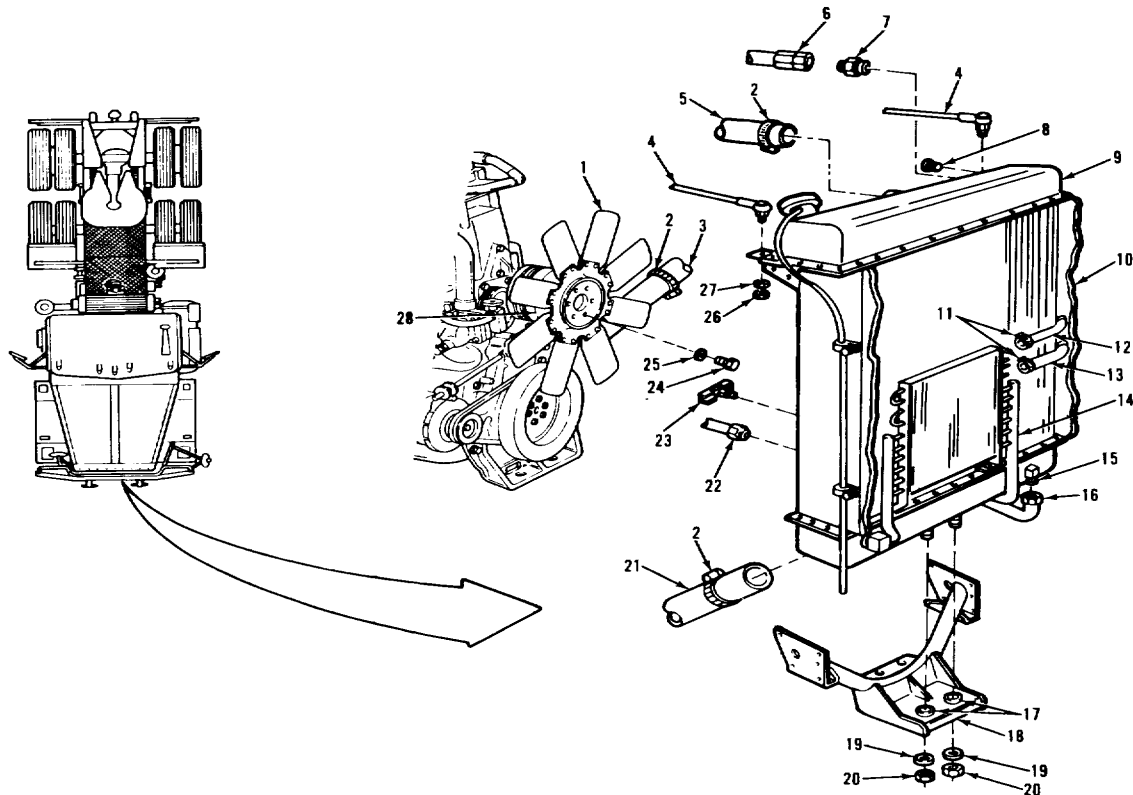

LEGEND:

- 1. FAN ASSEMBLY
- 2. RADIATOR HOSE CLAMP (3)
- 3. WATER PUMP BYPASS HOSE
- 4. RADIATOR SUPPORT ROD (2)
- 5. RADIATOR INLET HOSE
- 6. DEAERATION LINE HOSE ASSEMBLY
- 7. REDUCER
- 8. PIPE PLUG
- 9. RADIATOR ASSEMBLY
- 10. RADIATOR GRILLE SUPPORT BRACKET
- 11. HOSE CLAMP (2)
- 12. COOLER TO GEAR HOSE
- 13. COOLER TO PUMP HOSE
- 14. OIL COOLER ASSEMBLY

- 15. 90 DEGREE ELBOW
- 16. COOLER SUPPLY HOSE ASSEMBLY
- 17. INSULATOR (2)
- 18. FRONT CROSSMEMBER ASSEMBLY
- 19. HARDENED WASHER (2)
- 20. HEXAGON HEAD NUT (2)
- 21. RADIATOR OUTLET HOSE
- 22. COOLER RETURN HOSE ASSEMBLY
- 23. DRAINCOCK
- 24. HEXAGON HEAD SCREW (6)
- 25. LOCKWASHER (6)
- 26. HEXAGON HEAD NUT (2)
- 27. LOCKWASHER (2)
- 28. FAN CLUTCH ASSEMBLY

TA237114

COOLING SYSTEM

3-53. RADIATOR REPLACEMENT (Continued)

LOCATION/ITEM	ACTION	REMARKS
C. INSTALLATION (Continued)		
25. Two new insulators (17).	Install on studs of item (9).	Use tape to hold items (17) in place.
26. Radiator (9).	a. Line up studs with holes in item (18). b. Using lifting device, lower onto item (18) and tilt forward so that item (1) can be installed.	
27. Fan (1)	a. Position on item (28). b. Secure with six items (24) and (25).	Torque six items (24) to 25-31 lb-ft.
28. Radiator (9).	Using lifting device, tilt back to normal position on item (18).	
29. Two nuts (20) and washers (19).	Install onto studs of item (9), and tighten.	
30. Two rods (4).	a. Install into item (9). b. Secure with two nuts (26) and lockwashers (27).	
31. Radiator (9).	Remove lifting device.	
32. Hose (3), hose (5), hose (21), and three clamps (2).	a. Push items (3), (5), and (21) onto item (9). b. Position items (2) on ends of items (3), (5), and (21), and tighten screws.	

COOLING SYSTEM.

3-53. RADIATOR REPLACEMENT (Continued).

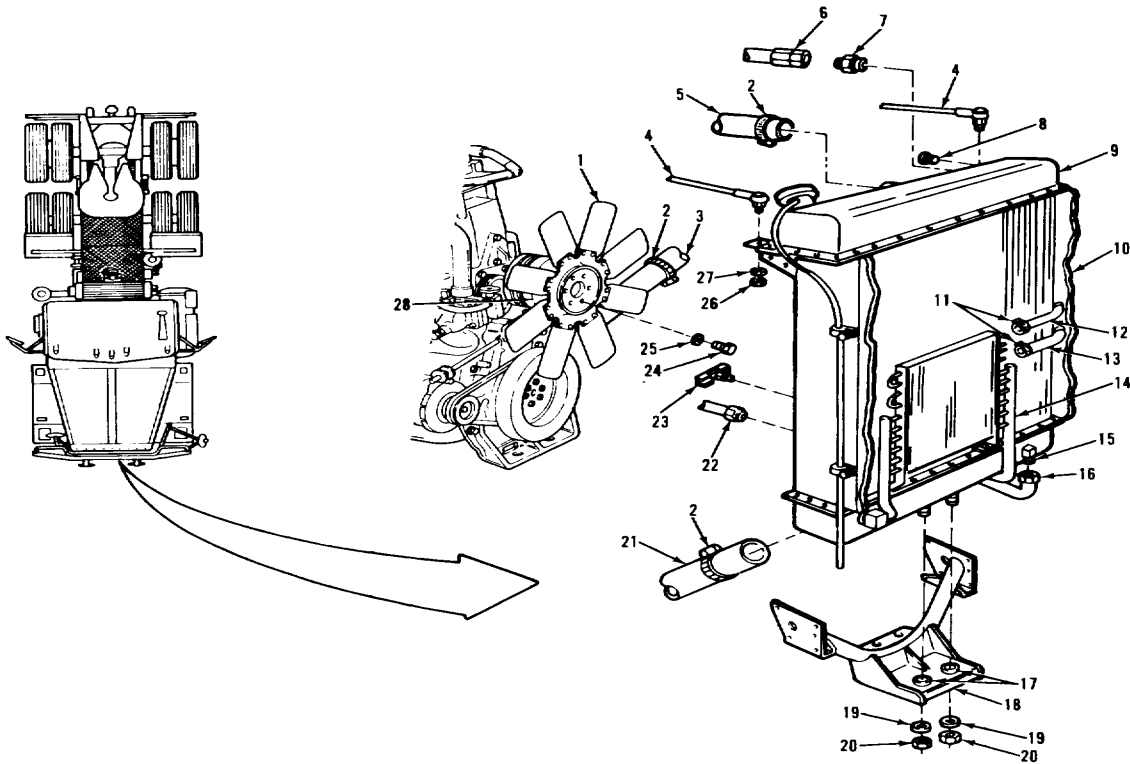

LEGEND:

- | | |
|---|---|
| <ul style="list-style-type: none"> 1. FAN ASSEMBLY 2. RADIATOR HOSE CLAMP (3) 3. WATER PUMP BYPASS HOSE 4. RADIATOR SUPPORT ROD (2) 5. RADIATOR INLET HOSE 6. DEAERATION LINE HOSE ASSEMBLY 7. REDUCER 8. PIPE PLUG 9. RADIATOR ASSEMBLY 10. RADIATOR GRILLE SUPPORT BRACKET 11. HOSE CLAMP (2) 12. COOLER TO GEAR HOSE 13. COOLER TO PUMP HOSE 14. OIL COOLER ASSEMBLY | <ul style="list-style-type: none"> 15. 90 DEGREE ELBOW 16. COOLER SUPPLY HOSE ASSEMBLY 17. INSULATOR (2) 18. FRONT CROSSMEMBER ASSEMBLY 19. HARDENED WASHER (2) 20. HEXAGON HEAD NUT (2) 21. RADIATOR OUTLET HOSE 22. COOLER RETURN HOSE ASSEMBLY 23. DRAINCOCK 24. HEXAGON HEAD SCREW (6) 25. LOCKWASHER (6) 26. HEXAGON HEAD NUT (2) 27. LOCKWASHER (2) 28. FAN CLUTCH ASSEMBLY |
|---|---|

TA 237115

COOLING SYSTEM

3-53. RADIATOR REPLACEMENT (Continued)

LOCATION/ITEM	ACTION	REMARKS
C. INSTALLATION (Continued).		
33. Hose (6) on item (7).	Install onto item (7).	Use thread sealing tape
34. Hose (16) and hose (22).	Install onto items (14) and (15).	
35. Hose (12), hose (13), and two clamps (11).	a. Push items (12) and (13) through item (10). b. Put one item (11) on each item (12) or (13). c. Push items (12) and (13) onto item (14). d. Position item (11) on ends of items (12) and (13), and tighten screws.	
NOTE		
Follow-on maintenance action required:		
Install grille (para 3-268). Install brush guard (para 3-236). Fill cooling system (para 3-52). Install hood (para 3-269). Check transmission fluid level and fill as required (para 3-135). Start vehicle and check for leaks (TM 9-2320-283-10).		

COOLING SYSTEM.

3-53. RADIATOR REPLACEMENT (Continued)

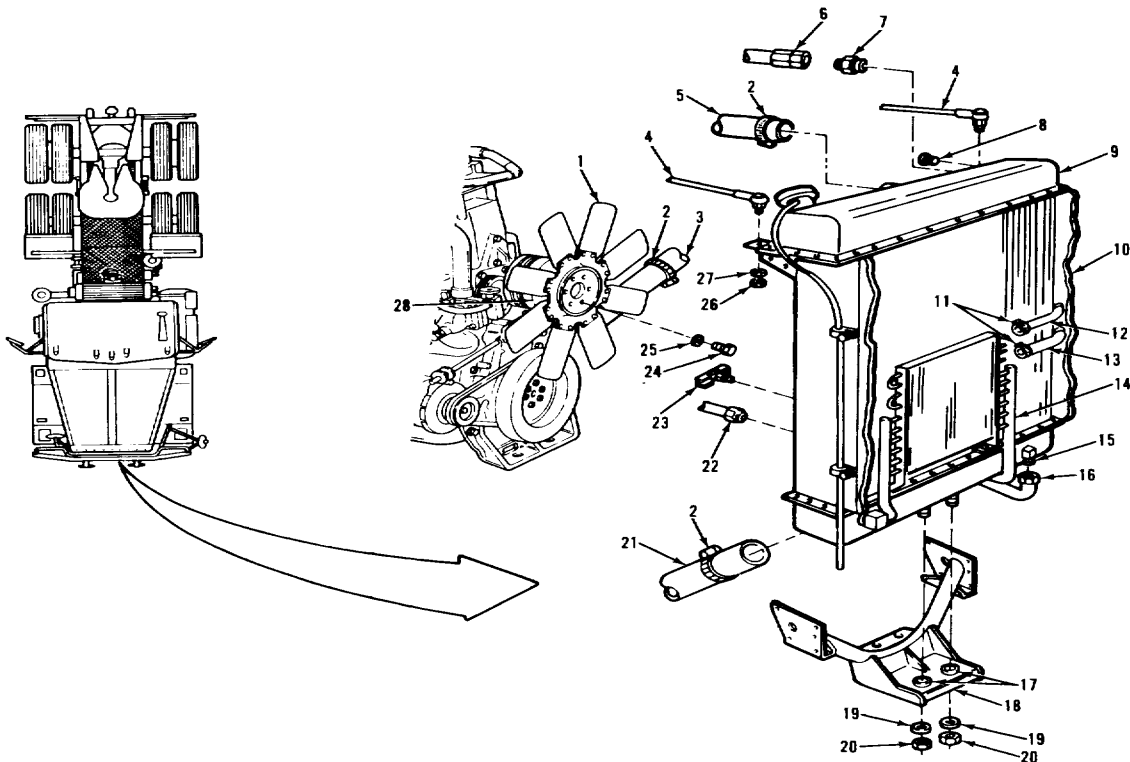

LEGEND:

- 1. FAN ASSEMBLY
- 2. RADIATOR HOSE CLAMP (3)
- 3. WATER PUMP BYPASS HOSE
- 4. RADIATOR SUPPORT ROD (2)
- 5. RADIATOR INLET HOSE
- 6. DEAERATION LINE HOSE ASSEMBLY
- 7. REDUCER
- 8. PIPE PLUG
- 9. RADIATOR ASSEMBLY
- 10. RADIATOR GRILLE SUPPORT BRACKET
- 11. HOSE CLAMP (2)
- 12. COOLER TO GEAR HOSE
- 13. COOLER TO PUMP HOSE
- 14. OIL COOLER ASSEMBLY

- 15. 90 DEGREE ELBOW
- 16. COOLER SUPPLY HOSE ASSEMBLY
- 17. INSULATOR (2)
- 18. FRONT CROSSMEMBER ASSEMBLY
- 19. HARDENED WASHER (2)
- 20. HEXAGON HEAD NUT (2)
- 21. RADIATOR OUTLET HOSE
- 22. COOLER RETURN HOSE ASSEMBLY
- 23. DRAINCOCK
- 24. HEXAGON HEAD SCREW (6)
- 25. LOCKWASHER (6)
- 26. HEXAGON HEAD NUT (2)
- 27. LOCKWASHER (2)
- 28. FAN CLUTCH ASSEMBLY

TA 237116

COOLING SYSTEM

3-53. RADIATOR REPLACEMENT (Continued)

This task covers:

- a. Removal
- b. Cleaning and Inspection
- c. Installation

INITIAL SETUP:

<p><u>APPLICABLE CONFIGURATIONS</u> All.</p> <p><u>TEST EQUIPMENT</u> None.</p> <p><u>SPECIAL TOOLS</u> None.</p> <p><u>MATERIALS/PARTS (P/N)</u> None.</p> <p><u>PERSONNEL REQUIRED</u> One (MOS-63S).</p> <p><u>REFERENCES (TM)</u> None.</p> <p><u>TROUBLESHOOTING REFERENCES</u> None.</p>	<p><u>EQUIPMENT CONDITION PARAGRAPH</u> None.</p> <p><u>SPECIAL ENVIRONMENTAL CONDITIONS</u> None.</p> <p><u>GENERAL SAFETY INSTRUCTIONS</u> Engine off. Transmission in neutral. Park brake set.</p>	<p><u>CONDITION DESCRIPTION</u> None.</p>
---	---	---

COOLING SYSTEM.

3-54. RADIATOR SUPPORT RODS REPLACEMENT (Continued).

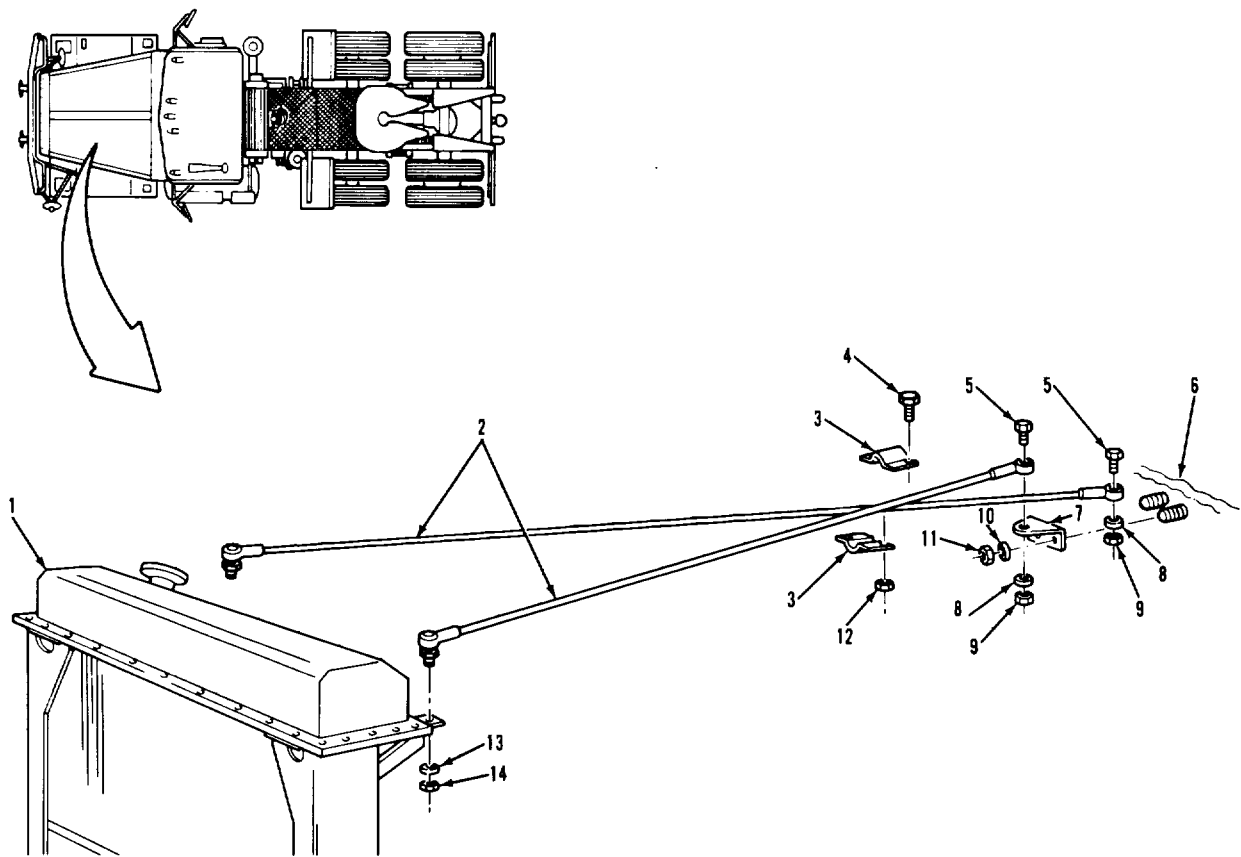

LEGEND:

- | | | | |
|----|---------------------------------------|-----|--------------------------|
| 1. | RADIATOR ASSEMBLY | 8. | WASHER (2) |
| 2. | RADIATOR SUPPORT ROD (2) | 9. | HEXAGON HEAD LOCKNUT (2) |
| 3. | RADIATOR SUPPORT ROD CLAMP (2) | 10. | WASHER (4) |
| 4. | HEXAGON HEAD SCREW (2) | 11. | HEXAGON HEAD NUT (4) |
| 5. | HEXAGON HEAD SCREW (2) | 12. | HEXAGON HEAD NUT (2) |
| 6. | CAB | 13. | LOCKWASHER (2) |
| 7. | RADIATOR SUPPORT ROD MOUNTING BRACKET | 14. | HEXAGON HEAD NUT (2) |

TA 297117

COOLING SYSTEM

3-53. RADIATOR REPLACEMENT (Continued)

LOCATION/ITEM	ACTION	REMARKS
A. REMOVAL.		
1. Two nuts (14) and lockwashers (13).	Remove from front end of two items (2).	
2. Two nuts (9), washers (8), and screws (5).	Remove from two items (7) and rear of two items (2).	
3. Two rods (2).	Remove from items (1) and (7).	
NOTE		
If support rods were removed for access only, skip steps 4 thru 8.		
4. Four nuts (11), washers (10), and two brackets (7).	Remove from item (6).	Pull insulation back as far as needed to remove two items (7).
5. Two nuts (12), screws (4), clamps (3), and rods (2).	Remove items (12) and (4), and separate items (3) and (2).	
B. CLEANING AND INSPECTION.		
6. All parts.	Clean and inspect.	Refer to paragraphs 3-4 and 3-5.
C. INSTALLATION.		
7. Two rods (2), clamps (3), screws (4), and nuts (12).	a. Hold items (2) together, and position items (3) so they are centered on items (2). b. Secure with items (4) and (12).	

COOLING SYSTEM.

3-54. RADIATOR SUPPORT RODS REPLACEMENT (Continued).

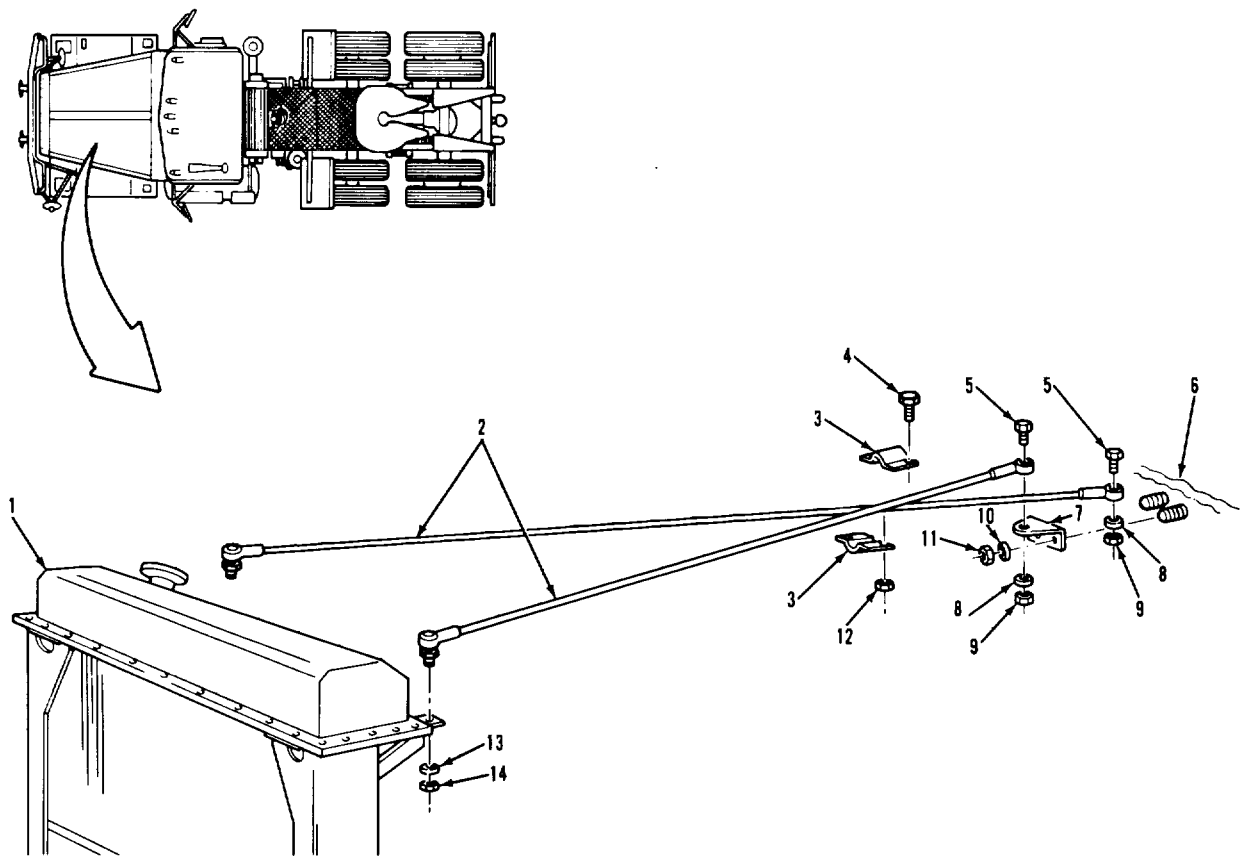

LEGEND:

- | | | | |
|----|---------------------------------------|-----|---------------------------|
| 1. | RADIATOR ASSEMBLY | 8. | WASHER (2) |
| 2. | RADIATOR SUPPORT ROD (2) | 9. | HEXAGON HEAD LOCKNUT (20) |
| 3. | RADIATOR SUPPORT ROD CLAMP (2) | 10. | WASHER (4) |
| 4. | HEXAGON HEAD SCREW (2) | 11. | HEXAGON HEAD NUT (4) |
| 5. | HEXAGON HEAD SCREW (2) | 12. | HEXAGON HEAD NUT (2) |
| 6. | CAB | 13. | LOCKWASHER (2) |
| 7. | RADIATOR SUPPORT ROD MOUNTING BRACKET | 14. | HEXAGON HEAD NUT (2) |

TA 297118

COOLING SYSTEM

3-54. RADIATOR SUPPORT RODS REPLACEMENT (Continued)

LOCATION/ITEM	ACTION	REMARKS
C. INSTALLATION (Continued).		
8. Two brackets (7).	a. Place on studs of item (6). b. Secure with four items (11) and (10).	
9. Two rods (2).	a. Place on two items (7) and in bracket of item (1). b. Secure rear with two items (5), (8), and (9). c. Secure front with two items (13) and (14).	
NOTE		
Follow-on maintenance action required:		
None.		
3-276		

COOLING SYSTEM.

3-54. RADIATOR SUPPORT RODS REPLACEMENT (Continued).

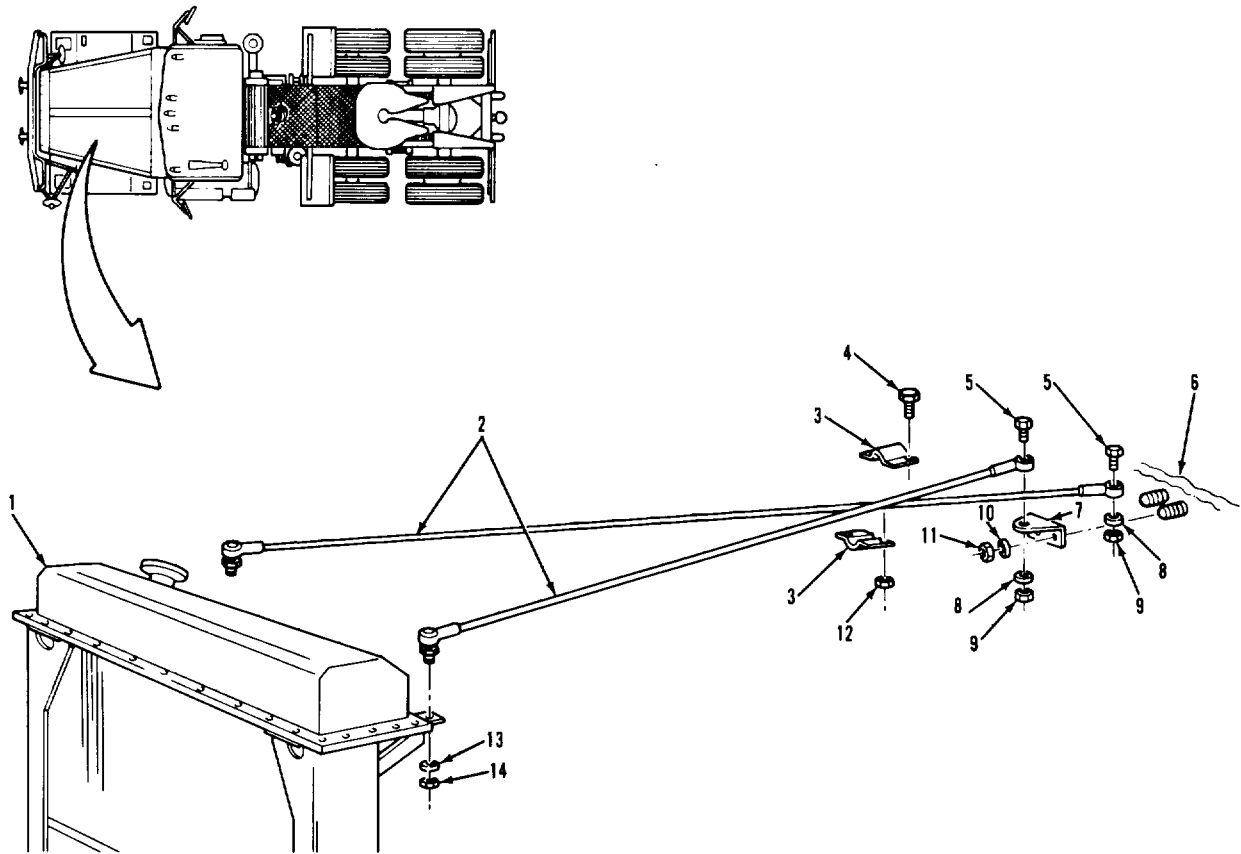

LEGEND:

- | | | | |
|----|---------------------------------------|-----|---------------------------|
| 1. | RADIATOR ASSEMBLY | 8. | WASHER (2) |
| 2. | RADIATOR SUPPORT ROD (2) | 9. | HEXAGON HEAD LOCKNUT (20) |
| 3. | RADIATOR SUPPORT ROD CLAMP (2) | 10. | WASHER (4) |
| 4. | HEXAGON HEAD SCREW (2) | 11. | HEXAGON HEAD NUT (4) |
| 5. | HEXAGON HEAD SCREW (2) | 12. | HEXAGON HEAD NUT (2) |
| 6. | CAB | 13. | LOCKWASHER (2) |
| 7. | RADIATOR SUPPORT ROD MOUNTING BRACKET | 14. | HEXAGON HEAD NUT (2) |

TA 297119

COOLING SYSTEM

3-55 TRANSMISSION AND STEERING SYSTEM COOLER REPLACEMENT.

This task covers:

- a. Removal
- b. Cleaning and Inspection
- c. Installation

INITIAL SETUP:

<p><u>APPLICABLE CONFIGURATIONS</u> All.</p>	<p><u>EQUIPMENT CONDITION PARAGRAPH</u> 3-236.</p>	<p><u>CONDITION DESCRIPTION</u> Brush guard removed.</p>
<p><u>TEST EQUIPMENT</u> None.</p>	<p>3-268. 3-237.</p>	<p>Grille removed Bumper removed.</p>
<p><u>SPECIAL TOOLS</u> None.</p>		
<p><u>MATERIALS/PARTS (P/N)</u> None.</p>		
<p><u>PERSONNEL REQUIRED</u> One (MOS-63S)</p>	<p><u>SPECIAL ENVIRONMENTAL CONDITIONS</u> None.</p>	
<p><u>REFERENCES (TM)</u> TM 9-2320-283-10.</p>	<p><u>GENERAL SAFETY INSTRUCTIONS</u> Engine off. Transmission in neutral. Park brake set.</p>	
<p><u>TROUBLESHOOTING REFERENCES</u> Paragraph 2-11.</p>	<p>Wait until transmission and steering fluids are cool.</p>	

COOLING SYSTEM.

3-53. TRANSMISSION AND STEERING SYSTEM COOLER REPLACEMENT (Continued).

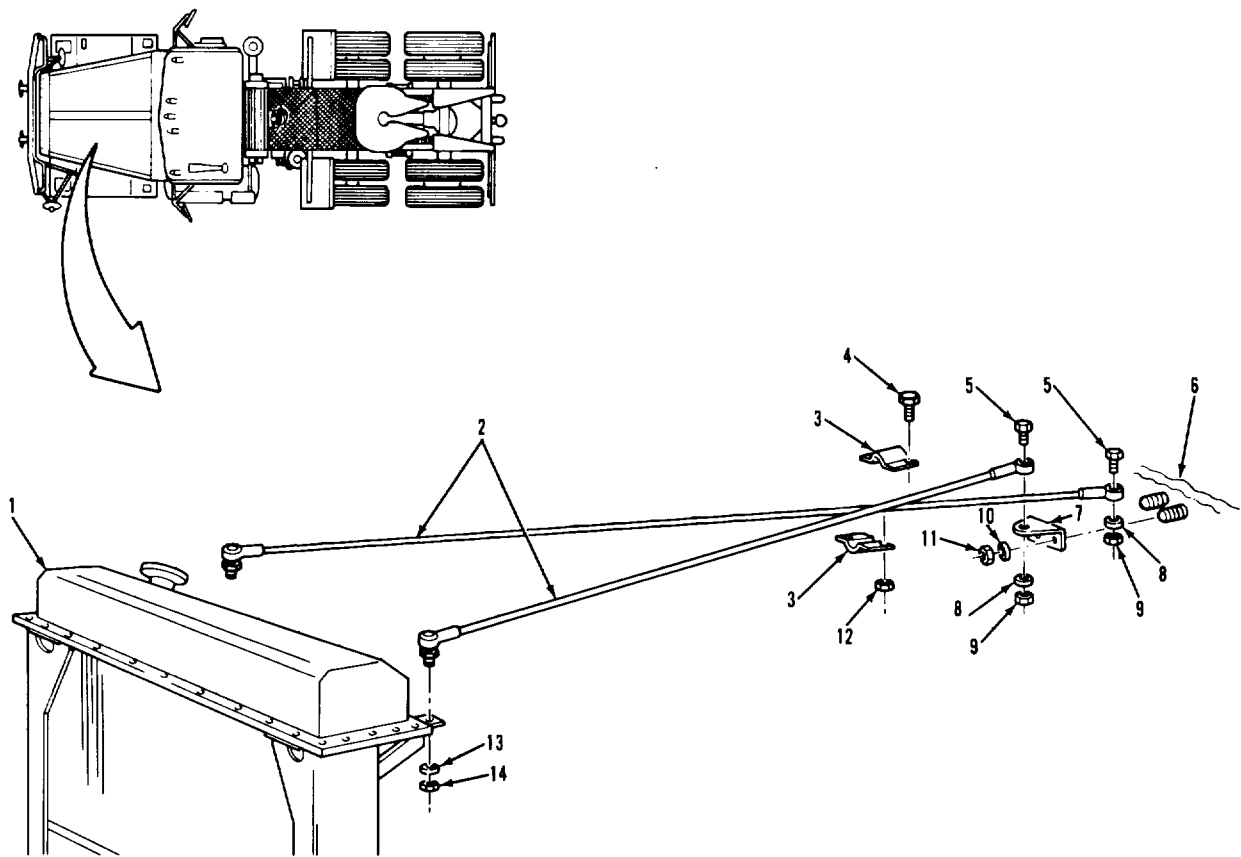

LEGEND:

- | | | | |
|----|---------------------------------------|-----|---------------------------|
| 1. | RADIATOR ASSEMBLY | 8. | WASHER (2) |
| 2. | RADIATOR SUPPORT ROD (2) | 9. | HEXAGON HEAD LOCKNUT (20) |
| 3. | RADIATOR SUPPORT ROD CLAMP (2) | 10. | WASHER (4) |
| 4. | HEXAGON HEAD SCREW (2) | 11. | HEXAGON HEAD NUT (2) |
| 5. | HEXAGON HEAD SCREW (2) | 12. | HEXAGON HEAD NUT (2) |
| 6. | CAB | 13. | LOCKWASHER (2) |
| 7. | RADIATOR SUPPORT ROD MOUNTING BRACKET | 14. | HEXAGON HEAD NUT (2) |

TA 297120

COOLING SYSTEM

3-53. RADIATOR REPLACEMENT (Continued)

LOCATION/ITEM	ACTION	REMARKS
A. REMOVAL.		
1. Hose (5), hose (6), and two clamps (7).	a. Loosen screws on two items (7). b. Pull items (5) and (6) off of item (1).	Have suitable container ready to catch oil. Leave items (7) on items (5) and (6).
2. Hose (8).	Remove from item (1).	Have suitable container ready to catch oil.
3. Two nuts (9), lock-washers (10), and screws (12).	Remove from items (4) and (1).	
4. Rod (2) and two nuts (3).	a. Unscrew item (3) on right side of item (2) while pulling item (2) out of item (4). b. Remove other item (3) from item (2).	
5. Two dampers (11). 6. Cooler (1).	Remove from item (1). a. Remove from item (13). b. Pull bottom away from item (4).	
7. Elbow (13).	Remove from item (4).	
8. Left side radiator grille support bracket.	Remove.	Refer to paragraph 3-268.

COOLING SYSTEM.

3-55. TRANSMISSION AND STEERING SYSTEM COOLER REPLACEMENT (Continued).

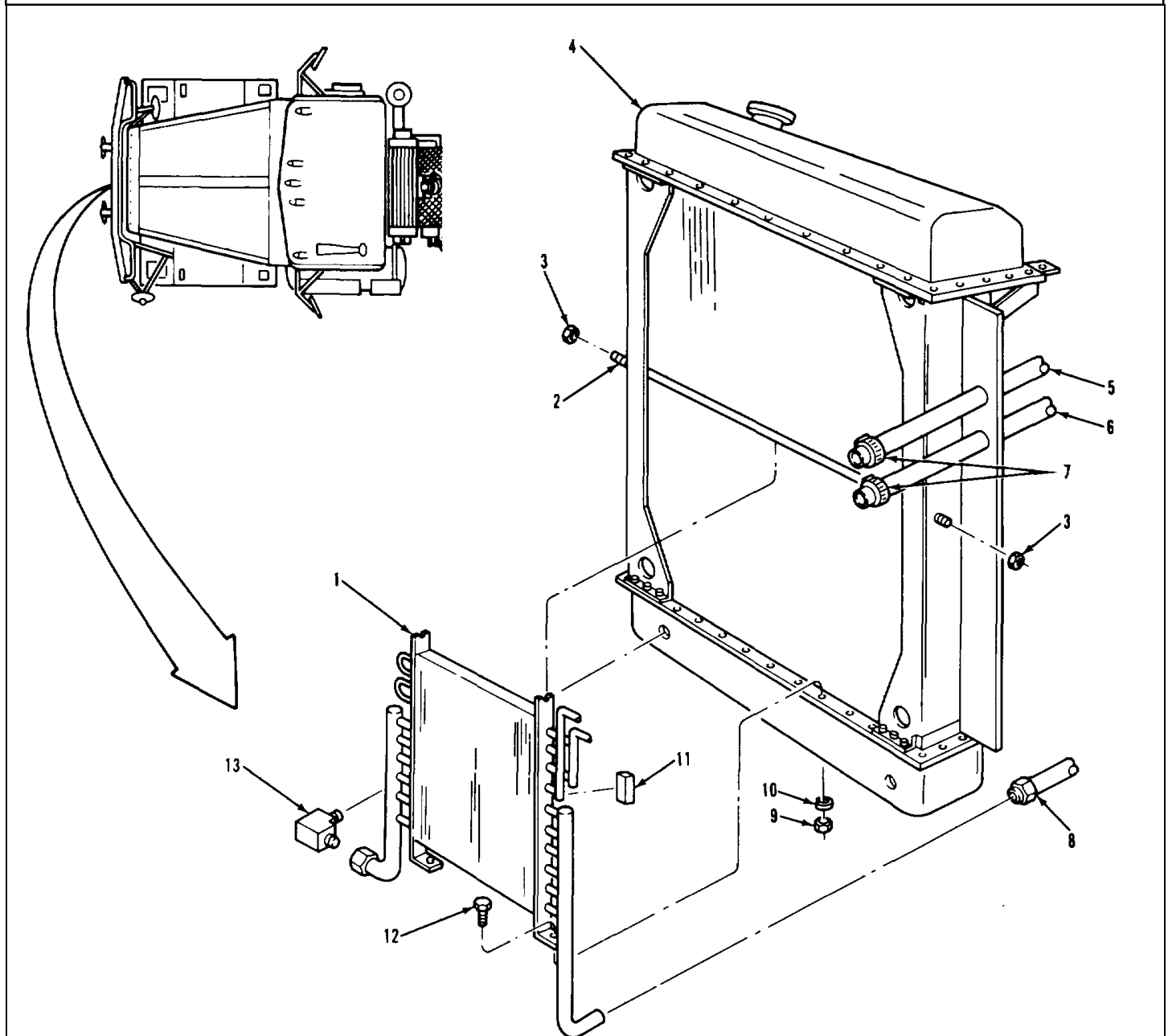

LEGEND:

- | | | | |
|----|---------------------------------------|-----|---------------------------|
| 1. | RADIATOR ASSEMBLY | 8. | WASHER (2) |
| 2. | RADIATOR SUPPORT ROD (2) | 9. | HEXAGON HEAD LOCKNUT (20) |
| 3. | RADIATOR SUPPORT ROD CLAMP (2) | 10. | WASHER (4) |
| 4. | HEXAGON HEAD SCREW (2) | 11. | HEXAGON HEAD NUT (2) |
| 5. | HEXAGON HEAD SCREW (2) | 12. | HEXAGON HEAD NUT (2) |
| 6. | CAB | 13. | LOCKWASHER (2) |
| 7. | RADIATOR SUPPORT ROD MOUNTING BRACKET | 14. | HEXAGON HEAD NUT (2) |

TA 297117

COOLING SYSTEM

3-53. RADIATOR REPLACEMENT (Continued)

LOCATION/ITEM	ACTION	REMARKS
B. CLEANING AND INSPECTION.		
9. All parts. and 3-5.	Clean and inspect.	Refer to paragraphs 3-4
10. Cooler (1).	Inspect for leaks, broken fins, and other damage.	Discard if leaking or damaged.
C. INSTALLATION		
11. Left side radiator grill support grill support bracket.	Install.	Refer to paragraph 3-268.
12. Elbow (13).	Install into item (4).	
13. Two dampers (11).	Install onto item (1).	
14. Cooler (1). (4).	a. Position bottom on item b. Install onto item (13). c. Secure to item (4) with two items (12), (10), and (9).	
15. Rod (2).	a. Install in item (4) and on item (1). b. Secure in place with two items (3).	When properly installed, item (2) should stick out past two items (3) the same amount on both sides.

COOLING SYSTEM.

3-55. TRANSMISSION AND STEERING COOLER SYSTEM REPLACEMENT (Continued).

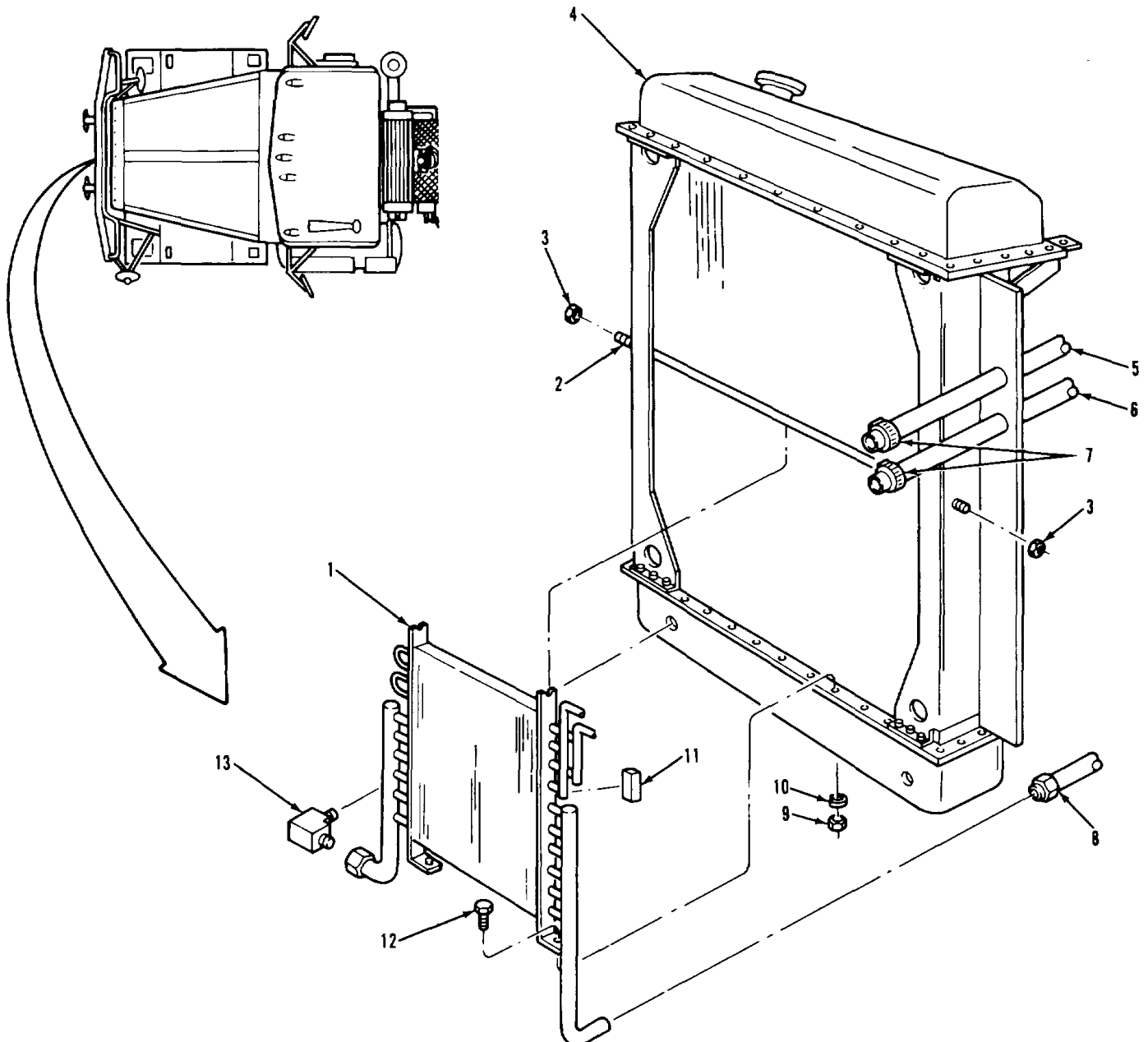

LEGEND:

- | | | | |
|----|---------------------------------------|-----|---------------------------|
| 1. | RADIATOR ASSEMBLY | 8. | WASHER (2) |
| 2. | RADIATOR SUPPORT ROD (2) | 9. | HEXAGON HEAD LOCKNUT (20) |
| 3. | RADIATOR SUPPORT ROD CLAMP (2) | 10. | WASHER (4) |
| 4. | HEXAGON HEAD SCREW (2) | 11. | HEXAGON HEAD NUT (2) |
| 5. | HEXAGON HEAD SCREW (2) | 12. | HEXAGON HEAD NUT (2) |
| 6. | CAB | 13. | LOCKWASHER (2) |
| 7. | RADIATOR SUPPORT ROD MOUNTING BRACKET | 14. | HEXAGON HEAD NUT (2) |

TA 297122

COOLING SYSTEM

3-55. TRANSMISSION AND STEERING COOLER SYSTEM REPLACEMENT (Continued).

LOCATION/ITEM	ACTION	REMARKS
C. INSTALLATION (Continued).		
16. Hose (8).	Install onto item (1).	
17. Hose (5), hose (6), and two clamps (7).	a. Push items (5) and (6) onto item (1). b. Position items (7) on ends of items (5) and (6), and tighten screws.	
NOTE		
Follow-on maintenance action required:		
Install bumper (para 3-237). Install grille (para 3-268). Install brush guard (para 3-236). Start vehicle and check for leaks (TM 9-2320-283-10).		
3-284		

COOLING SYSTEM.

3-55 RADIATOR REPLACEMENT (Continued).

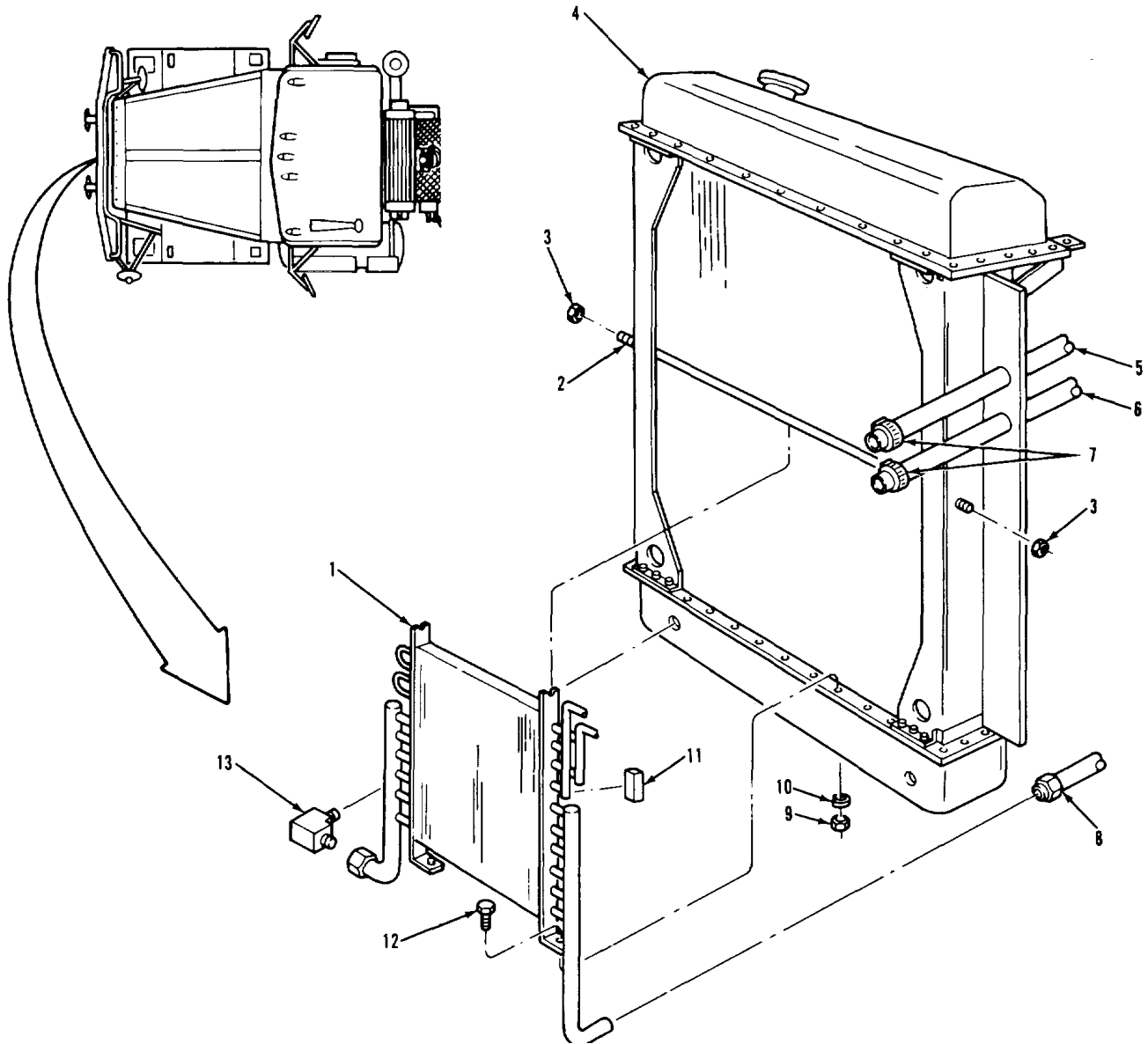

LEGEND:

- | | | | |
|----|---------------------------------------|-----|---------------------------|
| 1. | RADIATOR ASSEMBLY | 8. | WASHER (2) |
| 2. | RADIATOR SUPPORT ROD (2) | 9. | HEXAGON HEAD LOCKNUT (20) |
| 3. | RADIATOR SUPPORT ROD CLAMP (2) | 10. | WASHER (4) |
| 4. | HEXAGON HEAD SCREW (2) | 11. | HEXAGON HEAD NUT (2) |
| 5. | HEXAGON HEAD SCREW (2) | 12. | HEXAGON HEAD NUT (2) |
| 6. | CAB | 13. | LOCKWASHER (2) |
| 7. | RADIATOR SUPPORT ROD MOUNTING BRACKET | 14. | HEXAGON HEAD NUT (2) |

TA 297123

COOLING SYSTEM

3-56. UPPER FAN SHROUD REPLACEMENT (Continued)

This task covers:

- a. Removal
- b. Cleaning and Inspection
- c. Installation

INITIAL SETUP:

<p><u>APPLICABLE CONFIGURATIONS</u> All.</p>	<p><u>EQUIPMENT CONDITION PARAGRAPH</u> 3-52.</p>	<p><u>CONDITION DESCRIPTION</u> Coolant drained below level of radiator top tank.</p>
<p><u>TEST EQUIPMENT</u> None.</p>	<p>3-58.</p>	<p>Deaeration line removed.</p>
<p><u>SPECIAL TOOLS</u> None.</p>		
<p><u>MATERIALS/PARTS (P/N)</u> Tape, thread sealing Item 32, Appendix C.</p>		
<p><u>PERSONNEL REQUIRED</u> One (MOS-63S5)</p>	<p><u>SPECIAL ENVIRONMENTAL CONDITIONS</u> None.</p>	
<p><u>REFERENCES (TM)</u> TM 9-2320-283-10.</p>	<p><u>GENERAL SAFETY INSTRUCTIONS</u> Engine off. Transmission in neutral. Park brake set.</p>	
<p><u>TROUBLESHOOTING REFERENCES</u> None.</p>		

COOLING SYSTEM.

3-56. UPPER FAN SHROUD REPLACEMENT (Continued).

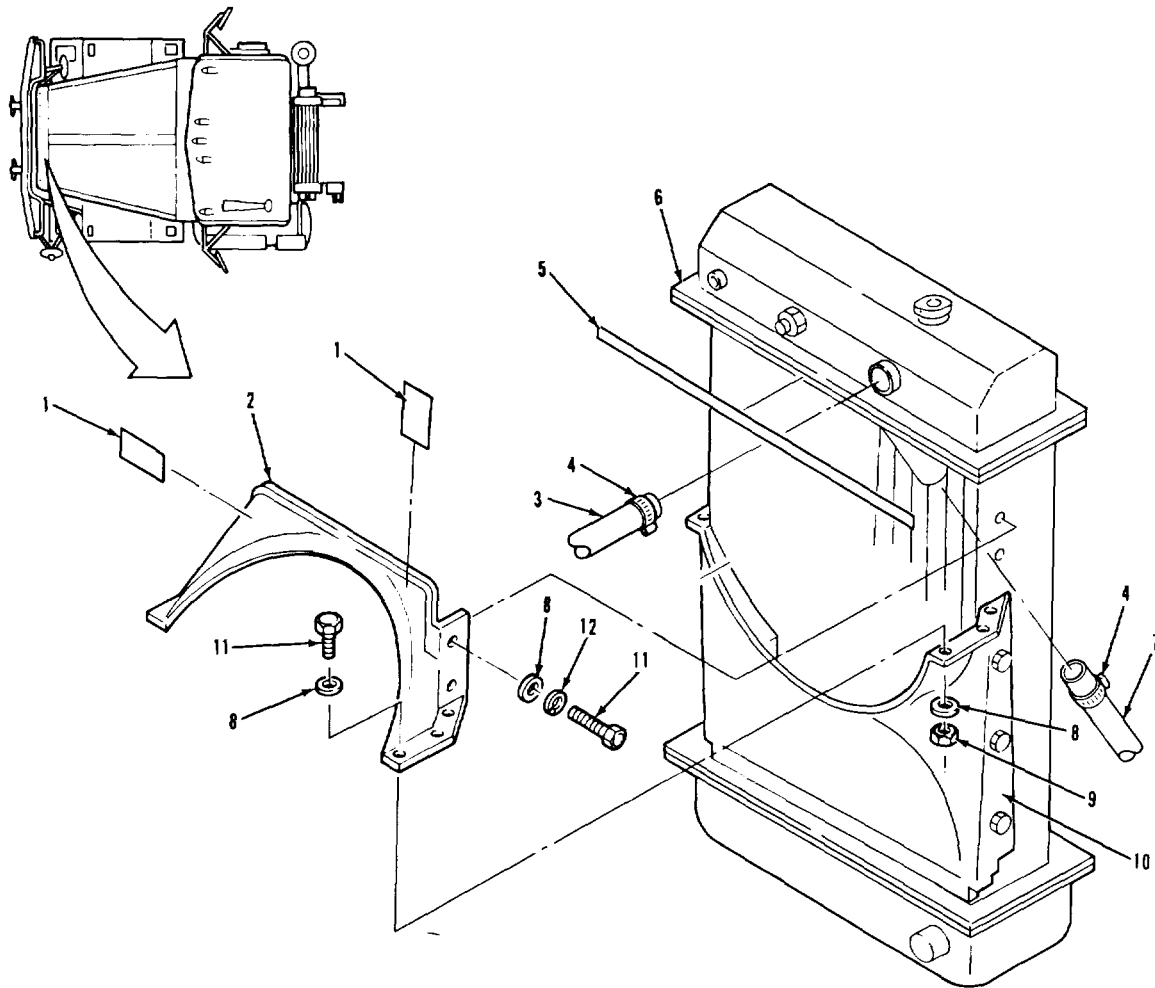

LEGEND:

- | | | | |
|----|--------------------------------|-----|------------------------|
| 1. | DECAL (2) | 7. | WATER PUMP BYPASS HOSE |
| 2. | UPPER SHROUD | 8. | FLAT WASHER (16) |
| 3. | RADIATOR INLET HOSE | 9. | HEXAGON HEAD NUT (6) |
| 4. | RADIATOR HOSE CLAMP (2) | 10. | LOWER SHROUD |
| 5. | UPPER RADIATOR FAN SHROUD SEAL | 11. | SCREW (10) |
| 6. | RADIATOR ASSEMBLY | 12. | LOCKWASHER (4) |

TA 237124

COOLING SYSTEM

3-56. UPPER FAN SHROUD REPLACEMENT (Continued)

LOCATION	ACTION	REMARKS
A. REMOVAL		
1. Hose (3), hose (7), and two clamps (4).	a. Loosen screws on two items (4). b. Pull items (3) and (7) from item (6).	Leave items (4) on items (3) and (7).
2. Four screws (11), lockwashers (12), and washers (8).	Remove from items (2) and (6).	
3. Six nuts (9), twelve washers (8), and six screws (11).	Remove from items (2) and (10).	
4. Shroud (2).	Remove from engine compartment.	Be careful not to bend item (2) too much during removal, or cracks could occur. It may be necessary to completely remove item (3) before removing item (2).
B. CLEANING AND INSPECTION.		
5. All parts.	Clean and inspect.	Refer to paragraphs 3-4 and 3-5.
6. Seal (5) and two decals (1)	Inspect for damage.	Remove and replace only if damaged.
C. INSTALLATION.		
7. Shroud (2).	a. Install into engine compartment and put into position on items (6) and (10).	Be careful not to bend item (2) too much during installation, or cracks could occur.

COOLING SYSTEM.

3-56. UPPER FAN SHROUD REPLACEMENT (Continued).

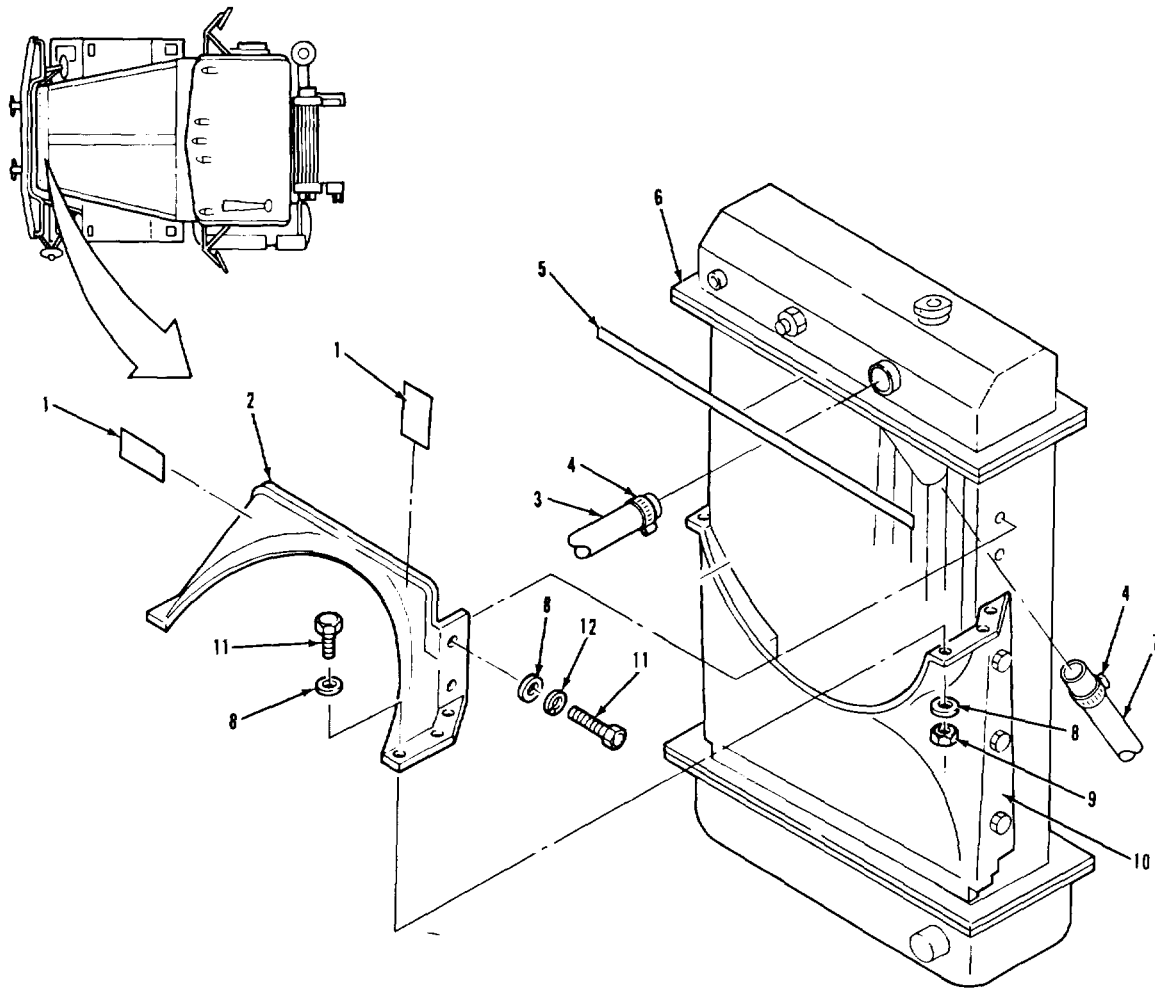

LEGEND:

- | | | | |
|----|--------------------------------|-----|------------------------|
| 1. | DECAL (2) | 7. | WATER PUMP BYPASS HOSE |
| 2. | UPPER SHROUD | 8. | FLAT WASHER (16) |
| 3. | RADIATOR INLET HOSE | 9. | HEXAGON HEAD NUT (6) |
| 4. | RADIATOR HOSE CLAMP (2) | 10. | LOWER SHROUD |
| 5. | UPPER RADIATOR FAN SHROUD SEAL | 11. | SCREW (10) |
| 6. | RADIATOR ASSEMBLY | 12. | LOCKWASHER (4) |

TA 237125

COOLING SYSTEM

3-53. UPPER FAN SHROUD REPLACEMENT (Continued)

LOCATION	ACTION	REMARKS
C. INSTALLATION (Continued).		
8. Shroud (2) (continued).	b. Secure to item (10) with six items (11), twelve items (8), and six items (9). c. Secure to item (6) with four items (11), (12), and (8).	
9. Hose (3), hose (7), and two clamps (4).	a. Push items (3) and (7) onto item (6). b. Position items (4) on end of items (3) and (7), and tighten screws.	Install other end of item (3) to thermostat housing if removed during step 4.
NOTE		
Follow-on maintenance action required:		
Install deaeration line (para 3-58). Fill cooling system (para 3-52). Start vehicle and check for leaks (TM 9-2320-283-10).		

COOLING SYSTEM.

3-56. UPPER FAN SHROUD REPLACEMENT (Continued).

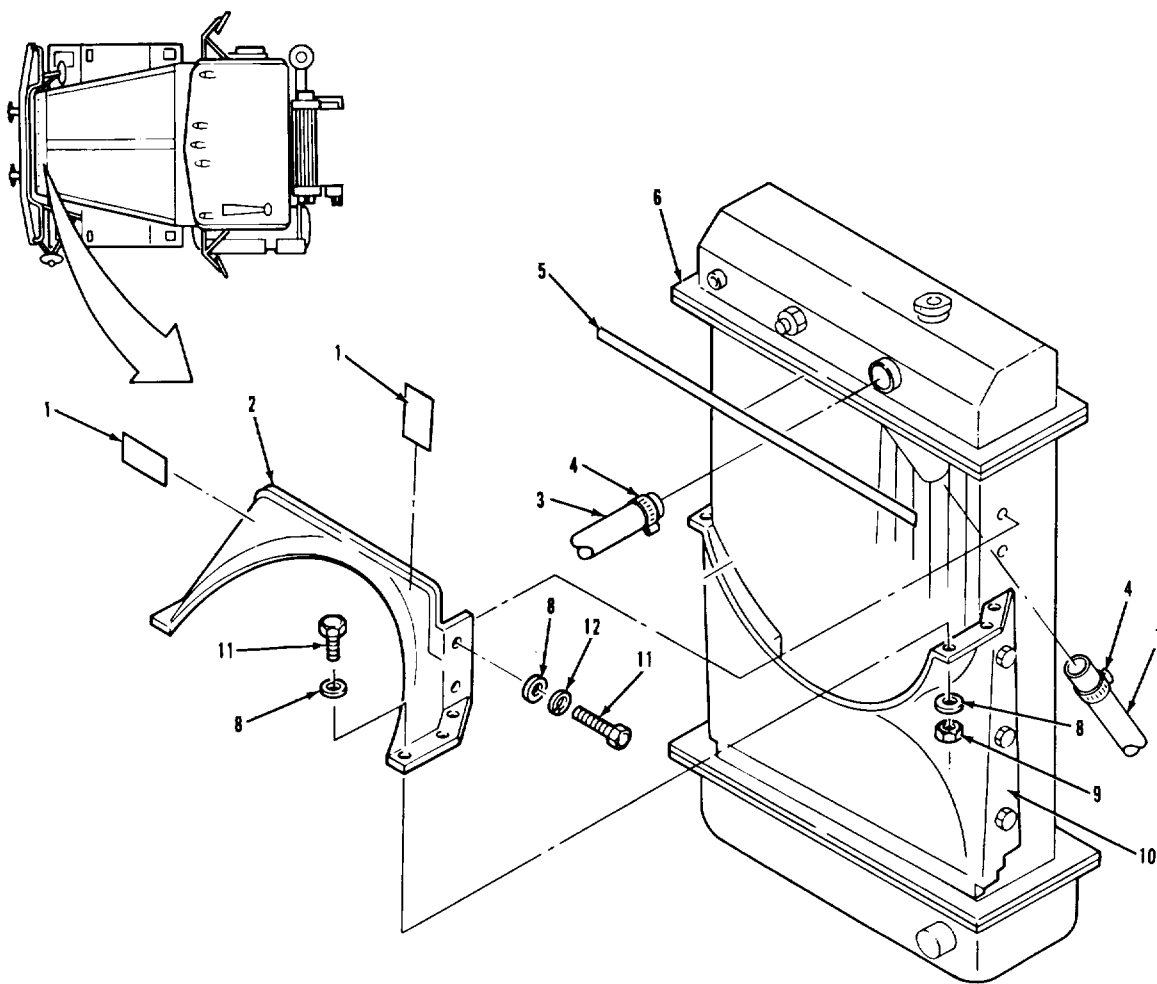

LEGEND:

- | | |
|-----------------------------------|---------------------------|
| 1. DECAL (2) | 7. WATER PUMP BYPASS HOSE |
| 2. UPPER SHROUD | 8. FLAT WASHER (16) |
| 3. RADIATOR INLET HOSE | 9. HEXAGON HEAD NUT (6) |
| 4. RADIATOR HOSE CLAMP (2) | 10. LOWER SHROUD |
| 5. UPPER RADIATOR FAN SHROUD SEAL | 11. SCREW (10) |
| 6. RADIATOR ASSEMBLY | 12. LOCKWASHER (4) |

COOLING SYSTEM.

3-57. LOWER FAN SHROUD REPLACEMENT.

THIS TASK COVERS

- a. Removal.
- b. Cleaning and Inspection.
- c. Installation.

INITIAL SETUP

APPLICABLE CONFIGURATIONS

All.

EQUIPMENT CONDITION

PARAGRAPH

3-53.

CONDITION DESCRIPTION

Radiator removed.

TEST EQUIPMENT

None.

SPECIAL TOOLS

None.

MATERIALS/PARTS (P/N)

None.

PERSONNEL REQUIRED

One (MOS-63S).

SPECIAL ENVIRONMENTAL CONDITIONS

None.

REFERENCES (TM)

None.

Transmission in neutral.

Park brake set.

GENERAL SAFETY INSTRUCTIONS

Engine off.

TROUBLESHOOTING REFERENCES

None.

COOLING SYSTEM.

3-57. LOWER FAN SHROUD REPLACEMENT (Continued).

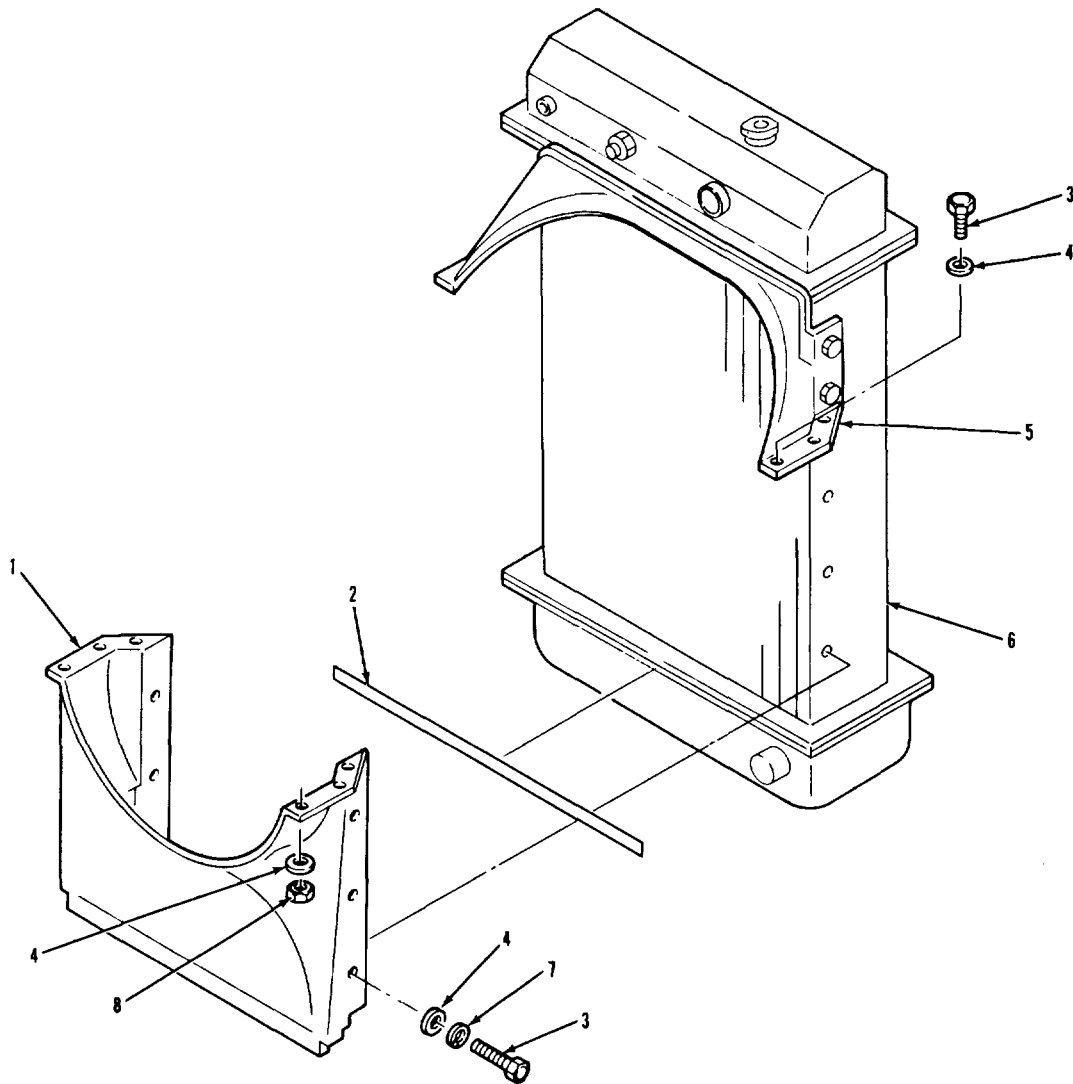

LEGEND:

- | | |
|-----------------------------------|-------------------------|
| 1. LOWER SHROUD | 5. UPPER SHROUD |
| 2. LOWER RADIATOR FAN SHROUD SEAL | 6. RADIATOR ASSEMBLY |
| 3. SCREW (12) | 7. LOCKWASHER (6) |
| 4. FLAT WASHER (18) | 8. HEXAGON HEAD NUT (6) |

COOLING SYSTEM.

3-57. LOWER FAN SHROUD REPLACEMENT (Continued).

LOCATION/ITEM	ACTION	REMARKS
---------------	--------	---------

A. REMOVAL.

- | | | |
|--|--------------------------------|--|
| 1. Six nuts (8), twelve washers (4), and six screws (3). | Remove from items (1) and (5). | |
| 2. Six screws (3), lockwashers (7), and washers (4). | Remove from items (1) and (6). | |
| 3. Shroud (1). | Remove from items (5) and (6). | |

B. CLEANING AND INSPECTION.

- | | | |
|---------------|---------------------------------|-------------------------|
| 4. All parts. | Clean and inspect. | Refer to paragraphs 3-4 |
| 5. Seal (2) | Inspect for damage. if damaged. | Remove and replace only |

C. INSTALLATION.

- | | | |
|----------------|--|--|
| 6. Shroud (1). | a. Position on items (5) and (6). | |
| | b. Secure to item (6) with six items (3), (7), and (4). | |
| | c. Secure to item (5) with six items (3), twelve items (4), and six items (8). | |

NOTE

Follow-on maintenance action required:
Install radiator (para 3-53).

COOLING SYSTEM.

3-57. LOWER FAN SHROUD REPLACEMENT (Continued).

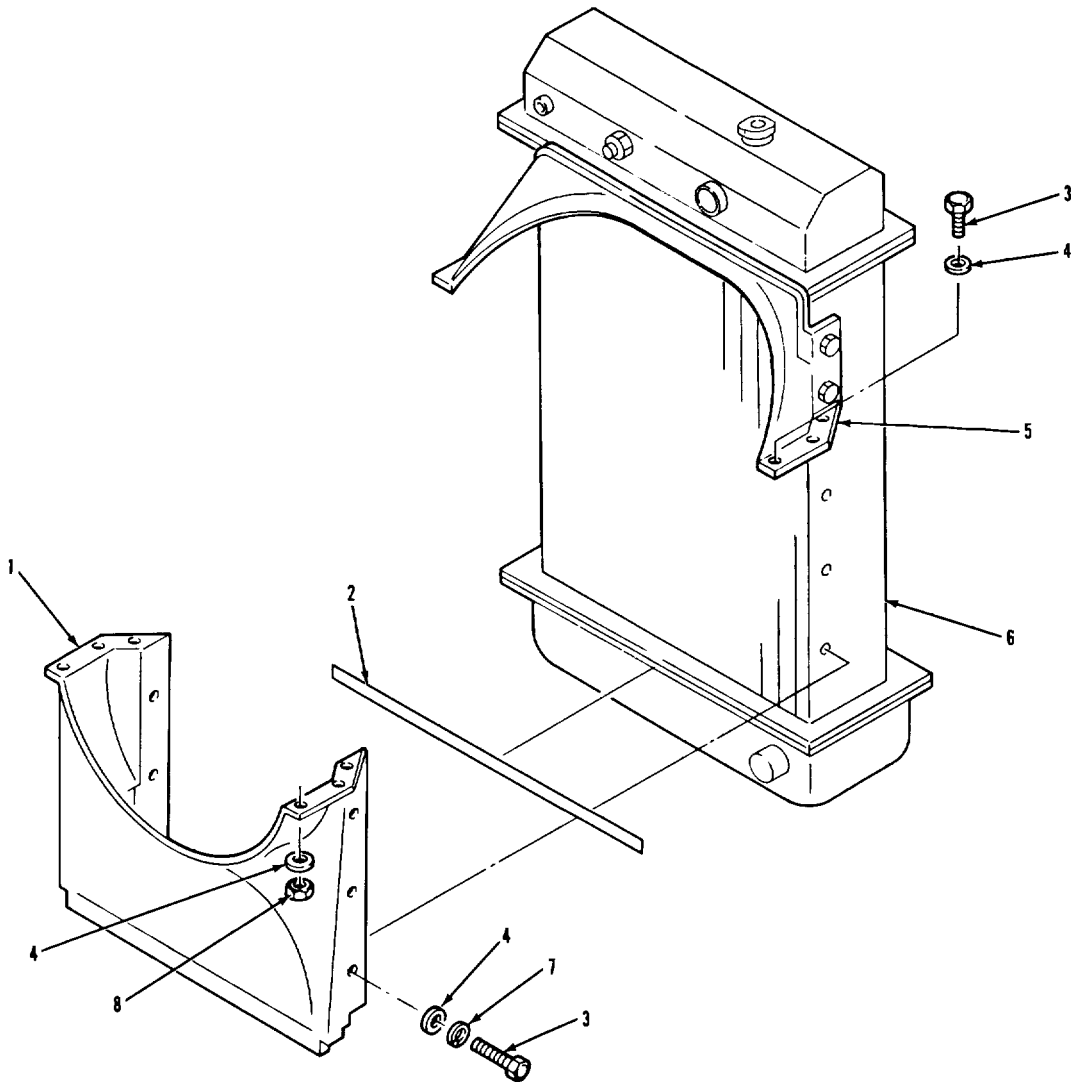

LEGEND:

- | | |
|-----------------------------------|-------------------------|
| 1. LOWER SHROUD | 5. UPPER SHROUD |
| 2. LOWER RADIATOR FAN SHROUD SEAL | 6. RADIATOR ASSEMBLY |
| 3. SCREW (12) | 7. LOCKWASHER (6) |
| 4. FLAT WASHER (18) | 8. HEXAGON HEAD NUT (6) |

COOLING SYSTEM.

<u>THIS TASK COVERS</u>		
<ul style="list-style-type: none"> a. Removal. b. Cleaning and Inspection. c. Installation. d. Water Pump Bypass Hose Replacement. e. Overflow Tube Replacement. 	<ul style="list-style-type: none"> f. Radiator Outlet Hoses and Tube Replacement. g. Water Bypass Tube Replacement. h. Water Transfer Tube Replacement. i. Water Pump to Radiator Connection Replacement 	
<u>INITIAL SETUP</u>		
<u>APPLICABLE CONFIGURATIONS</u>	<u>EQUIPMENT CONDITION PARAGRAPH</u>	<u>CONDITION DESCRIPTION</u>
All.	None.	None.
<u>TEST EQUIPMENT</u>		
None.		
<u>SPECIAL TOOLS</u>		
None.		
<u>MATERIALS/PARTS (P/N)</u>		
Tape, thread sealing (subparagraph b, d, g, and i only) Item 32, Appendix C.		
Oil, lubricating: OE/HDO-30 (subparagraph g and h only) Item 16, Appendix C.		
Grease, automotive and artillery (subparagraph i only) Item 7, Appendix C.		
O-ring (subparagraph g only) (15434) 43463-A.		
O-ring (2) (subparagraph h only) (15434) 212161.		
Gasket, water connection (subparagraph i only) (15434) 3024960.		
<u>PERSONNEL REQUIRED</u>	<u>SPECIAL ENVIRONMENTAL CONDITIONS</u>	
One (MOS-63S).	None.	
<u>REFERENCES (TM)</u>	<u>GENERAL SAFETY INSTRUCTIONS</u>	
TM 9-2320-283-10.	Engine off.	
TM 9-2320-283-20P.	Transmission in neutral.	
	Park brake set.	
<u>TROUBLESHOOTING REFERENCES</u>	Wait until cooling system components are cool.	
Paragraph 2-11.		

COOLING SYSTEM.

3-58. LINES, FITTINGS, AND HOSES REPLACEMENT (Continued).

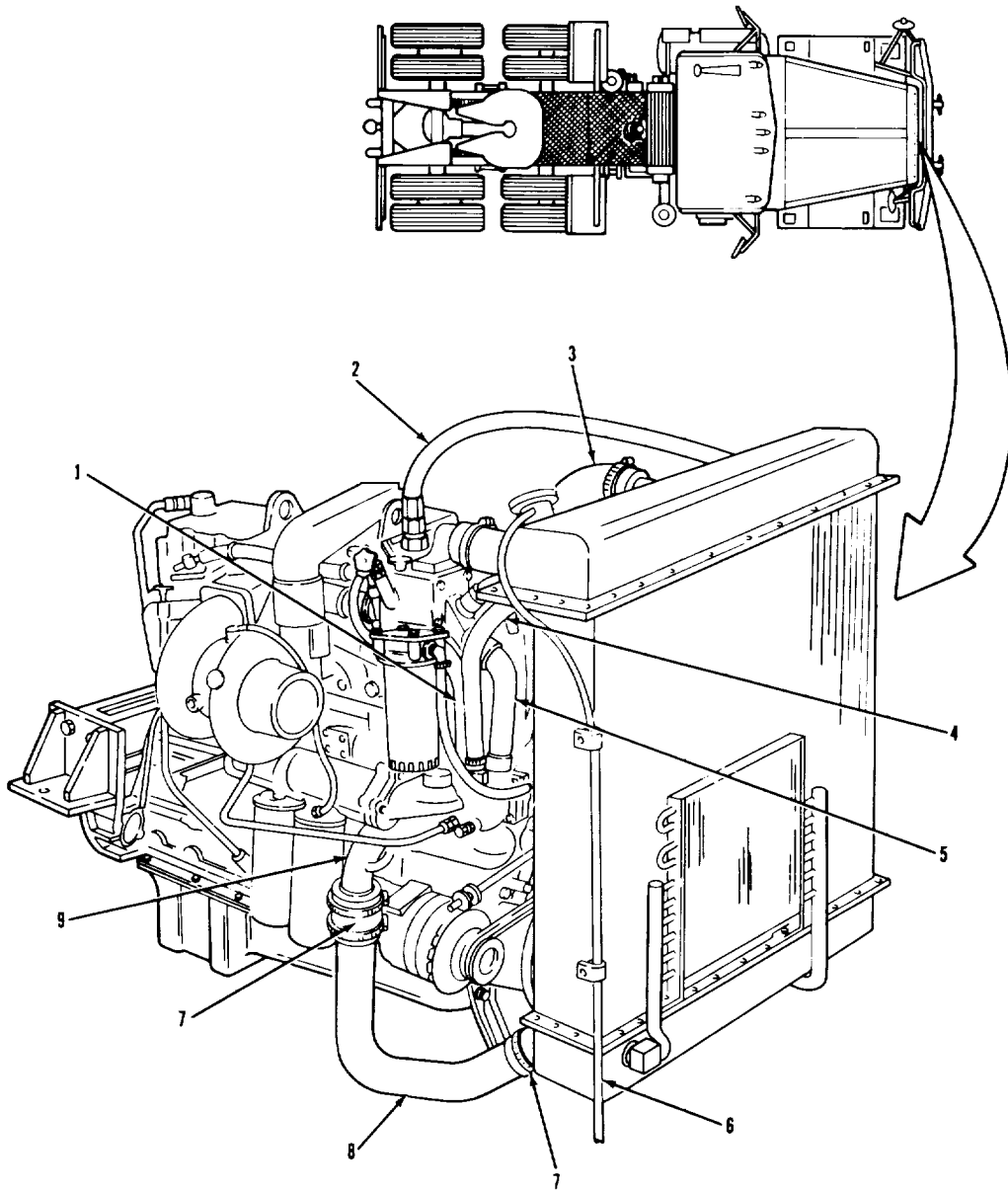

LEGEND

- | | |
|----------------------------------|--------------------------------------|
| 1. WATER TRANSFER TUBE | 6. OVERFLOW TUBE |
| 2. DEAERATION LINE HOSE ASSEMBLY | 7. RADIATOR OUTLET HOSE (2) |
| 3. RADIATOR INLET HOSE | 8. RADIATOR OUTLET TUBE |
| 4. WATER PUMP BYPASS HOSE | 9. WATER PUMP TO RADIATOR CONNECTION |
| 5. WATER BYPASS TUBE | |

COOLING SYSTEM.

3-58. LINES, FITTINGS, AND HOSES REPLACEMENT (Continued).

LOCATION/ITEM	ACTION	REMARKS
A. INSPECTION.		
1. All hoses and tubes (1) thru (9)	Inspect for leaks, cracks, kinks, stains, and other damage lowing: a. b. c.	If any item (1) thru (9) is damaged, do the following: Drain coolant to level below damaged part. Replace damaged part as shown in subparagraphs b thru i. Go to follow-on maintenance.
B. DEAERATION LINE REPLACEMENT.		
2. Hose (2)	Remove from items (12) and (13).	
3. Reducer (13)	Remove from item (14).	
4. Reducer (12) and connector (11)	Remove from item (10) and separate.	
5. All parts	Clean and inspect and 3-5.	Refer to paragraphs 3-4
6. Reducer (12) and connector (11)	a. Wrap threads with thread sealing tape. b. Screw together and install into item (10).	Refer to paragraph 3-7.
7. Reducer (13)	a. Wrap threads with thread sealing tape. b. Screw into item (14).	
8. Hose (2)	Install on items (12) and (13).	

COOLING SYSTEM.

3-58. LINES, FITTINGS, AND HOSES REPLACEMENT (Continued).

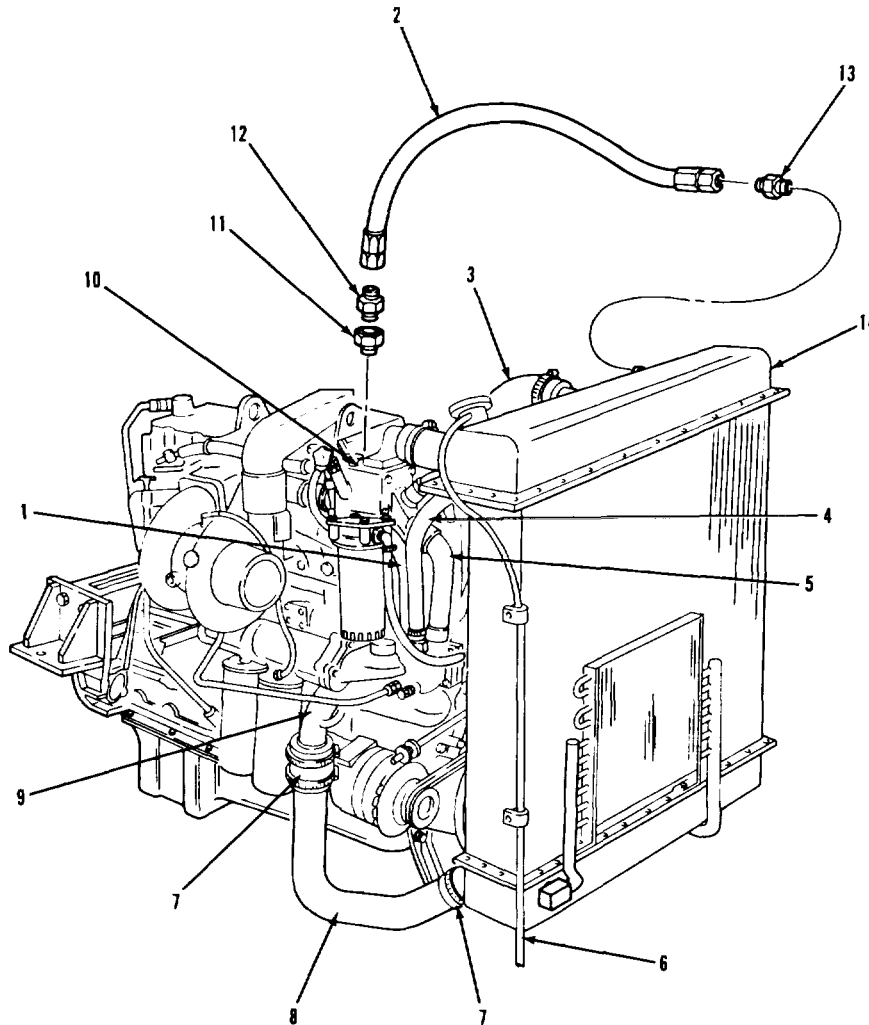

LEGEND:

- | | |
|----------------------------------|--------------------------------------|
| 1. WATER TRANSFER TUBE | 8. RADIATOR OUTLET TUBE |
| 2. DEAERATION LINE HOSE ASSEMBLY | 9. WATER PUMP TO RADIATOR CONNECTION |
| 3. RADIATOR INLET HOSE | 10. FRONT WATER MANIFOLD |
| 4. WATER PUMP BYPASS HOSE | 11. REDUCER |
| 5. WATER BYPASS TUBE | 12. MALE CONNECTOR |
| 6. OVERFLOW TUBE | 13. REDUCER |
| 7. RADIATOR OUTLET HOSE (2) | 14. RADIATOR ASSEMBLY |

COOLING SYSTEM.

3-58. LINES, FITTINGS, AND HOSES REPLACEMENT (Continued).

LOCATION/ITEM	ACTION	REMARKS
C. RADIATOR INLET HOSE REPLACEMENT.		
9. Hose (3) and two clamps (19)	<ul style="list-style-type: none"> a. Loosen screws on two items (19). b. Pull ends of item (3) off of item (14) and (18). c. Remove two items (19) from item (3). d. Clean and inspect and 3-5. e. Install two items (19) onto item (3). f. Push ends of item (3) onto items (14) and (18). g. Push two items (19) to ends of item (3), and tighten screws. 	Refer to paragraphs 3-4
D. WATER PUMP BYPASS HOSE REPLACEMENT.		
10. Hose (4) and two clamps (17)	<ul style="list-style-type: none"> a. Loosen screws on two items (17). b. Pull ends of item (4) off of items (14) and (15). c. Remove two items (17) from item (4). 	
11. Nipple (16)	Remove from item (15).	
12. All parts	Clean and inspect and 3-5.	Refer to paragraphs 3-4

COOLING SYSTEM.

3-58. LINES, FITTINGS, AND HOSES REPLACEMENT (Continued).

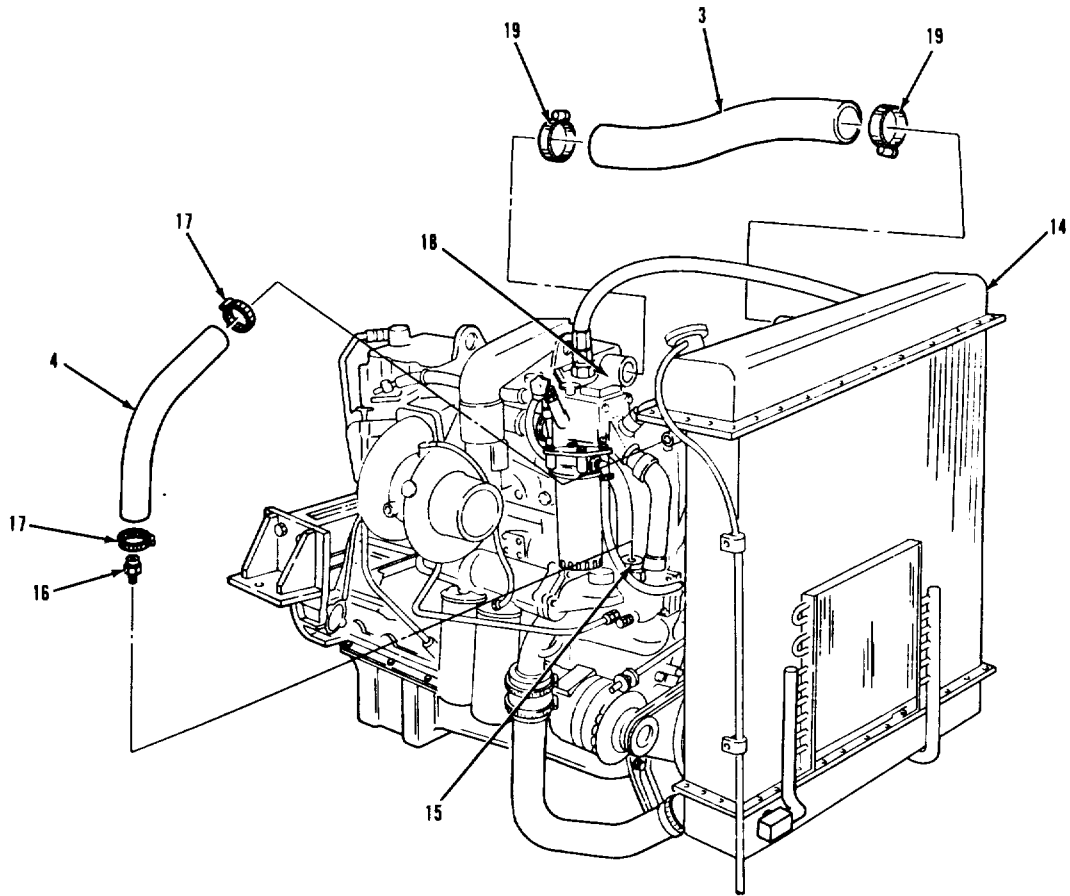

LEGEND:

- 3. RADIATOR INLET HOSE
- 4. WATER PUMP BYPASS HOSE
- 14. RADIATOR ASSEMBLY
- 15. WATER PUMP RADIATOR CONNECTION

- 16. STRAIGHT HOSE NIPPLE
- 17. HOSE CLAMP (2)
- 18. THERMOSTAT HOUSING
- 19. RADIATOR HOSE CLAMP (2)

TA237131

COOLING SYSTEM.

3-58. LINES, FITTINGS, AND HOSES REPLACEMENT (Continued).

LOCATION/ITEM	ACTION	REMARKS
D. WATER PUMP BYPASS HOSE REPLACEMENT (Continued).		
13. Nipple (16)	a. Wrap threads with thread sealing tape.	
14. Hose (4) and two clamps (17)	b. Install into item (15). a. Install two items (17) onto item (4). b. Push ends of item (4) onto items (14) and (15). c. Push two items (17) to ends of item (4), and tighten screws.	
E. OVERFLOW TUBE REPLACEMENT.		
15. Two screws (24), lockwashers (23), and washers (22).	Remove from two items (21) and item (14).	
16. Tube (20)	Remove from item (14) by turning and pulling.	
17. Two clips	Remove from item (20).	
18. All parts	Clean and inspect and 3-5.	Refer to paragraphs 3-4
19. Tube (20)	Install onto item (14) by turning and pushing.	
20. Two clips (21)	Install on item (20).	
21. Two screws (24), lockwashers (23), and nuts (22).	Install into two items (21) and item (14), and tighten.	

COOLING SYSTEM.

3-58. LINES, FITTINGS, AND HOSES REPLACEMENT (Continued).

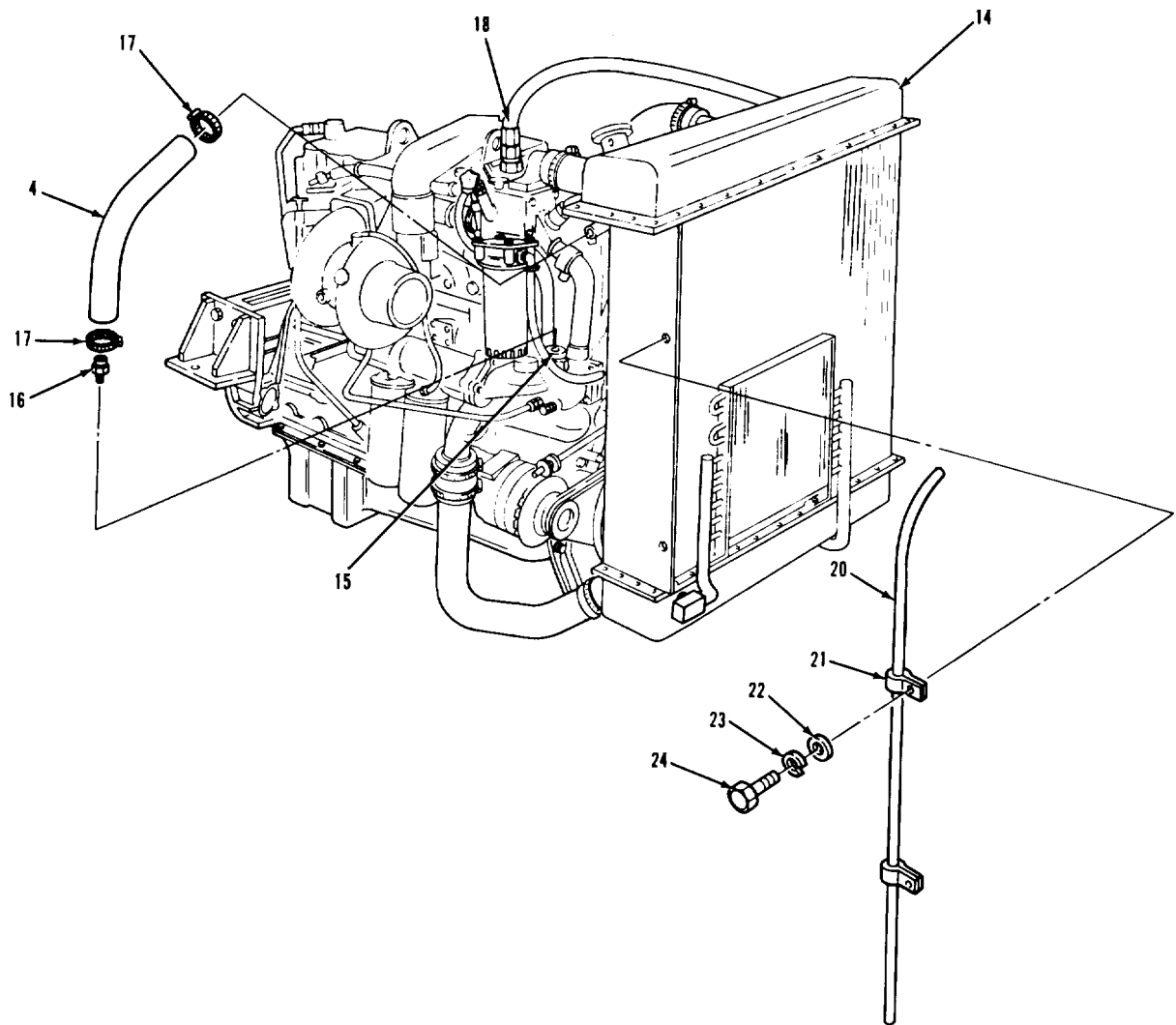

LEGEND:

- | | | | |
|-----|--------------------------------|-----|------------------------|
| 4. | WATER PUMP BYPASS TUBE | 20. | OVERFLOW TUBE |
| 14. | RADIATOR ASSEMBLY | 21. | OVERFLOW TUBE CLIP (2) |
| 15. | WATER PUMP RADIATOR CONNECTION | 22. | WASHER (2) |
| 16. | STRAIGHT HOSE NIPPLE | 23. | LOCKWASHER (2) |
| 17. | HOSE CLAMP (2) | 24. | HEXAGON HEAD SCREW (2) |

COOLING SYSTEM.

3-58. LINES, FITTINGS, AND HOSES REPLACEMENT (Continued).

LOCATION/ITEM	ACTION	REMARKS
F. RADIATOR OUTLET HOSES AND TUBE REPLACEMENT.		
22. Tube (8), two hoses (7), and four clamps (25).	a. Loosen screws on four items (25). b. Pull assembly off of items (9) and (14) from item (8). c. Separate. d. Clean and inspect and 3-5. e. Install two items (25) on each item (7). f. Push one item (7) onto each end of item (8). g. Push assembly onto items (9) and (14). h. Push four items (25) to ends of two items (7) and tighten screws.	Have suitable container ready to catch coolant Refer to paragraphs 3-4
G. WATER BYPASS TUBE REPLACEMENT.		
23. Screw (31) and clamp (30).	Remove from item (29).	
24. Tube (32)	Remove from item (33).	
25. Hose (27) and two clamps (26)	a. Loosen screws on two items (26). b. Pull item (27) off of item (18).	
26. Tube (5)	Wiggle out of item (29).	

COOLING SYSTEM.

3-58. LINES, FITTINGS, AND HOSES REPLACEMENT (Continued).

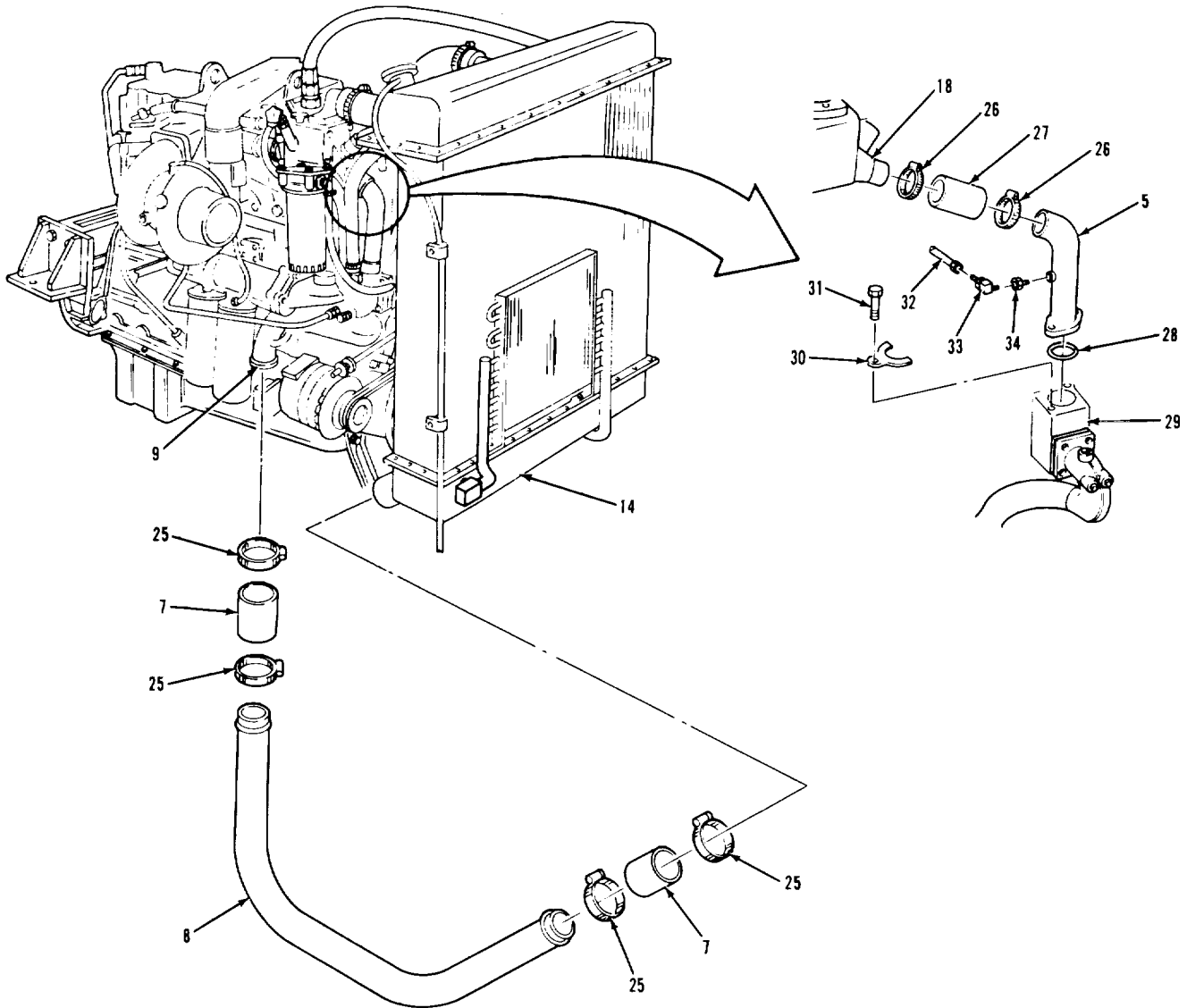

LEGEND:

- | | |
|--------------------------------------|--|
| 5. WATER BYPASS TUBE | 28. O-RING |
| 7. RADIATOR OUTLET HOSE (2) | 29. WATER PUMP ASSEMBLY |
| 8. RADIATOR OUTLET TUBE | 30. TUBE CLAMP |
| 9. WATER PUMP TO RADIATOR CONNECTION | 31. HEXAGON HEAD SCREW WITH CAPTIVE WASHER |
| 18. THERMOSTAT HOUSING | 32. COMPRESSOR COOLING WATER TUBE |
| 25. RADIATOR HOSE CLAMP (4) | 33. MALE ELBOW ADAPTER |
| 26. HOSE CLAMP (2) | 34. PLAIN STRAIGHT ADAPTER |
| 27. HOSE | |

COOLING SYSTEM.

3-58. LINES, FITTINGS, AND HOSES REPLACEMENT (Continued).

LOCATION/ITEM	ACTION	REMARKS
G. WATER BYPASS TUBE REPLACEMENT (Continued).		
27. Hose (27) and two clamps (26)	Remove from item (5) and separate.	
28. O-ring (28), adapter (33), and adapter (34).	Remove from item (5)	Discard item (28).
29. All parts and 3-5.	Clean and inspect	Refer to paragraphs 3-4
30. adapter (33) and adapter (34)	a. Wrap threads with thread sealing tape. b. Install into item (5).	
31. Hose (27) and two clamps (26)	a. Install two items (26) on item (27). b. Push item (27) onto end of item (5).	
32. New O-ring (28)	Coat with lubricating oil and install on end of item (5).	
33. Tube (5) and O-ring (28)	Wiggle into item (29) item (28) during installation.	Be careful not to damage
34. Hose (27) and two clamps (26)	a. Push end of item (27) onto item (18). b. Push two items (26) to ends of item (27), and tighten.	
35. Tube (32)	Install onto item (33).	
36. Clamp (30)	a. Position on item (29) b. Secure with item (31).	

COOLING SYSTEM.

3-58. LINES, FITTINGS, AND HOSES REPLACEMENT (Continued).

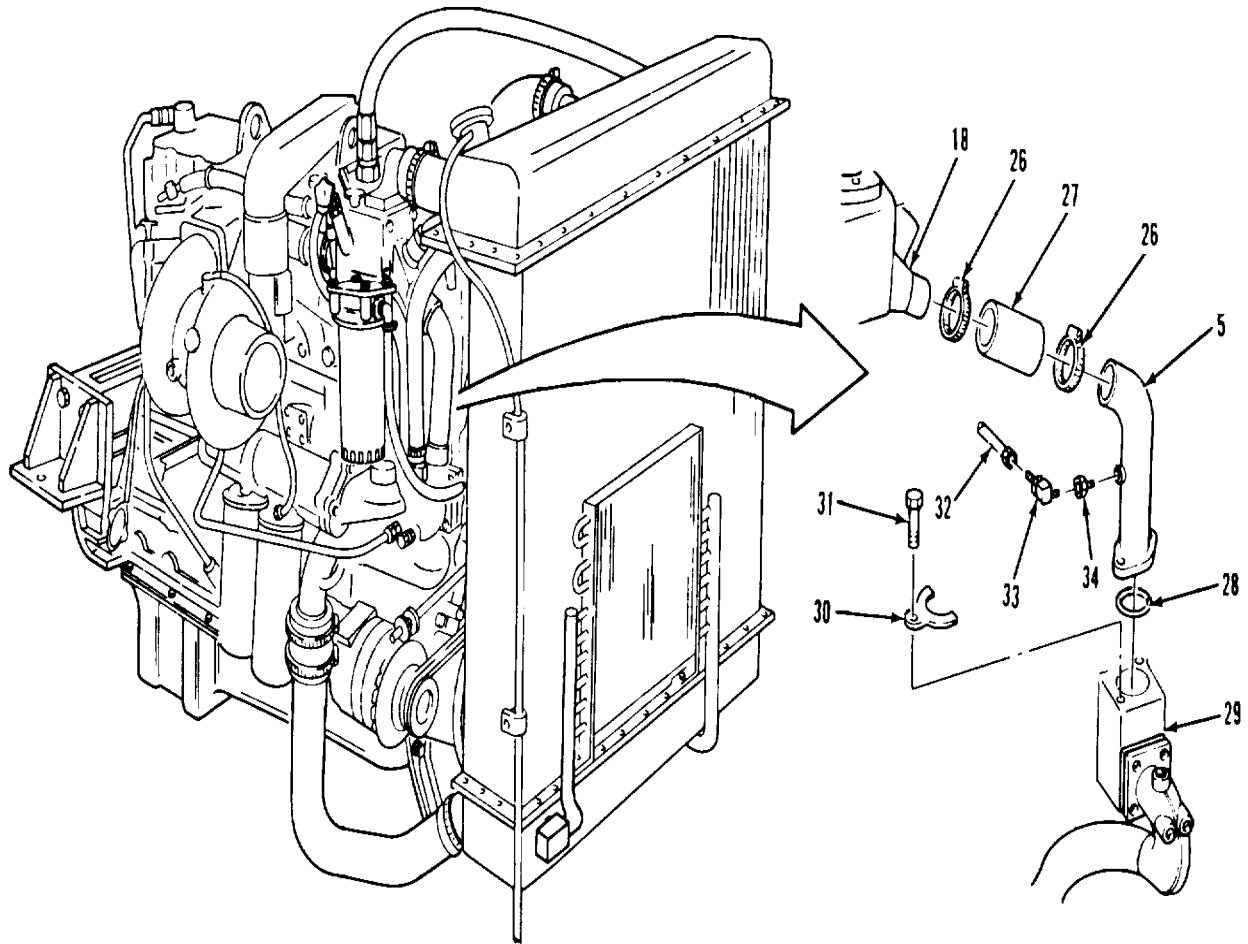

LEGEND:

- 5. WATER BYPASS TUBE
- 18. THERMOSTAT HOUSING
- 26. HOSE CLAMP (2)
- 27. HOSE
- 28. O-RING
- 29. WATER PUMP ASSEMBLY

- 30. TUBE CLAMP
- 31. HEXAGON HEAD SCREW WITH CAPTIVE WASHER
- 32. COMPRESSOR COOLING WATER TUBE
- 33. MALE ELBOW ADAPTER
- 34. PLAIN STRAIGHT ADAPTER

COOLING SYSTEM.

3-58. LINES, FITTINGS, AND HOSES REPLACEMENT (Continued).

LOCATION/ITEM	ACTION	REMARKS
H. WATER TRANSFER TUBE REPLACEMENT.		
37. Screw (37)	Remove from items (1) and (10).	
38. Tube (1) and (36).	Wiggle out of items (10)	
39. Two 0-rings (35)	Remove from item (1)	Discard items (35).
40. All parts	Clean and inspect and 3-5.	Refer to paragraphs 3-4
41. Two new 0-rings (35)	Coat with lubricating oil and install one on each end of item (1).	
42. Tube (1) and 0-rings (35) installation.	Wiggle into items (10) and (36) items (35) during	Be careful not to damage
43. Screw (37)	Install into items (1) and (10).	Torque to 30-35 lb-ft.
I. WATER PUMP TO RADIATOR CONNECTION REPLACEMENT.		
44. Hose (7) and two clamps (25)	a. Loosen screws on two items (25).	
	b. Pull item (7) off of item (9) item (7), and leave item (7) on item (8).	Leave two items (25) on
45. Screw (46) and washer (45)	Remove from items (9) and (47).	

COOLING SYSTEM.

3-58. LINES, FITTINGS, AND HOSES REPLACEMENT (Continued).

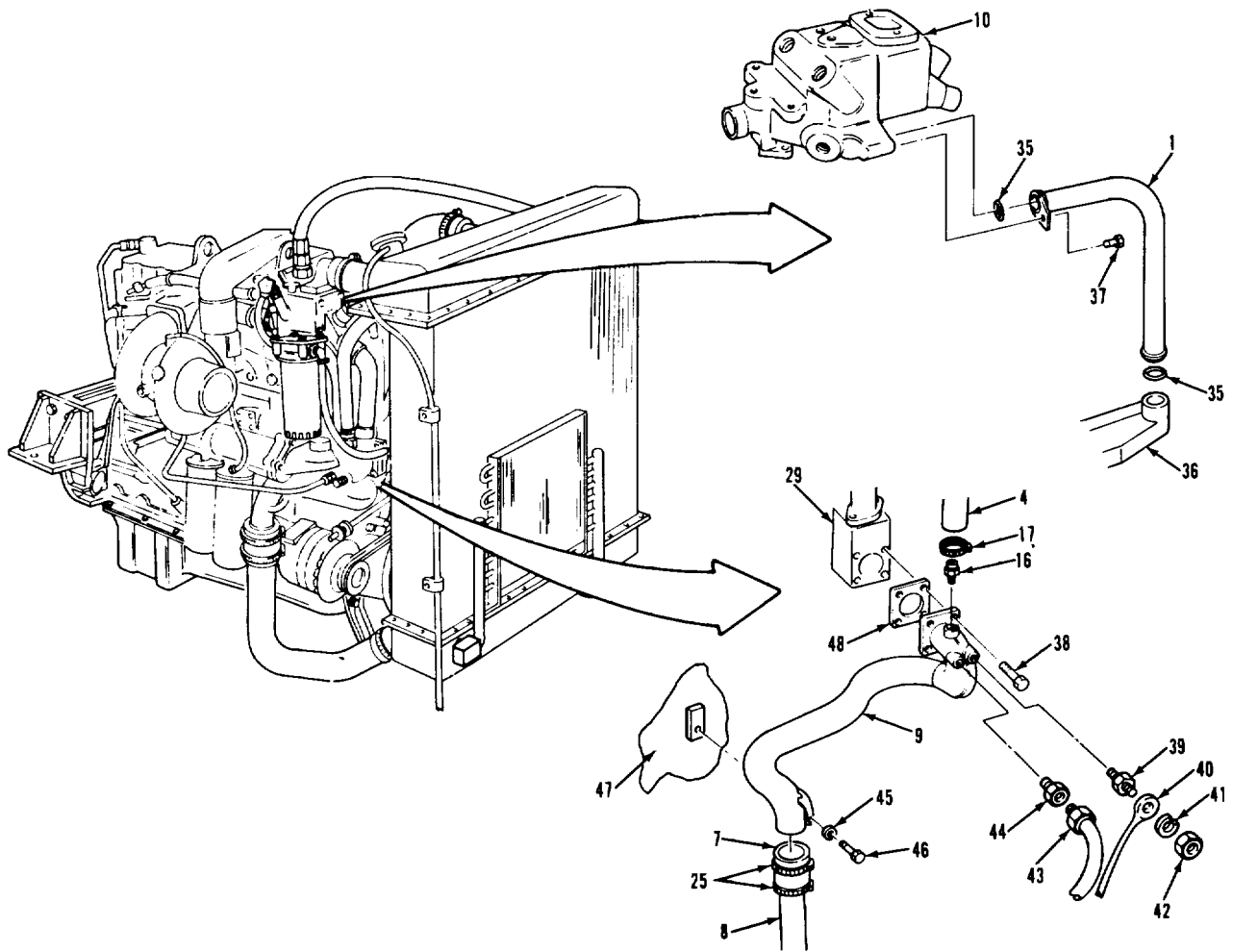

LEGEND:

- | | |
|--------------------------------------|---------------------------------------|
| 1. WATER TRANSFER TUBE | 38. SCREW (4) |
| 4. WATER PUMP BYPASS HOSE | 39. WATER TEMPERATURE SENDING UNIT |
| 7. RADIATOR OUTLET HOSE (2) | 40. WIRE |
| 8. RADIATOR OUTLET TUBE | 41. LOCKWASHER |
| 9. WATER PUMP TO RADIATOR CONNECTION | 42. NUT |
| 10. FRONT WATER MANIFOLD | 43. HEATER RETURN TUBE ASSEMBLY |
| 16. STRAIGHT HOSE NIPPLE | 44. CONNECTOR |
| 17. HOSE CLAMP | 45. PLAIN WASHER |
| 25. RADIATOR HOSE CLAMP (4) | 46. SCREW WITH CAPTIVE WASHER |
| 35. O-RING (2) | 47. ENGINE BLOCK |
| 36. OIL COOLER SUPPORT | 48. WATER CONNECTION GASKET TA 237135 |
| 37. SCREW WITH CAPTIVE WASHER | |

COOLING SYSTEM.

3-58. LINES, FITTINGS, AND HOSES REPLACEMENT (Continued).

LOCATION/ITEM	ACTION	REMARKS
I. WATER PUMP TO RADIATOR CONNECTION REPLACEMENT (Continued).		
46. Nut (42), lock-washer (41), and wire (40).	Remove from item (39).	
47. Tube (43)	Remove from item (44).	
48. Hose (4) and clamp (17)	a. Loosen screw on item (17). b. Pull item (4) off of item (16)	Leave item (17) on item (4).
49. Four screws (38)	Remove from items (9) and (29).	
50. Connection (9) and gasket (48)	Remove from item (29) and lift out of engine compartment item (9) (48).	Be careful not to damage any wires when removing Discard item
51. Nipple (16), sending unit (39), and connector (44).	Remove from item (9).	
52. All parts	Clean and inspect and 3-5. Be sure to clean all gasket material off items (9) and (29).	Refer to paragraph 3-4
53. Nipple (16), sending unit (39), and connector (44)	a. Wrap threads with thread sealing tape.	Refer to paragraph 3-7.
54. New gasket (48)	b. Install into item (9). Hold in place on item (9) with grease.	

COOLING SYSTEM.

3-58. LINES, FITTINGS, AND HOSES REPLACEMENT (Continued).

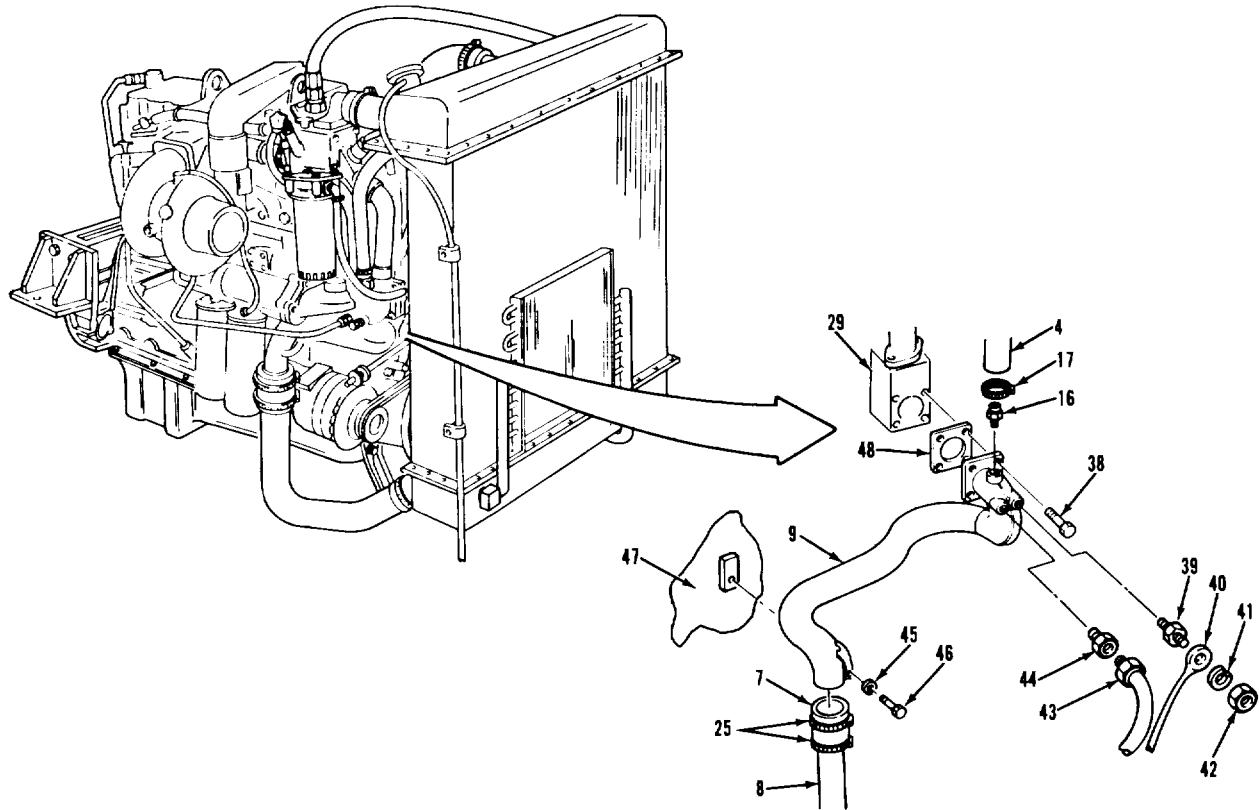

LEGEND:

- | | |
|--------------------------------------|---------------------------------|
| 4. WATER PUMP BYPASS HOSE | 40. WIRE |
| 7. RADIATOR OUTLET HOSE (2) | 41. LOCKWASHER |
| 8. RADIATOR OUTLET TUBE | 42. NUT |
| 9. WATER PUMP TO RADIATOR CONNECTION | 43. HEATER RETURN TUBE ASSEMBLY |
| 16. STRAIGHT HOSE NIPPLE | 44. CONNECTOR |
| 17. HOSE CLAMP | 45. PLAIN WASHER |
| 25. RADIATOR HOSE CLAMP (4) | 46. SCREW WITH CAPTIVE WASHER |
| 38. SCREW (4) | 47. ENGINE BLOCK |
| 39. WATER TEMPERATURE SENDING UNIT | 48. WATER CONNECTION GASKET |

COOLING SYSTEM.

3-58. LINES, FITTINGS, AND HOSES REPLACEMENT (Continued).

LOCATION/ITEM	ACTION	REMARKS
I. WATER PUMP TO RADIATOR CONNECTION REPLACEMENT (Continued).		
55. Connection (9) and gasket (48)	a. Lower into engine compartment and hold in place on item (29) b. Secure with four items (38) 35 lb-ft.	Be careful not to damage any wires when installing item (9). Torque items (38) to 30-
56. Hose (4) and clamp (17)	a. Push end of item (4) onto item (16). b. Push item (17) to end of item (4), and tighten screw.	
57. Tube (43)	a. Wrap threads with thread sealing tape. b. Install into item (44).	
58. Wire (40)	a. Position on item (39). b. Secure with items (42) and (41).	
59. Screw (46) and washer (45)	Install into items (9) and (47), and tighten.	
60. Hose (7) and two clamps (25)	a. Push end of item (7) onto item (9). b. Push two items (25) to ends of item (7), and tighten screws.	
<p>NOTE</p> <p>Follow-on maintenance action required:</p> <p>Fill cooling system (para 3-52). Start vehicle and check for leaks (TM 9-2320-283-10).</p>		

COOLING SYSTEM.

3-58. LINES, FITTINGS, AND HOSES REPLACEMENT (Continued).

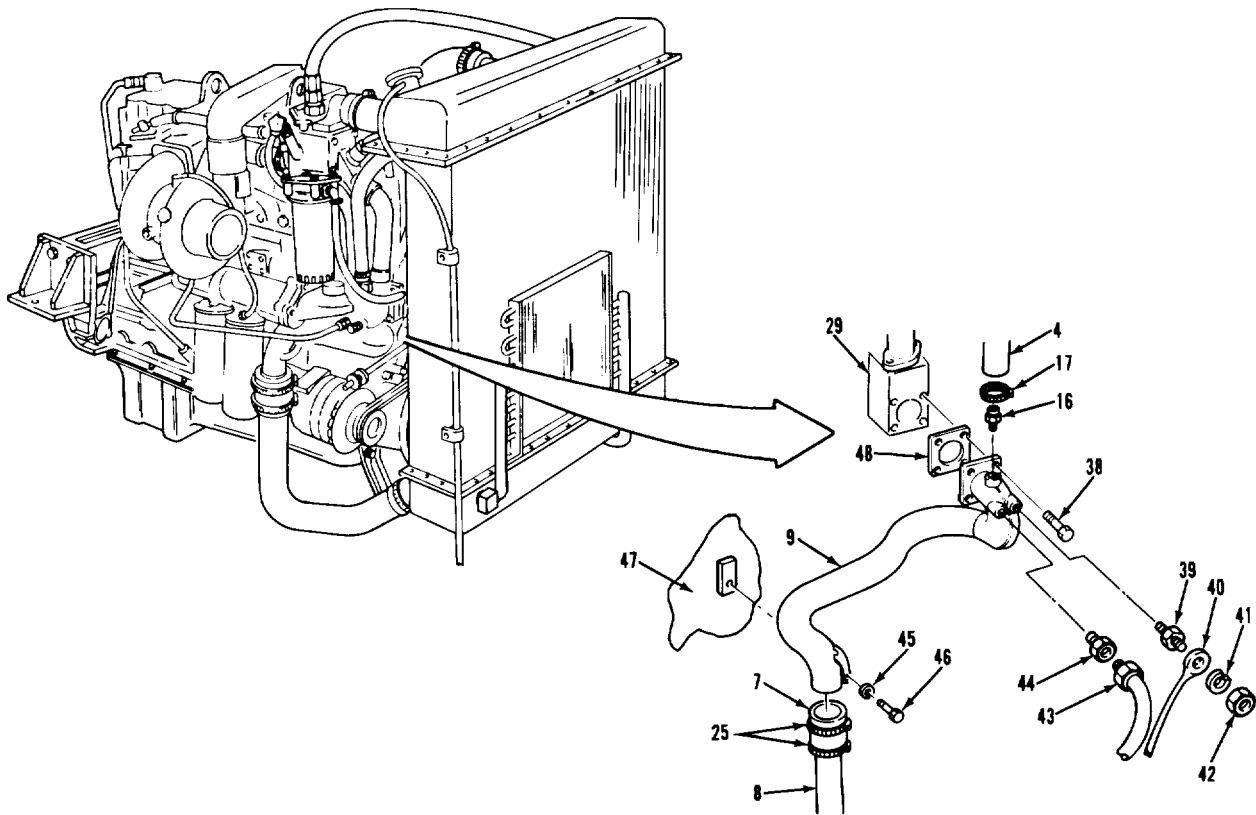

LEGEND:

- | | |
|--------------------------------------|---------------------------------|
| 4. WATER PUMP BYPASS HOSE | 40. WIRE |
| 7. RADIATOR OUTLET HOSE (2) | 41. LOCKWASHER |
| 8. RADIATOR OUTLET TUBE | 42. NUT |
| 9. WATER PUMP TO RADIATOR CONNECTION | 43. HEATER RETURN TUBE ASSEMBLY |
| 16. STRAIGHT HOSE NIPPLE | 44. CONNECTOR |
| 17. HOSE CLAMP | 45. PLAIN WASHER |
| 25. RADIATOR HOSE CLAMP (4) | 46. SCREW WITH CAPTIVE WASHER |
| 38. SCREW (4) | 47. ENGINE BLOCK |
| 39. WATER TEMPERATURE SENDING UNIT | 48. WATER CONNECTION GASKET |

COOLING SYSTEM.

3-59. THERMOSTAT AND THERMOSTAT HOUSING REPLACEMENT.

THIS TASK COVERS

- | | |
|-----------------------------|-----------------|
| a. Removal. | d. Testing |
| b. Cleaning and Inspection. | e. Assembly |
| c. Installation. | f. Installation |

INITIAL SETUP

APPLICABLE CONFIGURATIONS

All.

EQUIPMENT CONDITION

PARAGRAPH

3-52.

CONDITION DESCRIPTION

Coolant drained below level of thermostat housing.

TEST EQUIPMENT

None.

SPECIAL TOOLS

Seal mandrel
(15434) ST-1225.

MATERIALS/PARTS (P/N)

Tape, thread sealing
Item 32, Appendix C.
Grease, automotive and artillery
Item 7, Appendix C.
Gasket, thermostat housing
(15434) 208128.
Seal, housing
(15434) 186780.
Gasket, water outlet connection
(15434) 3019158.

PERSONNEL REQUIRED

One (MOS-63S).

SPECIAL ENVIRONMENTAL CONDITIONS

None.

REFERENCES (TM)

TM 9-2320-283-10.
TM 9-2320-283-20P.

GENERAL SAFETY INSTRUCTIONS

Engine off.
Transmission in neutral.
Park brake set.
Wait until cooling system components are cool.

TROUBLESHOOTING REFERENCES

Paragraph 2-11.

COOLING SYSTEM.

3-59. THERMOSTAT AND THERMOSTAT HOUSING REPLACEMENT (Continued).

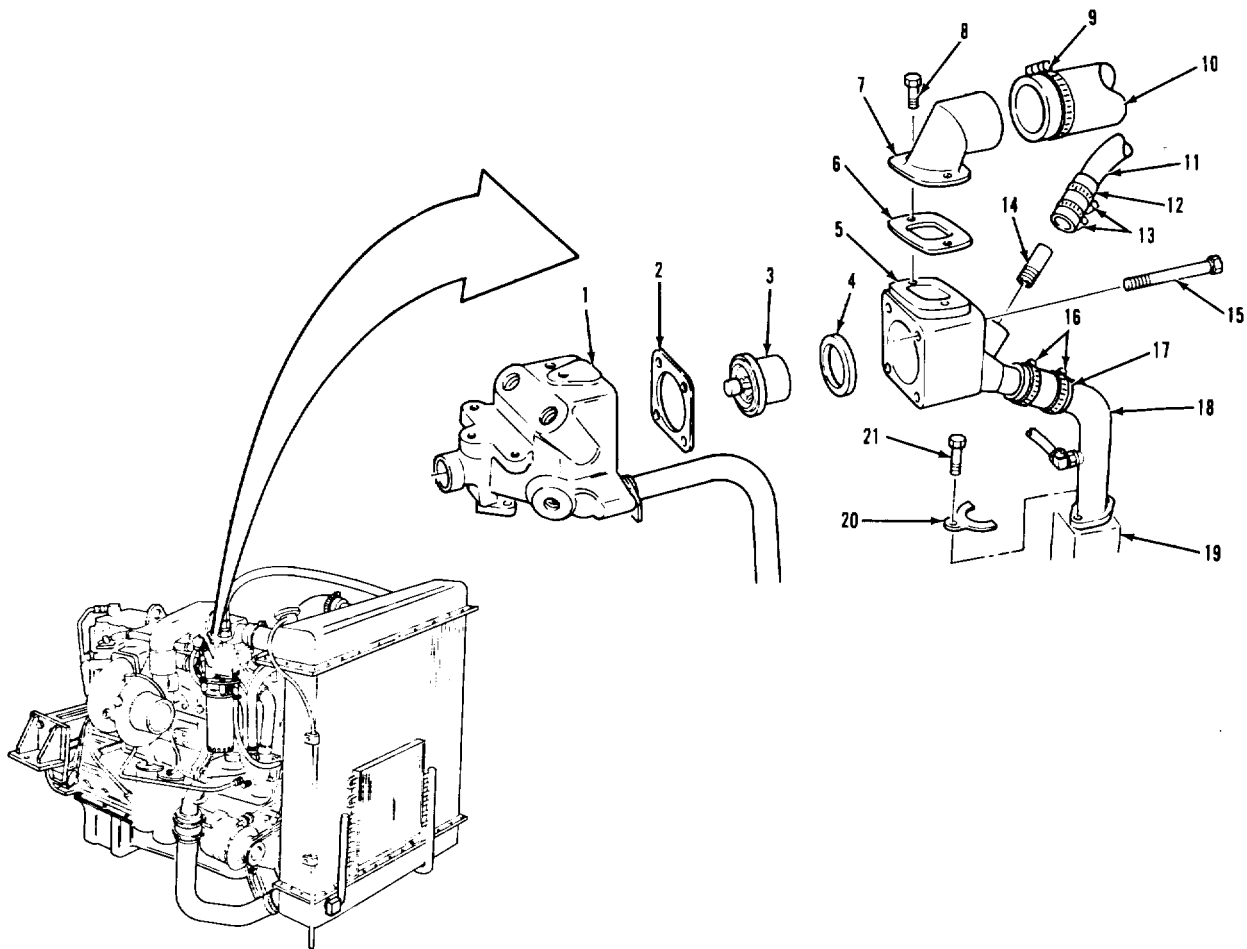

LEGEND:

- | | |
|-----------------------------------|--|
| 1. FRONT WATER MANIFOLD | 12. CONNECTION HOSE |
| 2. THERMOSTAT HOUSING GASKET | 13. HOSE CLAMP (2) |
| 3. 180 DEGREE THERMOSTAT | 14. HOSE NIPPLE |
| 4. HOUSING SEAL | 15. SCREW WITH CAPTIVE WASHER (4) |
| 5. THERMOSTAT HOUSING | 16. HOSE CLAMP (2) |
| 6. WATER OUTLET CONNECTION GASKET | 17. HOSE |
| 7. WATER OUTLET CONNECTION | 18. WATER BYPASS TUBE |
| 8. SCREW (2) | 19. WATER PUMP ASSEMBLY |
| 9. RADIATOR HOSE CLAMP | 20. TUBE CLAMP |
| 10. RADIATOR INLET HOSE | 21. HEXAGON HEAD SCREW WITH CAPTIVE WASHER |
| 11. WATER TRANSFER TUBE | |

COOLING SYSTEM.

3-59. THERMOSTAT AND THERMOSTAT HOUSING REPLACEMENT (Continued).

LOCATION/ITEM	ACTION	REMARKS
A. REMOVAL.		
1. Hose (10) and clamp (9) item (7)	a. Loosen screw on item (9). b. Pull item (10) off of (10).	Leave item (9) on item
2. Hose (12) and two clamps (13)	a. Loosen screws on two items (13). b. Pull item (12) off of item (14) item (12) on item (11). Remove from item (19).	Leave two items (13) on item (12), and leave
3. Screw (21) and clamp (20).	Remove from item (19).	
4. Hose (17) and two clamps (16)	a. Loosen screws on two items (16). b. Pull item (17) off of item (5) Leave two items (16) on item (17), and leave item (17) on item (18).	Do not pull item (18) out of item (19).
5. Four screws (15)	Remove from items (5) and (1).	
6. Housing (5) and gasket (2)	Remove from item (1) or mallet, if needed. Discard item (2).	Use soft-faced hammer
B. DISASSEMBLY.		
7. Thermostat (3)	Remove from item (5).	

COOLING SYSTEM.

3-59. THERMOSTAT AND THERMOSTAT HOUSING REPLACEMENT (Continued).

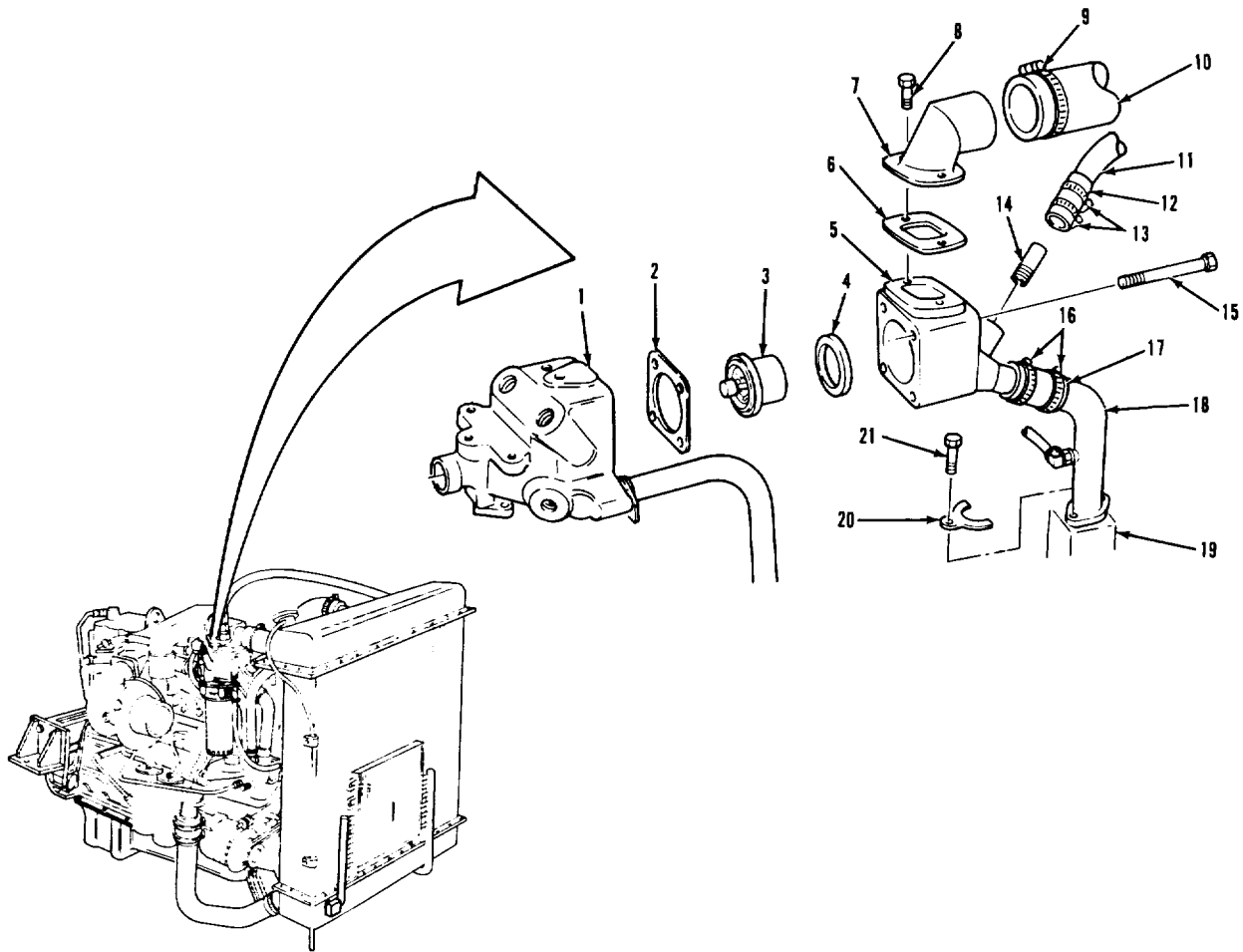

LEGEND:

- | | |
|-----------------------------------|--|
| 1. FRONT WATER MANIFOLD | 12. CONNECTION HOSE |
| 2. THERMOSTAT HOUSING GASKET | 13. HOSE CLAMP (2) |
| 3. 180 DEGREE THERMOSTAT | 14. HOSE NIPPLE |
| 4. HOUSING SEAL | 15. SCREW WITH CAPTIVE WASHER (4) |
| 5. THERMOSTAT HOUSING | 16. HOSE CLAMP (2) |
| 6. WATER OUTLET CONNECTION GASKET | 17. HOSE |
| 7. WATER OUTLET CONNECTION | 18. WATER BYPASS TUBE |
| 8. SCREW (2) | 19. WATER PUMP ASSEMBLY |
| 9. RADIATOR HOSE CLAMP | 20. TUBE CLAMP |
| 10. RADIATOR INLET HOSE | 21. HEXAGON HEAD SCREW WITH CAPTIVE WASHER |
| 11. WATER TRANSFER TUBE | |

COOLING SYSTEM.

3-59. THERMOSTAT AND THERMOSTAT HOUSING REPLACEMENT (Continued).

LOCATION/ITEM	ACTION	REMARKS
B. DISASSEMBLY (Continued).		
8. Seal (4)	Pry out of item (5) item (5) Discard item (4).	Be careful not to damage
9. Two screws (8), connection (7), and gasket (6).	Remove from item (5)	Discard item (6).
10. Nipple (14)	Remove from item (5).	
C. CLEANING AND INSPECTION.		
11. All parts	Clean and inspect and 3-5 Be sure to clean all gasket material off items (1), (5), and (7).	Refer to paragraph 3-4
D. TESTING.		
12. Thermostat (3)	<ul style="list-style-type: none"> a. Check that it is closed at room temperature b. Put item (3) and a thermometer into a suitable container of water not touch the container. c. Heat the water and observe item (3) at 180°F. d. Continue to heat the water until thermostat reads 195'-200'F if there is not at least a 0.375 inch space between seal sleeve and the brass part of item (3). 	<ul style="list-style-type: none"> Replace item (3) if it is open at room temperature. Use a device to hold item (3) and thermometer so that they do Replace item (3) if it does not begin to open Item (3) must be fully open at this temperature. Replace item (3)

COOLING SYSTEM.

3-59. THERMOSTAT AND THERMOSTAT HOUSING REPLACEMENT (Continued).

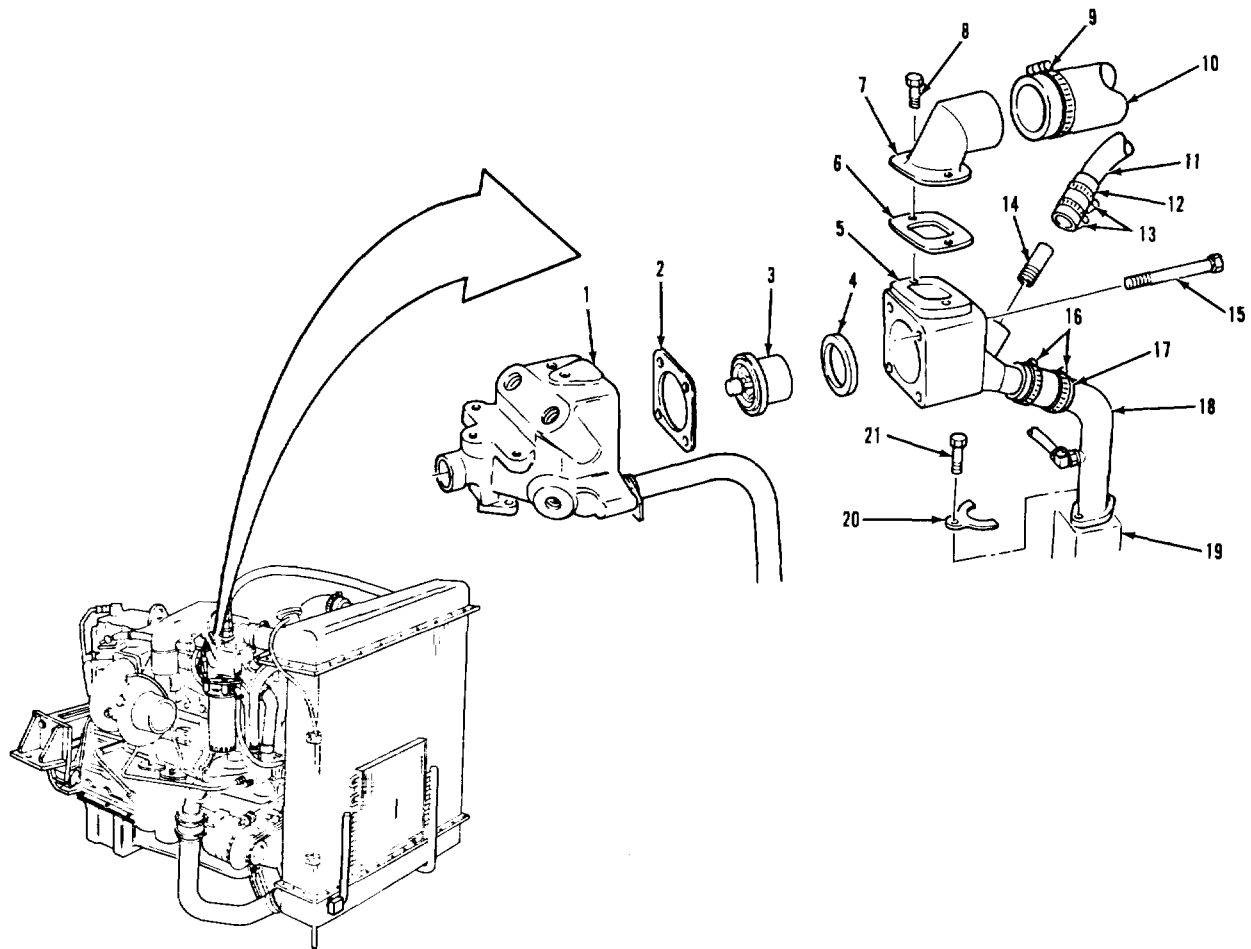

LEGEND:

- | | |
|-----------------------------------|--|
| 1. FRONT WATER MANIFOLD | 12. CONNECTION HOSE |
| 2. THERMOSTAT HOUSING GASKET | 13. HOSE CLAMP (2) |
| 3. 180 DEGREE THERMOSTAT | 14. HOSE NIPPLE |
| 4. HOUSING SEAL | 15. SCREW WITH CAPTIVE WASHER (4) |
| 5. THERMOSTAT HOUSING | 16. HOSE CLAMP (2) |
| 6. WATER OUTLET CONNECTION GASKET | 17. HOSE |
| 7. WATER OUTLET CONNECTION | 18. WATER BYPASS TUBE |
| 8. SCREW (2) | 19. WATER PUMP ASSEMBLY |
| 9. RADIATOR HOSE CLAMP | 20. TUBE CLAMP |
| 10. RADIATOR INLET HOSE | 21. HEXAGON HEAD SCREW WITH CAPTIVE WASHER |
| 11. WATER TRANSFER TUBE | |

COOLING SYSTEM.

3-59. THERMOSTAT AND THERMOSTAT HOUSING REPLACEMENT (Continued).

LOCATION/ITEM	ACTION	REMARKS
E. ASSEMBLY.		
13. Nipple (14)	a. Coat threads with thread sealing tape.	Refer to paragraph 3-7.
14. Connection (7) and new gasket (6).	b. Install into item (5). a. Position on item (5).	
15. New seal (4)	b. Secure with two items (8). Using seal mandrel, install into item (5) is toward mandrel to insure proper sealing. If item (5) is incorrectly installed, coolant can leak past seal, causing engine temperature to be colder than normal.	Make sure part number or metal side of item (5)
16. Thermostat (3) it seats in item (4).	Push into item (5) until	
F. INSTALLATION.		
17. New gasket (2)	Hold in place on item (5) with grease.	
18. Housing (5) and gasket (2)	a. Position on item (1). b. Secure with four items (15) 30-35 lb-ft.	Torque items (15) to
19. Hose (17) and two clamps (16) onto item (5).	a. Push end of item (17) b. Push two items (16) to ends of item (17), and tighten screws.	

COOLING SYSTEM.

3-59. THERMOSTAT AND THERMOSTAT HOUSING REPLACEMENT (Continued).

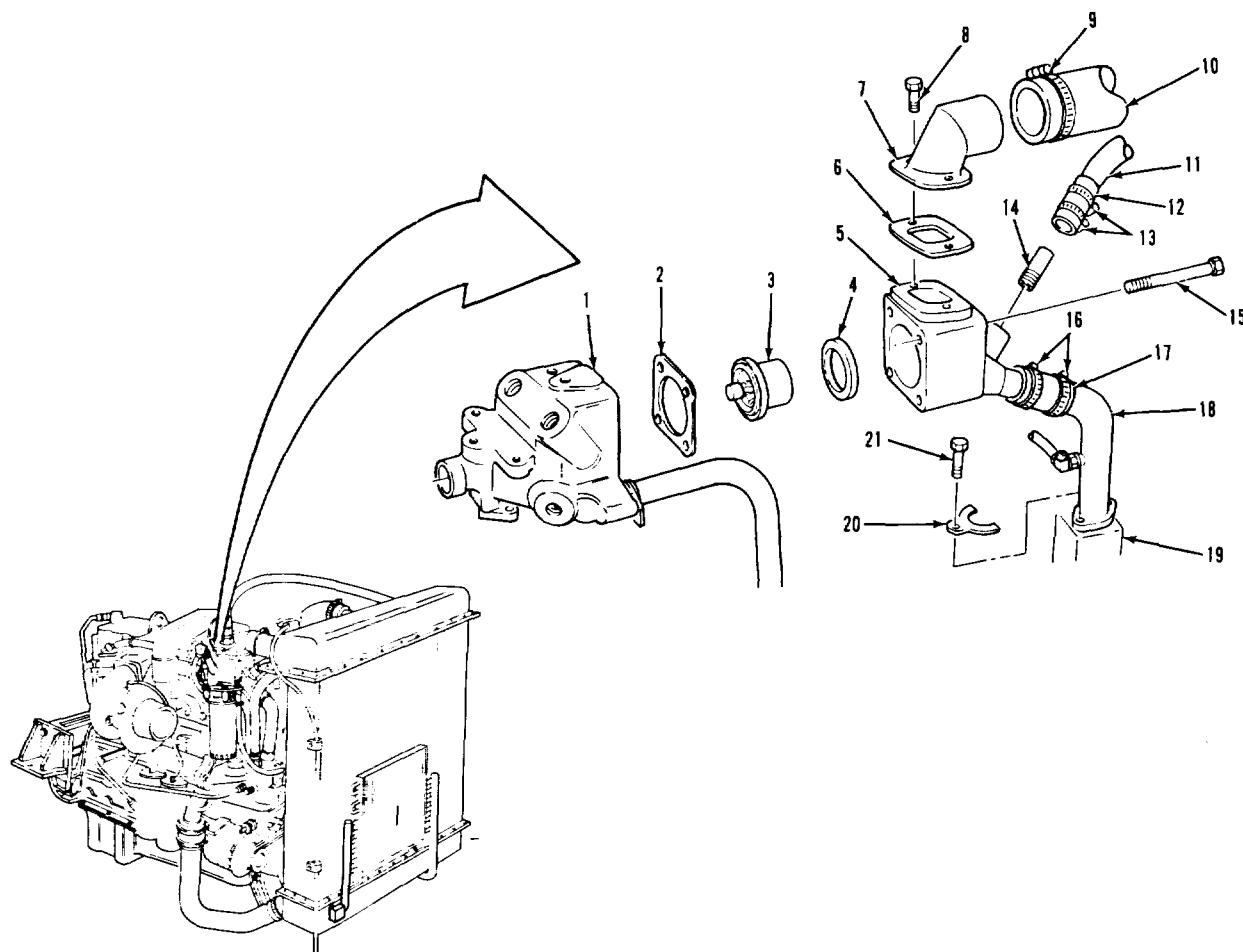

LEGEND:

- | | |
|-----------------------------------|--|
| 1. FRONT WATER MANIFOLD | 12. CONNECTION HOSE |
| 2. THERMOSTAT HOUSING GASKET | 13. HOSE CLAMP (2) |
| 3. 18° DEGREE THERMOSTAT | 14. HOSE NIPPLE |
| 4. HOUSING SEAL | 15. SCREW WITH CAPTIVE WASHER (4) |
| 5. THERMOSTAT HOUSING | 16. HOSE CLAMP (2) |
| 6. WATER OUTLET CONNECTION GASKET | 17. HOSE |
| 7. WATER OUTLET CONNECTION | 18. WATER BYPASS TUBE |
| 8. SCREW (2) | 19. WATER PUMP ASSEMBLY |
| 9. RADIATOR HOSE CLAMP | 20. TUBE CLAMP |
| 10. RADIATOR INLET HOSE | 21. HEXAGON HEAD SCREW WITH CAPTIVE WASHER |
| 11. WATER TRANSFER TUBE | |

TA237141

COOLING SYSTEM.

3-59. THERMOSTAT AND THERMOSTAT HOUSING REPLACEMENT (Continued).

LOCATION/ITEM	ACTION	REMARKS
F. INSTALLATION (Continued).		
20. Clamp (20).	a. Position on item (19). b. Secure with item (21).	
21. Hose (12) and two clamps (13).	a. Push end of item (12) onto item (14). b. Push two items (13) to ends of item (12), and tighten screws.	
22. Hose (10) and	a. Push end of item (10) clamp (9).onto item (7). b. Push item (9) to end of item (10), and tighten screw.	
NOTE		
Follow-on maintenance action required:		
Fill cooling system (para 3-52). Start vehicle and check for leaks (TM 9-2320-283-10).		

COOLING SYSTEM.

3-59. THERMOSTAT AND THERMOSTAT HOUSING REPLACEMENT (Continued).

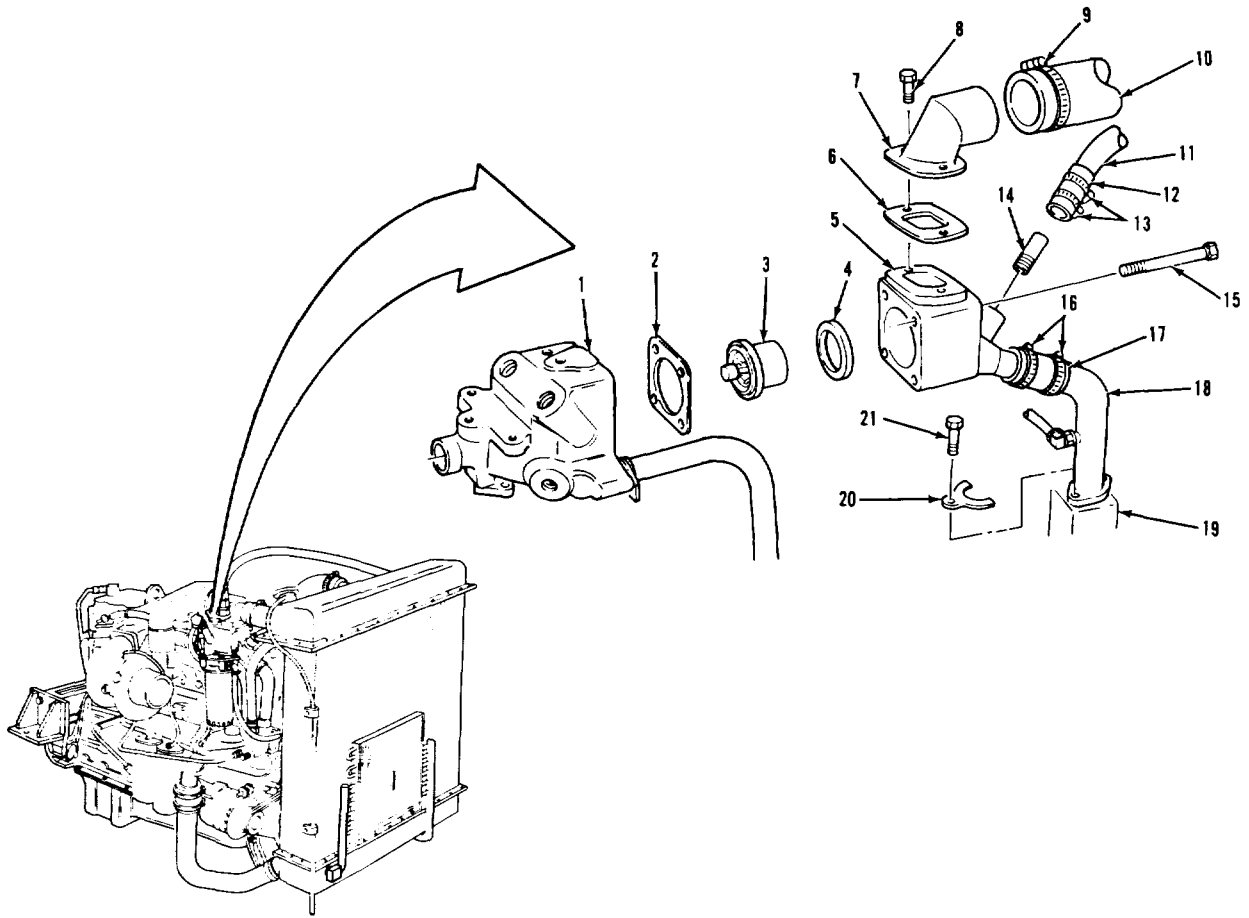

LEGEND:

- | | |
|-----------------------------------|--|
| 1. FRONT WATER MANIFOLD | 12. CONNECTION HOSE |
| 2. THERMOSTAT HOUSING GASKET | 13. HOSE CLAMP (2) |
| 3. 180 DEGREE THERMOSTAT | 14. HOSE NIPPLE |
| 4. HOUSING SEAL | 15. SCREW WITH CAPTIVE WASHER (4) |
| 5. THERMOSTAT HOUSING | 16. HOSE CLAMP (2) |
| 6. WATER OUTLET CONNECTION GASKET | 17. HOSE |
| 7. WATER OUTLET CONNECTION | 18. WATER BYPASS TUBE |
| 8. SCREW (2) | 19. WATER PUMP ASSEMBLY |
| 9. RADIATOR HOSE CLAMP | 20. TUBE CLAMP |
| 10. RADIATOR INLET HOSE | 21. HEXAGON HEAD SCREW WITH CAPTIVE WASHER |
| 11. WATER TRANSFER TUBE | |

TA237142

COOLING SYSTEM.

3-60. WATER MANIFOLDS REPLACEMENT.

THIS TASK COVERS

- a. Removal.
- b. Cleaning and Inspection.
- c. Installation.

INITIAL SETUP

<u>APPLICABLE CONFIGURATIONS</u>	<u>EQUIPMENT CONDITION PARAGRAPH</u>	<u>CONDITION DESCRIPTION</u>
All.	3-52.	Coolant drained below level of manifolds.
<u>TEST EQUIPMENT</u> None.	3-29.	Air cleaner assembly removed.
<u>SPECIAL TOOLS</u> None.	3-31.	Turbocharger air intake removed.
<u>MATERIALS/PARTS (P/N)</u> Tape, thread sealing Item 32, Appendix C. Grease, automotive and artillery Item 7, Appendix C. Oil, lubricating: OE/HDO-30 Item 16, Appendix C. Ring, sealing (6) (15434) 3024709.	0-ring, coupling (4) (15434) 70624. 0-ring (15434) 212161. Gasket thermostat housing (154345 208128.	
<u>PERSONNEL REQUIRED</u> One (MOS-63S).	<u>SPECIAL ENVIRONMENTAL CONDITIONS</u> None.	
<u>REFERENCES (TM)</u> TM 9-2320-283-10. TM 9-2320-283-20P.	<u>GENERAL SAFETY INSTRUCTIONS</u> Engine off. Transmission in neutral. Park brake set. Wait until cooling system components are cool.	
<u>TROUBLESHOOTING REFERENCES</u> Paragraph 2-11.		

COOLING SYSTEM.

3-60. WATER MANIFOLDS REPLACEMENT (Continued).

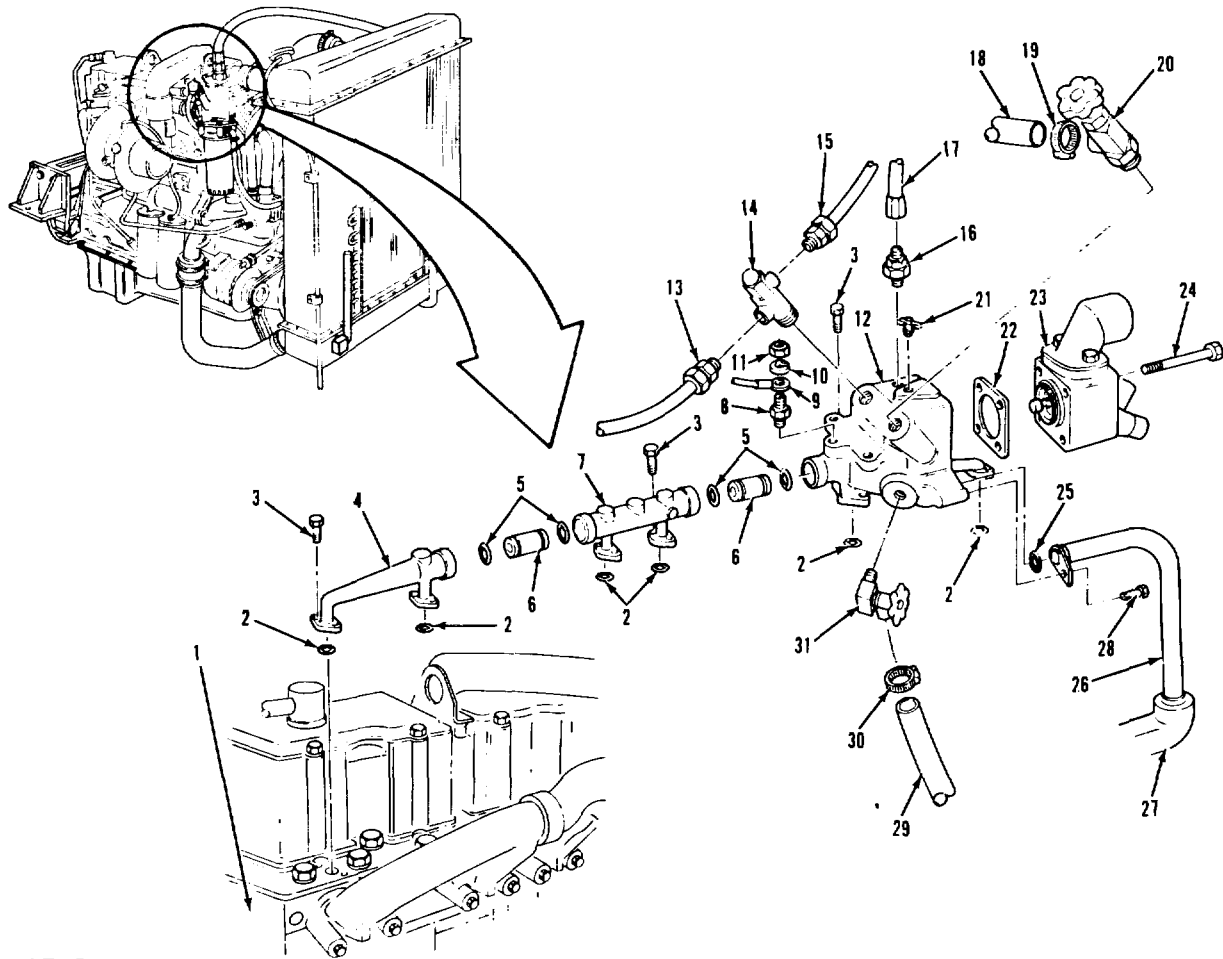

LEGEND:

- | | |
|--|--|
| 1. ENGINE BLOCK | 16. REDUCER AND MALE CONNECTOR |
| 2. SEALING RING (6) | 17. DEAERATION LINE |
| 3. HEXAGON HEAD SCREW WITH CAPTIVE WASHER (12) | 18. HEATER HOSE |
| 4. REAR WASHER MANIFOLD | 19. HOSE CLAMP |
| 5. COUPLING O-RING (4) | 20. HEATER SHUTOFF VALVE AND REDUCER |
| 6. MANIFOLD COUPLING (2) | 21. DRAINCOCK |
| 7. CENTER WATER MANIFOLD | 22. THERMOSTAT HOUSING GASKET |
| 8. HOT ENGINE TEMPERATURE SWITCH | 23. THERMOSTAT HOUSING |
| 9. WIRE | 24. SCREW WITH CAPTIVE WASHER (4) |
| 10. LOCKWASHER | 25. O-RING |
| 11. NUT | 26. WATER TRANSFER TUBE |
| 12. FRONT WATER MANIFOLD | 27. OIL COOLER SUPPORT |
| 13. NONMETALLIC TUBE | 28. SCREW WITH CAPTIVE WASHER |
| 14. AIR VALVE | 29. WATER HOSE |
| 15. NONMETALLIC TUBE | 30. HOSE CLAMP |
| | 31. WATER SHUTOFF VALVE AND STREET ELBOW |

TA 237143

COOLING SYSTEM.

3-60. WATER MANIFOLDS REPLACEMENT (Continued).

LOCATION/ITEM	ACTION	REMARKS
A. REMOVAL.		
1. Four screws (3).	Remove from items (4) and (1).	Use a universal joint socket and an extension to reach items (3).
2. Manifold (4) and coupling (6) (assembled).	Wiggle out of item (7).	
3. Two rings (2).	Remove from item (1).Discard items (2).	
4. Coupling (6).	Wiggle out of item (4).	
5. Two O-rings (5).	Remove from item (6).	Discard items (5).
6. Four screws (3).	Remove from items (7) and (1).	Use a universal joint socket and an extension to reach items (3).
7. Manifold (7) and coupling (6) (assembled).	Wiggle out of item (12).	
8. Two rings (2).	Remove from item (1).	Discard items (2).
9. Coupling (6).	Wiggle out of item (7).	
10. Two O-rings.	Remove from item (6).Discard items (5).	
11. Nut (11), lock-washer (10), and wire (9).	Remove from item (8).	

COOLING SYSTEM.

3-60. WATER MANIFOLDS REPLACEMENT (Continued).

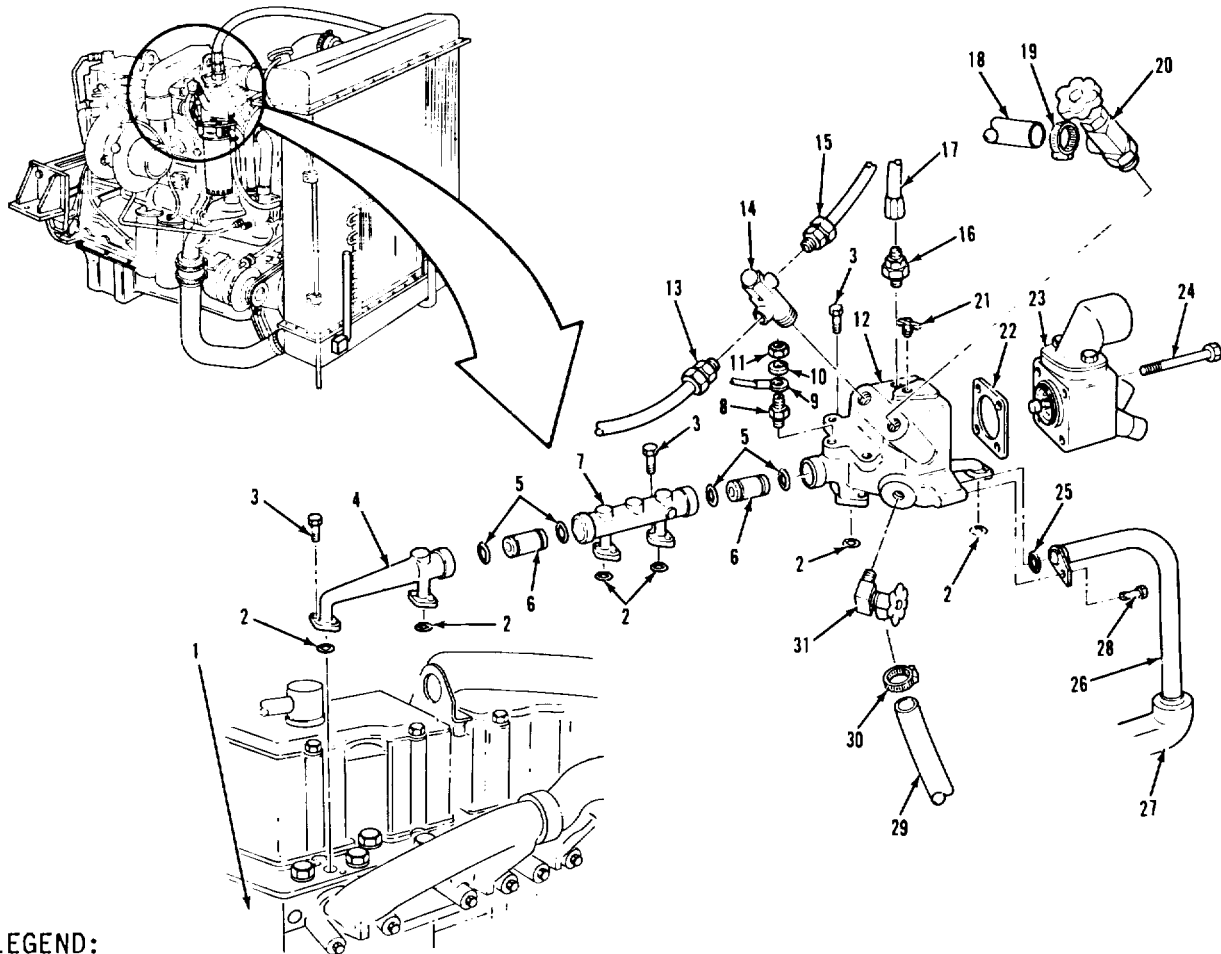

LEGEND:

- | | |
|--|--|
| 1. ENGINE BLOCK | 16. REDUCER AND MALE CONNECTOR |
| 2. SEALING RING (6) | 17. DEAERATION LINE |
| 3. HEXAGON HEAD SCREW WITH CAPTIVE WASHER (12) | 18. HEATER HOSE |
| 4. REAR WASHER MANIFOLD | 19. HOSE CLAMP |
| 5. COUPLING O-RING (4) | 20. HEATER SHUTOFF VALVE AND REDUCER |
| 6. MANIFOLD COUPLING (2) | 21. DRAINCOCK |
| 7. CENTER WATER MANIFOLD | 22. THERMOSTAT HOUSING GASKET |
| 8. HOT ENGINE TEMPERATURE SWITCH | 23. THERMOSTAT HOUSING |
| 9. WIRE | 24. SCREW WITH CAPTIVE WASHER (4) |
| 10. LOCKWASHER | 25. O-RING |
| 11. NUT | 26. WATER TRANSFER TUBE |
| 12. FRONT WATER MANIFOLD | 27. OIL COOLER SUPPORT |
| 13. NONMETALLIC TUBE | 28. SCREW WITH CAPTIVE WASHER |
| 14. AIR VALVE | 29. WATER HOSE |
| 15. NONMETALLIC TUBE | 30. HOSE CLAMP |
| | 31. WATER SHUTOFF VALVE AND STREET ELBOW |

TA 237144

COOLING SYSTEM.

3-60. WATER MANIFOLDS REPLACEMENT (Continued).		
LOCATION/ITEM	ACTION	REMARKS
A. REMOVAL (Continued).		
12. Hose (18) and clamp (19).	a. Loosen screw on item (19). b. Pull item (18) off of item (20).	Leave item (19) on item (18).
13. Tube (13) and tube (15).	Remove from item (14).	
14. Hose (17).	Remove from item (16).	
15. Hose (29) and clamp (30). item (31).	a. Loosen screw on item (30). b. Pull item (29) off of (29).	Leave item (30) on item
16. Screw (28).	Remove from items (26) and (12).	
17. Tube (26).	Wiggle out of item (12).	Do not remove item (26) from item (27).
18. O-ring (25).	Remove from item (26).	Discard item (25).
19. Four screws (3).	Remove from items (12) and (1).	Use a universal joint socket and an extension to reach items (3).
20. Four screws (24).	Remove from items (23) and (12).	
21. Manifold (12) and gasket (22).	Remove from item (23).	Use soft face hammer or mallet, if needed. Discard item (22).

COOLING SYSTEM.

3-60. WATER MANIFOLDS REPLACEMENT (Continued).

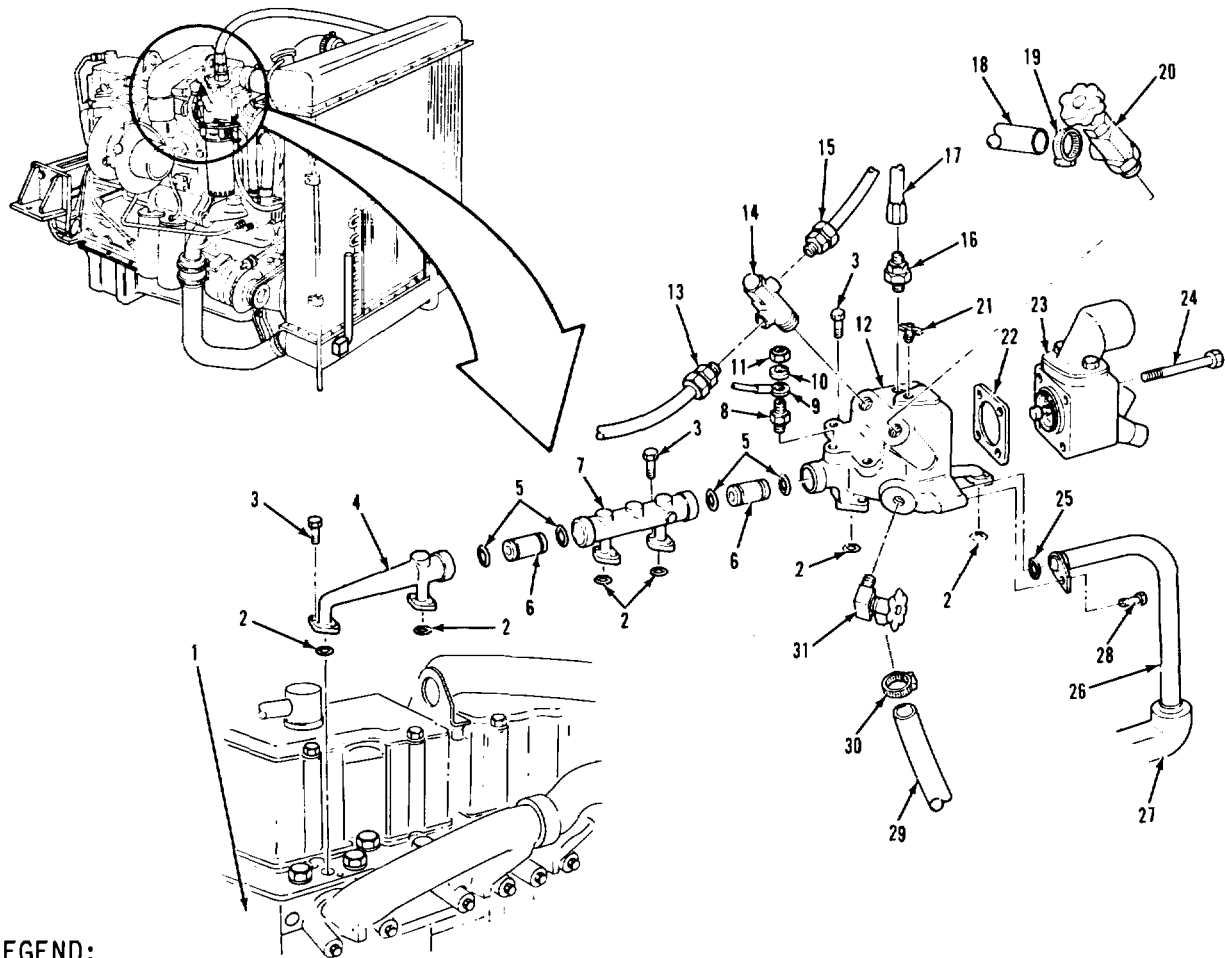

LEGEND:

- | | |
|--|--|
| 1. ENGINE BLOCK | 16. REDUCER AND MALE CONNECTOR |
| 2. SEALING RING (6) | 17. DEAERATION LINE |
| 3. HEXAGON HEAD SCREW WITH CAPTIVE WASHER (12) | 18. HEATER HOSE |
| 4. REAR WASHER MANIFOLD | 19. HOSE CLAMP |
| 5. COUPLING O-RING (4) | 20. HEATER SHUTOFF VALVE AND REDUCER |
| 6. MANIFOLD COUPLING (2) | 21. DRAINCOCK |
| 7. CENTER WATER MANIFOLD | 22. THERMOSTAT HOUSING GASKET |
| 8. HOT ENGINE TEMPERATURE SWITCH | 23. THERMOSTAT HOUSING |
| 9. WIRE | 24. SCREW WITH CAPTIVE WASHER (4) |
| 10. LOCKWASHER | 25. O-RING |
| 11. NUT | 26. WATER TRANSFER TUBE |
| 12. FRONT WATER MANIFOLD | 27. OIL COOLER SUPPORT |
| 13. NONMETALLIC TUBE | 28. SCREW WITH CAPTIVE WASHER |
| 14. AIR VALVE | 29. WATER HOSE |
| 15. NONMETALLIC TUBE | 30. HOSE CLAMP |
| | 31. WATER SHUTOFF VALVE AND STREET ELBOW |

TA 237145

COOLING SYSTEM.

3-60. WATER MANIFOLDS REPLACEMENT (Continued).

LOCATION/ITEM	ACTION	REMARKS
A. REMOVAL (Continued).		
22. Two rings (2).	Remove from item (1).	Discard items (2).
23. Switch (8), valve (14), valve and elbow (31), valve and reducer (20), reducer and connector (16), and draincock (21).	Remove from item (12).	
B. CLEANING AND INSPECTION.		
24. All parts.	Clean and inspect.	Refer to paragraphs 3-4 and 3-5. Be sure to clean all gasket material off items (12) and (23).
C. INSTALLATION.		
25. Switch (8), valve (14), valve and elbow (31), valve and reducer (20),	a. Wrap threads with thread sealing tape. b. Install into item (12). reducer and connector (16), and draincock (21).	Refer to paragraph 3-7.
26. Two new rings (2).	Coat with grease and install into item (1).	Make sure rubber side of items (2) face up.
27. New gaskets (22).	Hold in place on item (12) with grease.	
28. Manifold (12)	a. Position on item (23). and gasket (22). b. Secure with four items- (24).	

COOLING SYSTEM.

3-60. WATER MANIFOLDS REPLACEMENT (Continued).

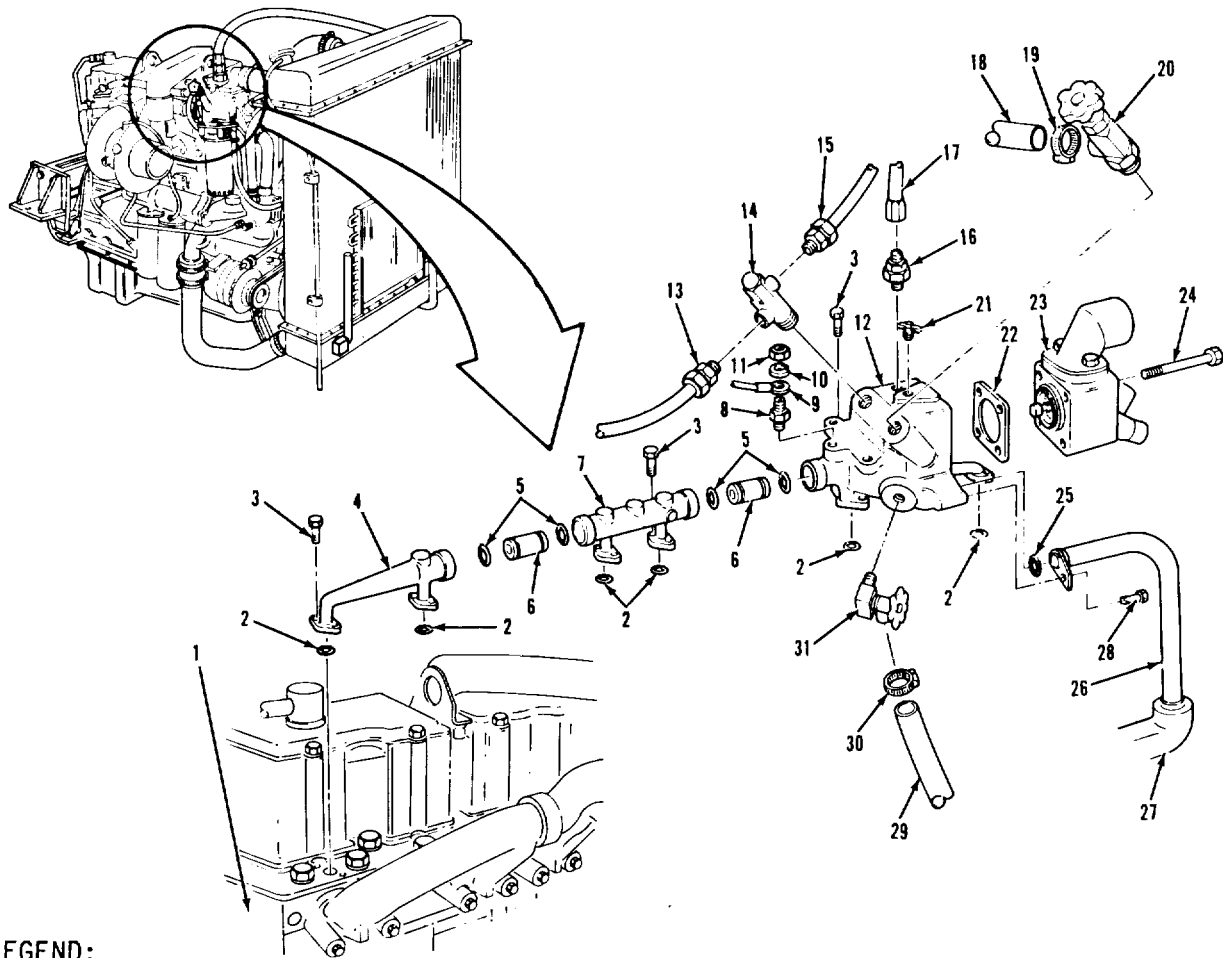

LEGEND:

- | | |
|--|--|
| 1. ENGINE BLOCK | 16. REDUCER AND MALE CONNECTOR |
| 2. SEALING RING (6) | 17. DEAERATION LINE |
| 3. HEXAGON HEAD SCREW WITH CAPTIVE WASHER (12) | 18. HEATER HOSE |
| 4. REAR WASHER MANIFOLD | 19. HOSE CLAMP |
| 5. COUPLING O-RING (4) | 20. HEATER SHUTOFF VALVE AND REDUCER |
| 6. MANIFOLD COUPLING (2) | 21. DRAINCOCK |
| 7. CENTER WATER MANIFOLD | 22. THERMOSTAT HOUSING GASKET |
| 8. HOT ENGINE TEMPERATURE SWITCH | 23. THERMOSTAT HOUSING |
| 9. WIRE | 24. SCREW WITH CAPTIVE WASHER (4) |
| 10. LOCKWASHER | 25. O-RING |
| 11. NUT | 26. WATER TRANSFER TUBE |
| 12. FRONT WATER MANIFOLD | 27. OIL COOLER SUPPORT |
| 13. NONMETALLIC TUBE | 28. SCREW WITH CAPTIVE WASHER |
| 14. AIR VALVE | 29. WATER HOSE |
| 15. NONMETALLIC TUBE | 30. HOSE CLAMP |
| | 31. WATER SHUTOFF VALVE AND STREET ELBOW |

TA 237146

COOLING SYSTEM.

3-60. WATER MANIFOLDS REPLACEMENT (Continued).

LOCATION/ITEM	ACTION	REMARKS
C. INSTALLATION (Continued).		
29. Four screws (3).	Install into items (12) and (1).	Torque items (3) to 30-35 lb-ft.
30. New O-ring (25).	Coat with lubricating oil and install on item (26).	
31. Tube (26) and O-ring (25).	Wiggle into item (12).	Be careful not to damage item (25) during installation
32. Screw (28).	Install into items (26) and (12).	Torque to 30-35 lb-ft.
33. Hose (29) and	a. Push end of item (29) clamp (30).onto item (31). b. Push item (30) to end of item (29) and tighten screw.	
34. Hose (17).	Install on item (16).	
35. Tube (13) and tube (15).	Install on item (14).	Wrap threads of item (14) with thread sealing tape.
36. Hose (18) and clamp (19).	a. Push end of item (18) onto item (20). b. Push item (19) to end of item (18) and tighten screw.	
37. Wire (9).	a. Position on item (8). b. Secure with items (10) and (11).	

COOLING SYSTEM.

3-60. WATER MANIFOLDS REPLACEMENT (Continued).

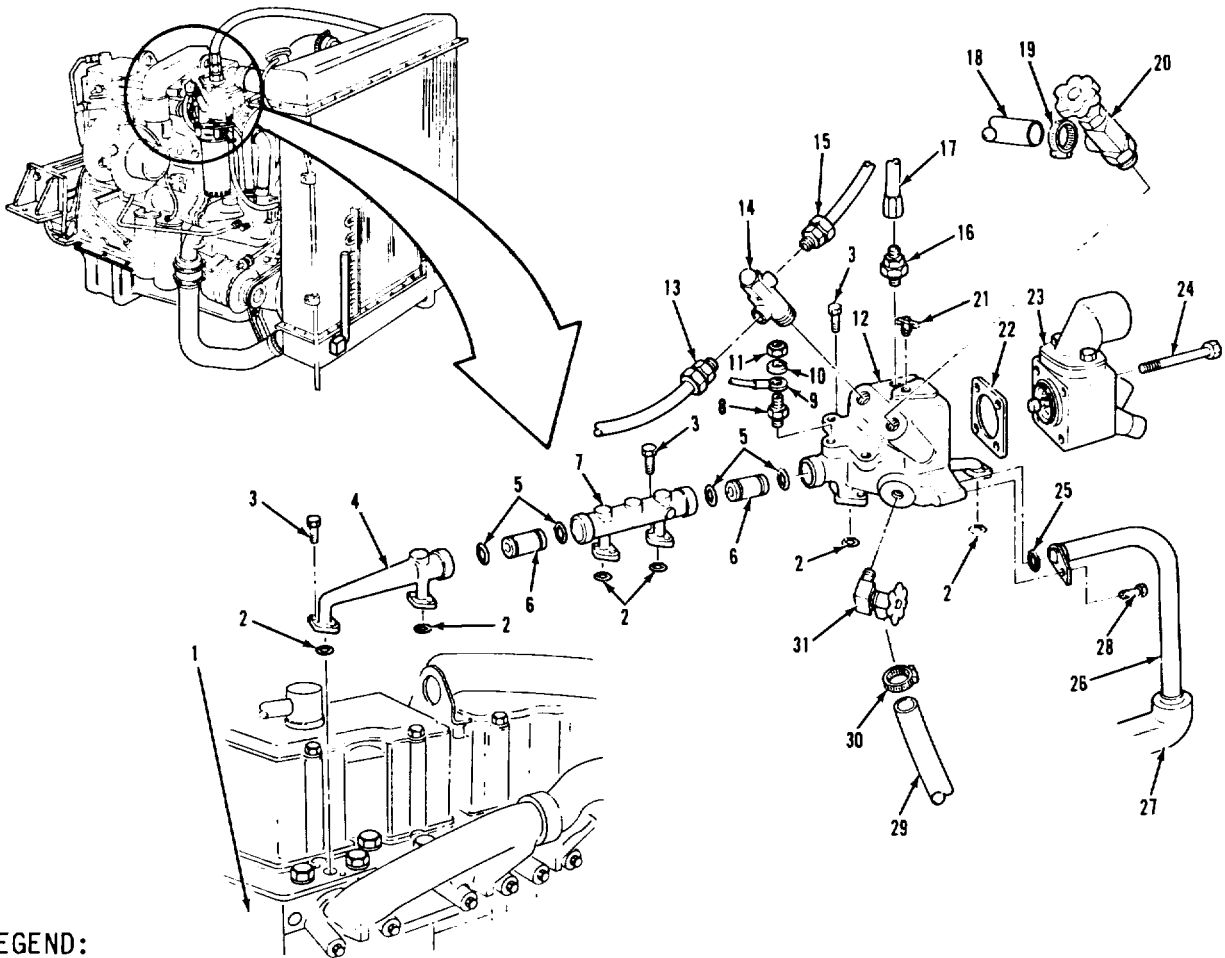

LEGEND:

- | | |
|--|--|
| 1. ENGINE BLOCK | 16. REDUCER AND MALE CONNECTOR |
| 2. SEALING RING (6) | 17. DEAERATION LINE |
| 3. HEXAGON HEAD SCREW WITH CAPTIVE WASHER (12) | 18. HEATER HOSE |
| 4. REAR WASHER MANIFOLD | 19. HOSE CLAMP |
| 5. COUPLING O-RING (4) | 20. HEATER SHUTOFF VALVE AND REDUCER |
| 6. MANIFOLD COUPLING (2) | 21. DRAINCOCK |
| 7. CENTER WATER MANIFOLD | 22. THERMOSTAT HOUSING GASKET |
| 8. HOT ENGINE TEMPERATURE SWITCH | 23. THERMOSTAT HOUSING |
| 9. WIRE | 24. SCREW WITH CAPTIVE WASHER (4) |
| 10. LOCKWASHER | 25. O-RING |
| 11. NUT | 26. WATER TRANSFER TUBE |
| 12. FRONT WATER MANIFOLD | 27. OIL COOLER SUPPORT |
| 13. NONMETALLIC TUBE | 28. SCREW WITH CAPTIVE WASHER |
| 14. AIR VALVE | 29. WATER HOSE |
| 15. NONMETALLIC TUBE | 30. HOSE CLAMP |
| | 31. WATER SHUTOFF VALVE AND STREET ELBOW |

TA 237147

COOLING SYSTEM.

3-60. WATER MANIFOLDS REPLACEMENT (Continued).

LOCATION/ITEM	ACTION	REMARKS
C. INSTALLATION (Continued).		
38. Two new O-rings (5).	Coat with lubricating oil and install on item (6).	
39. Coupling (6) and O-ring (5).	Wiggle into item (7).	Be careful not to damage item (5) during installation.
40. Two new rings (2).	Coat with grease and install into item (1).	Make sure rubber side of items (2) face up.
41. Manifold (7), coupling (6), and O-ring (5).	Wiggle into item (12).	Be careful not to damage item (5) during installation.
42. Four screws (3).	Install into items (7) and (11).	Torque items (3) to 30-35 lb-ft.
43. Two new O-rings (5).	Coat with lubricating oil and install on item (6).	
44. Coupling (6) and O-ring (5).	Wiggle into item (4).	Be careful not to damage item (5) during installation.
45. Two new rings (2).	Coat with grease and install into item (1).	Make sure rubber side of items (2) face up.
46. Manifold (4), coupling (6), and O-ring (5).	Wiggle into item (7).	Be careful not to damage item (5) during installation.
47. Four screws (3).	Install into items (4) and (1).	Torque items (3) to 30-35 lb-ft.

COOLING SYSTEM.

3-60. WATER MANIFOLDS REPLACEMENT (Continued).

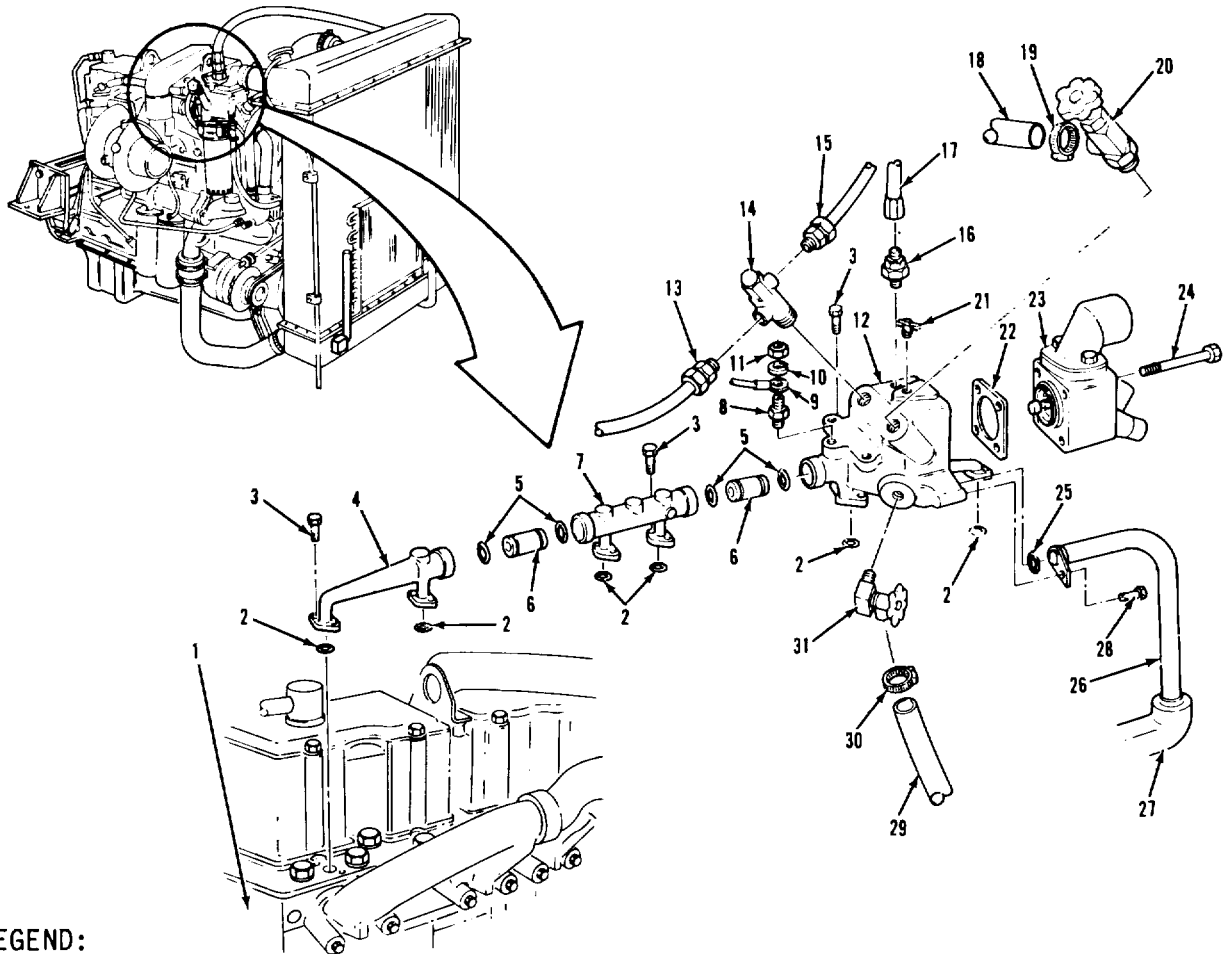

LEGEND:

- | | |
|--|--|
| 1. ENGINE BLOCK | 16. REDUCER AND MALE CONNECTOR |
| 2. SEALING RING (6) | 17. DEAERATION LINE |
| 3. HEXAGON HEAD SCREW WITH CAPTIVE WASHER (12) | 18. HEATER HOSE |
| 4. REAR WASHER MANIFOLD | 19. HOSE CLAMP |
| 5. COUPLING O-RING (4) | 20. HEATER SHUTOFF VALVE AND REDUCER |
| 6. MANIFOLD COUPLING (2) | 21. DRAINCOCK |
| 7. CENTER WATER MANIFOLD | 22. THERMOSTAT HOUSING GASKET |
| 8. HOT ENGINE TEMPERATURE SWITCH | 23. THERMOSTAT HOUSING |
| 9. WIRE | 24. SCREW WITH CAPTIVE WASHER (4) |
| 10. LOCKWASHER | 25. O-RING |
| 11. NUT | 26. WATER TRANSFER TUBE |
| 12. FRONT WATER MANIFOLD | 27. OIL COOLER SUPPORT |
| 13. NONMETALLIC TUBE | 28. SCREW WITH CAPTIVE WASHER |
| 14. AIR VALVE | 29. WATER HOSE |
| 15. NONMETALLIC TUBE | 30. HOSE CLAMP |
| | 31. WATER SHUTOFF VALVE AND STREET ELBOW |

TA 237148

COOLING SYSTEM.

3-60. WATER MANIFOLDS REPLACEMENT (Continued).

LOCATION/ITEM	ACTION	REMARKS
C. INSTALLATION (Continued).		
NOTE		
Follow-on maintenance action required:		
Install turbocharger air intake (para 3-31).		
Install air cleaner assembly (para 3-29).		
Fill cooling system (para 3-52).		
Start vehicle and check for leaks (TM 9-2320-283-10).		

COOLING SYSTEM.

3-60. WATER MANIFOLDS REPLACEMENT (Continued).

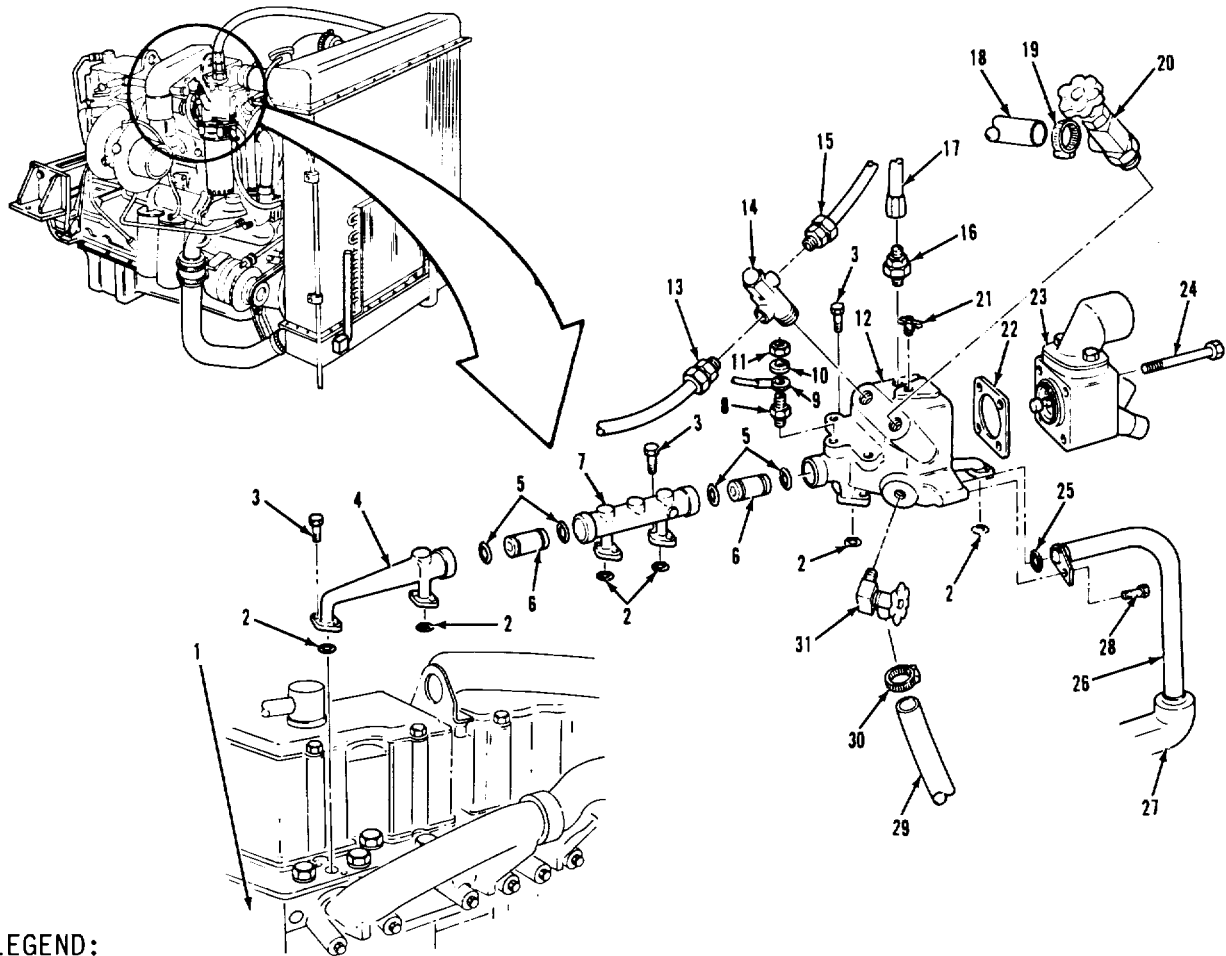

LEGEND:

- | | |
|--|--|
| 1. ENGINE BLOCK | 16. REDUCER AND MALE CONNECTOR |
| 2. SEALING RING (6) | 17. DEAERATION LINE |
| 3. HEXAGON HEAD SCREW WITH CAPTIVE WASHER (12) | 18. HEATER HOSE |
| 4. REAR WASHER MANIFOLD | 19. HOSE CLAMP |
| 5. COUPLING O-RING (4) | 20. HEATER SHUTOFF VALVE AND REDUCER |
| 6. MANIFOLD COUPLING (2) | 21. DRAINCOCK |
| 7. CENTER WATER MANIFOLD | 22. THERMOSTAT HOUSING GASKET |
| 8. HOT ENGINE TEMPERATURE SWITCH | 23. THERMOSTAT HOUSING |
| 9. WIRE | 24. SCREW WITH CAPTIVE WASHER (4) |
| 10. LOCKWASHER | 25. O-RING |
| 11. NUT | 26. WATER TRANSFER TUBE |
| 12. FRONT WATER MANIFOLD | 27. OIL COOLER SUPPORT |
| 13. NONMETALLIC TUBE | 28. SCREW WITH CAPTIVE WASHER |
| 14. AIR VALVE | 29. WATER HOSE |
| 15. NONMETALLIC TUBE | 30. HOSE CLAMP |
| | 31. WATER SHUTOFF VALVE AND STREET ELBOW |

TA 237149

COOLING SYSTEM.

3-61. WATER SHUTOFF VALVES AND LINES REPLACEMENT.

THIS TASK COVERS

- a. Removal.
- b. Cleaning and Inspection.
- c. Installation.

INITIAL SETUP

APPLICABLE CONFIGURATIONS

All.

EQUIPMENT CONDITION

PARAGRAPH

3-52.

CONDITION DESCRIPTION

Coolant drained below level of water shutoff valves and lines.

TEST EQUIPMENT

None.

SPECIAL TOOLS

None.

MATERIALS/PARTS (P/N)

Tape, thread sealing
Item 32, Appendix C.

PERSONNEL REQUIRED

One (MOS-63S).

SPECIAL ENVIRONMENTAL CONDITIONS

None.

REFERENCES (TM)

TM 9-2320-283-10.

GENERAL SAFETY INSTRUCTIONS

Engine off.
Transmission in neutral.
Park brake set.

TROUBLESHOOTING REFERENCES

Paragraph 2-11.

COOLING SYSTEM.

3-61. WATER SHUTOFF VALVES AND LINES REPLACEMENT (Continued).

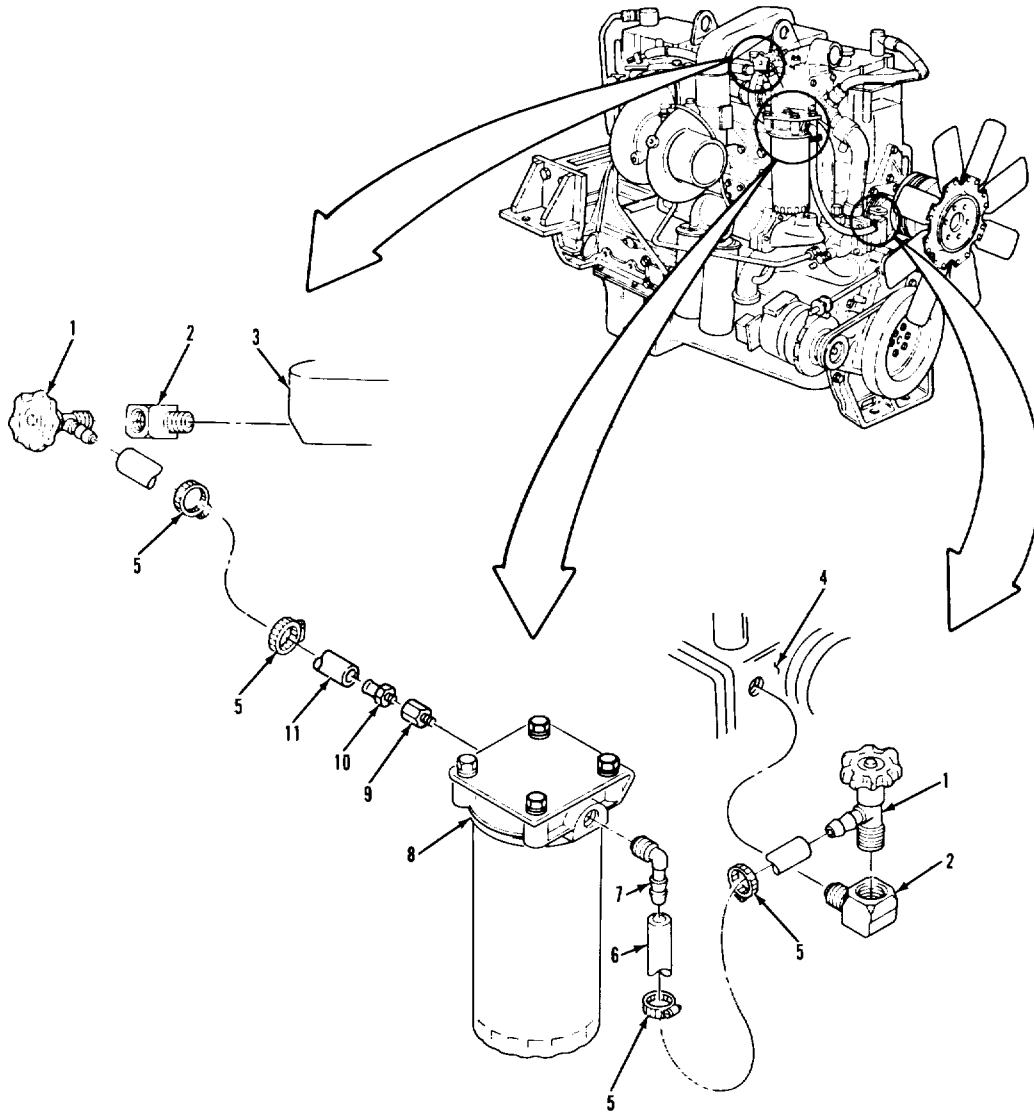

LEGEND:

- 1. WATER SHUTOFF VALVE (2)
- 2. STREET ELBOW (2)
- 3. FRONT WATER MANIFOLD
- 4. WATER PUMP ASSEMBLY
- 5. HOSE CLAMP (4)
- 6. WATER HOSE

- 7. ELBOW
- 8. FILTER HEAD
- 9. REDUCER
- 10. STRAIGHT-NOSED NIPPLE
- 11. WATER HOSE

TA 237150

COOLING SYSTEM.

3-61. WATER SHUTOFF VALVES AND LINES REPLACEMENT (Continued).

LOCATION/ITEM	ACTION	REMARKS
A. REMOVAL.		
1. Hose (6) and two clamps (5).	a. Loosen screws on item (5). b. Pull item (6) off of items (1) and (7). c. Remove items (5) from item (6).	
2. Elbow (7).	Remove from item (8).	
3. Valve (1) and elbow (2).	Remove from item (4) and separate item (1) from item (2).	
4. Hose (11) and two	a. Loosen screws on items clamps (5).(5). b. Pull item (11) off of items (1) and (10). c. Remove items (5) from item (11).	
5. Nipple (10) and reducer (9).	Remove from item (8) and separate item (10) and item (9).	
6. Valve (1) and elbow (2).	Remove from item (3) and separate item (1) from item (2).	
B. CLEANING AND INSPECTION.		
7. All parts.	Clean and inspect.	Refer to paragraphs 3-4 and 3-5.

COOLING SYSTEM.

3-61. WATER SHUTOFF VALVES AND LINES REPLACEMENT (Continued).

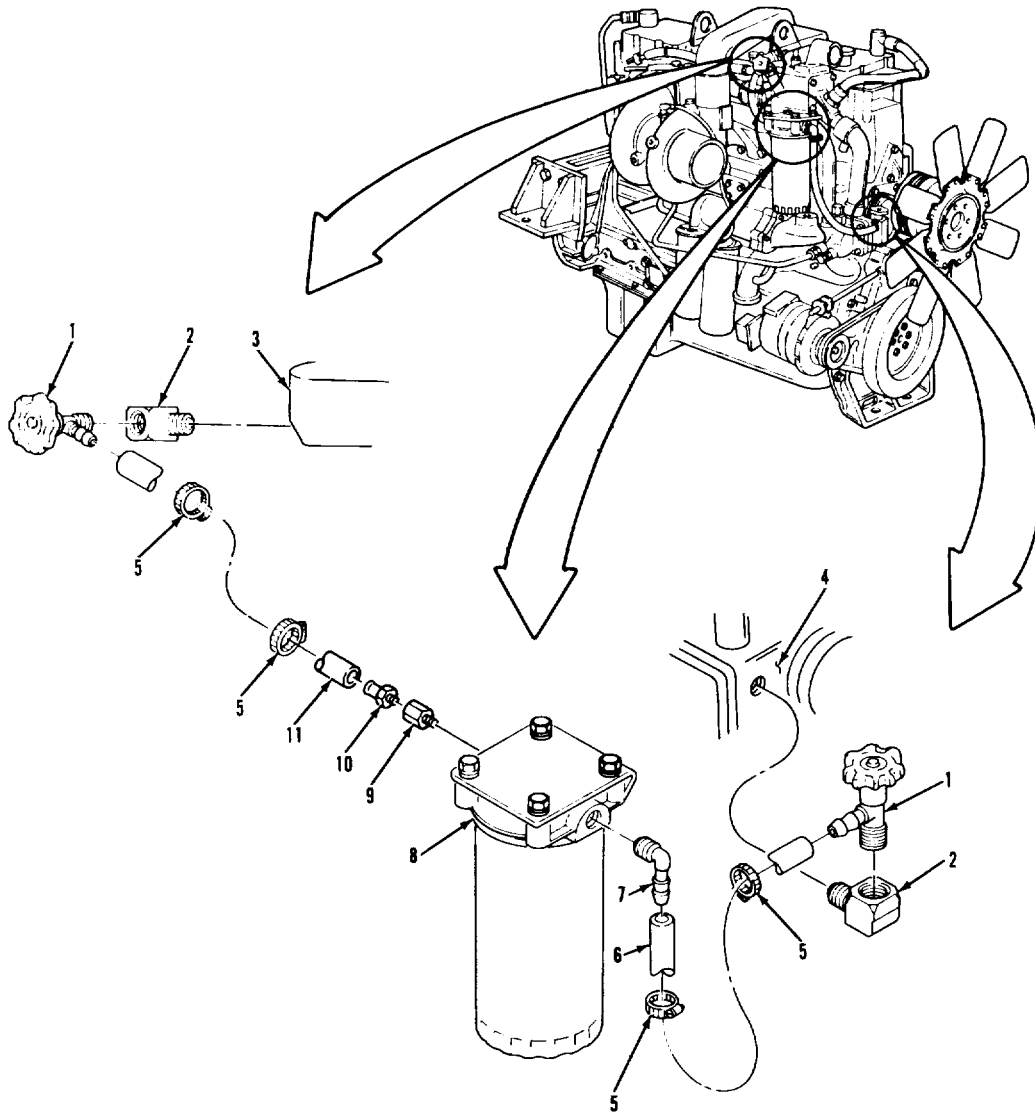

LEGEND:

- 1. WATER SHUTOFF VALVE (2)
- 2. STREET ELBOW (2)
- 3. FRONT WATER MANIFOLD
- 4. WATER PUMP ASSEMBLY
- 5. HOSE CLAMP (4)
- 6. WATER HOSE

- 7. ELBOW
- 8. FILTER HEAD
- 9. REDUCER
- 10. STRAIGHT-NOSED NIPPLE
- 11. WATER HOSE

TA 237151

COOLING SYSTEM.

3-61. WATER SHUTOFF VALVES AND LINES REPLACEMENT (Continued).

LOCATION/ITEM	ACTION	REMARKS
C. INSTALLATION.		
8. Valve (1) and	a. Wrap threads with thread elbow (2).sealing tape. b. Screw together and install into item (3).	Refer to paragraph 3-7.
9. Nipple (10) and	a. Wrap threads with thread reducer (9).sealing tape. b. Screw together and install into item (8).	Refer to paragraph 3-7.
10. Hose (11) and	a. Install items (5) on item two clamps (5).(11). b. Push ends of item (11) onto items (1) and (10). c. Push items (5) to ends of item (11), and tighten screws.	
11. Valve (1) and elbow (2).	a. Wrap threads with thread sealing tape. b. Screw together and install into item (4).	Refer to paragraph 3-7.
12. Elbow (7).	a. Wrap threads with thread sealing tape. b. Install into item (8).	Refer to paragraph 3-7.

COOLING SYSTEM.

3-61. WATER SHUTOFF VALVES AND LINES REPLACEMENT (Continued).

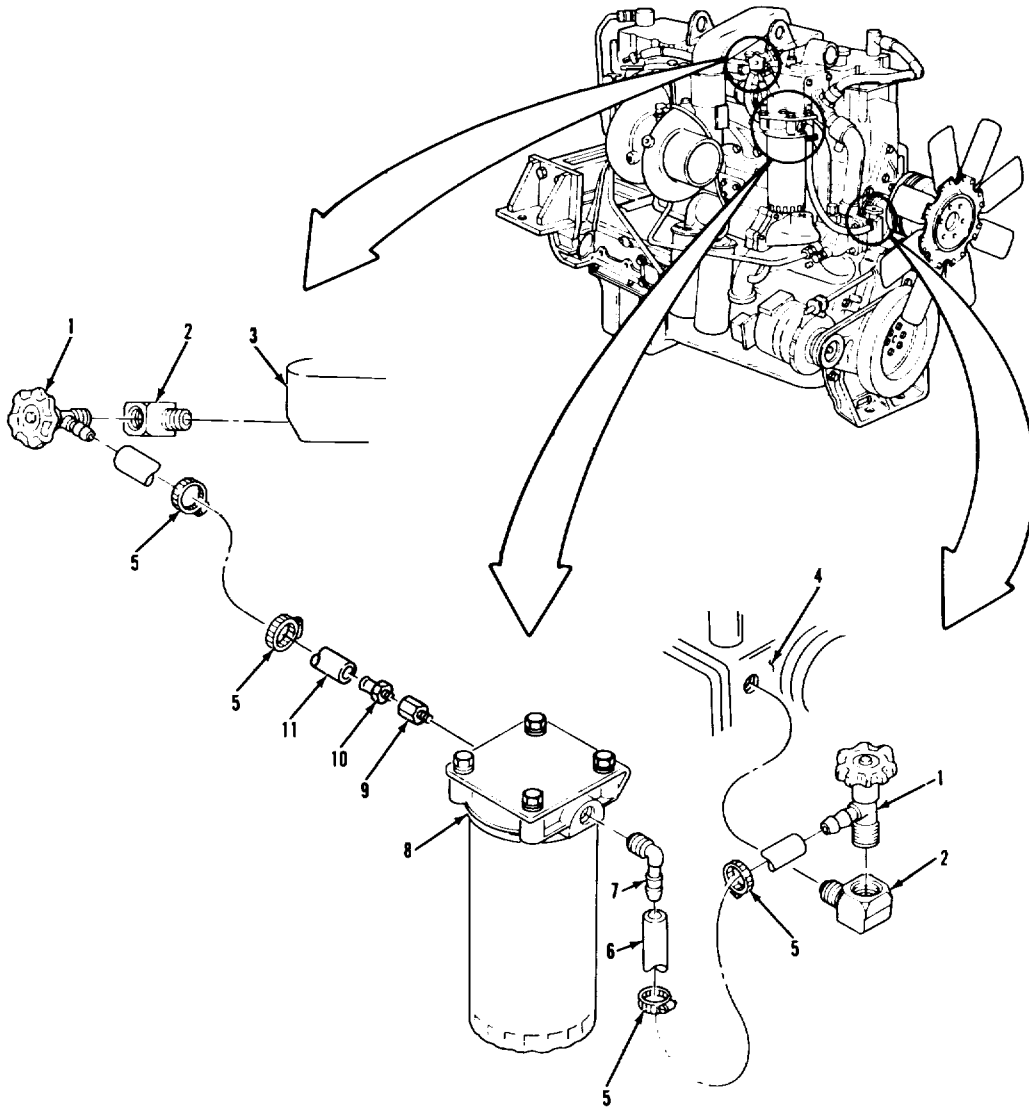

LEGEND:

- 1. WATER SHUTOFF VALVE (2)
- 2. STREET ELBOW (2)
- 3. FRONT WATER MANIFOLD
- 4. WATER PUMP ASSEMBLY
- 5. HOSE CLAMP (4)
- 6. WATER HOSE

- 7. ELBOW
- 8. FILTER HEAD
- 9. REDUCER
- 10. STRAIGHT-NOSED NIPPLE
- 11. WATER HOSE

TA 237152

COOLING SYSTEM.

3-61. WATER SHUTOFF VALVES AND LINES REPLACEMENT (Continued).

LOCATION/ITEM	ACTION	REMARKS
C. INSTALLATION (Continued).		
13. Hose (6) and two	<ul style="list-style-type: none"> a. Install items (5) on item clamps (5).(6). b. Push ends of item (6) into items (1) and (7). c. Push items (5) to ends of item (6), and tighten screws. 	
NOTE		
Follow-on maintenance action required:		
Fill cooling system (para 3-52). Start vehicle and check for leaks (TM 9-2320-283-10).		

COOLING SYSTEM.

3-61. WATER SHUTOFF VALVES AND LINES REPLACEMENT (Continued).

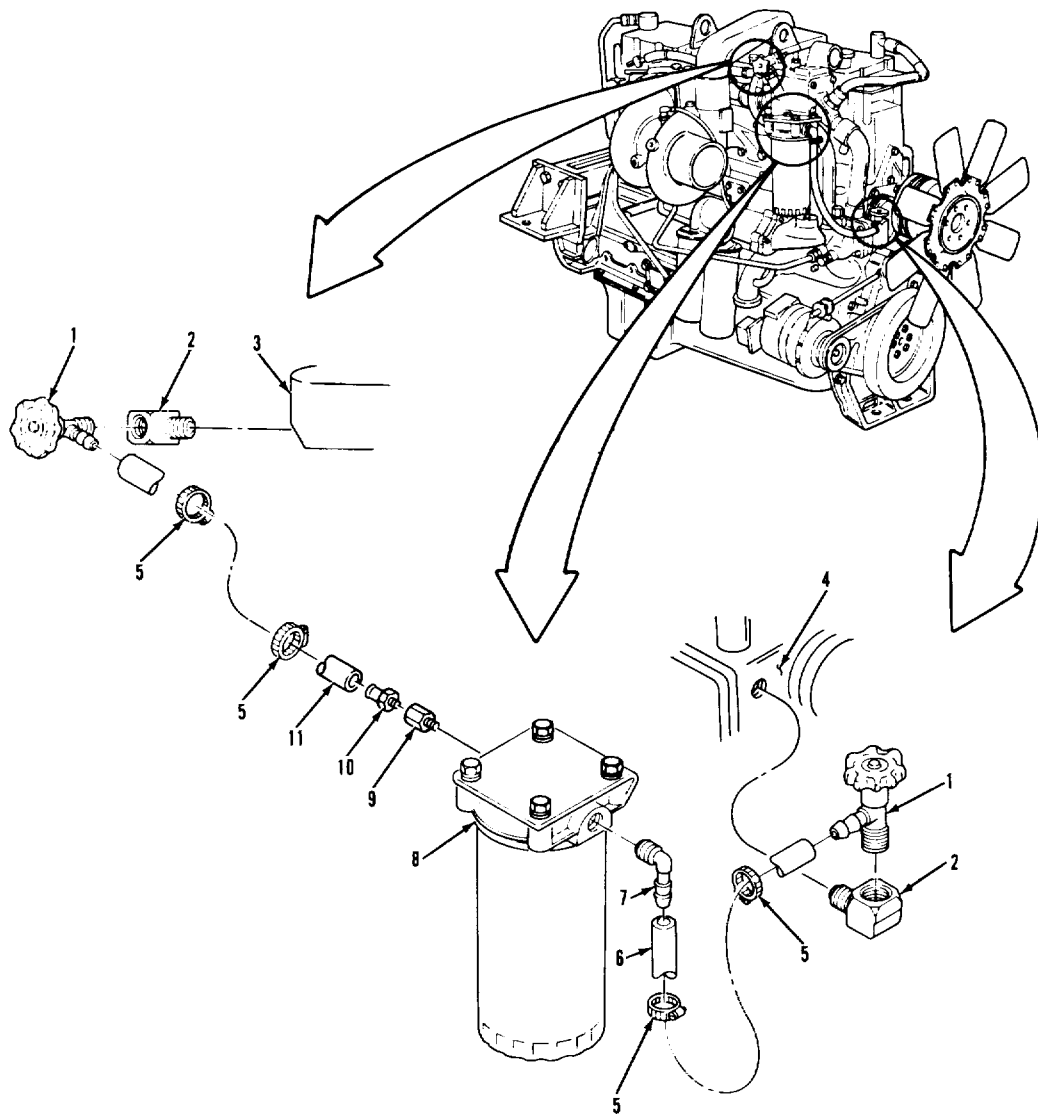

LEGEND:

- 1. WATER SHUTOFF VALVE (2)
- 2. STREET ELBOW (2)
- 3. FRONT WATER MANIFOLD
- 4. WATER PUMP ASSEMBLY
- 5. HOSE CLAMP (4)
- 6. WATER HOSE

- 7. ELBOW
- 8. FILTER HEAD
- 9. REDUCER
- 10. STRAIGHT-NOSED NIPPLE
- 11. WATER HOSE

TA 237153

COOLING SYSTEM.

3-62. WATER FILTER AND BRACKET REPLACEMENT.

THIS TASK COVERS

- a. Removal.
- b. Cleaning and Inspection.
- c. Installation.

INITIAL SETUP

<p><u>APPLICABLE CONFIGURATIONS</u> All.</p>	<p><u>EQUIPMENT CONDITION PARAGRAPH</u> None.</p>	<p><u>CONDITION DESCRIPTION</u> None.</p>
<p><u>TEST EQUIPMENT</u> None.</p>		
<p><u>SPECIAL TOOLS</u> None.</p>		
<p><u>MATERIALS/PARTS (P/N)</u> Tape, thread sealing Item 32, Appendix C. Anti-freeze Item 2 or 3, Appendix C.</p>		
<p><u>PERSONNEL REQUIRED</u> One (MOS-63S).</p>	<p><u>SPECIAL ENVIRONMENTAL CONDITIONS</u> None.</p>	
<p><u>REFERENCES (TM)</u> TM 9-2320-283-10. TM 9-750-254.</p>	<p><u>GENERAL SAFETY INSTRUCTIONS</u> Engine off. Transmission in neutral. Park brake set.</p>	
<p><u>TROUBLESHOOTING REFERENCES</u> Paragraph 2-11.</p>		

COOLING SYSTEM.

3-62. WATER FILTER AND BRACKET REPLACEMENT (Continued).

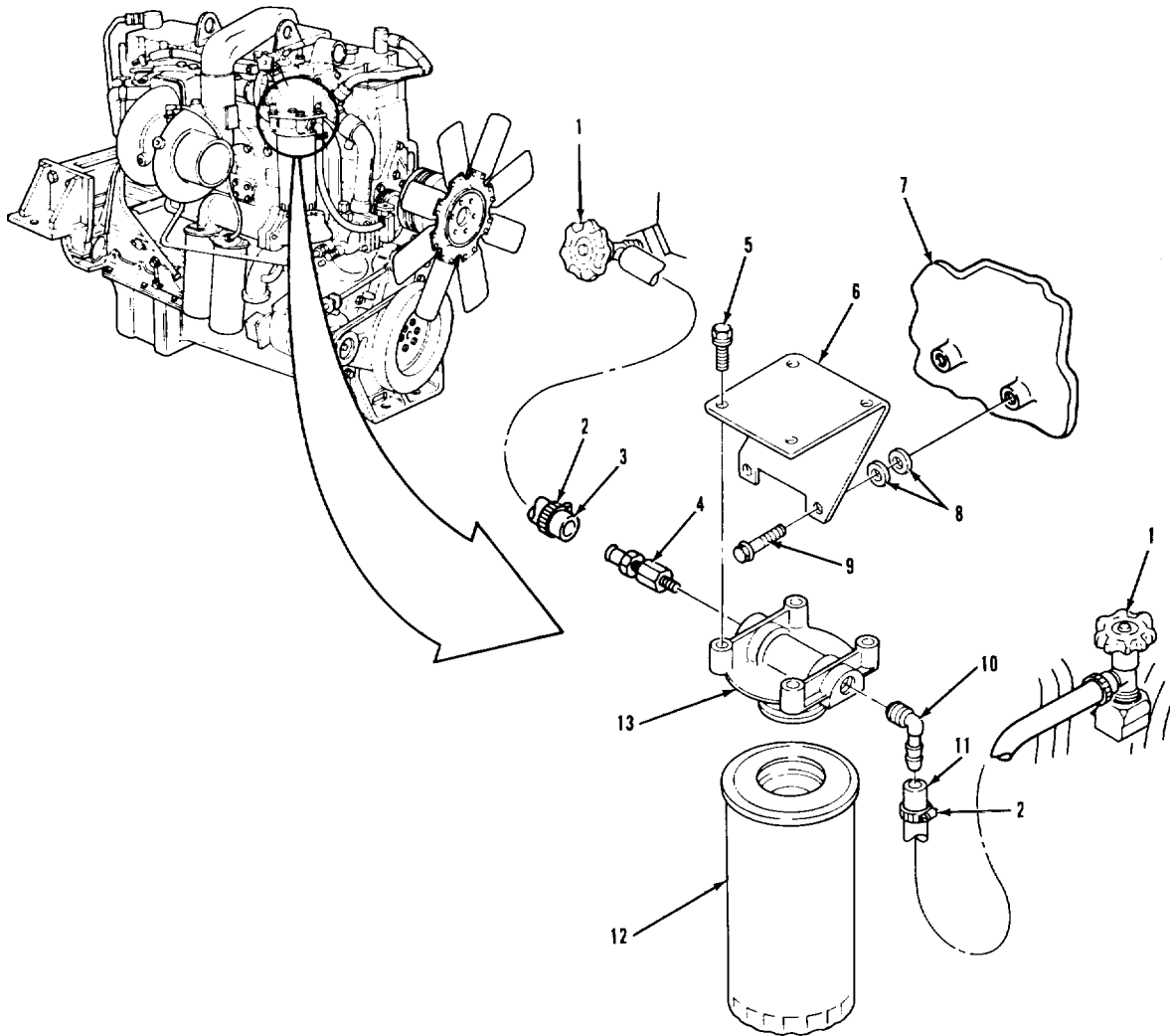

LEGEND:

- | | |
|---|---------------------------|
| 1. WATER SHUTOFF VALVE (2) | 7. EXHAUST MANIFOLD |
| 2. HOSE CLAMP (2) | 8. PLAIN WASHER (4) |
| 3. WATER HOSE | 9. HEXAGON HEAD SCREW (2) |
| 4. STRAIGHT HOSE NIPPLE AND REDUCER | 10. ELBOW |
| 5. HEXAGON HEAD SCREW WITH CAPTIVE WASHER (4) | 11. WATER HOSE |
| 6. FILTER MOUNTING BRACKET | 12. WATER FILTER |
| | 13. FILTER HEAD |

TA237154

COOLING SYSTEM.

3-62. WATER FILTER AND BRACKET REPLACEMENT (Continued).

LOCATION/ITEM	ACTION	REMARKS
A. REMOVAL.		
1. Two valves (1).	Close by turning clockwise as far as possible.	
2. Filter (12).	a. Unscrew and remove from item (13). b. Dump coolant into suitable container.	Have a suitable container ready to catch any coolant from item (12).
3. Hose (3) and clamp (2).	a. Loosen screw on item (2). b. Pull item (3) off of item (4).	Leave item (2) on item (3).
4. Hose (11) and clamp (2).	a. Loosen screw on item (2). b. Pull item (11) off of item (10).	Leave item (2) on item (11).
5. Four screws (5) and head (13).	Remove from item (6).	
6. Elbow (10) and nipple and reducer (4).	Remove from item (13).	
7. Two screws (9), four washers (8), and bracket (6).	Remove from item (7).	
B. CLEANING AND INSPECTION.		
8. All parts.	Clean and inspect.	Refer to paragraphs 3-4 and 3-5.
C. INSTALLATION.		
9. Bracket (6).	a. Position on item (7). b. Secure with two items (9) and four items (8).	Four items (8) are installed between items (6) and (7).

COOLING SYSTEM.

3-62. WATER FILTER AND BRACKET REPLACEMENT (Continued).

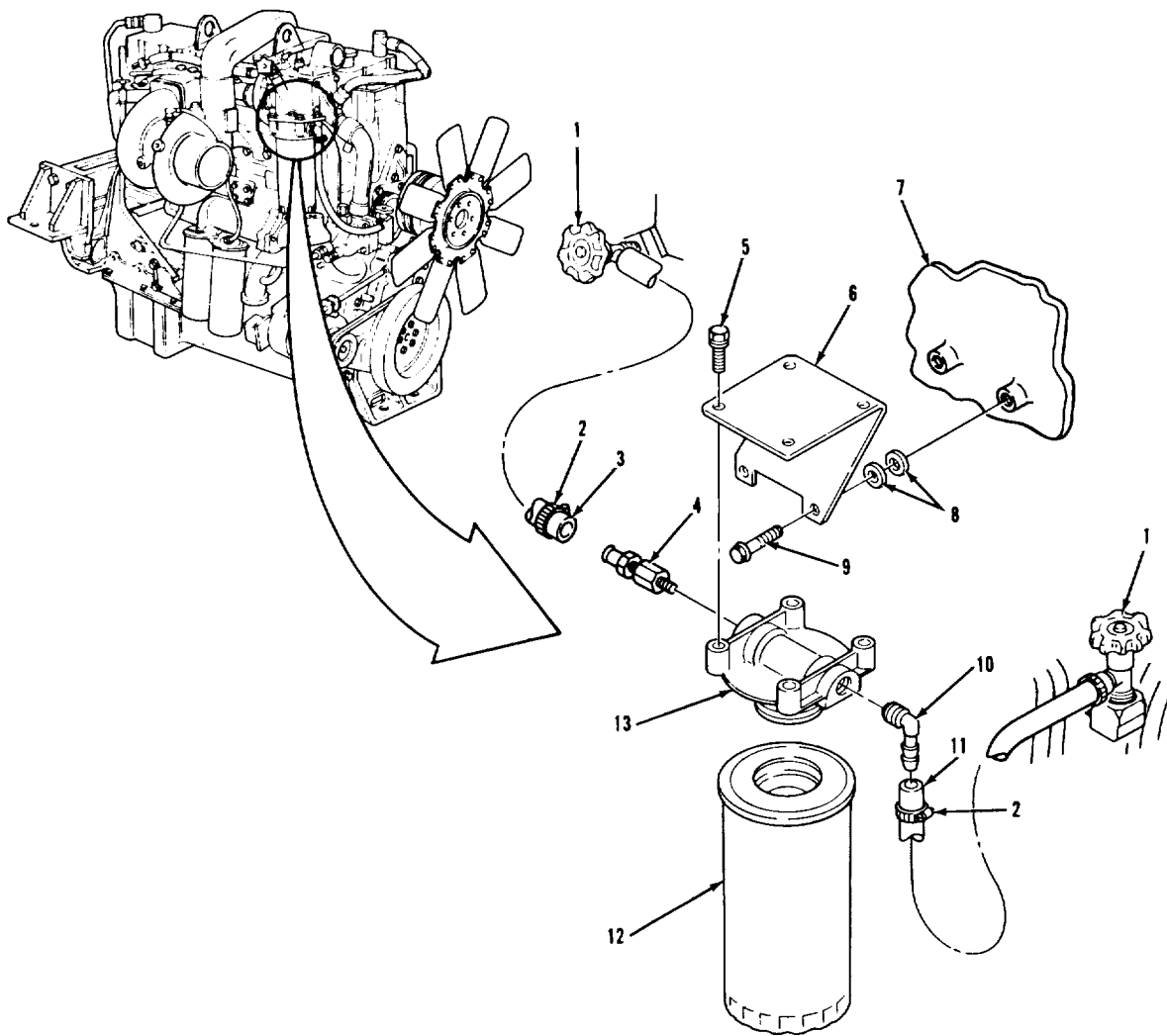

LEGEND:

- | | |
|---|---------------------------|
| 1. WATER SHUTOFF VALVE (2) | 7. EXHAUST MANIFOLD |
| 2. HOSE CLAMP (2) | 8. PLAIN WASHER (4) |
| 3. WATER HOSE | 9. HEXAGON HEAD SCREW (2) |
| 4. STRAIGHT HOSE NIPPLE AND REDUCER | 10. ELBOW |
| 5. HEXAGON HEAD SCREW WITH CAPTIVE WASHER (4) | 11. WATER HOSE |
| 6. FILTER MOUNTING BRACKET | 12. WATER FILTER |
| | 13. FILTER HEAD |

TA 237155

COOLING SYSTEM.

3-62. WATER FILTER AND BRACKET REPLACEMENT (Continued).

LOCATION/ITEM	ACTION	REMARKS
C. INSTALLATION (Continued).		
10. Elbow (10) and nipple and reducer (4).	a. Wrap threads with thread sealing tape. b. Install into item (13).	Refer to paragraph 3-7.
11. Head (13).	a. Position under item (6). b. Secure with four items (5).	
12. Hose (11) and clamp (2).	a. Push end of item (11) onto item (10). b. Push item (2) to end of item (11), and tighten screw.	
13. Hose (3) and clamp (2).	a. Push end of item (3) onto item (4). b. Push item (2) to end of item (3), and tighten screw.	
14. Filter (12).	a. Fill with clean coolant. b. Screw onto item (13) until gasket seal makes contact, then screw on 3/4 of a turn further.	See TM 9-750-254 for proper mixture. Do not overtighten item (12).
15. Two valves (1).	Open by turning counterclockwise as far as possible.	
NOTE		
Follow-on maintenance action required:		
Fill cooling system (para 3-52). Start vehicle and check for leaks (TM 9-2320-283-10).		

COOLING SYSTEM.

3-62. WATER FILTER AND BRACKET REPLACEMENT (Continued).

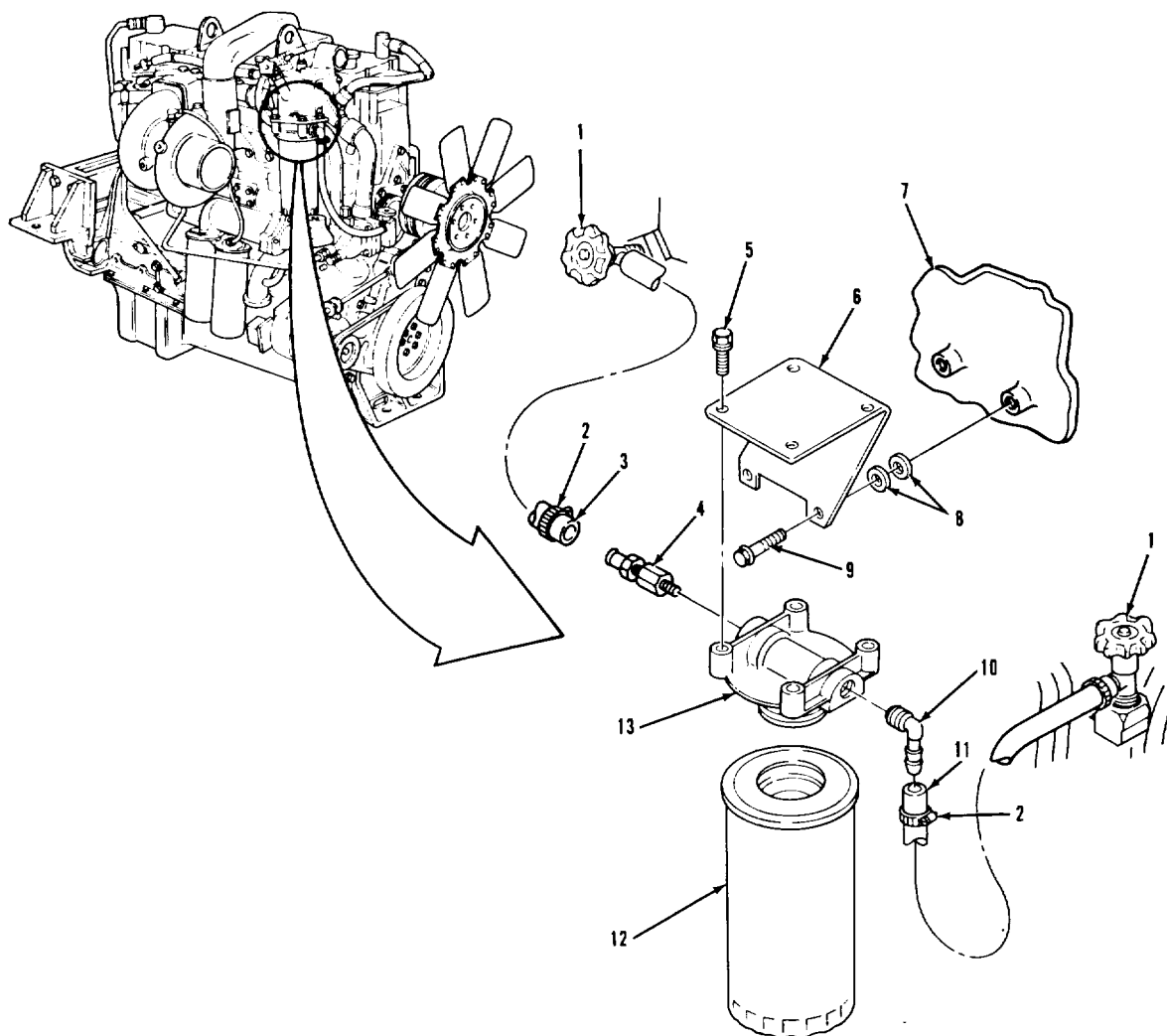

LEGEND:

- | | | | |
|---|--|----|------------------------|
| 1 | WATER SHUTOFF VALVE (2) | 7 | EXHAUST MANIFOLD |
| 2 | HOSE CLAMP (2) | 8 | PLAIN WASHER (4) |
| 3 | WATER HOSE | 9 | HEXAGON HEAD SCREW (2) |
| 4 | STRAIGHT HOSE NIPPLE AND REDUCER | 10 | ELBOW |
| 5 | HEXAGON HEAD SCREW WITH CAPTIVE WASHER (4) | 11 | WATER HOSE |
| 6 | FILTER MOUNTING BRACKET | 12 | WATER FILTER |
| | | 13 | FILTER HEAD |

TA 237156

COOLING SYSTEM.

3-63. WATER PUMP DRIVE BELT REPLACEMENT.

THIS TASK COVERS

- a. Removal.
- b. Installation.
- c. Adjustment.

INITIAL SETUP

APPLICABLE CONFIGURATIONS

All.

EQUIPMENT CONDITION
PARAGRAPH

3-67.

CONDITION DESCRIPTION

Fan clutch drive belts removed.

TEST EQUIPMENT

Belt tension gage.

SPECIAL TOOLS

None.

MATERIALS/PARTS (P/N)

None.

PERSONNEL REQUIRED

One (MOS-63S .

SPECIAL ENVIRONMENTAL CONDITIONS

None.

REFERENCES (TM)

TM 9-2320-283-20P.

GENERAL SAFETY INSTRUCTIONS

Engine off.
Transmission in neutral.
Park brake set.

TROUBLESHOOTING REFERENCES

Paragraph 2-11.

COOLING SYSTEM.

3-63. WATER PUMP DRIVE BELT REPLACEMENT (Continued).

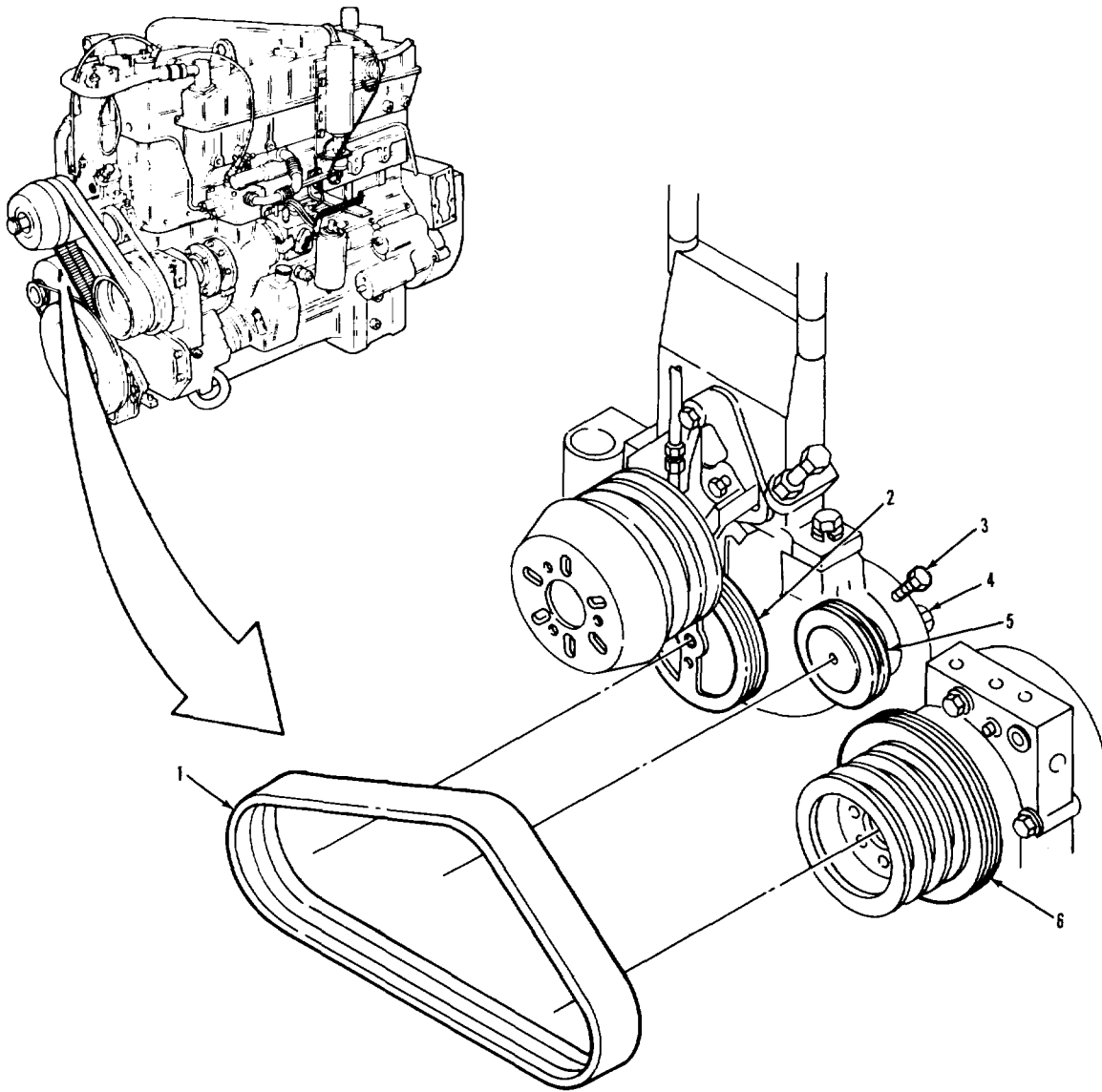

LEGEND:

- 1 V-RIBBED BELT
- 2 WATER PUMP PULLEY ASSEMBLY
- 3 HEXAGON SCREW

- 4 HEXAGON NUT
- 5 IDLER PULLEY
- 6 ACCESSORY DRIVE PULLEY ASSEMBLY

COOLING SYSTEM.

3-63. WATER PUMP DRIVE BELT REPLACEMENT (Continued).		
LOCATION/ITEM	ACTION	REMARKS
A. REMOVAL. I		
1. Nut (4).	Loosen, but do not remove.	
2. Screw (3).	Unscrew until item (1) can be removed.	
3. Belt (1).	a. Remove from items (2), (5), and (6). b. Clean and inspect.	Refer to paragraphs 3-4 and 3-5.
B. INSTALLATION.		
4. Belt (4).	Install on items (2), (5), and (6).	Do not use a screwdriver to force item (1) on items (2), (5), and (6)
C. ADJUSTMENT.		
5. Screw (3) and belt (1).	Adjust until belt tension is 90-100 lb-ft on belt tension gage.	Loosen item (4), if not already done.
6. Nut (4).	Torque to 50 lb-ft.	
<p>NOTE Follow-on maintenance action required: Install and adjust fan clutch drive belts (para 3-63).</p>		

COOLING SYSTEM.

3-63. WATER PUMP DRIVE BELT REPLACEMENT (Continued).

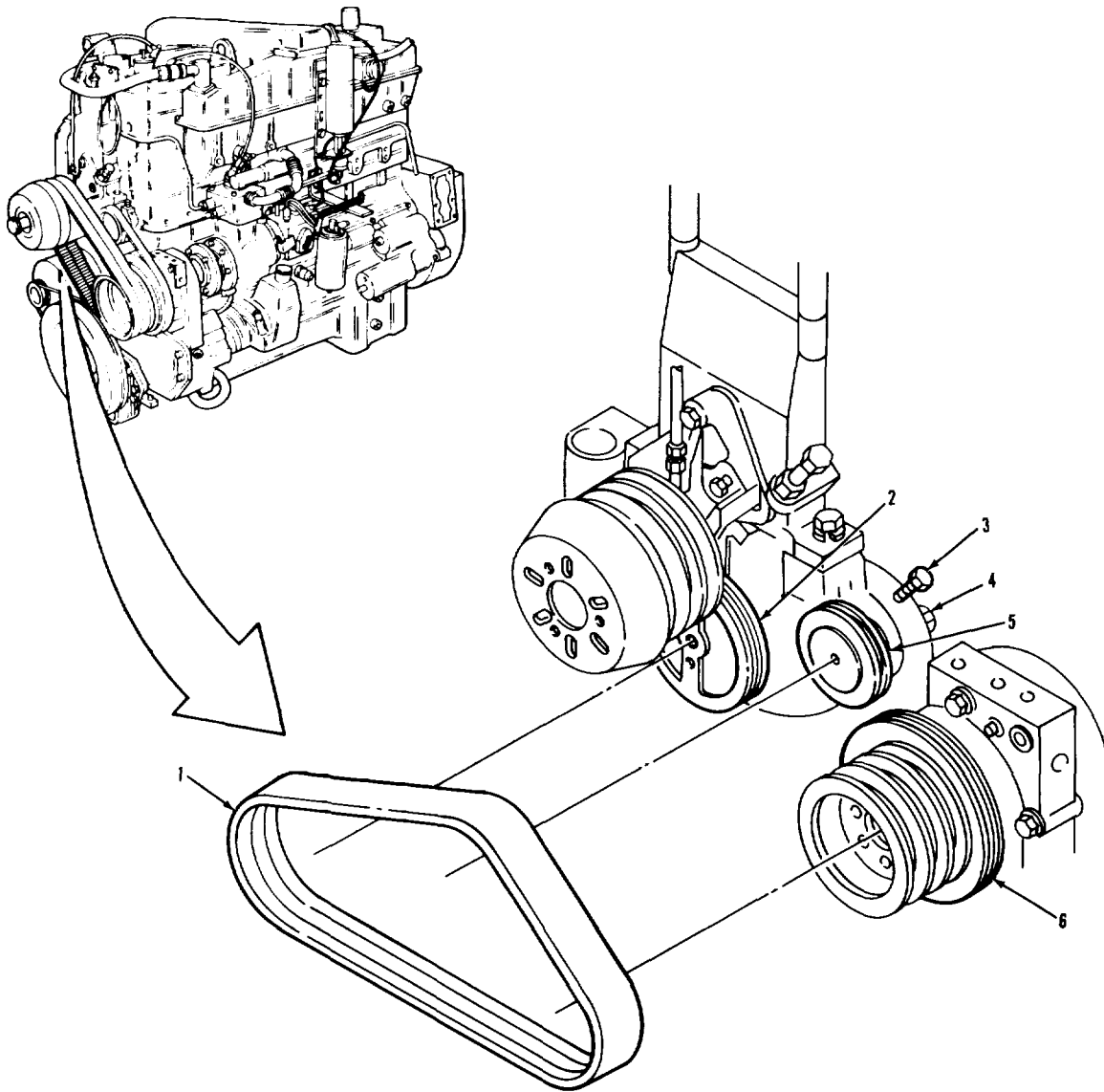

LEGEND:

- | | | | |
|---|----------------------------|---|---------------------------------|
| 1 | V-RIBBED BELT | 4 | HEXAGON NUT |
| 2 | WATER PUMP PULLEY ASSEMBLY | 5 | IDLER PULLEY |
| 3 | HEXAGON SCREW | 6 | ACCESSORY DRIVE PULLEY ASSEMBLY |

COOLING SYSTEM.

3-64. WATER PUMP REPLACEMENT.

THIS TASK COVERS

- a. Removal.
- b. Cleaning and Inspection.
- c. Installation.

INITIAL SETUP

APPLICABLE CONFIGURATIONS

All.

**EQUIPMENT CONDITION
PARAGRAPH**

3-65.

CONDITION DESCRIPTION

Fan and fan clutch removed.

TEST EQUIPMENT

None.

3-63.

Water pump drive belts removed.

3-52.

Coolant drained.

SPECIAL TOOLS

None.

MATERIALS/PARTS (P/N)

Oil, lubricating: OE/HDO-30

Item 16, Appendix C.

Tape, thread sealing

Item 32, Appendix C.

Grease, automotive and artillery

Item 7, Appendix C.

Gasket, water pump
(15434) 3002385.

Gasket, water connection
(15434) 3024960.

O-ring
(15434) 43463-A.

PERSONNEL REQUIRED

One (MOS-63S).

SPECIAL ENVIRONMENTAL CONDITIONS

None.

REFERENCES (TM)

TM 9-2320-283-10.

TM 9-2320-283-20P.

GENERAL SAFETY INSTRUCTIONS

Engine off.

Transmission in neutral.

Park brake set.

TROUBLESHOOTING REFERENCES

Paragraph 2-11.

COOLING SYSTEM.

3-64. WATER PUMP REPLACEMENT (Continued).

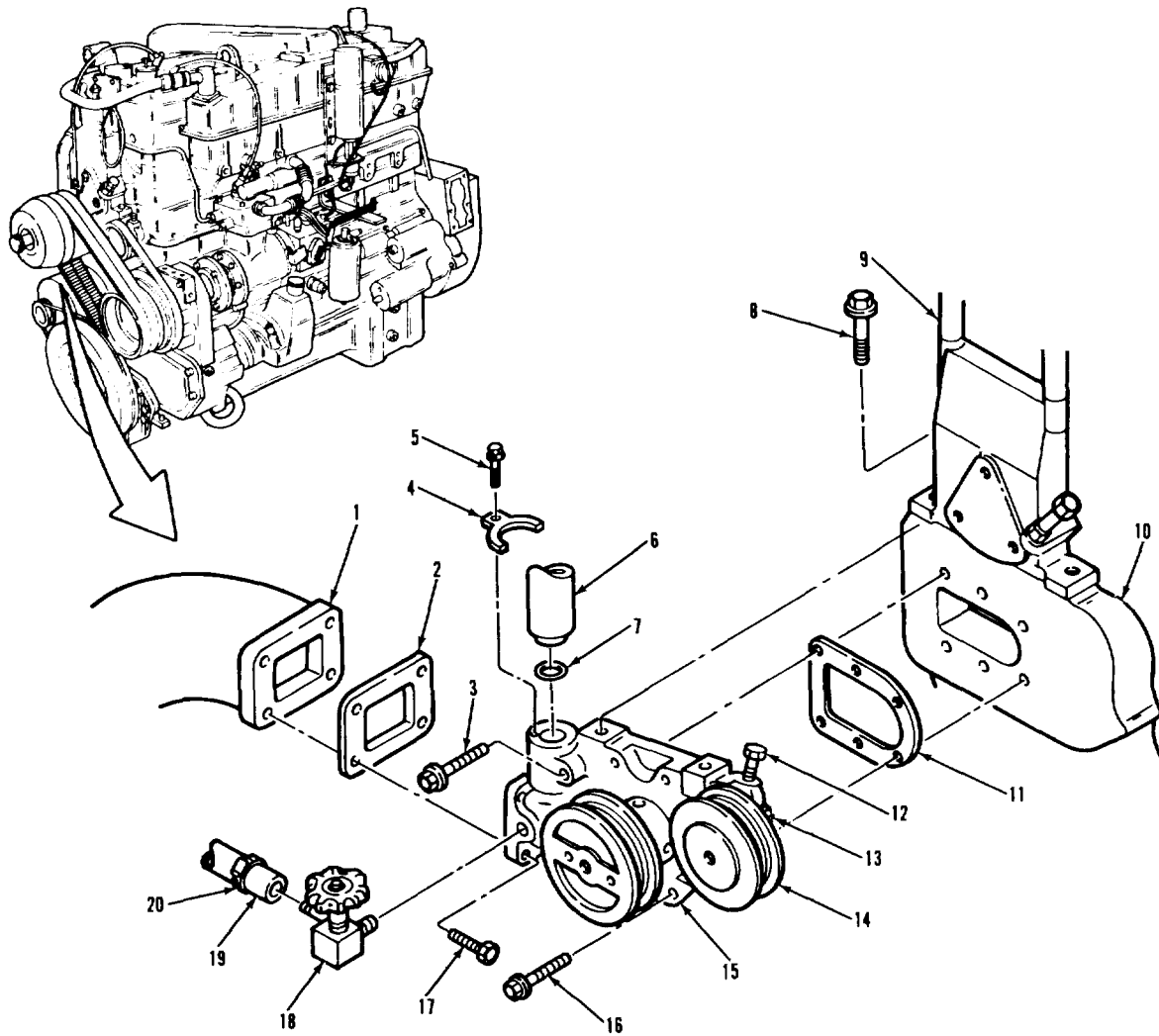

TA 237159

- 1 WATER PUMP TO RADIATOR CONNECTION
- 2 WATER CONNECTION GASKET
- 3 SCREW WITH CAPTIVE WASHER (2)
- 4 TUBE CLAMP
- 5 HEXAGON HEAD SCREW WITH CAPTIVE WASHER
- 6 WATER BYPASS TUBE
- 7 O-RING
- 8 SCREW WITH CAPTIVE WASHER (2)
- 9 FAN BRACKET
- 10. ENGINE BLOCK

- 11 WATER PUMP GASKET
- 12 HEXAGON SCREW
- 13 HEXAGON NUT
- 14 IDLER PULLEY
- 15 WATER PUMP ASSEMBLY
- 16 SCREW WITH CAPTIVE WASHER (4)
- 17 SCREW (4)
- 18 WATER SHUTOFF VALVE AND STREET ELBOW
- 19 WATER HOSE
- 20. HOSE CLAMP

COOLING SYSTEM.

3-64. WATER PUMP REPLACEMENT (Continued).

LOCATION/ITEM	ACTION	REMARKS
A. REMOVAL.		
1. Hose (19) and clamp (20).	a. Loosen screw on item (20).	
	b. Pull item (19) off of item (18).	Leave item (20) on item (19).
2. Two screws (8).	Remove from items (9) and (15).	
3. Nut (13).	Loosen, but do not remove.	
4. Screw (12).	Screw in, raising item (14) until it is clear of all items (16).	
5. Four screws (16) and two screws (3).	Remove from items (15) and (10).	
6. Screw (5) and clamp (4).	Remove from item (15).	
7. Four screws (17).	Remove from items (15) and (1).	
8. Pump (15), gasket (2), and gasket (11).	Remove from items (1), (6), and (10).	Have suitable container ready to catch coolant from item (15). Use soft faced mallet to remove item (15). Discard items (2) and (11).

COOLING SYSTEM.

3-64. WATER PUMP REPLACEMENT (Continued).

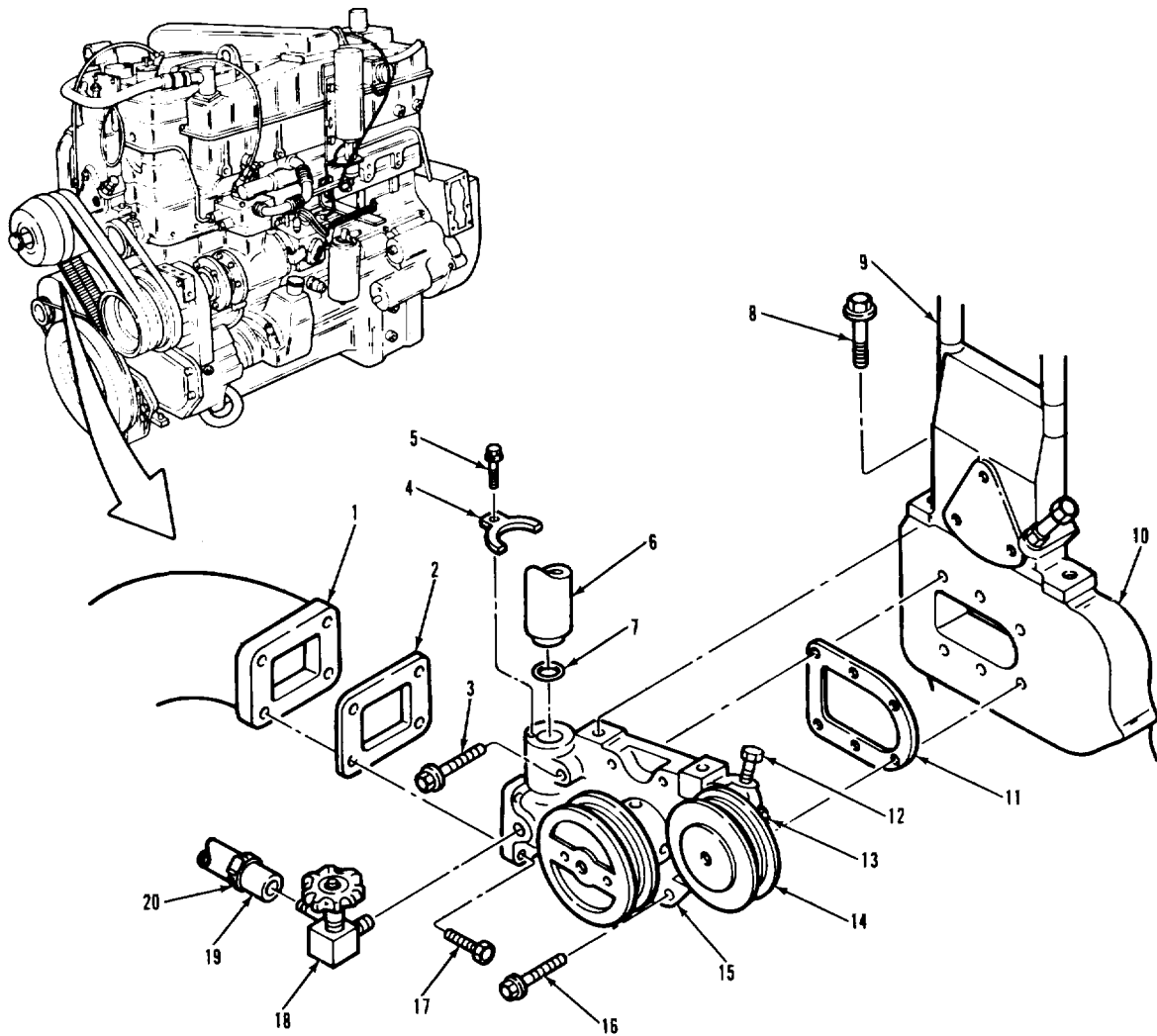

- 1 WATER PUMP TO RADIATOR CONNECTION
- 2 WATER CONNECTION GASKET
- 3 SCREW WITH CAPTIVE WASHER (2)
- 4 TUBE CLAMP
- 5 HEXAGON HEAD SCREW WITH CAPTIVE WASHER
- 6 WATER BYPASS TUBE
- 7 O-RING
- 8 SCREW WITH CAPTIVE WASHER (2)
- 9 FAN BRACKET
- 10. ENGINE BLOCK

- 11 WATER PUMP GASKET
- 12 HEXAGON SCREW
- 13 HEXAGON NUT
- 14 IDLER PULLEY
- 15 WATER PUMP ASSEMBLY
- 16 SCREW WITH CAPTIVE WASHER (4)
- 17 SCREW (4)
- 18 WATER SHUTOFF VALVE AND STREET ELBOW
- 19 WATER HOSE
- 20. HOSE CLAMP

TA 237160

COOLING SYSTEM.

3-64. WATER PUMP REPLACEMENT (Continued).

LOCATION/ITEM	ACTION	REMARKS
A. REMOVAL (Continued).		
9. Valve and elbow (18).	Remove from item (15).	
10. O-ring (7).	Remove from item (6).	Discard item (7).
B. CLEANING AND INSPECTION.		
11. All parts.	Clean and inspect and 3-5.	Refer to paragraphs 3-4 If item (15) is damaged, refer to DS/GS maintenance.
C. INSTALLATION.		
12. New O-ring (7)	Lubricate and install onto item (6).	
13. Valve and elbow (18)	a Wrap threads with thread sealing tape. b Install into item (15).	Refer to paragraph 3-7.
14. New gasket (2) and new gasket (11).	Hold in place on item (15) with grease.	
15. Pump (15), gasket (2), and gasket (11)	a Position on items (1), (6), and (10) b Secure to item (1) with four items (17) c Secure to item (10) with two items (3) and four items (16).	Be careful not to damage item (7) during installation. Torque items (17) to 30-35 lb-ft. Torque items (3) and (16) 30-35 lb-ft.

COOLING SYSTEM.

3-64. WATER PUMP REPLACEMENT (Continued).

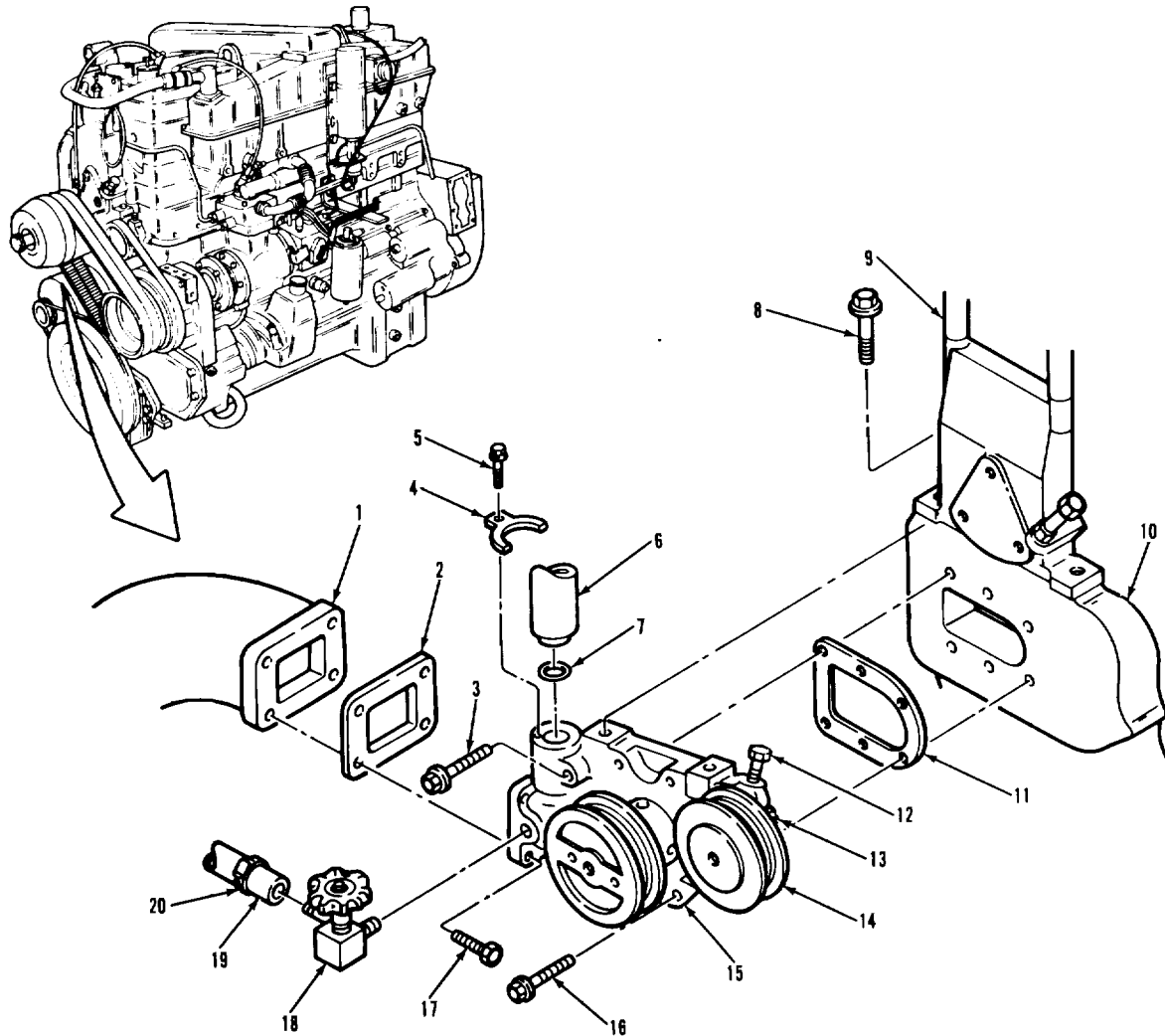

- 1 WATER PUMP TO RADIATOR CONNECTION
- 2 WATER CONNECTION GASKET
- 3 SCREW WITH CAPTIVE WASHER (2)
- 4 TUBE CLAMP
- 5 HEXAGON HEAD SCREW WITH CAPTIVE WASHER
- 6 WATER BYPASS TUBE
- 7 O-RING
- 8 SCREW WITH CAPTIVE WASHER (2)
- 9 FAN BRACKET
- 10 ENGINE BLOCK

- 11 WATER PUMP GASKET
- 12 HEXAGON SCREW
- 13 HEXAGON NUT
- 14 IDLER PULLEY
- 15 WATER PUMP ASSEMBLY
- 16 SCREW WITH CAPTIVE WASHER (4)
- 17 SCREW (4)
- 18 WATER SHUTOFF VALVE AND STREET ELBOW
- 19 WATER HOSE
- 20 HOSE CLAMP

TA 237161

COOLING SYSTEM.

3-64. WATER PUMP REPLACEMENT (Continued).

LOCATION/ITEM	ACTION	REMARKS
C. INSTALLATION (Continued).		
16. Clamp (4).	a. Position on item (15). b. Secure with item (5).	
17. Screw (12).	Unscrew until item (14) is at its lowest position in item (15).	
18. Two screws (8).	Screw into items (9) and (15), and tighten.	
19. Hose (19) and clamp (20).	a. Push end of item (19) onto item (18). b. Push item (20) to end of item (19), and tighten screw.	
<p style="text-align: center;">NOTE</p> Follow-on maintenance action required: Install and adjust water pump drive belt (para 3-63). Install fan and fan clutch (para 3-65). Adjust fan clutch drive belts (para 3-67). Fill cooling system (para 3-52). Start vehicle and check for leaks (TM 9-2320-283-10).		

COOLING SYSTEM.

3-64. WATER PUMP REPLACEMENT (Continued).

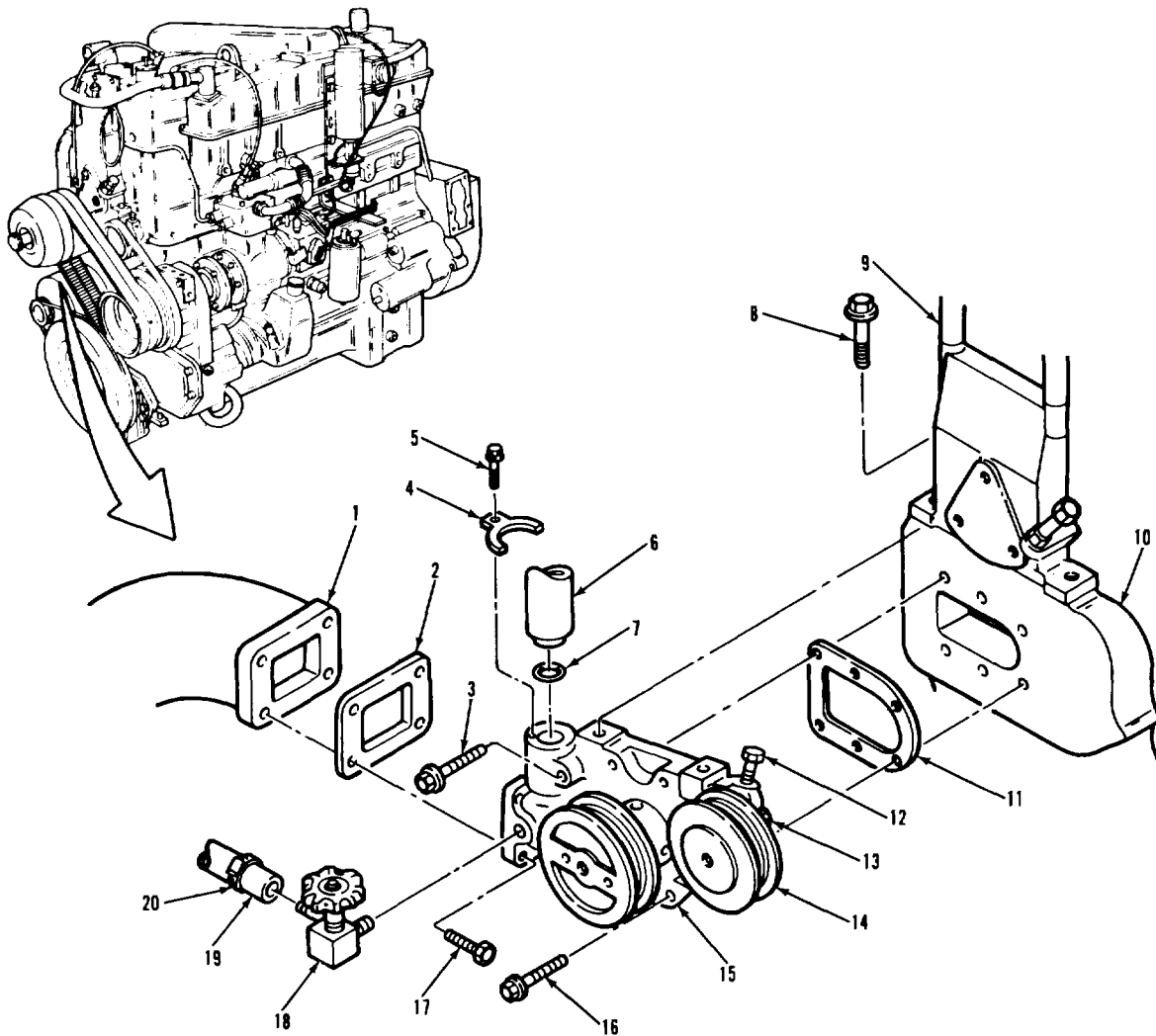

TA237162

- | | | | |
|-----|--|-----|--------------------------------------|
| 1 | WATER PUMP TO RADIATOR CONNECTION | 11 | WATER PUMP GASKET |
| 2 | WATER CONNECTION GASKET | 12 | HEXAGON SCREW |
| 3 | SCREW WITH CAPTIVE WASHER (2) | 13 | HEXAGON NUT |
| 4 | TUBE CLAMP | 14 | IDLER PULLEY |
| 5 | HEXAGON HEAD SCREW WITH CAPTIVE WASHER | 15 | WATER PUMP ASSEMBLY |
| 6 | WATER BYPASS TUBE | 16 | SCREW WITH CAPTIVE WASHER (4) |
| 7 | O-RING | 17 | SCREW (4) |
| 8 | SCREW WITH CAPTIVE WASHER (2) | 18 | WATER SHUTOFF VALVE AND STREET ELBOW |
| 9 | FAN BRACKET | 19 | WATER HOSE |
| 10. | ENGINE BLOCK | 20. | HOSE CLAMP |

COOLING SYSTEM.

3-65. FAN AND FAN CLUTCH REPLACEMENT.

THIS TASK COVERS

- a. Removal.
- b. Cleaning and Inspection.
- c. Installation.
- d. Operational Check.

INITIAL SETUP

APPLICABLE CONFIGURATIONS

All.

EQUIPMENT CONDITION
PARAGRAPH

3-56.

CONDITION DESCRIPTION

Upper fan shroud removed.

TEST EQUIPMENT

None.

SPECIAL TOOLS

None.

MATERIALS/PARTS (P/N)

Tape, thread sealing
Item 32, Appendix C.

PERSONNEL REQUIRED

Two (MOS-63S .

SPECIAL ENVIRONMENTAL CONDITIONS

None.

REFERENCES (TM)

TM 9-2320-283-10.

GENERAL SAFETY INSTRUCTIONS

Engine off.
Transmission in neutral.
Park brake set.

TROUBLESHOOTING REFERENCES

Paragraph 2-11.

COOLING SYSTEM.

3-65. FAN AND FAN CLUTCH REPLACEMENT (Continued).

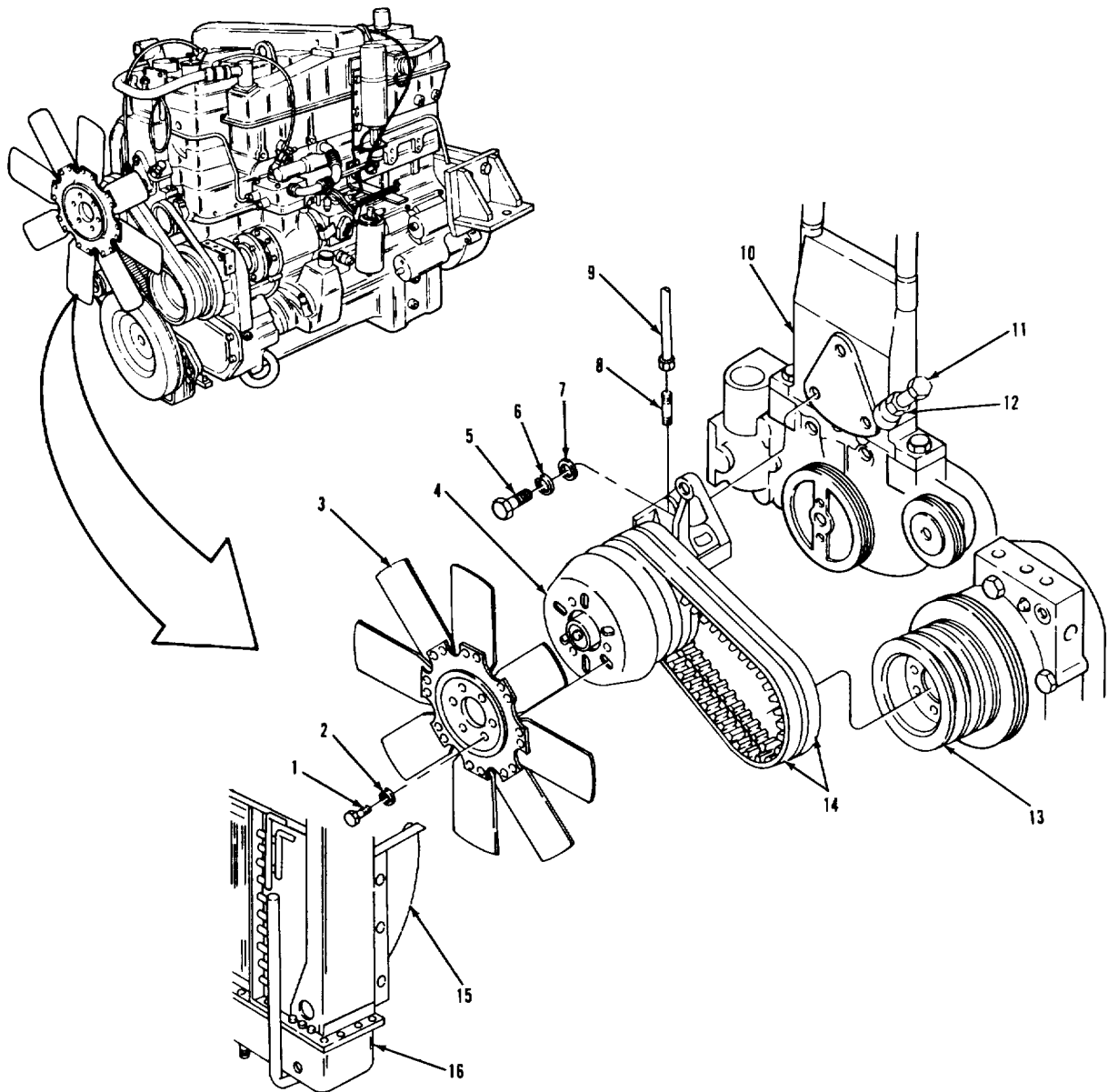

LEGEND:

- | | |
|---------------------------|----------------------------|
| 1. HEXAGON HEAD SCREW (6) | 9. NONMETALLIC TUBE |
| 2. LOCKWASHER (6) | 10. FAN BRACKET |
| 3. FAN ASSEMBLY | 11. ADJUSTING SCREW |
| 4. FAN CLUTCH ASSEMBLY | 12. HEXAGON JAM NUT |
| 5. HEXAGON HEAD SCREW (3) | 13. ACCESSORY DRIVE PULLEY |
| 6. LOCKWASHER (3) | 14. FAN DRIVE BELT (2) |
| 7. HARDENED WASHER (2) | 15. LOWER FAN SHROUD |
| 8. NIPPLE | 16. RADIATOR ASSEMBLY |

TA 237163

COOLING SYSTEM.

3-65. FAN AND FAN CLUTCH REPLACEMENT (Continued).

LOCATION/ITEM	ACTION	REMARKS
---------------	--------	---------

A:	REMOVAL.
----	----------

1	Six screws (1) and lockwashers (2)	Remove from items (3) and (4).	
2	Fan (3) set inside item (15)	Remove from item (4) and item (16).	Be careful not to damage
3	Tube (9)	Remove from item (8).	
4	Three screws (5)	Loosen, but do not take out.	
5	Nut (12) and screw (11)	Loosen until two items (14) can be removed.	
6	Two belts (14)	Remove from item (13).	

WARNING

Fan clutch is very heavy. To avoid injury to personnel or damage to radiator, have assistant hold fan clutch during steps 7 and 8.

7	Three screws (5), lockwashers (6), and two washers (7).	Remove from items (4) and (10)	Have assistant use two items (14) to hold item (4).
8	Clutch (4)	Remove from item (10)	Remove items (14) from item (4).
9	Nipple (8)	Remove from item (4).	
10	Fan (3)	Remove from item (15).	

COOLING SYSTEM.

3-65. FAN AND FAN CLUTCH REPLACEMENT (Continued).

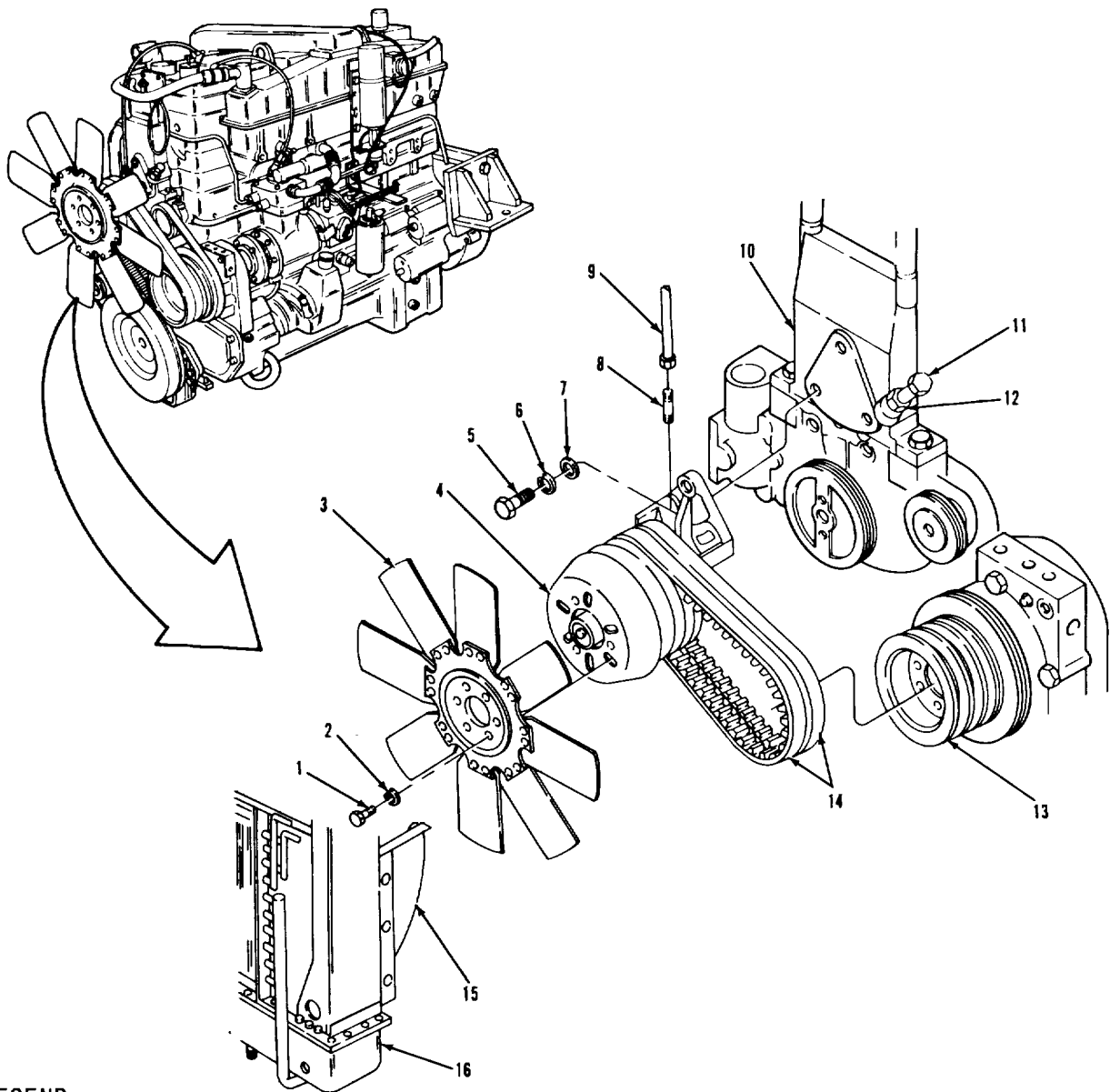

LEGEND:

- | | |
|---------------------------|----------------------------|
| 1. HEXAGON HEAD SCREW (6) | 9. NONMETALLIC TUBE |
| 2. LOCKWASHER (6) | 10. FAN BRACKET |
| 3. FAN ASSEMBLY | 11. ADJUSTING SCREW |
| 4. FAN CLUTCH ASSEMBLY | 12. HEXAGON JAM NUT |
| 5. HEXAGON HEAD SCREW (3) | 13. ACCESSORY DRIVE PULLEY |
| 6. LOCKWASHER (3) | 14. FAN DRIVE BELT (2) |
| 7. HARDENED WASHER (2) | 15. LOWER FAN SHROUD |
| 8. NIPPLE | 16. RADIATOR ASSEMBLY |

TA 237164

COOLING SYSTEM.

3-65. FAN AND FAN CLUTCH REPLACEMENT (Continued).

LOCATION/ITEM	ACTION	REMARKS
---------------	--------	---------

B. CLEANING AND INSPECTION.

11	All parts	Clean and inspect	Refer to paragraphs 3-4 and 3-5 If item (4) is damaged, refer to DS/GS maintenance. If either item (14) is damaged, replace both items (14).
----	-----------	-------------------	--

C. INSTALLATION.

12	Fan (3)	Set inside item (15)	Be careful not to damage item (16) Numbers on item (3) must face item (16).
13	Nipple (8)	a Wrap threads with thread sealing tape. b Install into item (4).	Refer to paragraph 3-7.

WARNING

Fan clutch is very heavy. To avoid injury to personnel or damage to radiator, have assistant hold fan clutch during step 14.

14	Clutch (4)	a Position on item (10) b Secure with three items (5), (6), and two items (7).	Have assistant use two items (14) to hold item (4). Two items (7) are used with lower two items (5). Do not tighten items (5).
----	------------	---	---

COOLING SYSTEM.

3-65. FAN AND FAN CLUTCH REPLACEMENT (Continued).

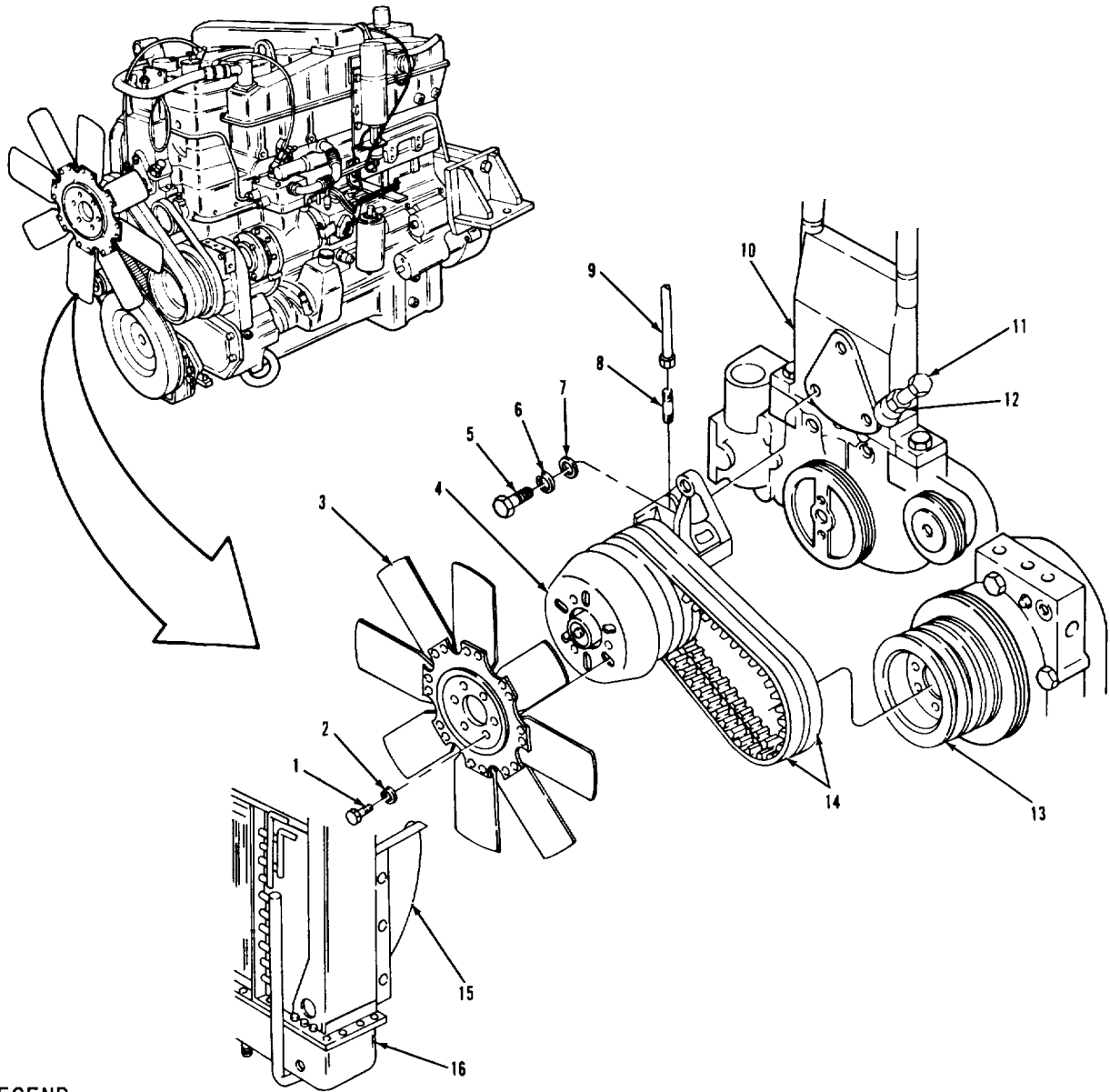

LEGEND:

- | | |
|---------------------------|----------------------------|
| 1. HEXAGON HEAD SCREW (6) | 9. NONMETALLIC TUBE |
| 2. LOCKWASHER (6) | 10. FAN BRACKET |
| 3. FAN ASSEMBLY | 11. ADJUSTING SCREW |
| 4. FAN CLUTCH ASSEMBLY | 12. HEXAGON JAM NUT |
| 5. HEXAGON HEAD SCREW (3) | 13. ACCESSORY DRIVE PULLEY |
| 6. LOCKWASHER (3) | 14. FAN DRIVE BELT (2) |
| 7. HARDENED WASHER (2) | 15. LOWER FAN SHROUD |
| 8. NIPPLE | 16. RADIATOR ASSEMBLY |

TA 237165

COOLING SYSTEM.

3-65. FAN AND FAN CLUTCH REPLACEMENT (Continued).

LOCATION/ITEM	ACTION	REMARKS
C. INSTALLATION (Continued).		
15 Two belts (14)	a Install on items (4) and (13).	
16 Tube (9)	b Adjust Install on item (8).	Refer to paragraph 3-67.
17 Fan (3)	a Lift out of item (15) and position on item (4). b Secure with six items (1) and (2)	Torque items (1) to 25-31 lb-ft.
18 Upper fan shroud	Install	Refer to paragraph 3-56.
D. OPERATIONAL CHECK.		
19 Engine	Start	Refer to TM 9-2320-283-10.
20 Fan (3)	a With temperature below 190°F and air system pressure below 75 psi, item (3) should be rotating b When air system pressure reaches 70-75 psi or more, item (3) should not be rotating. c With temperatures at or above 190°F, item (3) should rotate.	
21 Engine	Shutdown.	
NOTE		
Follow-on maintenance action required:		
None.		

COOLING SYSTEM.

3-65. FAN AND FAN CLUTCH REPLACEMENT (Continued).

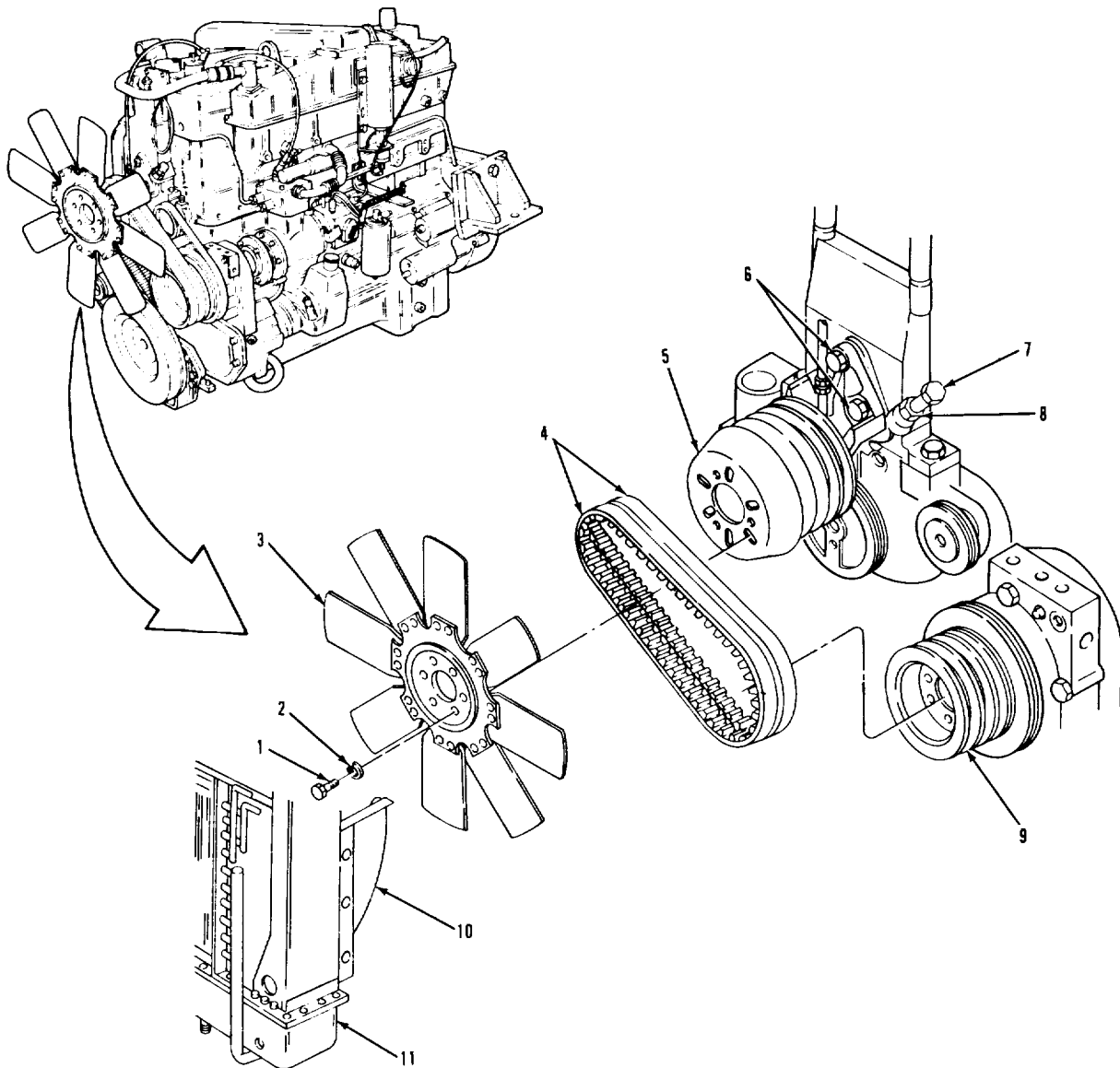

LEGEND:

- | | |
|---------------------------|----------------------------|
| 1. HEXAGON HEAD SCREW (6) | 9. NONMETALLIC TUBE |
| 2. LOCKWASHER (6) | 10. FAN BRACKET |
| 3. FAN ASSEMBLY | 11. ADJUSTING SCREW |
| 4. FAN CLUTCH ASSEMBLY | 12. HEXAGON JAM NUT |
| 5. HEXAGON HEAD SCREW (3) | 13. ACCESSORY DRIVE PULLEY |
| 6. LOCKWASHER (3) | 14. FAN DRIVE BELT (2) |
| 7. HARDENED WASHER (2) | 15. LOWER FAN SHROUD |
| 8. NIPPLE | 16. RADIATOR ASSEMBLY |

TA 237166

COOLING SYSTEM.

3-66. FAN CLUTCH AIR VALVE REPLACEMENT.

THIS TASK COVERS

- a. Removal.
- b. Cleaning and Inspection.
- c. Installation.
- d. Operational Check.

INITIAL SETUP

APPLICABLE CONFIGURATIONS

All.

EQUIPMENT CONDITION
PARAGRAPH

TM 9-2320-283-10.

CONDITION DESCRIPTION

Air drained from air system.

TEST EQUIPMENT

None.

3-52.

Coolant drained below level of fan clutch air valve.

SPECIAL TOOLS

None.

MATERIALS/PARTS 5P/N)

Tape, thread sealing
Item 32, Appendix C.

PERSONNEL REQUIRED

One (MOS-63S).

SPECIAL ENVIRONMENTAL CONDITIONS

None.

REFERENCES (TM)

TM 9-2320-283-10.

GENERAL SAFETY INSTRUCTIONS

Engine off.
Transmission in neutral.
Park brake set.

TROUBLESHOOTING REFERENCES

Paragraph 2-11.

COOLING SYSTEM.

3-66. FAN CLUTCH AIR VALVE REPLACEMENT (Continued).

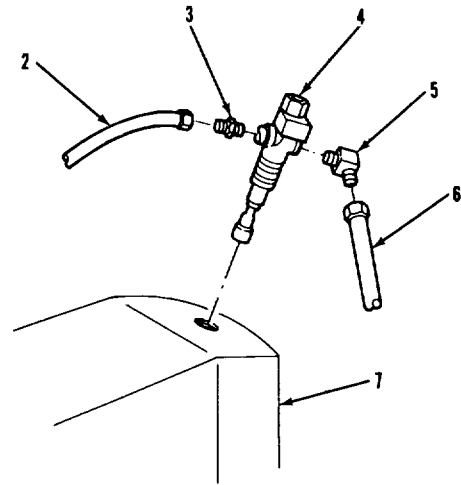
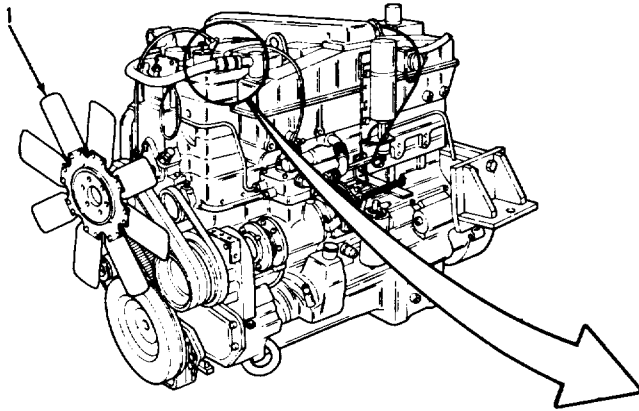

TA 237167

LEGEND:

- 1. FAN ASSEMBLY
- 2. NONMETALLIC TUBE
- 3. MALE CONNECTOR
- 4. AIR SHUTTERSTAT VALVE

- 5. ELBOW
- 6. NONMETALLIC TUBE
- 7. FRONT WATER MANIFOLD

COOLING SYSTEM.

3-66. FAN CLUTCH AIR VALVE REPLACEMENT (Continued).

LOCATION/ITEM	ACTION	REMARKS
A. REMOVAL.		
1 Tube (2) and tube (6)	Remove from items (3) and (5)	Tag items (2) and (6) to insure proper installation.
2 Valve (4) with connector (3) and elbow (5) attached.	Remove from item (7).	
3 Connector (3) and elbow (5).	Remove from item (4).	
B. CLEANING AND INSPECTION.		
4. All parts.	Clean and inspect.	Refer to paragraphs 3-4 and 3-5.
C. INSTALLATION.		
5. Connector (3) and elbow (5).	a. Wrap threads with thread sealing tape. b. Install into item (4).	
6. Valve (4) with connector (3) and elbow (5) attached.	a. Wrap threads with thread sealing tape. b. Install into item (7).	
7. Tube (2) and tube (6).	Install on items (3) and (5).	
8. Cooling system.	Fill.	Refer to paragraph 3-52.

COOLING SYSTEM.

3-66. FAN CLUTCH AIR VALVE REPLACEMENT (Continued).

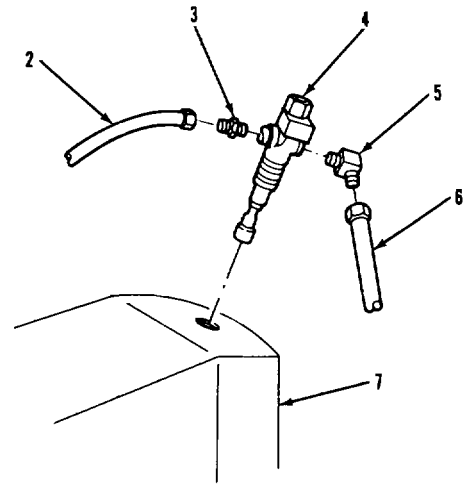
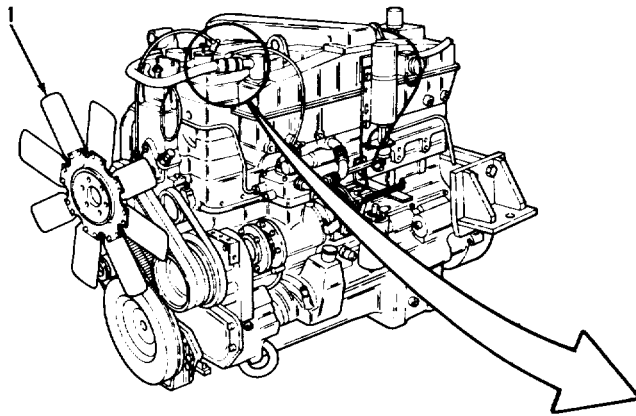

TA 237168

LEGEND:

- 1 FAN ASSEMBLY
- 2 NONMETALLIC TUBE
- 3 MALE CONNECTOR
- 4 AIR SHUTTERSTAT VALVE

- 5 ELBOW
- 6 NONMETALLIC TUBE
- 7 FRONT WATER MANIFOLD

COOLING SYSTEM.

3-66. FAN CLUTCH AIR VALVE REPLACEMENT (Continued).

LOCATION/ITEM	ACTION	REMARKS
D. OPERATIONAL CHECK.		
9 Engine	Start	Refer to TM 9-2320-283-10.
10 Fan (1)	a With air system pressure above 75 psi and engine water temperature below 190°F, item (1) should not be rotating.	
	b When engine water temperature reaches 190°F, item (1) should begin rotating.	
11 Engine	Shutdown	Refer to TM 9-2320-283-10.
NOTE		
Follow-on maintenance action required:		
None.		

COOLING SYSTEM.

3-66. FAN CLUTCH AIR VALVE REPLACEMENT (Continued).

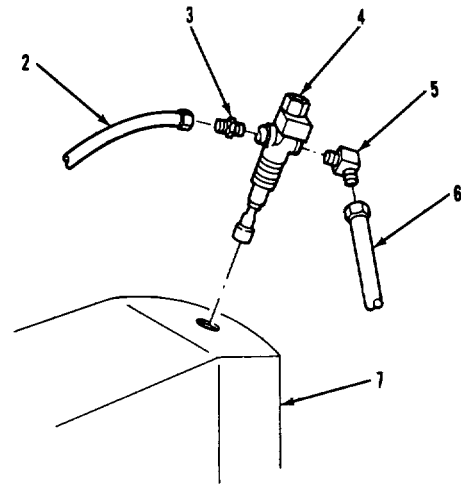
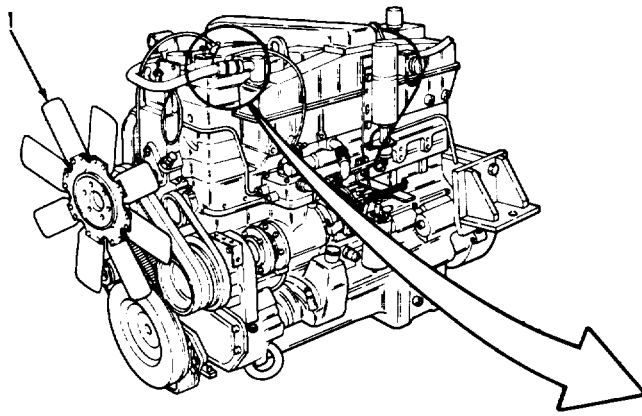

TA 237169

LEGEND:

- 1 FAN ASSEMBLY
- 2 NONMETALLIC TUBE
- 3 MALE CONNECTOR
- 4 AIR SHUTTERSTAT VALVE

- 5 ELBOW
- 6 NONMETALLIC TUBE
- 7 FRONT WATER MANIFOLD

COOLING SYSTEM.

3-67. FAN CLUTCH DRIVE BELTS REPLACEMENT.

THIS TASK COVERS

- a. Removal.
- b. Installation.
- c. Adjustment.

INITIAL SETUP

EQUIPMENT CONDITION

APPLICABLE CONFIGURATIONS

All.

PARAGRAPH

None.

CONDITION DESCRIPTION

None.

TEST EQUIPMENT

Belt tension gage.

SPECIAL TOOLS

None.

MATERIALS/PARTS (P/N)

None.

PERSONNEL REQUIRED

One (MOS-63S .

SPECIAL ENVIRONMENTAL CONDITIONS

None.

REFERENCES (TM)

TM 9-2320-283-20P.

Transmission in neutral.

Park brake set.

TROUBLESHOOTING REFERENCES

Paragraph 2-11.

GENERAL SAFETY INSTRUCTIONS

Engine off.

COOLING SYSTEM.

3-67. FAN CLUTCH DRIVE BELTS REPLACEMENT (Continued).

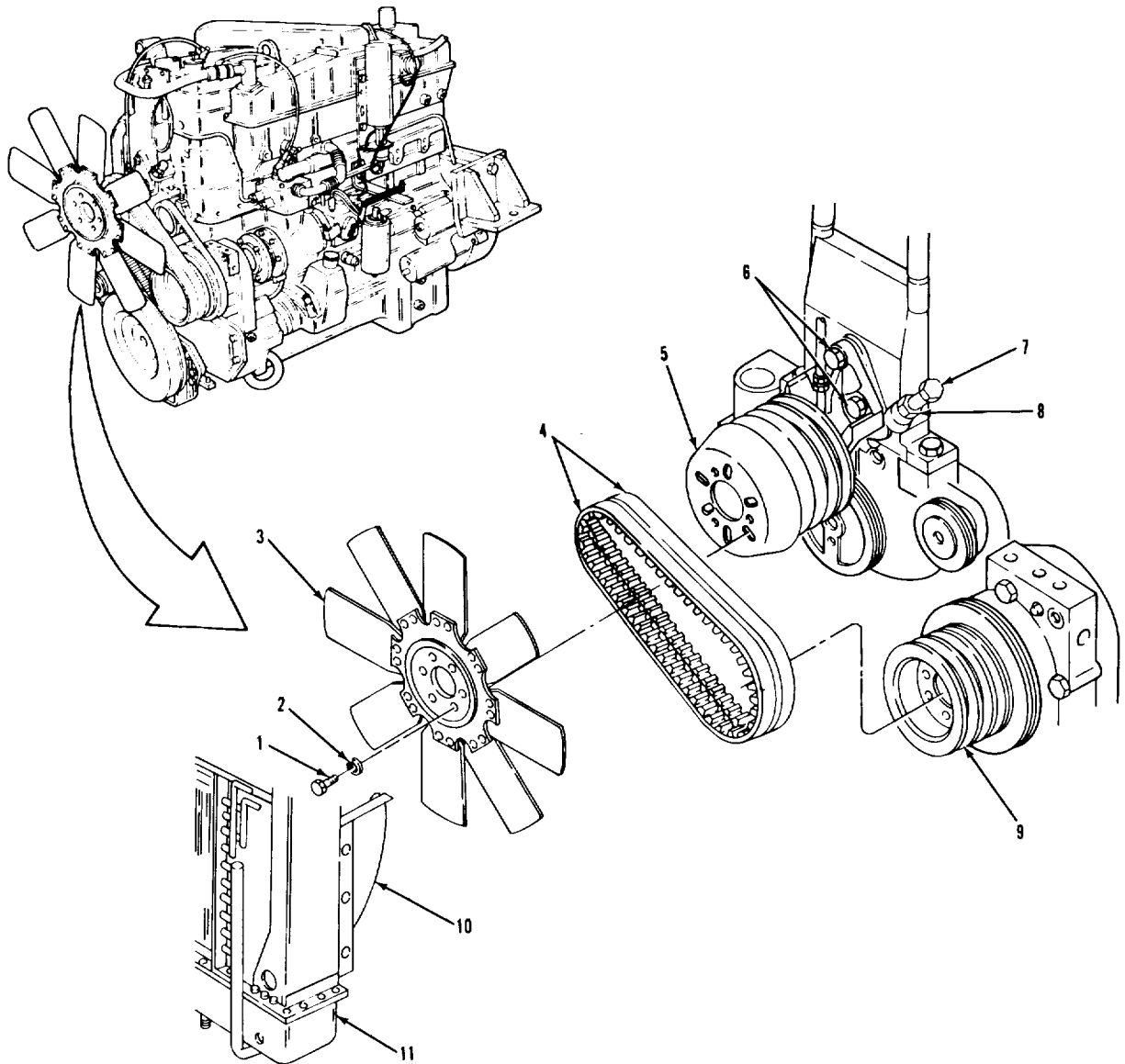

TA 237170

LEGEND:

- | | | | |
|---|------------------------|----|------------------------|
| 1 | HEXAGON HEAD SCREW (6) | 7 | ADJUSTING SCREW |
| 2 | LOCKWASHER (6) | 8 | HEXAGON JAM NUT |
| 3 | FAN ASSEMBLY | 9 | ACCESSORY DRIVE PULLEY |
| 4 | FAN DRIVE BELT (2) | 10 | LOWER FAN SHROUD |
| 5 | FAN CLUTCH ASSEMBLY | 11 | RADIATOR ASSEMBLY |
| 6 | HEXAGON HEAD SCREW (3) | | |

COOLING SYSTEM.

3-67. FAN CLUTCH DRIVE BELTS REPLACEMENT (Continued).

LOCATION/ITEM	ACTION	REMARKS	
A. REMOVAL.			
1	Upper fan shroud	Remove	Refer to paragraph 3-56.
2	Six screws (1) and lockwashers (2)	Remove from items (3) and (5).	
3	Fan (3)	Remove from item (5) and set inside item (10)	Be careful not to damage item (11).
4	Three screws (6)	Loosen, but do not remove.	
5	Nut (8) and screw (7)	Loosen until two items (4) can be removed.	
6	Two belts (4) and (9).	a Remove from items (5) b Clean and inspect	Refer to paragraphs 3-4 and 3-5. If either item (4) is damaged, replace both items (4).
B. INSTALLATION.			
7	Two belts (4) (9).	Install on item (5) and	
8	Fan (3)	a Lift out of item (10) and position on item (5). b Secure with six items (1) and (2)	Torque items (1) to 25-31 lb-ft.
9	Upper fan shroud	Install	Refer to paragraph 3-56.

COOLING SYSTEM.

3-67. FAN CLUTCH DRIVE BELTS REPLACEMENT (Continued).

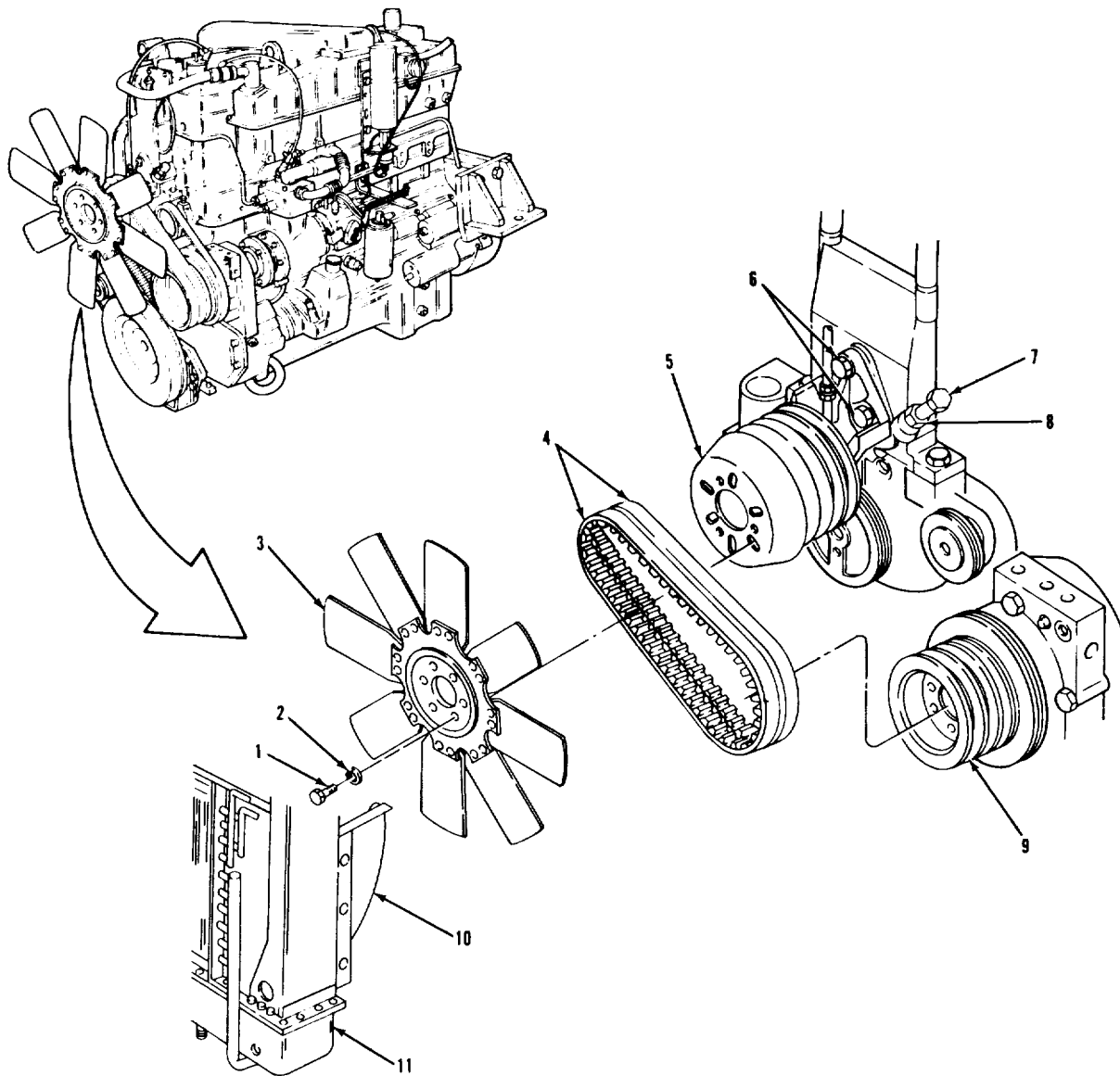

LEGEND:

- | | | | |
|---|------------------------|----|------------------------|
| 1 | HEXAGON HEAD SCREW (6) | 7 | ADJUSTING SCREW |
| 2 | LOCKWASHER (6) | 8 | HEXAGON JAM NUT |
| 3 | FAN ASSEMBLY | 9 | ACCESSORY DRIVE PULLEY |
| 4 | FAN DRIVE BELT (2) | 10 | LOWER FAN SHROUD |
| 5 | FAN CLUTCH ASSEMBLY | 11 | RADIATOR ASSEMBLY |
| 6 | HEXAGON HEAD SCREW (3) | | |

TA 237171

COOLING SYSTEM.

3-67. FAN CLUTCH DRIVE BELTS REPLACEMENT (Continued).

LOCATION/ITEM	ACTION	REMARKS
C. ADJUSTMENT.		
10 Screw (7) and two belts (4)	Adjust until belt tension is 120 lb-ft for new belts or 100 lb-ft for used belts as measured with belt tension Gage.	Loosen three items (6), if not already done. Make sure item (8) is loose during adjustment. Used belts are those that have more than 1,000 miles of use.
11 Three screws (6)	Torque to 70-85 lb-ft.	Belt tension should be the same as measured in step 10. If not, repeat steps 10, 11, and 12.
12 Two belts (4)	Recheck tension using belt tension gage	
13 Nut (8)	Tighten with holding item 1(7).	
<p>NOTE Follow-on maintenance action required: None.</p>		

COOLING SYSTEM.

3-67. FAN CLUTCH DRIVE BELTS REPLACEMENT (Continued).

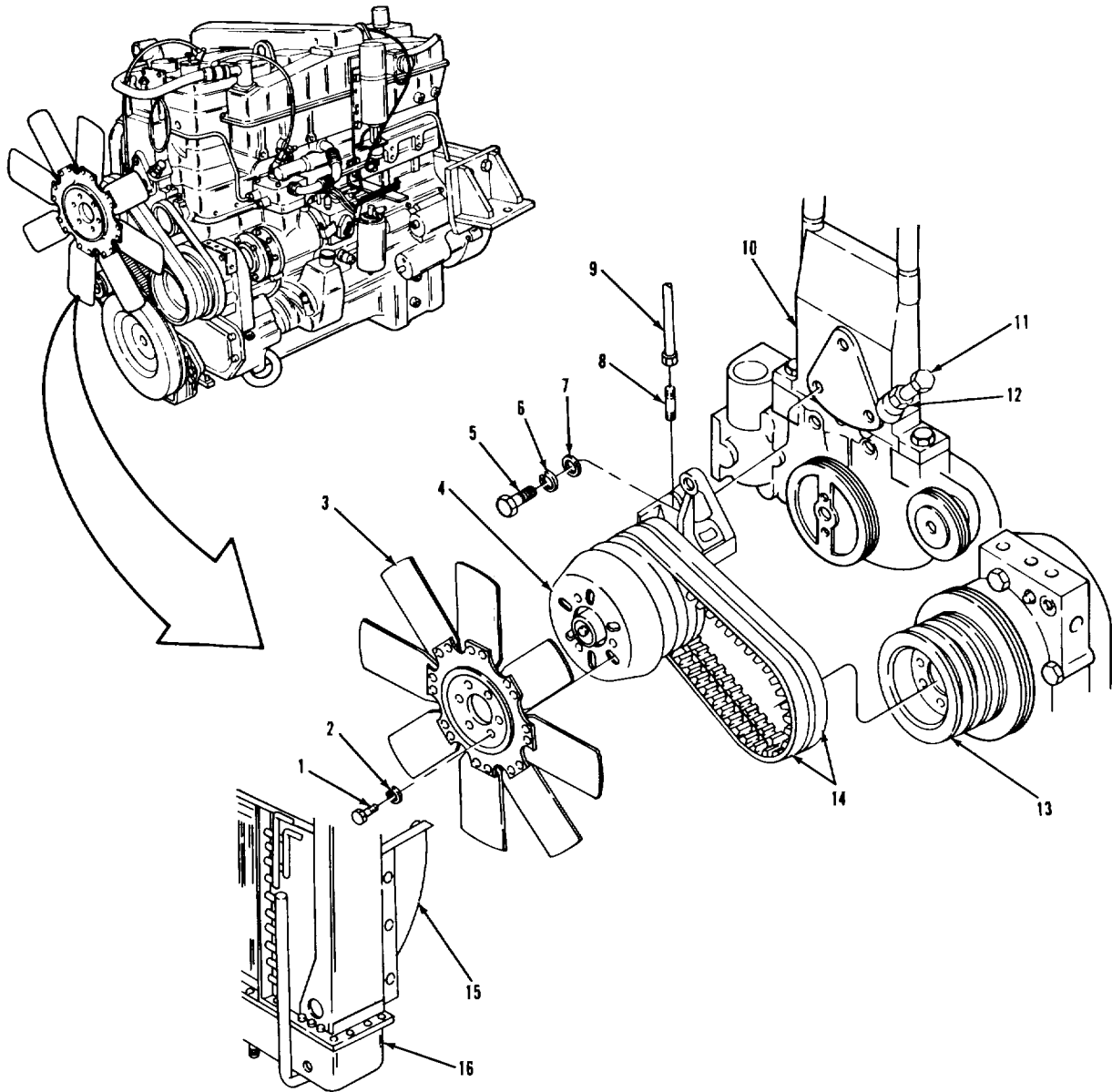

LEGEND:

- | | | | |
|---|------------------------|----|------------------------|
| 1 | HEXAGON HEAD SCREW (6) | 7 | ADJUSTING SCREW |
| 2 | LOCKWASHER (6) | 8 | HEXAGON JAM NUT |
| 3 | FAN ASSEMBLY | 9 | ACCESSORY DRIVE PULLEY |
| 4 | FAN DRIVE BELT (2) | 10 | LOWER FAN SHROUD |
| 5 | FAN CLUTCH ASSEMBLY | 11 | RADIATOR ASSEMBLY |
| 6 | HEXAGON HEAD SCREW (3) | | |

TA 237172

ALPHATICAL INDEX

Subject, Para**A**

Accelerator Pedal and Linkage Replacement, 3-41
 Accessory Items Maintenance Task Summary, 3-286
 Adjuster Replacement, Slack, 3-157
 Adjustment, Fifth Wheel, 3-244
 Air Cleaner Assembly Replacement, 3-29
 Air Cleaner Filter Element Replacement, 3-30
 Air Cleaner Restriction Gage and Bracket Replacement, 3-315
 Air Cleaner Restriction Gage Tube Replacement, 3-316
 Air Cleaner Tube Replacement, 3-32
 Air Crossover Connection Replacement, Turbocharger, 3-31
 Air Compressor Cooling Tubes Replacement, 3-18
 Air Compressor Intake Tube Replacement, 3-19
 Air Diffuser Assembly Replacement, 3-302
 Air Dryer Dehydrate Cartridge Replacement, 3-200
 Air Dryer Mounting Bracket Replacement, 3-227
 Air Dryer Repair, 3-19

Subject, Para

Air Dryer Replacement, 3-198
 Air Horn and Control Valve Replacement, 3-289
 Air Lines and Fittings Replacement, Brake System, 3-163
 Alinement, Front Wheel, 3-203
 Alternator and Bracket Replacement, 3-70
 Alternator Drive Belts Replacement, 3-71
 Anchor Pin Replacement, 3-161
 Assembly, General Maintenance Instructions 3-7
 Auxiliary Air-Powered Systems, Principles of Operation, 1-21

B

Battery Box Latch Replacement, 3-123
 Battery Box Replacement, 3-122
 Battery Cable Replacement, 2-124
 Battery Charging, 3-119
 Battery Power Disconnect and Connect Procedure, 3-120
 Battery Replacement, 3-121
 Bearings Replacement, Front, 3-205
 Bearings Replacement, Rear, 3-207

ALPHABETIC INDEX (Continued)

Subject, Para**B**

Belts, Replacement, Alternator Drive 3-71

Belts Replacement, Fan Clutch Drive 3-67

Belt Replacement, Seat, 3-282

Belt Replacement, Water Pump Drive, 3-63

Blackout Headlamp Assembly Replacement, 3-95

Blackout Marker Lamp and Headlamp Cable Replacement, 3-129

Blackout Marker Lamp Assembly Replacement, 3-94

Blackout Taillamp Assembly Replacement, 3-97

Blackout Taillamp Mounting Bracket Replacement, 3-233

Blackout Toggle Switch Replacement, 3-79

Blade Replacement, Wiper, 3-293

Box Replacement, Battery, 3-122

Brace Replacement, Fan, 3-24

Brace Replacement, Oil Level Dipstick Tube, 3-17

Bracket Replacement, Air Cleaner Restriction, 3-315

Bracket Replacement, Alternator, 3-70

Subject, Para

Bracket Replacement, Blackout Taillamp Mounting, 3-233

Bracket Replacement, Camshaft, 3-160

Bracket Replacement, Engine Lifting, 3-22

Bracket Replacement, Fire Extinguisher, 3-284

Bracket Replacement, Manual Reset Circuit Breaker, 3-114

Bracket Replacement, Padlock, 3-262

Bracket Replacement, Rear Mud Flap, 3-274

Bracket Replacement, Rear Tow Eye, 3-235

Bracket Replacement, Shifter Control Mounting, 3-139

Bracket Replacement, STE/ICE Connector, 3-131

Bracket Replacement, Taillamp, 3-234

Bracket Replacement, Trailer Receptacle, 3-130

Bracket Replacement, Transmission

Oil Filter Mounting, 3-231

Bracket Replacement, Water Filter Tube, 3-62

Bracket Replacement, Water Transfer, 3-21

Bracket Replacement, Trailer Coupling, 3-196

ALPHABETIC INDEX (Continued)

Subject, Para

Brake Assembly Replacement, 3-158

Brake Chamber Replacement, Forward Rear Axle, 3-166

Brake Chamber Replacement, Front Axle and Rear-Rear Axle, 3-164

Brake Chamber Repair, Front Axle and Rear-Rear Axle, 3-165

Brake Shoe Replacement, 3-159

Brake System Maintenance Task Summary, 3-156

Brake System, Principles of Operation, 1-20

Brake Treadle Valve Replacement, 3-174

Breather Tubes and Hoses Replacement 3-15

Brush Guard Replacement, 3-236

Bumper, Towing Eyes, and Vehicle Class Sign Replacement, 3-237

Button Replacement, Horn, 3-118

Buzzer Replacement, Low Air Pressure, 3-110

C

Cab and Body Maintenance Task Summary 3-253

Cab Clearance Lamp Assembly Replacement, 3-93

Cab Headliner Panel Replacement, 3-275

Subject, Para

Cab Heating and Ventilating System, Principles of Operation, 1-23

Cab Trim Panel Replacement, 3-276

Cable Replacement, Battery, 3-124

Cable Replacement, Blackout Marker Lamp, 3-129

Cable Replacement, Headlamp, 3-129

Cable Replacement, Shifter Control 3-138

Cable Replacement, Spare Tire Winch, 3-241

Cable Replacement, Ground, 3-128

Camshaft and Camshaft Bracket Replacement, 3-160

Cap Replacement, Rocker Cover Filler, 3-14

Carrier Replacement, Spare Tire, 3-240

Cartridge Replacement, Air Dryer Dehydrate, 3-200

Center Floor Pan Access Cover Replacement, 3-260

Charging, Battery, 3-119

Checking Unpacked Equipment, Service Upon Receipt, 2-5

Cigar Lighter Replacement, 3-83

Clamp Replacement, Oil Level Dipstick Tube, 3-17

Cleaning, General Maintenance Instructions, 3-4

ALPHABETIC INDEX (Continued)

Subject, Para

Clearance Lamp Replacement, 3-8
 Clevis Pin Replacement, 3-230
 Clutch Replacement, Fan, 3-65
 Column Repair, Lower Steering, 3-215
 Column Repair, Upper Steering, 3-215
 Column Replacement, Lower Steering, 3-215
 Column Replacement, Upper Steering, 3-214
 Common Tools and Equipment, 2-2
 Companion Seat Replacement, 3-2
 Companion Seat Riser, Fire Extinguisher, Brackets, and Tool Box Replacement, 3-284
 Compressed Air System, Principle of Operation, 1-19
 Connect Procedure, Battery Power 3-120
 Control Replacement, Modulator, 3-140
 Control Replacement, Shifter, 3
 Cooler Replacement, Transmission and Steering System, 3-55
 Control Replacement, Windshield Wiper, 3-292
 Cooling System Maintenance Task Summary, 3-51
 Cooling System, Principles of Operation, 1-14

Subject, Para

Cooling System Service, 3-52
 Cooling Tubes Replacement, Air Compressor, 3-18
 Couplings Replacement, Front External Air, 3-167
 Couplings Replacement, Trailer, 3-196
 Cover Replacement, Center Floor Pan Access, 3-260
 Cover Replacement, Rocker, 3-13
 Cylinder Replacement, Ether, 3-38

D

Data and Instruction Plates Replacement, 3-305
 Data Plate Replacement, Engine, 3-23
 Deck Replacement, Service, 3-239
 Defroster Fan Repair, 3-304
 Defroster Fan Replacement, 3-303
 Deprocessing Unpacked Equipment, Service Upon Receipt, 2-6
 Destruction of Army Materiel to Prevent Enemy Use, 1-4
 Differential Lock Pressure Switch Replacement, 3-107
 Differential Toggle Valve Replacement, 3-195
 Diode Replacement, Starting Circuit, 3-116

ALPHABETIC INDEX (Continued)

Subject, Para

Dipstick Replacement, Oil Level, 3-16
 Dipstick Tube Replacement, Oil Level 3-17
 Disconnect Procedure, Battery Power, 3-120
 Dome Lamp and Switch Replacement, 3-98
 Door Assembly Replacement, Glove Compartment, 3-257
 Door Frame Seal Replacement, 3-266
 Door Mirror Replacement, 3-287
 Door Plate Replacement, 3-265
 Double Check and Quick Release Valve Replacement, 3-182
 Double Check and Stop lamp Valve Replacement, 3-183
 Draincock Replacement, Primary and Secondary Reservoir, 3-188
 Driver's Seat Replacement, 3-280 Driver's Seat Riser Replacement, 3-281
 Drum Replacement, Front, 3-204 Drum Replacement, Rear Brake, 3-206
 Dryer Repair, Air, 3-199
 Dryer Replacement, Air, 3-198
 Dust Shield Replacement, 3-162

Subject, Para**E**

Electrical System Maintenance Task Summary, 3-69
 Engine Data Plate Replacement, 3-23
 Engine Fuel Lines and Fittings Replacement, 3-28
 Engine Lifting Bracket Replacement, 3-22
 Engine Maintenance Task Summary, 3-11
 Engine Oil Service, 3-12
 Engine, Principles of Operation, 1-11
 Engine Retarder Foot Switch Replacement, 3-89
 Equipment Characteristics, Capabilities, and Features, 1-8
 Equipment Data, 1-10
 Ether Cylinder Replacement, 3-38
 Ether Lamp and Clearance Lamp Replacement, 3-85
 Ether Quick Start Kit Replacement, 3-40
 Ether Quick Start Thermostat Replacement, 3-39
 Ether Start Switch Replacement, 3-76
 Exhaust Flex Pipe Replacement, 3-47
 Exhaust Stack Pipe Replacement, 3-46

ALPHABETIC INDEX

Subject, Para

Exhaust System Maintenance Task Summary, 3-44
 Exhaust System, Principles of Operation, 1-13
 External Air Couplings Replacement Front, 3-167
 Electrical System, Principles of Operation, 1-15

F

Fan and Fan Clutch Replacement,
 Fan Brace, Bracket, and Spacers Replacement, 3-24
 Fan Clutch Air Valve Replacement, 3-66
 Fan Clutch Drive Belts Replacement 3-67
 Fan Repair, Defroster, 3-304
 Fan Replacement, Defroster, 3-30
 Fender Replacement, Front, 3-271
 Fender Replacement, Quarter, 3-2;
 Fifth Wheel Adjustment, 3-244
 Fifth Wheel Ramp Replacement, 3-2
 Fifth Wheel Replacement, 3-245
 Fifth Wheel Toggle Valve Replacement, 3-194
 Filter Element Replacement, Air Cleaner, 3-30
 Filter Replacement, Engine Oil,

Subject, Para

Filter Replacement, Water, 3-62
 Filter Replacement, Water Separator Fuel, 3-37
 Firewall Double Check Valve Replacement, 3-184
 Fittings Replacement, Front Spring Pin, 3-249
 Fittings Replacement, Fuel, 3-36
 Fittings Replacement, Power Steering Lines, 3-220
 Fittings Replacement, Transmission, 3-141
 Fittings Replacement, Brake System, 3-163
 Fittings Replacement, Cooling System, 3-58
 Flasher Replacement, Turn Signal, 3-111
 Floor Mat Replacement, 3-279
 Forward-Rear Axle Brake Chamber Replacement, 3-166
 Forward-Rear Axle Quick Release Valve Replacement,
 3-178
 Forward-Rear Axle Stop Replacement, 3-232
 Frame and Towing Attachments Maintenance Task
 Summary, 3-222
 Front Axle and Rear-Rear Axle Brake Chamber Repair,
 3-165
 Front Axle and Rear-Rear Axle Brake Chamber
 Replacement, 3-164

ALPHABETIC INDEX (Continued)

Subject, Para

Front Axle and Suspension, Principles of Operation, 1-17
 Front Axle Maintenance Task Summary, 3-147
 Front Axle Ratio Valve Replacement 3-181
 Front Drum Replacement, 3-204
 Front Fender Replacement, 3-271
 Front Hub, Bearings, and Seals Replacement, 3-205
 Front Spring Pin Screws and Fitting Replacement, 3-249
 Front Wheel Alinement, 3-203
 Fuel Control Lever Replacement, 3-42
 Fuel Heater Replacement, 3-35
 Fuel Hoses and Fittings Replacement 3-36
 Fuel Level Sending Unit Replacement 3-105
 Fuel Lines and Fittings Replacement Engine, 3-28
 Fuel Pump Engine Retarder Switch Replacement, 3-90
 Fuel System Maintenance Task Summary, 3-26
 Fuel System, Principles of Operation, 1-12
 Fuel Tank Replacement, 3-34

Subject, Para**G**

Gage Replacement, Air Cleaner Restriction, 3-315
 Gage Replacement, Left- Hand Instrument Panel, 3-73
 Gage Replacement, Oil Level, 3-136
 Gage Replacement, Pressure, 3-314
 Gages (Non-electrical) Maintenance Task Summary, 3-300-
 Gasket Replacement, Rocker Cover, 3-13
 General, Accessory Items, 3-285
 General, Brake System, 3-155
 General, Cab and Body, 3-252
 General, Cooling System, 3-50
 General, Electrical System, 3-68
 General, Engine, 3-10
 General, Exhaust System, 3-43
 General, Frame and Towing Attachments, 3-221
 General, Front Axle, 3-146
 General, Fuel System, 3-25
 General, Gages (Non-electrical), 3-307
 General, Propeller Shafts and Universal Joints, 3-142
 General, Rear Axle, 3-151

ALPHABETIC INDEX (Continued)

Subject, Para

General, Springs, Shock Absorbers, Torque Rod, 3-247
 General, Steering System, 3-209
 General STE/ICE Components, 3-317
 General, Transmission, 3-133
 General Maintenance Instruction, 3.
 General, Wheels, 3-201
 Glove Compartment Door Assembly Replacement, 3-257
 Grille Replacement, 3-268
 Ground Strap and Cables Replacement 3-128
 Guard Replacement, Brush, 3-236

H

Handle Replacement, Inside Assist, 3-259
 Handle Replacement, Outside Front, 3-264
 Handle Replacement, Outside Rear, 3
 Headlamp Assembly Replacement, 3-9
 Headlamp Assembly Replacement, Blackout, 3-95
 Headlamp Cable Replacement, 3-129
 Headlamp Dimmer Switch Replacement 3-82
 Headlamp Switch Replacement, 3-78
 Heat Shield Replacement, Muffler, 3-45

Subject, Para

Heater Air Hose Replacement, 3-296
 Heater Blower Replacement, 3-299
 Heater Control Panel Repair, 3-301
 Heater Control Panel Replacement, 3-300
 Heater Control Valve and Hose Replacement, 3-297
 Heater Fan Switch Replacement, 3-81
 Heater Replacement, 3-298
 Heater Replacement, Fuel, 3-35
 Heater Valve, Hoses, Tubes, and Clamps Replacement, 3-297
 Hood Panel and Component Replacement, 3-270
 Hood Replacement, 3-269
 Horn Button Replacement, 3-118
 Horn Replacement, 3-117
 Hose Replacement, Heater Air, 3-296
 Hose Replacement, Heater Control Valve, 3-297
 Hose Replacement, Trailer, 3-196
 Hose Tender Replacement, 3-197
 Hoses Replacement, Cooling System, 3-58
 Hoses Replacement, Fuel, 3-36
 Hot Engine Temperature Switch Replacement, 3-100
 Housing Replacement, Thermostat, 3-59
 Hub Replacement, Front, 3-207

ALPHABETIC INDEX (Continued)

Subject, Para

Hub Replacement, Rear, 3-207

I

Ignition Switch Replacement, 3-74

Indicator Lamps Replacement, 3-87

Inside Assist Handle Replacement, 3-259

Inspection, General Maintenance Instructions, 3-5

Instrument Panel Assembly Replacement, 3-258

Instrument Panel Center Panel Assembly Replacement,
3-256

Instrument Panel Relays Replacement, 3-112

Instrument Panel 24 Volt Relay Replacement, 3-113

Insulation Replacement, 3-277

Insulator Replacement, 3-267

Intake Tube Replacement, Air Compressor, 3-19

Interaxle Propeller Shaft and Universal Joints
Replacement, 3-1**J**

Joints Replacement, Ball, 3-218

K

Kit Replacement, Ether Quick Star 3-40

Subject, Para**L**

Lamp Assembly Replacement, Blackout Marker, 3-94

Lamp Assembly Replacement, Cab Clearance, 3-93

Lamp Replacement, Clearance, 3-85

Lamp Replacement, Ether, 3-85

Lamp Replacement, Low Air Pressure, 3-84

Lamp Replacement, Marker Lamp, 3-92

Lamp Replacement, Turn Signal, 3-92

Lamp Replacement, Washer, 3-86

Lamp Replacement, Wiper, 3-86

Lamps Replacement, Warning and Indicator, 3-87

Latch Replacement, Battery Box, 3-123

Left- Hand Instrument Cluster Panel Assembly
Replacement, 3-255

Left- Hand Instrument Panel Gage Replacement, 3-73

Lever Replacement, Fuel Control, 3-42

Lifting Bracket Replacement, Vehicle, 3-229

Lighter Replacement, Cigar, 3-83

Lines and Fittings Replacement, Transmission, 3-141

Lines, Fittings, and Hoses Replacement, Cooling
System, 3-58

Linkage Replacement, Accelerator, 3-41

ALPHABETIC INDEX (Continued)

Subject, Para

Location and Description of Major Components, 1-9
 Low Air Pressure Buzzer Replacement 3-110
 Low Air Pressure Lamp Replacement, 3-84
 Low Air Pressure Switch Replacement 3-109
 Low Oil Pressure Sending Unit Replacement, 3-104
 Lower Fan Shroud Replacement, 3-57
 Lower Steering Column Replacement and Repair, 3-215

M

Maintenance Forms, Records, and Reports, 1-3
 Manifolds Replacement, Water, 3-60
 Manual Reset Circuit Breaker and
 Mounting Bracket Replacement, 3-11
 Map Lamp and Switch Replacement, 3
 Marker Lamp Replacement, 3-92
 Mat Replacement, Floor, 3-279
 Mirror Replacement, Door, 3-287
 Mirror Replacement, Spotter, 3-290
 Modulator Control Replacement, 3-1
 Motor Replacement, Windshield Wiper, 3-295

Subject, Para

Mountable Tee Replacement, 3-180
 Muffler and Heat Shield Replacement, 3-45
 Muffler Inlet Pipe Replacement, 3-49
 Muffler Inlet Pipe Support Replacement, 3-224

N

Neutral Safety Switch and Reverse Switch Replacement, 3-106

O

Oil Level Dipstick Replacement, 3-16
 Oil Level Dipstick Tube Brace and Clamp Replacement, 3-17
 Oil Level Gage and Tube Replacement, 3-136
 Oil Pressure Sending Unit Replacement, 3-102
 Operational Checks, General Maintenance Instructions, 3-8
 Organizational Preventive Maintenance Checks and Service (PMCS), Paragraph 2-1, 2-8
 Outside Front Handle Replacement, 3-264
 Outside Rear Handle Replacement, 3-263

P

Padlock Bracket Replacement, 3-252

ALPHABETIC INDEX (Continued)

Subject, Para

Panel Assembly Replacement, Instrument 2-258

Panel Assembly Replacement, Instrument Panel Center, 3-256

Panel Assembly Replacement, Left Instrument Cluster, 3-255

Panel Assembly Replacement, Right Hand Instrument, 3-254

Panel Repair, Heater Control, 3-301

Panel Replacement, Cab Headliner 3-275

Panel Replacement, Cab Trim, 3-2

Panel Replacement, Heater Control 3-300

Paragraph 2-1. Organizational Preventive Maintenance Checks and Services (PMCS), 2-8

Paragraph 2-2. Troubleshooting Procedure, 2-11

Paragraph 2-7. GO Chain Index, S 2-17

Paragraph 2-8. NO-GO Chain Index STE/ICE, 2-18

Paragraph 2-9. Vehicle Testing T shooting Procedure, STE/ICE, 2-1

Paragraph 3-1. Torque Limits, General Maintenance Instructions, 3-9

Park Brake Pressure Switch Replacement, 3-108

Park Brake Valve Repair, 3-172

Park Brake Valve Replacement, 3-

Subject, Para

Pedal Replacement, Accelerator, 3-41

Pin Replacement, Clevis, 3-230

Pin Replacement, Rear Tow Eye, 3-235

Pintle Replacement, Tow, 3-238

Pipe Replacement, Exhaust Flex, 3-47

Pipe Replacement, Exhaust Stack, 3-46

Pipe Replacement, Muffler Inlet, 3-49

Pipe Replacement, Turbocharger Outlet, 3-48

Plate Replacement, Door, 3-265

Plates Replacement, Data and Instruction, 3-305

Power Steering Lines and Fittings Replacement, 3-227

Pressure Gage Replacement, 3-314

Pressure Transducer Replacement, 3-320

Primary and Secondary Reservoir Draincock Replacement, 3-188

Primary Propeller Shaft and Universal Joints Replacement, 3-144

Primary Reservoir Replacement, 3-169

Propeller Shafts and Universal Joints Maintenance Task Summary, 3-143

Pump Replacement, Water, 3-64

Pushbutton Clearance Lamp Switch Replacement, 3-77

ALPHABETIC INDEX (Continued)

Subject, Para

Pushbutton Starter Switch Replacement 3-75
 Preparation for Storage or Shipment 1-5
 Primary Reservoir Drain Valve Replacement, 3-189
 Pulse Tachometer Replacement, 3-31

Q

Quarter Fender Replacement, 3-272

R

Radiator Replacement, 3-53
 Radiator Support Rods Replacement, 3-54
 Ramp Replacement, Fifth Wheel, 3-2
 Rear Axle Maintenance Task Summary 3-152
 Rear Axle Oil Service, 3-153
 Rear Axle Shaft Replacement, 3-154
 Rear Brake Drum Replacement, 3-206
 Rear Hub, Bearings, and Seals Replacement, 3-207
 Rear Mud Flap and Bracket Replacement, 3-274
 Rear-Rear Axle Brake Chamber Repair 3-165
 Rear-Rear Axle Brake Chamber Replacement, 3-164

Subject, Para

Rear-Rear Axle Quick Release Valve Replacement, 3-179
 Rear Tandem Axles, Principles of Operation, 1-18
 Rear Tow Eye Bracket, Shackle, and Pin Replacement, 3-235
 Receptacle Replacement, Slave Start, 3-125
 Receptacle Replacement, Work Lamp, 3-132
 Relay Replacement, Instrument Panel 24-Volt, 3-113
 Relay Replacement, Starter, 3-115
 Relay Valve Replacement, 3-177
 Relays Replacement, Instrument Panel, 3-112
 Repair, General Maintenance Instructions, 3-6
 Repair Parts, 2-4
 Reporting Equipment Improvement Recommendations (EIR), 1-6
 Reservoir Mounting Brackets Replacement, Secondary, 3-225
 Reservoir Replacement, Primary, 3-169
 Reservoir Replacement, Secondary, 3-170
 Reservoir Replacement, Supply, 3-168
 Reservoir Replacement, Steering Pump, 3-219

ALPHABETIC INDEX (Continued)

Subject, Para

Right-Hand Instrument Cluster Panel Assembly Replacement, 3-254

Rocker Cover and Gasket Replacement 3-13

Rocker Cover Filler Cap Replacement 3-14

Rods Replacement, Radiator Support 3-54

Rods Replacement, Torque, 3-251

S

Scope, 1-2

Screws Replacement, Front Spring P 3-249

Seal Replacement, Door Frame, 3-26

Seals Replacement, Front 3-205

Seals Replacement, Rear, 3-207

Seat Belt Replacement, 3-282

Seat Replacement, Companion, 3-283

Seat Replacement, Driver's, 3-280

Seat Riser Replacement, Driver's, 3-281

Secondary Reservoir Check Valve Replacement, 3-187

Secondary Reservoir Double Check Valve Replacement, 3-185

Secondary Reservoir Replacement, 3-170

Subject, Para

Secondary Reservoir Support Replacement, 3-223

Sending Unit Replacement, Fuel Level, 3-105

Sending Unit Replacement, Oil Pressure, 3-102

Sending Unit Replacement, Transmission Temperature, 3-103

Sending Unit Replacement, Water Temperature, 3-101

Service and Troubleshooting Instructions, 2-1

Service Deck Replacement, 3-239

Service, Cooling System, 3-52

Service, Engine Oil, 3-12

Service, Rear Axle Oil, 3-153

Service, Steering System, 3-211

Servicing, Transmission, 3-135

Shackle Replacement, Rear Tow Eye, 3-235

Shaft Replacement, Rear Axle, 3-154

Shaft Replacement, Speedometer, 3-310

Shaft Replacement, Tachometer, 3-312

Shield Replacement, Dust, 3-162

Shifter Control Cable Replacement, 3-138

Shifter Control Mounting Bracket Replacement, 3-139

ALPHABETIC INDEX (Continued)

Subject, Para

Shifter Control Replacement, 3-13

Shock Absorber Replacement, 3-250

Shroud Replacement, Lower Fan, 3-1

Shroud Replacement, Upper Fan, 3-1

Sign Replacement, Vehicle Class,

Slack Adjuster Replacement, 3-157

Slave Start Receptacle Replacement 3-125

Solenoid Replacement, Starter Mot(3-72

Solenoid Valve Replacement, 3-33

Spacers Replacement, 3-24

Spare Tire Carrier Replacement, 3-240

Spare Tire Winch Cable Replacement 3-241

Spare Tire Winch Pillar Replacement 3-243

Spare Tire Winch Replacement, 3-2

Special Tools, TMDE, and Support Equipment, 2-3

Speedometer Drive Sleeve Adapter Replacement, 3-311

Speedometer Driven Gear Replacement 3-312

Speedometer Shaft Replacement, 3-310

Spider and Anchor Pin Replacement 3-161

Subject, Para

Splash Shield Replacement, 3-273

Spotter Mirror Replacement, 3-288

Springs, Shock Absorbers, and Torque Rods Maintenance Task Summary, 3-248

Starter Motor and Solenoid Replacement, 3-72

Starter Relay Replacement, 3-115

Starting Circuit Diode Replacement, 3-116

STE/ICE, How To Use Chain Test Index, 2-13

STE/ICE Components Maintenance Task Summary, 3-318

STE/ICE Connector Bracket Replacement, 3-131

STE/ICE Description and Operation, 2-16

STE/ICE, Paragraph 2-7. GO Chain Index, 2-17

STE/ICE, GO Chain Tests, 2-20

STE/ICE, Paragraph 2-8. NO-GO Chain Index, 2-18

STE/ICE, NO-GO Chain Tests, 2-21

STE/ICE, Paragraph 2-9. Vehicle Testing Troubleshooting Procedure, 2-19

STE/ICE VTM Set-Up Procedure, 3-15

STE/ICE Vehicle Test Meter (VTM) Troubleshooting, 2-14

Steering Arm Replacement, Front Axle, 3-148

ALPHABETIC INDEX (Continued)

Subject, Para

Steering Arm Replacement, Steering System, 3-217

Steering Knuckle Assembly Replacement 3-149

Steering Pump and Reservoir Replacement, 3-219

Steering System Maintenance Task Summary, 3-210

Steering System, Principles of Operation, 1-22

Steering System Service, 3-211

Steering System Testing, 3-212

Steering Wheel Replacement, 3-213

Step Replacement, 3-226

Stop Replacement, Forward-Rear Axle 3-232

Stoplamp- Taillamp Assembly Replacement, 3-96

Strap Replacement, Ground, 3-128

Sun Visor Replacement, 3-278

Supply Reservoir Drain Valve Replacement, 3-190

Supply Reservoir Mounting Brackets Replacement, 3-225

Supply Reservoir Replacement, 3-16,

Supply Reservoir Safety Valve Replacement, 3-186

Supply Reservoir Single Check Valve Replacement, 3-191

Support Replacement, Muffler Inlet Pipe, 3-224

Subject, Para

Support Replacement, Secondary Reservoir, 3-223

Switch Replacement, Blackout Toggle, 3-79

Switch Replacement, Differential Lock Pressure, 3-107

Switch Replacement, Engine Retarder Foot, 3-89

Switch Replacement, Ether Start, 3-76

Switch Replacement, Fuel Pump Engine Retarder, 3-90

Switch Replacement, Headlamp, 3-78

Switch Replacement, Headlamp Dimmer, 3-82

Switch Replacement, Heater Fan, 3-81

Support Replacement, Secondary Reservoir, 3-223

Switch Replacement, Hot Engine Temperature, 3-100

Switch Replacement, Ignition, 3-74

Switch Replacement, Low Air Pressure, 3-109

Switch Replacement, Neutral Safety, 3-106

Switch Replacement, Park Brake Pressure, 3-108

Switch Replacement, Pushbutton Clearance Lamp, 3-77

Switch Replacement, Pushbutton Starter, 3-75

Switch Replacement, Reverse, 3-106

ALPHABETIC INDEX (Continued)

Subject, Para

Switch Replacement, Three Position Engine Retarder, 3-88

Switch Replacement, Turn Signal,

Symptom Index, Troubleshooting, 2

T

Tachograph Replacement, 3-309

Tachometer Replacement, Pulse, 3-

Tachometer Shaft Replacement, 3-3

Taillamp Bracket Replacement, 3-2

Tank Replacement, Fuel, 3-34

Task Summary, Accessory Items Maintenance, 3-286

Task Summary, Brake System Maintenance, 3-156

Task Summary, Cab and Body Maintenance, 3-253

Task Summary, Cooling System Maintenance, 3-51

Task Summary, Electrical System Maintenance, 3-69

Task Summary, Engine Maintenance, 3-11

Task Summary, Exhaust System Maintenance, 3-44

Task Summary, Frame and Towing Attachments, 3-229

Task Summary, Front Axle Maintenance 3-147

Subject, Para

Task Summary, Fuel System Maintenance, 3-26

Task Summary, Gages (Non-electrical) Maintenance, 3-308

Task Summary, Rear Axle Maintenance, 3-152

Task Summary, Springs, Shock Absorbers, and Torque Rods Maintenance, 3-248

Task Summary, Steering System Maintenance, 3-210

Task Summary, STE/ICE Components Maintenance, 3-318

Task Summary, Transmission Maintenance, 3-134

Task Summary, Wheel Maintenance, 3-202

Tee Replacement, Mountable, 3-180

Testing, Steering System, 3-212

Three Position Engine Retarder Switch Replacement, 3-88

Tiedown Bracket Replacement, 3-228

Tie Rod Arm Replacement, 3-150

Tire Replacement, 3-208

Thermostat and Thermostat Housing Replacement, 3-59

Thermostat Replacement, Ether Quick Start, 3-39

Tie Rod and Ball Joints Replacement, 3-218

Tool Box Replacement, 3-284

ALPHABETIC INDEX (Continued)

Subject, Para

Torque Limits, Paragraph 3-1. General Maintenance Instructions,

Torque Rods Replacement, 3-251

Tow Pintle Replacement, 3-238

Towing Eyes Replacement, Front, 2-

Tractor Protection Valve Replacement 3-192

Trailer Couplings, Brackets, and H Replacement, 3-196

Trailer Hand Brake Valve Replacement 3-173

Trailer Receptacle Bracket Replacement, 3-130

Trailer Supply Valve Repair, 3-176

Trailer Supply Valve Replacement, 3-175

Transducer Replacement, Pressure, 3-320

Transmission and Steering System Cooler Replacement, 3-55

Transmission Maintenance Task Summary, 3-134

Transmission Oil Filter Mounting Bracket Replacement, 3-231

Transmission, Principles of Operation, 1-16

Transmission Servicing, 3-135

Transmission Temperature Sending Unit Replacement, 3-103

Subject, Para

Troubleshooting Procedures, Paragraph 2-2, 2-11

Troubleshooting Symptom Index, 2-10

Tube Replacement, Air Cleaner, 3-32

Tube Replacement, Oil Level, 3-136

Tube Replacement, Water Crossover, 3-20

Tube Replacement, Water Transfer, 3-21

Turbocharger Air Crossover Connection Replacement, 3-31

Turbocharger Outlet Pipe Replacement, 3-48

Turn Signal and Marker Lamp Replacement, 3-92

Turn Signal Flasher Replacement, 3-111

Turn Signal Switch Replacement, 3-80

U

Universal Joints Replacement, Interaxle Propeller Shaft, 3-145

Universal Joints Replacement, Primary Propeller Shaft, 3-144

Upper Fan Shroud Replacement, 3-56

Upper Steering Column Replacement and Repair, 3-214

V

Valve Relay, Replacement, 3-177

Valve Repair, Park Brake, 3-172

ALPHABETIC INDEX (Continued)

Subject, Para

Valve Repair, Trailer Supply, 3-1
 Valve Replacement, Air Horn Control 3-289
 Valve Replacement, Brake Pedal Do Check, 3-193
 Valve Replacement, Brake Treadle, 3-174
 Valve Replacement, Differential Toggle, 3-195
 Valve Replacement, Double Check a Quick Release, 3-182
 Valve Replacement, Double Check a Stoplamp, 3-183
 Valve Replacement, Fan Clutch Air 3-66
 Valve Replacement, Fifth Wheel Toggle, 3-194
 Valve Replacement, Firewall Double Check, 3-184
 Valve Replacement, Forward-Rear P Quick Release, 3-178
 Valve Replacement, Front Axle Rat 3-181
 Valve Replacement, Heater Control 3-297
 Valve Replacement, Park Brake, 3-171
 Valve Replacement, Primary Reservoir Drain, 3-189

Subject, Para

Valve Replacement, Rear-Rear Axle Quick Release, 3-179
 Valve Replacement, Secondary Reservoir Check, 3-187
 Valve Replacement, Secondary Reservoir Double Check, 3-185
 Valve Replacement, Solenoid, 3-33
 Valve Replacement, Supply Reservoir Drain, 3-190
 Valve Replacement, Supply Reservoir Safety, 3-186
 Valve Replacement, Supply Reservoir Single Check, 3-191
 Valve Replacement, Tractor Protection, 3-192
 Valve Replacement, Trailer Hand Brake, 3-175
 Valve Replacement, Trailer Supply, 3-177
 Valve Replacement, Water Shutoff, 3-61
 Valve Replacement, Windshield Water Control, 3-291
 Vehicle Lifting Bracket Replacement, 3-229
 Vehicle Test Meter (VTM) Troubleshooting, STE/ICE, 2-14
 Ventilator Replacement, 3-261
 Vertical Link Replacement, 3-216
 Visor Replacement, Sun, 3-278

ALPHABETIC INDEX (Continued)

Subject, Para

W

Warning and Indicator Lamps Replacement, 3-87
 Warranty Information, 1-7
 Water Crossover Tube Replacement, 3-20
 Washer Lamp Replacement, 3-86
 Washer Replacement, Windshield, 3-290
 Water Filter and Bracket Replacement 3-62
 Water Manifolds Replacement, 3-60
 Water Pump Drive Belt Replacement, 3-63
 Water Pump Replacement, 3-64
 Water Separator Fuel Filter Replacement, 3-37
 Water Shutoff Valves and Lines Replacement, 3-61
 Water Temperature Sending Unit Replacement, 3-101
 Water Transfer Tube and Bracket Replacement, 3-21
 Wheels Maintenance Task Summary, 3-202
 Wheel Replacement, Steering, 3-213
 Winch Repair, Spare Tire, 3-242
 Winch Replacement, Spare Tire, 3-237

Subject, Para

Windshield Washer Control Valve Replacement, 3-291
 Windshield Washer Replacement, 3-290
 Windshield Wiper Assembly Replacement, 3-294
 Windshield Wiper Control Replacement, 3-292
 Windshield Wiper Motor Replacement, 3-295
 Winterization Kit, Principles of Operation, 1-24
 Winterization Kit (See TB 9-2320-283-14), 3-300
 Wiper Blade Replacement, 3-293
 Wiper Lamp and Washer Lamp Replacement, 3-86
 Wiring Harness Repair, 3-127
 Wiring Harness Replacement, 3-126
 Work Lamp Receptacle Replacement, 3-132

PRE-TEST INSPECTION	
1.	FAN BELTS/ALTERNATOR BELTS
2.	OIL LEVEL
3.	RADIATOR COOLANT LEVEL
4.	FUEL TANK FUEL LEVEL
5.	BATTERIES
TEST NO.	PERFORMANCE CHECKS
VISUAL	OIL AND COLLANT LEVEL
VISUAL	OIL PRESSURE (GAGE RADING) 10 PSI MIN @ IDLE 35-50 PSI @ HIGH IDLE
VISUAL	COLLANT TEMPERATURE (GAGE READING) 180-200°F
10	IDLE SPEED 580-650 RPM MAX GOVERNOR SPEED 2100 RPM CRANING SPEED 200 RPM
12	POWER 1160 RPM/SEC MIN
13	POWER (% POWER) - 75%
14	COMPRESSION UNBALANCE 0-8%
67	BATTERY VOLTAGE @ HIGH IDLE 24.8 - 27.6 VDC
72	STARTER CURRENT, FIRST PEAK 1000-1650 AMPS @ CRANKING
83	CRANKING BATTERY VOLTAGE 24.8 - 27.6 VDC @ HIGH IDLE

OPERATOR MESSAGES	
PASS	TEST SUCCESSFULLY COMPLETED
CAL	OFFSET TEST IN PROGRESS RELEASE TEST BUTTON
CIP	INITIATE CI POWER SIMULATION
CYL	ENTER NUMBER OF CYLINDERS OR CYLINDER PAIRS
FAIL	TEST FAILED
GO	CRANK ENGINE
OFF	IF CI POWER DECELERATE
UEH	ENTER VEHL IDENTIFICATION NUMBER
----	VTM ACCEPTING DATA OR INITIAL TURN-ON
0066	DIAL 99 PUSH TEST BUTTON
8888	CHECK DISPLAY

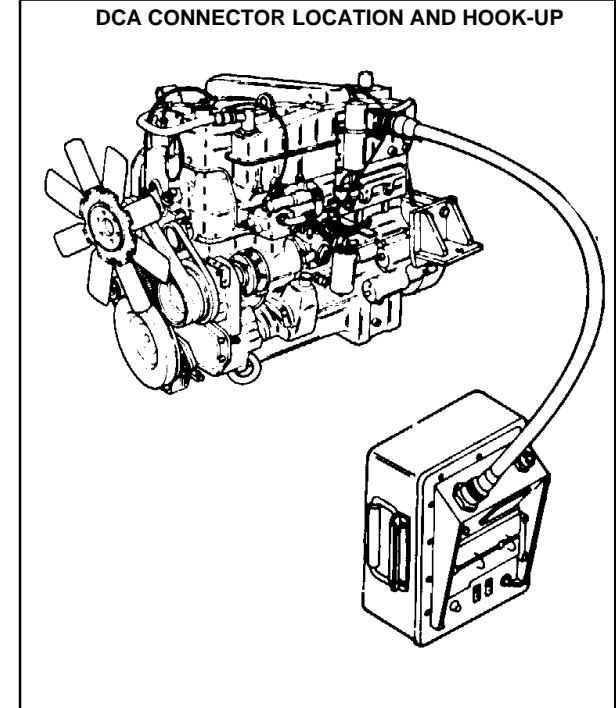

ERROR MESSAGES	
E000	INFORMATION NOT AVAILABLE
E001	TEST NON-EXISTENT
E002	TANSDUCER NOT CONNECTED
E004	VID OR NUMBER OF CYL NOT ENTERED
E005	CAL NOT PREFORMED
E006	NUMBER OF CYL NOT VALID
E007	NUMBER OF CYL CONFLICTS WITH VID
E008	TEST PROBE NOT CONNECTED
E009	ENGINE NOT RUNNING
E010	BAD VID
E011	ACCED/DECL TIME TOO LARGE
E012	TACH PICKUP MISSING
E013	BAD DATA
E014	BAD NUMBER OF CYLINDERS
E018	TEST DISCONTINUED EXCESSIVE TIME
9999	OVERLOAD OR NUMBER EXCEEDS DISPLAY CAPABILITY

CONTROL OF NEXT TEST	
01	INTERLEAVE WITH SPEED (RPM)
02	DISPLAY MIN VALUE
03	DISPLAY MAX VALUE
04	DISPLAY PEAK TO PEAK VALUE

POWER AND COMPRESSION TEST	
TEST 13	% POWER (VID - VEHICLE IDENTIFICATION NUMBER REQUIRED)
TEST 12	RPM/SEC (ENTER NUMBER OF CYLINDERS - TEST SELECT 58, ENTER 6)
TEST 14	COMPRESSION UNBALANCE (FUEL SOLENOID VALVE IN-LINE CONNECTOR DISCONNECTED -0 FUEL SHUTOFF)

INITIAL ENTRY	
58	NUMBER OF CYLINDERS ENTRY (6)
59	NUMBER OF CYLINDERS DISPLAY (6)
60	VID ENTRY (TO BE SUPPLIED)
61	VID DISPLAY
66	CONFIDENCE TEST (SECOND ENTRY 99)

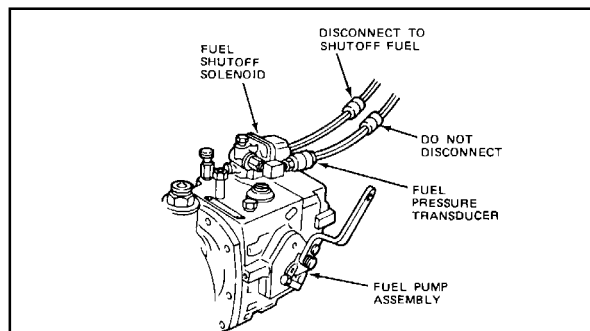

TEST LIST							
TEST NO.	OFFSET LIMITS	TEST MODE	TITLE	TEST NO.	OFFSET LIMITS	TEST MODE	TITLE
10		DCA	ENGINE RPM (AVERAGE)	72	±225	DCA/TK	STARTER CURRENT FIRST PEAK
12		DCA	POWER TEST (RPM/SEC)	73	±225	DCA/TK	INTERNAL BATTERY RESISTANCE
13		DCA	POWER TEST (% POWER-VID REQ'D)	74	±225	DCA/TK	STARTER CIRCUIT RESISTANCE
14		DCA	COMPRESSION UNBALANCE	75	±225	TK	BATTERY RESISTANCE CHANGE
24	±45	DCA	FUEL SUPPLY PRESSURE	77	±225	DCA/TK	INTERNAL BATTERY RESISTANCE
45	±4	TK	INLET FUEL PRESSURE (VACUUM 0-30" HG)	79	±225	DCA/TK	BATTERY RESISTANCE CHANGE (WHILE CRANKING)
50	±150	TK	LOW OIL PRESSURE	82		DCA	ALT/GEN OUTPUT VOLTAGE
67		DCA	BATTERY VOLTAGE	83		DCA	CRANKING BATTERIES VOLTAGE
68		DCA	STARTER VOLTAGE (WHILE CRANKING)	89	±6.8	TK	0-45 VDC
69		DCA	STARTER NEGATIVE CABLE DROP (WHILE CRANKING)	90	±225	TK	0-1500 AMPS DC
70		DCA	STARTER SOLENOID VOLTAGE (WHILE CRANKING)				

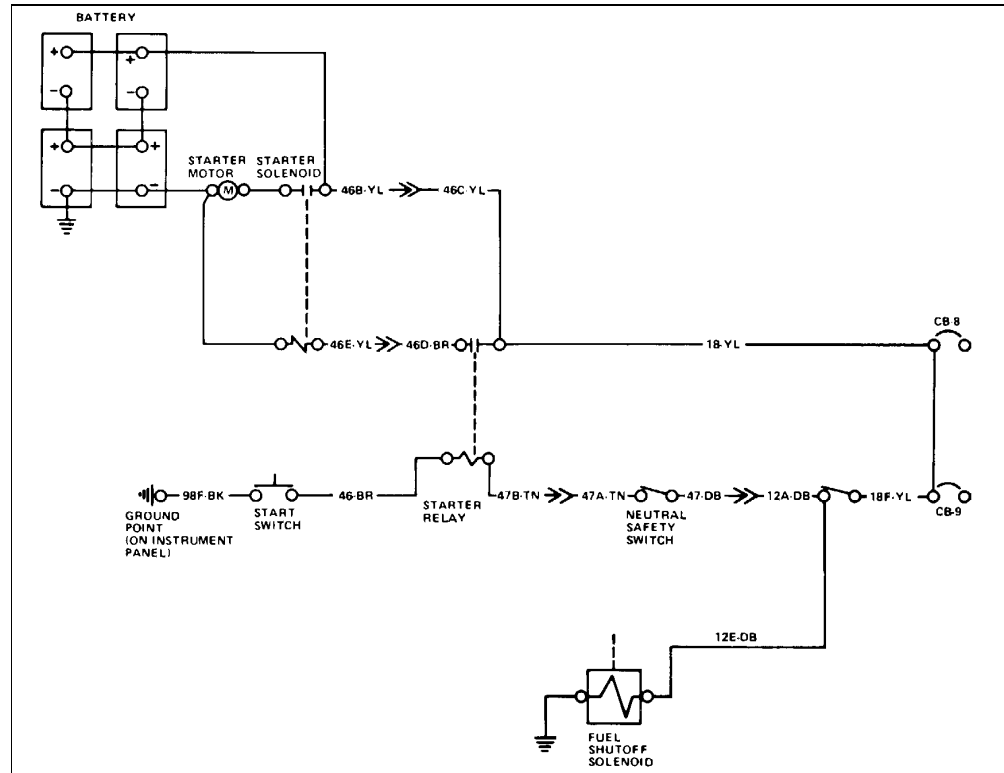
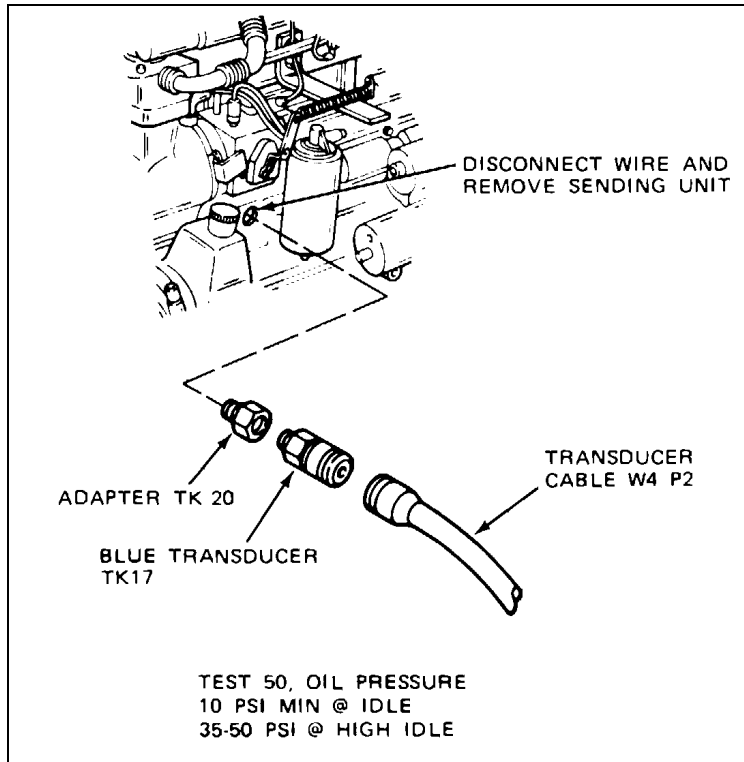

BATTERY/CABLE TESTS

WITH POWER CABLE OR DCA CABLE AND CURRENT PROBE

TEST 90 AVERAGE CRANKING CURRENT 300-400 AMPS

TEST 72 STARTER CURRENT FIRST PEAK 1000-1650 AMPS

TEST 73, 77 INTERNAL BATTERY RESISTANCE 13 MILLIOHMS MAX*

TEST 74 STARTER CIRCUIT RESISTANCE 20 MILLIOHMS MAX

TEST 75, 79 BATTERY RESISTANCE CHANGE 50 MILLIOHMS/SEC MAX PER BATTERY*

WITH POWER CABLE OR DCA CABLE

TEST 67 BATTERY VOLTS, 22 VOLTS MIN @ ENGINE OFF

TEST 67 CHARGING VOLTS, 24.8-27.6 VOLTS @ HIGH IDLE

*TEST LIMITS ARE FOR DELCO 1200 TYPE BATTERIES AS ORIGINALLY SUPPLIED WITH TRUCK. IF TRUCK CONTAINS OTHER TYPE BATTERIES SEE STE/ICE BATTERY TEST CARD FOR FURTHER INFORMATION.

BATTERY CHARGING CIRCUIT

ALTERNATOR & TESTS

TEST 90 ALTERNATOR OUTPUT CURRENT (PARTIALLY DISCHARGED BATTERIES AND TRUCK HEADLAMPS ON @ FAST IDLE)

- +24 VDC OUTPUT LINE 15 AMPS MAXIMUM
- +12 VDC OUTPUT LINE (CURRENT PROBE AROUND BOTH WIRES) 40 AMPS MINIMUM

STARTER CIRCUIT TESTS

TEST 10 CRANKING RPM. 200 RPM MIN

TEST 69 STARTER MOTOR NEGATIVE CABLE VOLTAGE DROP. 0.6 VOLTS MAX. (DCA MODE)

TEST 70 STARTER SOLENOID VOLTAGE 14.7 VOLTS MIN

TEST 72 STARTER CURRENT. 1000-1650 AMPS FIRST PEAK

TEST 74 STARTER CIRCUIT RESISTANCE. 20 MILLIOHMS MAX

TEST 89 STARTER MOTOR POSITIVE CABLE VOLTAGE DROP. 0.6 VOLTS MAX.

TEST 89 STARTER MOTOR NEGATIVE CABLE VOLTAGE DROP. 0.6 VOLTS MAX.

By Order of the Secretary of the Army:

E. C. MEYERS
General, United States Army
Chief of Staff

Official:

JOHN A. WICKHAM, JR.
Brigadier General, United States Army
The Adjutant General

Distribution:

To be distributed in accordance with DA Form 12-38, (qty rqr block No. 330), organizational maintenance requirements for Truck, Tractor, Line Haul, 6 x 4, 14-ton, M915A1.

THE METRIC SYSTEM AND EQUIVALENTS

LINEAR MEASURE

- 1 Centimeter = 10 Millimeters = 0.01 Meters = 0.3937 Inches
- 1 Meter = 100 Centimeters = 1,000 Millimeters = 39.37 Inches
- 1 Kilometer = 1,000 Meters = 0.621 Miles

SQUARE MEASURE

- 1 Sq Centimeter = 100 Sq Millimeters = 0.155 Sq Inches
- 1 Sq Meter = 10,000 Sq Centimeters = 10.76 Sq Feet
- 1 Sq Kilometer = 1,000,000 Sq Meters = 0.386 Sq Miles

CUBIC MEASURE

- 1 Cu Centimeter = 1,000 Cu Millimeters = 0.06 Cu Inches
- 1 Cu Meter = 1,000,000 Cu Centimeters = 35.31 Cu Feet

LIQUID MEASURE

- 1 Milliliter = 0.001 Liters = 0.0338 Fluid Ounces
- 1 Liter = 1,000 Milliliters = 33.82 Fluid Ounces

TEMPERATURE

- $5/9 (^{\circ}\text{F} - 32) = ^{\circ}\text{C}$
- 212 $^{\circ}$ Fahrenheit is equivalent to 100 $^{\circ}$ Celsius
- 90 $^{\circ}$ Fahrenheit is equivalent to 32.2 $^{\circ}$ Celsius
- 32 $^{\circ}$ Fahrenheit is equivalent to 0 $^{\circ}$ Celsius
- $9/5 \text{ C}^{\circ} + 32 = \text{F}^{\circ}$

WEIGHTS

- 1 Gram = 0.001 Kilograms = 1,000 Milligrams = 0.035 Ounces
- 1 Kilogram = 1,000 Grams = 2.2 lb.
- 1 Metric Ton = 1,000 Kilograms = 1 Megagram = 1.1 Short Tons

APPROXIMATE CONVERSION FACTORS

TO CHANGE	TO	MULTIPLY BY
Inches	Centimeters	2.540
Feet	Meters	0.305
Yards	Meters	0.914
Miles	Kilometers	1.609
Square Inches	Square Centimeters	6.451
Square Feet	Square Meters	0.093
Square Yards	Square Meters	0.836
Square Miles	Square Kilometers	2.590
Acres	Square Hectometers	0.405
Cubic Feet	Cubic Meters	0.028
Cubic Yards	Cubic Meters	0.765
Fluid Ounces	Milliliters	29.573
Pints	Liters	0.473
Quarts	Liters	0.946
Gallons	Liters	3.785
Ounces	Grams	28.349
Pounds	Kilograms	0.454
Short Tons	Metric Tons	0.907
Pound-Feet	Newton-Meters	1.356
Pounds Per Square Inch	Kilopascals	6.895
Miles Per Gallon	Kilometers Per Liter	0.425
Miles Per Hour	Kilometers Per Hour	1.609
TO CHANGE	TO	MULTIPLY BY
Centimeters	Inches	0.394
Meters	Feet	3.280
Meters	Yards	1.094
Kilometers	Miles	0.621
Square Centimeters	Square Inches	0.155
Square Meters	Square Feet	10.764
Square Meters	Square Yards	1.196
Square Kilometers	Square Miles	0.386
Square Hectometers	Acres	2.471
Cubic Meters	Cubic Feet	35.315
Cubic Meters	Cubic Yards	1.308
Milliliters	Fluid Ounces	0.034
Liters	Pints	2.113
Liters	Quarts	1.057
Liters	Gallons	0.264
Grams	Ounces	0.035
Kilograms	Pounds	2.205
Metric Tons	Short Tons	1.102
Newton-Meters	Pound-Feet	0.738
Kilopascals	Pounds Per Square Inch	0.145
Kilometers Per Liter	Miles Per Gallon	2.354
Kilometers Per Hour	Miles Per Hour	0.621

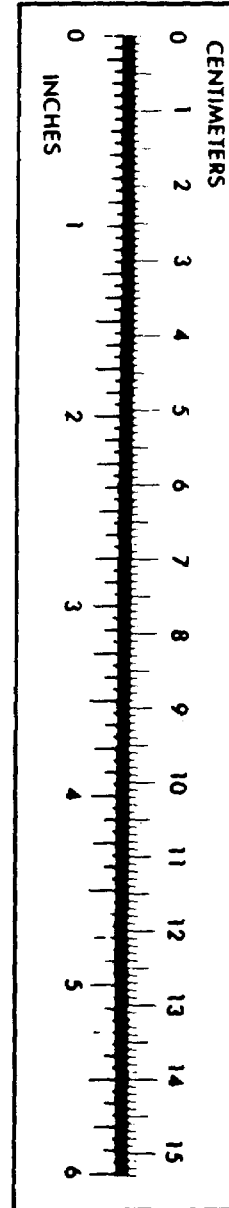

This page only for NON-SOFTWARE-related TM errors/improvements.

RECOMMENDED CHANGES TO EQUIPMENT TECHNICAL PUBLICATIONS

SOMETHING WRONG WITH THIS PUBLICATION?



THEN...JOT DOWN THE DOPE ABOUT IT ON THIS FORM. CAREFULLY TEAR IT OUT. FOLD IT AND DROP IT IN THE MAIL.

FROM: (PRINT YOUR UNIT'S COMPLETE ADDRESS)

DATE SENT

PUBLICATION NUMBER

PUBLICATION DATE

PUBLICATION TITLE

BE EXACT PIN-POINT WHERE IT IS

IN THIS SPACE TELL WHAT IS WRONG AND WHAT SHOULD BE DONE ABOUT IT:

PAGE NO.	PARA-GRAPH	FIGURE NO.	TABLE NO.
----------	------------	------------	-----------

TEAR ALONG PERFORATED LINE

PRINTED NAME GRADE OR TITLE AND TELEPHONE NUMBER

SIGN HERE

DA FORM 2028-2
1 JUL 79

PREVIOUS EDITIONS ARE OBSOLETE

P.S.—IF YOUR OUTFIT WANTS TO KNOW ABOUT YOUR RECOMMENDATION MAKE A CARBON COPY OF THIS AND GIVE IT TO YOUR HEADQUARTERS

PIN: 054559-000