

**TECHNICAL MANUAL**

**ORGANIZATIONAL  
MAINTENANCE**

**TRUCK TRACTOR, LINE HAUL,  
50,000 GVWR, 6 x 4, M015A1**

**(NSN 2320-01-125-2640)**

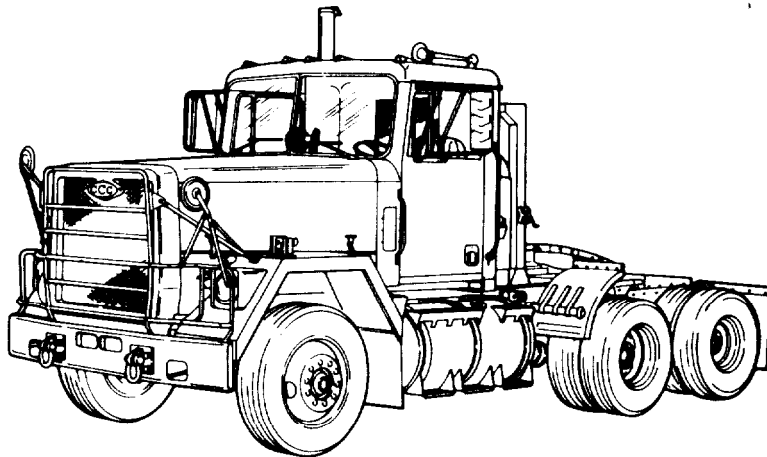

This copy is a reprint which includes current pages from Change 1.

**HEADQUARTERS,  
DEPARTMENT OF THE ARMY**

**WHEELS  
PAGE 3-1203**

**STEERING SYSTEM  
PAGE 3-1245**

**FRAME AND TOWING  
ATTACHMENTS  
PAGE 3-1329**

**SPRINGS, SHOCK ABSORBERS,  
AND TORQUE RODS  
PAGE 3-1470**

**CAB AND BODY  
PAGE 3-1492**

**ACCESSORY ITEMS  
PAGE 3-1672**

**GAGES (NON-ELECTRICAL)  
PAGE 3-1786**

**STE/ICE COMPONENTS  
PAGE 3-1832**

**APPENDICES  
PAGE A-1**

This manual may include copyrighted technical data of one or more of the following subcontractors of AM General Corporation:

© 1981	Alinabal, Division of MPB Corporation
© 1981	Anchorlock, Division of Lear Siegler, Inc.
© 1980	Argo Instruments, Inc.
© 1981	Bendix Corporation
© 1982	Bostrom, Division of UOP, Inc.
© 1976	The Budd Company
© 1982	Cole-Hersee Company
© 1982	Cummins Engine Company, Inc.
© 1980	Delco-Remy, Division of General Motors Corporation
© 1982	Detroit Diesel Allison, Division of General Motors Corporation
© 1981	Eaton Corporation, Axle Division
© 1981	Firestone Steel Products Company, Division of Firestone Tire and Rubber Company
© 1980	Goodyear Tire and Rubber Company
© 1981	Grote Manufacturing Company
© 1980	Gunitite, Division of Kelsey-Hayes Co.
© 1981	Holland Hitch Company
© 1980	Hupp, Mobile Products Division
© 1981	Leece-Neville, Sheller Globe Division
© 1982	McCord Heat Transfer, Division of Ex-Cell-0 Corporation
© 1979	Nelson Muffler, Division of Nelson Industries, Inc.
© 1982	Owatonna Tool Company
© 1979	Phillips Temco, Inc., Division of J. B. Carter
© 1982	Rockwell International
© 1978	Snap-On Tool Company

AM General has written permission from any and all such subcontractors holding copyrights to grant the United States Government a royalty free, non-exclusive and irrevocable license throughout the world for Governmental purposes to publish, translate, reproduce, deliver, perform, dispose of, and to authorize others so to do, all technical data now or hereafter covered by copyright. Any use other than that authorized above must be made with the express permission of AM General or the subcontractor whose copyrighted material is being used. This notice must be reproduced on all copies or portions thereof.

**WARNING****CARBON MONOXIDE (EXHAUST GAS) CAN KILL YOU**

Carbon monoxide is without color or smell, but it can kill you. Breathing air with carbon monoxide produces symptoms of headache, dizziness, loss of muscular control, a sleepy feeling, and coma. Brain damage or death can result from heavy exposure. Carbon monoxide occurs in the exhaust fumes of fuel-burning heaters and internal combustion engines. Carbon monoxide can become dangerously concentrated under conditions of no air movement. Precautions must be followed to ensure crew safety when the personnel heater, main engine, or auxiliary engine of any vehicle is operated for any purpose.

1. DO NOT operate personnel heater or engine of vehicle in a closed place, unless the place has a lot of moving air.
2. DO NOT idle engine for long periods without ventilator blower operating.
3. DO NOT drive any vehicle with inspection plates, cover plates, or engine compartment doors removed, unless necessary for maintenance purposes.
4. BE ALERT at all times during vehicle operation for exhaust odors and exposure symptoms. If either is present, IMMEDIATELY VENTILATE personnel compartments. If symptoms persist, remove affected crew to fresh air; keep warm; DO NOT PERMIT PHYSICAL EXERCISE; if necessary, give artificial respiration.

FOR ARTIFICIAL RESPIRATION, REFER TO FM 21-11.

5. BE AWARE: the field protective mask for chemical-biological-radiological (CBR) protection will not protect you from carbon monoxide poisoning.

THE BEST DEFENSE AGAINST CARBON MONOXIDE POISONING IS GOOD VENTILATION.

**WARNING**

Whenever hood is raised, insert the S-shaped safety hook through the two matching holes in the prop channels to prevent the hood from falling accidentally.

**WARNING**

Let radiator cool before removing cap. Remove radiator cap in two steps. First, place a thick cloth over the cap and slowly rotate cap counterclockwise to its first stop; pause, and let pressure escape from cooling system. Then rotate cap further counterclockwise until you can remove it. Failure to follow this procedure can result in serious burns.

**WARNING**

Do not smoke, have open flames, or make sparks around the batteries, especially if the caps are off. Battery gases can explode and cause injury.

**WARNING**

Particles blown by compressed air are hazardous. Always direct air stream away from the user and other persons in the area. User must wear a safety eyeshield when using compressed air in cleaning.

**WARNING**

Improper cleaning methods and use of unauthorized cleaning solvents could injure personnel and damage equipment. See TM 9-247 for proper cleaning methods and authorized solvents.

---

**WARNING**

---

Compressed air used for cleaning purposes will not exceed 30 psi. Use only with effective chip guarding and personnel protective equipment (goggles/shield, gloves, etc.).

---

**WARNING**

---

Ether is highly explosive. Dispose of ether cylinders properly. Be alert for the strong odor of spilled ether. Guard against flame or sparks in work area when servicing ether cylinder.

---

**WARNING**

---

During normal operation, the exhaust pipes and muffler can become very hot. Be careful not to touch these components with your bare hands. Do not allow your body to come in contact with the hot pipes or muffler. Exhaust system components may be hot enough to cause serious burns.

---

**WARNING**

---

Cooling system components become hot during operation. To avoid personal injury, do not service cooling system components until cooling system has cooled down.

---

**WARNING**

---

Always remove negative battery ground cables first and install them last to avoid sparks that can cause an explosion. Failure to follow this precaution may result in serious injury to you and other personnel.

**WARNING**

Transmission oil is hot. Use care when draining transmission oil to prevent personal injury.

**WARNING**

Never work on air system components without first draining air pressure. Failure to follow this precaution can result in serious injury.

Change

HEADQUARTERS,  
DEPARTMENT OF THE ARMY  
WASHINGTON, DC, 30 December 2005

No. 2

TECHNCIAL MANUAL  
ORGANIZATIONAL MAINTENANCE  
TRUCK TRACTOR, LINE HAUL,  
50,000 GVWR, 6x4, M915A1  
(NSN 2320-01-125-2640)

**DISTRIBUTION STATEMENT A- Approved for public release; distribution is unlimited.**

TM 9-2320-283-20-3, 8 December 1983, is changed as follows:

1. Remove old pages and insert new pages as indicated below.

Remove Pages

Insert Pages

B-1 through B-4  
B-5 through B-29

B-1 through B-4  
B-5 through B-26

2. File this change sheet in the front of the publication for information purposes.

This change implements Army Maintenance Transformation and changes the Maintenance Allocation Chart (MAC) to support Field and Sustainment Maintenance.

By Order of the Secretary of the Army:

PETER J. SCHOOMAKER  
*General, United States Army*  
*Chief of Staff*

Official:

  
SANDRA R. RILEY  
*Administrative Assistant to the*  
*Secretary of the Army*

0517807

DISTRIBUTION: To be distributed in accordance with the initial distribution requirements (IDN) 380322 for TM 9-2320-283-20-3.



CHANGE

No. 1

HEADQUARTERS  
DEPARTMENT OF THE ARMY  
Washington, D. C., 30 March 1993

**TECHNICAL MANUAL**

**ORGANIZATIONAL  
MAINTENANCE**

**TRUCK TRACTOR, LINE HAUL,  
50,000 GVWR, 6 x 4, M015A1**

**(NSN 2320-01-125-2640)**

TM 9-2320-283-20-3, 8 December 1983, is changed as follows:

1. Remove old pages and insert new pages as indicated below.
2. New or changed material is indicated by a vertical bar in the margin of the page and by a vertical bar adjacent to the TA number.

Remove Pages	Insert Pages
3-1297 through 3-1304	3-1297 through 3-1304.11 (blank)/ 3-1304.12
E-7 and E-8	E-7 and E-8
Index 15 and Index 16	Index 15 and Index 16

3. File this change sheet in front of the publication for reference purposes.

**By Order of the Secretary of the Army:**

**GORDON R. SULLIVAN**  
General, United States Army  
Chief of Staff

Official:

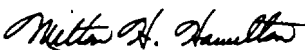
  
**MILTON H. HAMILTON**  
Administrative Assistant to the  
Secretary of the Army  
03620

Distribution:

To be distributed in accordance with DA Form 12-38-E, Block 0322, requirements for  
TM 9-2320-283-20-3.

**Approved for public release; distribution is unlimited.**



LIST OF EFFECTIVE PAGES

Dates of issue for original and change pages are:

Original . . . . .December 1983

Change 2. . . . .December 2005

TOTAL NUMBER OF PAGES IN THIS PUBLICATION IS 759 CONSISTING OF THE FOLLOWING:

Page No.	*Change No.
Cover (Back Blank)	0
A/(B Blank)	2
i thru vi	0
3-1203 thru 1296	0
3-1297 thru 3-1304	1
3-1305 thru A-3/(A-4 blank)	0
B1 through B-4	2
B5 through B-29	2
C-1 through E-6	0
E-7/(E-8 blank)	1
Glossary 1 (Glossary 2 blank)	0
Index 1 through Index 14	0
Index 15 thru 16	1
Index 17 through Metric Chart	0
Pin Page	2

\* Zero in this column indicates an original page or work package.

**ORGANIZATIONAL MAINTENANCE MANUAL**

**TRUCK TRACTOR, LINE HAUL,  
50,000 GVWR, 6 X 4, MØ15A1**

**REPORTING ERRORS AND RECOMMENDING IMPROVEMENTS**

You can help improve this manual. If you find any mistakes or if you know of a way to improve the procedures, please let us know. Mail your letter, DA Form 2028 (Recommended Changes to Publications and Blank Forms), or DA Form 2028-2 located in the back of this manual directly to Commander, U.S. Army Tank-Automotive Command, ATTN: DRSTA-MB, Warren, MI 48090. A reply will be furnished to you.

VOLUME 3 OF 3

	Page
Section XII. <b>WHEELS</b> . . . . .	3-1203
3-201. General . . . . .	3-1203
3-202. Task Summary . . . . .	3-1203
3-203. Front Wheel Alinement . . . . .	3-1206
3-204. Front Drum Replacement . . . . .	3-1210
3-205. Front Hub, Bearings, and Seals Replacement . . . . .	3-1214
3-206. Rear Brake Drum Replacement . . . . .	3-1222
3-207. Rear Hub, Bearings, and Seals Replacement . . . . .	3-1226
3-208. Tire Replacement . . . . .	3-1238
Section XIII. <b>STEERING SYSTEM</b> . . . . .	3-1245
3-209. General . . . . .	3-1245
3-210. Task Summary . . . . .	3-1245
3-211. Steering System Service . . . . .	3-1248
3-212. Steering System Testing . . . . .	3-1254
3-213. Steering Wheel Replacement . . . . .	3-1264

	Page
Section XIII.	<b>STEERING SYSTEM (Continued).</b>
3-214.	Upper Steering Column Replacement and Repair . . . 3-1270
3-215.	Lower Steering Column Replacement and Repair . . . 3-1282
3-216.	Vertical Link Replacement . . . . . 3-1292
3-217.	Steering Arm Replacement . . . . . 3-1298
3-218.	Tie Rod and Ball Joints Replacement . . . . . 3-1304
3-219.	Steering Pump and Reservoir Replacement . . . . . 3-1310
3-220.	Power Steering Lines and Fittings Replacement . . . . . 3-1318
Section XIV.	<b>FRAME AND TOWING ATTACHMENTS</b> . . . . . 3-1329
3-221.	General . . . . . 3-1329
3-222.	Task Summary . . . . . 3-1329
3-223.	Secondary Reservoir Support Replacement . . . . . 3-1334
3-224.	Muffler Inlet Pipe Support Replacement . . . . . 3-1338
3-225.	Supply Reservoir Mounting Brackets Replacement . . . . . 3-1344
3-226.	Step Replacement . . . . . 3-1350
3-227.	Air Dryer Mounting Bracket Replacement . . . . . 3-1358
3-228.	Tiedown Bracket Replacement . . . . . 3-1362
3-229.	Vehicle Lifting Bracket Replacement . . . . . 3-1366
3-230.	Clevis Pin Replacement . . . . . 3-1372
3-231.	Transmission Oil Filter Mounting Bracket Replacement . . . . . 3-1376
3-232.	Forward-Rear Axle Stop Replacement . . . . . 3-1380
3-233.	Blackout Taillamp Mounting Bracket Replacement . . . . . 3-1384
3-234.	Taillamp Bracket Replacement . . . . . 3-1388
3-235.	Rear Tow Eye Bracket, Shackle, and Pin Replacement . . . . . 3-1392
3-236.	Brush Guard Replacement . . . . . 3-1398
3-237.	Bumper, Towing Eyes, and Vehicle Class Sign Replacement . . . . . 3-1404
3-238.	Tow Pintle Replacement . . . . . 3-1412
3-239.	Service Deck Replacement . . . . . 3-1420
3-240.	Spare Tire Carrier Replacement . . . . . 3-1426
3-241.	Spare Tire Winch Cable Replacement . . . . . 3-1432
3-242.	Spare Tire Winch Replacement and Repair . . . . . 3-1438
3-243.	Spare Tire Winch Pillar Replacement . . . . . 3-1446
3-244.	Fifth Wheel Adjustment . . . . . 3-1452
3-245.	Fifth Wheel Replacement . . . . . 3-1458
3-246.	Fifth Wheel Ramp Replacement . . . . . 3-1466
Section XV.	<b>SPRINGS, SHOCK ABSORBERS, AND TORQUE RODS</b> . . . . . 3-1470
3-247.	General . . . . . 3-1470
3-248.	Task Summary . . . . . 3-1470
3-249.	Front Spring Pin Screws and Fittings Replacement . . . . . 3-1472
3-250.	Shock Absorber Replacement . . . . . 3-1478
3-251.	Torque Rods Replacement . . . . . 3-1484

	Page
Section XVI. <b>CAB AND BODY</b> . . . . .	3-1492
3-252. General . . . . .	3-1492
3-253. Task Summary . . . . .	3-1492
3-254. Right-Hand Instrument Cluster Panel Assembly Replacement . . . . .	3-1498
3-255. Left-Hand Instrument Cluster Panel Assembly Assembly Replacement . . . . .	3-1504
3-256. Instrument Panel Center Panel Assembly Replacement . . . . .	3-1510
3-257. Glove Compartment Door Assembly Replacement . . . . .	3-1516
3-258. Instrument Panel Assembly Replacement . . . . .	3-1522
3-259. Inside Assist Handle Replacement . . . . .	3-1528
3-260. Center Floor Pan Access Cover Replacement . . . . .	3-1532
3-261. Ventilator Replacement . . . . .	3-1536
3-262. Padlock Bracket Replacement . . . . .	3-1540
3-263. Outside Rear Handle Replacement. . . . .	3-1544
3-264. Outside Front Handle Replacement . . . . .	3-1548
3-265. Door Plate Replacement . . . . .	3-1552
3-266. Door Frame Seal Replacement . . . . .	3-1556
3-267. Insulator Replacement . . . . .	3-1560
3-268. Grille Replacement . . . . .	3-1566
3-269. Hood Replacement . . . . .	3-1576
3-270. Hood Panel and Component Replacement . . . . .	3-1584
3-271. Front Fender Replacement . . . . .	3-1600
3-272. Quarter Fender Replacement . . . . .	3-1612
3-273. Splash Shield Replacement . . . . .	3-1618
3-274. Rear Mud Flap and Bracket Replacement . . . . .	3-1622
3-275. Cab Headliner Panel Replacement . . . . .	3-1626
3-276. Cab Trim Panel Replacement . . . . .	3-1630
3-277. Insulation Replacement . . . . .	3-1634
3-278. Sun Visor Replacement . . . . .	3-1638
3-279. Floor Mat Replacement . . . . .	3-1642
3-280. Driver's Seat Replacement . . . . .	3-1646
3-281. Driver's Seat Riser Replacement . . . . .	3-1650
3-282. Seat Belt Replacement . . . . .	3-1654
3-283. Companion Seat Replacement . . . . .	3-1660
3-284. Companion Seat Riser, Fire Extinguisher Brackets, and Toolbox Replacement . . . . .	3-1664
Section XVII. <b>ACCESSORY ITEMS</b> . . . . .	3-1672
3-285. General . . . . .	3-1672
3-286. Task Summary . . . . .	3-1672
3-287. Door Mirror Replacement . . . . .	3-1676
3-288. Spotter Mirror Replacement . . . . .	3-1682
3-289. Air Horn and Control Valve Replacement . . . . .	3-1688
3-290. Windshield Washer Replacement . . . . .	3-1694
3-291. Windshield Washer Control Valve Replacement. . . . .	3-1700
3-292. Windshield Wiper Control Replacement . . . . .	3-1704

	Page
Section XVII.	<b>ACCESSORY ITEMS (Continued).</b>
3-293.	Windshield Wiper Blade Assembly Replacement . . . . . 3-1710
3-294.	Windshield Wiper Assembly Replacement . . . . . 3-1714
3-295.	Windshield Wiper Motor Replacement . . . . . 3-1720
3-296.	Heater Air Hose Replacement . . . . . 3-1726
3-297.	Heater Valve, Hoses, Tubes, and Clamps Replacement . . . . . 3-1730
3-298.	Heater Assembly Replacement and Repair . . . . . 3-1736
3-299.	Heater Blower Assembly Replacement and Repair . . . . . 3-1746
3-300.	Heater Control Panel Replacement . . . . . 3-1754
3-301.	Heater Control Panel Repair . . . . . 3-1760
3-302.	Air Diffuser Assembly Replacement . . . . . 3-1766
3-303.	Defroster Fan Replacement . . . . . 3-1772
3-304.	Defroster Fan Repair . . . . . 3-1776
3-305.	Data and Instruction Plates Replacement . . . . . 3-1782
3-306.	Winterization Kit (Refer to TB 9-2320-283-14)
Section XVIII.	<b>GAGES (NONELECTRICAL)</b> . . . . . 3-1786
3-307.	General . . . . . 3-1786
3-308.	Task Summary . . . . . 3-1786
3-309.	Tachograph Replacement . . . . . 3-1788
3-310.	Speedometer Shaft Replacement . . . . . 3-1798
3-311.	Speedometer Drive Sleeve Adapter Replacement . . . . . 3-1802
3-312.	Speedometer Driven Gear Replacement . . . . . 3-1806
3-313.	Tachometer Shaft Replacement . . . . . 3-1810
3-314.	Pressure Gage Replacement . . . . . 3-1816
3-315.	Air Cleaner Restriction Gage and Bracket Replacement . . . . . 3-1822
3-316.	Air Cleaner Restriction Gage Tube Replacement . . . . . 3-1828
Section XIX.	<b>STE/ICE COMPONENTS</b> . . . . . 3-1832
3-317.	General . . . . . 3-1832
3-318.	Task Summary . . . . . 3-1832
3-319.	Pulse Tachometer Replacement . . . . . 3-1834
3-320.	Pressure Transducer Replacement . . . . . 3-1838
APPENDIX A.	<b>REFERENCES</b> . . . . . A-1
	A-1. Publication Indexes . . . . . A-1
	A-2. Forms . . . . . A-1
	A-3. Other Publications . . . . . A-1

	Page
APPENDIX B. <b>MAINTENANCE ALLOCATION CHART</b> . . . . .	B- 1
Section I.    INTRODUCTION . . . . .	B- 1
B-1. General . . . . .	B- 1
B-2. Maintenance Functions . . . . .	B- 1
B-3. Explanation of Columns in the MAC, Section II . . . . .	B- 2
B-4. Explanation of Columns in Tool and Test Equipment Requirements, Section III . . . . .	B- 4
Section II.  MAINTENANCE ALLOCATION CHART . . . . .	B- 5
Section III. TOOL AND TEST EQUIPMENT REQUIREMENTS . . . . .	B- 24
APPENDIX C. <b>EXPENDABLE SUPPLIES AND MATERIALS LIST</b> . . . . .	C- 1
Section I.    INTRODUCTION . . . . .	C- 1
C-1. Scope . . . . .	C- 1
C-2. Explanation of Columns . . . . .	C- 1
Section II.  EXPENDABLE SUPPLIES AND MATERIALS LIST . . . . .	C- 2
APPENDIX D. <b>SCHEMATIC DIAGRAMS</b> . . . . .	D- 1
Section I.    INTRODUCTION . . . . .	D- 1
D-1. Scope . . . . .	D- 1
D-2. Electrical System Diagrams . . . . .	D- 1
D-3. Compressed Air System Diagrams . . . . .	D- 1
APPENDIX E. <b>ILLUSTRATED LIST OF MANUFACTURED ITEMS</b> . . . . .	E- 1
Section I.    INTRODUCTION . . . . .	E- 1
E-1. General . . . . .	E- 1
E-2. Manufactured Item Part Number Index . . . . .	E- 1
Section II.  ILLUSTRATED MANUFACTURING INSTRUCTIONS . . . . .	E- 2
GLOSSARY . . . . .	Glossary 1
Section I.    LIST OF ABBREVIATIONS . . . . .	Glossary 1
Section II.  DEFINITION OF UNUSUAL TERMS . . . . .	Glossary 1
ALPHABETICAL INDEX . . . . .	Index 1





**Section XII. WHEELS**

**3-201. GENERAL.**

This section provides procedures authorized at the organizational maintenance level to replace wheel components. To find a specific procedure contained in this section, see the task summary below.

**3-202. TASK SUMMARY.**

INITIAL SETUP

APPLICABLE CONFIGURATIONS

All.

EQUIPMENT CONDITION

PARAGRAPH

CONDITION DESCRIPTION

(Refer to specific paragraph for this information).

TEST EQUIPMENT

None.

SPECIAL TOOLS

Handle

(80201) 450237.

Adapter

(80201) 427.

Plug, bearing

(80201) 706.

Wrench, hexagon locknut,

2-1/4 inch

(45225) 1920.

Adapter

(80201) 446.

Plug

(80201) 715.

Wrench, hexagon locknut, 4-1/8 inch

(45225) 1915.

MATERIALS/PARTS (P/N)

Solvent, drycleaning, SD-2

Item 29, Appendix C.

Rag, wiping

Item 22, Appendix C.

Solution, soap

Item 28, Appendix C.

Antiseize compound

Item 5, Appendix C.

Sealant, flange

Item 23, Appendix C.

Pin, cotter

(52304) H1005727.

Seal assembly, front axle bearing

(80201) 35066.

Gasket, hubcap

(26151) 330-3009.

Oil, lubricating: Gear GO

Refer to LO 9-2320-283-12.

Seal, rear axle bearing

(80201) 47697.

PERSONNEL REQUIRED

Two (MOS-63S).

SPECIAL ENVIRONMENTAL CONDITIONS

Vehicle on level ground with front wheels straight.

WHEELS.

3-202. TASK SUMMARY (Continued).

INITIAL SETUP (Continued)

REFERENCES (TM)

TM 9-2320-283-10.  
 TM 9-214.  
 TM 9-2320-283-20P.  
 LO 9-2320-283-12.  
 TM 9-2610-200-20.

TROUBLESHOOTING REFERENCES

Paragraph 2-11.

GENERAL SAFETY INSTRUCTIONS

Engine off.  
 Transmission in neutral.  
 Park brake set.  
 Axle on safety stand.  
 Wheels chocked.  
 Vehicle parked on level ground.  
 Always remove air pressure from  
 tire before servicing. Personal  
 injury or part damage could re-  
 sult, from working on an inflated  
 tire.

LIST OF TASKS

TASK NO.	TASK	TASK REF	TROUBLESHOOTING REF NO. (PARA)
1	Front Wheel Alinement a. Checking Alinement. b. Adjust Alinement.	3-203 3-203a 3-203b	2-11
2	Front Drum Replacement a. Removal. b. Cleaning and Inspection. c. Installation.	3-204 3-204a 3-204b 3-204c	2-11
3	Front Hub, Bearings, and Seals Replacement a. Removal. b. Cleaning and Inspection. c. Installation.	3-205 3-205a 3-205b 3-205c	2-11
4	Rear Brake Drum Replacement a. Removal. b. Cleaning and Inspection. c. Installation.	3-206 3-206a 3-206b 3-206c	2-11

WHEELS.

3-202. TASK SUMMARY (Continued).			
LIST OF TASKS			
TASK NO.	TASK	TASK REF	TROUBLESHOOTING REF NO. (PARA)
5	Rear Hub, Bearings, and Seals Replacement	3-207	2-11
	a. Removal.	3-207a	
	b. Cleaning.	3-207b	
	c. Inspection.	3-207c	
	d. Installation.	3-207d	
6	Tire Replacement	3-208	2-11
	a. Removal.	3-208a	
	b. Cleaning and Inspection.	3-208b	
	c. Repair.	3-208c	
	d. Installation.	3-208d	

WHEELS.

3-203. FRONT WHEEL ALINEMENT.

THIS TASK COVERS

- a. Checking Alinement.
- b. Adjust Alinement.

INITIAL SETUP

APPLICABLE CONFIGURATIONS

All.

EQUIPMENT CONDITION  
PARAGRAPH

TM 9-2320-283-10.

CONDITION DESCRIPTION

Front tires properly inflated.

TEST EQUIPMENT

None.

SPECIAL TOOLS

None.

MATERIALS/PARTS (P/N)

None.

PERSONNEL REQUIRED

One (MDS-63S)

SPECIAL ENVIRONMENTAL CONDITIONS

Vehicle on level ground with front wheels straight.

REFERENCES (TM)

TM 9-2320-283-10.

GENERAL SAFETY INSTRUCTIONS

Engine off.  
Transmission in neutral.  
Park brake set.

TROUBLESHOOTING REFERENCES

Paragraph 2-11.

WHEELS.

3-203. FRONT WHEEL ALIGNMENT (Continued).

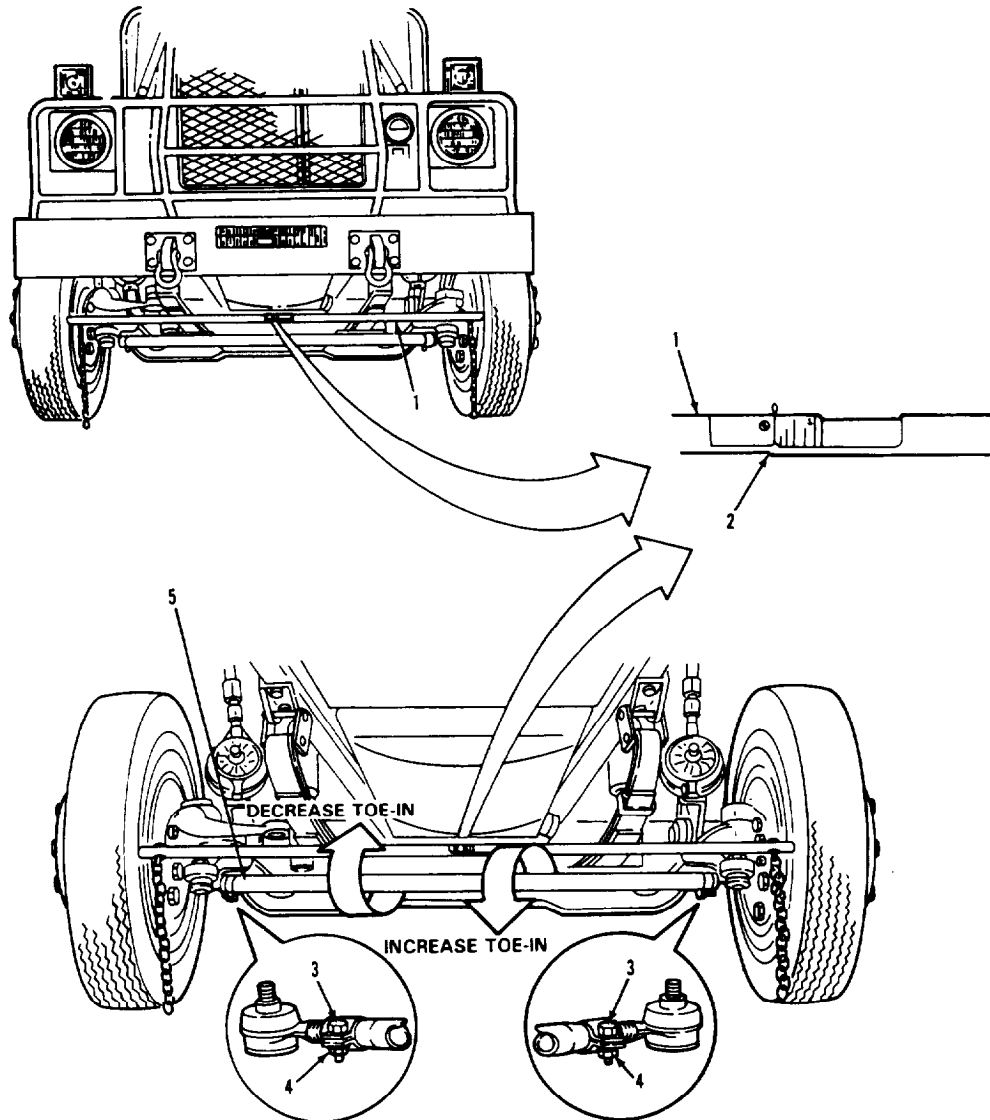

LEGEND:

- |                 |                          |
|-----------------|--------------------------|
| 1. TOE-IN GAGE  | 4. NUT (2)               |
| 2. GAGE POINTER | 5. TIE ROD TUBE ASSEMBLY |
| 3. SCREW (2)    |                          |

TA 237566

WHEELS.

3-203. FRONT WHEEL ALINEMENT (Continued).		
LOCATION/ITEM	ACTION	REMARKS
<b>A. CHECKING ALINEMENT.</b>		
1. Gage (1).	From the front of vehicle, install between tires so both chains just touch ground.	Gage (1) should be on same spot of both tires.
2. Pointer (2).	Set to read zero.	
3. Gage (1).	a. Remove. b. From behind front wheels, install between tires so both chains just touch ground.	Gage (1) should be on same spot of both tires.
4. Pointer (2).	Check reading.	Reading should be $1/32 \pm 1/32$ for both wheels. If not, adjust alignment.
<b>B. ADJUST ALINEMENT.</b>		
5. Two bolts (3) and nuts (4).	Loosen.	
6. Tie rod tube assembly (5).	a. Turn to adjust. b. Check alignment again.	As shown.
7. Two bolts (3) and nuts (4).	Torque between 40 and 55 lb-ft.	
<b>NOTE</b>		
Follow-on maintenance action required:		
None.		

WHEELS.

3-203. FRONT WHEEL ALINEMENT (Continued).

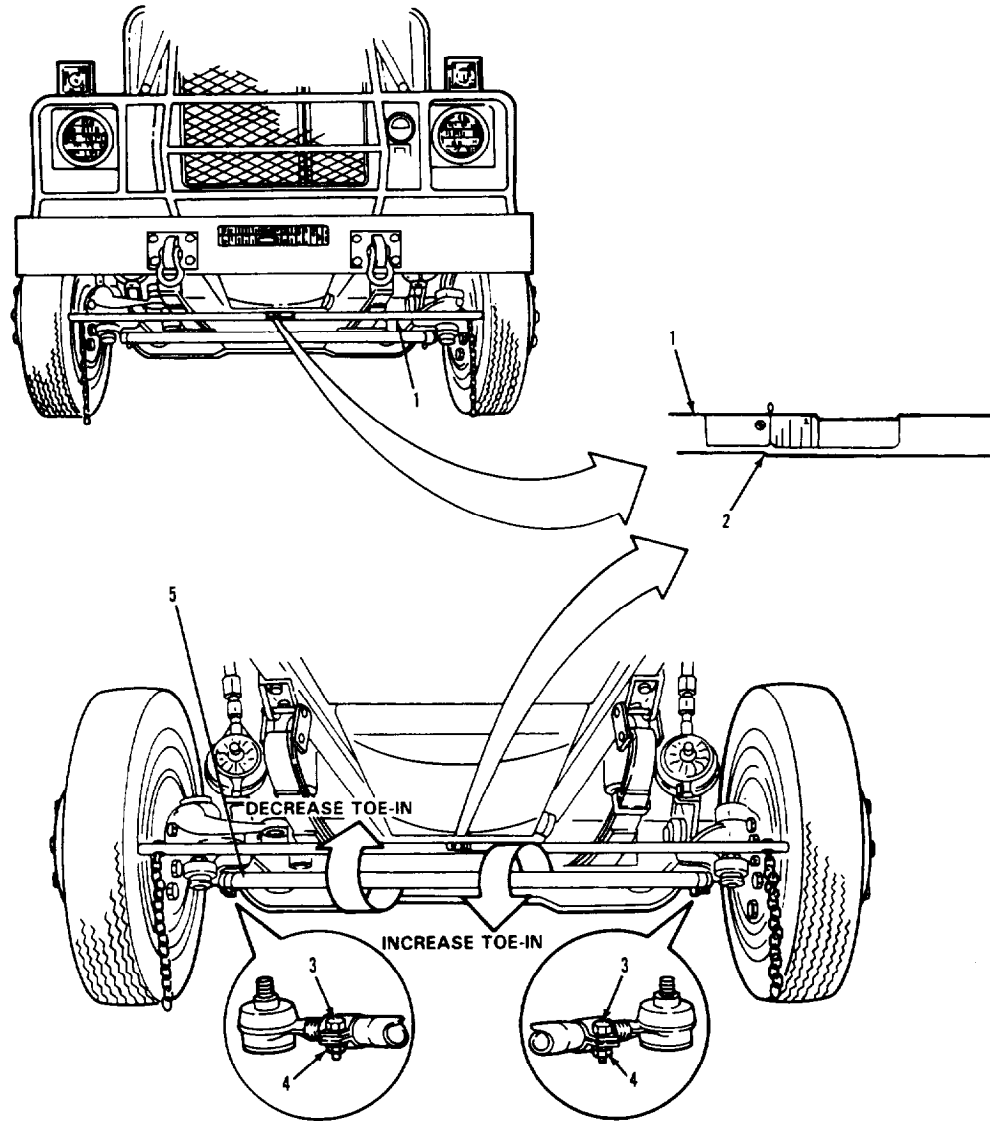

LEGEND:

- |                 |                          |
|-----------------|--------------------------|
| 1. TOE-IN GAGE  | 4. NUT (2)               |
| 2. GAGE POINTER | 5. TIE ROD TUBE ASSEMBLY |
| 3. SCREW (2)    |                          |

TA 237567



WHEELS.

3-204. FRONT DRUM REPLACEMENT.

THIS TASK COVERS

- a. Removal.
- b. Cleaning and Inspection.
- c. Installation.

INITIAL SETUP

APPLICABLE CONFIGURATIONS

All.

EQUIPMENT CONDITION  
PARAGRAPH

TM 9-2320-283-10.

CONDITION DESCRIPTION

Front wheel removed.

TEST EQUIPMENT

None.

SPECIAL TOOLS

None.

MATERIALS/PARTS (P/N)

Solvent, drycleaning, SD-2  
Item 29, Appendix C.  
Rag, wiping  
Item 22, Appendix C.  
Solution, soap  
Item 28, Appendix C.

PERSONNEL REQUIRED

Two (MOS-63S).

SPECIAL ENVIRONMENTAL CONDITIONS

None.

REFERENCES (TM)

TM 9-2320-283-10.

GENERAL SAFETY INSTRUCTIONS

Engine off.  
Transmission in neutral.  
Park brake set.  
Axle on safety stand.

TROUBLESHOOTING REFERENCES

Paragraph 2-11.

**WHEELS.**

**3-204. FRONT DRUM REPLACEMENT (Continued).**

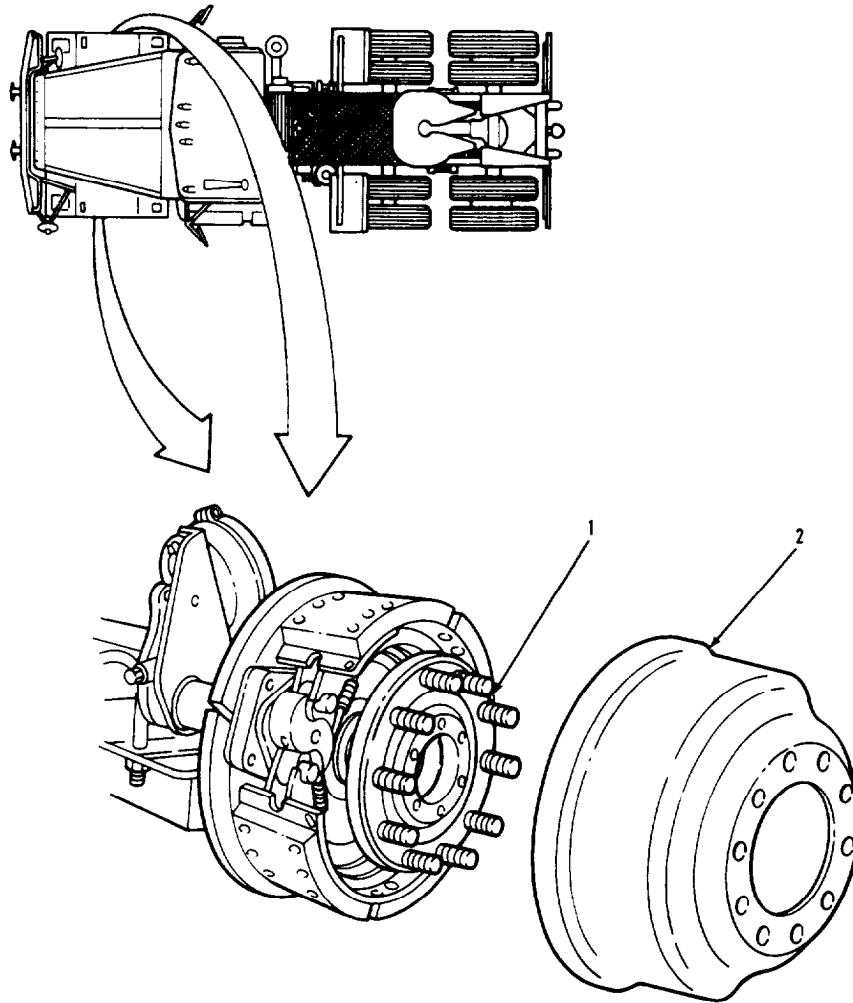

**LEGEND:**

- 1. HUB AND CUP ASSEMBLY
- 2. FRONT BRAKE DRUM

TA 237568

WHEELS.

3-204. FRONT DRUM REPLACEMENT (Continued).		
LOCATION/ITEM	ACTION	REMARKS
<p><b>WARNING</b></p> <p>Front drum is heavy. Two or more personnel are needed to lift drum.</p> <p><b>NOTE</b></p> <p>Replacement of front drums is the same for both sides.</p>		
<p><b>A. REMOVAL.</b></p>		
1. Drum (2).	Remove from item (1).	Tap with hammer if necessary.
<p><b>B. CLEANING AND INSPECTION.</b></p>		
2. Drum (2).	<p>a. Clean with solvent and rag, then with soap solution and water.</p> <p>b. Inspect for cracks, scores, gouges, heat spots, out-of-roundness, or a mirror-like shine.</p> <p>c. Measure inside diameter.</p>	<p>Refer to paragraph 3-4.</p> <p>If damaged, refer to DS/GS maintenance for repair.</p> <p>Replace if more than 16.580 inches.</p>
<p><b>C. INSTALLATION.</b></p>		
3. Drum (2).	Install on item (1).	
<p><b>NOTE</b></p> <p>Follow-on maintenance action required:</p> <p>Install front wheel (TM 9-2320-283-10).</p> <p>Adjust slack adjuster (para 3-157).</p>		

WHEELS.

3-204. FRONT DRUM REPLACEMENT (Continued).

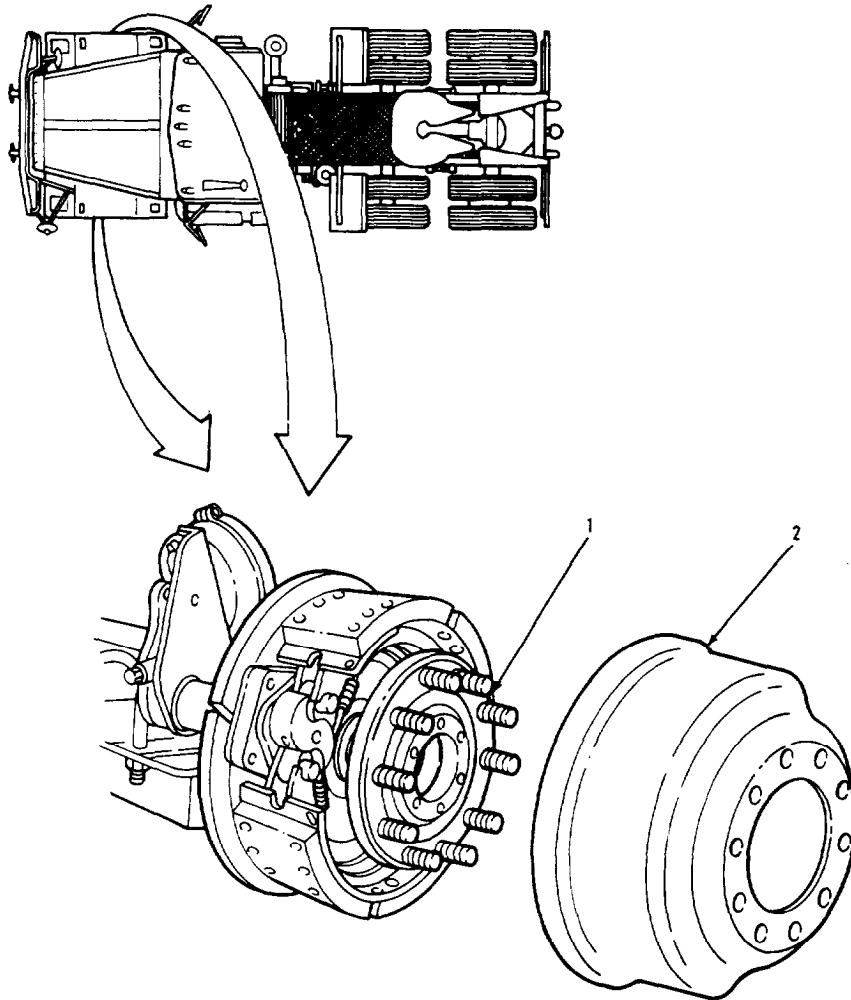

LEGEND:

- 1. HUB AND CUP ASSEMBLY
- 2. FRONT BRAKE DRUM

TA 237569

WHEELS.

3-205. FRONT HUB, BEARINGS, AND SEALS REPLACEMENT.

THIS TASK COVERS

- a. Removal.
- b. Cleaning and Inspection.
- c. Installation.

INITIAL SETUP

APPLICABLE CONFIGURATIONS

All.

EQUIPMENT CONDITION

PARAGRAPH

3-204.

CONDITION DESCRIPTION

Front drum removed.

TEST EQUIPMENT

None.

SPECIAL TOOLS

Handle  
(80201) 450237.  
Adapter  
(80201) 427.

Plug, bearing  
(80201) 706.  
Wrench, hexagon locknut, 2-1/4 inch  
(45225) 1920.

MATERIALS/PARTS (P/N)

Oil lubricating: Gear GO  
Refer to LO 9-2320-283-12  
Sealant, flange  
Item 23, Appendix C.  
Pin, cotter  
(52304) H1005727.

Seal assembly, front axle bearing  
(80201) 35066.  
Gasket, hubcap  
(26151) 330-3009.

PERSONNEL REQUIRED

One (MDS-63S).

SPECIAL ENVIRONMENTAL CONDITIONS

None.

REFERENCES (TM)

LO 9-2320-283-12.  
TM 9-2320-283-20P.

GENERAL SAFETY INSTRUCTIONS

Engine off.  
Transmission in neutral.  
Park brake set.  
Axle on safety stand.

TROUBLESHOOTING REFERENCES

Paragraph 2-11.

WHEELS.

3-205. FRONT HUB, BEARINGS, AND SEALS REPLACEMENT (Continued).

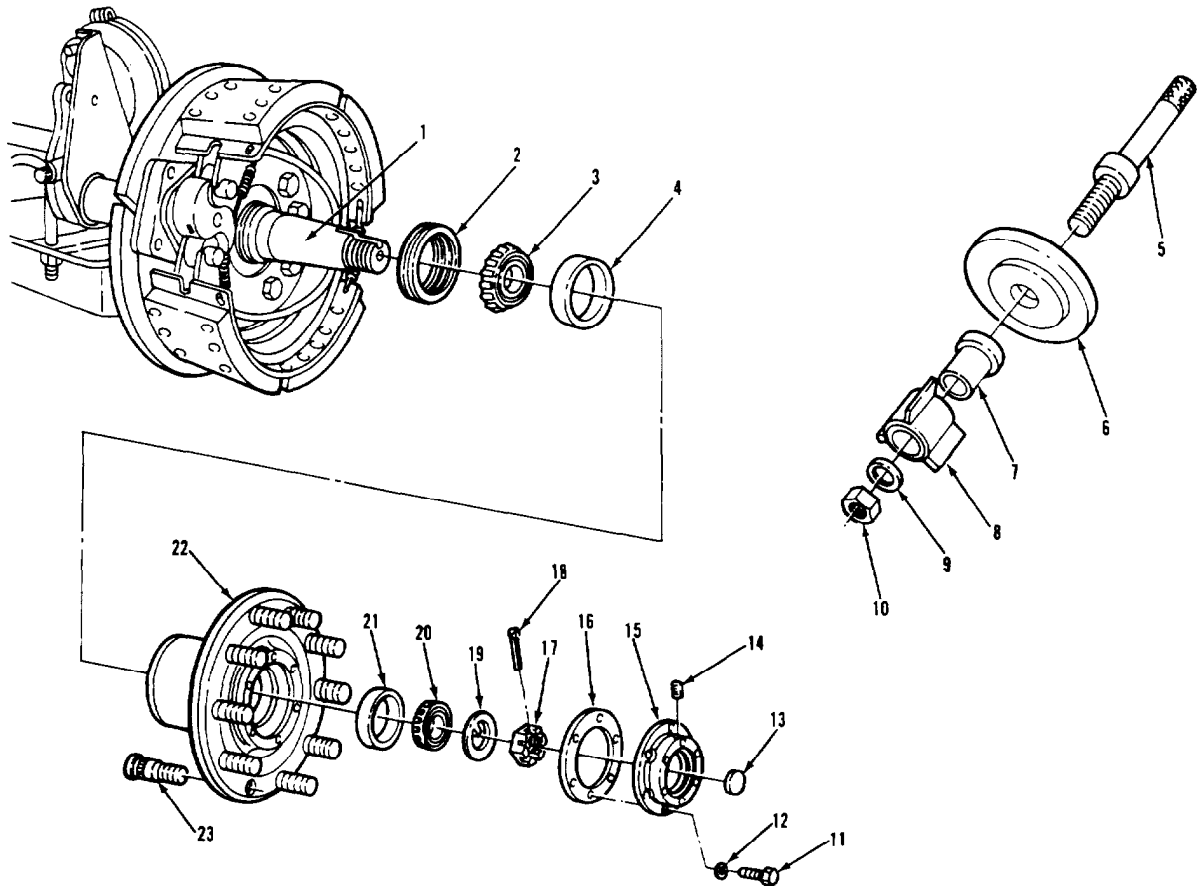

LEGEND:

- |                                     |                          |
|-------------------------------------|--------------------------|
| 1. FRONT NONDRIVING AXLE ASSEMBLY   | 13. VENT PLUG (OPTIONAL) |
| 2. FRONT AXLE BEARING SEAL ASSEMBLY | 14. PIPE PLUG            |
| 3. INNER BEARING CONE               | 15. HUBCAP               |
| 4. INNER CUP                        | 16. HUBCAP GASKET        |
| 5. HANDLE                           | 17. HEXAGON NUT          |
| 6. ADAPTER                          | 18. COTTER PIN           |
| 7. SPACER                           | 19. WASHER               |
| 8. BEARING PLUG                     | 20. OUTER BEARING CONE   |
| 9. LOCKWASHER                       | 21. OUTER CUP            |
| 10. NUT                             | 22. HUB                  |
| 11. SCREW (6)                       | 23. BOLT (10)            |
| 12. LOCKWASHER (6)                  |                          |

TA 237570

WHEELS.

3-205. FRONT HUB, BEARINGS, AND SEALS REPLACEMENT (Continued).		
LOCATION/ITEM	ACTION	REMARKS
<b>NOTE</b>		
Replacement of front hub, bearings, and seals is the same for both sides.		
<b>A. REMOVAL.</b>		
<b>NOTE</b>		
Have a suitable container ready to catch oil.		
1. Plug (14).	Remove from item (15).	Let oil drain.
2. Six screws (11) and lockwashers (12).	Remove from item (15).	
3. Hubcap (15) and gasket (16).	Remove from item (22).	Discard item (16).
<b>NOTE</b>		
Plug (13) is an optional item.		
4. Plug (13).	Remove from item (15).	
5. Pin (18).	Remove from item (17).	Discard item (18).
6. Nut (17), washer (19), cone (20), and hub (22).	Remove from item (1).	Use 2-1/4 inch hexagon locknut wrench.
7. Seal assembly (2) and bearing cone (3).	Remove from item (22).	a. Tap out with hammer and drift. b. Discard item (2).
<b>NOTE</b>		
Only remove bearing cups to replace them with new ones.		
8. Cup (4) and cup (21).	Remove from item (22).	a. Tap out with hammer and drift. b. Discard item (4) and item (21).

WHEELS.

3-205. FRONT HUB, BEARINGS, AND SEALS REPLACEMENT (Continued).

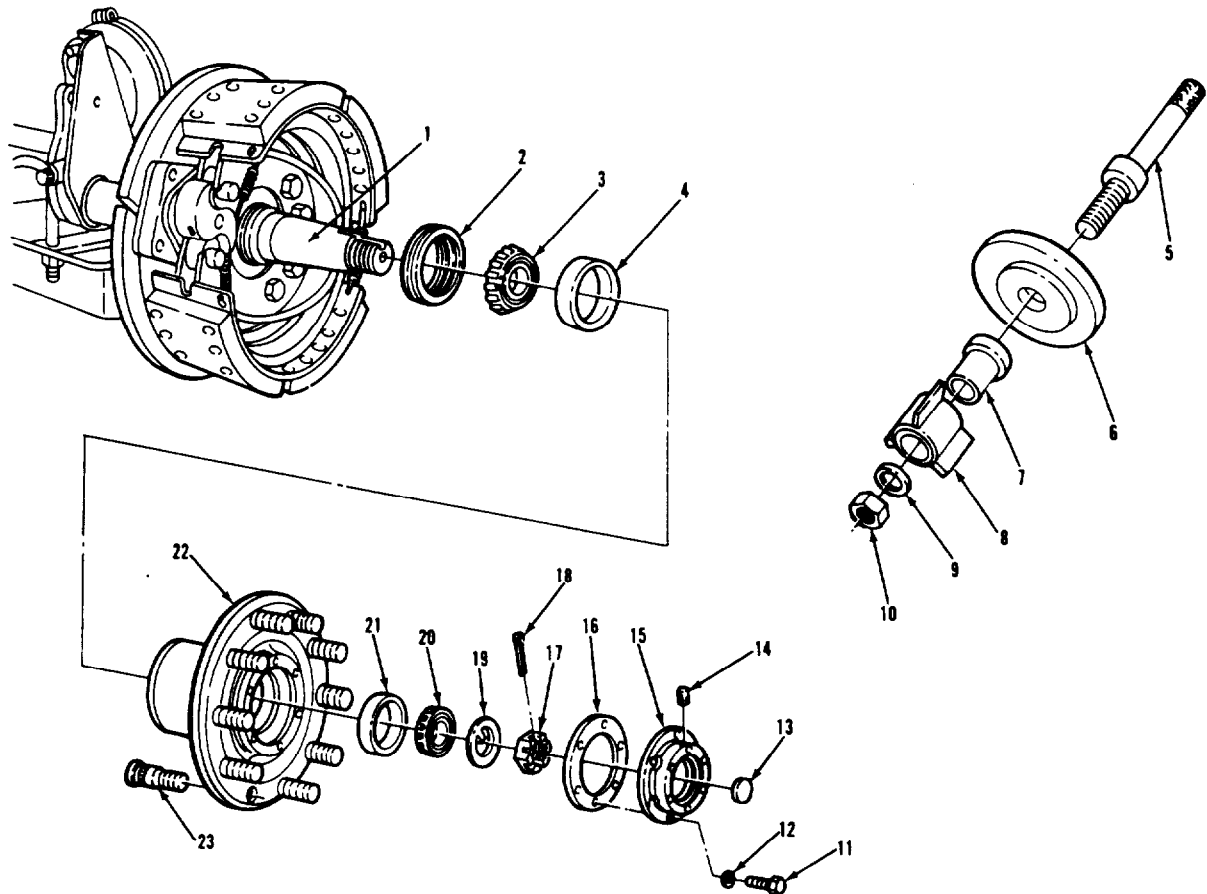

LEGEND:

- |                                     |                          |
|-------------------------------------|--------------------------|
| 1. FRONT NONDRIVING AXLE ASSEMBLY   | 13. VENT PLUG (OPTIONAL) |
| 2. FRONT AXLE BEARING SEAL ASSEMBLY | 14. PIPE PLUG            |
| 3. INNER BEARING CONE               | 15. HUBCAP               |
| 4. INNER CUP                        | 16. HUBCAP GASKET        |
| 5. HANDLE                           | 17. HEXAGON NUT          |
| 6. ADAPTER                          | 18. COTTER PIN           |
| 7. SPACER                           | 19. WASHER               |
| 8. BEARING PLUG                     | 20. OUTER BEARING CONE   |
| 9. LOCKWASHER                       | 21. OUTER CUP            |
| 10. NUT                             | 22. HUB                  |
| 11. SCREW (6)                       | 23. BOLT (10)            |
| 12. LOCKWASHER (6)                  |                          |

TA 237571



WHEELS.

3-205. FRONT HUB, BEARINGS, AND SEALS REPLACEMENT (Continued).		
LOCATION/ITEM	ACTION	REMARKS
<b>A. REMOVAL (Continued).</b>		
<b>NOTE</b>		
Only remove bolts (23) to replace them with new ones.		
9. Ten bolts (23).	Remove from item (22).	a. Use hammer or press. b. Discard items (23).
<b>B. CLEANING AND INSPECTION.</b>		
10. All parts.	Clean and inspect.	Refer to paragraph 3-4 and 3-5.
<b>C. INSTALLATION.</b>		
<b>NOTE</b>		
Put left-hand threaded bolts in left hub and right-hand threaded bolts in right hub.		
11. Ten new bolts (23).	Install in item (22).	Use hammer or press.
12. New cup (4) and new cup (21).	Install in item (22).	Use hammer and brass drift.
13. Cone (3).	Install in item (4).	Dip in clean oil.
14. New seal (2).	Install in item (22).	a. Put flange sealant on large outside edge. b. Use items (5) thru (10) assembled as shown. c. Small end of item (2) seats on item (6).

WHEELS.

3-205. FRONT HUB, BEARINGS, AND SEALS REPLACEMENT (Continued).

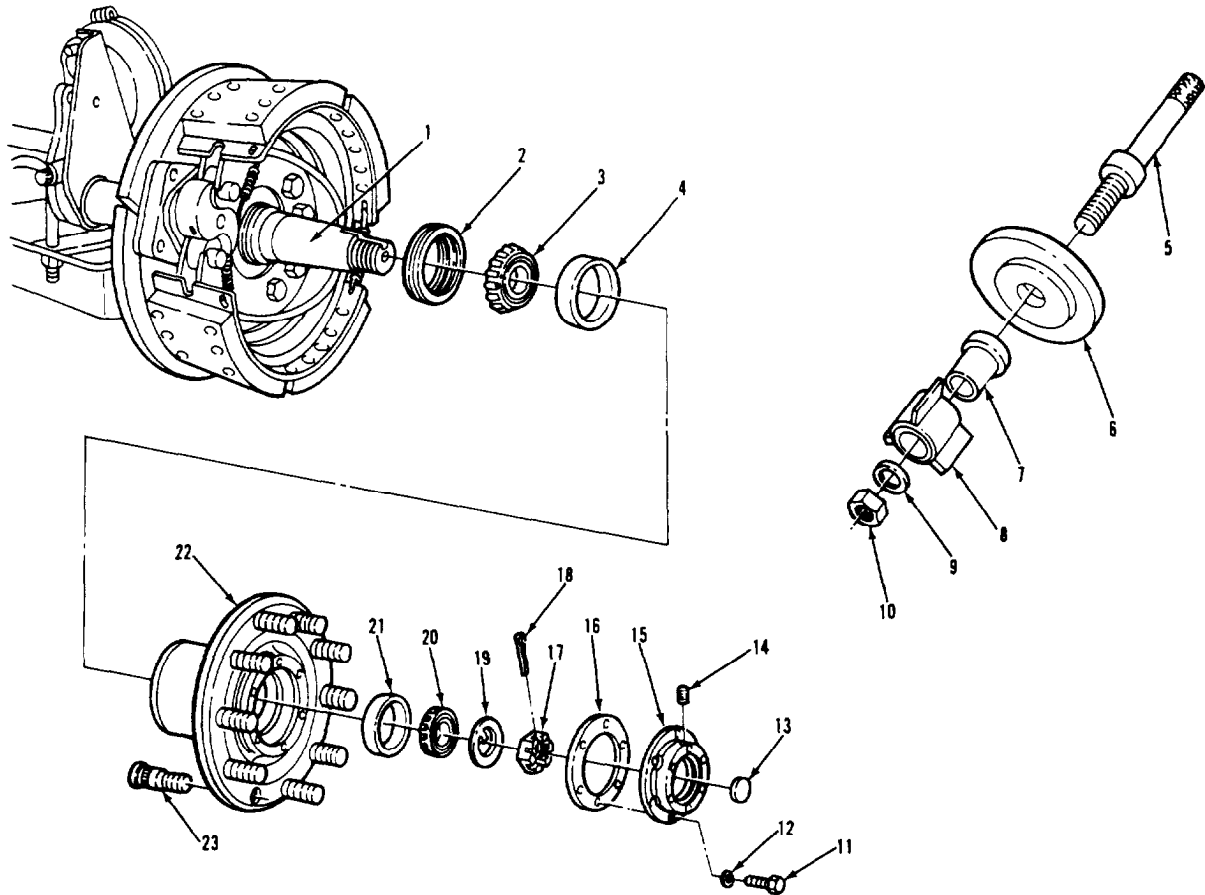

LEGEND:

- |                                     |                          |
|-------------------------------------|--------------------------|
| 1. FRONT NONDRIVING AXLE ASSEMBLY   | 13. VENT PLUG (OPTIONAL) |
| 2. FRONT AXLE BEARING SEAL ASSEMBLY | 14. PIPE PLUG            |
| 3. INNER BEARING CONE               | 15. HUBCAP               |
| 4. INNER CUP                        | 16. HUBCAP GASKET        |
| 5. HANDLE                           | 17. HEXAGON NUT          |
| 6. ADAPTER                          | 18. COTTER PIN           |
| 7. SPACER                           | 19. WASHER               |
| 8. BEARING PLUG                     | 20. OUTER BEARING CONE   |
| 9. LOCKWASHER                       | 21. OUTER CUP            |
| 10. NUT                             | 22. HUB                  |
| 11. SCREW (6)                       | 23. BOLT (10)            |
| 12. LOCKWASHER (6)                  |                          |

TA 237572

WHEELS.

3-205. FRONT HUB, BEARINGS, AND SEALS REPLACEMENT (Continued).

LOCATION/ITEM	ACTION	REMARKS
<b>C. INSTALLATION (Continued).</b>		
15. Hub (22), cone (20), washer (19), and nut (17).	Install on item (1).	Dip item (20) in clean oil.
16. Nut (17).	a. Torque to 50 lb-ft. b. Back off between 1/4 and 1/3 turn.	
17. New pin (18).	Install in item (17).	
18. Plug (13).	Install in item (15).	
19. Hubcap (15) and new gasket (16).	Put in place on item (22).	
20. Six screws (11) and lockwashers (12).	Secure item (15) to item (22).	
21. Hubcap (15).	Fill with oil to full mark.	Do not overfill.
22. Plug (14).	Install in item (15).	
<b>NOTE</b>		
Follow-on maintenance action required:		
Install front drum (para 3-204).		

WHEELS.

3-205. FRONT HUB, BEARINGS, AND SEALS REPLACEMENT (Continued).

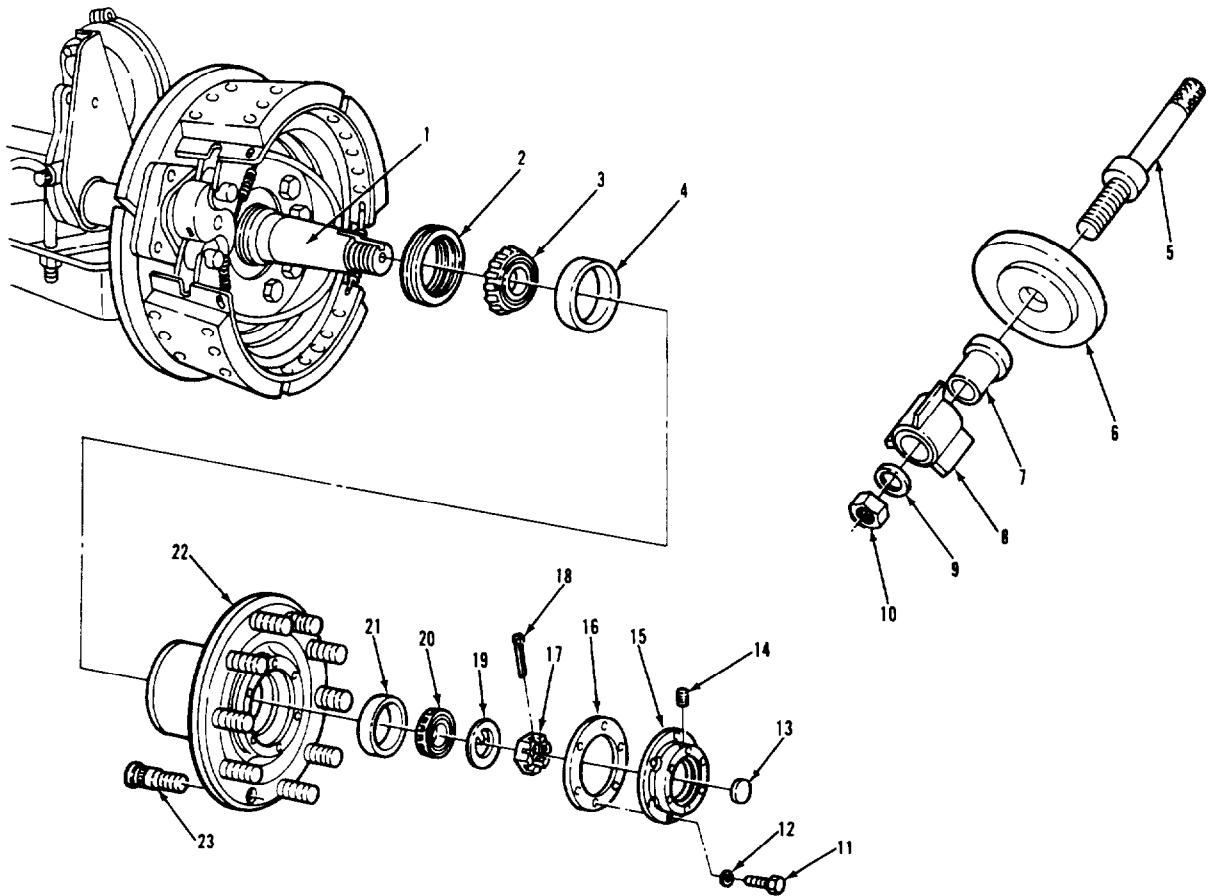

LEGEND:

- |                                     |                          |
|-------------------------------------|--------------------------|
| 1. FRONT NONDRIVING AXLE ASSEMBLY   | 13. VENT PLUG (OPTIONAL) |
| 2. FRONT AXLE BEARING SEAL ASSEMBLY | 14. PIPE PLUG            |
| 3. INNER BEARING CONE               | 15. HUBCAP               |
| 4. INNER CUP                        | 16. HUBCAP GASKET        |
| 5. HANDLE                           | 17. HEXAGON NUT          |
| 6. ADAPTER                          | 18. COTTER PIN           |
| 7. SPACER                           | 19. WASHER               |
| 8. BEARING PLUG                     | 20. OUTER BEARING CONE   |
| 9. LOCKWASHER                       | 21. OUTER CUP            |
| 10. NUT                             | 22. HUB                  |
| 11. SCREW (6)                       | 23. BOLT (10)            |
| 12. LOCKWASHER (6)                  |                          |

TA 237573

WHEELS.

3-206. REAR BRAKE DRUM REPLACEMENT.

THIS TASK COVERS

- a. Removal.
- b. Cleaning and Inspection.
- c. Installation.

INITIAL SETUP

APPLICABLE CONFIGURATIONS

All.

EQUIPMENT CONDITION  
PARAGRAPH

TM 9-2320-283-10.

CONDITION DESCRIPTION

Rear wheels removed.

TM 9-2320-283-10.

Spring brake(s) caged.

TEST EQUIPMENT

None.

SPECIAL TOOLS

None.

MATERIALS/PARTS (P/N)

Solvent, drycleaning, SD-2  
Item 29, Appendix C.  
Soap, solution  
Item 28, Appendix C.

PERSONNEL REQUIRED

Two (MOS-63S).

SPECIAL ENVIRONMENTAL CONDITIONS

Work area clean and away from blowing  
dirt and dust.

REFERENCES (TM)

TM 9-2320-283-10.

GENERAL SAFETY INSTRUCTIONS

Engine off.  
Transmission in neutral.  
Wheels chocked.  
Vehicle parked on level ground.  
Axle supported on safety stand.

TROUBLESHOOTING REFERENCES

Paragraph 2-11.

WHEELS.

3-206. REAR BRAKE DRUM REPLACEMENT (Continued).

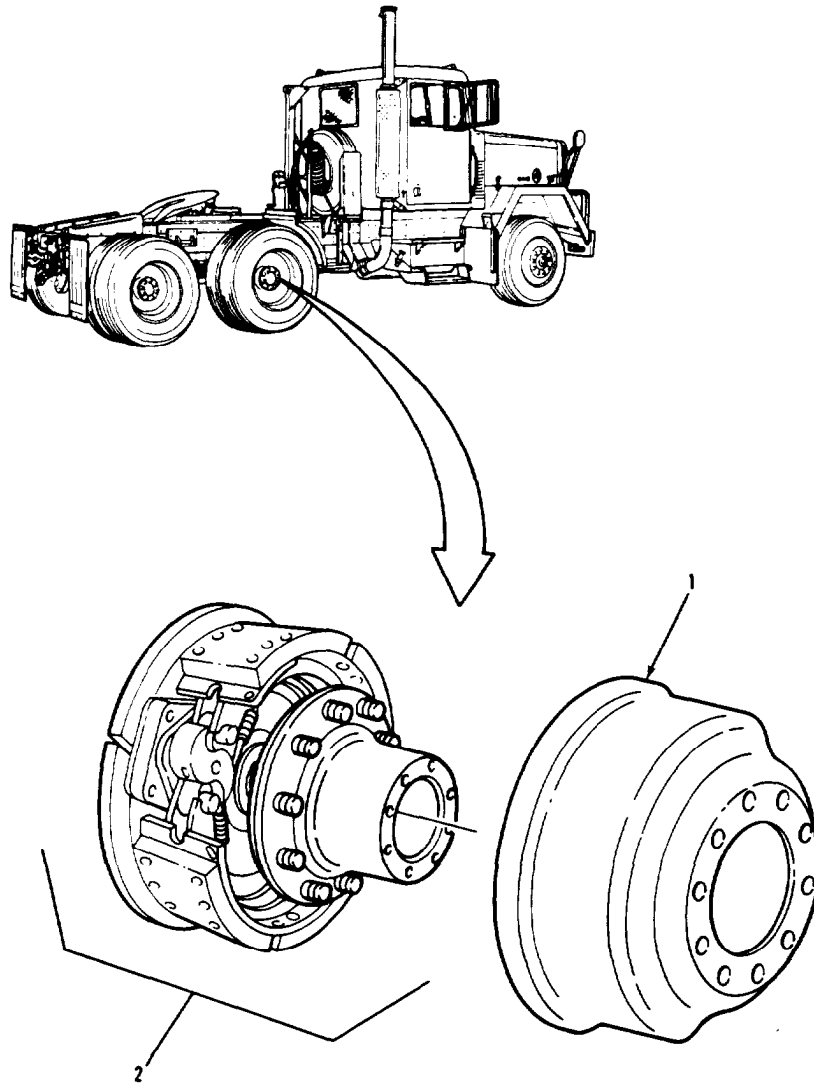

LEGEND:

- 1. BRAKE DRUM
- 2. HUB AND REAR AXLE TANDEM BRAKE ASSEMBLY

TA 237574

WHEELS.

3-206. REAR BRAKE DRUM REPLACEMENT (Continued).

LOCATION/ITEM	ACTION	REMARKS
<b><u>WARNING</u></b>		
Rear brake drums are heavy and awkward to handle. Use a suitable lifting device if available.		
<b>NOTE</b>		
Rear brake drum replacement is the same for both rear axles.		
<b>A. REMOVAL.</b>		
1. Drum (1).	Remove from item (2).	Tap with hammer if necessary.
<b>B. CLEANING AND INSPECTION.</b>		
2. Drum (1).	a. Clean grease with solvent and rags. For final cleaning use soap and water solution only.	Refer to paragraph 3-4.
	b. Inspect for cracks, scores, gouges, heat spots, out-of-roundness, or a mirror-like shine.	Replace if any of these conditions are found. Notify DS/GS Maintenance.
	c. Measure inside diameter.	Replace if diameter is greater than 16.580 inches.
<b>C. INSTALLATION.</b>		
3. Drum	Install on item (2).	
<b>NOTE</b>		
Follow-on maintenance action required:		
Install rear wheels (TM 9-2320-283-10). Adjust brakes (3-164).		

WHEELS.

3-206. REAR BRAKE DRUM REPLACEMENT (Continued).

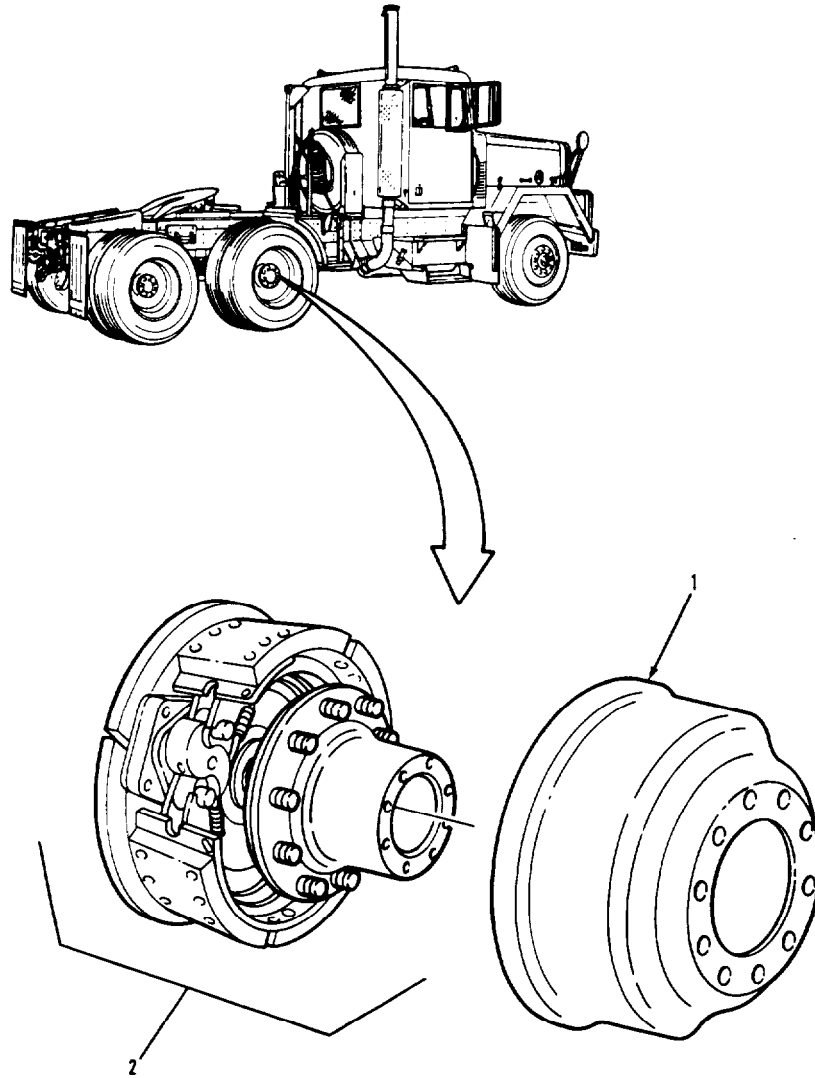

LEGEND:

- 1. BRAKE DRUM
- 2. HUB AND REAR AXLE TANDEM BRAKE ASSEMBLY

TA 237575



WHEELS.

3-207. REAR HUB, BEARINGS, AND SEALS REPLACEMENT.

THIS TASK COVERS

- a. Removal.
- b. Cleaning.
- c. Inspection.
- d. Installation.

INITIAL SETUP

<u>APPLICABLE CONFIGURATIONS</u>	<u>EQUIPMENT CONDITION PARAGRAPH</u>	<u>CONDITION DESCRIPTION</u>
All.	3-206.	Rear brake drum removed.

<u>TEST EQUIPMENT</u> None.	3-154.	Rear axle shaft removed.
--------------------------------	--------	--------------------------

SPECIAL TOOLS

Wrench hexagon locknut, 4-1/8 inch (45225) 1915.	Adapter (80201) 446.
Handle, rear hub bearing seal (80201) 450237.	Plug (80201) 715.

MATERIALS/PARTS (P/N)

Solvent, drycleaning, SD-2 Item 29, Appendix C.	Sealant, flange Item 23, Appendix C.
Antiseize compound Item 5, Appendix C.	Seal, rear axle bearing (80201) 47697.
Oil, lubricating: Gear GO Refer to LO 9-2320-283-12.	

PERSONNEL REQUIRED

One (MOS-63S).

SPECIAL ENVIRONMENTAL CONDITIONS

Work area clean and away from blowing dirt and dust.

REFERENCES (TM)

TM 9-2320-283-10.  
TM 9-214.  
TM 9-2320-283-20P.  
LO 9-2320-283-12.

GENERAL SAFETY INSTRUCTIONS

Engine off.  
Transmission in neutral.  
Wheels chocked.

TROUBLESHOOTING REFERENCES

Paragraph 2-11.

WHEELS.

3-207. REAR HUB, BEARINGS, AND SEALS REPLACEMENT (Continued).

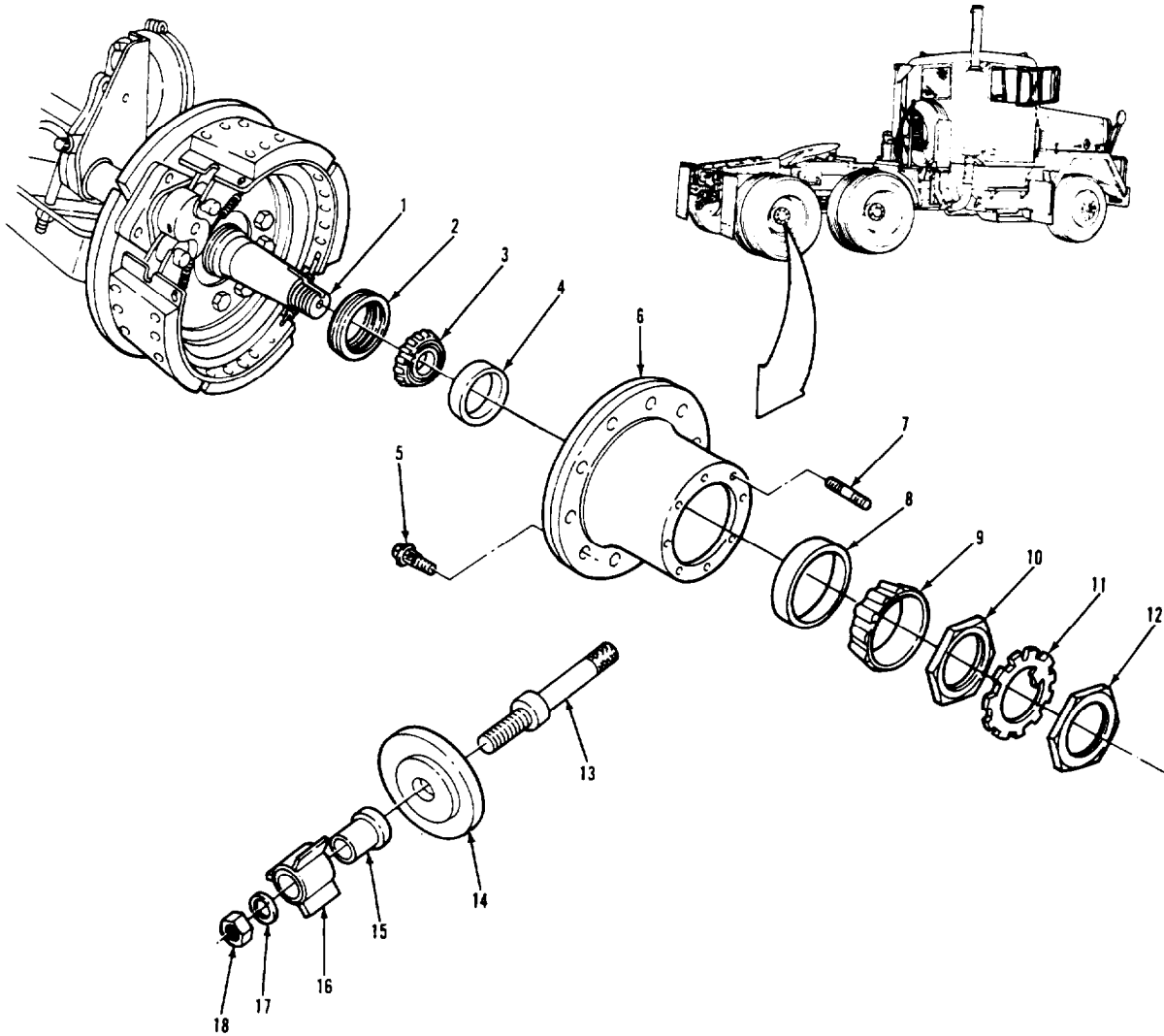

LEGEND:

- |                                |                           |
|--------------------------------|---------------------------|
| 1. SPINDLE                     | 10. INNER HUB BEARING NUT |
| 2. SEAL                        | 11. NUT LOCK              |
| 3. INNER BEARING CONE ASSEMBLY | 12. OUTER HUB BEARING NUT |
| 4. INNER BEARING CUP           | 13. HANDLE                |
| 5. WHEEL BOLT (10)             | 14. ADAPTER               |
| 6. HUB ASSEMBLY                | 15. SPACER                |
| 7. DRIVE FLANGE STUD (8)       | 16. BEARING PLUG          |
| 8. OUTER BEARING CUP           | 17. LOCKWASHER            |
| 9. OUTER BEARING CONE ASSEMBLY | 18. NUT                   |

TA 237576

WHEELS.

3-207. REAR HUB, BEARINGS, AND SEALS REPLACEMENT (Continued).		
LOCATION/ITEM	ACTION	REMARKS
<b>NOTE</b>		
Rear hub, bearings and seals replacement is the same for both rear axles.		
<b>A. REMOVAL.</b>		
1. Lock (11).	Bend tabs away from item (12) and item (10).	
2. Nut (12).	Unscrew and remove.	Use locknut wrench.
3. Lock (11).	Remove.	Discard if tabs are broken or badly misshapen.
4. Nut (10).	Unscrew and remove.	Use locknut wrench.
5. Outer bearing cone assembly (9).	Remove.	Do not drop.
6. Hub assembly (6).	Remove from item (1).	Items (2), (3), and (4) are pressed into item (6) and will follow.
7. Seal (2) and inner bearing cone assembly (3).	Remove from item (6).	a. Tap out with hammer and drift. b. Discard item (2).
<b>NOTE</b>		
It is not necessary to remove inner and outer bearing cups unless they are damaged or new bearings are installed.		

WHEELS.

3-207. REAR HUB, BEARINGS, AND SEALS REPLACEMENT (Continued).

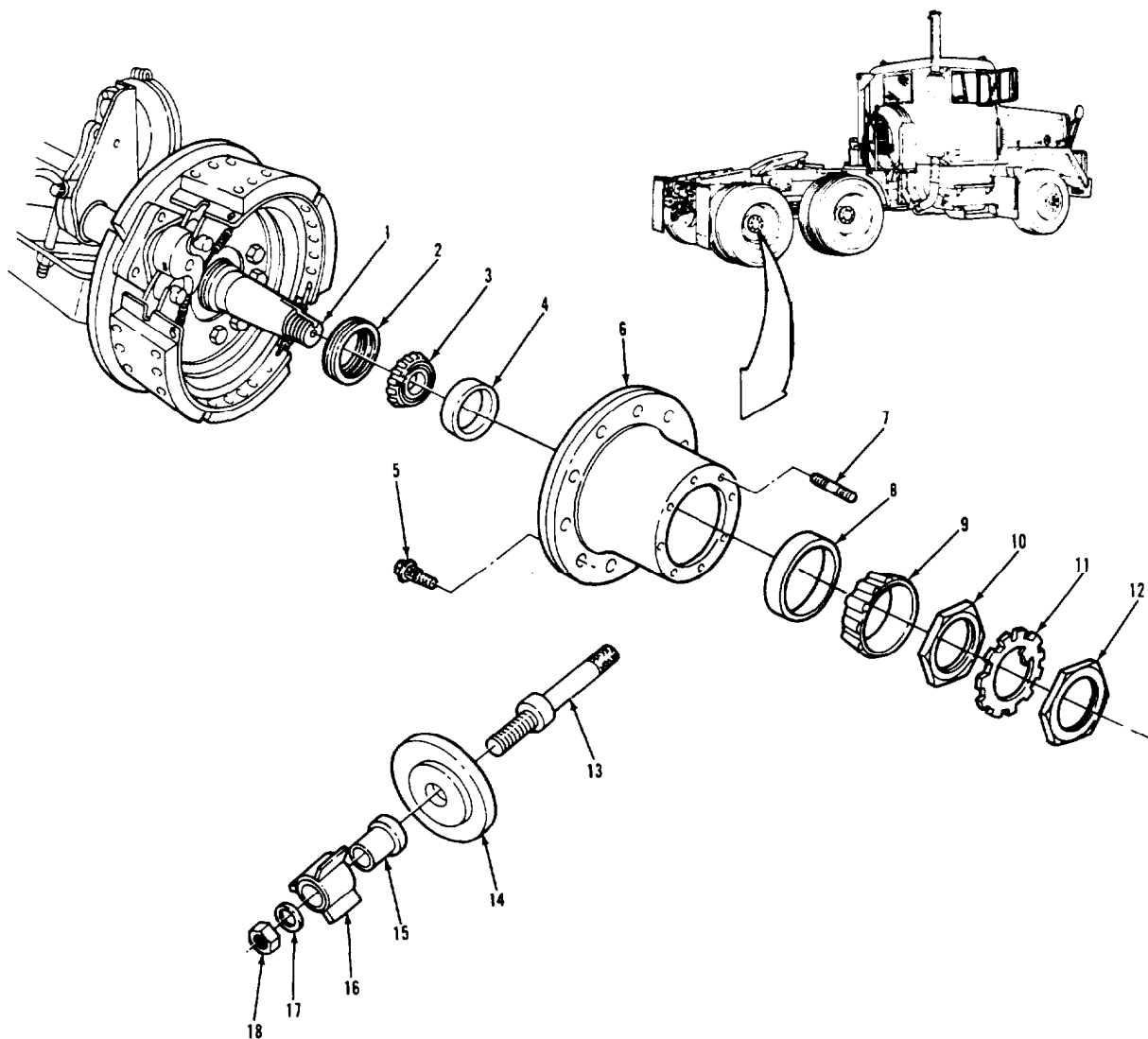

LEGEND:

- |                                |                           |
|--------------------------------|---------------------------|
| 1. SPINDLE                     | 10. INNER HUB BEARING NUT |
| 2. SEAL                        | 11. NUT LOCK              |
| 3. INNER BEARING CONE ASSEMBLY | 12. OUTER HUB BEARING NUT |
| 4. INNER BEARING CUP           | 13. HANDLE                |
| 5. WHEEL BOLT (10)             | 14. ADAPTER               |
| 6. HUB ASSEMBLY                | 15. SPACER                |
| 7. DRIVE FLANGE STUD (8)       | 16. BEARING PLUG          |
| 8. OUTER BEARING CUP           | 17. LOCKWASHER            |
| 9. OUTER BEARING CONE ASSEMBLY | 18. NUT                   |

TA 237577

WHEELS.

3-207. REAR HUB, BEARINGS, AND SEALS REPLACEMENT (Continued).

LOCATION/ITEM	ACTION	REMARKS
<b>A. REMOVAL (Continued).</b>		
8. Cup (4) and cup (8).	Remove.	Use suitable puller or long brass drift and tap alternately on outer edge until removed. Discard items (4) and (8).
9. Eight studs (7).	Remove.	
10. Ten bolts (5).	May be removed if damaged.	Press out.
<b>B. CLEANING.</b>		
<b><u>WARNING</u></b>		
Do not use compressed air to dry bearings. A spinning bearing can fly apart. Failure to heed warning can result in serious personal injury.		
11. All parts.	<ul style="list-style-type: none"> <li>a. Clean all parts in dry-cleaning solvent and allow parts to air dry.</li> <li>b. If bearings are to be reused:                             <ul style="list-style-type: none"> <li>1. Remove surface oil and gum deposits.</li> <li>2. Clean with drycleaning solvent.</li> <li>3. Wipe dry. Do not use compressed air.</li> <li>4. Coat with light film of oil. Wrap bearings in paper until you are ready to install them.</li> </ul> </li> </ul>	<p>Refer to paragraph 3-4.</p> <p>Refer to TM 9-214 for information on maintenance.</p>

WHEELS.

3-207. REAR HUB, BEARINGS, AND SEALS REPLACEMENT (Continued).

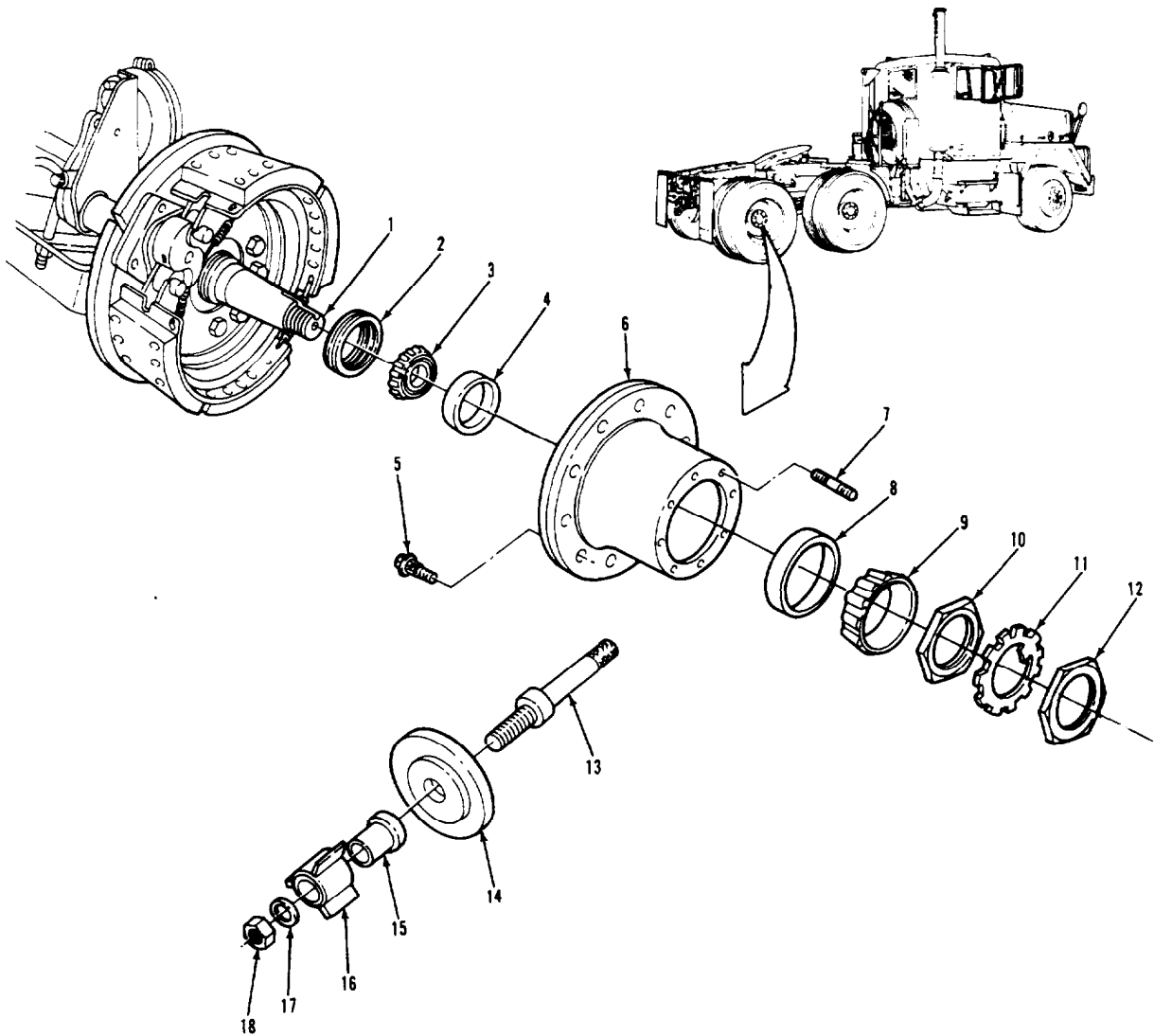

LEGEND:

- |                                |                           |
|--------------------------------|---------------------------|
| 1. SPINDLE                     | 10. INNER HUB BEARING NUT |
| 2. SEAL                        | 11. NUT LOCK              |
| 3. INNER BEARING CONE ASSEMBLY | 12. OUTER HUB BEARING NUT |
| 4. INNER BEARING CUP           | 13. HANDLE                |
| 5. WHEEL BOLT (10)             | 14. ADAPTER               |
| 6. HUB ASSEMBLY                | 15. SPACER                |
| 7. DRIVE FLANGE STUD (8)       | 16. BEARING PLUG          |
| 8. OUTER BEARING CUP           | 17. LOCKWASHER            |
| 9. OUTER BEARING CONE ASSEMBLY | 18. NUT                   |

TA 237578

WHEELS.

3-207. REAR HUB, BEARINGS, AND SEALS REPLACEMENT (Continued).

LOCATION/ITEM	ACTION	REMARKS
<b>C. INSPECTION.</b>		
12. All parts.	Inspect for cracking, pitting, scoring, and wear. Inspect item (3) and item (9) for missing rollers, flat, chipped, or pitted surfaces, discoloration, and secure fit.	Replace if damaged. Refer to TM 9-214 for inspection of bearings.
<b>D. INSTALLATION.</b>		
<b>NOTE</b>		
Use left-hand bolts in left hub and right-hand bolts in right hub.		
13. Ten bolts (5).	Install if removed.	Use press.
14. Eight studs (7).	Install and tighten.	Use antiseize compound on threads.
15. New cup (4) and new cup (8).	Install into item (6) if removed.	Press on or use brass drift and hammer. Make sure item (4) and item (8) are completely seated in item (6).
16. Inner bearing cone assembly (3).	Install in item (4).	
17. New seal (2).	Install in item (6).	<ul style="list-style-type: none"> <li>a. Put flange sealant on large outside edge.</li> <li>b. Use items (13) thru (18), assembled as shown.</li> <li>c. Small end of item (2) seats on item (14).</li> </ul>

WHEELS.

3-207. REAR HUB, BEARINGS, AND SEALS REPLACEMENT (Continued).

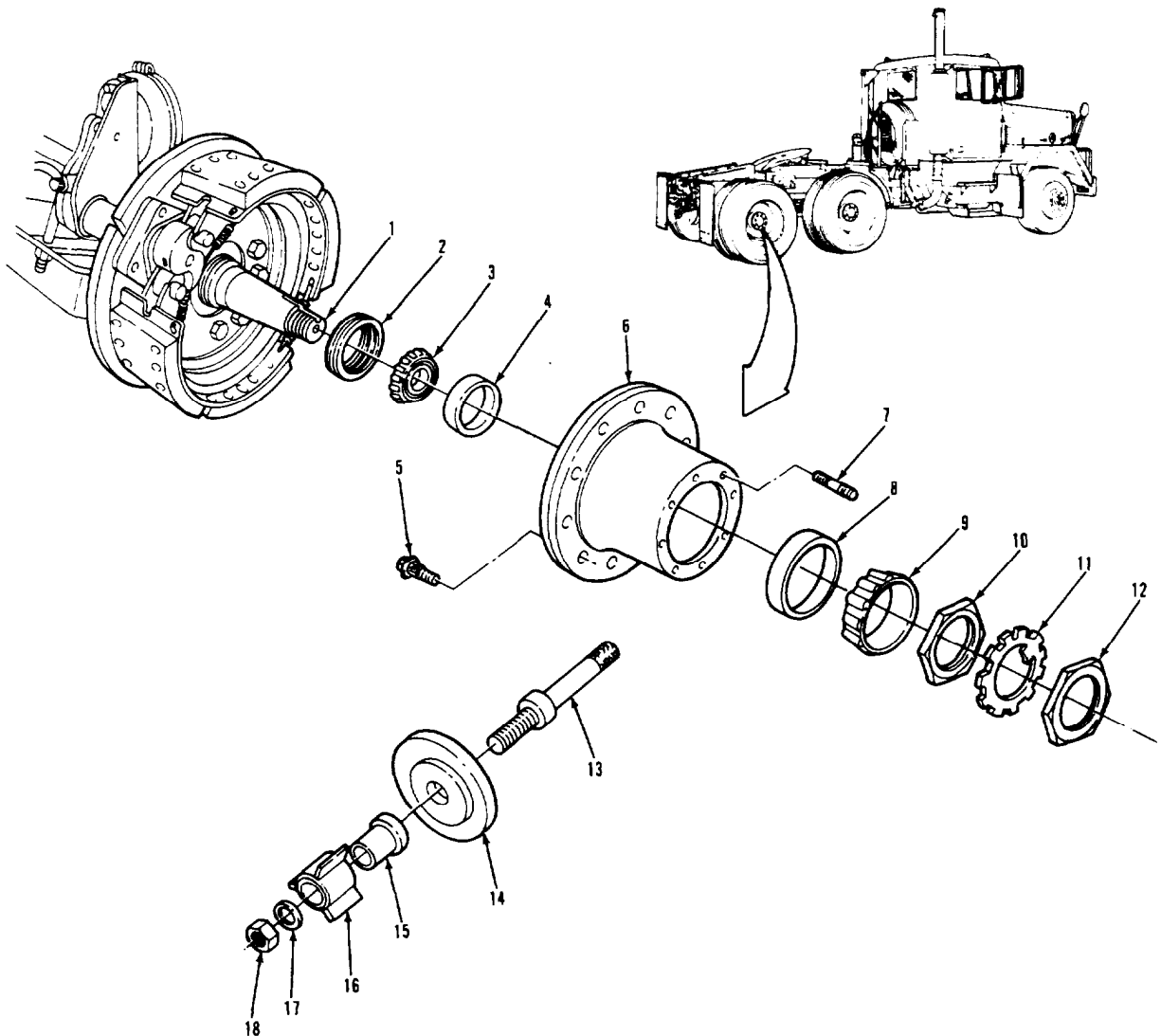

LEGEND:

- |                                |                           |
|--------------------------------|---------------------------|
| 1. SPINDLE                     | 10. INNER HUB BEARING NUT |
| 2. SEAL                        | 11. NUT LOCK              |
| 3. INNER BEARING CONE ASSEMBLY | 12. OUTER HUB BEARING NUT |
| 4. INNER BEARING CUP           | 13. HANDLE                |
| 5. WHEEL BOLT (10)             | 14. ADAPTER               |
| 6. HUB ASSEMBLY                | 15. SPACER                |
| 7. DRIVE FLANGE STUD (8)       | 16. BEARING PLUG          |
| 8. OUTER BEARING CUP           | 17. LOCKWASHER            |
| 9. OUTER BEARING CONE ASSEMBLY | 18. NUT                   |

TA 237579



WHEELS.

3-207. REAR HUB, BEARINGS, AND SEALS REPLACEMENT (Continued).		
LOCATION/ITEM	ACTION	REMARKS
<b>D. INSTALLATION (Continued).</b>		
18. Hub assembly (6).	Fill cavity between item (3) and item (8) with lubricant. Position item (6) on item (1). Center carefully. Do not damage item (2).	Refer to LO 9-2320-283-12.
19. Outer bearing cone assembly (9).	Install on item (1) and into item (8).	
20. Brake drum and wheel.	Install.	Refer to paragraph 3-206 and TM 9-2320-283-10.
21. Nut (10).	a. Install on item (1) with machined shoulder surface facing item (9).  b. Using torque wrench and 4-1/8 inch locknut wrench, tighten item (10) to 50 lb-ft, while turning wheel in forward and reverse directions. Back off item (10) 1/4 to 1/3 turn. Wheel should turn easily.	
22. Lock (11).	Put in item (1).	Use new item (11) if discarded in step (3).
23. Nut (12).	Install with machined surface facing out and tighten to 250-275 lb-ft.	
24. Wheel.	Rotate.	Wheel should rotate freely.

WHEELS.

3-207. REAR HUB, BEARINGS, AND SEALS REPLACEMENT (Continued).

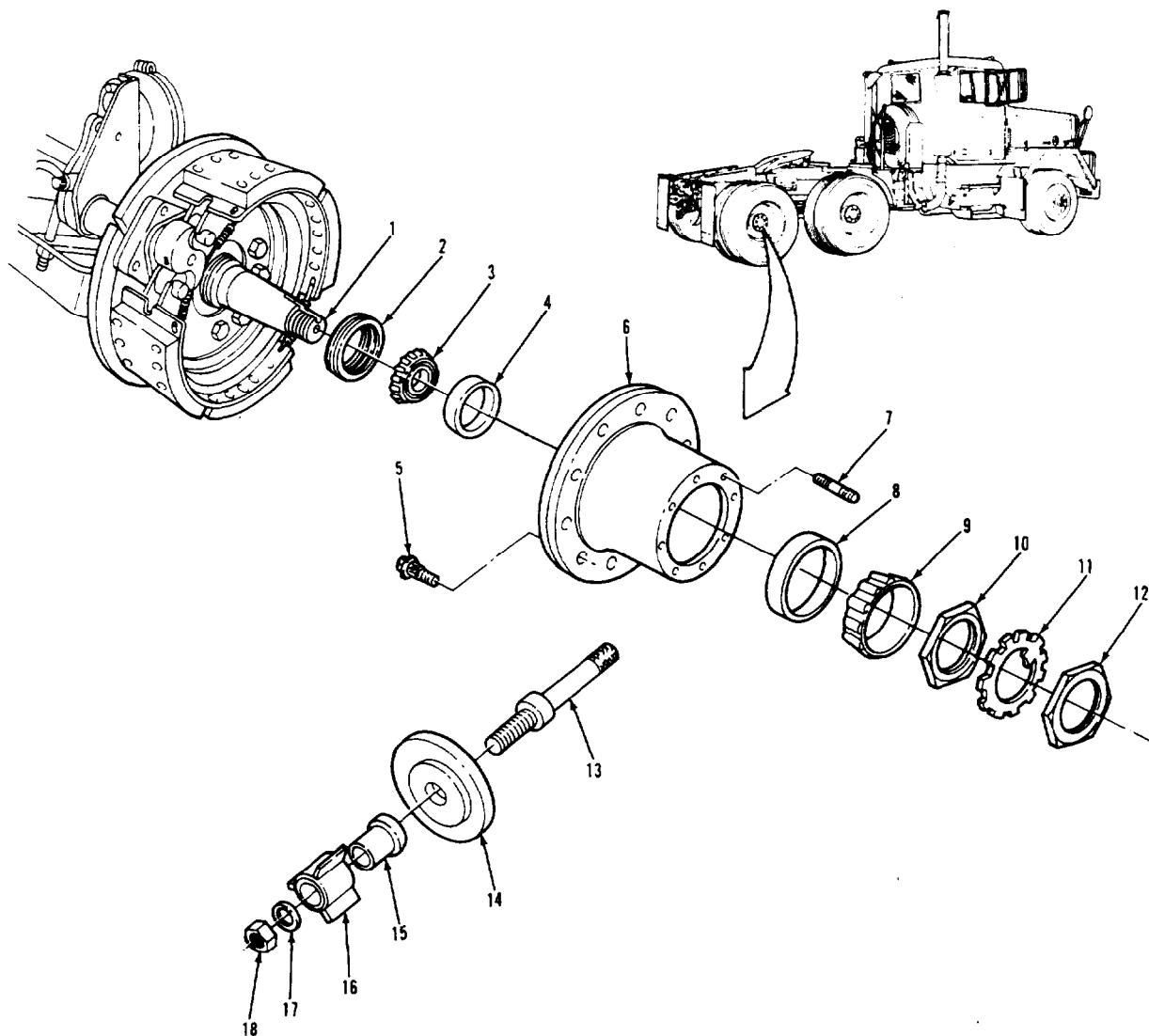

LEGEND:

- |                                |                           |
|--------------------------------|---------------------------|
| 1. SPINDLE                     | 10. INNER HUB BEARING NUT |
| 2. SEAL                        | 11. NUT LOCK              |
| 3. INNER BEARING CONE ASSEMBLY | 12. OUTER HUB BEARING NUT |
| 4. INNER BEARING CUP           | 13. HANDLE                |
| 5. WHEEL BOLT (10)             | 14. ADAPTER               |
| 6. HUB ASSEMBLY                | 15. SPACER                |
| 7. DRIVE FLANGE STUD (8)       | 16. BEARING PLUG          |
| 8. OUTER BEARING CUP           | 17. LOCKWASHER            |
| 9. OUTER BEARING CONE ASSEMBLY | 18. NUT                   |

TA 237580

WHEELS.

**3-207. REAR HUB, BEARINGS, AND SEALS REPLACEMENT (Continued).**

LOCATION/ITEM	ACTION	REMARKS
<b>D. INSTALLATION (Continued).</b>		
25. Lock (11).	Alternately bend one tab over each flat of item (10) and item (12).	
<b>NOTE</b>		
Follow-on maintenance action required:		
Install rear axle shaft (para 3-154).		

WHEELS.

3-207. REAR HUB, BEARINGS, AND SEALS REPLACEMENT (Continued).

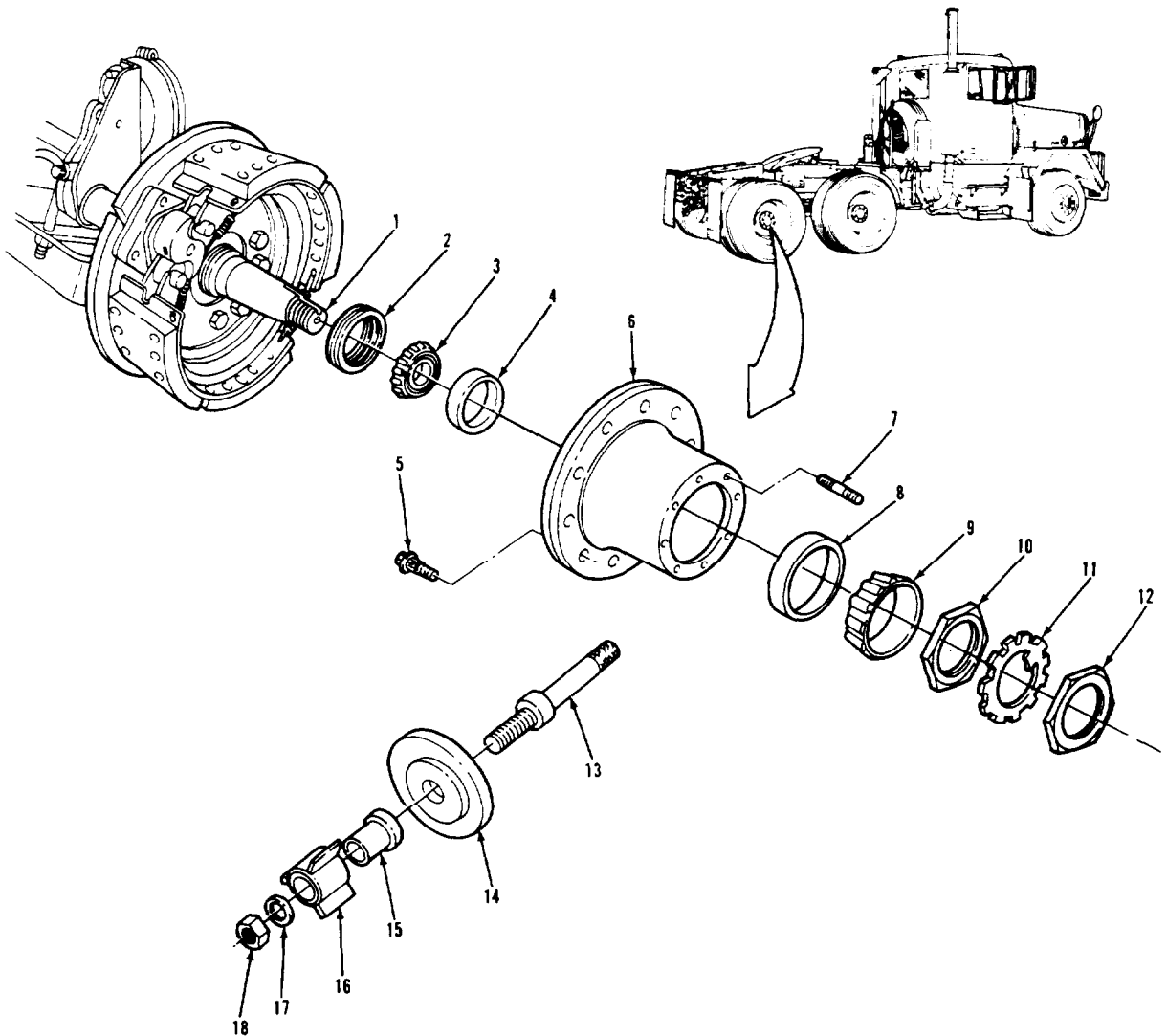

LEGEND:

- |                                |                           |
|--------------------------------|---------------------------|
| 1. SPINDLE                     | 10. INNER HUB BEARING NUT |
| 2. SEAL                        | 11. NUT LOCK              |
| 3. INNER BEARING CONE ASSEMBLY | 12. OUTER HUB BEARING NUT |
| 4. INNER BEARING CUP           | 13. HANDLE                |
| 5. WHEEL BOLT (10)             | 14. ADAPTER               |
| 6. HUB ASSEMBLY                | 15. SPACER                |
| 7. DRIVE FLANGE STUD (8)       | 16. BEARING PLUG          |
| 8. OUTER BEARING CUP           | 17. LOCKWASHER            |
| 9. OUTER BEARING CONE ASSEMBLY | 18. NUT                   |

TA 237581

WHEELS.

3-208. TIRE REPLACEMENT.

THIS TASK COVERS

- a. Removal.
- b. Cleaning and Inspection.
- c. Repair.
- d. Installation.

INITIAL SETUP

APPLICABLE CONFIGURATIONS

All.

EQUIPMENT CONDITION  
PARAGRAPH

TM 9-2320-283-10.

CONDITION DESCRIPTION

Wheel and tire assembly removed.

TEST EQUIPMENT

None.

SPECIAL TOOLS

None.

MATERIALS/PARTS (P/N)

Soap, solution  
Item 28, Appendix C.

PERSONNEL REQUIRED

One (MDS-63S).

SPECIAL ENVIRONMENTAL CONDITIONS

None.

REFERENCES (TM)

TM 9-2320-283-10.  
TM 9-2610-200-20.

GENERAL SAFETY INSTRUCTIONS

Always remove air pressure from tire before servicing. Personal injury or parts damage could result, from working on an inflated tire.

TROUBLESHOOTING REFERENCES

Paragraph 2-11.

WHEELS.

3-208. TIRE REPLACEMENT (Continued).

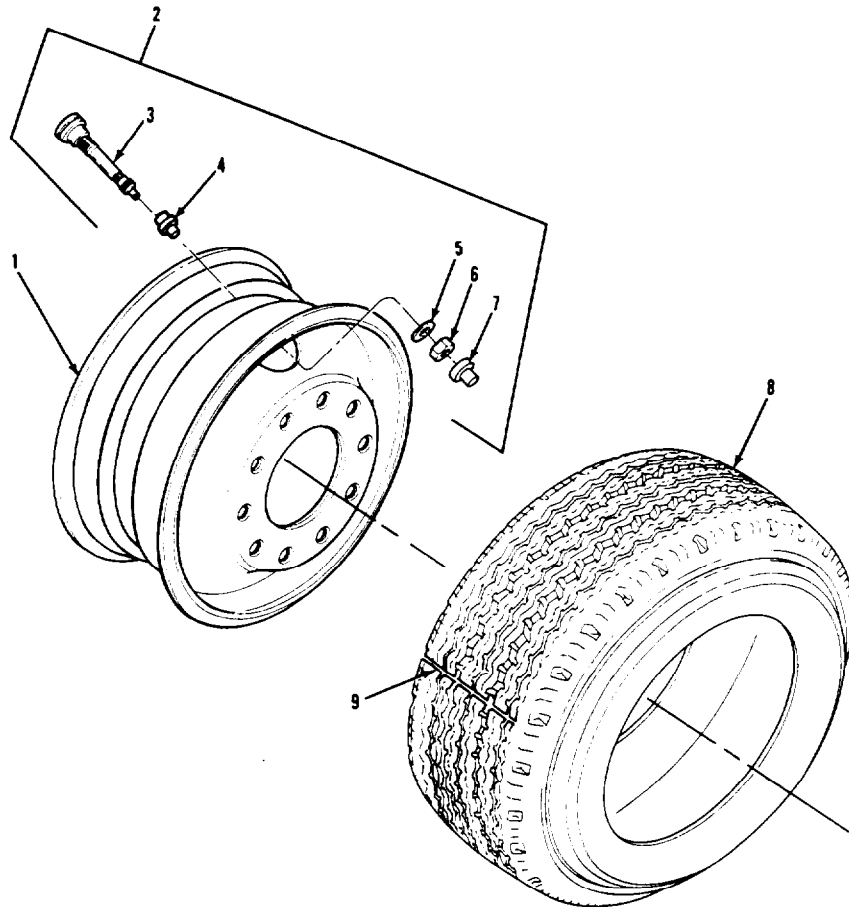

LEGEND:

- |                                    |                         |
|------------------------------------|-------------------------|
| 1. WHEEL                           | 6. NUT                  |
| 2. TUBELESS RIM AND VALVE ASSEMBLY | 7. VALVE CAP            |
| 3. VALVE                           | 8. TUBELESS RADIAL TIRE |
| 4. VALVE CORE                      | 9. WEAR BAR             |
| 5. WASHER                          |                         |

TA 237582

WHEELS.

3-208. TIRE REPLACEMENT (Continued).		
LOCATION/ITEM	ACTION	REMARKS
<b>A. REMOVAL.</b>		
<u>WARNING</u>		
Always remove the valve core and exhaust all air from a single tire and from both tires of a dual assembly before servicing. Personal injury or parts damage could result from working on an inflated tire.		
1. Cap (7) and core (4).	Remove.	Item (7) can be used to remove item (4).
2. Tire (8).	Remove from item (1).	Use available equipment.
3. Nut (6), washer (5), and valve (3).	Remove.	
<b>B. CLEANING AND INSPECTION.</b>		
4. Tubeless rim and valve assembly (2).	a. Wipe dirt from all parts.	Replace item (2) if any of its parts fail inspection.
	b. Inspect all parts for bends, cracks, or wear.	
5. Wheel (1).	Inspect for cracks, heavy corrosion, bent areas, or other damage.	Replace item (1) if any of these conditions are found.
6. Tire (8).	Inspect for excessive or uneven wear, cracks, or leaks.	Use a depth gage to check tread wear. (Refer to TM 9-2610-200-20 for information on tires). Replace item (8) if any of these conditions are found. On tires with item (9) replace if item (9) is even with tread surface.
7. Valve (3).	Check item (3) by running a piece of wire through it to make sure it is not plugged.	

WHEELS.

3-208. TIRE REPLACEMENT (Continued).

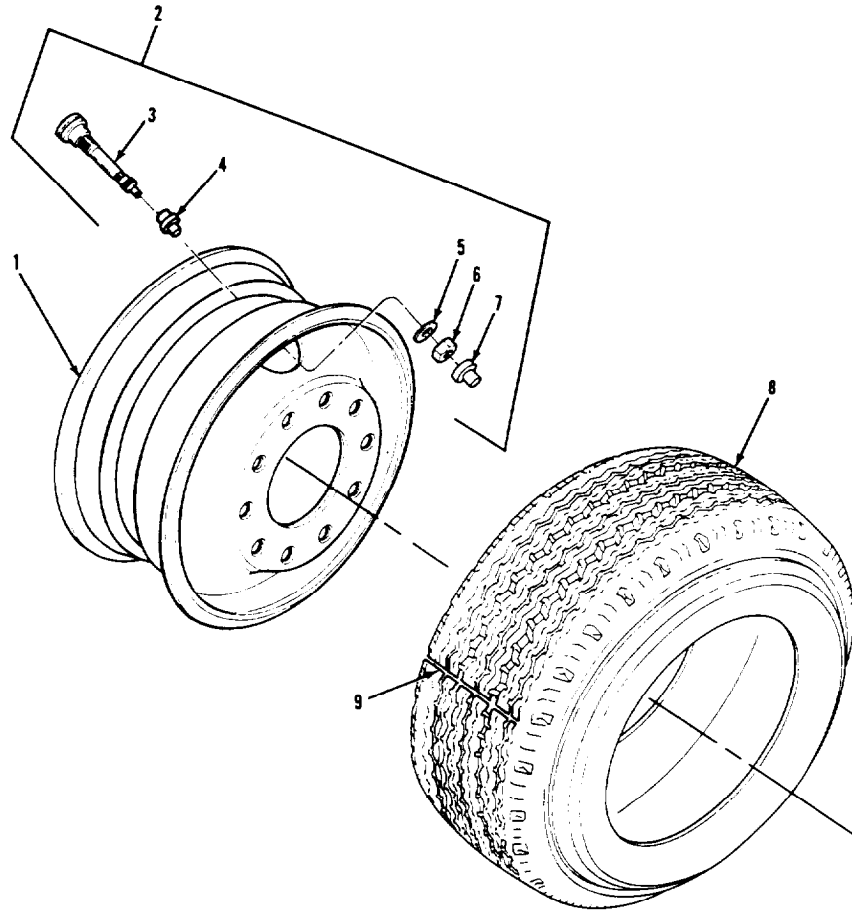

LEGEND:

- |                                    |                         |
|------------------------------------|-------------------------|
| 1. WHEEL                           | 6. NUT                  |
| 2. TUBELESS RIM AND VALVE ASSEMBLY | 7. VALVE CAP            |
| 3. VALVE                           | 8. TUBELESS RADIAL TIRE |
| 4. VALVE CORE                      | 9. WEAR BAR             |
| 5. WASHER                          |                         |

TA 237583



WHEELS.

3-208. TIRE REPLACEMENT (Continued).		
LOCATION/ITEM	ACTION	REMARKS
<b>C. REPAIR.</b>		
8. Wheel (1).	Remove all rust and scale.	Use a wire brush.
<b>D. INSTALLATION.</b>		
9. Valve (3).	Place into item (1).	
10. Nut (6) and washer (5).	a. Install onto item (3). b. Tighten item (6).	
NOTE		
Coat tire bead with soap solution for easier installation.		
11. Tire (8).	Install onto item (1).	Use available equipment.
12. Core (4).	Install into item (3).	
13. Tire (8).	Inflate to proper pressure.	
14. Cap (7).	Install onto item (3).	
15. Tire (8).	a. Check for leaks at rim of item (1) and at location of item (3). b. Correct all leaks.	
NOTE		
Follow-on maintenance action required:		
Install tire and wheel (TM 9-2320-283-10).		

WHEELS.

3-208. TIRE REPLACEMENT (Continued).

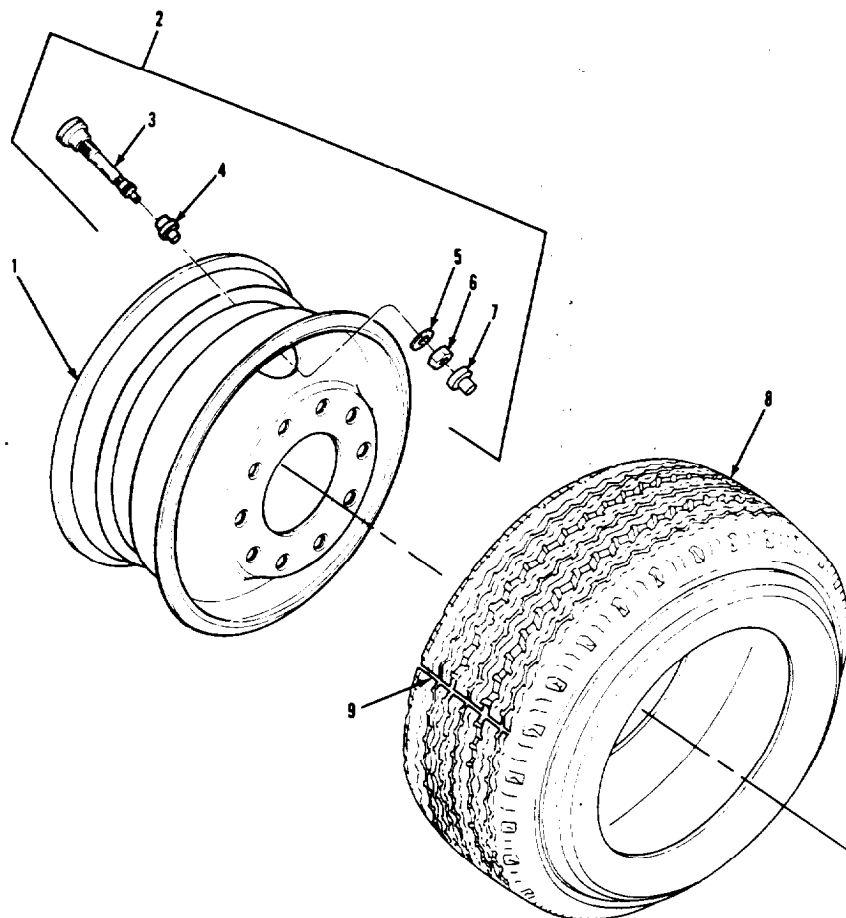

LEGEND:

- |                                    |                         |
|------------------------------------|-------------------------|
| 1. WHEEL                           | 6. NUT                  |
| 2. TUBELESS RIM AND VALVE ASSEMBLY | 7. VALVE CAP            |
| 3. VALVE                           | 8. TUBELESS RADIAL TIRE |
| 4. VALVE CORE                      | 9. WEAR BAR             |
| 5. WASHER                          |                         |

TA 237584



**Section XIII. STEERING SYSTEM**

**3-209. GENERAL.**

This section provides procedures authorized at the organizational maintenance level to replace steering system components. To find a specific procedure contained in this section, see the task summary below.

<b>3-210. TASK SUMMARY.</b>	
<u>INITIAL SETUP</u>	
<u>APPLICABLE CONFIGURATIONS</u>	<u>EQUIPMENT CONDITION</u>
Al 1.	<u>PARAGRAPH</u> <u>CONDITION DESCRIPTION</u> (Refer to specific paragraph for this information).
<u>TEST EQUIPMENT</u>	
None.	
<u>SPECIAL TOOLS</u>	
Power steering analyzer (33287) J26487.	
<u>MATERIALS/PARTS (P/N)</u>	
Tape, thread sealing Item, Appendix C.	Pin, cotter (2) (24617) 103389.
Oil, lubricating: OE/HDO- 10. Item 15, Appendix C.	Gasket, pump mounting (15434) 154916.
Grease, automotive and artillery Item 7, Appendix C.	O-ring (19954) 008761-026.
Sealing compound: automotive Item 26, Appendix C.	Strap, tie (as required) (24617) 11501906.
<u>PERSONNEL REQUIRED</u>	<u>SPECIAL ENVIRONMENTAL CONDITIONS</u>
Two (MOS- 63S).	Work area clean and away from blowing dirt and dust.
<u>REFERENCES (TM)</u>	<u>GENERAL SAFETY INSTRUCTIONS</u>
TM 9-2320-238-10: TM 9-2320-283-20P.	Engine off. Transmission in neutral. Park brake set.
<u>TROUBLESHOOTING REFERENCES</u>	
Paragraph 2-11.	

STEERING SYSTEM

3-210. TASK SUMMARY (Continued).

LIST OF TASKS

TASK NO.	TASK	TASK REF	TROUBLESHOOTING REF NO. (PARA)
1	Steering System Service Filling and Bleeding.	3-211 3-211	2-11
2	Steering System Testing a. Installing Power Steering Anaylzer. b. Power Steering Pump Pressure Test. c. Power Steering Pump Flow Test. d. Removing Power Steering Analyzer.	3-212 3-212a 3-212b 3-212c 3-212d	2-11
3	Steering Wheel Replacement. a. Removal. b. Cleaning and Inspection. c. Installation. d. Operational Check.	3-213 3-213a 3-213b 3-213c 3-213d	2-11
4	Upper Steering Column Replacement and Repair a. Removal. b. Disassembly c. Cleaning and Inspection. d. Assembly. e. Installation.	3-214 3-214a 3-214b 3-214c 3-214d 3-214e	2-11
5	Lower Steering Column Replacement and Repair a. Removal. b. Disassembly c. Cleaning and Inspection. d. Assembly. e. Installation.	3-215 3-215a 3-215b 3-215c 3-215d 3-215e	2-11
6	Vertical Link Replacement a. Removal. b. Cleaning and Inspection. c. Installation.	3-216 3-216a 3-216b 3-216c	2-11

STEERING SYSTEM

3-210. TASK SUMMARY (Continued).			
LIST OF TASKS			
TASK NO.	TASK	TASK REF	TROUBLESHOOTING REF NO. (PARA)
7	Steering Arm Replacement a. Removal. b. Cleaning and Inspection. c. Installation.	3-217 3-217a 3-217b 3-217c	2-11
8	Tie Rod and Ball Joints Replacement a. Removal. b. Cleaning and Inspection. c. Installation.	3-218 3-218a 3-218b 3-218c	2-11
9	Steering Pump and Reservoir Replacement a. Removal. b. Cleaning and Inspection. c. Installation.	3-219 3-219a 3-219b 3-219c	2-11
10	Power Steering Lines and Fittings Replacement a. Cooler to Pump Hose Replacement. b. Gear to Cooler Hose and Tube Replacement. c. Supply Hose Replacement.	3-220 3-220a 3-220b 3-220c	2-11

STEERING SYSTEM

3-211. STEERING SYSTEM SERVICE.

THIS TASK COVERS

Filling and Bleeding.

INITIAL SETUP

APPLICABLE CONFIGURATIONS

All.

EQUIPMENT CONDITION

PARAGRAPH

None.

CONDITION DESCRIPTION

None.

TEST EQUIPMENT

None.

SPECIAL TOOLS

None.

MATERIALS/PARTS (P/N)

None.

PERSONNEL REQUIRED

Two (MDS-63S).

SPECIAL ENVIRONMENTAL CONDITIONS

None.

REFERENCES (TM)

LO 9-2320-283-12.  
TM 9-2320-283-10.

GENERAL SAFETY INSTRUCTIONS

Engine off.  
Transmission in neutral.  
Park brake set.

TROUBLESHOOTING REFERENCES

Paragraph 2-11.

STEERING SYSTEM

3-211. STEERING SYSTEM SERVICE (Continued).

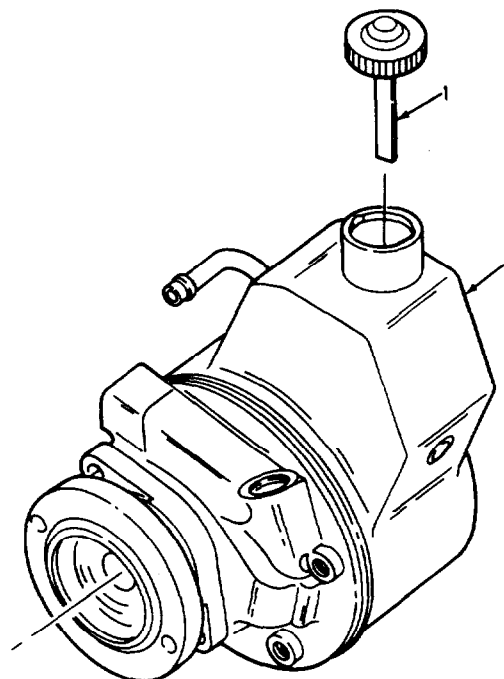
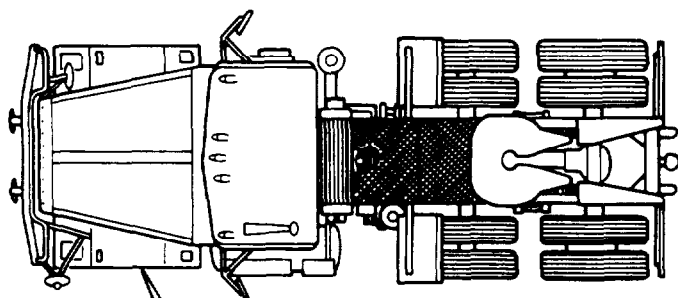

LEGEND:

- 1. FILLER CAP
- 2. RESERVOIR ASSEMBLY

TA 237585



STEERING SYSTEM

3-211. STEERING SYSTEM SERVICE (Continued).

LOCATION/ITEM	ACTION	REMARKS
<b>FILLING AND BLEEDING.</b>		
1. Cap (1).	Remove from item (2).	
2. Reservoir (2).	Fill with suitable steering fluid until almost full.	Refer to LO 9-2320-283-12 for proper steering fluid.
<u>CAUTION</u>		
To prevent air from entering the steering system during steps 3 and 4:		
. Do not turn steering wheel.		
. Do not allow fluid level to drop quickly.		
. Do not allow all fluid to run out of reservoir.		
Failure to prevent air from entering system could cause damage to the steering pump.		
3. Engine.	Crank for 10 seconds, but do not start, while assistant watches level of fluid in item (2).	Refer to TM 9-2320-283-10. If engine starts, shut it down at once.
4. Reservoir (2).	Check fluid level.	Refill, if necessary. Repeat steps 3 and 4 at least three times.
5. Engine.	a. Start, and let idle for two minutes.	Refer to TM 9-2320-283-10.
	b. Shutdown, and check fluid level in item (2).	Refer to TM 9-2320-283-10. Refill item (2), if if necessary.

STEERING SYSTEM

3-211. STEERING SYSTEM SERVICE (Continued).

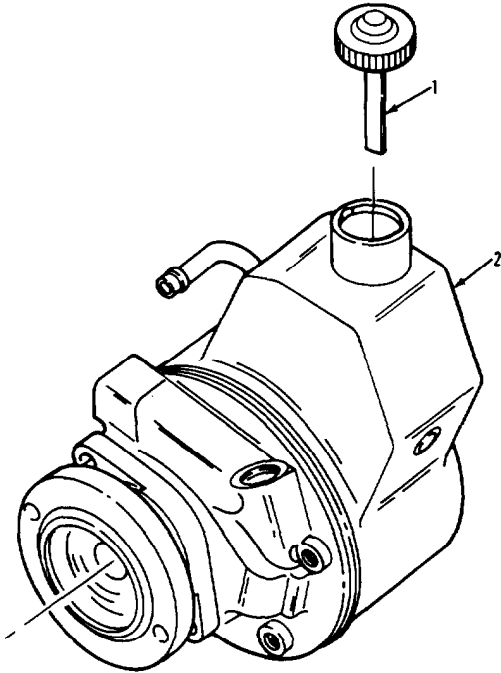
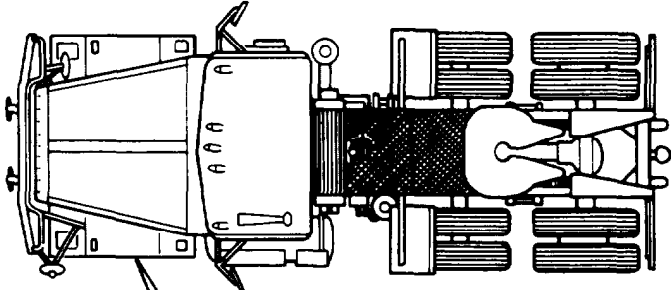

LEGEND:

- 1. FILLER CAP
- 2. RESERVOIR ASSEMBLY

TA 237586

STEERING SYSTEM

3-211. STEERING SYSTEM SERVICE (Continued).

LOCATION/ITEM	ACTION	REMARKS
<b>FILLING AND BLEEDING (Continued).</b>		
6. Engine.	Start.	Refer to TM 9-2320-283-10.
7. Front wheels.	Steer from full left turn to full right turn several times.	Refer to TM 9-2320-283-10. Add fluid to item (2) as necessary until it is at the proper level as shown on the dipstick of item (1). The steering gear poppet valves should open to relieve pressure at full left turn and full right turn. If one or both poppet valves do not work properly, notify DS/GS maintenance.
8. Engine.	Shut down.	Refer to TM 9-2320-283-10.
9. Cap (1).	Install on item (2).	
NOTE		
Follow-on maintenance action required:		
None.		

STEERING SYSTEM

3-211. STEERING SYSTEM SERVICE (Continued).

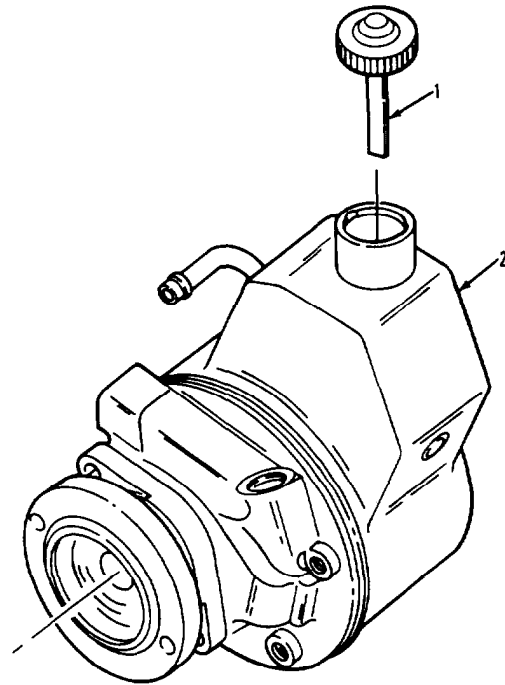
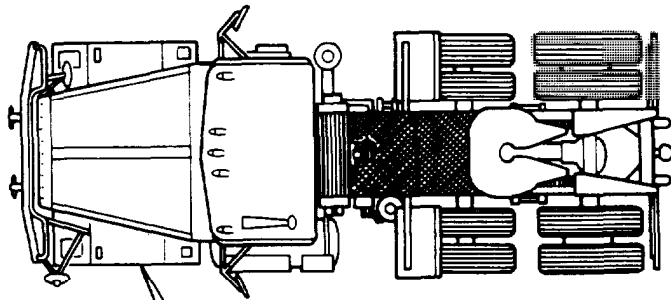

LEGEND:

- 1. FILLER CAP
- 2. RESERVOIR ASSEMBLY

TA 237587

STEERING SYSTEM

3-212. STEERING SYSTEM TESTING.

THIS TASK COVERS

- a. Installing Power Steering Analyzer.
- b. Power Steering Pump Pressure Test.
- c. Power Steering Pump Flow Test.
- d. Removing Power Steering Analyzer.

INITIAL SETUP

APPLICABLE CONFIGURATIONS  
All.

EQUIPMENT CONDITION  
PARAGRAPH  
None.

CONDITION DESCRIPTION  
None.

TEST EQUIPMENT  
Power steering analyzer  
(33287) J26487.

SPECIAL TOOLS  
None.

MATERIALS/PARTS (P/N)  
Tape, thread sealing  
Item 32, Appendix C.

PERSONNEL REQUIRED  
Two (MOS-63S).

SPECIAL ENVIRONMENTAL CONDITIONS  
None.

REFERENCES (TM)  
TM 9-2320-283-10

GENERAL SAFETY INSTRUCTIONS  
Engine off.  
Transmission in neutral.  
Park brake set.

TROUBLESHOOTING REFERENCES  
Paragraph 2-11.

STEERING SYSTEM

3-212. STEERING SYSTEM TESTING (Continued).

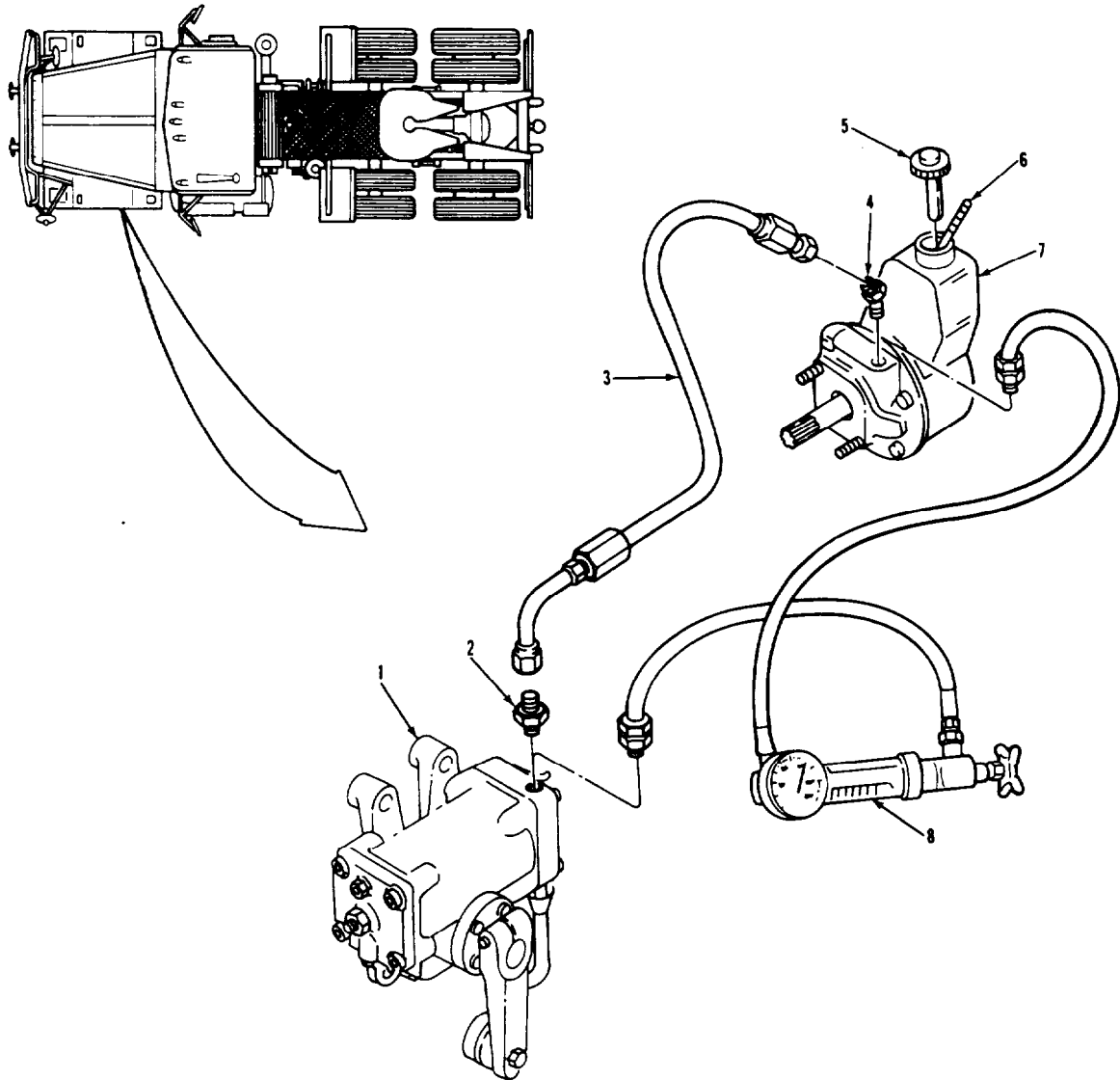

LEGEND:

- 1. STEERING GEAR ASSEMBLY
- 2. MALE CONNECTOR
- 3. SUPPLY HOSE ASSEMBLY
- 4. 45° ELBOW

- 5. FILLER CAP
- 6. THERMOMETER
- 7. RESERVOIR ASSEMBLY
- 8. POWER STEERING ANALYZER

TA 237508

STEERING SYSTEM

3-212. STEERING SYSTEM TESTING (Continued).		
LOCATION/ITEM	ACTION	REMARKS
<b>A. INSTALLING POWER STEERING ANALYZER.</b>		
1. Hose (3), elbow (4) and connector (2).	Remove from items (1) and (7).	
2. Analyzer (8).	Install into items (1) and (7) (as shown in illustration).	
3. Cap (5).	Remove from item (7).	
4. Thermometer (6).	Place in item (7).	
5. Engine.	Start and let idle at about 600 rpm.	Refer to TM 9-2320-283-10.
<u>CAUTION</u>		
Do not close valve of analyzer completely and leave it closed, or the pump may be damaged. At no time should fluid temperature exceed 180°F. To prevent damage from high temperatures, perform all tests within a temperature range of 125°F-135°F.		
6. Analyzer (6).	a. Close valve part way until pressure gage reads 1000 psi.  b. When item (6) shows between 125°F and 135°F, open valve.	

STEERING SYSTEM

3-212. STEERING SYSTEM TESTING (Continued).

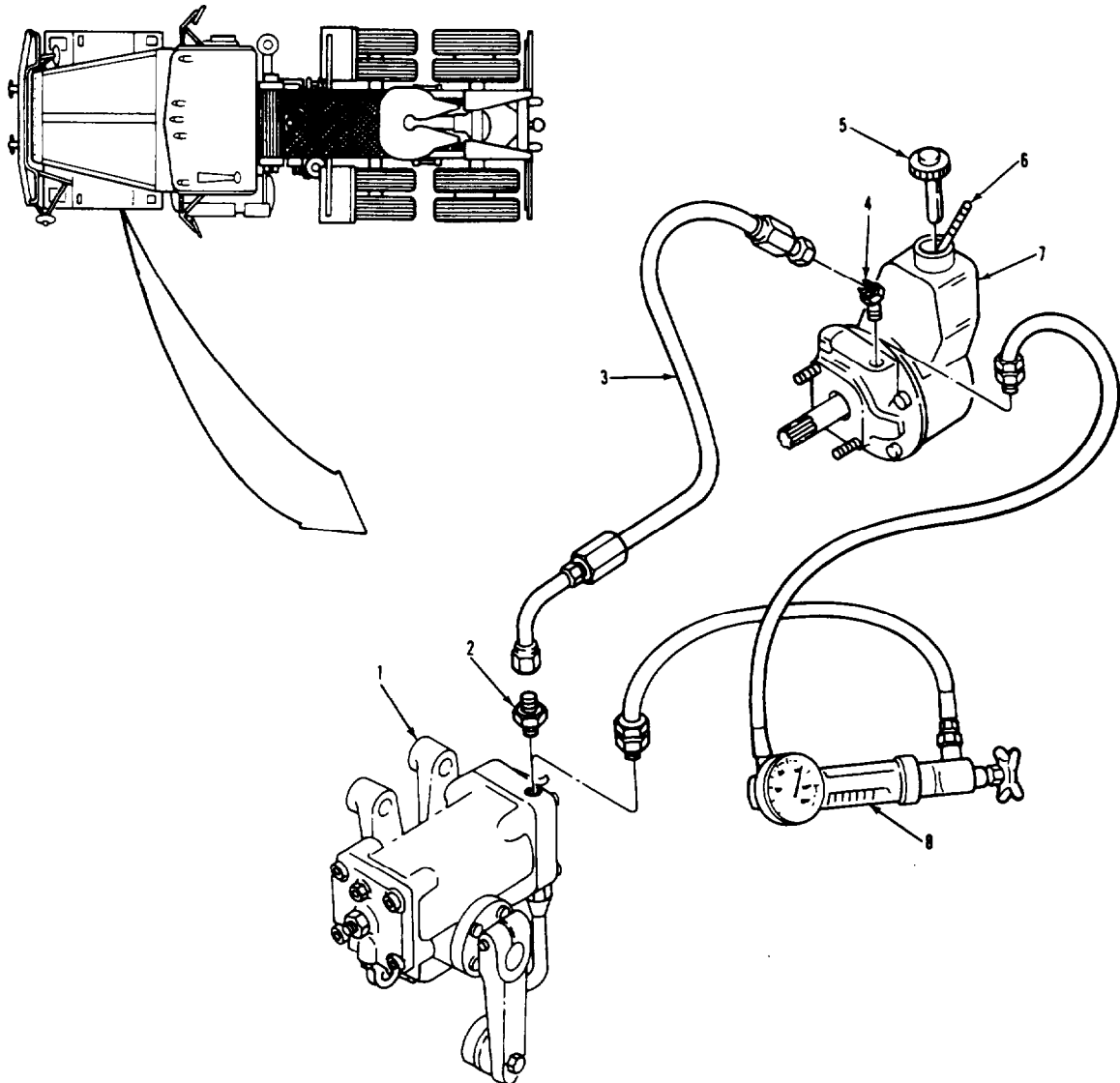

LEGEND:

- 1. STEERING GEAR ASSEMBLY
- 2. MALE CONNECTOR
- 3. SUPPLY HOSE ASSEMBLY
- 4. 45° ELBOW

- 5. FILLER CAP
- 6. THERMOMETER
- 7. RESERVOIR ASSEMBLY
- 8. POWER STEERING ANALYZER

TA 237589



STEERING SYSTEM.

3-212. STEERING SYSTEM TESTING (Continued).		
LOCATION/ITEM	ACTION	REMARKS
<b>B. POWER STEERING PUMP PRESSURE TEST.</b>		
7. Analyzer (8).	a. Install, if not already installed.	Refer to steps 1 thru 6.
<p><u>CAUTION</u></p> <p>To avoid damaging steering pump, do not keep the load valve closed for longer than 5 seconds.</p>		
	b. With engine idling, close valve and read pressure <b>gage</b>	Pressure should be at least 1850 psi. If pressure is below 1850 Psi, replace steering pump and reservoir (para 3-221). Pressure should not exceed 2000 psi.
<p>NOTE</p> <p>Before doing next test, allow fluid to cool to between 125°F and 135°F. If no other tests are to be done on steering system, go to step 9.</p>		
<b>C. POWER STEERING PUMP FLOW TEST.</b>		
8. Analyzer (8).	a. Install, if not already installed.	Refer to steps 1 thru 6.

STEERING SYSTEM

3-212. STEERING SYSTEM TESTING (Continued).

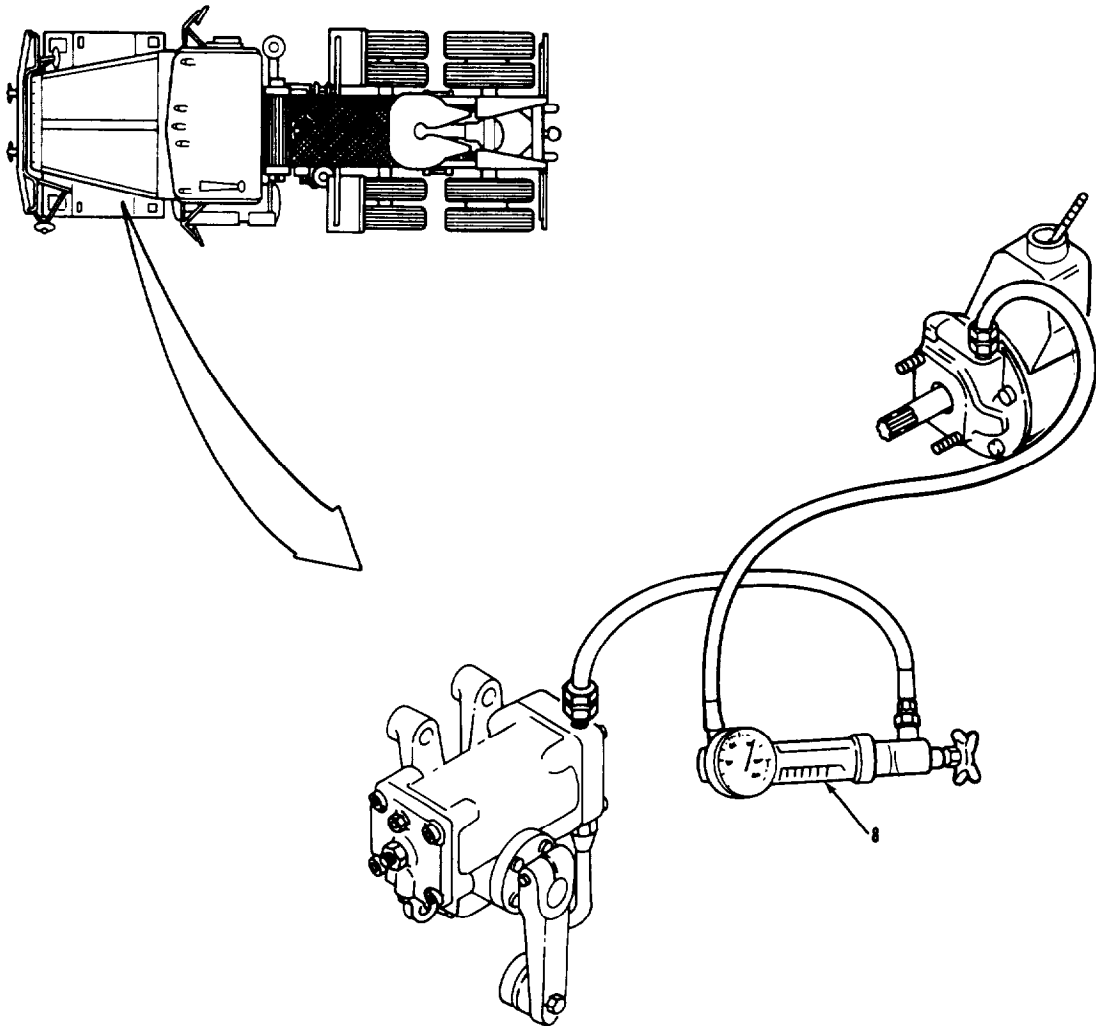

LEGEND:

8. POWER STEERING ANALYZER

TA 237590

STEERING SYSTEM

3-212. STEERING SYSTEM TESTING (Continued).

LOCATION/ITEM	ACTION	REMARKS
<b>C. POWER STEERING PUMP FLOW TEST (Continued).</b>		
8. Analyzer (8) (continued).	b. With engine idling and fluid temperature between 125°F and 135°F, check flow rate on flowmeter.	Flow rate should be at least 3.7 gpm. If flow rate is below 3.7 psi, replace steering pump and reservoir (para 3-221). Flow rate should be 4.3 to 5.0 gpm. Flow rate should not exceed 5.5 gpm at 2100 rpm.
<u>CAUTION</u>		
To avoid damaging steering pump, do not keep load valve closed for longer than 5 seconds.		
	c. With engine idling, close valve and read flow rate on flometer.	Flow rate should be zero gpm.
	d. Immediately open valve.	Flow rate must instantly return to original reading (from step 8b). If rate does not return instantly, replace steering pump and reservoir (para 3-221).
	e. With engine at governed speed (2100 rpm), repeat steps 8c and 8d.	Do this step three times to ensure proper operation of steering pump.

STEERING SYSTEM.

3-212. STEERING SYSTEM TESTING (Continued).

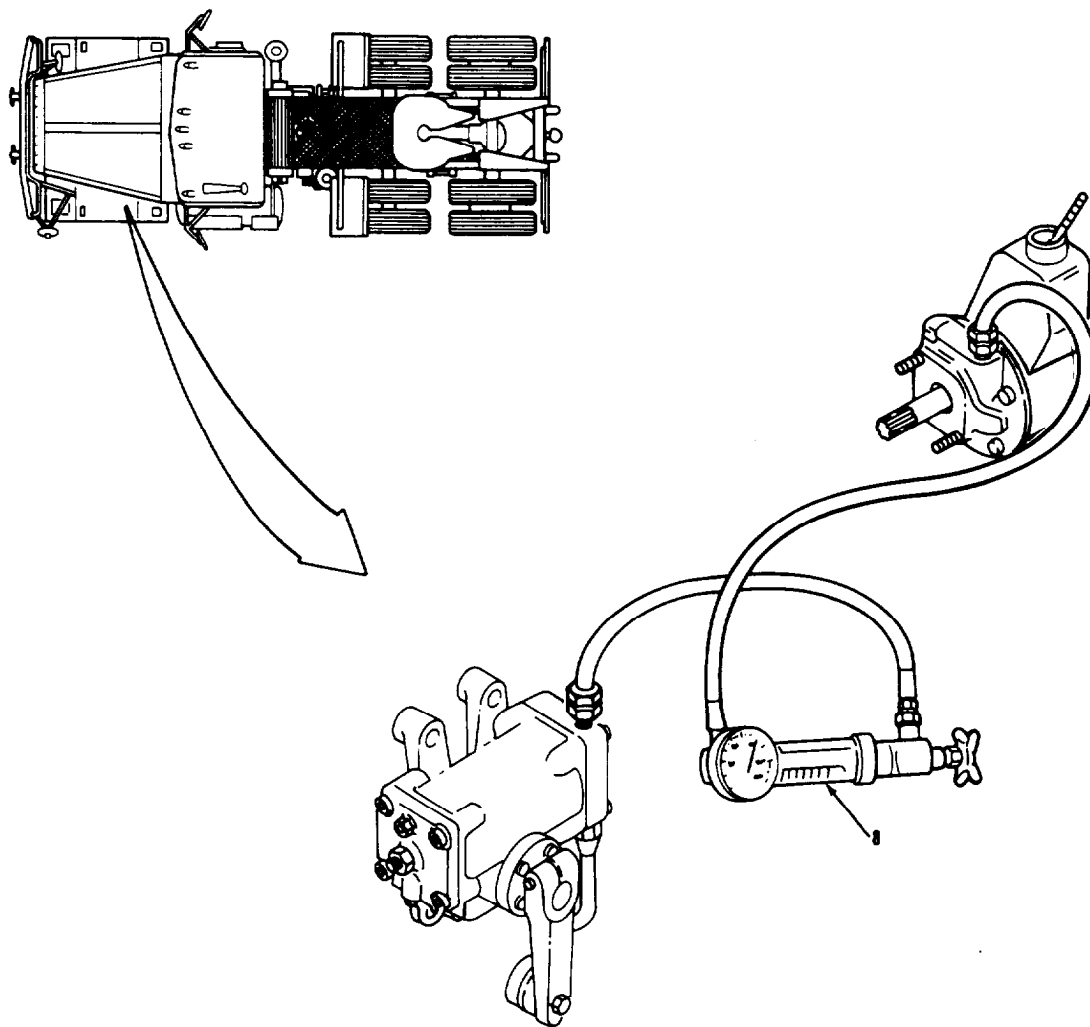

LEGEND:

8. POWER STEERING ANALYZER

TA 237591

STEERING SYSTEM.

3-212. STEERING SYSTEM TESTING (Continued).		
LOCATION/ITEM	ACTION	REMARKS
<b>D. REMOVING POWER STEERING ANALYZER.</b>		
9. Engine.	Shut down.	Refer to TM 9-2320-283-10.
10. Thermometer (6).	Remove from item (7).	
11. Cap (5).	Install onto item (7).	
12. Analyzer (8).	Remove from items (1) and (7).	
13. Elbow (4), connector (2), and hose (3).	Install on items (1) and (7) (as shown in illustration).	Wrap threads of items (4) and (2) with thread sealing tape.
NOTE		
Follow-on maintenance action required:		
Operate vehicle and check steering system for leaks and proper operation (TM 9-2320-283-10).		

STEERING SYSTEM

3-212. STEERING SYSTEM TESTING (Continued).

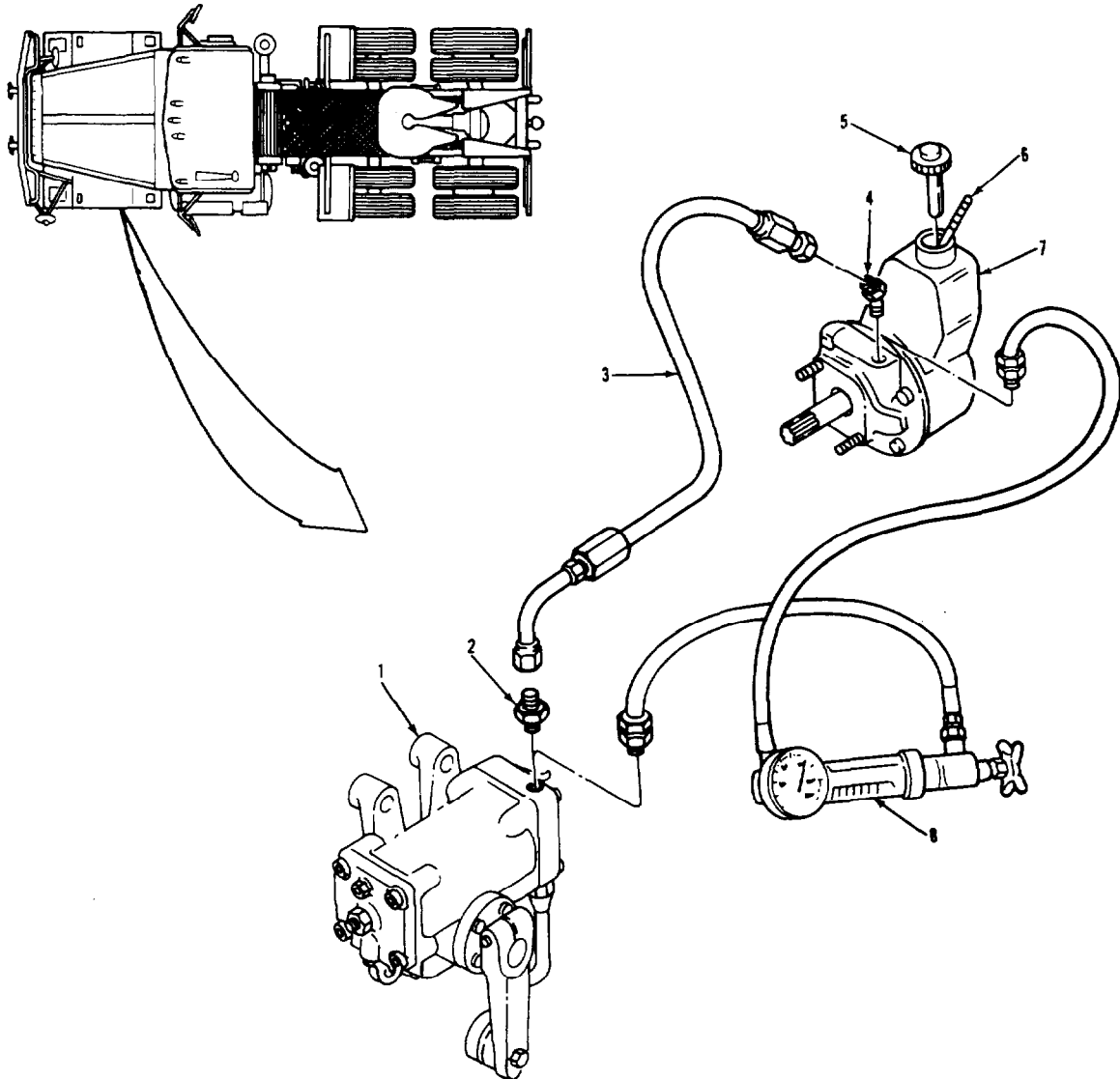

LEGEND:

- 1. STEERING GEAR ASSEMBLY
- 2. MALE CONNECTOR
- 3. SUPPLY HOSE ASSEMBLY
- 4. 45° ELBOW

- 5. FILLER CAP
- 6. THERMOMETER
- 7. RESERVOIR ASSEMBLY
- 8. POWER STEERING ANALYZER

TA 237592

STEERING SYSTEM.

3-213. STEERING WHEEL REPLACEMENT.

THIS TASK COVERS

- a. Removal.
- b. Cleaning and Inspection.
- c. Installation.
- d. Operational Check.

INITIAL SETUP

APPLICABLE CONFIGURATIONS  
All.

EQUIPMENT CONDITION  
PARAGRAPH  
3-118.

CONDITION DESCRIPTION  
Horn button removed.

TEST EQUIPMENT  
None.

SPECIAL TOOLS  
None.

MATERIALS/PARTS (P/N)  
None.

PERSONNEL REQUIRED  
One (MOS-63S).

SPECIAL ENVIRONMENTAL CONDITIONS  
None.

REFERENCES (TM)  
TM 9-2320-283-10.

GENERAL SAFETY INSTRUCTIONS  
Engine off.  
Transmission in neutral.  
Park brake set.

TROUBLESHOOTING REFERENCES  
Paragraph 2-11.

STEERING SYSTEM

3-213. STEERING WHEEL REPLACEMENT (Continued).

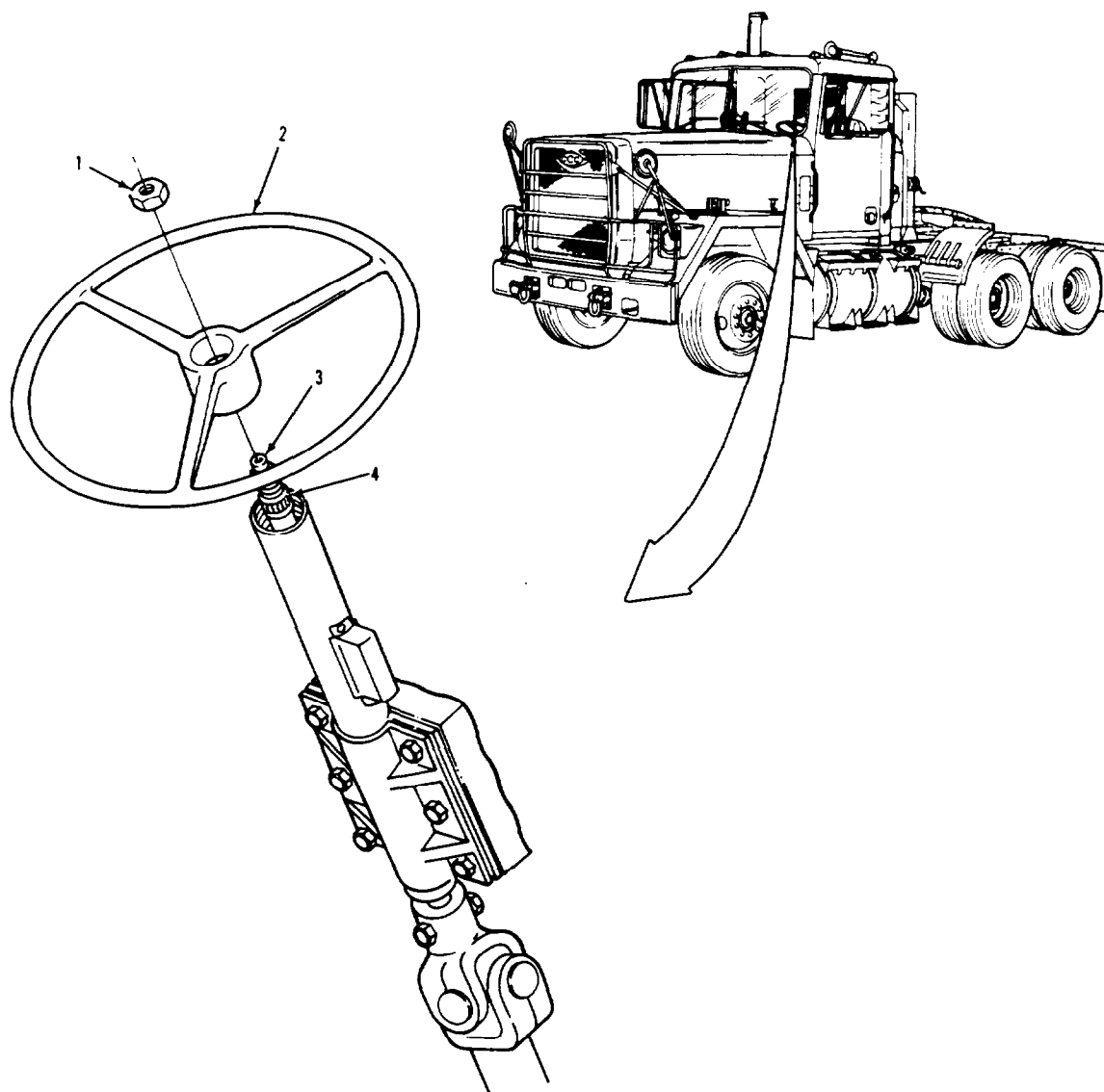

LEGEND:

- 1. HEXAGON NUT
- 2. STEERING WHEEL
- 3. HORN WIRE
- 4. STEERING SHAFT ASSEMBLY

TA 237593



STEERING SYSTEM

3-213. STEERING WHEEL REPLACEMENT (Continued).		
LOCATION/ITEM	ACTION	REMARKS
<b>A. REMOVAL.</b>		
1. Nut (1).	While holding item (2), remove from item (4).	
2. Wheel (2) and shaft (4).	a. Put an alinement mark on each, if not already done. b. Using suitable puller or leather mallet, remove item (2) from item (4).	Be careful not to damage item (3) if using puller to remove item (2).
<b>B. CLEANING AND INSPECTION.</b>		
3. All parts.	Clean and inspect.	Refer to paragraphs 3-4. and 3-5.
<b>C. INSTALLATION.</b>		
4. Wheel (2) and shaft (4).	a. Aline mark on item (2) with mark on item (4). b. Gently seat item (2) onto splines of item (4).	
5. Nut (1).	Install onto item (4) and tighten.	Hold item (2), if necessary.
<b>D. OPERATIONAL CHECK.</b>		
6. Engine.	Start.	Refer to TM 9-2320-283-10.

STEERING SYSTEM.

3-213. STEERING WHEEL REPLACEMENT (Continued).

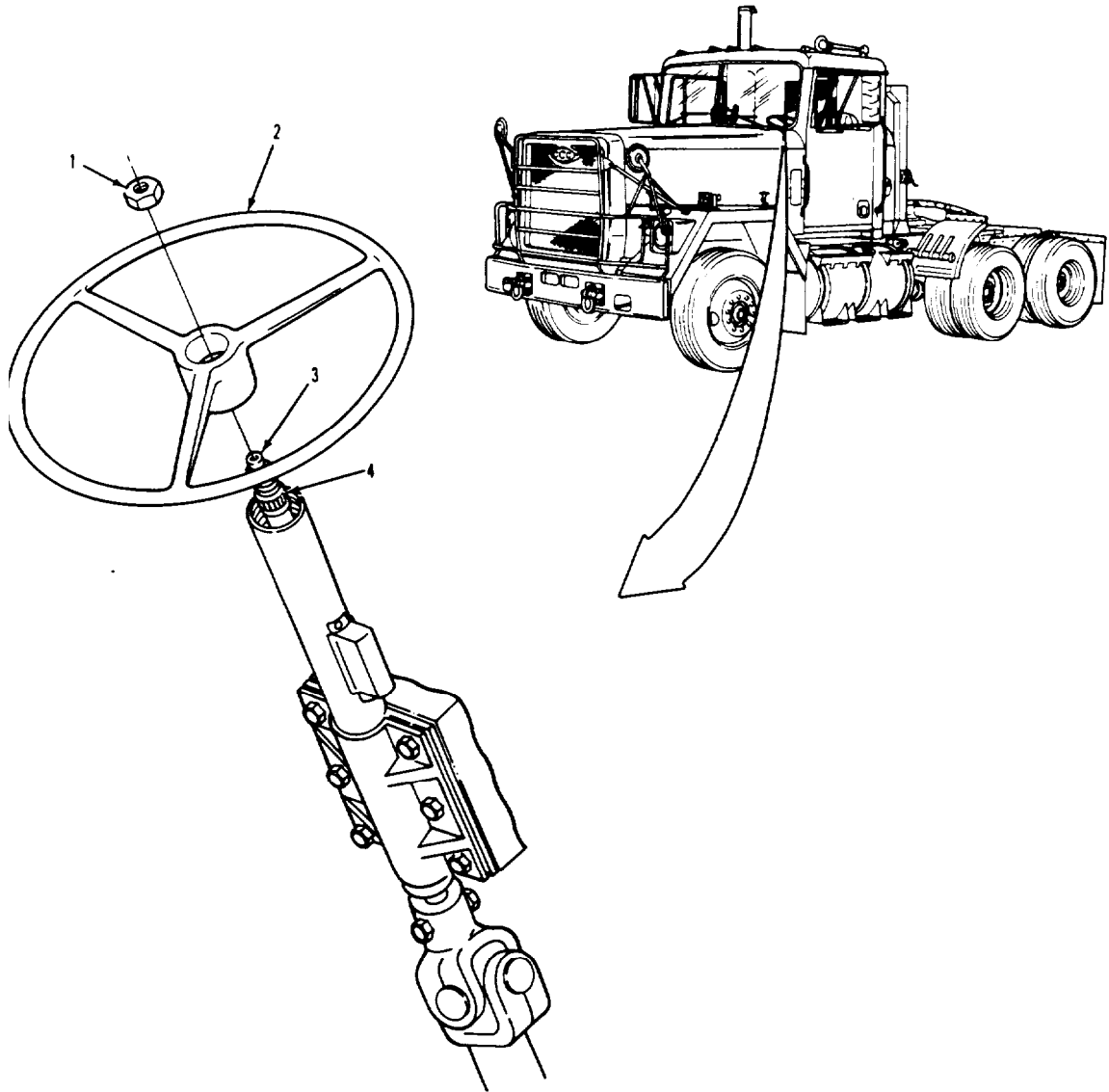

LEGEND:

- 1. HEXAGON NUT
- 2. STEERING WHEEL
- 3. HORN WIRE
- 4. STEERING SHAFT ASSEMBLY

TA 237594

STEERING SYSTEM

3-213. STEERING WHEEL REPLACEMENT (Continued).

LOCATION/ITEM

ACTION

REMARKS

D. OPERATIONAL CHECK (Continued).

7. Wheel (2).

Turn in both directions and check for proper operation of steering.

8. Engine.

Shut down.

Refer to TM 9-2320-283-10.

NOTE

Follow-on maintenance action required:

Install horn button (para 3-118).

STEERING SYSTEM

3-213. STEERING WHEEL REPLACEMENT (Continued).

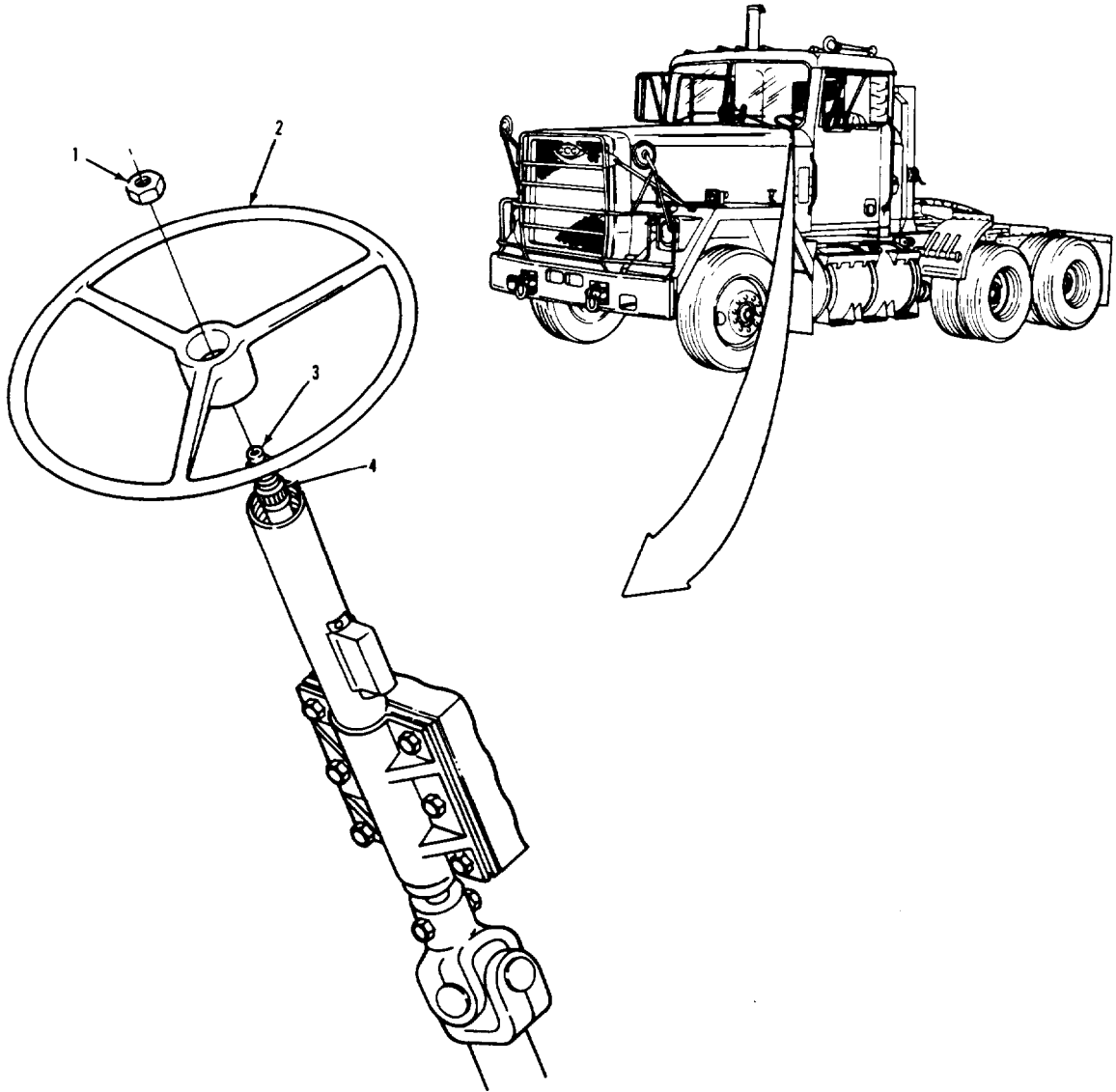

LEGEND:

1. HEXAGON NUT
2. STEERING WHEEL
3. HORN WIRE
4. STEERING SHAFT ASSEMBLY

TA 237595

STEERING SYSTEM

3-214. UPPER STEERING COLUMN REPLACEMENT AND REPAIR.

THIS TASK COVERS

- a. Removal.
- b. Disassembly.
- c. Cleaning and Inspection.
- d. Assembly.
- e. Installation.

INITIAL SETUP

<p><u>APPLICABLE CONFIGURATIONS</u> All.</p>	<p><u>EQUIPMENT CONDITION PARAGRAPH</u> 3-219.</p>	<p><u>CONDITION DESCRIPTION</u> Steering wheel removed.</p>
<p><u>TEST EQUIPMENT</u> None.</p>	<p>3-173.</p>	<p>Trailer hand brake valve removed.</p>
<p><u>SPECIAL TOOLS</u> None.</p>	<p>3-80.</p>	<p>Turn signal switch removed.</p>
<p><u>MATERIALS/PARTS (P/N)</u> Oil lubricating (81263) 54876 with lube.</p>		
<p><u>PERSONNEL REQUIRED</u> One (MDS-63S).</p>	<p><u>SPECIAL ENVIRONMENTAL CONDITIONS</u> None.</p>	
<p><u>REFERENCES (TM)</u> None.</p>	<p><u>GENERAL SAFETY INSTRUCTIONS</u> Engine off. Transmission in neutral. Park brake set.</p>	
<p><u>TROUBLESHOOTING REFERENCES</u> Paragraph 2-11.</p>		

STEERING SYSTEM

3-214. UPPER STEERING COLUMN REPLACEMENT AND REPAIR (Continued).

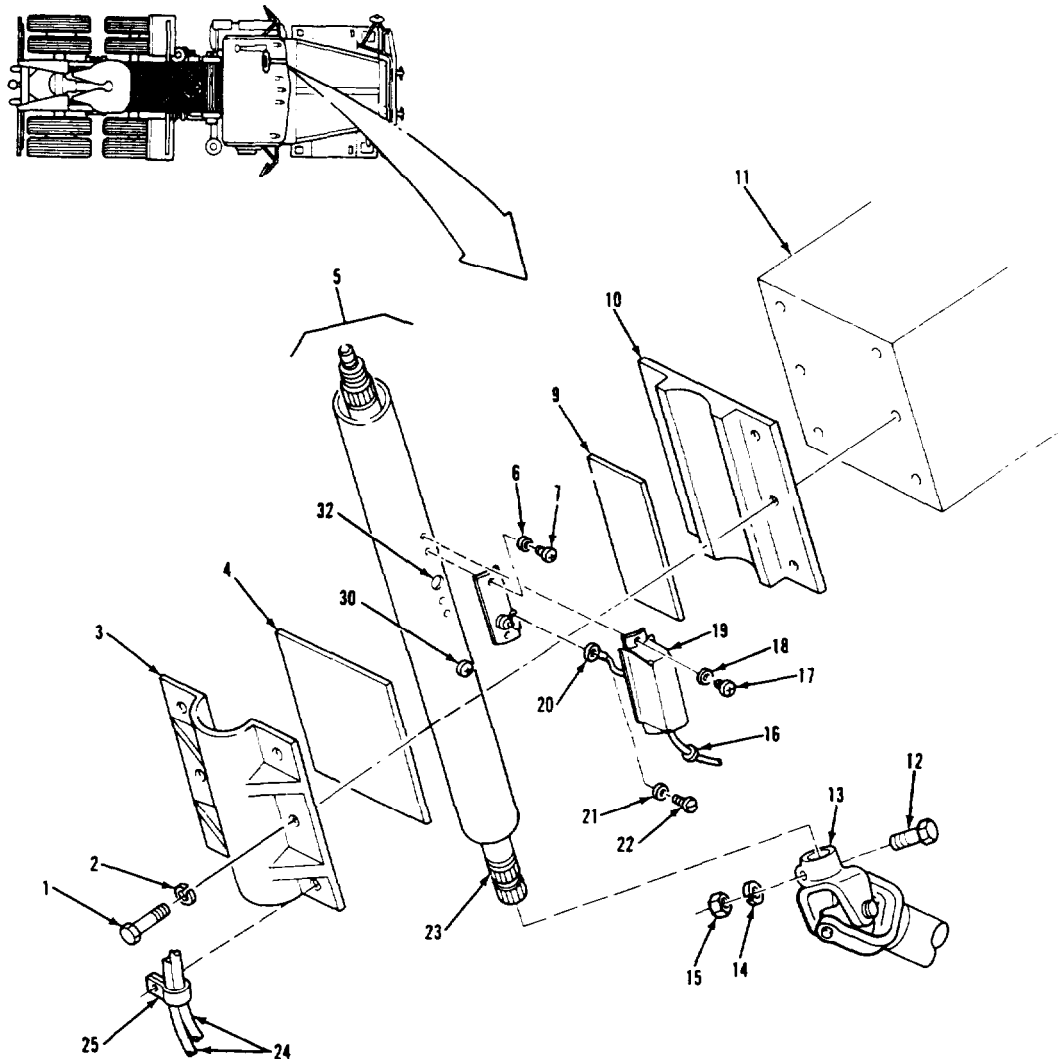

LEGEND:

- |                                   |                             |
|-----------------------------------|-----------------------------|
| 1. HEXAGON BOLT (6)               | 14. LOCKWASHER              |
| 2. LOCKWASHER (6)                 | 15. HEXAGON NUT             |
| 3. STEERING COLUMN OUTER CLAMP    | 16. GROMMET                 |
| 4. OUTER RUBBER INSULATOR         | 17. SELF-TAPPING SCREW (2)  |
| 5. UPPER STEERING COLUMN ASSEMBLY | 18. LOCKWASHER (2)          |
| 6. LOCKWASHER (2)                 | 19. HORN BRUSH COVER        |
| 7. SELF-TAPPING SCREW (2)         | 20. HORN BRUSH WIRE         |
| 8. HORN BRUSH ASSEMBLY            | 21. LOCKWASHER              |
| 9. INNER RUBBER INSULATOR         | 22. SCREW                   |
| 10. STEERING COLUMN INNER CLAMP   | 23. STEERING SHAFT ASSEMBLY |
| 11. CAB BRACKET                   | 24. NONMETALLIC TUBE (2)    |
| 12. CAPSCREW                      | 25. LOOP CLAMP              |
| 13. YOKE                          |                             |

TA 237596

STEERING SYSTEM

3-214. UPPER STEERING COLUMN REPLACEMENT AND REPAIR (Continued).		
LOCATION/ITEM	ACTION	REMARKS
<b>A. REMOVAL.</b>		
1. Two screws (17) and lockwashers (18).	Remove from items (19) and (5).	
2. Cover (19).	Remove from item (5) and slide down on item (20).	
NOTE		
Do steps 3 and 4 only if replacing brush assembly or cover.		
3. Screw (22), lock-washer (21), and wire (20).	Remove from item (8).	
4. Cover (19) and grommet (16).	Slide off item (20).	Do this step only if replacing item (19).
5. Two screws (7), lockwashers (6), and brush assembly (8).	Remove from item (5).	
6. Nut (15), lock-washer (14), and screw (12).	Remove from item (13).	
7. Yoke (13) and steering shaft assembly (23).	a. Put an alinement mark on each, if not already done. b. Pull item (13) off of item (23).	
8. Six bolts (1), lockwashers (2), clamp (25), clamp (3), insulator (4), column assembly (5), insulator (9), and clamp (10).	Remove from item (11) and separate.	Hold items (3), (5), and (10) before removing last item (1). Leave item (25) on two items (24).

STEERING SYSTEM

3-214. UPPER STEERING COLUMN REPLACEMENT AND REPAIR (Continued).

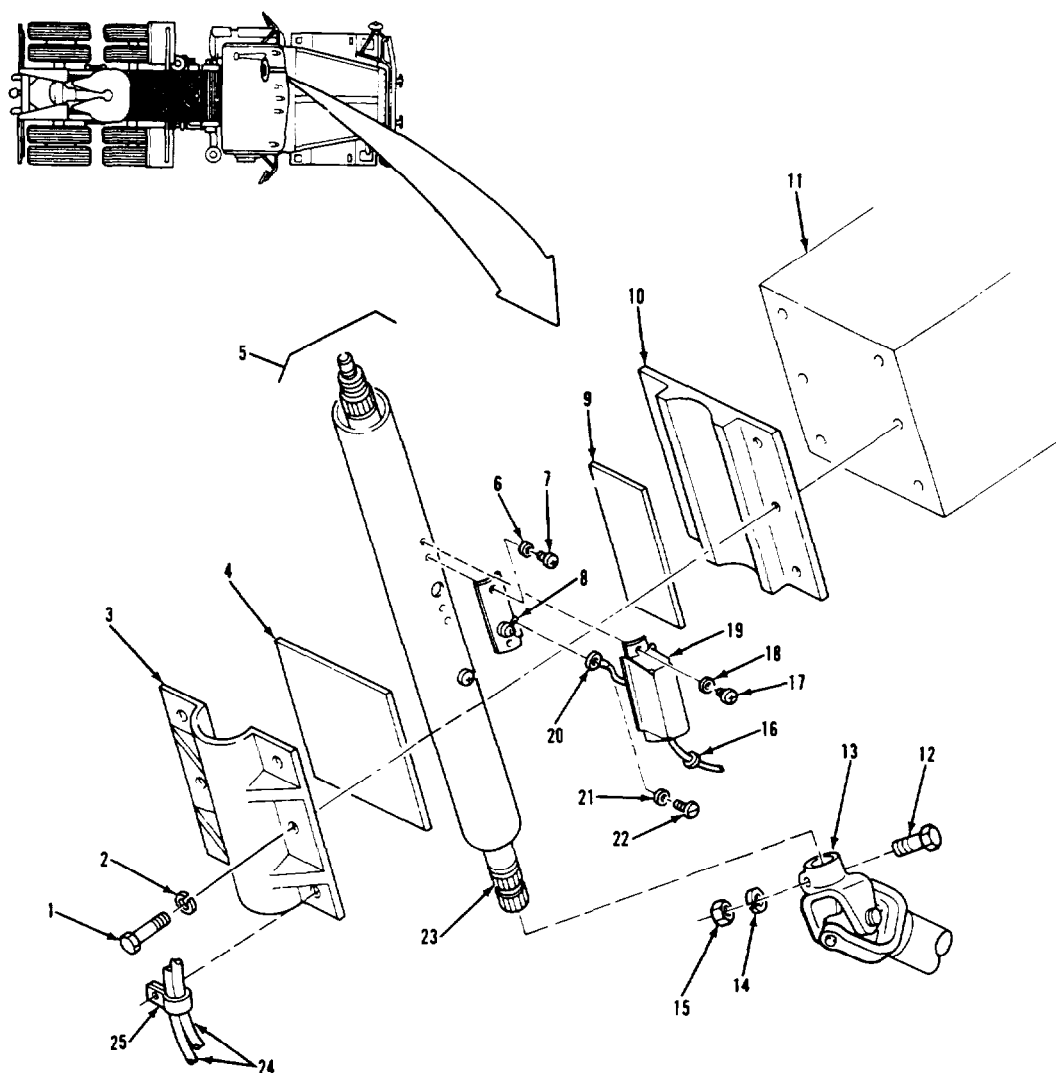

LEGEND:

- |                                   |                             |
|-----------------------------------|-----------------------------|
| 1. HEXAGON BOLT (6)               | 14. LOCKWASHER              |
| 2. LOCKWASHER (6)                 | 15. HEXAGON NUT             |
| 3. STEERING COLUMN OUTER CLAMP    | 16. GROMMET                 |
| 4. OUTER RUBBER INSULATOR         | 17. SELF-TAPPING SCREW (2)  |
| 5. UPPER STEERING COLUMN ASSEMBLY | 18. LOCKWASHER (2)          |
| 6. LOCKWASHER (2)                 | 19. HORN BRUSH COVER        |
| 7. SELF-TAPPING SCREW (2)         | 20. HORN BRUSH WIRE         |
| 8. HORN BRUSH ASSEMBLY            | 21. LOCKWASHER              |
| 9. INNER RUBBER INSULATOR         | 22. SCREW                   |
| 10. STEERING COLUMN INNER CLAMP   | 23. STEERING SHAFT ASSEMBLY |
| 11. CAB BRACKET                   | 24. NONMETALLIC TUBE (2)    |
| 12. CAPSCREW                      | 25. LOOP CLAMP              |
| 13. YOKE                          |                             |

TA 237587



STEERING SYSTEM

3-214. UPPER STEERING COLUMN REPLACEMENT AND REPAIR (Continued).

LOCATION/ITEM	ACTION	REMARKS
<b>B. DISASSEMBLY.</b>		
9. Spacer (26).	Bend out tang and remove from item (23).	Push down on item (29) if necessary.
10. Sleeve (27) and bearing assembly with seal (28).	Remove from item (29) and slide off of item (23).	
11. Bearing (34).	Remove from item (29).	
12. Tube (29).	Slide off of item (23).	
13. Ring (39), cage (38), spring (37), washer (36), sleeve (35), and bearing assembly with seal (34).	Remove from item (23).	Be careful not to damage serrated end of item (23) when removing item (39).
<b>C. CLEANING AND INSPECTION.</b>		
14. All parts.	Clean and inspect.	Refer to paragraphs 3-4 and 3-5. Remove and replace item (30) if damaged. Do steps 15 thru 19 if items (32) or (33) are damaged. Replace item (23) if item (31) is damaged.
15. Wire (31).	Unsolder and remove from item (32).	Do not remove item (31) from item (23).
16. Rivet (33).	Remove from item (32).	Discard item (33).

STEERING SYSTEM

3-214. UPPER STEERING COLUMN REPLACEMENT AND REPAIR (Continued).

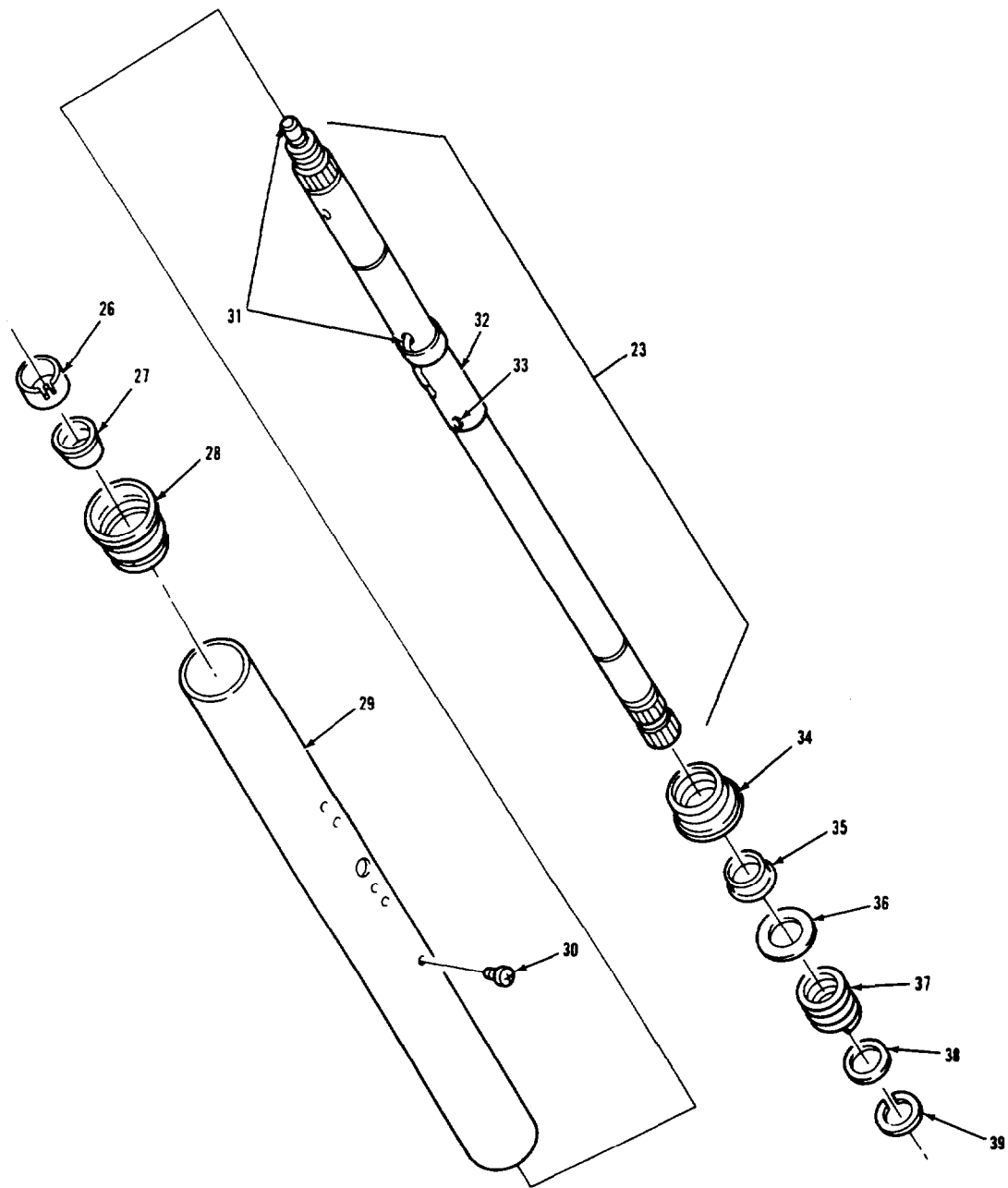

LEGEND:

- |                                |                                |
|--------------------------------|--------------------------------|
| 23. STEERING SHAFT ASSEMBLY    | 33. NYLON RIVET                |
| 26. SHAFT SPACER               | 34. BEARING ASSEMBLY WITH SEAL |
| 27. BEARING SLEEVE             | 35. BEARING SLEEVE             |
| 28. BEARING ASSEMBLY WITH SEAL | 36. FLAT WASHER                |
| 29. OUTER TUBE                 | 37. COMPRESSION SPRING         |
| 30. SELF-TAPPING SCREW         | 38. SPRING CAGE                |
| 31. HORN WIRE                  | 39. RETAINING RING             |
| 32. BRASS RING                 |                                |

TA 237598

STEERING SYSTEM

3-214. UPPER STEERING COLUMN REPLACEMENT AND REPAIR (Continued).

LOCATION/ITEM	ACTION	REMARKS
<b>C. CLEANING AND INSPECTION (Continued).</b>		
17. Ring (32).	Slide off of item (23).	
18. New ring (32).	a. Slide on item (23) and line up holes.  b. Secure with new item (33).	
19. Wire (31).	Position on item (32) and solder in place.	
<b>D. ASSEMBLY.</b>		
20. Bearing assembly with seal (34), sleeve (35), washer (36), spring (37), cage (38) and ring (39).	Install onto end of item (23) opposite item (31).	Be careful not to damage serrated end of item (23) when installing item (39).
21. Tube (29).	Slide onto item (23).	
22. Bearing assembly with seal (34).	Install into item (29).	
23. Bearing assembly with seal (28) and sleeve (27).	Slide on item (23) and install item (28) in item (29).	
24. Spacer (26).	Slide on item (23) and bend tang into index hole to hold it in place.	

STEERING SYSTEM

3-214. UPPER STEERING COLUMN REPLACEMENT AND REPAIR (Continued).

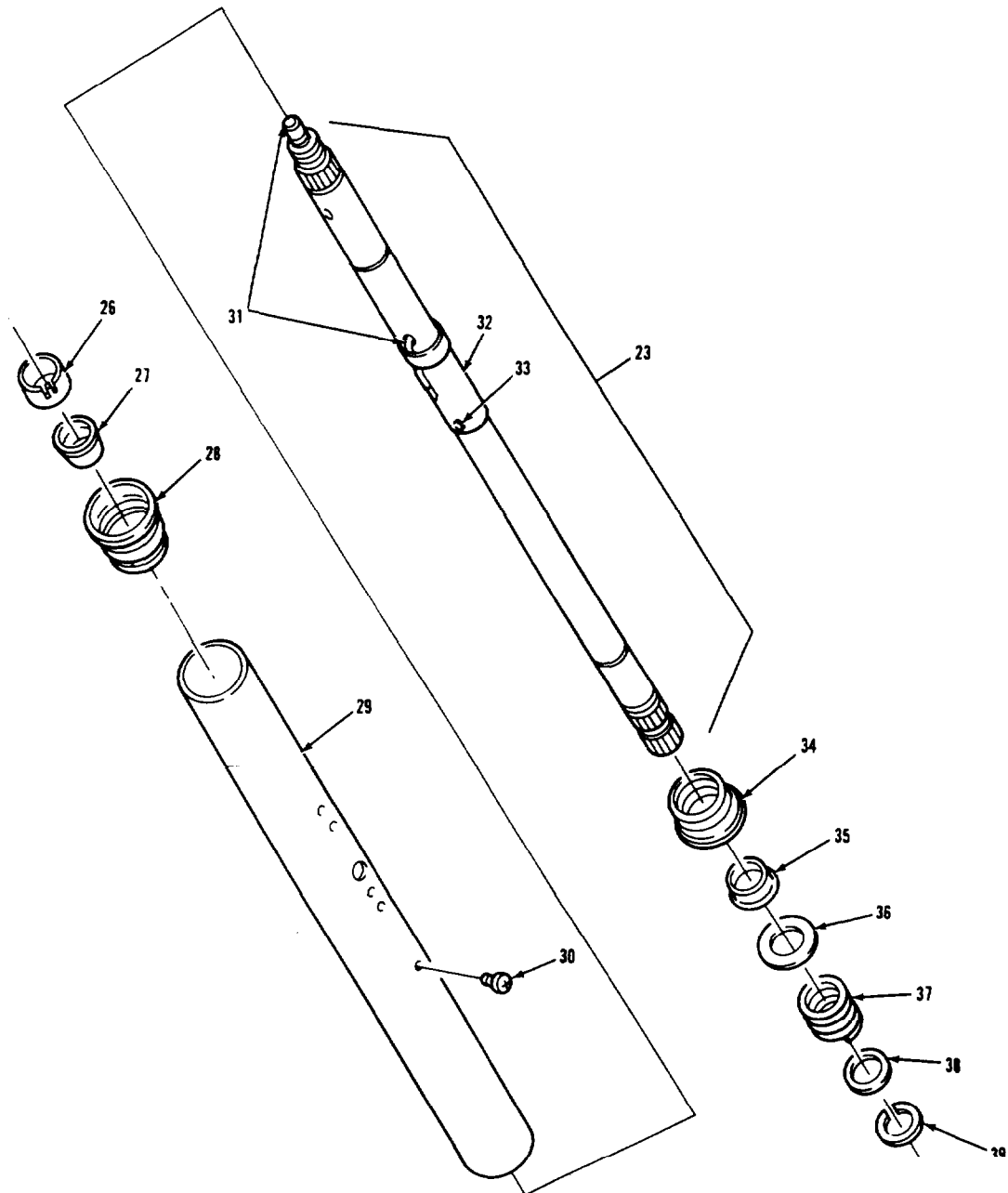

LEGEND:

- |                                |                                |
|--------------------------------|--------------------------------|
| 23. STEERING SHAFT ASSEMBLY    | 33. NYLON RIVET                |
| 26. SHAFT SPACER               | 34. BEARING ASSEMBLY WITH SEAL |
| 27. BEARING SLEEVE             | 35. BEARING SLEEVE             |
| 28. BEARING ASSEMBLY WITH SEAL | 36. FLAT WASHER                |
| 29. OUTER TUBE                 | 37. COMPRESSION SPRING         |
| 30. SELF-TAPPING SCREW         | 38. SPRING CAGE                |
| 31. HORN WIRE                  | 39. RETAINING RING             |
| 32. BRASS RING                 |                                |

TA 237599

STEERING SYSTEM

3-214. UPPER STEERING COLUMN REPLACEMENT AND REPAIR (Continued).

LOCATION/ITEM	ACTION	REMARKS
<b>E. INSTALLATION.</b>		
25. Clamp (3), insulator (4), insulator (9), and clamp (10).	Install onto item (5), just below item (30).	Make sure item (5) is positioned so that items (8) and (19) can be properly installed.
26. Clamp (10), steering column assembly (5), clamp (3), and clamp (25).	a. Position on item (11). b. Secure with six items (1) and (2).	Secure item (25) with lower right-hand items (1) and (2).
27. Yoke (13) and steering shaft assembly (23).	a. Line up mark on item (13) with mark on item (23). b. Push item (13) onto item (23) until holes in item (13) line up with groove in item (23).	
28. Screw (12), lock-washer (14), and nut (15).	Install in item (13) and tighten.	
29. Ring (32).	Lubricate brush contact surface with a small amount of lubricant.	
30. Horn brush assembly (8).	a. Position on item (5). b. Secure with two items (7) and (6).	

STEERING SYSTEM

3-214. UPPER STEERING COLUMN REPLACEMENT AND REPAIR (Continued).

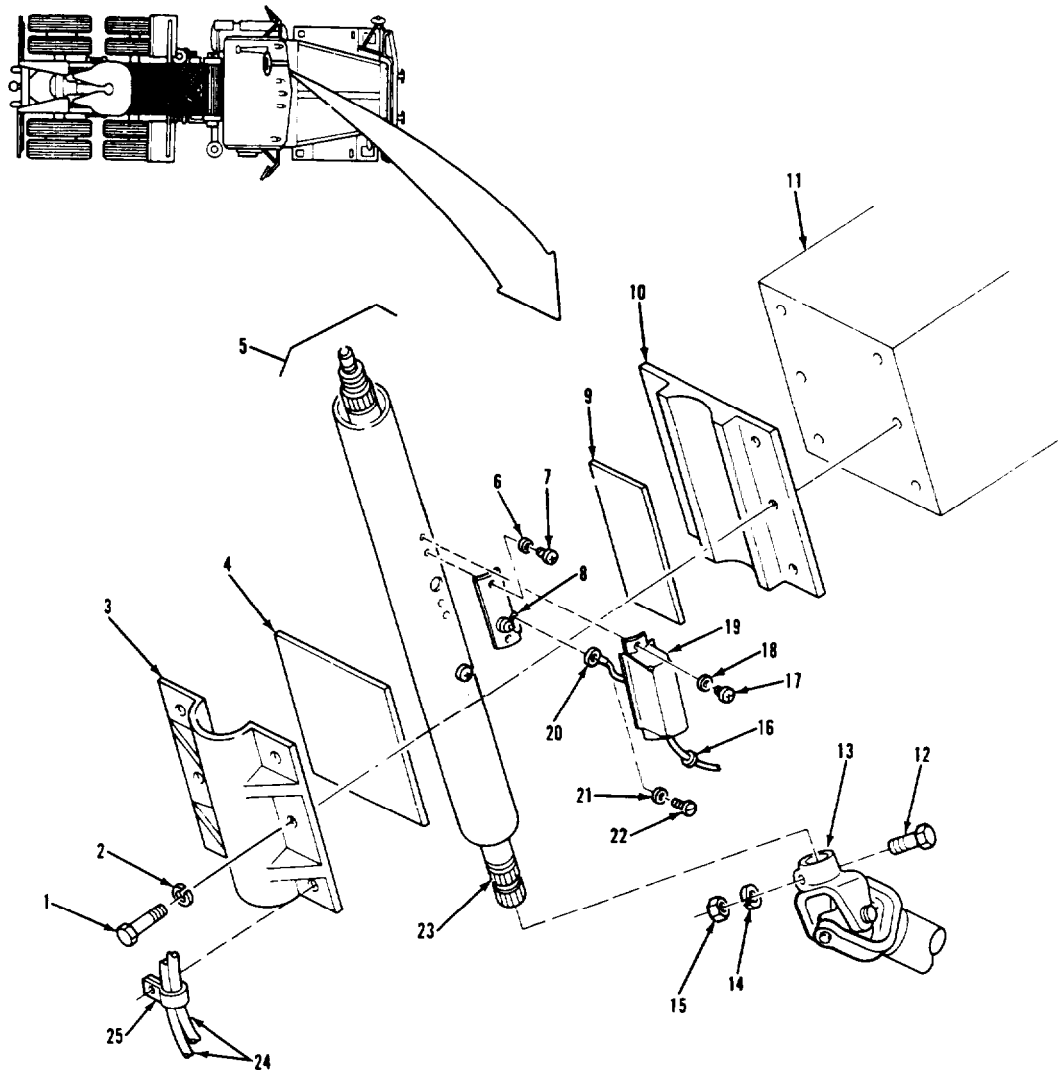

LEGEND:

- |                                   |                             |
|-----------------------------------|-----------------------------|
| 1. HEXAGON BOLT (6)               | 15. HEXAGON NUT             |
| 2. LOCKWASHER (6)                 | 16. GROMMET                 |
| 3. STEERING COLUMN OUTER CLAMP    | 17. SELF-TAPPING SCREW (2)  |
| 4. OUTER RUBBER INSULATOR         | 18. LOCKWASHER (2)          |
| 5. UPPER STEERING COLUMN ASSEMBLY | 19. HORN BRUSH COVER        |
| 6. LOCKWASHER (2)                 | 20. HORN BRUSH WIRE         |
| 7. SELF-TAPPING SCREW (2)         | 21. LOCKWASHER              |
| 8. HORN BRUSH ASSEMBLY            | 22. SCREW                   |
| 9. INNER RUBBER INSULATOR         | 23. STEERING SHAFT ASSEMBLY |
| 10. STEERING COLUMN INNER CLAMP   | 24. NONMETALLIC TUBE (2)    |
| 11. CAB BRACKET                   | 25. LOOP CLAMP              |
| 12. CAPSCREW                      | 30. SELF-TAPPING SCREW      |
| 13. YOKE                          | 32. BRASS RING              |
| 14. LOCKWASHER                    |                             |

TA 237600

STEERING SYSTEM

3-214. UPPER STEERING COLUMN REPLACEMENT AND REPAIR (Continued).		
LOCATION/ITEM	ACTION	REMARKS
<b>E. INSTALLATION (Continued).</b>		
NOTE		
Do steps 31 and 32 only if replacing brush assembly or cover.		
31. Cover (19) and grommet (16).	Slide onto item (20).	
32. Wire (20).	a. Position on item (8). b. Secure with items (22) and (21).	
33. Cover (19).	a. Position on item (5).  b. Secure with two items (17) and (18).	Make sure item (16) is properly installed in hole of item (19).
NOTE		
Follow-on maintenance action required:		
Install turn signal switch (para 3-80). Install trailer hand brake valve (para 3-173). Install steering wheel and perform operational test (para 3-219).		

STEERING SYSTEM

3-214. UPPER STEERING COLUMN REPLACEMENT AND REPAIR (Continued).

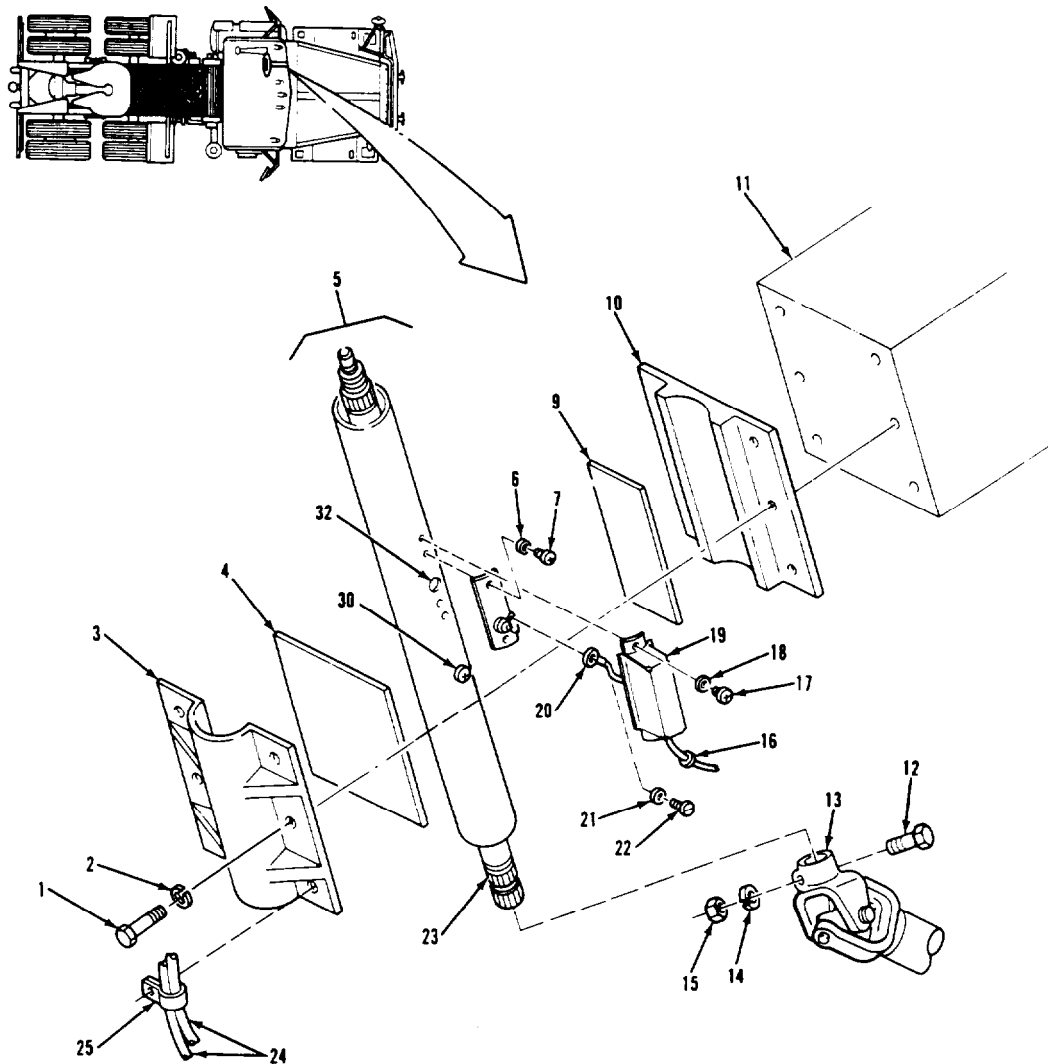

LEGEND:

- |                                   |                             |
|-----------------------------------|-----------------------------|
| 1. HEXAGON BOLT (6)               | 14. LOCKWASHER              |
| 2. LOCKWASHER (6)                 | 15. HEXAGON NUT             |
| 3. STEERING COLUMN OUTER CLAMP    | 16. GROMMET                 |
| 4. OUTER RUBBER INSULATOR         | 17. SELF-TAPPING SCREW (2)  |
| 5. UPPER STEERING COLUMN ASSEMBLY | 18. LOCKWASHER (2)          |
| 6. LOCKWASHER (2)                 | 19. HORN BRUSH COVER        |
| 7. SELF-TAPPING SCREW (2)         | 20. HORN BRUSH WIRE         |
| 8. HORN BRUSH ASSEMBLY            | 21. LOCKWASHER              |
| 9. INNER RUBBER INSULATOR         | 22. SCREW                   |
| 10. STEERING COLUMN INNER CLAMP   | 23. STEERING SHAFT ASSEMBLY |
| 11. CAB BRACKET                   | 24. NONMETALLIC TUBE (2)    |
| 12. CAPSCREW                      | 25. LOOP CLAMP              |
| 13. YOKE                          |                             |

TA 237601



STEERING SYSTEM

3-215. LOWER STEERING COLUMN REPLACEMENT AND REPAIR.

THIS TASK COVERS

- a. Removal.
- b. Disassembly.
- c. Cleaning and Inspection.
- d. Assembly.
- e. Installation.

INITIAL SETUP

APPLICABLE CONFIGURATIONS

All.

EQUIPMENT CONDITION  
PARAGRAPH

None.

CONDITION DESCRIPTION

None.

TEST EQUIPMENT

None.

SPECIAL TOOLS

None.

MATERIALS/PARTS (P/N)

Grease, automotive and artillery  
Item 7, Appendix C.

PERSONNEL REQUIRED

One (MDS-63S).

SPECIAL ENVIRONMENTAL CONDITIONS

None.

REFERENCES (TM)

LO 9-2320-283-12.

GENERAL SAFETY INSTRUCTIONS

Engine off.  
Transmission in neutral.  
Park brake set.

TROUBLESHOOTING REFERENCES

Paragraph 2-11.

STEERING SYSTEM

3-215. LOWER STEERING COLUMN REPLACEMENT AND REPAIR (Continued).

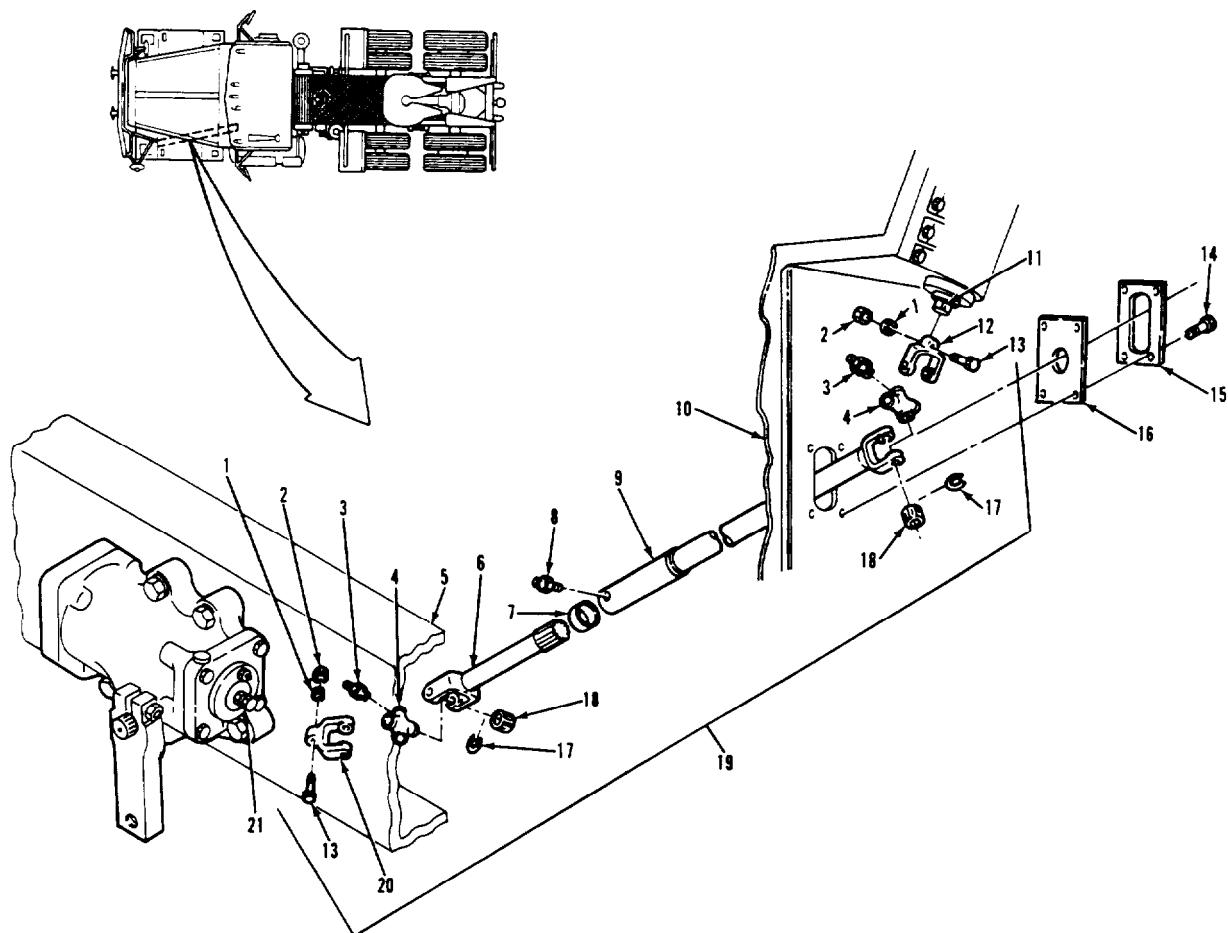

LEGEND:

- |                             |                                    |
|-----------------------------|------------------------------------|
| 1. LOCKWASHER (2)           | 12. YOKE                           |
| 2. HEXAGON NUT (2)          | 13. CAPSCREW (2)                   |
| 3. LUBRICATION FITTING (2)  | 14. SCREW (4)                      |
| 4. CROSS (2)                | 15. STEERING COLUMN COVER PLATE    |
| 5. FRAME RAIL               | 16. LOWER STEERING COLUMN SEAL     |
| 6. SLIP YOKE                | 17. SNAPRING (8)                   |
| 7. DUST CAP                 | 18. BEARING (8)                    |
| 8. LUBRICATION FITTING      | 19. LOWER STEERING COLUMN ASSEMBLY |
| 9. YOKE AND TUBE ASSEMBLY   | 20. YOKE                           |
| 10. CAB FIREWALL            | 21. WORMSHAFT                      |
| 11. STEERING SHAFT ASSEMBLY |                                    |

TA 237602

STEERING SYSTEM

3-215. LOWER STEERING COLUMN REPLACEMENT AND REPAIR (Continued).		
LOCATION/ITEM	ACTION	REMARKS
<b>A. REMOVAL.</b>		
NOTE		
. For better access, wheels should be turned completely to the left.		
. Mark all mating components before removal and disassembly.		
1. Nut (2), lock-washer (1), and capscrew (13).	Remove from item (12).	
2. Yoke (12).	Slide off of item (11).	
3. Nut (2), lock-washer (1), and capscrew (13).	Remove from item (20).	
4. Yoke (20).	Slide off of item (21) and set on item (5).	
5. Lower steering column assembly (19).	Pull through item (10) and lift out of engine compartment.	
6. Four screws (14), plate (15), and seal (16).	Remove from item (10).	
<b>B. DISASSEMBLY.</b>		
7. Eight snaprings (17).	Remove from eight items (18).	Tap items (18) if necessary, but only hard enough to break them away from items (17).

STEERING SYSTEM

3-215. LOWER STEERING COLUMN REPLACEMENT AND REPAIR (Continued).

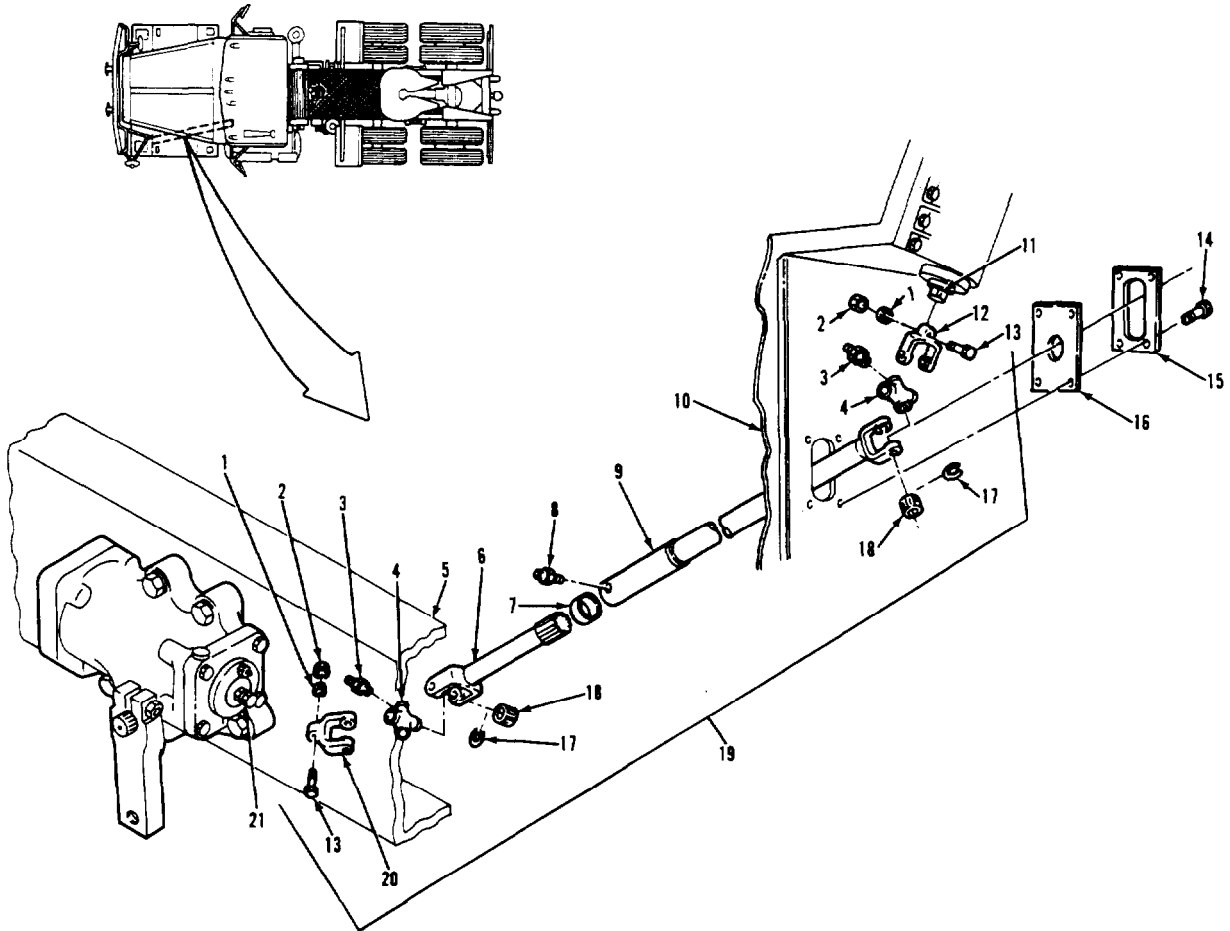

LEGEND:

- |                             |                                    |
|-----------------------------|------------------------------------|
| 1. LOCKWASHER (2)           | 12. YOKE                           |
| 2. HEXAGON NUT (2)          | 13. CAPSCREW (2)                   |
| 3. LUBRICATION FITTING (2)  | 14. SCREW (4)                      |
| 4. CROSS (2)                | 15. STEERING COLUMN COVER PLATE    |
| 5. FRAME RAIL               | 16. LOWER STEERING COLUMN SEAL     |
| 6. SLIP YOKE                | 17. SNAPRING (8)                   |
| 7. DUST CAP                 | 18. BEARING (8)                    |
| 8. LUBRICATION FITTING      | 19. LOWER STEERING COLUMN ASSEMBLY |
| 9. YOKE AND TUBE ASSEMBLY   | 20. YOKE                           |
| 10. CAB FIREWALL            | 21. WORMSHAFT                      |
| 11. STEERING SHAFT ASSEMBLY |                                    |

TA 237603

STEERING SYSTEM

3-215. LOWER STEERING COLUMN REPLACEMENT AND REPAIR (Continued).

LOCATION/ITEM	ACTION	REMARKS
<b>B. DISASSEMBLY (Continued).</b>		
8. Eight bearings (18).	Using suitable arbor press, remove from items (6), (20), (9), and (12).	Press on one item (18) to remove opposite item (18).
9. Yoke (20), two crosses (4), yoke (6), yoke and tube assembly (9), and yoke (12).	Separate.	
10. Yoke (6) and yoke and tube assembly (9).	a. Put alinement marks on each, if not already done. b. Pull item (6) out of item (9).	
11. Fitting (8) and two fittings (3).	Remove from item (9) and two items (4).	
<b>C. CLEANING AND INSPECTION.</b>		
12. All parts.	Clean and inspect.	Refer to paragraph 3-4 and 3-5. Use a fine stone to remove light scratch marks. If item (7) is damaged, pry up tabs and remove from item (9). Install new item (7) on item (9) and stake tabs with a center punch. Replace items (3), (4), (17), and (18) as a set.
13. Fitting (8) and two fittings (3).	Check for thread or ball tip damage, and replace as necessary.	

STEERING SYSTEM

3-215. LOWER STEERING COLUMN REPLACEMENT AND REPAIR (Continued).

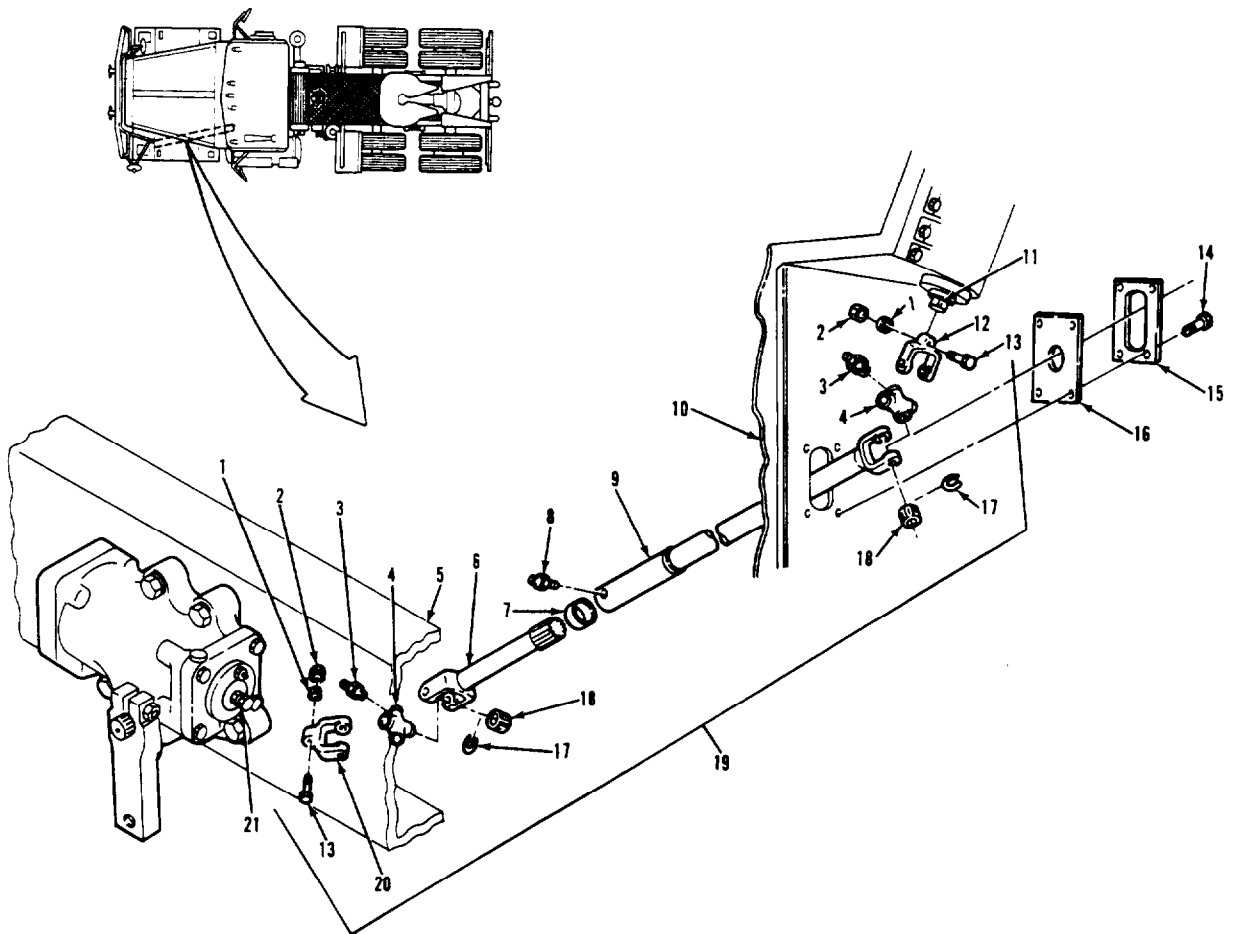

LEGEND:

- |                             |                                    |
|-----------------------------|------------------------------------|
| 1. LOCKWASHER (2)           | 12. YOKE                           |
| 2. HEXAGON NUT (2)          | 13. CAPSCREW (2)                   |
| 3. LUBRICATION FITTING (2)  | 14. SCREW (4)                      |
| 4. CROSS (2)                | 15. STEERING COLUMN COVER PLATE    |
| 5. FRAME RAIL               | 16. LOWER STEERING COLUMN SEAL     |
| 6. SLIP YOKE                | 17. SNAPRING (8)                   |
| 7. DUST CAP                 | 18. BEARING (8)                    |
| 8. LUBRICATION FITTING      | 19. LOWER STEERING COLUMN ASSEMBLY |
| 9. YOKE AND TUBE ASSEMBLY   | 20. YOKE                           |
| 10. CAB FIREWALL            | 21. WORMSHAFT                      |
| 11. STEERING SHAFT ASSEMBLY |                                    |

TA 237604

STEERING SYSTEM

3-215. LOWER STEERING COLUMN REPLACEMENT AND REPAIR (Continued).		
LOCATION/ITEM	ACTION	REMARKS
<b>D. ASSEMBLY.</b>		
NOTE		
Use marks made before removal and disassembly to align mating components.		
14. Fitting (8) and two fittings (3).	Install into item (9) and two items (4).	
15. Yoke (6) and yoke and tube assembly (9).	Line up marks and push item (6) into item (9).	
16. Yoke (20), two crosses (4), yoke (6), yoke and tube assembly (9), and yoke (12).	a. Assemble. b. Lubricate assembly with grease.	
17. Eight bearings (18).	a. Lubricate with grease. b. Using a soft hammer, carefully tap into items (6), (20), (9), and (12).	
18. Eight snaprings (17).	Install onto eight items (18).	
<b>E. INSTALLATION.</b>		
19. Plate (15) and seal (16).	a. Position on item (10). b. Secure with four items (14).	
20. Lower steering column assembly (19).	Lower into engine compartment, insert one end through item (10), and set other end on item (5).	

STEERING SYSTEM

3-215. LOWER STEERING COLUMN REPLACEMENT AND REPAIR (Continued).

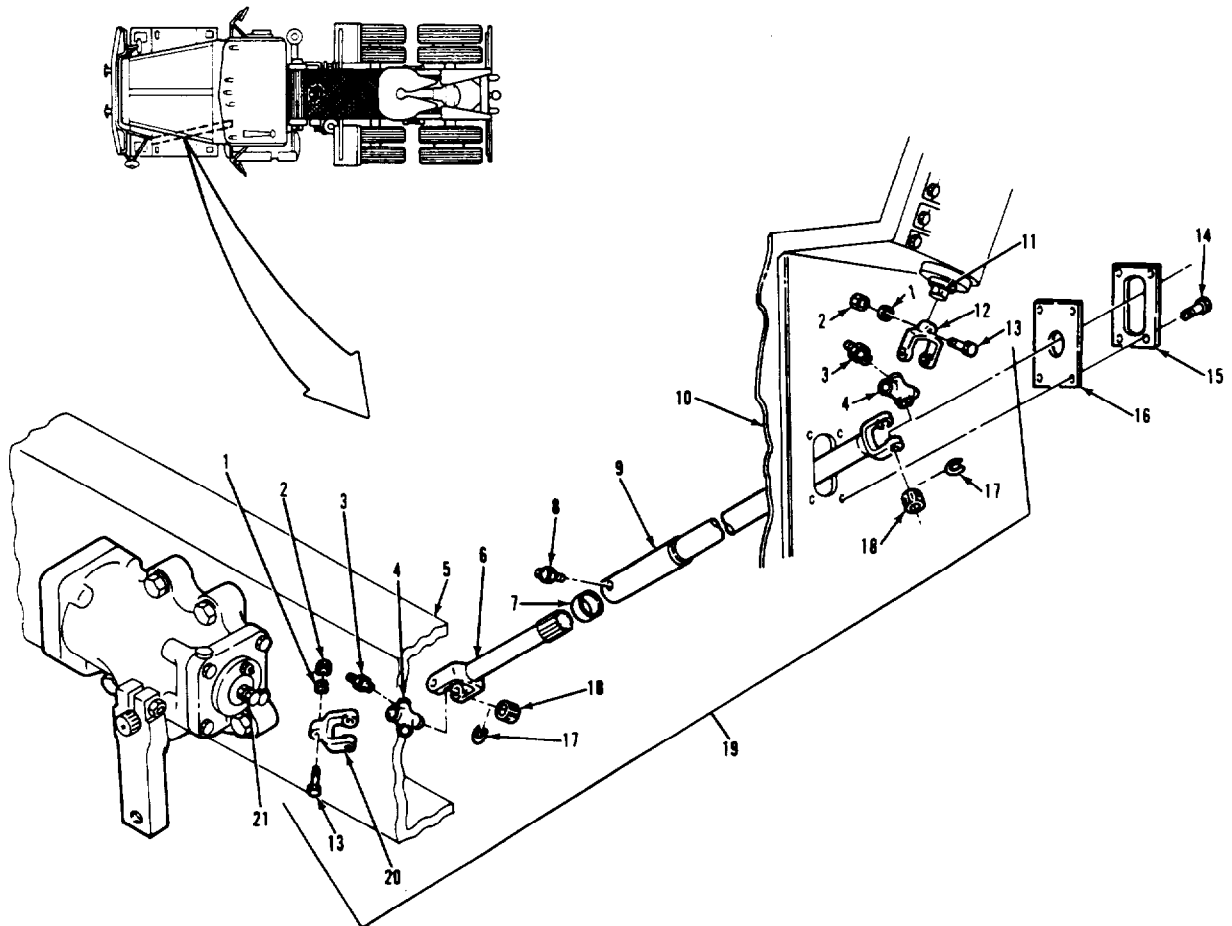

LEGEND:

- |                             |                                    |
|-----------------------------|------------------------------------|
| 1. LOCKWASHER (2)           | 12. YOKE                           |
| 2. HEXAGON NUT (2)          | 13. CAPSCREW (2)                   |
| 3. LUBRICATION FITTING (2)  | 14. SCREW (4)                      |
| 4. CROSS (2)                | 15. STEERING COLUMN COVER PLATE    |
| 5. FRAME RAIL               | 16. LOWER STEERING COLUMN SEAL     |
| 6. SLIP YOKE                | 17. SNAPRING (8)                   |
| 7. DUST CAP                 | 18. BEARING (8)                    |
| 8. LUBRICATION FITTING      | 19. LOWER STEERING COLUMN ASSEMBLY |
| 9. YOKE AND TUBE ASSEMBLY   | 20. YOKE                           |
| 10. CAB FIREWALL            | 21. WORMSHAFT                      |
| 11. STEERING SHAFT ASSEMBLY |                                    |

TA 237605



STEERING SYSTEM

3-215. LOWER STEERING COLUMN REPLACEMENT AND REPAIR (Continued).

LOCATION/ITEM	ACTION	REMARKS
<b>D. INSTALLATION (Continued).</b>		
21. Yoke (12).	a. Push onto item (11) until holes in item (12) line up with groove in item (11).	
	b. Secure with items (1), (2), and (13).	Torque item (2) to 35 lb-ft.
22. Yoke (20).	a. Push onto item (21) until holes in item (20) line up with groove in item (21).	
	b. Secure with items (1), (2), and (13).	Torque item (2) to 35 lb-ft.
23. Fitting (8) and two fittings (3).	Apply grease with grease gun.	LO 9-2320-283-12.
<b>NOTE</b>		
Follow-on maintenance action required: None.		

STEERING SYSTEM

3-215. LOWER STEERING COLUMN REPLACEMENT AND REPAIR (Continued).

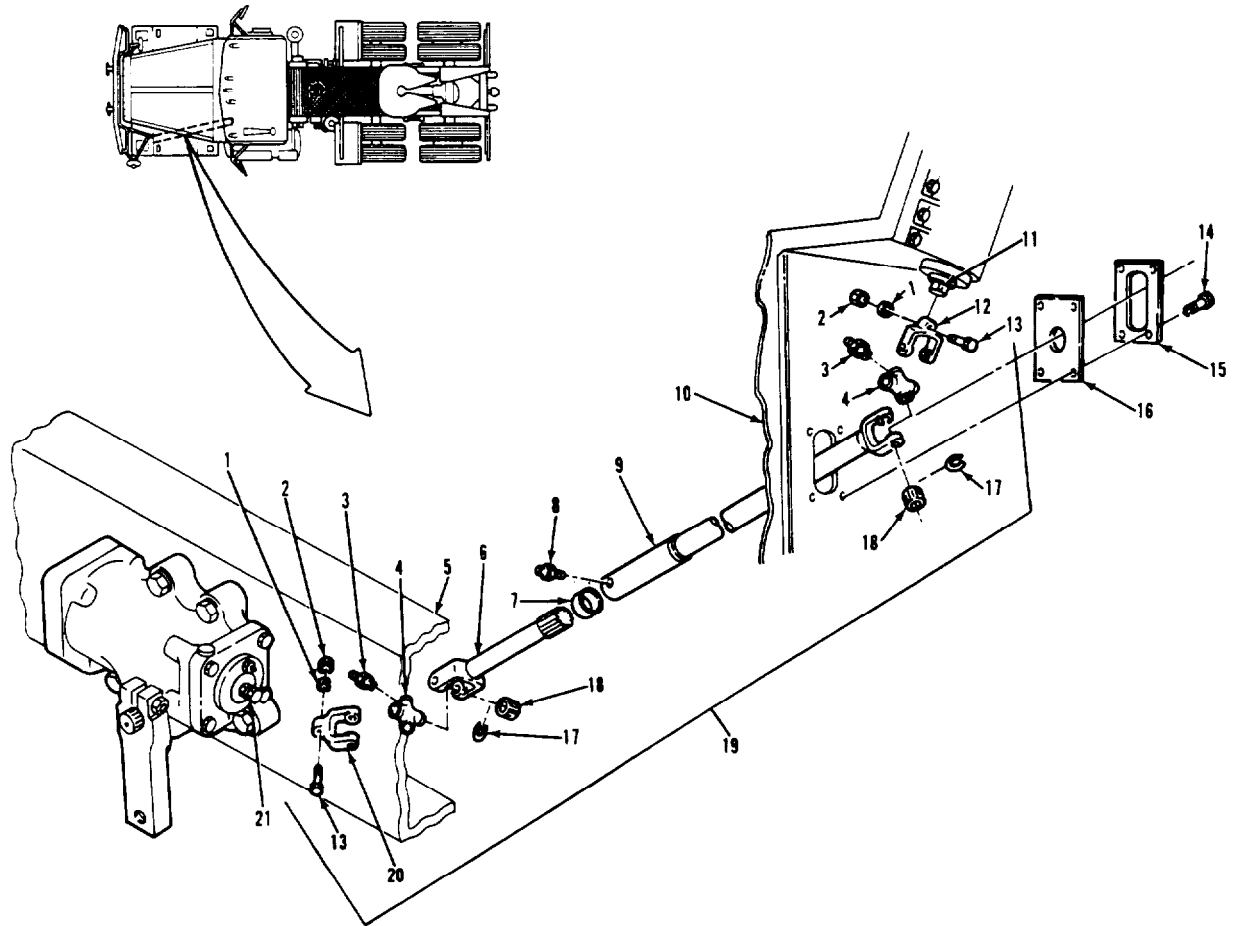

LEGEND:

- |                             |                                    |
|-----------------------------|------------------------------------|
| 1. LOCKWASHER (2)           | 12. YOKE                           |
| 2. HEXAGON NUT (2)          | 13. CAPSCREW (2)                   |
| 3. LUBRICATION FITTING (2)  | 14. SCREW (4)                      |
| 4. CROSS (2)                | 15. STEERING COLUMN COVER PLATE    |
| 5. FRAME RAIL               | 16. LOWER STEERING COLUMN SEAL     |
| 6. SLIP YOKE                | 17. SNAPRING (8)                   |
| 7. DUST CAP                 | 18. BEARING (8)                    |
| 8. LUBRICATION FITTING      | 19. LOWER STEERING COLUMN ASSEMBLY |
| 9. YOKE AND TUBE ASSEMBLY   | 20. YOKE                           |
| 10. CAB FIREWALL            | 21. WORMSHAFT                      |
| 11. STEERING SHAFT ASSEMBLY |                                    |

TA 237606

STEERING SYSTEM

3-216. VERTICAL LINK REPLACEMENT.

THIS TASK COVERS

- a. Removal.
- b. Cleaning and Inspection.
- c. Installation.

INITIAL SETUP

APPLICABLE CONFIGURATIONS

All.

EQUIPMENT CONDITION  
PARAGRAPH

TM 9-2320-283-10.

CONDITION DESCRIPTION

Front wheels turned completely to left.

TEST EQUIPMENT

None.

SPECIAL TOOLS

None.

MATERIALS/PARTS (P/N)

Grease, automotive and artillery  
Item 7, Appendix C.  
Pin, cotter (2)  
(24617) 103389.

PERSONNEL REQUIRED

One (MOS-63S).

SPECIAL ENVIRONMENTAL CONDITIONS

None.

REFERENCES (TM)

LO 9-2320-283-12.  
TM 9-2320-283-10.  
TM 9-2320-283-20P.

GENERAL SAFETY INSTRUCTIONS

Engine off.  
Transmission in neutral.  
Park brake set.

TROUBLESHOOTING REFERENCES

Paragraph 2-11.

STEERING SYSTEM

3-216. VERTICAL LINK REPLACEMENT (Continued).

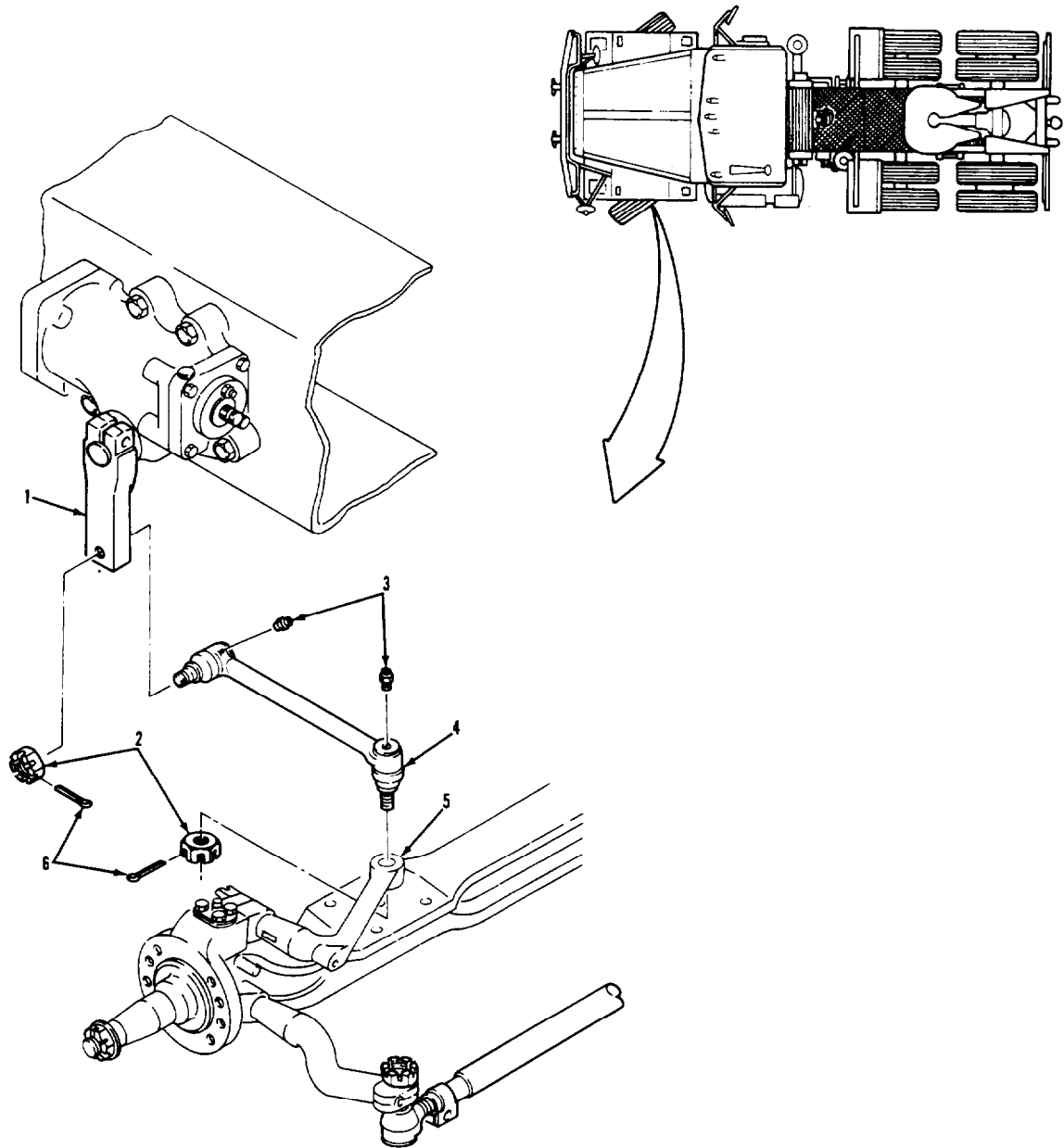

LEGEND:

- |                            |                   |
|----------------------------|-------------------|
| 1. STEERING ARM            | 4. VERTICAL LINK  |
| 2. CASTLE NUT (2)          | 5. STEERING ARM   |
| 3. LUBRICATION FITTING (2) | 6. COTTER PIN (2) |

TA 237607

STEERING SYSTEM

3-216. VERTICAL LINK REPLACEMENT (Continued).		
LOCATION/ITEM	ACTION	REMARKS
<b>A. REMOVAL.</b>		
1. Two pins (6).	Remove from items (2) and (4).	If items (6) are hard to remove, tighten or loosen two items (2) to align slots. Discard items (6).
2. Two nuts (2).	a. Unscrew until flush with threaded part of item (4). b. Using suitable hammer, hit end of items (2) until item (4) unseats. c. Unscrew and remove.	If item (4) cannot be unseated with hammer, use suitable puller.
3. Link (4).	Remove from items (1) and (5).	
4. Two fittings (3).	Remove from item (4).	
<b>B. CLEANING AND INSPECTION.</b>		
5. All parts.	Clean and inspect.	Refer to paragraphs 3-4 and 3-5. If any parts are damaged, troubleshoot steering system (para 2-11).
<b>C. INSTALLATION.</b>		
6. Two fittings (3).	Install in item (4).	
7. Link (4).	a. Position on items (1) and (5). b. Secure with two items (2).	Torque items (2) to 110-125 lb-ft.

STEERING SYSTEM

3-216. VERTICAL LINK REPLACEMENT (Continued).

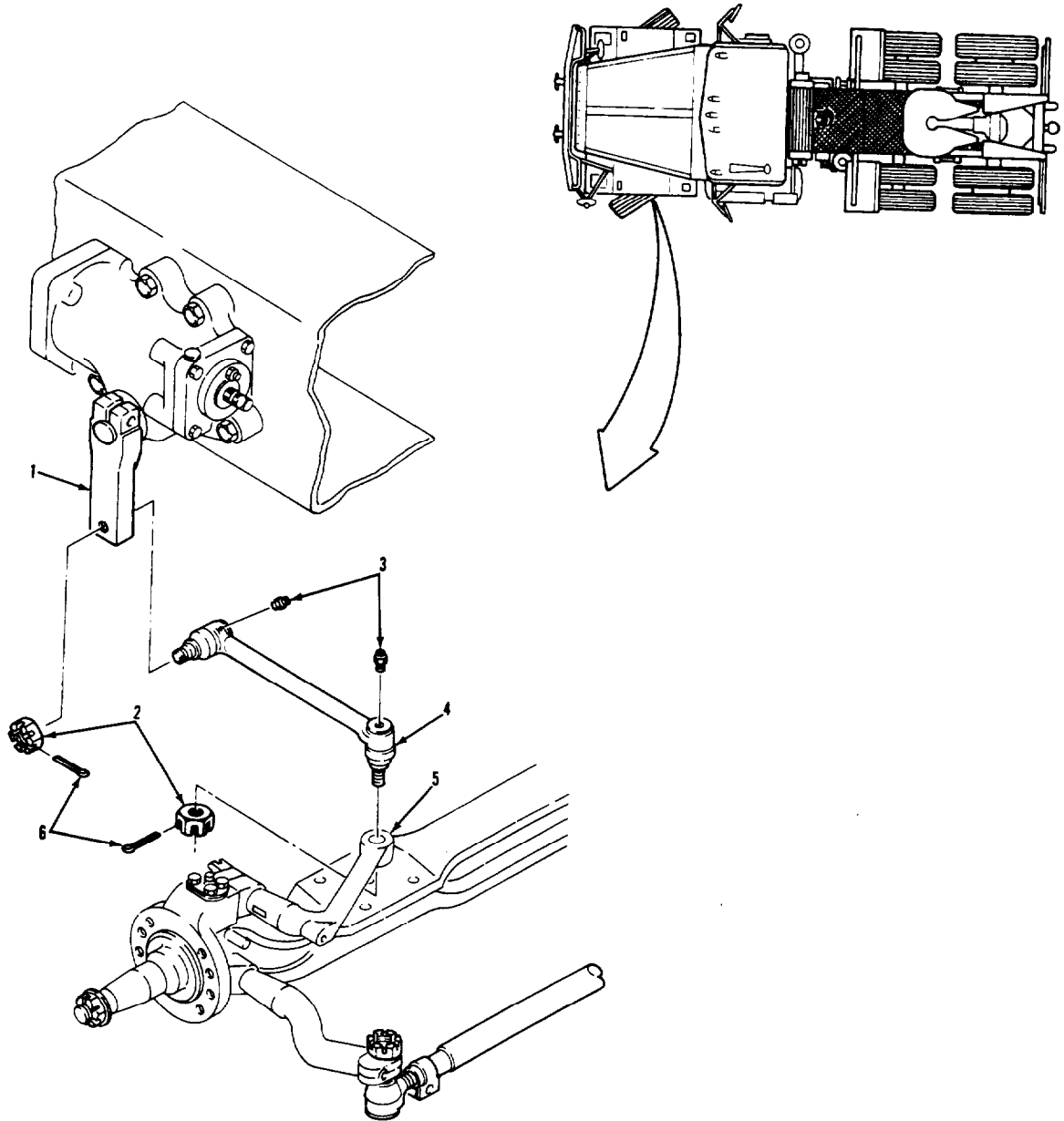

LEGEND:

- |                            |                   |
|----------------------------|-------------------|
| 1. STEERING ARM            | 4. VERTICAL LINK  |
| 2. CASTLE NUT (2)          | 5. STEERING ARM   |
| 3. LUBRICATION FITTING (2) | 6. COTTER PIN (2) |

TA 237608

STEERING SYSTEM

3-216. VERTICAL LINK REPLACEMENT (Continued).

LOCATION/ITEM	ACTION	REMARKS
<b>C. INSTALLATION (Continued).</b>		
8. Two new pins (6).	Install into items (2) and (4), and bend ends over.	It may be necessary to tighten two items (2) further in order to aline slots of items (2) with holes of item (4).
9. Two fittings (3).	Using grease gun, lubricate with grease.	Refer to LO 9-2320-283-12.
<b>NOTE</b>		
Follow-on maintenance action required:		
None.		

STEERING SYSTEM

3-216. VERTICAL LINK REPLACEMENT (Continued).

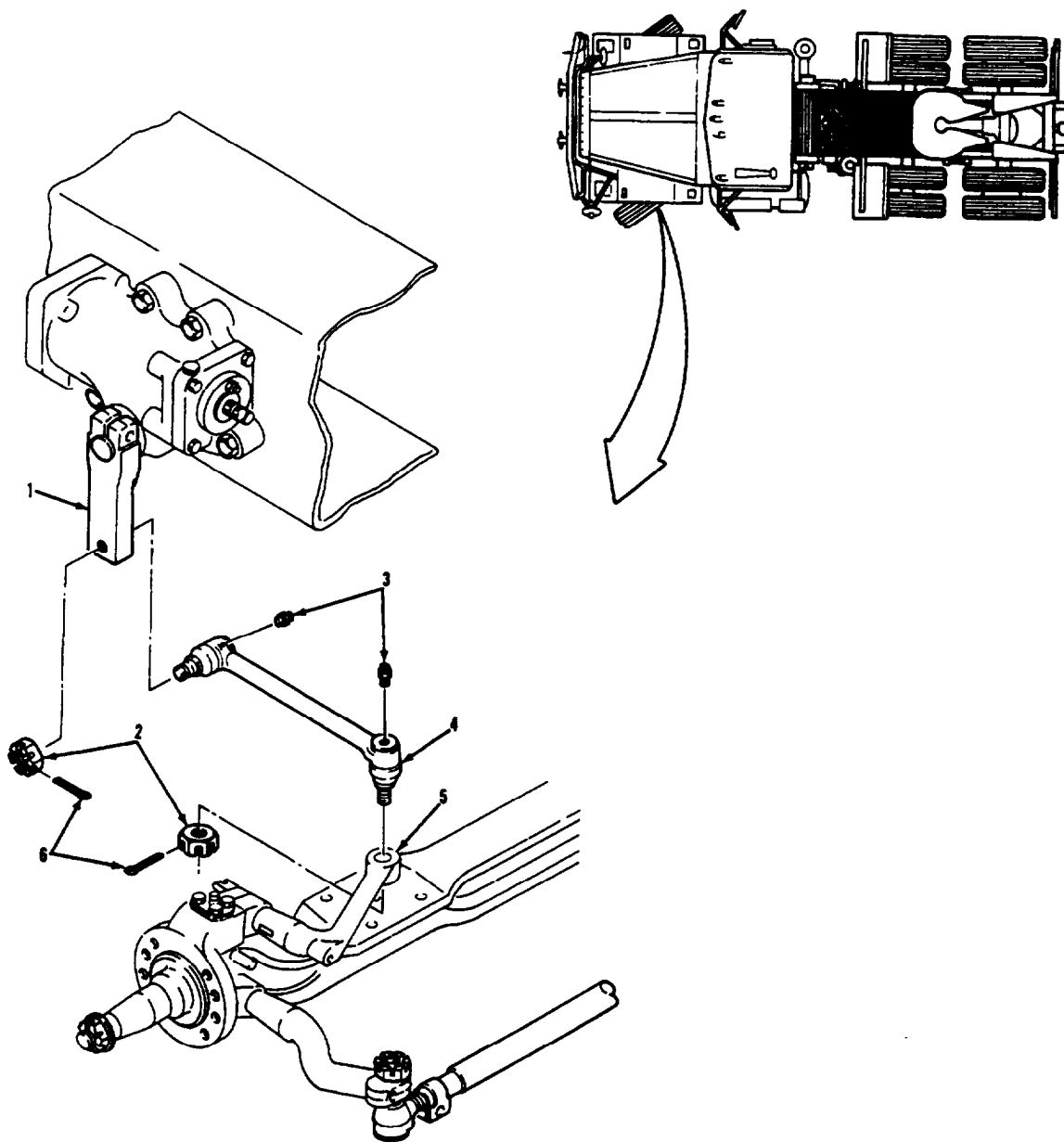

LEGEND:

- |                            |                   |
|----------------------------|-------------------|
| 1. STEERING ARM            | 4. VERTICAL LINK  |
| 2. CASTLE NUT (2)          | 5. STEERING ARM   |
| 3. LUBRICATION FITTING (2) | 6. COTTER PIN (2) |

TA 237809



**STEERING SYSTEM**

**3-217. STEERING ARM MAINTENANCE.**

**THIS TASK COVERS**

- a. Preparation.
- b. Removal.
- c. Cleaning/Inspection.
- d. Installation.

**INITIAL SETUP**

<u>APPLICABLE CONFIGURATIONS</u>	<u>EQUIPMENT CONDITION PARAGRAPH</u>	<u>CONDITION DESCRIPTION</u>
All.	None.	None.

**TEST EQUIPMENT**

Analyzer, Power Steering, NSN 4910-01-160-3618  
P/N J26487 (33287)

**SPECIAL TOOLS**

Pushrod Driver (fabricate IAW Appendix E, Figure E-8), P/N DTA177323 (19207)  
Puller, NSN 5120-00-595-9305  
P/N GGG-P-781 (81348)  
Torque Wrench, NSN 5120-00-221-7983  
P/N SW130-301 (10001)  
Multiplier, Torque Wrench,  
NSN 5120-01-142-6941 P/N 392 (87641)  
Steering Stop Template (fabricate IAW Appendix E, Figure E-9)

**MATERIALS/PARTS (P/N)**

Steering Arm Kit, 2MPS-3993 (78500)  
Includes:  
Cotter Pin, MS24665-498 (96906)  
Key, 16X202 (78500)  
Nut, Drag Link/Steering Arm, MS35692-69 (96906)  
Nut, Knuckle/Steering Arm, MS35692-1824 (96906)  
Boot, Grease, 415172C1 (89346)  
Steering Arm, 3133-G-6663 (78500)

**PERSONNEL REQUIRED**

One (MDS-63S)

**SPECIAL ENVIRONMENTAL CONDITIONS**

Vehicle Parked on Level Ground.

**REFERENCES (TM)**

- TM 9-2320-283-10
- TM 9-2320-283-24P
- TM 9-2320-283-34

**GENERAL SAFETY INSTRUCTIONS**

- Engine OFF.
- Transmission in Neutral.
- Parking Brake Set.
- Rear Wheels Chocked.

**TROUBLESHOOTING REFERENCES**

Paragraph 2-11.

STEERING SYSTEM

3-217. STEERING ARM MAINTENANCE (Continued).

LOCATION/ITEM	ACTION	REMARKS
---------------	--------	---------

**A. PREPARATION.**

1. Perform front axle toe-in/toe-out check. (See TM 9-2320-283-20).
2. Chock rear wheels.
3. Set parking brakes and break loose front wheel lug nuts.
4. Lift front of vehicle off ground and secure with floor jacks.
5. Remove both front wheels. See TM 9-2320-283-10).
6. Turn steering wheel fully left.

**B. REMOVAL.**

**NOTE**

Step 1 is performed to allow a socket to be installed onto the nut, securing the steering arm to the steering knuckle.

1. Pour bolts (1) securing camshaft bracket (2) to brake dust shield (3). Allow camshaft bracket (2) to hang loose.

Allow camshaft bracket (2) to hang loose. Disconnect and remove.

Do not remove O-ring (4) or camshaft bracket (2) from camshaft (5).

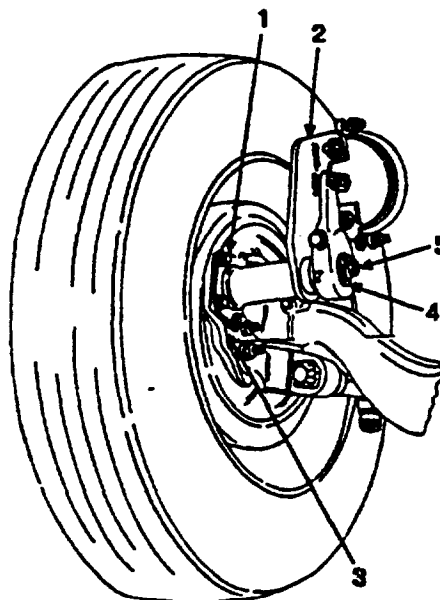

STEERING SYSTEM

3-217. STEERING ARM MAINTENANCE (Continued).

LOCATION/ITEM	ACTION	REMARKS
<p><b>B. REMOVAL (Continued).</b></p>		
<p>2. Cotter pin (6), and castle nut (7) and drag link (8).</p>	<p>Remove.</p>	<p>Discard cotter pin and castle nut.</p>
<p>3. Steering arm boss (10), drag link (8) steering arm (11) and dust boot (12).</p>	<p>Remove using puller tool (9).</p>	<p>Discard dust boot (12).</p>

STEERING SYSTEM

3-217. STEERING ARM MAINTENANCE (Continued).

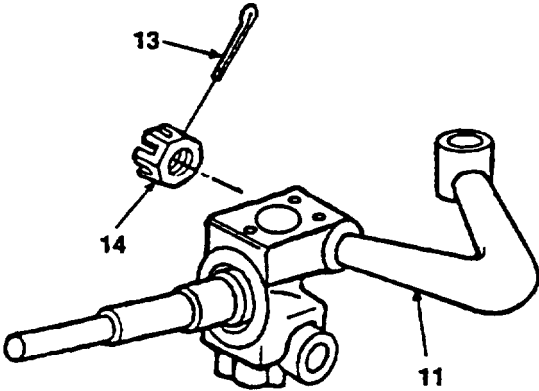
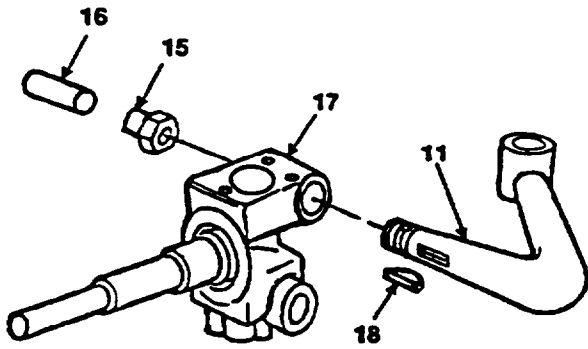
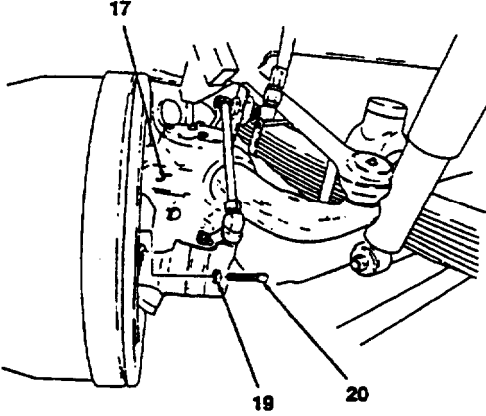
LOCATION/ITEM	ACTION	REMARKS
<b>B. REMOVAL (Continued).</b>		
4. Cotter pin (13), castle nut (14) and steering arm (11).	Remove.	Discard cotter pin and castle nut.
		
<b>NOTE</b>		
Wear safety glasses while performing step 5.		
5. Arm driver (15), steering arm (11) and knuckle housing (17).	Thread arm driver (15) onto threaded end of steering arm (11). Place an extended rod (16) squarely onto the arm driver (15) and using a suitable hammer strike extended rod (16) to drive steering arm out of knuckle housing (17).	
6. Key (18).	Remove.	Discard.
7. Steering arm (11).	Remove.	Destroy. (Not for reuse).
8. Jam nut (19) and stop bolt (20).	Remove bolt.	
		

STEERING SYSTEM

3-217. STEERING ARM MAINTENANCE (Continued).

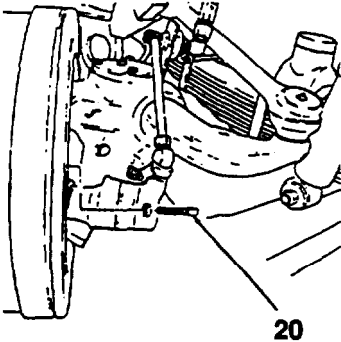
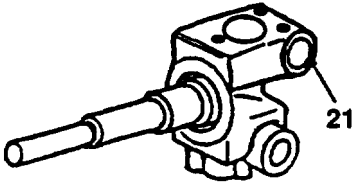
LOCATION/ITEM	ACTION	REMARKS
<b>C. CLEANING AND INSPECTION.</b>		
<ol style="list-style-type: none"> <li>Knuckle assembly bore (21).</li> <li>Stop bolt (20).</li> </ol>	<p>Clean off rust, burrs and foreign material.</p>	<p>Inspect for obvious damage. Inspect to see if bent or damaged.</p>
		
<b>D. INSTALLATION.</b>		
<b>NOTE</b>		
<p>Before performing step 1, verify that a new key (18) is in place on the tapered end of steering arm (11).</p>		
<ol style="list-style-type: none"> <li>Steering arm (11).</li> <li>Castle nut (14) and steering arm (11).</li> <li>Dust boot (12).</li> </ol>	<p>Clean and install into knuckle housing (17). Install castle nut (14). Install dust boot (12) onto drag link (8) and insert into steering arm boss (10).</p>	<p>Place nut on threaded end of steering arm (11) and finger tighten. (Do not torque at this time). Secure with castle nut (7) and finger tighten.</p>
<b>CAUTION</b>		
<ul style="list-style-type: none"> <li>Do not exceed 500 lb-ft (678 N•m). Do not back off castle nut (14) during this step.</li> <li>Do not exceed 130 lb-ft (177 N•m). Do not back off castle nut (7) during this step.</li> </ul>		

STEERING SYSTEM

3-217. STEERING ARM MAINTENANCE (Continued).

LOCATION/ITEM	ACTION	REMARKS
<b>D. INSTALLATION (Continued).</b>		
4. Castle nut (14) steering arm cotter pin hole (22).	Torque castle nut.	Torque to minimum of 360 lb-ft (488 N•m). Using torque wrench, continue to tighten nut (14) to align with steering arm cotter pin hole (22).
5. Cotter pin (13).	Install and secure.	
6. Castle nut (7) and drag link cotter pin hole (23).	Tighten castle nut.	Torque to minimum of 115 lb-ft (156 N•m). Using torque wrench, continue to tighten nut (7) to align with drag link cotter pin hole (23).
7. Cotter pin (6).	Install and secure.	

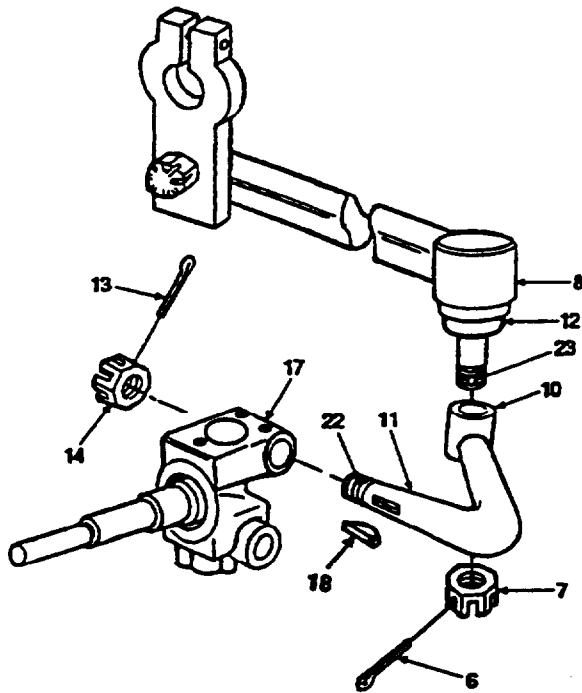

STEERING SYSTEM

3-217. STEERING ARM MAINTENANCE (Continued).

LOCATION/ITEM	ACTION	REMARKS
<b>D. INSTALLATION (Continued).</b>		
8. Camshaft bracket (2) and dust shield (3).	Secure camshaft bracket (2) to dust shield (3) using four bolts (1).	

**STEERING SYSTEM**

**3-217.1. STEERING STOP INSPECTION AND ADJUSTMENT PROCEDURE.**

**THIS TASK COVERS**

Inspection/Adjustment.

**INITIAL SETUP**

<b><u>APPLICABLE CONFIGURATIONS</u></b>	<b><u>EQUIPMENT CONDITION PARAGRAPH</u></b>	<b><u>CONDITION DESCRIPTION</u></b>
All.	None.	None.

**TEST EQUIPMENT**

Analyzer, Power Steering, NSN 4910-01-160-3618  
P/N J26487 (33287)

**SPECIAL TOOLS**

Pushrod Driver (fabricate IAW Appendix E, Figure E-8), P/N DTA177323 (19207)  
Puller, NSN 5120-00-595-9305  
P/N GGG-P-781 (81348)  
Torque Wrench, NSN 5120-00-221-7983  
P/N SW130-301 (10001)  
Multiplier, Torque Wrench,  
NSN 5120-01-142-6941 P/N 392 (87641)  
Steering Stop Template (fabricate IAW Appendix E, Figure E-9)

**MATERIALS/PARTS (P/N)**

Steering Arm Kit, 2MPS-3993 (78500)  
Includes:  
Cotter Pin, (MS24665-498 (96906)  
Key, 16X202 (78500)  
Nut, Drag Link/Steering Arm, MS35692-69 (96906)  
Nut, Knuckle/Steering Arm, MS35692-1824 (96906)  
Boot, Grease, 415172C1 (89346)  
Steering Arm, 3133-G-6663 (78500)

**PERSONNEL REQUIRED**

One (MOS-63S)

**SPECIAL ENVIRONMENTAL CONDITIONS**

Vehicle Parked on Level Ground.

**REFERENCES (TM)**

TM 9-2320-283-10  
TM 9-2320-283-24P  
TM 9-2320-283-34

**GENERAL SAFETY INSTRUCTIONS**

Engine OFF.  
Transmission in Neutral.  
Parking Brake Set.  
Rear Wheels Chocked.

**TROUBLESHOOTING REFERENCES**

Paragraph 2-11.



STEERING SYSTEM

3-217.1. STEERING STOP INSPECTION AND ADJUSTMENT PROCEDURES (Continued).

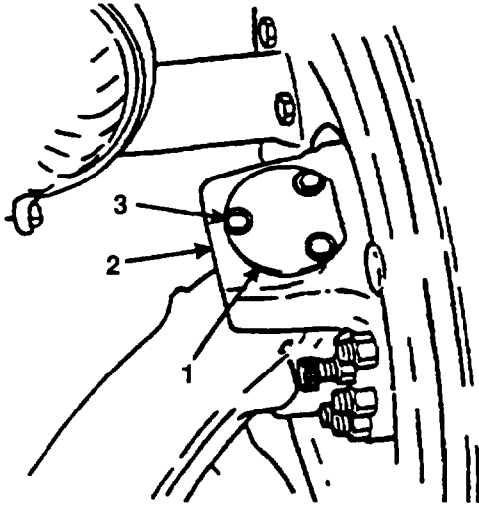
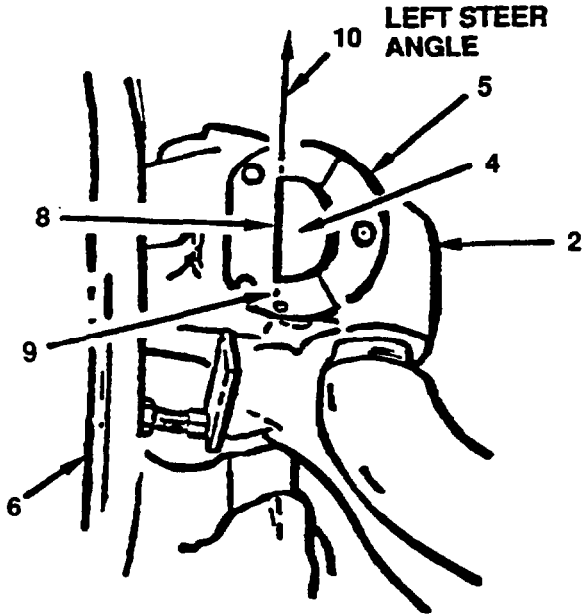
LOCATION/ITEM	ACTION	REMARKS
<b>INSPECTION/ADJUSTMENT.</b>		
<b>NOTE</b>		
Check that alignment marks on the pitman arm and steering gear sector shaft are in alignment before performing the steering stop adjustment procedure.		
1. King pin cover plate (1), steering knuckle (2) and three bolts (3).	Remove three bolts (3) and king pin cover plate (1) from steering knuckle (2).	Remove all grease from top of exposed king pin (4).
		<b>LEFT STEER ANGLE SHOW RIGHT STEER ANGLE OPPOSITE</b>
2. Template (5), steering knuckle housing (2) and three cover bolts (3).	Install.	Put template on top of housing, and partially install bolts to position template.

STEERING SYSTEM

3-217.1. STEERING STOP INSPECTION AND ADJUSTMENT PROCEDURES (Continued).

LOCATION/ITEM	ACTION	REMARKS
INSPECTION/ADJUSTMENT (Continued).		
3. Front wheel hub (6).	Center and measure.	Use a 24-inch ruler to make two measurements. First, measure the distance from the front leaf spring (7) to the front of the inner vehicle hub (6). Next, turn the vehicle hub (6) until the distance from the leaf spring (7) is the same between the inner hub (6) and the rear of the inner hub (6) edge.
<p>The diagram shows a perspective view of a front wheel hub assembly. A 24-inch ruler is positioned horizontally across the top of the hub. Two points on the ruler are marked with vertical lines, and dashed lines connect these points to the front and rear of the inner hub. Both dashed lines are labeled 'equal distance'. The front leaf spring is labeled '7' and the inner hub is labeled '6'. The ruler is labeled '24 inch ruler'.</p>		
4. Template (5).	Mark lines.	Scribe (mark) a line (8) across the zero degree reference line edge (9) of the template (5). Line (8) should be parallel to the line of travel (10).

STEERING SYSTEM

3-217.1. STEERING STOP INSPECTION AND ADJUSTMENT PROCEDURES (Continued).

LOCATION/ITEM	ACTION	REMARKS
INSPECTION/ADJUSTMENT (Continued).		
<b>NOTE</b>		
<ul style="list-style-type: none"> <li>• A 3/16-inch spacer must be used when adjusting the steering stops in order to acquire the correct steer angle.</li> <li>• Inspect stop bolts, replace if bent or damaged.</li> </ul>		
<p>5. 3/16-inch spacer (11), steering stop bolt (12), steering stop boss (13), wheel hub (6), king pin line (8) 32 degree reference line (14) and jam nut (15).</p>	<p>Position, adjust and tighten.</p>	<p>Position the spacer between the steering stop bolt and steering stop boss. Turn wheel hub full left until king pin line aligns with the 32 degree reference line on template. If the 32 degree reference line does not line up with the king pin line, adjust steering stop bolt inwards or outwards, as required, until the two lines align. Tighten jam nut and remove spacer.</p>
<p><b>LEFT STEER ANGLE SHOWN</b> <b>RIGHT STEER ANGLE OPPOSITE</b></p>		

STEERING SYSTEM

3-217.1. STEERING STOP INSPECTION AND ADJUSTMENT PROCEDURES (Continued).

LOCATION/ITEM	ACTION	REMARKS
INSPECTION/ADJUSTMENT (Continued).		
NOTE		
Brake drum must be turned full right before performing step 6.		
6. Template (5).	Remove.	Perform same procedure (steps 1 thru 5) for the right side steering stop adjustment.
7. King pin cover plate (1) and three bolts (3).	Install and secure onto steering knuckle housing (2).	
NOTE		
Follow-on maintenance action required:		
Paint new steering arm (TB 43-0209). Grease the steering knuckles and drag link (LO 9-2320-283-12). Install both front wheels and torque lug nuts (TM 9 2320-283-20).		

STEERING SYSTEM

3-217.2. STEERING GEAR POPPET ADJUSTMENT.

THIS TASK COVERS

Analyze/Adjustment.

INITIAL SETUP

<u>APPLICABLE CONFIGURATIONS</u>	<u>EQUIPMENT CONDITION PARAGRAPH</u>	<u>CONDITION DESCRIPTION</u>
All.	None.	None.

TEST EQUIPMENT

Analyzer, Power Steering, NSN 4910-01-160-3618  
P/N J26487 (33287)

SPECIAL TOOLS

Pushrod Driver (fabricate IAW Appendix E, Figure E-8), P/N DTA177323 (19207)  
Puller, NSN 5120-00-595-9305  
P/N GGG-P-781 (81348)  
Torque Wrench, NSN 5120-00-221-7983  
P/N SW130-301 (10001)  
Multiplier, Torque Wrench,  
NSN 5120-01-142-6941 P/N 392 (87641)  
Steering Stop Template (fabricate IAW Appendix E, Figure E-9)

MATERIALS/PARTS (P/N)

Steering Arm Kit, 2MPS-3993 (78500)  
Includes:  
Cotter Pin, (MS24665-498 (96906)  
Key, 16X202 (78500)  
Nut, Drag Link/Steering Arm, MS35692-69 (96906)  
Nut, Knuckle/Steering Arm, MS35692-1824 (96906)  
Boot, Grease, 415172C1 (89346)  
Steering Arm, 3133-G-6663 (78500)

PERSONNEL REQUIRED

One (MOS-63S)

SPECIAL ENVIRONMENTAL CONDITIONS

Vehicle Parked on Level Ground.

REFERENCES (TM)

TM 9-2320-283-10  
TM 9-2320-283-24P  
TM 9-2320-283-34

GENERAL SAFETY INSTRUCTIONS

Engine OFF.  
Transmission in Neutral.  
Parking Brake Set.  
Rear Wheels Chocked.

TROUBLESHOOTING REFERENCES

Paragraph 2-11.

STEERING SYSTEM

3-217.2. STEERING GEAR POPPET ADJUSTMENT (Continued).

LOCATION/ITEM	ACTION	REMARKS
<p><b>ANALYZE/ADJUSTMENT.</b></p>		
<p><b>NOTE</b></p>		
<p>The following procedure sets the steering gear poppet adjusting screws so that power steering system pressure is reduced before the steering stop bolts contact the axle beam boss. When at full lock (steering against axle stops) the poppet should be fully tripped and pressure shown on gage in discharge line should be between 450 and 900 psi (3103 and 6205 kPa).</p>		
<p>1. Discharge line (1) on power steering pump (2).</p>	<p>Remove line at pump side only.</p>	

STEERING SYSTEM

3-217.2. STEERING GEAR POPPET ADJUSTMENT (Continued).

LOCATION/ITEM	ACTION	REMARKS
<p>ANALYZE/ADJUSTMENT (Continued).</p>		
<p>2. Power steering analyzer (3) and valve (4).</p>	<p>Install and fully open valve on analyzer.</p>	
<p>3. Analyzer (3).</p>	<p>Start engine.</p>	<p>Run at low idle (600 rpm). Cycle steering wheel full left and right 3-4 times to purge all air from analyzer and warm fluid. Shut off engine. Check power steering fluid level and adjust as necessary. Restart engine.</p>
<p><b>CAUTION</b></p>		
<p>When setting poppets, do not hold steering in full lock position for more than 15 seconds. If full lock position is held for more than 15 seconds, excessive heat will build up in system and extensive damage may occur.</p>		
<p><b>NOTE</b></p>		
<p>Poppet adjusting screws are adjusted to relieve pressure at 32 degree steering angle. Make sure 3/16-inch (4.76 mm) spacer is between steering knuckle stop bolt and axle beam boss when adjusting poppet adjusting screws.</p>		

STEERING SYSTEM

3-217.2. STEERING GEAR POPPET ADJUSTMENT (Continued).

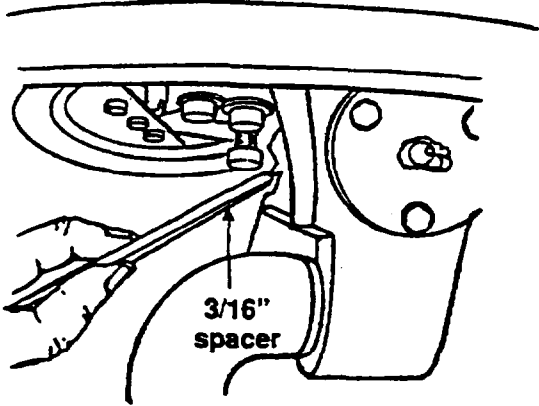
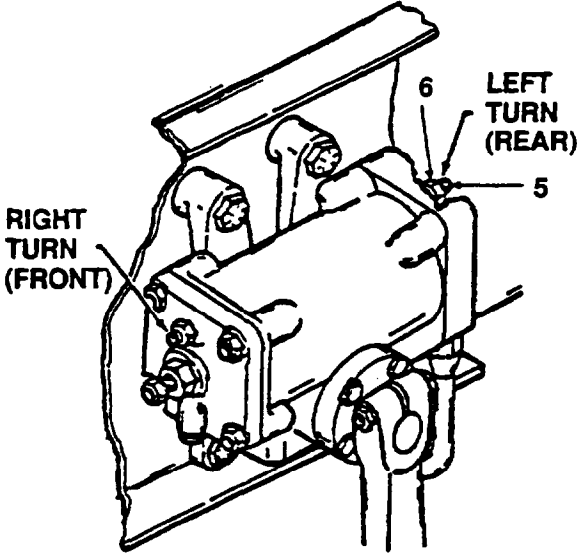
LOCATION/ITEM	ACTION	REMARKS
ANALYZE/ADJUSTMENT (Continued).		
		
<b>NOTE</b>		
<p>The power steering pump has an internal system relief valve to limit maximum pump pressure to 1850-2050 psi (12756-14135 kPa). Observed operating pressure is variable and dependent on the resistance within the steering system (e.g., tire inflation, floor surface). Typically, system pressure will be approximately 900-1500 psi (7480-10343 kPa) with properly inflated tires on concrete floor.</p>		
<p>4. Rear poppet adjusting screw (5), and locknut (6).</p>	<p>Adjust, lock and tighten.</p>	<p>Note system operating pressure on analyzer as you turn wheel from straight ahead position to the full left. Pressure should be above 900 psi (6205 kPa) until the steering stop contacts the 3/16-inch spacer and steering stop boss, then drops to 400-900 psi (2758-6205 kPa). If observed operating pressure does not hold until the stop makes contact, back out the left side (rear) poppet adjusting screw. If system pressure does not relieve as the stop makes contact, turn poppet adjusting screw in. Lock poppet adjusting screw in this position by tightening locknut. Torque to 12-18 lb-ft (16-24 N•m) and remove spacer.</p>
		



STEERING SYSTEM.

3-217.2. STEERING GEAR POPPET ADJUSTMENT (Continued).

LOCATION/ITEM	ACTION	REMARKS
ANALYZE/ADJUSTMENT (Continued).		
5. Right turn poppet adjusting screw (7).	Adjust, lock and tighten.	Repeat step 4 for the right side poppet adjusting screw.
6. Engine.	Shut off.	
7. Power steering analyzer (3).	Remove.	
8. Discharge line (1).	Install onto power steering pump.	Cycle system and recheck fluid level.
<b>NOTE</b>		
Perform Preventive Maintenance Checks and Services (PMCS) IAW TM 9-2320-283-10.		



STEERING SYSTEM

3-218. TIE ROD AND BALL JOINTS REPLACEMENT.

THIS TASK COVERS

- a. Removal.
- b. Cleaning and Inspection.
- c. Installation.

INITIAL SETUP

<u>APPLICABLE CONFIGURATIONS</u>	<u>EQUIPMENT CONDITION PARAGRAPH</u>	<u>CONDITION DESCRIPTION</u>
All.	None.	None.

TEST EQUIPMENT

None.

SPECIAL TOOLS

None.

MATERIALS/PARTS (P/N)

Grease, automotive and artillery  
Item 7, Appendix C.  
Pin, cotter (2)  
(24617) 103389.

PERSONNEL REQUIRED

One (MOS- 63S).

SPECIAL ENVIRONMENTAL CONDITIONS

None.

REFERENCES (TM

LO 9-2320-283-12.  
TM 9-2320-283-20P.

GENERAL SAFETY INSTRUCTIONS

Engine off.  
Transmission in neutral.  
Park brake set.

TROUBLESHOOTING REFERENCES

Paragraph 2-11.

STEERING SYSTEM

3-218. TIE ROD AND BALL JOINTS REPLACEMENT (Continued).

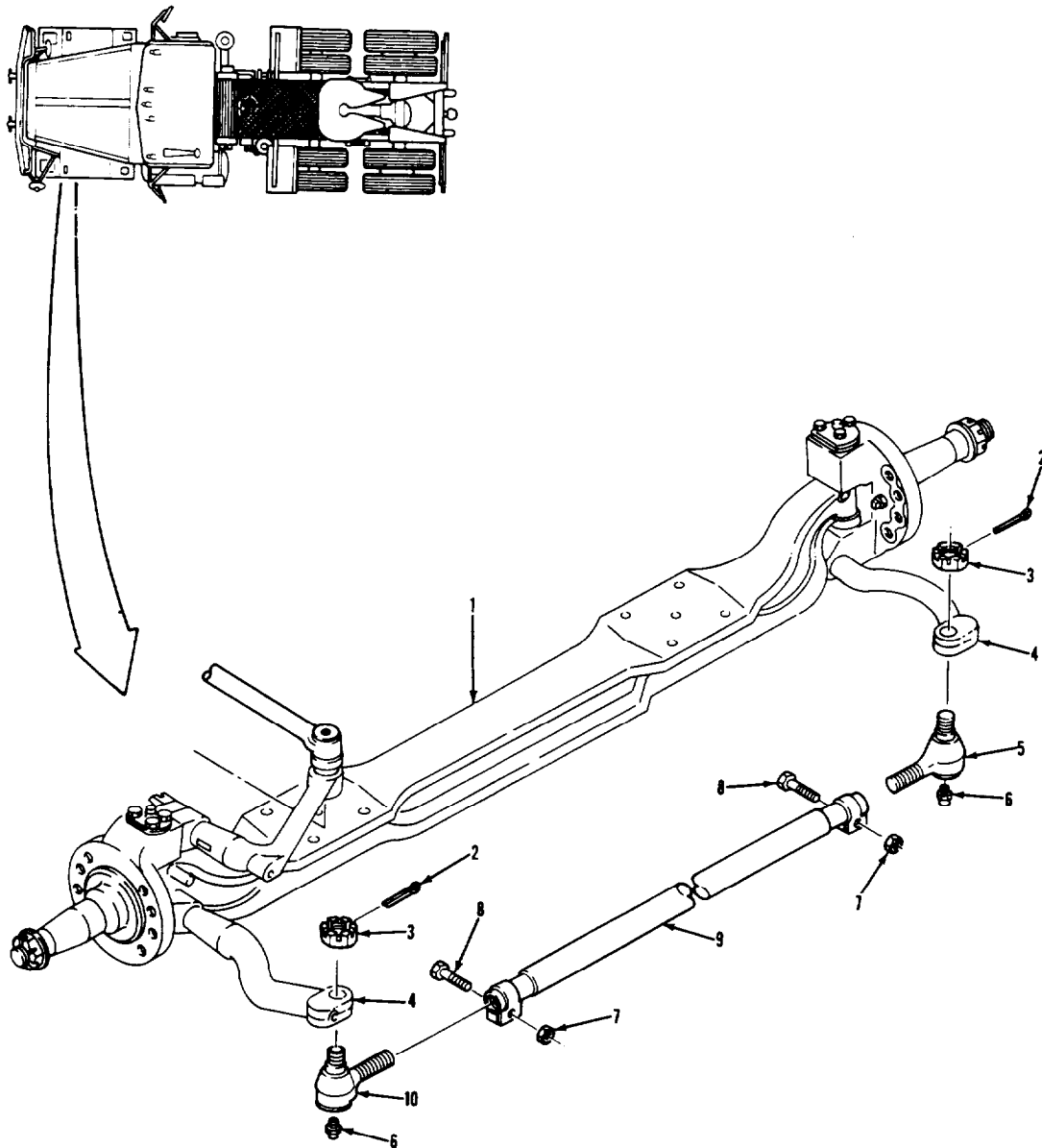

LEGEND:

- |                                   |                                   |
|-----------------------------------|-----------------------------------|
| 1. FRONT AXLE                     | 6. LUBRICATION FITTING (2)        |
| 2. COTTER PIN (2)                 | 7. NUT (2)                        |
| 3. CASTLE NUT (2)                 | 8. CLAMP BOLT (2)                 |
| 4. TIE ROD ARM (2)                | 9. TIE ROD TUBE ASSEMBLY          |
| 5. RIGHT-HAND THREADED BALL JOINT | 10. LEFT-HAND THREADED BALL JOINT |

TA 237613

STEERING SYSTEM

3-218. TIE ROD AND BALL JOINTS REPLACEMENT (Continued).

LOCATION/ITEM	ACTION	REMARKS
<b>A. REMOVAL.</b>		
1. Tie rod tube assembly (9).	Attach ends to item (1) with suitable rope.	If rope is not available, support item (9) with suitable jack.
2. Two pins (2) and nuts (3).	Remove from items (5) and (10).	If items (2) are hard to remove, tighten or loosen items (2) to align slots. Discard items (2).
3. Two joints (5) and (10).	Using a suitable puller or mallet, remove from two items (4).	
4. Tie rod tube assembly (9) and two joints (5) and (10).	Remove from under vehicle.	
5. Two bolts (8) and nuts (7).	Remove from item (9).	
6. Two joints (5) and (10).	Counting number of turns, unscrew from item (9).	Record number of turns for each item (5) and (10).
7. Two fittings (6).	Remove from item (5) and (10).	
<b>B. CLEANING AND INSPECTION.</b>		
8. All parts.	Clean and inspect.	Refer to paragraphs 3-4 and 3-5.
9. Two joints (5) and (10).	Hold threaded ends and check for any play or looseness.	Replace item (5) or (10) if there is any play or looseness.

STEERING SYSTEM

3-218. TIE ROD AND BALL JOINTS REPLACEMENT (Continued).

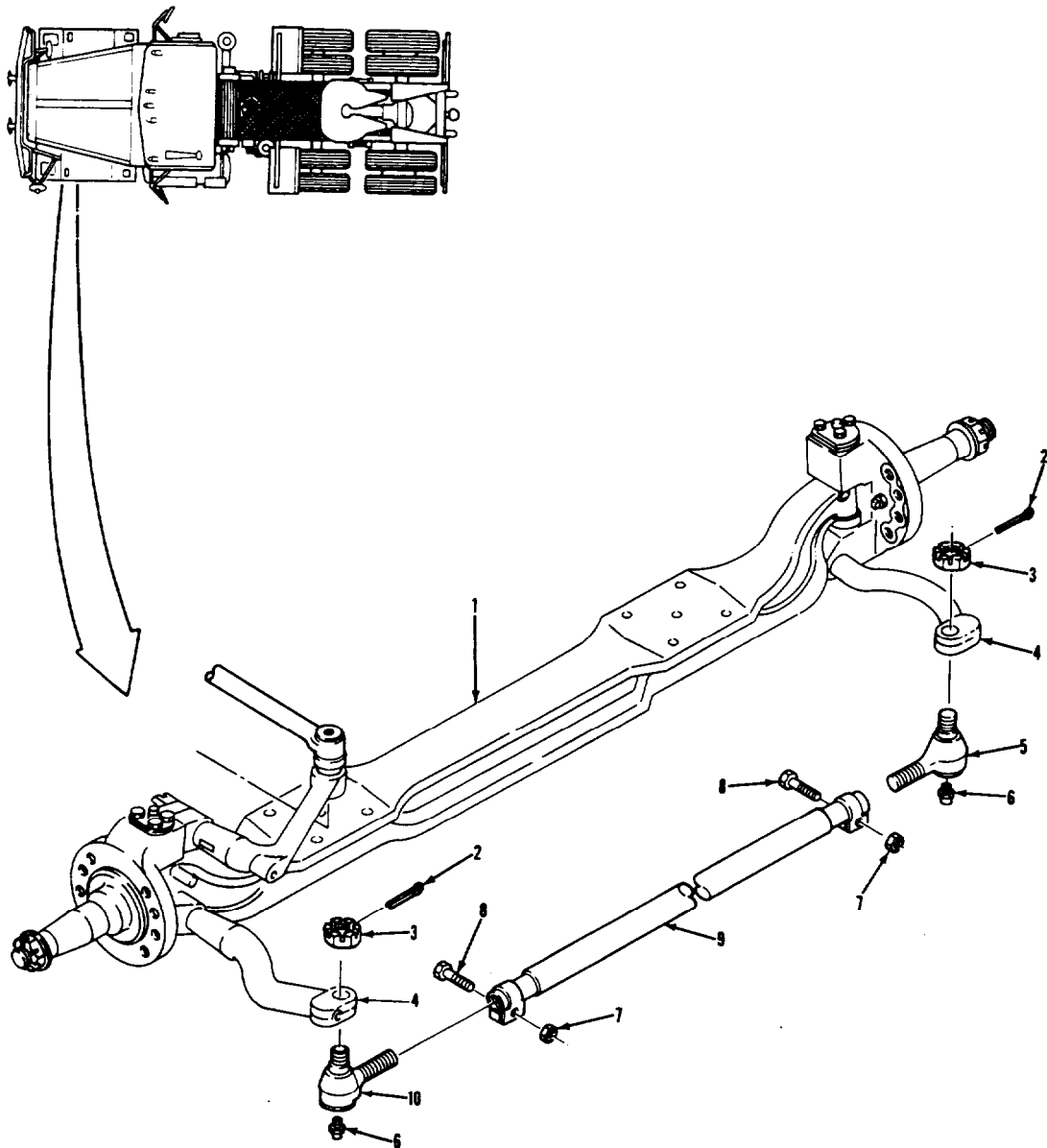

LEGEND:

- |                                   |                                   |
|-----------------------------------|-----------------------------------|
| 1. FRONT AXLE                     | 6. LUBRICATION FITTING (2)        |
| 2. COTTER PIN (2)                 | 7. NUT (2)                        |
| 3. CASTLE NUT (2)                 | 8. CLAMP BOLT (2)                 |
| 4. TIE ROD ARM (2)                | 9. TIE ROD TUBE ASSEMBLY          |
| 5. RIGHT-HAND THREADED BALL JOINT | 10. LEFT-HAND THREADED BALL JOINT |

TA 237614

STEERING SYSTEM

3-218. TIE ROD AND BALL JOINTS REPLACEMENT (Continued).		
LOCATION/ITEM	ACTION	REMARKS
<b>C. INSTALLATION.</b>		
10. Two fittings (6).	Install into items (5) and (10).	
11. Two joints (5) and (10).	Screw into item (9) using same number of turns as counted in step 6.	
12. Two bolts (8) and nuts (7).	Screw into item (9).	Torque items (7) to 40-55 lb-ft.
13. Tube (9) and two joints (5) and (10).	a. Position under vehicle.	
	b. Using suitable jack or rope sling, lift up until items (5) and (10) are in place in two items (4).	
	c. Secure items (5) and (10) to items (4) with two items (3).	Torque items (3) to 110-125 lb-ft.
14. Two new pins (2).	Install into items (3), (5), (10), and bend ends over.	It may be necessary to tighten two items (3) further in order to align slots of items (3) with holes of items (5) and (10).
15. Two fittings (6).	Using grease gun, lubricate with grease.	Refer to LO 9-2320-283-12.
<b>NOTE</b>		
Follow-on maintenance action required:		
Check front wheel alignment (para 3-203).		

STEERING SYSTEM

3-218. TIE ROD AND BALL JOINTS REPLACEMENT (Continued).

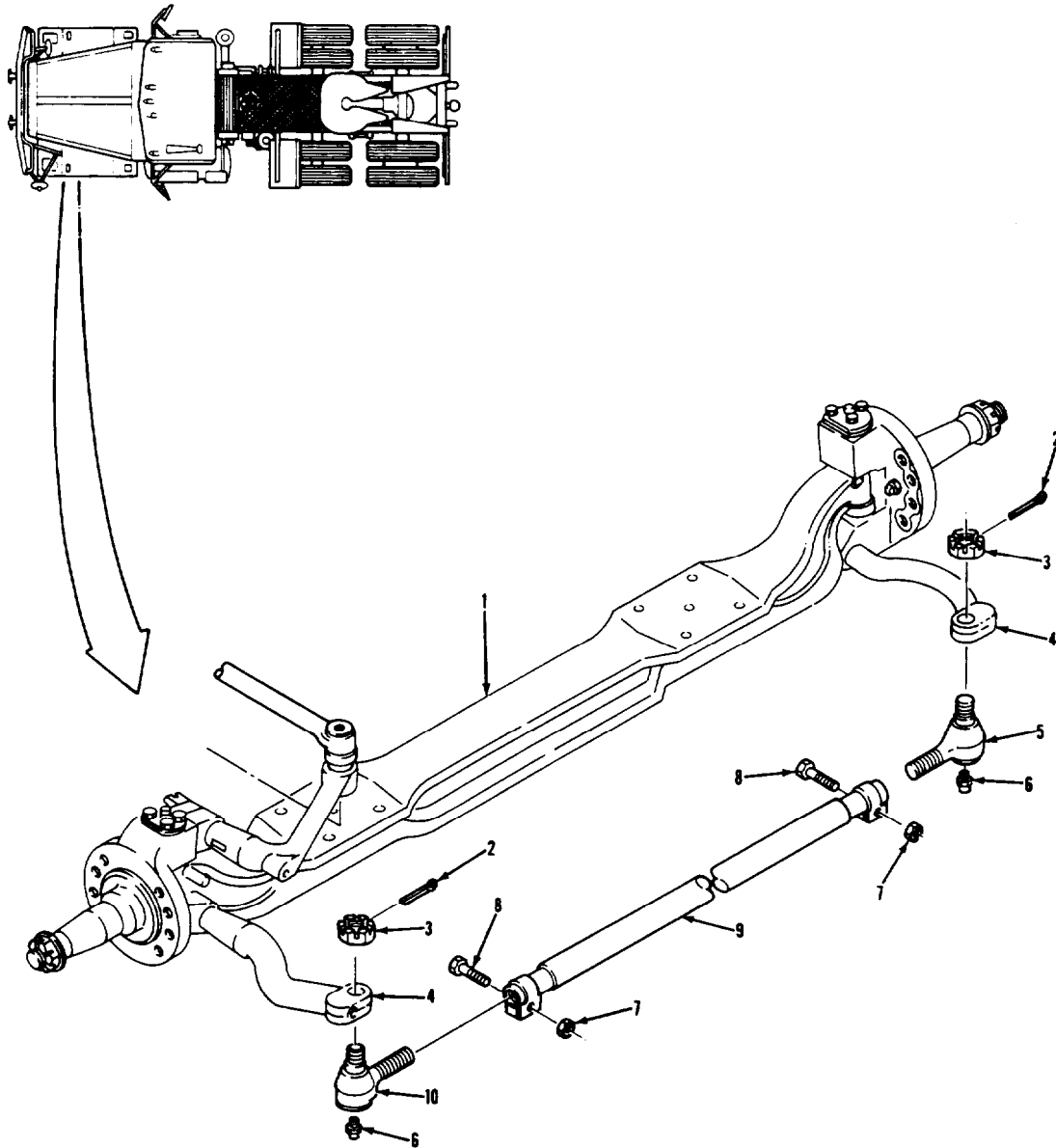

LEGEND:

- |                                   |                                   |
|-----------------------------------|-----------------------------------|
| 1. FRONT AXLE                     | 6. LUBRICATION FITTING (2)        |
| 2. COTTER PIN (2)                 | 7. NUT (2)                        |
| 3. CASTLE NUT (2)                 | 8. CLAMP BOLT (2)                 |
| 4. TIE ROD ARM (2)                | 9. TIE ROD TUBE ASSEMBLY          |
| 5. RIGHT-HAND THREADED BALL JOINT | 10. LEFT-HAND THREADED BALL JOINT |

TA 237615



STEERING SYSTEM

3-219. STEERING PUMP AND RESERVOIR REPLACEMENT.

THIS TASK COVERS

- a. Removal.
- b. Cleaning and Inspection.
- c. Installation.

INITIAL SETUP

<u>APPLICABLE CONFIGURATIONS</u>	<u>EQUIPMENT CONDITION PARAGRAPH</u>	<u>CONDITION DESCRIPTION</u>
All.	None.	None.

TEST EQUIPMENT  
None.

SPECIAL TOOLS  
None.

MATERIALS/PARTS (P/N)  
 Sealing compound: automotive  
 Item 26, Appendix C.  
 Oil, lubricating: OE/HDO-10.  
 Item 15, Appendix C.  
 Tape, thread sealing  
 Item 32, Appendix C.  
 Gasket, pump mounting  
 (15434) 154916.  
 O-ring  
 (19954) 008761-026.

PERSONNEL REQUIRED  
One (MOS-63S).

SPECIAL ENVIRONMENTAL CONDITIONS  
Work area clean and away from blowing dirt and dust.

REFERENCES (TM)  
TM 9-2320-283-20P.

GENERAL SAFETY INSTRUCTIONS  
 Engine off.  
 Transmission in neutral.  
 Park brake set.

TROUBLESHOOTING REFERENCES  
Paragraph 2-11.

STEERING SYSTEM

3-219. STEERING PUMP AND RESERVOIR REPLACEMENT (Continued).

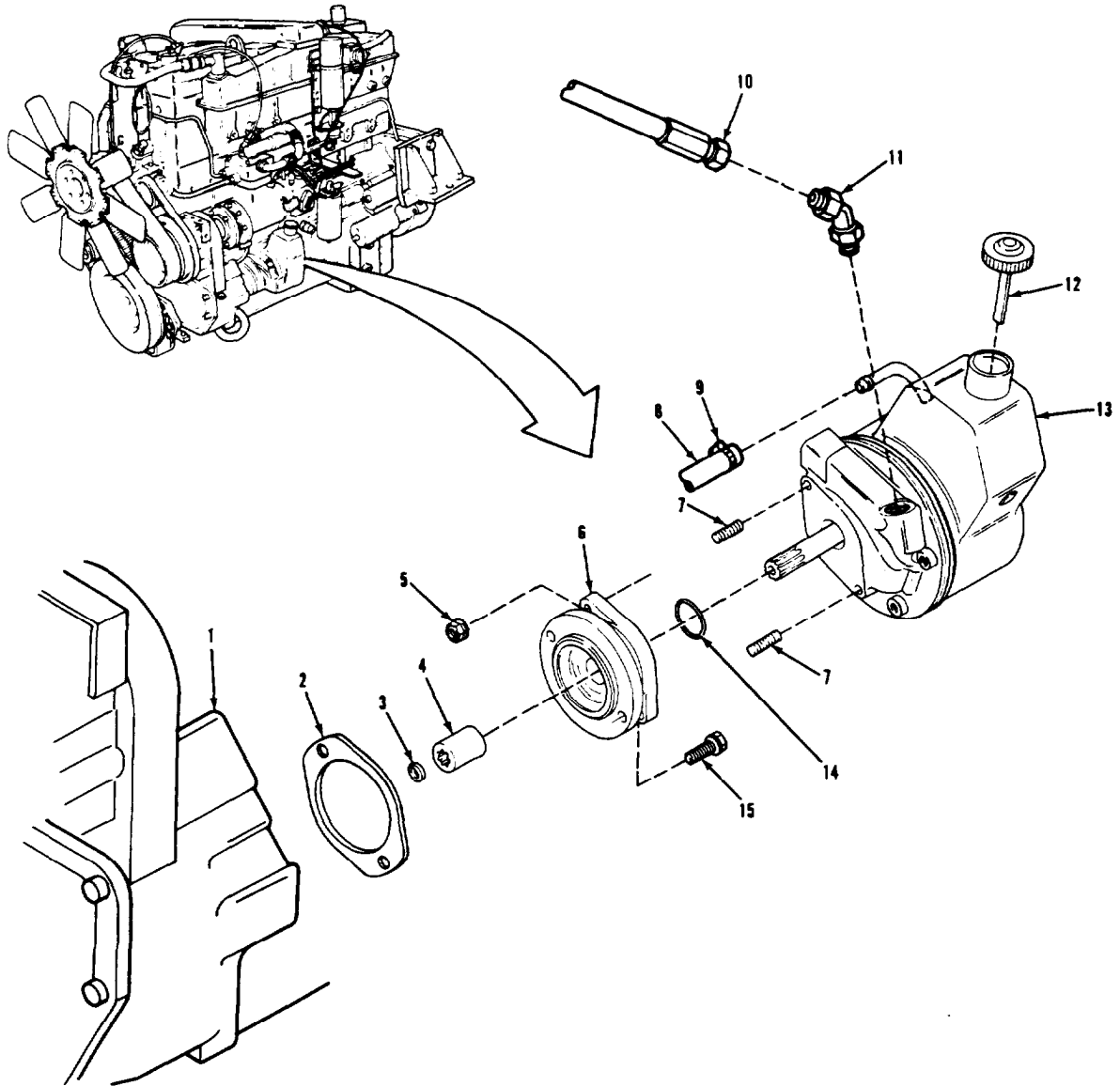

LEGEND:

- |                         |                                  |
|-------------------------|----------------------------------|
| 1. OIL PUMP ASSEMBLY    | 9. HOSE CLAMP                    |
| 2. PUMP MOUNTING GASKET | 10. SUPPLY HOSE ASSEMBLY         |
| 3. SNAPRING             | 11. 45 DEGREE ELBOW              |
| 4. PUMP DRIVE COUPLING  | 12. FILLER CAP                   |
| 5. FLANGE NUT (2)       | 13. POWER STEERING PUMP ASSEMBLY |
| 6. FLANGE               | 14. O-RING                       |
| 7. FLANGE STUD (2)      | 15. SCREW (2)                    |
| 8. COOLER TO PUMP HOSE  |                                  |

TA 237616

STEERING SYSTEM

3-219. STEERING PUMP AND RESERVOIR REPLACEMENT (Continued).

LOCATION/ITEM	ACTION	REMARKS
<b>A. REMOVAL.</b>		
<b><u>CAUTION</u></b>		
Dirt could severely damage the steering system. Make sure work area is clean, and cover openings in pump to keep out dust and dirt.		
1. Power steering pump assembly (13).	Wipe off dirt and grease.	
2. Clamp (9).	Loosen screw.	
3. Hose (8).	Pull off of item (13).	Leave item (9) on item (8). Plug openings at once.
4. Supply hose assembly (10).	Unscrew and remove from item (11).	Plug openings at once.
5. Two nuts (5) and pump (13).	a. While holding item (13), remove two items (5) from two items (7).	
	b. Remove item (13) from item (6) and from under vehicle.	If items (7) came out during step 5a, reinstall them into item (13) at this time.
6. O-ring (14).	Remove from item (6).	Discard item (14).
7. Elbow (11) and cap (12).	a. Remove from item (13).	
	b. Pour contents of item (13) into suitable container.	Plug openings as soon as item (13) has been drained.

STEERING SYSTEM

3-219. STEERING PUMP AND RESERVOIR REPLACEMENT (Continued).

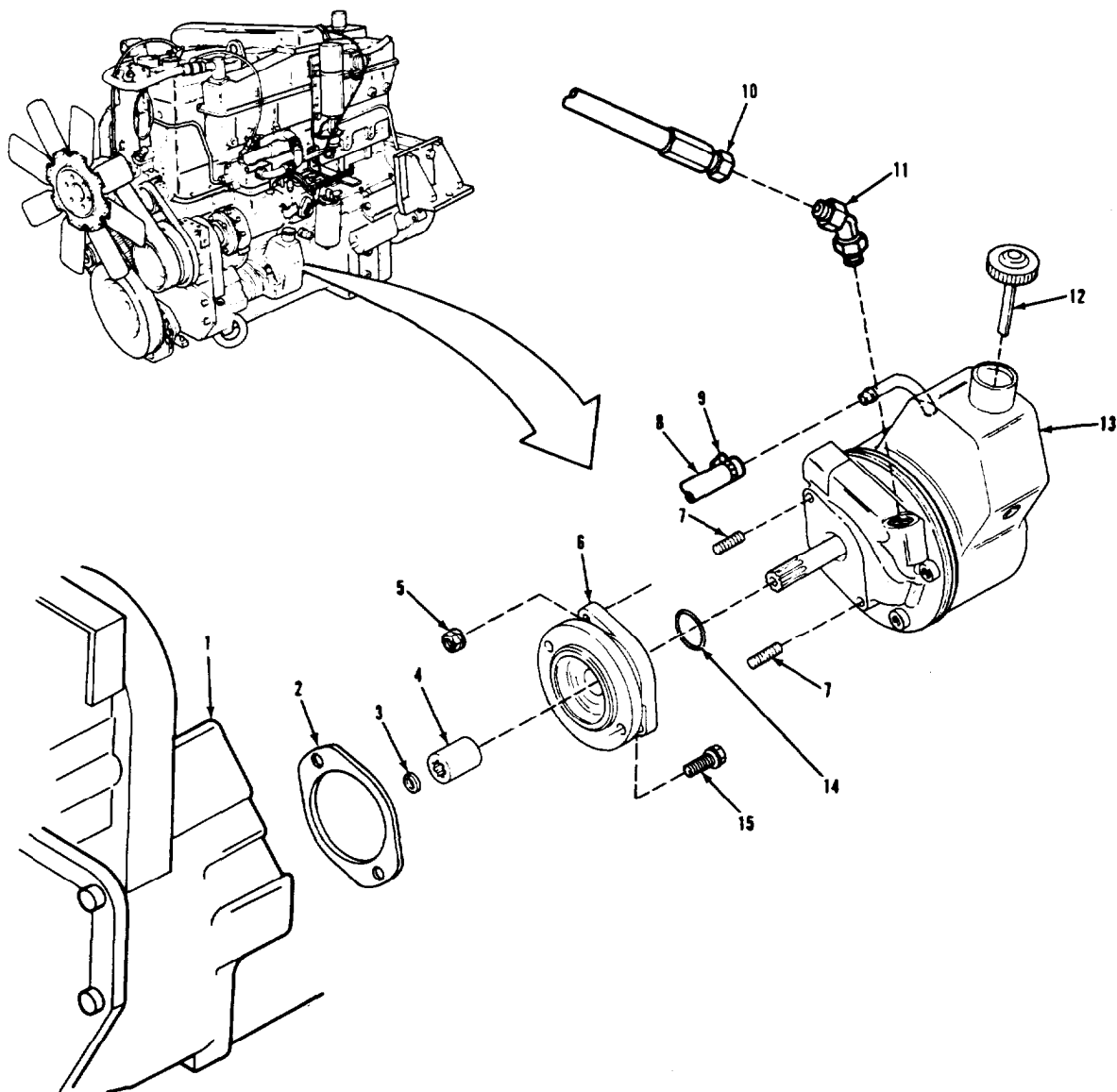

LEGEND:

- |                         |                                  |
|-------------------------|----------------------------------|
| 1. OIL PUMP ASSEMBLY    | 9. HOSE CLAMP                    |
| 2. PUMP MOUNTING GASKET | 10. SUPPLY HOSE ASSEMBLY         |
| 3. SNAPRING             | 11. 45 DEGREE ELBOW              |
| 4. PUMP DRIVE COUPLING  | 12. FILLER CAP                   |
| 5. FLANGE NUT (2)       | 13. POWER STEERING PUMP ASSEMBLY |
| 6. FLANGE               | 14. O-RING                       |
| 7. FLANGE STUD (2)      | 15. SCREW (2)                    |
| 8. COOLER TO PUMP HOSE  |                                  |

TA 237617

STEERING SYSTEM

3-219. STEERING PUMP AND RESERVOIR REPLACEMENT (Continued).		
LOCATION/ITEM	ACTION	REMARKS
<b>A. REMOVAL (Continued).</b>		
8. Two screws (15), flange (6), gasket (2), and coupling (4).	Remove from item (1).	Discard item (2).
9. Snapring (3).	Remove from item (4).	
<b>B. CLEANING AND INSPECTION.</b>		
10. All parts.	Clean and inspect.	Refer to paragraphs 3-4 and 3-5.
<b>C. INSTALLATION.</b>		
11. Snapring (3).	Install in item (4).	
12. Coupling (4).	Slide onto splined shaft of item (1).	
13. Flange (6) and new gasket (2).	a. Coat oil pump side of item (6) with sealing compound. b. Attach item (2) to oil pump side of item (6) and put in place on item (1). c. Secure with two items (15).	
14. Elbow (11) and cap (12).	Install into item (13).	Wrap threads of item (11) with thread sealing tape.
15. New O-ring (14).	Lubricate with oil and position in item (6).	

STEERING SYSTEM

3-219. STEERING PUMP AND RESERVOIR REPLACEMENT (Continued).

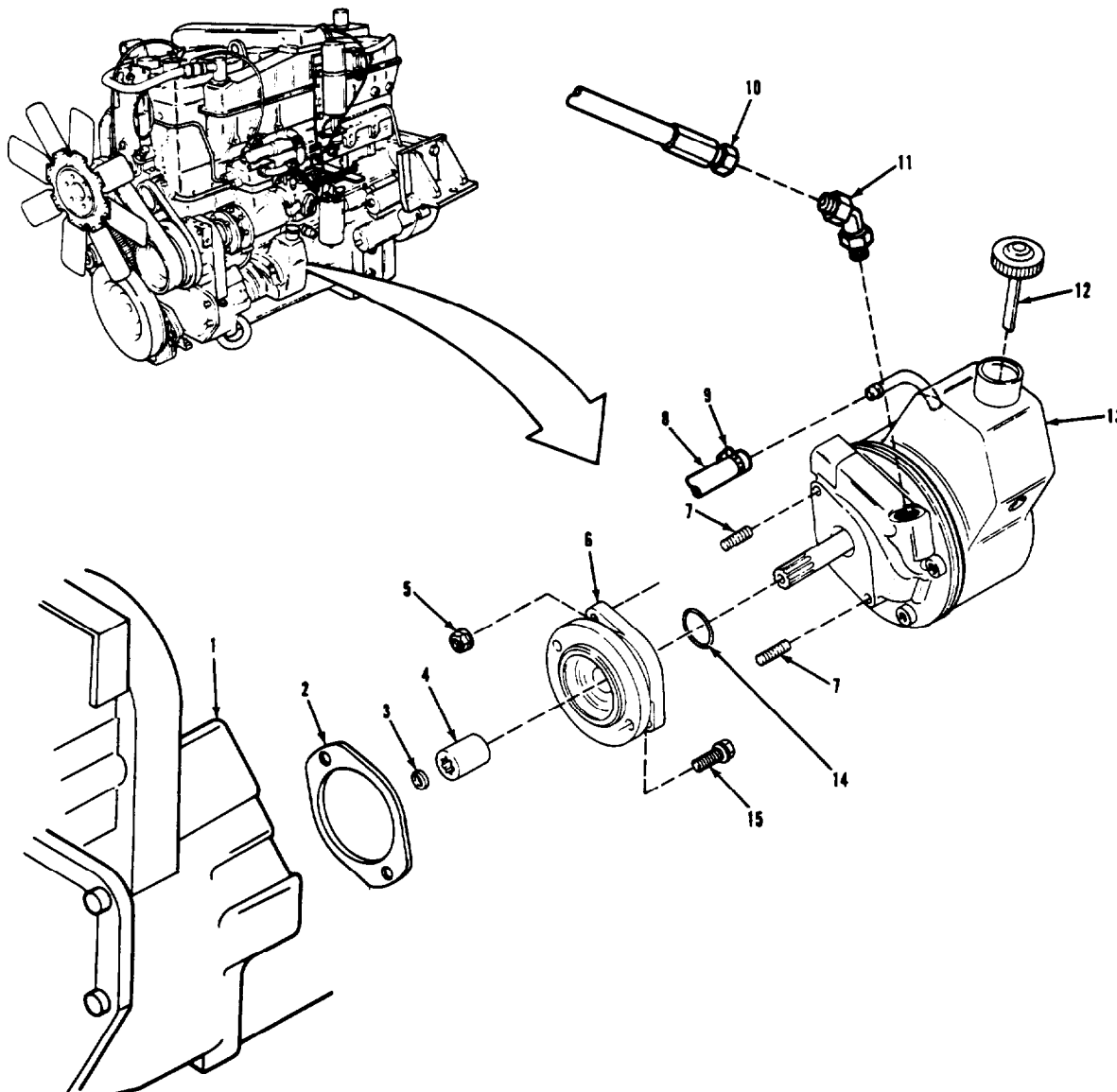

LEGEND:

- |                         |                                  |
|-------------------------|----------------------------------|
| 1. OIL PUMP ASSEMBLY    | 9. HOSE CLAMP                    |
| 2. PUMP MOUNTING GASKET | 10. SUPPLY HOSE ASSEMBLY         |
| 3. SNAPRING             | 11. 45 DEGREE ELBOW              |
| 4. PUMP DRIVE COUPLING  | 12. FILLER CAP                   |
| 5. FLANGE NUT (2)       | 13. POWER STEERING PUMP ASSEMBLY |
| 6. FLANGE               | 14. O-RING                       |
| 7. FLANGE STUD (2)      | 15. SCREW (2)                    |
| 8. COOLER TO PUMP HOSE  |                                  |

TA 237618

STEERING SYSTEM

3-219. STEERING PUMP AND RESERVOIR REPLACEMENT (Continued).

LOCATION/ITEM	ACTION	REMARKS
<b>C. INSTALLATION (Continued).</b>		
16. Flange (6).	Coat steering pump side with sealing compound.	
17. Power steering pump assembly (13).	<p>a. From under vehicle, push up between frame and engine and rest on frame rail.</p> <p>b. Push shaft into item (4) and position item (13) on item (6).</p> <p>c. Secure with two items (5).</p>	Item (13) may have to be turned slightly to aline splines of shaft with item (4).
18. Supply hose assembly (10).	Install onto item (11).	
19. Hose (8).	Push onto item (13).	
20. Clamp (9).	Push to end of item (8) and tighten screw.	
<b>NOTE</b>		
Follow-on maintenance action required:		
Fill and bleed steering system (para 3-211).		

STEERING SYSTEM

3-219. STEERING PUMP AND RESERVOIR REPLACEMENT (Continued).

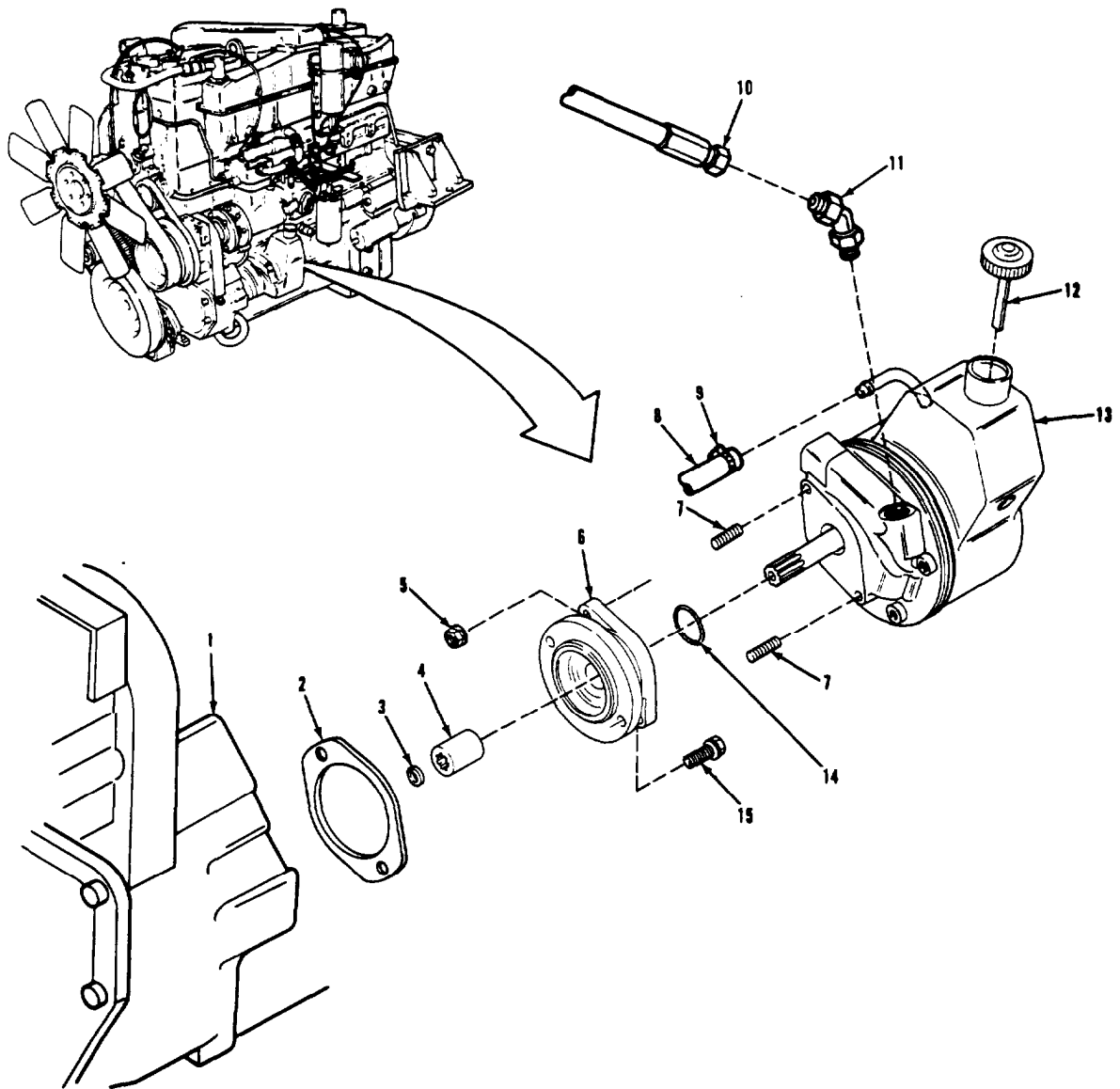

LEGEND:

- |                         |                                  |
|-------------------------|----------------------------------|
| 1. OIL PUMP ASSEMBLY    | 9. HOSE CLAMP                    |
| 2. PUMP MOUNTING GASKET | 10. SUPPLY HOSE ASSEMBLY         |
| 3. SNAPRING             | 11. 45 DEGREE ELBOW              |
| 4. PUMP DRIVE COUPLING  | 12. FILLER CAP                   |
| 5. FLANGE NUT (2)       | 13. POWER STEERING PUMP ASSEMBLY |
| 6. FLANGE STUD          | 14. O-RING                       |
| 7. FLANGE STUD (2)      | 15. SCREW (2)                    |
| 8. COOLER TO PUMP HOSE  |                                  |

TA 237619



STEERING SYSTEM

3-220. POWER STEERING LINES AND FITTINGS REPLACEMENT.

THIS TASK COVERS

- a. Cooler to Pump Hose Replacement.
- b. Gear to Cooler Hose and Tube Replacement.
- c. Supply Hose Replacement.

INITIAL SETUP

APPLICABLE CONFIGURATIONS

All.

EQUIPMENT CONDITION  
PARAGRAPH

None.

CONDITION DESCRIPTION

None.

TEST EQUIPMENT

None.

SPECIAL TOOLS

None.

MATERIALS/PARTS (P/N)

Tape, thread sealing  
Item 32, Appendix C.  
Strap, tie (as required)  
(24617) 11501906.

PERSONNEL REQUIRED

One (MOS- 63S).

SPECIAL ENVIRONMENTAL CONDITIONS

Work area clean and away from blowing  
dirt and dust.

REFERENCES (TM)

TM 9-2320-283-20P.

GENERAL SAFETY INSTRUCTIONS

Engine Off  
Transmission in neutral.  
Park brake set.

TROUBLESHOOTING REFERENCES

Paragraph 2-11.

STEERING SYSTEM

3-220. POWER STEERING LINES AND FITTINGS REPLACEMENT (Continued).

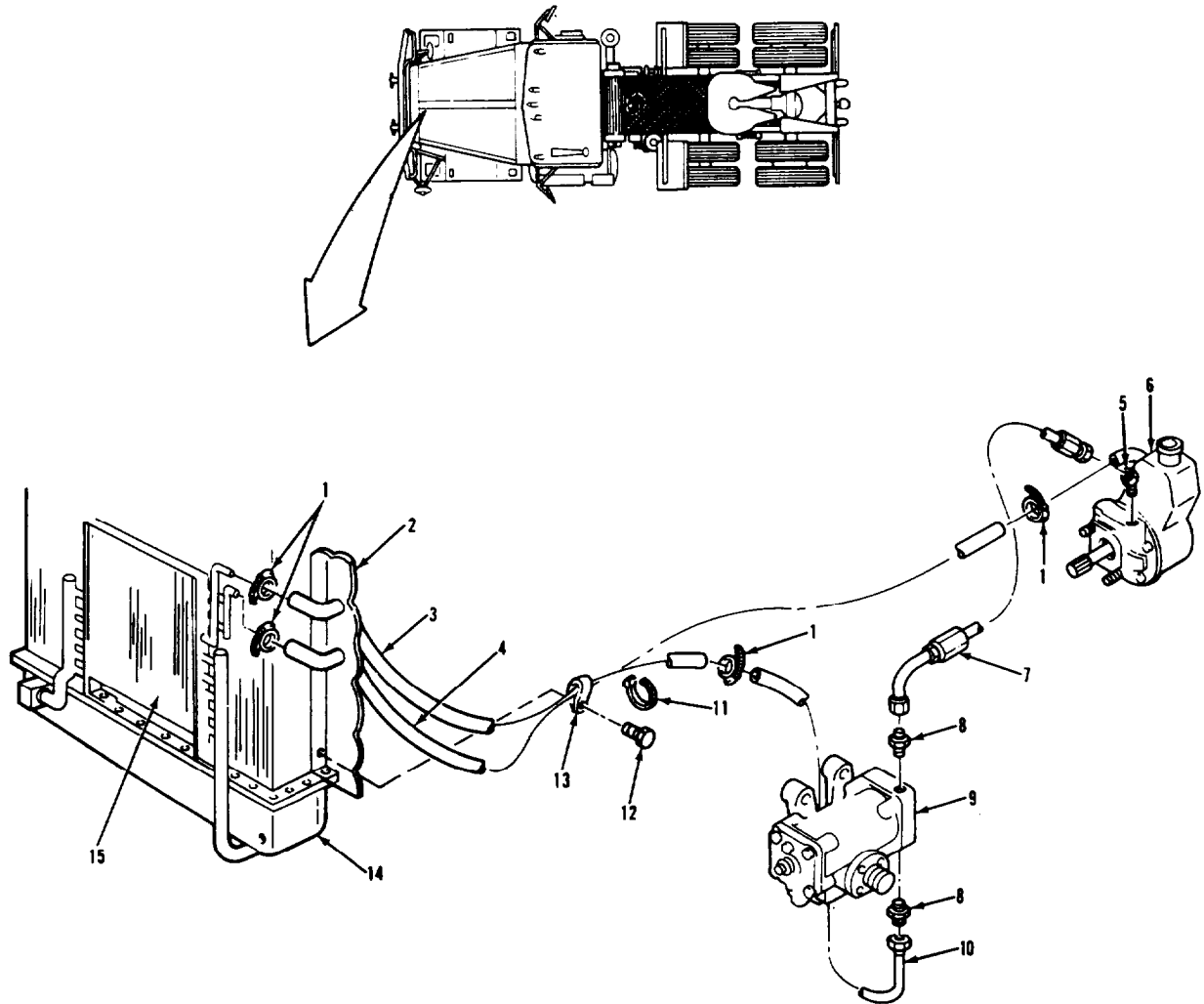

LEGEND:

- |                                    |                                  |
|------------------------------------|----------------------------------|
| 1. HOSE CLAMP (4)                  | 9. STEERING GEAR ASSEMBLY        |
| 2. RADIATOR GRILLE SUPPORT BRACKET | 10. GEAR TO COOLER TUBE ASSEMBLY |
| 3. COOLER TO GEAR HOSE             | 11. TIE STRAP (2)                |
| 4. COOLER TO PUMP HOSE             | 12. HEXAGON HEAD SCREW           |
| 5. 45 DEGREE ELBOW                 | 13. CLAMP                        |
| 6. POWER STEERING PUMP ASSEMBLY    | 14. RADIATOR ASSEMBLY            |
| 7. SUPPLY HOSE ASSEMBLY            | 15. OIL COOLER                   |
| 8. MALE CONNECTOR (2)              |                                  |

TA 237620

STEERING SYSTEM

3-220. POWER STEERING LINES AND FITTINGS REPLACEMENT (Continued).

LOCATION/ITEM	ACTION	REMARKS
<b><u>CAUTION</u></b>		
Dirt could severely damage the steering system. Make sure work area is clean, and cover openings to keep dust and dirt out.		
<b>A. COOLER TO PUMP HOSE REPLACEMENT.</b>		
1. Screw (12) and clamp (13).	Remove from items (14), (3), and (4).	
2. Two straps (11).	Cut off of items (3) and (4). Discard items (11).	
3. Grille.	Remove.	Refer to paragraph 3-263.
4. Hose (4) and two clamps (1).	a. Loosen screws on two items (1).	
	b. Pull ends of item (4) off of items (6) and (15).	Have a suitable container ready to catch an fluid from item (4). Plug openings at once.
	c. Remove two items (1) from item (4).	
	d. Pull item (4) out of item (2).	
5. All parts.	Clean and inspect.	Refer to paragraphs 3-4 and 3-5.
6. Hose (4) and two clamps (1).	a. Push one end of item (4) through hole in item (2).	
	b. Install two items (1) onto item (4).	

STEERING SYSTEM

3-220. POWER STEERING LINES AND FITTINGS REPLACEMENT (Continued).

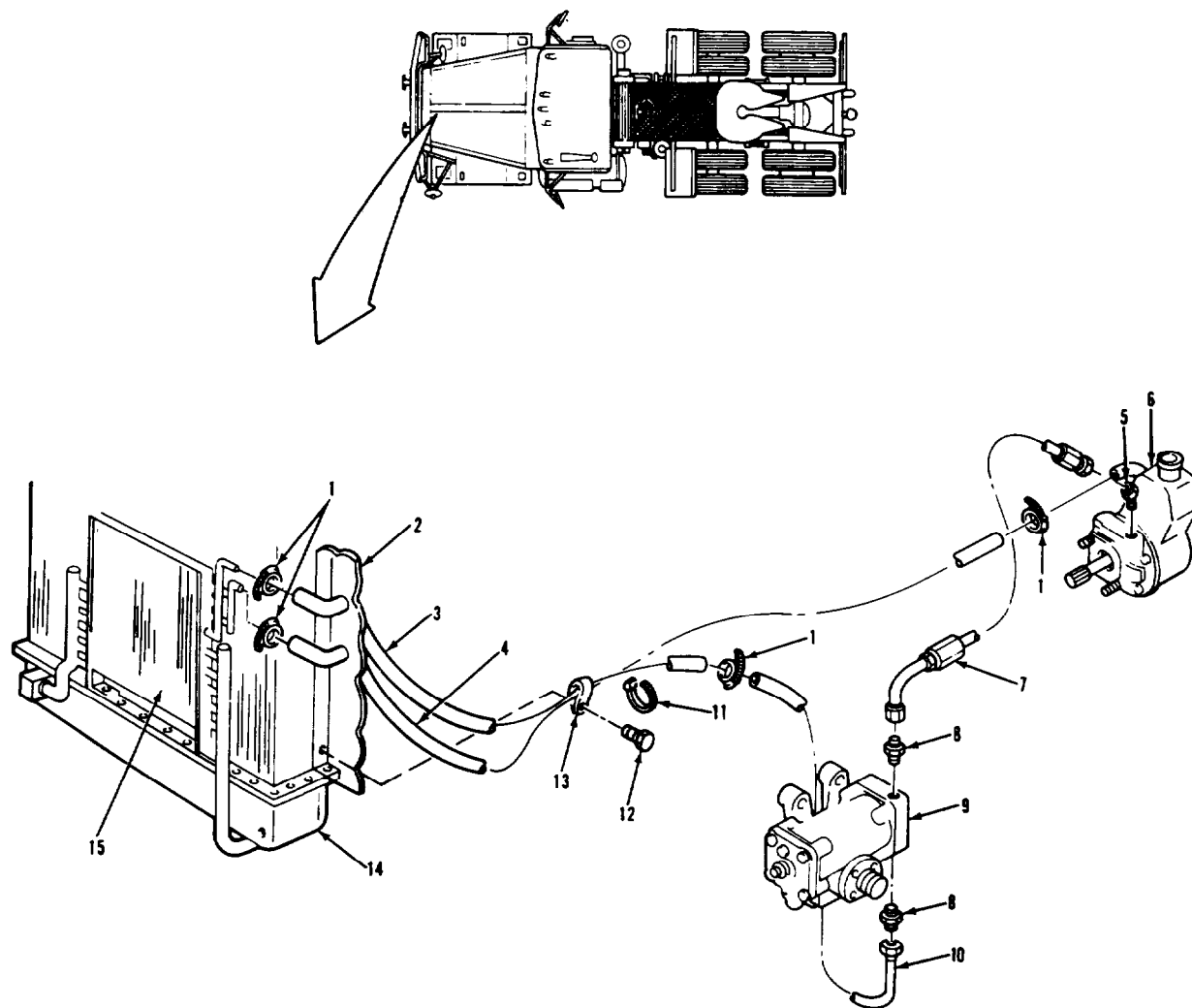

LEGEND:

- |                                    |                                  |
|------------------------------------|----------------------------------|
| 1. HOSE CLAMP (4)                  | 9. STEERING GEAR ASSEMBLY        |
| 2. RADIATOR GRILLE SUPPORT BRACKET | 10. GEAR TO COOLER TUBE ASSEMBLY |
| 3. COOLER TO GEAR HOSE             | 11. TIE STRAP (2)                |
| 4. COOLER TO PUMP HOSE             | 12. HEXAGON HEAD SCREW           |
| 5. 45 DEGREE ELBOW                 | 13. CLAMP                        |
| 6. POWER STEERING PUMP ASSEMBLY    | 14. RADIATOR ASSEMBLY            |
| 7. SUPPLY HOSE ASSEMBLY            | 15. OIL COOLER                   |
| 8. MALE CONNECTOR (2)              |                                  |

TA 237621

STEERING SYSTEM

3-220. POWER STEERING LINES AND FITTINGS REPLACEMENT (Continued).

LOCATION/ITEM	ACTION	REMARKS
<b>A. COOLER TO PUMP HOSE REPLACEMENT (Continued).</b>		
6. Hose (4) and two clamps (1) (Continued).	c. Push ends of item (4) onto items (6) and (15). d. Push two items (1) to ends of item (4) and tighten.	
7. Grille.	Install.	Refer to paragraph 3-263.
8. Two new straps (11).	Install on items (3) and (4).	
9. Clamp (13).	a. Install on items (3) and (4), and position on item (14). b. Secure with item (12).	
<b>B. GEAR TO COOLER HOSE AND TUBE REPLACEMENT.</b>		
10. Screw (12), clamp (13), two straps (11), and grille.	Remove.	Refer to steps 1 thru 3.
11. Hose (3) and two clamps (1).	a. Loosen screws on two items (1). b. Pull ends of item (3) off of items (10) and (15). c. Remove two items (1) from item (3). d. Pull item (3) out of item (2).	Have a suitable container ready to catch fluid from item (3). Plug openings at once.

STEERING SYSTEM

3-220. POWER STEERING LINES AND FITTINGS REPLACEMENT (Continued).

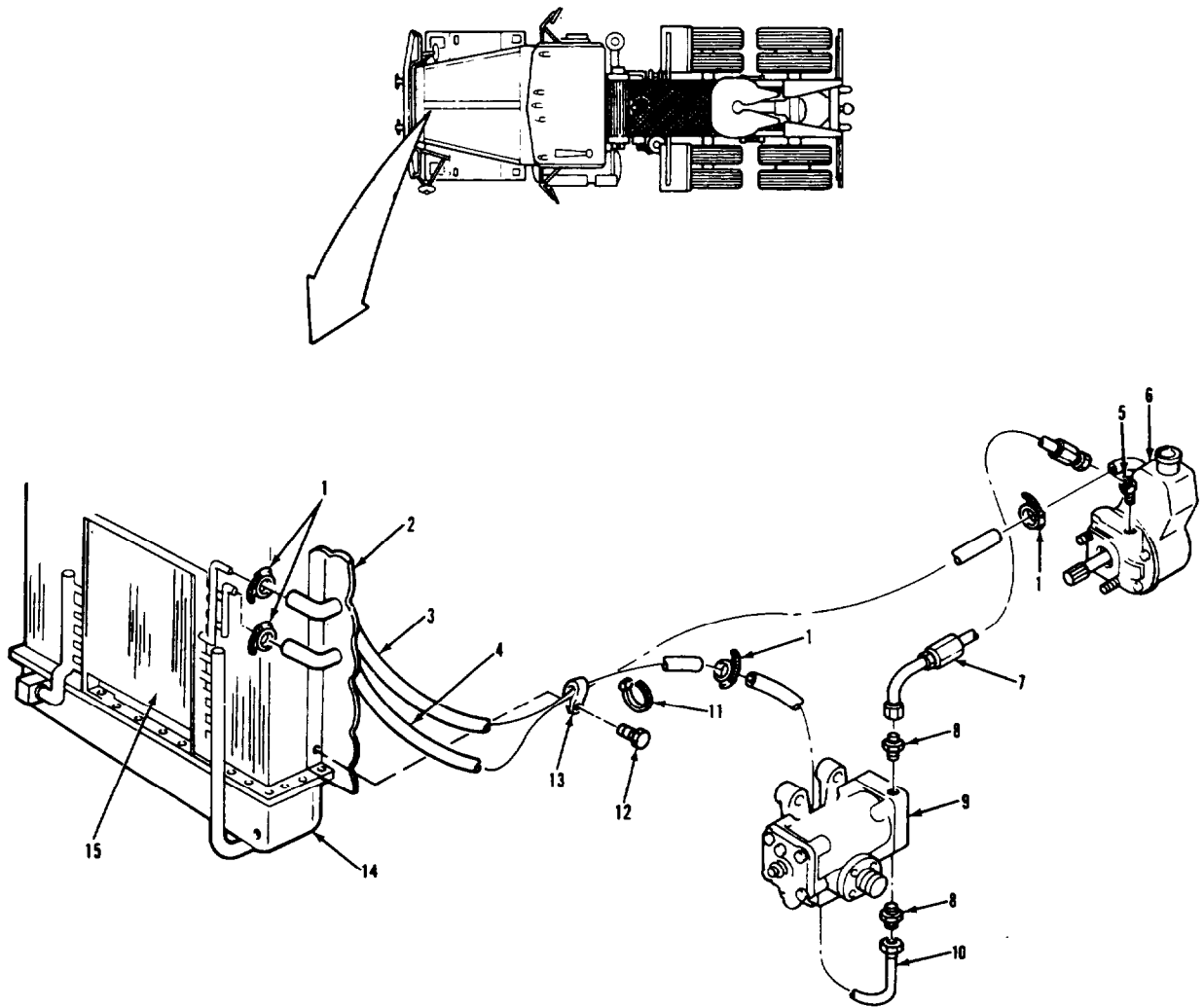

LEGEND:

- |                                    |                                  |
|------------------------------------|----------------------------------|
| 1. HOSE CLAMP (4)                  | 9. STEERING GEAR ASSEMBLY        |
| 2. RADIATOR GRILLE SUPPORT BRACKET | 10. GEAR TO COOLER TUBE ASSEMBLY |
| 3. COOLER TO GEAR HOSE             | 11. TIE STRAP (2)                |
| 4. COOLER TO PUMP HOSE             | 12. HEXAGON HEAD SCREW           |
| 5. 45 DEGREE ELBOW                 | 13. CLAMP                        |
| 6. POWER STEERING PUMP ASSEMBLY    | 14. RADIATOR ASSEMBLY            |
| 7. SUPPLY HOSE ASSEMBLY            | 15. OIL COOLER                   |
| 8. MALE CONNECTOR (2)              |                                  |

TA 237622

STEERING SYSTEM

3-220. POWER STEERING LINES AND FITTINGS REPLACEMENT (Continued).

LOCATION/ITEM	ACTION	REMARKS
<b>B. GEAR TO COOLER HOSE AND TUBE REPLACEMENT (Continued).</b>		
12. Gear to cooler tube assembly (10).	Unscrew and remove from item (8).	Have a suitable container ready to catch any fluid from item (10).
13. Connector (8).	Remove from item (9).	Plug opening at once.
14. All parts.	Clean and inspect.	Refer to paragraphs 3-4 and 3-5.
15. Connector (8).	a. Wrap threads with thread sealing tape.  b. Install in item (9).	Refer to paragraph 3-7.
16. Gear to cooler tube assembly (10).	Screw onto item (8).	
17. Hose (3) and two clamps (1).	a. Push one end of item (3) through hole in item (2).  b. Install two items (1) on item (3).  c. Push ends of item (3) onto items (10) and (15).  d. Push two items (1) to ends of item (3) and tighten screws.	
18. Grille, two new straps (11), clamp (13), and screws (12).	Install.	Refer to steps 7 thru 9.

STEERING SYSTEM

3-220. POWER STEERING LINES AND FITTINGS REPLACEMENT (Continued).

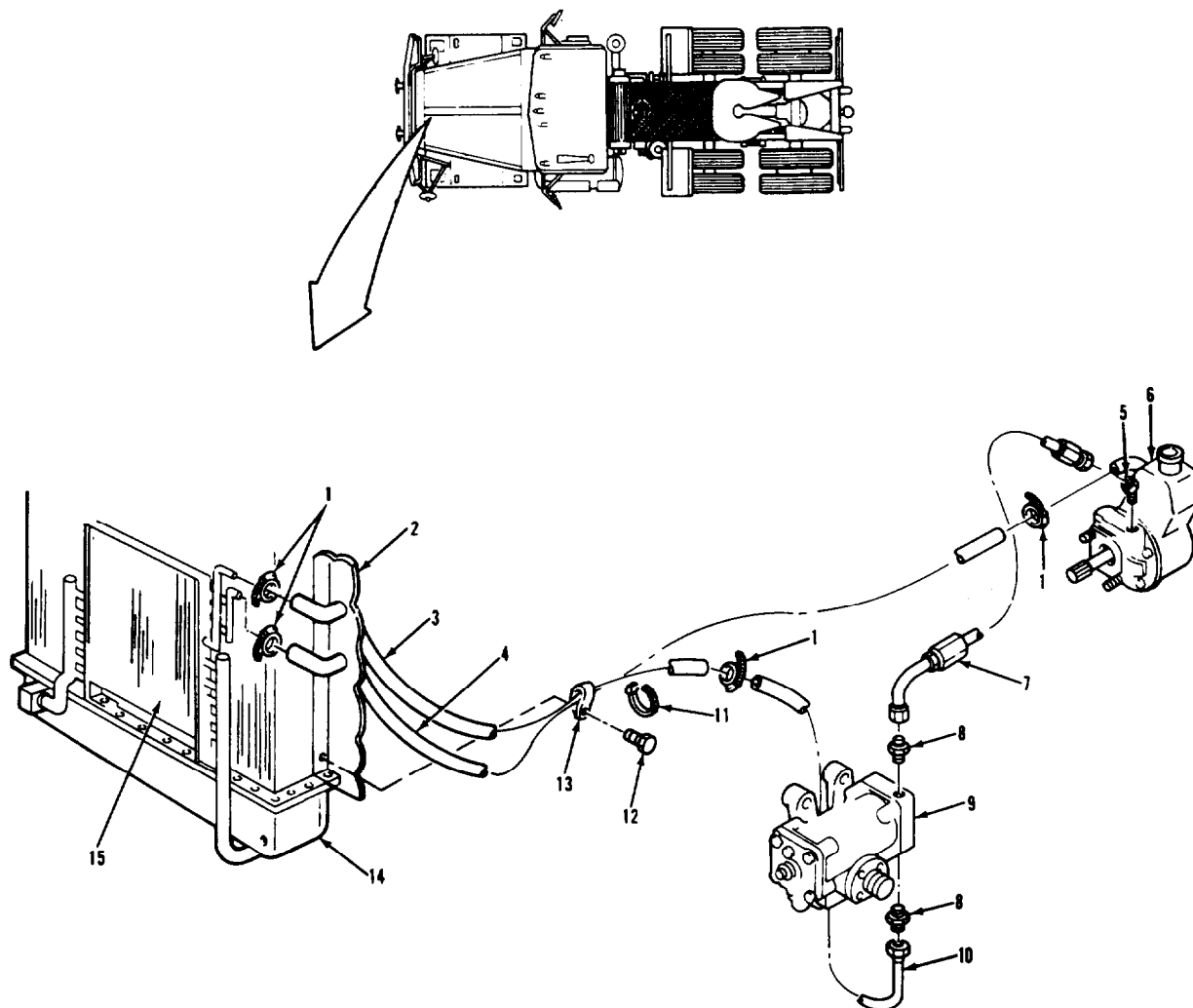

LEGEND:

- |                                    |                                  |
|------------------------------------|----------------------------------|
| 1. HOSE CLAMP (4)                  | 9. STEERING GEAR ASSEMBLY        |
| 2. RADIATOR GRILLE SUPPORT BRACKET | 10. GEAR TO COOLER TUBE ASSEMBLY |
| 3. COOLER TO GEAR HOSE             | 11. TIE STRAP (2)                |
| 4. COOLER TO PUMP HOSE             | 12. HEXAGON HEAD SCREW           |
| 5. 45 DEGREE ELBOW                 | 13. CLAMP                        |
| 6. POWER STEERING PUMP ASSEMBLY    | 14. RADIATOR ASSEMBLY            |
| 7. SUPPLY HOSE ASSEMBLY            | 15. OIL COOLER                   |
| 8. MALE CONNECTOR (2)              |                                  |

TA 237623



STEERING SYSTEM

3-220. POWER STEERING LINES AND FITTINGS REPLACEMENT (Continued).		
LOCATION/ITEM	ACTION	REMARKS
<b>C. SUPPLY HOSE REPLACEMENT.</b>		
19. Supply hose assembly (7).	Remove from items (5) and (8).	Have a suitable container ready to catch any fluid from item (7).
20. Connector (8).	Remove from item (9).	Plug opening at once.
21. Elbow (5).	Remove from item (6).	Plug opening at once.
22. All parts.	Clean and inspect.	Refer to paragraphs 3-4 and 3-5.
23. Elbow (5).	a. Wrap threads with thread sealing tape.	Refer to paragraph 3-7.
	b. Install in item (6).	
24. Connector (8).	a. Wrap threads with thread sealing tape.	Refer to paragraph 3-7.
	b. Install in item (9).	
25. Supply hose assembly (7).	Install on items (5) and (8).	
<b>NOTE</b>		
Follow-on maintenance action required:		
Fill and bleed steering system (para 3-211).		

STEERING SYSTEM

3-220. POWER STEERING LINES AND FITTINGS REPLACEMENT (Continued).

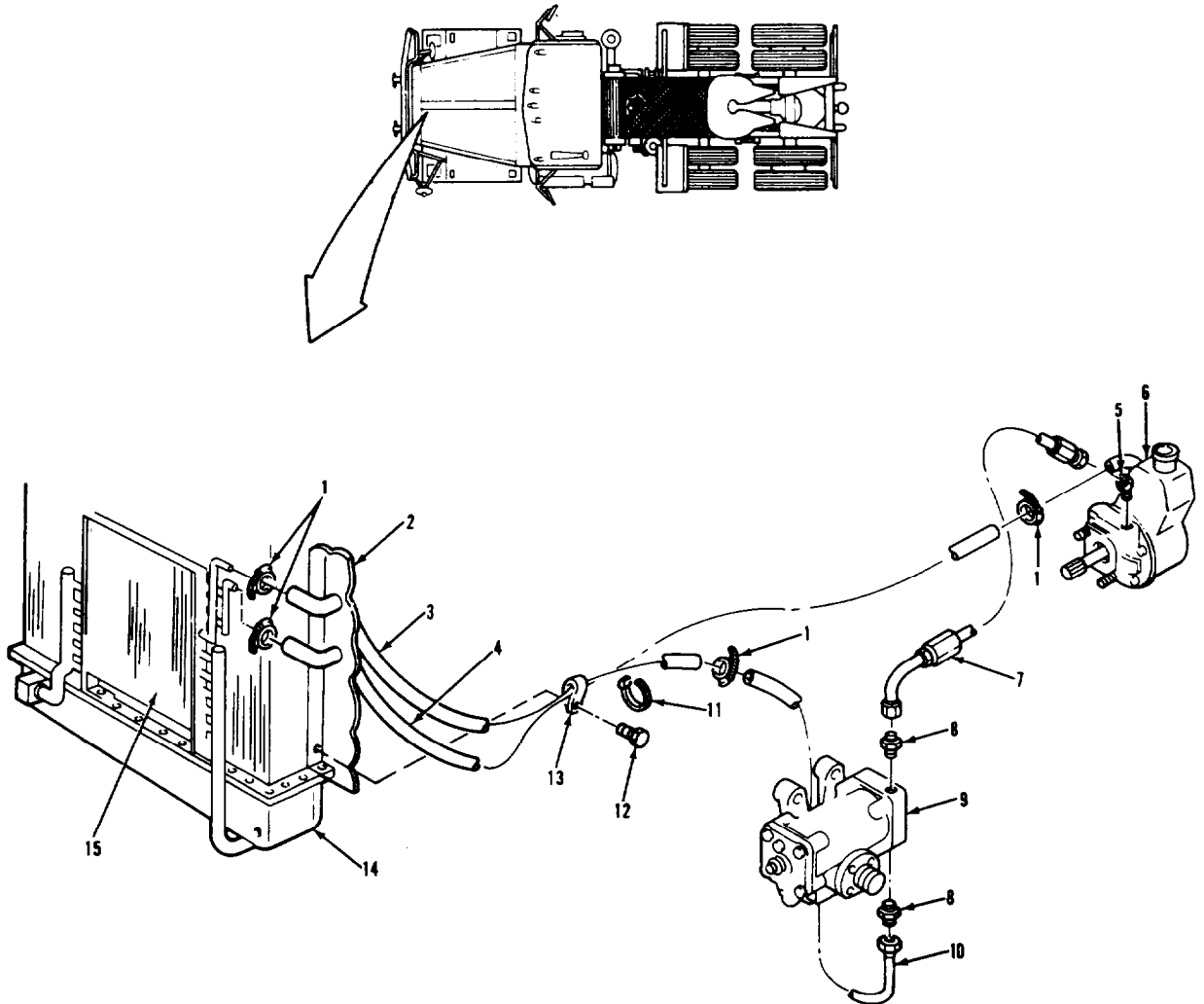

LEGEND:

- |                                    |                                  |
|------------------------------------|----------------------------------|
| 1. HOSE CLAMP (4)                  | 9. STEERING GEAR ASSEMBLY        |
| 2. RADIATOR GRILLE SUPPORT BRACKET | 10. GEAR TO COOLER TUBE ASSEMBLY |
| 3. COOLER TO GEAR HOSE             | 11. TIE STRAP (2)                |
| 4. COOLER TO PUMP HOSE             | 12. HEXAGON HEAD SCREW           |
| 5. 45 DEGREE ELBOW.                | 13. CLAMP                        |
| 6. POWER STEERING PUMP ASSEMBLY    | 14. RADIATOR ASSEMBLY            |
| 7. SUPPLY HOSE ASSEMBLY            | 15. OIL COOLER                   |
| 8. MALE CONNECTOR (2)              |                                  |

TA 237624



**Section XIV. FRAME AND TOWING ATTACHMENTS**

**3-221. GENERAL**

This section provides procedures authorized at the organizational maintenance level to replace frame and towing attachment components. To find a specific procedure contained in this section, see the task summary below.

<b>3-222. TASK SUMMARY.</b>	
<u>INITIAL SETUP</u>	
<u>APPLICABLE CONFIGURATIONS</u>	<u>EQUIPMENT CONDITION</u>
All	<u>PARAGRAPH</u> <u>CONDITION DESCRIPTION</u>
	-(Refer to specific paragraph for this information).
<u>TEST EQUIPMENT</u>	
None.	
<u>SPECIAL TOOLS</u>	
Tester, lock, fifth wheel (74410) TLN-100.	
<u>MATERIALS/PARTS (P/N)</u>	
Solvent, drycleaning, SD-2 Item 29, Appendix C.	Pin, cotter (as required) (24617) 108656.
Rag, wiping Item 22, Appendix C.	Pin, cotter (74410) 773.
Oil, lubricating: OE/HDO-10. Item 15, Appendix C.	Pin, cotter (74410) 119-1.
Grease, automotive and artillery Item 7, Appendix C.	Pin, cotter (74410) 770-1.
Pin, cotter (as required) (24617) 137259.	Pin, cotter (24617) 137185.
Pin, cotter (as required) (24617) 103421.	
<u>PERSONNEL REQUIRED</u>	<u>SPECIAL ENVIRONMENTAL CONDITIONS</u>
Two (MOS-63S).	None.
<u>REFERENCE (TM)</u>	<u>GENERAL SAFETY INSTRUCTIONS</u>
TM 9-2320-238-10.	Engine off.
TM 9-2320-283-20P.	Transmission in neutral.
LO 9-2320-283-12.	Park brake set.
<u>TROUBLESHOOTING REFERENCES</u>	
Paragraph 2-11.	

FRAME AND TOWING ATTACHMENTS.

3-222. TASK SUMMARY (Continued).			
LIST OF TASKS			
TASK NO.	TASK	TASK REF	TROUBLESHOOTING REF NO. (PARA)
1	Secondary Reservoir Support Replacement	3-223	
	a. Removal.	3-223a	
	b. Cleaning and Inspection.	3-223b	
	c. Installation.	3-223c	
2	Muffler Inlet Pipe Support Replacement	3-224	
	a. Removal.	3-224a	
	b. Cleaning and Inspection.	3-224b	
	c. Installation.	3-224c	
3	Supply Reservoir Mounting Brackets Replacement	3-225	
	a. Removal.	3-225a	
	b. Cleaning and Inspection.	3-225b	
	c. Installation.	3-225c	
4	Step Replacement	3-226	
	a. Right-Side Step Removal.	3-226a	
	b. Left-Side Step Removal.	3-226b	
	c. Cleaning and Inspection.	3-226c	
	d. Left-Side Step Installation.	3-226d	
	e. Right-Side Step Installation.	3-226e	
5	Air Dryer Mounting Bracket Replacement	3-227	
	a. Removal.	3-227a	
	b. Cleaning and Inspection.	3-227b	
	c. Installation.	3-227c	
6	Tiedown Bracket Replacement	3-228	
	a. Removal.	3-228a	
	b. Cleaning and Inspection.	3-228b	
	c. Installation.	3-228c	

FRAME AND TOWING ATTACHMENTS.

3-222. TASK SUMMARY (Continued).			
LIST OF TASKS			
TASK NO.	TASK	TASK REF	TROUBLESHOOTING REF NO. (PARA)
7	Vehicle Lifting Bracket Replacement a. Removal. b. Cleaning and Inspection. c. Installation.	3-229 3-229a 3-229b 3-229c	
8	Clevis Pin Replacement a. Removal. b. Cleaning and Inspection. c. Installation.	3-230 3-230a 3-230b 3-230c	
9	Transmission Oil Filter Mounting Bracket Replacement a. Removal. b. Cleaning and Inspection. c. Installation.	3-231 3-231 a 3-231 b 3-231c	
10	Forward-Rear Axle Stop Replacement a. Removal. b. Cleaning and Inspection. c. Installation.	3-232 3-232a 3-232b 3-232c	
11	Blackout Taillamp Mounting Bracket Replacement a. Removal. b. Cleaning and Inspection. c. Installation.	3-233 3-233a 3-233b 3-233c	
12	Taillamp Bracket Replacement a. Removal. b. Cleaning and Inspection. c. Installation.	3-234 3-234a 3-234b 3-234c	

FRAME AND TOWING ATTACHMENTS.

3-222. TASK SUMMARY (Continued).			
LIST OF TASKS			
TASK NO.	TASK	TASK REF	TROUBLESHOOTING REF NO. (PARA)
13	Rear Tow Eye Bracket, Shackle, and Pin Replacement	3-235	
	a. Shackle and Pin Removal.	3-235a	
	b. Bracket Removal.	3-235b	
	c. Cleaning and Inspection.	3-235c	
	d. Bracket Installation.	3-235d	
	e. Shackle and Pin Installation.	3-235e	
14	Brush Guard Replacement	3-236	
	a. Removal.	3-236a	
	b. Disassembly.	3-236b	
	c. Cleaning and Inspection.	3-236c	
	d. Assembly.	3-236d	
	e. Installation.	3-236e	
15	Bumper, Towing Eyes, and Vehicle Class Sign Replacement	3-237	
	a. Vehicle Class Sign Removal.	3-237a	
	b. Shackle and Pin Removal.	3-237b	
	c. Bumper and Towing Eyes Removal.	3-237c	
	d. Cleaning and Inspection.	3-237d	
	e. Bumper and Towing Eyes Installation.	3-237e	
	f. Shackle and Pin Installation.	3-237f	
	g. Vehicle Class Sign Installation.	3-237g	
16	Tow Pintle Replacement	3-238	2-11
	a. Pintle Hook Removal.	3-238a	
	b. Pintle Hook Disassembly.	3-238b	
	c. Bracket Removal.	3-238c	
	d. Cleaning and Inspection.	3-238d	
	e. Bracket Installation.	3-238e	
	f. Pintle Hook Assembly	3-238f	
	g. Pintle Hook Installation.	3-238g	
	h. Lubrication and Adjustment.	3-238h	
17	Service Deck Replacement	3-239	
	a. Removal.	3-239a	
	b. Cleaning and Inspection.	3-239b	
	c. Installation.	3-239c	

FRAME AND TOWING ATTACHMENTS.

3-222. TASK SUMMARY (Continued).			
LIST OF TASKS			
TASK NO.	TASK	TASK REF	TROUBLESHOOTING REF NO. (PARA)
18	Spare Tire Carrier Replacement	3-240	
	a. Removal.	3-240a	
	b. Cleaning and Inspection.	3-240b	
	c. Installation.	3-240c	
19	Spare Tire Winch Cable Replacement	3-241	
	a. Removal.	3-241a	
	b. Cleaning and Inspection.	3-241b	
	c. Installation.	3-241c	
20	Spare Tire Winch Replacement and Repair	3-242	
	a. Removal.	3-242a	
	b. Disassembly.	3-242b	
	c. Cleaning and Inspection.	3-242c	
	d. Assembly.	3-242d	
	e. Installation.	3-242e	
21	Spare Tire Winch Pillar Replacement	3-243	
	a. Removal.	3-243a	
	b. Cleaning and Inspection.	3-243b	
	c. Installation.	3-243c	
22	Fifth Wheel Adjustment	3-244	2-11
23	Fifth Wheel Replacement	3-245	2-11
	a. Removal.	3-245a	
	b. Cleaning and Inspection.	3-245b	
	c. Installation.	3-245c	
24	Fifth Wheel Ramp Replacement	3-246	
	a. Removal.	3-246a	
	b. Cleaning and Inspection.	3-246b	
	c. Installation.	3-246c	



FRAME AND TOWING ATTACHMENTS.

3-223. SECONDARY RESERVOIR SUPPORT REPLACEMENT.		
<u>THIS TASK COVERS</u>		
<ul style="list-style-type: none"> <li>a. Removal.</li> <li>b. Cleaning and Inspection.</li> <li>c. Installation.</li> </ul>		
<u>INITIAL SETUP</u>		
<u>APPLICABLE CONFIGURATIONS</u>	<u>EQUIPMENT PARAGRAPH</u>	<u>CONDITION DESCRIPTION</u>
All.	3-170.	Secondary reservoir removed.
<u>TEST EQUIPMENT</u>		
None.		
<u>SPECIAL TOOLS</u>		
None.		
<u>MATERIALS/PARTS (P/N)</u>		
Rags, wiping		
Item 22, Appendix B.		
Solvent, drycleaning, SD-2		
Item 29, Appendix B.		
<u>PERSONNEL REQUIRED</u>	<u>SPECIAL ENVIRONMENTAL CONDITIONS</u>	
One (MDS-63S)	None.	
<u>REFERENCES (TM)</u>	<u>GENERAL SAFETY INSTRUCTION</u>	
None.	None.	
<u>TROUBLESHOOTING REFERENCES</u>		
None.		

FRAME AND TOWING ATTACHMENTS.

3-223. SECONDARY RESERVOIR SUPPORT REPLACEMENT.

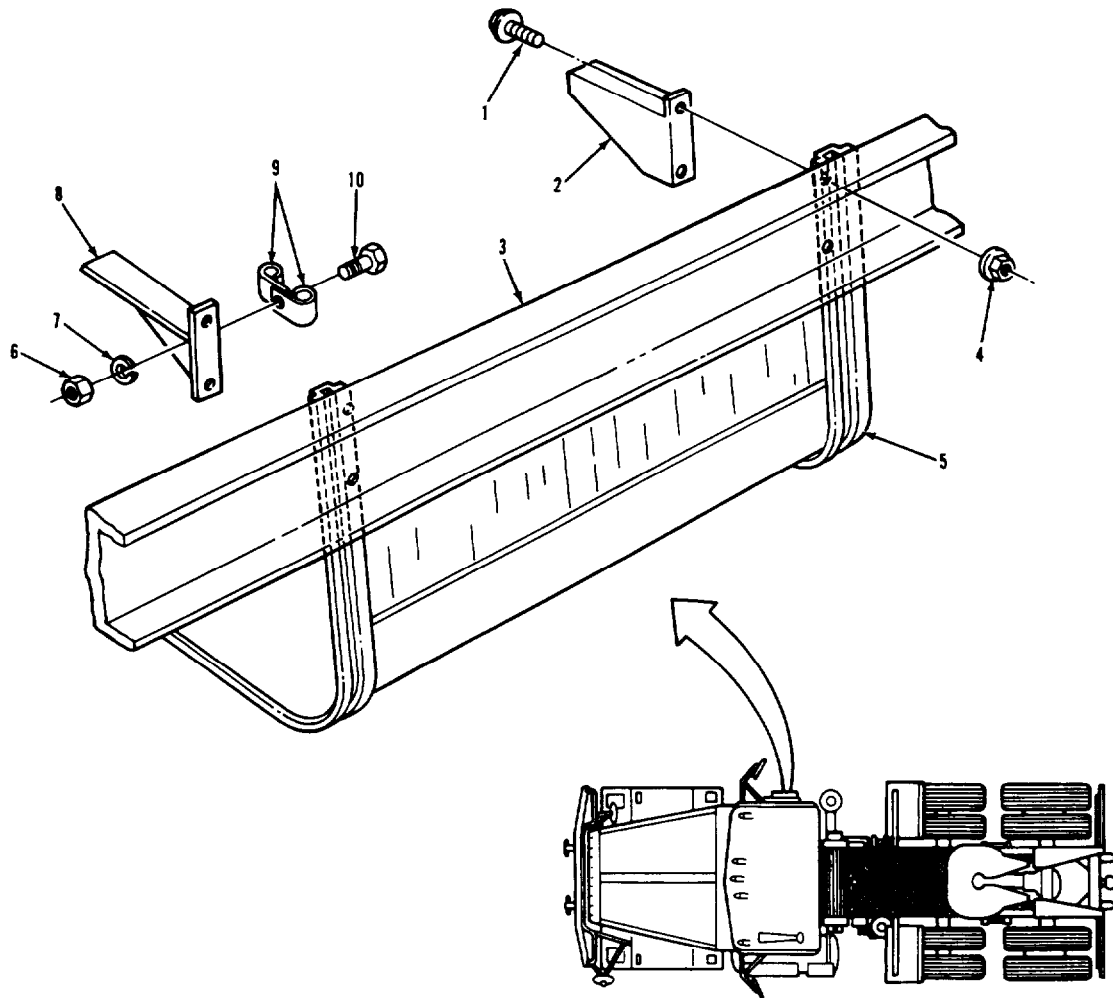

LEGEND:

- |                           |                           |
|---------------------------|---------------------------|
| 1. FLANGE HEAD BOLT (4)   | 6. HEXAGON NUT            |
| 2. AIR TANK REAR SUPPORT  | 7. LOCKWASHER             |
| 3. RIGHT-HAND MAIN RAIL   | 8. AIR TANK FRONT SUPPORT |
| 4. HEXAGON FLANGE NUT (4) | 9. CLAMP (2)              |
| 5. BATTERY BOX ASSEMBLY   | 10. HEXAGON BOLT          |

TA 237625

FRAME AND TOWING ATTACHMENTS.

3-223. SECONDARY RESERVOIR SUPPORT REPLACEMENT.		
LOCATION/ITEM	ACTION	REMARKS
<b>A. REMOVAL.</b>		
1. Nut (6), lockwasher (7), two clamps (9), and one bolt (10).	Remove from item (8).	Item (10) stays in item (9).
2. Four bolts (1) and nuts (4).	a. Remove from item (2), (8), and 3-5.  b. Remove item (2) from item (5).	
<b>B. CLEANING AND INSPECTION.</b>		
3. All parts.	Clean and inspect.	Refer to paragraphs 3-4 and 3-5.
<b>C. INSTALLATION.</b>		
4. Supports (2) and (8).	a. Line up holes in items (8) and (2) with holes in item (5) and (3).  b. Secure with four items (1) and (4).	If installing only item (2), then task ends here. Go to follow-on maintenance. If installing item (8), then do step 5,
5. Clamp (9) and bolt (10).	a. Position on item (8).  b. Secure with items (6) and (7).	
NOTE		
Follow-on maintenance action required:		
Install secondary reservoir (para 3-170).		

FRAME AND TOWING ATTACHMENTS.

3-223. SECONDARY RESERVOIR SUPPORT REPLACEMENT.

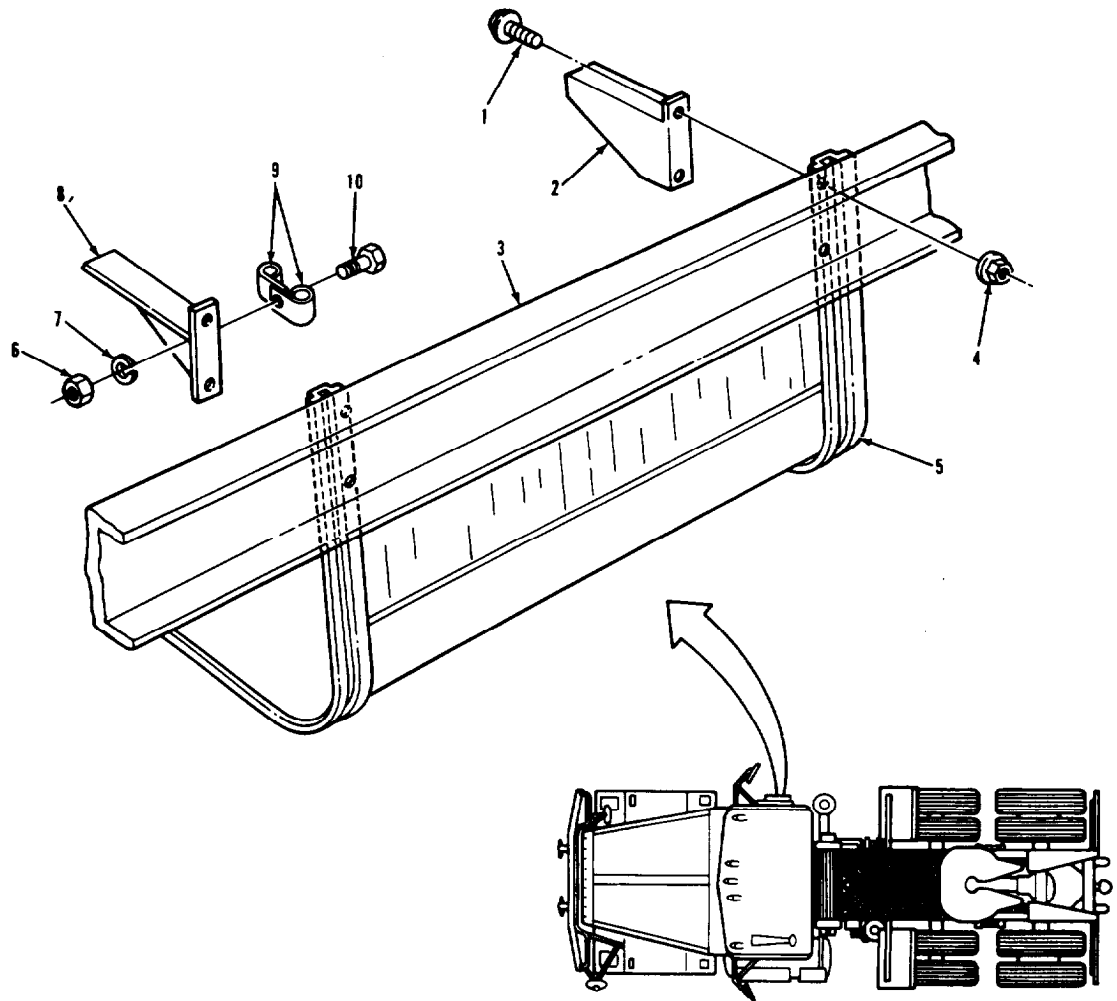

LEGEND:

- |                           |                           |
|---------------------------|---------------------------|
| 1. FLANGE HEAD BOLT (4)   | 6. HEXAGON NUT            |
| 2. AIR TANK REAR SUPPORT  | 7. LOCKWASHER             |
| 3. RIGHT-HAND MAIN RAIL   | 8. AIR TANK FRONT SUPPORT |
| 4. HEXAGON FLANGE NUT (4) | 9. CLAMP (2)              |
| 5. BATTERY BOX ASSEMBLY   | 10. HEXAGON BOLT          |

TA 237626

FRAME AND TOWING ATTACHMENTS.

3-224. MUFFLER INLET PIPE SUPPORT REPLACEMENT.

THIS TASK COVERS

- a. Removal.
- b. Cleaning and Inspection.
- c. Installation.

INITIAL SETUP

<u>APPLICABLE CONFIGURATIONS</u>	<u>EQUIPMENT CONDITION PARAGRAPH</u>	<u>CONDITION DESCRIPTION</u>
All.	None.	None.

TEST EQUIPMENT  
None.

SPECIAL TOOLS  
None.

MATERIALS/PARTS (P/N)  
Rags, wiping  
Item 22, Appendix B.  
Solvent, drycleaning, SD-2  
Item 29, Appendix B.

PERSONNEL REQUIRED  
One (MOS-63S).

SPECIAL ENVIRONMENTAL CONDITIONS  
None.

REFERENCES (TM)  
None.

GENERAL SAFETY INSTRUCTIONS  
None.

TROUBLESHOOTING REFERENCES  
None.

FRAME AND TOWING ATTACHMENTS.

3-224. MUFFLER INLET PIPE SUPPORT REPLACEMENT (Continued).

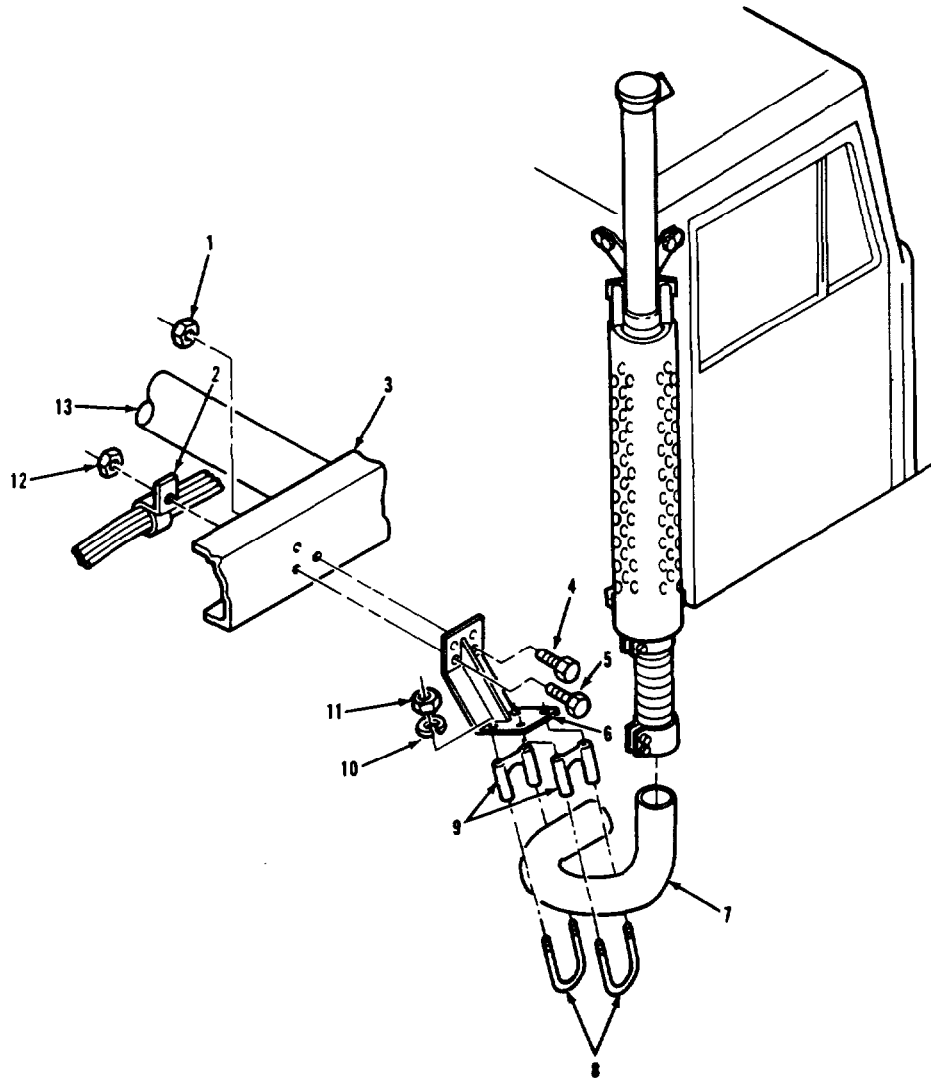

LEGEND:

- |  |                          |
|--|--------------------------|
| 1. FLANGE HEAD NUT                     | 8. U-BOLT (2)            |
| 2. TUBE SUPPORT BRACKET                | 9. CLAMP (2)             |
| 3. RIGHT-HAND MAIN RAIL                | 10. LOCKWASHER (4)       |
| 4. SCREW                               | 11. NUT (4)              |
| 5. SCREW (2)                           | 12. NUT (2)              |
| 6. MUFFLER INLET PIPE SUPPORT ASSEMBLY | 13. CROSSMEMBER ASSEMBLY |
| 7. MUFFLER INLET PIPE                  |                          |

TA 237627

FRAME AND TOWING ATTACHMENTS.

3-224. MUFFLER INLET PIPE SUPPORT REPLACEMENT (Continued).

LOCATION/ITEM	ACTION	REMARKS
<b>A. REMOVAL.</b>		
1. Four nuts (11) and lockwashers (10).	Remove from two items (8).	
2. Two clamps (9) and U-bolts (8).	Remove from item (7).	
3. Nut (1) and screw (4).	Remove from items (6) and (3).	
4. Two nuts (12) and screws (5).	a. Remove from items (6) and (2). b. Remove item (6) from item (3).	
<b>B. CLEANING AND INSPECTION.</b>		
5. All parts.	Clean and inspect.	Refer to paragraphs 3-4 and 3-5.
<b>C. INSTALLATION.</b>		
6. Support assembly (6).	a. Line up holes in item (6) with holes in item (3). b. Secure finger tight to item (3) with two items (5) and (12).	
7. Bracket (2).	a. Line up holes in item (2) with holes in item (6) and (3). b. Secure with items (1) and (4).	

FRAME AND TOWING ATTACHMENTS.

3-224. MUFFLER INLET PIPE SUPPORT REPLACEMENT (Continued).

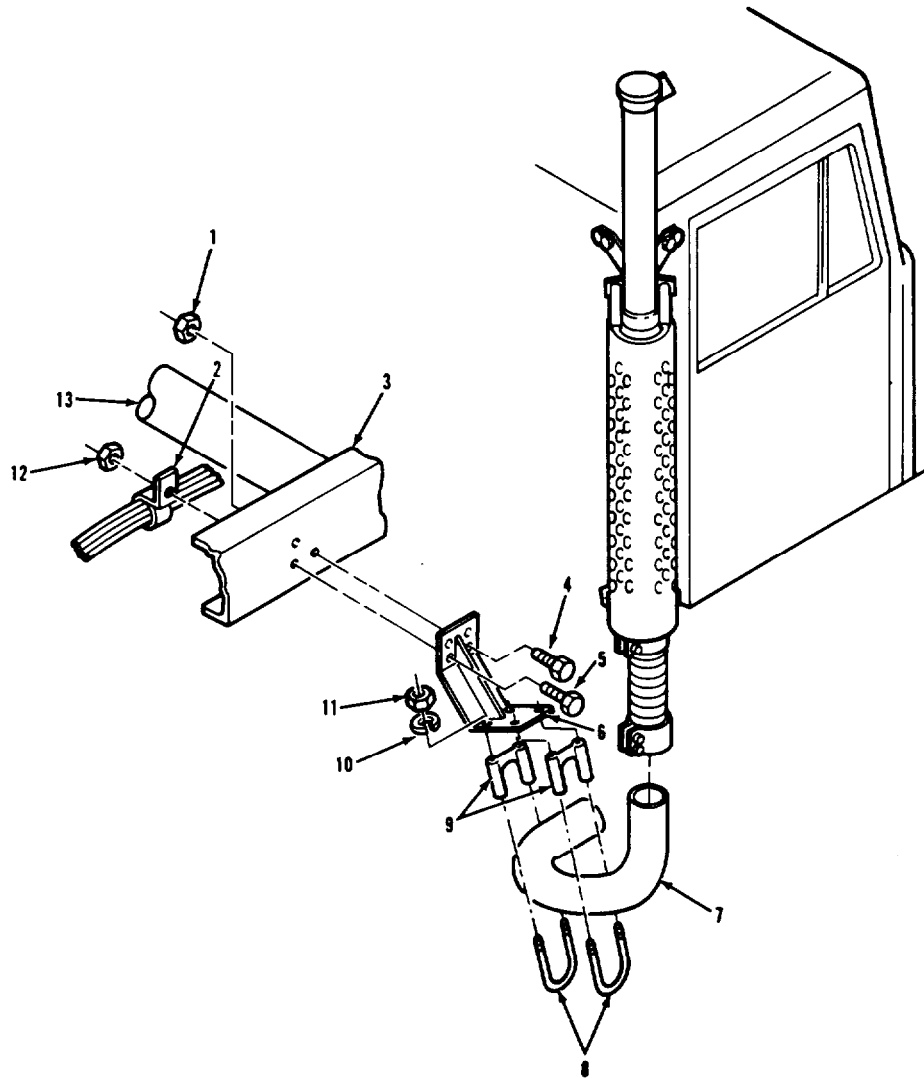

LEGEND:

- |  |                          |
|--|--------------------------|
| 1. FLANGE HEAD NUT                     | 8. U-BOLT (2)            |
| 2. TUBE SUPPORT BRACKET                | 9. CLAMP (2)             |
| 3. RIGHT-HAND MAIN RAIL                | 10. LOCKWASHER (4)       |
| 4. SCREW                               | 11. NUT (4)              |
| 5. SCREW (2)                           | 12. NUT (2)              |
| 6. MUFFLER INLET PIPE SUPPORT ASSEMBLY | 13. CROSSMEMBER ASSEMBLY |
| 7. MUFFLER INLET PIPE                  |                          |

TA 237628



FRAME AND TOWING ATTACHMENTS.

3-224. MUFFLER INLET PIPE SUPPORT REPLACEMENT (Continued).

LOCATION/ITEM	ACTION	REMARKS
<b>C. INSTALLATION (Continued).</b>		
8. Two clamps (9) and U-bolts (8).	Install on item (6) and around item (7).	
9. Four nuts (11) and lockwashers (10).	Secure to two items (8).	
NOTE		
Follow-on maintenance action required:		
None.		

FRAME AND TOWING ATTACHMENTS.

3-224. MUFFLER INLET PIPE SUPPORT REPLACEMENT (Continued).

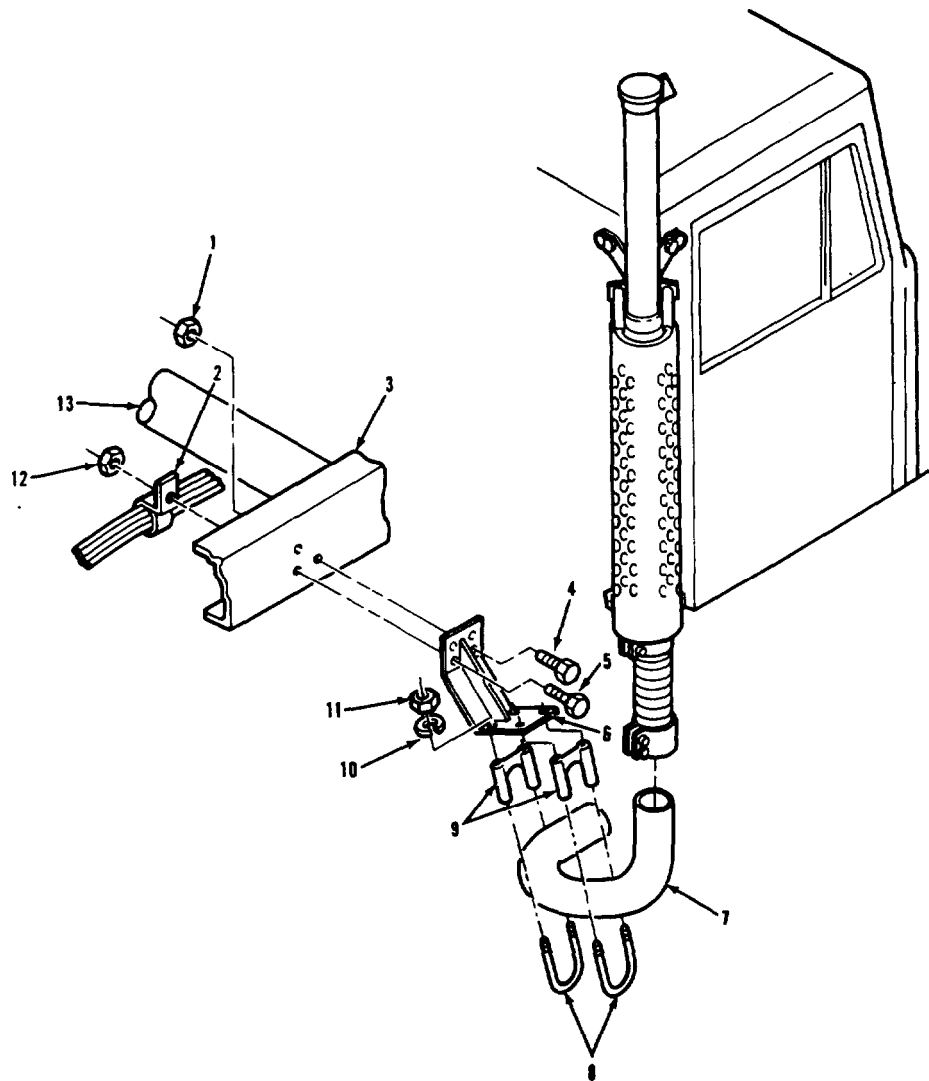

LEGEND:

- |  |                          |
|--|--------------------------|
| 1. FLANGE HEAD NUT                     | 8. U-BOLT (2)            |
| 2. TUBE SUPPORT BRACKET                | 9. CLAMP (2)             |
| 3. RIGHT-HAND MAIN RAIL                | 10. LOCKWASHER (4)       |
| 4. SCREW                               | 11. NUT (4)              |
| 5. SCREW (2)                           | 12. NUT (2)              |
| 6. MUFFLER INLET PIPE SUPPORT ASSEMBLY | 13. CROSSMEMBER ASSEMBLY |
| 7. MUFFLER INLET PIPE                  |                          |

TA 237629

FRAME AND TOWING ATTACHMENTS.

3-225. SUPPLY RESERVOIR MOUNTING BRACKETS REPLACEMENT.

THIS TASK COVERS

- a. Removal.
- b. Cleaning and Inspection.
- c. Installation.

INITIAL SETUP

<u>APPLICABLE CONFIGURATIONS</u> All.	<u>EQUIPMENT CONDITION PARAGRAPH</u> 3-239.	<u>CONDITION DESCRIPTION</u> Service deck removed for easier access.
<u>TEST EQUIPMENT</u> None.		
<u>SPECIAL TOOLS</u> None.		
<u>MATERIALS/PARTS (P/N)</u> None.		
<u>PERSONNEL REQUIRED</u> One (MDS-63S).	<u>SPECIAL ENVIRONMENTAL CONDITIONS</u> None.	
<u>REFERENCES (TM)</u>	<u>GENERAL SAFETY INSTRUCTIONS</u> None.	
<u>TROUBLESHOOTING REFERENCES</u> None.		

FRAME AND TOWING ATTACHMENTS.

3-225. SUPPLY RESERVOIR MOUNTING BRACKETS REPLACEMENT (Continued).

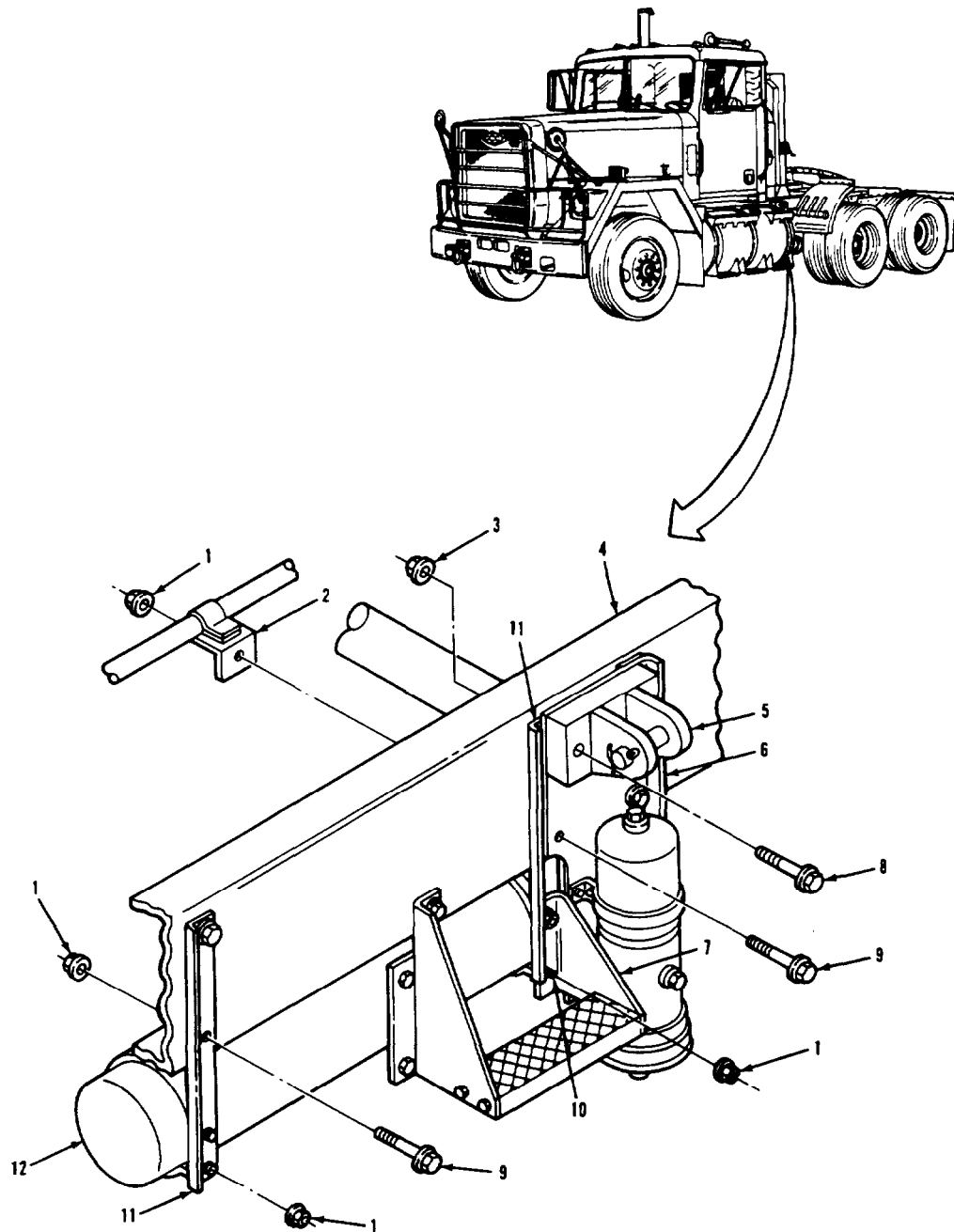

LEGEND:

- |  |   |
|--|---|
| 1. HEXAGON FLANGE NUT (7)              | 7. ASSIST STEP REAR BRACKET               |
| 2. TUBE SUPPORT BRACKET                | 8. FLANGE HEAD SCREW                      |
| 3. HEXAGON FLANGE NUT                  | 9. FLANGE HEAD SCREW (3)                  |
| 4. LEFT-HAND MAIN RAIL                 | 10. SUPPLY RESERVOIR MOUNTING BRACKET (2) |
| 5. LEFT-HAND TIE DOWN BRACKET ASSEMBLY | 11. AIR TANK MOUNTING BRACKET (2)         |
| 6. AIR DRYER MOUNTING BRACKET          | 12. AIR RESERVOIR                         |

TA 237630

FRAME AND TOWING ATTACHMENTS.

3-225. SUPPLY RESERVOIR MOUNTING BRACKETS REPLACEMENT (Continued).

LOCATION/ITEM	ACTION	REMARKS
<b>A. REMOVAL.</b>		
1. Reservoir (12).	Support with safety stands or tie to item (4) with rope.	
2. Four nuts (1).	Remove from studs on two items (10).	
3. Two screws (9) and nut (1).	Remove from front item (11).	
4. Screw (8) and nut (3).	Remove from item (5), item (6), rear item (11), and rear item (4).	
5. Screw (9) and nut (1).	Remove from item (6), rear item (11), item (4), and item (2).	
NOTE		
It may be necessary to loosen screws holding air dryer mounting bracket (6) to remove rear air tank mounting bracket.		
6. Two brackets (11). Remove.		
<b>B. CLEANING AND INSPECTION.</b>		
7. All parts.	Clean and inspect.	Refer to paragraphs 3-4 and 3-5.
<b>C. INSTALLATION.</b>		
8. Rear bracket (11).	Put in place between item (4) and item (6).	
9. Screw (8) and nut, (3).	Secure item (5), item (6), and item (11) to item (4).	

FRAME AND TOWING ATTACHMENTS.

3-225. SUPPLY RESERVOIR MOUNTING BRACKETS REPLACEMENT (Continued).

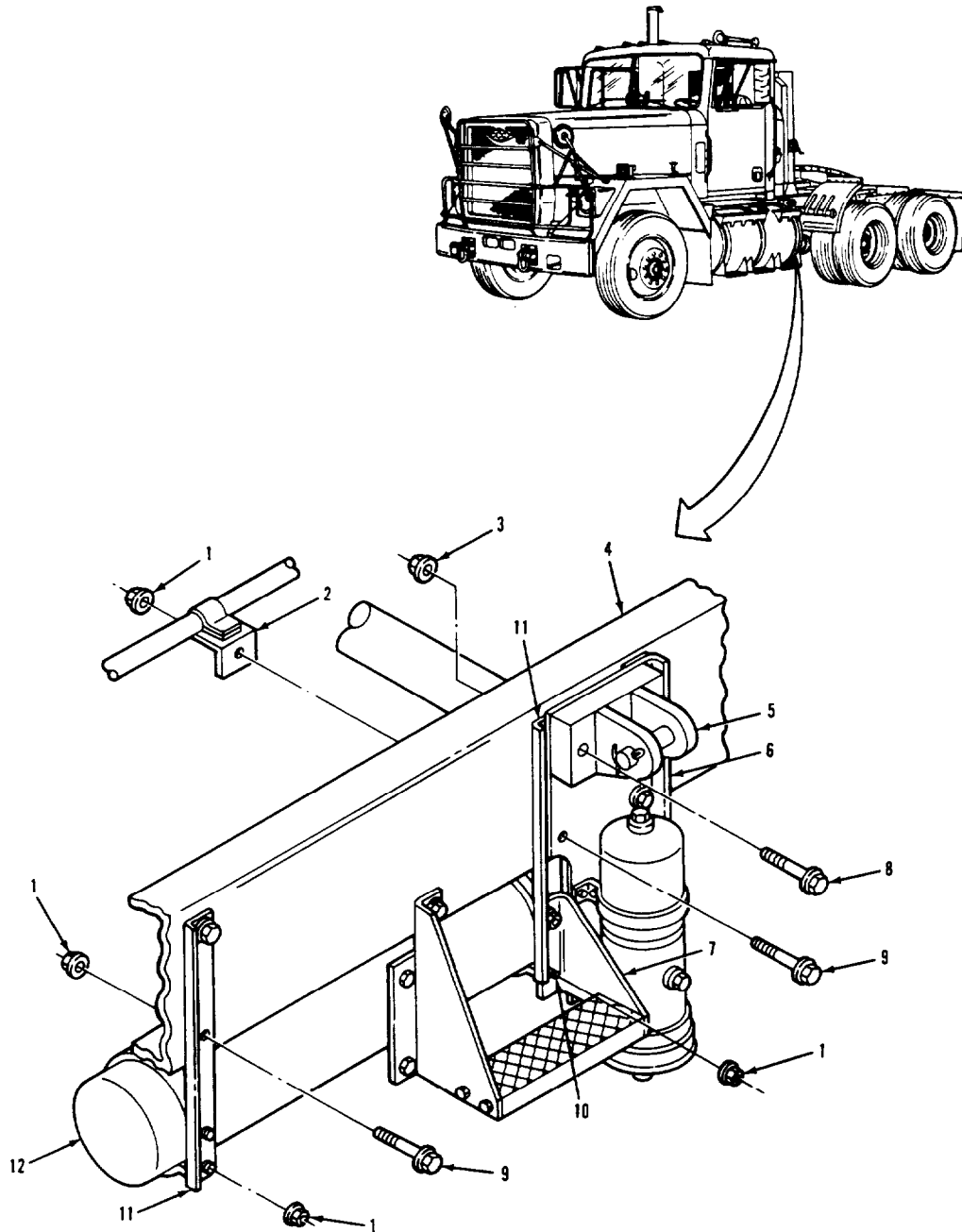

LEGEND:

- |  |   |
|--|---|
| 1. HEXAGON FLANGE NUT (7)              | 7. ASSIST STEP REAR BRACKET               |
| 2. TUBE SUPPORT BRACKET                | 8. FLANGE HEAD SCREW                      |
| 3. HEXAGON FLANGE NUT                  | 9. FLANGE HEAD SCREW (3)                  |
| 4. LEFT-HAND MAIN RAIL                 | 10. SUPPLY RESERVOIR MOUNTING BRACKET (2) |
| 5. LEFT-HAND TIE DOWN BRACKET ASSEMBLY | 11. AIR TANK MOUNTING BRACKET (2)         |
| 6. AIR DRYER MOUNTING BRACKET          | 12. AIR RESERVOIR                         |

TA 237631

FRAME AND TOWING ATTACHMENTS.

3-225. SUPPLY RESERVOIR MOUNTING BRACKETS REPLACEMENT (Continued).

LOCATION/ITEM	ACTION	REMARKS
<b>D. INSTALLATION (Continued).</b>		
10. Screw (9) and nut (1).	Secure item (6), item (11), and item (2) to item (4).	
11. Two screws (9) and nuts (1).	Secure front item (11) to item (4).	
12. Four nuts (1).	Install on studs on two items (10).	
NOTE		
Follow-on maintenance action required:		
Install service deck (para 3-239).		

FRAME AND TOWING ATTACHMENTS.

3-225. SUPPLY RESERVOIR MOUNTING BRACKETS REPLACEMENT (Continued).

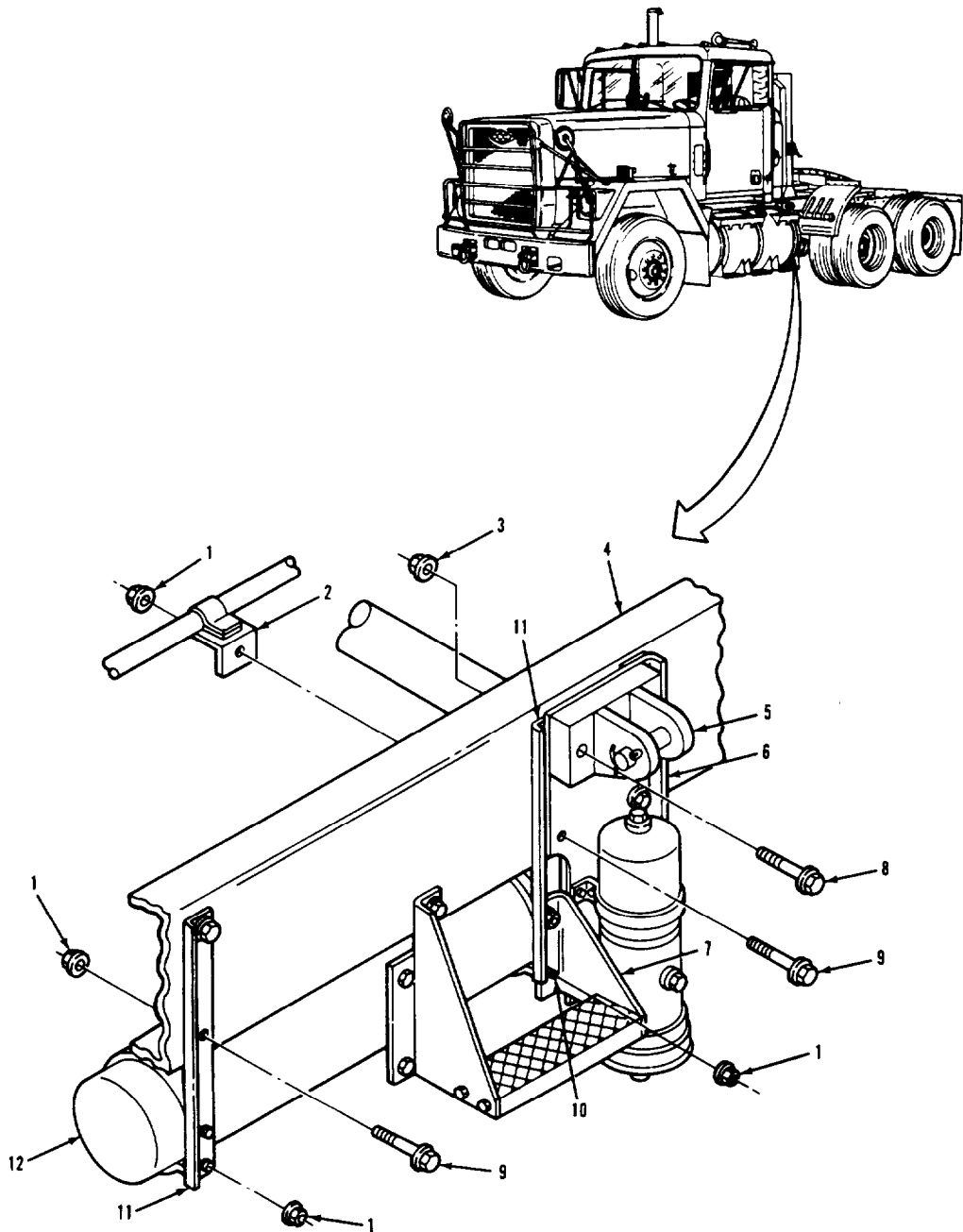

LEGEND:

- |  |   |
|--|---|
| 1. HEXAGON FLANGE NUT (7)              | 7. ASSIST STEP REAR BRACKET               |
| 2. TUBE SUPPORT BRACKET                | 8. FLANGE HEAD SCREW                      |
| 3. HEXAGON FLANGE NUT                  | 9. FLANGE HEAD SCREW (3)                  |
| 4. LEFT-HAND MAIN RAIL                 | 10. SUPPLY RESERVOIR MOUNTING BRACKET (2) |
| 5. LEFT-HAND TIE DOWN BRACKET ASSEMBLY | 11. AIR TANK MOUNTING BRACKET (2)         |
| 6. AIR DRYER MOUNTING BRACKET          | 12. AIR RESERVOIR                         |

TA 237632



FRAME AND TOWING ATTACHMENTS.

**3-226. STEP REPLACEMENT.**

THIS TASK COVERS

- |  |   |
|--|---|
| <ul style="list-style-type: none"> <li>a. Right-Side Step Removal.</li> <li>b. Left-Side Step Removal.</li> <li>c. Cleaning and Inspection.</li> </ul> | <ul style="list-style-type: none"> <li>d. Left-Side Step Installation.</li> <li>e. Right-Side Step Installation.</li> </ul> |
|--|---|

INITIAL SETUP

<u>APPLICABLE CONFIGURATIONS</u>	<u>EQUIPMENT CONDITION</u>	<u>CONDITION DESCRIPTION</u>
All.	None.	None.

TEST EQUIPMENT  
None.

SPECIAL TOOLS  
None.

MATERIALS/PARTS (P/N)  
Rags, wiping  
Item 22, Appendix B.  
Solvent, drycleaning, SD-2  
Item 29, Appendix B.

PERSONNEL REQUIRED  
One (MDS-63S).

SPECIAL ENVIRONMENTAL CONDITIONS  
None.

REFERENCE (TM)  
TM 9-2320-283-34P

GENERAL SAFETY INSTRUCTIONS  
None.

TROUBLESHOOTING REFERENCES  
None.

FRAME AND TOWING ATTACHMENTS.

3-226. STEP REPLACEMENT (Continued).

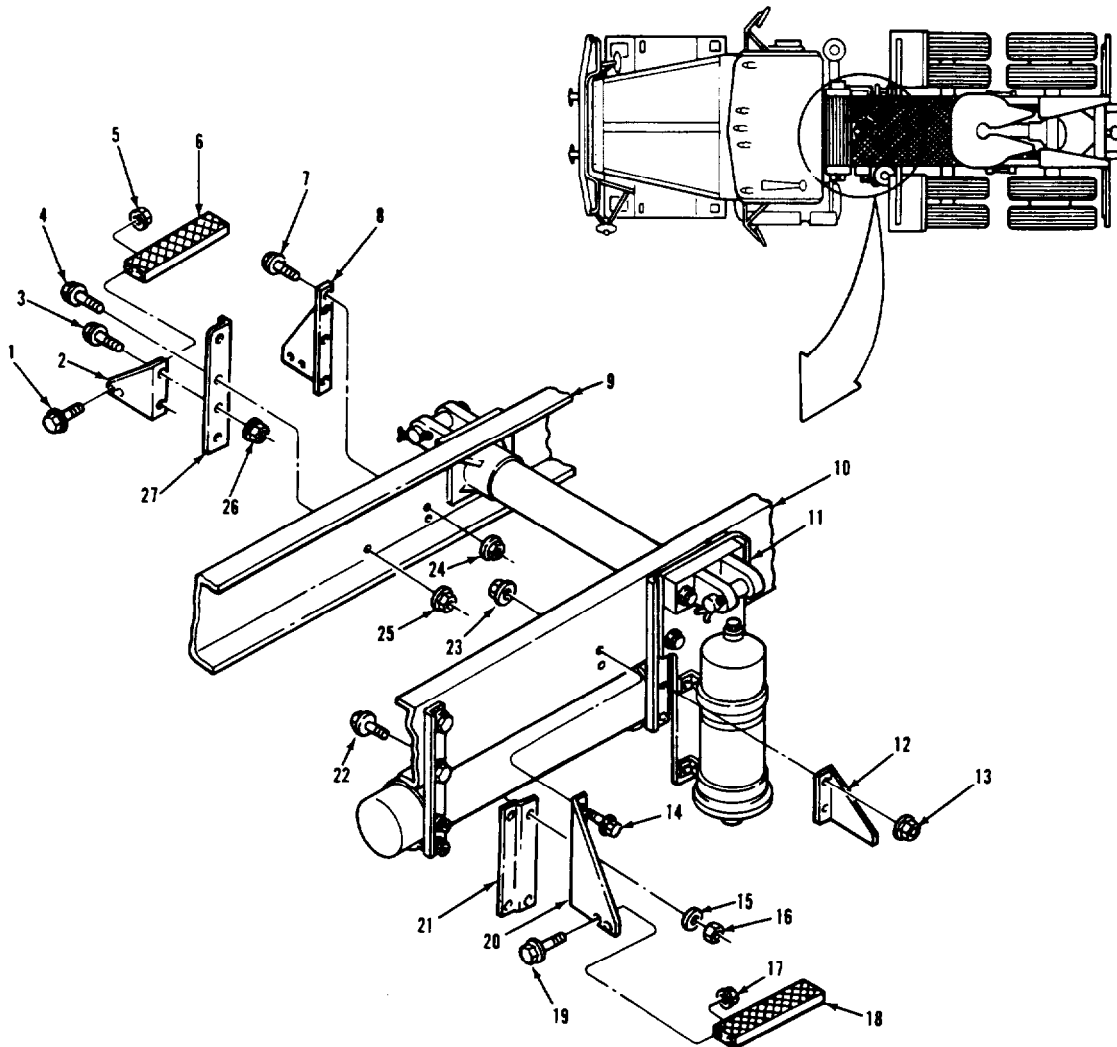

LEGEND:

- |   |                                   |
|---|-----------------------------------|
| 1. FLANGE HEAD BOLT (4)                 | 15. FLAT WASHER (2)               |
| 2. ASSIST STEP BRACKET                  | 16. HEXAGON FLANGE PT LOCKNUT (2) |
| 3. FLANGE HEAD BOLT (2)                 | 17. HEXAGON FLANGE NUT (4)        |
| 4. FLANGE HEAD BOLT (2)                 | 18. ASSIST STEP ASSEMBLY          |
| 5. HEXAGON FLANGE NUT (4)               | 19. FLANGE HEAD BOLT (4)          |
| 6. ASSIST STEP ASSEMBLY                 | 20. ASSIST STEP BRACKET           |
| 7. FLANGE HEAD BOLT (2)                 | 21. TUBE SUPPORT BRACKET          |
| 8. ASSIST STEP BRACKET                  | 22. HEXAGON FLANGE HEAD BOLT (2)  |
| 9. RIGHT-HAND MAIN RAIL                 | 23. HEXAGON FLANGE NUT (2)        |
| 10. LEFT-HAND MAIN RAIL                 | 24. HEXAGON FLANGE NUT (2)        |
| 11. AIR DRYER MOUNTING BRACKET ASSEMBLY | 25. HEXAGON FLANGE NUT (2)        |
| 12. ASSIST STEP BRACKET                 | 26. HEXAGON FLANGE NUT (2)        |
| 13. HEXAGON FLANGE NUT (2)              | 27. AIR TANK MOUNTING BRACKET     |
| 14. FLANGE HEAD BOLT (2)                |                                   |

TA 237633

FRAME AND TOWING ATTACHMENTS.

3-226. STEP REPLACEMENT (Continued).		
LOCATION/ITEM	ACTION	REMARKS
<b>A. RIGHT-SIDE STEP REMOVAL.</b>		
NOTE		
To remove step assembly and brackets without disassembling, only do steps 3 and 4.		
1. Four bolts (1), nuts (5), and step assembly (6).	Remove from items (2) and (8).	
2. Two bolts (3), nuts (26), and bracket (2).	Remove from item (27).	
3. Two bolts (4), nuts (25), and bracket (27).	Remove from item (9).	
4. Two bolts (7), nuts (24), and bracket (8).	Remove from item (9).	
<b>B. LEFT-SIDE STEP REMOVAL.</b>		
NOTE		
To remove step assembly and brackets without disassembling, only do steps 6, 7, and 8.		
5. Four bolts (19), nuts (17) and step assembly (18).	Remove from items (12) and (20).	
6. Two nuts (13) and bracket (12).	Remove from two studs on item (11).	
7. Two locknuts (16), washers (15), and bolts (22).	Remove from item (20).	One item (22) will stay in place.

FRAME AND TOWING ATTACHMENTS.

3-226. STEP REPLACEMENT (Continued).

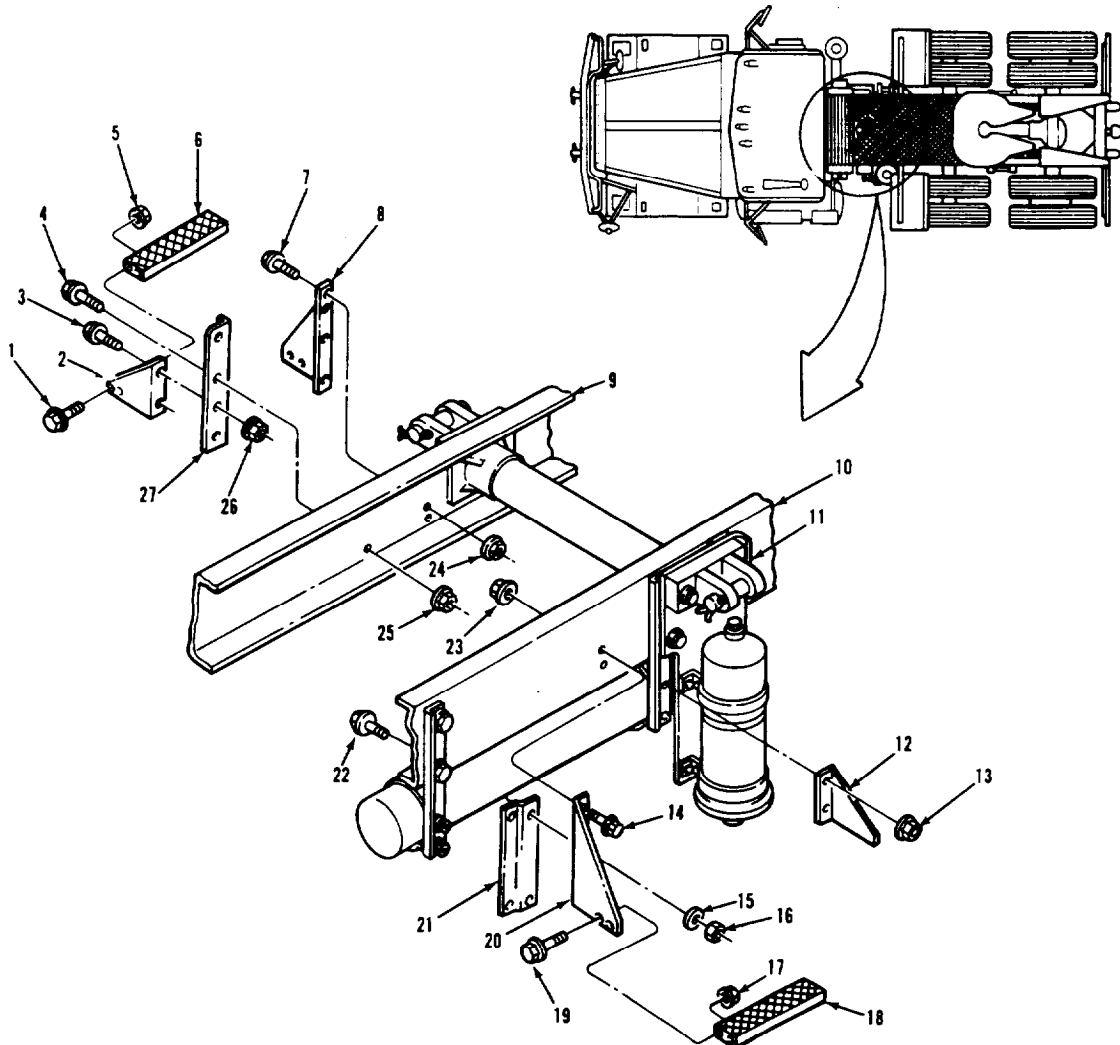

LEGEND:

- |   |                                   |
|---|-----------------------------------|
| 1. FLANGE HEAD BOLT (4)                 | 15. FLAT WASHER (2)               |
| 2. ASSIST STEP BRACKET                  | 16. HEXAGON FLANGE PT LOCKNUT (2) |
| 3. FLANGE HEAD BOLT (2)                 | 17. HEXAGON FLANGE NUT (4)        |
| 4. FLANGE HEAD BOLT (2)                 | 18. ASSIST STEP ASSEMBLY          |
| 5. HEXAGON FLANGE NUT (4)               | 19. FLANGE HEAD BOLT (4)          |
| 6. ASSIST STEP ASSEMBLY                 | 20. ASSIST STEP BRACKET           |
| 7. FLANGE HEAD BOLT (2)                 | 21. TUBE SUPPORT BRACKET          |
| 8. ASSIST STEP BRACKET                  | 22. HEXAGON FLANGE HEAD BOLT (2)  |
| 9. RIGHT-HAND MAIN RAIL                 | 23. HEXAGON FLANGE NUT (2)        |
| 10. LEFT-HAND MAIN RAIL                 | 24. HEXAGON FLANGE NUT (2)        |
| 11. AIR DRYER MOUNTING BRACKET ASSEMBLY | 25. HEXAGON FLANGE NUT (2)        |
| 12. ASSIST STEP BRACKET                 | 26. HEXAGON FLANGE NUT (2)        |
| 13. HEXAGON FLANGE NUT (2)              | 27. AIR TANK MOUNTING BRACKET     |
| 14. FLANGE HEAD BOLT (2)                |                                   |

TA 237634

FRAME AND TOWING ATTACHMENTS.

3-226. STEP REPLACEMENT (Continued).

LOCATION/ITEM	ACTION	REMARKS
<b>B. LEFT-SIDE STEP REMOVAL (Continued).</b>		
8. Two bolts (14), nuts (23), and bracket (20).	Remove from item (10) and (21).	
<b>C. CLEANING AND INSPECTION.</b>		
9. All parts.	Clean and inspect.	Refer to paragraphs 3-4 and 3-5.
<b>D. LEFT-SIDE STEP INSTALLATION.</b>		
NOTE		
If step assembly and brackets were removed as an assembly, then only do steps 11 and 12.		
10. Bracket (20).	<ul style="list-style-type: none"> <li>a. Position to item (10).</li> <li>b. Fasten finger tight with two items (14) and (23).</li> <li>c. Position to bracket (21).</li> <li>d. Secure with two items (22), (15), and (16)</li> <li>e. Tighten two items (14) and (23).</li> </ul>	
11. Bracket (12).	<ul style="list-style-type: none"> <li>a. Position onto two studs of item (11).</li> <li>b. Secure with two items (13).</li> </ul>	

FRAME AND TOWING ATTACHMENTS.

3-226. STEP REPLACEMENT (Continued).

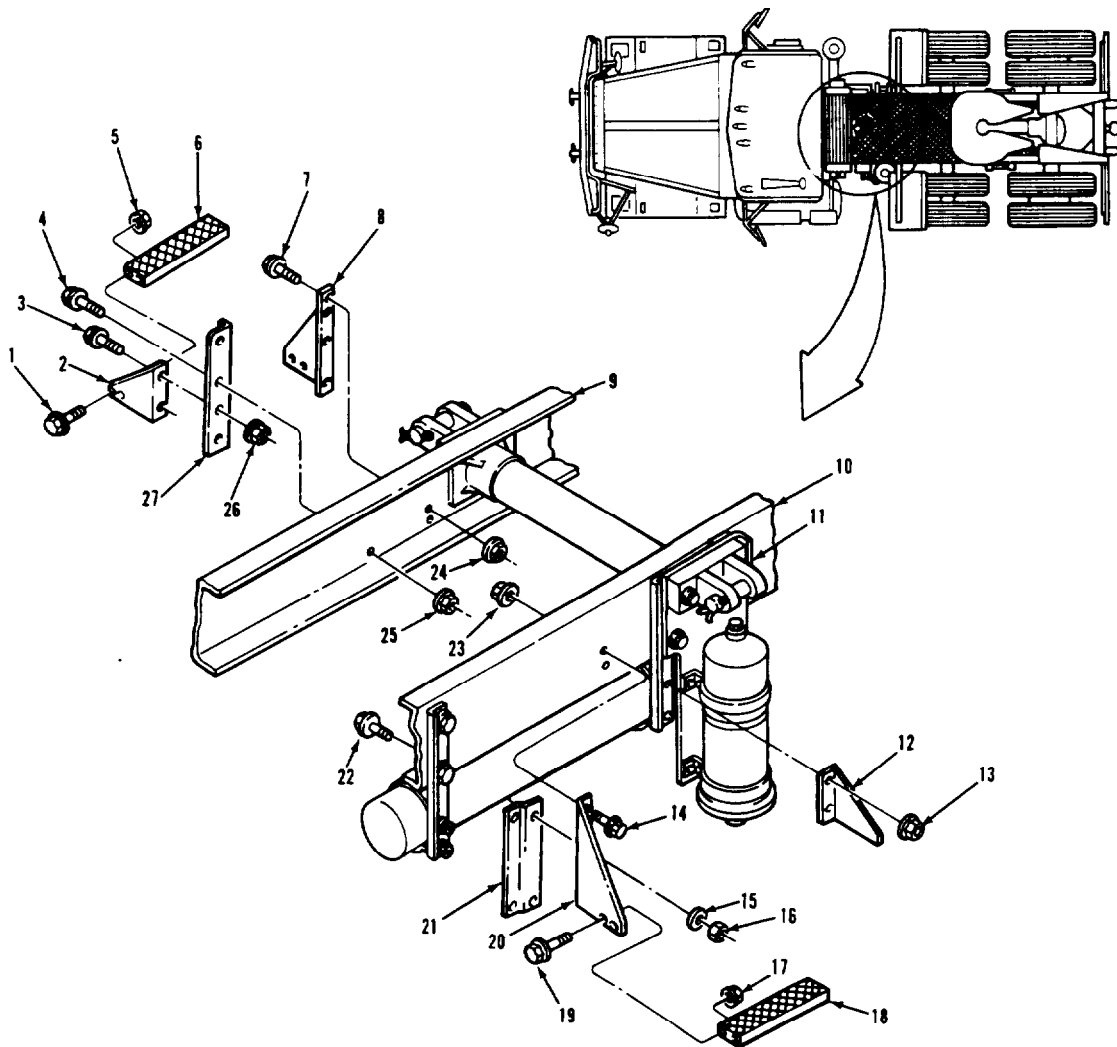

LEGEND:

- |   |                                   |
|---|-----------------------------------|
| 1. FLANGE HEAD BOLT (4)                 | 15. FLAT WASHER (2)               |
| 2. ASSIST STEP BRACKET                  | 16. HEXAGON FLANGE PT LOCKNUT (2) |
| 3. FLANGE HEAD BOLT (2)                 | 17. HEXAGON FLANGE NUT (4)        |
| 4. FLANGE HEAD BOLT (2)                 | 18. ASSIST STEP ASSEMBLY          |
| 5. HEXAGON FLANGE NUT (4)               | 19. FLANGE HEAD BOLT (4)          |
| 6. ASSIST STEP ASSEMBLY                 | 20. ASSIST STEP BRACKET           |
| 7. FLANGE HEAD BOLT (2)                 | 21. TUBE SUPPORT BRACKET          |
| 8. ASSIST STEP BRACKET                  | 22. HEXAGON FLANGE HEAD BOLT (2)  |
| 9. RIGHT-HAND MAIN RAIL                 | 23. HEXAGON FLANGE NUT (2)        |
| 10. LEFT-HAND MAIN RAIL                 | 24. HEXAGON FLANGE NUT (2)        |
| 11. AIR DRYER MOUNTING BRACKET ASSEMBLY | 25. HEXAGON FLANGE NUT (2)        |
| 12. ASSIST STEP BRACKET                 | 26. HEXAGON FLANGE NUT (2)        |
| 13. HEXAGON FLANGE NUT (2)              | 27. AIR TANK MOUNTING BRACKET     |
| 14. FLANGE HEAD BOLT (2)                |                                   |

TA 237635

FRAME AND TOWING ATTACHMENTS.

3-226. STEP REPLACEMENT (Continued).

LOCATION/ITEM	ACTION	REMARKS
<b>D. LEFT-SIDE STEP INSTALLATION (Continued).</b>		
12. Step assembly (18).	a. Place between items (12) and (20).  b. Secure with four items (19) and (17).	
<b>E. RIGHT-SIDE STEP INSTALLATION.</b>		
NOTE		
If step assembly and brackets were removed as an assembly, then only do steps 13, 14, and 15.		
13. Bracket (8).	a. Position to item (9).  b. Secure with two items (7) and (24).	
14. Bracket (27).	a. Position to item (9).  b. Secure with two items (4) and (25).	
15. Bracket (2).	a. Position to item (27).  b. Secure with two items (3) and (26).	
16. Step assembly (6).	a. Place between items (8) and (2).  b. Secure with four items (5) and (1).	
NOTE		
Follow-on maintenance action required:		
None.		

FRAME AND TOWING ATTACHMENTS.

3-226. STEP REPLACEMENT (Continued).

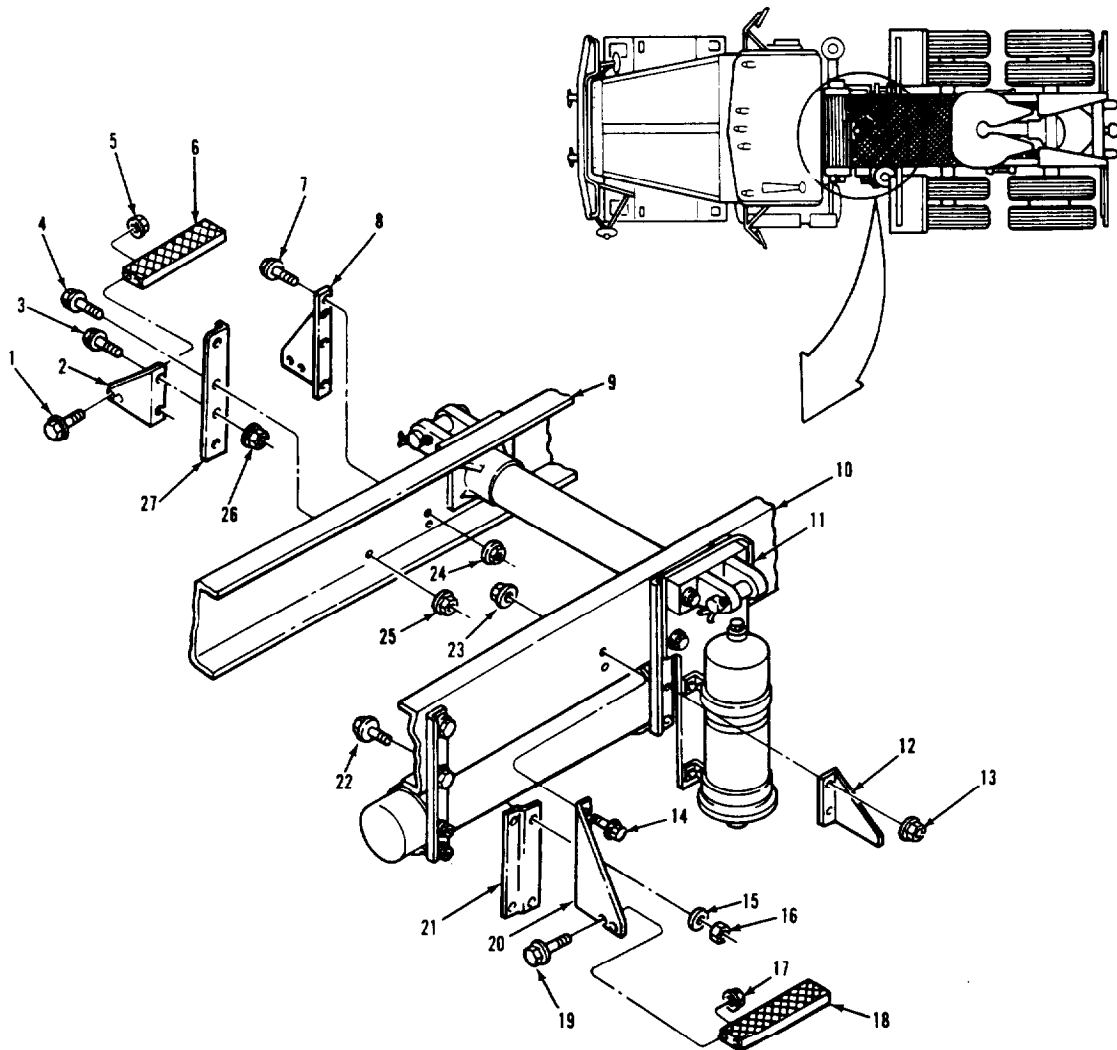

LEGEND:

- |   |                                   |
|---|-----------------------------------|
| 1. FLANGE HEAD BOLT (4)                 | 15. FLAT WASHER (2)               |
| 2. ASSIST STEP BRACKET                  | 16. HEXAGON FLANGE PT LOCKNUT (2) |
| 3. FLANGE HEAD BOLT (2)                 | 17. HEXAGON FLANGE NUT (4)        |
| 4. FLANGE HEAD BOLT (2)                 | 18. ASSIST STEP ASSEMBLY          |
| 5. HEXAGON FLANGE NUT (4)               | 19. FLANGE HEAD BOLT (4)          |
| 6. ASSIST STEP ASSEMBLY                 | 20. ASSIST STEP BRACKET           |
| 7. FLANGE HEAD BOLT (2)                 | 21. TUBE SUPPORT BRACKET          |
| 8. ASSIST STEP BRACKET                  | 22. HEXAGON FLANGE HEAD BOLT (2)  |
| 9. RIGHT-HAND MAIN RAIL                 | 23. HEXAGON FLANGE NUT (2)        |
| 10. LEFT-HAND MAIN RAIL                 | 24. HEXAGON FLANGE NUT (2)        |
| 11. AIR DRYER MOUNTING BRACKET ASSEMBLY | 25. HEXAGON FLANGE NUT (2)        |
| 12. ASSIST STEP BRACKET                 | 26. HEXAGON FLANGE NUT (2)        |
| 13. HEXAGON FLANGE NUT (2)              | 27. AIR TANK MOUNTING BRACKET     |
| 14. FLANGE HEAD BOLT (2)                |                                   |

TA 237636



FRAME AND TOWING ATTACHMENTS.

**3-227. AIR DRYER MOUNTING BRACKET REPLACEMENT.**

THIS TASK COVERS

- a. Removal.
- b. Cleaning and Inspection.
- c. Installation.

INITIAL SETUP

<u>APPLICABLE CONFIGURATIONS</u>	<u>EQUIPMENT CONDITION PARAGRAPH</u>	<u>CONDITION DESCRIPTION</u>
All.	3-198.	Air dryer removed.
	3-228.	Left-hand tiedown bracket assembly removed.
	3-239.	Service deck removed (for easier access).
<u>TEST EQUIPMENT</u> None.		
<u>SPECIAL TOOLS</u> None.		
<u>MATERIALS/PARTS (P/N)</u> None.		
<u>PERSONNEL REQUIRED</u> One (MDS-63S).	<u>SPECIAL ENVIRONMENTAL CONDITIONS</u> None.	
<u>REFERENCES (TM)</u> None.	<u>GENERAL SAFETY INSTRUCTIONS</u> None.	
<u>TROUBLESHOOTING REFERENCES</u> None.		

FRAME AND TOWING ATTACHMENTS.

3-227. AIR DRYER MOUNTING BRACKET REPLACEMENT (Continued).

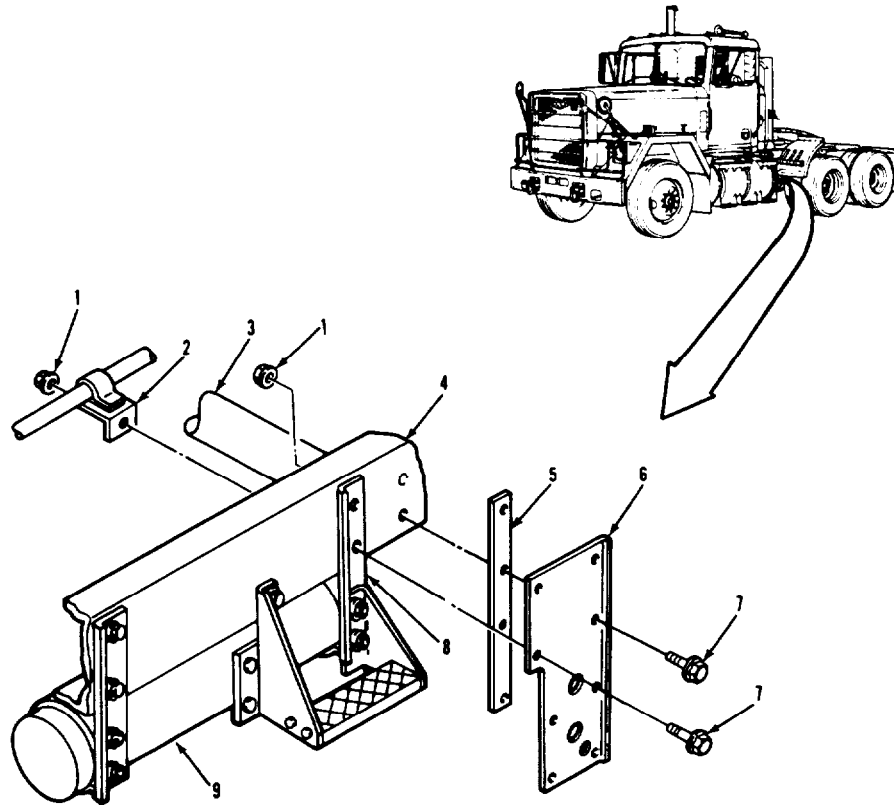

LEGEND:

- |                           |                               |
|---------------------------|-------------------------------|
| 1. HEXAGON FLANGE NUT (2) | 6. AIR DRYER MOUNTING BRACKET |
| 2. TUBE SUPPORT BRACKET   | 7. FLANGE HEAD BOLT (2)       |
| 3. CROSSMEMBER ASSEMBLY   | 8. AIR TANK MOUNTING BRACKET  |
| 4. LEFT-HAND MAIN RAIL    | 9. AIR RESERVOIR              |
| 5. SPACER PLATE           |                               |

TA 237637

FRAME AND TOWING ATTACHMENTS.

3-227. AIR DRYER MOUNTING BRACKET REPLACEMENT (Continued).		
LOCATION/ITEM	ACTION	REMARKS
<b>A. REMOVAL.</b>		
1. Two bolts (7) and two nuts (1).	Unscrew and remove from items (2), (3), (4), (5), (6), and (8).	Hold items (5) and (6) so they don't fall.
<b>B. CLEANING AND INSPECTION.</b>		
2. All parts.	Clean and inspect.	Refer to paragraphs 3-4 and 3-5.
<b>C. INSTALLATION.</b>		
3. Crossmember assembly (3), rail (4), plate (5), and brackets (6) and (8).	Aline mounting holes.	Tapered pins or bolts can be inserted through the top mounting holes to hold alinement.
4. Plate (5) and brackets (2) and (6).	Secure with two items (1) and (7), but do not tighten.	
5. Brackets (6) and (8), plate (5), and rail (4).	Aline top mounting holes and tighten two items (1) and (7).	Insert tapered pins or bolts through the top mounting holes to hold alinement while tightening.
NOTE		
Follow-on maintenance action required:		
Install left-hand tiedown bracket (para 3-228).		
Install air dryer (para 3-198).		
Install service deck (para 3-239).		

FRAME AND TOWING ATTACHMENTS.

3-227. AIR DRYER MOUNTING BRACKET REPLACEMENT (Continued).

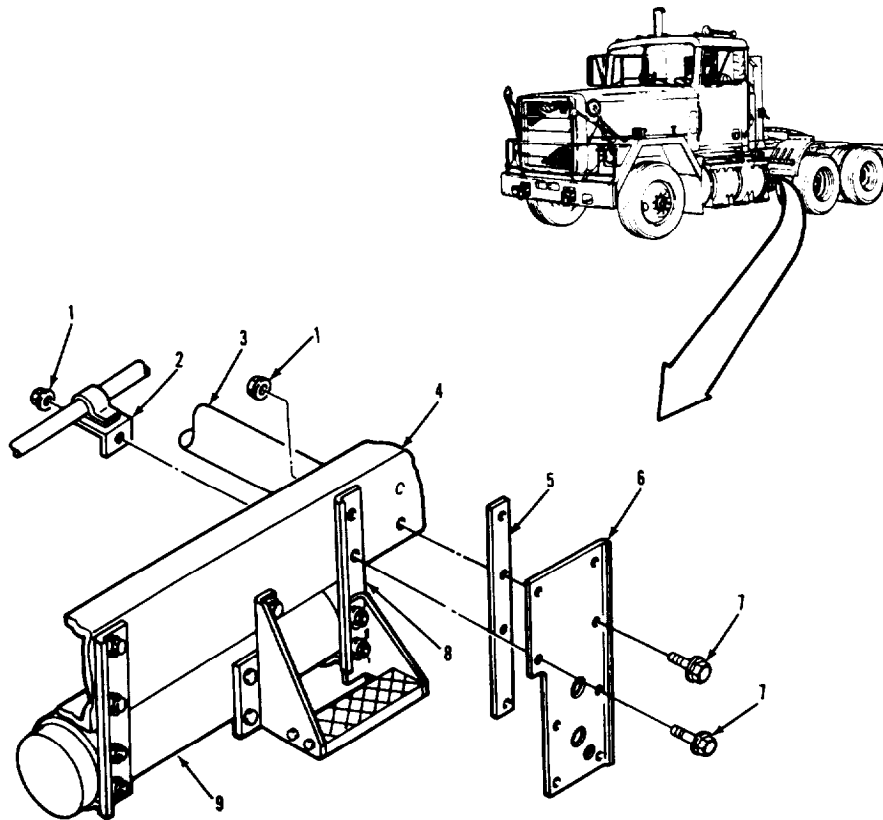

LEGEND:

- |                           |                               |
|---------------------------|-------------------------------|
| 1. HEXAGON FLANGE NUT (2) | 6. AIR DRYER MOUNTING BRACKET |
| 2. TUBE SUPPORT BRACKET   | 7. FLANGE HEAD BOLT (2)       |
| 3. CROSSMEMBER ASSEMBLY   | 8. AIR TANK MOUNTING BRACKET  |
| 4. LEFT-HAND MAIN RAIL    | 9. AIR RESERVOIR              |
| 5. SPACER PLATE           |                               |

TA 237638

**FRAME AND TOWING ATTACHMENTS.**

**3-228. TIEDOWN BRACKET REPLACEMENT.**

**THIS TASK COVERS**

- a. Removal.
- b. Cleaning and Inspection.
- c. Installation.

**INITIAL SETUP**

<u>APPLICABLE CONFIGURATIONS</u>	<u>EQUIPMENT CONDITION PARAGRAPH</u>	<u>CONDITION DESCRIPTION</u>
All	3-239.	Service deck removed (for easier access).

**TEST EQUIPMENT**

None.

**SPECIAL TOOLS**

None.

**MATERIALS/PARTS (P/N)**

None.

**PERSONNEL REQUIRED**

One (MDS-63S).

**SPECIAL ENVIRONMENTAL CONDITIONS**

None.

**REFERENCES (TM)**

None.

**GENERAL SAFETY INSTRUCTIONS**

None.

**TROUBLESHOOTING REFERENCES**

None.

FRAME AND TOWING ATTACHMENTS.

3-228. TIEDOWN BRACKET REPLACEMENT (Continued).

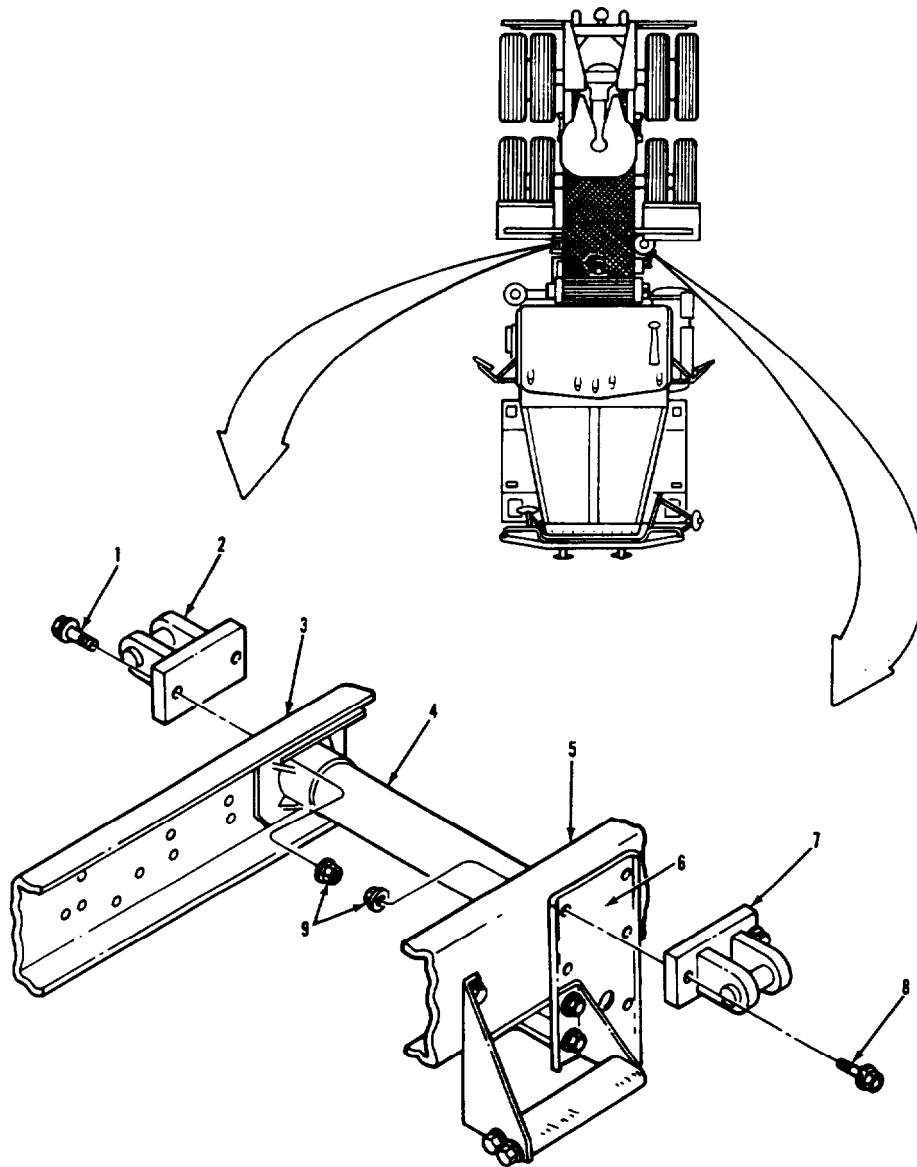

LEGEND:

- |  |                                       |
|--|---------------------------------------|
| 1. FLANGE HEAD BOLT (2)                | 6. AIR DRYER MOUNTING BRACKET         |
| 2. RIGHT-HAND TIEDOWN BRACKET ASSEMBLY | 7. LEFT-HAND TIEDOWN BRACKET ASSEMBLY |
| 3. RIGHT-HAND MAIN RAIL                | 8. FLANGE HEAD BOLT (2)               |
| 4. CROSSMEMBER ASSEMBLY                | 9. HEXAGON FLANGE NUT (4)             |
| 5. LEFT-HAND MAIN RAIL                 |                                       |

TA 237639

FRAME AND TOWING ATTACHMENTS.

3-228. TIEDOWN BRACKET REPLACEMENT (Continued).

LOCATION/ITEM	ACTION	REMARKS
<b>A. REMOVAL.</b>		
1. Right-hand bracket (2), two bolts (1), and nuts (9).	Remove from items (3) and (4).	
2. Left-hand bracket (7), two bolts (8), and nuts (9).	Remove from items (4), (5), and (6).	
<b>B. CLEANING AND INSPECTION.</b>		
3. All parts.	Clean and inspect.	Refer to paragraphs 3-4 and 3-5.
<b>C. INSTALLATION.</b>		
4. Right-hand bracket (2).	a. Place in position on item (3). b. Secure with two items (1) and (9).	
5. Left-hand bracket (7).	a. Place in position on item (6). b. Secure with two items (8) and (9).	
NOTE		
Follow-on maintenance action required:		
None.		

FRAME AND TOWING ATTACHMENTS.

3-228. TIEDOWN BRACKET REPLACEMENT (Continued).

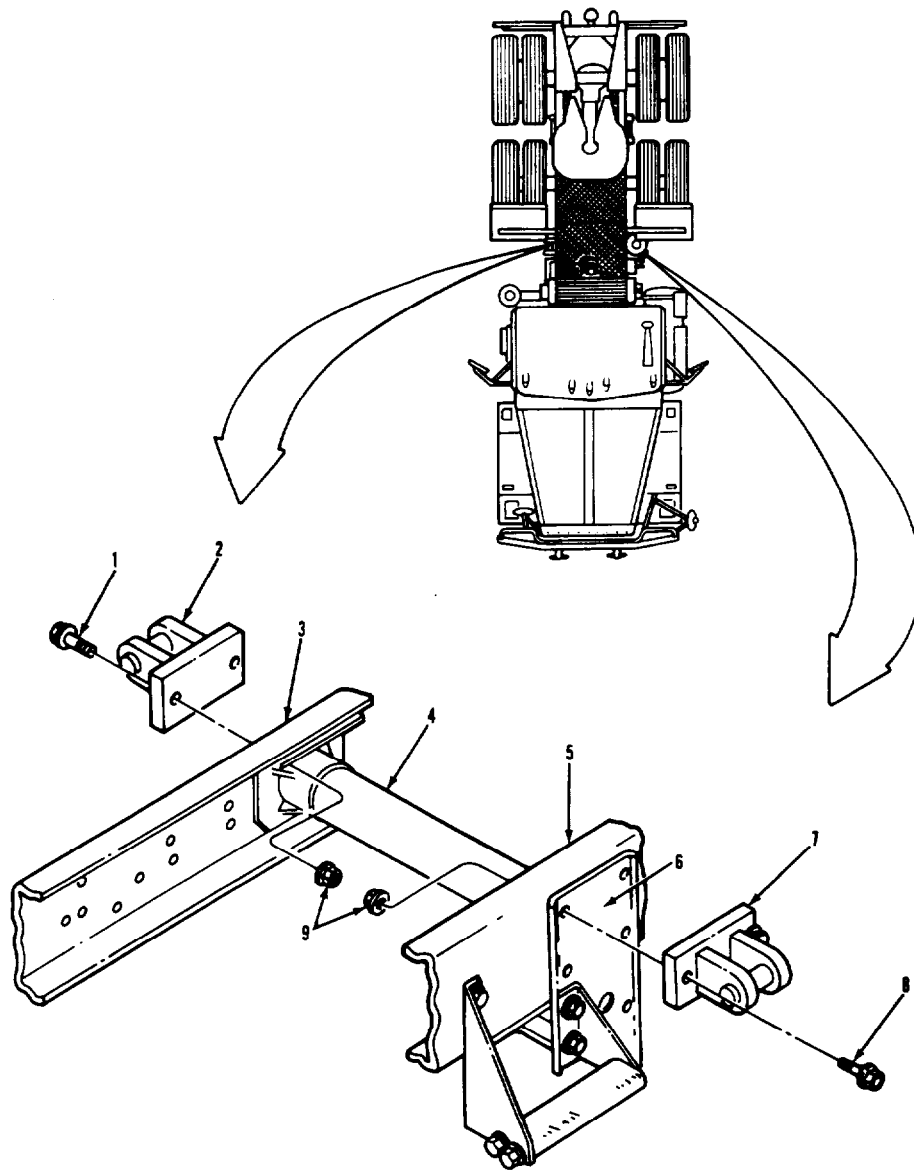

LEGEND:

- |  |                                       |
|--|---------------------------------------|
| 1. FLANGE HEAD BOLT (2)                | 6. AIR DRYER MOUNTING BRACKET         |
| 2. RIGHT-HAND TIEDOWN BRACKET ASSEMBLY | 7. LEFT-HAND TIEDOWN BRACKET ASSEMBLY |
| 3. RIGHT-HAND MAIN RAIL                | 8. FLANGE HEAD BOLT (2)               |
| 4. CROSSMEMBER ASSEMBLY                | 9. HEXAGON FLANGE NUT (4)             |
| 5. LEFT-HAND MAIN RAIL                 |                                       |

TA 237640



FRAME AND TOWING ATTACHMENTS.

3-229. VEHICLE LIFTING BRACKET REPLACEMENT.

THIS TASK COVERS

- a. Removal.
- b. Cleaning and Inspection.
- c. Installation.

INITIAL SETUP

<u>APPLICABLE CONFIGURATIONS</u>	<u>EQUIPMENT CONDITION PARAGRAPH</u>	<u>CONDITION DESCRIPTION</u>
All.	None.	None.

TEST EQUIPMENT

None

SPECIAL TOOLS

None.

MATERIALS/PARTS (P/N)

Rags, wiping  
Item 22, Appendix B.  
Solvent, drycleaning, SD-2  
Item 29, Appendix B.  
Pin, cotter (2)  
(24617) 103421.

PERSONNEL REQUIRED

One (MOS-63S).

SPECIAL ENVIRONMENTAL CONDITIONS

None.

REFERENCES (TM)

None.

GENERAL SAFETY INSTRUCTIONS

None.

TROUBLESHOOTING REFERENCES

None.

FRAME AND TOWING ATTACHMENTS.

3-229. VEHICLE LIFTING BRACKET REPLACEMENT (Continued).

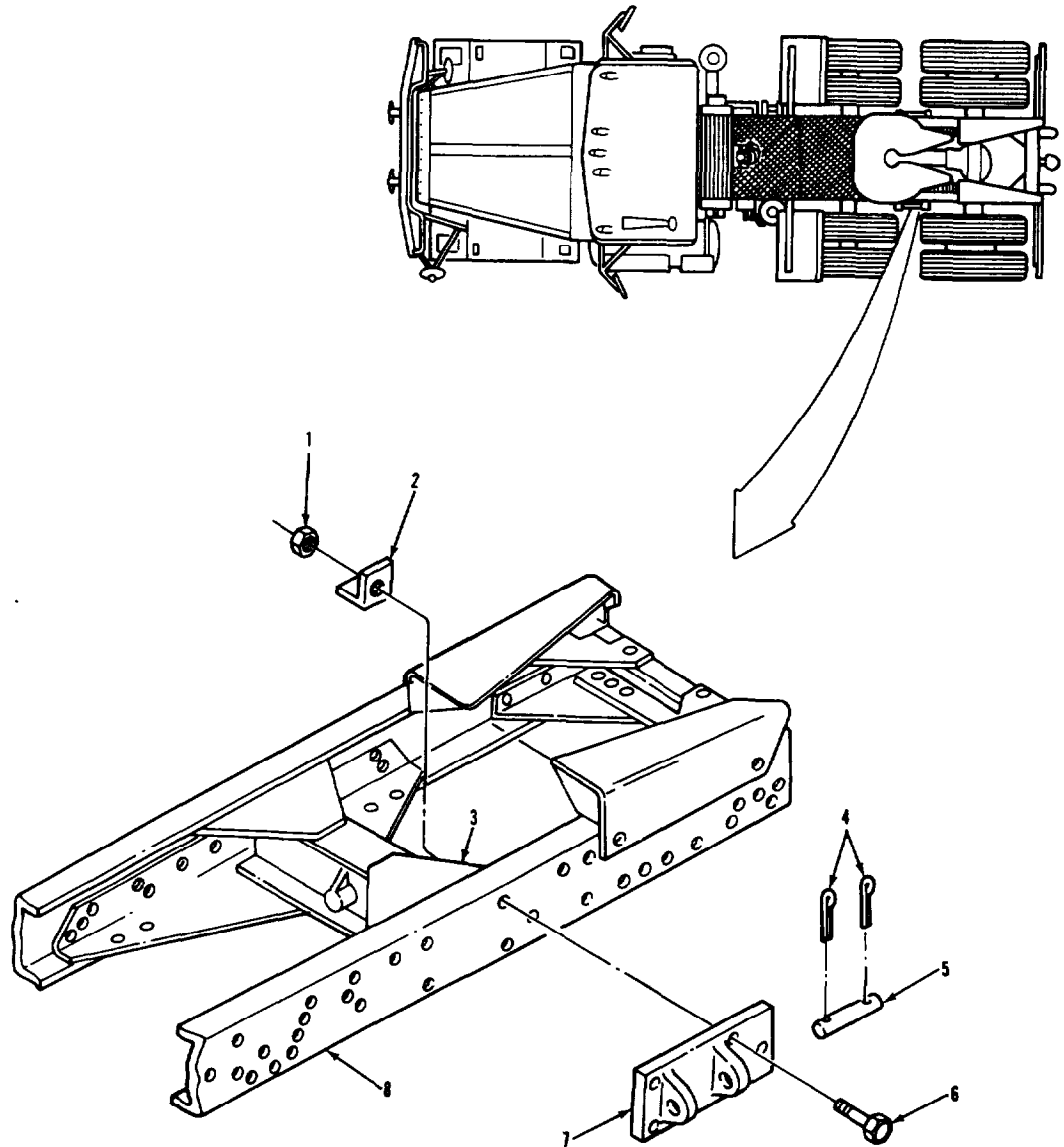

LEGEND:

- |   |   |
|---|---|
| 1. HEXAGON FLANGE NUT (5)               | 5. CLEVIS PIN                                 |
| 2. TUBE SUPPORT BRACKET                 | 6. FLANGE HEAD BOLT (5)                       |
| 3. REAR SUSPENSION CROSSMEMBER ASSEMBLY | 7. LEFT-HAND VEHICLE LIFTING BRACKET ASSEMBLY |
| 4. COTTER PIN (2)                       | 8. LEFT-HAND MAIN RAIL                        |

TA 237641

FRAME AND TOWING ATTACHMENTS.

3-229. VEHICLE LIFTING BRACKET REPLACEMENT (Continued).		
LOCATION/ITEM	ACTION	REMARKS
<b>A. REMOVAL.</b>		
NOTE		
Right-hand and left-hand bracket removal is similar. Left-hand bracket is shown here.		
1. Five nuts (1), bolts (6), and (7)	a. Remove from items (3) and (8).  b. Remove item (7) from item (8).	Item (2) stays against item (3).
NOTE		
If bracket is being removed for replacement, go to paragraph 3-230.		
<b>B. CLEANING AND INSPECTION.</b>		
2. All parts.	Clean and inspect.	Refer to paragraphs 3-4 and 3-5.

FRAME AND TOWING ATTACHMENTS.

3-229. VEHICLE LIFTING BRACKET REPLACEMENT (Continued).

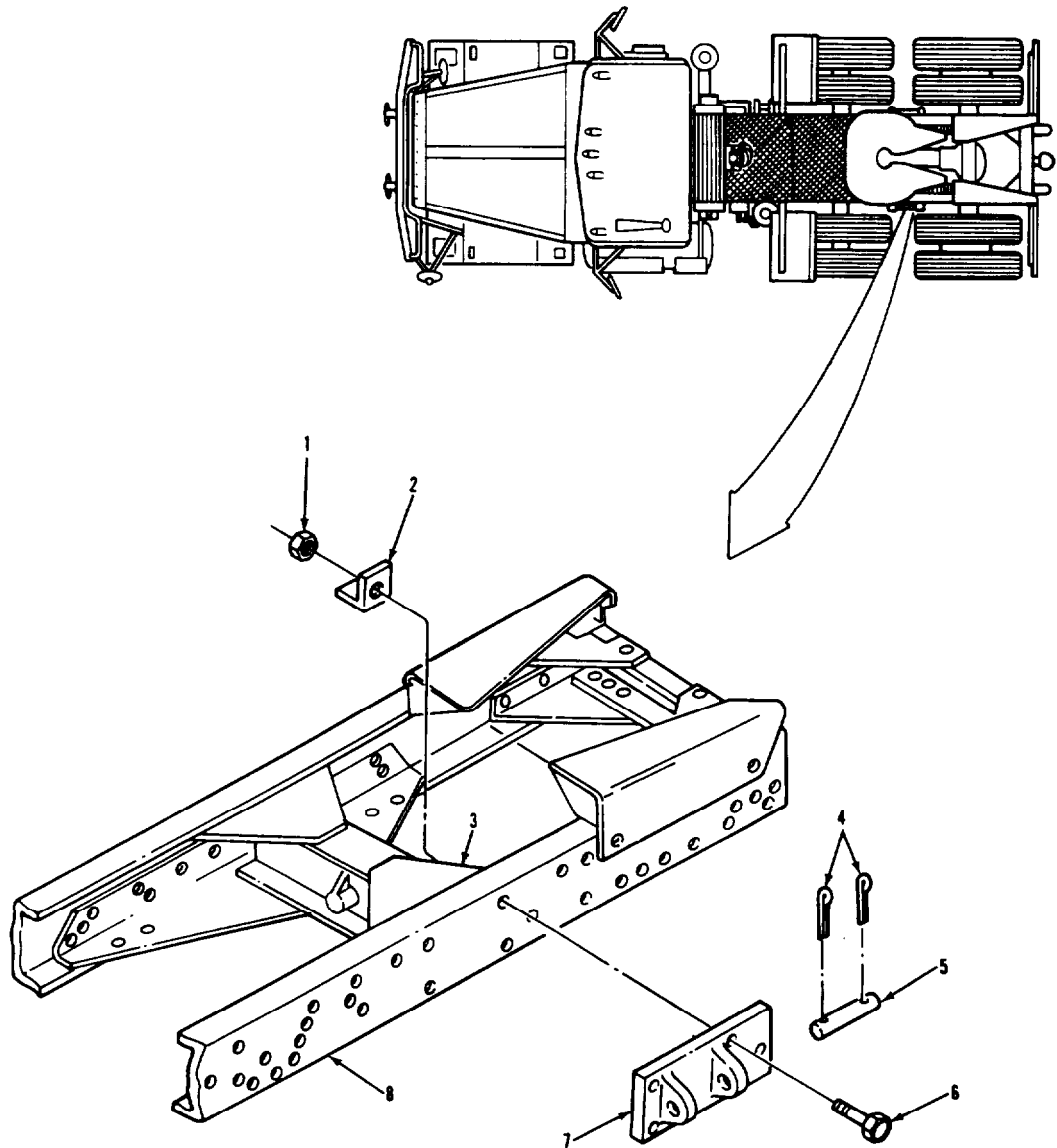

LEGEND:

- 1. HEXAGON FLANGE NUT (5)
- 2. TUBE SUPPORT BRACKET
- 3. REAR SUSPENSION CROSSMEMBER ASSEMBLY
- 4. COTTER PIN (2)

- 5. CLEVIS PIN
- 6. FLANGE HEAD BOLT (5)
- 7. LEFT-HAND VEHICLE LIFTING BRACKET ASSEMBLY
- 8. LEFT-HAND MAIN RAIL

TA 237642

FRAME AND TOWING ATTACHMENTS.

3-229. VEHICLE LIFTING BRACKET REPLACEMENT (Continued).

LOCATION/ITEM	ACTION	REMARKS
<b>C. INSTALLATION.</b>		
3. Bracket (7).	a. Line up holes in item (7) with holes in item (8).	
	b. Secure fingertight four items (1) and (6).	Leave upper right hole open.
4. Bracket (2).	a. Line up hole in item (2) with holes in items (3), (8), and (7).	
	b. Secure with one item (1) and (6).	
5. Five nuts (1) and bolts (6).	Tighten.	
<b>NOTE</b>		
Follow-on maintenance action required:		
None.		

FRAME AND TOWING ATTACHMENTS.

3-229. VEHICLE LIFTING BRACKET REPLACEMENT (Continued).

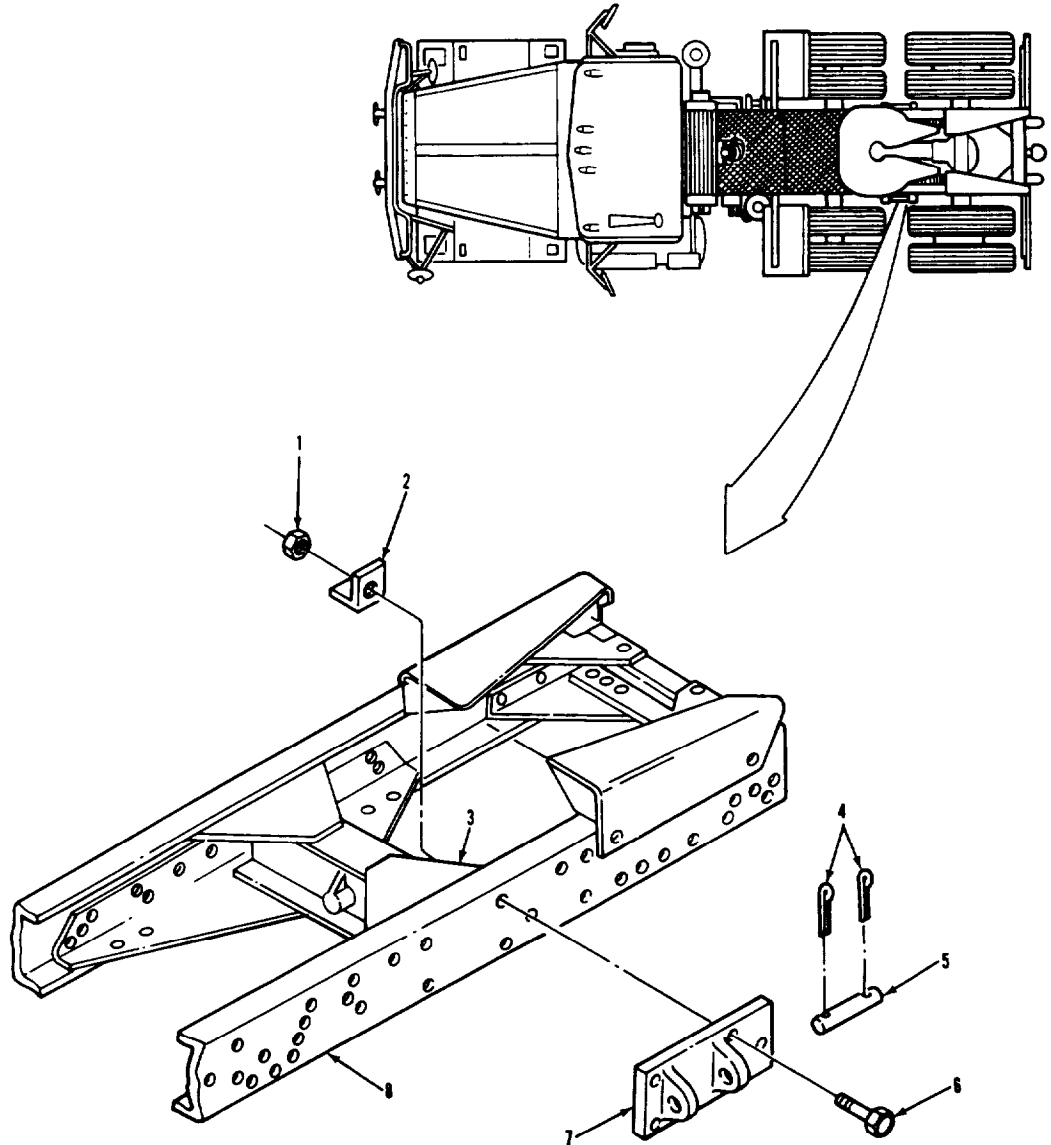

LEGEND:

- |   |   |
|---|---|
| 1. HEXAGON FLANGE NUT (5)               | 5. CLEVIS PIN                                 |
| 2. TUBE SUPPORT BRACKET                 | 6. FLANGE HEAD BOLT (5)                       |
| 3. REAR SUSPENSION CROSSMEMBER ASSEMBLY | 7. LEFT-HAND VEHICLE LIFTING BRACKET ASSEMBLY |
| 4. COTTER PIN (2)                       | 8. LEFT-HAND MAIN RAIL                        |

TA 237643

FRAME AND TOWING ATTACHMENTS.

3-230. CLEVIS PIN REPLACEMENT.		
<u>THIS TASK COVERS</u>		
<ul style="list-style-type: none"> <li>a. Removal.</li> <li>b. Cleaning and Inspection.</li> <li>c. Installation.</li> </ul>		
<u>INITIAL SETUP</u>		
<u>APPLICABLE CONFIGURATIONS</u>	<u>EQUIPMENT CONDITION PARAGRAPH</u>	<u>CONDITION DESCRIPTION</u>
All.	None.	None.
<u>TEST EQUIPMENT</u>		
None.		
<u>SPECIAL TOOLS</u>		
None.		
<u>MATERIALS/PARTS (P/N)</u>		
Pin, cotter (as required) (24617) 137259.		
Pin, cotter (as required) (24617) 103421.		
<u>PERSONNEL REQUIRED</u>	<u>SPECIAL ENVIRONMENTAL CONDITIONS</u>	
One (MOS- 63S).	None.	
<u>REFERENCES (TM)</u>	<u>GENERAL SAFETY INSTRUCTIONS</u>	
TM 9-2320-283-20P.	Engine off Transmission in neutral. Park brake set.	
<u>TROUBLESHOOTING REFERENCES</u>		
None.		

FRAME AND TOWING ATTACHMENTS.

3-230. CLEVIS PIN REPLACEMENT (Continued).

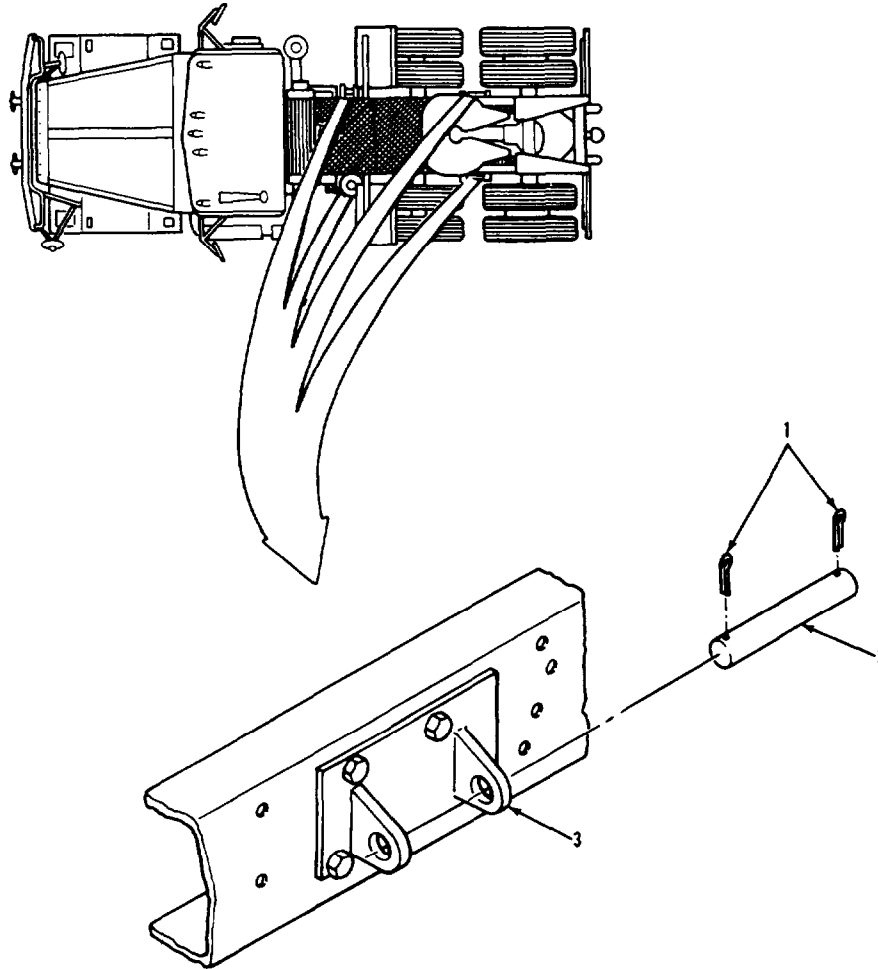

LEGEND:

- 1. COTTER PIN (2)
- 2. CLEVIS PIN
- 3. TIEDOWN BRACKET OR  
VEHICLE LIFTING BRACKET

TA 237644



FRAME AND TOWING ATTACHMENTS.

3-230. CLEVIS PIN REPLACEMENT (Continued).		
LOCATION/ITEM	ACTION	REMARKS
<p>NOTE</p> <p>Use this procedure to replace any one of the four clevis pins.</p>		
<p><b>A. REMOVAL.</b></p>		
1. Two pins (1).	Remove from item (2).	Discard item (1).
2. Pin (2).	Remove from item (3).	
<p><b>B. CLEANING AND INSPECTION.</b></p>		
3. All parts.	Clean and inspect.	Refer to paragraphs 3-4 and 3-5.
<p><b>C. INSTALLATION.</b></p>		
4. Pin (2).	Install in item (3).	
5. Two new pins (1).	Install in item (2) and bend over ends.	
<p>NOTE</p> <p>Follow-on maintenance action required:</p> <p>None.</p>		

FRAME AND TOWING ATTACHMENTS.

3-230. CLEVIS PIN REPLACEMENT (Continued).

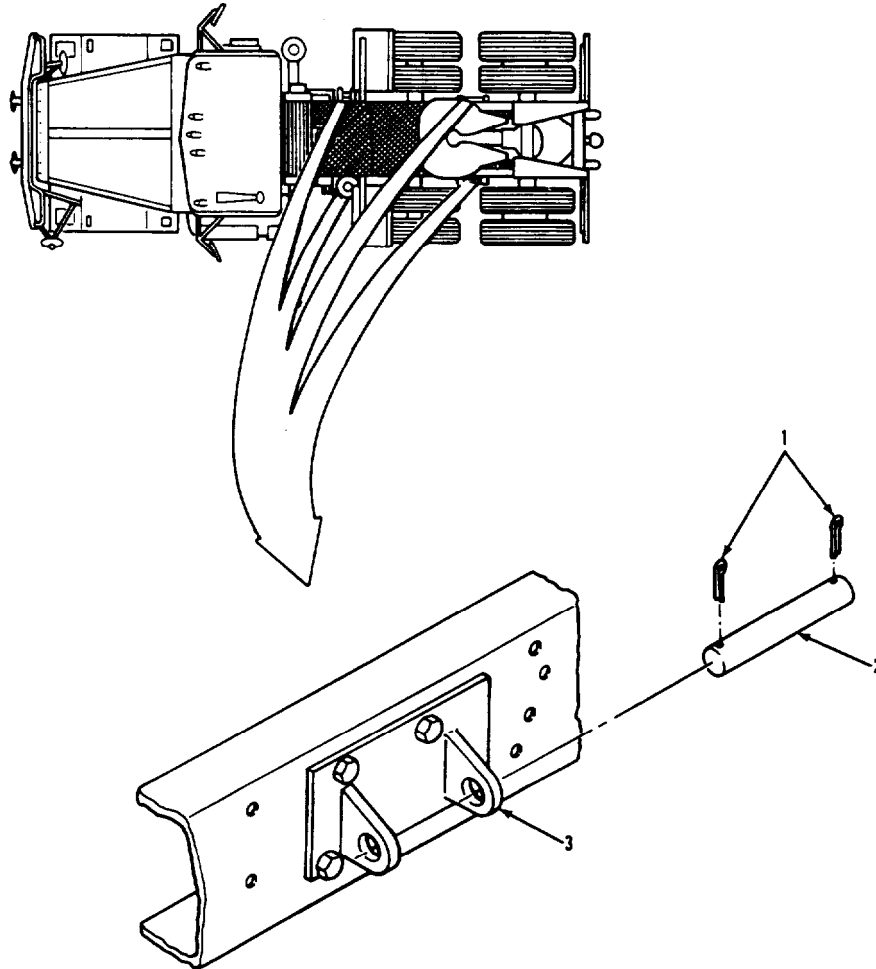

LEGEND:

1. COTTER PIN (2)
2. CLEVIS PIN
3. TIEDOWN BRACKET OR  
VEHICLE LIFTING BRACKET

TA 237645

FRAME AND TOWING ATTACHMENTS.

**3-231. TRANSMISSION OIL FILTER MOUNTING BRACKET REPLACEMENT.**

THIS TASK COVERS

- a. Removal.
- b. Cleaning and Inspection.
- c. Installation.

INITIAL SETUP

<p><u>APPLICABLE CONFIGURATIONS</u> All.</p>	<p><u>EQUIPMENT CONDITION PARAGRAPH</u> 3-35.</p>	<p><u>CONDITION DESCRIPTION</u> Fuel heater removed.</p>
<p><u>TEST EQUIPMENT</u> None.</p>	<p>3-135.</p>	<p>External oil filter removed.</p>
<p><u>SPECIAL TOOLS</u> None.</p>		
<p><u>MATERIALS/PARTS (P/N)</u> None.</p>		
<p><u>PERSONNEL REQUIRED</u> One (MOS-63S).</p>	<p><u>SPECIAL ENVIRONMENTAL CONDITIONS</u> None.</p>	
<p><u>REFERENCES (TM)</u> None.</p>	<p><u>GENERAL SAFETY INSTRUCTIONS</u> Engine off. Transmission in neutral. Park brake set.</p>	
<p><u>TROUBLESHOOTING REFERENCES</u> None.</p>		

FRAME AND TOWING ATTACHMENTS.

3-231. TRANSMISSION OIL FILTER MOUNTING BRACKET REPLACEMENT (Continued).

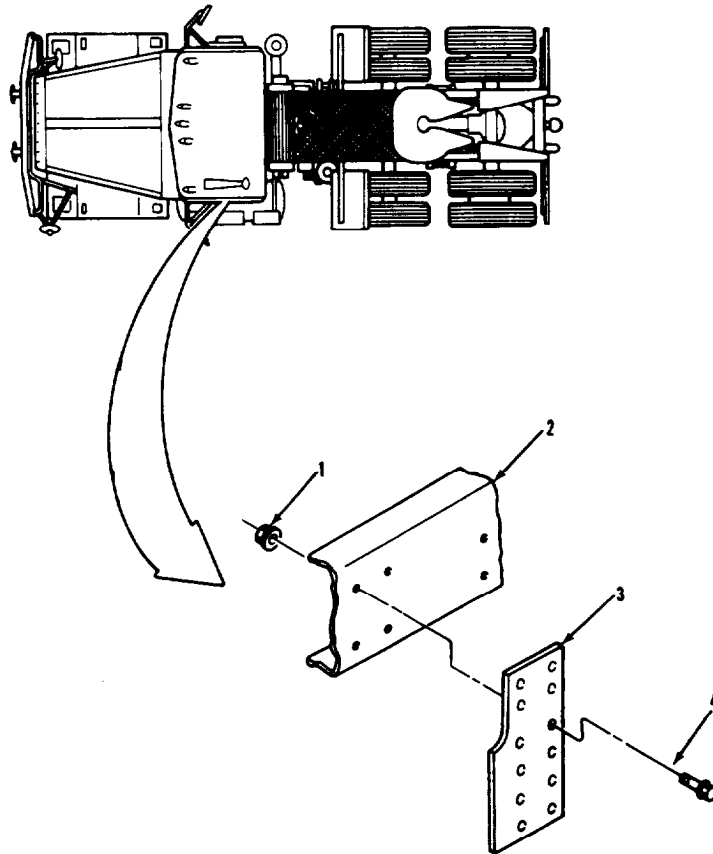

LEGEND:

- 1. HEXAGON FLANGE NUT (4)
- 2. FRAME RAIL
- 3. OIL FILTER MOUNTING BRACKET
- 4. FLANGE HEAD BOLT (4)

TA 237646

FRAME AND TOWING ATTACHMENTS.

3-231. TRANSMISSION OIL FILTER MOUNTING BRACKET REPLACEMENT (Continued).		
LOCATION/ITEM	ACTION	REMARKS
<b>A. REMOVAL.</b>		
1. Four nuts (1), bolts (4), and bracket (3).	Remove from item (2).	
<b>B. CLEANING AND INSPECTION.</b>		
2. All parts.	Clean and inspect.	Refer to paragraphs 3-4 and 3-5.
<b>C. INSTALLATION.</b>		
3. Bracket (3).	<ul style="list-style-type: none"> <li>a. Position on item (2).</li> <li>b. Secure with four items (1) and (4).</li> </ul>	
<b>NOTE</b>		
Follow-on maintenance action required:		
Install external oil filter (para 3-135). Install fuel heater (para 3-35).		

FRAME AND TOWING ATTACHMENTS.

3-231. TRANSMISSION OIL FILTER MOUNTING BRACKET REPLACEMENT (Continued).

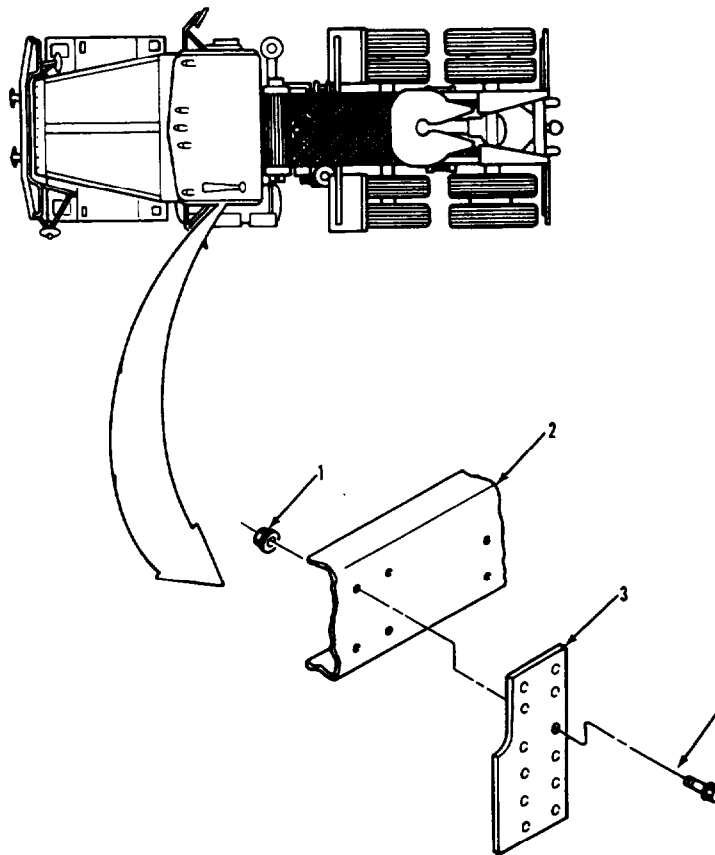

LEGEND:

- 1. HEXAGON FLANGE NUT (4)
- 2. FRAME RAIL
- 3. OIL FILTER MOUNTING BRACKET
- 4. FLANGE HEAD BOLT (4)

TA 237647

FRAME AND TOWING ATTACHMENTS.

3-232. FORWARD-REAR AXLE STOP REPLACEMENT.

THIS TASK COVERS

- a. Removal.
- b. Cleaning and Inspection.
- c. Installation.

INITIAL SETUP

APPLICABLE CONFIGURATIONS

All.

EQUIPMENT CONDITION  
PARAGRAPH

None.

CONDITION DESCRIPTION

None.

TEST EQUIPMENT

None.

SPECIAL TOOLS

None.

MATERIALS/PARTS (P/N)

None.

PERSONNEL REQUIRED

One (MDS-63S).

SPECIAL ENVIRONMENTAL CONDITIONS

None.

REFERENCES (TM)

None.

GENERAL SAFETY INSTRUCTIONS

Engine off.  
Transmission in neutral.  
Park brake set.

TROUBLESHOOTING REFERENCES

None.

FRAME AND TOWING ATTACHMENTS.

3-232. FORWARD-REAR AXLE STOP REPLACEMENT (Continued).

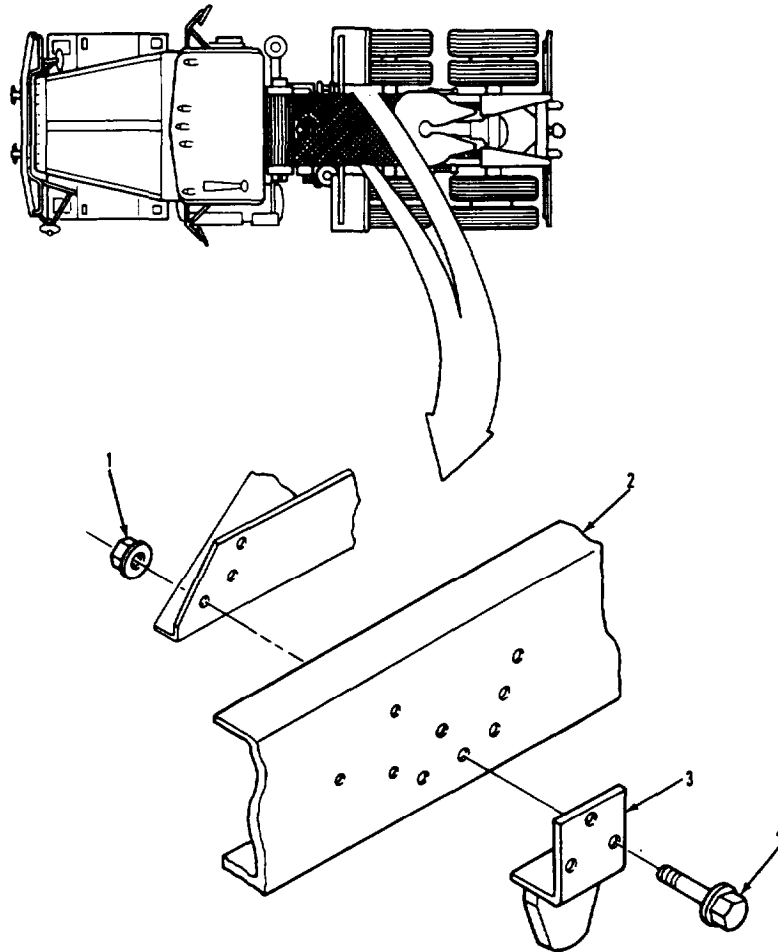

LEGEND:

- 1. HEXAGON FLANGE NUT (3)
- 2. FRAME RAIL
- 3. FORWARD-REAR AXLE STOP
- 4. FLANGE HEAD BOLT (3)

TA 237648



FRAME AND TOWING ATTACHMENTS.

3-232. FORWARD-REAR AXLE STOP REPLACEMENT (Continued).		
LOCATION/ITEM	ACTION	REMARKS
<p><b>NOTE</b></p> <p>Use this procedure to replace any one of the two forward-rear axle stops.</p>		
<p><b>A. REMOVAL.</b></p>		
1. Three nuts (1), bolts (4), and stop (3).	Remove from item (2).	
<p><b>B. CLEANING AND INSPECTION.</b></p>		
2. All parts.	Clean and inspect.	Refer to paragraphs 3-4 and 3-5.
<p><b>C. INSTALLATION.</b></p>		
3. Stop (3).	<p>a. Position on item (2).</p> <p>b. Secure with three items (1) and (4).</p>	
<p><b>NOTE</b></p> <p>Follow-on maintenance action required:</p> <p>None.</p>		

FRAME AND TOWING ATTACHMENTS.

3-232. FORWARD-REAR AXLE STOP REPLACEMENT (Continued).

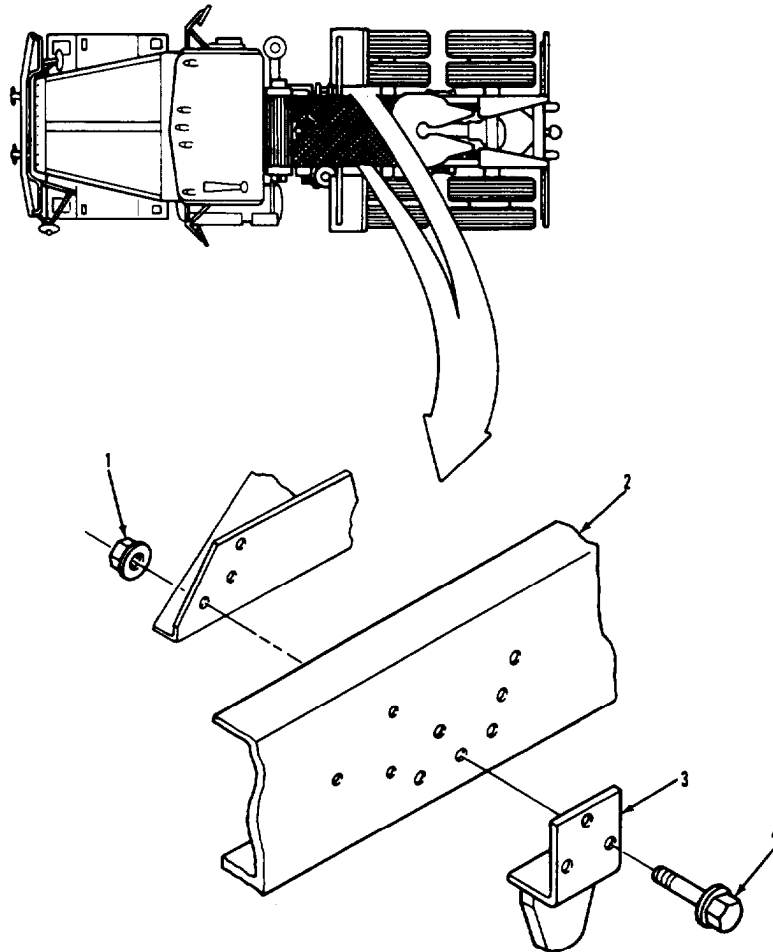

LEGEND:

- 1. HEXAGON FLANGE NUT (3)
- 2. FRAME RAIL
- 3. FORWARD-REAR AXLE STOP
- 4. FLANGE HEAD BOLT (3)

TA 23764

FRAME AND TOWING ATTACHMENTS.

3-233. BLACKOUT TAILLAMP MOUNTING BRACKET REPLACEMENT.

THIS TASK COVERS

- a. Removal.
- b. Cleaning and Inspection.
- c. Installation.

INITIAL SETUP

APPLICABLE CONFIGURATIONS

All.

EQUIPMENT CONDITION

PARAGRAPH

3-97.

CONDITION DESCRIPTION

Blackout taillamp  
assembly removed.

TEST EQUIPMENT

None.

SPECIAL TOOLS

None.

MATERIALS/PARTS (P/N)

None.

PERSONNEL REQUIRED

One (MDS-63S).

SPECIAL ENVIRONMENTAL CONDITIONS

None.

REFERENCES (TM)

None.

GENERAL SAFETY INSTRUCTIONS

Engine off.  
Transmission in neutral.  
Park brake set.

TROUBLESHOOTING REFERENCES

None.

FRAME AND TOWING ATTACHMENTS.

3-233. BLACKOUT TAILLAMP MOUNTING REPLACEMENT (Continued).

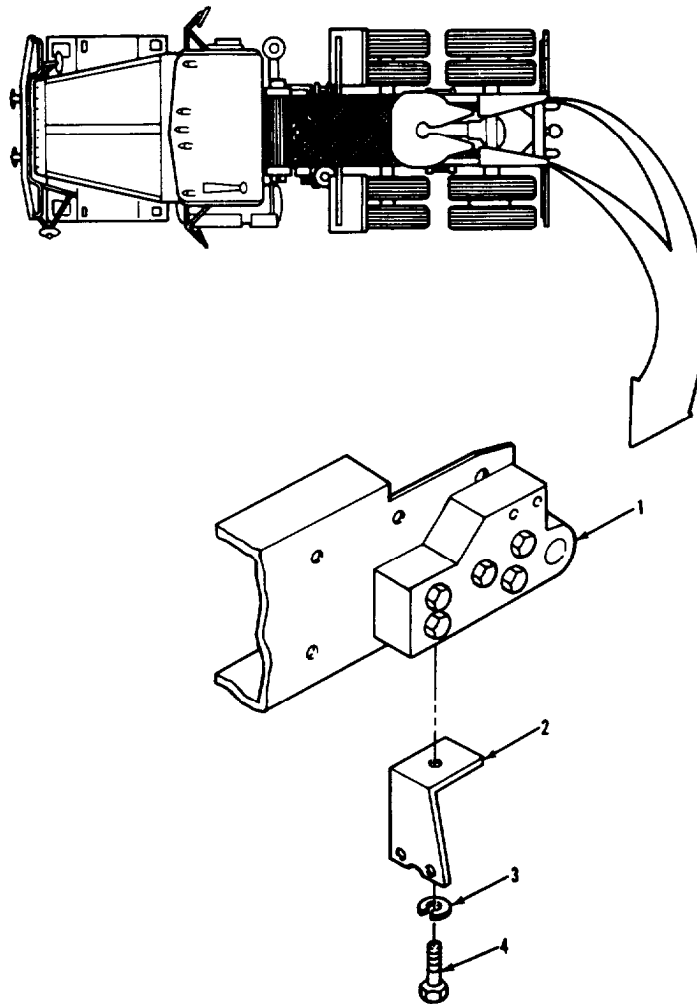

LEGEND:

1. TOW EYE BRACKET
2. REAR BLACKOUT LAMP MOUNTING BRACKET
3. LOCKWASHER
4. HEXAGON HEAD BOLT

TA 237650

FRAME AND TOWING ATTACHMENTS.

3-233. BLACKOUT TAILLAMP MOUNTING REPLACEMENT (Continued).

LOCATION/ITEM	ACTION	REMARKS
<b>NOTE</b>		
Use this procedure to replace any one of the two blackout taillamp mounting brackets.		
<b>A. REMOVAL</b>		
1. Bolt (4), lock-washer (3), and bracket (2).	Remove from item (1).	
<b>B. CLEANING AND INSPECTION.</b>		
2. All parts.	Clean and inspect.	Refer to paragraphs 3-4 and 3-5.
<b>C. INSTALLATION.</b>		
3. Bracket (2).	a. Position on item (1). b. Secure with items (3) and (4).	
<b>NOTE</b>		
Follow-on maintenance action required:		
Install blackout taillamp assembly (para 3-97).		

FRAME AND TOWING ATTACHMENTS.

3-233. BLACKOUT TAILLAMP MOUNTING REPLACEMENT (Continued).

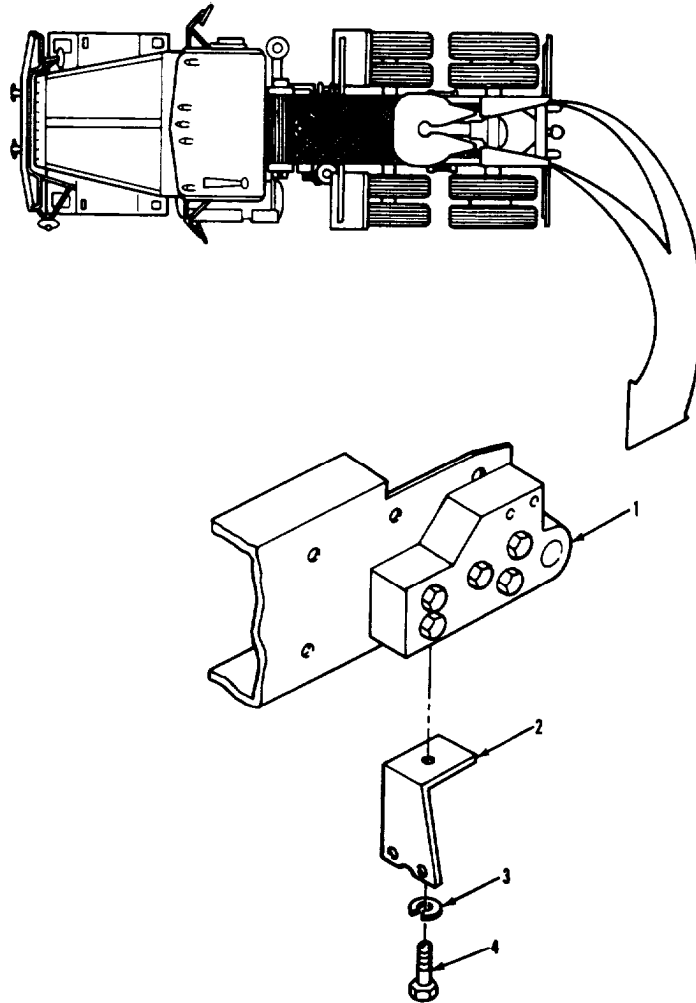

LEGEND:

1. TOW EYE BRACKET
2. REAR BLACKOUT LAMP MOUNTING BRACKET
3. LOCKWASHER
4. HEXAGON HEAD BOLT

TA 237651

FRAME AND TOWING ATTACHMENTS.

3-234. TAILLAMP BRACKET REPLACEMENT.

THIS TASK COVERS

- a. Removal.
- b. Cleaning and Inspection.
- c. Installation.

INITIAL SETUP

APPLICABLE CONFIGURATIONS

All.

EQUIPMENT CONDITION  
PARAGRAPH

3-96.

CONDITION DESCRIPTION

Stop lamp-tail lamp  
assembly removed.

TEST EQUIPMENT

None.

SPECIAL TOOLS

None.

MATERIALS/PARTS (P/N)

None.

PERSONNEL REQUIRED

One (MOS-63S).

SPECIAL ENVIRONMENTAL CONDITIONS

None.

REFERENCES (TM)

None.

GENERAL SAFETY INSTRUCTIONS

Engine off  
Transmission in neutral.  
Park brake set.

TROUBLESHOOTING REFERENCES

None.

FRAME AND TOWING ATTACHMENTS.

3-234. TAILLAMP BRACKET REPLACEMENT (Continued).

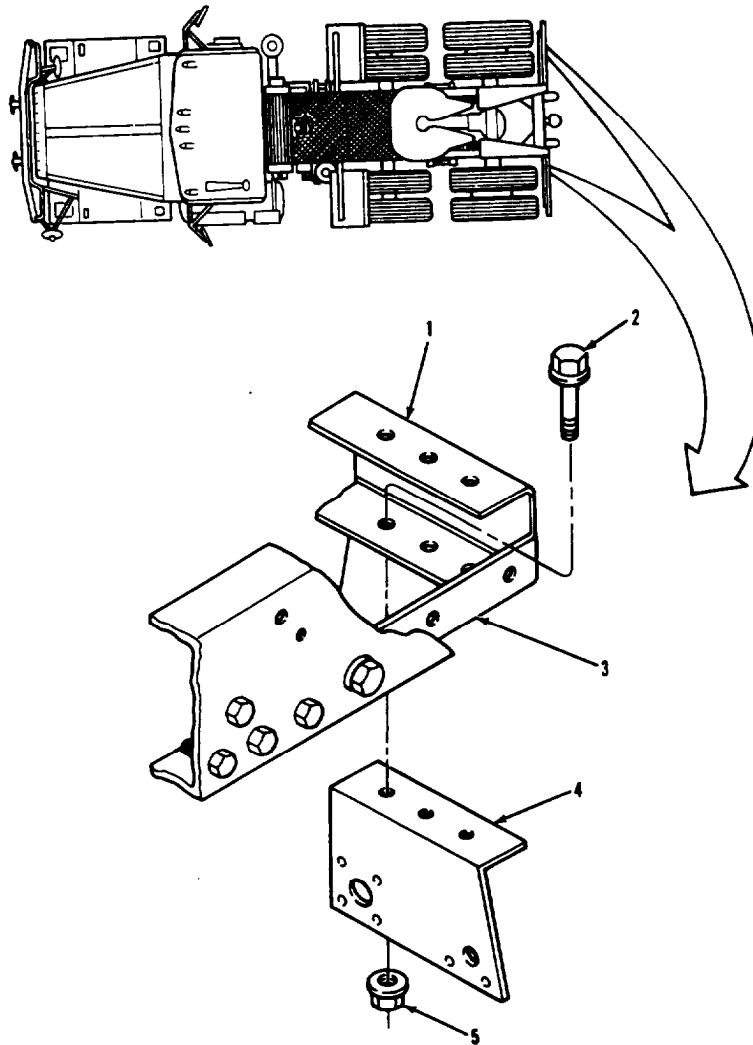

LEGEND:

- |                              |                           |
|------------------------------|---------------------------|
| 1. REAR CROSSMEMBER ASSEMBLY | 4. TAILLAMP BRACKET       |
| 2. FLANGE HEAD BOLT (3)      | 5. HEXAGON FLANGE NUT (3) |
| 3. REAR CROSSMEMBER GUSSET   |                           |

TA 237652



FRAME AND TOWING ATTACHMENTS.

3-234. TAILLAMP BRACKET REPLACEMENT (Continued).		
LOCATION/ITEM	ACTION	REMARKS
<p><b>NOTE</b></p> <p>Use this procedure to replace any one of the two taillamp brackets.</p>		
<p><b>A. REMOVAL.</b></p>		
1. Three nuts (5), screws (2), and bracket (4).	Remove from items (1) and (3).	
<p><b>B. CLEANING AND INSPECTION.</b></p>		
2. All parts.	Clean and inspect.	Refer to paragraphs 3-4 and 3-5.
<p><b>C. INSTALLATION.</b></p>		
3. Bracket (4).	<p>a. Position on item (3).</p> <p>b. Secure with three items (2) and (5).</p>	
<p><b>NOTE</b></p> <p>Follow-on maintenance action required:</p> <p>Install stoplamp-taillamp assembly (para 3-96).</p>		

FRAME AND TOWING ATTACHMENTS.

3-234. TAILLAMP BRACKET REPLACEMENT (Continued).

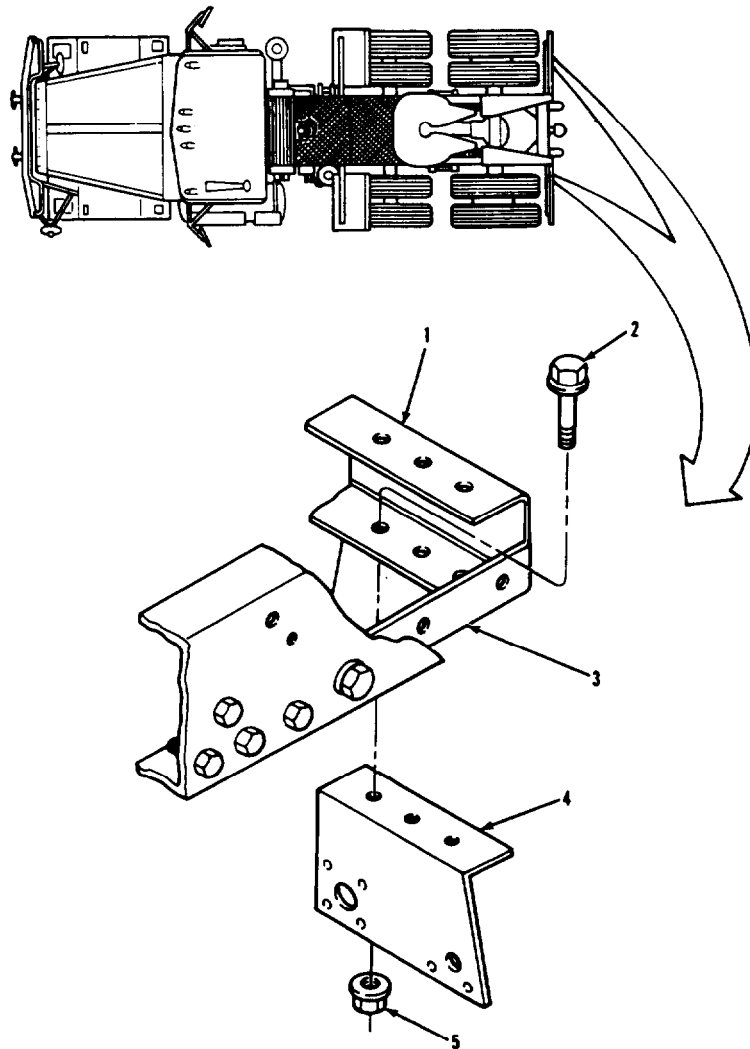

LEGEND:

- |                              |                           |
|------------------------------|---------------------------|
| 1. REAR CROSSMEMBER ASSEMBLY | 4. TAILLAMP BRACKET       |
| 2. FLANGE HEAD BOLT (3)      | 5. HEXAGON FLANGE NUT (3) |
| 3. REAR CROSSMEMBER GUSSET   |                           |

TA 237653

FRAME AND TOWING ATTACHMENTS.

3-235. REAR TOW EYE BRACKET, SHACKLE, AND PIN REPLACEMENT.

THIS TASK COVERS

- a. Shackle and Pin Removal.
- b. Bracket Removal.
- c. Cleaning and Inspection.
- d. Bracket Installation.
- e. Shackle and Pin Installation.

INITIAL SETUP

APPLICABLE CONFIGURATIONS

All.

EQUIPMENT CONDITION  
PARAGRAPH

None.

CONDITION DESCRIPTION

None.

TEST EQUIPMENT

None.

SPECIAL TOOLS

None.

MATERIALS/PARTS (P/N)

Pin, cotter  
(24617) 108656.

PERSONNEL REQUIRED

One (MOS-63S).

SPECIAL ENVIRONMENTAL CONDITIONS

None.

REFERENCES (TM)

TM 9-2320-283-20P.

GENERAL SAFETY INSTRUCTIONS

Engine off.  
Transmission in neutral.  
Park brake set.

TROUBLESHOOTING REFERENCES

None.

FRAME AND TOWING ATTACHMENTS.

3-235. REAR TOW EYE BRACKET, SHACKLE, AND PIN REPLACEMENT (Continued).

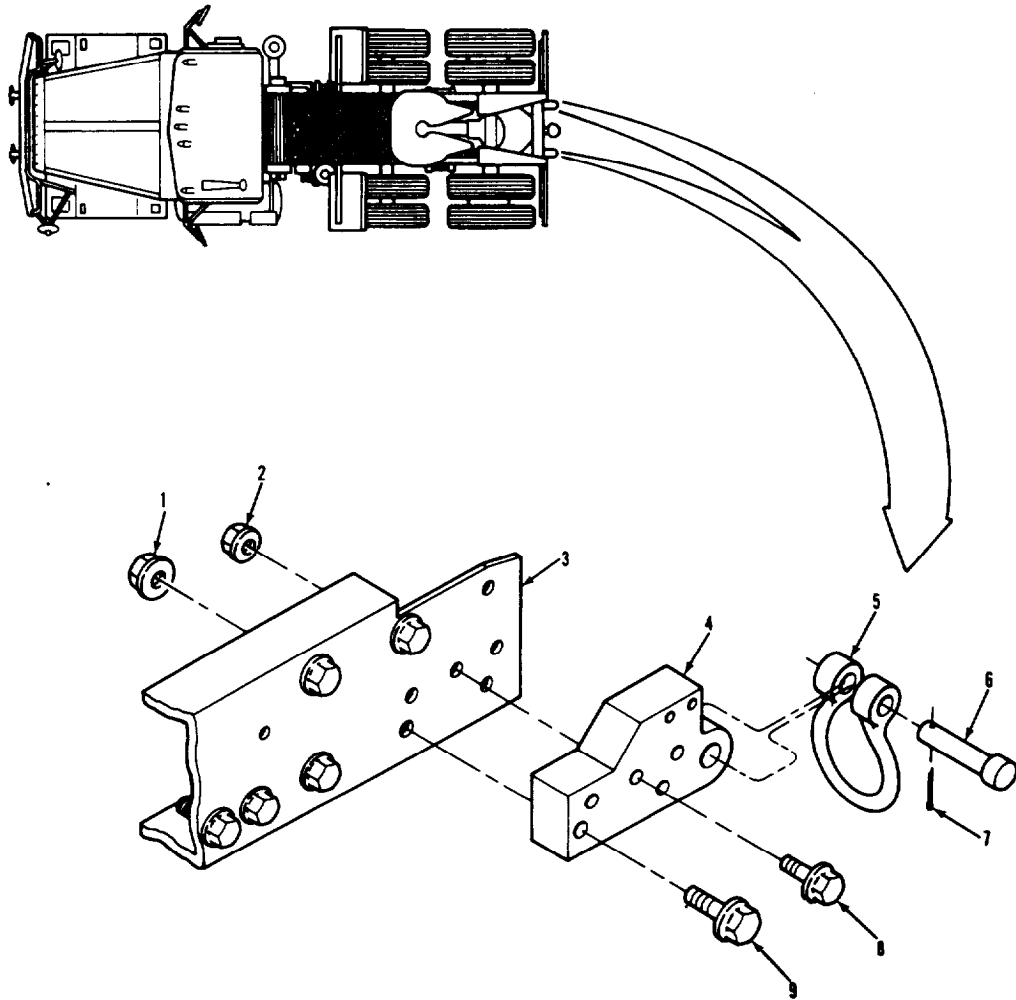

LEGEND:

- |                           |                         |
|---------------------------|-------------------------|
| 1. HEXAGON FLANGE NUT (2) | 6. PIN                  |
| 2. HEXAGON FLANGE NUT (3) | 7. COTTER PIN           |
| 3. FRAME RAIL             | 8. FLANGE HEAD BOLT (3) |
| 4. TOW EYE BRACKET        | 9. FLANGE HEAD BOLT (2) |
| 5. SHACKLE                |                         |

TA 237654

FRAME AND TOWING ATTACHMENTS.

3-235. REAR TOW EYE BRACKET, SHACKLE, AND PIN REPLACEMENT (Continued).

LOCATION/ITEM	ACTION	REMARKS
<b>NOTE</b>		
Use this procedure to replace any one of the two rear tow eye brackets, shackles, or pins.		
<b>A. SHACKLE AND PIN REMOVAL.</b>		
1. Pin (7).	Remove from item (6).	Discard item (7).
2. Pin (6) and shackle (5).	Remove from item (4).	
<b>B. BRACKET REMOVAL.</b>		
3. Rear mud flap and bracket.	Remove.	Refer to paragraph 3-274.
4. Blackout taillamp mounting bracket.	Remove.	Refer to paragraph 3-233.
5. Three bolts (8), three nuts (2), two bolts (9), two nuts and bracket (4).	Remove from item (3).	
<b>C. CLEANING AND INSPECTION.</b>		
6. All parts.	Clean and inspect.	Refer to paragraphs 3-4 and 3-5.

FRAME AND TOWING ATTACHMENTS.

3-235. REAR TOW EYE BRACKET, SHACKLE, AND PIN REPLACEMENT (Continued).

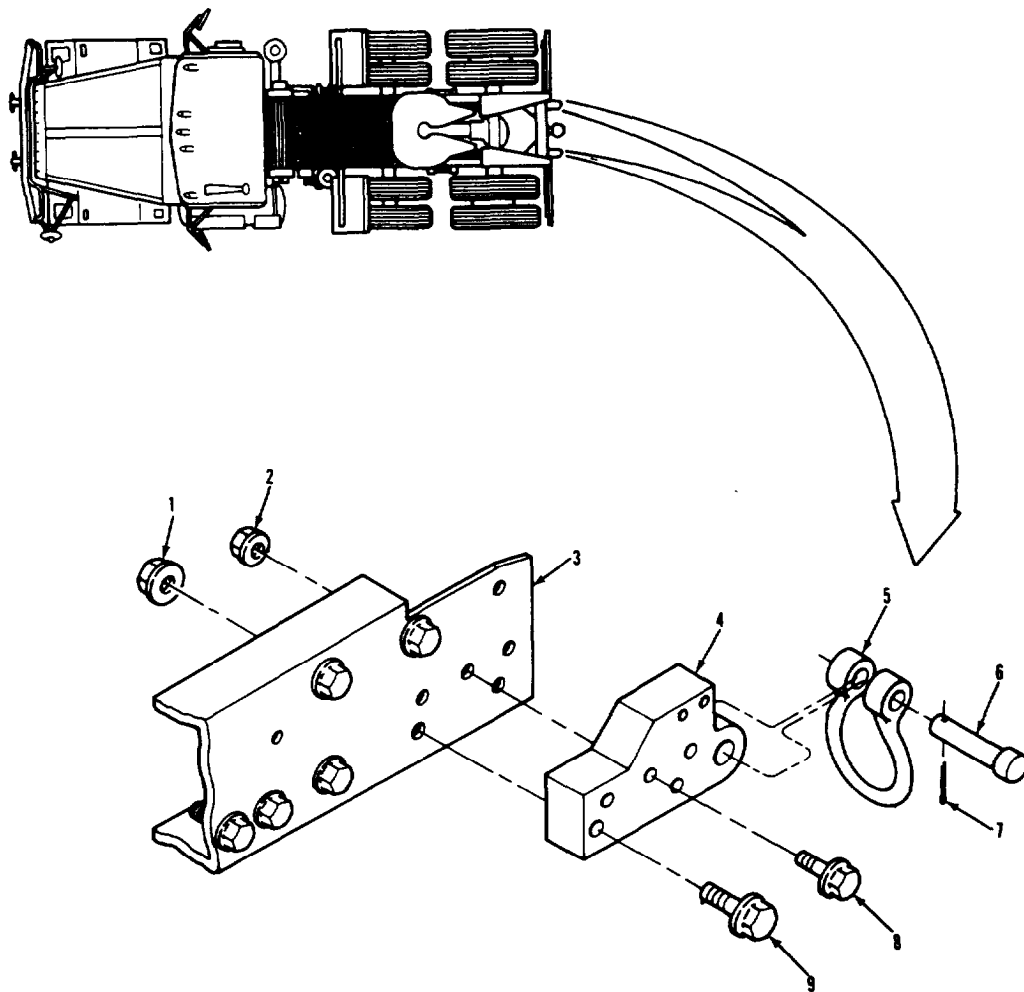

LEGEND:

- |                           |                         |
|---------------------------|-------------------------|
| 1. HEXAGON FLANGE NUT (2) | 6. PIN                  |
| 2. HEXAGON FLANGE NUT (3) | 7. COTTER PIN           |
| 3. FRAME RAIL             | 8. FLANGE HEAD BOLT (3) |
| 4. TOW EYE BRACKET        | 9. FLANGE HEAD BOLT (2) |
| 5. SHACKLE                |                         |

TA 237655

FRAME AND TOWING ATTACHMENTS.

3-235. REAR TOW EYE BRACKET, SHACKLE, AND PIN REPLACEMENT (Continued).

LOCATION/ITEM	ACTION	REMARKS
<b>D. BRACKET INSTALLATION.</b>		
7. Bracket (4).	a. Position on item (3). b. Secure with three items (2) and (8), and two items (1) and (9).	
8. Blackout taillamp mounting bracket.	Install.	Refer to paragraph 3-233.
9. Rear mud flap and bracket.	Install.	Refer to paragraph 3-274.
<b>E. SHACKLE AND PIN INSTALLATION.</b>		
10. Shackle (5).	a. Position on item (4). b. Secure with item (6).	
11. New pin (7).	Install into item (6) and bend over ends.	
<b>NOTE</b>		
Follow-on maintenance action required:		
None.		

FRAME AND TOWING ATTACHMENTS.

3-235. REAR TOW EYE BRACKET, SHACKLE, AND PIN REPLACEMENT (Continued).

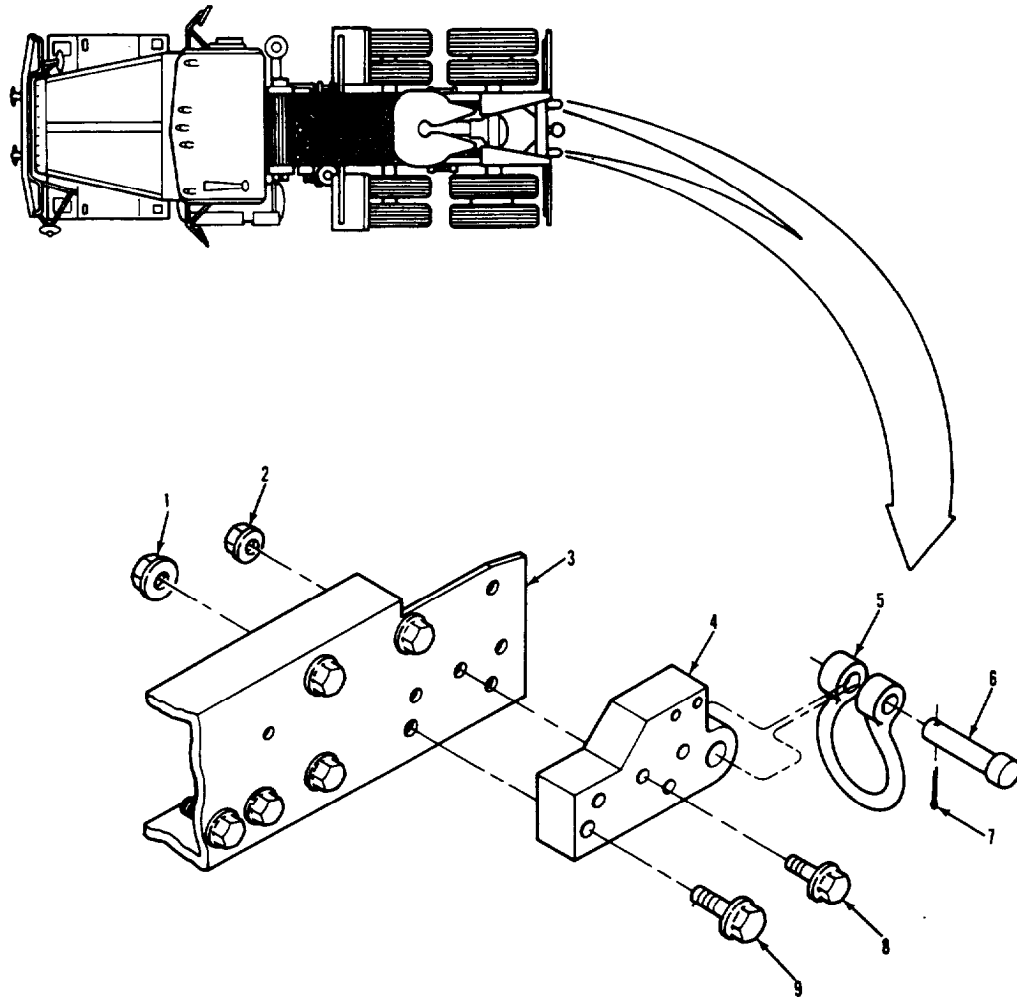

LEGEND:

- |                           |                         |
|---------------------------|-------------------------|
| 1. HEXAGON FLANGE NUT (2) | 6. PIN                  |
| 2. HEXAGON FLANGE NUT (3) | 7. COTTER PIN           |
| 3. FRAME RAIL             | 8. FLANGE HEAD BOLT (3) |
| 4. TOW EYE BRACKET        | 9. FLANGE HEAD BOLT (2) |
| 5. SHACKLE                |                         |

TA 237656



FRAME AND TOWING ATTACHMENTS.

3-236. BRUSH GUARD REPLACEMENT.

THIS TASK COVERS

- a. Removal.
- b. Disassembly.
- c. Cleaning and Inspection.
- d. Assembly.
- e. Installation.

INITIAL SETUP

APPLICABLE CONFIGURATIONS

All.

EQUIPMENT CONDITION  
PARAGRAPH

3-288.

CONDITION DESCRIPTION

Spotter mirrors  
removed.

TEST EQUIPMENT

None.

SPECIAL TOOLS

None.

MATERIALS/PARTS (P/N)

None.

PERSONNEL REQUIRED

One (MDS-63S).

SPECIAL ENVIRONMENTAL CONDITIONS

None.

REFERENCES (TM)

None.

GENERAL SAFETY INSTRUCTIONS

Engine off.  
Transmission in neutral.  
Park brake set.

TROUBLESHOOTING REFERENCES

None.

FRAME AND TOWING ATTACHMENTS.

3-236. BRUSH GUARD REPLACEMENT (Continued).

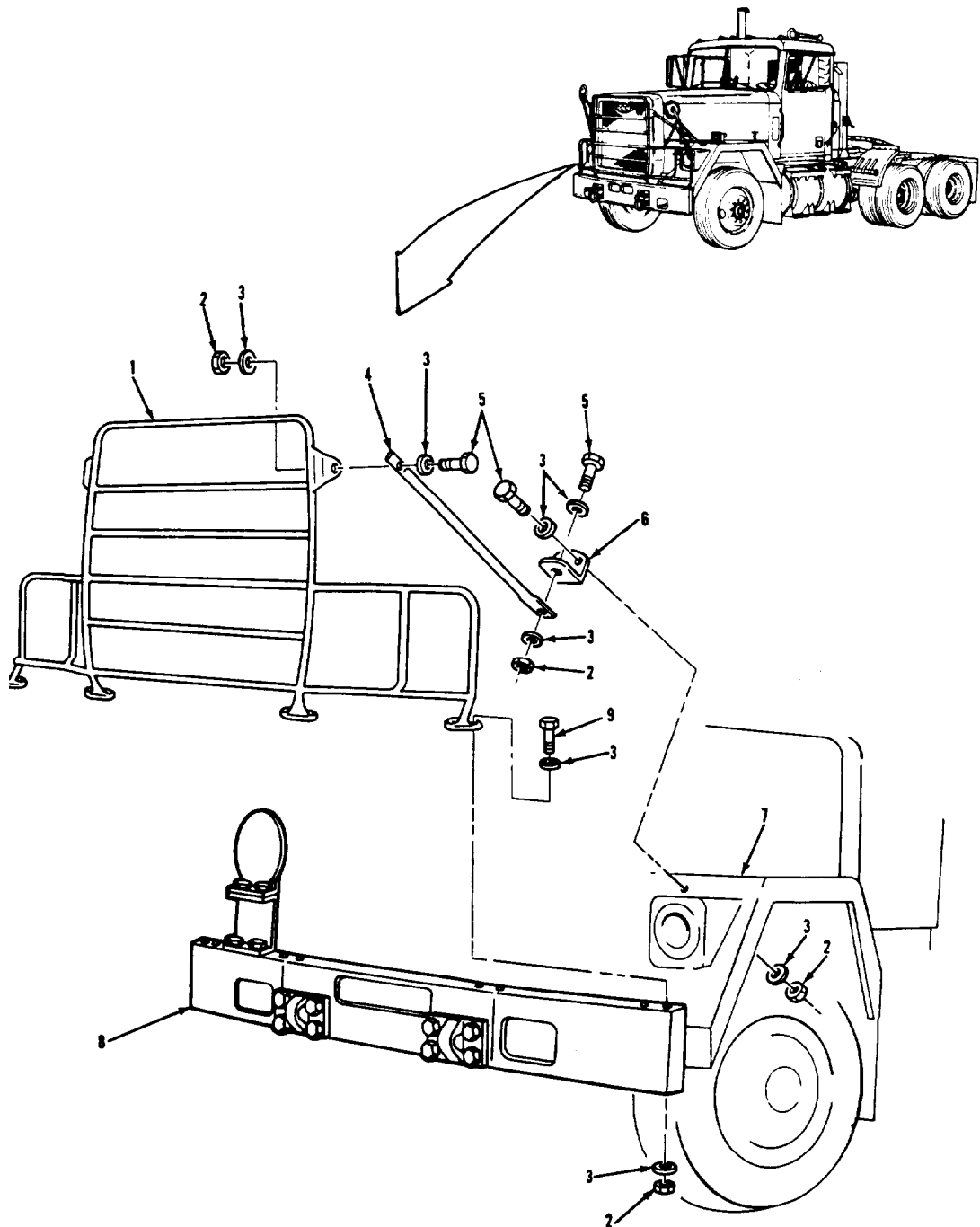

LEGEND:

- |                           |                                    |
|---------------------------|------------------------------------|
| 1. BRUSH GUARD ASSEMBLY   | 6. BRUSH GUARD BRACE BRACKET (2)   |
| 2. HEXAGON HEAD NUT (14)  | 7. FRONT FENDER PANEL ASSEMBLY (2) |
| 3. FLAT WASHER (28)       | 8. FRONT BUMPER ASSEMBLY           |
| 4. BRUSH GUARD BRACE      | 9. HEXAGON HEAD SCREW (8)          |
| 5. HEXAGON HEAD SCREW (8) |                                    |

TA 237657

FRAME AND TOWING ATTACHMENTS.

3-236. BRUSH GUARD REPLACEMENT (Continued).		
LOCATION/ITEM	ACTION	REMARKS
<b>A. REMOVAL.</b>		
1. Two nuts (2), washers (3), and screws (5).	Remove from items (6) and (7).	Repeat this step for other side of item (1).
2. Eight nuts (2), sixteen washers (3), eight screws (9), and brush guard assembly (1).	Remove from item (8).	
<b>B. DISASSEMBLY.</b>		
3. Nut (2), two washers (3), screw (5), and bracket (6).	Remove from item (4).	Repeat this step for other side of item (1).
4. Nut (2), two washers (3), screw (5), and brace (4).	Remove from item (1).	Repeat this step for other side of item (1).
<b>C. CLEANING AND INSPECTION.</b>		
5. All parts.	Clean and inspect.	Refer to paragraphs 3-4 and 3-5.
<b>D. ASSEMBLY.</b>		
6. Brace (4).	a. Position on item (1). b. Secure with item (2), two items (3), and item (5).	Repeat this step for other side of item (1).

FRAME AND TOWING ATTACHMENTS.

3-236. BRUSH GUARD REPLACEMENT (Continued).

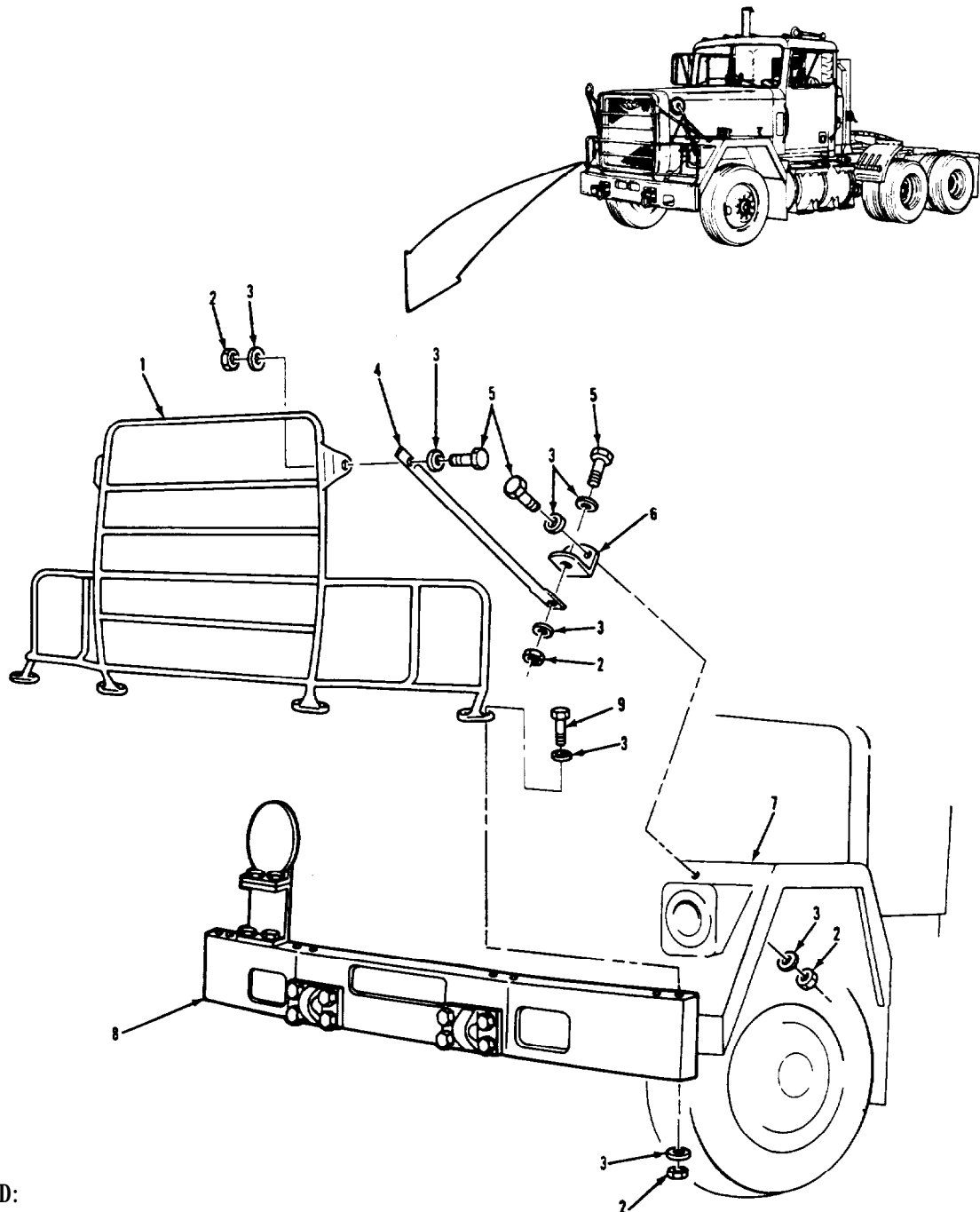

LEGEND:

- |                           |                                    |
|---------------------------|------------------------------------|
| 1. BRUSH GUARD ASSEMBLY   | 6. BRUSH GUARD BRACE BRACKET (2)   |
| 2. HEXAGON HEAD NUT (14)  | 7. FRONT FENDER PANEL ASSEMBLY (2) |
| 3. FLAT WASHER (28)       | 8. FRONT BUMPER ASSEMBLY           |
| 4. BRUSH GUARD BRACE      | 9. HEXAGON HEAD SCREW (8)          |
| 5. HEXAGON HEAD SCREW (8) |                                    |

TA 237658

FRAME AND TOWING ATTACHMENTS.

3-236. BRUSH GUARD REPLACEMENT (Continued).		
LOCATION/ITEM	ACTION	REMARKS
<b>D. ASSEMBLY (Continued).</b>		
7. Bracket (6).	a. Position on item (4). b. Secure with item (2), two items (3), and item (5).	Repeat this step for other side of item (1).
<b>E. INSTALLATION.</b>		
8. Brush guard assembly (1).	a. Position on item (8). b. Secure with eight items (2), sixteen items (3), and eight items (9).	
9. Bracket (6).	a. Position on item (7). b. Secure with two items (2), items (3), and items (5).	Repeat this step for other side of item (1).
<b>NOTE</b>		
Follow-on maintenance action required:		
Install spotter mirrors (para 3-288).		

FRAME AND TOWING ATTACHMENTS.

3-236. BRUSH GUARD REPLACEMENT (Continued).

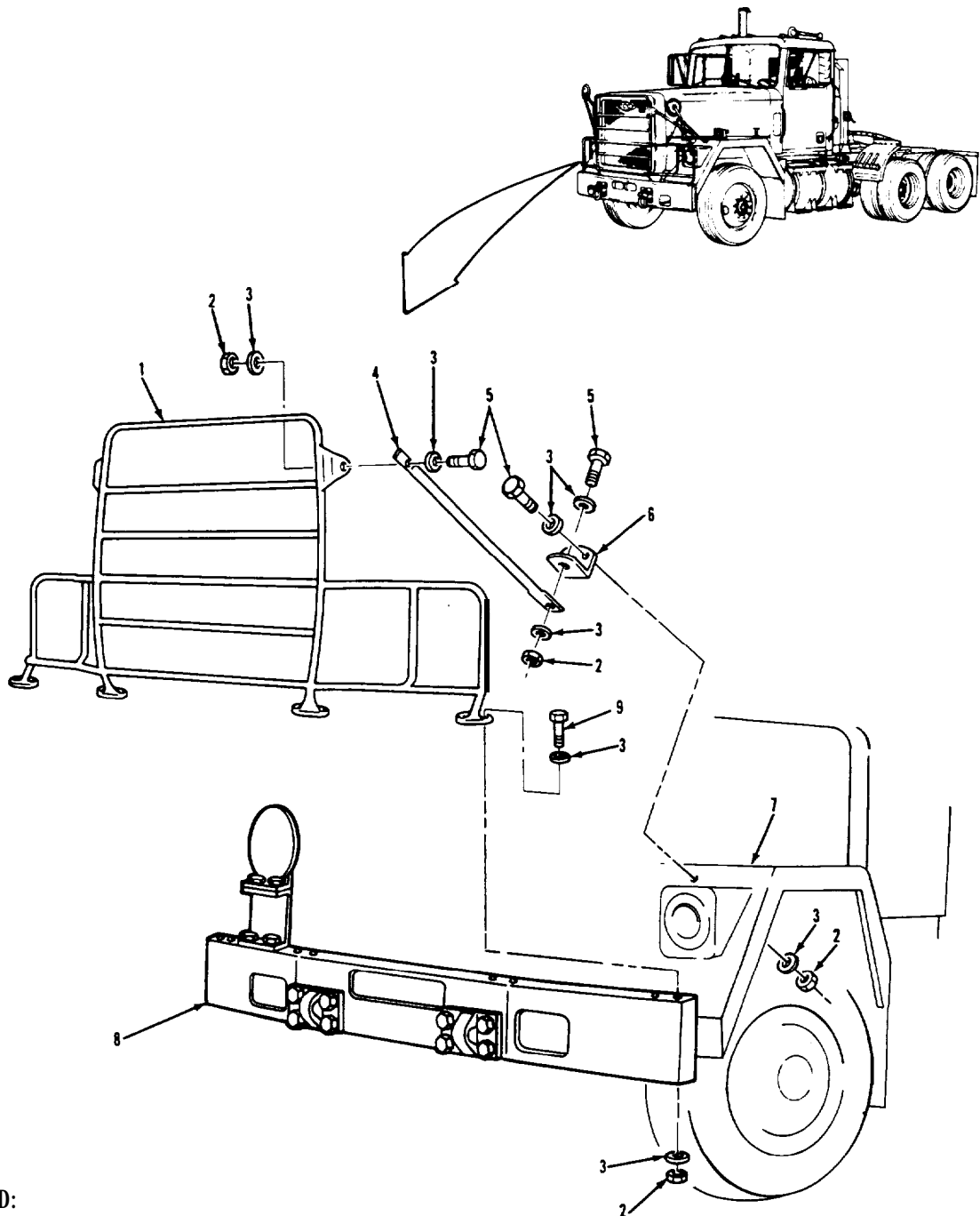

LEGEND:

- |                           |                                    |
|---------------------------|------------------------------------|
| 1. BRUSH GUARD ASSEMBLY   | 6. BRUSH GUARD BRACE BRACKET (2)   |
| 2. HEXAGON HEAD NUT (14)  | 7. FRONT FENDER PANEL ASSEMBLY (2) |
| 3. FLAT WASHER (28)       | 8. FRONT BUMPER ASSEMBLY           |
| 4. BRUSH GUARD BRACE      | 9. HEXAGON HEAD SCREW (8)          |
| 5. HEXAGON HEAD SCREW (8) |                                    |

TA 237659

FRAME AND TOWING ATTACHMENTS.

3-237. BUMPER, TOWING EYES, AND VEHICLE CLASS SIGN REPLACEMENT.

THIS TASK COVERS

- a. Vehicle Class Sign Removal.
- b. Shackle and Pin Removal.
- c. Bumper and Towing Eyes Removal.
- d. Cleaning and Inspection.
- e. Bumper and Towing Eyes Installation.
- f. Shackle and Pin Installation.
- g. Vehicle Class Sign Installation.

INITIAL SETUP

APPLICABLE CONFIGURATIONS

All.

EQUIPMENT CONDITION

PARAGRAPH

None.

CONDITION DESCRIPTION

None.

TEST EQUIPMENT

None.

SPECIAL TOOLS

None.

MATERIALS/PARTS (P/N)

Pin, cotter (as required)  
(24617) 108656.

PERSONNEL REQUIRED

Two (MDS-63S).

SPECIAL ENVIRONMENTAL CONDITIONS

None.

REFERENCES (TM)

TM 9-2320-283-20P.

GENERAL SAFETY INSTRUCTIONS

Engine off.  
Transmission in neutral.  
Park brake set.

TROUBLESHOOTING REFERENCES

None.

FRAME AND TOWING ATTACHMENTS.

3-237. BUMPER, TOWING EYES, AND VEHICLE CLASS SIGN REPLACEMENT (Continued).

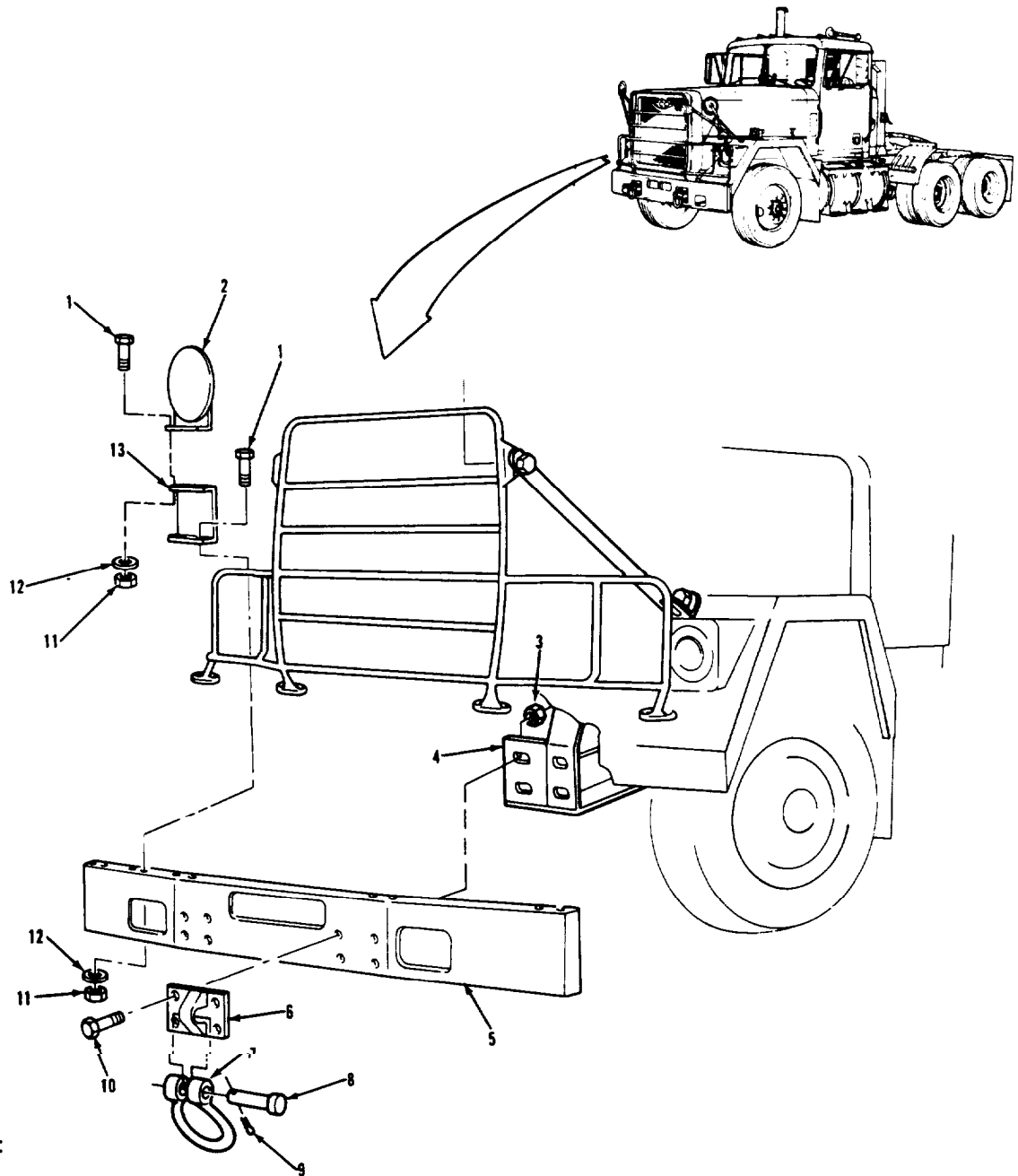

LEGEND:

- |                                    |                                |
|------------------------------------|--------------------------------|
| 1. HEXAGON HEAD SCREW (4)          | 8. PIN (2)                     |
| 2. VEHICLE CLASS SIGN KIT          | 9. COTTER PIN (2)              |
| 3. NUT (8)                         | 10. SCREW (8)                  |
| 4. FRAME FRONT SUPPORT BRACKET (2) | 11. NUT (4)                    |
| 5. FRONT BUMPER ASSEMBLY           | 12. LOCKWASHER (4)             |
| 6. HOOK EYE (2)                    | 13. VEHICLE CLASS SIGN BRACKET |
| 7. SHACKLE (2)                     |                                |

TA 237660



FRAME AND TOWING ATTACHMENTS.

3-237. BUMPER, TOWING EYES, AND VEHICLE CLASS SIGN REPLACEMENT (Continued).

LOCATION/ITEM	ACTION	REMARKS
<b>A. VEHICLE CLASS SIGN REMOVAL.</b>		
1. Two nuts (11), lockwashers (12), screws (1), and sign (2).	Remove from item (13).	
2. Two nuts (11), lockwashers (12), screws (1), bracket (13).	Remove from item (5).	
<b>B. SHACKLE AND PIN REMOVAL.</b>		
<b>NOTE</b>		
Use this procedure to remove any one of the two shackle and pin assemblies.		
3. Pin (9).	Remove from item (8).	Discard item (9).
4. Pin (8) and shackle (7).	Remove from item (6).	
<b>C. BUMPER AND TOWING EYES REMOVAL.</b>		
5. Two external air couplings.	Remove.	Refer to paragraph 3-167.
6. Brush guard.	Remove.	Refer to para 3-236.
7. Front bumper assembly (5).	Support with suitable lifting device.	
8. Eight nuts (3), screws (10), two eyes (6), and front bumper assembly (5).	Remove from two items (4).	Have assistant help steady item (5) during this step.

FRAME AND TOWING ATTACHMENTS.

3-237. BUMPER, TOWING EYES, AND VEHICLE CLASS SIGN REPLACEMENT (Continued).

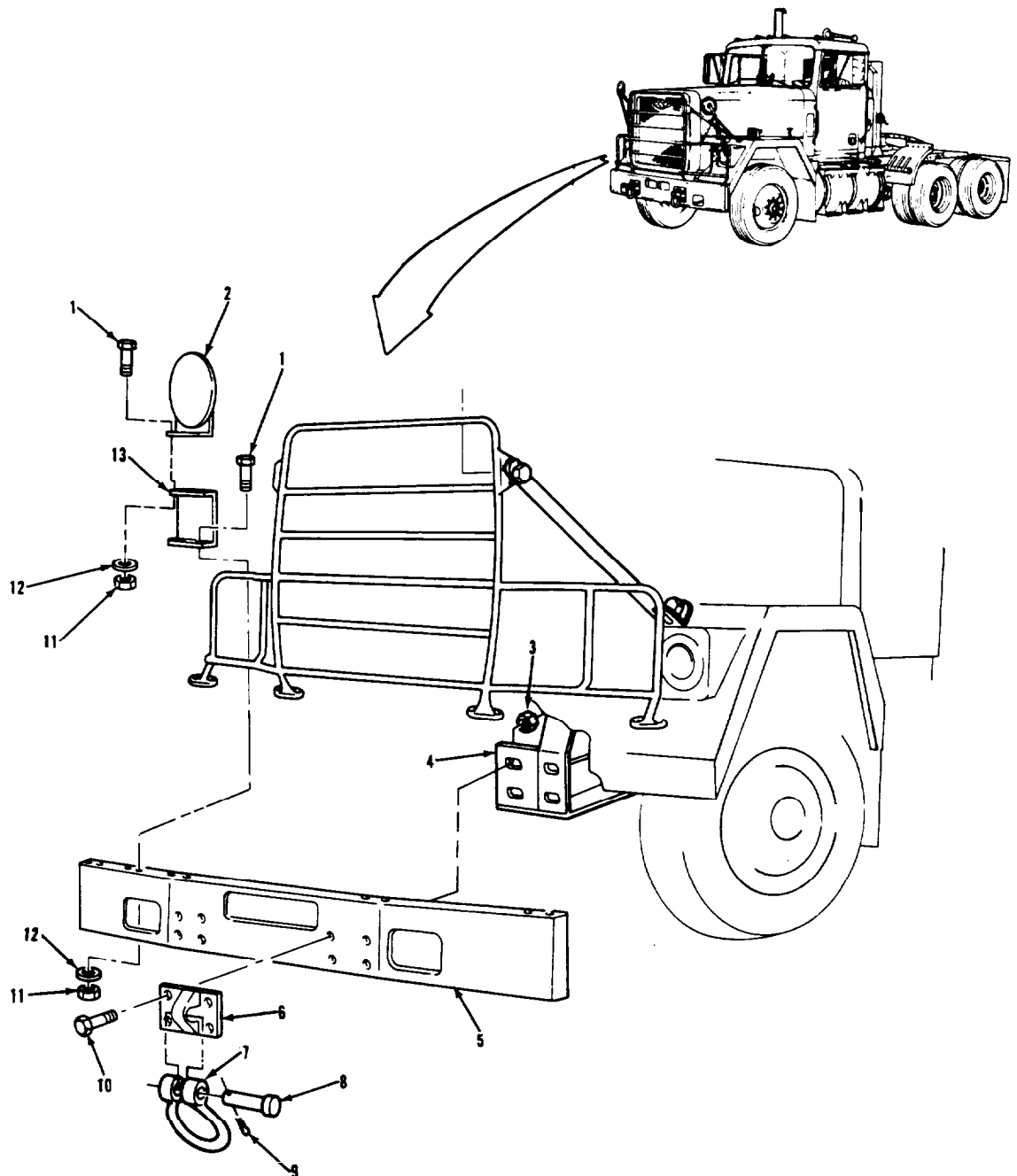

LEGEND:

- |                                    |                                |
|------------------------------------|--------------------------------|
| 1. HEXAGON HEAD SCREW (4)          | 8. PIN (2)                     |
| 2. VEHICLE CLASS SIGN KIT          | 9. COTTER PIN (2)              |
| 3. NUT (8)                         | 10. SCREW (8)                  |
| 4. FRAME FRONT SUPPORT BRACKET (2) | 11. NUT (4)                    |
| 5. FRONT BUMPER ASSEMBLY           | 12. LOCKWASHER (4)             |
| 6. HOOK EYE (2)                    | 13. VEHICLE CLASS SIGN BRACKET |
| 7. SHACKLE (2)                     |                                |

TA 237661

FRAME AND TOWING ATTACHMENTS.

3-237. BUMPER, TOWING EYES, AND VEHICLE CLASS SIGN REPLACEMENT (Continued).

LOCATION/ITEM	ACTION	REMARKS
<b>D. CLEANING AND INSPECTION.</b>		
9. All parts.	Clean and inspect.	Refer to paragraphs 3-4 and 3-5.
<b>E. BUMPER AND TOWING EYES INSTALLATION.</b>		
10. Front bumper assembly (5).	Using suitable lifting device, position on two items (4).	
11. Two eyes (6).	a. Position on item (5). b. Secure to items (5) and (4) with eight items (10) and (3).	
12. Brush guard.	Install.	Refer to paragraph 3-236.
13. Two external air couplings.	Install.	Refer to paragraph 3-167.
<b>F. SHACKLE AND PIN INSTALLATION.</b>		
<b>NOTE</b>		
Use this procedure to install any one of the two shackle and pin assemblies.		
14. Shackle (7).	a. Position on item (6). b. Secure with item (8).	
15. New pin (9).	Install into item (8) and bend over ends.	

FRAME AND TOWING ATTACHMENTS.

3-237. BUMPER, TOWING EYES, AND VEHICLE CLASS SIGN REPLACEMENT (Continued).

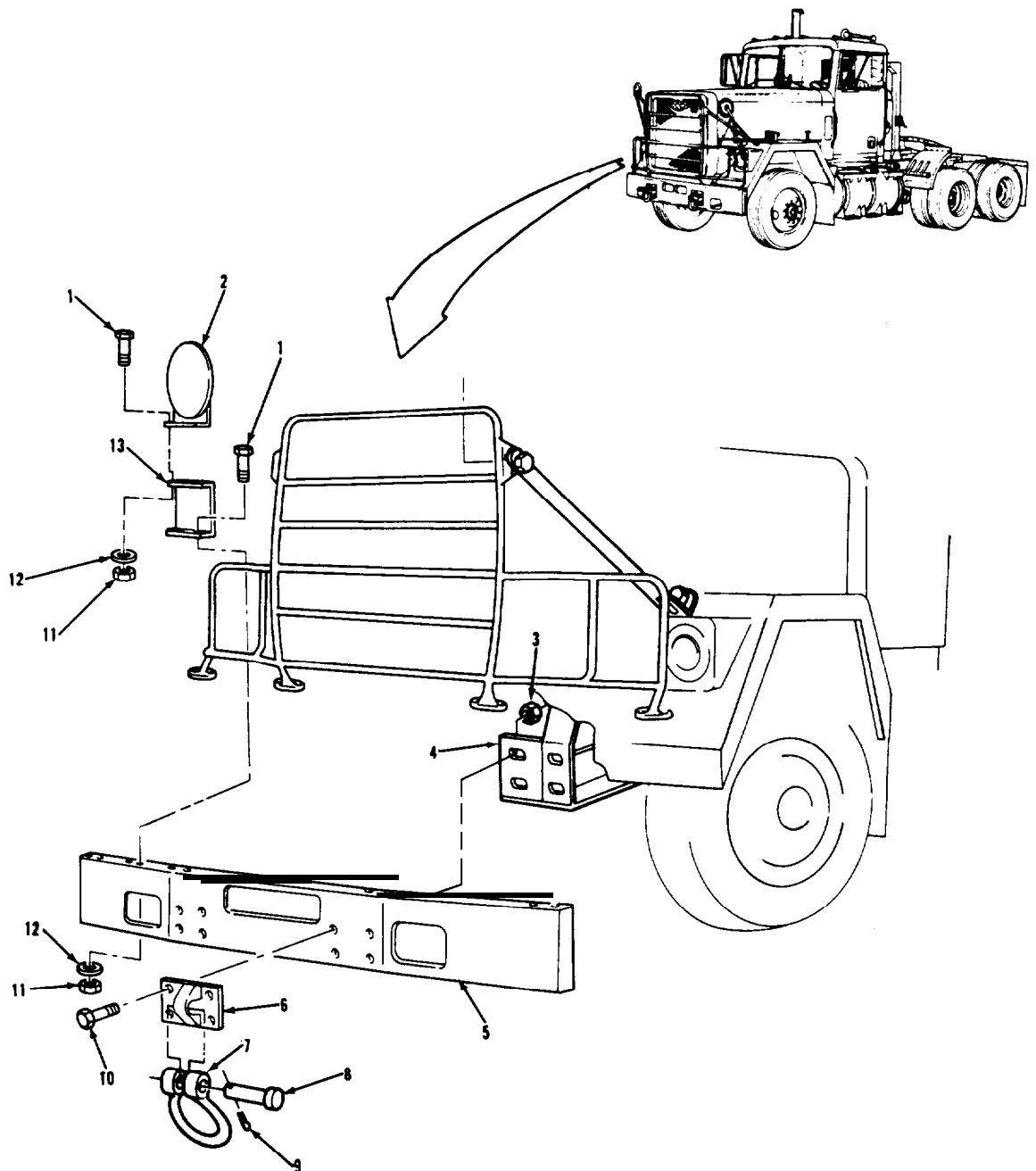

LEGEND:

- |                                    |                                |
|------------------------------------|--------------------------------|
| 1. HEXAGON HEAD SCREW (4)          | 8. PIN (2)                     |
| 2. VEHICLE CLASS SIGN KIT          | 9. COTTER PIN (2)              |
| 3. NUT (8)                         | 10. SCREW (8)                  |
| 4. FRAME FRONT SUPPORT BRACKET (2) | 11. NUT (4)                    |
| 5. FRONT BUMPER ASSEMBLY           | 12. LOCKWASHER (4)             |
| 6. HOOK EYE (2)                    | 13. VEHICLE CLASS SIGN BRACKET |
| 7. SHACKLE (2)                     |                                |

TA 237662

FRAME AND TOWING ATTACHMENTS.

3-237. BUMPER, TOWING EYES, AND VEHICLE CLASS SIGN REPLACEMENT (Continued).

LOCATION/ITEM	ACTION	REMARKS
<b>G. VEHICLE CLASS SIGN INSTALLATION.</b>		
16. Bracket (13).	a. Position on item (5). b. Secure with two items (1), (11), and (12).	
17. Sign (2).	a. Position on item (13). b. Secure with two items (1), (11), and (12).	
<b>NOTE</b>		
Follow-on maintenance action required:		
None.		

FRAME AND TOWING ATTACHMENTS.

3-237. BUMPER, TOWING EYES, AND VEHICLE CLASS SIGN REPLACEMENT (Continued).

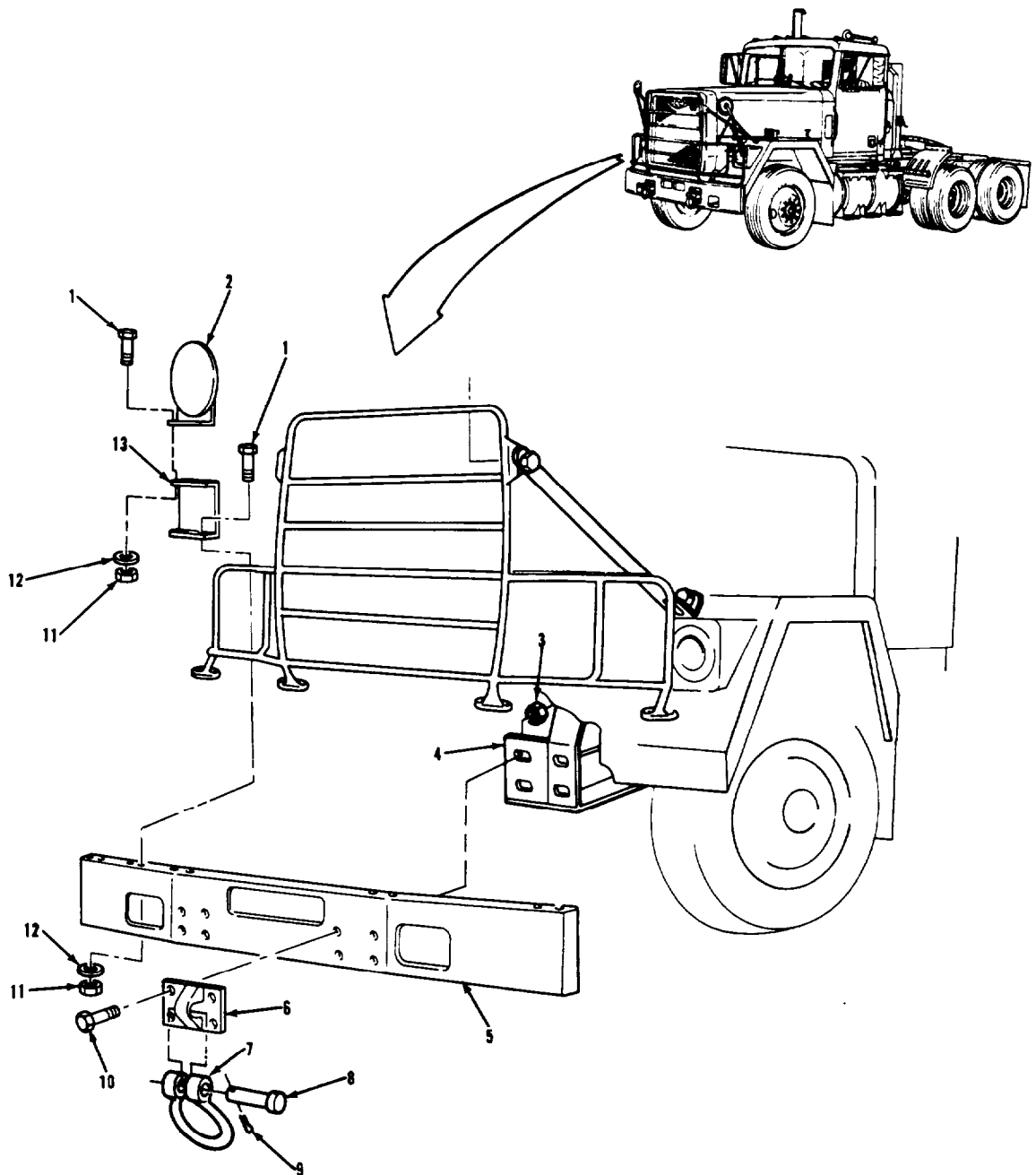

LEGEND:

- |                                    |                                |
|------------------------------------|--------------------------------|
| 1. HEXAGON HEAD SCREW (4)          | 8. PIN (2)                     |
| 2. VEHICLE CLASS SIGN KIT          | 9. COTTER PIN (2)              |
| 3. NUT (8)                         | 10. SCREW (8)                  |
| 4. FRAME FRONT SUPPORT BRACKET (2) | 11. NUT (4)                    |
| 5. FRONT BUMPER ASSEMBLY           | 12. LOCKWASHER (4)             |
| 6. HOOK EYE (2)                    | 13. VEHICLE CLASS SIGN BRACKET |
| 7. SHACKLE (2)                     |                                |

TA 237663

FRAME AND TOWING ATTACHMENTS.

3-238. TOW PINTLE REPLACEMENT.

THIS TASK COVERS

- a. Pintle Hook Removal.
- b. Pintle Hook Disassembly.
- c. Bracket Removal.
- d. Cleaning and Inspection.
- e. Bracket Installation.
- f. Pintle Hook Assembly.
- g. Pintle Hook Installation.
- h. Lubrication and Adjustment.

INITIAL SETUP

<u>APPLICABLE CONFIGURATIONS</u>	<u>EQUIPMENT CONDITION PARAGRAPH</u>	<u>CONDITION DESCRIPTION</u>
All.	None.	None.

TEST EQUIPMENT  
None.

SPECIAL TOOLS  
None.

MATERIALS/PARTS (P/N)  
Oil, lubricating: OE/HDO-10  
Item 15, Appendix C.  
Grease, automotive and artillery  
Item 7, Appendix C.  
Pin, cotter  
(74410) 773.  
Pin, cotter  
(74410) 119-1.  
Pin, cotter  
(74410) 770-1.

PERSONNEL REQUIRED  
One (MOS-63S).

SPECIAL ENVIRONMENTAL CONDITIONS  
None.

REFERENCES (TM)  
TM 9-2320-283-20P.

GENERAL SAFETY INSTRUCTIONS  
Engine off.  
Transmission in neutral,  
Park brake set.

TROUBLESHOOTING REFERENCES  
Paragraph 2-11.

FRAME AND TOWING ATTACHMENTS.

3-238. TOW PINTLE REPLACEMENT (Continued).

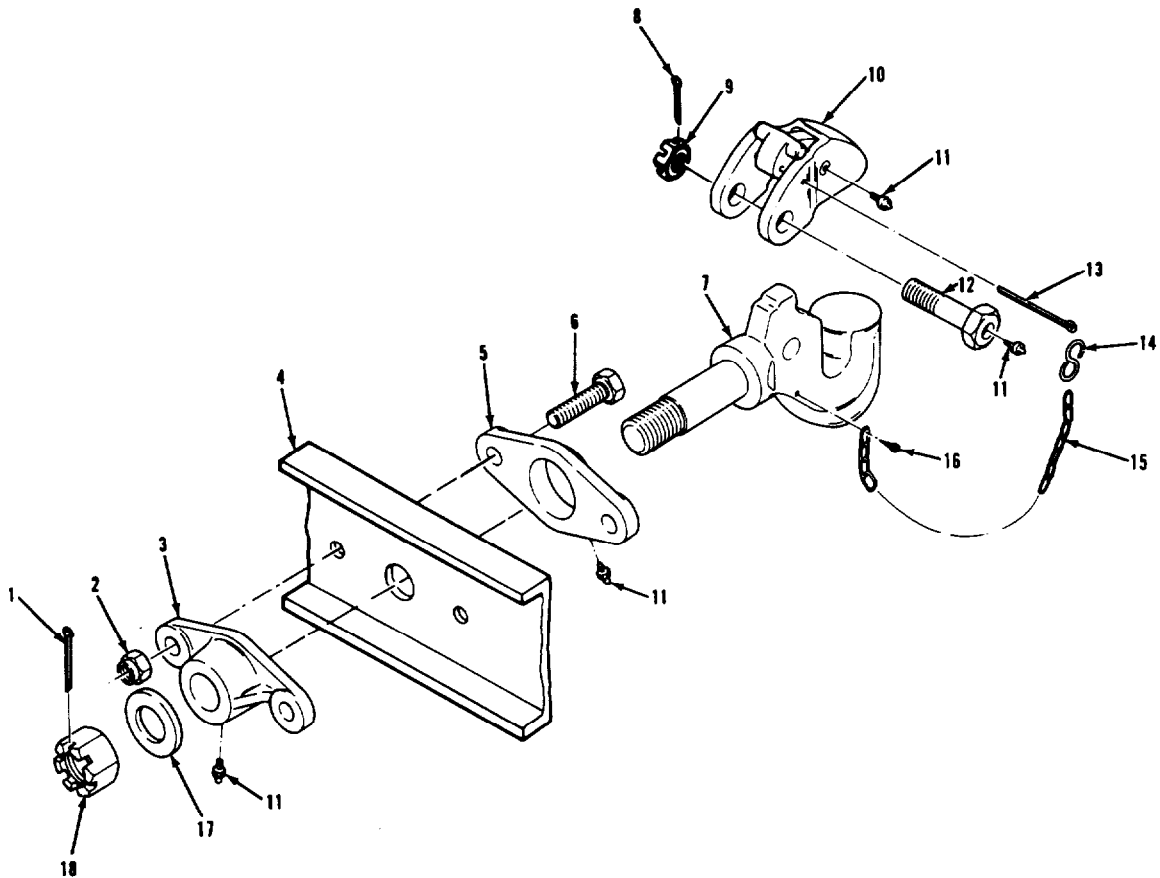

LEGEND:

- |                              |                        |
|------------------------------|------------------------|
| 1. COTTER PIN                | 10. PINTLE HOOK LATCH  |
| 2. NUT (2)                   | 11. GREASE FITTING (4) |
| 3. INNER BRACKET             | 12. BOLT               |
| 4. REAR CROSSMEMBER ASSEMBLY | 13. COTTER PIN         |
| 5. OUTER BRACKET             | 14. LINK               |
| 6. MACHINE BOLT (2)          | 15. CHAIN              |
| 7. HOOK                      | 16. DRIVE SCREW        |
| 8. COTTER PIN                | 17. WASHER             |
| 9. NUT                       | 18. SELF-LOCKING NUT   |

TA 237664



FRAME AND TOWING ATTACHMENTS.

3-238. TOW PINTLE REPLACEMENT (Continued).		
LOCATION/ITEM	ACTION	REMARKS
<b>A. PINTLE HOOK REMOVAL.</b>		
1. Pin (1).	Remove from item (7).	Discard item (1).
2. Nut (18), washer (17), and hook (7).	Remove from items (3), (4), and (5).	
<b>B. PINTLE HOOK DISASSEMBLY.</b>		
3. Pin (13).	Remove from item (10).	
4. Pin (8).	Remove from item (12).	Discard item (8).
5. Nut (9), bolt (12), and latch (10).	Remove from item (7).	
6. Pin (13).	Remove from item (14).	Discard item (13), if damaged.
7. Link (14).	Remove from item (15).	
8. Screw (16) and chain (15).	Remove from item (7).	Do this step only if items (7) or (15) are damaged. Discard item (16).
9. Two fittings (11).	Remove from items (10) and (12).	
<b>C. BRACKET REMOVAL.</b>		
10. Two nuts (2), bolts (6), bracket (3), and bracket (5).	Remove from item (4).	
11. Two fittings (11).	Remove from items (3) and (5).	

FRAME AND TOWING ATTACHMENTS.

3-238. TOW PINTLE REPLACEMENT (Continued).

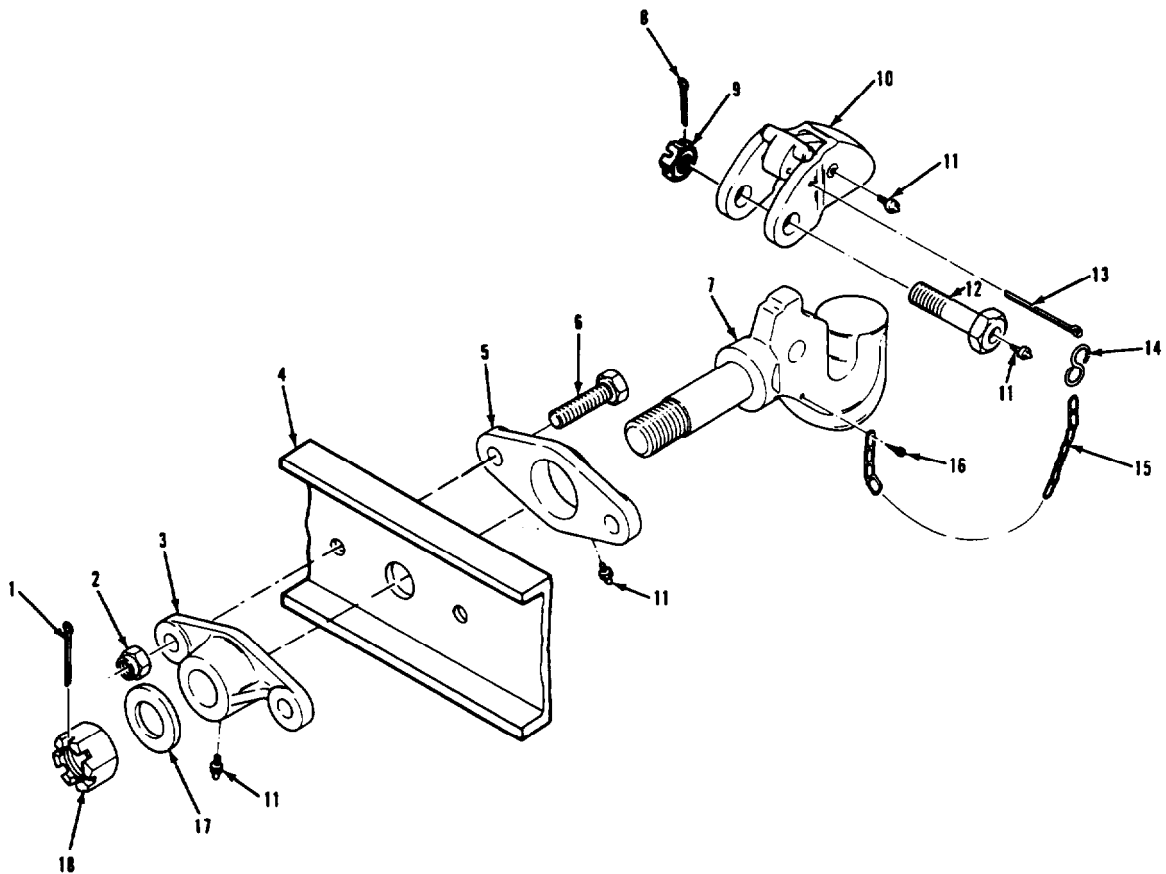

LEGEND:

- |                              |                        |
|------------------------------|------------------------|
| 1. COTTER PIN                | 10. PINTLE HOOK LATCH  |
| 2. NUT (2)                   | 11. GREASE FITTING (4) |
| 3. INNER BRACKET             | 12. BOLT               |
| 4. REAR CROSSMEMBER ASSEMBLY | 13. COTTER PIN         |
| 5. OUTER BRACKET             | 14. LINK               |
| 6. MACHINE BOLT (2)          | 15. CHAIN              |
| 7. HOOK                      | 16. DRIVE SCREW        |
| 8. COTTER PIN                | 17. WASHER             |
| 9. NUT                       | 18. SELF-LOCKING NUT   |

TA 237665

FRAME AND TOWING ATTACHMENTS.

3-238. TOW PINTLE REPLACEMENT (Continued).		
LOCATION/ITEM	ACTION	REMARKS
<b>D. CLEANING AND INSPECTION.</b>		
12. All parts.	a. Clean and inspect.	Refer to paragraphs 3-4 and 3-5.
	b. Lubricate with oil.	
<b>E. BRACKET INSTALLATION.</b>		
13. Two fittings (11).	Install into items (3) and (5).	
14. Bracket (3) and bracket (5).	a. Position on item (4).	Make sure items (11) face down.
	b. Secure with two items (2) and (6).	Do not tighten items (2) and (6) at this time.
<b>F. PINTLE HOOK ASSEMBLY.</b>		
15. Two fittings (11).	Install into items (10) and (12).	
16. Chain (15) and new screw (16).	Install on item (7).	
17. Link (14).	Install on item (15).	
18. Pin (13).	Install on item (14).	
19. Latch (10).	a. Position on item (7).	
	b. Secure with items (9) and (12).	
20. New pin (8).	Install in item (12) and bend ends over.	
21. Pin (13).	Install in item (10).	

FRAME AND TOWING ATTACHMENTS.

3-238. TOW PINTLE REPLACEMENT (Continued).

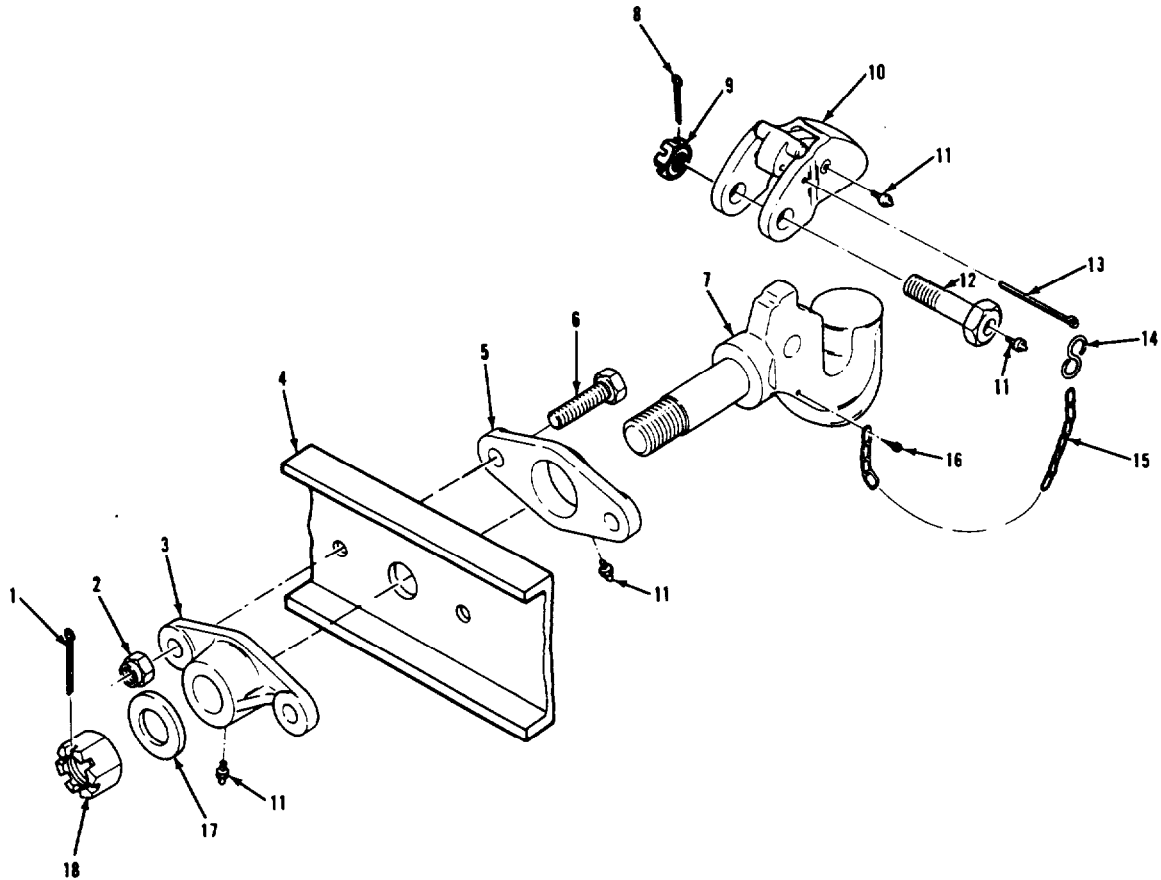

LEGEND:

- |                              |                        |
|------------------------------|------------------------|
| 1. COTTER PIN                | 10. PINTLE HOOK LATCH  |
| 2. NUT (2)                   | 11. GREASE FITTING (4) |
| 3. INNER BRACKET             | 12. BOLT               |
| 4. REAR CROSSMEMBER ASSEMBLY | 13. COTTER PIN         |
| 5. OUTER BRACKET             | 14. LINK               |
| 6. MACHINE BOLT (2)          | 15. CHAIN              |
| 7. HOOK                      | 16. DRIVE SCREW        |
| 8. COTTER PIN                | 17. WASHER             |
| 9. NUT                       | 18. SELF-LOCKING NUT   |

TA 237666

FRAME AND TOWING ATTACHMENTS.

3-238. TOW PINTLE REPLACEMENT (Continued).

LOCATION/ITEM	ACTION	REMARKS
<b>G. PINTLE HOOK INSTALLATION.</b>		
22. Hook (7).	Insert through items (5), (4), and (3).	
23. Nut (18) and washer (17).	Screw loosely onto item (7).	
24. Two bolts (6) and nuts (2).	Tighten, if not already done.	
<b>H. LUBRICATION AND ADJUSTMENT.</b>		
25. Four fittings (11).	Using grease gun, lubricate with grease.	
26. Nut (18).	a. Tighten until item (7) binds when turned.  b. Loosen until item (7) turns with some resistance.	
27. New pin (1).	Install into item (7) and bend ends over.	
<b>NOTE</b>		
Follow-on maintenance action required:		
None.		

FRAME AND TOWING ATTACHMENTS.

3-238. TOW PINTLE REPLACEMENT (Continued).

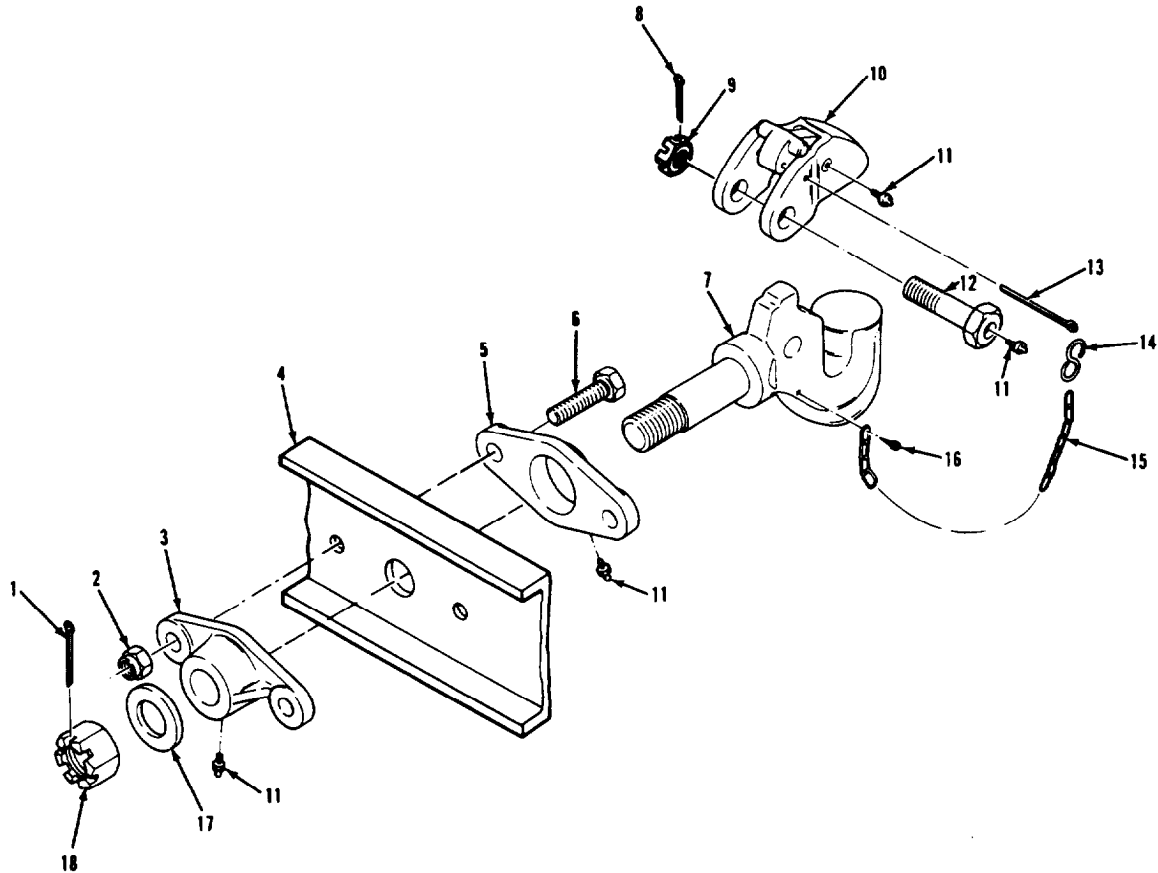

LEGEND:

- |                              |                        |
|------------------------------|------------------------|
| 1. COTTER PIN                | 10. PINTLE HOOK LATCH  |
| 2. NUT (2)                   | 11. GREASE FITTING (4) |
| 3. INNER BRACKET             | 12. BOLT               |
| 4. REAR CROSSMEMBER ASSEMBLY | 13. COTTER PIN         |
| 5. OUTER BRACKET             | 14. LINK               |
| 6. MACHINE BOLT (2)          | 15. CHAIN              |
| 7. HOOK                      | 16. DRIVE SCREW        |
| 8. COTTER PIN                | 17. WASHER             |
| 9. NUT                       | 18. SELF-LOCKING NUT   |

TA 237667

FRAME AND TOWING ATTACHMENTS.

3-239. SERVICE DECK REPLACEMENT.

THIS TASK COVERS

- a. Removal.
- b. Cleaning and Inspection.
- c. Installation.

INITIAL SETUP

APPLICABLE CONFIGURATIONS

All.

EQUIPMENT CONDITION  
PARAGRAPH

3-197.

CONDITION DESCRIPTION

Hose tender removed.

TEST EQUIPMENT

None.

SPECIAL TOOLS

None.

MATERIALS/PARTS (P/N)

None.

PERSONNEL REQUIRED

One (MDS-63S).

SPECIAL ENVIRONMENTAL CONDITIONS

None.

REFERENCES (TM)

None.

GENERAL SAFETY INSTRUCTIONS

Engine off  
Transmission in neutral.  
Park brake set.

TROUBLESHOOTING REFERENCES

None.

FRAME AND TOWING ATTACHMENTS.

3-239. SERVICE DECK REPLACEMENT (Continued).

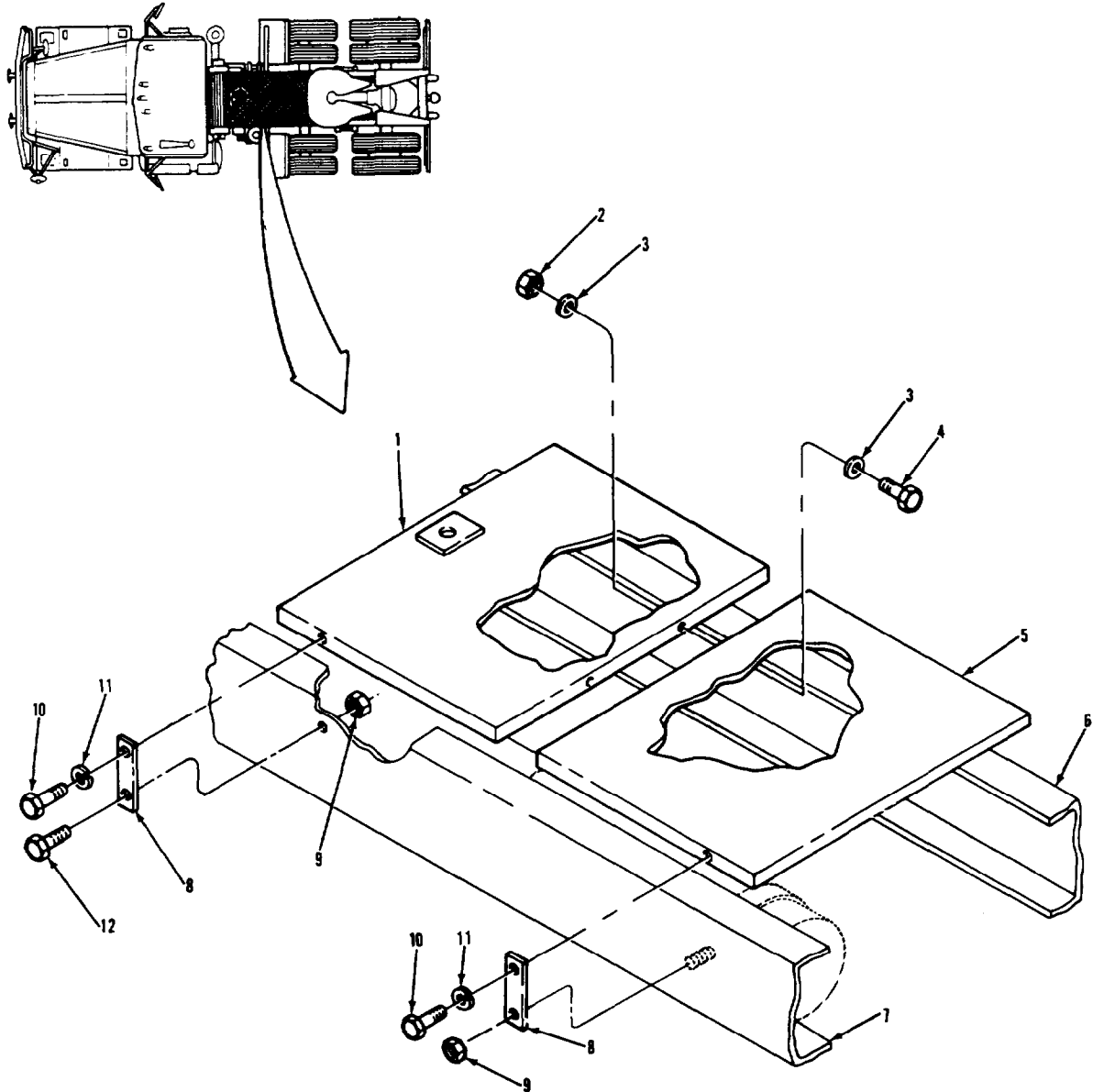

LEGEND:

- |   |                            |
|---|----------------------------|
| 1. SERVICE DECK HALF WITH POGO PLATE    | 7. LEFT-HAND FRAME RAIL    |
| 2. NUT (2)                              | 8. SERVICE DECK TAB (4)    |
| 3. PLAIN WASHER (4)                     | 9. NUT (4)                 |
| 4. HEXAGON SCREW (2)                    | 10. HEXAGON HEAD SCREW (4) |
| 5. SERVICE DECK HALF WITHOUT POGO PLATE | 11. LOCKWASHER (4)         |
| 6. RIGHT-HAND FRAME RAIL                | 12. SCREW (3)              |

TA 237668



FRAME AND TOWING ATTACHMENTS.

3-239. SERVICE DECK REPLACEMENT (Continued).		
LOCATION/ITEM	ACTION	REMARKS
<b>A. REMOVAL.</b>		
1. Four screws (10) and lockwashers (11).	Remove from items (1), (5), and four items (8).	
2. Two deck halves (1) and (5).	Remove from items (6) and (7).	
3. Two nuts (2), four washers (3), and two screws (4).	Remove, and separate items (1) and (5).	
4. Four nuts (9), three screws (12), and four tabs (8).	Remove from items (6) and (7).	
<b>B. CLEANING AND INSPECTION.</b>		
5. All parts.	Clean and inspect.	Refer to paragraphs 3-4 and 3-5.
<b>C. INSTALLATION.</b>		
6. Four tabs (8).	a. Position on items (6) and (7). b. Secure with three items (12) and four items (9).	
7. Two deck halves (1) and (5).	a. Hold together and line up holes. b. Secure with two items (4), four items (3), and two items (2).	

FRAME AND TOWING ATTACHMENTS.

3-239. SERVICE DECK REPLACEMENT (Continued).

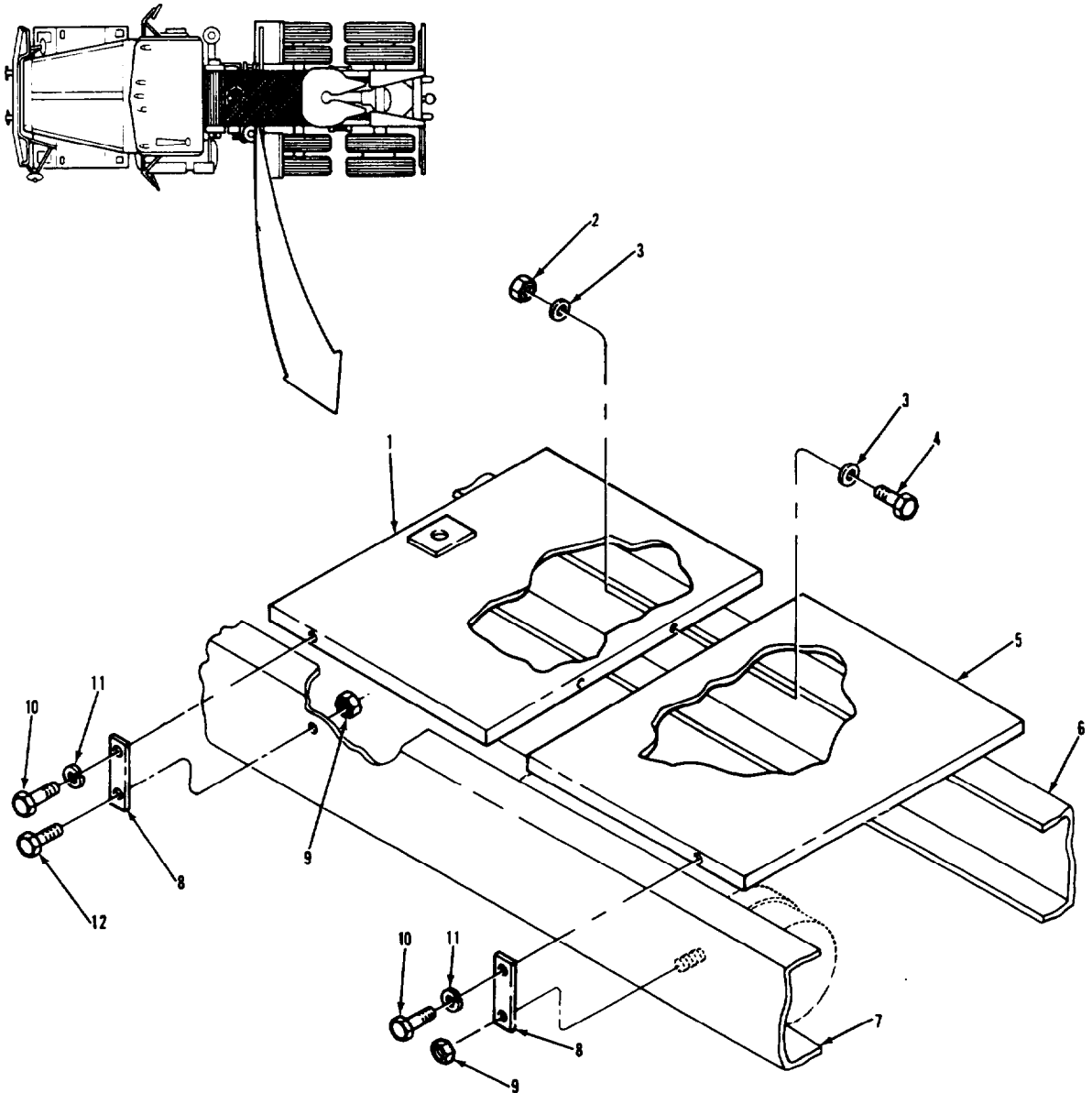

LEGEND:

- |   |                            |
|---|----------------------------|
| 1. SERVICE DECK HALF WITH POGO PLATE    | 7. LEFT-HAND FRAME RAIL    |
| 2. NUT (2)                              | 8. SERVICE DECK TAB (4)    |
| 3. PLAIN WASHER (4)                     | 9. NUT (4)                 |
| 4. HEXAGON SCREW (2)                    | 10. HEXAGON HEAD SCREW (4) |
| 5. SERVICE DECK HALF WITHOUT POGO PLATE | 11. LOCKWASHER (4)         |
| 6. RIGHT-HAND FRAME RAIL                | 12. SCREW (3)              |

TA 237669

FRAME AND TOWING ATTACHMENTS.

3-239. SERVICE DECK REPLACEMENT (Continued).

LOCATION/ITEM	ACTION	REMARKS
<b>C. INSTALLATION (Continued).</b>		
7. Two deck halves (1) and (5) (continued).	c. Position on items (6) and (7).  d. Line up holes with four items (8).  e. Secure with four items (10) and (11).	
<b>NOTE</b>		
Follow-on maintenance action required:		
Install hose tender (para 3-197).		

FRAME AND TOWING ATTACHMENTS.

3-239. SERVICE DECK REPLACEMENT (Continued).

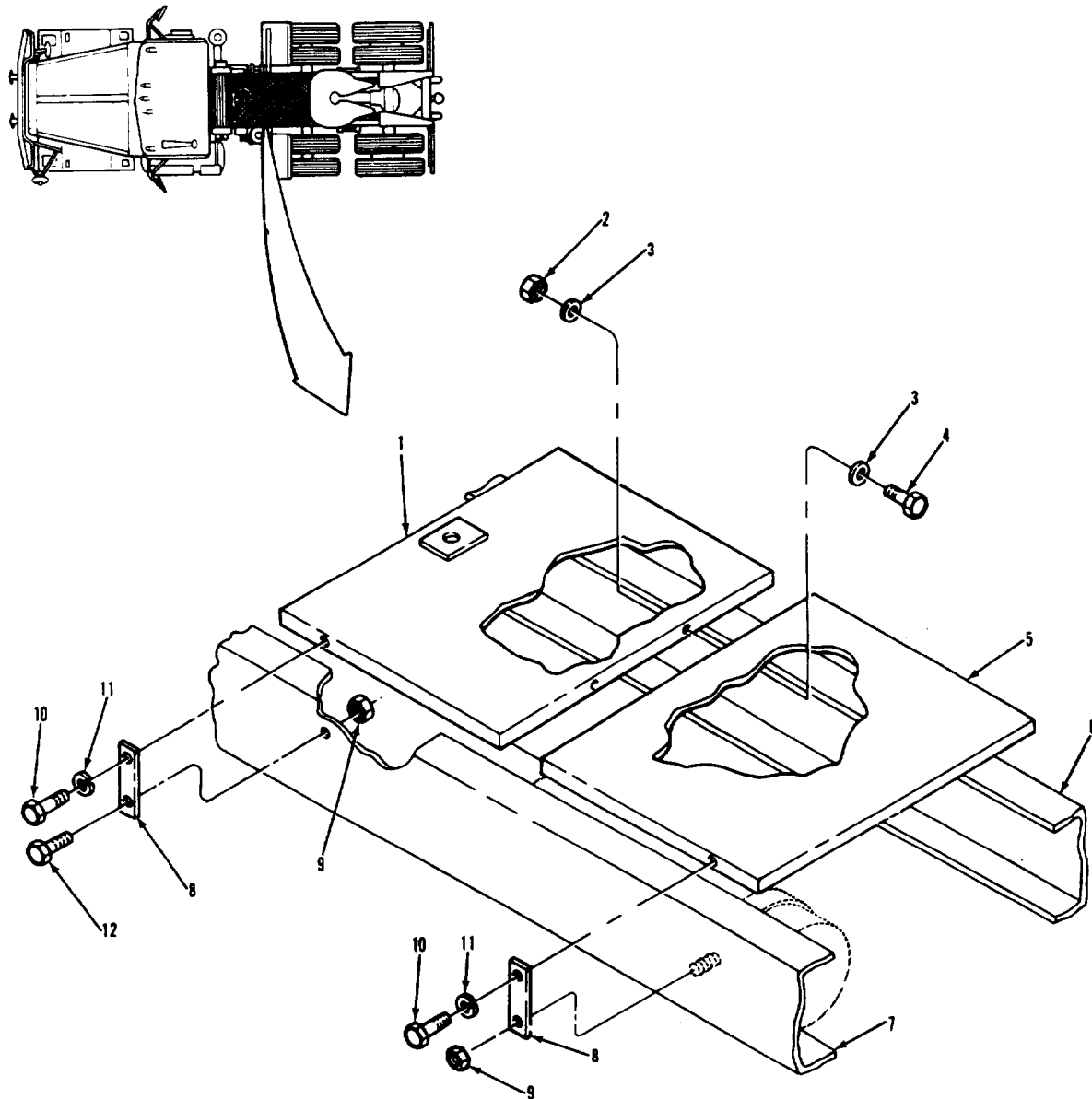

LEGEND:

- |   |                            |
|---|----------------------------|
| 1. SERVICE DECK HALF WITH POGO PLATE    | 7. LEFT-HAND FRAME RAIL    |
| 2. NUT (2)                              | 8. SERVICE DECK TAB (4)    |
| 3. PLAIN WASHER (4)                     | 9. NUT (4)                 |
| 4. HEXAGON SCREW (2)                    | 10. HEXAGON HEAD SCREW (4) |
| 5. SERVICE DECK HALF WITHOUT POGO PLATE | 11. LOCKWASHER (4)         |
| 6. RIGHT-HAND FRAME RAIL                | 12. SCREW (3)              |

TA 237670

FRAME AND TOWING ATTACHMENTS.

3-240. SPARE TIRE CARRIER REPLACEMENT.

THIS TASK COVERS

- a. Removal.
- b. Cleaning and Inspection.
- c. Installation.

INITIAL SETUP

APPLICABLE CONFIGURATIONS

All.

EQUIPMENT CONDITION  
PARAGRAPH

TM 9-2320-283-10.

CONDITION DESCRIPTION

Spare wheel and tire removed.

TEST EQUIPMENT

None.

SPECIAL TOOLS

None.

MATERIALS/PARTS (P/N)

None.

PERSONNEL REQUIRED

One (MDS-63S).

SPECIAL ENVIRONMENTAL CONDITIONS

None.

REFERENCES (TM)

TM 9-2320-283-10.

GENERAL SAFETY INSTRUCTIONS

Engine off.  
Transmission in neutral.  
Park brake set.

TROUBLESHOOTING REFERENCES

None.

FRAME AND TOWING ATTACHMENTS.

3-240. SPARE TIRE CARRIER REPLACEMENT (Continued).

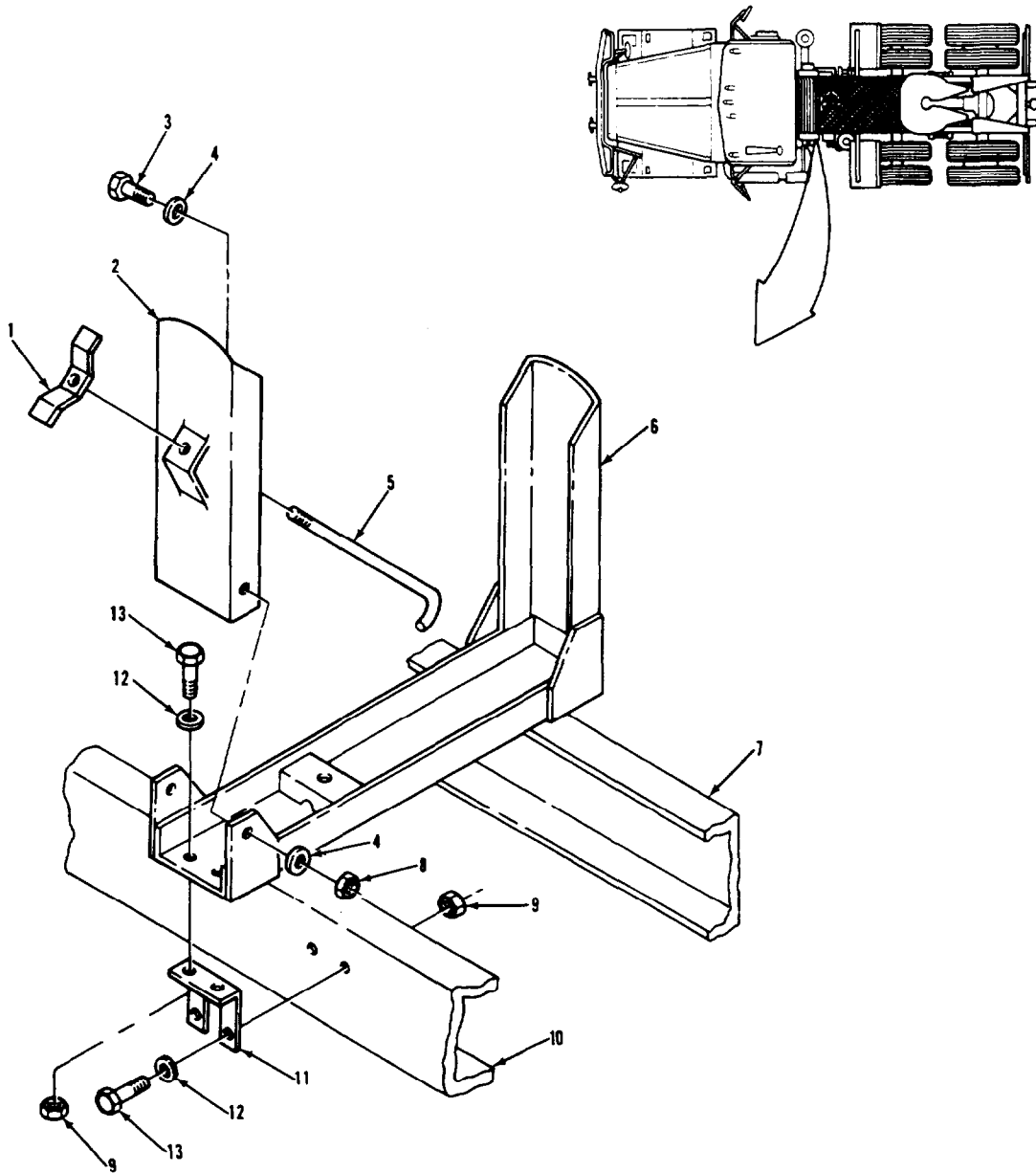

LEGEND:

- |  |                                       |
|--|---------------------------------------|
| 1. SPARE TIRE CARRIER WINGNUT          | 8. HEXAGON NUT (2)                    |
| 2. SPARE TIRE CARRIER SUPPORT ASSEMBLY | 9. LOCKNUT (8)                        |
| 3. SCREW (2)                           | 10. LEFT-HAND FRAME RAIL              |
| 4. FLAT WASHER (4)                     | 11. TIRE CARRIER MOUNTING BRACKET (2) |
| 5. SPARE TIRE CARRIER HOLDDOWN HOOK    | 12. HARDENED WASHER (8)               |
| 6. SPARE TIRE CARRIER ASSEMBLY         | 13. SCREW (8)                         |
| 7. RIGHT-HAND FRAME RAIL               |                                       |

TA 237671

FRAME AND TOWING ATTACHMENTS.

3-240. SPARE TIRE CARRIER REPLACEMENT (Continued).		
LOCATION/ITEM	ACTION	REMARKS
<b>A. REMOVAL.</b>		
1. Four nuts (9), washers (12), and screws (13).	Remove from item (6) and two items (11).	
2. Spare tire carrier assembly (6).	Remove from items (7) and (10).	
3. Two nuts (8), four washers (4), two screws (3), and spare tire carrier support assembly (2).	Remove from item (6).	
4. Four nuts (9), washers (12), screws (13), and two bracket (11).	Remove from items (7) and (10).	
<b>B. CLEANING AND INSPECTION.</b>		
5. All parts.	Clean and inspect.	Refer to paragraphs 3-4 and 3-5. Be sure to inspect items (1) and (5) for damaged threads.
<b>C. INSTALLATION.</b>		
6. Two brackets (11).	a. Position on items (7) and (10). b. Secure with four items (13), (12), and (9).	
7. Spare tire carrier support assembly (2).	a. Position in item (6). b. Secure with two items (3), four items (4), and two items (8).	

FRAME AND TOWING ATTACHMENTS.

3-240. SPARE TIRE CARRIER REPLACEMENT (Continued).

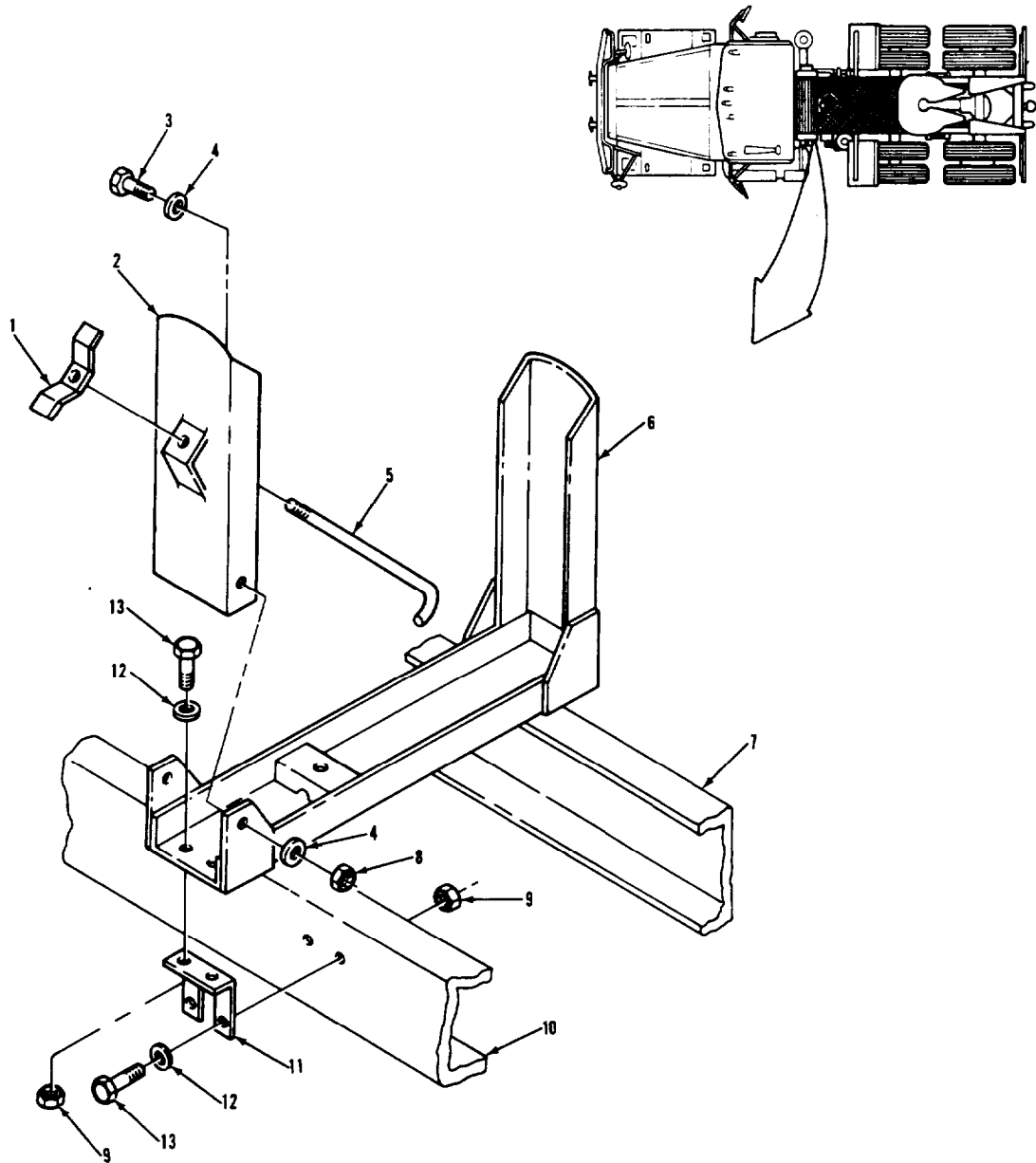

LEGEND:

- |  |                                       |
|--|---------------------------------------|
| 1. SPARE TIRE CARRIER WINGNUT          | 8. HEXAGON NUT (2)                    |
| 2. SPARE TIRE CARRIER SUPPORT ASSEMBLY | 9. LOCKNUT (8)                        |
| 3. SCREW (2)                           | 10. LEFT-HAND FRAME RAIL              |
| 4. FLAT WASHER (4)                     | 11. TIRE CARRIER MOUNTING BRACKET (2) |
| 5. SPARE TIRE CARRIER HOLDDOWN HOOK    | 12. HARDENED WASHER (8)               |
| 6. SPARE TIRE CARRIER ASSEMBLY         | 13. SCREW (8)                         |
| 7. RIGHT-HAND FRAME RAIL               |                                       |

TA 237672



FRAME AND TOWING ATTACHMENTS.

3-240. SPARE TIRE CARRIER REPLACEMENT (Continued).

LOCATION/ITEM	ACTION	REMARKS
<b>C. INSTALLATION (Continued).</b>		
8. Spare tire carrier assembly (6).	a. Position on items (7) and (10). b. Line up holes with two items (11). c. Secure with four items (13), (12), and (9).	
<b>NOTE</b>		
Follow-on maintenance action required:		
Install spare wheel and tire (TM 9-2320-283-10).		

FRAME AND TOWING ATTACHMENTS.

3-240. SPARE TIRE CARRIER REPLACEMENT (Continued).

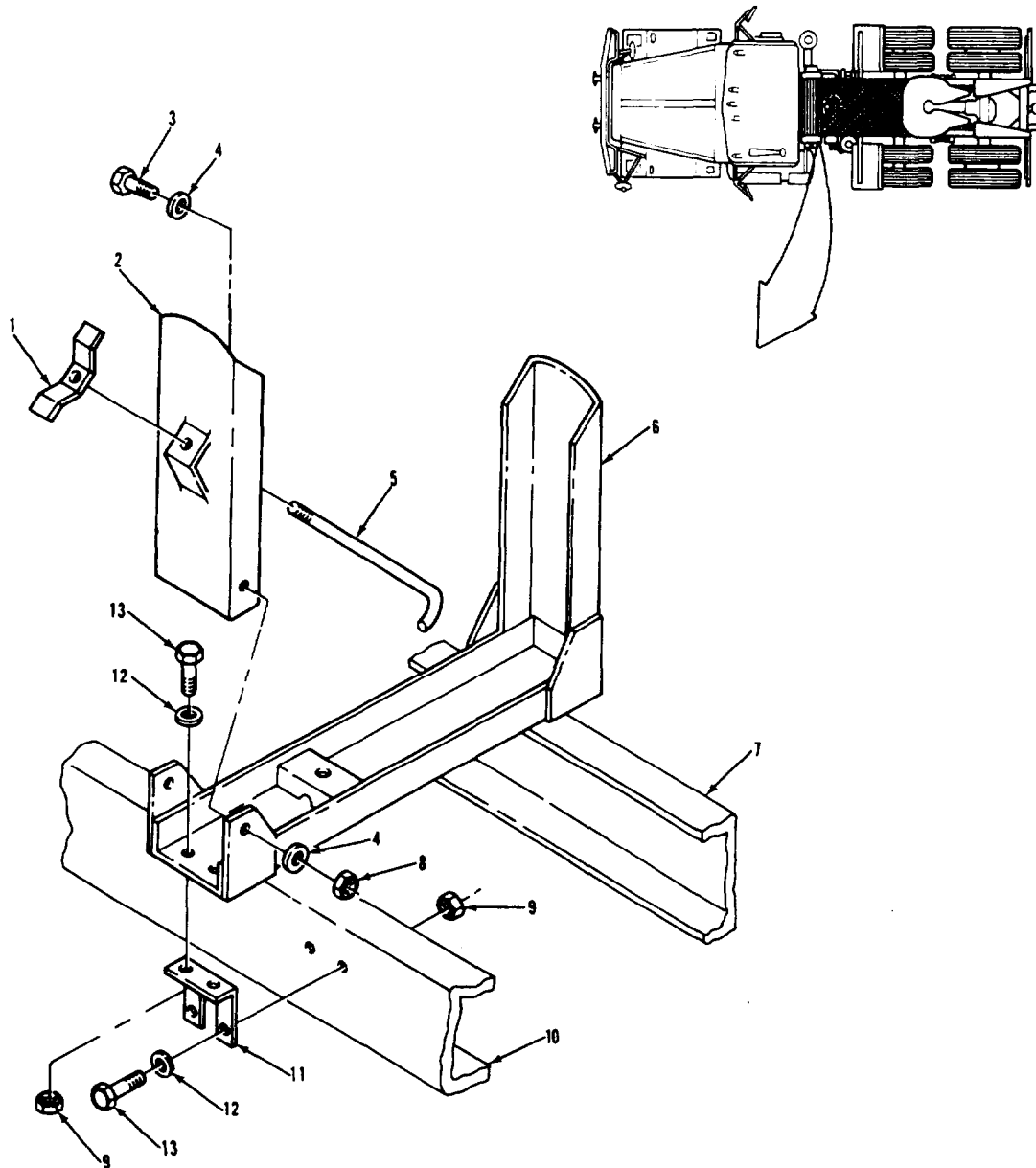

LEGEND:

- |  |                                       |
|--|---------------------------------------|
| 1. SPARE TIRE CARRIER WINGNUT          | 8. HEXAGON NUT (2)                    |
| 2. SPARE TIRE CARRIER SUPPORT ASSEMBLY | 9. LOCKNUT (8)                        |
| 3. SCREW (2)                           | 10. LEFT-HAND FRAME RAIL              |
| 4. FLAT WASHER (4)                     | 11. TIRE CARRIER MOUNTING BRACKET (2) |
| 5. SPARE TIRE CARRIER HOLDDOWN HOOK    | 12. HARDENED WASHER (8)               |
| 6. SPARE TIRE CARRIER ASSEMBLY         | 13. SCREW (8)                         |
| 7. RIGHT-HAND FRAME RAIL               |                                       |

TA 237673

FRAME AND TOWING ATTACHMENTS.

3-241. SPARE TIRE WINCH CABLE REPLACEMENT.

THIS TASK COVERS

- a. Removal.
- b. Cleaning and Inspection.
- c. Installation.

INITIAL SETUP

<u>APPLICABLE CONFIGURATIONS</u>	<u>EQUIPMENT CONDITION PARAGRAPH</u>	<u>CONDITION DESCRIPTION</u>
All.	None.	None.

TEST EQUIPMENT

None.

SPECIAL TOOLS

None.

MATERIALS/PARTS (P/N)

None.

PERSONNEL REQUIRED

One (MOS-63S).

SPECIAL ENVIRONMENTAL CONDITIONS

None.

REFERENCES (TM)

None.

GENERAL SAFETY INSTRUCTIONS

Engine off  
Transmission in neutral.  
Park brake set.

TROUBLESHOOTING REFERENCES

None.

FRAME AND TOWING ATTACHMENTS.

3-241. SPARE TIRE WINCH CABLE REPLACEMENT (Continued).

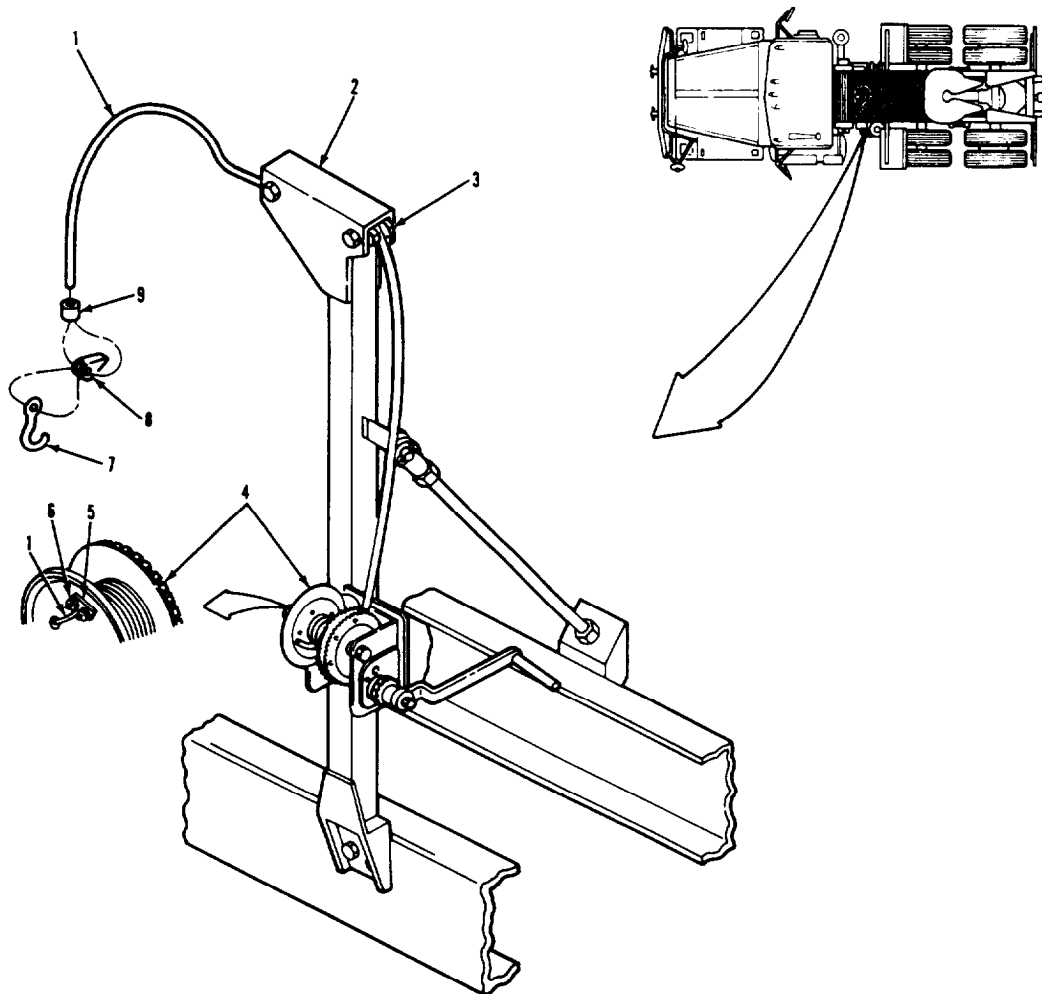

LEGEND:

- |                           |                   |
|---------------------------|-------------------|
| 1. SPARE TIRE WINCH CABLE | 6. NUT (2)        |
| 2. WINCH PILLAR ASSEMBLY  | 7. EYEHOOK        |
| 3. CABLE ROLLER (2)       | 8. LATCH ASSEMBLY |
| 4. DRUM ASSEMBLY          | 9. CLAMP SLEEVE   |
| 5. CABLE KEEPER           |                   |

TA 237674

FRAME AND TOWING ATTACHMENTS.

3-241. SPARE TIRE WINCH CABLE REPLACEMENT (Continued).

LOCATION/ITEM	ACTION	REMARKS
<b>A. REMOVAL.</b>		
1. Two nuts (6).	Loosen, but do not remove.	
2. Cable (1).	a. Pull end out from under item (6).  b. Unwind and remove from item (4).  c. Remove from item (2).	
<b>B. CLEANING AND INSPECTION.</b>		
3. All parts.	Clean and inspect.	Refer to paragraphs 3-4 and 3-5. If items (1), (7), or (8) are damaged, do step 4.
4. Cable (1), eyehook (7), latch assembly (8), and sleeve (9).	a. Cut item (1), and remove items (7), (8), and (9).  b. Slide new item (9) onto end of item (1).  c. Insert same end of item (1) through items (7) and (8), then insert it back through item (9).  d. Using suitable crimping tool, crimp item (9).	Do this step only if items (1), (7), and (8) are damaged. Discard item (9).

FRAME AND TOWING ATTACHMENTS.

3-241. SPARE TIRE WINCH CABLE REPLACEMENT (Continued).

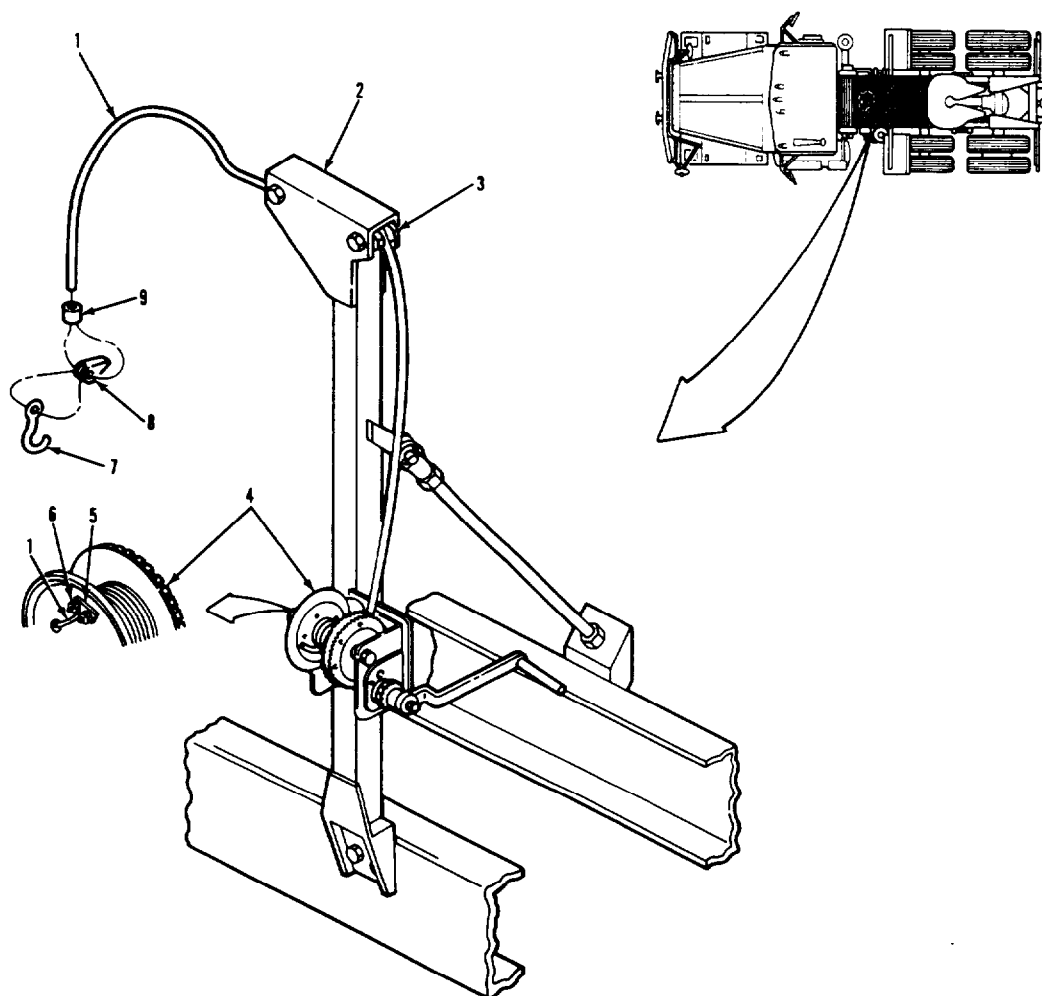

LEGEND:

- |                           |                   |
|---------------------------|-------------------|
| 1. SPARE TIRE WINCH CABLE | 6. NUT (2)        |
| 2. WINCH PILLAR ASSEMBLY  | 7. EYEHOOK        |
| 3. CABLE ROLLER (2)       | 8. LATCH ASSEMBLY |
| 4. DRUM ASSEMBLY          | 9. CLAMP SLEEVE   |
| 5. CABLE KEEPER           |                   |

TA 237675

FRAME AND TOWING ATTACHMENTS.

3-241. SPARE TIRE WINCH CABLE REPLACEMENT (Continued).

LOCATION/ITEM	ACTION	REMARKS
<b>C. INSTALLATION.</b>		
5. Cable (1).	<ul style="list-style-type: none"> <li>a. Install over two items (3).</li> <li>b. Push end through hole in item (4), and position under item (5).</li> <li>c. Secure by tightening two items (6).</li> <li>d. Wind onto item (4).</li> </ul>	
<b>NOTE</b>		
Follow-on maintenance action required:		
None.		

FRAME AND TOWING ATTACHMENTS.

3-241. SPARE TIRE WINCH CABLE REPLACEMENT (Continued).

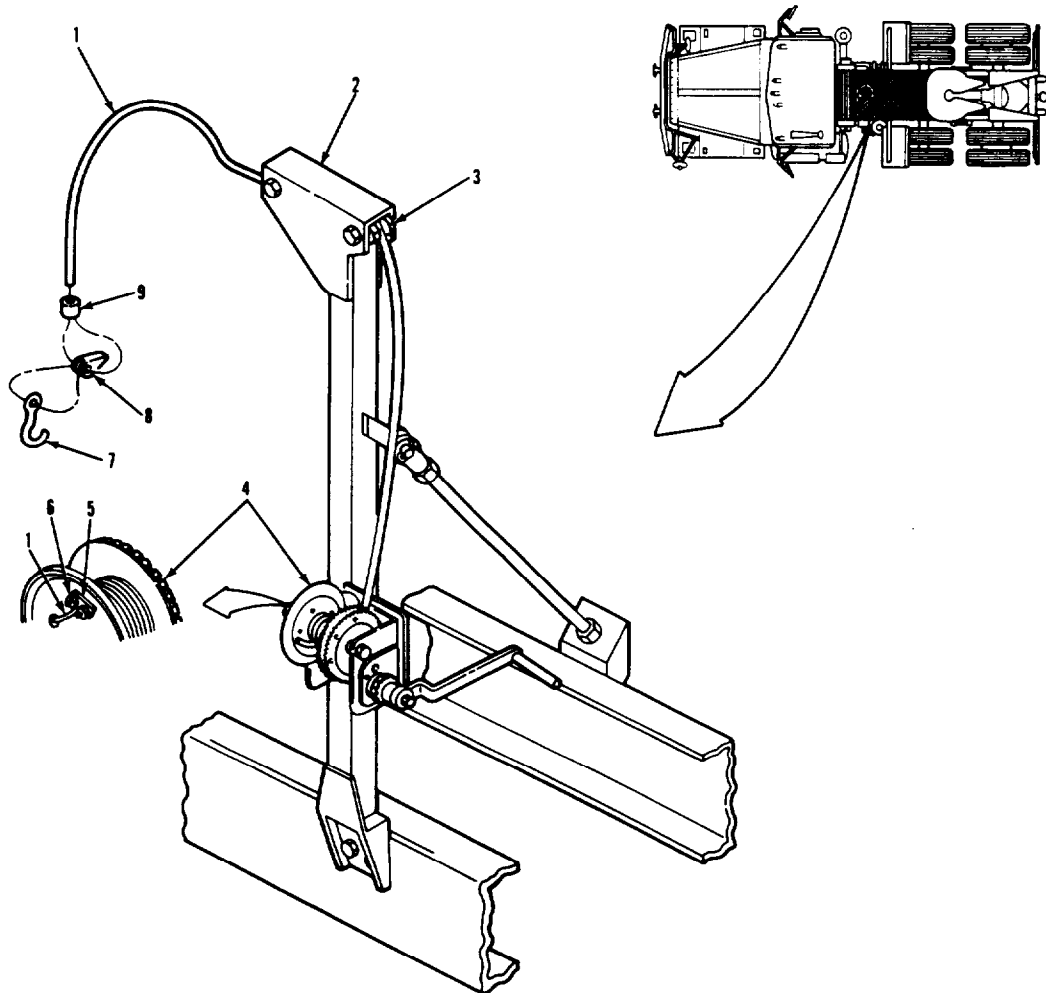

LEGEND:

- |                           |                   |
|---------------------------|-------------------|
| 1. SPARE TIRE WINCH CABLE | 6. NUT (2)        |
| 2. WINCH PILLAR ASSEMBLY  | 7. EYEHOOK        |
| 3. CABLE ROLLER (2)       | 8. LATCH ASSEMBLY |
| 4. DRUM ASSEMBLY          | 9. CLAMP SLEEVE   |
| 5. CABLE KEEPER           |                   |

TA 237676



FRAME AND TOWING ATTACHMENTS.

3-242. SPARE TIRE WINCH REPLACEMENT AND REPAIR.

THIS TASK COVERS

- a. Removal.
- b. Disassembly.
- c. Cleaning and Inspection.
- d. Assembly.
- e. Installation.

INITIAL SETUP

<u>APPLICABLE CONFIGURATIONS</u>	<u>EQUIPMENT CONDITION PARAGRAPH</u>	<u>CONDITION DESCRIPTION</u>
All.	3-241.	Spare tire winch cable removed.
<u>TEST EQUIPMENT</u>		
None.		
<u>SPECIAL TOOLS</u>		
None.		
<u>MATERIALS/PARTS (P/N)</u>		
None.		
<u>PERSONNEL REQUIRED</u>		<u>SPECIAL ENVIRONMENTAL CONDITIONS</u>
One (MDS-63S).		None.
<u>REFERENCES (TM)</u>		<u>GENERAL SAFETY INSTRUCTIONS</u>
None.		Engine off. Transmission in neutral. Park brake set.
<u>TROUBLESHOOTING REFERENCES</u>		
None.		

FRAME AND TOWING ATTACHMENTS.

3-242. SPARE TIRE WINCH REPLACEMENT AND REPAIR (Continued).

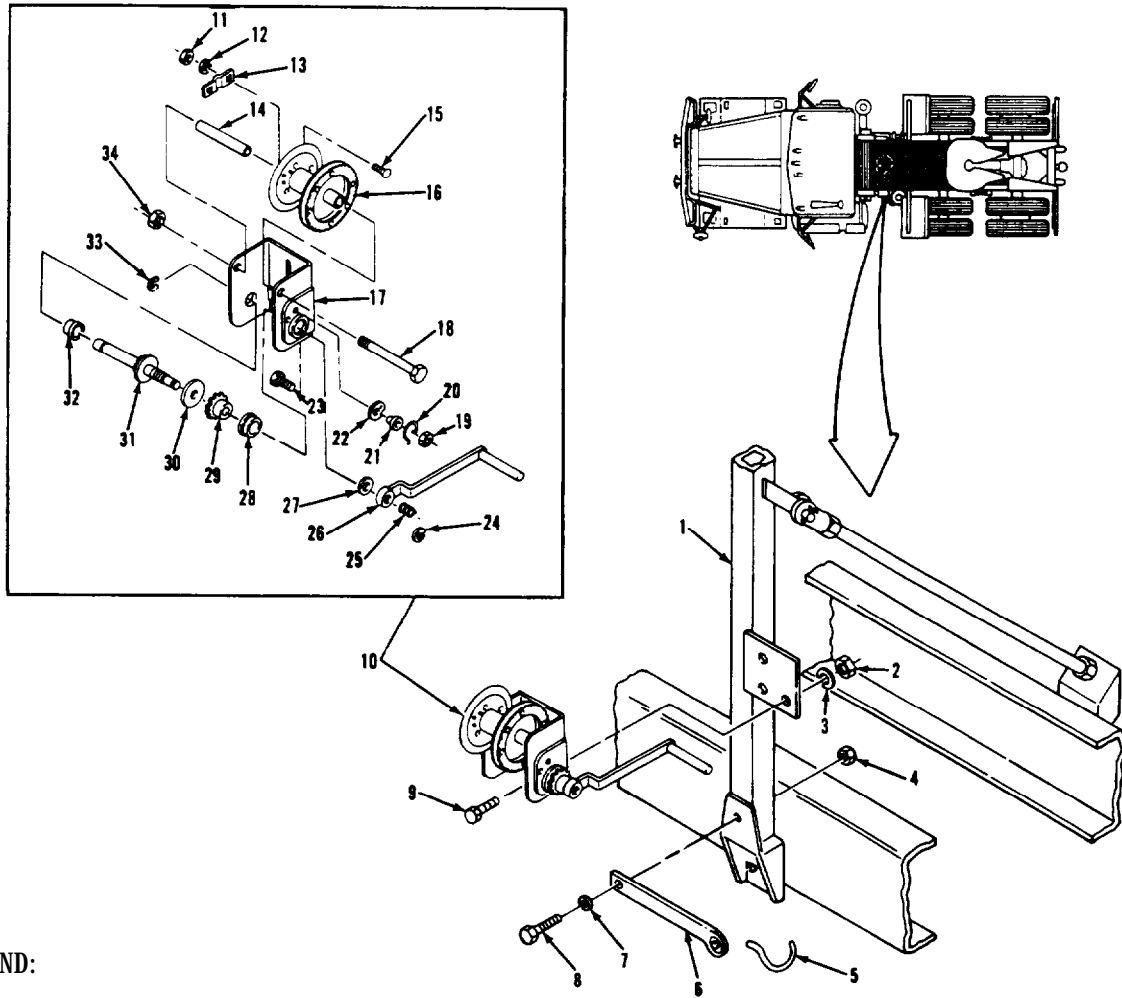

LEGEND:

- |                              |                           |
|------------------------------|---------------------------|
| 1. WINCH PILLAR ASSEMBLY     | 18. SCREW                 |
| 2. HEXAGON HEAD NUT (3)      | 19. LOCKNUT               |
| 3. LOCKWASHER (3)            | 20. RATCHET SPRING        |
| 4. LOCKNUT                   | 21. RATCHET SPACER        |
| 5. HOOK                      | 22. RATCHET PAWL          |
| 6. STRAP                     | 23. RATCHET SCREW         |
| 7. WASHER                    | 24. RETAINING RING        |
| 8. SCREW                     | 25. COIL SPRING           |
| 9. HEXAGON HEAD SCREW (3)    | 26. HANDLE ASSEMBLY       |
| 10. WORK WINCH               | 27. HANDLE DISK           |
| 11. NUT (2)                  | 28. BUSHING               |
| 12. LOCKWASHER (2)           | 29. RATCHET GEAR ASSEMBLY |
| 13. CABLE KEEPER             | 30. BRAKE FACE DISK       |
| 14. FRAME SPACER             | 31. PINION SHAFT ASSEMBLY |
| 15. CARRIAGE BOLT (2)        | 32. BUSHING               |
| 16. DRUM ASSEMBLY            | 33. RETAINING RING        |
| 17. FRAME AND PLATE ASSEMBLY | 34. LOCKNUT               |

T A 237677

FRAME AND TOWING ATTACHMENTS.

3-242. SPARE TIRE WINCH REPLACEMENT AND REPAIR (Continued).

LOCATION/ITEM	ACTION	REMARKS
<b>A. REMOVAL.</b>		
1. Screw (8), washer (7), and locknut (4).	Remove from item (6) and item (1).	
2. Three nuts (2), lockwashers (3), screws (4), and winch (10).	Remove from item (1).	
<b>B. DISASSEMBLY.</b>		
3. Ring (24) spring (25), handle (26), and disk (27).	Remove from item (31).	
4. Locknut (34), screw (18), drum (16), and spacer (14).	Remove from item (17).	
5. Ring (33).	Remove from item (31).	
6. Shaft (31), disk (30), and ratchet gear assembly (29).	Remove from item (17).	
7. Locknut (19), screw (23), spring (20), spacer (21), and pawl (22).	Remove from item (17).	
8. Bushing (28) and bushing (32).	Remove from item (17).	
9. Two nuts (11), lockwashers (12), bolts (15), and keeper (13).	Remove from item (16).	
10. Hook (5).	Remove from item (6).	Use pliers.

FRAME AND TOWING ATTACHMENTS.

3-242. SPARE TIRE WINCH REPLACEMENT AND REPAIR (Continued).

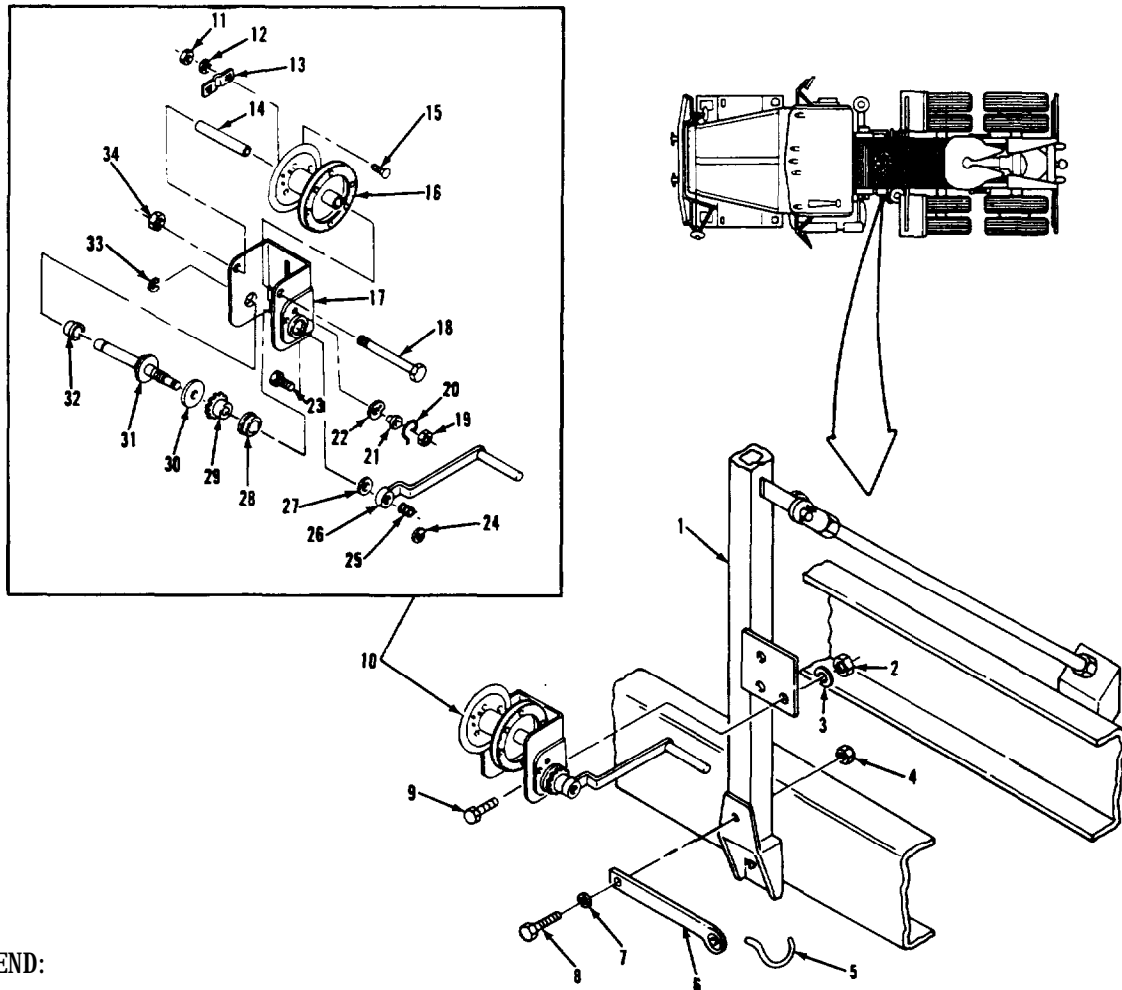

LEGEND:

- |                              |                           |
|------------------------------|---------------------------|
| 1. WINCH PILLAR ASSEMBLY     | 18. SCREW                 |
| 2. HEXAGON HEAD NUT (3)      | 19. LOCKNUT               |
| 3. LOCKWASHER (3)            | 20. RATCHET SPRING        |
| 4. LOCKNUT                   | 21. RATCHET SPACER        |
| 5. HOOK                      | 22. RATCHET PAWL          |
| 6. STRAP                     | 23. RATCHET SCREW         |
| 7. WASHER                    | 24. RETAINING RING        |
| 8. SCREW                     | 25. COIL SPRING           |
| 9. HEXAGON HEAD SCREW (3)    | 26. HANDLE ASSEMBLY       |
| 10. WORK WINCH               | 27. HANDLE DISK           |
| 11. NUT (2)                  | 28. BUSHING               |
| 12. LOCKWASHER (2)           | 29. RATCHET GEAR ASSEMBLY |
| 13. CABLE KEEPER             | 30. BRAKE FACE DISK       |
| 14. FRAME SPACER             | 31. PINION SHAFT ASSEMBLY |
| 15. CARRIAGE BOLT (2)        | 32. BUSHING               |
| 16. DRUM ASSEMBLY            | 33. RETAINING RING        |
| 17. FRAME AND PLATE ASSEMBLY | 34. LOCKNUT               |

TA 237678

FRAME AND TOWING ATTACHMENTS.

3-242. SPARE TIRE WINCH REPLACEMENT AND REPAIR (Continued).

LOCATION/ITEM	ACTION	REMARKS
<b>C. CLEANING AND INSPECTION.</b>		
11. All parts.	Clean and inspect.	Refer to paragraphs 3-4 and 3-5.
<b>D. ASSEMBLY.</b>		
12. Hook (5).	Install on item (6).	Use pliers.
13. Keeper (13).	a. Position on item (16). b. Secure with two items (11), (12), and (15).	
14. Bushing (28) and bushing (32).	Install into item (17).	
15. Pawl (22), spacer (21), and spring (20).	a. Position on item (17). b. Secure with items (19) and (23).	
16. Shaft (31), disk (30), and ratchet gear assembly (29).	a. Install items (30) and (29) on item (31). b. Slide item (31) into item (17). c. Secure with item (33).	
17. Spacer (14) and drum (16).	a. Position in item (17). b. Secure with items (18) and (34).	
18. Disk (27), handle (26), and spring (25).	a. Install on item (31). b. Secure with item (24).	

FRAME AND TOWING ATTACHMENTS.

3-242. SPARE TIRE WINCH REPLACEMENT AND REPAIR (Continued).

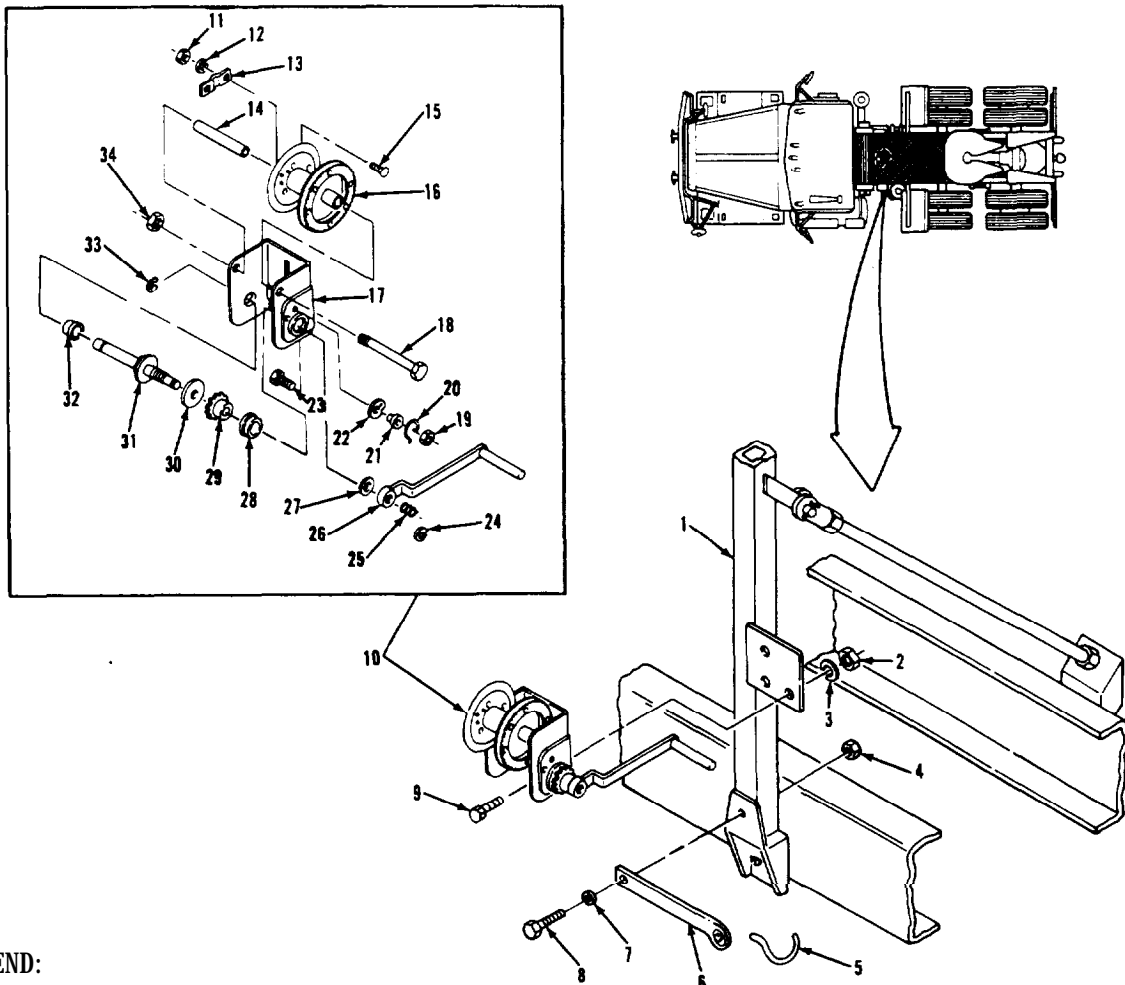

LEGEND:

- |                              |                           |
|------------------------------|---------------------------|
| 1. WINCH PILLAR ASSEMBLY     | 18. SCREW                 |
| 2. HEXAGON HEAD NUT (3)      | 19. LOCKNUT               |
| 3. LOCKWASHER (3)            | 20. RATCHET SPRING        |
| 4. LOCKNUT                   | 21. RATCHET SPACER        |
| 5. HOOK                      | 22. RATCHET PAWL          |
| 6. STRAP                     | 23. RATCHET SCREW         |
| 7. WASHER                    | 24. RETAINING RING        |
| 8. SCREW                     | 25. COIL SPRING           |
| 9. HEXAGON HEAD SCREW (3)    | 26. HANDLE ASSEMBLY       |
| 10. WORK WINCH               | 27. HANDLE DISK           |
| 11. NUT (2)                  | 28. BUSHING               |
| 12. LOCKWASHER (2)           | 29. RATCHET GEAR ASSEMBLY |
| 13. CABLE KEEPER             | 30. BRAKE FACE DISK       |
| 14. FRAME SPACER             | 31. PINION SHAFT ASSEMBLY |
| 15. CARRIAGE BOLT (2)        | 32. BUSHING               |
| 16. DRUM ASSEMBLY            | 33. RETAINING RING        |
| 17. FRAME AND PLATE ASSEMBLY | 34. LOCKNUT               |

TA 237679

FRAME AND TOWING ATTACHMENTS.

3-242. SPARE TIRE WINCH REPLACEMENT AND REPAIR (Continued).

LOCATION/ITEM	ACTION	REMARKS
<b>E. INSTALLATION.</b>		
19. Winch (10).	a. Position on item (1).  b. Secure with three items (4), (3), and (2).	
20. Screw (8), washer (7), and locknut (4).	Secure item (6) to item (1).	
<b>NOTE</b>		
Follow-on maintenance action required:		
Install spare tire winch cable (para 3-241).		

FRAME AND TOWING ATTACHMENTS.

3-242. SPARE TIRE WINCH REPLACEMENT AND REPAIR (Continued).

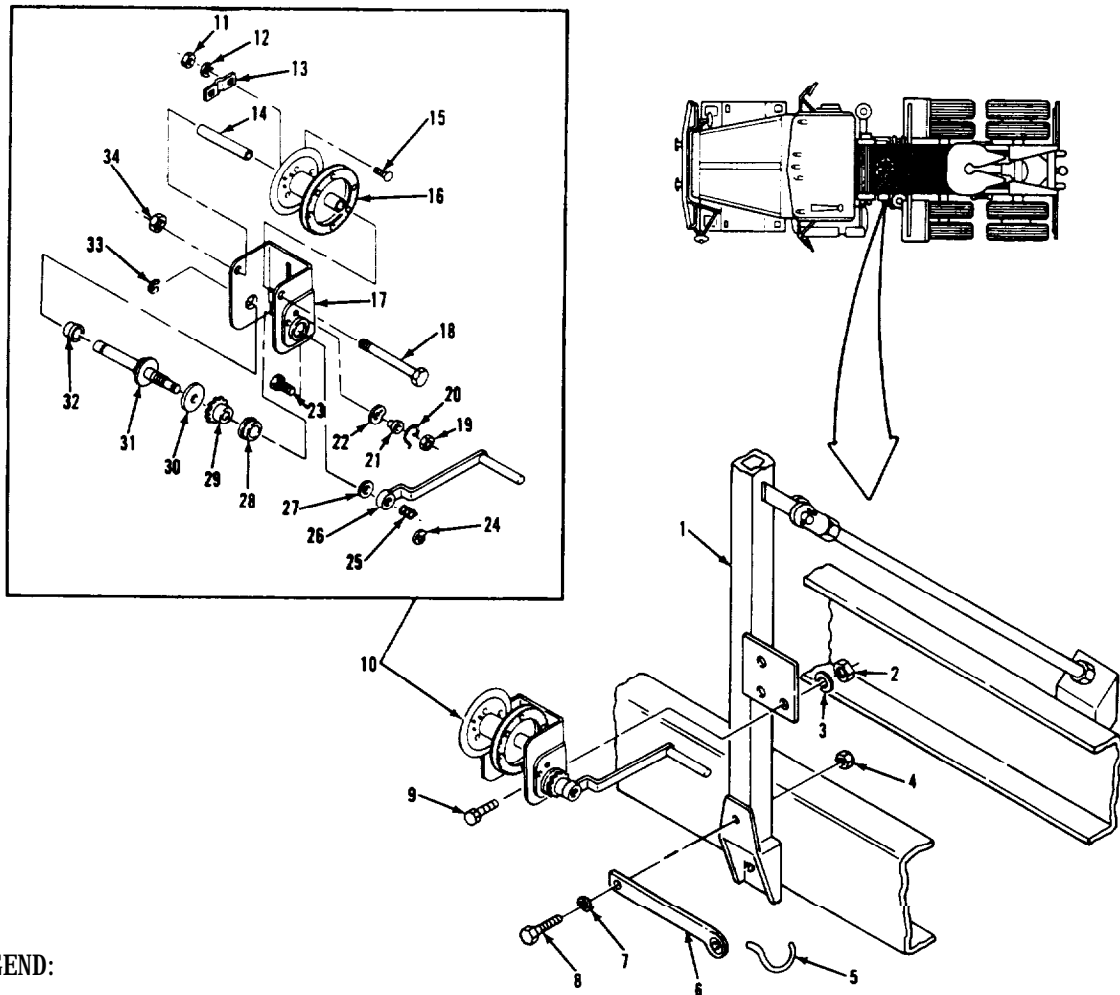

LEGEND:

- |                              |                           |
|------------------------------|---------------------------|
| 1. WINCH PILLAR ASSEMBLY     | 18. SCREW                 |
| 2. HEXAGON HEAD NUT (3)      | 19. LOCKNUT               |
| 3. LOCKWASHER (3)            | 20. RATCHET SPRING        |
| 4. LOCKNUT                   | 21. RATCHET SPACER        |
| 5. HOOK                      | 22. RATCHET PAWL          |
| 6. STRAP                     | 23. RATCHET SCREW         |
| 7. WASHER                    | 24. RETAINING RING        |
| 8. SCREW                     | 25. COIL SPRING           |
| 9. HEXAGON HEAD SCREW (3)    | 26. HANDLE ASSEMBLY       |
| 10. WORK WINCH               | 27. HANDLE DISK           |
| 11. NUT (2)                  | 28. BUSHING               |
| 12. LOCKWASHER (2)           | 29. RATCHET GEAR ASSEMBLY |
| 13. CABLE KEEPER             | 30. BRAKE FACE DISK       |
| 14. FRAME SPACER             | 31. PINION SHAFT ASSEMBLY |
| 15. CARRIAGE BOLT (2)        | 32. BUSHING               |
| 16. DRUM ASSEMBLY            | 33. RETAINING RING        |
| 17. FRAME AND PLATE ASSEMBLY | 34. LOCKNUT               |

TA 237680



FRAME AND TOWING ATTACHMENTS.

3-243. SPARE TIRE WINCH PILLAR REPLACEMENT.

THIS TASK COVERS

- a. Removal.
- b. Cleaning and Inspection.
- c. Installation.

INITIAL SETUP

<u>APPLICABLE CONFIGURATIONS</u>	<u>EQUIPMENT CONDITION PARAGRAPH</u>	<u>CONDITION DESCRIPTION</u>
All.	3-241.	Spare tire winch cable removed.
<u>TEST EQUIPMENT</u>		
None.	3-242.	Spare tire winch removed.
<u>SPECIAL TOOLS</u>		
None.		
<u>MATERIALS/PARTS (P/N)</u>		
Pin, cotter (24617) 137185.		
<u>PERSONNEL REQUIRED</u>	<u>SPECIAL ENVIRONMENTAL CONDITIONS</u>	
Two (MDS-63S).	None.	
<u>REFERENCES (TM)</u>	<u>GENERAL SAFETY INSTRUCTIONS</u>	
TM 9-2320-283-20P.	Engine off. Transmission in neutral. Park brake set.	
<u>TROUBLESHOOTING REFERENCES</u>		
None.		

FRAME AND TOWING ATTACHMENTS.

3-243. SPARE TIRE WINCH PILLAR REPLACEMENT (Continued).

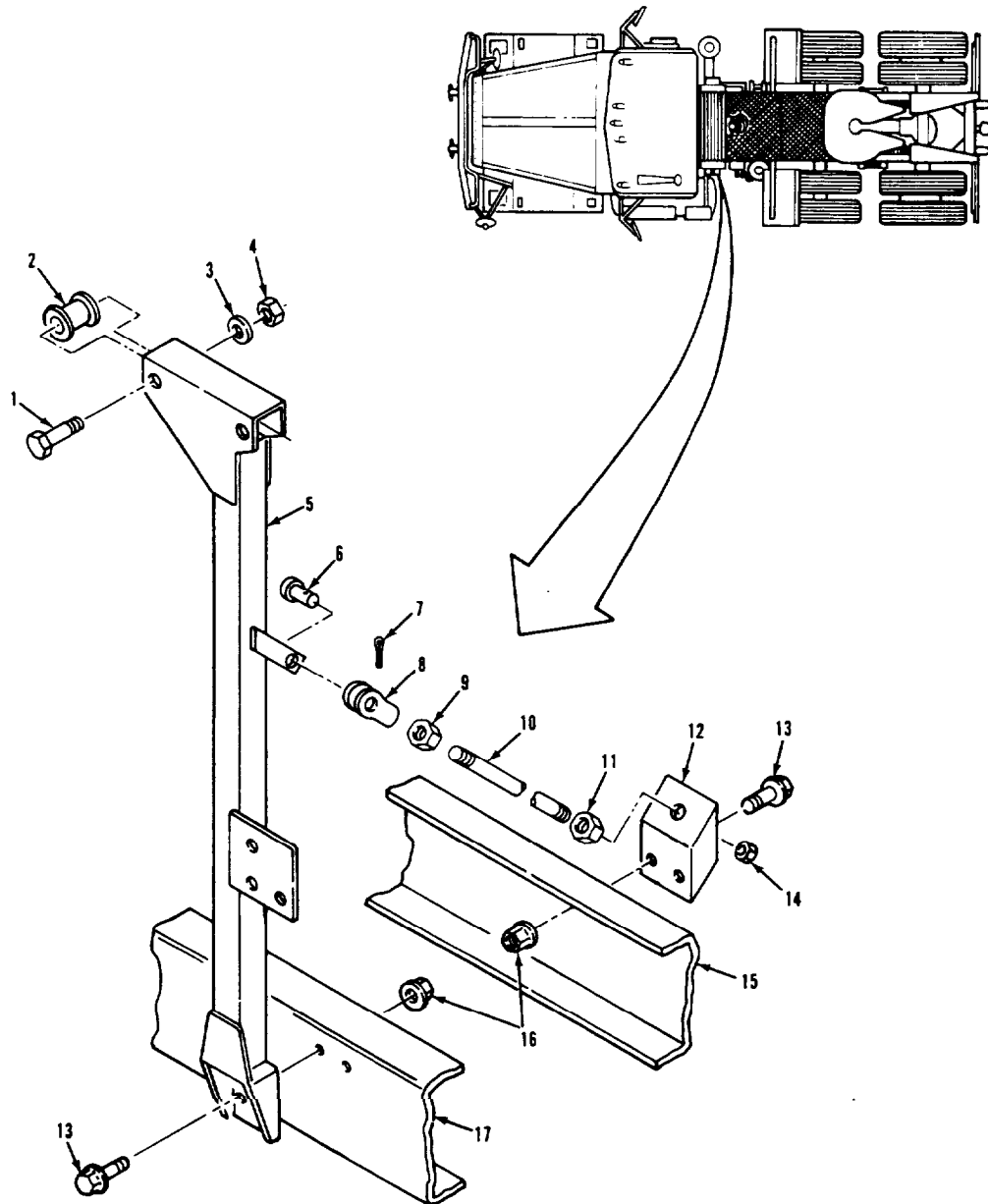

LEGEND:

- |                           |                                  |
|---------------------------|----------------------------------|
| 1. HEXAGON HEAD SCREW (2) | 10. TENSION ROD                  |
| 2. CABLE ROLLER (2)       | 11. NUT                          |
| 3. PLAIN WASHER (2)       | 12. TENSION ROD SUPPORT ASSEMBLY |
| 4. HEXAGON HEAD NUT (2)   | 13. HEXAGON HEAD SCREW (4)       |
| 5. WINCH PILLAR ASSEMBLY  | 14. FLANGE HEAD NUT              |
| 6. CLEVIS PIN             | 15. RIGHT-HAND FRAME RAIL        |
| 7. COTTER PIN             | 16. LOCKNUT (4)                  |
| 8. ROD END CLEVIS         | 17. LEFT-HAND FRAME RAIL         |
| 9. NUT                    |                                  |

TA 237681

FRAME AND TOWING ATTACHMENTS.

3-243. SPARE TIRE WINCH PILLAR REPLACEMENT (Continued).

LOCATION/ITEM	ACTION	REMARKS
<b>A. REMOVAL</b>		
1. Pin (7).	Remove from item (6).	Discard item (7).
2. Pin (6).	Remove from items (5) and (8).	
3. Nut (14) and rod (10).	Remove from item (12).	
4. Clevis (8), nut (9), and nut (11).	Remove from item (10).	
5. Two locknuts (16), screws (13), and pillar (5).	Remove from item (17).	Have assistant hold item (5) while items (16) and (13) are removed.
6. Two locknuts (16), screws (13), and tension rod support assembly (12).	Remove from item (15).	
7. Two nuts (4), washers (3), screws (1), and rollers (2).	Remove from item (5).	
<b>B. CLEANING AND INSPECTION.</b>		
8. All parts.	Clean and inspect.	Refer to paragraphs 3-4 and 3-5.
<b>C. INSTALLATION.</b>		
9. Two rollers (2).	a. Position in item (5).	
	b. Secure with two items (1), (3), and (4).	

FRAME AND TOWING ATTACHMENTS.

3-243. SPARE TIRE WINCH PILLAR REPLACEMENT (Continued).

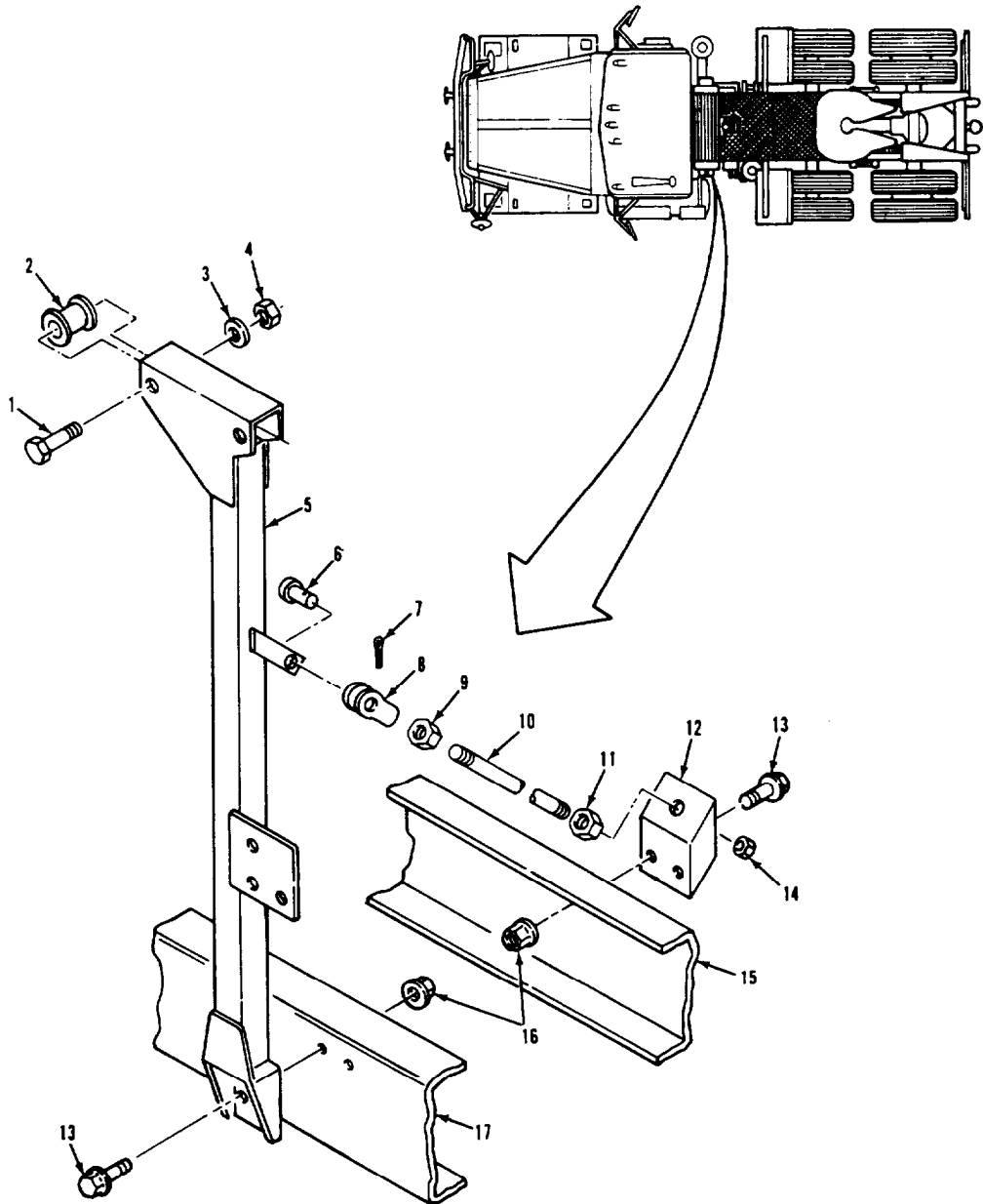

LEGEND:

- |                           |                                  |
|---------------------------|----------------------------------|
| 1. HEXAGON HEAD SCREW (2) | 10. TENSION ROD                  |
| 2. CABLE ROLLER (2)       | 11. NUT                          |
| 3. PLAIN WASHER (2)       | 12. TENSION ROD SUPPORT ASSEMBLY |
| 4. HEXAGON HEAD NUT (2)   | 13. HEXAGON HEAD SCREW (4)       |
| 5. WINCH PILLAR ASSEMBLY  | 14. FLANGE HEAD NUT              |
| 6. CLEVIS PIN             | 15. RIGHT-HAND FRAME RAIL        |
| 7. COTTER PIN             | 16. LOCKNUT (4)                  |
| 8. ROD END CLEVIS         | 17. LEFT-HAND FRAME RAIL         |
| 9. NUT                    |                                  |

TA 237682

FRAME AND TOWING ATTACHMENTS.

3-243. SPARE TIRE WINCH PILLAR REPLACEMENT (Continued).		
LOCATION/ITEM	ACTION	REMARKS
<b>C. INSTALLATION (Continued).</b>		
10. Support (12).	a. Position on item (15). b. Secure with two items (13), and (16).	
11. Pillar (5).	a. Have assistant position on item (17). b. Secure with two items (13), and (16).	
12. Nut (11), nut (9), and clevis (8).	Install on item (10).	
13. Rod (10).	Insert threaded end into hole of item (12).	
14. Clevis (8).	a. Position on item (5). b. Secure with item (6).	
15. New pin (7).	Install in item (6) and bend ends over.	
16. Nut (14).	Install on item (10), and tighten.	
<b>NOTE</b>		
Follow-on maintenance action required:		
Install spare tire winch (para 3-242). Install spare tire winch cable (para 3-241).		

FRAME AND TOWING ATTACHMENTS.

3-243. SPARE TIRE WINCH PILLAR REPLACEMENT (Continued).

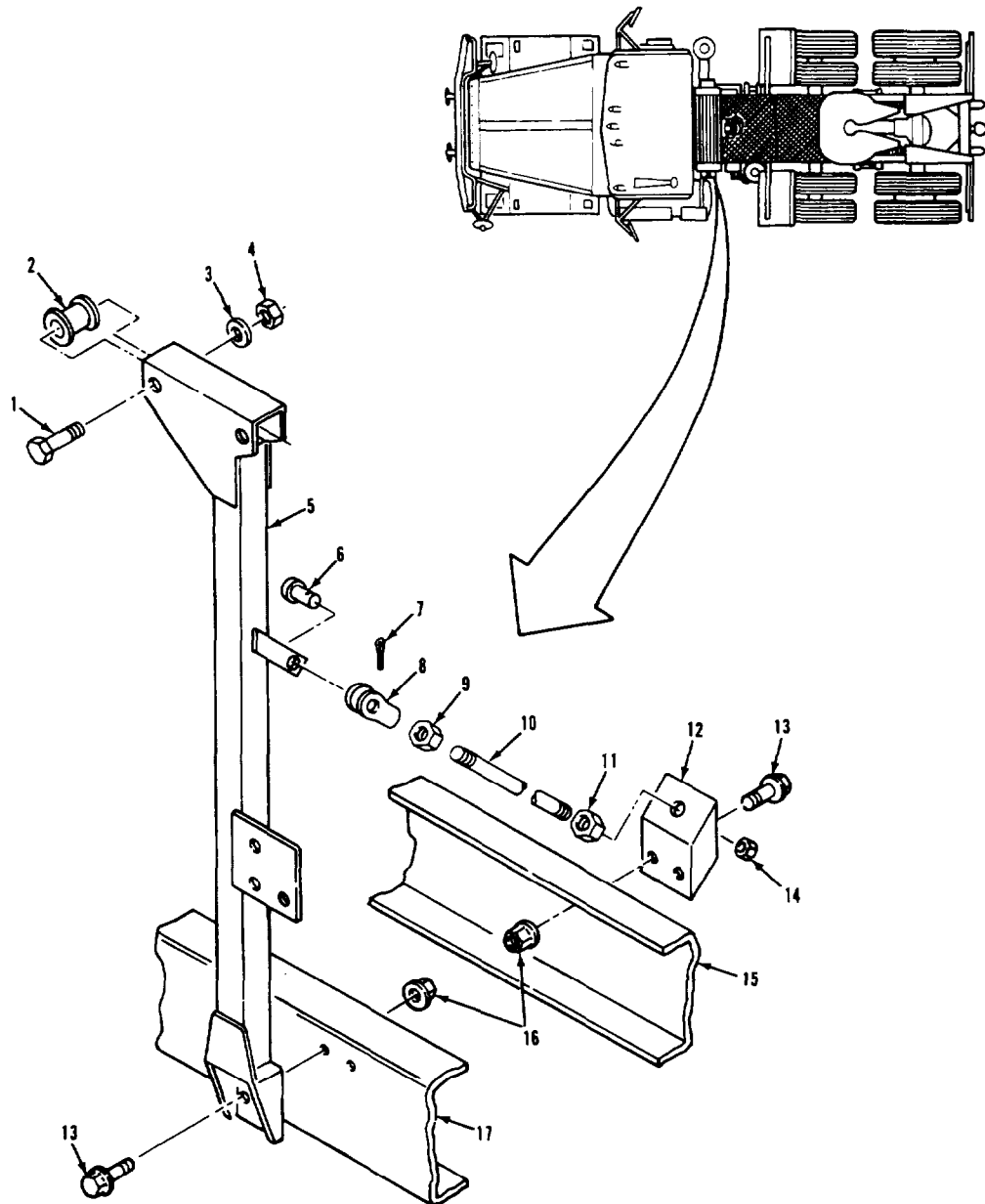

LEGEND:

- |                           |                                  |
|---------------------------|----------------------------------|
| 1. HEXAGON HEAD SCREW (2) | 10. TENSION ROD                  |
| 2. CABLE ROLLER (2)       | 11. NUT                          |
| 3. PLAIN WASHER (2)       | 12. TENSION ROD SUPPORT ASSEMBLY |
| 4. HEXAGON HEAD NUT (2)   | 13. HEXAGON HEAD SCREW (4)       |
| 5. WINCH PILLAR ASSEMBLY  | 14. FLANGE HEAD NUT              |
| 6. CLEVIS PIN             | 15. RIGHT-HAND FRAME RAIL        |
| 7. COTTER PIN             | 16. LOCKNUT (4)                  |
| 8. ROD END CLEVIS         | 17. LEFT-HAND FRAME RAIL         |
| 9. NUT                    |                                  |

TA 237683

FRAME AND TOWING ATTACHMENTS.

3-244. FIFTH WHEEL ADJUSTMENT.

THIS TASK COVERS

Adjustment.

INITIAL SETUP

APPLICABLE CONFIGURATIONS

All.

EQUIPMENT CONDITION  
PARAGRAPH

None.

CONDITION DESCRIPTION

None.

TEST EQUIPMENT

None.

SPECIAL TOOLS

Tester, lock, fifth wheel  
(74410) TLN-100.

MATERIALS/PARTS (P/N)

None.

PERSONNEL REQUIRED

One (MDS-63S).

SPECIAL ENVIRONMENTAL CONDITIONS

None.

REFERENCES (TM)

TM 9-2320-283-20P.

GENERAL SAFETY INSTRUCTIONS

Engine off.  
Transmission in neutral.  
Park brake set.

TROUBLESHOOTING REFERENCES

Paragraph 2-11.

FRAME AND TOWING ATTACHMENTS.

3-244. FIFTH WHEEL ADJUSTMENT (Continued).

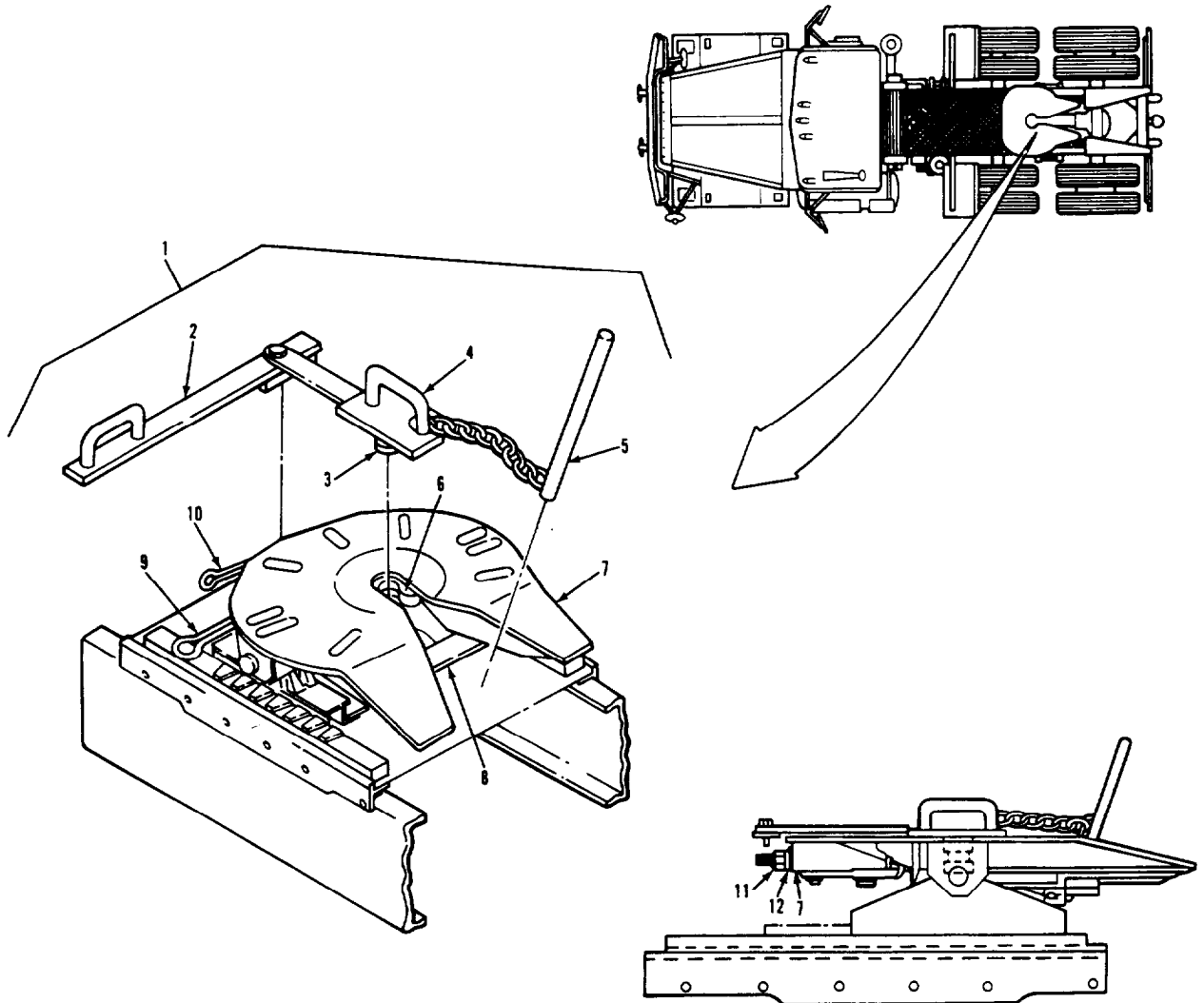

LEGEND:

- |                            |                               |
|----------------------------|-------------------------------|
| 1. FIFTH WHEEL LOCK TESTER | 7. FIFTH WHEEL PLATE ASSEMBLY |
| 2. LEVER                   | 8. CROSSTIE                   |
| 3. KINGPIN                 | 9. RELEASE HANDLE             |
| 4. KINGPIN PLATE           | 10. SECONDARY LOCK HANDLE     |
| 5. BAR                     | 11. HEXAGON HEAD NUT          |
| 6. LOCKJAW (2)             | 12. RUBBER BLOCK              |

TA 237684



FRAME AND TOWING ATTACHMENTS.

3-244. FIFTH WHEEL ADJUSTMENT (Continued).

LOCATION/ITEM	ACTION	REMARKS
<b>ADJUSTMENT.</b>		
<b>NOTE</b>		
<p>To install the fifth wheel lock tester, the fifth wheel lockjaws must be open. Do step 1 to open lockjaws, if necessary.</p>		
<p>1. Handle (10), handle (9), and two lockjaws (6).</p>	<p>a. Pull out item (10) until it catches on item (7).                      b. Pull out item (9) and pry open two items (6).</p>	
<p>2. Tester (1).</p>	<p>a. Grasp handle of item (4) and place item (3) into two items (6).                      b. Place item (2) over front of item (7).                      c. While pushing down on item (4), rotate item (2) away from item (7) until item (3) is locked in two items (6).                      d. Position item (5) over edge of item (8).                      e. Pry forward with item (2) and rearward with item (5) to check for play.</p>	<p>Be sure item (4) is flat against item (7) during this operation.                       Do step 3 to adjust items (6), if necessary.</p>
<p>3. Nut (11).</p>	<p>Tighten or loosen until item (12) fits snugly against item (7), but still can be turned by hand.</p>	<p>If there is still play after adjusting items (6), refer to DS/GS maintenance.</p>

FRAME AND TOWING ATTACHMENTS.

3-244. FIFTH WHEEL ADJUSTMENT (Continued).

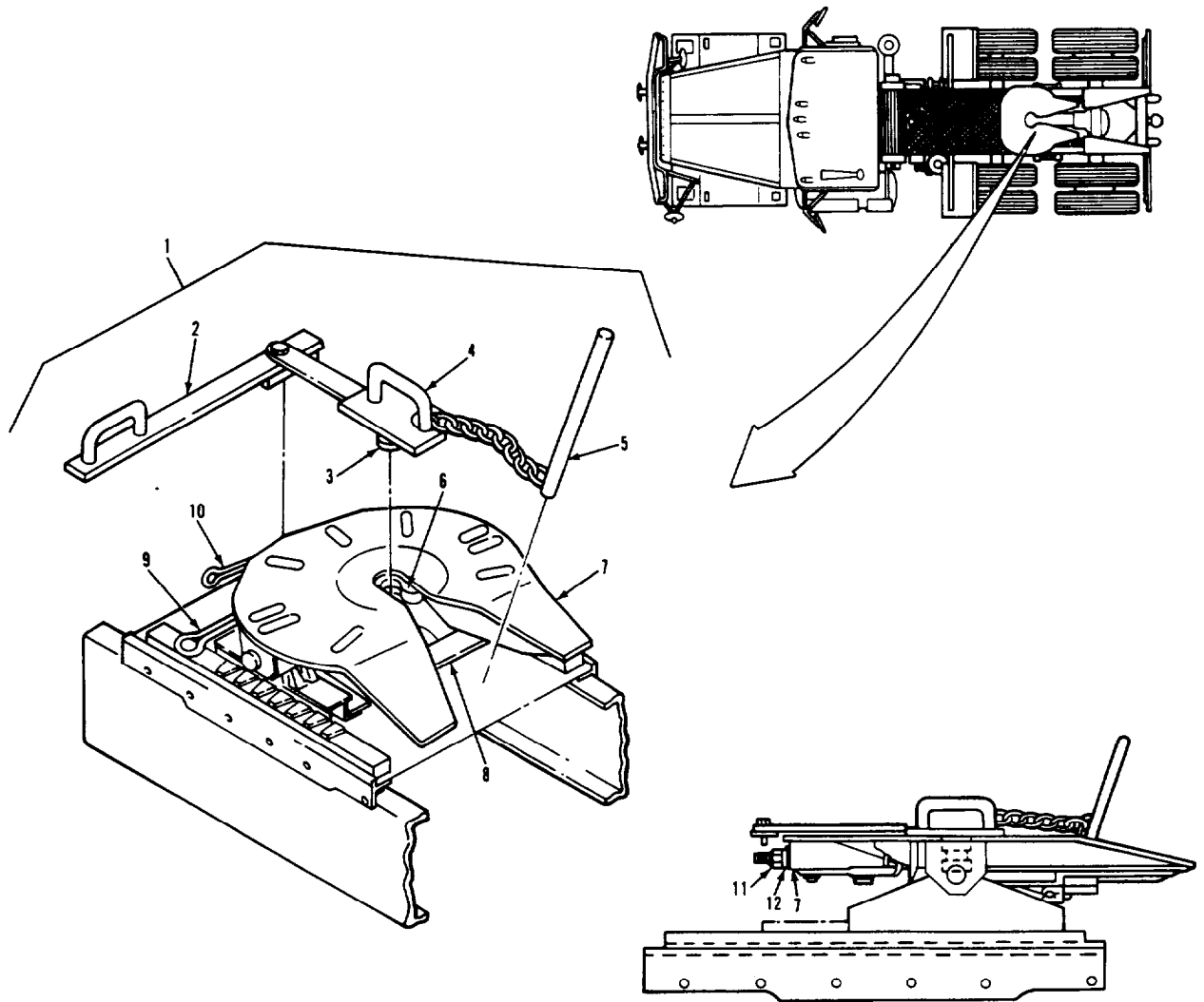

LEGEND:

- |                            |                               |
|----------------------------|-------------------------------|
| 1. FIFTH WHEEL LOCK TESTER | 7. FIFTH WHEEL PLATE ASSEMBLY |
| 2. LEVER                   | 8. CROSSTIE                   |
| 3. KINGPIN                 | 9. RELEASE HANDLE             |
| 4. KINGPIN PLATE           | 10. SECONDARY LOCK HANDLE     |
| 5. BAR                     | 11. HEXAGON HEAD NUT          |
| 6. LOCKJAW (2)             | 12. RUBBER BLOCK              |

TA 237685

FRAME AND TOWING ATTACHMENTS.

3-244. FIFTH WHEEL ADJUSTMENT (Continued).		
LOCATION/ITEM	ACTION	REMARKS
<b>ADJUSTMENT (Continued).</b>		
4. Tester (1).	a. Rotate item (2) towards item (7).  b. Position item (5) on edge of item (8), and using leverage, remove item (3) from two items (6).	
<b>NOTE</b>		
•Repeat this procedure to verify proper adjustment of fifth wheel.		
•Follow-on maintenance action required:		
None.		

FRAME AND TOWING ATTACHMENTS.

3-244. FIFTH WHEEL ADJUSTMENT (Continued).

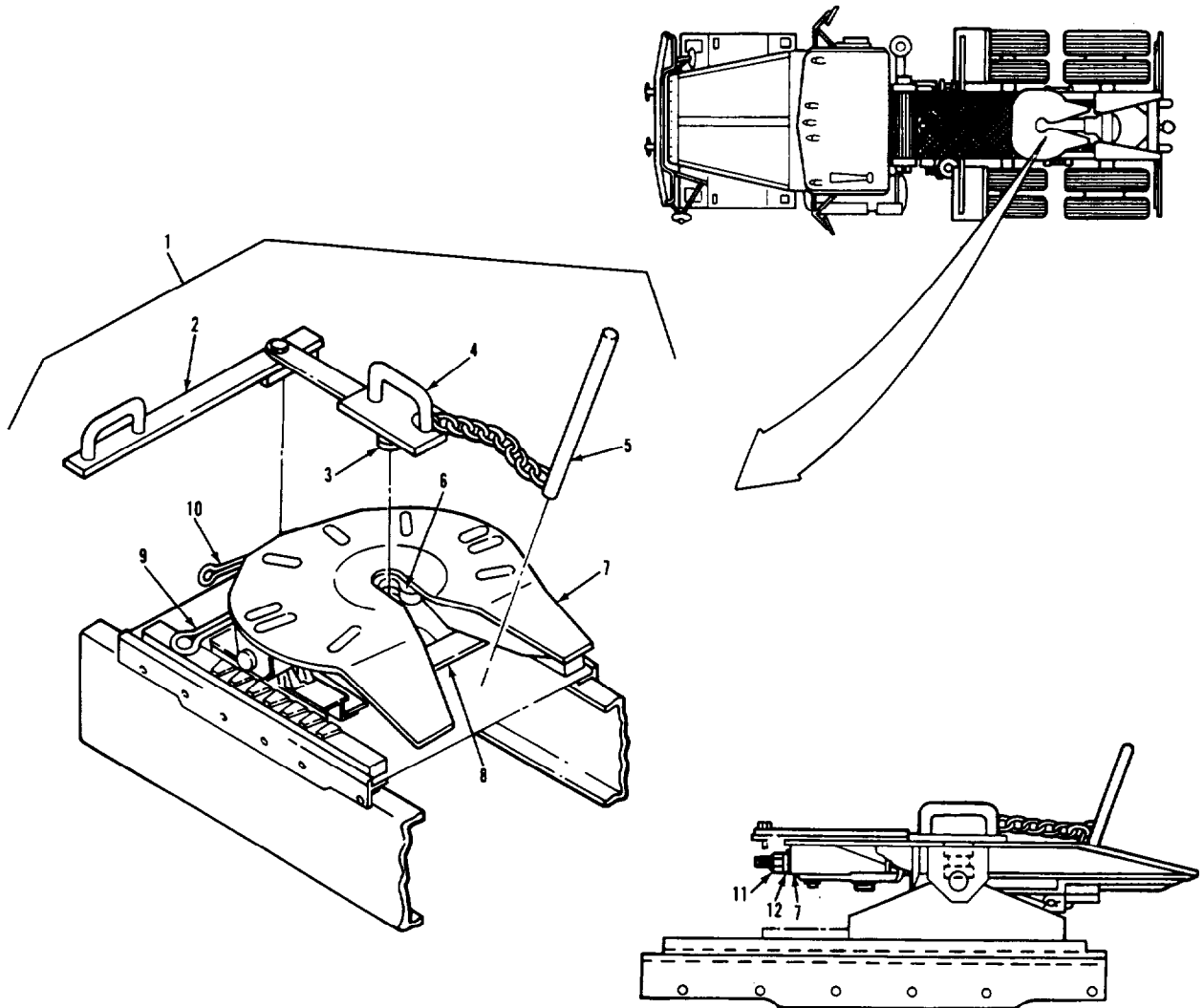

LEGEND:

- |                            |                               |
|----------------------------|-------------------------------|
| 1. FIFTH WHEEL LOCK TESTER | 7. FIFTH WHEEL PLATE ASSEMBLY |
| 2. LEVER                   | 8. CROSSTIE                   |
| 3. KINGPIN                 | 9. RELEASE HANDLE             |
| 4. KINGPIN PLATE           | 10. SECONDARY LOCK HANDLE     |
| 5. BAR                     | 11. HEXAGON HEAD NUT          |
| 6. LOCKJAW (2)             | 12. RUBBER BLOCK              |

TA 237686

FRAME AND TOWING ATTACHMENTS.

3-245. FIFTH WHEEL REPLACEMENT.

THIS TASK COVERS

- a. Removal.
- b. Cleaning and Inspection.
- c. Installation.

INITIAL SETUP

<u>APPLICABLE CONFIGURATIONS</u>	<u>EQUIPMENT CONDITION PARAGRAPH</u>	<u>CONDITION DESCRIPTION</u>
All.	3-239.	Service deck removed.
<u>TEST EQUIPMENT</u> None.	3-163.	Fifth wheel air cylinder air line disconnected.
<u>SPECIAL TOOLS</u> None.		
<u>MATERIALS/PARTS (P/N)</u> None.		
<u>PERSONNEL REQUIRED</u> Two (MOS-63S).	<u>SPECIAL ENVIRONMENTAL CONDITIONS</u> None.	
<u>REFERENCES (TM)</u> LO 9-2320-283-12.	<u>GENERAL SAFETY INSTRUCTIONS</u> Engine off Transmission in neutral. Park brake set.	
<u>TROUBLESHOOTING REFERENCES</u> Paragraph 2-11.		

FRAME AND TOWING ATTACHMENTS.

3-245. FIFTH WHEEL REPLACEMENT (Continued).

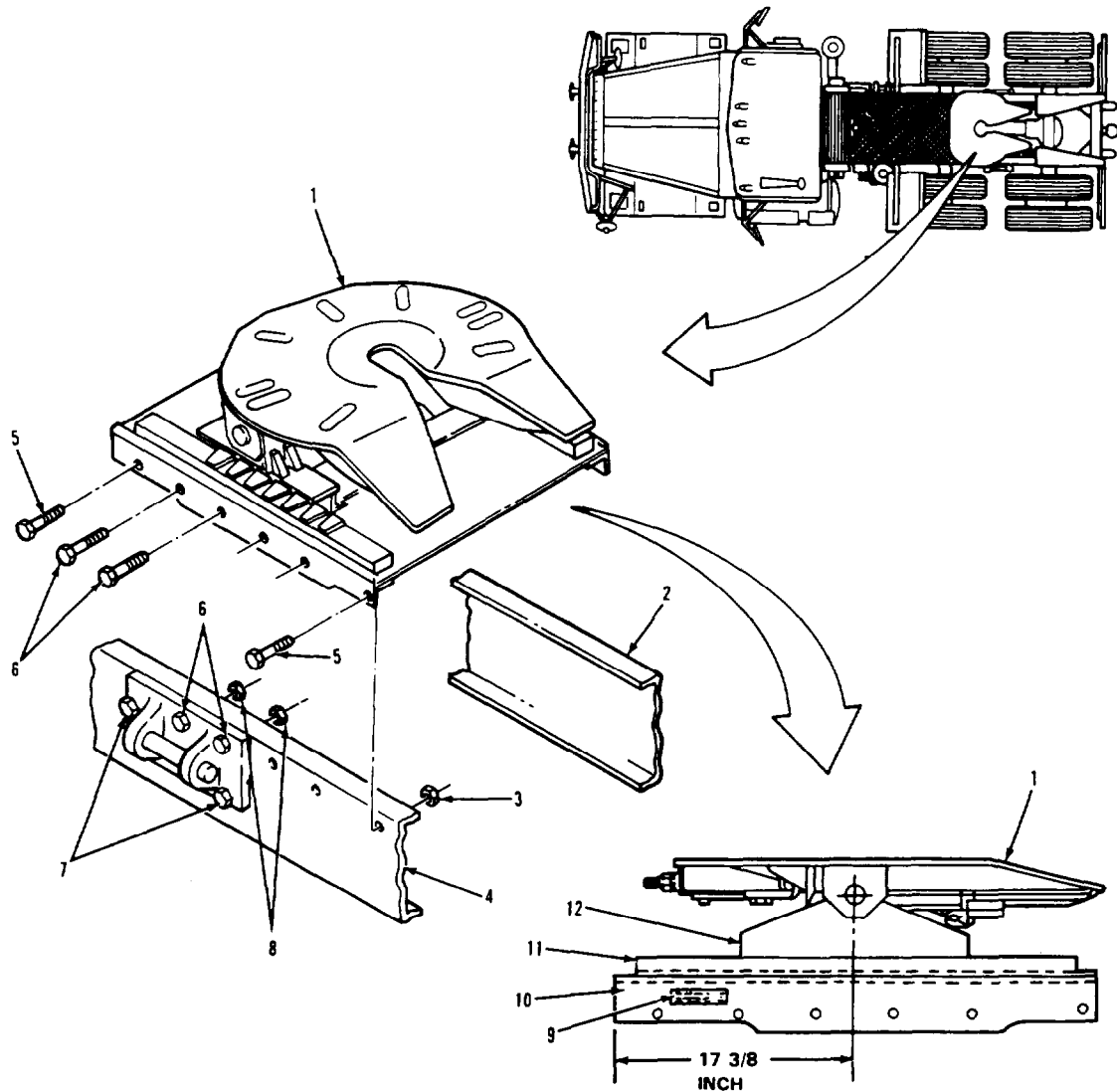

LEGEND:

- |                                  |                                  |
|----------------------------------|----------------------------------|
| 1. FIFTH WHEEL                   | 7. SCREW (6)                     |
| 2. RIGHT-HAND FRAME RAIL         | 8. HEXAGON FLANGED HEAD NUT (6)  |
| 3. HEXAGON FLANGED HEAD NUT (12) | 9. ALINEMENT DECAL (2)           |
| 4. LEFT-HAND FRAME RAIL          | 10. BASE PLATE ASSEMBLY W/ANGLES |
| 5. SCREW (4)                     | 11. GUIDE TRACK                  |
| 6. SCREW (8)                     | 12. SLIDE BRACKET                |

TA 237687

FRAME AND TOWING ATTACHMENTS.

3-245. FIFTH WHEEL REPLACEMENT (Continued).		
LOCATION/ITEM	ACTION	REMARKS
<p><b><u>WARNING</u></b></p> <p>The fifth wheel is very heavy and could cause serious injury if dropped. Before lifting, make the sure lifting device is firmly secured.</p>		
<p><b>A. REMOVAL.</b></p>		
1. Twelve nuts (3), four screws (5), and eight screws (6).	Remove from items (1), (2), and (4).	
2. Six screws (7) and nuts (8).	Loosen only from item (4).	
3. Fifth wheel (1).	<p>a. Attach suitable lifting device.</p> <p>b. Using lifting device, remove from items (2) and (4).</p>	<p>Have assistant help steady item (1) during removal. Set item (1) on wood blocks in a clean work area.</p>
<p><b>B. CLEANING AND INSPECTION.</b></p>		
4. All parts.	Clean and inspect.	Refer to paragraphs 3-4 and 3-5. If item (1) is damaged, refer to DS/GS maintenance.
<p><b>C. INSTALLATION.</b></p>		
5. Fifth wheel (1).	a. Using suitable lifting device, position on items (2) and (4).	

FRAME AND TOWING ATTACHMENTS.

3-245. FIFTH WHEEL REPLACEMENT (Continued).

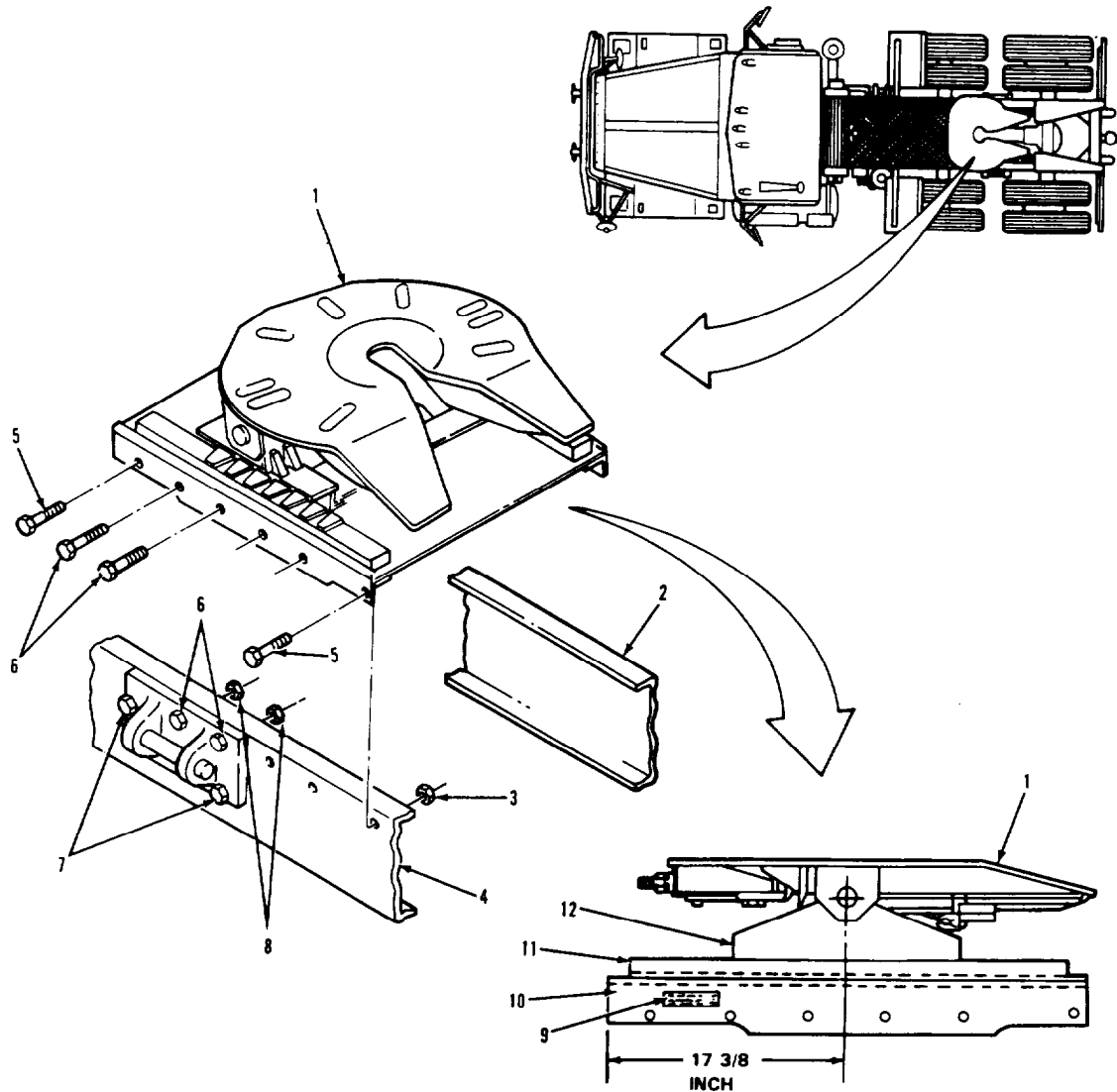

LEGEND:

- |                                  |                                  |
|----------------------------------|----------------------------------|
| 1. FIFTH WHEEL                   | 7. SCREW (6)                     |
| 2. RIGHT-HAND FRAME RAIL         | 8. HEXAGON FLANGED HEAD NUT (6)  |
| 3. HEXAGON FLANGED HEAD NUT (12) | 9. ALINEMENT DECAL (2)           |
| 4. LEFT-HAND FRAME RAIL          | 10. BASE PLATE ASSEMBLY W/ANGLES |
| 5. SCREW (4)                     | 11. GUIDE TRACK                  |
| 6. SCREW (8)                     | 12. SLIDE BRACKET                |

TA 237688



FRAME AND TOWING ATTACHMENTS.

3-245. FIFTH WHEEL REPLACEMENT (Continued).		
LOCATION/ITEM	ACTION	REMARKS
<b>C. INSTALLATION (Continued).</b>		
5. Fifth wheel (1) (continued).	b. Line up holes with items (2) and (4).  c. Insert four items (5) and eight items (6) into items (1), (2), and (4).  d. Remove lifting device.	Use two suitable drift pins.
6. Twelve nuts (3).	Install on four items (5) and eight items (6), and tighten.	
7. Six screws (7) and nuts (8).	Tighten on item (4).	
<p><b>NOTE</b></p> <p>Do steps 8 and 9 only if fifth wheel does not have alinement arrows and decal.</p>		
8. Base plate assembly w/angles (10).	Make a mark 17-3/8 inch from forward edge (see illustration).	
9. Fifth wheel (1).	a. Unlock and position so that centerline is alined with mark from step 8 (see illustration).  b. Using suitable stencil, paint arrows on items (11) and (12) (see illustration).	Refer to TM 9-2320-283-10. When item (1) is in correct position, relock it.  Repeat this step for other side of item (1).
10. Two decals (9)	Install one on each side of item (10) as shown in illustration.	Make sure surface of item (10) is clean before installing two items (9).

FRAME AND TOWING ATTACHMENTS.

3-245. FIFTH WHEEL REPLACEMENT (Continued).

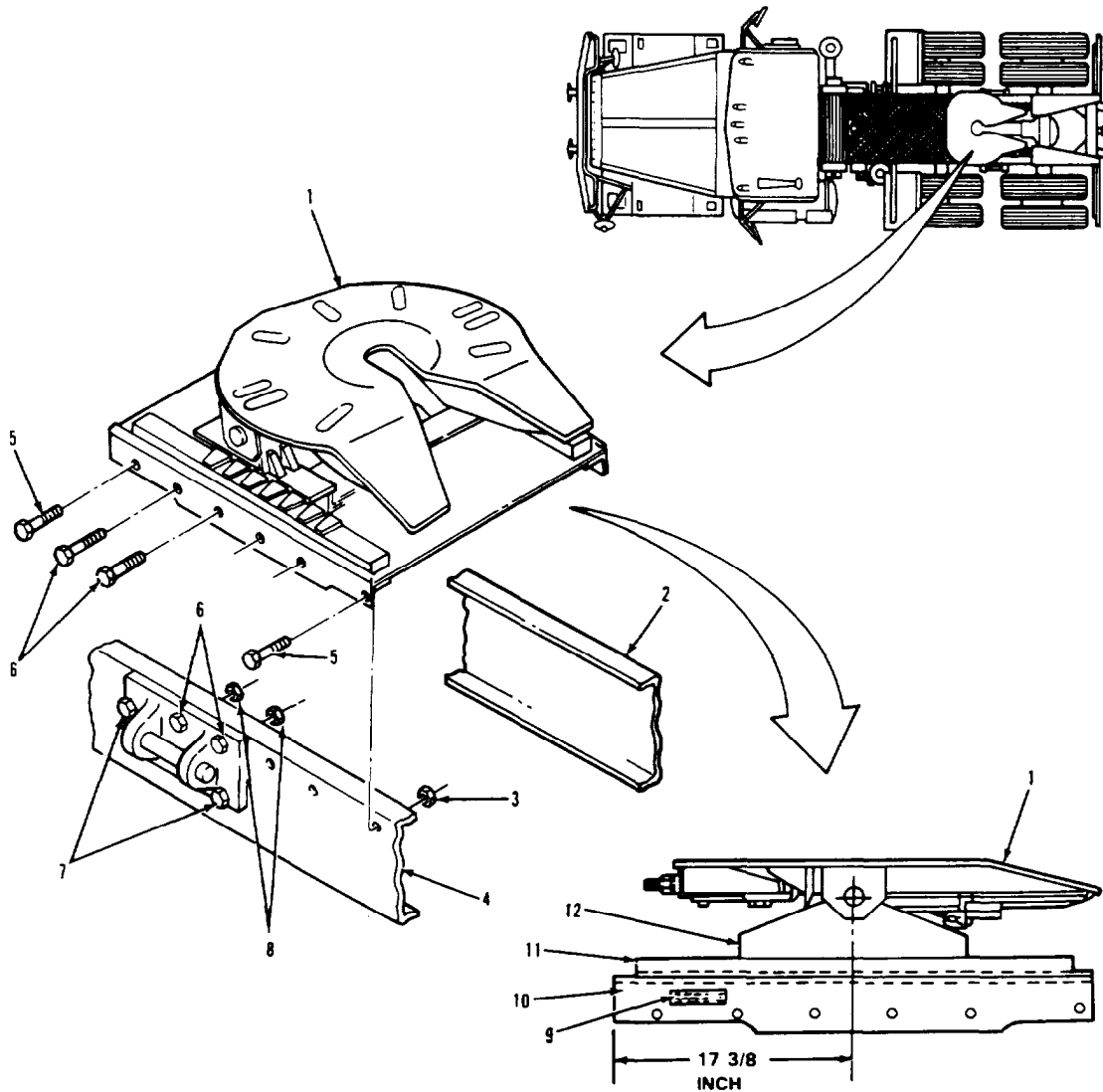

LEGEND:

- |                                  |                                  |
|----------------------------------|----------------------------------|
| 1. FIFTH WHEEL                   | 7. SCREW (6)                     |
| 2. RIGHT-HAND FRAME RAIL         | 8. HEXAGON FLANGED HEAD NUT (6)  |
| 3. HEXAGON FLANGED HEAD NUT (12) | 9. ALINEMENT DECAL (2)           |
| 4. LEFT-HAND FRAME RAIL          | 10. BASE PLATE ASSEMBLY W/ANGLES |
| 5. SCREW (4)                     | 11. GUIDE TRACK                  |
| 6. SCREW (8)                     | 12. SLIDE BRACKET                |

TA 237689

FRAME AND TOWING ATTACHMENTS.

3-245. FIFTH WHEEL REPLACEMENT (Continued).		
LOCATION/ITEM	ACTION	REMARKS
<b>C. INSTALLATION (Continued).</b>		
<b>NOTE</b>		
Follow-on maintenance action required:		
Connect fifth wheel air cylinder air line (para 3-163).		
Install service deck (para 3-239).		
Lubricate fifth wheel (LO 9-2320- 283-12).		
Adjust fifth wheel (para 3-244).		

FRAME AND TOWING ATTACHMENTS.

3-245. FIFTH WHEEL REPLACEMENT (Continued).

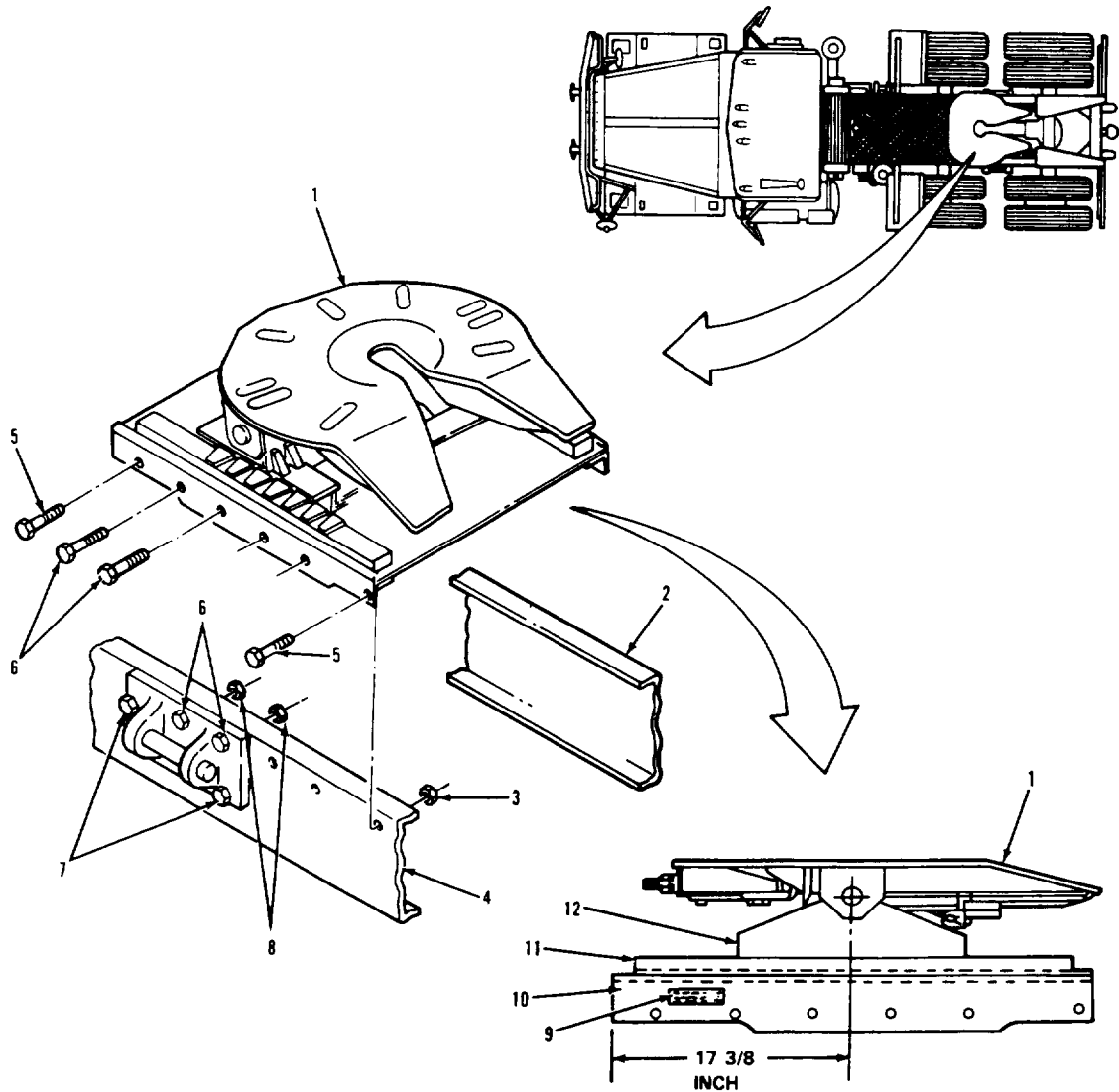

LEGEND:

- |                                  |                                  |
|----------------------------------|----------------------------------|
| 1. FIFTH WHEEL                   | 7. SCREW (6)                     |
| 2. RIGHT-HAND FRAME RAIL         | 8. HEXAGON FLANGED HEAD NUT (6)  |
| 3. HEXAGON FLANGED HEAD NUT (12) | 9. ALINEMENT DECAL (2)           |
| 4. LEFT-HAND FRAME RAIL          | 10. BASE PLATE ASSEMBLY W/ANGLES |
| 5. SCREW (4)                     | 11. GUIDE TRACK                  |
| 6. SCREW (8)                     | 12. SLIDE BRACKET                |

TA 237690

FRAME AND TOWING ATTACHMENTS.

3-246. FIFTH WHEEL RAMP REPLACEMENT.

THIS TASK COVERS

- a. Removal.
- b. Cleaning and Inspection.
- c. Installation.

INITIAL SETUP

<u>APPLICABLE CONFIGURATIONS</u>	<u>EQUIPMENT CONDITION PARAGRAPH</u>	<u>CONDITION DESCRIPTION</u>
All.	None.	None.

TEST EQUIPMENT

None.

SPECIAL TOOLS

None.

MATERIALS/PARTS (P/N)

None.

PERSONNEL REQUIRED

One (MDS-63S).

SPECIAL ENVIRONMENTAL CONDITIONS

None.

REFERENCES (TM)

None.

GENERAL SAFETY INSTRUCTIONS

Engine off.  
Transmission in neutral.  
Park brake set.

TROUBLESHOOTING REFERENCES

None.

FRAME AND TOWING ATTACHMENTS.

3-246. FIFTH WHEEL RAMP REPLACEMENT (Continued).

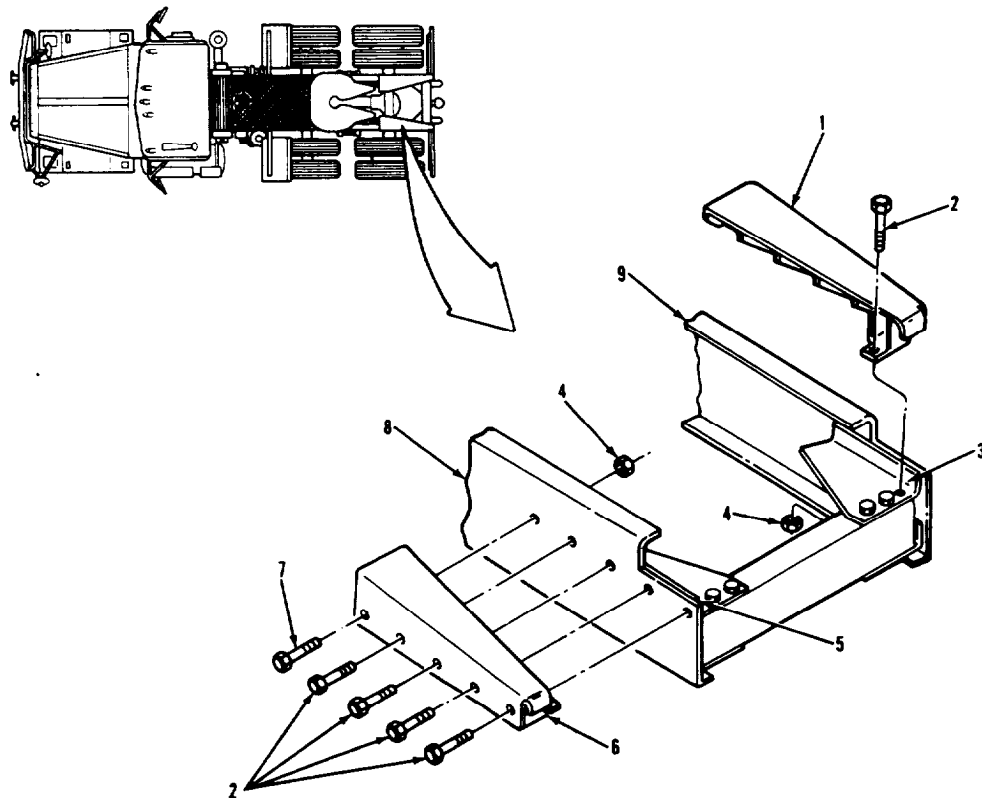

LEGEND:

- |                                       |                                   |
|---------------------------------------|-----------------------------------|
| 1. RIGHT FIFTH WHEEL RAMP ASSEMBLY    | 6. LEFT FIFTH WHEEL RAMP ASSEMBLY |
| 2. SCREW (10)                         | 7. SCREW (2)                      |
| 3. RIGHT-HAND REAR CROSSMEMBER GUSSET | 8. LEFT-HAND FRAME RAIL           |
| 4. HEXAGON FLANGED HEAD NUT (12)      | 9. RIGHT-HAND FRAME RAIL          |
| 5. LEFT-HAND REAR CROSSMEMBER GUSSET  |                                   |

TA 237691

FRAME AND TOWING ATTACHMENTS.

3-246. FIFTH WHEEL RAMP REPLACEMENT (Continued).

LOCATION/ITEM	ACTION	REMARKS
<b>NOTE</b>		
Use this procedure to replace either one of the two fifth wheel ramps.		
<b>A. REMOVAL.</b>		
1. Six nuts (4), five screws (2), screw (7), and ramp (1 or 6).	Remove from items (3) and (9), or items (5) and (8).	
<b>B. CLEANING AND INSPECTION.</b>		
2. All parts.	Clean and inspect.	Refer to paragraphs 3-4 and 3-5.
<b>C. INSTALLATION.</b>		
3. Fifth wheel ramp assembly (1 or 6).	a. Position on items (3) and (9), or items (5) and (8).  b. Secure with item (7), five items (2), and six items (4).	
<b>NOTE</b>		
Follow-on maintenance action required:		
None.		

FRAME AND TOWING ATTACHMENTS.

3-246. FIFTH WHEEL RAMP REPLACEMENT (Continued).

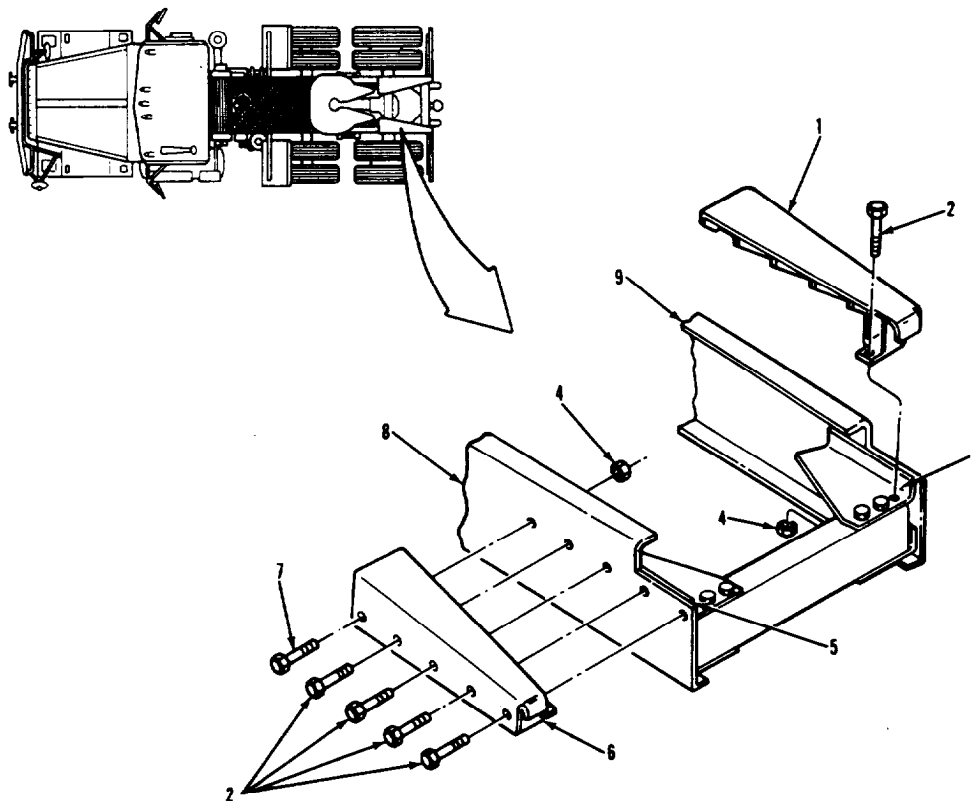

LEGEND:

- |                                       |                                   |
|---------------------------------------|-----------------------------------|
| 1. RIGHT FIFTH WHEEL RAMP ASSEMBLY    | 6. LEFT FIFTH WHEEL RAMP ASSEMBLY |
| 2. SCREW (10)                         | 7. SCREW (2)                      |
| 3. RIGHT-HAND REAR CROSSMEMBER GUSSET | 8. LEFT-HAND FRAME RAIL           |
| 4. HEXAGON FLANGED HEAD NUT (12)      | 9. RIGHT-HAND FRAME RAIL          |
| 5. LEFT-HAND REAR CROSSMEMBER GUSSET  |                                   |

TA 237692



**Section XV. SPRINGS, SHOCK ABSORBERS, AND TORQUE RODS**

**3-247. GENERAL.**

This section provides procedures authorized at the organizational maintenance level to replace spring, shock absorbers, and torque rods components. To find a specific procedure contained in this section, see the task summary below.

**3-248. TASK SUMMARY.**

INITIAL SETUP

APPLICABLE CONFIGURATIONS

All.

EQUIPMENT CONDITION

PARAGRAPH

CONDITION DESCRIPTION

(Refer to specific paragraph for this information).

TEST EQUIPMENT

None.

SPECIAL TOOLS

None.

MATERIALS/PARTS (P/N)

Grease, automotive and artillery, GAA Item-7, Appendix C.  
 Special shackle pin screw (34623) MB 25-20000.  
 Pin, cotter (24617) 103411.  
 Castellated nut (34623) M 216-20000.

Rubber bushings (8) (1207) 7409618.  
 Shock absorber (2) (24617) 7409617.  
 Nut, hexagon, PT (24617) 9422307.

PERSONNEL REQUIRED

One (MDS-63S).

SPECIAL ENVIRONMENTAL CONDITIONS

None.

REFERENCES (TM)

TM 9-2320-283-20P.

GENERAL SAFETY INSTRUCTIONS

Engine off.  
 Transmission in neutral.  
 Park brake set.

TROUBLESHOOTING REFERENCES

Paragraph 2-11.

SPRING, SHOCK ABSORBERS, AND TORQUE RODS.

3-248. TASK SUMMARY (Continued).			
LIST OF TASKS			
TASK NO.	TASK	TASK REF	TROUBLESHOOTING REF NO. (PARA)
1	Front Spring Pin Screws and Fittings Replacement	3-249	2-11
	a. Removal.	3-249a	
	b. Cleaning and Inspection.	3-249b	
	c. Installation.	3-249c	
2	Shock Absorber Replacement	3-250	2-11
	a. Removal.	3-250a	
	b. Cleaning and Inspection.	3-250b	
	c. Installation.	3-250c	
3	Torque Rods Replacement	3-251	2-11
	a. Removal.	3-251a	
	b. Cleaning and Inspection.	3-251b	
	c. Installation.	3-251c	

SPRING, SHOCK ABSORBERS, AND TORQUE RODS.

3-249. FRONT SPRING PIN SCREWS AND FITTINGS REPLACEMENT.

THIS TASK COVERS

- a. Removal.
- b. Cleaning and Inspection.
- c. Installation.

INITIAL SETUP

<u>APPLICABLE CONFIGURATIONS</u>	<u>EQUIPMENT CONDITION PARAGRAPH</u>	<u>CONDITION DESCRIPTION</u>
All.	None.	None.

TEST EQUIPMENT

None.

SPECIAL TOOLS

None.

MATERIALS/PARTS (P/N)

Grease, automotive and artillery  
Item 7, Appendix C.  
Screw, special shackle pin  
(34623) MB 25-20000.  
Pin, cotter  
(24617) 103411.  
Nut, castellated  
(34623) M 216-20000.

PERSONNEL REQUIRED

One (MOS-63S).

SPECIAL ENVIRONMENTAL CONDITIONS

None.

REFERENCES (TM)

TM 9-2320-283-20P.

GENERAL SAFETY INSTRUCTIONS

Engine off  
Transmission in neutral.  
Park brake set.

TROUBLESHOOTING REFERENCES

Paragraph 2-11.

SPRING, SHOCK ABSORBERS, AND TORQUE RODS.

3-249. FRONT SPRING PIN SCREWS AND FITTINGS REPLACEMENT (Continued).

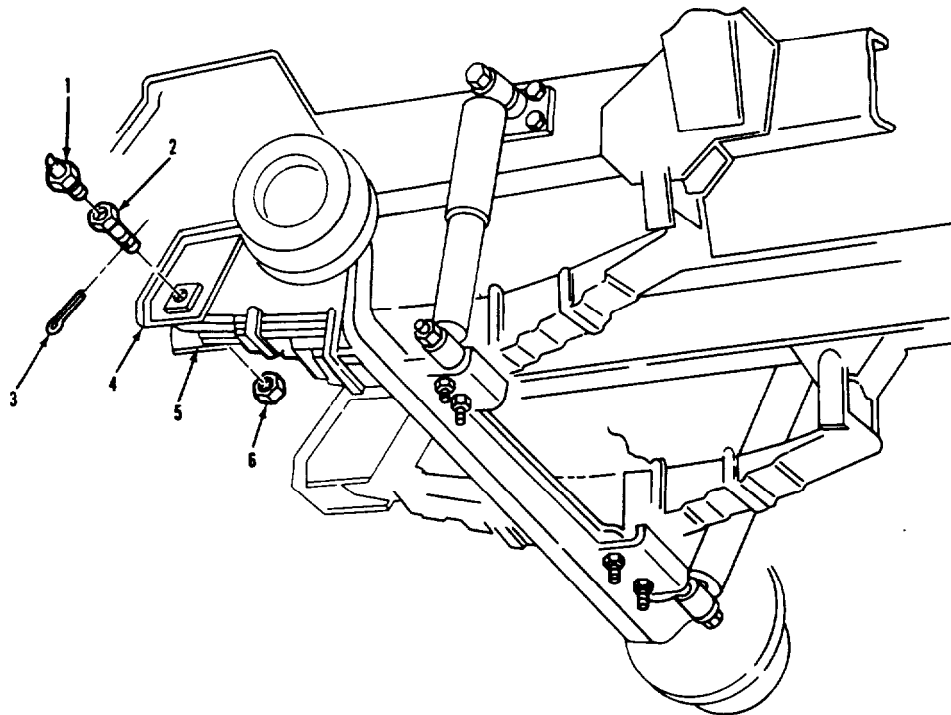
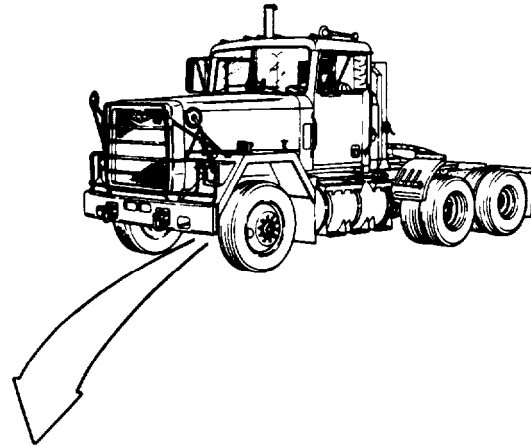

LEGEND:

- |                              |  |
|------------------------------|--|
| 1. FITTING                   | 4. LEFT-HAND FRAME FRONT SUPPORT<br>BRACKET ASSEMBLY |
| 2. SPECIAL SHACKLE PIN SCREW | 5. FRONT SPRING ASSEMBLY                             |
| 3. COTTER PIN                | 6. CASTELLATED NUT                                   |

TA 237693

SPRING, SHOCK ABSORBERS, AND TORQUE RODS.

3-249. FRONT SPRING PIN SCREWS AND FITTINGS REPLACEMENT (Continued).

LOCATION/ITEM	ACTION	REMARKS
<b>NOTE</b>		
<ul style="list-style-type: none"> <li>•There are six spring pins and fittings. All spring pins are replaced in same way, except as noted. Right front shown here.</li> <li>•Front spring pins require use of suitable portable hydraulic press and 500 psi pressure for removal and installation.</li> <li>•If removing right front spring pin, begin with step 1, otherwise start with step 2.</li> </ul>		
<b>A. REMOVAL.</b>		
1. Cooling system	a. Drained.	Refer to paragraph 3-52.
	b. Remove radiator outlet tube.	Refer to paragraph 3-58.
2. Fitting (1).	Remove from item (2).	
3. Pin (3).	Remove from item (2).	Discard item (3).
4. Nut (6).	Remove from item (2).	Discard item (6).
5. Screw (2).	Remove from items (4) and (5).	Discard item (2).
<b>B. CLEANING AND INSPECTION.</b>		
6. All metal parts.	Clean and inspect.	Refer to paragraphs 3-4 and 3-5.

SPRING, SHOCK ABSORBERS, AND TORQUE RODS.

3-249. FRONT SPRING PIN SCREWS AND FITTINGS REPLACEMENT (Continued).

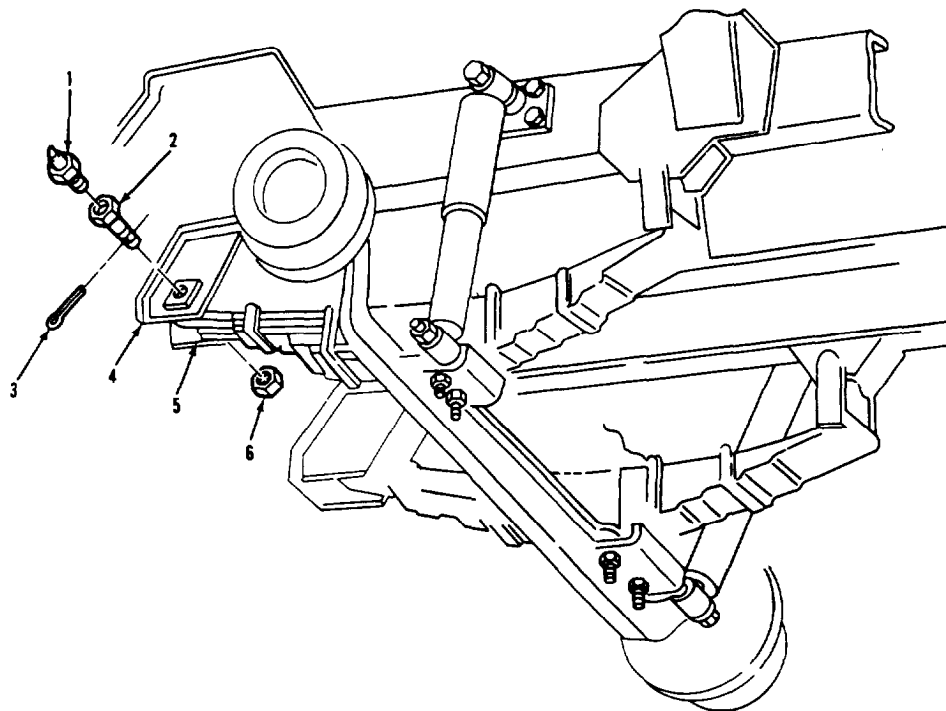
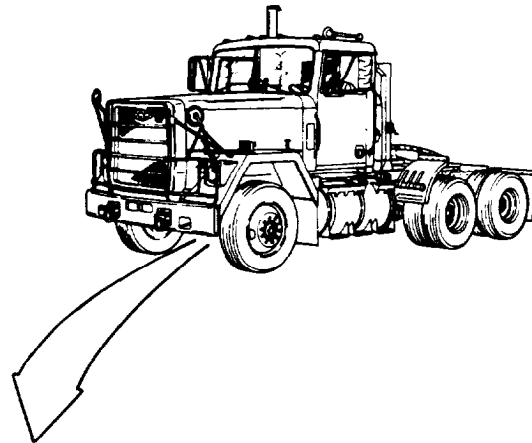

LEGEND:

- |                              |   |
|------------------------------|---|
| 1. FITTING                   | 4. LEFT-HAND FRAME FRONT SUPPORT BRACKET ASSEMBLY |
| 2. SPECIAL SHACKLE PIN SCREW | 5. FRONT SPRING ASSEMBLY                          |
| 3. COTTER PIN                | 6. CASTELLATED NUT                                |

TA 237694

SPRING, SHOCK ABSORBERS, AND TORQUE RODS.

3-249. FRONT SPRING PIN SCREWS AND FITTINGS REPLACEMENT (Continued).

LOCATION/ITEM	ACTION	REMARKS
<b>C. INSTALLATION.</b>		
7. New screw (2).	a. Install through hole in items (4) and (5). b. Apply light coat of grease to threads of item (2). c. Secure with new item (6).	Use suitable drift to align holes if necessary.  Torque item (6) to 300-400 lb-ft.
8. New pin (3) and fitting (1).	Install in item (2).	
<b>NOTE</b>		
If right front spring pin was removed, do steps 9 and 10; otherwise, go to follow-on maintenance.		
9. Radiator outlet tube.	Install.	Refer to paragraph 3-58.
10. Cooling system	Service.	Refer to paragraph 3-52.
<b>NOTE</b>		
Follow-on maintenance action required:		
None.		

SPRING, SHOCK ABSORBERS, AND TORQUE RODS.

3-249. FRONT SPRING PIN SCREWS AND FITTINGS REPLACEMENT (Continued).

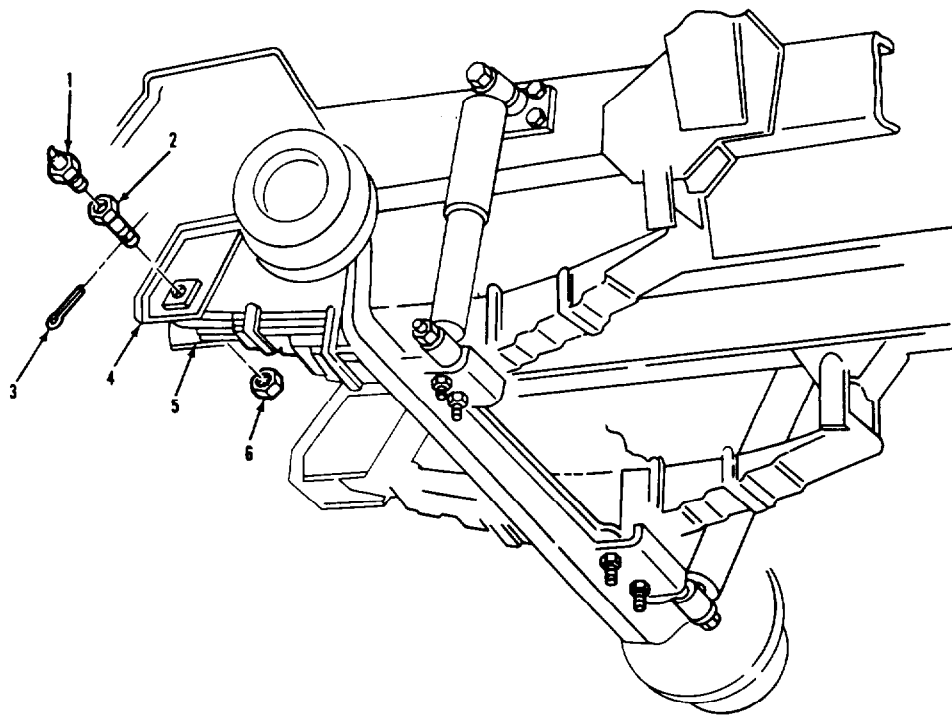
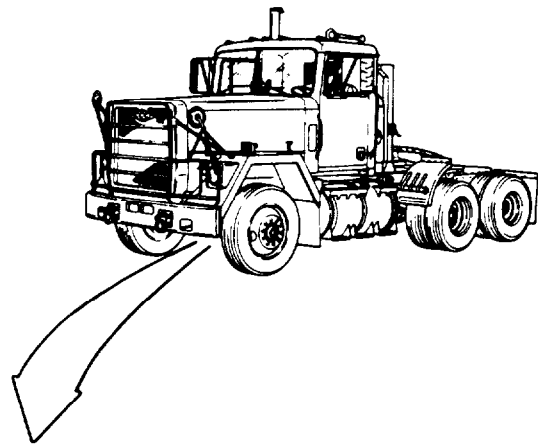

LEGEND:

- |                              |   |
|------------------------------|---|
| 1. FITTING                   | 4. LEFT-HAND FRAME FRONT SUPPORT BRACKET ASSEMBLY |
| 2. SPECIAL SHACKLE PIN SCREW | 5. FRONT SPRING ASSEMBLY                          |
| 3. COTTER PIN                | 6. CASTELLATED NUT                                |

TA 237695



SPRING, SHOCK ABSORBERS, AND TORQUE RODS.

3-250. SHOCK ABSORBER REPLACEMENT.

THIS TASK COVERS

- a. Removal.
- b. Cleaning and Inspection.
- c. Installation.

INITIAL SETUP

<u>APPLICABLE CONFIGURATIONS</u>	<u>EQUIPMENT CONDITION PARAGRAPH</u>	<u>CONDITION DESCRIPTION</u>
All.	None.	None.

TEST EQUIPMENT

None.

SPECIAL TOOLS

None.

MATERIALS/PARTS (P/N)

Grease, automotive and artillery  
Item 7, Appendix C.  
Bushing, rubber (8)  
(1207) 7409618.  
Shock absorber (2)  
(19207) 7409617.  
Nut, hexagon, PT  
(24617) 9422307.

PERSONNEL REQUIRED

One (MOS-63S).

SPECIAL ENVIRONMENTAL CONDITIONS

None.

REFERENCES (TM)

TM 9-2320-283-20P

GENERAL SAFETY INSTRUCTIONS

Engine off.  
Transmission in neutral.  
Park brake set.

TROUBLESHOOTING REFERENCES

Paragraph 2-11.

SPRING, SHOCK ABSORBERS, AND TORQUE RODS.

3-250. SHOCK ABSORBER REPLACEMENT (Continued).

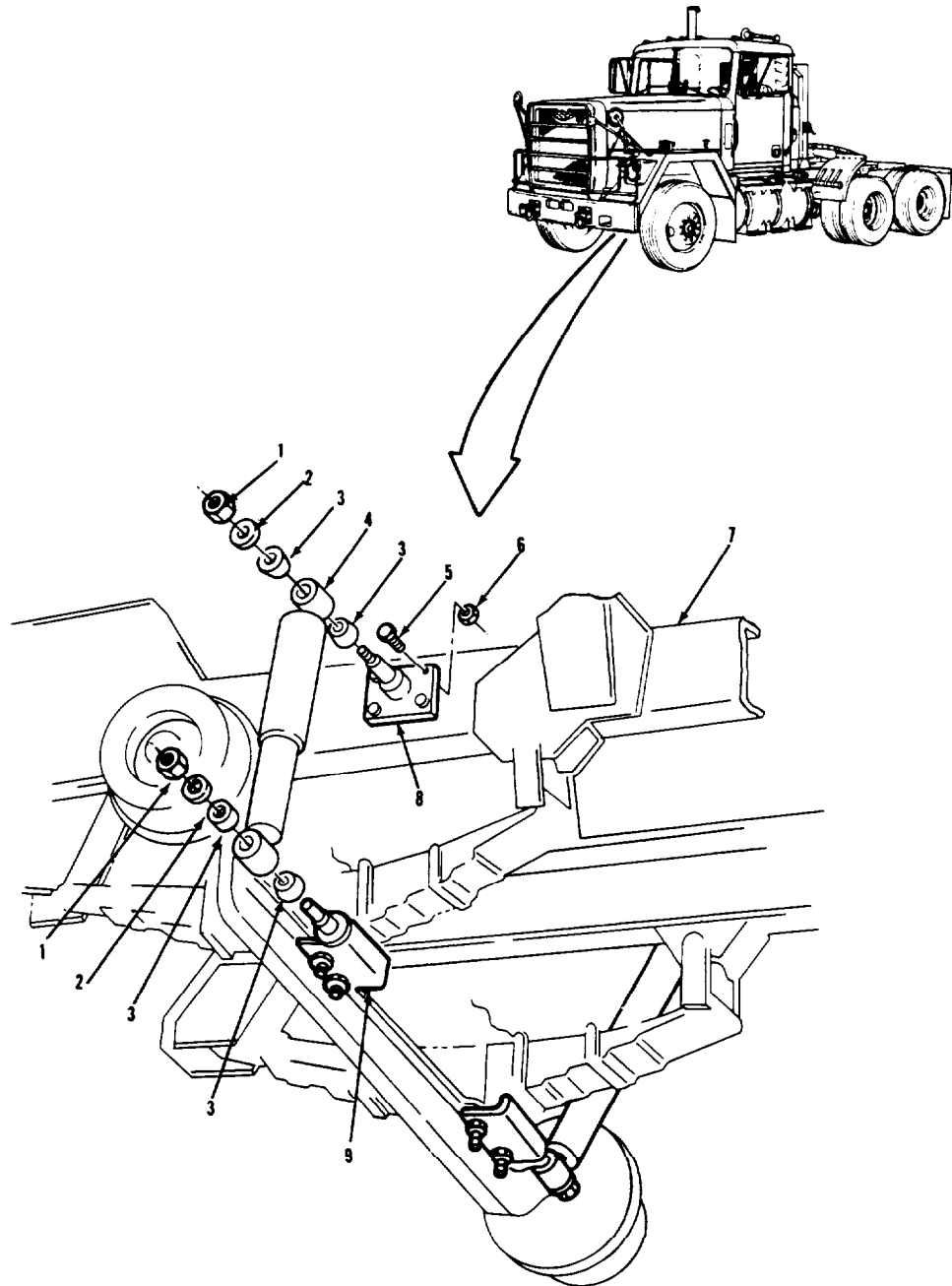

LEGEND:

- |                                  |  |
|----------------------------------|--|
| 1. PT HEXAGON NUT (2)            | 6. NUT (4)                               |
| 2. FLAT WASHER (2)               | 7. LEFT-HAND MAIN RAIL                   |
| 3. RUBBER BUSHING (4)            | 8. UPPER SHOCK MOUNTING BRACKET ASSEMBLY |
| 4. SHOCK ABSORBER                | 9. FRONT AXLE ASSEMBLY                   |
| 5. HEXAGON FLANGE HEAD SCREW (4) |  |

TA 237696

SPRING, SHOCK ABSORBERS, AND TORQUE RODS.

3-250. SHOCK ABSORBER REPLACEMENT (Continued).

LOCATION/ITEM	ACTION	REMARKS
NOTE		
<p>. Shock absorbers are replaced in pairs.</p> <p>. Right and left side shock absorbers are replaced in same way. Left side shown here.</p>		
<b>A. REMOVAL.</b>		
1. Two nuts (1) and washers (2).	Remove from item (4).	
2. Four bushings (3) and shock absorbers (4).	<p>a. Remove from items (8) and (9).</p> <p>b. Remove four items (3) from items (4).</p>	Discard four items (3).
NOTE		
<p>If upper shock mounting bracket assembly is damaged, do step 3; otherwise, go to cleaning and inspection.</p>		
3. Four screws (5) and nuts (6).	<p>a. Remove from item (8).</p> <p>b. Remove item (8) from item (7).</p>	
<b>B. CLEANING AND INSPECTION.</b>		
4. All metal and rubber parts.	Clean and inspect.	Refer to paragraphs 3-4 and 3-5.

SPRING, SHOCK ABSORBERS, AND TORQUE RODS.

3-250. SHOCK ABSORBER REPLACEMENT (Continued).

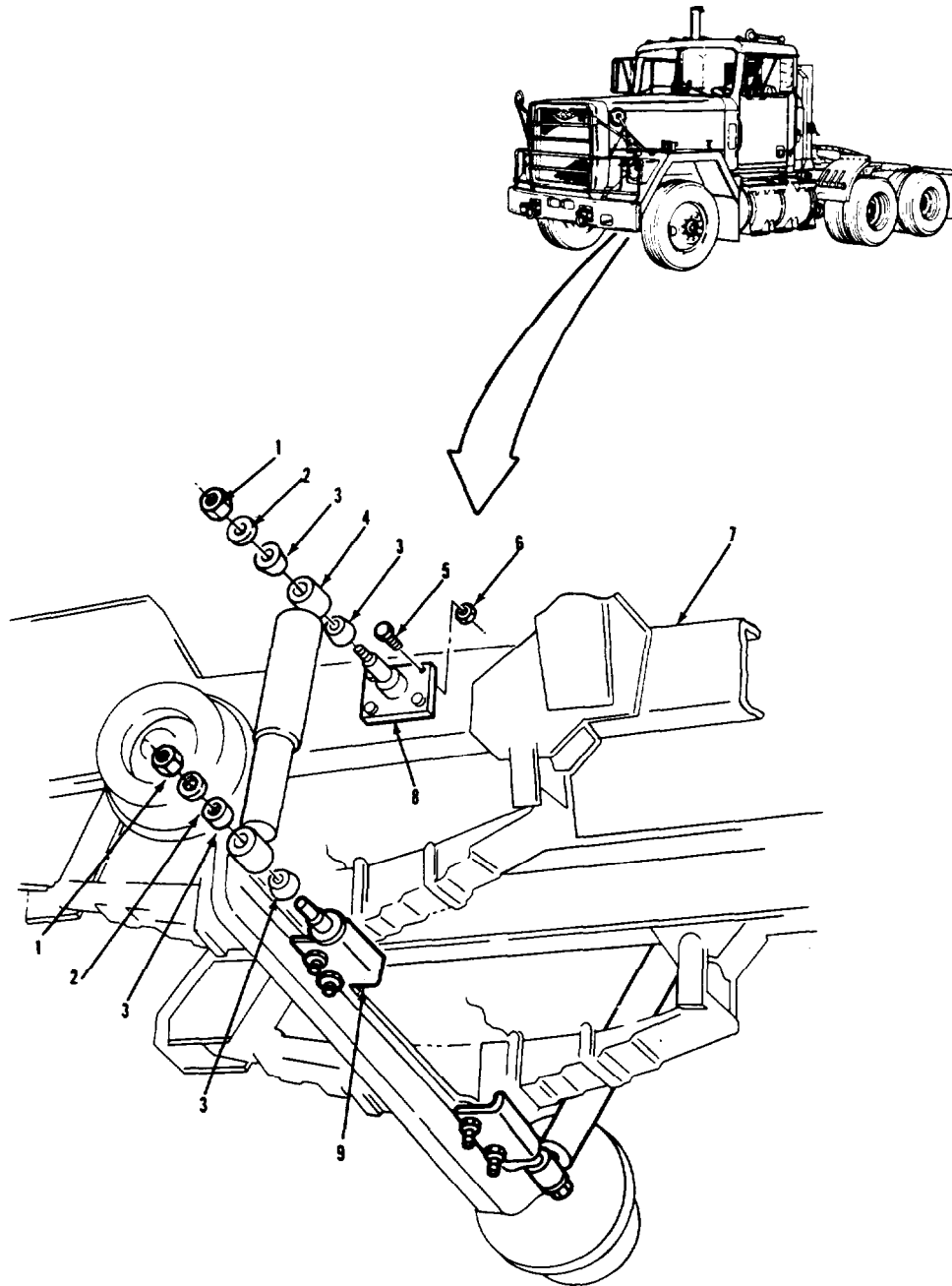

LEGEND:

- |                                  |  |
|----------------------------------|--|
| 1. PT HEXAGON NUT (2)            | 6. NUT (4)                               |
| 2. FLAT WASHER (2)               | 7. LEFT-HAND MAIN RAIL                   |
| 3. RUBBER BUSHING (4)            | 8. UPPER SHOCK MOUNTING BRACKET ASSEMBLY |
| 4. SHOCK ABSORBER                | 9. FRONT AXLE ASSEMBLY                   |
| 5. HEXAGON FLANGE HEAD SCREW (4) |  |

TA 237697

SPRING, SHOCK ABSORBERS, AND TORQUE RODS.

3-250. SHOCK ABSORBER REPLACEMENT (Continued).

LOCATION/ITEM	ACTION	REMARKS
<b>C. INSTALLATION.</b>		
NOTE		
If upper shock mounting bracket was removed, do step 6; otherwise, go to step 7.		
6. Bracket (8).	<ul style="list-style-type: none"> <li>a. Apply light coat of grease to threads of four items (5).</li> <li>b. Line up holes in item (8) with holes in item (7).</li> <li>c. Secure with four items (5) and (6).</li> </ul>	
7. Two inner bushings (3).	Place one on item (8) and one on item (9).	
8. Shock absorber (4).	Place against two inner items (3) on items (8) and (9)	
9. Two outer bushings (3).	<ul style="list-style-type: none"> <li>a. Apply light coat of grease to threads on items (8) and (9).</li> <li>b. Place one on item (8) and one on item (9).</li> </ul>	
	c. Secure with two items (1) and (2).	Torque to 125-165 lb-ft.
NOTE		
Follow-on maintenance action required:		
None.		

SPRING, SHOCK ABSORBERS, AND TORQUE RODS.

3-250. SHOCK ABSORBER REPLACEMENT (Continued).

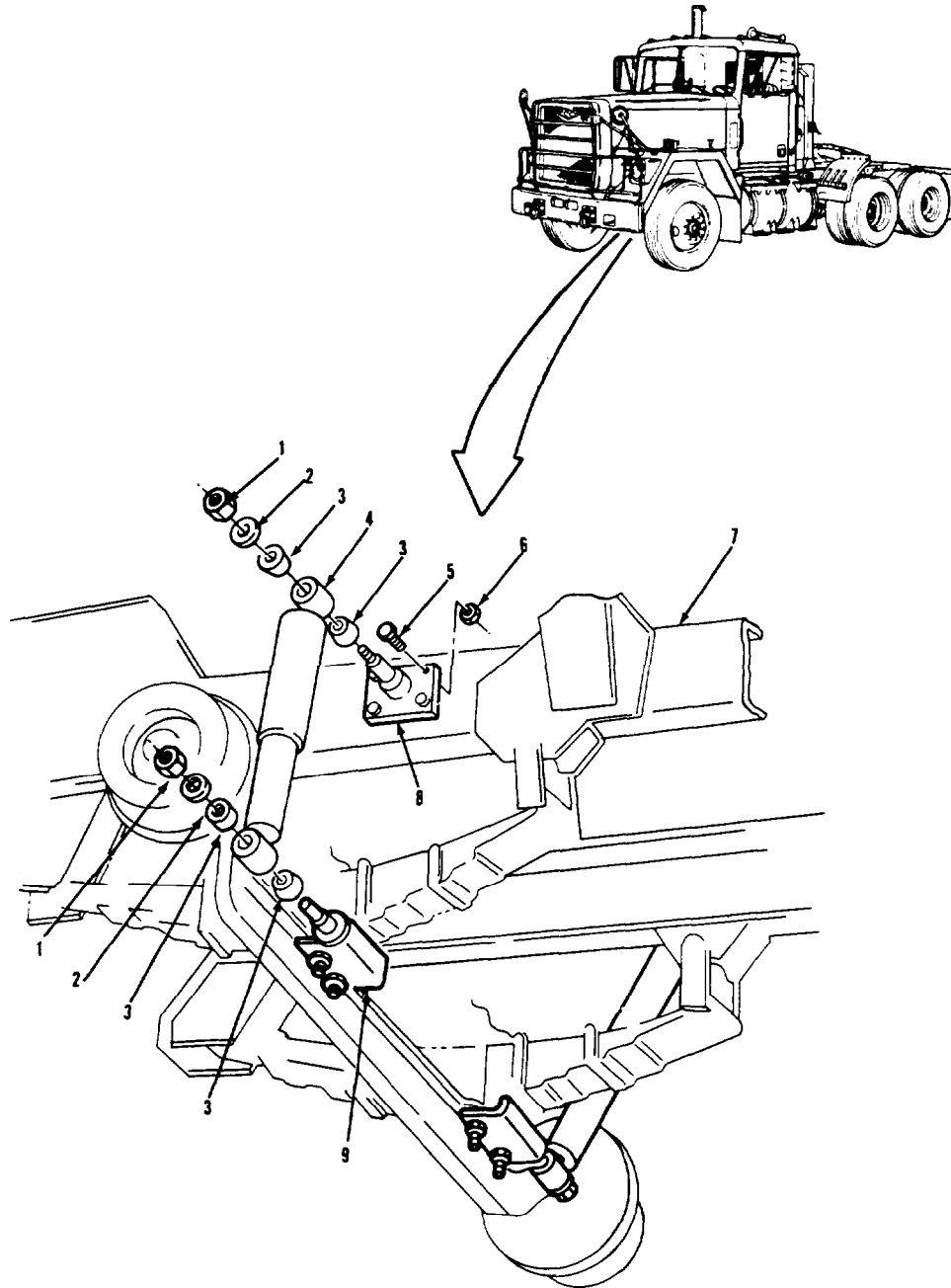

LEGEND:

- |                                  |  |
|----------------------------------|--|
| 1. PT HEXAGON NUT (2)            | 6. NUT (4)                               |
| 2. FLAT WASHER (2)               | 7. LEFT-HAND MAIN RAIL                   |
| 3. RUBBER BUSHING (4)            | 8. UPPER SHOCK MOUNTING BRACKET ASSEMBLY |
| 4. SHOCK ABSORBER                | 9. FRONT AXLE ASSEMBLY                   |
| 5. HEXAGON FLANGE HEAD SCREW (4) |  |

TA 237698

SPRING, SHOCK ABSORBERS, AND TORQUE RODS.

3-251. TORQUE RODS REPLACEMENT.

THIS TASK COVERS

- a. Removal.
- b. Cleaning and Inspection.
- c. Installation.

INITIAL SETUP

APPLICABLE CONFIGURATIONS

All.

EQUIPMENT CONDITION  
PARAGRAPH

3-239 |

CONDITION DESCRIPTION

Service deck removed.

TEST EQUIPMENT

None.

SPECIAL TOOLS

None.

MATERIALS/PARTS (P/N)

None.

PERSONNEL REQUIRED

One (MDS-63S).

SPECIAL ENVIRONMENTAL CONDITIONS

None.

REFERENCES (TM)

None.

GENERAL SAFETY INSTRUCTIONS

Engine off.  
Transmission in neutral.  
Park brake set.

TROUBLESHOOTING REFERENCES

Paragraph 2-11.

SPRING, SHOCK ABSORBERS, AND TORQUE RODS.

3-251. TORQUE RODS REPLACEMENT (Continued).

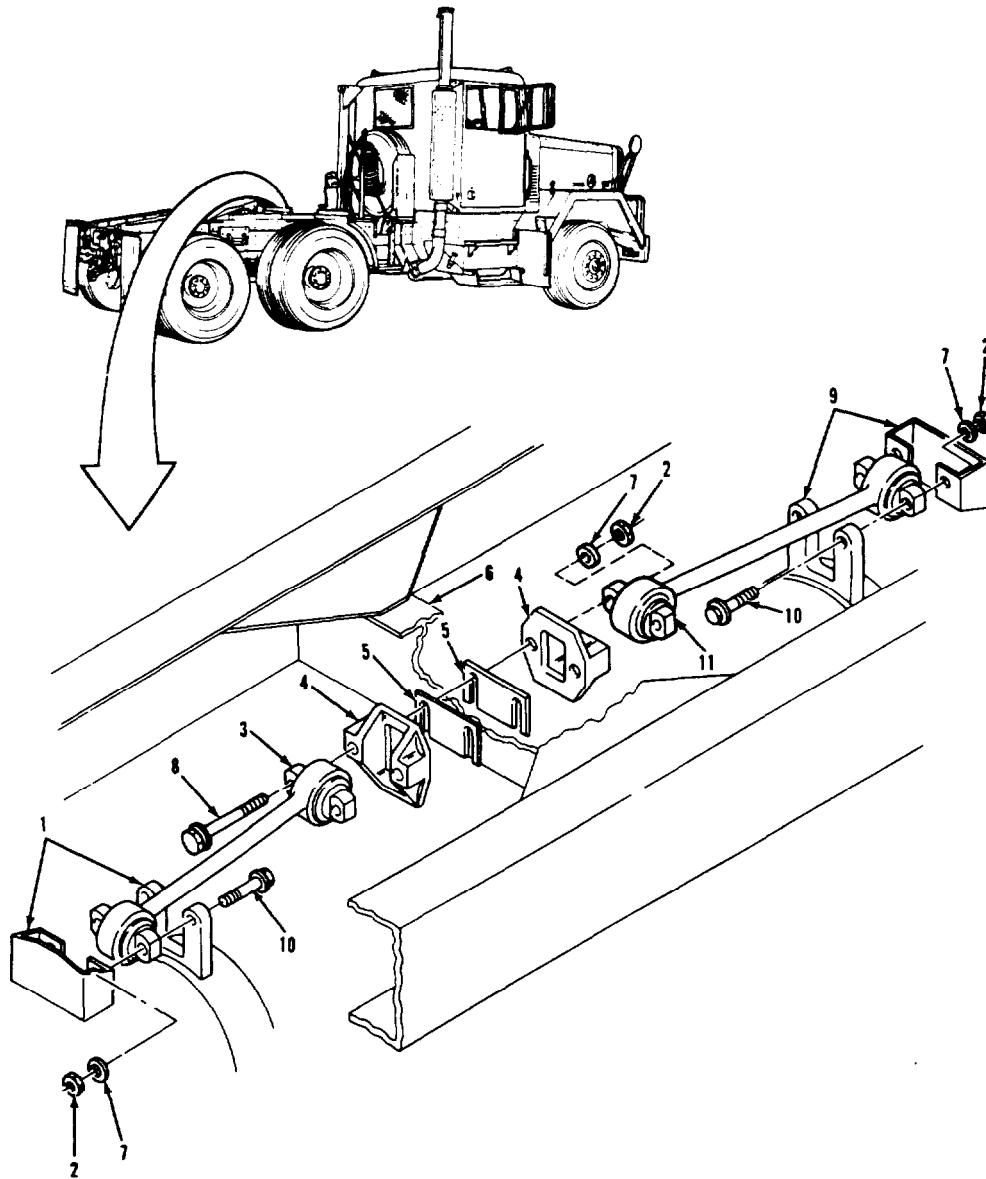

LEGEND:

- |   |                                  |
|---|----------------------------------|
| 1. REAR-REAR AXLE BRACKET               | 7. WASHER (6)                    |
| 2. HEXAGON FLANGE HEAD NUT (6)          | 8. HEXAGON FLANGE HEAD SCREW (2) |
| 3. REAR TORQUE ROD ASSEMBLY             | 9. FORWARD-REAR AXLE BRACKET     |
| 4. TORQUE ROD BRACKET (2)               | 10. SCREW (4)                    |
| 5. SHIM PACK (2)                        | 11. FORWARD TORQUE ROD ASSEMBLY  |
| 6. REAR SUSPENSION CROSSMEMBER ASSEMBLY |                                  |

TA 237699



SPRING, SHOCK ABSORBERS, AND TORQUE RODS.

3-251. TORQUE RODS REPLACEMENT (Continued).

LOCATION/ITEM	ACTION	REMARKS
<u>CAUTION</u>		
<p>There are two shim packs. Each pack contains four shims. Each shim is a different thickness. Do not mix up shims in one pack with shims in other pack.</p>		
<b>A. REMOVAL.</b>		
<p>1. Two screws (8), washers (7), and nuts (2).</p>	<p>Loosen far enough to remove two items (5).</p>	
<p>2. Two shim packs (5).</p>	<p>Remove two items (5) from between two items (4) and (6).</p>	
<p>3. Two screws (8), washers (7), nuts w , and brackets (4).</p>	<p>Remove from item (6).</p>	
NOTE		
<p>.If removing forward torque rod, do step 4 and skip step 5.</p>		
<p>.If removing rear torque rod, skip step 4 and do step 5.</p>		
<p>.If removing both torque rods, do both steps 4 and 5.</p>		
<p>4. Two screws (10), washers (7), and nuts (2).</p>	<p>a. Remove from item (11) and (9).</p>	
	<p>b. Remove item (11) from item (9).</p>	
<p>5. Two screws (10),</p>	<p>a. Remove from item (3) from item (1).</p>	
	<p>b. Remove item (3) from item (1)</p>	

SPRING, SHOCK ABSORBERS, AND TORQUE RODS.

3-251. TORQUE RODS REPLACEMENT (Continued).

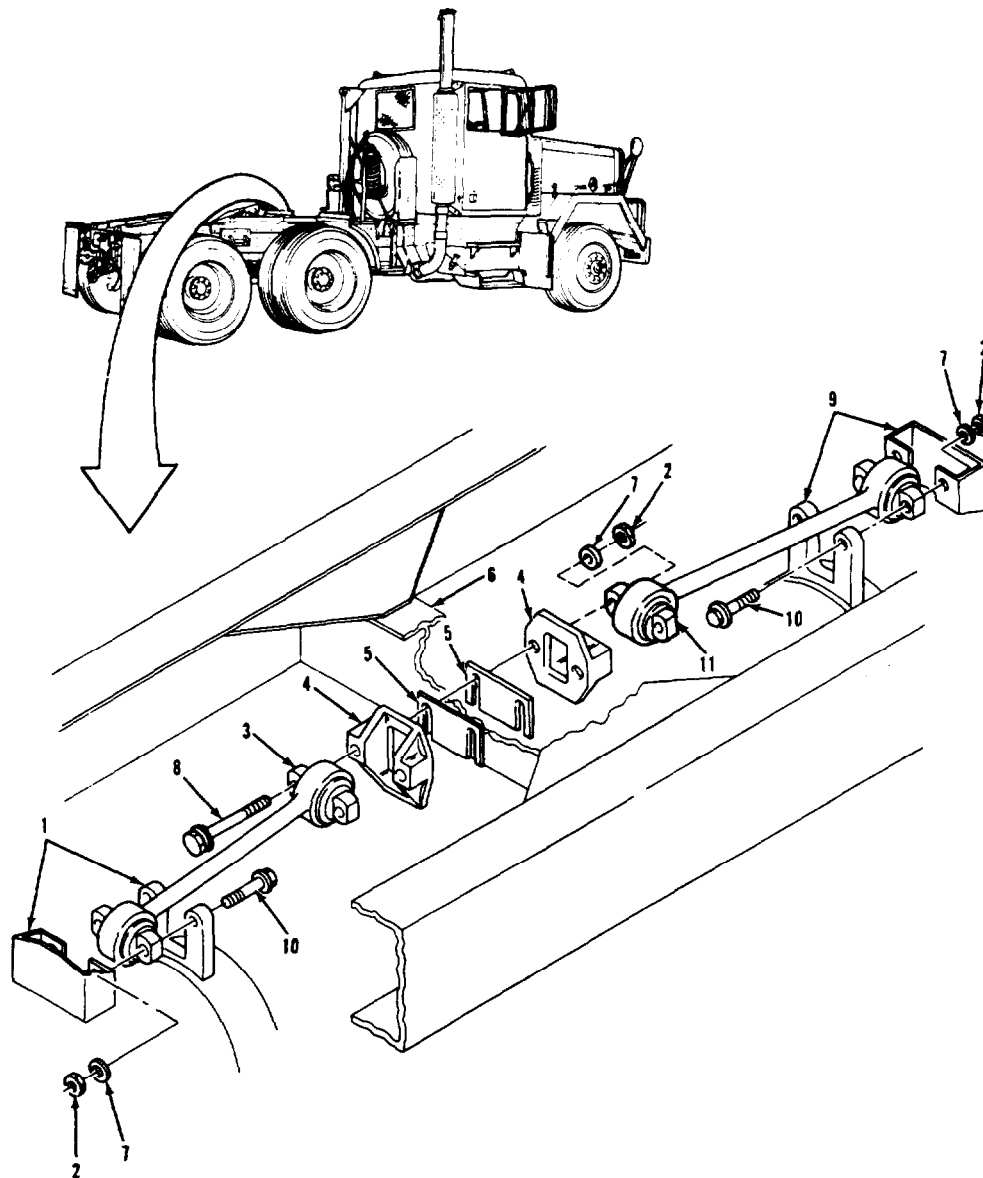

LEGEND:

- |   |                                  |
|---|----------------------------------|
| 1. REAR-REAR AXLE BRACKET               | 7. WASHER (6)                    |
| 2. HEXAGON FLANGE HEAD NUT (6)          | 8. HEXAGON FLANGE HEAD SCREW (2) |
| 3. REAR TORQUE ROD ASSEMBLY             | 9. FORWARD-REAR AXLE BRACKET     |
| 4. TORQUE ROD BRACKET (2)               | 10. SCREW (4)                    |
| 5. SHIM PACK (2)                        | 11. FORWARD TORQUE ROD ASSEMBLY  |
| 6. REAR SUSPENSION CROSSMEMBER ASSEMBLY |                                  |

TA 237700

SPRING, SHOCK ABSORBERS, AND TORQUE RODS.

3-251. TORQUE RODS REPLACEMENT (Continued).

LOCATION/ITEM	ACTION	REMARKS
<b>B. CLEANING AND INSPECTION.</b>		
6. All metal parts.	Clean and inspect.	Refer to paragraphs 3-4 and 3-5.
<b>C. INSTALLATION.</b>		
NOTE		
.If installing rear torque rod only, do step 7 and skip step 8.		
.If installing forward torque rod, skip step 7 and go to step 8.		
.If installing both torque rods, do both steps 7 and 8.		
7. Rear torque rod assembly (3).	a. Line up holes in item (3) with holes in item (1).  b. Secure together but do not tighten with two items (10), (7), and (2).	
8. Forward torque rod assembly (11).	a. Line up holes in item (11) with holes in item (9).  b. Secure together but do not tighten with two items (10), (7), and (2).	
9. Torque rod assemblies (3) and (11).	a. Line up holes in items (3) and (11) with holes in item (4) and (6).  b. Secure together but do not tighten with two items (8), (7), and (2).	

SPRING, SHOCK ABSORBERS, AND TORQUE RODS.

3-251. TORQUE RODS REPLACEMENT (Continued).

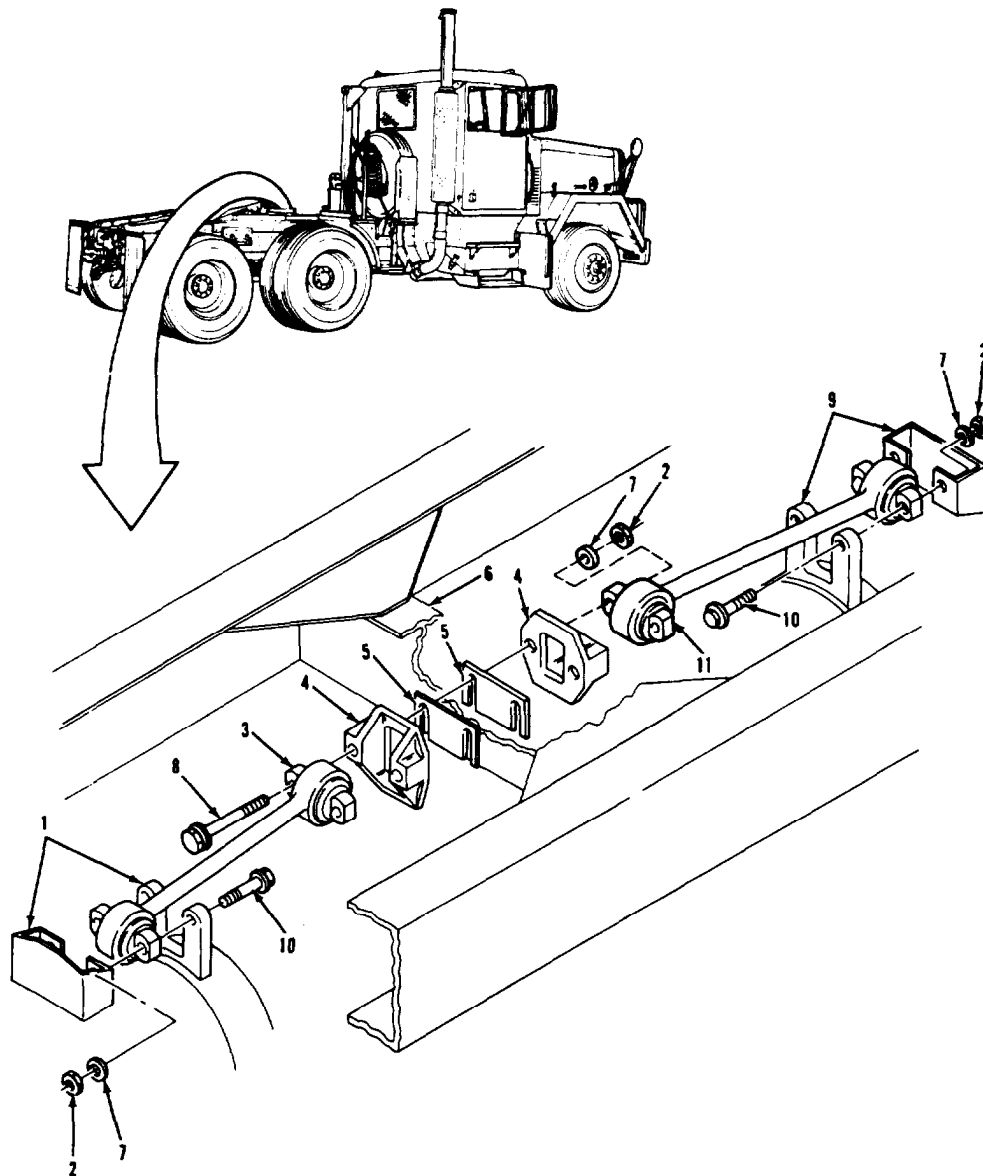

LEGEND:

- |   |                                  |
|---|----------------------------------|
| 1. REAR-REAR AXLE BRACKET               | 7. WASHER (6)                    |
| 2. HEXAGON FLANGE HEAD NUT (6)          | 8. HEXAGON FLANGE HEAD SCREW (2) |
| 3. REAR TORQUE ROD ASSEMBLY             | 9. FORWARD-REAR AXLE BRACKET     |
| 4. TORQUE ROD BRACKET (2)               | 10. SCREW (4)                    |
| 5. SHIM PACK (2)                        | 11. FORWARD TORQUE ROD ASSEMBLY  |
| 6. REAR SUSPENSION CROSSMEMBER ASSEMBLY |                                  |

TA 237701

SPRING, SHOCK ABSORBERS, AND TORQUE RODS.

3-251. TORQUE RODS REPLACEMENT (Continued).

LOCATION/ITEM	ACTION	REMARKS
<b>C. INSTALLATION (Continued).</b>		
10. Two shim packs (5) .	Position one item (5) on each side of item (6), between item (6) and items (4).	
11. Nuts (2).	Tighten.	Torque between 95-130 lb-ft.
NOTE		
Follow-on maintenance action required:		
Install service deck (para 3-239).		

SPRING, SHOCK ABSORBERS, AND TORQUE RODS.

3-251. TORQUE RODS REPLACEMENT (Continued).

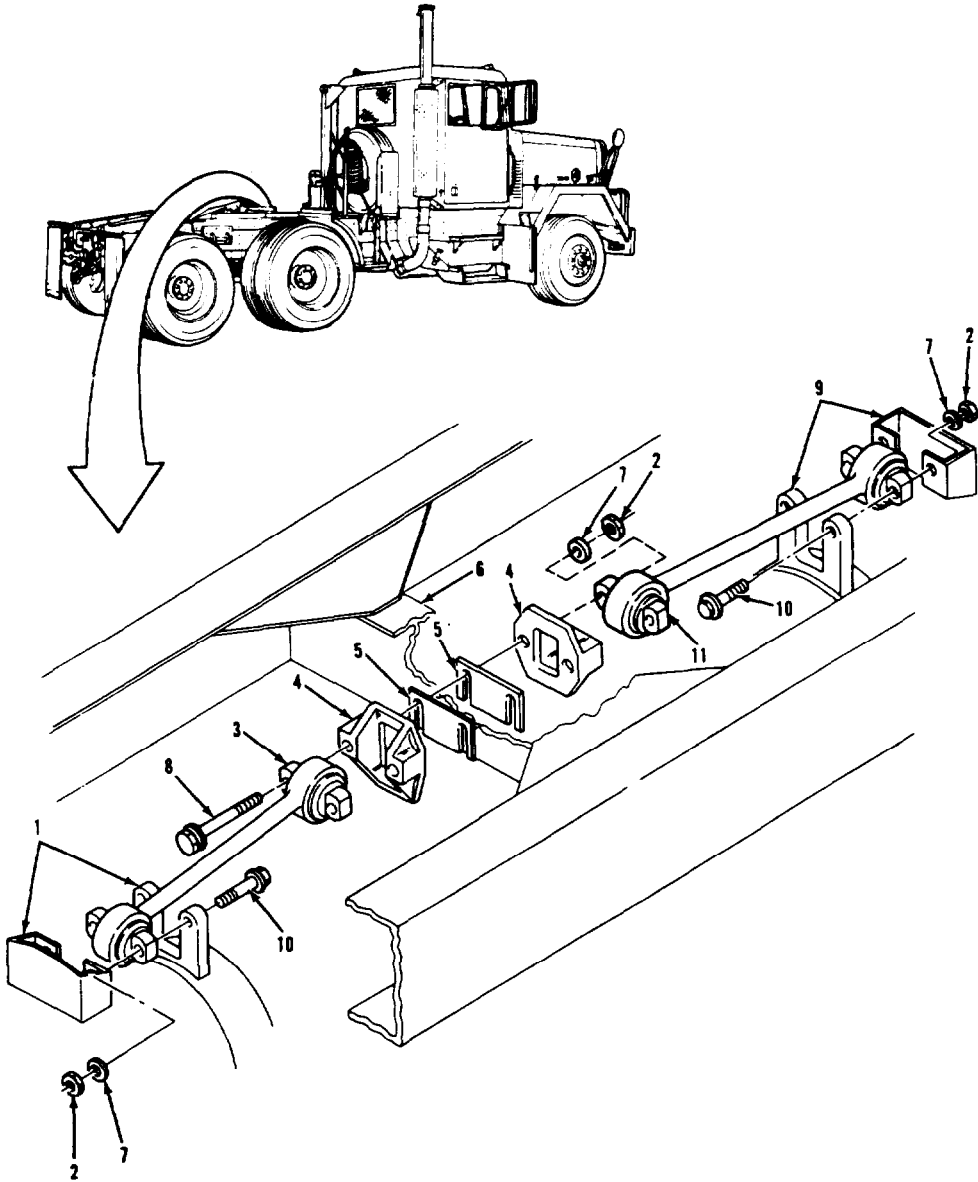

LEGEND:

- |   |                                  |
|---|----------------------------------|
| 1. REAR-REAR AXLE BRACKET               | 7. WASHER (6)                    |
| 2. HEXAGON FLANGE HEAD NUT (6)          | 8. HEXAGON FLANGE HEAD SCREW (2) |
| 3. REAR TORQUE ROD ASSEMBLY             | 9. FORWARD- REAR AXLE BRACKET    |
| 4. TORQUE ROD BRACKET (2)               | 10. SCREW (4)                    |
| 5. SHIM PACK (2)                        | 11. FORWARD TORQUE ROD ASSEMBLY  |
| 6. REAR SUSPENSION CROSSMEMBER ASSEMBLY |                                  |

TA 237702

Section XVI. CAB AND BODY

**3-252. GENERAL.**

This section provides procedures authorized at the organizational maintenance level to replace cab and body components. To find a specific procedure contained in this section, see the task summary below.

**3-253. TASK SUMMARY.**

INITIAL SETUP

APPLICABLE CONFIGURATIONS

All.

EQUIPMENT CONDITION PARAGRAPH

CONDITION DESCRIPTION

(Refer to specific paragraph for this information).

TEST EQUIPMENT

None.

SPECIAL TOOLS

None.

MATERIALS/PARTS (P/N)

Solvent, drycleaning, SD-2  
Item 29, Appendix C.  
Adhesive, rubber, type II  
Item 1, Appendix C.  
Rag, wiping  
Item 22, Appendix C.  
Retainer, quarter-turn screw (9)  
(94222) 85-34-101-20.  
Rivet, blind (14)  
(05693) SSPV086.  
Caplug (as required)  
(34623) MA207-20059.  
Clip, insulation fastener  
(as required)  
(85105) 101-301-104.  
Rivet, blind, 1/4 in., (40)  
(19738) 2771-0817.  
Rivet, blind, 1/16 in., (10)  
(11815) SSLQ-66.

Rivet, blind, 3/16 in., (30)  
(11815) SSLQ-64.  
Rivet (36)  
(11815) SSLQ-66.  
Rivet, blind (30)  
(05693) SSLQ-64.  
Insulation (as required)  
(35623) M/164-20000 (right-hand and  
left-hand center back panel).  
(34623) M/164-20001 (upper back panel).  
(34623) M/164-20002 (lower back panel).  
(34623) M/164-20003 (corner back panel).  
(34623) M/164-20004 (rear side panel).  
(34623) M/164-20017 (center back panel).  
(34623) M/164-20018 (roof).  
Rivet (as required)  
(11815) SSP-42.

PERSONNEL REQUIRED

Three (MOS-63S).

SPECIAL ENVIRONMENTAL CONDITIONS

None.

CAB AND BODY.

3-253. TASK SUMMARY (Continued).

INITIAL SETUP (Continued)

REFERENCES (TM)

LO 92320-283-12.  
 TM 9-2320-283-10:  
 TM 9-2320-283-20P.

GENERAL SAFETY INSTRUCTIONS

Engine off.  
 Transmission in neutral.  
 Park brake set.  
 Wear protective clothing (gloves, goggles, face mask, etc.) when working near insulation material.

TROUBLESHOOTING REFERENCES

Paragraph 2-11.

LIST OF TASKS

TASK NO.	TASK	TASK REF	TROUBLESHOOTING REF NO. (PARA)
1	Right-Hand Instrument Cluster Panel Assembly Replacement	3-254	
	a. Removal.	3-254a	
	b. Cleaning and Inspection.	3-254b	
	c. Installation.	3-254c	
2	Left-Hand Instrument Cluster Panel Assembly Replacement	3-255	
	a. Removal.	3-255a	
	b. Cleaning and Inspection.	3-255b	
	c. Installation.	3-255c	
3	Instrument Panel Center Panel Assembly Replacement	3-256	
	a. Removal.	3-256a	
	b. Cleaning and Inspection.	3-256b	
	c. Installation.	3-256c	
4	Glove Compartment Door Assembly Replacement	3-257	
	a. Removal.	3-257a	
	b. Installation.	3-257b	



CAB AND BODY.

3-253. TASK SUMMARY (Continued).			
LIST OF TASKS			
TASK NO.	TASK	TASK REF	TROUBLESHOOTING REF NO. (PARA)
5	Instrument Panel Assembly Replacement a. Removal. b. Installation.	3-258 3-258a 3-258b	
6	Inside Assist Handle Replacement a. Removal. b. Installation.	3-259 3-259a 3-259b	
7	Center Floor Pan Access Cover Replacement a. Removal. b. Cleaning and Inspection. c. Installation.	3-260 3-260a 3-260b 3-260c	
8	Ventilator Replacement a. Removal. b. Cleaning and Inspection. c. Installation.	3-261 3-261a 3-261b 3-261c	
9	Padlock Bracket Replacement a. Removal. b. Installation.	3-262 3-262a 3-262b	
10	Outside Rear Handle Replacement a. Removal. b. Cleaning and Inspection. c. Installation.	3-263 3-263a 3-263b 3-263c	
11	Outside Front Handle Replacement a. Removal. b. Cleaning and Inspection. c. Installation.	3-264 3-264a 3-264b 3-264c	
12	Door Plate Replacement a. Removal. b. Installation.	3-265 3-265a 3-265b	
13	Door Frame Seal Replacement a. Removal. b. Cleaning and Inspection c. Installation.	3-266 3-266a 3-266b 3-266c	2-11

CAB AND BODY.

3-253. TASK SUMMARY (Continued).

LIST OF TASKS

TASK NO.	TASK	TASK REF	TROUBLESHOOTING REF NO. (PARA)
14	Insulator Replacement	3-267	
	a. Removal.	3-267a	
	b. Cleaning and Inspection.	3-267b	
	c. Installation.	3-267c	
15	Grille Replacement	3-268	
	a. Grille and Screen Removal.	3-268a	
	b. Grille and Screen Disassembly.	3-268b	
	c. Grille and Screen Reassembly.	3-268c	
	d. Radiator Mounting Support and Bracket Removal and Disassembly.	3-268d	
	e. Radiator Mounting Support and Bracket Reassembly and Installation.	3-268e	
	f. Grille and Screen Installation.	3-268f	
16	Hood Replacement	3-269	
	a. Removal.	3-269a	
	b. Cleaning and Inspection.	3-269b	
	c. Installation.	3-269c	
17	Hood Panel and Component Replacement	3-270	
	a. Side Panel Removal.	3-270a	
	b. Side Panel Installation.	3-270b	
	c. Handle Replacement.	3-270c	
	d. Hook and Brackets Replacement.	3-270d	
	e. Panel and Hinge Assembly Replacement.	3-270e	
	f. Support Pad and Bracket Replacement.	3-270f	
	g. Prop and Bracket Replacement.	3-270g	
	h. Support and Hinge, Pivot, and Bracket Replacement.	3-270h	
	i. Left-Hand Seal Replacement.	3-270i	
	j. Right-Hand Seal Replacement.	3-270j	
	k. Front Seal Replacement.	3-270k	
	l. Rear Seal Replacement.	3-270l	

CAB AND BODY.

3-253. TASK SUMMARY (Continued).			
LIST OF TASKS			
TASK NO.	TASK	TASK REF	TROUBLESHOOTING REF NO. (PARA)
18	Front Fender Replacement	3-271	
	a. Front Fender Removal.	3-271a	
	b. Front Fender Installation.	3-271b	
	c. Front Fender Disassembly.	3-271c	
	d. Front Fender Reassembly.	3-271d	
	e. Front and Rear Support Removal.	3-271e	
	f. Front and Rear Support Installation.	3-271f	
	g. Mud Flap and Antisail Bracket Disassembly.	3-271g	
	h. Mud Flap and Antisail Bracket Reassembly.	3-271h	
19	Quarter Fender Replacement	3-272	
	a. Removal.	3-272a	
	b. Installation.	3-272b	
20	Splash Shield Replacement	3-273	
	a. Removal.	3-273a	
	b. Installation.	3-273b	
21	Rear Mud Flap and Bracket Replacement	3-274	
	a. Removal.	3-274a	
	b. Installation.	3-274b	
22	Cab Headliner Panel Replacement	3-275	
	a. Removal.	3-275a	
	b. Cleaning and Inspection.	3-275b	
	c. Installation.	3-275c	
23	Cab Trim Panel Replacement	3-276	
	a. Removal.	3-276a	
	b. Cleaning and Inspection.	3-276b	
	c. Installation.	3-276c	
24	Insulation Replacement	3-277	
	a. Removal.	3-277a	
	b. Installation.	3-277b	

CAB AND BODY.

3-253. TASK SUMMARY (Continued).			
LIST OF TASKS			
TASK NO.	TASK	TASK REF	TROUBLESHOOTING REF NO. (PARA)
25	Sun Visor Replacement	3-278	
	a. Removal.	3-278a	
	b. Cleaning and Inspection.	3-278b	
	c. Installation.	3-278c	
26	Floor Mat Replacement	3-279	
	a. Removal.	3-279a	
	b. Cleaning and Inspection.	3-279b	
	c. Installation.	3-279c	
27	Driver's Seat Replacement	3-280	2-11
	a. Removal.	3-280a	
	b. Cleaning and Inspection.	3-280b	
	c. Installation.	3-280c	
28	Driver's Seat Riser Replacement	3-281	
	a. Removal.	3-281a	
	b. Cleaning and Inspection.	3-281b	
	c. Installation.	3-281c	
29	Seat Belt Replacement	3-282	
	a. Driver's Seat Belt Replacement.	3-282a	
	b. Companion Seat Belt Replacement.	3-282b	
30	Companion Seat Replacement	3-283	2-11
	a. Removal.	3-283a	
	b. Cleaning and Inspection.	3-283b	
	c. Installation.	3-283c	
31	Companion Seat Riser, Fire Extinguisher Brackets, and Tool Box Replacement	3-284	
	a. Removal.	3-284a	
	b. Disassembly.	3-284b	
	c. Cleaning and Inspection.	3-284c	
	d. Assembly.	3-284d	
	e. Installation.	3-284e	

CAB AND BODY.

3-254. RIGHT-HAND INSTRUMENT CLUSTER PANEL ASSEMBLY REPLACEMENT.

THIS TASK COVERS

- a. Removal.
- b. Cleaning and Inspection.
- c. Installation.

INITIAL SETUP

<u>APPLICABLE CONFIGURATIONS</u>	<u>EQUIPMENT CONDITION PARAGRAPH</u>	<u>CONDITION DESCRIPTION</u>
All.	3-88.	Three position engine retarder switch - removed.
<u>TEST EQUIPMENT</u>	3-78.	Headlamp switch removed.
None.	3-79.	Blackout toggle switch removed.
<u>SPECIAL TOOLS</u>	3-87.	Warning and indicator panel removed.
None.		

MATERIALS/PARTS (P/N)  
 Retainer, quarter-turn screw (2)  
 (94222) 85-34-101-20.

PERSONNEL REQUIRED  
 One (MDS-63S).

SPECIAL ENVIRONMENTAL CONDITIONS  
 None.

REFERENCES (TM)  
 None.

GENERAL SAFETY INSTRUCTIONS  
 None.

TROUBLESHOOTING REFERENCES  
 None.

CAB AND BODY.

3-254. RIGHT-HAND INSTRUMENT CLUSTER PANEL ASSEMBLY REPLACEMENT (Continued).

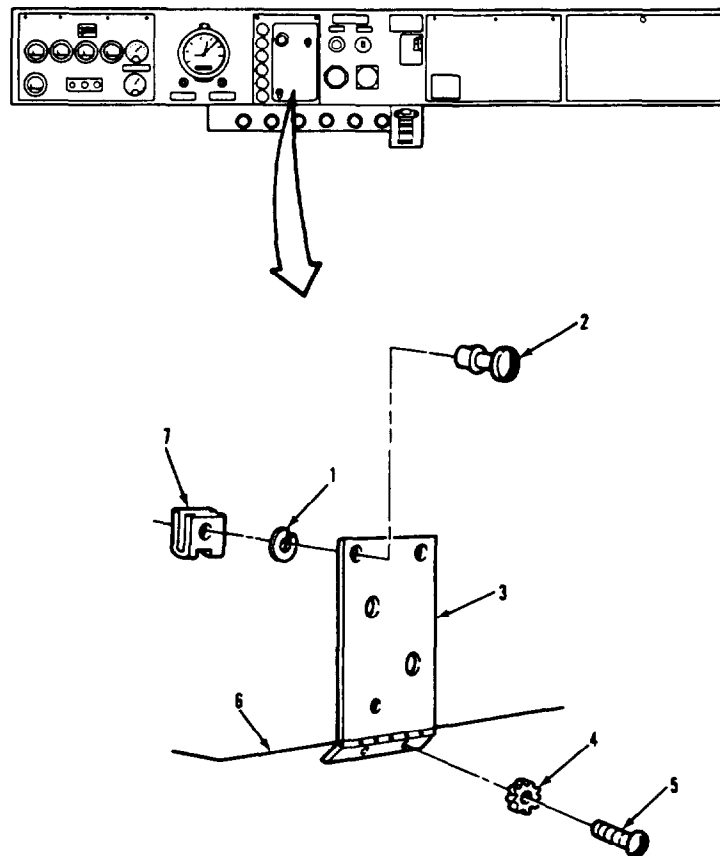

LEGEND:

- |  |                                     |
|--|-------------------------------------|
| 1. QUARTER-TURN STUD RETAINER (2)                  | 4. LOCKWASHER (2)                   |
| 2. QUARTER-TURN STUD (2)                           | 5. SCREW (2)                        |
| 3. INSTRUMENT CLUSTER RIGHT-HAND<br>PANEL ASSEMBLY | 6. INSTRUMENT PANEL ASSEMBLY        |
|  | 7. QUARTER-TURN STUD RECEPTACLE (2) |

TA 237703

CAB AND BODY.

3-254. RIGHT-HAND INSTRUMENT CLUSTER PANEL ASSEMBLY REPLACEMENT (Continued).

LOCATION/ITEM	ACTION	REMARKS
<b>A. REMOVAL.</b>		
1. Two studs (2).	Turn to the left a quarter-turn, and lower item (3).	
2. Two screws (5) and lockwasher (4).	Remove from item (3).	
3. Panel (3).	Remove from item (6).	
4. Two receptacles (7).	Remove from item (6).	
5. Two retainers (1).	Remove from item (2). Discard items (1).	Item (1) can be removed by cutting with diagonal pliers.
6. Two studs (2).	Remove from item (3).	
<b>B. CLEANING AND INSPECTION.</b>		
7. All metal parts.	Clean and inspect.	Refer to paragraphs 3-4 and 3-5.
<b>C. INSTALLATION.</b>		
8. Two studs (2).	Install in top holes of item (3).	
9. Two new retainers (1).	Install onto item (2).	
10. Two receptacles (7).	Install in two upper holes of item (6).	
11. Panel (3).	Aline hinge holes of item (3) with bottom holes of item (6).	
12. Two screws (5) and lockwasher (4).	Install and tighten in holes of items (3) and (6).	

CAB AND BODY.

3-254. RIGHT-HAND INSTRUMENT CLUSTER PANEL ASSEMBLY REPLACEMENT (Continued).

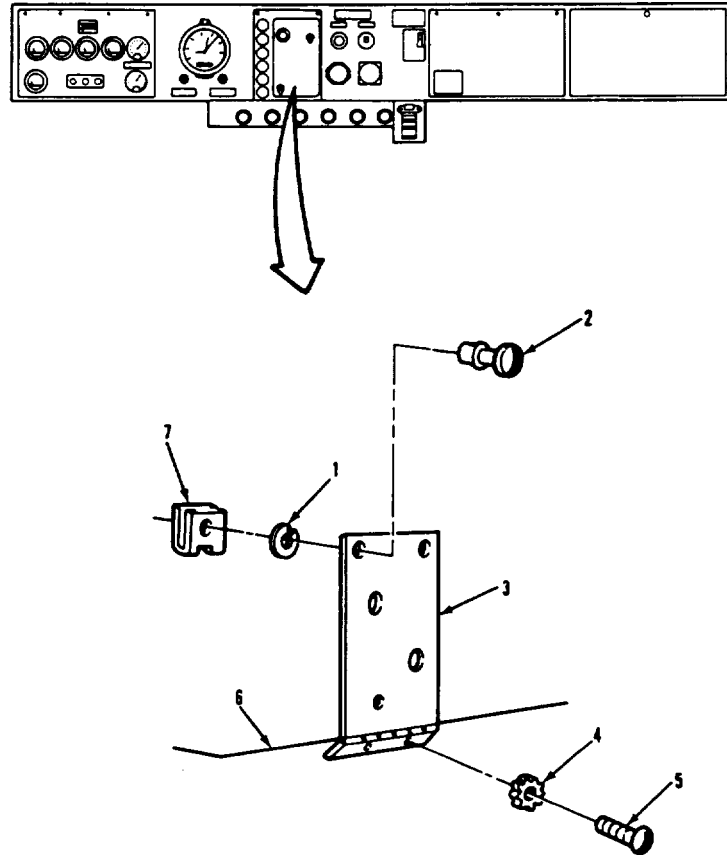

LEGEND:

- |  |                                     |
|--|-------------------------------------|
| 1. QUARTER-TURN STUD RETAINER (2)                  | 4. LOCKWASHER (2)                   |
| 2. QUARTER-TURN STUD (2)                           | 5. SCREW (2)                        |
| 3. INSTRUMENT CLUSTER RIGHT-HAND<br>PANEL ASSEMBLY | 6. INSTRUMENT PANEL ASSEMBLY        |
|  | 7. QUARTER-TURN STUD RECEPTACLE (2) |

TA 237704



CAB AND BODY.

3-254. RIGHT-HAND INSTRUMENT CLUSTER PANEL ASSEMBLY REPLACEMENT (Continued).

LOCATION/ITEM	ACTION	REMARKS
<b>C. INSTALLATION (Continued).</b>		
13. Panel (3).	Raise item (3) and secure two items (2) through two items (7).	Rotate clockwise two items (2) only a quarter of a turn.
NOTE		
Follow-on maintenance action required:		
Install three position engine retarder switch (para 3-88). Install headlamp switch (para 3-78). Install blackout toggle switch (para 3-79). Install warning and indicator panel (para 3-87). Install decal, as required (para 3-305).		

CAB AND BODY.

3-254. RIGHT-HAND INSTRUMENT CLUSTER PANEL ASSEMBLY REPLACEMENT (Continued).

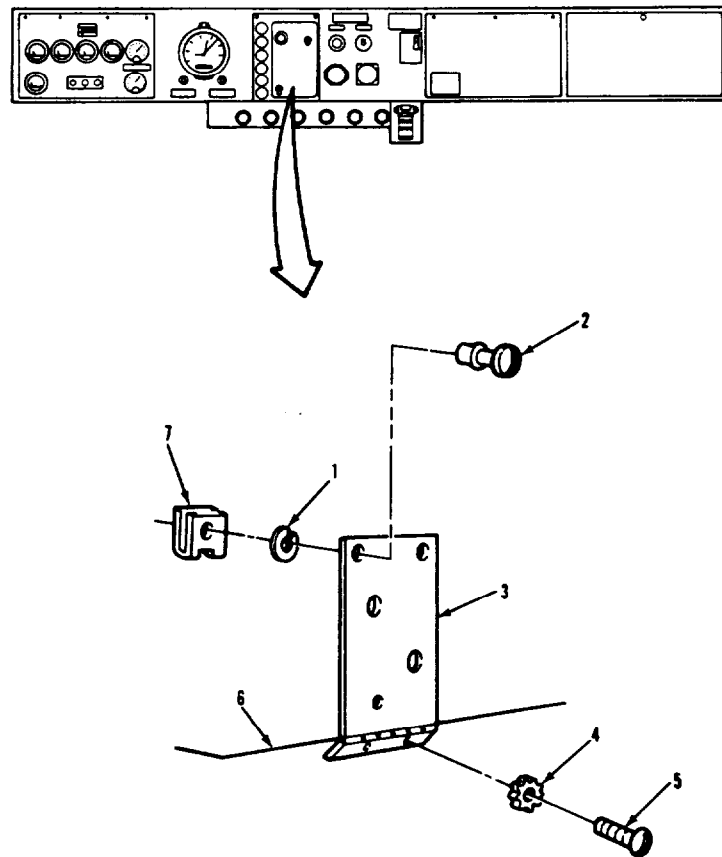

LEGEND:

- |  |                                     |
|--|-------------------------------------|
| 1. QUARTER-TURN STUD RETAINER (2)                  | 4. LOCKWASHER (2)                   |
| 2. QUARTER-TURN STUD (2)                           | 5. SCREW (2)                        |
| 3. INSTRUMENT CLUSTER RIGHT-HAND<br>PANEL ASSEMBLY | 6. INSTRUMENT PANEL ASSEMBLY        |
|  | 7. QUARTER-TURN STUD RECEPTACLE (2) |

TA 237705

CAB AND BODY.

3-255. LEFT-HAND INSTRUMENT CLUSTER PANEL ASSEMBLY REPLACEMENT.

THIS TASK COVERS

- a. Removal.
- b. Cleaning and Inspection.
- c. Installation.

INITIAL SETUP

<u>APPLICABLE CONFIGURATIONS</u>	<u>EQUIPMENT CONDITION PARAGRAPH</u>	<u>CONDITION DESCRIPTION</u>
All.	3-73.	All electrical gages removed.
	3-314.	Air pressure gages removed.
<u>TEST EQUIPMENT</u>		
None.	3-74.	Ignition switch removed.
	3-75.	Pushbutton starter switch removed.
<u>SPECIAL TOOLS</u>		
None.	3-83.	Cigar lighter removed.
	3-84.	Low air pressure lamp removed.
<u>MATERIALS/PARTS (P/N)</u>		
Retainer, quarter-turn stud (4) (94222) 85-34-101-20.		
<u>PERSONNEL REQUIRED</u>	<u>SPECIAL ENVIRONMENTAL CONDITIONS</u>	
One (MOS-63S).	None.	
<u>REFERENCES (TM)</u>	<u>GENERAL SAFETY INSTRUCTIONS</u>	
None.	None.	
<u>TROUBLESHOOTING REFERENCES</u>		
None.		

CAB AND BODY.

3-255. LEFT-HAND INSTRUMENT CLUSTER PANEL ASSEMBLY REPLACEMENT (Continued).

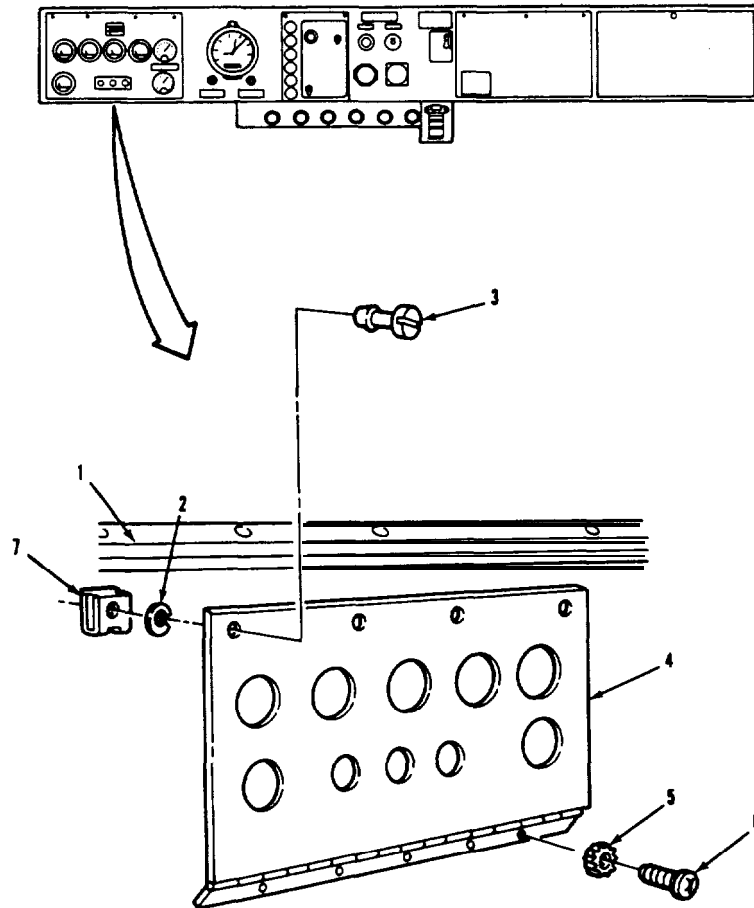

LEGEND:

- |   |                                     |
|---|-------------------------------------|
| 1. INSTRUMENT PANEL ASSEMBLY                      | 5. LOCKWASHER (5)                   |
| 2. QUARTER-TURN STUD RETAINER (4)                 | 6. SCREW (5)                        |
| 3. QUARTER-TURN STUD (4)                          | 7. QUARTER-TURN STUD RECEPTACLE (4) |
| 4. INSTRUMENT CLUSTER LEFT-HAND<br>PANEL ASSEMBLY |                                     |

TA 237706

CAB AND BODY.

3-255. LEFT-HAND INSTRUMENT CLUSTER PANEL ASSEMBLY REPLACEMENT (Continued).

LOCATION/ITEM	ACTION	REMARKS
<b>A. REMOVAL.</b>		
1. Four studs (3).	Turn to the left a quarter turn, and lower item (4).	
2. Five screws (6) and lockwashers (5).	Remove from item (4).	
3. Cluster panel (4).	Remove from item (1).	
4. Five receptacles (7).	Remove from item (1).	
5. Four retainers (4).	Remove from four items (3). Discard items (4).	Items (4) can be removed by cutting with diagonal pliers.
6. Four studs (3).	Remove from item (4).	
<b>B. CLEANING AND INSPECTION.</b>		
7. All metal parts.	Clean and inspect.	Refer to paragraphs 3-4 and 3-5.
<b>C. INSTALLATION.</b>		
8. Four studs (3).	Install in top holes of item (4).	
9. Four new retainers (2).	Install onto four items (3).	
10. Four receptacles (7).	Install in four upper holes of item (1).	

CAB AND BODY.

3-255. LEFT-HAND INSTRUMENT CLUSTER PANEL ASSEMBLY REPLACEMENT (Continued).

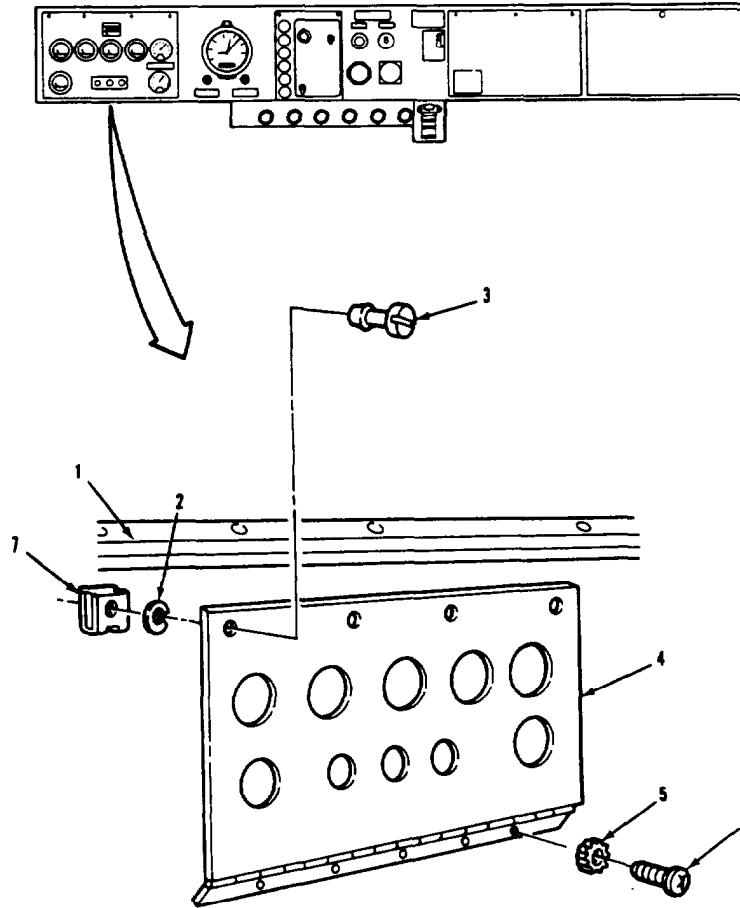

LEGEND:

- |   |                                     |
|---|-------------------------------------|
| 1. INSTRUMENT PANEL ASSEMBLY                      | 5. LOCKWASHER (5)                   |
| 2. QUARTER-TURN STUD RETAINER (4)                 | 6. SCREW (5)                        |
| 3. QUARTER-TURN STUD (4)                          | 7. QUARTER-TURN STUD RECEPTACLE (4) |
| 4. INSTRUMENT CLUSTER LEFT-HAND<br>PANEL ASSEMBLY |                                     |

TA 237707

CAB AND BODY.

3-255. LEFT-HAND INSTRUMENT CLUSTER PANEL ASSEMBLY REPLACEMENT (Continued).

LOCATION/ITEM	ACTION	REMARKS
<b>C. INSTALLATION (Continued).</b>		
11. Cluster panel (4).	Aline five hinge holes of item (4) with five holes of item (1).	
12. Five screws (6) and lockwashers (5).	Install and tighten in five holes of items (4) and (1).	
13. Cluster panel (4).	Raise item (4) and secure four items (3) through four items (7).	Rotate four items (3) a quarter of a turn clockwise.
NOTE		
Follow-on maintenance action required:		
Install electrical gages (para 3-73). Install air pressure gages (para 3-314). Install ignition switch (para 3-74). Install pushbutton starter switch (para 3-75). Install cigar lighter (para 3-83). Install low air pressure lamp (para 3-84). Install decals, as required (para 3-305).		

CAB AND BODY.

3-255. LEFT-HAND INSTRUMENT CLUSTER PANEL ASSEMBLY REPLACEMENT (Continued).

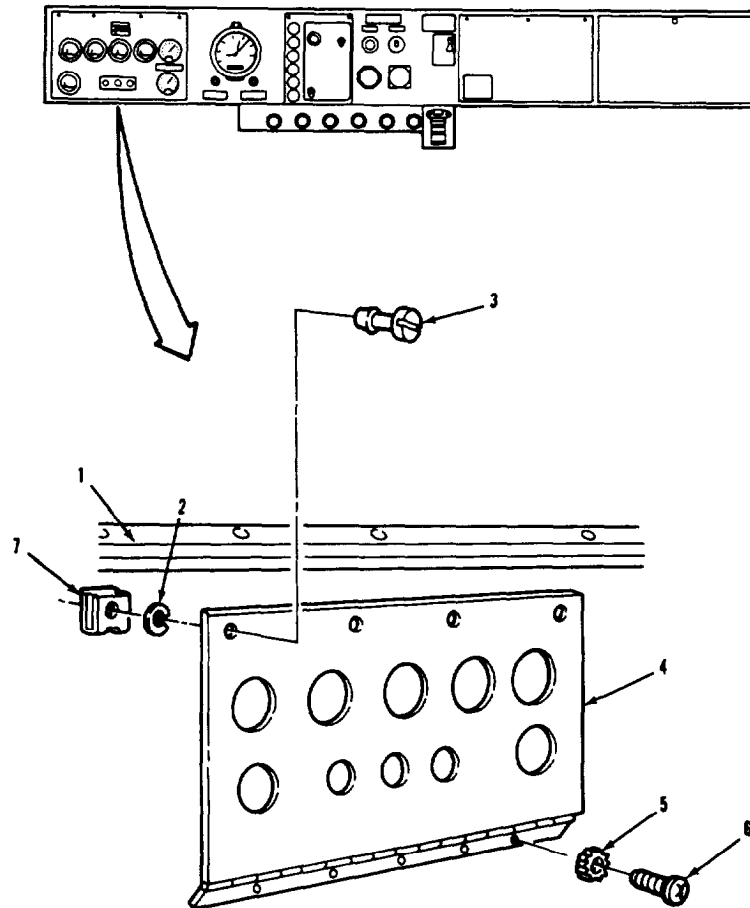

LEGEND:

- |  |                                     |
|--|-------------------------------------|
| 1. INSTRUMENT PANEL ASSEMBLY                   | 5. LOCKWASHER (5)                   |
| 2. QUARTER-TURN STUD RETAINER (4)              | 6. SCREW (5)                        |
| 3. QUARTER-TURN STUD (4)                       | 7. QUARTER-TURN STUD RECEPTACLE (4) |
| 4. INSTRUMENT CLUSTER LEFT-HAND PANEL ASSEMBLY |                                     |

TA 237708



CAB AND BODY.

3-256. INSTRUMENT PANEL CENTER PANEL ASSEMBLY REPLACEMENT.

THIS TASK COVERS

- a. Removal.
- b. Cleaning and Inspection.
- c. Installation.

INITIAL SETUP

APPLICABLE CONFIGURATIONS  
All.

EQUIPMENT CONDITION  
PARAGRAPH  
None.

CONDITION DESCRIPTION  
None.

TEST EQUIPMENT  
None

SPECIAL TOOLS  
None.

MATERIALS/PARTS (P/N)  
Retainer, quarter-turn stud (3)  
(94222) 85-34-101-20.

PERSONNEL REQUIRED  
One (MOS-63S).

SPECIAL ENVIRONMENTAL CONDITIONS  
None.

REFERENCES (TM)  
None.

GENERAL SAFETY INSTRUCTIONS  
None.

TROUBLESHOOTING REFERENCES  
None.

CAB AND BODY.

3-256. INSTRUMENT PANEL CENTER PANEL ASSEMBLY REPLACEMENT (Continued).

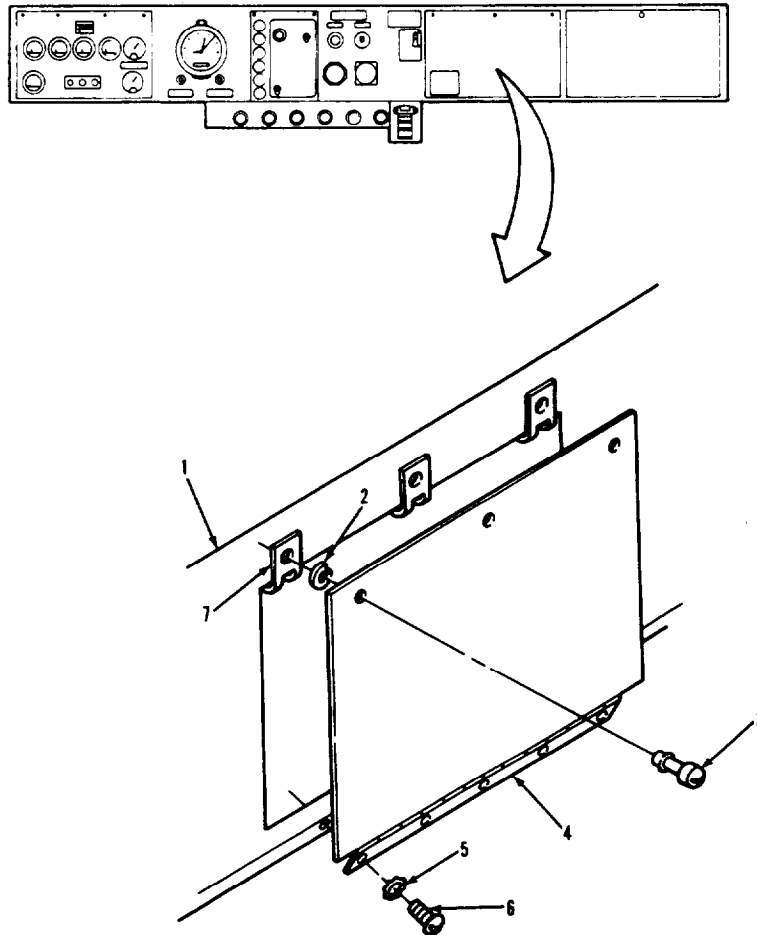

LEGEND:

- |  |                                     |
|--|-------------------------------------|
| 1. INSTRUMENT PANEL ASSEMBLY                 | 5. LOCKWASHER (4)                   |
| 2. QUARTER-TURN STUD RETAINER (3)            | 6. SCREW (4)                        |
| 3. QUARTER-TURN STUD (3)                     | 7. QUARTER-TURN STUD RECEPTACLE (3) |
| 4. INSTRUMENT PANEL CENTER<br>PANEL ASSEMBLY |                                     |

TA 237709

CAB AND BODY.

3-256. INSTRUMENT PANEL CENTER PANEL ASSEMBLY REPLACEMENT (Continued).		
LOCATION/ITEM	ACTION	REMARKS
<b>A. REMOVAL.</b>		
1. Three studs (3).	Turn to the left a quarter of a turn, and lower item (4).	
2. Four screws (6) and lockwashers (5).	Remove from item (4).	
3. Panel (4).	Remove from item (1).	
4. Three receptacles (7).	Remove from item (1).	
5. Three retainers (2).	Remove from items (3). Discard three items (2).	Items (2) can be removed by cutting with diagonal pliers.
6. Three studs (3).	Remove from item (4).	
<b>B. CLEANING AND INSPECTION.</b>		
7. All metal parts.	Clean and inspect.	Refer to paragraphs 3-4 and 3-5.
<b>C. INSTALLATION.</b>		
8. Three studs (3).	Install in top holes of item (4).	
9. Three new retainers (2).	Install onto three items (3).	
10. Three receptacles (7).	Install into upper three holes of item (1).	

CAB AND BODY.

3-256. INSTRUMENT PANEL CENTER PANEL ASSEMBLY REPLACEMENT (Continued).

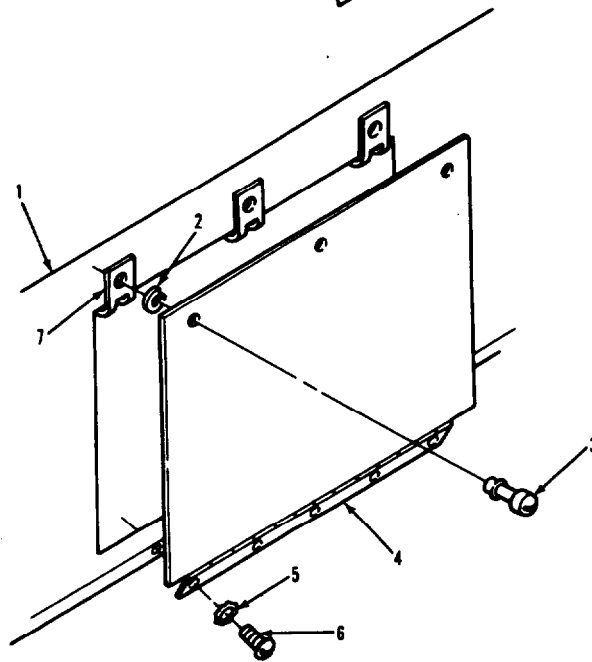
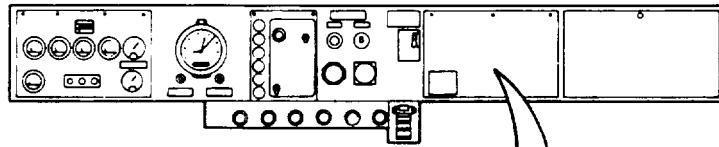

LEGEND:

- |   |                                     |
|---|-------------------------------------|
| 1. INSTRUMENT PANEL ASSEMBLY              | 5. LOCKWASHER (4)                   |
| 2. QUARTER-TURN STUD RETAINER (3)         | 6. SCREW (4)                        |
| 3. QUARTER-TURN STUD (3)                  | 7. QUARTER-TURN STUD RECEPTACLE (3) |
| 4. INSTRUMENT PANEL CENTER PANEL ASSEMBLY |                                     |

TA 237710

CAB AND BODY.

3-256. INSTRUMENT PANEL CENTER PANEL ASSEMBLY REPLACEMENT (Continued).

LOCATION/ITEM	ACTION	REMARKS
<b>C. INSTALLATION (Continued).</b>		
11. Panel (4).	Aline four hinge holes of item (4) with bottom four holes of item (1).	
12. Four screws (6) and washers (5).	Install and tighten in holes of item (4) and (7).	
13. Panel (4).	Raise item (4) and secure three items (3) in three items (7).	Rotate three items (3) a quarter of a turn clockwise.
NOTE		
Follow-on maintenance action required:		
Replace decal as required (para 3-305).		

CAB AND BODY.

3-256. INSTRUMENT PANEL CENTER PANEL ASSEMBLY REPLACEMENT (Continued).

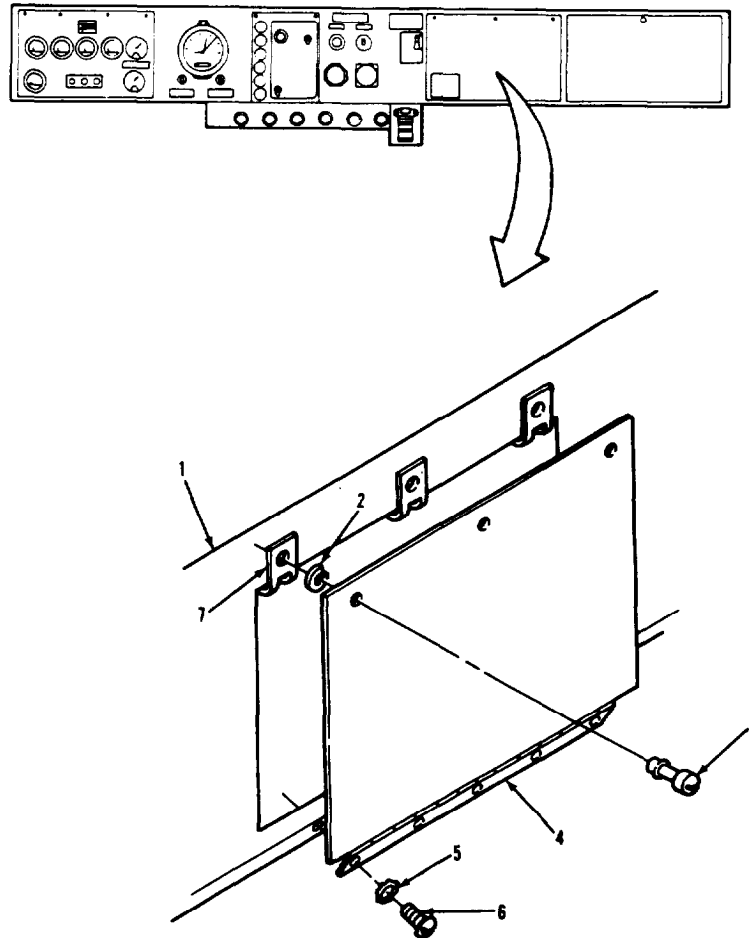

LEGEND:

- |  |                                     |
|--|-------------------------------------|
| 1. INSTRUMENT PANEL ASSEMBLY                 | 5. LOCKWASHER (4)                   |
| 2. QUARTER-TURN STUD RETAINER (3)            | 6. SCREW (4)                        |
| 3. QUARTER-TURN STUD (3)                     | 7. QUARTER-TURN STUD RECEPTACLE (3) |
| 4. INSTRUMENT PANEL CENTER<br>PANEL ASSEMBLY |                                     |

TA 237711

CAB AND BODY.

3-257. GLOVE COMPARTMENT DOOR ASSEMBLY REPLACEMENT.

THIS TASK COVERS

- a. Removal.
- b. Installation.

INITIAL SETUP

<u>APPLICABLE CONFIGURATIONS</u>	<u>EQUIPMENT CONDITION PARAGRAPH</u>	<u>CONDITION DESCRIPTION</u>
All.	None.	None.

TEST EQUIPMENT  
None.

SPECIAL TOOLS  
None.

MATERIALS/PARTS (P/N)  
None.

PERSONNEL REQUIRED  
One (MOS-63S).

SPECIAL ENVIRONMENTAL CONDITIONS  
None.

REFERENCES (TM)  
None.

GENERAL SAFETY INSTRUCTIONS  
Engine off.  
Transmission in neutral.  
Park brake set.

TROUBLESHOOTING REFERENCES  
Paragraph 2-11.

CAB AND BODY.

3-257. GLOVE COMPARTMENT DOOR ASSEMBLY REPLACEMENT (Continued).

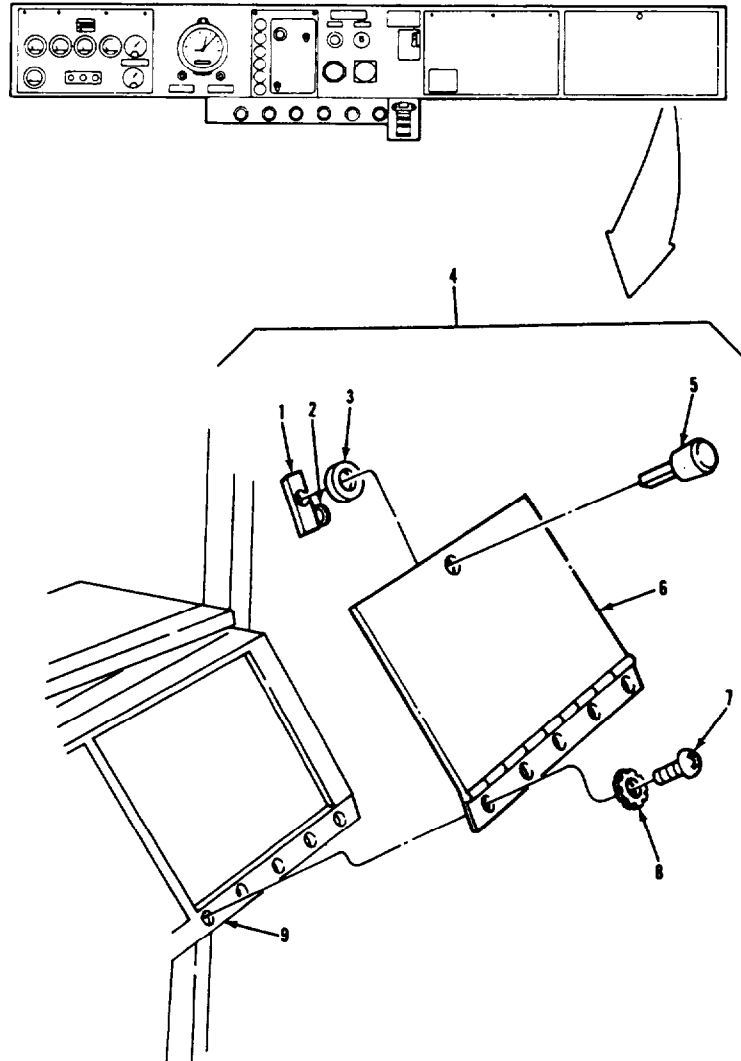

LEGEND:

- |  |   |
|--|---|
| <ul style="list-style-type: none"> <li>1. PAWL</li> <li>2. SETSCREW</li> <li>3. PUSH-ON CLIP</li> <li>4. GLOVE COMPARTMENT LATCH ASSEMBLY</li> <li>5. KNOB AND SHAFT ASSEMBLY</li> </ul> | <ul style="list-style-type: none"> <li>6. GLOVE COMPARTMENT DOOR ASSEMBLY</li> <li>7. SCREW (5)</li> <li>8. LOCKWASHER (5)</li> <li>9. INSTRUMENT PANEL ASSEMBLY</li> </ul> |
|--|---|

TA 237712



CAB AND BODY.

3-257. GLOVE COMPARTMENT DOOR ASSEMBLY REPLACEMENT (Continued).

LOCATION/ITEM	ACTION	REMARKS
<b>A. REMOVAL.</b>		
1. Glove compartment door assembly (6).	Open.	
2. Five screws (7) and five lock-washers (8).	Remove.	
3. Setscrews (2).	Loosen and remove.	
4. Pawl (1).	Remove.	
5. Push-on clip (3).	Remove.	Use small bladed screw-driver.
6. Knob and shaft assembly (5).	Remove.	
<b>B. INSTALLATION.</b>		
7. Glove compartment door assembly (6).	Aline with mounting.	
8. Five screws (7) and five lock-washers (8).	Install and tighten.	
9. Glove compartment latch assembly (4).	Insert item (5) through hole in item (6) with index arrow pointing up.	
10. Push-on clip (3).	Force item (3) over shaft of item (5) and seat firmly against inside of item (6) panel.	Install with cup shaped side out.

CAB AND BODY.

3-257. GLOVE COMPARTMENT DOOR ASSEMBLY REPLACEMENT (Continued).

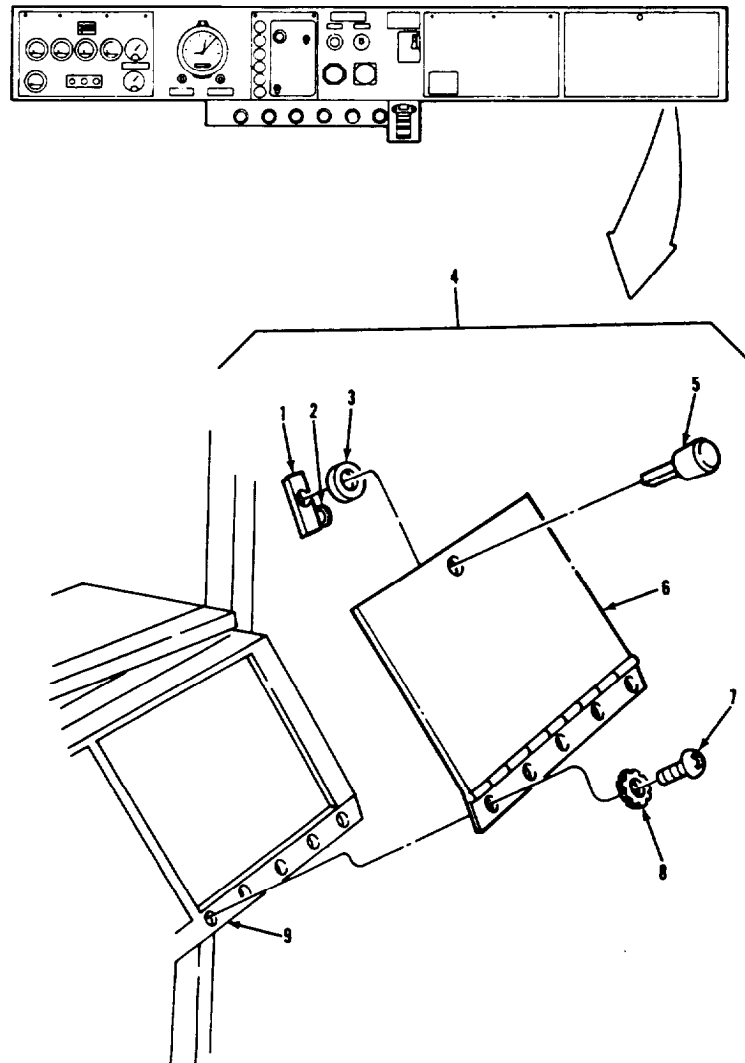

LEGEND:

- |                                     |                                    |
|-------------------------------------|------------------------------------|
| 1. PAWL                             | 6. GLOVE COMPARTMENT DOOR ASSEMBLY |
| 2. SETSCREW                         | 7. SCREW (5)                       |
| 3. PUSH-ON CLIP                     | 8. LOCKWASHER (5)                  |
| 4. GLOVE COMPARTMENT LATCH ASSEMBLY | 9. INSTRUMENT PANEL ASSEMBLY       |
| 5. KNOB AND SHAFT ASSEMBLY          |                                    |

TA 237713

CAB AND BODY.

3-257. GLOVE COMPARTMENT DOOR ASSEMBLY REPLACEMENT (Continued).

LOCATION/ITEM	ACTION	REMARKS
<b>B. INSTALLATION (Continued).</b>		
11. Pawl (1).	Install on item (5) shaft with long side facing up.	Index arrow on item (5) and long side of item (1) facing up.
12. Setscrew (2).	Adjust item (1) for desired grip, and tighten item (2).	
13. Glove compartment door assembly (6).	Close.	
NOTE		
Follow-on maintenance action required:		
None.		

CAB AND BODY.

3-257. GLOVE COMPARTMENT DOOR ASSEMBLY REPLACEMENT (Continued).

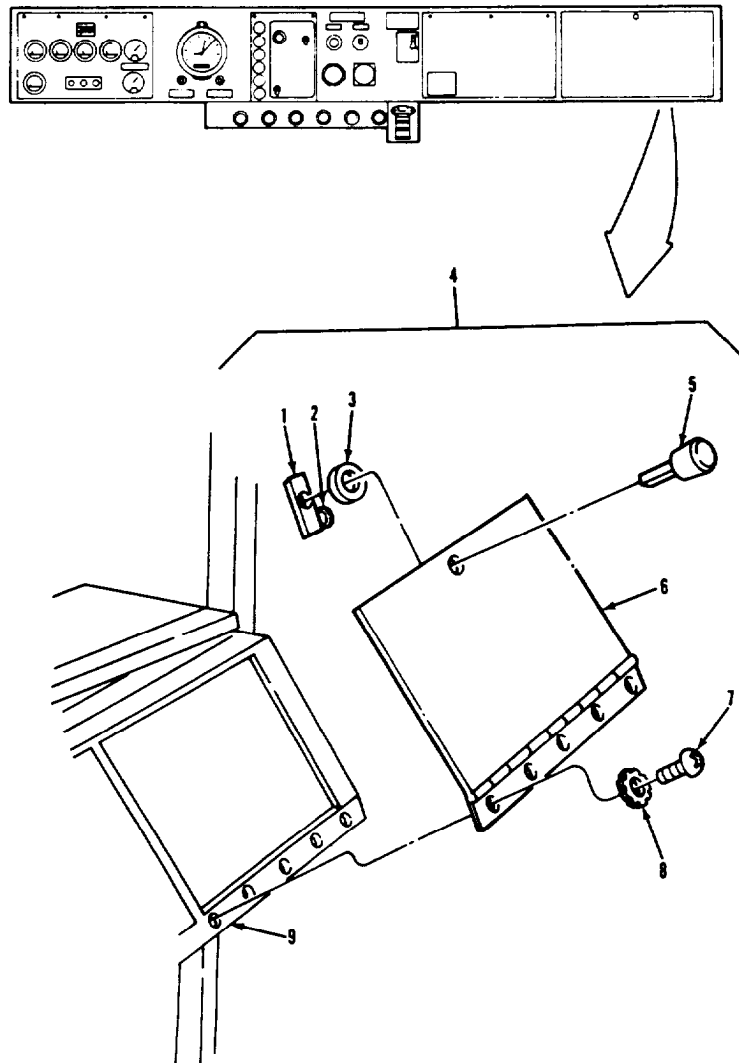

LEGEND:

- |                                     |                                    |
|-------------------------------------|------------------------------------|
| 1. PAWL                             | 6. GLOVE COMPARTMENT DOOR ASSEMBLY |
| 2. SETSCREW                         | 7. SCREW (5)                       |
| 3. PUSH-ON CLIP                     | 8. LOCKWASHER (5)                  |
| 4. GLOVE COMPARTMENT LATCH ASSEMBLY | 9. INSTRUMENT PANEL ASSEMBLY       |
| 5. KNOB AND SHAFT ASSEMBLY          |                                    |

TA 237714

CAB AND BODY.

3-258. INSTRUMENT PANEL ASSEMBLY REPLACEMENT.

THIS TASK COVERS

- a. Removal.
- b. Installation.

INITIAL SETUP

<u>APPLICABLE CONFIGURATIONS</u>	<u>EQUIPMENT CONDITION PARAGRAPH</u>	<u>CONDITION DESCRIPTION</u>
All.	3-86	Wiper lamp and washer lamp removed.
	3-175.	Trailer supply valve removed.
<u>TEST EQUIPMENT</u>		
None.	3-171.	Park brake valve removed.
	3-195.	Differential toggle valve removed.
<u>SPECIAL TOOLS</u>		
None.	3-254.	Right-hand instrument cluster panel assembly removed.
	3-255.	Left-hand instrument cluster panel assembly removed.
<u>MATERIALS/PARTS (P/N)</u>		
None.	3-256.	Instrument panel center panel assembly removed.
	3-257.	Glove compartment door assembly removed.
<u>PERSONNEL REQUIRED</u>		
two (MDS-63S).	3-291.	Windshield washer control valve removed.
	3-292.	Windshield wiper control removed.
	3-300.	Heater control panel removed.
<u>TROUBLESHOOTING REFERENCES</u>		
None.	3-315.	Air cleaner restriction gage and bracket removed.
	3-76.	Ether start switch removed.
<u>GENERAL SAFETY INSTRUCTIONS</u>		
Engine off	3-77.	Pushbutton clearance lamp switch removed.
Transmission in neutral.	3-85.	Ether lamp and clearance lamp removed.
Park brake set.	3-309.	Tachograph removed.
<u>SPECIAL ENVIRONMENTAL CONDITIONS</u>		
-None.		

CAB AND BODY.

3-258. INSTRUMENT PANEL ASSEMBLY REPLACEMENT (Continued).

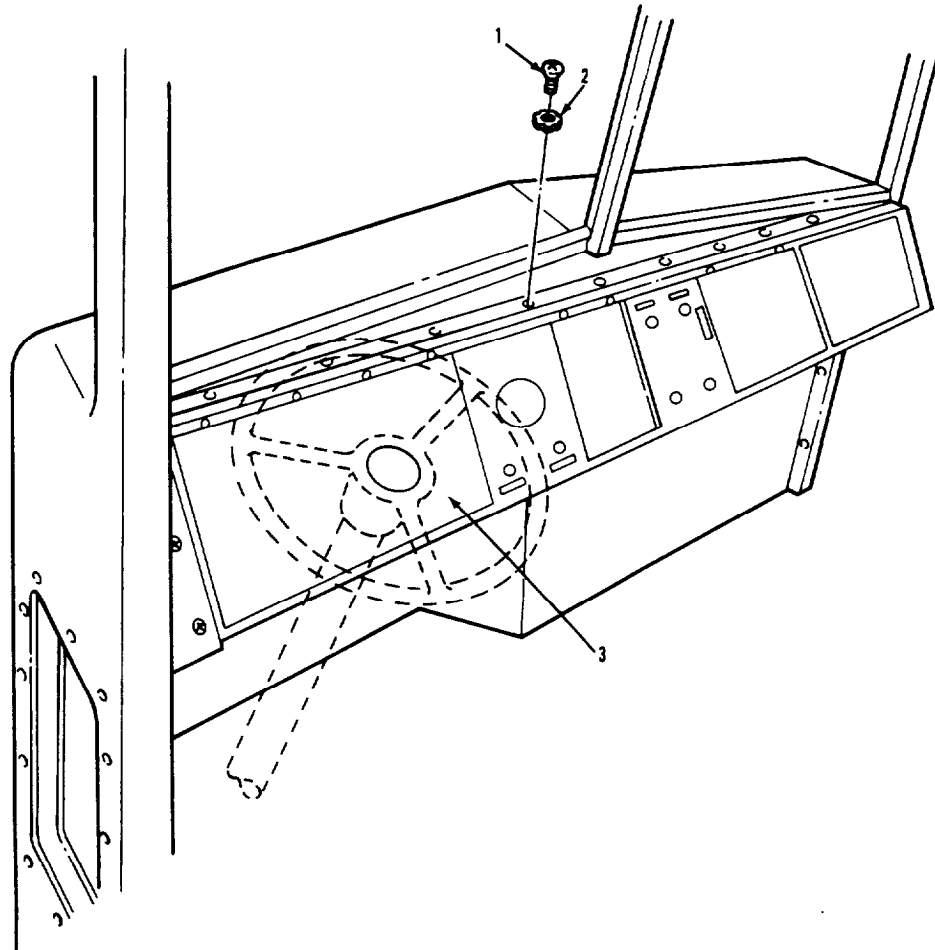

LEGEND:

- 1. SCREW (15)
- 2. LOCKWASHER (15)
- 3. INSTRUMENT PANEL ASSEMBLY

TA 237715

CAB AND BODY.

3-258. INSTRUMENT PANEL ASSEMBLY REPLACEMENT (Continued).

LOCATION/ITEM	ACTION	REMARKS
<b>A. REMOVAL.</b>		
1. Fifteen screws (1) and lockwashers (2).	Remove from item (3).	
2. Instrument panel assembly (3).	Remove.	First mechanic lifts left side. Second mechanic lifts right side.
<b>B. INSTALLATION.</b>		
3. Instrument panel assembly (3).	Aline and install.	
4. Fifteen screws (1) and lockwashers (2).	Install and tighten.	First mechanic holds item (3) while second mechanic installs items (1) and (2).
NOTE		
Follow-on maintenance action required:		
Install heater control panel (para 3-300). Install air cleaner restriction gage and bracket (para 3-315). Install tachograph (para 3-309). Install ether start switch (para 3-76). Install pushbutton clearance lamp (para 3-77). Install ether lamp and clearance lamp (para 3-85). Install windshield wiper control (para 3-292). Install windshield washer control valve (para 3-291).		

CAB AND BODY.

3-258. INSTRUMENT PANEL ASSEMBLY REPLACEMENT (Continued).

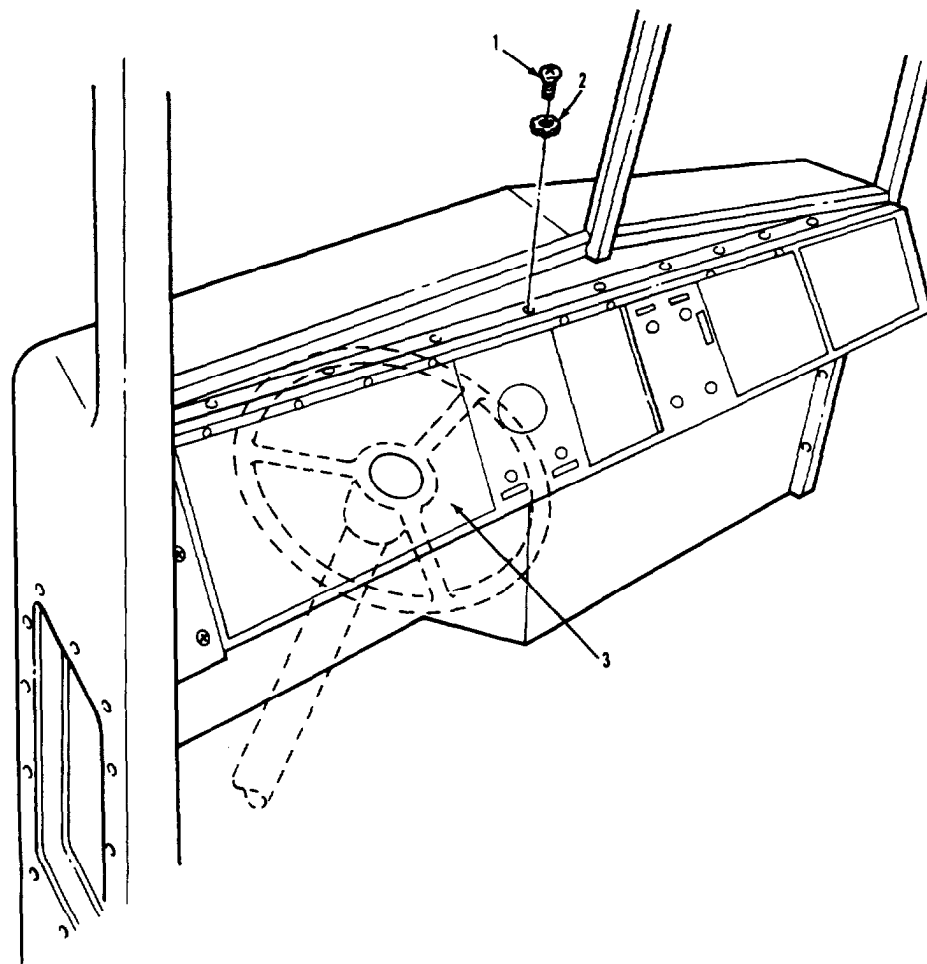

LEGEND:

- 1. SCREW (15)
- 2. LOCKWASHER (15)
- 3. INSTRUMENT PANEL ASSEMBLY

TA 237716



CAB AND BODY.

3-258. INSTRUMENT PANEL ASSEMBLY REPLACEMENT (Continued).

LOCATION/ITEM	ACTION	REMARKS
<b>B. INSTALLATION (Continued).</b>		
NOTE		
Follow-on maintenance action required (Continued):		
	Install glove compartment door assembly (para 3-257). Install instrument panel center panel assembly (para 3-256). Install left-hand instrument cluster panel assembly (para 3-255). Install right-hand instrument cluster panel assembly (para 3-254). Install park brake valve (para 3-171). Install wiper lamp and washer lamp (para 3-86). Install trailer supply valve (para 3-175). Install ether start decal (para 3-305). Install park data plate (para 3-305). Install interaxle differential decal (para 3-305). Install differential toggle valve (para 3-195).	

CAB AND BODY.

3-258. INSTRUMENT PANEL ASSEMBLY REPLACEMENT (Continued).

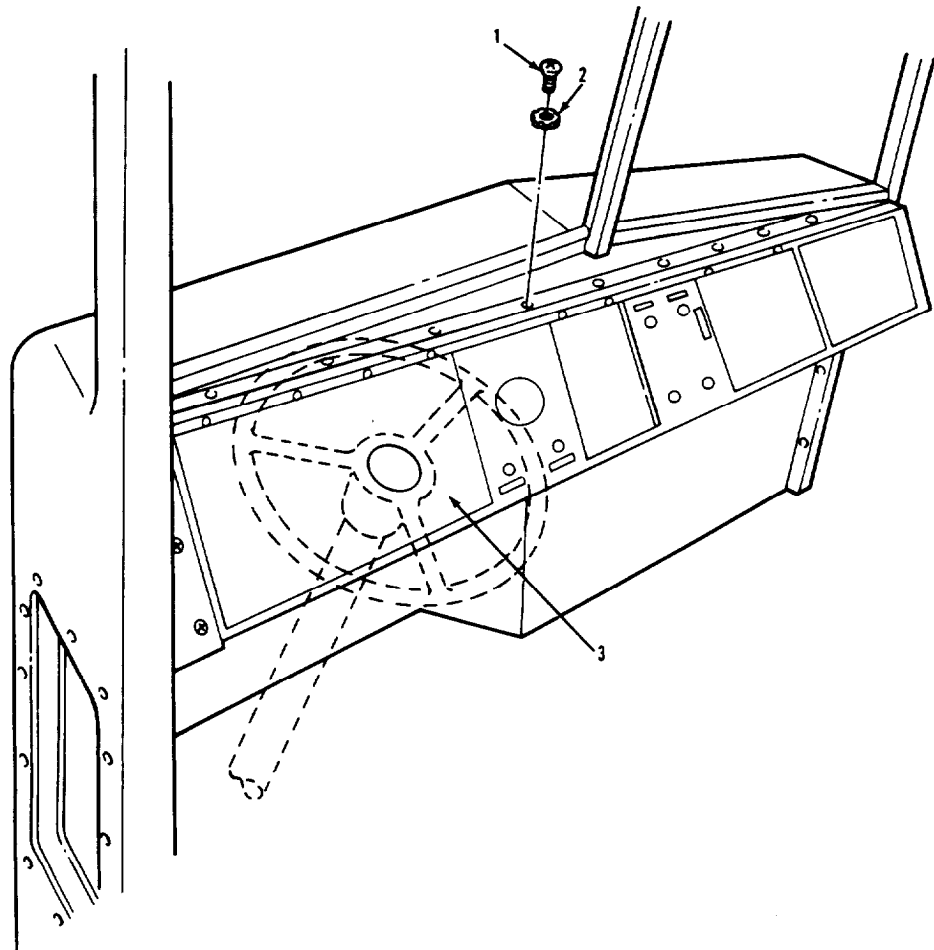

LEGEND:

- 1. SCREW (15)
- 2. LOCKWASHER (15)
- 3. INSTRUMENT PANEL ASSEMBLY

TA 237717

CAB AND BODY.

3-259. INSIDE ASSIST HANDLE REPLACEMENT.

THIS TASK COVERS

- a. Removal.
- b. Installation.

INITIAL SETUP

APPLICABLE CONFIGURATIONS  
All.

EQUIPMENT CONDITION  
PARAGRAPH  
None.

CONDITION DESCRIPTION  
None.

TEST EQUIPMENT  
None.

SPECIAL TOOLS  
None.

MATERIALS/PARTS (P/N)  
None.

PERSONNEL REQUIRED  
One (MDS-63S).

SPECIAL ENVIRONMENTAL CONDITIONS  
None.

REFERENCES (TM)  
None.

GENERAL SAFETY INSTRUCTIONS  
Engine off  
Transmission in neutral.  
Park brake set.

TROUBLESHOOTING REFERENCES  
Paragraph 2-11.

**CAB AND BODY.**

**3-259. INSIDE ASSIST HANDLE REPLACEMENT (Continued).**

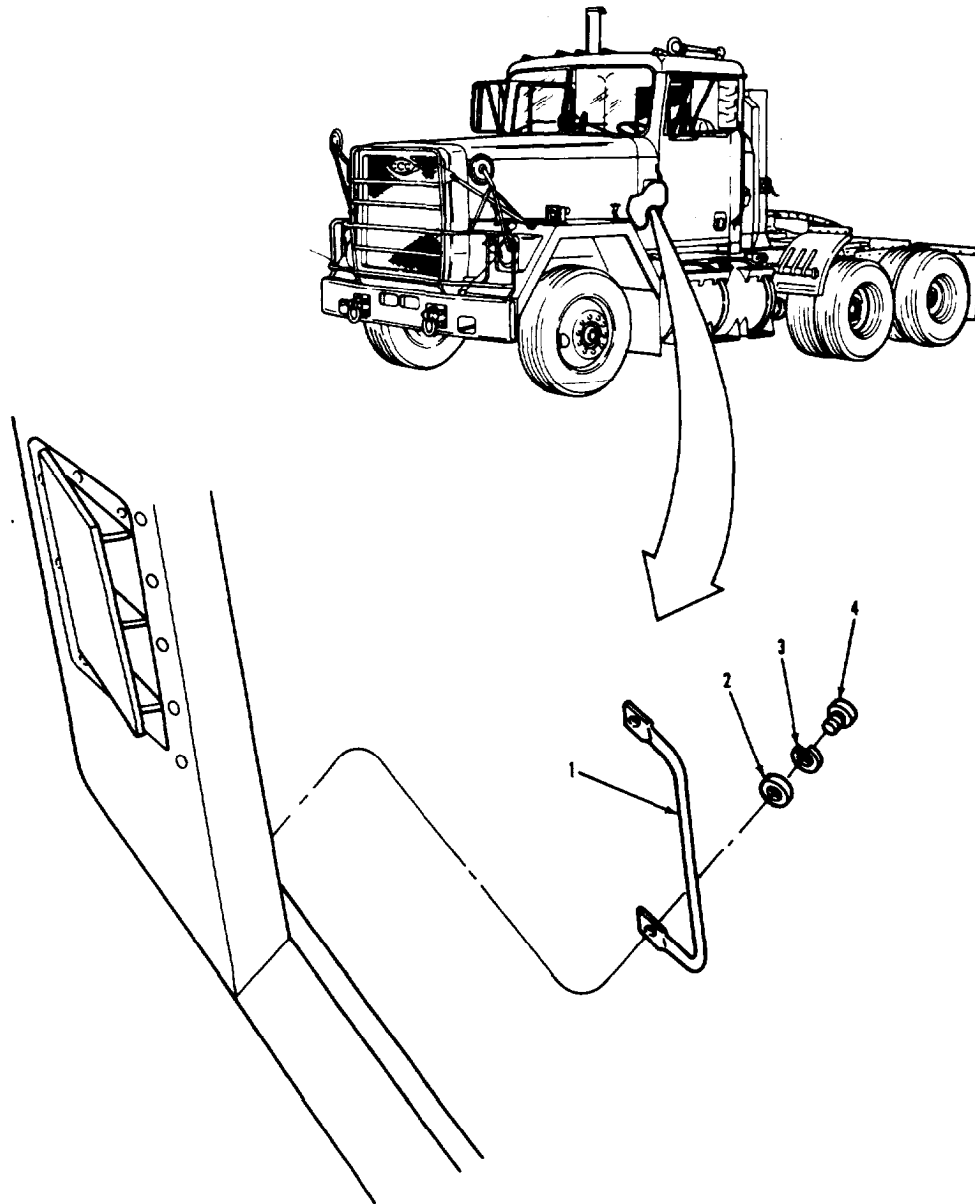

**LEGEND:**

- 1. ASSIST HANDLE
- 2. WASHER (2)
- 3. LOCKWASHER (2)
- 4. SCREW (2)

TA 237718

CAB AND BODY.

3-259. INSIDE ASSIST HANDLE REPLACEMENT (Continued).		
LOCATION/ITEM	ACTION	REMARKS
NOTE		
<p>Inside assist handle replacement is the same for both sides. This procedure covers replacement of the driver's side inside assist handle.</p>		
<b>A. REMOVAL.</b>		
1. Two screws (4), two lockwashers (3), and two washers (2).	Remove.	
2. Inside assist handle (1).	Remove.	
<b>B. INSTALLATION.</b>		
3. Inside assist handle (1).	Move into position and aline with mounting holes in cab.	
4. Two screws (4), two lockwashers (3), and two washers (2).	Install and tighten.	
NOTE		
Follow-on maintenance action required:		
None.		

CAB AND BODY.

3-259. INSIDE ASSIST HANDLE REPLACEMENT (Continued).

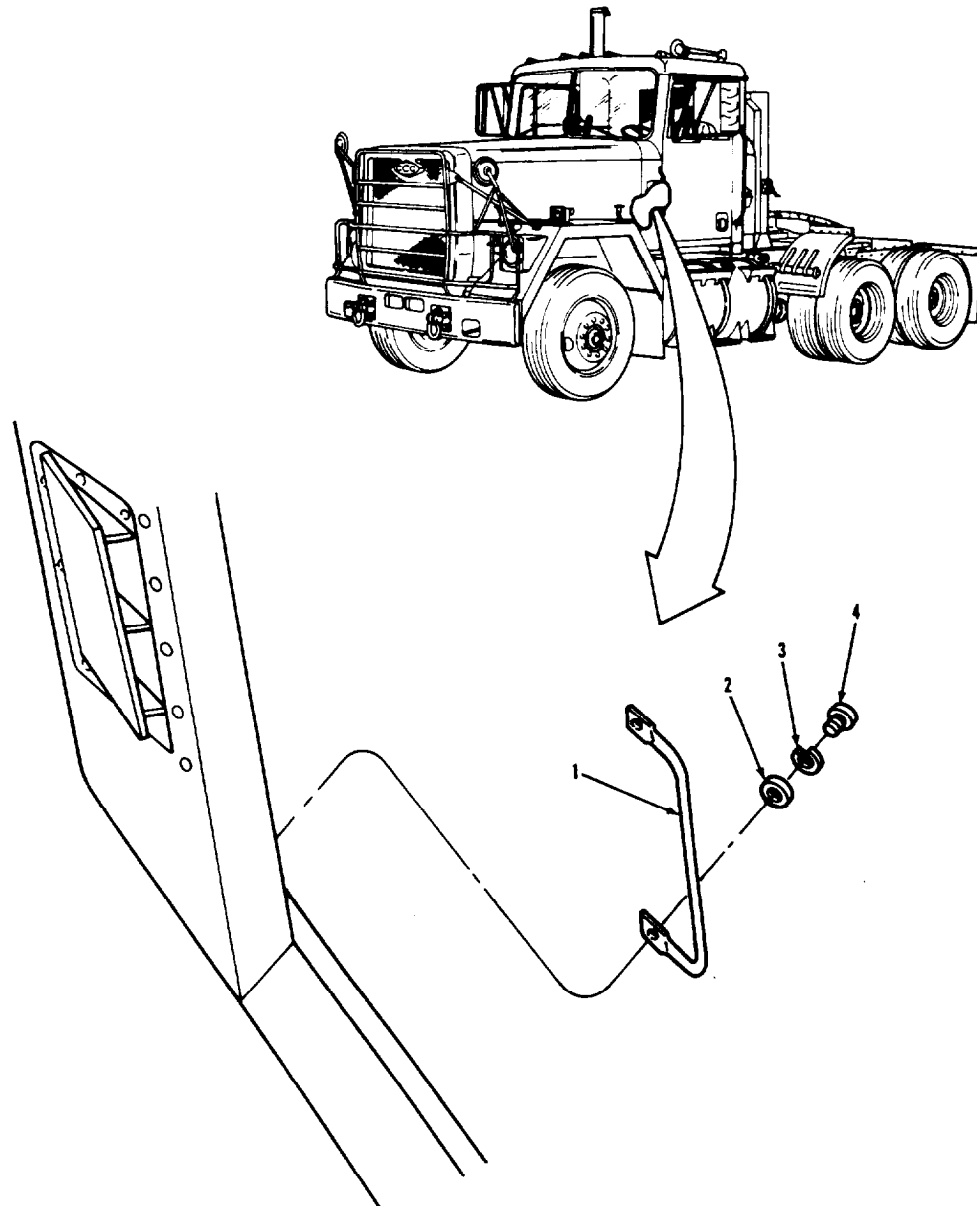

LEGEND:

- 1. ASSIST HANDLE
- 2. WASHER (2)
- 3. LOCKWASHER (2)
- 4. SCREW (2)

TA 237719

CAB AND BODY.

3-260. CENTER FLOOR PAN ACCESS COVER REPLACEMENT.

THIS TASK COVERS

- a. Removal.
- b. Cleaning and Inspection.
- c. Installation.

INITIAL SETUP

<u>APPLICABLE CONFIGURATIONS</u>	<u>EQUIPMENT CONDITION PARAGRAPH</u>	<u>CONDITION DESCRIPTION</u>
All.	3-137.	Shifter control removed.
<u>TEST EQUIPMENT</u> None.	3-139.	Shifter control mounting bracket removed.
<u>SPECIAL TOOLS</u> None.		
<u>MATERIALS/PARTS (P/N)</u> None.		
<u>PERSONNEL REQUIRED</u> One (MOS-63S).	<u>SPECIAL ENVIRONMENTAL CONDITIONS</u> None.	
<u>REFERENCES (TM)</u> None.	<u>GENERAL SAFETY INSTRUCTIONS</u> Engine off. Transmission in neutral. Park brake set.	
<u>TROUBLESHOOTING REFERENCES</u> None.		

CAB AND BODY.

3-260. CENTER FLOOR PAN ACCESS COVER REPLACEMENT (Continued).

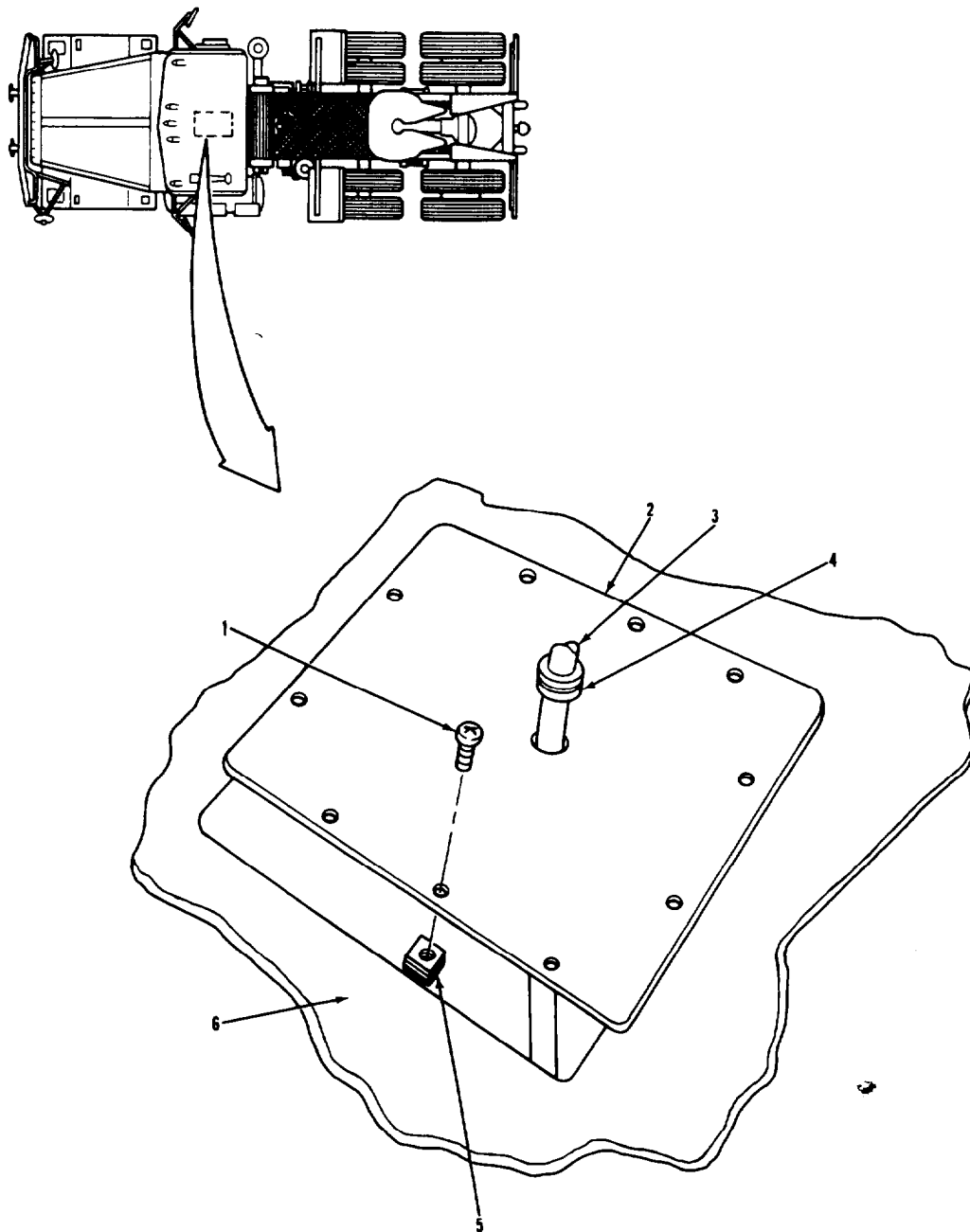

LEGEND:

- |  |                      |
|--|----------------------|
| 1. MACHINE SCREW (10)                        | 4. GROMMET           |
| 2. CENTER FLOOR PAN ACCESS COVER ASSEMBLY    | 5. RETAINER NUT (10) |
| 3. TRANSMISSION SHIFT CONTROL CABLE ASSEMBLY | 6. CAB FLOOR         |

TA 237720



**CAB AND BODY.**

**3-260. CENTER FLOOR PAN ACCESS COVER REPLACEMENT (Continued).**

LOCATION/ITEM	ACTION	REMARKS
<b>A. REMOVAL.</b>		
1. Ten screws (1).	Remove from item (2) and ten items (5).	
2. Cover (2).	Remove from item (3) and item (6).	
3. Grommet (4).	Remove from item (2).	
4. Ten nuts (5).	Remove from item (6).	
<b>B. CLEANING AND INSPECTION.</b>		
5. All parts.	Clean and inspect.	Refer to paragraphs 3-4 and 3-5.
<b>C. INSTALLATION.</b>		
6. Ten nuts (5).	Install on item (6).	
7. Grommet (4).	Install in item (2).	
8. Cover (2).	a. Slide onto item (3) and position on ten items (5) and item (6).  b. Secure with ten items (1).	
<b>NOTE</b>		
Follow-on maintenance action required:		
Install shifter control mounting bracket (para 3-139). Install shifter control (para 3-137).		

CAB AND BODY.

3-260. CENTER FLOOR PAN ACCESS COVER REPLACEMENT (Continued).

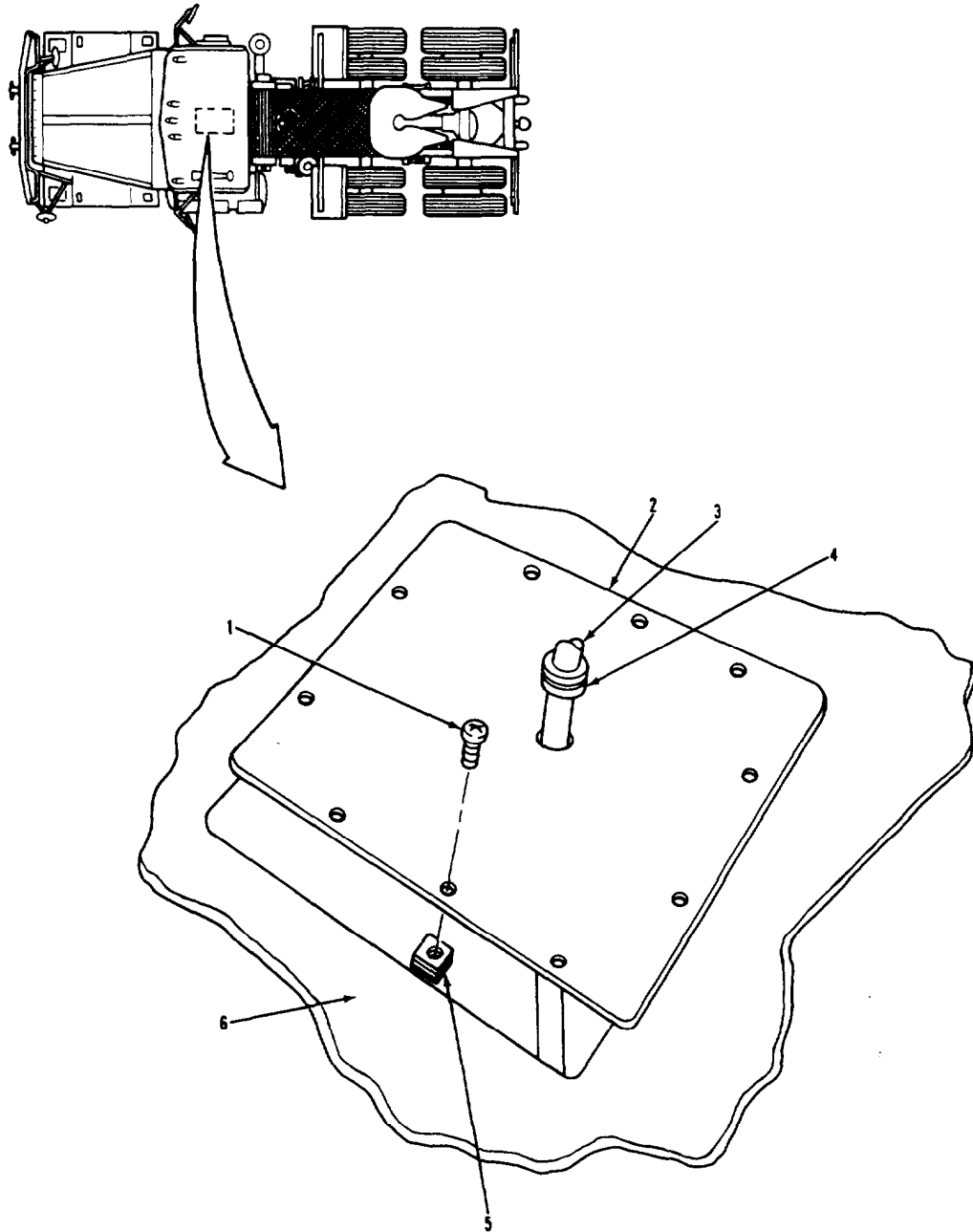

LEGEND:

- |  |                      |
|--|----------------------|
| 1. MACHINE SCREW (10)                        | 4. GROMMET           |
| 2. CENTER FLOOR PAN ACCESS COVER ASSEMBLY    | 5. RETAINER NUT (10) |
| 3. TRANSMISSION SHIFT CONTROL CABLE ASSEMBLY | 6. CAB FLOOR         |

TA 237721

CAB AND BODY.

3-261. VENTILATOR REPLACEMENT.

THIS TASK COVERS

- a. Removal.
- b. Cleaning and Inspection.
- c. Installation.

INITIAL SETUP

APPLICABLE CONFIGURATIONS

All.

EQUIPMENT CONDITION  
PARAGRAPH

None.

CONDITION DESCRIPTION

None.

TEST EQUIPMENT

None.

SPECIAL TOOLS

None.

MATERIALS/PARTS (P/N)

Rivet, blind (12)  
(05693) SSPV-86.

PERSONNEL REQUIRED

One (MOS-63S).

SPECIAL ENVIRONMENTAL CONDITIONS

None.

REFERENCES (TM)

TM 9-2320-283-20P.

GENERAL SAFETY INSTRUCTIONS

Engine off.  
Transmission in neutral  
Park brake set.

TROUBLESHOOTING REFERENCES

None.

CAB AND BODY.

3-261. VENTILATOR REPLACEMENT (Continued).

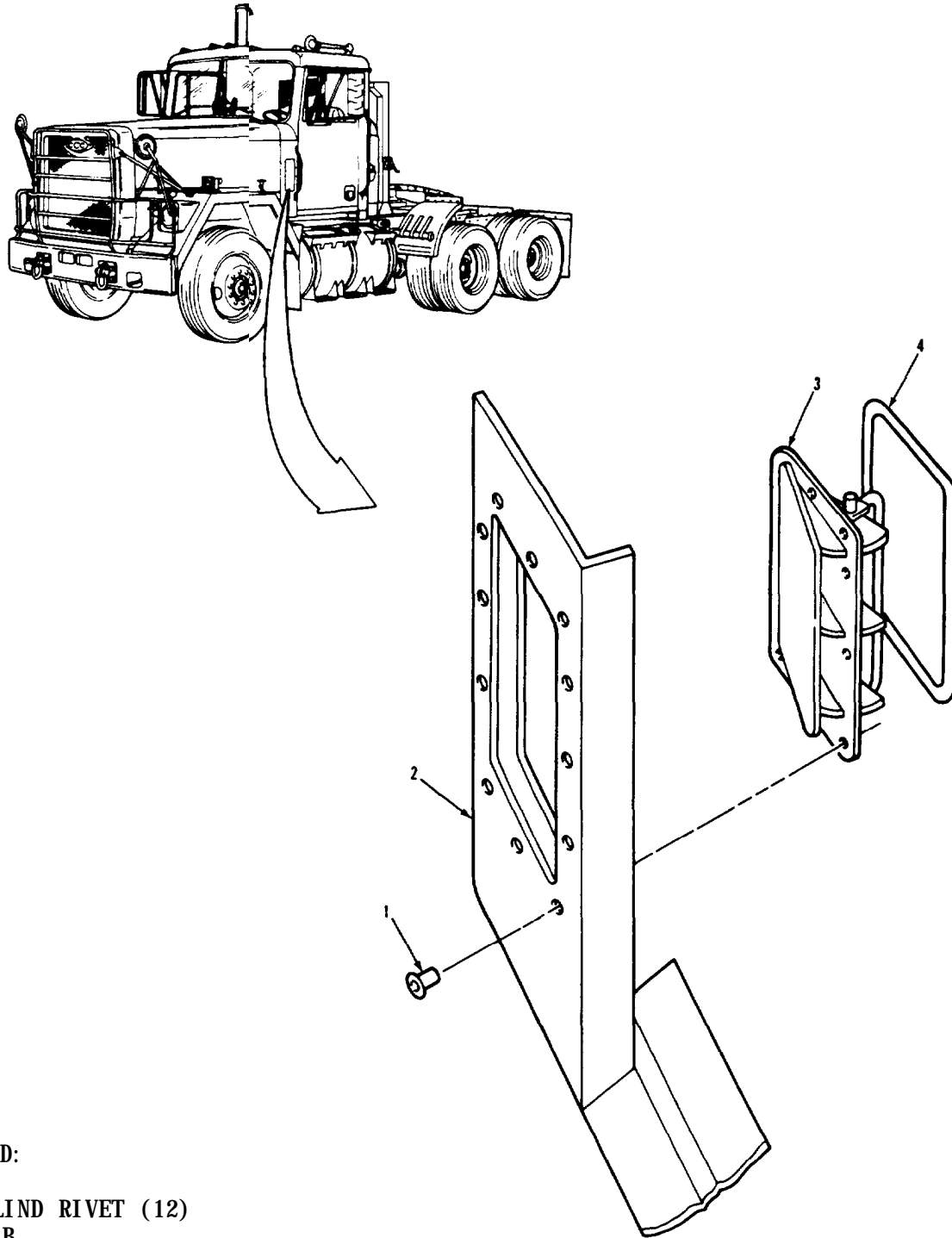

LEGEND:

- 1. BLIND RIVET (12)
- 2. CAB
- 3. VENTILATOR ASSEMBLY
- 4. EDGE SEAL

TA 237722

CAB AND BODY.

3-261. VENTILATOR REPLACEMENT (Continued).		
LOCATION/ITEM	ACTION	REMARKS
<b>A. REMOVAL.</b>		
1. Seal (4).	Remove from item (2).	
2. Twelve rivets (1) and ventilator (3).	Drill out items (1), and remove item (3) from item (2).	Discard items (1).
<b>B. CLEANING AND INSPECTION.</b>		
3. All parts.	Clean and inspect.	Refer to paragraphs 3-4 and 3-5.
<b>C. INSTALLATION.</b>		
4. Ventilator (3).	a. Position on item (2). b. Secure with twelve new items (1).	
5. Seal (4).	Install on item (2).	
NOTE		
Follow-on maintenance action required:		
None.		

**CAB AND BODY.**

**3-261. VENTILATOR REPLACEMENT (Continued).**

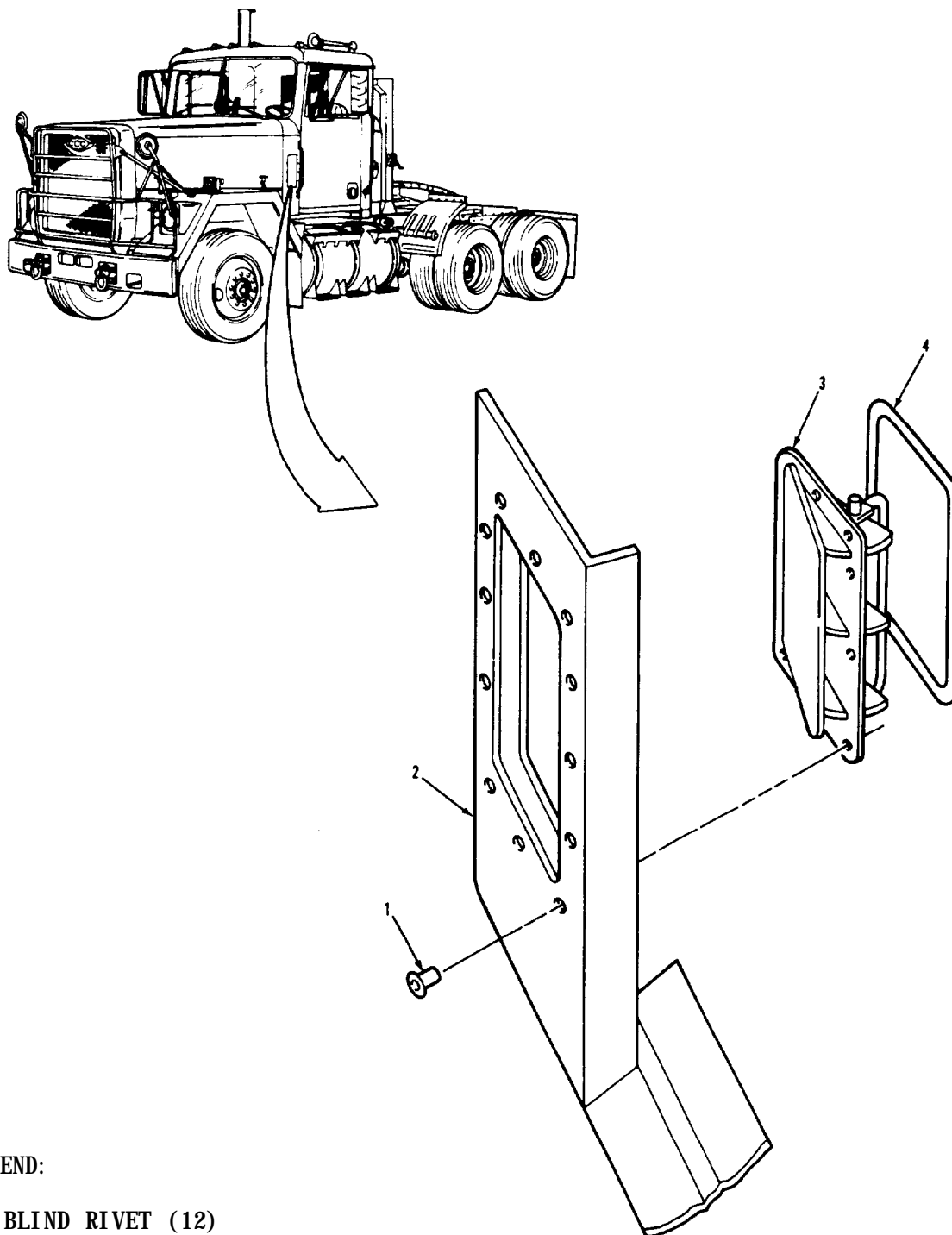

**LEGEND:**

- 1. BLIND RIVET (12)
- 2. CAB
- 3. VENTILATOR ASSEMBLY
- 4. EDGE SEAL

TA 237723

CAB AND BODY.

**3-262. PADLOCK BRACKET REPLACEMENT.**

**THIS TASK COVERS**

- a. Removal.
- b. Installation.

**INITIAL SETUP**

**APPLICABLE CONFIGURATIONS**

All.

**EQUIPMENT CONDITION  
PARAGRAPH**

None.

**CONDITION DESCRIPTION**

None.

**TEST EQUIPMENT**

None.

**SPECIAL TOOLS**

None.

**MATERIALS/PARTS (P/N)**

Rivet, blind (2)  
(05693) SSPV-86.

**PERSONNEL REQUIRED**

One (MOS-63S).

**SPECIAL ENVIRONMENTAL CONDITIONS**

None.

**REFERENCES (TM)**

TM 9-2320-283-20P.

**GENERAL SAFETY INSTRUCTIONS**

Engine off  
Transmission in neutral.  
Park brake set.

**TROUBLESHOOTING REFERENCES**

None.

CAB AND BODY.

3-262. PADLOCK BRACKET REPLACEMENT (Continued).

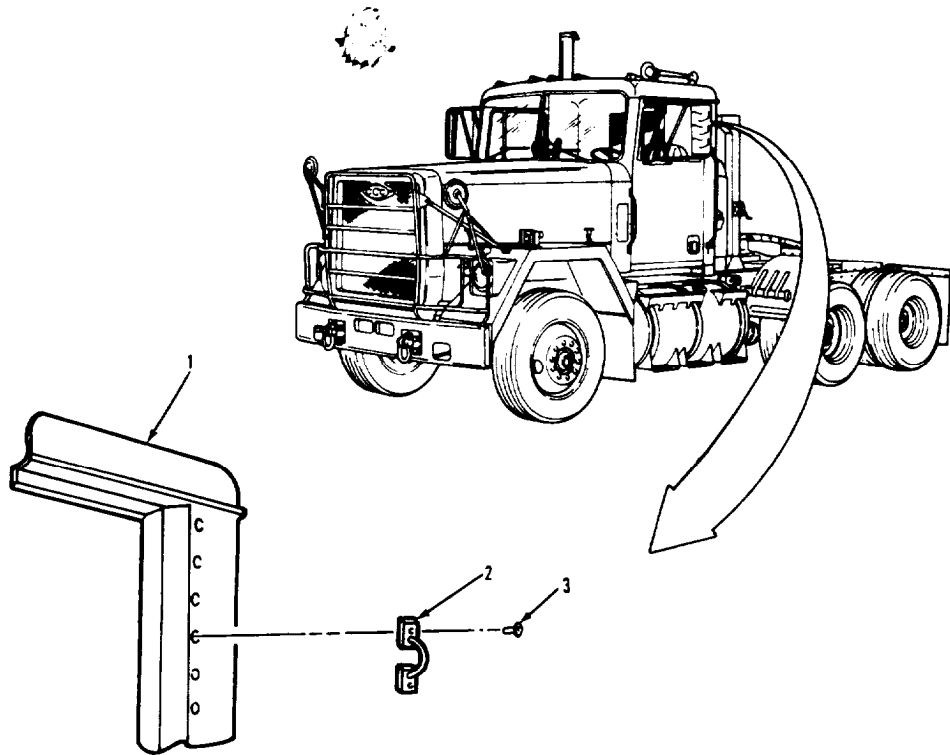

LEGEND:

- 1. CAB
- 2. PADLOCK BRACKET
- 3. BLIND RIVET (2)



CAB AND BODY.

3-262. PADLOCK BRACKET REPLACEMENT (Continued).

LOCATION/ITEM	ACTION	REMARKS
NOTE		
Use this procedure to replace any one of the the two padlock brackets.		
<b>A. REMOVAL.</b>		
1. Two rivets (3) and brackets (2).	Drill out two items (3), and remove item (2) from item (1).	Discard two items (3).
<b>B. INSTALLATION.</b>		
2. Bracket (2).	a. Position on item (1). b. Secure with two new items (3).	
NOTE		
Follow-on maintenance action required:		
None.		

**CAB AND BODY.**

**3-262. PADLOCK BRACKET REPLACEMENT (Continued).**

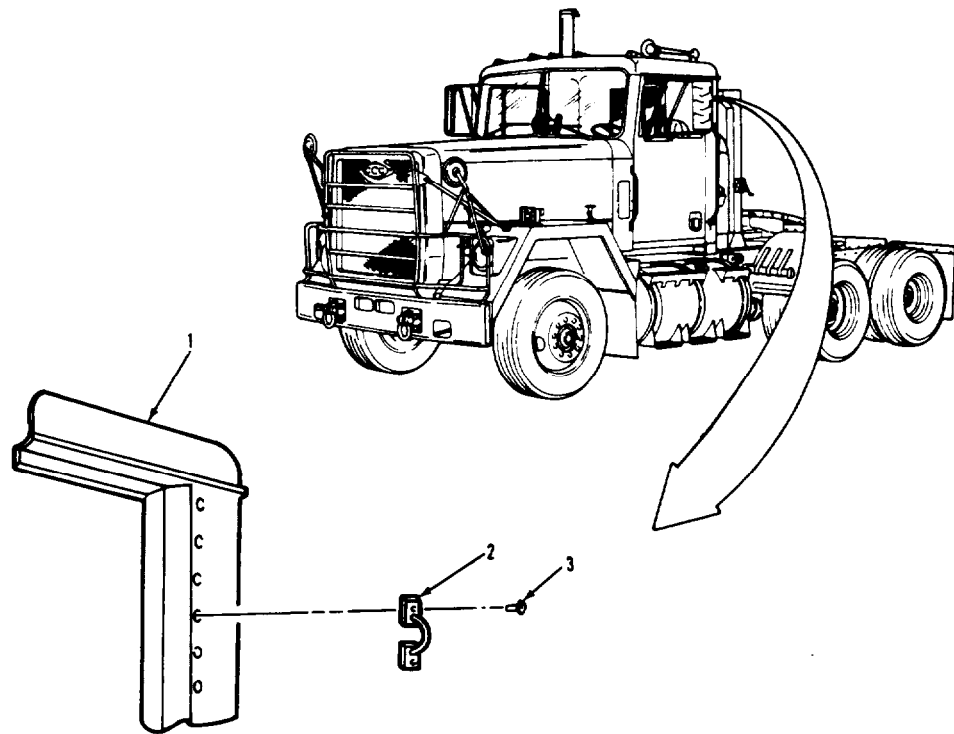

**LEGEND:**

- 1. CAB
- 2. PADLOCK BRACKET
- 3. BLIND RIVET (2)

TA 237725

CAB AND BODY.

3-263. OUTSIDE REAR HANDLE REPLACEMENT.

THIS TASK COVERS

- a. Removal.
- b. Cleaning and Inspection.
- c. Installation.

INITIAL SETUP

APPLICABLE CONFIGURATIONS  
All.

EQUIPMENT CONDITION  
PARAGRAPH  
None.

CONDITION DESCRIPTION  
None.

TEST EQUIPMENT  
None.

SPECIAL TOOLS  
None.

MATERIALS/PARTS (P/N)  
None.

PERSONNEL REQUIRED  
One (MOS-63S).

SPECIAL ENVIRONMENTAL CONDITIONS  
None.

REFERENCES (TM)  
None.

GENERAL SAFETY INSTRUCTIONS  
Engine off.  
Transmission in neutral.  
Park brake set.

TROUBLESHOOTING REFERENCES  
None.

CAB AND BODY.

3-263. OUTSIDE REAR HANDLE REPLACEMENT (Continued).

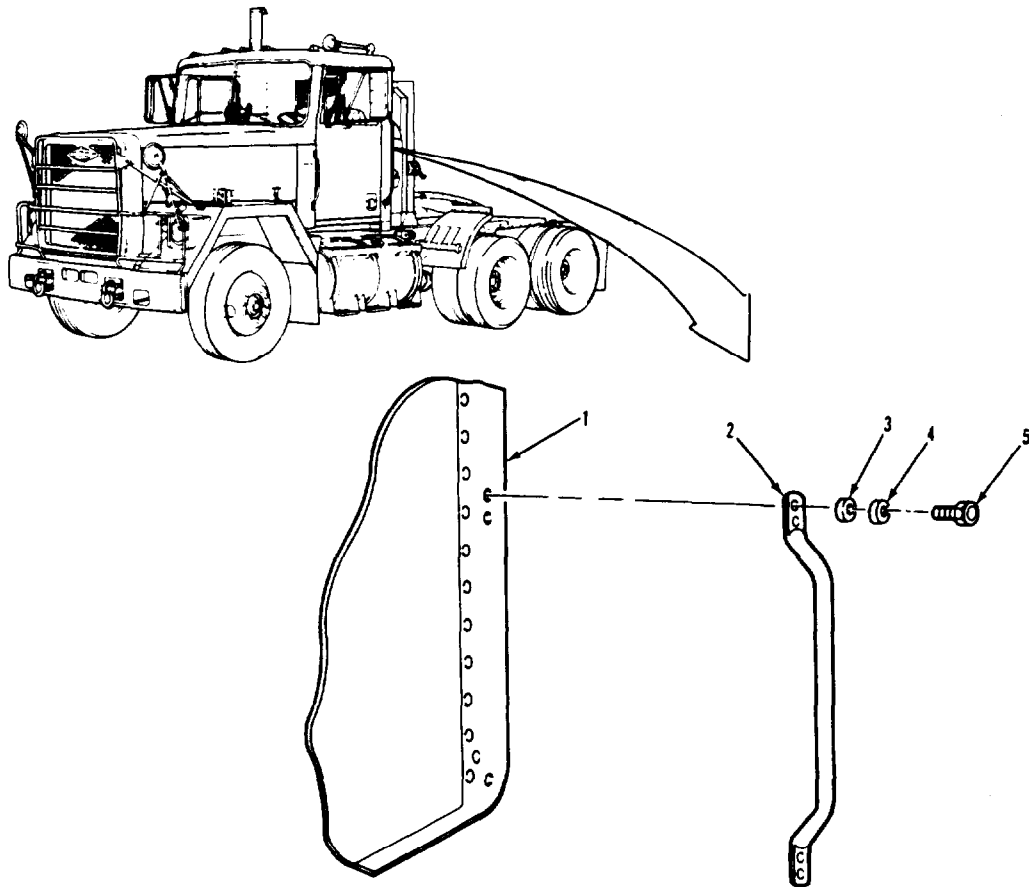

LEGEND:

- |                        |                      |
|------------------------|----------------------|
| 1. CAB                 | 4. LOCKWASHER (4)    |
| 2. OUTSIDE REAR HANDLE | 5. MACHINE SCREW (4) |
| 3. FLAT WASHER (4)     |                      |

TA 237726

CAB AND BODY.

3-263. OUTSIDE REAR HANDLE REPLACEMENT (Continued).		
LOCATION/ITEM	ACTION	REMARKS
NOTE		
Use this procedure to replace either of the two outside rear handles.		
<b>A. REMOVAL.</b>		
1. Four screws (5), lockwashers (4), washers (3), and handle (2).	Remove from item (1).	
<b>B. CLEANING AND INSPECTION.</b>		
2. All parts.	Clean and inspect.	Refer to paragraphs 3-4 and 3-5,
<b>C. INSTALLATION.</b>		
3. Handle (2).	a. Position on item (1). b. Secure with four items (5), (4), and (3).	
NOTE		
Follow-on maintenance action required:		
None.		

CAB AND BODY.

3-263. OUTSIDE REAR HANDLE REPLACEMENT (Continued).

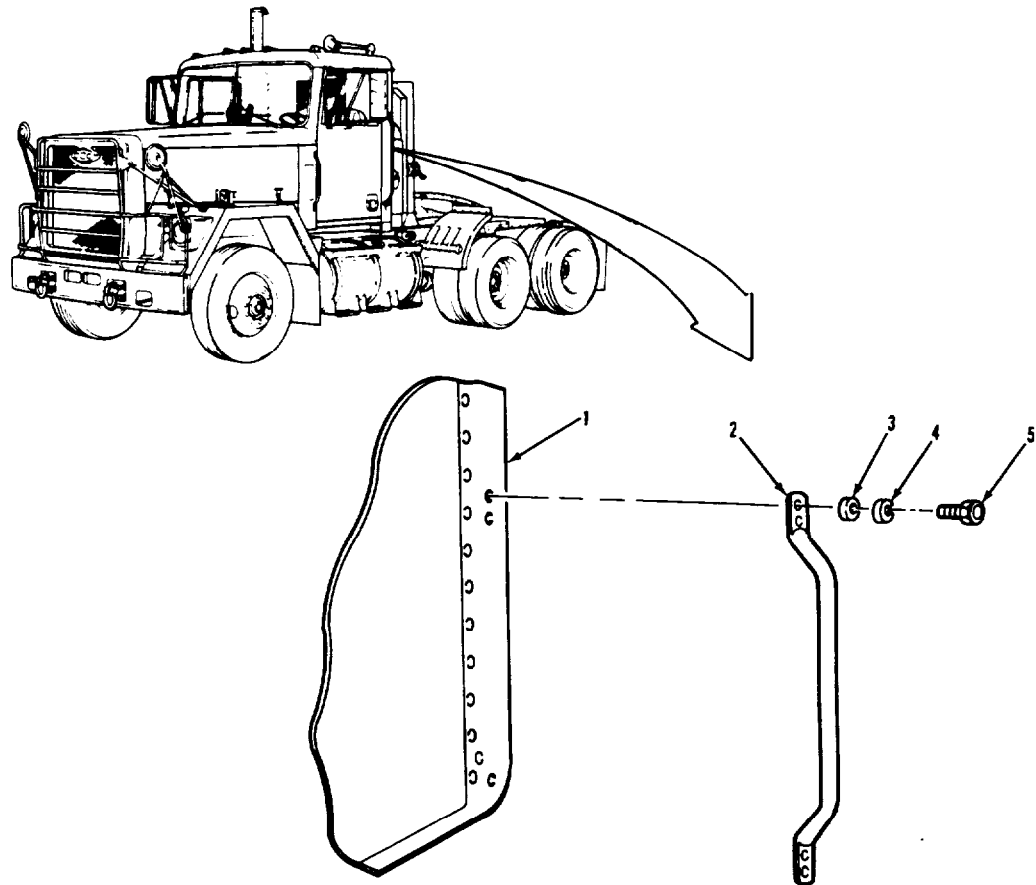

LEGEND:

- |                        |                      |
|------------------------|----------------------|
| 1. CAB                 | 4. LOCKWASHER (4)    |
| 2. OUTSIDE REAR HANDLE | 5. MACHINE SCREW (4) |
| 3. FLAT WASHER (4)     |                      |

TA 237727

CAB AND BODY.

3-264. OUTSIDE FRONT HANDLE REPLACEMENT.

THIS TASK COVERS

- a. Removal.
- b. Cleaning and Inspection.
- c. Installation.

INITIAL SETUP

APPLICABLE CONFIGURATIONS

All.

EQUIPMENT CONDITION  
PARAGRAPH

None.

CONDITION DESCRIPTION

None.

TEST- EQUIPMENT

None.

SPECIAL TOOLS

None.

MATERIALS/PARTS (P/N)

None.

PERSONNEL REQUIRED

One (MOS- 63S).

SPECIAL ENVIRONMENTAL CONDITIONS

None.

REFERENCES (TM)

None.

GENERAL SAFETY INSTRUCTIONS

Engine off.  
Transmission in neutral.  
Park brake set.

TROUBLESHOOTING REFERENCES

None.

CAB AND BODY.

3-264. OUTSIDE FRONT HANDLE REPLACEMENT (Continued).

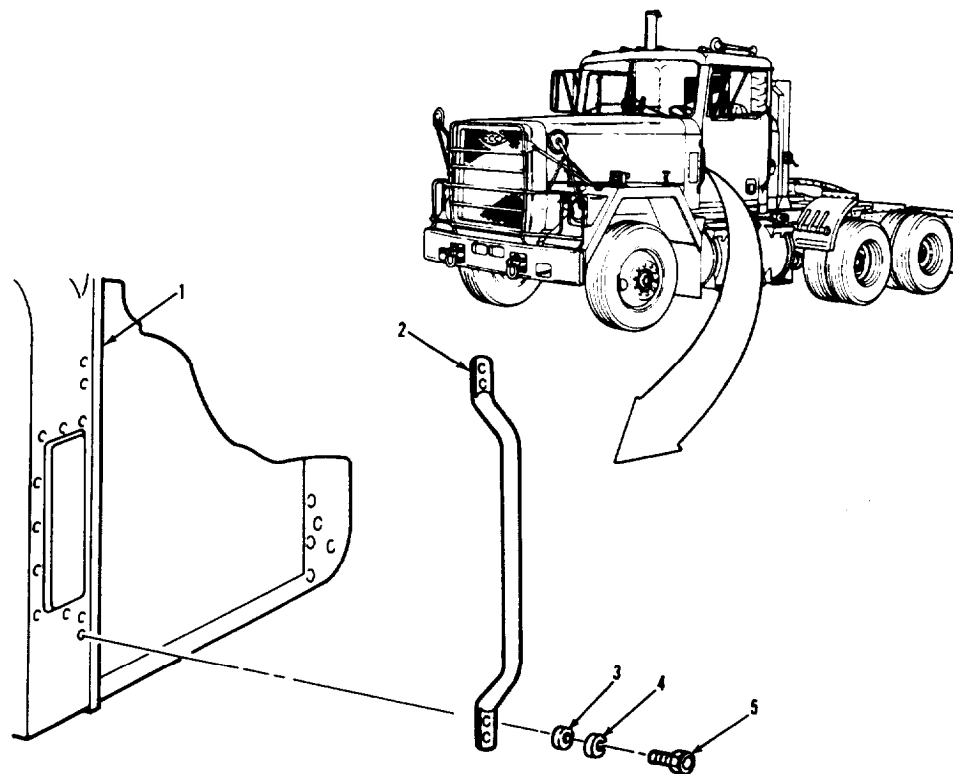

LEGEND:

- 1. CAB
- 2. OUTSIDE FRONT HANDLE
- 3. FLAT WASHER (4)

- 4. LOCKWASHER (4)
- 5. MACHINE SCREW (4)

TA 237728



CAB AND BODY.

3-264. OUTSIDE FRONT HANDLE REPLACEMENT (Continued).

LOCATION/ITEM	ACTION	REMARKS
NOTE		
Use this procedure to replace either of the two outside front handles.		
<b>A. REMOVAL.</b>		
1. Four screws (5), lockwashers (4), washers (3), and handle (2).	Remove from item (1).	
<b>B. CLEANING AND INSPECTION.</b>		
2. All parts.	Clean and inspect.	Refer to paragraphs 3-4 and 3-5.
<b>C. INSTALLATION.</b>		
3. Handle (2).	a. Position on item (1). b. Secure with four items (5), (4), and (3).	
NOTE		
Follow-on maintenance action required:		
None.		

CAB AND BODY.

3-264. OUTSIDE FRONT HANDLE REPLACEMENT (Continued).

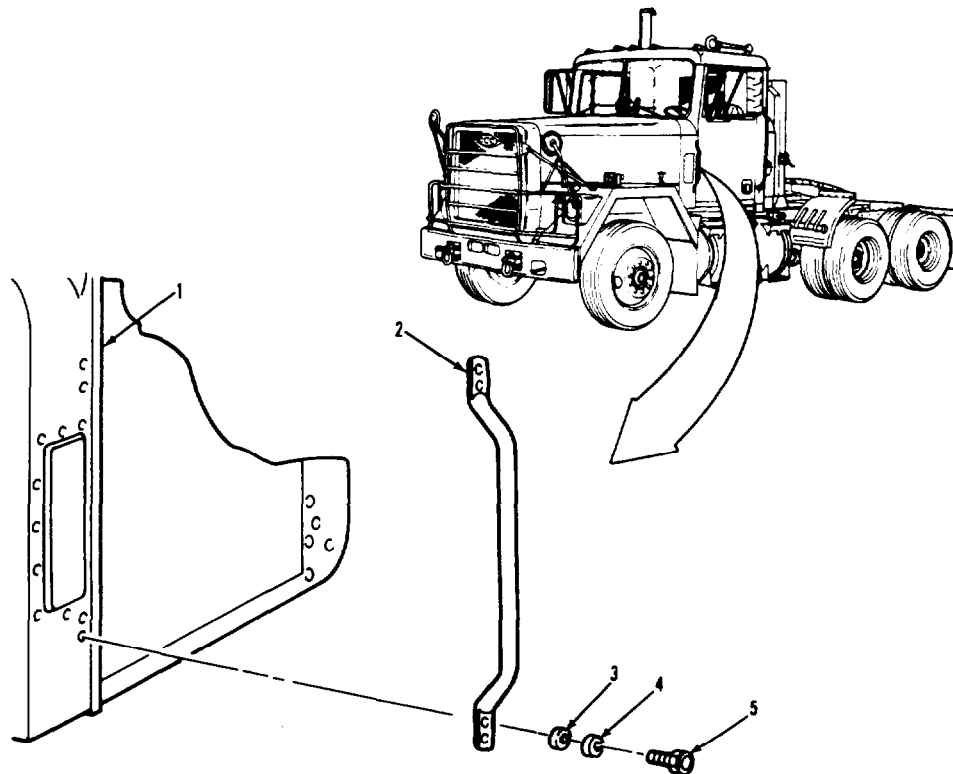

TA 237729

CAB AND BODY.

3-265. DOOR PLATE REPLACEMENT.

THIS TASK COVERS

- a. Removal.
- b. Installation.

INITIAL SETUP

APPLICABLE CONFIGURATIONS

All.

EQUIPMENT CONDITION  
PARAGRAPH

None.

CONDITION DESCRIPTION

None.

TEST EQUIPMENT

None.

SPECIAL TOOLS

None.

MATERIALS/PARTS (P/N)

None.

PERSONNEL REQUIRED

One (MOS-63S).

SPECIAL ENVIRONMENTAL CONDITIONS

None.

REFERENCES (TM)

None.

GENERAL SAFETY INSTRUCTIONS

Engine off  
Transmission in neutral.  
Park brake set.

TROUBLESHOOTING REFERENCES

None.

CAB AND BODY.

3-265. DOOR PLATE REPLACEMENT (Continued).

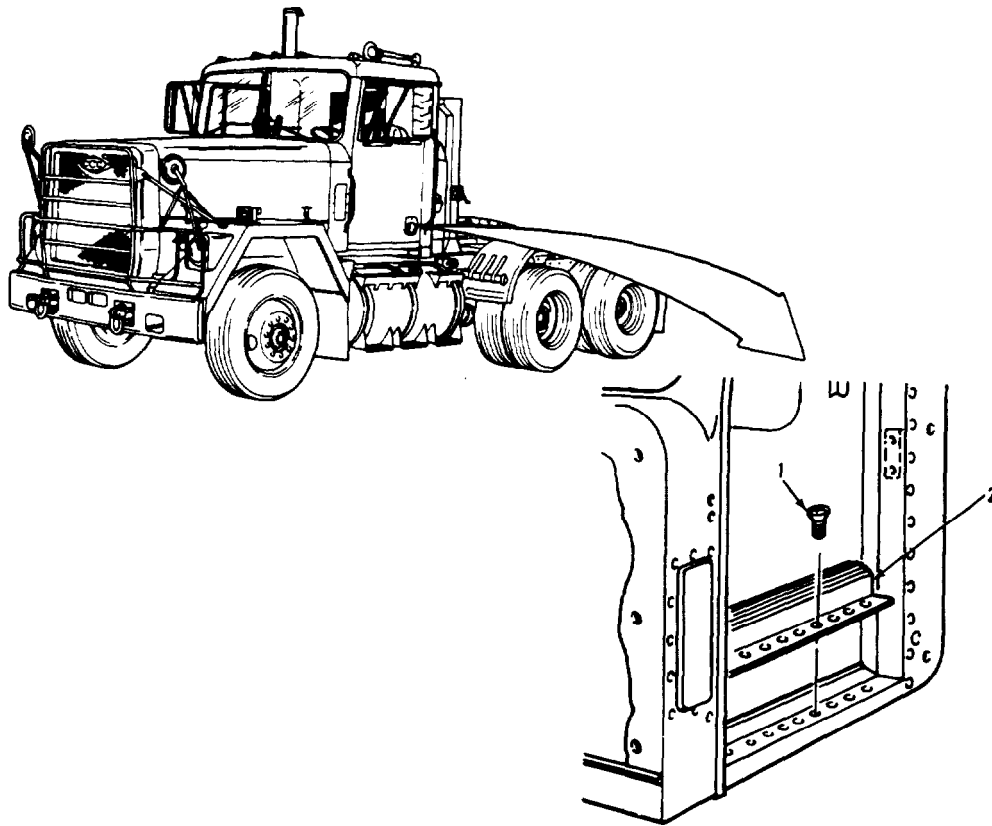

LEGEND:

1. SCREW (7)
2. DOOR PLATE

TA 2377.3n

CAB AND BODY.

3-265. DOOR PLATE REPLACEMENT (Continued).

LOCATION/ITEM	ACTION	REMARKS
NOTE		
<p>Door plate replacement is the same for both sides. This procedure covers replacement of the driver's side door plate.</p>		
<b>A. REMOVAL.</b>		
1. Seven screws (1).	Remove.	
2. Door plate (2).	Remove.	
<b>B. INSTALLATION.</b>		
3. Door plate (2).	Install.	Position over floor mat.
4. Seven screws (1).	Install and tighten.	
NOTE		
<p>Follow-on maintenance action required:</p>		
<p>None.</p>		

CAB AND BODY.

3-265. DOOR PLATE REPLACEMENT (Continued).

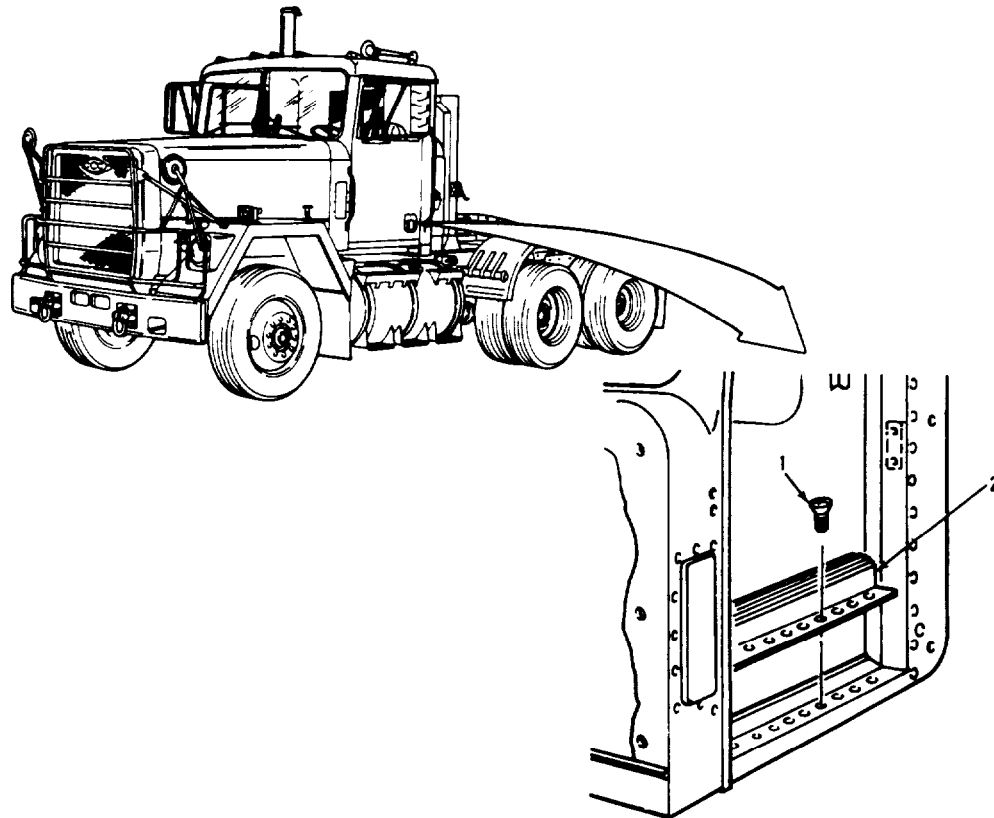

LEGEND:

- 1. SCREW (7)
- 2. DOOR PLATE

CAB AND BODY.

3-266. DOOR FRAME SEAL REPLACEMENT.

THIS TASK COVERS

- a. Removal.
- b. Cleaning and Inspection.
- c. Installation.

INITIAL SETUP

APPLICABLE CONFIGURATIONS

All.

EQUIPMENT CONDITION  
PARAGRAPH

None.

CONDITION DESCRIPTION

None.

TEST EQUIPMENT

None.

SPECIAL TOOLS

None.

MATERIALS/PARTS (P/N)

None.

PERSONNEL REQUIRED

One (MOS- 63S).

SPECIAL ENVIRONMENTAL CONDITIONS

None.

REFERENCES (TM)

None.

GENERAL SAFETY INSTRUCTIONS

Engine off.  
Transmission in neutral.  
Park brake set.

TROUBLESHOOTING REFERENCES

Paragraph 2-11.

CAB AND BODY.

3-266. DOOR FRAME SEAL REPLACEMENT (Continued).

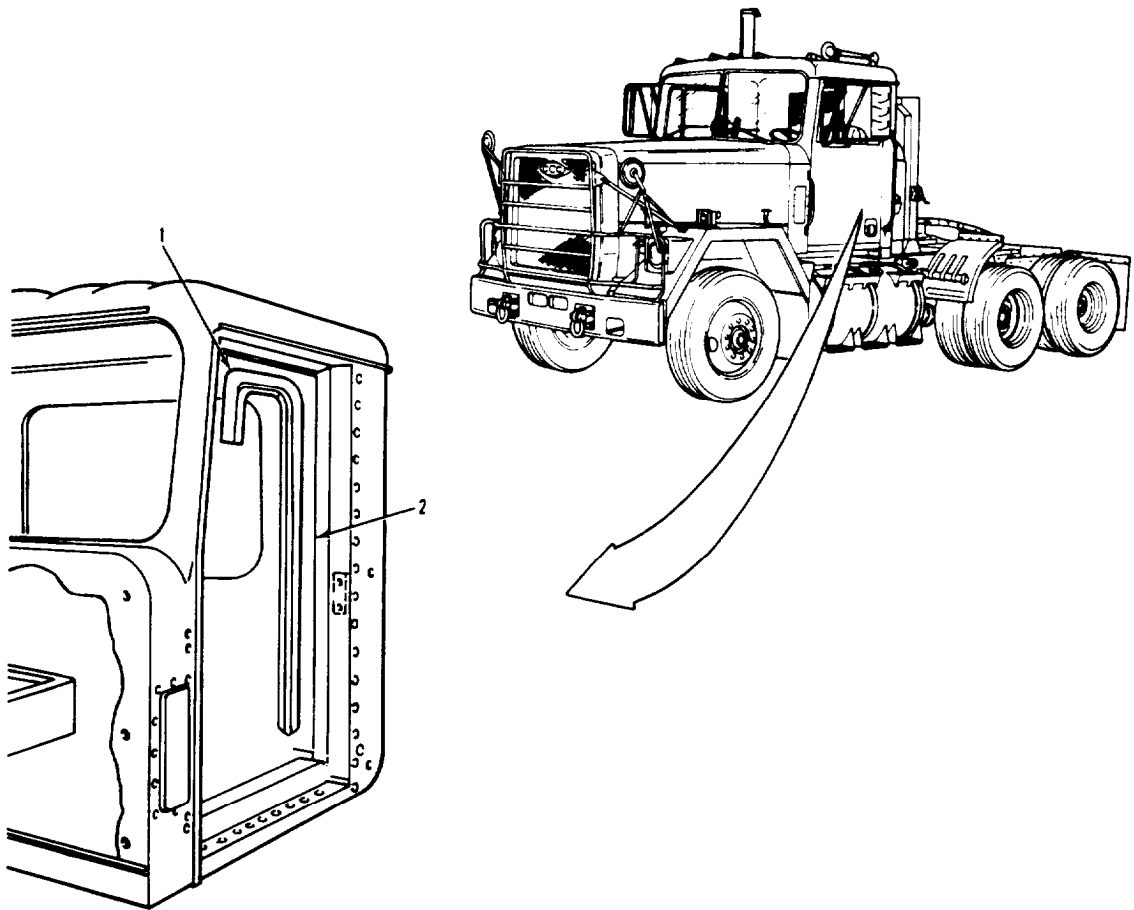

LEGEND:

- 1. DOOR FRAME SEAL
- 2. DOOR FRAME

TA 237732



CAB AND BODY.

3-266. DOOR FRAME SEAL REPLACEMENT (Continued).

LOCATION/ITEM	ACTION	REMARKS
NOTE		
Door frame seal replacement is the same for both sides. This procedure covers replacement of the driver's side door frame seal.		
<b>A. REMOVAL.</b>		
1. Door frame seal (1).	Remove.	Pull off starting at bottom.
<b>B. CLEANING AND INSPECTION.</b>		
2. Door frame (2).	Clean.	Scrape off any material sticking to item (2).
<b>C. INSTALLATION.</b>		
3. Door frame seal.	Install.	Ribbed side faces out.
NOTE		
Follow-on maintenance action required:		
None.		

CAB AND BODY.

3-266. DOOR FRAME SEAL REPLACEMENT (Continued).

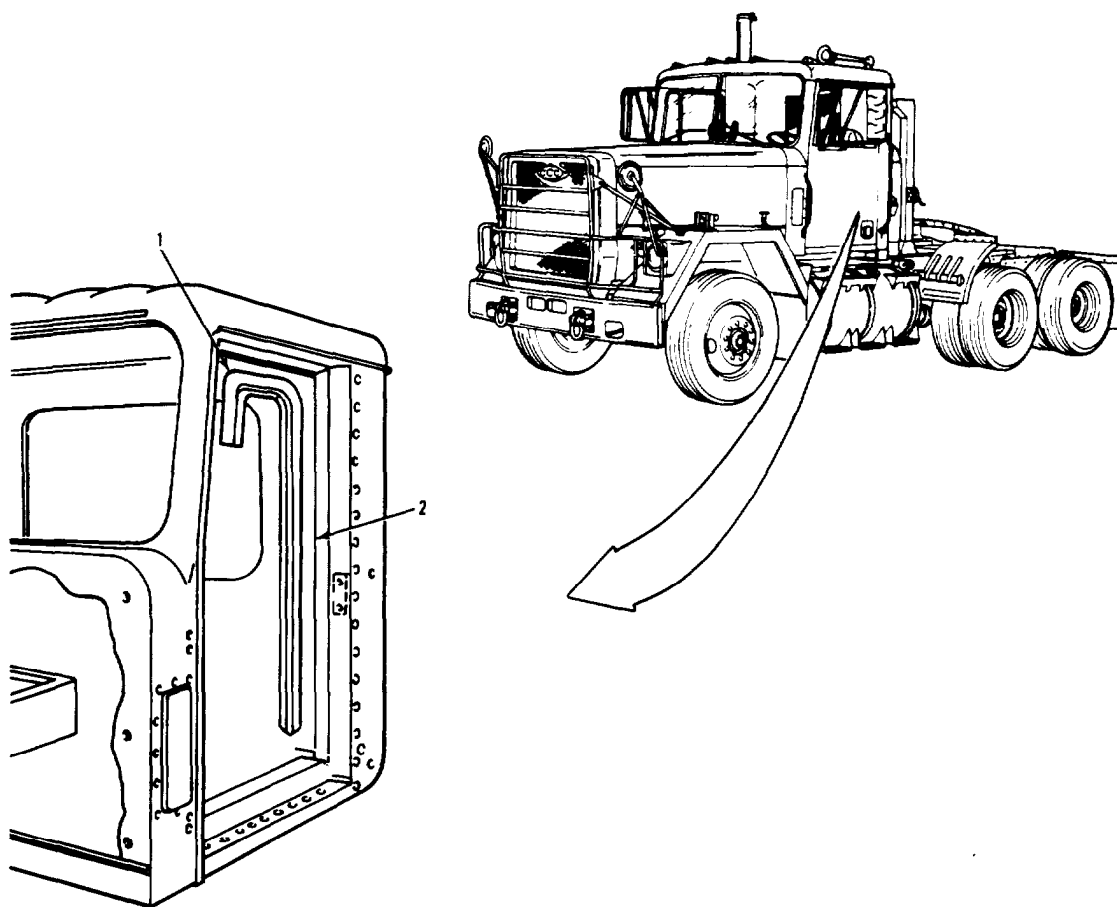

LEGEND:

- 1. DOOR FRAME SEAL
- 2. DOOR FRAME

TA 237733

CAB AND BODY.

3-267. INSULATOR REPLACEMENT.

THIS TASK COVERS

- a. Removal.
- b. Cleaning.
- c. Installation.

INITIAL SETUP

<u>APPLICABLE CONFIGURATIONS</u>	<u>EQUIPMENT CONDITION PARAGRAPH</u>	<u>CONDITION DESCRIPTION</u>
All.		NOTE
<u>TEST EQUIPMENT</u> None.		Perform as necessary.
<u>SPECIAL TOOLS</u> None.	3-120.	Battery power disconnected.
	3-29.	Air cleaner assembly removed.
<u>MATERIALS/PARTS (P/N)</u> Solvent, drycleaning, SD-2 Item 29, Appendix C. Caplug (as required) (34623) MA207-20059.	3-183.	Double check valve air lines and stoplamp valve wires disconnected.
Clip, insulation fastener (as required) (85105) 101-301-104.	3-184.	Firewall double check valve air lines disconnected.
	3-174.	Brake treadle valve firewall air lines disconnected.
<u>PERSONNEL REQUIRED</u> One (MDS-63S).	3-215.	Lower steering column removed.
	3-310.	Speedometer shaft disconnected.
<u>REFERENCES (TM)</u> TM 9-2320-283-20P.	3-313.	Tachometer shaft disconnected.
	3-297.	Heater control valve boden wire disconnected.
<u>TROUBLESHOOTING REFERENCES</u> None.	3-171.	Park brake valve air line disconnected at firewall
	3-195.	Differential toggle valve air line disconnected at firewall.
<u>GENERAL SAFETY INSTRUCTIONS</u> Engine off. Transmission in neutral. Park brake set.	3-175.	firewall disconnected. Trailer supply valve air line disconnected at firewall
<u>SPECIAL ENVIRONMENTAL CONDITIONS</u> None.		

CAB AND BODY.

3-267. INSULATOR REPLACEMENT (Continued).

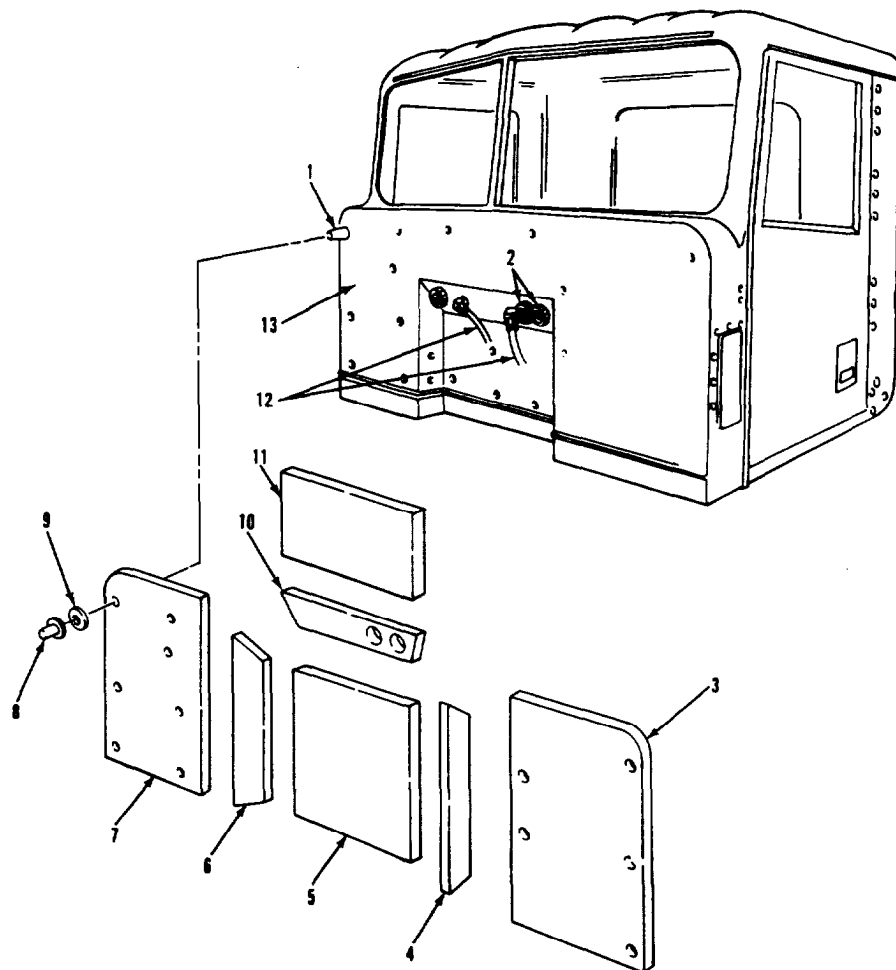

LEGEND:

- |                                  |                              |
|----------------------------------|------------------------------|
| 1. WELDED SPIKE (45)             | 8. CAPLUG (52)               |
| 2. CONNECTOR (2)                 | 9. CLIP (52)                 |
| 3. LEFT-HAND DASH INSULATOR      | 10. UPPER DOGHOUSE INSULATOR |
| 4. LEFT-HAND DOGHOUSE INSULATOR  | 11. CENTER DASH INSULATOR    |
| 5. CENTER DOGHOUSE INSULATOR     | 12. AIR LINE (2)             |
| 6. RIGHT-HAND DOGHOUSE INSULATOR | 13. CAB FIREWALL             |
| 7. RIGHT-HAND DASH INSULATOR     |                              |

TA 237734

CAB AND BODY.

3-267. INSULATOR REPLACEMENT (Continued).		
LOCATION/ITEM	ACTION	REMARKS
<p><b>WARNING</b></p> <p>Never work on air system components without first draining air pressure. Failure to follow this precaution can result in serious personal injury.</p> <p><b>NOTE</b></p> <p>This procedure covers removal and installation of all insulator sections. It is not necessary to replace all sections if only one or a few sections are damaged. Individual sections may be replaced as required.</p>		
<p><b>A. REMOVAL.</b></p>		
1. Two air lines (12) and two connectors (2).	Tag and disconnect.	
2. Caplug (8).	Remove as required.	Discard.
3. Clip (9).	Remove as required.	Discard.
4. Insulators (3, 4, 5, 6, 7, 10, or 11).	Remove as required.	Discard.
<p><b>B. CLEANING.</b></p>		
5. Cab firewall (13).	Use solvent to clean all areas to receive new insulator material.	

CAB AND BODY.

3-267. INSULATOR REPLACEMENT (Continued).

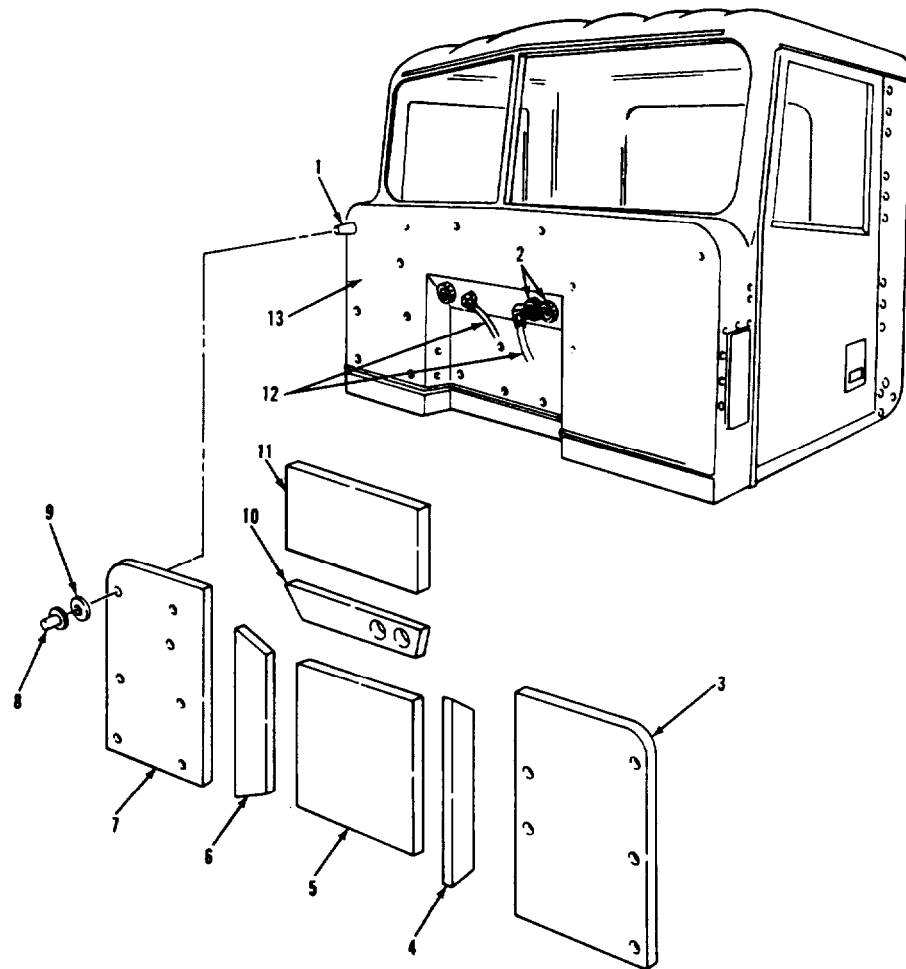

LEGEND:

- |                                  |                              |
|----------------------------------|------------------------------|
| 1. WELDED SPIKE (45)             | 8. CAPLUG (52)               |
| 2. CONNECTOR (2)                 | 9. CLIP (52)                 |
| 3. LEFT-HAND DASH INSULATOR      | 10. UPPER DOGHOUSE INSULATOR |
| 4. LEFT-HAND DOGHOUSE INSULATOR  | 11. CENTER DASH INSULATOR    |
| 5. CENTER DOGHOUSE INSULATOR     | 12. AIR LINE (2)             |
| 6. RIGHT-HAND DOGHOUSE INSULATOR | 13. CAB FIREWALL             |
| 7. RIGHT-HAND DASH INSULATOR     |                              |

TA 237735

CAB AND BODY.

3-267. INSULATOR REPLACEMENT (Continued).		
LOCATION/ITEM	ACTION	REMARKS
<b>C. INSTALLATION.</b>		
6. Insulators (3, 4, 5, 6, 7, 10, or 11).	a. Peel off paper backing. b. Install with aluminum film side facing out.	Shape foam around cutouts, hoses, lines, etc. Use as required. Make sure item (1) penetrates through.
7. Clip (9) and caplug (8).	Install as required.	
8. Two lines (12) and two connectors (2).	Connect.	
NOTE		
Follow-on maintenance action required:		
Connect differential toggle valve air line (para 3-195). Connect park brake valve air line (para 3-171). Connect trailer supply valve air line (para 3-175). Connect heater control valve boden wire (para 3-297). Connect tachometer shaft (para 3-313). Connect speedometer shaft (para 3-310). Install lower steering column (para 3-215). Connect brake treadle valve air line (para 3-174). Connect double check valve air line (para 3-184). Connect double check valve air lines and stoplamp valve wires (para 3-183). Connect battery power (para 3-120). Install air cleaner assembly (para 3-29).		

CAB AND BODY.

3-267. INSULATOR REPLACEMENT (Continued).

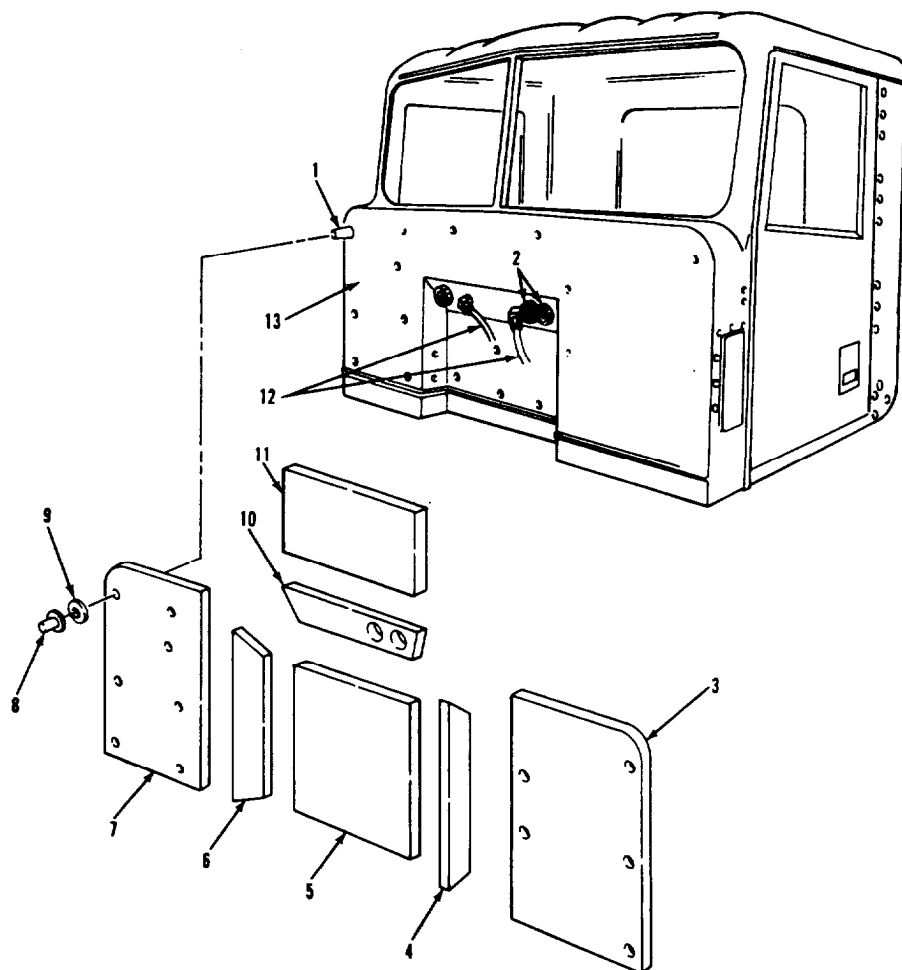

LEGEND:

- |                                  |                              |
|----------------------------------|------------------------------|
| 1. WELDED SPIKE (45)             | 8. CAPLUG (52)               |
| 2. CONNECTOR (2)                 | 9. CLIP (52)                 |
| 3. LEFT-HAND DASH INSULATOR      | 10. UPPER DOGHOUSE INSULATOR |
| 4. LEFT-HAND DOGHOUSE INSULATOR  | 11. CENTER DASH INSULATOR    |
| 5. CENTER DOGHOUSE INSULATOR     | 12. AIR LINE (2)             |
| 6. RIGHT-HAND DOGHOUSE INSULATOR | 13. CAB FIREWALL             |
| 7. RIGHT-HAND DASH INSULATOR     |                              |

TA 237736



CAB AND BODY.

3-268. GRILLE REPLACEMENT.

THIS TASK COVERS

- a. Grille and Screen Removal.
- b. Grille and Screen Disassembly.
- c. Grille and Screen Reassembly.
- d. Radiator Grille Support Bracket Removal and Disassembly.
- e. Radiator Grille Support Bracket Reassembly and Installation.
- f. Grille and Screen Installation.

INITIAL SETUP

<u>APPLICABLE CONFIGURATIONS</u>	<u>EQUIPMENT CONDITION PARAGRAPH</u>	<u>CONDITION DESCRIPTION</u>
All.	TM 9-2320-283-10.	Winter front removed.
	3-236.	Brush guard removed.
<u>TEST EQUIPMENT</u>		
None.	3-270.	Hood hinge panel removed.
<u>SPECIAL TOOLS</u>		
None.		
<u>MATERIALS/PARTS (P/N)</u>		
Rivet, blind, 1/4 in. (36) (19738) 2771-0817.		
Rivet, blind, 3/16 in. (4) (11815) SSLQ-66.		
Rivet, blind, 3/16 in. (30) (11815) SSLQ-64.		
<u>PERSONNEL REQUIRED</u>	<u>SPECIAL ENVIRONMENTAL CONDITIONS</u>	
Two (MDS-63S).	None.	
<u>REFERENCES (TM)</u>	<u>GENERAL SAFETY INSTRUCTIONS</u>	
TM 9-2320-283-10.	Engine off.	
	Transmission in neutral.	
	Park brake set.	
<u>TROUBLESHOOTING REFERENCES</u>		
None.		

CAB AND BODY.

3-268. GRILLE REPLACEMENT (Continued).

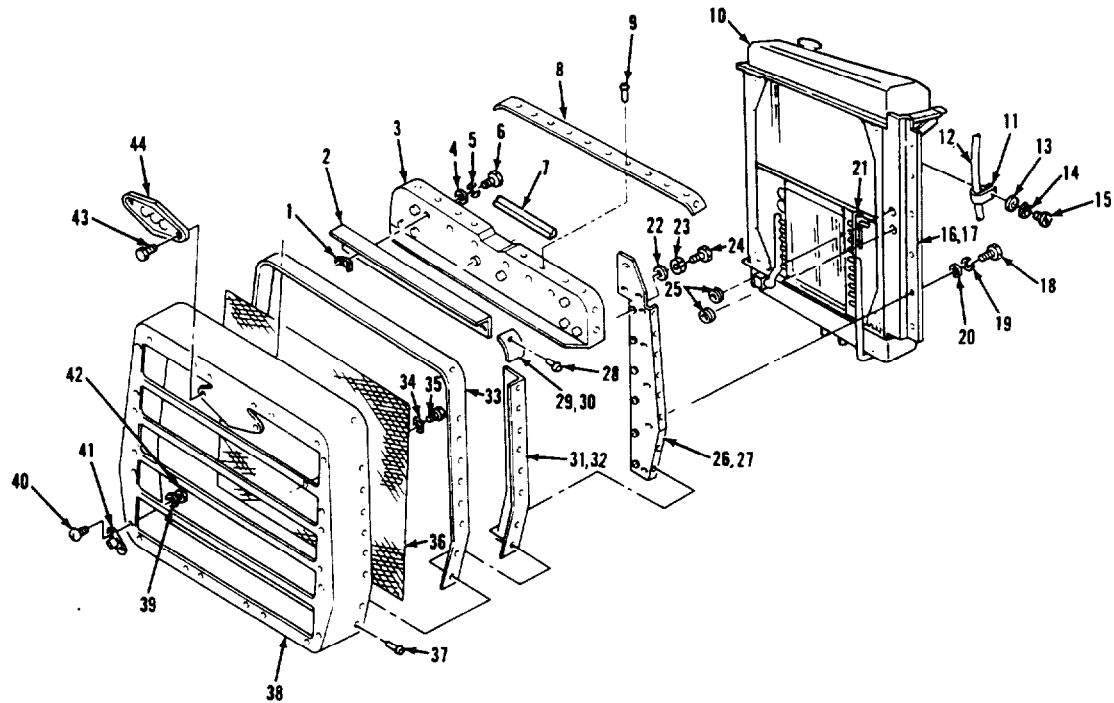

LEGEND:

- |  |  |   |
|--|--|---|
| 1. U-NUT (16)                                  | 18. SCREW (12)   | 31. LEFT-HAND GRILLE MOUNTING SIDE BRACKET  |
| 2. GRILLE MOUNTING BRACKET                     | 19. WASHER (12)  | 32. RIGHT-HAND GRILLE MOUNTING SIDE BRACKET |
| 3. GRILLE SUPPORT                              | 20. LOCKWASHER (12)                                    | 33. FILLER                                  |
| 4. WASHER (16)                                 | 21. POWER STEERING COOLANT LINE (2)                    | 34. SCREEN CLAMP PLATE (18)                 |
| 5. LOCKWASHER (16)                             | 22. WASHER (6)   | 35. POLYFAST SCREW (18)                     |
| 6. SCREW (16)                                  | 23. LOCKWASHER (6)                                     | 36. RADIATOR GRILLE SCREEN                  |
| 7. RUBBER CUSHION                              | 24. SCREW (6)  | 37. RIVET (36)                              |
| 8. SEAL  | 25. GROMMET (2)  | 38. GRILLE                                  |
| 9. RIVET (30)                                  | 26. LEFT-HAND RADIATOR MOUNTING SIDE SUPPORT ASSEMBLY  | 39. WASHER (24)                             |
| 10. RADIATOR                                   | 27. RIGHT-HAND RADIATOR MOUNTING SIDE SUPPORT ASSEMBLY | 40. SCREW (24)                              |
| 11. HOSE CLAMP (2)                             | 28. RIVET (4)  | 41. QUARTER-TURN FASTENER (12)              |
| 12. HOSE                                       | 29. LEFT-HAND GRILLE FILLER CORNER RETAINER            | 42. LOCKNUT (24)                            |
| 13. WASHER (10)                                | 30. RIGHT-HAND GRILLE FILLER CORNER RETAINER           | 43. SCREW (2)                               |
| 14. LOCKWASHER (10)                            |  | 44. NAMEPLATE                               |
| 15. SCREW (10)                                 |  |   |
| 16. LEFT-HAND RADIATOR GRILLE SUPPORT BRACKET  |  |   |
| 17. RIGHT-HAND RADIATOR GRILLE SUPPORT BRACKET |  |   |

TA 237737

CAB AND BODY.

3-268. GRILLE REPLACEMENT (Continued).

LOCATION/ITEM	ACTION	REMARKS
<b>A. GRILLE AND SCREEN REMOVAL.</b>		
1. Twelve screws (18), washers (19), and lockwashers (20).	Remove from items (16) and (17).	Have an assistant hold item (38) when items (18) (19), (20) are being removed.
2. Grille (38).	Remove from vehicle.	
<b>B. GRILLE AND SCREEN DISASSEMBLY.</b>		
3. Seal (8).	Remove from items (26), (27), and (3) by drilling out thirty items (9).	Discard items (9).
4. Six screws (24), washers (22), and lockwashers (23).	Remove from items (26) and (27).	
5. Left-hand and right-hand support assemblies (26) and (27).	Remove from item (3), (31), and (32).	
6. Rubber cushion (7)	Remove from item (3).	
7. Sixteen screws (4), washers (5), and lockwashers (6).	Remove from item (3).	
8. Grille support (3).	Remove from item (2).	

CAB AND BODY.

3-268. GRILLE REPLACEMENT (Continued).

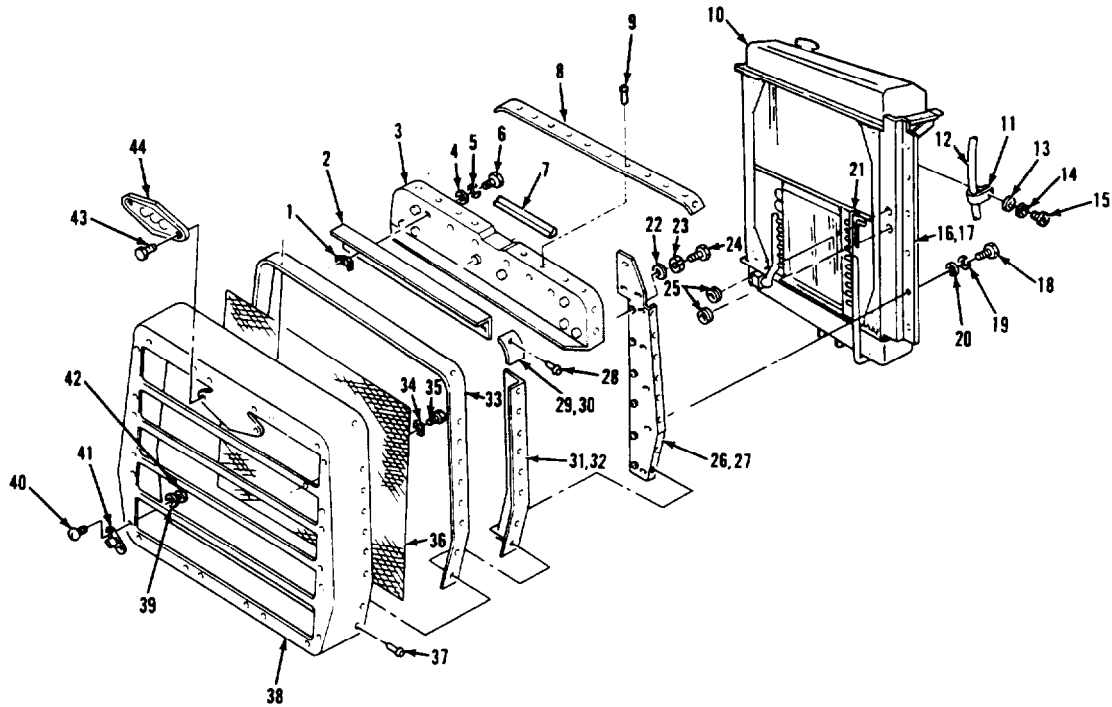

LEGEND:

- |  |  |   |
|--|--|---|
| 1. U-NUT (16)                                  | 18. SCREW (12)   | 31. LEFT-HAND GRILLE MOUNTING SIDE BRACKET  |
| 2. GRILLE MOUNTING BRACKET                     | 19. WASHER (12)  | 32. RIGHT-HAND GRILLE MOUNTING SIDE BRACKET |
| 3. GRILLE SUPPORT                              | 20. LOCKWASHER (12)                                    | 33. FILLER                                  |
| 4. WASHER (16)                                 | 21. POWER STEERING COOLANT LINE (2)                    | 34. SCREEN CLAMP PLATE (18)                 |
| 5. LOCKWASHER (16)                             | 22. WASHER (6)   | 35. POLYFAST SCREW (18)                     |
| 6. SCREW (16)                                  | 23. LOCKWASHER (6)                                     | 36. RADIATOR GRILLE SCREEN                  |
| 7. RUBBER CUSHION                              | 24. SCREW (6)  | 37. RIVET (36)                              |
| 8. SEAL  | 25. GROMMET (2)  | 38. GRILLE                                  |
| 9. RIVET (30)                                  | 26. LEFT-HAND RADIATOR MOUNTING SIDE SUPPORT ASSEMBLY  | 39. WASHER (24)                             |
| 10. RADIATOR                                   | 27. RIGHT-HAND RADIATOR MOUNTING SIDE SUPPORT ASSEMBLY | 40. SCREW (24)                              |
| 11. HOSE CLAMP (2)                             | 28. RIVET (4)  | 41. QUARTER-TURN FASTENER (12)              |
| 12. HOSE                                       | 29. LEFT-HAND GRILLE FILLER CORNER RETAINER            | 42. LOCKNUT (24)                            |
| 13. WASHER (10)                                | 30. RIGHT-HAND GRILLE FILLER CORNER RETAINER           | 43. SCREW (2)                               |
| 14. LOCKWASHER (10)                            |  | 44. NAMEPLATE                               |
| 15. SCREW (10)                                 |  |   |
| 16. LEFT-HAND RADIATOR GRILLE SUPPORT BRACKET  |  |   |
| 17. RIGHT-HAND RADIATOR GRILLE SUPPORT BRACKET |  |   |

TA 237738

CAB AND BODY.

3-268. GRILLE REPLACEMENT (Continued).

LOCATION/ITEM	ACTION	REMARKS
<b>B. GRILLE AND SCREEN DISASSEMBLY (Continued).</b>		
9. Eighteen screws (35) and plates (34).	Remove from items (36) and (38).	
10. Screen (36).	Remove from item (38).	
11. Thirty-six rivets (37) and four rivets (28).	Drill out from items (38) (33), (31), (32), (29), and (30). Discard items (37) and (28).	Items (37) are longer than items (28).
12. Three mounting brackets (2), (31), and (32), (29) and (30), and filler (33).	Remove from item (38).	
13. Two screws (43).	Remove from item (44).	
14. Nameplate (44).	Remove from item (38).	
15. Twenty-four screws (40), washers (39), nuts (42), and fasteners (41).	Remove from item (38).	
<b>C. GRILLE AND SCREEN REASSEMBLY.</b>		
16. Nameplate (44).	Install and secure with two items (43).	
17. Twelve fasteners (41).	Install on item (38). Secure with twenty-four items (40), (39), and (42).	

CAB AND BODY.

3-268. GRILLE REPLACEMENT (Continued).

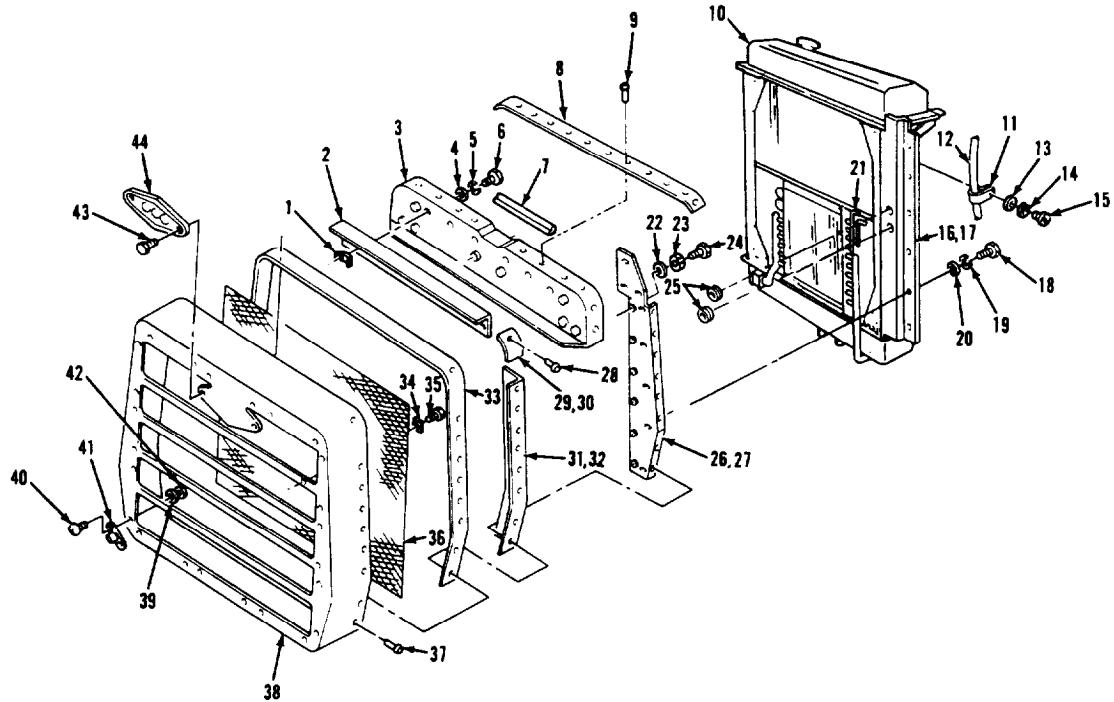

LEGEND:

- |  |  |   |
|--|--|---|
| 1. U-NUT (16)                                  | 18. SCREW (12)   | 31. LEFT-HAND GRILLE MOUNTING SIDE BRACKET  |
| 2. GRILLE MOUNTING BRACKET                     | 19. WASHER (12)  | 32. RIGHT-HAND GRILLE MOUNTING SIDE BRACKET |
| 3. GRILLE SUPPORT                              | 20. LOCKWASHER (12)                                    | 33. FILLER                                  |
| 4. WASHER (16)                                 | 21. POWER STEERING COOLANT LINE (2)                    | 34. SCREEN CLAMP PLATE (18)                 |
| 5. LOCKWASHER (16)                             | 22. WASHER (6)   | 35. POLYFAST SCREW (18)                     |
| 6. SCREW (16)                                  | 23. LOCKWASHER (6)                                     | 36. RADIATOR GRILLE SCREEN                  |
| 7. RUBBER CUSHION                              | 24. SCREW (6)  | 37. RIVET (36)                              |
| 8. SEAL  | 25. GROMMET (2)  | 38. GRILLE                                  |
| 9. RIVET (30)                                  | 26. LEFT-HAND RADIATOR MOUNTING SIDE SUPPORT ASSEMBLY  | 39. WASHER (24)                             |
| 10. RADIATOR                                   | 27. RIGHT-HAND RADIATOR MOUNTING SIDE SUPPORT ASSEMBLY | 40. SCREW (24)                              |
| 11. HOSE CLAMP (2)                             | 28. RIVET (4)  | 41. QUARTER-TURN FASTENER (12)              |
| 12. HOSE                                       | 29. LEFT-HAND GRILLE FILLER CORNER RETAINER            | 42. LOCKNUT (24)                            |
| 13. WASHER (10)                                | 30. RIGHT-HAND GRILLE FILLER CORNER RETAINER           | 43. SCREW (2)                               |
| 14. LOCKWASHER (10)                            |  | 44. NAMEPLATE                               |
| 15. SCREW (10)                                 |  |   |
| 16. LEFT-HAND RADIATOR GRILLE SUPPORT BRACKET  |  |   |
| 17. RIGHT-HAND RADIATOR GRILLE SUPPORT BRACKET |  |   |

TA 237739

CAB AND BODY.

3-268. GRILLE REPLACEMENT (Continued).

LOCATION/ITEM	ACTION	REMARKS
<b>C. GRILLE AND SCREEN REASSEMBLY (Continued).</b>		
18. Three mounting brackets (2), (31), and (32), two filler corners (29) and (30), and filler (33).	Install on item (38) and secure with thirty-six new items (37) and four new items (28).	Use suitable rivet tool for installing items (37) and (28).
19. Screen (36).	Position on item (38) and secure with eighteen items (35) and (34).	
20. Supports (3), (26), and (27).	Position on items (31), (32), and (2). Secure with sixteen items (4), (5), and (6).	Item (3) is positioned under the top corners of items (26) and (27).
21. Seal (8).	Position on items (3), (26), and (27). Secure with thirty new items (9).	Use suitable rivet tool for installing items (9).
22. Rubber cushion (7).	Position on item (3). Secure with rubber cement.	
<b>D. RADIATOR GRILLE SUPPORT BRACKET REMOVAL AND DISASSEMBLY.</b>		
23. Two lines (21).	Disconnect and plug.	Refer to paragraph 3-222.
24. Ten screws (15), lockwashers (14), and washers (13).	Remove from items (16), (17), and items (11).	Note mounting locations of two items (11) and position of item (12).
25. Two support brackets (16) and (17).	Remove from item (10).	
26. Two grommets (25). Remove from item (16).		

CAB AND BODY.

3-268. GRILLE REPLACEMENT (Continued).

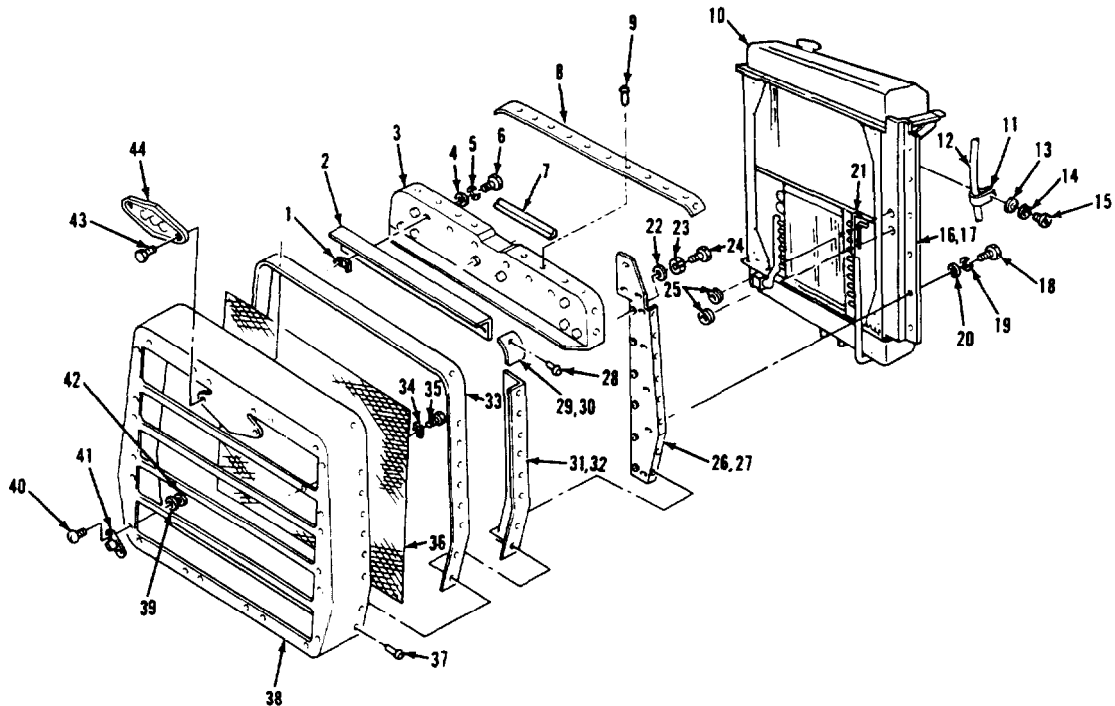

LEGEND:

- |  |  |   |
|--|--|---|
| 1. U-NUT (16)                                  | 18. SCREW (12)   | 31. LEFT-HAND GRILLE MOUNTING SIDE BRACKET  |
| 2. GRILLE MOUNTING BRACKET                     | 19. WASHER (12)  | 32. RIGHT-HAND GRILLE MOUNTING SIDE BRACKET |
| 3. GRILLE SUPPORT                              | 20. LOCKWASHER (12)                                    | 33. FILLER                                  |
| 4. WASHER (16)                                 | 21. POWER STEERING COOLANT LINE (2)                    | 34. SCREEN CLAMP PLATE (18)                 |
| 5. LOCKWASHER (16)                             | 22. WASHER (6)   | 35. POLYFAST SCREW (18)                     |
| 6. SCREW (16)                                  | 23. LOCKWASHER (6)                                     | 36. RADIATOR GRILLE SCREEN                  |
| 7. RUBBER CUSHION                              | 24. SCREW (6)  | 37. RIVET (36)                              |
| 8. SEAL  | 25. GROMMET (2)  | 38. GRILLE                                  |
| 9. RIVET (30)                                  | 26. LEFT-HAND RADIATOR MOUNTING SIDE SUPPORT ASSEMBLY  | 39. WASHER (24)                             |
| 10. RADIATOR                                   | 27. RIGHT-HAND RADIATOR MOUNTING SIDE SUPPORT ASSEMBLY | 40. SCREW (24)                              |
| 11. HOSE CLAMP (2)                             | 28. RIVET (4)  | 41. QUARTER-TURN FASTENER (12)              |
| 12. HOSE                                       | 29. LEFT-HAND GRILLE FILLER CORNER RETAINER            | 42. LOCKNUT (24)                            |
| 13. WASHER (10)                                | 30. RIGHT-HAND GRILLE FILLER CORNER RETAINER           | 43. SCREW (2)                               |
| 14. LOCKWASHER (10)                            |  | 44. NAMEPLATE                               |
| 15. SCREW (10)                                 |  |   |
| 16. LEFT-HAND RADIATOR GRILLE SUPPORT BRACKET  |  |   |
| 17. RIGHT-HAND RADIATOR GRILLE SUPPORT BRACKET |  |   |

TA 237740



CAB AND BODY.

**3-268. GRILLE REPLACEMENT (Continued).**

LOCATION/ITEM	ACTION	REMARKS
<b>E. RADIATOR GRILLE SUPPORT BRACKET REASSEMBLY AND INSTALLATION.</b>		
27. Two grommets (25).	Install in item (16).	
28. Brackets (16), (17), and clamp (11).	Position on item (10) and secure with ten items (13), (14), and (15).	Item (14) is positioned on the left-hand side of item (10).
29. Two lines (21).	Unplug and connect.	Refer to paragraph 3-222.
<b>F. GRILLE AND SCREEN INSTALLATION.</b>		
30. Grille (38).	Position on items (16) and (17) and secure with twelve items (18), (19), and (20).	Have an assistant hold grille (38) while moving into position.
<b>NOTE</b>		
Follow-on maintenance action required:		
Install hood hinge panel (para 3-270). Install brush guard (para 3-236). Install winter front as required (TM 9-2320-283-10).		

CAB AND BODY.

3-268. GRILLE REPLACEMENT (Continued).

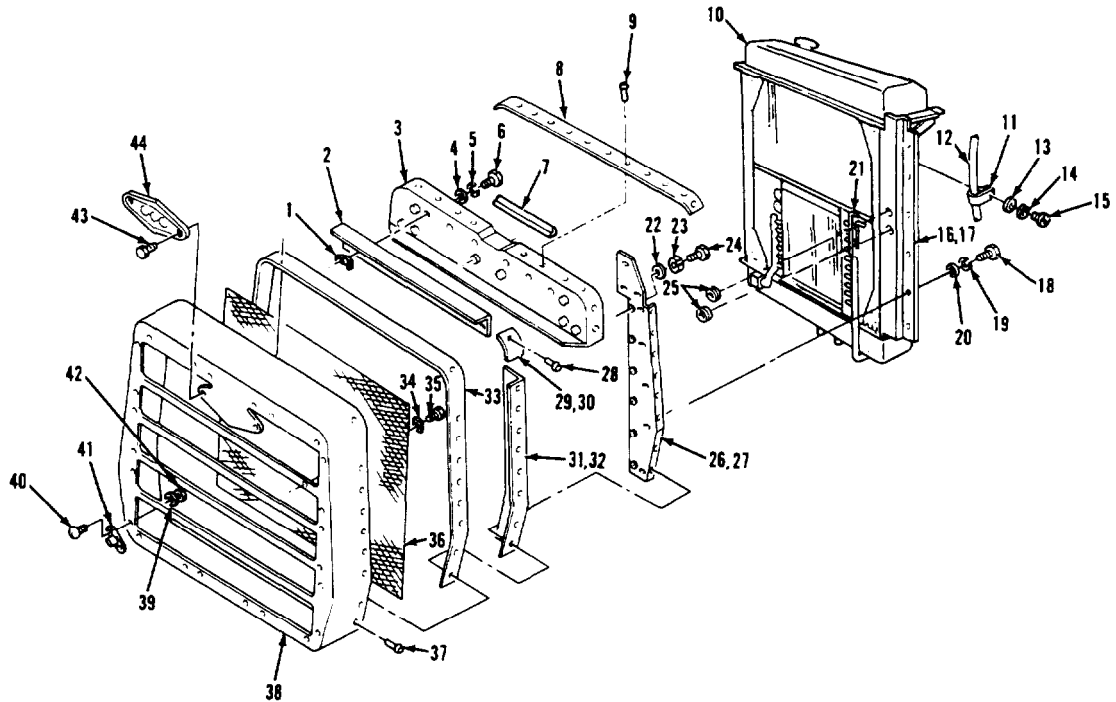

LEGEND:

- |  |  |   |
|--|--|---|
| 1. U-NUT (16)                                  | 18. SCREW (12)   | 31. LEFT-HAND GRILLE MOUNTING SIDE BRACKET  |
| 2. GRILLE MOUNTING BRACKET                     | 19. WASHER (12)  | 32. RIGHT-HAND GRILLE MOUNTING SIDE BRACKET |
| 3. GRILLE SUPPORT                              | 20. LOCKWASHER (12)                                    | 33. FILLER                                  |
| 4. WASHER (16)                                 | 21. POWER STEERING COOLANT LINE (2)                    | 34. SCREEN CLAMP PLATE (18)                 |
| 5. LOCKWASHER (16)                             | 22. WASHER (6)   | 35. POLYFAST SCREW (18)                     |
| 6. SCREW (16)                                  | 23. LOCKWASHER (6)                                     | 36. RADIATOR GRILLE SCREEN                  |
| 7. RUBBER CUSHION                              | 24. SCREW (6)  | 37. RIVET (36)                              |
| 8. SEAL  | 25. GROMMET (2)  | 38. GRILLE                                  |
| 9. RIVET (30)                                  | 26. LEFT-HAND RADIATOR MOUNTING SIDE SUPPORT ASSEMBLY  | 39. WASHER (24)                             |
| 10. RADIATOR                                   | 27. RIGHT-HAND RADIATOR MOUNTING SIDE SUPPORT ASSEMBLY | 40. SCREW (24)                              |
| 11. HOSE CLAMP (2)                             | 28. RIVET (4)  | 41. QUARTER-TURN FASTENER (12)              |
| 12. HOSE                                       | 29. LEFT-HAND GRILLE FILLER CORNER RETAINER            | 42. LOCKNUT (24)                            |
| 13. WASHER (10)                                | 30. RIGHT-HAND GRILLE FILLER CORNER RETAINER           | 43. SCREW (2)                               |
| 14. LOCKWASHER (10)                            |  | 44. NAMEPLATE                               |
| 15. SCREW (10)                                 |  |   |
| 16. LEFT-HAND RADIATOR GRILLE SUPPORT BRACKET  |  |   |
| 17. RIGHT-HAND RADIATOR GRILLE SUPPORT BRACKET |  |   |

CAB AND BODY.

3-269. HOOD REPLACEMENT.

THIS TASK COVERS

- a. Removal.
- b. Cleaning and Inspection.
- c. Installation.

INITIAL SETUP

APPLICABLE CONFIGURATIONS

All.

EQUIPMENT CONDITION

PARAGRAPH

None.

CONDITION DESCRIPTION

None.

TEST EQUIPMENT

None.

SPECIAL TOOLS

None.

MATERIALS/PARTS (P/N)

None.

PERSONNEL REQUIRED

Three (MOS-63S).

SPECIAL ENVIRONMENTAL CONDITIONS

None.

REFERENCES (TM)

None.

GENERAL SAFETY INSTRUCTIONS

Engine off.  
Transmission in neutral.  
Park brake set.

TROUBLESHOOTING REFERENCES

None.

CAB AND BODY.

3-269. HOOD REPLACEMENT (Continued).

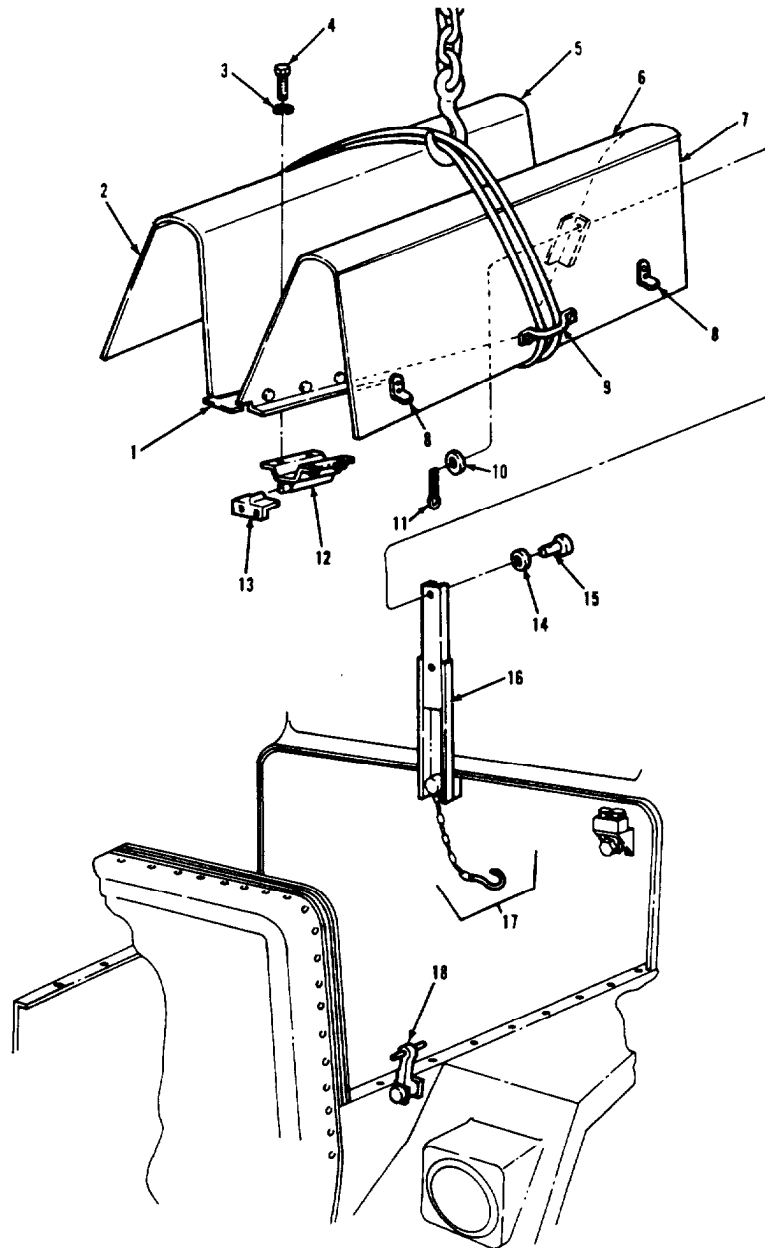

LEGEND:

- |  |                                     |
|--|-------------------------------------|
| 1. HINGE AND SUPPORT ASSEMBLY          | 10. FLAT WASHER (2)                 |
| 2. RIGHT-HAND SIDE HOOD PANEL          | 11. COTTER PIN (2)                  |
| 3. LOCKWASHER (8)                      | 12. HOOD SUPPORT PIVOT ASSEMBLY (2) |
| 4. HEXAGON SCREW (8)                   | 13. HOOD SUPPORT BRACKET (2)        |
| 5. RIGHT-HAND HINGE AND PANEL ASSEMBLY | 14. FLAT WASHER (2)                 |
| 6. LEFT-HAND HINGE AND PANEL ASSEMBLY  | 15. CLEVIS PIN (2)                  |
| 7. LEFT-HAND SIDE HOOD PANEL           | 16. TELESCOPING PROP ASSEMBLY (2)   |
| 8. HOOD HOOK BRACKET (2)               | 17. HOOD SAFETY CHAIN ASSEMBLY (2)  |
| 9. HOOD HANDLE (2)                     | 18. HOOD HOOK (4)                   |

TA 237742

CAB AND BODY.

3-269. HOOD REPLACEMENT (Continued).		
LOCATION/ITEM	ACTION	REMARKS
<b>A. REMOVAL.</b>		
1. Four hooks (18).	Remove from four items (8).	
2. Two panels (2) and (7).	Raise and secure with safety chains (17).	The safety chain hooks (17) should be placed in the alining holes of items (16).
<p><b>WARNING</b></p> <p>Two assistants are recommended for the remaining steps to prevent hood from dropping after the two prop assemblies have been removed from the hinge and panel assemblies.</p>		
3. Two pins (11).	Remove from items (15) on right-hand and left-hand side of vehicle.	
4. Two pins (15) and four washers (10) and (14).	Remove from upper halves on two items (16).	Items (16) will remain in the hood compartment. The two assistants are to remain on the fenders and hold onto each side of the hood panels.
5. Two hinge and panel assemblies (5) and (6), two panels (2) and (7), and hinge and support assembly (1).	Wrap items (5), (6), (2), and (1) around twice with each piece of rope going through item (9) as shown.	Make certain items (5), and (7) are secured tightly against each other.
6. Eight screws (4) and washers (3).	Remove from eight holes of item (1).	Two items (12) may drop when items (4) are removed.

CAB AND BODY.

3-269. HOOD REPLACEMENT (Continued).

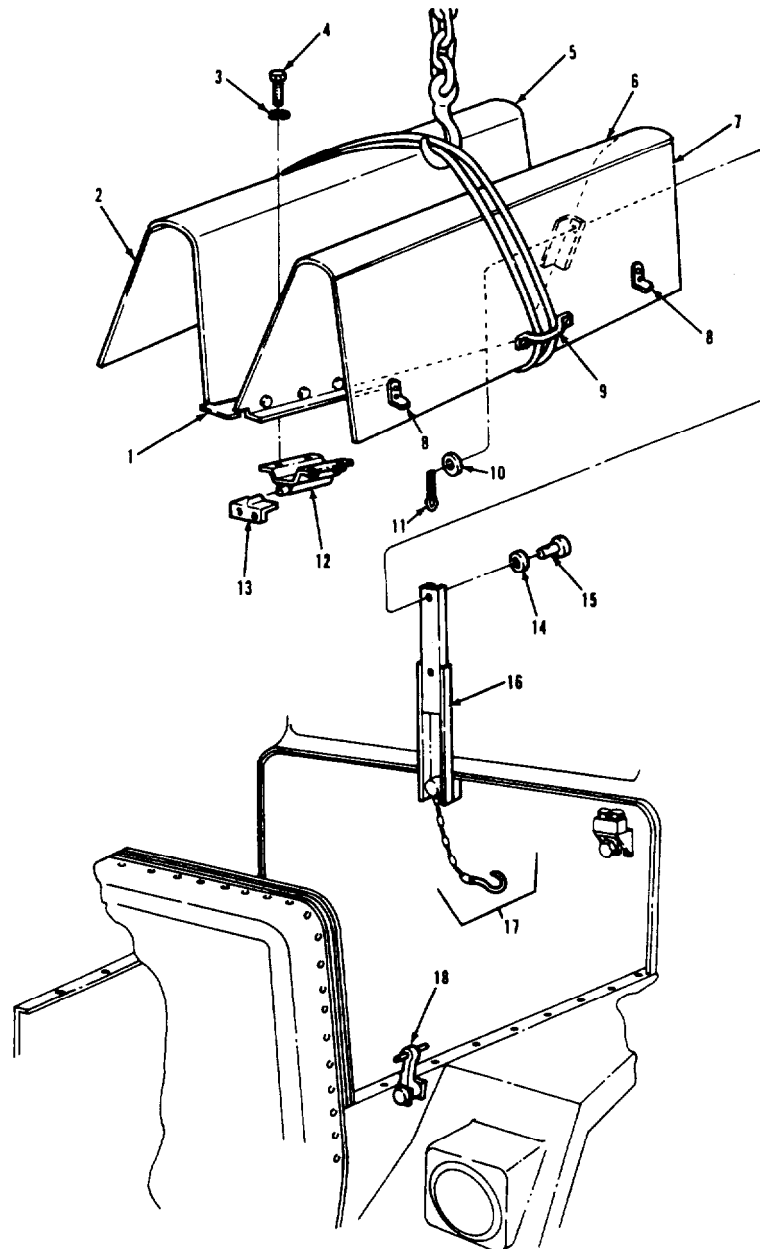

LEGEND:

- |  |                                     |
|--|-------------------------------------|
| 1. HINGE AND SUPPORT ASSEMBLY          | 10. FLAT WASHER (2)                 |
| 2. RIGHT-HAND SIDE HOOD PANEL          | 11. COTTER PIN (2)                  |
| 3. LOCKWASHER (8)                      | 12. HOOD SUPPORT PIVOT ASSEMBLY (2) |
| 4. HEXAGON SCREW (8)                   | 13. HOOD SUPPORT BRACKET (2)        |
| 5. RIGHT-HAND HINGE AND PANEL ASSEMBLY | 14. FLAT WASHER (2)                 |
| 6. LEFT-HAND HINGE AND PANEL ASSEMBLY  | 15. CLEVIS PIN (2)                  |
| 7. LEFT-HAND SIDE HOOD PANEL           | 16. TELESCOPING PROP ASSEMBLY (2)   |
| 8. HOOD HOOK BRACKET (2)               | 17. HOOD SAFETY CHAIN ASSEMBLY (2)  |
| 9. HOOD HANDLE (2)                     | 18. HOOD HOOK (4)                   |

TA 237743

CAB AND BODY.

3-269. HOOD REPLACEMENT (Continued).		
LOCATION/ITEM	ACTION	REMARKS
7. Two hinge and panel assemblies (5) and (6), two panels (2) and (7), and hinge and support assembly (1).	Attach a suitable lifting device to the rope and remove items (5), (6), (2), (7), and (1) as one assembly from vehicle.	
8. Two supports (12).	Remove from two items (13).	
9. All metal parts.	Clean and inspect.	Refer to paragraphs 3-4 and 3-5.
10. Two supports (12).	Install in two items (13).	
NOTE		
If rope was removed for cleaning and inspection, resecure rope as stated in step 5.		
11. Two hinge and panel assemblies (5) and (6), two panels (2) and (7), and hinge and support assembly (1).	Attach a suitable lifting device to the rope, and position items (5), (6), (2), (7), and (1) onto vehicle. Aline holes of item (1) with holes of two items (12) 1	
12. Eight screws (4) and washers (3).	Install and tighten in eight holes of item (1).	

CAB AND BODY.

3-269. HOOD REPLACEMENT (Continued).

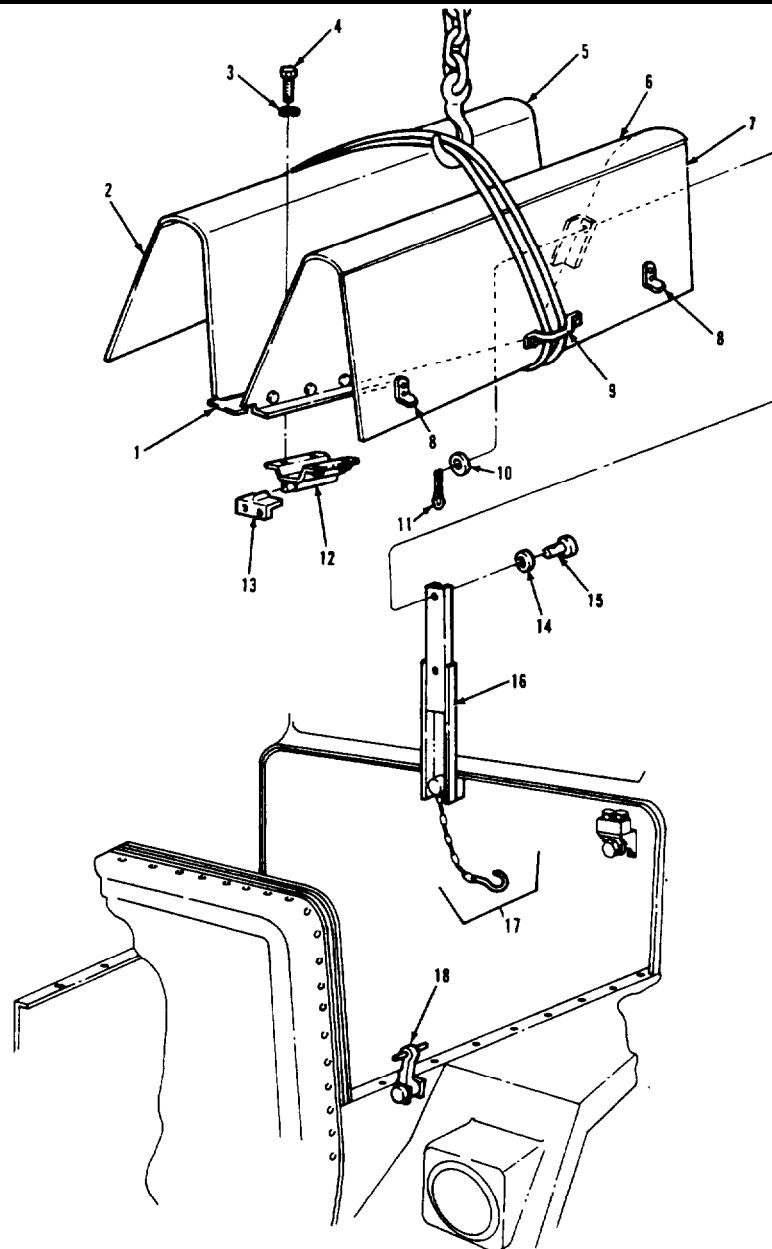

LEGEND:

- |  |                                     |
|--|-------------------------------------|
| 1. HINGE AND SUPPORT ASSEMBLY          | 10. FLAT WASHER (2)                 |
| 2. RIGHT-HAND SIDE HOOD PANEL          | 11. COTTER PIN (2)                  |
| 3. LOCKWASHER (8)                      | 12. HOOD SUPPORT PIVOT ASSEMBLY (2) |
| 4. HEXAGON SCREW (8)                   | 13. HOOD SUPPORT BRACKET (2)        |
| 5. RIGHT-HAND HINGE AND PANEL ASSEMBLY | 14. FLAT WASHER (2)                 |
| 6. LEFT-HAND HINGE AND PANEL ASSEMBLY  | 15. CLEVIS PIN (2)                  |
| 7. LEFT-HAND SIDE HOOD PANEL           | 16. TELESCOPING PROP ASSEMBLY (2)   |
| 8. HOOD HOOK BRACKET (2)               | 17. HOOD SAFETY CHAIN ASSEMBLY (2)  |
| 9. HOOD HANDLE (2)                     | 18. HOOD HOOK (4)                   |

TA 237744



CAB AND BODY.

3-269. HOOD REPLACEMENT (Continued).

LOCATION/ITEM	ACTION	REMARKS
<b>C. INSTALLATION (Continued).</b>		
<u><b>WARNING</b></u>		
An assistant on each side of the hood is recommended to hold onto the panels before and after the rope is removed and while the two prop assemblies are secured.		
13. Rope.	Remove from items (5), (6), (2), and (7).	
14. Two prop assemblies (16).	Aline upper holes of items (16) with two holes at the rear of items (5) and (6).	
15. Two pins (15) and four washers (12) and (14).	Install in two items (16) and items (5) and (6).	
16. Two pins (11).	Install in two items (15).	Bend over ends of two items (11).
17. Two chains (17).	Remove from two items (16) and position in rubber grommet.	
18. Two panels (2) and (7).	Lower.	
19. Four hooks (18).	Attach to four items (8).	
NOTE		
Follow-on maintenance action required:		
None.		

CAB AND BODY.

3-269. HOOD REPLACEMENT (Continued).

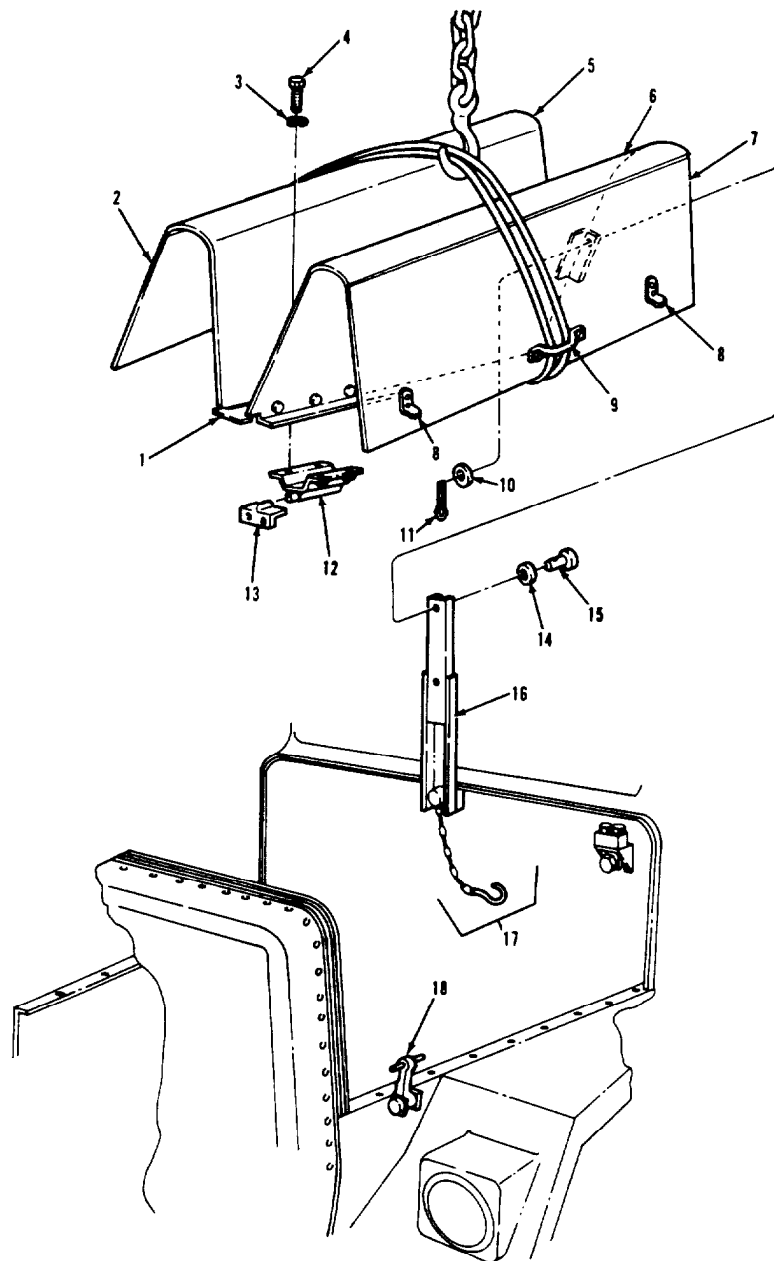

LEGEND:

- |  |                                     |
|--|-------------------------------------|
| 1. HINGE AND SUPPORT ASSEMBLY          | 10. FLAT WASHER (2)                 |
| 2. RIGHT-HAND SIDE HOOD PANEL          | 11. COTTER PIN (2)                  |
| 3. LOCKWASHER (8)                      | 12. HOOD SUPPORT PIVOT ASSEMBLY (2) |
| 4. HEXAGON SCREW (8)                   | 13. HOOD SUPPORT BRACKET (2)        |
| 5. RIGHT-HAND HINGE AND PANEL ASSEMBLY | 14. FLAT WASHER (2)                 |
| 6. LEFT-HAND HINGE AND PANEL ASSEMBLY  | 15. CLEVIS PIN (2)                  |
| 7. LEFT-HAND SIDE HOOD PANEL           | 16. TELESCOPING PROP ASSEMBLY (2)   |
| 8. HOOD HOOK BRACKET (2)               | 17. HOOD SAFETY CHAIN ASSEMBLY (2)  |
| 9. HOOD HANDLE (2)                     | 18. HOOD HOOK (4)                   |

TA 237745

CAB AND BODY.

3- 270. HOOD PANEL AND COMPONENT REPLACEMENT.

THIS TASK COVERS

- |  |   |
|--|---|
| a. Side Panel Removal.                   | h. Support and Hinge, Pivot, and Bracket Replacement. |
| b. Side Panel Installation.              | i. Left-Hand Seal Replacement.                        |
| c. Handle Replacement.                   | j. Right-Hand Seal Replacement.                       |
| d. Hook and Brackets Replacement.        | k. Front Seal Replacement.                            |
| e. Panel and Hinge Assembly Replacement. | l. Rear Seal Replacement.                             |
| f. Support Pad and Bracket Replacement.  |   |
| g. Prop and Bracket Replacement.         |   |

INITIAL SETUP

<u>APPLICABLE CONFIGURATIONS</u>	<u>EQUIPMENT CONDITION PARAGRAPH</u>	<u>CONDITION DESCRIPTION</u>
All.	TM 9- 2320- 283- 10.	Hood opened.

TEST EQUIPMENT

SPECIAL TOOLS

None.

MATERIALS/PARTS (P/N)

Rivet, (30) (11815) SSL Q- 66.	Rag, wiping Item 19, Appendix C.
Rivet, blind (30) (05693) SSL Q- 64.	Pin, cotter (2) (24617) 137155.
Adhesive, rubber, type II Item 1, Appendix C.	Seal, air inlet (34623) 5994938.
Solvent, drycleaning, SD- 2 Item 29, Appendix C.	

PERSONNEL REQUIRED

Two (MOS- 63S).

SPECIAL ENVIRONMENTAL CONDITIONS

None.

REFERENCES (TM)

GENERAL SAFETY INSTRUCTIONS

Engine off  
Transmission in neutral.  
Park brake set.

TROUBLESHOOTING REFERENCES

None.

CAB AND BODY.

3-270. HOOD PANEL AND COMPONENT REPLACEMENT (Continued).

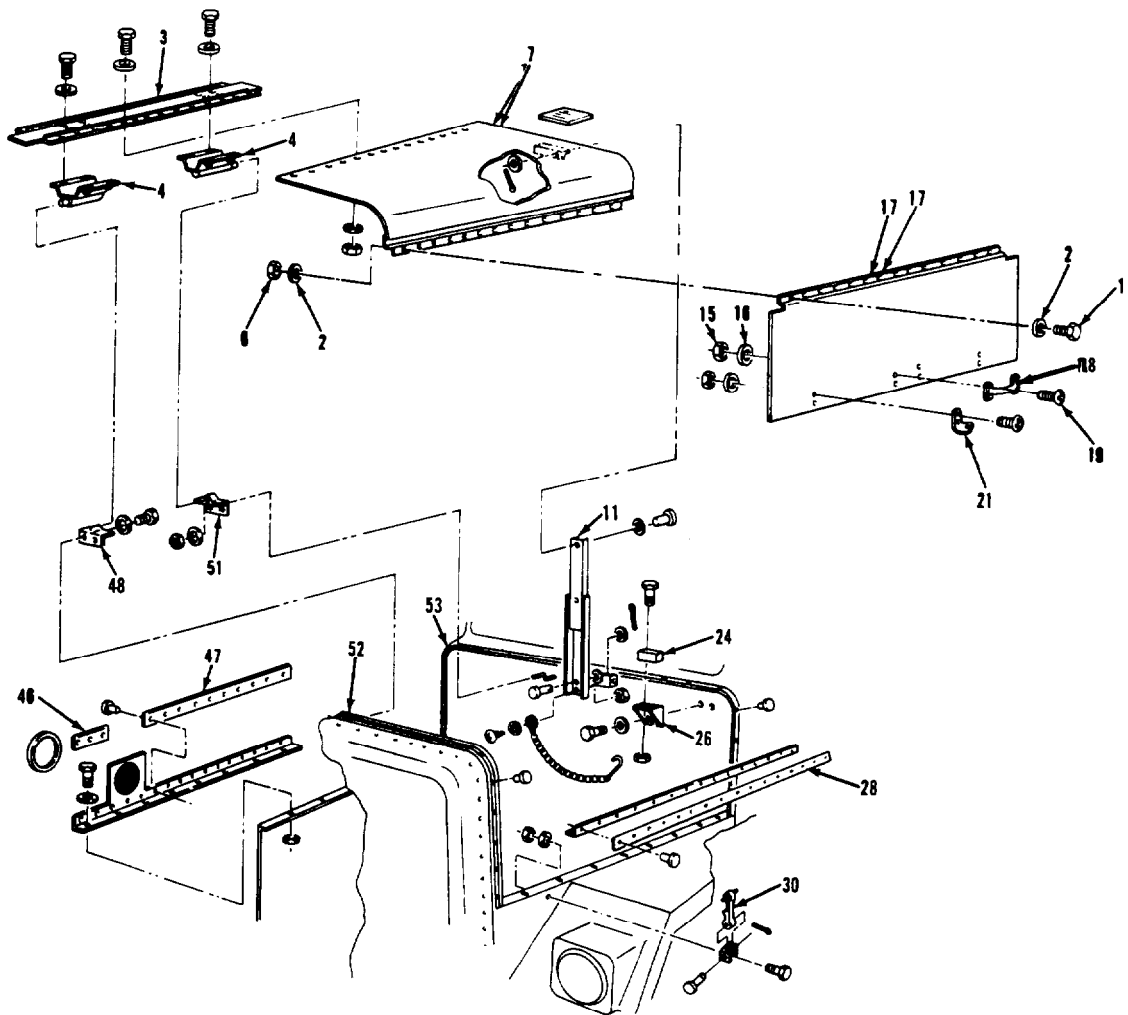

LEGEND:

- |                                    |   |
|------------------------------------|---|
| 3. SUPPORT AND HINGE ASSEMBLY      | 28. LEFT-HAND SIDE HOOD SEAL            |
| 4. HOOD SUPPORT PIVOT ASSEMBLY (2) | 30. HOOD HOOK                           |
| 7. PANEL AND HINGE ASSEMBLY        | 46. RIGHT-HAND FRONT SIDE HOOD SEAL     |
| 11. TELESCOPING PROP ASSEMBLY      | 47. RIGHT-HAND REAR SIDE HOOD SEAL      |
| 17. SIDE HOOD PANEL                | 48. FRONT HOOD SUPPORT BRACKET ASSEMBLY |
| 18. HOOD HANDLE                    | 51. REAR HOOD SUPPORT BRACKET ASSEMBLY  |
| 21. HOOD HOOK BRACKET              | 52. FRONT HOOD SEAL                     |
| 24. HOOD SUPPORT PAD               | 53. REAR HOOD SEAL                      |
| 26. HOOD SUPPORT PAD BRACKET       |   |

TA 237746

CAB AND BODY.

3-270. HOOD PANEL AND COMPONENT REPLACEMENT (Continued).

LOCATION/ITEM	ACTION	REMARKS
<b>A. SIDE PANEL REMOVAL.</b>		
NOTE		
Side panel removal is same for both sides.		
1. Fourteen screws (1), twenty-eight washers (2), and fourteen nuts (6).	Remove from item (17) and item (7).	Assistant holds item (17).
2. Panel (17).	Remove from item (7).	
<b>B. SIDE PANEL INSTALLATION.</b>		
NOTE		
Side panel installation is same for both sides.		
3. Panel (17).	Put in place on item (7).	Assistant holds item (17).
4. Fourteen screws (1), twenty-eight washers (2), and fourteen nuts (6).	Secure item (17) to item (7).	
<b>C. HANDLE REPLACEMENT.</b>		
NOTE		
Handle replacement is same for both sides.		
5. Four screws (19), lockwashers (16), and nuts (15).	Remove from item (18) and item (17).	
6. Four screws (19), lockwashers (16), and nuts (15).	Secure item (18) to item (17).	

CAB AND BODY.

3-270. HOOD PANEL AND COMPONENT REPLACEMENT (Continued).

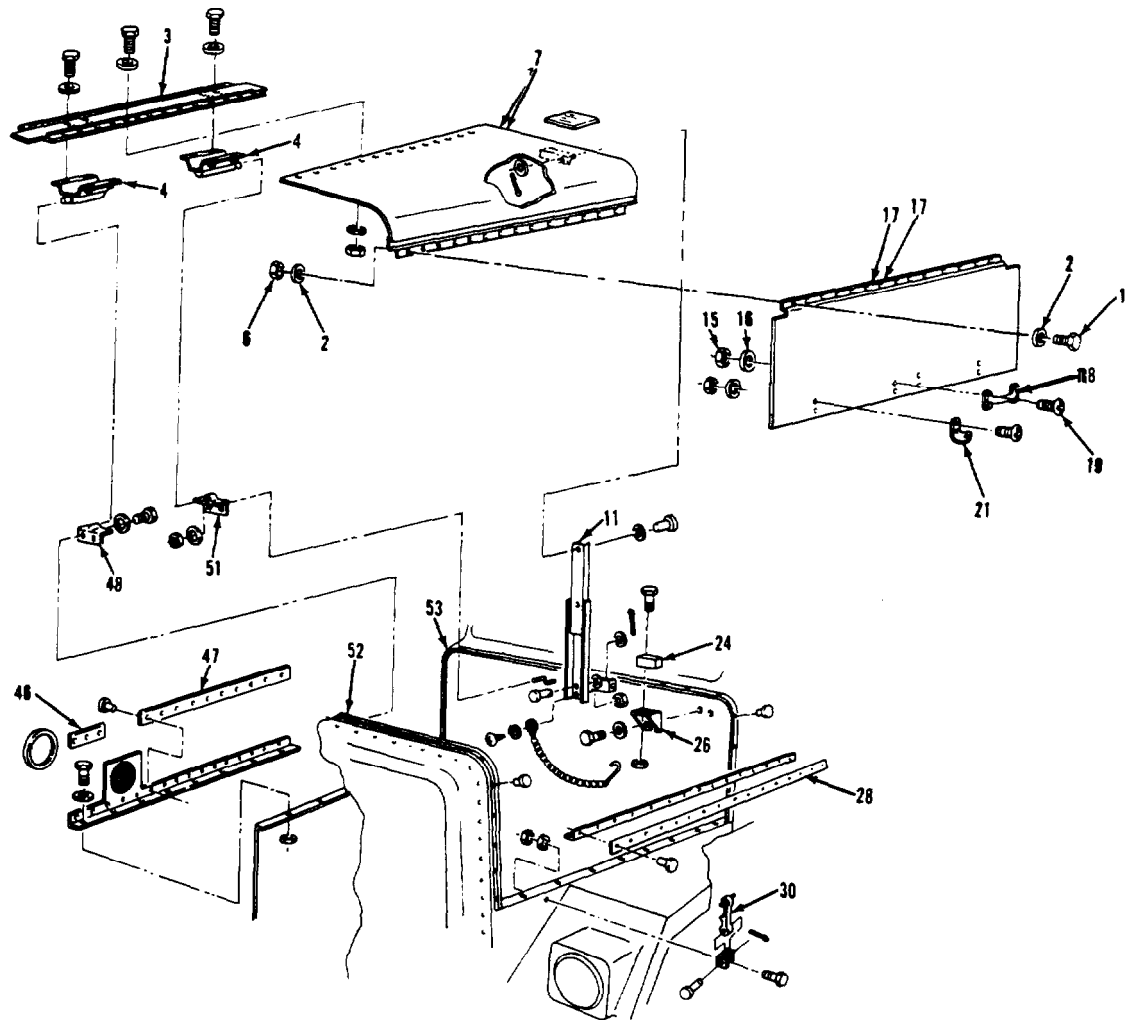

LEGEND:

- |                             |      |                       |
|-----------------------------|------|-----------------------|
| 1. SCREW (14)               | (28) | 16. LOCKWASHER (4)    |
| 2. FLAT WASHER (28)         |      | 17. SIDE HOOD PANEL   |
| 6. NUT (14)                 |      | 18. HOOD HANDLE       |
| 7. PANEL AND HINGE ASSEMBLY |      | 19. MACHINE SCREW (4) |
| 15. NUT (4)                 |      |                       |

TA 237747

CAB AND BODY.

3-270. HOOD PANEL AND COMPONENT REPLACEMENT (Continued).

LOCATION/ITEM	ACTION	REMARKS
<b>D. HOOK AND BRACKETS REPLACEMENT.</b>		
NOTE		
Hook and brackets replacement is the same for all four places.		
7. Two screws (20), lockwashers (22), and nuts (23).	Remove from item (21) and item (17).	
8. Pin (31).	Remove from item (34).	Discard item (31).
9. Pin (34).	Remove from item (33) and item (30).	
10. Hook (30).	Remove from item (33).	
11. Screw (32), washer (38), and nut (39).	Remove from item (33).	
12. Screw (32), washer (38), and nut (39).	Secure item (33) to fender.	
13. Hook (30).	Put in place in item (33).	
14. Pin (34).	Install in item (33) and item (30).	
15. New pin (31).	Install in item (34).	
16. Two screws (20) lockwashers (22), and nuts (23).	Secure item (21) to item (17).	

CAB AND BODY.

3-270. HOOD PANEL AND COMPONENT REPLACEMENT (Continued).

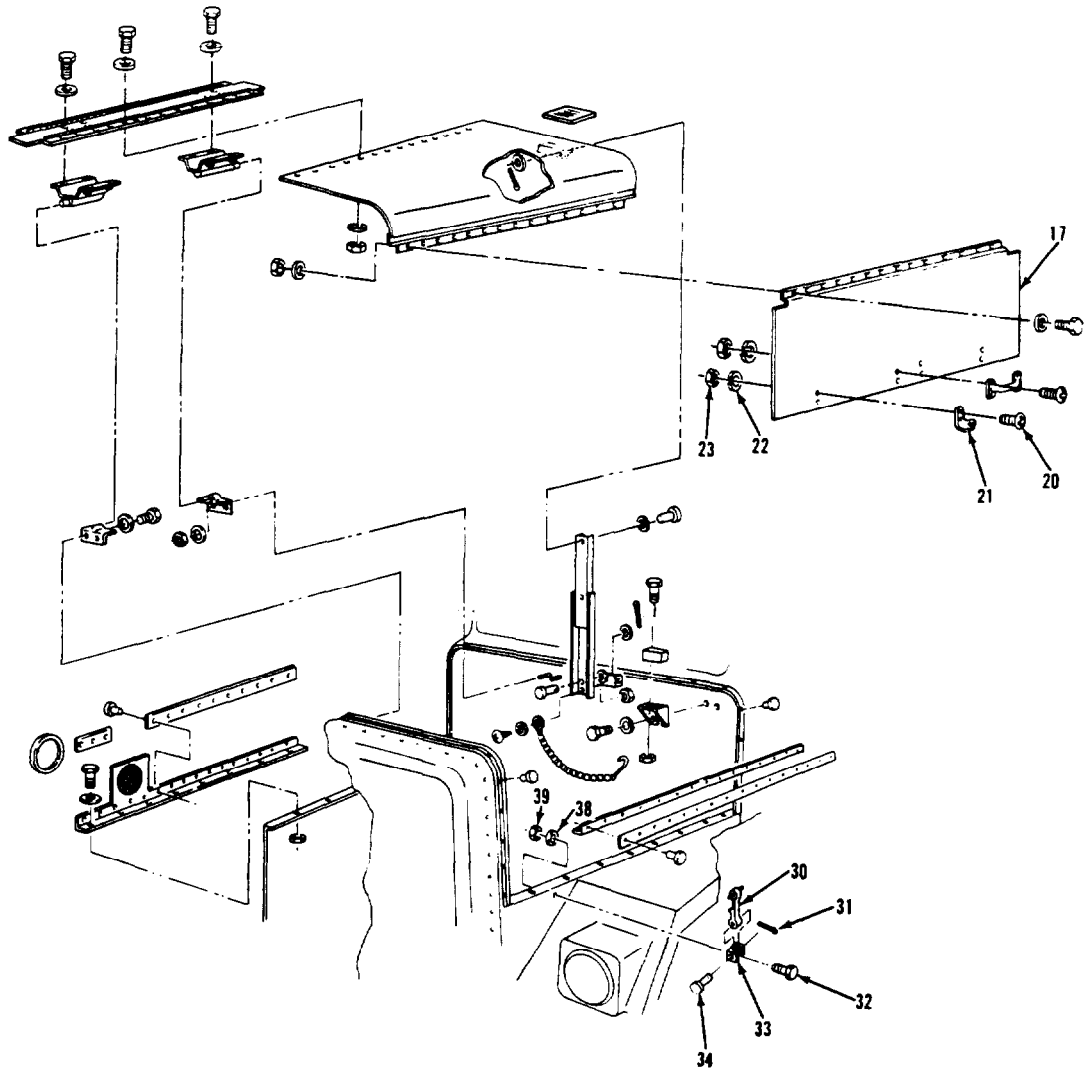

LEGEND:

- |                       |                 |
|-----------------------|-----------------|
| 17. SIDE HOOD PANEL   | 31. COTTER PIN  |
| 20. SCREW (2)         | 32. SCREW       |
| 21. HOOD HOOK BRACKET | 33. BRACKET     |
| 22. LOCKWASHER (2)    | 34. PIN         |
| 23. NUT (2)           | 38. FLAT WASHER |
| 30. HOOD HOOK         | 39. HEXAGON NUT |

TA 237748



CAB AND BODY.

3-270. HOOD PANEL AND COMPONENT REPLACEMENT (Continued).

LOCATION/ITEM	ACTION	REMARKS
<b>E. PANEL AND HINGE ASSEMBLY REPLACEMENT.</b>		
NOTE		
Panel and hinge assembly replacement is the same for both sides.		
17. Side panel.	Remove.	Refer to subparagraph A.
18. Pin (10).	Remove from item (13).	Discard item (10).
19. Pin (13), washer (9), and washer (12).	Remove from item (11) and item (7).	Assistant holds item (7).
20. Fourteen screws (1), twenty-eight washers (2), and fourteen nuts (6).	Remove from item (3) and item (7).	
21. Panel and hinge assembly (7).	Remove from item (3).	
22. Panel and hinge assembly (7).	Put in place on item (3).	Assistant hold in place.
23. Fourteen screws (1), twenty-eight washers (2), and fourteen nuts (6).	Secure item (7) to item (3).	
24. Pin (13), washer (9), and washer (12).	Install in item (11) and item (7).	
25. New pin (10).	Install in item (13).	
NOTE		
Be sure decal (8) is on item (7) and in good condition. To replace decal, refer to paragraph 3-305.		
26. Side panel.	Install.	Refer to subparagraph B.

CAB AND BODY.

3-270. HOOD PANEL AND COMPONENT REPLACEMENT (Continued).

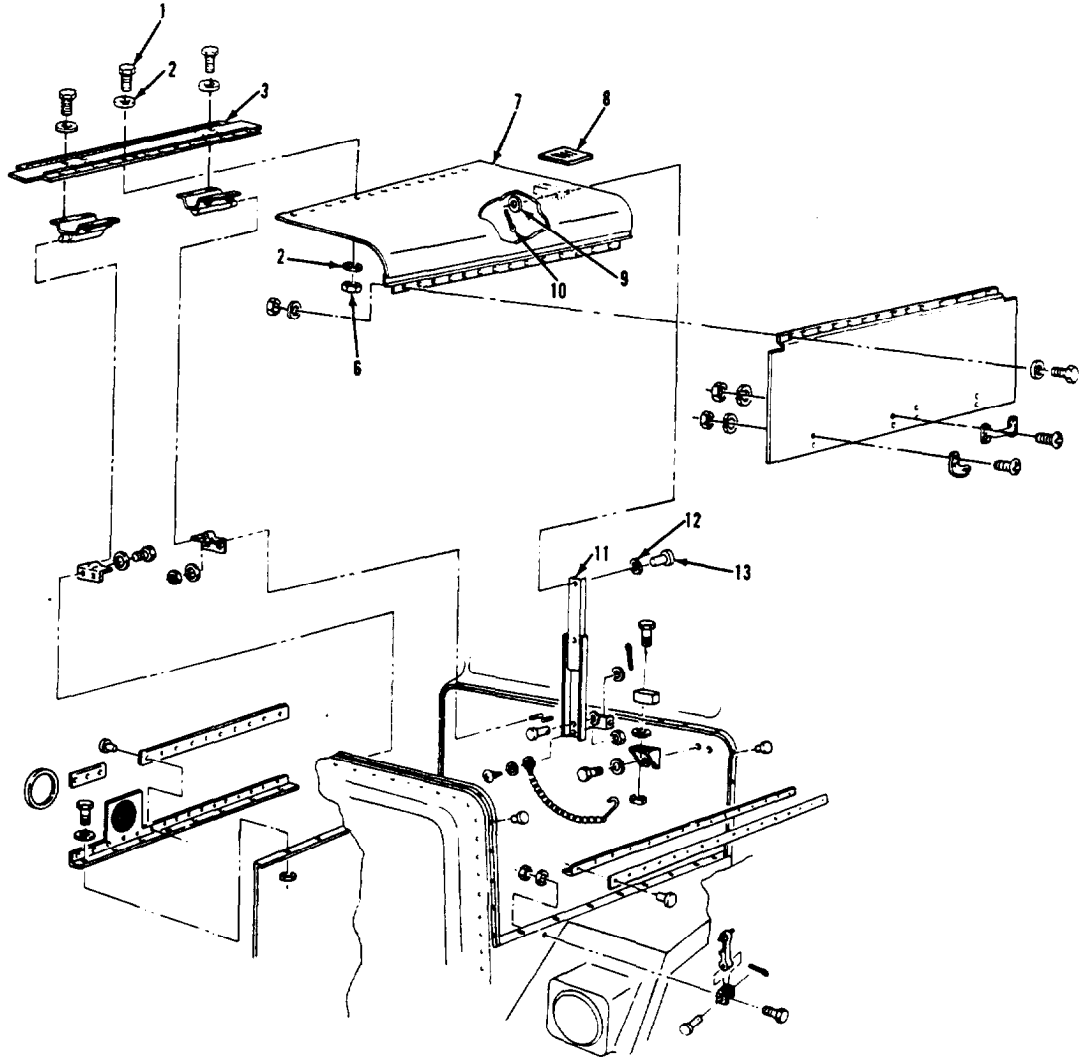

LEGEND:

- |  |                               |
|--|-------------------------------|
| 1. SCREW (14)                            | 9. FLAT WASHER                |
| 2. FLAT WASHER (28)                      | 10. COTTER PIN                |
| 3. SUPPORT AND HINGE ASSEMBLY            | 11. TELESCOPING PROP ASSEMBLY |
| 6. NUT (14)                              | 12. FLATWASHER                |
| 7. PANEL AND HINGE ASSEMBLY              | 13. CLEVIS PIN                |
| 8. HOOD PROP SAFETY DECAL MOUNTING PLATE |                               |

TA 237749

CAB AND BODY.

3-270. HOOD PANEL AND COMPONENT REPLACEMENT (Continued).

LOCATION/ITEM	ACTION	REMARKS
<b>F. SUPPORT PAD AND BRACKET REPLACEMENT.</b>		
NOTE		
Support pad and bracket replacement is the same for both sides.		
27. Two screws (37) and lockwashers (36).	Remove from item (26).	
28. Two screws (14), washers (2), and nuts (35).	Remove from item (24) and item (26).	Note quantity of item (2), if any, for installation.
29. Two screws (14), washers (2), and two nuts (35).	Secure item (24) to item (26) 1	Use same quantity of item (2) removed in step 28.
30. Two screws (37) and lockwashers (36).	Secure item (26) to fire-wall.	
<b>G. PROP AND BRACKET REPLACEMENT.</b>		
NOTE		
Prop and bracket replacement is the same for both sides.		
31. Hood.	Prop open securely.	Use pieces of wood, such as two by fours.
32. Two pins (10).	Remove from two items (13). Discard two items (10).	
33. Two pins (13), washers (9), and washers (12).	Remove from item (11) and item (7).	
34. Prop assembly (11).	Remove.	
35. Screw (43), washers (42), and nuts (25).	Remove from item (41) and item (11).	
36. Chain assembly (41).	Remove from item (11).	

CAB AND BODY.

3-270. HOOD PANEL AND COMPONENT REPLACEMENT (Continued).

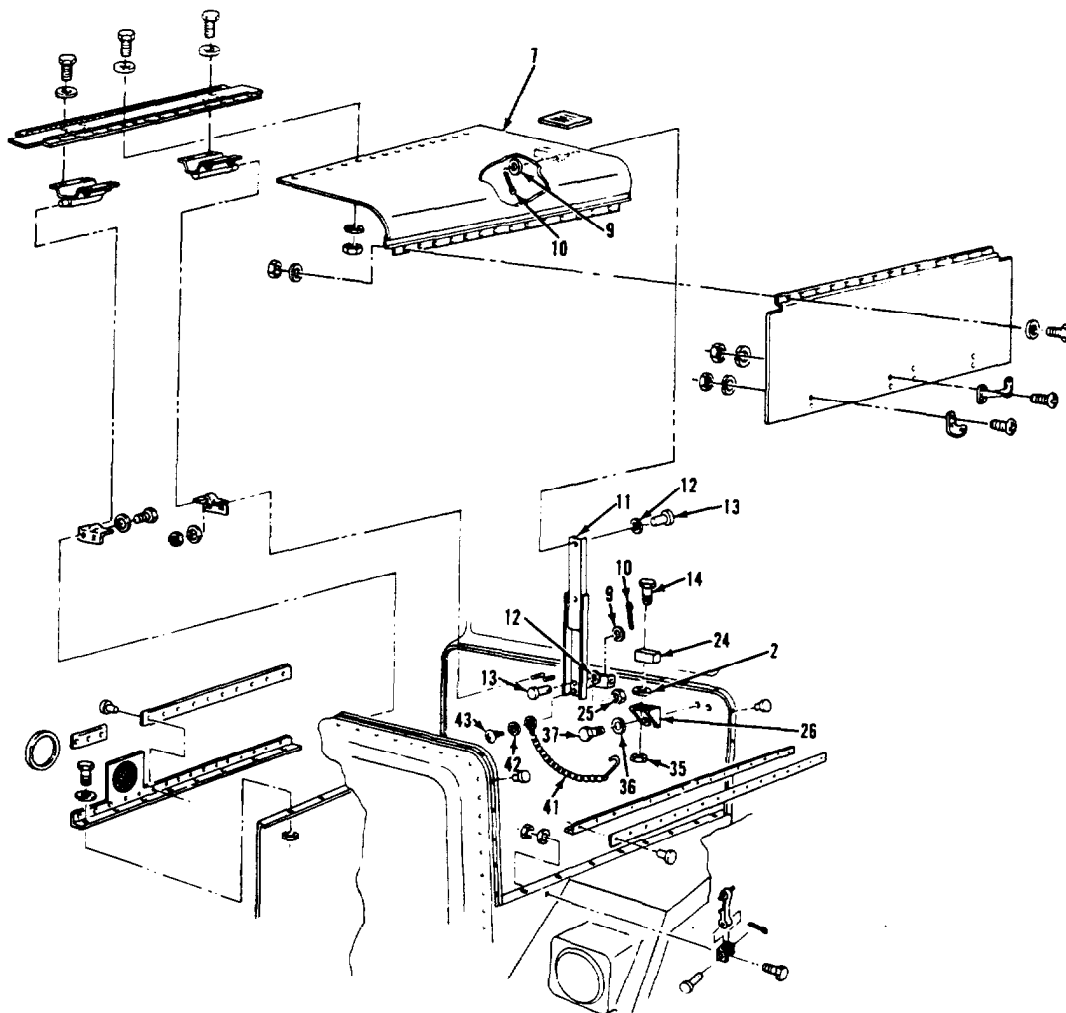

LEGEND:

- |                               |                                |
|-------------------------------|--------------------------------|
| 2. FLAT WASHER (AS REQUIRED)  | 25. NUT                        |
| 7. PANEL AND HINGE ASSEMBLY   | 26. HOOD SUPPORT PAD BRACKET   |
| 9. FLAT WASHER (2)            | 35. NUT (2)                    |
| 10. COTTER PIN (2)            | 36. LOCKWASHER (2)             |
| 11. TELESCOPING PROP ASSEMBLY | 37. MACHINE SCREW (2)          |
| 12. FLATWASHER (2)            | 41. HOOD SAFETY CHAIN ASSEMBLY |
| 13. CLEVIS PIN (2)            | 42. WASHER                     |
| 14. MACHINE SCREW (2)         | 43. MACHINE SCREW              |
| 24. HOOD SUPPORT PAD          |                                |

TA 237750

CAB AND BODY.

3-270. HOOD PANEL AND COMPONENT REPLACEMENT (Continued).		
LOCATION/ITEM	ACTION	REMARKS
<b>G. PROP AND BRACKET REPLACEMENT (Continued).</b>		
37. Screw (43), washer (42), and nut (25).	Secure item (41) to item (11).	
38. Prop assembly (1) l	Put in place on item (7) and firewall.	
39. Two pins (13), washers (9) and (12).	Secure item (11) to item (7) and firewall.	
40. Two new pins (9).	Install in two items (13).	
<b>H. SUPPORT AND HINGE, PIVOT, AND BRACKET REPLACEMENT.</b>		
41. Hood.	Remove.	Refer to paragraph 3-269.
42. Twenty-eight screws (1), fifty-six washers (2), and twenty-eight nuts (6).	Remove from item (3) and two items (7).	
43. Two pivot assemblies (4).	Remove from items (48) and (51).	
44. Two screws (49) and lockwashers (5).	Remove from item (48).	
45. Two nuts (50) and lockwashers (5).	Remove from item (51).	
46. Two nuts (50) and lockwashers (5).	Secure item (51) to firewall.	
47. Two screws (49) and lockwashers (5).	Secure item (48) to radiator grille.	
48. Two pivot assemblies (4).	Install in item (48) and item (51).	
49. Hood.	Install.	Refer to paragraph 3-269.

CAB AND BODY.

3-270. HOOD PANEL AND COMPONENT REPLACEMENT (Continued).

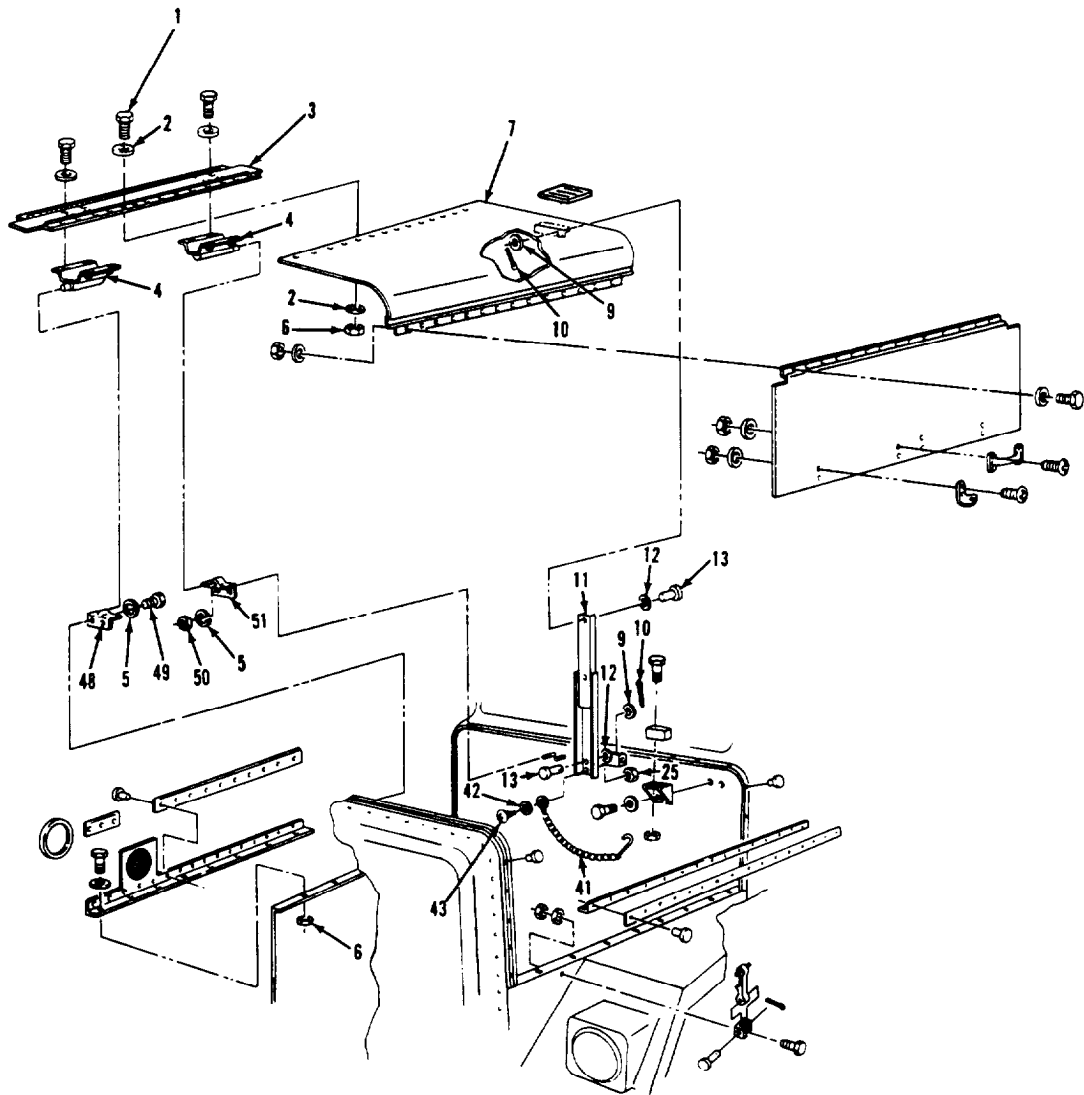

LEGEND:

- |                                    |   |
|------------------------------------|---|
| 1. SCREW (28)                      | 12. FLAT WASHER                         |
| 2. FLAT WASHER (56)                | 13. CLEVIS PIN (2)                      |
| 3. SUPPORT AND HINGE ASSEMBLY      | 25. NUT                                 |
| 4. HOOD SUPPORT PIVOT ASSEMBLY (2) | 41. HOOD SAFETY CHAIN ASSEMBLY          |
| 5. LOCKWASHER (4)                  | 42. WASHER                              |
| 6. NUT (28)                        | 43. MACHINE SCREW                       |
| 7. PANEL AND HINGE ASSEMBLY (2)    | 48. FRONT HOOD SUPPORT BRACKET ASSEMBLY |
| 9. FLAT WASHER (2)                 | 49. SCREW (2)                           |
| 10. COTTER PIN (2)                 | 50. HEXAGON NUT (2)                     |
| 11. TELESCOPING PROP ASSEMBLY      | 51. REAR HOOD SUPPORT BRACKET ASSEMBLY  |

TA 237751

CAB AND BODY.

3-270. HOOD PANEL AND COMPONENT REPLACEMENT (Continued).		
LOCATION/ITEM	ACTION	REMARKS
<b>I. LEFT-HAND SEAL REPLACEMENT.</b>		
50. Six screws (1), washers (2), and nuts (6).	Remove from item (28).	
51. Fifteen rivets (29).	Remove from item (27) and item (28).	Drill out and discard items (29).
52. Fifteen new rivets (29)	Secure item (27) to item (28).	
53. Six screws (1), washers (2), and nuts (6).	Secure item (28) to fender.	
<b>J. RIGHT-HAND SEAL REPLACEMENT.</b>		
54. Six screws (1), washers (2), and nuts (6).	Remove from item (44).	
55. Fifteen rivets (29).	Remove from item (46), item (47), and item (44).	Drill out and discard items (29).
56. Seal (45).	Remove from item (44).	Scrape off with putty knife.
57. Retainer (44).	Clean with solvent and rags.	Refer to paragraph 3-4.
58. New seal (45).	Install on item (44).	Use adhesive.
59. Fifteen new rivets (29).	Secure item (46) and item (47) to item (44).	
60. Six screws (1), washers (2), and nuts (6).	Secure item (44) to fender.	

CAB AND BODY.

3-270. HOOD PANEL AND COMPONENT REPLACEMENT (Continued).

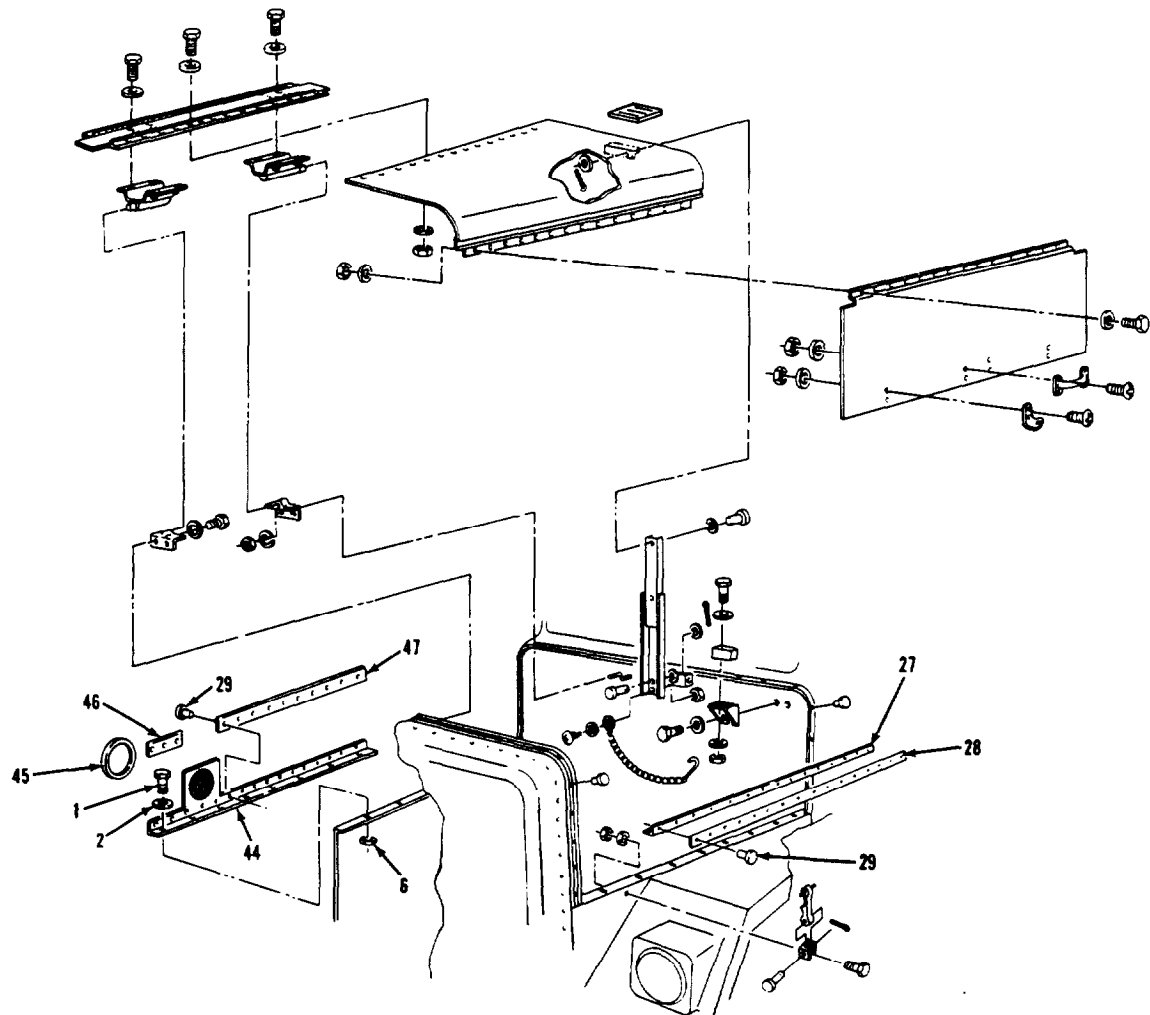

LEGEND:

- |                                  |                                     |
|----------------------------------|-------------------------------------|
| 1. SCREW (12)                    | 29. RIVET (30)                      |
| 2. FLAT WASHER (12)              | 44. RIGHT-HAND HOOD SEAL RETAINER   |
| 6. NUT (12)                      | 45. AIR INLET SEAL                  |
| 27. LEFT-HAND HOOD SEAL RETAINER | 46. RIGHT-HAND FRONT SIDE HOOD SEAL |
| 28. LEFT-HAND SIDE HOOD SEAL     | 47. RIGHT-HAND REAR SIDE HOOD SEAL  |

TA 237752



CAB AND BODY.

3-270. HOOD PANEL AND COMPONENT REPLACEMENT (Continued).

LOCATION/ITEM	ACTION	REMARKS
<b>K. FRONT SEAL REPLACEMENT.</b>		
61. Front fender filler.	Remove.	Refer to paragraph 3-266.
62. Thirty rivets (40).	Remove from item (52).	Drill out and discard items (40).
63. Seal (52).	Remove from radiator grille.	
64. Thirty new rivets (40).	Secure item (52) to radiator grille.	Use a suitable rivet gun.
65. Front fender fillers.	Install .	Refer to paragraph 3-266.
<b>L. REAR SEAL REPLACEMENT.</b>		
66. Seal (53).	Pull from firewall.	
67. Seal (53).	Push on firewall.	
NOTE		
Follow-on maintenance action required:		
Close hood (TM 9-2320-283-10).		

CAB AND BODY.

3-270. HOOD PANEL AND COMPONENT REPLACEMENT (Continued).

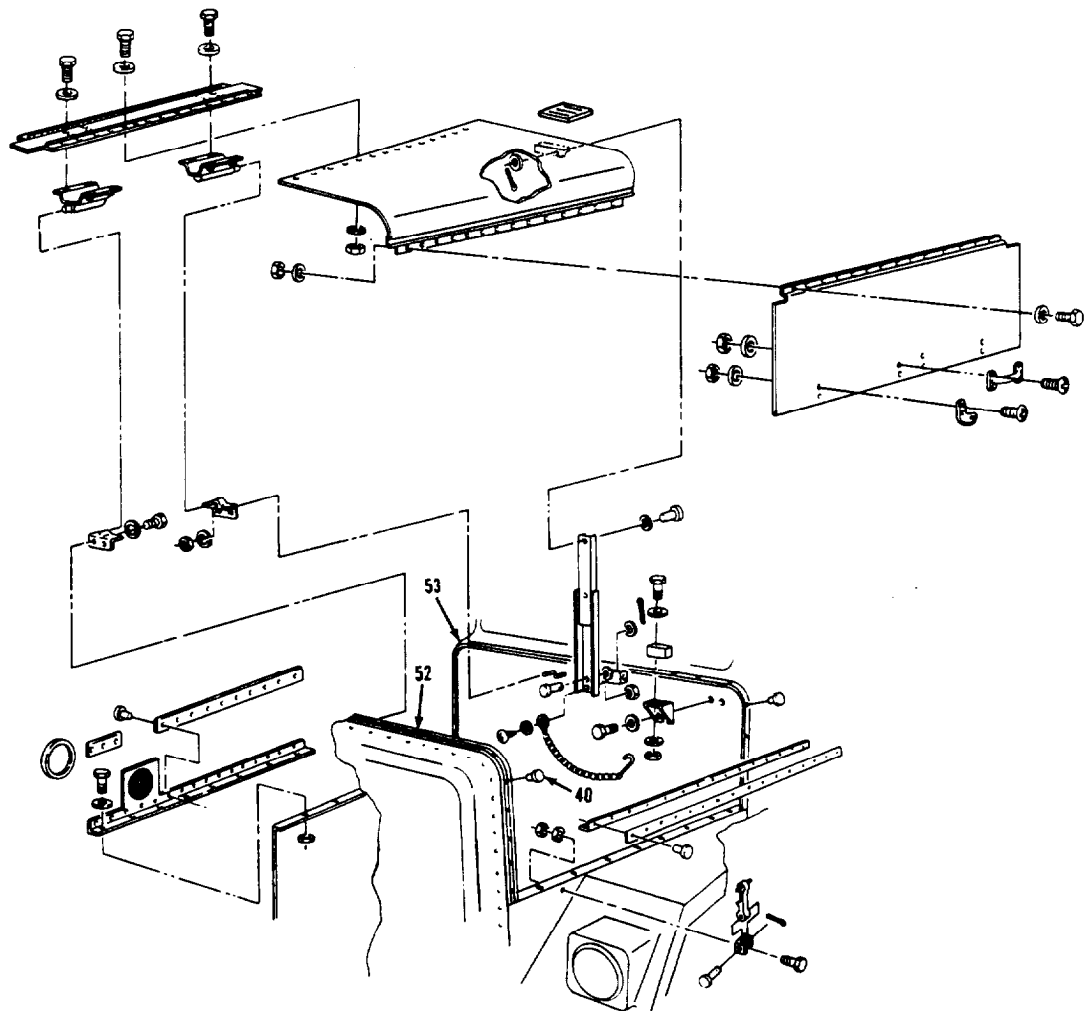

LEGEND:

- 40. BLIND RIVET (30)
- 52. FRONT HOOD SEAL
- 53. REAR HOOD SEAL

TA 237753

CAB AND BODY.

3-271. FRONT FENDER REPLACEMENT.

THIS TASK COVERS

- a. Front Fender Removal.
- b. Front Fender Installation.
- c. Front Fender Disassembly.
- d. Front Fender Reassembly.
- e. Front and Rear Support Removal.
- f. Front and Rear Support Installation.
- g. Mud Flap and Antisail Bracket Disassembly.
- h. Mud Flap and Antisail Bracket Reassembly.

INITIAL SETUP

APPLICABLE CONFIGURATIONS

All.

EQUIPMENT CONDITION  
PARAGRAPH

3-236.

CONDITION DESCRIPTION

Brush guard brace  
disconnected.

TEST EQUIPMENT

SPECIAL TOOLS

None.

MATERIALS/PARTS (P/N)

None.

PERSONNEL REQUIRED

Two (MDS-63S).

SPECIAL ENVIRONMENTAL CONDITIONS

None.

REFERENCES (TM)

TM 9-2320-283-10

GENERAL SAFETY INSTRUCTIONS

Engine off  
Transmission in neutral.  
Park brake set.

TROUBLESHOOTING REFERENCES

None.

CAB AND BODY.

3-271. FRONT FENDER REPLACEMENT (Continued).

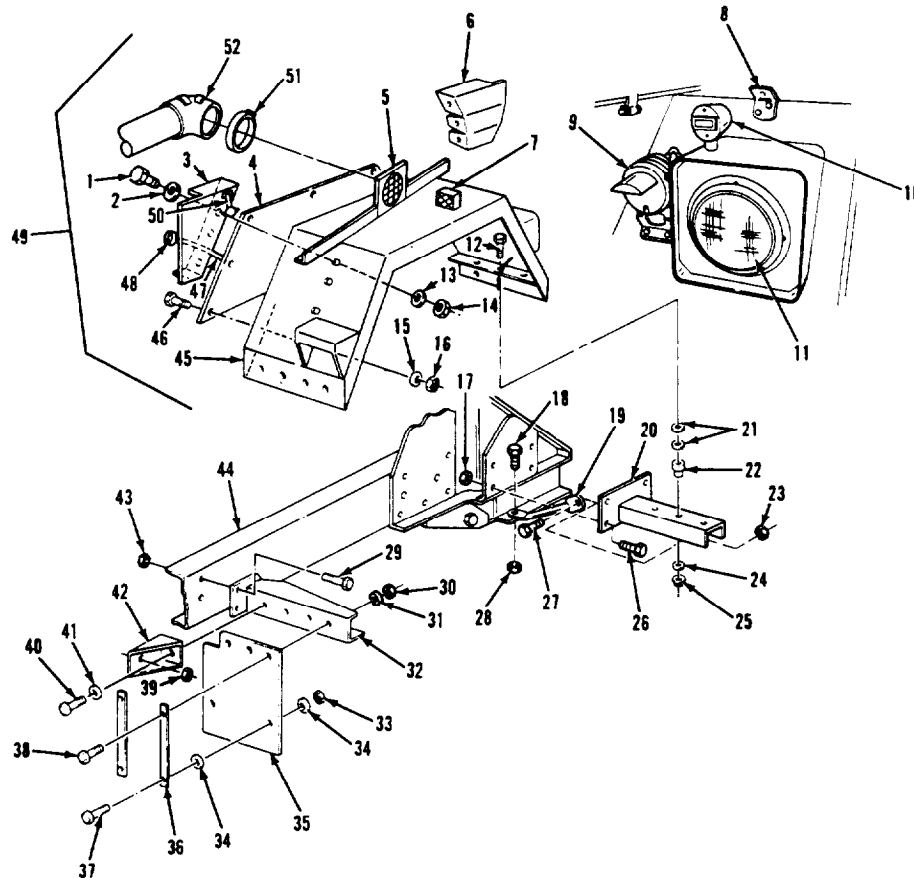

LEGEND:

- |  |                                |                                  |
|--|--------------------------------|----------------------------------|
| 1. SCREW (6)                                   | 15. WASHER (7)                 | 34. WASHER (2)                   |
| 2. WASHER (6)                                  | 16. NUT (7)                    | 35. MUD FLAP                     |
| 3. REAR FILLER                                 | 17. NUT (4)                    | 36. ANTISAIL BRACKET (2)         |
| 4. SPLASH SHIELD                               | 18. SCREW                      | 37. SCREW (2)                    |
| 5. HOOD SEAL AND<br>RETAINER                   | 19. BRACE                      | 38. SCREW (3)                    |
| 6. FRONT FILLER                                | 20. FRONT SUPPORT              | 39. NUT                          |
| 7. TURN SIGNAL AND<br>MARKER LAMP              | 21. WASHER (6)                 | 40. SCREW                        |
| 8. BRUSH GUARD BRACE<br>BRACKET                | 22. VIBRATION<br>INSULATOR (3) | 41. WASHER (4)                   |
| 9. BLACKOUT HEADLAMP<br>ASSEMBLY (LEFT SIDE)   | 23. NUT                        | 42. REINFORCEMENT BRACKET        |
| 10. BLACKOUT MARKER LAMP<br>AND CABLE ASSEMBLY | 24. WASHER (3)                 | 43. NUT (3)                      |
| 11. HEADLAMP AND CABLE<br>ASSEMBLY             | 25. NUT (4)                    | 44. FRAME                        |
| 12. SCREW (3)                                  | 26. SCREW (4)                  | 45. FENDER PANEL                 |
| 13. WASHER (6)                                 | 27. SCREW                      | 46. SCREW (7)                    |
| 14. NUT (6)                                    | 28. NUT                        | 47. FENDER WIRING HARNESS        |
|  | 29. SCREW (3)                  | 48. CONNECTOR                    |
|  | 30. NUT (4)                    | 49. FENDER ASSEMBLY              |
|  | 31. WASHER (4)                 | 50. HOOD HOOK AND<br>BRACKET (2) |
|  | 32. REAR SUPPORT               | 51. AIR INTAKE TUBE CLAMP        |
|  | 33. NUT (2)                    | 52. ELBOW                        |

TA 237754

CAB AND BODY.

3-271. FRONT FENDER REPLACEMENT (Continued).

LOCATION/ITEM	ACTION	REMARKS
NOTE		
<p>*Front fender replacement is the same for both sides. This procedure covers right front fender replacement.</p>		
<p>*If front fenders are being removed for access to engine, do subparagraphs A and B. If damaged front fenders are to be replaced, do subparagraphs C and D.</p>		
<b>A. FRONT FENDER REMOVAL.</b>		
1. Connector (48).	Disconnect.	Twist to unlock.
2. Clamp (51).	Loosen.	Right side only.
3. Elbow (52).	Remove from item (5).	Right side only.
4. Three screws (38), screw (40), four washers (41), washers (31), and nuts (30).	Remove from item (32).	
5. Flap (35).	Remove.	
6. Three screws (12), six washers (21), three washers (24), and nuts (25).	Remove from item (20).	
7. Fender assembly (49).	Remove.	Two mechanics.
<b>B. FRONT FENDER INSTALLATION.</b>		
8. Fender assembly (49).	Move into position and aline with mounting holes in items (32) and (20).	Two mechanics.

CAB AND BODY.

3-271. FRONT FENDER REPLACEMENT (Continued).

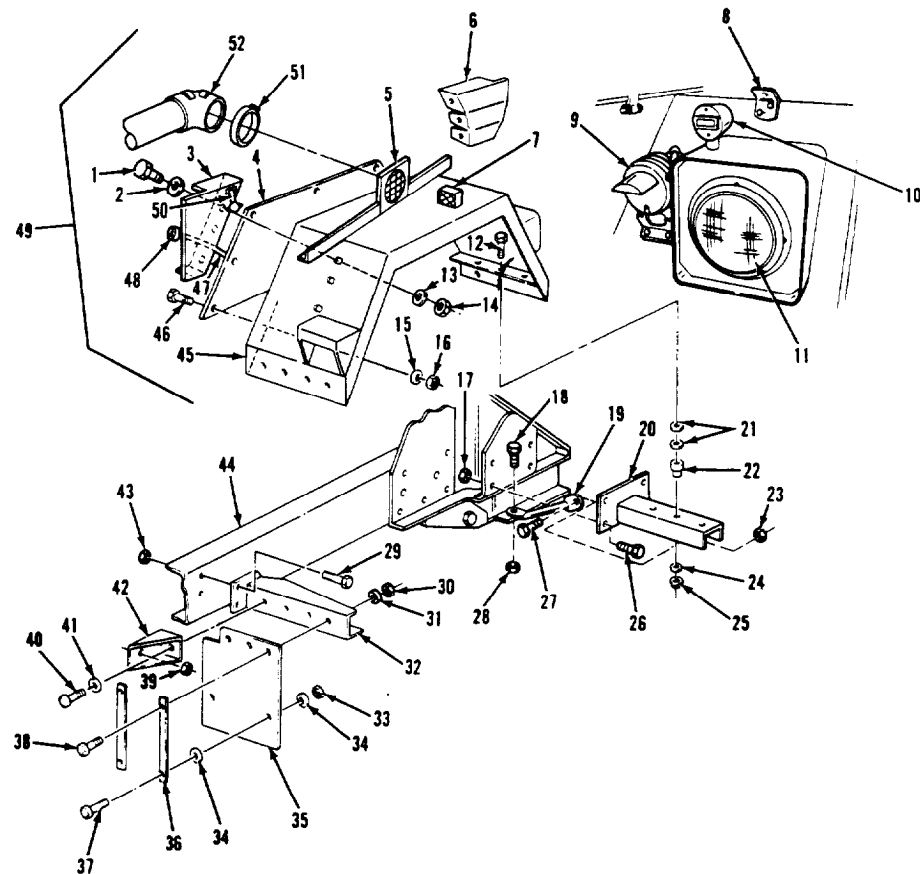

LEGEND:

- |  |                                |  |
|--|--------------------------------|--|
| 1. SCREW (6)                                   | 15. WASHER (7)                 | 34. WASHER (2)                         |
| 2. WASHER (6)                                  | 16. NUT (7)                    | 35. MUD FLAP                           |
| 3. REAR FILLER                                 | 17. NUT (4)                    | 36. ANTISAIL BRACKET (2)               |
| 4. SPLASH SHIELD                               | 18. SCREW                      | 37. SCREW (2)                          |
| 5. HOOD SEAL AND<br>RETAINER                   | 19. BRACE                      | 38. SCREW (3)                          |
| 6. FRONT FILLER                                | 20. FRONT SUPPORT              | 39. NUT                                |
| 7. TURN SIGNAL AND<br>MARKER LAMP              | 21. WASHER (6)                 | 40. SCREW                              |
| 8. BRUSH GUARD BRACE<br>BRACKET                | 22. VIBRATION<br>INSULATOR (3) | 41. WASHER (4)                         |
| 9. BLACKOUT HEADLAMP<br>ASSEMBLY (LEFT SIDE)   | 23. NUT                        | 42. REINFORCEMENT BRACKET              |
| 10. BLACKOUT MARKER LAMP<br>AND CABLE ASSEMBLY | 24. WASHER (3)                 | 43. NUT (3)                            |
| 11. HEADLAMP AND CABLE<br>ASSEMBLY             | 25. NUT (4)                    | 44. FRAME                              |
| 12. SCREW (3)                                  | 26. SCREW (4)                  | 45. FENDER PANEL                       |
| 13. WASHER (6)                                 | 27. SCREW                      | 46. SCREW (7)                          |
| 14. NUT (6)                                    | 28. NUT                        | 47. FENDER WIRING HARNESS<br>CONNECTOR |
|  | 29. SCREW (3)                  | 49. FENDER ASSEMBLY                    |
|  | 30. NUT (4)                    | 50. HOOD HOOK AND<br>BRACKET (2)       |
|  | 31. WASHER (4)                 | 51. AIR INTAKE TUBE CLAMP              |
|  | 32. REAR SUPPORT               | 52. ELBOW                              |
|  | 33. NUT (2)                    |  |

TA 237755

CAB AND BODY.

3-271. FRONT FENDER REPLACEMENT (Continued).

LOCATION/ITEM	ACTION	REMARKS
<b>B. FRONT FENDER INSTALLATION (Continued).</b>		
9. Three screws (12), six washers (21), three washers (24), and nuts (25).	Install finger tight.	
10. Three screws (38), screw (40) four washers (41) and (31), nuts (30), and flap (35).	Align, install, and tighten.	Tighten three items (12) and three items (25).
11. Elbow (52).	Install on item (5).	Right side only.
12. Clamp (51).	Tighten.	Right side only.
13. Connector (48).	Connect.	Twist to lock.
<b>C. FRONT FENDER DISASSEMBLY.</b>		
14. Fender assembly (49).	Remove.	Do steps 1, 2, 3, and 4.
15. Seal and retainer (5).	Remove.	Refer to paragraph 3-270.
16. Lamp (7).	Remove.	Refer to paragraph 3-92.
17. Blackout headlamp assembly (9).	Remove if left front fender is being removed.	Refer to paragraph 3-95
18. Bracket (8).	Remove.	Refer to paragraph 3-236.
19. Blackout marker lamp and cable assembly (10).	Remove.	Refer to paragraphs 3-94 and 3-129.
20. Headlamp and cable assembly (11).	Remove.	Refer to paragraphs 3-91 and 3-129.

CAB AND BODY.

3-271. FRONT FENDER REPLACEMENT (Continued).

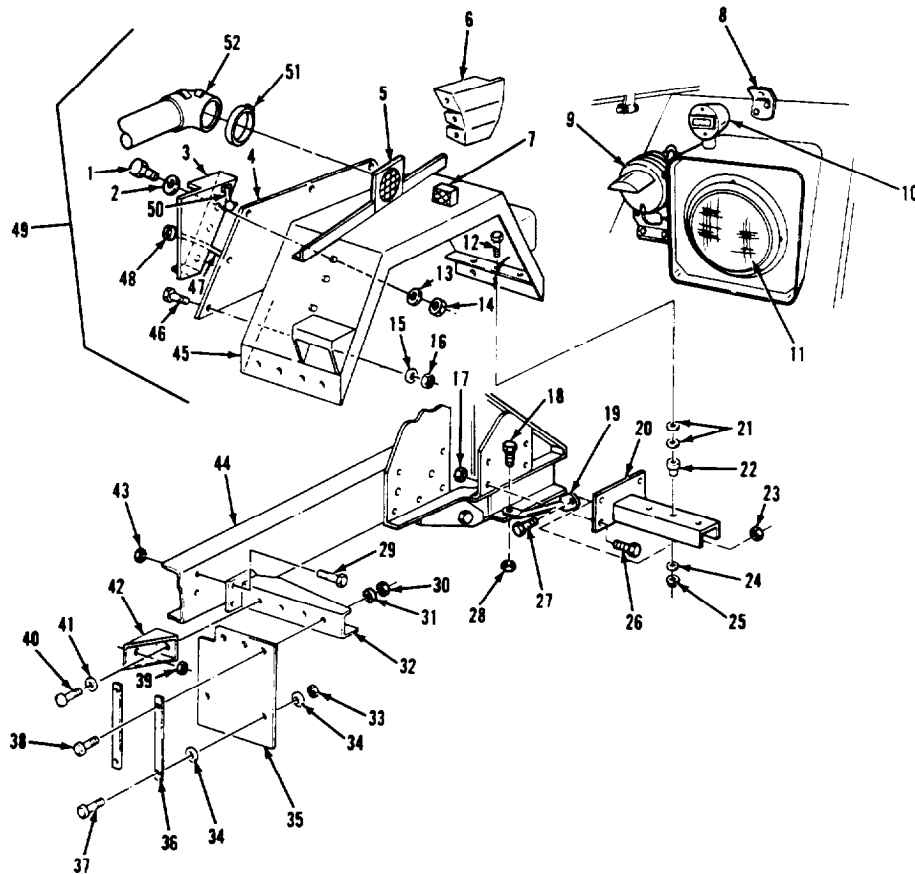

LEGEND:

- |  |                                |                                  |
|--|--------------------------------|----------------------------------|
| 1. SCREW (6)                                   | 15. WASHER (7)                 | 34. WASHER (2)                   |
| 2. WASHER (6)                                  | 16. NUT (7)                    | 35. MUD FLAP                     |
| 3. REAR FILLER                                 | 17. NUT (4)                    | 36. ANTISAIL BRACKET (2)         |
| 4. SPLASH SHIELD                               | 18. SCREW                      | 37. SCREW (2)                    |
| 5. HOOD SEAL AND<br>RETAINER                   | 19. BRACE                      | 38. SCREW (3)                    |
| 6. FRONT FILLER                                | 20. FRONT SUPPORT              |                                  |
| 7. TURN SIGNAL AND<br>MARKER LAMP              | 21. WASHER (6)                 | 40. SCREW                        |
| 8. BRUSH GUARD BRACE<br>BRACKET                | 22. VIBRATION<br>INSULATOR (3) | 41. WASHER (4)                   |
| 9. BLACKOUT HEADLAMP<br>ASSEMBLY (LEFT SIDE)   | 23. NUT                        | 42. REINFORCEMENT BRACKET        |
| 10. BLACKOUT MARKER LAMP<br>AND CABLE ASSEMBLY | 24. WASHER (3)                 | 43. NUT (3)                      |
| 11. HEADLAMP AND CABLE<br>ASSEMBLY             | 25. NUT (4)                    | 44. FRAME                        |
| 12. SCREW (3)                                  | 26. SCREW (4)                  | 45. FENDER PANEL                 |
| 13. WASHER (6)                                 | 27. SCREW                      | 46. SCREW (7)                    |
| 14. NUT (6)                                    | 28. NUT                        | 47. FENDER WIRING HARNESS        |
|  | 29. SCREW (3)                  | 48. CONNECTOR                    |
|  | 30. NUT (4)                    | 49. FENDER ASSEMBLY              |
|  | 31. WASHER (4)                 | 50. HOOD HOOK AND<br>BRACKET (2) |
|  | 32. REAR SUPPORT               | 51. AIR INTAKE TUBE CLAMP        |
|  | 33. NUT (2)                    | 52. ELBOW                        |

TA 237756



CAB AND BODY.

3-271. FRONT FENDER REPLACEMENT (Continued).

LOCATION/ITEM	ACTION	REMARKS
<b>C. FRONT FENDER DISASSEMBLY (Continued).</b>		
21. Harness (47).	Remove.	Refer to paragraph 3-126.
22. Two hooks and brackets (50).	Remove.	Refer to paragraph 3-270.
23. Seven screws (46), washers (15), and nuts (16).	Remove.	
24. Shield (4).	Remove from item (45).	
25. Six screws (1), washers (2), washers (13), and nuts (14):	Remove from items (3) and (6).	
26. Filler (3) and filler (6).	Remove from item (45).	
<b>D. FRONT FENDER REASSEMBLY.</b>		
27. Filler (3) and filler (6).	Install and secure with six items (1), (2), (13), and (14).	
28. Shield (4).	Install and secure with seven items (46), (15), and (16).	
29. Two hooks and brackets (50).	Install.	Refer to paragraph 3-270.
30. Harness (47).	Install.	Refer to paragraph 3-126.
31. Headlamp and cable assembly (11).	Install.	Refer to paragraphs 3-91 and 3-129.
32. Blackout marker lamp and cable assembly (10).	Install.	Refer to paragraphs 3-94 and 3-129.

CAB AND BODY.

3-271. FRONT FENDER REPLACEMENT (Continued).

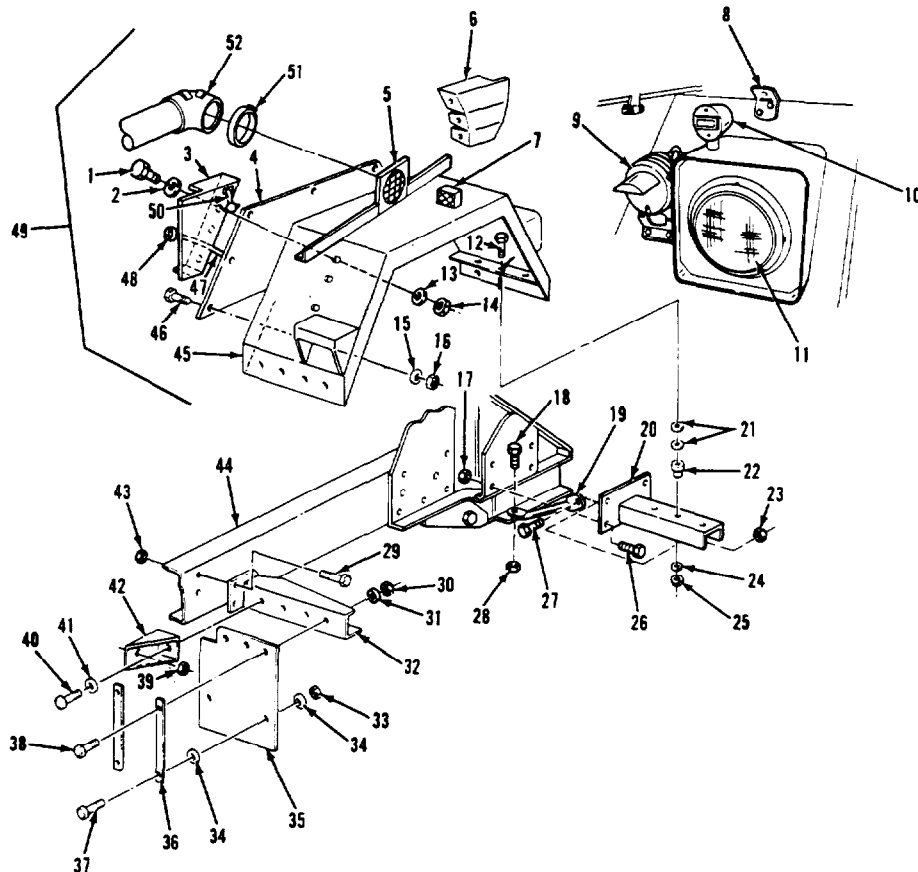

LEGEND:

- |  |                                |                                  |
|--|--------------------------------|----------------------------------|
| 1. SCREW (6)                                   | 15. WASHER (7)                 | 34. WASHER (2)                   |
| 2. WASHER (6)                                  | 16. NUT (7)                    | 35. MUD FLAP                     |
| 3. REAR FILLER                                 | 17. NUT (4)                    | 36. ANTISAIL BRACKET (2)         |
| 4. SPLASH SHIELD                               | 18. SCREW                      | 37. SCREW (2)                    |
| 5. HOOD SEAL AND<br>RETAINER                   | 19. BRACE                      | 38. SCREW (3)                    |
| 6. FRONT FILLER                                | 20. FRONT SUPPORT              | 39. NUT                          |
| 7. TURN SIGNAL AND<br>MARKER LAMP              | 21. WASHER (6)                 | 40. SCREW                        |
| 8. BRUSH GUARD BRACE<br>BRACKET                | 22. VIBRATION<br>INSULATOR (3) | 41. WASHER (4)                   |
| 9. BLACKOUT HEADLAMP<br>ASSEMBLY (LEFT SIDE)   | 23. NUT                        | 42. REINFORCEMENT BRACKET        |
| 10. BLACKOUT MARKER LAMP<br>AND CABLE ASSEMBLY | 24. WASHER (3)                 | 43. NUT (3)                      |
| 11. HEADLAMP AND CABLE<br>ASSEMBLY             | 25. NUT (4)                    | 44. FRAME                        |
| 12. SCREW (3)                                  | 26. SCREW (4)                  | 45. FENDER PANEL                 |
| 13. WASHER (6)                                 | 27. SCREW                      | 46. SCREW (7)                    |
| 14. NUT (6)                                    | 28. NUT                        | 47. FENDER WIRING HARNESS        |
|  | 29. SCREW (3)                  | 48. CONNECTOR                    |
|  | 30. NUT (4)                    | 49. FENDER ASSEMBLY              |
|  | 31. WASHER (4)                 | 50. HOOD HOOK AND<br>BRACKET (2) |
|  | 32. REAR SUPPORT               | 51. AIR INTAKE TUBE CLAMP        |
|  | 33. NUT (2)                    | 52. ELBOW                        |

TA 237757

CAB AND BODY.

3-271. FRONT FENDER REPLACEMENT (Continued).		
LOCATION/ITEM	ACTION	REMARKS
<b>D. FRONT FENDER REASSEMBLY (Continued).</b>		
33. Bracket (8).	Install.	Refer to paragraph 3-236.
34. Blackout headlamp assembly (9).	Install. (Left fender only).	Refer to paragraph 3-95.
35. Lamp (7).	Install.	Refer to paragraph 3-92.
36. Seal and retainer (5).	Install.	Refer to paragraph 3-270.
37. Fender assembly	Install.	Do steps 6, 7, 8, and 9.
<b>E. FRONT AND REAR SUPPORT REMOVAL.</b>		
38. Brace (19), screw (18), nut (28), screw (27), and nut (23).	Loosen and remove. Remove item (19).	
39. Four screws (26) and nuts (17).	Remove.	
40. Support (20).	Remove.	
41. Three insulators (22).	Remove from item (20).	
42. Nut (39).	Loosen and remove.	
43. Bracket (42).	Remove from item (44).	
44. Three screws (29) and nuts (43).	Remove.	
45. Support (32).	Remove from item (44).	

CAB AND BODY.

3-271. FRONT FENDER REPLACEMENT (Continued).

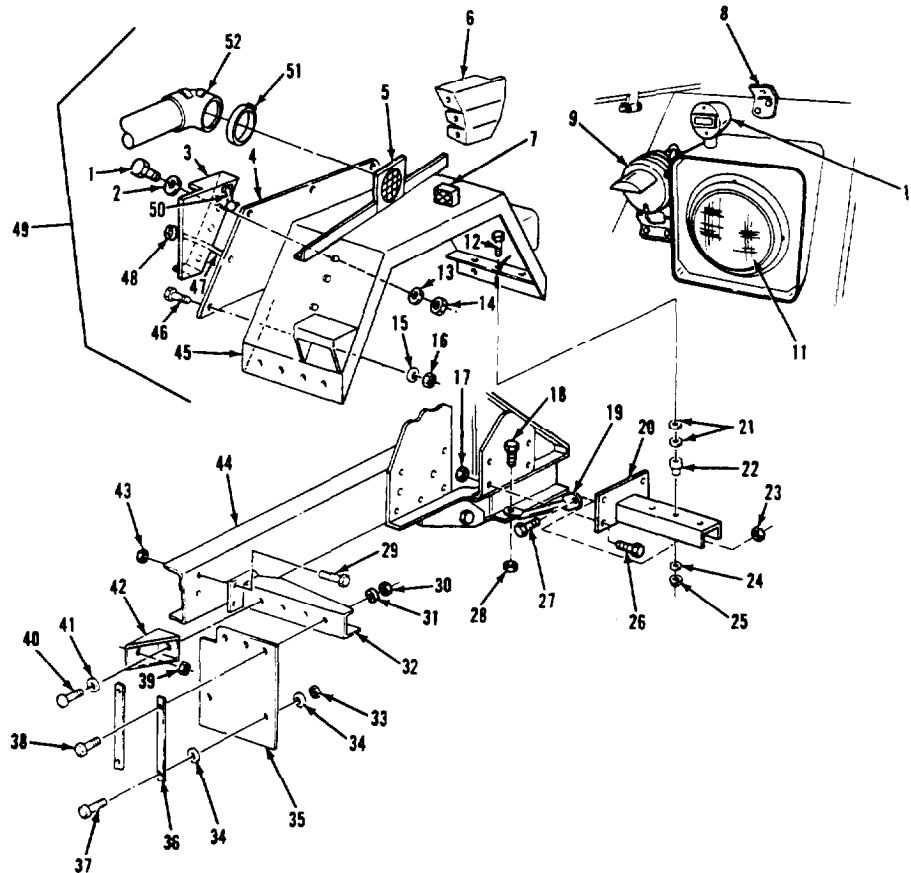

LEGEND:

- |  |                                |                                  |
|--|--------------------------------|----------------------------------|
| 1. SCREW (6)                                   | 15. WASHER (7)                 | 34. WASHER (2)                   |
| 2. WASHER (6)                                  | 16. NUT (7)                    | 35. MUD FLAP                     |
| 3. REAR FILLER                                 | 17. NUT (4)                    | 36. ANTISAIL BRACKET (2)         |
| 4. SPLASH SHIELD                               | 18. SCREW                      | 37. SCREW (2)                    |
| 5. HOOD SEAL AND<br>RETAINER                   | 19. BRACE                      | 38. SCREW (3)                    |
| 6. FRONT FILLER                                | 20. FRONT SUPPORT              | 39. NUT                          |
| 7. TURN SIGNAL AND<br>MARKER LAMP              | 21. WASHER (6)                 | 40. SCREW                        |
| 8. BRUSH GUARD BRACE<br>BRACKET                | 22. VIBRATION<br>INSULATOR (3) | 41. WASHER (4)                   |
| 9. BLACKOUT HEADLAMP<br>ASSEMBLY (LEFT SIDE)   | 23. NUT                        | 42. REINFORCEMENT BRACKET        |
| 10. BLACKOUT MARKER LAMP<br>AND CABLE ASSEMBLY | 24. WASHER (3)                 | 43. NUT (3)                      |
| 11. HEADLAMP AND CABLE<br>ASSEMBLY             | 25. NUT (4)                    | 44. FRAME                        |
| 12. SCREW (3)                                  | 26. SCREW (4)                  | 45. FENDER PANEL                 |
| 13. WASHER (6)                                 | 27. SCREW                      | 46. SCREW (7)                    |
| 14. NUT (6)                                    | 28. NUT                        | 47. FENDER WIRING HARNESS        |
|  | 29. SCREW (3)                  | 48. CONNECTOR                    |
|  | 30. NUT (4)                    | 49. FENDER ASSEMBLY              |
|  | 31. WASHER (4)                 | 50. HOOD HOOK AND<br>BRACKET (2) |
|  | 32. REAR SUPPORT               | 51. AIR INTAKE TUBE CLAMP        |
|  | 33. NUT (2)                    | 52. ELBOW                        |

TA 227758

CAB AND BODY.

3-271. FRONT FENDER REPLACEMENT (Continued).		
LOCATION/ITEM	ACTION	REMARKS
<b>F. FRONT AND REAR SUPPORT INSTALLATION.</b>		
46. Support (32).	Aline with mounting holes in side of item (44). Secure with three items (29) and (43).	
47. Bracket (42).	Aline with mounting holes in side of item (44). Secure with item (39).	
48. Support (20).	Aline and install. Secure with four items (26) and (17).	
49. Three insulators (22) 1	Install into item (20).	
50. Brace (19).	Aline and install. Secure with items (18), (28), (27),	
<b>G. MUD FLAP AND ANTISAIL BRACKET DISASSEMBLY.</b>		
51. Two screws (37), four washers (34), and two nuts (33).	Loosen and remove from item (35) and two items (36).	Inspect item (35) and two items (36) for serviceability. Replace if damaged.
<b>H. MUD FLAP AND ANTISAIL BRACKET REASSEMBLY.</b>		
52. Two screws (37), four washers (34), and two nuts (33).	Install into two items (36) and item (35). Tighten two items (33).	
NOTE		
Follow-on maintenance action required:		
Install brush guard brace (para 3-236).		
Close and latch hood (TM 9-2320-283-10).		

CAB AND BODY.

3-271. FRONT FENDER REPLACEMENT (Continued).

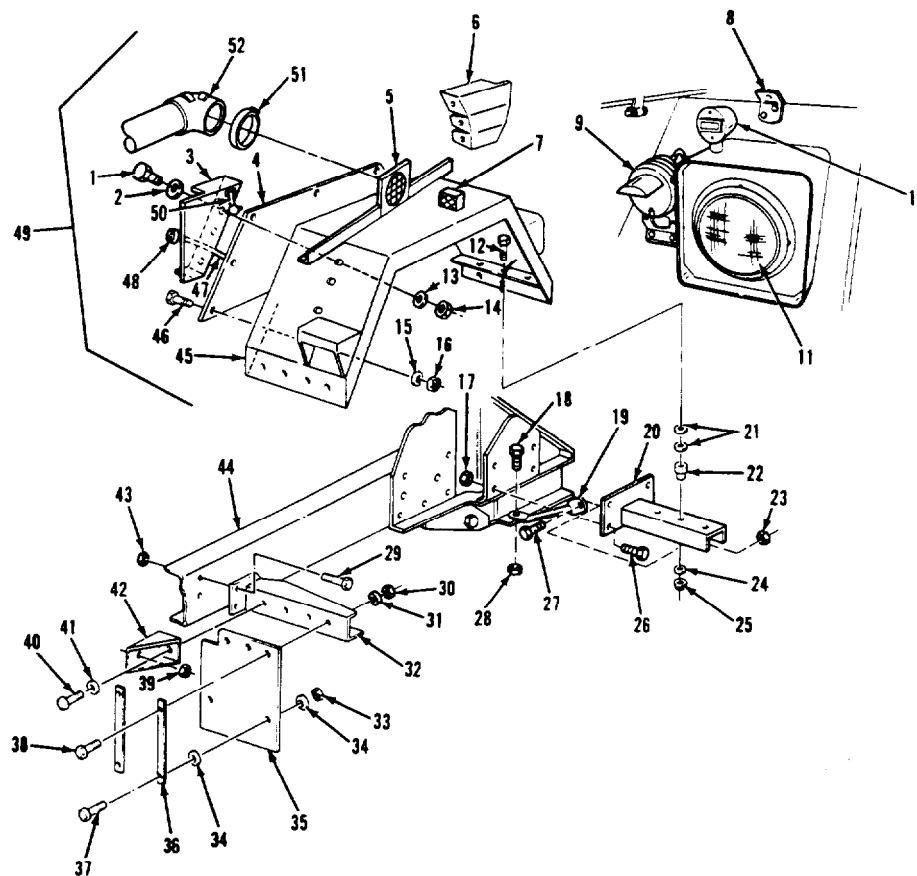

LEGEND:

- |  |                                |                                  |
|--|--------------------------------|----------------------------------|
| 1. SCREW (6)                                   | 15. WASHER (7)                 | 34. WASHER (2)                   |
| 2. WASHER (6)                                  | 16. NUT (7)                    | 35. MUD FLAP                     |
| 3. REAR FILLER                                 | 17. NUT (4)                    | 36. ANTISAIL BRACKET (2)         |
| 4. SPLASH SHIELD                               | 18. SCREW                      | 37. SCREW (2)                    |
| 5. HOOD SEAL AND<br>RETAINER                   | 19. BRACE                      | 38. SCREW (3)                    |
| 6. FRONT FILLER                                | 20. FRONT SUPPORT              | 39. NUT                          |
| 7. TURN SIGNAL AND<br>MARKER LAMP              | 21. WASHER (6)                 | 40. SCREW                        |
| 8. BRUSH GUARD BRACE<br>BRACKET                | 22. VIBRATION<br>INSULATOR (3) | 41. WASHER (4)                   |
| 9. BLACKOUT HEADLAMP<br>ASSEMBLY (LEFT SIDE)   | 23. NUT                        | 42. REINFORCEMENT BRACKET        |
| 10. BLACKOUT MARKER LAMP<br>AND CABLE ASSEMBLY | 24. WASHER (3)                 | 43. NUT (3)                      |
| 11. HEADLAMP AND CABLE<br>ASSEMBLY             | 25. NUT (4)                    | 44. FRAME                        |
| 12. SCREW (3)                                  | 26. SCREW (4)                  | 45. FENDER PANEL                 |
| 13. WASHER (6)                                 | 27. SCREW                      | 46. SCREW (7)                    |
| 14. NUT (6)                                    | 28. NUT                        | 47. FENDER WIRING HARNESS        |
|  | 29. SCREW (3)                  | 48. CONNECTOR                    |
|  | 30. NUT (4)                    | 49. FENDER ASSEMBLY              |
|  | 31. WASHER (4)                 | 50. HOOD HOOK AND<br>BRACKET (2) |
|  | 32. REAR SUPPORT               | 51. AIR INTAKE TUBE CLAMP        |
|  | 33. NUT (2)                    | 52. ELBOW                        |

TA 237759

CAB AND BODY.

**3- 272. QUARTER FENDER REPLACEMENT.**

**THIS TASK COVERS**

- a. Removal.
- b. Installation.

**INITIAL SETUP**

<b><u>APPLICABLE CONFIGURATIONS</u></b>	<b><u>EQUIPMENT CONDITION PARAGRAPH</u></b>	<b><u>CONDITION DESCRIPTION</u></b>
All.	None.	None.

**TEST EQUIPMENT**  
None.

**SPECIAL TOOLS**  
None.

**MATERIALS/PARTS (P/N)**  
None.

**PERSONNEL REQUIRED**  
One (MDS- 63S).

**SPECIAL ENVIRONMENTAL CONDITIONS**  
None.

**REFERENCES (TM)**

**GENERAL SAFETY INSTRUCTIONS**  
Engine off.  
Transmission in neutral.  
Park brake set.

**TROUBLESHOOTING REFERENCES**  
None.

CAB AND BODY.

3-272. QUARTER FENDER REPLACEMENT (Continued).

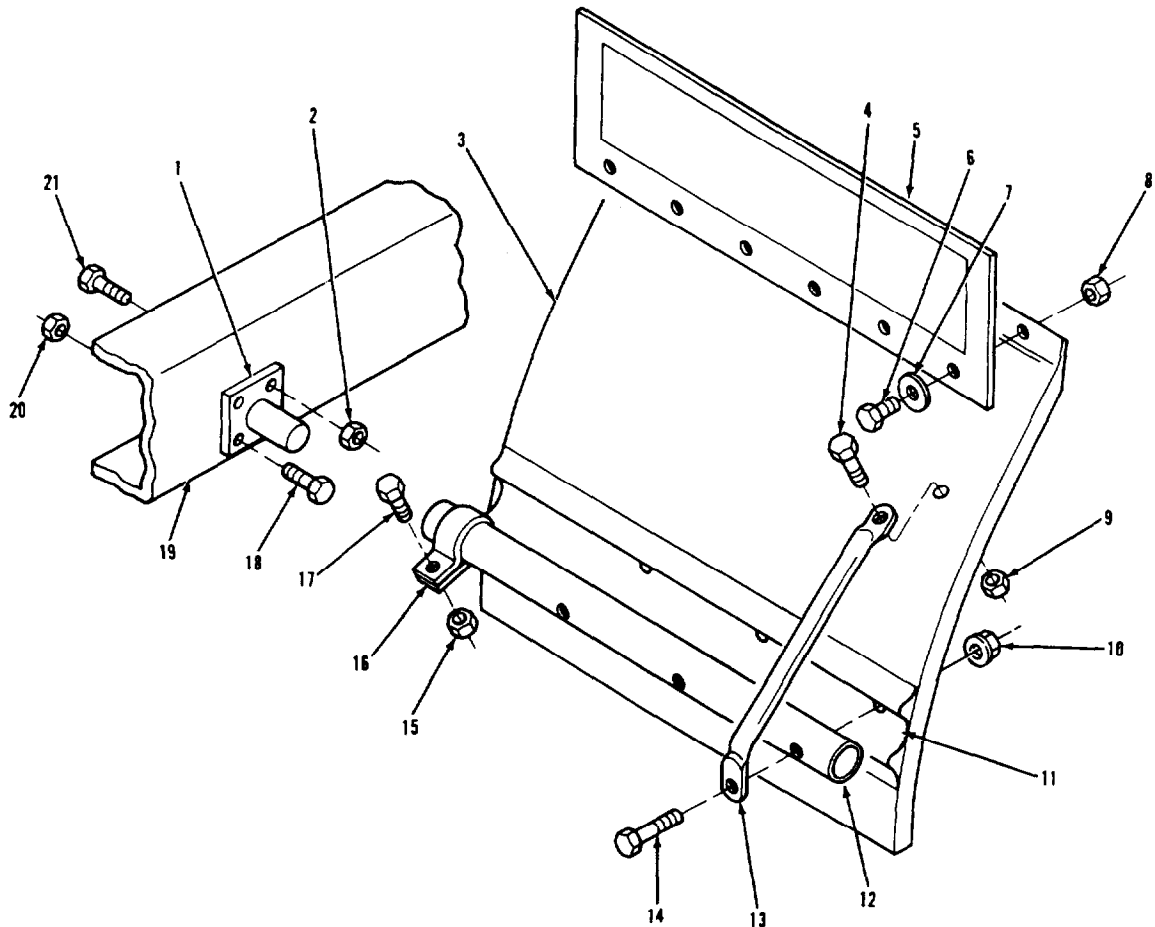

LEGEND:

- |                         |                          |
|-------------------------|--------------------------|
| 1. BRACKET              | 12. HANGER TUBE          |
| 2. NUT (2)              | 13. FENDER BRACE (3)     |
| 3. QUARTER FENDER       | 14. HEX BOLT LOCKNUT (3) |
| 4. HEX BOLT (3)         | 15. LOCKNUT              |
| 5. SPLASH GUARD         | 16. TUBE HANGER CLAMP    |
| 6. HEX BOLT (6)         | 17. HEX BOLT             |
| 7. WASHER (6)           | 18. HEX BOLT (2)         |
| 8. NUT (6)              | 19. FRAME                |
| 9. LOCKNUT (3)          | 20. NUT (2)              |
| 10. FLANGED LOCKNUT (3) | 21. HEX BOLT (2)         |
| 11. ADAPTER             |                          |

TA 237760



CAB AND BODY.

3-272. QUARTER FENDER REPLACEMENT (Continued).

LOCATION/ITEM	ACTION	REMARKS
NOTE		
<p>Quarter fender replacement is the same for both sides. This procedure covers replacement of the left quarter fender.</p>		
A. REMOVAL.		
1. Six bolts (6), washers (7), and nuts (8).	Loosen and remove from items (5) and (3).	
2. Guard (5).	Remove from item (3).	
3. Three bolts (4) and locknuts (9).	Loosen and remove from three items (13) and item (3).	
4. Three bolts (14) and locknuts (10).	Loosen and remove from three items (13), and items (12), (11), and (3).	
5. Fender (3), adapter (11), and three braces (13).	Remove.	
6. Bolt (17) and locknut (15).	Loosen.	
7. Tube (12).	Remove.	Tap with soft mallet, or heat junction of items (1) and (12).
8. Clamp (16).	Remove from item (12). Remove items (17) and (15) from item (16).	
9. Two bolts (18) and nuts (20).	Loosen and remove from items (1) and (19).	Remove primary reservoir if left item (1) is being removed. (Refer to paragraph 3-169).
10. Two nuts (2).	Loosen and remove. Do not remove two items (21) from item (19).	

CAB AND BODY.

3-272. QUARTER FENDER REPLACEMENT (Continued).

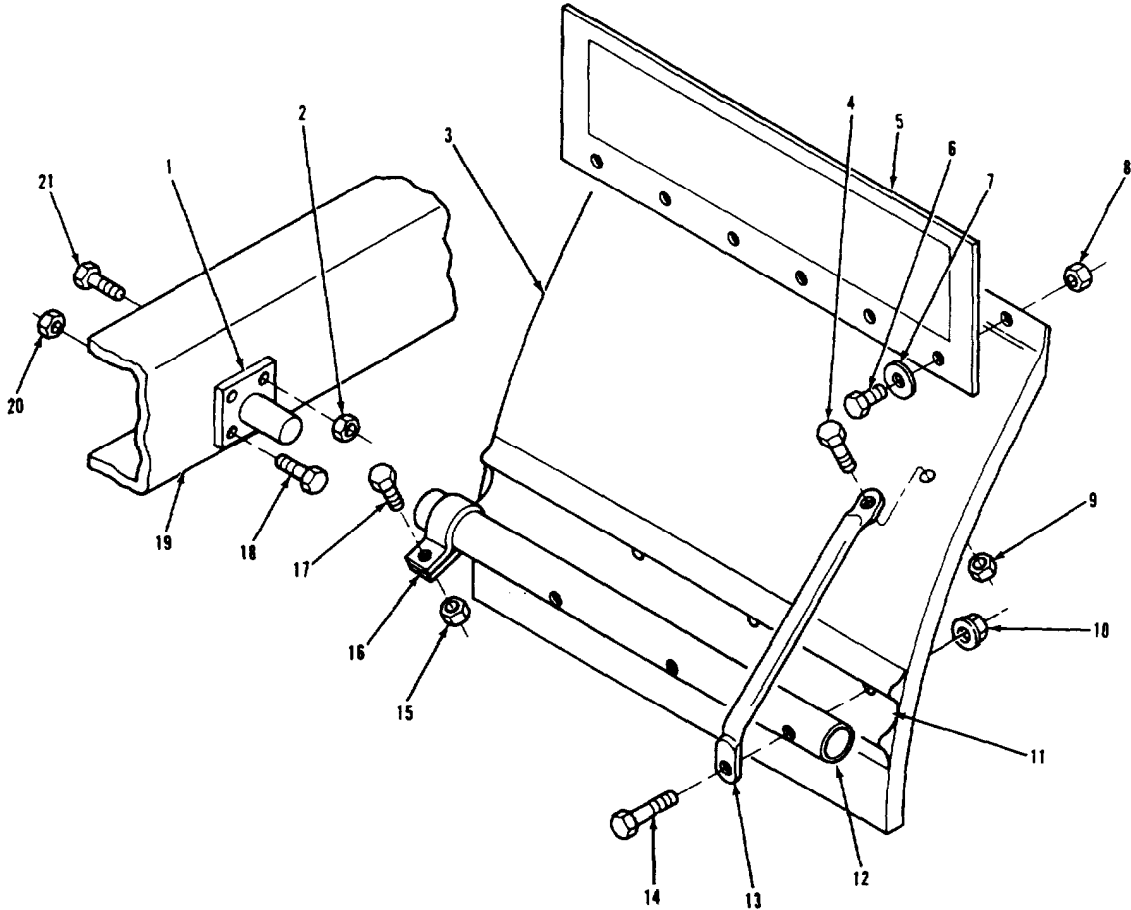

LEGEND:

- |                         |                          |
|-------------------------|--------------------------|
| 1. BRACKET              | 12. HANGER TUBE          |
| 2. NUT (2)              | 13. FENDER BRACE (3)     |
| 3. QUARTER FENDER       | 14. HEX BOLT LOCKNUT (3) |
| 4. HEX BOLT (3)         | 15. LOCKNUT              |
| 5. SPLASH GUARD         | 16. TUBE HANGER CLAMP    |
| 6. HEX BOLT (6)         | 17. HEX BOLT             |
| 7. WASHER (6)           | 18. HEX BOLT (2)         |
| 8. NUT (6)              | 19. FRAME                |
| 9. LOCKNUT (3)          | 20. NUT (2)              |
| 10. FLANGED LOCKNUT (3) | 21. HEX BOLT (2)         |
| 11. ADAPTER             |                          |

TA 23776

CAB AND BODY.

3-272. QUARTER FENDER REPLACEMENT (Continued).

LOCATION/ITEM	ACTION	REMARKS
<b>A. REMOVAL (Continued).</b>		
11. Bracket (1).	Remove from item (19).	
<b>B. INSTALLATION.</b>		
12. Bracket (1).	Aline with mounting holes in side of item (19). Secure with two items (18), (20), (21), and (2).	Install primary reservoir if removed in step 9. (Refer to paragraph 3-169).
13. Clamp (16).	Install on end of item (12). Install items (17) and (15) through item (16). Tighten item (15) finger tight.	
14. Tube (12).	Install on end of item (1). Position mounting holes for item (3) at nine o'clock. Tighten items (15) and (17).	Angle of item (3) may need to be adjusted after mounting.
15. Three braces (13), adapter (11) and fender (3).	Move into position and aline mounting holes. Attach with three items (14) and (10).	
16. Three bolts (4) and locknuts (9).	Install through three items (13), into item (3), and tighten.	
17. Guard (5).	Move into position and aline mounting holes with item (3). Attach with six items (6), (7), and (8).	
18. Tube (12) and fender (3).	Adjust angle to conform to shape of tire by loosening and tightening items (17), (16), and (15).	
NOTE		
Follow-on maintenance action required:		
None.		

CAB AND BODY.

3-272. QUARTER FENDER REPLACEMENT (Continued).

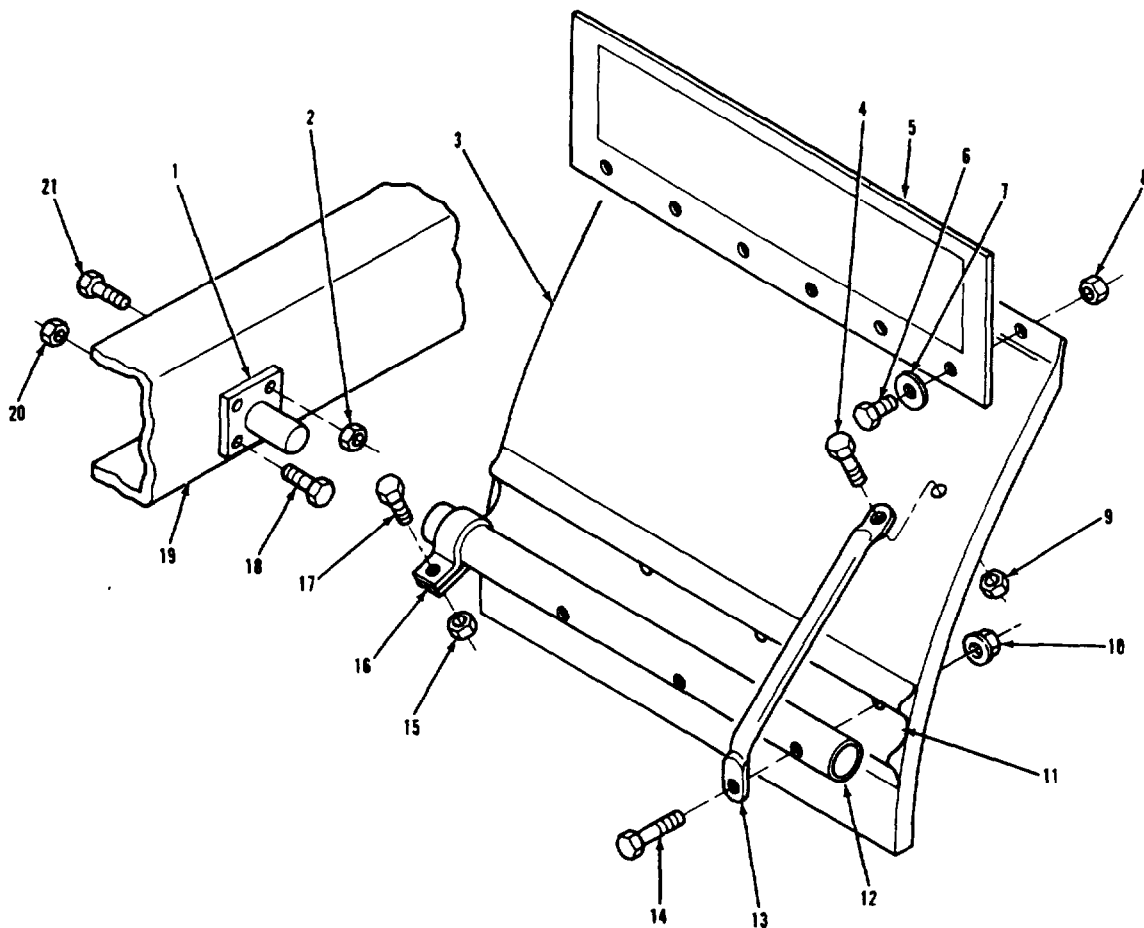

LEGEND:

- |                         |                          |
|-------------------------|--------------------------|
| 1. BRACKET              | 12. HANGER TUBE          |
| 2. NUT (2)              | 13. FENDER BRACE (3)     |
| 3. QUARTER FENDER       | 14. HEX BOLT LOCKNUT (3) |
| 4. HEX BOLT (3)         | 15. LOCKNUT              |
| 5. SPLASH GUARD         | 16. TUBE HANGER CLAMP    |
| 6. HEX BOLT (6)         | 17. HEX BOLT             |
| 7. WASHER (6)           | 18. HEX BOLT (2)         |
| 8. NUT (6)              | 19. FRAME                |
| 9. LOCKNUT (3)          | 20. NUT (2)              |
| 10. FLANGED LOCKNUT (3) | 21. HEX BOLT (2)         |
| 11. ADAPTER             |                          |

TA 237762

CAB AND BODY.

**3-273. SPLASH SHIELD REPLACEMENT.**

**THIS TASK COVERS**

- a. Removal.
- b. Installation.

**INITIAL SETUP**

<b><u>APPLICABLE CONFIGURATIONS</u></b>	<b><u>EQUIPMENT CONDITION PARAGRAPH</u></b>	<b><u>CONDITION DESCRIPTION</u></b>
All.	3-211.	Front fender removed.

**TEST EQUIPMENT**  
None.

**SPECIAL TOOLS**  
None.

**MATERIALS/PARTS (P/N)**  
None.

**PERSONNEL REQUIRED**  
One (MOS-63S).

**SPECIAL ENVIRONMENTAL CONDITIONS**  
None.

**REFERENCES (TM)**  
None.

**GENERAL SAFETY INSTRUCTIONS**  
Engine off  
Transmission in neutral.  
Park brake set.

**TROUBLESHOOTING REFERENCES**  
None.

CAB AND BODY.

3-273. SPLASH SHIELD REPLACEMENT (Continued).

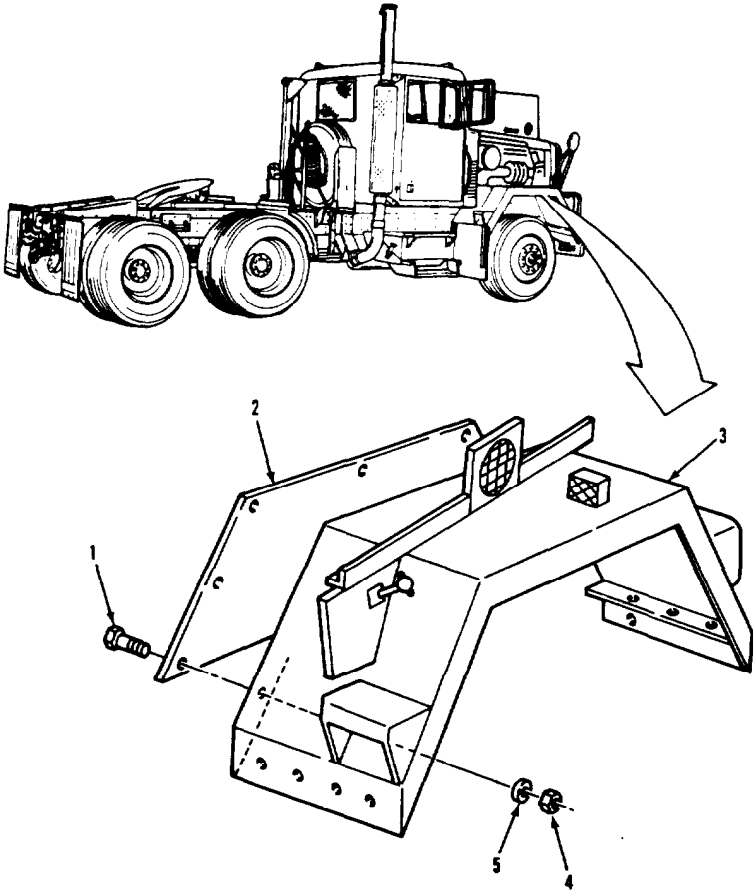

LEGEND:

- 1. SCREW (7)
- 2. SPLASH SHIELD
- 3. FENDER ASSEMBLY
- 4. NUT (7)
- 5. WASHER (7)

TA 23774

CAB AND BODY.

3-273. SPLASH SHIELD REPLACEMENT (Continued).

LOCATION/ITEM	ACTION	REMARKS
NOTE		
Splash shield replacement is the same for both sides. This procedure covers replacement of the right splash shield.		
<b>A. REMOVAL.</b>		
1. Seven screws (1), washers (5), and nuts (4).	Loosen and remove from item (3).	
2. Shield (2).	Separate from item (3).	
<b>B. INSTALLATION.</b>		
3. Shield (2).	Aline mounting holes in item (2) with item (3).	
4. Seven screws (1), washers (5), and nuts (4).	Install through items (2) and (3), and tighten.	
NOTE		
Follow-on maintenance action required:		
Install front fender (para 3-271).		

CAB AND BODY.

3-273. SPLASH SHIELD REPLACEMENT (Continued).

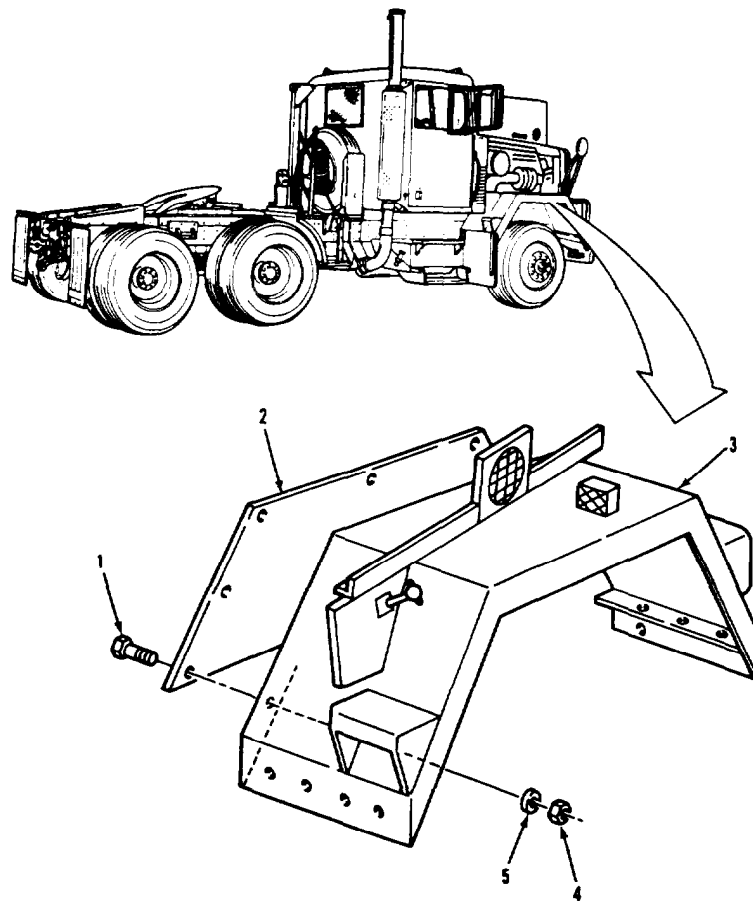

LEGEND:

- 1. SCREW (7)
- 2. SPLASH SHIELD
- 3. FENDER ASSEMBLY

- 4. NUT (7)
- 5. WASHER (7)

TA 23776



CAB AND BODY.

3- 274. REAR MUD FLAP AND BRACKET REPLACEMENT.

THIS TASK COVERS

- a. Removal.
- b. Installation.

INITIAL SETUP

APPLICABLE CONFIGURATIONS

All.

EQUIPMENT CONDITION  
PARAGRAPH

None.

CONDITION DESCRIPTION

None.

TEST EQUIPMENT

None.

SPECIAL TOOLS

None.

MATERIALS/PARTS (P/N)

None.

PERSONNEL REQUIRED

One (MOS- 63S).

SPECIAL ENVIRONMENTAL CONDITIONS

None.

REFERENCES (TM)

GENERAL SAFETY INSTRUCTIONS

Engine off  
Transmission in neutral.  
Park brake set.

TROUBLESHOOTING REFERENCES

None.

CAB AND BODY.

3-274. REAR MUD FLAP AND BRACKET REPLACEMENT (Continued).

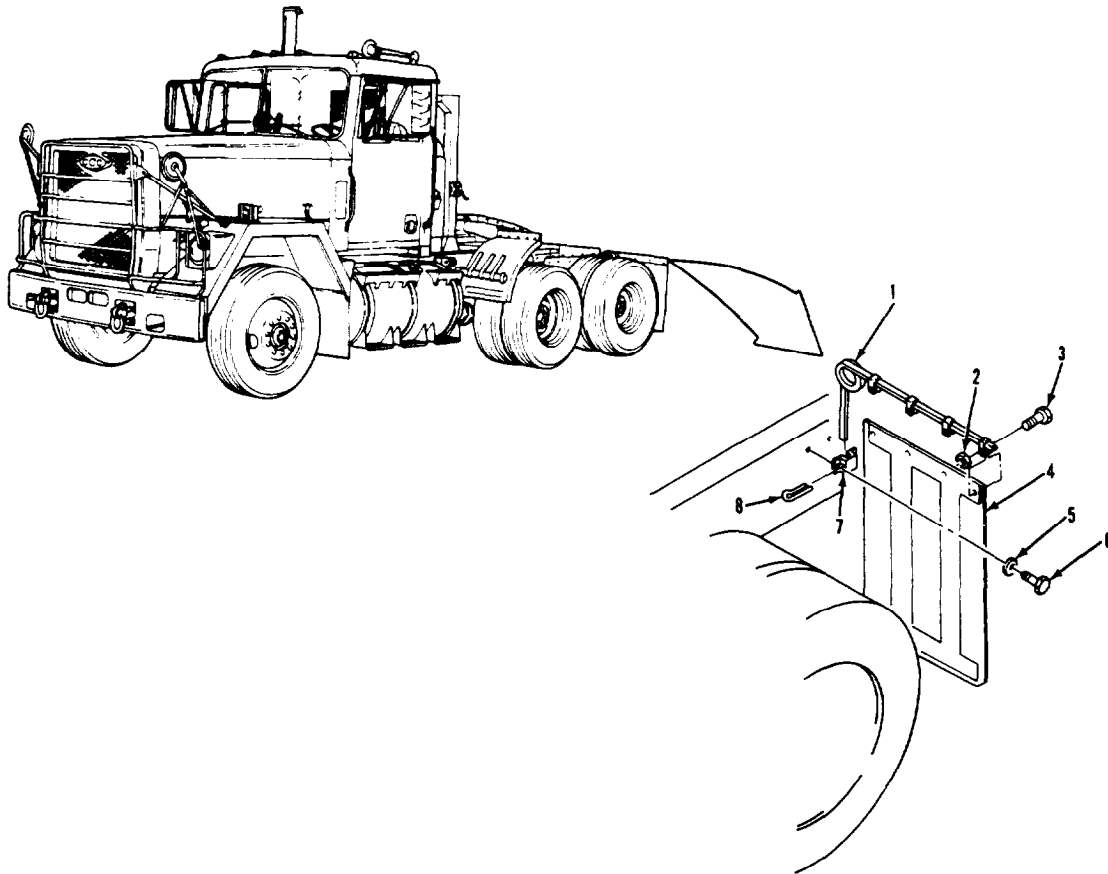

LEGEND:

- |                         |                            |
|-------------------------|----------------------------|
| 1. REAR MUD FLAP HOLDER | 5. LOCKWASHER (2)          |
| 2. PT NUT (4)           | 6. SCREW (2)               |
| 3. SCREW (4)            | 7. MUD FLAP HOLDER BRACKET |
| 4. REAR MUD FLAP        | 8. RETAINING PIN           |

TA 237765

CAB AND BODY.

3-274. REAR MUD FLAP AND BRACKET REPLACEMENT (Continued).		
LOCATION/ITEM	ACTION	REMARKS
NOTE		
Replacement of rear mud flap and bracket is same for both sides.		
<b>A. REMOVAL.</b>		
1. Pin (8).	Remove from item (7) and item (1).	
2. Holder (1).	Remove from item (7).	
3. Four screws (3) and nuts (2).	Remove from item (1) and item (4).	
4. Flap (4).	Remove from item (1).	
5. Two screws (6) and lockwashers (5).	Remove from item (7).	
6. Bracket (7).	Remove.	
<b>B. INSTALLATION.</b>		
7. Two screws (6) and lockwashers (5).	Secure item (7) to frame.	
8. Flap (4).	Put in place in item (1).	
9. Four screws (3) and nuts (2).	Secure item (4) in item (1).	
10. Holder (1).	Put in item (7).	
11. Pin (8).	Secure item (1) in item (7).	
NOTE		
Follow-on maintenance action required:		
None.		

CAB AND BODY.

3-274. REAR MUD FLAP AND BRACKET REPLACEMENT (Continued).

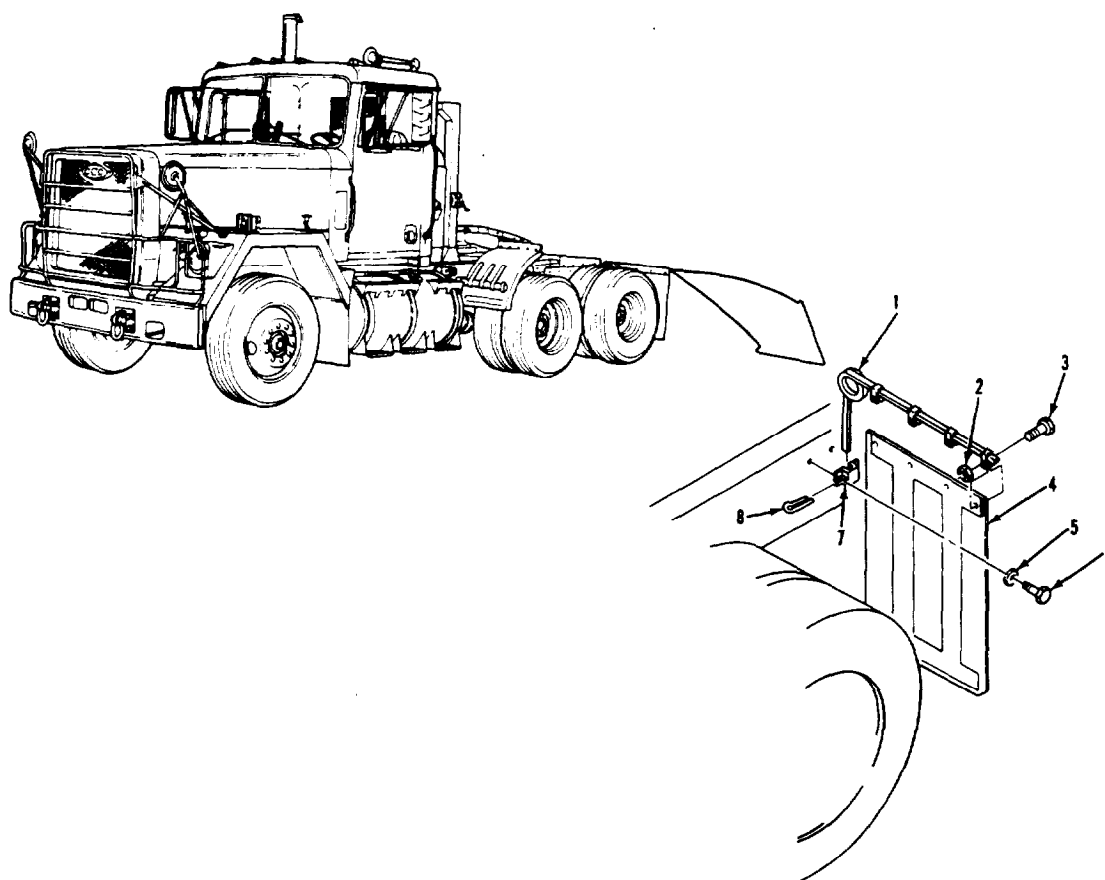

LEGEND:

- |                         |                            |
|-------------------------|----------------------------|
| 1. REAR MUD FLAP HOLDER | 5. LOCKWASHER (2)          |
| 2. PT NUT (4)           | 6. SCREW (2)               |
| 3. SCREW (4)            | 7. MUD FLAP HOLDER BRACKET |
| 4. REAR MUD FLAP        | 8. RETAINING PIN           |

TA 237766

CAB AND BODY.

**3- 275. CAB HEADLINER PANEL REPLACEMENT.**

**THIS TASK COVERS**

- a. Removal.
- b. Cleaning and Inspection.
- c. Installation.

**INITIAL SETUP**

<u>APPLICABLE CONFIGURATIONS</u>	<u>EQUIPMENT CONDITION PARAGRAPH</u>	<u>CONDITION DESCRIPTION</u>
All.	3- 98.	Dome lamp and switch removed.
<u>TEST- EQUIPMENT</u>	3- 99.	Map lamps and switches removed.
<u>SPECIAL TOOLS</u>	3- 289.	Air horn and control valve removed.
None.		
<u>MATERIALS/PARTS (P/N)</u>		
None.		
<u>PERSONNEL REQUIRED</u>	<u>SPECIAL ENVIRONMENTAL CONDITIONS</u>	
One (MDS- 63S).	None.	
<u>REFERENCES (TM)</u>	<u>GENERAL SAFETY INSTRUCTIONS</u>	
	Engine off Transmission in neutral. Park brake set.	
<u>TROUBLESHOOTING REFERENCES</u>	Wear protective clothing (gloves, goggles, face mask, etc.) when working near insulation material.	
None.		

CAB AND BODY.

3-275. CAB HEADLINER PANEL REPLACEMENT (Continued).

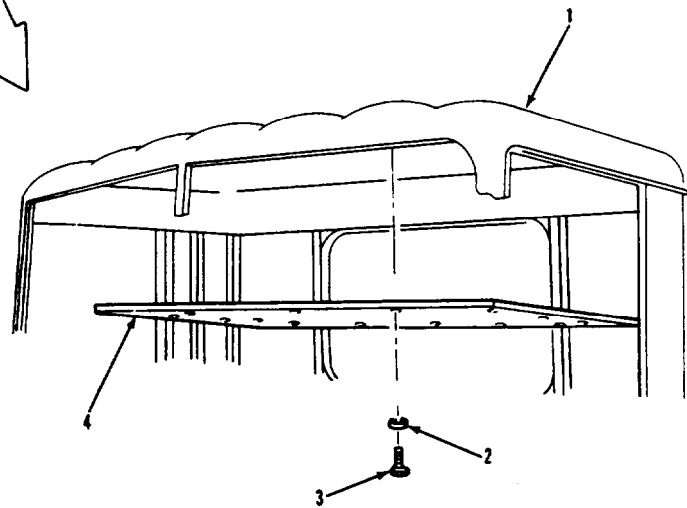
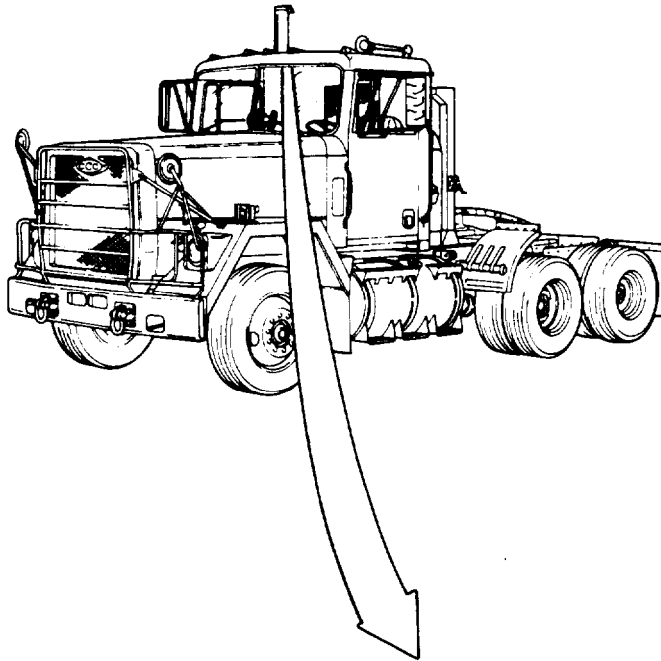

LEGEND:

- 1. CAB ROOF
- 2. FINISH WASHER (28)
- 3. SCREW (28)
- 4. CAB HEADLINER PANEL

TA 237767

CAB AND BODY.

3- 275. CAB HEADLINER PANEL REPLACEMENT (Continued).

LOCATION/ITEM	ACTION	REMARKS
<u><b>WARNING</b></u>		
Insulation material under cab headliner panel can cause personal injury. Always wear suitable protective clothing (gloves, goggles, face mask, etc.) whenever cab headliner panel is replaced.		
<b>A. REMOVAL.</b>		
1. Twenty-eight screws Remove from item (1). (3), washers (2), and panel (4).		
<b>B. CLEANING AND INSPECTION.</b>		
2. All parts.	Clean and inspect.	Refer to paragraphs 3-4 and 3-5.
<b>C. INSTALLATION.</b>		
3. Panel (4).	a. Position on item (1).  b. Secure with twenty-eight items (3) and (2).	
NOTE		
Follow-on maintenance action required:		
Install air horn and control valve (para 3-289). Install map lamps and switches (para 3-99). Install dome lamp and switch (para 3-98).		

CAB AND BODY.

3-275. CAB HEADLINER PANEL REPLACEMENT (Continued).

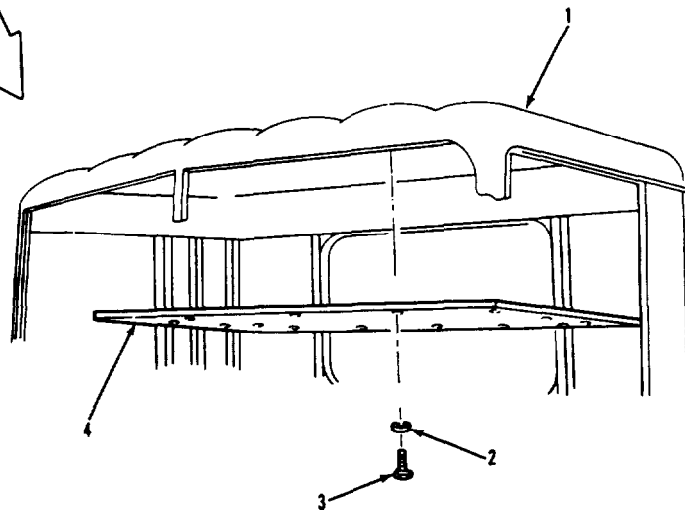
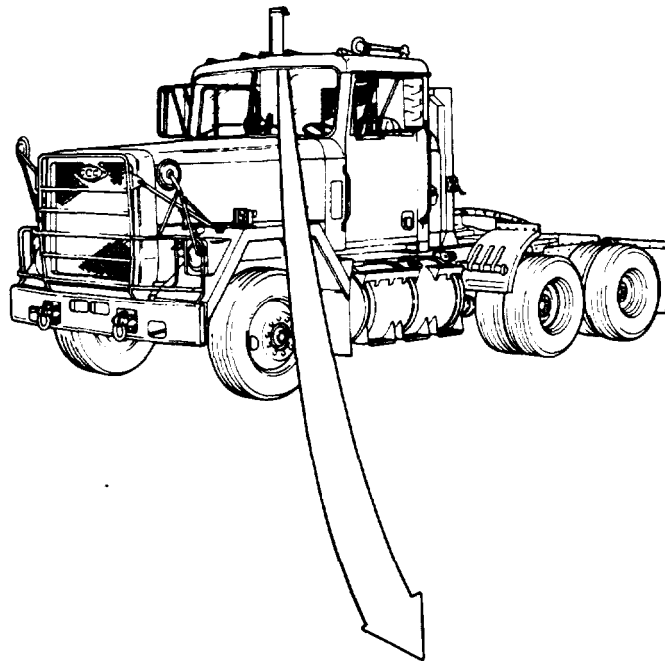

LEGEND:

- 1. CAB ROOF
- 2. FINISH WASHER (28)
- 3. SCREW (28)
- 4. CAB HEADLINER PANEL

TA 237768



CAB AND BODY.

3-276. CAB TRIM PANEL REPLACEMENT.

THIS TASK COVERS

- a. Removal.
- b. Cleaning and Inspection.
- c. Installation.

INITIAL SETUP

<p><u>APPLICABLE CONFIGURATIONS</u> All.</p>	<p><u>EQUIPMENT CONDITION PARAGRAPH</u> TM 9-2320-283-10.</p>	<p><u>CONDITION DESCRIPTION</u> Fire extinguisher removed (for replacement of right-hand cab trim panel only).</p>
<p><u>TEST EQUIPMENT</u> None.</p>		
<p><u>SPECIAL TOOLS</u> None.</p>		
<p><u>MATERIALS/PARTS (P/N)</u> None.</p>		
<p><u>PERSONNEL REQUIRED</u> One (MS-63S).</p>	<p><u>SPECIAL ENVIRONMENTAL CONDITIONS</u> None.</p>	
<p><u>REFERENCES (TM)</u> None.</p>	<p><u>GENERAL SAFETY INSTRUCTIONS</u> Engine off. Transmission in neutral. Park brake set. Wear protective clothing (gloves, goggles, face mask, etc.) when working near insulation material.</p>	
<p><u>TROUBLESHOOTING REFERENCES</u> None.</p>		

CAB AND BODY.

3-276. CAB TRIM PANEL REPLACEMENT (Continued).

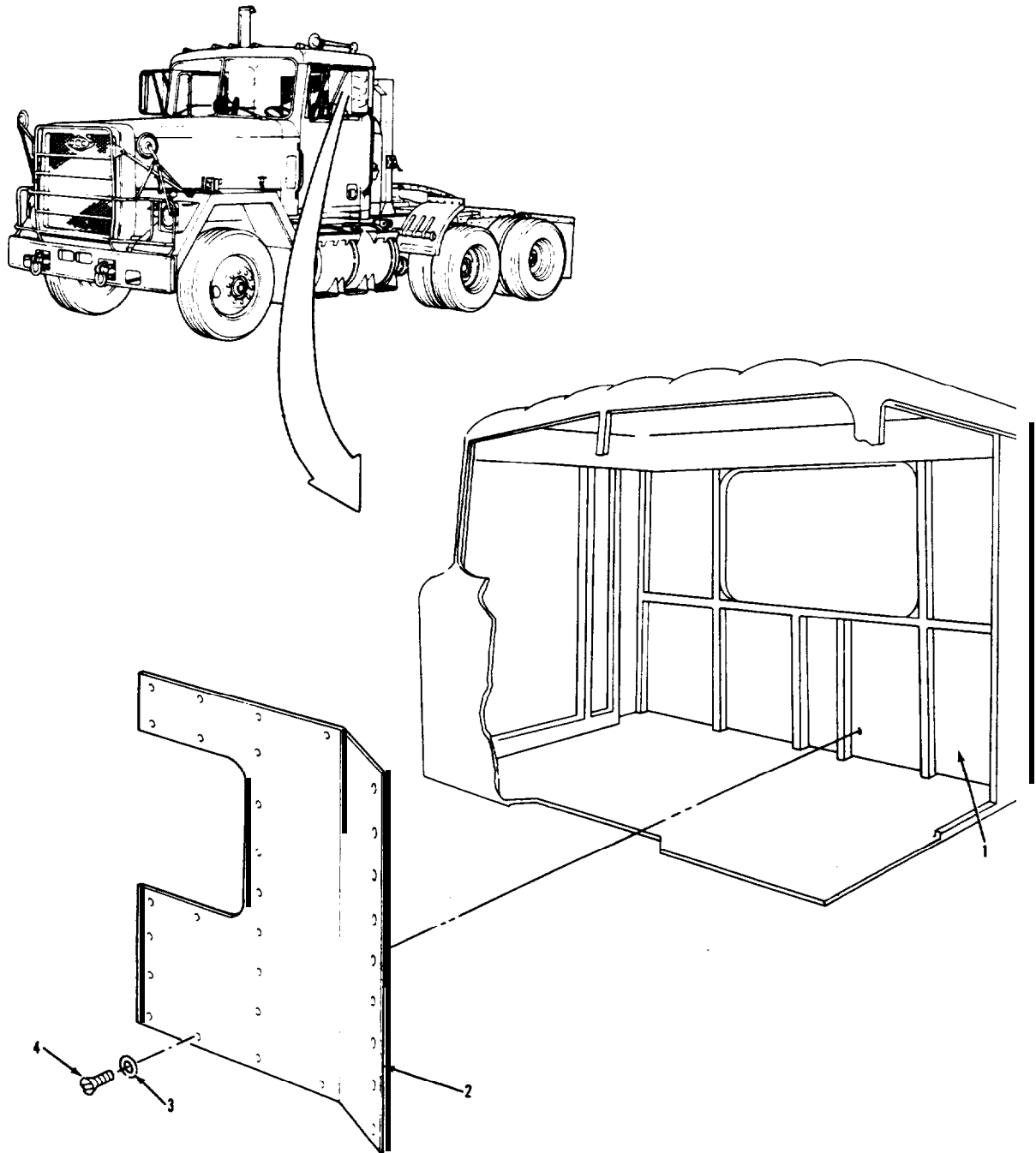

LEGEND:

1. CAB WALL
2. LEFT-HAND CAB TRIM PANEL
3. FINISH WASHER (26)
4. SCREW (26)

TA 237769

CAB AND BODY.

3-276. CAB TRIM PANEL REPLACEMENT (Continued).

LOCATION/ITEM	ACTION	REMARKS
<u>WARNING</u>		
Insulation material behind cab trim panel can cause personal injury. Always wear suitable protective clothing (gloves, goggles, face mask, etc.) whenever cab trim panel is replaced.		
NOTE		
Use this procedure to replace the right-hand or left-hand cab trim panel.		
<b>A. REMOVAL</b>		
1. Twenty-six screws (4), washers (3), and panel (2).	Remove from item (1).	
<b>B. CLEANING AND INSPECTION.</b>		
2. All parts.	Clean and inspect.	Refer to paragraphs 3-4 and 3-5.
<b>C. INSTALLATION</b>		
3. Panel (2).	a. Position on item (1).  b. Secure with twenty-six items (4) and (3).	
NOTE		
Follow-on maintenance action required:		
Install fire extinguisher, if necessary (TM 9-2320-283-10).		

CAB AND BODY.

3-276. CAB TRIM PANEL REPLACEMENT (Continued).

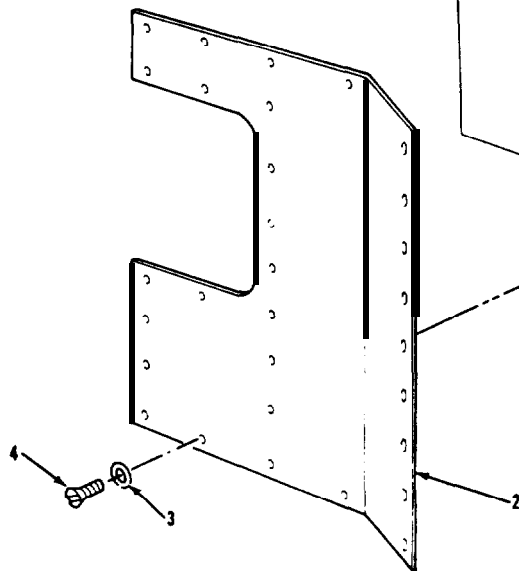
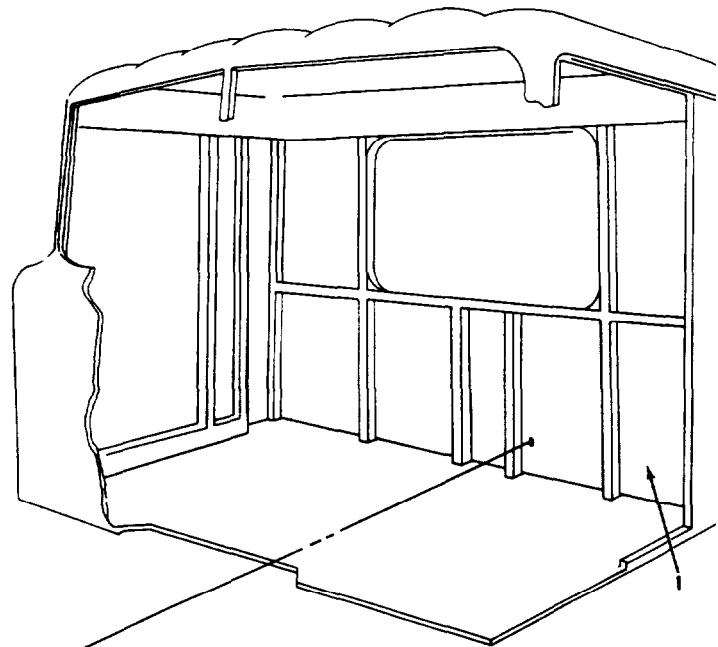
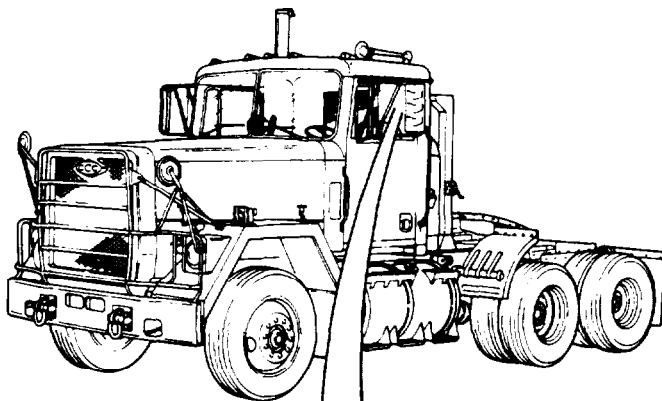

LEGEND:

1. CAB WALL
2. LEFT-HAND CAB TRIM PANEL
3. FINISH WASHER (26)
4. SCREW (26)

TA 237770

CAB AND BODY.

3-277. INSULATION REPLACEMENT.

THIS TASK COVERS

- a. Removal.
- b. Installation.

INITIAL SETUP

<u>APPLICABLE CONFIGURATIONS</u>	<u>EQUIPMENT CONDITION PARAGRAPH</u>	<u>CONDITION DESCRIPTION</u>
All.	None.	None.

TEST EQUIPMENT  
None.

SPECIAL TOOLS  
None.

MATERIALS/PARTS (P/N)  
 Insulation (as required)  
 (34623) M/164-20000 (right-hand and left-hand center back panel).  
 (34623) M/164-20001 (upper back panel).  
 (34623) M/164-20002 (lower back panel).  
 (34623) M/164-20003 (corner back panel).  
 (34623) M/164-20004 (rear side panel).  
 (34623) M/164-20017 (center back panel).  
 (34623) M/164-20018 (roof).

PERSONNEL REQUIRED  
One (MOS-63S).

SPECIAL ENVIRONMENTAL CONDITIONS  
None.

REFERENCES (TM)  
None.

GENERAL SAFETY INSTRUCTIONS  
 Engine off  
 Transmission in neutral.  
 Park brake set.  
 Wear protective clothing (gloves, goggles, face mask, etc.) when working near insulation material.

TROUBLESHOOTING REFERENCES  
None.

CAB AND BODY.

3-277. INSULATION REPLACEMENT (Continued).

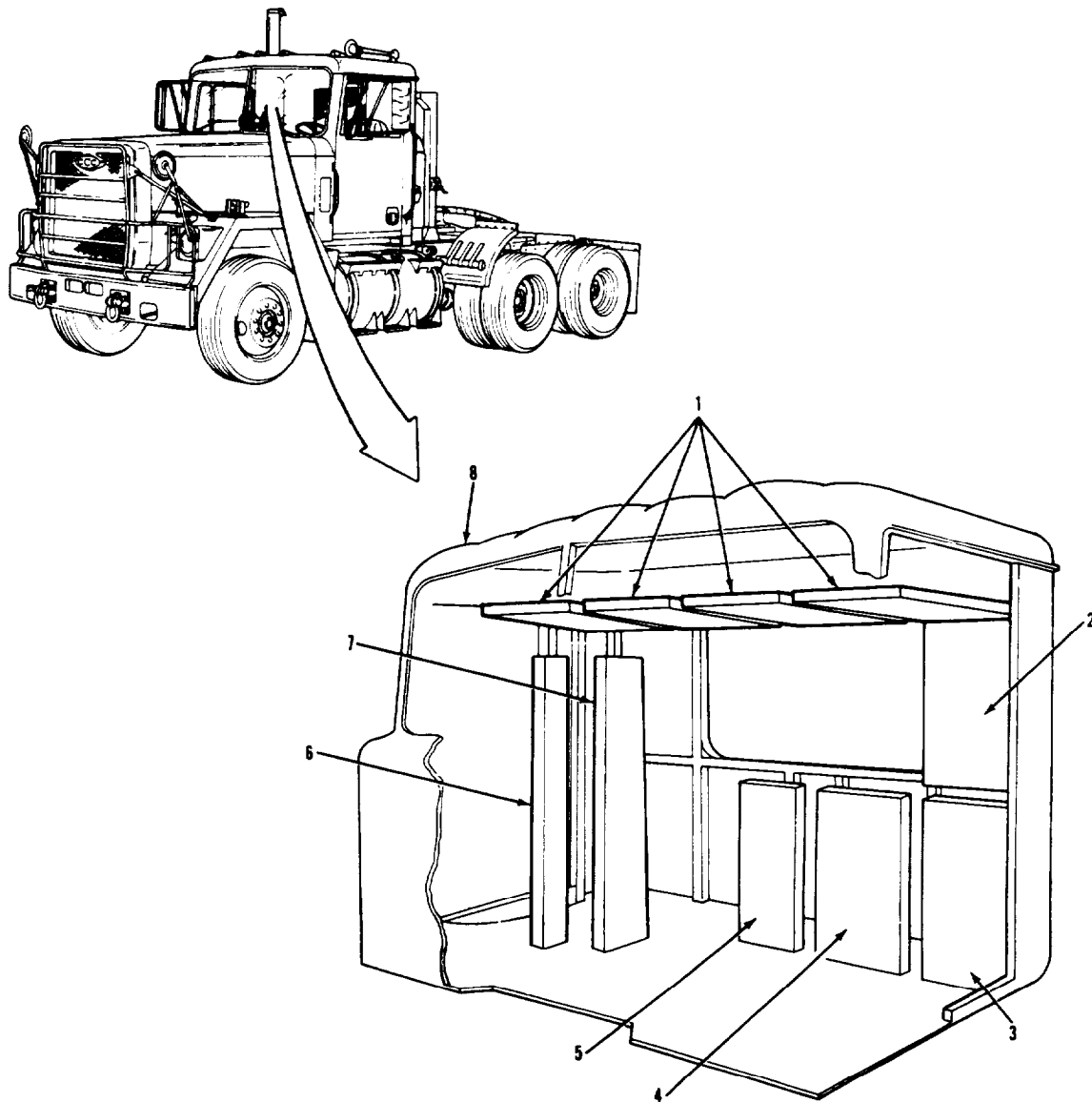

LEGEND:

- |   |                                     |
|---|-------------------------------------|
| 1. ROOF INSULATION (4)  | 5. CENTER BACK PANEL INSULATION (2) |
| 2. UPPER BACK PANEL INSULATION (2)                              | 6. CORNER BACK PANEL INSULATION (2) |
| 3. LOWER BACK PANEL INSULATION (2)                              | 7. REAR SIDE PANEL INSULATION (2)   |
| 4. RIGHT-HAND AND LEFT-HAND CENTER<br>BACK PANEL INSULATION (2) | 8. CAB                              |

TA 237771

CAB AND BODY.

3-277. INSULATION REPLACEMENT (Continued).		
LOCATION/ITEM	ACTION	REMARKS
<p><b>WARNING</b></p> <p>Insulation material can cause personal injury. Always wear suitable protective clothing (gloves, goggles, face mask, etc .) whenever insulation is replaced.</p> <p><b>NOTE</b></p> <p>To replace insulation on roof of cab, remove cab headliner panel (para 3-275). To replace insulation on wall of cab, remove right or left cab trim panel, as necessary (para 3-276).</p>		
<p><b>A. REMOVAL.</b></p>		
1. Insulation (1, 2, 3, 4, 5, 6, or 7).	Remove from item (8), and discard.	
<p><b>B. INSTALLATION.</b></p>		
2. New insulation (1, 2, 3, 4, 5, 6, or 7).	Put into place in item (8) by tucking it under metal bracing.	
<p><b>NOTE</b></p> <p>Follow-on maintenance action required:</p> <p>Install cab trim panel, if necessary (para 3-276). Install cab headliner panel, if necessary (para 3-275).</p>		

CAB AND BODY.

3-277. INSULATION REPLACEMENT (Continued).

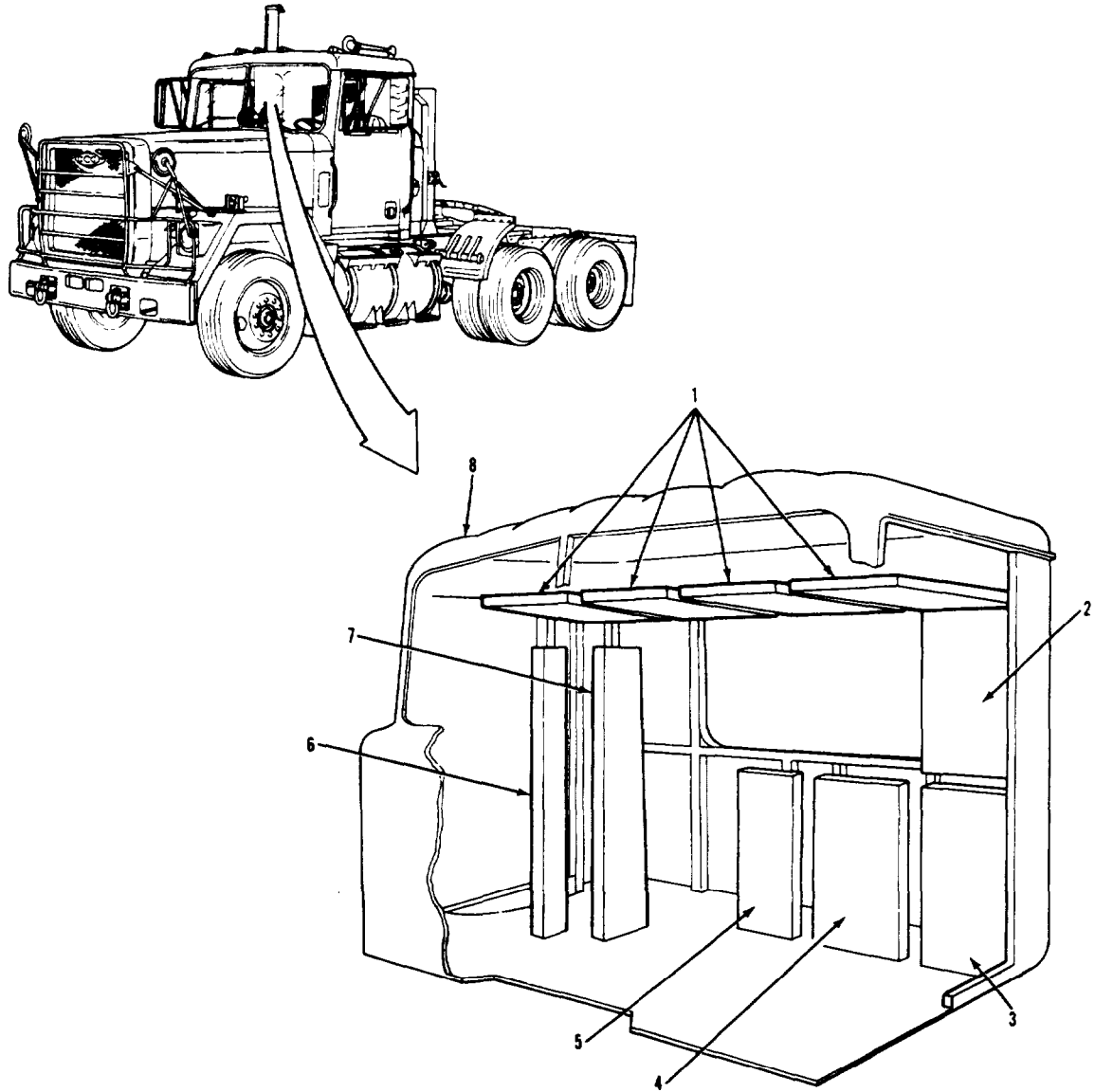

LEGEND:

- |   |                                     |
|---|-------------------------------------|
| 1. ROOF INSULATION (4)  | 5. CENTER BACK PANEL INSULATION (2) |
| 2. UPPER BACK PANEL INSULATION (2)                              | 6. CORNER BACK PANEL INSULATION (2) |
| 3. LOWER BACK PANEL INSULATION (2)                              | 7. REAR SIDE PANEL INSULATION (2)   |
| 4. RIGHT-HAND AND LEFT-HAND CENTER<br>BACK PANEL INSULATION (2) | 8. CAB                              |

TA 237772



CAB AND BODY.

3-278. SUN VISOR REPLACEMENT.

THIS TASK COVERS

- a. Removal.
- b. Cleaning and Inspection.
- c. Installation.

INITIAL SETUP

APPLICABLE CONFIGURATIONS  
All.

EQUIPMENT CONDITION  
PARAGRAPH  
None.

CONDITION DESCRIPTION  
None.

TEST EQUIPMENT

SPECIAL TOOLS  
None.

MATERIALS/PARTS (P/N)  
None.

PERSONNEL REQUIRED  
One (MOS-63S).

SPECIAL ENVIRONMENTAL CONDITIONS  
None.

REFERENCES (TM)  
None.

GENERAL SAFETY INSTRUCTIONS  
Engine off.  
Transmission in neutral.  
Park brake set.

TROUBLESHOOTING REFERENCES  
None.

CAB AND BODY.

3-278. SUN VISOR REPLACEMENT (Continued).

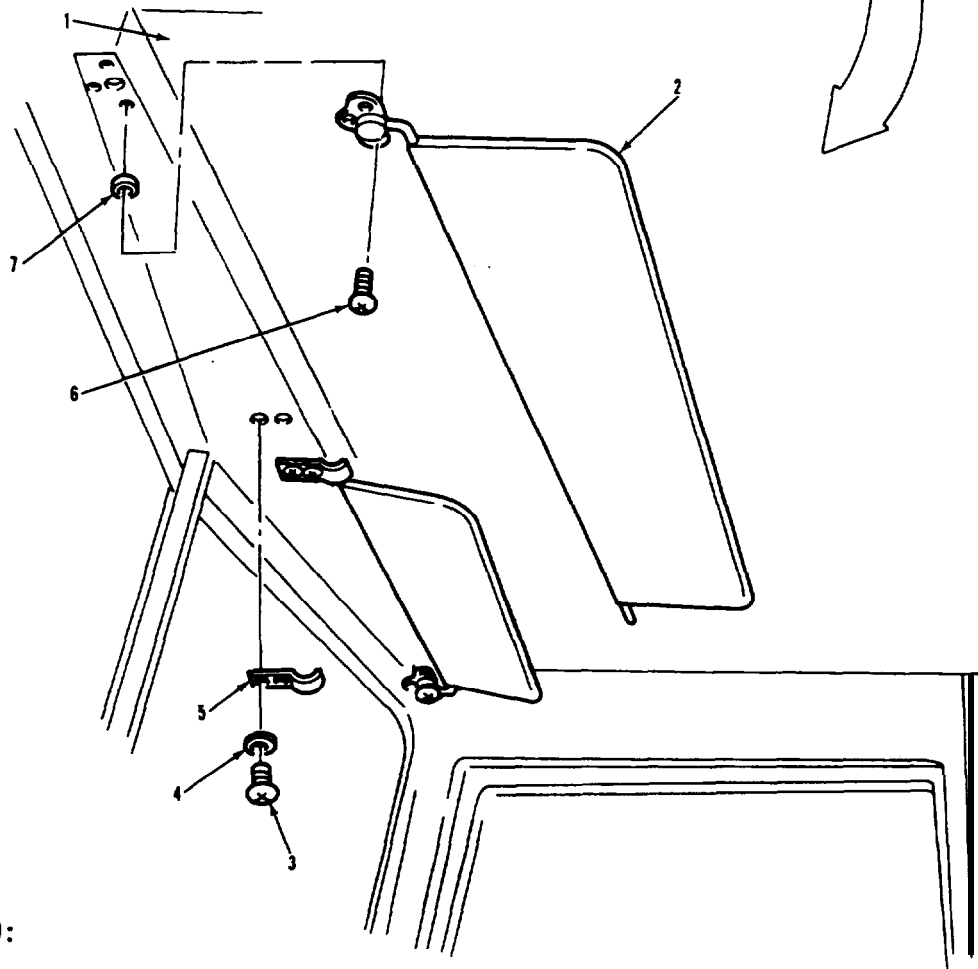
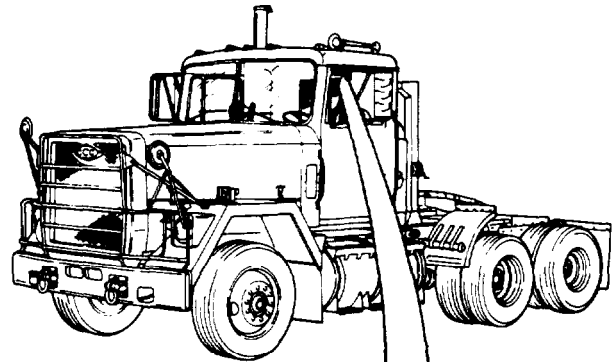

LEGEND:

- |                       |                      |
|-----------------------|----------------------|
| 1. CAB ROOF           | 5. SUN VISOR CLIP    |
| 2. SUN VISOR ASSEMBLY | 6. MACHINE SCREW (3) |
| 3. MACHINE SCREW (2)  | 7. NUTSERT (3)       |
| 4. FLAT WASHER (2)    |                      |

TA 237773

CAB AND BODY.

3-278. SUN VISOR REPLACEMENT (Continued).

LOCATION/ITEM	ACTION	REMARKS
NOTE		
Use this procedure to replace either of the two sun visors.		
<b>A. REMOVAL.</b>		
1. Visor (2).	Remove from item (5).	
2. Three screws (6) and visor (2).	Remove from item (1).	
3. Two screws (3), washers (4), and clip (5).	Remove from item (1).	
<b>B. CLEANING AND INSPECTION.</b>		
4. All parts.	Clean and inspect.	Refer to paragraphs 3-4 and 3-5. Remove and replace any items (7), if damaged.
<b>C. INSTALLATION</b>		
5. Clip (5).	a. Position on item (1). b. Secure with two items (3) and (4).	
6. Visor (2).	a. Position on item (1). b. Secure with three items (6). c. Push onto item (5).	
NOTE		
Follow-on maintenance action required:		
None.		

CAB AND BODY.

3-278. SUN VISOR REPLACEMENT (Continued).

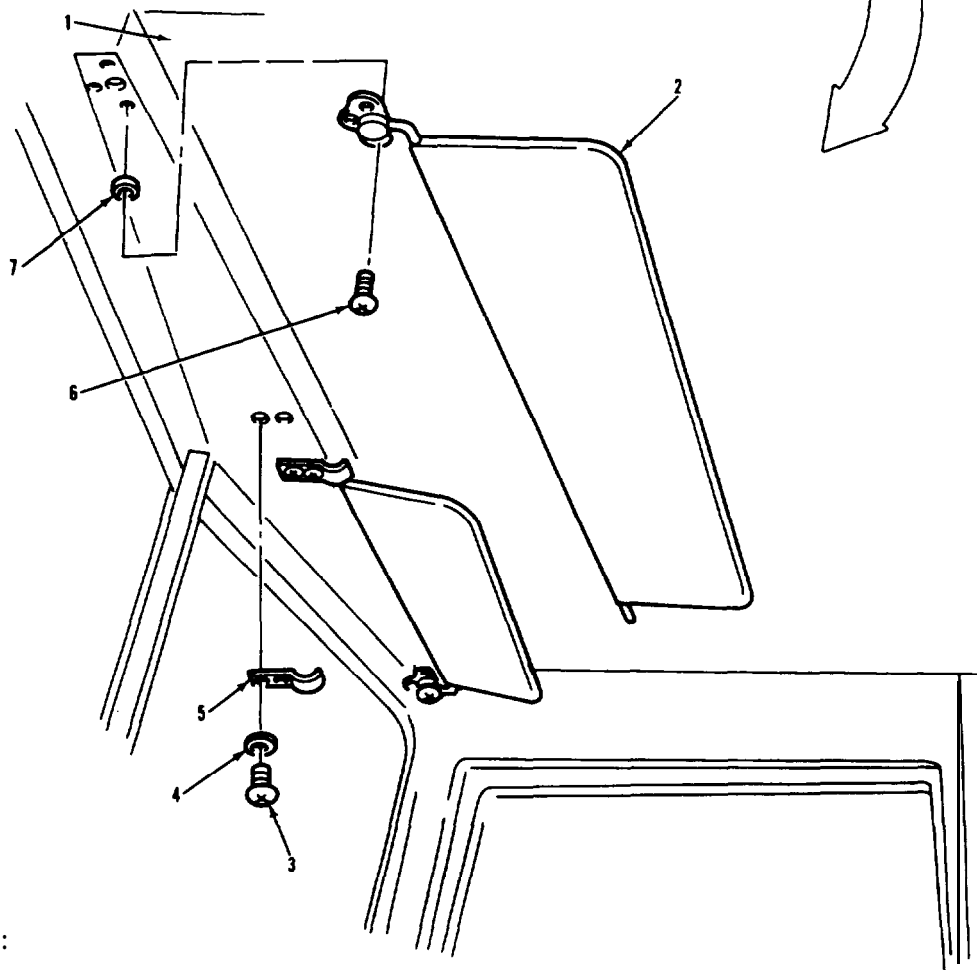
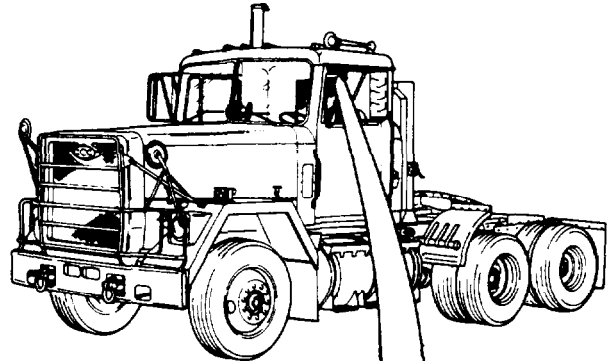

LEGEND:

- |                       |                      |
|-----------------------|----------------------|
| 1. CAB ROOF           | 5. SUN VISOR CLIP    |
| 2. SUN VISOR ASSEMBLY | 6. MACHINE SCREW (3) |
| 3. MACHINE SCREW (2)  | 7. NUTSERT (3)       |
| 4. FLAT WASHER (2)    |                      |

TA 237774

CAB AND BODY.

3-279. FLOOR MAT REPLACEMENT.

THIS TASK COVERS

- a. Removal.
- b. Cleaning and Inspection.
- c. Installation.

INITIAL SETUP

APPLICABLE CONFIGURATIONS

All.

EQUIPMENT CONDITION PARAGRAPH

3-41

CONDITION DESCRIPTION

Accelerator pedal removed.

TEST EQUIPMENT

None.

3-281.

Driver's seat riser removed.

SPECIAL TOOLS

None.

3-284

Companion seat riser and tool box removed.

3-282.

Companion seat belt removed.

MATERIALS/PARTS (P/N)

None.

PERSONNEL REQUIRED

One (MDS-63S).

SPECIAL ENVIRONMENTAL CONDITIONS

None.

REFERENCES (TM)

None.

GENERAL SAFETY INSTRUCTIONS

Engine off.  
Transmission in neutral.  
Park brake set.

TROUBLESHOOTING REFERENCES

None.

CAB AND BODY.

3-279. FLOOR MAT REPLACEMENT (Continued).

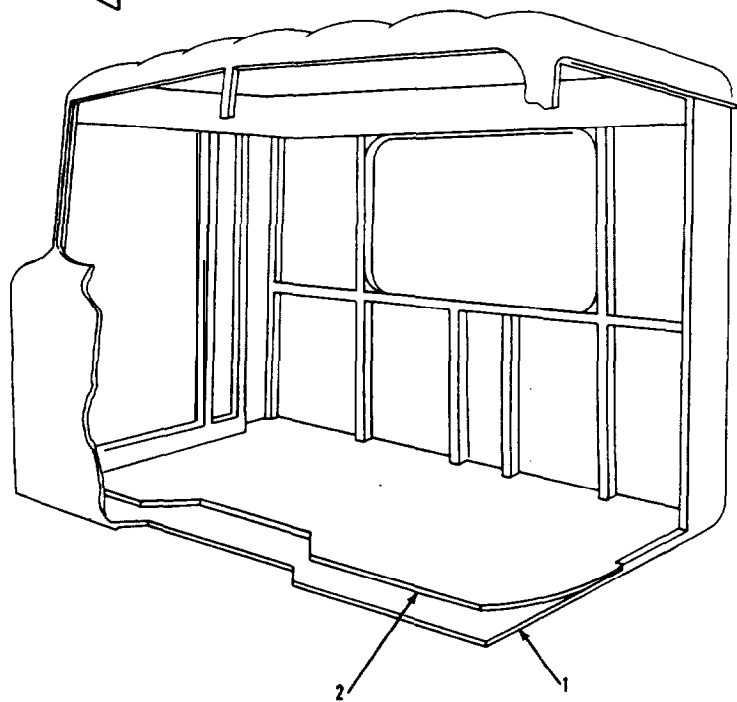
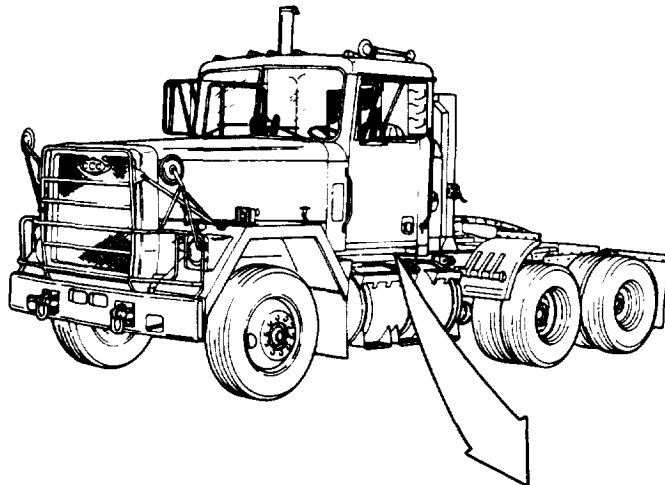

LEGEND:

- 1. CAB FLOOR
- 2. CAB FLOOR MAT

TA 237775

CAB AND BODY.

3-279. FLOOR MAT REPLACEMENT (Continued).

LOCATION/ITEM	ACTION	REMARKS
<b>A. REMOVAL.</b>		
1. Mat (2).	Lift up from item (1), and remove from cab compartment.	
<b>B. CLEANING AND INSPECTION.</b>		
2. All parts.	Clean and inspect.	Refer to paragraphs 3-4 and 3-5.
<b>C. INSTALLATION.</b>		
3. Mat (2).	Lift up into cab compartment, and position on item (1).	
NOTE		
Follow-on maintenance action required:		
Install companion seat belt (para 3-282). Install companion seat riser and tool box (para 2-284). Install driver's seat riser (para 3-281). Install accelerator pedal (para 3-41).		

CAB AND BODY.

3-279. FLOOR MAT REPLACEMENT (Continued).

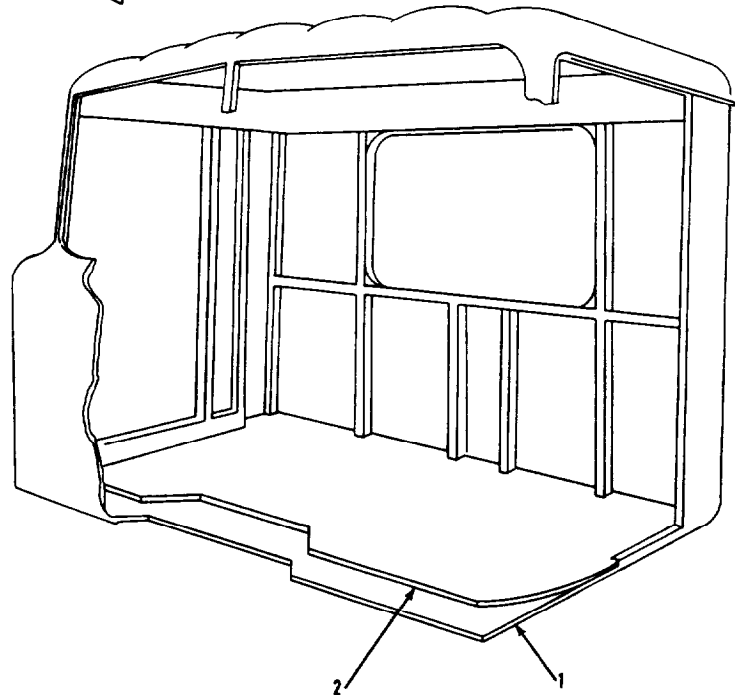
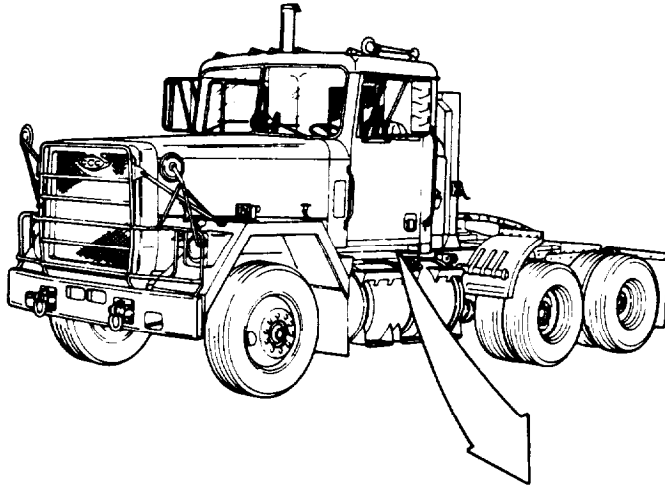

LEGEND:

- 1. CAB FLOOR
- 2. CAB FLOOR MAT

TA 237776



CAB AND BODY.

3-280. DRIVER'S SEAT REPLACEMENT.

THIS TASK COVERS

- a. Removal.
- b. Cleaning and Inspection.
- c. Installation.

INITIAL SETUP

APPLICABLE CONFIGURATIONS

All.

EQUIPMENT CONDITION

PARAGRAPH

None.

CONDITION DESCRIPTION

None.

TEST EQUIPMENT

None.

SPECIAL TOOLS

None.

MATERIALS/PARTS (P/N)

None.

PERSONNEL REQUIRED

Two (MDS-63S).

SPECIAL ENVIRONMENTAL CONDITIONS

None.

REFERENCES (TM)

LO 9-2320-283-12.

GENERAL SAFETY INSTRUCTIONS

Engine off.  
Transmission in neutral.  
Park brake set.

TROUBLESHOOTING REFERENCES

Paragraph 2-11.

CAB AND BODY.

3-280. DRIVER'S SEAT REPLACEMENT (Continued).

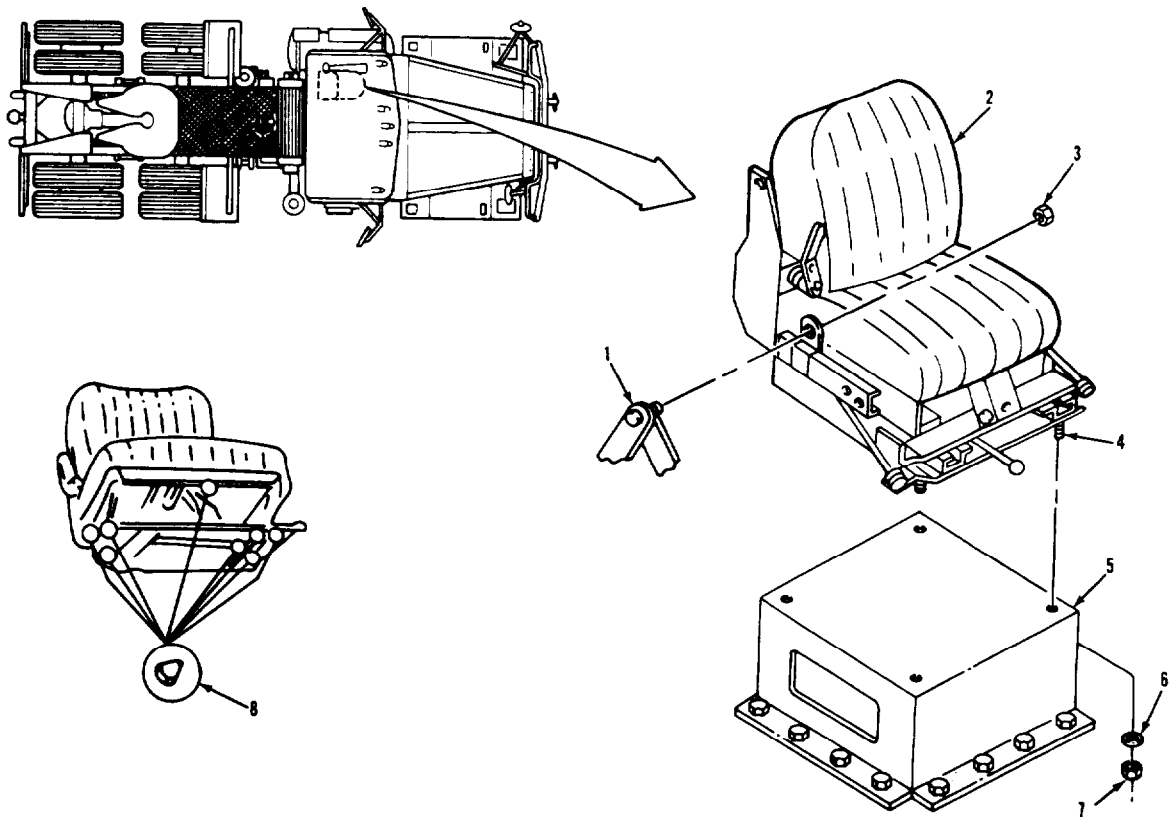

LEGEND:

- 1. DRIVER'S SEAT BELT ASSEMBLY (2)
- 2. DRIVER'S SEAT ASSEMBLY
- 3. NUT (2)
- 4. STUD (4)

- 5. DRIVER'S SEAT RISER ASSEMBLY
- 6. FLAT WASHER (4)
- 7. HEXAGON HEAD NUT (4)
- 8. LUBRICATION FITTING (9)

TA 237777

CAB AND BODY.

3-280. DRIVER'S SEAT REPLACEMENT (Continued).

LOCATION/ITEM	ACTION	REMARKS
<b>A. REMOVAL.</b>		
1. Two nuts (3) and belt assemblies (1).	Remove from item (2).	
2. Four nuts (7) and washers (6).	Remove from four items (4).	
3. Seat (2).	Lift off of item (5), and remove from cab compartment.	Have assistant help during this step.
<b>B. CLEANING AND INSPECTION.</b>		
4. All parts.	Clean and inspect.	Refer to paragraphs 3-4 and 3-5. Remove and replace any items (8) if damaged.
<b>C. INSTALLATION.</b>		
5. Seat (2).	Lift up into cab compartment, and lower onto item (5).	Have assistant help during this step. Four items (4) should fit into holes of item (5).
6. Four nuts (7) and washers (6).	Screw onto four items (4), and tighten.	
7. Two belt assemblies (1) and nuts (3).	Install on item (2).	
NOTE		
Follow-on maintenance action required:		
Lubricate driver's seat, if necessary (LO 9-2320-283-12).		

CAB AND BODY.

3-280. DRIVER'S SEAT REPLACEMENT (Continued).

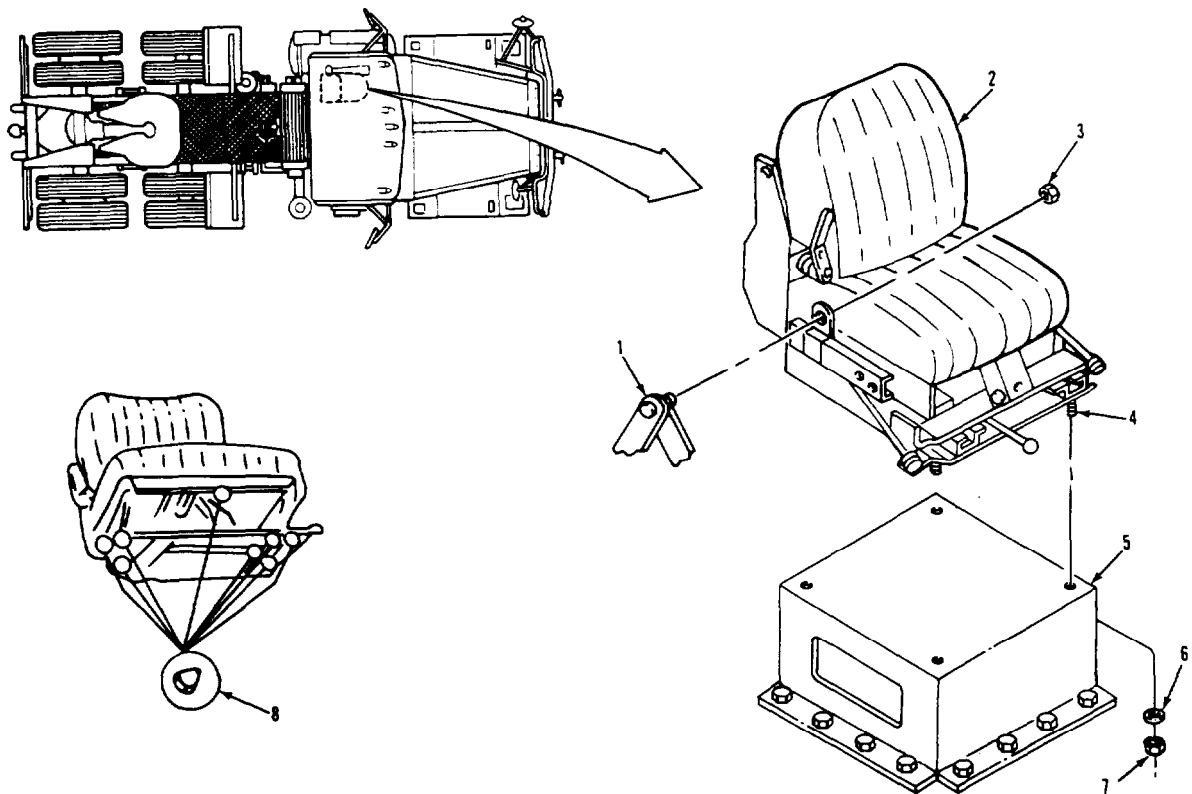

LEGEND:

- 1. DRIVER'S SEAT BELT ASSEMBLY (2)
- 2. DRIVER'S SEAT ASSEMBLY
- 3. NUT (2)
- 4. STUD (4)

- 5. DRIVER'S SEAT RISER ASSEMBLY
- 6. FLAT WASHER (4)
- 7. HEXAGON HEAD NUT (4)
- 8. LUBRICATION FITTING (9)

TA 237778

CAB AND BODY.

3-281. DRIVER'S SEAT RISER REPLACEMENT.

THIS TASK COVERS

- a. Removal.
- b. Cleaning and Inspection.
- c. Installation.

INITIAL SETUP

APPLICABLE CONFIGURATIONS

All.

EQUIPMENT CONDITION  
PARAGRAPH

3-280.

CONDITION DESCRIPTION

Driver's seat removed.

TEST EQUIPMENT

None.

SPECIAL TOOLS

None.

MATERIALS/PARTS (P/N)

None.

PERSONNEL REQUIRED

One (MDS-63S).

SPECIAL ENVIRONMENTAL CONDITIONS

None.

REFERENCES (TM)

None.

GENERAL SAFETY INSTRUCTIONS

Engine off  
Transmission in neutral.  
Park brake set.

TROUBLESHOOTING REFERENCES

None.

CAB AND BODY.

3-281. DRIVER'S SEAT RISER REPLACEMENT (Continued).

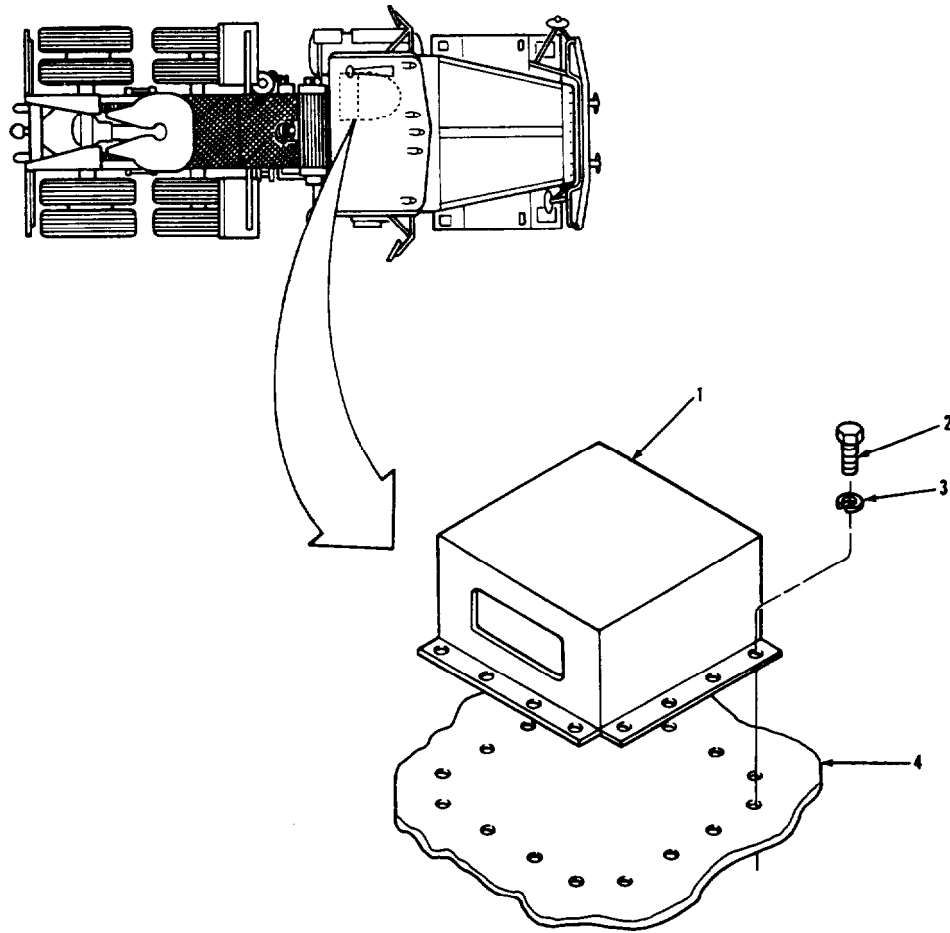

LEGEND:

- 1. DRIVER'S SEAT RISER ASSEMBLY
- 2. HEXAGON HEAD BOLT (16)
- 3. LOCKWASHER (16)
- 4. CAB FLOOR

TA 237779

CAB AND BODY.

3-281. DRIVER'S SEAT RISER REPLACEMENT (Continued).

LOCATION/ITEM	ACTION	REMARKS
<b>A. REMOVAL.</b>		
1. Sixteen bolts (2), lockwashers (3), and riser (1).	Remove from item (4).	
<b>B. CLEANING AND INSPECTION.</b>		
2. All parts.	Clean and inspect.	Refer to paragraphs 3-4 and 3-5.
<b>C. INSTALLATION.</b>		
3. Riser (1).	a. Position on item (4). b. Secure with sixteen items (2) and (3).	
NOTE		
Follow-on maintenance action required:		
Install driver's seat (para 3-280).		

CAB AND BODY.

3-281. DRIVER'S SEAT RISER REPLACEMENT (Continued).

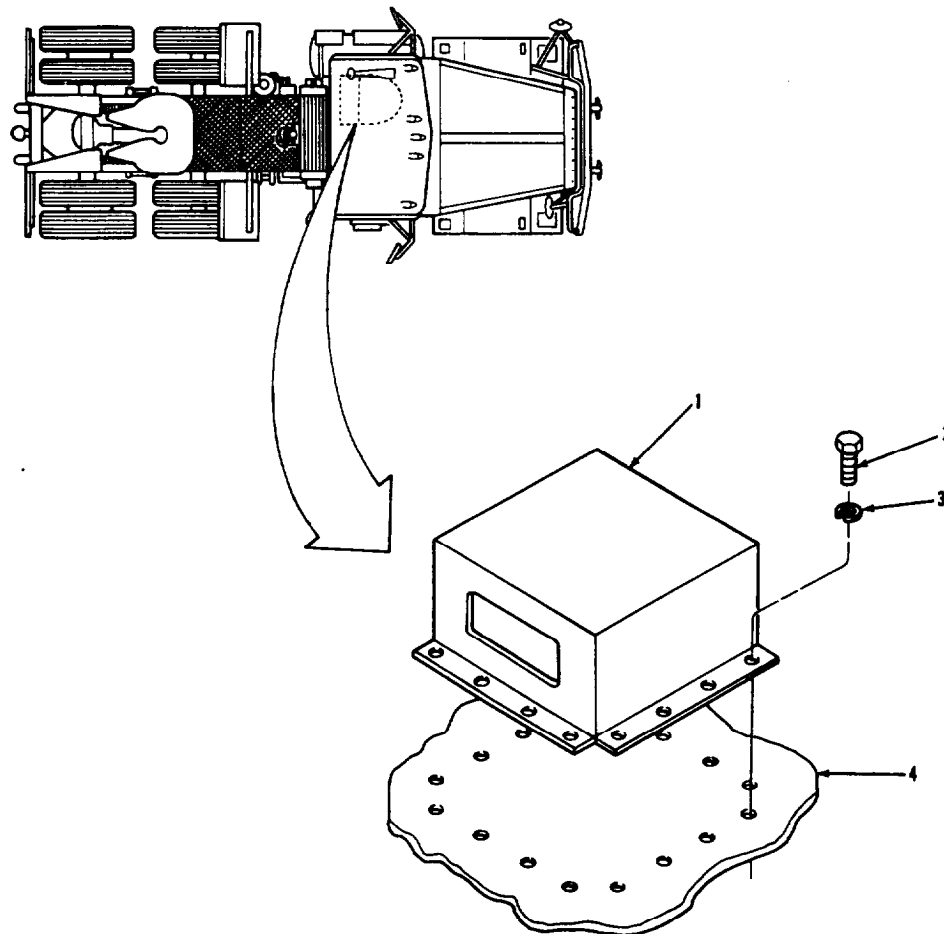

LEGEND:

- 1. DRIVER'S SEAT RISER ASSEMBLY
- 2. HEXAGON HEAD BOLT (16)
- 3. LOCKWASHER (16)
- 4. CAB FLOOR

TA 237780



CAB AND BODY.

3-282. SEAT BELT REPLACEMENT.

THIS TASK COVERS

- a. Driver's Seat Belt Replacement.
- b. Companion Seat Belt Replacement.

INITIAL SETUP

<u>APPLICABLE CONFIGURATIONS</u>	<u>EQUIPMENT CONDITION PARAGRAPH</u>	<u>CONDITION DESCRIPTION</u>
All.	None.	None.

TEST EQUIPMENT  
None.

SPECIAL TOOLS  
None.

MATERIALS/PARTS (P/N)  
None.

PERSONNEL REQUIRED  
One (MOS-63S).

SPECIAL ENVIRONMENTAL CONDITIONS  
None.

REFERENCES (TM)

GENERAL SAFETY INSTRUCTIONS

TROUBLESHOOTING REFERENCES  
None.

Engine off.  
Transmission in neutral.  
Park brake set.  
Wear protective clothing (gloves goggles, face mask, etc.) when working near insulation material.

CAB AND BODY.

3-282. SEAT BELT REPLACEMENT (Continued).

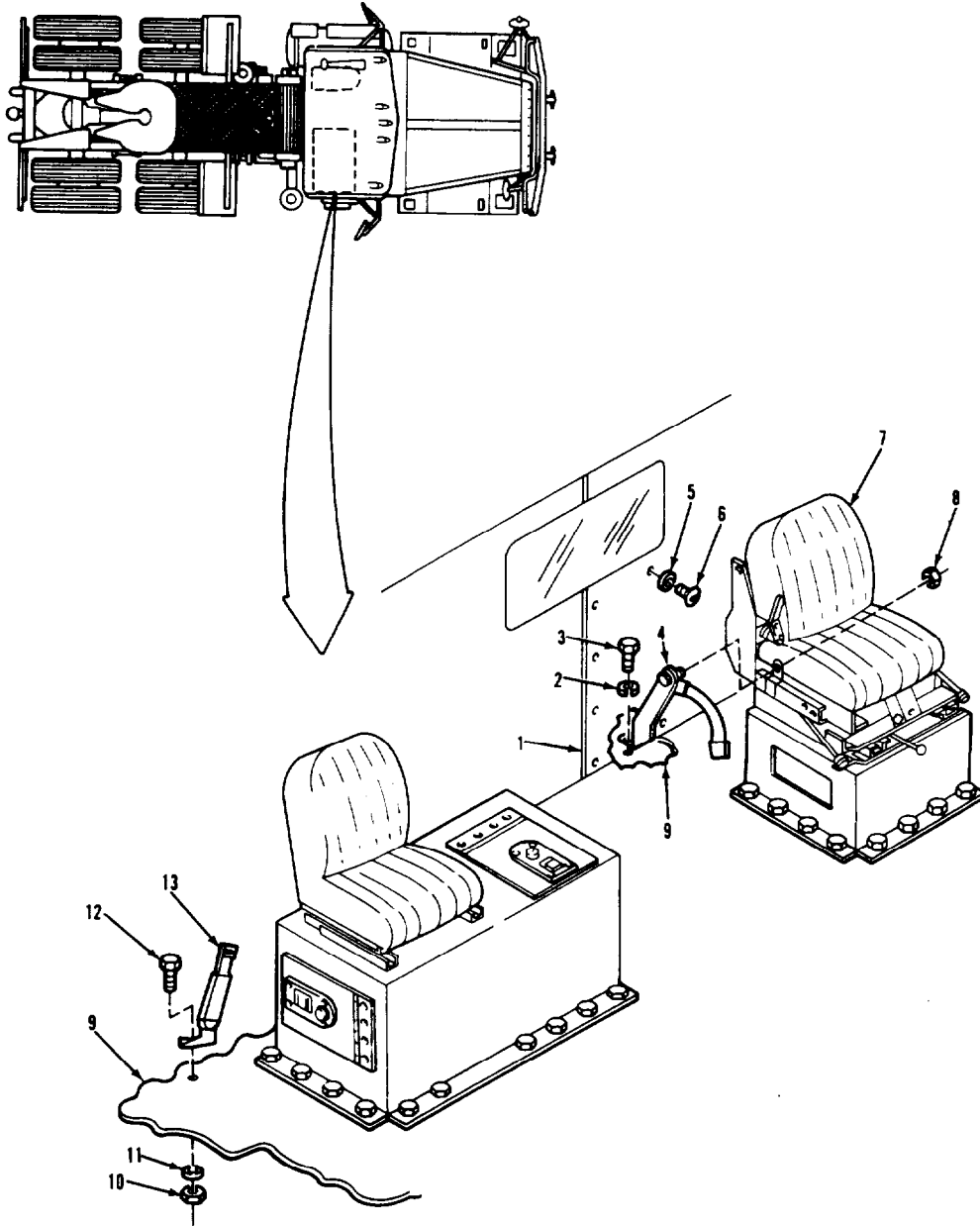

LEGEND:

- |  |  |
|--|--|
| 1. LEFT-HAND CAB TRIM PANEL                    | 8. NUT   |
| 2. LOCKWASHER                                  | 9. CAB FLOOR                                     |
| 3. HEXAGON HEAD SCREW                          | 10. HEXAGON HEAD LOCKNUT                         |
| 4. DRIVER'S SEAT BELT ASSEMBLY<br>(RIGHT SIDE) | 11. HARDENED WASHER                              |
| 5. FINISH WASHER (10)                          | 12. HEXAGON HEAD SCREW                           |
| 6. SCREW (10)                                  | 13. COMPANION SEAT BELT ASSEMBLY<br>(RIGHT SIDE) |
| 7. DRIVER'S SEAT ASSEMBLY                      |  |

TA 237781

CAB AND BODY.

3-282. SEAT BELT REPLACEMENT (Continued).

LOCATION/ITEM	ACTION	REMARKS
<b>A. DRIVER'S SEAT BELT REPLACEMENT.</b>		
NOTE		
Both sides of the driver's seat belt are replaced the same way, except as noted in steps 2 and 6.		
1. Nut (8) and belt assembly (4).	Remove from item (7).	
<u>WARNING</u>		
Insulation material behind cab trim panel can cause personal injury. Always wear suitable protective clothing (gloves, goggles, face mask, etc.) whenever cab trim panel is being removed.		
2. Panel (1).	<ul style="list-style-type: none"> <li>a. If removing right side of belt (4), remove ten items (6) and (5), and pull item (1) away from cab wall.</li> <li>b. If removing left side of belt (4), remove cab trim panel. (Refer to paragraph 3-276).</li> </ul>	
3. Screw (3), lock-washer (2), and belt assembly (4).	Remove from item (9).	
4. All parts.	Clean and inspect.	Refer to paragraphs 3-4 and 3-5.
5. Belt assembly (4).	<ul style="list-style-type: none"> <li>a. Position on item (9).</li> <li>b. Secure with items (3) and (2).</li> </ul>	

CAB AND BODY.

3-282. SEAT BELT REPLACEMENT (Continued).

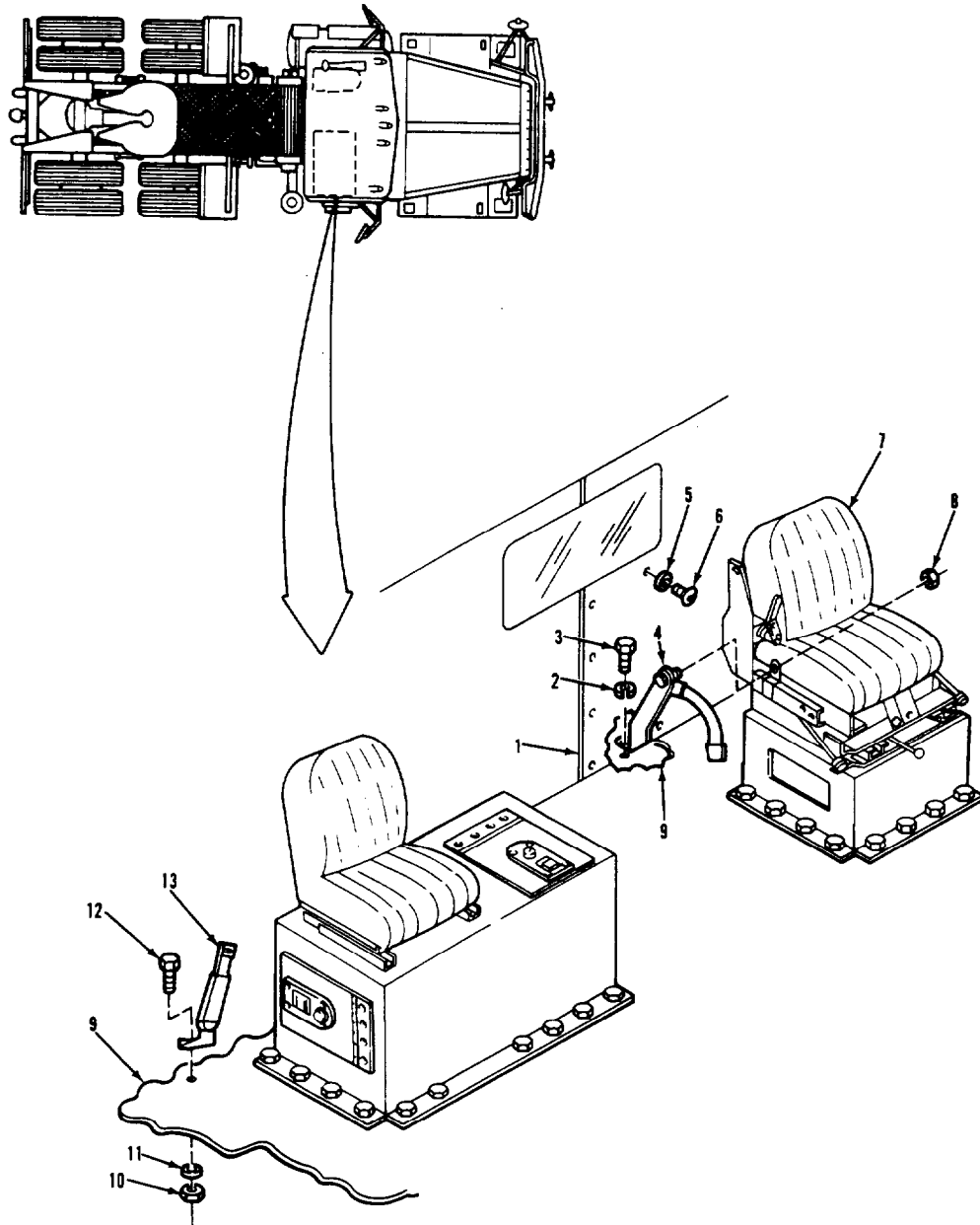

LEGEND:

- |  |  |
|--|--|
| 1. LEFT-HAND CAB TRIM PANEL                    | 8. NUT   |
| 2. LOCKWASHER                                  | 9. CAB FLOOR                                     |
| 3. HEXAGON HEAD SCREW                          | 10. HEXAGON HEAD LOCKNUT                         |
| 4. DRIVER'S SEAT BELT ASSEMBLY<br>(RIGHT SIDE) | 11. HARDENED WASHER                              |
| 5. FINISH WASHER (10)                          | 12. HEXAGON HEAD SCREW                           |
| 6. SCREW (10)                                  | 13. COMPANION SEAT BELT ASSEMBLY<br>(RIGHT SIDE) |
| 7. DRIVER'S SEAT ASSEMBLY                      |  |

TA 237782

CAB AND BODY.

3-282. SEAT BELT REPLACEMENT (Continued).

LOCATION/ITEM	ACTION	REMARKS
<b>A. DRIVER'S SEAT BELT REPLACEMENT (Continued).</b>		
6. Panel (1).	a. If installing right side of belt (4), secure item (1) to cab wall with ten items (6) and (5).  b. If installing left side of belt, install cab trim panel. (Refer to paragraph 3-271).	
7. Belt assembly (4).	a. Position on item (7).  b. Secure with item (8).	
<b>B. COMPANION SEAT BELT REPLACEMENT.</b>		
NOTE		
Both sides of the companion seat belt are replaced the same way.		
8. Nut (10), washer (11), screw (12), and belt (13).	Remove from item (9).	
9. All parts.	Clean and inspect.	Refer to paragraphs 3-4 and 3-5.
10. Belt (13).	a. Position on item (9).  b. Secure with items (12), (11), and (10).	
NOTE		
Follow-on maintenance action required:		
None.		

CAB AND BODY.

3-282. SEAT BELT REPLACEMENT (Continued).

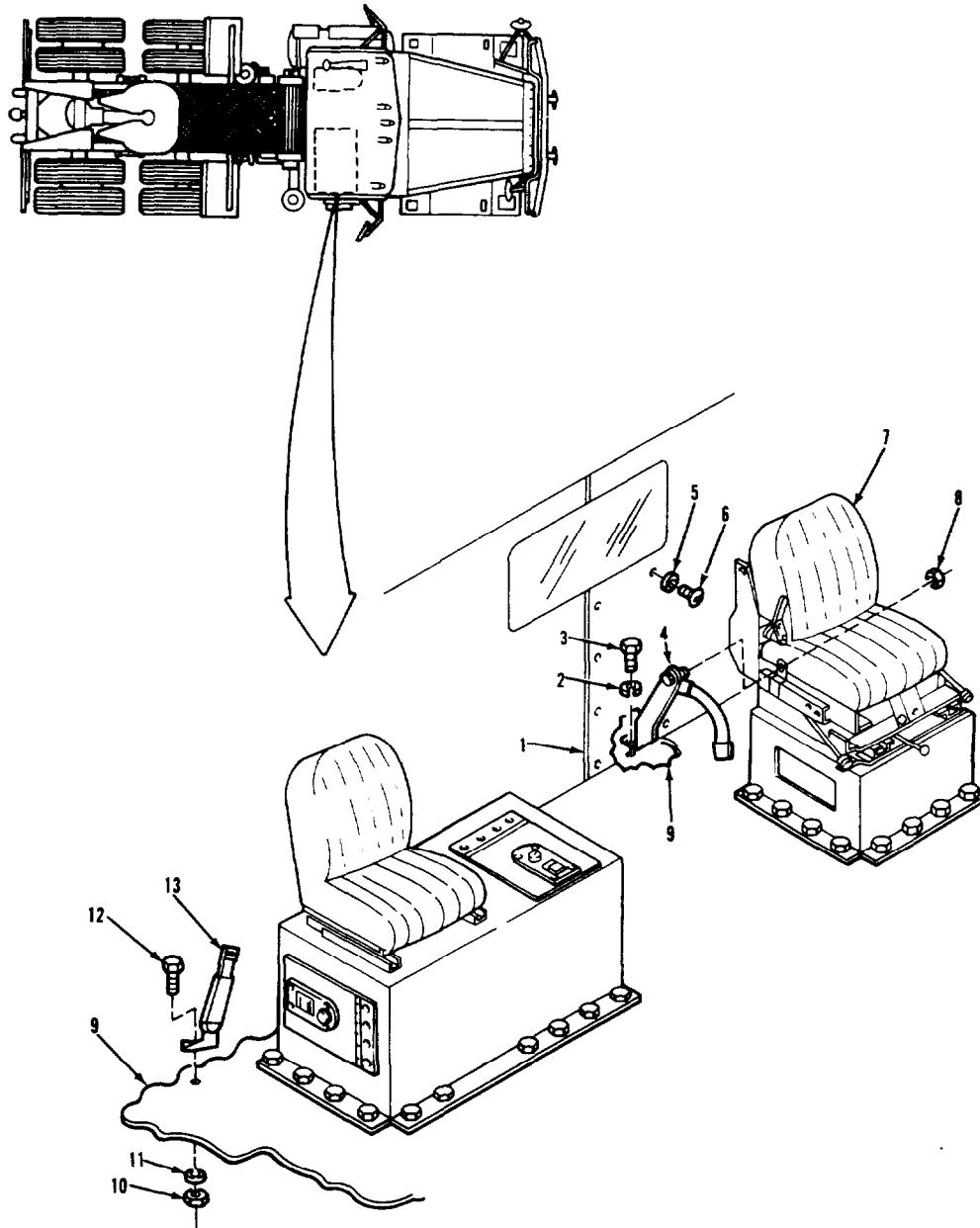

LEGEND:

- |  |  |
|--|--|
| 1. LEFT-HAND CAB TRIM PANEL                    | 8. NUT   |
| 2. LOCKWASHER                                  | 9. CAB FLOOR                                     |
| 3. HEXAGON HEAD SCREW                          | 10. HEXAGON HEAD LOCKNUT                         |
| 4. DRIVER'S SEAT BELT ASSEMBLY<br>(RIGHT SIDE) | 11. HARDENED WASHER                              |
| 5. FINISH WASHER (10)                          | 12. HEXAGON HEAD SCREW                           |
| 6. SCREW (10)                                  | 13. COMPANION SEAT BELT ASSEMBLY<br>(RIGHT SIDE) |
| 7. DRIVER'S SEAT ASSEMBLY                      |  |

TA 237783

CAB AND BODY.

3-283. COMPANION SEAT REPLACEMENT.

THIS TASK COVERS

- a. Removal.
- b. Cleaning and Inspection.
- c. Installation.

INITIAL SETUP

APPLICABLE CONFIGURATIONS

All.

EQUIPMENT CONDITION  
PARAGRAPH

None.

CONDITION DESCRIPTION

None.

TEST EQUIPMENT

None.

SPECIAL TOOLS

None.

MATERIALS/PARTS (P/N)

None.

PERSONNEL REQUIRED

One (MOS-63S).

SPECIAL ENVIRONMENTAL CONDITIONS

None.

REFERENCES (TM)

None.

GENERAL SAFETY INSTRUCTIONS

Engine off  
Transmission in neutral.  
Park brake set.

TROUBLESHOOTING REFERENCES

Paragraph 2-11.

CAB AND BODY.

3-283. COMPANION SEAT REPLACEMENT (Continued).

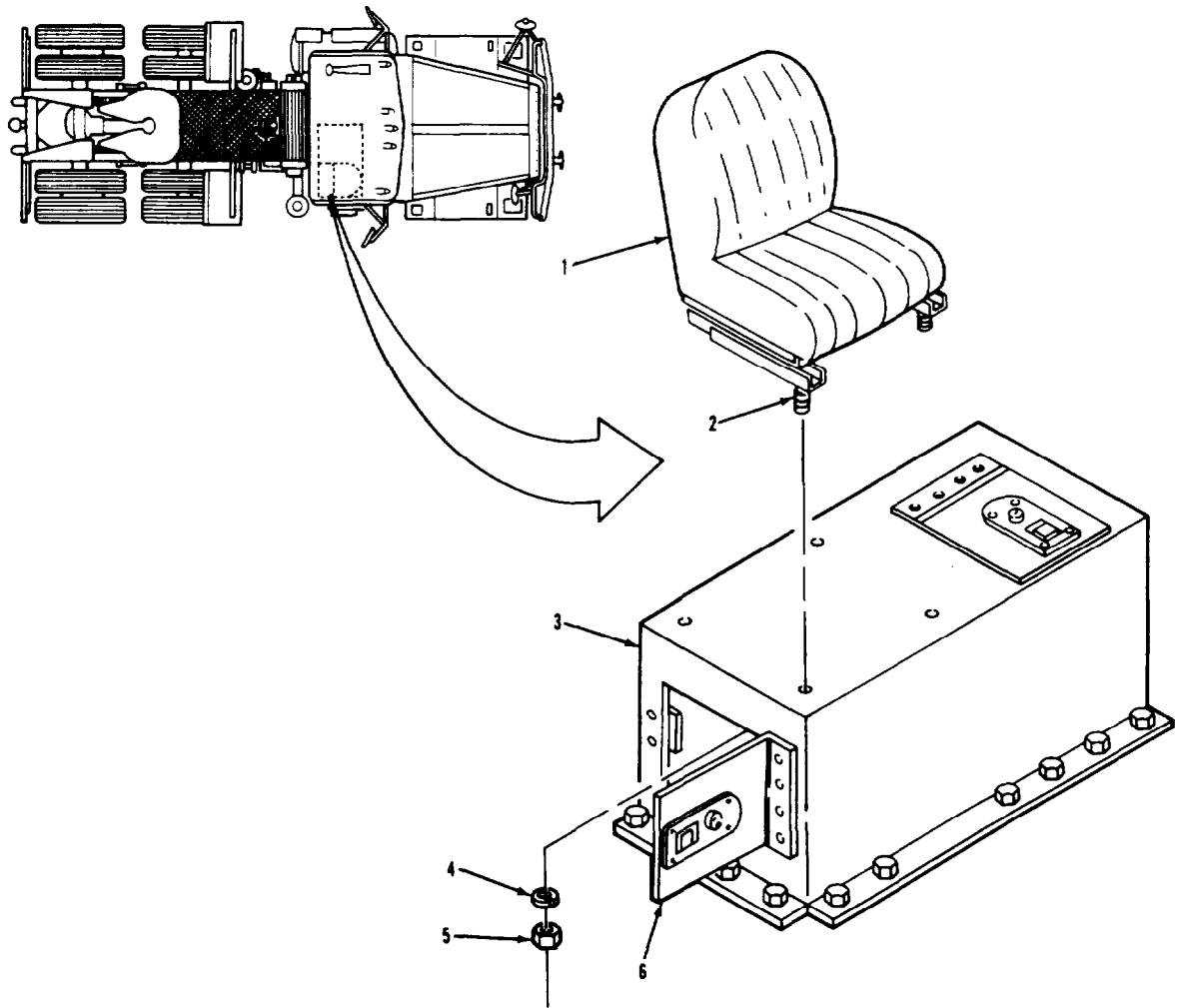

LEGEND:

- 1. COMPANION SEAT ASSEMBLY
- 2. STUD (4)
- 3. TOOLBOX ASSEMBLY

- 4. LOCKWASHER (4)
- 5. HEXAGON HEAD NUT (4)
- 6. TOOLBOX DOOR ASSEMBLY

TA 237784



CAB AND BODY.

3-283. COMPANION SEAT REPLACEMENT (Continued).

LOCATION/ITEM	ACTION	REMARKS
<b>A. REMOVAL.</b>		
1. Door (6).	Open.	
2. Four nuts (5) and lockwashers (4).	Remove from four items (2).	
3. Seat (1).	Lift off of item (3), and remove from cab compartment.	
<b>B. CLEANING AND INSPECTION.</b>		
4. All parts.	Clean and inspect.	Refer to paragraphs 3-4 and 3-5.
<b>C. INSTALLATION</b>		
5. Seat (1).	Lift up into cab compartment, and position on item (3).	Four items (2) should fit into holes of item (3).
6. Four nuts (5) and lockwashers (4).	Screw onto four items (2), and tighten.	
7. Door (6).	Close.	
NOTE		
Follow-on maintenance action required:		
None.		

CAB AND BODY.

3-283. COMPANION SEAT REPLACEMENT (Continued).

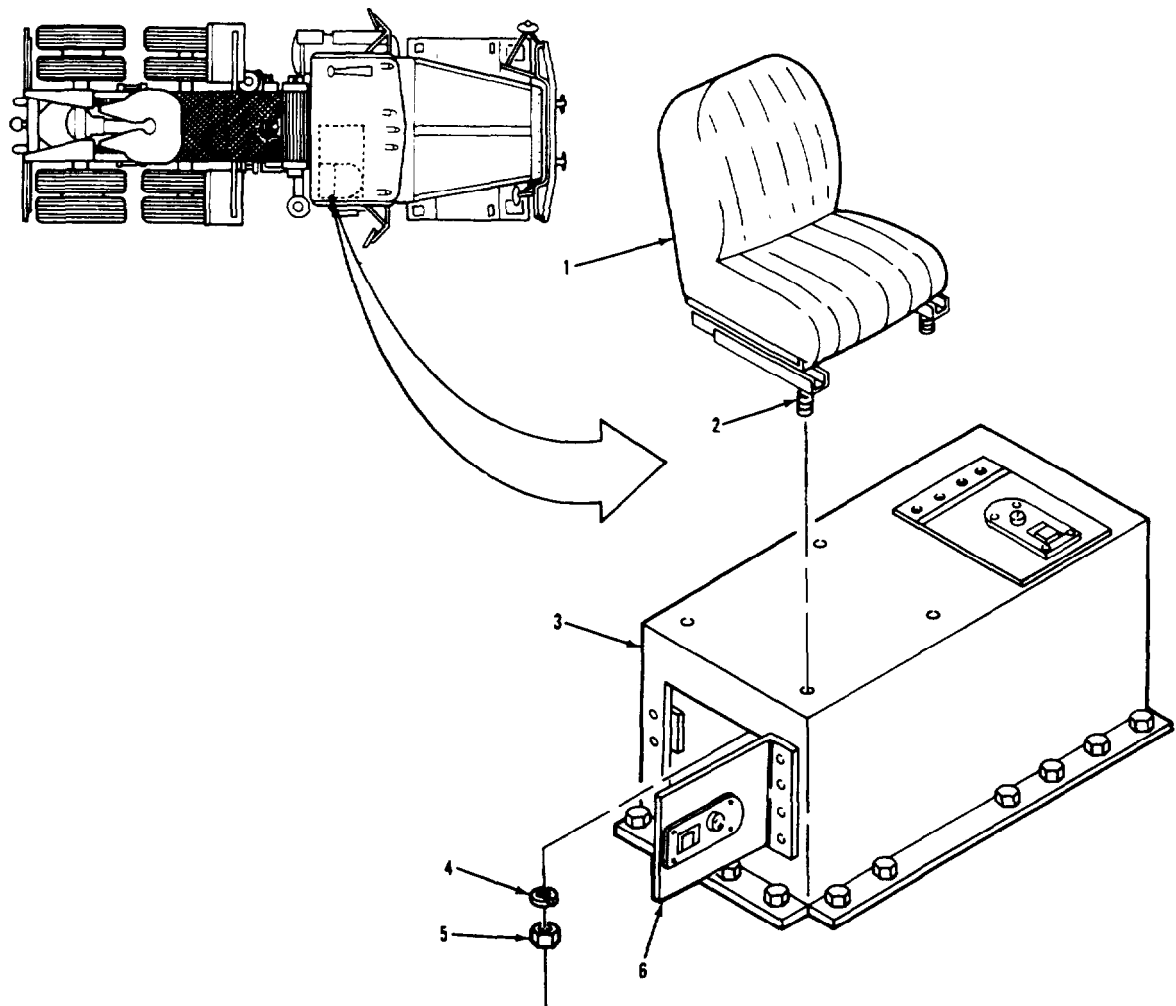

LEGEND:

- 1. COMPANION SEAT ASSEMBLY
- 2. STUD (4)
- 3. TOOLBOX ASSEMBLY

- 4. LOCKWASHER (4)
- 5. HEXAGON HEAD NUT (4)
- 6. TOOLBOX DOOR ASSEMBLY

TA 237785

CAB AND BODY.

3-284. COMPANION SEAT RISER, FIRE EXTINGUISHER BRACKETS, AND TOOLBOX REPLACEMENT.

THIS TASK COVERS

- |                             |                  |
|-----------------------------|------------------|
| a. Removal.                 | d. Assembly.     |
| b. Disassembly.             | e. Installation. |
| c. Cleaning and Inspection. |                  |

INITIAL SETUP

<u>APPLICABLE CONFIGURATIONS</u> All.	<u>EQUIPMENT CONDITION PARAGRAPH</u> TM 9-2320-283-10.	<u>CONDITION DESCRIPTION</u> Fire extinguisher removed.
<u>TEST EQUIPMENT</u> None.	3-283.	Companion seat removed.
<u>SPECIAL TOOLS</u> None.		
<u>MATERIALS/PARTS (P/N)</u> Rivet (as required) (11815) SSP-42.		
<u>PERSONNEL REQUIRED</u> Two (MDS-63S).	<u>SPECIAL ENVIRONMENTAL CONDITIONS</u> None.	
<u>REFERENCES (TM)</u> TM 9-2320-283-10. TM 9-2320-283-20P.	<u>GENERAL SAFETY INSTRUCTIONS</u> Engine off. Transmission in neutral. Park brake set.	
<u>TROUBLESHOOTING REFERENCES</u> None.		

CAB AND BODY.

3-284. COMPANION SEAT RISER, FIRE EXTINGUISHER BRACKETS, AND TOOLBOX REPLACEMENT (Continued).

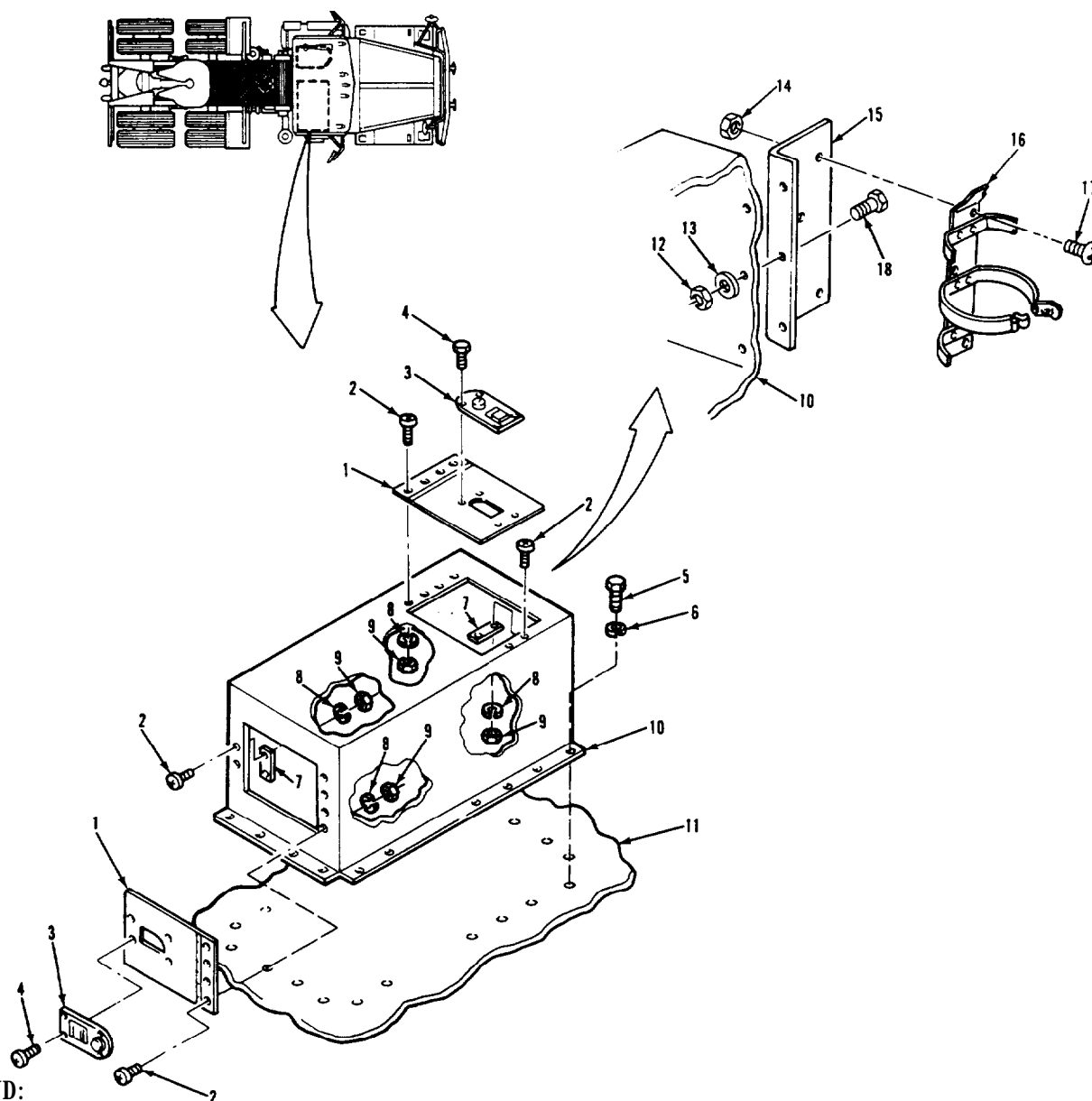

LEGEND:

- |                                    |  |
|------------------------------------|--|
| 1. TOOLBOX DOOR ASSEMBLY (2)       | 10. TOOLBOX ASSEMBLY                   |
| 2. SCREW (12)                      | 11. CAB FLOOR                          |
| 3. TOOLBOX DOOR LATCH ASSEMBLY (2) | 12. NUT (3)                            |
| 4. RIVET (8)                       | 13. FLAT WASHER (3)                    |
| 5. HEXAGON HEAD BOLT (20)          | 14. LOCKNUT (4)                        |
| 6. LOCKWASHER (20)                 | 15. FIRE EXTINGUISHER ANGLE BRACKET    |
| 7. TOOLBOX LATCH STRIKER (2)       | 16. FIRE EXTINGUISHER BRACKET ASSEMBLY |
| 8. LOCKWASHER (12)                 | 17. MACHINE SCREW (4)                  |
| 9. HEXAGON NUT (12)                | 18. MACHINE SCREW (3)                  |

TA 237786

CAB AND BODY.

3-284. COMPANION SEAT RISER, FIRE EXTINGUISHER BRACKETS, AND TOOLBOX REPLACEMENT (Continued).

LOCATION/ITEM	ACTION	REMARKS
<b>A. REMOVAL.</b>		
1. Twenty bolts (5) and lockwashers (6).	Remove from items (10) and (11).	
2. Toolbox assembly (10).	Lift off of item (11), and remove from cab compartment.	Have assistant help during this step.
<b>B. ASSEMBLY.</b>		
NOTE		
Do steps 3 thru 5 to remove either door assembly.		
3. Four nuts (9), lockwashers (8), screws (2), and door assembly (1).	Remove from item (10).	
4. Two nuts (9), lockwashers (8), screws (2), and striker (7).	Remove from item (10).	
5. Four rivets (4) and latch assembly (3).	Drill out items (4), and remove item (3) from item (11).	Discard items (4).
6. Four locknuts (14), screws (17), and bracket assembly (16).	Remove from item (15).	
7. Three nuts (12), washers (13), screws (18), and bracket (15).	Remove from item (10).	

CAB AND BODY.

3-284. COMPANION SEAT RISER, FIRE EXTINGUISHER BRACKETS, AND TOOLBOX REPLACEMENT (Continued).

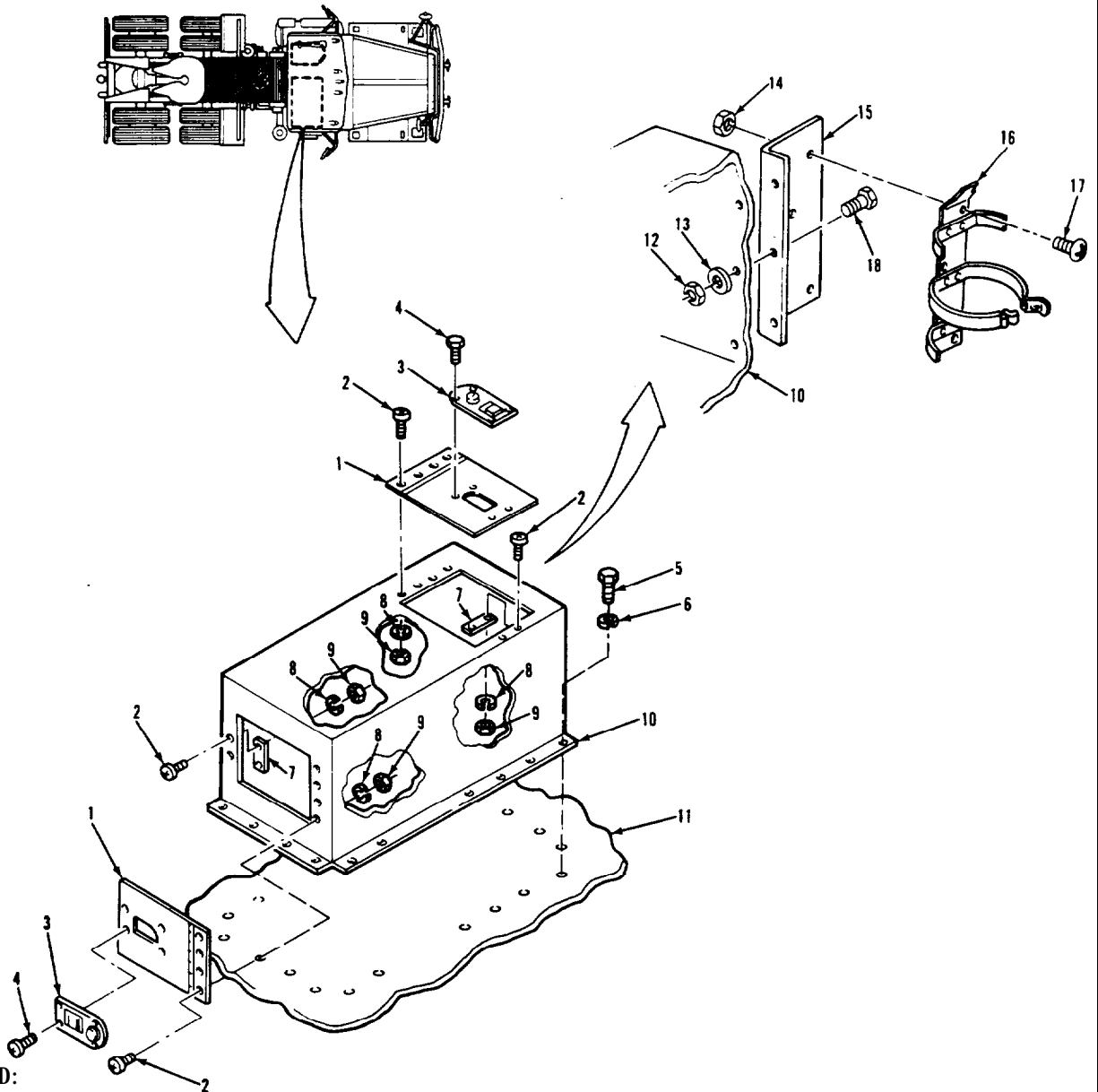

LEGEND:

- |                                    |  |
|------------------------------------|--|
| 1. TOOLBOX DOOR ASSEMBLY (2)       | 10. TOOLBOX ASSEMBLY                   |
| 2. SCREW (12)                      | 11. CAB FLOOR                          |
| 3. TOOLBOX DOOR LATCH ASSEMBLY (2) | 12. NUT (3)                            |
| 4. RIVET (8)                       | 13. FLAT WASHER (3)                    |
| 5. HEXAGON HEAD BOLT (20)          | 14. LOCKNUT (4)                        |
| 6. LOCKWASHER (20)                 | 15. FIRE EXTINGUISHER ANGLE BRACKET    |
| 7. TOOLBOX LATCH STRIKER (2)       | 16. FIRE EXTINGUISHER BRACKET ASSEMBLY |
| 8. LOCKWASHER (12)                 | 17. MACHINE SCREW (4)                  |
| 9. HEXAGON NUT (12)                | 18. MACHINE SCREW (3)                  |

TA 237787

CAB AND BODY.

3-284. COMPANION SEAT RISER, FIRE EXTINGUISHER BRACKETS, AND TOOLBOX REPLACEMENT (Continued).		
LOCATION/ITEM	ACTION	REMARKS
<b>C. CLEANING AND INSPECTION.</b>		
8. All parts.	Clean and inspect.	Refer to paragraphs 3-4 and 3-5.
<b>D. ASSEMBLY.</b>		
9. Bracket (15).	<ul style="list-style-type: none"> <li>a. Position on item (10).</li> <li>b. Secure with three items (18), (13), and (12).</li> </ul>	
10. Bracket (16).	<ul style="list-style-type: none"> <li>a. Position on item (15).</li> <li>b. Secure with four items (17) and (14).</li> </ul>	
NOTE		
Do steps 11 thru 13 to install either door assembly.		
11. Latch (3).	<ul style="list-style-type: none"> <li>a. Position on item (1).</li> <li>b. Secure with four new items (4).</li> </ul>	
12. Striker (7).	<ul style="list-style-type: none"> <li>a. Position on item (10).</li> <li>b. Secure with two items (2), (8), and (9).</li> </ul>	
13. Door (1).	<ul style="list-style-type: none"> <li>a. Position on item (10).</li> <li>b. Secure with four items (2), (8), and (9).</li> </ul>	

CAB AND BODY.

3-284. COMPANION SEAT RISER, FIRE EXTINGUISHER BRACKETS, AND TOOLBOX REPLACEMENT (Continued).

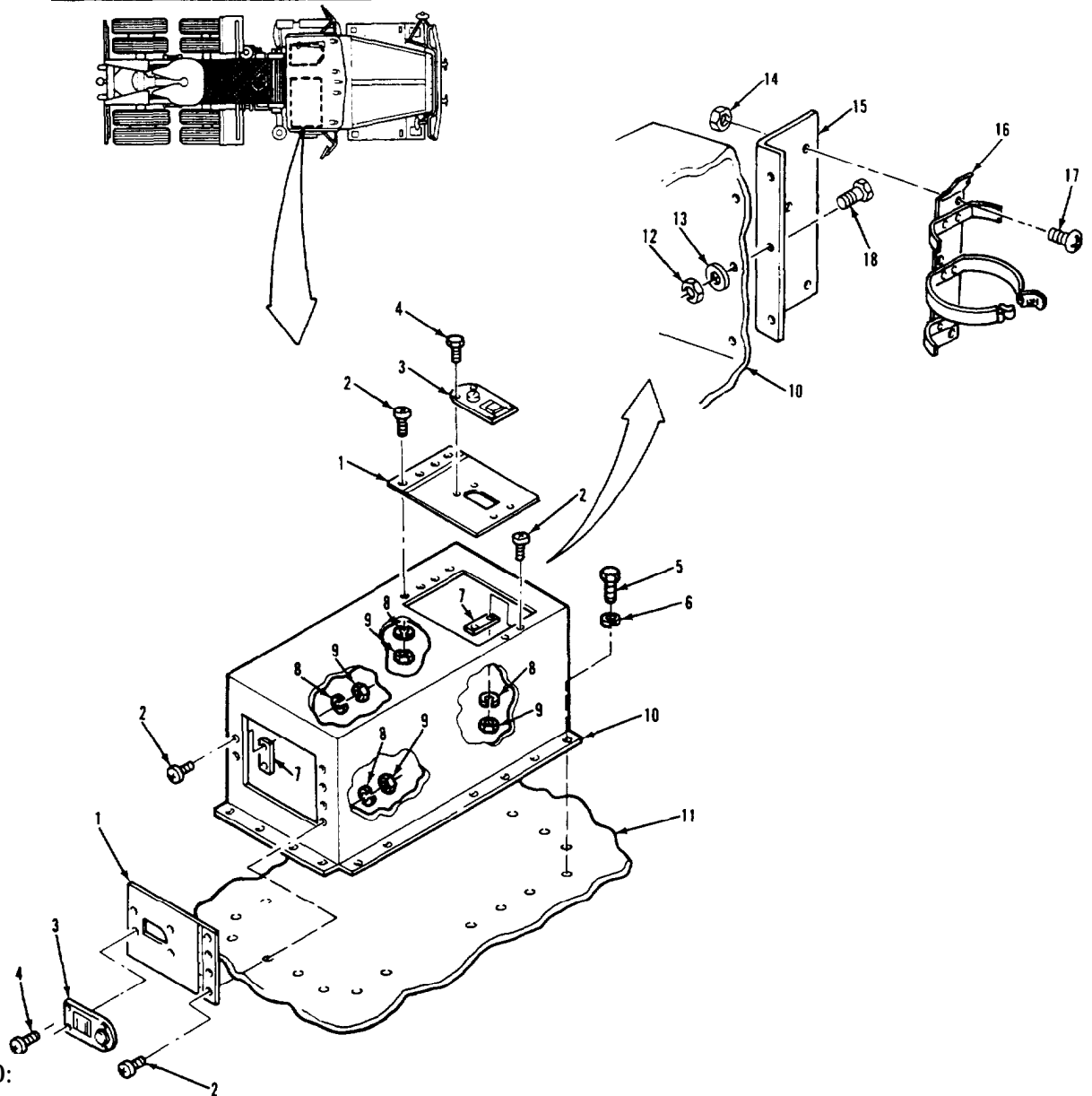

LEGEND:

- |                                    |  |
|------------------------------------|--|
| 1. TOOLBOX DOOR ASSEMBLY (2)       | 10. TOOLBOX ASSEMBLY                   |
| 2. SCREW (12)                      | 11. CAB FLOOR                          |
| 3. TOOLBOX DOOR LATCH ASSEMBLY (2) | 12. NUT (3)                            |
| 4. RIVET (8)                       | 13. FLAT WASHER (3)                    |
| 5. HEXAGON HEAD BOLT (20)          | 14. LOCKNUT (4)                        |
| 6. LOCKWASHER (20)                 | 15. FIRE EXTINGUISHER ANGLE BRACKET    |
| 7. TOOLBOX LATCH STRIKER (2)       | 16. FIRE EXTINGUISHER BRACKET ASSEMBLY |
| 8. LOCKWASHER (12)                 | 17. MACHINE SCREW (4)                  |
| 9. HEXAGON NUT (12)                | 18. MACHINE SCREW (3)                  |

TA 237788



CAB AND BODY.

3-284. COMPANION SEAT RISER, FIRE EXTINGUISHER BRACKETS, AND TOOLBOX REPLACEMENT (Continued).

LOCATION/ITEM	ACTION	REMARKS
<b>E. INSTALLATION.</b>		
14. Toolbox assembly (10).	a. Lift up into cab compartment, and position on item (11).  b. Secure with twenty items (5) and (6).	Have assistant help during this step.
<b>NOTE</b>		
Follow-on maintenance action required:		
Install companion seat (para 3-283). Install fire extinguisher (TM 9-2320-283-10).		

CAB AND BODY.

3-284. COMPANION SEAT RISER, FIRE EXTINGUISHER BRACKETS, AND TOOLBOX REPLACEMENT (Continued).

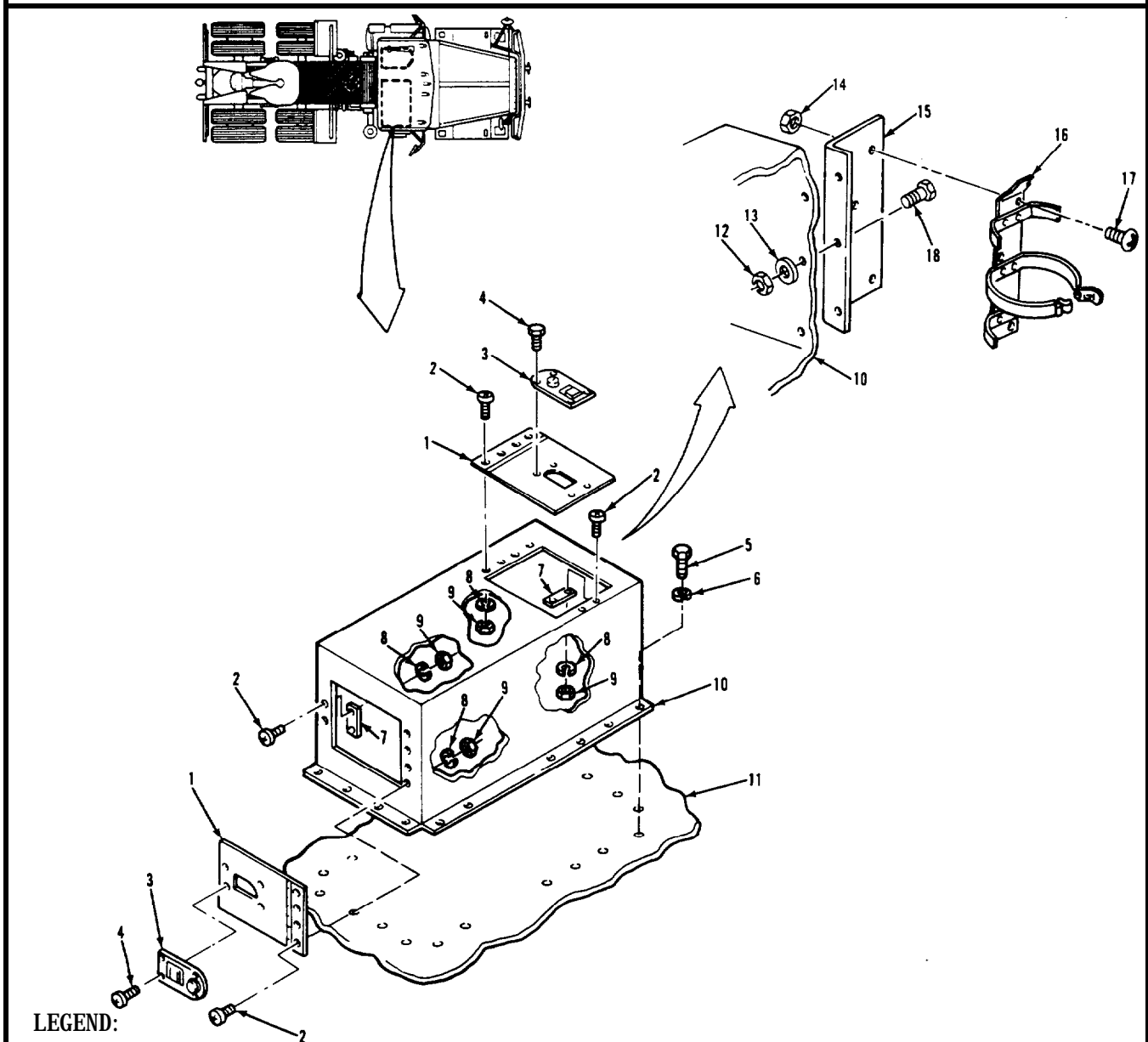

LEGEND:

- |                                    |  |
|------------------------------------|--|
| 1. TOOLBOX DOOR ASSEMBLY (2)       | 10. TOOLBOX ASSEMBLY                   |
| 2. SCREW (12)                      | 11. CAB FLOOR                          |
| 3. TOOLBOX DOOR LATCH ASSEMBLY (2) | 12. NUT (3)                            |
| 4. RIVET (8)                       | 13. FLAT WASHER (3)                    |
| 5. HEXAGON HEAD BOLT (20)          | 14. LOCKNUT (4)                        |
| 6. LOCKWASHER (20)                 | 15. FIRE EXTINGUISHER ANGLE BRACKET    |
| 7. TOOLBOX LATCH STRIKER (2)       | 16. FIRE EXTINGUISHER BRACKET ASSEMBLY |
| 8. LOCKWASHER (12)                 | 17. MACHINE SCREW (4)                  |
| 9. HEXAGON NUT (12)                | 18. MACHINE SCREW (3)                  |

TA 237789

**Section XVII. ACCESSORY ITEMS**

**3-285. GENERAL.**

This section provides procedures authorized at the organizational maintenance level to replace accessory items. To find a specific procedure contained in this section, see the task summary below.

**3-286. TASK SUMMARY.**

**INITIAL SETUP**

**APPLICABLE CONFIGURATIONS**

All.

**EQUIPMENT CONDITION**

**PARAGRAPH**

**CONDITION DESCRIPTION**

(Refer to specific paragraph for this information).

**TEST EQUIPMENT**

None.

**SPECIAL TOOLS**

None.

**MATERIALS/PARTS (P/N)**

Tape, thread sealing  
Item 32, Appendix C.  
Rags, wiping  
Item 22, Appendix C.  
Solvent, drycleaning, SD-2  
Item 29, Appendix C.  
Tape, electrical  
Item 30, Appendix C.  
Solution, soap  
Item 28, Appendix C.  
Liner, rubber  
(26501) 1724.

Gasket, pedestal mount  
(26501) 1783.  
Gasket, horn base  
(26501) 1715.  
Clamp, hose (4)  
(60703) 79896-6.  
Tie, cable, heavy, black (3)  
(06383) PLT4H-L0.  
Tie, cable  
(96906) MS3367-1-9.

**PERSONNEL REQUIRED**

Two (MDS-63S).

**SPECIAL ENVIRONMENTAL CONDITIONS**

None.

**REFERENCES (TM)**

TM 9-2320-283-10.  
TM 9-2320-283-20P.

**GENERAL SAFETY INSTRUCTIONS**

Engine off  
Transmission in neutral.  
Park brake set.

**TROUBLESHOOTING REFERENCES**

Paragraph 2-11.

ACCESSORY ITEMS.

3-286. TASK SUMMARY (Continued).			
LIST OF TASKS			
TASK NO.	TASK	TASK REF	TROUBLESHOOTING REF NO. (PARA)
1	Door Mirror Replacement	3-287	2-11
	a. Mirror Head Removal.	3-287a	
	b. Mirror Assembly Removal.	3-287b	
	c. Disassembly.	3-287c	
	d. Assembly.	3-287d	
	e. Mirror Assembly Installation.	3-287e	
2	Spotter Mirror Replacement	3-288	2-11
	a. Right-Hand Mirror Removal.	3-288a	
	b. Right-Hand Mirror Installation.	3-288b	
	c. Left-Hand Mirror Removal.	3-288c	
	d. Left-Hand Mirror Installation.	3-288d	
	e. Left-Hand Mirror Removal.	3-288c	
3	Air Horn and Control Valve Replacement	3-289	2-11
	a. Removal.	3-289a	
	b. Installation.	3-289b	
4	Windshield Washer Replacement	3-290	2-11
	a. Removal.	3-290a	
	b. Cleaning and Inspection.	3-290b	
	c. Installation.	3-290c	
5	Windshield Washer Control Valve Replacement	3-291	2-11
	a. Removal.	3-291 a	
	b. Cleaning and Inspection.	3-291b	
	c. Installation.	3-291c	
6	Windshield Wiper Control Replacement	3-292	2-11
	a. Removal.	3-292a	
	b. Cleaning and Inspection.	3-292b	
	c. Installation.	3-292c	
7	Windshield Wiper Blade Assembly Replacement	3-293	2-11
	a. Removal.	3-293a	
	b. Installation.	3-293b	

ACCESSORY ITEMS.

3-286. TASK SUMMARY (Continued).			
LIST OF TASKS			
TASK NO.	TASK	TASK REF	TROUBLESHOOTING REF NO. (PARA)
8	Windshield Wiper Assembly Replacement a. Removal. b. Cleaning and Inspection. c. Installation.	3-294 3-294a 3-294b 3-294c	2-11
9	Windshield Wiper Motor Replacement a. Removal. b. Cleaning and Inspection. c. Installation.	3-295 3-295a 3-295b 3-295c	2-11
10	Heater Air Hose Replacement a. Removal. b. Installation.	3-296 3-296a 3-296c	2-11
11	Heater Valve, Hoses, Tubes, and Clamps Replacement a. Heater Hoses, Tubes, and Clamps Replacement. b. Control Valve Removal. c. Control Valve Installation. d. Shut-off Valve Removal. e. Shut-off Valve Installation.	3-297 3-297a 3-297b 3-297c 3-297d 3-297e	2-11
12	Heater Assembly Replacement and Repair a. Removal. b. Disassembly. c. Cleaning and Inspection. d. Assembly. e. Installation.	3-298 3-298a 3-298b 3-298c 3-298d 3-298e	2-11
13	Heater Blower Assembly Replacement and Repair a. Removal. b. Disassembly. c. Cleaning and Inspection. d. Assembly. e. Installation.	3-299 3-299a 3-299b 3-299c 3-299d 3-299e	

ACCESSORY ITEMS.

3-286. TASK SUMMARY (Continued).			
LIST OF TASKS			
TASK NO.	TASK	TASK REF	TROUBLESHOOTING REF NO. (PARA)
14	Heater Control Panel Replacement. a. Removal. b. Installation.	3-300 3-300a 3-300b	2-11
15	Heater Control Panel Repair. a. Disassembly. b. Cleaning and Inspection. c. Assembly.	3-301 3-301a 3-301b 3-301c	2-11
16	Air Diffuser Assembly Replacement a. Removal. b. Cleaning and Inspection. c. Installation. d. Operational Check.	3-302 3-302a 3-302b 3-302c 3-302d	2-11
17	Defroster Fan Replacement a. Removal. b. Installation.	3-303 3-303a 2-303b	2-11
18	Defroster Fan Repair a. Disassembly. b. Cleaning and Inspection. c. Assembly.	3-304 3-304a 3-304b 3-304c	2-11
19	Data and Instruction Plates Cleaning and Replacement.	3-305 3-305	
20	Winterization Kit (See TB 9-2320-283-14).	3-306	

ACCESSORY ITEMS.

3-287. DOOR MIRROR REPLACEMENT.

THIS TASK COVERS

- |                             |                                  |
|-----------------------------|----------------------------------|
| a. Mirror Head Removal.     | d. Assembly.                     |
| b. Mirror Assembly Removal. | e. Mirror Assembly Installation. |
| c. Disassembly.             | f. Mirror Head Installation.     |

INITIAL SETUP

APPLICABLE CONFIGURATIONS

All.

EQUIPMENT CONDITION  
PARAGRAPH

None.

CONDITION DESCRIPTION

None.

TEST EQUIPMENT

None.

SPECIAL TOOLS

None.

MATERIALS/PARTS (P/N)

None.

PERSONNEL REQUIRED

One (MDS-63S).

SPECIAL ENVIRONMENTAL CONDITIONS

None.

REFERENCES (TM)

None.

GENERAL SAFETY INSTRUCTIONS

Engine off.  
Transmission in neutral.  
Park brake set.

TROUBLESHOOTING REFERENCES

None.

ACCESSORY ITEMS.

3-287. DOOR MIRROR REPLACEMENT (Continued).

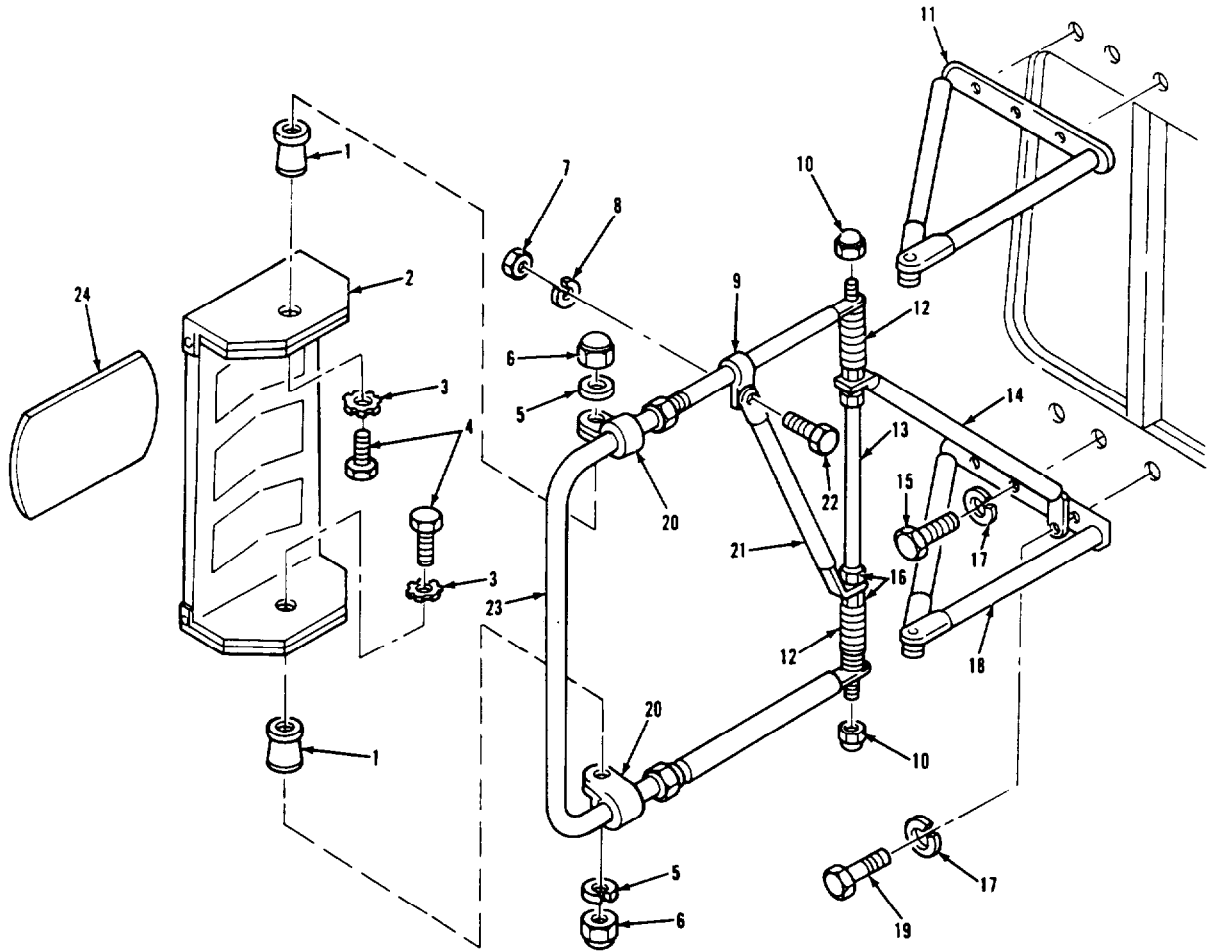

LEGEND:

- |                            |                                |
|----------------------------|--------------------------------|
| 1. SPACER (2)              | 13. PIVOT ROD                  |
| 2. MIRROR HEAD ASSEMBLY    | 14. BRACKET CROSS BRACE        |
| 3. SHAKEPROOF WASHER (2)   | 15. TAPPING HEX HEAD SCREW     |
| 4. HEX HEAD SCREW (2)      | 16. JAM NUT (4)                |
| 5. LOCKWASHER (2)          | 17. LOCKWASHER (6)             |
| 6. ACORN NUT (2)           | 18. BRACKET                    |
| 7. ACORN NUT               | 19. TAPPING HEX HEAD SCREW (5) |
| 8. LOCKWASHER              | 20. TUBE CLAMP (2)             |
| 9. TUBE CLAMP              | 21. LOOP CROSS BRACE           |
| 10. ACORN NUT (2)          | 22. HEX HEAD CAPSCREW          |
| 11. BRACKET                | 23. LOOP DETENT ASSEMBLY       |
| 12. COMPRESSION SPRING (2) | 24. STICK-ON CONVEX MIRROR     |

TA 237790



ACCESSORY ITEMS.

3-287. DOOR MIRROR REPLACEMENT (Continued).		
LOCATION/ITEM	ACTION	REMARKS
NOTE		
Replacement is the same for both sides.		
<b>A. MIRROR HEAD REMOVAL.</b>		
1. Two screws (4), washers (3), spacers (1), lockwashers (5), and nuts (6).	Remove from item (2) and two items (20).	
2. Head assembly (2).	Remove from two items (20).	
<b>B. MIRROR ASSEMBLY REMOVAL.</b>		
3. Five screws (19), screw (15), and six lockwashers (17).	Remove from item (11) and item (18).	
<b>C. DISASSEMBLY.</b>		
4. Two clamps (20).	Remove from item (23).	
5. Two nuts (10), brackets (11) and (18).	Remove from item (13).	
6. Capscrew (22), lockwasher (8), and nut (7).	Remove from item (21) and item (9).	
7. Detent assembly (23) and two springs (12).	Remove from item (13).	
8. Clamp (9).	Remove from item (23).	
9. Four nuts (16), brace (21), and brace (14).	Remove from item (13).	

ACCESSORY ITEMS.

3-287. DOOR MIRROR REPLACEMENT (Continued).

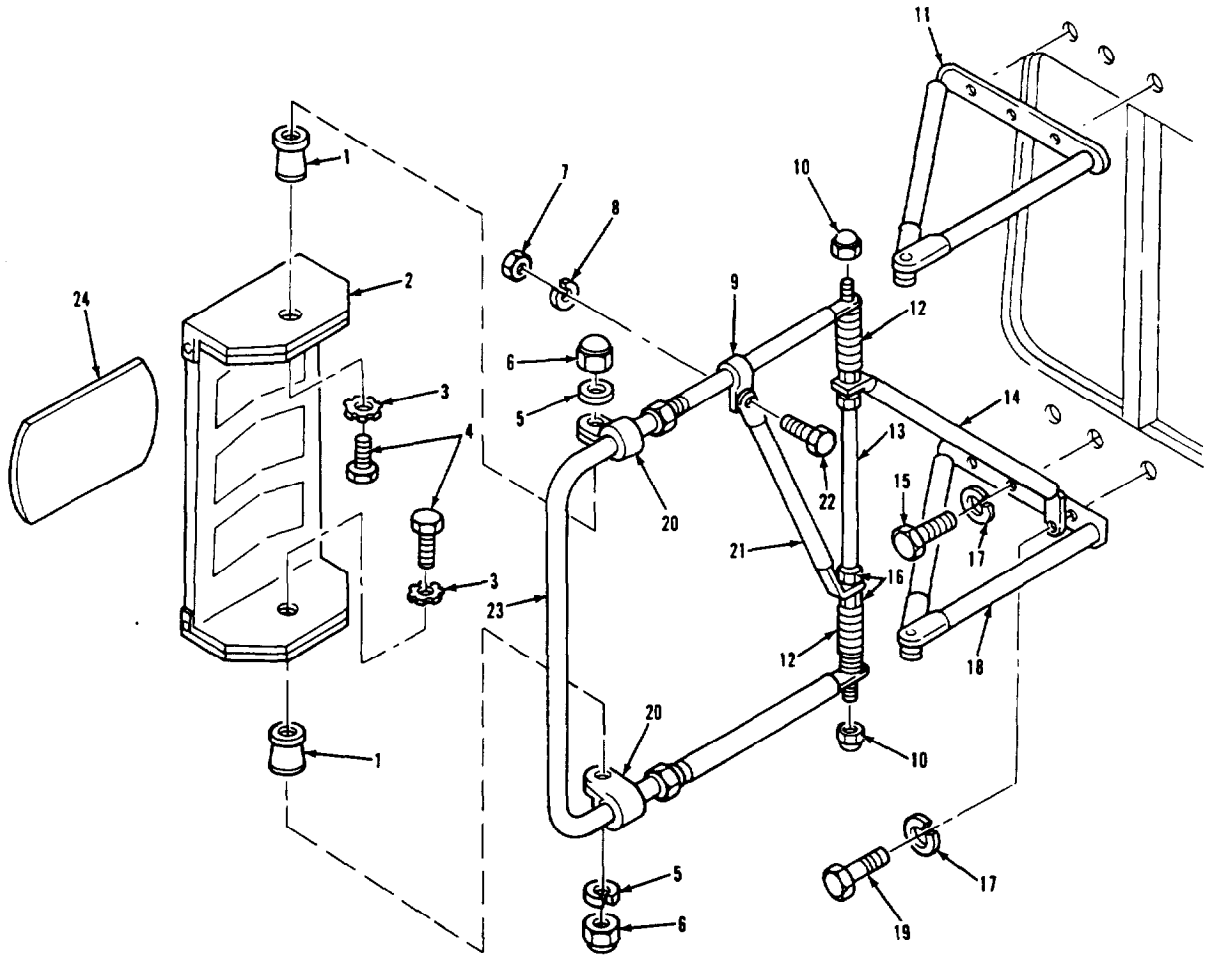

LEGEND:

- |                            |                                |
|----------------------------|--------------------------------|
| 1. SPACER (2)              | 13. PIVOT ROD                  |
| 2. MIRROR HEAD ASSEMBLY    | 14. BRACKET CROSS BRACE        |
| 3. SHAKEPROOF WASHER (2)   | 15. TAPPING HEX HEAD SCREW     |
| 4. HEX HEAD SCREW (2)      | 16. JAM NUT (4)                |
| 5. LOCKWASHER (2)          | 17. LOCKWASHER (6)             |
| 6. ACORN NUT (2)           | 18. BRACKET                    |
| 7. ACORN NUT               | 19. TAPPING HEX HEAD SCREW (5) |
| 8. LOCKWASHER*             | 20. TUBE CLAMP (2)             |
| 9. TUBE CLAMP              | 21. LOOP CROSS BRACE           |
| 10. ACORN NUT (2)          | 22. HEX HEAD CAPSCREW          |
| 11. BRACKET                | 23. LOOP DETENT ASSEMBLY       |
| 12. COMPRESSION SPRING (2) | 24. STICK-ON CONVEX MIRROR     |

TA 237791

ACCESSORY ITEMS.

3-287. DOOR MIRROR REPLACEMENT (Continued).

LOCATION/ITEM	ACTION	REMARKS
<b>D. ASSEMBLY.</b>		
10. Four nuts (16), brace (21), and brace (14).	Install on item (13).	
11. Clamp (9).	Install on item (23).	
12. Detent assembly (23) and two springs (12).	Install on item (13).	
13. Capscrew (22), lockwasher (8), and nut (7).	Secure item (21) to item (9).	
14. Two nuts (10).	Secure item (11) and item (18) to item (13).	
15. Two clamps (20).	Install on item (23).	
<b>E. MIRROR ASSEMBLY INSTALLATION.</b>		
16. Five screws (19), screw (15), and six lockwasher (17).	Secure item (11), item (18), and item (14) to door.	Longer screw (15) goes through item (14).
<b>F. MIRROR HEAD INSTALLATION.</b>		
17. Two screws (4), washers (3), spacers (1), lockwashers (5), and nuts (6).	Secure item (2) to two items (20).	
18. New mirror (24).	Install on item (2).	Only if item (2) is new.
NOTE		
Follow-on maintenance action required:		
None.		

ACCESSORY ITEMS.

3-287. DOOR MIRROR REPLACEMENT (Continued).

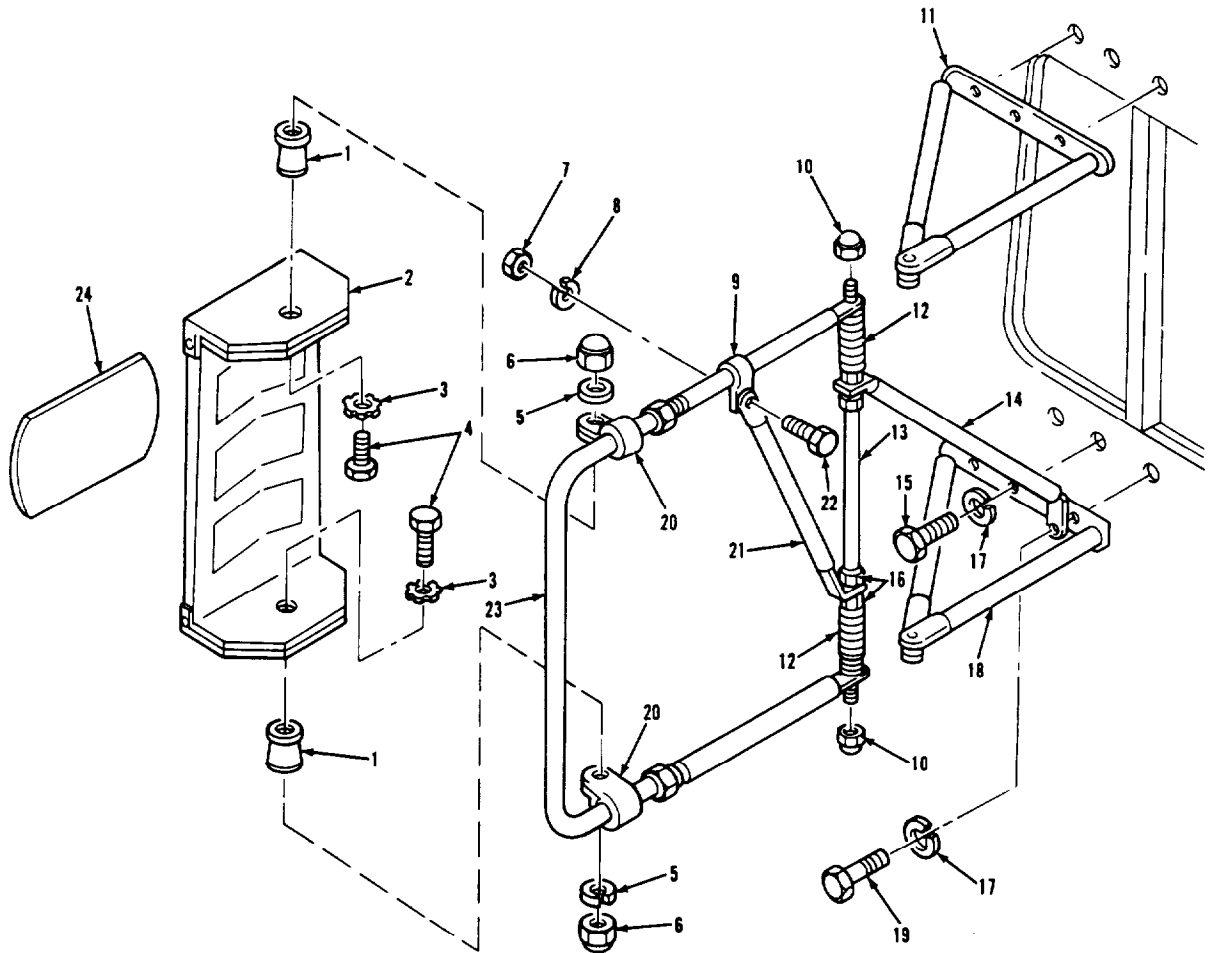

LEGEND:

- |                            |                                |
|----------------------------|--------------------------------|
| 1. SPACER (2)              | 13. PIVOT ROD                  |
| 2. MIRROR HEAD ASSEMBLY    | 14. BRACKET CROSS BRACE        |
| 3. SHAKEPROOF WASHER (2)   | 15. TAPPING HEX HEAD SCREW     |
| 4. HEX HEAD SCREW (2)      | 16. JAM NUT (4)                |
| 5. LOCKWASHER (2)          | 17. LOCKWASHER (6)             |
| 6. ACORN NUT (2)           | 18. BRACKET                    |
| 7. ACORN NUT               | 19. TAPPING HEX HEAD SCREW (5) |
| 8. LOCKWASHER              | 20. TUBE CLAMP (2)             |
| 9. TUBE CLAMP              | 21. LOOP CROSS BRACE           |
| 10. ACORN NUT (2)          | 22. HEX HEAD CAPSCREW          |
| 11. BRACKET                | 23. LOOP DETENT ASSEMBLY       |
| 12. COMPRESSION SPRING (2) | 24. STICK-ON CONVEX MIRROR     |

TA 237792

ACCESSORY ITEMS.

3-288. SPOTTER MIRROR REPLACEMENT.

THIS TASK COVERS

- a. Right-Hand Mirror Removal.
- b. Right-Hand Mirror Installation.
- c. Left-Hand Mirror Removal.
- d. Left-Hand Mirror Installation.

INITIAL SETUP

<u>APPLICABLE CONFIGURATIONS</u>	<u>EQUIPMENT CONDITION PARAGRAPH</u>	<u>CONDITION DESCRIPTION</u>
All.	None.	None.

TEST EQUIPMENT  
None.

SPECIAL TOOLS  
None.

MATERIALS/PARTS (P/N)  
None.

PERSONNEL REQUIRED  
One (MOS-63S).

SPECIAL ENVIRONMENTAL CONDITIONS  
None.

REFERENCES (TM)  
None.

GENERAL SAFETY INSTRUCTIONS  
Engine off  
Transmission in neutral.  
Park brake set.

TROUBLESHOOTING REFERENCES  
Paragraph 2-11.

ACCESSORY ITEMS.

3-288. SPOTTER MIRROR REPLACEMENT (Continued).

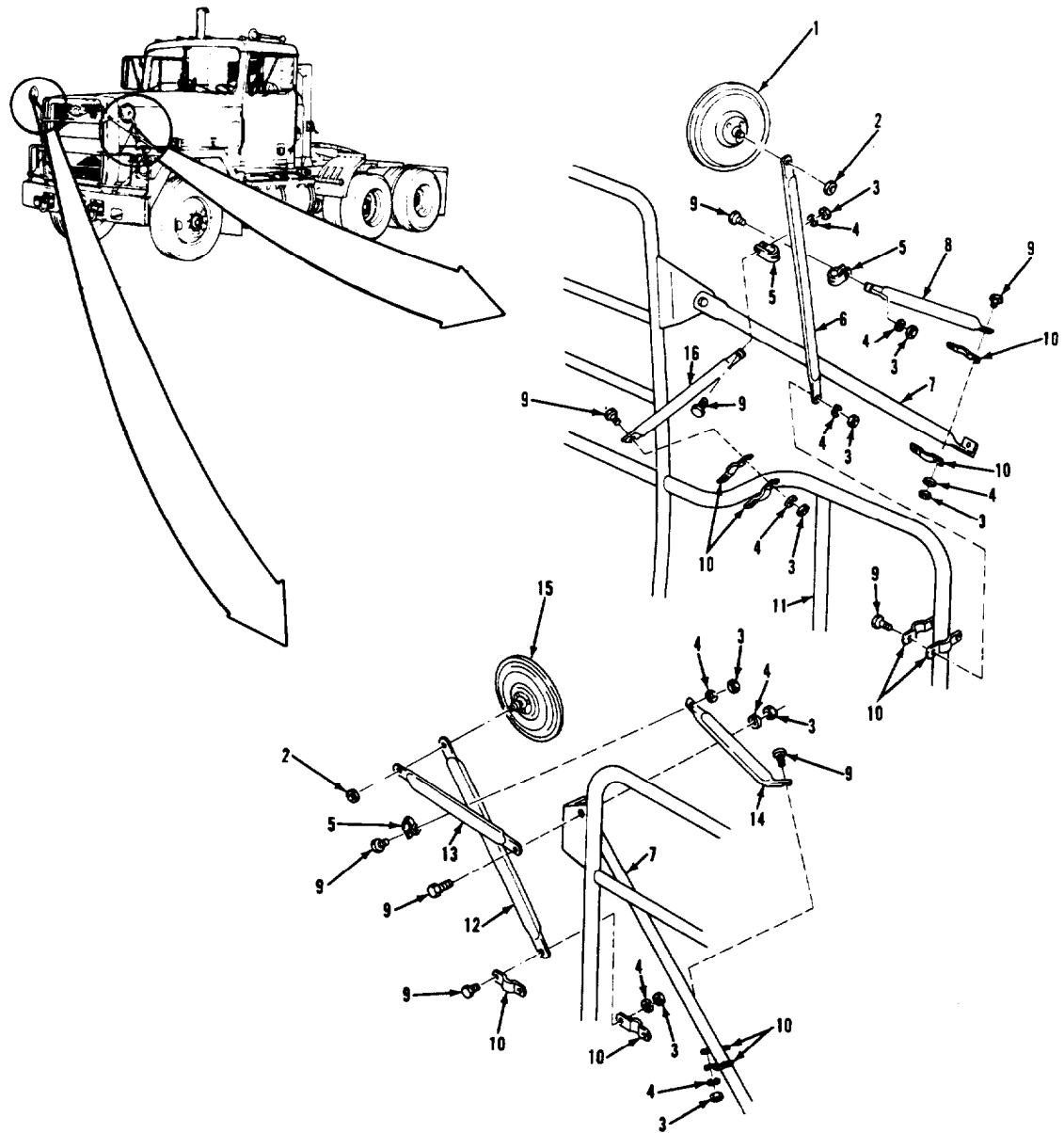

LEGEND:

- |                          |                          |
|--------------------------|--------------------------|
| 1. CROSSOVER MIRROR      | 9. SCREW (14)            |
| 2. NUT (2)               | 10. CLAMP HALF (10)      |
| 3. PT NUT (1)            | 11. BRUSH GUARD ASSEMBLY |
| 4. PLAIN WASH R (14)     | 12. MIRROR SUPPORT ARM   |
| 5. CLAMP (3)             | 13. SUPPORT ARM          |
| 6. MIRROR SUPPORT ARM    | 14. BENT SUPPORT ARM     |
| 7. BRUSH GUARD BRACE (2) | 15. MIRROR               |
| 8. SUPPORT ARM           | 16. SUPPORT ARM          |

TA 237793

ACCESSORY ITEMS.

3-288. SPOTTER MIRROR REPLACEMENT (Continued).

LOCATION/ITEM	ACTION	REMARKS
<b>A. RIGHT-HAND MIRROR REMOVAL.</b>		
1. Nut (2).	Remove from item (15).	
2. Mirror (15).	Remove from item (12) and item (13).	
3. Screw (9), washer (4), and nut (3).	Remove from item (13) and item (11).	
4. Arm (13).	Remove.	
5. Four screws (9), washers (4), and nuts (3).	Remove from four items (10), item (14), and item (12).	
6. Screw (9), washer (4), and nut (3).	Remove from item (5) and item (14).	
7. Clamp (5).	Remove from item (14) and item (12).	
<b>B. RIGHT-HAND MIRROR INSTALLATION.</b>		
8. Clamp (5), screw (9), washer (4), and nut (3).	Install on item (12) and item (14).	Do not tighten.
9. Four clamp halves (10), screws (9), washers (4), and nuts (3).	Install on item (14), item (12), item (7), and item (11).	Do not tighten.
10. Screw (9), washer (4), and nut (3).	Install in item (13) and item (11).	Do not tighten.
11. Mirror (15) and nut (2).	Install in item (12) and item (13).	
12. Six screws (9), washers (4), and nuts (3).	Tighten.	

ACCESSORY ITEMS.

3-288. SPOTTER MIRROR REPLACEMENT (Continued).

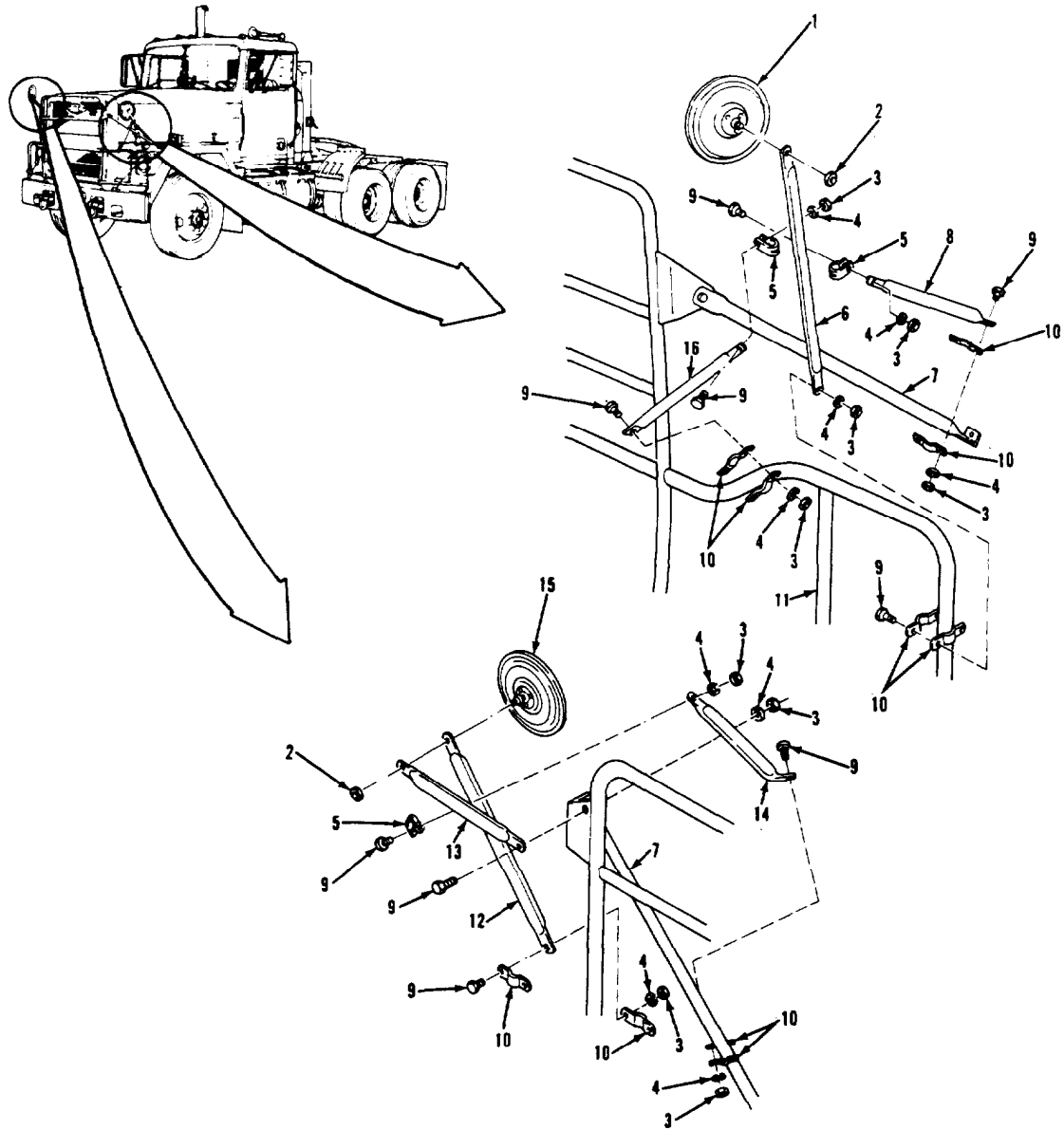

LEGEND:

- |                          |                          |
|--------------------------|--------------------------|
| 1. CROSSOVER MIRROR      | 9. SCREW (14)            |
| 2. NUT (2)               | 10. CLAMP HALF (10)      |
| 3. PT NUT (14)           | 11. BRUSH GUARD ASSEMBLY |
| 4. PLAIN WASHER (14)     | 12. MIRROR SUPPORT ARM   |
| 5. CLAMP (3)             | 13. SUPPORT ARM          |
| 6. MIRROR SUPPORT ARM    | 14. BENT SUPPORT ARM     |
| 7. BRUSH GUARD BRACE (2) | 15. MIRROR               |
| 8. SUPPORT ARM           | 16. SUPPORT ARM          |

TA 237794



ACCESSORY ITEMS.

3-288. SPOTTER MIRROR REPLACEMENT (Continued).

LOCATION/ITEM	ACTION	REMARKS
<b>C. LEFT-HAND MIRROR REMOVAL.</b>		
13. Nut (2).	Remove from item (1).	
14. Mirror (1).	Remove from item (6).	
15. Six screws (9), washers (4), and nuts (3).	Remove from six items (10), item (8), item (6), and item (16).	
16. Two screws (9), washers (4), and nuts (3).	Remove from two items (5), item (8), and item (16).	
17. Two clamps (5).	Remove from item (8), item (6), and item (16).	
<b>D. LEFT-HAND MIRROR INSTALLATION.</b>		
18. Two clamps (5), screws (9), washers (4), and nuts (3).	Install on item (8), item (6), and item (16).	Do not tighten.
19. Six clamp halves (10), screws (9), washers (4), and nuts (3).	Install on item (8), item (6), item (16), item (7), and item (11).	
20. Two screws (9) and nuts (3).	Tighten two items (5).	
21. Mirror (1).	Put in item (6).	
22. Nut (2).	Secure item (1) to item (6).	
NOTE		
Follow-on maintenance action required:		
None.		

ACCESSORY ITEMS.

3-288. SPOTTER MIRROR REPLACEMENT (Continued).

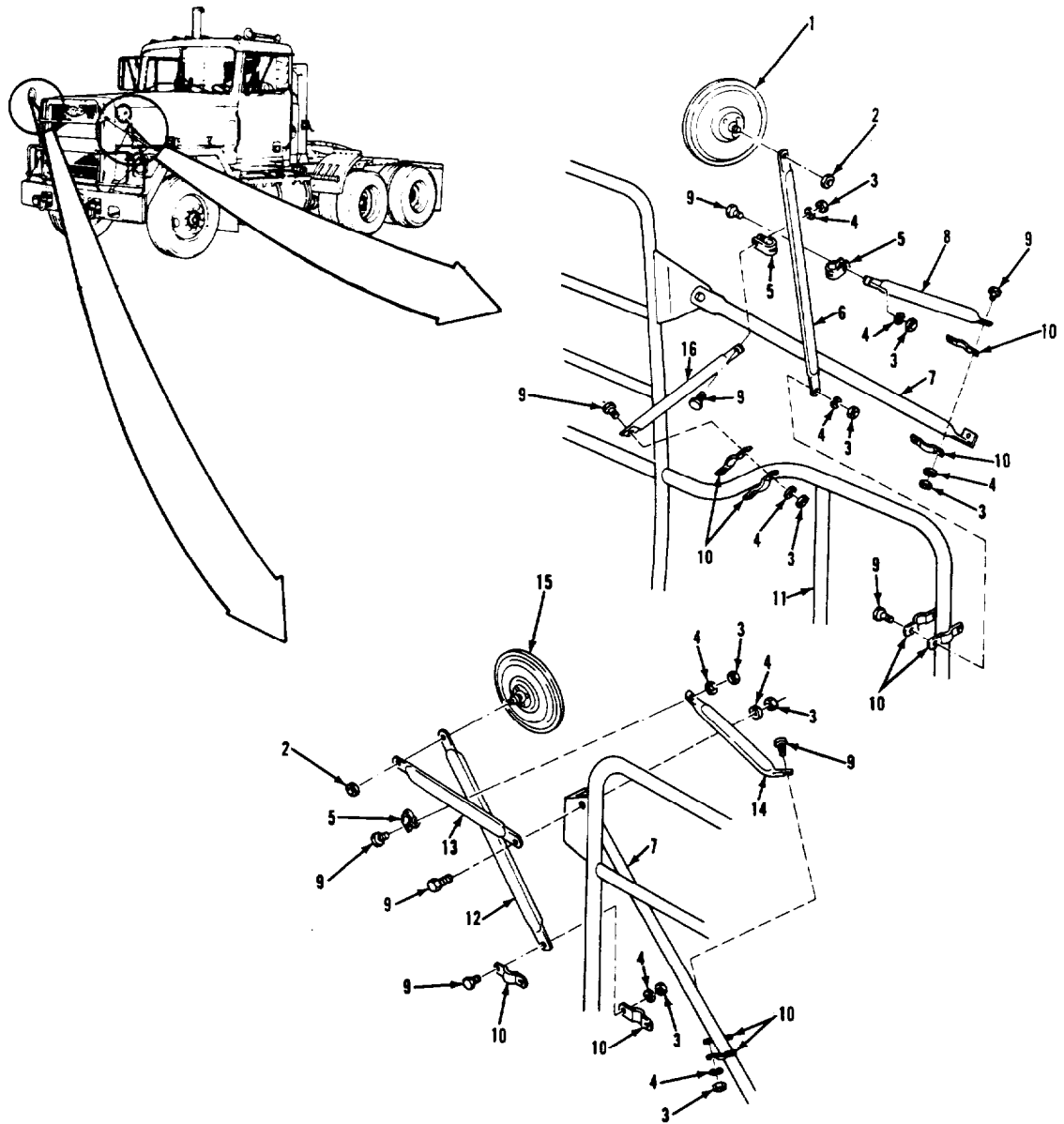

LEGEND:

- |                          |                          |
|--------------------------|--------------------------|
| 1. CROSSOVER MIRROR      | 9. SCREW (14)            |
| 2. NUT (2)               | 10. CLAMP HALF (10)      |
| 3. PT NUT (14)           | 11. BRUSH GUARD ASSEMBLY |
| 4. PLAIN WASHER (14)     | 12. MIRROR SUPPORT ARM   |
| 5. CLAMP (3)             | 13. SUPPORT ARM          |
| 6. MIRROR SUPPORT ARM    | 14. BENT SUPPORT ARM     |
| 7. BRUSH GUARD BRACE (2) | 15. MIRROR               |
| 8. SUPPORT ARM           | 16. SUPPORT ARM          |

TA 237795

ACCESSORY ITEMS.

3-289. AIR HORN AND CONTROL VALVE REPLACEMENT.

THIS TASK COVERS

- a. Removal.
- b. Installation.

INITIAL SETUP

APPLICABLE CONFIGURATIONS

All.

EQUIPMENT CONDITION  
PARAGRAPH

None.

CONDITION DESCRIPTION

None.

TEST EQUIPMENT

None.

SPECIAL TOOLS

None.

MATERIALS/PARTS (P/N)

Tape, thread sealing  
Item 24, Appendix C.  
Liner, rubber  
(26501) 1724.  
Gasket, pedestal mount  
(26501) 1783.  
Gasket, horn base  
(26501) 1715.

PERSONNEL REQUIRED

One (MOS-63S).

SPECIAL ENVIRONMENTAL CONDITIONS

None.

REFERENCES (TM)

TM 9-2320-283-20P.

GENERAL SAFETY INSTRUCTIONS

Engine off.  
Transmission in neutral.  
Park brake set.

TROUBLESHOOTING REFERENCES

Paragraph 2-11.

ACCESSORY ITEMS.

3-289. AIR HORN AND CONTROL VALVE REPLACEMENT (Continued).

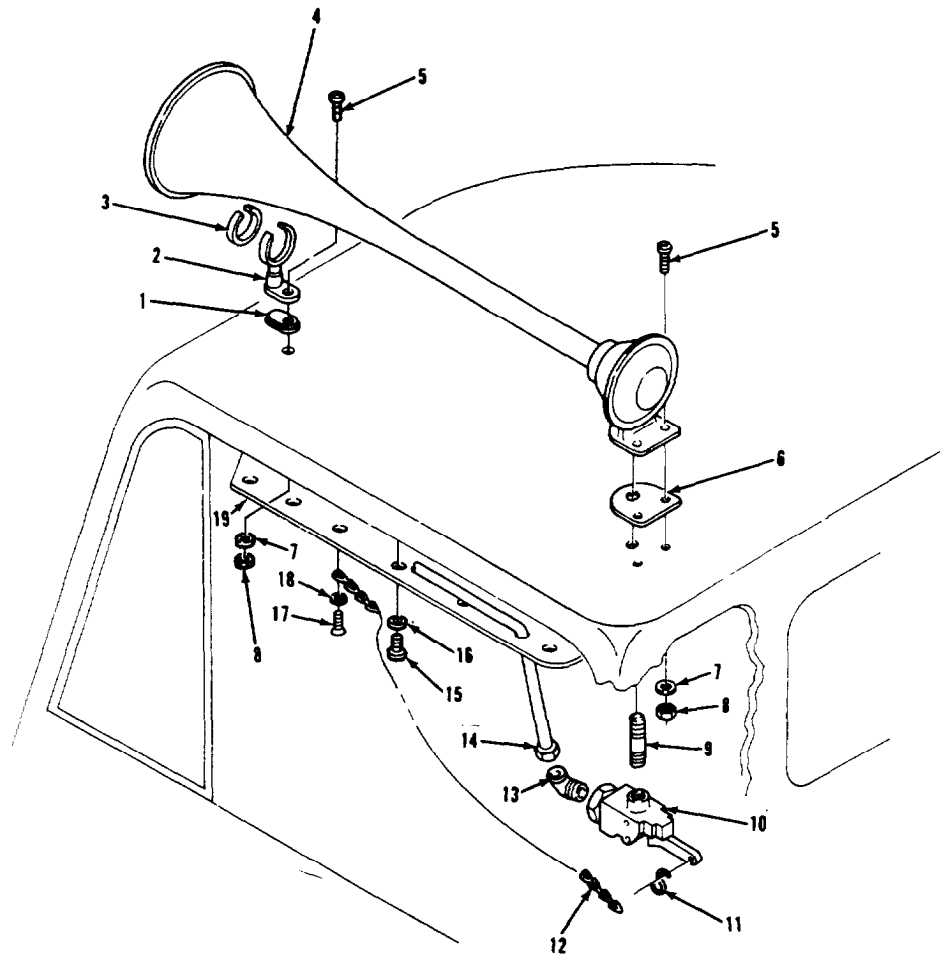

LEGEND:

- |                          |  |
|--------------------------|--|
| 1. PEDESTAL MOUNT GASKET | 11. S-TYPE HOOK                                |
| 2. PEDESTAL              | 12. HORN VALVE PULL CHAIN                      |
| 3. RUBBER LINER          | 13. ELBOW                                      |
| 4. AIR HORN ASSEMBLY     | 14. TUBE                                       |
| 5. SCREW (3)             | 15. SCREW (AS REQUIRED)                        |
| 6. HORN BASE GASKET      | 16. FINISH WASHER (AS REQUIRED)                |
| 7. FLAT WASHER (3)       | 17. SCREW                                      |
| 8. NUT (3)               | 18. WASHER                                     |
| 9. NIPPLE                | 19. HEADLINER CAB PANEL AND<br>ROOF INSULATION |
| 10. AIR HORN VALVE       |  |

TA 237796

ACCESSORY ITEMS.

3-289. AIR HORN AND CONTROL VALVE REPLACEMENT (Continued).

LOCATION/ITEM	ACTION	REMARKS
<u>WARNING</u>		
Never work on air system components without first draining air pressure. Failure to follow this precaution can result in serious personal injury.		
<b>A. REMOVAL.</b>		
1. Tube (14).	Remove from item (13).	
2. Hook (11).	Remove from item (10) and item (12).	Use pliers.
3. Elbow (13).	Remove from item (10).	
4. Valve (10).	Remove from item (9).	
5. Screw (17) and washer (18).	Remove from item (12).	
6. Screws (15) and washers (16).	Remove from item (19).	Remove as many as needed to pull down item (19) for access.
7. Two screws (5), washers (7), and nuts (8).	Remove from item (4) and item (6).	
8. Horn assembly (4).	Remove from item (2).	
9. Gasket (6).	Remove from item (4).	Discard item (6).
10. Nipple (9).	Remove from item (4).	
11. Screw (5), washer (7), and nut (8).	Remove from item (2) and item (1).	Discard item (1).
12. Liner (3).	Remove from item (2).	Discard item (3).

ACCESSORY ITEMS.

3-289. AIR HORN AND CONTROL VALVE REPLACEMENT (Continued).

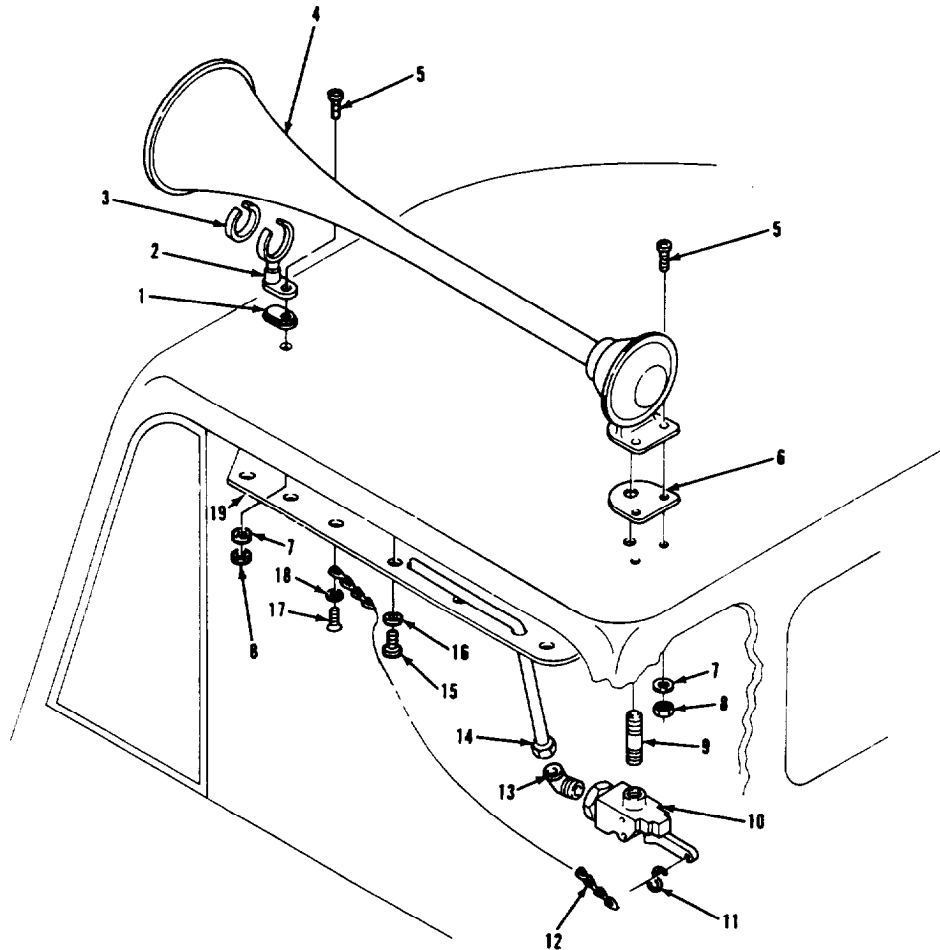

LEGEND:

- |                          |   |
|--------------------------|---|
| 1. PEDESTAL MOUNT GASKET | 11. S-TYPE HOOK                             |
| 2. PEDESTAL              | 12. HORN VALVE PULL CHAIN                   |
| 3. RUBBER LINER          | 13. ELBOW                                   |
| 4. AIR HORN ASSEMBLY     | 14. TUBE                                    |
| 5. SCREW (3)             | 15. SCREW (AS REQUIRED)                     |
| 6. HORN BASE GASKET      | 16. FINISH WASHER (AS REQUIRED)             |
| 7. FLAT WASHER (3)       | 17. SCREW                                   |
| 8. NUT (3)               | 18. WASHER                                  |
| 9. NIPPLE                | 19. HEADLINER CAB PANEL AND ROOF INSULATION |
| 10. AIR HORN VALVE       |   |

TA 237797

ACCESSORY ITEMS.

3-289. AIR HORN AND CONTROL VALVE REPLACEMENT (Continued).

LOCATION/ITEM	ACTION	REMARKS
<b>B. INSTALLATION.</b>		
13. New liner (3).	Install in item (2).	
14. Pedestal (2) and new gasket (1).	Put in place on cab roof.	
15. Screw (5), washer (7), and nut (8).	Secure item (2) and item (1) to cab roof.	
16. Nipple (9).	Install in item (4).	Put thread sealing tape on threads.
17. New gasket (6).	Install on item (4).	
18. Horn assembly (4).	Put in place in item (2) and on cab roof.	
19. Two screws (5), washers (7), and nuts (8).	Secure item (4) to cab roof.	
20. Screws (15) and washers (16).	Secure item (19) to cab roof.	
21. Valve (10).	Install on item (9).	Put thread sealing tape on threads.
22. Elbow (13).	Install in item (10).	Put thread sealing tape on threads.
23. Hook (11).	Install on item (10) and item (12).	Use pliers.
24. Tube (14).	Install on item (13).	
25. Screw (17) and washer (18).	Secure item (12) to item (19) and cab roof.	
NOTE		
Follow-on maintenance action required:		
None.		

ACCESSORY ITEMS.

3-289. AIR HORN AND CONTROL VALVE REPLACEMENT (Continued).

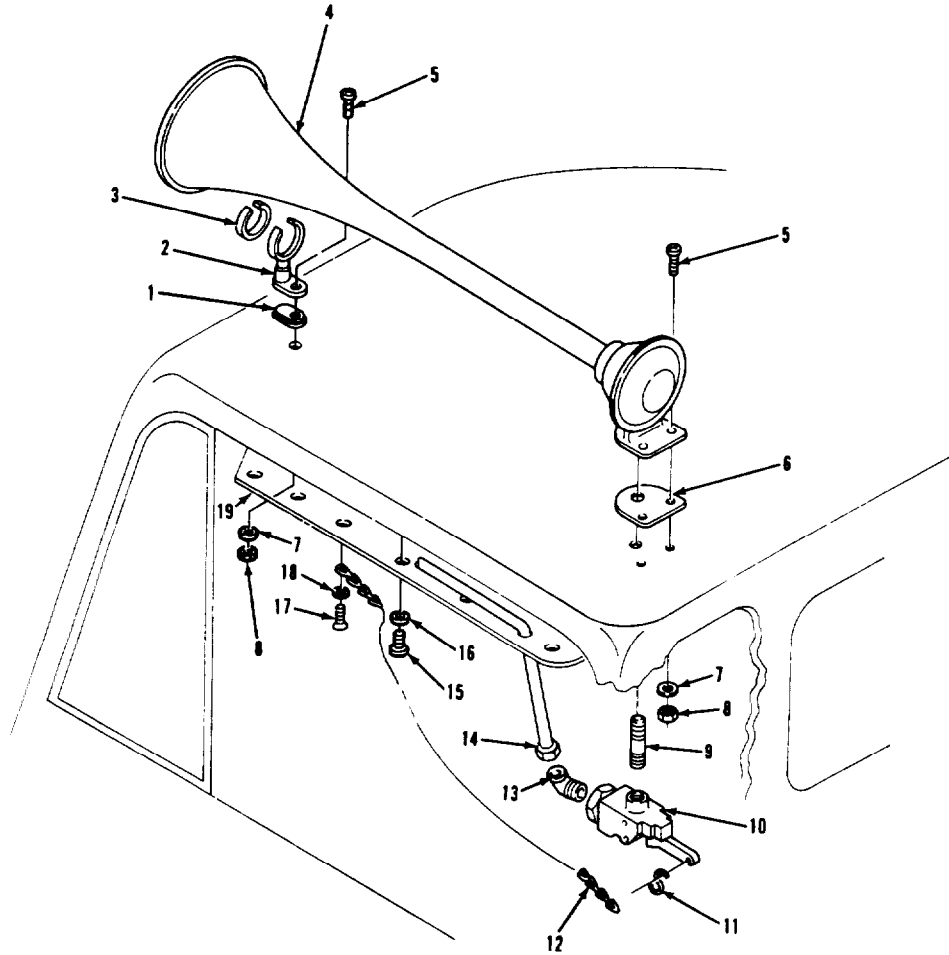

LEGEND:

- |                          |   |
|--------------------------|---|
| 1. PEDESTAL MOUNT GASKET | 11. S-TYPE HOOK                             |
| 2. PEDESTAL              | 12. HORN VALVE PULL CHAIN                   |
| 3. RUBBER LINER          | 13. ELBOW                                   |
| 4. AIR HORN ASSEMBLY     | 14. TUBE                                    |
| 5. SCREW (3)             | 15. SCREW (AS REQUIRED)                     |
| 6. HORN BASE GASKET      | 16. FINISH WASHER (AS REQUIRED)             |
| 7. FLAT WASHER (3)       | 17. SCREW                                   |
| 8. NUT (3)               | 18. WASHER                                  |
| 9. NIPPLE                | 19. HEADLINER CAB PANEL AND ROOF INSULATION |
| 10. AIR HORN VALVE       |   |

TA 237798



ACCESSORY ITEMS.

3-290. WINDSHIELD WASHER REPLACEMENT.

THIS TASK COVERS

- a. Removal.
- b. Cleaning and Inspection.
- c. Installation.

INITIAL SETUP

APPLICABLE CONFIGURATIONS

All.

EQUIPMENT CONDITION  
PARAGRAPH

None.

CONDITION DESCRIPTION

None.

TEST EQUIPMENT

None.

SPECIAL TOOLS

None.

MATERIALS/PARTS (P/N)

Rags, wiping  
Item 22, Appendix C.  
Clamp, hose (4)  
(60703) 7989606.

PERSONNEL REQUIRED

One (MOS-63S).

SPECIAL ENVIRONMENTAL CONDITIONS

None.

REFERENCES (TM)

TM 9-2320-283-20P.

GENERAL SAFETY INSTRUCTIONS

Engine off.  
Transmission in neutral.  
Park brake set.

TROUBLESHOOTING REFERENCES

Paragraph 2-11.

ACCESSORY ITEMS.

3-290. WINDSHIELD WASHER REPLACEMENT (Continued).

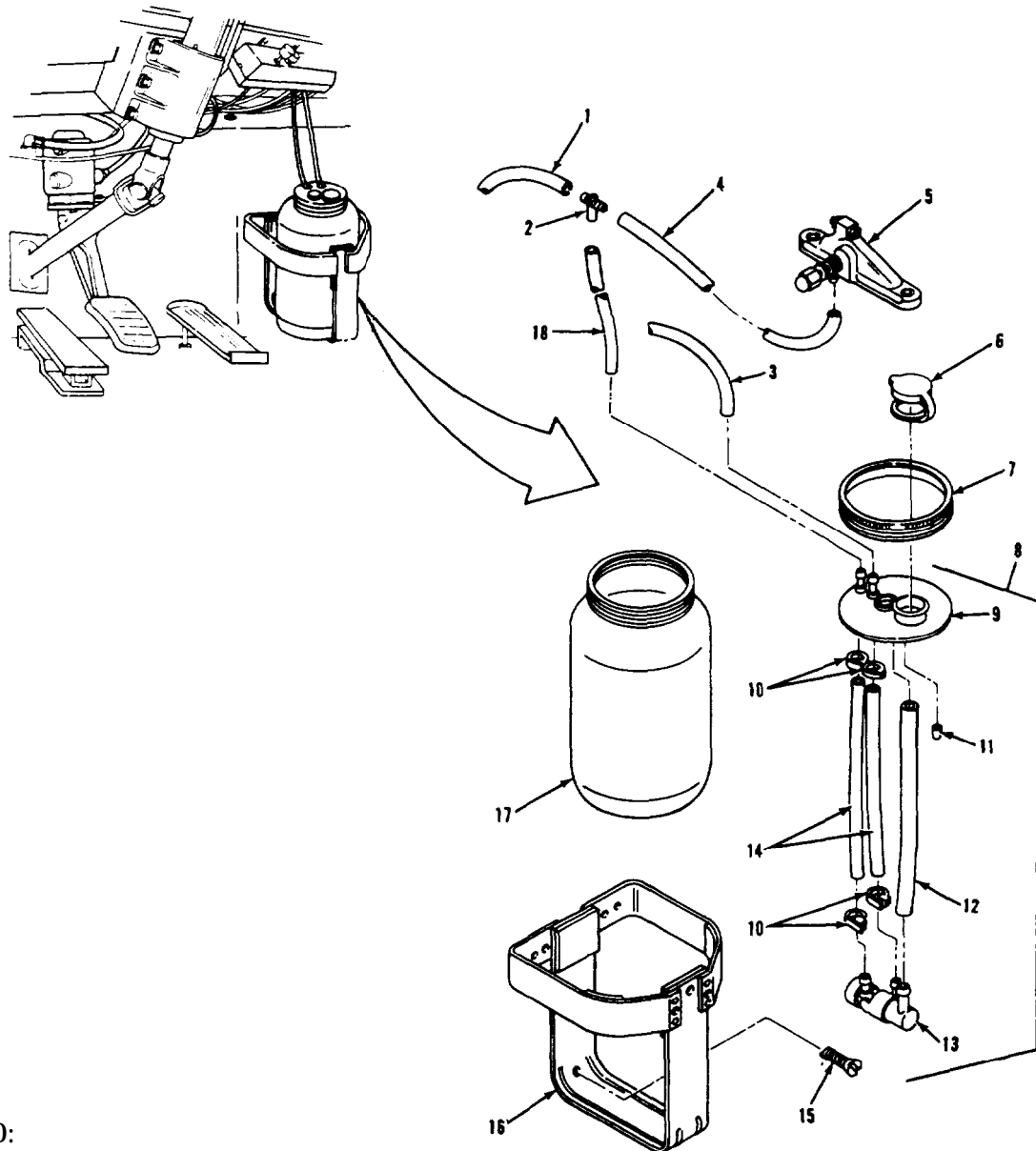

LEGEND:

- |  |                                |
|--|--------------------------------|
| 1. RUBBER HOSE                           | 10. HOSE CLAMP (4)             |
| 2. HOSE TEE                              | 11. VENT NIPPLE                |
| 3. RUBBER HOSE                           | 12. TUBING                     |
| 4. RUBBER HOSE                           | 13. CENTRIFUGAL PUMP           |
| 5. PIVOT BODY ASSEMBLY (2)               | 14. HOSE (2)                   |
| 6. FILLER OPENING COVER                  | 15. PAN HEAD SCREW (3)         |
| 7. JAR CAP                               | 16. BRACKET AND STRAP ASSEMBLY |
| 8. CONNECTOR AND HOSE ASSEMBLY JAR COVER | 17. PLASTIC JAR                |
| 9. JAR COVER CONNECTOR ASSEMBLY          | 18. RUBBER HOSE                |

TA 237799

ACCESSORY ITEMS.

3-290. WINDSHIELD WASHER REPLACEMENT (Continued).

LOCATION/ITEM	ACTION	REMARKS
<b>A. REMOVAL.</b>		
1. Hose (3) and hose (18).	Remove from item (9).	
2. Hose (18).	Remove from item (2).	
3. Tee (2).	Remove from item (1) and item (4).	
4. Hose (1) and hose (4).	Remove from two items (5).	Remove heater air hose to access item (4). (Refer to paragraph 3-296).
5. Jar (17).	Remove from item (16).	
6. Cap (7).	Remove from item (9) and item (17).	
7. Cover assembly (8).	Remove from item (17).	
8. Cover (6).	Remove from item (9).	
9. Four clamps (10).	Cut from two items (14).	a. Take care not to cut items (14). b. Discard four items (10).
10. Two hoses (14) and tubing (12).	Remove from item (13) and item (9).	
11. Nipple (11).	Remove from item (9).	
12. Three screws (15).	Remove from item (16).	
<b>B. CLEANING AND INSPECTION.</b>		
13. All parts.	a. Wipe clean with damp rag. b. Inspect.	Refer to paragraph 3-5.

ACCESSORY ITEMS.

3-290. WINDSHIELD WASHER REPLACEMENT (Continued).

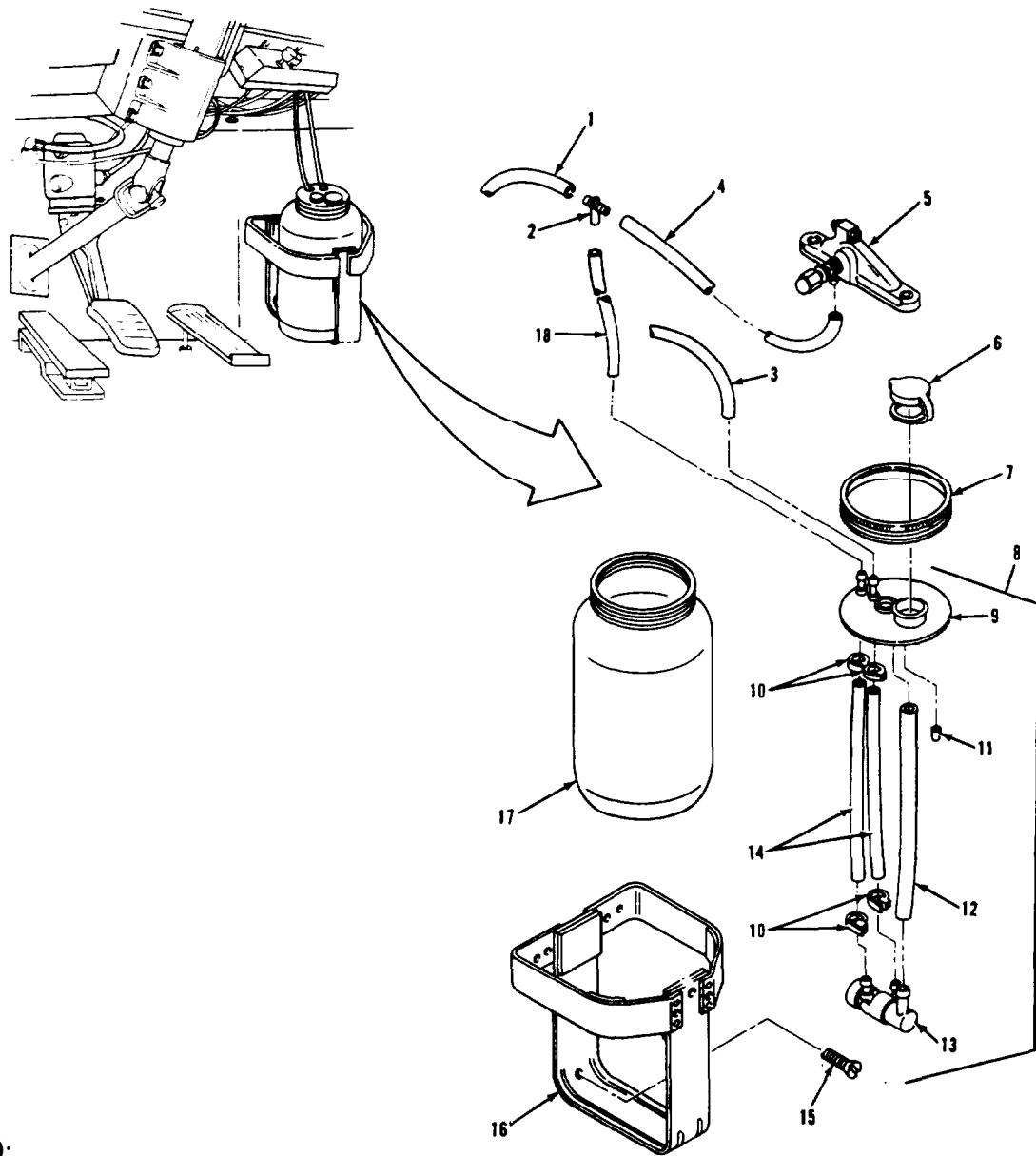

LEGEND:

- |  |                                |
|--|--------------------------------|
| 1. RUBBER HOSE                           | 10. HOSE CLAMP (4)             |
| 2. HOSE TEE                              | 11. VENT NIPPLE                |
| 3. RUBBER HOSE                           | 12. TUBING                     |
| 4. RUBBER HOSE                           | 13. CENTRIFUGAL PUMP           |
| 5. PIVOT BODY ASSEMBLY (2)               | 14. HOSE (2)                   |
| 6. FILLER OPENING COVER                  | 15. PAN HEAD SCREW (3)         |
| 7. JAR CAP                               | 16. BRACKET AND STRAP ASSEMBLY |
| 8. CONNECTOR AND HOSE ASSEMBLY JAR COVER | 17. PLASTIC JAR                |
| 9. JAR COVER CONNECTOR ASSEMBLY          | 18. RUBBER HOSE                |

TA 237800

ACCESSORY ITEMS.

3-290. WINDSHIELD WASHER REPLACEMENT (Continued).

LOCATION/ITEM	ACTION	REMARKS
<b>C. INSTALLATION.</b>		
14. Bracket (16).	Put in place.	
15. Three screws (15).	Secure bracket (16).	
16. Nipple (11).	Install on item (9).	
17. Two hoses (14) and tubing (12).	Install on item (9) and item (13).	
18. Four new clamps (10).	Secure two items (14).	
19. Cover (6).	Install on item (9).	
20. Cover assembly (9).	Install in item (17).	
21. Cap (7).	Secure item (9) to item (17).	
22. Jar (17).	Put in item (16).	
23. Hose (1) and hose (4).	Install on two items (5).	Install heater air hose removed in step 4, to access hose (4). (Refer to para 3-296).
24. Tee (2).	Install in item (1) and item (4).	
25. Hose (18).	Install on item (2).	
26. Hose (3) and hose (18).	Install on item (9).	Hose (3) goes to "A".
NOTE		
Follow-on maintenance action required:		
None.		

ACCESSORY ITEMS.

3-290. WINDSHIELD WASHER REPLACEMENT (Continued).

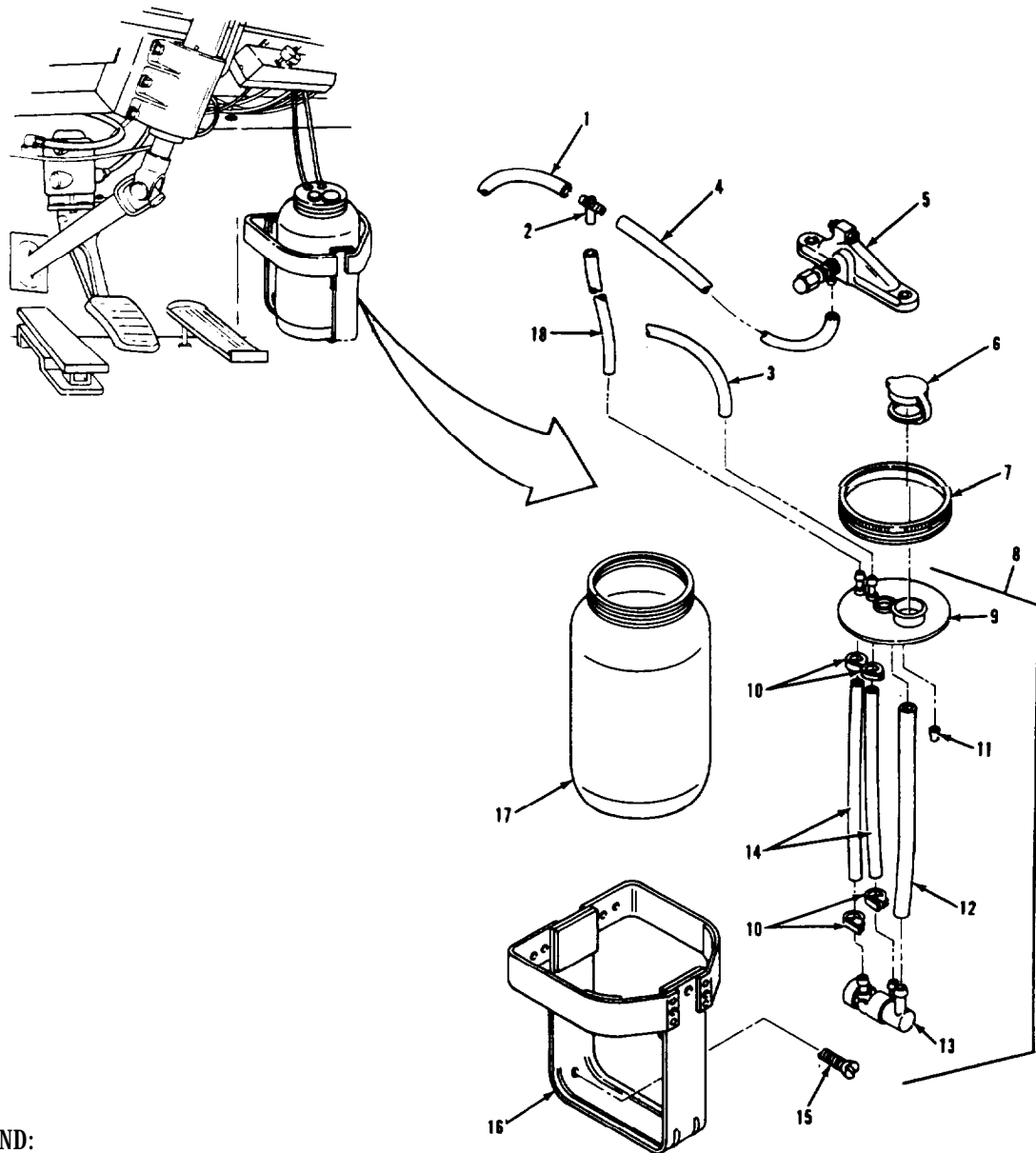

LEGEND:

- |  |                                |
|--|--------------------------------|
| 1. RUBBER HOSE                           | 10. HOSE CLAMP (4)             |
| 2. HOSE TEE                              | 11. VENT NIPPLE                |
| 3. RUBBER HOSE                           | 12. TUBING                     |
| 4. RUBBER HOSE                           | 13. CENTRIFUGAL PUMP           |
| 5. PIVOT BODY ASSEMBLY (2)               | 14. HOSE (2)                   |
| 6. FILLER OPENING COVER                  | 15. PAN HEAD SCREW (3)         |
| 7. JAR CAP                               | 16. BRACKET AND STRAP ASSEMBLY |
| 8. CONNECTOR AND HOSE ASSEMBLY JAR COVER | 17. PLASTIC JAR                |
| 9. JAR COVER CONNECTOR ASSEMBLY          | 18. RUBBER HOSE                |

TA 237801

ACCESSORY ITEMS.

3-291. WINDSHIELD WASHER CONTROL VALVE REPLACEMENT.

THIS TASK COVERS

- a. Removal.
- b. Cleaning and Inspection.
- c. Installation.

INITIAL SETUP

APPLICABLE CONFIGURATIONS

All.

EQUIPMENT CONDITION  
PARAGRAPH

3-292.

CONDITION DESCRIPTION

Windshield wiper  
control removed.

TEST EQUIPMENT

None.

SPECIAL TOOLS

None.

MATERIALS/PARTS (P/N)

Tape, thread sealing  
Item 32, Appendix C.

PERSONNEL REQUIRED

One (MOS-63S).

SPECIAL ENVIRONMENTAL CONDITIONS

None.

REFERENCES (TM)

None.

GENERAL SAFETY INSTRUCTIONS

Engine off  
Transmission in neutral.  
Park brake set.

TROUBLESHOOTING REFERENCES

Paragraph 2-11.

ACCESSORY ITEMS.

3-291. WINDSHIELD WASHER CONTROL VALVE REPLACEMENT (Continued).

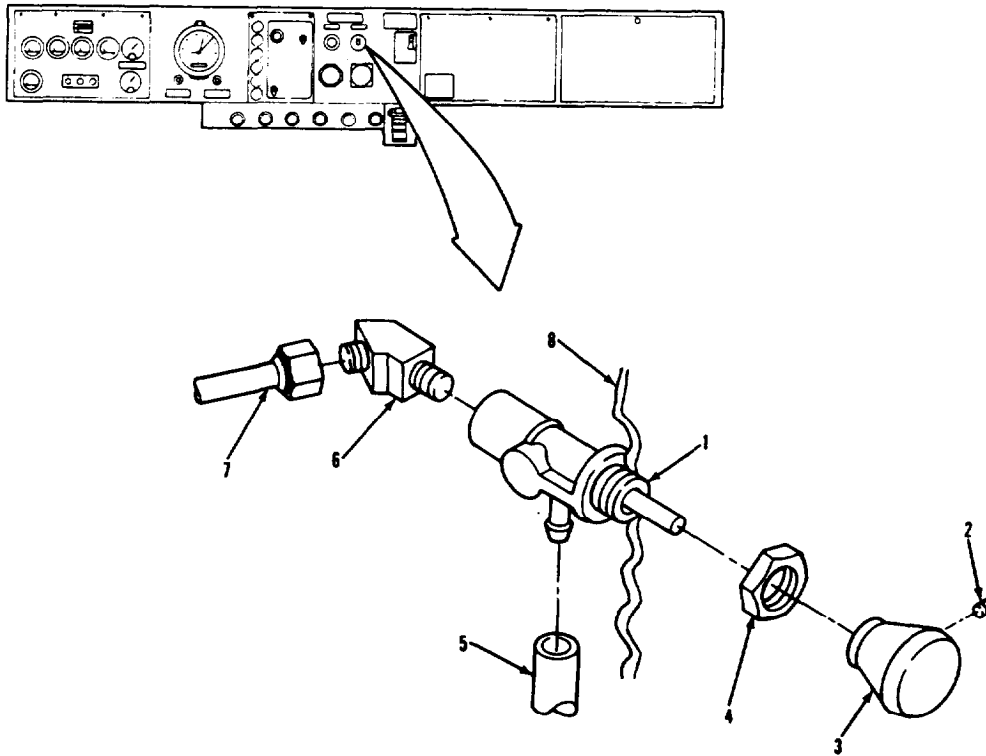

LEGEND:

- |                                    |                              |
|------------------------------------|------------------------------|
| 1. WINDSHIELD WASHER CONTROL VALVE | 5. RUBBER HOSE               |
| 2. SETSCREW                        | 6. 45 DEGREE MALE ELBOW      |
| 3. KNOB                            | 7. AIR LINE                  |
| 4. HEX NUT                         | 8. INSTRUMENT PANEL ASSEMBLY |

TA 237802



ACCESSORY ITEMS.

3-291. WINDSHIELD WASHER CONTROL VALVE REPLACEMENT (Continued).		
LOCATION/ITEM	ACTION	REMARKS
<b>A. REMOVAL.</b>		
1. Setscrew (2).	Loosen.	
2. Knob (3).	Remove from item (1).	
3. Nut (4).	Remove from item (1).	
4. Valve (1).	Remove from item (8).	
5. Hose (5).	Remove from item (1).	
6. Air line (7).	Remove from item (6).	
7. Elbow (6).	Remove from item (1).	
<b>B. CLEANING AND INSPECTION.</b>		
8. All parts.	Clean and inspect.	Refer to paragraphs 3-4 and 3-5.
<b>C. INSTALLATION.</b>		
9. Elbow (6).	Install in item (1).	a. Put thread sealing tape on pipe threads. b. Point towards left of vehicle.
10. Air line (7).	Install on item (6).	
11. Hose (5).	Install on item (1).	
12. Valve (1).	Put in item (8).	
13. Nut (4).	Secure item (1) to item (8).	
14. Knob (3).	Put on item (1).	
15. Setscrew (2).	Tighten.	
NOTE		
*Follow-on maintenance action required:		
Install windshield wiper control (para 3-292).		

ACCESSORY ITEMS.

3-291. WINDSHIELD WASHER CONTROL VALVE REPLACEMENT (Continued).

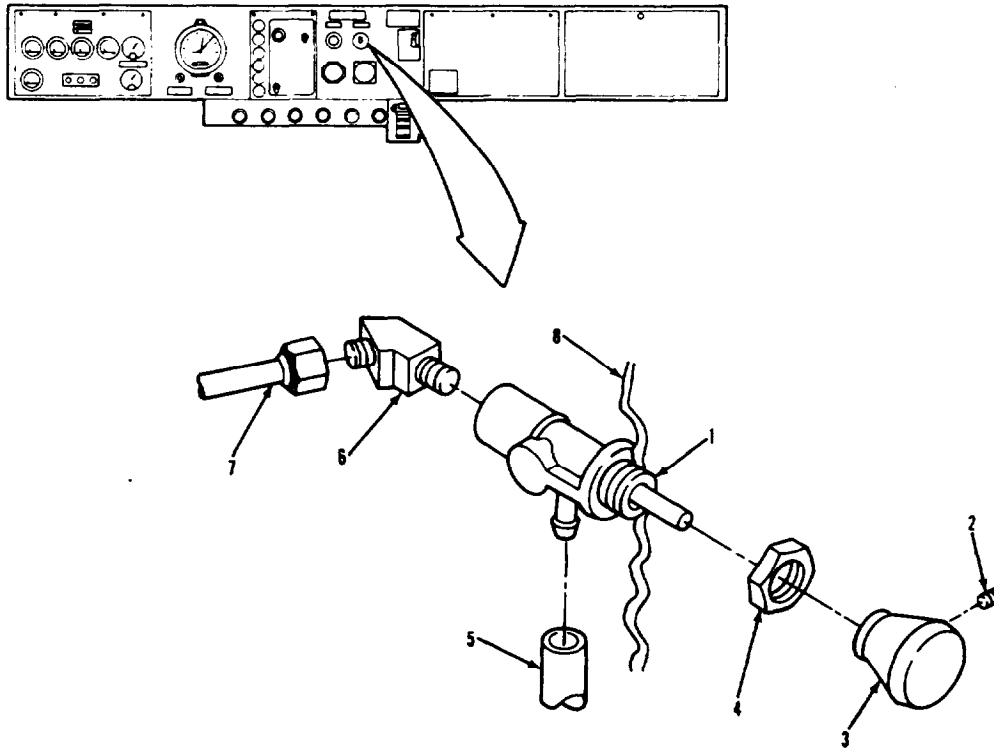

LEGEND:

- |                                    |                              |
|------------------------------------|------------------------------|
| 1. WINDSHIELD WASHER CONTROL VALVE | 5. RUBBER HOSE               |
| 2. SETSCREW                        | 6. 45 DEGREE MALE ELBOW      |
| 3. KNOB                            | 7. AIR LINE                  |
| 4. HEX NUT                         | 8. INSTRUMENT PANEL ASSEMBLY |

TA 237803

ACCESSORY ITEMS.

3-292. WINDSHIELD WIPER CONTROL REPLACEMENT.

THIS TASK COVERS

- a. Removal.
- b. Cleaning and Inspection.
- c. Installation.

INITIAL SETUP

APPLICABLE CONFIGURATIONS

All.

EQUIPMENT CONDITION

PARAGRAPH

3-120.

CONDITION DESCRIPTION

Battery power  
disconnected.

TEST EQUIPMENT

None.

SPECIAL TOOLS

None.

MATERIALS/PARTS (P/N)

Rags, wiping  
Item 22, Appendix C.  
Solvent, drycleaning SD-2  
Item 29, Appendix C.  
Tape, thread sealing  
Item 32, Appendix C.

PERSONNEL REQUIRED

One (MDS-63S).

SPECIAL ENVIRONMENTAL CONDITIONS

None.

REFERENCES (TM)

None.

GENERAL SAFETY INSTRUCTIONS

Engine off  
Transmission in neutral.  
Park brake set.

TROUBLESHOOTING REFERENCES

Paragraph 2-11.

ACCESSORY ITEMS.

3-292. WINDSHIELD WIPER CONTROL REPLACEMENT (Continued).

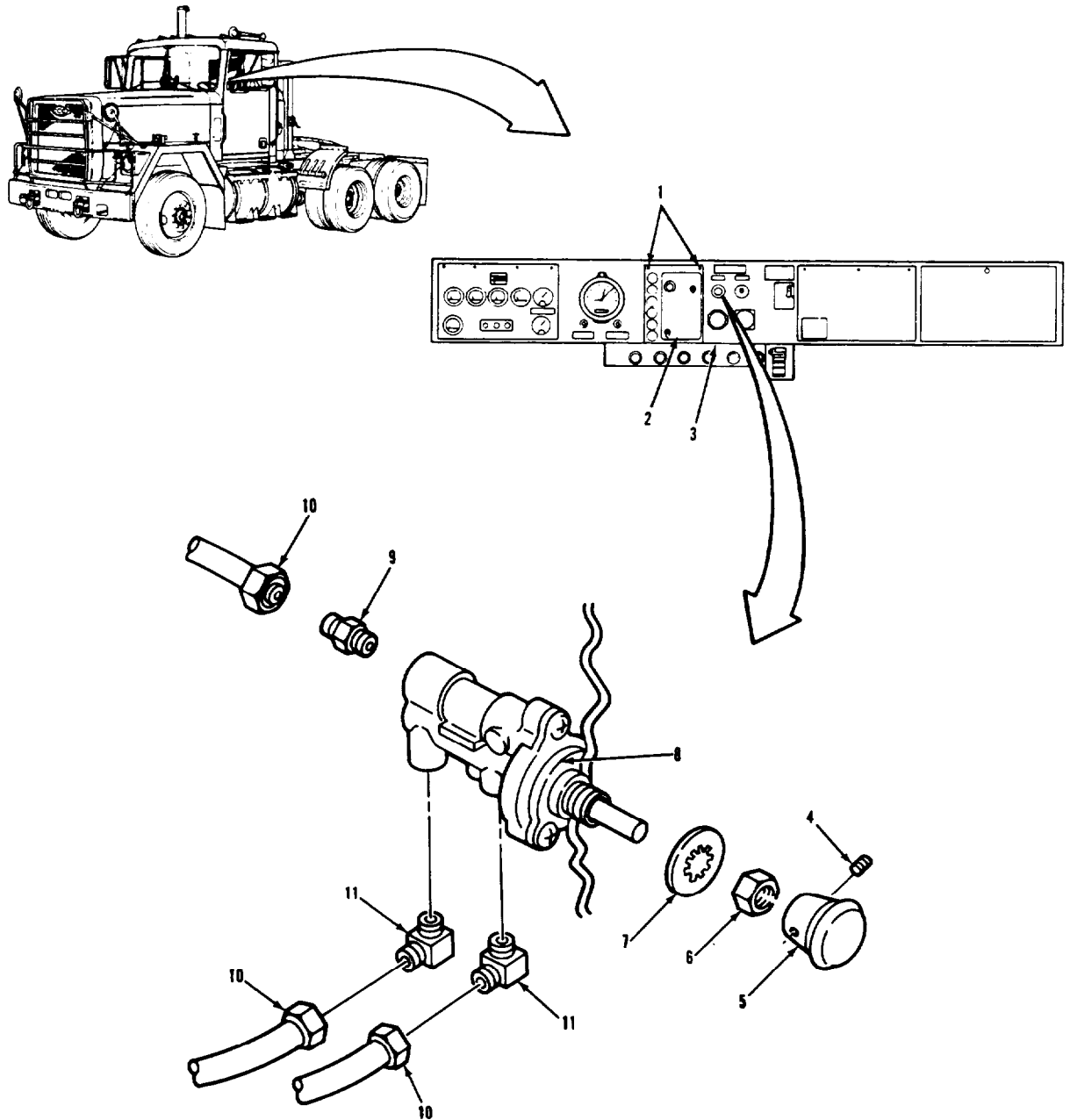

LEGEND:

- |  |                  |
|--|------------------|
| 1. QUARTER-TURN STUD (2)               | 6. HEX NUT       |
| 2. RIGHT-HAND INSTRUMENT CLUSTER PANEL | 7. LOCKWASHER    |
| 3. INSTRUMENT PANEL ASSEMBLY           | 8. CONTROL VALVE |
| 4. SETSCREW                            | 9. CONNECTOR     |
| 5. KNOB                                | 10. AIR LINE (3) |
|  | 11. ELBOW (2)    |

TA 237804

ACCESSORY ITEMS.

3-292. WINDSHIELD WIPER CONTROL REPLACEMENT (Continued).		
LOCATION/ITEM	ACTION	REMARKS
<b>A. REMOVAL.</b>		
1. Two studs (1).	Loosen.	
2. Panel (2).	Open.	
3. Setscrew (4).	Loosen.	
4. Knob (5).	Remove from item (8).	
5. Nut (6) and lock-washer (7).	Remove from item (8).	
6. Valve (8).	Remove from item (3).	
7. Three air lines (10).	Remove from item (9) and two items (11).	Tag air lines (10).
8. Connector (9) and two elbows (11).	Remove from item (8).	
<b>B. CLEANING AND INSPECTION.</b>		
9. All parts.	Clean and inspect.	Refer to paragraphs 3-4 and 3-5.
<b>C. INSTALLATION.</b>		
10. Two elbows (11) and connector (9).	Install in item (8).	a. Put thread sealing tape on threads.  b. Point elbows (11) to left.
11. Three air lines (10).	Install on two items (11) and item (9).	
12. Valve (8).	Put in place through item (3).	

ACCESSORY ITEMS.

3-292. WINDSHIELD WIPER CONTROL REPLACEMENT (Continued).

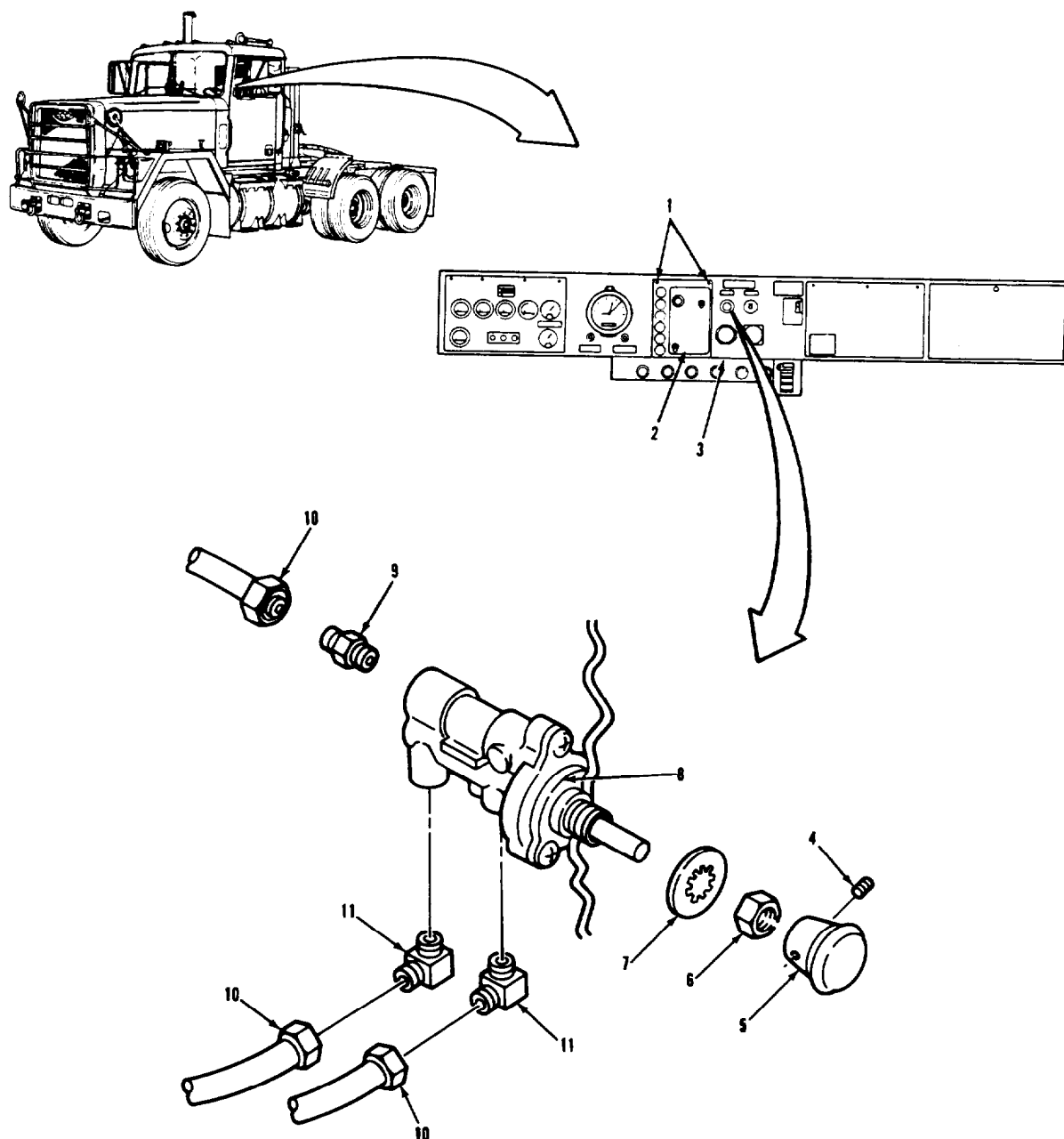

LEGEND:

- |  |                  |
|--|------------------|
| 1. QUARTER-TURN STUD (2)               | 6. HEX NUT       |
| 2. RIGHT-HAND INSTRUMENT CLUSTER PANEL | 7. LOCKWASHER    |
| 3. INSTRUMENT PANEL ASSEMBLY           | 8. CONTROL VALVE |
| 4. SETSCREW                            | 9. CONNECTOR     |
| 5. KNOB                                | 10. AIR LINE (3) |
|  | 11. ELBOW (2)    |

TA 237805

ACCESSORY ITEMS.

3-292. WINDSHIELD WIPER CONTROL REPLACEMENT (Continued).		
LOCATION/ITEM	ACTION	REMARKS
<b>C. INSTALLATION (Continued).</b>		
13. Nut (6) and lockwasher (7).	Secure item (8) to item (3).	
14. Knob (5).	Install on item (8).	
15. Setscrew (4).	Tighten.	
16. Panel (2).	Close.	
17. Two studs (1).	Secure item (2).	
NOTE		
Follow-on maintenance action required:		
Connect battery power (para 3-120).		

ACCESSORY ITEMS.

3-292. WINDSHIELD WIPER CONTROL REPLACEMENT (Continued).

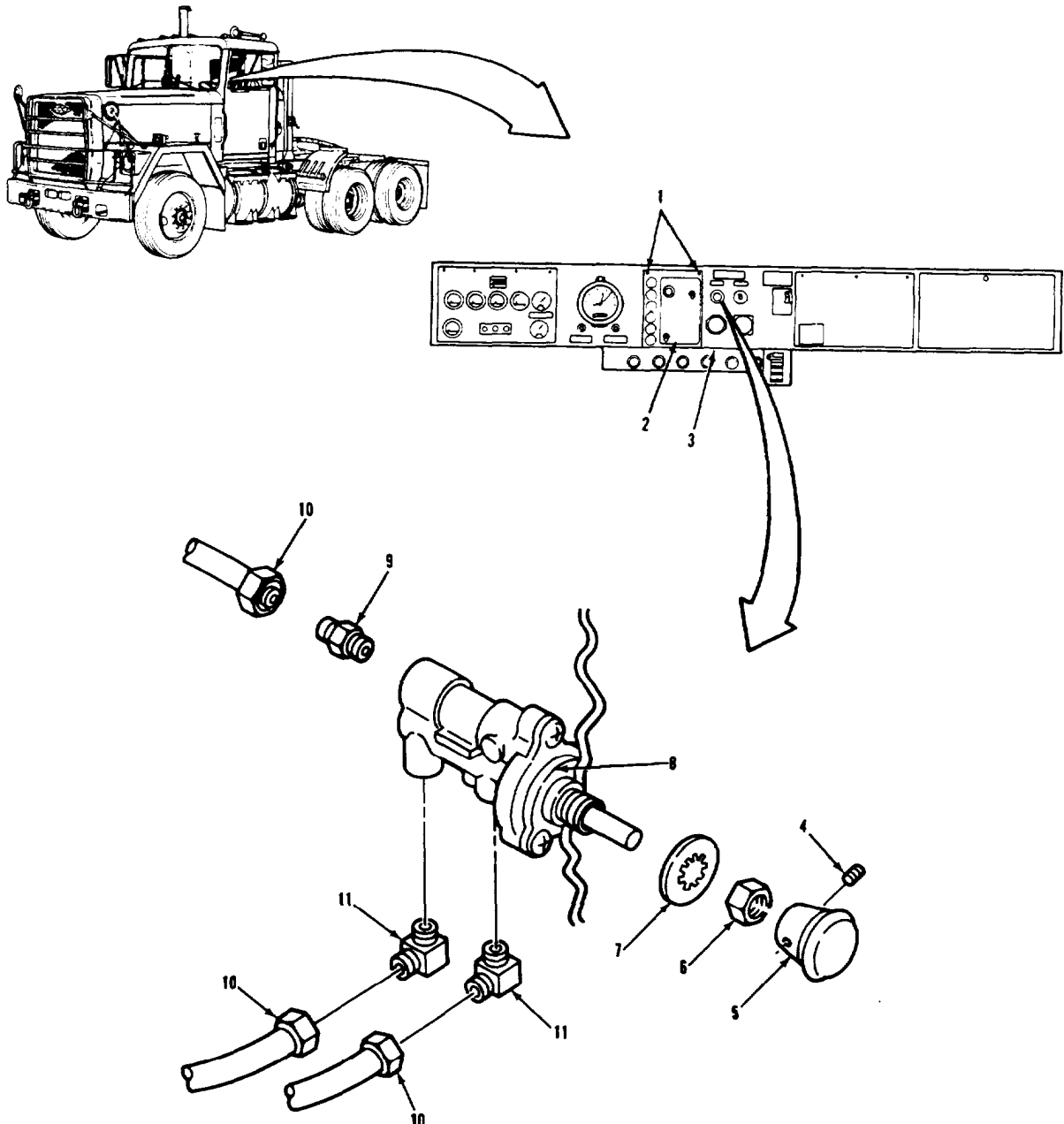

LEGEND:

- |  |                  |
|--|------------------|
| 1. QUARTER-TURN STUD (2)               | 6. HEX NUT       |
| 2. RIGHT-HAND INSTRUMENT CLUSTER PANEL | 7. LOCKWASHER    |
| 3. INSTRUMENT PANEL ASSEMBLY           | 8. CONTROL VALVE |
| 4. SETSCREW                            | 9. CONNECTOR     |
| 5. KNOB                                | 10. AIR LINE (3) |
|  | 11. ELBOW (2)    |

TA 237806



ACCESSORY ITEMS.

3-293. WINDSHIELD WIPER BLADE ASSEMBLY REPLACEMENT.

THIS TASK COVERS

- a. Removal.
- b. Installation.

INITIAL SETUP

<u>APPLICABLE CONFIGURATIONS</u>	<u>EQUIPMENT CONDITION PARAGRAPH</u>	<u>CONDITION DESCRIPTION</u>
All.	None.	None.

TEST EQUIPMENT  
None.

SPECIAL TOOLS  
None.

MATERIALS/PARTS (P/N)  
None.

PERSONNEL REQUIRED  
One (MOS-63S).

SPECIAL ENVIRONMENTAL CONDITIONS  
None.

REFERENCES (TM)  
None.

GENERAL SAFETY INSTRUCTIONS  
Engine off.  
Transmission in neutral.  
Park brake set.

TROUBLESHOOTING REFERENCES  
Paragraph 2-11.

ACCESSORY ITEMS.

3-293. WINDSHIELD WIPER BLADE ASSEMBLY REPLACEMENT (Continued).

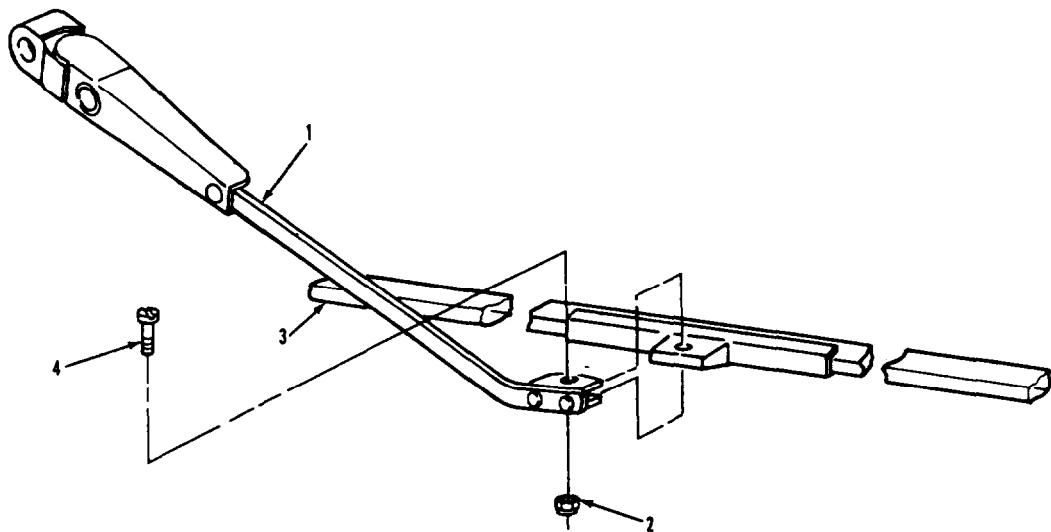

LEGEND:

1. WINDSHIELD WIPER ARM ASSEMBLY
2. HEX NUT
3. WINDSHIELD WIPER BLADE ASSEMBLY
4. FILLISTER HEAD SCREW

TA 237807

ACCESSORY ITEMS.

3-293. WINDSHIELD WIPER BLADE ASSEMBLY REPLACEMENT (Continued).

LOCATION/ITEM	ACTION	REMARKS
NOTE		
Replacement procedure is the same for both sides.		
<b>A. REMOVAL.</b>		
1. Screw (4) and nut (2).	Remove from item (1) and item (3).	
2. Blade assembly (3).	Remove from item (1).	
<b>B. INSTALLATION.</b>		
3. Blade assembly (3).	Put in place in item (1).	
4. Screw (4) and nut (2).	Secure item (3) to item (1).	
NOTE		
Follow-on maintenance action required:		
None.		

ACCESSORY ITEMS.

3-293. WINDSHIELD WIPER BLADE ASSEMBLY REPLACEMENT (Continued).

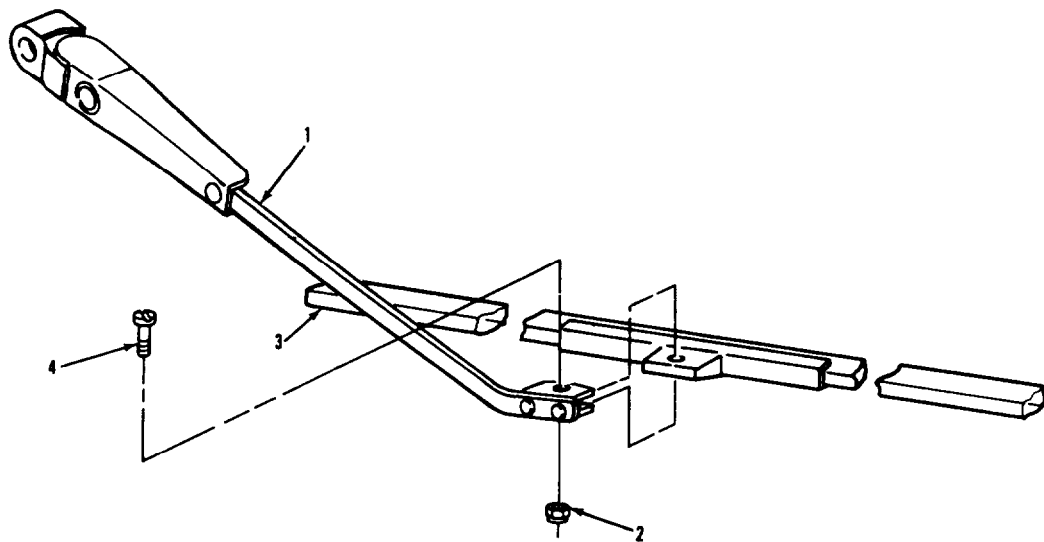

LEGEND:

1. WINDSHIELD WIPER ARM ASSEMBLY
2. HEX NUT
3. WINDSHIELD WIPER BLADE ASSEMBLY
4. FILLISTER HEAD SCREW

TA 237808

ACCESSORY ITEMS.

3-294. WINDSHIELD WIPER ASSEMBLY REPLACEMENT.

THIS TASK COVERS

- a. Removal.
- b. Cleaning and Inspection.
- c. Installation.

INITIAL SETUP

<u>APPLICABLE CONFIGURATIONS</u>	<u>EQUIPMENT CONDITION PARAGRAPH</u>	<u>CONDITION DESCRIPTION</u>
All.	3-293.	Wiper blade removed.
<u>TEST EQUIPMENT</u> None.	3-296.	Heater air hoses removed (right-side only).
<u>SPECIAL TOOLS</u> None.		
<u>MATERIALS/PARTS (P/N)</u> Rags, wiping Item 22, Appendix C. Solvent, drycleaning, SD-2 Item 29, Appendix C.		
<u>PERSONNEL REQUIRED</u> Two (MOS-63S).	<u>SPECIAL ENVIRONMENTAL CONDITIONS</u> None.	
<u>REFERENCES (TM)</u> None.	<u>GENERAL SAFETY INSTRUCTIONS</u> Engine off Transmission in neutral. Park brake set.	
<u>TROUBLESHOOTING REFERENCES</u> Paragraph 2-11.		

ACCESSORY ITEMS.

3-294. WINDSHIELD WIPER ASSEMBLY REPLACEMENT (Continued).

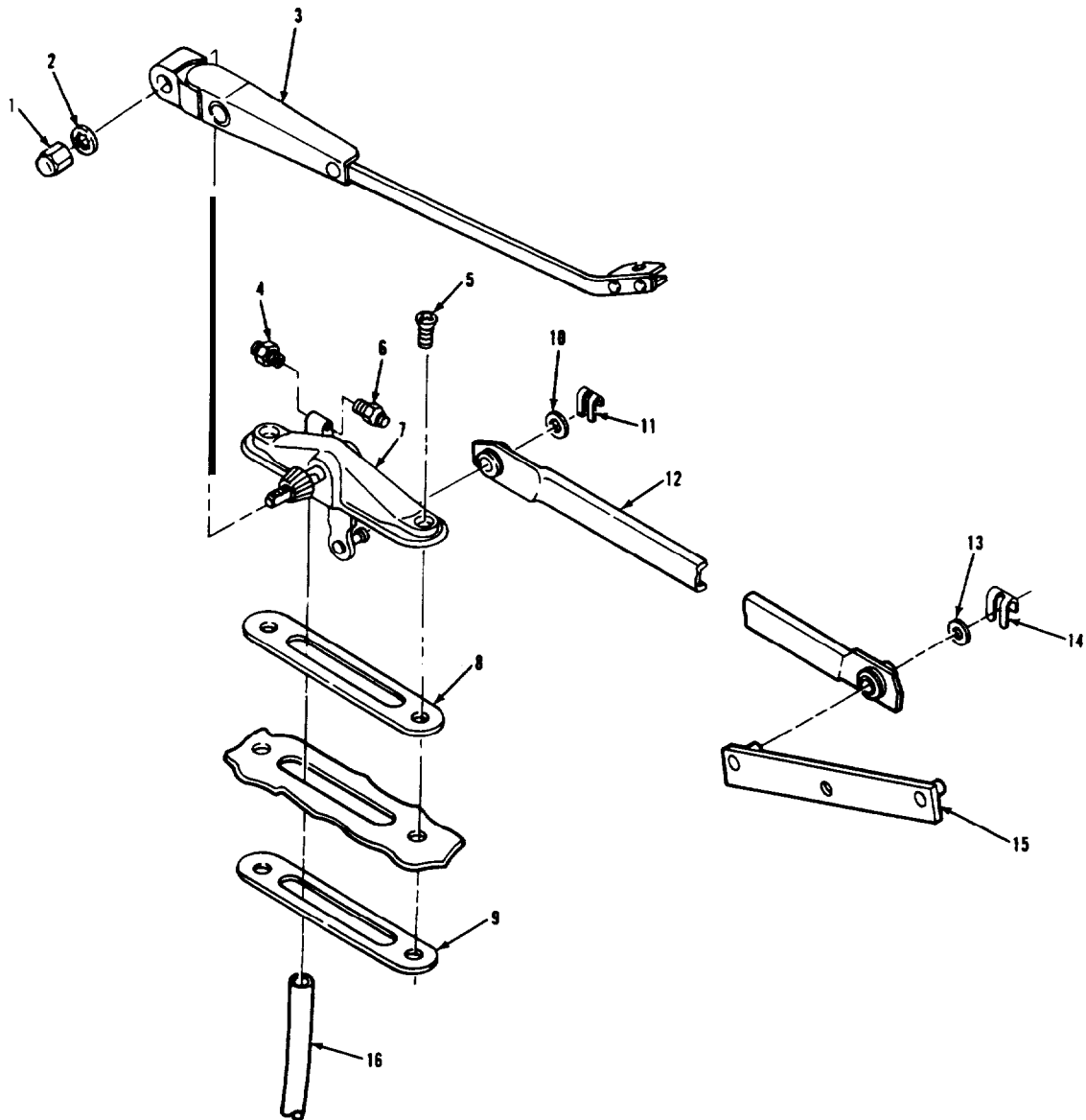

LEGEND:

- |                                      |                             |
|--------------------------------------|-----------------------------|
| 1. PLAIN CAPNUT                      | 9. CLAMPING PLATE           |
| 2. LOCKWASHER                        | 10. FLAT WASHER             |
| 3. WINDSHIELD WIPER ARM ASSEMBLY     | 11. SPRING TENSION CLIP     |
| 4. 20 DEGREE WINDSHIELD WIPER NOZZLE | 12. CONNECTING ARM ASSEMBLY |
| 5. OVAL HEAD SCREW (2)               | 13. FLAT WASHER             |
| 6. 90 DEGREE WINDSHIELD WIPER NOZZLE | 14. SPRING TENSION CLIP     |
| 7. PIVOT BODY ASSEMBLY               | 15. DRIVE LEVER ASSEMBLY    |
| 8. GASKET                            | 16. RUBBER HOSE             |

TA 237809

ACCESSORY ITEMS.

3-294. WINDSHIELD WIPER ASSEMBLY REPLACEMENT (Continued).		
LOCATION/ITEM	ACTION	REMARKS
NOTE		
Replacement is the same for both sides.		
<b>A. REMOVAL.</b>		
1. Capnut (1) and lockwasher (2).	Remove from item (3) and item (7).	
2. Arm assembly (3).	Pull from item (7).	
3. Hose (16).	Remove from item (7).	Access from under instrument panel.
4. Clip (11) and washer (10).	Remove from item (12) and item (7).	
5. Arm assembly (12).	Remove from item (7).	
6. Clip (14) and washer (13).	Remove from item (12) and item (15).	
7. Arm assembly (12).	Remove from item (15).	
8. Two screws (5).	Remove from items (7), (8), and (9).	Item (9) will fall.
9. Pivot body assembly (7) and gasket (8).	Remove.	
10. Nozzle (4) and nozzle (6).	Remove from item (7).	
<b>B. CLEANING AND INSPECTION.</b>		
11. All parts except gasket (8).	Clean with solvent and rags.	Refer to paragraph 3-4.
12. Gasket (8).	Wipe clean with damp rag.	
13. All parts.	Inspect.	Refer to paragraph 3-5.

ACCESSORY ITEMS.

3-294. WINDSHIELD WIPER ASSEMBLY REPLACEMENT (Continued).

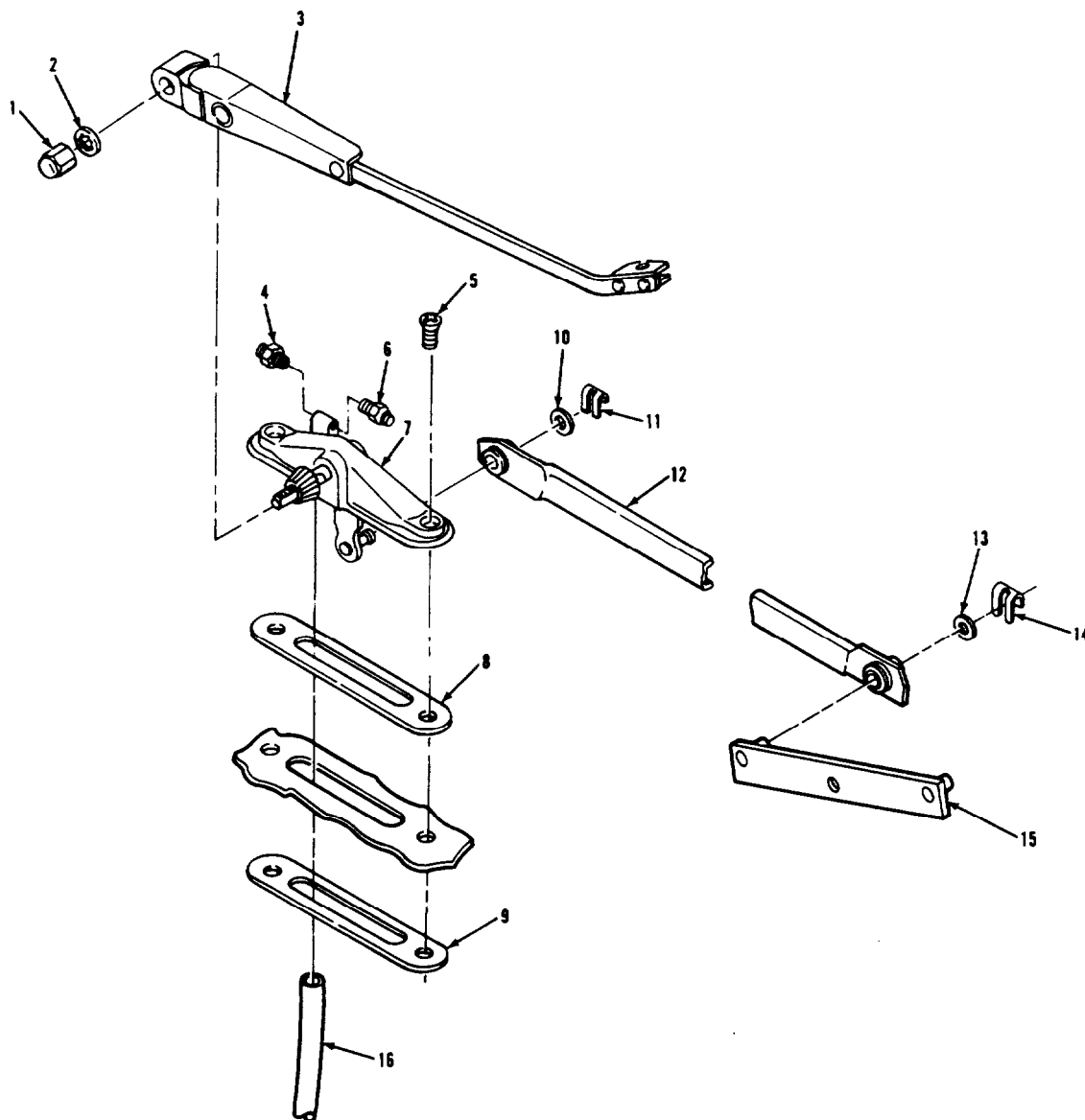

LEGEND:

- |                                      |                             |
|--------------------------------------|-----------------------------|
| 1. PLAIN CAPNUT                      | 9. CLAMPING PLATE           |
| 2. LOCKWASHER                        | 10. FLAT WASHER             |
| 3. WINDSHIELD WIPER ARM ASSEMBLY     | 11. SPRING TENSION CLIP     |
| 4. 20 DEGREE WINDSHIELD WIPER NOZZLE | 12. CONNECTING ARM ASSEMBLY |
| 5. OVAL HEAD SCREW (2)               | 13. FLAT WASHER             |
| 6. 90 DEGREE WINDSHIELD WIPER NOZZLE | 14. SPRING TENSION CLIP     |
| 7. PIVOT BODY ASSEMBLY               | 15. DRIVE LEVER ASSEMBLY    |
| 8. GASKET                            | 16. RUBBER HOSE             |

TA 237810



ACCESSORY ITEMS.

3-294. WINDSHIELD WIPER ASSEMBLY REPLACEMENT (Continued).

LOCATION/ITEM	ACTION	REMARKS
<b>C. INSTALLATION.</b>		
14. Nozzle (4) and nozzle (6).	Install in item (7).	
15. Pivot body assembly (7), gasket (8), and plate (9).	Put in place.	Assistant holds item (9).
16. Two screws (5).	Secure item (7), item (8), and item (9).	
17. Arm assembly (12).	Put on item (15) and item (7).	
18. Clip (14) and washer (13).	Secure item (12) to item (15).	
19. Clip (11) and washer (10).	Secure item (12) to item (7).	
20. Arm assembly (3).	Put on item (7).	Put in same position as arm on other side.
21. Capnut (1) and lockwasher (20).	Secure item (3) to item (7).	
22. Hose (16).	Install on item (7).	
<b>NOTE</b>		
Follow-on maintenance action required:		
Install heater air hoses (right side only) (para 3-296). Install wiper blade (para 3-293).		

ACCESSORY ITEMS.

3-294. WINDSHIELD WIPER ASSEMBLY REPLACEMENT (Continued).

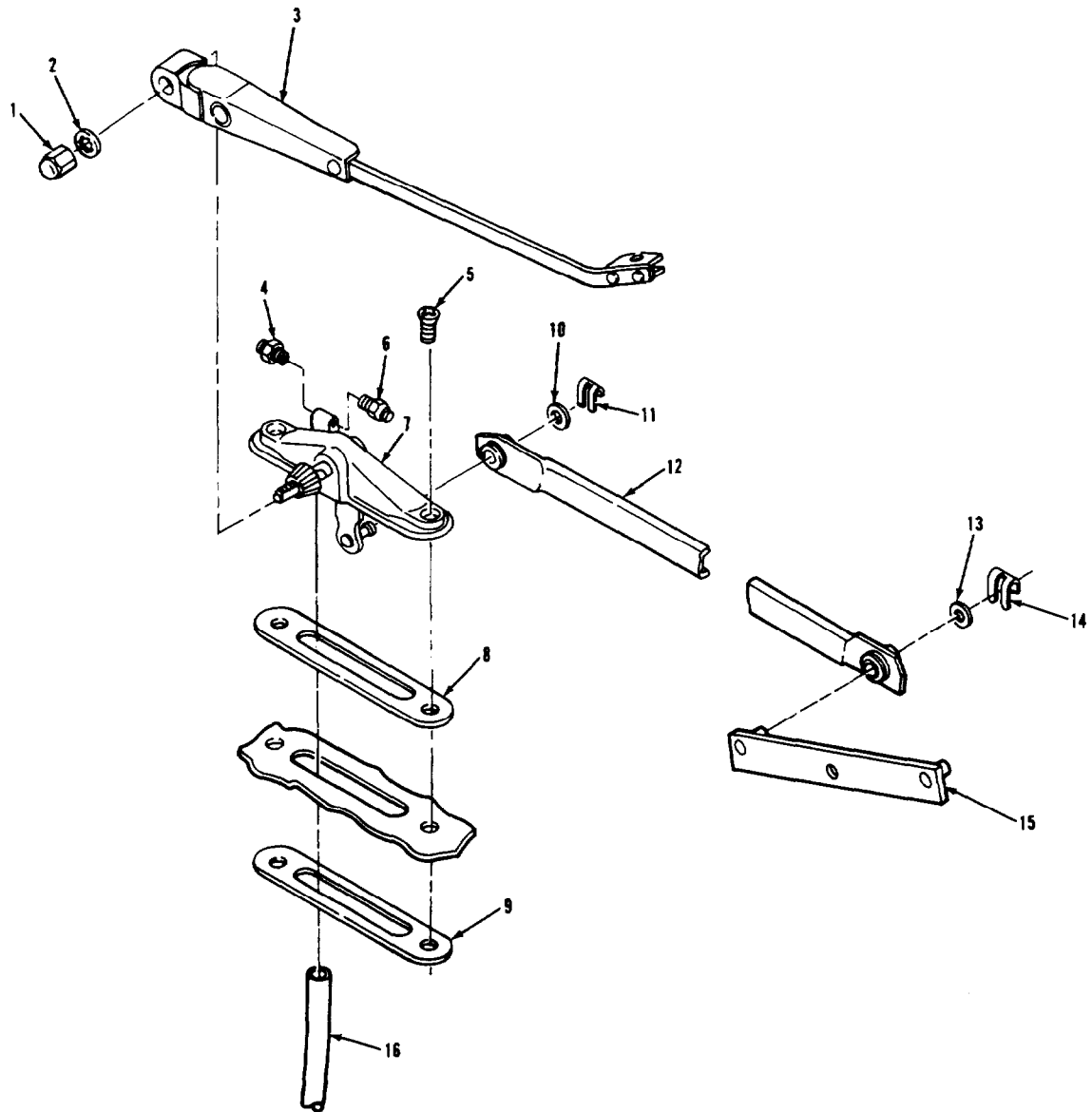

LEGEND:

- |                                      |                             |
|--------------------------------------|-----------------------------|
| 1. PLAIN CAPNUT                      | 9. CLAMPING PLATE           |
| 2. LOCKWASHER                        | 10. FLAT WASHER             |
| 3. WINDSHIELD WIPER ARM ASSEMBLY     | 11. SPRING TENSION CLIP     |
| 4. 20 DEGREE WINDSHIELD WIPER NOZZLE | 12. CONNECTING ARM ASSEMBLY |
| 5. OVAL HEAD SCREW (2)               | 13. FLAT WASHER             |
| 6. 90 DEGREE WINDSHIELD WIPER NOZZLE | 14. SPRING TENSION CLIP     |
| 7. PIVOT BODY ASSEMBLY               | 15. DRIVE LEVER ASSEMBLY    |
| 8. GASKET                            | 16. RUBBER HOSE             |

TA 237811

ACCESSORY ITEMS.

3-295. WINDSHIELD WIPER MOTOR REPLACEMENT.

THIS TASK COVERS

- a. Removal.
- b. Cleaning and Inspection.
- c. Installation.

INITIAL SETUP

APPLICABLE CONFIGURATIONS

All.

EQUIPMENT CONDITION  
PARAGRAPH

3-120.

CONDITION DESCRIPTION

Battery power  
disconnected.

TEST EQUIPMENT

None.

SPECIAL TOOLS

None.

MATERIALS/PARTS (P/N)

Rags, wiping  
Item 22, Appendix C.  
Solvent, drycleaning, SD-2  
Item 29, Appendix C.  
Tape, thread sealing  
Item 32, Appendix C.

PERSONNEL REQUIRED

Two (MOS-63S).

SPECIAL ENVIRONMENTAL CONDITIONS

None.

REFERENCES (TM)

None.

GENERAL SAFETY INSTRUCTIONS

Engine off  
Transmission in neutral.  
Park brake set.

TROUBLESHOOTING REFERENCES

Paragraph 2-11.

ACCESSORY ITEMS.

3-295. WINDSHIELD WIPER MOTOR REPLACEMENT (Continued).

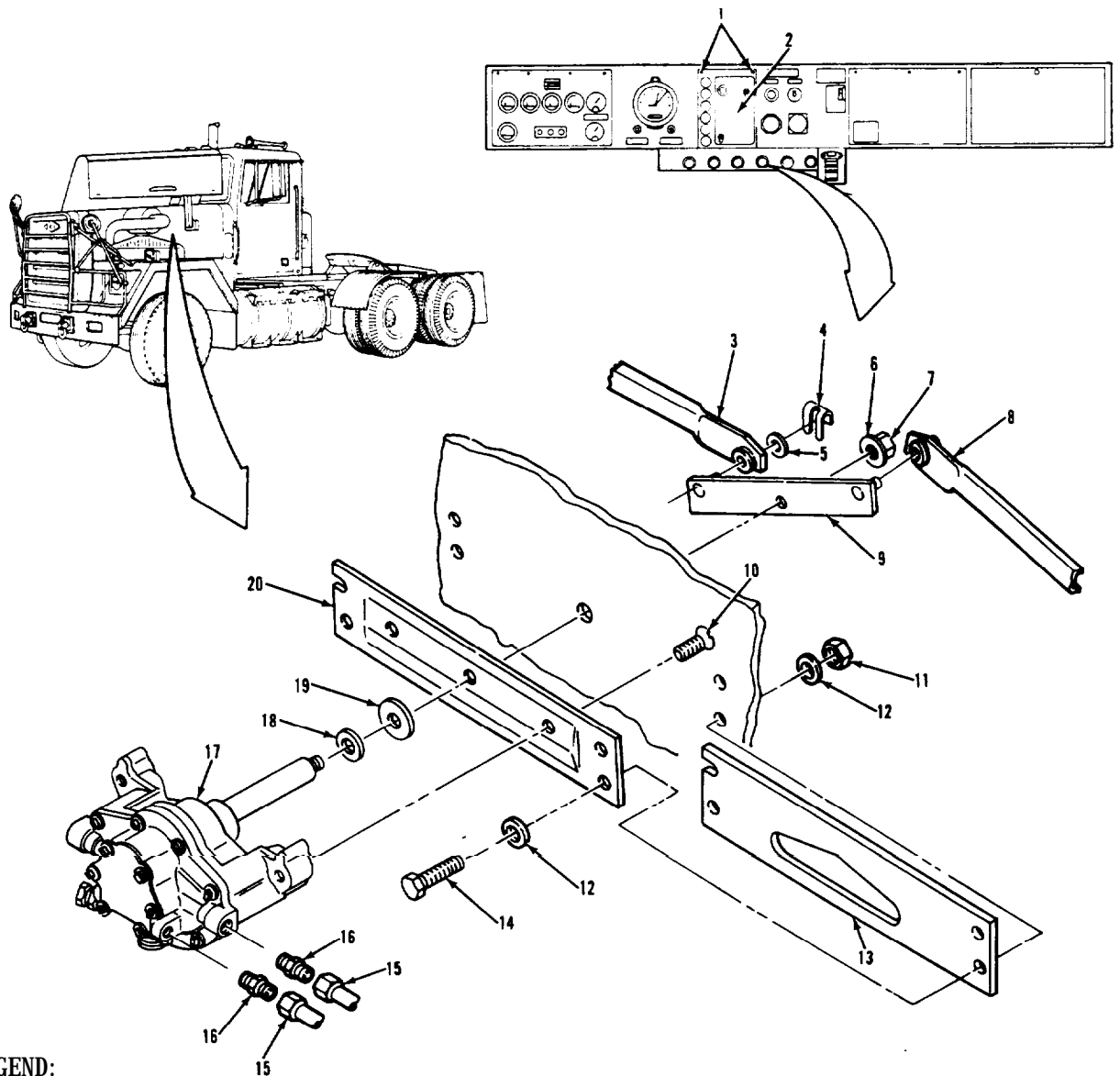

LEGEND:

- |  |                                     |
|--|-------------------------------------|
| 1. QUARTER-TURN STUD (2)                           | 10. FLAT HEAD SCREW (2)             |
| 2. RIGHT-HAND INSTRUMENT CLUSTER<br>PANEL ASSEMBLY | 11. HEX NUT (4)                     |
| 3. RIGHT-HAND CONNECTING ARM<br>ASSEMBLY           | 12. WASHER (8)                      |
| 4. SPRING TENSION CLIP (2)                         | 13. RUBBER GASKET                   |
| 5. FLAT WASHER (2)                                 | 14. SCREW (4)                       |
| 6. WASHER  | 15. AIR LINE (2)                    |
| 7. HEX NUT   | 16. CONNECTOR (2)                   |
| 8. LEFT-HAND CONNECTING ARM ASSEMBLY               | 17. WINDSHIELD WIPER MOTOR ASSEMBLY |
| 9. DRIVE LEVER ASSEMBLY                            | 18. FLAT WASHER                     |
|  | 19. RUBBER WASHER                   |
|  | 20. MOTOR MOUNTING PLATE            |

TA 237812

ACCESSORY ITEMS.

3-295. WINDSHIELD WIPER MOTOR REPLACEMENT (Continued).		
LOCATION/ITEM	ACTION	REMARKS
<b>A. REMOVAL.</b>		
1. Two studs (1).	Loosen.	
2. Panel (2).	Open.	
3. Two clips (4), washers (5), arm assemblies (3) and (8).	Remove from item (3).	Access through open item (2).
4. Nut (7) and washer (6).	Remove from item (9) and item (17).	
5. Lever assembly (9).	Remove from item (17).	
6. Two air lines (15).	Remove from two items (16).	Tag lines.
7. Four screws (14), eight washers (12), and four nuts (11).	Remove from item (20).	
8. Plate (20), motor (17), and gasket (13).	Remove from firewall.	
9. Two screws (10).	Remove from item (20) and item (17).	
10. Plate (20) and washers (19) and (18).	Remove from item (17).	
11. Two connectors (16).	Remove from item (17).	
<b>B. CLEANING AND INSPECTION.</b>		
12. All parts except washer (19) and gasket (13).	Clean with solvent and rags.	Refer to paragraph 3-4.
13. Washer (19) and gasket (13).	Wipe clean with damp rag.	
14. All parts.	Inspect.	Refer to paragraph 3-5.

ACCESSORY ITEMS.

3-295. WINDSHIELD WIPER MOTOR REPLACEMENT (Continued).

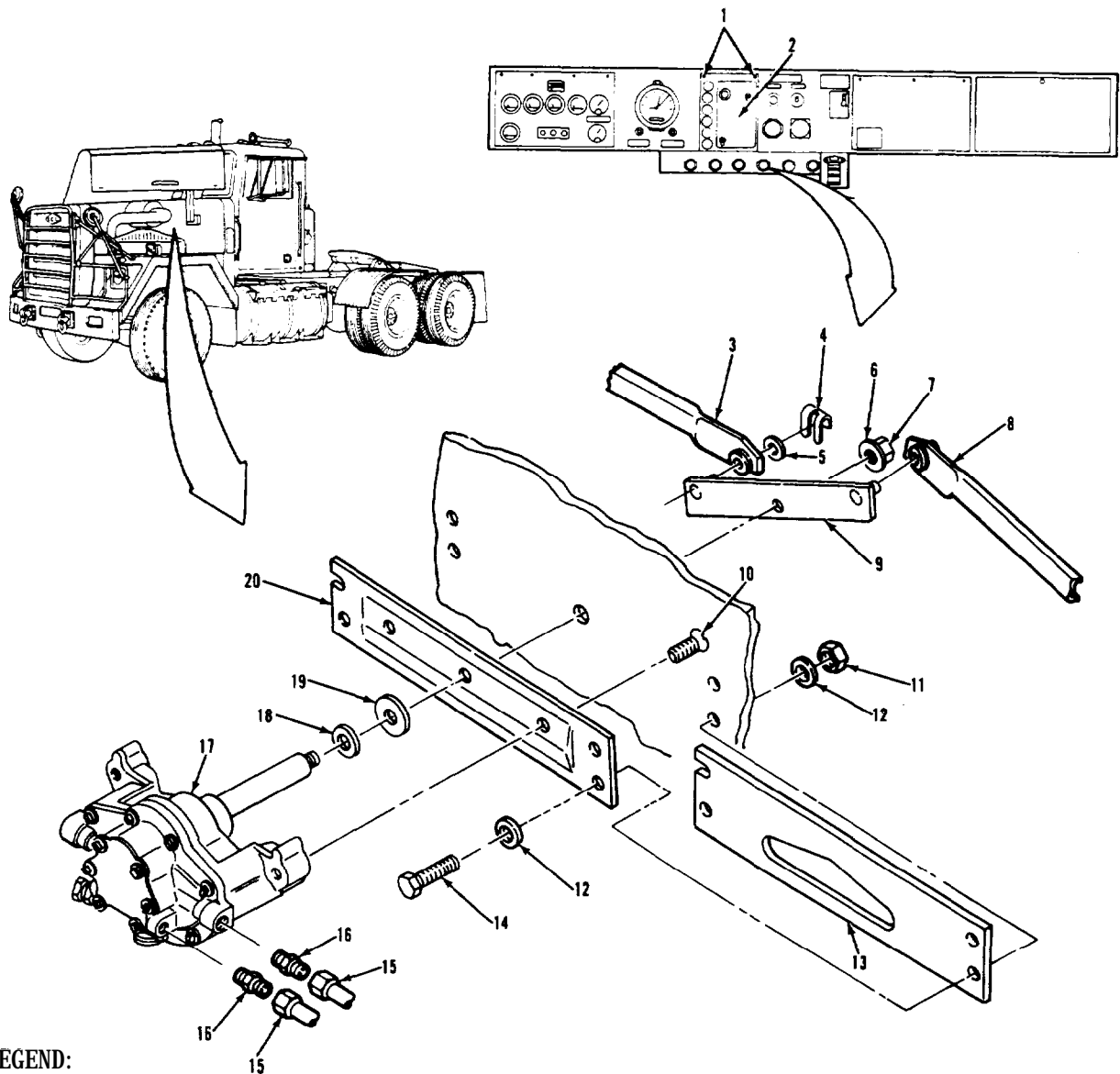

LEGEND:

- |   |                                     |
|---|-------------------------------------|
| 1. QUARTER-TURN STUD (2)                        | 10. FLAT HEAD SCREW (2)             |
| 2. RIGHT-HAND INSTRUMENT CLUSTER PANEL ASSEMBLY | 11. HEX NUT (4)                     |
| 3. RIGHT-HAND CONNECTING ARM ASSEMBLY           | 12. WASHER (8)                      |
| 4. SPRING TENSION CLIP (2)                      | 13. RUBBER GASKET                   |
| 5. FLAT WASHER (2)                              | 14. SCREW (4)                       |
| 6. WASHER                                       | 15. AIR LINE (2)                    |
| 7. HEX NUT                                      | 16. CONNECTOR (2)                   |
| 8. LEFT-HAND CONNECTING ARM ASSEMBLY            | 17. WINDSHIELD WIPER MOTOR ASSEMBLY |
| 9. DRIVE LEVER ASSEMBLY                         | 18. FLAT WASHER                     |
|   | 19. RUBBER WASHER                   |
|   | 20. MOTOR MOUNTING PLATE            |

TA 237813

ACCESSORY ITEMS.

3-295. WINDSHIELD WIPER MOTOR REPLACEMENT (Continued).

LOCATION/ITEM	ACTION	REMARKS
<b>C. INSTALLATION.</b>		
15. Washer (18), washer (19), and plate (20).	Put on item (17).	
16. Two screws (10).	Secure item (20) to item (17).	
17. Two connectors (16).	Install in item (17).	Put thread sealing tape on threads.
18. Gasket (13), plate (20), and motor (17).	Put in place on firewall.	
19. Four screws (14), eight washers (12), and four nuts (11).	Secure item (13), item (20), and item (17) to firewall.	
20. Two air lines (15).	Install on two items (16).	
21. Lever assembly (9).	Put on item (17).	
22. Nut (7) and washer (6).	Secure item (9) to item (17).	
23. Arm assembly (3) and arm assembly (8).	Put on item (9).	
24. Two clips (4) and washers (5).	Secure item (3) and item (8) to item (9).	
25. Panel (2).	Close.	
26. Two studs (1).	Secure item (2).	
NOTE		
Follow-on maintenance action required:		
Connect battery power (para 3-120).		

ACCESSORY ITEMS.

3-295. WINDSHIELD WIPER MOTOR REPLACEMENT (Continued).

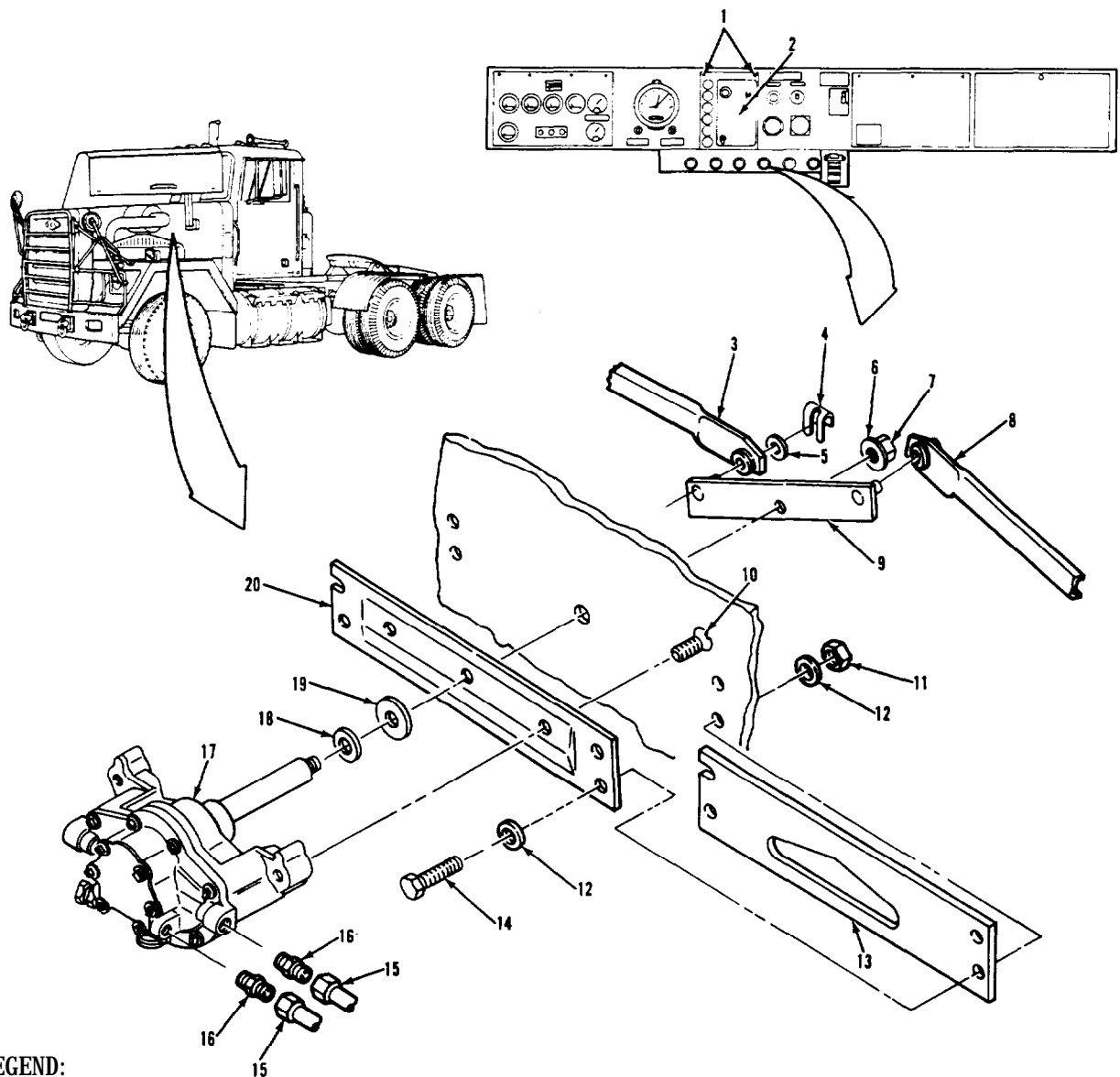

LEGEND:

- |   |                                     |
|---|-------------------------------------|
| 1. QUARTER-TURN STUD (2)                        | 10. FLAT HEAD SCREW (2)             |
| 2. RIGHT-HAND INSTRUMENT CLUSTER PANEL ASSEMBLY | 11. HEX NUT (4)                     |
| 3. RIGHT-HAND CONNECTING ARM ASSEMBLY           | 12. WASHER (8)                      |
| 4. SPRING TENSION CLIP (2)                      | 13. RUBBER GASKET                   |
| 5. FLAT WASHER (2)                              | 14. SCREW (4)                       |
| 6. WASHER                                       | 15. AIR LINE (2)                    |
| 7. HEX NUT                                      | 16. CONNECTOR (2)                   |
| 8. LEFT-HAND CONNECTING ARM ASSEMBLY            | 17. WINDSHIELD WIPER MOTOR ASSEMBLY |
| 9. DRIVE LEVER ASSEMBLY                         | 18. FLAT WASHER                     |
|   | 19. RUBBER WASHER                   |
|   | 20. MOTOR MOUNTING PLATE            |

TA 237814



ACCESSORY ITEMS.

3-296. HEATER AIR HOSE REPLACEMENT.

THIS TASK COVERS

- a. Removal.
- b. Installation.

INITIAL SETUP

<u>APPLICABLE CONFIGURATIONS</u>	<u>EQUIPMENT CONDITION PARAGRAPH</u>	<u>CONDITION DESCRIPTION</u>
All.	3-120.	Battery power disconnected.

TEST EQUIPMENT  
None.

SPECIAL TOOLS  
None.

MATERIALS/PARTS (P/N)  
Tie, cable, heavy, black (3)  
(06383) PLT4H-L0.

PERSONNEL REQUIRED  
One (MDS-63S).

SPECIAL ENVIRONMENTAL CONDITIONS  
None.

REFERENCES (TM)  
TM 9-2320-283-20P.

GENERAL SAFETY INSTRUCTIONS  
Engine off  
Transmission in neutral.  
Park brake set.

TROUBLESHOOTING REFERENCES  
None.

ACCESSORY ITEMS.

3-296. HEATER AIR HOSE REPLACEMENT (Continued).

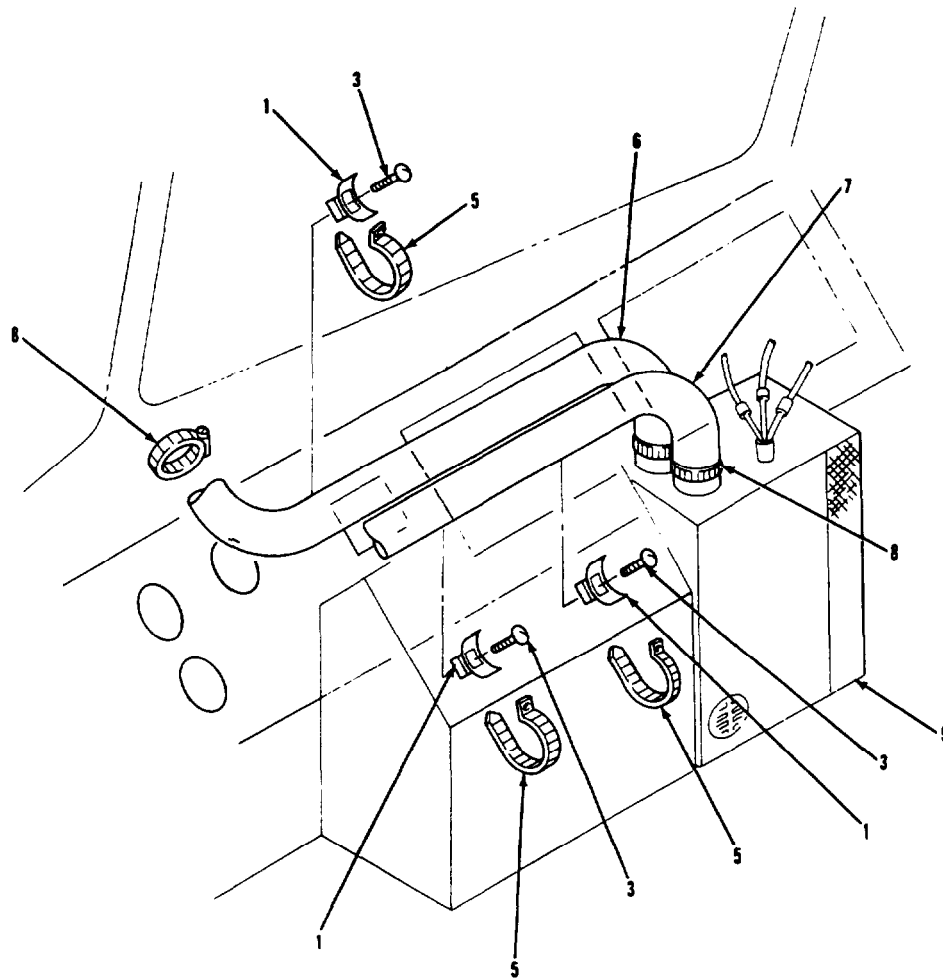
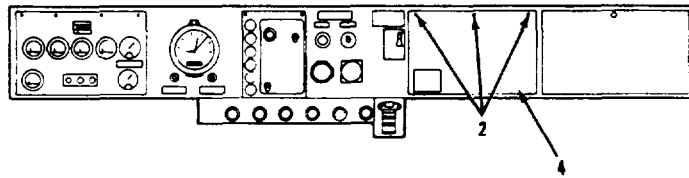

LEGEND:

- |   |                              |
|---|------------------------------|
| 1. TIE MOUNTING CABLE BASE (3)            | 5. BLACK HEAVY CABLE TIE (3) |
| 2. QUARTER-TURN SCREW (3)                 | 6. DEFROSTER HOSE            |
| 3. PAN HEAD SCREW (3)                     | 7. DRIVER HEAT HOSE          |
| 4. INSTRUMENT PANEL CENTER PANEL ASSEMBLY | 8. HOSE CLAMP (3)            |
|   | 9. HEATER ASSEMBLY           |

TA 237815

ACCESSORY ITEMS.

3-296. HEATER AIR HOSE REPLACEMENT (Continued).

LOCATION/ITEM	ACTION	REMARKS
<b>A. REMOVAL.</b>		
1. Two clamps (8).	Loosen.	
2. Hose (6), hose (7), and two clamps (8).	Remove from item (9).	
3. Three screws (2).	Loosen.	
4. Panel (4).	Open.	
5. Clamp (8).	Loosen.	
6. Hose (6) and clamp (8).	Remove from flange on cab.	
7. Three ties (5).	Cut from items (6) and (7).	Take care not to cut items (6) and (7).
8. Hose (6) and hose (7).	Remove.	
9. Three screws (3).	Remove from three items (1).	
<b>B. INSTALLATION.</b>		
10. Three screws (3).	Secure three items (1) to cab.	
11. Hose (6) and clamp (8).	Install on flange on cab.	
12. Hose (6), hose (7), and two clamps (8).	Install on item (9).	
13. Three new ties (5).	Install through three items (1).	
14. Panel (4).	Close.	
15. Three screws (2).	Tighten.	
<b>NOTE</b>		
Follow-on maintenance action required:		
Connect battery power (para 3-120).		

ACCESSORY ITEMS.

3-296. HEATER AIR HOSE REPLACEMENT (Continued).

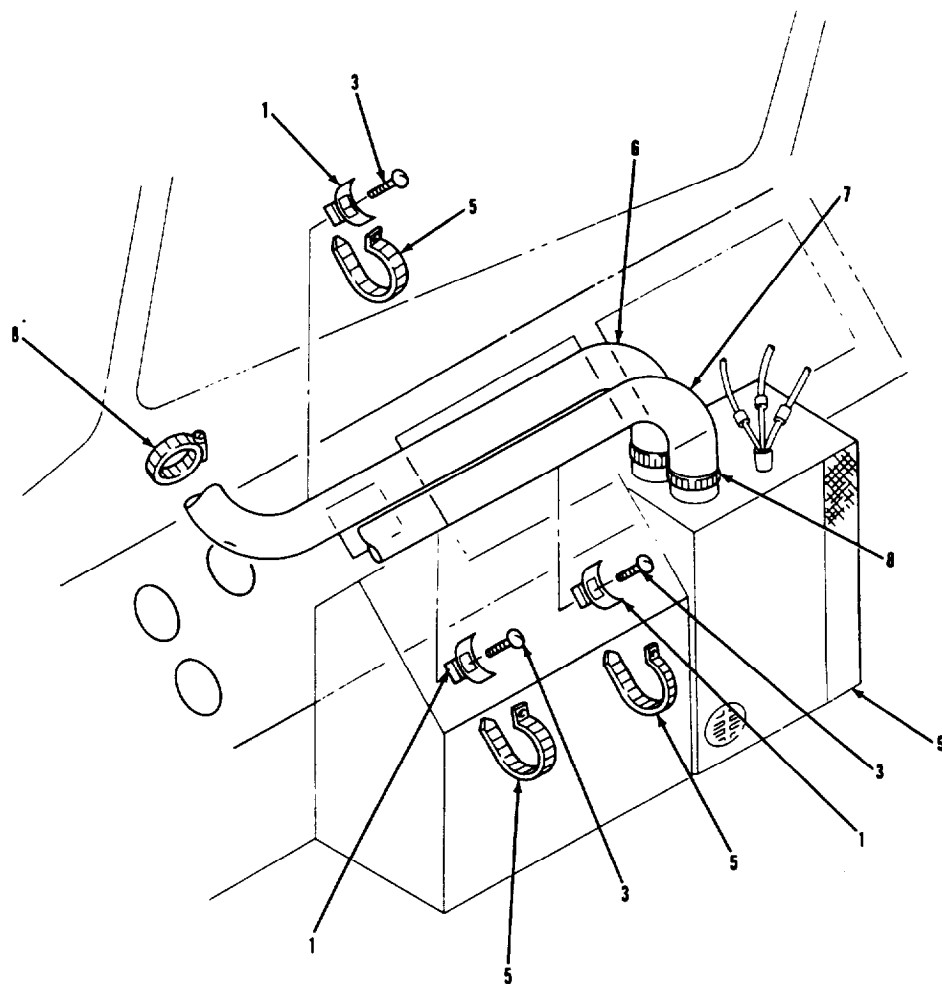
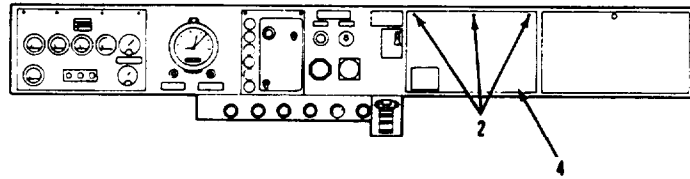

LEGEND:

- |   |                              |
|---|------------------------------|
| 1. TIE MOUNTING CABLE BASE (3)            | 5. BLACK HEAVY CABLE TIE (3) |
| 2. QUARTER-TURN SCREW (3)                 | 6. DEFROSTER HOSE            |
| 3. PAN HEAD SCREW (3)                     | 7. DRIVER HEAT HOSE          |
| 4. INSTRUMENT PANEL CENTER PANEL ASSEMBLY | 8. HOSE CLAMP (3)            |
|   | 9. HEATER ASSEMBLY           |

TA 237816

ACCESSORY ITEMS.

3-297. HEATER VALVE, HOSES, TUBES, AND CLAMPS REPLACEMENT.

THIS TASK COVERS

- a. Heater Hoses, Tubes, and Clamps Replacement.
- b. Control Valve Removal.
- c. Control Valve Installation.
- d. Shutoff Valve Removal.
- e. Shutoff Valve Installation.

INITIAL SETUP

<u>APPLICABLE CONFIGURATIONS</u>	<u>EQUIPMENT CONDITION PARAGRAPH</u>	<u>CONDITION DESCRIPTION</u>
All.	3-52.	Coolant drained.

TEST EQUIPMENT

None.

SPECIAL TOOLS

None.

MATERIALS/PARTS (P/N)

Tape, thread sealing  
Item 32, Appendix C.

PERSONNEL REQUIRED

One (MOS-63S).

SPECIAL ENVIRONMENTAL CONDITIONS

None.

REFERENCES (TM)

TM 9-2320-283-10.

GENERAL SAFETY INSTRUCTIONS

Engine off.  
Transmission in neutral.  
Park brake set.

TROUBLESHOOTING REFERENCES

None.

ACCESSORY ITEMS.

3-297. HEATER VALVES, HOSES, TUBES, AND CLAMPS REPLACEMENT (Continued).

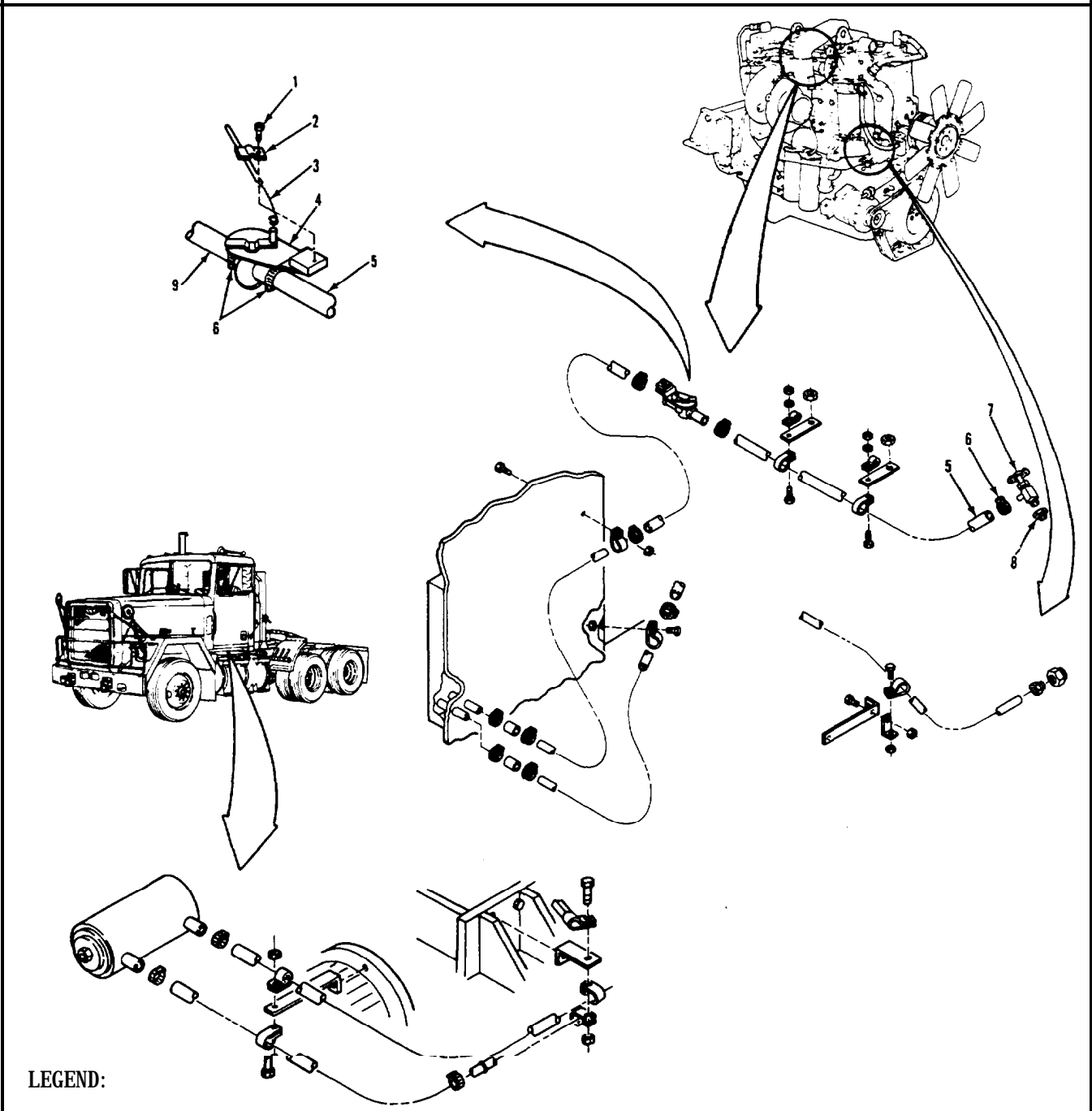

LEGEND:

- |   |   |
|---|---|
| 1. SCREW  | 6. HOSE CLAMP (3)                       |
| 2. CLIP   | 7. HEATER SHUTOFF VALVE                 |
| 3. BODEN WIRE                                   | 8. REDUCER                              |
| 4. HEATER CONTROL VALVE                         | 9. HEATER HOSE CONTROL VALVE TO HEATER) |
| 5. HEATER HOSE (SHUTOFF VALVE TO CONTROL VALVE) |   |

TA 237817

ACCESSORY ITEMS.

3-297. HEATER VALVES, HOSES, TUBES, AND CLAMPS REPLACEMENT (Continued).		
LOCATION/ITEM	ACTION	REMARKS
<b>A. HEATER HOSES, TUBES, AND CLAMPS REPLACEMENT.</b>		
<b>NOTE</b>		
	<ul style="list-style-type: none"> <li>· Use standard shop maintenance practices to replace heater hoses, tubes, and clamps.</li> <li>· For routing and location information refer to illustration.</li> <li>· For specifications on making new heater hoses refer to Appendix E.</li> </ul>	
<b>B. CONTROL VALVE REMOVAL.</b>		
1. Screw (1) and clip (2).	Remove from item (4).	
2. Wire (3).	Remove from item (4).	
3. Two clamps (6).	Loosen.	
4. Valve (4) and two clamps (6).	Remove from item (9) and item (5).	
<b>C. CONTROL VALVE INSTALLATION.</b>		
5. Two clamps (6) and valve (4).	Install in item (5) and item (9).	
6. Valve (4).	Manually turn off (counterclockwise).	
7. Heater control knob.	Push in.	Refer to TM 9-2320-283-10.
8. Wire (3).	Install on item (4).	
9. Screw (1) and clip (2).	Secure item (3) to item (4).	

ACCESSORY ITEMS.

3-297. HEATER VALVES, HOSES, TUBES, AND CLAMPS REPLACEMENT (Continued).

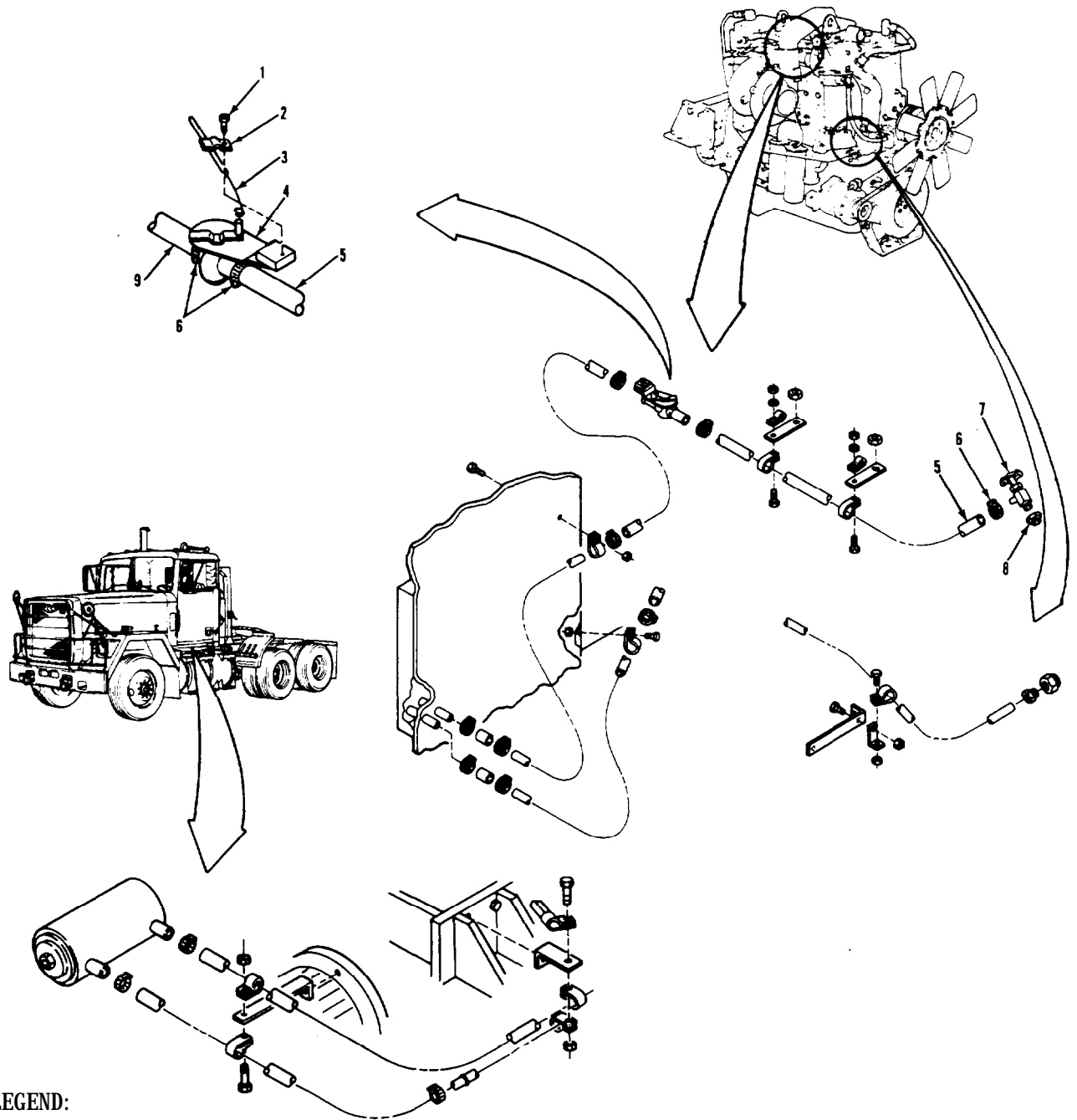

LEGEND:

- |   |                              |
|---|------------------------------|
| 1. SCREW  | 6. HOSE CLAMP (3)            |
| 2. CLIP   | 7. HEATER SHUTOFF VALVE      |
| 3. BODEN WIRE                                   | 8. REDUCER                   |
| 4. HEATER CONTROL VALVE                         | 9. HEATER HOSE CONTROL VALVE |
| 5. HEATER HOSE (SHUTOFF VALVE TO CONTROL VALVE) |                              |

TA 237818



ACCESSORY ITEMS.

3-297. HEATER VALVES, HOSES, TUBES, AND CLAMPS REPLACEMENT (Continued).

LOCATION/ITEM	ACTION	REMARKS
<b>D. SHUTOFF VALVE REMOVAL.</b>		
10. Clamp (6).	Loosen.	
11. Hose (5).	Remove from item (7).	
12. Valve (7).	Remove from item (8).	
13. Reducer (8).	Remove from engine.	
<b>E. SHUTOFF VALVE INSTALLATION.</b>		
14. Reducer (8).	Install in engine.	Put thread sealing tape on threads.
15. Valve (7).	Install in item (8).	Put thread sealing tape on threads.
16. Hose (5) and clamp (6).	Install on item (7).	
17. Clamp (6).	Tighten.	
<b>NOTE</b>		
Follow-on maintenance action required:		
Fill cooling system (TM 9-2320-283-10).		

ACCESSORY ITEMS.

3-297. HEATER VALVES, HOSES, TUBES, AND CLAMPS REPLACEMENT (Continued).

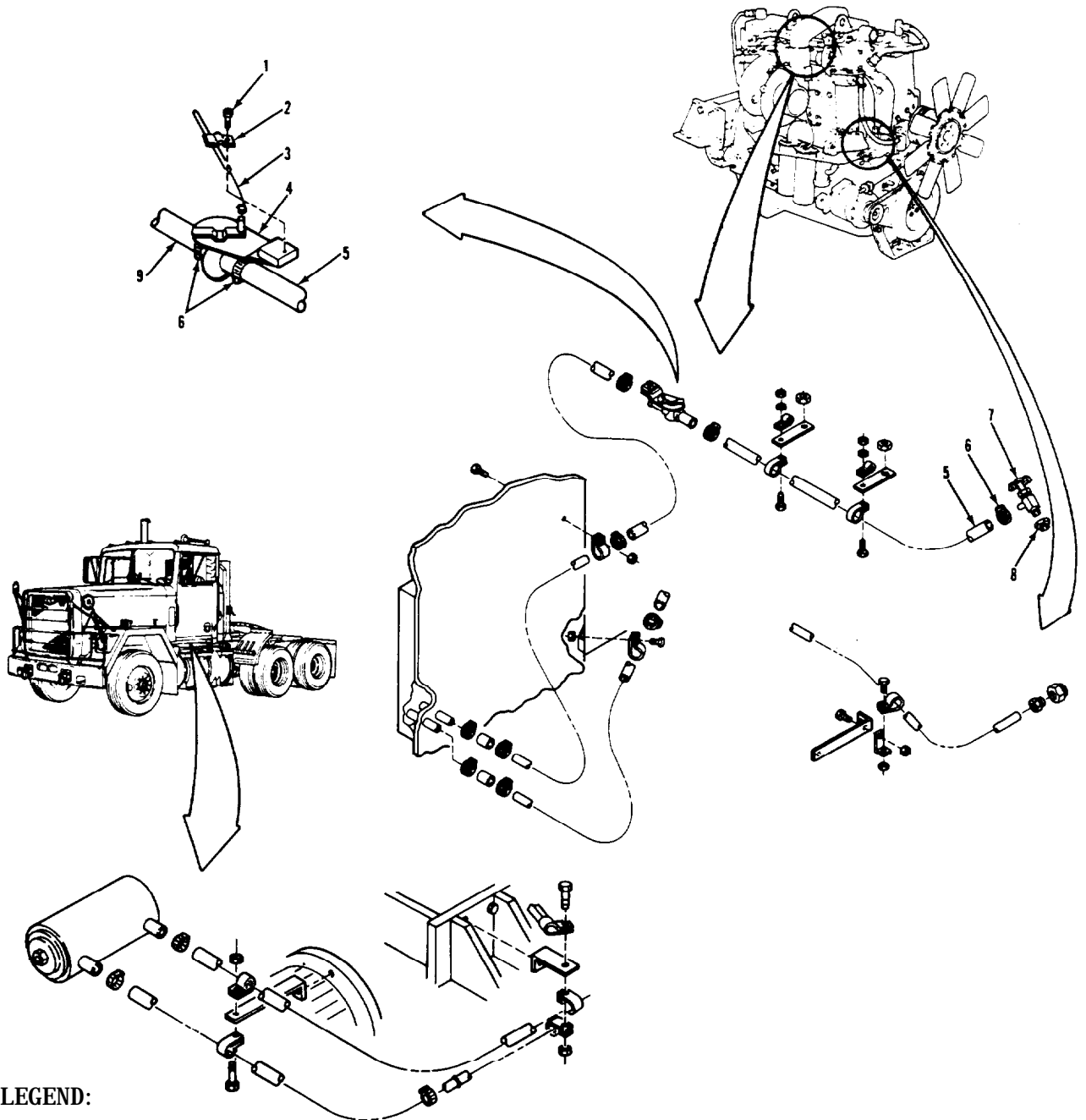

LEGEND:

- |   |                              |
|---|------------------------------|
| 1. SCREW  | 6. HOSE CLAMP (3)            |
| 2. CLIP   | 7. HEATER SHUTOFF VALVE      |
| 3. BODEN WIRE                                   | 8. REDUCER                   |
| 4. HEATER CONTROL VALVE                         | 9. HEATER HOSE CONTROL VALVE |
| 5. HEATER HOSE (SHUTOFF VALVE TO CONTROL VALVE) | TO HEATER)                   |

TA 237819

ACCESSORY ITEMS.

3-298. HEATER ASSEMBLY REPLACEMENT AND REPAIR.

THIS TASK COVERS

- a. Removal.
- b. Disassembly.
- c. Cleaning and Inspection.
- d. Assembly.
- e. Installation.

INITIAL SETUP

<u>APPLICABLE CONFIGURATIONS</u>	<u>EQUIPMENT CONDITION PARAGRAPH</u>	<u>CONDITION DESCRIPTION</u>
All.	3-29.	Air cleaner assembly removed.

<u>TEST EQUIPMENT</u> None.	3-52.	Radiator drained.
--------------------------------	-------	-------------------

SPECIAL TOOLS

None.

MATERIALS/PARTS (P/N)

Tape, electrical  
Item 30, Appendix C.  
Rags, wiping  
Item 22, Appendix C.  
Solvent, drycleaning, SD-2  
Item 29, Appendix C.  
Rubber drain tube seal (2)  
(21102) HV028000.  
Rubber strip (as required)  
(21102) BL011655.

PERSONNEL REQUIRED

One (MOS-63S).

SPECIAL ENVIRONMENTAL CONDITIONS

None.

REFERENCES (TM)

TM 9-2320-283-20P.

GENERAL SAFETY INSTRUCTIONS

Engine off  
Transmission in neutral.  
Park brake set.

TROUBLESHOOTING REFERENCES

Paragraph 2-11.

ACCESSORY ITEMS.

3-298. HEATER ASSEMBLY REPLACEMENT AND REPAIR (Continued).

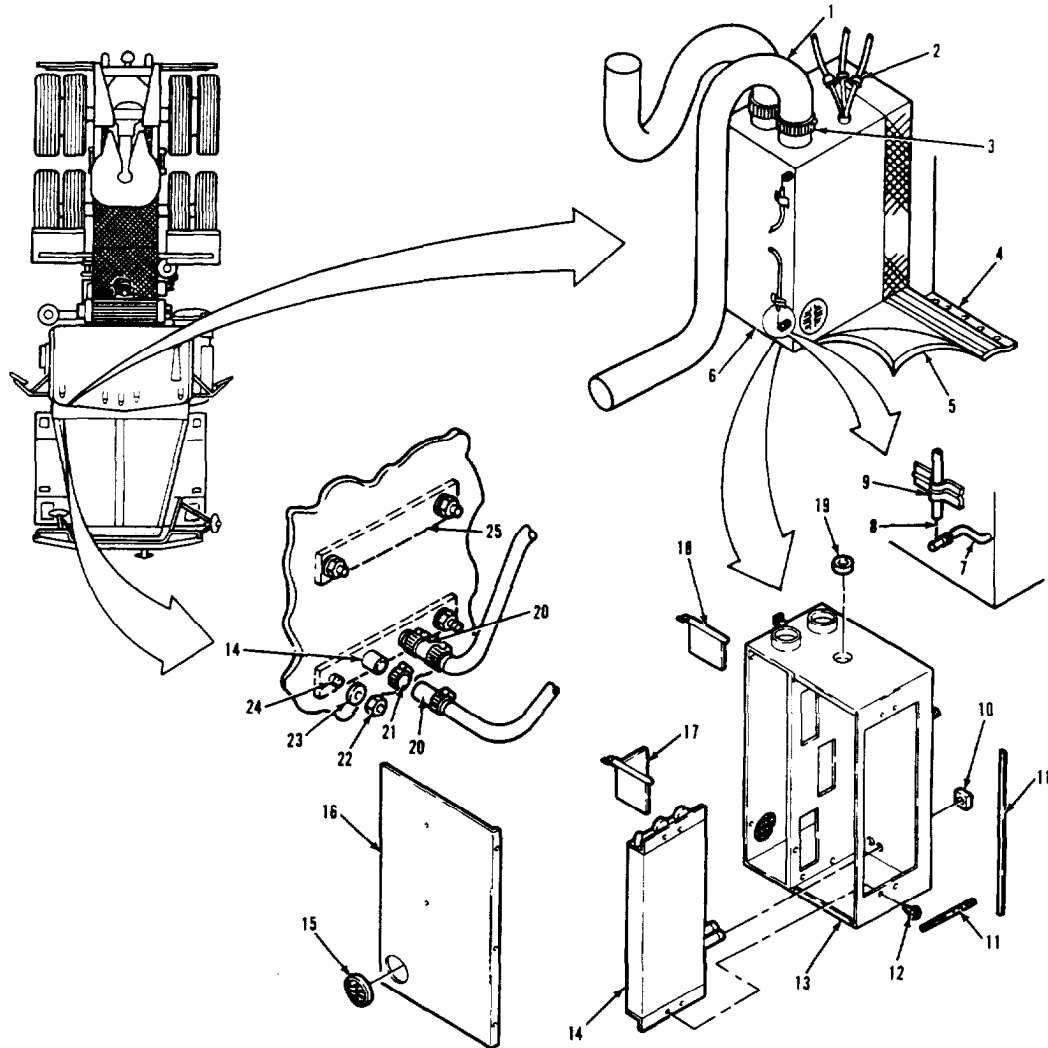

LEGEND:

- |                                |                                     |
|--------------------------------|-------------------------------------|
| 1. AIR HOSE (2)                | 14. HEATER CORE                     |
| 2. WIRE (3)                    | 15. AIR DEFLECTOR                   |
| 3. HOSE CLAMP (2)              | 16. WRAPPER COVER                   |
| 4. DOOR PLATE                  | 17. BOTTOM SHUTTER AND ROD ASSEMBLY |
| 5. FLOOR MAT                   | 18. TOP SHUTTER AND ROD ASSEMBLY    |
| 6. HEATER ASSEMBLY             | 19. GROMMET                         |
| 7. ROD (2)                     | 20. HEATER HOSE (2)                 |
| 8. BODEN WIRE (2)              | 21. HOSE CLAMP (2)                  |
| 9. BODEN CLIP (2)              | 22. HEX NUT (4)                     |
| 10. DRAIN TUBE SEAL (2)        | 23. FLAT WASHER (4)                 |
| 11. RUBBER STRIP (AS REQUIRED) | 24. STUD (4)                        |
| 12. HEXAGON HEAD SCREW (4)     | 25. HEATER INSULATOR (2)            |
| 13. WRAPPER ASSEMBLY           |                                     |

TA 237820

ACCESSORY ITEMS.

3-298. HEATER ASSEMBLY REPLACEMENT AND REPAIR (Continued).		
LOCATION/ITEM	ACTION	REMARKS
<b>A. REMOVAL.</b>		
1. Two clamps (21).	Loosen from two items (20).	
2. Two hoses (20).	Disconnect from item (14).	Keep two items (20) raised to prevent coolant from running out.
3. Four nuts (22) and washers (23).	Remove from four items (24).	
4. Three wires (2).	Remove electrical tape and disconnect three items (2).	Tag items (2).
5. Two clamps (3).	Loosen from two items (1).	
6. Two hoses (1).	Remove from item (6).	
7. Two clips (9).	Remove from item (6) and two items (8).	
8. Two wires (8).	Remove from two items (7).	
9. Mat (5).	a. Pull out from under item (4). b. Pull back, away from item (6).	
10. Heater assembly (6).	Remove from cab.	Pull item (6) from bottom and turn clockwise.
<b>NOTE</b>		
Only remove insulators if they are damaged.		
11. Two insulators (25).	Remove from four items (24).	

ACCESSORY ITEMS.

3-298. HEATER ASSEMBLY REPLACEMENT AND REPAIR (Continued).

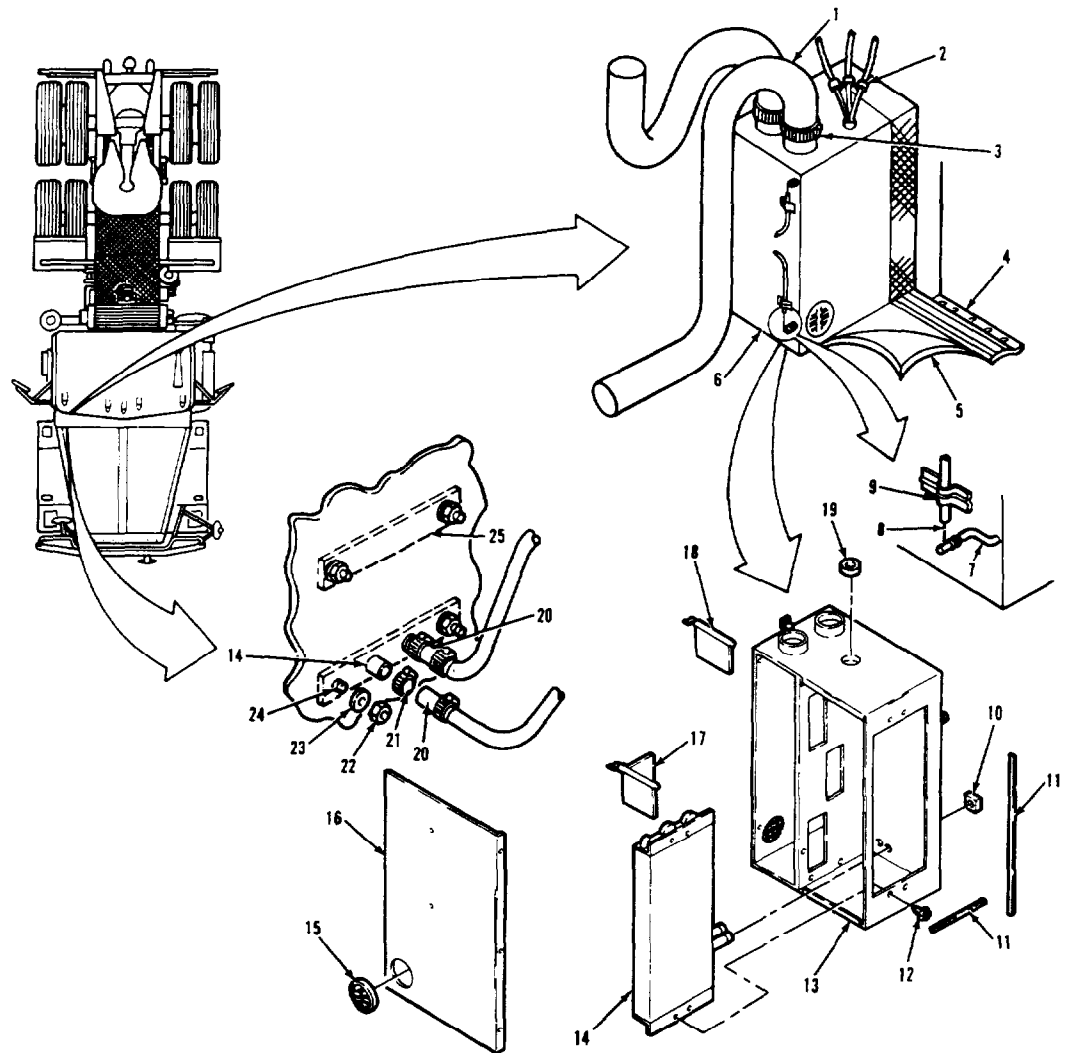

LEGEND:

- |                                |                                     |
|--------------------------------|-------------------------------------|
| 1. AIR HOSE (2)                | 14. HEATER CORE                     |
| 2. WIRE (3)                    | 15. AIR DEFLECTOR                   |
| 3. HOSE CLAMP (2)              | 16. WRAPPER COVER                   |
| 4. DOOR PLATE                  | 17. BOTTOM SHUTTER AND ROD ASSEMBLY |
| 5. FLOOR MAT                   | 18. TOP SHUTTER AND ROD ASSEMBLY    |
| 6. HEATER ASSEMBLY             | 19. GROMMET                         |
| 7. ROD (2)                     | 20. HEATER HOSE (2)                 |
| 8. BODEN WIRE (2)              | 21. HOSE CLAMP (2)                  |
| 9. BODEN CLIP (2)              | 22. HEX NUT (4)                     |
| 10. DRAIN TUBE SEAL (2)        | 23. FLAT WASHER (4)                 |
| 11. RUBBER STRIP (AS REQUIRED) | 24. STUD (4)                        |
| 12. HEXAGON HEAD SCREW (4)     | 25. HEATER INSULATOR (2)            |
| 13. WRAPPER ASSEMBLY           |                                     |

TA 237821

ACCESSORY ITEMS.

3-298. HEATER ASSEMBLY REPLACEMENT AND REPAIR (Continued).		
LOCATION/ITEM	ACTION	REMARKS
<b>B. DISASSEMBLY.</b>		
12. Heater blower assembly.	Remove.	Refer to paragraph 3-299.
13. Grommet (19).	Remove from item (13).	
14. Top shutter and rod assembly (18).	Rotate fully counterclockwise and lift up and out of hole and notch in item (13).	
15. Bottom shutter and rod assembly (17).	Rotate fully counterclockwise and slide over and pull out of hole and notch in item (13).	
<b><u>CAUTION</u></b>		
Hold heater core in place when removing mounting screws. Core can be damaged if it should drop.		
16. Four screws (12).	<ul style="list-style-type: none"> <li>a. Remove from item (13).</li> <li>b. Pull water tubes of item (14) from opening in two items (10).</li> <li>c. Remove item (14) from item (13).</li> </ul>	
17. Two seals (10).	Remove from item (8).	Discard items (5).
18. Strips (11).	Remove from item (13).	Discard items (11).
19. Deflector (15).	Push in four tabs and push from item (16).	
<b>C. CLEANING AND INSPECTION.</b>		
20. All parts.	Clean and inspect.	Refer to paragraphs 3-4 and 3-5.

ACCESSORY ITEMS.

3-298. HEATER ASSEMBLY REPLACEMENT AND REPAIR (Continued).

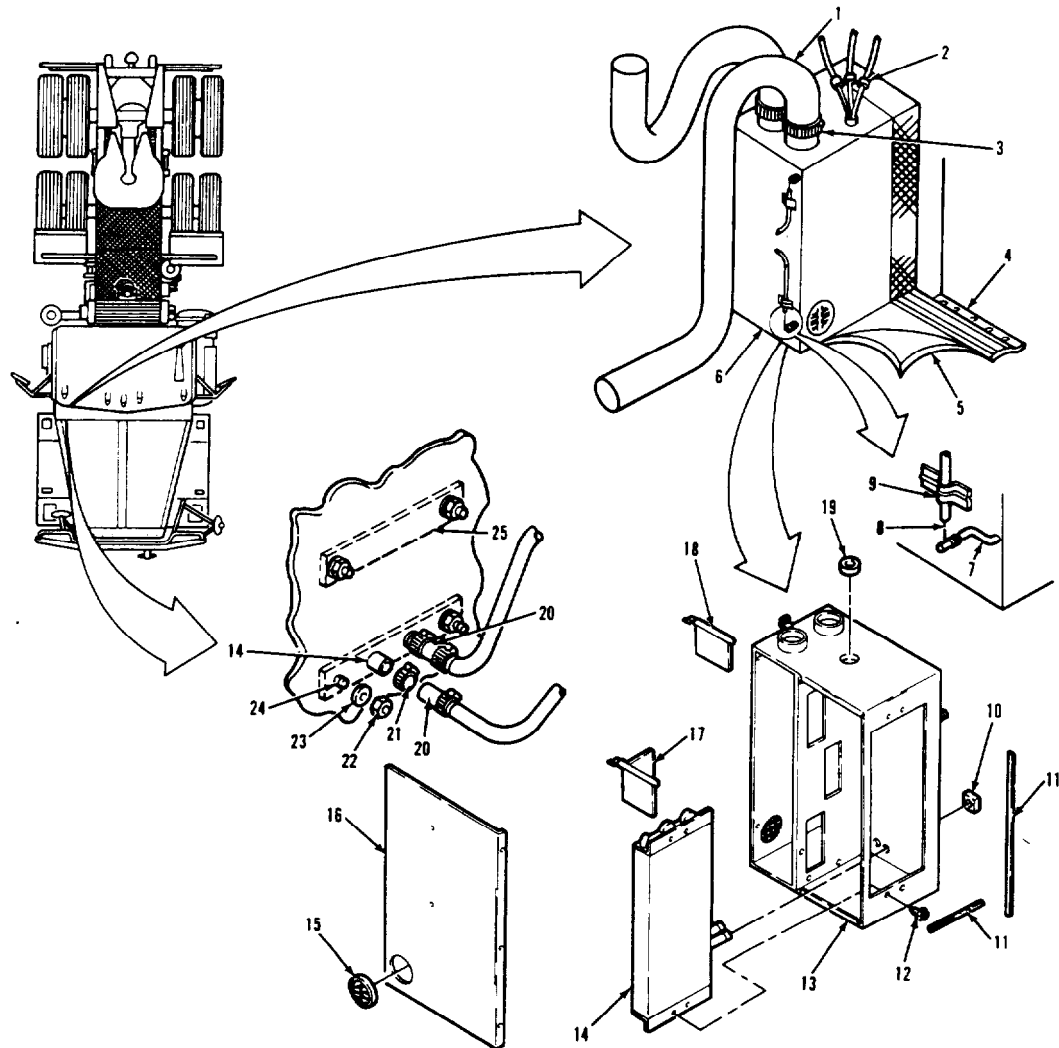

LEGEND:

- |                                |                                     |
|--------------------------------|-------------------------------------|
| 1. AIR HOSE (2)                | 14. HEATER CORE                     |
| 2. WIRE (3)                    | 15. AIR DEFLECTOR                   |
| 3. HOSE CLAMP (2)              | 16. WRAPPER COVER                   |
| 4. DOOR PLATE                  | 17. BOTTOM SHUTTER AND ROD ASSEMBLY |
| 5. FLOOR MAT                   | 18. TOP SHUTTER AND ROD ASSEMBLY    |
| 6. HEATER ASSEMBLY             | 19. GROMMET                         |
| 7. ROD (2)                     | 20. HEATER HOSE (2)                 |
| 8. BODEN WIRE (2)              | 21. HOSE CLAMP (2)                  |
| 9. BODEN CLIP (2)              | 22. HEX NUT (4)                     |
| 10. DRAIN TUBE SEAL (2)        | 23. FLAT WASHER (4)                 |
| 11. RUBBER STRIP (AS REQUIRED) | 24. STUD (4)                        |
| 12. HEXAGON HEAD SCREW (4)     | 25. HEATER INSULATOR (2)            |
| 13. WRAPPER ASSEMBLY           |                                     |

TA 237822



ACCESSORY ITEMS.

3-298. HEATER ASSEMBLY REPLACEMENT AND REPAIR (Continued).		
LOCATION/ITEM	ACTION	REMARKS
<b>D. ASSEMBLY.</b>		
21. Deflector (15).	Push in item (16).	
22. New strips (11).	Install on item (13).	
23. Two new seals (10).	Install on item (13).	
24. Core (14).	a. Slide into position by pushing water tubes on items (14) through holes in items (10). b. Secure with four items (12).	Be sure items (10) stays in position in item (13).
25. Bottom shutter and rod assembly (17).	a. Insert end of item (17) in hole in item (13). b. Slide over and push down into notch in item (13). Rotate item (13) in position.	
26. Top shutter and rod assembly (18).	a. Insert end of item (18) in hole in item (13). b. Slide over and push down into notch in item (13). Rotate item (18) in position.	
27. Grommet (19).	Push into hole in item (13).	
28. Heater blower assembly.	Install.	Refer to paragraph 3-299.
<b>E. INSTALLATION.</b>		
29. Two insulators (25).	Install on four items (24).	

ACCESSORY ITEMS.

3-298. HEATER ASSEMBLY REPLACEMENT AND REPAIR (Continued).

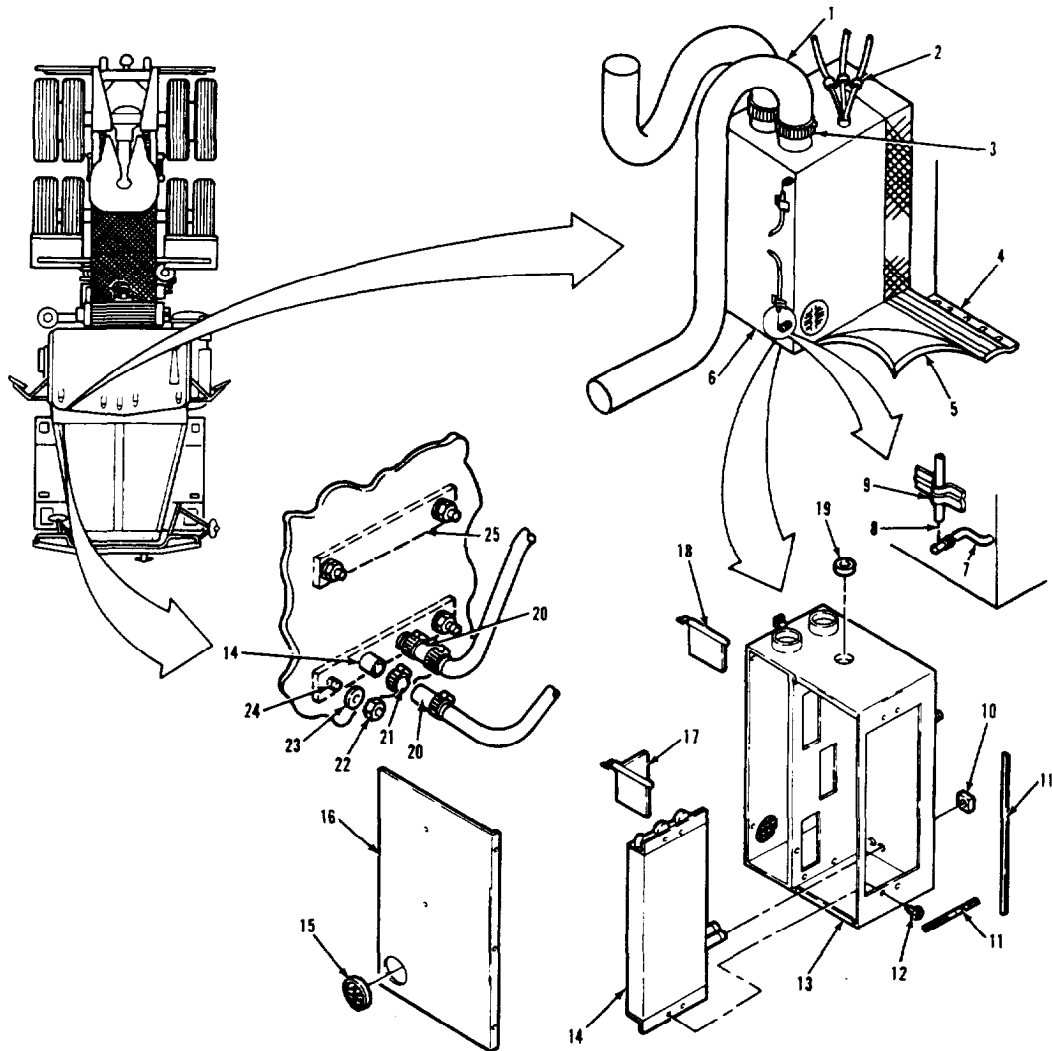

LEGEND:

- |                                |                                     |
|--------------------------------|-------------------------------------|
| 1. AIR HOSE (2)                | 14. HEATER CORE                     |
| 2. WIRE (3)                    | 15. AIR DEFLECTOR                   |
| 3. HOSE CLAMP (2)              | 16. WRAPPER COVER                   |
| 4. DOOR PLATE                  | 17. BOTTOM SHUTTER AND ROD ASSEMBLY |
| 5. FLOOR MAT                   | 18. TOP SHUTTER AND ROD ASSEMBLY    |
| 6. HEATER ASSEMBLY             | 19. GROMMET                         |
| 7. ROD (2)                     | 20. HEATER HOSE (2)                 |
| 8. BODEN WIRE (2)              | 21. HOSE CLAMP (2)                  |
| 9. BODEN CLIP (2)              | 22. HEX NUT (4)                     |
| 10. DRAIN TUBE SEAL (2)        | 23. FLAT WASHER (4)                 |
| 11. RUBBER STRIP (AS REQUIRED) | 24. STUD (4)                        |
| 12. HEXAGON HEAD SCREW (4)     | 25. HEATER INSULATOR (2)            |
| 13. WRAPPER ASSEMBLY           |                                     |

TA 237823

ACCESSORY ITEMS.

3-298. HEATER ASSEMBLY REPLACEMENT AND REPAIR (Continued).		
LOCATION/ITEM	ACTION	REMARKS
<b>E. INSTALLATION (Continued).</b>		
30. Heater assembly (6).	Set in place in cab.	Pull back item (5) as necessary.
31. Two hoses (1) and clamps (3).	Put on item (6).	
32. Two clamps (3).	Tighten.	
33. Two rods (7).	Put in closed position.	Push top item (7) up, push bottom item (7) down.
34. Two wires (8).	Put on two items (7).	
35. Two clips (9).	Put on item (6) and two items (8).	Keep two items (8) tight with two items (7) in closed position.
36. Three wires (2).	a. Connect. b. Wrap connections with electrical tape.	
37. Mat (5).	Install under item (4).	
38. Four nuts (22) and washers (23).	Install on four items (24).	
39. Two hoses (20) and clamps (21).	Put on items (14).	
40. Two clamps (21).	Tighten.	
<b>NOTE</b>		
Follow-on maintenance action required:		
Install air cleaner assembly (para 3-29). Service cooling system (para 3-52).		

ACCESSORY ITEMS.

3-298. HEATER ASSEMBLY REPLACEMENT AND REPAIR (Continued).

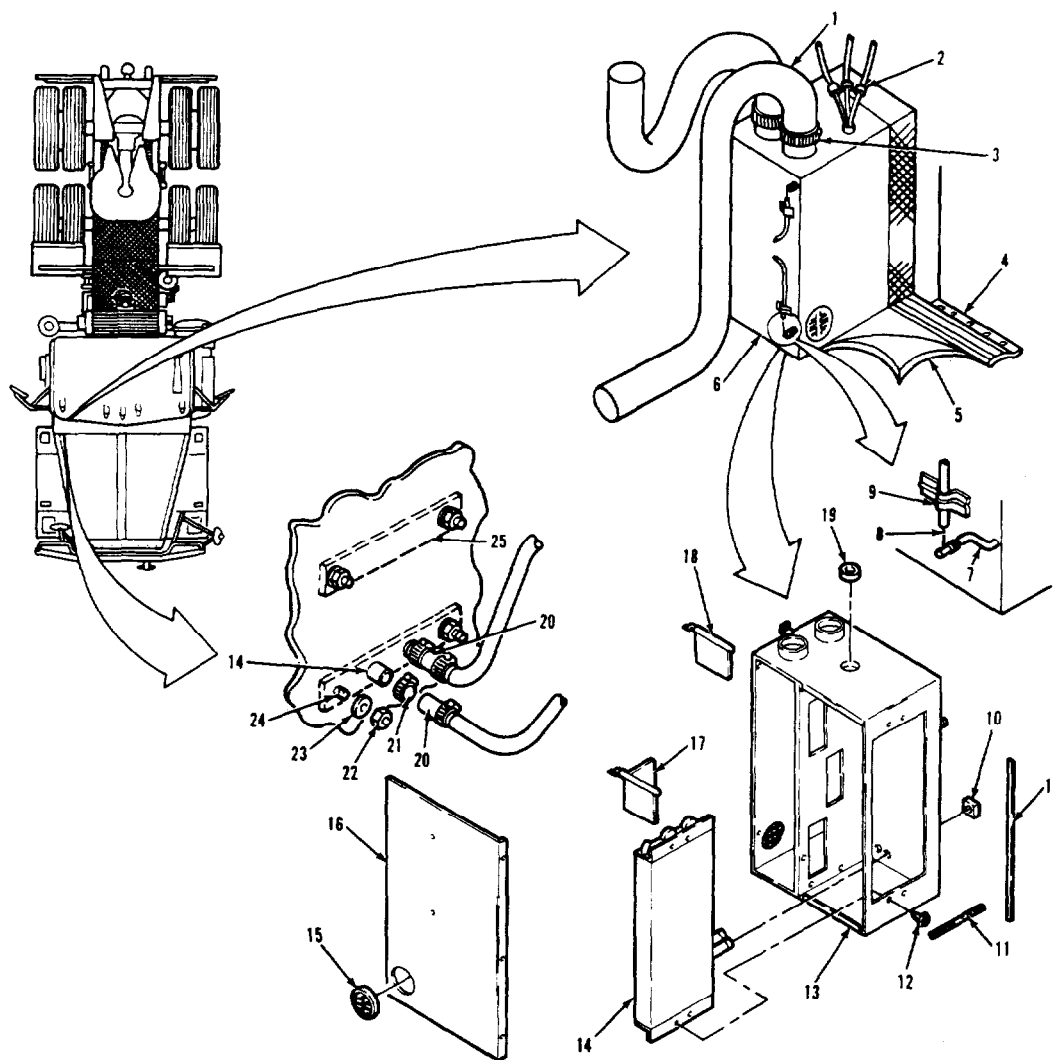

LEGEND:

- |                                |                                     |
|--------------------------------|-------------------------------------|
| 1. AIR HOSE (2)                | 14. HEATER CORE                     |
| 2. WIRE (3)                    | 15. AIR DEFLECTOR                   |
| 3. HOSE CLAMP (2)              | 16. WRAPPER COVER                   |
| 4. DOOR PLATE                  | 17. BOTTOM SHUTTER AND ROD ASSEMBLY |
| 5. FLOOR MAT                   | 18. TOP SHUTTER AND ROD ASSEMBLY    |
| 6. HEATER ASSEMBLY             | 19. GROMMET                         |
| 7. ROD (2)                     | 20. HEATER HOSE (2)                 |
| 8. BODEN WIRE (2)              | 21. HOSE CLAMP (2)                  |
| 9. BODEN CLIP (2)              | 22. HEX NUT (4)                     |
| 10. DRAIN TUBE SEAL (2)        | 23. FLAT WASHER (4)                 |
| 11. RUBBER STRIP (AS REQUIRED) | 24. STUD (4)                        |
| 12. HEXAGON HEAD SCREW (4)     | 25. HEATER INSULATOR (2)            |
| 13. WRAPPER ASSEMBLY           |                                     |

TA 237824

ACCESSORY ITEMS.

3-299. HEATER BLOWER ASSEMBLY REPLACEMENT AND REPAIR.

THIS TASK COVERS

- a. Removal.
- b. Disassembly.
- c. Cleaning and Inspection.
- d. Assembly.
- e. Installation.

INITIAL SETUP

<u>APPLICABLE CONFIGURATIONS</u>	<u>EQUIPMENT CONDITION PARAGRAPH</u>	<u>CONDITION DESCRIPTION</u>
All.	None.	None.

TEST EQUIPMENT  
None.

SPECIAL TOOLS  
None.

MATERIALS/PARTS (P/N)  
None.

PERSONNEL REQUIRED  
One (MDS-63S).

SPECIAL ENVIRONMENTAL CONDITIONS  
None.

REFERENCES (TM)  
None.

GENERAL SAFETY INSTRUCTIONS  
Engine off.  
Transmission in neutral  
Park brake set.

TROUBLESHOOTING REFERENCES  
Paragraph 2-11.

ACCESSORY ITEMS.

3-299. HEATER BLOWER ASSEMBLY REPLACEMENT AND REPAIR (Continued).

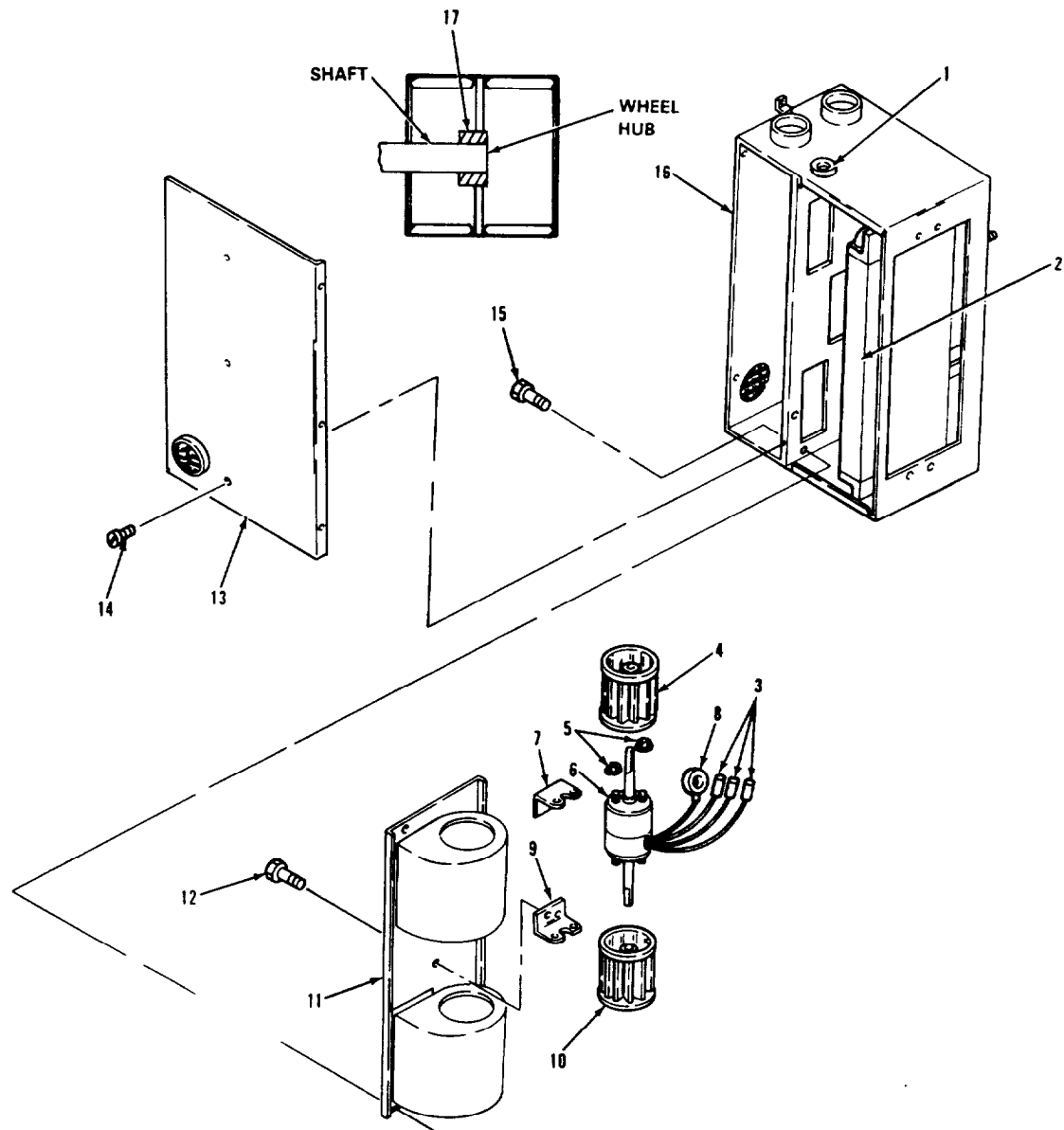

LEGEND:

- |                                  |                                   |
|----------------------------------|-----------------------------------|
| 1. GROMMET                       | 10. COUNTERCLOCKWISE BLOWER WHEEL |
| 2. HEATER CORE                   | 11. BLOWER HOUSING                |
| 3. WIRE (3)                      | 12. MACHINE SCREW (4)             |
| 4. CLOCKWISE BLOWER WHEEL        | 13. WRAPPER COVER                 |
| 5. HEXAGON MACHINE SCREW NUT (4) | 14. HEXAGON HEAD SCREW (9)        |
| 6. DC MOTOR                      | 15. MACHINE SCREW (4)             |
| 7. LEFT-HAND BRACKET             | 16. WRAPPER ASSEMBLY              |
| 8. RING TERMINAL                 | 17. SETSCREW (2)                  |
| 9. RIGHT-HAND BRACKET            |                                   |

TA 237825

ACCESSORY ITEMS.

3-299. HEATER BLOWER ASSEMBLY REPLACEMENT AND REPAIR (Continued).

LOCATION/ITEM	ACTION	REMARKS
<b>A. REMOVAL.</b>		
1. Nine screws (14).	Remove from item (13).	
2. Cover (13).	Remove from item (16).	
3. Three wires (3).	a. Remove electrical tape and disconnect. b. Pull through item (1).	Tag items (3).
4. Four screws (15).	Remove from item (16) and item (11).	
<b><u>CAUTION</u></b>		
Be careful not to damage heater core when removing housing.		
5. Housing (11).	Remove from item (16).	
<b>B. DISASSEMBLY.</b>		
6. Two setscrews (17).	Loosen.	Access from between blades on item (4) and item (10).
7. Wheel (4) and wheel (10).	Remove from item (6).	
8. Four screws (12).	Remove from item (11), item (7), and item (9).	
9. Four nuts (5) and terminal (8).	Remove from item (7) and item (9).	
10. Motor (6), bracket (7), and bracket (8).	Remove from item (11).	

ACCESSORY ITEMS.

3-299. HEATER BLOWER ASSEMBLY REPLACEMENT AND REPAIR (Continued).

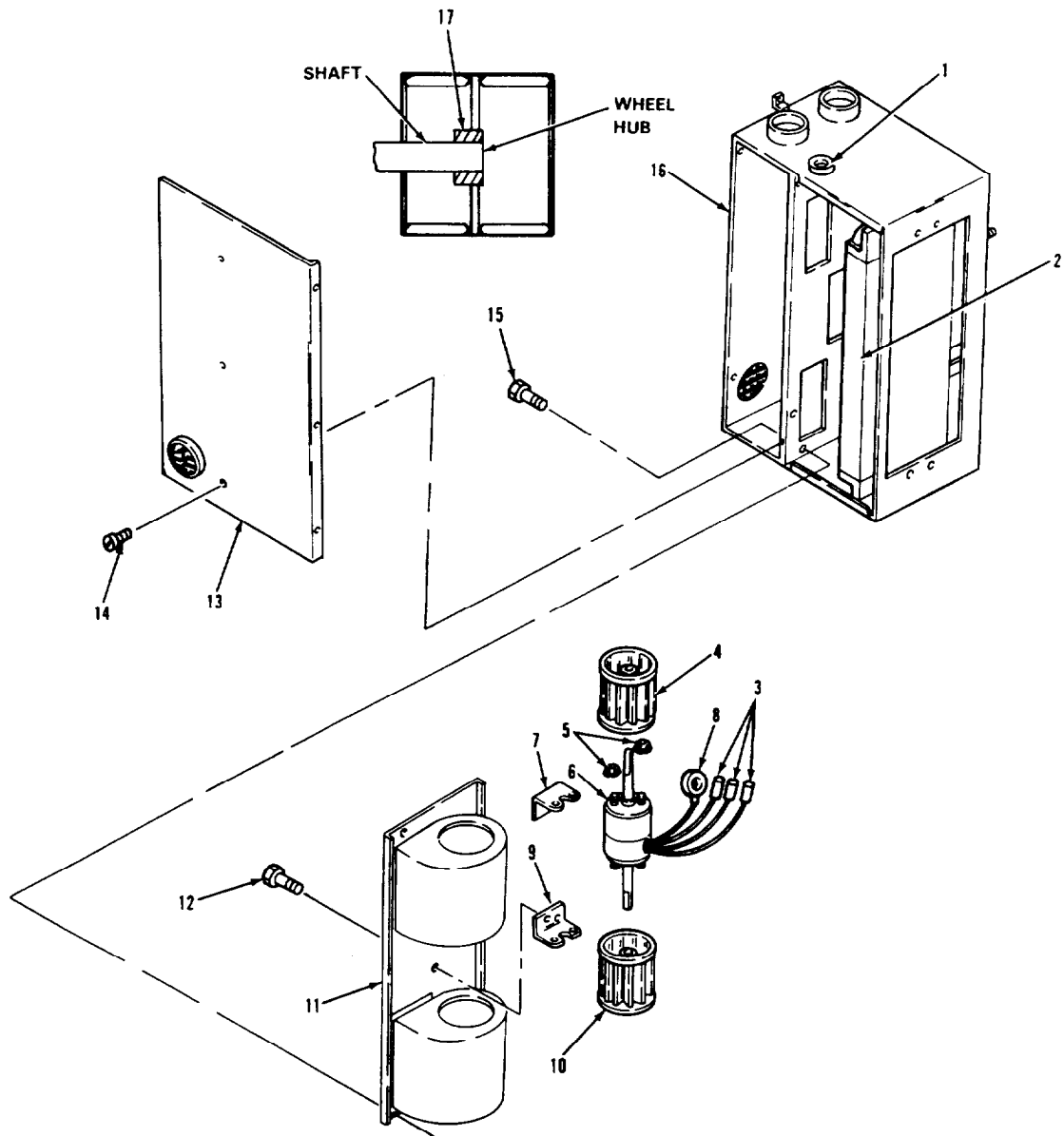

LEGEND:

- |                                  |                                   |
|----------------------------------|-----------------------------------|
| 1. GROMMET                       | 10. COUNTERCLOCKWISE BLOWER WHEEL |
| 2. HEATER CORE                   | 11. BLOWER HOUSING                |
| 3. WIRE (3)                      | 12. MACHINE SCREW (4)             |
| 4. CLOCKWISE BLOWER WHEEL        | 13. WRAPPER COVER                 |
| 5. HEXAGON MACHINE SCREW NUT (4) | 14. HEXAGON HEAD SCREW (9)        |
| 6. DC MOTOR                      | 15. MACHINE SCREW (4)             |
| 7. LEFT-HAND BRACKET             | 16. WRAPPER ASSEMBLY              |
| 8. RING TERMINAL                 | 17. SETSCREW (2)                  |
| 9. RIGHT-HAND BRACKET            |                                   |

TA 237826



ACCESSORY ITEMS.

3-299. HEATER BLOWER ASSEMBLY REPLACEMENT AND REPAIR (Continued).		
LOCATION/ITEM	ACTION	REMARKS
<b>C. CLEANING AND INSPECTION.</b>		
11. All parts.	Clean and inspect.	Refer to paragraphs 3-4 and 3-5.
<b>D. ASSEMBLY.</b>		
12. Motor (6), bracket (7), and bracket (9).	Put in place on item (11).	
13. Four nuts (5) and terminal (8).	Secure item (7) and item (9) to item (6).	
14. Four screws (12).	Secure item (7) and item (9) to item (11).	
15. Wheel (4) and wheel (10).	Install on item (6).	End of shaft should be flush with hub of wheel as shown.
16. Two setscrews (17).	Tighten.	
<b>E. INSTALLATION.</b>		
17. Housing (11).	Put in place in item (16).	
18. Four screws (12).	Secure item (11) to item (16).	
19. Three wires (3).	a. Put in place through item (1). b. Connect and wrap with electrical tape.	
20. Cover (13).	Put in place on item (16).	

ACCESSORY ITEMS.

3-299. HEATER BLOWER ASSEMBLY REPLACEMENT AND REPAIR (Continued).

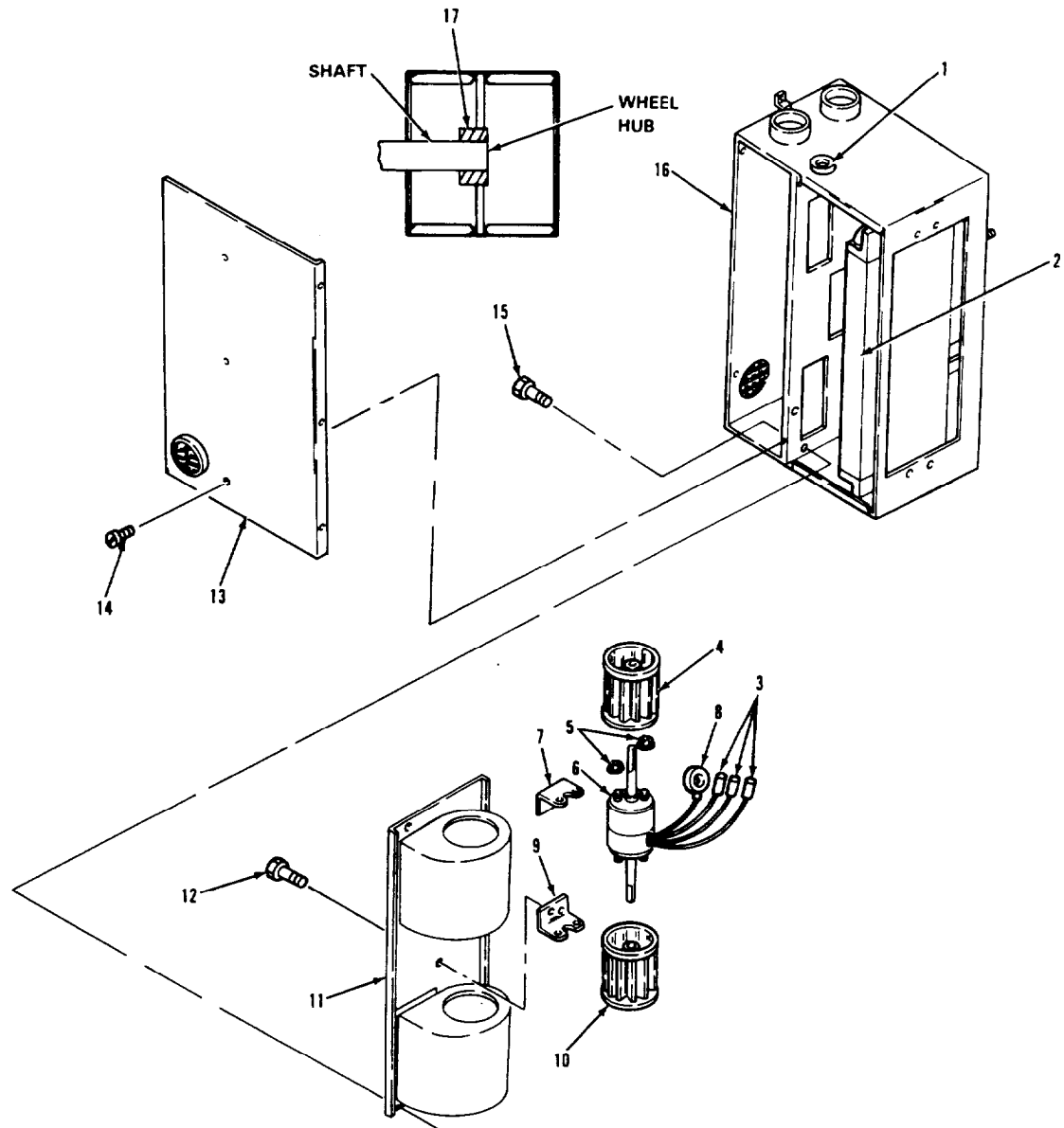

LEGEND:

- |                                  |                                   |
|----------------------------------|-----------------------------------|
| 1. GROMMET                       | 10. COUNTERCLOCKWISE BLOWER WHEEL |
| 2. HEATER CORE                   | 11. BLOWER HOUSING                |
| 3. WIRE (3)                      | 12. MACHINE SCREW (4)             |
| 4. CLOCKWISE BLOWER WHEEL        | 13. WRAPPER COVER                 |
| 5. HEXAGON MACHINE SCREW NUT (4) | 14. HEXAGON HEAD SCREW (9)        |
| 6. DC MOTOR                      | 15. MACHINE SCREW (4)             |
| 7. LEFT-HAND BRACKET             | 16. WRAPPER ASSEMBLY              |
| 8. RING TERMINAL                 | 17. SETSCREW (2)                  |
| 9. RIGHT-HAND BRACKET            |                                   |

TA 237827

ACCESSORY ITEMS.

3-299. HEATER BLOWER ASSEMBLY REPLACEMENT AND REPAIR (Continued).

LOCATION/ITEM	ACTION	REMARKS
<b>E. INSTALLATION (Continued).</b>		
21. Nine screws (14).	Secure item (13) to item (16).	
<b>NOTE</b>		
Follow-on maintenance action required:		
None.		

ACCESSORY ITEMS.

3-299. HEATER BLOWER ASSEMBLY REPLACEMENT AND REPAIR (Continued).

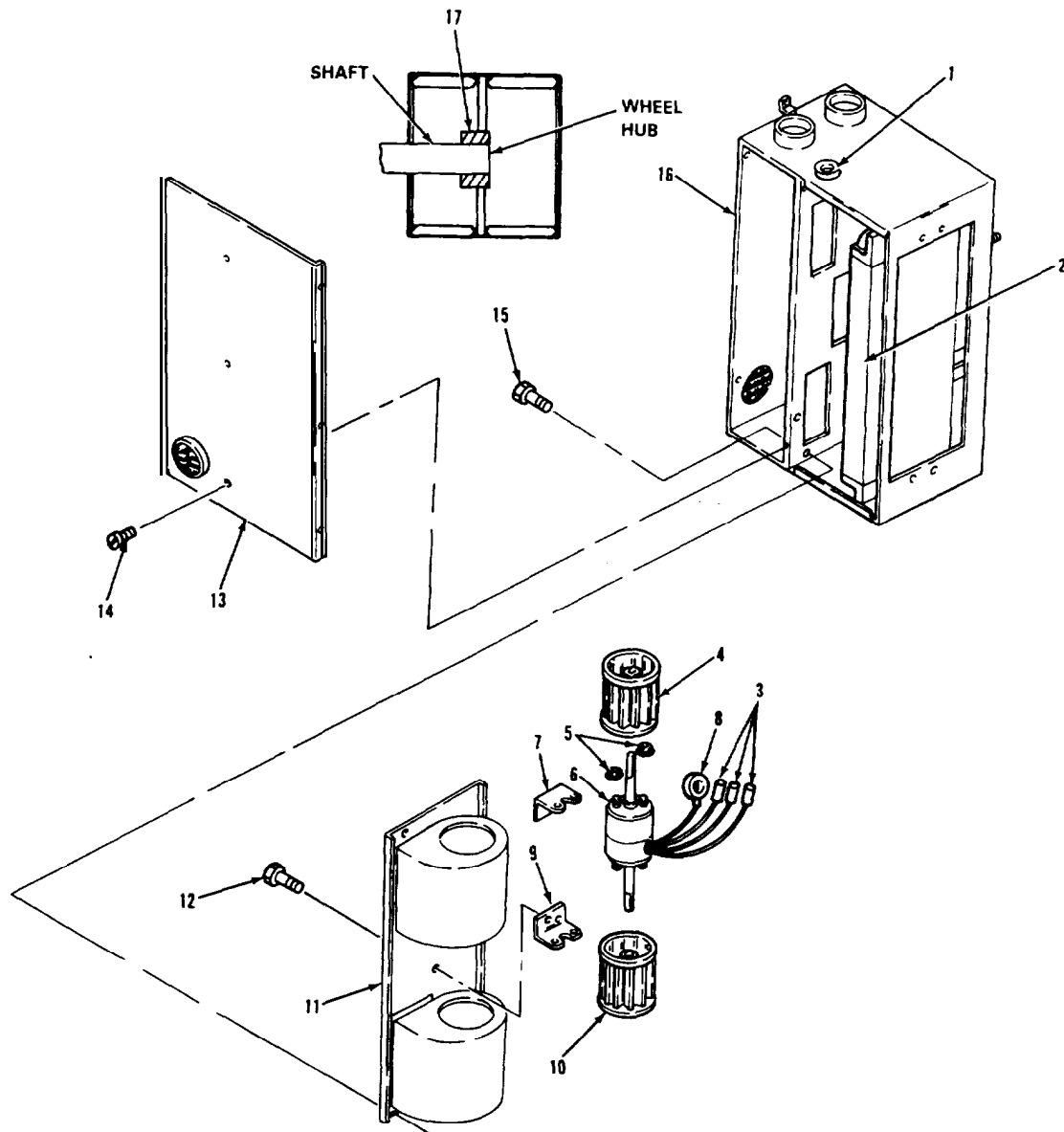

LEGEND:

- |                                  |                                   |
|----------------------------------|-----------------------------------|
| 1. GROMMET                       | 10. COUNTERCLOCKWISE BLOWER WHEEL |
| 2. HEATER CORE                   | 11. BLOWER HOUSING                |
| 3. WIRE (3)                      | 12. MACHINE SCREW (4)             |
| 4. CLOCKWISE BLOWER WHEEL        | 13. WRAPPER COVER                 |
| 5. HEXAGON MACHINE SCREW NUT (4) | 14. HEXAGON HEAD SCREW (9)        |
| 6. DC MOTOR                      | 15. MACHINE SCREW (4)             |
| 7. LEFT-HAND BRACKET             | 16. WRAPPER ASSEMBLY              |
| 8. RING TERMINAL                 | 17. SETSCREW (2)                  |
| 9. RIGHT-HAND BRACKET            |                                   |

TA 237828

ACCESSORY ITEMS.

3-300. HEATER CONTROL PANEL REPLACEMENT.

THIS TASK COVERS

- a. Removal.
- b. Installation.

INITIAL SETUP

<p><u>APPLICABLE CONFIGURATIONS</u> All.</p>	<p><u>EQUIPMENT CONDITION PARAGRAPH</u> 3-114.</p>	<p><u>CONDITION DESCRIPTION</u> Manual reset circuit breaker mounting bracket removed.</p>
<p><u>TEST EQUIPMENT</u> None.</p>		
<p><u>SPECIAL TOOLS</u> None.</p>		
<p><u>MATERIALS/PARTS (P/N)</u> Tape, electrical Item 30, Appendix C. Tie, cable (96906) MS3367-1-9.</p>		
<p><u>PERSONNEL REQUIRED</u> One (MOS-63S).</p>	<p><u>SPECIAL ENVIRONMENTAL CONDITIONS</u> None.</p>	
<p><u>REFERENCES (TM)</u> TM 9-2320-283-20P.</p>	<p><u>GENERAL SAFETY INSTRUCTIONS</u> Engine off. Transmission in neutral. Park brake set.</p>	
<p><u>TROUBLESHOOTING REFERENCES</u> Paragraph 2-11.</p>		

ACCESSORY ITEMS.

3-300. HEATER CONTROL PANEL REPLACEMENT (Continued).

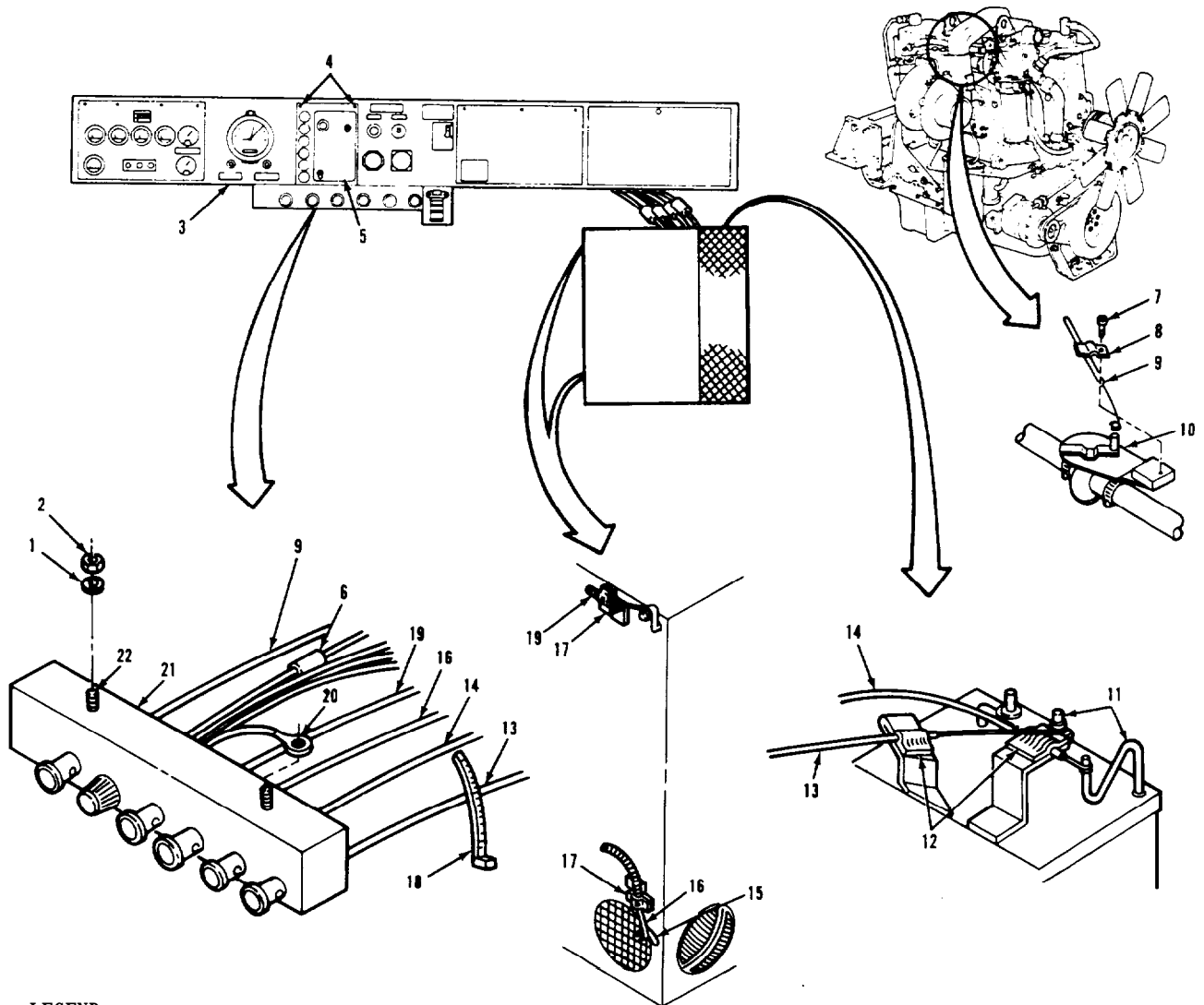

LEGEND:

- |  |                                  |
|--|----------------------------------|
| 1. LOCKWASHER (2)                                  | 12. BODEN CLIP (2)               |
| 2. NUT (2)   | 13. BODEN WIRE                   |
| 3. INSTRUMENT PANEL ASSEMBLY                       | 14. BODEN WIRE                   |
| 4. QUARTER-TURN SCREW (2)                          | 15. SHUTTER AND ROD ASSEMBLY (2) |
| 5. RIGHT-HAND INSTRUMENT CLUSTER<br>PANEL ASSEMBLY | 16. BODEN WIRE                   |
| 6. WIRE (5)  | 17. BODEN CLIP (2)               |
| 7. SCREW   | 18. CABLE TIE                    |
| 8. CLIP  | 19. BODEN WIRE                   |
| 9. BODEN WIRE                                      | 20. TERMINAL                     |
| 10. HEATER CONTROL VALVE                           | 21. HEATER CONTROL               |
| 11. SHUTTER (2)                                    | 22. STUD (2)                     |

TA 237829

ACCESSORY ITEMS.

3-300. HEATER CONTROL PANEL REPLACEMENT (Continued).		
LOCATION/ITEM	ACTION	REMARKS
<b>A. REMOVAL.</b>		
1. Two clips (12).	Remove from item (13) and item (14).	
2. Wires (13) and (14).	Remove from two items (11).	
3. Two clips (17).	Remove from item (16) and item (19).	
4. Wires (16) and (19).	Remove from two items (15).	
5. Screw (7) and clip (8).	Remove from item (9) and item (10).	
6. Wire (9).	Remove from item (10).	
7. Two screws (4).	Loosen.	
8. Panel (5).	Open.	
9. Five wires (6).	Remove electrical tape and unplug.	Tag wires (6).
10. Two nuts (2), lockwashers (1), and terminal (20).	Remove from two items (22).	
11. Tie (18).	Cut off and discard.	
12. Control (21).	Remove.	
<b>B. INSTALLATION.</b>		
13. Control (21).	Put in place under item (3).	a. Be sure to feed item (9) through firewall. b. Push all knobs in.
14. Two nuts (2) and lockwashers (1).	Secure items (21) and (20) to item (3).	
15. Five wires (6).	a. Connect.	

ACCESSORY ITEMS.

3-300. HEATER CONTROL PANEL REPLACEMENT (Continued).

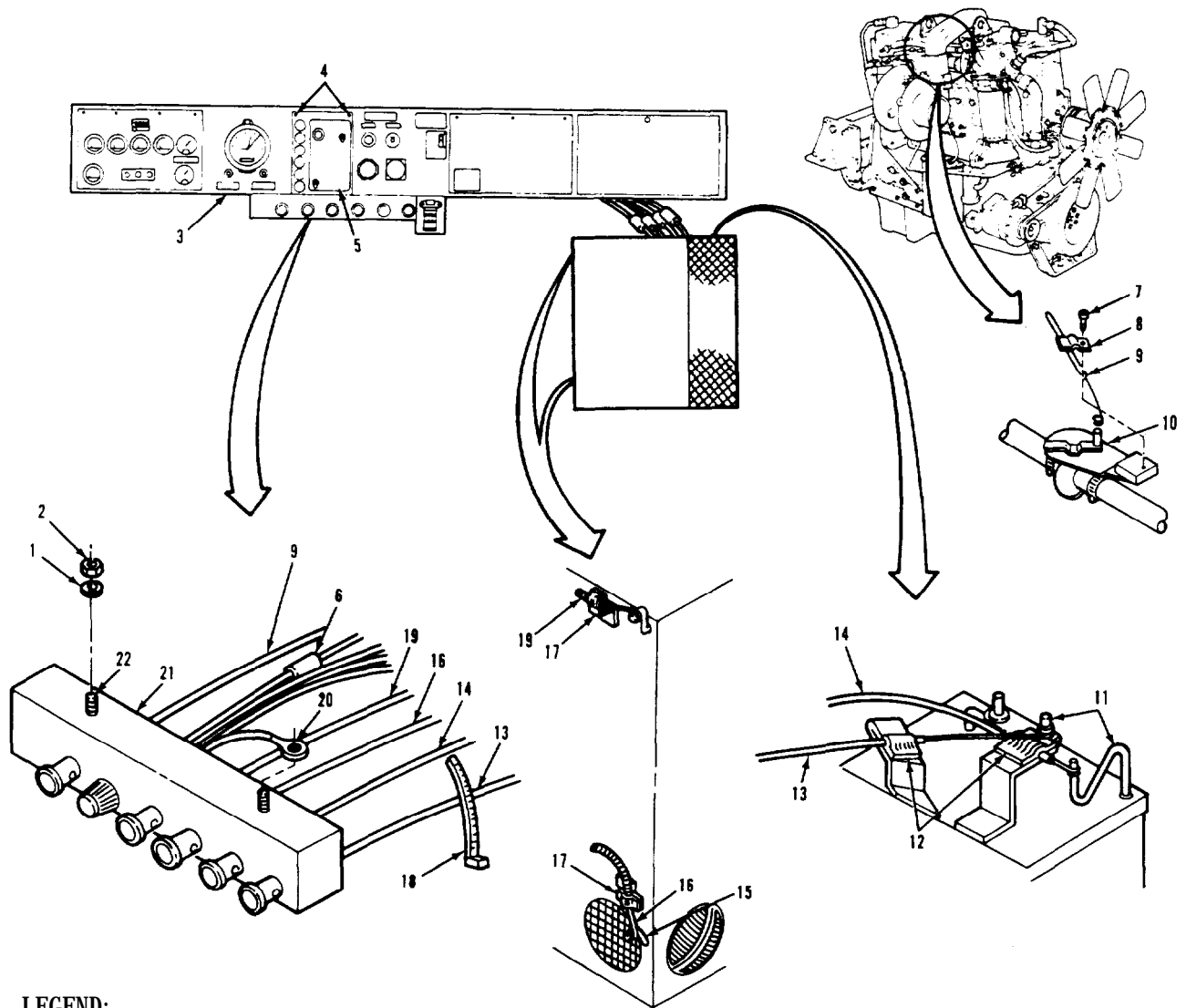

LEGEND:

- |  |                                  |
|--|----------------------------------|
| 1. LOCKWASHER (2)                                  | 12. BODEN CLIP (2)               |
| 2. NUT (2)   | 13. BODEN WIRE                   |
| 3. INSTRUMENT PANEL ASSEMBLY                       | 14. BODEN WIRE                   |
| 4. QUARTER-TURN SCREW (2)                          | 15. SHUTTER AND ROD ASSEMBLY (2) |
| 5. RIGHT-HAND INSTRUMENT CLUSTER<br>PANEL ASSEMBLY | 16. BODEN WIRE                   |
| 6. WIRE (5)  | 17. BODEN CLIP (2)               |
| 7. SCREW   | 18. CABLE TIE                    |
| 8. CLIP  | 19. BODEN WIRE                   |
| 9. BODEN WIRE                                      | 20. TERMINAL                     |
| 10. HEATER CONTROL VALVE                           | 21. HEATER CONTROL               |
| 11. SHUTTER (2)                                    | 22. STUD (2)                     |

TA 237830



ACCESSORY ITEMS.

3-300. HEATER CONTROL PANEL REPLACEMENT (Continued).		
LOCATION/ITEM	ACTION	REMARKS
<b>B. INSTALLATION (Continued).</b>		
15. Five wires (6). (continued).	b. Wrap connections with electrical tape.	
16. Valve (10).	Manually put in closed position (counterclockwise).	
17. Wire (9).	Put on item (10).	
18. Screw (7) and clip (8).	Secure item (9) to item (10).	
19. Two shutter and rod assemblies (15).	Put in closed position.	Push top item (15) up, push bottom item (15) down.
20. Wires (16) and (19).	Put on two items (15).	
21. Two clips (17).	Secure items (16) and (19) to two items (15).	
22. Two shutter and rod assemblies (11).	Put in closed position.	
23. Wires (13) and (14).	Put on two items (11).	
24. Two clips (12).	Secure items (13) and (14) to two items (11).	
25. Panel (5).	Close.	
26. Two screws (4).	Tighten.	
27. New tie (18).	Install on items (13), (14), (16), (19), and (9).	
<b>NOTE</b>		
Follow-on maintenance action required:		
Install manual reset circuit breaker mounting bracket (para 3-114).		

ACCESSORY ITEMS.

3-300. HEATER CONTROL PANEL REPLACEMENT (Continued).

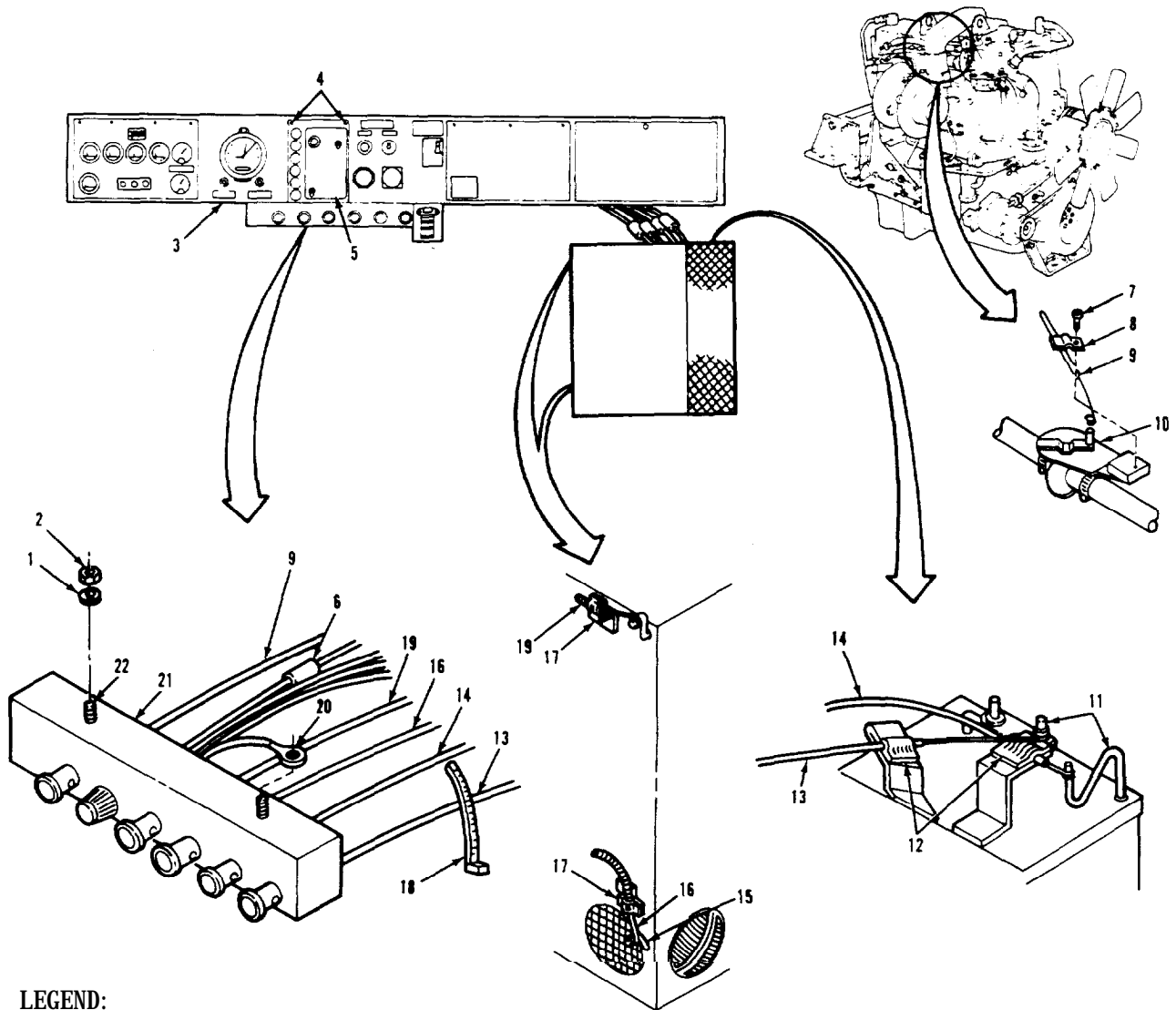

LEGEND:

- |  |                                  |
|--|----------------------------------|
| 1. LOCKWASHER (2)                                  | 12. BODEN CLIP (2)               |
| 2. NUT (2)   | 13. BODEN WIRE                   |
| 3. INSTRUMENT PANEL ASSEMBLY                       | 14. BODEN WIRE                   |
| 4. QUARTER-TURN SCREW (2)                          | 15. SHUTTER AND ROD ASSEMBLY (2) |
| 5. RIGHT-HAND INSTRUMENT CLUSTER<br>PANEL ASSEMBLY | 16. BODEN WIRE                   |
| 6. WIRE (5)  | 17. BODEN CLIP (2)               |
| 7. SCREW   | 18. CABLE TIE                    |
| 8. CLIP  | 19. BODEN WIRE                   |
| 9. BODEN WIRE                                      | 20. TERMINAL                     |
| 10. HEATER CONTROL VALVE                           | 21. HEATER CONTROL               |
| 11. SHUTTER (2)                                    | 22. STUD (2)                     |

TA 237831

ACCESSORY ITEMS.

3-301. HEATER CONTROL PANEL REPAIR.

THIS TASK COVERS

- a. Disassembly.
- b. Cleaning and Inspection.
- c. Assembly.

INITIAL SETUP

APPLICABLE CONFIGURATIONS  
All.

EQUIPMENT CONDITION  
PARAGRAPH  
3-300.

CONDITION DESCRIPTION  
Heater control panel removed.

TEST EQUIPMENT  
None.

SPECIAL TOOLS  
None.

MATERIALS/PARTS (P/N)  
None.

PERSONNEL REQUIRED  
One (MOS-63S).

SPECIAL ENVIRONMENTAL CONDITIONS  
None.

REFERENCES (TM)  
None.

GENERAL SAFETY INSTRUCTIONS  
None.

TROUBLESHOOTING REFERENCES  
Paragraph 2-11.

ACCESSORY ITEMS.

3-301. HEATER CONTROL PANEL REPAIR (Continued).

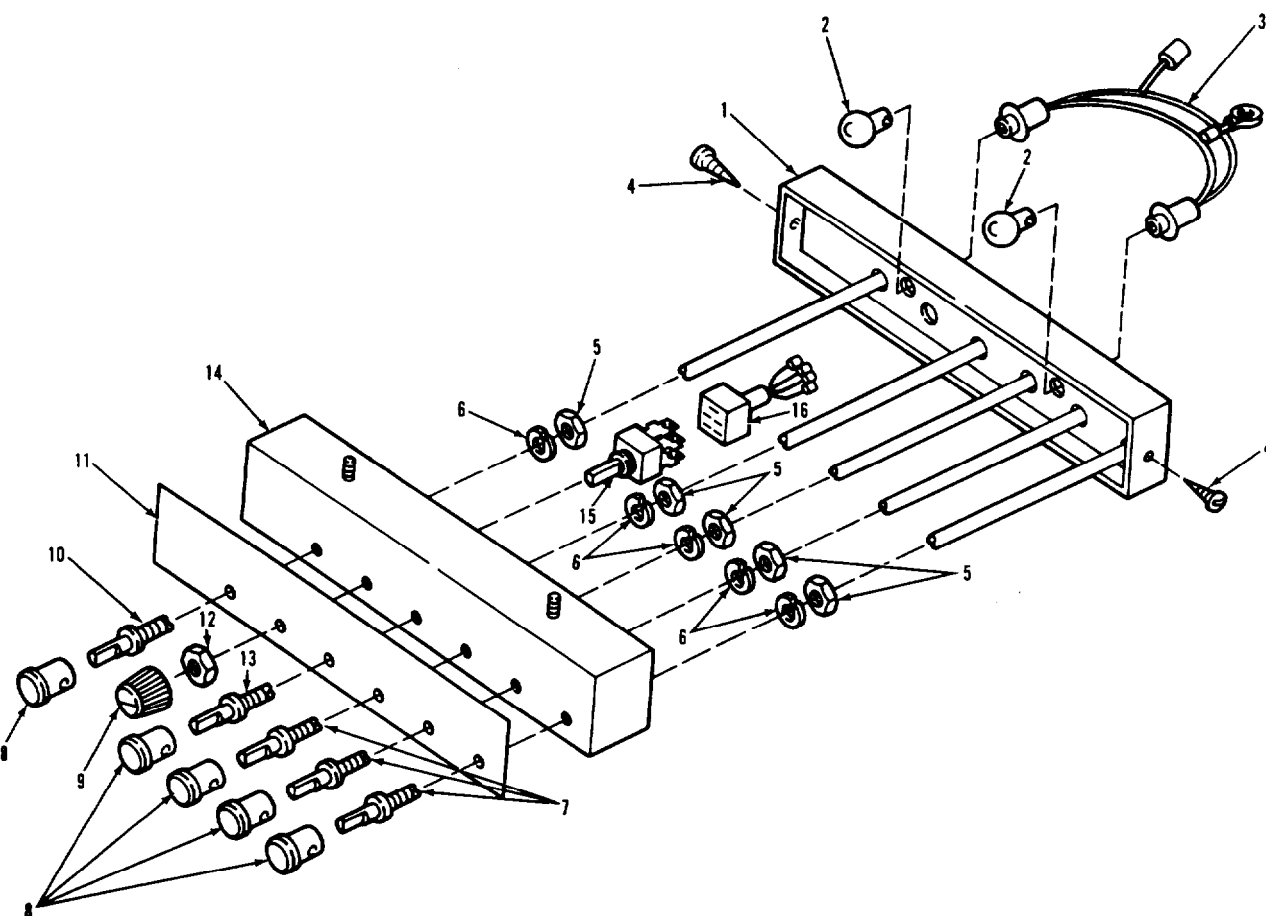

LEGEND:

- |                           |                           |
|---------------------------|---------------------------|
| 1. REAR COVER             | 9. SWITCH KNOB            |
| 2. INCANDESCENT LAMP (2)  | 10. BODEN WIRE            |
| 3. LIGHT HARNESS ASSEMBLY | 11. DESIGNATION PLATE     |
| 4. MACHINE SCREW (2)      | 12. HEX NUT               |
| 5. HEX NUT (5)            | 13. BODEN WIRE            |
| 6. LOCKWASHER (5)         | 14. CONTROL PANEL WRAPPER |
| 7. BODEN WIRE (3)         | 15. SWITCH                |
| 8. KNOB (5)               | 16. HARNESS               |

TA 237832

ACCESSORY ITEMS.

3-301. HEATER CONTROL PANEL REPAIR (Continued).		
LOCATION/ITEM	ACTION	REMARKS
<b>A. DISASSEMBLY.</b>		
1. Harness (3).	Remove from item (1).	
2. Two lamps (2).	Remove from item (3).	
3. Two screws (4).	Remove from item (1).	
4. Cover (1).	Remove.	
5. Harness (16).	Remove from item (15).	
6. Knob (9).	Pull from item (15).	
7. Nut (12).	Remove from item (15).	
8. Switch (15).	Remove from item (14).	
9. Five knobs (8).	Remove from item (10), item (13), and three items (7).	Loosen setscrews to remove items (8).
10. Five nuts (5) and lockwashers (6).	Remove from item (10), item (13), and three items (7).	
<b>NOTE</b>		
Only remove designation plate to replace with a new one.		
11. Plate (11).	Scrape from item (14) with a putty knife.	
<b>B. CLEANING AND INSPECTION.</b>		
12. All parts.	Clean and inspect.	Refer to paragraphs 3-4 and 3-5.

ACCESSORY ITEMS.

3-301. HEATER CONTROL PANEL REPAIR (Continued).

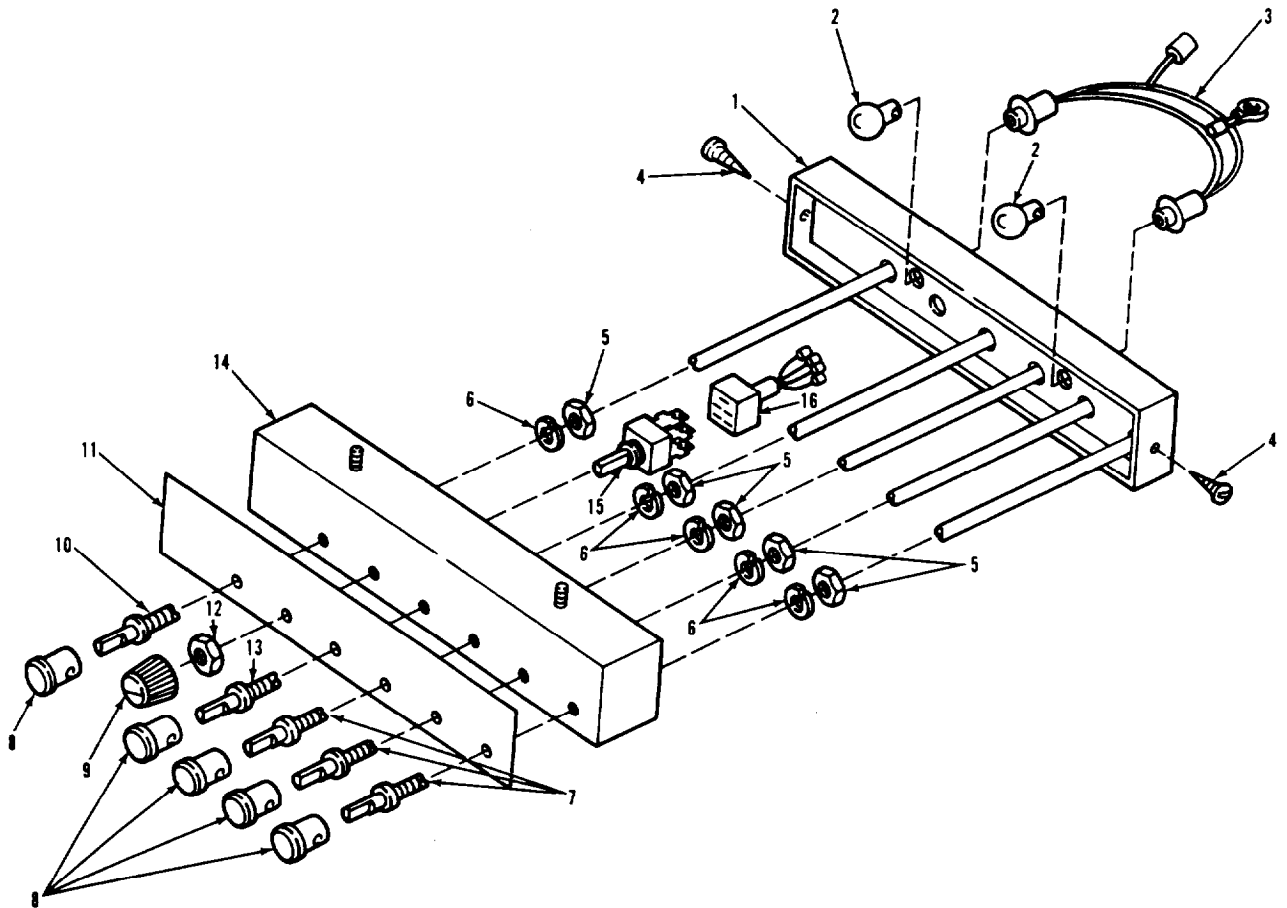

LEGEND:

- |                           |                           |
|---------------------------|---------------------------|
| 1. REAR COVER             | 9. SWITCH KNOB            |
| 2. INCANDESCENT LAMP (2)  | 10. BODEN WIRE            |
| 3. LIGHT HARNESS ASSEMBLY | 11. DESIGNATION PLATE     |
| 4. MACHINE SCREW (2)      | 12. HEX NUT               |
| 5. HEX NUT (5)            | 13. BODEN WIRE            |
| 6. LOCKWASHER (5)         | 14. CONTROL PANEL WRAPPER |
| 7. BODEN WIRE (3)         | 15. SWITCH                |
| 8. KNOB (5)               | 16. HARNESS               |

TA 237833

ACCESSORY ITEMS.

3-301. HEATER CONTROL PANEL REPAIR (Continued).		
LOCATION/ITEM	ACTION	REMARKS
<b>C. ASSEMBLY.</b>		
13. New plate (11).	Install on item (14).	
14. Wire (10), wire (13), and three wires (7).	Install in item (14).	
15. Five nuts (5) and lockwashers (6).	Secure item (10), item (13), and three items (7) to item (14).	
16. Five knobs (8).	Install on item (10), item (13), and three items (7).	Tighten setscrews.
17. Switch (15).	Install in item (14).	
18. Nut (12).	Secure item (15) to item (14).	
19. Knob (9).	Install on item (15).	
20. Harness (16).	Install on item (15).	
21. Cover (1).	Install on item (14).	
22. Two screws (4).	Secure item (1) to item (14).	
23. Two lamps (2).	Install in item (3).	
24. Harness (3).	Install in item (1).	
<b>NOTE</b>		
Follow-on maintenance action required:		
Install heater control panel (para 3-300).		

ACCESSORY ITEMS.

3-301. HEATER CONTROL PANEL REPAIR (Continued).

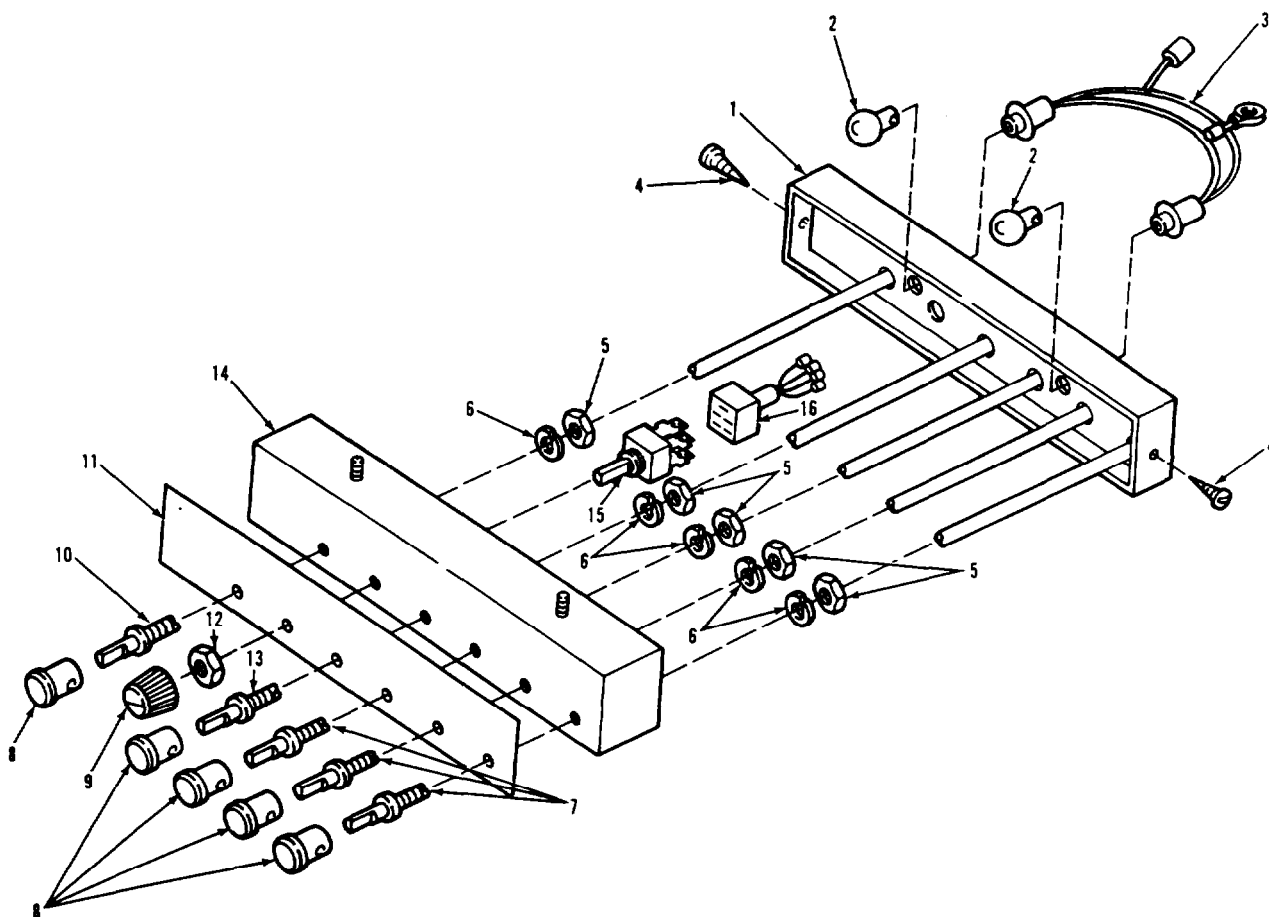

LEGEND:

- |                           |                           |
|---------------------------|---------------------------|
| 1. REAR COVER             | 9. SWITCH KNOB            |
| 2. INCANDESCENT LAMP (2)  | 10. BODEN WIRE            |
| 3. LIGHT HARNESS ASSEMBLY | 11. DESIGNATION PLATE     |
| 4. MACHINE SCREW (2)      | 12. HEX NUT               |
| 5. HEX NUT (5)            | 13. BODEN WIRE            |
| 6. LOCKWASHER (5)         | 14. CONTROL PANEL WRAPPER |
| 7. BODEN WIRE (3)         | 15. SWITCH                |
| 8. KNOB (5)               | 16. HARNESS               |

TA 237834



ACCESSORY ITEMS.

3-302. AIR DIFFUSER ASSEMBLY REPLACEMENT.

THIS TASK COVERS

- a. Removal.
- b. Cleaning and Inspection.
- c. Installation.
- d. Operational Check.

INITIAL SETUP

<u>APPLICABLE CONFIGURATIONS</u>	<u>EQUIPMENT CONDITION PARAGRAPH</u>	<u>CONDITION DESCRIPTION</u>
All.	3-298.	Heater assembly removed.

TEST EQUIPMENT  
None.

SPECIAL TOOLS  
None.

MATERIALS/PARTS (P/N)  
Rags, wiping  
Item 22, Appendix C.  
Solvent, drycleaning, SD-2  
Item 29, Appendix C.

PERSONNEL REQUIRED  
One (MOS-63S).

SPECIAL ENVIRONMENTAL CONDITIONS  
None.

REFERENCES (TM)  
TM 9-2320-283-10.

GENERAL SAFETY INSTRUCTIONS  
Engine off.  
Transmission in neutral.  
Park brake set.

TROUBLESHOOTING REFERENCES  
Paragraph 2-11.

ACCESSORY ITEMS.

3-302. AIR DIFFUSER ASSEMBLY REPLACEMENT (Continued).

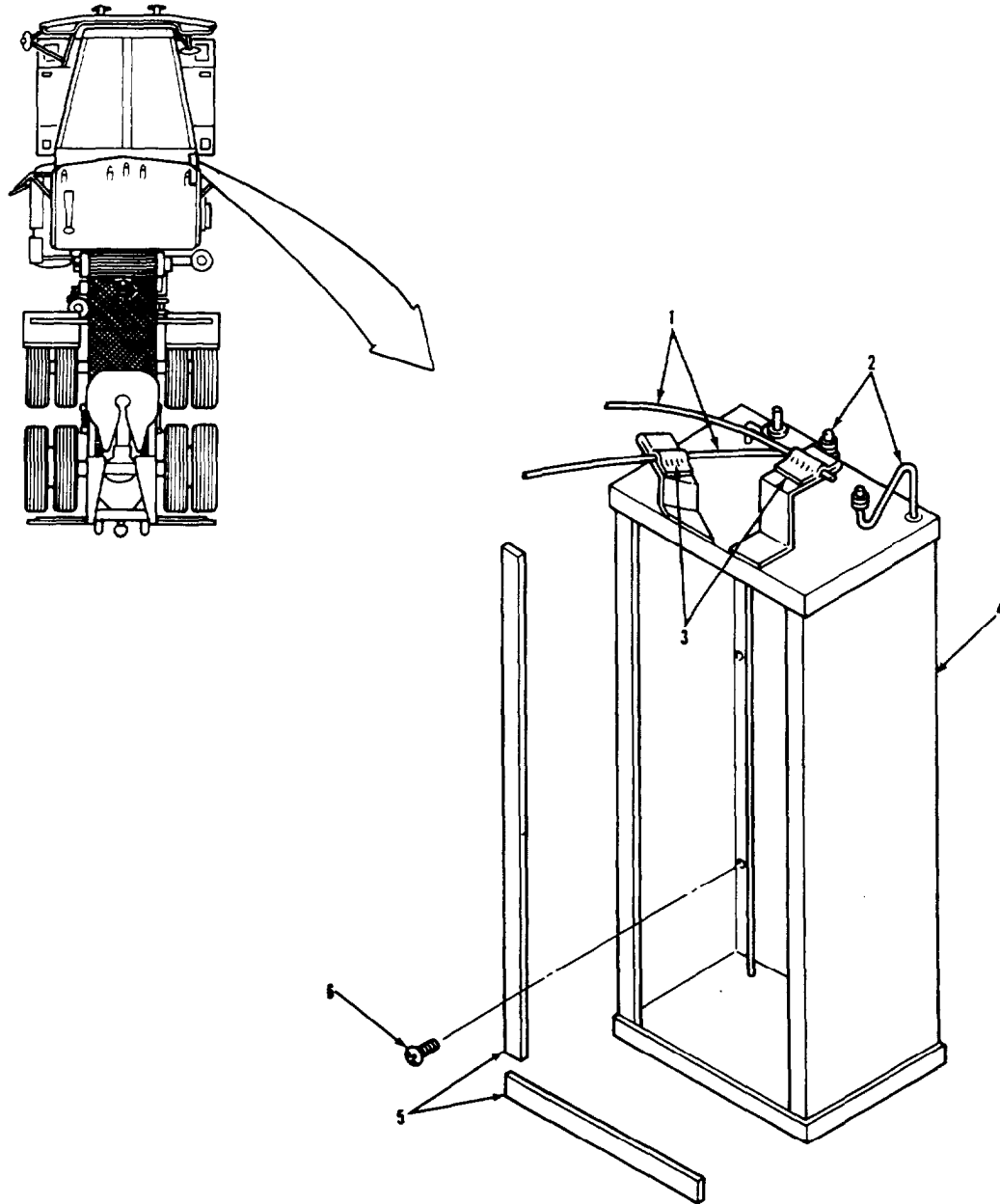

LEGEND:

- 1. BODEN WIRE (2)
- 2. SHUTTER (2)
- 3. BODEN CLIP (2)

- 4. AIR DIFFUSER ASSEMBLY
- 5. RUBBER STRIP
- 6. ROUND HEAD SCREW (4)

TA 237835

ACCESSORY ITEMS.

3-302. AIR DIFFUSER ASSEMBLY REPLACEMENT (Continued).		
LOCATION/ITEM	ACTION	REMARKS
<b>A. REMOVAL.</b>		
1. Two clips (3).	Remove from item (4) and two items (1).	
2. Two wires (1).	Remove from two items (2).	Tag items (1).
3. Four screws (6).	Remove from item (4).	
4. Diffuser (4).	Remove from cab.	
<b>NOTE</b>		
Only remove rubber strips if they are damaged.		
5. Rubber strips (5).	Scrape from item (4).	
<b>B. CLEANING AND INSPECTION.</b>		
6. All parts.	Clean with solvent and rags.	Refer to paragraph 3-4.
7. All parts.	Inspect.	Refer to paragraph 3-5.
<b>C. INSTALLATION.</b>		
8. Rubber strips (5).	Install on item (4).	Peel off backing and press on.
9. Diffuser (4).	Position in cab.	
10. Four screws (6).	Secure item (4).	
11. Two wires (1).	Put on two items (2).	Have two items (2) in closed position.
12. Two clips (3).	Put on item (4) and two items (1).	

ACCESSORY ITEMS.

3-302. AIR DIFFUSER ASSEMBLY REPLACEMENT (Continued).

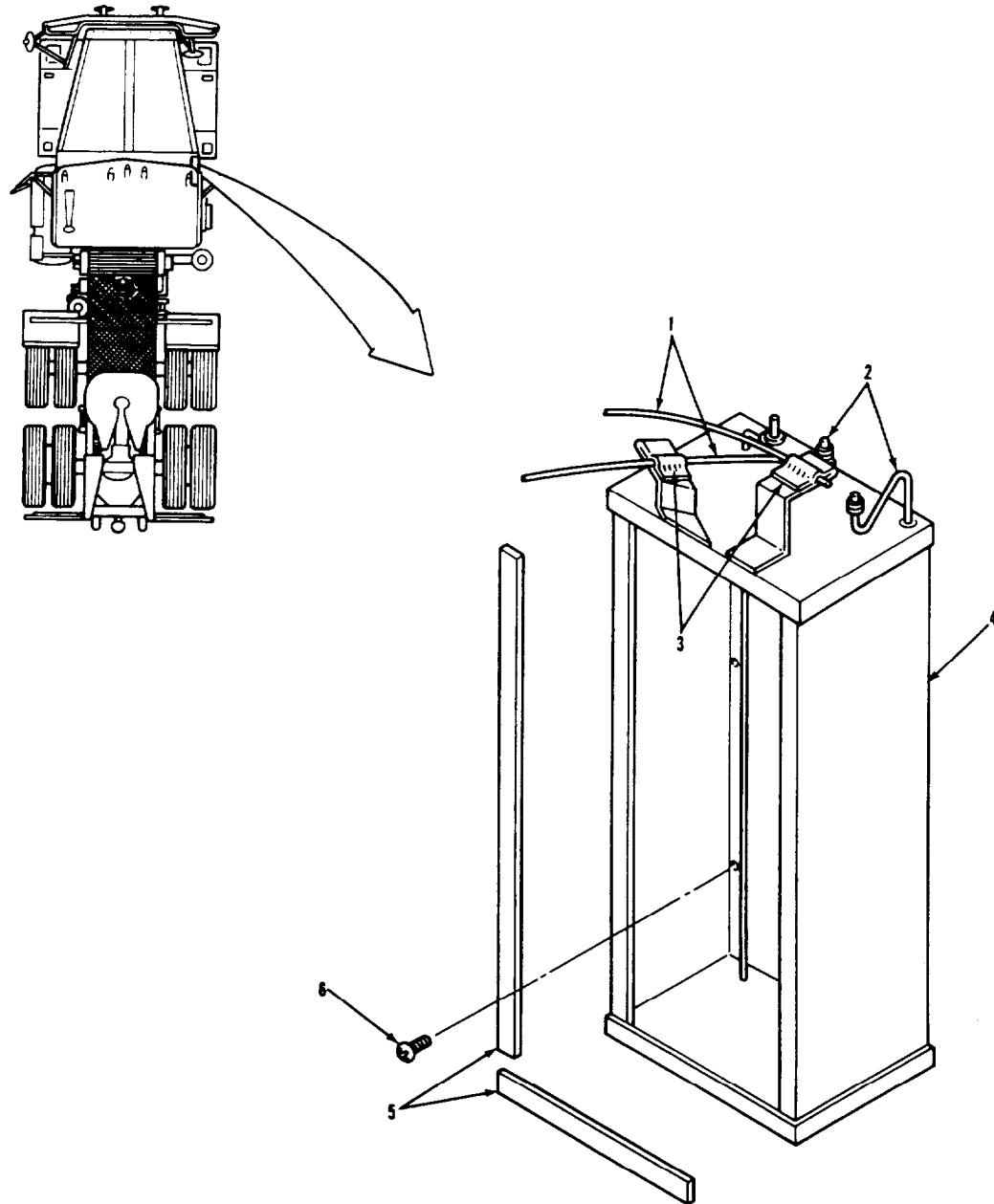

LEGEND:

- 1. BODEN WIRE (2)
- 2. SHUTTER (2)
- 3. BODEN CLIP (2)

- 4. AIR DIFFUSER ASSEMBLY
- 5. RUBBER STRIP
- 6. ROUND HEAD SCREW (4)

TA 237836

ACCESSORY ITEMS.

3-302. AIR DIFFUSER ASSEMBLY REPLACEMENT (Continued).

LOCATION/ITEM	ACTION	REMARKS
<b>D. OPERATIONAL CHECK.</b>		
13. FRESH VENT knob and RECIR VENT knob.	Pull and push.	a. Refer to TM 9-2320- 283-10.  b. Items (2) should open and close freely.
<b>NOTE</b>		
Follow-on maintenance actions required:		
Install heater assembly (para 3-298).		

ACCESSORY ITEMS.

3-302. AIR DIFFUSER ASSEMBLY REPLACEMENT (Continued).

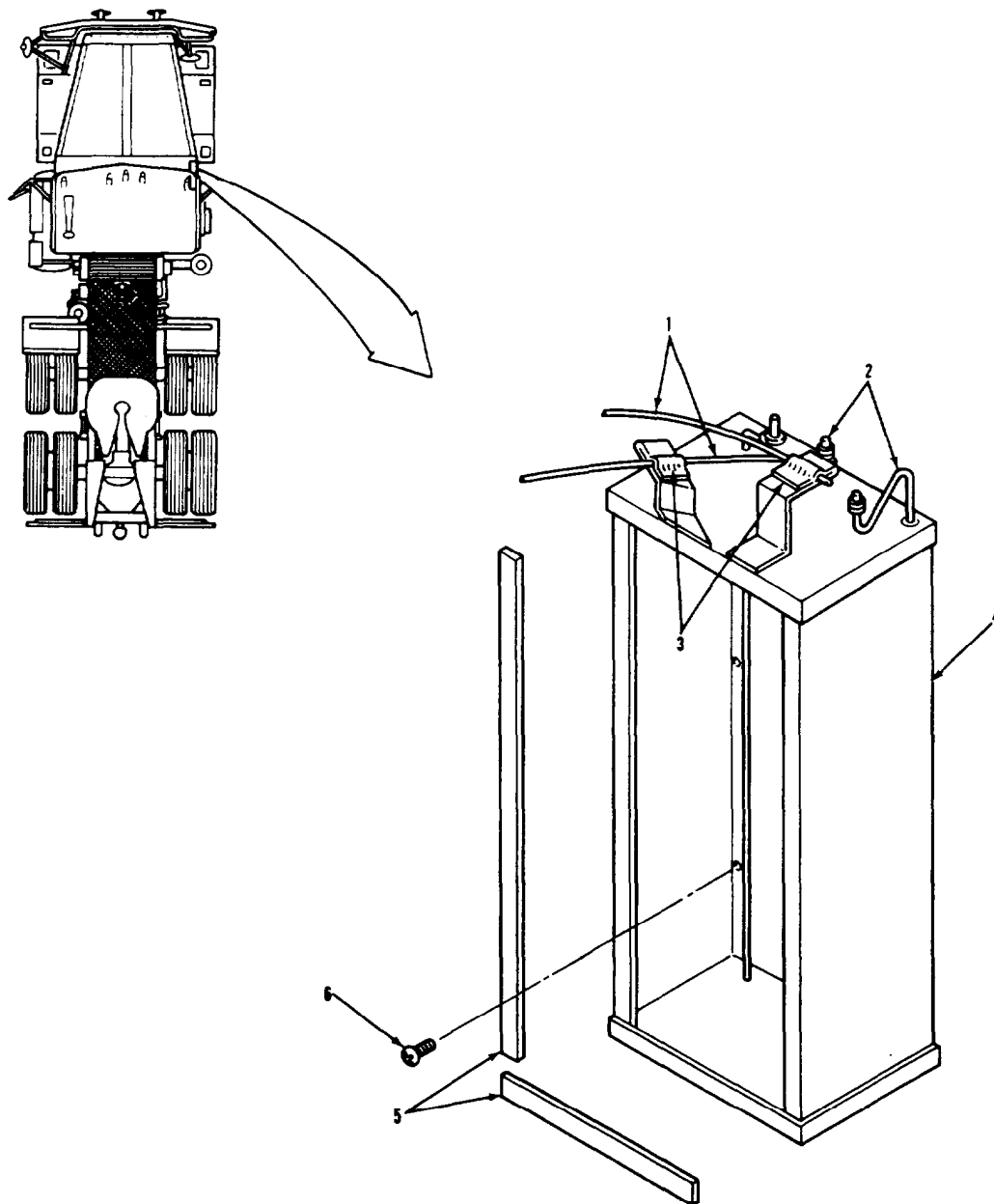

LEGEND:

- |                   |                          |
|-------------------|--------------------------|
| 1. BODEN WIRE (2) | 4. AIR DIFFUSER ASSEMBLY |
| 2. SHUTTER (2)    | 5. RUBBER STRIP          |
| 3. BODEN CLIP (2) | 6. ROUND HEAD SCREW (4)  |

TA 237837

ACCESSORY ITEMS.

3-303. DEFROSTER FAN REPLACEMENT.

THIS TASK COVERS

- a. Removal.
- b. Installation.

INITIAL SETUP

APPLICABLE CONFIGURATIONS  
All.

EQUIPMENT CONDITION  
PARAGRAPH  
None.

CONDITION DESCRIPTION  
None.

TEST EQUIPMENT  
None.

SPECIAL TOOLS  
None.

MATERIALS/PARTS (P/N)  
None.

PERSONNEL REQUIRED  
One (MDS-63S).

SPECIAL ENVIRONMENTAL CONDITIONS  
None.

REFERENCES (TM)  
None.

GENERAL SAFETY INSTRUCTIONS  
Engine off.  
Transmission in neutral.  
Park brake set.

TROUBLESHOOTING REFERENCES  
Paragraph 2-11.

ACCESSORY ITEMS.

3-303. DEFROSTER FAN REPLACEMENT (Continued).

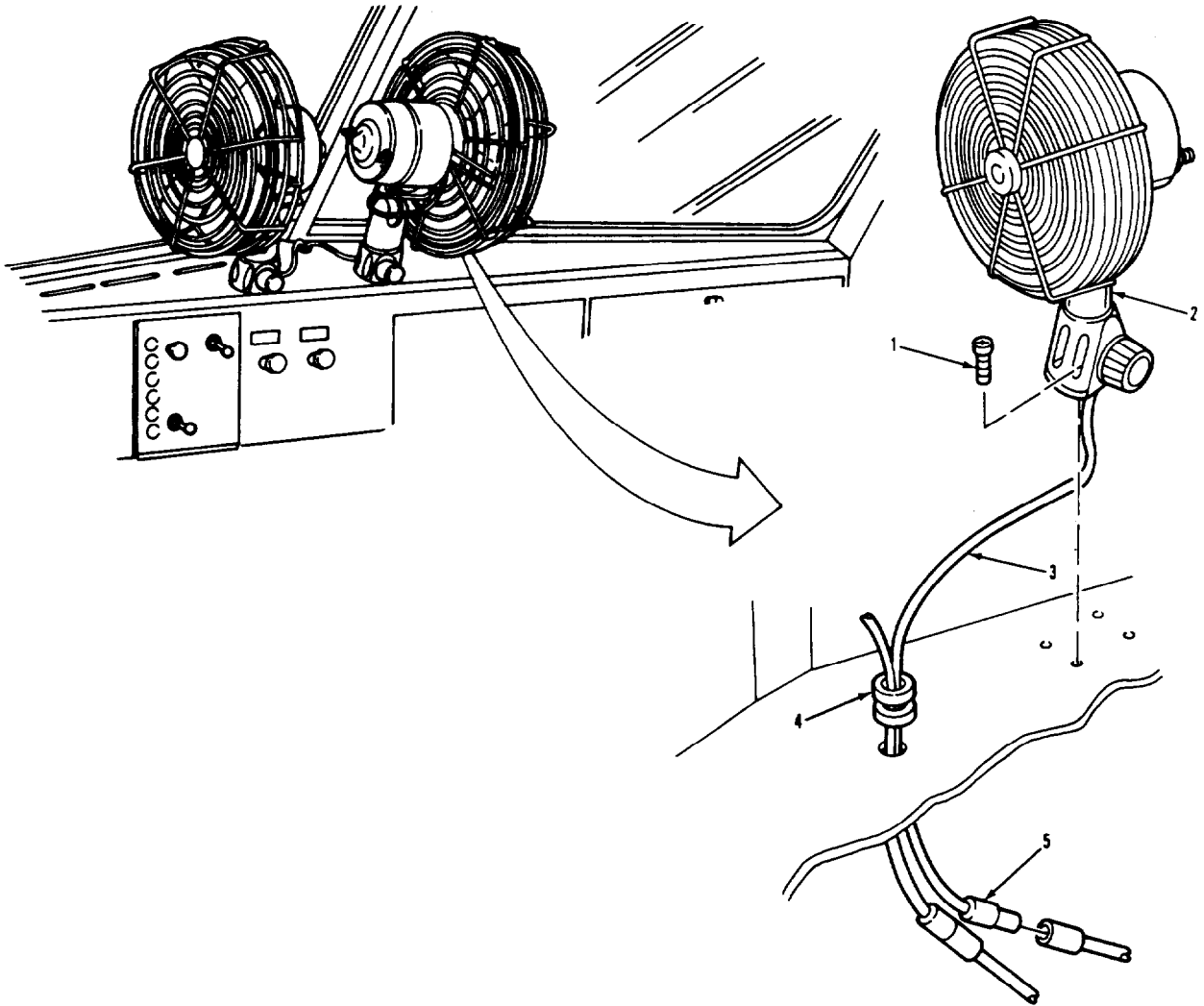

LEGEND:

- 1. SCREW (4)
- 2. DEFROSTER FAN
- 3. WIRE
- 4. NONMETALLIC GROMMET
- 5. ELECTRICAL PLUG (2)

TA 237838



ACCESSORY ITEMS.

3-303. DEFROSTER FAN REPLACEMENT (Continued).		
LOCATION/ITEM	ACTION	REMARKS
<b>NOTE</b>		
Replacement is the same for both fans.		
<b>A. REMOVAL.</b>		
1. Two plugs (5).	Disconnect.	Access from under center of instrument panel.
2. Wire (3).	Pull through item (4).	
3. Four screws (1).	Remove from item (2).	
4. Fan (2).	Remove.	
<b>B. INSTALLATION.</b>		
5. Fan (2).	Put in place.	Do not smash wire (3).
6. Four screws (1).	Secure item (2).	
7. Wire (3).	Put through item (4).	
8. Two plugs (5).	Connect.	
<b>NOTE</b>		
Follow-on maintenance action required:		
None.		

ACCESSORY ITEMS.

3-303. DEFROSTER FAN REPLACEMENT (Continued).

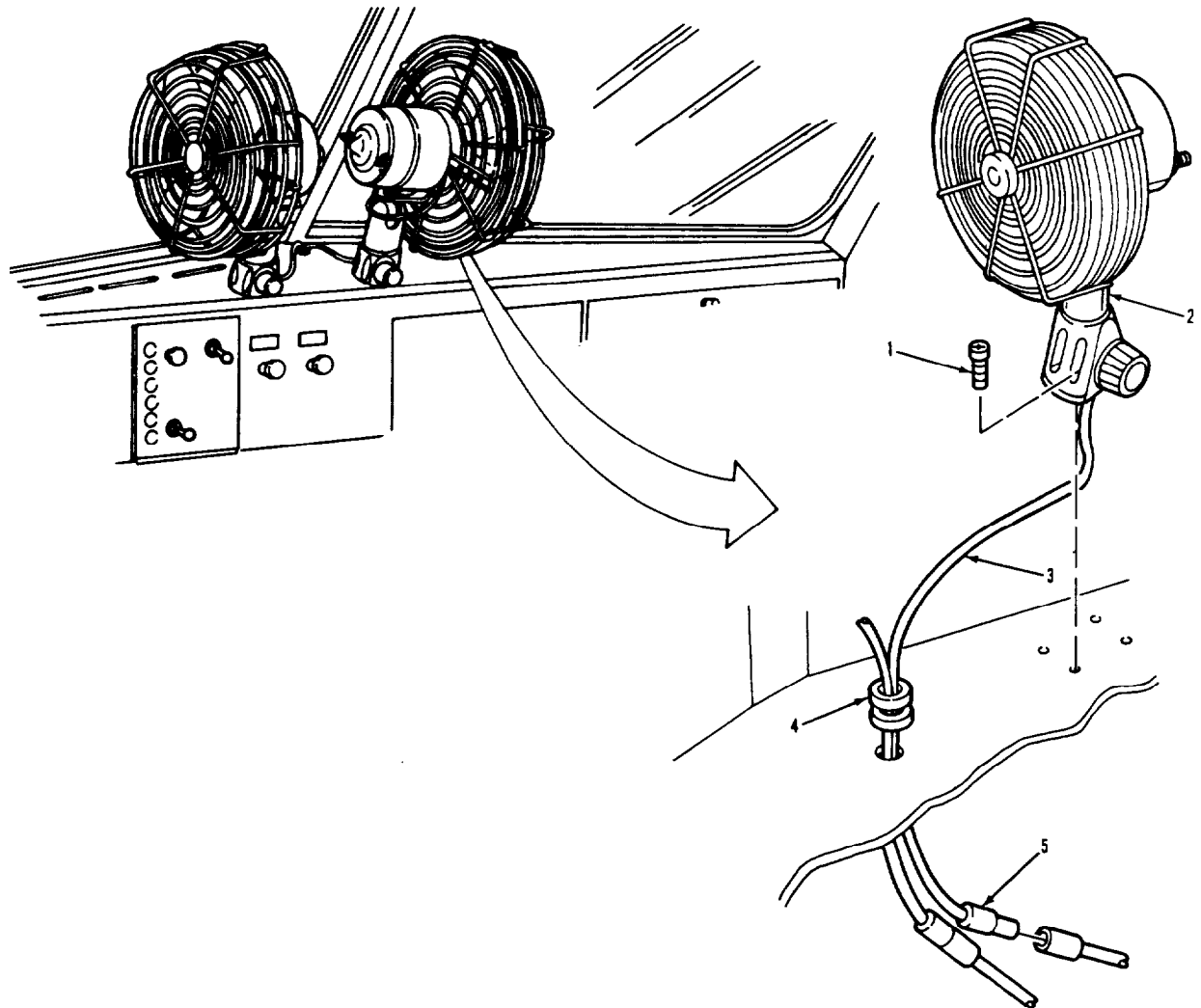

LEGEND:

- 1. SCREW (4)
- 2. DEFROSTER FAN
- 3. WIRE
- 4. NONMETALLIC GROMMET
- 5. ELECTRICAL PLUG (2)

TA 237839

ACCESSORY ITEMS.

3- 304. DEFROSTER FAN REPAIR.

THIS TASK COVERS

- a. Disassembly.
- b. Cleaning and Inspection.
- c. Assembly.

INITIAL SETUP

APPLICABLE CONFIGURATIONS

All.

EQUIPMENT CONDITION  
PARAGRAPH

3- 303.

CONDITION DESCRIPTION

Defroster fan removed.

TEST EQUIPMENT

None.

SPECIAL TOOLS

None.

MATERIALS/PARTS (P/N)

None.

PERSONNEL REQUIRED

One (MOS- 63S).

SPECIAL ENVIRONMENTAL CONDITIONS

None.

REFERENCES (TM)

None.

GENERAL SAFETY INSTRUCTIONS

None.

TROUBLESHOOTING REFERENCES

Paragraph 2- 11.

ACCESSORY ITEMS.

3-304. DEFROSTER FAN REPAIR (Continued).

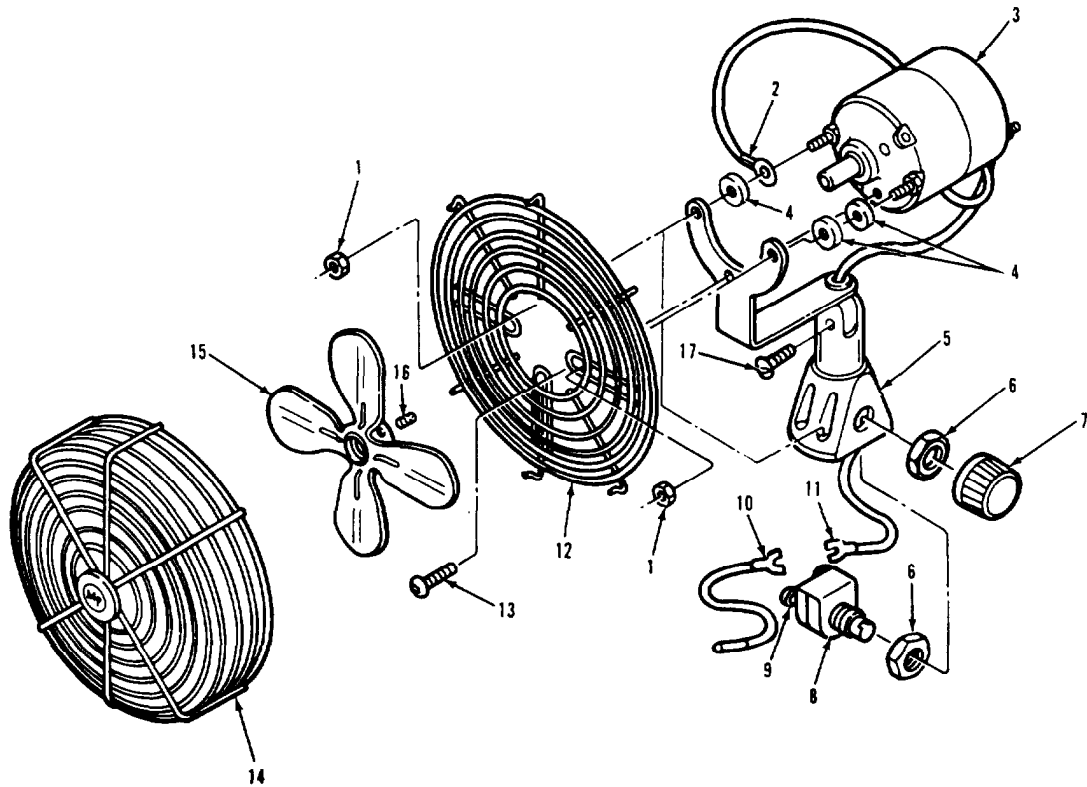

LEGEND:

- |                    |                        |
|--------------------|------------------------|
| 1. HEX NUT (2)     | 10. WIRE               |
| 2. WIRE            | 11. WIRE               |
| 3. FAN MOTOR       | 12. REAR GRILLE GUARD  |
| 4. FLAT WASHER (3) | 13. SCREW              |
| 5. BASE ASSEMBLY   | 14. FRONT GRILLE GUARD |
| 6. HEX NUT (2)     | 15. FAN                |
| 7. KNOB            | 16. SETSCREW           |
| 8. SWITCH          | 17. THUMBSCREW         |
| 9. SCREW (2)       |                        |

TA 237840

ACCESSORY ITEMS.

3-304. DEFROSTER FAN REPAIR (Continued).		
LOCATION/ITEM	ACTION	REMARKS
<b>A. DISASSEMBLY.</b>		
1. Guard (14).	Pry from item (12).	
2. Setscrew (16).	Remove from item (15).	
3. Fan (15).	Remove from item (3).	
4. Knob (7).	Pull from item (8).	
5. Nut (6).	Remove from item (8).	
6. Switch (8).	Remove from item (5).	
7. Two screws (9).	Loosen.	
8. Wire (10) and wire (11).	Remove from item (8).	
9. Nut (6).	Remove from item (8).	
10. Screw (13) and two nuts (1).	Remove from item (12).	
11. Guard (12).	Remove from item (5).	
12. Motor (3), three washers (4), and wire (2).	Remove from item (5).	
13. Screw (17).	Remove from item (5).	
<b>B. CLEANING AND INSPECTION</b>		
14. All parts.	Clean and inspect.	Refer to paragraphs 3-4 3-5.

ACCESSORY ITEMS.

3-304. DEFROSTER FAN REPAIR (Continued).

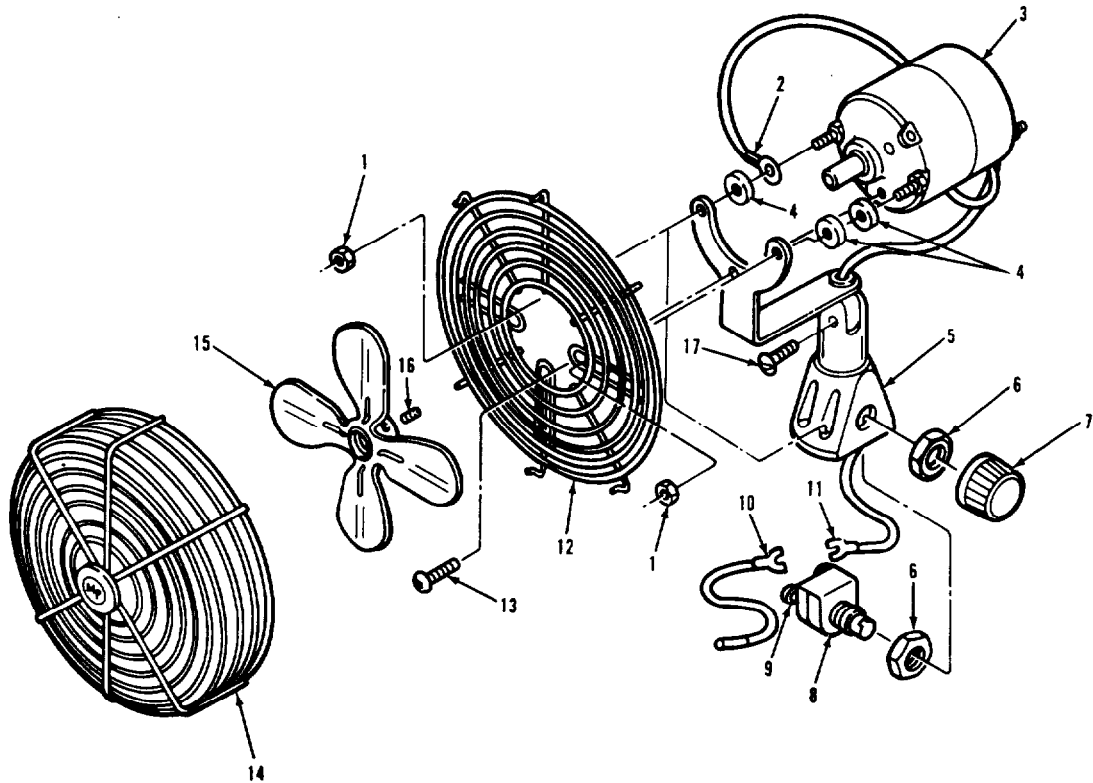

LEGEND:

- |                    |                        |
|--------------------|------------------------|
| 1. HEX NUT (2)     | 10. WIRE               |
| 2. WIRE            | 11. WIRE               |
| 3. FAN MOTOR       | 12. REAR GRILLE GUARD  |
| 4. FLAT WASHER (3) | 13. SCREW              |
| 5. BASE ASSEMBLY   | 14. FRONT GRILLE GUARD |
| 6. HEX NUT (2)     | 15. FAN                |
| 7. KNOB            | 16. SETSCREW           |
| 8. SWITCH          | 17. THUMBSCREW         |
| 9. SCREW (2)       |                        |

TA 237841

ACCESSORY ITEMS.

3-304. DEFROSTER FAN REPAIR (Continued).		
LOCATION/ITEM	ACTION	REMARKS
<b>C. ASSEMBLY.</b>		
15. Motor (3), three washers (4), and wire (2).	Install on item (5).	Feed item (11) through item (5).
16. Guard (12).	Install on item (5) and item (3).	
17. Screw (13) and two nuts (1).	Secure item (12) and item (3) to item (5).	
18. Wire (10) and wire (11).	Install on item (8).	
19. Two screws (9).	Tighten.	
20. Nut (6).	Install on item (8).	
21. Switch (8).	Install in item (5).	
22. Nut (6).	Secure item (8) to item (5).	
23. Knob (7).	Install on item (8).	
24. Fan (15).	Install on item (3).	
25. Setscrew (16).	Secure item (15) to item (3).	
26. Guard (14).	Install on item (12).	
27. Screw (17).	Install in item (5).	
<b>NOTE</b>		
Follow-on maintenance action required:		
Install defroster fan (para 3-303).		

ACCESSORY ITEMS.

3-304. DEFROSTER FAN REPAIR (Continued).

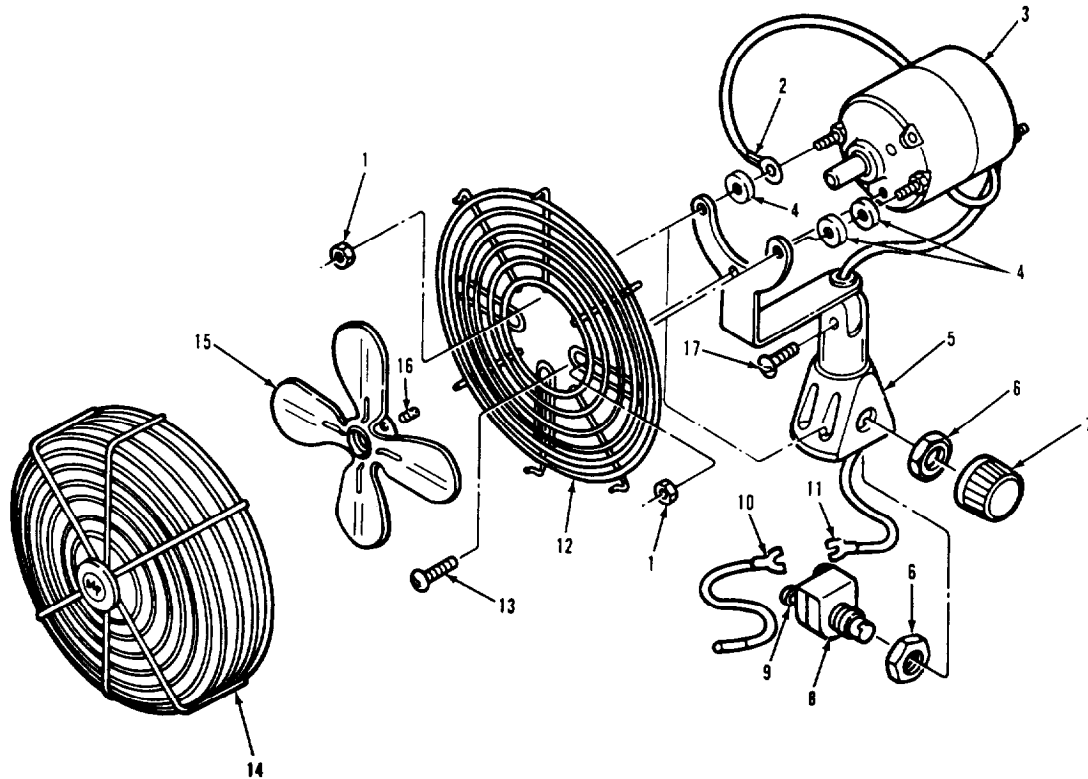

LEGEND:

- |                    |                        |
|--------------------|------------------------|
| 1. HEX NUT (2)     | 10. WIRE               |
| 2. WIRE            | 11. WIRE               |
| 3. FAN MOTOR       | 12. REAR GRILLE GUARD  |
| 4. FLAT WASHER (3) | 13. SCREW              |
| 5. BASE ASSEMBLY   | 14. FRONT GRILLE GUARD |
| 6. HEX NUT (2)     | 15. FAN                |
| 7. KNOB            | 16. SETSCREW           |
| 8. SWITCH          | 17. THUMBSCREW         |
| 9. SCREW (2)       |                        |

TA 237842



ACCESSORY ITEMS.

3-305. DATA AND INSTRUCTION PLATES.

THIS TASK COVERS

Cleaning and Replacement.

INITIAL SETUP

APPLICABLE CONFIGURATIONS

All.

EQUIPMENT CONDITION  
PARAGRAPH

None.

CONDITION DESCRIPTION

None.

TEST EQUIPMENT

None.

SPECIAL TOOLS

None.

MATERIALS/PARTS (P/N)

Rag, wiping  
Item 22, Appendix C.  
Solution, soap  
Item 28, Appendix C.  
Solvent, drycleaning, SD-2  
Item 29, Appendix C.

PERSONNEL REQUIRED

One (MOS-63S).

SPECIAL ENVIRONMENTAL CONDITIONS

None.

REFERENCES (TM)

TM 9-2320-283-10.

GENERAL SAFETY INSTRUCTIONS

Engine off.  
Transmission in neutral.  
Park brake set.

TROUBLESHOOTING REFERENCES

None.

## ACCESSORY ITEMS.

## 3-305. DATA AND INSTRUCTION PLATES (Continued).

**CLEANING AND REPLACEMENT.****NOTE**

- All data and instruction plates are identified in TM 9-2320-283-10.
- Maintenance is limited to cleaning and replacement.
- To clean, use a rag and soap solution.
- To replace:
  1. Scrape off plate with a putty knife.
  2. Clean area with solvent and rag.
  3. Peel off backing and press new plate in place.

ACCESSORY ITEMS.

3- 306. WINTERIZATION KIT.

THIS TASK COVERS

See note on next page.

INITIAL SETUP

<u>APPLICABLE CONFIGURATIONS</u>	<u>EQUIPMENT CONDITION PARAGRAPH</u>	<u>CONDITION DESCRIPTION</u>
All.	None.	None.

TEST EQUIPMENT  
None.

SPECIAL TOOLS  
None.

MATERIALS/PARTS (P/N)  
None.

PERSONNEL REQUIRED  
None.

SPECIAL ENVIRONMENTAL CONDITIONS  
None.

REFERENCES (TM)  
None.

GENERAL SAFETY INSTRUCTIONS  
None.

TROUBLESHOOTING REFERENCES  
None.

ACCESSORY ITEMS.

3-306. WINTERIZATION KIT (Continued).

**NOTE**

- Refer to TB 9-2320-283-14 for information pertaining to components of the M915A1 winterization kit.

- Follow-on maintenance action required:  
None.

Section XVIII. GAGES (NONELECTRICAL)

**3-307. GENERAL.**

This section provides procedures authorized at the organizational maintenance level to replace nonelectrical gages. To find a specific procedure contained in this section, see the task summary below.

**3-308. TASK SUMMARY.**

INITIAL SETUP

APPLICABLE CONFIGURATIONS

All.

EQUIPMENT CONDITION

PARAGRAPH

CONDITION DESCRIPTION

(Refer to specific paragraph for this information).

TEST EQUIPMENT

None.

SPECIAL TOOLS

None.

MATERIALS/PARTS (P/N)

Tape, thread sealing  
 Item 32, Appendix C.  
 Chart, 7 Day, Package of 10  
 (59197) C1-0-9806.  
 Cable tie  
 (96906) MS 3367-7-9.

PERSONNEL REQUIRED

One (MOS-63S).

SPECIAL ENVIRONMENTAL CONDITIONS

None.

REFERENCES (TM)

TM 9-2320-283-10.

GENERAL SAFETY INSTRUCTIONS

Engine off.  
 Transmission in neutral.  
 Park brake set.

TROUBLESHOOTING REFERENCES

Paragraph 2-11.

## GAGES (NONELECTRICAL).

3-308. TASK SUMMARY (Continued).			
LIST OF TASKS			
TASK NO.	TASK	TASK REF	TROUBLESHOOTING REF NO. (PARA)
1	Tachograph Replacement	3-309	2-11
	a. Removal.	3-309a	
	b. Cleaning and Inspection.	3-309b	
	c. Installation.	3-309c	
	d. Reading Tachograph Disk.	3-309d	
	e. Chart Removal.	3-309e	
	f. Chart Installation.	3-309f	
2	Speedometer Shaft Replacement	3-310	
	a. Removal.	3-310a	
	b. Cleaning and Inspection.	3-310b	
	c. Installation.	3-310c	
3	Speedometer Drive Sleeve Adapter Replacement	3-311	
	a. Removal.	3-311a	
	b. Installation.	3-311b	
4	Speedometer Driven Gear Replacement	3-312	2-11
	a. Removal.	3-312a	
	b. Installation.	3-312b	
5	Tachometer Shaft Replacement	3-313	2-11
	a. Removal.	3-313a	
	b. Cleaning and Inspection.	3-313b	
	c. Installation.	3-313c	
	d. Operational Check.	3-313d	
6	Pressure Gage Replacement	3-314	2-11
	a. Removal.	3-314a	
	b. Cleaning and Inspection.	3-314b	
	c. Installation.	3-314c	
7	Air Cleaner Restriction Gage and Bracket Replacement	3-315	2-11
	a. Removal.	3-315a	
	b. Cleaning and Inspection.	3-315b	
	c. Installation.	3-315c	
8	Air Cleaner Restriction Gage Tube Replacement	3-316	
	a. Removal.	3-316a	
	b. Cleaning and Inspection.	3-316b	
	c. Installation.	3-316c	

GAGES (NONELECTRICAL).

3-309. TACHOGRAPH REPLACEMENT.

THIS TASK COVERS

- |                             |                              |
|-----------------------------|------------------------------|
| a. Removal.                 | d. Reading Tachograph Chart. |
| b. Cleaning and Inspection. | e. Chart Removal.            |
| c. Installation.            | f. Chart Installation.       |

INITIAL SETUP

<u>APPLICABLE CONFIGURATIONS</u>	<u>EQUIPMENT CONDITION PARAGRAPH</u>	<u>CONDITION DESCRIPTION</u>
All.	3-310.	Speedometer shaft assembly removed from tachograph.
<u>TEST EQUIPMENT</u> None.	3-313.	Tachometer shaft removed from tachograph.
<u>SPECIAL TOOLS</u> None.		
<u>MATERIALS/PARTS (P/N)</u> Chart, 7-day, package of 10 (59197) C1-0-9806.		
<u>PERSONNEL REQUIRED</u> One (MOS-63S).	<u>SPECIAL ENVIRONMENTAL CONDITIONS</u> None.	
<u>REFERENCES (TM)</u> TM 9-2320-283-10.	<u>GENERAL SAFETY INSTRUCTIONS</u> Engine off. Transmission in neutral. Park brake set.	
<u>TROUBLESHOOTING REFERENCES</u> Paragraph 2-11.		

GAGES (NONELECTRICAL).

3-309. TACHOGRAPH REPLACEMENT (Continued).

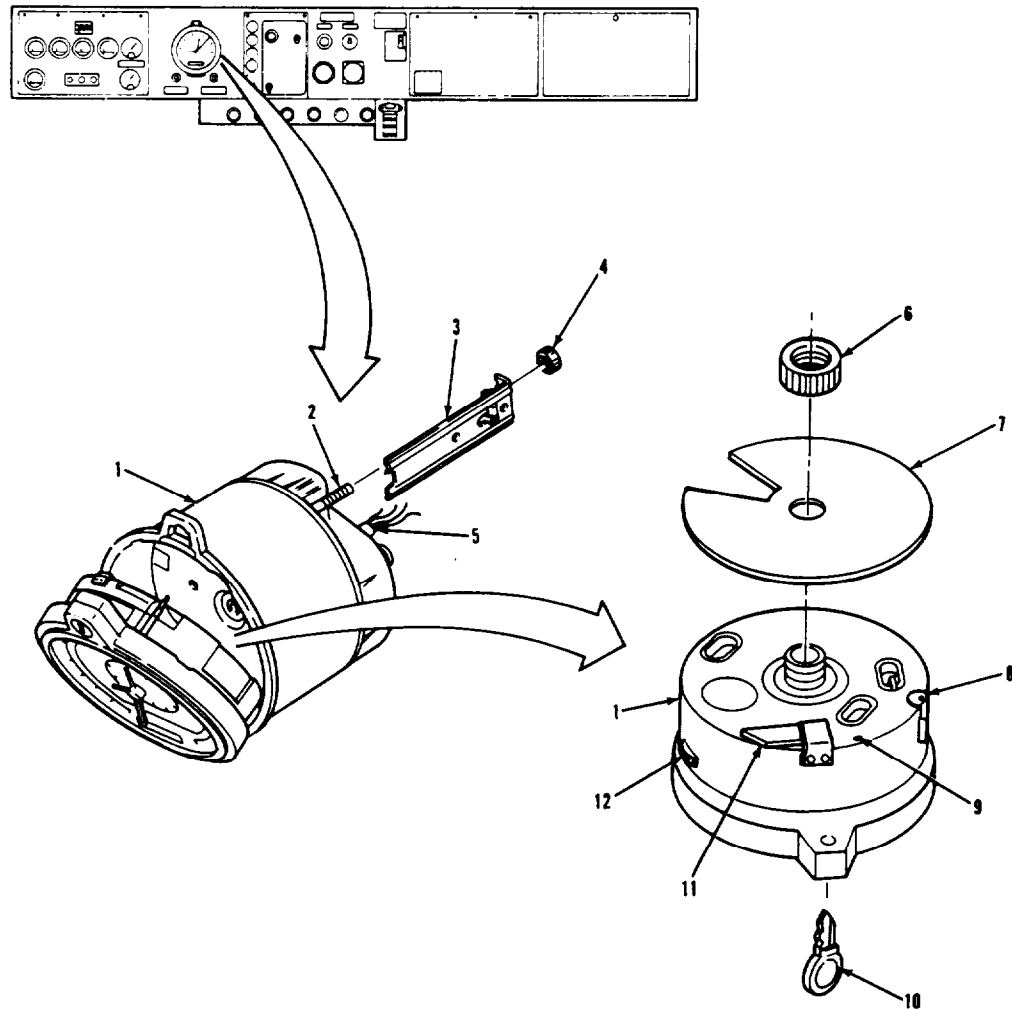

LEGEND:

- |                    |                           |
|--------------------|---------------------------|
| 1. TACHOGRAPH      | 7. 7 DAY CHART            |
| 2. STUD (2)        | 8. RPM INDICATOR TRANSFER |
| 3. BRACKET (2)     | 9. RED DOT                |
| 4. KNURLED NUT (2) | 10. KEY                   |
| 5. WIRE CONNECTOR  | 11. SEPARATING KNIFE      |
| 6. FASTENING RING  | 12. SETTING WHEEL         |

TA 237843



GAGES (NONELECTRICAL).

3- 309. TACHOGRAPH REPLACEMENT (Continued).

LOCATION/ITEM	ACTION	REMARKS
<b>NOTE</b>		
<ul style="list-style-type: none"> <li>•The access panel may be lowered for visibility. Removal is done by reaching from under dash.</li> <li>•Move the trailer hand brake downward.</li> </ul>		
<b>A. REMOVAL.</b>		
1. Wire connector (5).	Remove from item (1).	
2. Two nuts (4).	Remove from two items (3).	
3. Two brackets (3).	Remove from two items (2).	
4. Tachograph (1).	Remove from dash.	
<b>B. CLEANING AND INSPECTION.</b>		
<b><u>CAUTION</u></b>		
<p>Do not submerge tachograph in cleaning solution. To do so will cause permanent damage. Clean external surfaces only.</p>		
5. All parts.	Clean and inspect.	Refer to paragraphs 3-4 and 3-5.

GAGES (NONELECTRICAL).

3-309. TACHOGRAPH REPLACEMENT (Continued).

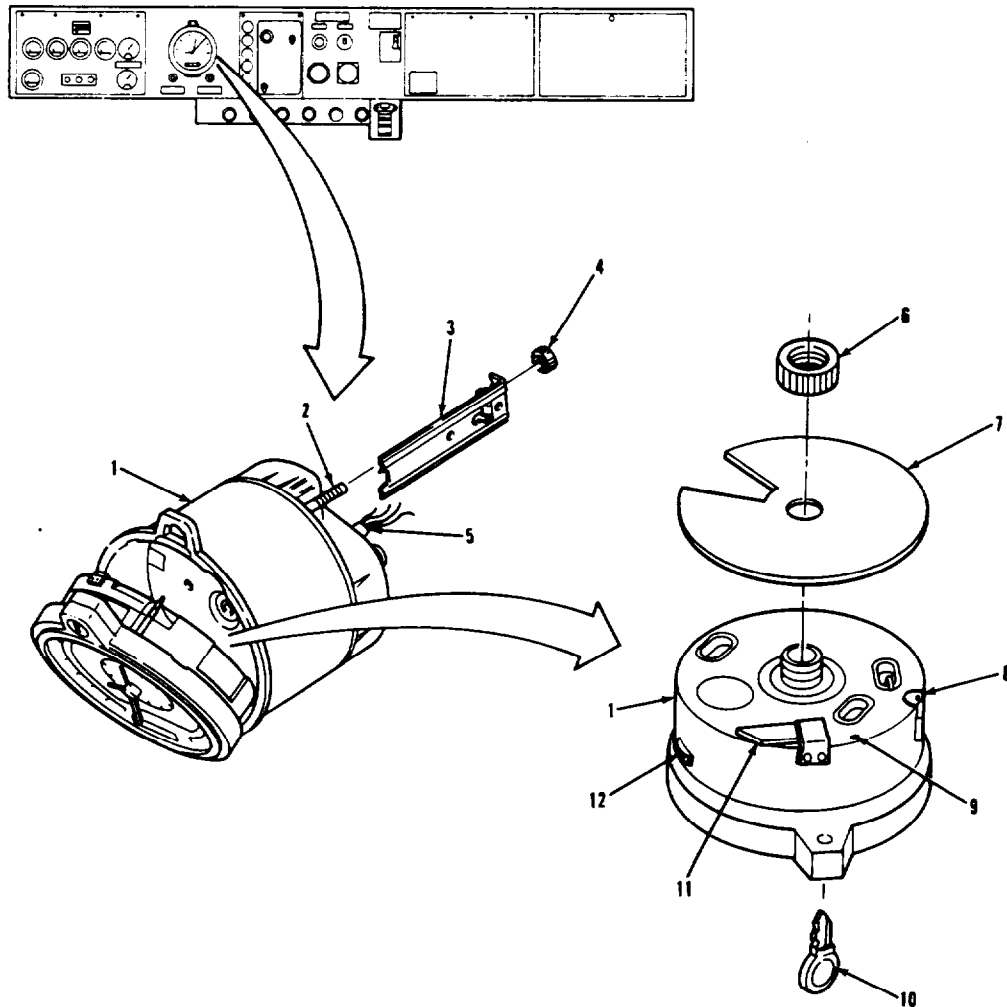

LEGEND:

- |                    |                           |
|--------------------|---------------------------|
| 1. TACHOGRAPH      | 7. 7 DAY CHART            |
| 2. STUD (2)        | 8. RPM INDICATOR TRANSFER |
| 3. BRACKET (2)     | 9. RED DOT                |
| 4. KNURLED NUT (2) | 10. KEY                   |
| 5. WIRE CONNECTOR  | 11. SEPARATING KNIFE      |
| 6. FASTENING RING  | 12. SETTING WHEEL         |

TA 237844

GAGES (NONELECTRICAL).

3-309. TACHOGRAPH REPLACEMENT (Continued).

LOCATION/ITEM	ACTION	REMARKS
<b>C. INSTALLATION.</b>		
6. Tachograph (1).	Position in dash.	
7. Wire connector (5).	Install in item (1).	
8. Two brackets (3).	Install on two items (2).	
9. Two nuts (4).	Install and tighten onto two items (3).	
10. Speedometer shaft assembly.	Install.	Refer to paragraph 3-310.
11. Tachometer shaft assembly.	Install.	Refer to paragraph 3-313.

GAGES (NONELECTRICAL).

3-309. TACHOGRAPH REPLACEMENT (Continued).

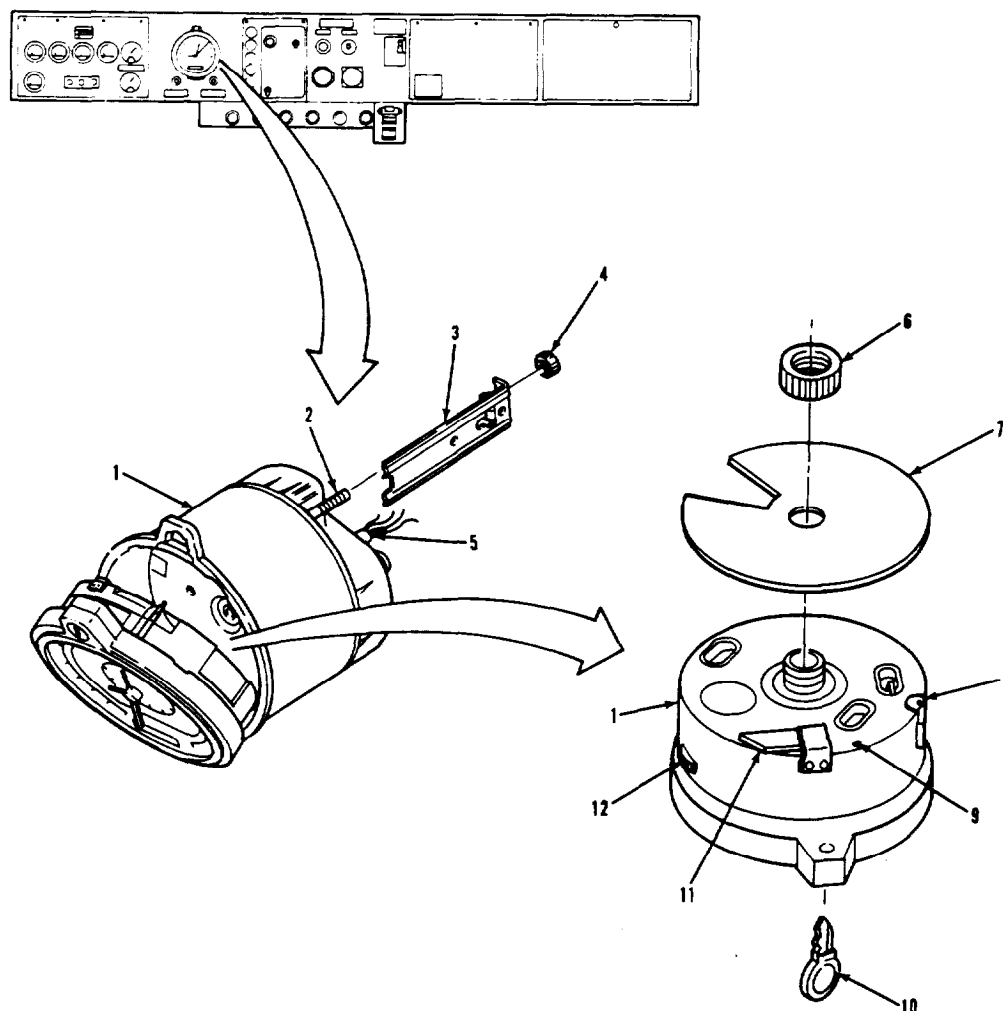

LEGEND:

- |                    |                           |
|--------------------|---------------------------|
| 1. TACHOGRAPH      | 7. 7 DAY CHART            |
| 2. STUD (2)        | 8. RPM INDICATOR TRANSFER |
| 3. BRACKET (2)     | 9. RED DOT                |
| 4. KNURLED NUT (2) | 10. KEY                   |
| 5. WIRE CONNECTOR  | 11. SEPARATING KNIFE      |
| 6. FASTENING RING  | 12. SETTING WHEEL         |

TA 237845

GAGES (NONELECTRICAL).

3-309. TACHOGRAPH REPLACEMENT (Continued).		
LOCATION/ITEM	ACTION	REMARKS
<b>D. READING TACHOGRAPH CHART.</b>		
TIME		The outer ring of the chart has markings for 24 hours. Any events shown on the chart by the markings happened at the time shown on the outer ring of the chart. Also, each time the tachograph is opened, a small tic mark is put onto the chart by each stylus. (There is a stylus for vehicle speed, engine speed, and distance).
SPEED		Next to the outer marks for time there is a band about 3/4" wide. The stylus moving in this area records vehicle speed at any moment. You can see at a glance if an operator has been speeding.
RPM		After the speed band, there is a narrower band about 1/2" wide. Another stylus moves in this area, recording engine RPM. You can see if the engine RPM have been too high. You can also determine whether the driver warmed up the engine before moving out. To see this, compare RPM reading with vehicle speed. The chart should record the RPM for the proper number of minutes before vehicle speed is recorded.
DISTANCE		A third stylus moves in the narrowest band, closest to the chart center. This stylus moves away from the center for 5 miles and then toward the center for 5 miles.
<p>In the chart shown, the vehicle did not move from midnight to about 5:37 AM. Then the engine was started, run momentarily at about 1800 RPM, then idled at 600 RPM for six or seven minutes, accelerated 2100 RPM momentarily, then shut-down at about 5:46. At 7:10 AM the engine was started again, idled for 22 minutes. At 7:32 it was moved out, attaining a speed of about 28 mph, then stopped and idled for eight minutes. Then it moved out, accelerated to about 45 mph and did stop-and-go driving about 32 minutes, accelerating from 0 to about 45 mph three times and traveling about 15 miles. At 8:11 it stopped, having traveled about 15 miles, it idled for about 48 minutes and then was shutdown at about 9 AM.</p>		

GAGES (NONELECTRICAL).

3-309. TACHOGRAPH REPLACEMENT (Continued).

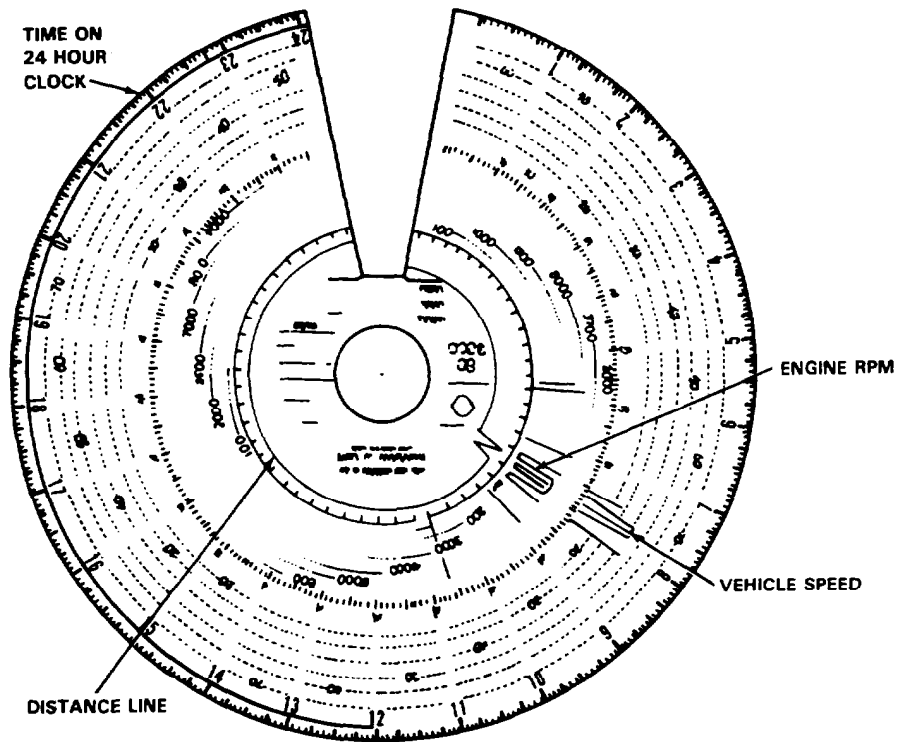

TA 237846

GAGES (NONELECTRICAL).

3-309. TACHOGRAPH REPLACEMENT (Continued).		
LOCATION/ITEM	ACTION	REMARKS
<b>E. CHART REMOVAL.</b>		
<b><u>CAUTION</u></b>		
The disk pack must be changed before the end of the seventh day to prevent stylus damage.		
15. Key (10).	Unlock item (1) by turning item (10) counterclockwise.	Use item (10) as a handle.
16. Fastening ring (6).	a. Turn counterclockwise and remove. b. Lift out used item (7).	
<b>G. CHART INSTALLATION.</b>		
17. New 7 day chart (7).	a. Enter date, driver's name, vehicle number, and mileage. b. Ensure pack is under item (11) and under item (8). c. Aline item at installation with item (9) on item (7). d. With item (7) in position on center hub, position item (6) in place and turn clockwise. e. Close face of item (1) and lock with item (10).	Enter in center field on new item (7).  If chart is not properly installed, instruments and dials may not function.
<b>NOTE</b>		
Follow-on maintenance action required: Start engine and verify that tachograph is fully operational before operating vehicle (Refer to TM 9-2320-283-10).		

GAGES (NONELECTRICAL).

3-309. TACHOGRAPH REPLACEMENT (Continued).

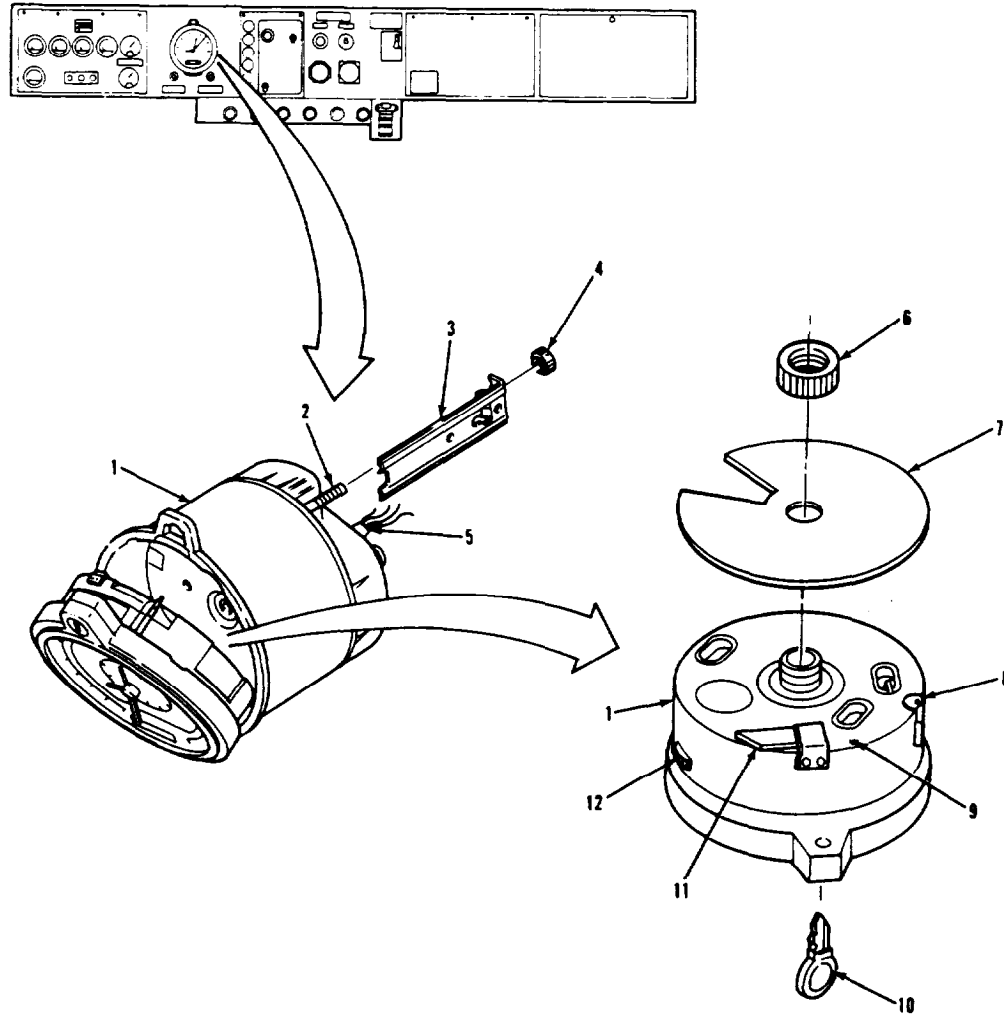

LEGEND:

- |                    |                           |
|--------------------|---------------------------|
| 1. TACHOGRAPH      | 7. 7 DAY CHART            |
| 2. STUD (2)        | 8. RPM INDICATOR TRANSFER |
| 3. BRACKET (2)     | 9. RED DOT                |
| 4. KNURLED NUT (2) | 10. KEY                   |
| 5. WIRE CONNECTOR  | 11. SEPARATING KNIFE      |
| 6. FASTENING RING  | 12. SETTING WHEEL         |

TA 237847



GAGES (NONELECTRICAL).

3-310. SPEEDOMETER SHAFT REPLACEMENT.

THIS TASK COVERS

- a. Removal.
- b. Cleaning and Inspection.
- c. Installation.

INITIAL SETUP

APPLICABLE CONFIGURATIONS

All.

EQUIPMENT CONDITION

PARAGRAPH

None.

CONDITION DESCRIPTION

None.

TEST EQUIPMENT

None.

SPECIAL TOOLS

None.

MATERIALS/PARTS (P/N)

Cable tie  
(96906) MS 3367-7-9.

PERSONNEL REQUIRED

One (MDS-63S).

SPECIAL ENVIRONMENTAL CONDITIONS

None.

REFERENCES (TM)

None.

GENERAL SAFETY INSTRUCTIONS

Engine off.  
Transmission in neutral.  
Park brake set.

TROUBLESHOOTING REFERENCES

None.

GAGES (NONELECTRICAL).

3-310. SPEEDOMETER SHAFT REPLACEMENT (Continued).

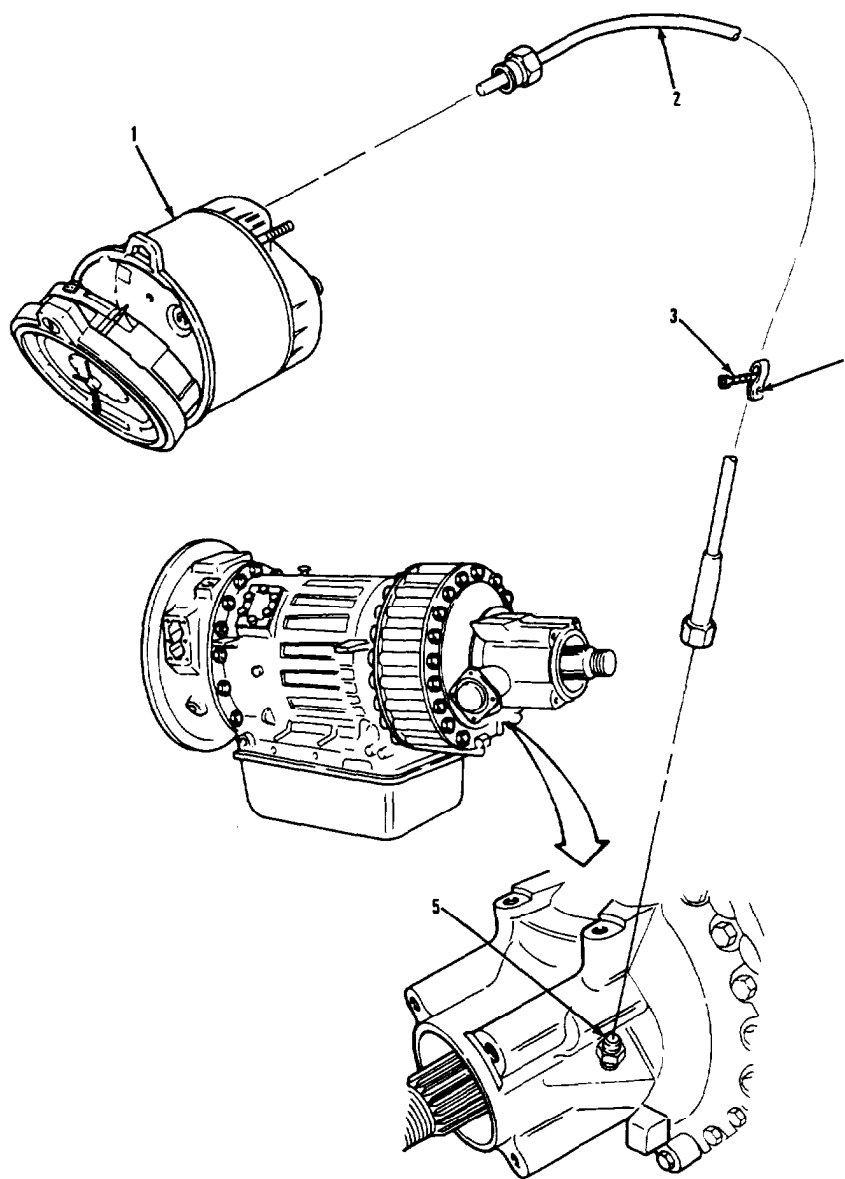

LEGEND:

1. TACHOGRAPH ASSEMBLY
2. SPEEDOMETER SHAFT ASSEMBLY
3. CABLE TIE
4. CLOSED CLAMP
5. SPEEDOMETER DRIVE ADAPTER SLEEVE

TA 237848

GAGES (NONELECTRICAL).

3-310. SPEEDOMETER SHAFT REPLACEMENT (Continued).

LOCATION/ITEM	ACTION	REMARKS
<b>A. REMOVAL.</b>		
1. Speedometer shaft (2).	a. Remove from the back of of item (1).	Remove item (2) by reaching from under dash. Item (2) is on the left-hand side of item (1) and has a hexagon nut.
	b. Push through firewall.	
2. Cable tie (3).	Remove by cutting from item (4).	Discard item (3).
3. Speedometer shaft (2).	a. Remove from item (5). b. Remove from under vehicle.	
<b>B. CLEANING AND INSPECTION.</b>		
4. All metal parts.	Clean and inspect.	Refer to paragraphs 3-4 and 3-5.
<b>C. INSTALLATION.</b>		
5. Speedometer shaft (2).	a. Push small nut end of item (2) through hole in fire-wall and into cab. b. Install onto back of item (1). c. Install other end onto item (5).	
6. New cable tie (3).	Insert one end of item (3) through item (4) and around item (2). Secure item (3).	
<b>NOTE</b>		
Follow-on maintenance action required:		
None.		

GAGES (NONELECTRICAL).

3-310. SPEEDOMETER SHAFT REPLACEMENT (Continued).

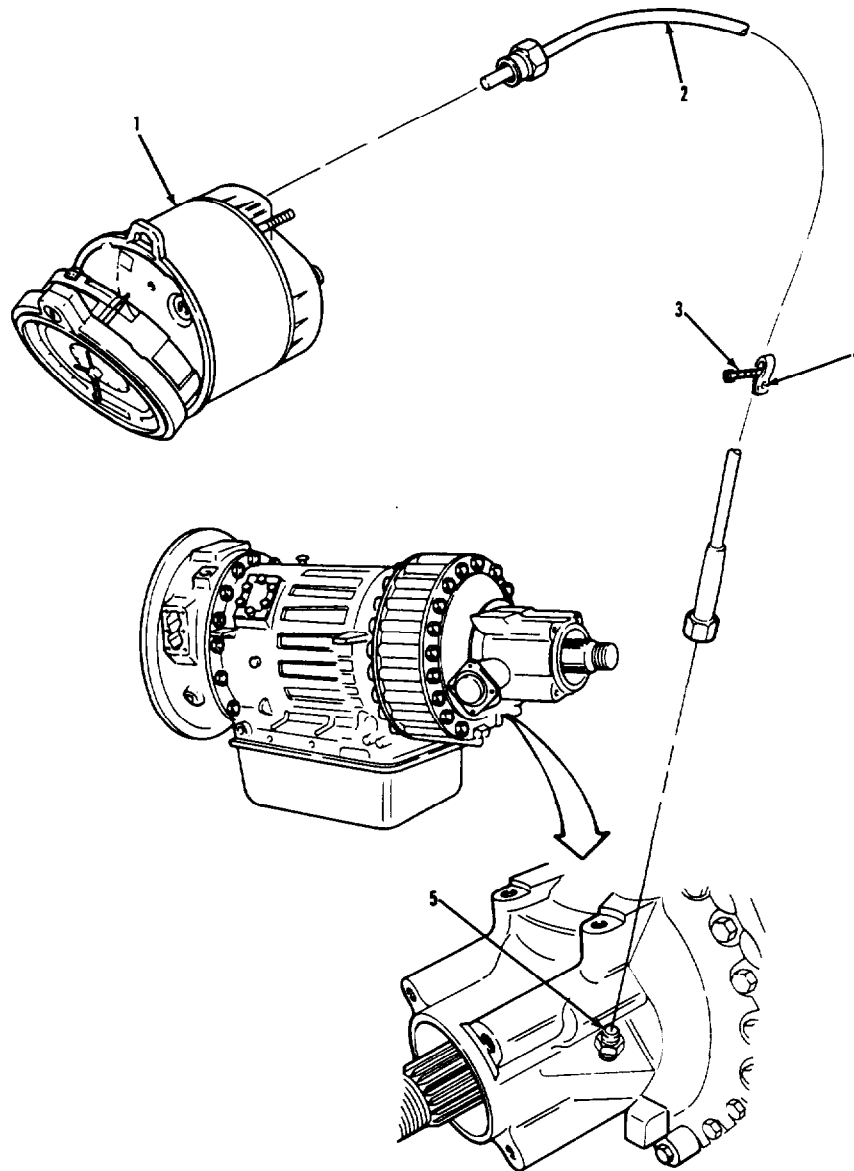

LEGEND:

1. TACHOGRAPH ASSEMBLY
2. SPEEDOMETER SHAFT ASSEMBLY
3. CABLE TIE
4. CLOSED CLAMP
5. SPEEDOMETER DRIVE ADAPTER SLEEVE

TA 237849

GAGES (NONELECTRICAL).

3-311. SPEEDOMETER DRIVE SLEEVE ADAPTER REPLACEMENT.

THIS TASK COVERS

- a. Removal.
- b. Installation.

INITIAL SETUP

APPLICABLE CONFIGURATIONS  
All.

EQUIPMENT CONDITION  
PARAGRAPH  
None.

CONDITION DESCRIPTION  
None.

TEST EQUIPMENT  
None.

SPECIAL TOOLS  
None.

MATERIALS/PARTS (P/N)  
None.

PERSONNEL REQUIRED  
One (MOS-63S).

SPECIAL ENVIRONMENTAL CONDITIONS  
None.

REFERENCES (TM)  
None.

GENERAL SAFETY INSTRUCTIONS  
Engine off.  
Transmission in neutral.  
Park brake set.

TROUBLESHOOTING REFERENCES  
None.

GAGES (NONELECTRICAL).

3-311. SPEEDOMETER DRIVE SLEEVE ADAPTER REPLACEMENT (Continued).

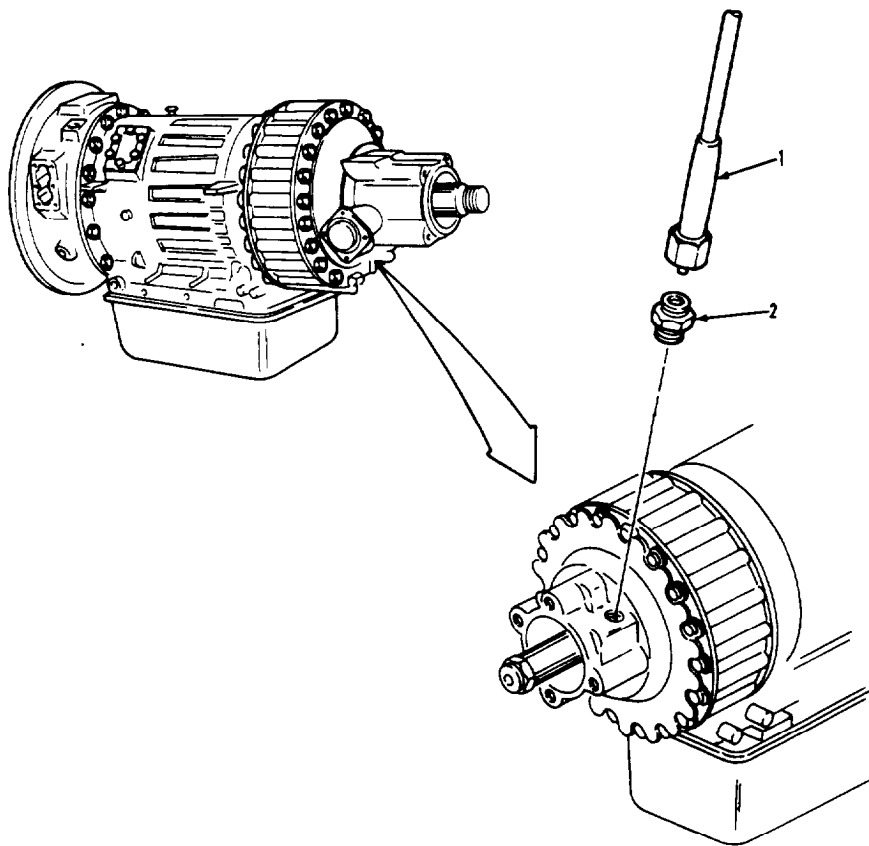

LEGEND:

1. SPEEDOMETER SHAFT ASSEMBLY
2. SPEEDOMETER DRIVE SLEEVE ADAPTER

TA 237850

GAGES (NONELECTRICAL).

3- 311. SPEEDOMETER DRIVE SLEEVE ADAPTER REPLACEMENT (Continued).

LOCATION/ITEM	ACTION	REMARKS
<b>A. REMOVAL.</b>		
1. Shaft (1).	Remove from item (2).	
2. Sleeve adapter (2).	Remove from transmission.	
<b>B. INSTALLATION.</b>		
3. Sleeve adapter (2).	Install in transmission.	
4. Shaft (1).	Install on item (2).	
<b>NOTE</b>		
Follow-on maintenance action required:		
None.		

GAGES (NONELECTRICAL).

3-311. SPEEDOMETER DRIVE SLEEVE ADAPTER REPLACEMENT (Continued).

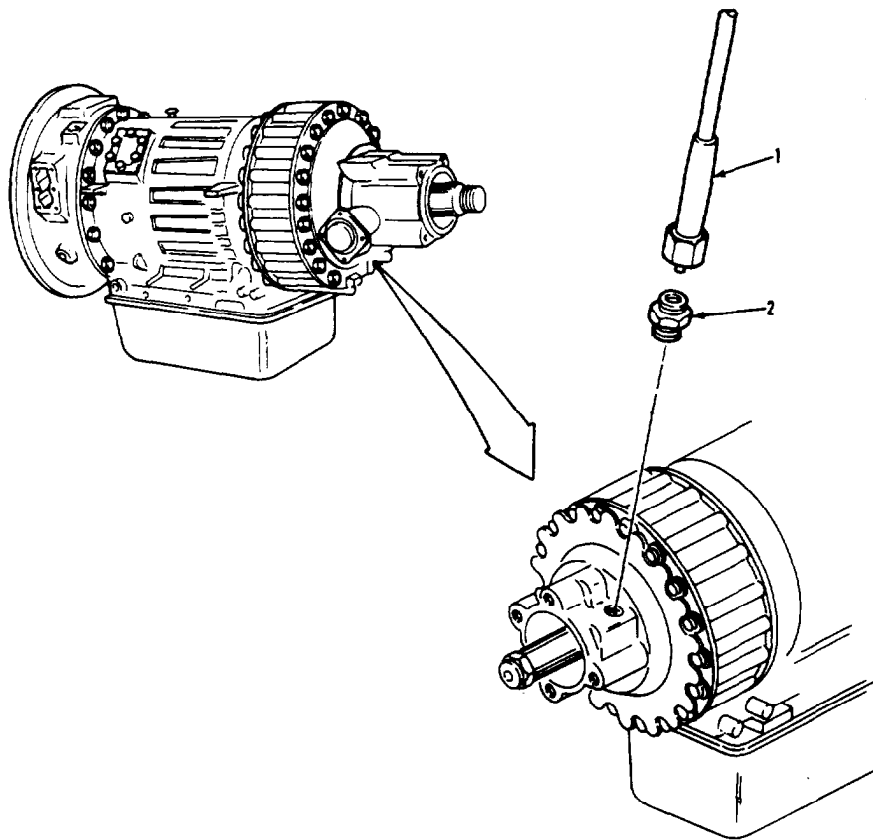

LEGEND:

1. SPEEDOMETER SHAFT ASSEMBLY
2. SPEEDOMETER DRIVE SLEEVE ADAPTER

TA 237851



GAGES (NONELECTRICAL).

3-312. SPEEDOMETER DRIVEN GEAR REPLACEMENT.

THIS TASK COVERS

- a. Removal.
- b. Installation.

INITIAL SETUP

APPLICABLE CONFIGURATIONS

All.

EQUIPMENT CONDITION

PARAGRAPH

3-311.

CONDITION DESCRIPTION

Speedometer drive sleeve adapter removed.

TEST EQUIPMENT

None.

SPECIAL TOOLS

None.

MATERIALS/PARTS (P/N)

None.

PERSONNEL REQUIRED

One (MDS-63S).

SPECIAL ENVIRONMENTAL CONDITIONS

None.

REFERENCES (TM)

None.

GENERAL SAFETY INSTRUCTIONS

Engine off.  
Transmission in neutral.  
Park brake set.

TROUBLESHOOTING REFERENCES

Paragraph 2-11.

GAGES (NONELECTRICAL).

3-312. SPEEDOMETER DRIVEN GEAR REPLACEMENT (Continued).

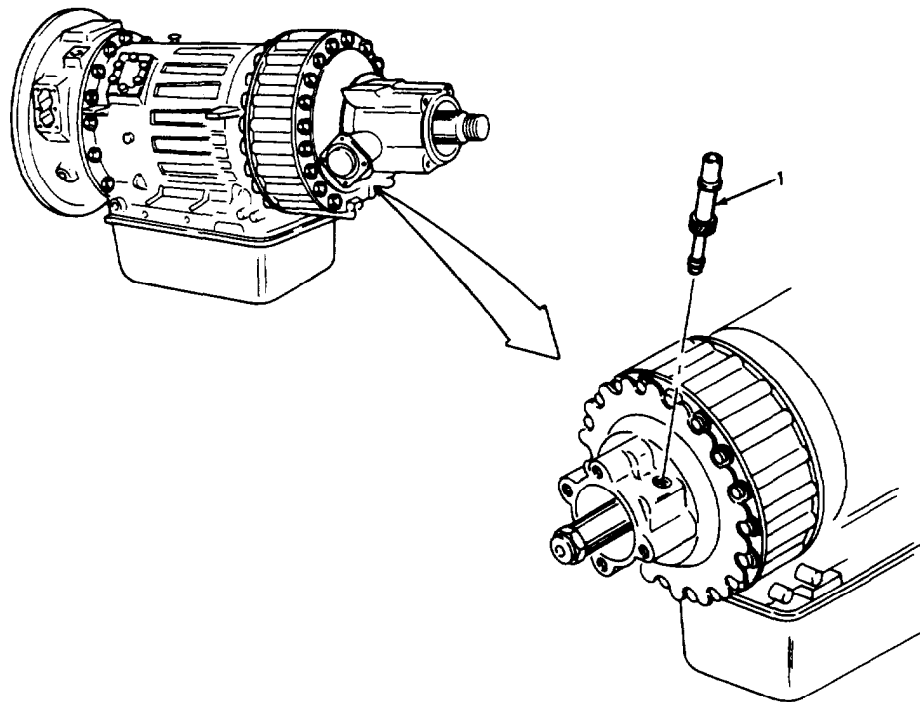

LEGEND:

1. SPEEDOMETER DRIVEN GEAR

TA 237852

GAGES (NONELECTRICAL).

3-312. SPEEDOMETER DRIVEN GEAR REPLACEMENT (Continued).

LOCATION/ITEM	ACTION	REMARKS
<b><u>CAUTION</u></b>		
Be careful not to drop gear into transmission. Be sure to install gear straight in transmission.		
<b>A. REMOVAL.</b>		
1. Gear (1).	Pull from transmission.	
<b>B. INSTALLATION.</b>		
2. Gear (1).	Put in place in transmission.	
<b>NOTE</b>		
Follow-on maintenance action required:		
Install speedometer drive sleeve adapter (para 3-311).		

GAGES (NONELECTRICAL).

3-312. SPEEDOMETER DRIVEN GEAR REPLACEMENT (Continued).

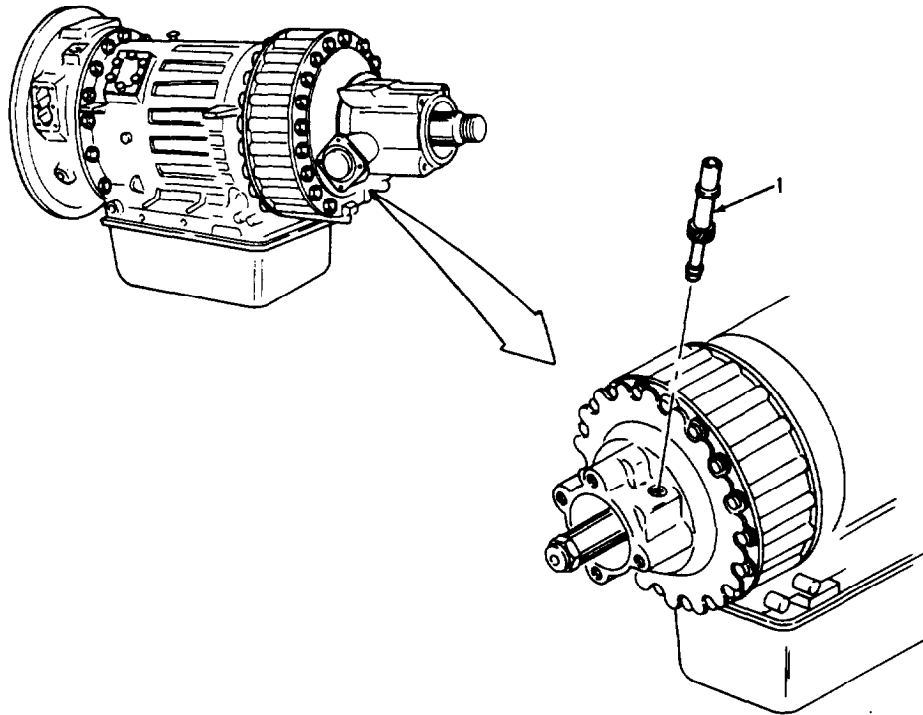

LEGEND:

- 1. SPEEDOMETER DRIVEN GEAR

TA 237853

GAGES (NONELECTRICAL).

3-313. TACHOMETER SHAFT REPLACEMENT.

THIS TASK COVERS

- a. Removal.
- b. Cleaning and Inspection.
- c. Installation.
- d. Operational Check.

INITIAL SETUP

<u>APPLICABLE CONFIGURATIONS</u>	<u>EQUIPMENT CONDITION PARAGRAPH</u>	<u>CONDITION DESCRIPTION</u>
All.	None.	None.
<u>TEST EQUIPMENT</u>		
None.		
<u>SPECIAL TOOLS</u>		
None.		
<u>MATERIALS/PARTS (P/N)</u>		
None.		
<u>PERSONNEL REQUIRED</u>	<u>SPECIAL ENVIRONMENTAL CONDITIONS</u>	
One (MOS-63S).	None.	
<u>REFERENCES (TM)</u>	<u>GENERAL SAFETY INSTRUCTIONS</u>	
TM 9-2320-283-10.	Engine off. Transmission in neutral. Park brake set.	
<u>TROUBLESHOOTING REFERENCES</u>		
Paragraph 2-11.		

GAGES (NONELECTRICAL).

3-313. TACHOMETER SHAFT REPLACEMENT (Continued).

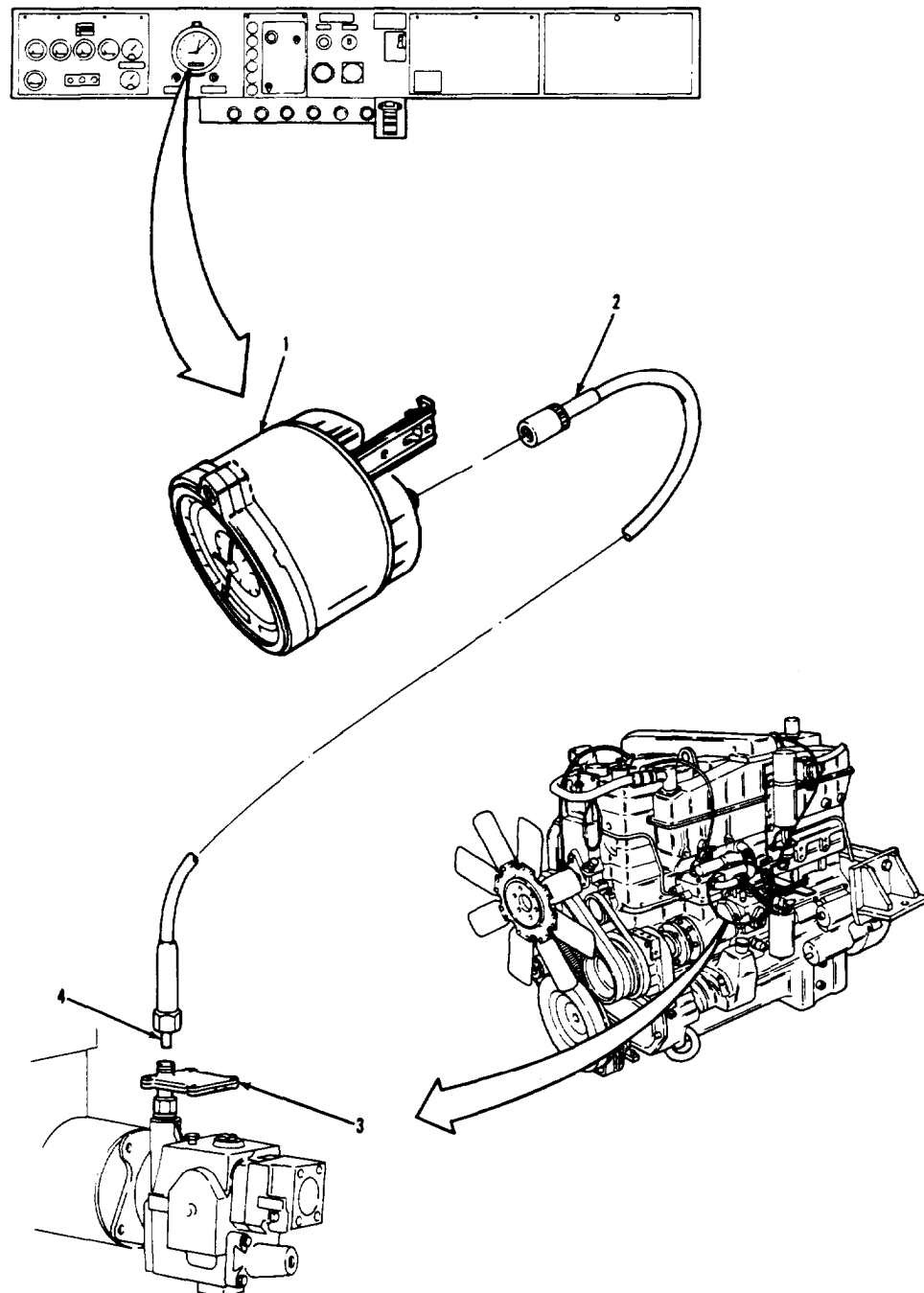

LEGEND:

- 1. TACHOGRAPH ASSEMBLY
- 2. TACHOGRAPH SHAFT ASSEMBLY
- 3. PULSE TACHOMETER
- 4. DRIVE END

TA 237854

GAGES (NONELECTRICAL).

3-313. TACHOMETER SHAFT REPLACEMENT (Continued).		
LOCATION/ITEM	ACTION	REMARKS
<b>A. REMOVAL.</b>		
1. Shaft (2).	a. Remove from item (1).	Remove item (2) by reaching from under dash. Item (2) is on the right-hand side of item (1) and has a round knurled end.
	b. Remove other end from item (3).	It may be necessary to grasp stem of item (3) with pliers to prevent it from turning while loosening the nut of item (2). Item (4) remains with item (2).
	c. Remove by slowly pulling through firewall.	
<b>B. CLEANING AND INSPECTION.</b>		
2. All metal parts.	Clean and inspect.	Refer to paragraphs 3-4 and 3-5.
<b>C. INSTALLATION.</b>		
3. Shaft (2).	a. Push round end through firewall and into cab.	
	b. Install onto back of item (1).	
	c. Install onto item (3).	Refer to remarks in step 1b.

GAGES (NONELECTRICAL).

3-313. TACHOMETER SHAFT REPLACEMENT (Continued).

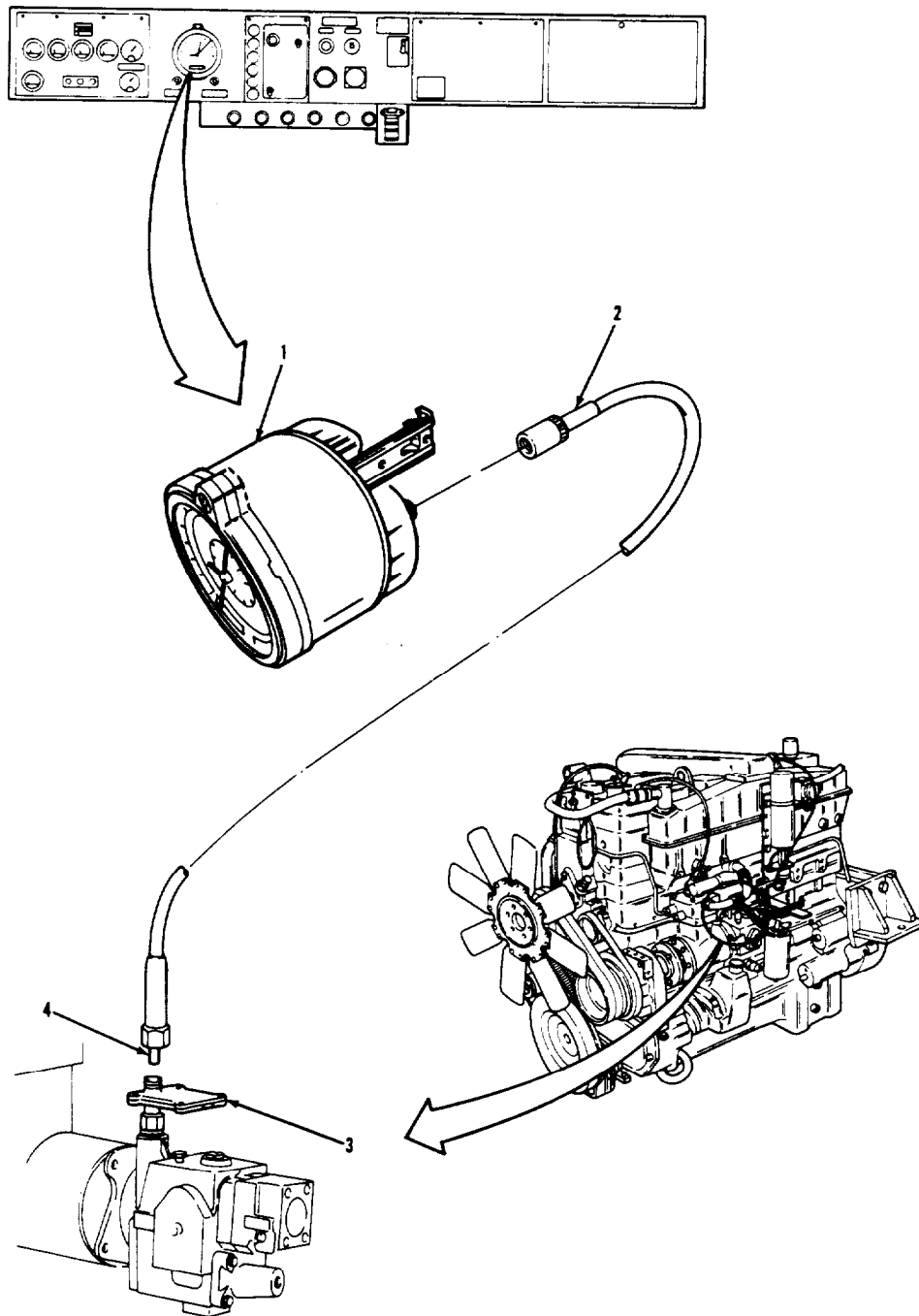

LEGEND:

- 1. TACHOGRAPH ASSEMBLY
- 2. TACHOGRAPH SHAFT ASSEMBLY
- 3. PULSE TACHOMETER
- 4. DRIVE END

TA 237855



CAGES (NONELECTRICAL).

3-313. TACHOMETER SHAFT REPLACEMENT (Continued).

LOCATION/ITEM

ACTION

REMARKS

**D. OPERATIONAL CHECK.**

- |                             |                  |                            |
|-----------------------------|------------------|----------------------------|
| 4. Engine.                  | Start.           | Refer to TM 9-2320-283-10. |
| 5. Tachograph assembly (7). | Check operation. |                            |
| 6. Engine.                  | Shut down.       | Refer to TM 9-2320-283-10. |

**NOTE**

Follow-on maintenance action required:

None.

GAGES (NONELECTRICAL).

3-313. TACHOMETER SHAFT REPLACEMENT (Continued).

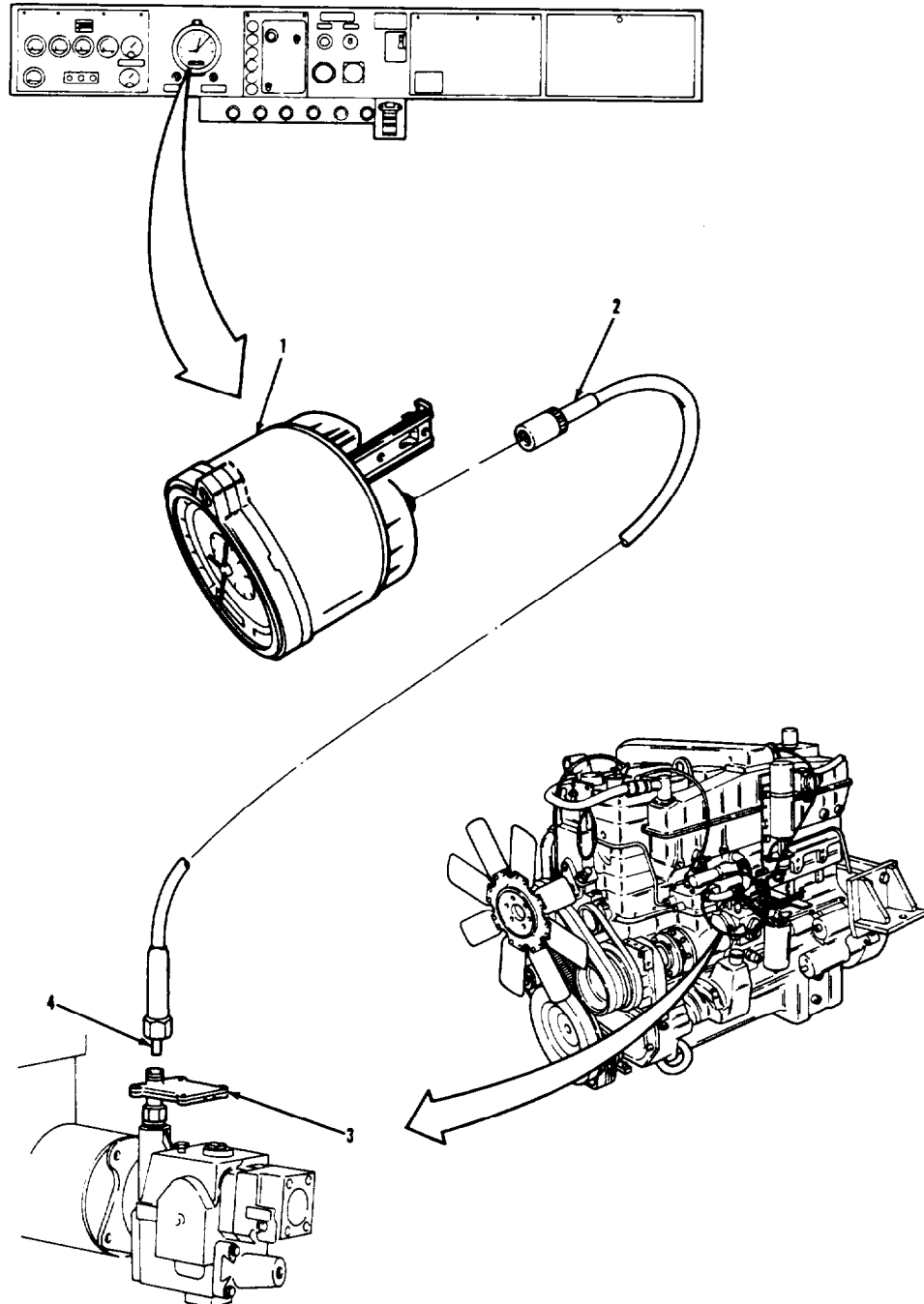

LEGEND:

- 1. TACHOGRAPH ASSEMBLY
- 2. TACHOGRAPH SHAFT ASSEMBLY
- 3. PULSE TACHOMETER
- 4. DRIVE END

TA 237856

GAGES (NONELECTRICAL).

3-314. PRESSURE GAGE REPLACEMENT.

THIS TASK COVERS

- a. Removal.
- b. Cleaning and Inspection.
- c. Installation.

INITIAL SETUP

APPLICABLE CONFIGURATIONS

All.

EQUIPMENT CONDITION  
PARAGRAPH

TM 9-2320-283-10.

CONDITION DESCRIPTION

Air system draincocks  
opened.

TEST EQUIPMENT

None.

SPECIAL TOOLS

None.

MATERIALS/PARTS (P/N)

None.

PERSONNEL REQUIRED

One (MDS-63S).

SPECIAL ENVIRONMENTAL CONDITIONS

None.

REFERENCES (TM)

TM 9-2320-283-10.

GENERAL SAFETY INSTRUCTIONS

Engine off.  
Transmission in neutral.  
Park brake set.

TROUBLESHOOTING REFERENCES

Paragraph 2-11.

GAGES (NONELECTRICAL).

3-314. PRESSURE GAGE REPLACEMENT (Continued).

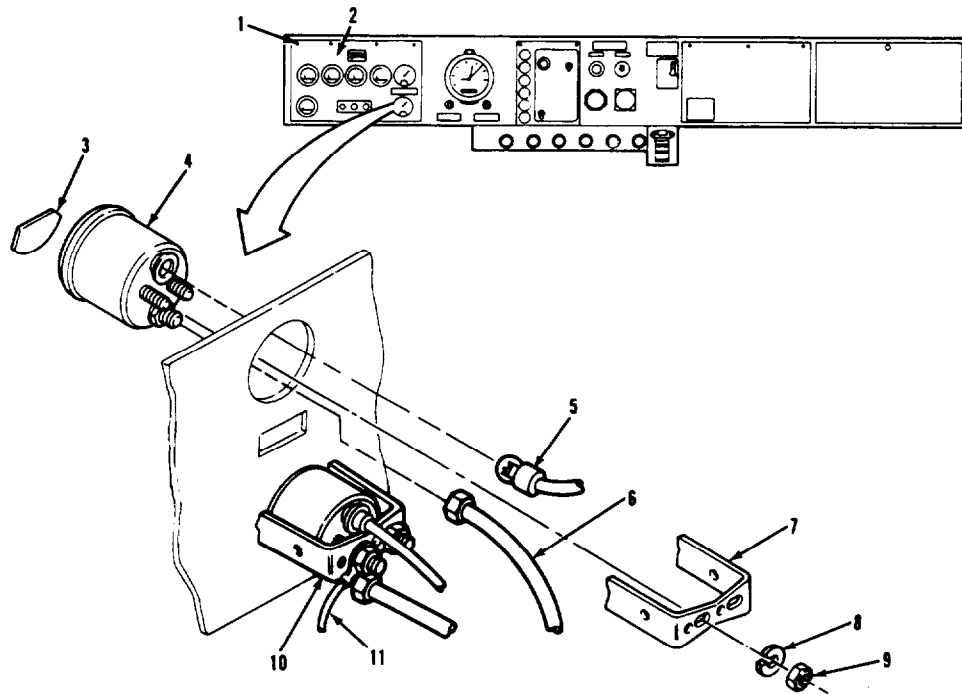

LEGEND:

- |  |  |
|--|--|
| 1. QUARTER-TURN SCREW (4)                      | 6. NONMETALLIC TUBE                      |
| 2. LEFT-HAND INSTRUMENT CLUSTER PANEL ASSEMBLY | 7. MOUNTING BRACKET                      |
| 3. FRONT AIR PSI GAGE IDENTIFICATION OVERLAY   | 8. LOCKWASHER (2)                        |
| 4. FRONT AIR PRESSURE DIAL GAGE ASSEMBLY       | 9. HEXAGON PLAIN NUT (2)                 |
| 5. SOCKET AND BULB ASSEMBLY                    | 10. REAR AIR PRESSURE DIAL GAGE ASSEMBLY |
|  | 11. GROUND WIRE                          |

TA 237857

GAGES (NONELECTRICAL).

3-314. PRESSURE GAGE REPLACEMENT (Continued).

LOCATION/ITEM	ACTION	REMARKS
<b>NOTE</b>		
Use this procedure to replace any one of the two air pressure gages. Lower gage has an additional nut and ground wire.		
<b>A. REMOVAL.</b>		
1. Panel (2).	Loosen four items (1), and open.	Use a screwdriver to prop item (2) open.
2. Socket and bulb (5).	Remove from item (4).	
3. Tube (6).	Remove from item (4).	
4. Two nuts (9), lock-washers (8), and bracket (7).	Remove from item (4).	
5. Gage (4).	Remove from item (2).	
6. Overlay (3).	Remove from item (4).	If damaged.
<b>B. CLEANING AND INSPECTION.</b>		
7. All parts.	Clean and inspect.	Refer to paragraphs 3-4 and 3-5.
<b>C. INSTALLATION.</b>		
8. Overlay (3).	Install on item (4).	If removed.
9. Gage (4).	Position in item (2).	

GAGES (NONELECTRICAL).

3-314. PRESSURE GAGE REPLACEMENT (Continued).

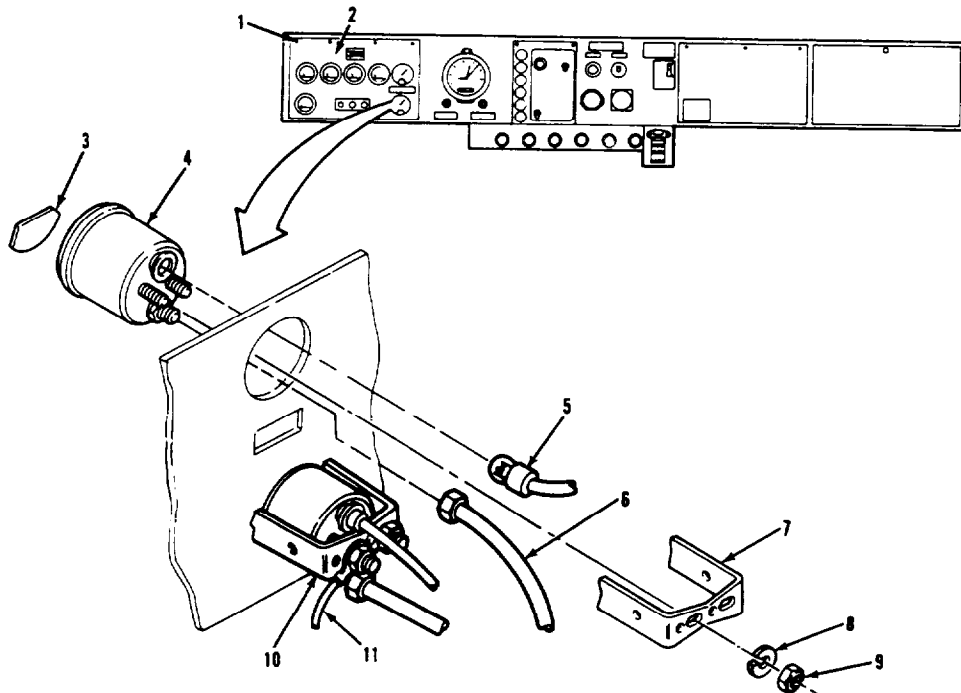

LEGEND:

- |  |  |
|--|--|
| 1. QUARTER-TURN SCREW (4)                      | 6. NONMETALLIC TUBE                      |
| 2. LEFT-HAND INSTRUMENT CLUSTER PANEL ASSEMBLY | 7. MOUNTING BRACKET                      |
| 3. FRONT AIR PSI GAGE IDENTIFICATION OVERLAY   | 8. LOCKWASHER (2)                        |
| 4. FRONT AIR PRESSURE DIAL GAGE ASSEMBLY       | 9. HEXAGON PLAIN NUT (2)                 |
| 5. SOCKET AND BULB ASSEMBLY                    | 10. REAR AIR PRESSURE DIAL GAGE ASSEMBLY |
|  | 11. GROUND WIRE                          |

TA 237858

GAGES (NONELECTRICAL).

3-314. PRESSURE GAGE REPLACEMENT (Continued).		
LOCATION/ITEM	ACTION	REMARKS
<b>C. INSTALLATION (Continued).</b>		
10. Bracket (7).	a. Position on item (4). b. Secure with two items (9) and (8).	
11. Tube (6).	Install on item (4).	
12. Socket and bulb (5).	Install in item (4).	
13. Panel (2).	Close, and tighten four items (1).	
<b>NOTE</b>		
Follow-on maintenance action required:		
Close air system draincocks and start engine (TM 9-2320-283-10). Check air system for leaks (para 3-8).		

GAGES (NONELECTRICAL).

3-314. PRESSURE GAGE REPLACEMENT (Continued).

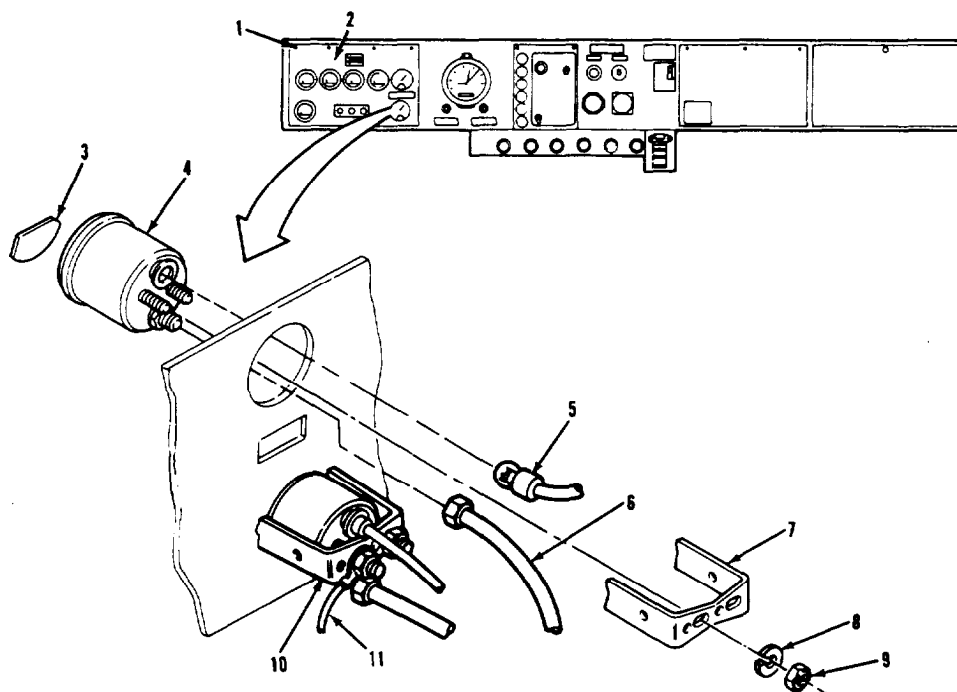

LEGEND:

- |   |   |
|---|---|
| 1. QUARTER-TURN SCREW (4)                         | 6. NONMETALLIC TUBE                         |
| 2. LEFT-HAND INSTRUMENT<br>CLUSTER PANEL ASSEMBLY | 7. MOUNTING BRACKET                         |
| 3. FRONT AIR PSI GAGE<br>IDENTIFICATION OVERLAY   | 8. LOCKWASHER (2)                           |
| 4. FRONT AIR PRESSURE DIAL<br>GAGE ASSEMBLY       | 9. HEXAGON PLAIN NUT (2)                    |
| 5. SOCKET AND BULB ASSEMBLY                       | 10. REAR AIR PRESSURE DIAL<br>GAGE ASSEMBLY |
|   | 11. GROUND WIRE                             |

TA 237859



GAGES (NONELECTRICAL).

3- 315. AIR CLEANER RESTRICTION GAGE AND BRACKET REPLACEMENT.

THIS TASK COVERS

- a. Removal.
- b. Cleaning and Inspection.
- c. Installation.

INITIAL SETUP

<p><u>APPLICABLE CONFIGURATIONS</u> All.</p>	<p><u>EQUIPMENT CONDITION PARAGRAPH</u> None.</p>	<p><u>CONDITION DESCRIPTION</u> None.</p>
<p><u>TEST EQUIPMENT</u> None.</p>		
<p><u>SPECIAL TOOLS</u> None.</p>		
<p><u>MATERIALS/PARTS (P/N)</u> Tape, thread sealing Item 32, Appendix C.</p>		
<p><u>PERSONNEL REQUIRED</u> One (MOS- 63S).</p>	<p><u>SPECIAL ENVIRONMENTAL CONDITIONS</u> None.</p>	
<p><u>REFERENCES (TM)</u> None.</p>	<p><u>GENERAL SAFETY INSTRUCTIONS</u> Engine off. Transmission in neutral. Park brake set.</p>	
<p><u>TROUBLESHOOTING REFERENCES</u> Paragraph 2- 11.</p>		

GAGES (NONELECTRICAL).

3-315. AIR CLEANER RESTRICTION GAGE AND BRACKET REPLACEMENT (Continued).

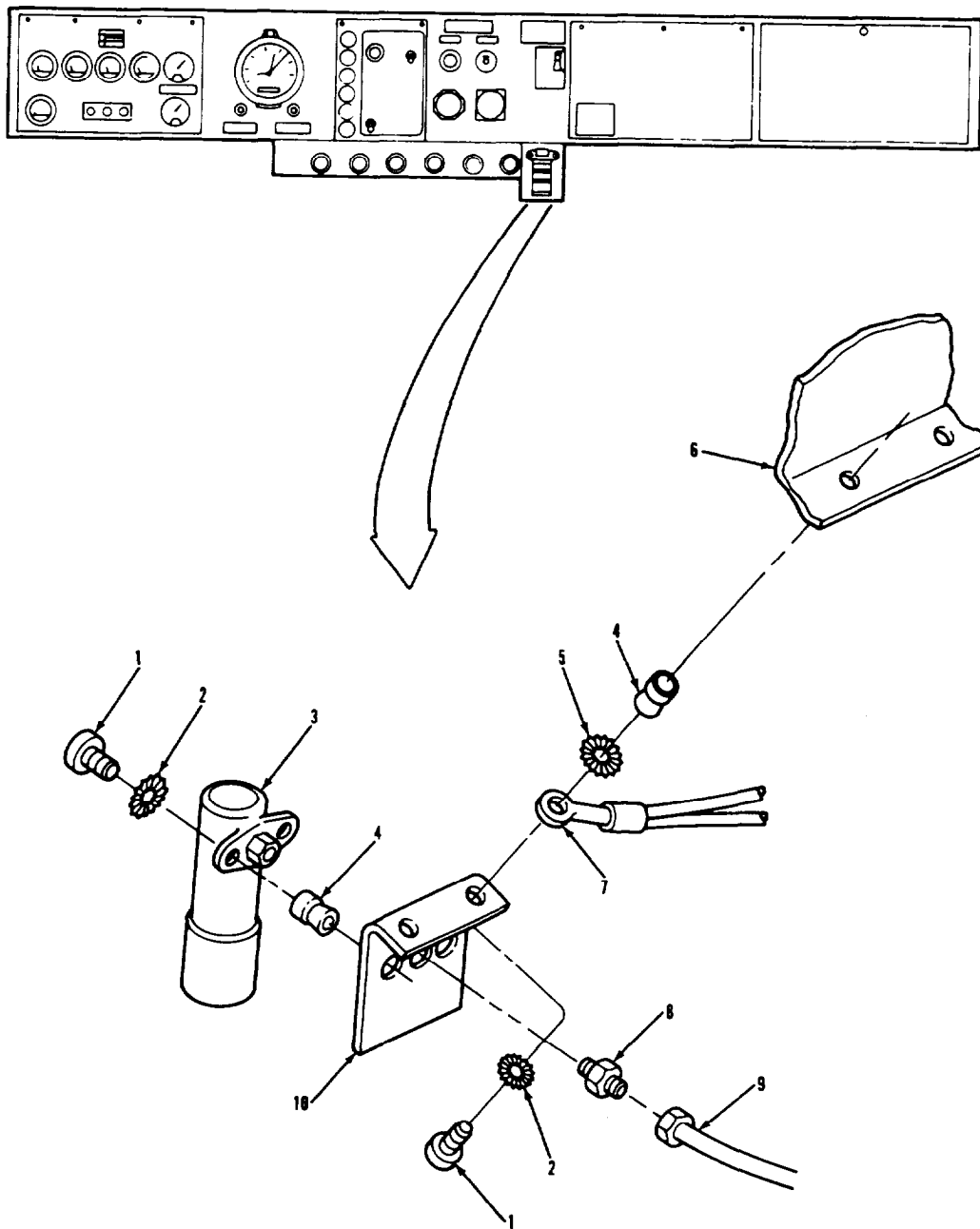

LEGEND:

- |                   |                              |
|-------------------|------------------------------|
| 1. SCREW (4)      | 6. INSTRUMENT PANEL ASSEMBLY |
| 2. LOCKWASHER (4) | 7. TERMINAL (2)              |
| 3. GAGE ASSEMBLY  | 8. NIPPLE                    |
| 4. NUTSERT (4)    | 9. NONMETALLIC TUBE          |
| 5. LOCKWASHER (2) | 10. GAGE BRACKET             |

TA 237860

GAGES (NONELECTRICAL).

3-315. AIR CLEANER RESTRICTION GAGE AND BRACKET REPLACEMENT (Continued).		
LOCATION/ITEM	ACTION	REMARKS
<b>A. REMOVAL.</b>		
1. Tube (9).	Remove from item (3).	
2. Two screws (1), lockwashers (2), and gage (3).	Remove from item (10).	
3. Nipple (8).	Remove from item (3).	
4. Two screws (1), lockwashers (2), bracket (10), two terminals (7), and lockwasher (5).	Remove from item (6).	
<b>B. CLEANING AND INSPECTION.</b>		
5. All parts.	Clean and inspect.	Refer to paragraphs 3-4 and 3-5. Remove and replace any items (4), if damaged.
<b>C. INSTALLATION.</b>		
6. Bracket (10), two terminals (7), and lockwashers (5).	a. Position on item (6). b. Secure with two items (1) and (2).	
7. Nipple (8).	a. Wrap threads with thread sealing tape. b. Install in item (3).	Refer to paragraph 3-7.

GAGES (NONELECTRICAL).

3-315. AIR CLEANER RESTRICTION GAGE AND BRACKET REPLACEMENT (Continued).

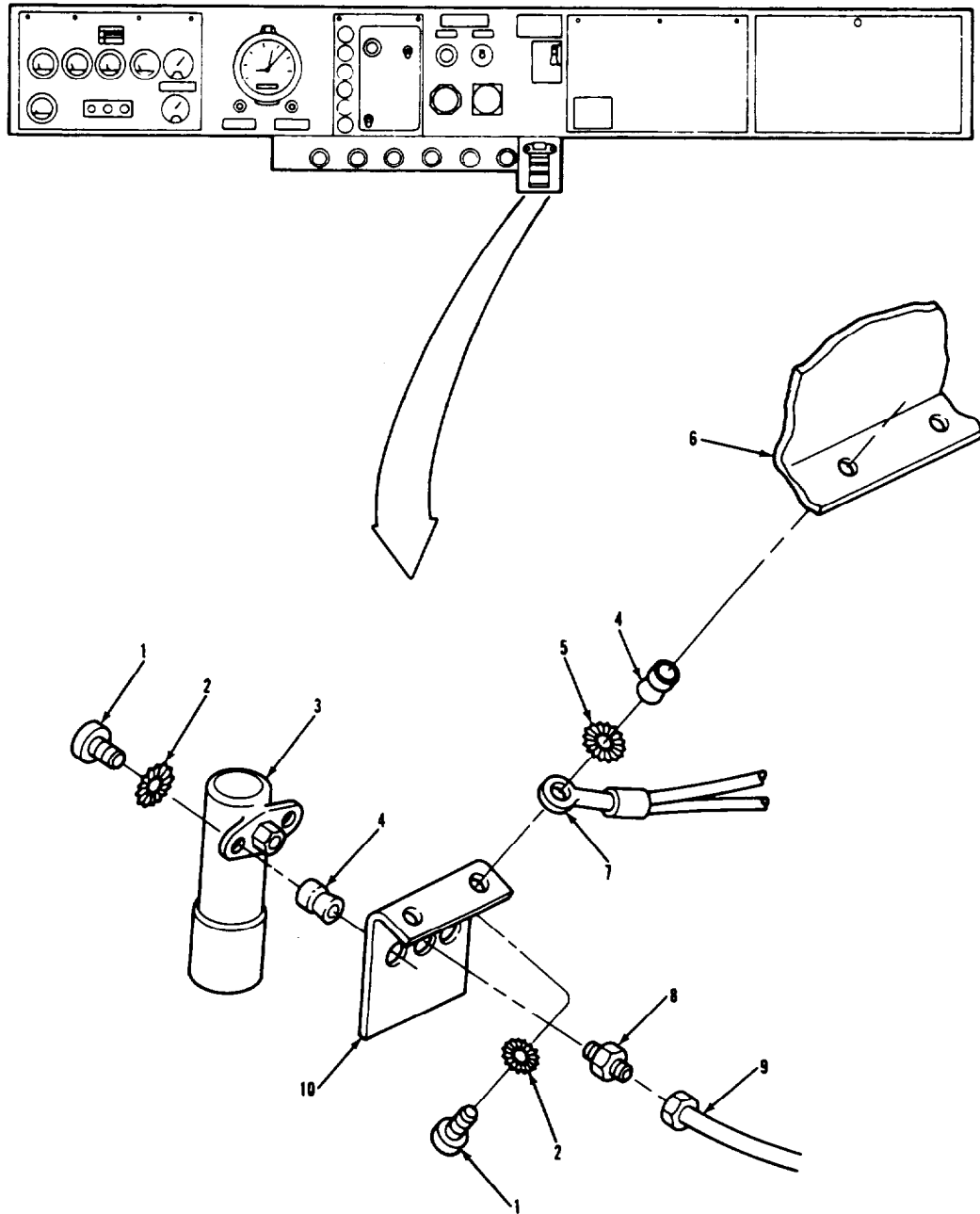

LEGEND:

- |                   |                              |
|-------------------|------------------------------|
| 1. SCREW (4)      | 6. INSTRUMENT PANEL ASSEMBLY |
| 2. LOCKWASHER (4) | 7. TERMINAL (2)              |
| 3. GAGE ASSEMBLY  | 8. NIPPLE                    |
| 4. NUTSERT (4)    | 9. NONMETALLIC TUBE          |
| 5. LOCKWASHER (2) | 10. GAGE BRACKET             |

TA 237861

GAGES (NONELECTRICAL).

3-315. AIR CLEANER RESTRICTION GAGE AND BRACKET REPLACEMENT (Continued).

LOCATION/ITEM	ACTION	REMARKS
<b>C. INSTALLATION (Continued).</b>		
8. Gage (3).	a. Position on item (10).	
	b. Secure with two items (1) and (2).	
9. Tube (9).	Install on item (8).	
<b>NOTE</b>		
Follow-on maintenance action required:		
None.		

GAGES (NONELECTRICAL).

3-315. AIR CLEANER RESTRICTION GAGE AND BRACKET REPLACEMENT (Continued).

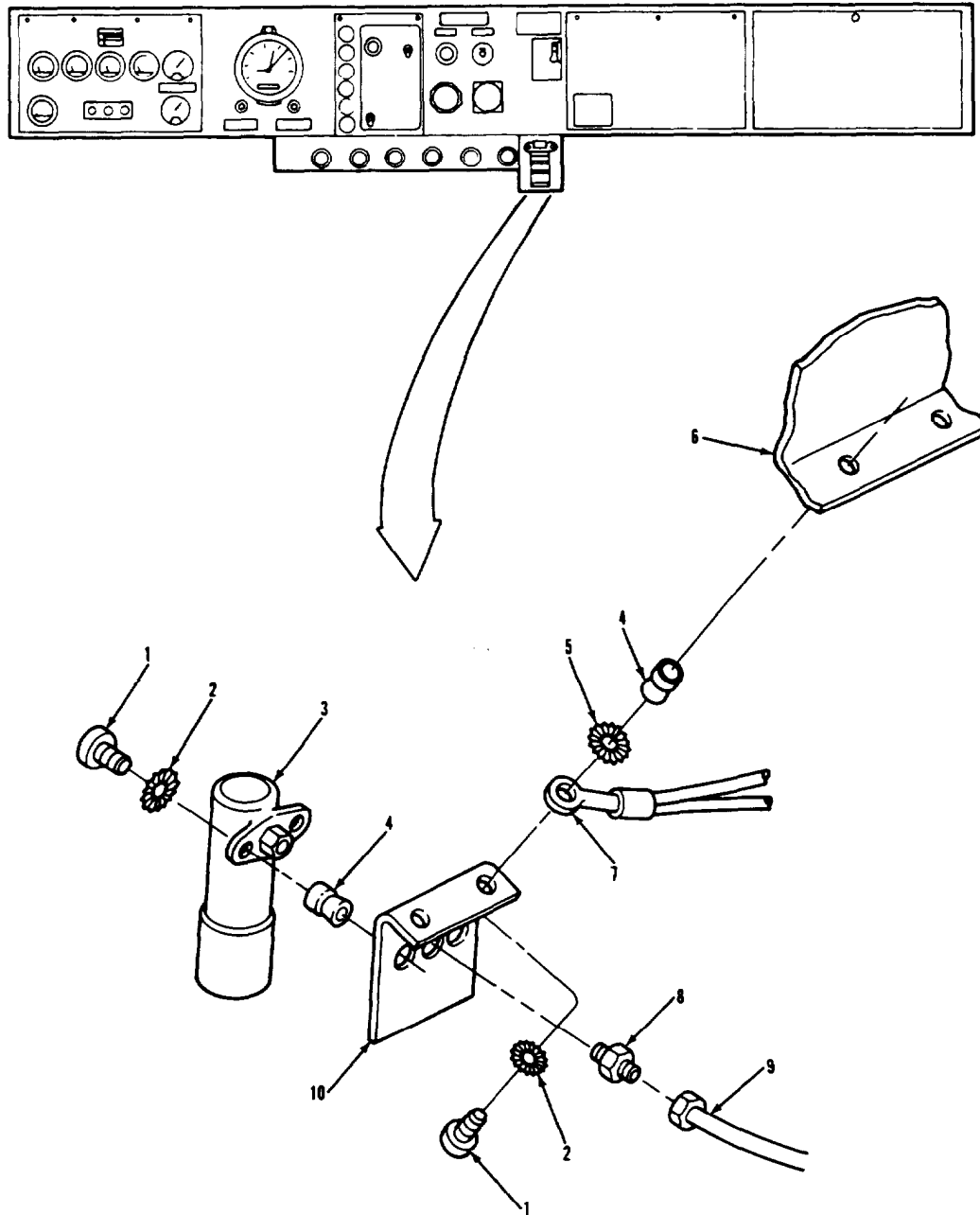

LEGEND:

- |                   |                              |
|-------------------|------------------------------|
| 1. SCREW (4)      | 6. INSTRUMENT PANEL ASSEMBLY |
| 2. LOCKWASHER (4) | 7. TERMINAL (2)              |
| 3. GAGE ASSEMBLY  | 8. NIPPLE                    |
| 4. NUTSERT (4)    | 9. NONMETALLIC TUBE          |
| 5. LOCKWASHER (2) | 10. GAGE BRACKET             |

TA 237862

GAGES (NONELECTRICAL).

3-316. AIR CLEANER RESTRICTION GAGE TUBE REPLACEMENT.

THIS TASK COVERS

- a. Removal.
- b. Cleaning and Inspection.
- c. Installation.

INITIAL SETUP

APPLICABLE CONFIGURATIONS  
All.

EQUIPMENT CONDITION PARAGRAPH  
None.

CONDITION DESCRIPTION  
None.

TEST EQUIPMENT  
None.

SPECIAL TOOLS  
None.

MATERIALS/PARTS (P/N)  
Tape, thread sealing  
Item 32, Appendix C.

PERSONNEL REQUIRED  
One (MDS-63S).

SPECIAL ENVIRONMENTAL CONDITIONS  
None.

REFERENCES (TM)  
None.

GENERAL SAFETY INSTRUCTIONS  
Engine off.  
Transmission in neutral.  
Park brake set.

TROUBLESHOOTING REFERENCES  
None.

GAGES (NONELECTRICAL).

3-316. AIR CLEANER RESTRICTION GAGE TUBE REPLACEMENT (Continued).

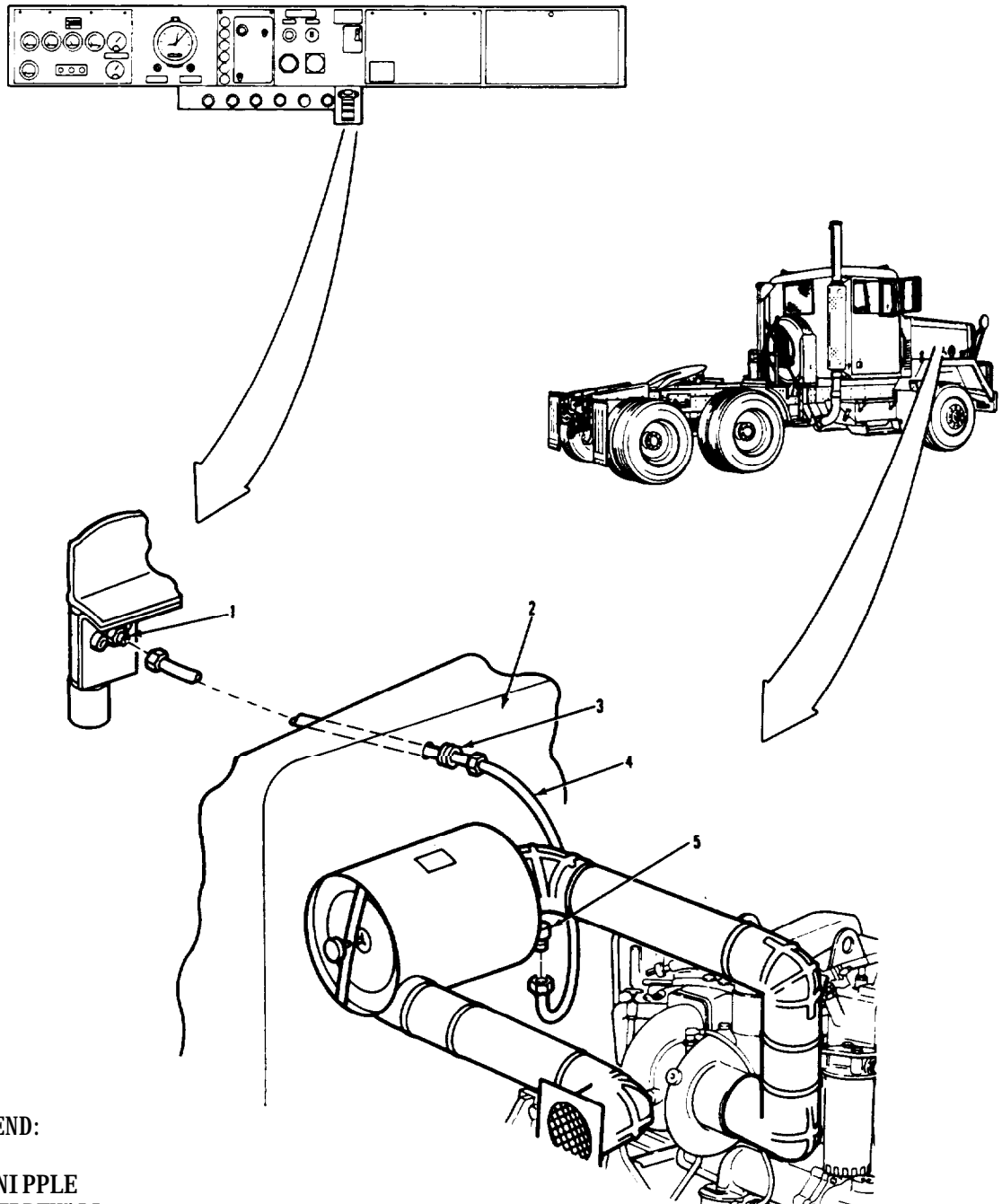

LEGEND:

- 1. NIPPLE
- 2. FIREWALL
- 3. GROMMET
- 4. NONMETALLIC TUBE
- 5. 90 DEGREE ELBOW

TA 237863



GAGES (NONELECTRICAL).

3-316. AIR CLEANER RESTRICTION GAGE TUBE REPLACEMENT (Continued).		
LOCATION/ITEM	ACTION	REMARKS
<b>A. REMOVAL.</b>		
1. Tube (4).	a. Remove from items (1) and (5). b. Pull out from item (2).	
2. Grommet (3).	Remove from item (2) or item (4).	
<b>B. CLEANING AND INSPECTION.</b>		
3. All parts.	Clean and inspect.	Refer to paragraphs 3-4 and 3-5.
<b>C. INSTALLATION.</b>		
4. Tube (4).	Push through hole in item (2).	
5. Grommet (3).	Slide onto item (4), and position in hole of item (2).	
6. Nipple (1) and elbow (5).	Wrap threads with thread sealing tape.	Refer to paragraph 3-7.
7. Tube (4).	Install onto items (1) and (5).	
<b>NOTE</b>		
Follow-on maintenance action required:		
None		

GAGES (NONELECTRICAL).

3-316. AIR CLEANER RESTRICTION GAGE TUBE REPLACEMENT (Continued).

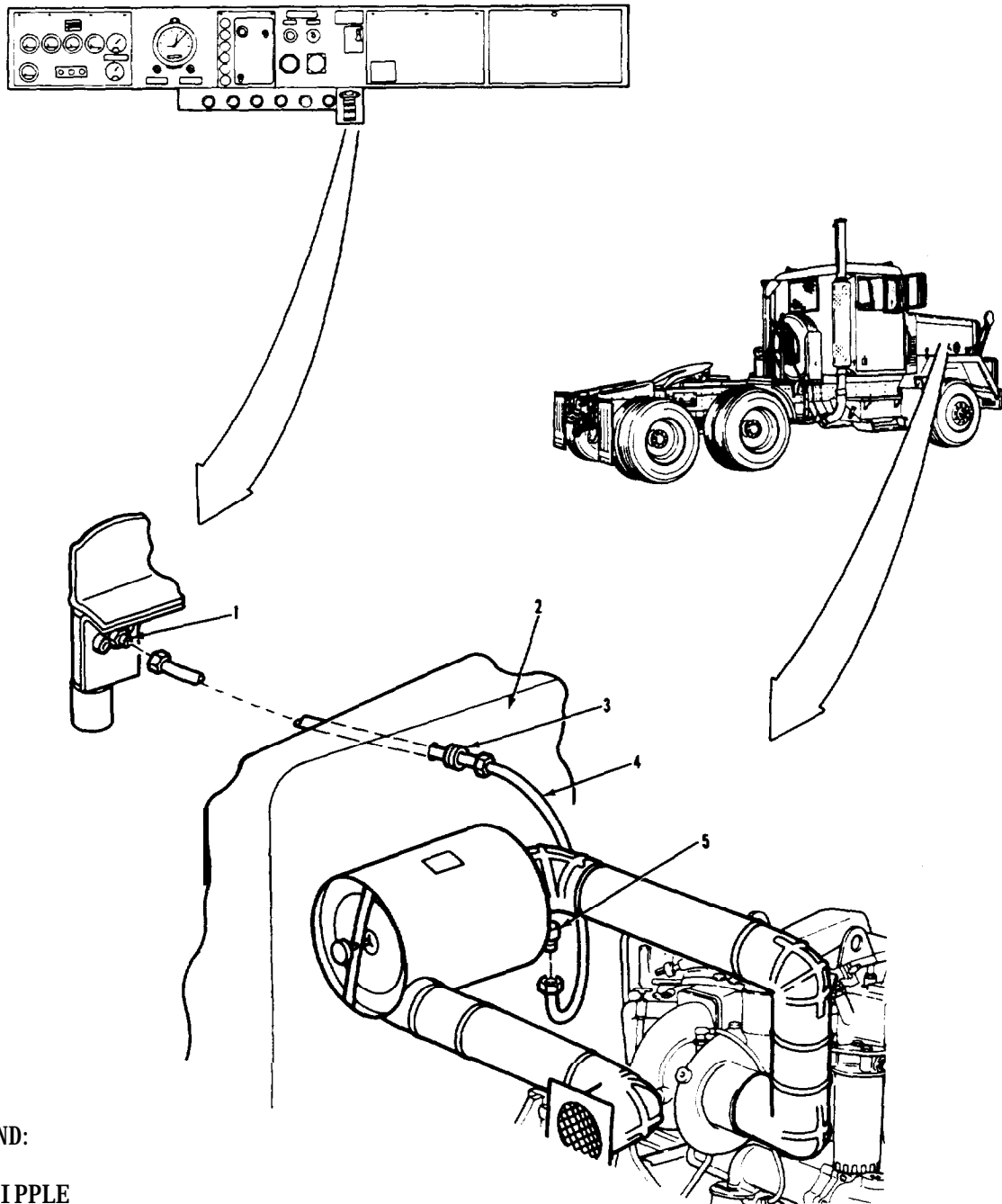

LEGEND:

- 1. NIPPLE
- 2. FIREWALL
- 3. GROMMET
- 4. NONMETALLIC TUBE
- 5. 90 DEGREE ELBOW

TA 237864

Section XIX. STE/ICE COMPONENTS

3-317. GENERAL.

This section provides procedures authorized at the organizational maintenance level to replace STE/ICE components. To find a specific procedure contained in this section, see the task summary below.

3-318. TASK SUMMARY.	
<u>INITIAL SETUP</u>	
<u>APPLICABLE CONFIGURATIONS</u> All.	<u>EQUIPMENT CONDITION PARAGRAPH</u> <u>CONDITION DESCRIPTION</u> (Refer to specific paragraph for this information).
<u>TEST EQUIPMENT</u> None.	
<u>SPECIAL TOOLS</u> None.	
<u>MATERIALS/PARTS (P/N)</u> Tape, thread sealing Item 32, Appendix C.	
<u>PERSONNEL REQUIRED</u> One (MDS-63S).	<u>SPECIAL ENVIRONMENTAL CONDITIONS</u> None.
<u>REFERENCES (TM)</u> None.	<u>GENERAL SAFETY INSTRUCTIONS</u> Engine off. Transmission in neutral. Park brake set.
<u>TROUBLESHOOTING REFERENCES</u> Paragraph 2-11.	

STE/ICE COMPONENTS.

3-318. TASK SUMMARY (Continued).

LIST OF TASKS

TASK NO.	TASK	TASK REF	TROUBLESHOOTING REF NO. (PARA)
1	Pulse Tachometer Replacement a. Removal. b. Cleaning and Inspection. c. Installation.	3-319 3-319a 3-319b 3-319c	2-11
2	Pressure Transducer Replacement a. Removal. b. Cleaning and Inspection. c. Installation.	3-320 3-320a 3-320b 3-320c	2-11

STE/ICE COMPONENTS.

3-319. PULSE TACHOMETER REPLACEMENT.

THIS TASK COVERS

- a. Removal.
- b. Cleaning and Inspection.
- c. Installation.

INITIAL SETUP

APPLICABLE CONFIGURATIONS

All.

EQUIPMENT CONDITION  
PARAGRAPH

None.

CONDITION DESCRIPTION

None.

TEST EQUIPMENT

None.

SPECIAL TOOLS

None.

MATERIALS/PARTS (P/N)

None.

PERSONNEL REQUIRED

One (MOS-63S).

SPECIAL ENVIRONMENTAL CONDITIONS

None.

REFERENCES (TM)

None.

GENERAL SAFETY INSTRUCTIONS

Engine off.  
Transmission in neutral.  
Park brake set.

TROUBLESHOOTING REFERENCES

Paragraph 2-11.

STE/ICE COMPONENTS.

3-319. PULSE TACHOMETER REPLACEMENT (Continued).

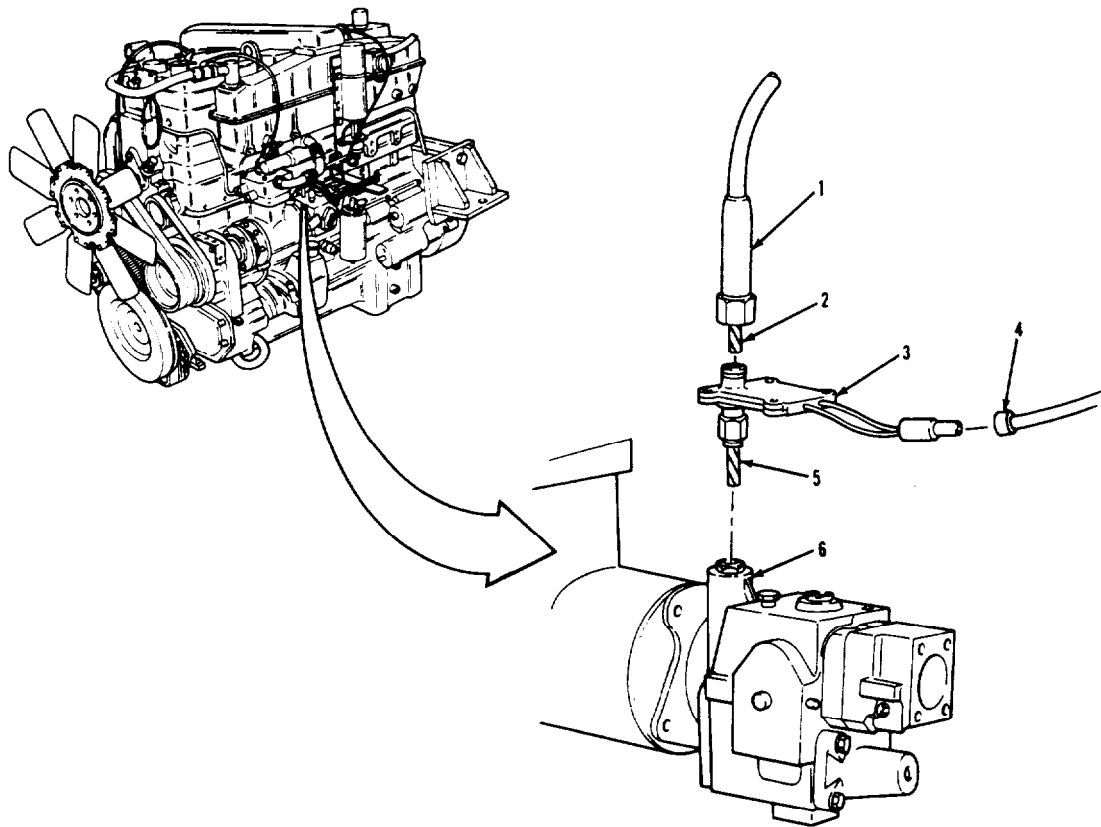

LEGEND:

- |                              |                           |
|------------------------------|---------------------------|
| 1. TACHOMETER SHAFT ASSEMBLY | 4. PLUG                   |
| 2. TACHOMETER SHAFT DRIVE    | 5. PULSE TACHOMETER DRIVE |
| 3. PULSE TACHOMETER          | 6. FUEL PUMP ASSEMBLY     |

TA 237865

STE/ICE COMPONENTS.

3- 319. PULSE TACHOMETER REPLACEMENT (Continued).

LOCATION/ITEM	ACTION	REMARKS
<b>A. REMOVAL.</b>		
1. Plug (4).	Disconnect from item (3).	
2. Shaft (1).	Unscrew and remove from item (3).	Item (2) should remain in item (1).
3. Tachometer (3).	Unscrew and remove from item (6).	Item (5) should remain in item (3).
<b>B. CLEANING AND INSPECTION.</b>		
4. All parts.	Clean and inspect.	Refer to paragraphs 3-4 and 3-5.
<b>C. INSTALLATION.</b>		
5. Tachometer (3).	Screw into item (6).	Make sure item (5) is in place.
6. Shaft (1).	Screw onto item (3).	Make sure item (2) is in place.
7. Plug (4).	Connect to item (3).	
<b>NOTE</b>		
Follow-on maintenance action required:		
None.		

STE/ICE COMPONENTS.

3-319. PULSE TACHOMETER REPLACEMENT (Continued).

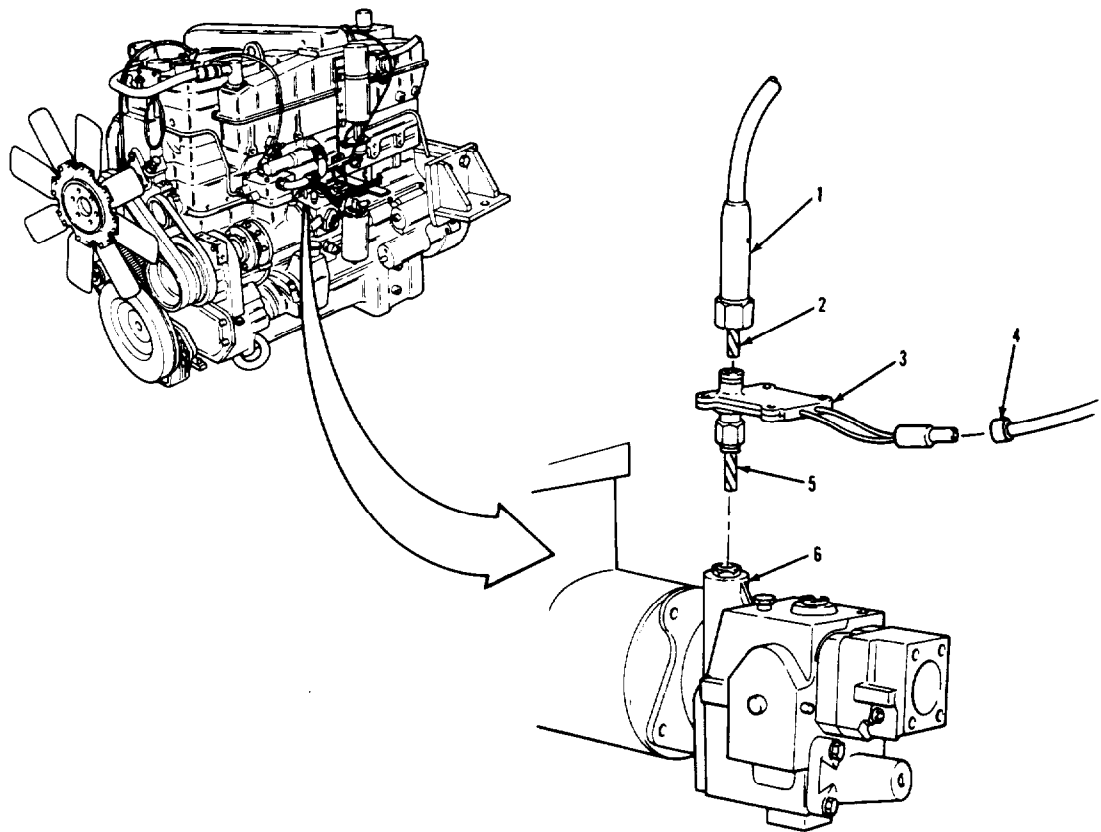

LEGEND:

- 1. TACHOMETER SHAFT ASSEMBLY
- 2. TACHOMETER SHAFT DRIVE
- 3. PULSE TACHOMETER

- 4. PLUG
- 5. PULSE TACHOMETER DRIVE
- 6. FUEL PUMP ASSEMBLY

TA 237866



STE/ICE COMPONENTS.

3-320. PRESSURE TRANSDUCER REPLACEMENT.

THIS TASK COVERS

- a. Removal.
- b. Cleaning and Inspection.
- c. Installation.

INITIAL SETUP

APPLICABLE CONFIGURATIONS

All.

EQUIPMENT CONDITION

PARAGRAPH

None.

CONDITION DESCRIPTION

None.

TEST EQUIPMENT

None.

SPECIAL TOOLS

None.

MATERIALS/PARTS (P/N)

Tape, thread sealing  
Item 32, Appendix C.

PERSONNEL REQUIRED

One (MOS-63S).

SPECIAL ENVIRONMENTAL CONDITIONS

None.

REFERENCES (TM)

None.

GENERAL SAFETY INSTRUCTIONS

Engine off.  
Transmission in neutral.  
Park brake set.

TROUBLESHOOTING REFERENCES

Paragraph 2-11.

STE/ICE COMPONENTS.

3-320. PRESSURE TRANSDUCER REPLACEMENT (Continued).

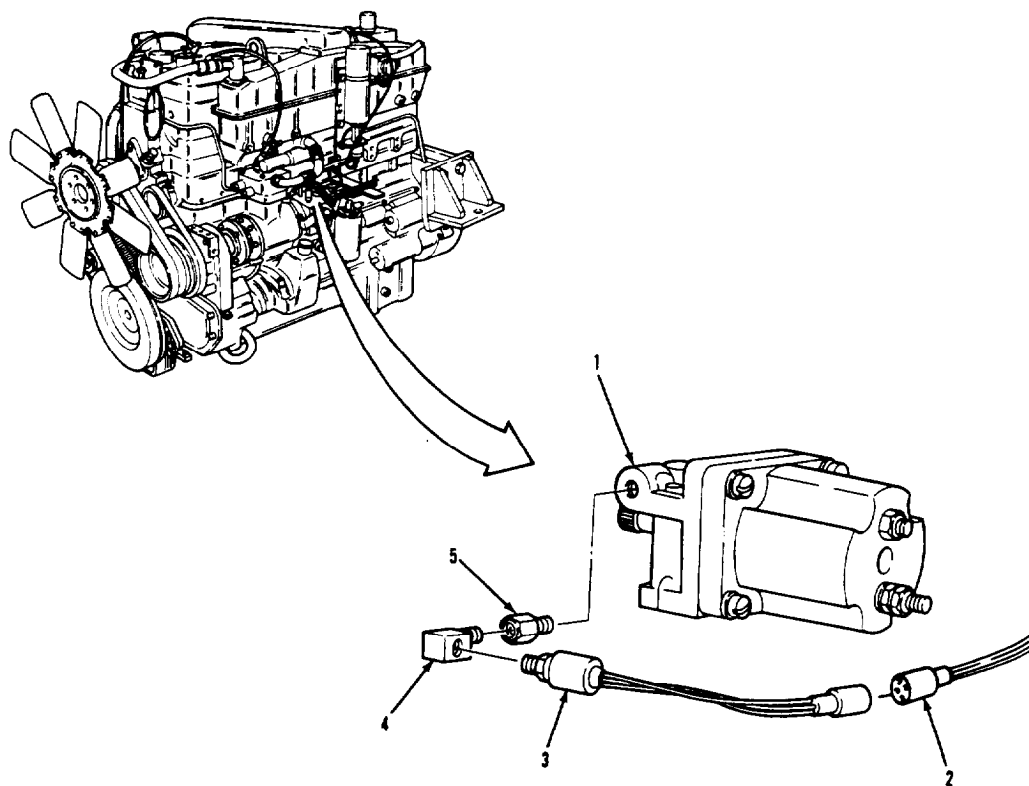

LEGEND:

1. SOLENOID VALVE
2. PLUG
3. PRESSURE TRANSDUCER
4. 90 DEGREE ELBOW
5. REDUCER

TA 237867

STE/ICE COMPONENTS.

3-320. PRESSURE TRANSDUCER REPLACEMENT (Continued).

LOCATION/ITEM	ACTION	REMARKS
<b>A. REMOVAL.</b>		
1. Transducer (3).	a. Disconnect from item (2).	
	b. Unscrew from item (4).	
2. Elbow (4) and reducer (5).	Remove from item (1), and separate.	
<b>B. CLEANING AND INSPECTION.</b>		
3. All parts.	Clean and inspect.	Refer to paragraphs 3-4 and 3-5.
<b>C. INSTALLATION.</b>		
4. Elbow (4) and reducer (5).	a. Wrap threads with thread sealing tape.	Refer to paragraph 3-7.
	b. Screw together, and install into item (1).	
5. Transducer (3).	a. Wrap threads with thread sealing tape.	Refer to paragraph 3-7.
	b. Screw into item (4).	
	c. Connect to item (2).	
<b>NOTE</b>		
Follow-on maintenance action required:		
None.		

STE/ICE COMPONENTS.

3-320. PRESSURE TRANSDUCER REPLACEMENT (Continued).

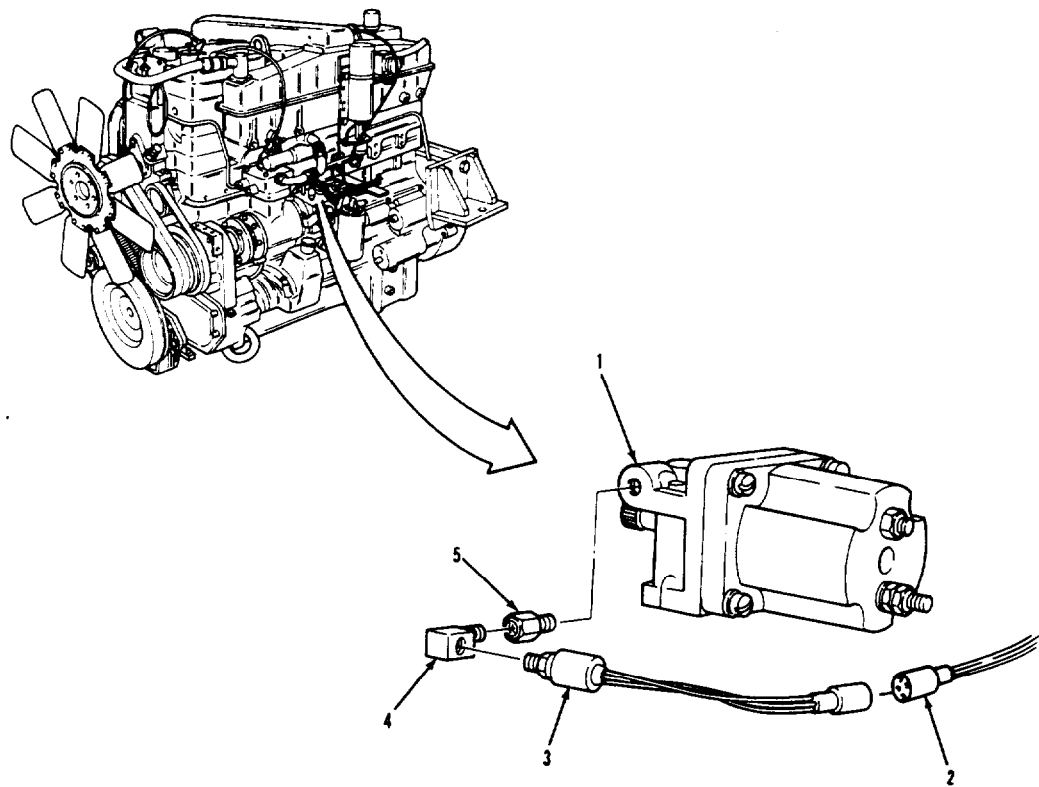

LEGEND:

- 1. SOLENOID VALVE
- 2. PLUG
- 3. PRESSURE TRANSDUCER
- 4. 90 DEGREE ELBOW
- 5. REDUCER

TA 237868



APPENDIX A

REFERENCES

**A-1. PUBLICATION INDEXES.**

The following indexes should be consulted frequently for latest changes or revisions and for new publications relating to material covered in this technical manual.

- Index of Army Motion Pictures and Related Audiovisual Aids..... DA PAM 108-1
- Consolidated Index of Army Publications and Blank Forms..... DA PAM 310-1
- Index of Army Equipment Modification Work Orders..... DA PAM 750-10

**A-2. FORMS.**

The following forms pertain to this materiel. (Refer to DA Pamphlet 310-1 for index of blank forms).

- Standard Form 46, U. S. Government Motor Vehicle Operator's Identification Card.
- Standard Form 91, Operator Report of Motor Vehicle Accidents.
- Recommended Changes to DA Publications, DA Form 2028.

Refer to TM 38-750, The Army Maintenance Management System (TAMMS), for instructions on the use of maintenance forms pertaining to this materiel.

**A-3. OTHER PUBLICATIONS.**

The following publications contain information pertinent to the major item materiel and associated equipment.

a. Operating Vehicle

- Operator's Manual for M915A1 Truck Tractor..... TM 9-2320-283-10
- Army Motor Transport Units and Operations..... FM 55-30
- Manual for the Wheeled Vehicle Driver..... FM 21-305
- Prevention of Motor Vehicle Accidents..... AR 385-55
- Accident Reporting and Records..... AR 385-40

**A-3. OTHER PUBLICATIONS (Continued).**

**b. Maintenance and Repair**

Organizational Maintenance for M915A1 Truck Tractor..... TM 9-2320-283-20

Organizational Maintenance Repair Parts and Special  
Tools List for M915A1 Truck Tractor..... TM 9-2320-283-20P

Lubrication Order for M915A1 Truck Tractor..... LO 9-2320-283-12

Direct Support and General Support Repair Parts and  
Special Tools List for M915A1 Truck Tractor..... TM 9-2320-283-34P

Operator's, Organizational Maintenance Manual Including  
Repair Parts and Special Tools List for Simplified Test  
Equipment for Internal Combustion Engines (STE/ICE)..... TM 9-4910-571-12&P

Organizational Care, Maintenance, and Repair of  
Pneumatic Tires, Inner Tubes, and Radial Tires..... TM 9-2610-200-20

Description, Use, Bonding Techniques, and  
Properties of Adhesives..... TB ORD 1032

Materials Used for Cleaning, Preserving, Abrading,  
and Cementing Ordnance Materiel and Related  
Materials, Including Chemicals..... TM 9-247

Metal Body Repair and Related Operations..... FM 43-2

Welding Theory and Application..... TM 9-237

Painting Instructions for Field Use..... TM 43-0139

Inspection, Care, and Maintenance of Antifriction  
Bearings..... TM 9-214

Use of Antifreeze Solutions and Cleaning Compounds  
in Engine Cooling System..... TB 750-651

Cooling System: Tactical Vehicles..... TM 750-254

Functional Grouping Codes..... TB 750-93-1

**c. Cold Weather Operation and Maintenance**

Basic Cold Weather Manual ..... FM 31-70

Northern Operations..... TM 31-71

**A-3. OTHER PUBLICATIONS (Continued).**

c. Cold Weather Operation and Maintenance (Continued)

Operation and Maintenance of Ordnance Materiel  
in Extreme Cold Weather (0°F to -65°F) ..... FM 9-207

Personnel Heater and Winterization Kit Policy for  
Tank-Automotive, Construction, and Materiel Handling Equipment.....SB 9-16

M915A1 Winterization Kit..... TB 9-2320-283-14

d. Decontamination

Chemical, Biological, and Radiological (CBR)  
Decontamination ..... TM 3-220

NBC (Nuclear, Biological, and Chemical) Defense..... FM 21-40

e. General

Principles of Automotive Vehicles..... TM 9-8000

Camouflage..... FM 5-20

Procedures for Destruction of Tank-Automotive  
Equipment to Prevent Enemy Use..... TM 750-244-6

Administrative Storage of Equipment..... TM 740-90-1

Color, Marking, and Camouflage Painting of Military  
Vehicles, Construction Equipment, and Materiel  
Handling Equipment..... TB 42-0209

Packaging of Materiel Preservation..... TM 38-230-1  
and  
TM 38-230-2

Shipment and Limited Storage..... MIL-V-62038

Military Standard Abbreviations for Use on Drawings,  
Specifications, Standards and in Technical Documents..... MIL-STD-12D

Authorized Abbreviations and Brevity Codes..... AR 310-50

f. M915A1 Warranty..... TB 9-2300-295-15/20





---

**APPENDIX B**  
**MAINTENANCE ALLOCATION CHART**

---

**Section I. INTRODUCTION****THE ARMY MAINTENANCE SYSTEM (AMS)**

This introduction provides a general explanation of all maintenance and repair functions authorized at the two maintenance levels under the Two-Level Maintenance System concept.

The MAC (immediately following the introduction) designates overall authority and responsibility for the performance of maintenance functions on the identified end item or component. The application of the maintenance functions to the end item or component shall be consistent with the capacities and capabilities of the designated maintenance levels, which are shown on the MAC in column 4 as:

Field - includes two subcolumns, Unit C (operator/crew) and O (unit/organizational maintenance) and Direct Support (F) maintenance

Sustainment - includes two subcolumns, general support (H) and depot (D).

The tools and test equipment requirements (immediately following the MAC) list the tools and test equipment (both special tools and common tool sets) required for each maintenance function as referenced from the MAC.

The remarks (immediately following the tools and test equipment requirements) contain supplemental instructions and explanatory notes for a particular maintenance function.

**MAINTENANCE FUNCTIONS**

Maintenance functions are limited to and defined as follows:

1. Inspect. To determine the serviceability of an item by comparing its physical, mechanical, and/or electrical characteristics with established standards through examination (e.g., by sight, sound, or feel).
2. Test. To verify serviceability by measuring the mechanical, pneumatic, hydraulic, or electrical characteristics of an item and comparing those characteristics with prescribed standards on a scheduled basis, i.e., load testing of lift devices and hydrostatic testing of pressure hoses.
3. Service. Operations required periodically to keep an item in proper operating condition: e.g., to clean (includes decontaminate, when required), to preserve, to drain, to paint, or to replenish fuel, lubricants, chemical fluids, or gases.
4. Adjust. To maintain or regulate, within prescribed limits, by bringing into proper position, or by setting the operating characteristics to specified parameters.
5. Align. To adjust specified variable elements of an item to bring about optimum or desired performance.

**MAINTENANCE FUNCTIONS - Continued**

- 6. Calibrate. To determine and cause corrections to be made or to be adjusted on instruments of test, measuring, and diagnostic equipment used in precision measurement. Consists of comparisons of two instruments, one of which is a certified standard of known accuracy, to detect and adjust any discrepancy in the accuracy of the instrument being compared.
- 7. Remove/Install. To remove and install the same item when required to perform service or other maintenance functions. Install may be the act of emplacing, seating, or fixing into position a spare, repair part, or module (component or assembly) in a manner to allow the proper functioning of an equipment or system.
- 8. Replace. To remove an unserviceable item and install a serviceable counterpart in its place. "Replace" is authorized by the MAC and assigned maintenance level is shown as the third position code of the Source, Maintenance and Recoverability (SMR) code.

**NOTE**

The following definitions are applicable to the "repair" maintenance function:

Services. Inspect, test, service, adjust, align, calibrate, and/or replace.

Fault location/troubleshooting. The process of investigating and detecting the cause of equipment malfunctioning: the act of isolating a fault within a system or Unit Under Test (UUT).

Disassembly/assembly. The step-by-step breakdown (taking apart) of a spare/functional group coded item to the level of its least component, that is assigned an SMR code for the level of maintenance under consideration (i.e., identified as maintenance significant).

Actions. Welding, grinding, riveting, straightening, facing, machining, and/or resurfacing.

- 9. Repair. The application of maintenance services, including fault location/troubleshooting, removal/installation, disassembly/assembly procedures, and maintenance actions to identify troubles and restore serviceability to an item by correcting specific damage, fault, malfunction, or failure in a part, subassembly, module (component or assembly), end item, or system.
- 10. Overhaul. That maintenance effort (service/action) prescribed to restore an item to a completely serviceable/operational condition as required by maintenance standards in appropriate technical publications. Overhaul is normally the highest degree of maintenance performed by the Army. Overhaul does not normally return an item to like new condition.
- 11. Rebuild. Consists of those services/actions necessary for the restoration of unserviceable equipment to a like new condition in accordance with original manufacturing standards. Rebuild is the highest degree of material maintenance applied to Army equipment. The rebuild operation includes the act of returning to zero those age measurements (e.g., hours/miles) considered in classifying Army equipment/components.

**EXPLANATION OF COLUMNS IN THE MAC**

**Column 1, Group Number.** Column 1 lists FGC numbers, the purpose of which is to identify maintenance significant components, assemblies, subassemblies, and modules with the Next Higher Assembly (NHA).

**Column 2, Component/Assembly.** Column 2 contains the item names of components, assemblies, subassemblies, and modules for which maintenance is authorized.

**Column 3, Maintenance Function.** Column 3 lists the functions to be performed on the item listed in Column 2. (For a detailed explanation of these functions, refer to "Maintenance Functions" outlined above.)

---

**EXPLANATION OF COLUMNS IN THE MAC - Continued**

**Column 4, Maintenance Level.** Column 4 specifies each level of maintenance authorized to perform each function listed in Column 3, by indicating work time required (expressed as manhours in whole hours or decimals) in the appropriate subcolumn. This work time figure represents the active time required to perform that maintenance function at the indicated level of maintenance. If the number or complexity of the tasks within the listed maintenance function varies at different maintenance levels, appropriate work time figures are to be shown for each level. The work time figure represents the average time required to restore an item (assembly, subassembly, component, module, end item, or system) to a serviceable condition under typical field operating conditions. This time includes preparation time (including any necessary disassembly/assembly time), troubleshooting/fault location time, and quality assurance time in addition to the time required to perform the specific tasks identified for the maintenance functions authorized in the MAC. The symbol designations for the various maintenance levels are as follows:

**Field:**

C Operator or crew maintenance  
O Unit maintenance  
F Direct support maintenance

**Sustainment:**

H General support maintenance  
D Depot maintenance

**NOTE**

The "L" maintenance level is not included in Column 4 of the MAC. Functions to this level of maintenance are identified by a work time figure in the "H" column of Column 4, and an associated reference code is used in the REMARKS Column 6. This code is keyed to the remarks and the SRA complete repair application is explained there.

**Column 5, Tools and Equipment Reference Code.** Column 5 specifies, by code, those common tool sets (not individual tools), common Test, Measurement and Diagnostic Equipment (TMDE), and special tools, special TMDE and special support equipment required to perform the designated function. Codes are keyed to the entries in the tools and test equipment table.

**Column 6, Remarks Code.** When applicable, this column contains a letter code, in alphabetical order, which is keyed to the remarks table entries.

## EXPLANATION OF COLUMNS IN THE TOOLS AND TEST EQUIPMENT REQUIREMENTS

**Column 1, Tool or Test Equipment Reference Code.** The tool or test equipment reference code correlates with a code used in Column 5 of the MAC.

**Column 2, Maintenance Level.** The lowest level of maintenance authorized to use the tool or test equipment.

**Column 3, Nomenclature.** Name or identification of the tool or test equipment.

**Column 4, National Stock Number (NSN).** The NSN of the tool or test equipment.

**Column 5, Tool Number.** The manufacturer's part number, model number, or type number.

### Explanation of Columns in the Remarks

**Column 1, Remarks Code.** The code recorded in Column 6 of the MAC.

**Column 2, Remarks.** This column lists information pertinent to the maintenance function being performed as indicated in the MAC.

Section II. MAINTENANCE ALLOCATION CHART

(1) Group Number	(2) Component/ Assembly	(3) Maintena nce Function	(4) Maintenance Level					(5) Tools and Equipment	(6) Remarks
			Field		Sustainment				
			Unit		DS	GS	Depot		
			C	O	F	H	D		
01	ENGINE								
0100	Engine (Diesel)	Service Replace Repair	2.0				16.0 65.0	83 143	
	Engine Mount	Inspect Replace		0.2	0.4				
0101	Cylinder Head	Inspect Replace Repair			1.0 7.0		10.4	84,86,87, 88,90,91, 95 thru 99 103,104, 109,110 112,114 121 thru 124,126, 141, 168	
	Engine Block	Inspect Repair					2.0 40.0	144,145, 158,170, 171	
	Cylinder and Sleeve Assembly	Inspect Replace					0.5 18.0	166	
0102	Crankshaft and Main Bearings	Inspect Replace					0.5 17.3	143	
	Main Seals	Inspect Replace			0.1		20.0	100,172	
	Vibration Damper	Inspect Replace			0.5 1.0				
0103	Disk and Gear Assembly	Replace					13.0		
0104	Connecting Rods, Bearings And Pistons Assembly	Inspect Replace Repair					0.3 27.0 8.0	135,138, 161,154 133,134, 147	
0105	Valves	Inspect Adjust Replace			0.8 1.8		14.0		
	Camshaft and Bearing	Inspect Replace			0.8 27.0				

Section II. MAINTENANCE ALLOCATION CHART (continued)

(1) Group Number	(2) Component/ Assembly	(3) Maintenance Function	(4) Maintenance Level					(5) Tools and Equipment	(6) Remarks
			Field		Sustainment				
			Unit		DS	GS	Depot		
			C	O	F	H	D		
01	ENGINE (Continued)								
	Cam Follower Housing	Inspect Replace				0.2 12.0			
	Cam Follower	Inspect Replace				0.2 14.0			
	Push Tubes (Valve)	Inspect Replace				0.1 8.0			
	Timing Gear	Inspect Replace				0.6 24.0	106,113, 117		
	Rocker Arm Assembly	Inspect Replace			0.6 2.5		93		
	Valve Cover and Gasket	Inspect Replace		0.1 0.5					
0106	Oil Pump	Inspect Replace Repair			1.5 2.5		3.0	142,165	
	Oil Filter	Service Replace		0.6 0.2				82	
	Oil Filter Adapter	Replace		0.8					
	Oil Pan	Inspect Replace Repair	0.1			2.0 1.3			
	External Lines	Inspect Replace		0.1 1.0					
	Oil Breather	Inspect Service Replace		0.1 0.2 0.2					
	Oil Cooler	Inspect Service Replace		0.1	3.0		2.0		
	Oil Pressure Regulator	Inspect Test Replace			0.1 0.8 0.2				
	Level Gage (dipstick)	Replace		0.1					
0108	After Cooler	Inspect Repair Replace		0.1		2.0 2.5			

Section II. MAINTENANCE ALLOCATION CHART (continued)

(1) Group Number	(2) Component/ Assembly	(3) Maintenance Function	(4) Maintenance Level					(5) Tools and Equipment	(6) Remarks
			Field		Sustainment				
			Unit		DS	GS	Depot		
			C	O	F	H	D		
01	ENGINE (Continued)								
	Exhaust Manifold	Inspect Replace		0.1	2.8				
0109	Accessory Drive	Inspect Repair Replace			0.5	2.0 4.5	111,129 129		
0112	Engine Retarder	Inspect Repair Replace Adjust		0.5	3.0 1.5	6.0	121,130		
0121	Air Compressor	Replace Repair			4.0	2.0	117 34,43,50, 94,101		
03	FUEL SYSTEM								
0301	Fuel Injector Assembly	Test  Adjust Replace Calibrate Repair			0.8  4.0 4.0	1.0 1.8	140,149,151, 174,176,177  119,107 153 139,150		
0302	Fuel Pump Assembly Service of Filter & Screen	Inspect Service Test  Replace Calibrate Repair		0.5 0.2	4.8  2.0	3.5 8.9	155,162, 164 118 156,164 85,132,137, 152,160,163, 167		
0302	Engine Fuel Lines and Fittings	Inspect Replace		0.5 1.5					
0304	Air Cleaner Assembly	Inspect Service Replace	0.1	0.2 0.5					
0305	Turbocharger	Inspect Replace Repair	0.1		1.8	3.0			
	Turbocharger Air Inlet	Inspect Replace		0.1 0.3					



Section II. MAINTENANCE ALLOCATION CHART (continued)

(1) Group Number	(2) Component/ Assembly	(3) Maintenance Function	(4) Maintenance Level					(5) Tools and Equipment	(6) Remarks
			Field		Sustainment				
			Unit		DS	GS	Depot		
			C	O	F	H	D		
03	FUEL SYSTEM(Continued)								
0306	Fuel Solenoid Shutoff Valve	Replace Repair (Electrical) (Mechanical)		0.3 0.2	0.2				
0306	Fuel Tank	Inspect Service Repair Replace	0.1 0.2	2.0		1.5		Requires Welding	
0306	Fuel Heater	Inspect Replace	0.1	1.0					
0308	Governor Housing & Fuel Control	Replace Repair				0.2 0.5	85,152,173		
0309	Fuel Filter	Inspect Service Replace	0.1	0.3 0.3					
0309	Fuel Damper	Replace Repair			0.3 0.4				
0311	Ether Quick-Start Kit	Inspect Service Replace Repair	0.1	0.3 0.5 0.5					
0312	Accelerator Pedal and Linkage	Inspect Replace Repair		0.1 0.8 0.5					
	Fuel Control Lever	Inspect Replace Adjust		1.0 0.2 0.2					
04	EXHAUST SYSTEM								
	Muffler	Inspect Replace	0.1	0.5					
	Exhaust Pipe	Inspect Replace	0.1	0.4					
	Flex Tube	Inspect Replace	0.1	0.4					

Section II. MAINTENANCE ALLOCATION CHART (continued)

(1) Group Number	(2) Component/ Assembly	(3) Maintenance Function	(4) Maintenance Level					(5) Tools and Equipment	(6) Remarks
			Field		Sustainment				
			Unit		DS	GS	Depot		
			C	O	F	H	D		
04	EXHAUST SYSTEM (Continued)								
	Extension Tube	Inspect Replace	0.1	0.4					
	Tailpipe	Inspect Replace	0.1	0.2					
05	COOLING SYSTEM								
0501	Draincock	Inspect Replace	0.1	0.2					
	Radiator Assembly and Crossbar Supports	Inspect Service Replace Repair Test	0.2 0.2	3.0	2.0 0.3				
0503	Lines, Fittings, and Hoses	Inspect Replace	0.1	2.5					
	Thermostat	Replace		1.0					
	Thermostat Housing	Inspect Replace		0.2 1.0			81		
	Water Manifold	Inspect Replace Repair		0.2 2.0 2.0					
	Water Control Valve	Inspect Replace		0.2 0.4					
0504	Water Pump	Inspect Replace Repair	0.1	3.0		2.0	89,102 105,108, 120,125, 127		
0505	Fan	Inspect Replace	0.1	0.5					
	Fan Clutch & Air Valve	Inspect Replace Repair	0.1	1.5		1.5	25		

Section II. MAINTENANCE ALLOCATION CHART (continued)

(1) Group Number	(2) Component/ Assembly	(3) Maintenance Function	(4) Maintenance Level					(5) Tools and Equipment	(6) Remarks
			Field		Sustainment				
			Unit		DS	GS	Depot		
			C	O	F	H	D		
05	COOLING SYSTEM (Continued)								
	Water Pump Idler Pulley	Replace		0.5					
	Crankshaft Pulley	Replace		0.1					
	Accessory Drive Belts	Inspect Adjust Replace		0.2 0.2 1.0					
06	ELECTRICAL SYSTEM								
0601	Alternator & Regulator	Inspect Replace Adjust (Internal) Test Repair	0.2	1.0		0.5 0.5 2.0			
	Alternator Drive Belts	Inspect Adjust Replace	0.1	0.1 0.3					
0603	Starter Motor and Solenoid	Replace Repair		0.9		1.8			
	Starter Relay	Inspect Replace	0.1	0.5					
0607	Instrument Gages	Replace		0.5					
0608	Ignition Switch	Replace		0.5					
	Start Switch	Replace		0.5					
	Ether Quick-Start Button Switch	Replace		0.5					
	Clearance Lamp Switch	Replace		0.5					
	Headlamp Switch	Replace		0.5					
	Blackout Toggle Switch	Replace		0.5					
	Engine Retarder Selector Switch	Replace		0.5					
	Engine Retarder Foot Switch	Replace		0.5					

Section II. MAINTENANCE ALLOCATION CHART (continued)

(1) Group Number	(2) Component/ Assembly	(3) Maintenance Function	(4) Maintenance Level					(5) Tools and Equipment	(6) Remarks
			Field		Sustainment				
			Unit		DS	GS	Depot		
			C	O	F	H	D		
06	ELECTRICAL SYSTEM (Continued)								
	Turn Signal Control	Replace		0.5					
	Heater Fan Switch	Replace		0.5					
	Dimmer Switch	Replace		0.5					
0609	Service Headlamps	Replace		0.6					
	Marker & Turn Signal Lamps	Replace		0.3					
	Clearance Lamps	Replace		0.3					
	Taillamp, Brake, Turn Signal, Stoplamp, and Backup Lamps	Replace		0.3					
	Blackout Headlamps	Replace		0.3					
	Blackout Taillamp & Stoplamps	Replace		0.3					
	Dome Lamp & Switch	Replace		0.3					
	Map Lamps	Replace		0.3					
	Instrument Illumination Lamps	Replace		0.3					
0610	Sending Units								
	Fuel Level	Replace		0.4					
	Water Temperature	Replace		0.2					
	Oil Pressure	Replace		0.2					
	Transmission Oil Temperature	Replace		0.2					
	Switches & Relays	Replace		0.2					
	High Engine Water Temperature Switch	Replace		0.2					
	Low Engine Oil Pressure Switch	Replace		0.2					

Section II. MAINTENANCE ALLOCATION CHART (continued)

(1) Group Number	(2) Component/ Assembly	(3) Maintenance Function	(4) Maintenance Level					(5) Tools and Equipment	(6) Remarks
			Field		Sustainment				
			Unit		DS	GS	Depot		
			C	O	F	H	D		
06	ELECTRICAL SYSTEM (Continued)								
	Low Air Pressure Switch	Replace		0.2					
	Low Air Buzzer	Replace		0.2					
	Backup Switch	Replace		0.2					
0610	Park Brake Pressure Switch	Replace		0.2					
	Turn Signal Pressure Switch	Replace		0.2					
	Neutral Safety Switch	Replace		0.2					
	Differential Lockout Switch	Replace		0.2					
0610	Instrument Panel Circuit Breakers	Replace		0.2					
	Instrument Panel Relays	Replace		0.2					
0611	Horn	Replace		0.4					
	Horn Button	Replace		0.5					
0612	Batteries	Inspect Replace	0.5	0.6					
	Battery Box	Inspect Replace Repair	0.2	1.5 1.0					
	Battery Cable	Inspect Replace	0.2	0.5					
0613	Chassis Wiring Harness	Inspect Replace Repair	0.2	3.5 1.0					
	Trailer Coupling (Electric)	Inspect Replace	0.2	0.2					

Section II. MAINTENANCE ALLOCATION CHART (continued)

(1) Group Number	(2) Component/ Assembly	(3) Maintenance Function	(4) Maintenance Level					(5) Tools and Equipment	(6) Remarks
			Field		Sustainment				
			Unit		DS	GS	Depot		
			C	O	F	H	D		
07	TRANSMISSION								
0700	Transmission Mounts	Inspect Replace		0.2	1.0				
0705	Shift Control, Cables & Shift Points	Inspect Adjust Replace Repair		0.2 0.3 1.0 1.5			78		
0708	Torque Converter	Repair				2.5	23,34,38, 39,52,54, 64,68		
0710	Transmission	Inspect Service Replace Repair	0.3	1.0	6.0	18.0	32,34,44 46,50,51, 52,53,54, 55,60,62, 65,67,69		
0710	Oil Pan & Internal Filter	Replace Service		0.5 0.5			1		
0710	Output Shaft Seal	Inspect Replace		0.1	1.3		21,22,32, 34,41,42, 47,55,57		
0713	Clutches	Inspect Replace				8.0 8.0	33 thru 37, 40,42,45 46,48,52, 71,79		
0714	Control Valve & Governor	Replace				1.2	55,57		
0714	Trimmer Valves	Repair				0.6			
0721	Cooler, Lines & Fittings	Inspect Replace	0.3	2.2					
0721	Oil Charging Pump	Replace Repair				3.3 3.3			

Section II. MAINTENANCE ALLOCATION CHART (continued)

(1) Group Number	(2) Component/ Assembly	(3) Maintenance Function	(4) Maintenance Level					(5) Tools and Equipment	(6) Remarks
			Field		Sustainment				
			Unit		DS	GS	Depot		
			C	O	F	H	D		
07	TRANSMISSION (Continued)								
0721	External Filter & Lines	Inspect Replace	0.3	1.5					
09	PROPELLER SHAFTS & UNIVERSAL JOINTS								
	Universal Joints	Inspect Service Replace		0.3 0.2 1.4					
	Propeller Shafts	Inspect Service Replace		0.3 0.2 1.0					
10	FRONT AXLE								
	Axle Assembly	Inspect Service Repair Replace	0.1	0.3		6.0			
1004	Front Axle End Assembly (Steering Mechanism)	Inspect Replace	0.5	2.0	4.0		2,3		
11	REAR AXLE								
1100	Rear Bogie Axle	Inspect Service Replace Repair Overhaul	0.1	0.7	4.0	4.0 17.5			
1102	Differential and Carrier	Replace Repair Overhaul			9.8	9.8 11.5	7 74		
	Flange, Companion Drive Pinion	Inspect Replace	0.1		1.0		7		
	Seal, Oil, Drive Pinion Bearing	Inspect Replace	0.1		1.5		7		
1104	Rear Axle Shaft, Right or Left	Replace		3.5					

Section II. MAINTENANCE ALLOCATION CHART (continued)

(1) Group Number	(2) Component/ Assembly	(3) Maintenance Function	(4) Maintenance Level					(5) Tools and Equipment	(6) Remarks
			Field		Sustainment				
			Unit		DS	GS	Depot		
			C	O	F	H	D		
10	FRONT AXLE (Continued)								
1105	Differential Lockout	Repair Replace			1.0 1.0				
12	BRAKES								
1201	Park Brake Assembly	Inspect Adjust Repair Replace	0.1	0.5 1.4	0.8				
1202	Foundation Brakes								
	Brake Shoe Assemblies	Inspect Adjust Repair Replace		1.0 0.5 3.0	3.5				
	Slack Adjuster	Replace		0.3					
	S-Cam Mechanism	Replace		3.0					
1208	Air Lines and Fittings	Inspect Replace	0.1	2.2					
	Air Reservoirs	Inspect Service Replace	0.2 0.1	1.1					
1208	Air Brake Chambers	Adjust Replace Repair		0.2 2.0 2.2					
	Double Brake Chambers	Adjust Replace Repair		0.2 2.0		2.2			
1208	Dual Brake Valve and Pedal	Replace Repair		1.5		1.3			
	Trailer Protection Valve	Replace		1.5					
	Relay Valve	Replace		1.5					



Section II. MAINTENANCE ALLOCATION CHART (continued)

(1) Group Number	(2) Component/ Assembly	(3) Maintenance Function	(4) Maintenance Level					(5) Tools and Equipment	(6) Remarks
			Field		Sustainment				
			Unit		DS	GS	Depot		
			C	O	F	H	D		
12	BRAKES (Continued)								
	Quick Release Valve	Replace		1.5					
	Limiting Valve	Replace		1.5					
	Double Check Valves	Replace		1.5					
	Air Compressor Governor	Adjust Replace Repair			1.0 0.5		1.5		
	Air Dryer	Inspect Service Replace	0.1	1.5 0.8					
1211	Trailer Hand Brake Valve	Inspect Replace Repair	0.1	1.8 1.5					
	Trailer Connector, Brake Lines, and Couplings	Inspect Replace Repair	0.1	1.0	1.3				
13	WHEELS								
1300	Wheel Alinement	Inspect Adjust		0.8 0.5					
1311	Hub Assemblies	Replace		0.5			4,5		
	Drums	Replace Repair		1.5		1.5			
	Bearings and Seals	Service Replace		1.5 1.5			8 thru 12		
	Wheel Assembly	Inspect Replace Service	0.1 0.5 0.3						
1313	Tire	Inspect Replace Service	0.3	2.1 1.3					

Section II. MAINTENANCE ALLOCATION CHART (continued)

(1) Group Number	(2) Component/ Assembly	(3) Maintenance Function	(4) Maintenance Level					(5) Tools and Equipment	(6) Remarks
			Field		Sustainment				
			Unit		DS	GS	Depot		
			C	O	F	H	D		
14	STEERING								
1401	Steering Wheel	Inspect Replace	0.1	0.5					
	Upper Steering Column	Replace Repair		3.0 3.5					
	Lower Steering Column	Replace Repair		1.0 0.5					
	Drag Links	Inspect Adjust Replace Repair	0.1	0.3 1.0 1.5					
	Pitman Arm	Replace		0.8					
	Tie Rod	Inspect Adjust Replace Repair	0.1	0.1 1.5 1.0					
1407	Steering Gear	Inspect Adjust Replace	0.5		1.0 1.5				
1410	Hydraulic Steering Pump and Reservoir Assembly	Test Inspect Service Replace Repair	0.1 0.2	0.5 1.0		2.0	6		
15	FRAME ASSEMBLY								
1501	Frame Components	Inspect Replace	0.5			1.0			
	Bumper	Replace		1.0					
	Steps	Inspect Replace	0.1	1.0					

Section II. MAINTENANCE ALLOCATION CHART (continued)

(1) Group Number	(2) Component/ Assembly	(3) Maintenance Function	(4) Maintenance Level					(5) Tools and Equipment	(6) Remarks
			Field		Sustainment				
			Unit		DS	GS	Depot		
			C	O	F	H	D		
15	FRAME ASSEMBLY (Continued)								
1503	Pintle Hook Assembly	Inspect Replace Repair	0.1	0.6 0.2					
1504	Spare Wheel Carrier	Replace		0.5					
1506	Fifth Wheel Assembly	Inspect Adjust Service Repair Replace	0.5	1.0 0.5 4.0		3.0	20 76		
16	SPRINGS, SHOCK ABSORBERS, AND TORQUE RODS								
1601	Tandem Axle Suspension	Inspect Replace Repair		0.3	5.0	8.0			
1601	Springs	Inspect Service Replace Repair	0.1	0.2	4.0	6.0	26 thru 30		
	Front Spring Pins	Replace		0.1					
1604	Shock Absorbers	Inspect Replace	0.1	1.0					
1605	Torque Rods	Replace Repair		1.0		1.0	26		
18	CAB AND BODY								
1801	Cab Mounts	Inspect Replace	0.1		1.0				

Section II. MAINTENANCE ALLOCATION CHART (continued)

(1) Group Number	(2) Component/ Assembly	(3) Maintenance Function	(4) Maintenance Level					(5) Tools and Equipment	(6) Remarks
			Field		Sustainment				
			Unit		DS	GS	Depot		
			C	O	F	H	D		
18	CAB AND BODY (Continued)								
	Cab	Inspect Repair Replace	0.1	2.0			20.0		
	Doors	Inspect Replace Repair	0.1		2.0 1.0				
1801	Hood Panels	Inspect Replace Repair	0.1	0.5 0.2					
	Ventilators & Controls	Inspect Replace Repair	0.1	0.2 0.5					
	Grille	Inspect Replace Repair	0.1	0.5 0.5					
	Splash Shields	Inspect Replace	0.1	0.3					
1802	Fenders	Inspect Replace Repair	0.1	1.5 1.0					
	Windshield Door Glass & Sliding Rear Window	Inspect Replace	0.1		1.2			31	
1806	Seats	Inspect Replace Repair	0.1	0.5	0.5				
1808	Stowage Box	Inspect Replace Repair	0.1	0.1 0.1					

Section II. MAINTENANCE ALLOCATION CHART (continued)

(1) Group Number	(2) Component/ Assembly	(3) Maintenance Function	(4) Maintenance Level					(5) Tools and Equipment	(6) Remarks
			Field		Sustainment				
			Unit		DS	GS	Depot		
			C	O	F	H	D		
22	ACCESSORY ITEMS								
	Windshield Wiper Motors	Replace		0.8					
	Windshield Wiper Controls	Replace		0.3					
	Arm and Wiper Blades	Inspect Replace	0.1	0.2					
	Mirrors	Inspect Replace	0.1	0.3					
	Windshield Washer	Inspect Service Replace	0.1 0.2	0.5					
	Windshield Washer Control	Replace		0.3					
	Air Horn and Control Valve	Replace		0.3					
2207	Personnel Heater	Inspect Replace Repair	0.1	2.0 1.0					
	Air Ducts	Inspect Replace	0.1	0.8					
	Heater Control Valve and Cable	Adjust Replace		0.2 0.5					
	Heater Control Panel	Replace Repair		1.0 1.0					
	Defrost Fan	Replace Repair		0.5 0.5					
2210	Data and Instruction Plates	Inspect Replace	0.1	0.5					

Section II. MAINTENANCE ALLOCATION CHART (continued)

(1) Group Number	(2) Component/ Assembly	(3) Maintenance Function	(4) Maintenance Level					(5) Tools and Equipment	(6) Remarks
			Field		Sustainment				
			Unit		DS	GS	Depot		
			C	O	F	H	D		
47	GAGES (NONELECTRICAL)								
4701	Tachograph	Service Replace		0.2 0.3					
	Speedometer Cable	Replace		0.4					
	Tachometer Cable	Replace		0.4					
4702	Pressure Gages	Inspect Replace	0.1						
	Air Cleaner Restriction Indicator	Inspect Replace	0.1						
6715	STE/ICE COMPONENTS	Test Replace		0.5 1.0					

Section III. TOOLS AND TEST EQUIPMENT REQUIREMENTS

Tools or Test Equipment Reference Code	Maintenance Level	Nomenclature	National Stock Number	Tool Number
		<u>CHASSIS TOOLS AND TEST EQUIPMENT</u>		
1	O	PIN, OIL PAN GUIDE	5315-01-151-1106	J-3387-2
2	O	INDICATOR SET, DIAL	5120-00-402-9619	J7872
3	O	DRIVER, BUSHING	5120-01-159-1841	700291
4	O	WRENCH, HEXAGON LOCKNUT, 4-1/8 INCH	5120-01-145-5793	1915
5	O	WRENCH, HEXAGON LOCKNUT, 2-1/4 INCH	5120-01-089-9068	1920
6	O	ANALYZER, POWER STEERING	4910-01-160-3618	J26487-A
7	O	BAR, HOLDING, PINION YOKE AND FLANGE	4910-01-166-0573	J 3453
8	O	HANDLE	4910-01-165-8193	450237
9	O	ADAPTER	4910-01-165-8192	427
10	O	PLUG, BEARING	4910-01-165-8195	706
11	O	ADAPTER	4910-01-165-8194	446
12	O	PLUG, BEARING	4910-01-168-9544	715
13	O	REMOVAL TOOL, CONTACT	5120-01-158-4707	114010
14	O	REMOVAL TOOL, CONTACT	5120-01-158-4708	0411-204-1605
15	O	CRIMPING TOOL	5120-00-251-3990	5417
16	O	CRIMPING TOOL	5120-00-165-3912	MS3191-4
17	O	LOCATOR, SOCKET CONTACT	5120-01-131-0138	600092
18	O	INSERTION TOOL, CONTACT	5120-01-131-0140	CIT-F80-16
19	O	EXTRACTION TOOL, CONTACT	5120-01-131-0139	CET-F80-16
20	O	TESTER, LOCK FIFTH WHEEL, 2 INCHES	4190-01-157-3571	TLN-1000
21	F	REMOVER, SEAL AND DUST SHIELD	5120-01-048-2153	J 24171
22	F	INSTALLER, OUTPUT SHAFT SEAL	5120-01-159-1852	J 24202-1A
23	F	HANDLE, DRIVER	5120-01-054-4048	J 24202-4
24	F	JACK, TRANSMISSION	4910-00-585-3622	49
25	F	TOOL, SPANNER		294514
26	F	SERVICE SET, TORQUE ROD BUSHING	4910-01-159-1734	Y-820
27	F	SERVICE SET, EQUALIZING	5180-01-084-6010	Y-850-A
28	F	TUBE, RECEIVING	4910-01-159-1735	Y-860
29	F	ADAPTER, REMOVING	5120-01-159-1843	Y-861
30	F	ADAPTER, INSTALLING	5120-01-159-1845	Y-862
31	F	REMOVER AND INSTALLER, WINDSHIELD		C-4009-B
32	H	HANDLE, DRIVER	5120-00-677-2259	J 8092
33	H	GAGE, CLEARANCE CLUTCH PACK, 0.080-0.120 INCH	5210-01-048-2161	J 24192
34	H	GAGE, CLEARANCE, CLUTCH PACK, 0.060-0.120 INCH	5210-01-048-2162	J 24193
35	H	GAGE, CLEARANCE, CLUTCH PACK, 0.095-0.145 INCH	5210-01-048-5283	J24194
36	H	BRACKET, LIFTING, CENTER SUPPORT	5120-01-116-6048	J 24195
37	H	BRACKET, LIFTING, MAINSHAFT	5120-01-115-1157	J 24196
38	H	INSTALLER, BEARING, FRONT SUPPORT HUB	5120-01-115-1160	J 24197

## Section III. TOOLS AND TEST EQUIPMENT REQUIREMENTS

Tools or Test Equipment Reference Code	Maintenance Level	Nomenclature	National Stock Number	Tool Number
		<u>CHASSIS TOOLS AND TEST EQUIPMENT</u>		
39	H	INSTALLER, OIL SEAL, OIL PUMP	5120-01-054-4049	J 24198
40	H	INSTALLER AND STAKING SET, COLLECTOR RING	5120-01-048-3124	J 24200
41	H	INSTALLER, BUSHING, OUTPUT SHAFT	5120-01-115-9174	J 24203
42	H	COMPRESSOR, CLUTCH SPRING	5120-01-048-3129	J 24204
43	H	INSTALLER AND REMOVER, SPEEDOMETER BUSHING	5120-01-116-5017	J 24205-A
44	H	INSTALLER, SLEEVE, FRONT PLANETARY BUSHING	4910-01-158-3989	J24207
45	H	COMPRESSOR SET, CENTER SUPPORT	5120-01-116-5016	J 24208-C
46	H	FIXTURE, LIFTING, FOURTH CLUTCH	5120-01-115-1159	J 24209
47	H	PROTECTOR, INNER SEAL, CLUTCH PISTON	5120-01-048-2156	J 24210
48	H	PROTECTOR, SEAL, FORWARD CLUTCH	5120-01-048-2157	J 24216-01
49	H	INSTALLER MAINSHAFT ORIFICE	5120-01-115-1162	J24217
50	H	RING RETAINER, STATOR CAMSPRING AND ROLLER	5120-01-115-1158	J24218-2
51	H	COMPRESSOR, SPRING	5120-01-048-2160	J24219
52	H	FIXTURE, ALINEMENT, FOURTH CLUTCH	5120-01-115-1156	J 24221
53	H	FIXTURE, HOLDING, TRANSMISSION	5120-01-115-1165	J 24310
54	H	PIN SET, GUIDE	5120-01-115-1163	J 24315
55	H	LIFTING TOOL, FLYWHEEL	5120-01-116-6049	J 24365
56	H	INSTALLER, BUSHING, REAR PLANETARY CARRIER	5120-01-159-1844	J 24368
57	H	INSTALLER, ORIFICE PLUG	5120-01-054-4053	J 24369
58	H	PULLER, UNIVERSAL	5120-00-999-4053	J 24420
59	H	INSTALLER, BEARING, REAR	5120-01-054-4054	J 24447
60	H	INSTALLER, RETAINING RING	5120-01-054-4050	J 24453
61	H	REMOVER, REAR BEARING, IN-VEHICLE	5120-01-054-0188	J 24534
62	H	INSTALLER, SEAL, SHIFT LEVER	5120-01-115-1161	J 26282
63	H	REMOVER, SEAL, SHIFT LEVER	5120-01-118-6264	J 26401
64	H	REMOVER AND INSTALLER, SNAPRING, PUMP		J 26598-A
65	H	STAKING TOOL, BUSHING, SUN GEAR		J26997-A
66	H	REAMER SET, BUSHING, SUN GEAR	5110-01-150-9755	J 28489
67	H	INSTALLER AND STAKING SET, BUSHING, CENTER SUPPORT	4910-01-158-3971	J 28525
68	H	INSTALLER, BEARING	5120-01-159-1842	J 28646-A
69	H	INSTALLER, PIN, GOVERNOR SUPPORT	5120-01-122-1179	J 28684
70	H	GAGE, RING, CENTER AND FRONT SUPPORT SEAL	5210-01-133-6888	J 29198-3
71	H	LIFTER, CLUTCH ASSEMBLY	4910-01-159-1736	J 33079
72	H	REMOVER AND INSTALLER, DRIVEN GEAR SHAFT		J 33080
73	H	SCALE, TENSION	4910-00-779-6832	J 8129



Section III. TOOLS AND TEST EQUIPMENT REQUIREMENTS

Tools or Test Equipment Reference Code	Maintenance Level	Nomenclature	National Stock Number	Tool Number
		<u>CHASSIS TOOLS AND TEST EQUIPMENT</u>		
74	H	STAKING TOOL		J 26883
75	H	STAND, REPAIR, DIFFERENTIAL	4910-01-085-7729	J 3409-01
76	H	COMPRESSOR, SPRING, SLIDER		TLN-2500
77	H	DRIVER BUSHING	4910-01-158-3986	J 24201
78	H	ADJUSTING TOOL, VALVE RING		J 24314
79	H	FIXTURE SET, GEAR REMOVING		J 26899
		<u>ENGINE TOOLS AND TEST EQUIPMENT</u>		
80	O	GAGE, MANIFOLD PRESSURE	6620-01-147-9954	ST-1273
81	O	MANDREL, THERMOSTAT SEAL	4910-01-097-6948	ST-1225
82	O	WRENCH, OIL AND FUEL FILTER, SPIN-ON	5120-01-160-8863	3375049
83	F	FIXTURE, ENGINE LIFTING	2815-00-362-2042	ST-125
84	F	TOOL, VALVE SEAT INSERT	4910-00-345-3708	ST-257
85	F	VICE, BALL JOINT	4910-00-999-1506	ST-302
86	F	COMPRESSOR, VALVE SPRING	5120-01-145-7293	ST-448
87	F	FIXTURE, HEAD HOLDING	4920-00-711-9307	ST-583
88	F	SPACER, CROSSHEAD GUIDE	4910-00-150-5797	ST-633
89	F	MANDREL, WATER PUMP BEARING	4910-00-097-6986	ST-658
90	F	CUTTER, VALVE SEAT INSERT	5133-00-999-1208	ST-662
91	F	ARBOR, VALVE GUIDE	3640-00-999-1173	ST-663
92	F	ADAPTER, TORQUE WRENCH	5120-00-103-4687	ST-669
93	F	BLOCK AND MANDREL, ROCKER LEVER	3460-00-999-1210	ST-691
94	F	PLATE, AIR COMPRESSOR MOUNTING	4910-01-159-8701	ST-749
95	F	TOOL, BEAD CUTTING	5110-00-932-2089	ST-788
96	F	TOOL, INJECTOR SEAT CUTTING	4910-00-925-0755	ST-824
97	F	BRUSH, FUEL PASSAGE CLEANING	7920-00-168-3244	ST-876
98	F	EXPANDER, INJECTOR SLEEVE	3441-00-922-6699	ST-880
99	F	CUTTER, INJECTOR SEAT	4910-00-981-3105	ST-884
100	F	DRIVER, CRANKSHAFT OIL SEAL	4910-00-150-5810	ST-997
101	F	MANDREL, AIR COMPRESSOR BUSHING		ST-1105
102	F	FIXTURE, BEARING DISASSEMBLY	4910-01-097-6987	ST-1114
103	F	DRIVER, VALVE SEAT INSERT STAKING TOOL	4910-00-150-5843	ST-1122
104	F	PILOT, VALVE SEAT INSERT STAKING TOOL	4910-00-150-5844	ST-1124
105	F	MANDREL, SEAL WEAR SLEEVE	4910-01-097-6988	ST-1159
106	F	MANDREL, SEAL	4910-01-161-2115	ST-1173
107	F	TOOL, INJECTOR SLEEVE HOLDING	5120-00-104-1795	ST-1179
108	F	DRIVER, OIL SEAL	5120-01-160-8867	ST-1191
109	F	DRIVER, INJECTOR SLEEVE	5120-00-981-3108	ST-1227
110	F	PULLER, INJECTOR SLEEVE	5120-00-113-5271	ST-1244
111	F	PULLER	5120-01-128-2678	3376663
112	F	TESTER, VALVE VACUUM	4910-01-128-2691	ST-1257-A

## Section III. TOOLS AND TEST EQUIPMENT REQUIREMENTS

Tools or Test Equipment Reference Code	Maintenance Level	Nomenclature	National Stock Number	Tool Number
113	F	INSTALLER, OIL SEAL	4910-01-106-0492	ST-1259
114	F	EXTRACTOR, VALVE SEAT	5120-01-128-2679	ST-1279
115	F	ATTACHMENT, DIAL GAGE	4910-01-097-6972	ST-1325
116	F	TOOL, BLOWBY CHECKING	4910-01-085-9211	3375150
117	F	EXPANDER, OIL SEAL		3375151
118	F	WRENCH, AIR COMPRESSOR	5120-01-072-2952	3375159
119	F	PULLER, INJECTOR		3375161
120	F	PILOT, OIL SEAL	4910-01-097-6989	3375180
121	F	TESTER, SPRING	4910-01-142-4929	3375182
122	F	DRIVER, EXPANSION PLUG, 3/4"	4910-01-143-3336	3375190
123	F	DRIVER, EXPANSION PLUG, 1"	4910-01-143-3337	3375191
124	F	DRIVER, EXPANSION PLUG, 1-1/4"	4910-01-143-2023	3375192
125	F	PULLER	5120-01-155-3795	3375257
126	F	DRIVER, VALVE GUIDE	4910-01-097-6971	3375282
127	F	MANDREL, WATER PUMP SEAL	5120-01-128-2675	3375448
128	F	DIAL INDICATOR AND SLEEVE ASSEMBLY	5210-01-157-2291	3376050
129	F	ASSEMBLY TOOL, PULLEY INSTALLATION	5120-01-156-4183	3376326
130	F	WRENCH, SOLENOID VALVE		011494
131	F	SOCKET, SPECIAL, 5/8" X 1/2" DRIVE		SINL-200
132	H	FIXTURE, REAM	5110-00-981-3107	ST-490
133	H	GAGE, PISTON RING GROOVE	5210-00-999-1209	ST-560
134	H	FIXTURE, CONNECTING ROD CHECKING	4910-00-977-7507	ST-561
135	H	MANDREL, CONNECTING ROD LOCATING	4910-01-146-7130	ST-563
136	H	TOOL, BURNISHING	4910-00-999-1503	ST-708
137	H	PULLER, GOVERNOR WEIGHT	5120-00-999-1504	ST-709
138	H	EXPANDER, PISTON RING	5120-00-150-7486	ST-763
139	H	WRENCH, INJECTOR CUP	5120-00-150-7492	ST-995
140	H	EXTENSION, PLUNGER	4910-00-150-5819	ST-1089
141	H	EXTRACTOR, DOWEL PIN	4910-00-150-5848	ST-1134
142	H	MANDREL, SPACER	4910-01-097-6913	ST-1157
143	H	PULLER, MAIN BEARING CAP	5120-01-141-5777	ST-1178
144	H	CLAMP, CYLINDER LINER	5120-00-104-1816	ST-1184
145	H	DRIVER, LINER	5120-00-999-1206	ST-1229
146	H	TOOL, PLUNGER PROTRUSION CHECKING	4910-01-141-8388	ST-1241
147	H	DRIVER, CONNECTING ROD BUSHING	4910-01-098-1914	ST-1242
148	H	CONVERSION KIT	4910-01-147-7896	ST-1261
149	H	INJECTOR, MASTER "K"	4910-01-154-6406	ST-1262
150	H	STAND, INJECTOR	4910-01-082-1346	ST-1298
151	H	POT, INJECTOR ADAPTER	4910-00-185-8508	3375086
152	H	PLATE, FUEL PUMP MOUNTING	4910-01-128-2685	3375133
153	H	FIXTURE, SETTING, TOP STOP INJECTOR	4910-01-097-6926	3375160
154	H	CXCOMPRESSOR, PISTON RING	5120-01-128-2758	3375162
155	H	TOOL KIT, AFC FUEL PUMP ADJUSTING TOOL	5180-01-102-8418	3375189

Section III. TOOLS AND TEST EQUIPMENT REQUIREMENTS

Tools or Test Equipment Reference Code	Maintenance Level	Nomenclature	National Stock Number	Tool Number
156	H	TOOL, INSTALLING, THROTTLE SHAFT BALL	4910-01-118-3747	3375204
157	H	KIT, CRACK DETECTION	6850-00-145-0255	3375432
158	H	TOOL, CYLINDER BLOCK COUNTERBORE	4910-01-150-9713	3375455
159	H	FIXTURE, INJECTION TIMING	4910-00-999-1269	3375522
160	H	PULLER, AFC BARREL	5120-01-128-2688	3375599
161	H	PIN, CONNECTING ROD GUIDE		3375601
162	H	INDICATOR, LEVEL & ANGLE	4910-01-074-0020	3375855
163	H	DRIVER, PRESSURIZING VALVE	4910-01-143-2034	3375959
164	H	TOOL, ADJUSTING, FUEL PUMP IDLE	4910-00-150-5805	3375981
165	H	FIXTURE, AFC PRESSURE VALVE	4910-01-152-2743	3376011
166	H	PULLER, CYLINDER LINER, UNIVERSAL	5120-01-143-2032	3376015
167	H	DRIVER, LOCK CUP	4910-00-150-5801	3376136
168	H	BLOCK, GAGE	5210-01-157-3091	3376220
169	H	WRENCH, TORQUE, INCH-POUND	4910-01-097-6929	3376592
170	H	KIT, CAMSHAFT BUSHING DRIVER	5120-01-146-7131	3376633
171	H	DRIVER, CAMSHAFT BUSHING	5120-01-156-6186	3376637
172	H	OIL SEAL ASSEMBLY TOOL	5120-00-896-8097	ST-419
173	H	FRONT COVER & MAINSHAFT ASSEMBLY TOOL		3375175
174	H	TESTER, INJECTOR LEAKAGE	5120-01-029-6861	ST-990
175	H	STAND, INJECTOR TEST	4910-01-128-9810	ST-790
176	H	TESTER, INJECTOR CUP SPRAY	4910-00-999-1501	ST-668
177	H	LINK		ST790-362
178	H	ORIFICE		ST790-363
179	H	INJECTOR ADAPTER POT		ST-1254
180	H	KIT, K-CAM		J 33113

APPENDIX C  
EXPENDABLE SUPPLIES AND MATERIALS LIST

SECTION I. INTRODUCTION

**C-1. SCOPE.**

This appendix lists expendable supplies and material you will need to operate and maintain the M915A1 Truck Tractor. These items are authorized to you by CTA 50-970, Expendables Items (Except Medical, Class V, Repair Parts, and Heraldic Items).

**C-2. EXPLANATION OF COLUMNS.**

a. Column (1) - Item number. This number is assigned to the entry in the listing and is referenced in the narrative instructions to identify the material (e. g., "Use grease, Item 4, Appendix C").

b. Column (2) - Level. This column identifies the lowest level of maintenance that requires the listed item.

C - Operator/Crew

0 - Organizational Maintenance

c. Column (3) - National Stock Number. This is the national stock number assigned to the item; use it to request or requisition the item.

d. Column (4) - Description. Indicates the federal item name and, if required, a description to identify the item. The last line for each item indicates the Federal Supply Code for Manufacturer (FSCM) in parenthesis followed by the part number.

e. Column (5) - Unit of Measure (U/M). Indicates the measure used in performing the actual maintenance function. This measure is expressed by a two-character alphabetical abbreviation (e. g., ea, in., pr). If the unit of measure differs from the unit of issue, requisition the lowest unit of issue that will satisfy your requirements.

SECTION II. EXPENDABLE SUPPLIES AND MATERIALS LIST.

(1) ITEM NUMBER	(2) LEVEL	(3) NATIONAL STOCK NUMBER	(4) DESCRIPTION	(5) U/M
1	0		ADHESIVE, RUBBER, TYPE II, 3-OZ BOTTLE	OZ
2	0		ANTIFREEZE, ARTIC GRADE (90° F) 0-1490, MIL-C-11755 55-GAL DRUM	GAL.
3	0		ANTIFREEZE, PERMANENT ETHYLENE GLYCOL (60° F) INHIBITED, 0-A-548, TYPE I, MIL-A-46153 1-GAL. CONTAINER 5-GAL. CONTAINER 55-GAL. CONTAINER	GAL. GAL. GAL.
4	0		BLACK ACIDPROOF PAINT	PT
5	0	8030-00-616-7694	COMPOUND, ANTISEIZE, MIL-A-907	LB
6	0		COMPOUND, GASKET, PERMATEX®, NO. 2C	
7	C		GREASE, AUTOMOTIVE AND ARTILLERY, GAA, MIL-G-10924C 2-1/2 OZ TUBE 14-OZ CARTRIDGE 1-LB CAN 5-LB CAN 35-LB CAN 120-LB DRUM	OZ OZ LB LB LB LB
		9150-00-065-0029		
		9150-00-935-1017		
		9150-00-190-0904		
		9150-00-190-0905		
		9150-00-190-0907		
		9150-00-190-7369		
8	0		GREASE, PNEUMATIC	LB
9	0		GREASE, SILICONE, LUBRICATION	OZ
10	0		LOCTITE® (THREAD LOCKING COMPOUND)	PT
11	0		LUBRIPLATE®	PT
12	C		OIL, FUEL: DIESEL, ARTIC A DFA BULK 5-GAL. DRUM 55-GAL. DRUM, 16-GAGE 55-GAL. DRUM, 18-GAGE	GAL. GAL. GAL. GAL.
		9150-00-286-5283		
		9150-00-286-5282		
		9150-00-286-5284		
		9150-00-286-5285		

**SECTION II. EXPENDABLE SUPPLIES AND MATERIALS LIST (Continued).**

(1) ITEM NUMBER	(2) LEVEL	(3) NATIONAL STOCK NUMBER	(4) DESCRIPTION	(5) U/M
13	C	9140-00-286-5294 9140-00-286-5295 9140-00-286-5296 9140-00-286-5297	OIL, FUEL: DIESEL, REGULAR DF-2, VV-F-800 BULK 5-GAL. CAN 55-GAL. DRUM, 16-GAGE 55-GAL. DRUM, 18-GAGE	GAL. GAL. GAL. GAL.
14	C	9140-00-286-5286 9140-00-286-5287 9140-00-286-5288	OIL, FUEL: DIESEL, WINTER DF-1, VV-F-800 BULK 5-GAL. CAN 55-GAL. DRUM, 16 GAGE	GAL. GAL. GAL.
15	C	9150-00-189-6727 9150-00-186-6618 9150-00-265-9429 9150-00-191-2772 9150-00-183-7807	OIL, LUBRICATING: OE/HDO 10 MIL-L-2104C 1-QT CAN 5-GAL. DRUM 55-GAL. DRUM, 16-GAGE 55-GAL. DRUM, 18-GAGE BULK	QT GAL. GAL. GAL. GAL.
16	C	9150-00-186-6681 9150-00-188-9858 9150-00-265-9436 9150-00-189-6729 9150-00-183-7808	OIL, LUBRICATING: OE/HDO 30 MIL-L-2140C 1-QT CAN 5-GAL. DRUM 55-GAL. DRUM, 16-GAGE 55-GAL. DRUM, 18-GAGE BULK	QT GAL. GAL. GAL. GAL.
17	C	9150-00-265-9440 9150-00-265-9442 9150-00-265-9441	OIL, LUBRICATING: OE/HDO 50 MIL-L-2104C 1-QT CAN 5-GAL. DRUM 55-GAL. DRUM	QT GAL. GAL.
18	C	9150-00-402-4478 9150-00-402-2372 9150-00-491-7197	OIL, LUBRICATING: ICE SUBZERO OEA, MIL-L-46167 1-QT CAN 5-GAL. DRUM 55-GAL. DRUM	QT GAL. GAL.

**SECTION II. EXPENDABLE SUPPLIES AND MATERIALS LIST (Continued).**

(1) ITEM NUMBER	(2) LEVEL	(3) NATIONAL STOCK NUMBER	(4) DESCRIPTION	(5) U/M
19	0		OIL, LUBRICATING: GEAR GO-75 MIL-L-2105C 1- QT CAN 5- GAL. DRUM	QT GAL.
20	0		OIL, LUBRICATING: GEAR GO-80/90 MIL-L-2105C 1- QT CAN 5- GAL. DRUM 55- GAL. DRUM	QT GAL. GAL.
21	0		PUTTY, LINSEED OIL, WHITE LEAD (TT-P-791)	LB
22	0		RAG, WIPING, 50-POUND BALE	LB
23	0		SEALANT, FLANGE (34623) 5571180	ML
24	0	8030-00-246-0933	SEALANT, PIPE, MIL-5-15204	OZ
25	0		SEALER, NONHARDENING	OZ
26	0		SEALING COMPOUND: AUTOMOTIVE, SEMI SOLID, RUBBER, MIL-S-3802	LB
27	0		SODIUM BICARBONATE	LB
28	C	N/A	SOLUTION, SOAP	N/A
29	0		SOLVENT, DRYCLEANING, SD-2, FED SPEC P-D-680 TYPE II 1- QT CAN 1- GAL. CAN 5- GAL. CAN 55- GAL. DRUM, 16- GAGE 55- GAL. DRUM, 18- GAGE	QT GAL. GAL. GAL. GAL.
30	0		TAPE, ELECTRICAL	YD
31	0		TAPE, PRESSURE SENSITIVE ADHESIVE, MASKING, 1-INCH WIDE, 60-YARD ROLL	YD

**SECTION II. EXPENDABLE SUPPLIES AND MATERIALS LIST (Continued).**

(1) ITEM NUMBER	(2) LEVEL	(3) NATIONAL STOCK NUMBER	(4) DESCRIPTION	(5) U/M
32	0		TAPE, THREAD SEALING (TEFLON®) 50-FT ROLL, 1/4-INCH WIDE 50-FT ROLL, 1/2-INCH WIDE	FT FT
33	0	8040-00-865-8991	THREAD SEALANT, LIQUID (TEFLON®) 1-PT CAN, MIL-A-46106 1-QT CAN	PT QT
34	C	6850-00-926-2275	WINDSHIELD, CLEANING COMPOUND FOR 1-PT CAN	PT
35	C	9150-00-698-2382 9150-00-057-4959	DEXTRON, ATF 1 QT CAN 5 GAL. CAN	QT GAL.





**APPENDIX D**

**SCHEMATIC DIAGRAMS**

**Section I. INTRODUCTION**

**D-1. SCOPE.**

This appendix provides you with electrical and compressed air system schematic diagrams.

**NOTE**

Fold out diagrams are located at the end of this technical manual.

**D-2. ELECTRICAL SYSTEM DIAGRAMS.**

	<b>Page</b>
Figure F0-1. Right-Hand and Left-Hand Front Signal Lamp Harness Assemblies . . . . .	F0-1
Figure FD-2. Right-Hand and Left-Hand Fender Harness Assemblies . .	F0-3
Figure F0-3. Engine Harness Assembly . . . . .	F0-5
Figure F0-4. Cab Marker Lamps Harness Assembly . . . . .	F0-7
Figure F0-5. Cab Front and Underbody Harness Assembly . . . . .	F0-9
Figure F0-6. Chassis Harness Assembly . . . . .	F0-11
Figure F0-7. Instrument Panel Harness Assembly . . . . .	F0-13
Figure F0-8. M915A1 Wiring Diagram . . . . .	F0-15

**D-3. COMPRESSED AIR SYSTEM DIAGRAM**

	<b>Page</b>
Figure F0-9. M915A1 Air and Brake System Diagram . . . . .	F0-17

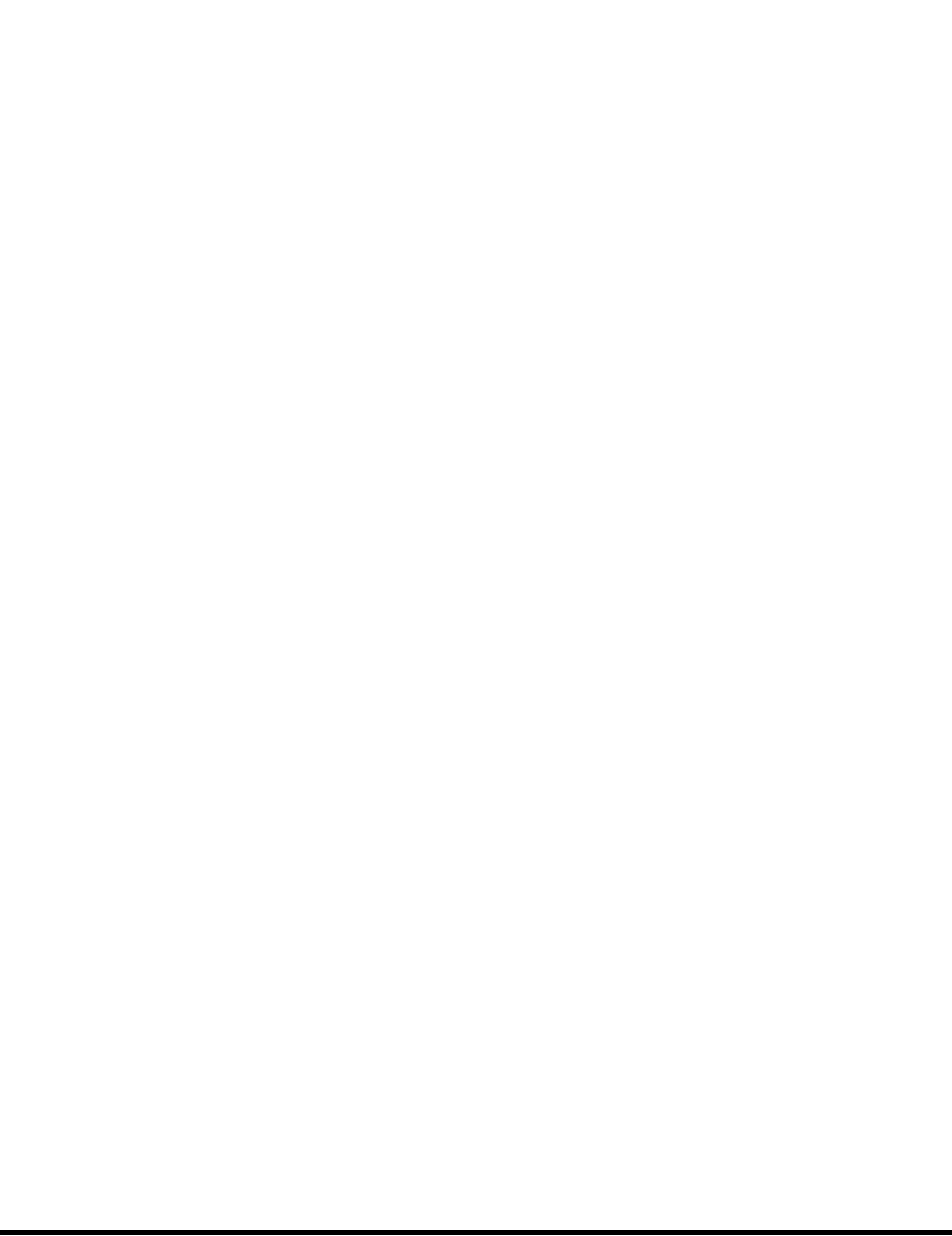

APPENDIX E

ILLUSTRATED LIST OF MANUFACTURED ITEMS

Section I. INTRODUCTION.

**E-1. GENERAL**

a. This appendix includes complete instructions for making items authorized to be manufactured or fabricated at organizational maintenance.

b. A part number index in alphanumeric order is provided for cross-referencing the part number of the item to be manufactured to the figure which covers fabrication criteria.

c. All bulk materials needed for manufacture of an item are listed by part number or specifications number in a tabular list on the illustration.

**E-2. MANUFACTURED ITEM PART NUMBER INDEX.**

PART NO.	FIGURE/ITEM NO.	PART NO.	FIGURE/ITEM NO.
5571108	E-4/1	M/357-20005	E-3/10
5571109	E-2/6	M/357-20009	E-4/3
5571110	E-3/3 and 4	M/357-20012	E-4/2
5571111	E-2/7	M/357-20055	E-3/7
5571112	E-3/6	M/357-20057	E-3/8
5571113	E-2/1	M/357-20061	E-2/3
5571117	E-1/1	M/357-20062	E-1/2
5571126	E-3/11	M/357-20063	E-1/11
5571141	E-6/1	M/357-20066	E-1/10
5571150	E-6/3	M/357-20067	E-1/9
5571151	E-6/4	M/357-20069	E-2/2
5571159	E-1/6	M/357-20070	E-2/8
5571160	E-1/7	M/357-20071	E-1/13
5571161	E-1/15	M/357-20072	E-1/12
5571162	E-3/1	M/357-20073	E-1/14
5571163	E-1/4	M/357-20074	E-3/9
5571164	E-2/4	M/357-20075	E-3/2
5571165	E-2/9	M/357-20102	E-1/5, 16, and 17
5571166	E-2/10	M/357-20116	E-3/5
5571167	E-1/8	M/357-20129	E-2/5
5995197	E-5/2	MA145-20001	E-6/2
5995198	E-5/1	MB147-20001	E-7/1

**Section II. ILLUSTRATED MANUFACTURING INSTRUCTIONS.**

<b>MATERIAL BLOCK</b>		
<b>STOCK SIZE</b>	<b>DESCRIPTION</b>	<b>SPECIFICATION</b>
1/4" OUTER DIAMETER	TUBE, NONMETALLIC AND FITTINGS	SAEJ844, TYPE 3A SAEJ246 AND J1131

ITEM NO.	NONMETALLIC TUBE PART NUMBER			END FITTINGS PART NUMBER	
	TUBE OR HOSE PART NUMBER	CUT LENGTH (INCHES)	MANUFACTURED FROM NSN	END FITTING PART NUMBER	END FITTING PART NUMBER
1	5571117	37.00	4720-01-058-7213	272NTA-4-4	68NTA-4-6
2	M/357-20062	12.00	4720-01-058-7213	1480X4	269NTA-4-4
3	M/357-20062	12.00	4720-01-058-7213	1480X4	271NTA-4-4
4	5571163	21.00	4720-01-058-7213	1469X4	62NTA-4
5	M/357-20102	24.00	4720-01-058-7213	269NTA-4-4	269NTA-4-4
6	5571159	32.00	4720-01-058-7213	1468X4	271NTA-4-4
7	5571160	140.00	4720-01-058-7213	1469X4	269NTA-4-4
8	5571167	17.00	4720-01-058-7213	271NTA-4-4	1468X4
9	M/357-20067	17.50	4720-01-058-7213	1469X4	1468X4
10	M/357-20066	20.75	4720-01-058-7213	1469X4	1468X4
11	M/357-20063	109.00	4720-01-058-7213	68NTA-4-4	279NTA-4-4
12	M/357-20072	19.00	4720-01-058-7213	270NTA-4-2	269NTA-4-4
13	M/357-20071	18.00	4720-01-058-7213	270NTA-4-2	269NTA-4-4
14	M/357-20073	58.25	4720-01-058-7213	264NTA-4	269NTA-4-4
15	5571161	27.00	4720-01-058-7213	264NTA-4	271NTA-4-2
16	M/357-20102	21.00	4720-01-058-7213	1469X4	271NTA-4-2
17	M/357-20102	21.00	4720-01-058-7213	1466X4	1468X4

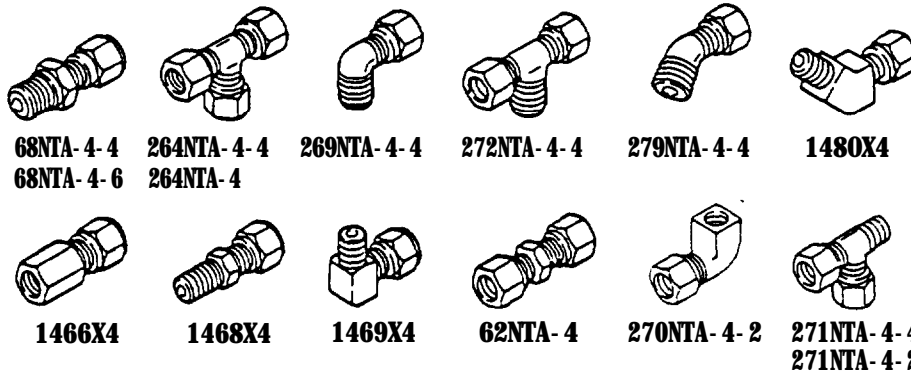

Figure E-1. 1/4" NONMETALLIC TUBING AND FITTINGS

**INSTRUCTIONS:**

1. Determine tube part number needed from RPSTL and cut squarely to correct length as shown above.
2. Select proper end fittings based upon tube part number.
3. Insert tube into fitting and tighten nut with wrench until one thread remains visible on the fitting body.

TA 237869

**Section II. ILLUSTRATED MANUFACTURING INSTRUCTIONS (Continued).**

<b>MATERIAL BLOCK</b>		
<b>STOCK SIZE</b>	<b>DESCRIPTION</b>	<b>SPECIFICATION</b>
3/8" OUTER DIAMETER	TUBE, NONMETALLIC AND FITTINGS	SAEJ844, TYPE 3A SAEJ246 AND J1131

NONMETALLIC TUBE PART NUMBER			END FITTINGS PART NUMBER		
ITEM	TUBE OR HOSE PART NUMBER	CUT LENGTH (INCHES)	MANUFACTURED FROM NSN	END FITTING PART NUMBER	END FITTING PART NUMBER
1	5571113	29.00	4720-01-014-4915	1469X8	1489X8
2	M/357-20069	11.50	4720-01-014-4915	269NTA-6-4	269NTA-6-6
3	M/357-20061	9.50	4720-01-014-4915	269NTA-6-4	269NTA-6-4
4	5571164	134.00	4720-01-014-4915	269NTA-6-4	269NTA-6-6
5	M/357-20129	157.00	4720-01-014-4915	68NTA-6-8	269NTA-6-8
6	5571109	126.90	4720-01-014-4915	269NTA-6-8	68NTA-6-6
7	5571111	123.00	4720-01-014-4915	68NTA-6-8	68NTA-6-6
8	M/357-20070	11.00	4720-01-014-4915	68NTA-6-6	269NTA-6-6
9	5571165	29.50	4720-01-014-4915	68NTA-6-4	269NTA-6-6
10	5571166	21.00	4720-01-014-4915	68NTA-6-4	269NTA-6-6

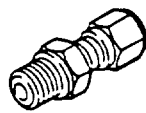

**68NTA-6-4  
68NTA-6-6  
68NTA-6-8**

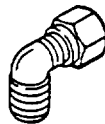

**269NTA-6-4  
269NTA-6-6  
269NTA-6-8**

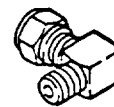

**1469X8**

Figure E-2. 3/8" NONMETALLIC TUBING AND FITTINGS.

**INSTRUCTIONS:**

1. Determine tube part number needed from RPSTL and cut squarely to correct length as shown above.
2. Select proper end fittings based upon tube part number.
3. Insert tube into fitting and tighten nut with wrench until one thread remains visible on the fitting body.

TA 237870

**Section II. ILLUSTRATED MANUFACTURING INSTRUCTIONS (Continued).**

MATERIAL BLOCK		
STOCK SIZE	DESCRIPTION	SPECIFICATION
1/2" OUTER DIAMETER	TUBE, NONMETALLIC AND FITTINGS	SAEJ844, TYPE 3A SAEJ246 AND J1131

ITEM NO.	NONMETALLIC TUBE PART NUMBER			END FITTINGS PART NUMBER	
	TUBE OR HOSE PART NUMBER	CUT LENGTH (INCHES)	MANUFACTURED FROM NSN	END FITTING PART NUMBER	END FITTING PART NUMBER
1	5571162	78.00	4720-01-040-0592	1480X8X8	1469X8
2	M/357-20075	41.00	4720-01-040-0592	1469X8	68NTA-8-6
3	5571110	17.00	4720-01-040-0592	279NTA-8-6	68NTA-8-6
4	5571110	17.00	4720-01-040-0592	279NTA-8-6	68NTA-8-6
5	M/357-20116	20.50	4720-01-040-0592	279NTA-8-6	279NTA-8-6
6	5571112	20.00	4720-01-040-0592	279NTA-8-6	279NTA-8-6
7	M/357-20055	22.50	4720-01-040-0592	279NTA-8-6	68NTA-8-6
8	M/357-20057	23.00	4720-01-040-0592	279NTA-8-6	68NTA-8-6
9	M/357-20074	75.00	4720-01-040-0592	1469X8	1480X8X8
10	M/357-20005	14.00	4720-01-040-0592	1469X8X12	68NTA-8-6
11	5571126	45.00	4720-01-040-0592	1469X8	68NTA-8-6

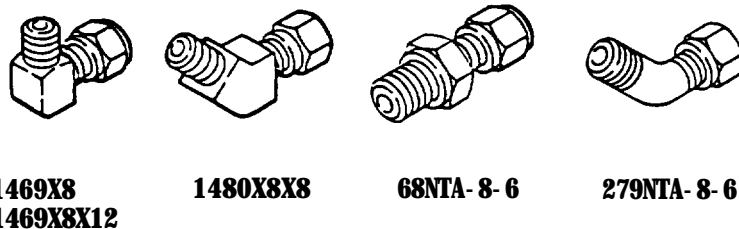

Figure E-3. 1/2" NONMETALLIC TUBING AND FITTINGS.

**INSTRUCTIONS:**

1. Determine tube part number needed from RPSTL and cut squarely to correct length as shown above.
2. Select proper end fittings based upon tube part number.
3. Insert tube into fitting and tighten nut with wrench until one thread remains visible on the fitting body.

TA 237871

**Section II. ILLUSTRATED MANUFACTURING INSTRUCTIONS (Continued).**

MATERIAL BLOCK		
STOCK SIZE	DESCRIPTION	SPECIFICATION
5/8" OUTER DIAMETER	TUBE, NONMETALLIC AND FITTINGS	SAEJ844, TYPE 3A SAEJ246 AND J1131

NONMETALLIC TUBE PART NUMBER				END FITTINGS PART NUMBER	
ITEM NO.	TUBE OR HOSE PART NUMBER	CUT LENGTH (INCHES)	MANUFACTURED FROM NSN	END FITTING PART NUMBER	END FITTING PART NUMBER
1	5571108	36.50	4720-01-009-9058	1468X10X12	1480X10
2	M/357-20012	53.50	4720-01-009-9058	1468X10	1468X10X6
3	M/357-20009	30.00	4720-01-009-9058	1468X10	1468X10X6



**146X10  
1468X10X6  
1468X10X12**

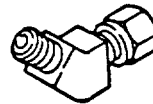

**1480X10**

Figure E-4. 5/8" NONMETALLIC TUBING AND FITTINGS.

**INSTRUCTIONS:**

1. Determine tube part number needed from RPSTL and cut squarely to correct length as shown above.
2. Select proper end fittings based upon tube part number.
3. Insert tube into fitting and tighten nut with wrench until one thread remains visible on the fitting body.

TA 237872



**Section II. ILLUSTRATED MANUFACTURING INSTRUCTIONS (Continued).**

<b>MATERIAL BLOCK</b>																													
<b>STOCK SIZE</b>		<b>DESCRIPTION</b>		<b>SPECIFICATION</b>																									
1/2" OUTER DIAMETER		STEERING PUMP HOSE																											
<table border="1" style="width: 100%; border-collapse: collapse;"> <thead> <tr> <th colspan="4">STEERING PUMP HOSE PART NUMBER</th> <th colspan="2">END FITTINGS PART NUMBER</th> </tr> <tr> <th>ITEM</th> <th>TUBE OR HOSE</th> <th>CUT LENGTH (INCHES)</th> <th>MANUFACTURED FROM NSN</th> <th>END FITTING PART NUMBER</th> <th>END FITTING PART NUMBER</th> </tr> </thead> <tbody> <tr> <td style="text-align: center;">1</td> <td style="text-align: center;">5995198</td> <td style="text-align: center;">54.00</td> <td style="text-align: center;">208-8</td> <td style="text-align: center;">NONE</td> <td style="text-align: center;">NONE</td> </tr> <tr> <td style="text-align: center;">2</td> <td style="text-align: center;">5995197</td> <td style="text-align: center;">39.00</td> <td style="text-align: center;">208-8</td> <td style="text-align: center;">NONE</td> <td style="text-align: center;">NONE</td> </tr> </tbody> </table>						STEERING PUMP HOSE PART NUMBER				END FITTINGS PART NUMBER		ITEM	TUBE OR HOSE	CUT LENGTH (INCHES)	MANUFACTURED FROM NSN	END FITTING PART NUMBER	END FITTING PART NUMBER	1	5995198	54.00	208-8	NONE	NONE	2	5995197	39.00	208-8	NONE	NONE
STEERING PUMP HOSE PART NUMBER				END FITTINGS PART NUMBER																									
ITEM	TUBE OR HOSE	CUT LENGTH (INCHES)	MANUFACTURED FROM NSN	END FITTING PART NUMBER	END FITTING PART NUMBER																								
1	5995198	54.00	208-8	NONE	NONE																								
2	5995197	39.00	208-8	NONE	NONE																								

Figure E-5. 1/2" STEERING PUMP HOSE.

<b>MATERIAL BLOCK</b>					
<b>STOCK SIZE</b>		<b>DESCRIPTION</b>		<b>SPECIFICATION</b>	
5/8" OUTER DIAMETER		HEATER HOSE			

HEATER HOSE PART NUMBER				END FITTINGS PART NUMBER	
ITEM NO.	TUBE OR HOSE PART NUMBER	CUT LENGTH (INCHES)	MANUFACTURED FROM NSN	END FITTING PART NUMBER	END FITTING PART NUMBER
1	5571141	11.00	M/145-20038	NONE	NONE
2	M/145-20001	3.00	M/145-20038	NONE	NONE
3	5571150	51.00	M/145-20038	NONE	NONE
4	5571150	33.00	M/145-20038	NONE	NONE

Figure E-6. 5/8" HEATER HOSE

**INSTRUCTIONS:**

Determine hose part number needed from RPSTL and cut squarely to correct length as shown above.

**Section II. ILLUSTRATED MANUFACTURING INSTRUCTIONS (Continued).**

MATERIAL BLOCK		
STOCK SIZE	DESCRIPTION	SPECIFICATION
2-1/2" INSIDE DIAMETER	RADIATOR OUTLET HOSE	

RADIATOR OUTLET HOSE PART NUMBER			END FITTINGS PART NUMBER		
ITEM NO.	TUBE OR HOSE PART NUMBER	CUT LENGTH (INCHES)	MANUFACTURED FROM NSN	END FITTING PART NUMBER	END FITTING PART NUMBER
1	MB 147-20001	4.00	4720-00-203-3031	NONE	NONE

Figure E-7. 2-1/2" RADIATOR OUTLET HOSE.

**INSTRUCTIONS:**

Determine hose part number needed from RPSTL and cut squarely to correct length as shown above.

**Section II. ILLUSTRATED MANUFACTURING INSTRUCTIONS (Continued).**

MATERIAL BLOCK		
STOCK SIZE	DESCRIPTION	SPECIFICATION
DIMENSIONS AS SHOWN	PUSHROD DRIVER AND STEERING STOP TEMPLATE	SPECIFICATIONS AS SHOWN

NOTES:

1. APPLICABLE STANDARDS:
  - A. DOD-STD-00100D (AR)
  - B. ANSI-Y14.5M-1982
2. MATERIAL: STEEL CARSON, 1010-1025  
SPEC ASTM A108 OR ASTM A576
3. ALL EDGES SHALL BE FREE FROM BURNS AND BROKEN .005-.030.
4. WELD PER MIL-STD-1261 CLASS 1.
5. APPLY PROTECTIVE FINISH PER DTA175782.

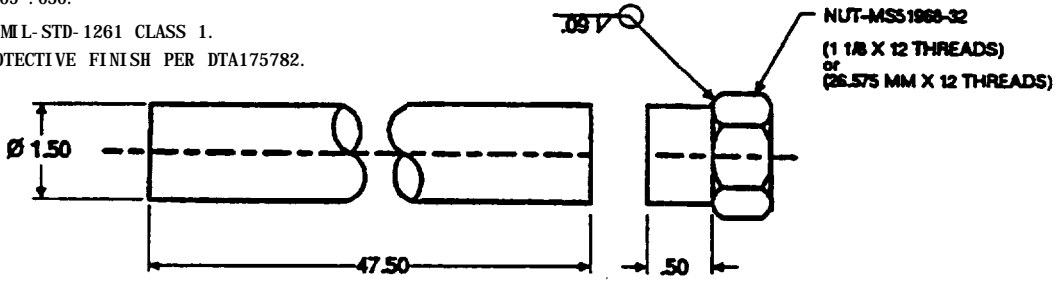
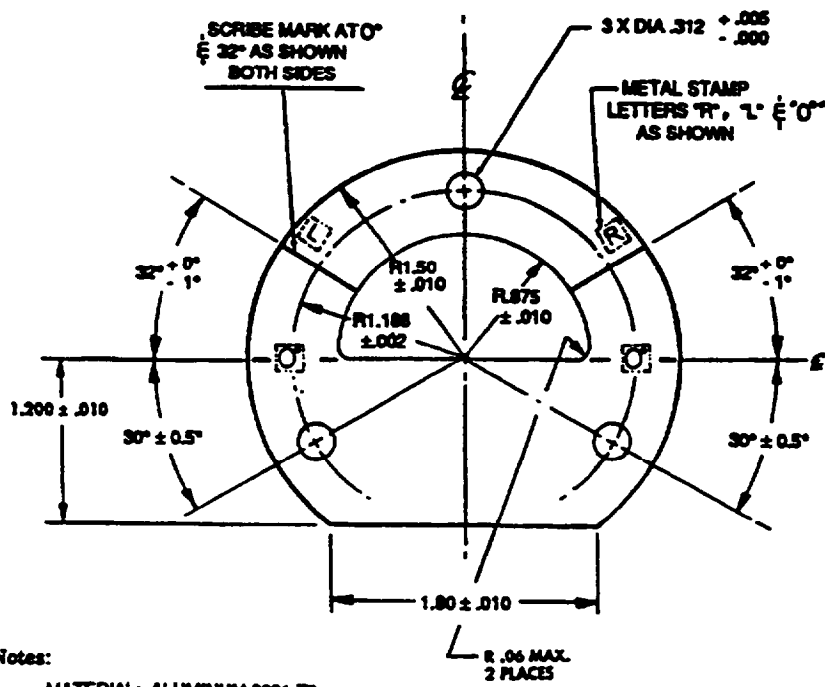

Figure E-8. PUSHROD DRIVER.



Notes:

- MATERIAL: ALUMINUM 6061-T6  
0.18 INCH THICK
- ALL DIMENSIONS ARE SHOWN  
IN INCHES

Figure E-9. STEERING STOP TEMPLATE.

**GLOSSARY****Section I. LIST OF ABBREVIATIONS**

AR	As Required
CB	Circuit Breaker
e. g.	for example
EIR	Equipment Improvement Recommendation
FO	Fold out
Hex	Hexagon
i. e.	that is
k	x1000
MAC	Maintenance Allocation Chart
para	paragraph
PMCS	Preventive Maintenance Checks and Services
PT	Prevailing Torque
STE/ICE	Simplified Test Equipment for Internal Combustion Engines
TMDE	Test, Measurement, and Diagnostic Equipment

Refer to AR 310-50 (Authorized Abbreviations and Brevity Codes) and MIL-STD-12D (Military Standard Abbreviations for Use on Drawings, Specifications, Standards and in Technical Documents).

**Section II: DEFINITION OF UNUSUAL TERMS**

None applicable to this technical manual.



ALPHABETICAL INDEX

Subject, Para

Subject, Para

**A**

Accelerator Pedal and Linkage Replacement, 3-41

Accessory Items Maintenance Task Summary, 3-286

Adjuster Replacement, Slack, 3-157

Adjustment, Fifth Wheel, 3-244

Air Cleaner Assembly Replacement, 3-29

Air Cleaner Filter Element Replacement, 3-30

Air Cleaner Restriction Gage and Bracket Replacement, 3-315

Air Cleaner Restriction Gage Tube Replacement, 3-316

Air Cleaner Tube Replacement, 3-32

Air Crossover Connection Replacement, Turbocharger, 3-31

Air Compressor Cooling Tubes Replacement, 3-18

Air Compressor Intake Tube Replacement, 3-19

Air Diffuser Assembly Replacement, 3-302

Air Dryer Dehydrate Cartridge Replacement, 3-200

Air Dryer Mounting Bracket Replacement, 3-227

Air Dryer Repair, 3-199

Air Dryer Replacement, 3-198

Air Horn and Control Valve Replacement, 3-289

Air Lines and Fittings Replacement, Brake System, 3-163

Alinement, Front Wheel, 3-203

Alternator and Bracket Replacement, 3-70

Alternator Drive Belts Replacement, 3-71

Anchor Pin Replacement, 3-161

Assembly, General Maintenance Instructions 3-7

Auxiliary Air-Powered Systems, Principles of Operation, 1-21

**B**

Battery Box Latch Replacement, 3-123

Battery Box Replacement, 3-122

Battery Cable Replacement, 2-124

Battery Charging, 3-119

Battery Power Disconnect and Connect Procedure, 3-120

Battery Replacement, 3-121

Bearings Replacement, Front, 3-205

Bearings Replacement, Rear, 3-207

**ALPHABETICAL INDEX (Continued)**

Subject, Para

Subject, Para

**B**

Belts, Replacement, Alternator Drive, 3-71

Belts Replacement, Fan Clutch Drive, 3-67

Belt Replacement, Seat, 3-282

Belt Replacement, Water Pump Drive, 3-63

Blackout Headlamp Assembly Replacement, 3-95

Blackout Marker Lamp and Headlamp Cable Replacement, 3-129

Blackout Marker Lamp Assembly Replacement, 3-94

Blackout Taillamp Assembly Replacement, 3-97

Blackout Taillamp Mounting Bracket Replacement, 3-233

Blackout Toggle Switch Replacement, 3-79

Blade Replacement, Wiper, 3-293

Box Replacement, Battery, 3-122

Brace Replacement, Fan, 3-24

Brace Replacement, Oil Level Dipstick Tube, 3-17

Bracket Replacement, Air Cleaner Restriction, 3-315

Bracket Replacement, Alternator, 3-70

Bracket Replacement, Blackout Taillamp Mounting, 3-233

Bracket Replacement, Camshaft, 3-160

Bracket Replacement, Engine Lifting, 3-22

Bracket Replacement, Fire Extinguisher, 3-284

Bracket Replacement, Manual Reset Circuit Breaker, 3-114

Bracket Replacement, Padlock, 3-262

Bracket Replacement, Rear Mud Flap, 3-274

Bracket Replacement, Rear Tow Eye, 3-235

Bracket Replacement, Shifter Control Mounting, 3-139

Bracket Replacement, STE/ICE Connector, 3-131

Bracket Replacement, Taillamp, 3-234

Bracket Replacement, Trailer Receptacle, 3-130

Bracket Replacement, Transmission Oil Filter Mounting, 3-231

Bracket Replacement, Water Filter Tube, 3-62

Bracket Replacement, Water Transfer, 3-21

Bracket Replacement, Trailer Coupling, 3-196

**ALPHABETICAL INDEX (Continued)**

Subject, Para

Brake Assembly Replacement, 3-158  
 Brake Chamber Replacement, Forward-Rear Axle, 3-166  
 Brake Chamber Replacement, Front Axle and Rear-Rear Axle, 3-164  
 Brake Chamber Repair, Front Axle and Rear-Rear Axle, 3-165  
 Brake Shoe Replacement, 3-159  
 Brake System Maintenance Task Summary, 3-156  
 Brake System, Principles of Operation, 1-20  
 Brake Treadle Valve Replacement, 3-174  
 Breather Tubes and Hoses Replacement 3-15  
 Brush Guard Replacement, 3-236  
 Bumper, Towing Eyes, and Vehicle Class Sign Replacement, 3-237  
 Button Replacement, Horn, 3-118  
 Buzzer Replacement, Low Air Pressure, 3-110

**C**

Cab and Body Maintenance Task Summary, 3-253  
 Cab Clearance Lamp Assembly Replacement, 3-93  
 Cab Headliner Panel Replacement, 3-275

Subject, Para

Cab Heating and Ventilating System, Principles of Operation, 1-23  
 Cab Trim Panel Replacement, 3-276  
 Cable Replacement, Battery, 3-124  
 Cable Replacement, Blackout Marker Lamp, 3-129  
 Cable Replacement, Headlamp, 3-129  
 Cable Replacement, Shifter Control 3-138  
 Cable Replacement, Spare Tire Winch, 3-241  
 Cable Replacement, Ground, 3-128  
 Camshaft and Camshaft Bracket Replacement, 3-160  
 Cap Replacement, Rocker Cover Filler, 3-14  
 Carrier Replacement, Spare Tire, 3-240  
 Cartridge Replacement, Air Dryer Dehydrate, 3-200  
 Center Floor Pan Access Cover Replacement, 3-260  
 Charging, Battery, 3-119  
 Checking Unpacked Equipment, Service Upon Receipt, 2-5  
 Cigar Lighter Replacement, 3-83  
 Clamp Replacement, Oil Level Dipstick Tube, 3-17  
 Cleaning, General Maintenance Instructions, 3-4



**ALPHABETICAL INDEX (Continued)**

Subject, Para	Subject, Para
Clearance Lamp Replacement, 3-85	Cooling System Service, 3-52
Clevis Pin Replacement, 3-230	Cooling Tubes Replacement, Air Compressor, 3-18
Clutch Replacement, Fan, 3-65	Couplings Replacement, Front External Air, 3-167
Column Repair, Lower Steering, 3-215	Couplings Replacement, Trailer, 3-196
Column Repair, Upper Steering, 3-214	Cover Replacement, Center Floor Pan Access, 3-260
Column Replacement, Lower Steering, 3-215	Cover Replacement, Rocker, 3-13
Column Replacement, Upper Steering, 3-214	Cylinder Replacement, Ether, 3-38
Common Tools and Equipment, 2-2	
Companion Seat Replacement, 3-283	<b>D</b>
Companion Seat Riser, Fire Extinguisher, Brackets, and Tool Box Replacement, 3-284	Data and Instruction Plates Replacement, 3-305
Compressed Air System, Principles of Operation, 1-19	Data Plate Replacement, Engine, 3-23
Connect Procedure, Battery Power, 3-120	Deck Replacement, Service, 3-239
Control Replacement, Modulator, 3-140	Defroster Fan Repair, 3-304
Control Replacement, Shifter, 3-137	Defroster Fan Replacement, 3-303
Cooler Replacement, Transmission and Steering System, 3-55	Deprocessing Unpacked Equipment, Service Upon Receipt, 2-6
Control Replacement, Windshield Wiper, 3-292	Destruction of Army Materiel to Prevent Enemy Use, 1-4
Cooling System Maintenance Task Summary, 3-51	Differential Lock Pressure Switch Replacement, 3-107
Cooling System, Principles of Operation, 1-14	Differential Toggle Valve Replacement, 3-195
	Diode Replacement, Starting Circuit, 3-116

ALPHABETICAL INDEX (Continued)

Subject, Para

Subject, Para

Dipstick Replacement, Oil Level,  
3-16

Dipstick Tube Replacement, Oil Level,  
3-17

Disconnect Procedure, Battery  
Power, 3-120

Dome Lamp and Switch Replacement,  
3-98

Door Assembly Replacement, Glove  
Compartment, 3-257

Door Frame Seal Replacement, 3-266

Door Mirror Replacement, 3-287

Door Plate Replacement, 3-265

Double Check and Quick Release  
Valve Replacement, 3-182

Double Check and Stoplamp Valve  
Replacement, 3-183

Draincock Replacement, Primary  
and Secondary Reservoir, 3-188

Driver's Seat Replacement, 3-280

Driver's Seat Riser Replacement,  
3-281

Drum Replacement, Front, 3-204

Drum Replacement, Rear Brake,  
3-206

Dryer Repair, Air, 3-199

Dryer Replacement, Air, 3-198

Dust Shield Replacement, 3-162

E

Electrical System Maintenance Task  
Summary, 3-69

Engine Data Plate Replacement, 3-23

Engine Fuel Lines and Fittings  
Replacement, 3-28

Engine Lifting Bracket Replacement,  
3-22

Engine Maintenance Task Summary, 3-11

Engine Oil Service, 3-12

Engine, Principles of Operation, 1-11

Engine Retarder Foot Switch Replace-  
ment, 3-89

Equipment Characteristics, Capabilities,  
and Features, 1-8

Equipment Data, 1-10

Ether Cylinder Replacement, 3-38

Ether Lamp and Clearance Lamp Replace-  
ment, 3-85

Ether Quick Start Kit Replacement, 3-40

Ether Quick Start Thermostat Replace-  
ment, 3-39

Ether Start Switch Replacement, 3-76

Exhaust Flex Pipe Replacement, 3-47

Exhaust Stack Pipe Replacement, 3-46

ALPHABETICAL INDEX (Continued)

Subject, Para

Exhaust System Maintenance Task  
Summary, 3-44

Exhaust System, Principles of  
Operation, 1-13

External Air Couplings Replacement,  
Front, 3-167

Electrical System, Principles of  
Operation, 1-15

F

Fan and Fan Clutch Replacement, 3-65

Fan Brace, Bracket, and Spacers  
Replacement, 3-24

Fan Clutch Air Valve Replacement,  
3-66

Fan Clutch Drive Belts Replacement,  
3-67

Fan Repair, Defroster, 3-304

Fan Replacement, Defroster, 3-303

Fender Replacement, Front, 3-271

Fender Replacement, Quarter, 3-272

Fifth Wheel Adjustment, 3-244

Fifth Wheel Ramp Replacement, 3-246

Fifth Wheel Replacement, 3-245

Fifth Wheel Toggle Valve Replace-  
ment, 3-194

Filter Element Replacement, Air  
Cleaner, 3-30

Filter Replacement, Engine Oil, 3-12

Subject, Para

Filter Replacement, Water, 3-62

Filter Replacement, Water Separator  
Fuel, 3-37

Firewall Double Check Valve Replace-  
ment, 3-184

Fittings Replacement, Front Spring Pin,  
3-249

Fittings Replacement, Fuel, 3-36

Fittings Replacement, Power Steering  
Lines, 3-220

Fittings Replacement, Transmi ssi on,  
3-141

Fittings Replacement, Brake System,  
3-163

Fittings Replacement, Cooling System,  
3-58

Flasher Replacement, Turn Signal, 3-111

Floor Mat Replacement, 3-279

Forward-Rear Axle Brake Chamber  
Replacement, 3-166

Forward-Rear Axle Quick Release Valve  
Replacement, 3-178

Forward-Rear Axle Stop Replacement,  
3-232

Frame and Towing Attachments Maintenance  
Task Summary, 3-222

Front Axle and Rear-Rear Axle Brake  
Chamber Repair, 3-165

Front Axle and Rear-Rear Axle Brake  
Chamber Replacement, 3-164

**ALPHABETICAL INDEX (Continued)**

Subject, Para

Subject, Para

Front Axle and Suspension, Principles of Operation, 1-17

Front Axle Maintenance Task Summary, 3-147

Front Axle Ratio Valve Replacement, 3-181

Front Drum Replacement, 3-204

Front Fender Replacement, 3-271

Front Hub, Bearings, and Seals Replacement, 3-205

Front Spring Pin Screws and Fittings Replacement, 3-249

Front Wheel Alinement, 3-203

Fuel Control Lever Replacement, 3-42

Fuel Heater Replacement, 3-35

Fuel Hoses and Fittings Replacement, 3-36

Fuel Level Sending Unit Replacement, 3-105

Fuel Lines and Fittings Replacement, Engine, 3-28

Fuel Pump Engine Retarder Switch Replacement, 3-90

Fuel System Maintenance Task Summary, 3-26

Fuel System, Principles of Operation, 1-12

Fuel Tank Replacement, 3-34

**G**

Gage Replacement, Air Cleaner Restriction, 3-315

Gage Replacement, Left-Hand Instrument Panel, 3-73

Gage Replacement, Oil Level, 3-136

Gage Replacement, Pressure, 3-314

Gages (Nonelectrical) Maintenance Task Summary, 3-300

Gasket Replacement, Rocker Cover, 3-13

General, Accessory Items, 3-285

General, Brake System, 3-155

General, Cab and Body, 3-252

General, Cooling System, 3-50

General, Electrical System, 3-68

General, Engine, 3-10

General, Exhaust System, 3-43

General, Frame and Towing Attachments, 3-221

General, Front Axle, 3-146

General, Fuel System, 3-25

General, Gages (Nonelectrical), 3-307

General, Propeller Shafts and Universal Joints, 3-142

General, Rear Axle, 3-151

**ALPHABETICAL INDEX (Continued)**

Subject, Para	Subject, Para
General, Springs, Shock Absorbers, and Torque Rod, 3-247	Heater Air Hose Replacement, 3-296
General, Steering System, 3-209	Heater Blower Replacement, 3-299
General STE/ICE Components, 3-317	Heater Control Panel Repair, 3-301
General, Transmission, 3-133	Heater Control Panel Replacement, 3-300
General Maintenance Instruction, 3-1	Heater Control Valve and Hose Replacement, 3-297
General, Wheels, 3-201	Heater Fan Switch Replacement, 3-81
Glove Compartment Door Assembly Replacement, 3-257	Heater Replacement, 3-298
Grille Replacement, 3-268	Heater Replacement, Fuel, 3-35
Ground Strap and Cables Replacement, 3-128	Heater Valve, Hoses, Tubes, and Clamps Replacement, 3-297
Guard Replacement, Brush, 3-236	Hood Panel and Component Replacement, 3-270
<b>H</b>	
Handle Replacement, Inside Assist, 3-259	Hood Replacement, 3-269
Handle Replacement, Outside Front, 3-264	Horn Button Replacement, 3-118
Handle Replacement, Outside Rear, 3-263	Horn Replacement, 3-117
Headlamp Assembly Replacement, 3-91	Hose Replacement, Heater Air, 3-296
Headlamp Assembly Replacement, Blackout, 3-95	Hose Replacement, Heater Control Valve, 3-297
Headlamp Cable Replacement, 3-129	Hose Replacement, Trailer, 3-196
Headlamp Dimmer Switch Replacement, 3-82	Hose Tender Replacement, 3-197
Headlamp Switch Replacement, 3-78	Hoses Replacement, Cooling System, 3-58
Heat Shield Replacement, Muffler, 3-45	Hoses Replacement, Fuel, 3-36
	Hot Engine Temperature Switch Replacement, 3-100
	Housing Replacement, Thermostat, 3-59
	Hub Replacement, Front, 3-207

**ALPHABETICAL INDEX (Continued)**

Subject, Para

Subject, Para

Hub Replacement, Rear, 3-207

**L**

**I**

Ignition Switch Replacement, 3-74

Lamp Assembly Replacement, Blackout  
Marker, 3-94

Indicator Lamps Replacement, 3-87

Lamp Assembly Replacement, Cab  
Clearance, 3-93

Inside Assist Handle Replacement,  
3-259

Lamp Replacement, Clearance, 3-85

Lamp Replacement, Ether, 3-85

Inspection, General Maintenance  
Instructions, 3-5

Lamp Replacement, Low Air Pressure, 3-84

Instrument Panel Assembly Replace-  
ment, 3-258

Lamp Replacement, Marker Lamp, 3-92

Lamp Replacement, Turn Signal, 3-92

Instrument Panel Center Panel  
Assembly Replacement, 3-256

Lamp Replacement, Washer, 3-86

Lamp Replacement, Wiper, 3-86

Instrument Panel Relays Replace-  
ment, 3-112

Lamps Replacement, Warning and Indicator,  
3-87

Instrument Panel 24 Volt Relay  
Replacement, 3-113

Latch Replacement, Battery Box, 3-123

Insulation Replacement, 3-277

Left-Hand Instrument Cluster Panel  
Assembly Replacement, 3-255

Insulator Replacement, 3-267

Left-Hand Instrument Panel Gage Replace-  
ment, 3-73

Intake Tube Replacement, Air  
Compressor, 3-19

Lever Replacement, Fuel Control, 3-42

Interaxle Propeller Shaft and  
Universal Joints Replacement, 3-145

Lifting Bracket Replacement, Vehicle,  
3-229

**J**

Lighter Replacement, Cigar, 3-83

Joints Replacement, Ball, 3-218

Lines and Fittings Replacement,  
Transmission, 3-141

**K**

Kit Replacement, Ether Quick Start,  
3-40

Lines, Fittings, and Hoses Replacement,  
Cooling System, 3-58

Linkage Replacement, Accelerator, 3-41

ALPHABETICAL INDEX (Continued)

Subject, Para

Subject, Para

Location and Description of Major Components, 1-9

Mountable Tee Replacement, 3-180

Low Air Pressure Buzzer Replacement, 3-110

Muffler and Heat Shield Replacement, 3-45

Low Air Pressure Lamp Replacement, 3-84

Muffler Inlet Pipe Replacement, 3-49

Low Air Pressure Switch Replacement, 3-109

Muffler Inlet Pipe Support Replacement, 3-224

Low Oil Pressure Sending Unit Replacement, 3-104

N

Neutral Safety Switch and Reverse Switch Replacement, 3-106

Lower Fan Shroud Replacement, 3-57

O

Lower Steering Column Replacement and Repair, 3-215

Oil Level Dipstick Replacement, 3-16

M

Oil Level Dipstick Tube Brace and Clamp Replacement, 3-17

Maintenance Forms, Records, and Reports, 1-3

Oil Level Gage and Tube Replacement, 3-136

Manifolds Replacement, Water, 3-60

Oil Pressure Sending Unit Replacement, 3-102

Manual Reset Circuit Breaker and Mounting Bracket Replacement, 3-114

Operational Checks, General Maintenance Instructions, 3-8

Map Lamp and Switch Replacement, 3-99

Organizational Preventive Maintenance Checks and Service (PMCS), Paragraph 2-1, 2-8

Marker Lamp Replacement, 3-92

Outside Front Handle Replacement, 3-264

Mat Replacement, Floor, 3-279

Outside Rear Handle Replacement, 3-263

Mirror Replacement, Door, 3-287

Mirror Replacement, Spotter, 3-290

P

Modulator Control Replacement, 3-140

Padlock Bracket Replacement, 3-252

Motor Replacement, Windshield Wiper, 3-295

## ALPHABETICAL INDEX (Continued)

Subject, Para	Subject, Para
Panel Assembly Replacement, Instrument, 2-258	Pedal Replacement, Accelerator, 3-41
Panel Assembly Replacement, Instrument Panel Center, 3-256	Pin Replacement, Clevis, 3-230
Panel Assembly Replacement, Left-Hand Instrument Cluster, 3-255	Pin Replacement, Rear Tow Eye, 3-235
Panel Assembly Replacement, Right-Hand Instrument, 3-254	Pintle Replacement, Tow, 3-238
Panel Repair, Heater Control, 3-301	Pipe Replacement, Exhaust Flex, 3-47
Panel Replacement, Cab Headliner, 3-275	Pipe Replacement, Exhaust Stack, 3-46
Panel Replacement, Cab Trim, 3-276	Pipe Replacement, Muffler Inlet, 3-49
Panel Replacement, Heater Control, 3-300	Pipe Replacement, Turbocharger Outlet, 3-48
Paragraph 2-1. Organizational Preventive Maintenance Checks and Services (PMCS), 2-8	Plate Replacement, Door, 3-265
Paragraph 2-2. Troubleshooting Procedure, 2-11	Plates Replacement, Data and Instruction, 3-305
Paragraph 2-7. GO Chain Index, STE/ICE, 2-17	Power Steering Lines and Fittings Replacement, 3-227
Paragraph 2-8. NO-GO Chain Index, STE/ICE, 2-18	Pressure Gage Replacement, 3-314
Paragraph 2-9. Vehicle Testing Troubleshooting Procedure, STE/ICE, 2-19	Pressure Transducer Replacement, 3-320
Paragraph 3-1. Torque Limits, General Maintenance Instructions, 3-9	Primary and Secondary Reservoir Draincock Replacement, 3-188
Park Brake Pressure Switch Replacement, 3-108	Primary Propeller Shaft and Universal Joints Replacement, 3-144
Park Brake Valve Repair, 3-172	Primary Reservoir Replacement, 3-169
Park Brake Valve Replacement, 3-171	Propeller Shafts and Universal Joints Maintenance Task Summary, 3-143
	Pump Replacement, Water, 3-64
	Pushbutton Clearance Lamp Switch Replacement, 3-77



ALPHABETICAL INDEX (Continued)

Subject, Para

Subject, Para

Pushbutton Starter Switch Replacement,  
3-75

Rear-Rear Axle Quick Release Valve  
Replacement, 3-179

Preparation for Storage or Shipment,  
1-5

Rear Tandem Axles, Principles of  
Operation, 1-18

Primary Reservoir Drain Valve  
Replacement, 3-189

Rear Tow Eye Bracket, Shackle, and  
Pin Replacement, 3-235

Pulse Tachometer Replacement, 3-313

Receptacle Replacement, Slave Start,  
3-125

Q

Quarter Fender Replacement, 3-272

Receptacle Replacement, Work Lamp,  
3-132

R

Radiator Replacement, 3-53

Relay Replacement, Instrument Panel  
24-Volt, 3-113

Radiator Support Rods Replacement,  
3-54

Relay Replacement, Starter, 3-115

Ramp Replacement, Fifth Wheel, 3-246

Relay Valve Replacement, 3-177

Rear Axle Maintenance Task Summary,  
3-152

Relays Replacement, Instrument Panel,  
3-112

Rear Axle Oil Service, 3-153

Repair, General Maintenance  
Instructions, 3-6

Rear Axle Shaft Replacement, 3-154

Repair Parts, 2-4

Rear Brake Drum Replacement, 3-206

Reporting Equipment Improvement  
Recommendations (EIR), 1-6

Rear Hub, Bearings, and Seals  
Replacement, 3-207

Reservoir Mounting Brackets Replacement,  
Secondary, 3-225

Rear Mud Flap and Bracket Replace-  
ment, 3-274

Reservoir Replacement, Primary, 3-169

Rear-Rear Axle Brake Chamber Repair,  
3-165

Reservoir Replacement, Secondary, 3-170

Rear-Rear Axle Brake Chamber  
Replacement, 3-164

Reservoir Replacement, Supply, 3-168

Reservoir Replacement, Steering Pump,  
3-219

**ALPHABETICAL INDEX (Continued)**

Subject, Para

Subject, Para

Right-Hand Instrument Cluster Panel  
Assembly Replacement, 3-254

Secondary Reservoir Support  
Replacement, 3-223

Rocker Cover and Gasket Replacement,  
3-13

Sending Unit Replacement, Fuel  
Level, 3-105

Rocker Cover Filler Cap Replacement,  
3-14

Sending Unit Replacement, Oil  
Pressure, 3-102

Rods Replacement, Radiator Support,  
3-54

Sending Unit Replacement, Trans-  
mission Temperature, 3-103

Rods Replacement, Torque, 3-251

Sending Unit Replacement, Water  
Temperature, 3-101

**S**

Scope, 1-2

Service and Troubleshooting  
Instructions, 2-1

Screws Replacement, Front Spring Pin,  
3-249

Service Deck Replacement, 3-239

Seal Replacement, Door Frame, 3-266

Service, Cooling System, 3-52

Seals Replacement, Front 3-205

Service, Engine Oil, 3-12

Seals Replacement, Rear, 3-207

Service, Rear Axle Oil, 3-153

Seat Belt Replacement, 3-282

Service, Steering System, 3-211

Seat Replacement, Companion, 3-283

Servicing, Transmission, 3-135

Seat Replacement, Driver's, 3-280

Shackle Replacement, Rear Tow Eye,  
3-235

Seat Riser Replacement, Driver's,  
3-281

Shaft Replacement, Rear Axle, 3-154

Secondary Reservoir Check Valve  
Replacement, 3-187

Shaft Replacement, Speedometer, 3-310

Secondary Reservoir Double Check  
Valve Replacement, 3-185

Shaft Replacement, Tachometer, 3-312

Secondary Reservoir Replacement,  
3-170

Shield Replacement, Dust, 3-162

Shifter Control Cable Replacement,  
3-138

Shifter Control Mounting Bracket  
Replacement, 3-139

ALPHABETICAL INDEX (Continued)

Subject, Para	Subject, Para
Shifter Control Replacement, 3-137	Splash Shield Replacement, 3-273
Shock Absorber Replacement, 3-250	Spotter Mirror Replacement, 3-288
Shroud Replacement, Lower Fan, 3-57	Springs, Shock Absorbers, and Torque Rods Maintenance Task Summary, 3-248
Shroud Replacement, Upper Fan, 3-56	Starter Motor and Solenoid Replacement, 3-72
Sign Replacement, Vehicle Class, 3-237	Starter Relay Replacement, 3-115
Slack Adjuster Replacement, 3-157	Starting Circuit Diode Replacement, 3-116
Slave Start Receptacle Replacement, 3-125	STE/ICE, How To Use Chain Test Index, 2-13
Solenoid Replacement, Starter Motor, 3-72	STE/ICE Components Maintenance Task Summary, 3-318
Solenoid Valve Replacement, 3-33	STE/ICE Connector Bracket Replacement, 3-131
Spacers Replacement, 3-24	STE/ICE Description and Operation, 2-16
Spare Tire Carrier Replacement, 3-240	STE/ICE, Paragraph 2-7. GO Chain Index, 2-17
Spare Tire Winch Cable Replacement, 3-241	STE/ICE, GO Chain Tests, 2-20
Spare Tire Winch Pillar Replacement, 3-243	STE/ICE, Paragraph 2-8. NO-GO Chain Index, 2-18
Spare Tire Winch Replacement, 3-242	STE/ICE, NO-GO Chain Tests, 2-21
Special Tools, TMDE, and Support Equipment, 2-3	STE/ICE, Paragraph 2-9. Vehicle Testing Troubleshooting Procedure, 2-19
Speedometer Drive Sleeve Adapter Replacement, 3-311	STE/ICE VTM Set-Up Procedure, 3-15
Speedometer Driven Gear Replacement, 3-312	STE/ICE Vehicle Test Meter (VTM) Troubleshooting, 2-14
Speedometer Shaft Replacement, 3-310	Steering Arm Replacement, Front Axle, 3-148
Spider and Anchor Pin Replacement, 3-161	

## ALPHABETICAL INDEX (Continued)

Subject, Para	Subject, Para
■ Steering Arm Maintenance, 3-217	Supply Reservoir Single Check Valve Replacement, 3-191
■ Steering Gear Poppet Adjustment, 3-217.2	Support Replacement, Muffler Inlet Pipe, 3-224
Steering Knuckle Assembly Replacement, 3-149	Support Replacement, Secondary Reservoir, 3-223
Steering Pump and Reservoir Replacement, 3-219	Switch Replacement, Blackout Toggle, 3-79
■ Steering Stop Inspection and Adjustment Procedure, 3-217.1	Switch Replacement, Differential Lock Pressure, 3-107
Steering System Maintenance Task Summary, 3-210	Switch Replacement, Engine Retarder Foot, 3-89
Steering System, Principles of Operation, 1-22	Switch Replacement, Ether Start, 3-76
Steering System Service, 3-211	Switch Replacement, Fuel Pump Engine Retarder, 3-90
Steering System Testing, 3-212	Switch Replacement, Headlamp, 3-78
Steering Wheel Replacement, 3-213	Switch Replacement, Headlamp Dimmer, 3-82
Step Replacement, 3-226	Switch Replacement, Heater Fan, 3-81
Stop Replacement, Forward-Rear Axle, 3-232	Switch Replacement, Hot Engine Temperature, 3-100
Stoplamp-Taillight Assembly Replacement, 3-96	Switch Replacement, Ignition, 3-74
Strap Replacement, Ground, 3-128	Switch Replacement, Low Air Pressure, 3-109
Sun Visor Replacement, 3-278	Switch Replacement, Neutral Safety, 3-106
Supply Reservoir Drain Valve Replacement, 3-190	Switch Replacement, Park Brake Pressure, 3-108
Supply Reservoir Mounting Brackets Replacement, 3-225	Switch Replacement, Pushbutton Clearance Lamp, 3-77
Supply Reservoir Replacement, 3-168	Switch Replacement, Pushbutton Starter, 3-75
Supply Reservoir Safety Valve Replacement, 3-186	Switch Replacement, Reverse, 3-106

ALPHABETICAL INDEX (Continued)

Subject, Para

Switch Replacement, Three Position Engine Retarder, 3-88

Switch Replacement, Turn Signal, 3-80

Symptom Index, Troubleshooting, 2-10

T

Tachogram Replacement, 3-309

Tachometer Replacement, Pulse, 3-319

Tachometer Shaft Replacement, 3-313

Taillamp Bracket Replacement, 3-234

Tank Replacement, Fuel, 3-34

Task Summary, Accessory Items Maintenance, 3-286

Task Summary, Brake System Maintenance, 3-156

Task Summary, Cab and Body Maintenance, 3-253

Task Summary, Cooling System Maintenance, 3-51

Task Summary, Electrical System Maintenance 3-69

Task Summary, Engine Maintenance, 3-11

Task Summary, Exhaust System Maintenance, 3-44

Task Summary, Frame and Towing Attachments, 3-229

Task Summary, Front Axle Maintenance, 3-147

Subject, Para

Task Summary, Fuel System Maintenance, 3-26

Task Summary, Gages (Nonelectrical) Maintenance, 3-308

Task Summary, Rear Axle Maintenance, 3-152

Task Summary, Springs, Shock Absorbers, and Torque Rods Maintenance, 3-248

Task Summary, Steering System Maintenance, 3-210

Task Summary, STE/ICE Components Maintenance, 3-318

Task Summary, Transmission Maintenance, 3-134

Task Summary, Wheel Maintenance, 3-202

Tee Replacement, Mountable, 3-180

Testing, Steering System, 3-212

Three Position Engine Retarder Switch Replacement, 3-88

Tiedown Bracket Replacement, 3-228

Tie Rod Arm Replacement, 3-150

Tire Replacement, 3-208

Thermostat and Thermostat Housing Replacement, 3-59

Thermostat Replacement, Ether Quick Start, 3-39

Tie Rod and Ball Joints Replacement, 3-218

Tool Box Replacement, 3-284

**ALPHABETICAL INDEX (Continued)**

Subject, Para	Subject, Para
Torque Limits, Paragraph 3-1. General Maintenance Instructions, 3-9	Troubleshooting Procedures, Paragraph 2-2, 2-11
Torque Rods Replacement, 3-251	Troubleshooting Symptom Index, 2-10
Tow Pintle Replacement, 3-238	Tube Replacement, Air Cleaner, 3-32
Towing Eyes Replacement, Front, 2-237	Tube Replacement, Oil Level, 3-136
Tractor Protection Valve Replacement, 3-192	Tube Replacement, Water Crossover, 3-20
Trailer Couplings, Brackets, and Hose Replacement, 3-196	Tube Replacement, Water Transfer, 3-21
Trailer Hand Brake Valve Replacement, 3-173	Turbocharger Air Crossover Connection Replacement, 3-31
Trailer Receptacle Bracket Replacement, 3-130	Turbocharger Outlet Pipe Replacement, 3-48
Trailer Supply Valve Repair, 3-176	Turn Signal and Marker Lamp Replacement, 3-92
Trailer Supply Valve Replacement, 3-175	Turn Signal Flasher Replacement, 3-111
Transducer Replacement, Pressure, 3-320	Turn Signal Switch Replacement, 3-80
Transmission and Steering System Cooler Replacement, 3-55	
Transmission Maintenance Task Summary, 3-134	<b>U</b>
Transmission Oil Filter Mounting Bracket Replacement, 3-231	Universal Joints Replacement, Inter-axle Propeller Shaft, 3-145
Transmission, Principles of Operation, 1-16	Universal Joints Replacement, Primary Propeller Shaft, 3-144
Transmission Servicing, 3-135	Upper Fan Shroud Replacement, 3-56
Transmission Temperature Sending Unit Replacement, 3-103	Upper Steering Column Replacement and Repair, 3-214
	<b>V</b>
	Valve Relay, Replacement, 3-177
	Valve Repair, Park Brake, 3-172

ALPHABETICAL INDEX (Continued)

Subject, Para	Subject, Para
Valve Repair, Trailer Supply, 3-176	Valve Replacement, Rear-Rear Axle Quick Release, 3-179
Valve Replacement, Air Horn Control, 3-289	Valve Replacement, Secondary Reservoir Check, 3-187
Valve Replacement, Brake Pedal Double Check, 3-193	Valve Replacement, Secondary Reservoir Double Check, 3-185
Valve Replacement, Brake Treadle, 3-174	Valve Replacement, Solenoid, 3-33
Valve Replacement, Differential Toggle, 3-195	Valve Replacement, Supply Reservoir Drain, 3-190
Valve Replacement, Double Check and Quick Release, 3-182	Valve Replacement, Supply Reservoir Safety, 3-186
Valve Replacement, Double Check and Stoplamp, 3-183	Valve Replacement, Supply Reservoir Single Check, 3-191
Valve Replacement, Fan Clutch Air, 3-66	Valve Replacement, Tractor Protection, 3-192
Valve Replacement, Fifth Wheel Toggle, 3-194	Valve Replacement, Trailer Hand Brake, 3-175
Valve Replacement, Firewall Double Check, 3-184	Valve Replacement, Trailer Supply, 3-177
Valve Replacement, Forward-Rear Axle Quick Release, 3-178	Valve Replacement, Water Shutoff, 3-61
Valve Replacement, Front Axle Ratio, 3-181	Valve Replacement, Windshield Water Control, 3-291
Valve Replacement, Heater Control, 3-297	Vehicle Lifting Bracket Replacement, 3-229
Valve Replacement, Park Brake, 3-171	Vehicle Test Meter (VTM) Troubleshooting, STE/ICE, 2-14
Valve Replacement, Primary Reservoir Drain, 3-189	Ventilator Replacement, 3-261
	Vertical Link Replacement, 3-216
	Visor Replacement, Sun, 3-278

**ALPHABETICAL INDEX (Continued)**

Subject, Para

Subject, Para

**W**

- |   |  |
|---|--|
| <p>Warning and Indicator Lamps Replacement, 3-87</p> <p>Warranty Information, 1-7</p> <p>Water Crossover Tube Replacement, 3-20</p> <p>Washer Lamp Replacement, 3-86</p> <p>Washer Replacement, Windshield, 3-290</p> <p>Water Filter and Bracket Replacement, 3-62</p> <p>Water Manifolds Replacement, 3-60</p> <p>Water Pump Drive Belt Replacement, 3-63</p> <p>Water Pump Replacement, 3-64</p> <p>Water Separator Fuel Filter Replacement, 3-37</p> <p>Water Shutoff Valves and Lines Replacement, 3-61</p> <p>Water Temperature Sending Unit Replacement, 3-101</p> <p>Water Transfer Tube and Bracket Replacement, 3-21</p> <p>Wheels Maintenance Task Summary, 3-202</p> <p>Wheel Replacement, Steering, 3-213</p> <p>Winch Repair, Spare Tire, 3-242</p> <p>Winch Replacement, Spare Tire, 3-237</p> | <p>Windshield Washer Control Valve Replacement, 3-291</p> <p>Windshield Washer Replacement, 3-290</p> <p>Windshield Wiper Assembly Replacement, 3-294</p> <p>Windshield Wiper Control Replacement, 3-292</p> <p>Windshield Wiper Motor Replacement, 3-295</p> <p>Winterization Kit, Principles of Operation, 1-24</p> <p>Winterization Kit (See TB 9-2320-283-14), 3-300</p> <p>Wiper Blade Replacement, 3-293</p> <p>Wiper Lamp and Washer Lamp Replacement, 3-86</p> <p>Wiring Harness Repair, 3-127</p> <p>Wiring Harness Replacement, 3-126</p> <p>Work Lamp Receptacle Replacement, 3-132</p> |
|---|--|





Insulation Color	Abbreviation
White	WH
Red	RD
Pink	PK
Orange	OR
Yellow	YL
Light Green	LG
Dark Green	DG
Light Blue	LB
Dark Blue	DB
Purple	PP
Tan	TN
Brown	BR
Gray	GY
Black	BK

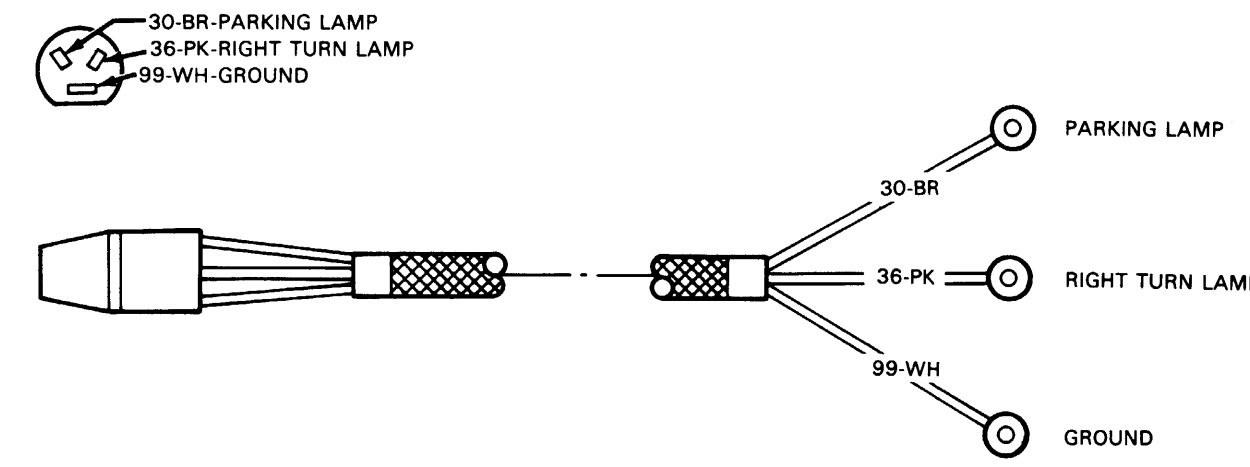
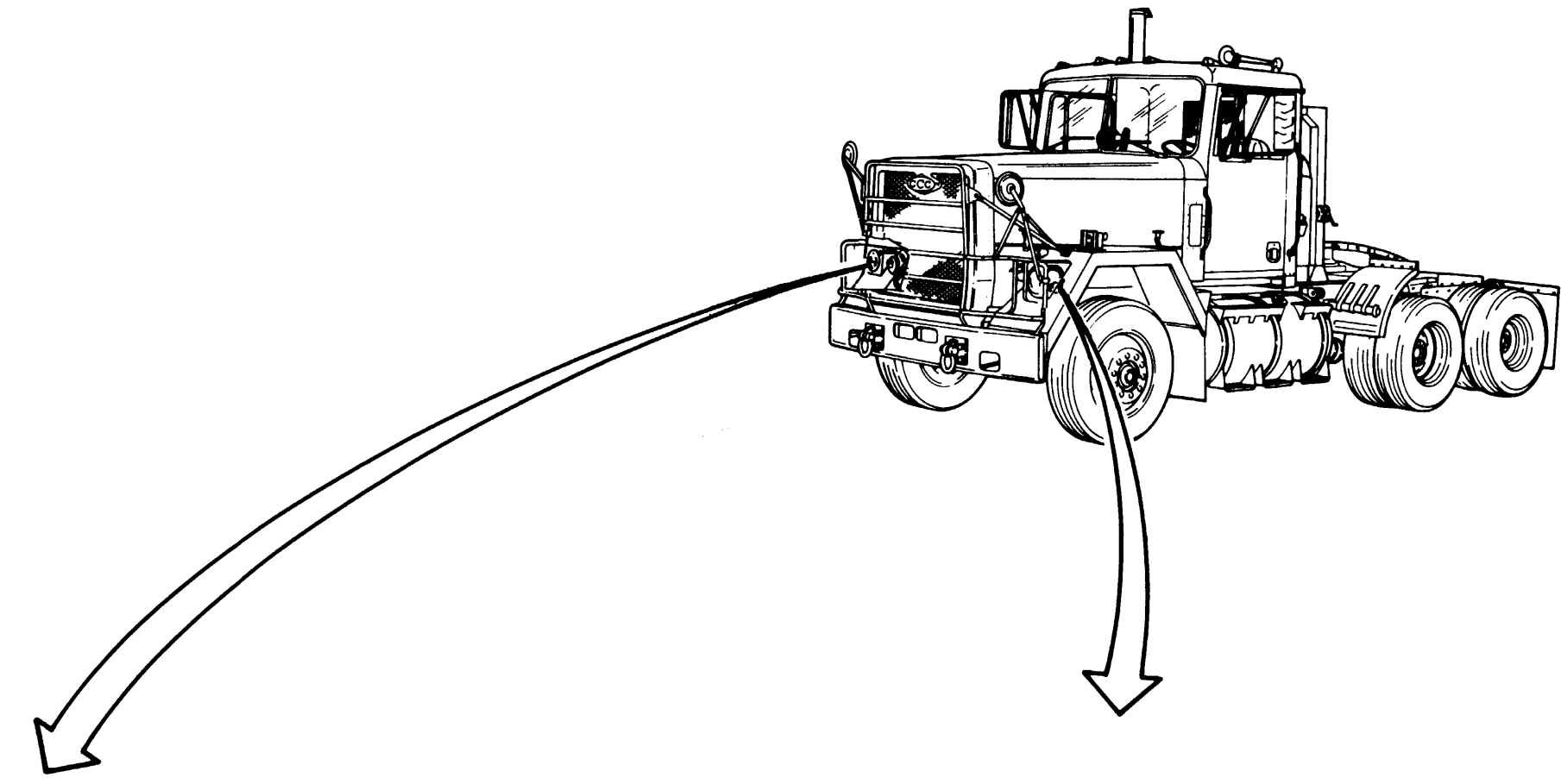

RIGHT HAND HARNESS

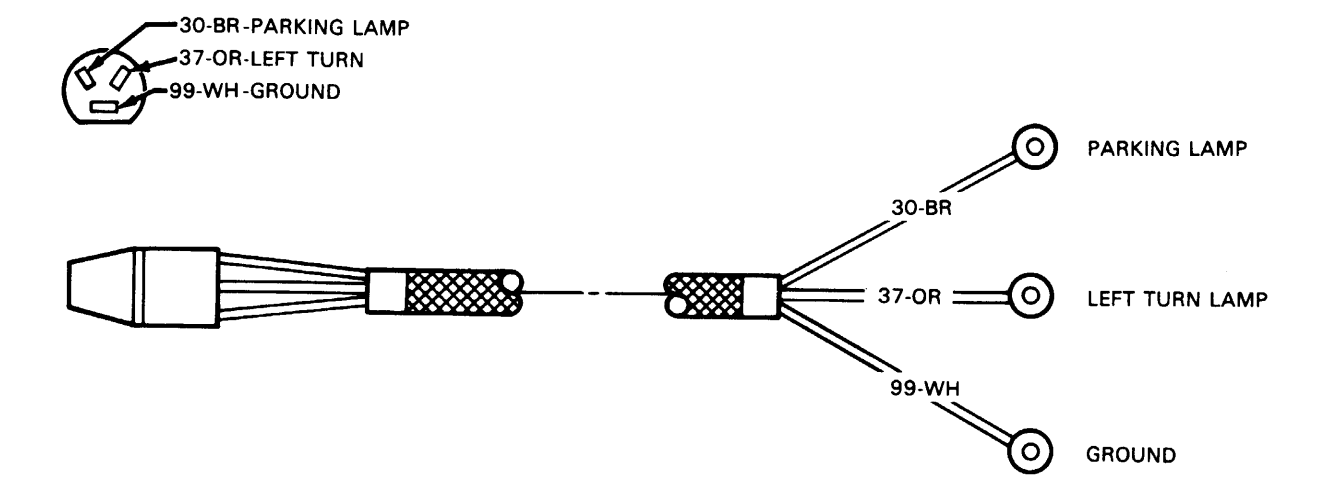

LEFT HAND HARNESS

TA 237873  
Figure FO-1. Right and Left Front Signal Lamp Harness Assemblies  
FO-1 (FO-2 BLANK)

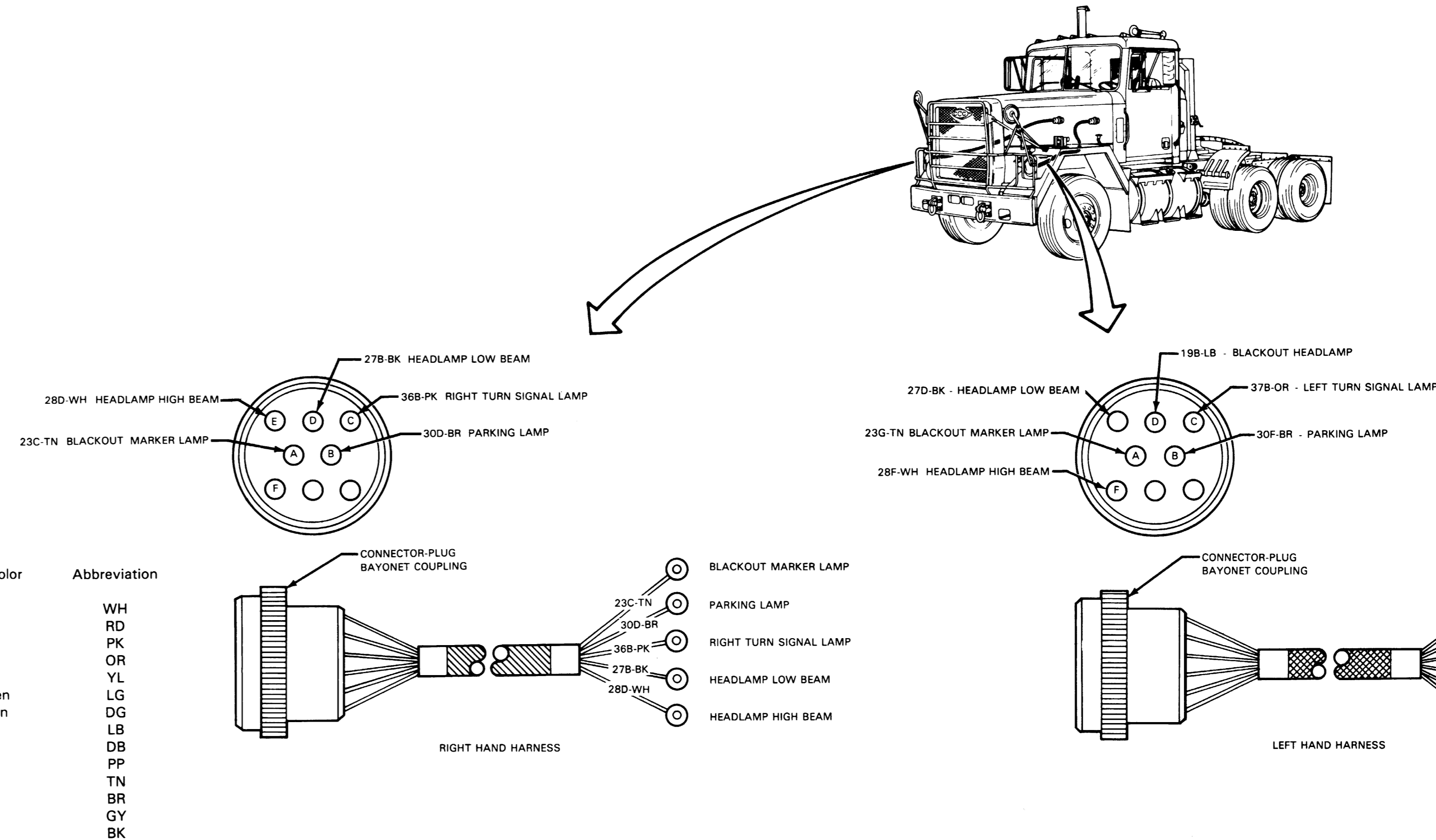

TA 237874

Figure FO-3. Right and Left Fender Harness Assemblies

FO-3 (FO-4 BLANK)

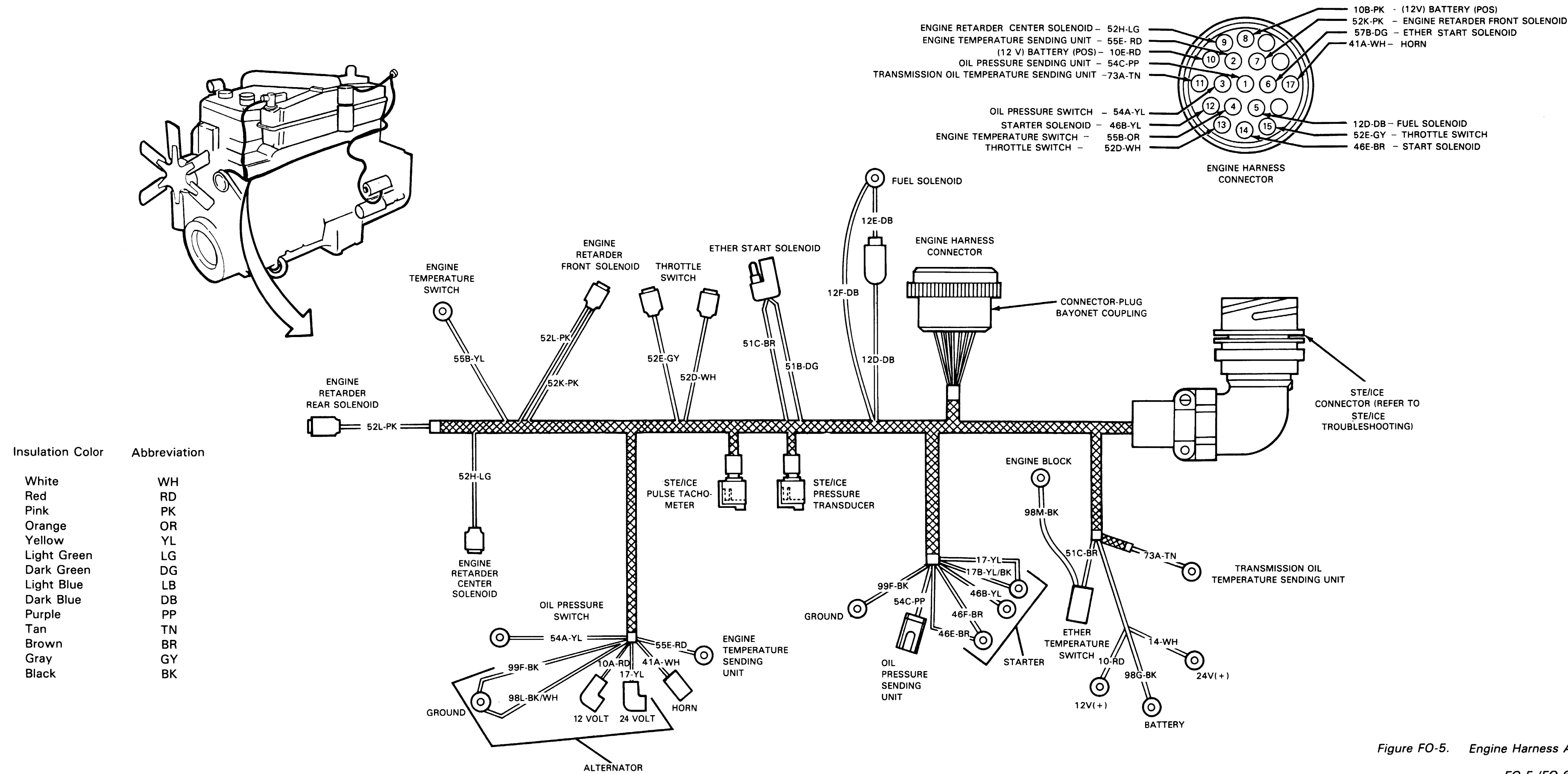
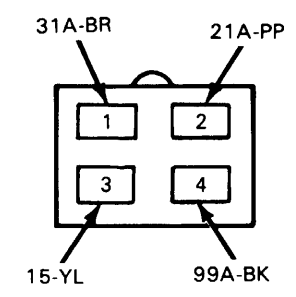
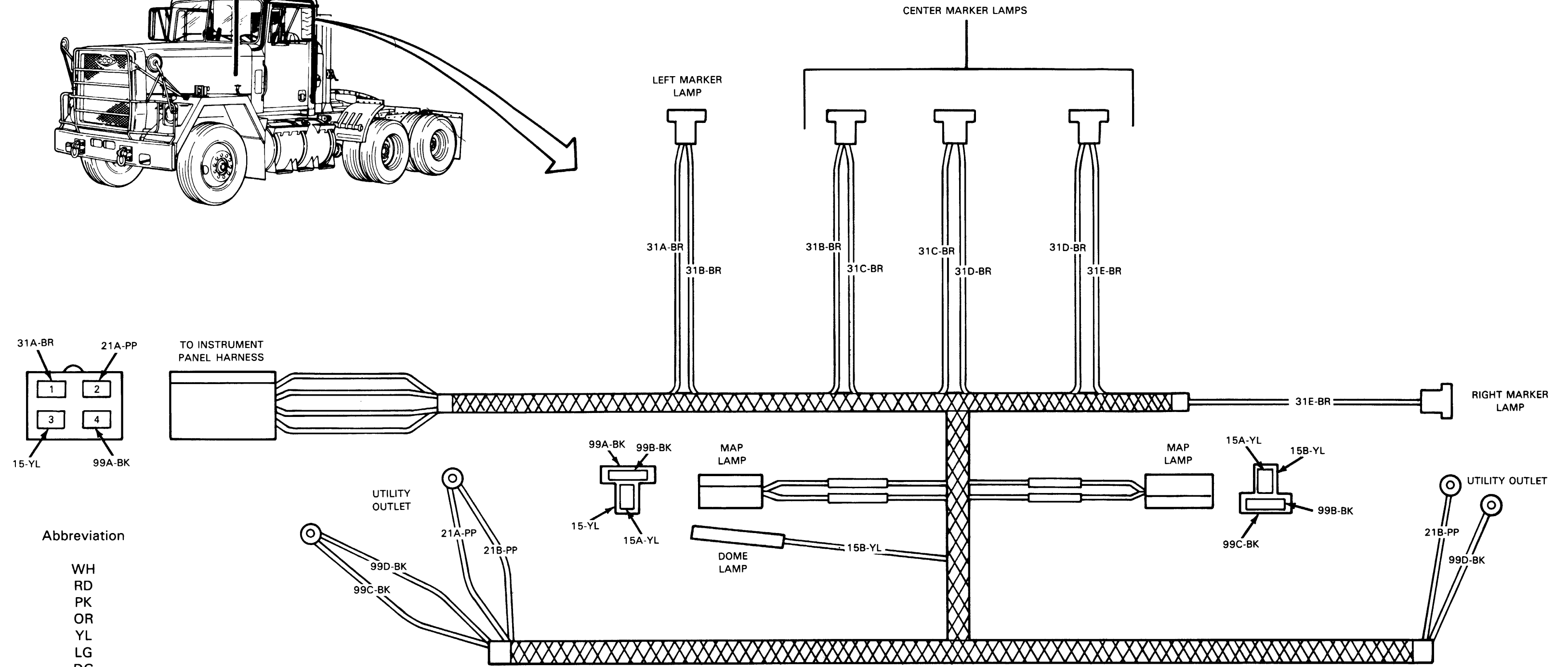
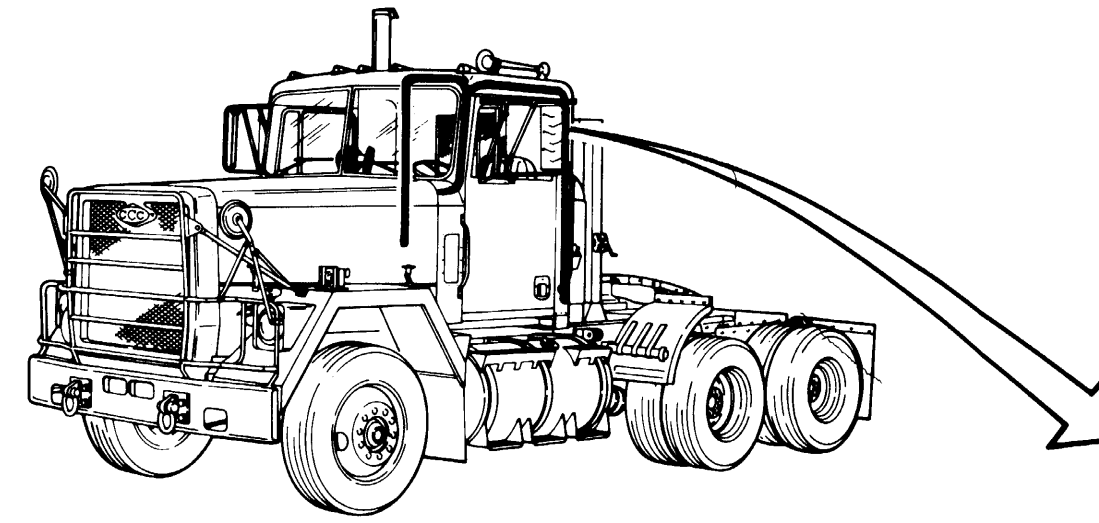

Figure FO-5. Engine Harness Assembly

FO-5 (FO-6 BLANK)



Insulation Color	Abbreviation
White	WH
Red	RD
Pink	PK
Orange	OR
Yellow	YL
Light Green	LG
Dark Green	DG
Light Blue	LB
Dark Blue	DB
Purple	PP
Tan	TN
Brown	BR
Gray	GY
Black	BK

TA 237876

Figure FO-7. Cab Marker Lamps Harness Assembly

FO-7 (FO-8 BLANK)

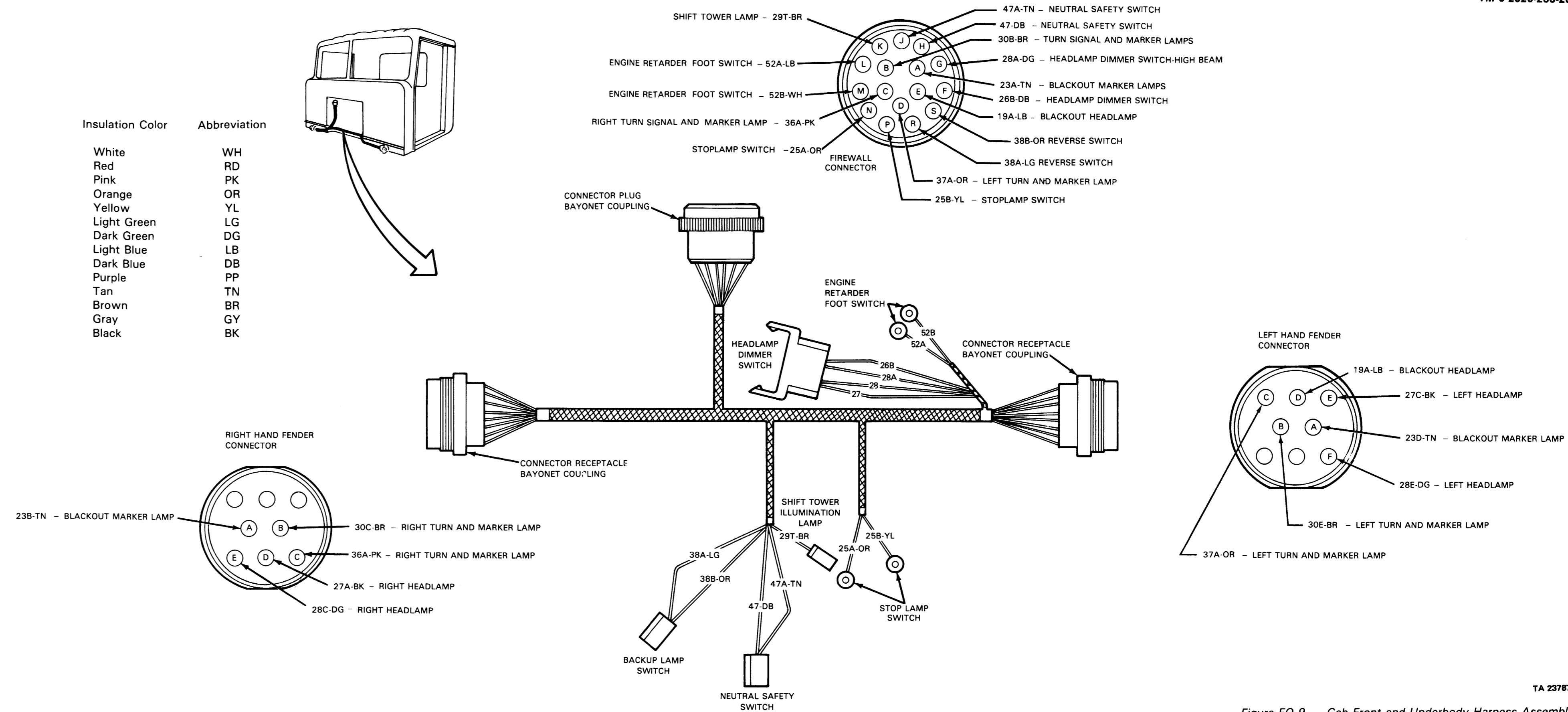

Figure FO-9. Cab Front and Underbody Harness Assembly



Insulation Color	Abbreviation
White	WH
Red	RD
Pink	PK
Orange	OR
Yellow	YL
Light Green	LG
Dark Green	DG
Light Blue	LB
Dark Blue	DB
Purple	PP
Tan	TN
Brown	BR
Gray	GY
Black	BK

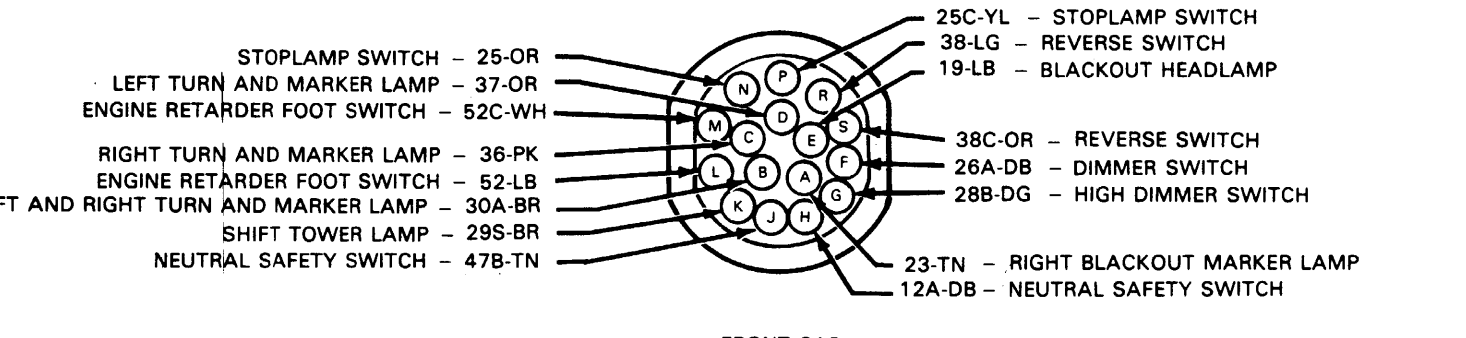
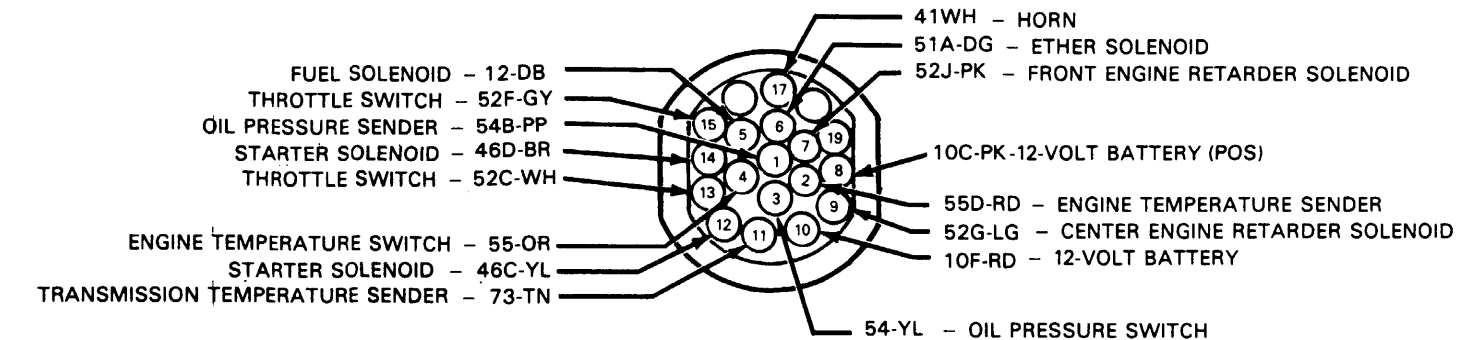
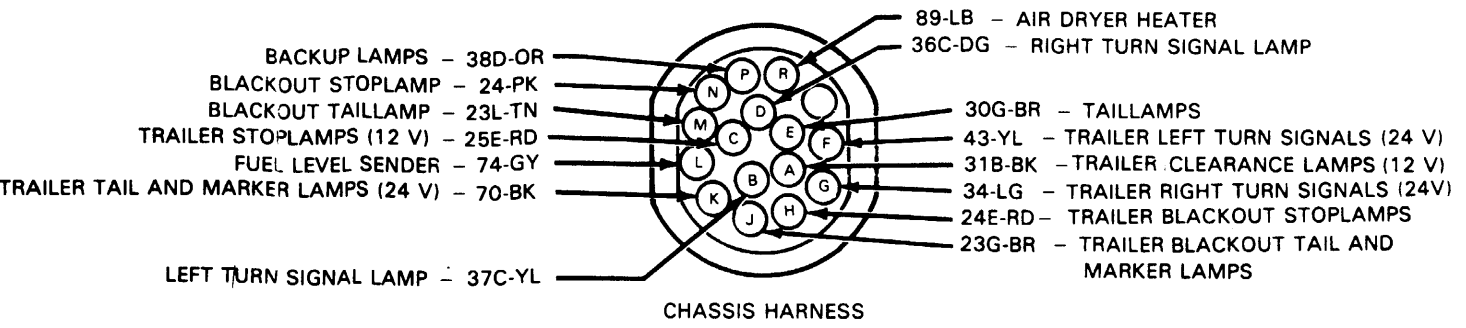
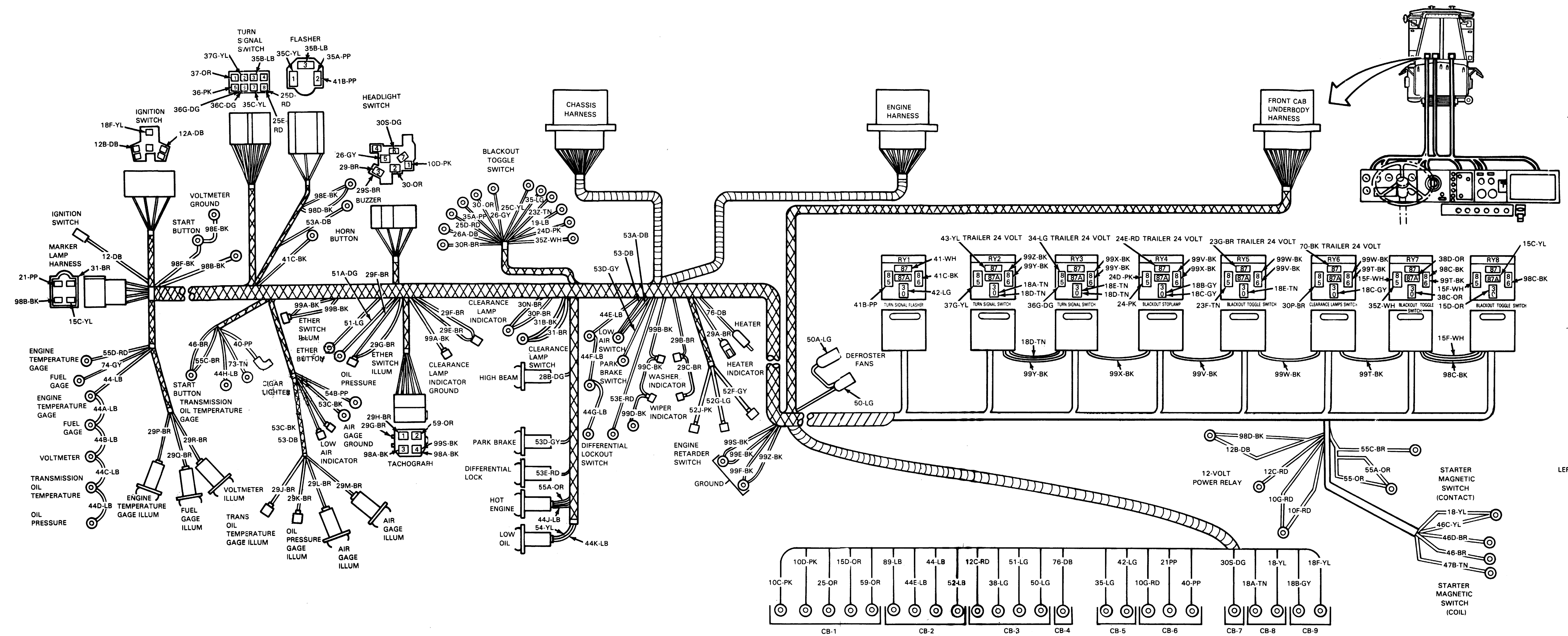
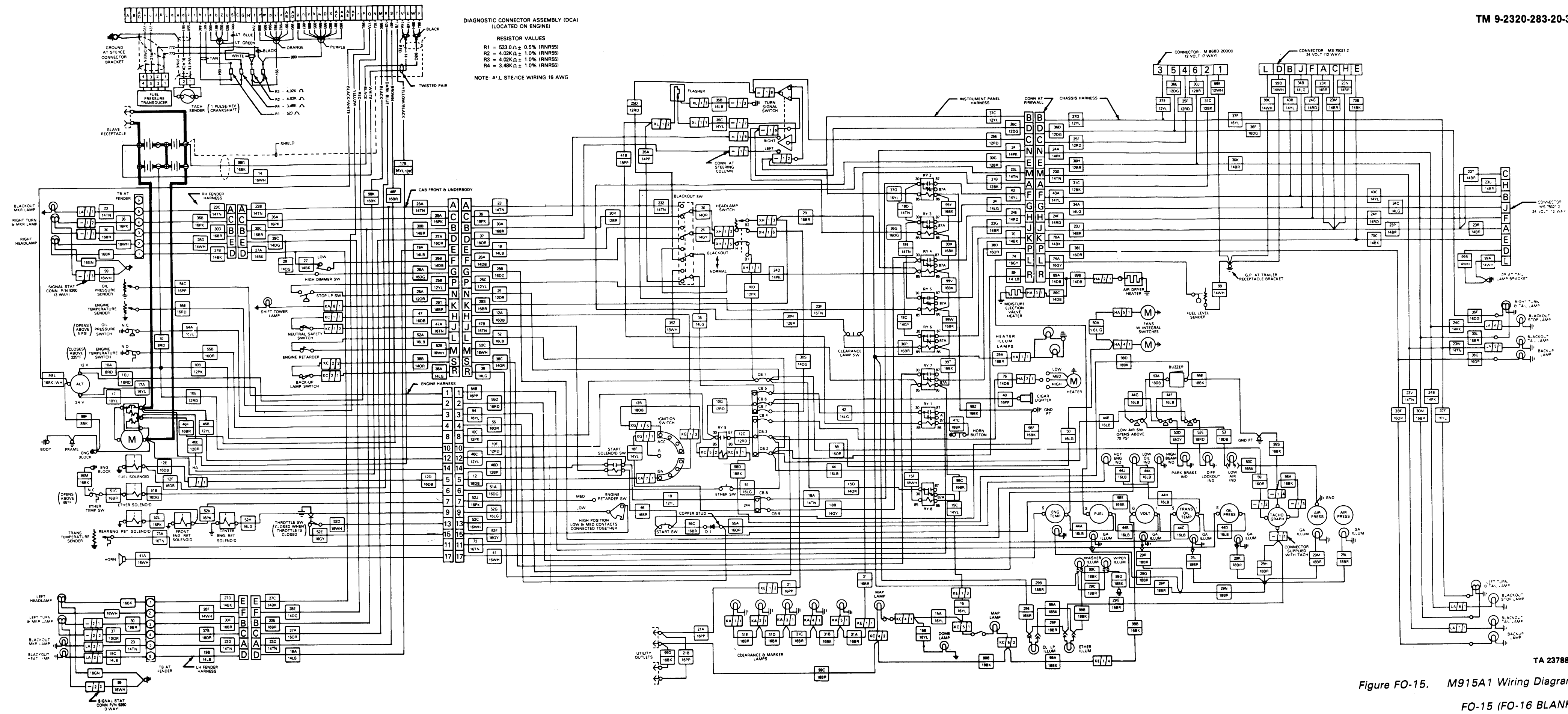

Figure FO-13. Instrument Panel Harness Assembly





TA 237880

Figure FO-15. M915A1 Wiring Diagram

FO-15 (FO-16 BLANK)

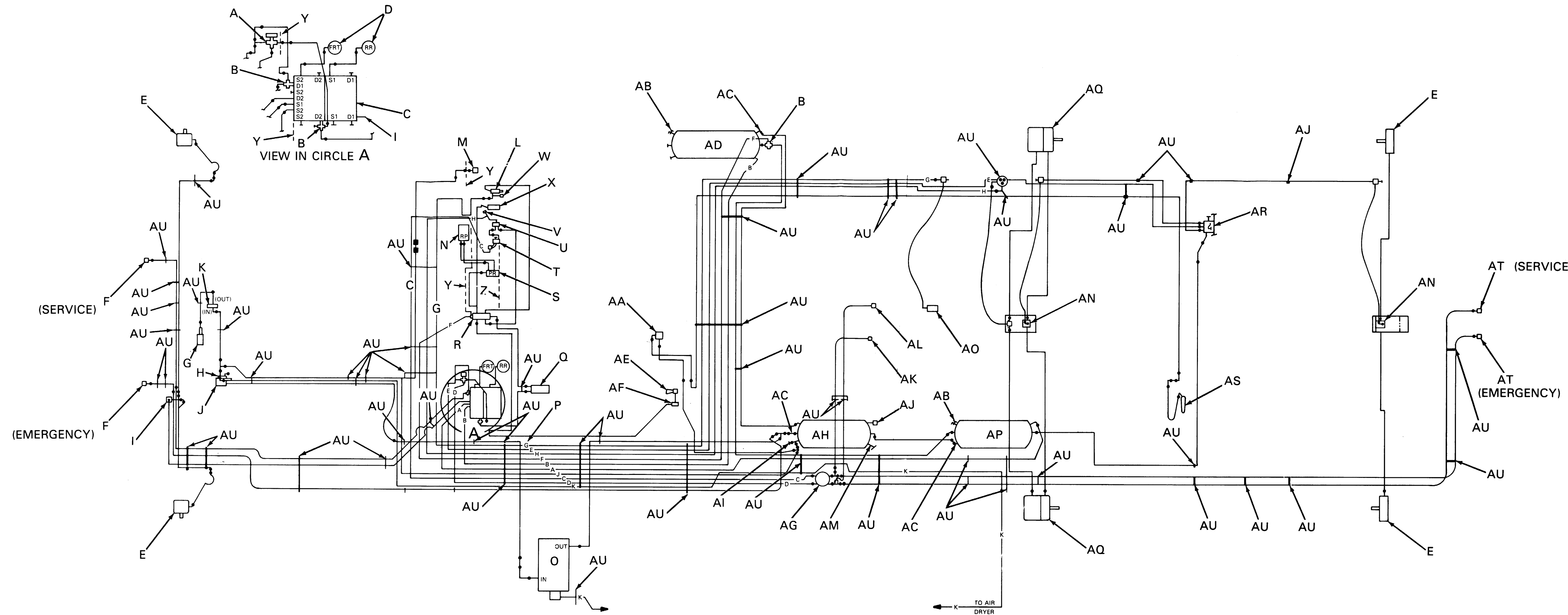

- |   |  |    |                            |
|---|--|----|----------------------------|
| A | DOUBLE CHECK AND STOP LAMP SWITCH      | AA | FIFTH WHEEL UNLOCK VALVE   |
| B | DOUBLE CHECK VALVE                     | AB | DRAINCOCK                  |
| C | BRAKE VALVE AND PEDAL                  | AC | CHECK VALVE                |
| D | FRONT AND REAR AIR PRESSURE GAGES      | AD | SECONDARY RESERVOIR        |
| E | BRAKE ACTUATOR                         | AE | AIR HORN                   |
| F | FRONT GLADHAND                         | AF | HORN VALVE                 |
| G | FAN CLUTCH                             | AG | TRACTOR PROTECTION VALVE   |
| H | GOVERNOR                               | AH | SUPPLY RESERVOIR           |
| I | RATIO VALVE                            | AI | SAFETY VALVE               |
| J | AIR COMPRESSOR                         | AJ | AUTOMATIC DRAIN VALVE      |
| K | FAN CLUTCH ACTUATOR                    | AK | EMERGENCY HOSE COUPLING    |
| L | DIFFERENTIAL VALVE                     | AL | SERVICE COUPLING           |
| M | LOW AIR PRESSURE SWITCH                | AM | QUICK-DISCONNECT COUPLER   |
| N | WINDSHIELD WIPER MOTOR                 | AN | QUICK-RELEASE VALVE        |
| O | AIR DRYER                              | AO | DIFFERENTIAL LOCK CYLINDER |
| P | CHASSIS AIR HARNESS                    | AP | PRIMARY RESERVOIR          |
| Q | TRAILER HAND BRAKE CONTROL VALVE       | AQ | SPRING BRAKE CHAMBER       |
| R | MANIFOLD                               | AR | RELAY VALVE                |
| S | WINDSHIELD WIPER VALVE                 | AS | FIFTH WHEEL AIR PISTON     |
| T | TRAILER SUPPLY VALVE                   | AU | CLAMP                      |
| U | PARK BRAKE VALVE                       | AV | QUICK RELEASE VALVE        |
| V | PRESSURE SWITCH - PARK ON              | W  | DOUBLE CHECK               |
| W | PRESSURE SWITCH - DIFFERENTIAL LOCKOUT | X  | WINDSHIELD WASHER VALVE    |
| X | WINDSHIELD WASHER VALVE                | Y  | FIREWALL                   |
| Y | FIREWALL                               | Z  | DASHBOARD                  |
| Z | DASHBOARD                              |    |                            |

Figure FO-17. M915A1 Air and Brake System Diagram

TA 237881

By Order of the Secretary of the Army:

**E. C. MEYERS**  
*General, United States Army*  
*Chief of Staff*

Official:

**JOHN A. WICKHAM, JR.**  
*Brigadier General, United States Army*  
*The Adjutant General*

Distribution:

To be distributed in accordance with DA Form 12-38, (qty rqr block No. 330), organizational maintenance requirements for Truck, Tractor, Line Haul, 6 x 4, 14-ton, MØ15A1.

\*U.S. GOVERNMENT PRINTING OFFICE : 1997 - 418-292 (66543)



<b>RECOMMENDED CHANGES TO PUBLICATIONS AND BLANK FORMS</b>						Use Part II (reverse) for Repair Parts and Special Tool Lists (RPSTL) and Supply Catalogs/Supply Manuals (SC/SM).	DATE Date you filled out this form.
For use of this form, see AR 25-30; the proponent agency is ODISC4.							
TO: (Forward to proponent of publication or form) (Include ZIP Code) AMSTALC-LPIT / TECH PUBS, TACOM-RI 1 Rock Island Arsenal Rock Island, IL 61299-7630						FROM: (Activity and location) (Include ZIP Code)  Your mailing address	
<b>PART I – ALL PUBLICATIONS (EXCEPT RPSTL AND SC/SM) AND BLANK FORMS</b>							
PUBLICATION/FORM NUMBER TM 9-2320-283-20-3				DATE 8 December 1983	TITLE Truck Tractor, Line Haul: 50,000 GVWR, 6x4, M915A1		
ITEM NO.	PAGE NO.	PARA-GRAPH	LINE NO. *	FIGURE NO.	TABLE NO.	RECOMMENDED CHANGES AND REASON (Provide exact wording of recommended changes, if possible).	
	0004 00-2	4-7				Wrong POC is listed.  <div style="border: 1px solid black; padding: 20px; text-align: center; font-size: 48px; font-weight: bold; transform: rotate(-10deg);">SAMPLE</div>	
<i>*Reference to line numbers within the paragraph or subparagraph.</i>							
TYPED NAME, GRADE OR TITLE  Your Name				TELEPHONE EXCHANGE/AUTOVON, PLUS EXTENSION		SIGNATURE  Your Signature	

<b>TO:</b> <i>(Forward direct to addressee listed in publication)</i> AMSTALC-LPIT / TECH PUBS, TACOM-RI 1 Rock Island Arsenal Rock Island, IL 61299-7630	<b>FROM:</b> <i>(Activity and location) (Include ZIP Code)</i> Your address	<b>DATE</b> Date you filled out this form
--	--	--

**PART II – REPAIR PARTS AND SPECIAL TOOL LISTS AND SUPPLY CATALOGS/SUPPLY MANUALS**

PUBLICATION NUMBER TM 9-2320-283-20-3	DATE 8 December 1983	TITLE Truck Tractor, Line Haul: 50,000 GVWR, 6x4, M915A1
--	-------------------------	---

PAGE NO.	COLM NO.	LINE NO.	NATIONAL STOCK NUMBER	REFERENCE NO.	FIGURE NO.	ITEM NO.	TOTAL NO. OF MAJOR ITEMS SUPPORTED	RECOMMENDED ACTION

**PART III – REMARKS** *(Any general remarks or recommendations, or suggestions for improvement of publications and blank forms. Additional blank sheets may be used if more space is needed.)*

TYPED NAME, GRADE OR TITLE Your Name	TELEPHONE EXCHANGE/AUTOVON, PLUS EXTENSION	SIGNATURE Your Signature
---	--	-----------------------------

<b>RECOMMENDED CHANGES TO PUBLICATIONS AND BLANK FORMS</b>						Use Part II (reverse) for Repair Parts and Special Tool Lists (RPSTL) and Supply Catalogs/Supply Manuals (SC/SM).	DATE
For use of this form, see AR 25-30; the proponent agency is ODISC4.							
<b>TO:</b> (Forward to proponent of publication or form) (Include ZIP Code) AMSTALC-LPIT / TECH PUBS, TACOM-RI 1 Rock Island Arsenal Rock Island, IL 61299-7630						<b>FROM:</b> (Activity and location) (Include ZIP Code)	
<b>PART I - ALL PUBLICATIONS (EXCEPT RPSTL AND SC/SM) AND BLANK FORMS</b>							
PUBLICATION/FORM NUMBER TM 9-2320-283-20-3				DATE 8 December 1983		TITLE Truck Tractor, Line Haul: 50,000 GVWR, 6x4, M915A1	
ITEM NO.	PAGE NO.	PARA-GRAPH	LINE NO. *	FIGURE NO.	TABLE NO.	RECOMMENDED CHANGES AND REASON (Provide exact wording of recommended changes, if possible).	
<i>*Reference to line numbers within the paragraph or subparagraph.</i>							
TYPED NAME, GRADE OR TITLE				TELEPHONE EXCHANGE/AUTOVON, PLUS EXTENSION		SIGNATURE	

<b>TO:</b> <i>(Forward direct to addressee listed in publication)</i> AMSTALC-LPIT / TECH PUBS, TACOM-RI 1 Rock Island Arsenal Rock Island, IL 61299-7630	<b>FROM:</b> <i>(Activity and location) (Include ZIP Code)</i>	<b>DATE</b>
--	--	-------------

**PART II – REPAIR PARTS AND SPECIAL TOOL LISTS AND SUPPLY CATALOGS/SUPPLY MANUALS**

PUBLICATION NUMBER TM 9-2320-283-20-3	DATE 8 December 1983	TITLE Truck Tractor, Line Haul: 50,000 GVWR, 6x4, M915A1
--	-------------------------	---

PAGE NO.	COLM NO.	LINE NO.	NATIONAL STOCK NUMBER	REFERENCE NO.	FIGURE NO.	ITEM NO.	TOTAL NO. OF MAJOR ITEMS SUPPORTED	RECOMMENDED ACTION

**PART III – REMARKS** *(Any general remarks or recommendations, or suggestions for improvement of publications and blank forms. Additional blank sheets may be used if more space is needed.)*

TYPED NAME, GRADE OR TITLE	TELEPHONE EXCHANGE/AUTOVON, PLUS EXTENSION	SIGNATURE
----------------------------	--	-----------



<b>RECOMMENDED CHANGES TO PUBLICATIONS AND BLANK FORMS</b>						Use Part II (reverse) for Repair Parts and Special Tool Lists (RPSTL) and Supply Catalogs/Supply Manuals (SC/SM).	DATE
For use of this form, see AR 25-30; the proponent agency is ODISC4.							
TO: (Forward to proponent of publication or form) (Include ZIP Code) AMSTALC-LPIT / TECH PUBS, TACOM-RI 1 Rock Island Arsenal Rock Island, IL 61299-7630						FROM: (Activity and location) (Include ZIP Code)	
<b>PART I - ALL PUBLICATIONS (EXCEPT RPSTL AND SC/SM) AND BLANK FORMS</b>							
PUBLICATION/FORM NUMBER TM 9-2320-283-20-3					DATE 8 December 1983	TITLE Truck Tractor, Line Haul: 50,000 GVWR, 6x4, M915A1	
ITEM NO.	PAGE NO.	PARA-GRAPH	LINE NO. *	FIGURE NO.	TABLE NO.	RECOMMENDED CHANGES AND REASON (Provide exact wording of recommended changes, if possible).	
<i>*Reference to line numbers within the paragraph or subparagraph.</i>							
TYPED NAME, GRADE OR TITLE				TELEPHONE EXCHANGE/AUTOVON, PLUS EXTENSION		SIGNATURE	

<b>TO:</b> <i>(Forward direct to addressee listed in publication)</i> AMSTALC-LPIT / TECH PUBS, TACOM-RI 1 Rock Island Arsenal Rock Island, IL 61299-7630	<b>FROM:</b> <i>(Activity and location) (Include ZIP Code)</i>	<b>DATE</b>
--	--	-------------

**PART II - REPAIR PARTS AND SPECIAL TOOL LISTS AND SUPPLY CATALOGS/SUPPLY MANUALS**

PUBLICATION NUMBER TM 9-2320-283-20-3	DATE 8 December 1983	TITLE Truck Tractor, Line Haul: 50,000 GVWR, 6x4, M915A1
--	-------------------------	---

PAGE NO.	COLM NO.	LINE NO.	NATIONAL STOCK NUMBER	REFERENCE NO.	FIGURE NO.	ITEM NO.	TOTAL NO. OF MAJOR ITEMS SUPPORTED	RECOMMENDED ACTION

**PART III - REMARKS** *(Any general remarks or recommendations, or suggestions for improvement of publications and blank forms. Additional blank sheets may be used if more space is needed.)*

TYPED NAME, GRADE OR TITLE	TELEPHONE EXCHANGE/AUTOVON, PLUS EXTENSION	SIGNATURE
----------------------------	--	-----------

**THE METRIC SYSTEM AND EQUIVALENTS**

**LINEAR MEASURE**

1 Centimeter = 10 Millimeters = 0.01 Meters = 0.3937 Inches  
 1 Meter = 100 Centimeters = 1000 Millimeters = 39.37 Inches  
 1 Kilometer = 1000 Meters = 0.621 Miles

**SQUARE MEASURE**

1 Sq Centimeter = 100 Sq Millimeters = 0.155 Sq Inches  
 1 Sq Meter = 10,000 Sq Centimeters = 10.76 Sq Feet  
 1 Sq Kilometer = 1,000,000 Sq Meters = 0.386 Sq Miles

**WEIGHTS**

1 Gram = 0.001 Kilograms = 1000 Milligrams = 0.035 Ounces  
 1 Kilogram = 1000 Grams = 2.2 Lb  
 1 Metric Ton = 1000 Kilograms = 1 Megagram = 1.1 Short Tons

**CUBIC MEASURE**

1 Cu Centimeter = 1000 Cu Millimeters = 0.06 Cu Inches  
 1 Cu Meter = 1,000,000 Cu Centimeters = 35.31 Cu Feet

**LIQUID MEASURE**

1 Milliliter = 0.001 Liters = 0.0338 Fluid Ounces  
 1 Liter = 1000 Milliliters = 33.82 Fluid Ounces

**TEMPERATURE**

$5/9 (°F - 32) = °C$   
 212° Fahrenheit is equivalent to 100° Celsius  
 90° Fahrenheit, is equivalent to 32.2° Celsius  
 32° Fahrenheit is equivalent to 0° Celsius  
 $9/5 C° + 32 = F°$

**APPROXIMATE CONVERSION FACTORS**

<u>TO CHANGE</u>	<u>TO</u>	<u>MULTIPLY BY</u>
Inches . . . . .	Centimeters . . . . .	2.540
Feet . . . . .	Meters . . . . .	0.305
Yards . . . . .	Meters . . . . .	0.914
Miles . . . . .	Kilometers . . . . .	1.609
Square Inches . . . . .	Square Centimeters . . . . .	6.451
Square Feet . . . . .	Square Meters . . . . .	0.093
Square Yards . . . . .	Square Meters . . . . .	0.836
Square Miles . . . . .	Square Kilometers . . . . .	2.590
Acres . . . . .	Square Hectometers . . . . .	0.405
Cubic Feet . . . . .	Cubic Meters . . . . .	0.028
Cubic Yards . . . . .	Cubic Meters . . . . .	0.765
Fluid Ounces . . . . .	Milliliters . . . . .	29.573
Pints . . . . .	Liters . . . . .	0.473
Quarts . . . . .	Liters . . . . .	0.946
Gallons . . . . .	Liters . . . . .	3.785
Ounces . . . . .	Grams . . . . .	28.349
Pounds . . . . .	Kilograms . . . . .	0.454
Short Tons . . . . .	Metric Tons . . . . .	0.907
Pound-Feet . . . . .	Newton-Meters . . . . .	1.356
Pounds per Square Inch . . . . .	Kilopascals . . . . .	6.895
Miles per Gallon . . . . .	Kilometers per Liter . . . . .	0.425
Miles per Hour . . . . .	Kilometers per Hour . . . . .	1.609

<u>TO CHANGE</u>	<u>TO</u>	<u>MULTIPLY BY</u>
Centimeters . . . . .	Inches . . . . .	0.394
Meters . . . . .	Feet . . . . .	3.280
Meters . . . . .	Yards . . . . .	1.094
Kilometers . . . . .	Miles . . . . .	0.621
Square Centimeters . . . . .	Square Inches . . . . .	0.155
Square Meters . . . . .	Square Feet . . . . .	10.764
Square Meters . . . . .	Square Yards . . . . .	1.196
Square Kilometers . . . . .	Square Miles . . . . .	0.386
Square Hectometers . . . . .	Acres . . . . .	2.471
Cubic Meters . . . . .	Cubic Feet . . . . .	35.315
Cubic Meters . . . . .	Cubic Yards . . . . .	1.308
Milliliters . . . . .	Fluid Ounces . . . . .	0.034
Liters . . . . .	Pints . . . . .	2.113
Liters . . . . .	Quarts . . . . .	1.057
Liters . . . . .	Gallons . . . . .	0.264
Grams . . . . .	Ounces . . . . .	0.035
Kilograms . . . . .	Pounds . . . . .	2.205
Metric Tons . . . . .	Short Tons . . . . .	1.102
Newton-Meters . . . . .	Pound-Feet . . . . .	0.738
Kilopascals . . . . .	Pounds per Square Inch . . . . .	0.145
Kilometers per Liter . . . . .	Miles per Gallon . . . . .	2.354
Kilometers per Hour . . . . .	Miles per Hour . . . . .	0.621

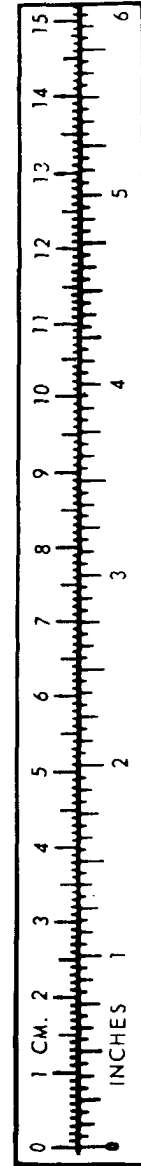

TA089991

