

Spicer® CTIS  
(Central Tire Inflation System)



**SPICER®**  
*Drivetrain Products*

# Troubleshooting Guide

---

**AXTS0015**

**July 2010**

## General Information

The description and specifications contained in the service publication are current at the time of printing.

Dana reserves the right to discontinue or modify its models and/or procedures and to change specifications at any time without notice.

Any reference to brand name in this publication is made as an example of the types of tools and materials recommended for use and should not be considered an endorsement. Equivalents may be used.

### IMPORTANT NOTICE

This symbol is used throughout this manual to call attention to procedures where carelessness or failure to follow specific instructions may result in personal injury and/or component damage.

Departure from the instructions, choice of tools, materials and recommended parts mentioned in this publication may jeopardize the personal safety of the service technician or vehicle operator.

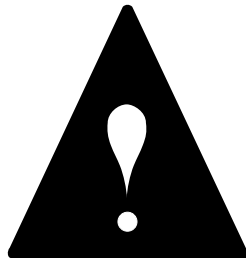

**WARNING:** Failure to follow indicated procedures creates a high risk of personal injury to the servicing technician.

**CAUTION:** Failure to follow indicated procedures may cause component damage or malfunction.

**IMPORTANT:** Highly recommended procedures for proper service of this unit.

**Note:** Additional service information not covered in the service procedures.

**Tip:** Helpful removal and installation procedures to aid in the service of this unit.

*Always use genuine Spicer replacement parts.*

Every effort has been made to endure the accuracy of all information in this guide. **However, Dana Commercial Vehicle Systems Division makes no expressed or implied warranty or representation based on the enclosed information.**

Any errors or omissions may be reported to:  
Marketing Services  
Dana Commercial Vehicle Systems Division  
P.O. Box 4097  
Kalamazoo, MI 49003

**General Information**

Central Tire Inflation System (CTIS) . . . . . 1  
 Key Features . . . . . 1  
 Component Description . . . . . 2  
 Central Tire Inflation System Components . . . . . 3  
 Simplified System Schematic . . . . . 4

**Operator Instructions**

Flange or Panel  
     Operator Controls . . . . . 5  
     Warning Signals . . . . . 7  
 Driver Display Module (DDM)  
     Operator Controls . . . . . 9  
     Warning Signals . . . . . 10

**Diagnostics**

Diagnostics . . . . . 11  
 Service Codes Summary . . . . . 14  
 Troubleshooting Tips . . . . . 20

**Service Codes**

5 Flashing Lights or DDM – Dashes "--"  
     Low Pressure (Codes 26, 27) . . . . . 21  
     Low Air Supply (Code 32) . . . . . 23  
     Atmospheric (Code 35) . . . . . 25  
     Inflate Trend (Codes 36, 37) . . . . . 27  
     Deflate Trend (Code 14) . . . . . 29  
     PCU Sensor (Codes 33, 34) . . . . . 31  
     Pressure Switch (Code 31) . . . . . 33  
 4 Flashing Lights or CHECK TIRES Flashing  
     Tire Leak (Imbalance) (Codes 44, 45) . . . . . 35  
     Tire Leak (Confirm) (Codes 41, 42) . . . . . 37  
 2 Terrain Lights on Solid or DDM – Dashes "--"  
     Between Modes (Codes 23, 24) . . . . . 39  
     Deflate Signal (Codes 11, 12, 16) . . . . . 41  
 No Terrain Lights or DDM – Dashes "--"  
     PCU Solenoid (Supply, Deflate, Control, Front,  
         or Rear) (Codes 51, 52, 54, 55, 56) . . . . . 43  
 No Terrain Lights or DDM – Blank Display  
     Power (Code 17) . . . . . 45  
 DDM – Dashes "--"  
     Display Control Communications (Code 75) . . . . . 47  
 Lights Sequentially Flashing  
     Configuration Error . . . . . 49  
 Solid Warning Lamp or Solid OVER SPEED  
     Speed Signal (Codes 18, 76, 77) . . . . . 51  
 No Indication or DDM – Dashes "--"  
     Miscellaneous Output (Codes 53, 57, 58, 67, 68) 53  
 No Indication  
     Wheel Valve Shut Off (Codes 61, 62, 64, 65) . . . 55

No Code  
 Miscellaneous . . . . . 57

**Service Guidelines**

CTIS Service . . . . . 59  
 Joint Compounds and Fittings . . . . . 59  
 Air Filter Change . . . . . 60

**Wire Harness**

Connector Illustrations . . . . . 61  
 M939 Wiring Diagram (676422 and 676603) . . . . . 62  
 Flange Mount Wiring Diagram . . . . . 63  
 Panel Mount Wiring Diagram . . . . . 64  
 Chassis ECU with DDM Wiring Diagram  
     Separate Power and Switched Ignition . . . . . 65  
     All Power Switched . . . . . 66  
 Configuration Options . . . . . 67

## Central Tire Inflation System (CTIS)

Spicer's Central Tire Inflation System features driver control of tire air pressure through:

- Simple push button operation.
- Electronic braking priority for air system.
- Vehicle speed sensing and response capability.
- Self-diagnostics.
- Optional independent front and rear operation.
- Optional load selection.

### Key Features

#### Depressurized Control Lines

The only time the system is pressurized is when changing tire pressures or during pressure checks. Wheel valves isolate the tires from the rest of the system.

#### Electronic Braking Priority

A pressure switch, installed in the supply tank, controls the CTIS and use of air. This optimizes and protects the brake system's primary tank pressures during system operation.

#### Self-Diagnostic and Auto Shut-Down

The Spicer CTIS provides self-diagnosis during operation. If the system detects a problem, it will display a series of flashing lights on the Electronic Control Unit (ECU) panel to alert the driver. If necessary, it will close the wheel valves and shut down.

#### Diagnostic Capability

The Spicer CTIS provides for easy troubleshooting using PC-based or industry standard tools. Personal computer-supported diagnostics improve troubleshooting and reduce maintenance time. The diagnostics provide for manual control of CTIS test sequences and gives historical and active service code data.

#### Speed/Pressure Control and Warning

If truck speed exceeds the maximum allowable speed for a given setting, a panel-mounted light is activated by CTIS to warn the driver. If speed is not reduced, the system automatically inflates the tires to the appropriate pressure.

#### Manual Tire Inflation/Deflation

A valve stem has been included on each wheel valve, and may be used for manual inflation, deflation, or measurement of tire pressures.

#### Run Flat Operation

The CTIS normally checks tire pressures at intervals of 15 minutes. If possible tire damage is detected, the system will activate Auto RUN FLAT. RUN FLAT reduces the pressure check interval to 15 seconds, helping to assure that the tire will remain inflated despite minor tire damage.

## Component Description

### Wheel Valve (WV)

All axles use a Wheel Valve (WV) at each end. Dual wheels are typically connected to one WV to provide tire pressure balance between duals. When the system is idle, the WV isolates the tire(s). A standard tank valve is included for manual inflation.

### Quick Release Valve (QRV)

The Quick Release Valve (one per axle) receives pneumatic signals from the Pneumatic Control Unit (PCU) and either inflates the tires, or vents air from the tires causing them to deflate. The QRV can be vented through the air stack to provide for vehicle deep water fording.

### Air Transport Valve (ATV)—Optional

The Air Transport Valve (ATV) may be added in-line between the Wheel Valve and the tire. Its purpose is to manually lower the tire pressure significantly, decreasing the height of the vehicle, to allow the vehicle to be loaded onto planes, etc. with low clearances.

### Load Selection/Sensing—Optional

Some CTI systems make use of either a user selectable load setting or an automatic load setting, which adjusts pressure targets based on the load of the vehicle.

### Electronic Control Unit (ECU)

The Electronic Control Unit (ECU) is the control center for the entire Central Tire Inflation System. The ECU receives commands from the driver through push buttons, and transmits and monitors appropriate signals throughout the system.

### Pneumatic Control Unit (PCU)

The Pneumatic Control Unit (PCU) is a solenoid controlled manifold that controls the air system. It also contains the PCU sensor (transducer) which reads tire pressures.

### Speed Sensor or Speed Input

Speed is read from the vehicle data link or a separate speed sensor.

### Pressure Switch (PS)

The Pressure Switch (PS) acts as an electronic brake priority switch. It prevents the Central Tire Inflation System from using air from the supply tank until the brake system is fully charged. The PS also ensures that enough pressure exists for the system to operate properly.

### Air Lines

The Central Tire Inflation System uses a dedicated pneumatic system plumbed from the vehicles' exiting supply tank. Air lines between the Pneumatic Control Unit and the Quick Release Valves (QRV) are called "Upper Control Lines". Air lines between the QRVs and the Wheel Valves are called "Lower Control Lines".

### Central Tire Inflation System Components

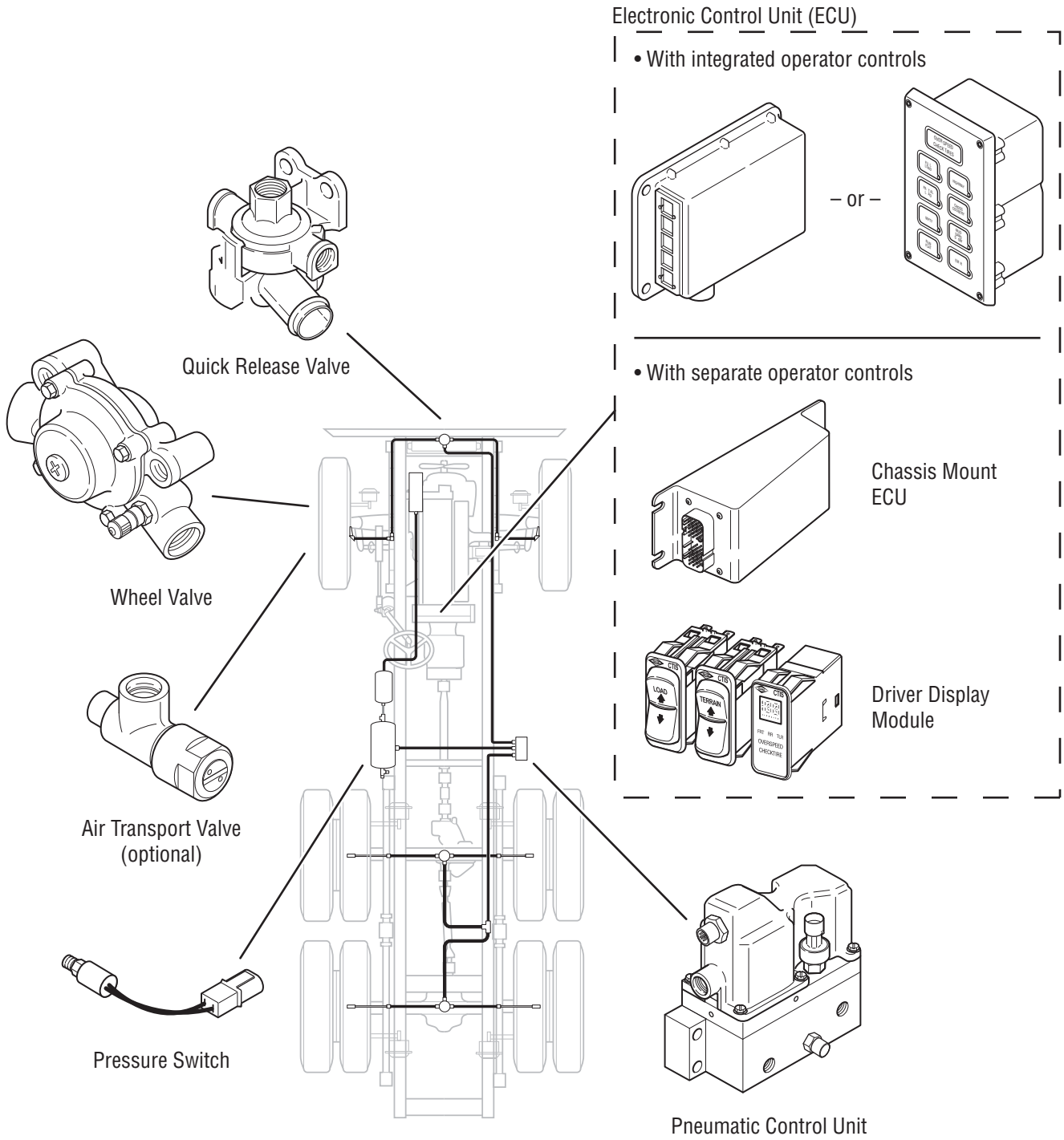

## Simplified System Schematic

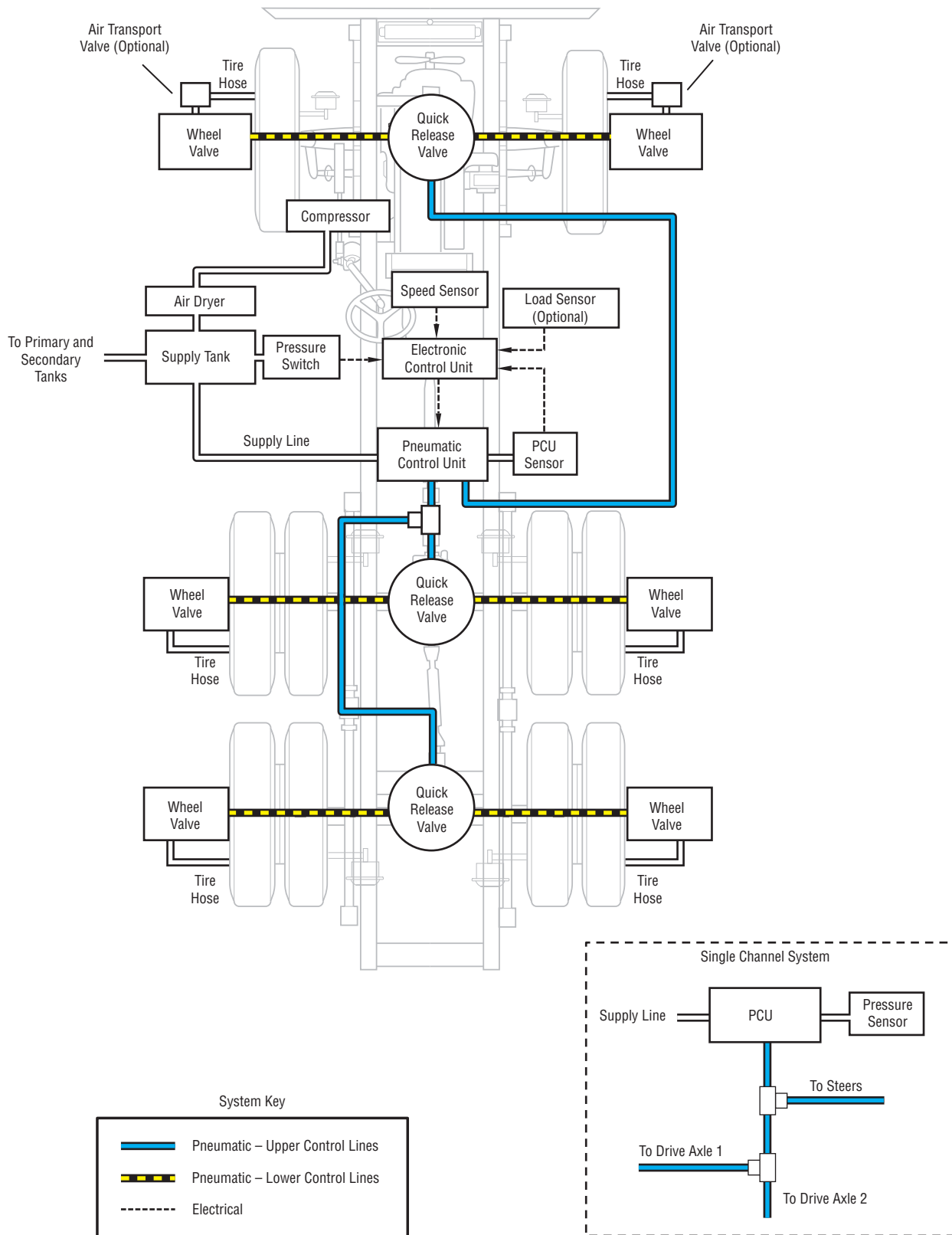

CTIS Components

## Flange or Panel—Operator Controls

The integrated push button/display is the primary interface for display of system information and for push button entry of system instructions. The following sections explain the purpose and operation of the ECU controls and display.

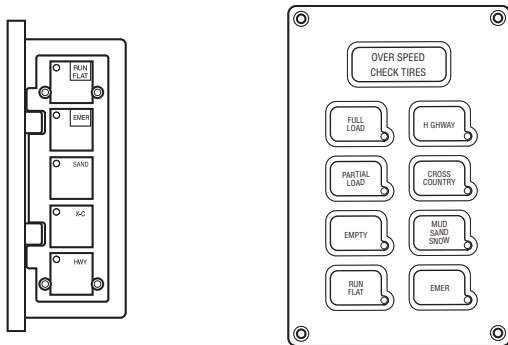

## Terrain Selection

These keys select pressures appropriate for different surface conditions. Any mode may be selected at any time (within built in speed limitations). Depressing the button for the current mode will result in a pressure check.

**HWY** (Highway)—For operation on improved paved surfaces.

**XC** (Cross Country)—For operation on non-paved secondary roads.

**SAND** (Sand)—For operation on trails and other unimproved surfaces.

**EMER** (Emergency)—For selection of extremely low tire pressures to help free a stuck vehicle, or to traverse a short distance over a terrain known to require very low tire pressures. Since this is an extremely low pressure, the warning lamp will flash whenever this pressure is utilized.



**The EMER key is for extreme conditions only and should not be used for normal driving.**

## Load Selection (Optional)

This feature allows selection of pressures appropriate for different vehicle load conditions (full load, partial-load, empty). Switching the load setting will result in a pressure check and subsequent changing of the pressures as determined by the system.

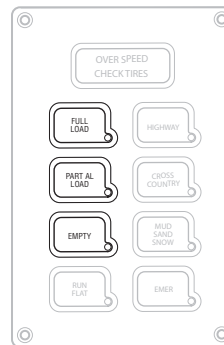

## Mode Annunciator Lights

The associated annunciator lights indicate the selected mode and signal one of two states:

### If the light is flashing:

The system is in the process of checking or changing pressures to attain the pressure(s) associated with that mode light.

Some clicking may be heard from the PCU as the system cycles to achieve the new pressure(s). A deflate will be periodically interrupted as the system checks tire pressures to determine how much further deflation is necessary.

**Note:** Adequate supply system pressure is required to begin or continue any pressure changing sequence.

### If the light is on steady:

The selected pressure has been achieved, the tires have been isolated and the system is depressurized. The system will cycle periodically to assure that tire pressure is maintained.

**Note:** The system is designed to allow tire pressure increase due to heat buildup during vehicle use. This system will not automatically deflate these pressure buildups—a lower pressure mode must be selected to initiate a deflate.



## Run Flat Key and Annunciator Light

This key instructs the system to check tire pressures at more frequent intervals. This key also allows the operator to override the “4 flashing lights” (tire leak imbalance) codes and reattempt 2 lights and some 5 lights codes. (See Warning Signals in next section). While the system is in RUN FLAT mode, the RUN FLAT light will flash on and off. The “RUN FLAT” feature will automatically deselect after 10 minutes, or may be shut off by pressing the button a second time.

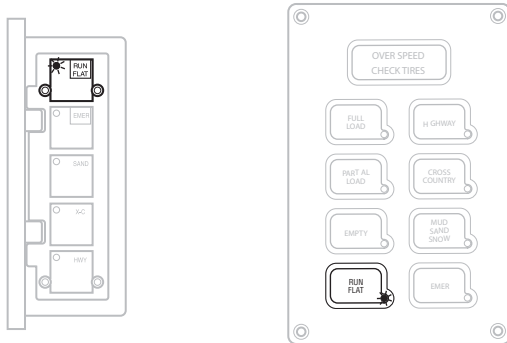

### CAUTION

**Selecting RUN FLAT to enable the system to inflate a significantly low tire may cause other tires on that channel to temporarily lose pressure. This condition will be corrected once the low tires is inflated to the pressure of the other tires.**

## Flange or Panel—Warning Signals

Several warning signals report operating problems. The Central Tire Inflation System uses general sequences displayed on the electronic control unit lights and an instrument panel-mounted warning lamp to identify the type and area of fault.

### Single Terrain Light

- Flashing - System is working to achieve new pressures associated with that mode light.
- Solid - Pressure is achieved, system is not active, and wheel valves are closed.

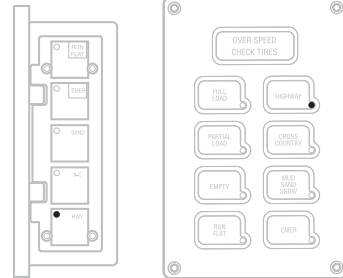

### 2 Terrain Lights on Solid

System has shut off, closing wheel valves, with tire pressure between two mode settings.

- Inflating or deflating tires is taking too long.
- CTIS is still operational.
- Select any mode button to re-attempt pressure change.
- On 2-channel systems, normal operation continues on unaffected channel.
- Frequent occurrences may indicate need for service.

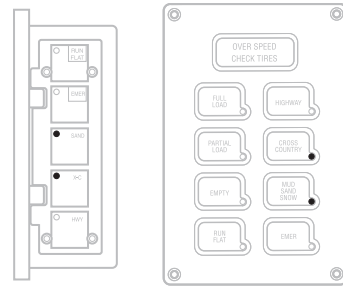

### 4 Terrain Lights Flashing or CHECK TIRES Flashing

Indicates low pressure in one or more tires. Stop vehicle and identify damage.

- System shuts off, closing wheel valves, and waits for operator instruction.
- Tire damage is possible.
- CTIS should not be operated if major tire damage is found. Repair tire before continuing to operate vehicle.
- On 2-channel systems, normal operation will continue on the unaffected channel.
- If tire damage is minimal, operate CTIS by selecting RUN FLAT.

**Note:** Repeated use of RUN FLAT to override mode light warnings may result in tires inflating higher than set point.

**Note:** Excessive air seal leakage on cold weather startup may result in "4-5 Mode Lights" warning. If no tire damage exists, this condition will self-correct as seals warm up with use.

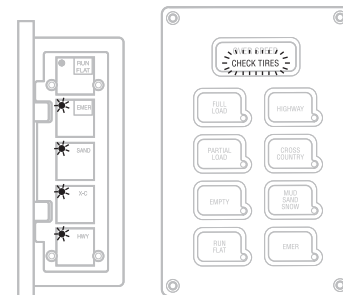

### 5 Lights Flashing

System shuts off at least one channel due to fault detection on a CTIS component.

- System closes wheel valves.
- System may periodically cycle PCU to determine if fault still exists.
- On 2-channel systems, operation may be allowed on the unaffected channel.
- Get service at next opportunity.
- No ability to override system.

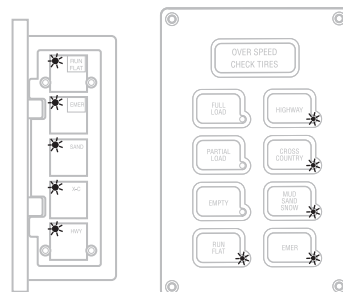

### RUN FLAT Flashing (with a Terrain Light)

RUN FLAT is selected, and tire pressures are checked at more frequent intervals.

- If RUN FLAT is pushed to clear a "4 Mode Lights" flashing display, imbalance and confirmation fault detection is overridden for the duration of RUN FLAT.
- Turn off by depressing RUN FLAT again or it will "time-out" after 10 minutes.

**Warning:** RUN FLAT should not be used to inflate tires with substantial damage/defects. Use of RUN FLAT can result in other tires on channel losing pressure.

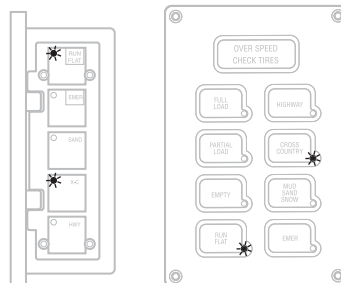

### No Terrain Lights

CTIS senses either a low system voltage or an electrical fault with a Pneumatic Control Unit solenoid.

- System shuts off, closing wheel valves.
- Vehicle power is inadequate.

### Flashing Warning Lamp and/or Buzzer or OVER SPEED Flashing

Vehicle speed is too fast for pressure selected.

- Reduce speed or select higher pressure by pressing appropriate key.
- Continued operation in this mode will result in automatic selection of more appropriate pressure setting.
- Warning lamp may flash while system is in EMERGENCY mode.

Lamp on Instrument Panel

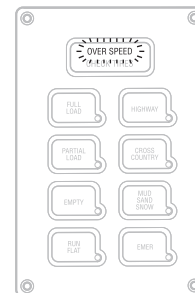

### Solid Warning Lamp or Solid OVER SPEED

ECU has seen 25-50 ignition cycles without seeing any speed signal.

- If no problem exists with speed circuit wiring or sensor, lamp will go off when vehicle is moved.

Lamp on Instrument Panel

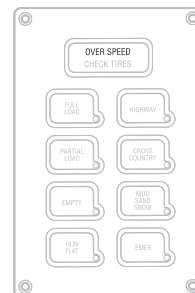

### Lights Sequentially Flashing (one after another)

A configuration error has occurred and the CTIS memory has been "reloaded" from the system defaults.

- System reloads default configuration values.
- Pressing HWY and RUN FLAT buttons together may clear display.
- Any past changes of target pressure, etc. should be updated.

## Driver Display Module—Operator Controls

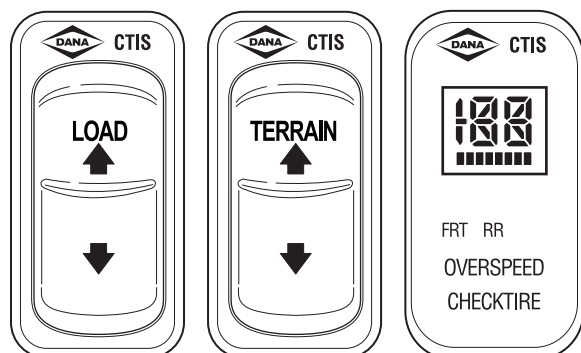

### Load Selection

Vehicle load selection is represented by a horizontal bar graph under the mode display. Depress the load rocker switch to change the selection, up for increasing load and down for decreasing load.



**Operating a loaded vehicle at unloaded tire pressures may result in tire overheating and reduced tire life or blowout.**

### Terrain Selection

The terrain selection is changed by depressing the terrain rocker switch, up to increase pressures and down to decrease pressures. Any switch operation which does not change pressures will command the system to do a pressure check.

Tire pressures for the following terrains can be programmed and may be selected by the operator:

- **(HY) Highway** - For travel on paved surfaces at higher speeds.
- **(CC) Cross Country** - For reduced speed operation on secondary roads.
- **(SS) Mud Sand Snow** - For reduced speed operation on unpaved surfaces.
- **(E) Emergency** - For selection of extremely low tire pressures to help free a stuck vehicle.



**The Emergency selection is for extreme conditions only and should not be used for normal driving.**

### Display

The Driver Display Module (DDM) uses a multi-function display to indicate the current selections. The display will show HY for highway pressures, CC for cross-country pressures, SS for mud-sand-snow pressures, and E for emergency pressures.

**Note:** The system is designed to allow tire pressure increase due to heat buildup during vehicle use. It will not automatically deflate these pressure buildups.

### Channel Indicators

The DDM indicates FRT or RR, respectively, for front or rear axle groups. A flashing indicator identifies a group which is changing or checking pressures. A solid indicator identifies a group that has achieved target pressure.

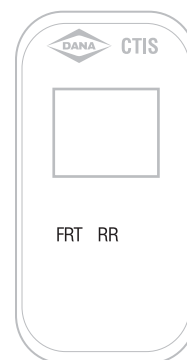

### Service Code Indication

The DDM will not display service codes directly but will display two dashes if service is required. (Accessing the service codes requires a diagnostic tool). Also, a solid over speed indicator identifies a loss of expected vehicle speed input.

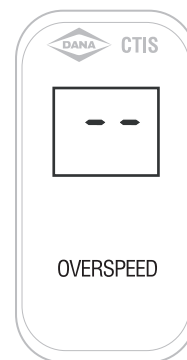

## Driver Display Module (DDM)—Warning Signals

CTIS includes two distinct warnings to report possible tire problems and inappropriate vehicle operation. You must take immediate action to either reduce vehicle speed or check tire condition whenever these warnings are displayed.

### Over Speed Flashing

This signal reports that the vehicle speed is too fast for the pressure selected. You must either reduce speed or select a higher pressure by pressing the appropriate key. Continued operation in this mode will result in the system automatically selecting a more appropriate pressure setting.

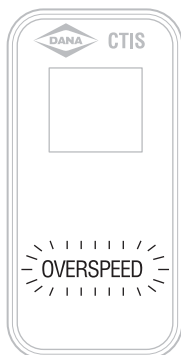

### Check Tire Flashing

This signal reports that one or more tires may be at a significantly lower pressure than the others and could indicate that a tire is not holding pressure. Blinking channel indicators (FRT or RR) indicate the fault location. Stop the vehicle immediately in a safe place and identify the extent of tire damage.

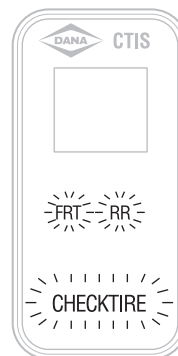

#### ⚠ IMPORTANT

Tires can still go flat! Although the Central Tire Inflation System is designed to identify under-inflated tires and fill these tires to the desired operating pressure, you can still expect that tires will occasionally be punctured or otherwise damaged during normal use and no longer retain air reliably. A daily walk-around inspection of the vehicle at the start of the day, including a manual check of the tires, is still an important responsibility of the vehicle operator. Tire damage is more apparent after the vehicle has been idle overnight and will be more difficult to detect visually once the CTIS equipped vehicle is in operation. Although observation of excessive inflation periods through the driver interface can help identify a tire problem, you should have damaged tires replaced prior to placing the vehicle in operation.

## Diagnostics

This section covers the equipment and procedures used to find and correct CTIS problems.

### Test Equipment

CTIS troubleshooting can be performed at three levels:

1. PC diagnostics.
2. Handheld tester.
3. ECU warning signals (flashing light combinations).

Regardless of the testing equipment used, the troubleshooting procedures will be based upon the diagnostic service codes. Diagnostic tools offer the advantages of computer-aided testing without interpreting service codes.

### CTIS Diagnostics

The onboard system diagnostics are an important feature of Spicer's CTIS. This section describes the use of service codes to identify CTIS operating problems.

The CTIS uses a code to identify service issues. The codes can be extracted from the ECU memory using a diagnostic service tool equipped with the appropriate software. Refer to the Service Codes Summary for more detailed information on service codes.

### Service Codes

Codes are described in the Service Codes Summary section. Some service codes identify the component that is associated with the problem. A list of possible causes is shown in order of most likely occurrence.

In addition, the system stores service codes in the memory of the ECU. These historical codes can only be accessed by a diagnostic tool. Historical codes are automatically cleared after 50 ECU resets with no active faults.

### Test Modes

Diagnostic tools allow the system to be placed in several diagnostic modes:

**Info**—Display ECU information and configuration.

**Codes**—Active and historic codes are listed as reported by the ECU.

**Monitor (Normal)**—CTIS operates normally, while status of system components is observed.

**Test**—The following operations can be performed on each channel (axle group):

- **Check & Hold**—System checks and displays the pressures, then holds pressure in air lines (quick test of control line and seal integrity).
- **Deflate**—System "manually" deflates (test the deflation signal).
- **Inflate**—System "manually" inflates (test for large leaks).
- **Hold**—Pressure is held in control lines (test for small leaks).

**Setup**—Allows the technician to modify parameters such as target tire pressures, etc.

## PC Diagnostics

**CAUTION**

**A battery charger is not an adequate source of power.**

Visit [www.dana.com](http://www.dana.com) for free download of Dana Diagnostic Tool (DDT).

PC diagnostics are easy to use and provide the quickest diagnostic capabilities.

- Retrieve historical data, faults and tire pressures.
- Pressurize system to detect leaks.
- Access troubleshooting flowcharts and service procedures.

To use this program, an RP1210A compatible interface box and cables are needed to connect the PC to the vehicle.

For these types of interface boxes to work with the Dana Diagnostic Tool program, you must install a "RP1210 driver" program provided by the manufacturer of the interface box. If you do not have this program, it can normally be obtained from the manufacturer's web site. Please contact the manufacturer of your interface box if you have any questions regarding this process.

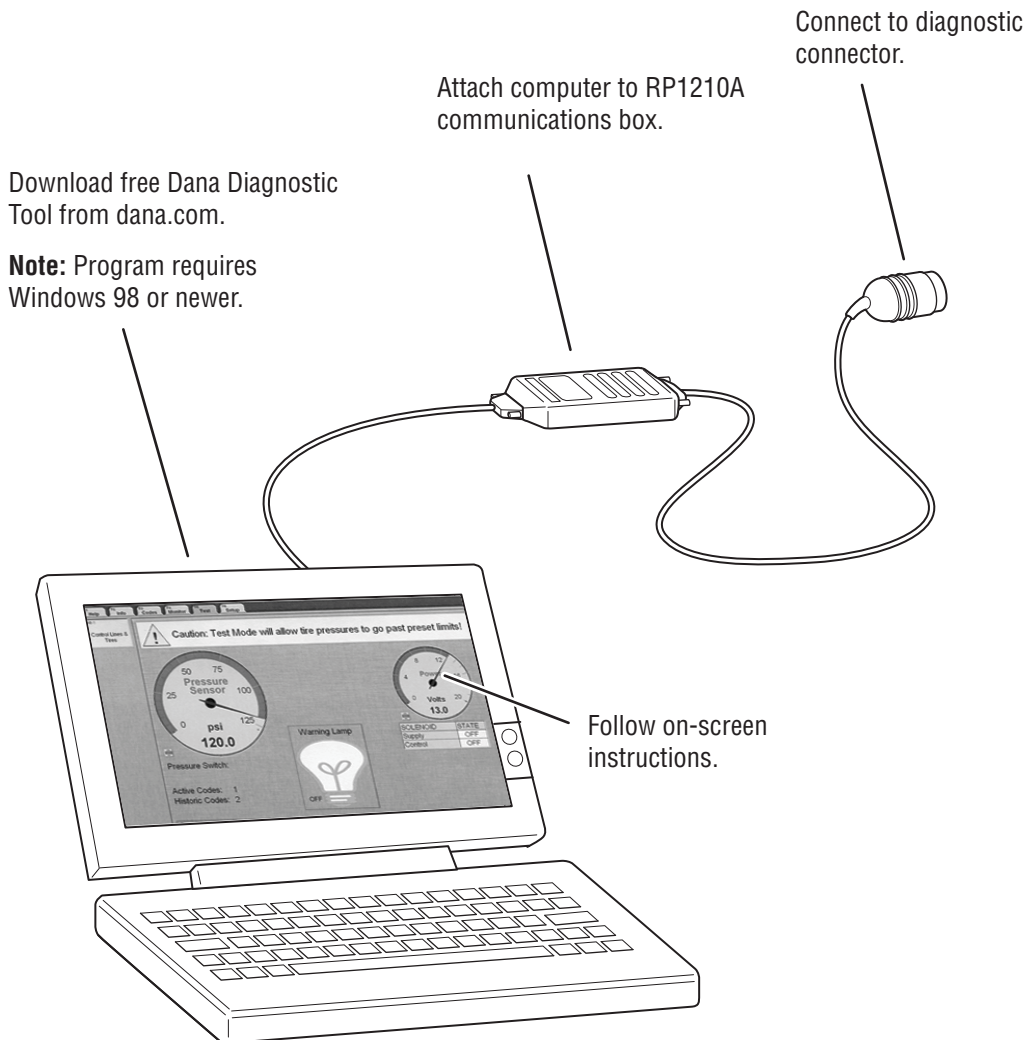

## Handheld Tester

A Prolink handheld tester may be used to read and clear service codes and to obtain a short description of failures. The tester can initiate test sequences for controller outputs and can also read system parameters when equipped with the Dana program card.

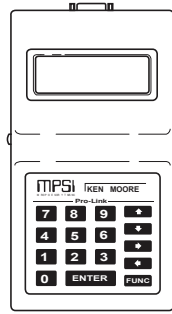

## Multimeter

Based upon system schematics and aided by component specific service codes, a multimeter can be used to check sensor and solenoid resistances and to find wiring harness faults. The multimeter can be used to check the Tire Pressure Control System wiring and components for:

- Continuity
- Ground
- Broken wires
- Open circuits
- Shorted circuits
- Incorrect battery voltage

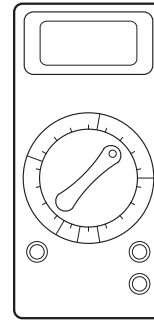



## Service Codes Summary

The following chart provides a brief overview of the Central Tire Inflation System (CTIS) service codes and the effect on the system.

**Note:** Any reference to a “channel” on a single-channel system refers to all control lines and wheel ends.

5 Flashing LIGHTs or DDM – Dashes "--"	Code No.	Causes (numbered in order of likely occurrence)
Low Pressure	26, 27	<p>CHANNEL PRESSURE LOSS (Channel only checks pressures): Pressure check of given channel returns low reading (&lt; 5 psig) indicating an extreme loss of pressure. Repair and request pressure check to clear (press any mode button or run flat).</p> <ol style="list-style-type: none"> <li>1) Open or broken line between PCU and wheel valve</li> <li>2) Significant hub air seal leakage</li> <li>3) Kinked or plugged line between supply tank and PCU</li> <li>4) Faulty PCU sensor (ex. frozen water contamination)</li> <li>5) PCU failure (supply off or control off)</li> <li>6) Pressure switch failure (shorted closed)</li> </ol>
Low Air Supply	32	<p>PRESSURE SWITCH REMAINS OPEN (System non-operative until switch closes): For 4 minutes at vehicle speed &gt; 20 mph pressure switch failed to close. Repair and allow pressure switch to close to clear.</p> <ol style="list-style-type: none"> <li>1) Compressor governor cutout set too low</li> <li>2) Pressure switch unplugged, or open wire</li> <li>3) Faulty pressure switch (failed open)</li> <li>4) Faulty compressor</li> <li>5) Broken, kinked, or plugged line from compressor to supply tank</li> </ol>
Atmospheric	35	<p>OUT OF RANGE ATMOSPHERIC READING (System waits to check pressures): Atmospheric pressure check indicates vented PCU pressure is outside of valid atmospheric range (5-20 psia). Repair and request pressure check to clear (press any mode button or run flat).</p> <ol style="list-style-type: none"> <li>1) Poor ground connection to PCU sensor</li> <li>2) Faulty PCU sensor (ex. frozen water contamination)</li> <li>3) Faulty PCU or blocked PCU exhaust vent</li> </ol>
Inflate Trend	36, 37	<p>INFLATE PRESSURE LOSS (System disables given channel): Given channel loses &gt; 6 psi while inflating. Repair and cycle ignition to clear.</p> <ol style="list-style-type: none"> <li>1) Damaged tire or tire leakage</li> <li>2) Leaking lines or seals</li> <li>3) Faulty PCU (control solenoid off or additional channel stuck on)</li> </ol>
Deflate Trend	14	<p>FAILURE TO DEFLATE PROPERLY (System disables deflates): System gains &gt;10 psi pressure while attempting to deflate, or does not lower tires by even a small amount of the intended change. Repair and cycle ignition to clear.</p> <ol style="list-style-type: none"> <li>1) Plugged or restricted PCU vent line</li> <li>2) Faulty PCU relief valve</li> <li>3) Poor ground connection to PCU sensor</li> <li>4) Contaminated PCU</li> <li>5) Faulty PCU</li> </ol>

**Service Codes Summary (continued)**

<b>5 Flashing LIGHTs or DDM – Dashes "--"</b>	<b>Code No.</b>	<b>Causes (numbered in order of likely occurrence)</b>
PCU Sensor	33, 34	NO PCU SENSOR READING (System non-operative): No sensor voltage to ECU. Clears 5 seconds following a valid reading. 1) Sensor is electrically disconnected 2) Pressure signal wire (XDCR SIGNAL) is shorted to ground, or open 3) PCU sensor VREF wire is shorted to ground, or open 4) Faulty sensor
		PCU SENSOR READING TOO HIGH (System non-operative): Sensor voltage higher than allowed. Clears 5 seconds following a valid reading. 1) Pressure signal wire (XDCR SIGNAL) is shorted to power or XDCR VREF 2) Faulty sensor
Pressure Switch	31	PRESSURE SWITCH SHORTED or FAILED CLOSED (System waits to check pressures): Pressure switch is read as closed, but pressure check of supply tank indicates insufficient air pressure to continue. Repair and request pressure check to clear (press any mode button or RUN FLAT). 1) Wire to pressure switch shorted to ground 2) Faulty pressure switch (failed closed) 3) Faulty PCU (leaks air during supply tank check)

<b>5 Flashing LIGHTs and CHECK TIRES Solid</b>	<b>Code No.</b>	<b>Causes (numbered in order of likely occurrence)</b>
Inflate Trend	36, 37	INFLATE PRESSURE LOSS (System disables given channel): Given channel loses > 6 psi while inflating. Repair and cycle ignition to clear. 1) Damaged tire or tire leakage 2) Leaking lines or seals 3) Faulty PCU (control solenoid off or additional channel stuck on)

**Service Codes Summary (continued)**

<b>4 Flashing LIGHTs or CHECK TIRES Flashing</b>	<b>Code No.</b>	<b>Causes (numbered in order of likely occurrence)</b>
Tire Leak (Imbalance)	44, 45	<p>TIRES IMBALANCED (System only checks pressures on given channel): Pressure check indicates a tire on the given channel may be significantly lower than other tires on same channel. RUN FLAT will override this fault.</p> <ol style="list-style-type: none"> <li>1) Significant tire pressure loss (i.e. overnight leakdown)</li> <li>2) Significant tire damage or leaks</li> <li>3) Leaking lines or seals</li> <li>4) Contaminated wheel valve filters</li> <li>5) Restricted tire valve stem</li> <li>6) Faulty wheel valve (leaking back through QRV)</li> <li>7) Kinked or restricted control lines</li> </ol>
Tire Leak (Confirm)	41, 42	<p>CONFIRMATION FAILURE (System disables given channel): Given channel fails to confirm 10 times in a row. RUN FLAT will override this fault.</p> <ol style="list-style-type: none"> <li>1) Damaged tire or tire leakage</li> <li>2) Leaking hose between wheel valve and tire</li> <li>3) Faulty wheel valve (leaking back through QRV)</li> <li>4) Restricted air passage between QRV and wheel valve</li> </ol>

<b>2 Terrain Lights on Solid or DDM – Dashes "--"</b>	<b>Code No.</b>	<b>Causes (numbered in order of likely occurrence)</b>
Between Modes	23, 24	<p>SLOW INFLATE (Channel only checks pressures): Given channel takes too long (&gt; 40 minutes) in active inflate (pressure switch closed) to achieve requested mode. Repair and request pressure check to clear (any mode button or run flat).</p> <ol style="list-style-type: none"> <li>1) Insufficient air supply</li> <li>2) Contaminated wheel valve filters</li> <li>3) Kinked, plugged, or leaking lines</li> </ol>
		<p>SLOW DEFLATE (Channel only checks pressures): Given channel takes too long in active deflate (&gt; 20 minutes) to achieve requested mode. Repair and request pressure check to clear (any mode button or run flat).</p> <ol style="list-style-type: none"> <li>1) Contaminated wheel valve filters</li> <li>2) Restricted tire valve stem</li> <li>3) Leaking upper control lines</li> <li>4) Faulty PCU relief valve</li> <li>5) Restricted QRV exhaust</li> <li>6) Restricted PCU vent line</li> </ol>

### Service Codes Summary (continued)

<b>2 Terrain Lights on Solid or DDM – Dashes "--"</b>	<b>Code No.</b>	<b>Causes (numbered in order of likely occurrence)</b>
Deflate Signal	11, 12, 16	<p>INCORRECT DEFLATE PRESSURE: Deflate signal reads outside of configured range for 30 seconds. If occurs during multi-channel deflate, system will reattempt deflates on individual channels.</p> <p>Repair and request pressure check to clear. (any mode button or run flat).</p> <ol style="list-style-type: none"> <li>1) Faulty PCU relief valve</li> <li>2) Leaking upper control lines</li> <li>3) PCU internal leaks</li> <li>4) Deflate solenoid poppet stuck in non-energized position</li> <li>5) Poor ground connection to PCU sensor or faulty sensor</li> </ol>

<b>No Terrain Lights or DDM – Dashes "--"</b>	<b>Code No.</b>	<b>Causes (numbered in order of likely occurrence)</b>
PCU Solenoid	51, 52, 54, 55, 56	<p>ELECTRICAL SOLENOID FAILURE (System non-operative): Solenoid fails electrical diagnostics for approximately 2 seconds.</p> <p>Repair &amp; cycle ignition to clear.</p> <ol style="list-style-type: none"> <li>1) Solenoid or harness wire is shorted to ground</li> <li>2) Solenoid or harness wire is shorted to power</li> <li>3) Faulty solenoid</li> </ol>

<b>No Terrain Lights or DDM – Blank Display</b>	<b>Code No.</b>	<b>Causes (numbered in order of likely occurrence)</b>
Power	17	<p>POWER (System non-operative): After initialization, voltage drops below 18V for &gt; 15 seconds.</p> <p>Clears immediately when voltage &gt; = 18V.</p> <ol style="list-style-type: none"> <li>1) Low battery voltage</li> <li>2) Poor ground connection to ECU</li> <li>3) Poor power connection to ECU</li> </ol>

<b>DDM – Dashes "--"</b>	<b>Code No.</b>	<b>Causes (numbered in order of likely occurrence)</b>
Display Control Communications	75	<p>NO COMMUNICATION TO DDM: ECU not receiving data from DDM user interface.</p> <p>Repair to clear.</p> <ol style="list-style-type: none"> <li>1) No data link connection to DDM (damaged harness wiring)</li> <li>2) Faulty DDM</li> </ol>

**Service Codes Summary (continued)**

<b>Lights Sequentially Flashing</b>	<b>Code No.</b>	<b>Causes (numbered in order of likely occurrence)</b>
Configuration Error	N/A	<p>CONFIGURATION ERROR (System is "Limp-Home"): System has reloaded the system defaults, eliminating any changes (target pressures, etc.) previously programmed via a diagnostic tool. Pressing HWY and RUN FLAT at the same time may clear the display...updated config data should be reprogrammed.</p> <p>1) Configuration connector loose or missing 2) Faulty ECU (if repeatedly occurs)</p>

<b>Solid Warning Lamp or Solid OVER SPEED</b>	<b>Code No.</b>	<b>Causes (numbered in order of likely occurrence)</b>
Speed Signal	18	<p>NO SPEED SIGNAL (System operation is normal): ECU has been reset 25-50 times without any speed input to ECU. Note: Fault will be set immediately on power up. Any speed input (driving vehicle with good speed sense operation) will clear fault.</p> <p>1) Vehicle has been started approximately 25-50 times without being moved (no speed input). 2) Sensor is electrically disconnected 3) Either speed sense wire is open or shorted to ground 4) Faulty speed sensor 5) Sensor actuation failure (Tang broken/disconnected on mechanical sensor, or incorrect gap on pole sensor) 6) Both speed sense wires are shorted together</p>
	76, 77	Expected data link message not received

<b>No Indication or DDM – Dashes "--"</b>	<b>Code No.</b>	<b>Causes (numbered in order of likely occurrence)</b>
Miscellaneous Output	53, 57, 58, 67, 68	<p>SPARE OUTPUT OR COMPONENT FAILURE:</p> <p>1) Harness wire is shorted to ground 2) Harness wire is shorted to power 3) Faulty component</p>

<b>No Indication</b>	<b>Code No.</b>	<b>Causes (numbered in order of likely occurrence)</b>
Wheel Valve Shut Off	61, 62, 64, 65	<p>LOSS OF PRESSURE DURING SHUT OFF:</p> <p>1) Wheel valve shut off failure 2) Air passage restriction</p>

## **Inaccurate Tire Pressures**

May be caused by leaking control lines, clogged wheel valve filters or valve stems, or closed Air Transport Valves.

## **Run Flat Definition**

Pressing the RUN FLAT button once during normal system operation puts the system in Run Flat Mode for 10 minutes and causes several things to happen:

- The RUN FLAT light will flash along with the selected mode light.
- A full pressure check (including atmospheric) is requested.
- After 10 minutes Run Flat will automatically deselect...OR... pushing RUN FLAT button again will deselect it. It can be reselected by pressing the button again after timeout.
- Tire pressures are checked at more frequent intervals.

In addition, pressing the RUN FLAT button while the ECU is displaying a “4 lights” flashing code will cause all “4 mode lights” flashing codes (imbalance and confirmation) to be overridden for the duration of RUN FLAT.

**Note:** ECU replacement—ECUs are NOT a typical cause of problems. If an ECU is replaced, the system should be carefully rechecked to make sure the problem has been fixed, and does not reoccur.

## Troubleshooting Tips

This checklist outlines some general hints and guidelines that will be helpful in tracking down and correcting operating problems.

- ✓ **The ECU only displays one active code.**  
Only the most recent service code displays on the ECU lights. In troubleshooting, be alert for related codes. Use of a diagnostic tool offers the advantage of spotting multiple active codes as well as retrieving historical codes.
- ✓ **A cleared code alone does not indicate a corrected problem.**  
A code is set by a specific fault condition and may be cleared by switching the ignition off, and then on. It's possible to clear a code (i.e., clear the flashing lights) only to have it display again when the fault condition reoccurs. To ensure that a problem is fixed, you must run the system through the same operating modes that caused the problem and verify that the service code does not reappear.
- ✓ **Electrical faults are often connection problems.**  
The most likely cause of electrical faults will be damaged wires or connections. As a first step in troubleshooting all electrical codes, switch off vehicle ignition, then disconnect applicable connectors and inspect for damage. (Switching off the ignition is required before disconnecting the harness at the Electronic Control Unit, but is also a recommended practice before all other electrical system disconnections.) Clean or repair all bad connections before proceeding.
- ✓ **Disconnect the Electronic Control Unit connector with ignition off.**  
To avoid setting electrical fault codes, make sure that the ignition is off before unplugging the wire harness connection at the Electronic Control Unit module. Reconnect the connector before switching on the ignition.
- ✓ **System is not continually pressurized.**  
When troubleshooting pneumatic faults, keep in mind that the air system is only pressurized as needed (for example, in the inflate mode). This means that such procedures as checking for leaks require the system to be in an active pressurized state. This can be accomplished most easily by using a diagnostic tool.
- ✓ **Basic vehicle air and power systems are not covered in this guide.**  
The Central Tire Inflation System requires air pressure and electrical power supply from the base vehicle systems. Diagnosis and service of these systems is outside the scope of this manual.
- ✓ **2-Channel (front/rear) systems may respond differently than single-channel systems.**  
If a fault can be isolated to a specific channel, a 2-channel system may allow continued operation on the unaffected channel. When troubleshooting, use a diagnostic tool to determine which channel has the fault.

## 5 Flashing Lights or DDM – Dashes "--" (Codes 26, 27)

**Type: Low Pressure**

System Mode	Condition	Possible Causes (listed in order of likely occurrence)
System waits to check pressures	Faulty pneumatic system, or extremely low pressure reading	<ul style="list-style-type: none"> <li>• Open line between PCU and wheel valve</li> <li>• Significant hub air seal leakage</li> <li>• Open solenoid (PCU electrically or pneumatically disconnected)</li> <li>• Crimped or plugged line between supply tank and PCU</li> <li>• Faulty PCU sensor (ex. frozen water contamination)</li> <li>• PCU failure, supply or control off</li> <li>• Pressure switch failure, shorted closed</li> <li>• Faulty ECU</li> </ul>

### Air Pressure Check

Note that the Central Tire Inflation System is not continuously pressurized; pressure checks occur on a periodic basis. During tire pressure checks, the system delivers compressed air to each channel for approximately two seconds while monitoring the pressure in that channel.

### Code Description

A “Low Pressure” code indicates an extreme low pressure reading. The most likely cause is an open line which would have a clearly audible leak during a pressure check. A secondary cause could be a faulty air delivery system (i.e. Pneumatic Control Unit [PCU] Low Pressure (Codes 26, 27) electrically or pneumatically disconnected).

Other components that can cause a Low Pressure code are:

- Electrically or pneumatically disconnected PCU
- Faulty PCU
- Restricted line between the supply tank and PCU
- Faulty PCU sensor
- Open line from PCU to Quick Release Valve
- Open line from Quick Release Valve to Wheel Valve

To correctly diagnose the faulty component, connect the Diagnostic Tool (see "Diagnostics" for test equipment and descriptions) and follow the procedure in the Low Pressure troubleshooting tree.

See “Troubleshooting Tips” for general guidelines on system diagnostics.



## Low Pressure (Codes 26, 27)

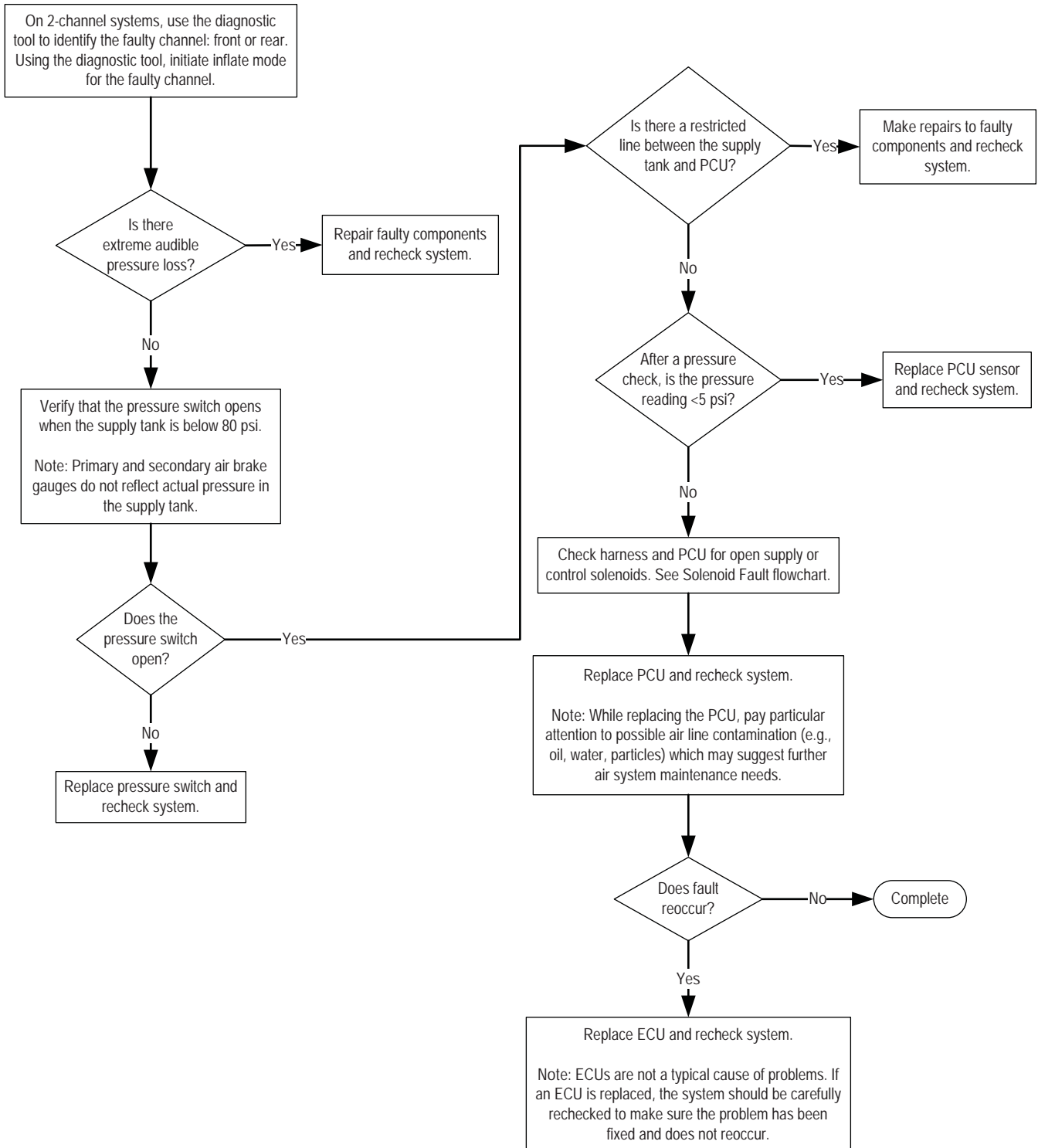

## 5 Flashing Lights or DDM – Dashes "--" (Code 32)

Type: Low Air Supply

System Mode	Condition	Possible Causes (listed in order of likely occurrence)
System waits to check pressures	Pressure switch won't close	<ul style="list-style-type: none"> <li>• Compressor governor cutout set too low</li> <li>• Air dryer needs service</li> <li>• Pressure switch unplugged</li> <li>• Faulty pressure switch</li> <li>• Faulty compressor</li> <li>• Open or broken line from supply tank to PCU</li> <li>• Crimped or plugged line from supply tank to PCU</li> </ul>

### Air Pressure Check

Note that the Central Tire Inflation System is not continuously pressurized; pressure checks occur on a periodic basis. During tire pressure checks, the system delivers compressed air to the tires for approximately two seconds while monitoring the pressure.

### Code Description

A “Low Air Supply” code displays if system air pressure is inadequate to perform a tire pressure check.

This occurs when the pressure switch will not close. The components that can cause the pressure switch to remain open include:

- Compressor governor cutout set too low
- Pressure switch unplugged
- Faulty pressure switch
- Faulty compressor
- Open or broken line from supply tank to Pneumatic Control Unit (PCU)
- Crimped or plugged line from supply tank to PCU

To correctly diagnose the faulty component, connect the Diagnostic Tool (see "Diagnostics" for test equipment and descriptions) and follow the procedure in the Low Air Supply troubleshooting tree.

See “Troubleshooting Tips” for general guidelines on system diagnostics.

Pressure Switch Harness Connector

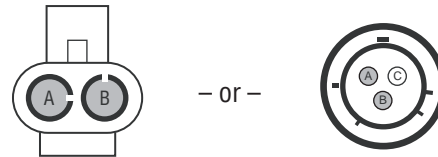

ECU Harness Connector

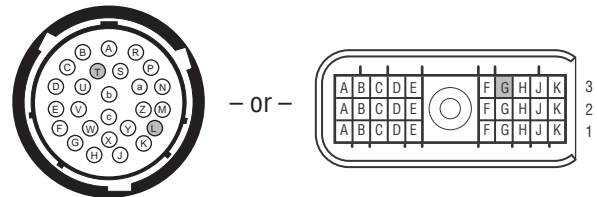

### Low Air Supply (Code 32)

Identify vehicle pressure switch:

- Part #673345 (black)
- Part #676770 (blue)

Pressure Switch Part Number	Minimum Supply Tank Pressure
673345 (black)	120 psig
676770 (blue)	125 psig

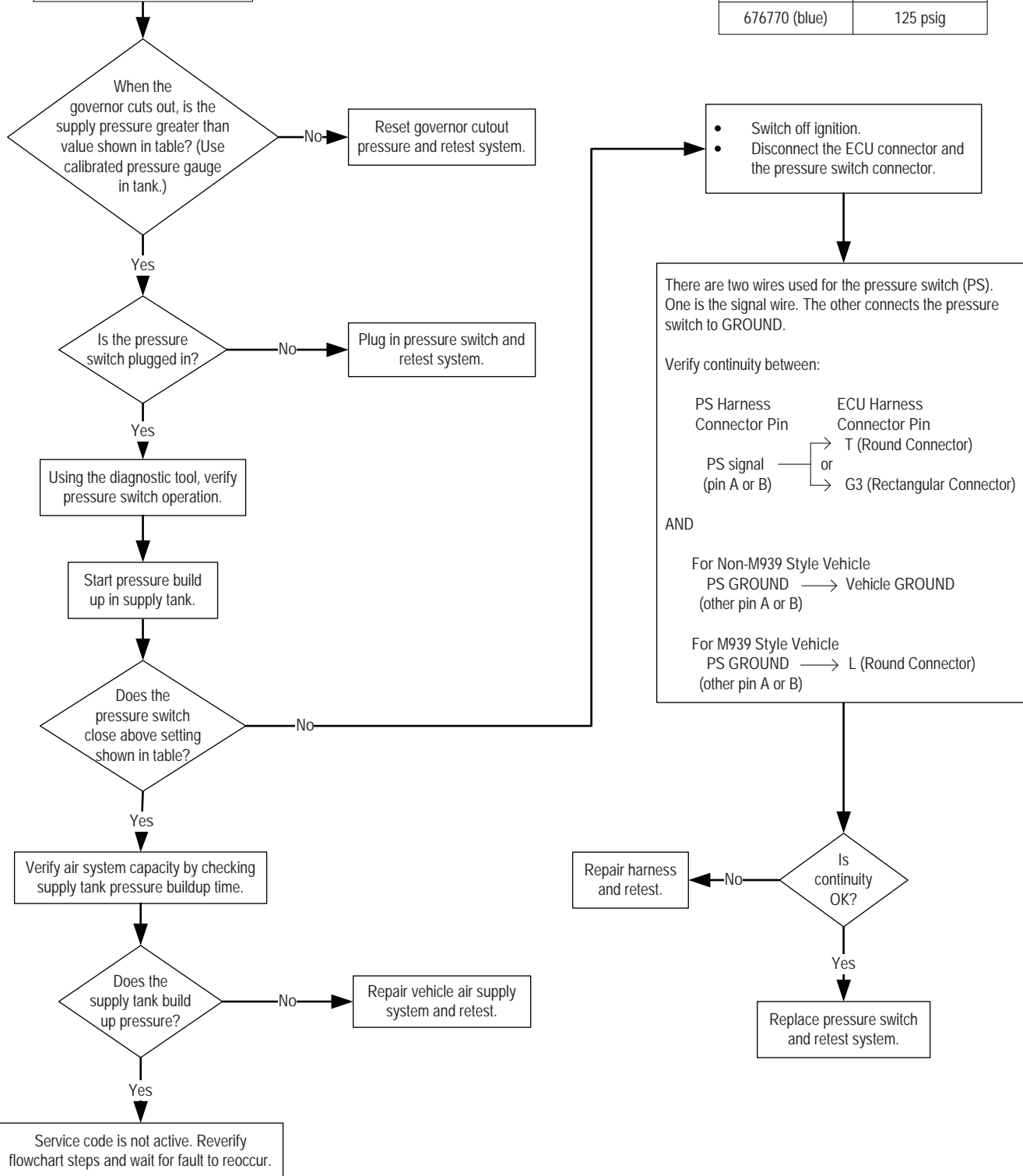

## 5 Flashing Lights or DDM – Dashes "--" (Code 35)

Type: Atmospheric

System Mode	Condition	Possible Causes (listed in order of likely occurrence)
System waits to check pressures	PCU pressure out of range when PCU is "vented"	<ul style="list-style-type: none"> <li>• Frozen water or other contaminant in PCU sensor</li> <li>• Plugged PCU vent</li> <li>• Poor ground connection to PCU sensor</li> <li>• Faulty PCU sensor</li> <li>• Faulty PCU</li> </ul>

### Air Pressure Check

Note that the Central Tire Inflation System is not continuously pressurized; pressure checks occur on a periodic basis. During tire pressure checks, the system delivers compressed air to the tires for approximately two seconds while monitoring the pressure.

### Code Description

An "Atmospheric" code is logged if the atmospheric pressure reading is out of range. The atmospheric pressure reading can be out of range as a result of a blocked or restricted Pneumatic Control Unit (PCU) or vent line, contaminated PCU sensor (i.e. frozen water), air bleeding back into the PCU or because of a faulty PCU sensor.

The components that can cause this code to be set include:

- Faulty or contaminated PCU sensor
- Faulty or contaminated PCU
- Faulty Electronic Control Unit (ECU)

To correctly diagnose the faulty component, connect the Diagnostic Tool (see "Diagnostics" for test equipment and descriptions) and follow the procedure in the Atmospheric troubleshooting tree.

See "Troubleshooting Tips" for general guidelines on system diagnostics.

PCU Sensor Harness Connector

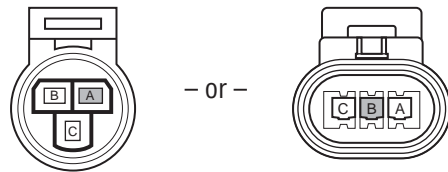

ECU Harness Connector

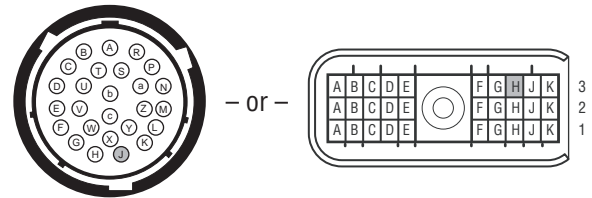

## Atmospheric (Code 35)

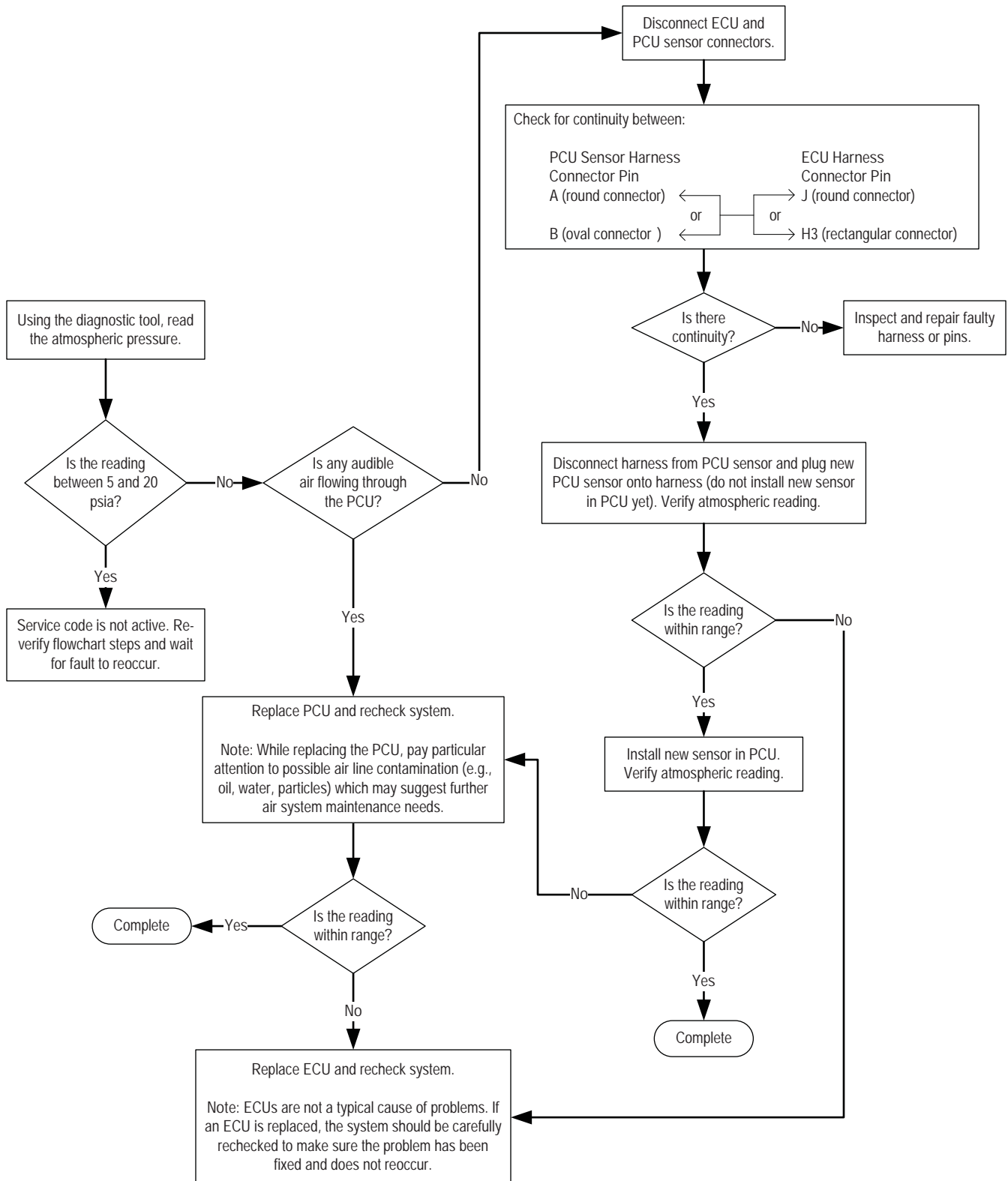

## 5 Flashing Lights or DDM – Dashes "---" or 5 Flashing Lights and Check Tires Solid (Codes 36, 37)

### Type: Inflate Trend

System Mode	Condition	Possible Causes (listed in order of likely occurrence)
Channel inoperative	Loss of channel pressure in inflate mode	<ul style="list-style-type: none"> <li>• Damaged or leaking tire</li> <li>• Leaking lines</li> <li>• Leaking seals</li> <li>• Leaking QRV</li> <li>• Leaking wheel valve</li> <li>• Faulty PCU</li> </ul>

### Code Description

An "Inflate Trend" code displays when tire pressure readings are dropping while in inflate mode. Tire damage, which the compressor cannot keep up with, may have occurred after starting an inflate sequence. When possible, a 2-channel system will isolate this fault to a given channel.

The air leak can be located either before or after the wheel valve location. The components located before the wheel valve that may cause this include:

- Leaking control lines
- Leaking Quick Release Valve (QRV) exhaust port
- Leaking wheel air seals

Components located after the wheel valve that may cause this include:

- Tire damage
- Rim leaks
- Leaking air lines
- Faulty wheel valve

To correctly diagnose the faulty component, connect the Diagnostic Tool (see "Diagnostics" for test equipment and descriptions) and follow the procedure in the Inflate Trend troubleshooting tree.

See "Troubleshooting Tips" for general guidelines on system diagnostics.

## Inflate Trend (Codes 36, 37)

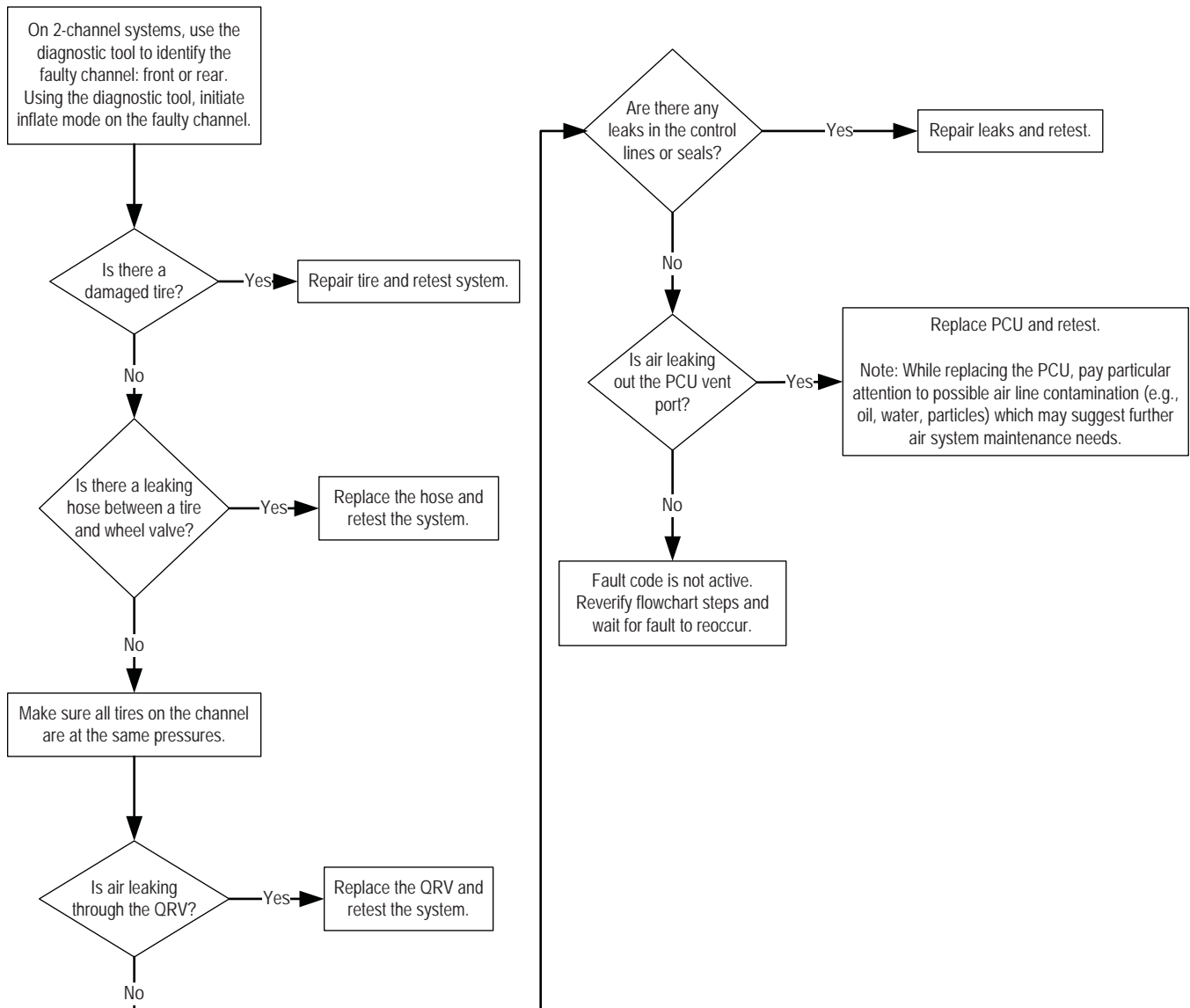

## 5 Flashing Lights or DDM – Dashes "---" (Code 14)

Type: Deflate Trend

System Mode	Condition	Possible Causes (listed in order of likely occurrence)
Inflate only	Improper deflate sequence	<ul style="list-style-type: none"> <li>• Upper control line leak</li> <li>• Plugged or restricted PCU vent line</li> <li>• Faulty PCU relief valve</li> <li>• Poor ground connection to PCU sensor</li> <li>• Contaminated PCU</li> <li>• Faulty PCU</li> </ul>

### Code Description

A “Deflate Trend” code displays when the system has determined that a deflate sequence is not functioning correctly. This is the result of either a pressure increase during a deflation, or the system failing to lower the tires even a small amount of the desired pressure drop.



## Deflate Trend (Code 14)

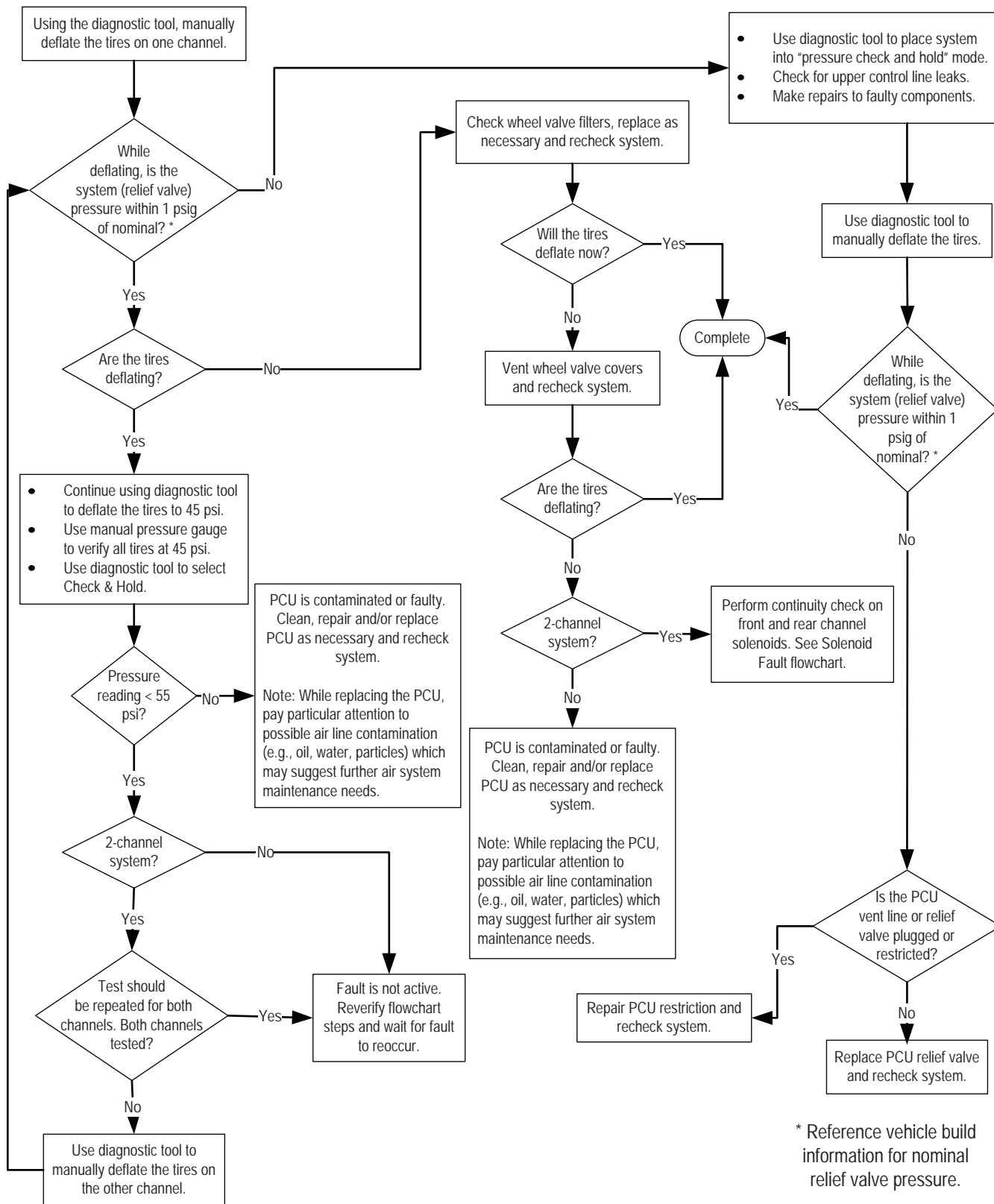

\* Reference vehicle build information for nominal relief valve pressure.

## 5 Flashing Lights or DDM – Dashes "--" (Codes 33, 34)

Type: PCU Sensor

System Mode	Condition	Possible Causes (listed in order of likely occurrence)
No operation	No PCU sensor reading	<ul style="list-style-type: none"> <li>• Sensor electrically disconnected</li> <li>• Pressure signal wire open</li> <li>• Pressure signal wire shorted to ground</li> <li>• PCU sensor VREF wire open</li> <li>• PCU sensor VREF wire shorted to ground</li> <li>• PCU sensor ground wire open</li> <li>• Faulty sensor</li> <li>• Faulty ECU</li> </ul>
No operation	High PCU sensor reading	<ul style="list-style-type: none"> <li>• Pressure signal wire shorted to VBAT or VREF</li> <li>• Faulty sensor</li> <li>• Faulty ECU</li> </ul>

### Code Description

A "Pneumatic Control Unit (PCU) Sensor" code occurs when the Electronic Control Unit (ECU) receives an unusually high or low reading from the PCU sensor. A diagnostic tool will specify which of the two conditions is responsible for setting the code.

Initial troubleshooting steps involve checking for a shorted-to-ground or an open PCU sensor circuit.

If the circuits check out OK, secondary causes could involve a faulty sensor or a faulty ECU.

See "Troubleshooting Tips" for general guidelines on system diagnostics.

PCU Sensor Harness Connector

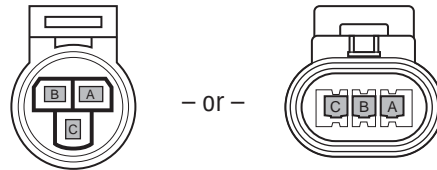

ECU Harness Connector

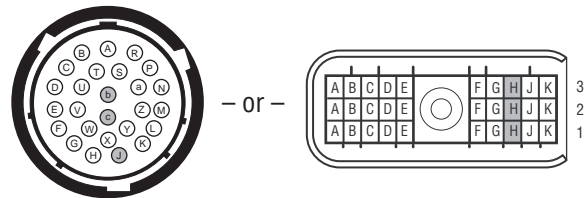

## PCU Sensor (Codes 33, 34)

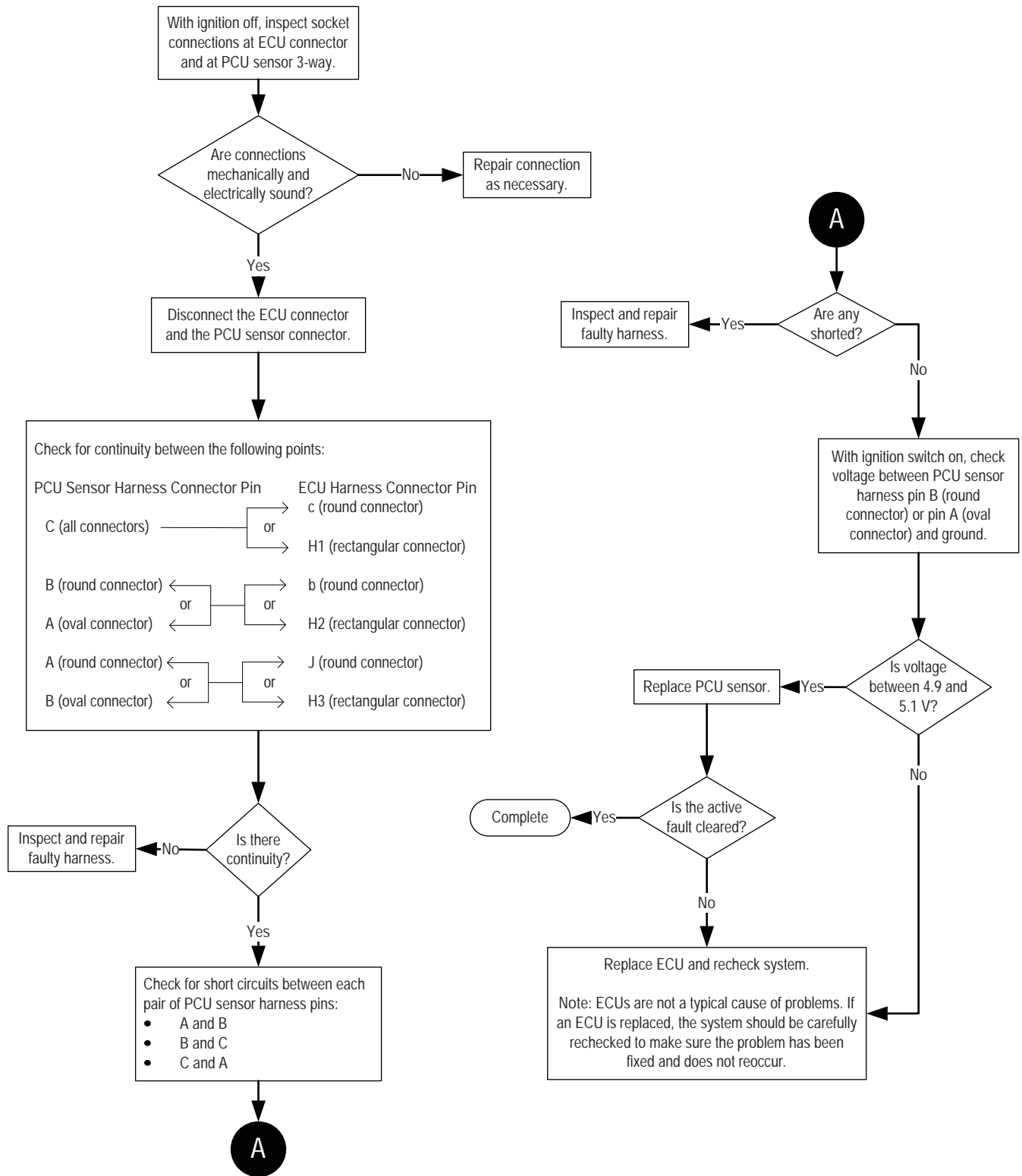

## 5 Flashing Lights or DDM – Dashes "--" (Code 31)

### Type: Pressure Switch

System Mode	Condition	Possible Causes (listed in order of likely occurrence)
Pressure check only	Pressure switch shorted or won't open.	<ul style="list-style-type: none"> <li>• Pressure switch wire shorted to ground</li> <li>• Faulty pressure switch (failed closed)</li> <li>• Faulty PCU (leaks air during supply tank check)</li> </ul>

### Air Pressure Check

Note that the Central Tire Inflation System is not continuously pressurized; pressure checks occur on a periodic basis. During tire pressure checks, the system delivers compressed air to each channel for approximately two seconds while monitoring the pressure in that channel.

### Code Description

A "Pressure Switch" code displays if system air pressure is inadequate to perform a tire pressure check, yet the pressure switch status is "closed".

This occurs when the pressure switch will not open. The components that can cause the pressure switch to remain closed include:

- Pressure switch wire shorted to ground.
- Faulty pressure switch (failed closed).

To correctly diagnose the faulty component, connect the Diagnostic Tool (see "Diagnostics" for test equipment and descriptions) and follow the procedure in the Pressure Switch troubleshooting tree.

**Note:** This feature is only available on 2-channel systems. This fault could be logged as a result of a single-channel system (with a single-channel Pneumatic Control Unit [PCU]) being configured as a two-channel system. See "Configuration Error" troubleshooting tree to verify correct harness configuration selection.

See "Troubleshooting Tips" for general guidelines on system diagnostics.

ECU Harness Connector

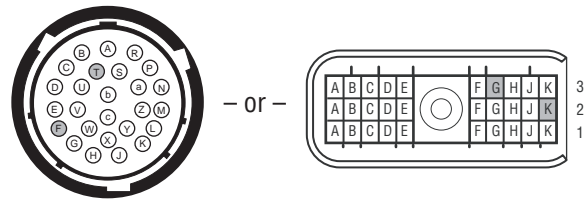

## Pressure Switch (Code 31)

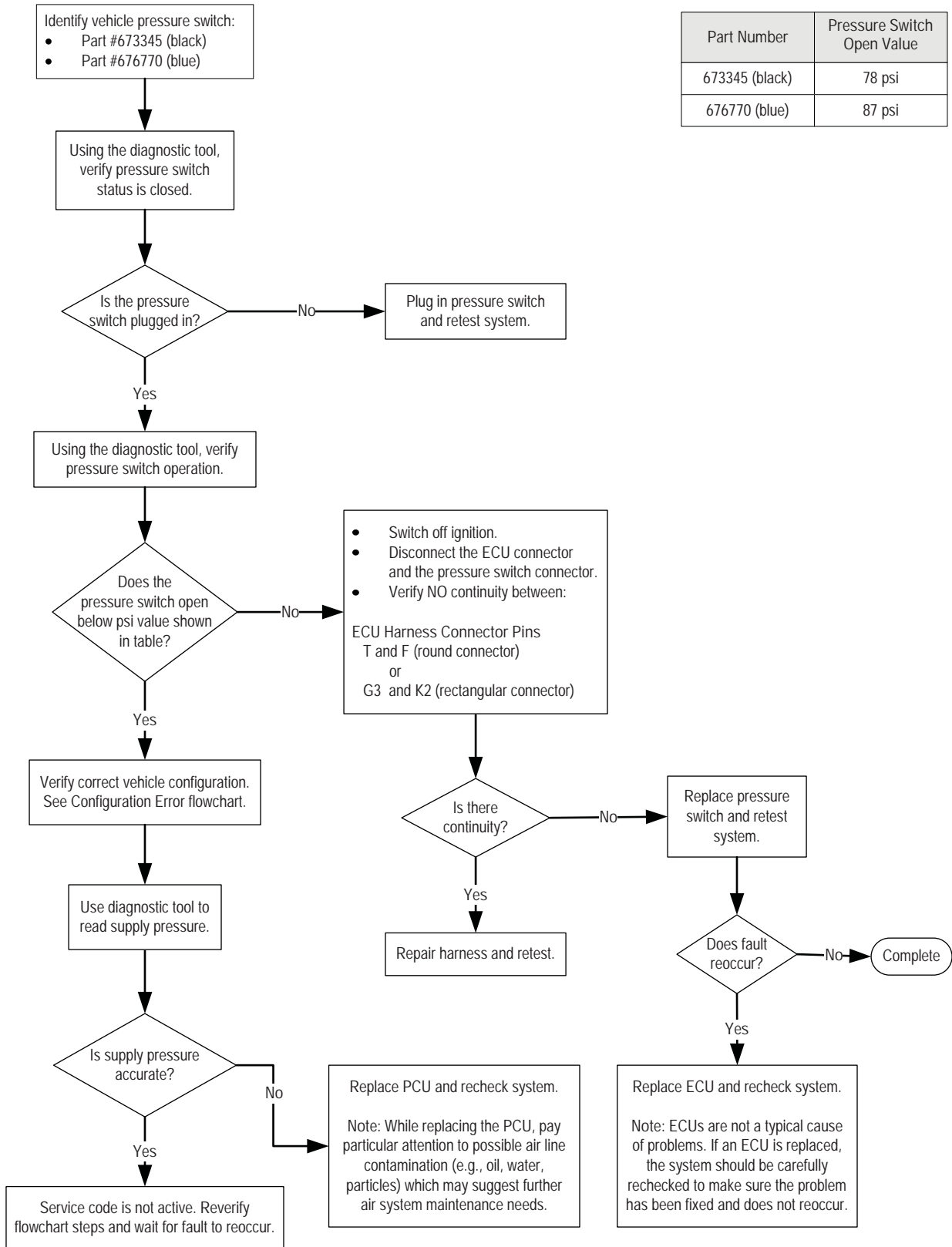

Part Number	Pressure Switch Open Value
673345 (black)	78 psi
676770 (blue)	87 psi

Pressure Switch (Code 31)

## 4 Flashing Lights or CHECK TIRES Flashing (Codes 44, 45)

### Type: Tire Leak (Imbalance)

**Note:** RUN FLAT overrides this fault.

System Mode	Condition	Possible Causes (listed in order of likely occurrence)
Channel only checks pressures.	Tire pressure lower on one tire than others.	<ul style="list-style-type: none"> <li>• Minor tire leakage at startup (leaked overnight)</li> <li>• Severe tire damage or leaks</li> <li>• Contaminated wheel valve filters</li> <li>• Restricted tires valve stem</li> <li>• Leaking lines</li> <li>• Leaking seals</li> <li>• Leaking wheel valve</li> <li>• Crimped or restricted control lines</li> </ul>

### Air Pressure Check

Note that the Central Tire Inflation System is not continuously pressurized; pressure checks occur on a periodic basis. During tire pressure checks, the system delivers compressed air to each channel for approximately two seconds while monitoring the pressure in that channel.

### Code Description

An “Imbalance” code indicates that either the tire pressure on one tire or wheel end was read lower than the other tires, or there is an air leak someplace in the system.

Low tire pressure can be caused by a damaged tire, plugged wheel valve filter or leaking air lines. An air leak can be located either before or after the wheel valve.

**Note:** When using a diagnostic tool to inflate or inflate-hold a channel with one low tire, air may be heard leaking out or the Quick Release Valves (QRV) by the higher pressure tires. This is normal and should stop once the low tire is inflated to the pressure of the other tires.

The components located before the wheel valve that may cause a “Tire Leak (Imbalance)” code include:

- Leaking wheel air seals
- Leaking control lines
- Restricted QRV exhaust port

Components located after the wheel valve that may cause an imbalance include:

- Damaged tire
- Rim leaks
- Clogged or restricted Wheel Valve filter or valve stem
- Leaking air lines
- Wheel valve damage

To correctly diagnose the faulty component, connect the Diagnostic Tool (see "Diagnostics" for test equipment and descriptions) and follow the procedure in the Tire Leak (Imbalance) troubleshooting tree.

See “Troubleshooting Tips” for general guidelines on system diagnostics.

## Tire Leak (Imbalance) (Codes 44, 45)

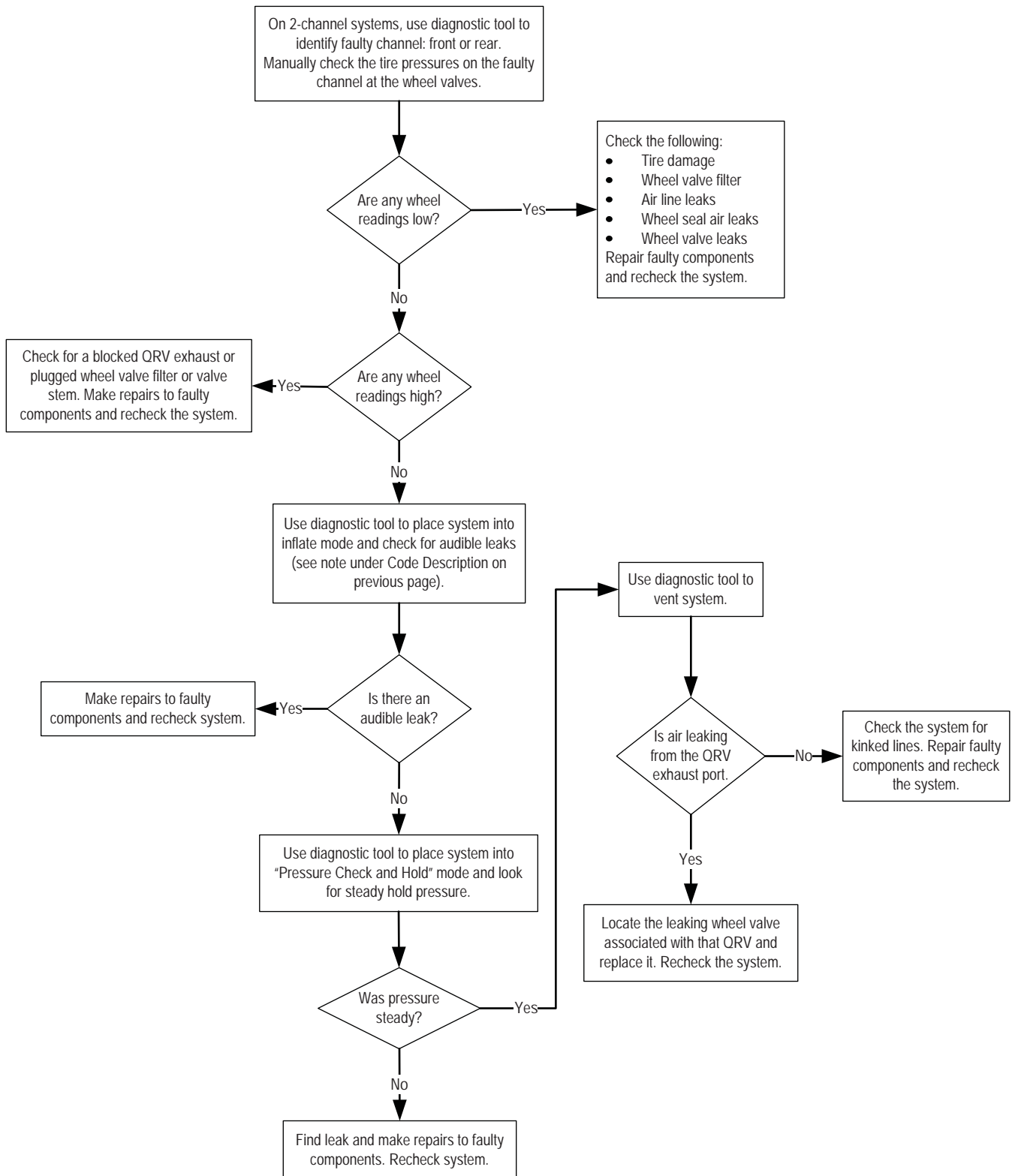

## 4 Flashing Lights or CHECK TIRES Flashing (Codes 41, 42)

### Type: Tire Leak (Confirm)

**Note:** RUN FLAT overrides this fault.

System Mode	Condition	Possible Causes (listed in order of likely occurrence)
Channel inoperative	Channel confirmation failure	<ul style="list-style-type: none"> <li>• Damaged or leaking tire</li> <li>• Leaking line between wheel valve and tire</li> <li>• Plugged or restricted QRV</li> <li>• Leaking wheel valve</li> <li>• Plugged or restricted PCU vent line</li> <li>• Restricted air passage between QRV and wheel valve</li> </ul>

### Air Pressure Check

Note that the Central Tire Inflation System is not continuously pressurized; pressure checks occur on a periodic basis. During tire pressure checks, the system delivers compressed air to each channel for approximately two seconds while monitoring the pressure in that channel.

### Code Description

A “Tire Leak” occurs if a channel fails to confirm tire pressure. Following an inflate or deflate sequence, the Central Tire Inflation System will return to confirm, or “double-check” the new pressure. If the pressure has dropped, the system will re-inflate, and then reconfirm the tires. After multiple failed confirmation attempts, the system will log a Tire Leak (Confirm) code and the system will become inoperative.

A confirmation failure can be caused by:

- Damaged or leaking tire
- Leaking air line between the wheel valve and tire
- Plugged or restricted Quick Release Valve (QRV)
- Leaking wheel valve
- Plugged or restricted Pneumatic Control Unit (PCU) vent line
- Restricted air passage between QRV and wheel valve

To correctly diagnose the faulty component, connect the Diagnostic Tool (see "Diagnostics" for test equipment and descriptions) and follow the procedure in the Tire Leak (Confirm) troubleshooting tree.

See “Troubleshooting Tips” for general guidelines on system diagnostics.



## Tire Leak (Confirm) (Codes 41, 42)

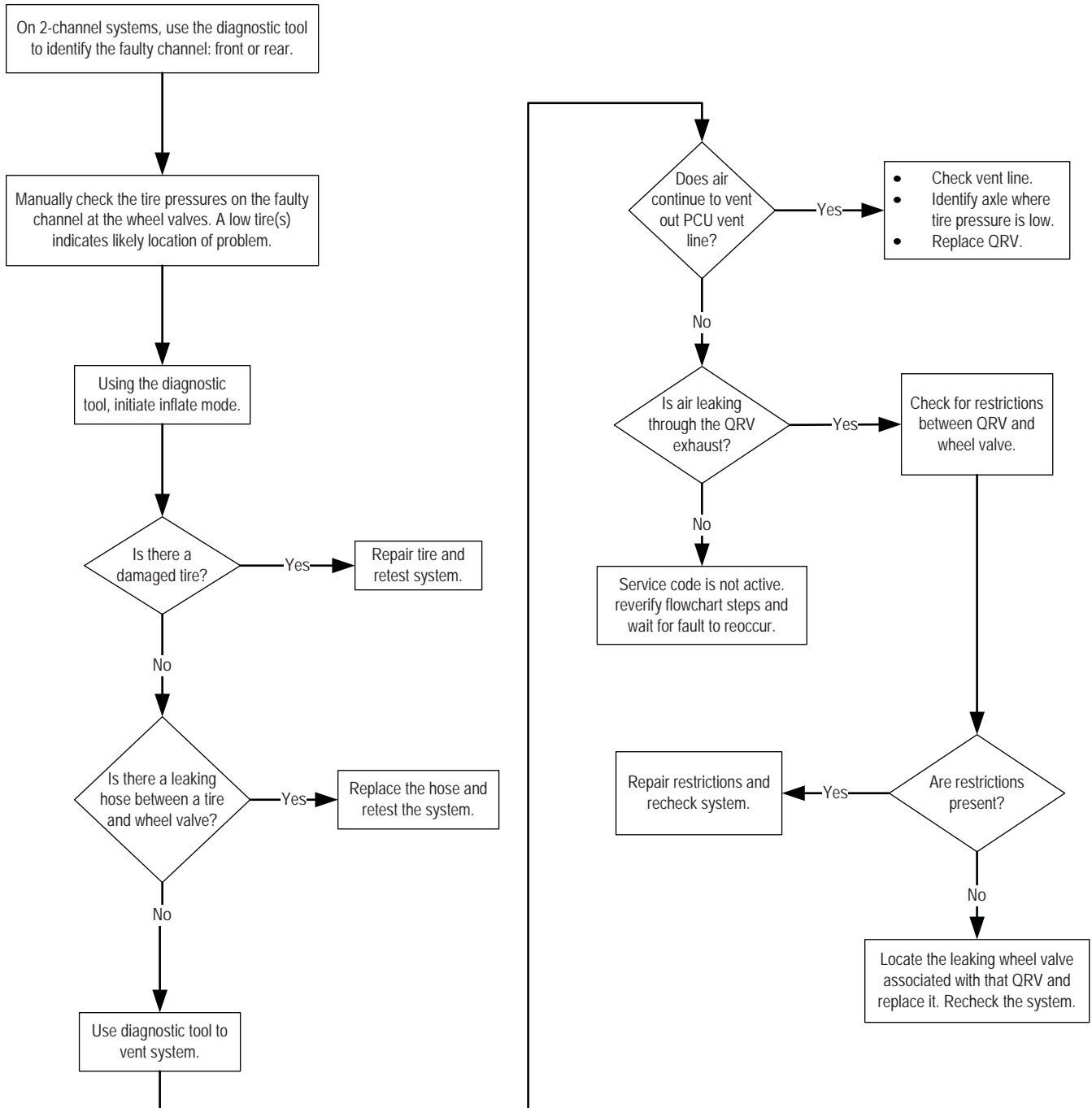

Tire Leak (Confirm) (Codes 41, 42)

## 2 Terrain Lights on Solid or DDM – Dashes "---" (Codes 23, 24)

**Type: Between Modes**

System Mode	Condition	Possible Causes (listed in order of likely occurrence)
Pressure check only	Slow inflate	<ul style="list-style-type: none"> <li>• Faulty compressor</li> <li>• Restricted flow at wheel valve air filters</li> <li>• Crimped or plugged lines</li> </ul>
Pressure check only	Slow deflate	<ul style="list-style-type: none"> <li>• Restricted flow at wheel valve air filters or valve stem</li> <li>• Leaking upper control lines</li> <li>• Plugged or restricted PCU vent port</li> <li>• Restricted tire valve stem</li> <li>• Faulty PCU relief valve</li> <li>• Restricted QRV exhaust port</li> </ul>

### Code Description

A “Between Modes” occurs if a channel inflates or deflates too slowly. The maximum allotted time for an inflate is 40 minutes, or 20 minutes for a deflate. The most likely cause for a slow inflate is a faulty compressor or similar problem resulting in inadequate air supply to the Central Tire Inflation System. The most likely cause for a slow deflate is a leaking upper control line, causing the deflate signal to be low.

If the system is able to generate a sufficient air supply, a “Between Modes” code means that a leak or restriction exists in an air passage. The components that may contain a restricted or leaking air passage include:

- Wheel valve air filters
- Quick Release Valve (QRV)
- Pneumatic Control Unit (PCU) vent port restriction
- Air supply lines
- Restricted tire valve stem
- Faulty PCU relief valve
- Restricted QRV exhaust

To correctly diagnose the faulty component, connect the Diagnostic Tool (see "Diagnostics" for test equipment and descriptions) and follow the procedure in the Between Modes troubleshooting tree.

See “Troubleshooting Tips” for general guidelines on system diagnostics.

## Between Modes (Codes 23, 24)

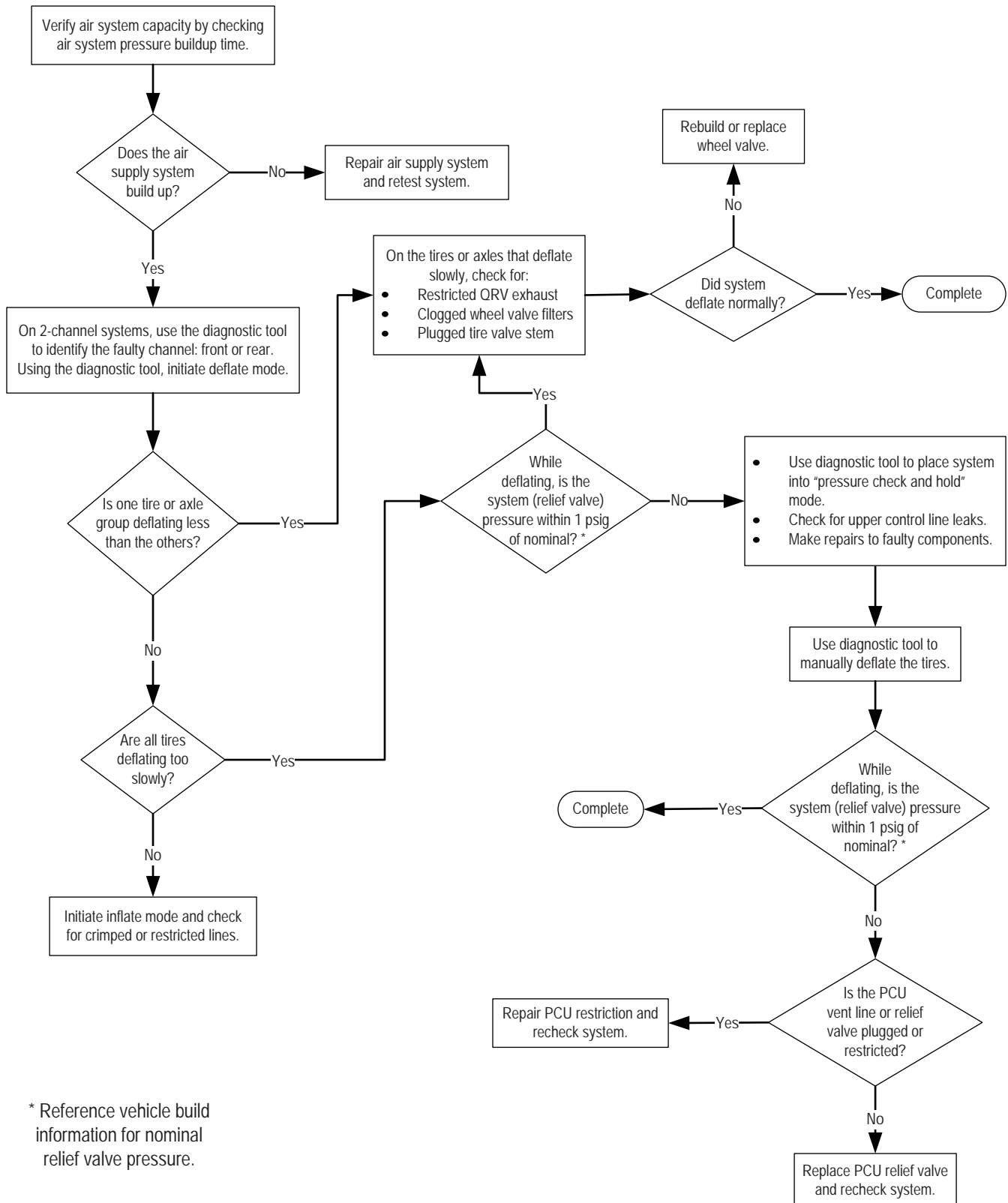

\* Reference vehicle build information for nominal relief valve pressure.

## 2 Terrain Lights on Solid or DDM – Dashes "--" (Codes 11, 12, 16)

### Type: Deflate Signal

System Mode	Condition	Possible Causes (listed in order of likely occurrence)
Inflate only	Inadequate deflate signal in the PCU and control lines	<ul style="list-style-type: none"> <li>• Plugged or restricted PCU vent line</li> <li>• Faulty PCU relief valve</li> <li>• Faulty PCU</li> <li>• Poor ground connector to PCU sensor</li> <li>• Faulty PCU sensor</li> </ul>

### Code Description

A "Deflate Signal" indicates inadequate deflate signal in the Pneumatic Control Unit (PCU) or failure to sustain the signal in the control lines of a given channel.

When a deflate is requested, the system drops the control line pressure to a preset level which is established by the PCU's relief valve. 2-channel systems may start separate channels at different times.

If the proper pressure (vehicle specific, but typically a subset of 6-22 psi) cannot be maintained by the PCU, either a Channel Deflate Loss or Loss of Deflate signal code is logged.

On 2-channel systems, if the relief valve pressure (deflate signal) cannot be maintained while both channels are deflating, the system will attempt to deflate the channels individually and will log "Deflate Signal" codes for an individual channel with a problem.

This can be caused by:

- Faulty PCU (relief valve)
- Plugged or restricted PCU vent line
- Line leak

To correctly diagnose the faulty component, connect the Diagnostic Tool (see "Diagnostics" for test equipment and descriptions) and follow the procedure in the Deflate Signal troubleshooting tree.

See "Troubleshooting Tips" for general guidelines on system diagnostics.

PCU Sensor Harness Connector

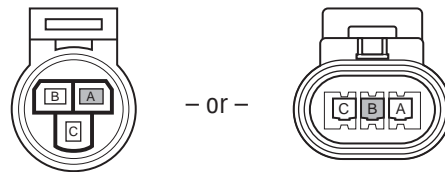

ECU Harness Connector

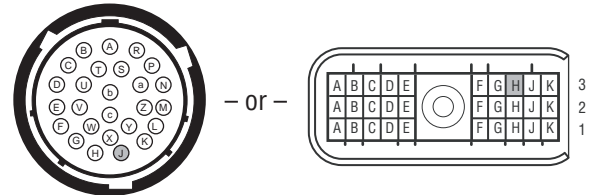

**Deflate Signal (Codes 11, 12, 16)**

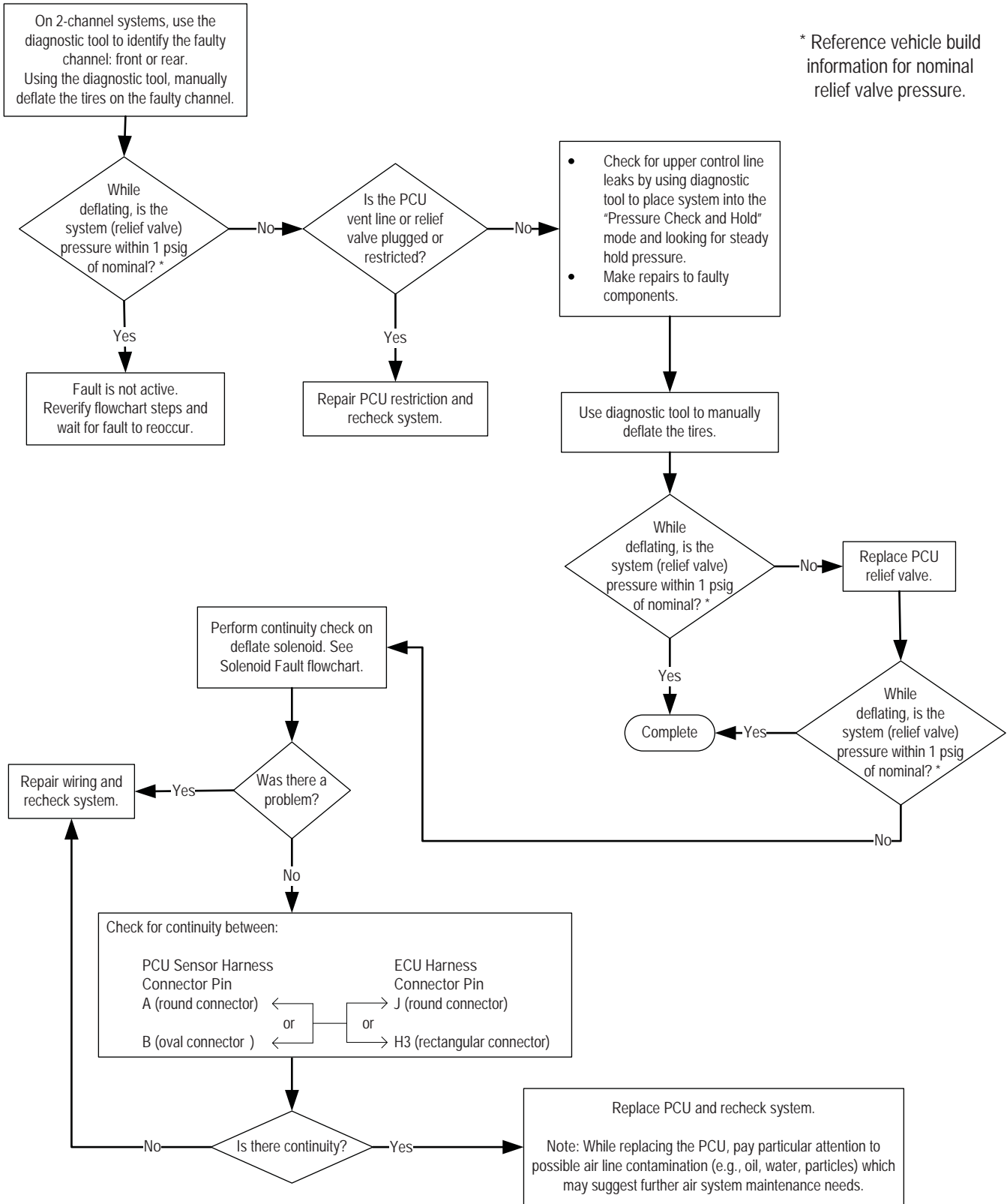

## No Terrain Lights or DDM – Dashes "---" (Codes 51, 52, 54, 55, 56)

**Type: PCU Solenoid  
(Supply, Deflate, Control, Front, or Rear)**

System Mode	Condition	Possible Causes (listed in order of likely occurrence)
No Operation	PCU solenoid failed electrical diagnostic test	<ul style="list-style-type: none"> <li>• Solenoid wire shorted to ground</li> <li>• Solenoid wire shorted to power</li> <li>• Faulty solenoid</li> <li>• Faulty ECU</li> </ul>

### Code Description

A “Solenoid Fault” code indicates an electrical fault in the Pneumatic Control Unit (PCU). System operation is disabled when these faults are detected.

The system shuts down in a fail-safe mode and turns off the power to the solenoids.

The troubleshooting tree first tests internal solenoid circuitry. Resistance outside the specified range of 30 to 80 ohms indicates a defective solenoid. Succeeding steps check continuity of the wire harness circuits between the PCU and the Electronic Control Unit (ECU). If the problem can be traced to a faulty circuit or connector, make the necessary repairs. If the troubleshooting routine leads to a problem with the solenoid itself, the PCU must be repaired or replaced. If both the solenoid and the circuitry check out OK, the ECU is faulty.

See “Troubleshooting Tips” for general guidelines on system diagnostics.

PCU Component Connector

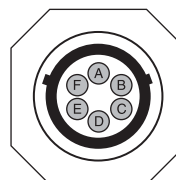

PCU Harness Connector



ECU Harness Connector

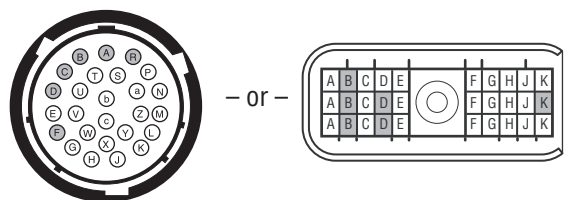

## PCU Solenoid (Codes 51, 52, 54, 55, 56)

Use diagnostic tool to identify which solenoid to troubleshoot.

- Switch off ignition.
- Disconnect harness at PCU connector.

Measure solenoid coil resistance on PCU connector for identified coil. Resistance should be 30-80 ohms.

On 1-Channel Systems	On 2-Channel Systems
Control: B – D	Control: A – D
Deflate: A – E	Deflate: A – E
Supply: A – F	Supply: A – F
	Front: A – C
	Rear: A – B

Are resistance measurements OK?

Repair or replace connections, coils or PCU.

Yes

- Check for shorts between PCU connector pins D, E, F and vehicle ground.
- On 2-channel systems, check for shorts between PCU connector pins C, B and vehicle ground.

Are any pins shorted to ground?

Repair or replace connections, coils or PCU.

No

1. Disconnect ECU harness connector.
2. Check for continuity between:
 

PCU Solenoid Harness Connector Pin	ECU Harness Connector Pin
A	→ F (flange round connector)
	→ G (M939 round connector)
	→ K2 (rectangular connector)
or	
3. On 1-channel systems, also check for continuity between:
 

PCU Solenoid Harness Connector Pin	ECU Harness Connector Pin
B	→ F (round connector)
	→ W (M939 round connector)
	→ K2 (rectangular connector)
or	
4. Check continuity of harness pin(s) shown in table for given service code (PCU harness connector to ECU harness connector).

Each code matches one specific solenoid. When the troubleshooting instructions refer to connector test points, use chart to select the pin test point for use with the particular fault code you are diagnosing.

Fault Code	Supply (51)	Deflate (52)	Control (54)	Front (55)	Rear (56)
PCU Harness Connector	F	E	D	C	B
ECU Harness Connector (round)	B	C	R	D	A
ECU Harness Connector (rectangular)	B1	B2	B3	D1	D2

Are circuits continuous?

Repair or replace harness.

Yes

Measure at PCU harness connector.

Non-M939 Style Vehicle

- On 1-channel systems, verify continuity between A and B.
- Verify no continuity between any combination of pins D, E, F on PCU harness connector and A on PCU harness connector.
- On 2-channel systems, verify no continuity between any combination of pins C or B on PCU harness and pin A on PCU harness.

M939 Style Vehicle

- Verify no continuity between D, E, F on PCU harness connector and A on PCU harness connector.
- Verify no continuity between D, E, F on PCU harness connector and B on PCU harness connector.

Are connections OK?

Repair or replace harness.

Yes

Replace ECU.

Note: ECUs are not a typical cause of problems. If an ECU is replaced, the system should be carefully rechecked to make sure the problem has been fixed and does not reoccur.

## No Terrain Lights or DDM – Blank Display (Code 17)

Type: Power

System Mode	Condition	Possible Causes (listed in order of likely occurrence)
No Operation	Power out of range	<ul style="list-style-type: none"> <li>• Low voltage</li> <li>• Poor ground connection to ECU</li> <li>• Poor power connection to ECU</li> <li>• High vehicle electrical system voltage</li> <li>• Faulty ECU</li> </ul>

### Code Description

A “Power” code indicates a power fault and sets when the system power is outside a 24-volt system’s acceptable range of 18 to 32 Volts. The fault could be caused by low battery power or some other problem with the basic vehicle electrical system.

If the vehicle power system checks out satisfactorily, other possible causes include bad Electronic Control Unit (ECU) connections, or a faulty ECU.

In inspecting circuits and connections for a Power code, pay particular attention to a bad ground connection, which could be causing the fault.

See “Troubleshooting Tips” for general guidelines on system diagnostics.

ECU Harness Connector

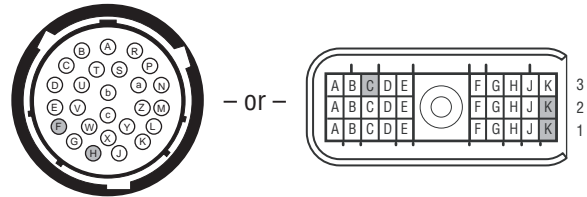



## Power (Code 17)

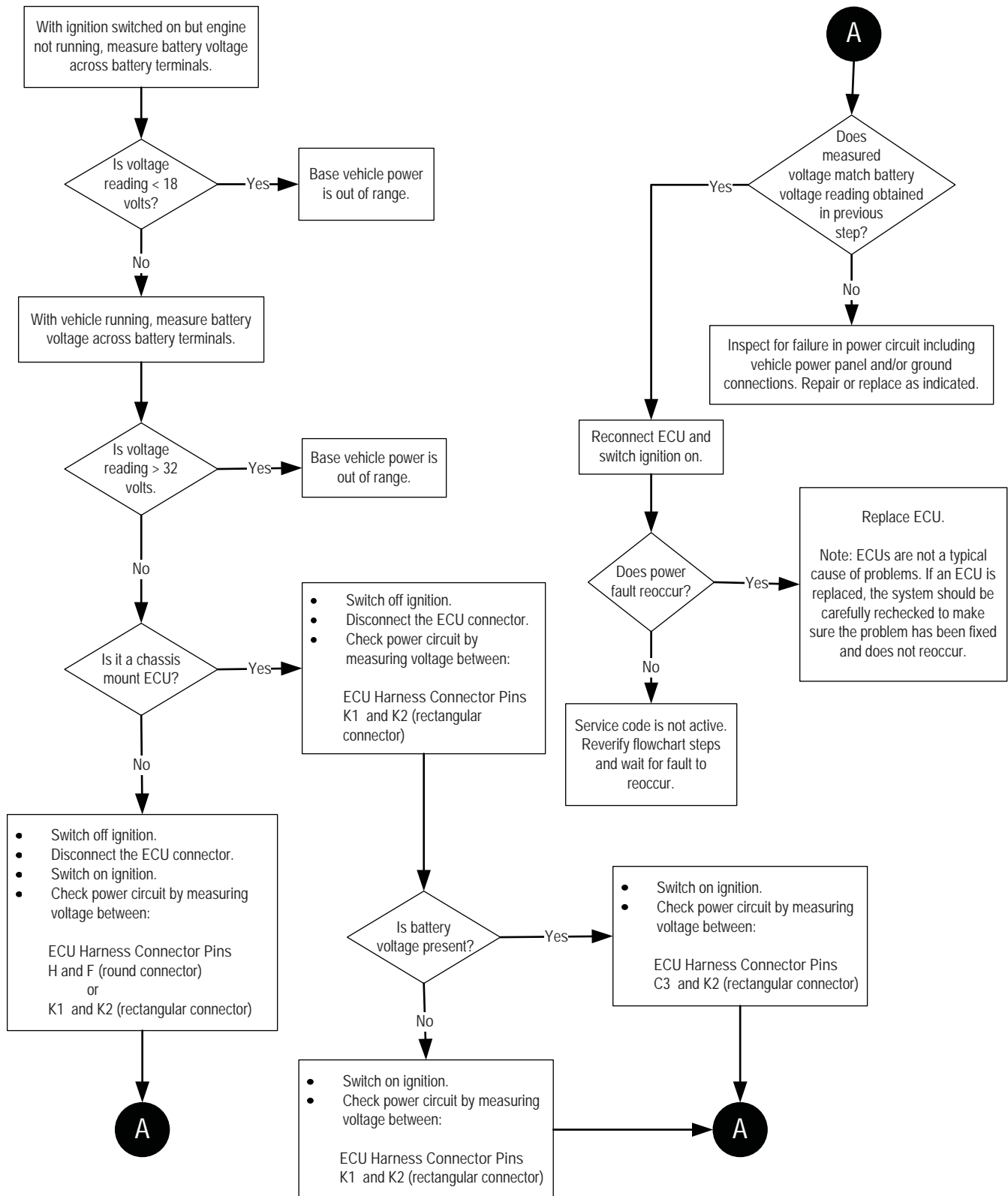

Power (Code 17)

## DDM – Dashes "--" (Code 75)

Type: Display Control Communications

System Mode	Condition	Possible Causes (Listed in Likely Order of Occurrence)
Inflate Only	Blank Display	<ul style="list-style-type: none"> <li>• No power to DDM</li> <li>• No ground connection to DDM</li> <li>• System voltage out of range (9-32 volts DC)</li> </ul>
Inflate Only	DDM displays dash dash (nothing else on display)	<ul style="list-style-type: none"> <li>• No power or ground to ECU</li> <li>• DDM to ECU wires open</li> <li>• DDM to ECU wires shorted to ground</li> <li>• DDM to ECU wires shorted to power</li> <li>• DDM to ECU wires shorted together</li> <li>• Faulty Driver Display Module</li> <li>• Faulty Electronic Control Unit</li> </ul>

### Code Description

Code 75 indicates a communication problem between the Electronic Control Unit (ECU) and the Driver Display Module.

All of the troubleshooting steps for code 75 involve checking the condition of Electronic Control Unit and DDM circuits. If no circuit problems are found, code 75 indicates either a faulty DDM or a faulty Electronic Control Unit.

See "Troubleshooting Tips" for general guidelines on system diagnostics.

DDM Display Harness Connector

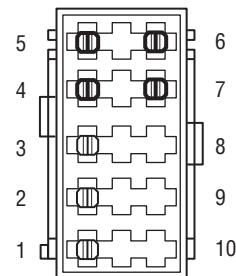

ECU Harness Connector

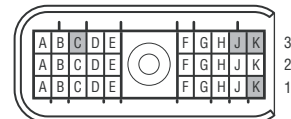

### Display Control Communications (Code 75)

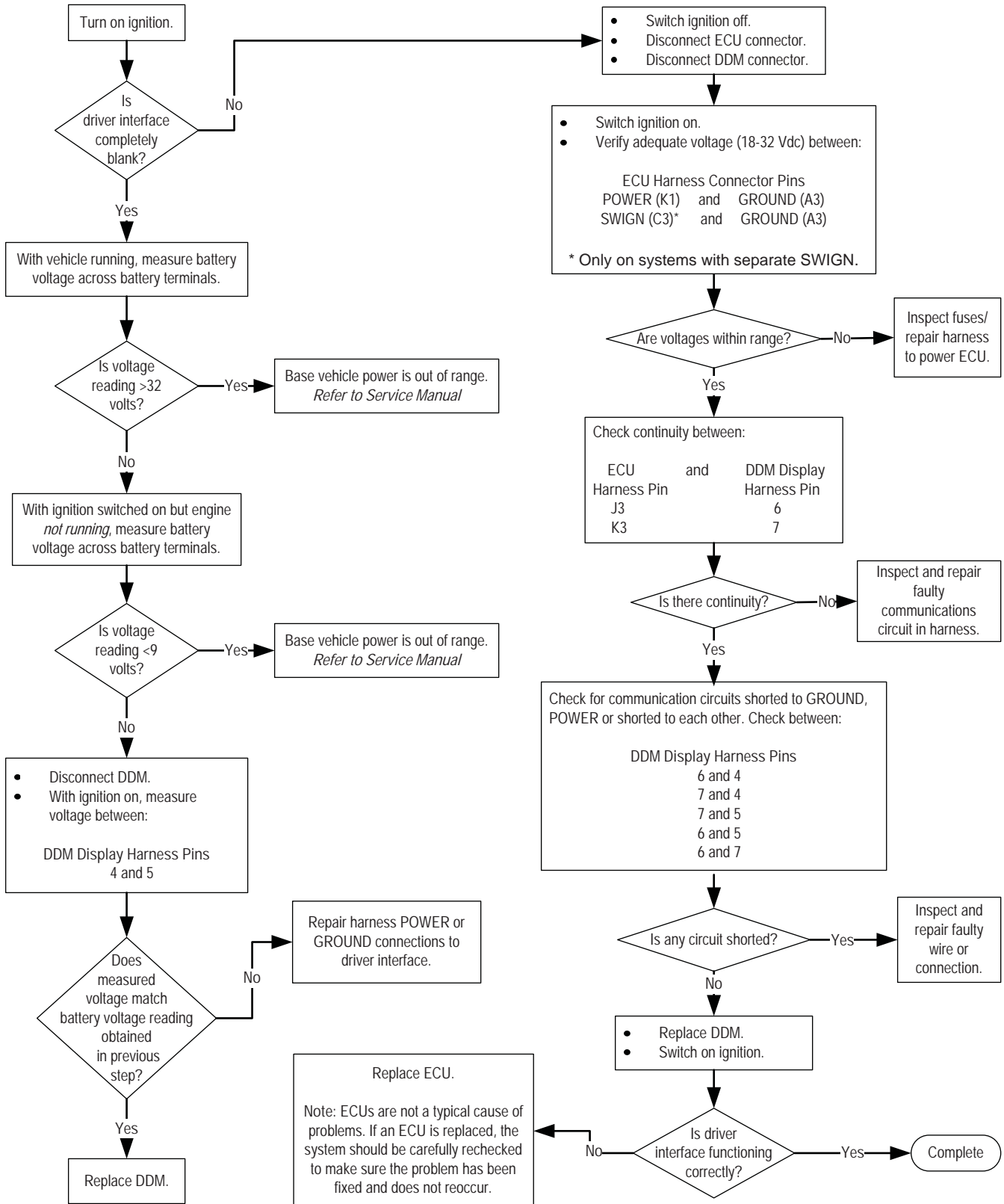

## Lights Sequentially Flashing

### Type: Configuration Error

System Mode	Condition	Possible Causes (listed in order of likely occurrence)
Limp Home / Normal Operation	System using default values	<ul style="list-style-type: none"> <li>• Harness configuration requires a downloaded file</li> <li>• Loss of programmed values</li> </ul>

### Code Description

Spicer's CTIS supports multiple vehicles or setups (tire pressure targets, etc.) within a single Electronic Control Unit (ECU). This allows the ECU to be moved from vehicle to vehicle and change its parameters according to vehicle type. Setups can either be selected through harness wiring configurations or "downloaded" to the ECU. Additional modifications can be made using Dana's PC based diagnostic tool.

A "Configuration Error" code results from one of two conditions:

- Typically it is the result of a system that has been harness selected for a downloadable configuration (customized), but has not yet been downloaded. Downloading the appropriate OEM setup file will clear the display indication. ECU's that are marked "S-307x-xxx" normally require this special attention. A download file can be obtained from the OEM or Dana Engineering.
- In addition, on some legacy systems a "Configuration Error" code display indicates an automatic memory reload has occurred. In this case, pressing the HWY and RUN FLAT buttons simultaneously will clear the display indication. The system has reloaded the system defaults into ECU memory, eliminating any customization or changes (target pressures, etc.) previously programmed.

The troubleshooting procedure involves verifying that the harness configuration selection wires are making a good connection. If the configuration wires are good, and the problem repeatedly occurs, the ECU may need to be replaced.

Configuration Harness Connector

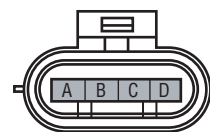

Configuration Component Connector

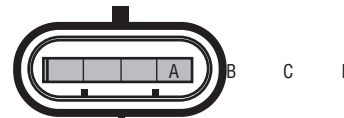

ECU Harness Connector

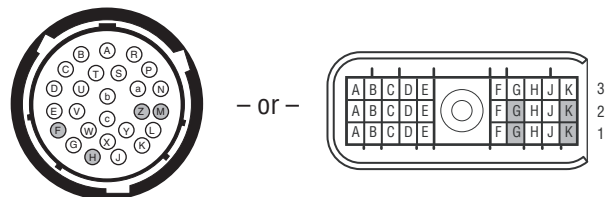

## Configuration Error

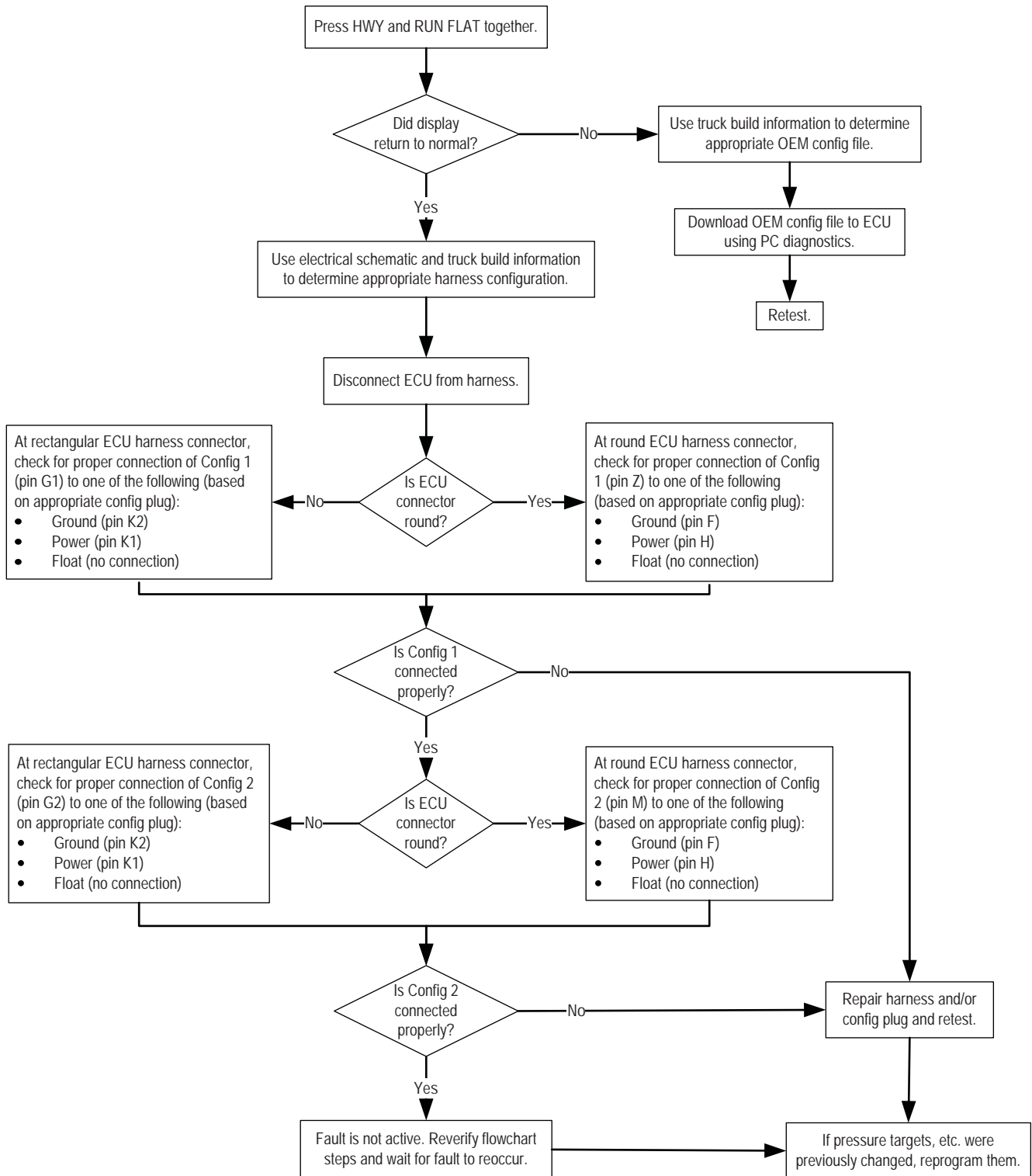

Note: ECUs are not a typical cause of problems; however, if this fault reoccurs multiple times and wiring harness has been confirmed to be good, ECU replacement may be necessary.

## Solid Warning Lamp or Solid OVER SPEED (Codes 18, 76, 77)

### Type: Speed Signal

System Mode	Condition	Possible Causes (listed in order of likely occurrence)
Normal Operation	No speed signal	<ul style="list-style-type: none"> <li>• ECU power cycled 50 times without vehicle being moved.</li> <li>• Sensor disconnected or loose plug.</li> <li>• Either speed sensor wire is open (broken wire).</li> <li>• Either speed sensor wire is shorted to ground (bare wire is touching the frame).</li> <li>• Faulty speed sensor.</li> <li>• Sensor actuation failure.</li> <li>• Tang drive broken/disconnected on mechanical sensor.</li> <li>• Gap not adjusted correctly on pole sensor.</li> <li>• Sensor wires shorted together.</li> <li>• Expected data link message not received</li> </ul>

### Code Description

A “Speed Signal” code indicates a faulty speed sensor signal. In general, the system is configured to accept speed signals from any one of several sources (analog, digital, J1708/1587 or J1939). In this standard configuration, a loss of speed signal fault is indicated by code 18. In some specific instances, a vehicle may be configured to only accept speed from a specific data link. In these cases, codes 76 (SAE J1708/1587) and code 77 (SAE J1939) may be used to indicate a speed signal fault.

- A wiring or sensor connection.
- A misadjusted or faulty sensor.
- A missing data link speed signal. (J1708/1587 or J1939)

**Note:** These codes will occur if Electronic Control Unit (ECU) power has been cycled 50 times and no speed signal is received. Fifty power cycles can occur after 25 engine starts without moving the vehicle, however the code will clear as soon as a speed signal is received.

See “Troubleshooting Tips” for general guidelines on system diagnostics.

Speed Sensor  
Harness Connector

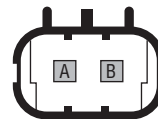

ECU Harness Connector

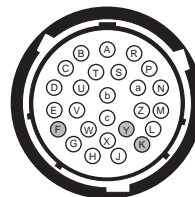

– or –

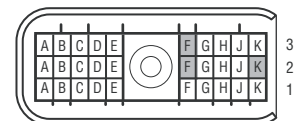

3  
2  
1

## Speed Signal (Code 18, 76, 77)

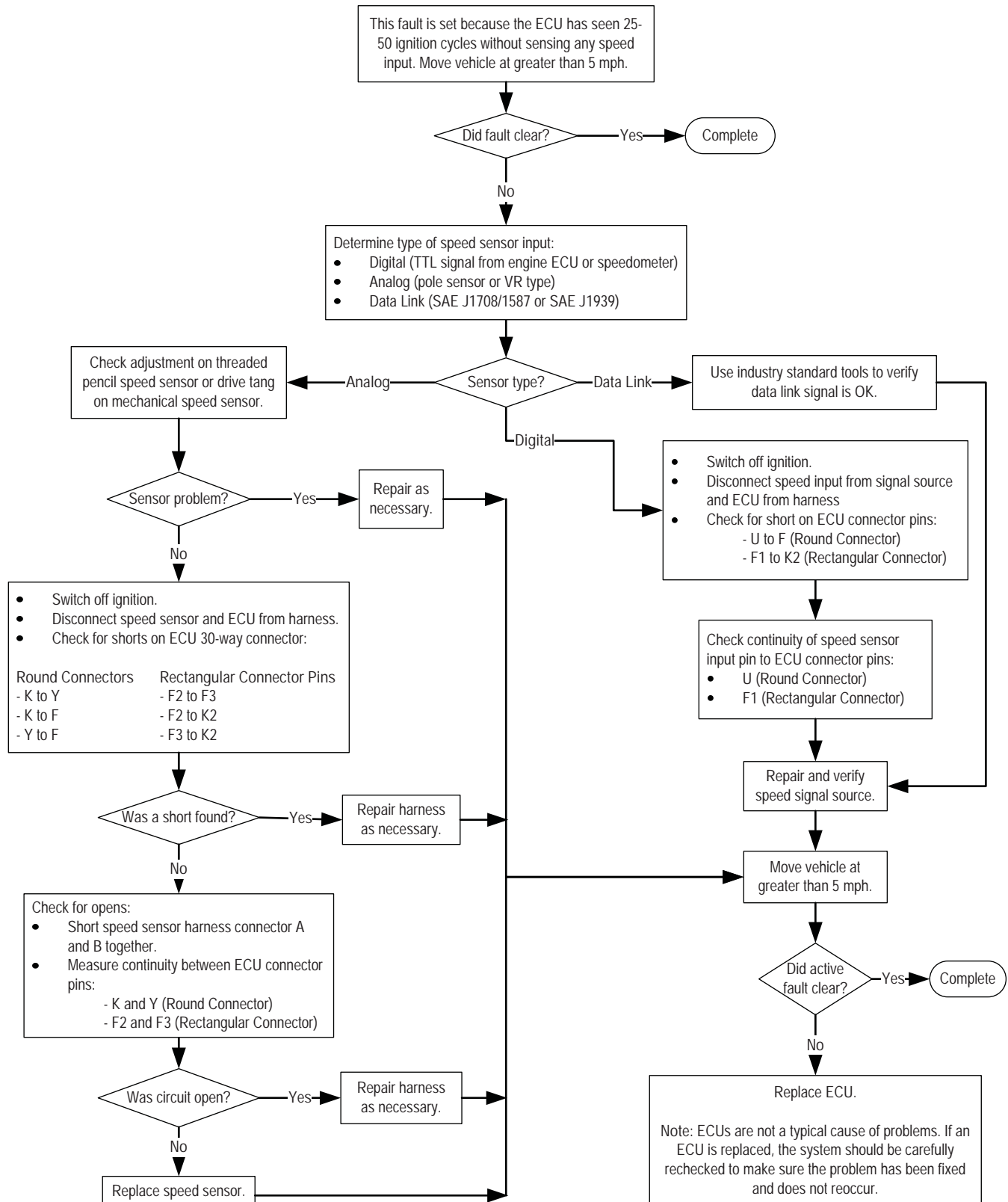

Speed Signal (Codes 18, 76, 77)

**No Indication or DDM – Dashes "--" (Implementation Specific) (Codes 53, 57, 58, 67, 68)**

**Type: Miscellaneous Output  
(Spare1, Spare2, Spare3, Warning Lamp, Buzzer)**

System Mode	Condition	Possible Causes (listed in order of likely occurrence)
Normal Operation	Miscellaneous output failed electrical diagnostic test	<ul style="list-style-type: none"> <li>• Spare output wire shorted to ground</li> <li>• Spare output wire shorted to power</li> <li>• Faulty component</li> <li>• Faulty ECU</li> </ul>

**Code Description**

A “Miscellaneous Output Fault” code indicates an electrical fault in an OEM specific spare output, warning lamp or buzzer. System operation is not affected when these faults are detected.

The troubleshooting tree first tests that the associated ECU harness pin is not shorted to ground and is continuous to the component. If continuity exists, the component must be repaired or replaced.

See "Troubleshooting Tips" for general guidelines on system diagnostics.

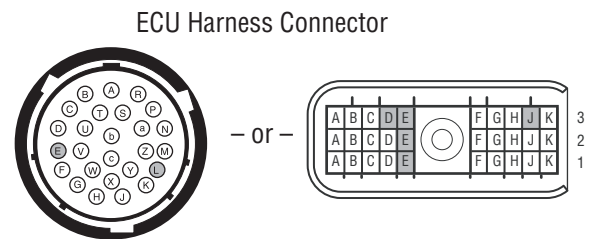



## Miscellaneous Output (Codes 53, 57, 58, 67, 68)

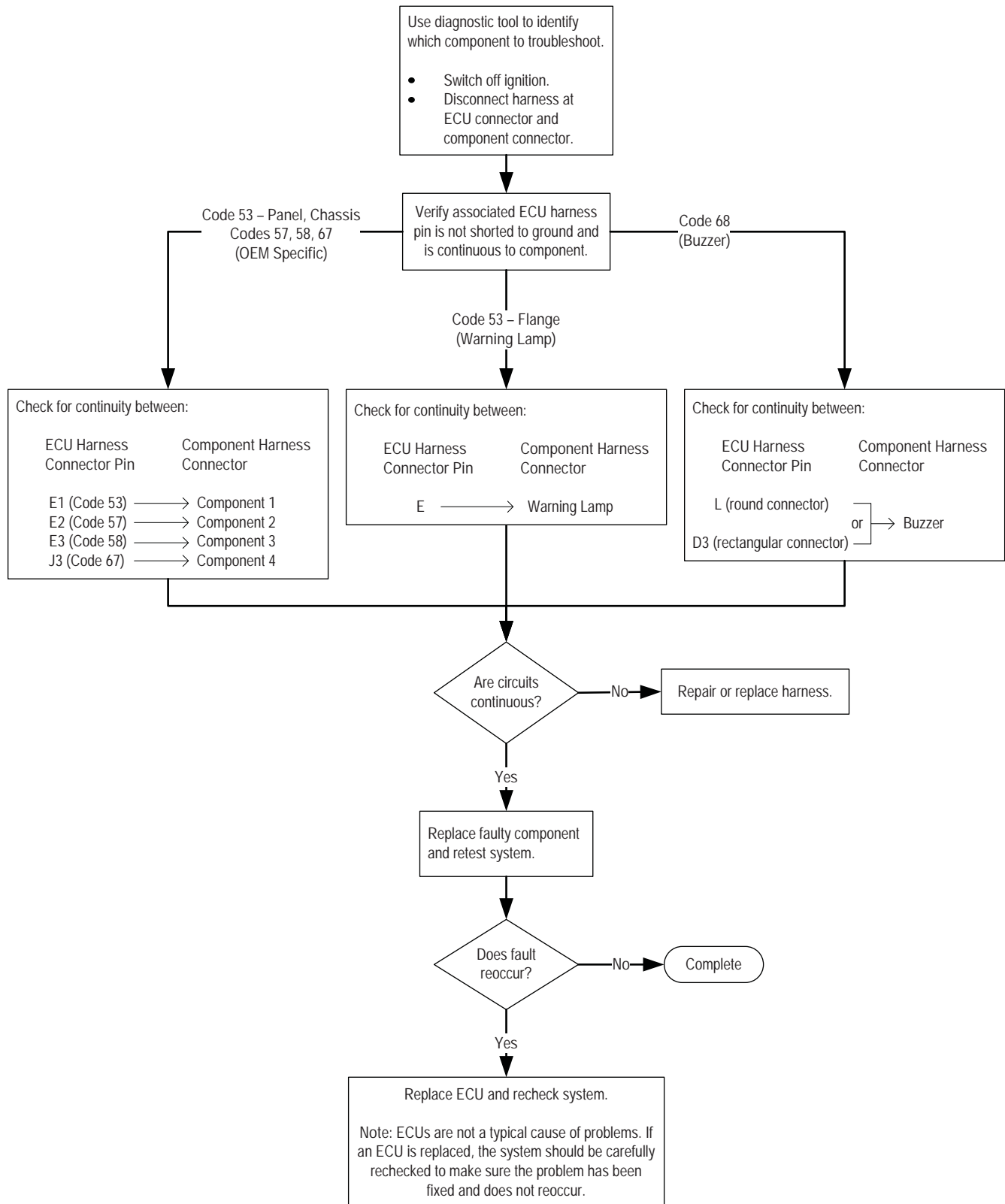

## No Indication (Codes 61, 62, 64, 65)

### Type: Wheel Valve Shut Off

System Mode	Condition	Possible Causes (listed in order of likely occurrence)
Normal Operation	Loss of pressure during shut off	<ul style="list-style-type: none"> <li>• Wheel valve shut off failure</li> <li>• Air passage restriction</li> </ul>

### Air Pressure Check

The Central Tire Inflation System is not continuously pressurized; pressure checks occur on a periodic basis. During tire pressure checks, the system delivers compressed air to each channel for approximately two seconds while monitoring the pressure in that channel.

### Code Description

The "Wheel Valve Shut Off" code indicates that the system is unable to confirm that tires on a given channel are able to sustain the target pressure when the channel is depressurized. After any change of pressure on a given channel, the Central Tire Inflation System will return to that channel to confirm, or "double-check" the new pressure before returning to the periodic check interval. If the pressure is not the same, or more than the last reading, the system will inflate again, and then reconfirm that channel. After 7 - 10 confirmation attempts, the system will log a code, and complete operations on the other channel. The system will classify the loss of air due to wheel valve closure as minor (codes 61 and 62 on front and rear) or major (codes 64 and 65 on front and rear respectively).

**Note:** Leaks from the tire(s) may be noted after the truck has been idle overnight, as the tire(s) lose(s) air when the truck is off and the system inoperative. By observing the time required to achieve normal tire pressures after starting the vehicle, many tire punctures can be identified well before the tire incurs non-repairable damage.

A confirmation failure can be caused by:

- Damaged or leaking tire(s).
- Leaking air line between the wheel valve and tire.
- Air passage restriction between the Pneumatic Control Unit (PCU) and the wheel valve.
- Wheel valve contamination or failure.

To identify the root cause of the problem, connect the diagnostic tool (see Diagnostics Section for test equipment and descriptions) and follow the procedure in the Tire Leak (code 41) Troubleshooting Tree.

See "Troubleshooting Tips" for general guidelines on system diagnostics.

## Wheel Valve Shut Off (Codes 61, 62, 64, 65)

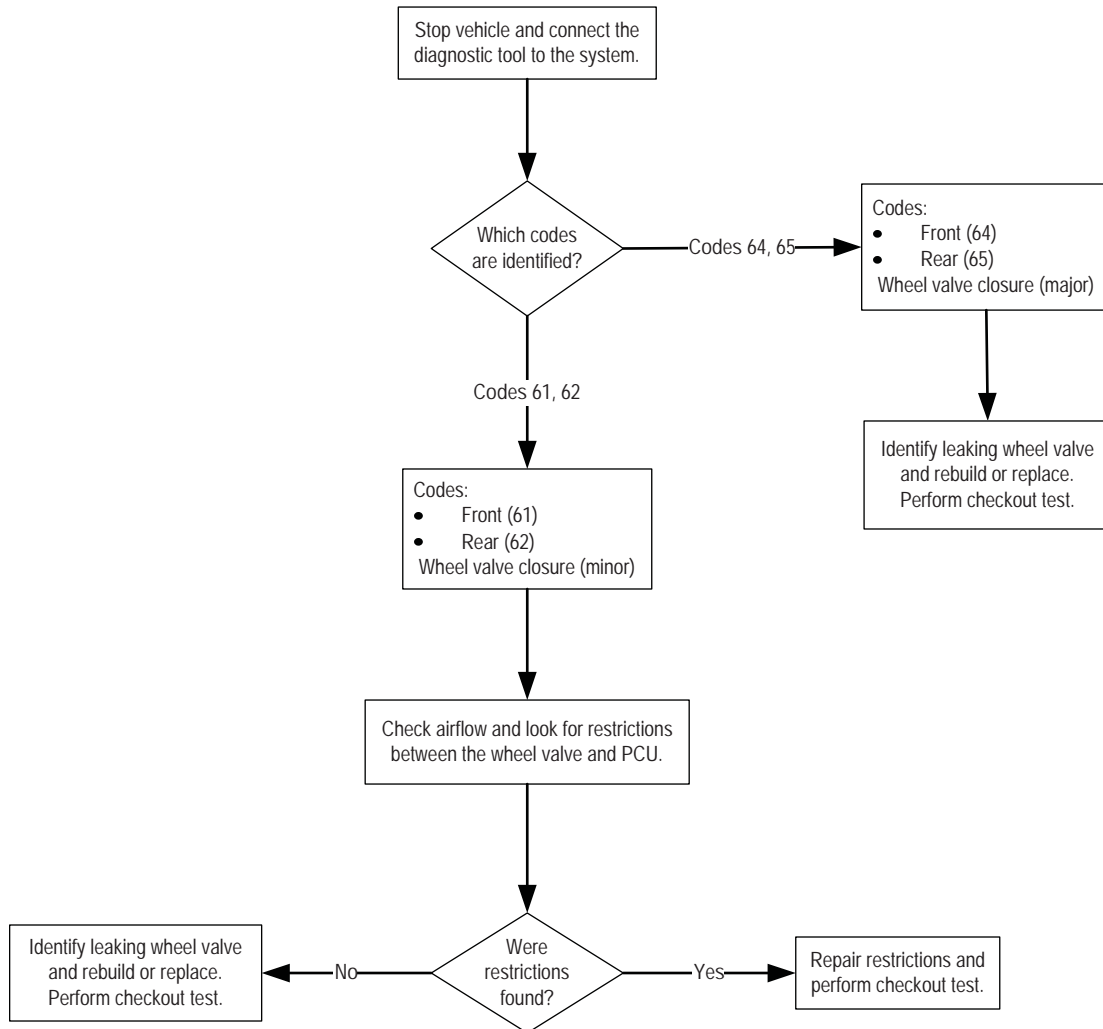

## No Code

### Type: Miscellaneous

Although the Central Tire Inflation System is self-diagnosing, there are some operating problems that do not trigger a fault code. The following chart lists these conditions along with possible causes and solutions.

Condition	Possible Causes*	Solution
<b>Operating problems that do not trigger a fault code.</b>	<b>Since a fault code was not set, these conditions may be universal and not call for a troubleshooting routine.</b>	<b>Where fault codes appear, refer to the troubleshooting procedures under that code.</b>
<b>ELECTRONIC CONTROL UNIT (ECU) DISPLAY</b>		
Blank ECU display or DDM display	<ul style="list-style-type: none"> <li>• Power fuse blown</li> <li>• Bad ground to ECU</li> <li>• Bad power or switched ignition line to ECU</li> <li>• Faulty ECU</li> </ul>	Check Fuses See "Power" code
System loses programmed tire pressure settings	<ul style="list-style-type: none"> <li>• Improperly followed programming procedure</li> <li>• Faulty ECU</li> </ul>	Reference programming procedure Replace ECU
<b>TIRE PRESSURE</b>		
Diagnostic tool display shows tires at higher pressure than target, yet system does not attempt to deflate	Tire pressure rises due to temperature, are not bled off by the Central Tire Inflation System. This is normal operation.	System will only initiate a deflate if a mode with a lower target pressure than current target is selected
No apparent inflate or deflate	Pressure switch not closed	See "Low Air Supply" code
Pressure imbalance (tires on same channel at different pressures)	Defective hose, clogged filters	See "Tire Leak (Imbalance)" code
No inflate or deflate or particular tire	<ul style="list-style-type: none"> <li>• Valve stem core not removed on tire</li> <li>• Clogged wheel valve filter or valve stem</li> </ul>	Remove hose from tire valve stem and remove core. Replace hose. Change filter.
Actual tire pressures do not match programmed targets.**	<ul style="list-style-type: none"> <li>• Leaking control lines</li> <li>• Faulty PCU sensor</li> </ul>	See "Atmospheric" and "Tire Leak (Imbalance)" codes
Incorrect tire pressures	<ul style="list-style-type: none"> <li>• System defaults to original targets</li> <li>• Replacement ECU not programmed</li> </ul>	See "Configuration Error" code

\* Possible causes are listed in order of likely occurrence.

\*\* The system is designed to allow tire pressure increase due to heat buildup during vehicle use. This system will not automatically deflate these pressure buildups—a lower pressure mode must be selected to initiate a deflate.

## No Code

### Type: Miscellaneous

Condition	Possible Causes*	Solution
<b>Operating problems that do not trigger a fault code.</b>	<b>Since a fault code was not set, these conditions may be universal and not call for a troubleshooting routine.</b>	<b>Where fault codes appear, refer to the troubleshooting procedures listed under that code.</b>
<b>AIR LEAKS</b>		
Air bleeding from rear axle vents	<ul style="list-style-type: none"> <li>• Air seal leaks (Extreme cold temperatures)</li> </ul>	Drive vehicle to “warm up” seals
Tires fail to deflate when lower pressures are requested	<ul style="list-style-type: none"> <li>• Pneumatic system problem</li> </ul>	See “Deflate Signal” code
Leaking tires	<ul style="list-style-type: none"> <li>• Damaged tire</li> <li>• Loose connection between wheel valve and tire</li> <li>• Faulty wheel valve</li> </ul>	Repair as needed
Air bleeding (audible) through QRV when ignition is turned off	Wheel valve is leaking back through control lines	Identify tire with low pressure and replace faulty wheel valve
	QRV vent plugged	Unplug or replace QRV
<b>OTHER</b>		
Apparent continuous operation, or slow inflates or deflates	<ul style="list-style-type: none"> <li>• Too long changing pressures</li> <li>• Loss of pressure during inflate</li> </ul>	See “Between Modes”, “Tire Leak (Confirm)”, “Inflate Trend” codes
System stopped in middle of inflate or deflate (display shows steady mode light before reaching targeted pressures)	<ul style="list-style-type: none"> <li>• Intermittent PCU sensor short or open</li> </ul>	See “PCU Sensor” code
Wheel end oil leak	<ul style="list-style-type: none"> <li>• Faulty air or oil seal</li> </ul>	Repair as needed
Optional “load” switch seems to have no effect	<ul style="list-style-type: none"> <li>• Broken, shorted, or open wire to load switch</li> <li>• Faulty load switch</li> </ul>	<ul style="list-style-type: none"> <li>- Use diagnostic tool in monitor mode to verify load status changes when switch position changes</li> <li>- Use wiring diagram to test harness for shorts or open</li> <li>- Replace load switch</li> </ul>

\* Possible causes are listed in order of likely occurrence.

## Service Guidelines

### CTIS Service

The Central Tire Inflation System requires normal maintenance much the same as other systems on the vehicle. Following are some general rules that apply to Central Tire Inflation service:

#### Clean and Dry Air Supply

The Spicer Central Tire Inflation System requires a constant supply of clean dry air. An adequately sized and properly maintained air dryer is critical for continued proper operation of the Central Tire Inflation System. Even though the air dryer may be working properly, moisture can accumulate in the supply tank during normal operation due to the increase in air consumption. It is important to drain the supply tank daily. Draining the supply tank completely (releasing all air pressure) when the truck is not in use will also help keep moisture under control.

#### Line Replacement and Routing

When replacing air lines, do not allow kinks, sharp bends or stretching in order to tighten joints. If any tube or hose segment does not appear to fit easily, it could mean you are not using the proper part or that you are not following service procedures properly. Ensure that replacement lines are the correct length and size. Be cautious of any contaminants (rubber flash, plastic particles, etc.) getting in the lines when replacing them.

Each segment of the pneumatic system must be secured to the vehicle frame or other installed line. After completing assembly of each segment, use cable ties to anchor the segment at approximately 18" intervals.

**⚠ CAUTION**

**Proper Central Tire Inflation System operation requires correct air line diameters and lengths. Incorrect air line replacement can affect both performance and operation of the system.**

### Joint Compounds and Fittings

Here are some important “Do’s” and “Don’ts” regarding the use of thread sealant:

- **Do** apply a thin coating of compound on male threads of pipe joints, tubing connections, and other system fittings.
- **Don’t** use any compound on O-ring, compression, or flare fitting connections. Instead, apply a thin coat of silicone grease to O-rings and flares.
- **Don’t** use Teflon thread tape anywhere in the air system. (Teflon tape shreds can become lodged in valving.)
- **Do** follow manufacturer recommended guidelines when tightening fittings.

## Air Filter Change

The graphic below shows the location of the air filter in each wheel valve. **Air filters should not be cleaned or reused. This filter must be replaced with a new filter whenever the tire or wheel valve is serviced.** Use the illustration as reference in completing the air filter replacement as follows:

### Wheel Valve with Tire Hose

1. Working quickly to prevent air loss, remove the tire hose assembly from the fitting on the tire port (nearest the tire fill valve) of the wheel valve. Cap hose to prevent air loss.
2. Use a flat blade screwdriver to dislodge (unscrew counterclockwise) the air filter from the wheel valve. Discard the used air filter.
3. Install new air filter by pressing it straight into wheel valve tire port (oriented as shown below).
4. Remove cap and install tire hose assembly to wheel valve outlet port and torque to 16-19 lb. ft.

### Integrated Wheel Valve

1. Remove all air from tire.
2. Remove valve from wheel (watch for o-rings on back).
3. Remove air filter from wheel and discard. Install new air filter by pressing it straight into the wheel (oriented as shown below).
4. Ensure both o-rings are installed on back side of valve and reinstall to wheel.
5. Re-inflate tire.

### Wheel Valve with Tire Hose

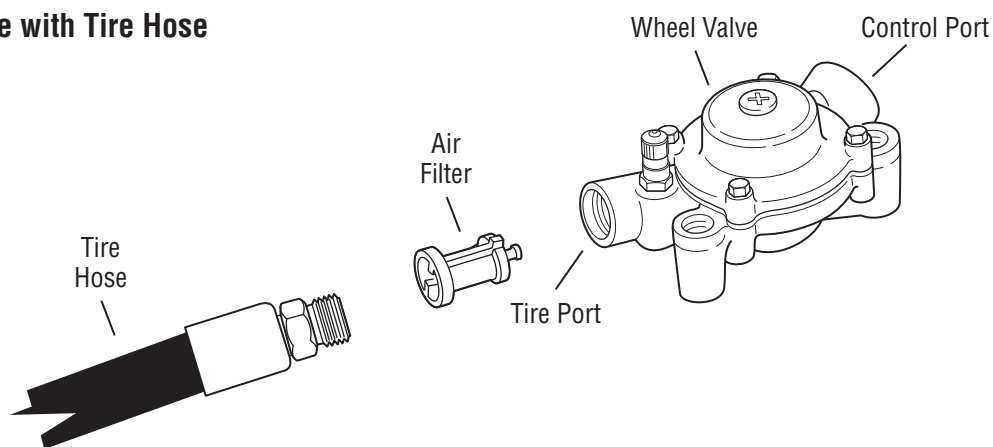

### Integrated Wheel Valve

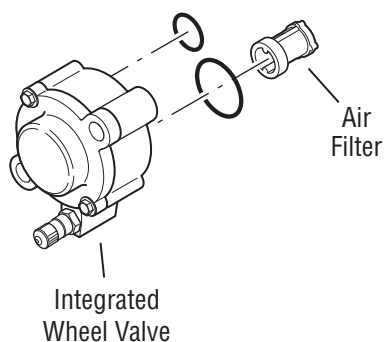

## Connector Illustrations (All views are looking into the connector.)

Harness Connectors

Component Connectors

ECU

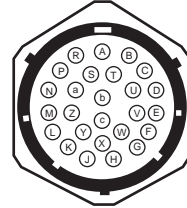
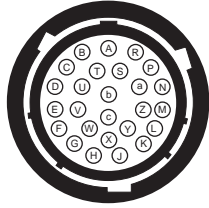

- or -

- or -

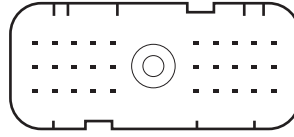
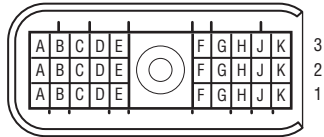

PCU

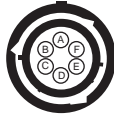

PCU Sensor

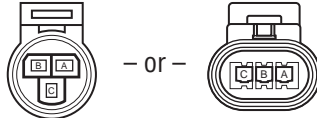

- or -

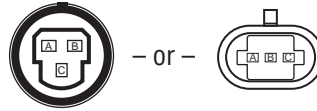

- or -

Diagnostic

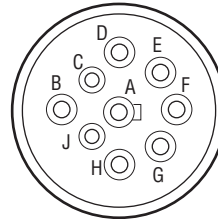
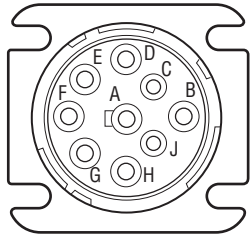

Pressure Switch

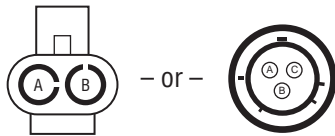

- or -

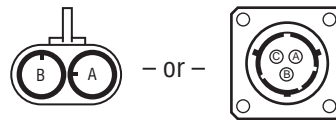

- or -

Speed Sensor

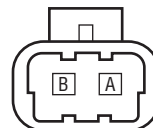
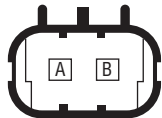

Configuration

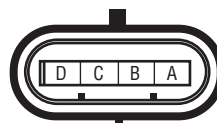



## M939 Wiring Diagram (676422 and 676603)

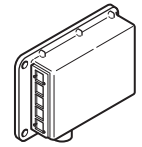
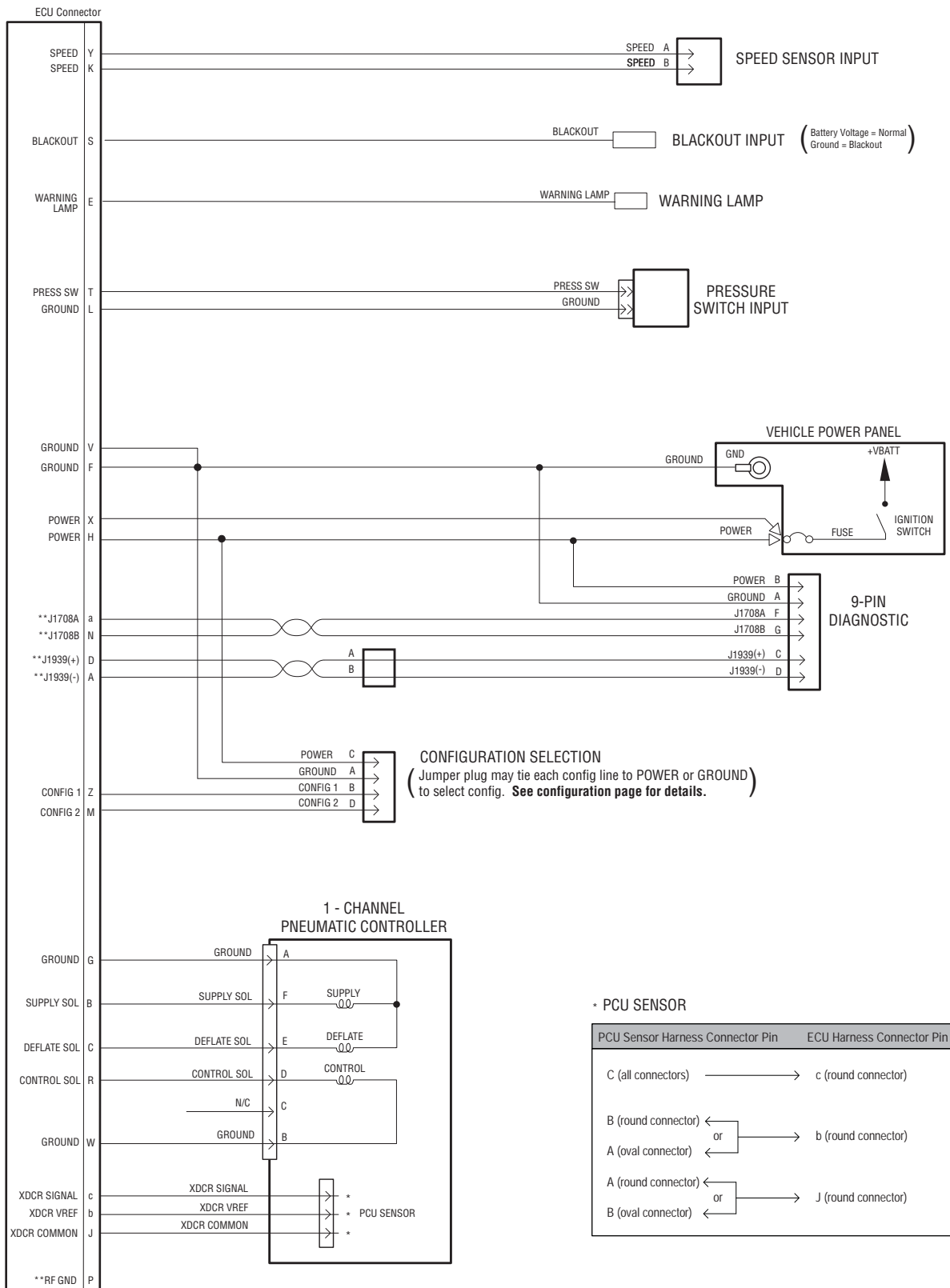

\*\* MAY EXIST ON SOME SYSTEMS AND NOT ON OTHERS

## Flange Mount Wiring Diagram

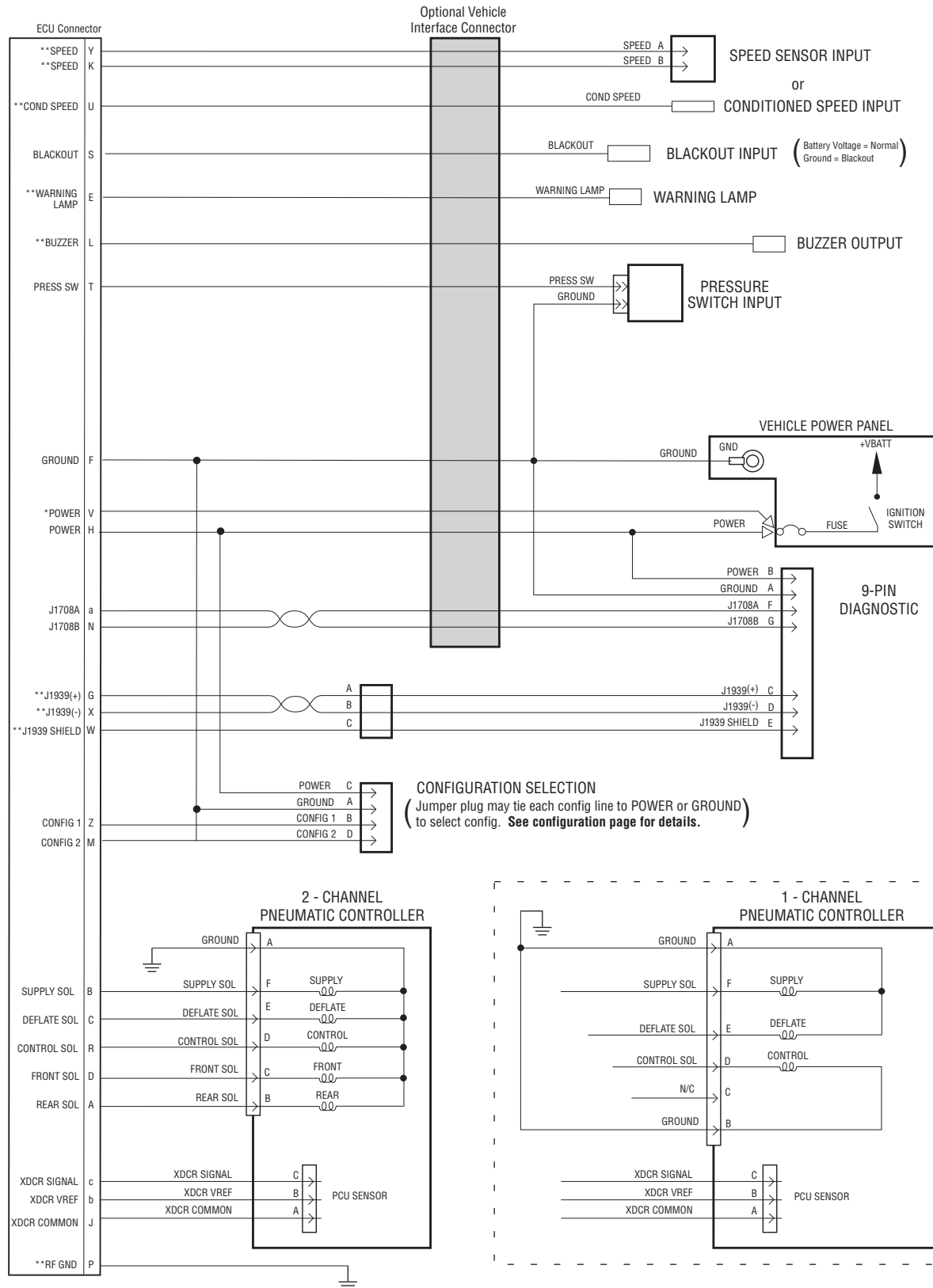

\* 12V SYSTEMS ONLY

\*\* MAY EXIST ON SOME SYSTEMS AND NOT ON OTHERS

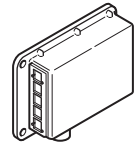

## Panel Mount Wiring Diagram

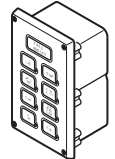
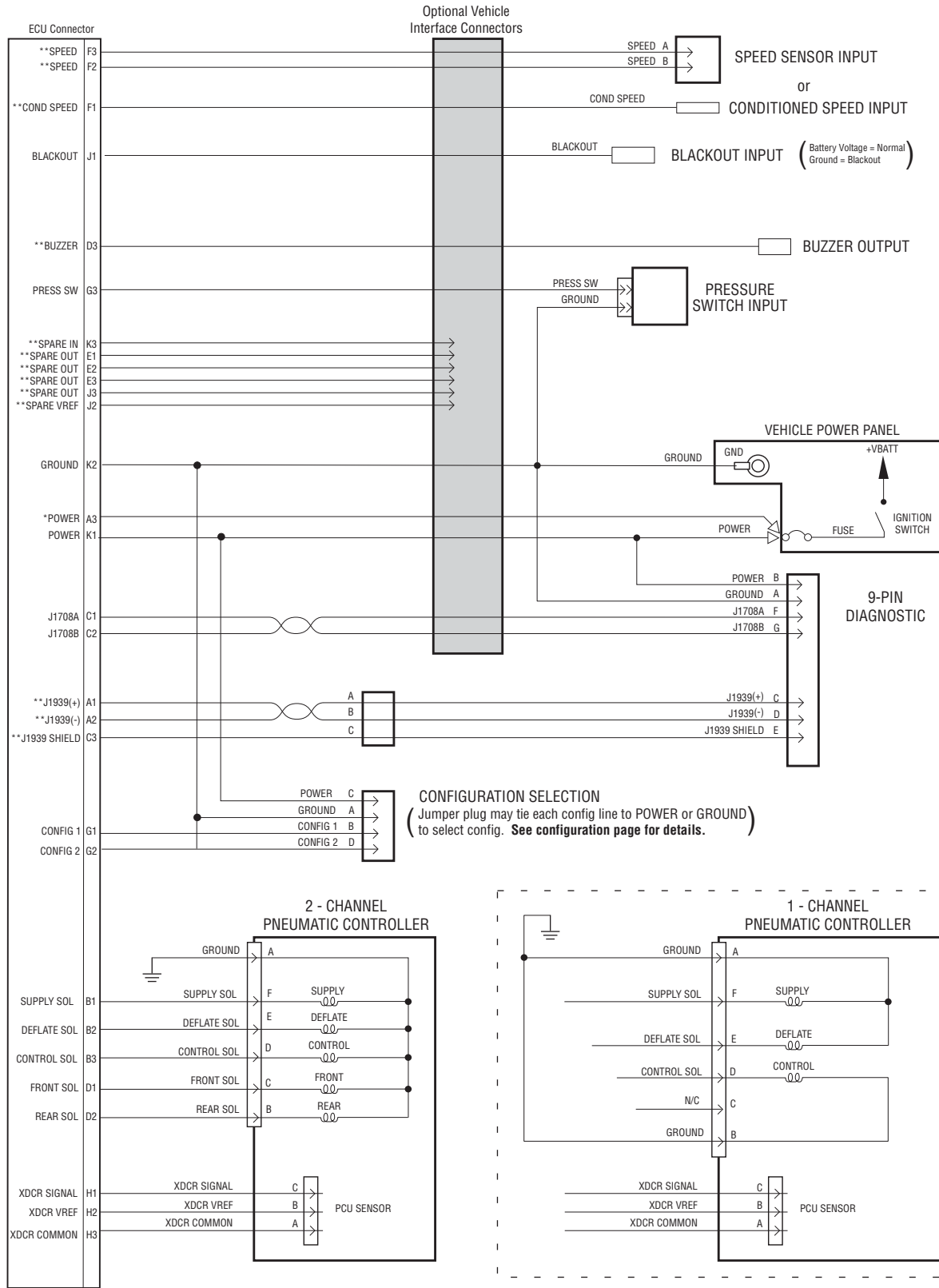

\* 12V SYSTEMS ONLY

\*\* MAY EXIST ON SOME SYSTEMS AND NOT ON OTHERS

## Chassis ECU with DDM (Separate Power and Switched Ignition) Wiring Diagram

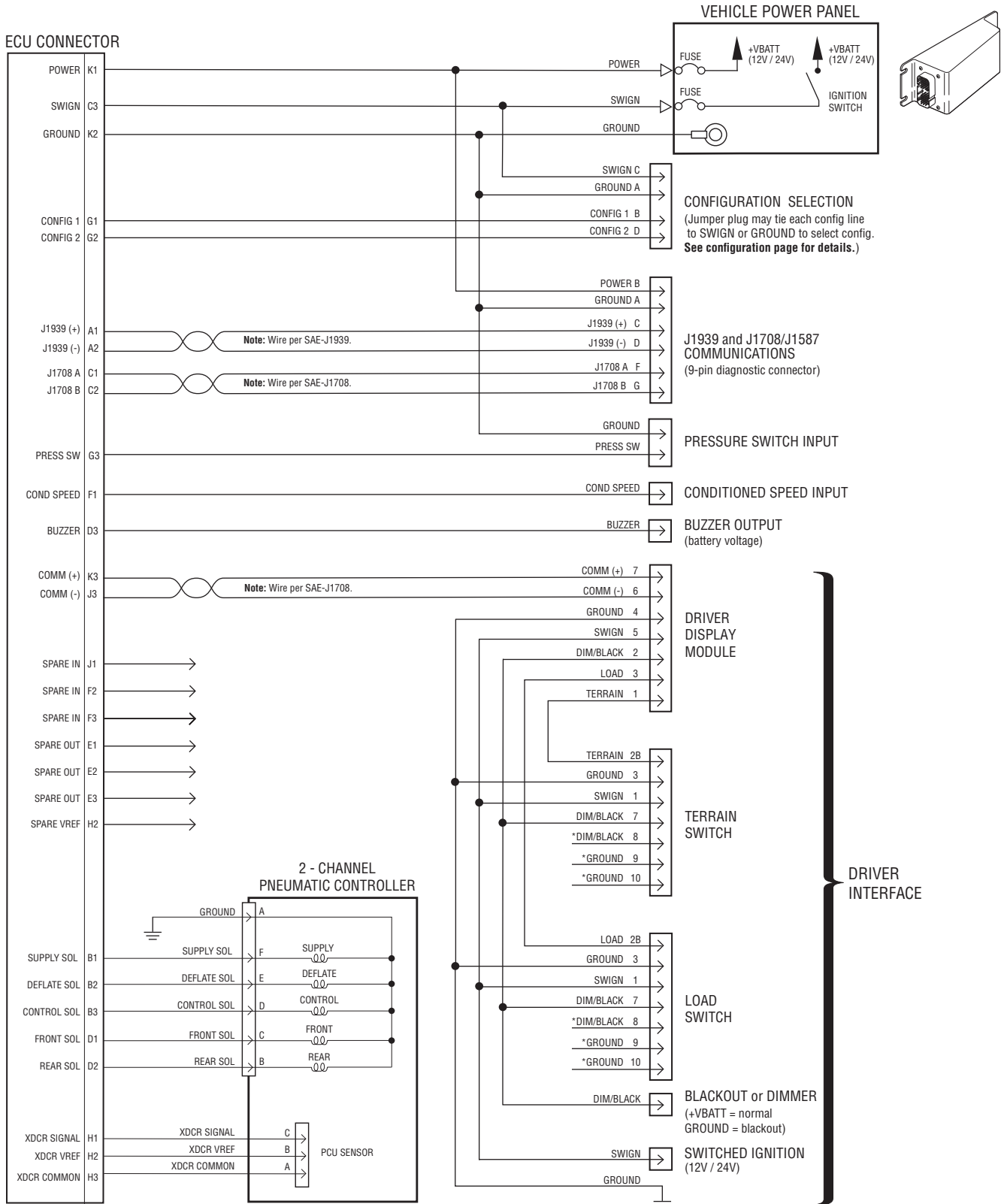

\*Connections to pins 8, 9, and 10 are made internally. Earlier versions of the switches required these connections to be made in the harness.

## Chassis ECU with DDM (all Power Switched) Wiring Diagram

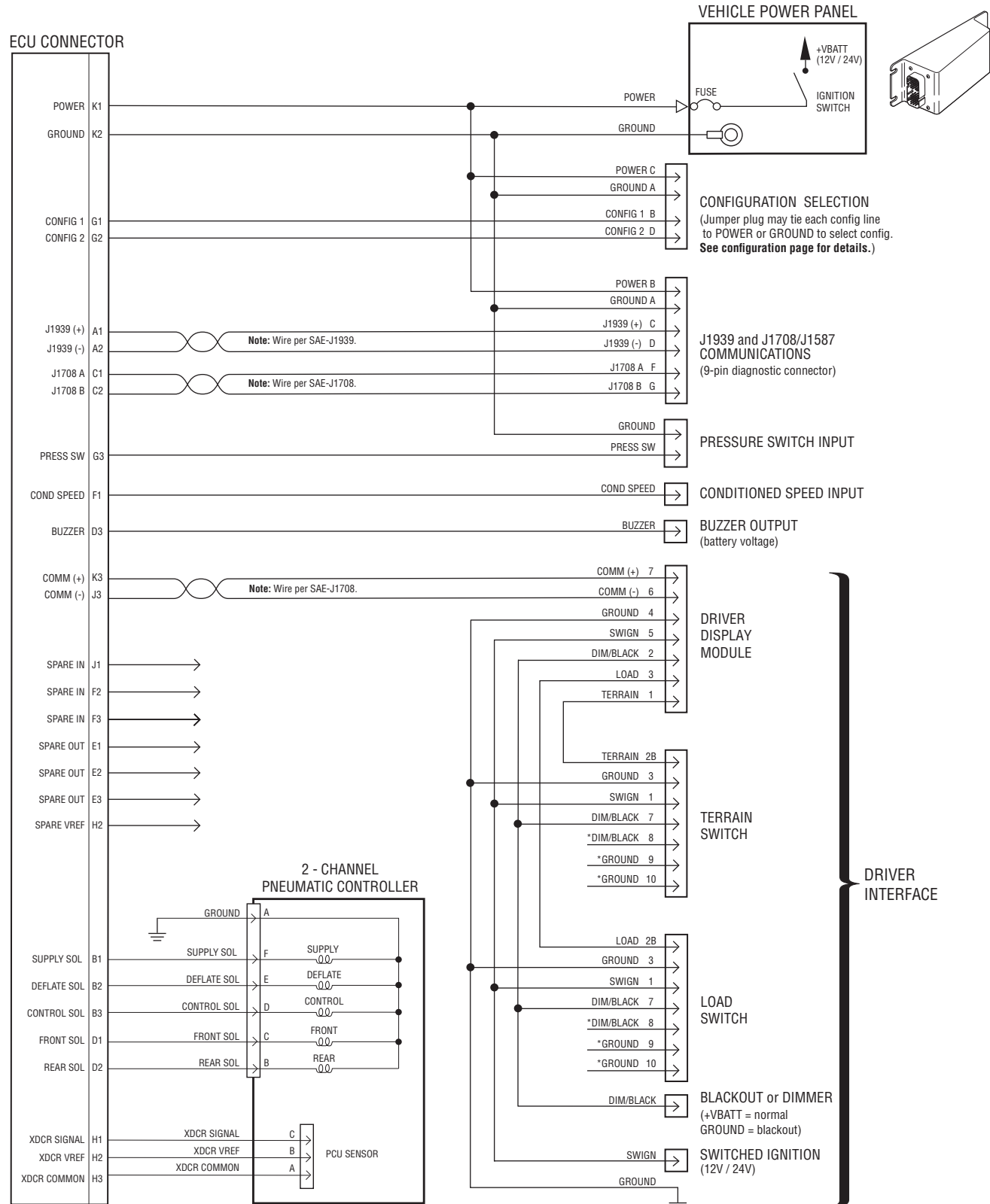

\*Connections to pins 8, 9, and 10 are made internally. Earlier versions of the switches required these connections to be made in the harness.

Configuration Options

Harness Connector

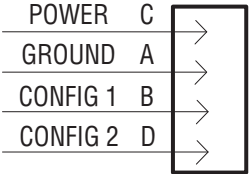

Configurations Options

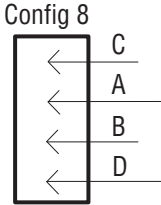
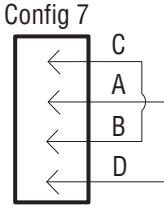
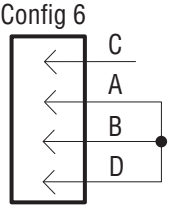
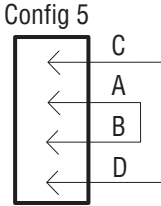
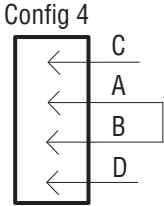
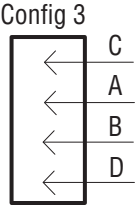
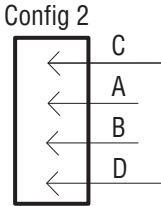
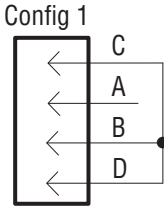
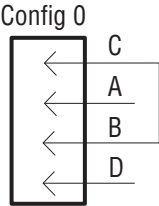

This page intentionally left blank.

For specifying or service assistance, call 1-877-777-5360 or visit our website at [www.dana.com](http://www.dana.com)

**Dana Commercial Vehicle Products Group**

3939 Technology Drive  
Maumee, Ohio, USA 43537

[www.dana.com](http://www.dana.com)



**SPICER<sup>®</sup>**

*Drivetrain Products*