



MERITOR™
A Heritage of Rockwell Technology

Revised 02-95
\$2.50

Wedge Brakes

Maintenance Manual No. 4R

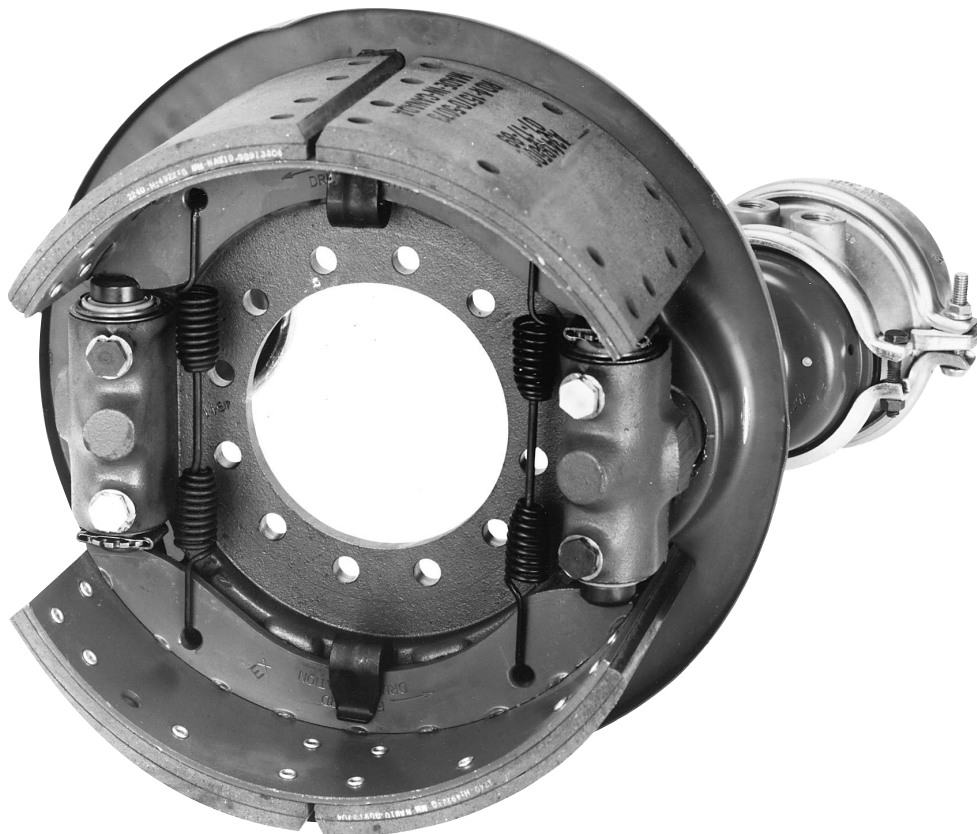

RDA Brake

This publication provides maintenance and service procedures for Meritor's Meritor wedge brakes. The information contained in this publication was current at the time of printing and is subject to revision without notice or liability.

1. You must understand all procedures and instructions before you begin maintenance and service procedures.
2. You must follow your company's maintenance and service guidelines.
3. You must use special tools, when required, to avoid serious personal injury and damage to components.

Meritor uses the following notations to alert the user of possible safety issues and to provide information that will help to prevent damage to equipment and components.



WARNING

A WARNING indicates a procedure that you must follow exactly to avoid serious personal injury.



CAUTION

A CAUTION indicates a procedure that you must follow exactly to avoid damaging equipment or components. Serious personal injury can also occur.

NOTE: A **NOTE** indicates an operation, procedure or instruction that is important for proper service. A **NOTE** can also supply information that will help to make service quicker and easier.



This symbol indicates that fasteners must be tightened to a specific torque.

Visit Our Web Site

Visit the Technical Library section of www.meritorauto.com for additional product and service information on Meritor's heavy vehicle systems component lineup.

Technical Electronic Library on CD

The CD includes product and service information on Meritor's heavy vehicle systems component lineup. \$20. Order TP-9853.

Additional Publications

Lubrication

(Maintenance Manual No. 1)

How to Order

Call Meritor's Customer Service Center at 800-535-5560.



Asbestos and Non-Asbestos Fibers Warnings1

Section 1: Introduction

- Exploded Views2
- Single Actuated Brakes4
- Dual Actuated Brakes
- Identification Tags5
- Brake Application
- Brake Release
- Automatic Adjustment (RSA, RDA)6

Section 2: Disassemble Brakes

- Remove the Brake Shoes8
- Remove the Air Chamber and the Wedge Assembly9
- Disassemble the Wedge Assembly
- Disassemble the Air Chamber
- Remove the Plungers and Bolt-On Plunger Housings10

Section 3: Clean, Inspect and Reline

- Clean11
- Corrosion Protection
- Inspect and Reline
- Air System
- Air Chamber
- Wedge Assembly12
- Brake Drums
- Brake Spider or Backing Plate
- Dust Shields
- Actuator Components
- Brake Shoes and Linings

Section 4: Assemble Brakes

- Install the Plungers and Bolt-On Plunger Housings14
- Assemble the Air Chamber16
- Wedge Brakes With Air Chamber Tube Support Brackets
- Assemble the Wedge Assembly17
- Install the Air Chamber and the Wedge Assembly
- Install the Brake Shoes18

Section 5: Lubrication, Maintenance and Adjustment

- Lubrication20
- Preventive Maintenance21
- Every Two Months or 25-30,000 Miles (40-48,000 km)
- Once a Year or Every 100,000 Miles (160,000 km)22
- Adjust the Brake

Section 6: Diagnostics23

Section 7: Visual Inspection of the Brake System26

Section 8: Fastener Torque Specifications27



ASBESTOS FIBERS WARNING

The following procedures for servicing brakes are recommended to reduce exposure to asbestos fiber dust, a cancer and lung disease hazard. Material Safety Data Sheets are available from Meritor.

Hazard Summary

Because some brake linings contain asbestos, workers who service brakes must understand the potential hazards of asbestos and precautions for reducing risks. Exposure to airborne asbestos dust can cause serious and possibly fatal diseases, including asbestosis (a chronic lung disease) and cancer, principally lung cancer and mesothelioma (a cancer of the lining of the chest or abdominal cavities). Some studies show that the risk of lung cancer among persons who smoke and who are exposed to asbestos is much greater than the risk for non-smokers. Symptoms of these diseases may not become apparent for 15, 20 or more years after the first exposure to asbestos.

Accordingly, workers must use caution to avoid creating and breathing dust when servicing brakes. Specific recommended work practices for reducing exposure to asbestos dust follow. Consult your employer for more details.

Recommended Work Practices

1. **Separate Work Areas.** Whenever feasible, service brakes in a separate area away from other operations to reduce risks to unprotected persons. OSHA has set a maximum allowable level of exposure for asbestos of 0.1 f/cc as an 8-hour time-weighted average and 1.0 f/cc averaged over a 30-minute period. Scientists disagree, however, to what extent adherence to the maximum allowable exposure levels will eliminate the risk of disease that can result from inhaling asbestos dust. OSHA requires that the following sign be posted at the entrance to areas where exposures exceed either of the maximum allowable levels:

**DANGER: ASBESTOS
CANCER AND LUNG DISEASE HAZARD
AUTHORIZED PERSONNEL ONLY
RESPIRATORS AND PROTECTIVE CLOTHING
ARE REQUIRED IN THIS AREA.**

2. **Respiratory Protection.** Wear a respirator equipped with a high-efficiency (HEPA) filter approved by NIOSH or MSHA for use with asbestos at all times when servicing brakes, beginning with the removal of the wheels.

3. **Procedures for Servicing Brakes.**

- a. Enclose the brake assembly within a negative pressure enclosure. The enclosure should be equipped with a HEPA vacuum and worker arm sleeves. With the enclosure in place, use the HEPA vacuum to loosen and vacuum residue from the brake parts.
- b. As an alternative procedure, use a catch basin with water and a biodegradable, non-phosphate, water-based detergent to wash the brake drum or rotor and other brake parts. The solution should be applied with low pressure to prevent dust from becoming airborne. Allow the solution to flow between the brake drum and the brake support or the brake rotor and caliper. The wheel hub and brake assembly components should be thoroughly wetted to suppress dust before the brake shoes or brake pads are removed. Wipe the brake parts clean with a cloth.
- c. If an enclosed vacuum system or brake washing equipment is not available, employers may adopt their own written procedures for servicing brakes, provided that the exposure levels associated with the employer's procedures do not exceed the levels associated with the enclosed vacuum system or brake washing equipment. Consult OSHA regulations for more details.
- d. Wear a respirator equipped with a HEPA filter approved by NIOSH or MSHA for use with asbestos when grinding or machining brake linings. In addition, do such work in an area with a local exhaust ventilation system equipped with a HEPA filter.
- e. **NEVER** use compressed air by itself, dry brushing, or a vacuum not equipped with a HEPA filter when cleaning brake parts or assemblies. **NEVER** use carcinogenic solvents, flammable solvents, or solvents that can damage brake components as wetting agents.

4. **Cleaning Work Areas.** Clean work areas with a vacuum equipped with a HEPA filter or by wet wiping. **NEVER** use compressed air or dry sweeping to clean work areas. When you empty vacuum cleaners and handle used rags, wear a respirator equipped with a HEPA filter approved by NIOSH or MSHA for use with asbestos. When you replace a HEPA filter, wet the filter with a fine mist of water and dispose of the used filter with care.

5. **Worker Clean-Up.** After servicing brakes, wash your hands before you eat, drink or smoke. Shower after work. Do not wear work clothes home. Use a vacuum equipped with a HEPA filter to vacuum work clothes after they are worn. Launder them separately. Do not shake or use compressed air to remove dust from work clothes.

6. **Waste Disposal.** Dispose of discarded linings, used rags, cloths and HEPA filters with care, such as in sealed plastic bags. Consult applicable EPA, state and local regulations on waste disposal.

Regulatory Guidance

References to OSHA, NIOSH, MSHA, and EPA, which are regulatory agencies in the United States, are made to provide further guidance to employers and workers employed within the United States. Employers and workers employed outside of the United States should consult the regulations that apply to them for further guidance.



NON-ASBESTOS FIBERS WARNING

The following procedures for servicing brakes are recommended to reduce exposure to non-asbestos fiber dust, a cancer and lung disease hazard. Material Safety Data Sheets are available from Meritor.

Hazard Summary

Most recently manufactured brake linings do not contain asbestos fibers. These brake linings may contain one or more of a variety of ingredients, including glass fibers, mineral wool, aramid fibers, ceramic fibers and silica that can present health risks if inhaled. Scientists disagree on the extent of the risks from exposure to these substances. Nonetheless, exposure to silica dust can cause silicosis, a non-cancerous lung disease. Silicosis gradually reduces lung capacity and efficiency and can result in serious breathing difficulty. Some scientists believe other types of non-asbestos fibers, when inhaled, can cause similar diseases of the lung. In addition, silica dust and ceramic fiber dust are known to the State of California to cause lung cancer. U.S. and international agencies have also determined that dust from mineral wool, ceramic fibers and silica are potential causes of cancer.

Accordingly, workers must use caution to avoid creating and breathing dust when servicing brakes. Specific recommended work practices for reducing exposure to non-asbestos dust follow. Consult your employer for more details.

Recommended Work Practices

1. **Separate Work Areas.** Whenever feasible, service brakes in a separate area away from other operations to reduce risks to unprotected persons.

2. **Respiratory Protection.** OSHA has set a maximum allowable level of exposure for silica of 0.1 mg/m³ as an 8-hour time-weighted average. Some manufacturers of non-asbestos brake linings recommend that exposures to other ingredients found in non-asbestos brake linings be kept below 1.0 f/cc as an 8-hour time-weighted average. Scientists disagree, however, to what extent adherence to these maximum allowable exposure levels will eliminate the risk of disease that can result from inhaling non-asbestos dust.

Therefore, wear respiratory protection at all times during brake servicing, beginning with the removal of the wheels. Wear a respirator equipped with a high-efficiency (HEPA) filter approved by NIOSH or MSHA, if the exposure levels may exceed OSHA or manufacturers' recommended maximum levels. Even when exposures are expected to be within the maximum allowable levels, wearing such a respirator at all times during brake servicing will help minimize exposure.

3. **Procedures for Servicing Brakes.**

- a. Enclose the brake assembly within a negative pressure enclosure. The enclosure should be equipped with a HEPA vacuum and worker arm sleeves. With the enclosure in place, use the HEPA vacuum to loosen and vacuum residue from the brake parts.
- b. As an alternative procedure, use a catch basin with water and a biodegradable, non-phosphate, water-based detergent to wash the brake drum or rotor and other brake parts. The solution should be applied with low pressure to prevent dust from becoming airborne. Allow the solution to flow between the brake drum and the brake support or the brake rotor and caliper. The wheel hub and brake assembly components should be thoroughly wetted to suppress dust before the brake shoes or brake pads are removed. Wipe the brake parts clean with a cloth.
- c. If an enclosed vacuum system or brake washing equipment is not available, carefully clean the brake parts in the open air. Wet the parts with a solution applied with a pump-spray bottle that creates a fine mist. Use a solution containing water, and, if available, a biodegradable, non-phosphate, water-based detergent. The wheel hub and brake assembly components should be thoroughly wetted to suppress dust before the brake shoes or brake pads are removed. Wipe the brake parts clean with a cloth.
- d. Wear a respirator equipped with a HEPA filter approved by NIOSH or MSHA when grinding or machining brake linings. In addition, do such work in an area with a local exhaust ventilation system equipped with a HEPA filter.
- e. **NEVER** use compressed air by itself, dry brushing, or a vacuum not equipped with a HEPA filter when cleaning brake parts or assemblies. **NEVER** use carcinogenic solvents, flammable solvents, or solvents that can damage brake components as wetting agents.

4. **Cleaning Work Areas.** Clean work areas with a vacuum equipped with a HEPA filter or by wet wiping. **NEVER** use compressed air or dry sweeping to clean work areas. When you empty vacuum cleaners and handle used rags, wear a respirator equipped with a HEPA filter approved by NIOSH or MSHA, to minimize exposure. When you replace a HEPA filter, wet the filter with a fine mist of water and dispose of the used filter with care.

5. **Worker Clean-Up.** After servicing brakes, wash your hands before you eat, drink or smoke. Shower after work. Do not wear work clothes home. Use a vacuum equipped with a HEPA filter to vacuum work clothes after they are worn. Launder them separately. Do not shake or use compressed air to remove dust from work clothes.

6. **Waste Disposal.** Dispose of discarded linings, used rags, cloths and HEPA filters with care, such as in sealed plastic bags. Consult applicable EPA, state and local regulations on waste disposal.

Regulatory Guidance

References to OSHA, NIOSH, MSHA, and EPA, which are regulatory agencies in the United States, are made to provide further guidance to employers and workers employed within the United States. Employers and workers employed outside of the United States should consult the regulations that apply to them for further guidance.

Exploded Views

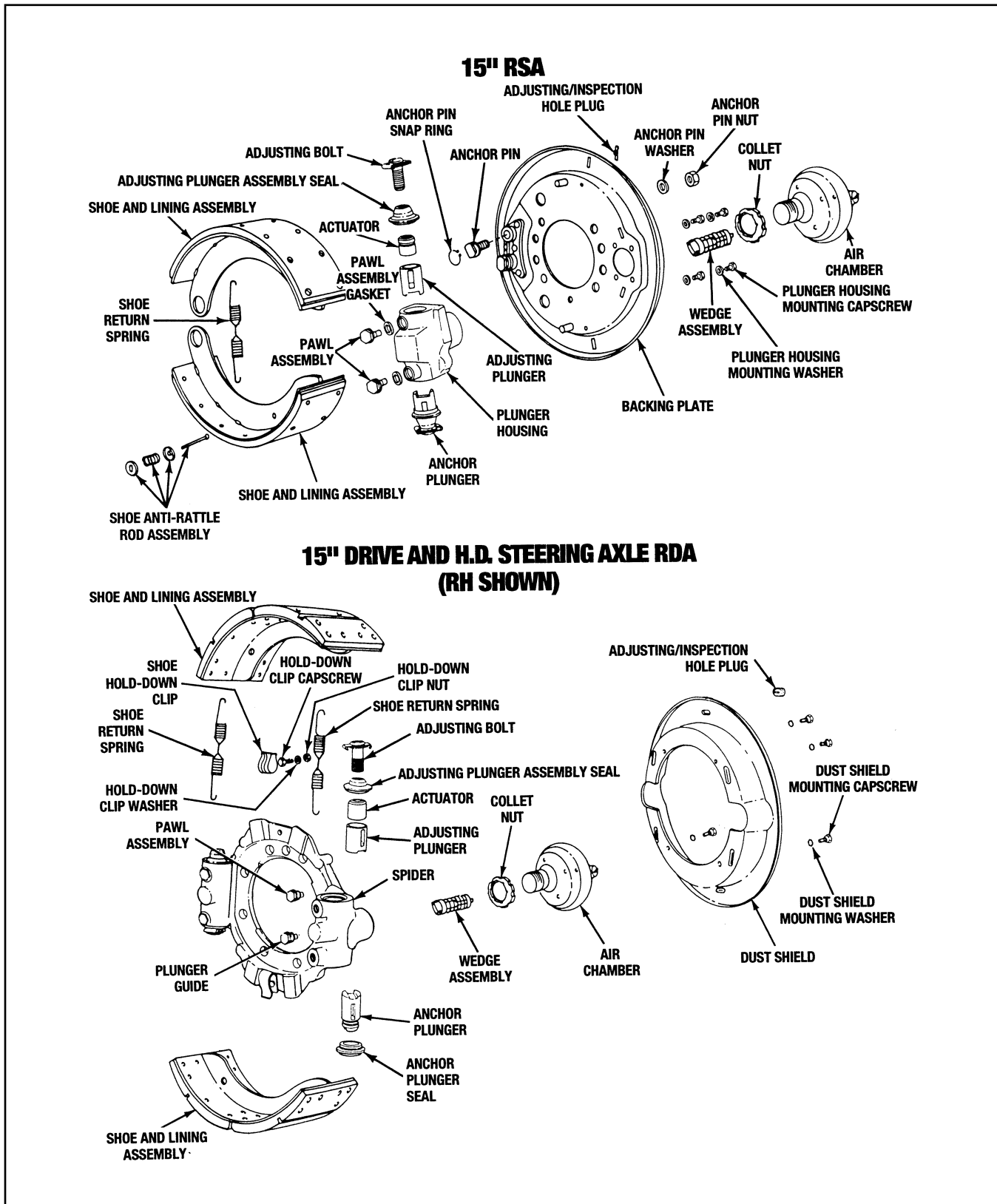

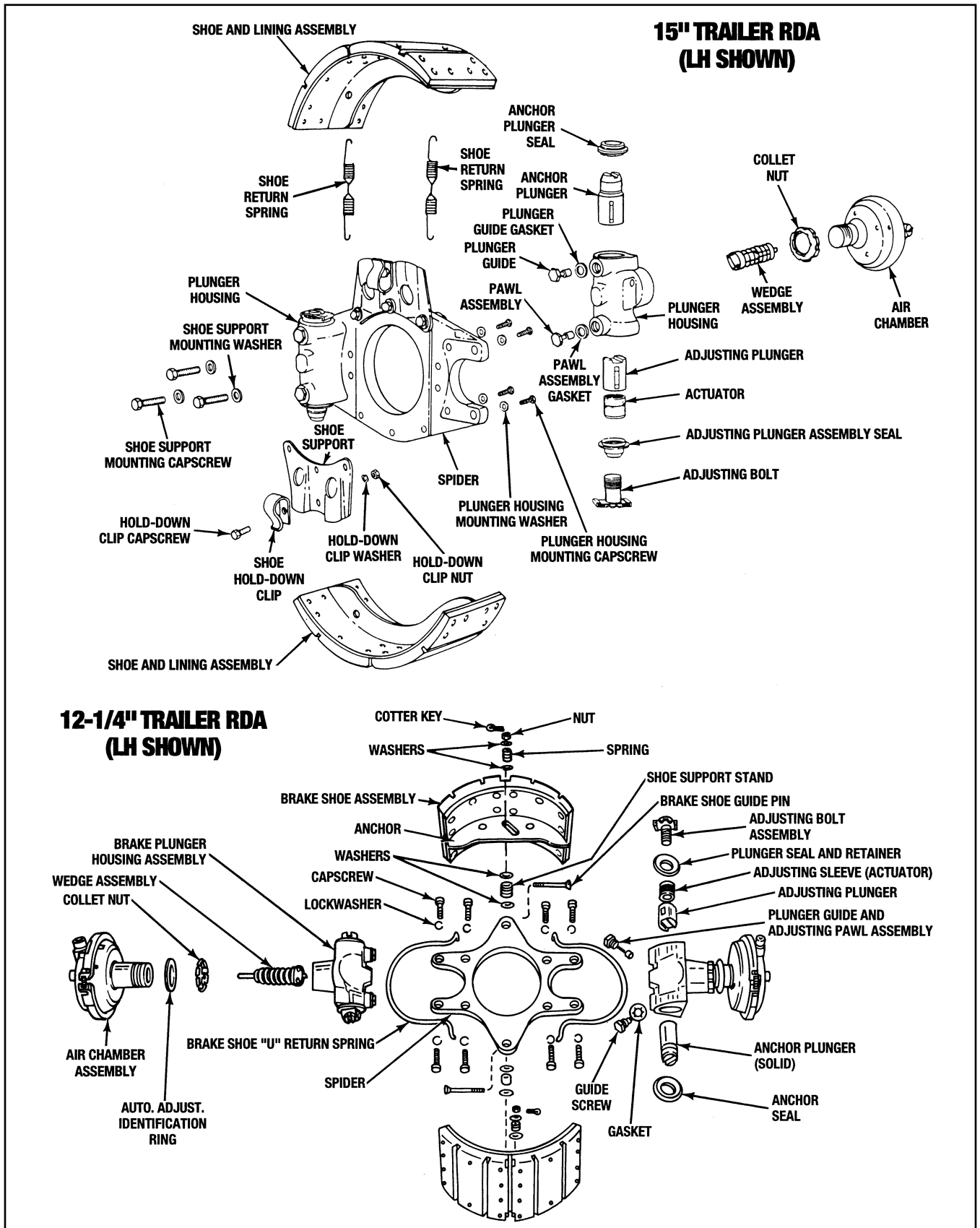

Section 1 Introduction



WARNING

To prevent serious eye injury, always wear safe eye protection when you perform vehicle maintenance or service.

NOTE: This manual only covers air actuated wedge brakes. For information on hydraulic actuated wedge brakes, refer to Maintenance Manual No. 4P, *Stopmaster® Off-Highway Heavy Duty Brakes*.

Meritor Stopmaster® brakes for on-highway vehicles are air actuated wedge brakes. The brakes come in two basic models: single actuated (RSA) and dual actuated (RDA). Both types of brakes are available with 12-, 14- or 16-degree wedge angles.

Single Actuated Brakes

RSA brakes are typically used on steering axles with a capacity of 12,000 pounds or less. RSA brakes are mounted on a stamped backing plate that is bolted to the axle. The single plunger housing has two adjusting plungers and is bolted to the backing plate. RSA brakes are 15-inches in diameter and 4-inches wide. RSA brake shoes have coiled return springs and are held in place by anti-rattle rods. **Figure 1.1.**

Figure 1.1



RSA BRAKE

Dual Actuated Brakes

RDA brakes are typically used on drive axles, trailer axles and steering axles with a capacity greater than 12,000 pounds. Each of the two plunger housings on an RDA brake has one anchor plunger and one adjusting plunger.

RDA brakes for trailers have forged spiders that are welded to the axle and plunger housings that are bolted to the spider. Trailer axle brakes are 12-1/4-inches or 15-inches in diameter and 7-inches wide. **Figure 1.2** and **Figure 1.3.** The brake shoes have coiled return springs and are held in place by clips.

Figure 1.2

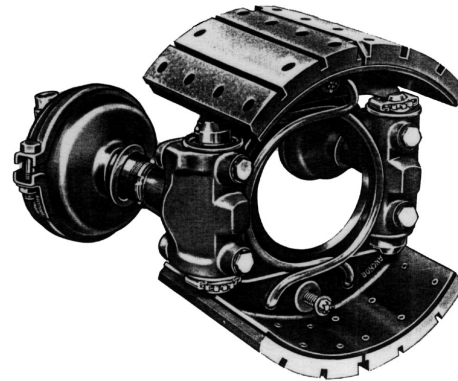

RDA BRAKE

Figure 1.3

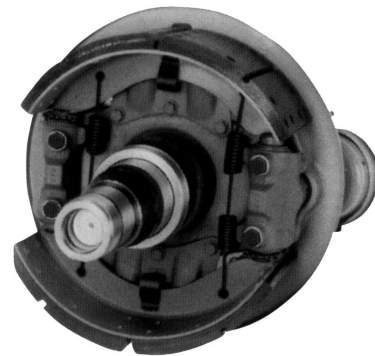

RDA BRAKE

RDA brakes for drive axles and steering axles have cast spiders that are bolted to the axle. The plunger housings are cast integrally with the spider. These brakes are 15-inches in diameter and are available in widths of 5-, 6- or 7-inches. The brake shoes have coiled return springs and are held in place by clips. **Figure 1.4.**

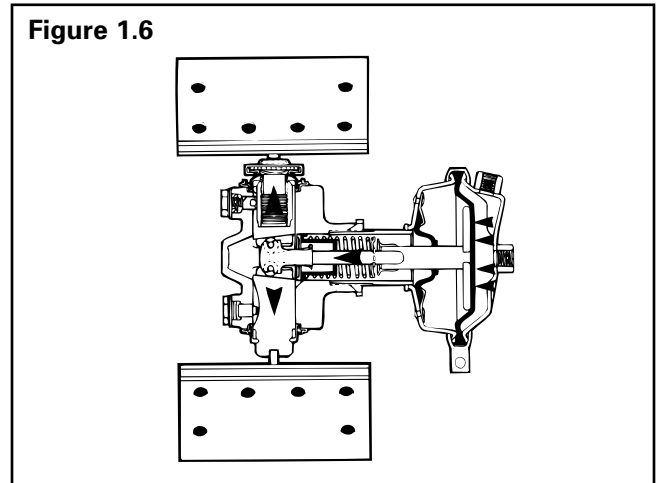
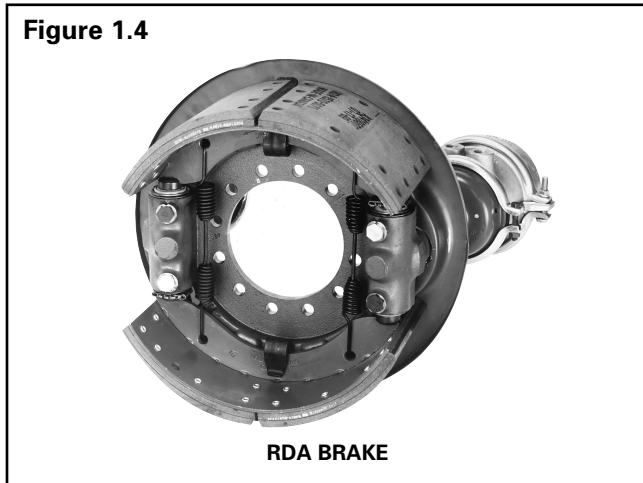

Identification Tags

An identification tag is typically located on the dust shield. **Figure 1.5** explains the meaning of the information on the tag.

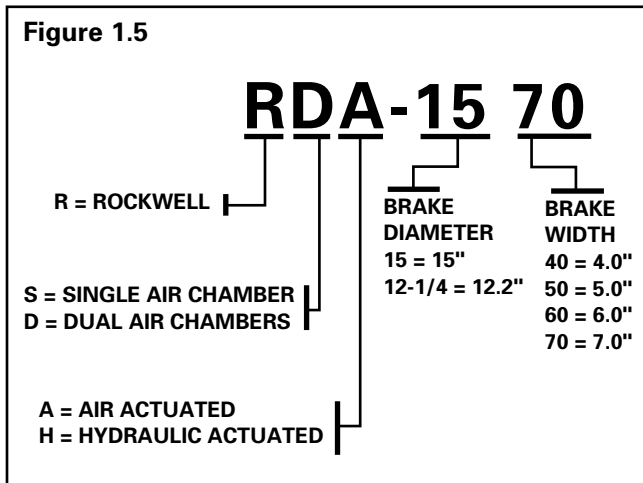

Brake Application

Air pressure moves the air chamber diaphragm and push rod. The push rod moves the wedge assembly forward, and the wedge head forces apart the two rollers and plungers. The outward movement of the plungers forces the shoes and linings against the drum, which stops the vehicle. **Figure 1.6.**

Brake Release

When air pressure is released, the wedge return spring retracts the wedge from between the rollers. The movement of the wedge forces the push rod and air chamber diaphragm back to their original positions. At the same time, the shoe return springs retract the shoes, and the shoes push the plungers back into the housings. **Figure 1.7.**

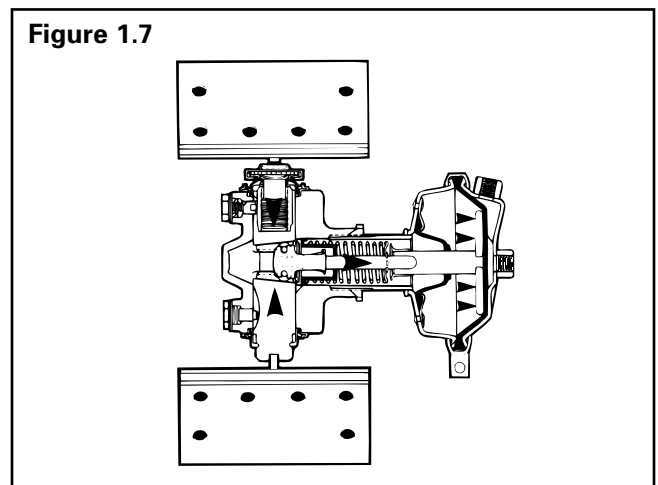

Automatic Adjustment (RSA, RDA)

Correct lining to drum clearance is maintained by the built-in automatic adjustment mechanism. The mechanism includes the adjusting bolt, actuator, adjusting plunger and the pawl assembly.

The mechanism is assembled as follows: The adjusting bolt is threaded into the actuator. The actuator slides freely inside the plunger. The plunger slides freely inside the housing. The pawl assembly is threaded into the side of the housing, and the pawl fits through a slot in the plunger. The pawl teeth engage the actuator teeth. **Figure 1.8.** Note that the teeth are shaped to slide past each other only when the actuator is moving outward. **Figure 1.9.**

Each time the brake is applied, the adjusting plunger, actuator and adjusting bolt move outward. This movement of the actuator forces the pawl against its spring, and the teeth begin to disengage. **Figure 1.10.** As long as the lining to drum clearance is within specification, the actuator will not move far enough to completely disengage the teeth. When the brake is released, the teeth re-engage again.

Eventually, the lining wears enough that applying the brake moves the actuator so far that the teeth disengage and move past each other. After they pass, the pawl spring forces the teeth to re-engage. **Figure 1.11.**

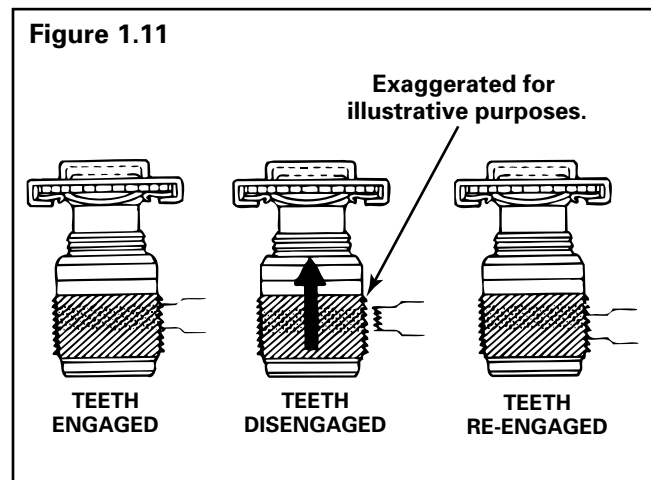
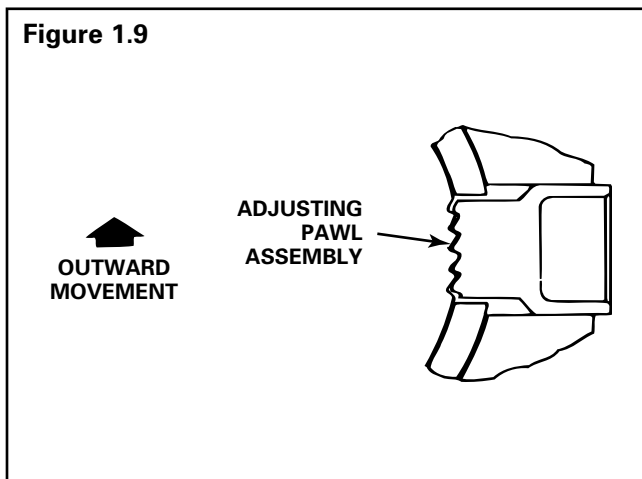
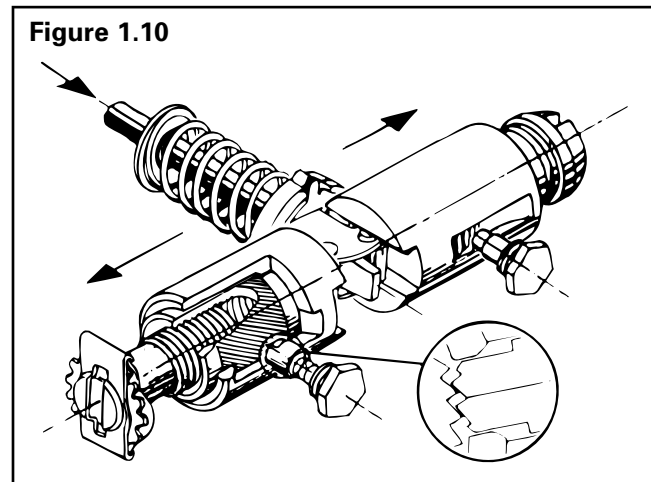
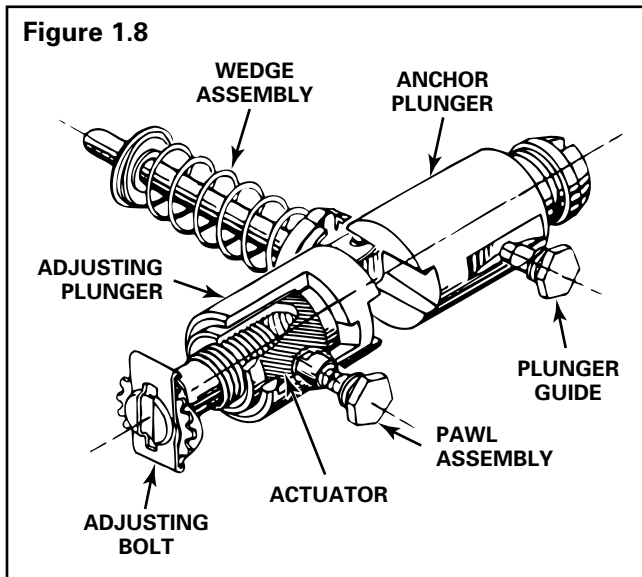

During brake release, the shoe return springs retract the shoes, which force the adjusting bolt and actuator back into the housing. Because the actuator teeth are spiral, engagement with the pawl teeth causes the actuator to rotate as it retracts. Rotating the actuator causes the adjusting bolt to unthread outward from the actuator. The outward movement of the adjusting bolt moves the shoe out and reduces the clearance caused by lining wear. **Figure 1.12.**

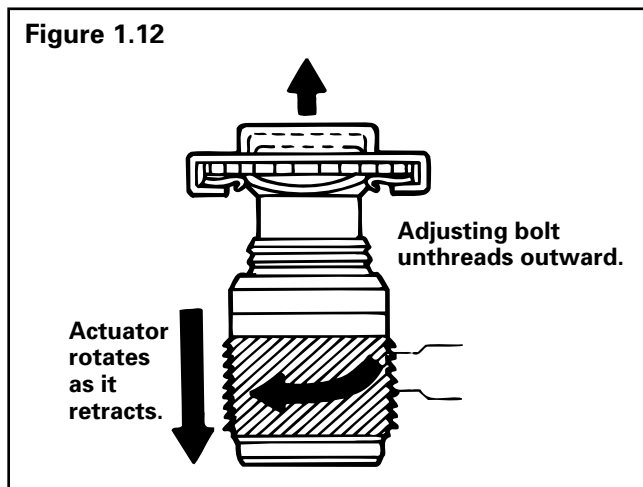

Section 2 Disassemble Brakes



WARNING

To prevent serious eye injury, always wear safe eye protection when you perform vehicle maintenance or service.

Park the vehicle on a level surface. Block the wheels to prevent the vehicle from moving. Support the vehicle with safety stands. Do not work under a vehicle supported only by jacks. Jacks can slip and fall over. Serious personal injury can result.

Remove all pressure from the air system before you disconnect any components. Pressurized air can cause serious personal injury.

When you work on a spring chamber, carefully follow the service instructions of the chamber manufacturer. Sudden release of a compressed spring can cause serious personal injury.

ASBESTOS AND NON-ASBESTOS FIBERS WARNING

Some brake linings contain asbestos fibers, a cancer and lung disease hazard. Some brake linings contain non-asbestos fibers, whose long-term effects to health are unknown. You must use caution when you handle both asbestos and non-asbestos materials.

Remove the Brake Shoes

WARNING

When you work on a spring chamber, carefully follow the service instructions of the chamber manufacturer. Sudden release of a compressed spring can cause serious personal injury.

Remove the wheel, hub and drum according to the vehicle manufacturer's instructions.

NOTE: When necessary, use an adjusting spoon to turn the adjusters and retract the shoes from the drum. Meritor KIT 1184 includes an adjusting spoon plus a brake spring tool and a seal driver. The kit or the individual tools are available from Meritor Aftermarket Parts and Services, 7975 Dixie Highway, Florence, KY 41042.

Remove the shoes as follows:

RSA Brakes (Figure 2.1)

- Use a brake spring tool to remove the return spring.
- Remove the anti-rattle rods: Compress the spring and twist the rod, so that its tabs fit through the retainer slots.
- Remove the snap rings from the anchor pins.
- Remove the shoes.

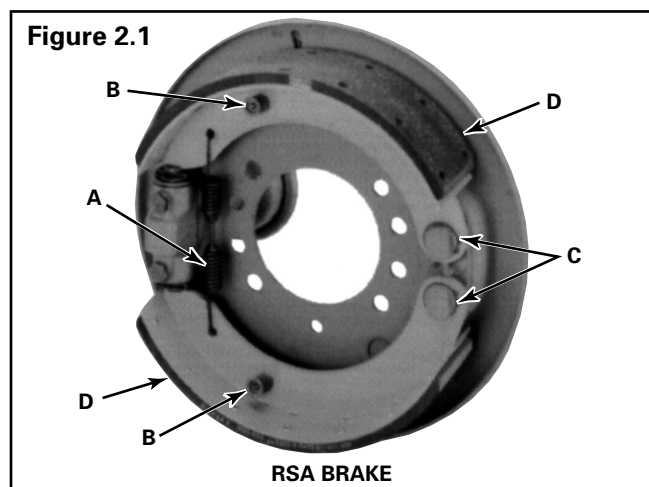

RDA Brakes (Figure 2.2)

- Use a brake spring tool to remove the return springs.
- Remove the shoes.

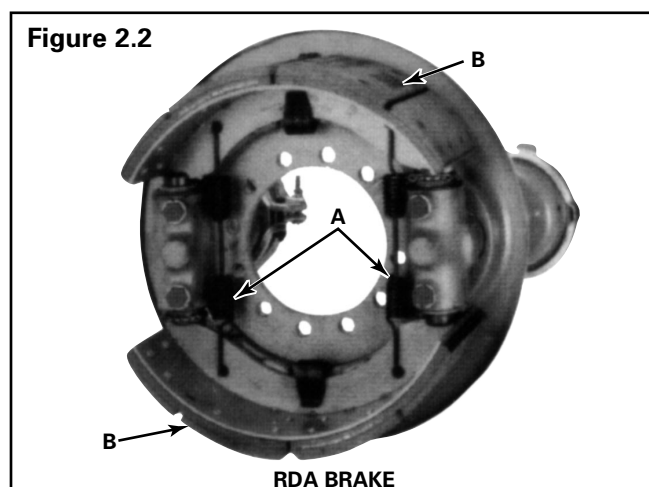

Remove the Air Chamber and the Wedge Assembly

1. Remove all air from the air brake system. When the brake has a spring chamber, cage the spring.
2. Label the air lines. Disconnect them from the air chamber. Plug the lines and ports to keep contamination out of the system.
3. Remove any support brackets from the air chamber.
4. Use a brass drift and a hammer to loosen the collet nut on the air chamber.
5. Remove the air chamber.
6. Remove the wedge assembly.

Disassemble the Wedge Assembly

Figure 2.3

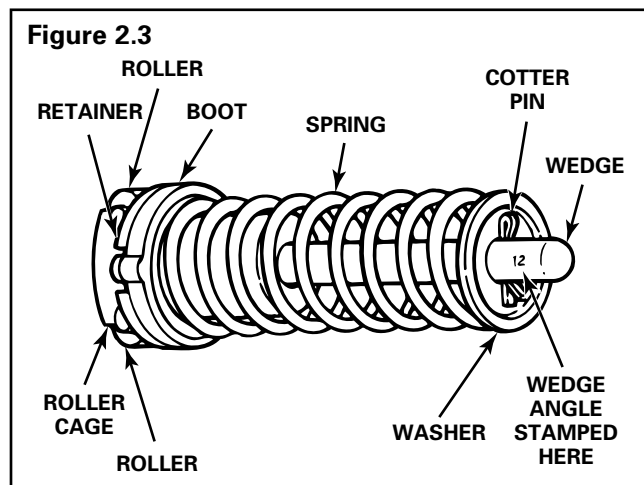

WARNING

Hold the spring when you remove the cotter pin. Sudden release of a compressed spring can cause serious personal injury.

1. Compress the spring. Remove the cotter pin. Slowly release the spring.
2. Remove the washer, spring, boot and retainer.

CAUTION

Do not force open the roller cage more than necessary to remove the rollers. Do not force the rollers through the slots in the cage. Do not force the wedge through the rollers. Damage to the roller cage will result.

3. Use a screwdriver between the wedge and the roller cage to carefully force open the cage just enough to remove the rollers. **Figure 2.4.**
4. Remove the roller cage from the wedge.

Figure 2.4

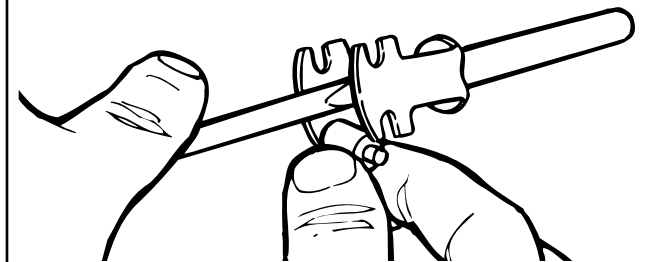

Disassemble the Air Chamber

Figure 2.5

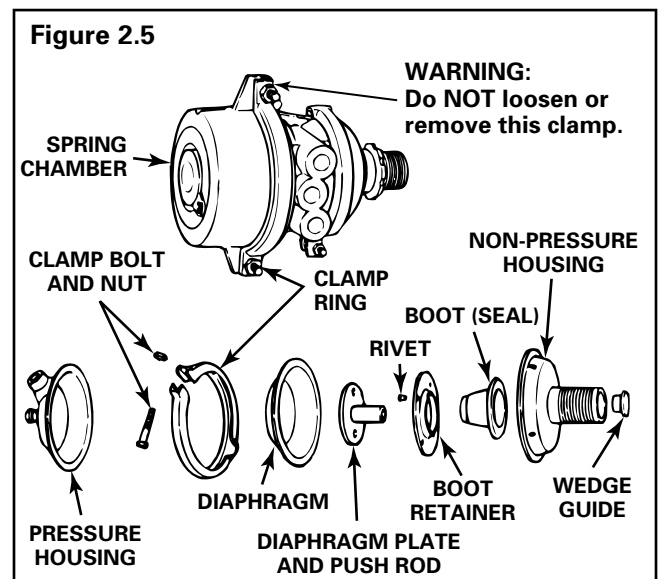

Section 2 Disassemble Brakes



WARNING

When you work on a spring chamber, carefully follow the service instructions of the chamber manufacturer. Sudden release of a compressed spring can cause serious personal injury.

1. Remove the clamp nut and bolt. Spread the clamp. Remove the non-pressure housing from the rest of the assembly.
2. Remove the diaphragm.
3. Remove the wedge guide from the push rod.
4. Remove the plate and push rod assembly.
5. Remove the rivets that hold the boot retainer to the non-pressure housing. Remove the old boot.

Remove the Plungers and Bolt-On Plunger Housings

NOTE: To remove the plunger housing, plungers and air chamber from the trailer as a unit, complete Step 1, then skip to Step 6.

NOTE: An RSA housing has two adjusting plungers.

NOTE: Each RDA housing has an adjusting plunger and an anchor plunger.

1. Remove the wheel, hub and drum according to the vehicle manufacturer's instructions. Remove the brake shoes. When necessary, remove the dust shield and the air chamber.
2. Remove the anchor plunger guides and the pawl assemblies.
3. Use a pry bar or a drift to loosen the seals from the plunger housings. **Figure 2.6.**

Figure 2.6

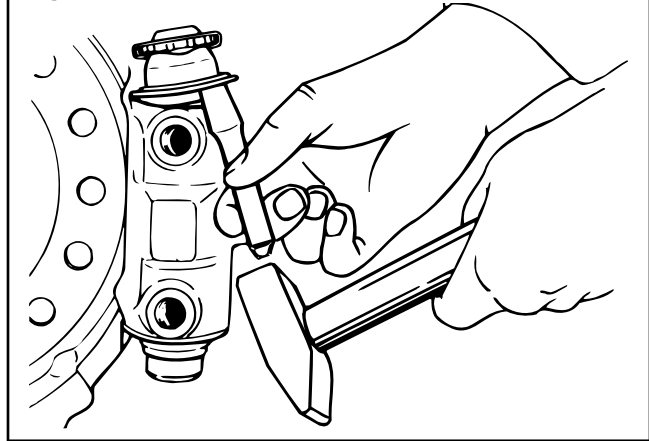

4. Remove the seals and the actuating components from the housing.
5. Remove the actuators and seals from the adjusting bolts. Remove the seals from the anchor plungers.
6. Remove the mounting capscrews and remove the plunger housing.

Clean

 **WARNING**

To prevent serious eye injury, always wear safe eye protection when you perform vehicle maintenance or service.

Solvent cleaners can be flammable, poisonous and cause burns. Examples of solvent cleaners are carbon tetrachloride, emulsion-type cleaners and petroleum-based cleaners. To avoid serious personal injury when you use solvent cleaners, you must carefully follow the manufacturer's product instructions and these procedures:

- *Wear safe eye protection.*
 - *Wear clothing that protects your skin.*
 - *Work in a well-ventilated area.*
 - *Do not use gasoline, or solvents that contain gasoline. Gasoline can explode.*
 - *You must use hot solution tanks or alkaline solutions correctly. Follow the manufacturer's instructions carefully.*
1. Use solvent cleaners to clean all metal parts that have ground or polished surfaces. Examples of ground or polished parts are the rollers, wedge and the inner bores of the plunger housing.
 2. Use a wire brush to clean the teeth and threads of the actuator components.
 3. Metal parts with rough surfaces can be cleaned with solvent cleaners or with alkaline solutions.
 4. When necessary, clean non-metal parts that are not replaced at overhaul with soap and water.
 5. Use isopropyl alcohol to clean the brake linings when necessary.
 6. Immediately after cleaning, dry all parts with clean paper, rags or compressed air.

Corrosion Protection

 **CAUTION**

Do not apply grease to the brake linings or the brake drum.

Clean and dry parts. Apply a thin layer of brake grease to undamaged parts that are to be immediately assembled.

 **CAUTION**

Do not apply anti-corrosive material to the brake linings or the brake drum.

To store parts, apply an anti-corrosive compound or place parts inside anti-corrosive paper or other material that prevents corrosion.

Inspect and Reline

During a reline, major inspection or overhaul, always inspect components for wear or damage. Replace parts as necessary. Use the following guidelines to inspect components.

Air System

1. Check for worn hoses and connectors. With air pressure at 100 psi, brakes released and engine off, loss of tractor air pressure must not exceed two psi a minute. Total tractor and trailer loss must not exceed three psi per minute.
2. The air compressor drive belt must be tight. Air system pressure must rise to approximately 100 psi in two minutes.
3. The governor must be set to the vehicle manufacturer's specifications.
4. The tractor and trailer air systems must match the vehicle manufacturer's specifications.
5. If equipped, the spring brakes must retract completely when air is applied to release them.

Air Chamber

Replace a cut or damaged boot or diaphragm.
Replace a worn wedge guide.

Section 3

Clean, Inspect and Reline



Wedge Assembly

Replace a worn or pitted wedge head or rollers. Replace a bent cage that does not allow roller journals to fit properly into the slots. Replace a weak or damaged spring or cotter pin.

Brake Drums



CAUTION

Do not operate the vehicle with the brake drum worn or machined beyond the discard dimension indicated on the drum. The brake system may not operate correctly. Damage to components and serious personal injury can result.

1. Replace a drum that has cracks, severe heat checking, heat spotting, scoring, pitting or distortion. Meritor recommends that you do **NOT** turn or rebore brake drums. Strength and heat capacity of the drum will be decreased.
2. Measure the inner diameter of the drum at several locations. Replace the drum when the diameter exceeds the drum manufacturer's specifications.

Brake Spider or Backing Plate

All mounting bolts must be tightened to the vehicle manufacturer's specifications. Replace distorted spiders or backing plates. On RSA brakes, replace worn anchor pins.

Dust Shields

Repair or replace damaged or distorted dust shields.

Actuator Components

NOTE: Actuator parts and seals are critical brake parts. Replace scored, damaged or excessively worn parts and seals.

1. Plunger housing mounting bolts must be tightened to 30-40 lb-ft (41-54 N•m). 
2. Carefully inspect seals. Replace a seal that is cut, torn or damaged in any way.
3. Check the housing bores and the inner and outer diameters of the plungers for nicks, scratches or corrosion. Repair minor damage with crocus cloth. Replace the plunger housing or the plunger when major damage is evident.

4. Check the wedge ramps and all slots in the plungers for wear or damage. Replace as needed.
5. Check the threads of the adjusting bolt and the actuator. Replace the parts when thread damage is evident.
6. Replace the adjusting bolt when the detent spring is loose or damaged.
7. Check the pawl and actuator teeth for wear or damage. The pawl and actuator teeth must have sharp, undamaged edges with no displaced metal anywhere on the teeth. Replace damaged or excessively worn parts.
8. Replace the pawl assembly when the spring is weak or broken.

Brake Shoes and Linings

Check the shoe retaining hardware (guide pins, clips, springs, washers, etc.) for wear or damage. Replace as needed.

NOTE: Weak return springs can cause many brake problems. The springs must completely retract the shoes when the brakes are released. Meritor recommends that you install new return springs at each reline.

1. Check the shoes for damage or distortion. The web must be straight and not twisted off line. The ends of the web that engage the plungers must not be flat or "mushroomed." Check for cracked or broken welds between the web and table. Check for any cracks in the table or the web.
2. Always replace linings worn past the minimum thickness indicated by the groove or scallops in the lining.
3. Always replace linings that have grease or oil on them.
4. Always reline with the linings specified by the vehicle manufacturer. Vehicle brake systems must have the correct friction material. These requirements can change from vehicle to vehicle.
5. Meritor recommends that you reline both wheels of a single axle, and all four wheels of a tandem axle, at the same time. Always install the same linings and drums on both wheels of a single axle and on all four wheels of a tandem axle. The front and rear axles do not need the same linings and drums.

6. When you install linings, the rivets must be the correct body diameter, head size, shape, length and material or loose linings may result. Use of proper rivets can prevent loose linings.
7. A maximum gap of 0.010-inch (0.25 mm) between the shoe and lining is acceptable.

NOTE: For complete procedures and specifications on riveting brake linings, refer to Meritor publication TP-9239.

Section 4 Assemble Brakes



WARNING

To prevent serious eye injury, always wear safe eye protection when you perform vehicle maintenance or service.

Park the vehicle on a level surface. Block the wheels to prevent the vehicle from moving. Support the vehicle with safety stands. Do not work under a vehicle supported only by jacks. Jacks can slip and fall over. Serious personal injury can result.

Remove all pressure from the air system before you disconnect any components. Pressurized air can cause serious personal injury.

When you work on a spring chamber, carefully follow the service instructions of the chamber manufacturer. Sudden release of a compressed spring can cause serious personal injury.

ASBESTOS AND NON-ASBESTOS FIBERS WARNING

Some brake linings contain asbestos fibers, a cancer and lung disease hazard. Some brake linings contain non-asbestos fibers, whose long-term effects to health are unknown. You must use caution when you handle both asbestos and non-asbestos materials.

Install the Plungers and Bolt-On Plunger Housings

CAUTION

Anchor plungers are marked "L" or "R" to indicate the side of the vehicle they must be installed on. "L" = left (driver's) side. "R" = right (passenger's) side. Install the plungers as shown in Figure 4.1. Plungers installed in the wrong location will not allow the automatic adjusters to operate correctly. Stopping distances will increase as the linings wear and the brake fails to adjust. Damage to components can result.

Wedges and plungers are marked to indicate their angles (12, 14 or 16 degrees). To maintain brake performance as originally designed for the application, do not change angles and do not mix parts with different angles. Damage to components can result.

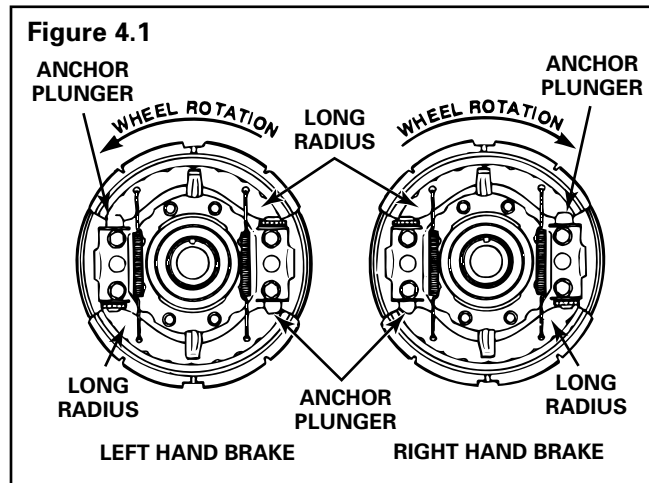

NOTE: An RSA housing has two adjusting plungers. Each RDA housing has an adjusting plunger and an anchor plunger.

1. To help prevent premature wear, generously grease the plunger housing and actuator components as shown in Section 5, **Figure 5.1**. Use O-616-A (NLGI Grade 1) or O-645 (NLGI Grade 2) Meritor-specified lubrication. However, do not pack the housing with too much grease, which can prevent components from moving freely.
2. Note the difference between the anchor plunger seal and the adjusting plunger seal. **Figure 4.2**. Lubricate the lips of the seals and install them, being careful not to damage the seal lips.
 - Fit the seal lip into the groove of the anchor plunger.
 - Fit the seal lip on the smooth part of the adjusting bolt, as near as possible to the adjusting teeth.
 - Fill the cavity between the seal and the plunger or bolt with grease.

Figure 4.2

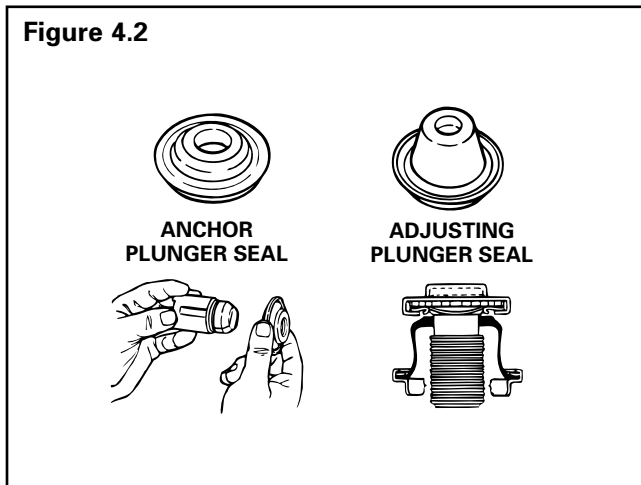

3. Install the anchor plunger in its bore so that the slot in its side aligns with the hole for the plunger guide. Install the plunger guide to hold the plunger in place. Tighten the plunger guide to 15-25 lb-ft (20-34 N•m). 

 **CAUTION**

When you service a pre-1982 unit, replace adjuster components (actuator, adjusting plunger and pawl assembly) on both sides of the axle at the same time. Do not mix pre-1982 components (old style) with components manufactured from 1982 (new style) on the same axle. Damage to components can result. Figure 4.3.

Figure 4.3

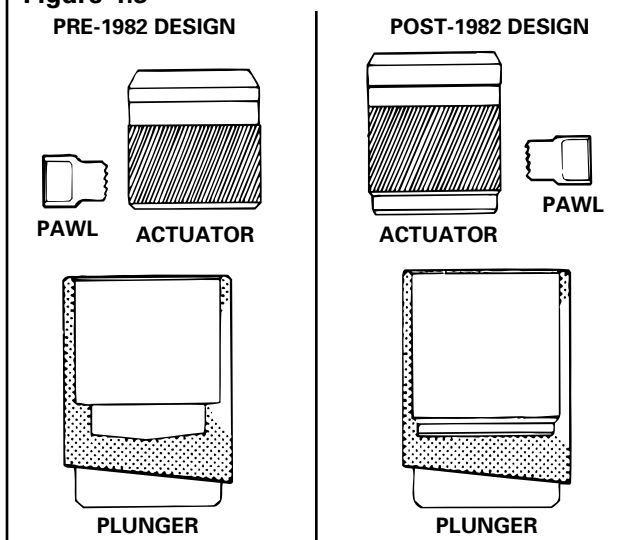

4. Install the adjusting plunger assembly as follows:
 - a. Thread the adjusting bolt into the actuator until the end of the bolt is two or three threads from the bottom of the actuator. The bolt **must** turn freely. Back out the bolt when you feel resistance, which means that the seal is pinched between the bolt and the actuator.

 **CAUTION**

When the adjusting bolt extends past the bottom of the actuator or does not turn freely, the automatic adjuster will not work correctly. Stopping distances will increase as the linings wear and the brake fails to adjust. Damage to components can result.

- b. Install the plunger in its bore. The slot in the plunger must align with the hole for the pawl.
 - c. Install the actuator and adjusting bolt inside the plunger. Install the pawl assembly so the pawl fits through the slot in the plunger and engages the teeth on the actuator. Tighten the pawl to 15-25 lb-ft (20-34 N•m).



5. Use the correct size seal driver to seat the seals in the housing. For **RSA** brakes, use a 1-3/8-inch diameter driver with a 7/8-inch x 1-inch notch to clear the adjusting bolt. For **RDA** brakes, use a 1-7/8-inch driver with a 1-3/16-inch notch to clear the adjusting bolt. **Figure 4.4.**

Figure 4.4

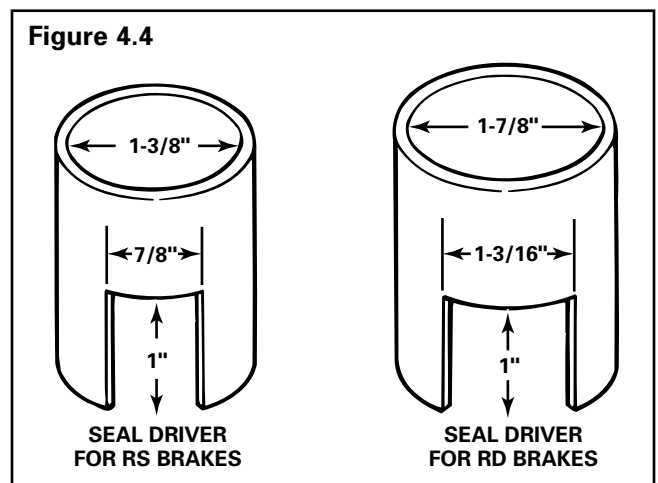

Section 4

Assemble Brakes



NOTE: Meritor KIT 1184 includes a seal driver for RDA brakes plus a brake spring tool and an adjusting spoon. The kit or the individual tools are available from Meritor Aftermarket Parts and Services, 7975 Dixie Highway, Florence, KY 41042.

- If removed, install the plunger housing. Apply Loctite® 242 or equivalent to the capscrew threads. Tighten the capscrews to 30-40 lb-ft (41-54 N•m).

Assemble the Air Chamber

Figure 4.5

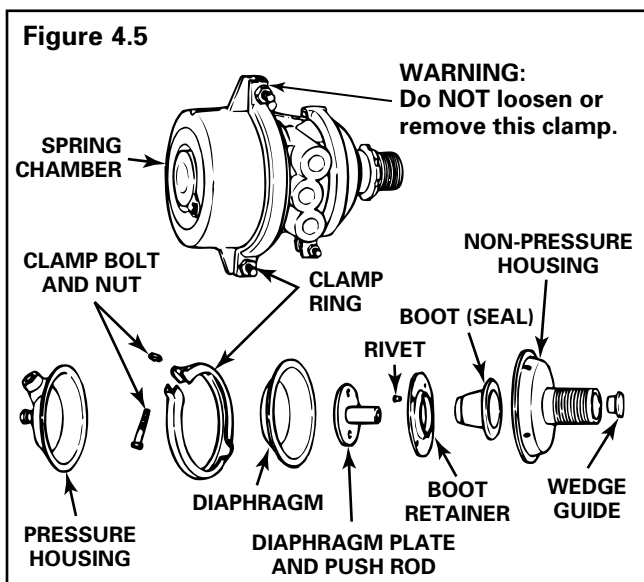

- Fasten the non-pressure housing and diaphragm to the pressure housing or spring brake chamber by using the clamp, bolt and nut.

Wedge Brakes With Air Chamber Tube Support Brackets

When wedge brakes are equipped with air chamber support brackets, the centerline of the tube must remain within 20 degrees of the axle horizontal centerline. The same limitations apply when the centerline of the air chamber support bracket is located toward the front of the vehicle.

Figure 4.6

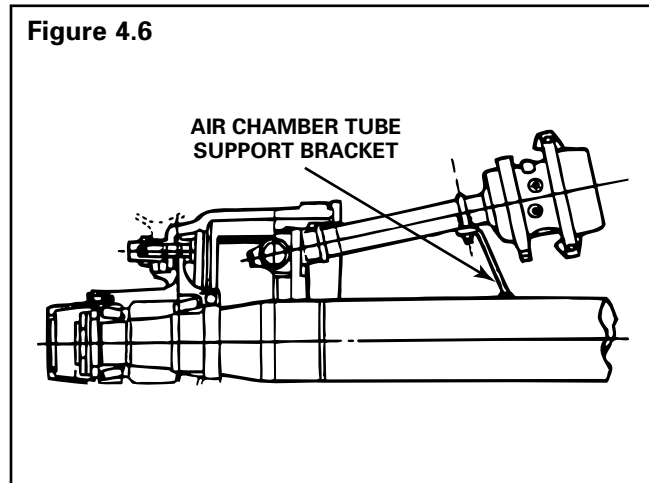

- Install the new boot as follows:
 - Put the new boot and retainer in the housing. Tightly fasten the retainer and housing with nuts and bolts through two rivet holes 180 degrees apart.
 - Install rivets from the outside of the housing through the other two rivet holes. Use a rivet set to form the heads of the rivets. Tightly clamp the boot and retainer to the housing.
 - Replace the two nuts and bolts with rivets.
- Install the plate and push rod assembly through the boot. Install the wedge guide on the end of the push rod.
- Install the diaphragm.

Figure 4.7

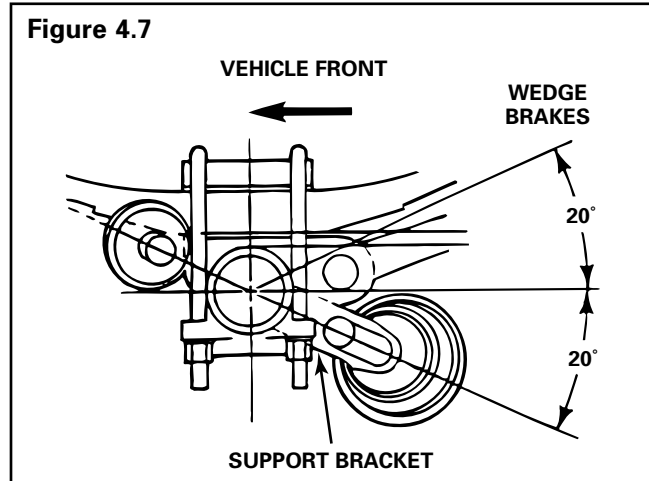

Assemble the Wedge Assembly

Figure 4.8

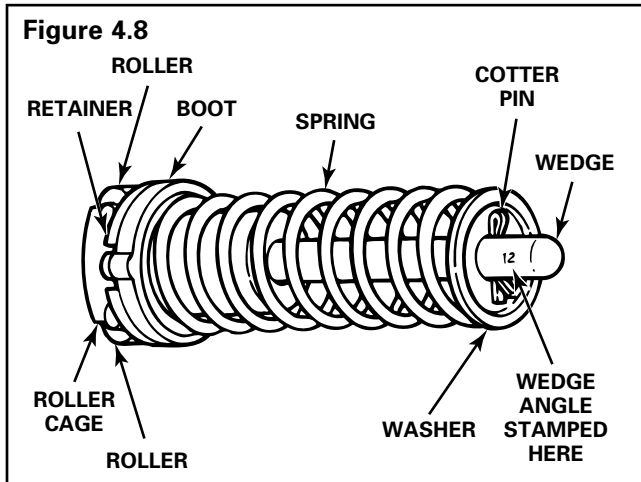

1. Put the roller cage on the wedge so that the angled faces of the wedge are visible.

CAUTION

Do not force open the roller cage more than necessary to install the rollers. Do not force the rollers through the slots in the cage. Do not force the wedge through the rollers. Damage to the roller cage will result.

2. Use a screwdriver between the wedge and the roller cage to carefully force open the cage just enough to install the rollers. Install the rollers to rest on the angled faces of the wedge and their journals fit in the cage slots.
3. Install the retainer so that any raised lip on its outer diameter is toward the wedge head.
4. Install the boot, spring and washer.

WARNING

Be careful when you compress the spring to install the cotter pin. Sudden release of a compressed spring can cause serious personal injury.

5. Compress the spring and install the cotter pin.

Install the Air Chamber and the Wedge Assembly

CAUTION

Wedges and plungers are marked to indicate their angles (12, 14 or 16 degrees). To maintain brake performance as originally designed for the application, do not change angles. Do not mix parts with different angles. Damage to components can result.

1. Lubricate the wedge head, the rollers and the ramps in the plungers.
2. Grease the cavity between the two plungers in the housing until the grease is approximately 1/4-inch below the wedge seat. Install the wedge assembly in its bore, so that the tabs of the wedge spring retainer engage the slots in the bore. **Figure 4.9.** Check that the wedge is installed correctly by pushing the end of the wedge rod. The wedge must lift the plungers.
3. Install the collet nut on the air chamber with the tapered side of the nut toward the plunger housing. Install the nut as far as possible onto the threads.

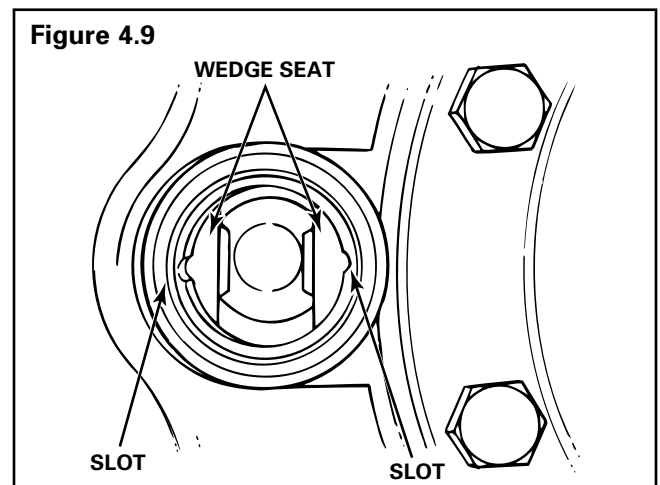

4. Apply a non-hardening sealant (Meritor part number A-2297-F-4114 or equivalent) to the first three threads on the chamber.
5. Check that the collet nut does not prevent you from tightening the chamber completely into the plunger housing. Tighten the chamber completely into the plunger housing. Then loosen the chamber no more than one turn to align and connect the air lines to the ports.

Section 4 Assemble Brakes



NOTE: Support brackets must be used on trailer axles where the chambers have tubes equal to or longer than shown in **Figure 4.10**. Weld the bracket to the axle. Attach the tube with a U-bolt and saddle bracket as close as possible to the chamber. For information on welding, refer to Meritor Maintenance Manual No. 14.

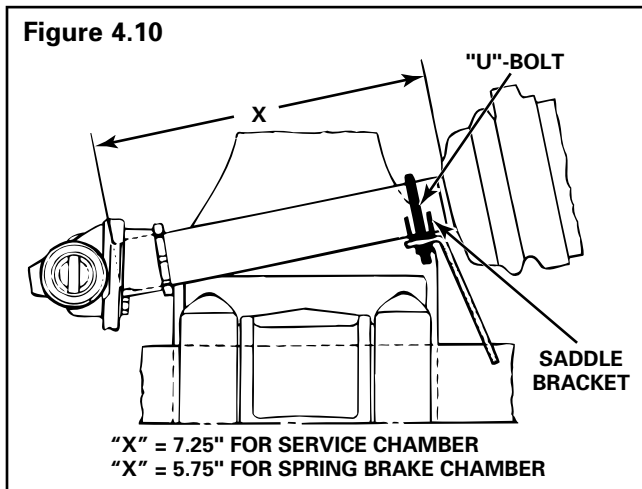

6. The bottom drain hole in the non-pressure housing must be open.
7. Tighten the collet nut against the plunger housing by hand. Then use a brass drift and hammer to tighten the collet nut an additional 1/4–1/2 turn.

WARNING

When you work on a spring chamber, carefully follow the service instructions of the chamber manufacturer. Sudden release of a compressed spring can cause serious personal injury.

8. When the brake has a spring chamber, release the spring.
9. Apply the brakes and check for leaks at all connections.

Install the Brake Shoes

ASBESTOS AND NON-ASBESTOS FIBERS WARNING

Some brake linings contain asbestos fibers, a cancer and lung disease hazard. Some brake linings contain non-asbestos fibers, whose long-term effects to health are unknown. You must use caution when you handle both asbestos and non-asbestos materials.

1. Apply lubricant to the plunger and adjusting bolt slots and all areas of the spider and retaining hardware that contact the shoe. Use O-616-A (NLGI Grade 1) or O-645 (NLGI Grade 2) Meritor-specified lubrication.

WARNING

Be careful when installing springs. Sudden release of spring tension can cause serious personal injury.

2. Follow the instructions on pages 18 and 19 to install the brake shoes.

RSA Brakes (Figure 4.11)

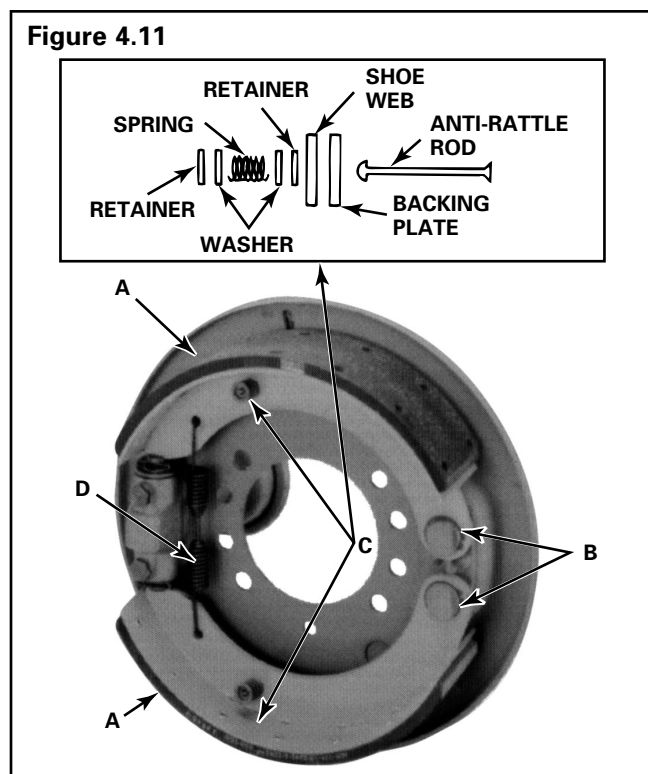

- Install the shoes on the anchor pins. Fit the other end of the webs into the adjusting bolt slots.
- Install the snap rings onto the anchor pins.
- Install the anti-rattle rod through the backing plate, shoes and retaining hardware. Compress the spring. Twist the rod to lock its tabs into the retainer.
- Use a brake spring tool to install the return spring.
- Install the hub, drum and wheel according to the vehicle manufacturer's instructions.
- Adjust the brake as described in Section 5.

RDA Brakes (Figure 4.12)

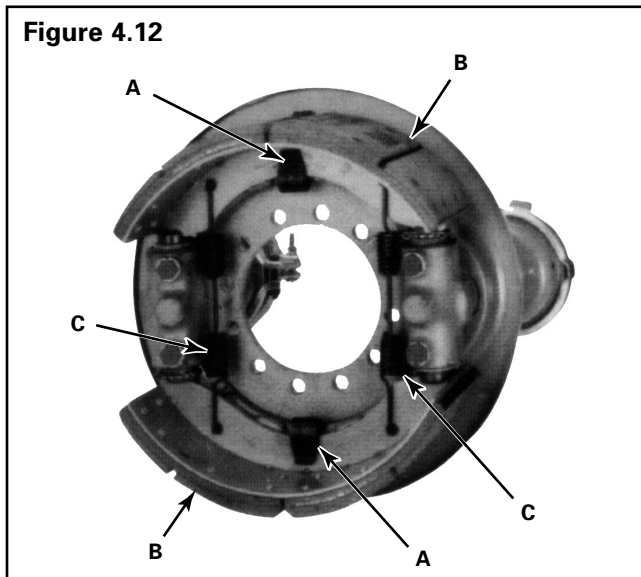

- If removed, install the shoe hold-down clips.
- The shoe ends are labeled "anchor" and "adjuster." Install the shoes correctly as shown in **Figure 4.13**. Install the top shoe with its ends engaged with the plunger and adjusting bolt. Hold the bottom shoe in place.

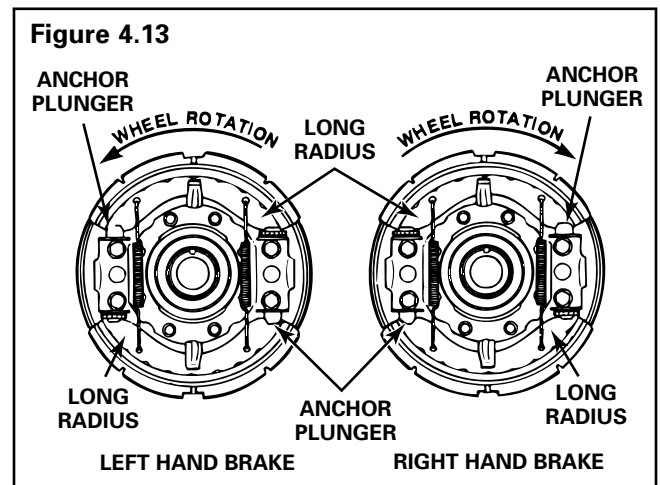

- Use a brake spring tool to install the return springs.
- Install the hub, drum and wheel according to the vehicle manufacturer's instructions.
- Adjust the brake as described in Section 5.

Section 5 Lubrication, Maintenance and Adjustment



Lubrication

Lubricate the components shown in **Figure 5.1** every 100,000 miles (160,000 km), or once a year, or when any of the following occur:

- The seals are replaced.
- The plungers are removed.
- The brake is relined.
- The grease becomes contaminated or hardened.

Use generous amounts of grease to prevent premature wear. However, do not pack the housing with so much grease that the components cannot move freely.

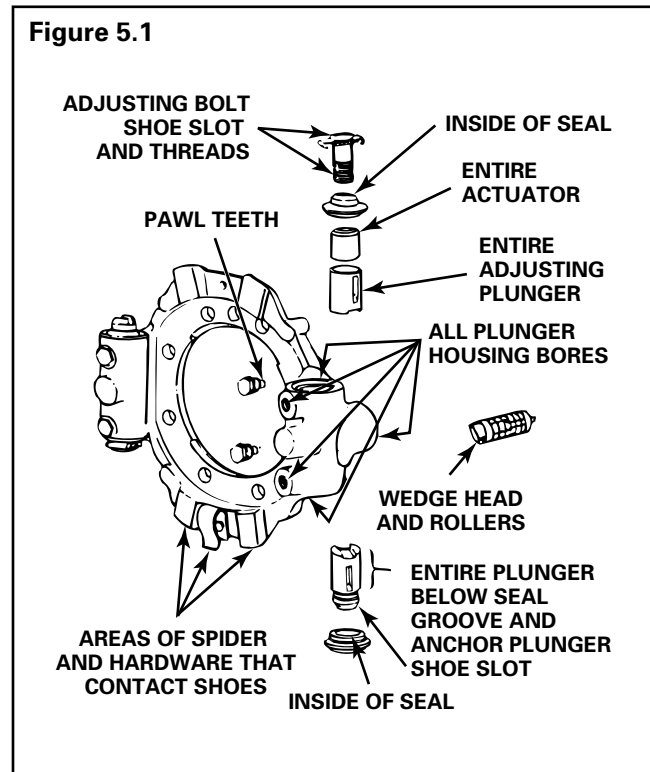

Table A: Wedge Brake Grease Specifications

Component	Meritor Specification	NLGI Grade	Grease Description	Outside Temperature
<ul style="list-style-type: none"> • All Actuating Components • All Areas Where Shoes Contact Spider 	O-616-A	1	Clay Base	Down to -40°F (-40°C)
<ul style="list-style-type: none"> • Anchor Plungers • Adjusting Bolts or Retainer Hardware 	O-645	2	Synthetic Oil, Clay Base	Down to -65°F (-54°C)

Preventive Maintenance

⚠ WARNING

To prevent serious eye injury, always wear safe eye protection when you perform vehicle maintenance or service.

Park the vehicle on a level surface. Block the wheels to prevent the vehicle from moving. Support the vehicle with safety stands. Do not work under a vehicle supported only by jacks. Jacks can slip and fall over. Serious personal injury can result.

Every Two Months or 25-30,000 Miles (40-48,000 km)

Remove the plugs from the inspection holes in the dust cover. Check for lining wear and lining to drum clearance. Check for correct operation of the service and parking brake systems as follows:

1. Some linings have a groove in the edge of the lining. Some linings are scalloped at the four inner corners. **Figure 5.2**. When linings are worn so that the groove or the scallops are not visible, replace the linings.

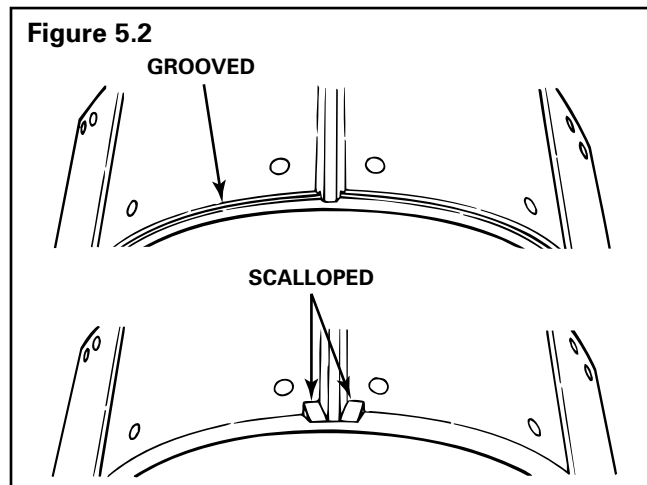

2. On **RDA** brakes, the linings on both shoes should wear at approximately the same rate. If one shoe wears much faster than the other, use **Table B: Troubleshooting** in Section 6 to correct the problem before you replace the linings.

On **RSA** brakes, it is normal for the leading shoe to wear faster than the trailing shoe. The leading shoe is the first shoe past the plunger housing in the direction of forward wheel rotation. When the plunger housing is behind the axle, the top shoe is the leading shoe. When the plunger housing is in front of the axle, the bottom shoe is the leading shoe. **Figure 5.3**.

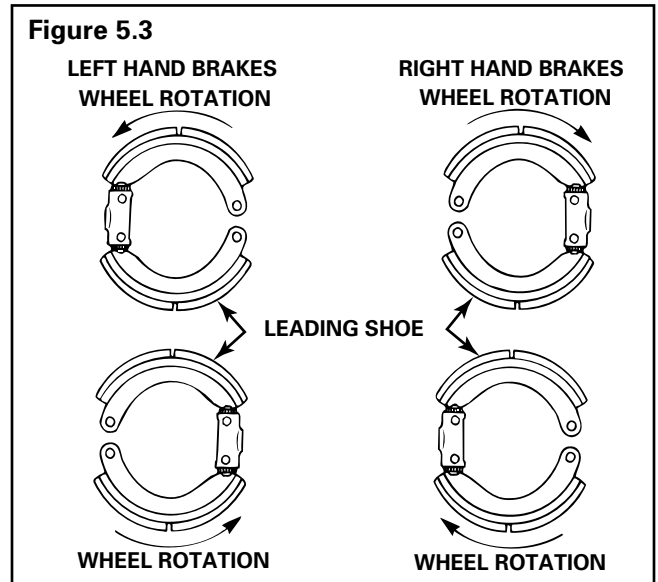

3. While someone operates the service and parking brake systems, check each brake to make sure it operates correctly. Use a ruler to measure movement at the center of each shoe to determine the lining to drum clearance. Clearance of a shoe must not exceed 0.090-inch (2.3 mm). Total clearance of the two shoes must not exceed 0.120-inch (3.05 mm). When clearance exceeds these limits, the automatic adjusters are not working correctly. Use **Table B: Troubleshooting** in Section 6 to correct the problem before you adjust the brake.

Section 5

Lubrication, Maintenance and Adjustment



Once a Year or Every 100,000 Miles (160,000 km)

Remove the wheels and drums and inspect and lubricate the brake as follows:

1. Inspect the air system, brake shoes, linings, drums, spider and dust shields as described in Section 3.
2. Disassemble the plunger housings. Clean and inspect the housing bores, actuator components and wedge assembly as described in Section 4. Lubricate the components as described earlier in this section. Assemble the brake using new seals.

Adjust the Brake



WARNING

You must manually adjust the brake after you perform maintenance or service. Do not depend on the automatic adjusters to remove the excessive clearance created when you back off the brake during service. The automatic adjusters are designed to compensate for normal lining wear. Damage to components and serious personal injury can occur.

Park the vehicle on a level surface. Block the wheels to prevent the vehicle from moving. Support the vehicle with safety stands. Do not work under a vehicle supported only by jacks. Jacks can slip and fall over. Serious personal injury can result.

1. Raise the vehicle so the wheel is off the ground.



WARNING

When you work on a spring chamber, carefully follow the service instructions of the chamber manufacturer. Sudden release of a compressed spring can cause serious personal injury.

2. If the brake has a spring chamber, cage the spring. Rotate the drum to verify that the brake is completely released.
3. Remove the plugs from the adjustment and inspection slots on the dust shield.

4. While you rotate the drum, use an adjusting spoon to turn the adjusting bolt until the linings drag heavily on the drum. Turn the adjusting bolt 10-20 teeth in the opposite direction until the lining to drum clearance is 0.020-0.040-inch (0.51-1.02 mm). Operate the brakes. Use a ruler to measure movement at the center of the shoe to determine the lining to drum clearance.
5. Repeat Step 4 for the other adjuster on the brake.
6. If the brake has a spring chamber, release the spring.

NOTE: Meritor KIT 1184 includes an adjusting spoon plus a seal driver and a brake spring tool. The kit or the individual tools are available from Meritor Aftermarket Parts and Services, 7975 Dixie Highway, Florence, KY 41042. Adjusting spoons available from tool manufacturers include: Kent-Moore J-34061, Proto 2006 and Snap-On S-9523.

Table B: Troubleshooting

Condition	Possible Causes	Correction
Brakes do not apply.	<ol style="list-style-type: none"> 1. Plugged or damaged air lines/valves. 2. Plungers seized in housing. 3. Push rod not connected to wedge. 4. Brakes not adjusted correctly. 	<ol style="list-style-type: none"> 1. Repair or replace air lines or valves. 2. Inspect seals, lubricant and plungers. Service as necessary. 3. Inspect and correct as needed. 4. Adjust brakes correctly.
Brakes do not have enough torque during application.	<ol style="list-style-type: none"> 1. Automatic adjusters not working. 2. Linings worn below minimum thickness, damaged or missing. 3. Incorrect lining friction rating. 4. Air/spring chamber not threaded completely into plunger housing. 5. Plungers seized in housing. 6. Grease or oil on linings. 7. Damaged diaphragm in air chamber. 8. Leaks in the air system. 9. Worn components. 	<ol style="list-style-type: none"> 1. Refer to "Automatic adjusters not working." on next page. 2. Replace linings. 3. Replace with correct lining. 4. Install chamber correctly. 5. Inspect seals, lubricant and plungers. Service as necessary. 6. Clean or replace linings. Check wheel seals for leaks. 7. Repair or replace air chamber. 8. Repair leaks. 9. Replace components.
<p>One shoe lining wears faster than the other. (RDA models only.)</p> <p>NOTE: The leading shoe lining normally wears faster on RSA models.</p>	<ol style="list-style-type: none"> 1. Wedge not correctly installed in air chamber. 2. Brake shoes installed backwards. 3. Weak/damaged shoe return springs. 4. Wedge and roller assembly not correctly installed in plunger ramp. 5. Lining friction ratings do not match. 6. One wedge roller is out of cage. 7. Grease or dirt on linings. 8. Loose, worn or missing shoe retaining hardware. 9. Lightweight or out-of-round drums. 10. Automatic adjuster not operating correctly. 11. Brakes are dragging. 12. Unequal pressure in air chambers. 13. Loose wheel bearings. 	<ol style="list-style-type: none"> 1. Install wedge and air chamber correctly. 2. Install shoes correctly. 3. Replace return springs. 4. Install correctly. 5. Use matched linings. 6. Repair or replace wedge assembly. 7. Clean or replace linings. Check wheel seal for leaks. 8. Repair or replace retaining hardware. 9. Replace drums. 10. Refer to "Automatic adjusters not working." on next page. 11. Refer to "Brakes drag." on next page. 12. Determine cause and repair or replace as needed. 13. Adjust wheel bearings correctly.

Section 6 Diagnostics



Condition	Possible Causes	Correction
Brakes grab or vibrate during application.	<ol style="list-style-type: none"> 1. Low air pressure at air chamber. 2. Grease or dirt on linings. 3. Wedge and roller assembly not correctly installed in plunger ramp. 4. Incorrect lining friction rating. 5. Linings worn below minimum thickness, damaged or missing. 6. Shoes bind due to improper assembly or weak, worn out shoes. 7. Weak/damaged shoe return springs. 	<ol style="list-style-type: none"> 1. Inspect and repair air delivery system. 2. Clean or replace linings. Check wheel seals for leaks. 3. Install correctly. 4. Replace with correct lining. 5. Replace linings. 6. Install shoes correctly or replace as needed. 7. Replace return springs.
Brakes drag.	<ol style="list-style-type: none"> 1. Spring brake not completely released. 2. Weak/damaged return springs. 3. Air lines connected to wrong ports. 4. Leaks in the air system. 5. Air trapped in air chamber when brakes are released. 6. Brake drum out-of-round. 7. Loose wheel bearings. 8. Push rod not connected to wedge. 9. Plungers seized in housing. 10. Damaged return spring or cotter pin on wedge assembly. 11. Grease or dirt on linings. 12. Loose, worn or missing shoe retaining hardware. 13. Incorrect manual adjustment. 	<ol style="list-style-type: none"> 1. Inspect and repair air system and spring chamber. 2. Replace return springs. 3. Connect air lines correctly. 4. Repair leaks. 5. Repair or replace release valves. 6. Replace drum. 7. Adjust wheel bearings correctly. 8. Inspect and correct as needed. 9. Inspect seals, lubricant and plungers. Service as necessary. 10. Replace spring or cotter pin. 11. Clean or replace linings. Check wheel seals for leaks. 12. Repair or replace retaining hardware. 13. Adjust brake correctly.

Condition	Possible Causes	Correction
Automatic adjusters not working.	<ol style="list-style-type: none"> 1. Damaged shoe retainer/detent clip on head of adjusting bolt. 2. Adjusting bolt threads extend through bottom of actuator. 3. Adjusting bolt threaded too tightly. 4. Brake shoes installed backwards. 5. Foreign material on threads of adjusting bolt or actuator. 6. Lack of lubrication, contamination, corrosion, damaged seals. 7. Damaged teeth on pawl or actuator. 8. Damaged pawl spring. 9. Weak/damaged shoe return springs. 10. Pawl seized in its bore. 11. Anchor plungers installed in wrong locations. 	<ol style="list-style-type: none"> 1. Replace adjusting bolt. 2. Install adjusting bolt so threads do not extend past bottom of actuator. 3. Make sure bolt turns freely. 4. Install brake shoes correctly. 5. Clean or replace adjusting bolt and actuator. Replace seals as needed. 6. Replace adjuster parts and seals as needed. Lubricate at scheduled intervals. 7. Replace pawl and plunger assembly. 8. Replace pawl assembly. 9. Replace return springs. 10. Clean and replace pawl or housing as needed. 11. Install plungers in correct locations as shown in Figure 4.1.
Spring brake does not hold.	<ol style="list-style-type: none"> 1. Broken power spring. 2. Power spring unable to expand completely (spring still caged). 3. Hold-off air not being exhausted. 4. Air chamber assembly not threaded completely into plunger housing. 5. Brakes not adjusted correctly. 6. Grease or dirt on linings. 	<ol style="list-style-type: none"> 1. Repair or replace assembly as described by manufacturer. 2. Determine cause and repair or replace as described by manufacturer. 3. Determine cause and repair or replace as described by manufacturer. 4. Correctly thread air chamber into housing. Tighten collet nut to prevent loosening. 5. Adjust brakes correctly. 6. Clean or replace linings. Check wheel seals for leaks.

Section 7

Visual Inspection of the Brake System



For safe operating conditions and longer component life, make these visual inspections before the vehicle is put into service:

1. Check the complete air system for worn hoses and connectors. With air pressure at 100 psi, brakes released and engine off, loss of tractor air pressure must not exceed two psi a minute. Total tractor and trailer loss must not exceed three psi per minute.
2. Check to see that the air compressor drive belt is tight. Air system pressure must rise to approximately 100 psi in two minutes.
3. The governor must be checked and set to the specifications supplied by the vehicle manufacturer.
4. Both the tractor and trailer air systems must match the specifications supplied by the vehicle manufacturer.
5. Both wheel ends of each axle must have the same linings and drums. All four wheel ends of tandem axles must also have the same linings and drums. The front axle brakes do not have to be the same as the rear driving axle brakes. **Figure 7.1.**

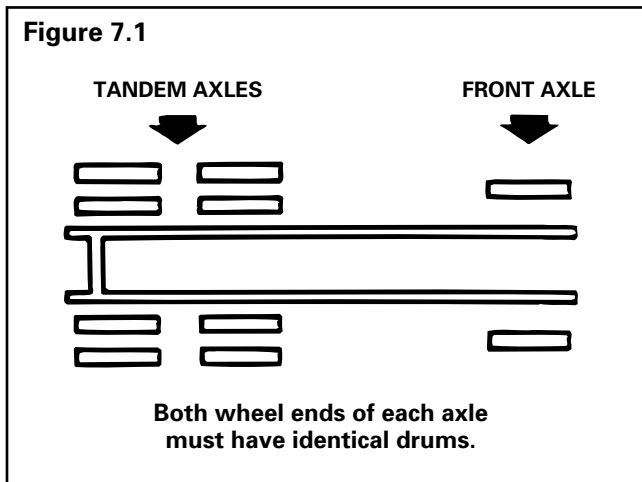

6. Friction material requirements for brake systems can vary from vehicle to vehicle. Always follow the vehicle manufacturer's specifications to ensure that the correct lining is used.
7. Make sure that the return springs completely retract the shoes when the brakes are released. Replace the return springs each time the brakes are relined. Make sure that the spring brakes retract completely when they are released.

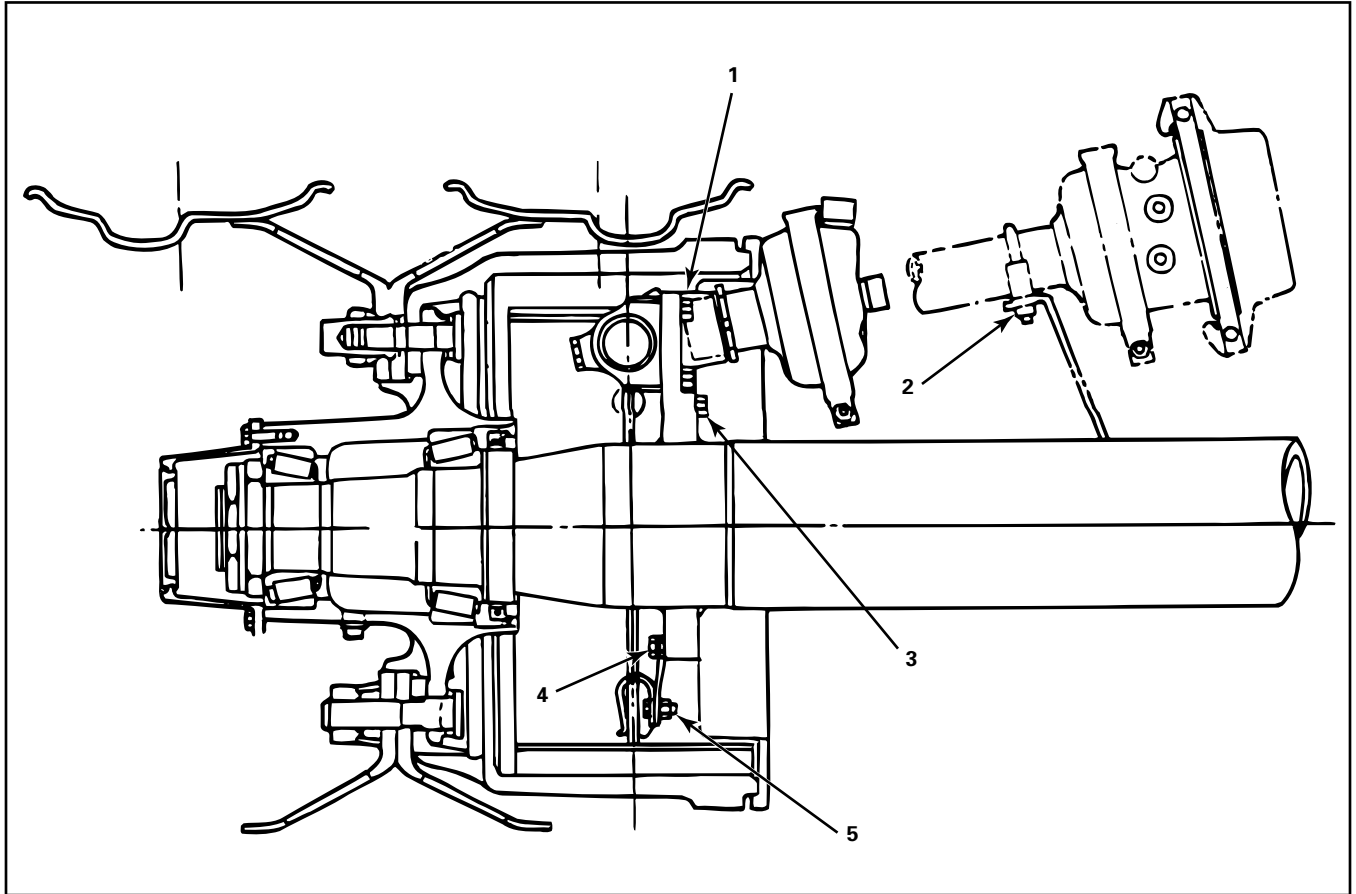



Table C: Wedge Brakes

Description	Torque Range 		Fastener Size
	(lb-ft)	N•m	
1. Actuator housing bolts	30-40	41-54	0.38-16
2. Support lock nuts	10-15	13-20	0.31-18
3. Dust shield bolts	15-20	13-20	0.38-24
4. Spider mounting support bolts	30-40	41-54	0.38-24
5. Shoe retainer clip bolt	15-20	20-27	0.31-18



MERITOR[™]
A Heritage of Rockwell Technology

Meritor Heavy Vehicle Systems, LLC
2135 West Maple Road
Troy, MI 48084 USA
800-535-5560
www.meritorauto.com

Information contained in this publication was in effect at the time the publication was approved for printing and is subject to change without notice or liability. Meritor Heavy Vehicle Systems, LLC, reserves the right to revise the information presented or discontinue the production of parts described at any time.

© Copyright 1995
Meritor Automotive, Inc.
All Rights Reserved

Printed in the USA

Maintenance Manual No. 4R
Revised 02-95
16579/24240