

**URGENT**

**MWO effective date is 1 March, 1997, and completion date is 31 January, 2000.**

**MWO 9-2320-272-20-8**

**MODIFICATION WORK ORDER**

**MODIFICATION OF 5-TON**

**M939A2 SERIES TRUCKS**

**ACCELERATOR LINKAGE  
MODIFICATION KIT**

<b>NOMENCLATURE</b>	<b>NSN</b>	<b>EIC</b>
Truck, Cargo, Dropside	2320-01-230-0307	BS7
Truck, Cargo, Dropside	2320-01-230-0308	B88
Truck, Cargo, XLWB	2320-01-230-0309	BS9
Truck, Cargo, XLWB	2320-01-230-0310	BTM
Truck, Dump	2320-01-230-0305	BTN
Truck, Dump	2320-01-230-0306	BTO
Truck, Tractor	2320-01-230-0302	BTP
Truck, Tractor	2320-01-230-0303	BTQ
Truck, Van, Expansibile	2320-01-230-0300	BTR
Truck, Medium, Wrecker	2320-01-230-0304	BTT
Chassis	2320-01-230-0287	
Chassis	2320-01-230-0288	

**Headquarters, Department of the Army, Washington, D.C.  
1 March 1997**

**REPORTING OF ERRORS' AND RECOMMENDING IMPROVEMENTS**

You can help improve this MWO. If you find any mistakes or if you know of a way to improve these procedures, please let us know. Write a letter or complete and mail a DA Form 2028, Recommended Changes to Publications and Blank Forms, to: U.S. Army Tank-automotive and Armaments Command, ATTN: AMSTA-IM-OPIT, Warren, MI 48397-5000. A reply will be furnished to you.

**DISTRIBUTION ,STATEMENT A. Approved for Public Release; Distribution is Unlimited.**

**1. PURPOSE.**

The purpose of the Accelerator Linkage Modification Kit is to reduce excessive pedal force.

**2. PRIORITY.**

This modification is classified as URGENT.

**3. END ITEM TO BE MODIFIED.**

- a. 5-ton, 6x6, M939A2 series trucks.

NOMENCLATURE	NSN	EIC	PART NO.	CAGEC	MODEL NO.
Truck, Cargo, Dropside	2320-01-230-0307	BS7	8750177	19207	M923A2
Truck, Cargo, Dropside	2320-01-230-0308	BS8	8750179	19207	M925A2
Truck, Cargo, XLWB	2320-01-230-0309	BS9	8750181	19207	M927A2
Truck, Cargo, XLWB	2320-01-230-0310	BTM	8750182	19207	M928A2
Truck, Dump	2320-01-230-0305	BTN	8750183	19207	M929A2
Truck, Dump	2320-01-230-0306	BTO	8750184	19207	M930A2
Truck, Tractor	2320-01-230-0302	BTP	8750185	19207	M931A2
Truck, Tractor	2320-01-230-0303	BTQ	8750186	19207	M932A2
Truck, Van, Expansibile	2320-01-230-0300	BTR	8750187	19207	M934A2
Truck, Medium, Wrecker	2320-01-230-0304	BTT	8750189	19207	M936A2
Chassis	2320-01-230-0287		8750190	19207	M942A2
Chassis	2320-01-230-0288		8750191	19207	M942A2

- b. Vehicle's National Stock Number (NSN) will not change as a result of this MWO.

**4. MODULE TO BE MODIFIED.**

Not applicable.

**5. PARTS TO BE MODIFIED.**

Not applicable.

**6. APPLICATION.**

- a. Time compliance statement: MWO effective date is 1 March, 1997, and completion date is 31 January, 2000.
- b. The lowest level of maintenance authorized to apply the MWO is unit maintenance.
- c. Work force and man-hour requirements for application of the MWO to a single unit, end item, or system are as follows:

REQUIREMENTS	
WORK FORCE/SKILLS	MAN-HOURS
Two Wheeled Vehicle Mechanics (MOS 63B) or equivalent	1
Total man-hours required for a single application of this MWO is 2 hours.	

- d. There is no other MWO that must be applied prior to the application of this MWO.
- e. There is no additional information necessary to apply this MWO.

**7. TECHNICAL PUBLICATIONS AFFECTED/CHANGED AS A RESULT OF THIS MWO.**

<u>Technical Publication</u>	<u>Date</u>
TM 9-2320-358-24&P	21 October 1992

**8. MWO KITS, PARTS, AND THEIR DISPOSITION.**

a. The following kit is required to accomplish this modification. The security classification of the kit is unclassified. Shipping data is (estimated):

Weight 1.1 lbs.; Measurements 18.5-in. x 1.9-in. x 1.1-in.; Volume 0.022 cu. ft.

<u>NOMENCLATURE</u>	<u>NSN</u>	<u>CAGEC</u>	<u>PART NO.</u>
Accelerator Linkage Modification Kit	2590-01-424-1705	19207	57K0281

b. The Accelerator Linkage Modification Kit component parts are listed below. The listing is used to inventory the kit for completeness.

<u>NOMENCLATURE</u>	<u>NSN</u>	<u>CAGEC</u>	<u>PART NO.</u>	<u>QTY</u>
MWO Instruction Plate	9905-00-8585682	19207	10930014	1
Throttle Linkage Rod Assembly	xxxx-xx-xxx-xxxx	19207	12363294-2	1
Throttle Lever Extension	xxxx-xx-xxx-xxxx	19207	12363633-1	1
Accelerator Pedal Rod	xxxx-xx-xxx-xxxx	19207	12255972-2	1
Screw	xxxx-xx-xxx-xxxx	24617	454468	1
Screw	xxxx-xx-xxx-xxxx	80204	B18234B06016N	1
Nut	xxxx-xx-xxx-xxxx	80204	B18244B06	1
Drivescrew	5305-00-253-5615	96906	MS21318-20	1
Cotter Pin	5315-00-815-1405	96906	MS24665-161	2
Nut	5310-00-935-9022	96906	MS51943-2	1
Spring Pin	5315-00-814-3530	96906	MS16562-223	1
Washer	5310-00-527-3634	96906	MS35335-61	1
Lock Pin	xxxx-xx-xxx-xxxx	88044	AN415-8	1

c. There are no bulk or expendable materials required for the application of the Accelerator Linkage Modification Kit.

d. Parts Disposition. All parts and materials removed and not reused during installation of kit will be returned to stock for disposition in accordance with AR 725-50.

**9. SPECIAL TOOLS; TOOL KITS; JIG; TEST, MEASUREMENT, AND DIAGNOSTIC EQUIPMENT (TMDE); AND FIXTURES REQUIRED.**

Hand tools necessary to apply the MWO are contained in the following tool kit:

<b>NOMENCLATURE</b>	<b>NSN</b>	<b>CAGEC</b>	<b>SUPPLY CATALOG</b>
Tool Kit, General Mechanic's	5180-00-177-7033	50980	SC 5180-90-CL-N26

**10. MODIFICATION PROCEDURES.**

- a. Vehicle Preparation.
- (1) Set parking brake I(TM 9-2320-272-10).
  - (2) Raise and secure hood (TM 9-2320-272-10).
  - (3) Remove engine splash shield (TM 9-2320-272-10).
  - (4) Depress spring socket and remove accelerator linkage from ball joint on throttle lever as shown in figure 1.
  - (5) Disconnect throttle return spring from accelerator linkage as shown in figure 2.
  - (6) Loosen jamnut and remove accelerator linkage from ball joint on bellcrank as shown in figure 2.

**NOTE**

**Position and location of jamnut must be noted for future installation purposes.**

- (7) Measure distance from jamnut to threaded end of accelerator linkage as shown in figure 2.
- (8) Remove jamnut, spring pin, yoke, and spring from accelerator rod as shown in figure 3.
- (9) Remove two cotter pins, washers, and accelerator pedal rod from bellcrank and accelerator pedal as shown in figure 4.
- (10) Remove spring from throttle lever as shown in figure 5.
- (11) Remove clip pin, washer, and modulator cable from throttle lever as shown in figure 5.

**NOTE**

**Mark location of shoulder pin on throttle lever prior to removal for future installation purposes.**

- (12) Remove nut, washer, and shoulder pin from throttle lever as shown in figure 5.
- (13) Remove ball joint, washer, screw, and throttle lever from fuel pump as shown in figure 6.

**NOTE**

**Ensure leads of throttle control solenoid are facing upward when rotated.**

- (14) Remove two screws and throttle control solenoid from bracket. Rotate throttle control solenoid 180 degrees and secure on bracket with two existing screws as shown in figure 6.

## b. Accelerator Linkage Modification Kit Installation.

- (1) Transfer mark from existing throttle lever to 12363633-1 throttle extension lever as shown in figures 5 and 7.
- (2) Install MS35335-61 washer and ball joint on throttle lever extension (12363633-1) with B18244B06 nut as shown in figure 7.
- (3) Install throttle lever extension (12363633-1) on fuel pump with existing screw and B18234B06016N screw as shown in figure 7.

**NOTE**

**Align shoulder pin to mark on throttle extension lever.**

- (4) Install shoulder pin on throttle lever extension (12363633-1) with washer and MS51943-2 nut as shown in figure 8.
- (5) Install modulator cable on throttle lever extension (12363633-1) and shoulder pin with washer and AN415-8 lock pin as shown in figure 8.
- (6) Install spring on throttle lever extension (12363633-1) as shown in figure 8.
- (7) Install 12255972-2 accelerator pedal rod on bellcrank and accelerator pedal with two existing washers and MS24665-151 cotter pins as shown in figure 9.
- (8) Loosen jamnut and adjust stopscrew 0.75 in. (19.1 mm) from cab floor as shown in figure 9. Tighten jamnut.
- (9) Install spring and yoke on 12363294-2 throttle linkage rod assembly with MS 16562-223 spring pin as shown in figure 10.

**NOTE**

**Before performing next step, refer to Section 'A', step '7'.**

- (10) Install jamnut on throttle linkage rod assembly (12363294-2) to previously noted position as shown in figure 10. Finger tighten jamnut.

**WARNING**

**Bend end of throttle control cable away from bellcrank to prevent accelerator pedal from binding. Failure to do so may result in injury to personnel or damage to equipment.**

- (11) Bend end of throttle control cable away from bellcrank as shown in figure 2.
- (12) Install accelerator linkage into ball joint on bellcrank as shown in figure 2.
- (13) Connect throttle return spring on accelerator linkage as shown in figure 2.
- (14) Depress spring socket and install accelerator linkage on ball joint as shown in figure 11.

## c. Vehicle Equipment.

- (1) Start engine CTM 9-2320-272-10) and check engine idle.

**NOTE**

- **Engine idle should be between 550-650 rpm.**
- **Perform steps -' and 3''' to adjust accelerator linkage if not within limits.**

- (2) Loosen jamnut and turn yoke until engine idle is within limits. If necessary, turn throttle linkage rod assembly (12363294-2) as shown in figure 12. Tighten jamnuts.
- (3) Depress accelerator pedal and check that engine speed reaches 2100-2300 rpm. If necessary, loosen jamnut and adjust stopscrew on cab floor until proper engine speed is reached. Refer to Section 'B', step '8".
- (4) Check modulator cable adjustment L(TM 9-2320-358-24&P).

**11. CALIBRATION REQUIREMENTS.**

Not applicable to this MWO.

**12. WEIGHT AND BALANCE DATA.**

Weight and balance are not significantly affected by this MWO.

**13. QUALITY ASSURANCE REQUIREMENTS.**

a. General. The following information is supplied to ensure the proper application of this modification and provide clarification in regard to the adequacy of the installer's inspection methods and procedures applicable to quality assurance. The procedures include, but are not limited to, installer responsibilities, government verification, and in-process and workmanship inspections. Inspections shall be in accordance with TM 750-245-4.

b. Installer Responsibilities. The installer is responsible for compliance with quality assurance requirements specified herein. These requirements and the installer's plan of inspection, or quality program, constitute the minimum examinations and tests necessary to assure compliance with established requirements.

Requirements contained in this MWO shall be included in the installer's inspection plan or quality program.

These requirements shall not be construed as eliminating the installer's responsibility from complete compliance with all provisions of the contract. Specific installer responsibilities for modification work order are as follows: The installer is responsible for following instructions contained in this MWO for installation of the Accelerator Linkage Modification Kit and for follow-on tasks IAW MWO 9-2320-272-20-8. Installer is responsible for notifying the Government representative if kit was received incomplete or received in open or damaged condition. The installer is responsible for quality workmanship.

c. In-Process Inspection. During normal assembly operations, paragraph 10, Modification Procedures, will be used to check the installer's work. If accelerator linkage fails to operate properly after kit installation, servicing will be conducted in accordance with PMCS procedures found in TM 9-2320-272-10. All defects will be corrected by the installer before the vehicle is placed in service. All vehicles modified during a production shift will be checked to ensure product quality.

d. Workmanship Inspection. Inspect components removed, installed, or replaced during the modification for security of mounting. Inspect painted areas of cab for missing, chipped, or cracked paint, and correct if necessary.

**14. RECORDING AND REPORTING OF THE MODIFICATION.**

- a. Records and Report Forms. Refer to DA Pam 738-750, DA Pam 738-751, and TB 9-1100-803-15.
- b. Marking Equipment.
  - (1) After the Accelerator Linkage Modification Kit is installed, mark MWO number "9-2320-272-20-8" and date applied in the MWO and date blocks on 10930014 MWO Instruction Plate as shown in figure 13.
  - (2) Install MWO data plate by drilling a 0.104-inch diameter hole (#37 drill) in cab body reinforcement panel and secure with MS21318-20 drivescrew as shown in figure 13.
  - (3) After drivescrew is installed, flatten or remove protruding excess drivescrew material from inside of cab body reinforcement panel.

**15. MATERIAL CHANGE (MC) NUMBER.**

This MWO is authorized by MC number 1-96-06-4501.

**16. MODIFICATION IDENTIFICATION.**

- a. When installed correctly, the Accelerator Linkage Modification Kit will appear as shown in figure 12.
- b. After the Accelerator Linkage Modification Kit is installed, the accelerator linkage should be tested for proper operation. Any faults detected, or discrepancies noted, will be corrected before the vehicle is returned to normal service.

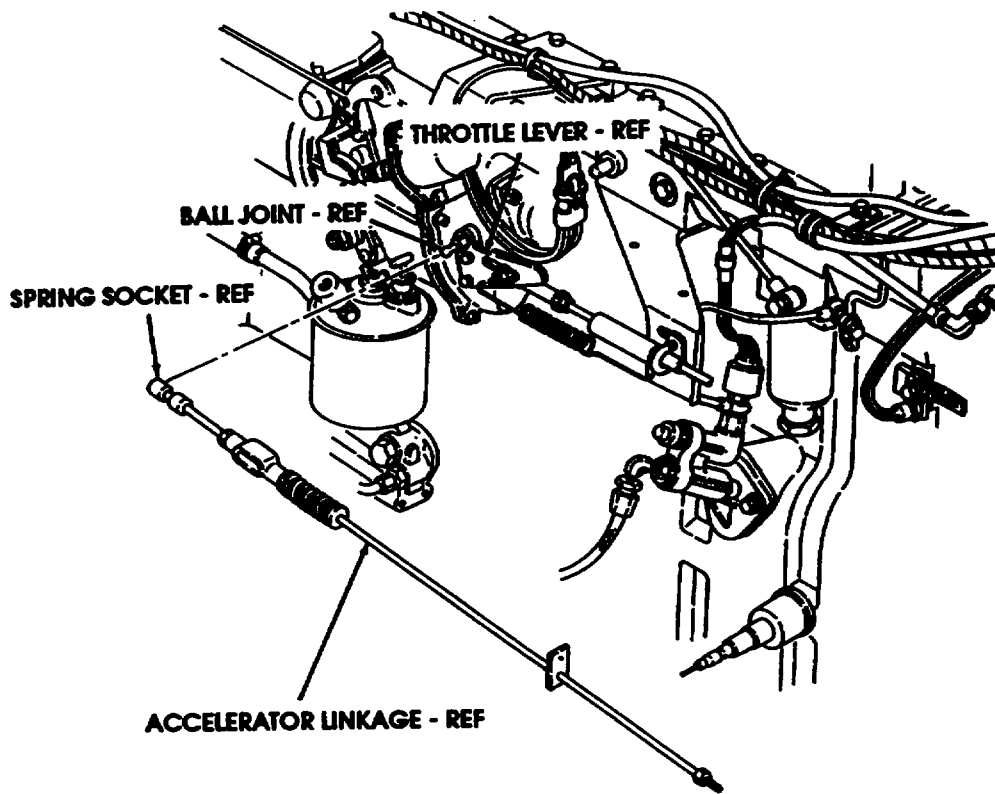

Figure 1

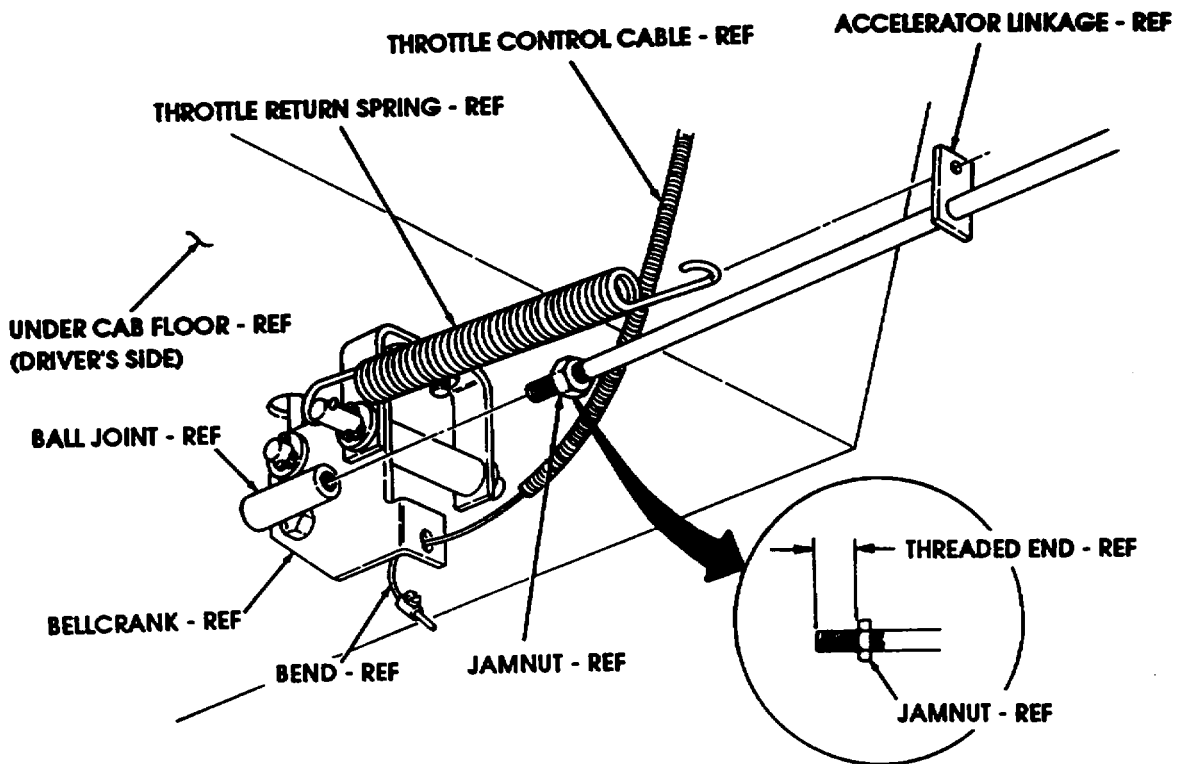

FIGURE 2



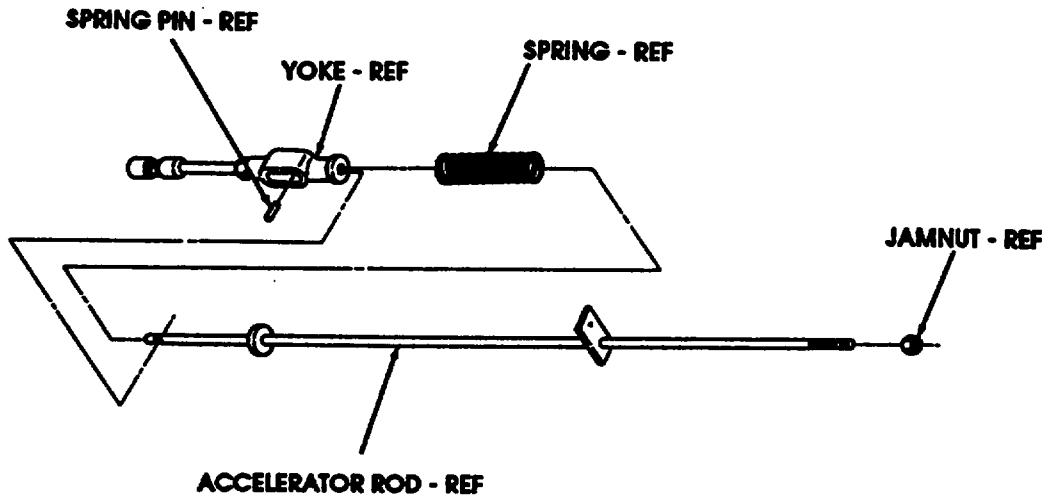

FIGURE 3

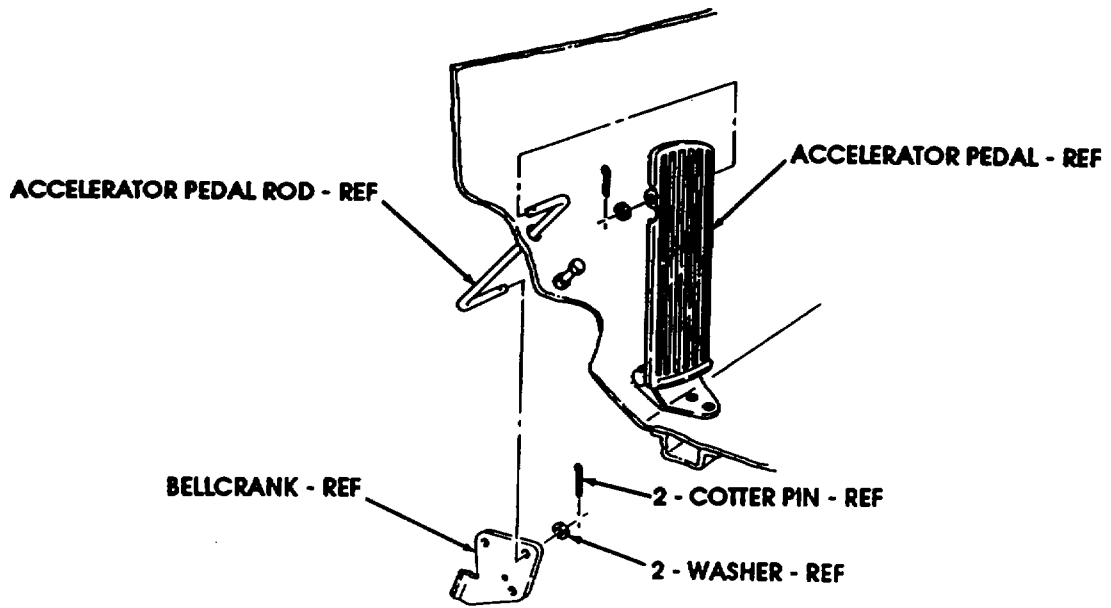

FIGURE 4

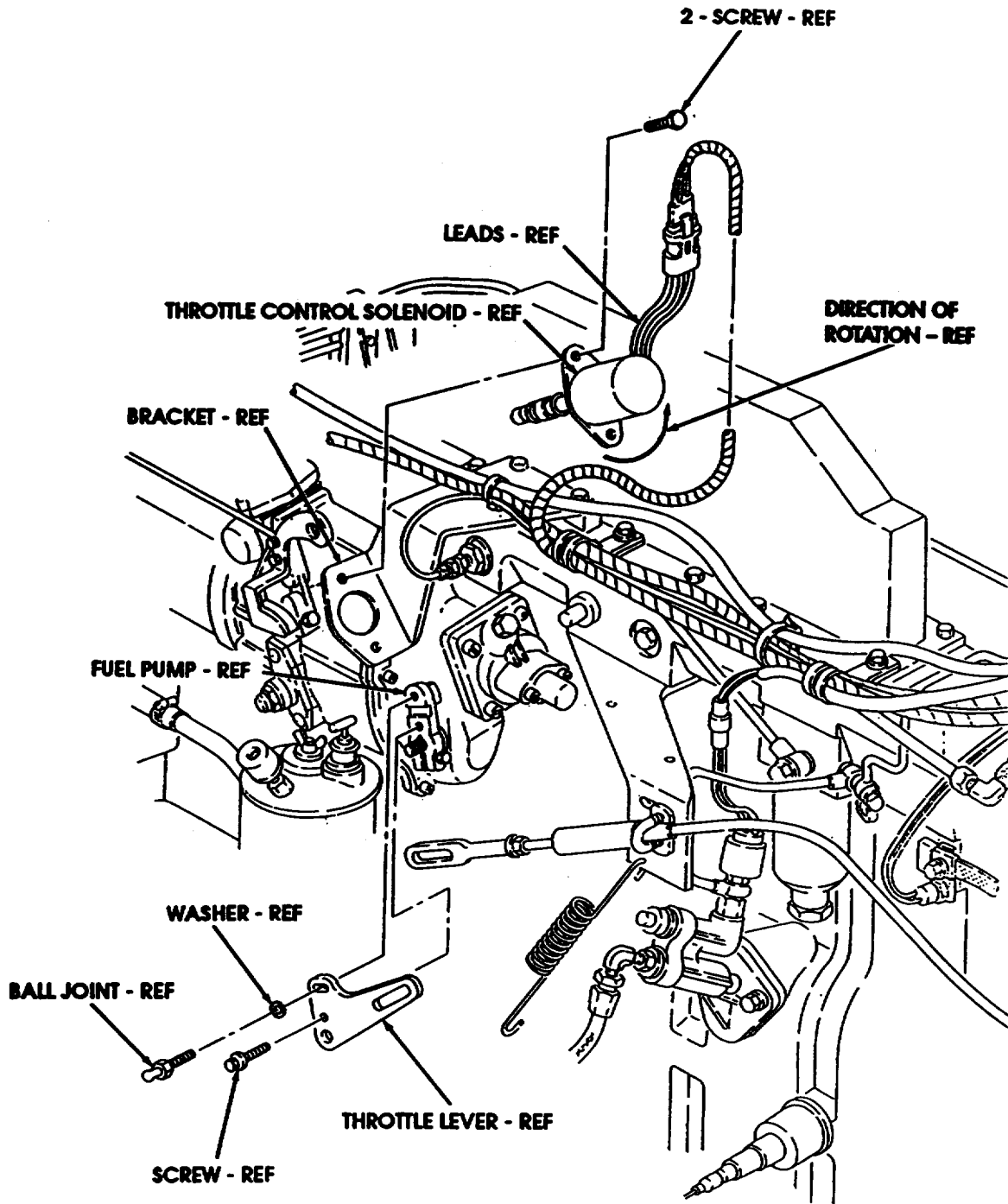

FIGURE 5

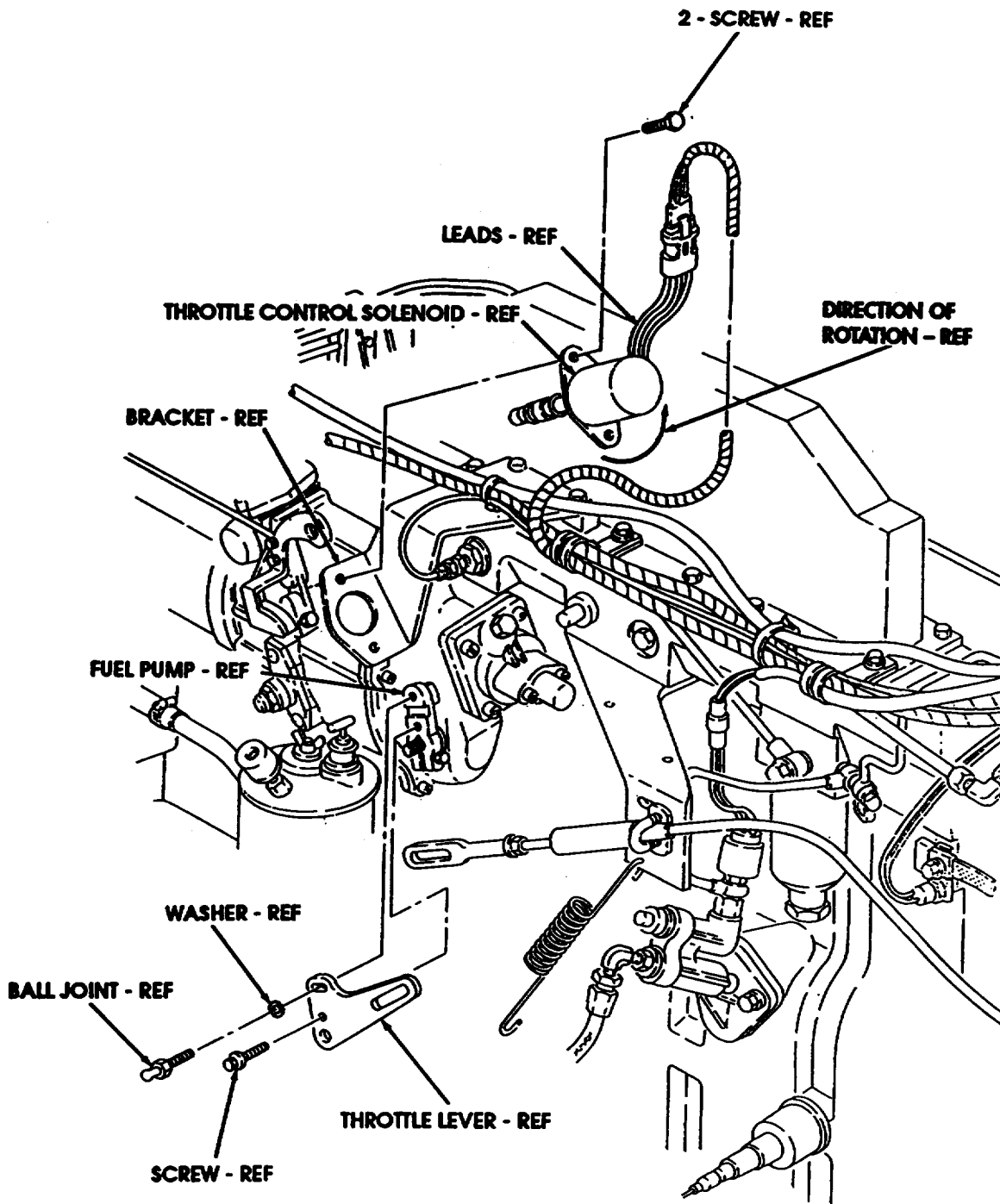

FIGURE 6

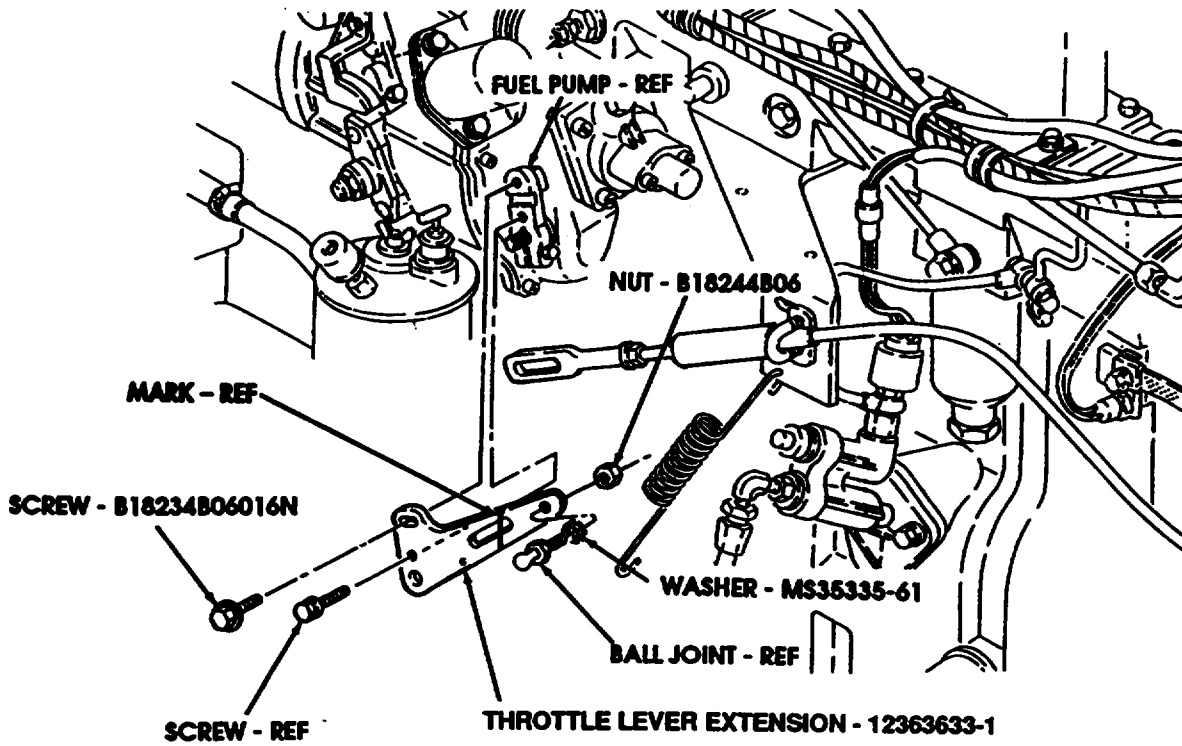

FIGURE 7

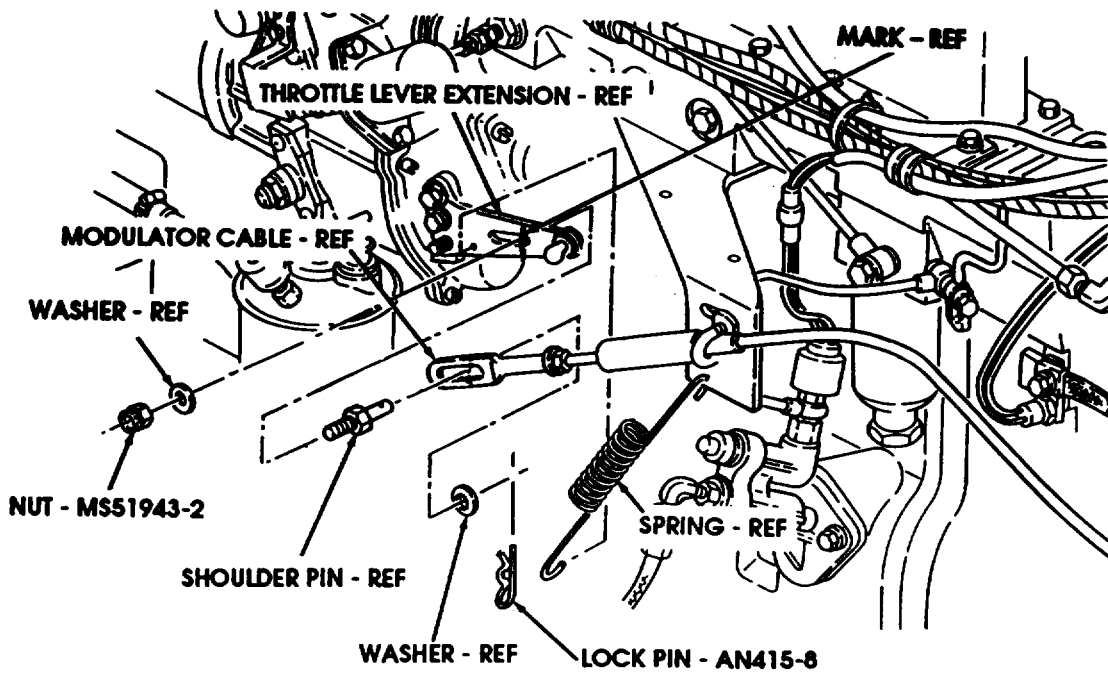

FIGURE 8

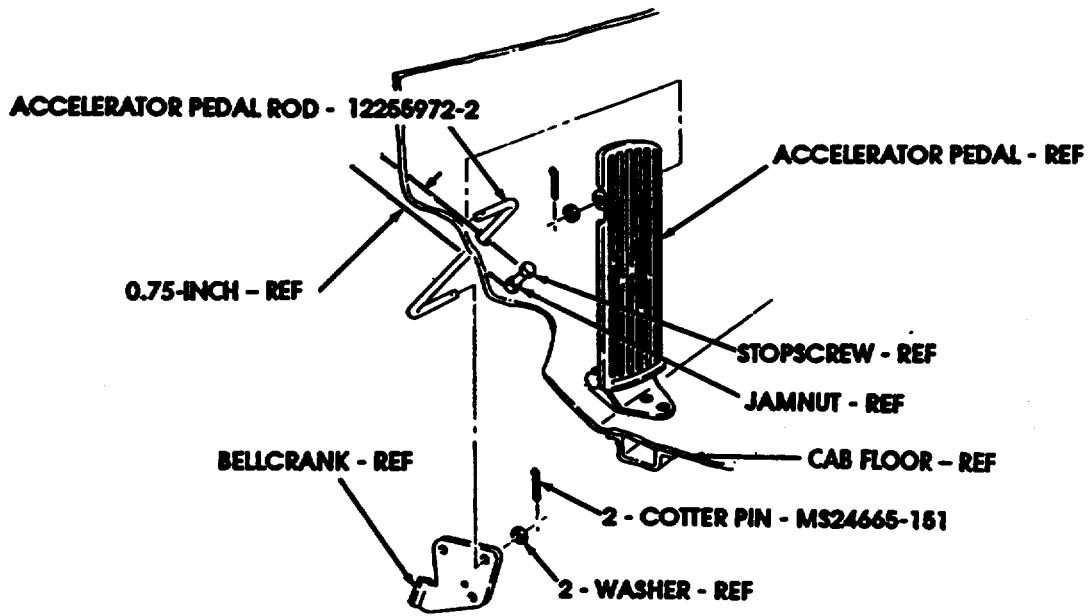

FIGURE 9

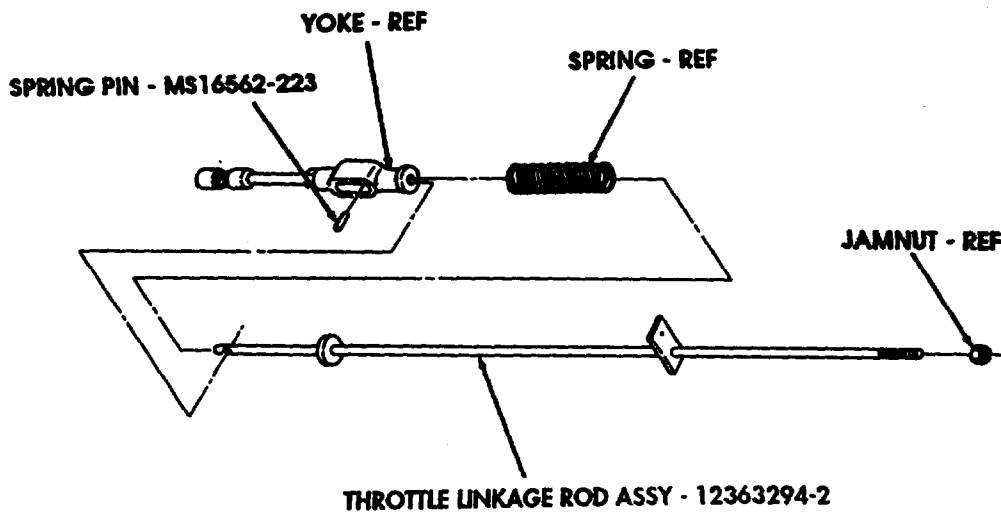

FIGURE 10

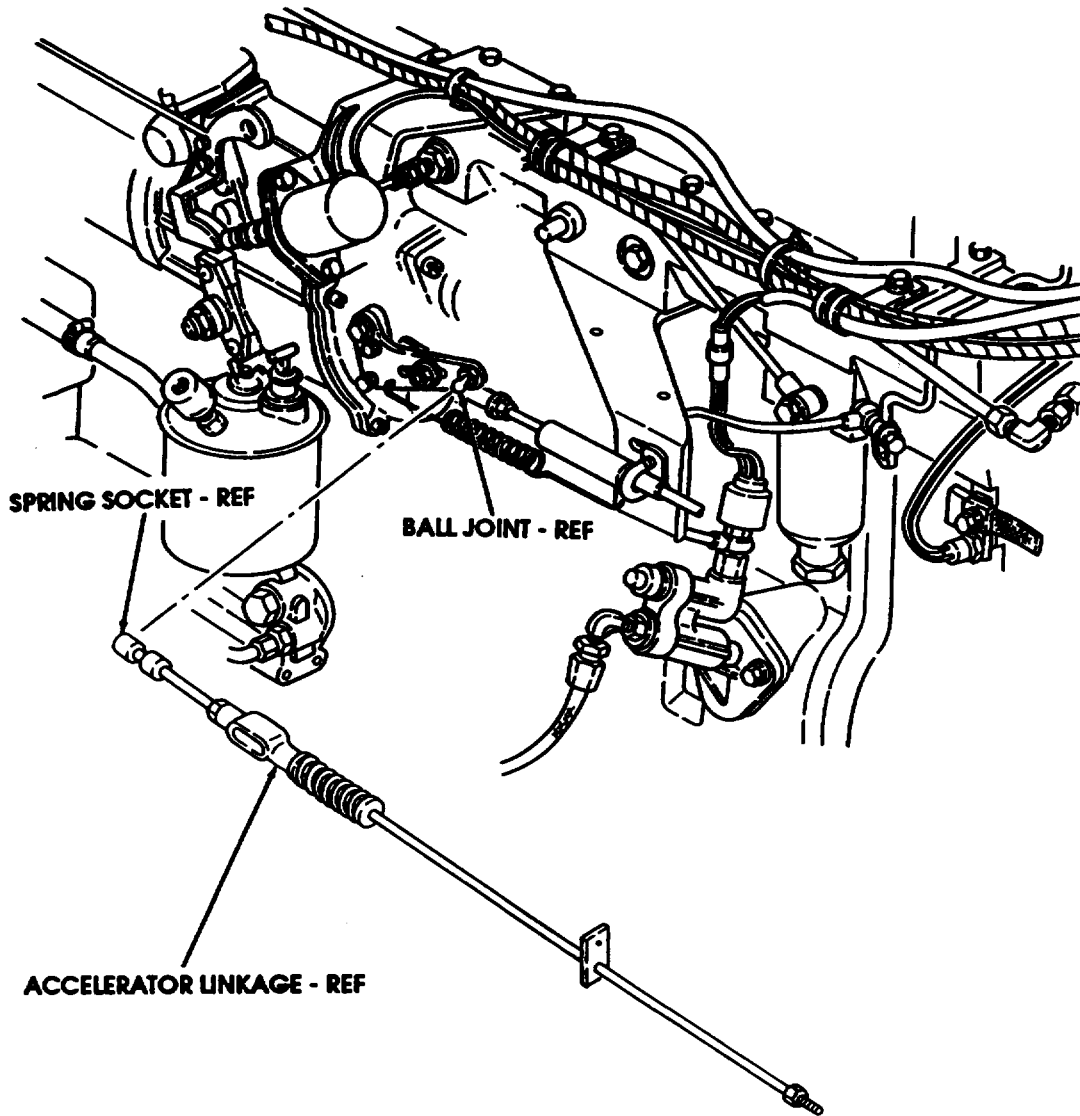

FIGURE 11

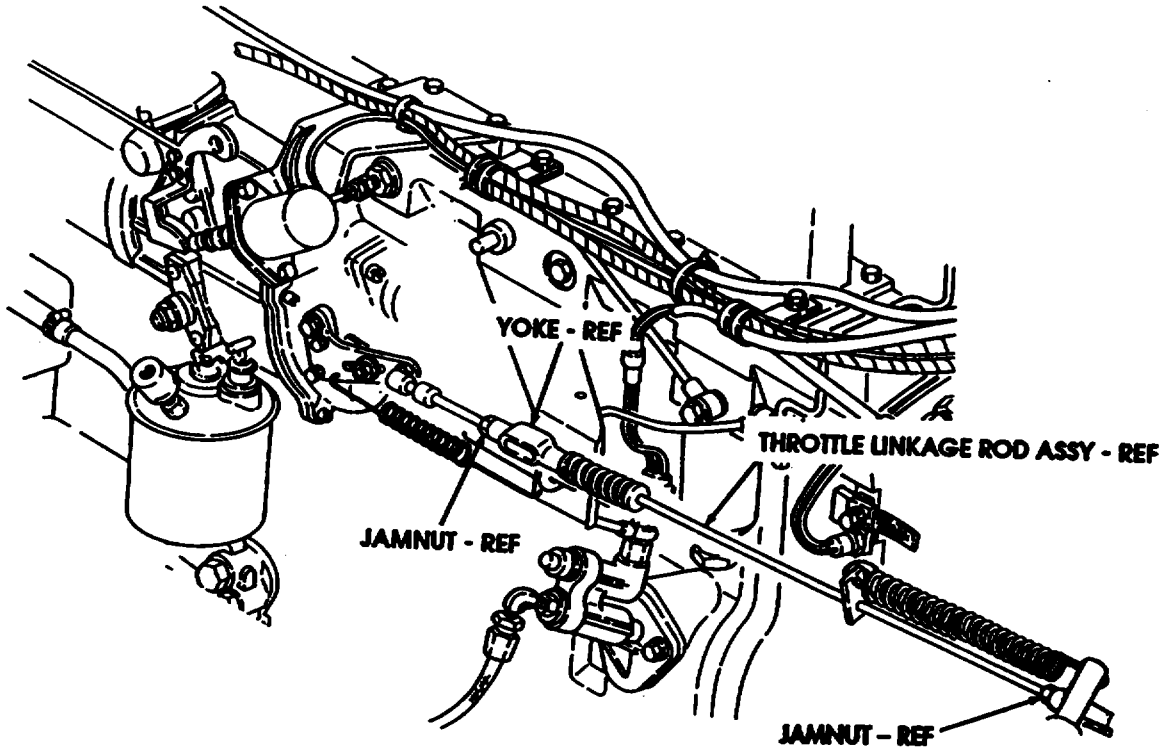

Figure 12

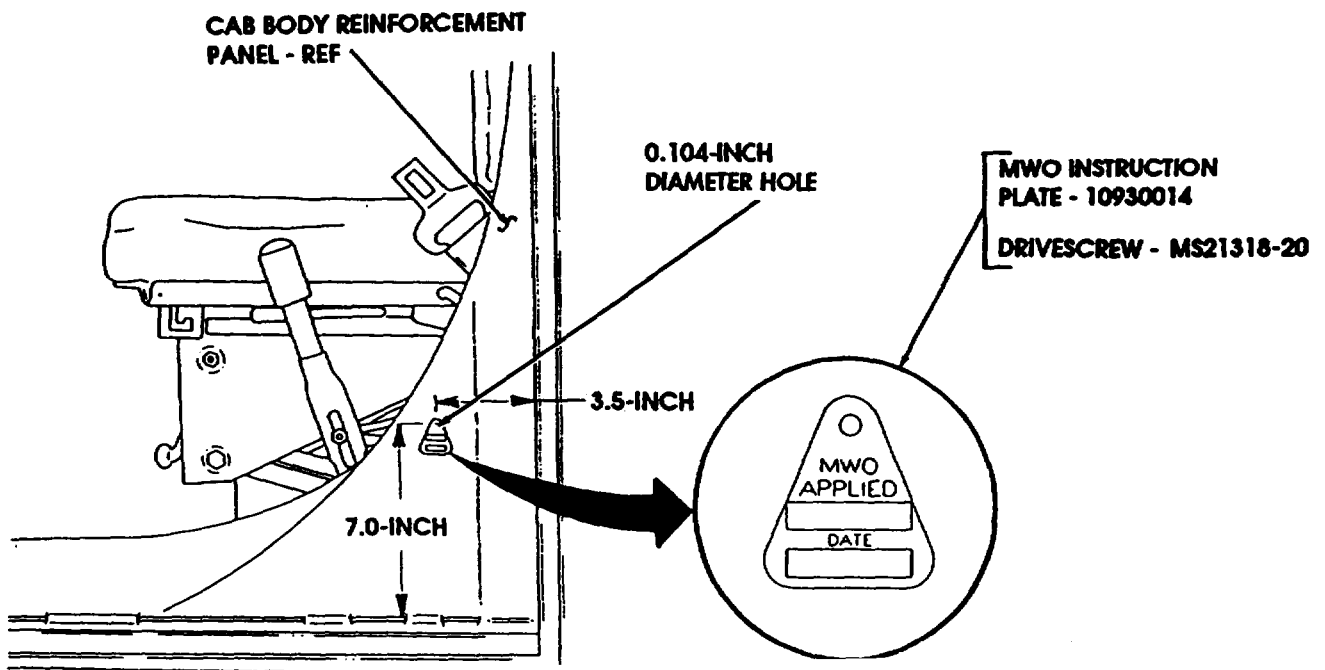

Figure 13  
15

By Order of the Secretary of the Army:

Official: 

JOEL B. HUDSON  
*Administrative Assistant to the  
Secretary of the Army*  
03421

DENNIS J. REIMER  
*General, United States Army  
Chief of Staff*

DISTRIBUTION:

To be distributed in accordance with the initial distribution number (IDN) 381045, requirements for MWO9-2320-272-20-8.

\* U. S. GOVERNMENT PRINTING OFFICE: 1997 545-010/60513



RECOMMENDED CHANGES TO EQUIPMENT TECHNICAL PUBLICATIONS



THEN... JOT DOWN THE DOPE ABOUT IT ON THIS FORM, CAREFULLY TEAR IT OUT, FOLD IT AND DROP IT IN THE MAIL!

**SOMETHING WRONG WITH THIS PUBLICATION?**

FROM: (PRINT YOUR UNIT'S COMPLETE ADDRESS)

DATE SENT

PUBLICATION NUMBER

PUBLICATION DATE

PUBLICATION TITLE

BE EXACT... PIN-POINT WHERE IT IS

PAGE NO.

PARA-GRAPH

FIGURE NO.

TABLE NO.

IN THIS SPACE TELL WHAT IS WRONG AND WHAT SHOULD BE DONE ABOUT IT:

TEAR ALONG PERFORATED LINE

PRINTED NAME, GRADE OR TITLE, AND TELEPHONE NUMBER

SIGN HERE:

DA FORM 2028-2  
1 JUL 79

PREVIOUS EDITIONS ARE OBSOLETE.

P.S.—IF YOUR OUTFIT WANTS TO KNOW ABOUT YOUR RECOMMENDATION MAKE A CARBON COPY OF THIS AND GIVE IT TO YOUR HEADQUARTERS.

**PIN: 075384-000**