

TECHNICAL MANUAL  
ORGANIZATIONAL MAINTENANCE MANUAL  
(INCLUDING REPAIR PARTS AND SPECIAL TOOLS LIST)  
FOR  
LAUNCHER, GRENADE, SMOKE: SCREENING, RP, M250  
(1040-00-000-0138)

HEADQUARTERS, DEPARTMENT OF THE ARMY

14 MAY 1982

This copy is a reprint which  
includes current pages from  
change 1

EXPENDABLE SUPPLIES  
AND MATERIALS LIST  
D-1

REPAIR PARTS AND  
SPECIAL TOOLS LIST  
C-0

MAINTENANCE  
ALLOCATION CHART  
B-0

MAINTENANCE  
PROCEDURES  
2-12

TROUBLESHOOTING  
2-4

SERVICE UPON RECEIPT  
2-1

## **FIRST AID**

For first aid information, refer to FM 21-11.

TM 3-1040-268-20&P  
C1

CHANGE }  
No. 1 }

HEADQUARTERS  
DEPARTMENT OF THE ARMY  
WASHINGTON, DC, 30 April 1986

**TECHNICAL MANUAL  
ORGANIZATIONAL MAINTENANCE MANUAL  
(INCLUDING REPAIR PARTS  
AND SPECIAL TOOLS LIST)  
FOR LAUNCHER, GRENADE,  
SMOKE: SCREENING, RP, M250  
(1040-00-000-0138)**

TM 3-1040-268-20&P, 14 May 1982, is changed as follows:

1. Remove old pages and insert new pages as indicated below.
2. New or changed materials is indicated by a vertical bar in the margin of the page.

Remove Pages

1-1 and 1-2  
C-5 through C-8

Insert Pages

1-1 and 1-2  
C-5 through C-8

File this change sheet in the back of the publication for reference purposes.

By Order of the Secretary of the Army:

JOHN A. WICKHAM, JR.  
*General, United States Army*  
*Chief of Staff*

Official:

R. L. DILWORTH  
*Brigadier General, United States Army*  
*The Adjutant General*

**DISTRIBUTION:**

To be distributed in accordance with DA Form 12-40, Organizational maintenance requirements for Launcher, Grenade, Smoke, M250.

TECHNICAL MANUAL }  
 No. 3-1040-268-20&P }

HEADQUARTERS  
 DEPARTMENT OF THE ARMY  
 Washington, D.C. 14 May 1982

**Organizational Maintenance Manual  
 (including Repair Parts and Special Tools List)  
 for  
 LAUNCHER, GRENADE, SMOKE: SCREENING, RP, M250  
 (1040-00-000-0138)**

**REPORTING ERRORS AND RECOMMENDING IMPROVEMENTS**

You can help improve this manual. If you find any mistakes or if you know of a way to improve the procedures, please let us know. Mail your letter, DA Form 2028 (Recommended Changes to Publications and Blank Forms), or DA Form 2028-2 located in the back of this manual direct to: Commander, US Army Armament Materiel Readiness Command, Attn: DRSAR-MAS-C, Aberdeen Proving Ground, MD21010. A reply will be furnished to you.

**TABLE OF CONTENTS**

		Page
	<b>HOW TO USE THIS MANUAL</b> .....	iii
<b>CHAPTER 1</b>	<b>INTRODUCTION</b> .....	1-1
Section I.	General Information .....	1-1
Section II.	Equipment Description and Data... ..	1-2
Section III.	Principles of Operation .....	1-4
<b>CHAPTER 2</b>	<b>MAINTENANCE INSTRUCTIONS</b> .....	2-1
Section I.	Repair Parts, Special Tools, TMDE, and Support Equipment .....	2-1
Section II.	<div style="border: 1px solid black; display: inline-block; padding: 2px;">Service Upon Receipt</div> .....	2-1
Section III.	Preventive Maintenance Checks and Services (PMCS) .....	2-4

Section IV.	<b>Troubleshooting</b> .....	2-4
Section V.	<b>Maintenance Procedures</b> .....	2-12
Section VI.	Preparation for Storage or Shipment .....	2-32
<b>APPENDIX A</b>	REFERENCES .....	A-1
<b>APPENDIX B</b>	<b>MAINTENANCE ALLOCATION CHART</b> .....	B-0
Section I.	Introduction .....	B-0
Section II.	Maintenance Allocation Chart for Launcher, Grenade, Smoke: Screening, RP, M250 .....	B-1
Section III.	Tool and Test Equipment Requirements .....	B-1
<b>APPENDIX C</b>	<b>REPAIR PARTS AND SPECIAL TOOLS LIST</b> .....	C-0
Section I.	Introduction .....	C-0
Section II.	Repair Parts List .....	C-4
Group 00	Launcher, Grenade, Smoke, M250 .....	C-5
Group 01	Smoke grenade discharger .....	C-7
Group 0999	Bulk Material .....	C-9
Section III.	Special Tools List (Nonapplicable) .....	C-9
Section IV.	National Stock Number and Pati Number Index .....	C-10
<b>APPENDIX D</b>	<b>EXPENDABLE SUPPLIES AND MATERIALS LIST</b> .....	D-1
Section I.	Introduction .....	D-1
Section II.	Expendable Supplies and Materials List .....	D-2
	<b>ALPHABETICAL INDEX</b> .....	Index-1

## HOW TO USE THIS MANUAL

### NOTE

Illustrations throughout this manual will show the LEFT-HAND discharger for most procedures. Procedures will be identical for both dischargers.

### GENERAL

When using this manual:

- a. The launcher is either being prepared for installation on a combat tank or has been removed for maintenance.
- b. You must familiarize yourself with the entire maintenance procedures before beginning the maintenance task.
- c. References are to pages, paragraphs, or other publications.

### INDEXES

For quick access to parts of this manual, there are three indexes.

- a. *Front Cover Index*. Important sections and appendixes are tabbed. Tabs are keyed to page locations.
- b. *Table of Contents*. Lists in order all chapters, sections, and appendixes. Gives page references.
- c. *Alphabetical Index*. Lists page numbers for each paragraph and appendix.

### INTRODUCTION

Chapter 1 describes the launcher and its principles of operation.

### MAINTENANCE INSTRUCTIONS

Chapter 2 covers:

- a. *Service Upon Receipt*. Gives procedures for servicing launchers upon receipt.
- b. *Troubleshooting*. Provides detailed illustrated procedures for troubleshooting discharger.
- c. *Maintenance Procedures*. Provides initial setup and detailed procedures for performing maintenance functions authorized by the maintenance allocation chart (MAC), appendix B.
- d. *Preparation for Storage or Shipment*. Gives criteria for storing or shipping launchers.

### APPENDIXES

The appendixes contain:

- a. A list of all references used
- b. The MAC
- c. The RPSTL with illustrations
- d. A list of expendable supplies you'll need

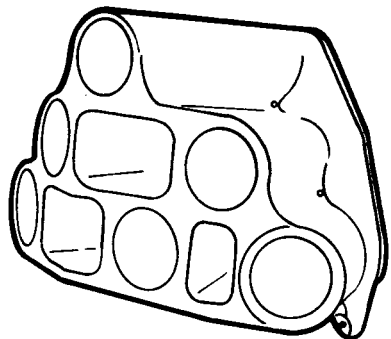

(LEFT HAND)  
DISCHARGER, SMOKE GRENADE: LH, No. 19, MK2

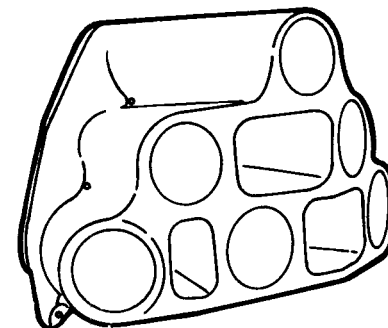

(RIGHT HAND)  
DISCHARGER, SMOKE GRENADE: RH, No. 19, MK2

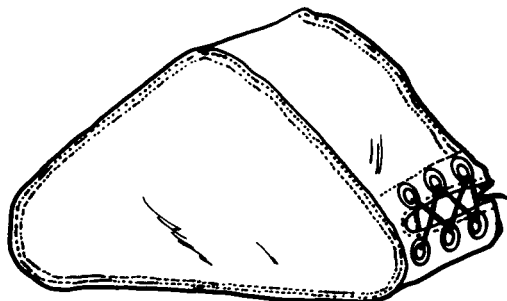

COVER, PROTECTIVE, DISCHARGER: LH

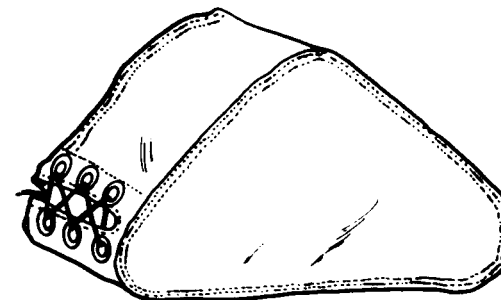

COVER, PROTECTIVE, DISCHARGER: RH

LAUNCHER, GRENADE, SMOKE: Screening, RP, M250

# CHAPTER 1 INTRODUCTION

## Section I. GENERAL INFORMATION

### 1-1. SCOPE.

#### NOTE

Illustrations throughout this manual will show the LEFT-HAND discharger for most procedures. Procedures will be identical for both dischargers.

a. *Type of Manual:* Organizational Maintenance Manual, including Repair Parts and Special Tools List.

b. *Mode/ Number and Equipment Name:* M250 RP screening smoke grenade launcher.

c. *Purpose of Equipment.* To project smoke grenades from a combat vehicle to screen it from enemy view.

**1-2. MAINTENANCE FORMS, RECORDS, AND REPORTS.** Department of the Army forms and procedures used for equipment maintenance will be those prescribed by DA PAM 738-750 Change 1, The Army Maintenance Management System.

**1-3. DESTRUCTION OF ARMY MATERIEL TO PREVENT ENEMY USE.** Destroy launcher components by using demolition or mechanical methods described in TM 43-0002-31.

**1-4. PREPARATION FOR STORAGE OR SHIPMENT.** Refer to paragraphs 2-10 through 2-13 for instructions on how to prepare launcher for storage or shipment.

**1-5. NOMENCLATURE CROSS-REFERENCE LIST AND LIST OF ABBREVIATIONS.** This listing includes nomenclature cross-references used in this manual.

<i>Common Name</i>	<i>Official Nomenclature</i>
Discharger(s)	DISCHARGER, SMOKE GRENADE: (RH, LH, or both)
Discharger cover(s)	COVER, PROTECTIVE DISCHARGER: (RH, LH, or both)

<i>Common Name</i>	<i>Official Nomenclature</i>
Electrical Receptacle Connector Grenade	CONNECTOR, RECEPTACLE, ELECTRICAL GRENADE, LAUNCHER, SMOKE: Screening, RP, UK L8A1, M76
Launcher	LAUNCHER, GRENADE, SMOKE: Screening, RP, M250
Left Hand Discharger	DISCHARGER, SMOKE GRENADE: LH, No. 19, MK2
Left Hand Discharger Cover	COVER, PROTECTIVE, DISCHARGER: LH
M250 Launcher	LAUNCHER, GRENADE, SMOKE: Screening, RP, M250
Multimeter Resistor	MULTIMETER: TS-352B/U or equivalent RESISTOR PACK ASSEMBLY
Right Hand Discharger	DISCHARGER, SMOKE GRENADE: RH, No. 19, MK2
Right Hand Discharger Cover	COVER, PROTECTIVE, DISCHARGER: RH
Smoke Grenade Launcher	LAUNCHER, GRENADE, SMOKE: Screening, RP, M250

<i>Abbreviations</i>	<i>Explanation</i>
RP .....	Red phosphorous
UK .....	United Kingdom

**1-6. REPORTING EQUIPMENT IMPROVEMENT RECOMMENDATIONS (EIR).** If your smoke grenade launcher needs improvement, let us know. Send us an EIR. You, the user, are the only one who can tell us what you don't like about your equipment, Let us know why you don't like the design, Put it on an SF 368 (Quality Deficiency Report), Mail it to us at: Commander, US Army Armament Materiel Readiness Command, ATTN: DRSAR-MAP-A, Aberdeen Proving Ground, MD 21010. We'll send you a reply.

Section II. EQUIPMENT DESCRIPTION AND DATA

1-7. EQUIPMENT CHARACTERISTICS, CAPABILITIES, AND FEATURES.

- a. *Characteristics.* When mounted on a combat vehicle:
- Launches screening smoke grenades by electrical ignition.
  - Fires salvo of six or twelve grenades.

- b. *Capabilities and Features.*
- Modular design permits adaptation to more than one type of vehicle.
  - Durable components reduce maintenance workload.
  - Simple electrical circuits are easy to check and maintain.
  - Each major component can be maintained by itself.
  - Requires no special tools or TMDE for maintenance.

1-8. LOCATION AND DESCRIPTION OF MAJOR COMPONENTS.

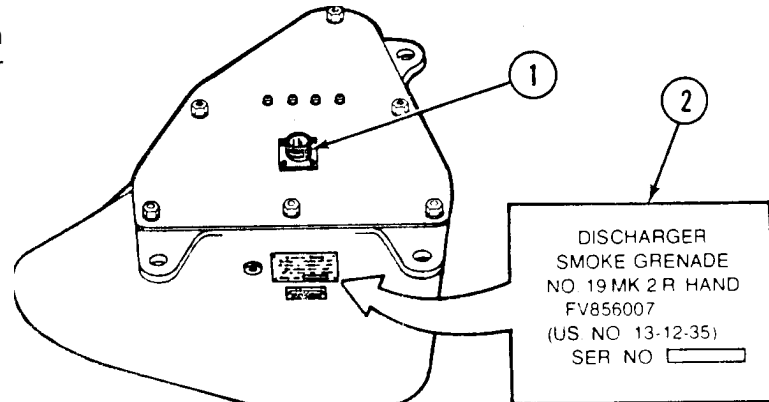
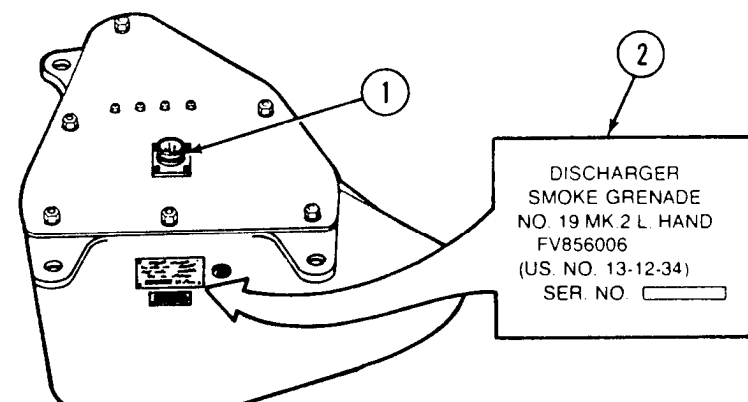
LOCATION	DESCRIPTION
<p>(A) RIGHT HAND DISCHARGER</p>	<p>Aluminum casting with six barrels angled to launch grenades in an arc. Electrical receptacle connector (1) connects discharger to tank's electrical system. Nameplate (2) on top identifies launcher.</p> 
<p>(B) LEFT HAND DISCHARGER</p>	<p>Aluminum casting with six barrels angled to launch grenades in an arc. Electrical receptacle connector (1) connects discharger to tank's electrical system. Nameplate (2) on top identifies launcher.</p> 

- C
**RIGHT HAND DISCHARGER COVER**
Canvas cover fits right hand discharger. When installed, cover protects discharger barrels.

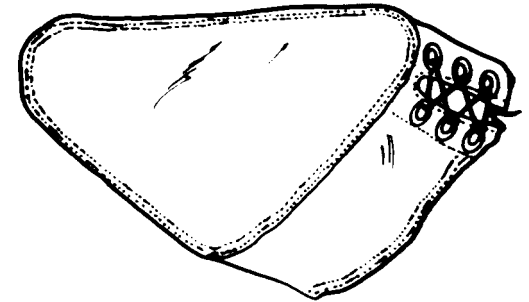

- D
**LEFT HAND DISCHARGER COVER**
Canvas cover fits left hand discharger. When installed, cover protects discharger barrels.

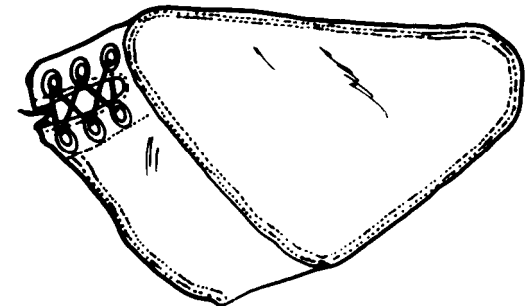

**1-9. EQUIPMENT DATA.**

	<i>US Customary</i>	<i>(Metric)</i>		<i>US Customary</i>	<i>(Metric)</i>
<b>DISCHARGER</b>					
Height .....	.11 in.	(279mm)	Depth .....	16 in.	(406mm)
Width .....	12 in.	(305mm)	Weight .....	33 lb	(15 kg)
Power Source .....	24Vdc				

## Section III. PRINCIPLES OF OPERATION

**1-10. M250 LAUNCHER.**

a. *Electrical Connections.* The launcher uses the vehicle's electrical system. Electrical receptacle connector on each discharger (fig. 1-1) connects them to electrical cables in the vehicle.

b. *Loading Dischargers.* Smoke grenades are muzzle-loaded into discharger barrels.

c. *Arming.* Moving a spring-loaded READY/SAFE switch in tank turret to READY and holding it there closes electrical circuit. A POWER LIGHT, next to the POWER SWITCH, goes on to warn that launcher is armed for firing.

d. *Firing.* Pressing one of two push switches in turret sends electrical charge to dischargers. Dischargers are wired to fire grenades from alternate barrels. Inside each discharger are two resistor assemblies wired to the electrical receptacle connector to reduce current. Each resistor assembly has three wires connected to jack connectors in three discharger barrels. One resistor is connected to pin A of the electrical receptacle connector and to barrels 3,4, and 6. The other resistor is connected to pin C and barrels 1,2, and 5. (A ground wire connects pin B to discharger body.) Pressing one push switch routes current to three of the jack connectors in each discharger and launches a salvo of six grenades (three from each discharger). Pressing both switches launches a salvo of twelve grenades. The charge flows through an electrical contact in grenade base and fires grenade's squib fuze.

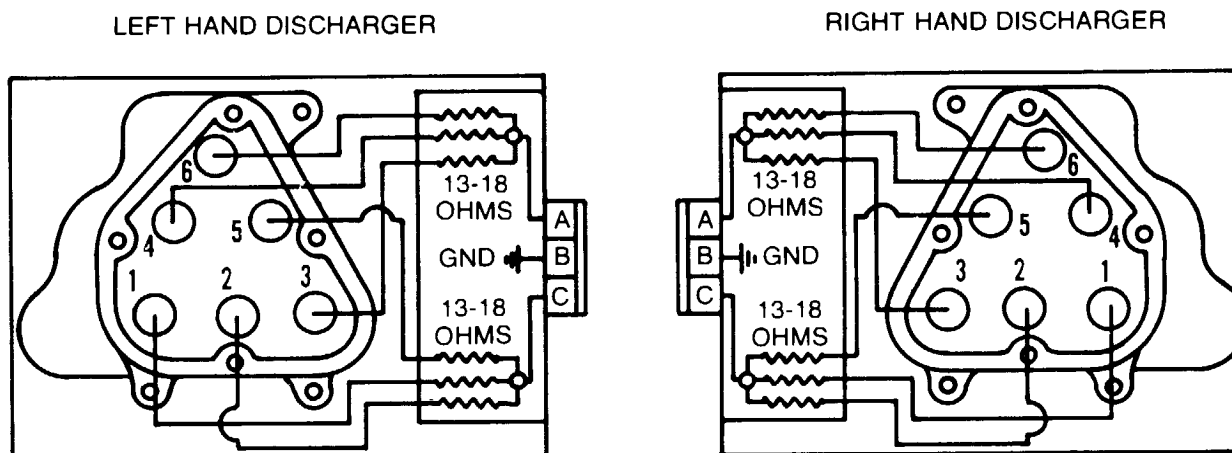

Figure 1-1. Launcher wiring diagram

**CHAPTER 2  
MAINTENANCE INSTRUCTIONS**

**Section I. REPAIR PARTS, SPECIAL TOOLS, TMDE, AND SUPPORT EQUIPMENT**

**2-1. COMMON TOOLS AND EQUIPMENT.** For authorized common tools and equipment, refer to the Modified Table of Organization and Equipment (MTOE) applicable to your unit. For tools and test equipment used to maintain launcher, refer to appendix B, section III.

**2-2. SPECIAL TOOLS, TM DE, AND SUPPORT EQUIPMENT.** None needed.

**2-3. REPAIR PARTS AND MATERIALS.** Repair parts to maintain launcher are listed and illustrated in appendix C. Expendable supplies and materials are listed in appendix D.

**Section II. SERVICE UPON RECEIPT**

**2-4. SERVICE UPON RECEIPT - LAUNCHER.**

LOCATION	ITEM	ACTION	REMARKS
1 Shipping Container	Launcher	Unpack.	
2 M250 Launcher	Components	<ul style="list-style-type: none"> <li>a. Inspect the equipment for damage incurred during shipment. If the equipment has been damaged, report the damage on SF 364, Report of Discrepancy.</li> <li>b. Check the equipment against the packing slip to M250 launcher consists of:                             <ul style="list-style-type: none"> <li>a. One left hand discharger and one right hand discharger.</li> <li>b. One left hand discharger cover and one right hand discharger cover.</li> </ul> </li> <li>c. Check to see whether the equipment has been modified. Refer to DA PAM 310-7.</li> </ul>	

**2-4. SERVICE UPON RECEIPT - LAUNCHER (CONT).**

LOCATION	ITEM	ACTION	REMARKS
3 Dischargers	a. Outer surfaces and parts	Inspect for dirt and grease. If dirty, wipe off dirt and grease with cloth (item 2, app D). Use stiff wire to unclog drain holes. Wash with soap (item 5, app D) and water. Rinse thoroughly with clean water. Allow to dry.	Low pressure (10 psig or less) compressed air may be used to speed drying and clear drain holes.
	b. Bores (1)	Inspect for dirt or grease. if dirty, clean with cleaning compound (item 1, app D). Wipe dry with clean cloth (item 2, app D).	
	c. Jack connectors (2)	Inspect for dirt or grease. If dirty, clean with cleaning compound (item 1, app D). Wipe dry with clean cloth (item 2, app D). Make sure no residue remains on any part after cleaning.	
	d. Discharger body (3) and cover plate (4)	<p>a. Inspect for cracks and missing screws (5) and bolts (6).</p> <p>b. Replace missing screws and bolts.</p> <p>c. Replace discharger if cracked.</p>	

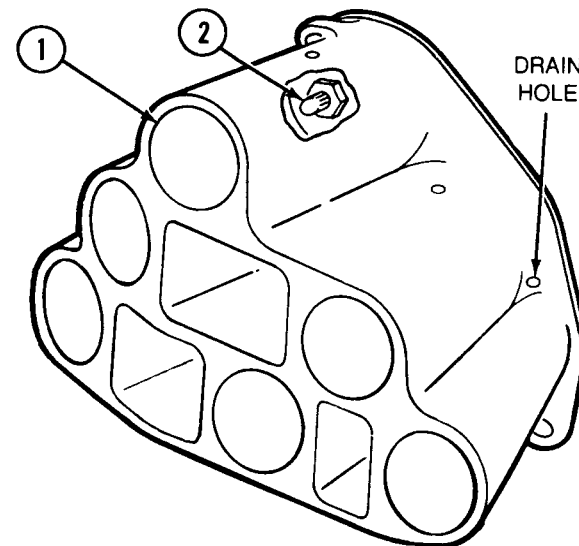

- e. Electrical receptacle connector (7)
- a. Inspect for broken shell, bent or missing pins, and missing screws (8).
  - b. Replace missing screws.
  - c. Straighten bent pins.
  - d. If shell is broken or pins are missing, replace electrical receptacle connector (7). See para 2-8c.

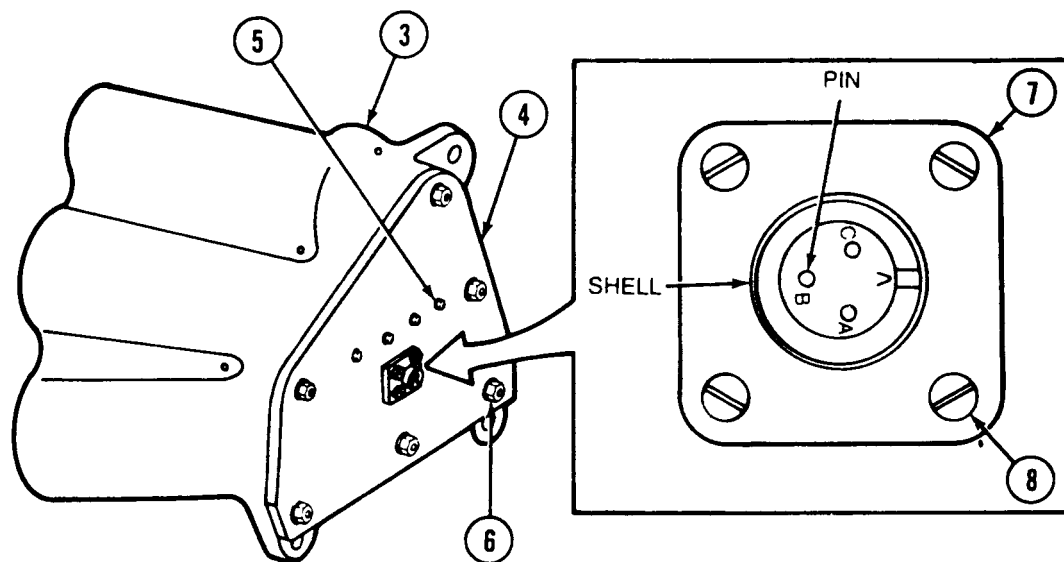

**2-4. SERVICE UPON RECEIPT - LAUNCHER (CONT).**

LOCATION	ITEM	ACTION	REMARKS
	f. Electrical circuits	Test for continuity.	See Table 2-1.
4 Discharger Covers	All surfaces	a. Inspect for cuts, tears, and punctures. b. Replace if damaged.	

**Section III. PREVENTIVE MAINTENANCE CHECKS AND SERVICES (PMCS)**

**2-5. PMCS PROCEDURES.** PMCS for the launcher is performed only when mounted on vehicles as part of scheduled PMCS for the vehicles.

**Section IV. TROUBLESHOOTING**

**2-6. TROUBLESHOOTING PROCEDURES.** This section contains those checks and actions that will isolate defects that can be corrected by performing the maintenance functions authorized by the MAC in appendix B. Table 2-1 lists

the common malfunctions that you may find during the operation or maintenance of the launcher or its components. You should perform the tests or inspections and corrective actions in the order listed.

Table 2-1 TROUBLESHOOTING PROCEDURES

MALFUNCTION	TEST OR INSPECTION	CORRECTIVE ACTION
-------------	--------------------	-------------------

1. DISCHARGER WON'T FIRE.

**NOTE**

Electrical receptacle connector key location (V) and position of pins A, B, and C are marked on insulator inside of shell. Electrical receptacle connector key on left hand discharger points to right. On right hand discharger, key points to left.

- Step 1. Inspect electrical receptacle connector (1) on cover plate (2) for broken shell and broken or bent pins A, B, and C,
- a. If shell or pins are broken, replace electrical receptacle connector. Remove and install (para 2-8c).
  - b. If pins are bent, straighten.

Step 2. Place discharger(s) on bench and mark barrels 1 through 6 as shown.

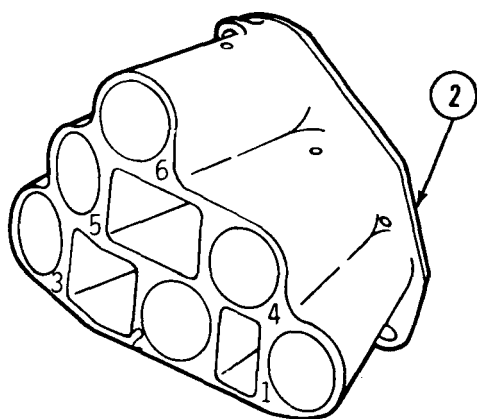

LEFT HAND

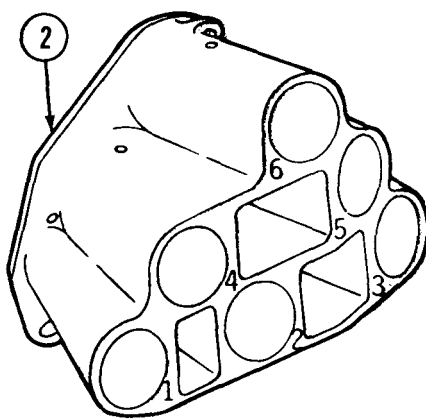

RIGHT HAND

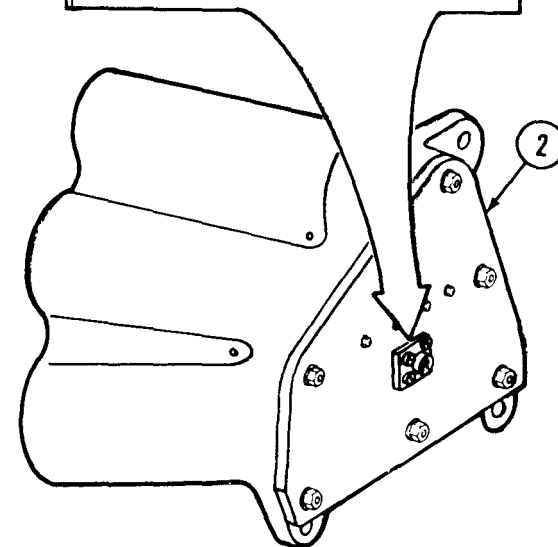
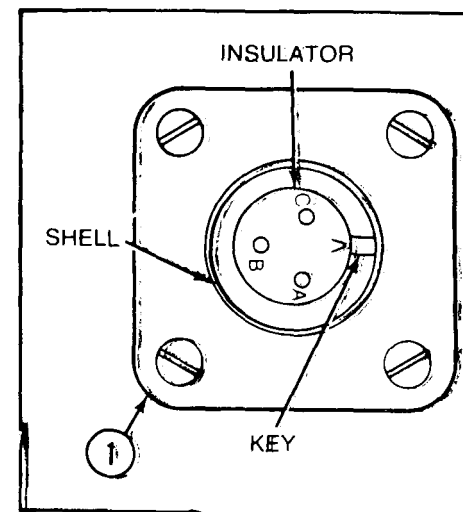

Table 2-1. TROUBLESHOOTING PROCEDURES (CONT)

MALFUNCTION	TEST OR INSPECTION	CORRECTIVE ACTION
-------------	--------------------	-------------------

1. DISCHARGER WON'T FIRE (CONT).

**NOTE**

Do not let multimeter probe prod touch connector rim. This will cause wrong reading.



Insure good contact by multi meter probe prod on test point. Poor contact will cause false meter reading.

Step 3. Set range switch on Rx1000 and zero multimeter. Touch red probe prod on pin B (ground) of electrical receptacle connector (1). Touch black probe prod on bolt (2) on cover plate.

a. If meter reads zero (0) on OHMS scale, no fault.

Go to step 4.

b. If meter reads infinity ( $\infty$ ) on OHMS scale, open ground connection.

Replace ground wire. Remove and install (para 2-8d).

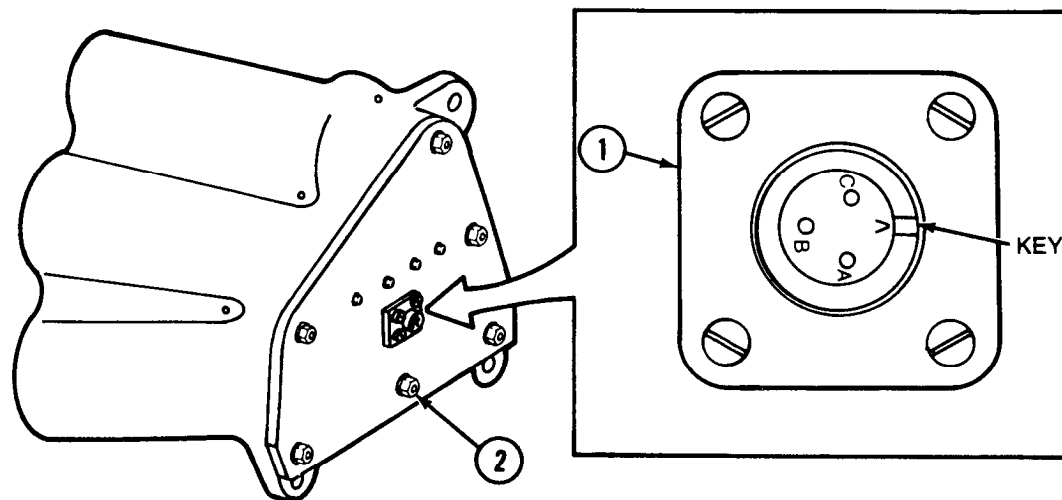

- Step 4. Set range switch on Rxl and zero multi meter. Touch red probe prod on pin A of electrical receptacle connector (1). Touch black probe prod on contact pin of jack connector (3) inside discharger barrels 3, 4, and 6.
- a. If meter reads 13 to 18 on OHMS scale, no fault.
    - Go to step 5.
  - b. If meter reads below 13 or above 18 on OHMS scale, loose connection between resistor and jack connector or bad resistor.
    - Replace resistor connected to pin A. Remove and install (para 2-8b).

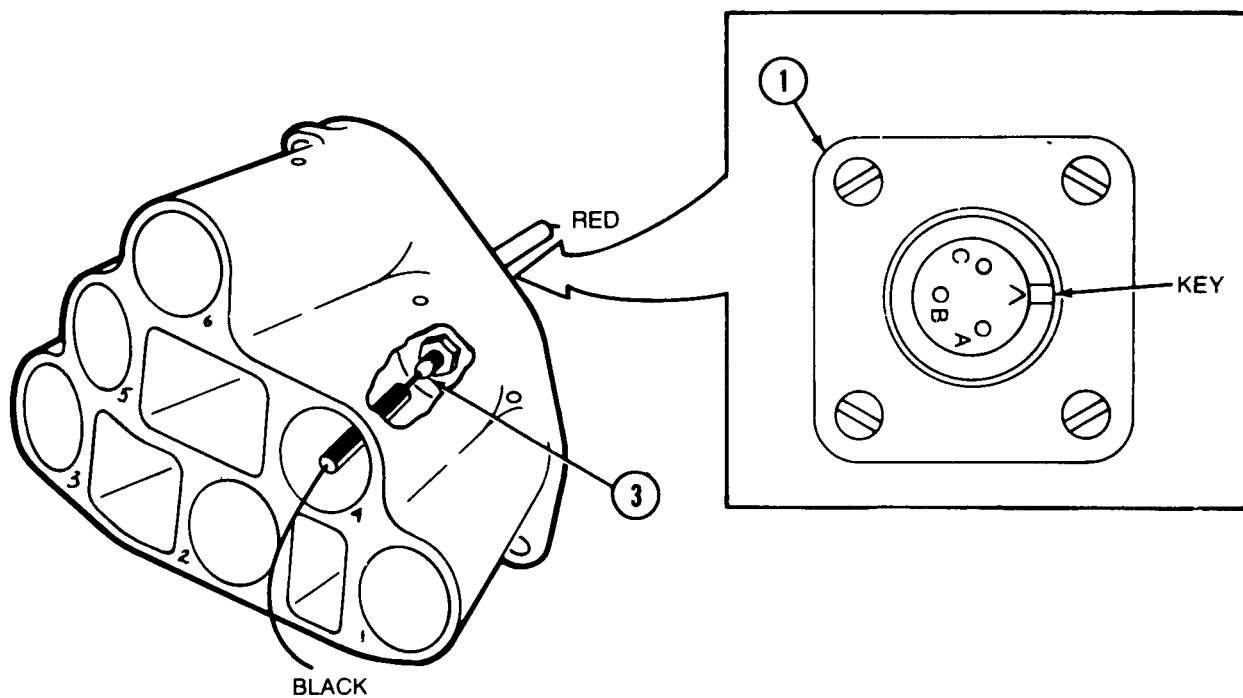

Table 2-1. TROUBLESHOOTING PROCEDURES (CONT)

MALFUNCTION	TEST OR INSPECTION	CORRECTIVE ACTION
-------------	--------------------	-------------------

1. DISCHARGER WON'T FIRE (CONT).

Step 5. With range switch on RxI, zero multi meter. Touch red probe prod on pin C of electrical receptacle connector (1 ). Touch black probe prod on contact pin of jack connector (2) inside barrels 1, 2, and 5.

a. If meter reads 13 to 18 on OHMS scale, no fault.

Go to step 6.

b. If meter reads below 13 or above 18 on OHMS scale, loose connection between resistor and jack connector or bad resistor.

Replace resistor connected to pin C. Remove and install (para 2-8 b).

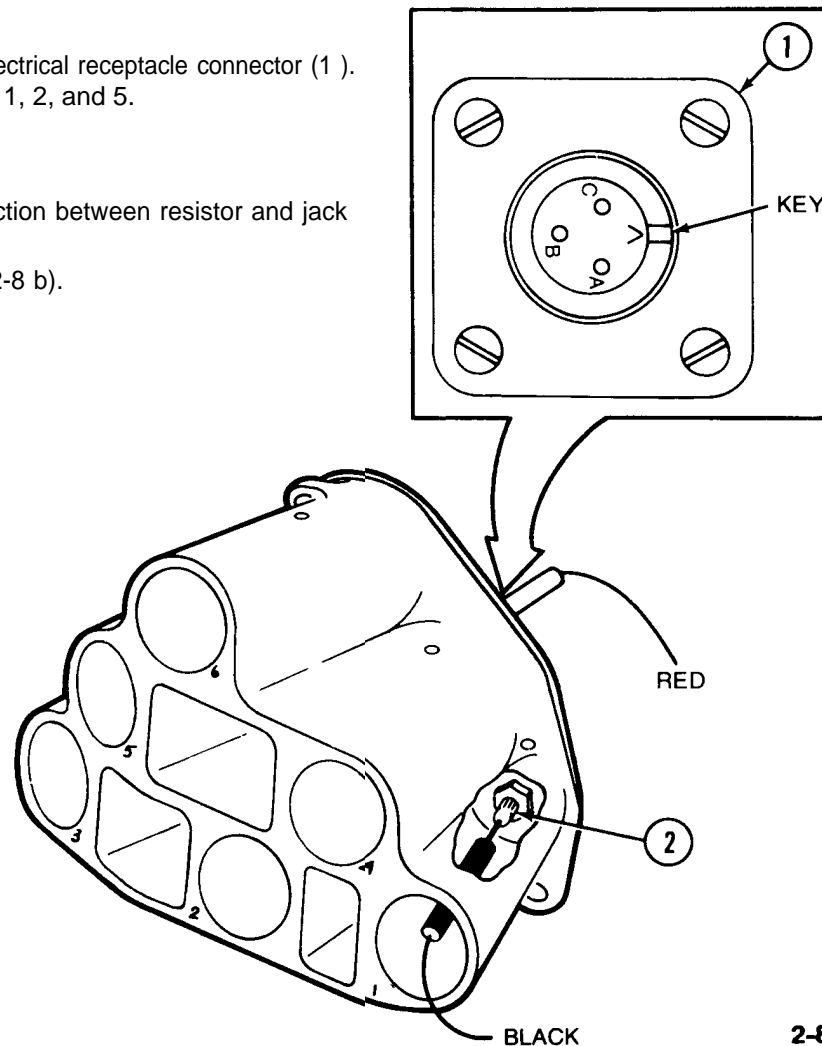

Step 6. Set range switch on Rx 1000 and zero multimeter. Touch red probe prod on pin B (ground) of electrical receptacle connector (1). Touch black probe prod on flat hex surface of jack connector (2) inside each barrel.

a. If meter reads zero (0) on OHMS scale, no fault,

Go to step 7.

b. If any other reading, corrosion is between jack connector and body.

(1) Remove jack connector, remove corrosion (clean), and install same jack connector (para 2-8a).

(2) Recheck jack connector, then go to step 7.

Step 7. With range switch on Rx1000, zero multimeter. Touch red probe prod on pin A of electrical receptacle connector (1). Touch black probe prod on flat hex surface of jack connector (2) inside barrels 3, 4, and 6.

a. If meter reads infinity (  $\infty$  ) on OHMS scale, no fault.

Go to step 8.

b. If meter reads zero (0) on OHMS scale, bad jack connector.

Replace jack connector. Remove and install (para 2-8a).

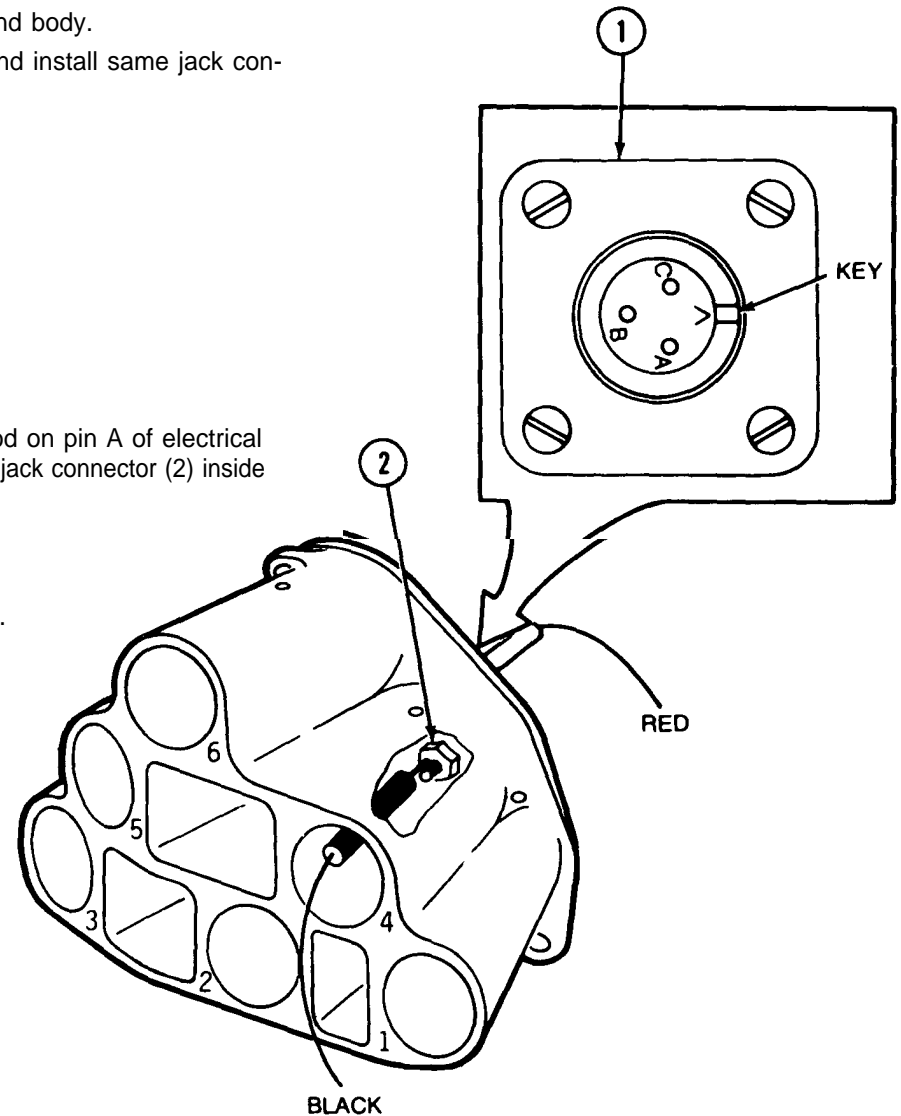

Table 2-1. TROUBLESHOOTING PROCEDURES (CONT)

---

MALFUNCTION	TEST OR INSPECTION	CORRECTIVE ACTION
-------------	--------------------	-------------------

---

## 1. DISCHARGER WON'T FIRE (CONT).

*Step 8.* With range switch on RX1000, zero multimeter. Touch red probe prod on pin C of electrical receptacle connector (1). Touch black probe prod on flat hex surface of jack connector (2) inside barrels 1, 2, and 5.

a. If meter reads infinity ( $\infty$ ) on OHMS scale, no fault.

Go to step 9.

b. If meter reads zero (0) on OHMS scale, bad jack connector.

Replace jack connector. Remove and install (para 2-8a).

*Step 9.* With range switch on Rx1000, zero multimeter. Touch red probe prod on pin B (ground) of electrical receptacle connector (1). Touch black probe prod first on pin A, then on pin C.

- a. If meter reads infinity (  $\infty$  ) on OHMS scale, no fault.
- b. If meter reads zero (0) on OHMS scale, bad electrical receptacle connector.  
Replace electrical receptacle connector. Remove and install (para 2-8c).

## 2. DISCHARGER ALWAYS FIRES SIX GRENADES.

*Step 1.* With range switch on Rx1000, zero multimeter. Touch red probe prod on pin A of electrical receptacle connector (1). Touch black probe prod on pin C.

- a. If meter reads infinity (  $\infty$  ) on OHMS scale, no fault.
- b. If any other reading, bad electrical receptacle connector.

Replace electrical receptacle connector. Remove and install (para 2-8c).

## Section V. MAINTENANCE PROCEDURES

**2-7. INTRODUCTION.** The following procedures are authorized to be performed by organizational maintenance personnel. Personnel are not listed because one M1 Combat Tank Turret Mechanic MOS 45E can do the task. No special environmental conditions are listed because none are required.

**NOTE**

Barrels and connector wires are numerically referenced on illustrations to aid maintenance personnel. Circled numeric callouts with arrows will reference specific items identified in text.

**2-8. DISCHARGERS - MAINTENANCE INSTRUCTIONS.**

This task covers:

- |  |  |
|--|--|
| <ul style="list-style-type: none"> <li>a. Removal</li> <li>b. Cleaning</li> <li>c. Inspection</li> </ul> | <ul style="list-style-type: none"> <li>d. Installation</li> <li>e. Testing</li> <li>f. Painting</li> </ul> |
|--|--|

## INITIAL SETUP

*Test Equipment*

Multimeter TS-352B/U or equal

*Tools*

SC 4910-95-CL-A74 Automotive Maintenance and Repair Shop Equipment,  
Common No. 1 NSN 4910-00-754-0654  
SC 5180-91-CL-R13 Electronic Equipment Tool Kit, TK-101/G NSN  
5180-00-064-5178  
SC 5180-95-CL-A51 Turret Mechanic's Tool Kit NSN 5180-00-695-0139

*Materials/Parts*

Cleaning compound (item 1, app D)  
Cloth (item 2, app D)  
Enamel (item 3, app D)  
Primer coating (item 4, app D)  
Solder (item 6, app D)  
Packing with retainer NSN 5330-00-119-7501

*References*

SC 4910-95-CL-A74  
SC 5180-91-CL-R13  
SC 5180-95-CL-A51  
TB SIG 222  
TM 11-6625-366-10  
TM 43-0139

*Troubleshooting References*

Table 2-1, malfunction 1. Discharger Won't Fire.  
Table 2-1, malfunction 2. Discharger Always Fires Six Grenades.

LOCATION	ITEM	ACTION	REMARKS
----------	------	--------	---------

a. Jack Connectors - Maintenance Instructions.

**REMOVAL**

**CAUTION**

To avoid damage to discharger, do not put strain on wires.

**NOTE**

This procedure is used to replace any of six jack connectors.

Body

- |   |   |
|---|---|
| <ul style="list-style-type: none"> <li>a. Cover plate (1)</li> <li>b. Ground wire B</li> <li>c. Jack connector (6)</li> </ul> | <ul style="list-style-type: none"> <li>a. Remove six bolts (2) and six lockwashers (3).</li> <li>b. Remove cover plate from body (4).</li> <li>c. Rotate 360° to unwind wires.</li> <li>d. Prop against body.</li> <li>Remove ground screw (5) and disconnect terminal.</li> <li>a. Remove six self-locking nuts (7) and disconnect resistor wires 1 through 6.</li> <li>b. Using socket wrench handle with extension and socket, hold adapter (8).</li> <li>c. Turn large nut (9) with wrench. Remove nut and lockwasher (10).</li> <li>d. Remove faulty jack connector (6) including bonded seal (11).</li> </ul> |
|---|---|

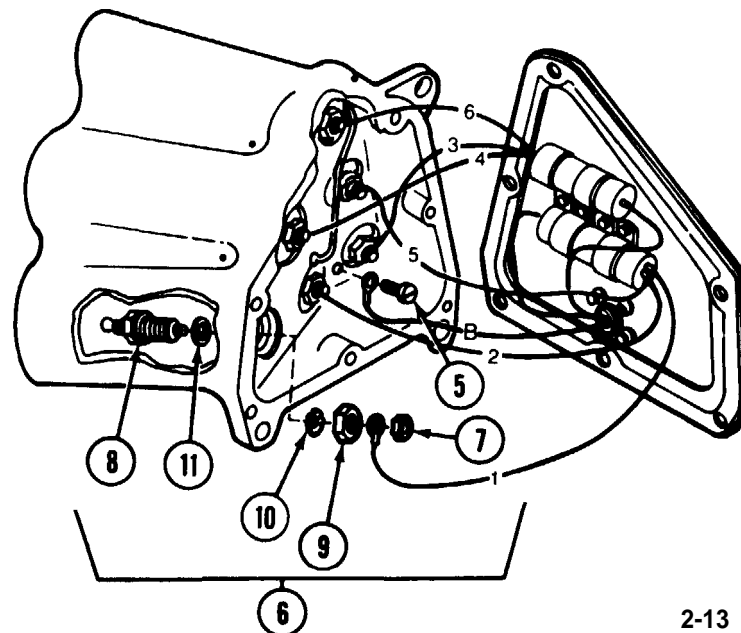
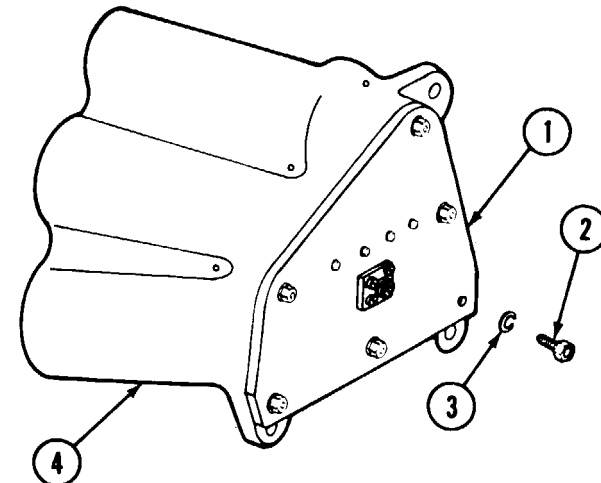

**2-8. DISCHARGERS - MAINTENANCE INSTRUCTIONS (CONT).**

LOCATION	ITEM	ACTION	REMARKS
----------	------	--------	---------

a. Jack Connectors - Maintenance Instructions (Cont).

**CLEANING**

Body	Barrel base (1)	Clean barrel base with cleaning compound (item 1, app D) on paint brush. Wipe dry with clean cloth (item 2, app D).	
------	-----------------	---	--

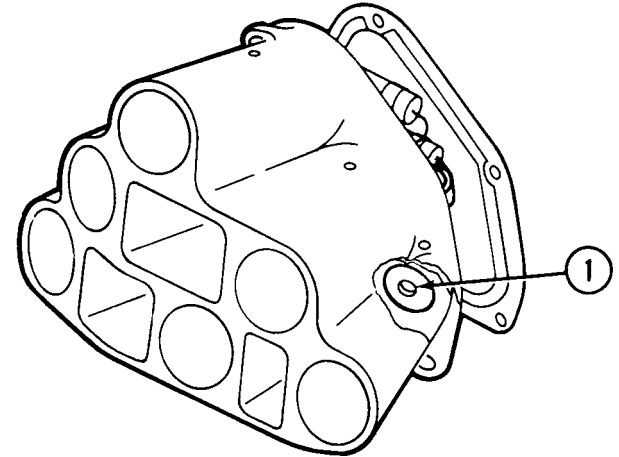

**INSPECTION**

Cover Plate	Gasket (1)	<ol style="list-style-type: none"> <li>Check material. If brittle or torn, scrape gasket from mating surfaces.</li> <li>Remove protective paper from adhesive on cover plate side of new gasket.</li> <li>Install new gasket on cover plate (2).</li> </ol>	
-------------	------------	---	--

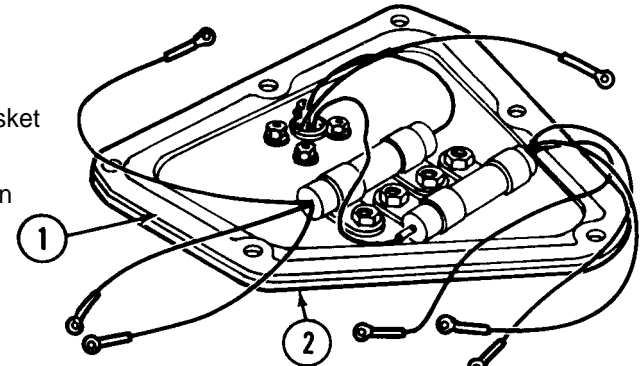

**INSTALLATION**

Body	a. Jack connector (1)	<ol style="list-style-type: none"> <li>Remove self-locking nut (2), large nut (3), and lockwasher (4) from new adapter (5). Leave bond seal (6) on adapter.</li> <li>Push adapter (5) and bond seal (6) through hole in discharger base.</li> </ol>	
------	-----------------------	---	--

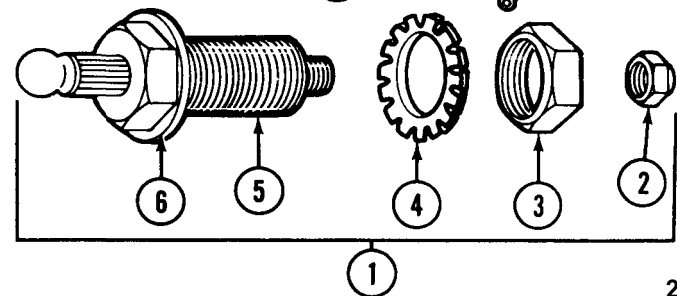

- c. Install lockwasher (4) and large nut (3) on adapter (5). Torque nut to 120 to 144 inch-pounds while holding adapter with socket wrench.
- d. Connect resistor wire terminals 1 through 6 to end of six jack connectors (1) and install six self-locking nuts (2). Tighten.

b. Ground screw (7)

Connect ground wire B to base with ground screw.

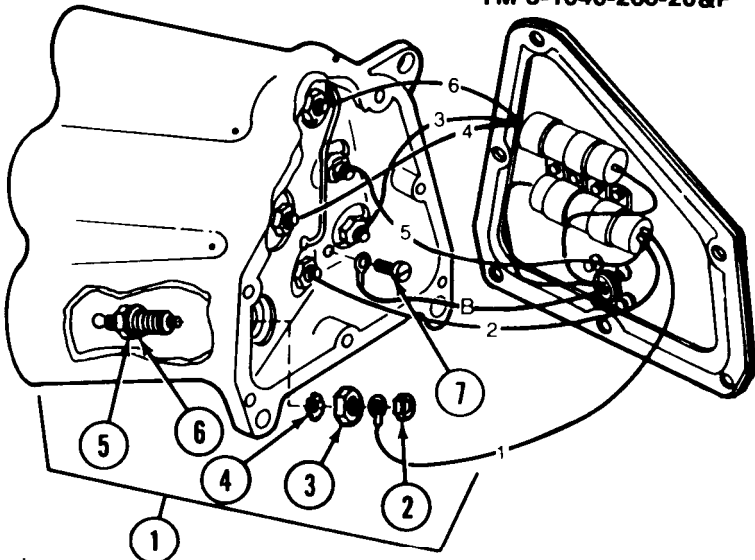

**CAUTION**

To avoid damage to discharger, do not pinch wires between cover plate and body.

- c. Cover plate (8)
- d. Bolts (10)

- a. Rotate 360° to wind wires.
- b. Install on discharger base (9) with six bolts (10) and six lockwashers (11). Torque to 48 to 72 inch-pounds.

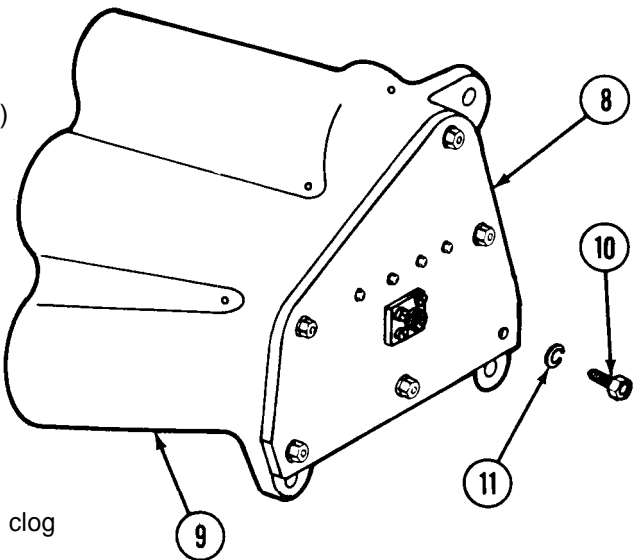

Troubleshoot, using multimeter do steps 7 and 8 under malfunction 1 in Table 2-1 (para 2-6).

**NOTE**

Do not paint electrical receptacle connector, jack connectors, nameplate, or screws. Do not let paint clog mounting holes or drain holes.

**TESTING**

Discharger

Jack connector

**PAINTING**

Discharger

All outside surfaces

- a. Remove burrs, corrosion, and chipped paint. See TM 43-0139.
- b. Touch up with primer coating (item 4, app D) and enamel (item 3, app D).

**2-8. DISCHARGER - MAINTENANCE INSTRUCTIONS (CONT).**

LOCATION	ITEM	ACTION	REMARKS
----------	------	--------	---------

b. Resistors - Maintenance instructions.

**REMOVAL**

**CAUTION**

To avoid damage to discharger, do not put strain on wires.

**NOTE**

This procedure is used to replace either of two resistors.

1 Body

- |  |  |
|--|--|
| <ul style="list-style-type: none"> <li>a. Cover plate (1)</li> </ul> | <ul style="list-style-type: none"> <li>a. Remove six bolts (2) and six lockwashers (3).</li> <li>b. Remove cover plate from body (4).</li> <li>c. Rotate 360° to unwind wires.</li> <li>d. Prop against body.</li> </ul> |
|--|--|

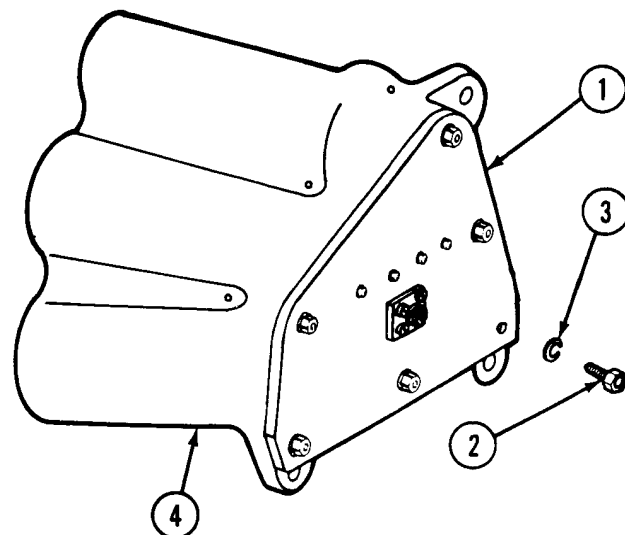

- |   |   |
|---|---|
| <ul style="list-style-type: none"> <li>b. Jack connector (5)</li> <li>c. Ground wire B</li> </ul> | <ul style="list-style-type: none"> <li>Remove six self-locking nuts (6) and disconnect resistor wires 1 through 6.</li> <li>Remove ground screw (7) and disconnect terminal.</li> </ul> |
|---|---|

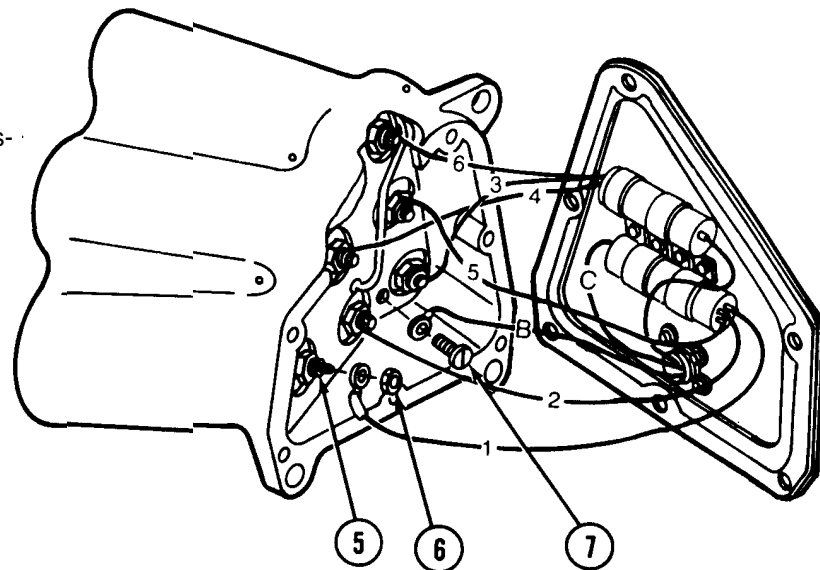

2 Cover Plate

a. Electrical receptacle connector (8)

- a. Using remover, remove pin A and resistor wire A or pin C and resistor wire C.
- b. Remove insulation sleeving and unsolder resistor wire lead from pin A or C.

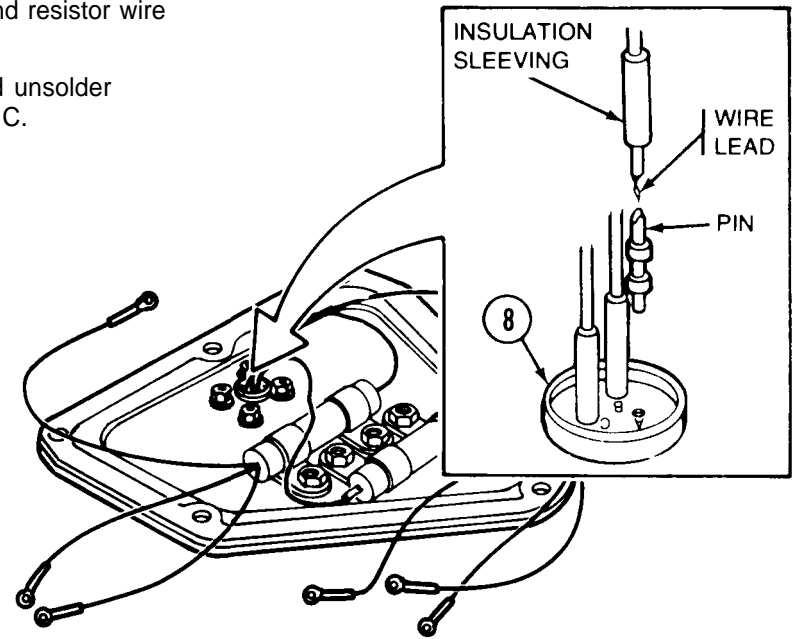

b. Resistor (9)

Remove two self-locking nuts (10) and two washers (11) from two clamps (12). Remove two screws (13) and preformed packing (14) from cover plate (1).

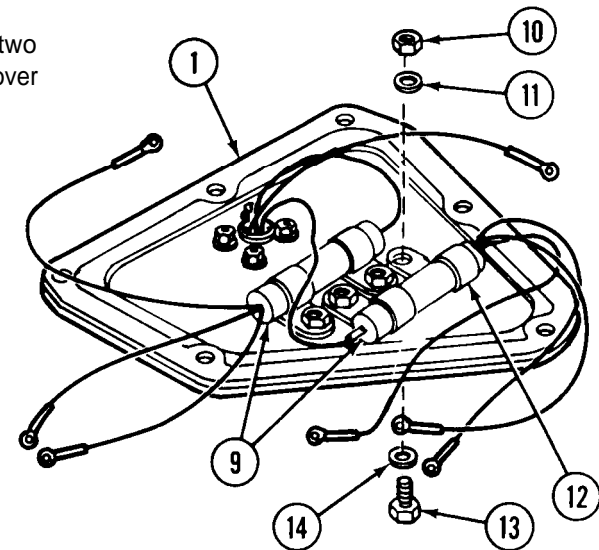

**2-8. DISCHARGERS - MAINTENANCE INSTRUCTIONS (CONT).**

LOCATION	ITEM	ACTION	REMARKS
----------	------	--------	---------

b. Resistors - Maintenance Instructions (Cont).

**TESTING**

1 Multimeter	Range switch	Set range switch on Rx1 and zero multimeter.	
2 Resistor	New resistor (1)	Touch black probe on single wire lead and place red probe on terminal for each of three wires, one at a time. a. If meter reads 13 to 18 on OHMS scale, resistance is good. b. If anyone of three readings is not between 13 to 18 ohms, replace resistor (1).	

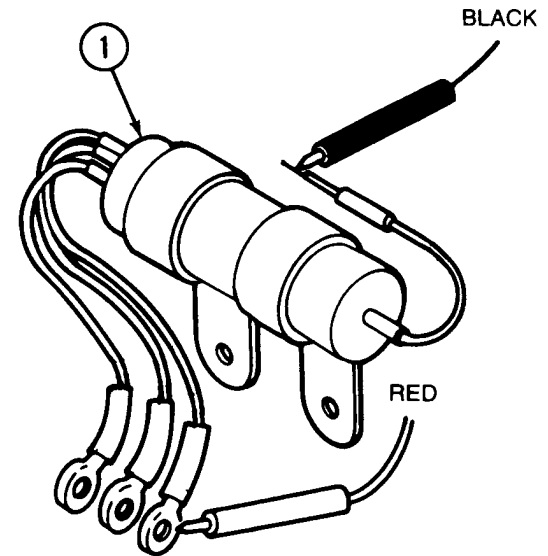

**INSPECTION**

Cover Plate	Gasket (1)	a. Check material. If brittle or torn, scrape gasket from mating surfaces. b. Remove protective paper from adhesive on cover plate side of new gasket. c. Install new gasket on cover plate (2).	
-------------	------------	--	--

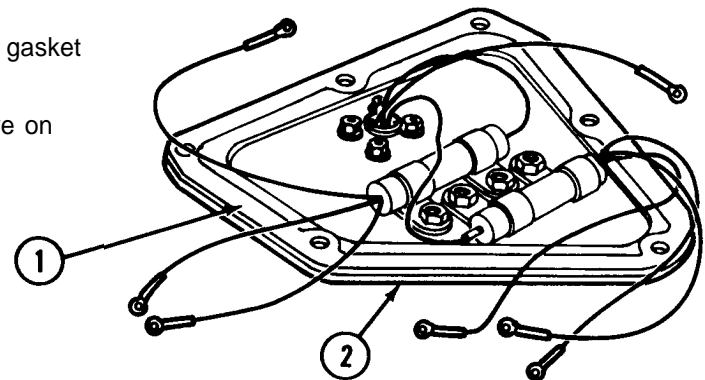

**INSTALLATION**

1 Cover Plate

a. Resistor (1)

Mount on cover plate (2) by installing two clamps (3) with preformed packing (4), two screws (5), two washers (6), and two self-locking nuts (7). Tighten.

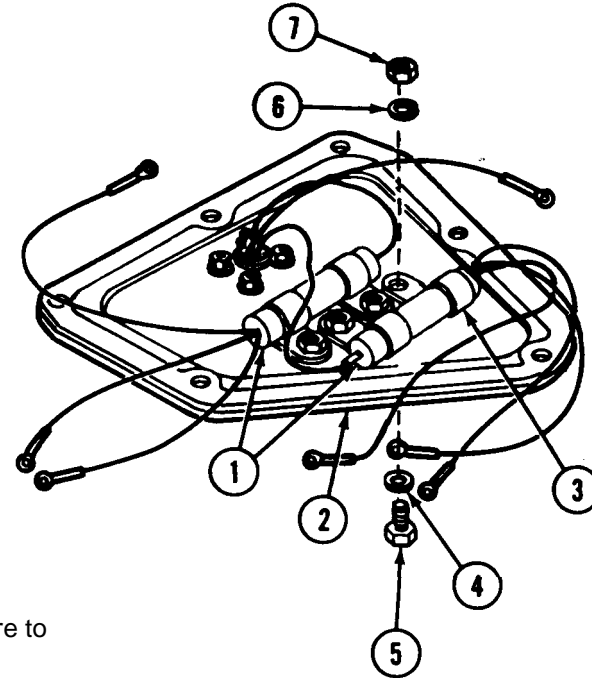

**CAUTION**

Do not break strands on wire when stripping insulation.

b. Electrical receptacle connector (8)

- a. Strip wire insulation on single resistor wire to depth of solder well.
- b. Cut a piece of insulation sleeving 3/4-inch long.
- c. Slide new insulation sleeving on wire A or C.

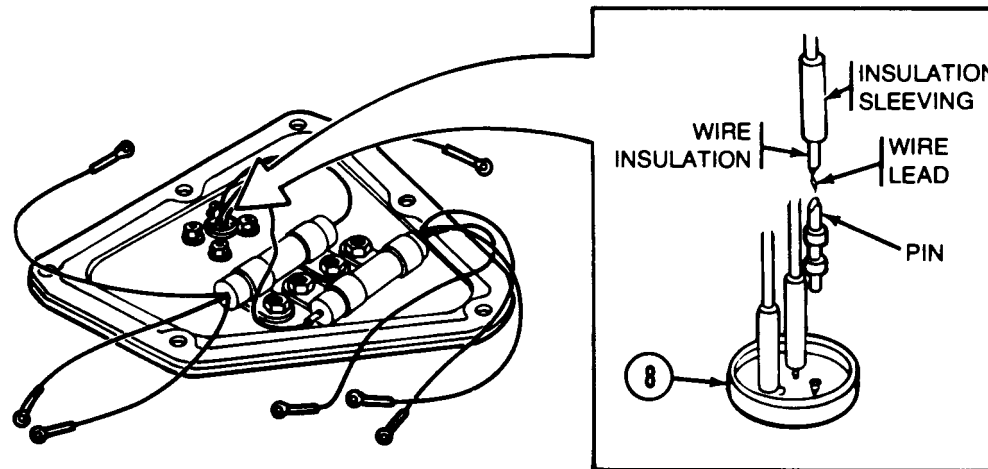

**2-8. DISCHARGERS - MAINTENANCE INSTRUCTIONS (CONT).**

LOCATION	ITEM	ACTION	REMARKS
----------	------	--------	---------

b. Resistors - Maintenance Instructions (Cont).

**INSTALLATION (Cont).**

1 Cover Plate (Cont).

- d. Insert wire lead into pin A or C and solder (item 6, app D). See TB SIG 222
- e. Slide insulation sleeving over soldered connection and heatshrink.
- f. Using remover, insert **A or C into electrical receptacle connector (8).**

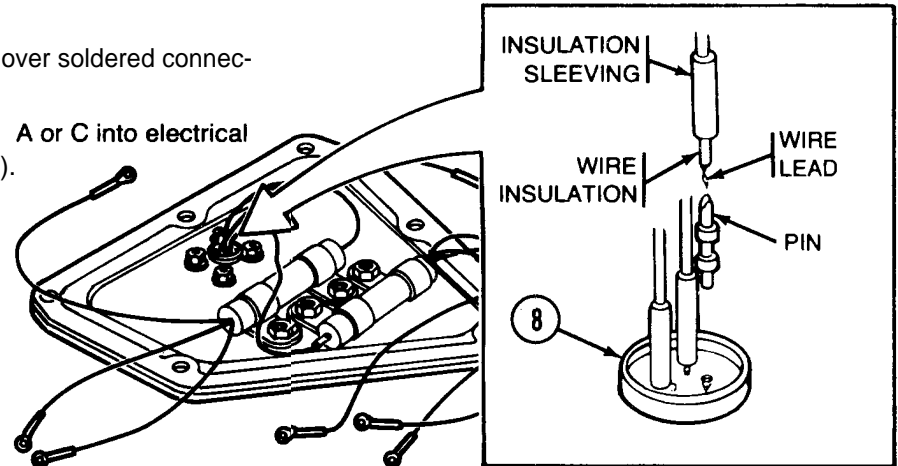

c. Resistor

Connect resistor wire terminals 1 through 6 to end of six jack connectors (9) and install six self-locking nuts (10).

d. Ground wire B

Connect terminal to body with screw (11). Tighten.

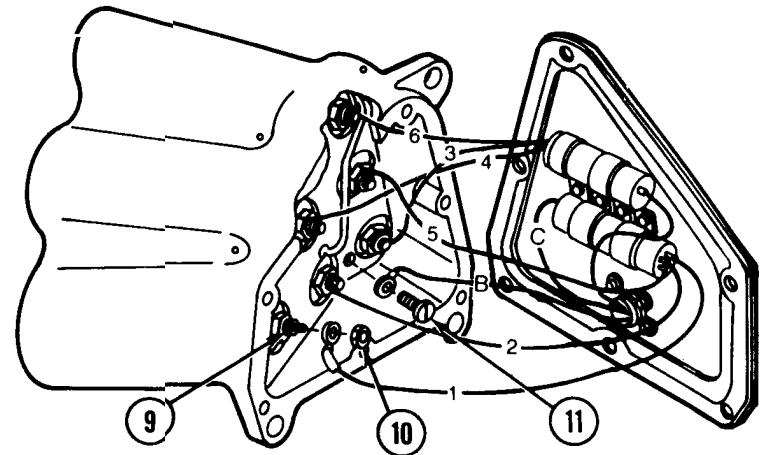

**CAUTION**

To avoid damage to discharger, do not pinch wires between cover plate and body.

2 Body

a. Cover plate (2)

a. Rotate 360° to wind wires.

b. Install on discharger base (12) with six bolts (13) and six lockwashers (14).

b. Bolts (13)

Torque to 48 to 72 inch-pounds.

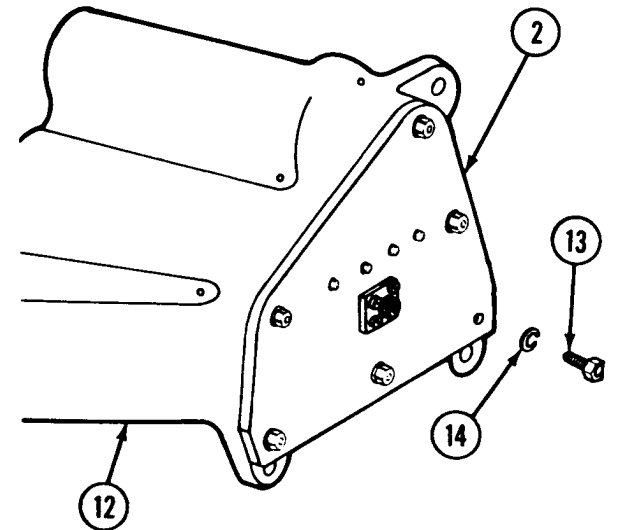

**TESTING**

Discharger

Electrical circuits

Troubleshoot, using multimeter do steps 4 and 5 under malfunction 1 in table 2-1 (para 2-6).

**PAINTING**

Discharger

All outside surfaces

a. Remove burrs, corrosion, and chipped paint.  
 b. Touch up with primer coating (item 4, app D) and enamel (item 3, app D).

See TM 43-0139.

**NOTE**

Do not paint electrical receptacle connector, jack connectors, nameplate, or screws. Do not let paint clog mounting holes or drain holes.

**2-8. DISCHARGERS - MAINTENANCE INSTRUCTIONS (CONT).**

LOCATION	ITEM	ACTION	REMARKS
----------	------	--------	---------

c. Electrical Receptacle Connector - Maintenance Instructions.

**REMOVAL**

**CAUTION**

To avoid damage to discharger, do not put strain on wires.

Make sure electrical receptacle connector key location is marked on cover plate so it can be installed in the same place. If not done, wires can be damaged.

1 Body	a. Cover plate (1)	a. Mark electrical receptacle connector (2) key location.
--------	--------------------	---

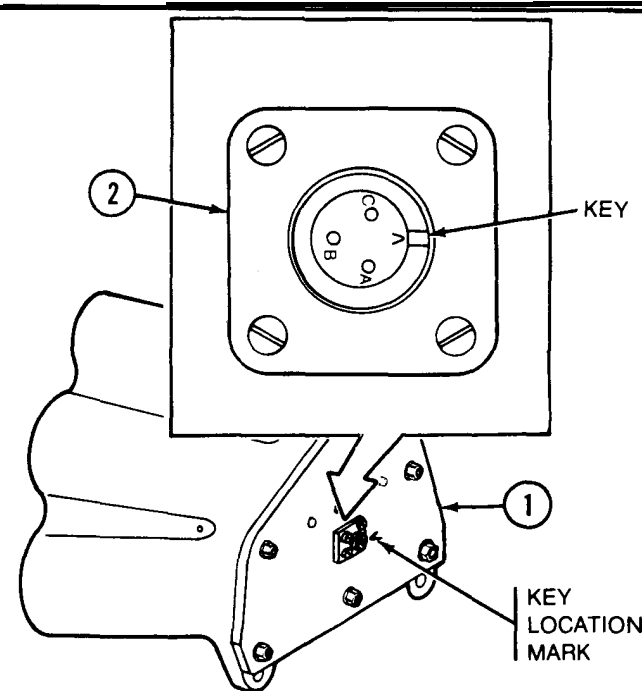

- b. Remove six bolts (3) and six lockwashers (4).
- c. Remove cover plate from body (5).
- d. Rotate 360° to unwind wires.
- e. Prop against body.

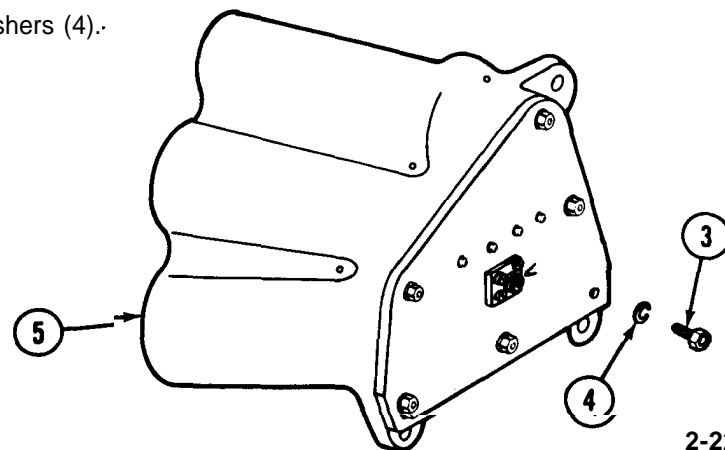

b. Jack connectors (6)

Remove six self-locking nuts (7) and disconnect resistor wires 1 through 6.

c. Ground wire B

Remove ground screw (8) and disconnect terminal.

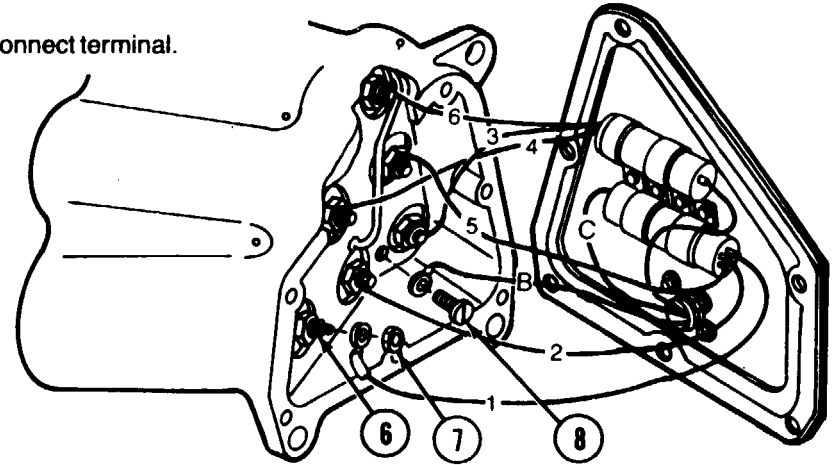

2 Cover Plate

Electrical receptacle connector (2)

a. Remove insulation sleeving and unsolder wire leads from three pins (A, B, and C).

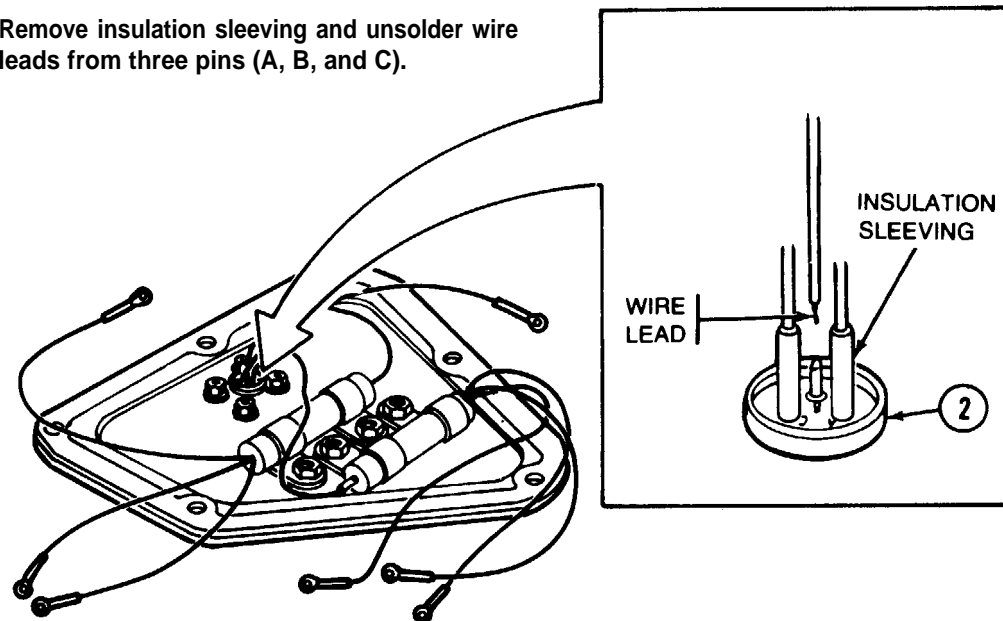

2-8. DISCHARGERS - MAINTENANCE INSTRUCTIONS (CONT).

LOCATION	ITEM	ACTION	REMARKS
----------	------	--------	---------

c. Electrical Receptacle Connector - Maintenance Instructions (Cent).

**REMOVAL (Cent).**

2 Cover Plate (Cent).

Electrical Receptacle Connector (2) (Cent).

- b. Remove four self-locking nuts (9), packings with retainers (10), and screws (11).
- c. Remove electrical receptacle con-plate (1).
- d. Discard items 2 and 10.

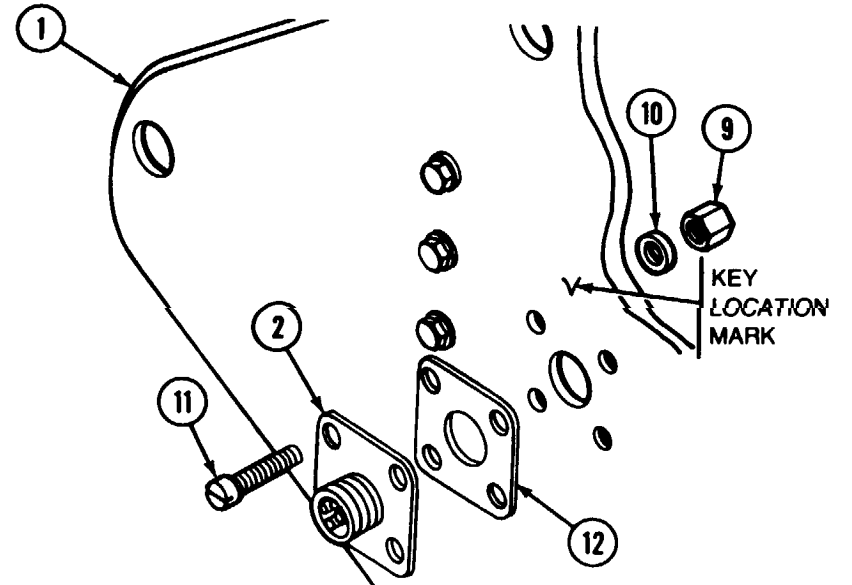

**INSPECTION**

1 Cover Plate

Gasket (1)

- a. Check material. If brittle or torn, scrape gasket from mating surfaces.
- b. Remove protective paper from adhesive on cover plate side of gasket.
- c. Install new gasket on cover plate (2).

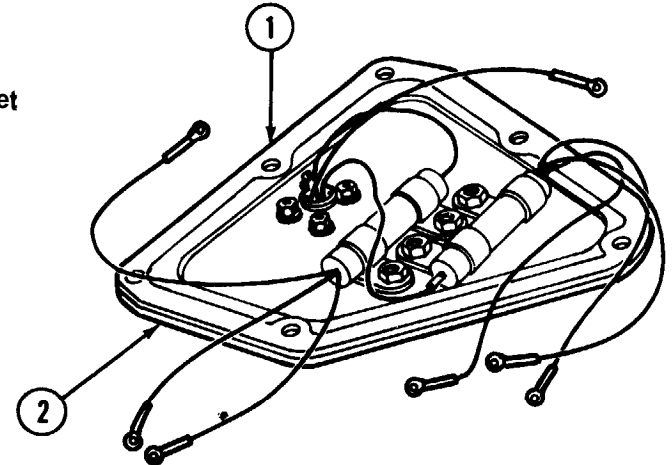

2 Electrical Receptacle Connector

Gasket (3)

Check material, if brittle or torn, replace,

TM 3-1040-268-20&P

**INSTALLATION**

1 Cover Plate

a. Electrical receptacle connector (1)

- a. Insert four screws (2) in electrical receptacle connector (1).
- b. Place gasket (3) on electrical receptacle connector (1).
- c. Aline key with location mark on outside of cover plate (4).
- d. Install on cover plate (4) with four packings with retainers (5) and four self-locking nuts (6). Tighten.

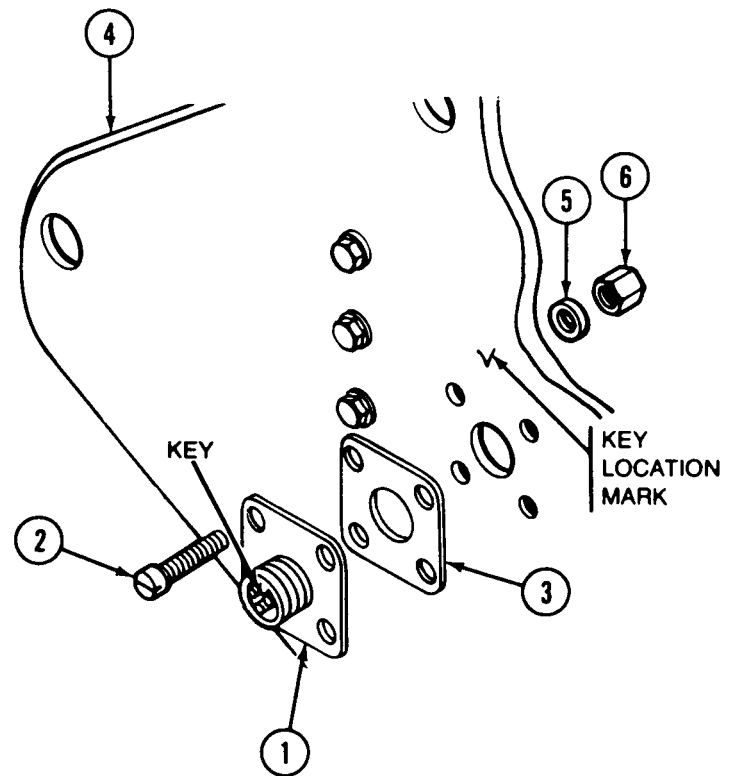
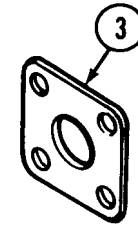

**2-8. DISCHARGERS - MAINTENANCE INSTRUCTIONS (CONT).**

LOCATION	ITEM	ACTION	REMARKS
----------	------	--------	---------

c. Electrical Receptacle Connector - Maintenance Instructions (Cont).

**INSTALLATION (Cont).**

- |                       |  |   |
|-----------------------|--|---|
| 1 Cover Plate (Cont), | a. Electrical Receptacle connector (1) (Cont). | e. Cut three pieces of insulation sleeving 3/4-inch long.<br>f. Slide new insulation sleeveings on wires A, B, and C.<br>g. Using remover, remove pins A, B, and C.<br>h. Insert wire leads into pins A, B, and C and solder See TB SIG 222. (item 6, app D).<br>i. Slide insulation sleeveings over soldered connections and heatshrink. |
|-----------------------|--|---|

**CAUTION**

Make sure that pins soldered to wires A and C are matched with holes A and C in electrical receptacle connector or discharger will fire improper smoke pattern.

- j. Using remover, insert pins A, B, and C into electrical receptacle connector (1).

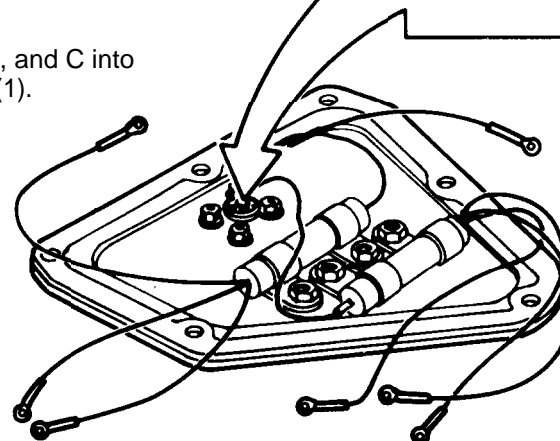
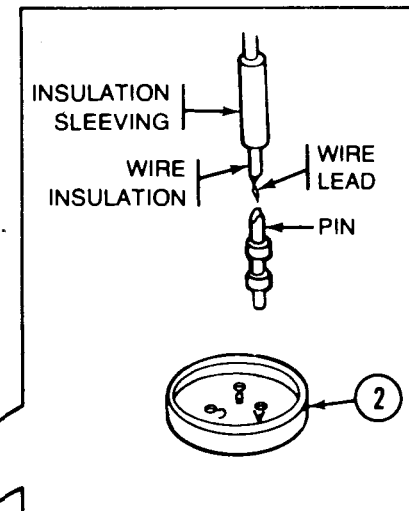

- b. Resistors                      Connect resistor wire terminals 1 through 6 to end of six jack connectors (7) and install six self-locking nuts (8). Tighten.
- c. Ground wire B                Connect terminal to base with screw (9). Tighten.

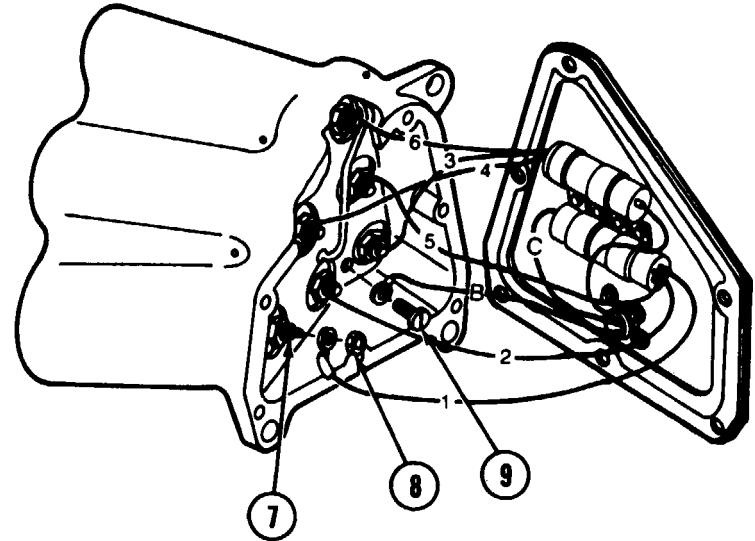

**CAUTION**

To avoid damage to discharger, do not pinch wires between cover plate and discharger base.

2 Body

- a. Cover plate (4)                a. Rotate 360° to wind wires,  
b. Install on body (10) with six bolts (11) and six lockwashers (12).
- b. Bolts (11)                      Torque to 48 to 72 inch-pounds.

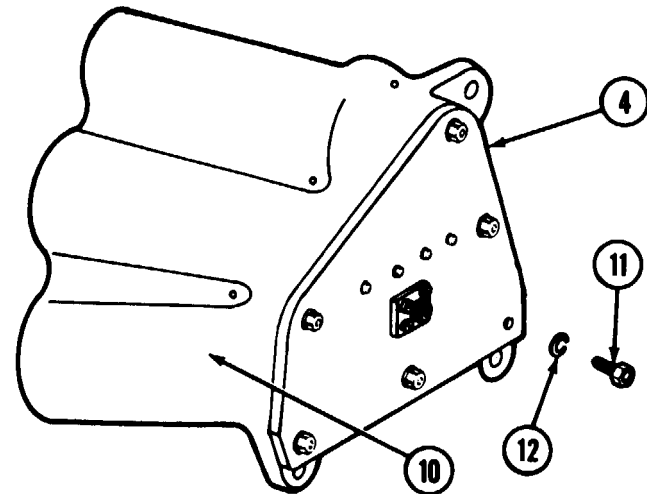

**2-8. DISCHARGERS - MAINTENANCE INSTRUCTIONS (CONT).**

LOCATION	ITEM	ACTION	REMARKS
----------	------	--------	---------

c. Electrical Receptacle Connector - Maintenance Instructions (Cont).

**TESTING**

Discharger	Electrical circuits	Troubleshoot, using multimeter do step 9 under malfunction 1 and step 2, malfunction 2 in table 2-1 (para 2-6).	
------------	---------------------	---	--

**PAINTING**

**NOTE**

Do not paint electrical receptacle connector, jack connectors, nameplate, or screws. Do not let paint clog mounting holes or drain holes.

Discharger	All outside surfaces	a. Remove burrs, corrosion, and chipped paint. b. Touch up with primer coating (item 4, app D), See TM 43-0139. and enamel (item 3, app D).	
------------	----------------------	--	--

**REMOVAL**

**CAUTION**

To avoid damage to discharger, do not put strain on wires.

1 Body

a. Cover plate (1)

a. Remove six bolts (2) and six lockwashers (3).

b. Remove cover plate from body (4).

c. Rotate 360° to unwind wires.

d. Prop against body.

b. Ground wire B

Remove ground screw (5) and disconnect terminal (6).

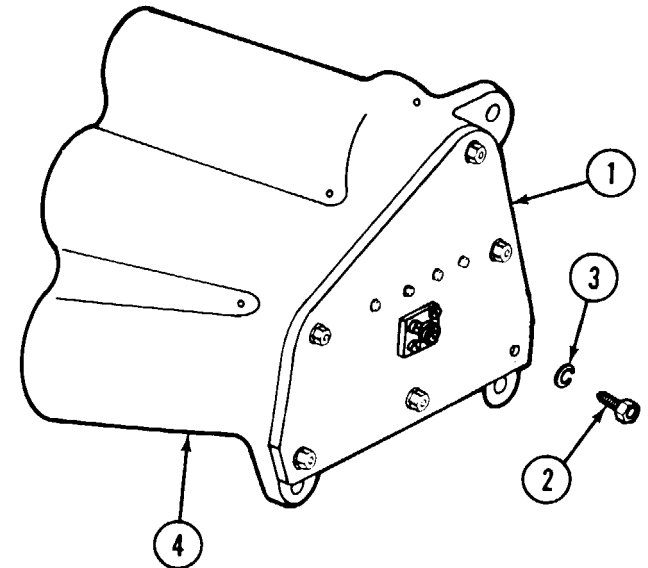

2 Cover Plate

Electrical receptacle connector (7)

a. Using remover, remove pin B.

b. Remove insulation sleeving from ground wire B and unsolder pin B.

c. Keep pin B.

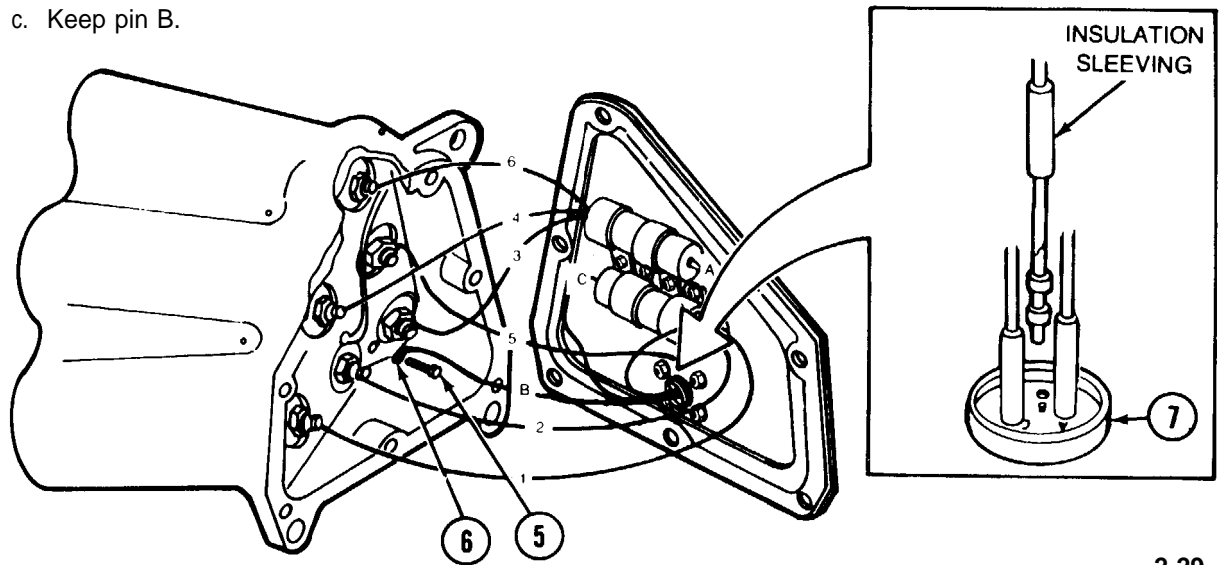

**2-8. DISCHARGERS - MAINTENANCE INSTRUCTIONS (CONT).**

LOCATION	ITEM	ACTION	REMARKS
----------	------	--------	---------

d. Ground Wire - Maintenance Instructions (Cont).

**INSPECTION**

Cover Plate                      Gasket (1)

- Check material. If brittle or torn, scrape gasket from mating surfaces.
- Remove protective paper from adhesive on cover plate side of gasket.
- Install new gasket on cover plate (2).

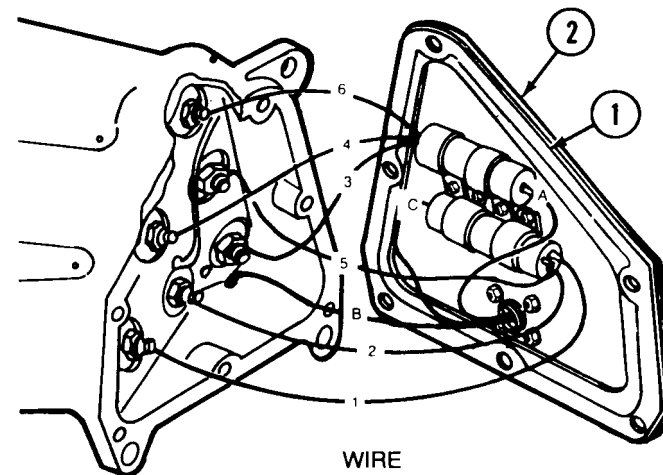

**INSTALLATION**

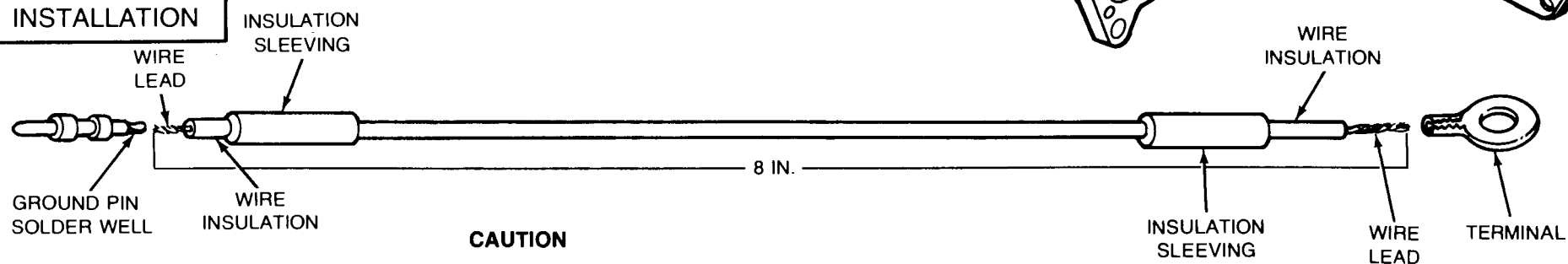

**CAUTION**

Do not break strands on wire when stripping insulation.

1 Electrical Receptacle Connector

Ground wire B

- Cut new wire about 8 inches long.
- Strip insulation to length of terminal sleeve. Insert wire into terminal. Crimp terminal and solder (item 6, app D).
- Cut two pieces of insulation sleeving 3/4 inch long and slide to center of wire.
- Strip insulation to depth of solder well of pin B.
- Insert ground wire B into solder well and solder (item 6, app D).

See TB SIG 222.

See TB SIG 222.

- f. Slide one piece of insulation sleeving over terminal sleeve and heatshrink.
- g. Slide the other piece of insulation sleeving over pin soldered connection and heatshrink.
- h. Using remover, insert pin B into electrical receptacle connector (1).

2 Body

a. Ground wire B

Connect terminal (2) to base with screw (3). Tighten.

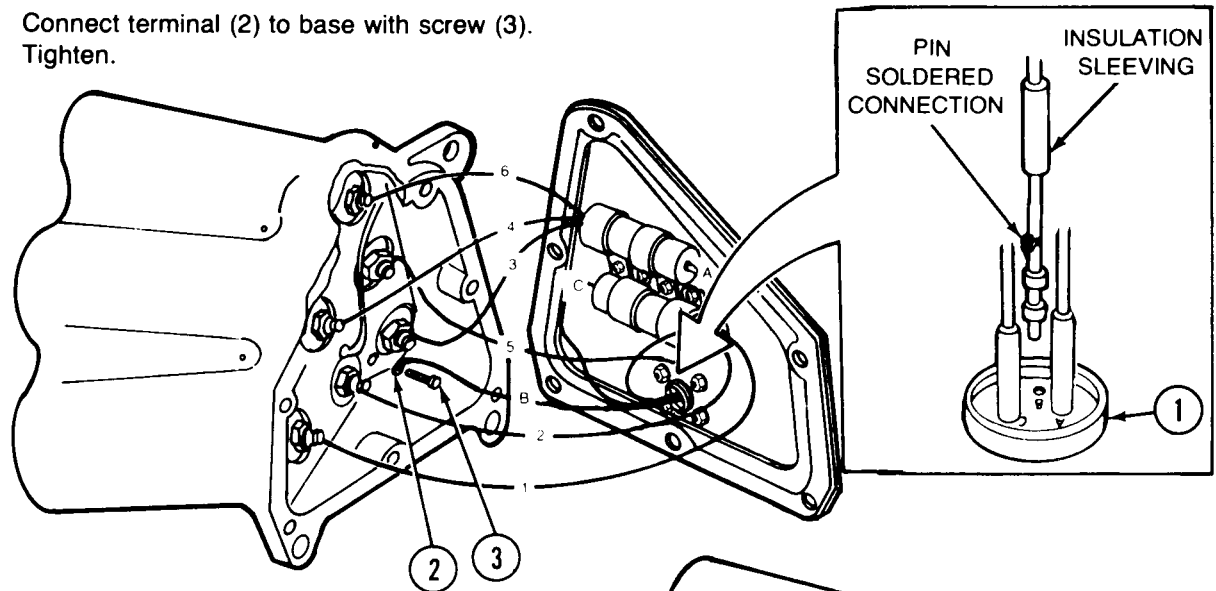

**CAUTION**

To avoid damage to discharger, do not pinch wires between cover plate and discharger base.

- b. Cover plate (4)
- c. Bolts (6)

- a. Rotate 360° to wind wires.
  - b. Install on body (5) with six bolts (6) and six lockwashers (7).
- Torque to 48 to 72 inch-pounds.

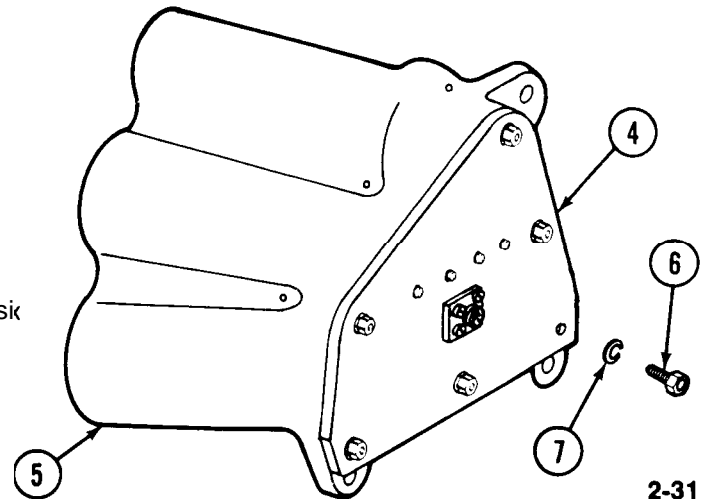

**2-8. DISCHARGERS - MAINTENANCE INSTRUCTIONS (CONT).**

LOCATION	ITEM	ACTION	REMARKS
----------	------	--------	---------

d. Ground Wire - Maintenance Instructions (Cont).

**TESTING**

Discharger	Electrical circuits	Troubleshoot, using multimeter do step 3 under malfunction 1 in table 2-1 (para 2-6).	
------------	---------------------	---	--

**PAINTING**

**NOTE**

Do not paint electrical receptacle connector, jack connectors, nameplate, or screws. Do not let paint clog mounting holes or drain holes.

Discharger	All outside surfaces	a. Remove burrs, corrosion, and chipped paint. b. Touch up with primer coating (item 4, app D), See TM 43-0139. and enamel (item 3, app D).	
------------	----------------------	--	--

**2-9. DISCHARGER COVERS - MAINTENANCE INSTRUCTIONS.** See Section II Service Upon Receipt.

**Section VI. PREPARATION FOR STORAGE OR SHIPMENT**

**2-10. SECURITY PROCEDURES,** The launcher is a nonsensitive item and may be stored or shipped using standard storage and transportation handling procedures.

**2-11. PRESERVATION, PACKAGING, PACKING, MARKING, AND SHIPPING REQUIREMENTS.** Prior to being installed on the combat vehicle, the launcher will be stored in its original shipping container using the same preservation and packing materials described in Section II, Service Upon Receipt.

**2-12. PRESERVATION MATERIALS.** No special preservation materials are required for storage or shipment of the launcher.

**2-13. TYPE OF STORAGE.** Usually, the launcher will require only short term storage of 1 to 45 days before being installed on the combat vehicle. This equipment will be placed in administrative storage (TM 740-90-1) where it can be readied for mission performance within 24 hours. The administrative storage site should protect the launcher from the elements and allow access for visual inspection. No special storage facilities are needed.

## APPENDIX A REFERENCES

---

### A-1. TECHNICAL MANUALS.

TM 11-6625-366-10 . . . . .	Operator's Manual for Multimeter TS-352B/U (NSN 6625-00-552-0142)
TM 38-750 . . . . .	The Army Maintenance Management System (TAMMS)
TM 43-0002-31 . . . . .	Destruction of Chemical Weapons and Defense Equipment to Prevent Enemy Use
TM 43-0139 . . . . .	Painting Instructions for Field Use
TM 740-90-1 . . . . .	Administrative Storage of Equipment

### A-2. TECHNICAL BULLETINS.

TB SIG 222 . . . . .	Solder and Soldering
----------------------	----------------------

### A-3. PAMPHLETS.

DA PAM 310-7 . . . . .	Military Publications: US Army Equipment Index of Modification Work Orders
------------------------	--

### A-4. FIELD MANUALS.

FM 21-11 . . . . .	First Aid for Soldiers
--------------------	------------------------

### A-5. SUPPLY CATALOGS.

SC 4910-95-CL-A74 . . . . .	Shop Equipment Automotive Maintenance and Repair: Organizational Maintenance, Common No. 1, Less Power (NSN 491 0-00-754-0654)(LINW32593) and MAP only (NSN 4910-00-919-0098)
SC 5180-91-CL-R13 . . . . .	Tool Kit, Electronic Equipment, TK-101/G (NSN 5180-00-064-5178) (LINW37483)
SC 5180-95-CL-A51 . . . . .	Tool Kit, Turret Mechanics: (51 80-00-695-01 39) (W57801)

### A-6. SUPPLY BULLETINS.

SB 708-42 . . . . .	Federal Supply Code for Manufacturers'; United States and Canada-Code to Name, (Cataloging Handbook H4-2) (GSA-FSS-H4-2)
---------------------	--

### A-7. COMMON TABLE OF ALLOWANCES.

CTA 50-970 . . . . .	Expendable Items: (Except: Medical Class V, Repair Parts and Heraldic Items)
----------------------	--

### A-8. BLANK FORMS.

DA Form 2028 . . . . .	Recommended Changes to Publications and Blank Forms
DA Form 2028 -2 . . . . .	Recommended Changes to Equipment Technical Manuals
SF 364 . . . . .	Report of Item Discrepancy (ROID)
SF 368 . . . . .	Quality Deficiency Report (Category II)

**APPENDIX B  
MAINTENANCE ALLOCATION CHART**

**Section I. INTRODUCTION**

**B-1. GENERAL.**

a. This section provides a general explanation of all maintenance and repair functions authorized at various maintenance categories.

b. The Maintenance Allocation Chart (MAC) in section II designates overall responsibility for the performance of maintenance functions on the identified end item or component. The implementation of the maintenance functions upon the end item or component will be consistent with the assigned maintenance functions.

c. Section III lists the special tools and test equipment required for each maintenance function as referenced from section II.

**B-2. MAINTENANCE FUNCTIONS.** Maintenance functions will be limited to and defined as follows:

a. *Inspect.* To determine the serviceability of an item by comparing its physical, mechanical, and/or electrical characteristics with established standards through examination.

b. *Test.* To verify serviceability by measuring the mechanical or electrical characteristics of an item and comparing those characteristics with prescribed standards.

c. *Replace.* The act of substituting a serviceable like type part, subassembly, or module (component or assembly) for an unserviceable counterpart.

d. *Repair.* The application of maintenance services or other maintenance actions to restore serviceability to an item by correcting specific damage, fault, malfunction, or failure in a part, subassembly, module (component or assembly), end item, or system.

**B-3. EXPLANATION OF COLUMNS IN THE MAC, SECTION II.**

a. *Column 7, Group Number.* Column 1 lists functional group code numbers, the purpose of which is to identify components, assemblies, subassemblies, and modules with the next higher assembly.

b. *Column 2, Component/Assembly.* Column 2 contains the names of components, assemblies, subassemblies, and modules for which maintenance is authorized.

c. *Column 3, Maintenance Function.* Column 3 lists the functions to be performed on the item listed in column 2. (For detailed explanation of these functions, see para B-2.)

d. *Column 4, Maintenance Category.* Column 4 specifies, by the listing of a work time figure in the appropriate subcolumn(s), the category of maintenance authorized to perform the maintenance function at the indicated category of maintenance. If the number or complexity of the tasks within the listed maintenance function vary at different maintenance categories, appropriate work time figures will be shown for each category. The work time figure represents the average time required to restore an item (assembly, subassembly, component, module, end item, or system) to a serviceable condition under typical field operating conditions. This time includes preparation time, troubleshooting time, and quality assurance/quality control time in addition to the time required to perform the specific tasks identified for the maintenance functions authorized in the maintenance allocation chart. The symbol designations for the various maintenance categories are as follows:

O . . . . . Organizational maintenance.

e. *Column 5, Tools and Equipment.* Column 5 specifies, by code, those common tool sets (not individual tools) and special tools, TMDE, and support equipment required to perform the designated function.

f. *Column 6, Remarks.* This column shall, when applicable, contain a letter code, in alphabetical order, which shall be keyed to the remarks contained in section IV.

**B-4. Explanation OF COLUMNS IN TOOL AND TEST EQUIPMENT REQUIREMENTS, SECTION III.**

- a. Column 1, *Reference Code*. The tool and test equipment reference code correlates with a code used in the MAC, section II. column 5.
- b. *Column 2, Maintenance Category*. The lowest category of maintenance authorized to use the tool or test equipment.

- c. *Column 3, Nomenclature*. Name or identification of the tool or test equipment.
- d. *Column 4, National Stock Number*. The National stock number of the tool or test equipment.
- e. *Column 5, Tool Number*. The manufacturer's part number.

**Section II. MAINTENANCE ALLOCATION CHART  
FOR  
LAUNCHER, GRENADE, SMOKE: SCREENING, RP, M250**

(1) GROUP NUMBER	(2) COMPONENT/ASSEMBLY	(3) MAINTENANCE FUNCTION	(4) MAINTENANCE CATEGORY					(5) TOOLS AND EQUIPMENT	(6) REMARKS
			C	O	F	H	D		
00	M250 SMOKE GRENADE LAUNCHER								
01	SMOKE GRENADE DISCHARGER	Inspect Test Replace Repair		0.2 0.5 0.3 1,5				1 2, 3, 4 2, 3, 4	

**Section III. TOOL AND TEST EQUIPMENT REQUIREMENTS  
FOR  
LAUNCHER, GRENADE, SMOKE: SCREENING, RP, M250**

(1) TOOL OR TEST EQUIPMENT REFERENCE CODE	(2) MAINTENANCE CATEGORY	(3) NOMENCLATURE	(4) NATIONAL/NATO STOCK NUMBER	(5) TOOL NUMBER
1	0	Multimeter	6625-00-553-0142	TS-352B/U or equal
2	0	Tool Kit, Turret Mechanic's	5180-00-695-0139	SC 5180-95-CL-A51
3	0	Electronic Equipment Tool Kit	5180-00-064-5178	SC 5180-91-CL-R13
4	0	Automotive Maintenance and Repair Shop Equipment, Common No. 1	491 0-00-754-0654	SC 4910-95-CL-A74

**APPENDIX C**  
**ORGANIZATIONAL MAINTENANCE REPAIR PARTS AND SPECIAL TOOLS LIST**

Current as of 14 December 1981

**Section I. INTRODUCTION**

**C-1. SCOPE.** This appendix lists spares and repair parts required for performance of organizational maintenance of the grenade launcher. It authorizes the requisitioning and issue of spares and repair parts as indicated by the source and maintenance codes.

**C-2. GENERAL.** This Repair Parts and Special Tools List is divided into the following sections:

a. *Section II. Repair Parts List.* A list of spares and repair parts authorized for use in the performance of maintenance. The list also includes parts which must be removed for replacement, in numerical sequence, with the parts in each group listed in figure and item number sequence. Bulk materials are listed in National Stock Number (NSN) sequence.

b. *Section III. Special Tools List.* Not applicable.

c. *Section IV. National Stock Number and Part Number Index.* A list in National Item Identification Number (NIIN) sequence, of all NSNS appearing in the listings, followed by a list in alphameric sequence of all part numbers appearing in the listings. NSNS and part numbers are cross-referenced to each illustration figure and item number appearance. This index is followed by a cross-reference list of reference designators to figure and item numbers.

**C-3. EXPLANATION OF COLUMNS.**

a. *Illustration.* This column is divided as follows:

(1) *Figure number.* Indicates the figure number of the illustration on which the item is shown.

(2) *Item number.* The number used to identify item called out in illustration.

b. *Source, Maintenance, and Recoverability (SMR) Codes.*

(1) *Source code.* Source codes indicate the manner of acquiring support items for maintenance, repair, or overhaul of end items. Source codes are entered in the first and second positions of the Uniform SMR Code format as follows:

Code	Definition
PA	Item procured and stocked for anticipated or known usage.
PB	Item procured and stocked for insurance purposes because essentiality dictates that a minimum quantity be available in the supply system.
PC	Item procured and stocked and which otherwise would be coded PA except that it is deteriorative in nature.
PD	Support item, excluding support equipment, procured for initial issue or outfitting and stocked only for subsequent or additional initial issues or outfittings. Not subject to automatic replenishment.
PE	Support equipment procured and stocked for initial issue or outfitting to specified maintenance repair activities.
PF	Support equipment which will not be stocked but which will be centrally procured on demand.
PG	Item procured and stocked to provide for sustained support for the life of the equipment. It is applied to an item peculiar to the equipment which, because of probable discontinuance or shutdown of production facilities, would prove uneconomical to reproduce at a later time.
KD	An item of a depot overhaul/repair kit and not purchased separately. Depot kit defined as a kit that provides items required at the time of overhaul or repair.
KF	An item of a maintenance kit and not purchased separately. Maintenance kit defined as a kit that provides an item that can be replaced at organizational or intermediate levels of maintenance.
KB	Item included in both a depot overhaul/repair kit and a maintenance kit.
MO	Item to be manufactured or fabricated at organizational level.
MF	Item to be manufactured or fabricated at the direct support maintenance level.

Code	Definition
MH	Item to be manufactured or fabricated at the general support maintenance level.
MD	Item to be manufactured or fabricated at the depot maintenance level.
AO	Item to be assembled at organizational level.
AF	Item to be assembled at direct support maintenance level.
AH	Item to be assembled at general support maintenance level.
AD	Item to be assembled at depot maintenance level.
XA	Item is not procured or stocked because the requirements for the item will result in the replacement of the next higher assembly.
XB	Item is not procured or stocked. If not available through salvage, requisition.
XC	Installation drawing, diagram, instruction sheet, field service drawing, that is identified by manufacturer's part number.
XD	A support item that is not stocked. When required, item will be procured through normal supply channels.

**NOTE**

Cannibalization or salvage maybe used as a source of supply for any items coded above, except those coded XA.

(2) *Maintenance code.* Maintenance codes are assigned to indicate the levels of maintenance authorized to USE and REPAIR support items. The maintenance codes are entered in the third and fourth positions of the Uniform SMR Code format as follows:

(a) The maintenance code entered in the third position will indicate the lowest maintenance level authorized to remove, replace, and use the support item. The maintenance code entered in the third position will indicate one of the following levels of maintenance.

Code	Application/Explanation
C	Crew or operator maintenance performed within organizational maintenance.
O	Support item is removed, replaced, used at the organizational level.
F	Support item is removed, replaced, used at the direct support level.
H	Support item is removed, replaced, used at the general support level.

Code	Application/Explanation
D	Support items that are removed, replaced, used at depot, mobile depot, or specialized repair activity only.  (b) The maintenance code entered in the fourth position indicates whether the item is to be repaired and identifies the lowest maintenance level with the capability to perform complete repair (i.e., all authorized maintenance functions). This position will contain one of the following maintenance codes:

Code	Application/Explanation
O	The lowest maintenance level capable of complete repair of the support item is the organizational level.
F	The lowest maintenance level capable of complete repair of the support item is the direct support level.
H	The lowest maintenance level capable of complete repair of the support item is the general support level.
D	The lowest maintenance level capable of complete repair of the support item is the depot level.
L	Repair restricted to specialized repair activity. Not applicable.
Z	Nonreparable. No repair is authorized.
B	No repair is authorized. The item may be reconditioned by adjusting, lubricating, etc, at the user level. No parts or special tools are procured for the maintenance of this item.

(3) *Recoverability code.* Recoverability codes are assigned to support items to indicate the disposition action on unserviceable items. The recoverability code is entered in the fifth position of the Uniform SMR Code format as follows:

Recoverability Code	Definition
Z	Nonreparable item. When unserviceable, condemn and dispose at the level indicated in position 3.
O	Reparable item. When uneconomically repairable, condemn and dispose at organizational level.
F	Reparable item. When uneconomically repairable, condemn and dispose at the direct support level.

Recoverability Code	Definition
H	Reparable item. When uneconomically reparable, condemn and dispose at the general support level.
D	Reparable item. When beyond lower level repair capability, return to depot. Condemnation and disposal not authorized below depot level.
L	Reparable item. Repair, condemnation, and disposal not authorized below depot/specialized repair activity level.
A	Item requires special handling or condemnation procedures because of specific reasons (i.e., precious metal content, high dollar value, critical material, or hazardous material). Refer to appropriate manuals/directives for specific instructions.

- c. *National Stock Number.* Indicates the NSN assigned to the item and which will be used for requisitioning.
- d. *Part Number.* Indicates the primary number used by the manufacturer (individual, company, firm, corporation, or Government activity), which controls the design and characteristics of the item by means of its engineering drawings, specifications, standards, and inspection requirements to identify an item or range of items.

**NOTE**

When a stock numbered item is requisitioned, the item received may have a different part number than the part being replaced.

- e. *Federal Supply Code for Manufacturer (FSCM).* The FSCM is a 5-digit numeric code listed in SB 708-42 which is used to identify the manufacturer, distributor, or government agency, etc.
- f. *Description.* Indicates the Federal item name and, if required, a minimum description to identify the item. The physical security classification of the item is indicated by the parenthetical entry. Items that are included in kits and sets are listed below the name of the kit or set with the quantity of each item in the kit or set indicated in the quantity incorporated in unit column. When the part to be used differs between serial numbers of the same model, the effective serial numbers are shown as the last line of the description. In the Special Tools List, the initial basis of issue (BOI) appears as the last line in the entry for each special tool, special TM DE, and other special support equipment. When density of equipments supported exceeds density spread indicated in the basis of issue, the total authorization is increased accordingly.
- g. *Unit of Measure (UIM).* Indicates the standard of the basic quantity of the listed item as used in performing the actual maintenance function. This

measure is expressed by a two-character alphabetical abbreviation (e.g., ea, in., pr, etc). When the unit of measure differs from the unit of issue, the lowest unit of issue that will satisfy the required units of measure will be requisitioned.

h. *Quantity Incorporated in Unit.* Indicated the quantity of the item used in the breakout shown on the illustration figure, which is prepared for a functional group, subfunctional group, or an assembly. A “V” appearing in this column in lieu of a quantity indicates that no specific quantity is applicable, (e.g., shims, spacers, etc.).

**C-4. HOW TO LOCATE REPAIR PARTS.**

- a. *When National Stock Number or Part Number is Unknown:*
  - (1) *First.* Using the table of contents, determine the functional group within which the repair part belongs. This is necessary since illustrations are prepared for functional groups, and listings are divided into the same groups.
  - (2) *Second.* Find the illustration covering the functional group to which the repair part belongs.
  - (3) *Third.* Identify the repair part on the illustration and note the illustration figure and item number of the repair part.
  - (4) *Fourth.* Using the Repair Parts Listing, find the figure and item number noted on the illustration.
- b. *When National Stock Number or Part Number is Known:*
  - (1) *First.* Using the Index of National Stock numbers and Parl numbers, find the pertinent NSN or part number. This index is in NIIN sequence followed by a list of part numbers in alphameric sequence, cross-referenced to the illustration figure number and item number.
  - (2) *Second.* After finding the figure and item number, locate the figure and item number in the repair parts list.

**C-5. ABBREVIATIONS.**

Abbreviation	Explanation
CAD-PLTD	cadmium plated
HD	head
IN.	inch
LH	left hand
NO.	number
RH	right hand
STL	steel
UNC	Unified coarse thread
UNJF	Unified national series fine thread



Section II. REPAIR PARTS LIST

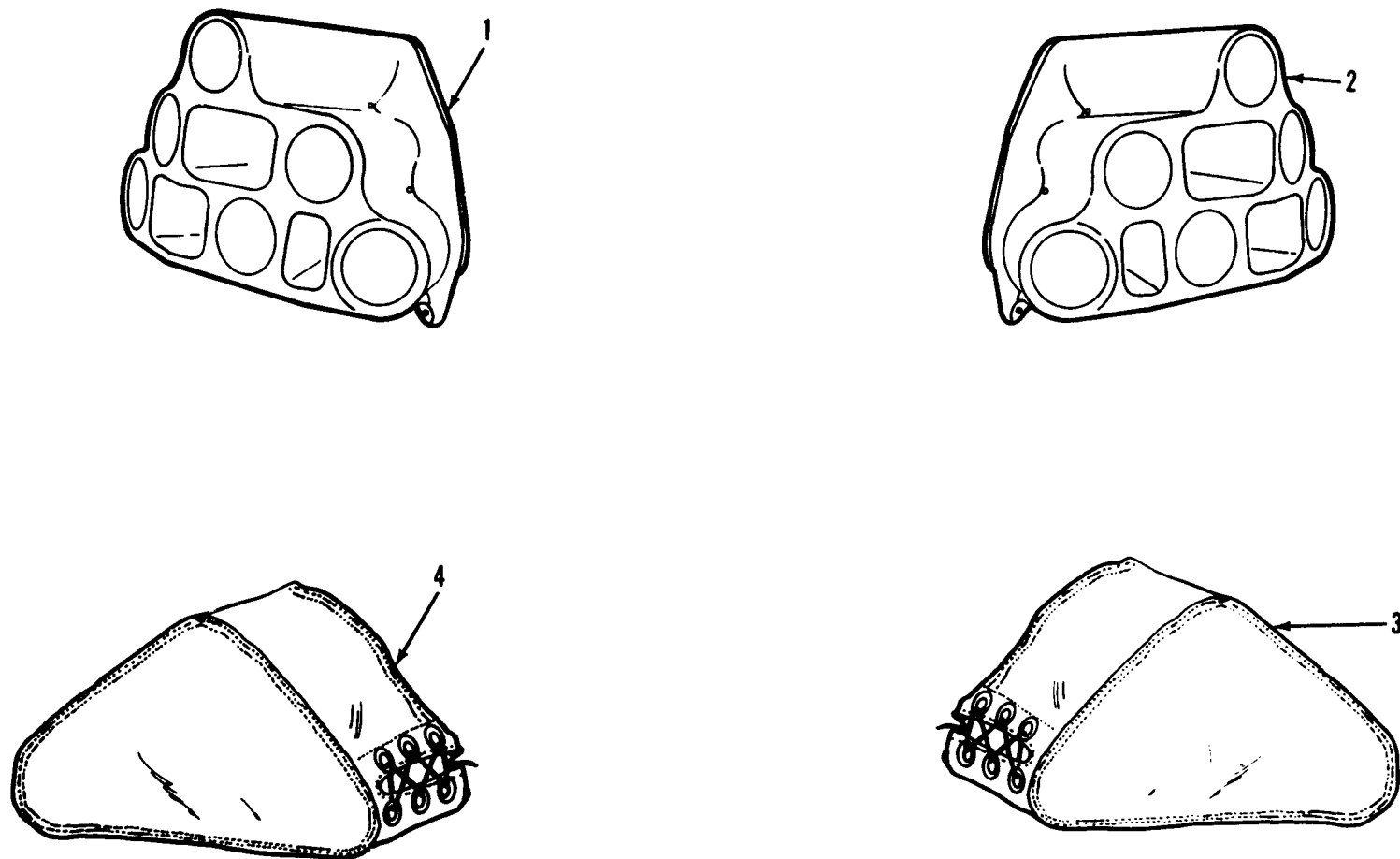

ARA81-0104

Figure C-1. M250 RP Screening Smoke Grenade Launcher Components

(G3 Blank)/C-4

(1) ILLUSTRATION (a) FIG NO	(2) (b) ITEM NO	(3) SMR CODE	(4) NATIONAL STOCK NUMBER	(5) FSCM	(6) PART NUMBER	(7) DESCRIPTION USABLE ON CODE	(8) QTY INC IN UNIT
						TM3-1040-258-20&P GROUP 00 M250 SMOKE GRENADE LAUNCHER	
C-1	1	PAOOO	1040-99-965-8028	U0795	13-12-34	DISCHARGER, SMOKE GRENADE, L.H., NO 19, MK 2	EA 1
C-1	2	PAOOO	1040-99-965-8029	U0795	13-12-35	DISCHARGER, SMOKE GRENADE, R.H., NO 19, MK 2	EA 1
C-1	3	PAOZZ	1040-01-043-7896	K6897	13-12-35	COVER, PROTECTIVE, DISCHARGER, RH	EA 1
C-1	4	PAOZZ	1040-01-042-3861	K6897	13-12-34	COVER, PROTECTIVE, DISCHARGER, LH	EA 1

CHANGE 1

C-5



(1) ILLUSTRATION (a) FIG NO	(2) (b) ITEM NO	(3) SMR CODE	(4) NATIONAL STOCK NUMBER	(5) PART NUMBER	TM3-1040-268-20&P (6) DESCRIPTION	(7) USABLE ON CODE U/M	(8) QTY INC IN UNIT
					GROUP 01 SMOKE GRENADE DISCHARGER, MK 2		
					RH- 13-12-35 LH- 13-12-34		
C-2	1	XAOZZ		81361 13-12-52	BODY,L.H.	EA	1
C-2	1	XAOZZ		81361 13-12-51	BODY, R.H.	EA	1
C-2	2	PAOZZ	330-01-181-351	81361 13-12-71	GASKET	EA	2
C-2	3	PAOZZ	5310-00-176-634	96906 MS17830-06C	NUT,SELF-LOCKING,HE STL,0.138-32UNC-3B	EA	4
C-2	4	PAOZZ	5310-00-880-597	96906 MS15795-806	WASHER,FLAT CRES,DIA 0.156	EA	4
C-2	5	PAOZZ	1040-99-965-803	81361 13-12-73	RESISTOR PACK ASSEMBLY	EA	1
C-2	6	PAOZZ	1040-01-172-472	81361 13-12-50	COVER,ACCESS	EA	1
C-2	7	PAOZZ	5330-01-014-122	80205 NAS1523C06B	PACKING WITH RETAINER CRES,BUNA-N, NO.6 SCREW SIZE	EA	4
C-2	8	PAOZZ	5305-00-054-665	96906 MS51957-30	SCREW, MACHINE CRES, 0.138-32UNC-2A X 0.500	EA	4
C-2	9	PAOZZ	5330-00-641-433	96906 MS52000-4	GASKET SYNTHETIC RUBBER	EA	1
C-2	10	PAOZZ	5935-00-801-661	96906 MS3102R14S7P	CONNECTOR, RECEPTACL ELECTRICAL, STYLE 10, CONTACT STYLE AD9	EA	1
C-2	11	PAOZZ	5305-00-054-565	96906 MS51957-17	SCREW, MACHINE PAN HEAD, CRES, NO 4-40UNC-2A X 0.500	EA	4
C-2	12	PAOZZ	5306-00-021-362	96906 MS35307-331	BOLT, MACHINE CRES, 0.312-1BNC-2A X 0.625 LO	EA	6
C-2	13	PAOZZ	5310-00-974-662	96906 MS35338-140	WASHER, LOCK ST1,OD 0.586 IN, HOLE DIA 0.138 IN	EA	6
C-2	14	PAOZZ	5330-00-119-750	80205 NAS1523C04Y	PACKING WITH RETAINER CRES AND BUNA-N, NO. 4 SCREW SIZE	EA	4
C-2	15	PAOZZ	5310-00-177-133	96906 MS17830-04C	NUT, SELF-LOCKING, HE CRES, 0.112-40UNC-3B	EA	4
C-2	16	PADZZ	1040-99-965-803	81361 13-12-72	RESISTOR PACK ASSEMBLY	EA	1
C-2	17	MOOZZ		81349 MIL-W-16878/7	WIRE, ELECTRICAL MFD FROM NSN 6145-00-477-0409	EA	2
C-2	18	PAOZZ	5305-00-054-666	96906 MS51957-42	SCREW,MACHINE CRES,0.164-32UNC-2A X 0.312	EA	1

CHANGE 1

C-7

(1) ILLUSTRATION (a) FIG NO	(2) (b) ITEM NO	(3) SMR CODE	(4) NATIONAL STOCK NUMBER	(5) FSCM	(6) PART NUMBER	(6) DESCRIPTION	(7) USABLE ON CODE	(7) U/M	(8) QTY INC IN UNIT
C-2	19	PAOZZ	5940-00-079-8324	96906	MS35430-5	TERMINAL,LUG		EA	1
C-2	20	MOOZZ		81349	M23053/5-104-0	INSULATION SLEEVING MFD FROM NSN 5970-00-812-2969		EA	1
C-2	21	PAOZZ	5305-00-253-5612	96906	MS21318-15	SCREW,DRIVE ROUND HEAD TYPE U STEEL CADE PLD		EA	4
C-2	22	PBOZZ	9905-01-188-5901	81361	13-12-67-1	PLATE,IDENTIFICATION		EA	1
C-2	22	PBOZZ	9905-01-181-5629	81361	13-12-67-2	PLATE,IDENTIFICATION		EA	1
C-2	23	PAOZZ	1040-99-965-8869	81361	13-12-99	CONTACT, ELECTRICAL		EA	6

(1) ILLUSTRATION (a) FIG NO	(2) (b) ITEM NO	(3) SMR CODE	(4) NATIONAL STOCK NUMBER	(5) FSCM	(6) PART NUMBER	TM3-1040-268-20&P DESCRIPTION	(7) USABLE ON CODE U/M	(8) QTY INC IN UNIT
						GROUP 0999 -BULK MATERIAL		
BULK	PADZZ		5970-00-812-2969	81349	M23053/5-104-0	INSULATION SLEEVING ELECTRICAL	FT	V
BULK	PAOZZ		6145-00-477-0409	81349	MIL-W-16878/7	WIRE,ELECTRICAL	FT	V

SECTION III. SPECIAL TOOLS LIST

NOT APPLICABLE.

SECTION IV. NATIONAL STOCK NUMBER AND PART NUMBER INDEX

STOCK NUMBER	FIGURE NO.	ITEM NO.	STOCK NUMBER	FIGURE NO.	ITEM NO.
5306-00-021-3623	C-2	19	5310-00-974-6623	C-2	18
5305-00-054-5651	C-2	16	5310-00-989-5525	C-2	5
5305-00-054-6654	C-2	13	5330-01-014-1228	C-2	12
5305-00-054-6667	C-2	24	1040-01-042-3861	C-1	4
5940-00-079-8324	C-2	25	1040-01-043-7896	C-1	3
5330-00-119-7501	C-2	20	1040-99-965-8028	C-1	1
5310-00-176-6341	C-2	8	1040-99-965-8029	C-1	2
5310-00-177-1332	C-2	21	1040-99-965-8032	C-2	10
6145-00-477-0409	BULK		1040-99-965-8033	C-2	22
5330-00-641-4338	C-2	14	5330-99-965-8034	C-2	7
5935-00-801-6616	C-2	15	5330-99-965-8035	C-2	7
5970-00-812-2969	BULK		1040-99-965-8869	C-2	1
5310-00-880-5976	C-2	9			

FSCM	PART NUMBER	FIGURE NO.	ITEM NO.	FSCM	PART NUMBER	FIGURE NO.	ITEM NO.
K6897	FV578934	C-1	3	96906	MS17830-04C	C-2	21
K6897	FV578937	C-1	4	96906	MS17830-06C	C-2	8
U0795	FV754932, FV435710, FV754935	C-2	2	96906	MS3102R14S7P	C-2	15
U0795	FV754942	C-2	1	96906	MS35307-331	C-2	19
U0795	FV856006	C-1	1	96906	MS35335-65	C-2	4
U0795	FV856007	C-1	2	96906	MS35338-140	C-2	18
K6897	FV856008	C-2	26	96906	MS35430-5	C-2	25
K6897	FV856009	C-2	26	96906	MS35691-39	C-2	5
K6897	FV856015	C-2	11	96906	MS51957-17	C-2	16
U0795	FV856018	C-2	7	96906	MS51957-30	C-2	13
U0795	FV856019	C-2	7	96906	MS51957-42	C-2	24
U0795	FV856026	C-2	10	96906	MS52000-4	C-2	14
U0795	FV856027	C-2	22	81349	M23053/5-104-0	C-2	17
81349	MIL-W-16878-7	C-2	23	81349	M23053/5-104-0	BULK	
81349	MIL-W-16878/7	BULK		80205	NAS1523C04Y	C-2	20
96906	MS15795-806	C-2	9	80205	NAS1523C06B	C-2	12
96906	MS178030-06C	C-2	6	K6897	300-010-1911-02	C-2	3

**APPENDIX D  
EXPENDABLE SUPPLIES AND MATERIALS LIST**

---

**Section I. INTRODUCTION**

**D-1. SCOPE.** This appendix lists expendable supplies and materials you will need to operate and maintain the launcher. These items are authorized to you by CTA 50-970, Expendable Items (Except Medical, Class V, Repair Parts, and Heraldic Items).

**D-2. EXPLANATION OF COLUMNS.**

a. *Column 1--Item Number.* This number is assigned to the entry in the listing and is referenced in the narrative instructions to identify the material (e.g., "Use cleaning compound, item 1, app D").

b. *Column 2--Level.* This column identifies the lowest level of maintenance that requires the listed item.

O . . . . . Organizational Maintenance

c. *Column 3--National Stock Number.* This is the National stock number assigned to the item; use it to request or requisition the item.

d. *Column 4--Description.* Indicates the Federal item name and, if required, a description to identify the item. The last line for each item indicates the Federal Supply Code for Manufacturer (FSCM) in parentheses followed by the part number.

e. *Column 5--Unit of Measure (U/M).* Indicates the measure used in performing the actual maintenance function. This measure is expressed by a two-character alphabetical abbreviation (e.g., ea, in., pr). If the unit of measure differs from the unit of issue, requisition the lowest unit of issue that will satisfy your requirements.



SECTION II. EXPENDABLE SUPPLIES AND MATERIALS LIST				
(1)	(2)	(3)	(4)	(5)
ITEM NUMBER	LEVEL	NATIONAL STOCK NUMBER	DESCRIPTION	U/M
1	0	6850-00-224-6663	CLEANING COMPOUND, RIFLE BORE: (RBC), 1-GAL (3.785 LITERS) CAN (81349) MIL-C-372	GL
2	0	8305-00-222-2423	CLOTH, CHEESECLOTH: COTTON, 38-1/2 IN. (97.790 CM) W (81348) FED SPEC CCC-C-440, TYPE 1 CLASS 1	YD
3	0	8010-00-111-7937	ENAMEL: FOREST GREEN, (81349) MIL-E-52798	GL
4	0	8010-00-582-5318	PRIMER COATING: 1 GAL CAN (81348) TT-P-1757	GL
5	0	8520-00-228-0598	SOAP, TOILET: LIQUID, 1-GAL (3.785 LITERS) CONTAINER (81348) FED SPEC P-S-624, TYPE 1	GL
6	0	3439-00-555-4629	SOLDER, TIN ALLOY: ROSEN CORE, SN 60, TYPE SN60WRP2 1 LB (81348) QQ-S-571	SL

ALPHABETICAL INDEX

<i>Subject</i>	<i>Page</i>	<i>Subject</i>	<i>Page</i>
<b>A</b>		<b>F</b>	
Abbreviations . . . . .	1-1	Forms, records, and reports, maintenance . . . . .	1-1
Alphabetical Index . . . . .	Index-1	<b>G</b>	
<b>C</b>		General information . . . . .	1-1
Checking unpacked equipment . . . . .	2-1	Grenade discharger-smoke-maintenance instructions . . . . .	2-12
Cleaning- discharger . . . . .	2-14	<b>H</b>	
<b>D</b>		How to use this manual . . . . .	iii
Common tools and equipment. . . . .	2-1	<b>I</b>	
Connector, discharger electrical receptacle-maintenance instructions . . . . .	2-22	improvement recommendations (EIR), reporting equipment . . . . .	1-1
Connectors, discharger jack-maintenance instructions . . . . .	2-13	Initial setup Discharger-maintenance instructions . . . . .	2-12
<b>E</b>		Inspection Service upon receipt-launcher . . . . .	2-1
Destruction of Army materiel to prevent enemy use . . . . .	1-1	Installation Discharger covers . . . . .	2-32
Discharger-maintenance instructions . . . . .	2-12	Discharger electrical receptacle connector . . . . .	2-25
Discharger covers-maintenance instructions . . . . .	2-32	Discharger jack connectors . . . . .	2-14
Discharger electrical receptacle connector-maintenance instructions . . . . .	2-22	Discharger resistors . . . . .	2-19
Discharger jack connectors-maintenance instructions . . . . .	2-13	Instructions, maintenance . . . . .	2-12
Discharger resistor-maintenance instructions . . . . .	2-16	Introduction-maintenance procedures . . . . .	2-12
<b>E</b>		<b>J</b>	
(EIR)Reporting equipment improvement recommendations . . . . .	1-1	Jack connectors, discharger-maintenance procedures . . . . .	2-13
Electrical receptacle connector, discharger-maintenance instructions . . . . .	2-22		
Equipment description and data . . . . .	1-2		
Equipment characteristics, capabilities, and features . . . . .	1-2		
Equipment data . . . . .	1-3		
Location and description of major components . . . . .	1-2		
Expendable Supplies and Materials List . . . . .	D-1		

<i>Subject</i>	<i>Page</i>
<b>L</b>	
Launcher	
Principles of operation . . . . .	1-4
Service upon receipt . . . . .	2-1
Location and description of major components . . . . .	1-2
<b>M</b>	
Maintenance allocation chart . . . . .	B-0
Maintenance forms, records, and reports . . . . .	1-1
Maintenance instructions . . . . .	2-1
Discharger . . . . .	2-12
Discharger covers . . . . .	2-32
Discharger electrical receptacle connector . . . . .	2-22
Discharger jack connectors . . . . .	2-13
Discharger resistor . . . . .	2-16
Smoke grenade discharger . . . . .	2-12
M250 Launcher	
Principles of operation . . . . .	1-4
<b>N</b>	
Nomenclature cross-reference list . . . . .	1-1
<b>P</b>	
Painting-discharger . . . . .	2-28
Preparation for storage or shipment . . . . .	1-1
Preservation materials . . . . .	2-32
Preservation, packaging, packing, marking, and shipping, requirements . . . . .	2-32
Security procedures . . . . .	2-32
Type of storage . . . . .	2-32
Preventive Maintenance Checks and Services (PMCS)	
PMCS procedures . . . . .	2-4
Principles of Operation	
M250 Launcher . . . . .	1-4

<i>Subject</i>	<i>Page</i>
<b>R</b>	
References . . . . .	A-1
Repair parts, special tools list . . . . .	C-0
Repair parts, special tools, TMDE, and support equipment . . . . .	2-1
Common tools and equipment. . . . .	2-1
Repair parts and materials . . . . .	2-1
Special tools, TMDE, and support equipment . . . . .	2-1
Removal	
Discharger electrical receptacle connector . . . . .	2-22
Discharger jack connectors . . . . .	2-13
Discharger resistors . . . . .	2-16
Reporting equipment improvement recommendations (EIR) . . . . .	1-1
Resistor discharger-maintenance instructions . . . . .	2-16
<b>S</b>	
Security procedures . . . . .	2-32
Service upon receipt . . . . .	2-1
Checking unpacked equipment . . . . .	2-1
Service upon receipt-launcher. . . . .	2-1
Smoke grenade discharger, maintenance instructions . . . . .	2-12
Special tools, TMDE, and support equipment . . . . .	2-1
<b>T</b>	
Testing	
Discharger electrical receptacle connector . . . . .	2-27
Discharger jack connectors . . . . .	2-15
Discharger resistors . . . . .	2-18
Service upon receipt-launcher . . . . .	2-1
Troubleshooting	
Discharger won't fire . . . . .	2-5
Discharger always fires six grenades . . . . .	2-11
Troubleshooting procedures. . . . .	2-5
Type of storage . . . . .	2-32

RECOMMENDED CHANGES TO EQUIPMENT TECHNICAL PUBLICATIONS



THEN...JOT DOWN THE DOPE ABOUT IT ON THIS FORM. CAREFULLY TEAR IT OUT, FOLD IT AND DROP IT IN THE MAIL!

SOMETHING WRONG WITH THIS PUBLICATION?

FROM: (PRINT YOUR UNIT'S COMPLETE ADDRESS)  
Your mailing address.

DATE SENT

PUBLICATION NUMBER  
TM 3-1040-268-20&P

PUBLICATION DATE  
Date of TM

PUBLICATION TITLE Org Maint Manual  
(Including RPSTL) Launcher, Grenade,  
Smoke: screening RP, M250.

BE EXACT...PIN-POINT WHERE IT IS

PAGE NO.	PARA-GRAPH	FIGURE NO.	TABLE NO.
2-4	STEP 3b		2-1

IN THIS SPACE TELL WHAT IS WRONG AND WHAT SHOULD BE DONE ABOUT IT:

DELETE "continuity."

REASON: There is no "continuity" on the face of the meter. The desired location on the meter is 0 (zero).

NOTE TO THE READER:

Your comments will go directly to the writer responsible for this manual, who will prepare the reply that is returned to you. To help evaluation of your recommendations, please explain the reason for each of your recommendations, unless the reason is obvious. All comments will be appreciated, and will be given immediate attention. Handwritten comments are acceptable.

For your convenience, blank "tear out" forms, preprinted, addressed, and ready to mail, are included in this manual.

**SAMPLE**

TEAR ALONG DOTTED LINE

PRINTED NAME, GRADE OR TITLE, AND TELEPHONE NUMBER

SIGN HERE  
Your Name



RECOMMENDED CHANGES TO EQUIPMENT TECHNICAL PUBLICATIONS



THEN...JOT DOWN THE DOPE ABOUT IT ON THIS FORM. CAREFULLY TEAR IT OUT, FOLD IT AND DROP IT IN THE MAIL!

SOMETHING WRONG WITH THIS PUBLICATION?

FROM: (PRINT YOUR UNIT'S COMPLETE ADDRESS)

DATE SENT

PUBLICATION NUMBER

TM 3-1040-268-20&P

PUBLICATION DATE

14 May 82

PUBLICATION TITLE

Org Maint Manual  
(Including RPSTL) Launcher, Grenade,  
Smoke: screening RP, M250.

BE EXACT...PIN-POINT WHERE IT IS

PAGE NO.	PARA-GRAPH	FIGURE NO.	TABLE NO.

IN THIS SPACE TELL WHAT IS WRONG AND WHAT SHOULD BE DONE ABOUT IT:

TEAR ALONG DOTTED LINE

PRINTED NAME, GRADE OR TITLE, AND TELEPHONE NUMBER

SIGN HERE

FILL IN YOUR  
UNIT'S ADDRESS

FOLD BACK

DEPARTMENT OF THE ARMY

OFFICIAL BUSINESS

Commander  
US Army Armament Materiel Readiness Command  
ATTN: DRSAR-MAS-C  
Aberdeen Proving Ground, MD 21010

TEAR ALONG DOTTED LINE



FILL IN YOUR  
UNIT'S ADDRESS

FOLD BACK

**DEPARTMENT OF THE ARMY**

**OFFICIAL BUSINESS**

TEAR ALONG DOTTED LINE

Commander  
US Army Armament Materiel Readiness Command  
ATTN: DRSAR-MAS-C  
Aberdeen Proving Ground, MD 21010

RECOMMENDED CHANGES TO EQUIPMENT TECHNICAL PUBLICATIONS



THEN...JOT DOWN THE DOPE ABOUT IT ON THIS FORM, CAREFULLY TEAR IT OUT, FOLD IT AND DROP IT IN THE MAIL!

SOMETHING WRONG WITH THIS PUBLICATION?

FROM: (PRINT YOUR UNIT'S COMPLETE ADDRESS)

DATE SENT

PUBLICATION NUMBER

TM 3-1040-268-20&P

PUBLICATION DATE

14 May 82

PUBLICATION TITLE

Org Maint Manual  
(Including RPSTL) Launcher, Grenade,  
Smoke: screening RP, M250.

BE EXACT...PIN-POINT WHERE IT IS

PAGE NO.	PARA-GRAPH	FIGURE NO.	TABLE NO.
----------	------------	------------	-----------

IN THIS SPACE TELL WHAT IS WRONG AND WHAT SHOULD BE DONE ABOUT IT:

TEAR ALONG DOTTED LINE

PRINTED NAME, GRADE OR TITLE, AND TELEPHONE NUMBER

SIGN HERE

FILL IN YOUR  
UNIT'S ADDRESS



FOLD BACK

**DEPARTMENT OF THE ARMY**

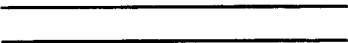

**OFFICIAL BUSINESS**

TEAR ALONG DOTTED LINE

Commander  
US Army Armament Materiel Readiness Command  
ATTN: DRSAR-MAS-C  
Aberdeen Proving Ground, MD 21010

By Order of the Secretary of the Army

Official:

ROBERT M. JOYCE  
*Brigadier General, United States Army*  
*The Adjutant General*

E. C. MEYER  
*General, United States Army*  
*Chief of Staff*

Distribution:

To be distributed in accordance with DA Fom 12-28, Organizational Maintenance Requirements for Launcher, Grenade, Smoke: Screening, RP, M250.

